

Installing the Hurry-up Hybrid Pistol Wing-T

Installation of the Hybrid Pistol Wing-T with Run
and Play Action Passes



Multi-media Instructional Guides

Jerry Campbell

Dedication / Introduction

DEDICATION

I would like to dedicate this manual to Lyle Lansdel. I consider Coach Lansdel one of the finest football coaches anywhere based upon his dedication to the game and to helping young people become better people and to appreciate the lessons that football teaches us all. Coach Lansdel thanks for all you have done for the Campbell family.

INTRODUCTION

The following information is designed to take those coaches interested in installing the Hybrid Pistol Wing-T Offense through the complete installation with terms and illustrations. The Hybrid Pistol Wing-T Offense is designed to formation an offense into controlling the box, spreading the defense with multiple formations, motion, misdirection plays and reading uncovered receivers. The difference between the Wing-T Offense and the Hybrid Pistol Wing-T Offense is the location of the fullback and the quarterback. With the Gun Offense you have a back that is offset to one side of the quarterback and with the Pistol Offense you have the back located directly behind the quarterback. By aligning the running back behind the quarterback you create fewer tendencies.

This manual is designed in playbook form and designed to take you through terms and definitions, which will give you a foundation for which to build your Hybrid Pistol Wing-T Offense. The blocking schemes included in this manual are built around the use of zone and man blocking schemes. A few coaches I meet, say why zone blocking! Well, zone blocking is the easiest way for picking up blitzes and tracking linebackers while working in tandem with another lineman; zone blocking is the easiest way to make blocking adjustments when requiring a combination between two adjacent players whether it comes from our tight end and wing or two inside linemen.

I have had the great pleasure to have coached in several different states in this country with each state with its own influences. I have found through my experience that trying to gain advantages by controlling the number of defenders a defense puts in the box can be done by using multiple formations, motion, misdirection plays, passing and running the option. The option game is an offense of its own.

Things To Think About

It will always be my great pleasure to help any coach or football program that would like to know more about the installation of the Hybrid Pistol Wing-T Offense.

THINGS TO THINK ABOUT

The following statements outline a few basic ideas to follow when talking about the Hybrid Pistol Wing-T Offense:

The offensive philosophy centers on misdirection, no huddle and a fast pace tempo when running plays.

Coaches and players must PREPARE, PRACTICE, and PERFORM with a real sense of urgency. Achieve your first goal "WIN THE GAME."

Must make your opponent defend your multiple Formations and stop the misdirection plays along with an option attack with the Quarterback, Fullback, and Wing Backs in the running game.

Control the box by FORMATIONS, MOTION, MISDIRECTION, PLAY ACTION PASSES and OPTION GAME.

Use a variety of formations to help the Pistol Wing-T sets vs defensive schemes.

Establish the RUN and PASSING game through the Hybrid Pistol Wing-T offense with multiple formations. Use motion to achieve movement by the defense, and get best possible position for your play action and sprint out passing game.

Slow the defense by utilizing misdirection running plays along with the option game, straight dropback pass, sprint out and play action game. The option game with the Hybrid Pistol Wing-T installation is primarily used to control the BOX. Don't allow your opponent the ability to gang up on your offense inside.

Things To Think About

Make your opponent honor the outside run so you can set up the inside game.

Don't hold a coaching clinic at practice. Practice means practice; REPETITION, REPETITION.

Have a goal for each practice segment, create enthusiasm, and work with a real sense of urgency.

A goal for group and team periods during practice should be to run 2 ½ plays per minute. Coach on the run.

Make all TECHNIQUE and DRILLS fit your offense. Think your drills and technique out. Only practice technique and use drills that apply to plays that fit the offense.

Always technique situations, talk technique as it applies to certain defensive situations. Talk the WHAT IF's.

Push the PLAYERS and COACHES to perform on the run. Don't allow your opponent to teach you that lesson.

Must capitalize on what the defense gives you (fumbles, interceptions) return the favor (score).

Never underestimate your player's ability to learn. Their inability to learn is usually a coach's inability to understand his teaching progression as it applies to the offense.

The offensive installation will be installed according to open and tight sides. Don't use the words strong and weak.

As you start a football game you can sequence your formations to see how your opponent lines up - does their alignment confirm your scouting reports.

Coaches and players should never embarrass the team, themselves and the offense. The coaching staff must understand the system better than anyone else. TAKE PRIDE IN YOUR WORK.

Things To Think About

Keep in mind when making suggestions for changes; does it fit the head coaches and offensive coordinators philosophy as it applies to the overall success of the team and to the offense.

The offense is broken down into 6 phases:

- 1.Regular Run Plays
- 2.Misdirection Running Plays
- 3.Passing Game
- 4.Goal Line
- 5.Sudden Change
- 6.2 minute

Quarterbacks will never understand their pre-snap reads if their coach doesn't understand them.

Quarterbacks must be schooled to understand their pre-snap reads as it applies to the way the offense is being installed.

EXAMPLE: What can we run Vs the following defensive alignments?

- 5 - 7 Technique
- 9 Technique
- 3 - 2 Technique

Running Back's can't be satisfied with just carrying the ball, they must be able to block and catch.

Running back coach must understand the offensive line blocking schemes so he can convey this to his running backs.

Coaches must understand the defensive drops and alignments by the secondary to better understand the passing game, watch video.

Wide Receiver's in the Hybrid Pistol Wing-T offensive approach must be blockers first, and catchers second. Remember, the Wide Receiver's ability to run block will set up the passing game.

Basic Practice and Development Considerations For Installing and Developing Your Position Players

Basic Practice and Development Considerations For Installing and Developing Your Position Players

1. Give each player a chance to succeed and be positive; we are only as good as the last guy. So, how good will that player be?
2. Push players to max physical efforts.
3. Make your group "Drill Atmosphere" full speed.
4. Teach at top position skill level.
5. Correct all techniques and assignment errors "Immediately".
6. Maintain position discipline - control action - stress execution.
7. Teach high percentage repetitions, with low percentage group discussion, develop position skills.
8. Skills are perfected by "Repetition" - move players fast during drills.
9. Begin new practice segments as fast as possible - predict effort.
10. We must continuously teach tackling and proper pursuit and contain, emphasis first key reactions.
11. Teach the easiest way to complete the assignment - learn from repetitions.
12. As a position coach stress basic skill techniques, the game is secondary.
13. Instill a practice work ethic - force players to practice "Hard".
14. Be persistent in demanding that techniques are performed correctly.
15. Coach at near game like player reaction.
16. Plan and only use position drills that relate to specific position assignments.
17. End practice segments on the whistle - start new drill as soon as possible.
18. Always bring practice schedule with you to practice.
19. When working with other groups (example OL vs DL) get your group ready quickly - do not wait for the other group - you need reps.
20. The most important point to remember is; your coaching image can change the football life of your position players.

Defensive Position Recognition

Defensive Position Recognition

The following information will give you the defensive terminology used throughout this manual to describe position assignments.

E- Defensive End

T-Defensive Tackle

M-Mike (callside) Inside Linebacker

W-Will (backside) Inside Linebacker

S-Sam (callside) Outside Invert

R-Rover (backside) Outside invert

F - Free Safety

C -Corner

It should be noted that depending upon the type of coverage being used, the Outside Inverts Sam and Rover could be aligned in several different positions. As you examine the different offensive plays the following legend is used to illustrate the different defensive positions.

INSTALLING THE SNAP COUNT

The following instructions for installing the Hybrid Pistol Wing-T snap count is the key to making this a unique hybrid style of an offense. Due to the fact that the Hybrid Pistol Wing-T is a hurry-up offense the snap count is a little different and motion is used on almost every play. Motion is started when the quarterback raises his hands to accept the snap from center.

Snap Counts:

Set - Go is the basic snap count used to get plays started and the ball snapped.

When the quarterback hears the formation called from the sideline he will repeat it to his teammates. After the quarterback sees that everyone is lined up properly he will raise his hands up from his side to receive the snap and the motion player will start his motion. The ball is snapped on the "S" of Set- "Go". You can use the freeze snap by using the Set-Go, Go, Go. By utilizing the Freeze snap you now have the advantage of a varied snap count.

The following pages will illustrate and demonstrate the full implementation of the Pistol offense. The Pistol is a natural for moving from a Gun Formation to a Pistol set.

So Goes The Offense; So Goes The Offensive Line
"The Little Things"

SO GOES THE OFFENSE; SO GOES THE OFFENSIVE LINE.
"THE LITTLE THINGS"

There is no position in football that requires more discipline or technique than being an offensive lineman. The success of any football team, hinges on its ability to control the line of scrimmage. To win consistently, you must win in the trenches and that means playing on your opponent's side of the line of scrimmage, not yours. Information contained in this section is my personal beliefs, which you can use to install the Hybrid Pistol Wing-T Offense.

It is my approach, like many other line coaches that we out - execute our opponents. This is a lot easier said than done! To take this approach and to believe in this philosophy means a great deal of time must be spent on fundamentals and blocking technique. My primary goal as I prepare our blocking schemes is that they be simple and that they have a basic rule that can tie them all into one another. Thus, we try keeping the rules and line calls simple, it will give us the chance to perfect our techniques and perform them in an aggressive manner.

To be a good offensive line requires more than just discipline or good blocking technique. It requires "PRIDE" -- pride in yourself; your group; and your team. A team with "PRIDE" is a hard team to beat. It's my believe, the faster your offensive line understands that working for common goals as a group not as individuals builds your foundation for UNITY and PRIDE.

A group that's unified is more apt to do the "LITTLE THINGS" that most teams are not willing to do. No detail should ever be overlooked, regardless of how non-important it may look on the surface. The difference between WINNING and LOSING often lies in the failure to do the little things! Not every offensive lineman that plays for you will make it to the NFL or COLLEGE or be an ALL-AMERICAN or even a STARTER, but every offensive lineman that decides to play for you can hustle and hit and be a good TEAM PLAYER.

The Basic Fundamentals - "The Little Things"

The following examples are the "LITTLE THINGS" that I expect from my offensive line.

THE BASIC FUNDAMENTALS - "THE LITTLE THINGS"

THE HUDDLE - The Hybrid Pistol Wing-T is a no huddle hurry up offense from the Pistol instead of under center which makes it a Hybrid offense for Wing-T football. Once a play has been run the offense will get back to the line of scrimmage with a sense of urgency waiting for the next call to be made. All eleven offensive players work off of wrist bands that have codes in which plays will be called. By working off of wrist bands allows you to huddle on the line of scrimmage thus keeping your opponent from running players in and out of the game. You will have one coach designated to signal or yell verbally first the formation to be used and then the code for the wrist bands.

THE SNAP COUNT - In order to control the L.O.S., it is extremely important that you execute the starting count. The single greatest advantage that the offensive line has over the defense is that you know when the ball will be snapped and where the play is going. Not enough emphasis can be put on the line to get off on the snap count together. It's my experience that sometimes we get so caught up in the football game that we don't hear the snap count or we just forget it prior to the snap of the ball. So, how do I ask for the snap count while on the L.O.S.? What I teach is the following:

THE PRE-SNAP SET - can be handled in several different ways, according to the beliefs of the coach. In our system the offensive line is required upon reaching the L.O.S. to get down in their pre-snap playing position, which is a three-point stance. The center becomes a very important factor when getting to the L.O.S. It is the center that the rest of the offensive line sets their stance on, so, the center must get to the L.O.S. and get set.

The Basic Fundamentals - "The Little Things"

THE STANCE - GUARDS/ TACKLES- I believe that a good stance no matter what level of football you are coaching is basic to sound execution. The stance you are teaching must directly relate to the plays you are running. Without a good stance, your offensive line will be unable to execute their assignments and techniques properly. The stance we teach is a three-point stance with the weight basically distributed over the inside of the feet with as little weight on the down hand as possible. It is extremely important that you be consistent with your stance - be able to make all necessary movements from the same stance. Your run stance must look like your passing stance. Defensive players are always "alert" for anyone "tipping" their intentions by changing their stance.

NOTE: We will allow the offensive line to alter their stance only in short yardage, goal line, and obvious passing situations.

Base: - Shoulder width but never wider. (If the base is too wide, it tends to cause to false step or to over extend the base on the snap of the ball).

Feet: - "Toes" pointing slightly out - to get to this position you need to emphasize "heels" slightly in. This position will force your power through the inside of the knee to the "balls" of your feet. NEVER allow the back heel on the staggered foot to come off the ground more than 1/2 inch. This is important for maximum traction on get-off.

Stagger: - Stagger the feet so that there is a 2 to 3 inch relationship between the up foot and the back foot. Never more than a heel to toe relationship. The stagger relationship is geared to the right and left handed stance. The offensive linemen playing on the right side of the center will play from a right handed stance and those playing on the left side will play from a left handed stance. The purpose for the right and left handed stance helps to keep the zone steps uniform and to help with our drop back pass protection.

Elbows and Hands: Elbows resting slightly above the knee or off to the side. The hands should be relaxed and not forming a fist, this helps in their get-off (don't be tense).

Shoulders - Back - Tail: You want your shoulders square to the L.O.S. with the back flat or parallel to the ground. The tail should be an extension of the back and NOT in a squatted or drooping position.

Head and Neck: You want the head and neck to be an extension to shoulders, back, and tail. You want the neck to be in a semi-bowed position but not in a "bulled-neck" position that forces the tail to drop.

The Basic Fundamentals - "The Little Things"

Power Producing Angles: The stagger of the feet places the up foot in a position to create power producing angles in the ankles and knees. This is called a "Z" in the knee. To get this position, slightly roll the This will place the weight on the balls of the feet - outside heel may come slightly off the ground.

INITIAL MOVEMENT: As an offensive lineman you must be able to explode out of your stance; your back parallel to the ground - make sure your going FORWARD NOT UPWARD. We want our offensive linemen always stepping with their near foot when exploding off the L.O.S. as it applies to scheme and play called. It will be necessary at times to shift your weight from one foot to the other - this can be a mental shift rather than a physical one.

CENTER'S STANCE AND EXCHANGE: The stance that I teach the offensive center is a three point stance with weight distributed evenly over the "full bottom" of both feet, with little weight forward. I want very little weight placed on the football itself.

Base: Slightly wider than the shoulders with the feet perpendicular to the L.O.S. - no stagger.

Feet: The feet must be parallel as much as possible but never more than 2 to 3 inch stagger.

Shoulders - Back - Tail: Shoulders must be square to the L.O.S. with the back parallel to the ground. I want the center's tail to be at least as high as the shoulders (this will keep his hips up) to facilitate the snap.

Initial Movement: We want the center to explode out of his stance with his back parallel. Step with the near foot when exploding out to block or as it applies to the blocking scheme. **DO NOT ANTICIPATE THE SNAP COUNT.** Snapping the ball early penalizes the rest of the offensive linemen by giving the defense an advantage. Snap the ball on the proper command.

Position of the Ball: The ball should be placed slightly to the right eye and forward of the center's head. **EXTENDING THE BALL IN FRONT OF YOU** will give you better cut-off angles, because the defenders will not be as close to you or the rest of the offensive line.

The Grip: The football is placed so that the laces are facing up. Grip the ball by placing your right thumb between the second and third lace nearest the front end of the ball. The fingers and palm of the hand will grip the ball on the side so as to have complete control of the ball. The arm should be extended with your wrist straight. **NEVER** allow your arm to be bent, as this will cause a bad snap.

The Basic Fundamentals - "The Little Things"

Effecting the Snap: Snap the ball by turning the wrist one-quarter turn without bending your elbows. This should be one quick movement and is a lifting action. Slap the ball against the quarterback's hand. The quarterback should take the ball from you - NEVER throw the ball to the quarterback. Snapping and stepping with the proper foot should be one of continuous movement. The Center must be the quarterback of the offensive line. The center is responsible for making calls recognizing defensive fronts and alerting the rest of the offensive line to all changes. The center must have a clear understanding of the concept of plays used in the offense. The center must make calls loud and clear!

ALIGNMENT AND SPLITS - "THE LITTLE THINGS" make the difference. In order for an offensive line to be successful with its plays, they need to play smart. Understanding splits as it applies to the inside run and outside run becomes an important factor. An offensive lineman needs to understand that a wider split helps the inside game and a tighter split benefits the outside game (helps restrict the defense). Certain plays that require combination blocks by two adjoining linemen must have a sense about themselves when working together.

OFFENSIVE LINE CONCEPTS

INSTALLING THE HYBRID DIAMOND and PISTOL WING-T OFFENSE

To be fundamentally tough and sound, each offensive lineman must know what is required of him and how to master these requirements. Descriptive words can help this process. Blocking can be developed to a greater degree than any other phase of football because it is the most un-natural task. It requires patience and many hours of "hard work" there are many things to learn.

The more techniques you can learn and master, the easier it will be to cope with various situations. Repetition must be accepted as a way of life for a blocker, success can only be brought about with tremendous confidence in one's ability. Concentration, self-discipline, communication, and the willingness to pay the price are part of being a respected offensive lineman.

Determined, intelligent, and aggressive blocking is an indispensable quality of a great football team, from both a technical and psychological standpoint. It is difficult for a team, to have outstanding morale, confidence, and enthusiasm when it lacks the ability to sustain a great ground game or provide adequate protection for the passer. As an offensive line coach you must reinforce daily to your players the importance of controlling the football. A goal for our football team is that whenever we start the game with the football, we must make a first down.

The Basic Fundamentals - "The Little Things"

You must make a statement to your opponents, that indeed, we can move the football on them. Make a psychological statement as well as a physical one.

The difference between a great blocker and a fair one is the fractional time between contact and the follow through. The finishing off of any block must be constantly repeated and reinforced on a daily basis. Effective line play begins in the huddle. Upon hearing the play called by the quarterback, start to visualize your assignment and possible adjustments or calls at the line of scrimmage. Keep the snap count continually in mind. If an offensive lineman is slow getting off on the snap count for any reason, he can expect to get beat. It is impossible to be aggressive when you are uncertain. The following phrases and words help me describe technique.

Nine Phases of A Proper Base Block: (one - on - one)

- 1.Short first position step, also called base step.
- 2.Second step must be an explosive up field base step.
- 3.Low shoulder level. (pad control)
- 4.Good punch.
- 5.Good arm extension.
- 6.Strike a blow.
- 7.Wide base.
- 8.Heels in - toes out.
- 9.Finish.

A term I use and one I picked up from Les Steckels when he coached for Denver Broncos is "THE FIRST STEP TIES, THE SECOND STEP WINS" its that second step that helps the finish. Keep your feet alive. Plays with a base don't allow your feet to come together. The following terms are descriptive terms that I will use throughout the following chapters.

Descriptive Terms To Be Used:

Descriptive Terms To Be Used:

1. Get off! Ability to accelerate off the L.O.S. using proper technique.
2. Short steps - never allow yourself to over stride (big, long, or high choppy steps). Must keep your feet in the ground where you have power.
3. Keep "heels in - toes out" focus your energy on the inside of your feet, this gives you more push power.
4. Never get too much weight going forward, don't allow your weight to get out over your toes. Be fast, but also under control.
5. Make contact by rolling the hips through the defender. Hit on the rise, head-up, bull the neck.
6. Punch up through the defenders chest. Control the peck plates on the shoulder pads.
7. Become part of the tackle on each play. Stick to the defender. Maintain a good wide base at all times which will allow you to stick to the defender without being shed off.
8. Versus any type of movement, nothing should change. Short steps will allow you to react to the defender. To get a feel for when a defender is going to stunt, he usually is going to change his alignment up, sense it and prepare mentally, make your calls accordingly.
9. Once you've developed the art of the one - on - one base block, this will now carry over into all different types of blocking schemes.
10. Two important points to remember when run blocking:
 - a. Always take the proper step in the direction you are going (no false steps).
 - b. Proper point of aim. Must understand the play and where it is going.

Descriptive Terms To Be Used:

The word "Base" is an alert word used in a one - on - one blocking situation and you have no combo responsibility. Any combination block such as ACE, DEUCE and TREY alerts that two adjacent linemen will be working in combo with each other looking for a down lineman and linebacker combination.

The following terms will help tie in the running and passing game, which will be, illustrated in future chapters.

"TERMS"DEFINITIONS

Be Part of the Tackle: Always stick to the defender, using all of your basic fundamentals and techniques. Never find yourself on the ground.

Point of Aim (P.O.A.): Must know where the ball is going, use the proper steps and know where you strike point is. Using the proper P.O.A. will help eliminate the defender from crossing your face.

1/2 Man Advantage: Term used to explain proper positioning in pass pro. Always work from an inside out position on the defender take the 1/2 man advantage, make the defender pass rush you from the outside not from the inside. Used in drop back protection.

Front Door / Back Door: This expression is used to describe possible shades that defenders will play through. If a defender is on the front side of a combination block he is considered a front door player. If a defender is playing on an inside shade of the outer most blocker he is considered a back door player.

Look up Thru the Window: The window is the positioning of the hands in pass pro. Bring the two thumbs together forming a window. When punching a defender on pass rush look up thru the window, this will help in keeping the butt down.

Punch up Thru the Window: Punch up thru the window with the point of aim thru the top of the defenders numbers.

Shoulders Opposite The Punch: In pass pro never allow the shoulders drifting out over your center of gravity. Whenever a punch is delivered the shoulders should always go opposite the punch. You don't want the shoulders to follow the punch.

Descriptive Terms To Be Used:

From Low to High: Term used for run blocking. Starts with good low shoulder level, working into the defender and gradually rising into the defender. Use your base for power. Heels in toes out.

Use Your Eyes: The best tools an offensive lineman has are his eyes. What you see tells your brain what to do. If your head is down, nothing goes into your brain. Eyes up, see what you strike.

Show Your Numbers: Term used for pass blocking. To get into the correct pass blocking position, expose the numbers on your chest.

Shoulders Parallel: In pass protection never allow a pass rusher to get his shoulder out of parallel to the blocker. The Defender is trying to make you turn your hips.

Drop Step Cross Over Rip Through: This phrase applies to a full zone scheme when trying to get the ball outside, on a running play. The offensive lineman will drop step according to the shade of the defender. The wider the shade the deeper the drop step. The crossover the second step.

Don't Allow Your Chin Over your Toes: Term used to describe too much weight rolled forward when run blocking, you'll end up on your chin. You will not be able to react to movement by a defender when you have too much weight forward.

Kick Step or Kick Slide: Pass blocking term. Short step with your back foot. The depth of the kick is determined by the width of the defender. When you kick slide always replace the step with the trail foot. Never get over extended. The second step is a slide step, don't pick it up off the ground. Maintain a good base.

Quick Draw: Term used to describe quick placement of the hands to the chest of the defender. It's the person who can get his hands on the other the fastest that wins.

Punch and Run: Explains pad control. Once pad control has been established, move your feet maintaining a great base. Finish the block, run the defender, get him on his heels.

First Level: Refers to the defenders on the L.O.S. (usually down lineman). Must get movement on first level defenders.

Descriptive Terms To Be Used:

Second Level: Refers to the defenders at linebacker depth. Come off on second level defenders after pushing first level defenders to the second level.

Run Through: A linebacker stunting. Must prevent linebackers from running through combination blocks. Can prevent run throughs by keeping the head up.

Piggy Back: Term used to describe the position on combination blocks the trail blocker (uncovered lineman) works for on the lead blocker. The trail lineman works to an outside position up and behind the lead blocker.

Slanter: Defensive lineman slanting inside or outside. On combination or zone blocks the inside slanter is picked up by the trailblocker. It is important to get the head between the slanter and the P.O.A.

Stretched: When the defensive lineman reacts in the direction the lead blocker is tracking, the lead blocker will be stretched wider. It is OK to be stretched as long as the blocker stays square and keeps working the defender off the L.O.S. On outside zone plays it is vitally important that the blocker doesn't get flattened. If this happens, the defender will get penetration and escape to the outside into the ball carrier. The blocker must strive to stay square, maintain contact and work the defender off the L.O.S. By doing so, the ball carrier will have room to threaten the outside and read the seams.

Offensive Line Phrases and Coaching Points

The Running Game

Offensive Line Phrases and Coaching Points The Running Game

Must Practice Like The Best No Mental Mistakes
Must Act Like The Best Great Effort
Must Be The Best Be Physical
Must Believe You're The Best Steps and Sets
Landmarks and Techniques

Running Game Phrases and Terms

Step Hinge - Used by the backside tackle when checking on double read of LBer to defensive end

Show Your Numbers - Term used to teach the finish on run blocks

Sit Down In The Chair - Phrase used to set the hips underneath you.

Show Me That It's OK - Turn the thumbs up sets the elbows down

Drop Step Crossover Rip Through and Come Around - The dropping of the playside foot for fast rotating zone plays

Stomp The Arches - Term used to explain the push off the inside of blockers feet, heels in toes out

Big Eyes - Get the eyes big when drive blocking a defender with the initial punch

Part The Sea - Term used at the point of attack for all Isolation plays

Take It Back 2's & 3's - Taking scheme away from the point of attack.

Counter Rotate 4's & 5's - Used when blocking any ISO or Belly play / Part The Sea

Circle The Wagon 8's & 9's - Term used for the footwork for fast zone blocks, bring it around.

Fast Zone - Used with Toss and Load plays that requires our offensive linemen to come around fast on the zone-blocking scheme.

Offensive Line Phrases and Coaching Points

The Running Game

Full Zone (Stretch Scheme) - Used with all Stretch plays / Offensive linemen tracking next number over, drop step stay on track.

Pick'in Grass (Show Me The Grass) - Technique used by offensive linemen to keep from dragging their backside shoulder on inside releases (veer, Midline)

Cut The Near Knee - Used by offensive linemen on backside of fast combos versus a 7 technique as EMLOS towards the play called.

Paint The Grass - A technique used by offensive linemen when going down in their stance. By painting the grass, weight will be evenly distributed.

See Your Backers - When working Ace, Duece, or Trey combos must see your potential run through.

Track Your Backers - Adjacent blockers staying on combo while tracking their flowing Lber

Slap The Dog / Punch The Chicken - Phrase used when pulling for trap and counters

Gain Depth To Gain Vision - Phrase used for the second puller on counters as he looks for his linebacker assignment

White - An alert by the playside linemen to the location of the defender being trapped on short pulls

Black - An alert by the playside linemen to the location of the defender being trapped long pull

Party In The End Zone - All members meeting in the end zone after scoring

L - Step - Footwork used for running blocks / 8's & 9's not included.

Hippo - Two adjacent blockers getting hip to hip

Blocking Structure For The Offensive Line

THE BASE BLOCKING TECHNIQUE - INSIDE RUN PLAYS

THE BASE BLOCK - The BASE BLOCK is the "BREAD and BUTTER" block in your running game. This technique will be used by our offensive linemen when blocking at the point of attack. Our offensive linemen will have the option of blocking the defender whatever way the defender wishes to go as long as he gets movement. The type of movement desired is to blow the defender straight back off the L.O.S. or at least get movement that takes a defender back and parallel to the L.O.S., but this sometimes is unrealistic because of defensive alignments or stunts.

Landmarks: On each running play, you will be given a landmark which is an aiming point for your head gear. This landmark or aiming point is the near ear to give you the leverage to force the defender away from the point of attack. In running the inside zone (BEND, DIVES, TRAPS, and COUNTERS) we ask that our offensive linemen always keep their shoulders parallel to the L.O.S., we don't want to open any doors that the defender can run through. We want to force the defender to take a side allowing the back to option his run off the offensive lineman's block, while reading the defenders path. This is very important in the approach part of the base block.

Approach: Explode off the L.O.S. on the correct snap count. This is accomplished by first taking a lateral step (flat step) with the near foot or playside foot and exploding or rolling off the takeoff foot. As our offensive linemen take their base step or lateral step, it is important to work to get a BASE (width of the feet). As the offensive line explodes out of their stances it is important that we always keep our backs parallel and our shoulders square to the L.O.S. (don't open doors). This will aid in our offensive lines ability to get under the defender's pads. Aim the "nose" of your helmet (hairline) for the proper landmark making sure that your head is up and the neck is bowed forming a "bull-neck" position.

Contact: First contact MUST be with the hands followed by the "nose" of the helmet in order to control the charge of the defensive man. Upon making contact, we want the blocker to whip his "fists" or "palms" up into the defender's chest with a lifting type action. This will aid the blocker in getting the roll-of-the-hips into the block and to control the defender. It is important that the power producing angles remain in the legs and that the shoulders remain higher than the hips. The blocker must now arch his back and get his feet underneath him.

Blocking Structure For The Offensive Line

ZONE BLOCKING PRINCIPLES - Combination Blocks

Zone blocking consists of offensive lineman blocking an area instead of a man. The purpose of using the zone blocking scheme is to stop penetration, create movement on level one and also seal off the outside linebacker, level two or filling linebacker to the call side. ALL ZONE BLOCKS initially start out as an inside out double team. As movement begins, either the OUTSIDE blocker or INSIDE blocker will gain control over the down defender on level one, allowing the other blocker to come off his block to handle the linebacker on level two. In this type of blocking scheme, it is critical to create movement on level one before coming off for the linebacker.

INSIDE BLOCKER - (uncovered offensive linemen). Take a drop step with the playside foot followed by a crossover step aiming for the near hip of the defender aligned on the next offensive blocker to the playside. This is referred to as a ZONE STEP. As the inside blocker takes this zone step, it is important to read the movement of the defensive man aligned on him. Use a one hand read if the linebacker stays in front or just behind the offensive blocker. Concentrate on his playside number, look at the linebacker and feel the defensive end. If the offensive blocker feels the defender's near hip coming towards him, explode up and under the defender's chin making sure to stop penetration. Upon making contact, whip your arms and your feet like pistons working to get movement up the field. If the defender has locked - on or is widening with the outside blocker - PUNCH and PUSH OFF the defender and explode to the 2 level to block outside or playside breast of the linebacker. NOTE: When in a pre-stance alignment read the positions of the defender on the outside blocker. This may give you a feel by his alignment if he is going to come inside or not. Listen for slug or moby call by outside lineman for possible inside slant by the defender.

OUTSIDE BLOCKER - (Covered offensive lineman). The outside blocker must read the alignment of the defender aligned on him so he can hit the proper landmark and initially create movement on level one. If the defender is aligned outside eye or shoulder the outside blocker will drop step with his near foot and then crossover step with the back foot, ripping the backside arm through and aiming your head gear for the outside breast or number. If the defender is aligned head up, he will step with his playside foot aiming his head gear under the chin of the defender. If he is aligned inside-eye or shoulder, you will pivot step with your outside foot to block the near number of the defender. If the defender loops-out or locks-on, you want the outside blocker to maintain contact and work the defender off the L.O.S. This movement off the L.O.S. is important in ZONE BLOCKING PRINCIPLES.

Blocking Structure For The Offensive Line

If the defender remains inside of you, continue to drive and maintain contact - once you feel contact from the inside blocker now you can block the scrapping linebacker on level 2. If the defender aligned on you that slants inside - PUNCH and PUSH-OFF the defender and explode to the 2nd level to block the onside linebacker. Block the linebacker by exploding up and through his numbers by using a good base block technique. DO NOT allow linebacker to cross your face, you may have to run with him.

OFFENSIVE COMBINATION BLOCKS & TECHNIQUES

Combination blocks can be between any two offensive lineman responsible for blocking two defenders in a specific area. All combo blocks start as a double team on level one - as movement begins either the POST MAN or the DRIVE MAN (outside blocker) will control the defender, allowing the other blocker to come off the block to handle the linebacker. It is important to create movement on level one or at the point of attack before one man leaves to handle the linebacker (have patience while looking for level two).

POST MAN (Inside Blocker) - You are responsible for stopping penetration and for preventing the defender from "splitting" the initial double team. Step with the near foot using a flat lateral step to insure all the good elements of a base block. Aiming point for both hand and foot placement is the inside number of the defender.

DRIVE MAN (Outside Blocker) - Power step with the inside foot by taking a flat lateral step to the inside with your aiming point being the playside number. The aiming point for hand placement is the play side number. If the defenders playside number starts to disappear inside, punch and push the defender inside and look for the second level with patience, so to allow the second level to come to you (don't open any doors).

Blocking Structure For The Offensive Line

The following calls are the different COMBINATION BLOCKS used between adjacent offensive linemen when installing the running game.

"ACE": A combination block between the CENTER and GUARD In order to handle nose tackle all the way over to a playside 3 technique. The CENTER will make the call to re-affirm the blocking assignment Center also will use a Ram (Right Guard) and Lion (Left Guard) call to alert which guard he will be working with.

"DUECE": A combination block between the GUARD and TACKLE in order to handle a defensive tackle and middle or playside LBer. The guard will make the call to re-affirm the blocking assignment and the technique.

"TREY": A combination block between the TACKLE and Tight End in order to handle the defensive end and playside LBer or strong safety. The playside tackle will re-affirm the blocking assignment and technique.

FOLD - IT BLOCKING SCHEMES - JACK & JILL

(Fold - it) blocking schemes are an exchange of assignments between two offensive linemen at or away from the point of attack. The offensive linemen responsible for blocking back from the playside will always go first in this scheme. The lineman blocking back will use an ANGLE DRIVE TECHNIQUE - Drop step with your near foot towards the hip to block his near number. This will place the offensive lineman approximately in the middle of the numbers or through the defenders playside ear. Upon making contact with the "nose" of the helmet, whip your arms and use all the same elements of a base block. The lineman stepping around will use a drop step with his near foot allowing the first man to cross his face. He will then explode up through the hole to the second level and block the linebacker's play side number.

ACE JACK / JILL - Exchange between CENTER and GUARD. This call can be made by either the center or guard and will depend upon the play that is being run. The Center will block back first with the guard stepping around and up through the hole to the second level.

DUECE JACK / JILL - Exchange between the GUARD and TACKLE. This call will basically be made by the tackle when the defender aligns on the inside eye or shoulder in a shade technique. The playside tackle will block back first with the guard stepping around and up through the hole to the second level.

Blocking Structure For The Offensive Line

TREY JACK / JILL - Exchange between the TACKLE and TIGHT END. This will basically be made by the Tight End when the defender aligns on the inside eye or shoulder. The Tight End will block back first with the tackle around.

DOWNFIELD BLOCKING (LOOKING FOR A GOOD RELEASE & CHASING LEVEL 2 TO LEVEL 3)

DESIRE, HUSTLE, AND DETERMINATION are the key ingredients in becoming a successful downfield blocker. Locate the defender you are to block on your first two steps and focus your eyes on him all the way. Convince yourself that YOUR BLOCK is the key to the success on each and every play. Lay your "ears back" and go all-out till the whistle blows and you will be a GREAT ONE because when advancing to the next level of football it will be the determination shown here that scouts are most interested in.

BLOCKING OUTSIDE ON SUPPORT - As you start your approach get width and depth as if you are going to "HOOK" the defender. Make him think that the play is going outside of him. When you are approximately four to five yards from the defender - get INSIDE-OUT position on him giving the defender only one way to go. Since most secondary people are smaller than you, they will try and "JUKE" you in order to get you out of position. Once the defender has committed himself, get close enough so you can step on his "toes" and explode up through him kicking him into the "CHEAP SEATS".

BLOCKING DEEP SECONDARY - When blocking downfield on deep secondary people, you want the offensive blocker to stay on his feet and run through or over the defender. Never look back for the ball carrier - it is his job to run off the offensive linemen's block. As you approach the defender, step on his "toes" dip slightly at the waist, and explode up through the man. A cross body block may be used if you are not in a position to use your helmet and shoulder pads. Concentrate on driving your inside arm and shoulder (like throwing a right and left cross) through the outside hip of the defender. Aim high at the defender's numbers and roll him up by whipping your legs and hips through him. If you cannot get ahead of the ball carrier, "PEEL BACK" on pursuit. Always use good judgment - NEVER CLIP or throw a block when the ball carrier has scored or is about to score.

Blocking Structure For The Offensive Line

PULLING TECHNIQUES

I install several different types of pulling techniques that will basically can be used by your offensive Tackles, guards and/or center in order to clear an area preceding a ball carrier. Determining who will pull be written into the rule for each particular play. It is extremely important to be in a good stance so as not to tip off your anticipated technique. Speed and quickness are of the utmost importance when pulling, but getting your body into the proper position is just as important.

PULLING TO THE RIGHT AND LEFT - This will be called a **DROP WHIP** and **PIVOT**. We want the offensive lineman to push off his extended fingers, whipping the play side arm back rapidly (slap the dog). This is important, as this will help you get your body into the proper position. Upon whipping your arm, you want to pivot on your up foot while taking a short directional step with your right foot. This must be one **CONTINUOUS MOTION**. It is important to stay low and to keep your head-up and eyes focused on the direction you are pulling.

PULL AND LEAD TECHNIQUE - This technique will be used when pulling to block a linebacker or pulling to block support. Use the proper pull technique getting width and some depth. Depth is especially important for the backside tackle when pulling to run the **COUNTER**. The trail blocker must get depth in order to spy and read the location of the **LBer** in order to block of the linebacker.

PULL AND TRAP TECHNIQUE - Use the proper method to pull and take an inside-out approach. This is called a **TRAPPER'S ARC**. Immediately focus your eyes on the defender to be trapped and stay low as you explode towards your target area. Explode up and through the man on contact by whipping your arms and moving your feet like pistons. Drive the defender out of the hole. Don't try and turn him or work your "butt" into the hole until you have established movement and this is accomplished by getting your base big on contact. Most defenders are taught to play underneath any type of kick-out block, so by allowing your base to get big on contact will eliminate any defender the opportunity to play underneath. Use all the good elements of a **BASE BLOCK** - especially the short power steps, **HELMET ADJUST**.

Introduction To The Hybrid Pistol Wing-T Passing Game

INTRODUCTION TO THE HYBRID PISTOL WING-T PASSING GAME

The following information contained in the Hybrid Pistol Wing-T Passing Game is a combination of my experience plus conversations with many coaches who believe in and use multiple formations and One Back sets.

This portion of the Hybrid Pistol Wing-T Offense primarily is dedicated to the Running Game to set up the Passing Game. I know and understand that many other plays exist, but, have included and discussed only the ones that I have been associated with.

The Hybrid Pistol Wing-T passing game is designed to give you a look at many different plays from many different formations. I have tried to make the transition into each phase of the passing game as smooth as possible, without making the terminology too difficult to understand.

The Hybrid Pistol Wing-T Offense will give you the ability to incorporate one, two, three, four, and five receivers into your offensive passing attack. I've broken down the installation of the pass offense into different formations trying to get the best possible pass protection schemes for the offensive line and to get the defense misaligned. If at all possible the best scenario is to break down your opponent by the way they align to formations, meaning give the defense several formations in order to get the best possible play.

Included into the Hybrid Pistol Wing-T Offense is the installation of the option game to make your opponents have to defend the Tailback, and Quarterback in the running game, this makes for the defense having to play assignment football. By adding the option game this makes the defense have to defend the entire field and thus, helps promote the passing game.

Introduction To The Hybrid Pistol Wing-T Passing Game

100 SERIES PASSING GAME

Play Action Passing Game

The play action passing game in side this manual will be designated by 100 series followed by the type of run play that would come off this type of pass. In the play action passing game your offensive line will follow basic protection schemes with an aggressive demeanor of applied pressure to your Big-On-Big blocking principles.

DROPPACK SERIES PASSES

- 1.Pre-snap read.
- 2.How does the defense react to motion.
- 3.Key playside flat defender.
- 4.Throw to open receiver.
- 5.Uncovered rule - must know down and distance.

Quarterback L.O.S. Check List: Receiver Rules - Basic Principles

- 1.Recognize zone or man (reaction to motion).
- 2.Determine by reaction of defender the proper route adjustment.
- 3.Utilize proper splits.
- 4.Always sit down in open hole.
- 5.Run north and south after the catch.
- 6.Always be alert for audible if you are uncovered.
- 7.Be aware of complimentary routes.

Route Description for Tight End:

Widen - use this release when uncovered. Widened look for the Ball quickly. If you don't get the ball continue up field and look for seam in the defense.

Ease - use this release when uncovered. Release easy outside and look quick for the ball. If you don't get the ball continue staying inside.

Over the top Release - use this release when defender is playing on your inside shoulder or attempting to wall you off to the outside. Explode off the L.O.S. and run by the defender.

Underneath Release - use this release when the defender is taking the Outside away and you feel you are able to get underneath him.

Introduction To The Hybrid Pistol Wing-T Passing Game

RECEIVER BLOCKING TERMINOLOGY AND RULES

Listed below are some general ideas concerning some expectations you might expect from a receiver. A good knowledge of these rules will give you an idea of the points a coach should emphasize and how to do them.

Have a daily goal or objective. Work to improve one area of your game each day.

The receiver must have confidence in his ability to catch the ball. Believe you are the best.

One thing that must be determined from practice is who will make the third down catch. Which receiver can you call upon on 3rd and long situations?

Make a great catch. Do it enough and it will become routine in the game.

This is the order in which you can evaluate your receivers:

- A.Hands (concentration and poise).
- B.Toughness (the ability to catch the ball in a crowd).
- C.Quickness.
- D.Speed.

Speed - it is an asset, but not the most important factor. The Receiver must explode off the L.O.S. And force the defender to turn his hips under 17 yards.

Quickness and acceleration - the receiver must escape the hard corner quickly and accelerate up field to push the safety deep and to create separation between him and the corner.

Hit someone on every play. Do not avoid contact. You need to build a reputation as wide receivers that are always looking to hit, cut, crack-back, and block anyone. A defensive back should not feel comfortable with the receiver in his zone.

A receiver must want to be a great receiver. Like anything else it takes hard work.

Four basic rules in catching: 1. SEE, 2. CATCH, 3 TUCK, 4. COVER.

Introduction To The Hybrid Pistol Wing-T Passing Game

See the dot on the tip of the ball as it rotates.

A receiver must always align inside; see the football know your spot. Watch the ball during the cadence.

A receiver must be knowledgeable in coverage's and conversion routes.

The backside receiver must always be alert in the passing game. Run a full speed route.

On a receiver's release he should, explode off the L.O.S. and threaten the defender deep immediately. Run or pass, the receivers release should always be the same.

Breaks and cuts must be under control. Be an athlete.

A receiver must be able to snap his head and shoulders around quickly. Be ready for an early throw.

Always run the proper depth on routes.

Use the sidelines to control the clock. Remember the objective, score.

Attack the ball aggressively on under throws and high balls. Prevent the interception. If the receiver cannot catch the ball, the defender should not be able to catch it either.

Always see the alignment of the defender defending you. Know what angle you will use to attack the defender.

Understanding the Quarterback Responsibilities

Quarterback L.O.S. Check List:

1. Pre-snap read.
2. How does the defense react to motion?
3. Key playside flat defender.
4. Throw to open receiver.
5. Uncovered rule - must know down and distance.

Receiver Rules - Basic Principles:

1. Recognize zone or man (reaction to motion).
2. Determine by reaction of the defender proper route adjustment.
3. Utilize proper splits.
4. Always sit down in open hole.
5. Run north and south after the catch.
6. Always be alert for audible if you are uncovered.

As you read the Pistol Wing-T passing game you will find that I have, added all the little particulars up front and then gave you the passing illustrations. With each diagram and play, I have added exactly how you can call the plays in the huddle. If you find the wording for calling plays confusing, just adjust your descriptive words to the Pistol passing game (must feel comfortable for you). Be aware of complimentary routes.

The Hybrid Pistol Wing-T Offense

Option Game Section

THE HYBRID PISTOL WING-T OFFENSE OPTION GAME SECTION

1. Why Option Football with the Hybrid Pistol Wing-T Offense
2. Common Objections for Running Option
3. Things to Think About With Option Football
4. Inside Veer - Triple Option
5. Speed Option
6. Mid - Line Option
7. Rules for Running Right Option
8. Having the Option to Option
9. Setting the Box for Best Option

WHY ADD OPTION FOOTBALL TO THE HYBRID PISTOL WING-T OFFENSE

Best way to get the ball on the perimeter and attack the outside third, while the defense spreads attempting to contain the triple option, fullback in the offense gets more explosive.

Don't need dominate offensive lineman, philosophy stays consistent with offense.

Makes defense play assignment football by defending the option on each and every play. Forces defense to play discipline football; defense tends to be more predictable.

The option game helps your pass offense dramatically, because it predicts secondary coverage.

The Option game controls random blitzing; one wrong stunt and its six points.

Option football neutralizes dominant players by forcing them to play assignment football.

COMMON OBJECTIONS FOR NOT RUNNING TRIPLE OPTION FOOTBALL

It is a high risk offense: Statistically speaking, there is no evidence to support this statement. Taking care of the football is like anything else, if it's important to you, work at it. Make a commitment to work ball handling drills on a daily basis.

It is a run offense only: When it's working why pass? The passing game becomes even more effective because of the defensive emphasis on stopping the run. You can get mismatches and coverage's that are easily exploited.

Option football requires a quarterback with exceptional speed. Find the best competitor on your football team, option doesn't require speed it requires

Good weather offense: Option football has been run in snow, rain, and mud.

The Hybrid Pistol Wing-T Offense

Option Philosophy

OPTION PHILOSOPHY

Makes defense concentrate on the fullback, makes the "A" Back game go.

Use multiple formations and motion shifts, to run the same option.

Find the flank; determine which side of the formation is softer.

Option allows the Wing Back to catch the pitch as an outside runner and the fullback to be the inside runner.

Utilize play action pass off the option game; places the defense in a run play mode.

Staff must be united behind option football and commit practice time to it.

Run multiple options from multiple formations.

Gets ball out onto the perimeter fast, makes the defense defend entire field.

Use the drop back passing game to prevent the defense from ganging up on the option.

Run an offense, not a bunch of unrelated plays.

Personnel, what can your athletes do! quarterback is the key! Your quarterback must be your best competitor, regardless of ability.

Offensive staff must research their option coaching assignments.

Installing the option game takes commitment and work.

Use motion to try and cause confusion with defensive assignments.

The Hybrid Pistol Wing-T Offense Option Philosophy

THINGS TO THINK ABOUT WHEN RUNNING YOUR OPTION

1. Rules for running 12-13 Veer - Double and/or Triple Option

A. You teach your quarterback about the two outside inverts as he views the defense. This simple concept of counting defensive personnel and running to the side with the fewest defenders sets your option game up. If the defense shows you with inverts to both sides means a six-man box. Run at the box with zone run plays or mid-line option.

2. Rules For Running 18 - 19 Load, 18 - 19 Block, 18 - 19 Speed Option:

A. Only run load option when your opponent has aligned with 5 and 9 technique and /or seven towards the tight end side. The purpose here is to get the Trey block on the five or 7 technique and then combo off to the playside linebacker. The quarterback will read the inside shoulder of the nine technique. If an invert is aligned outside the 9 technique "Check" to veer weak.

B. For best results run load option to a 7 technique because of the combo Trey block by the tackle and tight end to the playside linebacker. QB will now read the outside invert. When running speed option weak the best case scenario is when the defense starts to reduce weak with invert walking up and the 5 technique reducing to an inside 4i alignment. A 4i puts this into a duece combination block between the tackle and guard, with QB taking option out to invert and pitching off him.

Load and Speed Option - Double Option

One way for the defense to take the triple option away is to run linebackers through the offensive line. This forces the offense into handing the ball off to the fullback. By giving the defense a look at the load option will force linebackers to have to play in a position to chase outside, or there will not be enough defenders to pursue the option wide. The load option or double option eliminates the read key and forces the end man on the L.O.S. to be the option key. Usually the load option is pitched quickly and outside before the defense can react. Load option keeps the linebackers from playing tight into the L.O.S. thus, creating a softer defense in which to run your zone plays.

3. Rules For Running Mid-Line Or 10 - 11 Option: Tight End Side Only

A. Only run the mid-line to a three or two technique. The tight dive by the fullback restricts the defense. The tight dive by the fullback prevents fast flow by the linebackers and secondary defenders, especially the free safety.

B. Quarterback works 1 1/2 yards off the L.O.S., this negates minimal penetration.

C. Quarterback faces out when reading his keys, thus, allowing him to make faster reads.

D. Mid-line keeps the free safety in cover 3 from running the alley as fast. Must check the dive of the fullback first.

E. Slows down the three technique, makes an easy read for the quarterback, keeps the three technique from penetrating up-field.

The Hybrid Pistol Wing-T Offense

Option Philosophy

- F. Creates natural lanes for the quarterback to run.
- G. Keeps the backside five technique from chasing down the quarterback.

Mid-Line Option - Double and/or Triple Option

The mid-line option creates a whole set of problems for the defense, it gives you another option when the defense has taken load and veer option away. The mid-line makes the path of the fullback right over the center. This changes the read key one man inside. This takes the read away from the 5 technique and moves it to the defensive tackle or three technique and moves it to the defensive tackle or three technique rather than the defensive end. The mid-line changes the game on the defense and forces players on defense to try and figure out which option scheme is coming at them.

4. The Use of Multiple Formations and Option Schemes:

- A. Using multiple formations and back field sets, forces the defense to be assignment sound.
- B. Option limits the defenses package.
- C. Using option rules helps you with the numbers game, gives proper blocking angles.
- D. Helps the passing game due to the fact it forces the defense to use fewer coverage's.
- E. If your opponent knows that you run option, they tend to blitz less often, helps with blitz pick-up in the passing game.
- F. Option forces the defense to take time away from regular game preparation.

Since defenses have grown more complex, the option game has been included in the Hybrid Pistol Wing-T Offense to create three specific areas that are diametrically opposed to each other. That is, whatever specific defense a team chooses to stop one scheme with, it creates a weakness that is exploited by the other scheme. The four basic option schemes are 1.) Inside veer, triple option. 2.) Mid-line triple or double option. 3.) load option, double option. 4.) Speed option, double option. When you add the play action passing game to this group you create a balance to your option offense. This philosophy dictates to the defense that it must remain sound against all four schemes while still trying to defend the passing game. With the option game you are trying to create a balanced defense that is forced to play assignment football. If you can force the defense to do that it will open the rest of the Pistol Offense package up, thus, giving your players the best possible chance for success.

Reasons For Running The Hybrid Pistol Wing-T

The Pistol Formation allows the Quarterback to have vision.

Quarterback poses more of a run threat.

It's a System

It puts young players in conflict

Formation Friendly.

Can Drive the ball with a solid power game.

Deception with a four back running attack as well as having a five receiver passing attack at the same moment.

The Pistol High Hybrid Wing-T features a no huddle hurry up offense working with the ability to work off verbal alerts or hand signals from the sideline along with player wrist bands that feature a code that allows for fast play calling. This feature of a hurry-up and gun formations is what makes for a Hybrid Gun Wing-T offense.

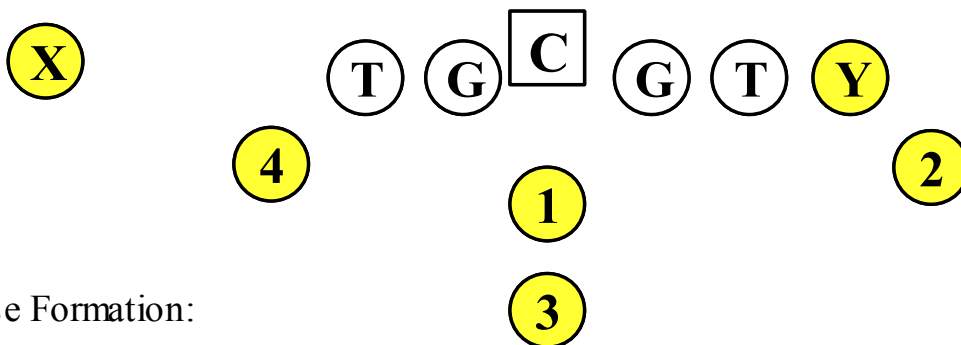

Base Formation:

1 = Quarterback

2 = Right Wing will always align to the right side of the offense.

3 = Fullback Always aligned behind the Quarterback.

4 = Left Wing will always align to the left side of the offense.

Reasons For Running The No Huddle Hurry Up Pistol Wing-T

What The No Huddle Offense Provides:

At the end of each half, you may 1. need the overdrive-speed version, not the slower one which is the hurry-up and wait approach because there simply are not enough seconds on the clock to be calling cadence.

The effectiveness of a whole-game no-huddle is inversely proportional to the number of seconds that elapse 2. between the ready-to-play verbal alert and the snap. In other words, the faster you snap, the more you screw up the opposing defense. In other words, if you're going to run a whole-game no-huddle, go for the gold.

The over-drive Hurry-up no huddle speed has more benefits than you would imagine:
knocks opposing defense • off balance

Makes it hard for defense to huddle between plays

Makes it hard for defense to substitute

Makes it hard for defense to vary defenses and stunts

Makes it easier for youth football coaches to comply with • minimum-play rules

Approximately doubles the number of offensive plays you run (assuming you can get first downs) from 60 and 70 plays to 90 to 100 plays depending on where your official game length falls.

Makes your practices far more efficient

Turns your normal practice periods into conditioning also thereby eliminating the need for pure stamina, which you can coach, rather than speed, which you cannot coach

Knowing how to do the warp-speed makes it easy to also put in the “four-minute drill” or maximum • slow down which like the warp speed, you absolutely must have for clock-management reasons

Makes your defense much better at • defending other teams' no-huddle offenses

Since the opponent does not know how to run a warp-speed no-huddle, they get • freaked out by your players' ability to do it

Conditioning periods

Fatigues • your opponents' defenses in hot weather, • dehydrates your opponents' defense

Fast Paced Over Drive No-Huddle Pistol Wing-T

Why the Hurry-up No-Huddle

Reasons for considering the Hurry-up no-huddle.

How it affects linemen. If linemen move seven and one-half yards from the ball to the huddle and jog that same distance back to the LOS, by the end of each play they have traveled fifteen yards. Multiply that by a minimum 60 plays and you can see we save our linemen approximately 900 yards per game. Therefore, they should be fresher in the fourth quarter.

By not using a huddle, you can run approximately one-third more plays in practice. (For example, we used to a team goal of running 2 1/2 plays per minute now we have advanced to 3 1/2 plays per minute. Now we run 35 plays in a 15-minute approximately during group and team periods.

How it affects our QB by verbally alerting calls to him at the LOS, our QB gains an extra three or four seconds to scan the defense. This gives him a better understanding of what the defense is doing.

How no huddle hurry-up over drive affects the tempo of the game. Tempo is one of the most obvious offensive advantages because it limits defensive personnel packages and challenges the defenses conditioning factor. This changes the tempo with the no-huddle, you can control the tempo at any time. By hurry-up run the play or hurry-up and wait now you have the ability to speed up the game or slow it down according to your game plan not theirs. This keeps the defense off balance.

How it affects the defense. The defense needs to prepare differently for a no-huddle offense. They must shift into a whole other gear when trying to duplicate their opponents no huddle over drive offense. As the offensive coordinator and head coach I also use an extreme unbalanced formation to make the defense take additional time away from our plays and approach to just get their players lined up correctly.

During a defense's preparation time several other factors come into play when preparing for a no-huddle offense. First, as coaches we teach what is important. Since the huddle has nothing to do with winning or losing the game, we end up spending more time on fundamentals and the actual plays we use.

Next, the no-huddle allows coaches to make corrections visually. Often in a huddle, we try to explain how we want something done - a blocking scheme, back's cut, etc. For us, all corrections are done at the LOS, and the players see exactly what we want. The defense is right in front of them.

Again, since we can run more plays in practice, a lot more conditioning occurs during the entire practice. Therefore, we are able to cut back on the amount of sprint work as the season continues. During the game, since more plays are being run and we are at the LOS for every play, our concentration has improved, especially when we are tired.

Finally, we have found that communication and execution of our over drive no huddle offense is much easier. Our players are accustomed to hearing the play called from the LOS and are better able to handle the hurry-up situation. Also, speeding up play at times in our regular offense gives them a better concept of the faster pace we want in or over drive situations.

Fast Paced Over Drive No-Huddle Pistol Wing-T

Communication

We verbally signal formation and play at the same time. An advantage we have in our Pistol Wing-T offense is that we do not flip-flop a lot of people. Only our TE and 3 Back (Fullback) change. Our Quarterback will point to the assigned player needed to go if motion is necessary.

To call the play at the LOS from the sideline I as the play caller will verbally alert formation and play to our Quarterback in turn will repeat the play call to the rest of the offense. The cadence is fast paced as an example "Set Go" is our cadence to hurry-up the play being run. By using a verbal command I can have the next play for the Quarterback before the offensive line gets back and set up on the line of scrimmage.

Whenever a play calls for motion the designated player will begin his motion once the Quarterback raises his hands up from his side.

The question is asked can defenses be able to figure it out or codes. I've been using a coded word approach for several years and teams have not been able to figure out yet what the play being called is since each play has several worded descriptions for or offense. It is a little too complicated for the untrained ear. Second, I sure hope they try. Every minute they spend trying to decipher our calls is another minute they are not working to defeat our plays.

Once again we don't need to signal the needed snap count because it's built into the play. To help facilitate our hurry-up overdrive offense the offensive line plays from a two point stance and no wrist bands being used which takes extra time for them to locate the play. All our offensive line does is listen for the quarterback to verbally use coded words to call the play. If you use this method, you must devise some way to derive the snap count for plays in the 0, 5, 6, 7, 8, and 9 holes. I no longer use numbers for hole numbers and direction, that is done by using the alert word even and odd for the direction, all odd alerts is the play running left and even alert the play is running right. You will be surprised to see how quickly the players can learn this method.

Communication at the LOS is easier than ever in the no-huddle. Our linemen are accustomed to being informed at the line and pay close attention to every word the QB says. We also have tried to make our audible system easier by pairing our plays. This gives the QB the option to say only the word "even or odd", and we can attack the other side of the defense with the same play

Fast Paced Over Drive No-Huddle Pistol Wing-T

No-Huddle Hurry-up Offensive Procedures:

Never Huddle up only even after incomplete pass, team time out, only huddle when the quarterback calls for a huddle, or waste time at the end of the game.

Have a designated formation to always line up in when in your two-minute offense. For the Pistol Offense I would recommend that you determine an offensive formation that you want to get into.

Sell your players on the fact "Don't Panic", their ability to execute when the pressure is on is the key.

Our system tells the quarterback to look towards his bench for the next play to be called he must do so with a sense of urgency. He must look to the sideline for next play as soon as the ball has been snapped. Never stop hustling.

Sell your players on getting the ball out of bounds when using your two-minute offense.

Receiver's should always (after a tough catch or sideline catch) come up and show ball to the referee. The receivers should act like they have made the catch. If there is any question in the referee's mind this might change it.

Offensive Line will play from a 2 point stance to facilitate get plays called and ball snapped.

Our "X" and "Z" will not flip-flop, remain on the same side as previous play.

The receivers must listen for the formation call to determine whether or not if they are off or on with their formation alignment.

All members of the offense must hustle back to their pre-call alignment in a no huddle offense when a play has been blown dead by the official.

Notes: a. When you want to stop the clock with a spike of the football or incomplete pass the quarterback can use the alert word "Kill - Kill".

b. After any play in a two minute situation in which the clock is not stopped, the quarterback should always look to the bench for a potential signal:

1. Call "Time Out" - can be signaled by any designated coach.

2. Call "Clock" - signal can be a clockwise motion of the right hand.

Example: TWO MINUTE OFFENSE

The quarterback keeps two minute offense going by yelling "On The Ball". Everyone lines up on the L.O.S. in ace formation (or formation that is called by the QB on the L.O.S.). Quarterback will call the strength of the formation by raising his fist to the side he wants.

Huddle up only when ball is dead, after incomplete pass or time out has been called. The exception to this rule is when the Quarterback gets a sign from the bench to huddle the team.

Example of How the Wrist Codes Work Players Wrist Band Codes

	Alabama, Oregon, Fresno		Nebraska, Omaha, Denver		Tampa, Miami, Seattle
1	Texas 40 Bend	1	Larry 27 QB Blast Naked	1	Larry Grizzly Lt.
2	Randy 35 Belly Follow	2	Randy 27 Joker Lt.	2	Randy 46 Buck Rt.
3	Dorthy All Go	3	Randy 35 Belly Option	3	Larry Boot Rt. Cruise
4	Dallas 27 Blast	4	Tractor 211	4	Randy 35 Belly
5	Randy Grizzly Rt.	5	Randy 48 QB Throwback	5	Larry 21 TT
6	Larry 47 Power	6	Randy 46 Blast	6	Larry 48 Jet
7	Larry 29 QB Throwback	7	Randy 22 Read	7	Randy 35 Belly Pass
8	Larry 46 Joker Rt.	8	Randy Boot Lt. Cruise	8	Louisiana 21 Bend
9	Randy 10 Jill	9	Dallas 35 Belly Follow	9	Randy 19 Jet QB Follow
10	Utah 19 QB Jet	10	Trailer Sprint Lt. Wide	10	Trailer 2 Slant
11	Larry 42 Read	11	Randy 40 TT	11	Randy 46 Power
12	Larry 34 Belly	12	Larry 47 Buck	12	Randy 4 Bubble Pass
13	Randy 46 Blast Pass	13	Tractor 2 Bubble Pass	13	Larry 34 Belly Option
14	Tractor Sprint Rt. Wide	14	Larry 27 Blast Pass	14	Dallas All Go
15	Randy 26 QB Blast Naked	15	Randy 29 Jet	15	Larry 11 Jill

The information included here is an example on how you would set up your players wrist codes. The alerts (Alabama, Oregon), at the top can be used to get your players on the field to the correct column you wish to call the next play from. Don't forget the desired offensive formation is signaled from the side line in which the Quarterback will repeat this allows the receivers and backs to get lined up correctly and then the code will be given and the play called from the wrist bands.

Example: Coach from the sideline signals the formation needed calls the play. We are running:

This is where the Hybrid fast tempo comes into play. Once a play is over and the official blows his whistle the offensive line will get back to the line of scrimmage waiting for the next play to be signaled. Receivers and backs will get into their pre-huddle alignment behind the center waiting for the formation signal as well which is alerted by the quarterback and then will get to their position as fast as possible.

If you follow the format for wrist codes by dividing your codes into 3 columns with numbers to one side you can fit 45 plays on a single side. Some quarterback wrist sleeves will feature upwards to three sleeves. This can be left up to your personal preference.

Hurry-Up No Huddle Offense Using Verbal Alert Codes

No Huddle Procedures

Our goal for running a no huddle offense is to press the tempo and keep our opponent from running personnel in and out and to limit their defensive package to only couple of alignment options.

Our goal when we go into a game is to run 2 1/2 plays per minute and in order to do this several things must take place such as:

1. Once the official blows a play dead the offense will hustle to the ball with the offensive line getting aligned in their two point stance and ready to receive a verbal play alert from our quarterback.
2. Z and X Receivers will always lineup in their designated position. "Z" Receiver will always align to the right side of the formation with, the "X" Receiver always aligning to the left side of the formation. We will not flip-flop the Z & X receivers.
3. The Quarterback will receive verbal commands from the side line and then will give verbal play alert to the offensive team. At this point we use a fast snap count which, is "Set Go". Ball will be snapped as soon as the first sound comes out of the QB's mouth.
4. Motion does not have to be alerted it is automatic to the play called. The receivers are always looking inward towards the quarterback and the QB will point to the offensive player he wants in motion.
5. Motion begins as soon as the quarterback raises his arms up from his side.

Offense pre-set alignment waiting for the formation and play

L.O.S.

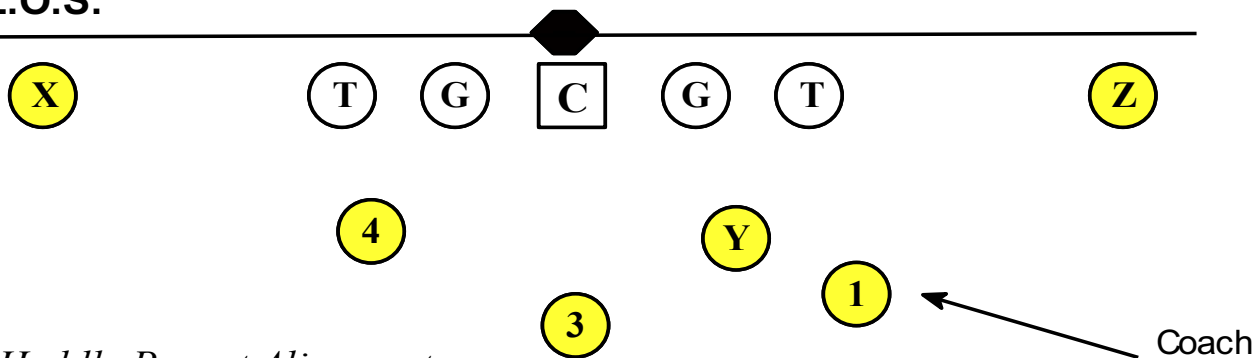

No Huddle Pre-set Alignment

Calling Plays with Coded Words

The following terms is how I call plays without using signs, wrist bands, or hand signals in order to put the offense in over drive or extreme hurry-up. Must remember and I have always said if you have a systematic way to teach then kids have a systematic way to learn. Codes can be anything you want them to be. The following are examples and terms that I use in order to alert formations, direction and type of play. It is to be noted that when we use motion the Quarterback will point to the player he wants to motion and then the designated motion player will start his motion as soon as the Quarterback raises his hands and arm from his side.

Running Game Alerts

Raven Even Mark:

Raven

Eagle Odd Mollie:

Eagle

Navajo Even Goose:

Navajo

Apache Odd Maverick:

Apache

Fresno Odd Bullet:

Fresno

Florida Even Bullet

Florida

Passing Game Alerts

Rip Even Victoria Poppa:

Rip

throwing the ball

Liz Odd Victoria Poppa:

Liz

throwing the ball

Ace Even Houston Poppa:

Ace

throwing the ball

Invert Odd Houston Poppa:

Invert

throwing the ball

No-Huddle Hurry Up High Tempo Approach

To understand this type of style, you must first understand the goals of it. The main goals of this offensive approach is not to sling the ball all over the field like may spread offenses you see in today's game. The goals are simple:

1. Allow the offense to set the pace of the game. Keep defenses on their heels.
2. Give the offense more opportunities to get the ball in play makers hands.
3. Score quick to get opposing team to get away from game plan early
4. Play sideline to sideline and end-zone to end-zone At least 3 shots down field a quarter!
5. Make the game 5 quarters. Take a game from 60 offensive plays to 80+.

The common misunderstanding to this offense is that it is a spread offense because it is fast paced. While it has certain characteristics of a spread, it is really more of a combination of the old wing-t, zone read option offenses meet the run and shoot. The only difference you will see is more motion and different looks. This approach uses a lot of H-back/TE sets, 2 RB formations, and you will very rarely see more than 3 WR. The offense likes to be 50% run and 50% pass and likes to pound the defense with counters, traps, zone read option with the QB, and then hit you with a jet sweep or a play action pass down field.

Most spreads use the pass to set up the run. This offense uses the run to set up the pass just like the old school run and shoot but the difference is they do it at lightning pace. Almost all passes are based off play action. The goal is to get the snap off within 5 seconds of the ball being spotted. This makes it very difficult for a defensive coordinator to have time to look at down and distance tendencies so the defense has a hard time getting into the correct call. This allows the offense to dictate the pace of play and get the defense into the looks they want. When thinking about it, one may wonder why more teams do not implement the offense! Well, the same thing goes for the offense as the defense. It takes a sharp mind to get the play calls into the offense fast enough to properly execute. The play caller has to be quick and precise with their calls in order to get the play signaled in to the QB. The QB from the sidelines has to be a confident play caller with balls of steel.

This is one reason there are not many plays in this offense. The key to it is to be simple for the offense to execute but difficult for the defense to understand. They will throw many different looks at you but run very simple and traditional plays. This offense is very difficult for an opposing team to replicate in practice because of the tempo, speed, and the many different formations. The HUNH wears a defense down physically and mentally. This is a big reason Auburn dominated most teams in the 4th quarter last season. The fast pace basically adds a 5th quarter to the game. The defense must maintain focus for longer than the typical 4 quarter game. When you get physically tired, it is harder to be mentally tough.

Hybrid Pistol Wing-T (High Tempo)

No Huddle
High Tempo

Randy Formation

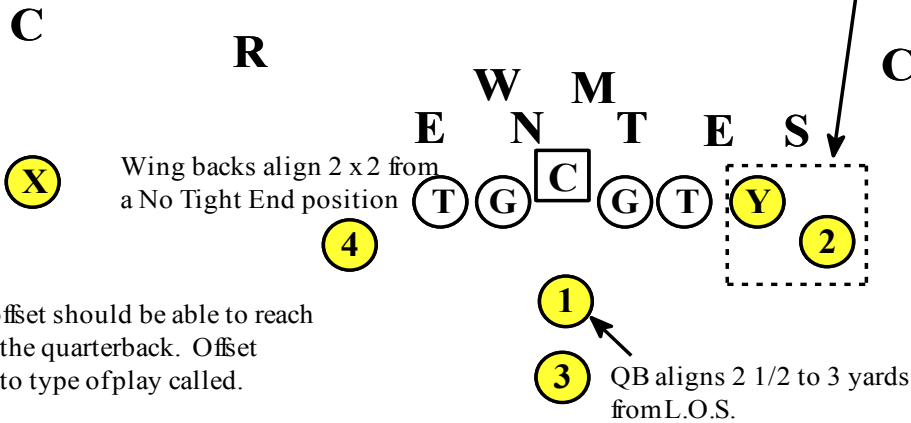

How To Call Plays
1. Formation
2. Play
3. Direction

Offensive Line
Blocking Rules
Zone or Gap, Down,
LBer

Larry Formation

3 Top Plays
1. Trap
2. Boot Cruise
3. Buck Sweep

"Ego Free"
22 Play Script

1. Belly
2. Belly Option
3. Belly Pass
4. Tackle Trap

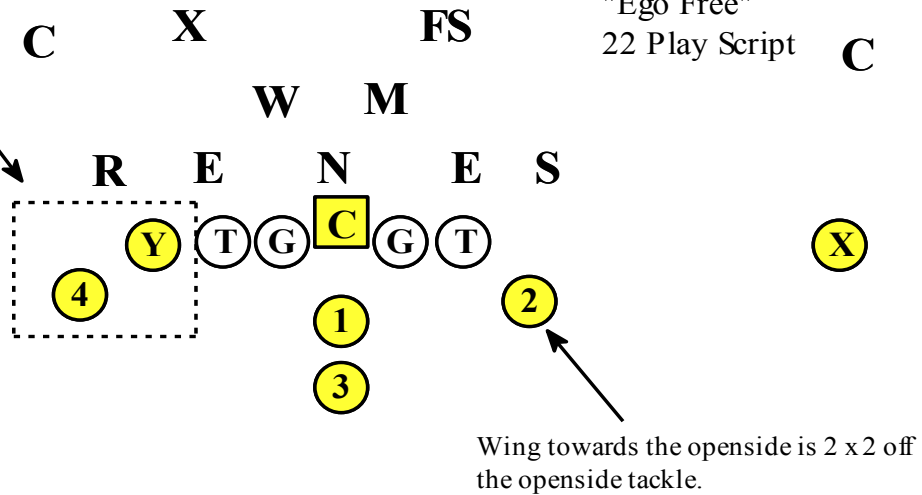

Buck Series

1. Buck, Buck Speedy
2. Bend
3. Boot (Cruise)
4. Joker
5. Blast
6. Blast Pass (switch)

Motion backs work off square cuts

Must run Buck Drill
over and over (repetition)

Boot Drill

Weak Cruise, Weak Buck

Offensive line puts their nose of the hip of the center.
2 foot splits across the front

The alert word "House" brings both guards to the same side.

Formation Discription

Left Formation (Y)

Larry - Randy (Base Formation)

Dallas - Dorothy (Two Sloted
Receivers)

Louisiana - Utah (X Over)

Oscar - Nick
the same side)

Baltimore - Bird (Bunch)

Alaska - Texas (Tackle Over
Unbalanced)

Louie - Roger (Empty)

Duck

Wacky

From my tradition manuals that I have written in the past I have always used tradition explanations for formation discription but, I will now use different types of words to describe our formations in this manual. Since we are in a no huddle mode using a fast past tempo we must be able to eliminate excessive use of words for our wrist bands and communication of plays. I will show and demonstrate how to call and communicate your call sheet along with your players wrist bands.

Formation Identification

If You're Going To Be Different,
Then You Have To Act Different

Randy

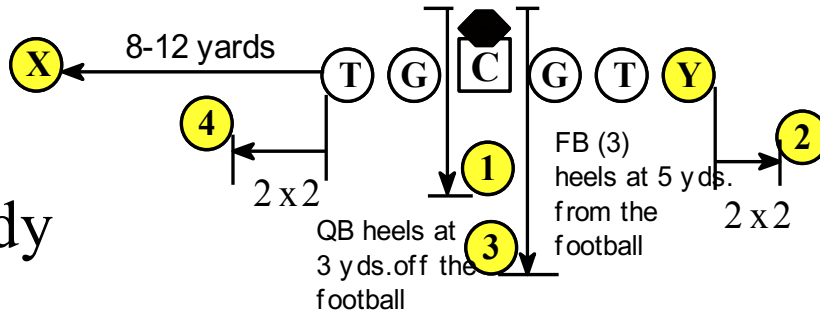

Louisiana ("X" over Left)

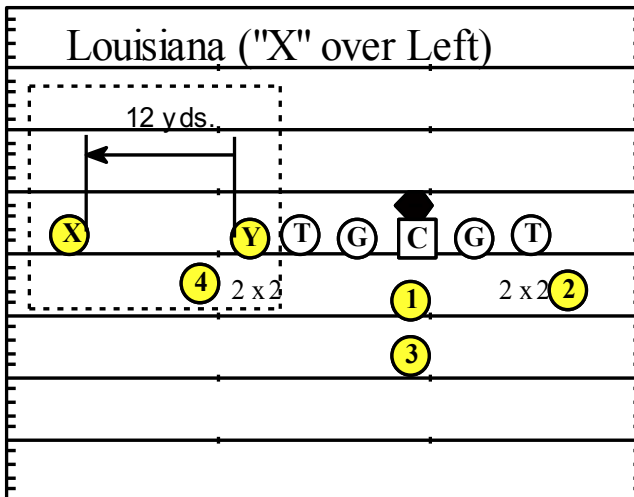

Utah ("X" over Right)

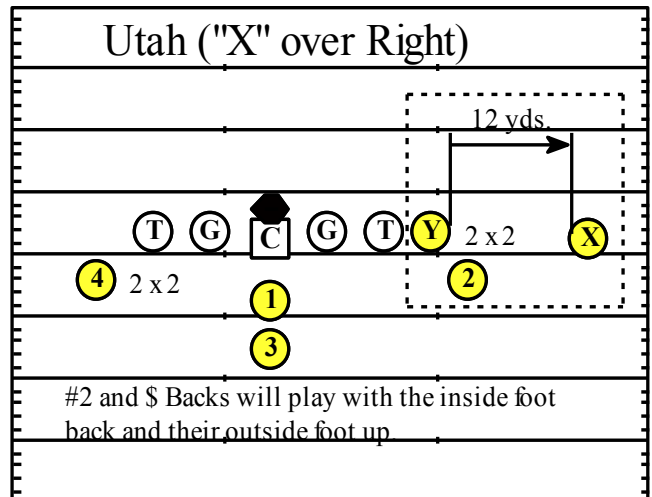

Dallas

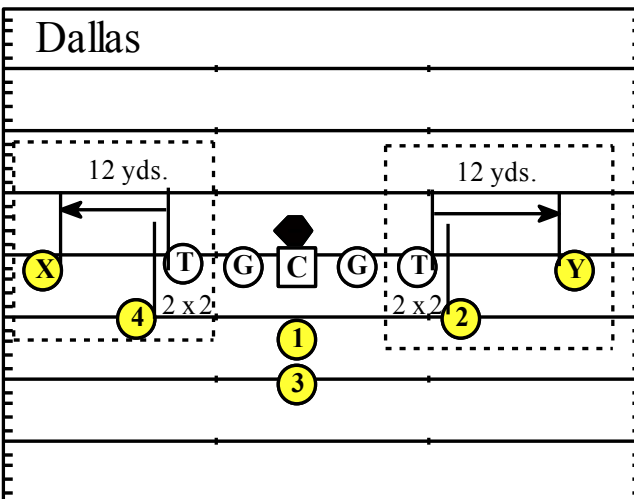

Dorthy

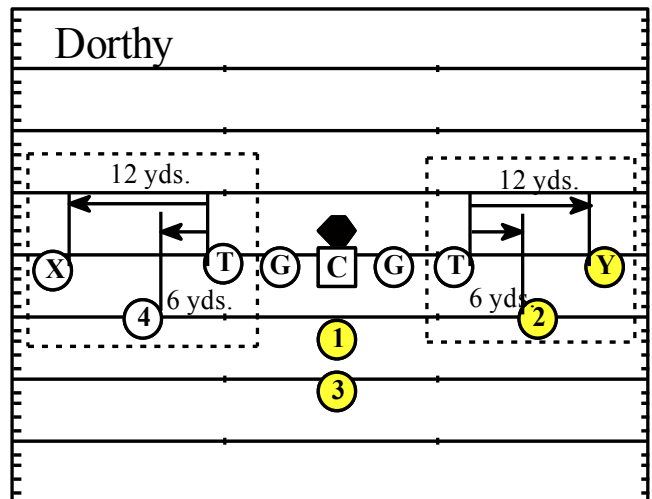

◆ Formation Identification ◆

Oscar (3 Receivers towards TE Lt.)

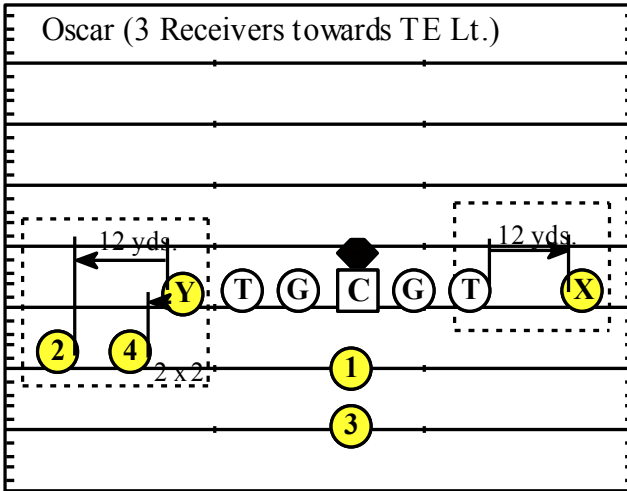

Nick (3 Receivers towards TE Rt.)

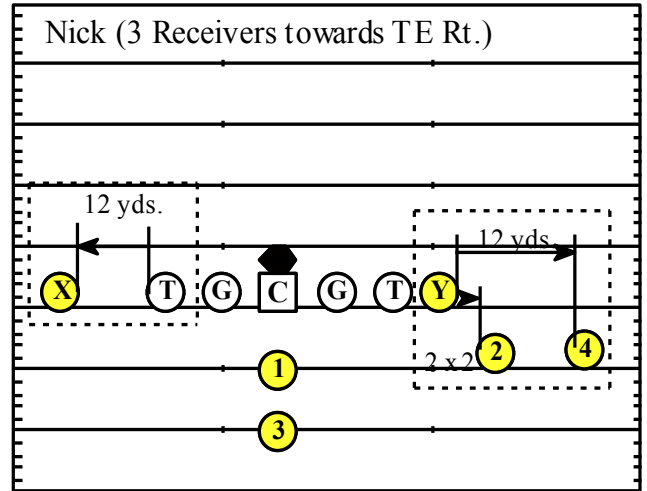

Trailer (Three receivers away from TE)

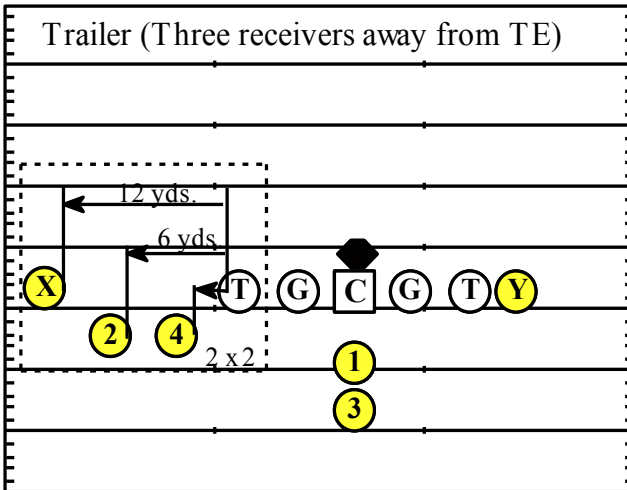

Tractor (Three receivers away from TE)

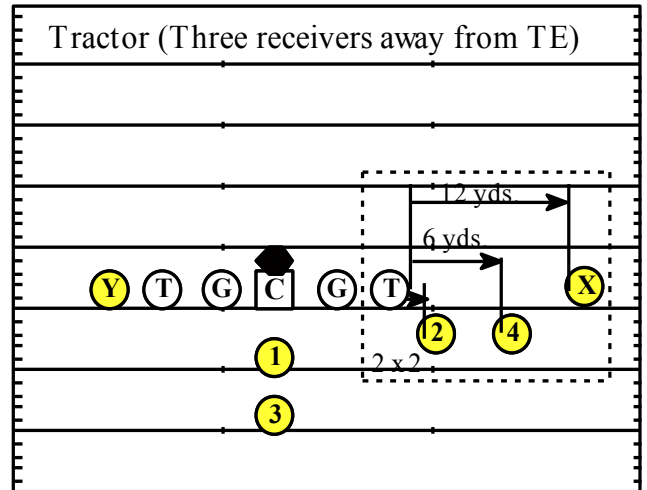

Alaska (Tackle Over Lt. Unbalanced)

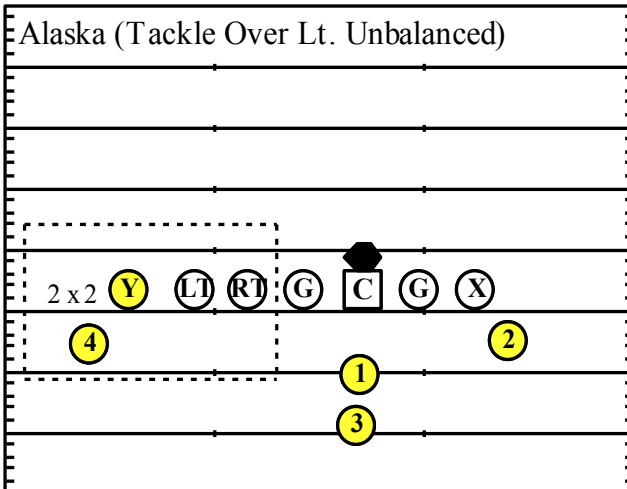

Texas (Tackle Over Rt. Unbalanced)

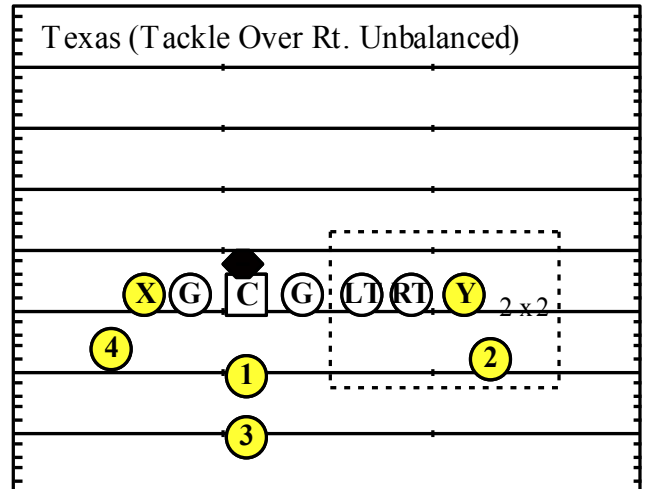

◆ Formation Identification ◆

Baltimore (Bunch Left)

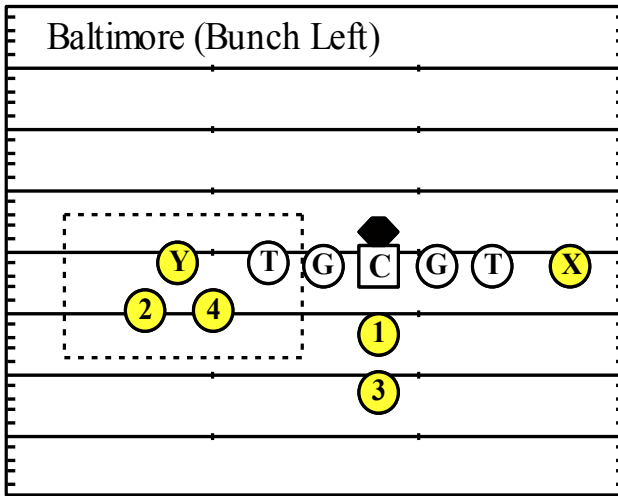

Bird (Bunch Right)

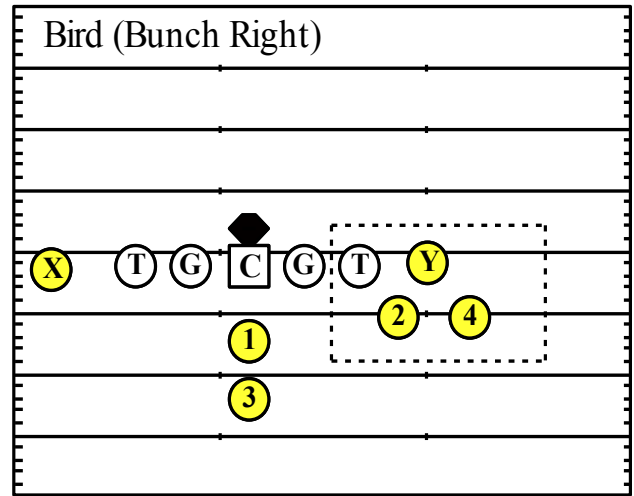

Louie (Empty Lt.)

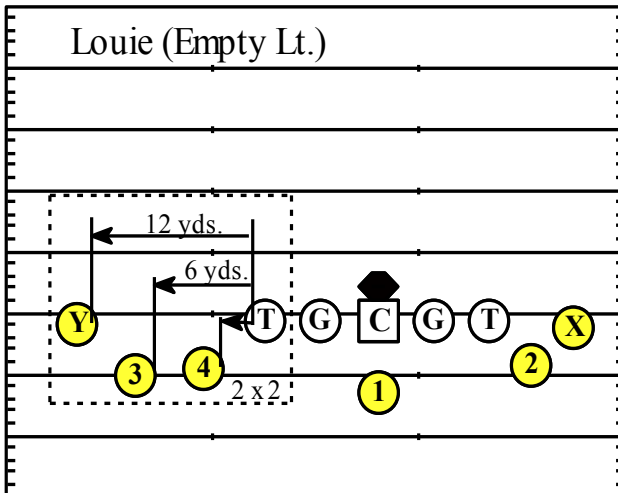

Roger (Empty Rt.)

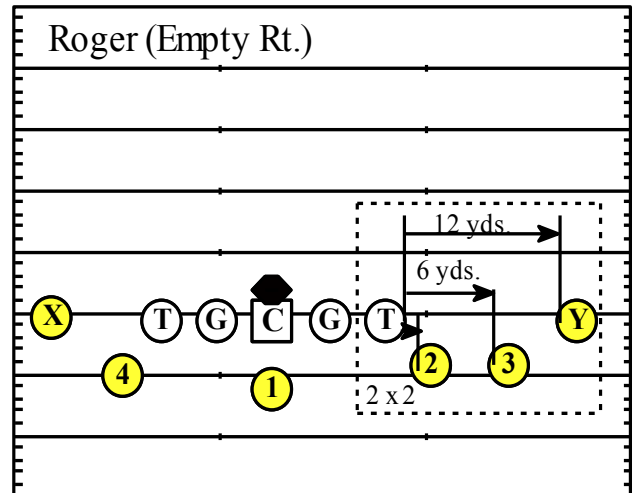

Remember, the tags being used to explain formation identification can be anything you would like to use. The names I used are ones I can use from the sideline to get our players lined up without our opponents understanding what we are doing.

Openside vs Tightside

Randy Formation

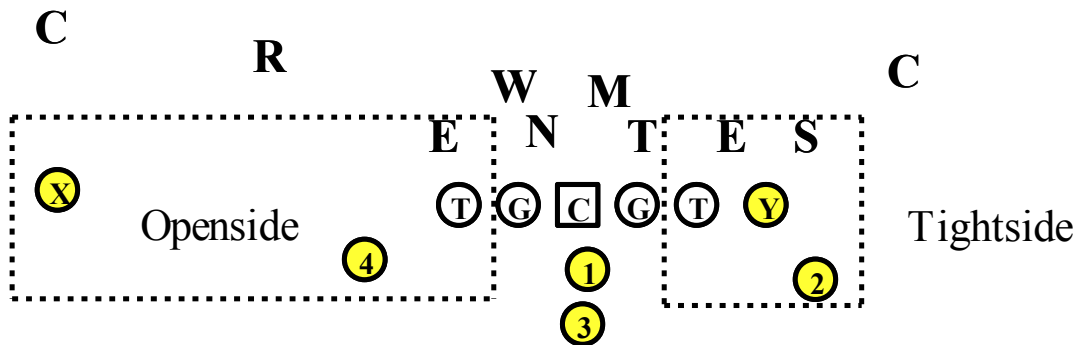

Dorthy Formation

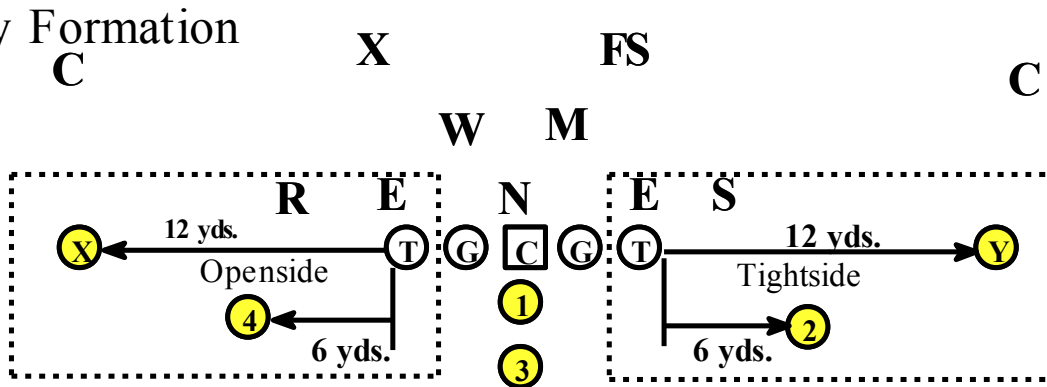

Utah Formation

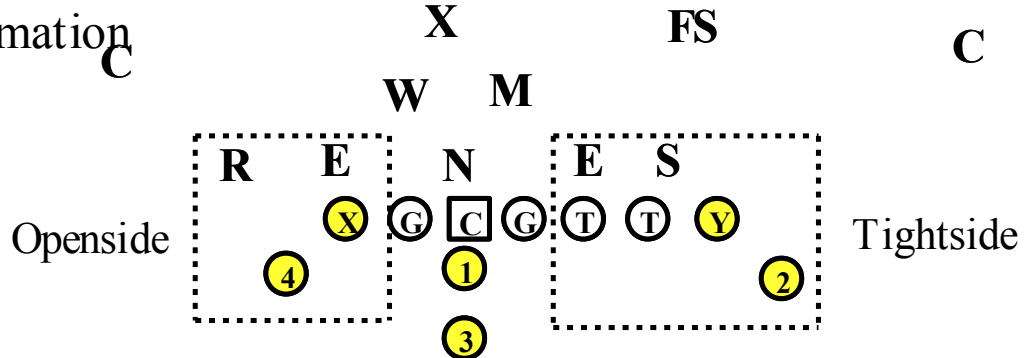

Louie Formation

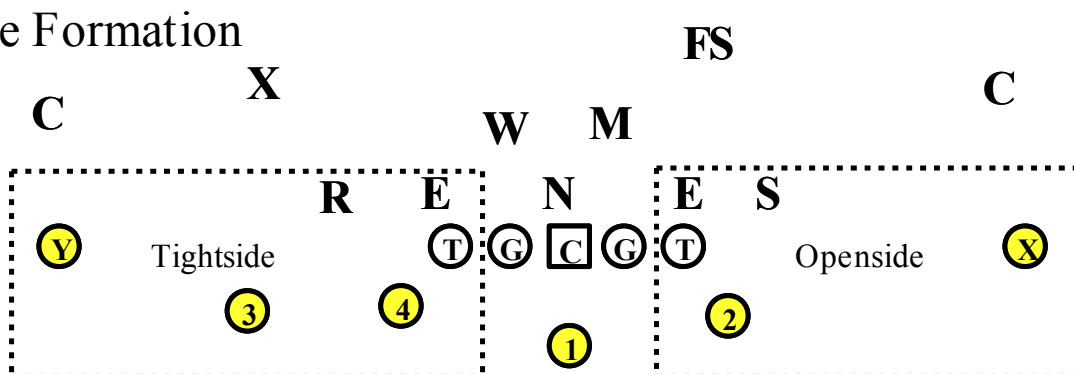

Odd Formations and Backfield Sets

Duck Right

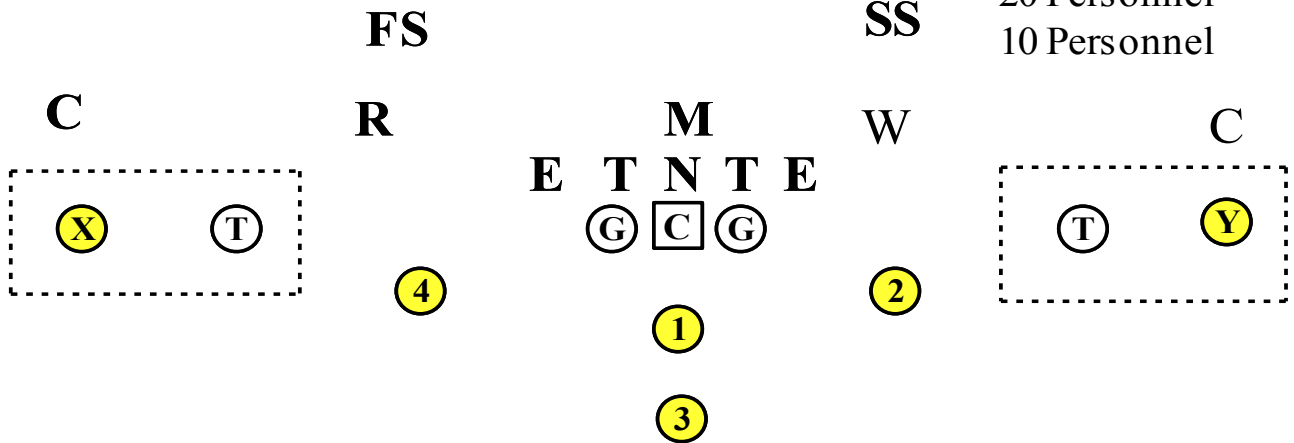

Wacky Right

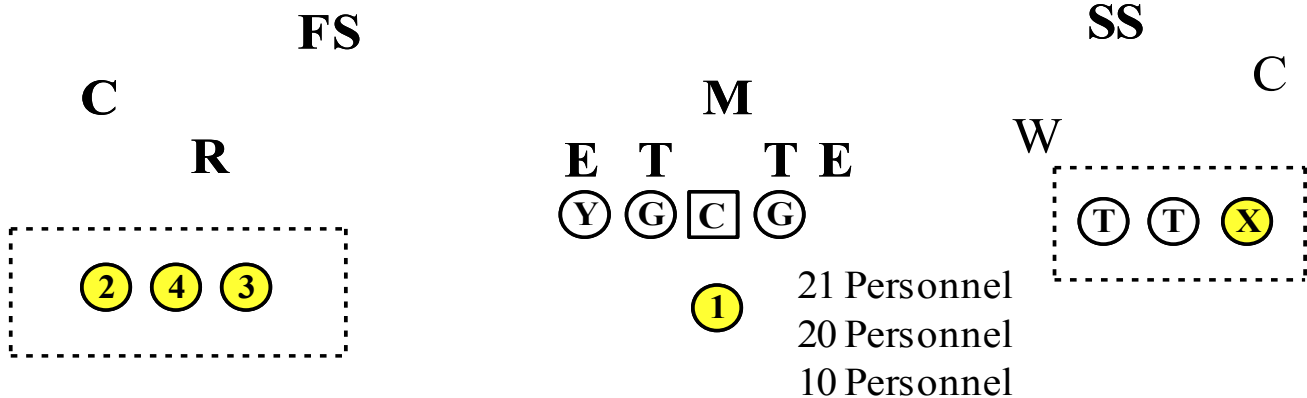

The formations illustrated in this section can be modified to fit your athletes and type of defensive schemes you might face. The depth of the QB and Fullback can be moved around in regards to the depth from behind the center. The more inside runs the more you might consider moving your QB up and the wider the running play you might consider setting the QB deeper behind the center.

One advantage the pistol has over the Gun is the depth in which the center has to snap the ball. Another advantage of the pistol offense is the running backs position behind the QB instead of off to the side. By putting the back behind the QB he now can go either direction on the snap without creating a potential tendency by setting him to one side or the other.

Personnel Groupings

Personnel groupings are indicated below and will be used to alert certain players to certain formations and plays that they maybe associated with:

00 Personnel = 0 Backs, 0 Tight Ends & 5 Wide Receivers

01 Personnel = 0 Backs, 1 Tight End & 4 Wide Receivers

10 Personnel = 1 Back, 0 Tight Ends & 4 Wide Receivers

11 Personnel = 1 Back, 1 Tight End & 3 Wide Receivers

12 Personnel = 1 Back, 2 Tight Ends & 2 Wide Receivers

13 Personnel = 1 Back, 3 Tight Ends & 0 Wide Receivers

20 Personnel = 2 Backs, 0 Tight Ends & 3 Wide Receivers

21 Personnel = 2 Backs, 1 Tight End & 2 Wide Receivers

22 Personnel = 2 Backs, 2 Tight Ends & 1 Wide Receiver

23 Personnel = 2 Backs, 3 Tight Ends & 0 Wide Receivers

32 Personnel = 3 Backs, 2 Tight Ends (Power Football)

The first digit 0, 1, 2, or 3 indicates how many backs you have in the called formation.

The second digit indicates how many Tight Ends if any you are lining up with.

If the second digit is a "0" then it means how many receivers you are playing with predicated by how many backs you have called.

With your formation identification I have color coded the positions:

Gold indicates the QB and Backs

Yellow indicates the offensive line.

Orange indicates your Tight End.

Light Blue your "X" and "Z" receivers.

Alignment and Splits

Offensive line splits are 2 feet, 3 feet between the Tackle and Tight End. The Guards, Tackles, and Tight End line up on the Center's heels. Everyone's eyes are up with little or no weight on their down hand.

The Fullback lines up with his heels five yards from the line of scrimmage and directly behind the Quarterback in a two point stance.

Wings line up 2 yards by 2 yards from the Tight End in a receivers stance with the inside foot back.

Wingbacks or the slots aligned to an openside away from the Tight End will align 2 yards by 2 yards off the Tackle to their side in a receivers stance with their inside foot back.

The outside Receivers will align at the top of the numbers or follow their split rule used in the passing game.

The Quarterback lines up in shotgun with his heels at 2 1/2 to 3 yards deep behind the football.

Cadence

With the Hybrid Pistol Wing-T we will use a quick cadence using Set-Go to snap the football.

Remember, the Hybrid Pistol Wing-T is a fast past tempo offense and will not huddle. The formation will be called from the side line, once the Quarterback hears the formation called he will repeat it to the rest of his teammates. After the Quarterback sees that everyone is lined up properly he will raise his hands to receive the football and if motion is required this will start the designated player in motion. The ball will be hiked on the "S" of Set-Go. We can also freeze play (third set-go). By utilizing Freeze we have the advantage of a varied cadence.

Because of the Set-Go cadence this will help facilitate the fast pace tempo of the game. Whenever the ball is snapped it will create a triangle look from the Quarterback, Fullback, and Motion player.

Motion Discription

Motion:

We use three types of motion Mo, Mo & Jo, Jo, Orbit, and Cowboy.

Mo, Mo is a motion that is used in our Buck Series. Mo, Mo puts the intended motion man running at a 70% effort.

Jo, Jo Motion is used in all other series and puts the intended motion player running at 100% effort.

Cowboy mimics orbit motion then retreats to option relationship to original position.

Mo, Mo, and Jo, Jo Motions

Mo, Mo and Jo, Jo motions do not have to be alerted they are automatically built into the system

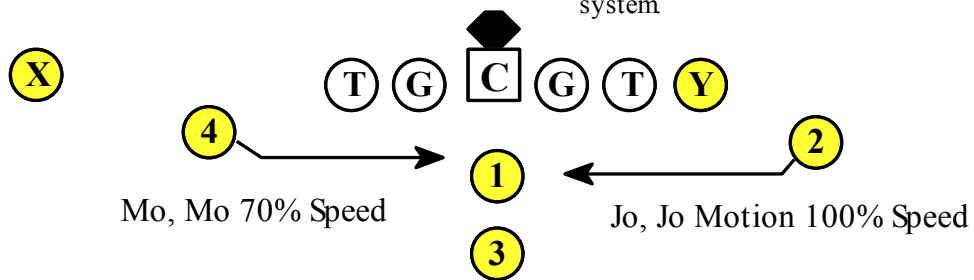

Cowboy Motion - Return Motion by the intended Motion Player.

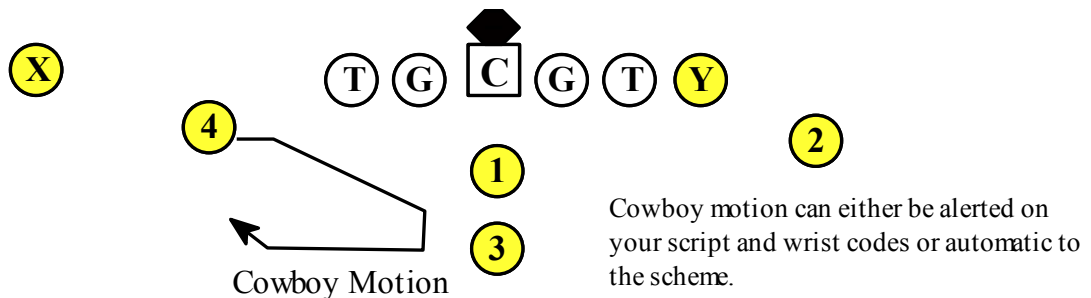

Orbit Motion

Orbit motion can either be alerted on your script and wrist codes or automatic to the scheme.

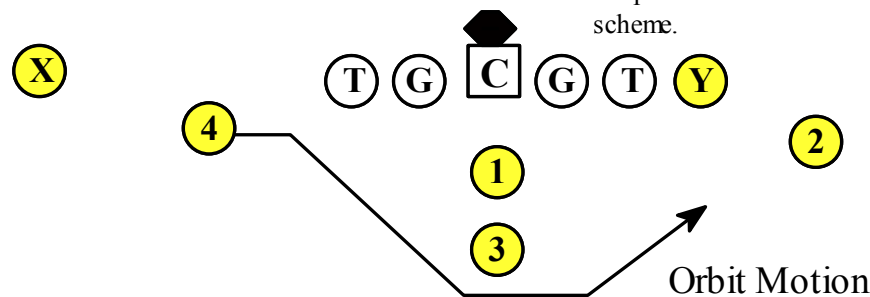

Putting Motion Into the Pistol Wing-T (High Tempo) Offense

Randy Formation

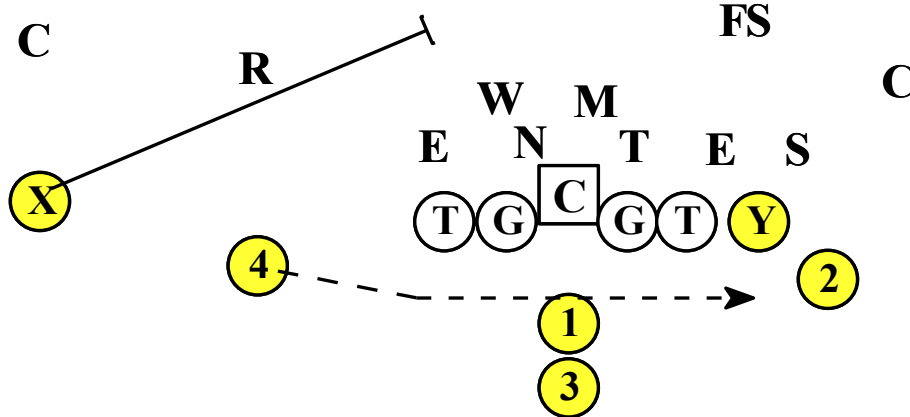

- How To Alert Motion
1. Formation
 2. Play
 3. Direction

Larry Formation

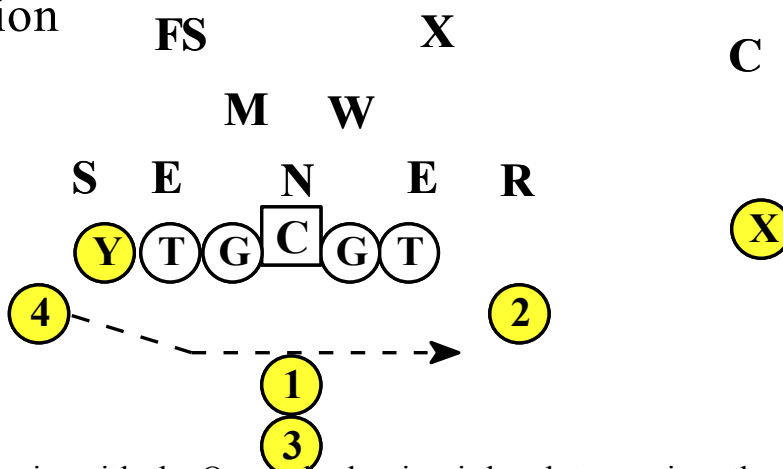

2 & 4 Motion begins with the Quarterback raises his hands to receive the football from his center snap.

Fullback (3) Motion

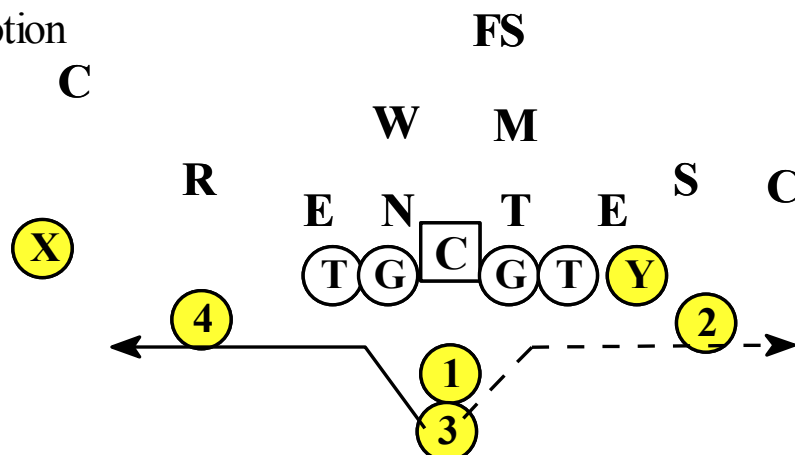

The Fullback motion will be alerted by using Hump & Jump

Jump motion will always alert the fullback (3) to motion away from the play called.

Hump motion will always put the Fullback (3) in motion towards the play called.

Cowboy The Pitchman

Randy 13 Veer
Larry 12 Veer

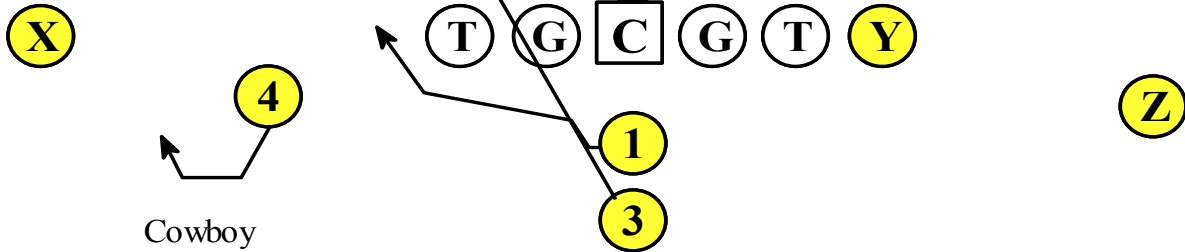

The Cowboy will drop step with outside foot and will work into a pitch relationship with the Quarterback.

Tractor 12 Veer
Trailer 13 Veer

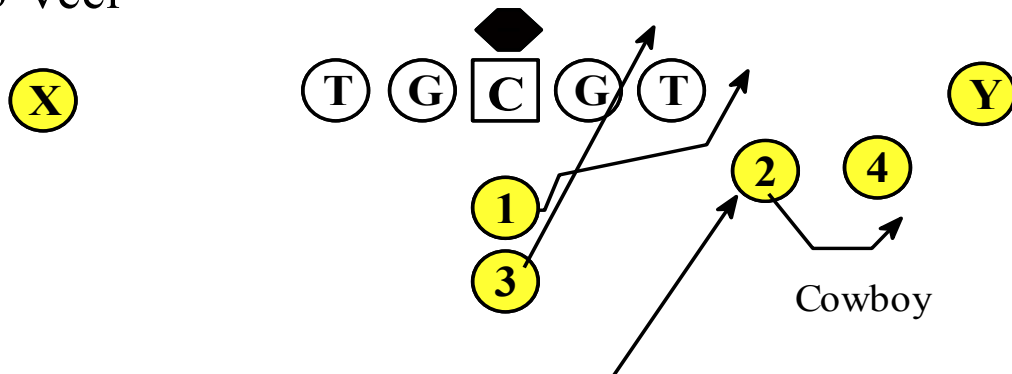

Any slot can Cowboy and turn into a pitchman

Dorthy Best Play
Dallas Best Play

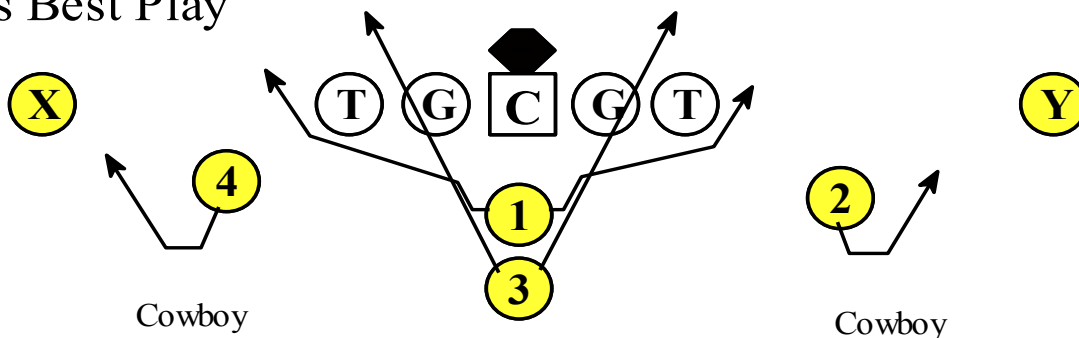

Cowboy The Pitchman From A Slot Formation

Dallas 13 Veer
Dorthy 13 Veer

The Cowboy technique challenges the outside invert to make a decision on whether or not to take the Quarterback or the pitchman, this sets up the convoy screen..

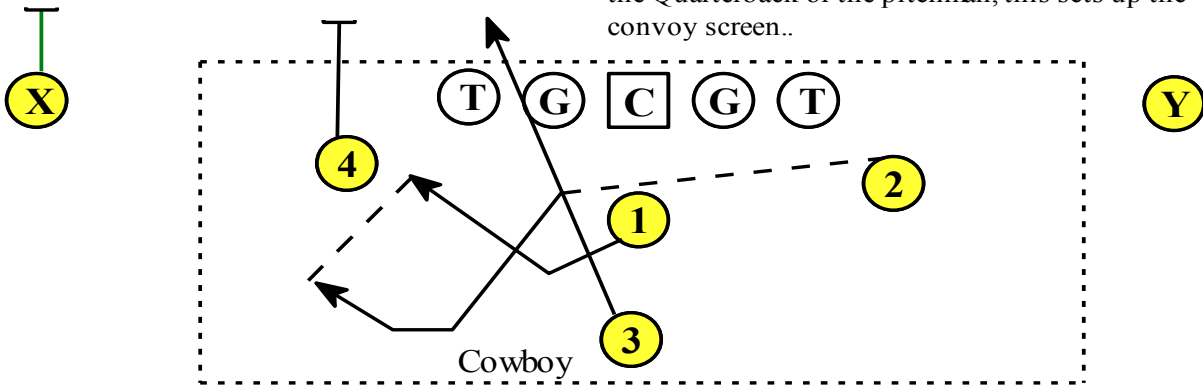

The Cowboy technique has the pitchman taking one step forward with his outside foot and then a 45 degree angle step with his inside foot to work into the proper pitch relationship.

Tractor 12 Veer
Trailer 13 Veer

No need to over coach the cowboy technique, your players will figure it out. The biggest adjustment is how far you will split the slot outside the tackle.

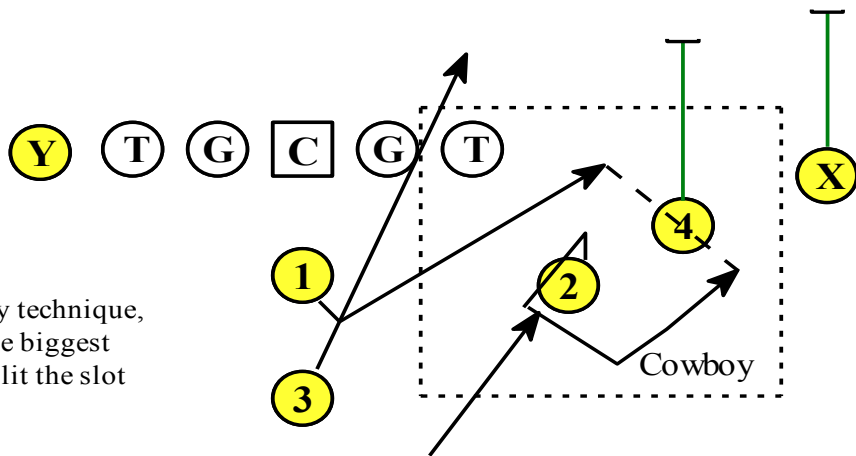

Any slot can Cowboy and turn into a pitchman

Dorthy Best Play
Dallas Best Play

The Cowboy will first step with his outside foot to challenge the invert and then a 45 degree angle back with the inside foot, this sets the Cowboy technique up.

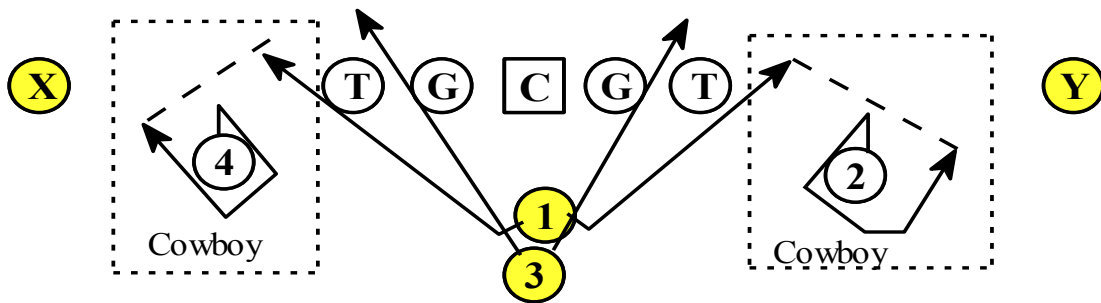

When aligning in a formation that gives you a slot to either side you can audible into best play depending upon the read by the quarterback thus, either slot could possible cowboy into a pitchman our into the Bubble screen.

Defensive Alignment and Gap or Area of Responsibility

The following information will describe gap responsibilities and how you name the area between each offensive blocker. Whenever a defender takes up a shade on an offensive blocker he has for the most part taken up a gap responsibility. An example of this would be a 3 technique aligned on the outside shade of a guard becomes a "B" gap defender. Any defender aligned on the outside shade of the tight end or is aligned as a ghost nine technique has what we call outside responsibility, this normally is contain responsibility. The following illustrations will explain a defender's area of responsibility according to his defensive alignment.

Whenever a defender is aligned head-up on an offensive blocker he is considered in a read alignment which may give him either gap to the side the play is going.

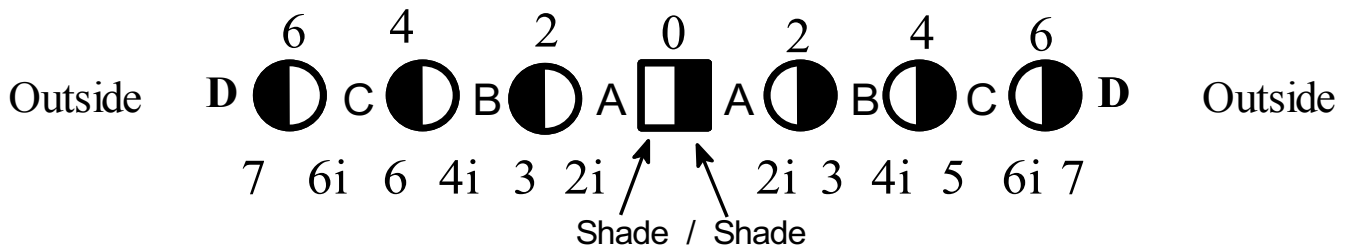

Once with the illustration below we demonstrate the area of gap responsibility according to the alignment of the defender.

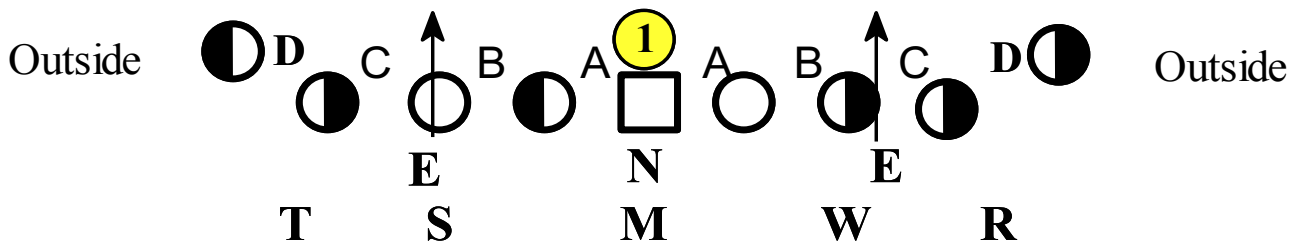

Whenever a defender is aligned head-up in either a 0, 2, 4, 6, or 8 alignment he is considered in a read technique. Normally his area of responsibility will be dictated by the direction the play is going.

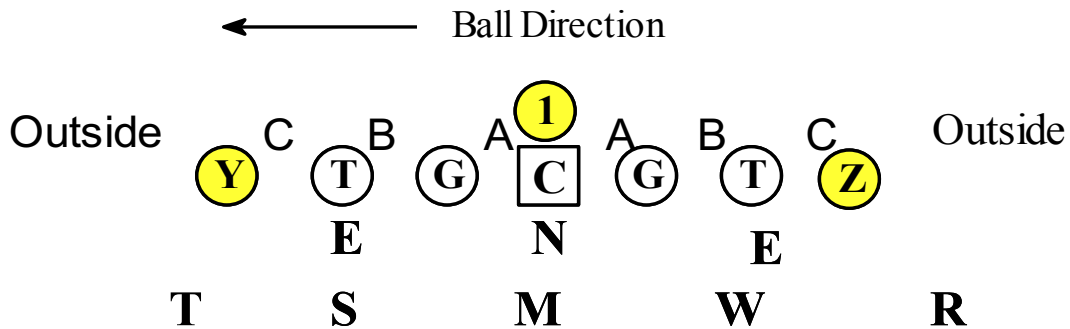

Offensive Line Run Block Phrases and Terms

The following terms will be used as a method for teaching our offensive line when run and pass blocking.

Feet Parallel or Slight Stagger:

schemes work out at angles so depending upon the type of play called they could either step right or left. So, we ask our linemen to balance their stances with only a slight outside stagger of the foot.

Paint The Grass:

linemen will take their down hand and use their hand as a paint brush going back and forth against the grass it will set their weight distribution for their stance.

Hand Down On the Inside Of The Knee:

back by your offensive lineman you want to drop the down hand right inside the knee to the down hand.

Toes In / Heels Out

resemble a frog make sure your offensive linemen turn their toes in and heels out. The toes in and toes out will also help with a flat back.

Eyes Focus To The Top Of The Numbers (Big Eyes):

get down into their stance have them focus their eyes on the top of the numbers of the down defender.

Punch To The Top Of The Numbers

linemen fire out have them punch to the top of the jersey number of the down defender, this will help your linemen to set down in their chair. The term show me that its OK happens once your lineman punches to the top of the jersey number the the down defender, the lineman wants to turn his thumbs up in a fashion that shows its OK. Once the thumbs are turned up then the fingers rotate underneath the peck plates (shoulder pads) which gives the offensive lineman more control of the defender.

Show Your Jersey Numbers:

linemen to show their jersey numbers to the down defender whenever they feel the defender on his back heels, this creates the finish.

Sit Down In The Chair:

underneath him. To assist with a lineman sitting down in the chair would be to show your jersey numbers.

Offensive Line Run Block Phrases and Terms

The following terms will be used as a method for teaching our offensive line when run blocking.

Stomp the Arches

inside arches. By pushing on the inside arch you get more of your foot in the ground thus, producing more push on your defender.

See Your Backers:

track their linebacker according to type of play called. By looking for your backer you prevent run throughs.

Track Your Backers:

help prevent Linebacker run throughs.

Get Hippo

together should keep their hips together in order to keep defenders from penetrating on the play called.

Circle The Wagons:

plays and sprint out game. With any scheme with a 8 or 9 in it which also includes the sprint out game requires the offensive line to bring their body position around as the ball heads outside.

Part The Sea

offensive linemen will find the nearest ear of their down defender and counter rotate the blocking scheme that creates a parting at the point of attack thus, the "Parting of The Sea"

Whats For Dinner:

for dinner is a term that can be used by any offensive player for the snap count to be repeated.

Trap - White (Short Trap):

defender to be trapped. A White alert traps the first defender on or past the offensive guard.

Trap - Black (Long Trap):

to be trapped. A Black alert traps any defender on or past the offensive tackle.

Gain Depth To Gain Vision:

defender. The second trailing blocker on the counter we ask them to gain depth to gain vision on the linebacker they are tracking.

Slap The Dog, Punch The Donkey:

initial move by an offensive lineman we ask him to slap the dog on his first step, take the hand to the side you pull towards and act if you are back handing your dog and then on the second step take the back hand and bring it through as if you are punching a donkey. Slap the Dog and Punch the Donkey gets your lineman into a position to run and react when pulling.

Easy, Easy:

quarterback goes Easy, Easy it means also the ball will be snapped on one.

Gap, Down, Backer

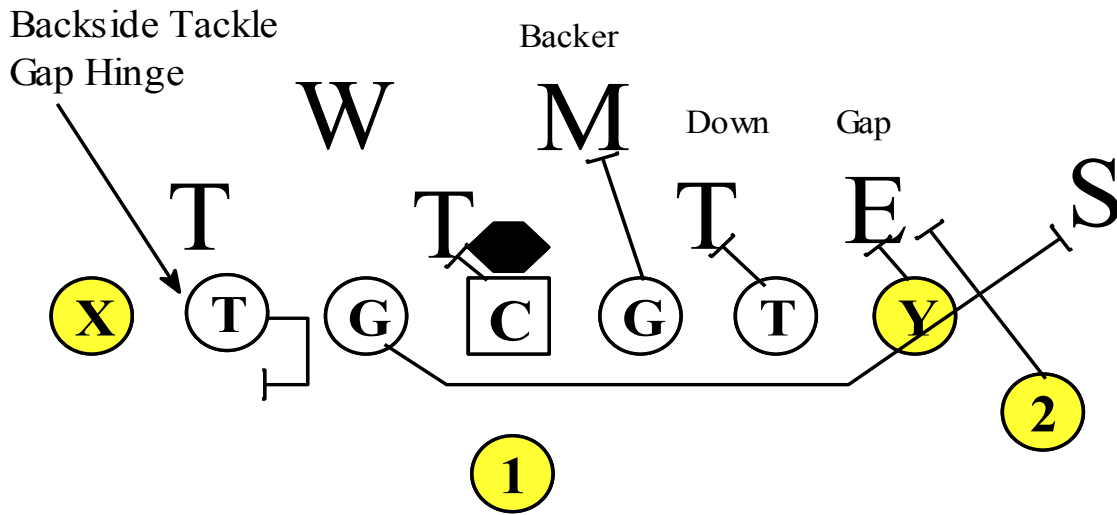

Gap, Down, Backer pertains to a blocking scheme by the offensive line. The meaning of Gap, Down, Backer simple means to block the first defender to your inside whether he is aligned in a gap, on the next lineman inside or uncovered take path towards the inside linebacker.

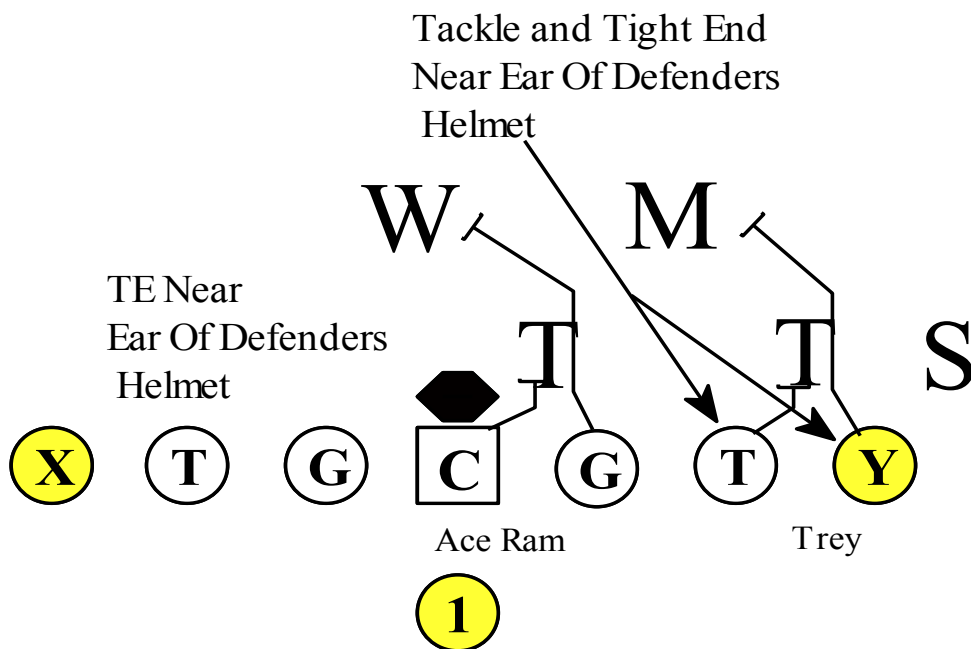

Landmark and Helmet placement: Near Ear Rule

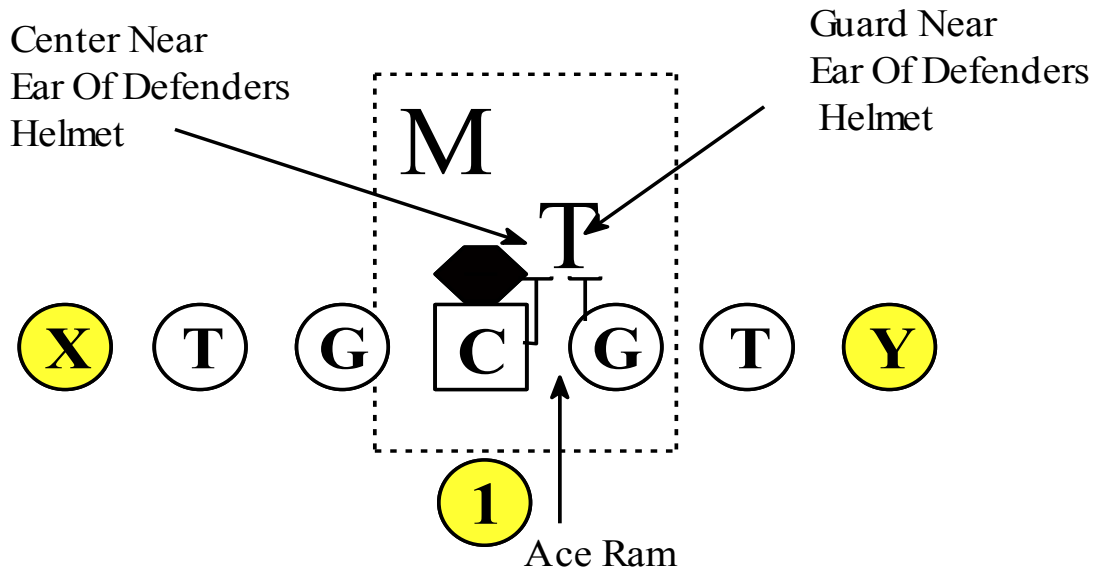

The near ear rule is how the blocking schemes are set. According to type of play called will determine where your offensive linemen will place their helmet on the down defender in the running game. With all numbers 0-1, 2-3, 4-5 our offensive linemen will landmark the near ear of the defenders helmet for who he will block and where he will place his helmet on the snap of the ball. 6 & 7's puts the offensive line tracking through the outside number for play side combo and next number over for the backside combo linemen. The footwork and technique used here is a drop step with the lineman ripping his backside arm through the playside jersey number of the down defender.

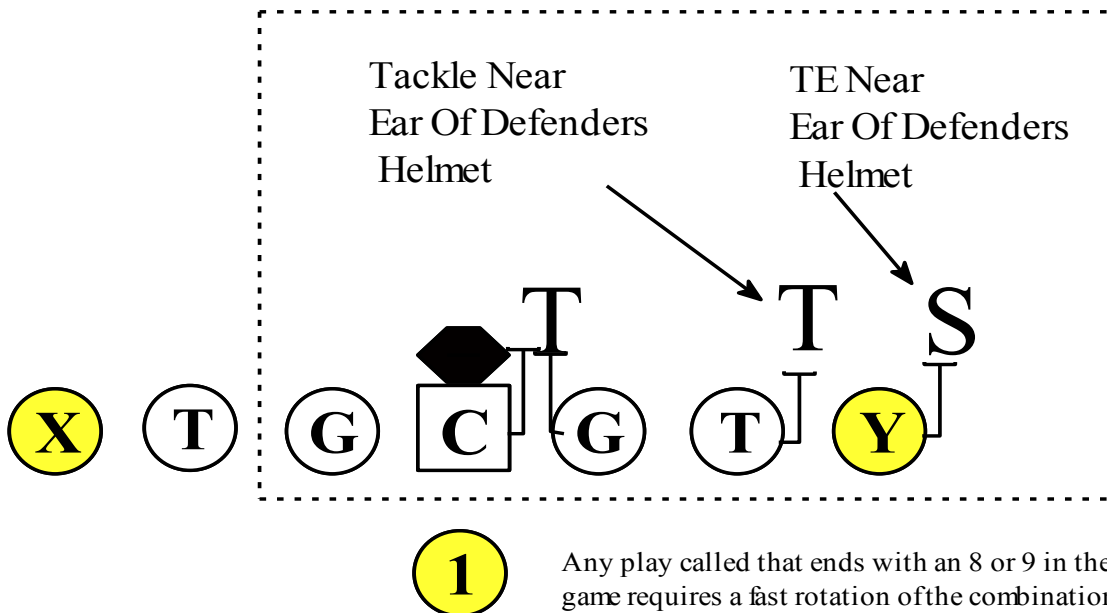

Any play called that ends with an 8 or 9 in the running game requires a fast rotation of the combination or base block. The fast rotation is dictated by how the ball is delivered, for example the toss play.

Base and Combination Blocks / Base, Ace, Deuce, and Trey

The offensive line the backbone of the offense. The following information will give you an over view of how I install out blocking schemes, techniques, and Line Calls. The blocking schemes and alerts are designed for keeping the offensive line in the best possible blocking scheme.

The following pages will illustrate the use of base blocks as well as combination schemes. Combination blocks are between adjacent linemen. Any combination between the center and a guard is considered a Ace combination and depending which guard you work with will either be a Lion or Ram call. Ram for the right guard and Lion for the left guard. A combination between the guard and tackle is a Duece, and any combination between the tackle and tight end is a trey combination.

A combination Ace, Duece, Trey means be between a down defender and a linebacker. A big coaching point when teaching the art of the combo is to see your linebacker. Combination blocks are geared to tracking down defenders to second level linebackers, So,

As you read through the following pages sometimes a change in a blocking scheme may be required and a fold scheme used. Our fold schemes are known as Jack and Jill and the Jack and Jill scheme can be used with any combination block called. If Jill is alerted it means the inside blocker on the combo blocks out and the outside blocker comes around. If a Jack alert is used it means the outside blocker is down inside first with the inside blocker coming around and outside.

The following pages will illustrate the use of the Base Block, Ace (Ram, Lion), Duece, Trey and Jack and Jill fold scheme.

Base
Ace
Deuce
Trey

Setting Your Line Calls For Your Blocking Schemes

The following illustrations will demonstrate line calls used to set the different combination blocks when two adjacent linemen are working with each other. Remember, offensive linemen will rotate and make their alert calls according to the multiple alignments encountered during a game and type of play called. The footwork used by an offensive is directly related to how the ball gets delivered to the running back. The line calls mentioned below apply to all the formations previously mentioned.

ACE Combo's

Center will alert the player he will be comboing with by using the alert words Lion (Left) or Ram (Right)



DUECE Combo's

The Duece combo will always be between the right and left guard.



TREY Combo's

The Trey combo will always be between either the Right guard and right tackle or the left tackle and left guard depending upon the formation called.

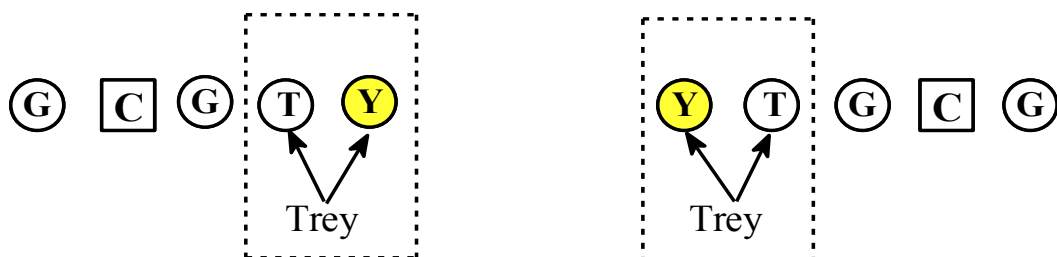

Setting Your Line Calls For Your Blocking Schemes

The following illustrations will demonstrate line calls used to set the different combination blocks when two adjacent linemen work with each other. Remember, offensive linemen will rotate and make their alert calls according to the multiple defensive alignments encountered during a game. The line calls mentioned below follow the line blocking for zone blocking schemes. If you happen to use man rules then you can take and replace those mentioned here and replace with your philosophy.

Ace: Combo between Center and Guard.

Deuce: Combo between a Guard and Tackle.

Trey: Combo between a Tight End and Tackle.

ACE Combo's

Center will alert the player he will be combo with by using the alert words Lion (Left) or Ram (Right)

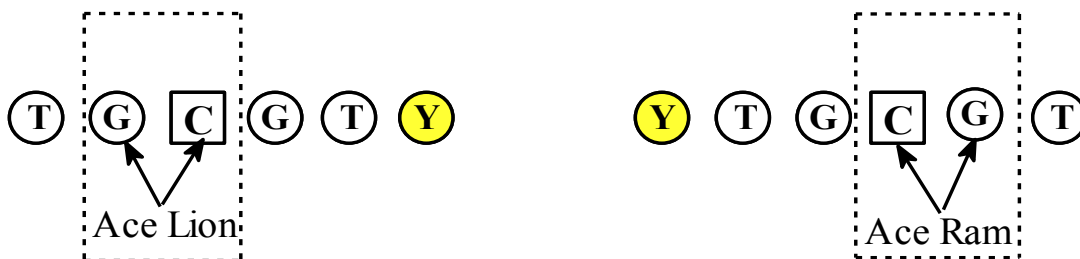

DUECE Combo's

The Deuce combo with tradition formations will be between the guard and tackle.

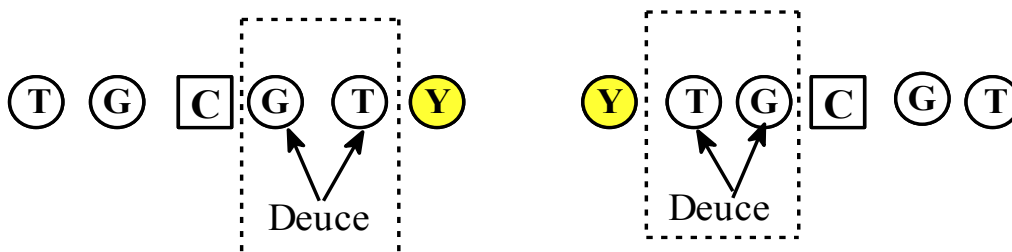

TREY Combo's

The Trey combo in a traditional formation will be between the Tight End and Tackle.

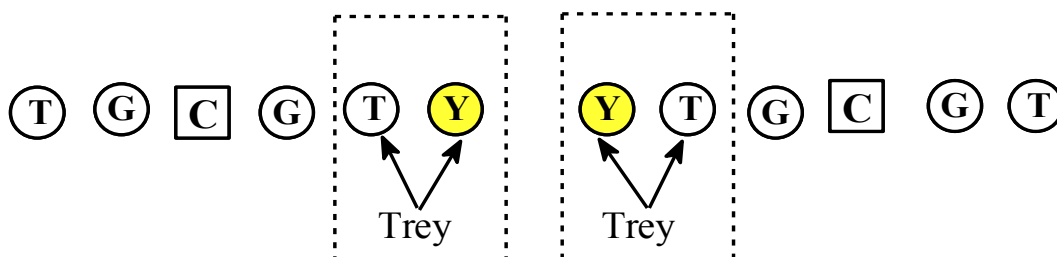

Ace Fold Schemes

Ace Lion Jack

Center and Left Guard
vs ODD DEFENSE

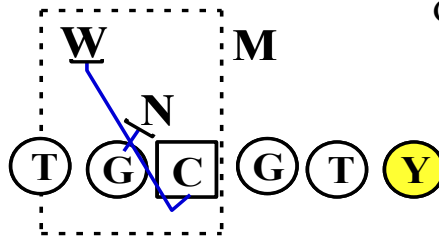

Ace Lion Jack

Guard first, Center around

Jack is an alert for the outside of the combo to block down. The outside lineman in the combo goes first.

Ace Ram Jack

Center and Right Guard
vs ODD DEFENSE

Lineman responsible for the fold should always stay as tight as possible with his dropstep when working off the backside of the fold.

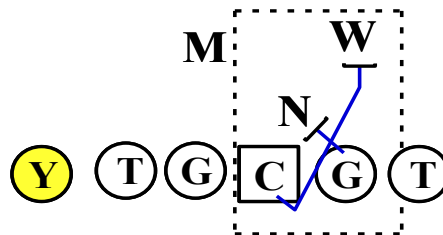

Ace Ram Jack

Guard first, Center around

Lineman responsible for the dropstep should always drop the foot nearest the combo partner.

Ace Lion Jill

Center and Left Guard
vs 4 -3

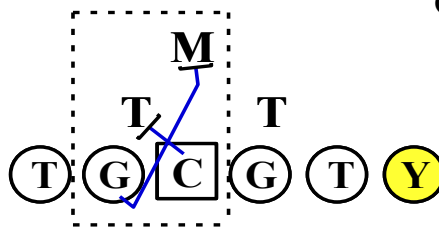

Ace Lion Jill

Center first, Guard around

Jill will always put the inside lineman blocking out with plays run inside.

Ace Ram Jill

Center and Right Guard
vs 4 -3

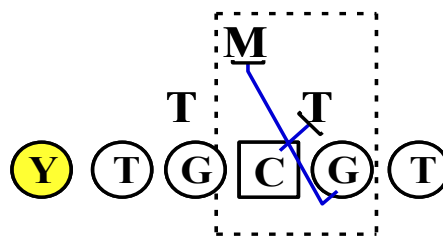

Ace Ram Jill

Center first, Guard around

Deuce Fold Schemes

Deuce Jill

Guard and Tackle

Guard first, Tackle around

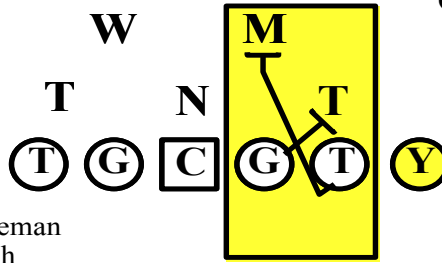

Deuce - Jill

The "JILL" Technique for the lineman coming around is to drop step with their inside foot workig as tight as possible to the near hip of the lineman blocking out.

Deuce Jack

Guard and Tackle

Tackle down, Guard around

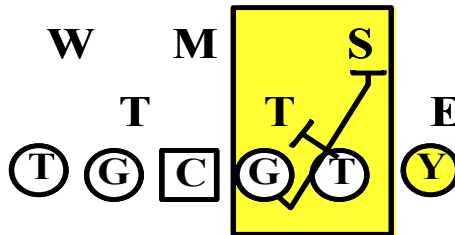

Deuce Jack

"JACK" scheme puts the lineman on the outside of the fold blocking down. With the backside of the fold using a dropstep to come around the down block.

Deuce Jack

Guard and Tackle

Tackle down, Guard around

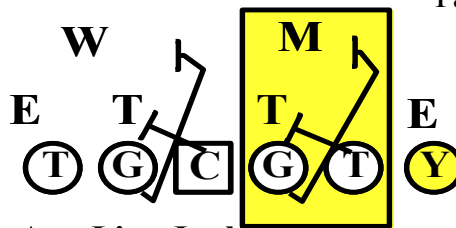

Ace Lion Jack
Deuce Jack

Deuce Jill

Guard and Tackle

Guard first, Tackle around

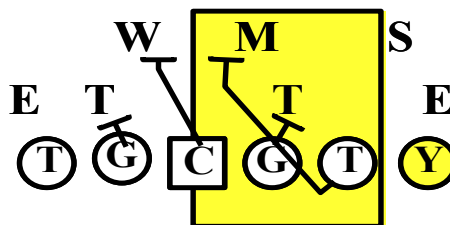

Base Base
Deuce Jill

Trey Fold Schemes

Trey Jill
Tackle and Tight End

Tackle out and Tight End around

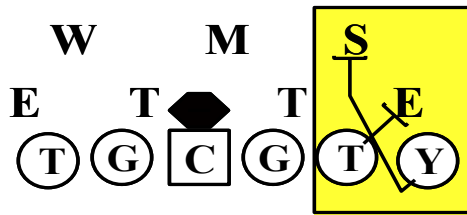

Trey Jill

Trey Jill
Tackle and Tight End

Tackle out and Tight End around

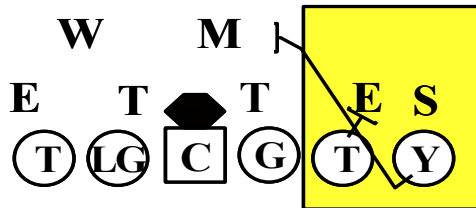

Trey Jill

Trey Jack
Tackle and Tight End

Tight End down and Tackle around

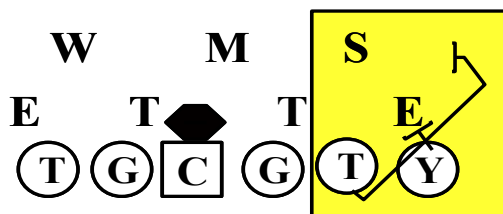

Trey Jack

Trey Jack
Tackle Tight End

Tight End down and Tackle around

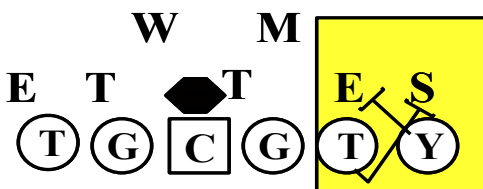

Trey Jack

Hybrid Pistol Wing-T Running Game By Series

Buck Series

46 & 27 Buck

46 & 27 Buck Speedy

46 & 27 Buck Biggy

46 & 27 Blast

146 & 127 Blast Pass

QB Bend 10 & 11

Belly Series

34 & 35 Belly

34 & 35 Belly Option

34 & 35 Belly Follow

34 & 35 Belly Sweep

134 & 135 Belly Pass

Option Series

10 & 11 Jill

12 & 13 Veer

12 & 13 Crazy

18 & 19 Load

18 & 19 Block

Trap Series

10 & 11 Bend

30 & 31 Bend (Trap)

40 & 21 TT (Tackle Trap)

40 & 21 TT Option

Jet Series

18 - 19 Jet Follow

48 - 29 Jet

48 - 29 Sweep

48 - 49 Stretch

18 - 19 / 38 - 39 / 48 - 39 Sweep, Fly Sweep

Series Page

Buck

Buck Rt / Lt
Bend Rt / Lt
Buck Rt / Lt Wide
Buck Rt / Lt Speedy
Blast Rt / Lt
G - Blast Rt / Lt
Buck Rt / Lt Reverse
Joker Rt / Lt
Boot Rt / Lt Cruise
Boot Rt / Lt - Push / Go
Blast Pass Rt / Lt
Sally Rt / Lt
QB Bend Rt / Lt

Screen

Wing Screen
FB Screen
WR Screen

Option Game

Jill
Army
Veer
Wall
Bump

Belly

Belly Rt / Lt
Belly Option Rt / Lt
Belly Pass
Belly Sweep Rt / Lt

Non-Series Play

Trey Rt / Lt
Jet Rt / Lt
QB Trey Rt / Lt
QB Jet Rt / Lt
QB Jet Rt / Lt Follow

Sprint

Rt / Lt 1-Cut
Rt / Lt 15
Rt / Lt 55
Rt / Lt 47

Hot (3-Step)

Swamp 211 13
Reno Scissors 31
All Stick 33
Fades

Midline vs a 2 or 3 Technique

Next Step Read the Three Technique

10 - 11 Jill: After quarterback sees that the triangle is intact towards the openside he then looks towards the tight end side for his next option. The area over the tightside guard is the area he will consider for running the midline option or 10 & 11 Jill. Quarterback needs a 3 or 2 technique for best results. Midline is best run towards the tight end because of the blocking scheme that is afforded this play.

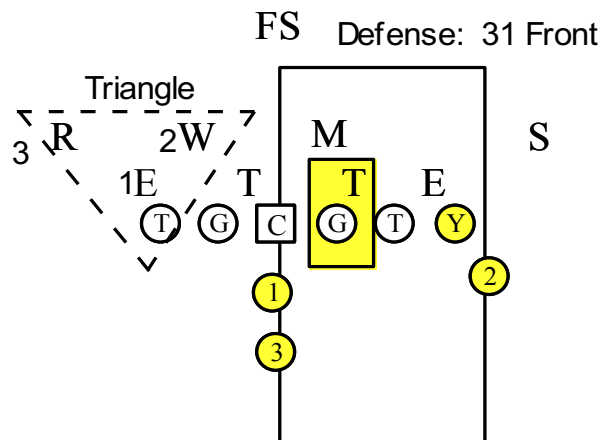

The midline is considered the easiest option for the quarterback to read because of the location of the three technique and his ability to get his eyes on the inside jersey number.

Remember, no matter what your backfield set is when playing with a tight end or slot you must have two trackers for the playside linebacker and free safety. The midline must be a play we perfect because it will force defense to reduce in order to defend this play. When defending the midline it will force defensive fronts and outside invert to reduce, thus setting up the outside option game.

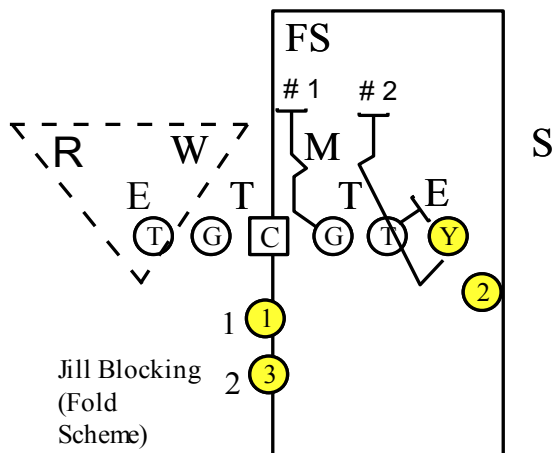

Our base scheme for the midline is the Jill fold scheme which puts the playside tackle blocking out on the 6i technique and the end drop stepping inside to track the playside linebacker to free safety. It should be noted that the reason this scheme is called Jill is because of the fold by the tackle and tight end. Anytime you have a combination between two adjacent linemen and the inside blocker blocks out and the outside blocker drop steps inside is known as a Jill scheme. If you had the outside blocker going first and the inside blocker drop stepping and going outside the down block then it would be known as a "Jack" scheme or fold.

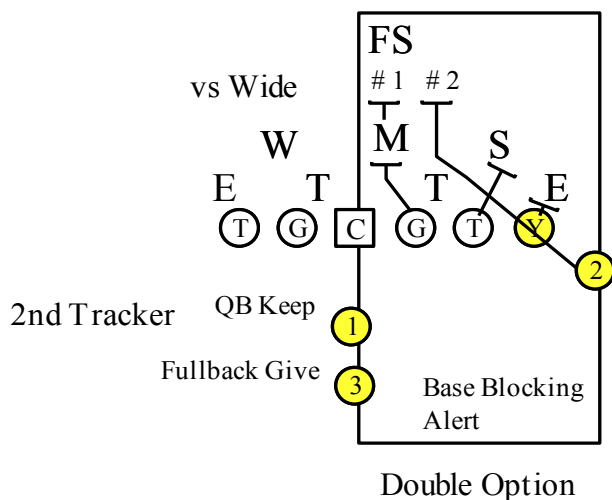

With the Jill scheme we will always have the ability to check the blocking rule to a Base alert whenever the tight end and tackle can no longer work the Jill fold together. The tight end will be responsible for the "Base" alert if faced with a 7 technique and no one covering up his tackle. With the "Base" alert the tackle will now take first threat over the top of him. The "Base" alert puts the tailback becoming the second tracker along with the playside guard. This is known as an "Army" scheme, tailback tracking middle linebacker to free safety.

The Base alert turns the Jill scheme from a triple option to a double option based upon the tight ends alert.

Quarterback Mechanics and Mesh For 10 -11 Midline Option

The midline option read is considered one of the easiest options to install due to the closeness of the read. Our midline option is called 10 or 11, we will want to run the midline towards a 2 or 3 technique only for best results and for best midline mechanics. On the midline line option we want to teach our quarterback to read the inside jersey number of the two or three technique (defensive tackle).

The footwork we will teach our quarterbacks will be to push off the playside foot. We will take when pushing off the playside foot a 45 degree angle step with the backside foot. Once the quarterback pushes away from the read he then will want to step at six o'clock with his playside foot reaching the ball back to the fullback as deep as possible. Also, by the quarterback pushing away from the read it will help in getting out of the way of the fullback who takes a path at the mid point of his center. The following illustrations will help to demonstrate the midline mechanics by the quarterback.

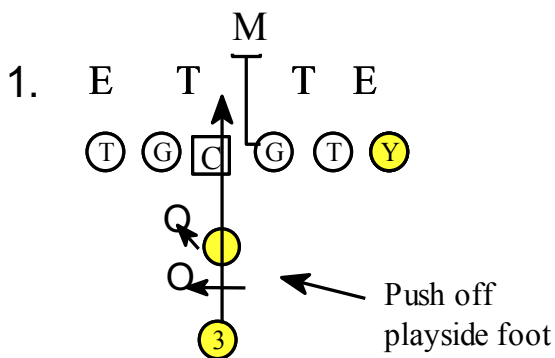

In illustration # 1 the quarterback will push parallel to the line of scrimmage with his backside foot. You push away to get out of the way of the fullback.

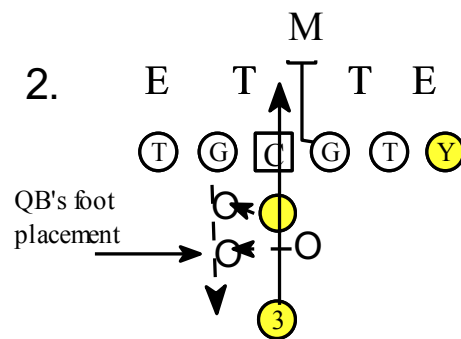

In illustration # 2 the quarterback will after pushing off his playside foot, step at 6:00 o'clock getting his feet perpendicular to each other. Quarterback will reach the ball back as deep as possible.

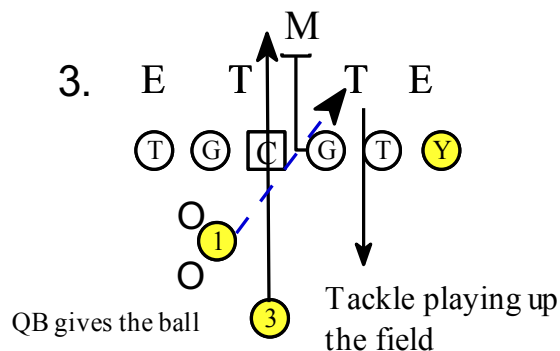

Illustration # 3 demonstrates the eye location of the quarterback as he reads the 3 technique. The quarterback wants to get his eyes to the inside jersey number of his read as fast as possible. If the inside jersey number goes upfield the quarterback will give the football to his fullback. After giving the ball the quarterback should carry out his fake as if running with the ball. Carrying out the fake by the quarterback is a key coaching point and should always be emphasized.

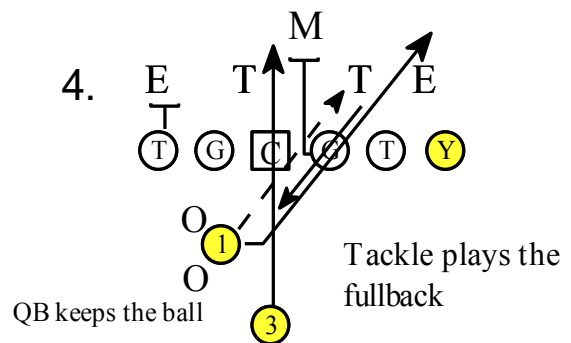
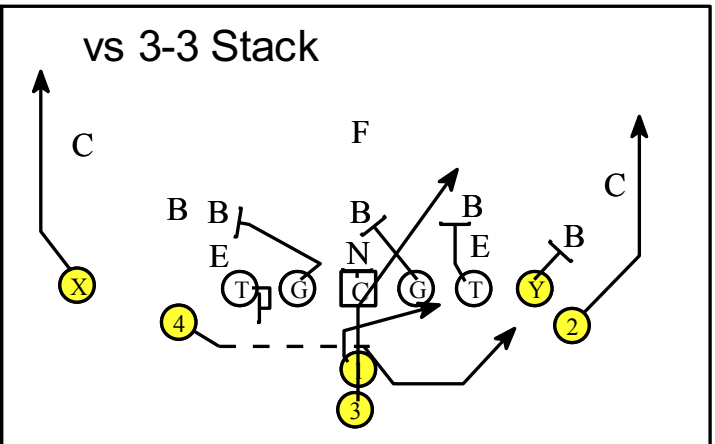
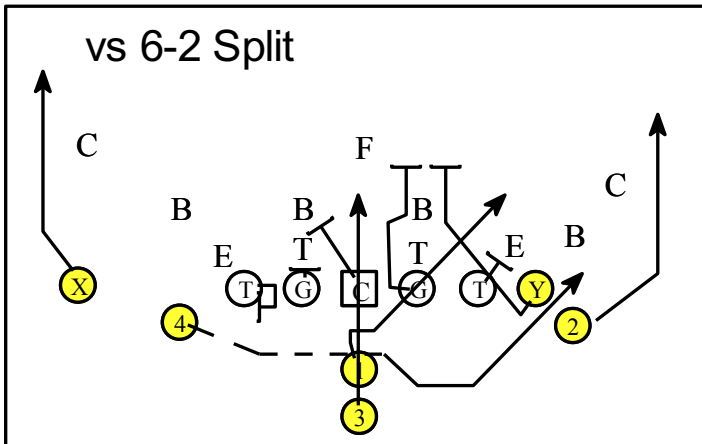

Illustration # 4 demonstrates what the quarterback would do if the inside jersey number of the tackle closes down inside as the 3 technique attacks the fullback. When the quarterback sees the three technique close down inside he will pull the ball off the mesh of the fullback ride and replace the three techniques original alignment.

*Formation: Randy & Larry
Play: 10 & 11 Jill (Midline Option)*



PST - Possible Jill fold with TE. Vs any odd front tackle inside veer releases to near LBer.

PSG - Inside picking grass working up an onto the playside LBer. Aiming point inside jersey number.

C - Block man on or combo with your backside guard tracking backside LBer.

BSG - Combo with your center vs a down defender to the backside LBer.

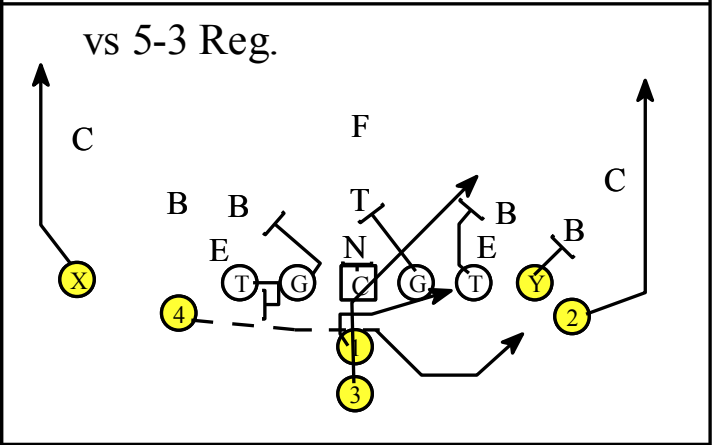

BST - Gap Hinge making defender have to run around you don't allow him to cross your face.

TE - Possible Jill fold with our tackle vs a 9 technique go base and turn defensive end out.

PSW - Possible Jill Fold onto the playside LBer or outside fade route depending on formation.

BSW - Quick fly motion and then Cowboy into pitch relationship with your quarterback. Run at outside jersey number of the outside Invert.

FB - Run path over top of your center creating soft mesh pocket with quarterback, run to daylight.

X - Wide Fade Route

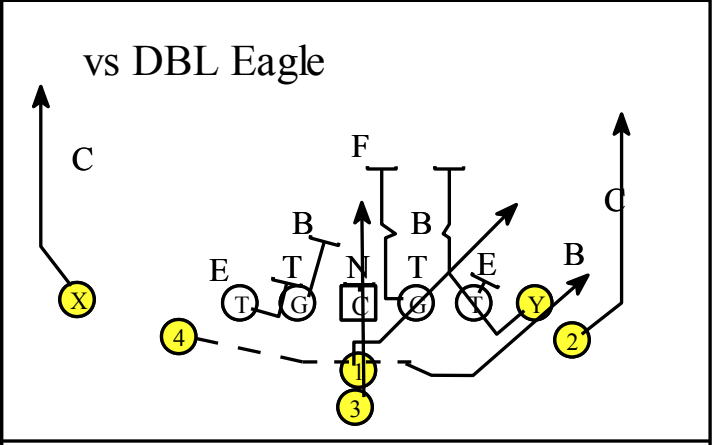

QB - Option 3 technique tracking inside jersey number of your read. If pull replace 3 technique running out at a 45 degree angle off the outside hip of the fold.

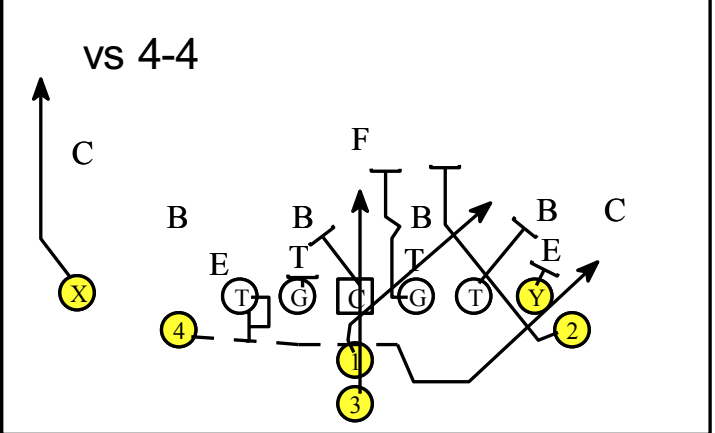

Formation: Randy & Larry
Play: 10 & 11 Army (Midline Option)

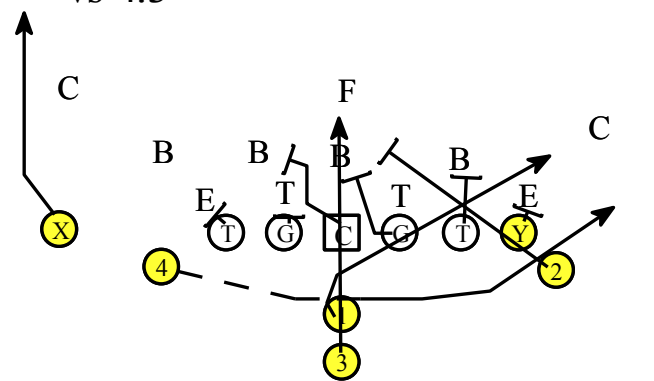
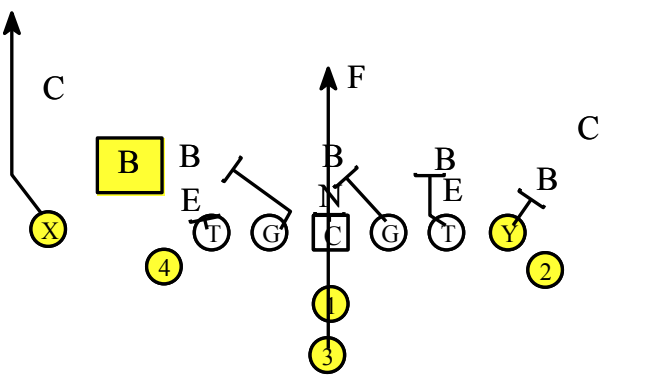
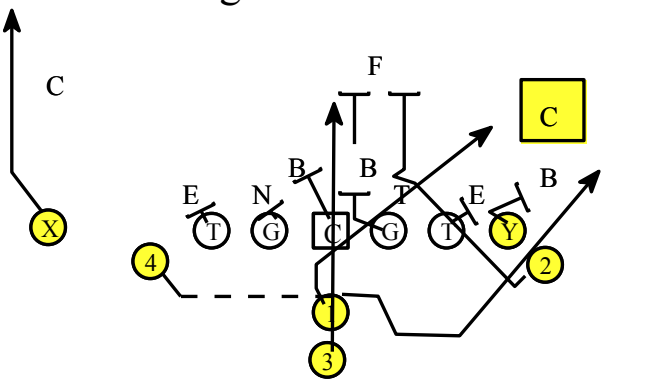
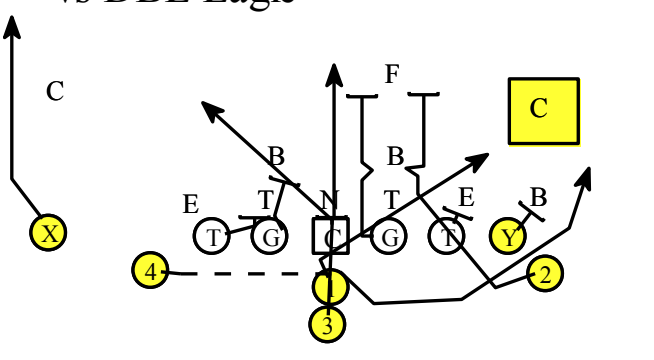
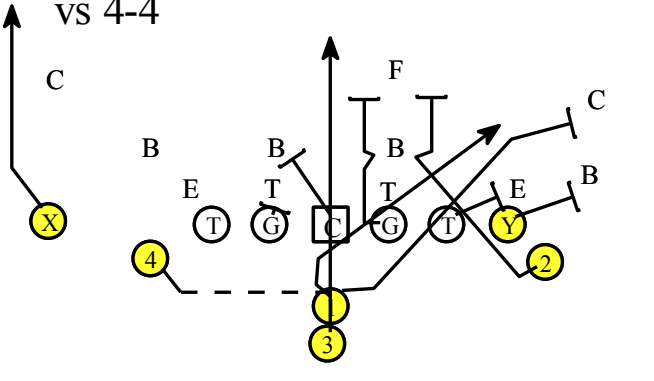
<p>vs 4.3</p> 	<p>vs 3.5.3 Stack</p> 
<p>PST - Gap - Down - Backer</p>	<p>vs 5-3 Reg.</p> 
<p>PSG - 45 - 45 - Scrape Paint - Kick-out (KO)</p>	<p>vs DBL Eagle</p> 
<p>C - Reach Area, (then) Away</p>	<p>vs 4-4</p> 
<p>BSG - Flat - 45 - Scrape Paint - Join Wall (inside to head up threat)</p>	
<p>BST - Gap Hinge</p>	
<p>TE - Gap - Down - Backer</p>	
<p>PSW - Gap - Down - Backer (do not block EMLOS)</p>	
<p>BSA - Mo, Mo To 3.5, Square Cut At PST, Attack The Hole</p>	
<p>FB - fake Opposite A-Gap of Buck, Big Arms, Bend Back To Frontside A-Gap.</p>	
<p>X - Wide Fade Route</p>	
<p>QB - Open To FB Fake, Give To BSW, Run Boot Fake.</p>	

Installing Buck Sweep

Playside Wing

man in your inside gap, down block him. If there is someone over the man next to you, down block him. Otherwise, stay on your track and block a second level linebacker.

Tight End

man in your inside gap, down block him. If there is someone over the tackle, down block him or go Trey combo with your tackle using the near ear rule. Otherwise stay on your track and block a second level linebacker or the first person that crosses your face.

Playside Tackle

combo with your guard following your near ear rule. Otherwise stay on your down track and block the first opposite colored jersey that crosses your face.

Playside Guard

parallel to the line of scrimmage and then one more 45 degree angle step to get downhill and the kick out the first opposite colored jersey. Keep your shoulders square to the line of scrimmage.

Center

backside pulling guard.

Backside Guard

alley tracking the playside linebacker in the alley. Log the first opposite colored jersey inside the alley keeping your shoulders square.

Backside Tackle

linebacker. If no one threatens your "B" gap then hinge backside on first defender off the edge.

Backside Wing

quarterback and run parallel to the line of scrimmage at 75% speed, looking for the alley to open up. Square cut and attack the line of scrimmage once to clear the down block by your playside wing.

Receiver (X)

Fullback (3)

the ball. Open your arms and cradle as if you have the football as you run towards the line of scrimmage. Fullback must carry out a great fake to freeze the inside linebackers.

Quarterback

his second step. Hand the ball to the Wing on the inside and then fake boot.

Buck Sweep

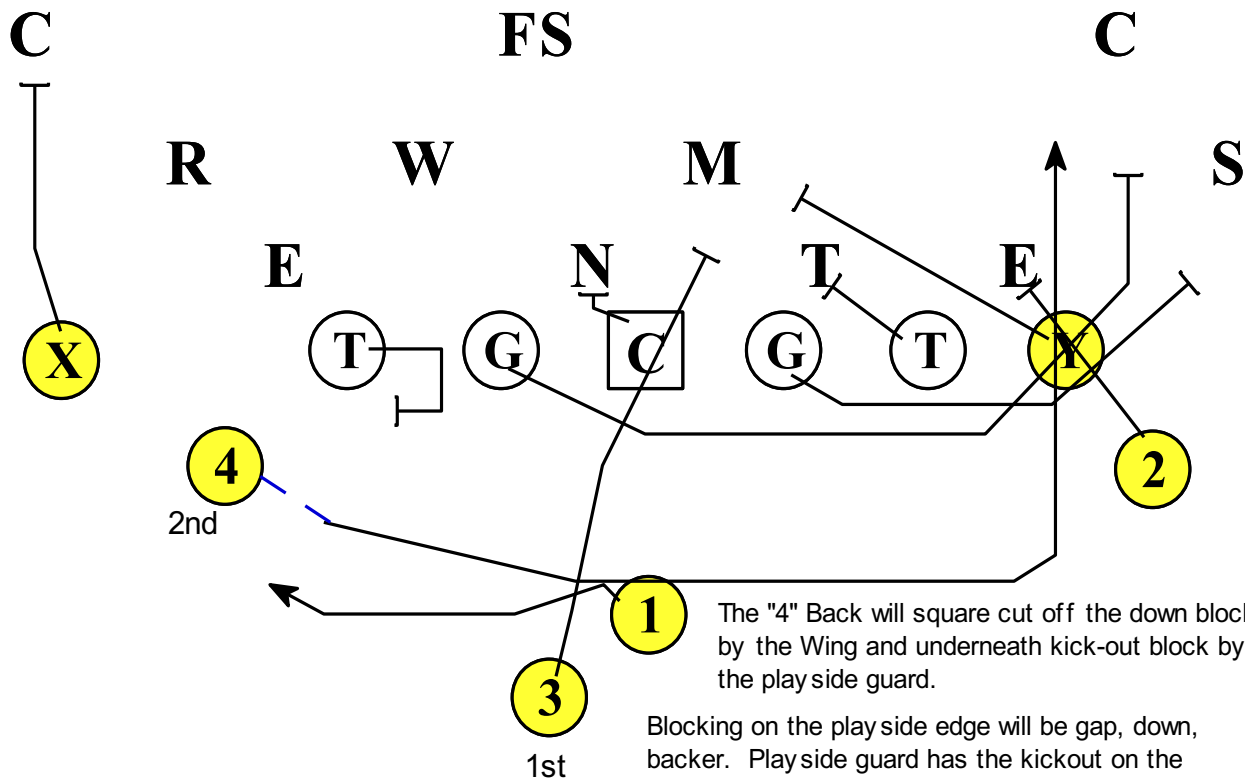

Raven Buck Rt.

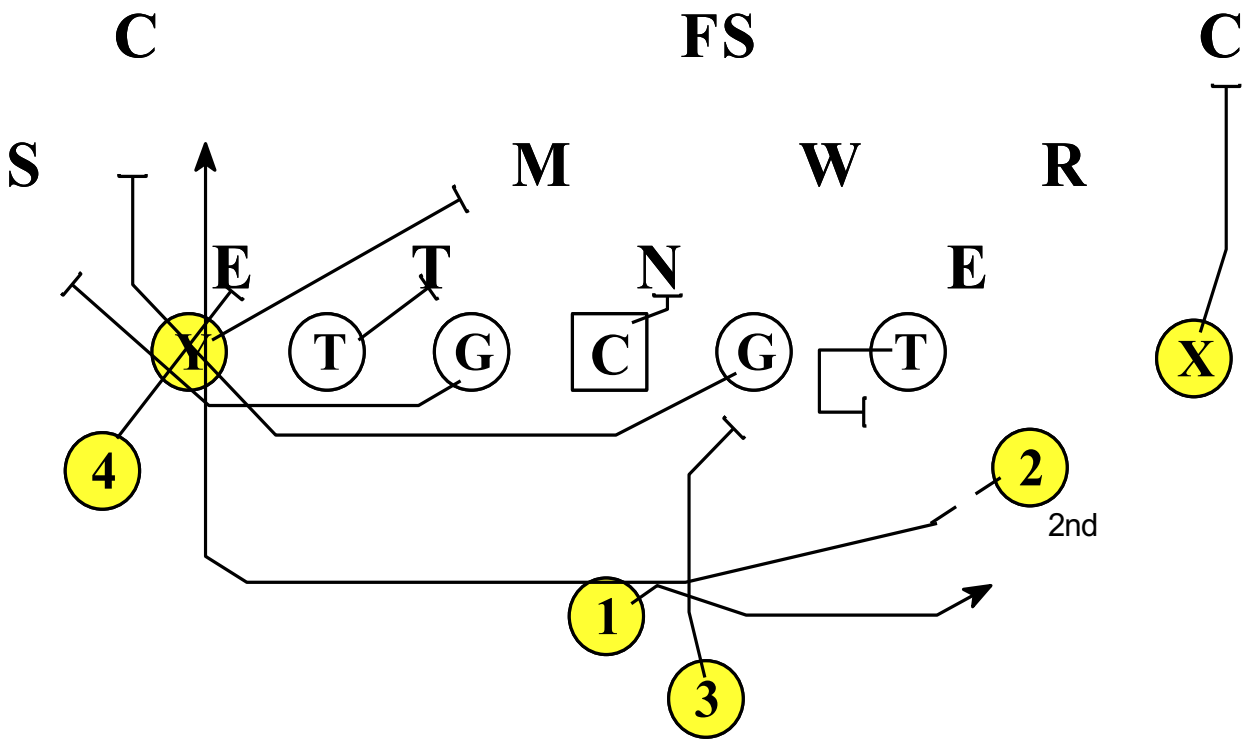

Eagle Buck Lt.

Formation: Randy & Larry

Play: 46 & 27 Buck

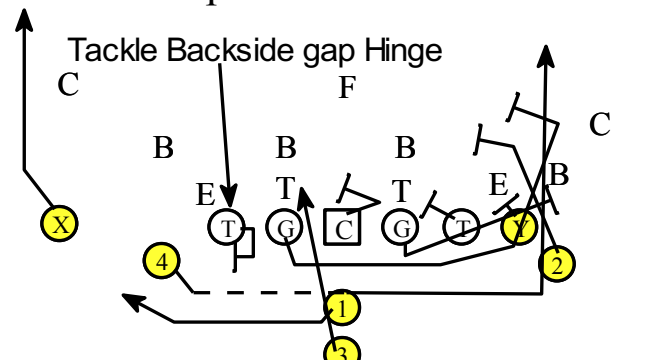
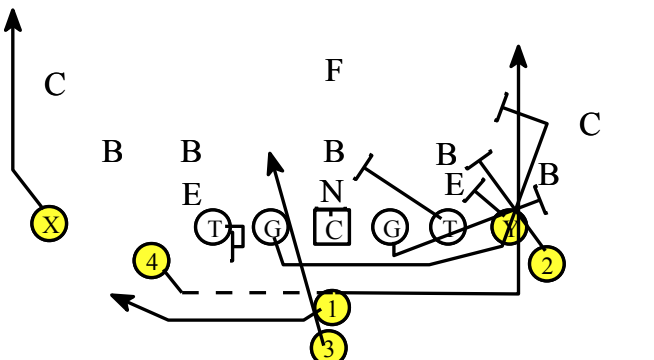
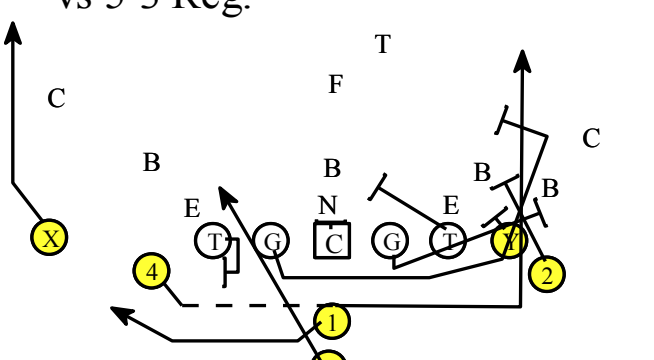
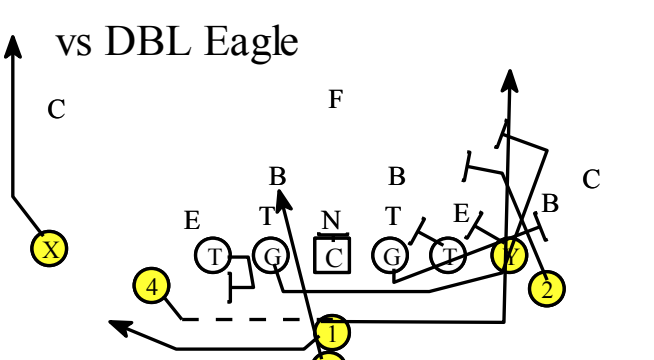
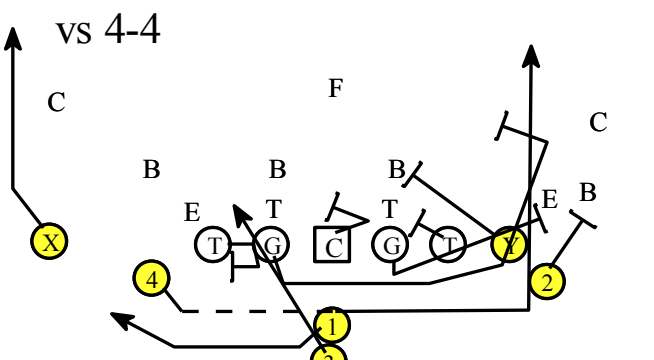
<p>vs 6-2 Split</p> 	<p>vs 3-3 Stack</p> 
<p>PST - Gap - Down - Backer</p>	<p>vs 5-3 Reg.</p> 
<p>PSG - 45 - 45 - Scrape Paint - Kick-out (KO)</p>	<p>vs DBL Eagle</p> 
<p>C - Reach Area, (then) Away</p>	<p>vs 4-4</p> 
<p>BSG - Flat - 45 - Scrape Paint - Join Wall (inside to head up threat)</p>	
<p>BST - Gap Hinge</p>	
<p>TE - Gap - Down - Backer</p>	
<p>PSW - Gap - Down - Backer (do not block EMLOS)</p>	
<p>BSA - Mo, Mo To 3.5, Square Cut At PST, Attack The Hole</p>	
<p>FB - fake Opposite A-Gap of Buck, Big Arms, Bend Back To Frontside A-Gap.</p>	
<p>X - Wide Fade Route</p>	
<p>QB - Open To FB Fake, Give To BSW, Run Boot Fake.</p>	

46 & 27 Buck Drill

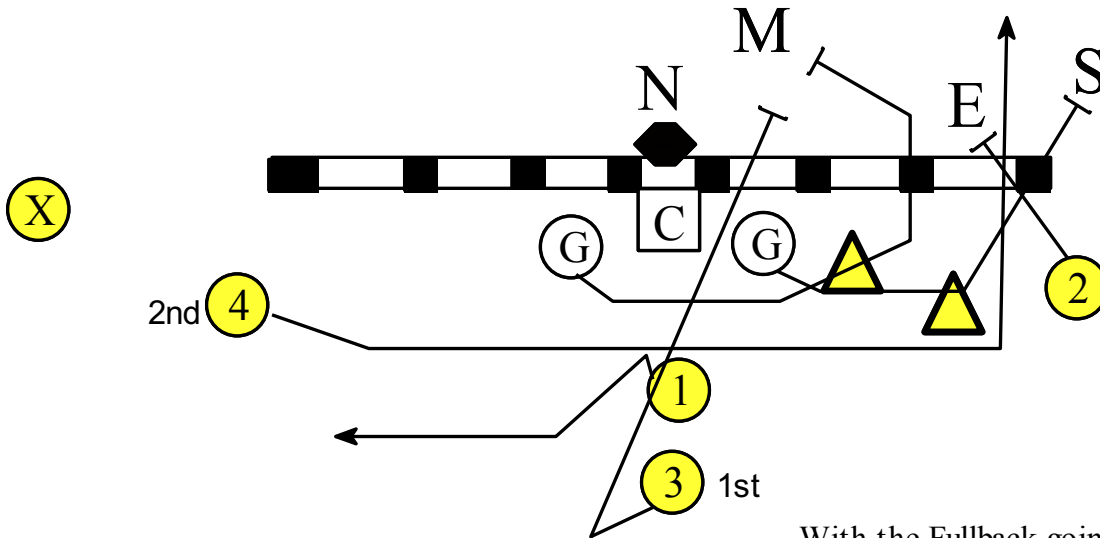

The Wing Back who carries the ball will receive the football and square cut underneath the kickout block by the playside guard on the outside linebacker and off the down block by the tight end.

With the Fullback going first this will hide the football from the linebacker as the wing comes behind the Fullback.

30 & 31 Trap (Bend) Drill

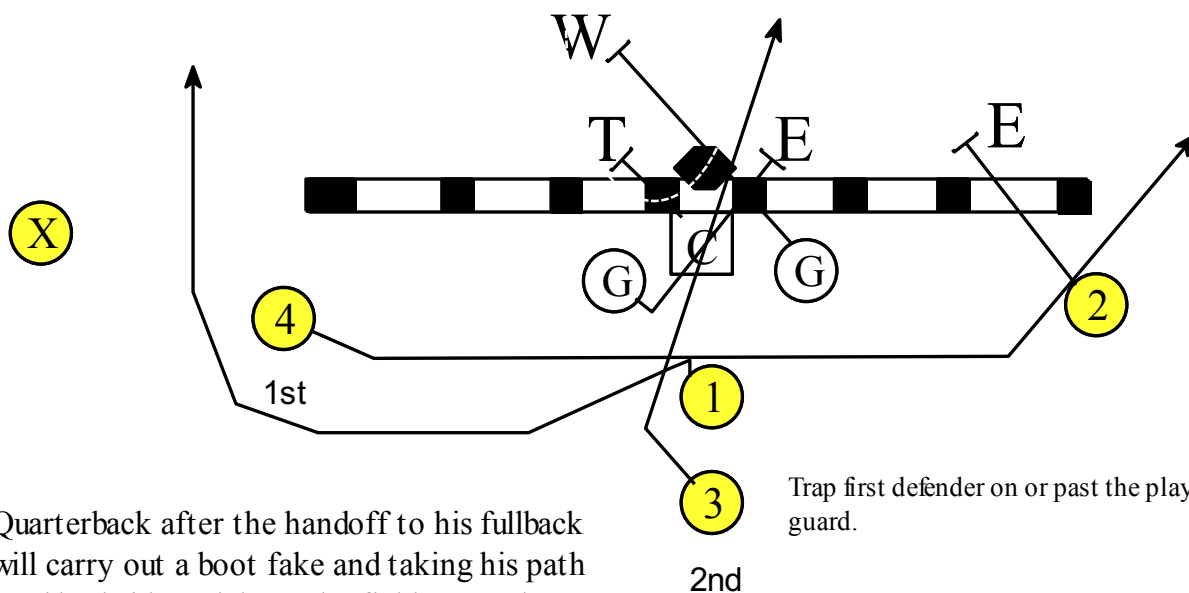

Quarterback after the handoff to his fullback will carry out a boot fake and taking his path hard backside and down the field 15 yards.

Trap first defender on or past the playside guard.

Installing 30 & 31 Bend (Trap)

30 - 31 Trap

Playside Wing

or follows the fake to the outside, let im go. This may be a double team.

Tight End

follows the fake to the outside, let im go. This may be a double team.

Playside Tackle

or follows the fake to the outside, let im go. This may be a double team.

Playside Guard

your center. Away, if combo our base you are tracking the backside linebacker.

Center

combo track down lineman to backside linebacker with your guard.

Backside Guard

of your playside guard. Trap first defender on our outside of the playside guard.

Backside Tackle

end or a blitzing linebacker. If no one threatens your "B" gap then hinge backside on first defender off the edge.

Backside Wing

arms and cradle as if you received the ball as you run past the quarterback. Must sell a great fake to get the linebackers to follow you.

Receiver (X)

Fullback (3)

playside "A" gap on the snap of the ball. Run inside the kickout block by your pulling guard. If traping a 4 to a 5 technique turn up inside the "B" gap.

Quarterback

ball as the Wing takes his second step. Hand the ball to the Fullback on backside of the hole then sprintout opposite the play.

Bend (Trap)

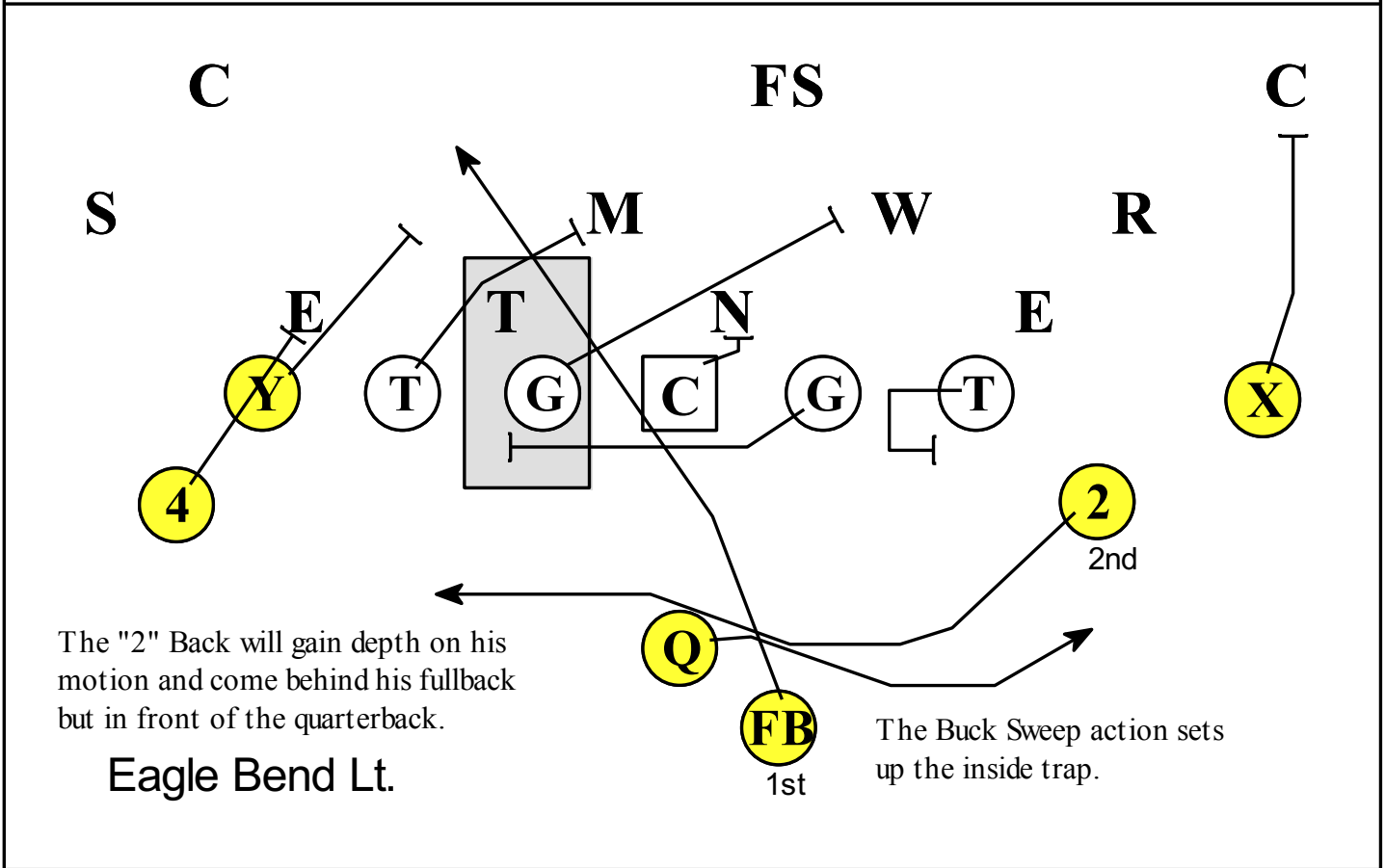
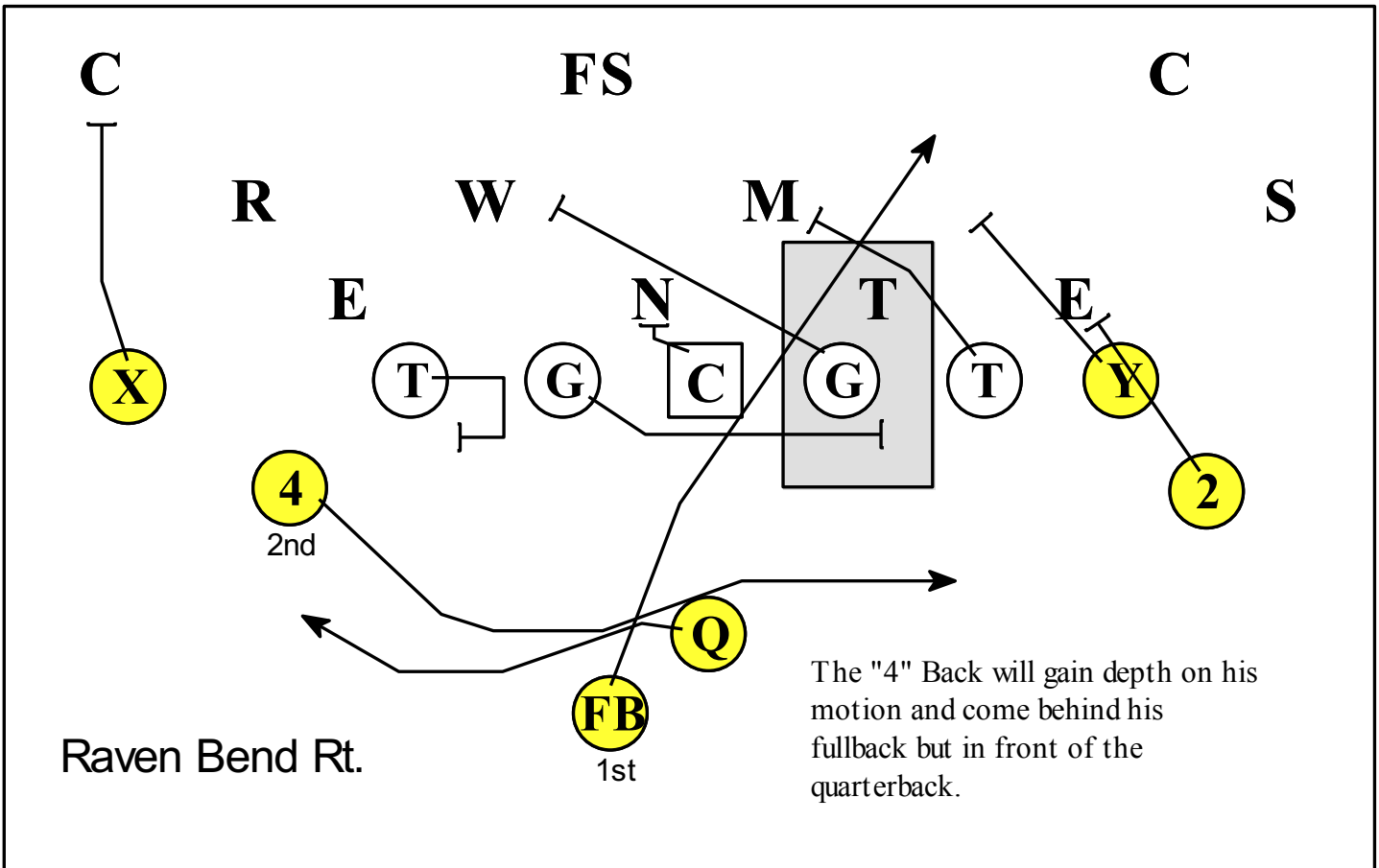

Quick Trap

Quick Trap: Max Even

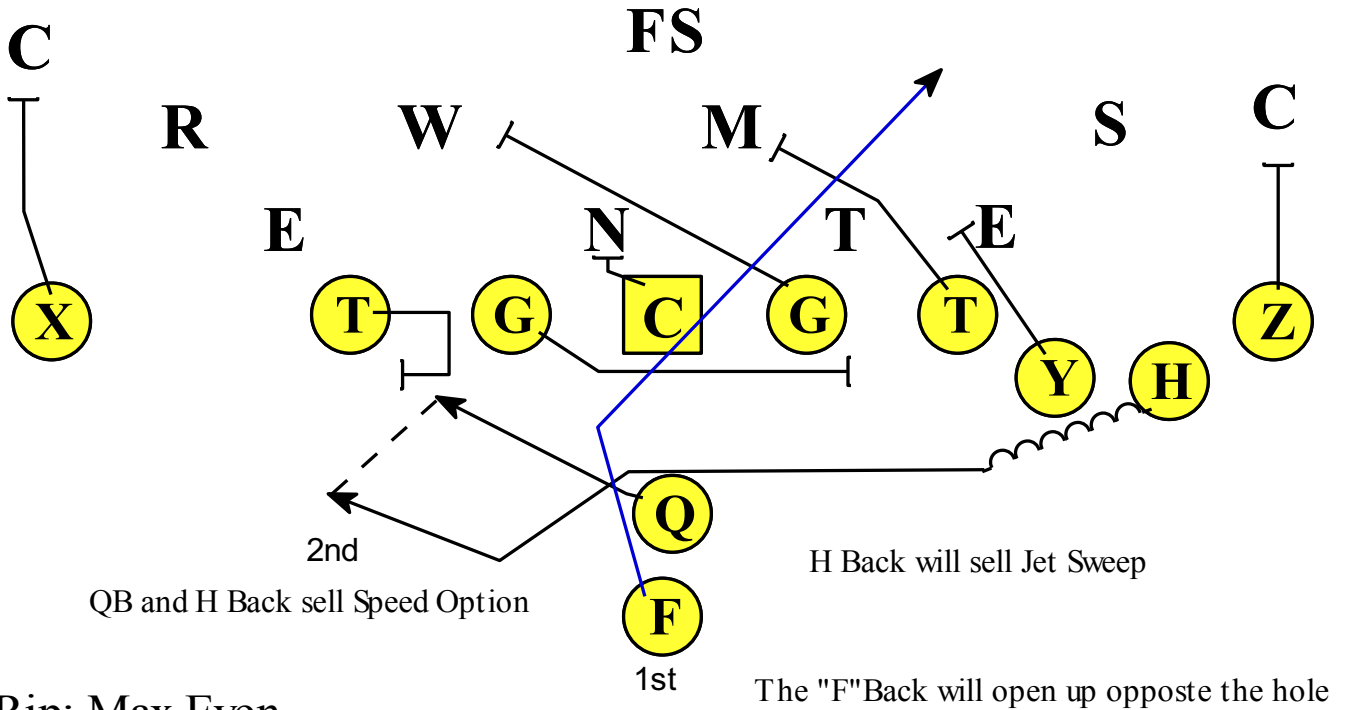

Rip: Max Even

Quick Trap: Leo Odd

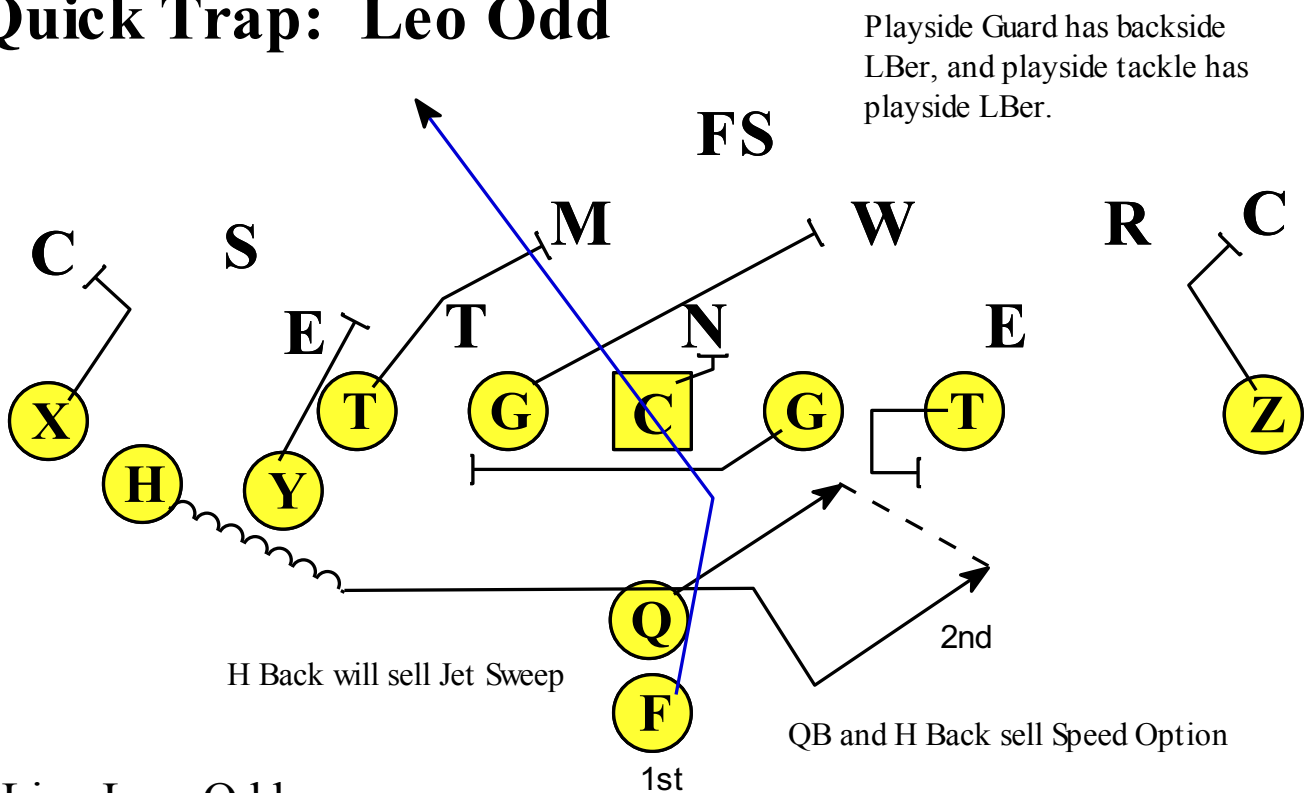

Liz: Leo Odd

Formation: Randy & Larry
Play: 31 & 30 Bend (Trap)

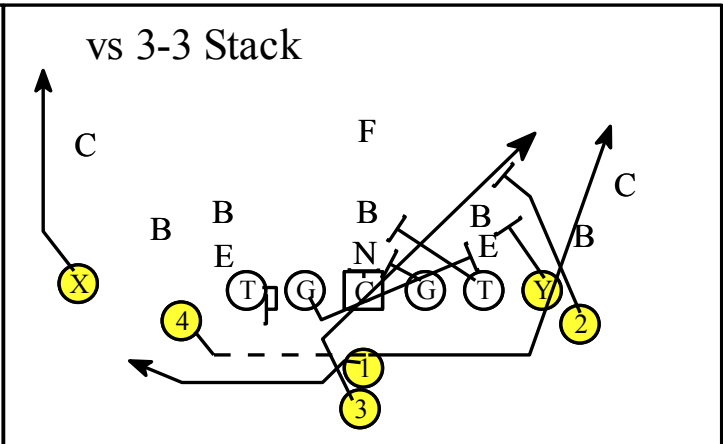
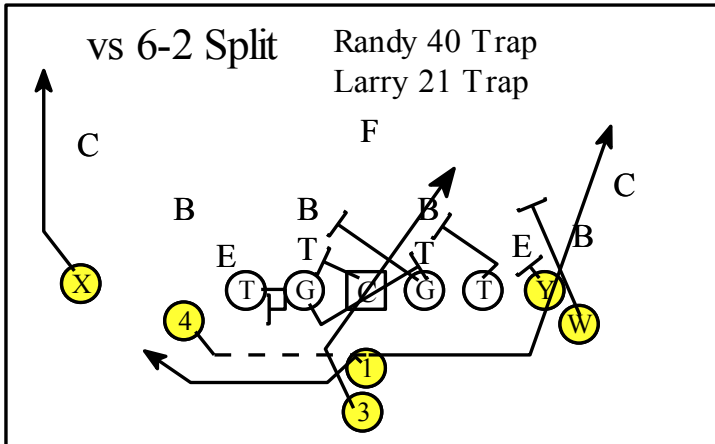

PST-crowther To MLB

PSG - Gap - Down - Backer

C-vs Odd - Front = Double w/PSG, vs Even - Front = Block Backside To Cover

BSG - Trap - Pull To Playside, Scrape Paint, KO 1st Man On/Outside PSG

BST - Step Hinge

TE - Double w/PST On MLB.

"Wing" Back - Block Playside OLB

"A" Back - Mo, Mo To Buck Fake.

FB - Attack A-Gap Away, Bend To Frontside A-Gap (unless there is a "long call" - bend wider)

X - Run Wide Fade Route

QB - Open To And Give To FB, Fake Buck To BSW, Fake Boot.

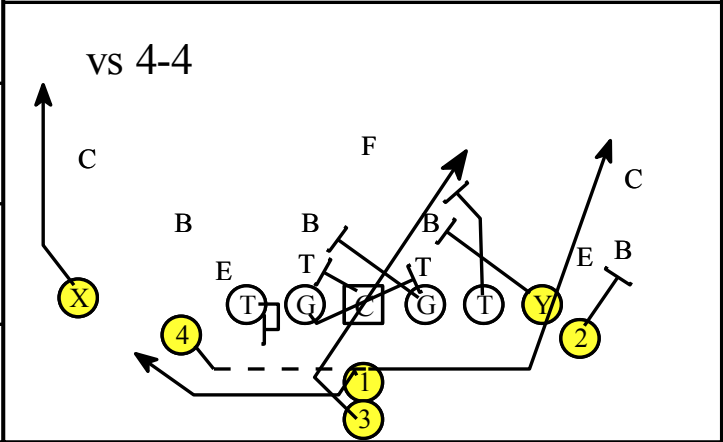
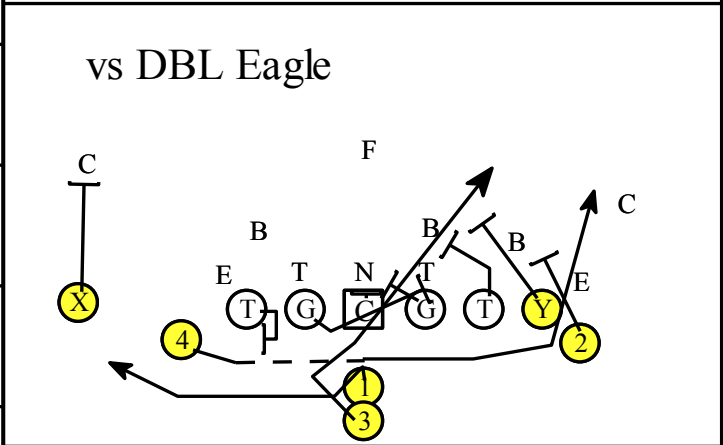
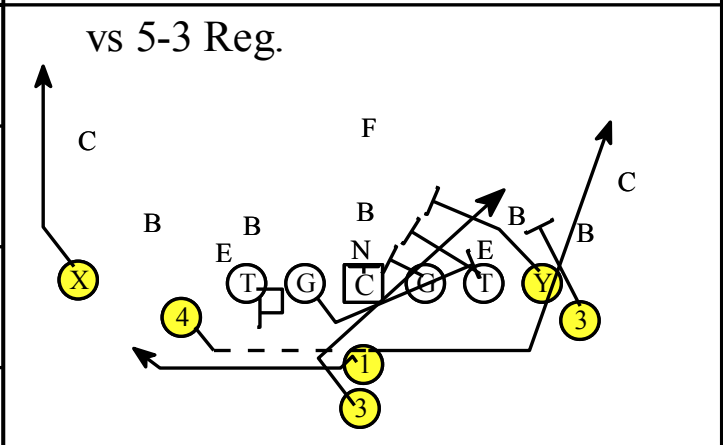

Rules for Running Inside Veer

The following information will be used as your rules for running Inside Veer.

- 12 - 13 Veer: Run only towards an openside when no invert is located off and outside the openside tackle. When the outside invert has been removed this breaks the triangle and only gives the defense two defenders to defend a triple option threat which consists of
 1. Fullback Give
 2. Quarterback Keep
 3. Wingback Pitch.

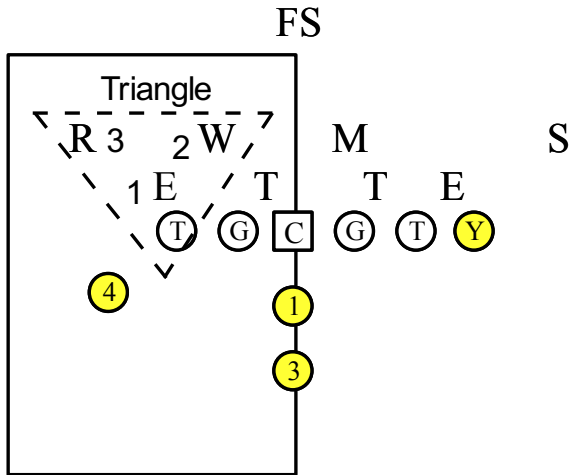

Whenever the quarterback sees an outside invert off the line of scrimmage towards the openside he starts to look for a better option that puts the offensive line into a better blocking scheme towards the tight end side and the defense into a position to be outnumbered when defending the option game.

Notice the triangle in this illustration, the defense has three defenders to defend our triple option threat with the inside veer play. In other words three to defend three.

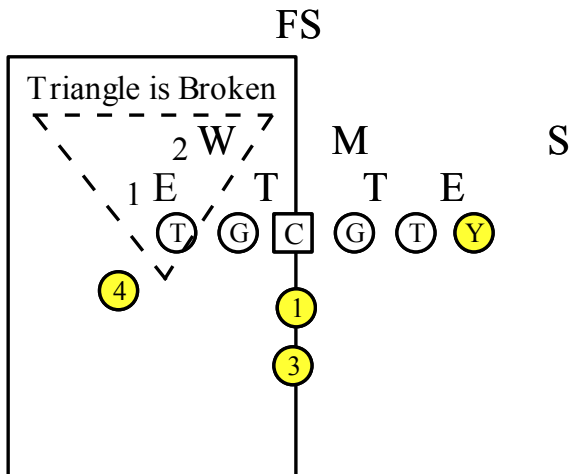

With this illustration you will find the triangle broken, in other words no outside invert towards the openside. Because most defenses will understand that they must overload the tight end side to defend both the midline and load options this opens up the inside veer towards the openside.

Option on me is designed to control the amount of defenders that a defense can play inside the box. When the triangle is broken the defense only has two to defend three potential ball carriers on the perimeter.

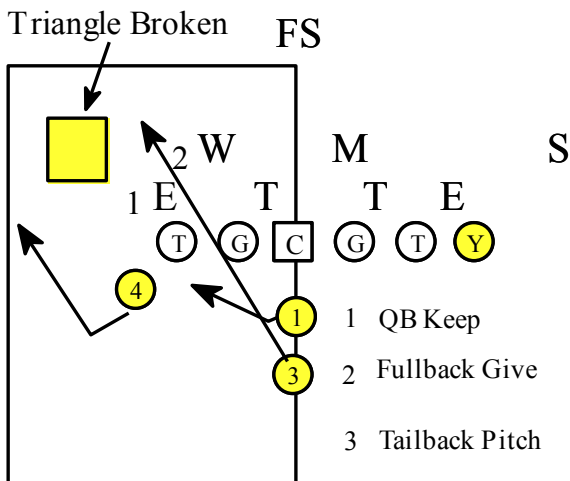

The success of the inside veer lies with the thought that the inside veer release tackle will miss or be unable to block the playside lber. By running into the broken triangle with the outside invert missing the defense only has two defenders (defensive end, linebacker) to defend the triple option threat that the inside veer gives.

Inside veer to an openside allows the quarterback to read a 5 technique. By adjusting the outside invert to a deeper secondary alignment or rolling him over to the Tight End side sets up the inside veer.

Quarterback Rules and Mesh Mechanics For 12 & 13 Inside Veer

The numbering systems mentioned previously for inside veer is 12 - 13. Inside veer is designed as a triple option threat when running with two backs which features a 1. Dive Back (Fullback) 2. Quarterback Keep 3. Pitchback (Tailback).

Inside Veer will be an option that allows the quarterback to read the inside jersey number of a five technique and can be run from either an openside or tightside position.

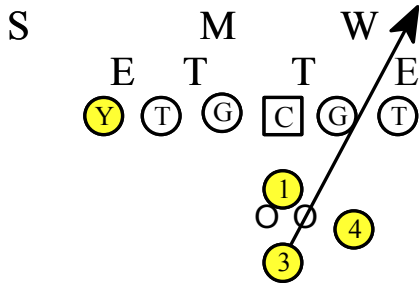

Inside Veer is designed to attack the outside hip of the playside guard. In order for the quarterback to get in a proper mesh ride he will open up parallel with his playside foot. Like the midline the quarterback wants to reach the ball back as deep as possible for the long ride. It becomes important that the quarterback rides the ball into the line of scrimmage and that his upfield shoulder follows the ride, this helps in negating penetration.

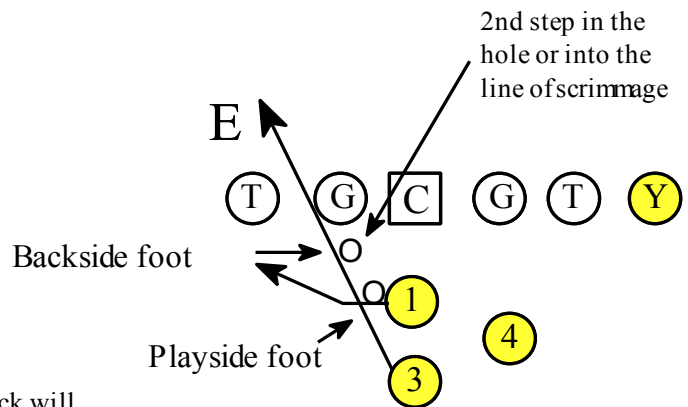
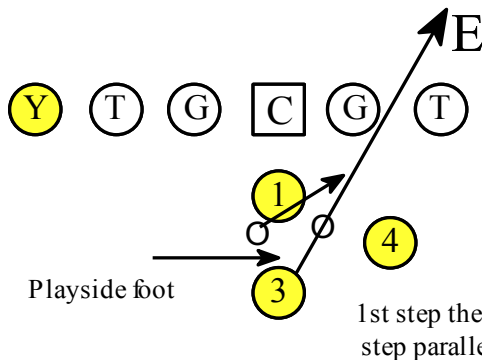

Once again the footwork for Inside Veer after receiving the snap from center is to open playside at a 45 degree angle with the playside foot. The first step parallel times the mesh and ride out. The second step by the quarterback should be towards the outside hip of the guard and into the line of scrimmage, this creates the proper angle for the fullback running through the mesh. The second step into the line of scrimmage helps negate penetration by the defense and helps get his path after any pull read downhill and to the inside jersey number of the five technique. Must not allow the quarterback to bubble his path after the pull read because this will allow the five technique to slow play the inside veer thus, allowing the five technique to string the play out.

Upon taking the parallel open step the quarterback will reach the ball back to the fullback (dive back) as deep as possible, while reading the inside jersey number of the five technique. The quarterback should get his eyes to the inside jersey number of the give or keep read as quickly as possible. (A key coaching point here is never allow the quarterback to look back at the fullback this tends to bubble the quarterbacks path and does not allow for the long ride into the line of scrimmage).

The mesh point on the ride usually comes off the front hip of the quarterback. What this means is that if the ride or mesh goes past the front hip of the quarterback it will probably turn into a give to the fullback. It's important that the fullback maintain a soft pocket while running through the ride, this is accomplished by keeping his eyes up and continues to show his jersey numbers to the linebacker his side.

Quarterback Rules and Mesh Mechanics For 12 & 13 Inside Veer

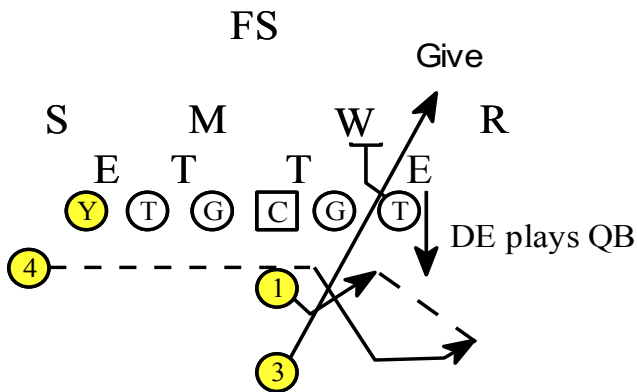

Whenever running Inside Veer into a 5 technique with a 1 shade this is considered best case scenario for running this play. The quarterback will read the inside jersey number of the 5 technique, if the inside jersey number goes upfield then the quarterback will give the football to his fullback. The reason this is considered the best case scenario is because of the ability of the tackle to get a good inside veer release.

The tackle as he inside releases will be asked to "Pick Grass" a term that is used for getting the backside shoulder reduced harder, keeps from dragging the shoulder. Whenever the tackle attempts to pick grass and can get his backside shoulder reduced it helps the 5 technique to squeeze harder on the tackles veer release inside thus making him more apt to take the dive.

The quarterback should ride the mesh into the hole and off his front hip as he keeps his eyes on the inside jersey number of the five technique. Remember the ride into the hole becomes the most important technique that the quarterback uses because it makes the defender commit one way or the other and keeps him from stringing the option out.

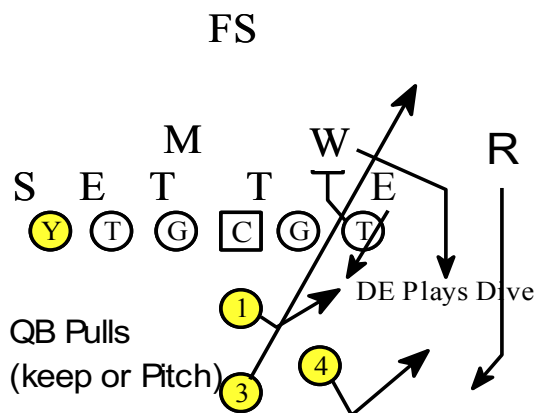

Whenever the quarterback gets a pull read and the defensive end or five technique attacks the dive his next read should go to the scraping linebacker. If the inside veer release tackle can seal the playside linebacker then the eyes of the quarterback goes to the outside invert.

The quarterback mechanics for the pitch goes as follows: Quarterback attacks inside jersey number of the read defender if the quarterback gets a pitch read he wants to fade into the line of scrimmage instead of fading towards the pitch. Many coaches differ here, but the reason we want to keep the quarterback with an inside body lean on the pitch, keeps the five technique from following and playing both the quarterback and or the pitch defender.

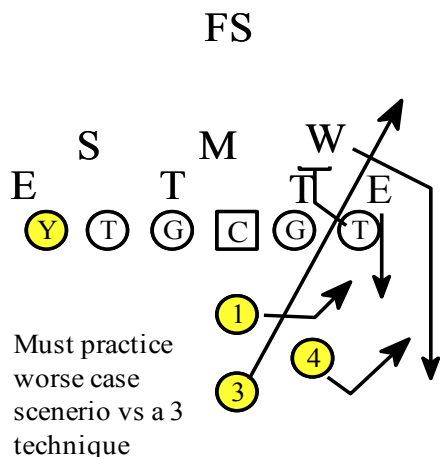

The hardest defensive front alignment to run inside veer to is a five and three technique. The difficulty here lies in the ability of the duece combo on the three technique to get movement. Must practice the mesh mechanics on vs this alignment the hardest. When a quarterback recognizes a five to a three technique he should almost believe that his read by the five technique will be a give. When running into a five to a three technique, the five will probably play the quarterback and the three technique the dive.

The quarterback must practice the mesh with the fullback against a three technique, this becomes a worst case scenerio. Fullback can either veer outside or back inside depending upon the three technique stretching or not.

Blocking Adjustments For 12 & 13 Inside Veer

The best case scenario for running inside veer is to a 5 to a 1 technique. This situation allows the tackle to get a good inside veer release to the playside linebacker. The mesh and the ride for the quarterback and fullback is easier to establish.

The alert call by the tackle is "Base" because he doesn't have to work a combo with his guard thus, allowing the other blocks to counter rotate away from the play.

Inside Veer vs 5 to a 1 technique

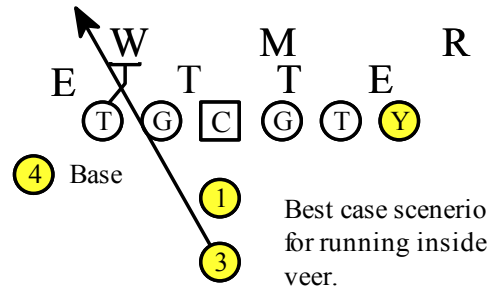

Best case scenario for running inside veer.

Inside veer to a 3 technique becomes worst case scenario and one that needs to be practiced against numerous times. The problem posed here is the 3 technique stretching outside if the tackle and guard can't get him washed down inside. With this situation the fullback must be able and taught to cut backside of the three technique if he stretches as shown in the illustration.

Must be able to give the inside veer to a three technique a lot of reps.

Inside Veer vs a 3 technique

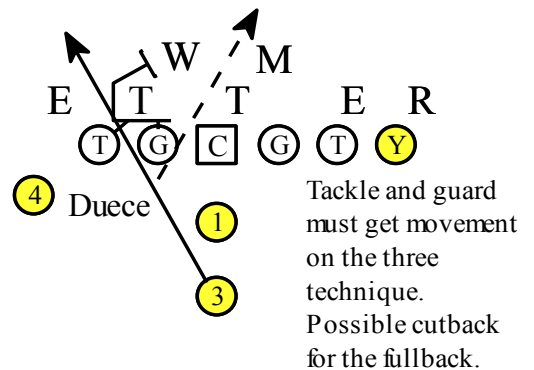

Tackle and guard must get movement on the three technique. Possible cutback for the fullback.

Whenever you get a 2 technique aligned head up on the guard and the center is uncovered you will get an ace combo. The alert word "Ace" becomes the trigger for the tackle as he releases inside to give the 2 technique a hand check. The hand check helps the guard to come around on the combo, the hand check keeps the two technique from stretching.

Inside Veer vs a 2 technique

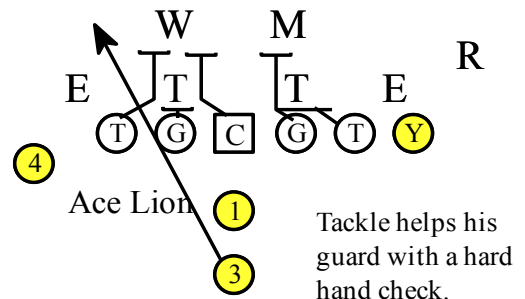

Tackle helps his guard with a hard hand check.

Vs a 4 technique you will get a duece fast call because of the location of the defensive end aligned head-up over his tackle.

Against a 4 technique the guard must come over to seal the inside shoulder of the defensive end thus, creating a tough mesh and ride for the quarterback and fullback.

Inside Veer vs a 4 technique

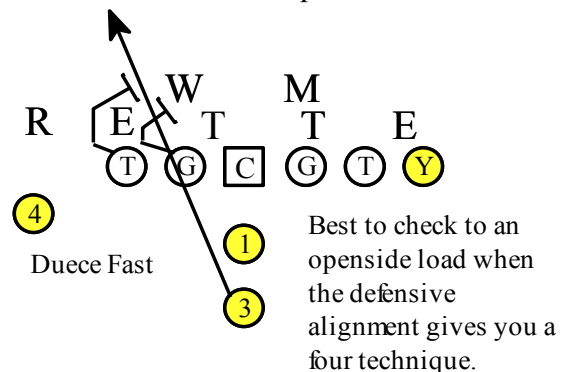

Best to check to an openside load when the defensive alignment gives you a four technique.

Blocking Adjustments For Inside Veer Tightside

The best case scenerio for running inside veer is to a 5 to a 1 technique. This situation allows the tackle to get a good inside veer release to the playside linebacker. The mesh and the ride for the quarterback and fullback is easier to establish.

The alert call by the tackle is "Base" because he doesn't have to work a combo with his guard thus, allowing the other blocks to counter rotate away from the play.

Inside Veer vs 9, 5 to a 1 technique

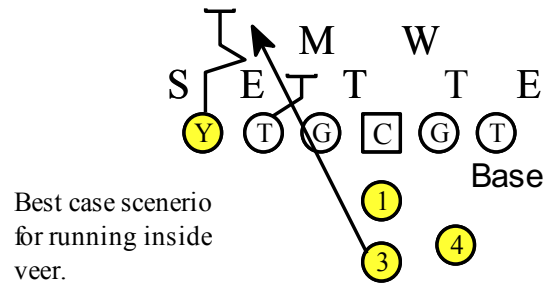

Best case scenerio for running inside veer.

Inside veer to a 3 technique becomes worst case scenerio and one that needs to be practiced against numerous times. The problem posed here is the three technique stretching outside if the tackle and guard can't get him washed down inside. With this situation the fullback must be able and taught to cut backside of the three technique if he stretches as shown in the illustration.

Tight end will take easiest release vs a nine and five technique he will release inside tracking playside linebacker to free safety.

Inside Veer vs 7, 5, and 3 technique

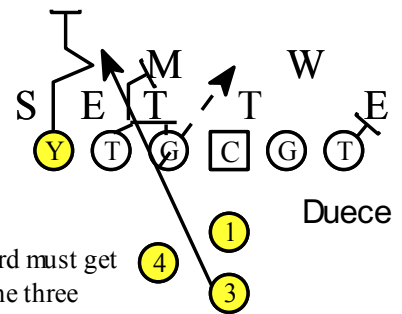

Tackle and guard must get movement on the three technique. Possible cutback for the fullback.

Inside veer to a three technique becomes worst case scenerio and one that needs to be practiced against numerous times. The problem posed here is the three technique stretching outside if the tackle and guard can't get him washed down inside. With this situation the fullback must be able and taught to cut backside of the three technique if he stretches as shown in the illustration.

Tight end will take easiest release vs a seven technique he will outside veer release to the outside jersey number of the outside invert.

Inside Veer vs a 7 to a 3 technique

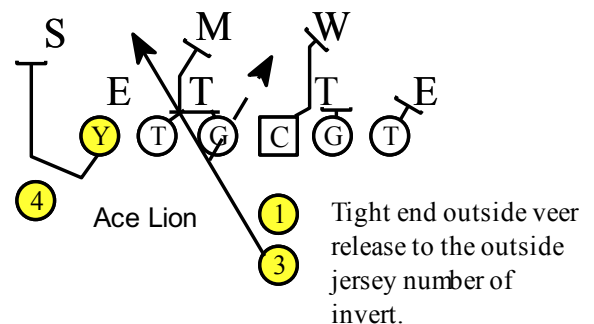

Whenever you get a 2 technique aligned head up on the guard and the center is uncovered you will get an ace combo. The alert word "Ace" becomes the trigger for the tackle as he releases inside to give the 2 technique a hand check. The hand check helps the guard to come around on the combo, the hand check keeps the 2 technique from stretching. The tight end will use easiest release in this example vs the 4-3 scheme and a nine technique he has first linebacker inside.

Inside Veer vs 7 to a 2 technique

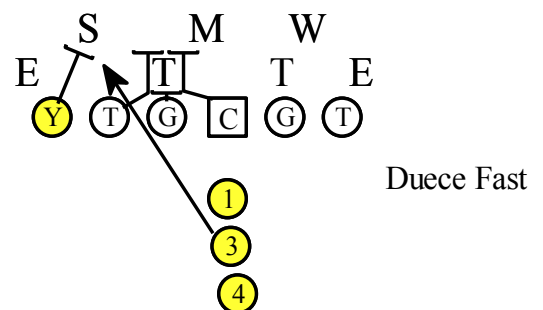

Veer Release Technique

(Pick'in Grass)

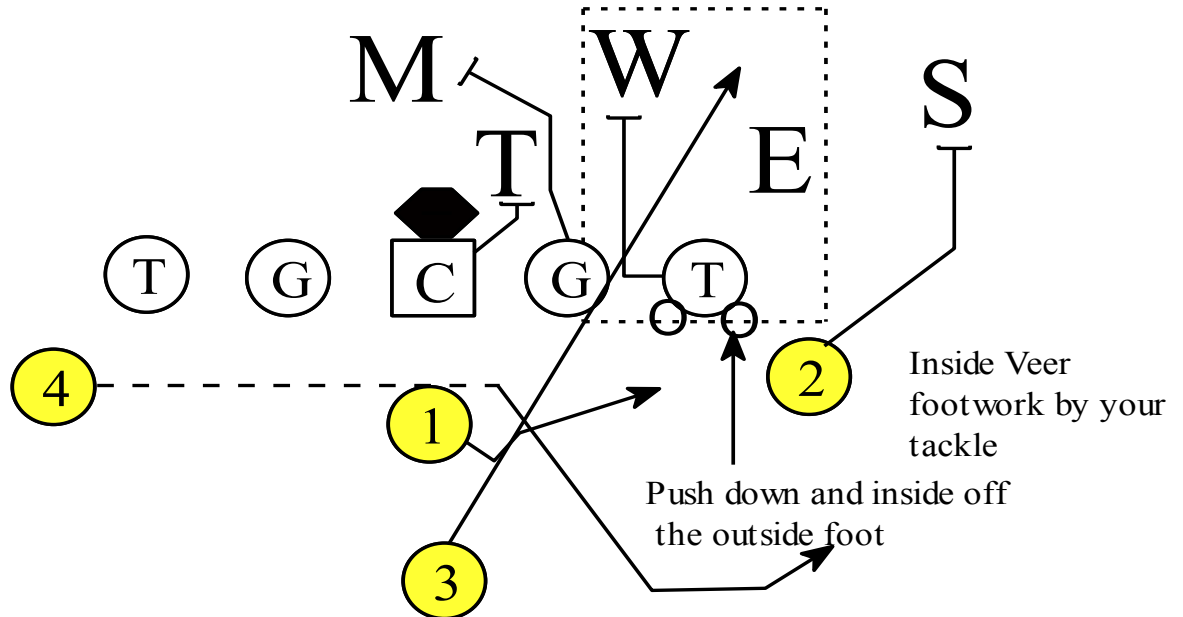

Inside Veer release technique by your offensive tackle and inside veer release by your guard on all midline plays is taught using a termpick'in grass. Since the Inside Veer is best run towards a 1 technique we ask the offensive tackle to push laterally to the L.O.S. with his outside foot and as he does this we ask him to over emphasis getting his shoulders reduced by reaching down grabbing grass with his outside or playside hand. By grabbing grass your inside veer release lineman won't drag his shoulder thus, reducing the squeeze surface the defender has to squeeze when working to keep the offensive lineman off the linebacker.

Another way to teach this technique is to lay a towel on the ground and when your linemen inside veer releases have them reach and grab the towel. Your linemen want to push away from the defender by pushing inside off the outside foot. By pushing off the outside foot this will force a faster attempt to squeeze your tackle or guard by the defender who is being taught not to let the veer release inside on the linebacker. Your offensive guard will use the exact same technique on the midline for his inside release as the tackle on all inside veer plays.

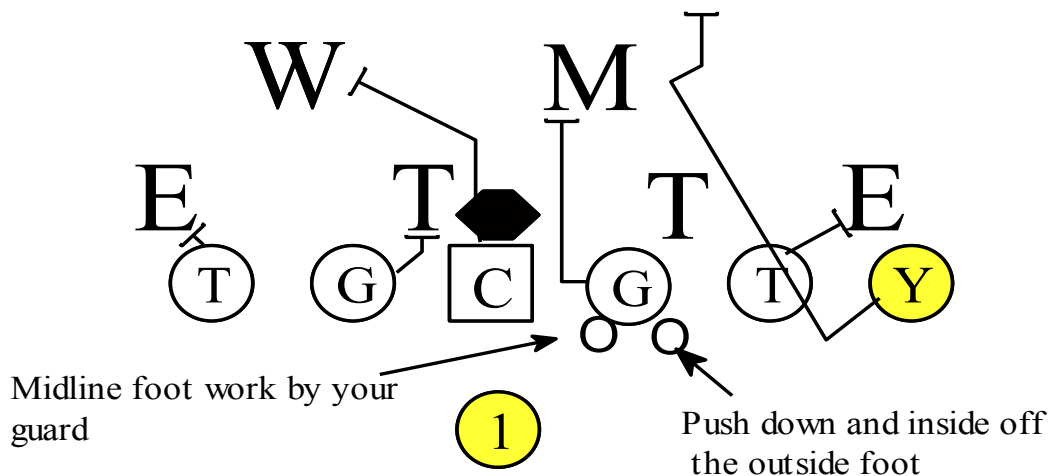

Play: 12 - 13 Veer

Dallas 13 Veer
Dorothy 12 Veer

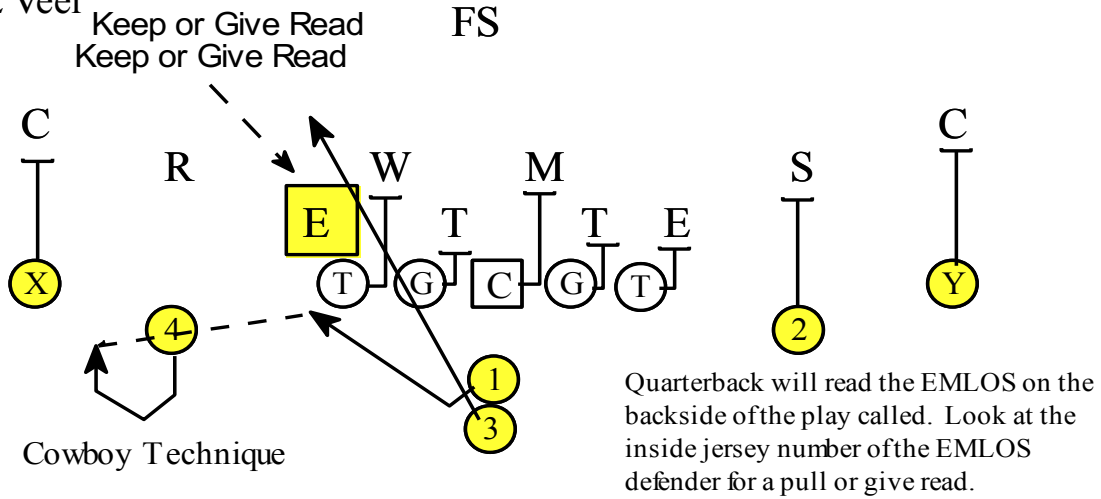

Trailer Open. 13 Veer

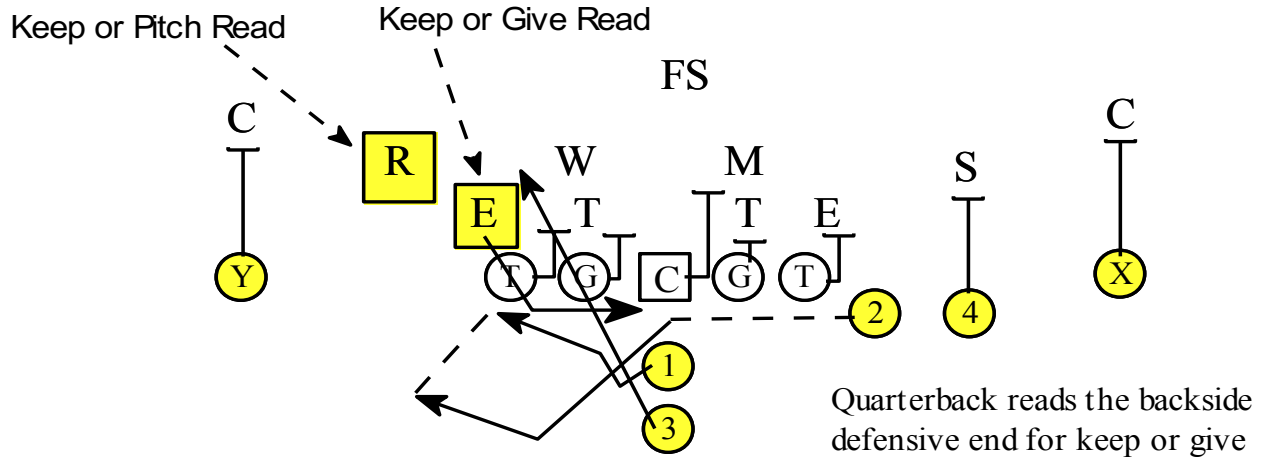

Randy 2 Orbit 13 Veer

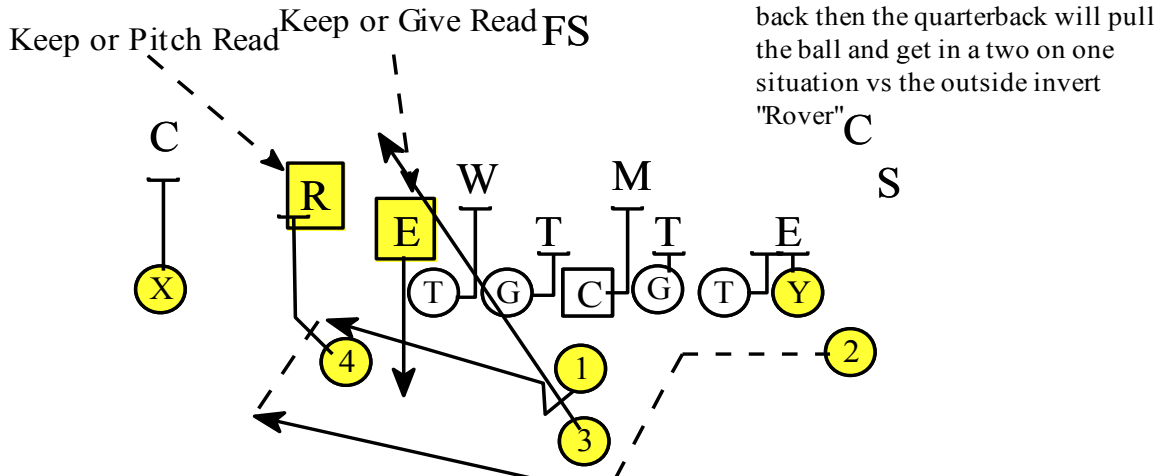

Play: 12 - 13 Crazy

Dorthy 12 Crazy

QB reads defensive E.M.L.O.S. for Shovel or Speed Option.

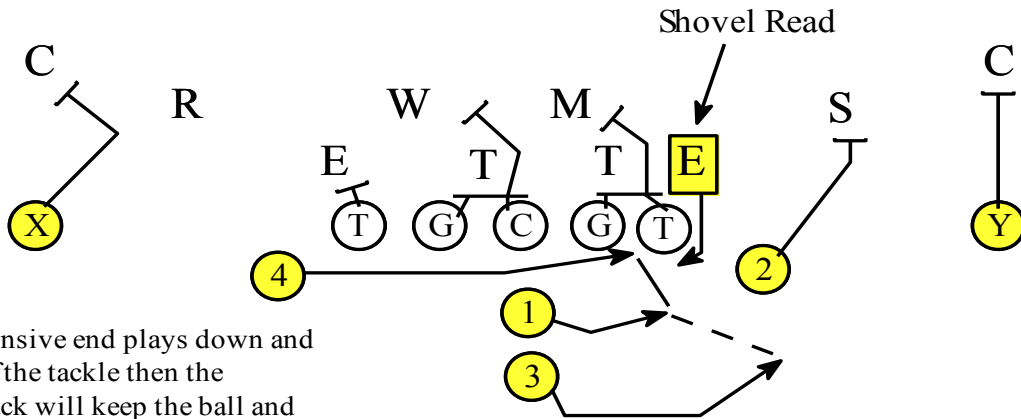

If the defensive end plays down and inside of the tackle then the quarterback will keep the ball and run the speed option.

Randy 13 Crazy

The backside running back will run in front of the quarterback while attempting to run underneath the EMLOS. The quarterback will shovel the ball off the the back running underneath if end plays upfield.

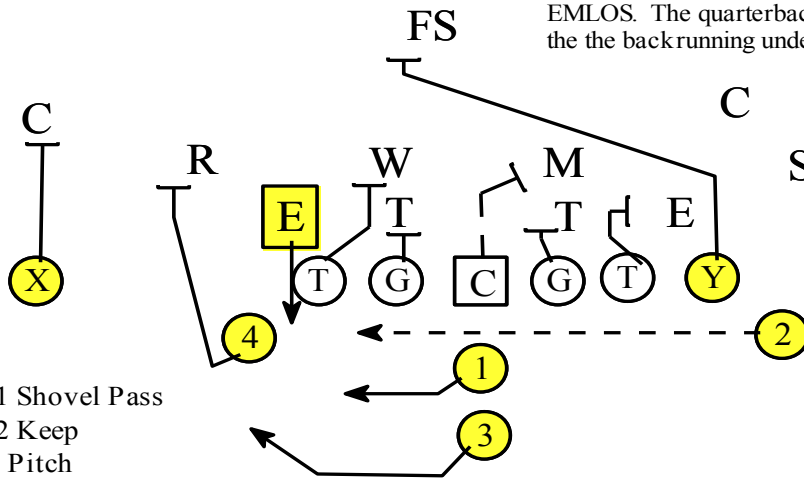

Option Read - #1 Shovel Pass
Option Read - #2 Keep
Option read - #3 Pitch

Nick. 13 Crazy

Whenever the shovel pass is executed and the running back drops the ball it is considered a pass and the play is whistled dead.

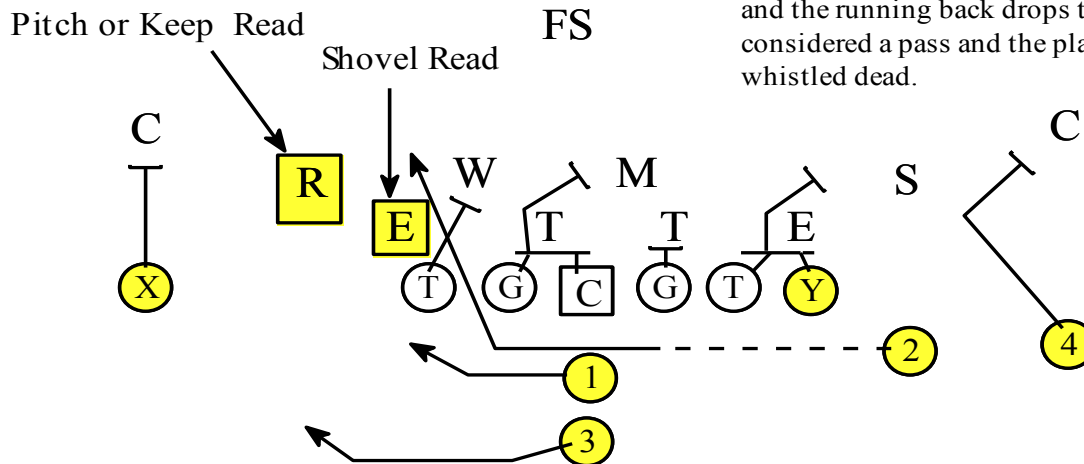

Blast

Grey Lucy Brad Even

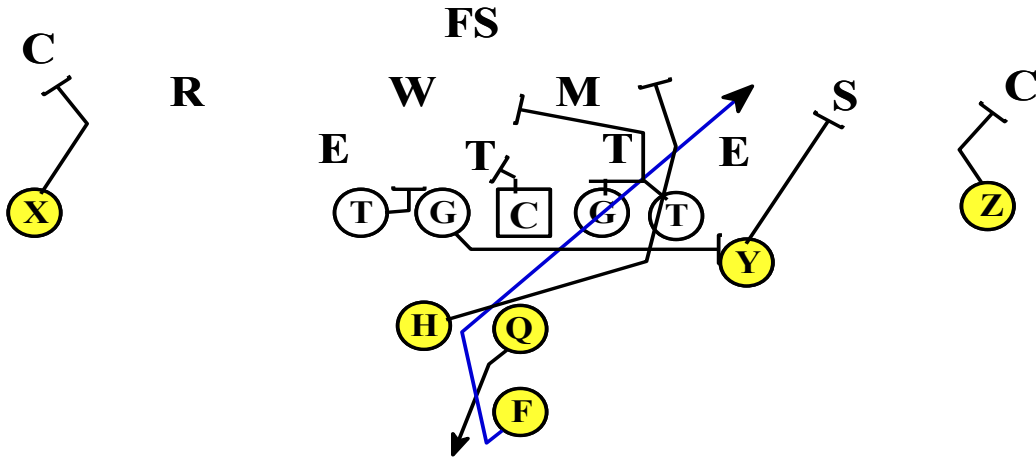

Green Odd Billy

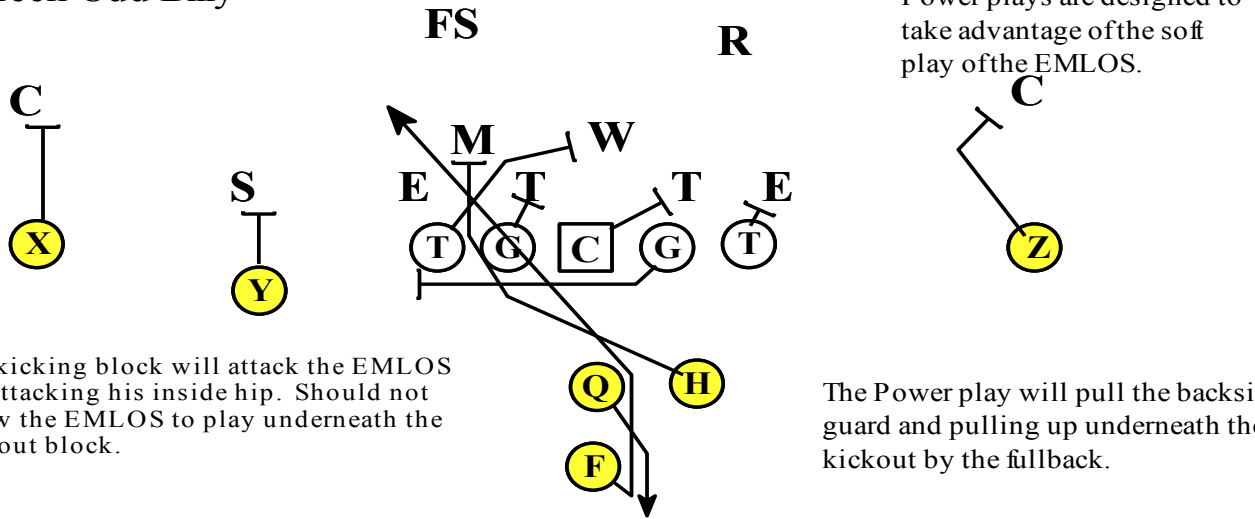

The kicking block will attack the EMLOS by attacking his inside hip. Should not allow the EMLOS to play underneath the kickout block.

The Power play will pull the backside guard and pulling up underneath the kickout by the fullback.

Rip Brad Odd

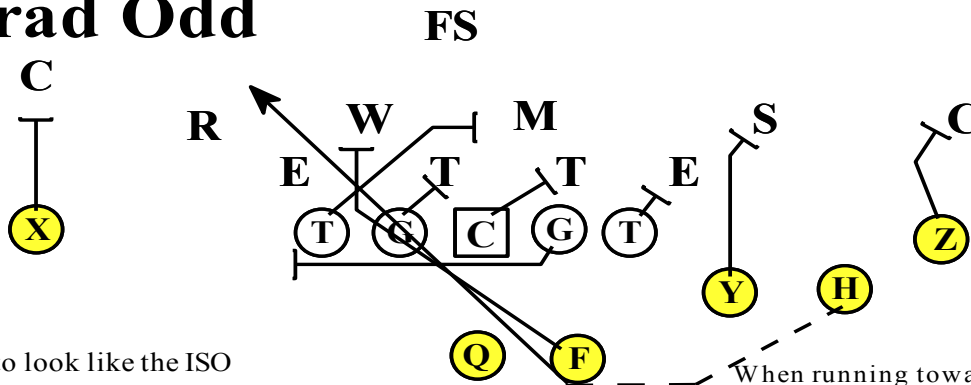

This play starts to look like the ISO play by the actions of the fullback and tailback. The ball is delivered to the tailback using the same mechanics and steps as the ISO plays.

When running towards the tight end he will take easiest release. Vs a seven technique TE will outside veer release and vs a 5 & 9 combination he will try block to backside linebacker with their combo

Formation: Randy & Larry
Play: 27 & 46 Blast

<p>vs 6-2 Split Randy 42 Blast Larry 23 Blast</p>	<p>vs 3-3 Stack</p>
<p>PST - Gap, Down, Backer</p>	<p>vs 5-3 Reg.</p>
<p>PSG - Gap - Down - Backer</p>	<p>vs DBL Eagle</p>
<p>C -vs Odd - Front = Double w/PSG, vs Even - Front = Block Backside To Cover for BS pulling Guard</p>	<p>vs 4-4</p>
<p>BSG -Pull To Playside, Scrape Paint, you have playside LBer.</p>	
<p>BST - Gap, Hinge</p>	
<p>TE - Double w/PST On MLB.</p>	
<p>PSW - Block Playside OLB</p>	
<p>"A" Back - Mo, Mo Receive Ball From QB and Run Underneath Kickout by your Fullback</p>	
<p>FB - Fullback is responsible for leading the wing thru the hole and blocks playside linebacker.</p>	
<p>X - Run Wide Fade Route</p>	
<p>QB - Open To And Give To the "A" Back, Fake Buck To BSW, Fake Boot.</p>	

QB Blast

Rip Empty QB Blast Left

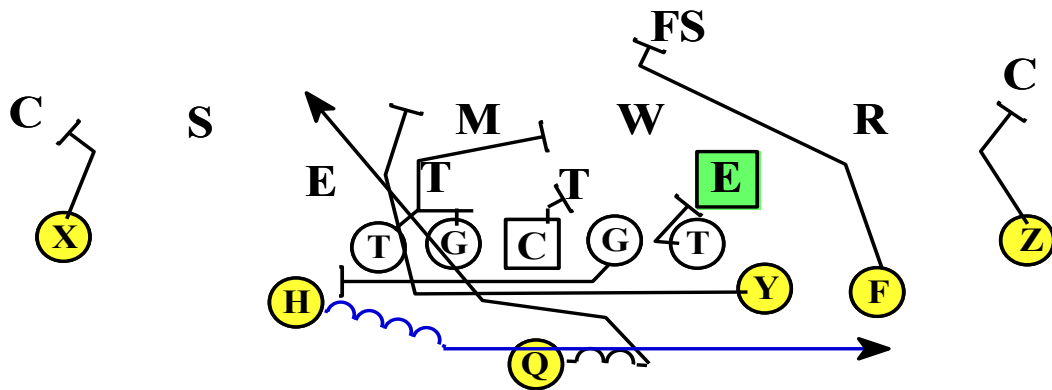

Liz Empty QB Blast Right

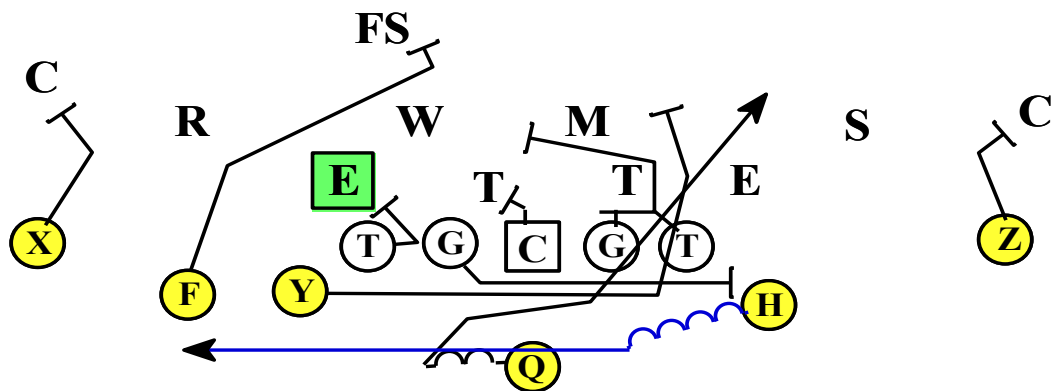

Power

Playside Wing

scrimmage. Block the first linebackr you see inside.

Tight End

block him. If there is someone over the tackle, down block him. Otherwise stay on your track and block a linebacker.

Playside Tackle

gap, down block him. If there is someone over the guard, down block him. Otherwise look to Trey Combo with your Tight End.

Playside Guard

your inside gap then down block him. Otherwise look to Duece Combo with your Tackle.

Center

the backside.

Backside Guard

to the line of scrimmage and look to block the first opposite colored jersey that shows inside.

Backside Tackle

end or a blitzing linebacker. If no one threatens your "B" gap then hinge backside on first defender off the edge.

Backside Wing

to your side. Take the handoff, plant and get downhill in a hurry. Run inside the fullbacks kickout block.

Receiver (X)

Fullback (3)

the line of scrimmage to block, look to kickout the outside linebacker.

Quarterback

the Wing takes his second step. After the handoff fake as if you are running to the opposite "B" gap and help block the backside.

Play: 27 & 46 Power

Randy 42 Power
Larry 23 Power

FS

Power plays are designed to take advantage of the soft play of the EMLOS.

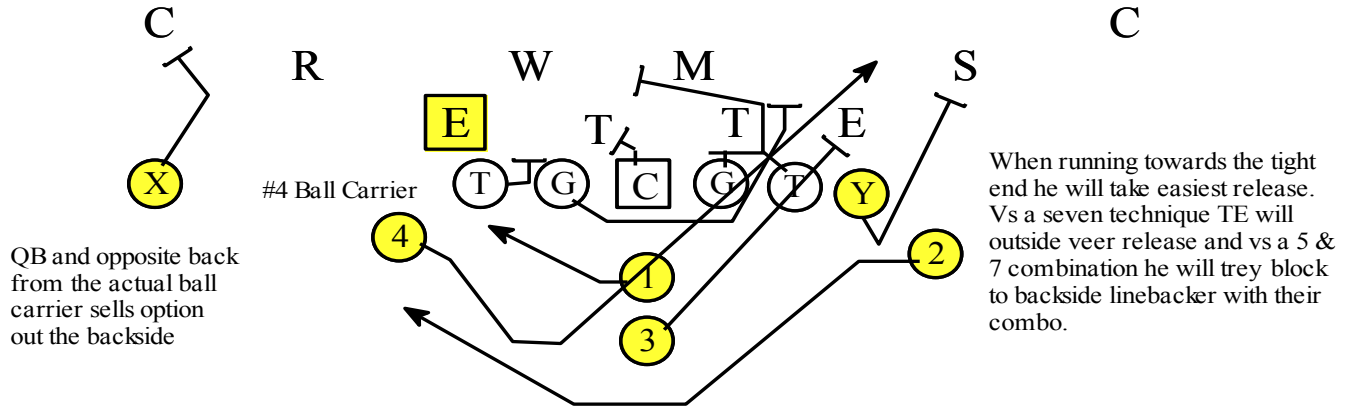

Larry 46 Power

FS

R

The quarterback will open up at a 45 degree angle playside.

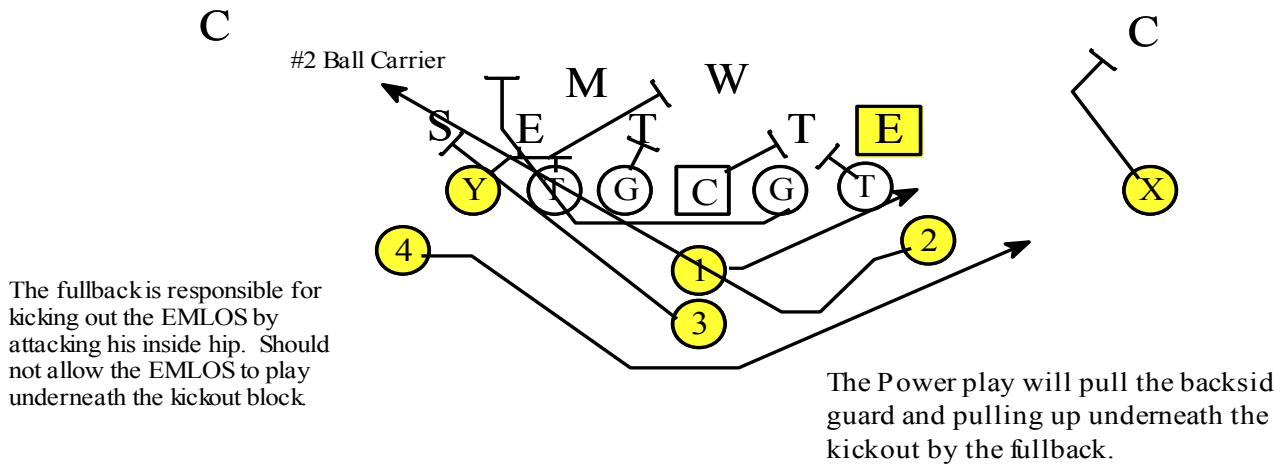

Randy 27 Power

FS

C

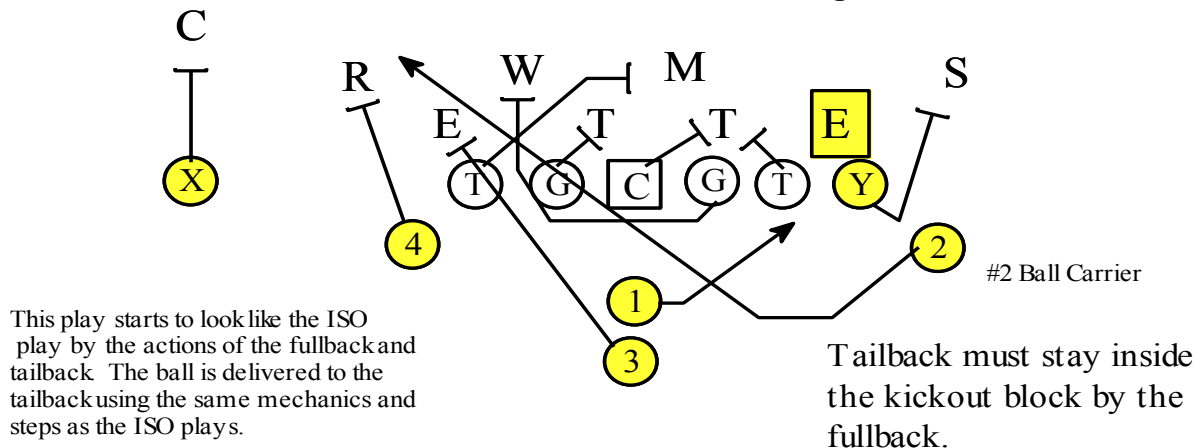

Belly

Playside Wing

tackle and guard and lead up on the playside linebacker.

Playside Tackle

Playside Guard

combo with you center if uncovered. If Ace combo track backside linebacker.

Center

go Ace combo to backside linebacker.

Backside Guard

if you are uncovered. Any combo tracks opposite colored jersey backside.

Backside Tackle

near ear rule.

Tight End

Backside Wing

quarterback and then bubble back to get into pitch relationship with the quarterback to hold the outside linebacker.

Receiver (X)

Fullback (3)

player has cleared, this puts you as number two following your wing through the hole.

Quarterback

ball as the Wing takes his second step. Once you run fake with your Wingback then turn towards the fullback and hand him the ball. Ride the fullback into the hole and then fake speed option with your motion Wingback.

Belly

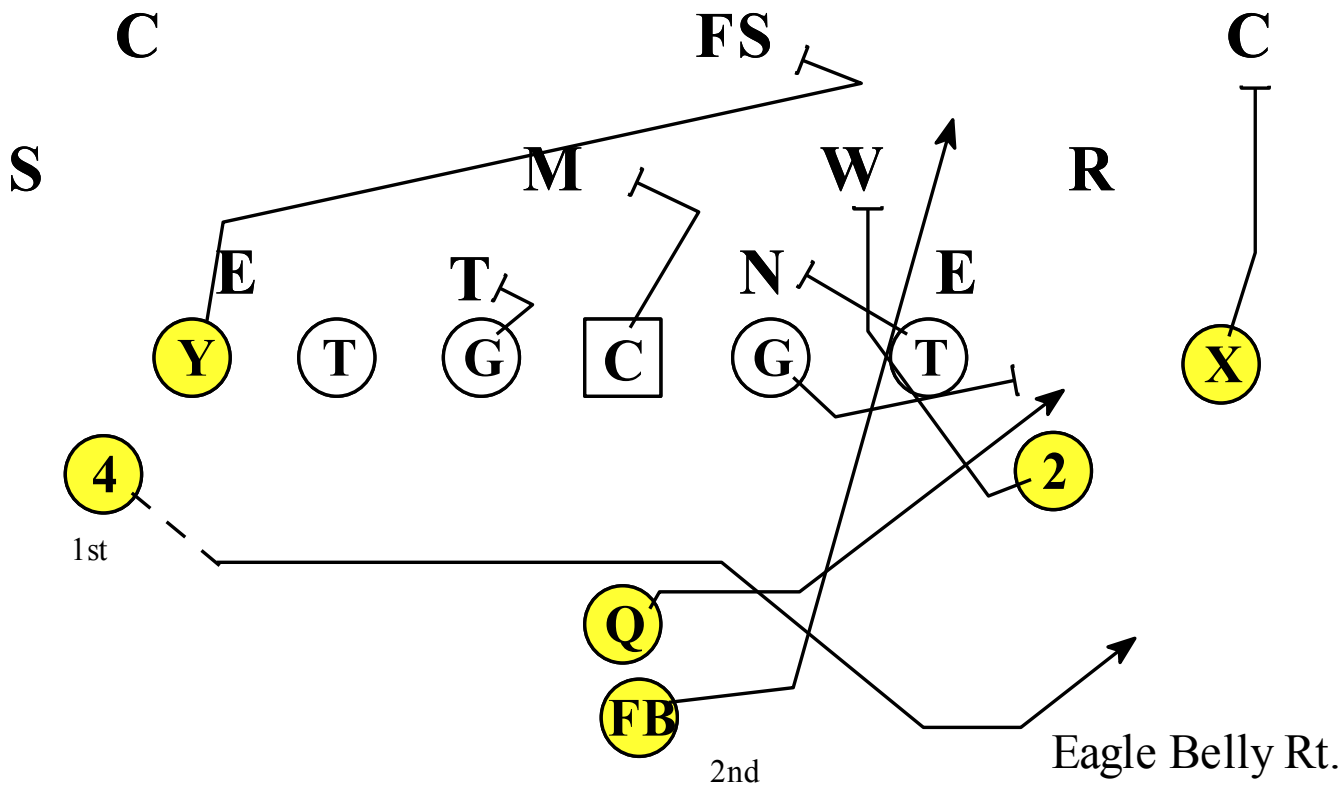
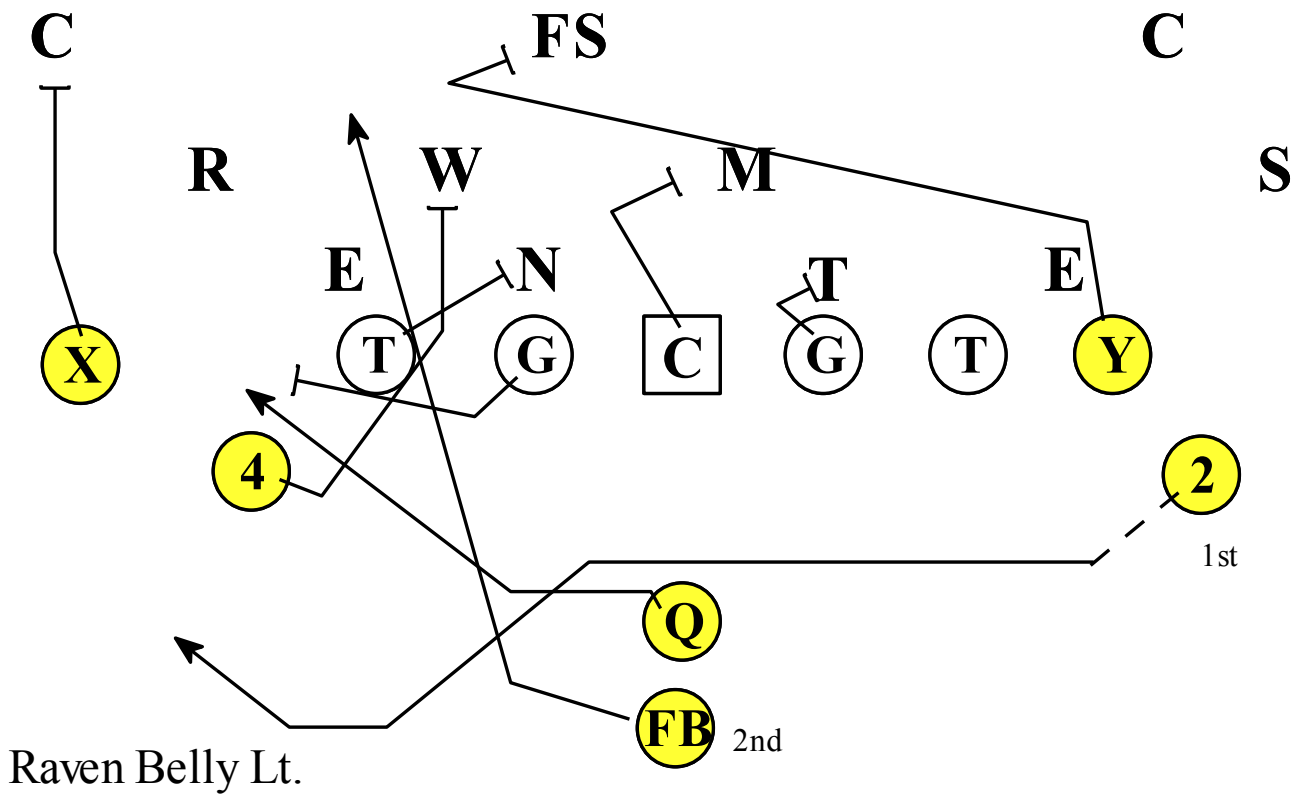

Belly QB Follow

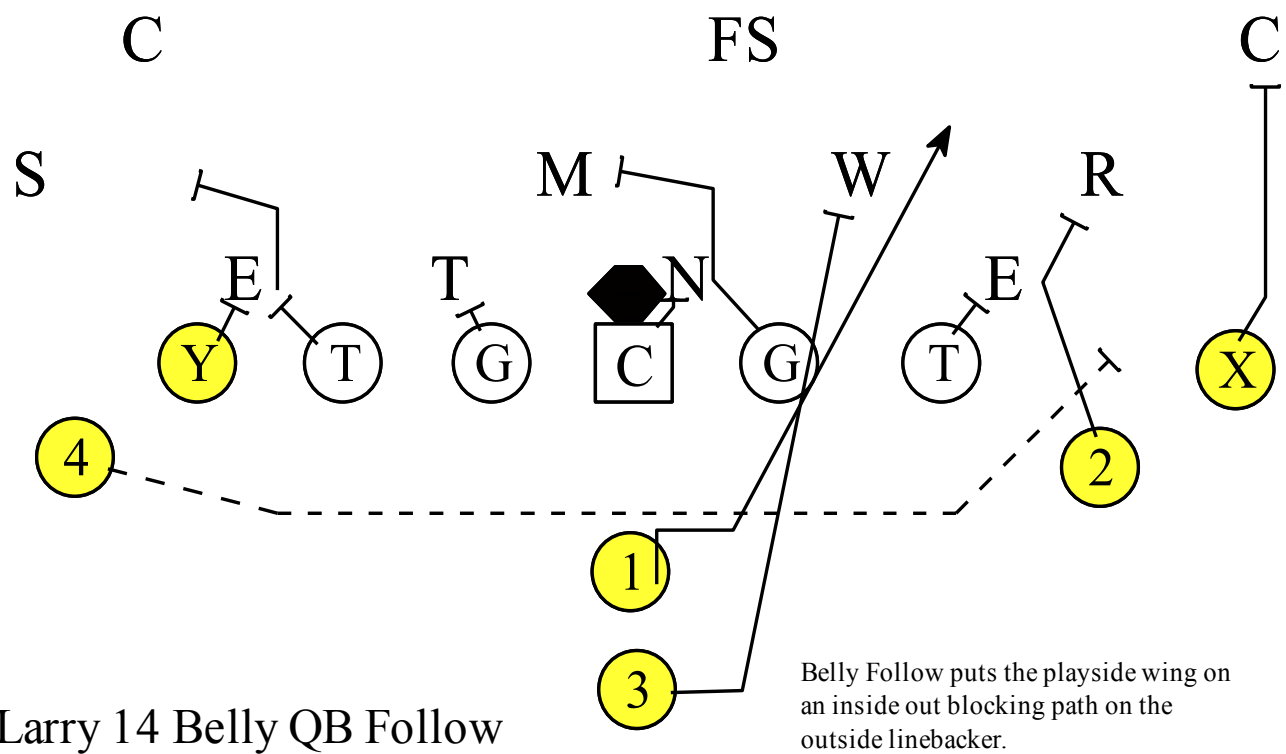
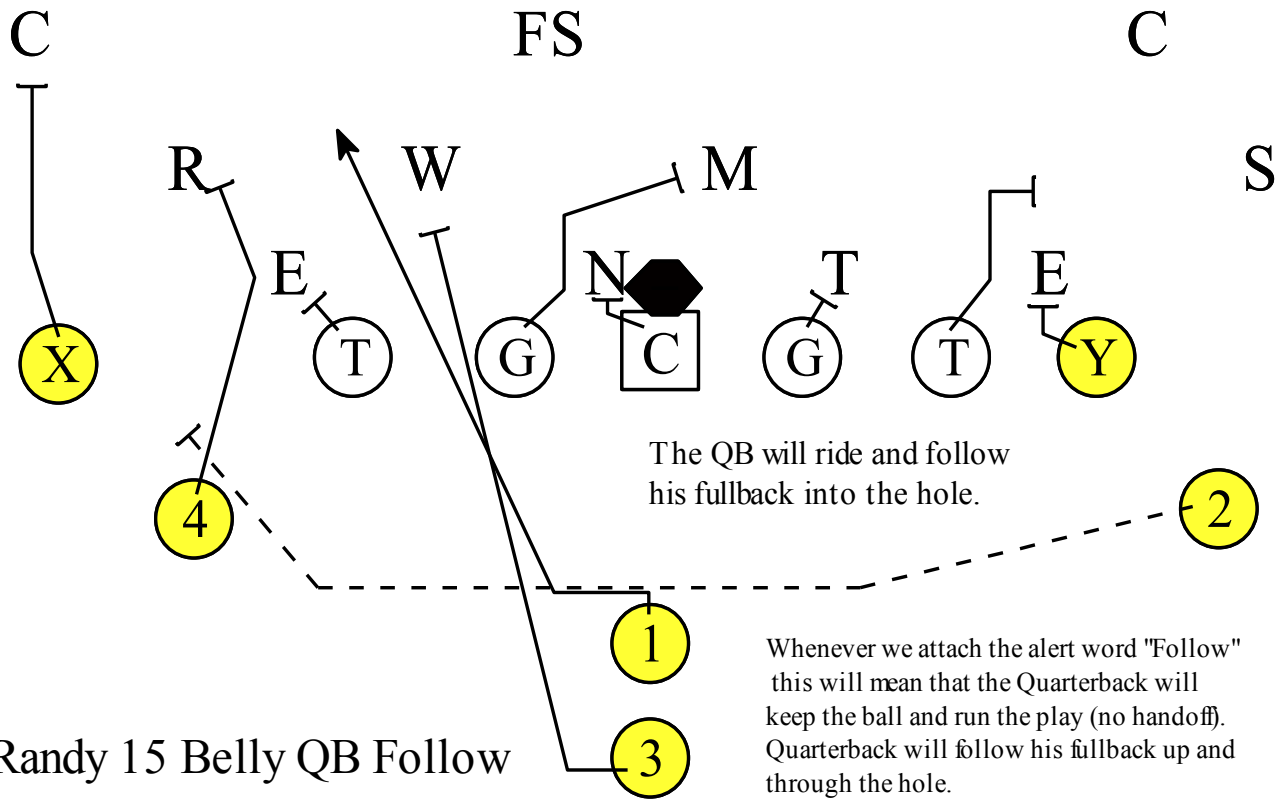

Formation: Randy & Larry

Play: 34 & 35 Belly Option

vs 6-2 Split

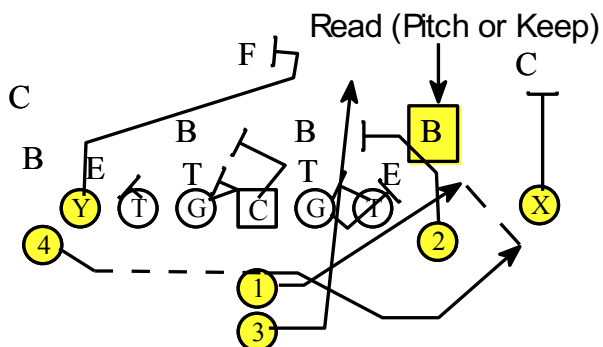

vs 3-3 Stack

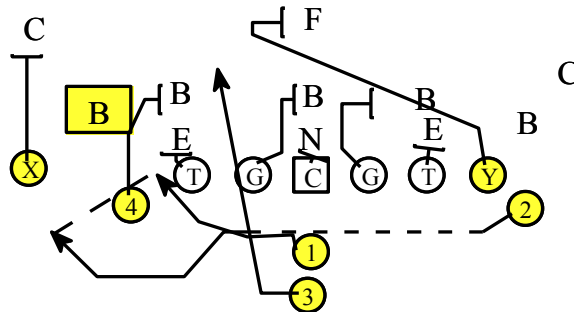

PST - "Skull" or "Crusader" Call

PSG - "Skull" or "Crusader" call

C - Reach Playside.

BSG - Seal Man On/Over

BST - Seal Man On/Over

TE - Track To MLB

PSW - Inside/Outside Track To Playside LB.

"Wing" Back - Mo, Mo To Option Relationship w/QB Pitch..

FB - Lateral Playside Step, Attack The Hole, Read PSW Block (listen for skull/crusader call).

"X" - Stalk Block.

QB - Quick Fake To BSW, Fake Handoff To FB, Run Option, Read Number One Force-Contain.

vs 5-3 Reg.

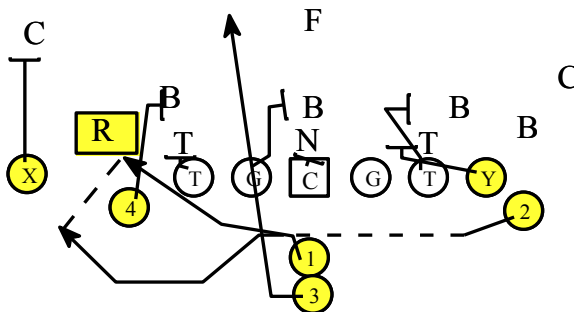

vs DBL Eagle

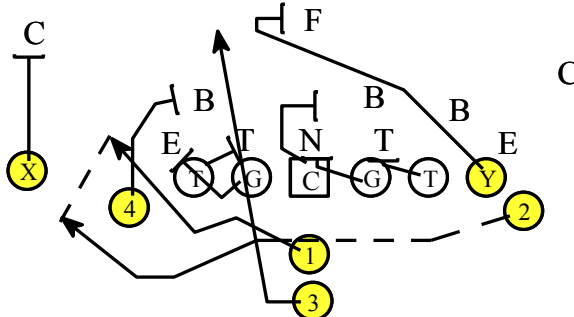

vs 4-4

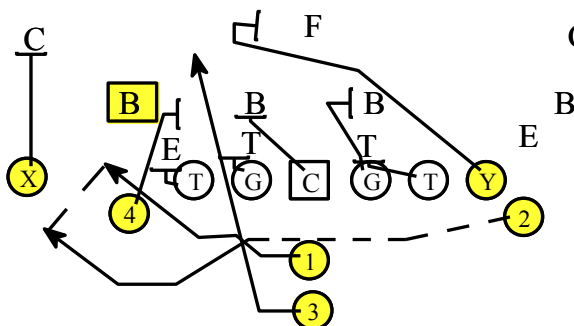

Quarterback Counter

Ace QB Counter Left

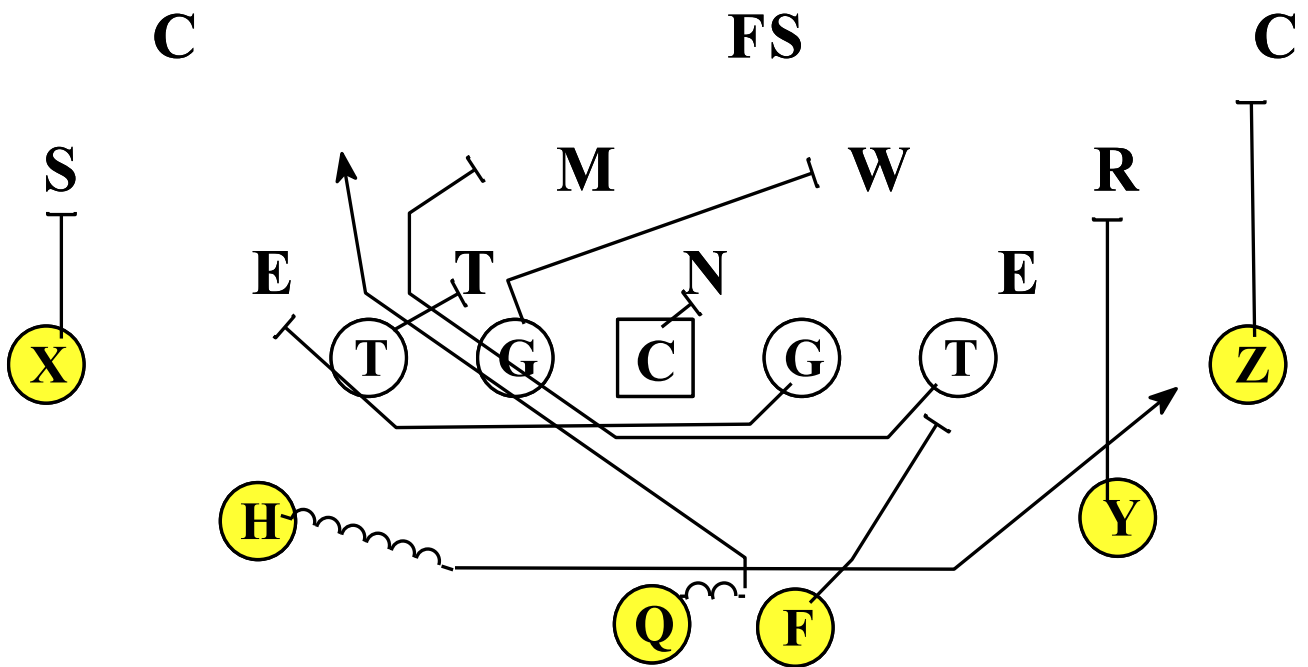

Doubles QB Counter Right

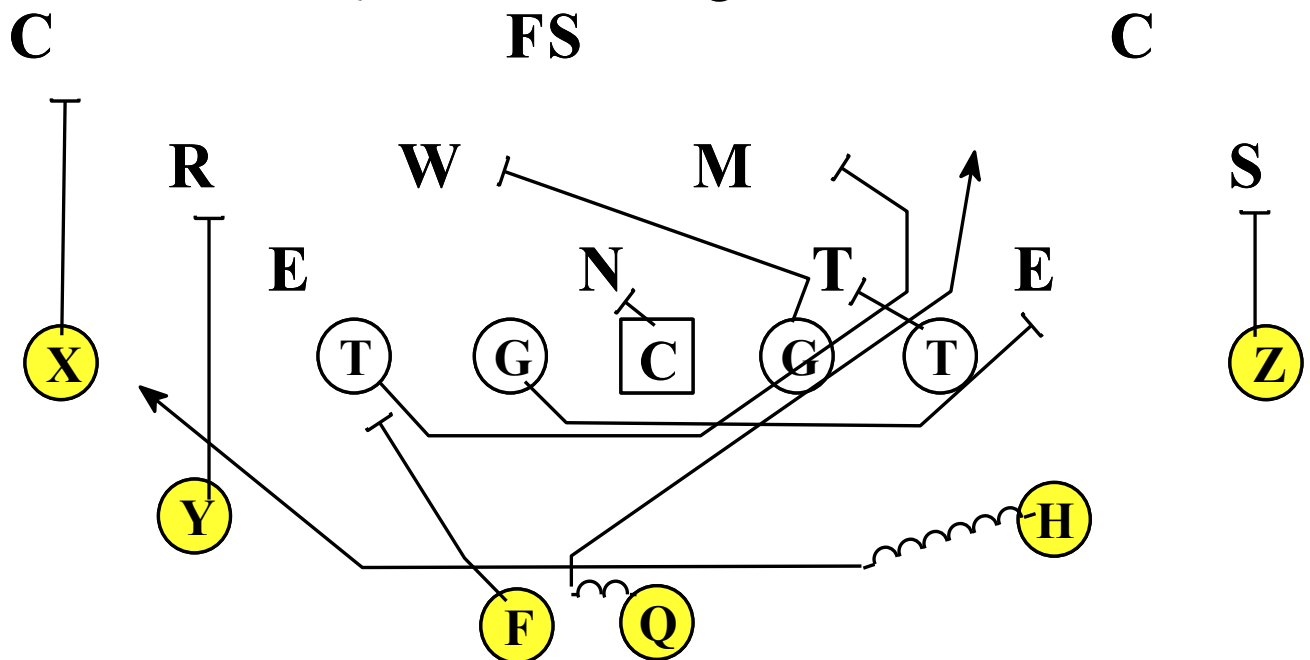

Hybrid Pistol Wing-T Blocking Schemes and Techniques Running Jet Sweep Towards and Openside

The Jet Sweep has become a very popular offensive play because it allows for a full sprint from depth that allows the motion back more vision and speed to the perimeter. The Jet sweep is based on the full sprint motion from one or two backs crossing the formation in front of the pistol Quarterback while incorporating a full zone blocking concept. The motion back places the defense in even greater conflict because of the speed of the motion back.

The speed in which the motion back hits this play allows the offensive scheme the ability to not have to block the backside of the Jet Sweep which brings more blockers to bare towards the point of attack. The Jet Sweep can be run from all formations mentioned in this manual.

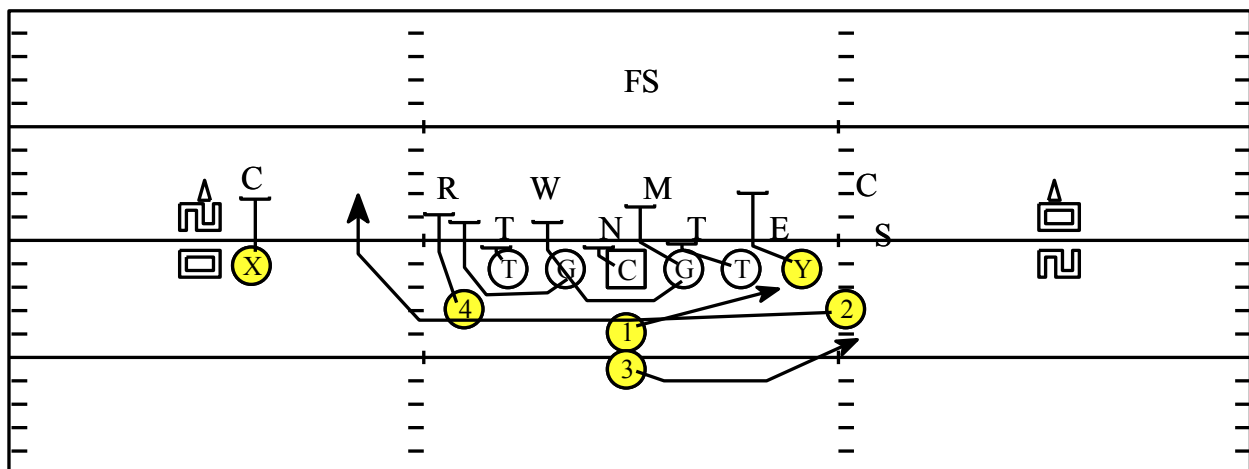
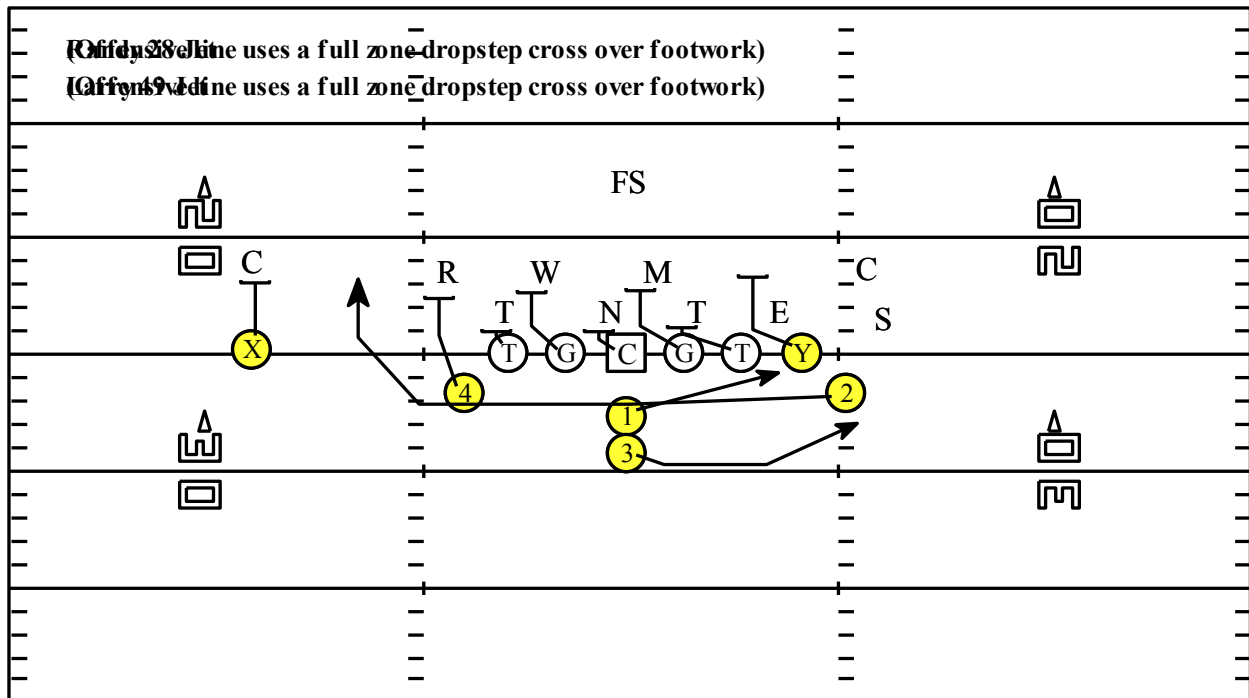

Randy 28 Jet Sweep (Pulls both guards playside)
Larry 49 Jet Sweep (Pulls both guards playside)

Jet Sweep

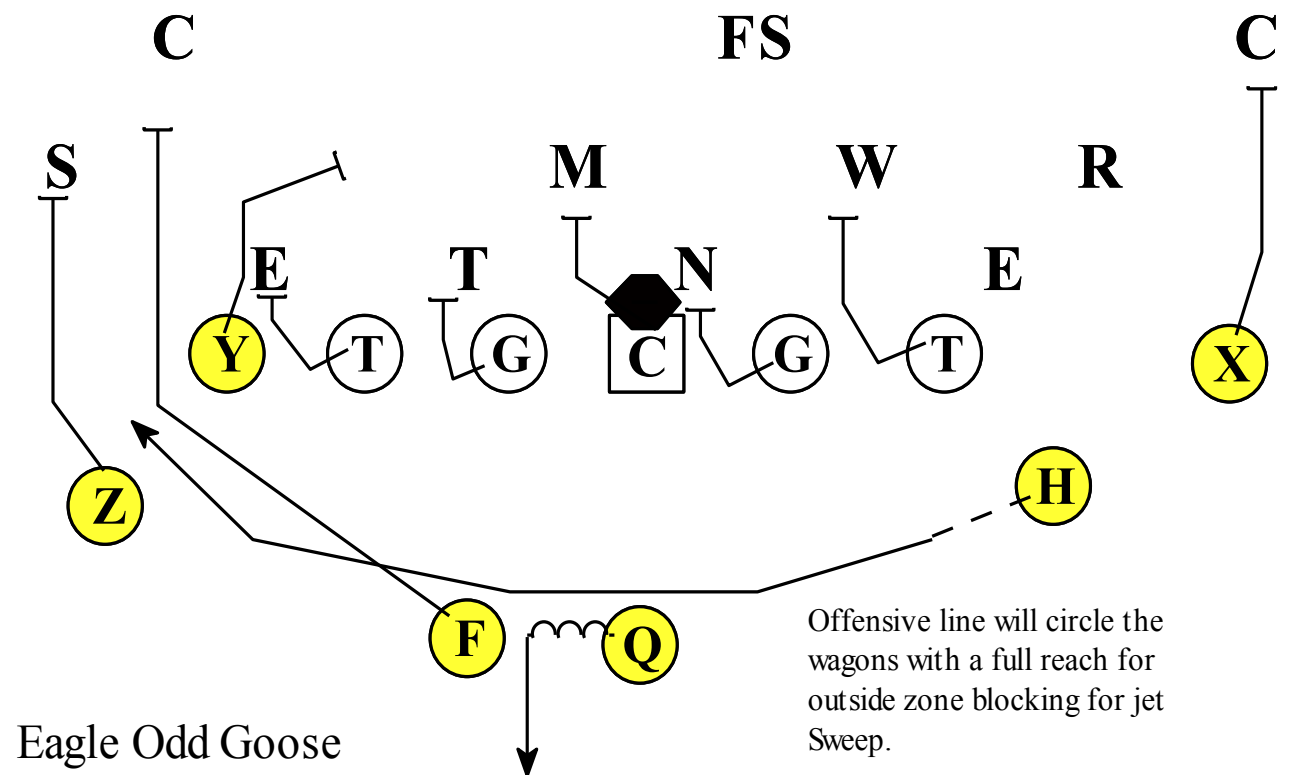
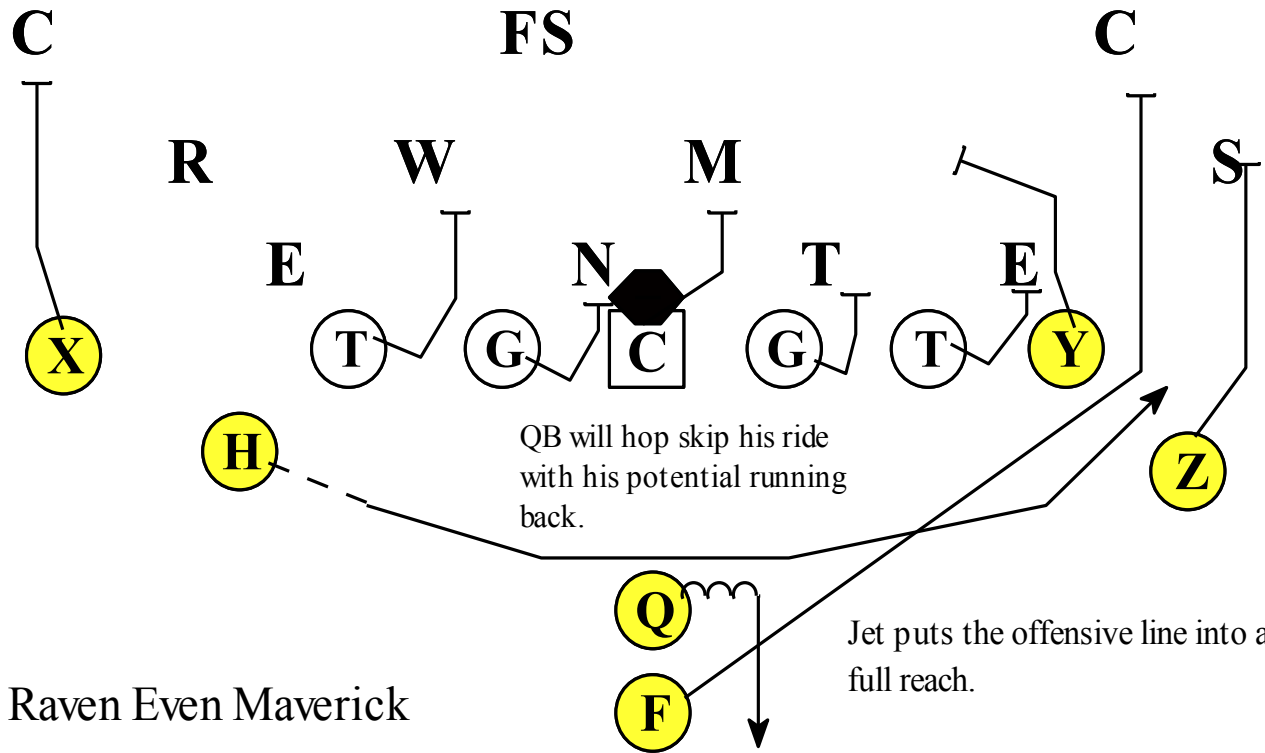

Joker: Batman & Robin

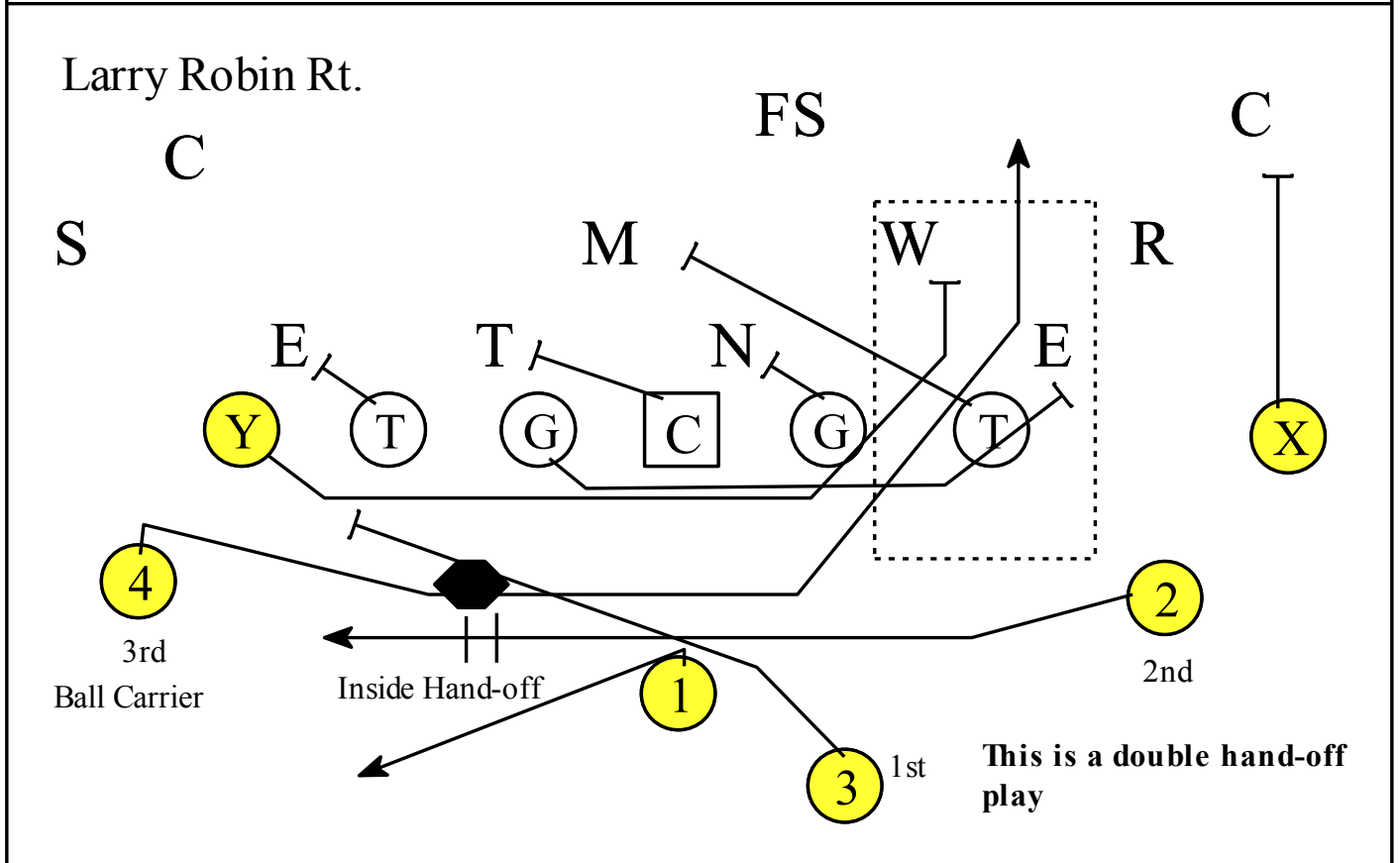
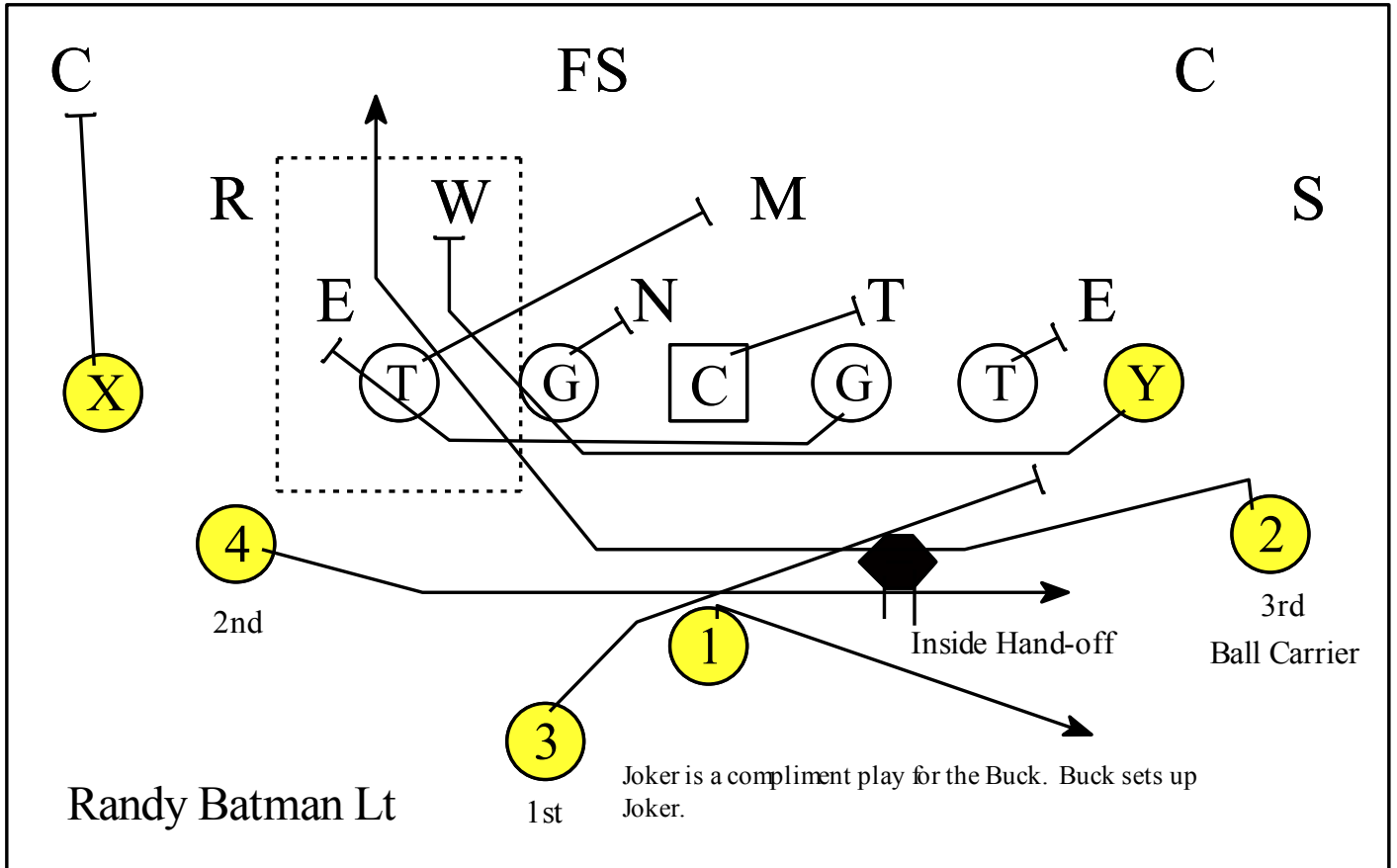

Passing Game

Dropback Passing Game

Randy All Go
Larry All Go
Dallas, Dorthy All Go
Tractor & Trailer All Go
Fresno 211
Dallas 47
Tractor & Trailer "W" Slant
Trips Lt. "W" Slant
Apache Rt. Mo, Mo "W" Slant

Sprint Out Passing

Randy Sprint Lt. Wide
Larry Sprint Rt. Wide
Randy Sprint Lt. Curl
Larry Sprint Rt. Curl
Dallas & Dorthy Sprint Rt. / Lt. Wide

Boots & Play Action

Randy & Larry Boot Cruise
Randy & Larry Boot Wide
Randy Boot Lt. Cruise Booty
Larry Boot Rt. Cruise Booty
Randy Buck Rt. Push & Green
Randy Buck Rt. Tiger Blood
Larry Buck Lt. Tiger Blood
Randy Belly Pop Pass Right
Randy Belly Pass Left
Larry Belly Pop Pass Left
Larry Belly Pass Right
Randy Buck Rt. Tiger Wood

Screens

Dallas Mo, Mo "A" Bubble
Trips Rt. "A" Bubble

Larry Sprint Rt. Fullback Screen Lt.
Randy Sprint Lt. Fullback Screen Rt.

Larry Sprint Rt. "Y" Screen Left
Randy Sprint Lt. "Y" Screen Right

Outside Receiver Route Tree

- 8 - Post
- 7 - Post - Corner
- 6 - Curl
- 5 - Push
- 4 - Stop
- 3 - Out
- 2 - Slant (One Step)
- 1 - Go

The routes shown in this diagram represent quick passing game so, when designing your short passing game you want to consider the following routes for the "X" and "Z" receivers.

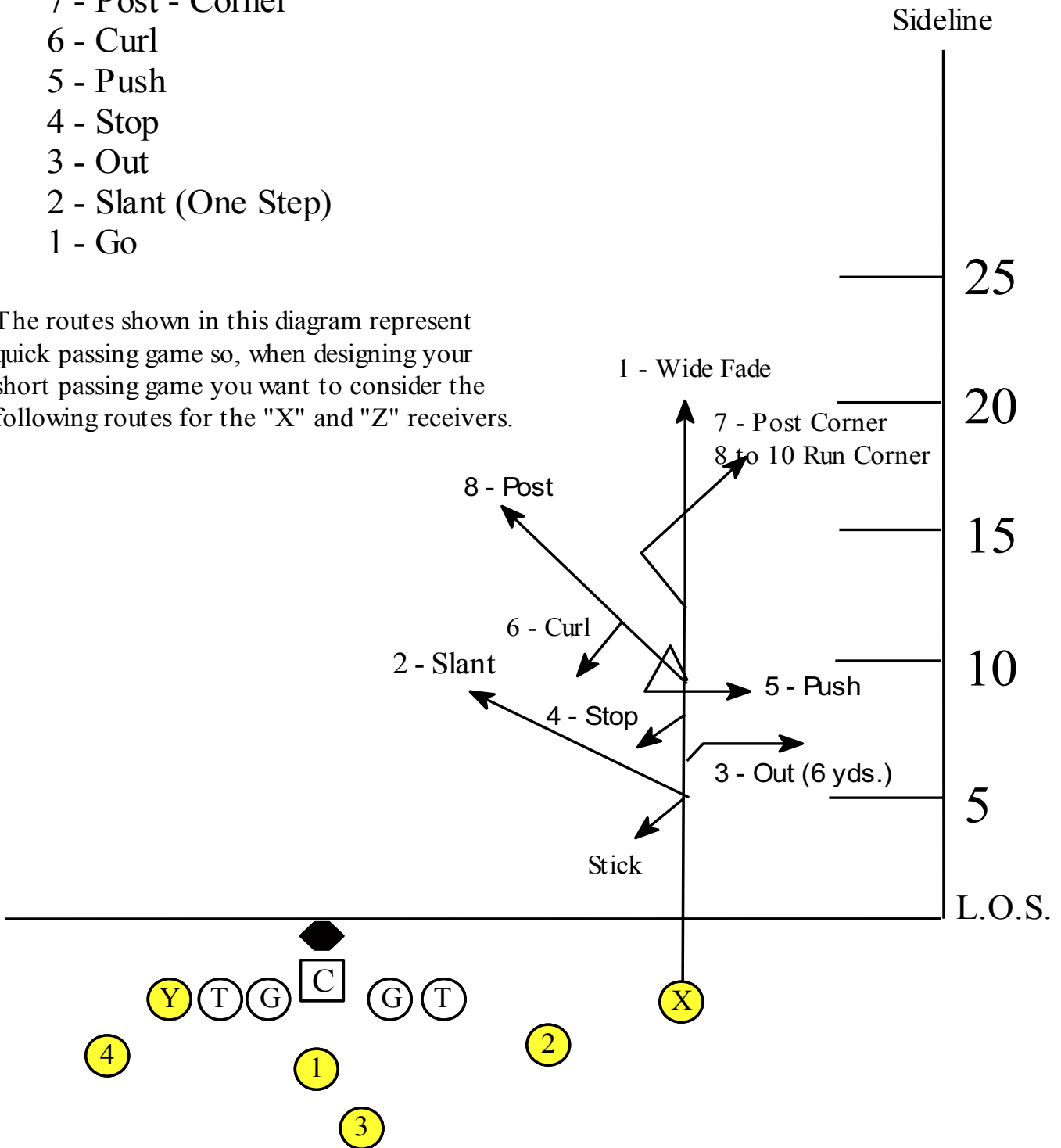

Slot Back or Tailback and Tight End (Y) Passing Tree

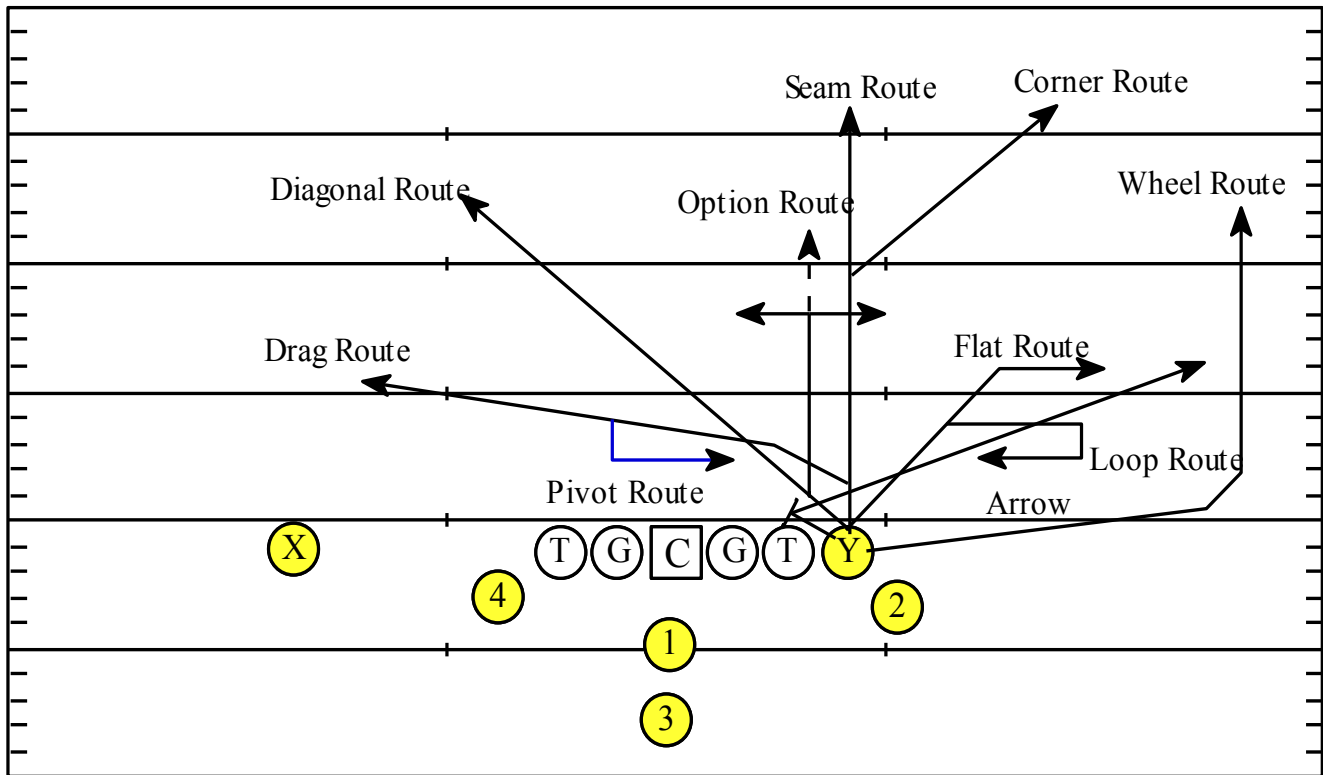

Slot and Tight End Route Designations:

Corner Route - Make route cut at 12 yards.

Delay Route - Tight End delays his release according to the type of play called. Run and climb to a depth of 6 yards.

Diagonal Route - Push inside underneath the first linebacker inside, climb behind the backside linebacker to a depth of 14 to 16 yards.

Drag Route - Push the inside release underneath the playside linebacker. Climb behind the backside linebacker and continue across the formation to a depth of 8 to 10 yards. Don't get bumped off.

Flat Route - Run to a depth upfield to 6 yards then cut off inside foot breaking to sideline. Snap head around on the third step. If you get within 5 to 6 yards of the sideline turn the route into a Wheel route running up the sideline.

Hunt Route - Work this route off the first linebacker inside. If tight end can't get inside then come behind the linebacker, work to a depth of 8 to 10 yards, get the first down.

Option Route - Push the outside shoulder of the outside invert or safety. Take route opposite of where the defender drops. Let the defender get to his drop, or just get open. If free safety disappears then run the Go route.

Seam Route - Take easiest release pushing the defenders outside shoulder, use speed to get past defender. After clearing the inside linebacker's look for the football, vs cover 2 get the the middle of the coverage.

Loop Route - Push 45 degrees towards the sideline. Plant inside foot and spin back inside. Stay flat as you come back inside, take route to a depth of 5 to 6 yards.

Pivot - Inside release at near linebacker planting on the up field foot and then work back outside.

Wheel Route - Outside release by the tight end climbing to a depth of 6 yards while running towards the sideline. Once reaching 5 to 6 yards from the sideline then turn up sideline running fade route.

Tight End Slice, Drag, and Shallow Route Discription

Slice Route

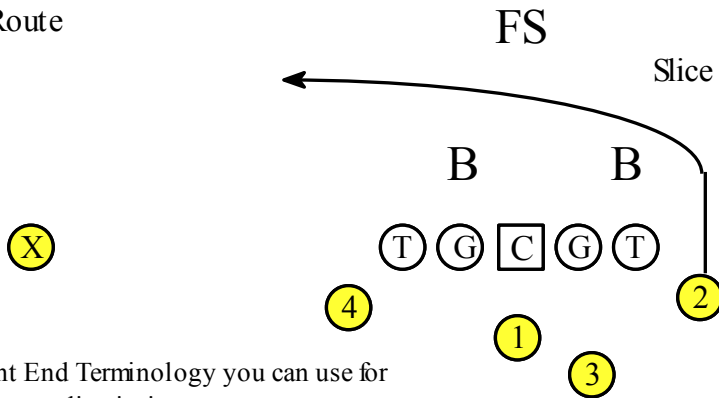

Whenever running a Slice route sell a Go route and then cut route off running behind the Linebackers and in front of the safety.

(Y)

Possible Tight End Terminology you can use for establishing route discription.

Drag Route

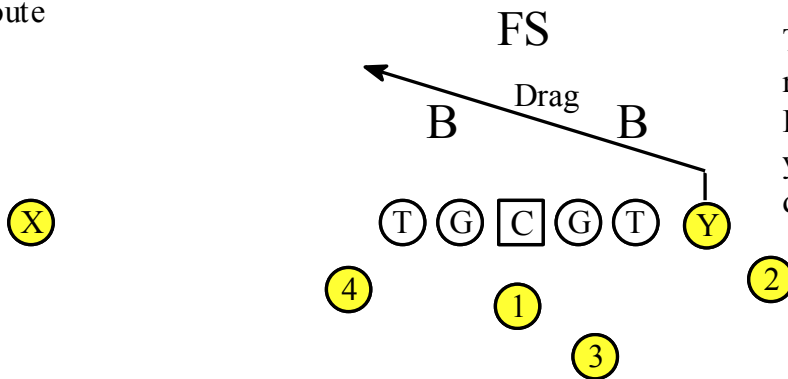

The Drag route takes a receiver between the Inside Linebackers to a depth of 6 yards and then climbs no deeper than 12 yards.

Shallow Route

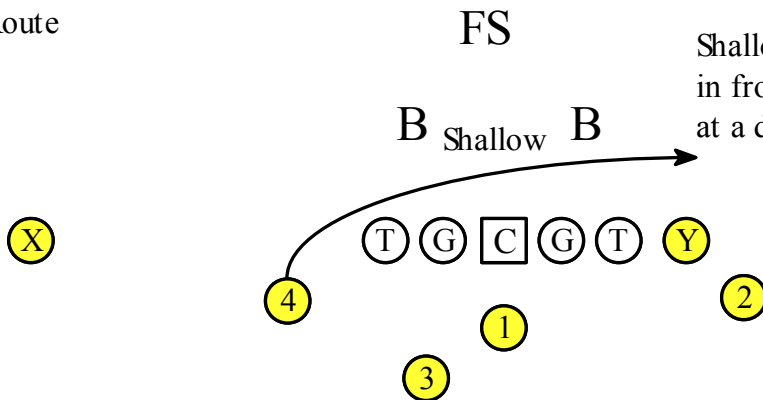

Shallow route is a route that runs in front of the Inside Linebackers at a depth of 4 to 6 yards..

Combination Shallow, Drag and Slice Routes

Slice In Back of Linebackers and In Front of Safety

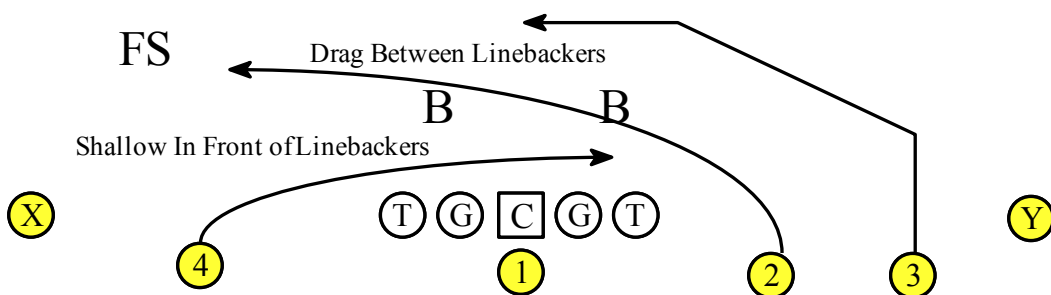

Whenever running a combination Slice and Shallow routes the Shallow route will come underneath the Drag route.

Hand Signals: Converting Routes

The quarterback must approach the line of scrimmage the same way on every play (look left-middle-right); find the safeties (one or two), the uncovered ("inverts"), the number of defenders in the front, and weakside flat defender. If throwing the football, the quarterback must look off the intended receiver: i.e., do not watch the receiver you intend to throw to until ready to deliver the ball. If running the football, the eyes must go immediately to the read key. Some additional keys for the quarterback include:

Identify the "inverts"

- * One or Two
- * Are they in a run or pass alignment?

Steal Yardage;

- * Are they uncovered inside receivers?
- * Are the corners soft?

Know The Keys;

- * Who is the read defender?
- * Know the route progression or line-of-sight for each pattern

Know Down and Distance;

- * Determine if the defense is in a blitz situation or alignment; i.e., can they blitz from their alignment?
- * Throw the ball to where the blitz is coming from.

The Quarterback and the receivers will occasionally use hand signals to communicate. The hand signals are:

Hands together forming an "O" changes route to a "Choice" route. The quarterback must acknowledge the route adjustment. The choice route is a vertical route, challenging the defender deep, however at ten (10) yards, if the receiver is even with the defender they continue deep, but if there is a cushion the receiver immediately hooks, typically at twelve (12) yards. We refer to it as "at ten, if your even, your leave'n".

Cross Forearms is used in conjunction with an "alert" call. The receiver is letting the quarterback know that they will sight adjust to the defender over them, if their defender blitzes,

Pat Back of Helmet to let the quarterback know that the receiver is uncovered. Uncovered is no defender within 6 yards for the inside receiver or eight (8) yards for an outside receiver. The quarterback must acknowledge the route adjustment. Quarterback will throw the "Stop" route.

Open hand changes the route to a "Slant". The quarterback must acknowledge the route adjustment.

A Tight Fist changes the route to a "Fade". The quarterback must acknowledge the route adjustment.

Converting Routes / Taking What The Defense Gives Us

Route Description for Conversions:

Simple 4th step, turn back inside towards QB

Slant towards post on 5th step

Blocking Route deep.

Receiver Hand Signals: The following information describes how we convert routes according to a defender's alignment or an uncovered receiver recognition. Hand signals will be used to communicate a route adjustment between the Quarterback and Receivers.

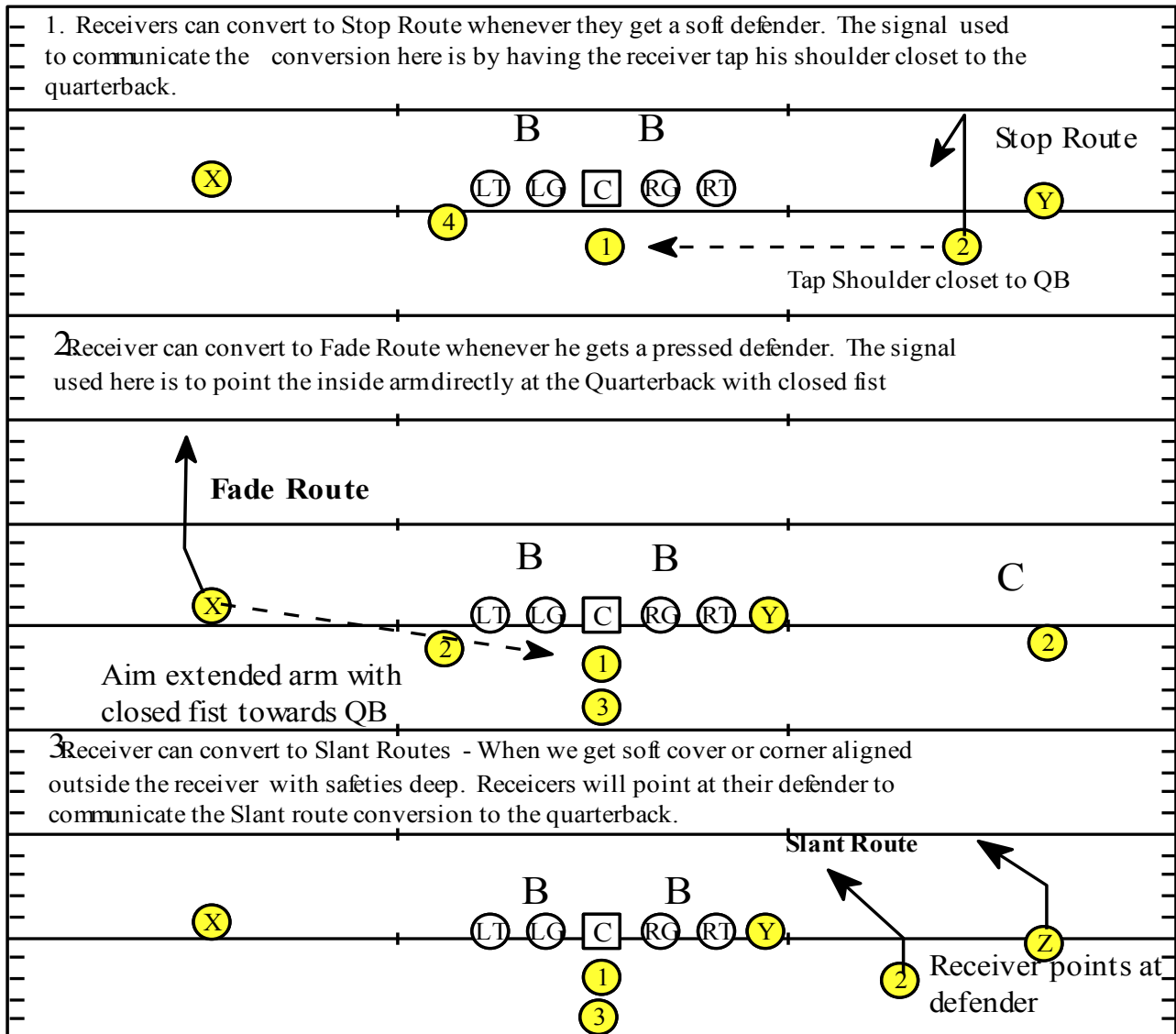

4. Uncovered Receivers -
- inside receiver that does not have a defender within 6 yards is considered uncovered.
 - outside receiver that does not have a defender within 8 yards is considered uncovered.

When an inside or outside receiver is uncovered he will signal by rubbing the back of his head. If the Quarterback acknowledges the signal with eye contact, he then will throw the ball to the receiver. The receiver will pivot inside and catch the ball.

Pattern Alerts Using Combination and Flood Routes

Tag Alerts:

A Tag alert is a combination series typically using two receivers ("twins") type set, but can be run from a three receiver (trips, orange) type set as well. Examples of calling routes is done in the following manner: 300 Slant would tell the offense that we are throw a 3 step protection, quareback and primary recivers located right with the number one receiver running a slant and the number two receiver running an arrow route (comp), the arrow route by the number two receiver is automatic to the scheme.

Whenever running a three receiver set the number three receiver will automatically run a Slice Route unless told differently. As a rule of thumb any two reciver formation will be known as combination series passing scheme and then any formation that uses three receivers to one side will be known as a flood series. So, a twins, doubles formation is a combination series and any three receiver formation such as trips and orange for example is known as a flood series.

Modifications To A Passing Scheme

The following terms can modify the "Combinations" or "Flood" patterns called. These terms are:

Change:

to the play called will tell the inside receiver #2 and the outside receiver #1 to "change" routes. Thus, the #2 receiver will run the #1 route and the #1 receiver will run the #2 route.

Example: Doubles Rt. 300 Stop Change

Switch:

the play called in the huddle this will tell the inside receiver #3 to switch routes with the #2 receiver.

Example: Orange Rt. 500 Curl Switch

Mirror:

backside receivers to mirror their routes as called to the frontside.

Example: 300 Slant Mirror

Choice:

aligned over the top of him. If the defender is off run a "Stop" route and if, the defender is pressed run a "Seam" or "Fade" route.

Example: Orange Rt. 300 Choice

Thus, the following modifications can be attached to the pass play called which gives your offensive passing game more options with out having to add additional plays.

Modifications are easy to learn with repetition.

Mollie / Collie: Teaching The Double Read Off B.O.B Concepts

"Mollie" talks to a uncovered guard to the backside of the right and left call. Uncovered will always listen for the tuff and soft call made by the tackle. The tackle on the backside becomes the eyes for the uncovered lineman, he will use a tuff, soft call to alert him to how fast or slow he can react to any outside threat. As you set your protections in a straight drop back scheme make sure you can keep your linemen in an inside out position on the down defender and any possible blitz by a linebacker or outside invert.

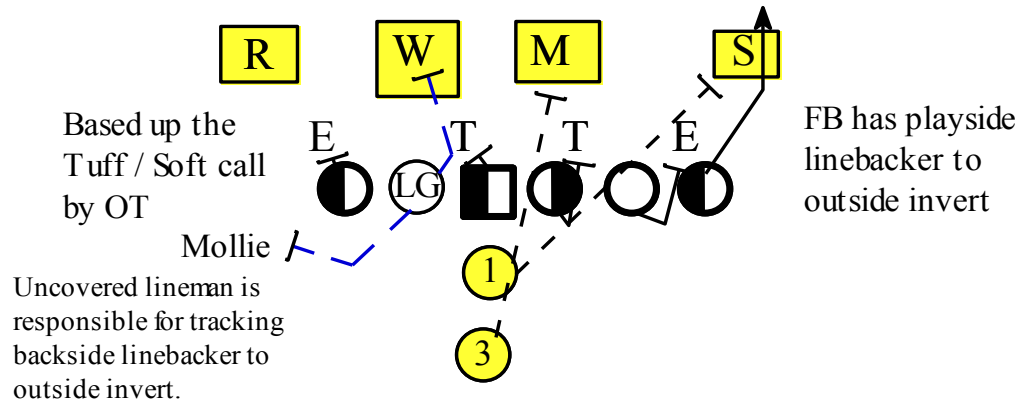

The fullback when you set your protection scheme will be responsible for the playside to outside invert. On the snap of the ball the fullback will first check the playside linebacker, if he drops he then will check for possible outside invert off the edge on a blitz. Fullback will also have to listen for possible "Nasty" alert in the event a linebacker walks up into the line of scrimmage.

"Collie" talks to the center. A "Collie" alert usually comes off an under front, split six, and 40 Stack schemes in which he will be responsible for the double read. The double read for the center is just like that for the guard. The center on "Collie" will listen for his soft, tuff call from his offensive tackle.

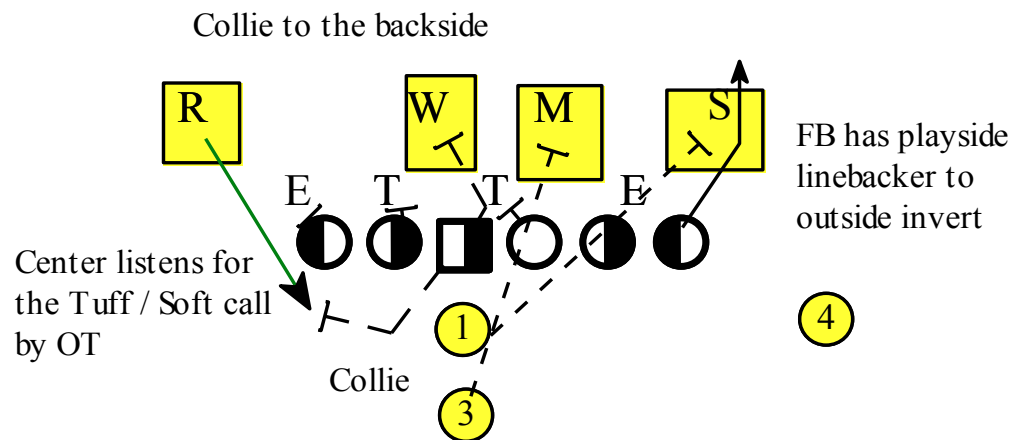

The kick slide is used by any uncovered lineman when checking for any outside pressure. With a straight dropback scheme make sure your fullback and uncovered lineman backside attack their responsibility from an inside out position.

Pass Protection: Understanding The 1/2 Man Advantage

Both the center and the guard have the 1/2 man advantage so this is called a pick up and put down, while setting the anchor. The anchor being their outside foot.

The 1/2 man advantage for straight dropback protection as mentioned is built off the B.O.B. (Big on Big) principle.

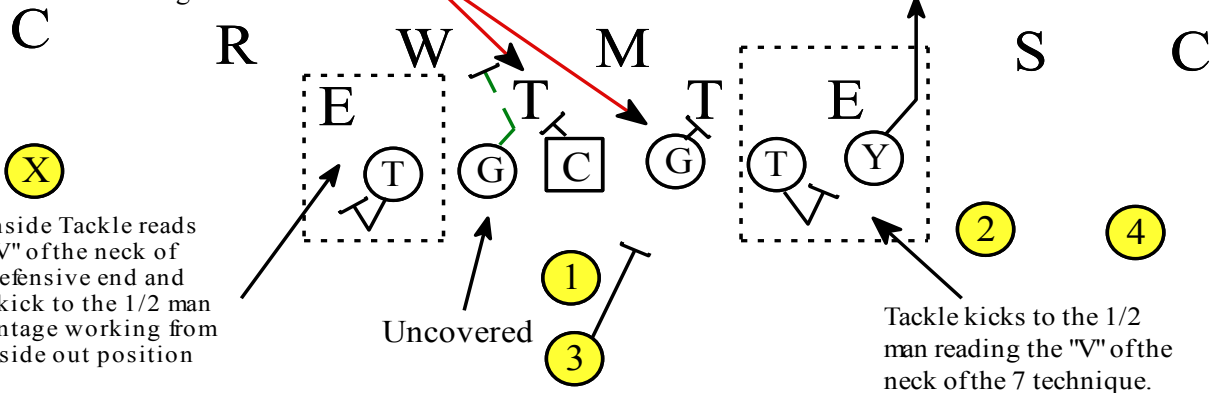

Openside Tackle reads the "V" of the neck of the defensive end and will kick to the 1/2 man advantage working from an inside out position

Tackle kicks to the 1/2 man reading the "V" of the neck of the 7 technique.

vs 13 Tight or Under Front

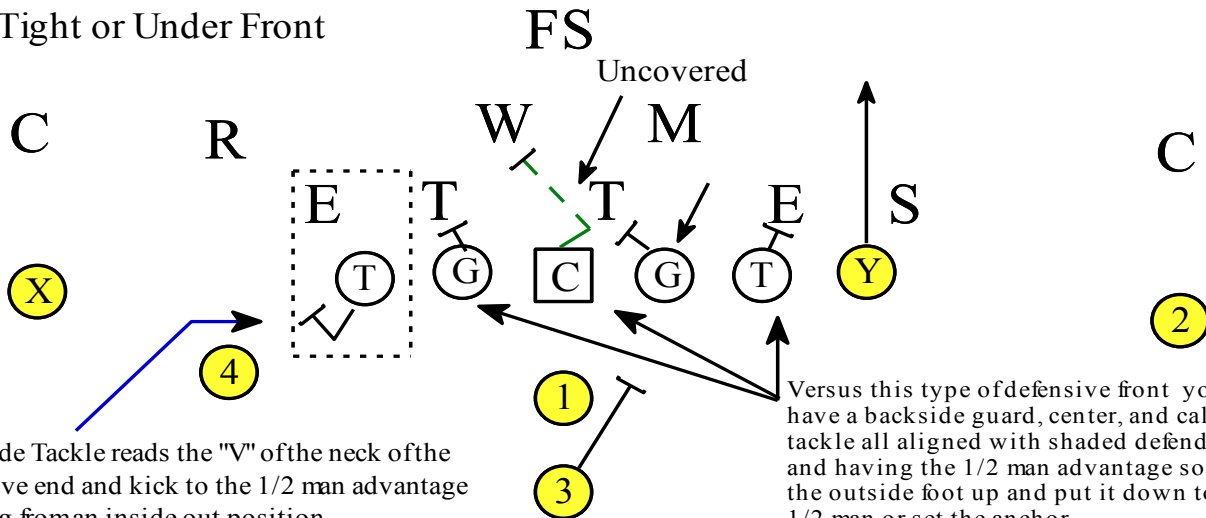

Openside Tackle reads the "V" of the neck of the defensive end and kick to the 1/2 man advantage working from an inside out position

Versus this type of defensive front you have a backside guard, center, and callside tackle all aligned with shaded defenders and having the 1/2 man advantage so, pick the outside foot up and put it down to the 1/2 man or set the anchor.

vs 31 Wide or 4-3

Callside Tackle reads the "V" of the neck of the defensive end and will kick to the 1/2 man advantage working from an inside out position

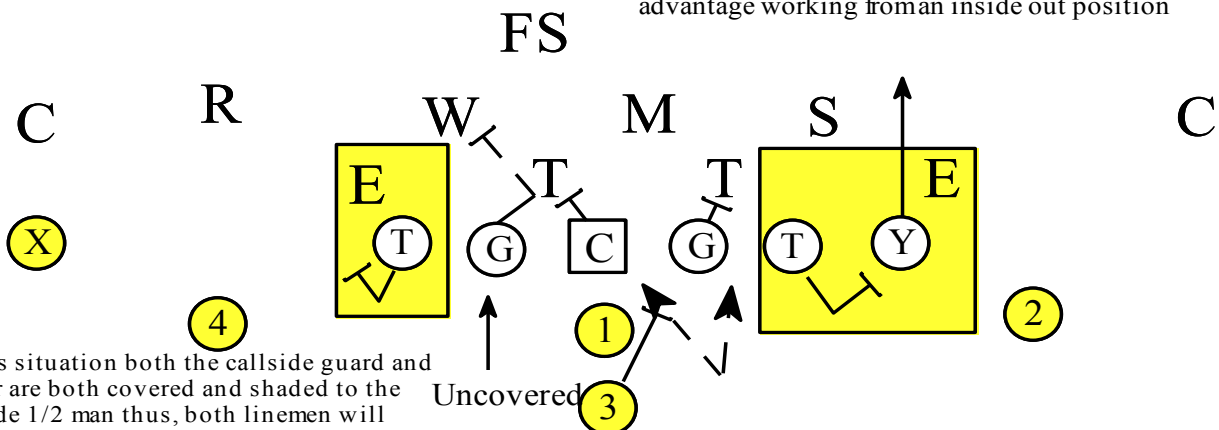

In this situation both the callside guard and center are both covered and shaded to the outside 1/2 man thus, both linemen will be a pick-up put down to the 1/2 man.

146 Buck Rt. QB Throwback Lt.

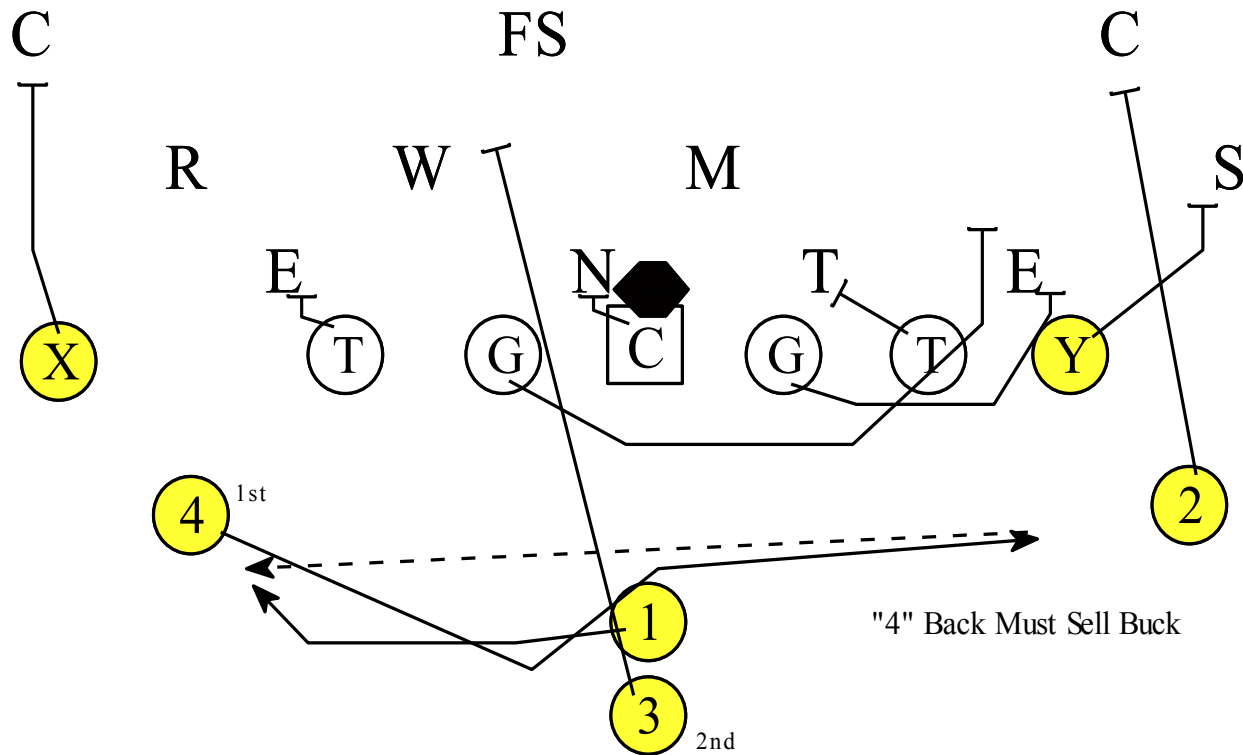

Randy 146 Buck Rt. QB Throwback Lt.

Larry 127 Buck Lt. QB Throwback Rt

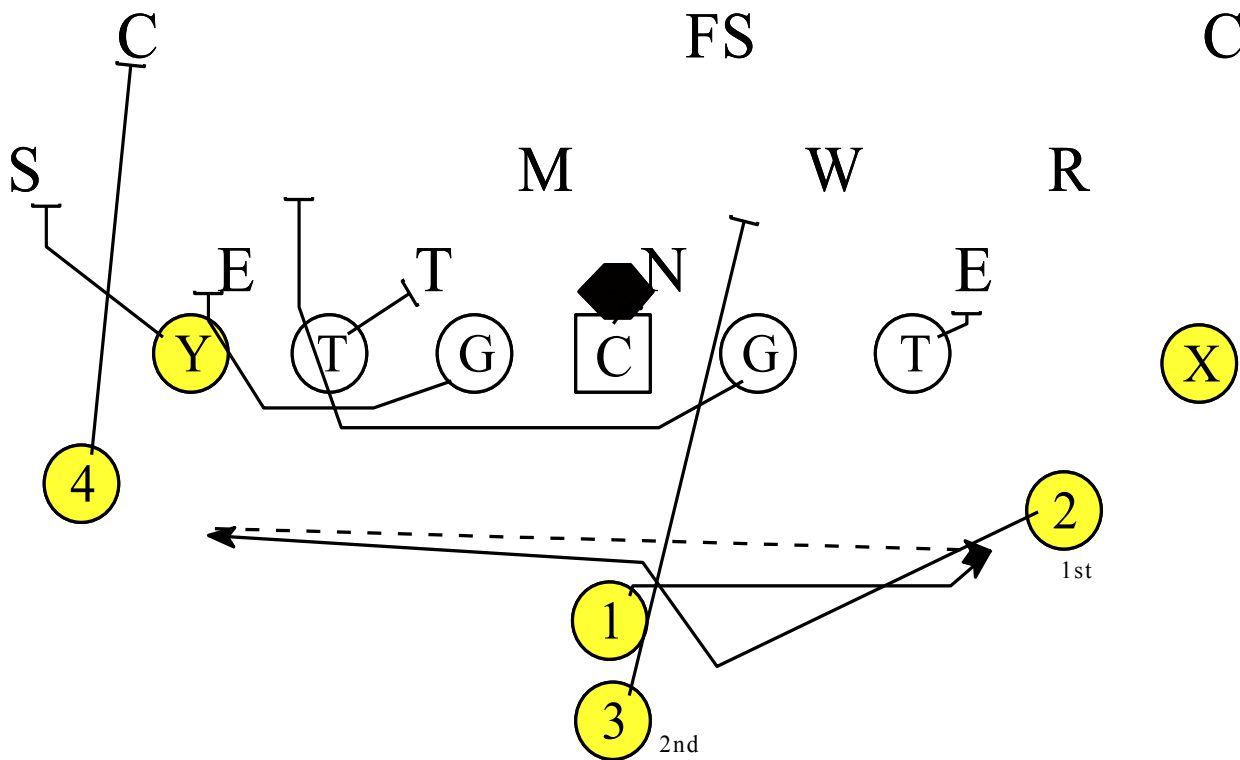

Formation: Randy

Play: 146 Blast Pass & 127 Blast Pass

<p>vs 6-2 Split</p>	<p>vs 3-3 Stack</p>
<p>PST - Block aggressive B.O.B.</p>	<p>vs 5-3 Reg.</p>
<p>PSG - Block aggressive B.O.B</p>	<p>vs DBL Eagle</p>
<p>C - Block B.O.B. checking stack linebacker to backside linebacker vs 3.5.3</p>	<p>vs 4-4</p>
<p>BSG - Block B.O.B. Aggressive if uncovered double read backside linebacker to backside invert.</p>	
<p>BST - Block B.O.B. aggressive.</p>	
<p>TE - Run Seam Route</p>	
<p>Playside Wing run wide fade route</p>	
<p>Backside Wing use Mo, Mo and run flat route.</p>	
<p>FB - Fullback is responsible for checking playside linebacker to outside invert.</p>	
<p>X - Run Wide Fade Route</p>	
<p>QB - Sell the blast looking to hit the seam route first and the look wide fade and then flat route.</p>	

Play: 122 & 142 Read

Louisiana 122 Read

Texas 142 Read

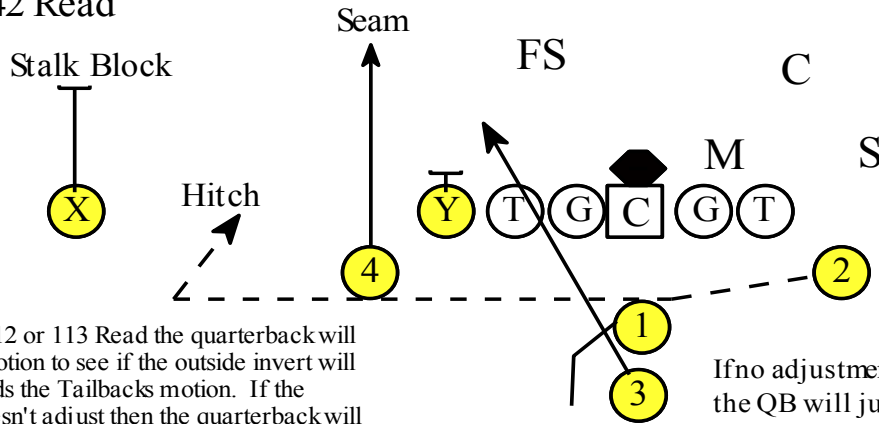

When running 112 or 113 Read the quarterback will use Rip or Liz motion to see if the outside invert will adjust out towards the Tailback's motion. If the outside invert doesn't adjust then the quarterback will throw to the Tailback on a Hitch route to his inside.

If no adjustment to the Tailback the QB will just take the snap, pull up and throw to him.

Dorothy 142 Read

Dorothy 122 Read

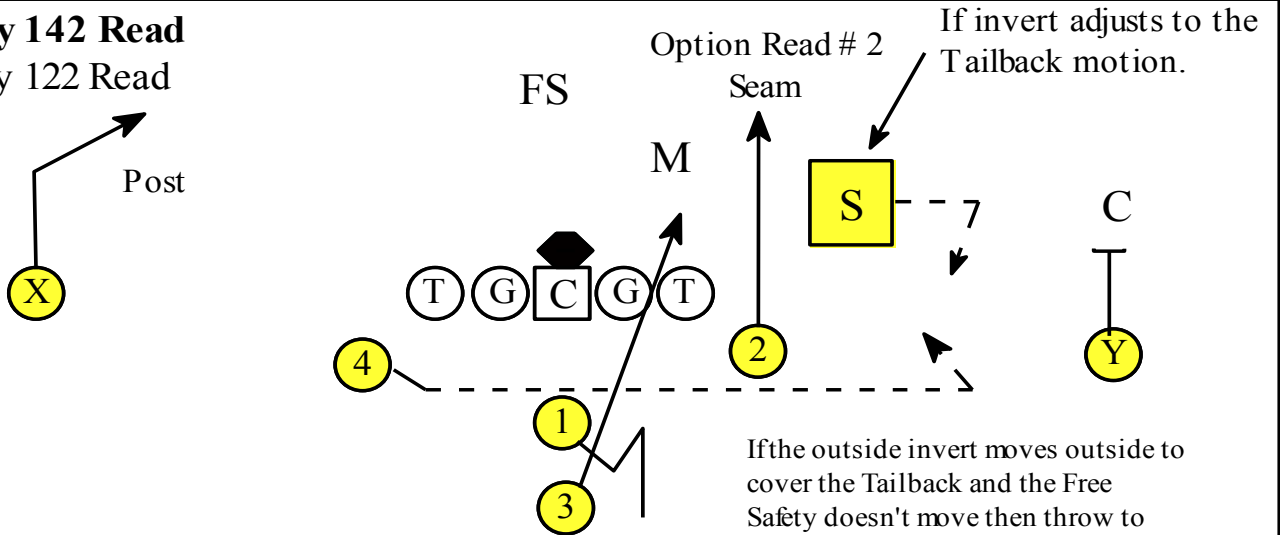

If invert adjusts to the Tailback motion.

If the outside invert moves outside to cover the Tailback and the Free Safety doesn't move then throw to your Tight End on a seam route.

Randy 113 Read

Larry 112 Read

If invert adjusts to the Tailback motion.

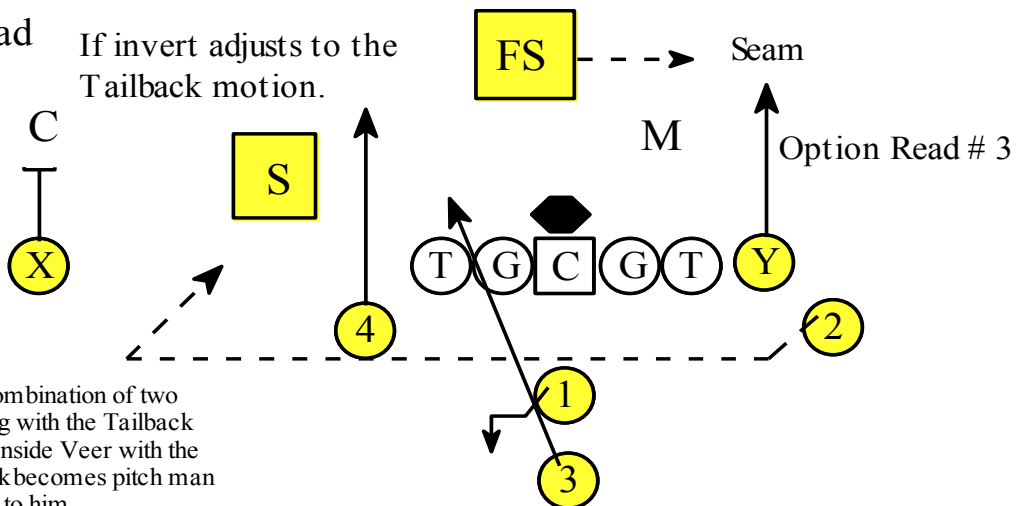

If you get any combination of two defenders moving with the Tailback motion then run Inside Veer with the Fullback, Tailback becomes pitch man if ball not thrown to him.

Play: 111 & 110 Mid

Dorthy 111

Dorthy 110

Play action pass off the sideline.

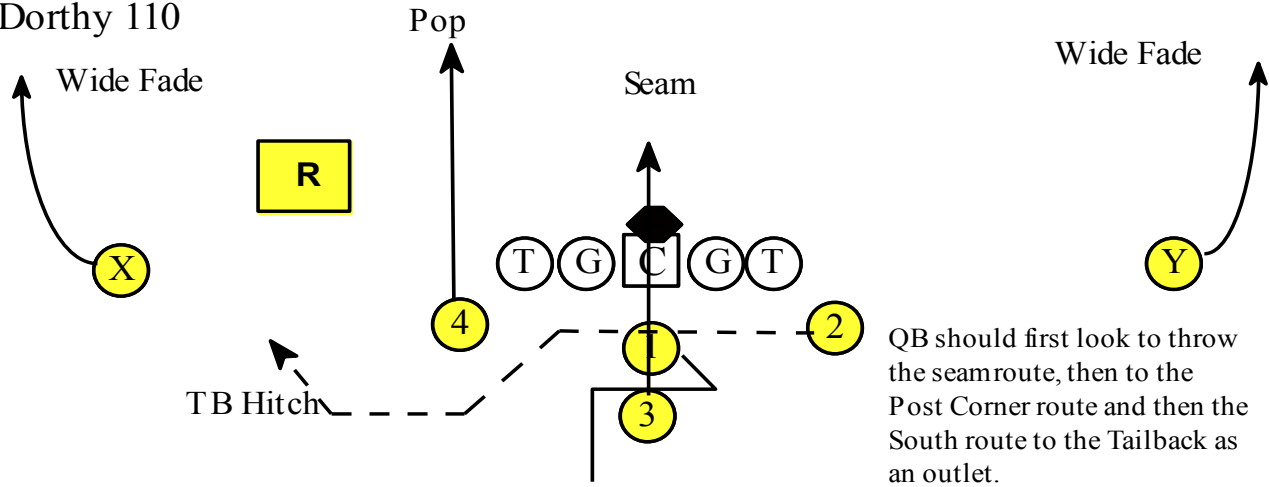

Randy 110

Larry 111

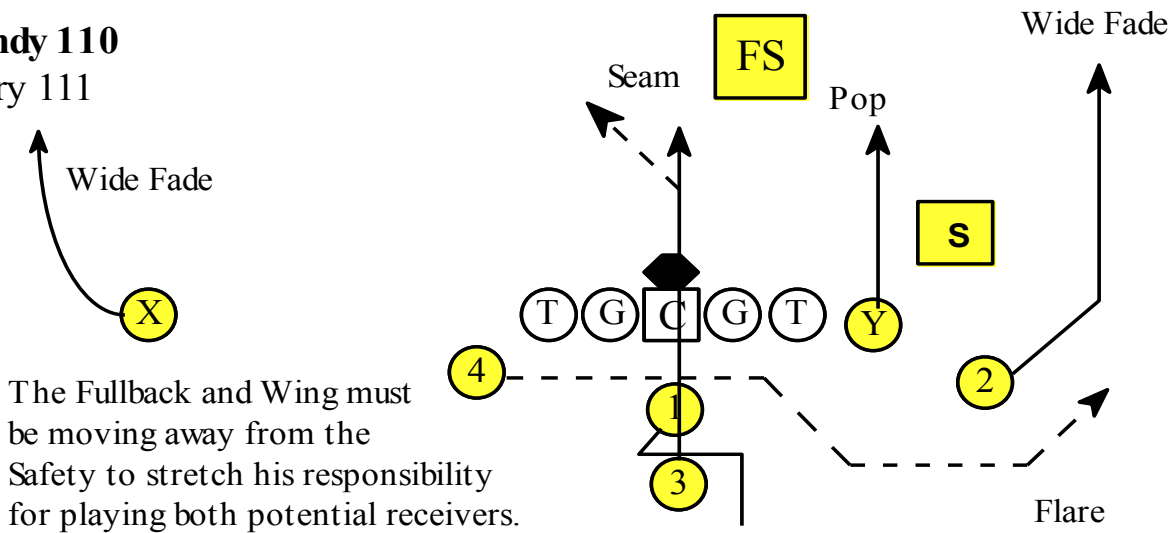

Nick 110

Oscar 111

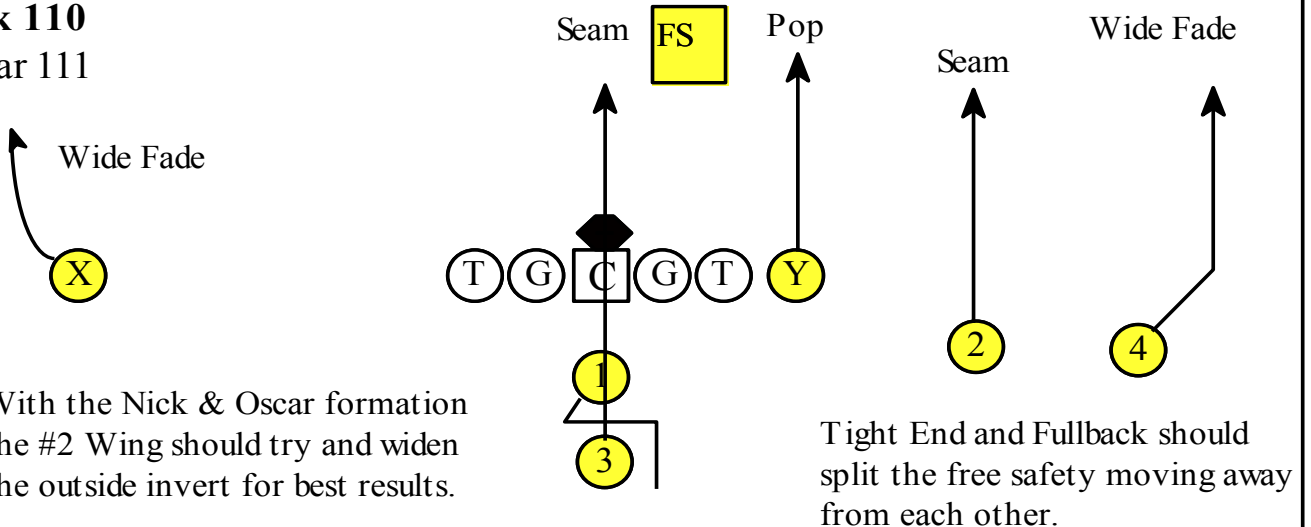

Play: 113 & 112 Veer Pass

Dorthy 113 Veer Pass Dorthy 112 Veer Pass

112 - 113 is designed first to take advantage of an over active safety. Quarterback should always look to throw the seamroute first.

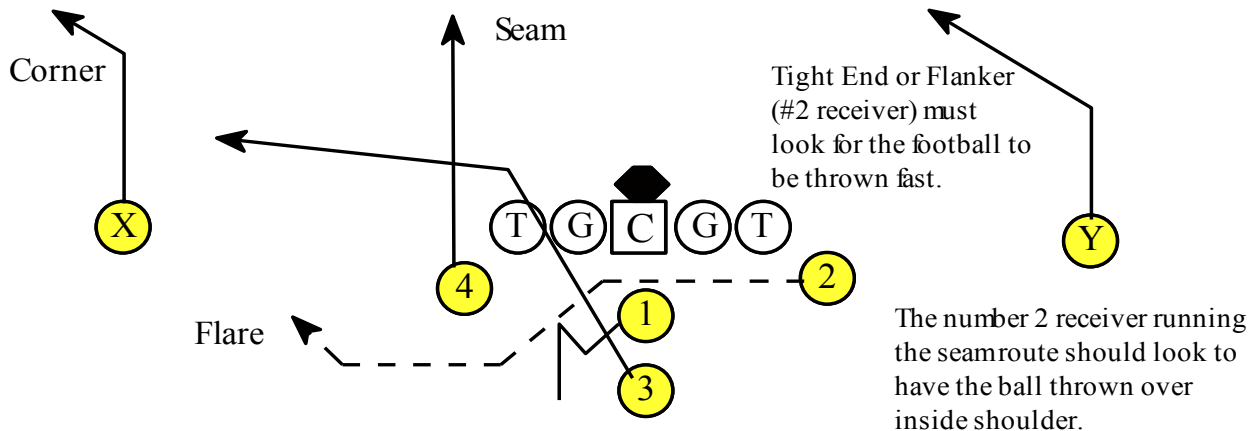

Dallas 112 Veer Pass Dallas. 113 Veer Pass

Quarterback will look to throw the seamroute first. Qb should flash fake the fullback getting depth off the short side of the fullback.

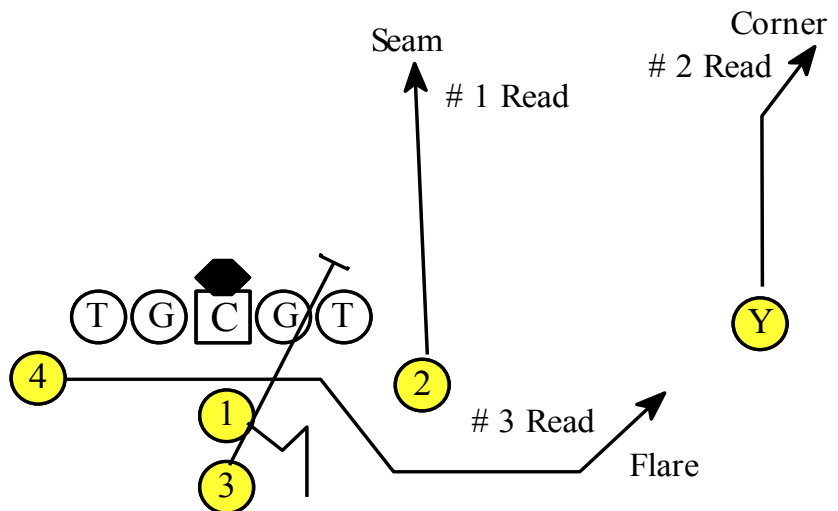

Tractor 112 Veer Pass Trailer 113 Veer Pass

Offensive line will aggressive run block B.O.B

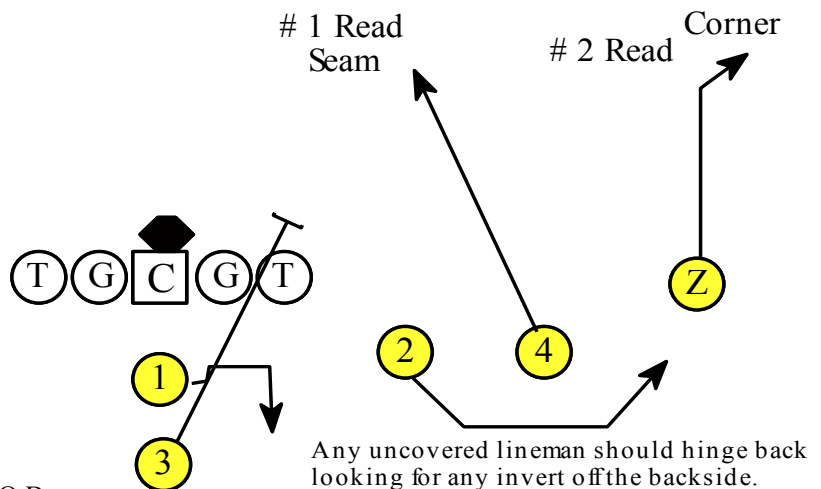

Play: Trailer Veer Pass Rt.

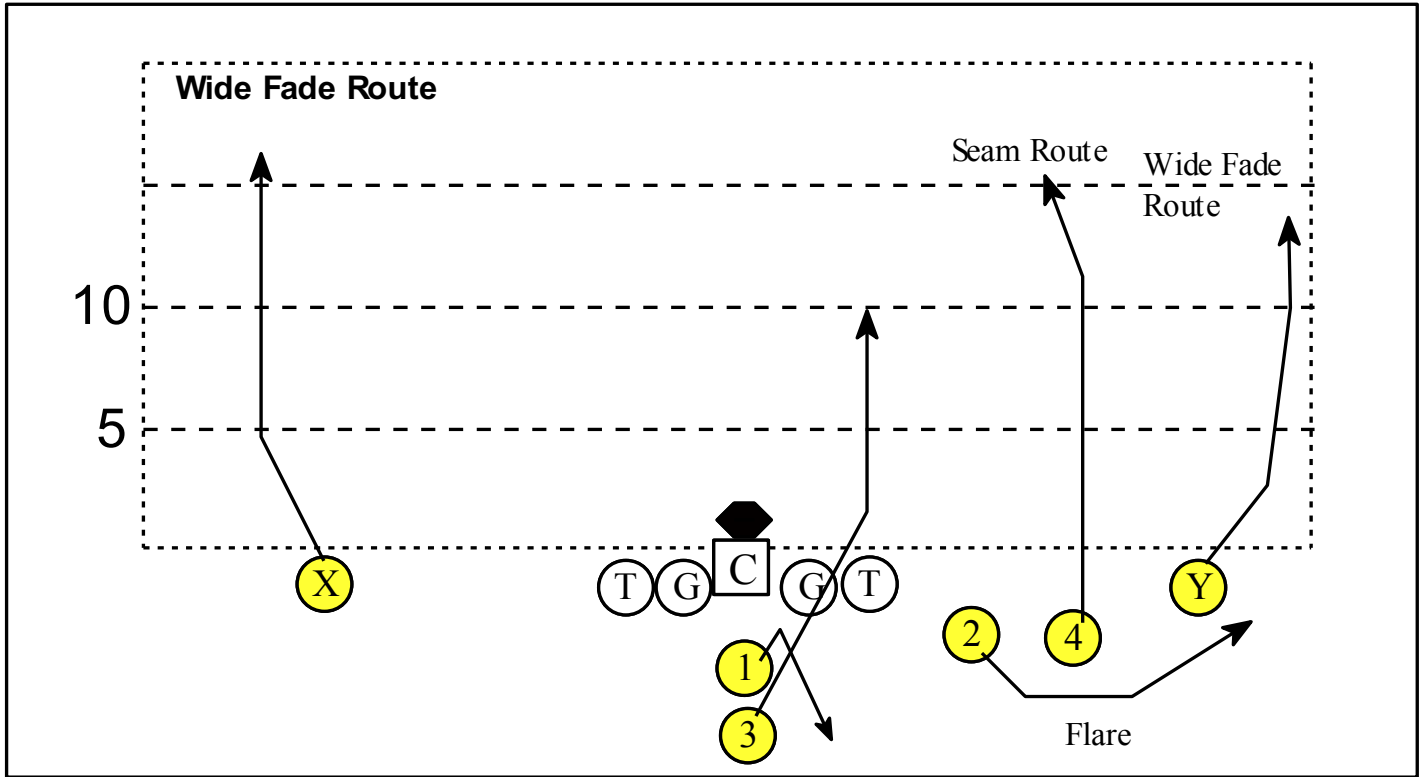

Play: Dorothy Sprint Rt. Wide

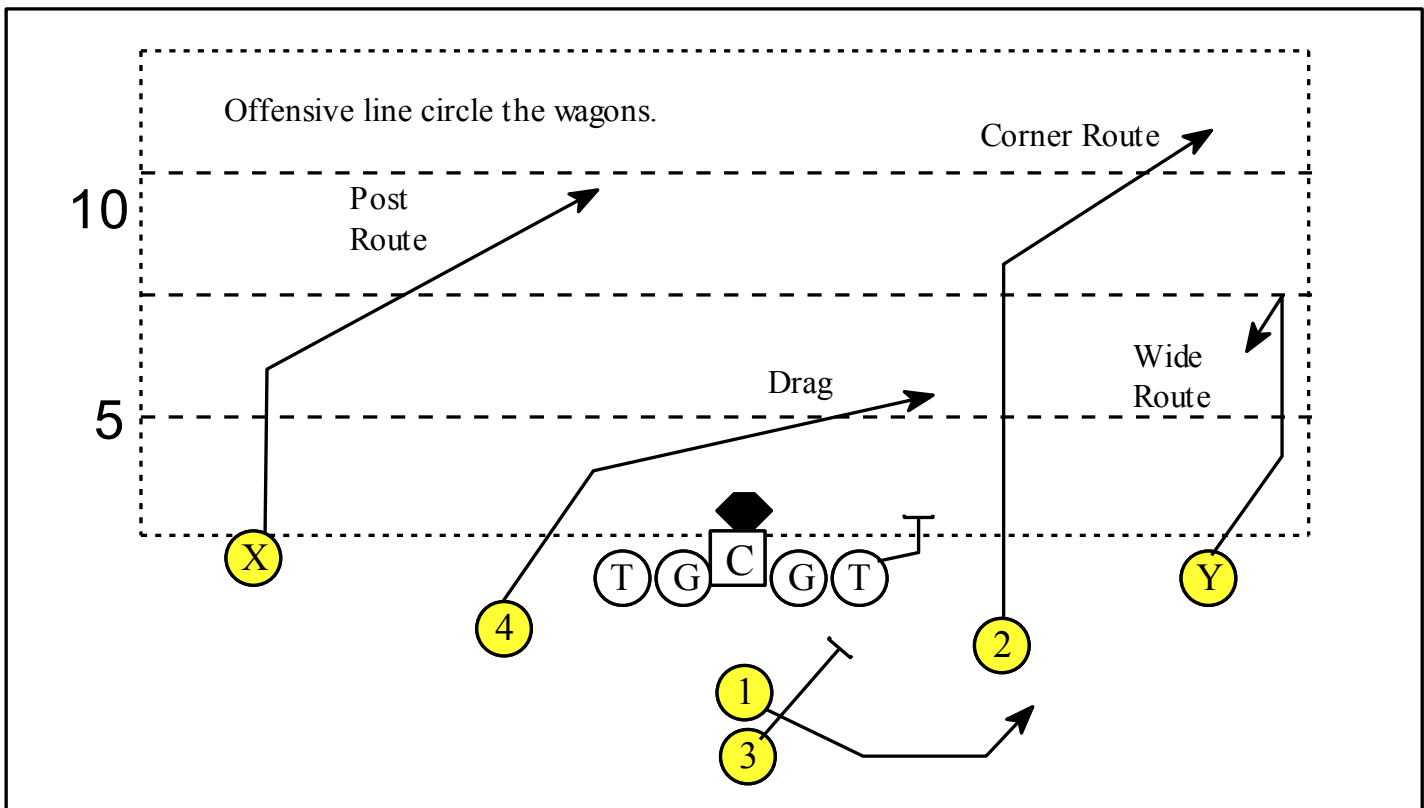

Play: Trailer Veer Pass Rt.

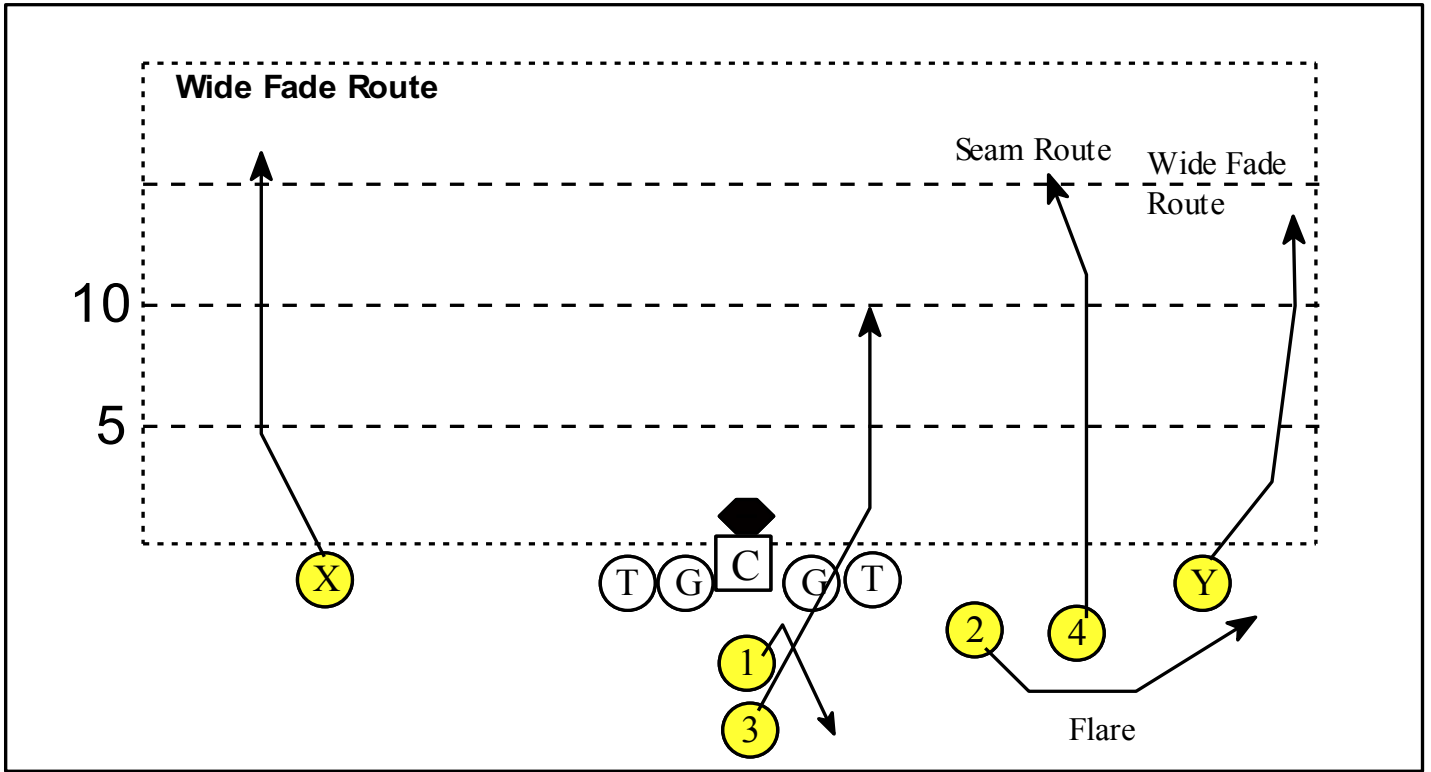

Play: Dorothy Sprint Rt. Wide

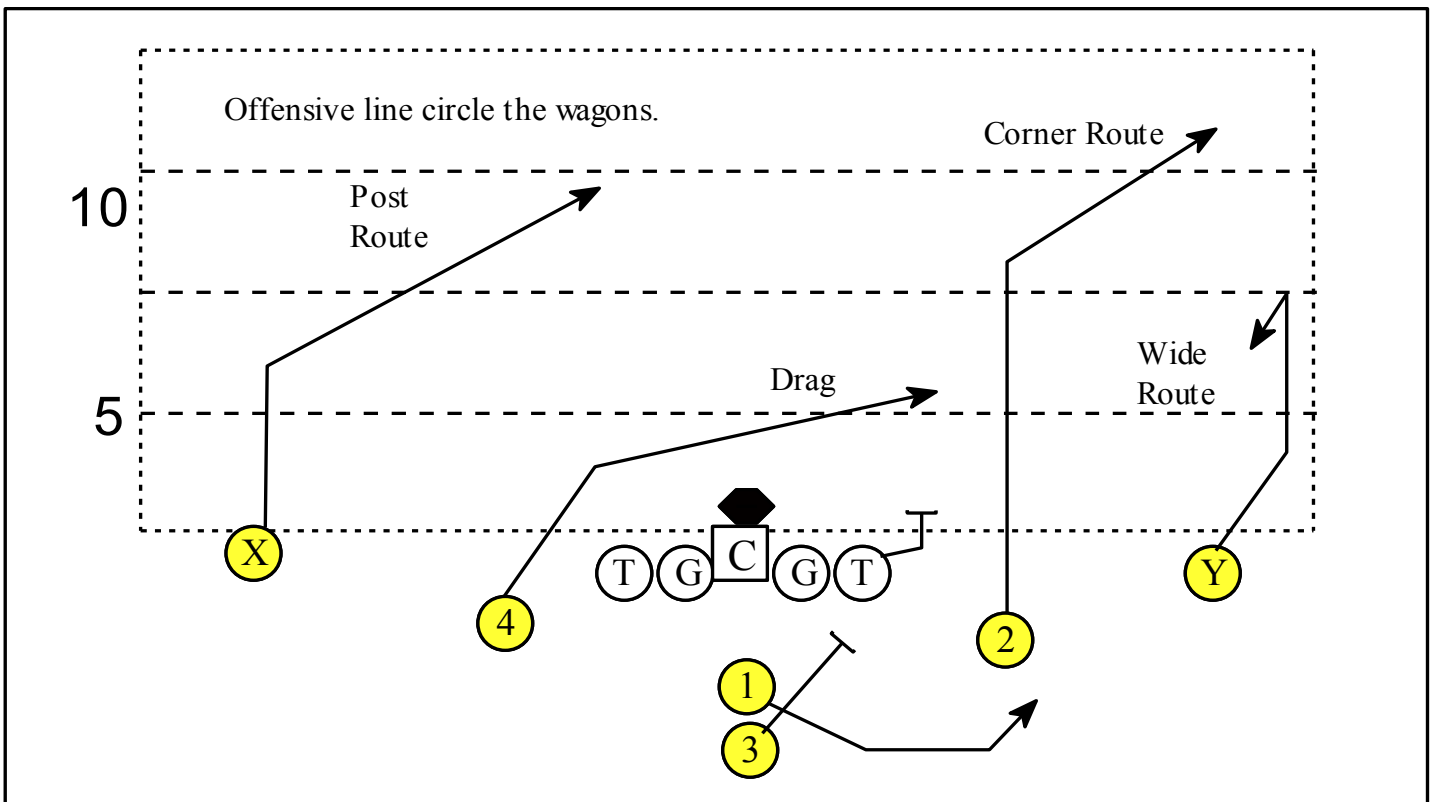

Play: Randy Boot Lt. Cruise

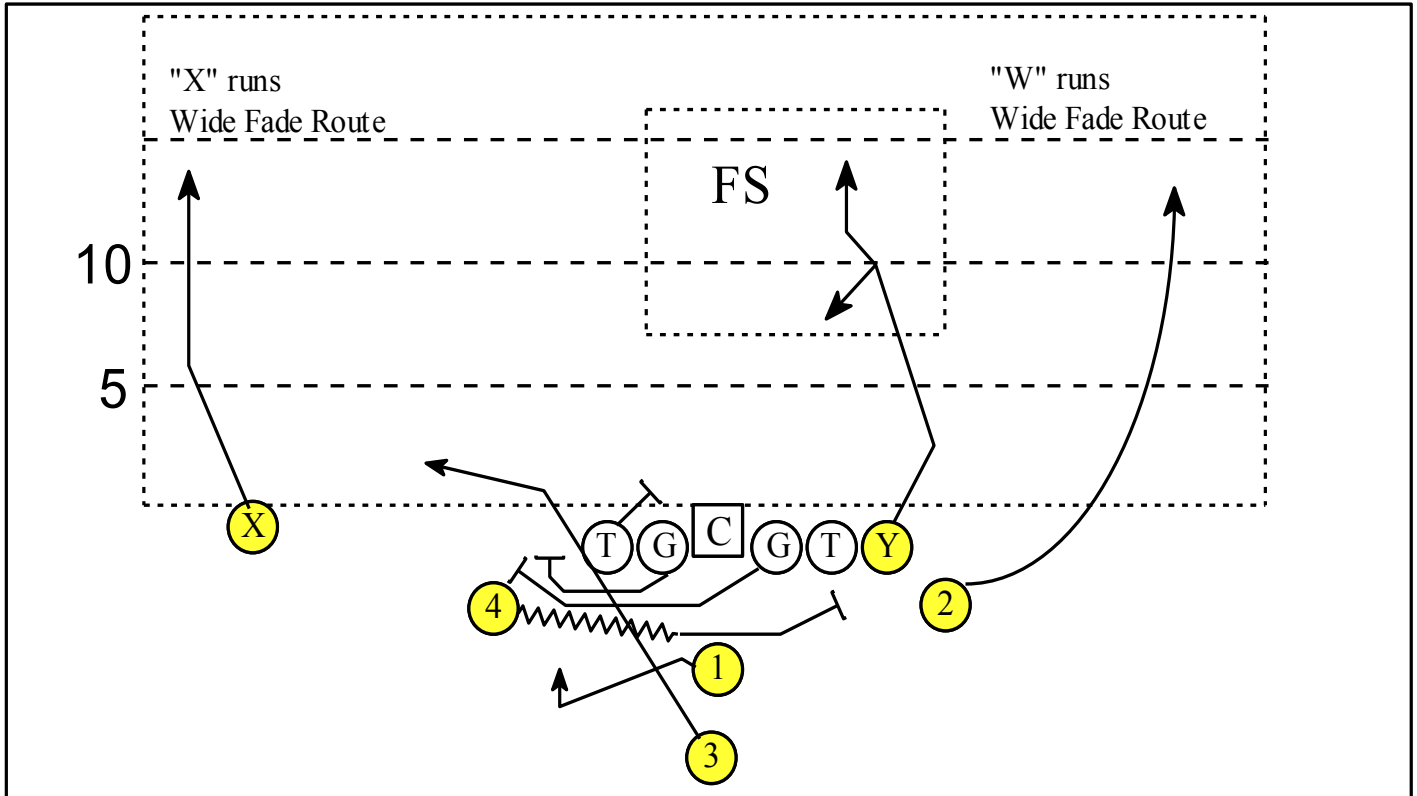

Play: Larry Boot Rt. Cruise

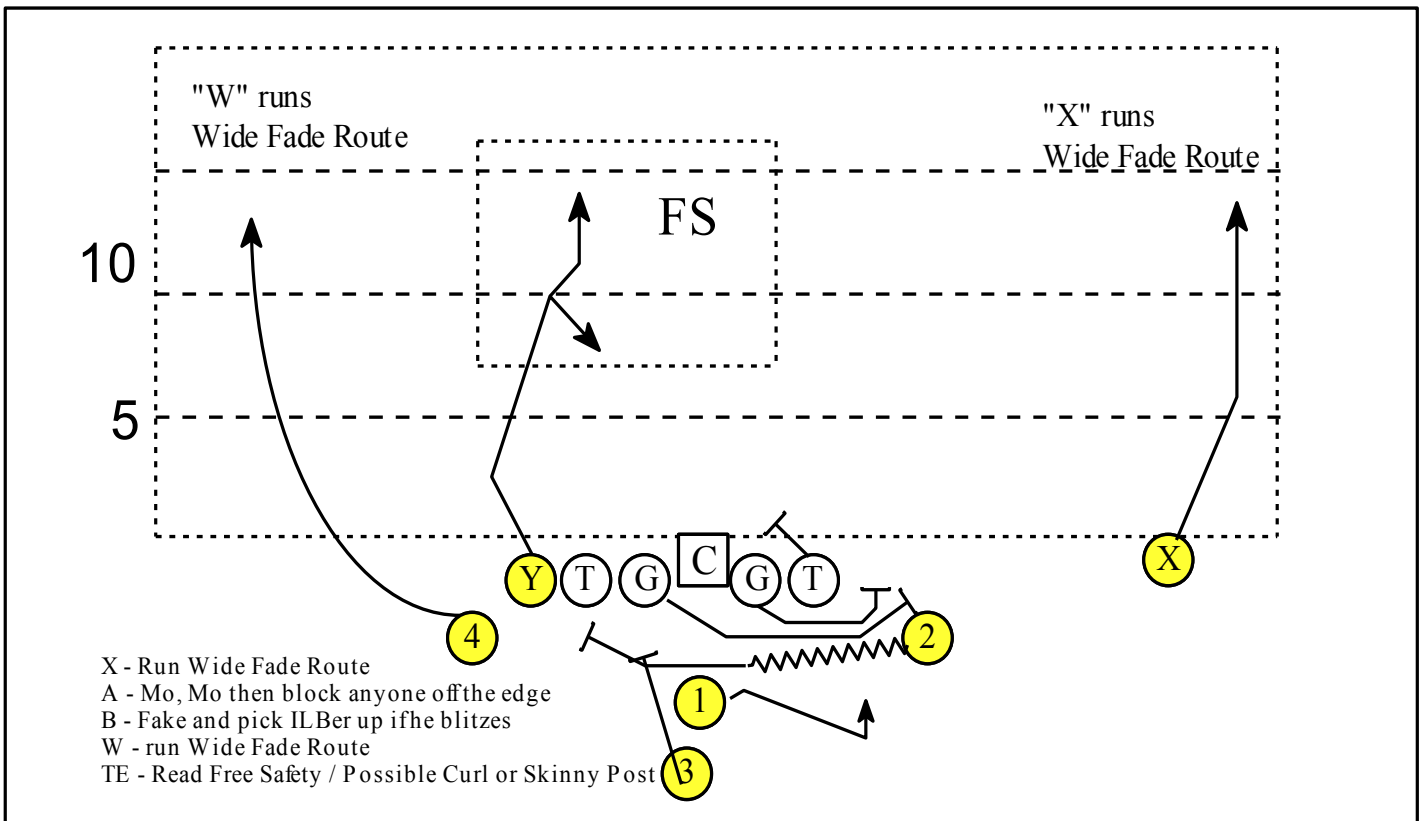

Play: Randy Boot Lt. Cruise Booty

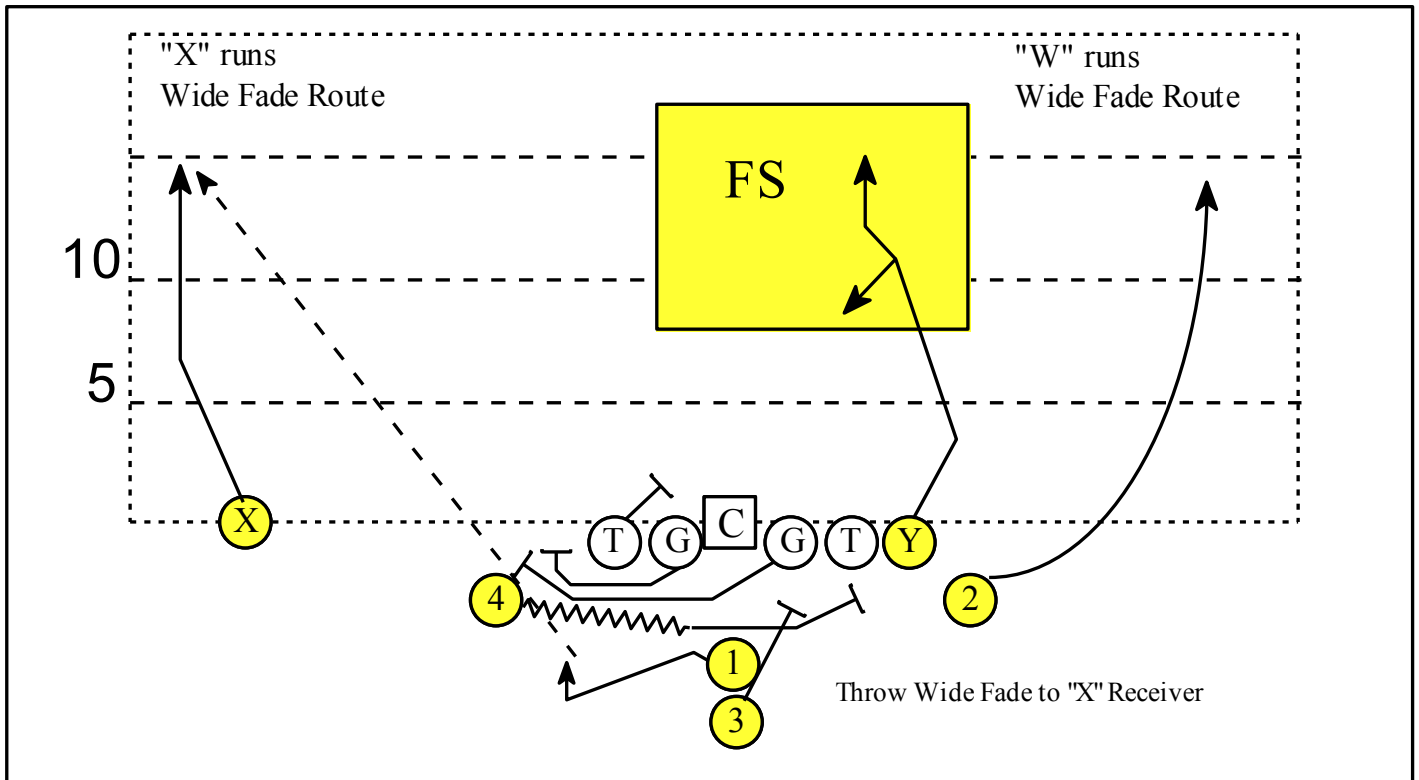

Play: Larry Boot Rt. Cruise Booty

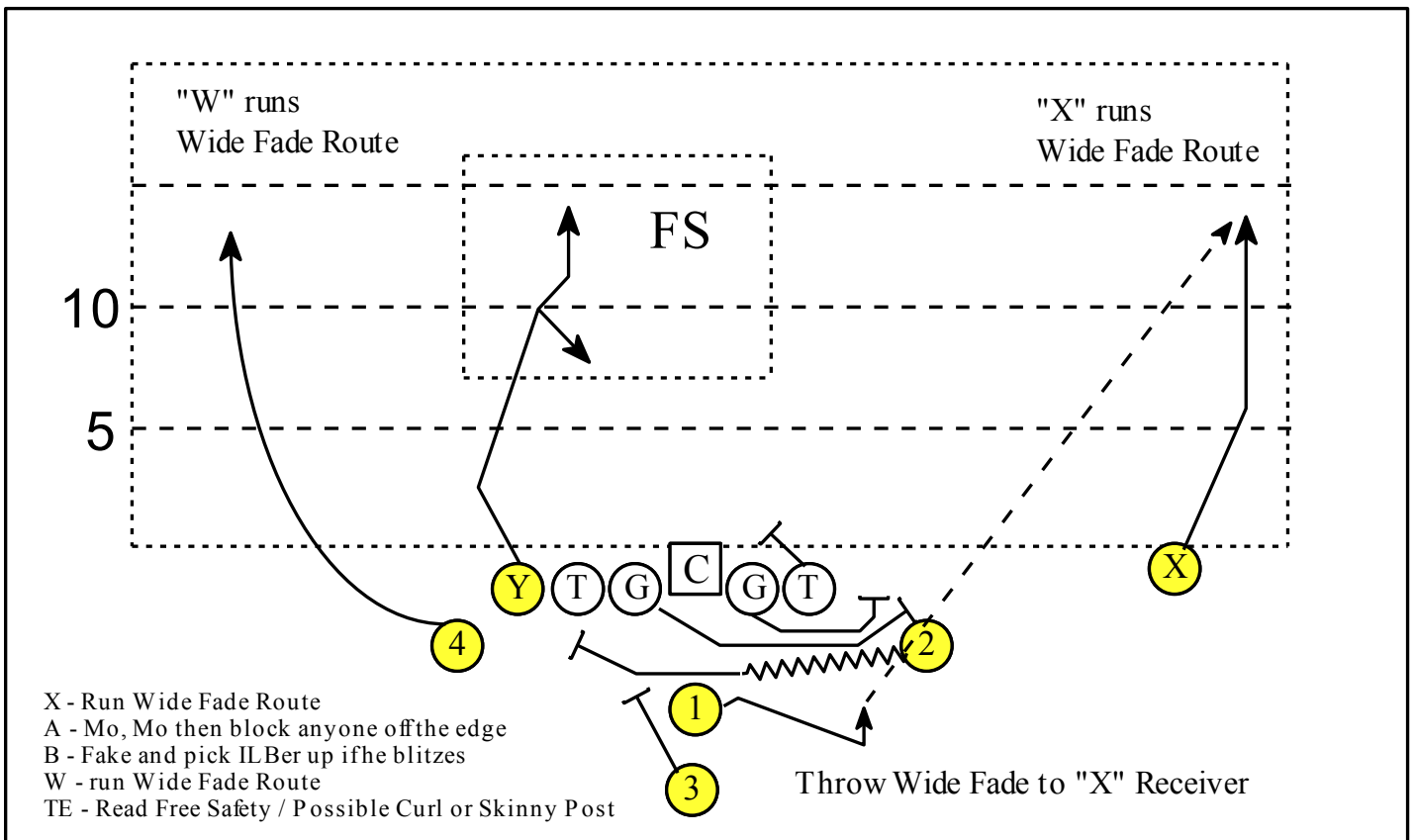

Play: Randy Boot Lt. Corner

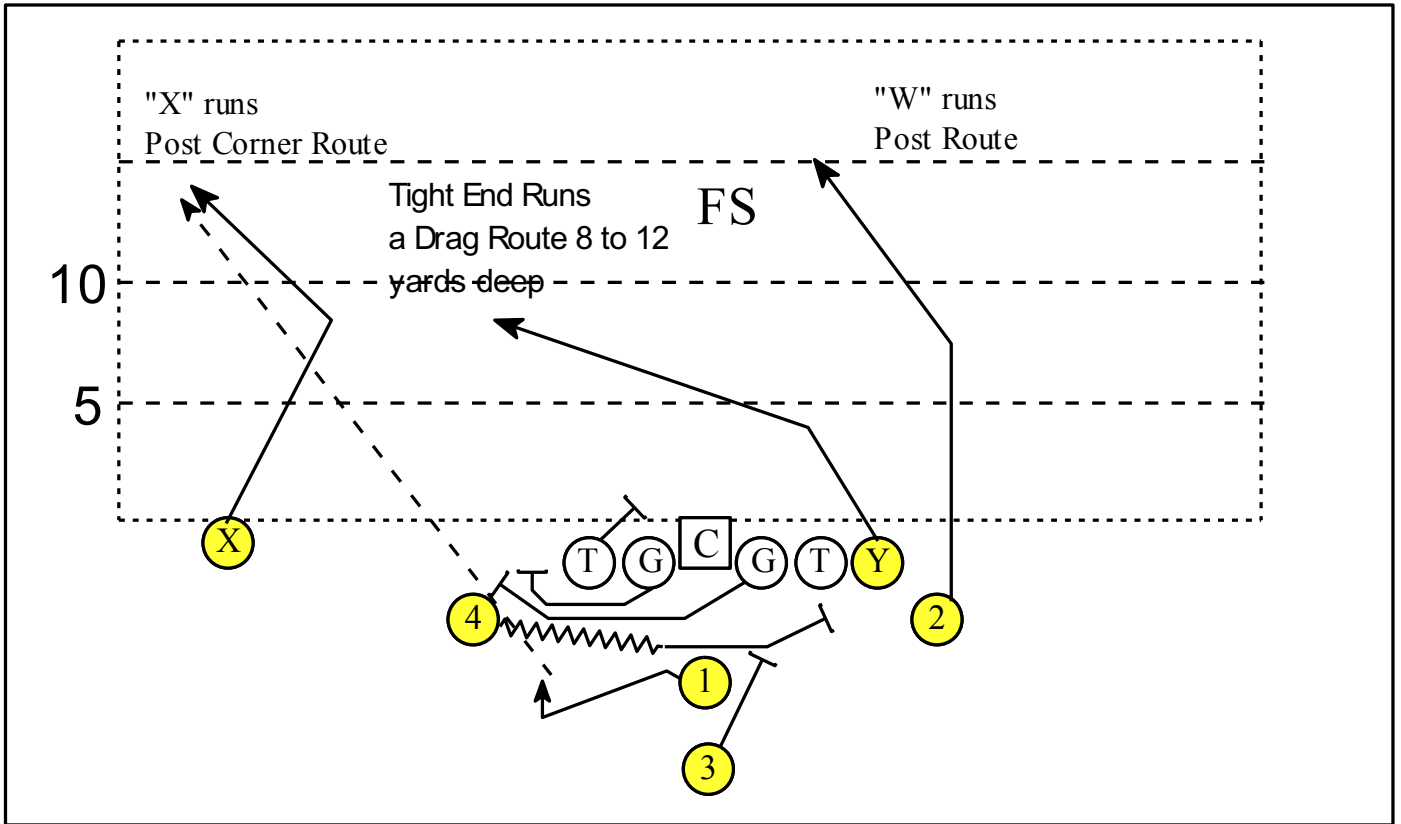

Play: Larry Boot Rt. Corner

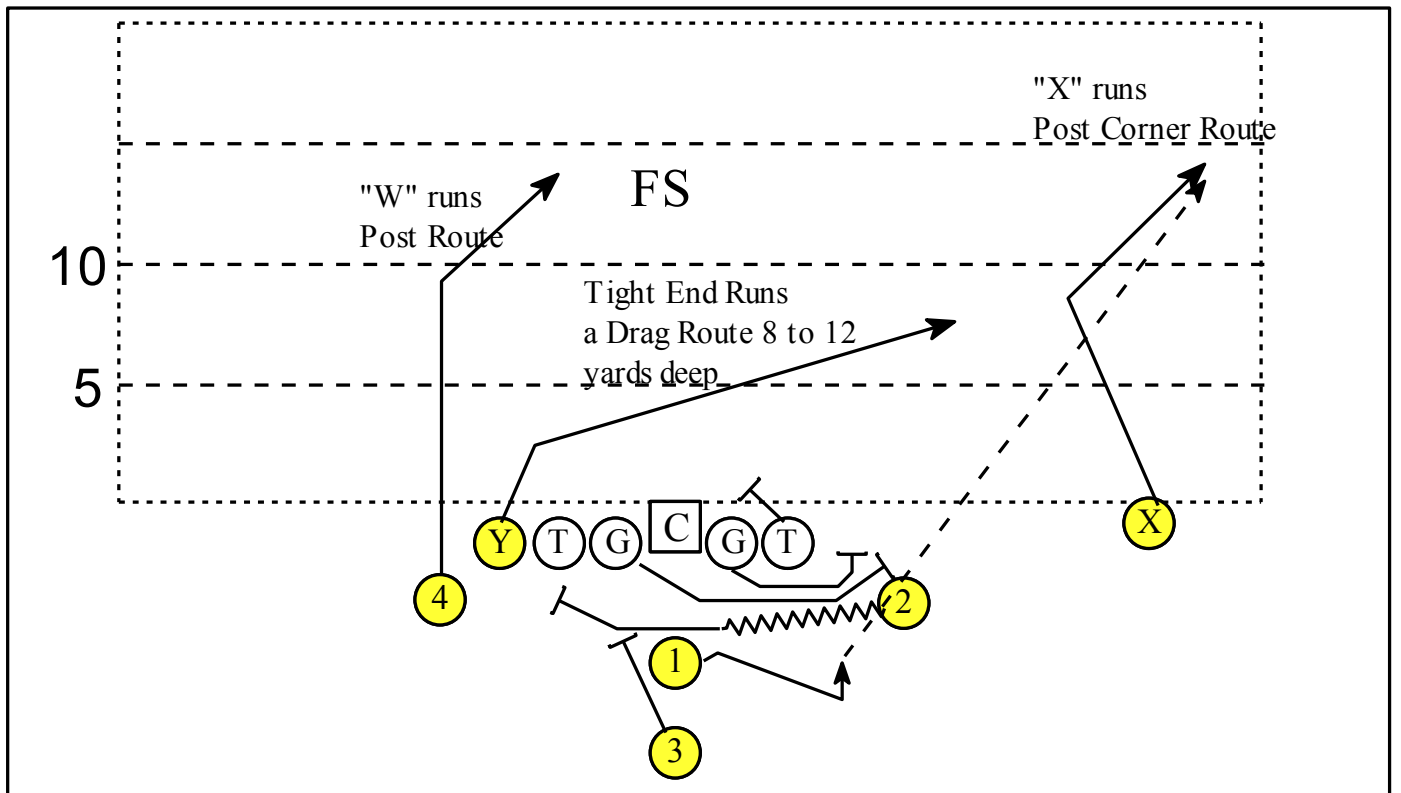

Play: Randy All Go

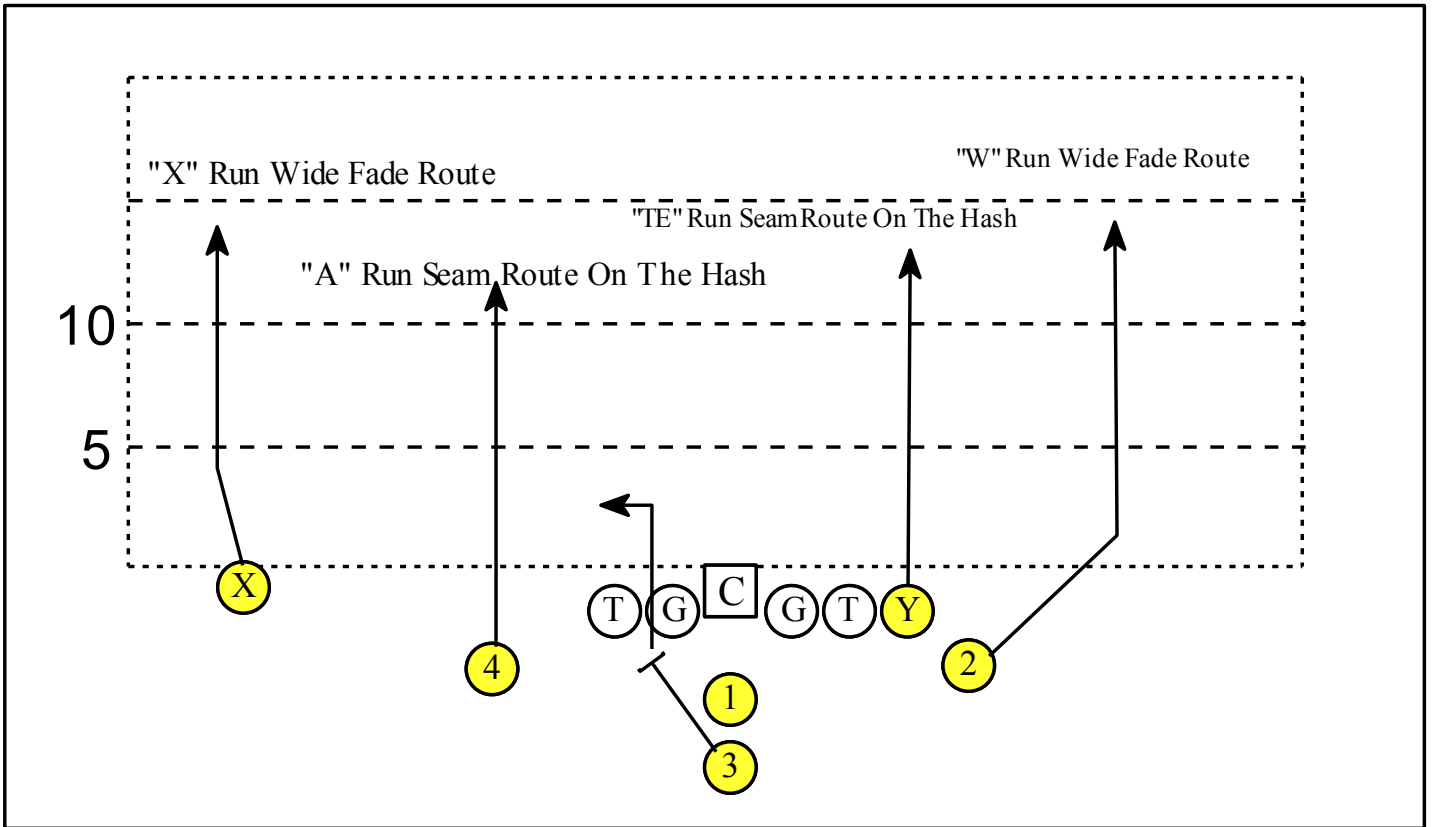

Play: Dallas All Go

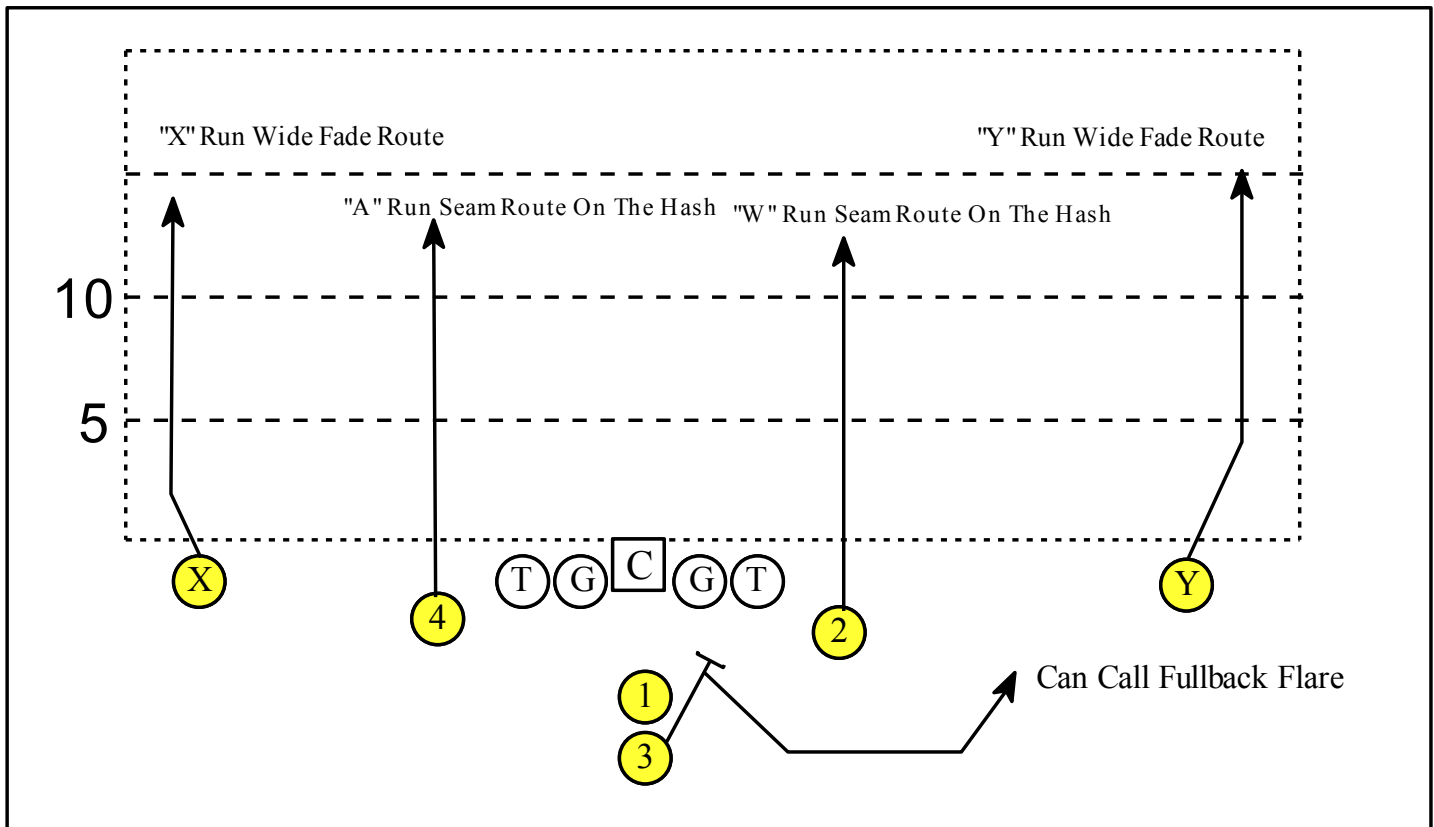

Play: Tractor Sprint Rt. Curl

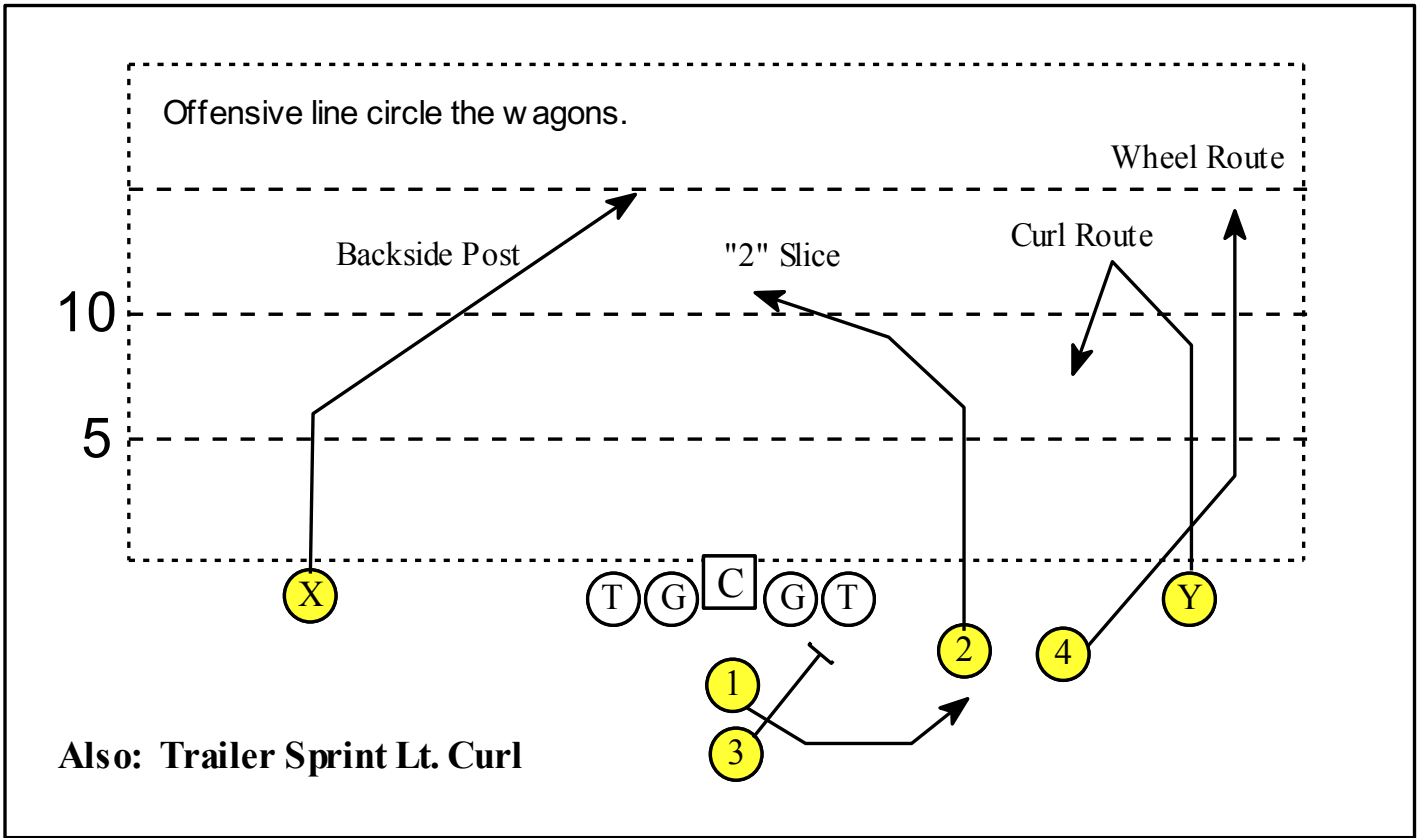

Play: Dorothy Sprint Rt. Curl

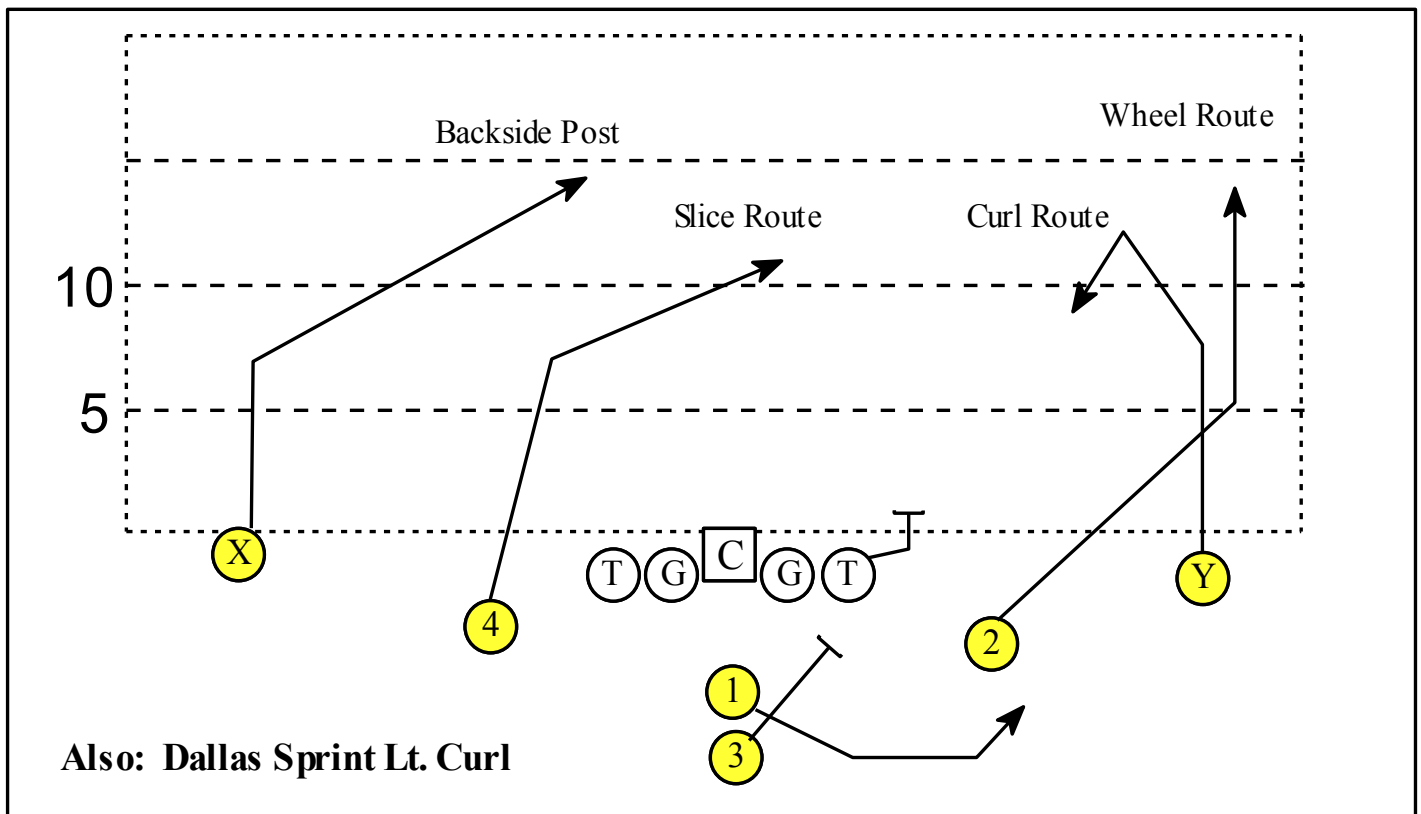

Formation: Randy

Play: 134 & 135 Belly Pass Weak

vs 6-2 Split

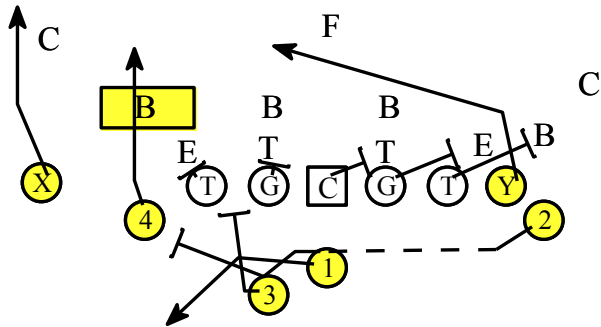

vs 3-3 Stack

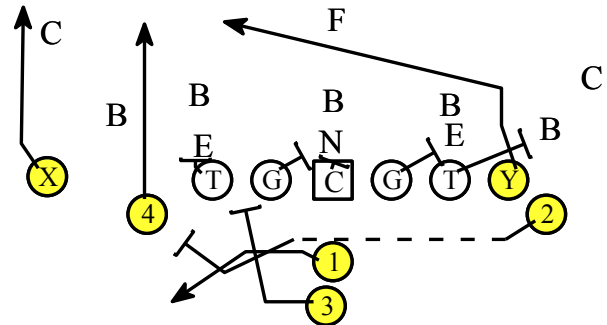

PST - Block BOB

PSG -Block BOB

C - Block BOB

BSG -Block BOB

BST -Block BOB

TE - Track To MLB

"A" - Run Seam Route

BSW - Motion To Option Relationship w/QB Pitch..

FB - Lateral Playside Step, Attack The Hole, Read PSW Block (listen for skull/crusader call).

X - Run Wide Fade

QB - Quick Fake To BSW, Fake HandoffTo FB, Run Option, Read Number One Force-Contain.

vs 5-3 Reg.

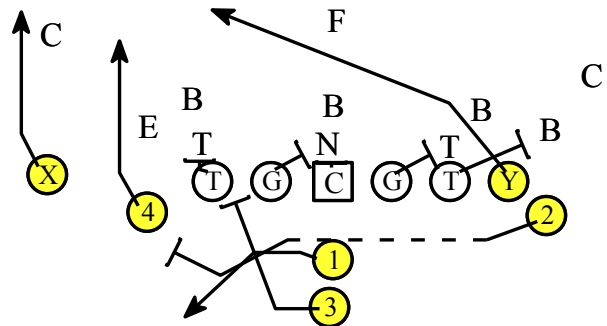

vs DBL Eagle

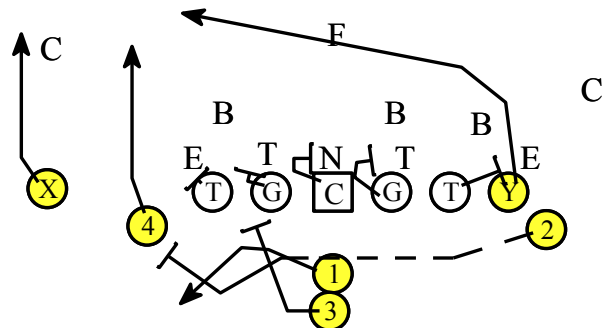

vs 4-4

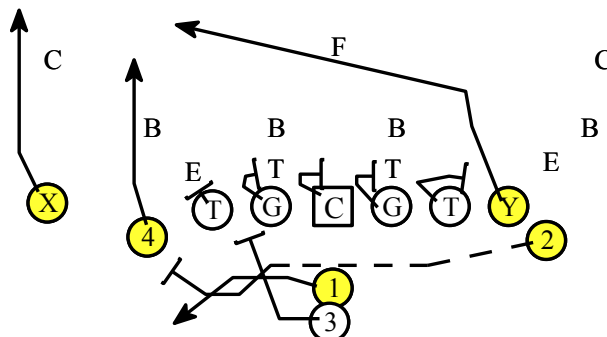

Formation: Randy, Larry

Play: 134 & 135 Belly Pop Pass Strong

vs 6-2 Split

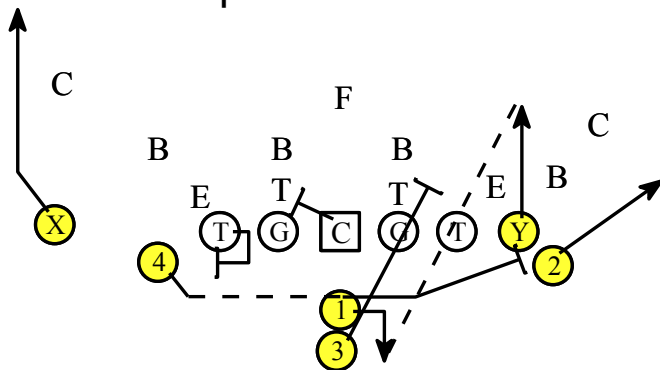

vs 3-3 Stack

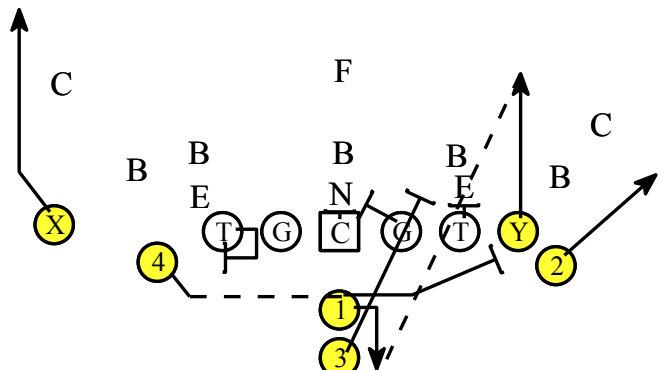

PST - Gap, Down, Backer

PSG - Gap - Down - Backer

C-vs Odd - Front = Double w/PSG, vs Even - Front = Block Backside To Cover for BS pulling Guard

BSG -Pull To Playside, Scrape Paint, you have playside LBer.

BST - Gap, Hinge

TE - Double w/PST On MLB.

PSW - Block Playside OLB

"A" Back - Mo, Mo Receive Ball From QB and Run Underneath Kickout by your Fullback

FB -Attack A-Gap Away, Bend To Frontside A-Gap (unless there is a "long call" - bend wider)

X - Run Wide Fade Route

QB - Open To And Give To the "A" Back, Fake Buck To BSW, Fake Boot.

vs 5-3 Reg.

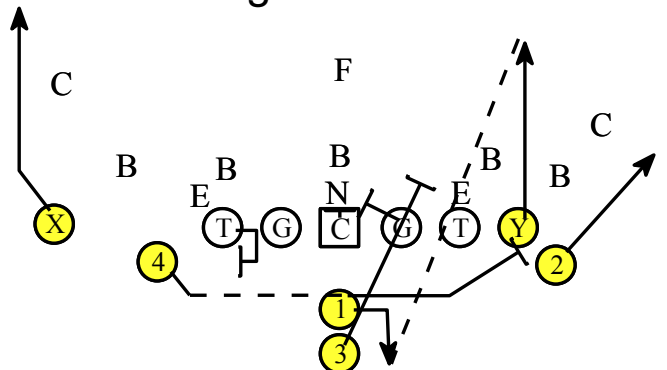

vs DBL Eagle

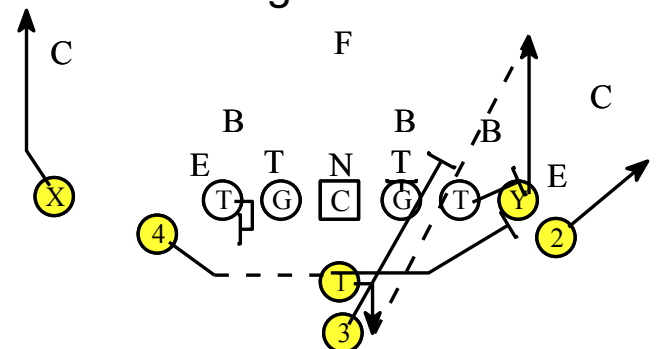

vs 4-4

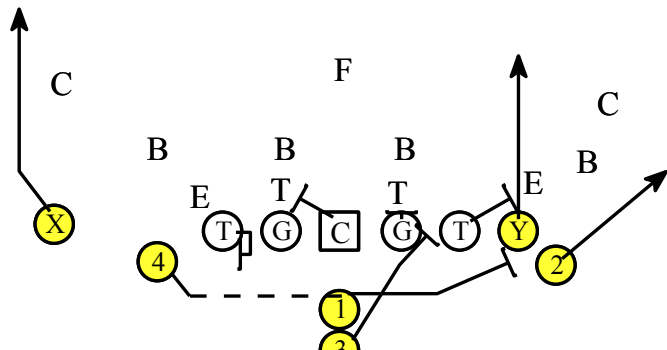

Play: Dallas Sprint Lt. Wide

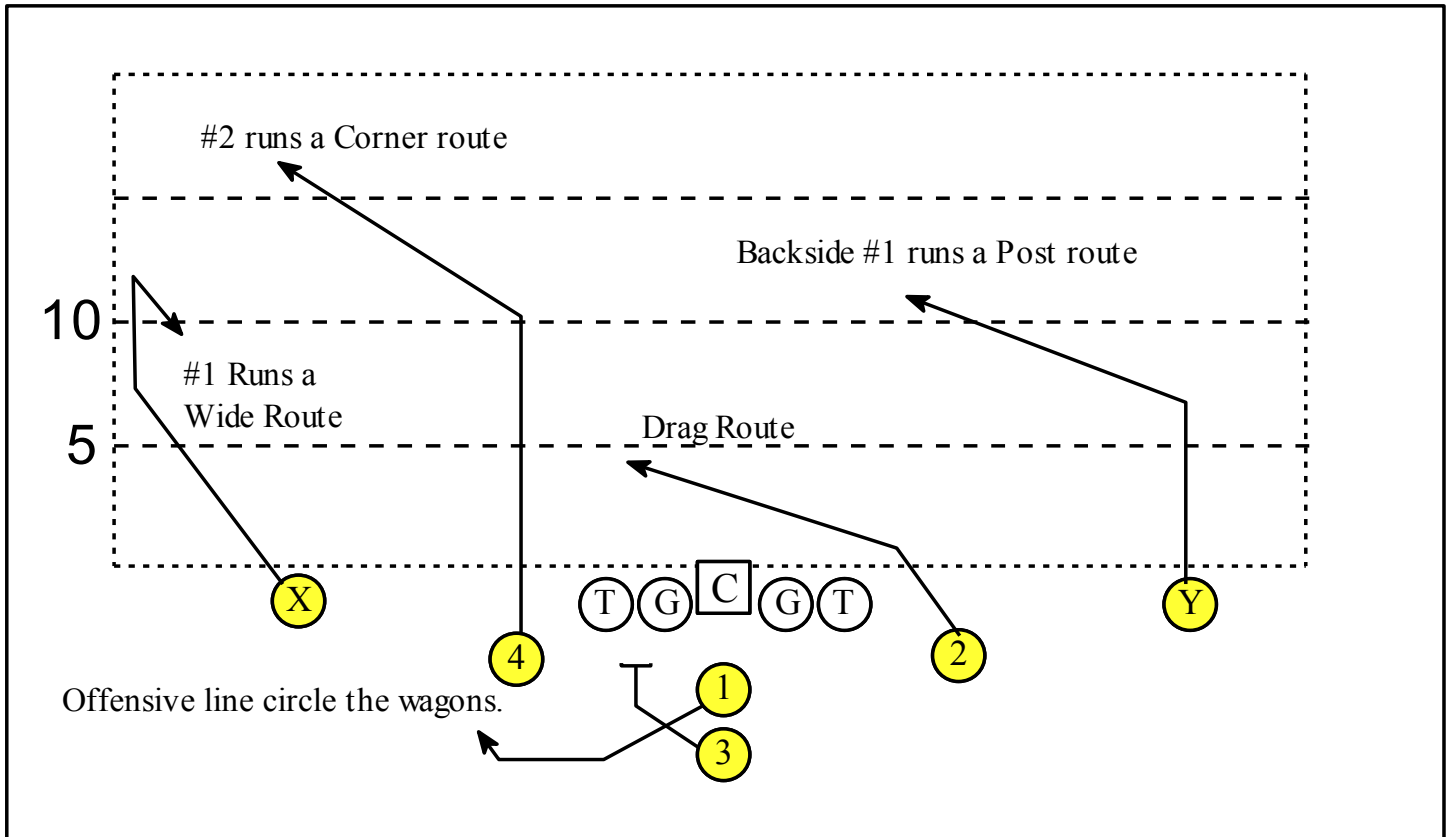

Play: Dorothy Sprint Rt Wide

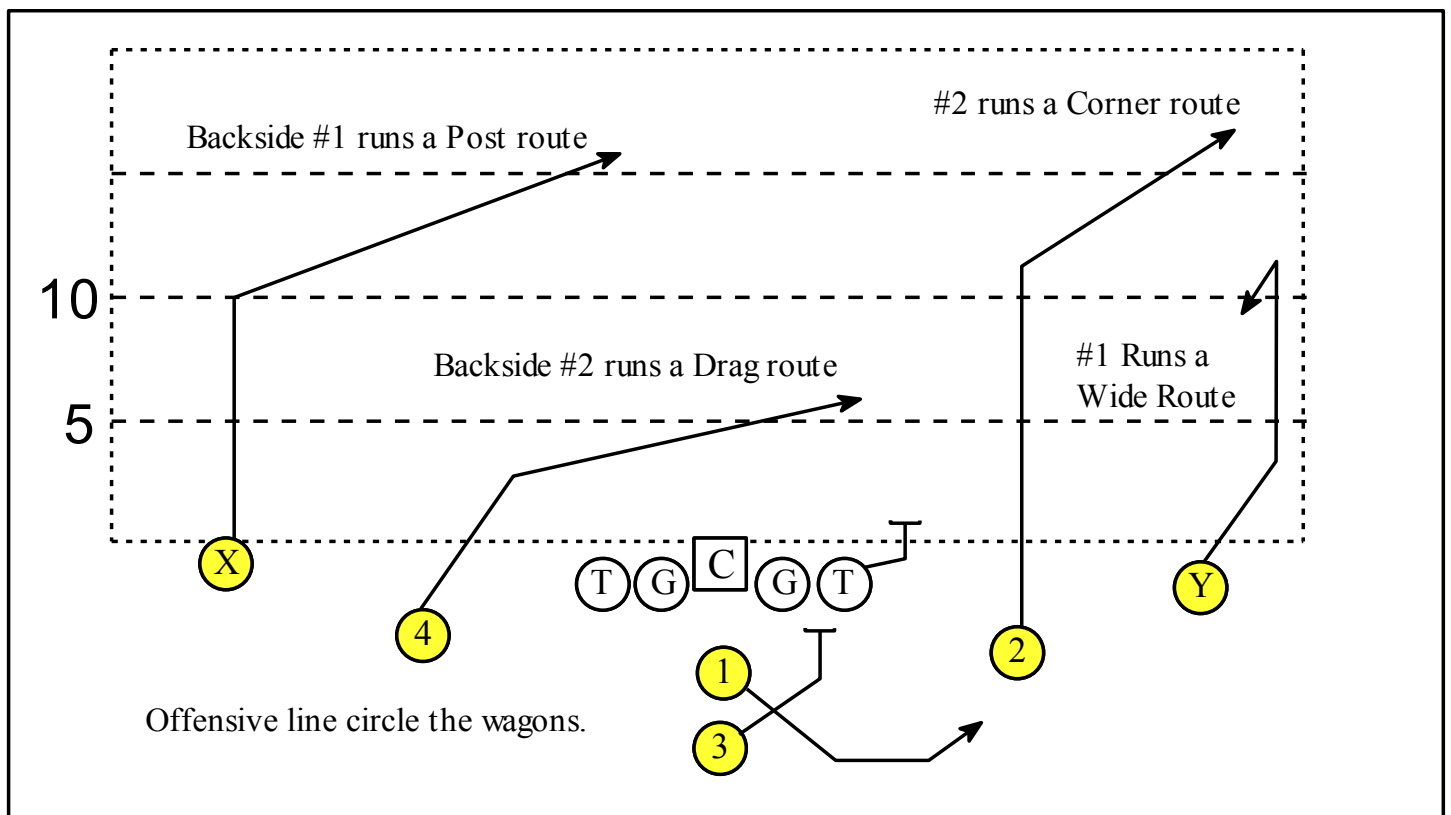

Play: Tractor Sprint Rt. Wide

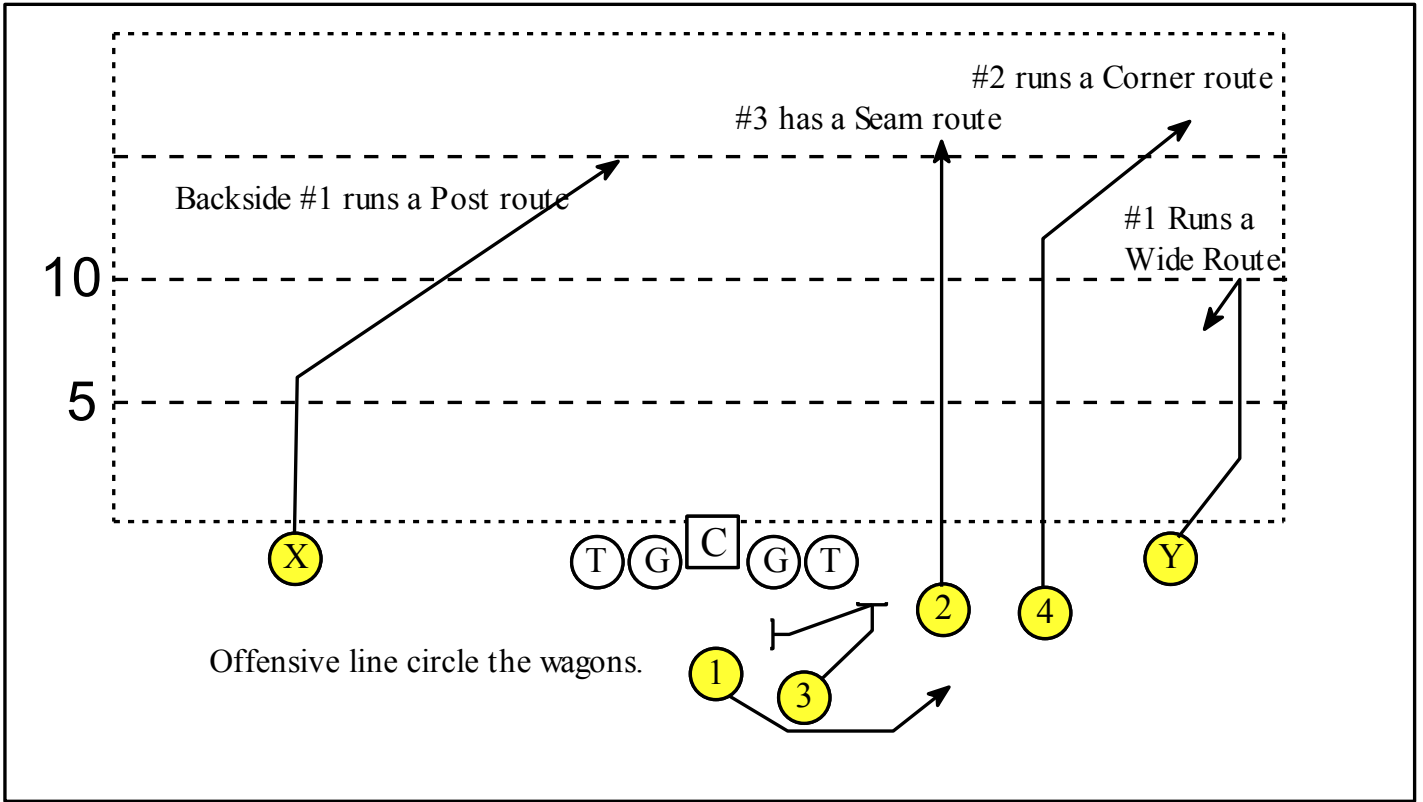

Play: Empty Rt. Sprint Rt. Wide

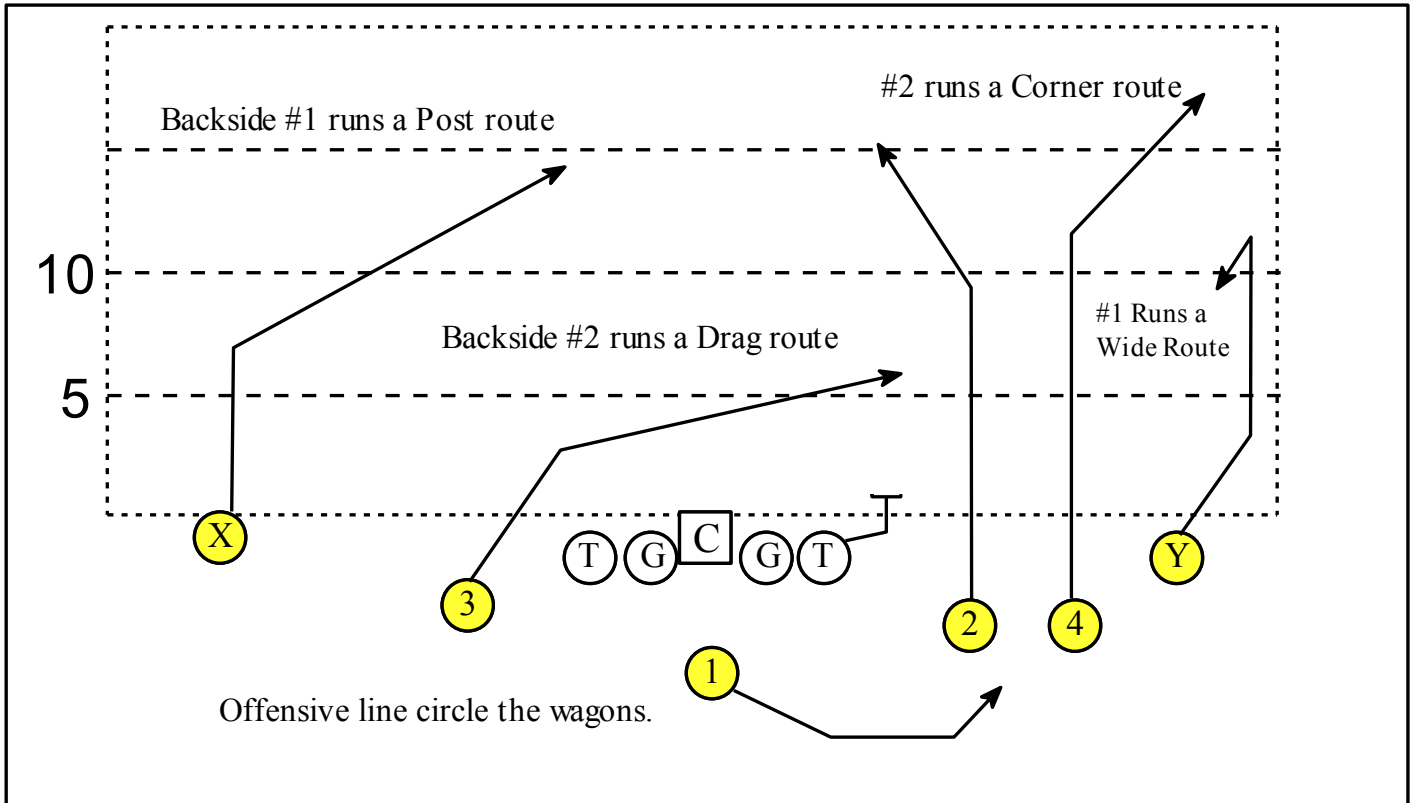

Play: Randy "140" Bubble Lt.

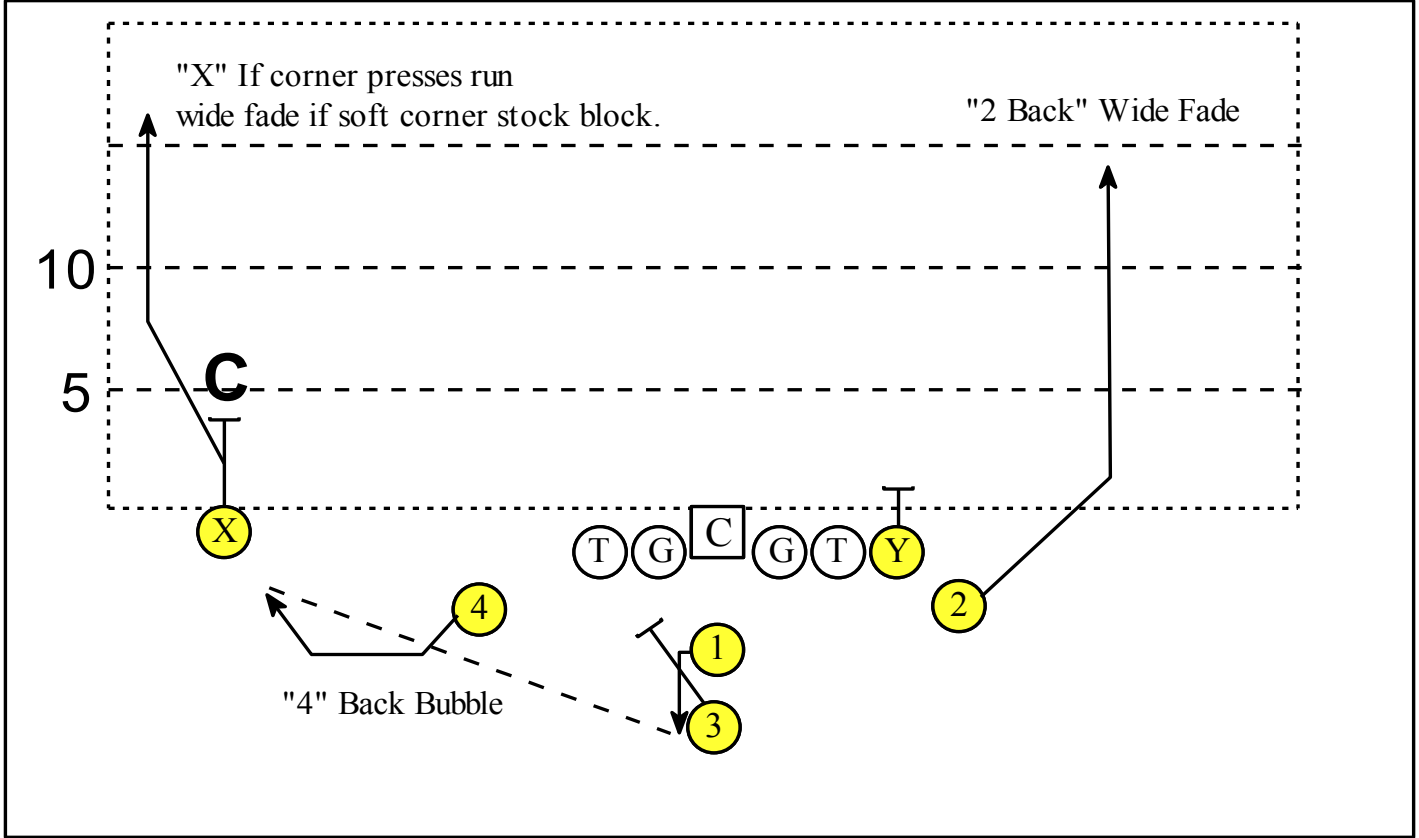

Play: Trailer "120" Bubble

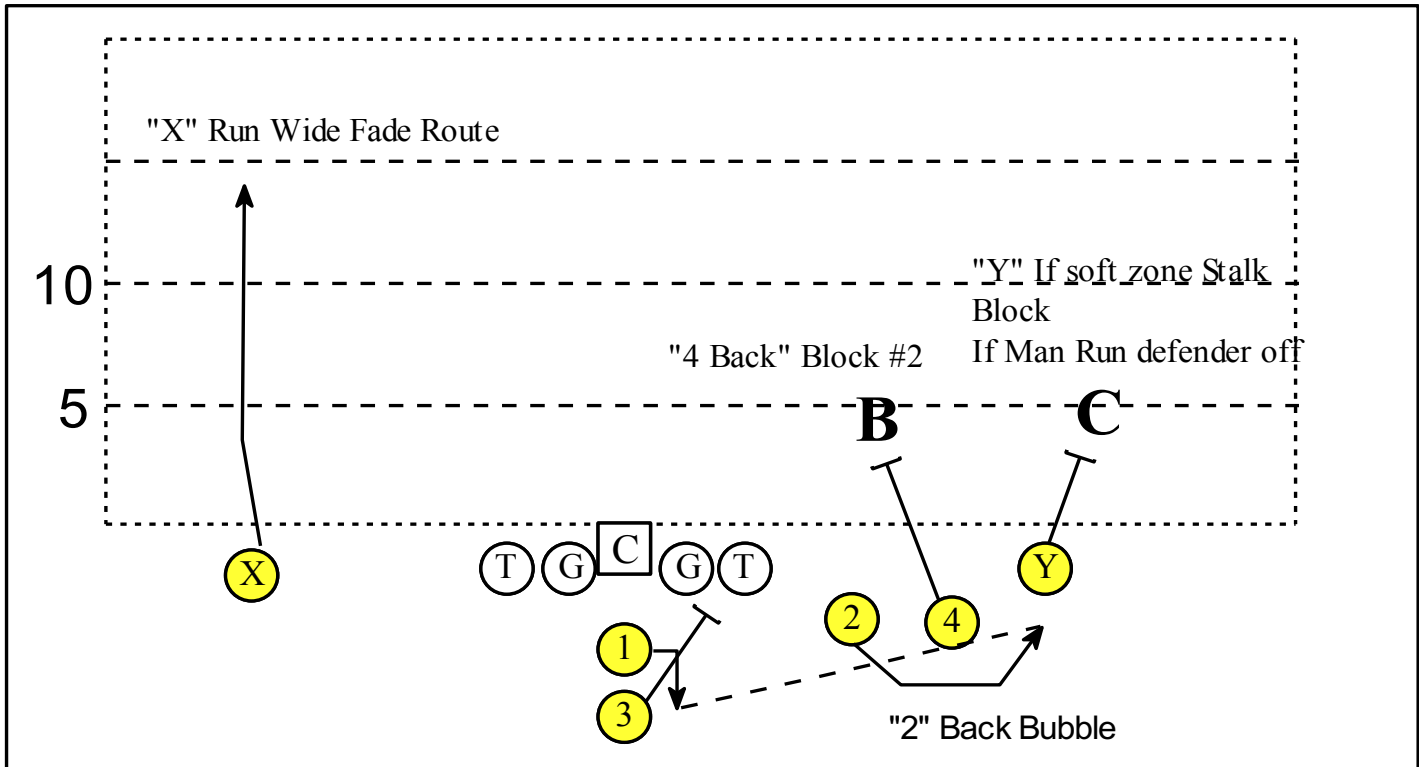

Play: Tractor "120" Bubble SPECIAL

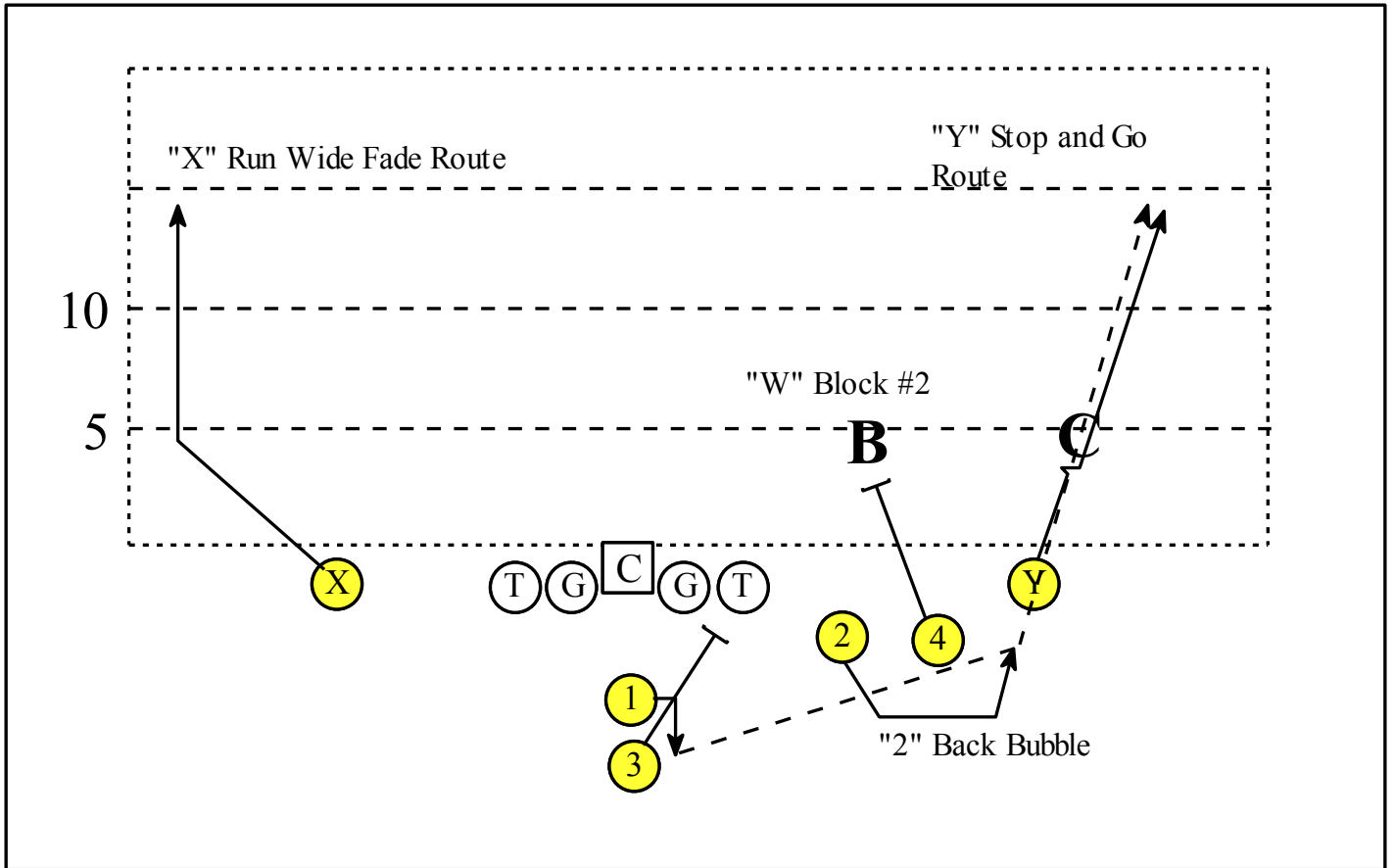

Play: Trailer "120" Slant

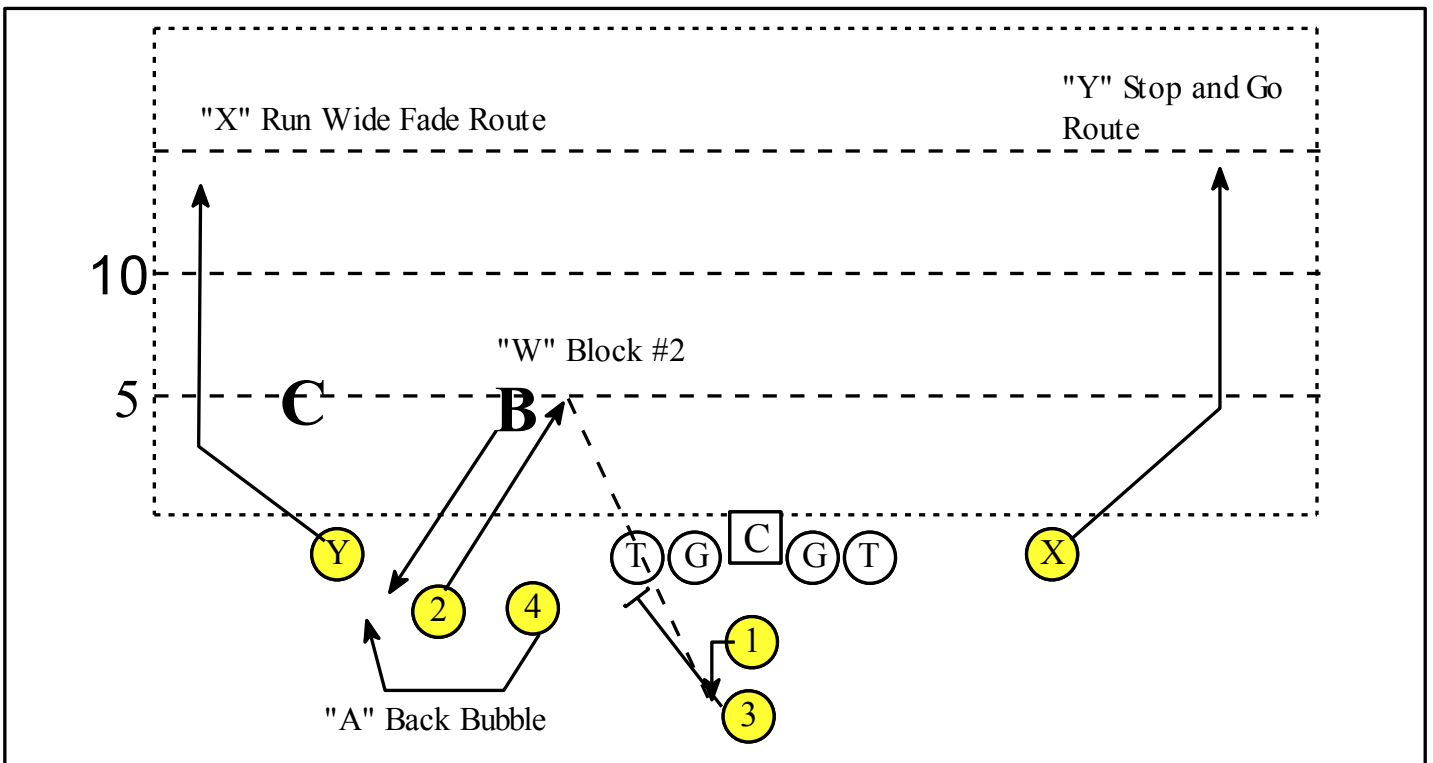

Jet Pop Pass

Apache Odd Maverick Portland

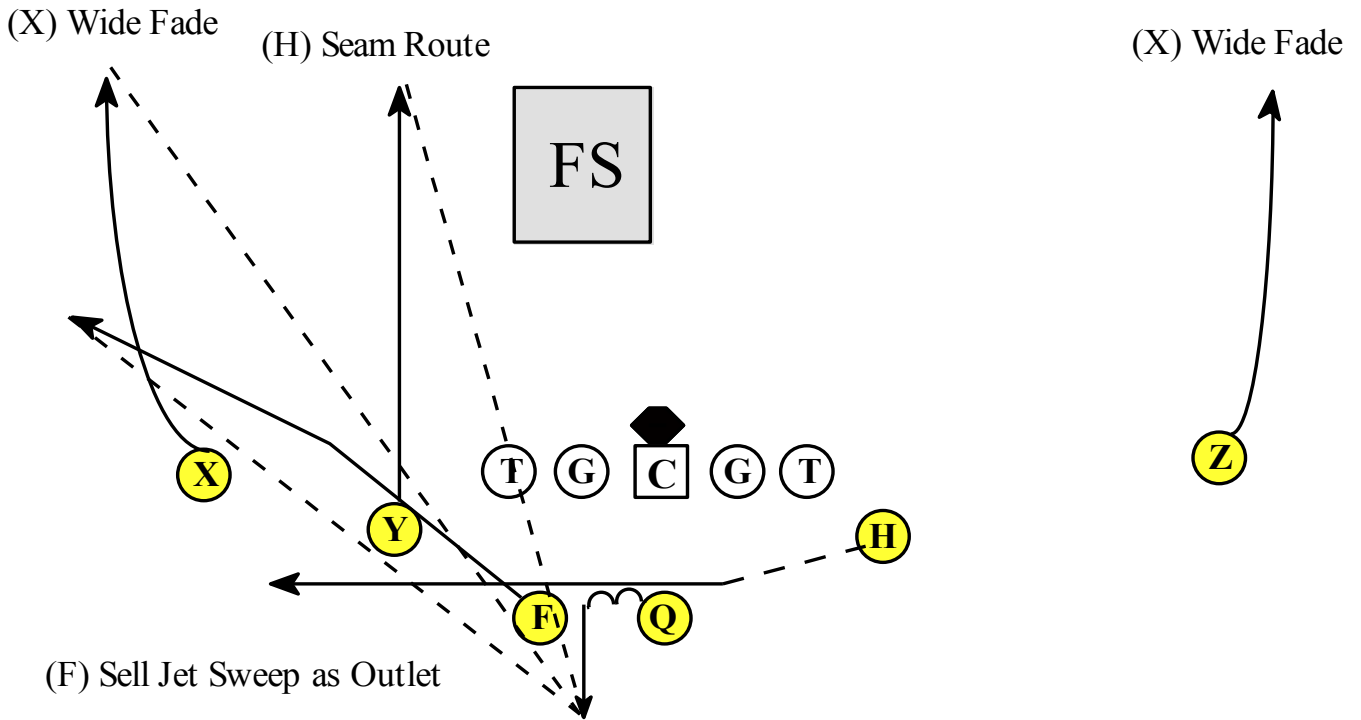

Rip Even Maverick Portland

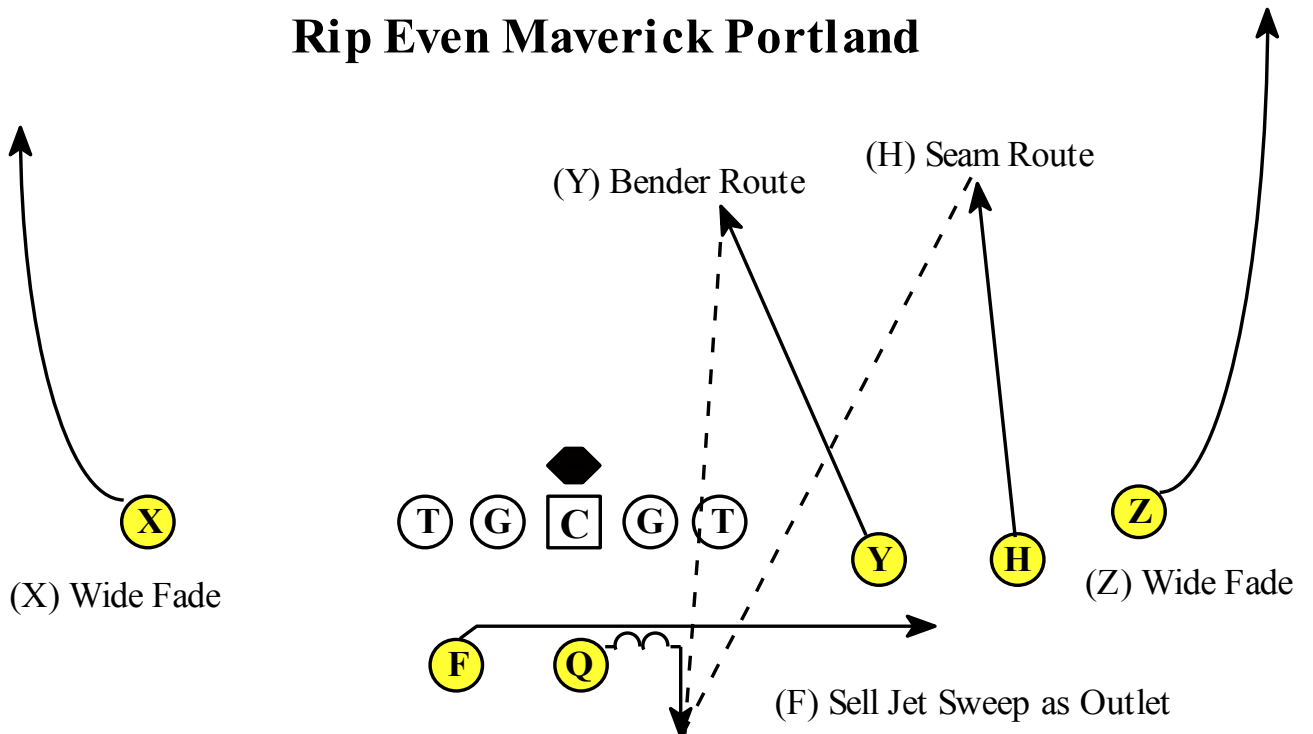

Summary

Summary:

In summary while reading and installing the Hybrid Pistol Wing-T it will allow you to attack an opponent in many different ways. The fast paced approach that you want to install in this offense certainly provides a great advantage controlling the tempo of the game. The mentality that must be instilled into your team is of one that wants to pressure and challenge another team's conditioning and their mental capacity to hang with a fast paced approach.

Remember, you are working off of verbal commands and will not huddle. You will feature the ability to work off of none conventional terminology this facilitates how fast plays can be called. Being able to eliminate verbiage is key.

I've coached at many different levels of play which includes the youth, high school and college levels and as everyone knows many different ways exist to skin a cat; these are just a few adjustments that you may want to use as you develop your passing game philosophy.

Good luck and let's get started installing the Hybrid Pistol Wing-T Offense, if I can ever be of assistance to you or your staff I can be contacted at my e-mail address: midlineopt@aol.com.