

Product Support Files

PROPERTY OF
TECHNICAL REFERENCE

PRODUCT SUPPORT FILES
BLDG
POST

LEVEL

**CHANGE
NOTICE**

THESE ARE SUPERSEDING OR SUPPLEMEN-
TARY PAGES TO SAME PUBLICATION OF
PREVIOUS DATE

Insert these pages into basic publication
Destroy superseded pages

NAVAIR 00-120A-1

**GENERAL
INFORMATION 1**

**SPARROW III
AIM-7C,D,E,F 2**

**BULLPUP
AGM-12B 3**

**BULLPUP
AGM-12C 4**

**SIDEWINDER
AIM-9C,D 5**

**MISSILE TARGET
AQM-37A 6**

**PHOENIX
AIM-54A 7**

**SHRIKE
AGM-45A 8**

**CONDOR
AGM-53A 9**

**STANDARD ARM
AGM-78A 10**

HANDBOOK NAVAL AIR LAUNCHED GUIDED MISSILES (U)

This publication shall not be carried in aircraft on combat missions or when there is a reasonable chance of its falling into the hands of an unfriendly nation unless specifically authorized by the "Operational Commander."

PUBLISHED BY DIRECTION OF
THE COMMANDER OF THE NAVAL AIR SYSTEMS COMMAND

15 October 1967
CHANGE 15 AUGUST 1971

TABLE OF ABBREVIATIONS

AC	- ALTERNATING CURRENT
AGM	- AIR, SURFACE ATTACK, GUIDED MISSILE
AIM	- AIR, INTERCEPT-AERIAL, GUIDED MISSILE
AL	- ALUMINUM
AMR	- ADVANCE MATERIAL REQUEST
APPROX	- APPROXIMATE
AQM	- AIR LAUNCHED DRONE, GUIDED MISSILE
CAP	- CAPACITY
CFM	- CUBIC FEET PER MINUTE
CG	- CENTER OF GRAVITY
COMP	- COMPOSITION
CPS	- CYCLES PER SECOND
CVA	- ATTACK AIRCRAFT CARRIER
DC	- DIRECT CURRENT
ECH	- ELECTRONIC COUNTER MEASURES
ELECT	- ELECTRIC, ELECTRICAL
G & C	- GUIDANCE AND CONTROL
GR	- GEAR
HP	- HORSEPOWER
HV	- HIGH VOLTAGE
IR	- INFRARED
IRR	- IMPROVED REARMING RATES
LIQ	- LIQUID
MDI	- MISS DISTANCE INDICATOR
MGT	- MOUNTING
PRESS	- PRESSURE
PSI (G)	- POUNDS PER SQUARE INCH (GAGE)
RF	- RADIO FREQUENCY
RPM	- REVOLUTIONS PER MINUTE
S-A	- SAFETY ARMING
SECT	- SECTION
SPEC	- SPECIFICATION
STA	- STATION
TDD	- TARGET DETECTING DEVICE
TEMP	- TEMPERATURE
TMD	- TARGET MARKING DEVICE
VA	- VOLT AMPERE
WP	- WHITE PHOSPHORUS

TABLE OF CONTENTS

INTRODUCTION	i
TABLE OF ABBREVIATIONS	iii

SECTION 1 GENERAL INFORMATION

COMPARISON OF OVERALL DIMENSIONS	
SHEET 1 OF 2	1-1
SHEET 2 OF 2	1-2
COMPARISON OF COMPONENTS	
SHEET 1 OF 2	1-3
SHEET 2 OF 2	1-4

SECTION 2 SPARROW III AIM-7C/D/E/F GUIDED MISSILES

ASSEMBLED MISSILE & MAJOR COMPONENTS

GENERAL ARRANGEMENT - AIM-7C PHASE "A" ANTENNA	2-1
CHART - MISSILE COMPONENTS, AIM-7C PHASE "A" ANTENNA	2-2
GENERAL ARRANGEMENT - AIM-7C PHASE "C" ANTENNA	2-3
CHART - MISSILE COMPONENTS, AIM-7C PHASE "C" ANTENNA	2-4
GENERAL ARRANGEMENT - AIM-7D PHASE "C" ANTENNA	2-5
CHART - MISSILE COMPONENTS, AIM-7D PHASE "C" ANTENNA	2-6
GENERAL ARRANGEMENT - AIM-7E PHASE "C" ANTENNA	2-7
CHART - MISSILE COMPONENTS, AIM-7E PHASE "C" ANTENNA	2-8
GENERAL ARRANGEMENT - XAIM-7F	2-9
HARD SPOT LOCATIONS - PHASE "A" AND "C" ANTENNAS	2-10
{BLANK}	2-11
{BLANK}	2-12
CHART - MISSILE COMPONENT INTERCHANGEABILITY	2-13
GUIDANCE AND CONTROL SECTION	2-14
WARHEADS MK 11, 18 & 38 MODS 0	2-15
MOTOR SECTION MK 6 MOD 3 - PHASE "A" ANTENNA	2-16
MOTOR SECTION MK 6 MOD 3 & MK 38 MOD 0 - PHASE "C" ANTENNAS	2-17
FORWARD FIN	2-18
AFT FIN	2-19
PHASE "A" ANTENNA TUNNEL, REAR ANTENNA AND BAND	2-20
PHASE "C" ANTENNA WAVEGUIDE	2-21
FLASH SIGNAL MK 37 MOD 0	2-22
IGNITER ASSEMBLY MK 258 MOD 0	2-23
IGNITER ASSEMBLY MK 265 MOD 0	2-24

CONTAINERIZATION

CHART - SHIPPING CONTAINERS	2-25
GUIDANCE AND CONTROL CONTAINER	2-26
FIN CONTAINER	2-27
WARHEAD CONTAINER MK 224 MOD 0	2-28
MOTOR CONTAINER	2-29
IGNITER CONTAINER (MK 258 IGNITER)	2-30
PHASE "A" ANTENNA CONTAINER	2-31
PHASE "C" ANTENNA CONTAINER	2-32
GUIDED MISSILE CRADLE MK 12 MOD 0	2-33
GUIDED MISSILE CONTAINER MK 438 MOD 0	2-34
STORAGE CONTAINER CHU-166/E	2-34A

FLEET ISSUE UNIT LOADS

CHART - FLEET ISSUE UNIT LOADS	2-35
UNIT LOAD WR-54/107A; G & C GROUPS	2-36
UNIT LOAD WR-54/108A MOTOR SECTIONS	2-37
UNIT LOAD MK 78 MOD 0 (WR-54/109); WARHEADS	2-38
UNIT LOAD WR-54/171; AIM-7D/E/F SPARROWS	2-38A
UNIT LOAD WR-54/176; AIM-7D/E WINGS & FIRS	2-38B

HANDLING EQUIPMENT & TOOLS

TABLE - HANDLING EQUIPMENT AND TOOLS	
SHEET 1 OF 2	2-39
SHEET 2 OF 2	2-40

MISSILE TEST EQUIPMENT

CHART - MISSILE TEST EQUIPMENT AN/DPM-14	2-41
MISSILE CONTROL AND GUIDANCE TEST SET TS-2074/DPM-14	2-42
HYDRAULIC PUMPING UNIT ND-654/DPM-14	2-43
GUIDED MISSILE TEST SET GROUP OA-6621/DPM-14	2-44

DOCUMENTATION

TABLE - PUBLICATIONS AND SPECIFICATIONS	2-45
---	------

SECTION 3 BULLPUP AGM-12B, 12B-2/3 GUIDED MISSILES

ASSEMBLED MISSILE & MAJOR COMPONENTS

GENERAL ARRANGEMENT - AGM-12B	3-1
CHART - MISSILE COMPONENTS, AGM-12B	3-2
GENERAL ARRANGEMENT - AGM-12B-2/3	3-3
CHART - MISSILE COMPONENTS, AGM-12B-2/3	3-4
HARD SPOT LOCATIONS - AGM-12B, 12B-2/3	3-5
(BLANK)	3-6
CHART - MISSILE COMPONENT INTERCHANGEABILITY	3-7
NOSE SECTION (GUIDANCE & CONTROL) AGM-12B	3-8
NOSE SECTION (GUIDANCE & CONTROL) AGM-12B-2/3	3-9
TARGET DETECTING DEVICE MK 15 MODS (RF)	3-10
CENTER SECTION (WARHEAD)	3-11
AFT SECTION (SOLID MOTOR)	3-12
AFT SECTION (LIQUID ENGINE)	3-13
CONTROL VANE	3-14
WING ASSEMBLY	3-15
RECEIVER CRYSTAL	3-16
LIQUID ENGINE IGNITER	3-17
TRACKING FLARE MK 27 MODS	3-18
SOLID MOTOR TAIL CONE	3-19

CONTAINERIZATION

CHART - SHIPPING CONTAINERS	3-20
GUIDED MISSILE CRADLE MK 15 MOD 0	3-21
MISSILE CONTAINER MK 441 MOD 0	3-22
NOSE SECTION CONTAINER - REUSABLE	3-23
NOSE SECTION CONTAINER - DISPOSABLE	3-24
TARGET DETECTION DEVICE CONTAINER MK 129 MOD 0	3-25
CENTER SECTION CONTAINER - REUSABLE	3-26
CENTER SECTION CONTAINER - DISPOSABLE	3-27
AFT SECTION CONTAINER - (SOLID MOTOR) REUSABLE	3-28
AFT SECTION CONTAINER - (SOLID MOTOR) DISPOSABLE	3-29
AFT SECTION CONTAINER - (LIQUID ENGINE) DISPOSABLE	3-30
WING & CONTROL VANE CONTAINER	3-31
RECEIVER CRYSTAL CONTAINER - DISPOSABLE	3-32
LIQUID ENGINE IGNITER CONTAINER	3-33
TRACKING FLARE CONTAINER	3-34

PALLETIZED UNIT LOADS

CHART - PALLETIZED UNIT LOADS	3-35
UNIT LOAD: NOSE SECTIONS	3-36
UNIT LOAD: CENTER SECTIONS	3-37
UNIT LOAD: AFT SECTIONS	3-38
UNIT LOAD: AGM-12B, 12B-2 3 BULLPUPS	3-38A

SUPPORT EQUIPMENT

TABLE - SHIPBOARD SUPPORT EQUIPMENT	3-39
SOLID MOTOR THRUST NEUTRALIZER	3-40
TORQUE WRENCH, 100 INCH POUND	3-41

DOCUMENTATION

TABLE - PUBLICATIONS AND SPECIFICATIONS	3-42
---	------

SECTION 4 BULLPUP AGM-12C, 12C-2 GUIDED MISSILES

ASSEMBLED MISSILE & MAJOR COMPONENTS

GENERAL ARRANGEMENT - AGM-12C	4-1
CHART - MISSILE COMPONENTS, AGM-12C	4-2
GENERAL ARRANGEMENT - AGM-12C-2	4-3
CHART - MISSILE COMPONENTS, AGM-12C-2	4-4
HARD SPOT LOCATIONS - AGM-12C, 12C-2	4-5
(BLANK).....	4-6
CHART - MISSILE COMPONENT INTERCHANGEABILITY	4-7
NOSE SECTION (GUIDANCE & CONTROL), AGM-12C	4-8
NOSE SECTION (GUIDANCE & CONTROL) AGM-12C-2	4-9
TARGET DETECTING DEVICE MK 15 MODS (RF).....	4-10
CENTER SECTION (WARHEAD)	4-11
AFT SECTION (LIQUID ENGINE)	4-12
CONTROL VANE	4-13
WING ASSEMBLY	4-14
RECEIVER CRYSTAL	4-15
ENGINE IGNITER	4-16
TRACKING FLARE MK 27 MODS	4-17

CONTAINERIZATION

CHART - SHIPPING CONTAINERS	4-19
MISSILE CONTAINER MK 443 MOD 0	4-20
NOSE SECTION CONTAINER MK 407 MOD 0	4-21
TARGET DETECTION DEVICE CONTAINER MK 129 MOD 0	4-22
CENTER SECTION CONTAINER MK 408 MOD 0	4-23
AFT SECTION CONTAINER MK 409 MOD 0	4-24
WING & CONTROL VANE CONTAINER MK 406 MOD 0	4-25
RECEIVER CRYSTAL CONTAINER - DISPOSABLE	4-26
ENGINE IGNITER CONTAINER	4-27
TRACKING FLARE CONTAINER	4-28

PALLETIZED UNIT LOADS

CHART - PALLETIZED UNIT LOADS	4-29
UNIT LOAD MK 65 MOD 0; NOSE SECTIONS	4-30
UNIT LOAD MK 66 MOD 0; CENTER SECTIONS	4-31
UNIT LOAD MK 66 MOD 1; AFT SECTIONS	4-32
UNIT LOAD (WR-54 71); WINGS & CONTROL VANES	4-33

SUPPORT EQUIPMENT

TABLE - SHIPBOARD SUPPORT EQUIPMENT	4-34
TORQUE WRENCH, 100 INCH POUND	4-35

DOCUMENTATION

TABLE - PUBLICATIONS AND SPECIFICATIONS	4-36
---	------

SECTION 5 SIDEWINDER AIM-9B/C/D GUIDED MISSILES

ASSEMBLED MISSILE & MAJOR COMPONENTS

GENERAL ARRANGEMENT, AIM-9B	5-1
CHART - MISSILE COMPONENTS, AIM-9B	5-2
(BLANK)	5-3
GENERAL ARRANGEMENT, AIM-9C	5-4
CHART - MISSILE COMPONENTS, AIM-9C	5-5
GENERAL ARRANGEMENT, AIM-9D	5-6
CHART - MISSILE COMPONENTS, AIM-9D	5-7
ASSEMBLY SEQUENCE, AIM-9C 'D'	5-8
CHART - MISSILE COMPONENT INTERCHANGEABILITY	5-9
GUIDANCE & CONTROL GROUP MK 1 MODS	5-10
GUIDANCE & CONTROL GROUP MK 12 MODS	5-11
GUIDANCE & CONTROL GROUP MK 18 MOD 2	5-12
CONTACT FUZE MK 304 MODS	5-13
INFLUENCE FUZE MK 303 MODS	5-14
TARGET DETECTING DEVICE MK 15 MODS (RF)	5-15
TARGET DETECTING DEVICE MK 24 MODS (IR)	5-16
SAFETY - ARMING DEVICE MK 13 MOD 0	5-17
WARHEAD MK 8 MODS	5-18
WARHEAD MK 48 MOD 0	5-19
ROCKET MOTOR MK 17 MODS	5-20
ROCKET MOTOR MK 36 MODS	5-21
FIN ASSEMBLY, AIM-9C	5-22
FIN ASSEMBLY, AIM-9D	5-23
WING AND ROLLERON ASSEMBLY	5-24
WING ASSEMBLY MK 1 MOD 0	5-25
TRACKING FLARE MK 21 MOD 0	5-26

CONTAINERIZATION

CHART - SHIPPING CONTAINERS	5-27
GUIDED MISSILE CRADLE MK 16 MOD 0	5-28
GUIDANCE & CONTROL CONTAINER MK 33 MOD 0	5-29
GUIDANCE & CONTROL CONTAINER MK 270 MOD 1	5-30
GUIDANCE & CONTROL CONTAINER MK 241 MOD 1	5-31
CONTACT FUZE CONTAINER MK 127 MOD 0 - INNER	5-32
CONTACT FUZE CONTAINER MK 131 MOD 0 - OUTER	5-33
INFLUENCE FUZE CONTAINER MK 389 MOD 0 - INNER	5-34
INFLUENCE FUZE CONTAINER MK 129 MOD 0 - OUTER	5-35
TDD CONTAINER MK 129 MOD 0 (MK 15/24 TDD)	5-36
S-A DEVICE CONTAINER MK 127 MOD 0 - INNER	5-37
S-A DEVICE CONTAINER MK 131 MOD 0 - OUTER	5-38
WARHEAD CONTAINER MK 34 MOD 0	5-39
WARHEAD CONTAINER MK 386 MOD 0	5-40
ROCKET MOTOR CONTAINER MK 37 MOD 0	5-41
ROCKET MOTOR CONTAINER MK 287 MOD 0	5-42
FIN CONTAINER MK 314 MOD 0	5-43
FIN CONTAINER MK 430 MOD 0	5-44

WING AND ROLLERON CONTAINER	5-45
WING CONTAINER MK 418 MOD 0	5-46
TRACKING FLARE CONTAINER	5-47

FLEET ISSUE UNIT LOADS

CHART - FLEET ISSUE UNIT LOADS	5-49
UNIT LOAD MK 19 MOD 0 (WR-54/19); MOTORS	5-50
UNIT LOAD MK 20 MOD 0 (WR-54/20); WARHEADS	5-51
UNIT LOAD MK 21 MOD 0 (WR-54/21); CONTACT FUZES	5-52
UNIT L34J MK 22 MOD 0 (WR-54/22); INFLUENCE FUZES	5-53
UNIT LOAD MK 23 MOD 0 (WR-54/23); WING & ROLLERON ASSYS	5-54
UNIT LOAD MK 24 MOD 0 (WR-54/24); G & C GROUPS	5-55
UNIT LOAD WR-54/38A; FINS	5-56
UNIT LOAD MK 45 MOD 0 (WR-54/39); WARHEADS	5-57
UNIT LOAD MK 49 MOD 0 (WR-54/42); G & C GROUPS	5-58
UNIT LOAD MK 73 MOD 0 (WR-54/106A); FIN ASSYS	5-59
UNIT LOAD WR-54/148; MOTORS	5-60
UNIT LOAD WR-54/156; AIM-9C/D TARGET DETECTING DEVICES	5-60A
UNIT LOAD WR-54/157; AIM-9C/D WING ASSEMBLIES	5-60B
UNIT LOAD WR-54/158; AIM-9C/D SAFETY ARMING DEVICES	5-60C
UNIT LOAD WR-54/40; WING & ROLLERON ASSYS	5-60D
UNIT LOAD WR-54/169A; AIM-9C OR 96 SIDEWINDER	5-60E

HANDLING EQUIPMENT & TOOLS

TABLE - HANDLING EQUIPMENT AND TOOLS	5-61
TOOL BOX	5-62
CHART - SHIPBOARD MAINTENANCE REFERENCE	5-63
DOME PROTECTOR, AIM-9B/C	5-64
DOME PROTECTOR, AIM-9D	5-65
PROTECTIVE RUBBER BOOT, AIM-9B	5-66
INFLUENCE FUZE COVER, AIM-9B	5-67
TARGET DETECTION DEVICE COVER, AIM-9C/D	5-68
SHORTING CLIP, AIM-9B	5-69
PROTECTOR COVER, AIM-9C/D	5-70
NON-PROPULSIVE ATTACHMENT, AIM-9B	5-71
MOTOR COVERS, AIM-9C/D	5-72
HANGER SCREW EXTRACTOR	5-72A

MISSILE TEST EQUIPMENT

CHART - MISSILE TEST EQUIPMENT	5-73
TEST SET MK 409 MOD 0	5-74
GENERAL ARRANGEMENT - MK 401 MOD 1 TEST SET	5-75
ANECHOIC CHAMBER - TEST SET MK 401 MOD 1	5-76
CONTROL SECTION - TEST SET MK 401 MOD 1	5-77
MECHANICAL ADAPTER - TEST SET MK 401 MOD 1	5-78

DOCUMENTATION

TABLE - PUBLICATIONS AND SPECIFICATIONS	5-79
---	------

SECTION 6 MISSILE TARGET AQM-37A

ASSEMBLED MISSILE & MAJOR COMPONENTS

GENERAL ARRANGEMENT - AQM-37A	6-1
HARD SPOT LOCATIONS	6-2
CHART - MISSILE COMPONENTS	6-3
(BLANK).....	6-4
RADOME	6-5
CANARD	6-6
WING & AILERON	6-7
VERTICAL STABILIZER	6-8
INFRARED FLARE MK 37	6-9

CONTAINERIZATION

CHART - SHIPPING CONTAINERS	6-11
TARGET BODY CONTAINER MK 311 MOD 0	6-12
FLIGHT SURFACES & ANTENNA SPIKES CONTAINER MK 309 MOD 0	6-13
INFRARED FLARE CONTAINER MK 312 MOD 0	6-14
BATTERY CONTAINER MK 310 MOD 0.- REUSABLE	6-15
MISSILE TARGET BATTERY CONTAINER - DISPOSABLE	6-16
IMPULSE CARTRIDGES SHIPPING CONTAINER - INNER AND OUTER	6-16A

FLEET ISSUE UNIT LOADS

UNIT LOAD WR-54 110; FLIGHT SURFACES & COMPONENTS	6-16B
---	-------

HANDLING EQUIPMENT & TOOLS

TABLE - HANDLING EQUIPMENT & TOOLS	6-17
NITROGEN COUPLING ASSEMBLY	6-18

MISSILE TEST EQUIPMENT

GENERAL ARRANGEMENT - AN/USM-179 TEST SET	6-19
ELECTRICAL SQUIB TEST SET AN/USM-179	6-20

DOCUMENTATION

TABLE - PUBLICATIONS AND SPECIFICATIONS	6-21
---	------

SECTION 7 PHOENIX AIM-54A GUIDED MISSILE

ASSEMBLED MISSILE & MAJOR COMPONENTS

GENERAL ARRANGEMENT - AIM-54A	7-1
HARD SPOT LOCATIONS	7-2
CHART - MISSILES COMPONENTS.....	7-3
(BLANK)	7-4
GUIDANCE SECTION	7-5
ARMAMENT SECTION	7-6
MOTOR SECTION	7-7
CONTROL SECTION.....	7-8
WING	7-9
CONTROL SURFACE	7-10

CONTAINERIZATION

PHOENIX TWO - WEAPON CONTAINER	7-11
PHOENIX WING & CONTROL SURFACE CONTAINER	7-12

HANDLING EQUIPMENT & TOOLS

TABLE - HANDLING EQUIPMENT & TOOLS	
SHEET 1 OF 3	7-12A
SHEET 2 OF 3	7-12B
SHEET 3 OF 3	7-13

MISSILE TEST EQUIPMENT

CHART - MISSILE TEST EQUIPMENT AN DSM-73	
SHEET 1 OF 3	7-14
SHEET 2 OF 3	7-15
SHEET 3 OF 3	7-16
GENERAL ARRANGEMENT - AN DSM-73 (XN-1) TEST SET	7-17
FOUNDATION PLAN - AN DSM-73 (XN-1) TEST SET	7-18
CHECKOUT AND ASSEMBLY STAND AN DSM-73 (XN-1)	7-19
FREE SPACE RADAR ECHO SIMULATOR AN DSM-73 (XN-1)	7-20
TEST SET AN DSM-73 (XN-1)	7-21
TEMPERATURE CONTROL STAND AN DSM-73 (XN-1)	7-22

DOCUMENTATION

TABLE - PUBLICATIONS AND SPECIFICATIONS	7-23
---	------

SECTION 8 SHRIKE AGM-45A GUIDED MISSILE

ASSEMBLED MISSILE & MAJOR COMPONENTS

GENERAL ARRANGEMENT - AGM-45A	8-1
HARD SPOT LOCATIONS	8-2
CHART - MISSILE COMPONENTS	8-3
(BLANK)	8-4
CHART - MISSILE COMPONENT INTERCHANGEABILITY	8-5
GUIDANCE SECTION MK 21 MODS	8-6
ARMAMENT SECTIONS MK 52, 68 AND 69 MOD 0	8-7
CONTROL SECTION MK 1 MOD 2	8-8
PROPULSION SECTION MK 39 MODS	8-9
WING ASSEMBLY MK 2 MOD 1	8-10
TAIL FIN ASSEMBLY MK 21 MOD 1	8-11
(BLANK).....	8-12

CONTAINERIZATION

CHART - SHIPPING CONTAINERS	8-13
MISSILE CONTAINER MK 399 MOD 0	8-14
GUIDANCE SECTION CONTAINER MK 395 MOD 0	8-15
ARMAMENT SECTION CONTAINER MK 396 MOD 0	8-16
CONTROL SECTION CONTAINER MK 394 MOD 0	8-17
PROPULSION SECTION CONTAINER MK 397 MOD 0	8-18
WING CONTAINER MK 392 MOD 0	8-19
TAIL FIN CONTAINER MK 393 MOD 0	8-20
GUIDED MISSILE CONTAINER MK 14 MOD 9	8-21
MOTOR CONTAINER	8-22

FLEET ISSUE UNIT LOADS

CHART - FLEET ISSUE LOADS	8-23
UNIT LOAD MK 68 MOD 0 (WR-54/101); WINGS	8-24
UNIT LOAD MK 69 MOD 0 (WR-54/102); TAIL FINS	8-25
UNIT LOAD MK 70 MOD 0 (WR-54/103); CONTROL SECTIONS	8-26
UNIT LOAD MK 71 MOD 0 (WR-54/104); GUIDANCE SECTIONS	8-27
UNIT LOAD MK 72 MOD 0 (WR-54/105); ARMAMENT SECTIONS	8-28
UNIT LOAD (WR-54/108A); MOTOR SECTIONS	8-28A
UNIT LOAD (WR-54/172) AGM 45A LESS WINGS AND FINS	8-28B
UNIT LOAD (WR-54/179) AGM 45A LESS WINGS AND FINS	8-28C

HANDLING EQUIPMENT & TOOLS

TABLE - HANDLING EQUIPMENT AND TOOLS	8-29
CHART - SHIPBOARD MAINTENANCE REFERENCE	8-30

MISSILE TEST EQUIPMENT

CHART - MISSILE TEST EQUIPMENT AN/DSM-68	8-31
GENERAL ARRANGEMENT - AN/DSM-68 TEST SET	8-32
GUIDED MISSILE TEST SET AN/DSM-68	8-33

DOCUMENTATION

TABLE - PUBLICATIONS AND SPECIFICATIONS	8-34
---	------

SECTION 9 CONDOR AGM-53A GUIDED MISSILE

ASSEMBLED MISSILE & MAJOR COMPONENTS

GENERAL ARRANGEMENT - AGM-53A	9-1
HARD SPOT LOCATIONS	9-2
GENERAL ARRANGEMENT - AIRCRAFT POD	9-3
WING	9-4
CONTROL SURFACE	9-5

CONTAINERIZATION

AIRCRAFT POD	9-6
WINGS AND CONTROL SURFACES	9-7

SECTION 10 STANDARD ARM AGM-78A GUIDED MISSILE

ASSEMBLED MISSILE & MAJOR COMPONENTS

GENERAL ARRANGEMENT - AGM-78A	10-1
HARD SPOT LOCATIONS	10-2

CONTAINERIZATION

MISSILE CONTAINER	10-3
RADOME CONTAINER	10-4

HANDLING EQUIPMENT & TOOLS

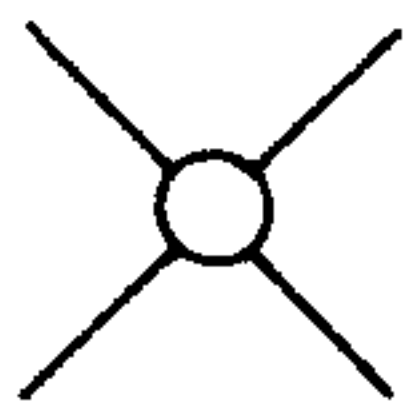
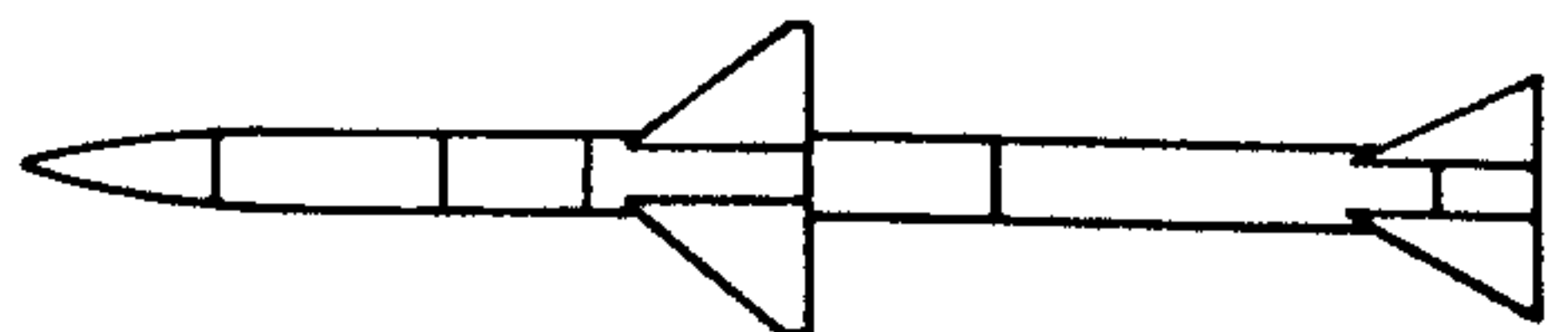

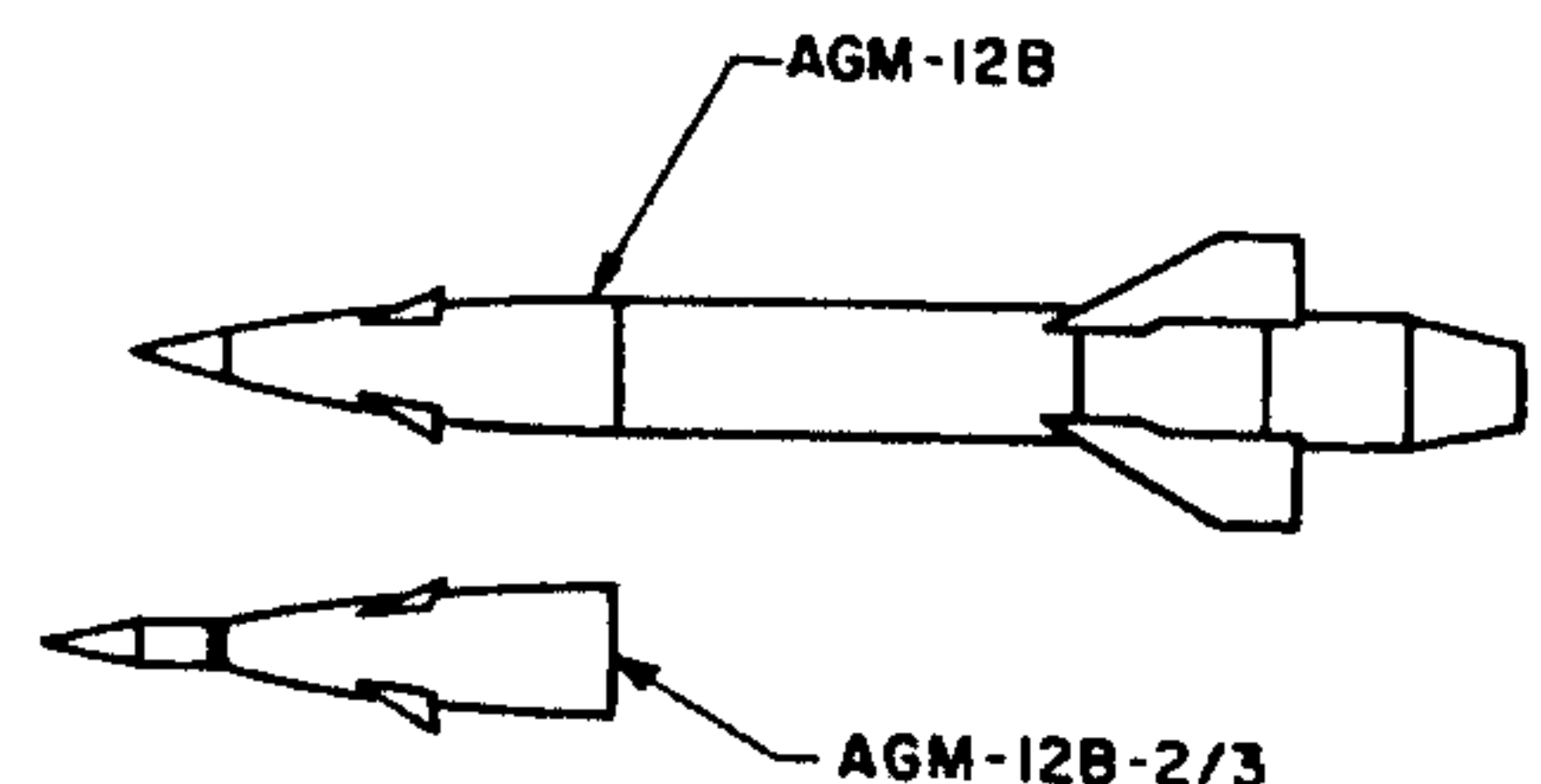
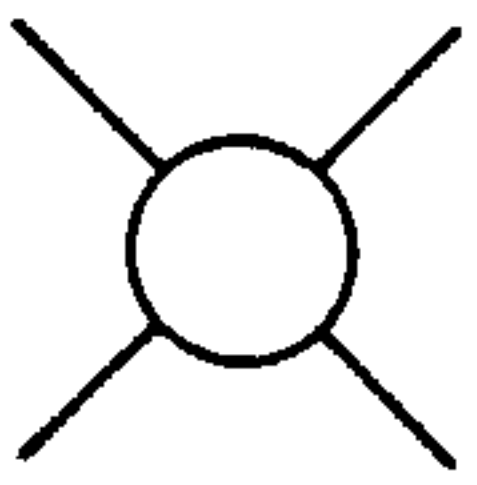
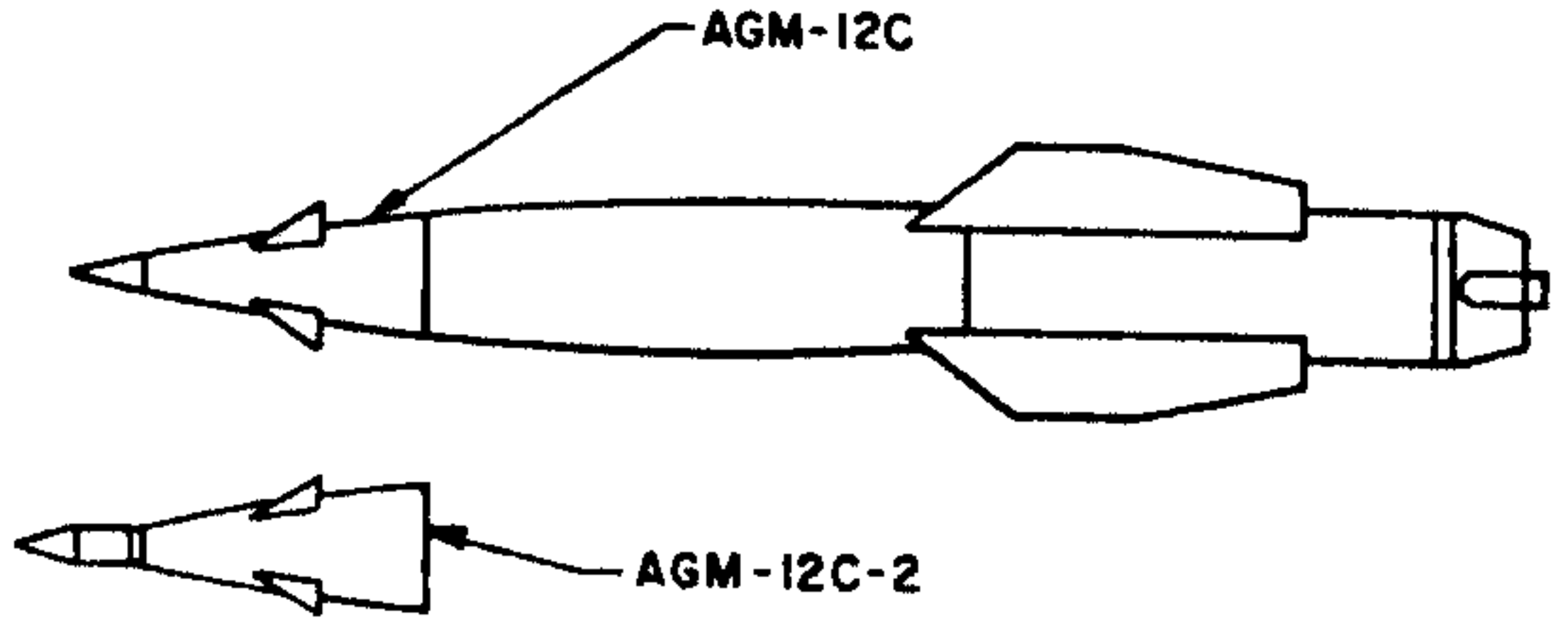

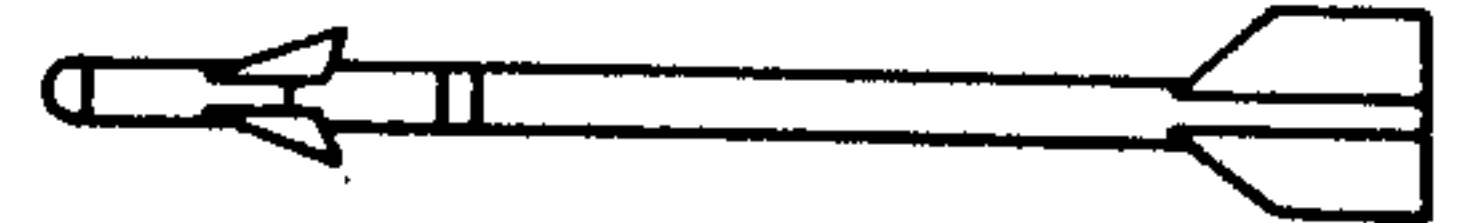

TABLE - HANDLE EQUIPMENT AND TOOLS	10-5
--	------

DOCUMENTATION

TABLE - PUBLICATIONS AND SPECIFICATIONS	10-6
---	------

COMPARISON OF OVERALL DIMENSIONS

SHEET 1 OF 2

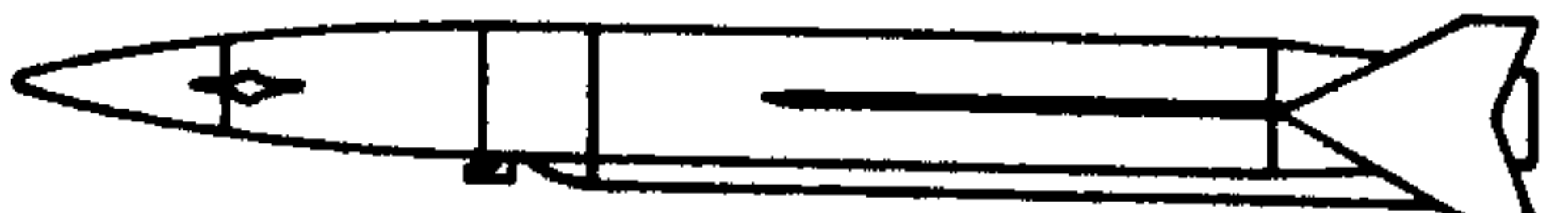
MISSILE	BODY	LENGTH (IN.)	WEIGHT (LBS.)	FRONT VIEW	ELEVATION
SPARROW III AIM-7C, 7D, 7E XAIM-7F	8. BODY DIA	144	378 TO 444		
	40.2 FWD FIN SPAN				
BULLPUP AGM-12B, 12B-2, 12B-3	12 BODY DIA	125 TO 134	564 TO 614		
	37.8 WING SPAN				
BULLPUP AGM-12C, 12C-2	17.3 BODY DIA	160 TO 169	1789 TO 1802		
	44 WING SPAN				
SIDEWINDER AIM-9B, 9C, 9D	5 BODY DIA	111 TO 118	160 TO 210		 (AIM-9B SHOWN)
	22 TO 24.8 WING SPAN				
MISSILE TARGET AQM-37A	13 BODY DIA	150	562		
	39.5 WING SPAN				

COMPARISON OF OVERALL DIMENSIONS

SHEET 2 OF 2

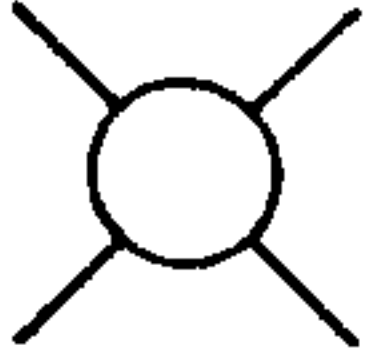
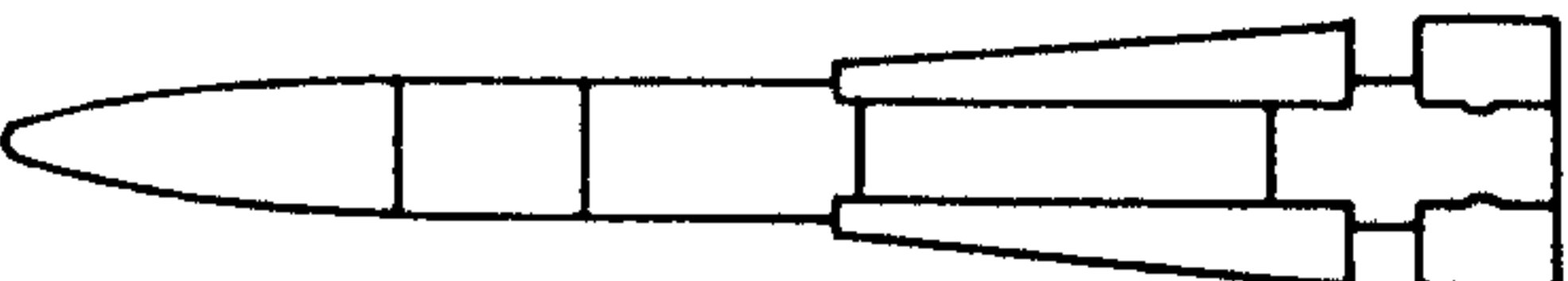
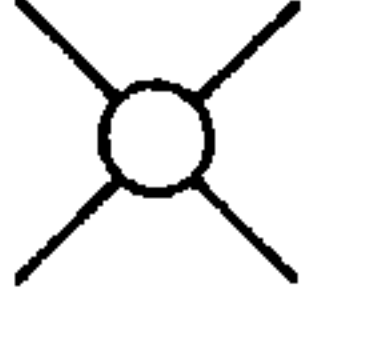
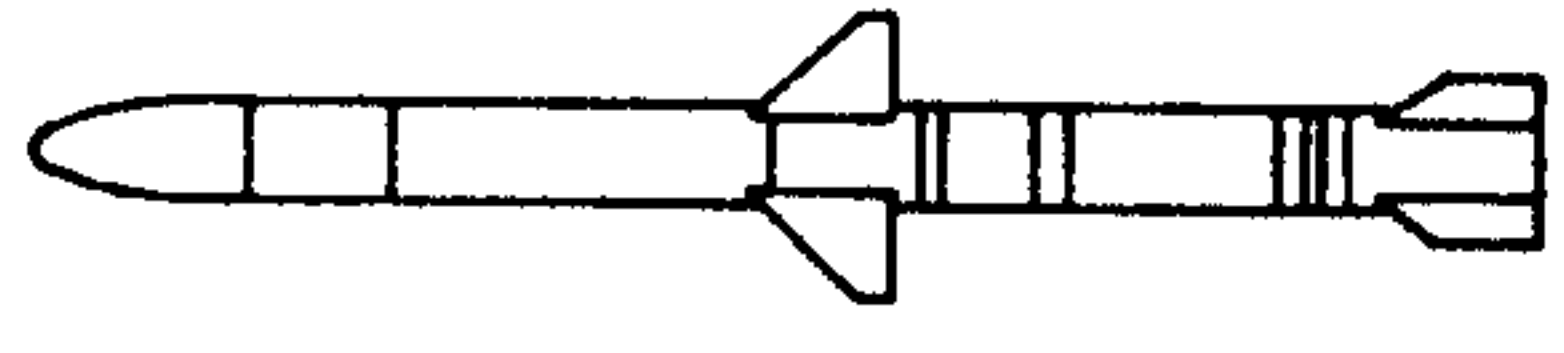
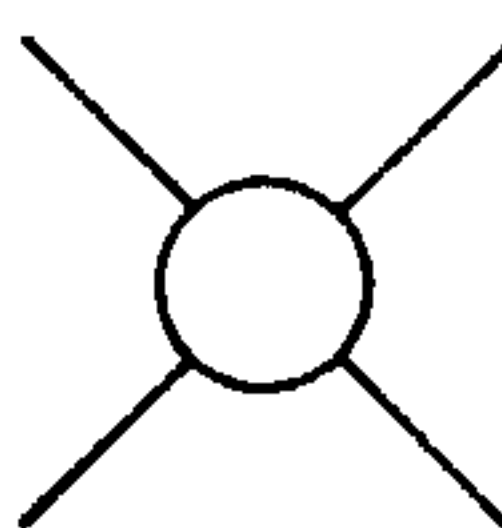
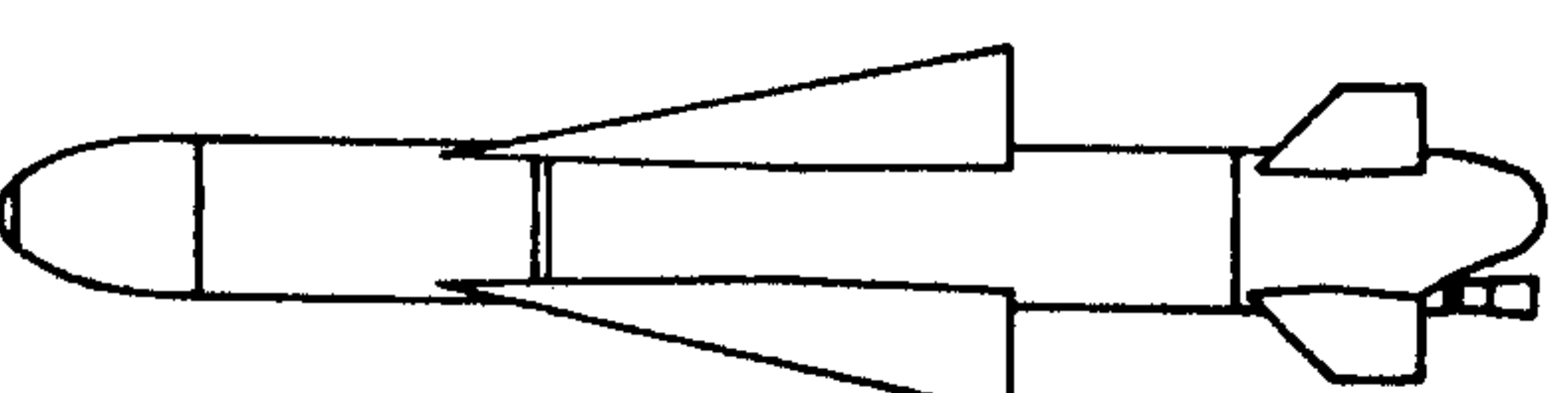
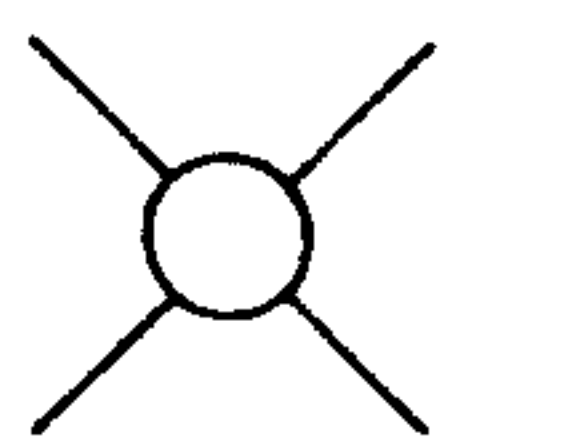
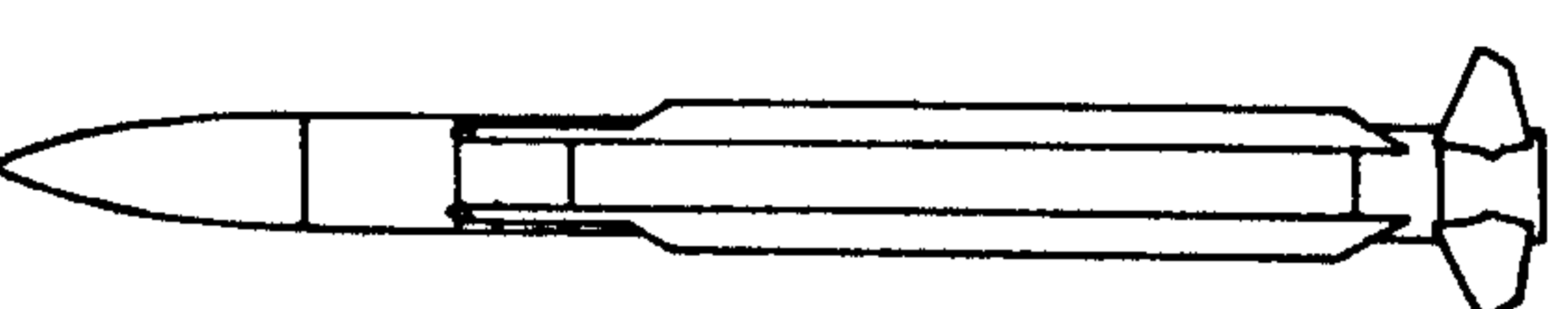
MISSILE	BODY	LENGTH (IN.)	WEIGHT (LBS.)	FRONT VIEW	ELEVATION
PHOENIX AIM-54A	15 BODY DIA	156	1010		
	36 WING SPAN				
SHRIKE AGM-45A	8 BODY DIA	120	402		
	36.2 WING SPAN				
CONDOR AGM-53A	17 BODY DIA	166	1885		
	53 WING SPAN				
STANDARD ARM AGM-78A	13.5 BODY DIA	180	1368		
	42.5 WING SPAN				







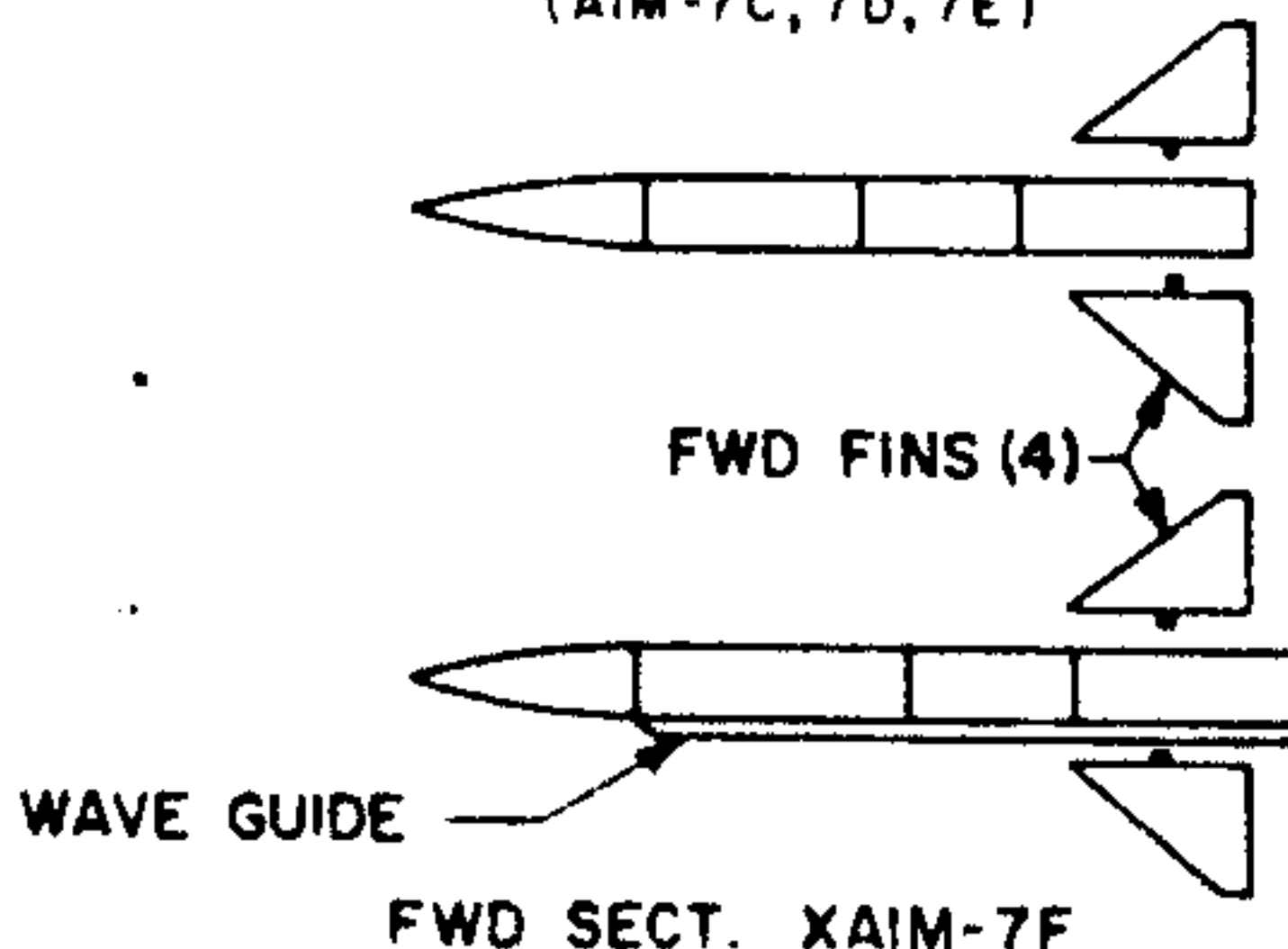

COMPARISON OF COMPONENTS

SHEET 2 OF 2

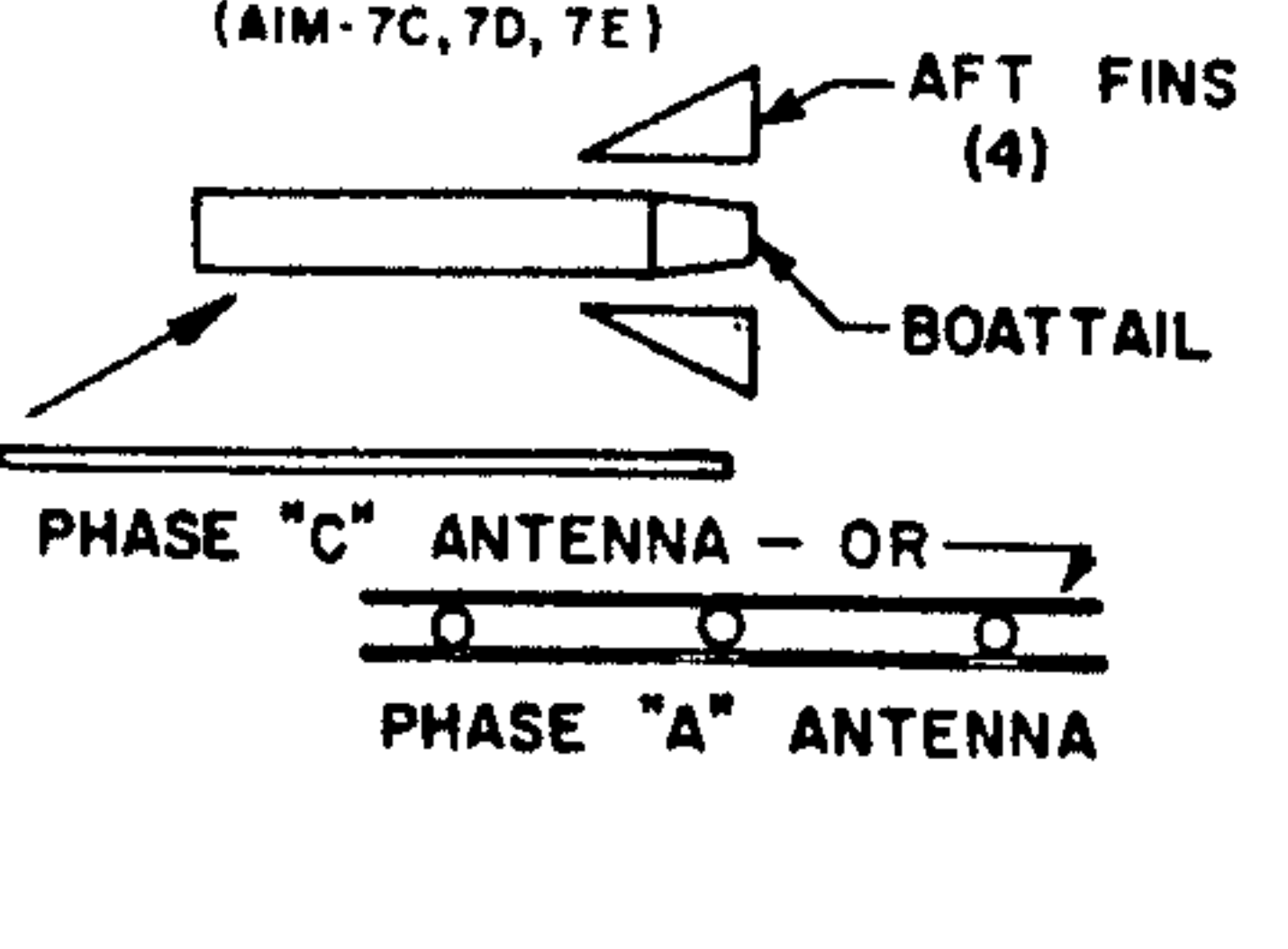
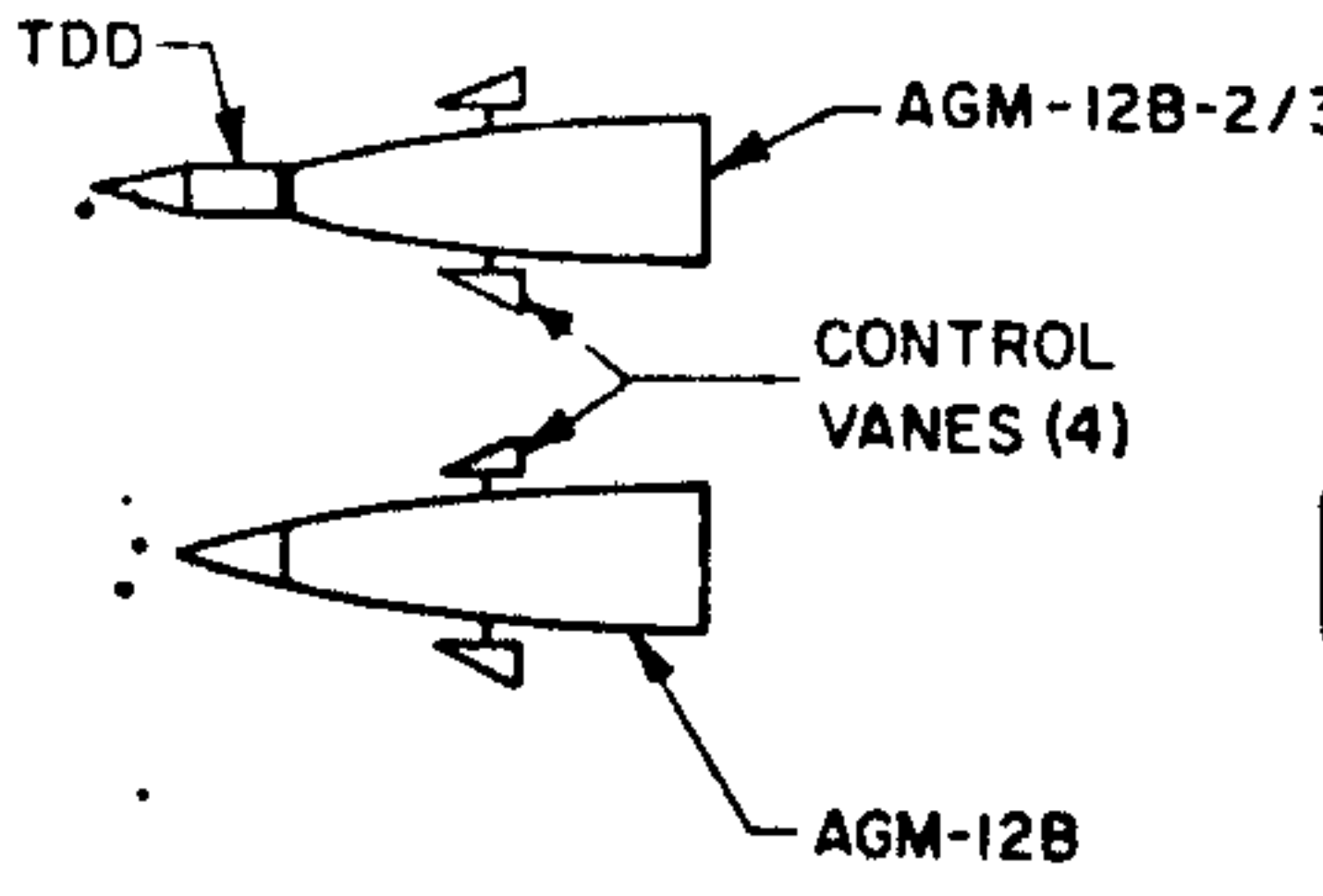
<p>MISSILE TARGET AQM-37A</p>	
<p>PHOENIX AIM-54A</p>	
<p>SHRIKE AGM-45A</p>	
<p>CONDOR AGM-53A</p>	
<p>STANDARD ARM AGM-78A</p>	

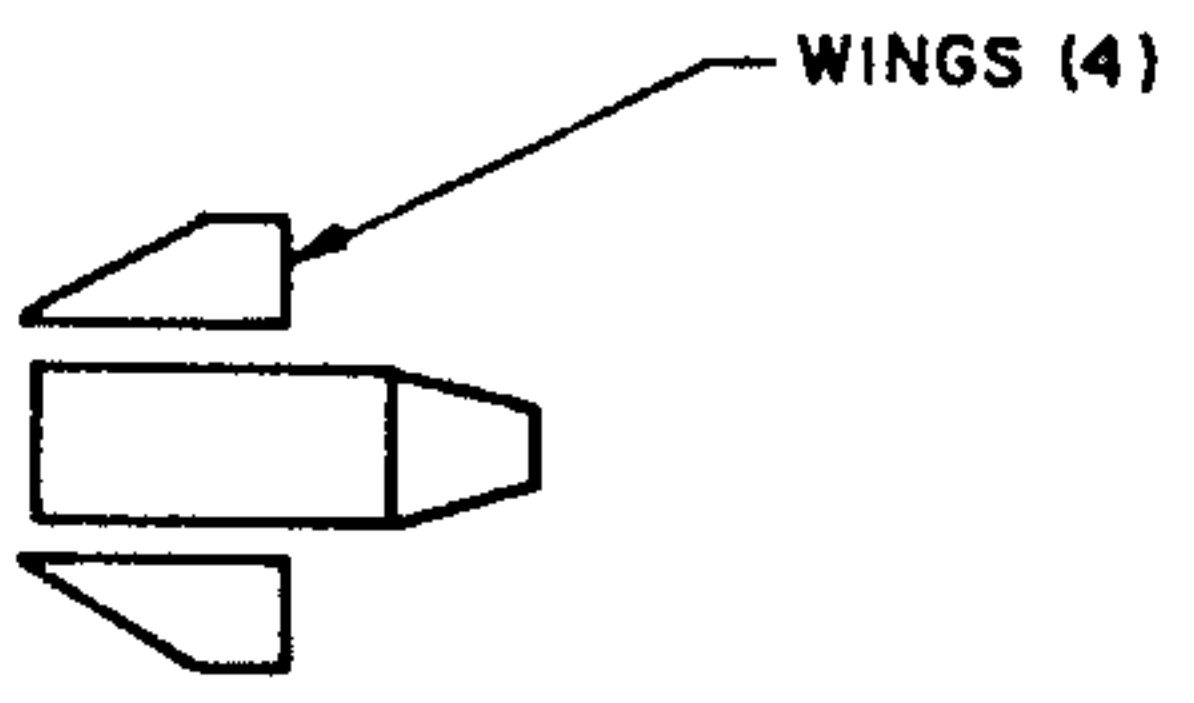
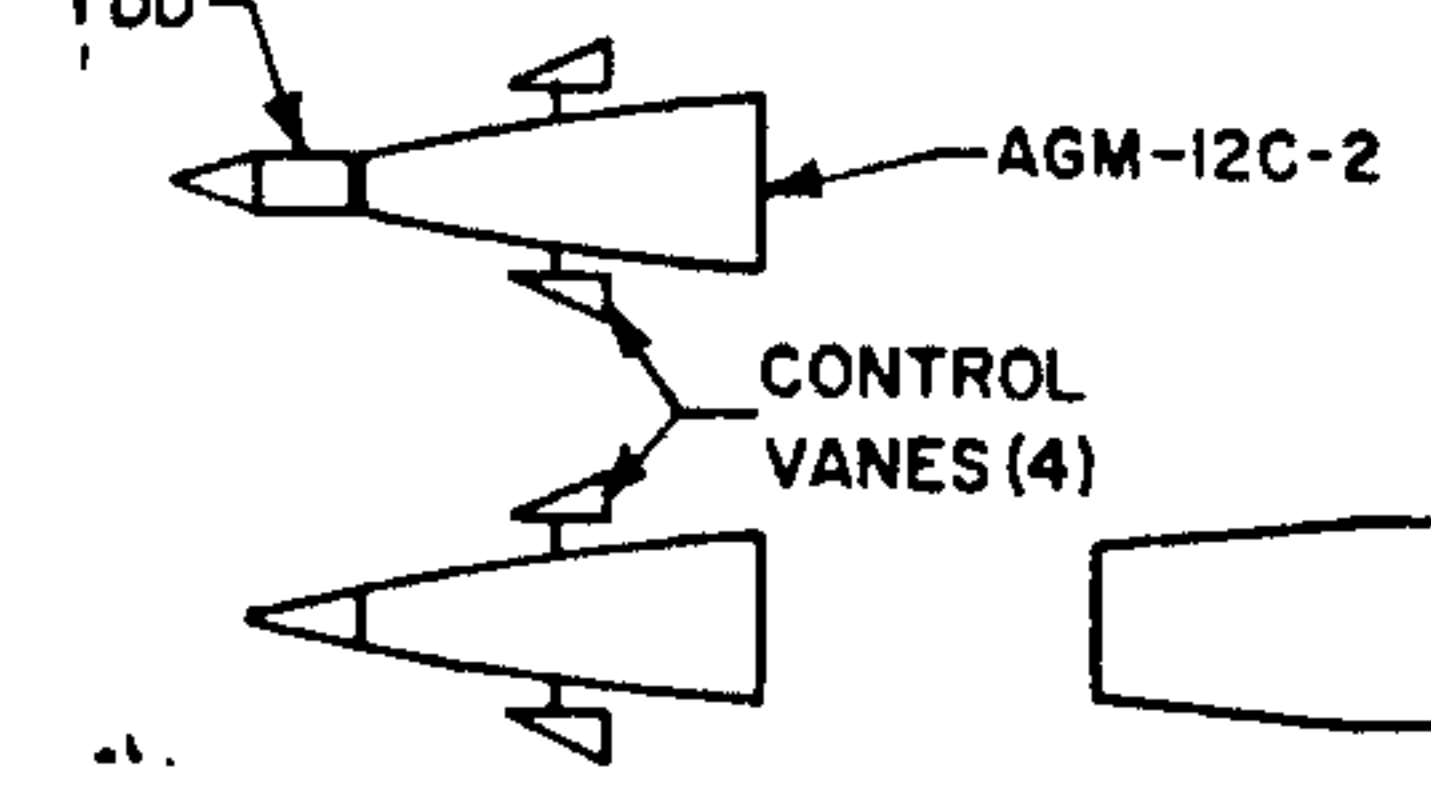
COMPARISON OF COMPONENTS

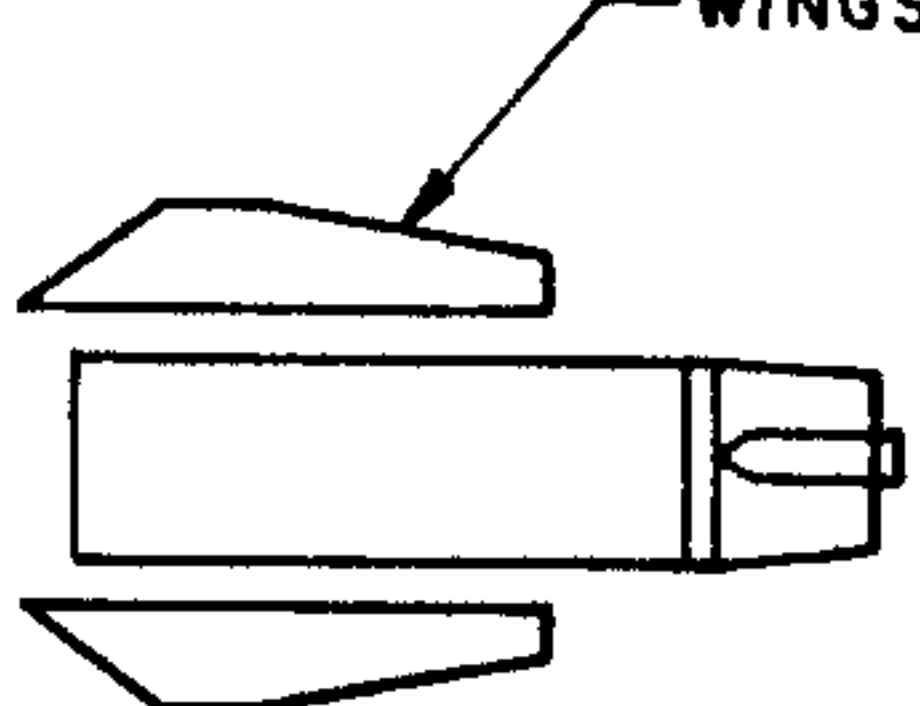
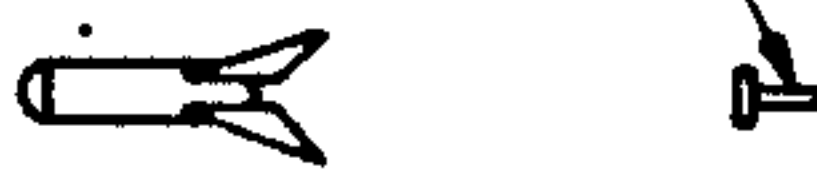
SHEET 1 OF 2

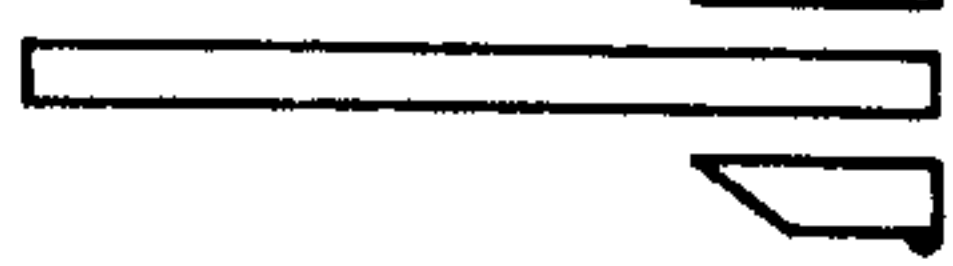
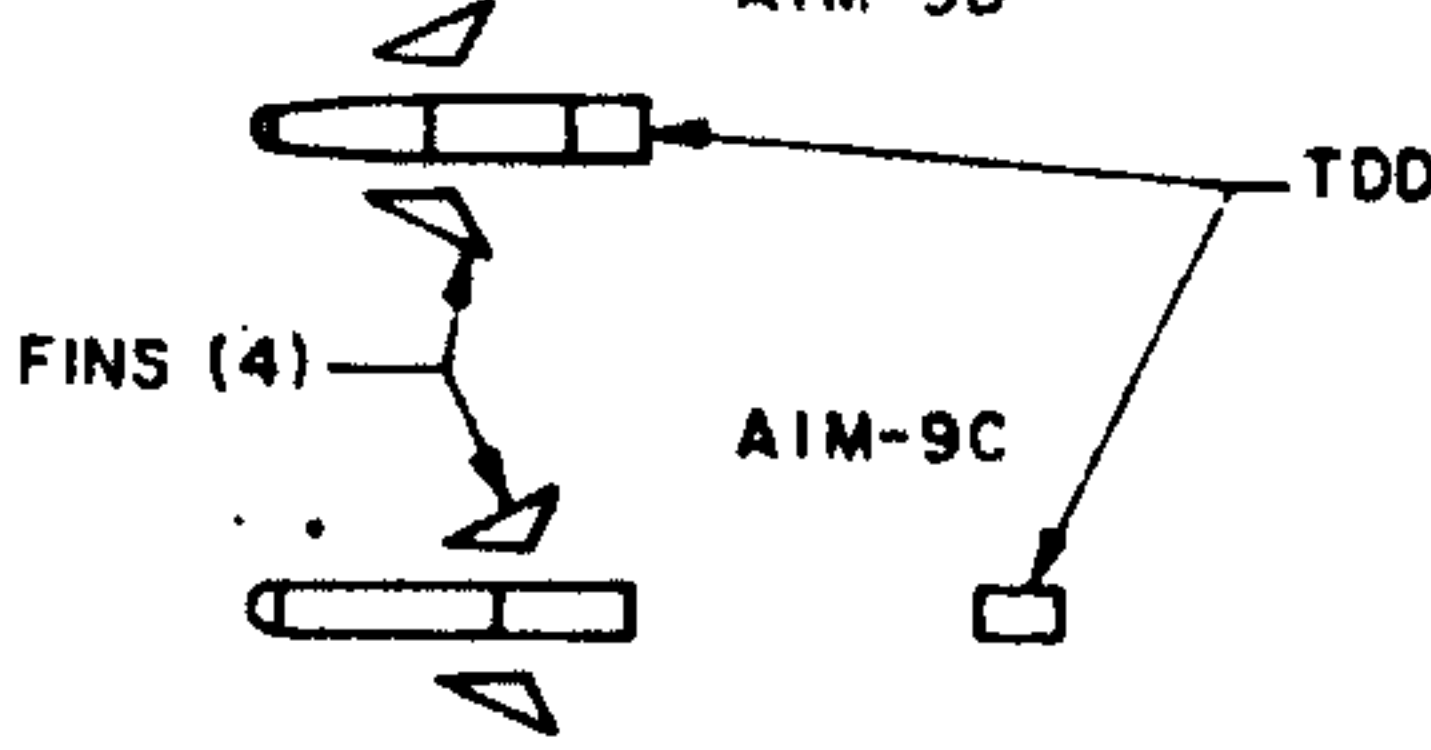
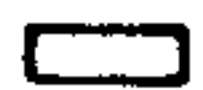
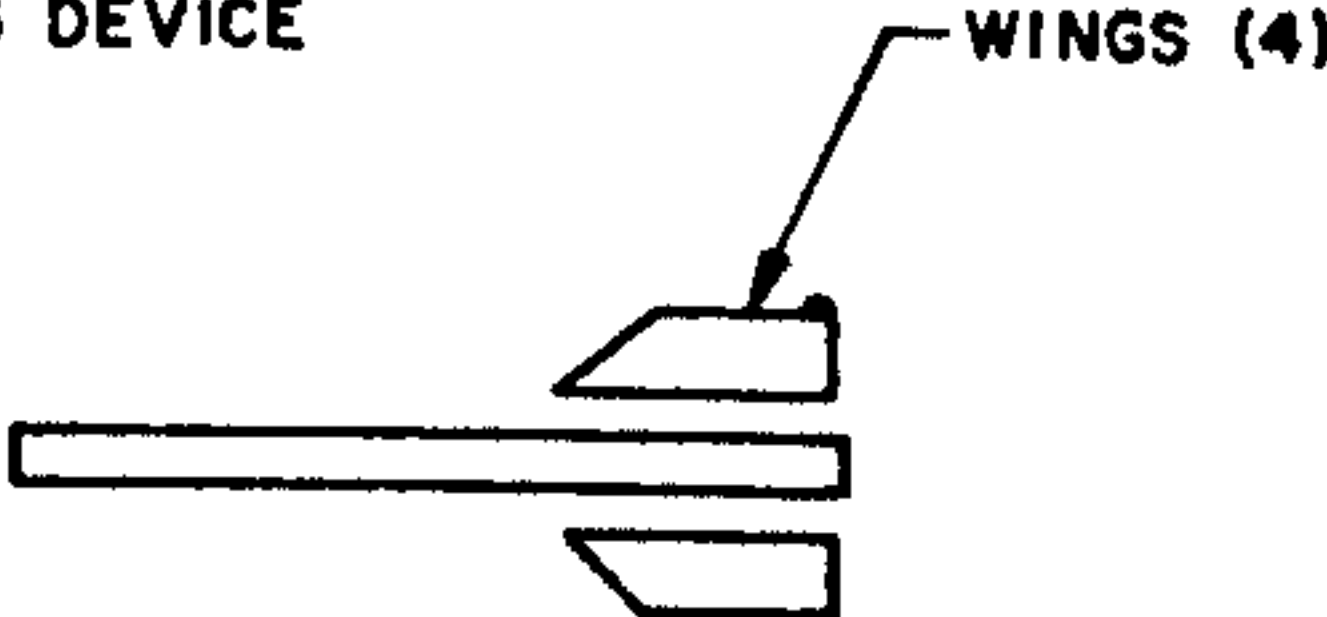
<p>SPARROW III AIM-7C, 7D, 7E XAIM-7F</p>	<p>GUIDANCE & CONTROL SECT. (AIM-7C, 7D, 7E)</p>  <p>FWD FINS (4)</p> <p>WAVE GUIDE</p> <p>FWD SECT. XAIM-7F (GUIDANCE, WARHEAD & CONTROL)</p>	<p>WARHEAD (AIM-7C, 7D, 7E)</p>  <p>AFT FINS (4)</p> <p>AFT SECT. XAIM-7F (MOTOR)</p>	<p>MOTOR SECT. (AIM-7C, 7D, 7E)</p>  <p>AFT FINS (4)</p> <p>BOATTAIL</p> <p>PHASE "C" ANTENNA - OR</p> <p>PHASE "A" ANTENNA</p>
<p>BULLPUP AGM-12B, 12B-2, 12B-3</p>	<p>TDD</p>  <p>AGM-12B-2/3</p> <p>CONTROL VANES (4)</p> <p>AGM-12B</p> <p>NOSE SECT.</p>	 <p>CENTER SECT.</p>	 <p>WINGS (4)</p> <p>AFT SECT.</p>
<p>BULLPUP AGM-12C, 12C-2</p>	<p>TDD</p>  <p>AGM-12C-2</p> <p>CONTROL VANES (4)</p> <p>NOSE SECT.</p>	 <p>CENTER SECT.</p>	 <p>WINGS (4)</p> <p>AFT SECT.</p>
<p>SIDEWINDER AIM-9B</p>	<p>CONTACT FUZE</p>  <p>GUIDANCE & CONTROL GROUP</p>	<p>WARHEAD</p>  <p>INFLUENCE FUZE</p>	 <p>WINGS (4)</p> <p>MOTOR</p>
<p>SIDEWINDER AIM-9C, 9D</p>	<p>AIM-9D</p>  <p>FINS (4)</p> <p>TDD</p> <p>AIM-9C</p> <p>GUIDANCE & CONTROL GROUP</p>	<p>SAFETY ARMING DEVICE</p>  <p>WARHEAD</p>	 <p>WINGS (4)</p> <p>MOTOR</p>

SPARROW III AIM-7C GENERAL ARRANGEMENT

PHASE "A" ANTENNA - MISSILES R-1 TO R-1375

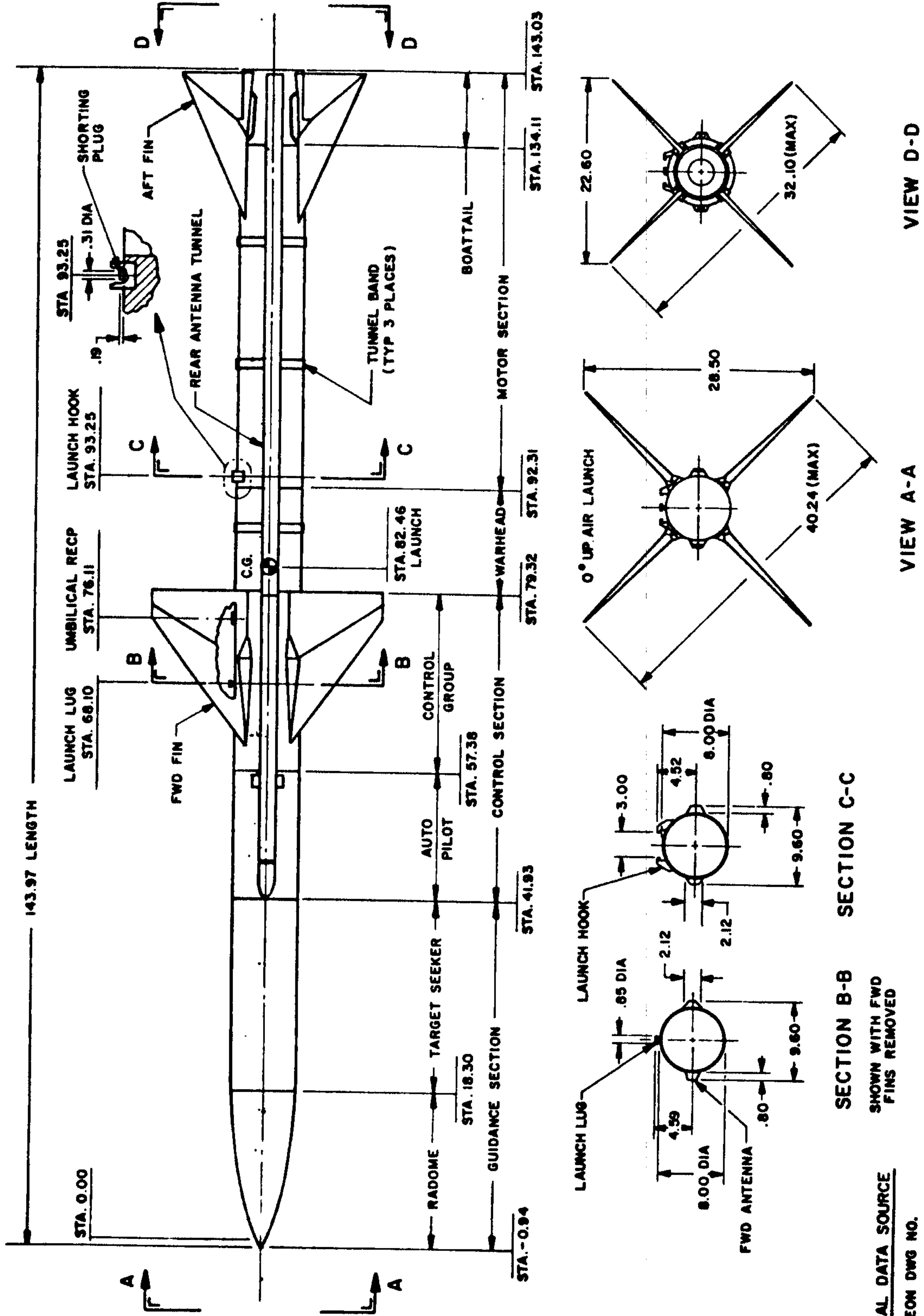

ORIGINAL DATA SOURCE
 RAYTHEON DWG NO.
 138314 REV E
 DATED 21 FEB. 1966
 NAVWEP5 01-2656MAD-9
 DATED 1 MARCH 1967

SECTION B-B SECTION C-C

SHOWN WITH FWD
 FINS REMOVED

NOTES:

1. APPROXIMATE WEIGHT - 377.5 LBS.
2. MISSILE LAUNCHED FROM TYPE AERO 4A LAUNCHER.

SPARROW III AIM-7C MISSILE COMPONENTS

PHASE "A" ANTENNA - MISSILES R-1 TO R-1375

COMPONENT	CONTRACTORS NAME & PART NO. OR TYPE	PART SIZE L X W X H	PART WT.	QTY MSL	REMARKS
GUIDANCE & CONTROL SECT.	RAYTHEON SX101-8009	8.0 DIA X 80.3	138.9	1	NITROGEN CHARGED HPU INTEGRAL BATTERY / INVERTER
WARHEAD MK 18 MOD 0 MK 11 MOD 0	BUORD DWG 1519431	8.0 DIA X 14.0	69.6 65.0	1	
WARHEAD MK 38 MOD 0	BUORD DWG 1519431	8.0 DIA X 14.0	69.4	1	SEE NAVWEPS 01-265 GMAD-9 PARA. 2-41 FOR USAGE
MOTOR SECT. MK 6 MOD 3	RAYTHEON HJ-SX101-8009	8.0 DIA X 51.9	127.4	1	BOATTAIL ASSEMBLED TO MOTOR
IGNITER MK 258 MOD 0	BUWEPS DWG 2313631	2.9 HEX X 3.7	—	1	FOR MOTOR SECTION
FORWARD FIN	RAYTHEON 2063-5035	18.6 X 2.5 X 17.9	7.9 EA	4	
FORWARD FIN	RAYTHEON 5504-5076	18.6 X 2.5 X 17.9	8.5 EA.	4	SEE NAVWEPS 01-265 GMAD-9 PARA. 2-41 FOR USAGE
AFT FIN	RAYTHEON 2070-1021	18.5 X .9 X 12.7	2.8 EA.	4	
AFT FIN	RAYTHEON 2070-5018	18.5 X .9 X 12.7	3.0 EA.	4	SEE NAVWEPS 01-265 GMAD-9 PARA. 2-41 FOR USAGE
REAR ANTENNA TUNNEL	RAYTHEON VC-7150575-2491	64.8 X 2.6 X 1.6	1.1 EA	2	
REAR ANTENNA	RAYTHEON HJ-2146-1051	65.2 X 1.8 X .8	1.0	1	
TUNNEL BAND	RAYTHEON HC-2146-1064	8.0 DIA X .9	.3 EA	3	

SPARROW III AIM-7C OPERATIONAL CHARACTERISTICS

- | | |
|---|--|
| 1. TYPE DETECTION - SEMI-ACTIVE CW RADAR HOMING | 7. TYPE FUZING - INFLUENCE |
| 2. TYPE GUIDANCE - PROPORTIONAL NAVIGATION | 8. TYPE PROPULSION - SOLID PROPELLANT |
| 3. GUIDANCE TIME DURATION - | 9. NOMINAL MOTOR BURN TIME - |
| 4. TYPE CONTROL - HYDRAULICALLY OPERATED | 10. SPEED - SUPERSONIC |
| 5. TYPE WARHEAD - CONTINUOUS ROD | 11. RANGE - 9 MILES |
| 6. WARHEAD KILL RADIUS - | 12. MAX OPERATING ALTITUDE - 60,000 FEET |

NOTE:

1. WEAPON IS RECEIVED ABOARD SHIP IN COMPONENT FORM AND IS STOWED IN THIS CONDITION EXCEPT FOR A NUMBER OF READY SERVICE WEAPONS.

ORIGINAL DATA SOURCE

NAVWEPS 01-265GMAD-9
DATED 1 MARCH 1967

SPARROW III AIM-7C GENERAL ARRANGEMENT

PHASE "C" ANTENNA - MISSILES R-1376 TO R-3454

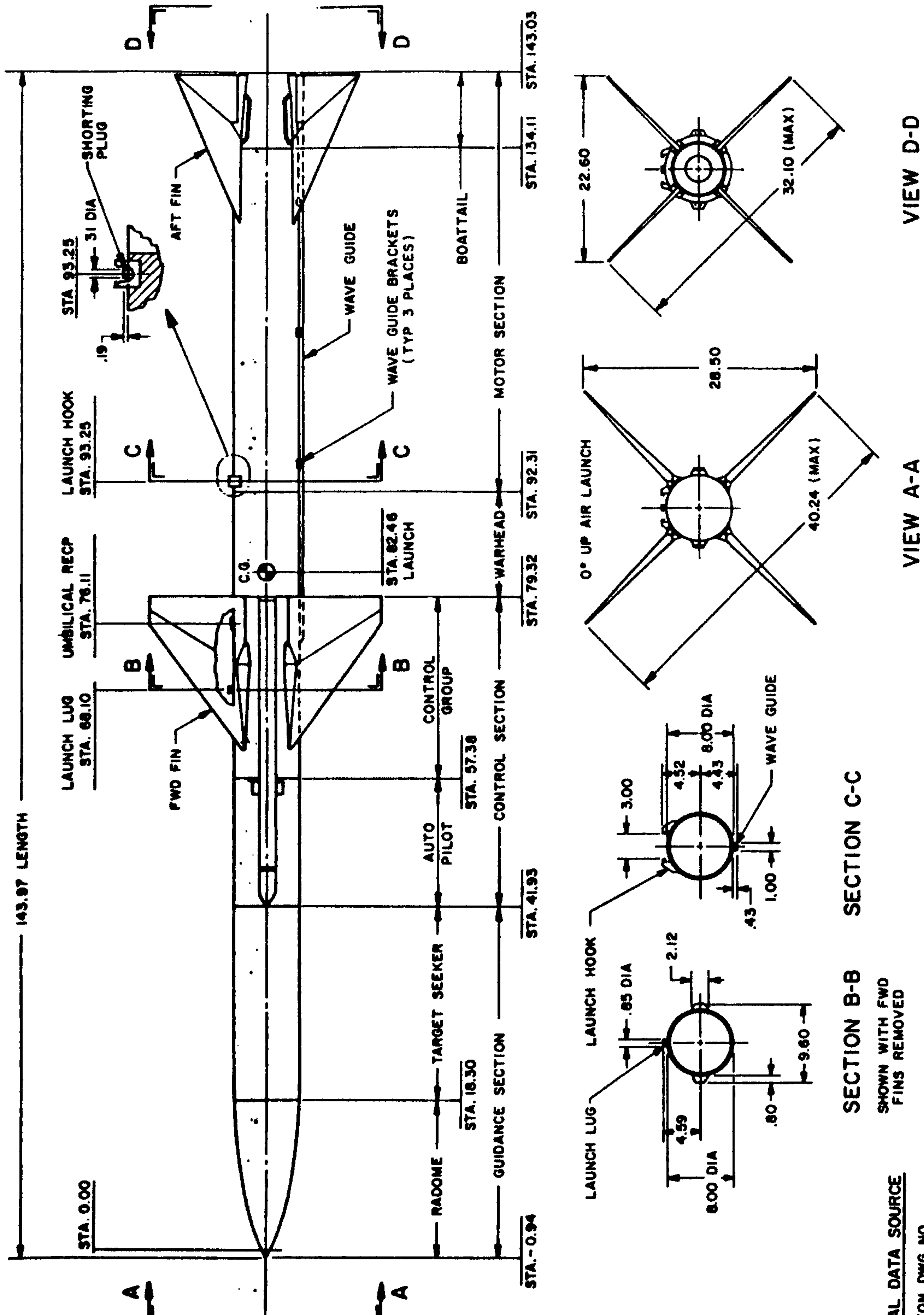

ORIGINAL DATA SOURCE
 RAYTHEON DWG NO. 138314 REV E
 DATED 21 FEB. 1966
 NAVWEPS 01-265GMAD-9
 DATED 1 MARCH 1967

SECTION B-B
 SHOWN WITH FWD
 FINS REMOVED

SECTION C-C

VIEW A-A

VIEW D-D

NOTES:

1. APPROXIMATE WEIGHT - 377.5 LBS.
2. MISSILE IS LAUNCHED FROM TYPE AERO 4A AND LAU-17A LAUNCHERS.

SPARROW III AIM-7C MISSILE COMPONENTS

PHASE "C" ANTENNA-MISSILES R-1376 TO R-3454

COMPONENT	CONTRACTORS NAME & PART NO. OR TYPE	PART SIZE L X W X H	PART WT.	QTY MSL	REMARKS
GUIDANCE & CONTROL SECT.	RAYTHEON SX-110-8009	8.0 DIA X 80.3	138.9	1	NITROGEN CHARGED HPU POWDER GRAIN EPU FOR MISSILES R-1376 TO R-1804 ONLY
GUIDANCE & CONTROL SECT.	RAYTHEON SX-110-8009	8.0 DIA X 80.3	138.9	1	NITROGEN CHARGED HPU; POWDER GRAIN EPU; ROLL COMMAND ENGLISH BIAS FOR MISSILES R-1805 TO R-3454 ONLY
WARHEAD MK 18 MOD 0 MK 11 MOD 0	BUORD DWG. 1519431	8.0 DIA X 14.0	69.6 65.0	1	
WARHEAD MK 38 MOD 0	BUORD DWG. 1519431	8.0 DIA X 14.0	69.4	1	SEE NAVWEPS 01-265 GMAD-9 PARA. 2-41 FOR USAGE
MOTOR SECT. MK 6 MOD 3	RAYTHEON HJ-SX101 - 8009	8.0 DIA X 51.9	127.4	1	BOATTAIL ASSEMBLED TO MOTOR
IGNITER MK 258 MOD 0	BUWEPS DWG. 2313631	2.9 HEX X 3.7	-	1	FOR MOTOR SECTION
FORWARD FIN	RAYTHEON 2063-5035	18.6 X 2.5 X 17.9	7.9 EA.	4	
FORWARD FIN	RAYTHEON 5504-5076	18.6 X 2.5 X 17.9	8.5 EA.	4	SEE NAVWEPS 01-265 GMAD-9 PARA. 2-41 FOR USAGE
AFT FIN	RAYTHEON 2070-1021	18.5 X 9 X 12.7	2.8 EA.	4	
AFT FIN	RAYTHEON 2070-5018	18.5 X 9 X 12.7	3.0 EA.	4	SEE NAVWEPS 01-265 GMAD-9 PARA. 2-41 FOR USAGE
WAVEGUIDE	RAYTHEON VO-7108707-900	69.2 X 1.5 X 1.0	1.5	1	

SPARROW III AIM-7C OPERATIONAL CHARACTERISTICS

- | | |
|---|--|
| 1. TYPE DETECTION - SEMI ACTIVE CW RADAR HOMING | 7. TYPE FUZING - INFLUENCE |
| 2. TYPE GUIDANCE - PROPORTIONAL NAVIGATION | 8. TYPE PROPULSION - SOLID PROPELLANT |
| 3. GUIDANCE TIME DURATION - | 9. NOMINAL MOTOR BURN TIME - |
| 4. TYPE CONTROL - HYDRAULICALLY OPERATED | 10. SPEED - SUPERSONIC |
| 5. TYPE WARHEAD - CONTINUOUS ROD | 11. RANGE - 9 MILES |
| 6. WARHEAD KILL RADIUS - | 12. MAX OPERATING ALTITUDE - 60,000 FEET |

NOTE:

1. WEAPON IS RECEIVED ABOARD SHIP IN COMPONENT FORM AND IS STOWED IN THIS CONDITION EXCEPT FOR A NUMBER OF READY SERVICE WEAPONS.

ORIGINAL DATA SOURCE

NAVWEPS 01-265 GMAD-9
DATED 1 MARCH 1967

SPARROW III AIM-7D GENERAL ARRANGEMENT

PHASE "C" ANTENNA - MISSILES R-3455 TO R-11083

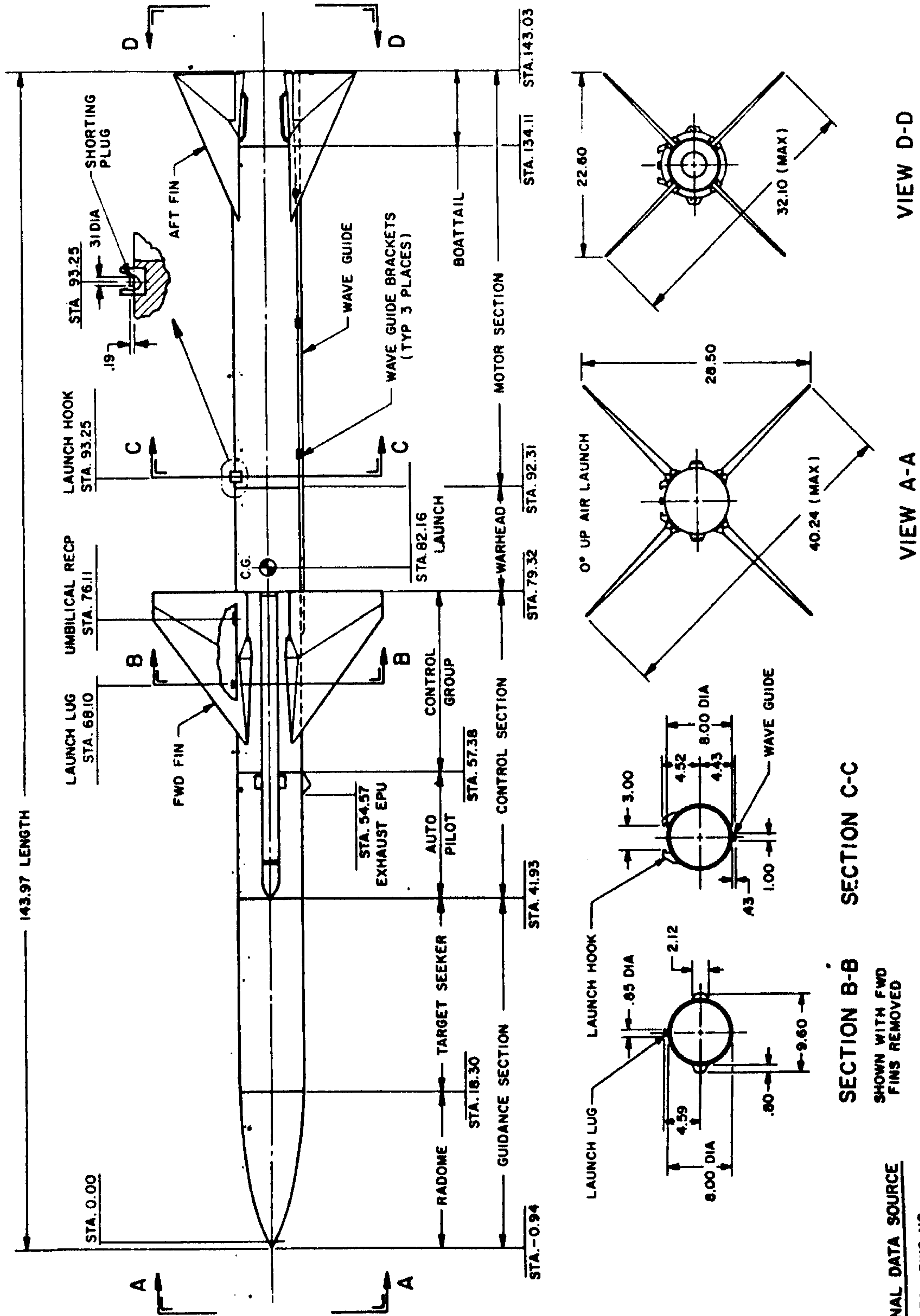

ORIGINAL DATA SOURCE
 RAYTHEON DWG NO. 138314 REV E
 DATED 21 FEB. 1966
 NAVWEPS 01-265GMAD-9
 DATED 1 MARCH 1967

NOTES:
 1. APPROXIMATE WEIGHT - 397.9 LBS.
 2. MISSILE LAUNCHED FROM TYPE AERO 4A, AERO 7A OR LAU-17/A LAUNCHERS.

SECTION B-B SECTION C-C
 SHOWN WITH FWD
 FINS REMOVED

SPARROW III AIM-7D MISSILE COMPONENTS

PHASE "C" ANTENNA - MISSILES R-3455 TO R-11083

COMPONENT	CONTRACTORS NAME & PART NO. OR TYPE	PART SIZE L X W X H	PART WT.	QTY MSL	REMARKS
GUIDANCE & CONTROL SECT	RAYTHEON SX-101-8009	8.0 DIA X 80.3	150.1	1	NITROGEN CHARGED HPU; POWDER GRAIN EPU, ROLL COMMAND ENGLISH BIAS
GUIDANCE & CONTROL SECT.	RAYTHEON SX-101-8009	8.0 DIA X 80.3	150.1	1	HYDRAULIC POWER UNIT MIDSECTION; POWDER GRAIN EPU; ROLL COMMAND ENGLISH BIAS FOR MISSILES R-3455 TO R-8125 MUST BE MODIFIED AS PER ALMC #5
GUIDANCE & CONTROL SECT.	RAYTHEON SX 101-8009	8.0 DIA X 80.3	150.1	1	HYDRAULIC POWER UNIT MIDSECTION, POWDER GRAIN EPU; ROLL COMMAND ENGLISH BIAS FOR MISSILES R-8126 TO 11083
WARHEAD MK 18 MOD 0	BUORD DWG 1519431	8.0 DIA X 14.0	69.6	1	
WARHEAD MK 38 MOD 0	BUORD DWG 1519431	8.0 DIA X 14.0	69.4	1	SEE NAVWEPS 01-265 GMAD-9 PARA. 2-41 FOR USAGE
MOTOR SECT. MK 6 MOD 3	RAYTHEON HU-SX 101-8009	8.0 DIA X 51.9	127.4	1	BOATTAIL ASSEMBLED TO MOTOR
IGNITER MK 258 MOD 0	BUWEPS DWG 2313631	2.9 HEX X 3.7	—	1	FOR MOTOR SECTION
FORWARD FIN	RAYTHEON 5504-5076	18.6 X 2.5 X 17.9	8.5 EA.	4	
FORWARD FIN	RAYTHEON 2063-5147	18.6 X 2.5 X 17.9	9.4 EA.	4	SEE NAVWEPS 01-265 GMAD-9 PARA. 2-41 FOR USAGE
AFT FIN	RAYTHEON 2070-1021	18.5 X .9 X 12.7	2.8 EA.	4	
AFT FIN	RAYTHEON 2070-5018	18.5 X .9 X 12.7	3.0 EA.	4	SEE NAVWEPS 01-265 GMAD-9 PARA. 2-41 FOR USAGE
WAVEGUIDE	RAYTHEON VD-7108707-900	69.2 X 1.5 X 1.0	1.5	1	

SPARROW III AIM-7D OPERATIONAL CHARACTERISTICS

- | | |
|---|--|
| 1. TYPE DETECTION - SEMI-ACTIVE CW RADAR HOMING | 7. TYPE FUZING - INFLUENCE |
| 2. TYPE GUIDANCE - PROPORTIONAL NAVIGATION | 8. TYPE PROPULSION - SOLID PROPELLANT |
| 3. GUIDANCE TIME DURATION - | 9. NOMINAL MOTOR BURN TIME - |
| 4. TYPE CONTROL - HYDRAULICALLY OPERATED | 10. SPEED - SUPERSONIC |
| 5. TYPE WARHEAD - CONTINUOUS ROD | 11. RANGE - 10 MILES |
| 6. WARHEAD KILL RADIUS - | 12. MAX OPERATING ALTITUDE - 70,000 FEET |

NOTES:

- WEAPONS ARE PRESENTLY RECEIVED ABOARD SHIP IN COMPONENT FORM AND STOWED IN THIS CONDITION EXCEPT FOR A NUMBER OF READY SERVICE WEAPONS.
- UPON IMPLEMENTATION OF THE IRR PROGRAM, WEAPONS WILL BE RECEIVED ABOARD SHIP ASSEMBLED (LESS FINS), THREE PER MK 12 MOD 2 CRADLE. WEAPONS WILL BE STOWED IN THIS CONDITION EXCEPT FOR A NUMBER OF READY SERVICE.

ORIGINAL DATA SOURCE

NAVWEPS 01-265GMAD-9
DATED 1 MARCH 1967

SPARROW III AIM-7E GENERAL ARRANGEMENT

PHASE "C" ANTENNA- MISSILES R-1-B AND SUBSEQUENT

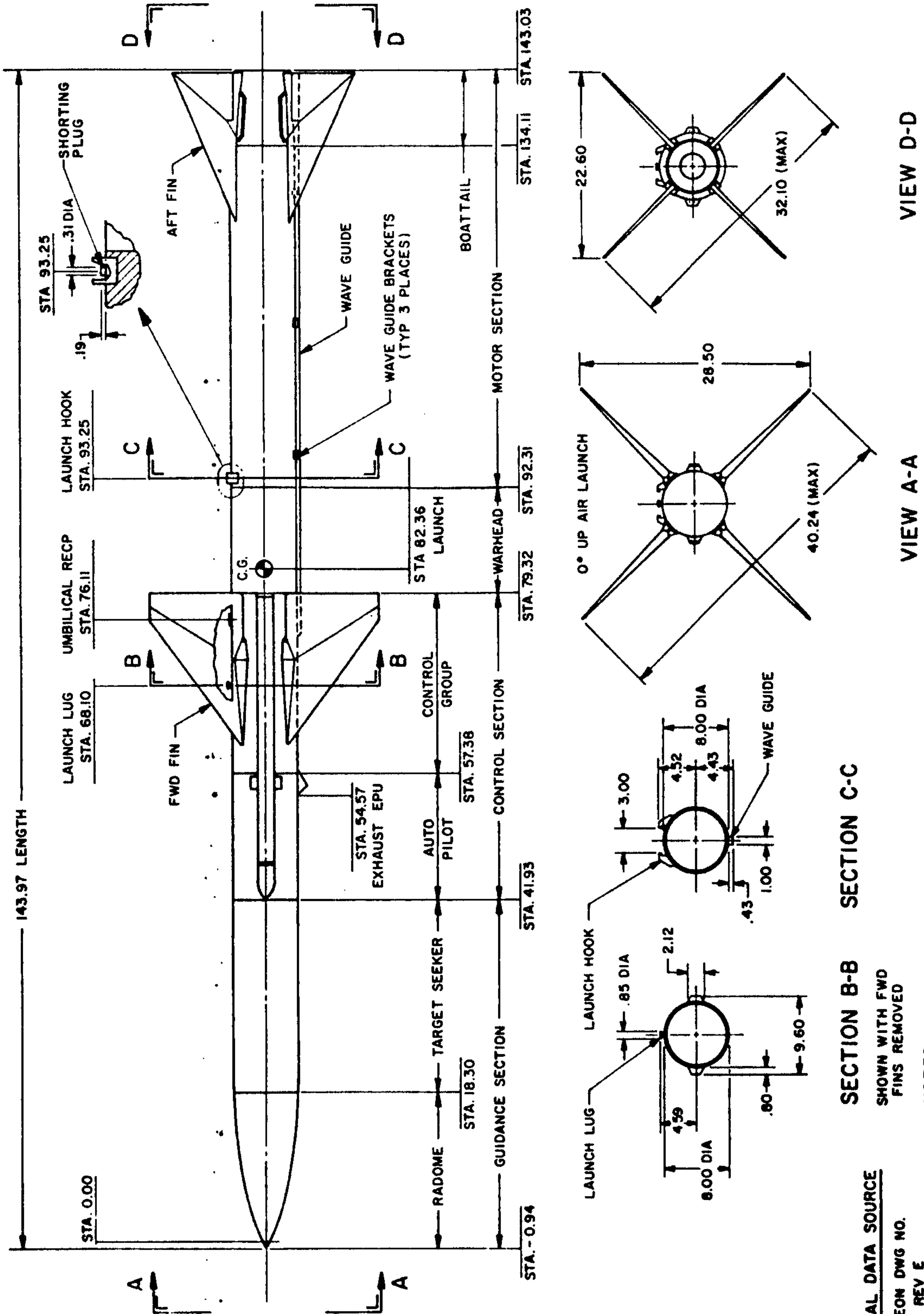

ORIGINAL DATA SOURCE
 RAYTHEON DWG NO. 138314 REV E
 DATED 21 FEB. 1966
 NAVWEPS 01-265GMAD-9
 DATED 1 MARCH 1967

SECTION B-B SECTION C-C

SHOWN WITH FWD
 FINS REMOVED

NOTES:

1. APPROXIMATE WEIGHT - 435.1 LBS.
2. MISSILE IS LAUNCHED FROM TYPE AERO 7A AND LAU-17/A LAUNCHERS.

SPARROW III AIM-7E MISSILE COMPONENTS

PHASE "C" ANTENNA - MISSILES R-I-B AND SUBSEQUENT

COMPONENT	CONTRACTORS NAME & PART NO. OR TYPE	PART SIZE L X W X H	PART WT.	QTY MSL	REMARKS
GUIDANCE & CONTROL SECT.	RAYTHEON SX-101-8009	8.0 DIA X 80.3	155.7	1	HYDRAULIC POWER UNIT MIDSECTION; POWDER GRAIN EPU; ROLL COMMAND ENGLISH BIAS
WARHEAD MK 38 MOD 0	BUORD DWG 1519431	8.0 DIA X 14.0	69.4	1	
MOTOR SECT. MK 38 MOD 0	RAYTHEON VD-7150575-2681	8.0 DIA X 51.9	155.5	1	BOATTAIL INTEGRAL PART OF MOTOR SECTION
IGNITER MK 265 MOD 0	NAA DWG 801308	1.8 HEX X 8.9	1.4	1	FOR MOTOR SECTION
FORWARD FIN	RAYTHEON 2063-5147	18.6 X 2.6 X 17.9	9.4 EA.	4	
AFT FIN	RAYTHEON 2070-5018	18.5 X 9 X 12.7	3.0 EA.	4	
WAVEGUIDE	RAYTHEON VD-7108707-900	69.2 X 1.5 X 1.0	1.5	1	

SPARROW III AIM-7E OPERATIONAL CHARACTERISTICS

- | | |
|---|--|
| 1. TYPE DETECTION - SEMI-ACTIVE CW RADAR HOMING | 7. TYPE FUZING - INFLUENCE AND CONTACT |
| 2. TYPE GUIDANCE - PROPORTIONAL NAVIGATION | 8. TYPE PROPULSION - SOLID PROPELLANT |
| 3. GUIDANCE TIME DURATION - | 9. NOMINAL MOTOR BURN TIME - |
| 4. TYPE CONTROL - HYDRAULICALLY OPERATED | 10. SPEED - SUPERSONIC |
| 5. TYPE WARHEAD - CONTINUOUS ROD | 11. RANGE - 13 MILES |
| 6. WARHEAD KILL RADIUS - | 12. MAX OPERATING ALTITUDE - 90,000 FEET |

NOTES:

- WEAPONS ARE PRESENTLY RECEIVED ABOARD SHIP IN COMPONENT FORM AND STOWED IN THIS CONDITION EXCEPT FOR A NUMBER OF READY SERVICE WEAPONS.
- UPON IMPLEMENTATION OF THE IRR PROGRAM, WEAPONS WILL BE RECEIVED ABOARD SHIP ASSEMBLED (LESS FINS), THREE PER MK 12 MOD 2 CRADLE. WEAPONS WILL BE STOWED IN THIS CONDITION EXCEPT FOR A NUMBER OF READY SERVICE.

ORIGINAL DATA SOURCE
 NAVWEPS 01-265GMAD-9
 DATED 1 MARCH 1967

SPARROW III XAIM-7F GENERAL ARRANGEMENT

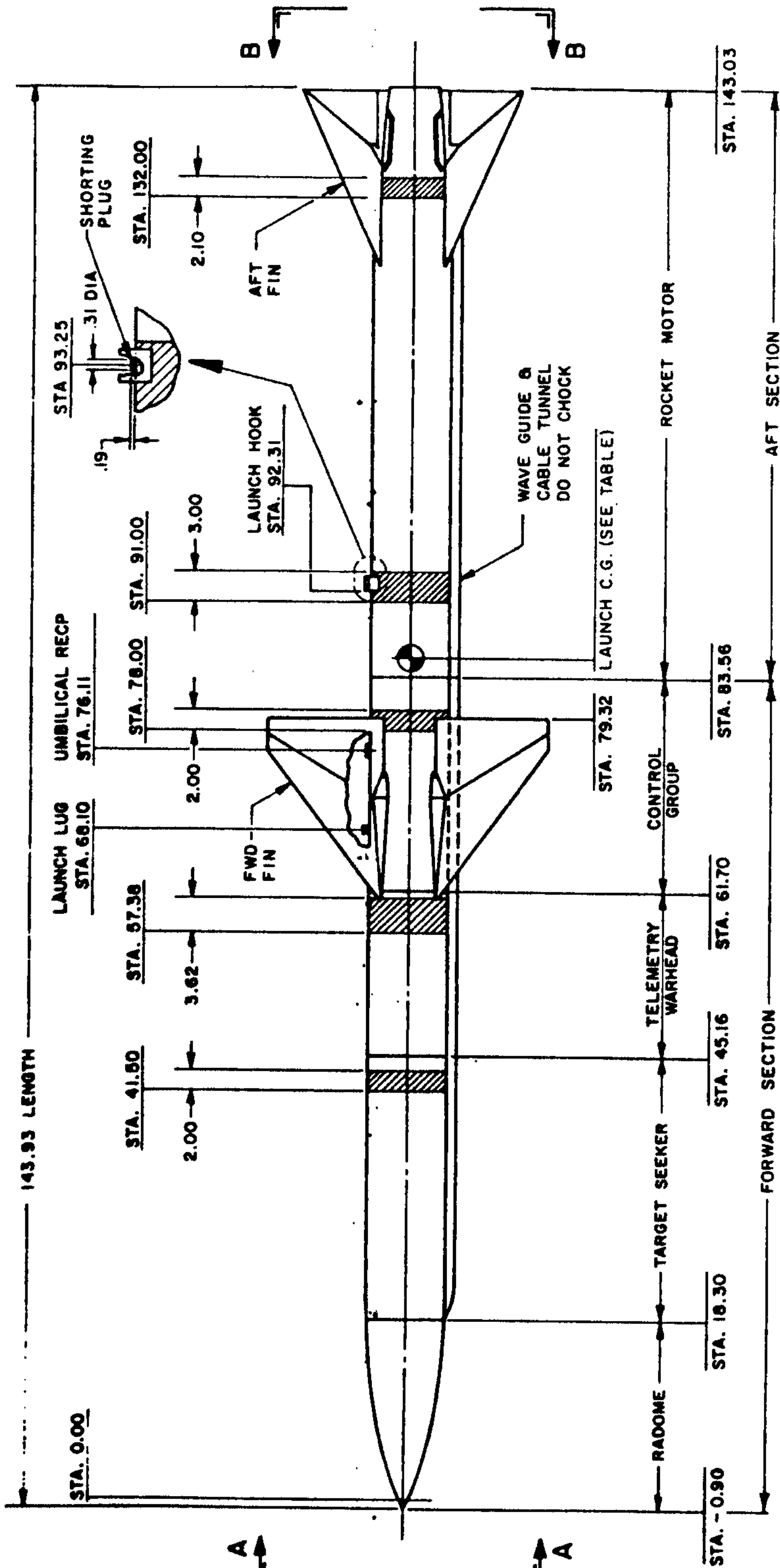

MISSILE ASSY	C.G. AT LAUNCH	LAUNCH WEIGHT	C.G. AT BURNOUT	BURNOUT WEIGHT
XAIM 7F-1	STA 82.2	455.6 LBS	↑	358.3 LBS
XAIM 7F-2	STA 81.8	472.8 LBS	STA 73.0	375.5 LBS
XAIM 7F-3	STA 83.7	499.6 LBS	↓	365.1 LBS
XAIM 7F-4	STA 83.4	516.9 LBS	↓	382.4 LBS

NOTES:

1. FINS SIMILAR TO THOSE USED ON AIM-7E.
2. [Hatched Area Symbol] DENOTES HARD AREA.
3. APPROXIMATE WEIGHT (LESS FINS) - 453.1 LBS (MAX)

ORIGINAL DATA SOURCE

RAYTHEON REPORT BR 4311
DATED JUNE 1967

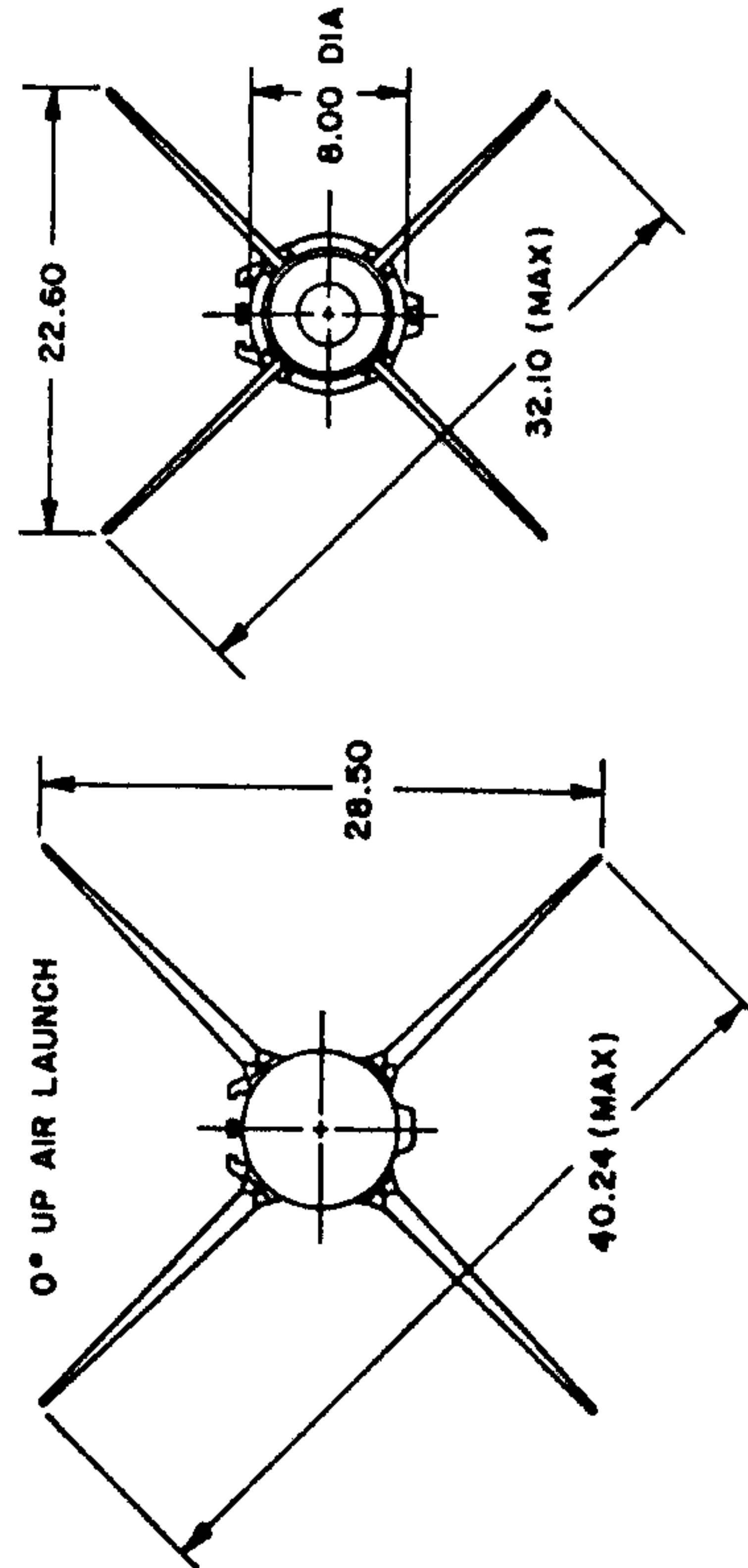

VIEW A-A

VIEW B-B

PRELIMINARY

SPARROW III AIM-7 HARD SPOT LOCATIONS

PHASE "A" AND "C" ANTENNAS

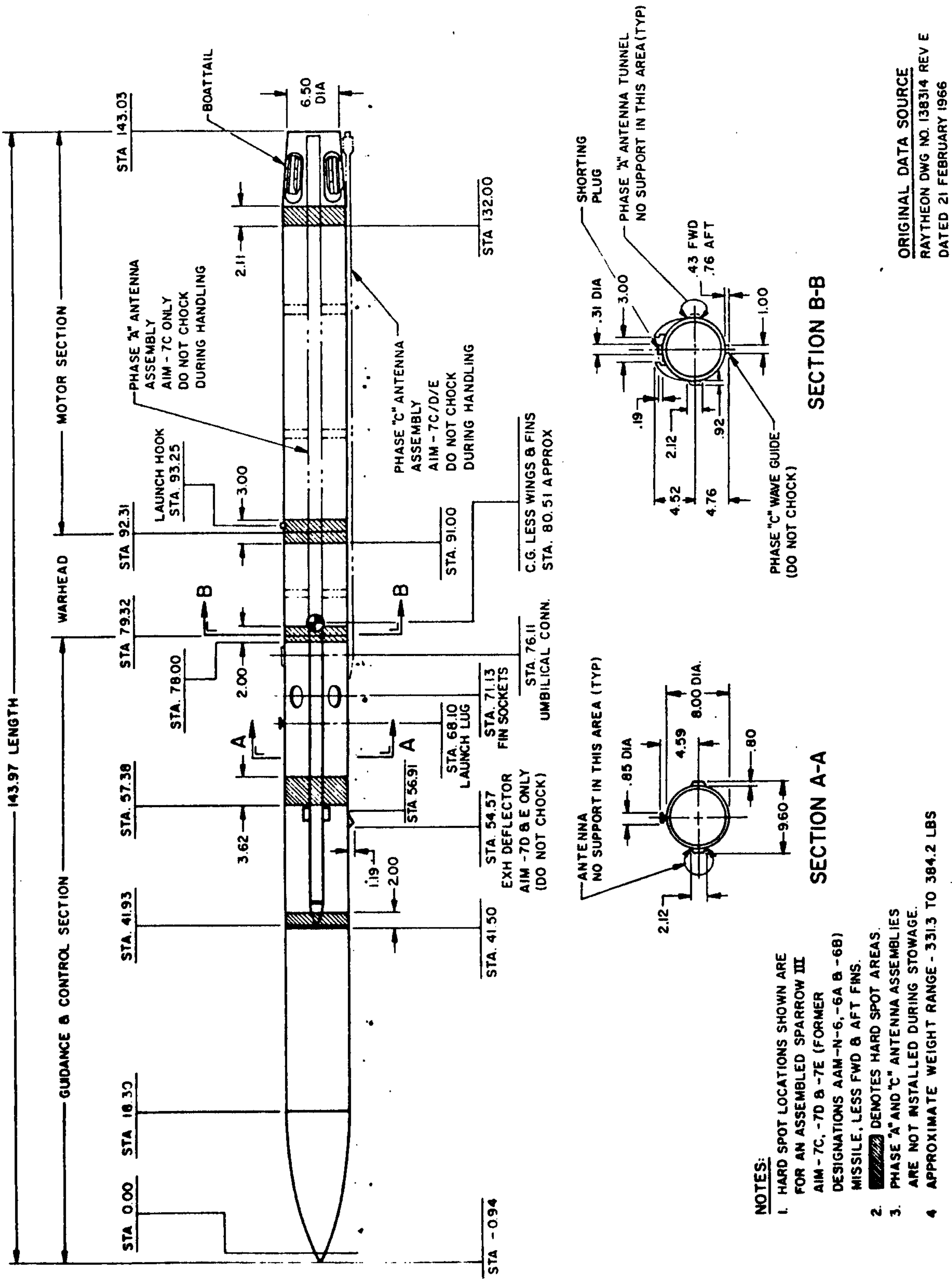

ORIGINAL DATA SOURCE
RAYTHEON DWG NO. 138314 REV E
DATED 21 FEBRUARY 1966

GUIDANCE AND CONTROL SECTION SPARROW III AIM-7C/D/E

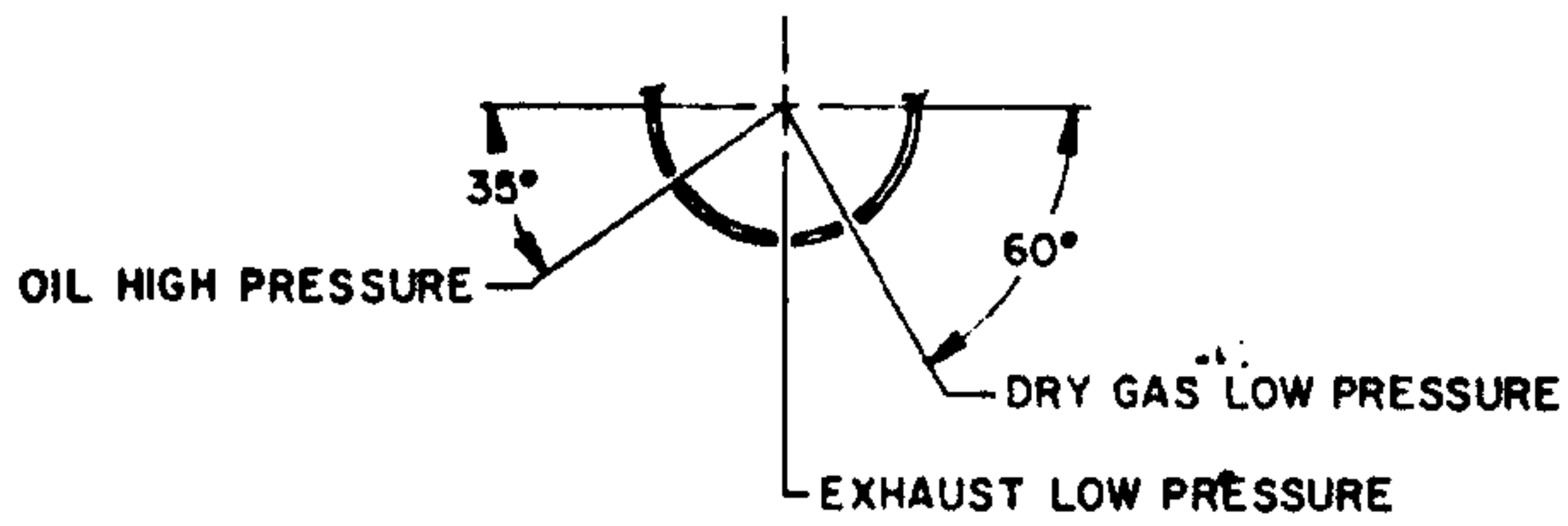
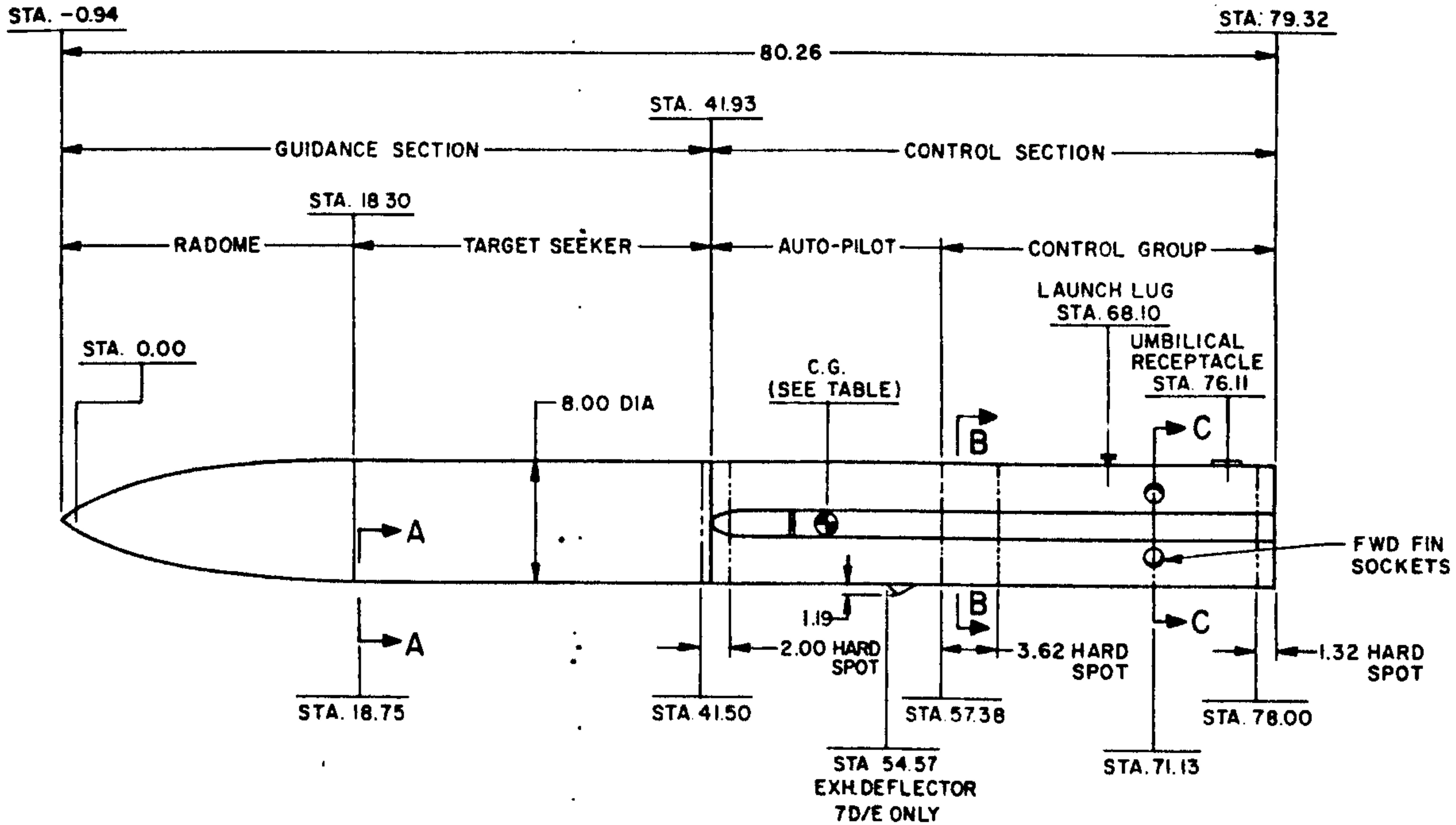

SECTION A-A

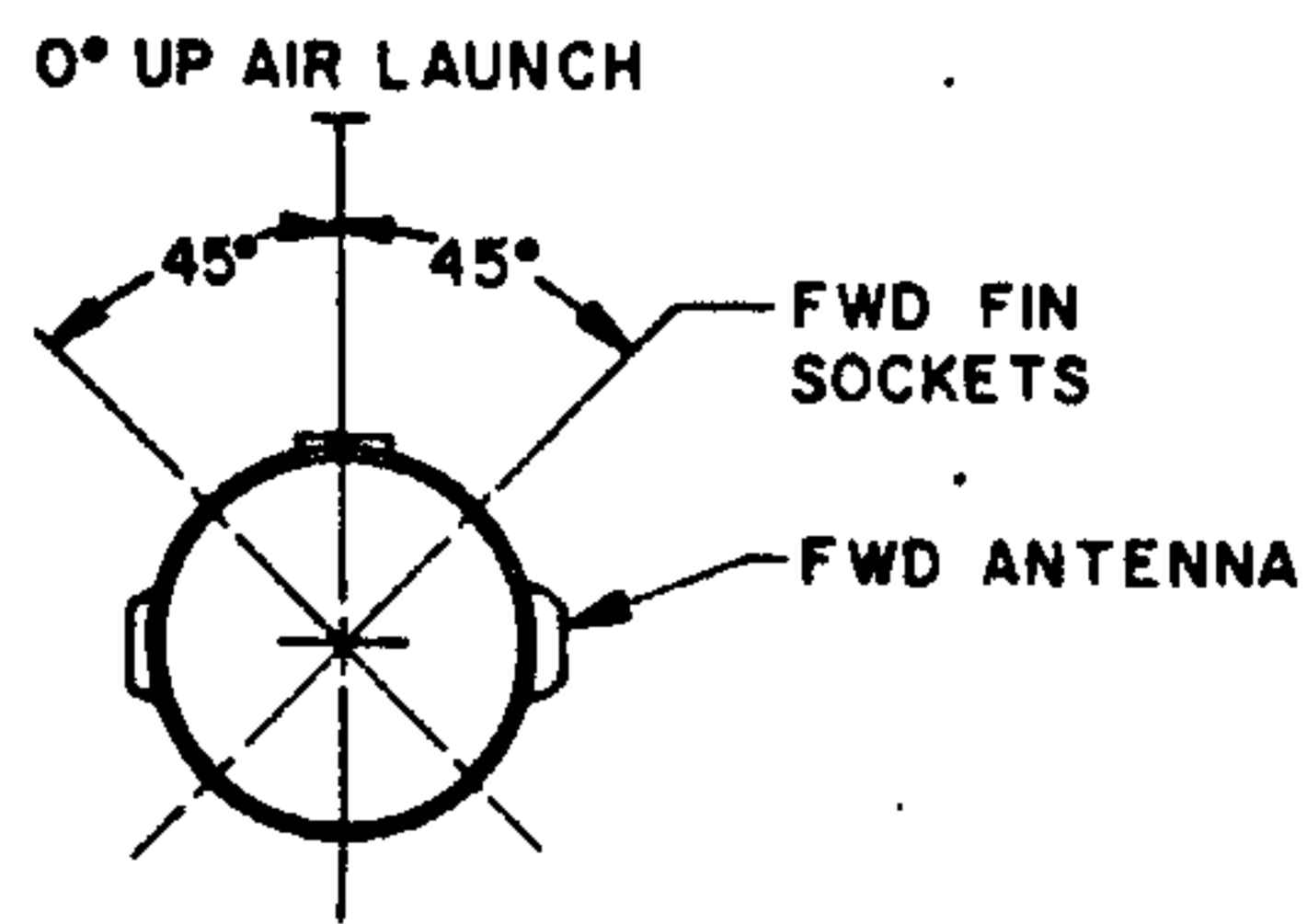

SECTION C-C

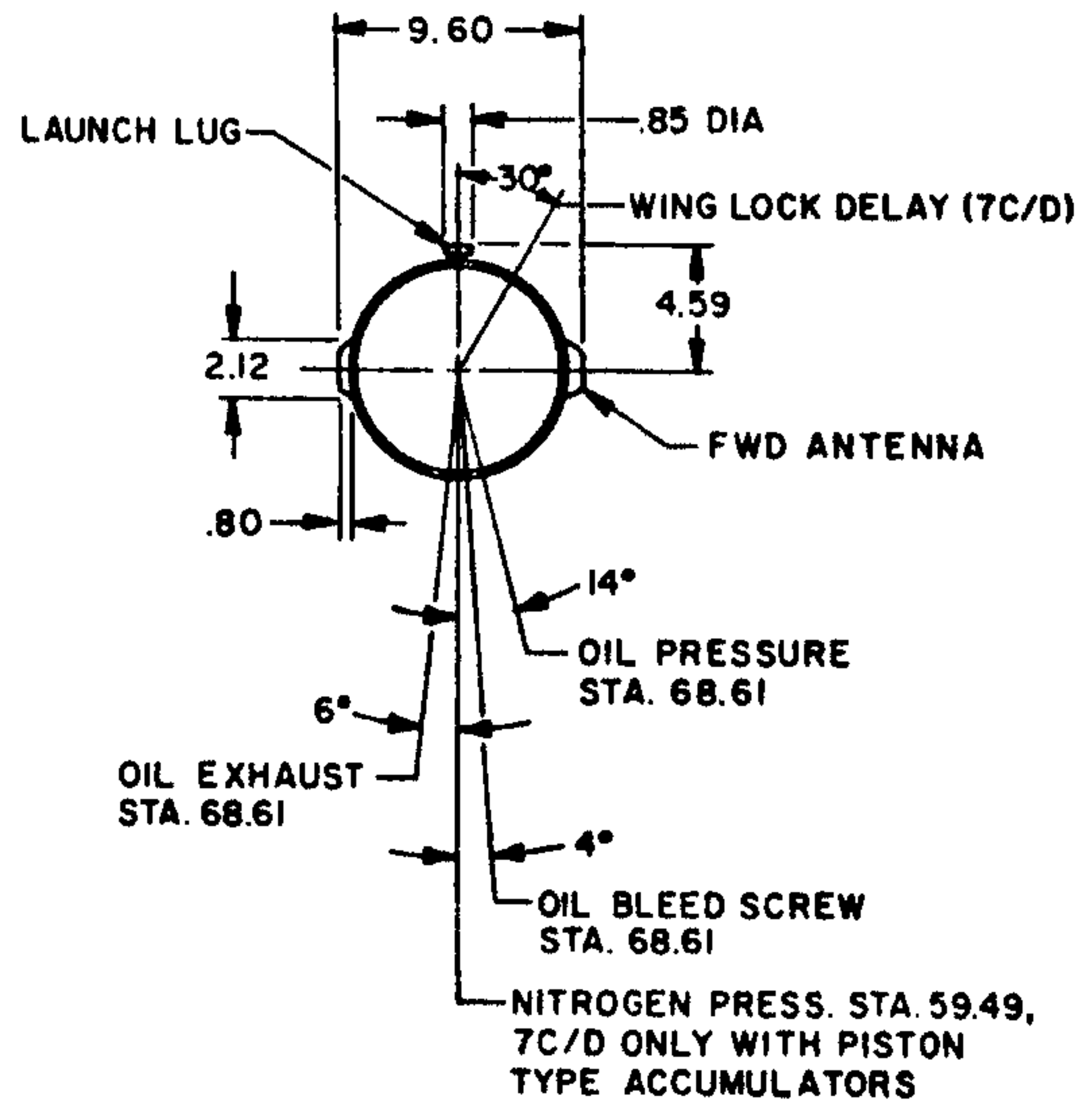

SECTION B-B

G & C	WEIGHT (LBS)	C.G. STA.
AIM-7C	138.9	49.30
AIM-7D	150.1	47.90
AIM-7E	155.7	48.80

NOTE:

- THE SECTIONS FOR PHASE "A" ANTENNA ARE NOT INTERCHANGEABLE WITH PHASE "C" ANTENNA SECTIONS. THE DIFFERENCES DO NOT AFFECT STOWAGE.

ORIGINAL DATA SOURCE
RAYTHEON DWG NO. 138314 REV E
DATED 21 FEBRUARY 1966
NAVWEPS OI-265GMAD-9
DATED 1 MARCH 1967

FORWARD FIN

SPARROW III AIM-7C/D/E

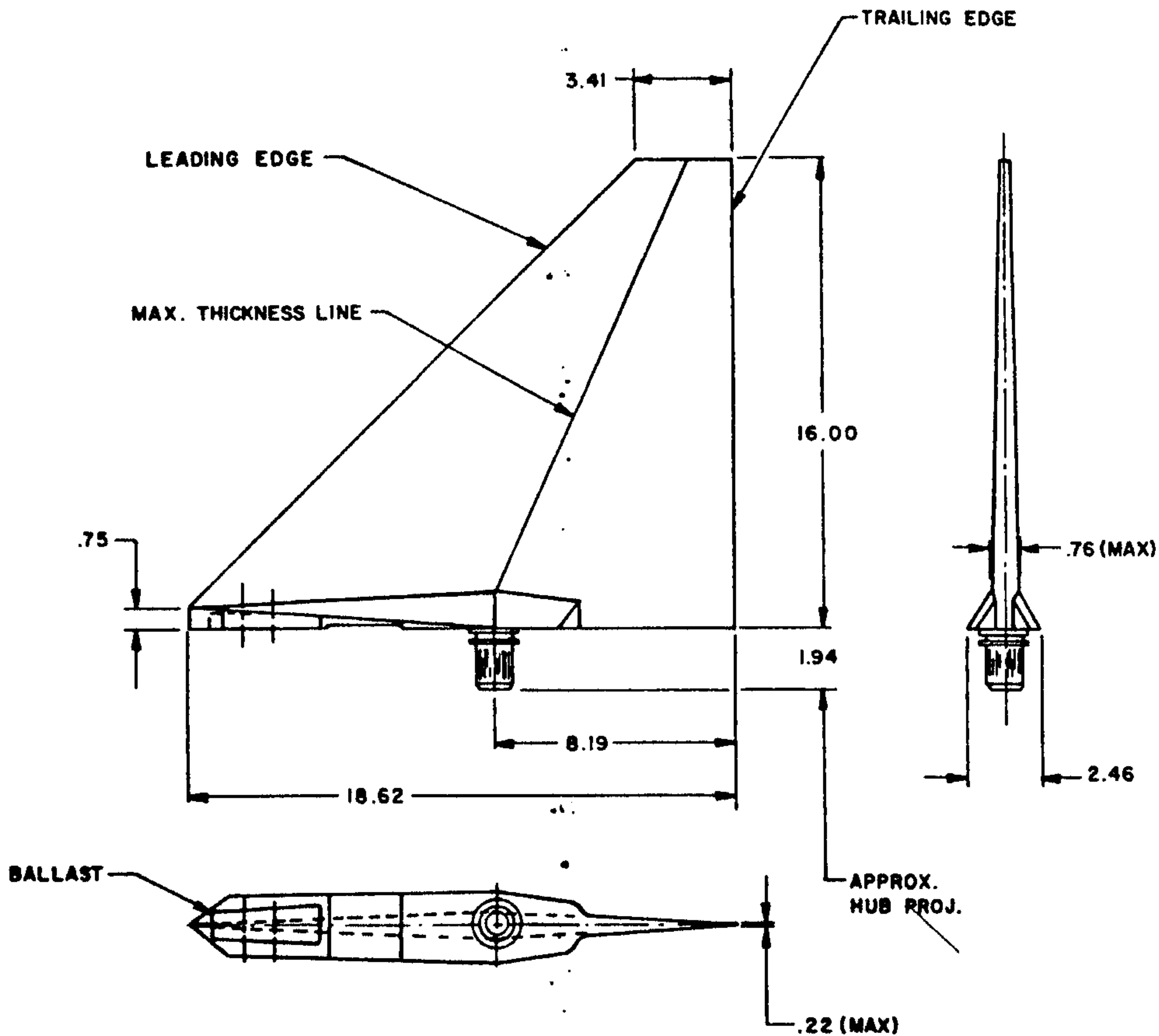

NOTES:

1. FOUR FORWARD FINS SHOWN ARE REQUIRED PER MISSILE.
2. DIMENSIONS SHOWN ARE BASIC, AND APPLY TO ALL SPARROW III FORWARD FINS.
3. APPROXIMATE WEIGHTS (SET OF 4):
 - AIM-7C FINS - 31.5 LBS
 - AIM-7D FINS - 33.8 LBS.
 - AIM-7E FINS - 37.4 LBS.

ORIGINAL DATA SOURCE
RAYTHEON DWG NO.
2063-1717 REV D
DATED 27 FEBRUARY 1964
138314 REV E
DATED 21 FEBRUARY 1966
NAVWEPS 01-265GMAD-9
DATED 1 MARCH 1967

AFT FIN

SPARROW III AIM-7C/D/E

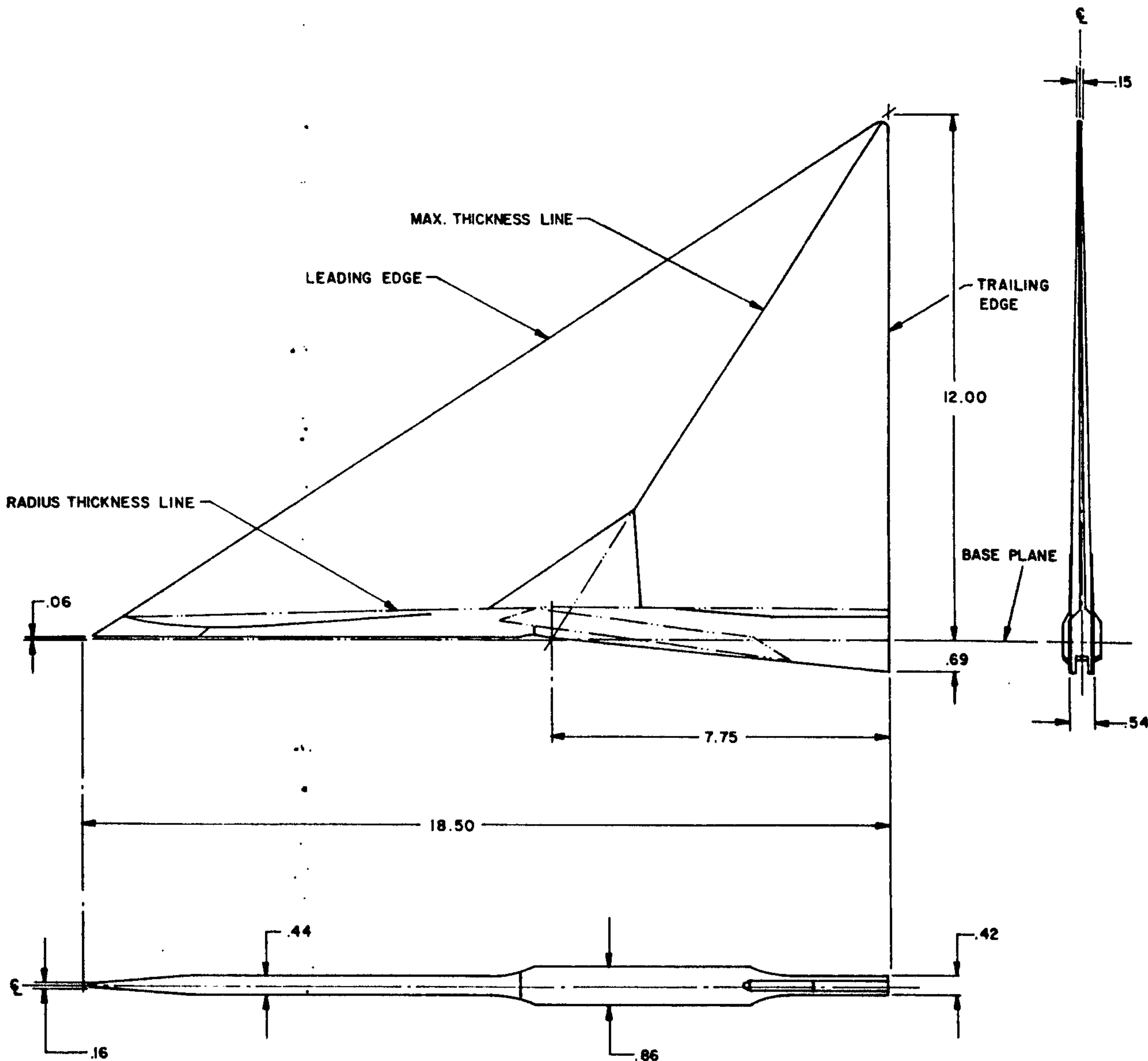

NOTES:

1. FOUR AFT FINS SHOWN ARE REQUIRED PER MISSILE.
2. DIMENSIONS SHOWN ARE BASIC, AND APPLY TO ALL SPARROW III AFT FINS.
3. APPROXIMATE WEIGHTS (SET OF FOUR):
 - AIM-7C FINS - 11.3 LBS
 - AIM-7D FINS - 11.3 LBS
 - AIM-7E FINS - 12.0 LBS

ORIGINAL DATA SOURCE
RAYTHEON DWG NO.
2070-1045 REV D
DATED 7 MARCH 1963
138314 REV E
DATED 21 FEBRUARY 1966
NAVWEP5 01-265GMAD-9
DATED 1 MARCH 1967

BULLPUP AGM-12B GENERAL ARRANGEMENT

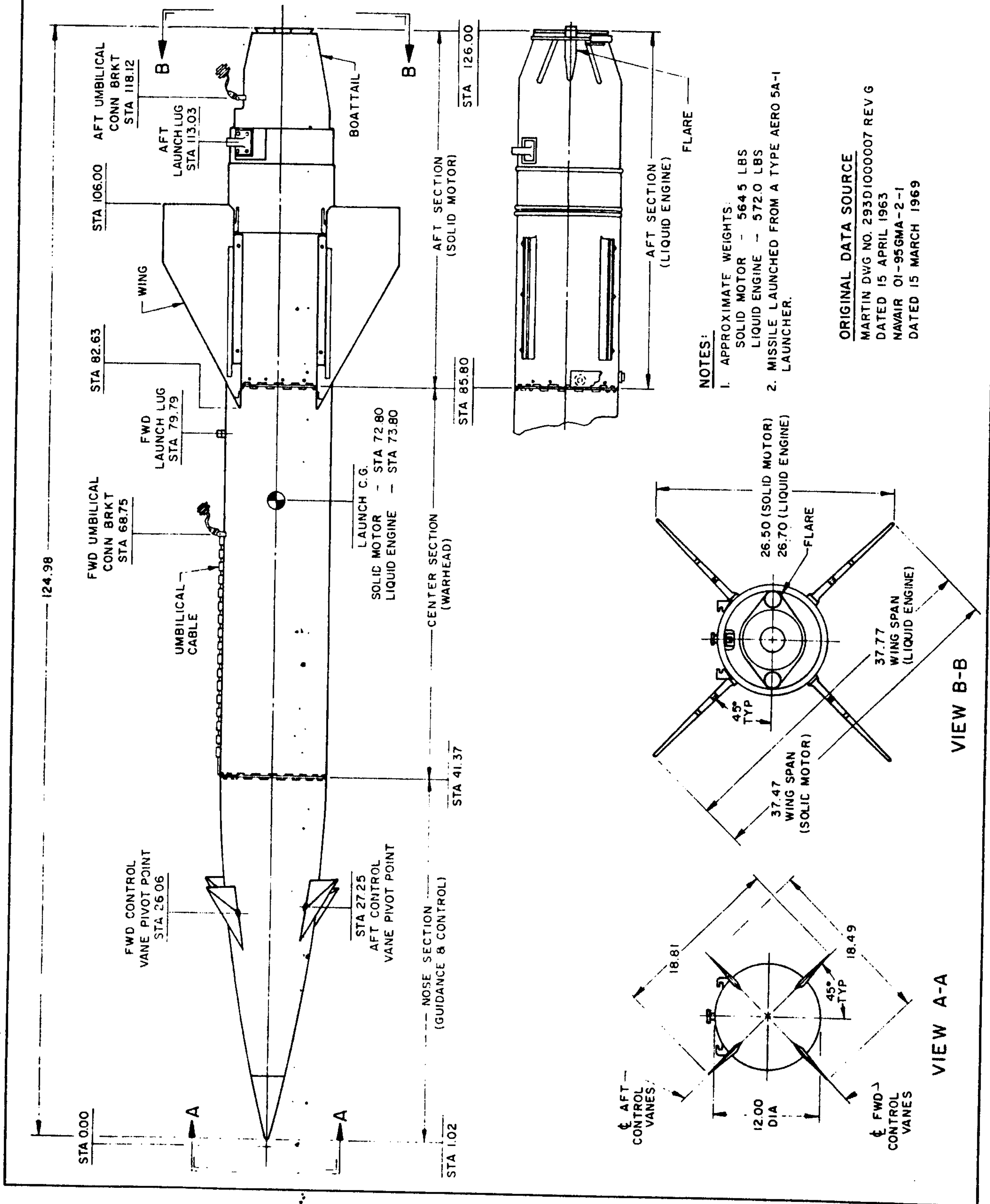

BULLPUP AGM-12B-2/3 GENERAL ARRANGEMENT

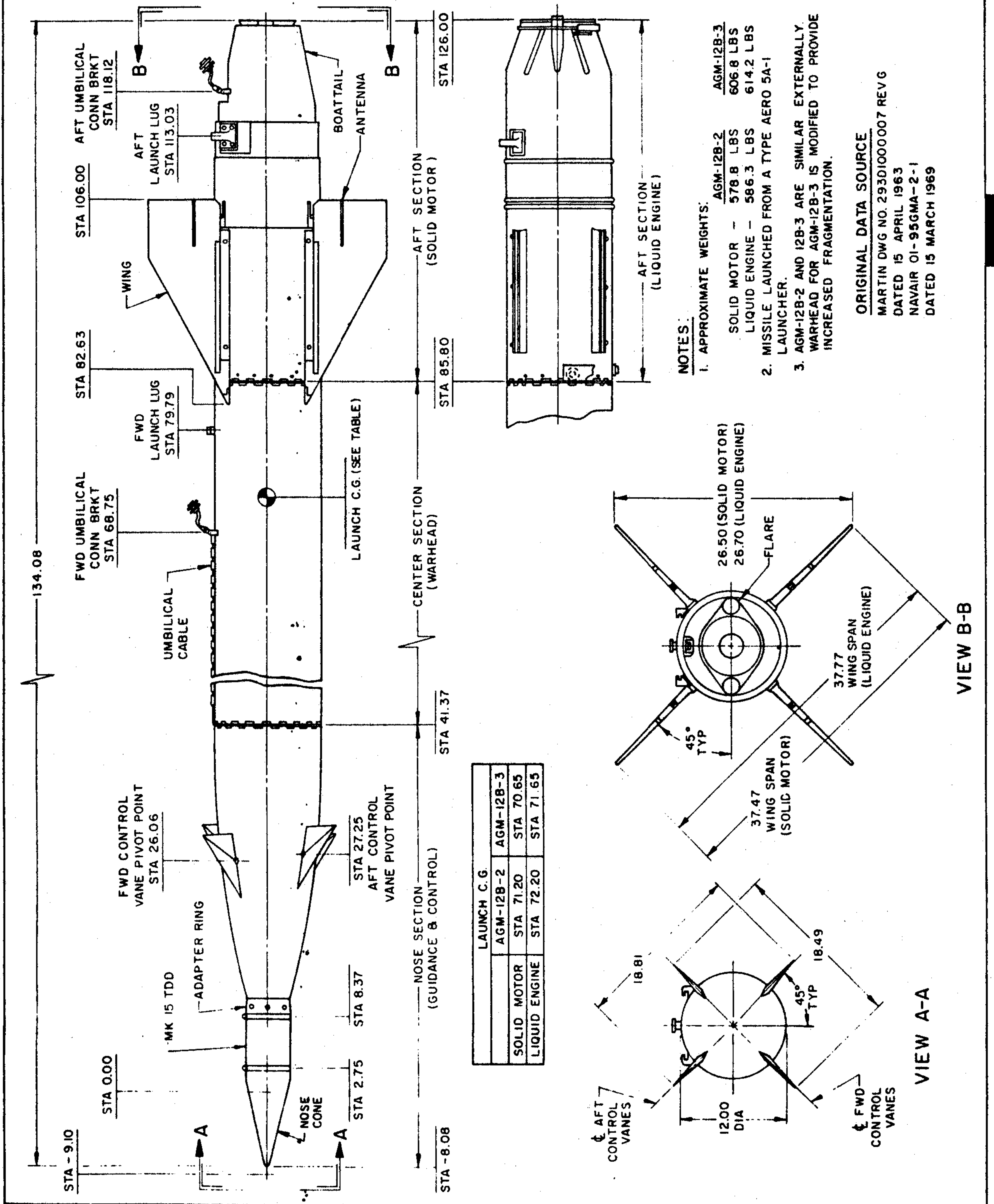

- NOTES:**
- APPROXIMATE WEIGHTS:

AGM-12B-2	AGM-12B-3
SOLID MOTOR - 578.8 LBS	606.8 LBS
LIQUID ENGINE - 586.3 LBS	614.2 LBS
 - MISSILE LAUNCHED FROM A TYPE AERO 5A-1 LAUNCHER.
 - AGM-12B-2 AND 12B-3 ARE SIMILAR EXTERNALLY. WARHEAD FOR AGM-12B-3 IS MODIFIED TO PROVIDE INCREASED FRAGMENTATION.

ORIGINAL DATA SOURCE
 MARTIN DWG NO. 293D1000007 REV G
 DATED 15 APRIL 1963
 NAVAIR 01-95GMA-2-1
 DATED 15 MARCH 1969

BULLPUP AGM-12B, 12B-2/3 HARD SPOT LOCATIONS

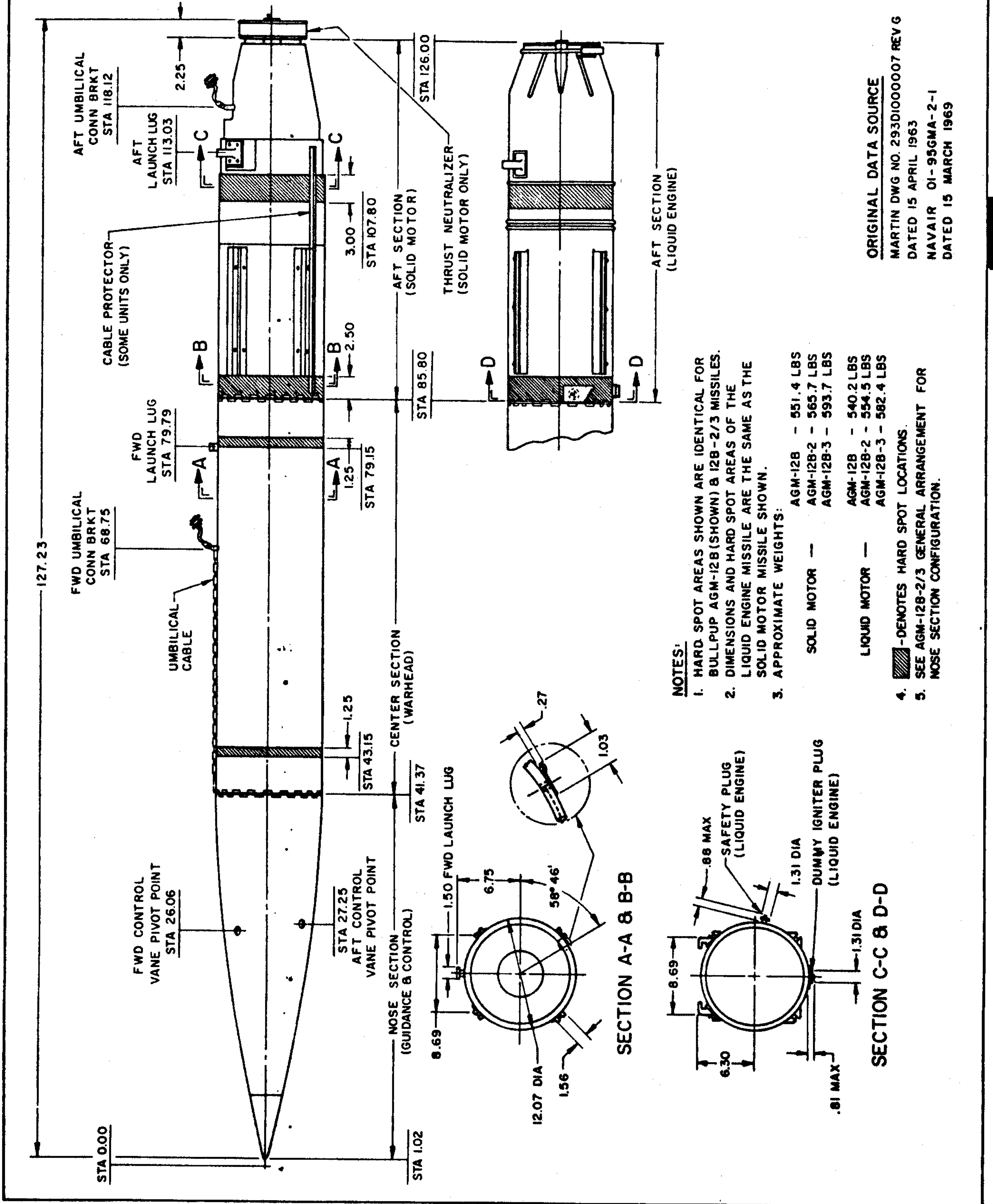

NOSE SECTION (GUIDANCE & CONTROL)

BULLPUP AGM-12B

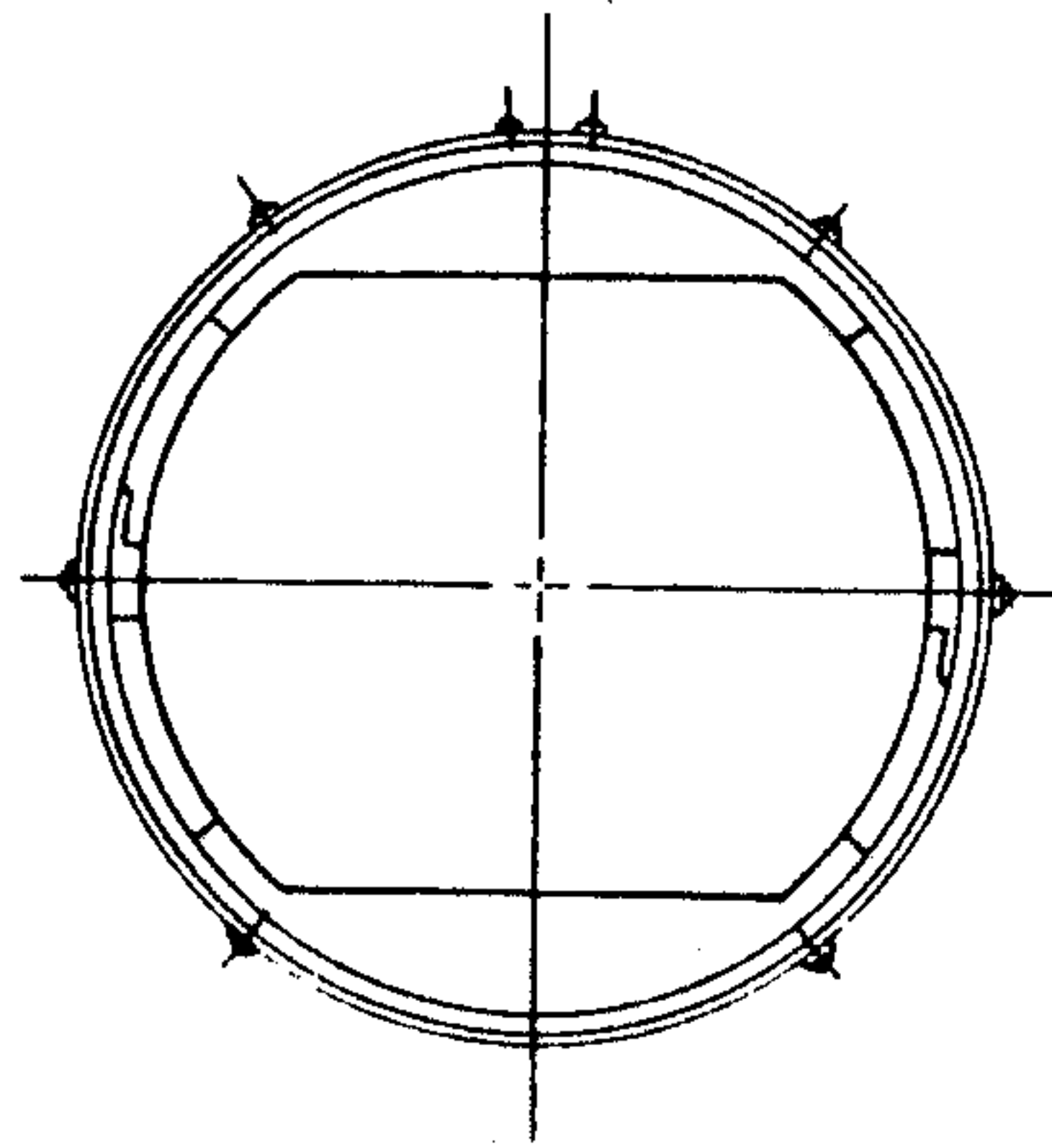
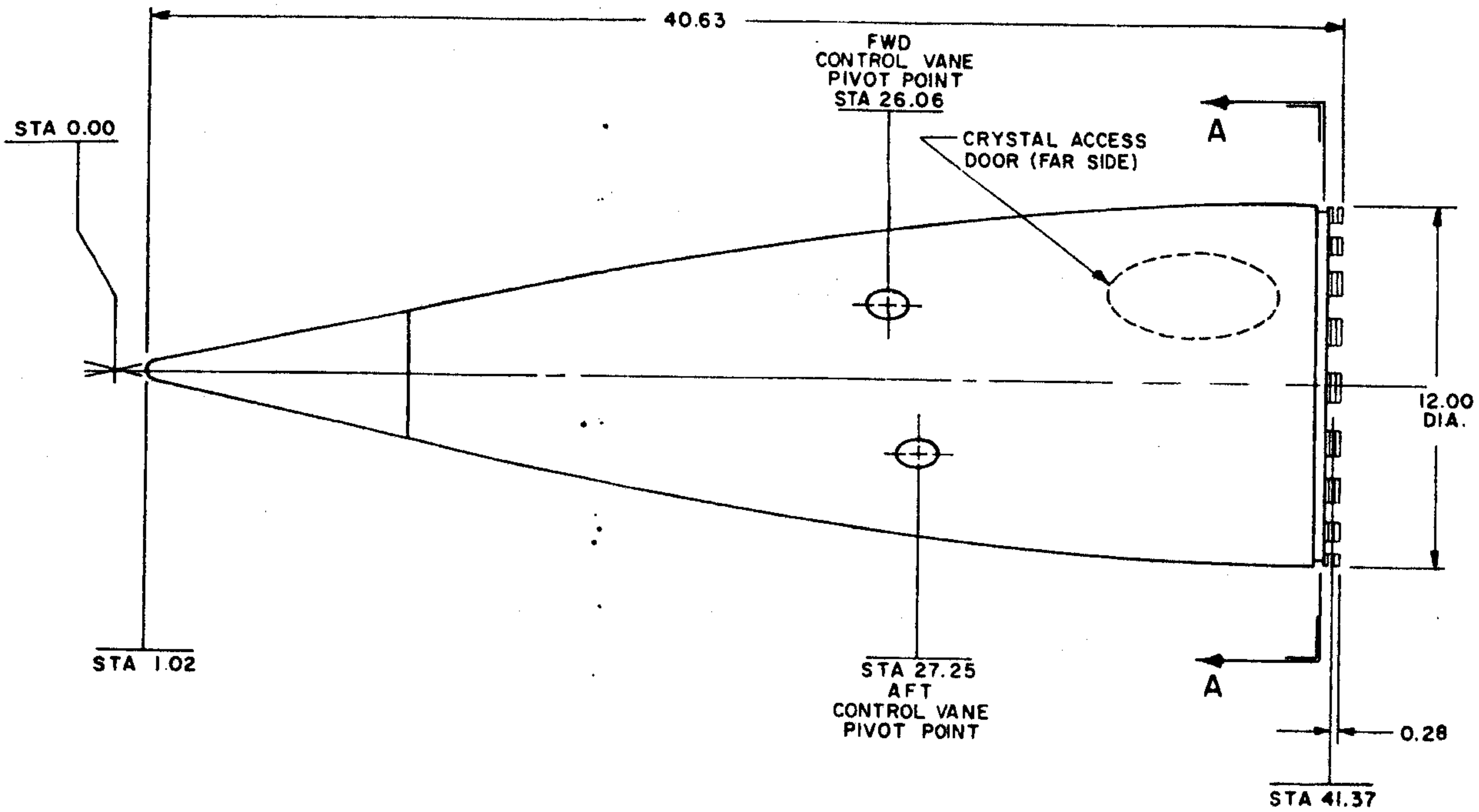

VIEW A-A

NOTES:

1. NOSE SECTION SHOW IS "UNIVERSAL" APPLICABLE TO AGM-12B AND AGM-12C.
2. APPROXIMATE WEIGHT—58.1 LBS.
3. REF FSN 1420-858-4296(X459)

ORIGINAL DATA SOURCE

MARTIN DWG NO
293E6000000 REV N
DATED 4 MAY 1964
NAVAIR 01-95GMA-2-1
DATED 15 MARCH 1969

NOSE SECTION (GUIDANCE & CONTROL)

BULLPUP AGM-12B-2/3

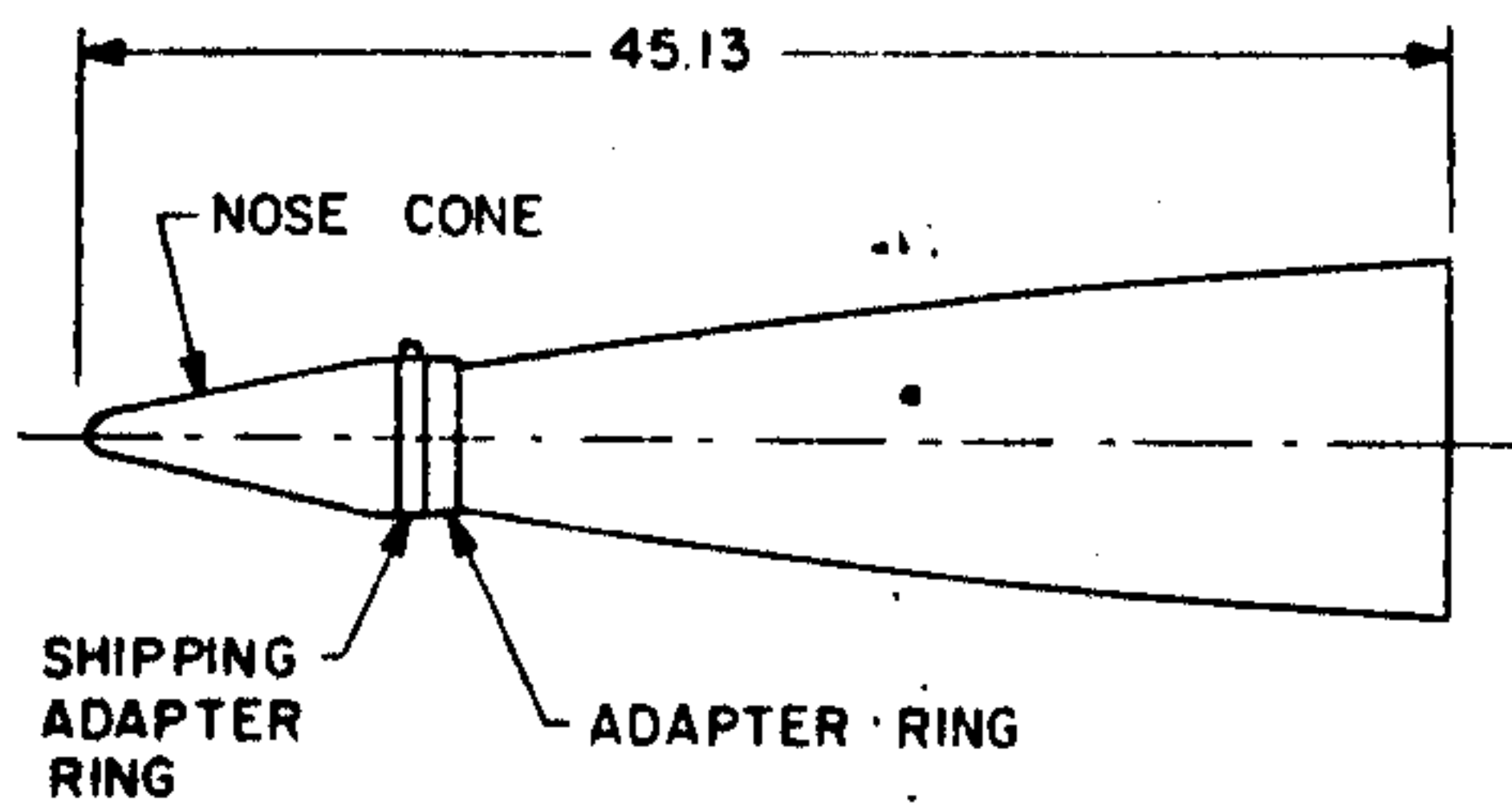
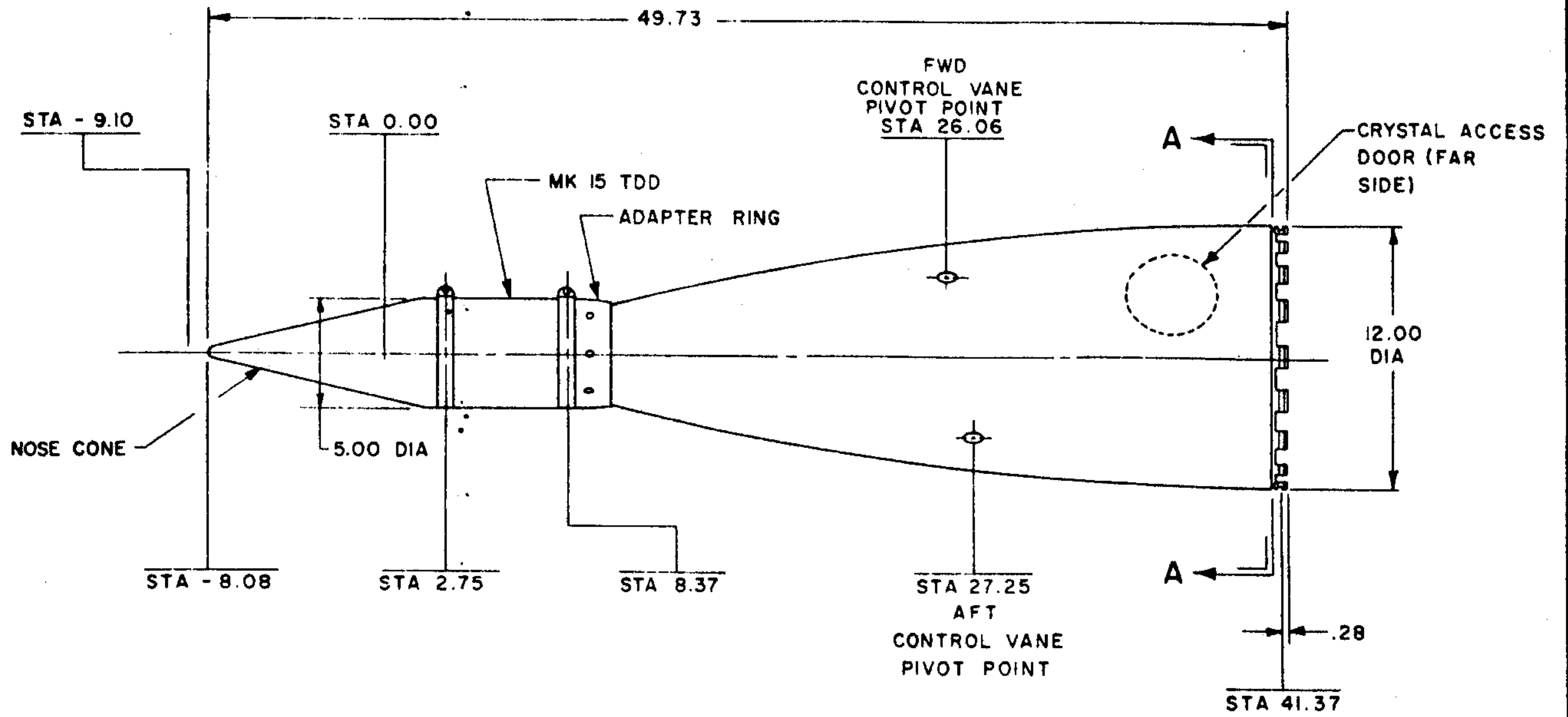

SHOWN AS SHIPPED
LESS MK 15 TDD

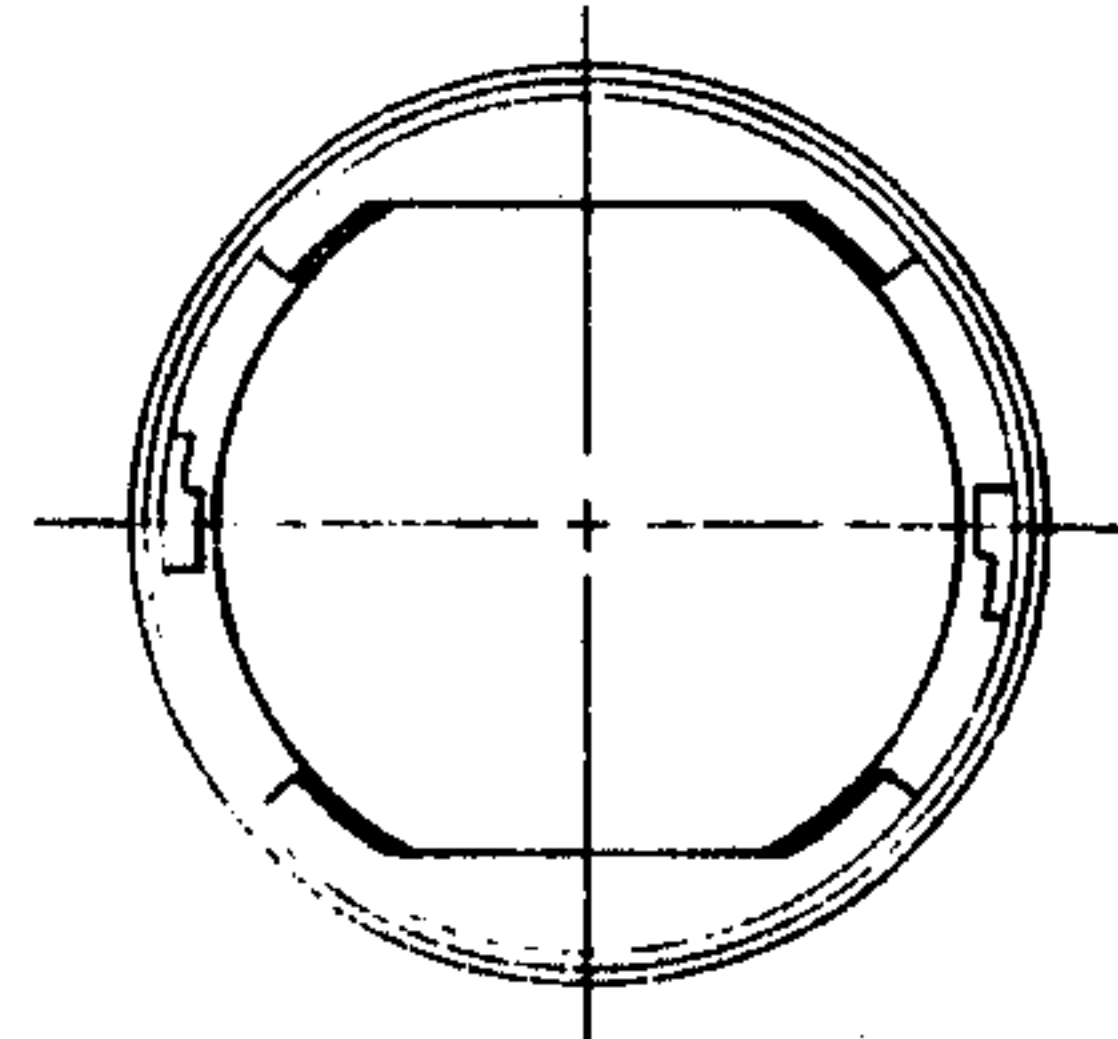

NOTES:

1. APPROXIMATE WEIGHTS:
AS SHIPPED — 62.9 LBS
TDD INSTALLED — 72.4 LBS
2. MODIFIED NOSE, LESS TDD, MAY BE USED ON AGM-12B MISSILE.
3. REF FSN 1420-999-1146(X486)

ORIGINAL DATA SOURCE

NAVAIR 01-95GMA-2-1
DATED 15 MARCH 1969

AFT SECTION (SOLID MOTOR)

BULLPUP AGM-12B, 12B-2/3

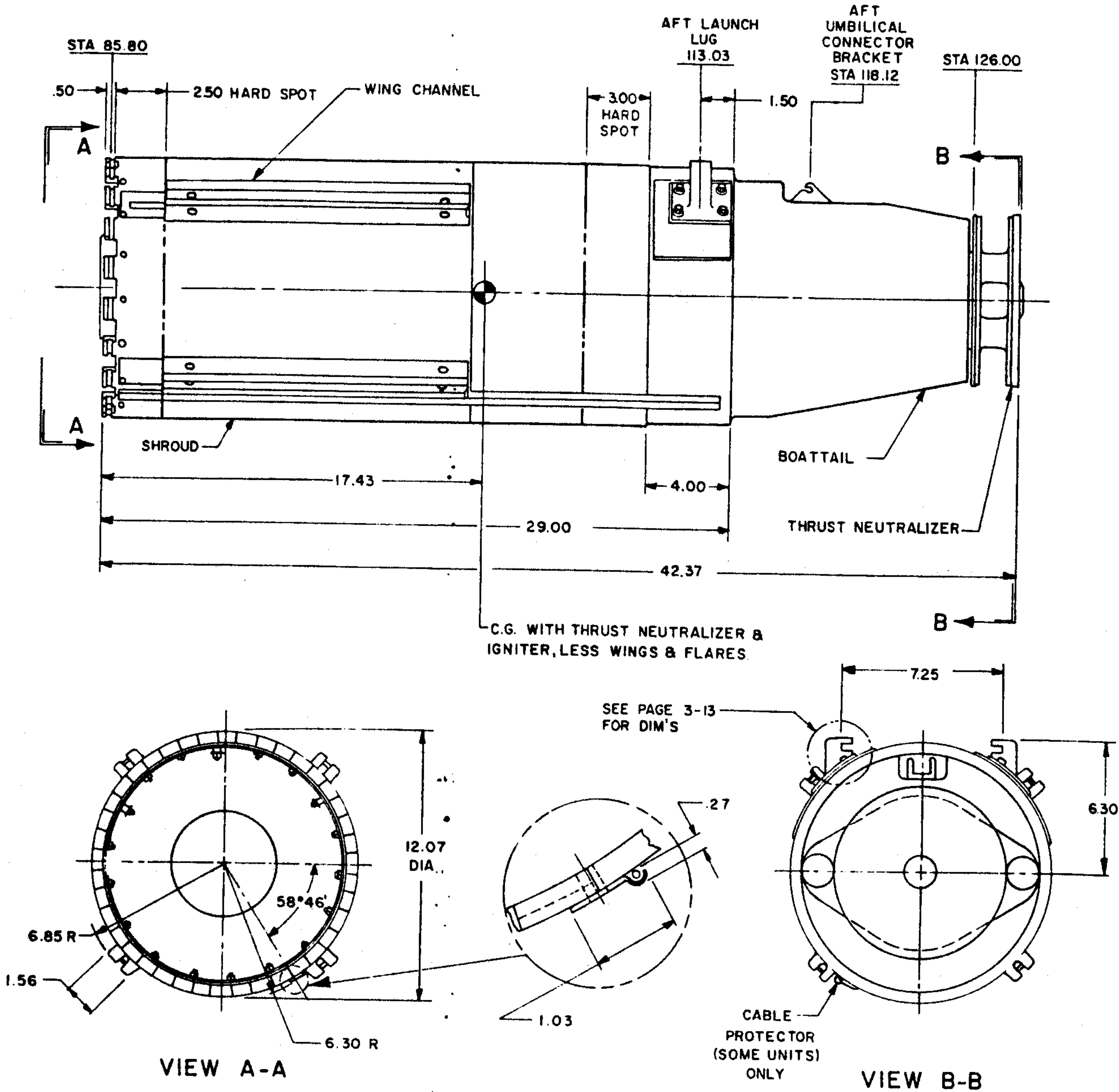

NOTES

1. APPROXIMATE WEIGHT - 221.5 LBS (WITH THRUST NEUTRALIZER)
197.0 LBS (LESS THRUST NEUTRALIZER)
2. AFT SECTION SHOWN WILL BE SHIPPED & STOWED WITH
IGNITER & THRUST NEUTRALIZER INSTALLED,
3. REF FSN 1337-770-6370(V294)

ORIGINAL DATA SOURCE

MARTIN DWG NO
293C8000000 REV. M
DATED 29 JUNE 1963
NAVAIR 01-95GMA-2-1
DATED 15 MARCH 1969

AFT SECTION (LIQUID ENGINE)

BULLPUP AGM-12B, 12B-2/3

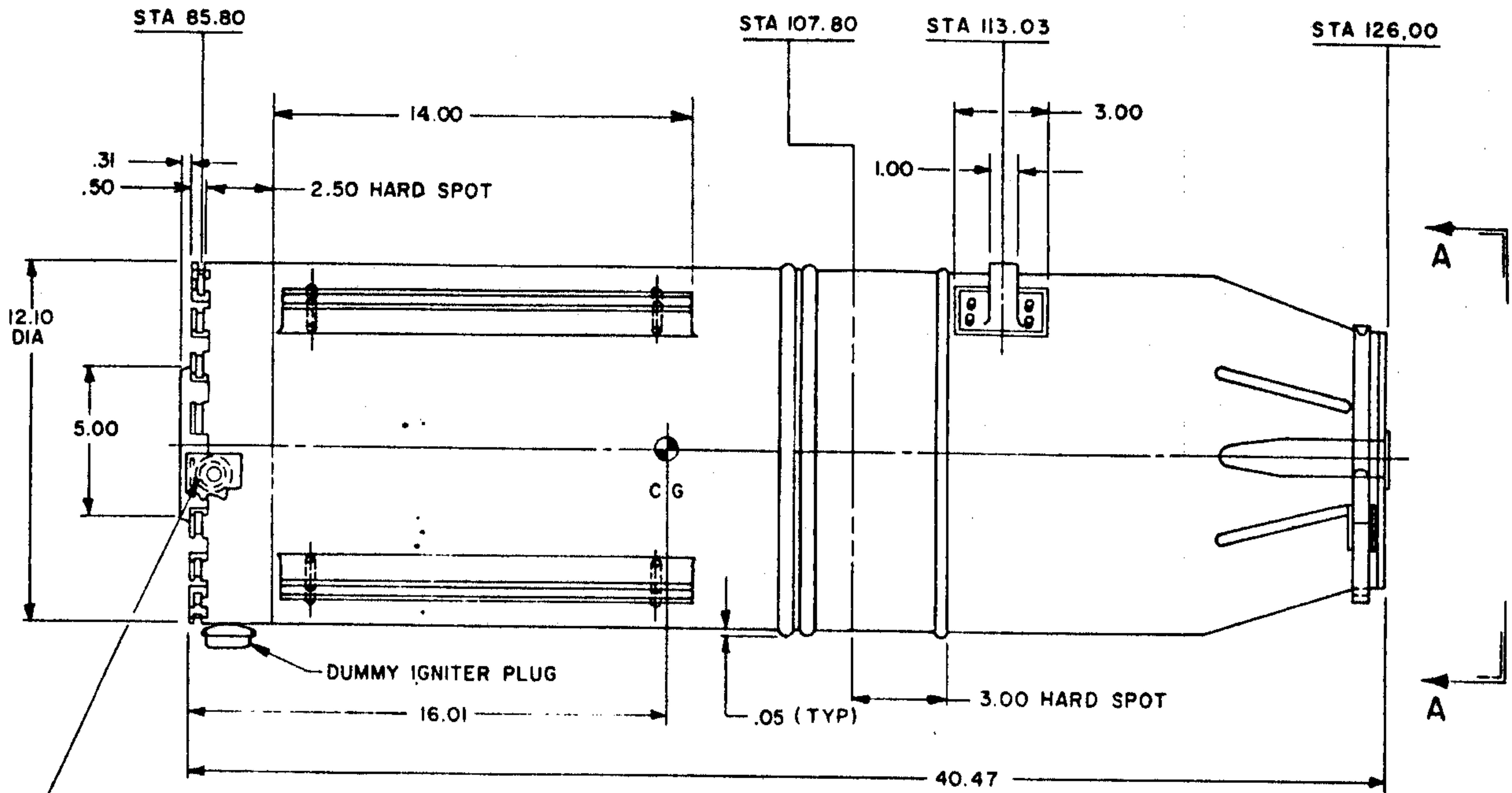

ORDNANCE SAFETY SWITCH
SHORTING PLUG

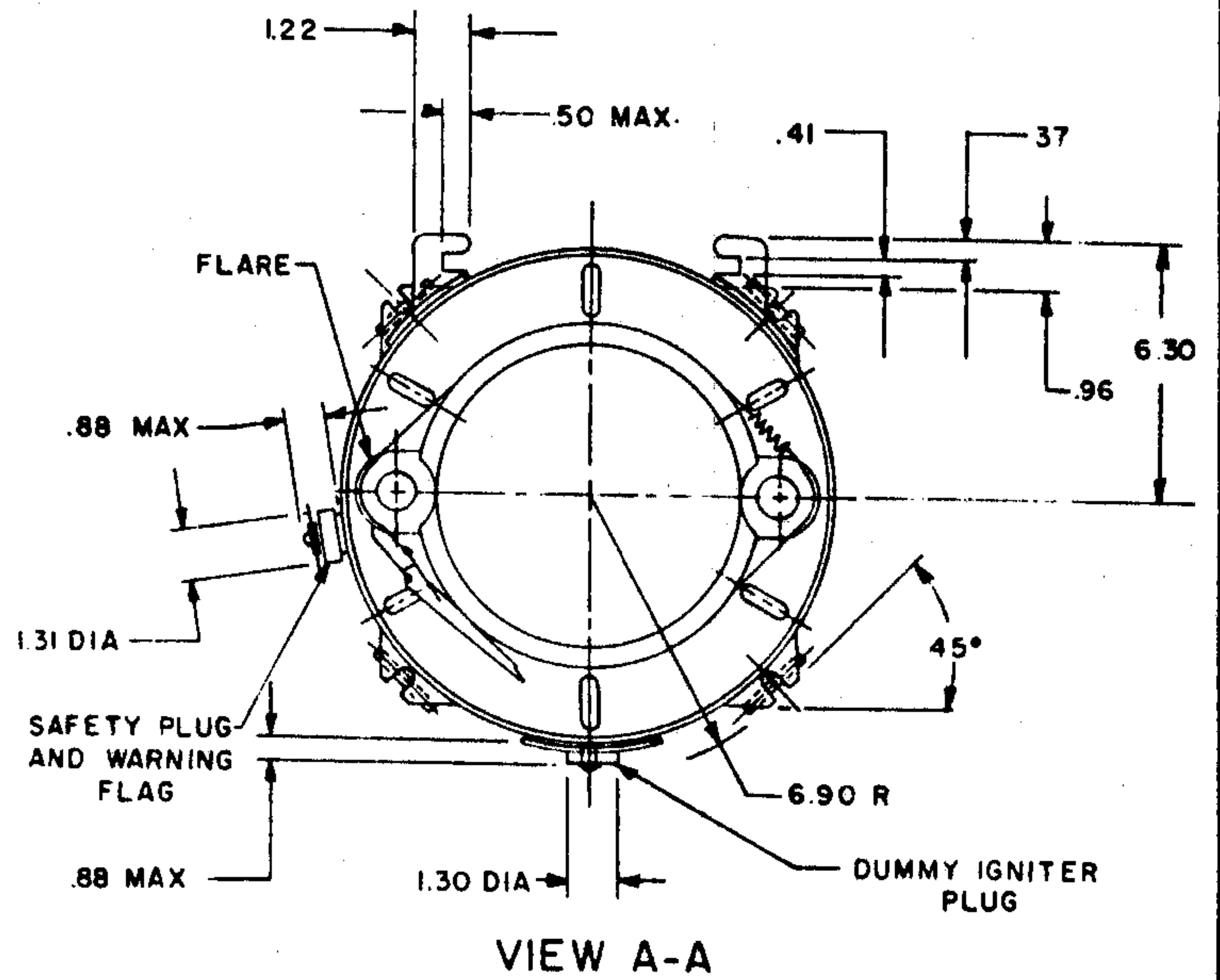

VIEW A-A

NOTES:

- 1 ASSEMBLY SHOWN IS A PREPACKAGED LIQUID FUEL AND OXIDIZER UNIT FOR THE BULLPUP AGM-12B, 12B-2/3 MISSILE.
- 2 APPROXIMATE WEIGHT -198.8 LBS (LR-58-RM-4 ENGINE)
3. REF FSN 2485-801-7532(X455)

ORIGINAL DATA SOURCE
THIokol CHEMICAL CORP.
DWG NO 313207 REV J
DATED 22 APRIL 1960
NAVAIR 01-95GMA-2-1
DATED 15 MARCH 1969

CONTROL VANE

BULLPUP AGM-12B, 12B-2/3

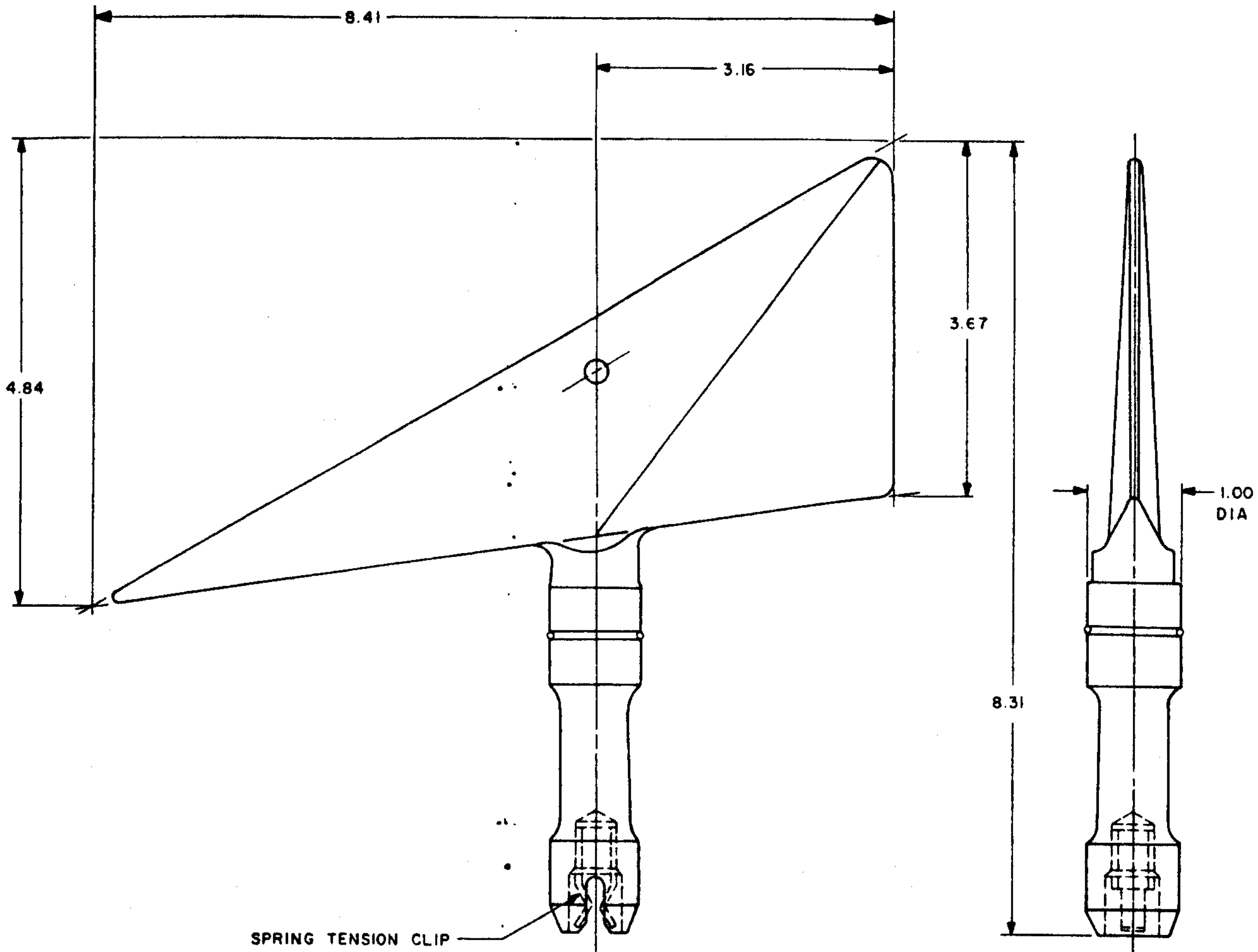

NOTES:

1. FOUR CONTROL VANES REQUIRED PER MISSILE.
2. APPROXIMATE WEIGHT — .7 LBS EACH
3. REF FSN 1420-770-6371(X919)

ORIGINAL DATA SOURCE

MARTIN DWG NO
293B6000006 REV G
DATED 1 APRIL 1964
NAVAIR 01-95GMA-2-1
DATED 15 MARCH 1969

WING ASSEMBLY

BULLPUP AGM-12B, 12B-2/3

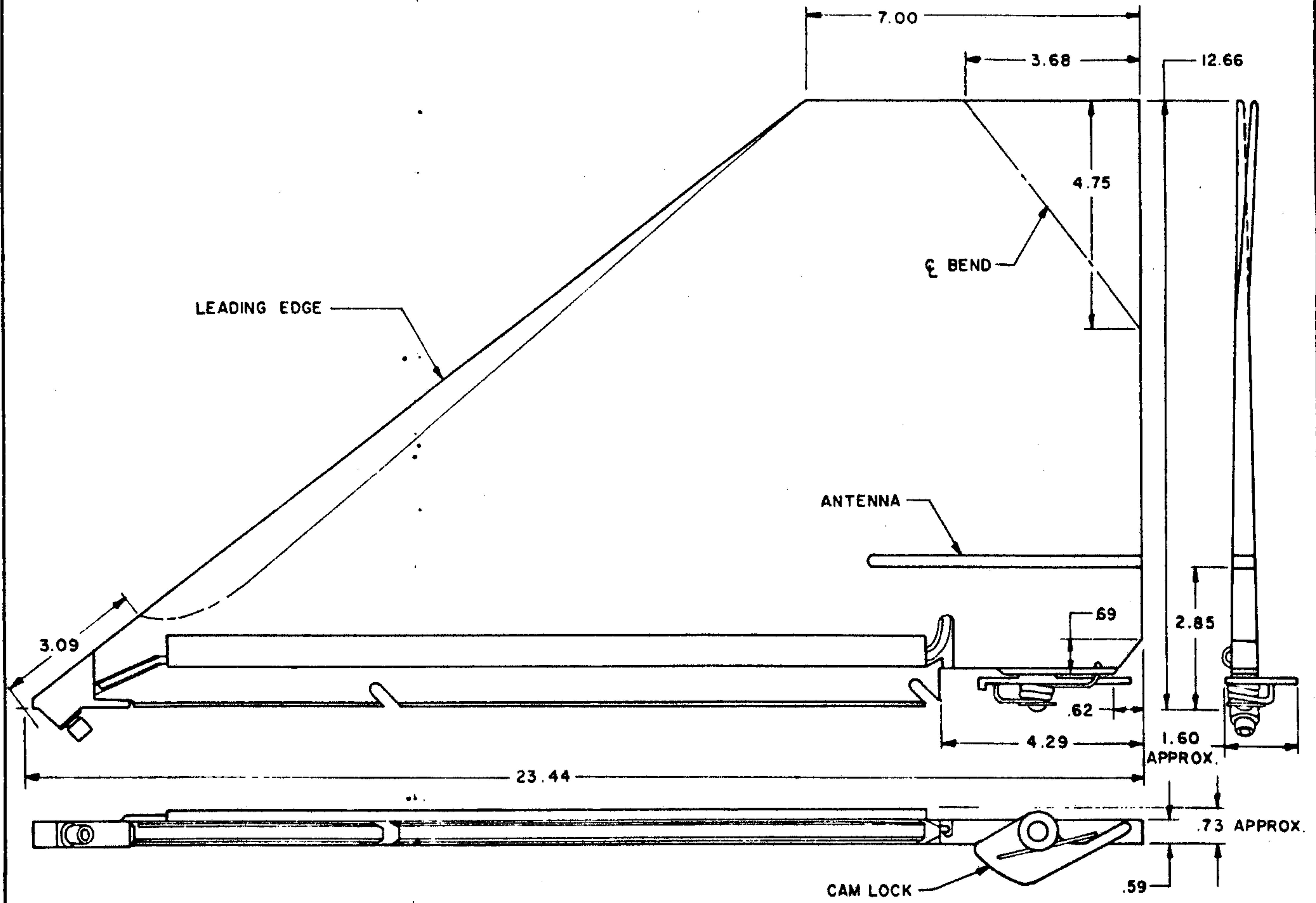

NOTES:

1. FOUR WINGS SHOWN ARE REQUIRED PER MISSILE.
2. APPROXIMATE WEIGHT — 6.2 LBS EACH
3. REF FSN 1420-770-6371 (X919)

ORIGINAL DATA SOURCE

MARTIN DWG NO
293D3000000 - 9 REV L
DATED 26 JUNE 1964
NAVAIR 01-95GMA-2-1
DATED 15 MARCH 1969

TRACKING FLARE MK 27 MODS

BULLPUP AGM-12B, 12B-2/3

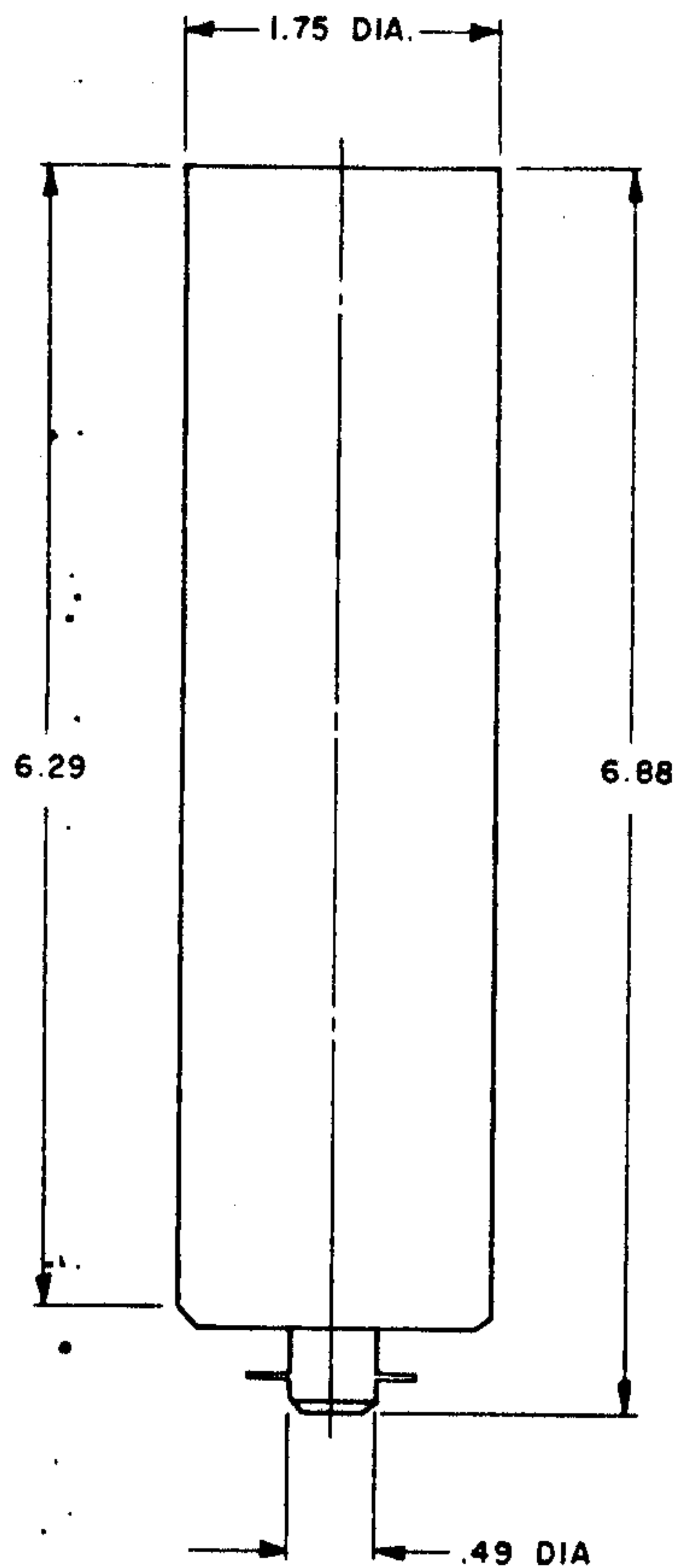

NOTES:

1. FLARE IS INSTALLED IN THE AFT END OF THE MISSILE AFT SECTION.
2. APPROXIMATE WEIGHT - 1.4 LBS
3.2 LBS (WITH EXTENSION)
3. TWO FLARES REQUIRED PER MISSILE.
4. FLARE EXTENSIONS (NOT SHOWN) ARE REQUIRED WHEN INSTALLING FLARES ON SOLID MOTOR.
5. REF FSN 1370-787-2788 (L 49)

ORIGINAL DATA SOURCE

MARTIN CO. REPORT NO.
OR 1207-2
DATED 15 NOVEMBER 1961
NAVAIR 01-95GMA-2-1
DATED 15 MARCH 1969

SOLID MOTOR TAIL CONE

BULLPUP AGM-12B,12B-2/3

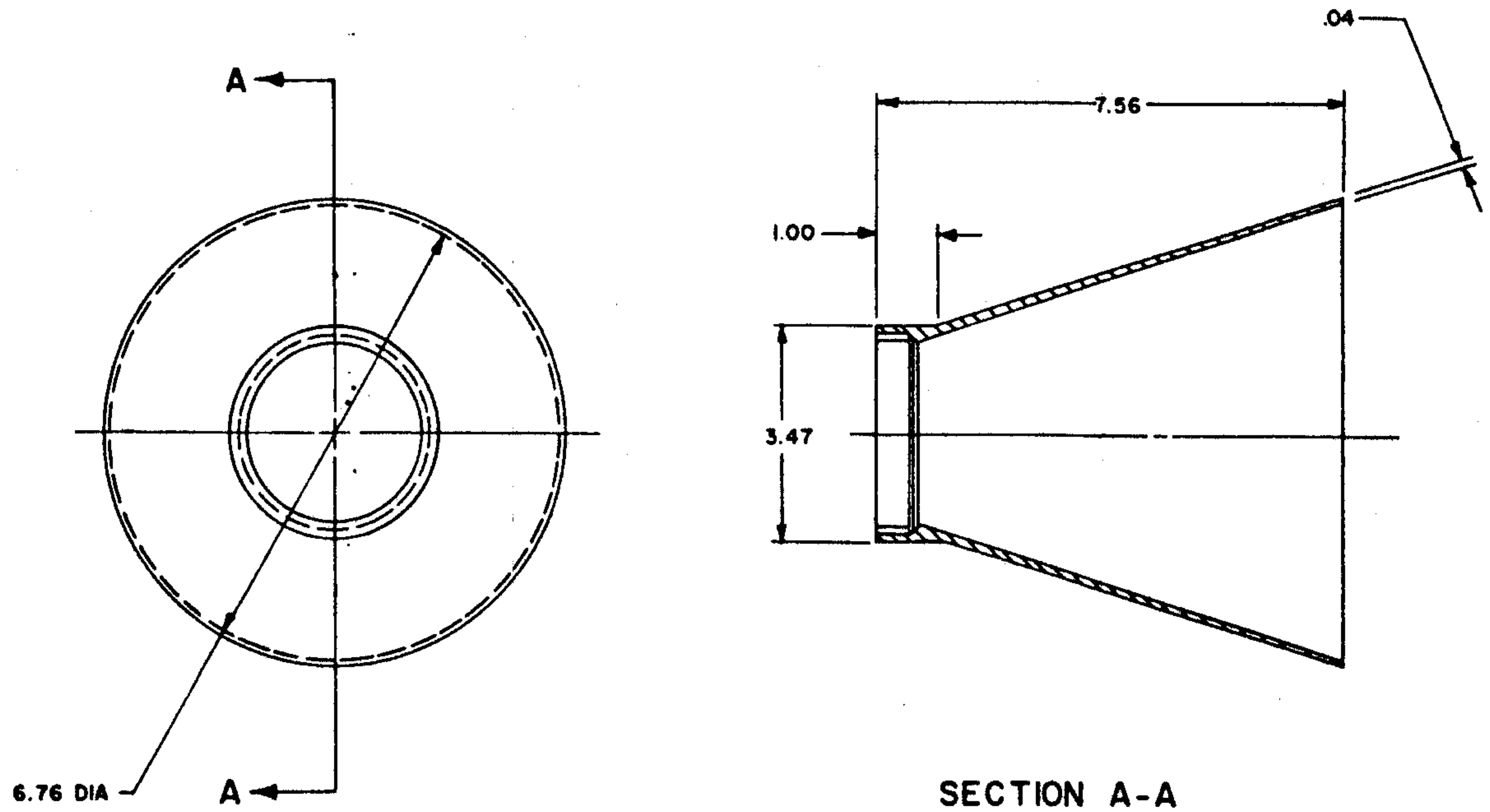

NOTES:

1. TAIL CONE IS INSTALLED ON THE SOLID MOTOR AFTER REMOVING THRUST NEUTRALIZER.
2. APPROXIMATE WEIGHT - 2.5 LBS

ORIGINAL DATA SOURCE

BUWEPS DWG NO 1274063
DATED 15 APRIL 1958
NAVAIR 01-95GMA-2-1
DATED 15 MARCH 1969

BULLPUP AGM-12C GENERAL ARRANGEMENT

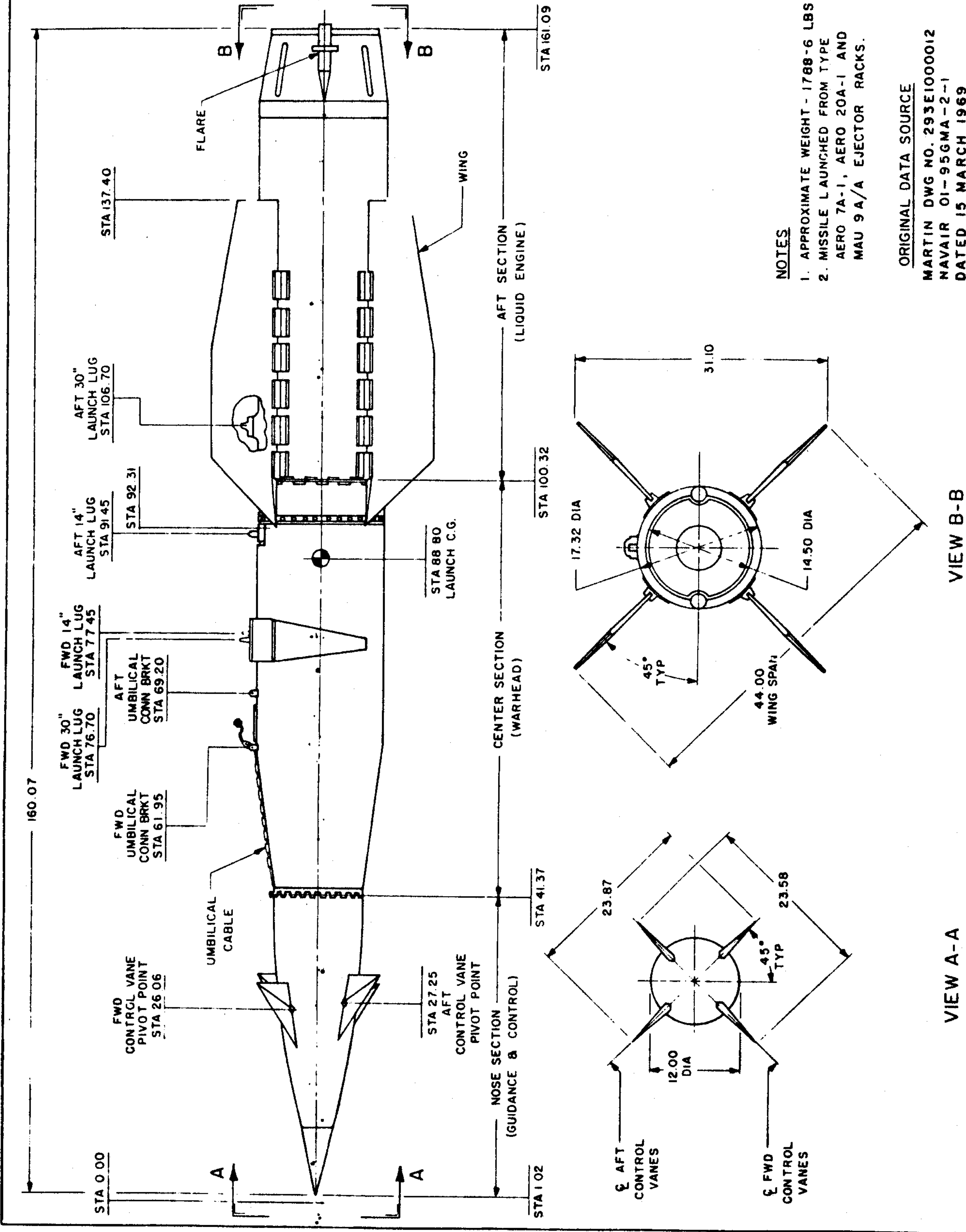

BULLPUP AGM-12C-2 GENERAL ARRANGEMENT

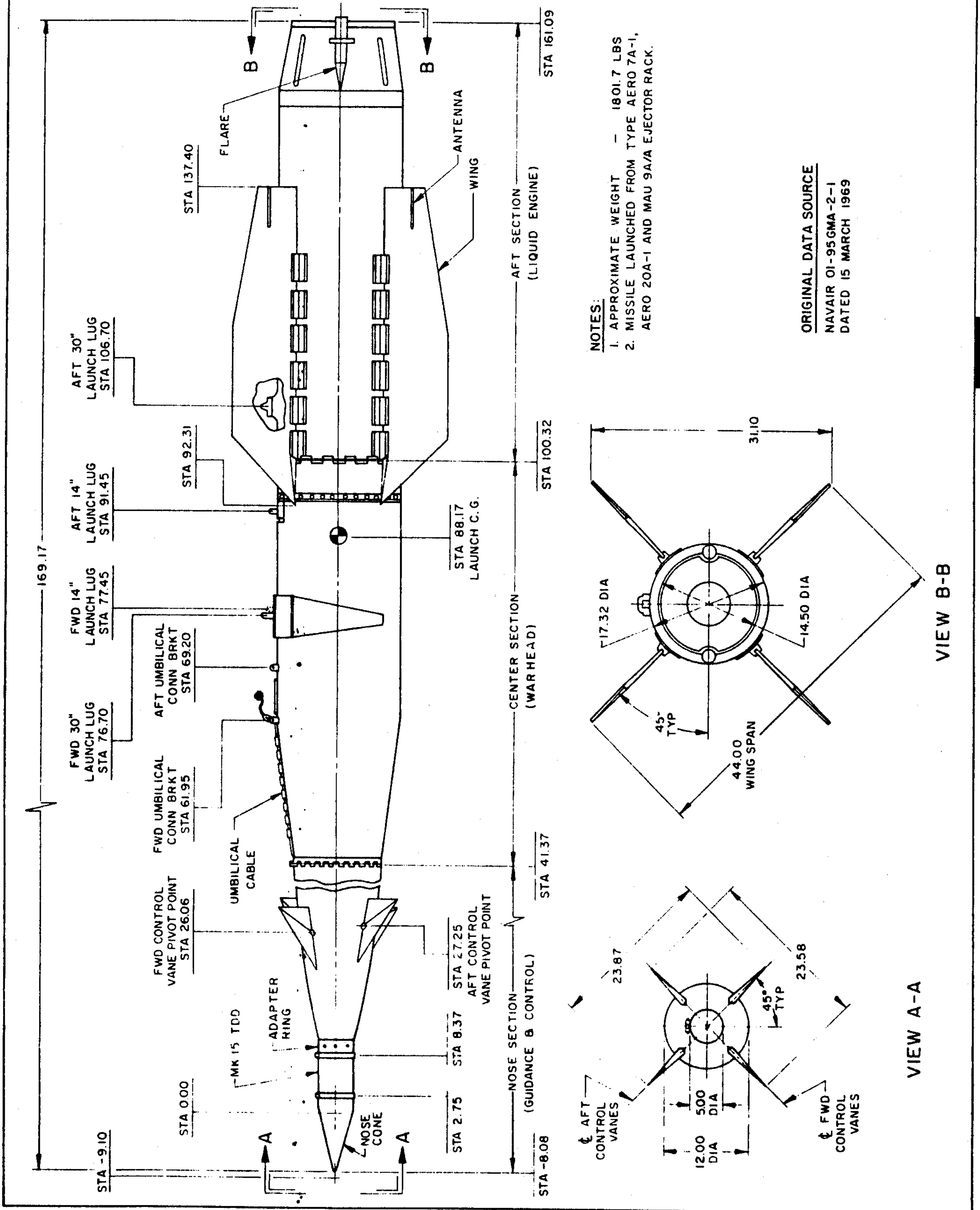

- NOTES:**
1. APPROXIMATE WEIGHT - 1801.7 LBS
 2. MISSILE LAUNCHED FROM TYPE AERO 7A-1, AERO 20A-1 AND MAU 9A/A EJECTOR RACK.

ORIGINAL DATA SOURCE
 NAVAIR 01-95GMA-2-1
 DATED 15 MARCH 1969

BULLPUP AGM-12C, 12C-2 HARD SPOT LOCATIONS

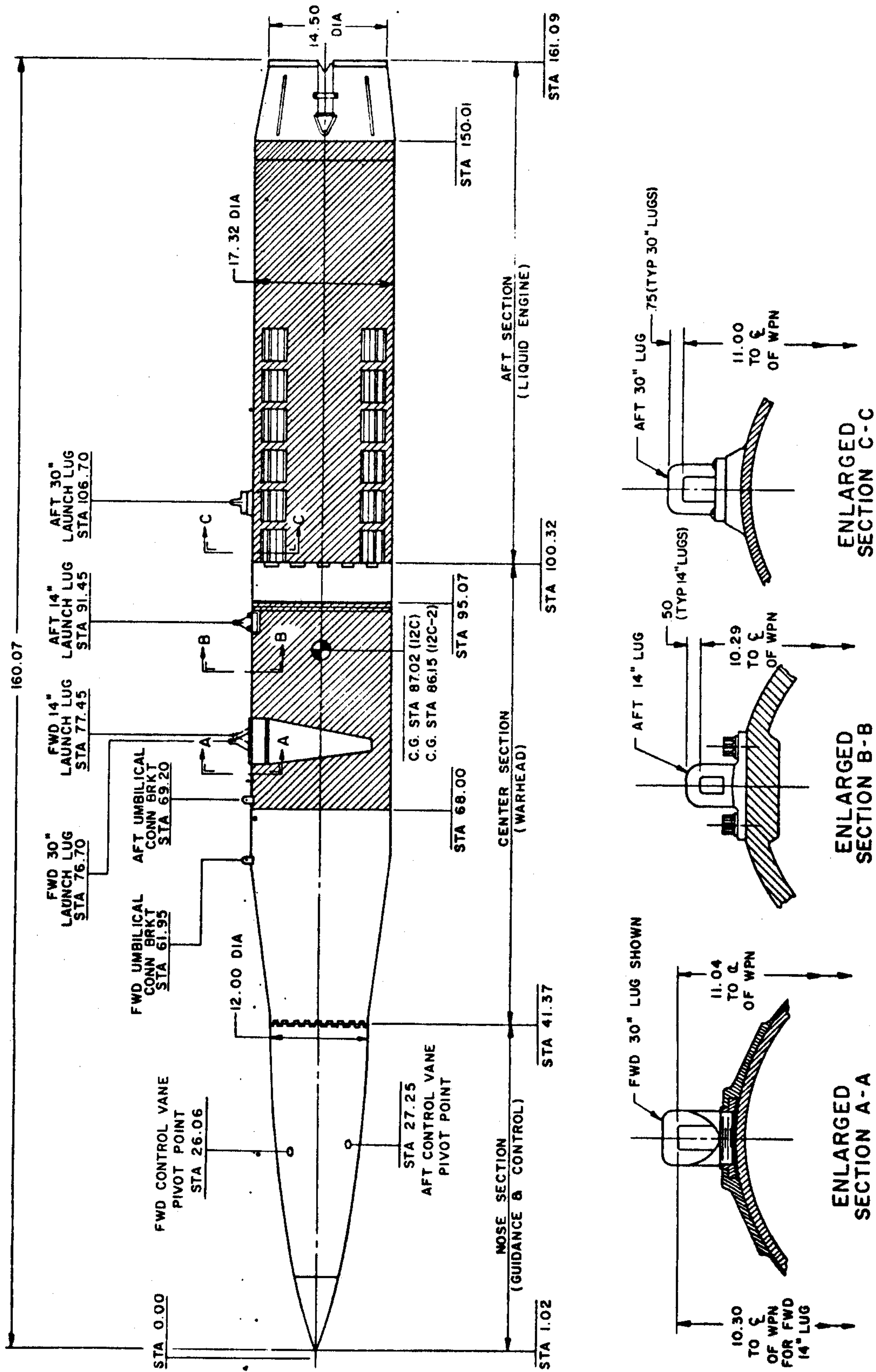

NOTES:

1. HARD SPOT AREAS SHOWN ARE IDENTICAL FOR BULLPUP AGM 12C (SHOWN) & 12C-2 MISSILES.
2. APPROXIMATE WEIGHTS:
AGM 12C - 1722.2 LBS
AGM 12C-2 - 1735.3 LBS
3. [Hatched Area Symbol] DENOTES HARD SPOT LOCATIONS.
4. SEE AGM-12C-2 GENERAL ARRANGEMENT FOR NOSE SECTION CONFIGURATION.

ORIGINAL DATA SOURCE
MARTIN DWG NO. 293E1000012
NAVAIR 01-95GMA-2-1
DATED 15 MARCH 1969

NOSE SECTION (GUIDANCE & CONTROL)

BULLPUP AGM-12C

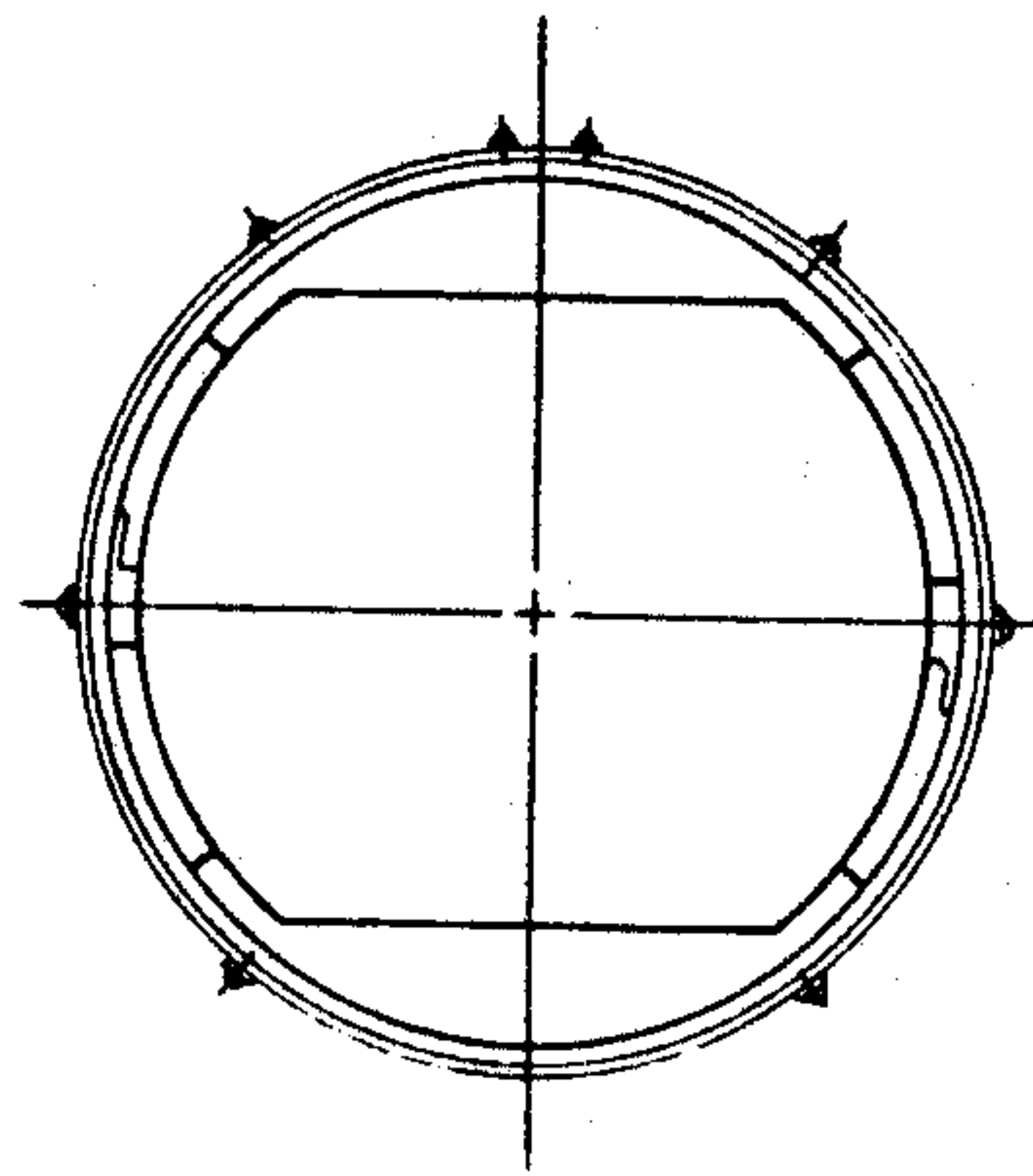
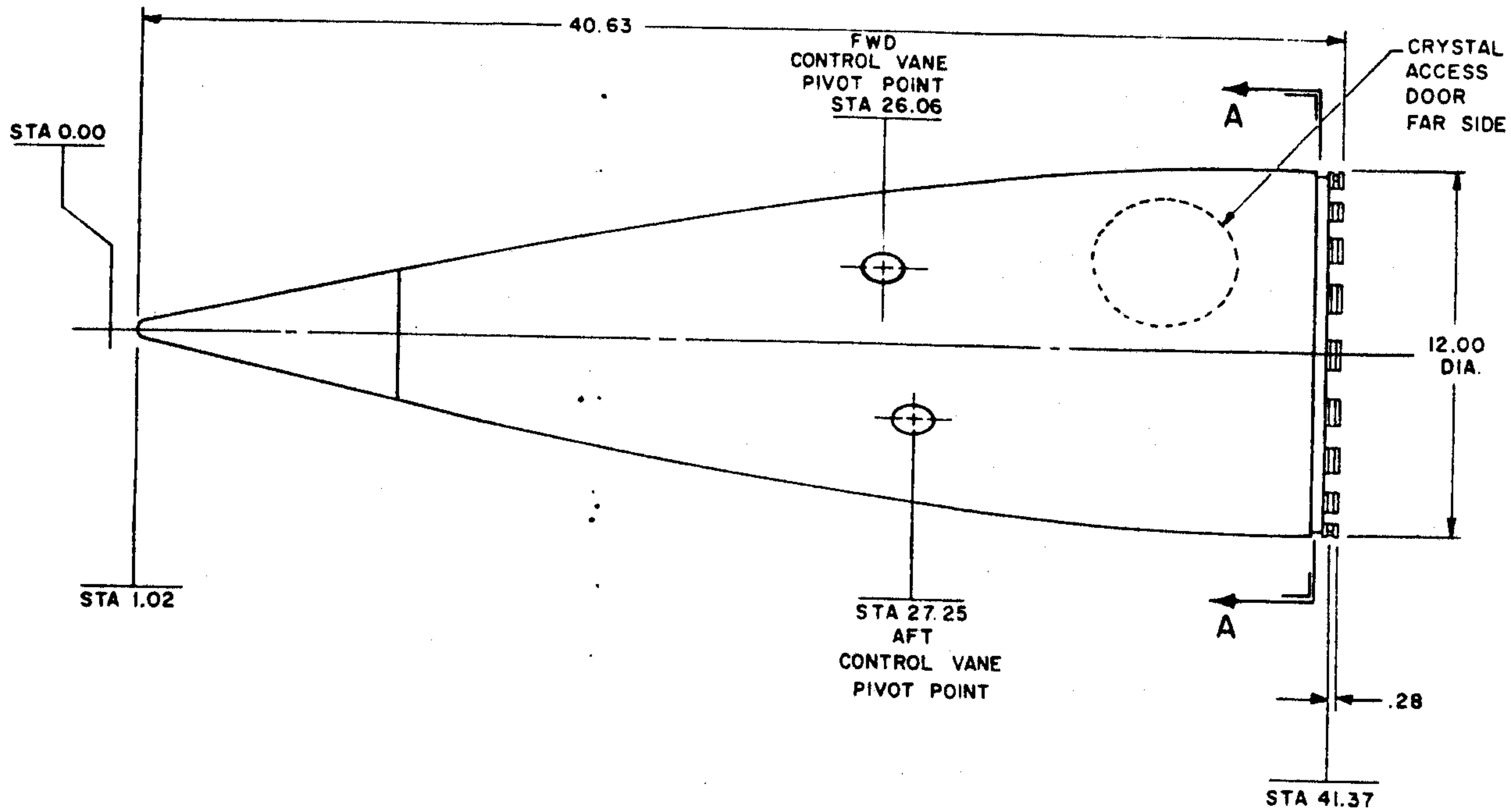

SECTION A-A

NOTES:

1. NOSE SECTION SHOWN IS "UNIVERSAL" TYPE APPLICABLE TO AGM-12C AND AGM-12B.
2. APPROXIMATE WEIGHT — 58.1 LBS
3. REF FSN 1420-858-4296(X459)

ORIGINAL DATA SOURCE
MARTIN DWG NO 293E6000000
NAVAIR 01-95GMA-2-1
DATED 15 MARCH 1969

NOSE SECTION (GUIDANCE & CONTROL)

BULLPUP AGM-12C-2

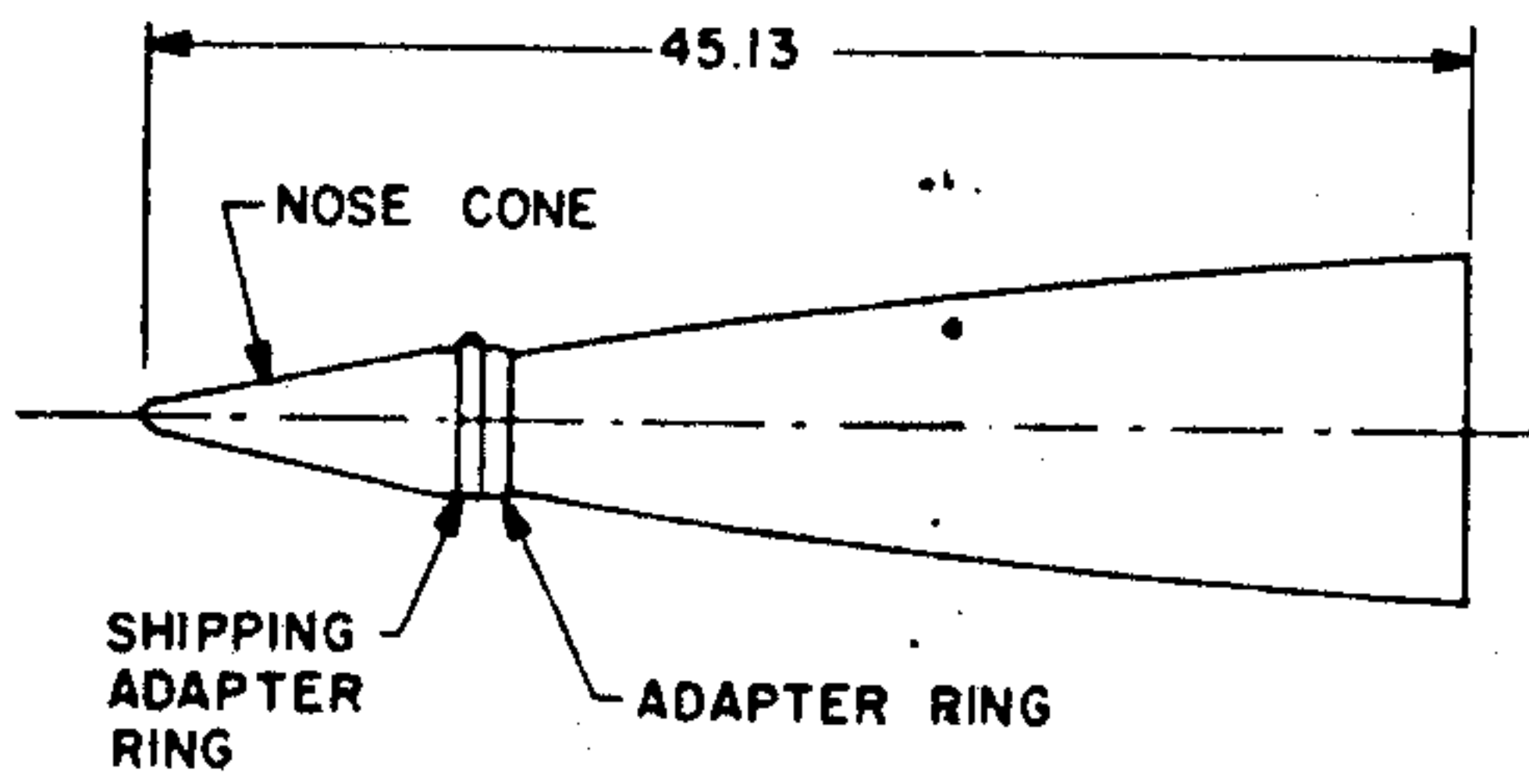
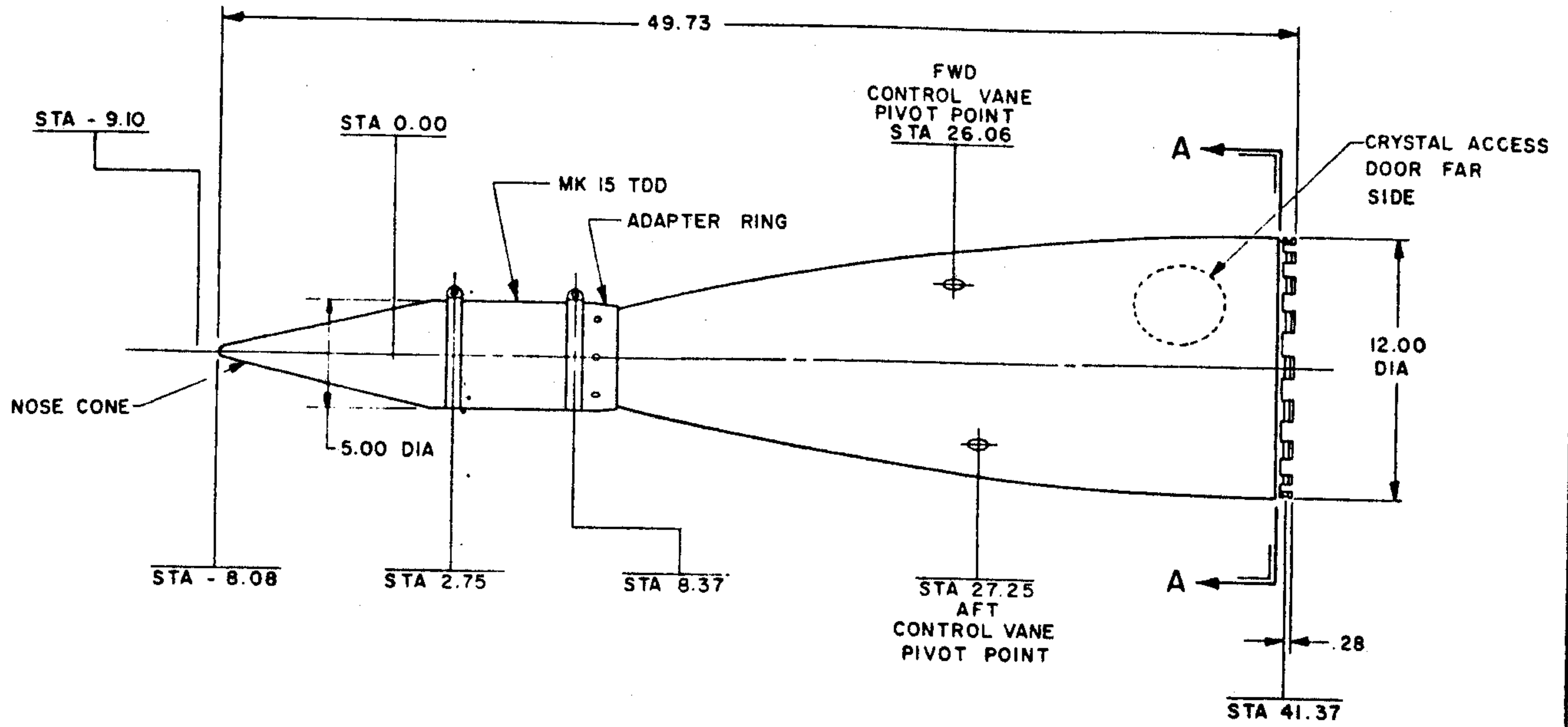

SHOWN AS SHIPPED
LESS MK 15 TOD

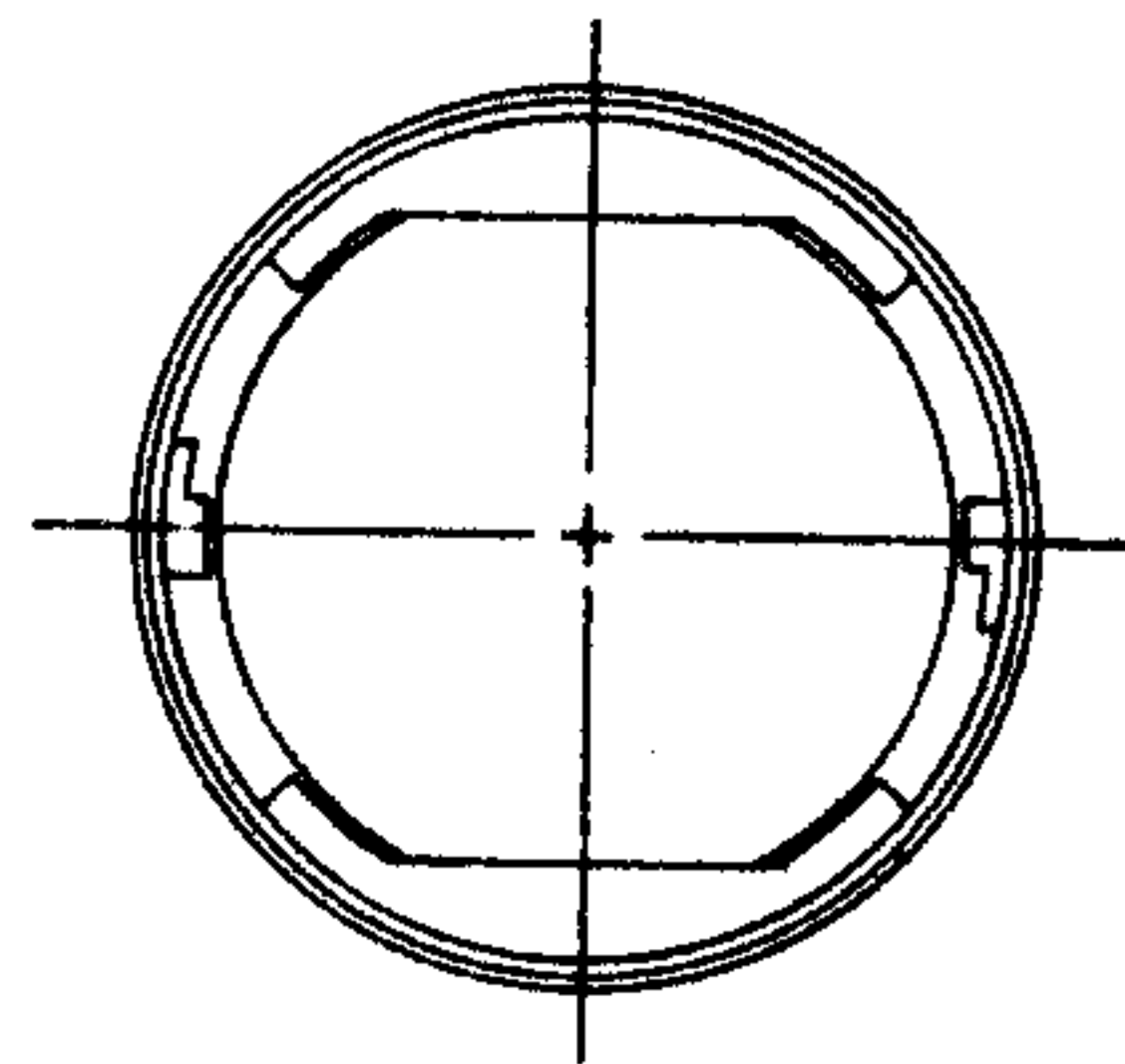

NOTES:

1. APPROXIMATE WEIGHTS:
AS SHIPPED - 62.9 LBS
TDD INSTALLED - 72.4 LBS
2. MODIFIED NOSE, LESS TOD, MAY BE USED ON AGM-12C MISSILE.
3. REF FSN 1420-999-1146(X486)

ORIGINAL DATA SOURCE

NAVAIR 01-95GMA-2-1
DATED 15 MARCH 1969

CENTER SECTION (WARHEAD)

BULLPUP AGM-12C,12C-2

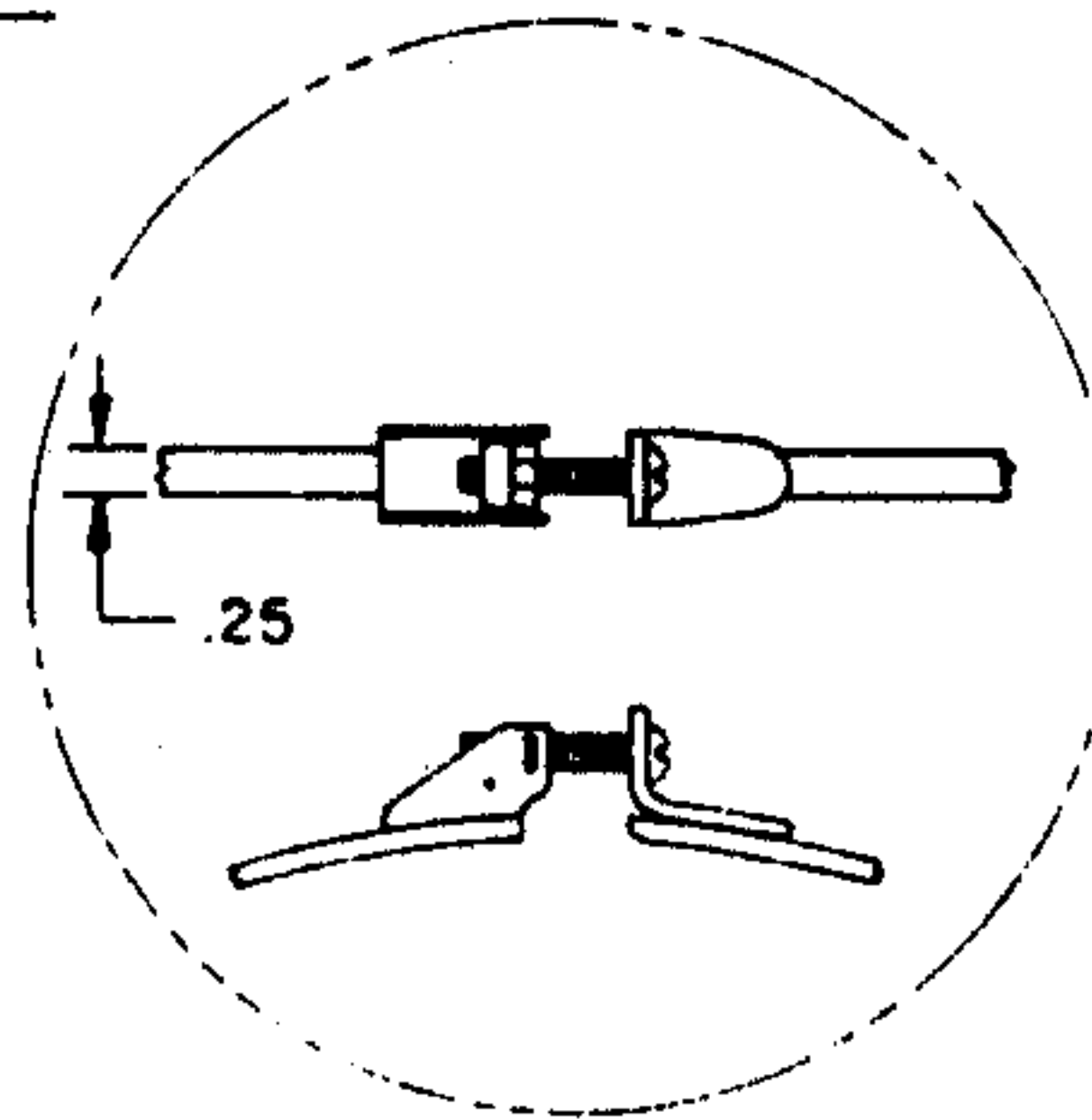
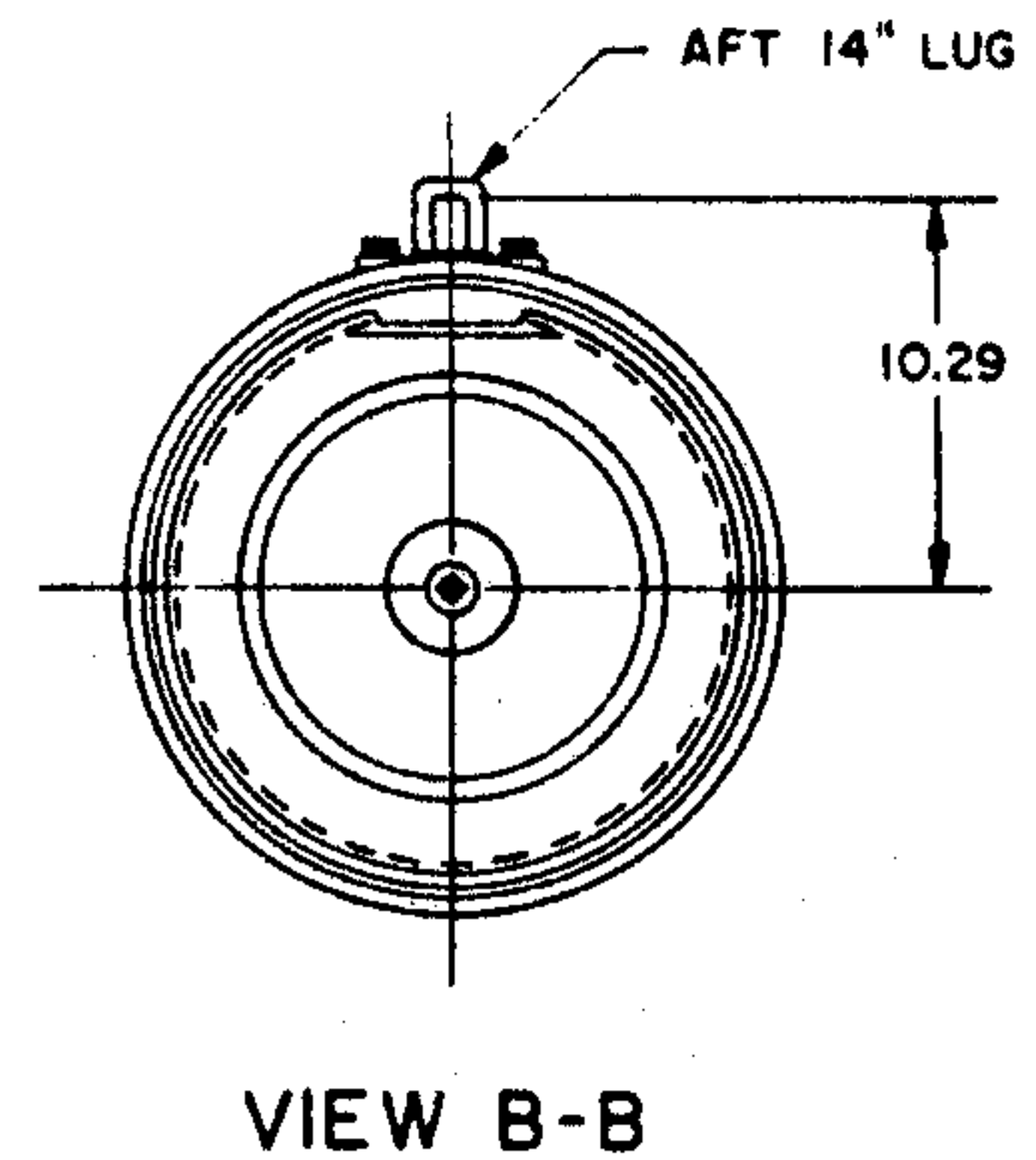
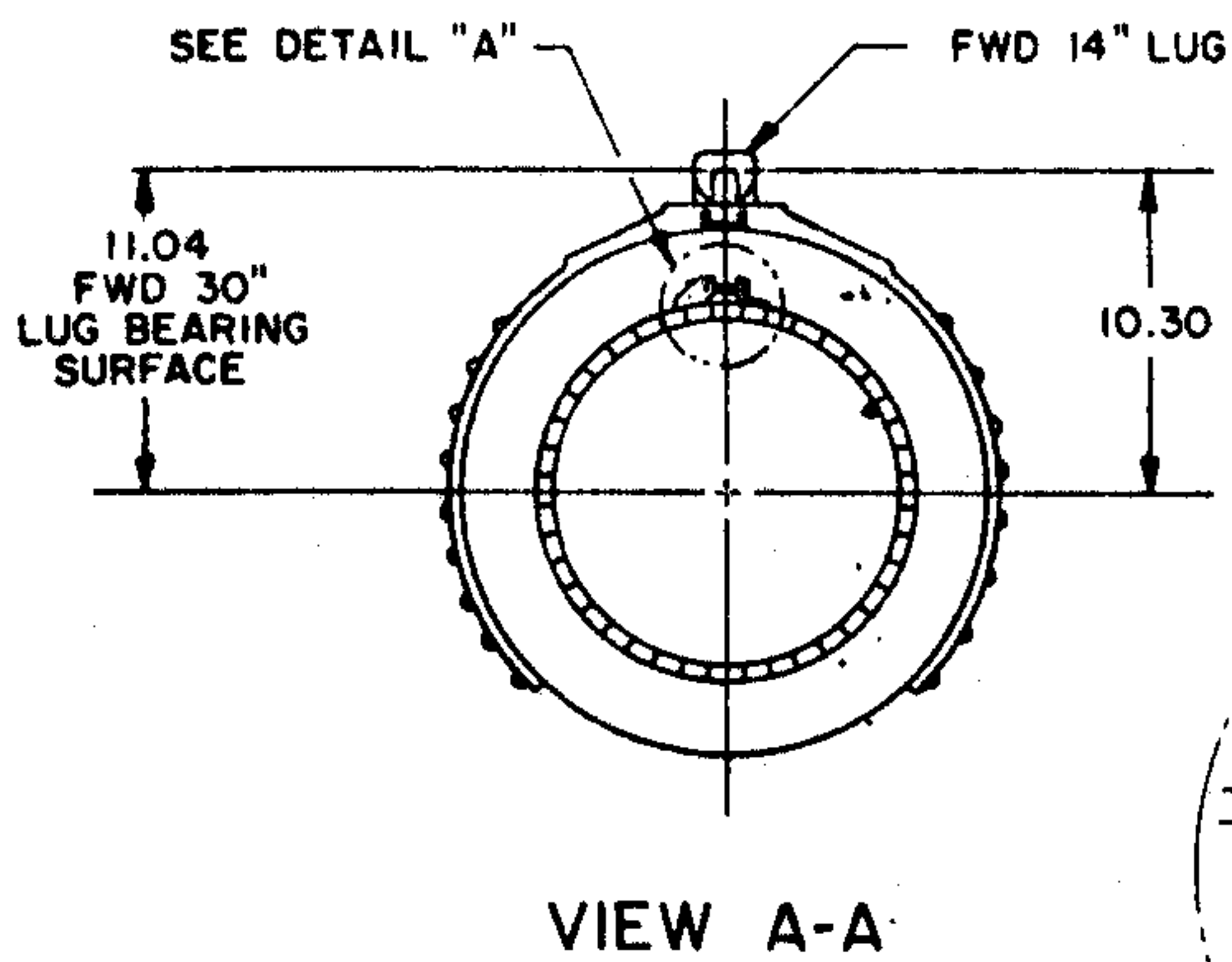
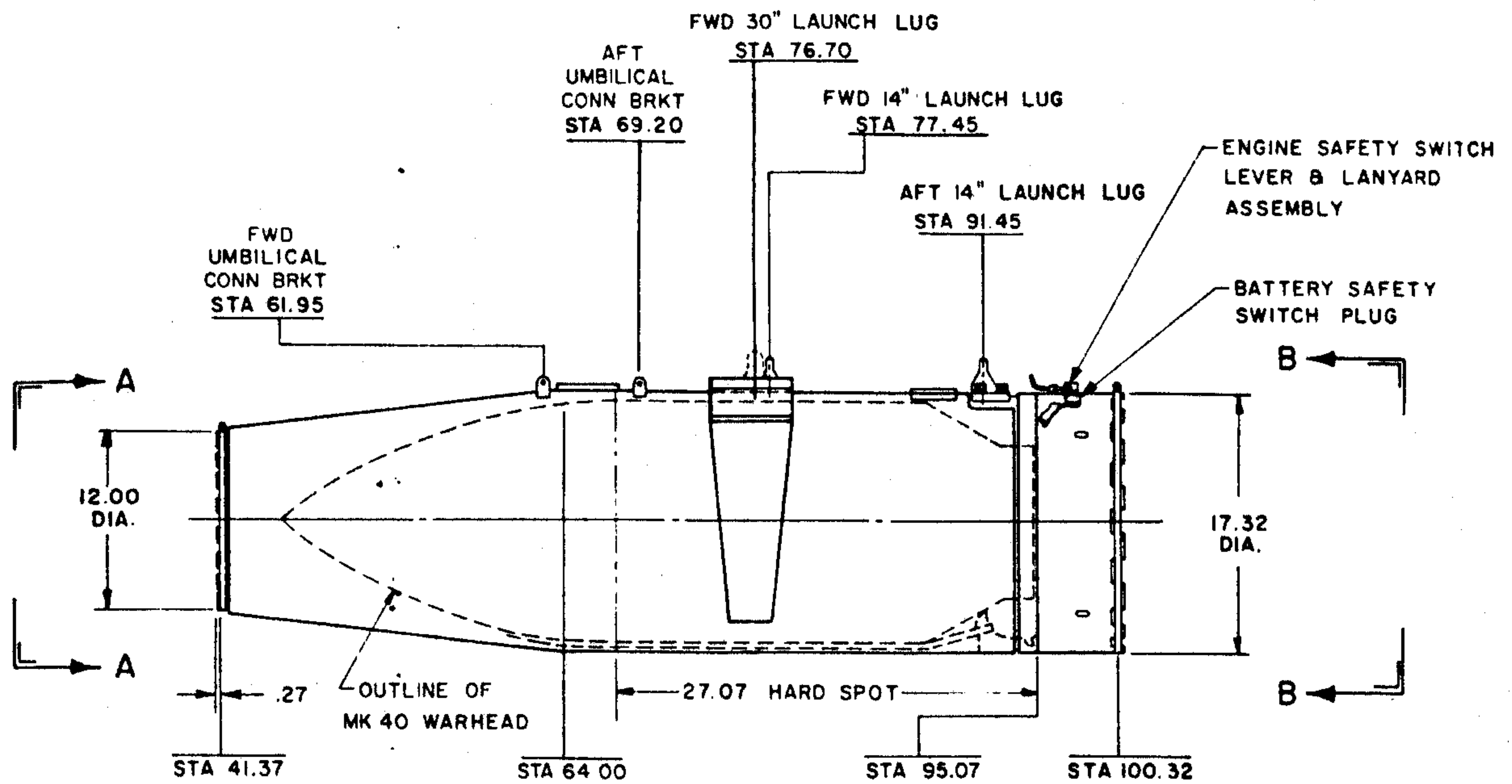

NOTES:

1. AGM-12C, 12C-2 CENTER SECTIONS ARE IDENTICAL EXCEPT FOR INTERNAL WIRING. AGM-12C-2 CENTER SECTION IS STENCILED "FOR USE WITH AGM-12C-2".
2. AGM-12C-2 CENTER SECTION MAY BE USED WITH AGM-12C-2 NOSE SECTION
3. APPROXIMATE WEIGHT — 1098.8 LBS
4. REF FSN 1336-930-1649(V502)

ORIGINAL DATA SOURCE

MARTIN DWG NO. 293E7000000
NAVAIR 01-95GMA-2-1
DATED 15 MARCH 1969

AFT SECTION (LIQUID ENGINE)

BULLPUP AGM-12C, 12C-2

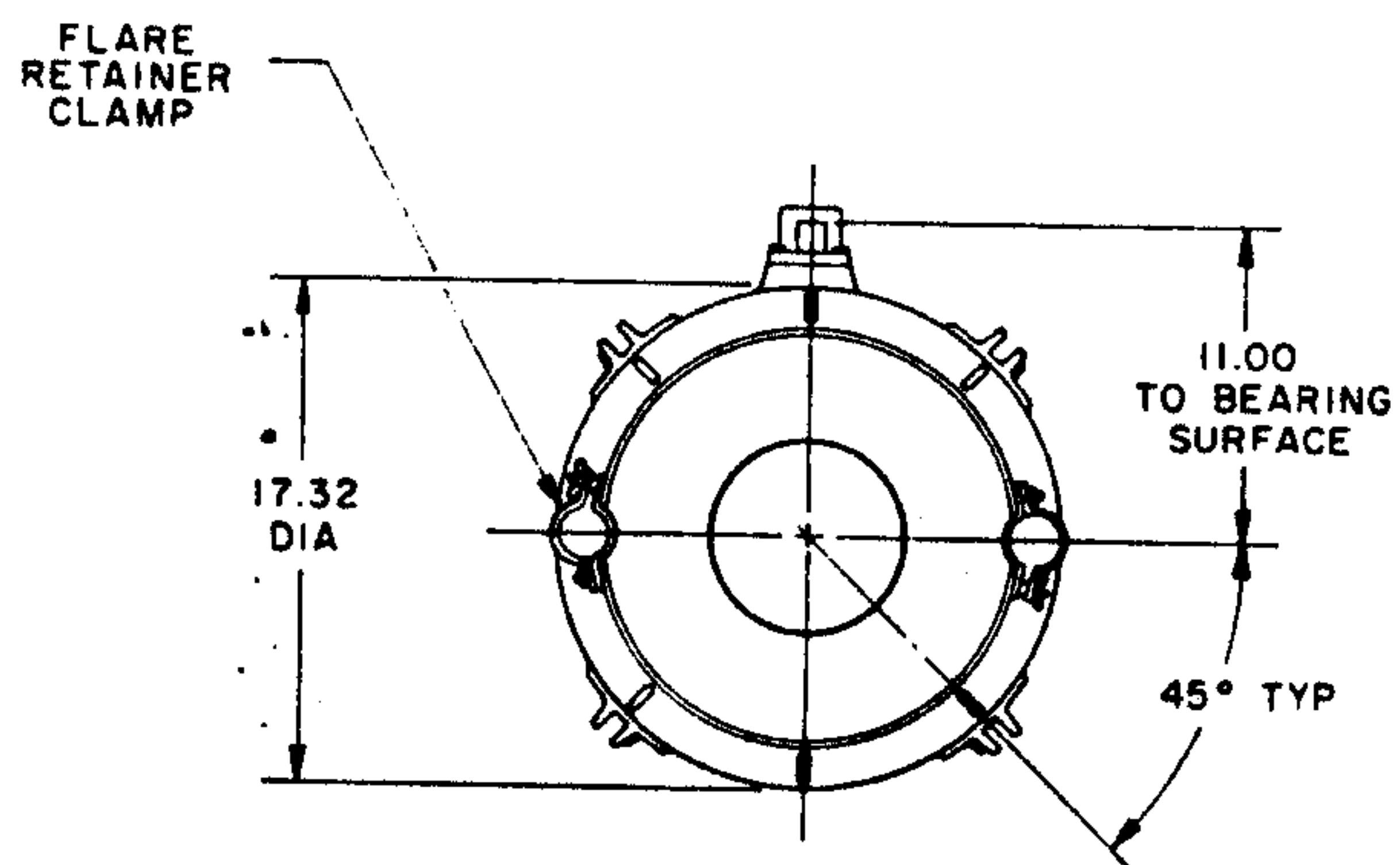
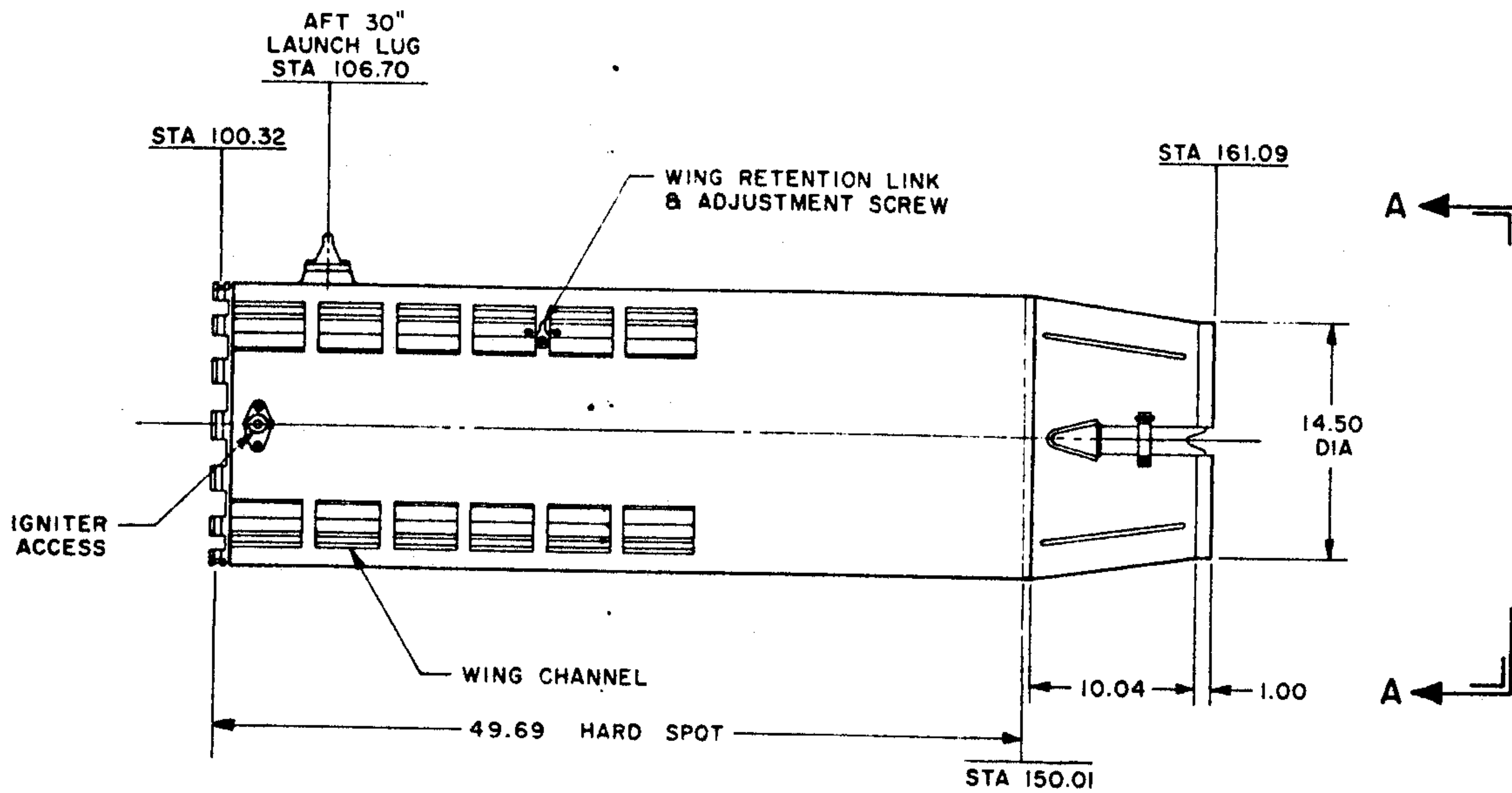

VIEW A-A

NOTES

- APPROXIMATE WEIGHTS:
 - LR 62-RM-2 ENGINE - 568.3 LBS
 - LR 62-RM-4 ENGINE - 573.0 LBS
- REF FSN 2845-858-4303(X457)

ORIGINAL DATA SOURCE

MARTIN DWG 293-0400005
NAVAIR 01-95GMA-2-1
DATED 15 MARCH 1969

CONTROL VANE

BULLPUP AGM-12C, 12C-2

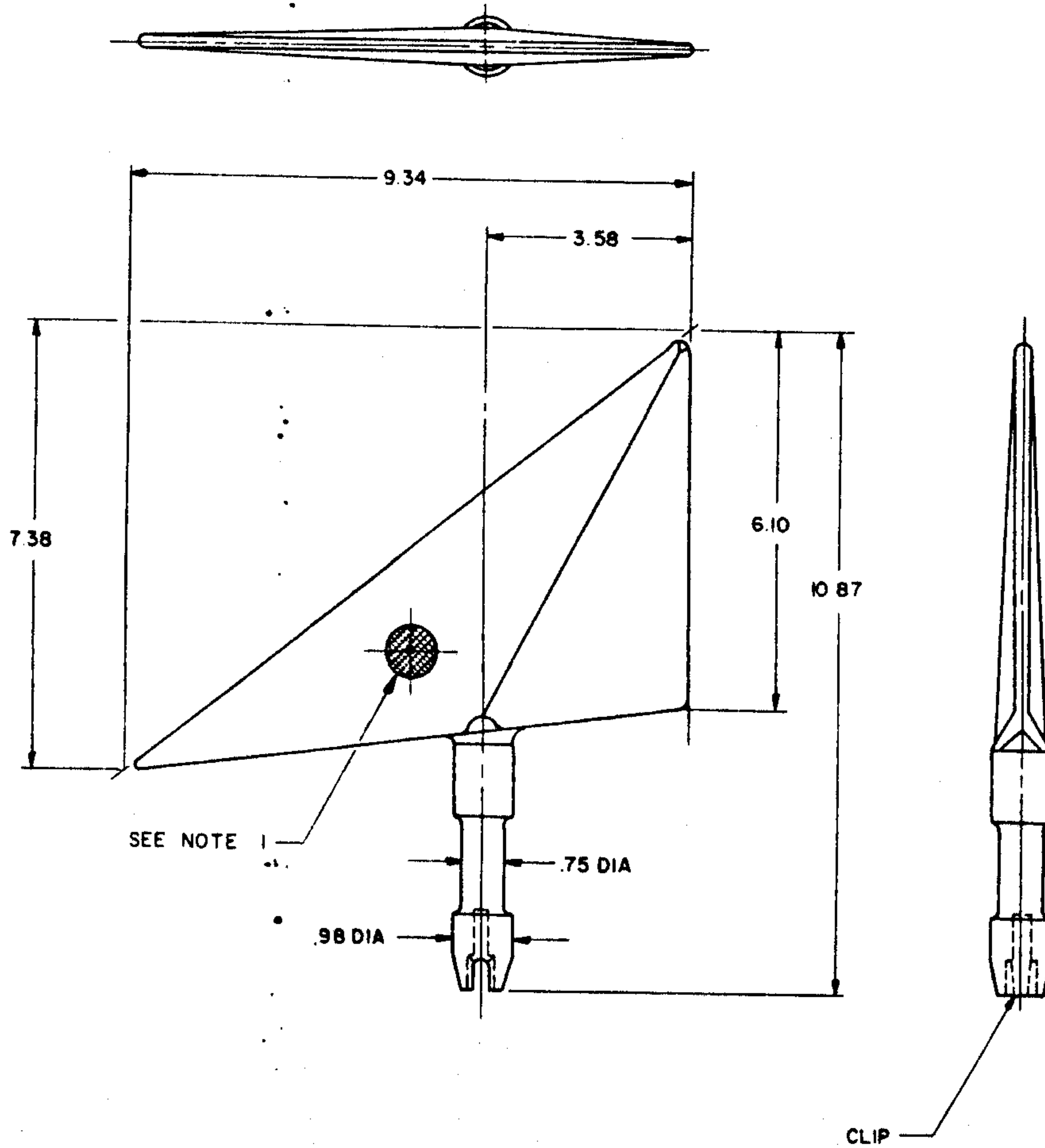

NOTES :

1. BLACK DOT 2.00 INCHES DIA IS APPLIED TO BOTH SIDES OF CONTROL VANE TO DISTINGUISH IT FROM THE BULLPUP AGM-12B CONTROL VANE.
2. APPROXIMATE WEIGHT — 1.1 LBS EACH
3. FOUR CONTROL VANES ARE REQUIRED PER MISSILE.
4. REF FSN 1420-858-4305(X456)

ORIGINAL DATA SOURCE

MARTIN DWG NO . 293E6000006
 NAVAIR 01-95GMA-2-1
 DATED 15 MARCH 1969

SIDEWINDER AIM-9B GENERAL ARRANGEMENT

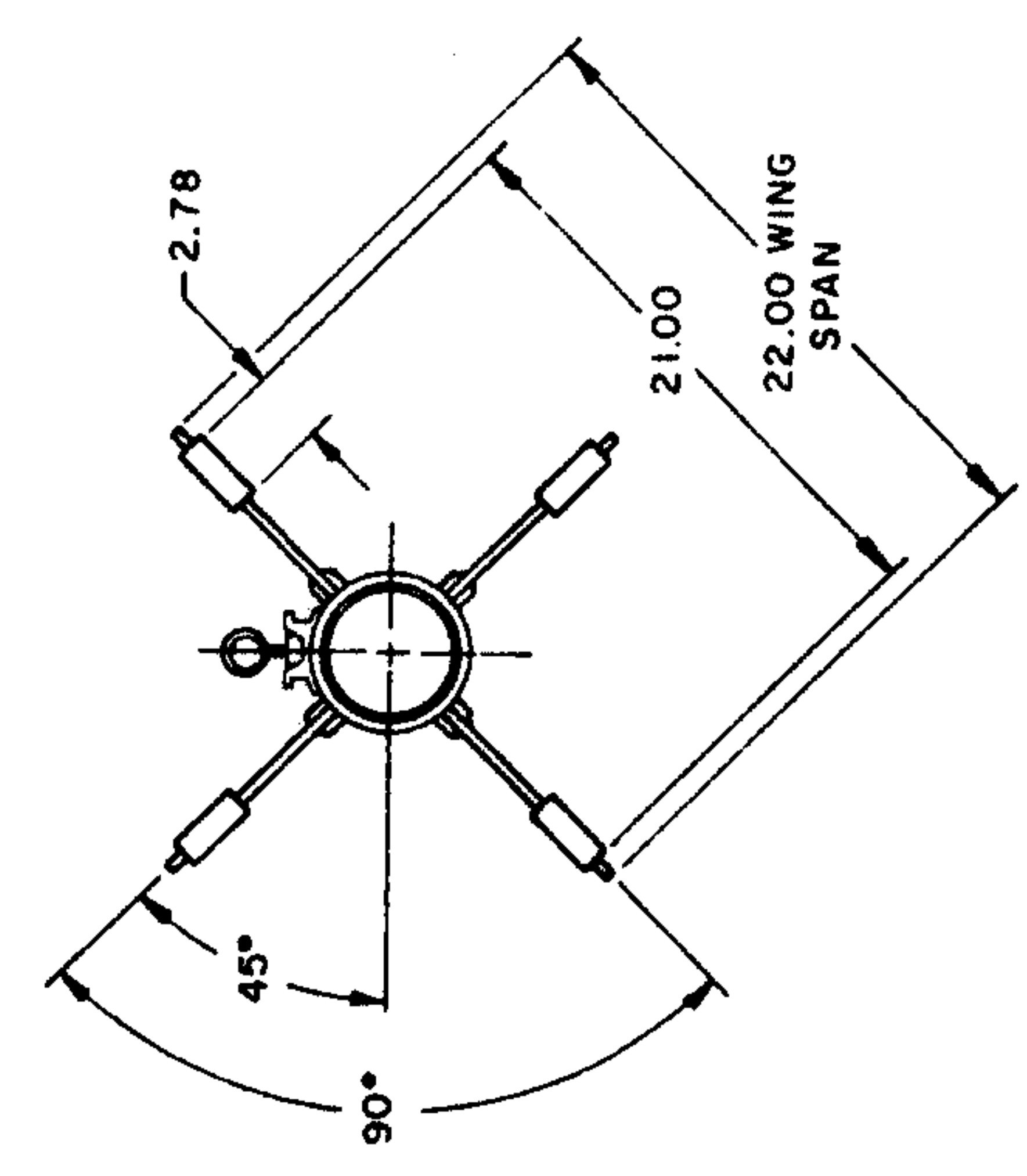
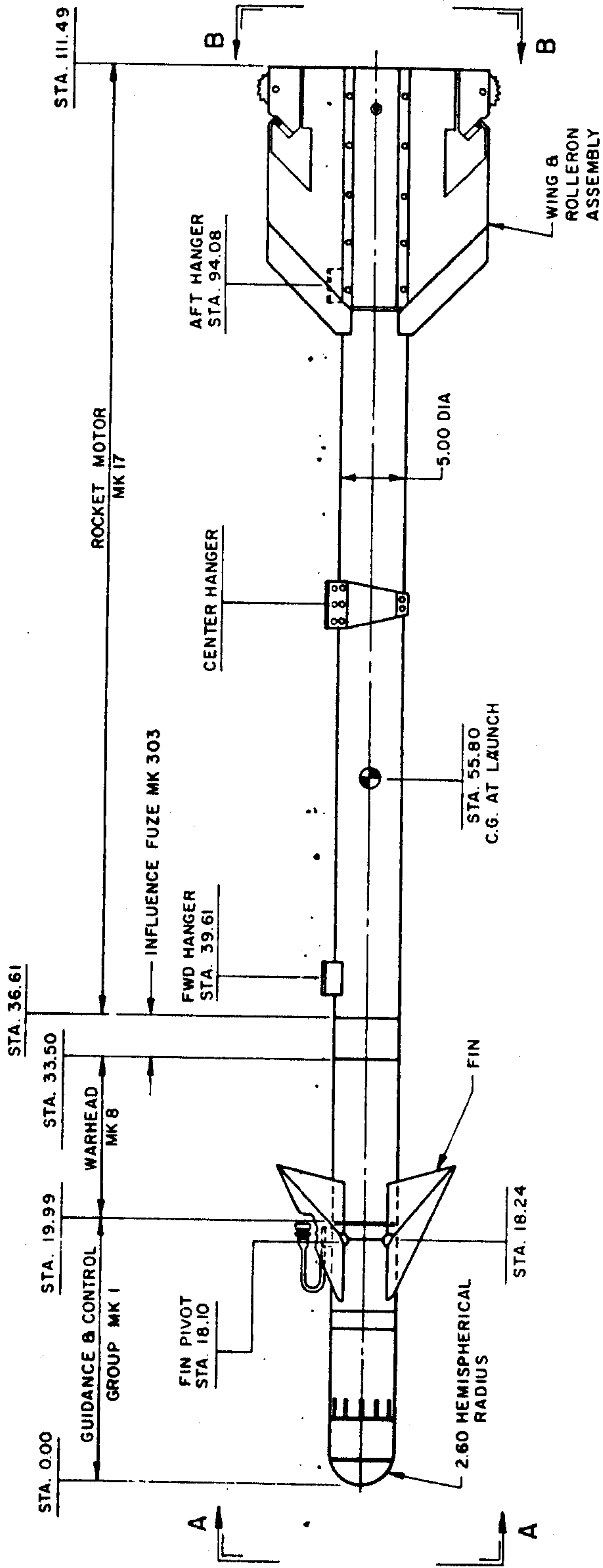

VIEW B-B

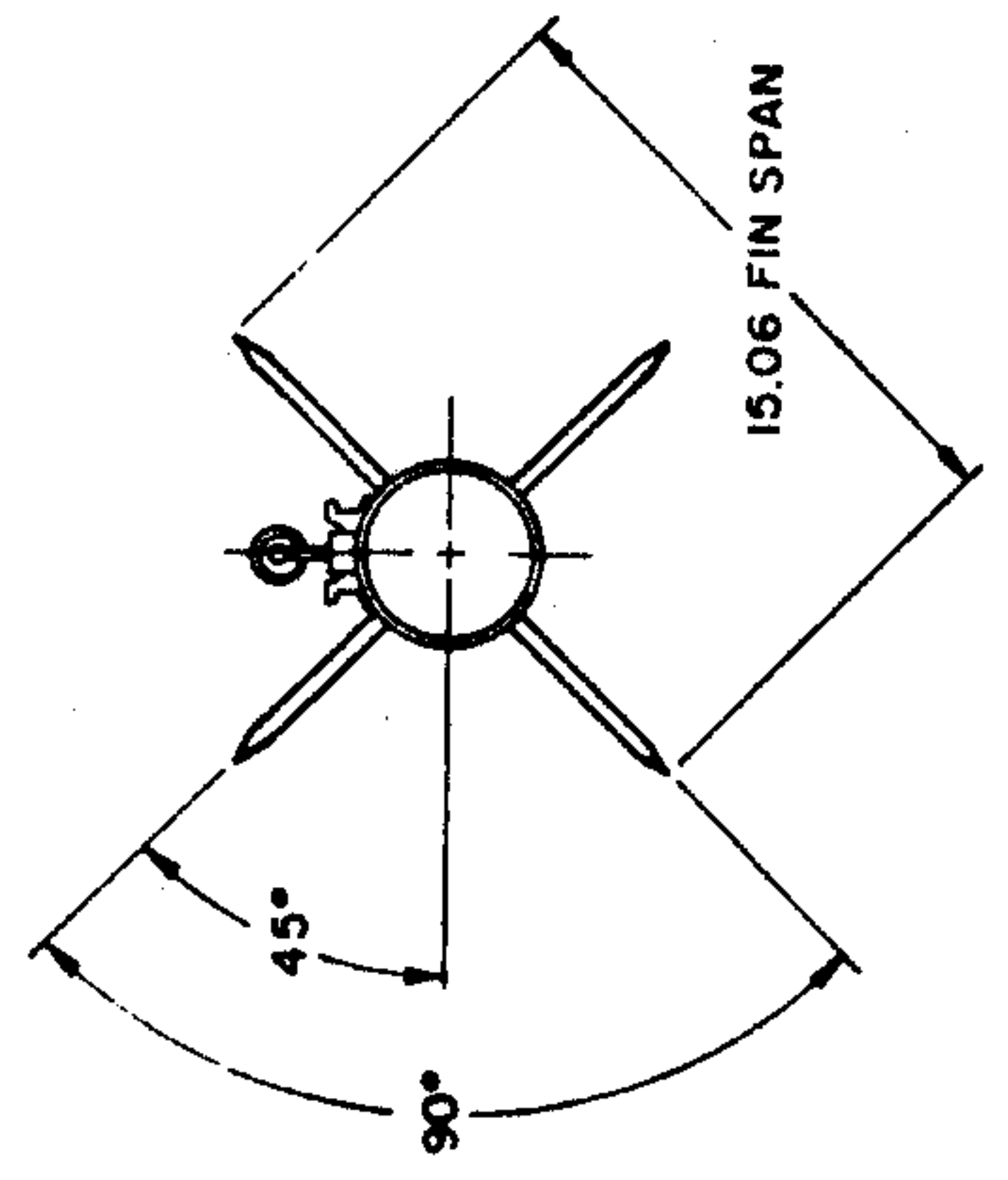

VIEW A-A

ORIGINAL DATA SOURCE
 BUORD DWG NO. SK 44176 REV 8
 DATED 20 FEBRUARY 1958
 NAVWEPS OP 3366
 DATED 15 APRIL 1966

- NOTES:**
1. APPROXIMATE WEIGHT - 160.0 LBS.
 2. MISSILE LAUNCHED FROM TYPE AERO 3A LAUNCHER, AND LAU-7/A LAUNCHER WITH ELECTRICAL ADAPTER PART NO. 1517359.

SIDEWINDER AIM-9C GENERAL ARRANGEMENT

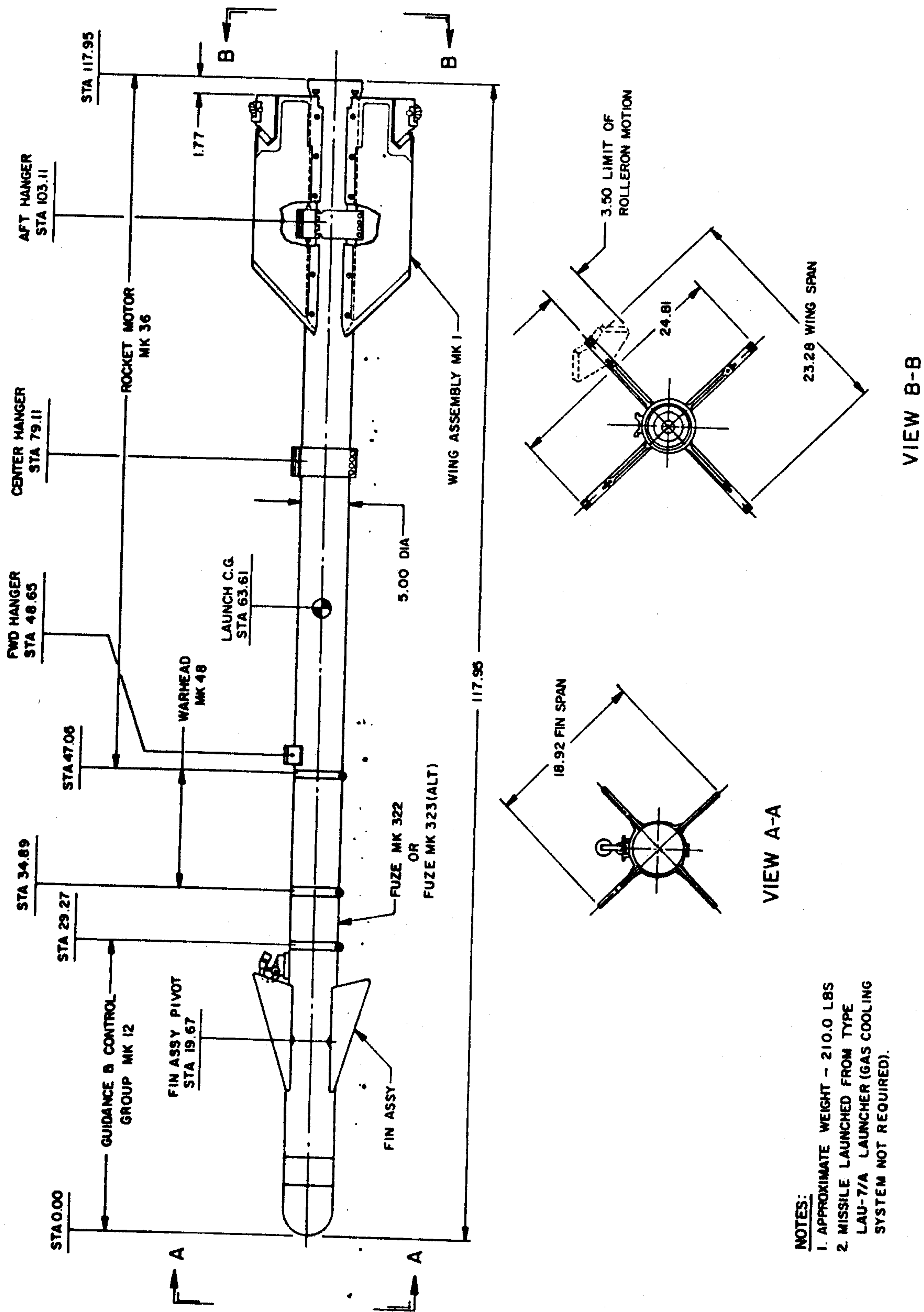

- NOTES:**
1. APPROXIMATE WEIGHT - 210.0 LBS
 2. MISSILE LAUNCHED FROM TYPE LAU-7/A LAUNCHER (GAS COOLING SYSTEM NOT REQUIRED).

SIDEWINDER AIM-9D GENERAL ARRANGEMENT

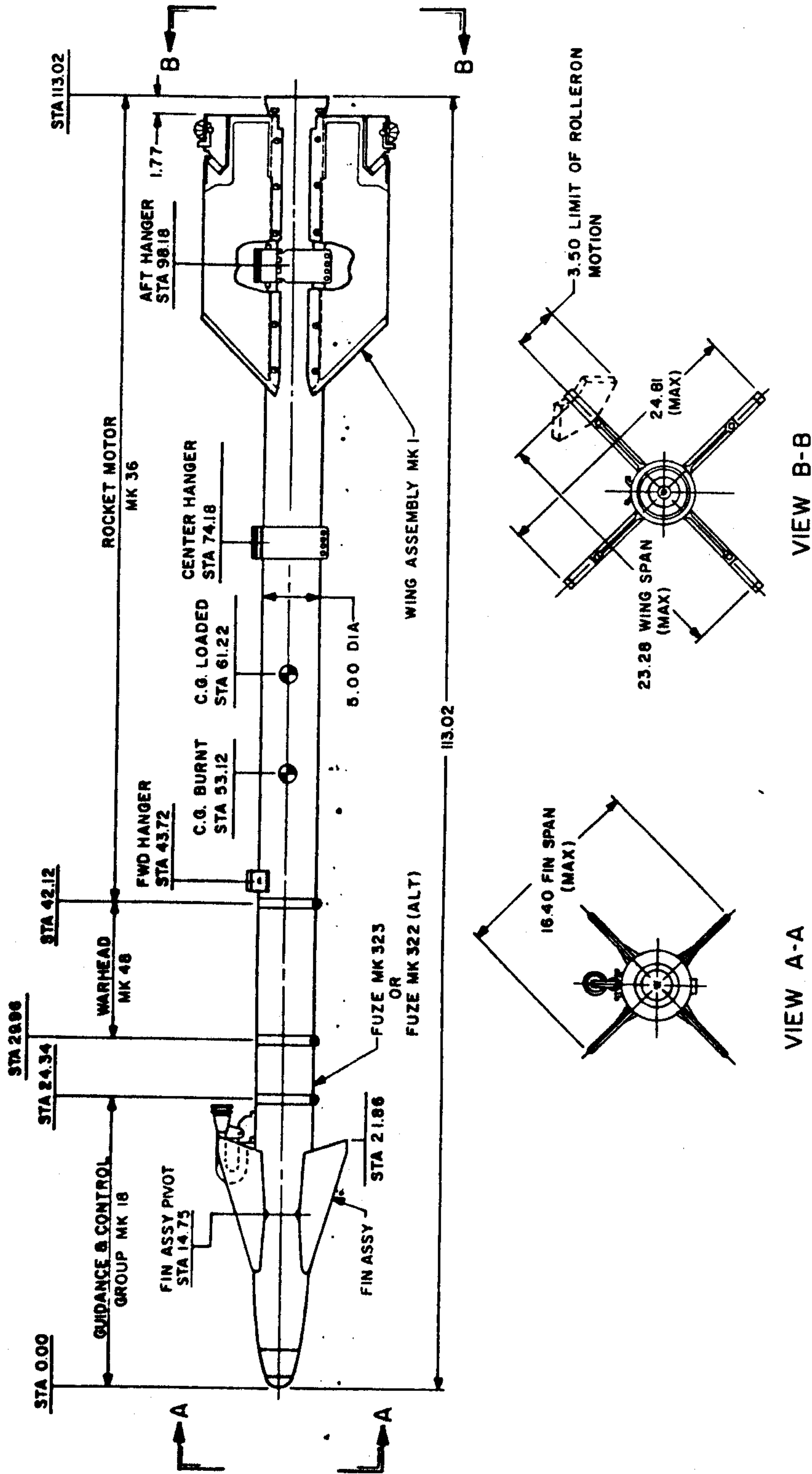

NOTES:

1. APPROXIMATE WEIGHTS:
 LOADED- 195.0 LBS.
 BURNT- 125.0 LBS.
2. MISSILE LAUNCHED FROM TYPE
 LAU-7/A LAUNCHER.

ORIGINAL DATA SOURCE
 BUWEP'S DWG. NO. 258111 REV B
 DATED 3 MARCH 1967

GUIDANCE & CONTROL GROUP MK I MODS

SIDEWINDER AIM-9B

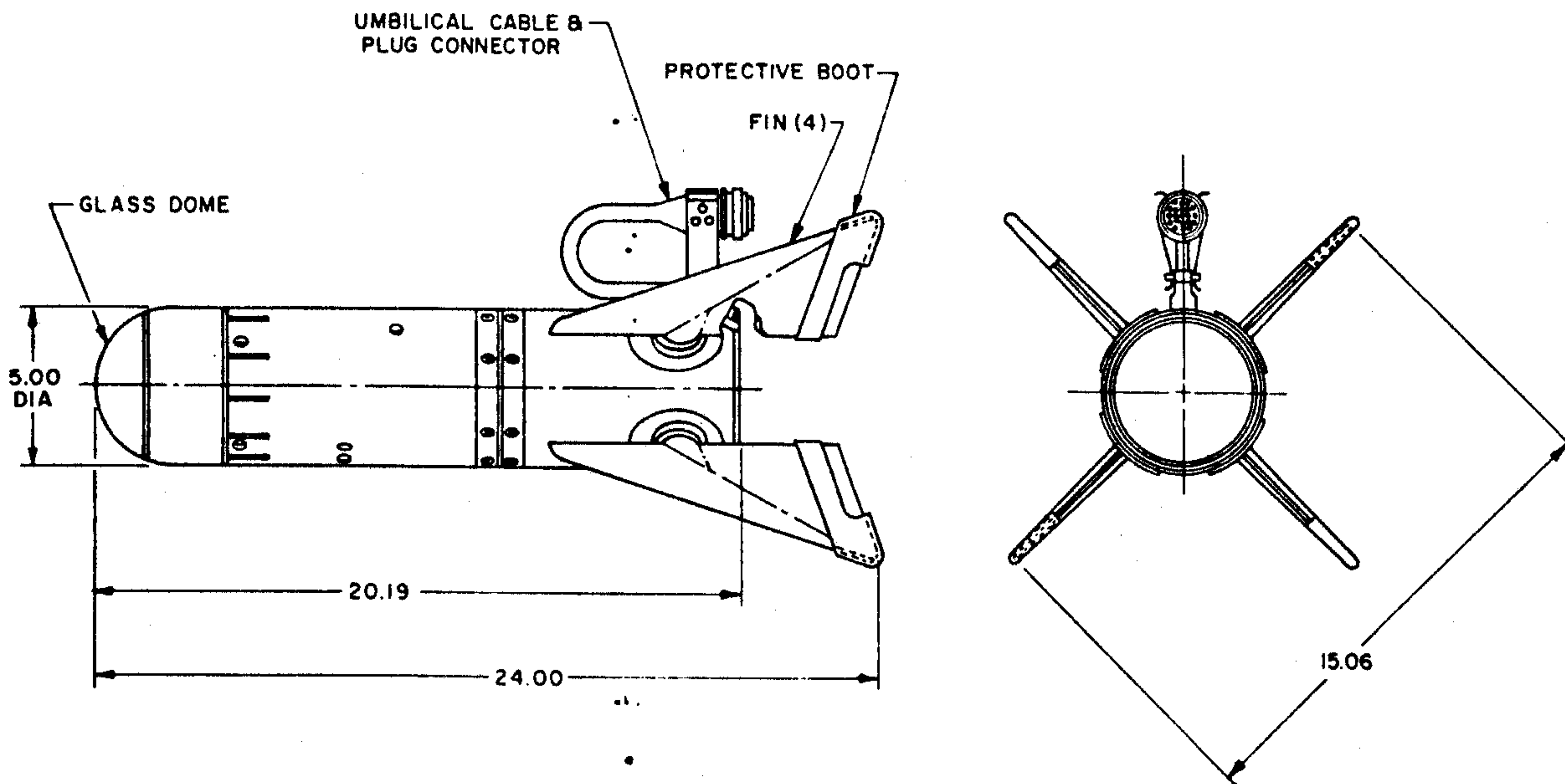

APPROXIMATE WEIGHT - 36.0 LBS

ORIGINAL DATA SOURCE
BUORD DWG NO. 1804173 REV F
DATED 25 JUNE 1964

GUIDANCE & CONTROL GROUP MK 12 MODS SIDEWINDER AIM-9C

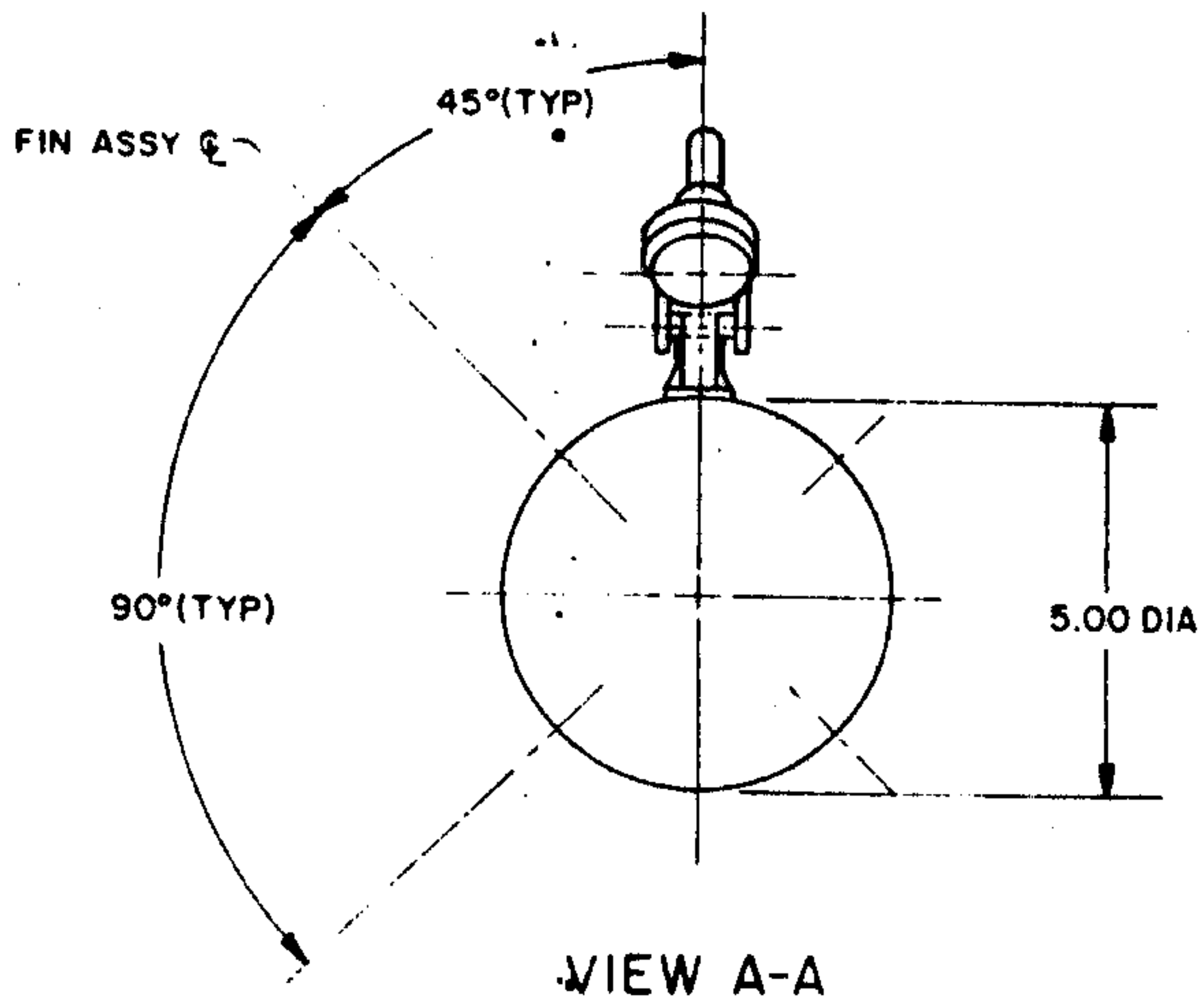
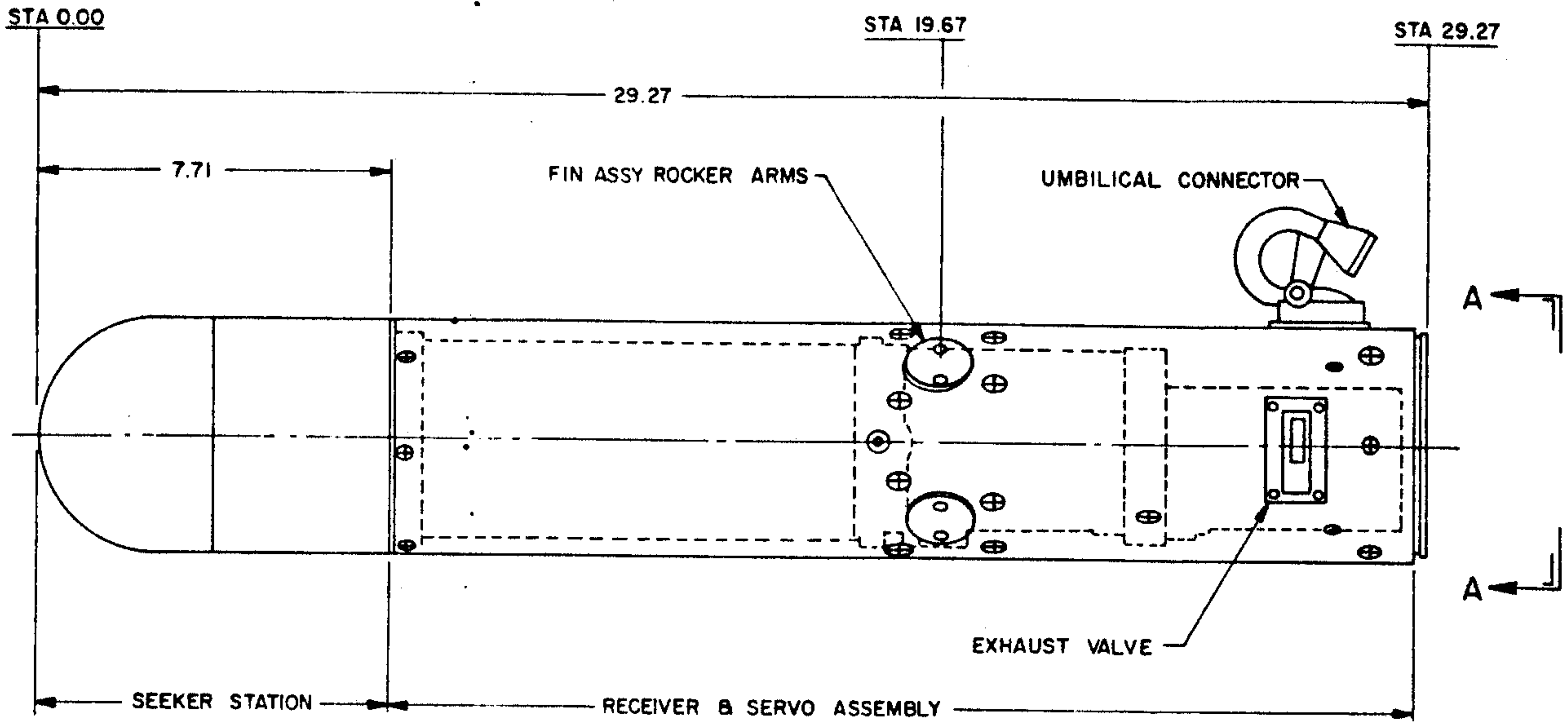

APPROXIMATE WEIGHT - 55.0 LBS.

ORIGINAL DATA SOURCE
BUORD DWG NO. 2197654 REV G
DATED 10 DECEMBER 1964

GUIDANCE & CONTROL GROUP MK 18 MOD 2 SIDEWINDER AIM-9D

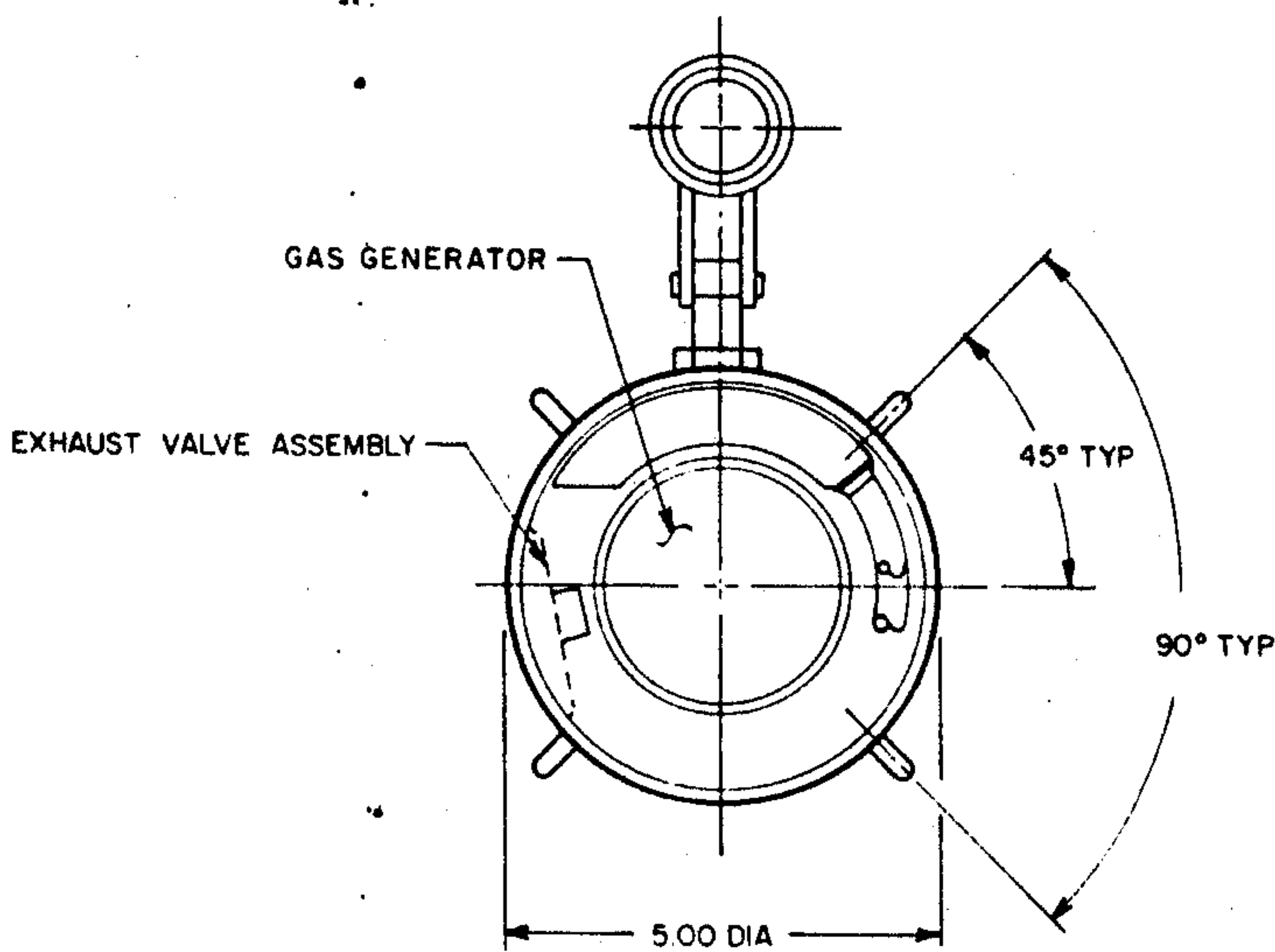
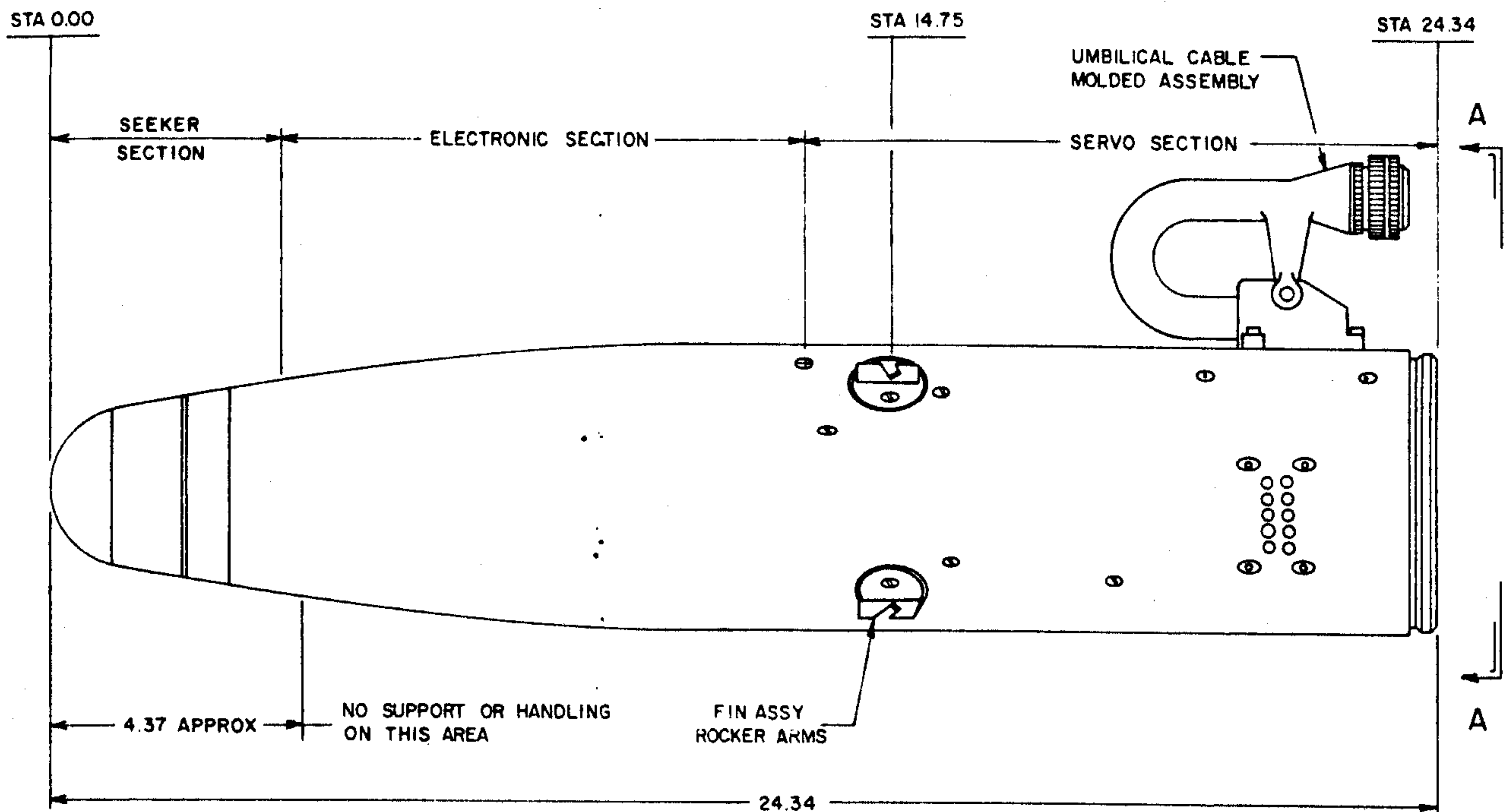

VIEW A-A

NOTE:

- I. APPROXIMATE WEIGHTS:
- GUIDANCE & CONTROL GROUP WITH TDD MK 24 - 43.5 LBS
- GUIDANCE & CONTROL GROUP LESS TDD MK 24 - 36.5 LBS

ORIGINAL DATA SOURCE

BUORD DWG NO. 2439934 REV J
DATED 30 APRIL 1965

ROCKET MOTOR MK 36 MODS

SIDEWINDER AIM-9C/D

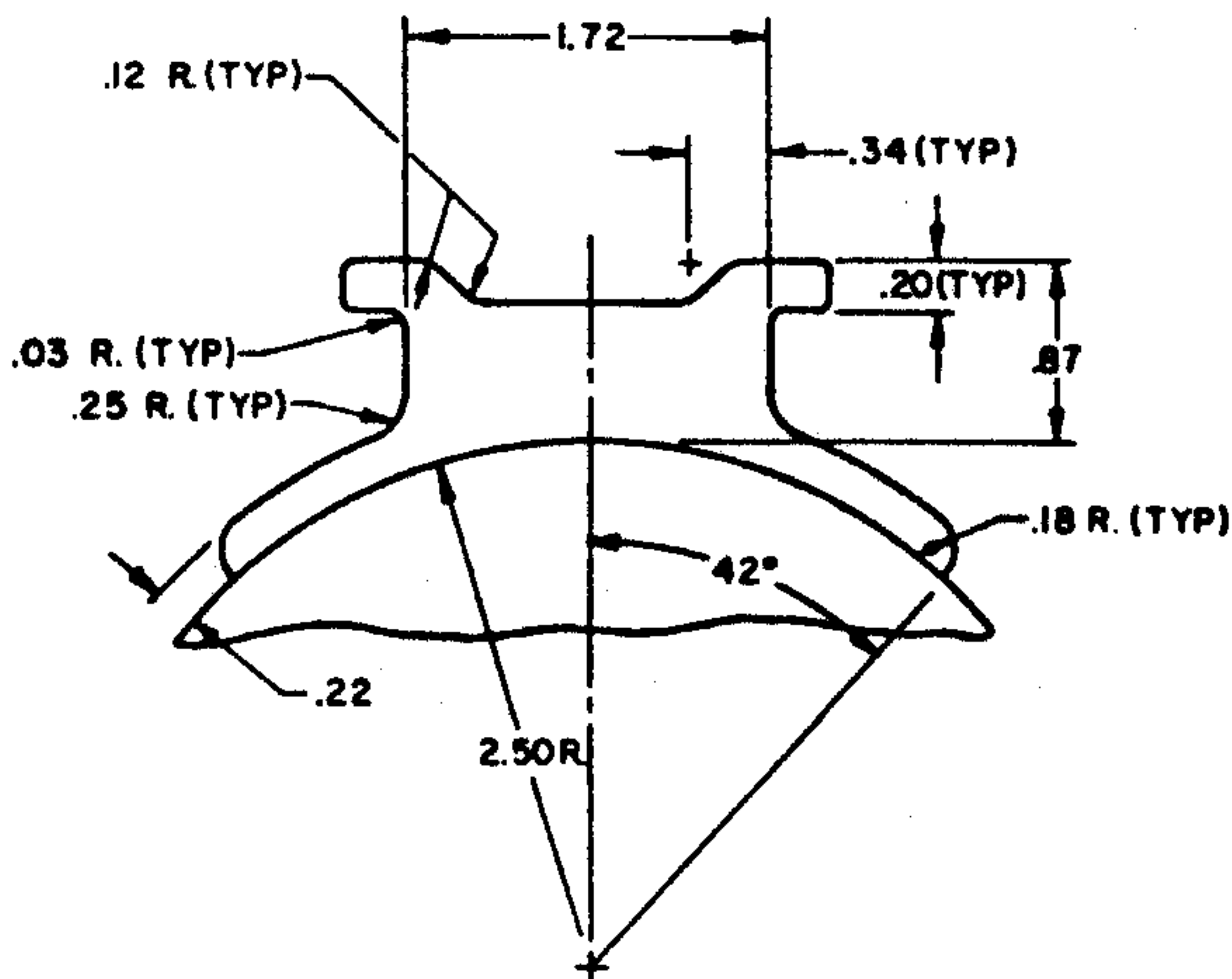
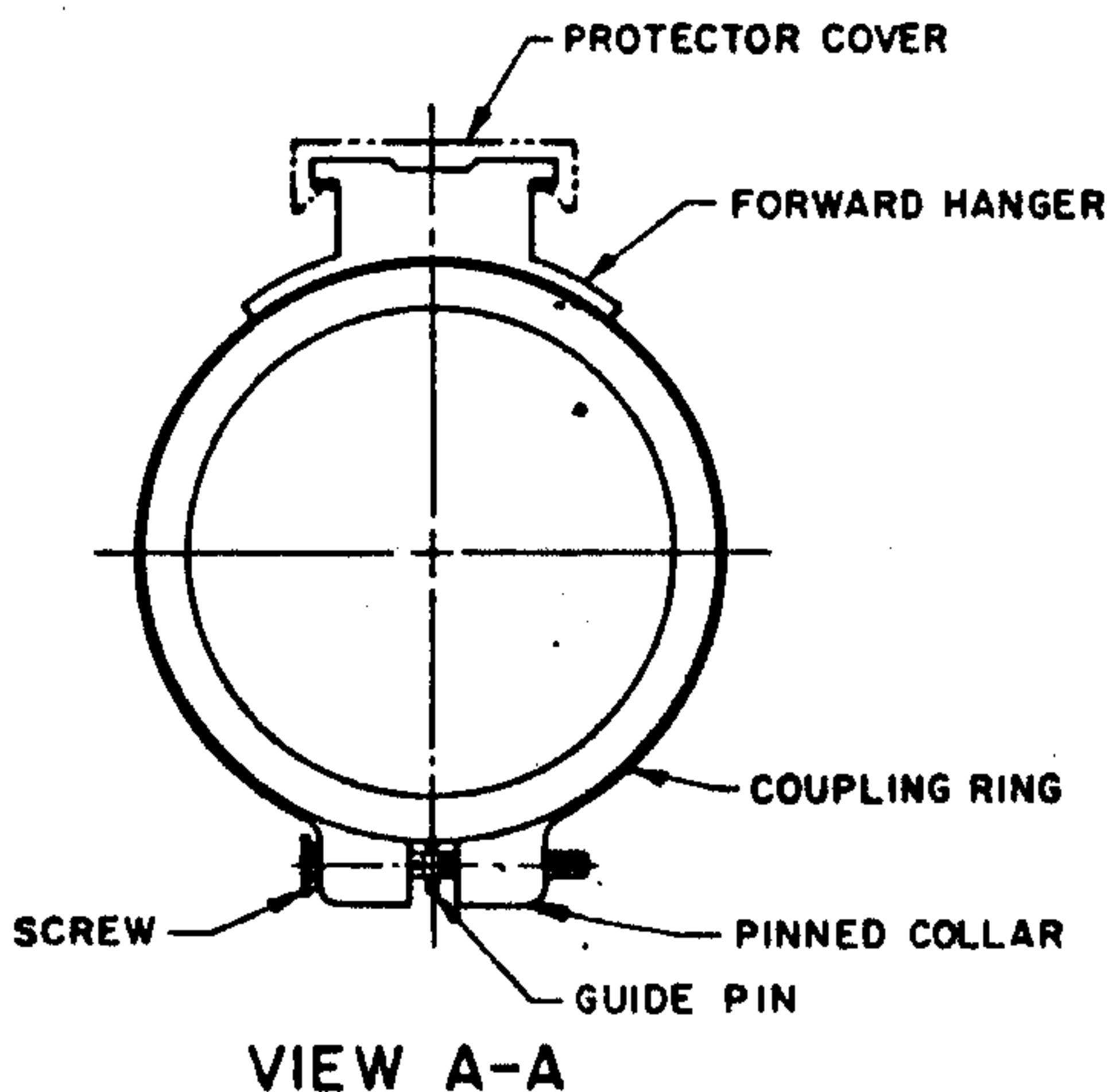
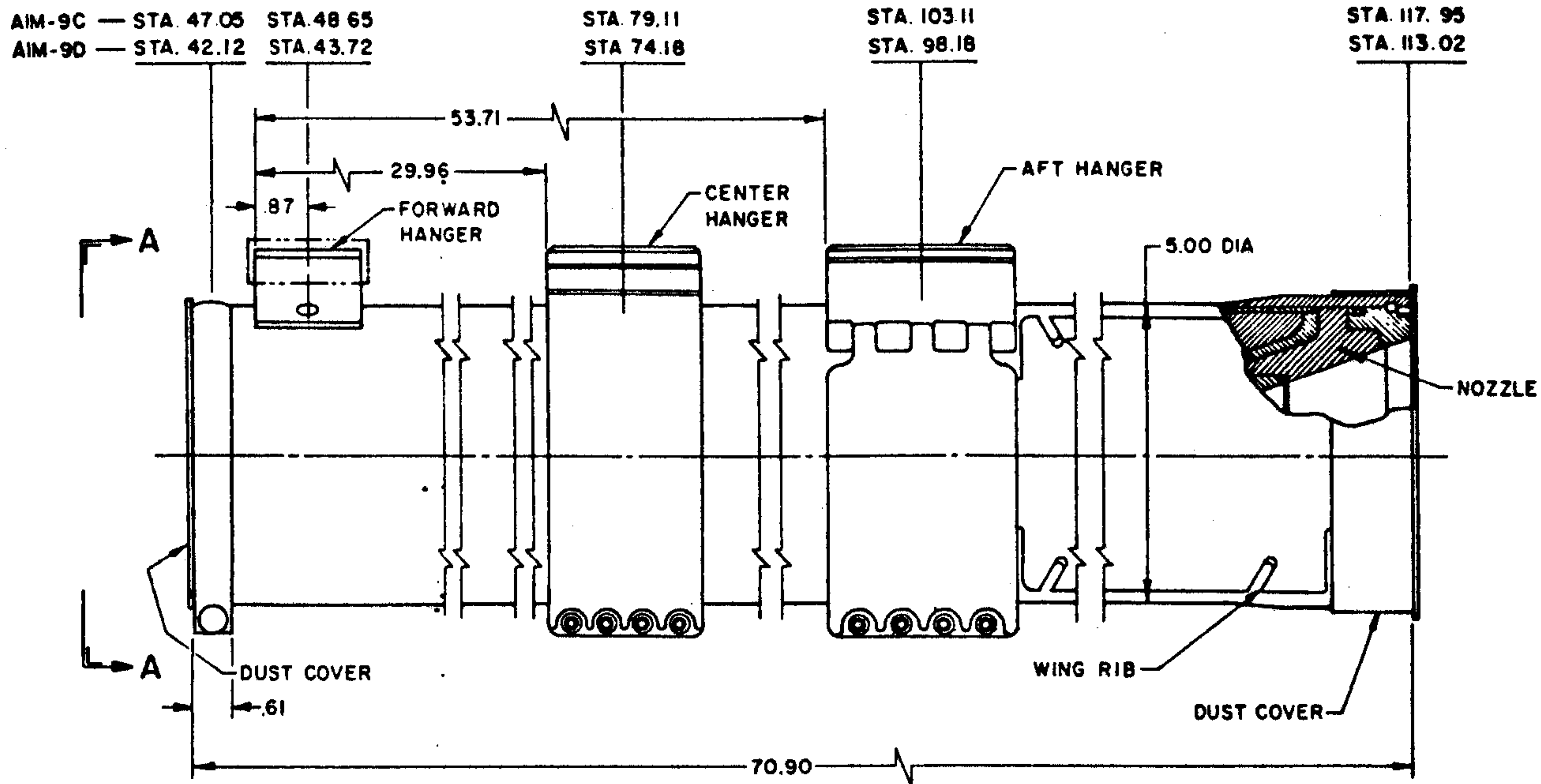

ENLARGED DETAIL OF FORWARD HANGER

NOTE:
 1 APPROXIMATE WEIGHT - 99.0 LBS

ORIGINAL DATA SOURCE
 BUWPS DWG NO. 2580611 REV D
 DATED 17 JULY 1969
 BUWPS DWG NO. 2580620
 DATED 4 JANUARY 1966
 (PRELIMINARY)

FIN ASSEMBLY

SIDEWINDER AIM-9C

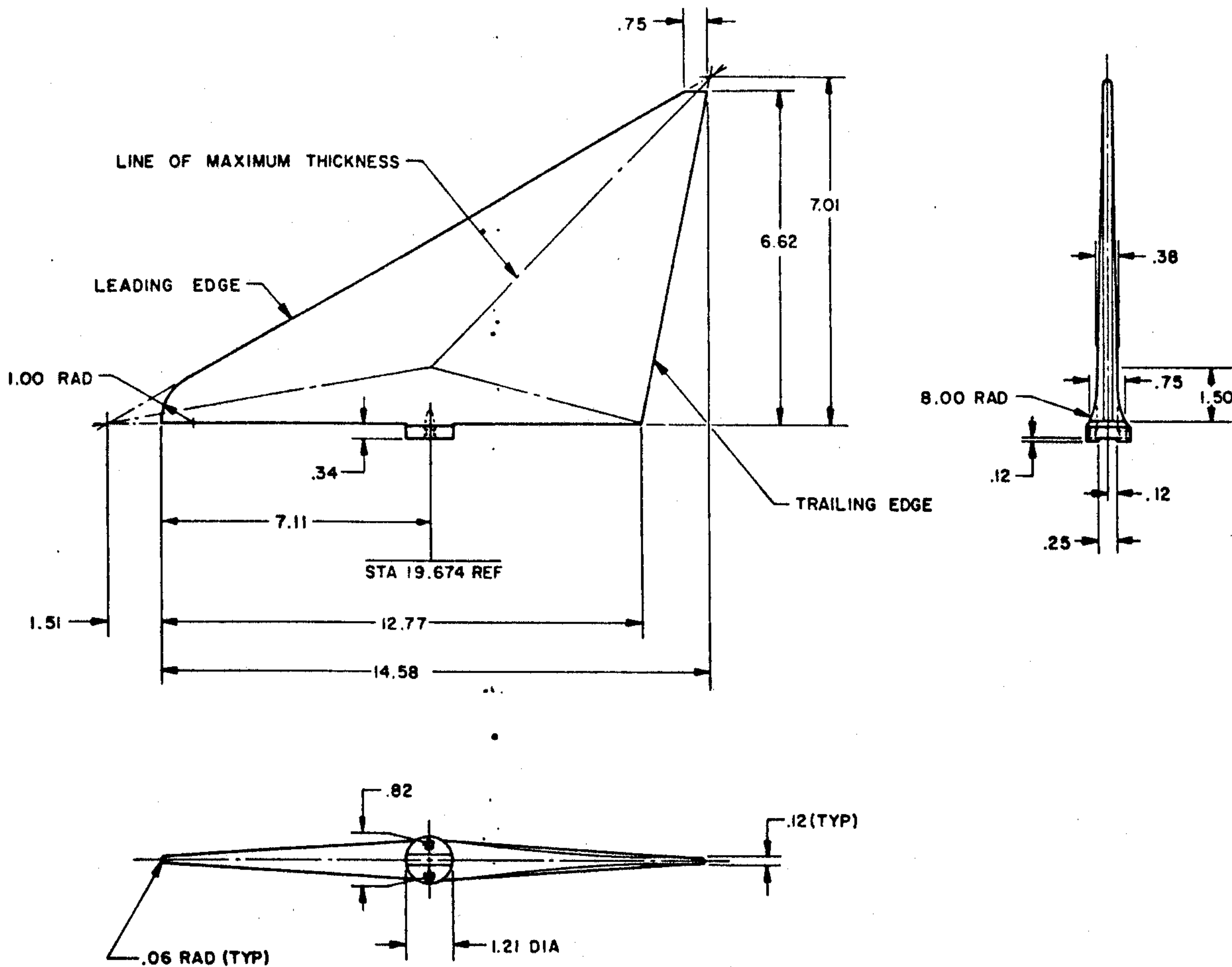

NOTES:

- 1. FOUR FIN ASSEMBLIES ARE REQUIRED PER MISSILE.
- 2. APPROXIMATE WEIGHT -1.25 LBS EACH.

ORIGINAL DATA SOURCE

BUORD DWG NO. 1517568
DATED 14 AUGUST 1963

FIN ASSEMBLY

SIDEWINDER AIM-9D

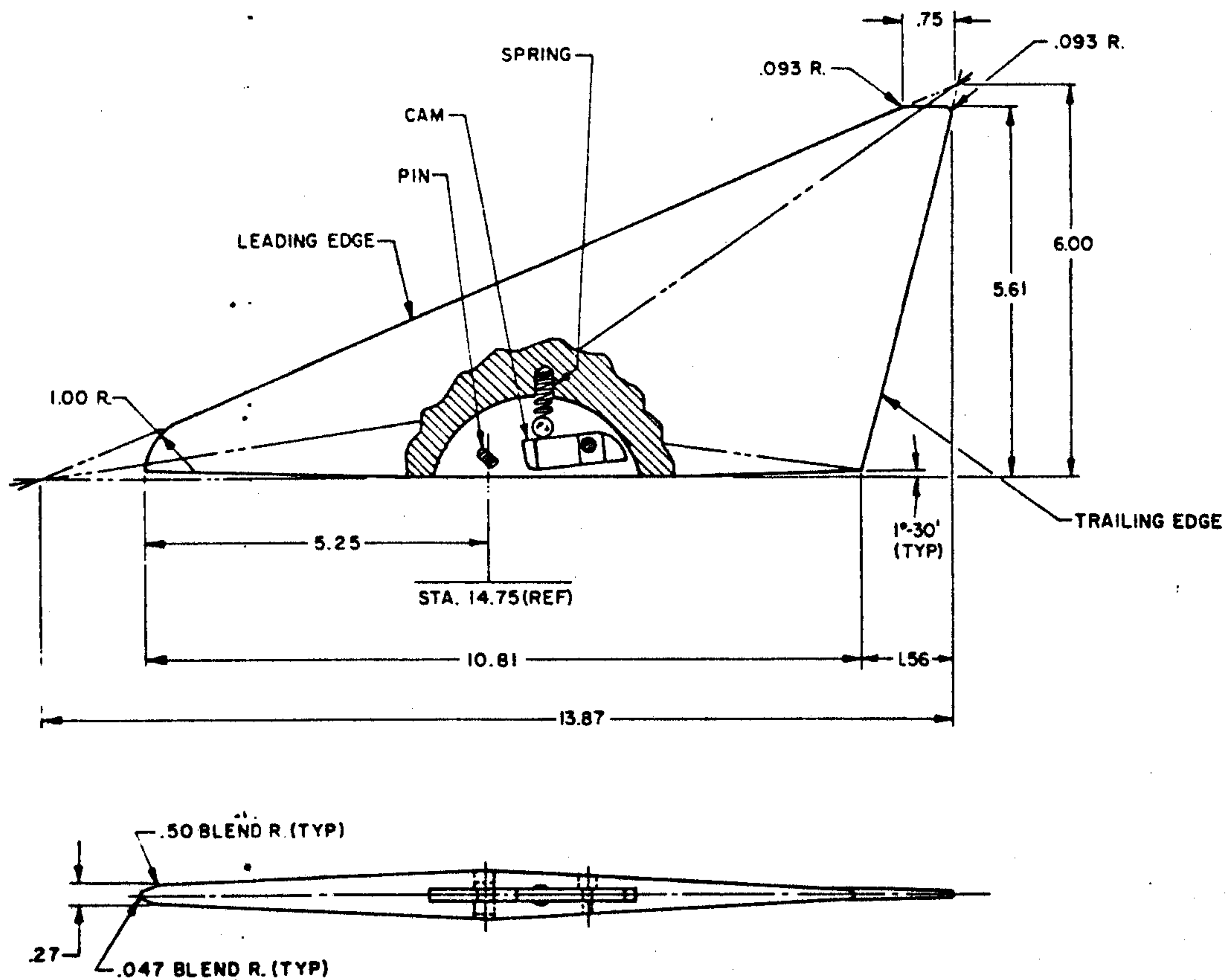

NOTES:

1. FOUR FIN ASSEMBLIES ARE REQUIRED PER MISSILE.
2. APPROXIMATE WEIGHT - .5 LBS EACH.

ORIGINAL DATA SOURCE

BUWEPs DWG NO. 1517810 REV D
DATED 18 JULY 1969
NOTS REV DIRECTIVE 5883
DATED 26 OCTOBER 1966

WING AND ROLLERON ASSEMBLY

SIDEWINDER AIM-9B

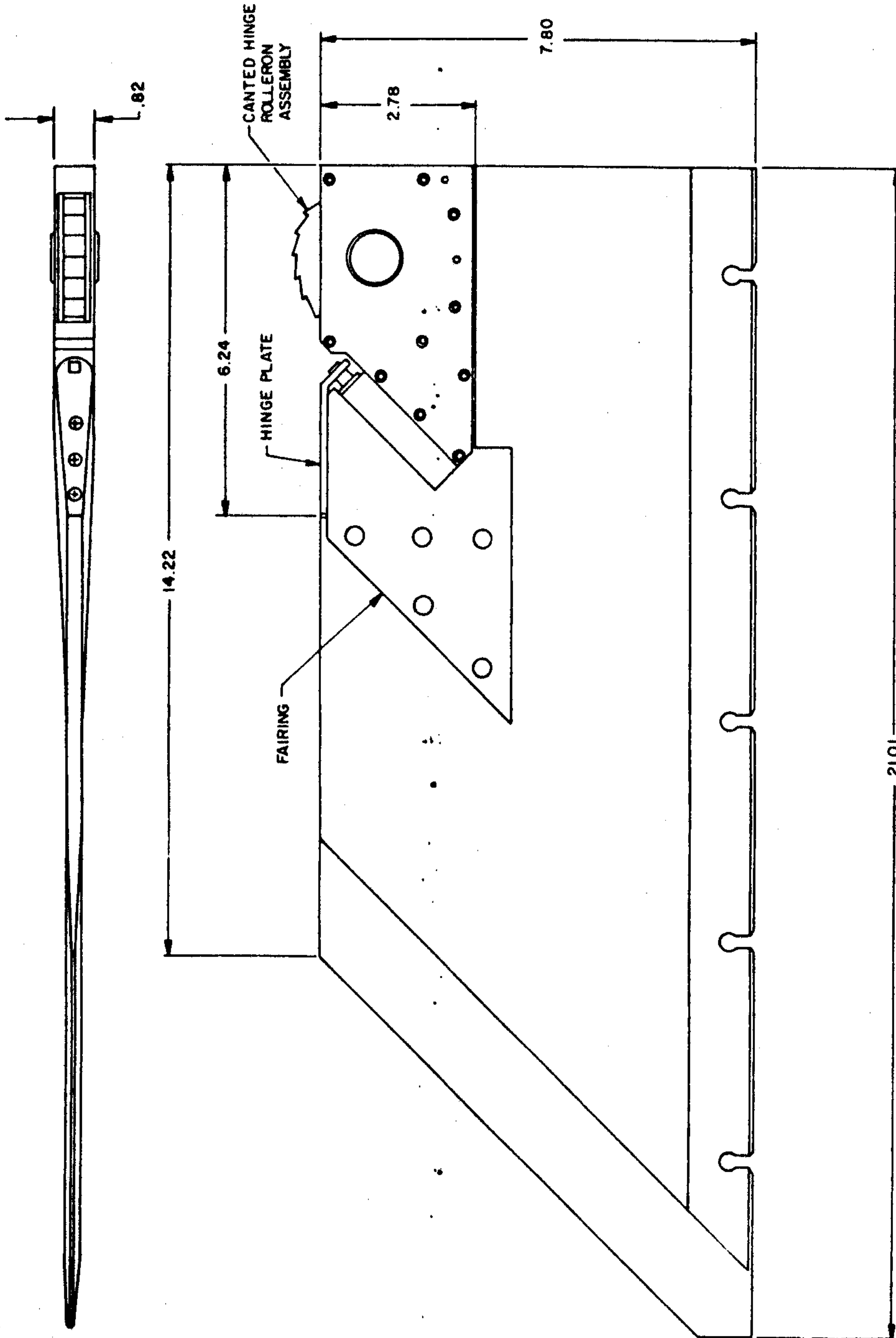

NOTES:

1. WING SHOWN IS USED WITH ROCKET MOTOR MK 17 MOD 5.
2. APPROXIMATE WEIGHT - 3.2 LBS
3. FOUR WINGS REQUIRED PER MISSILE.
4. STRAIGHT-HINGE ROLLERON ASSY IS USED WITH ROCKET MOTOR MK 17 MOD 1.

ORIGINAL DATA SOURCE
BUWEPS DWG NO. 1568339 REV C
DATED 4 DECEMBER 1967

WING ASSEMBLY MK I MOD 0

SIDEWINDER AIM-9C/D

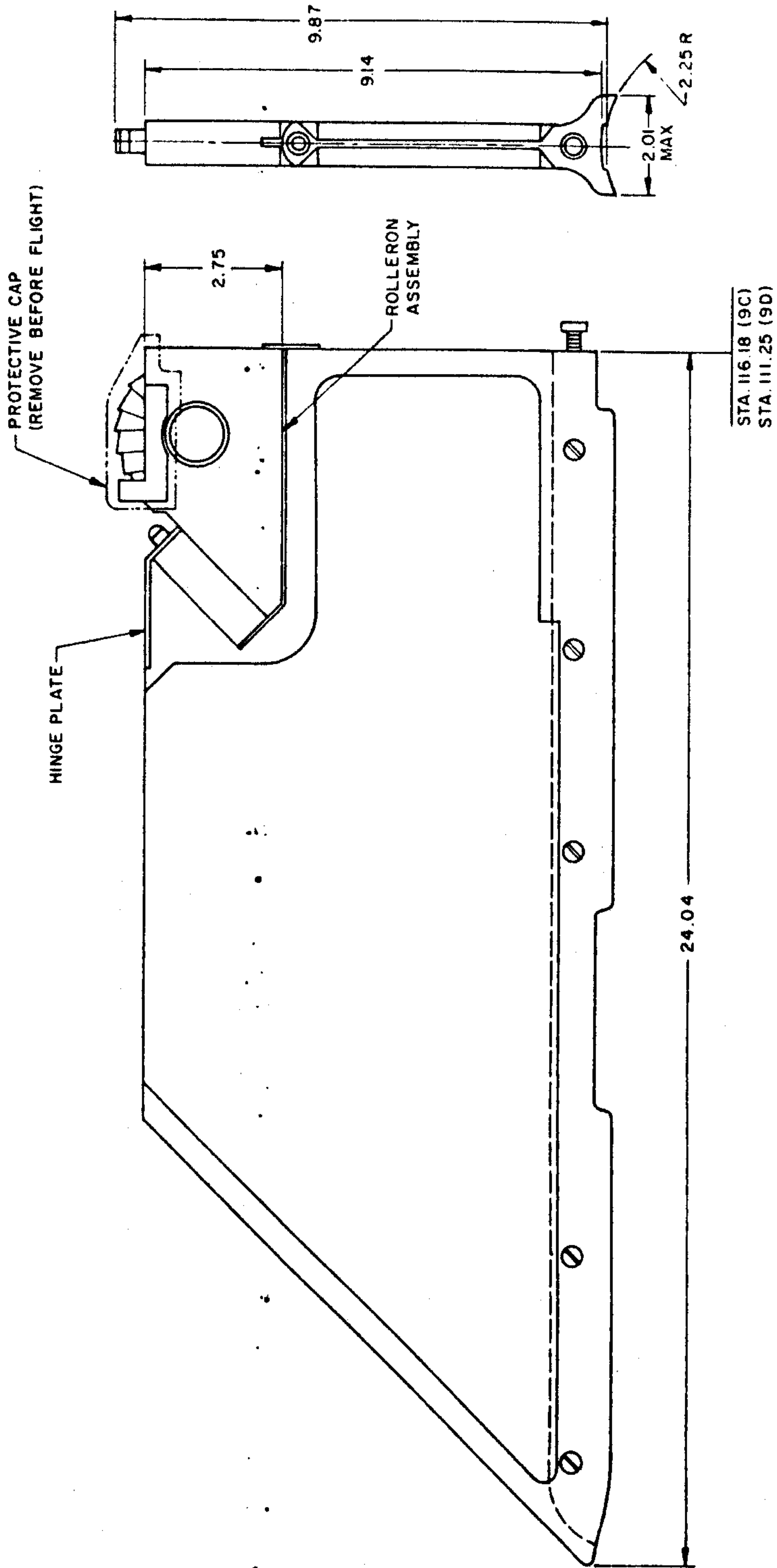

NOTES:

1. WING SHOWN IS USED WITH ROCKET MOTOR
MK 36 MODS
2. APPROXIMATE WEIGHT - 5.0 LBS
3. FOUR WINGS REQUIRED PER MISSILE.

ORIGINAL DATA SOURCE
BUWEP DWG NO. 1517535 REV D
DATED 9 JUNE 1969

MISSILE TARGET AQM-37A GENERAL ARRANGEMENT

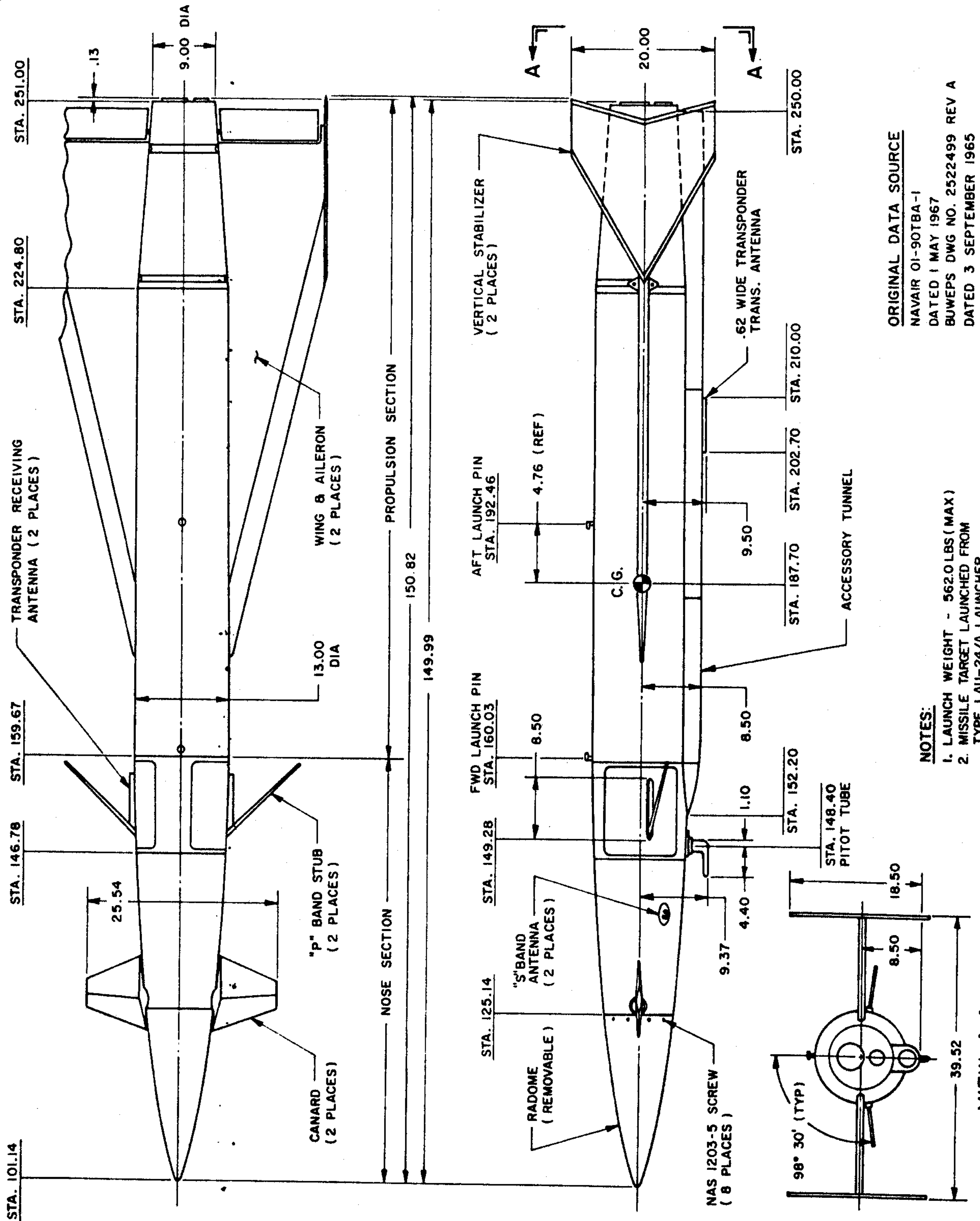

ORIGINAL DATA SOURCE
NAVAIR 01-90TBA-1
DATED 1 MAY 1967
BUWEPS DWG NO. 2522499 REV A
DATED 3 SEPTEMBER 1965

NOTES:
1. LAUNCH WEIGHT - 562.0 LBS (MAX)
2. MISSILE TARGET LAUNCHED FROM
TYPE LAU-24/A LAUNCHER.

MISSILE TARGET HARD SPOT LOCATIONS

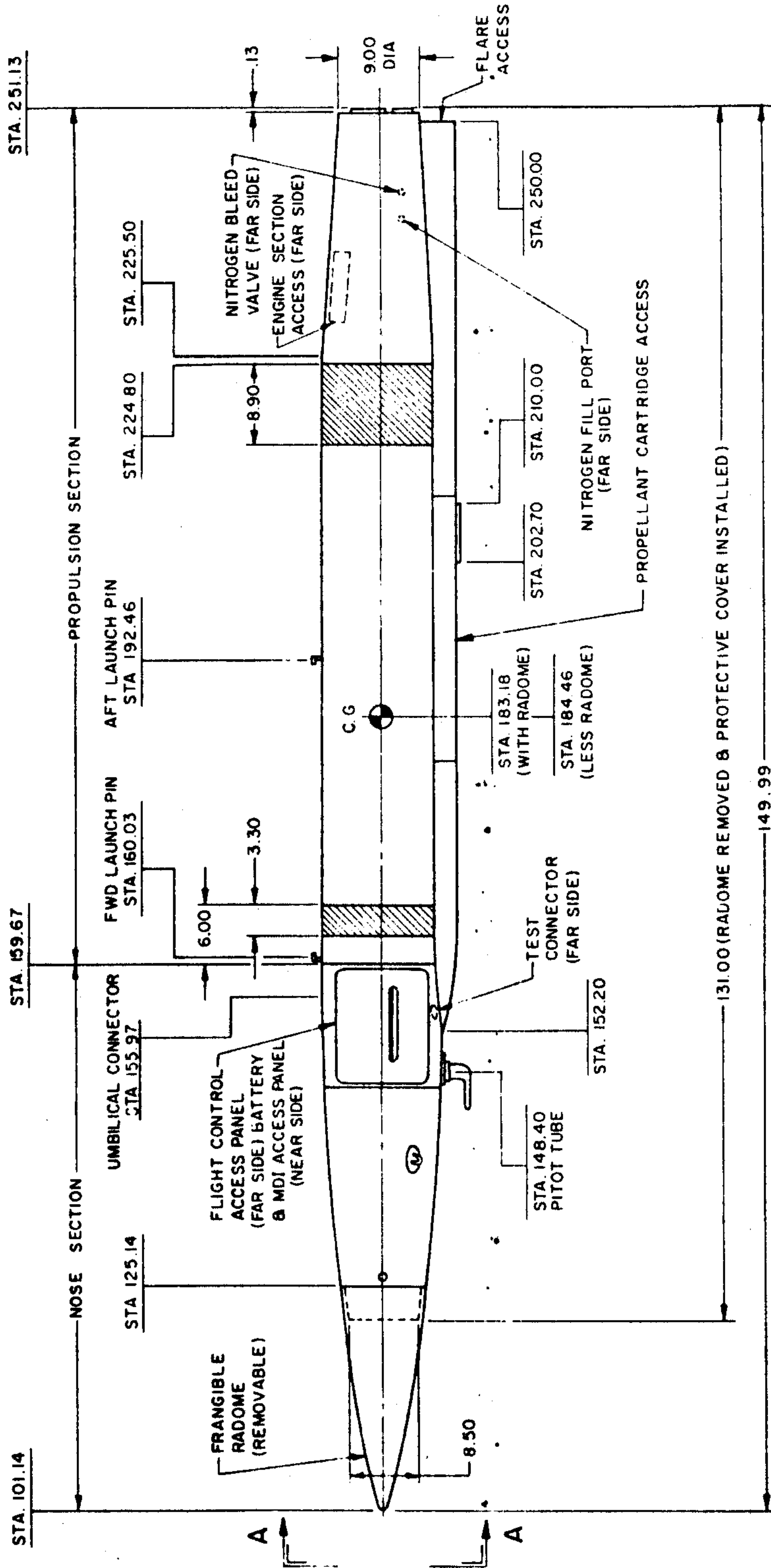

NOTES:

1. APPROXIMATE WEIGHTS WITH CANARDS, STABILIZERS & "P" BAND STUBS REMOVED:
 WITH RADOME, BATTERY, TRANSPONDER 521.0 LBS.
 & FLARE INSTALLED 481.0 LBS.
 LESS THE ABOVE ITEMS
 [Hatched Area] INDICATES HARD SPOT AREA.
2. [Hatched Area] INDICATES HARD SPOT AREA.
3. C.G.'S INDICATED ARE LESS BATTERY, TRANSPONDER AND FLARE.

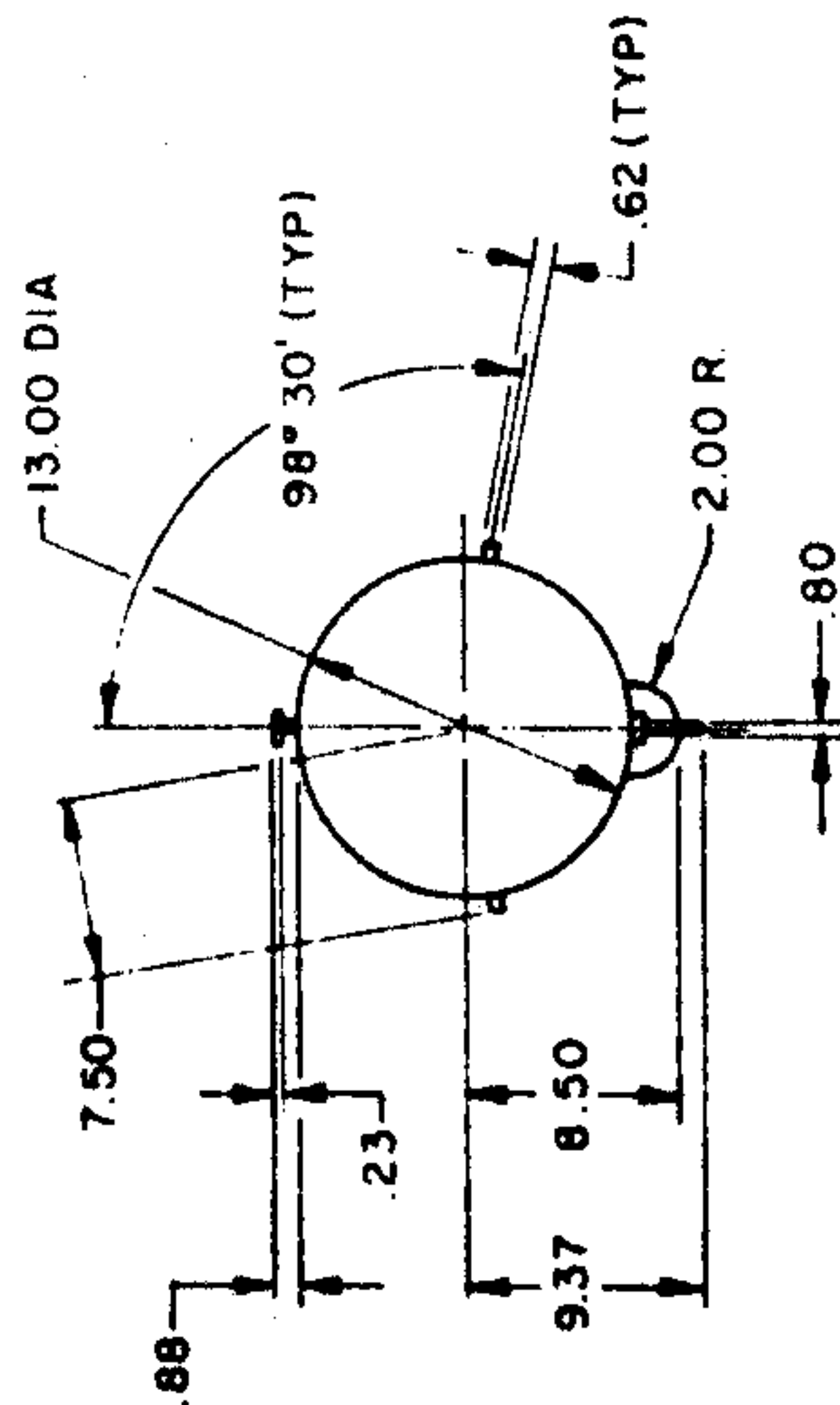

VIEW A-A

ORIGINAL DATA SOURCE
 BUWEP DWG NO. 2522499 REV A
 DATED 3 SEPTEMBER 1965
 NAVAIR 01-90TBA-1
 DATED 1 MAY 1967

MISSILE TARGET RADOME

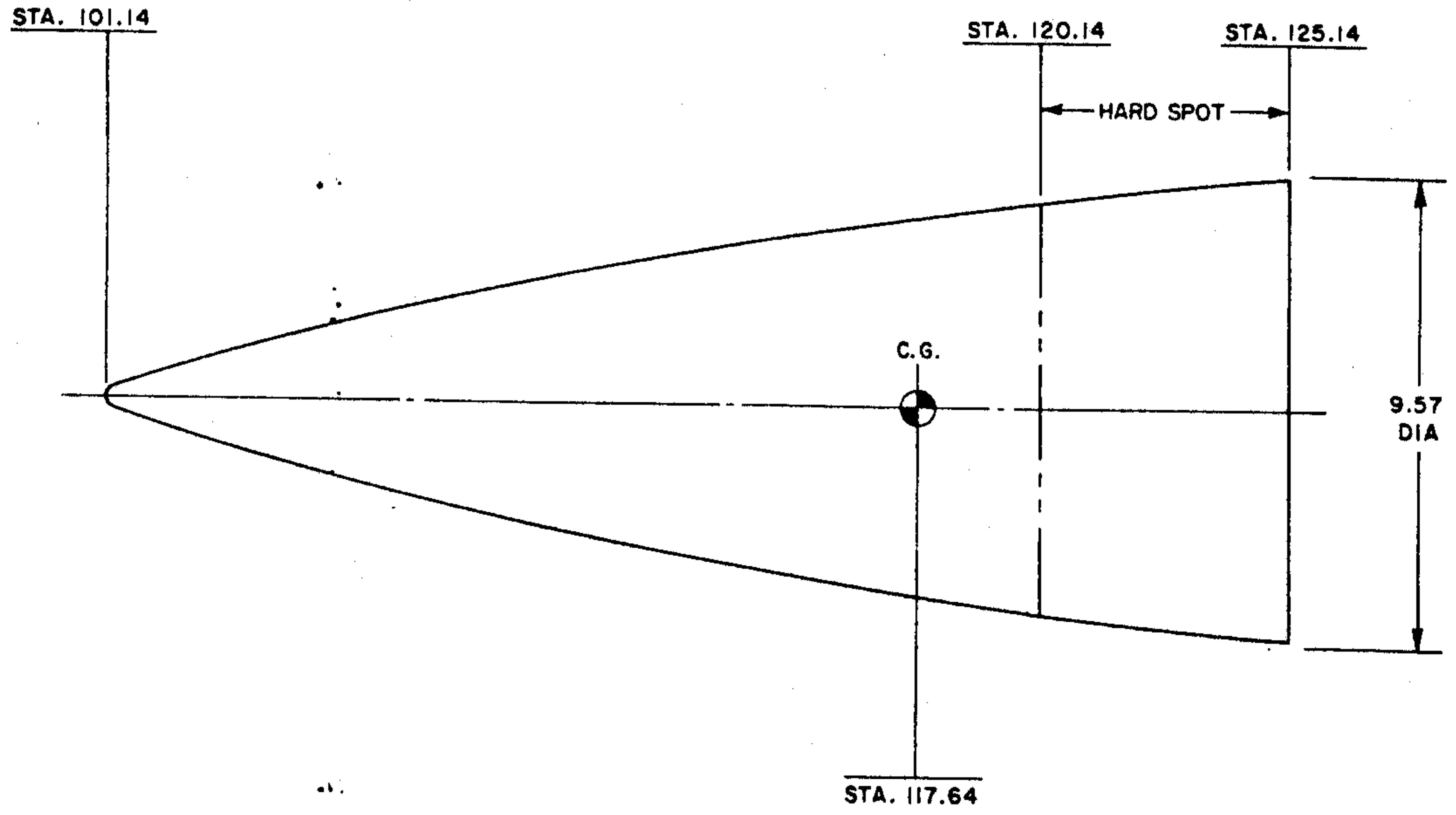

APPROXIMATE WEIGHT — 9.7 LBS.

ORIGINAL DATA SOURCE
BUWEPs DWG NO. 2522499

MISSILE TARGET CANARD

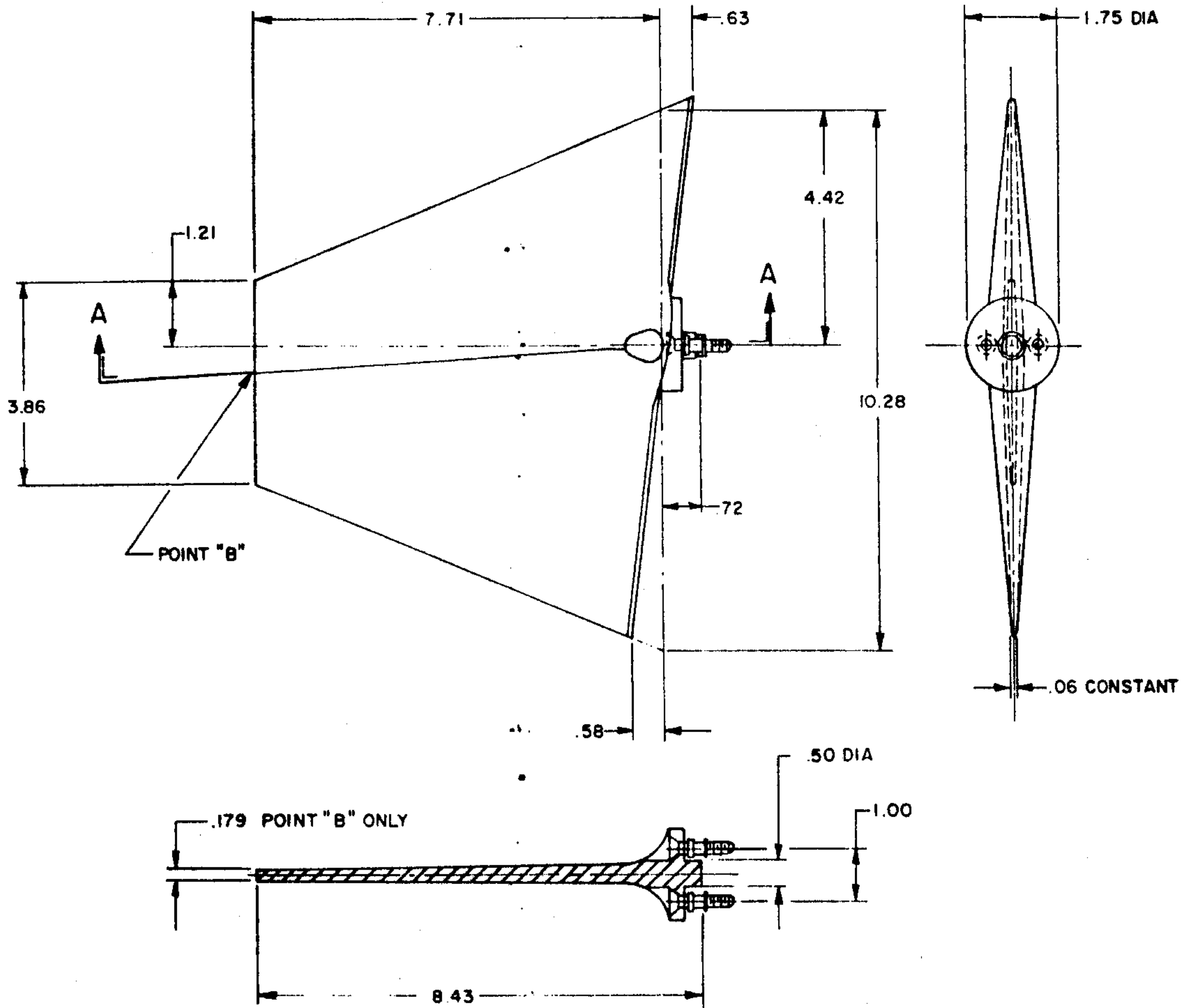

SECTION A-A

NOTES:

1. TWO CANARDS SHOWN ARE REQUIRED FOR EACH MISSILE TARGET.
2. MATERIAL - ALUMINUM ALLOY BONDED HONEYCOMB SANDWICH.
3. WEIGHT - 1.2 LBS. EACH.

ORIGINAL DATA SOURCE
BEECH DWG NO. 1019-660005 REV. E

MISSILE TARGET WING & AILERON

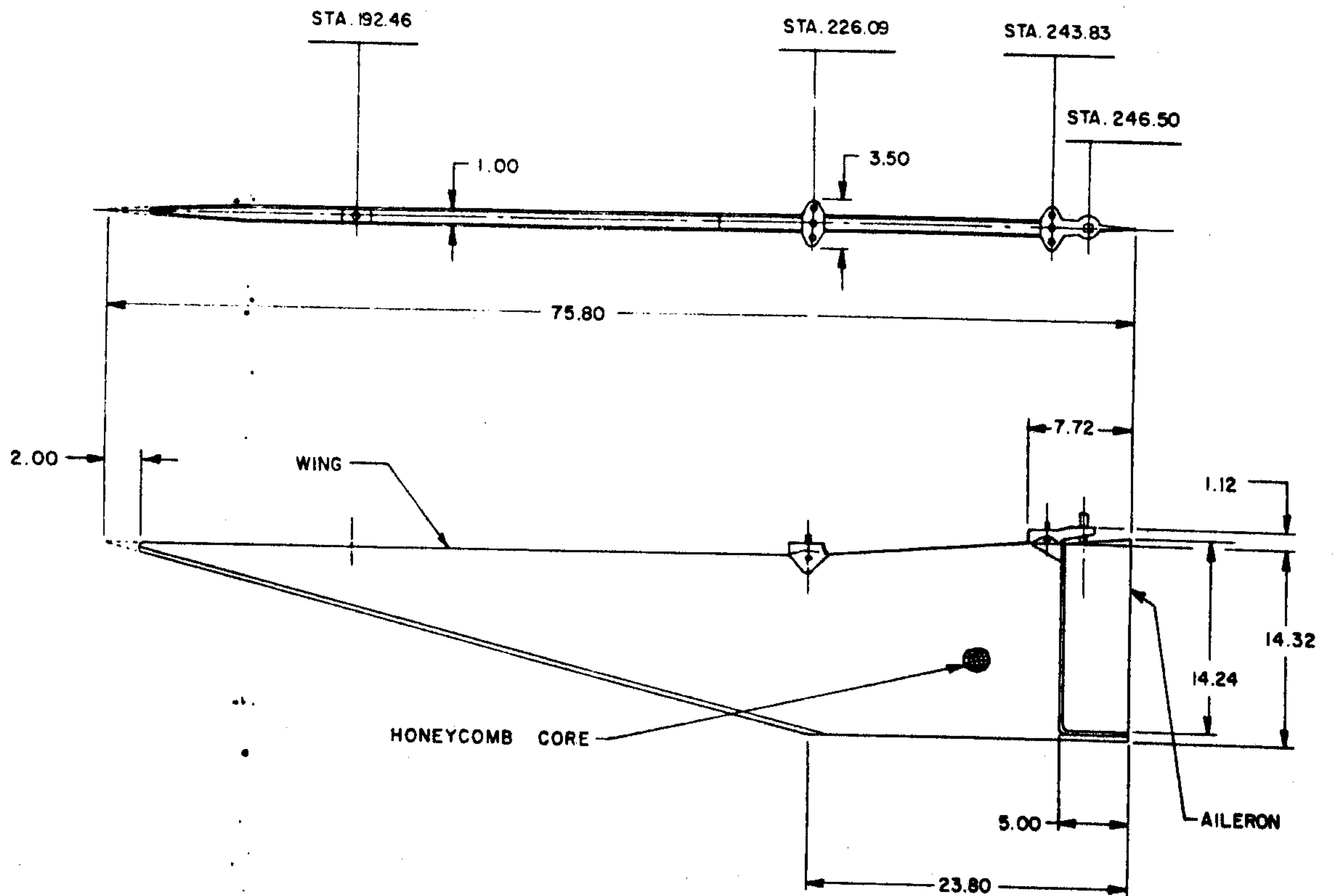

NOTES:

1. TWO WINGS SHOWN ARE REQUIRED PER MISSILE TARGET.
2. MATERIAL - ALUMINUM ALLOY BONDED HONEYCOMB SANDWICH.
3. WEIGHT - 16.1 LBS EACH

ORIGINAL DATA SOURCE

BEECH DWG NO S.
1019-100000 REV H
1019-130001 REV C

MISSILE TARGET VERTICAL STABILIZER

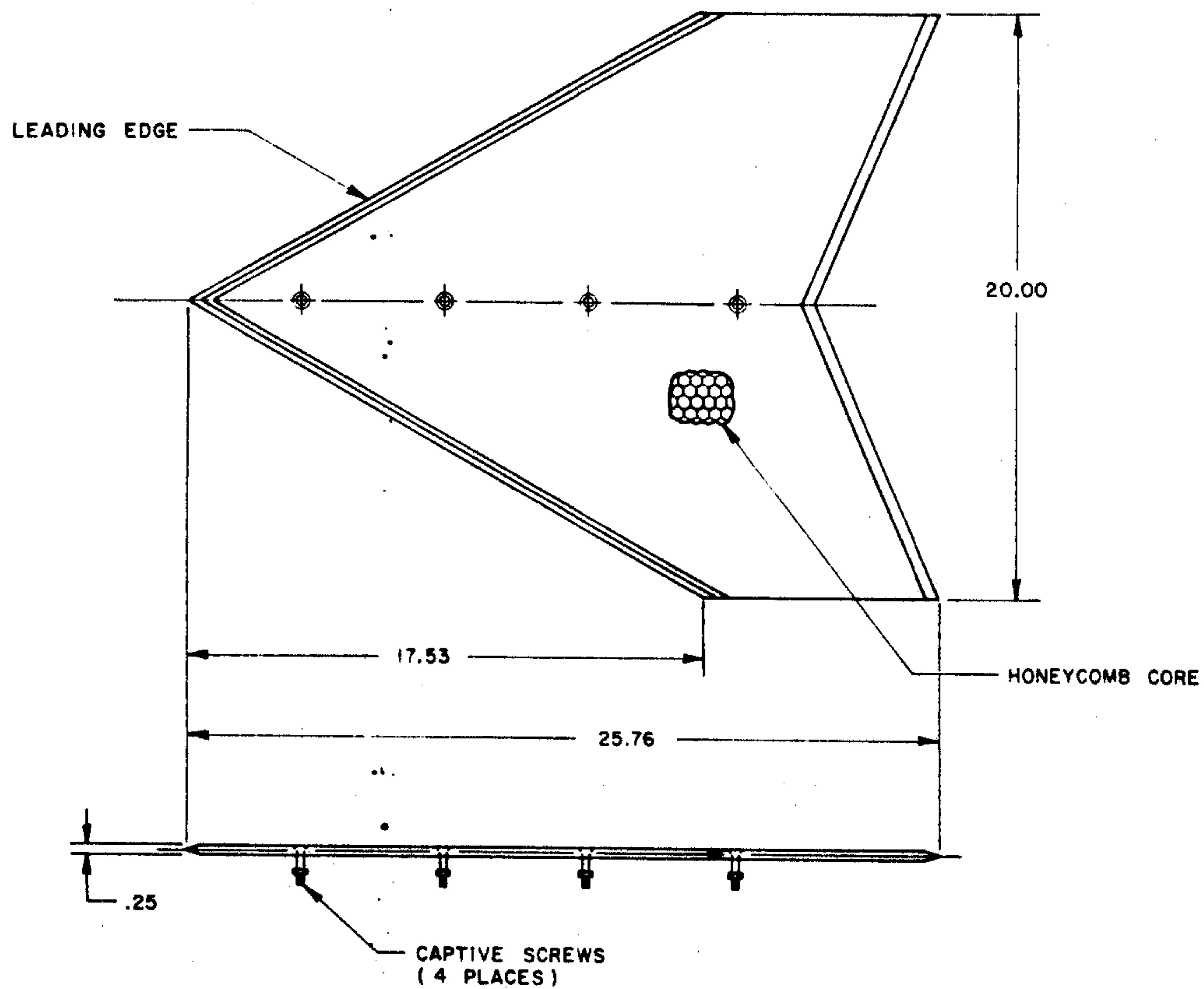

NOTES:

1. LEFT HAND VERTICAL STABILIZER SHOWN, RIGHT OPPOSITE.
2. ONE LEFT AND ONE RIGHT HAND VERTICAL STABILIZERS ARE REQUIRED PER MISSILE TARGET.
3. MATERIAL - ALUMINUM ALLOY BONDED HONEYCOMB SANDWICH.
4. WEIGHT - 3.2 LBS EACH

ORIGINAL DATA SOURCE
BEECH DWG NO. 1019-640001 REV E

MISSILE TARGET INFRARED FLARE MK 37

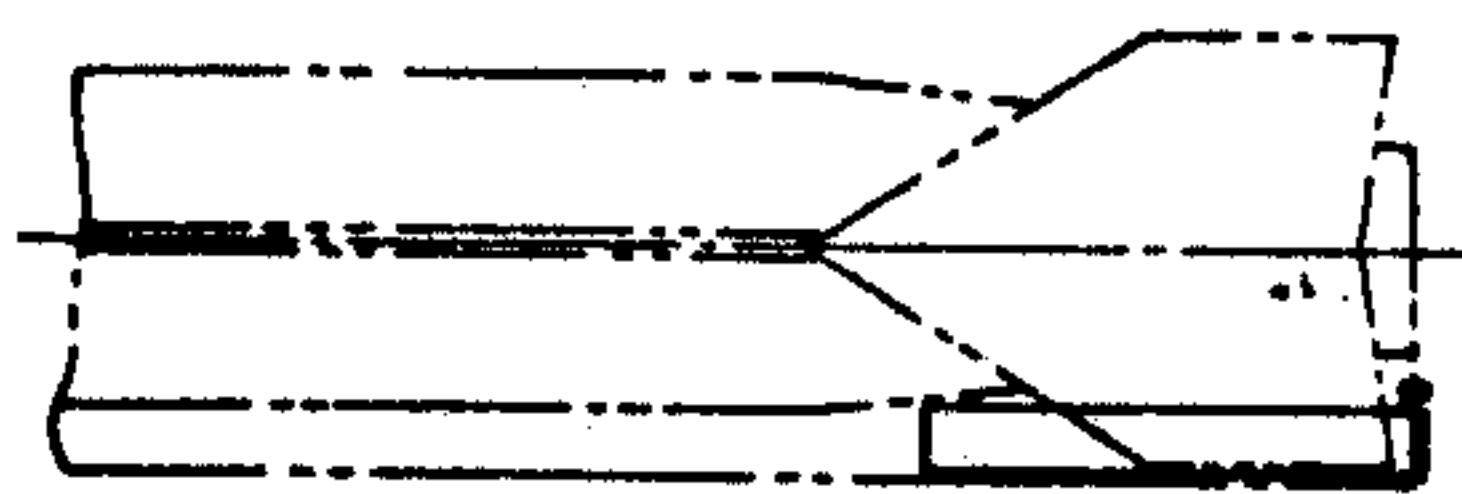
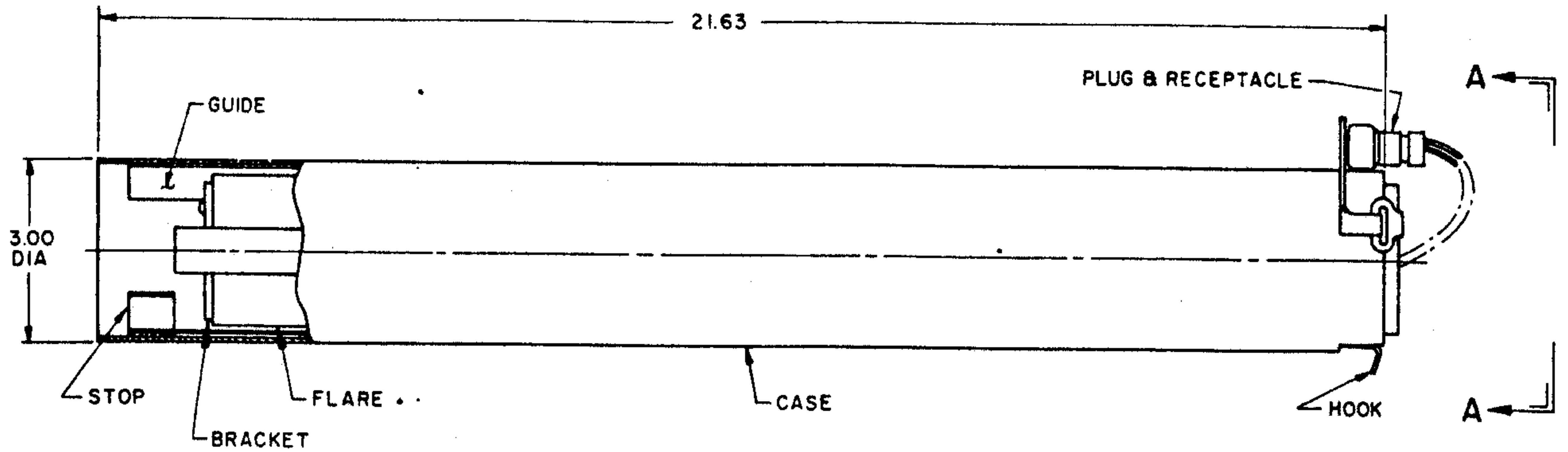

FLARE INSTALLATION

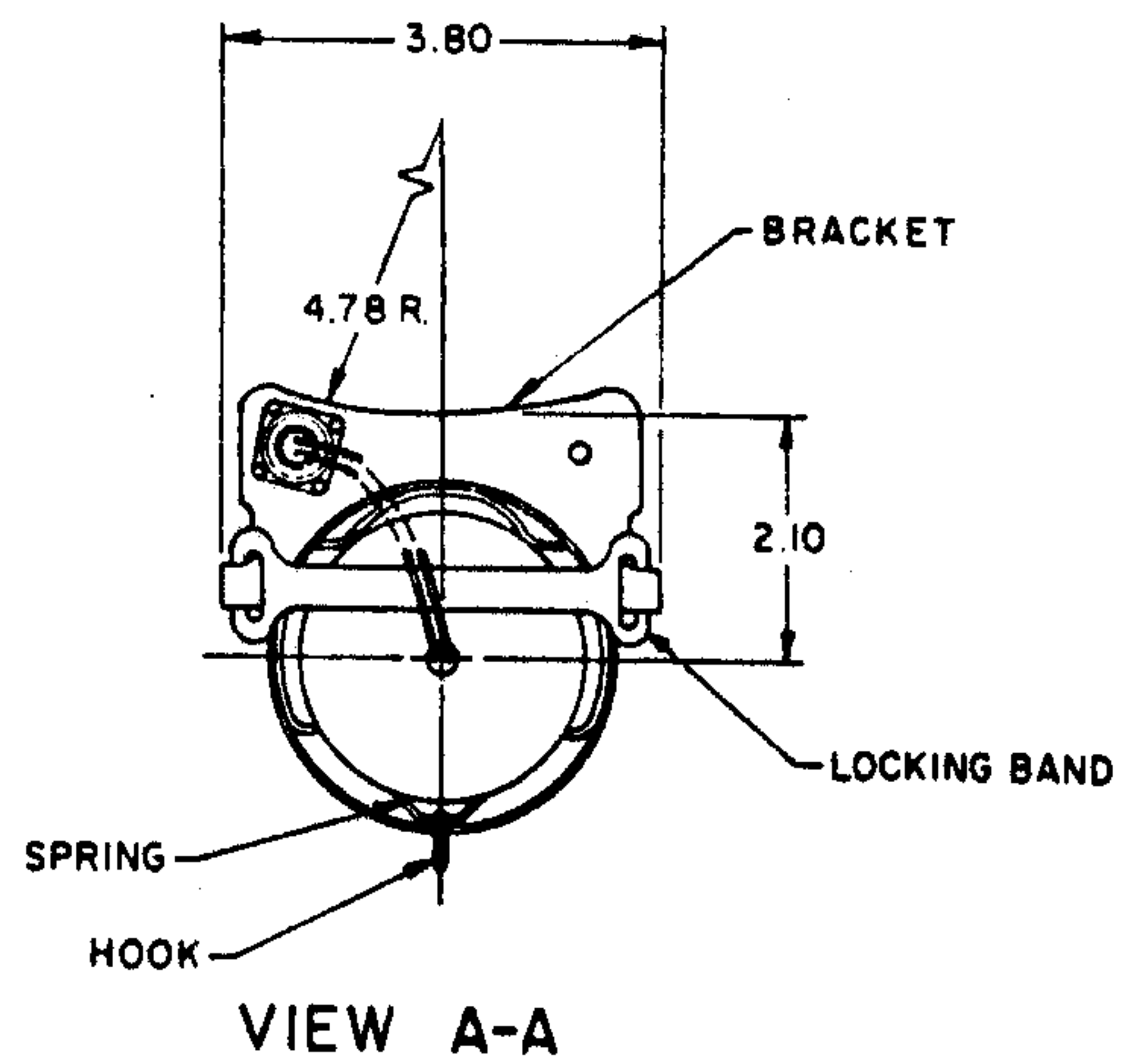
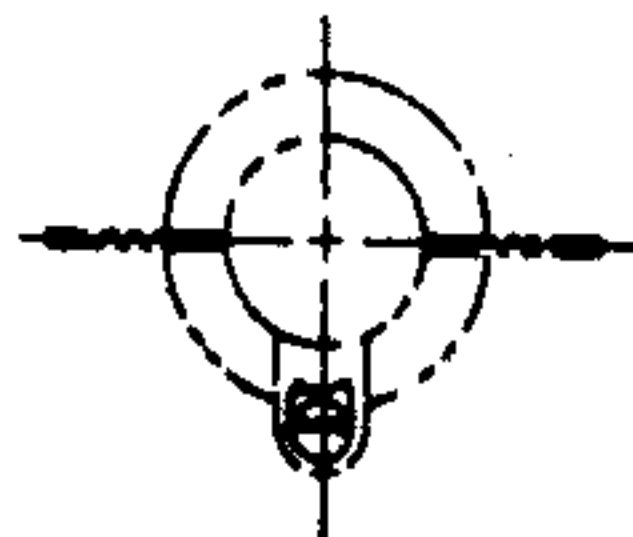

NOTES:

1. FLARE SHOWN PROVIDES INFRARED RADIATION INTENSITY AUGMENTATION FOR THE MISSILE TARGET. THE FLARE IS AN OPTIONAL PIECE OF EQUIPMENT.
2. WEIGHT - 15.5 LBS

ORIGINAL DATA SOURCE
BEECH DWG NO. 1019-360111 REV E

PHOENIX AIM-54A GENERAL ARRANGEMENT

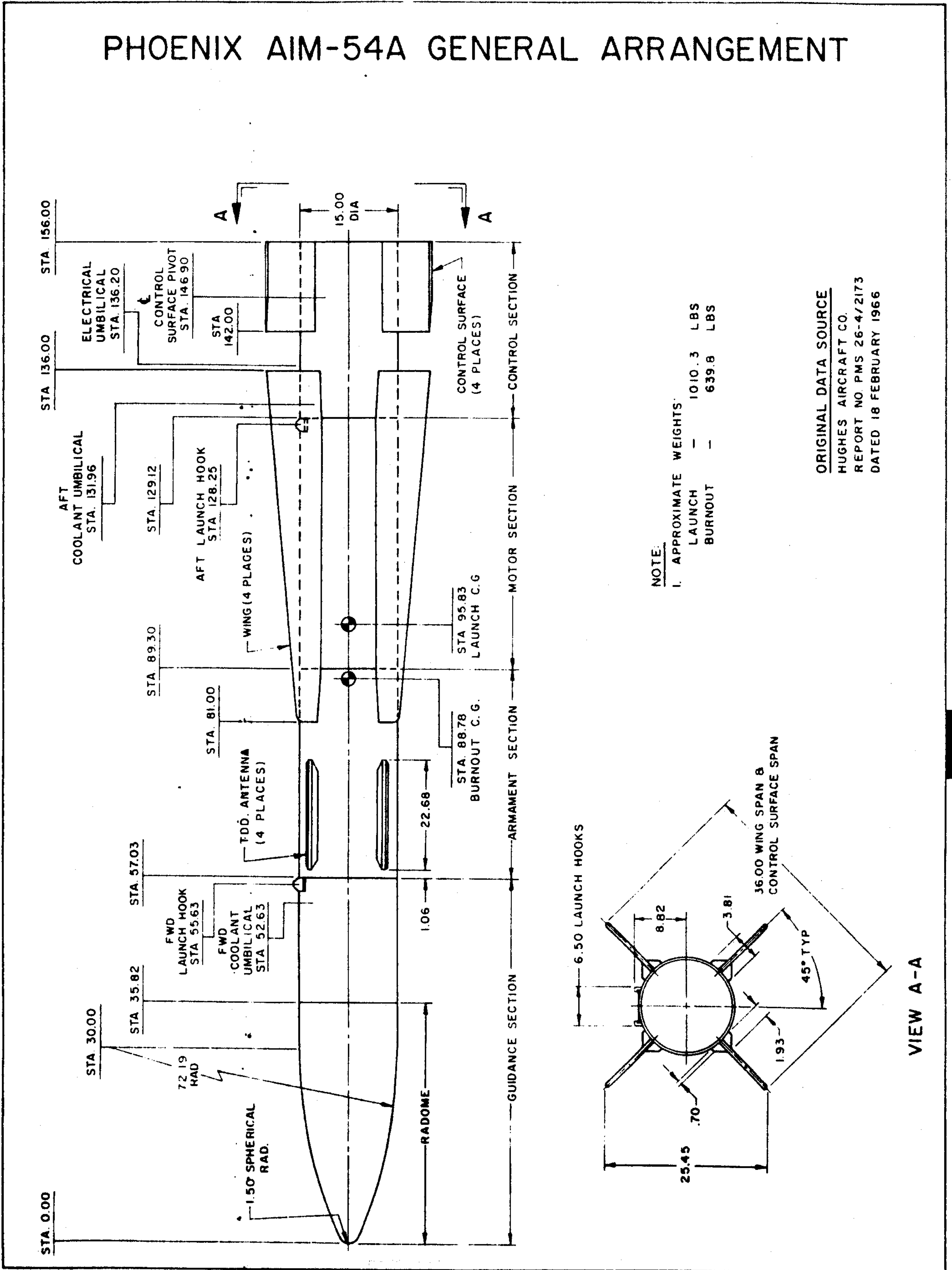

NOTE:

I. APPROXIMATE WEIGHTS

LAUNCH	1010.3	LBS
BURNOUT	639.8	LBS

ORIGINAL DATA SOURCE
 HUGHES AIRCRAFT CO.
 REPORT NO. PMS 26-4/2173
 DATED 18 FEBRUARY 1966

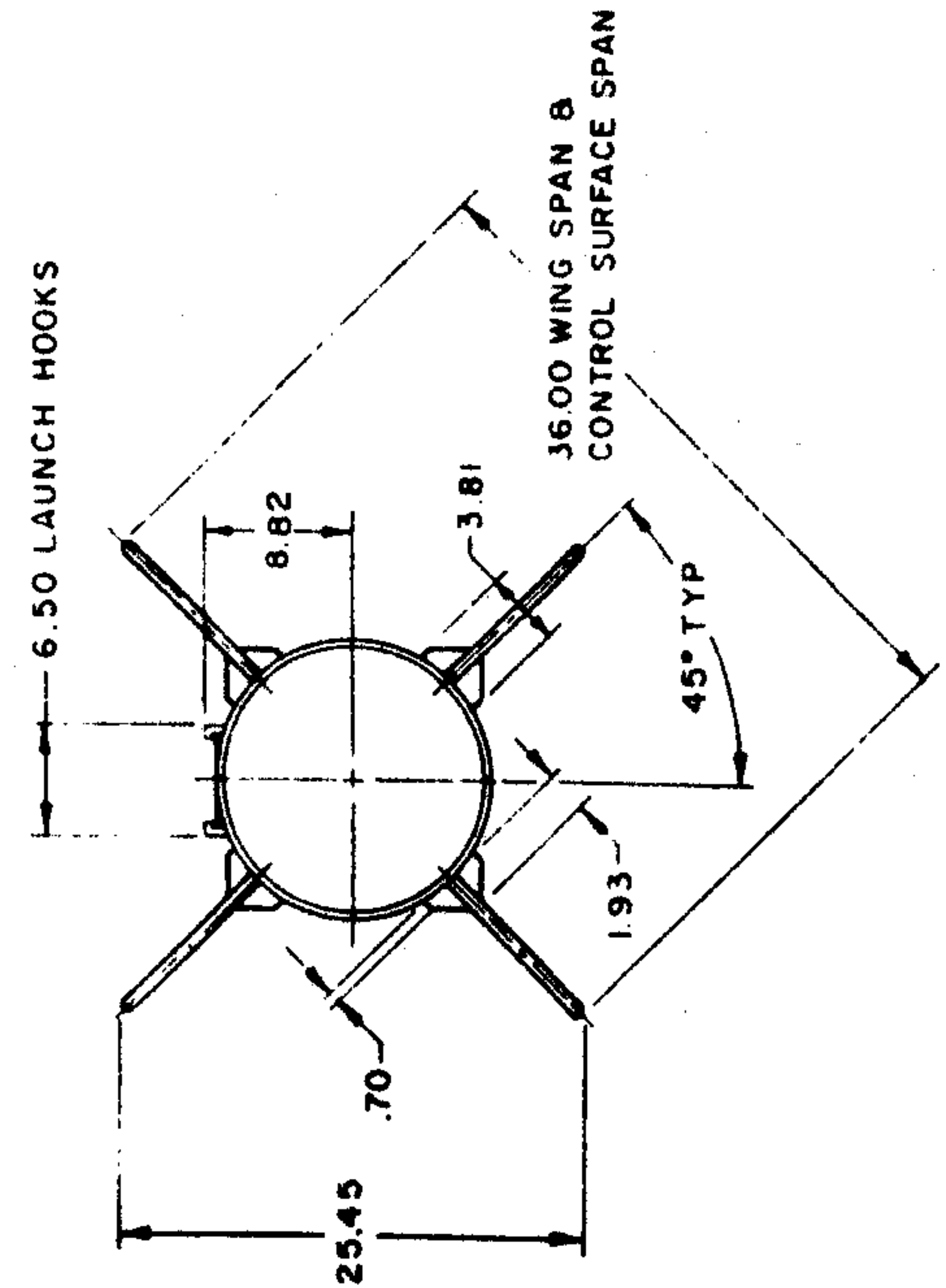

VIEW A-A

PHOENIX HARD SPOT LOCATIONS

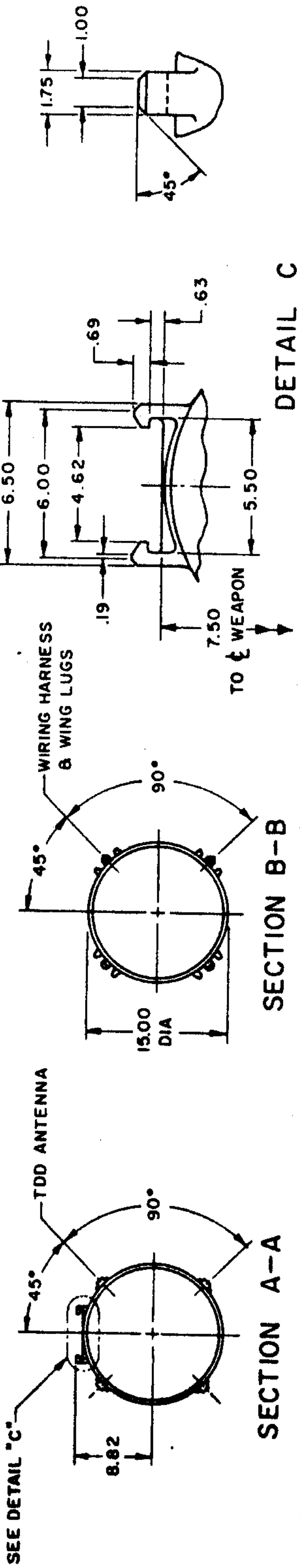
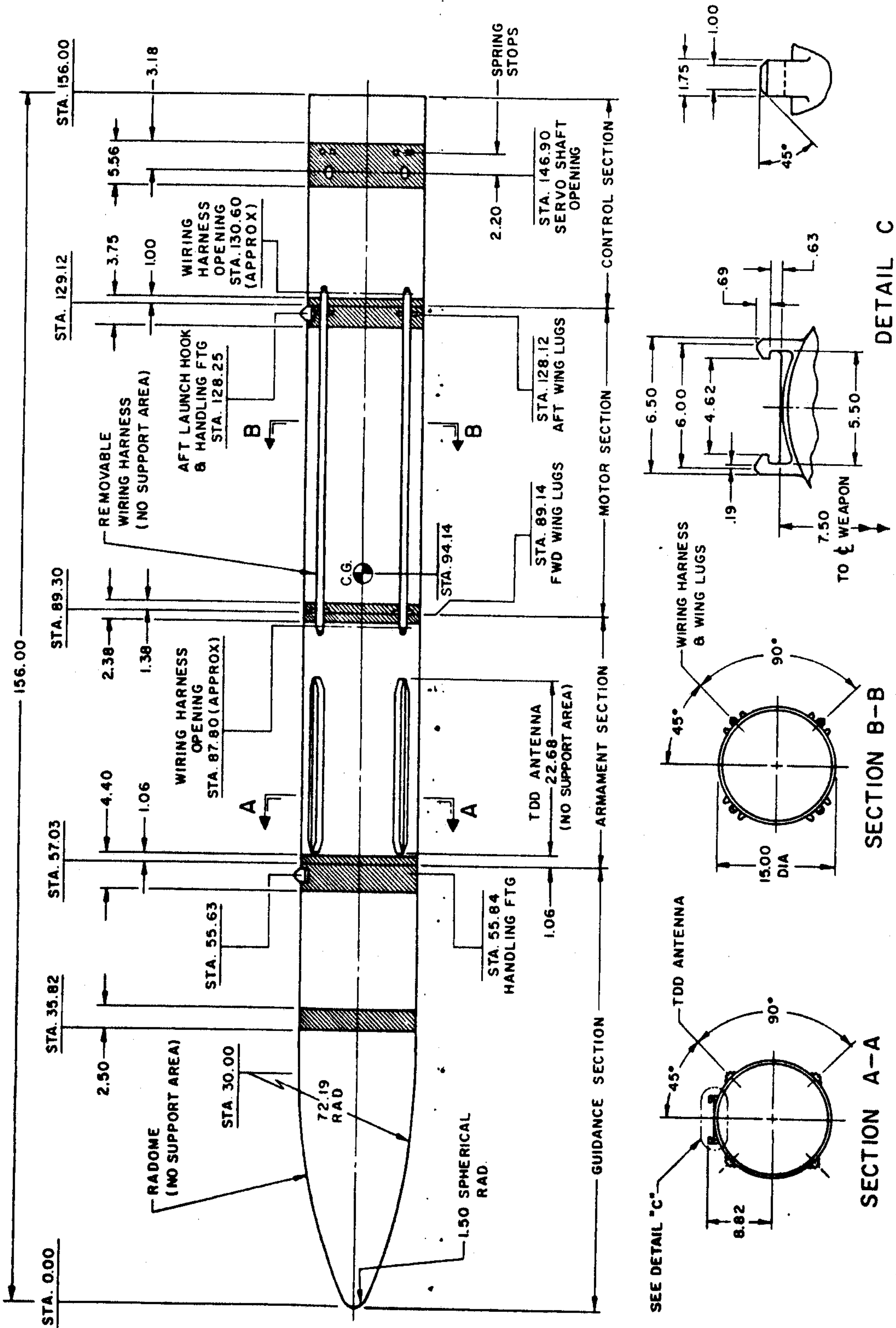

NOTES:

1. APPROXIMATE WEIGHT - 927.0 LBS
2. FOR DETAILS OF TDD ANTENNA, WIRING HARNESS, WING LUGS & SPRING STOPS. (SEE APPROPRIATE MISSILE FUSELAGE SECTION DRAWING.)
3. SYMBOL  DENOTES HARD SPOT AREA.

ORIGINAL DATA SOURCE
 HUGHES AIRCRAFT CO.
 REPORT NO. PMS 26-4/2173
 DATED 18 FEBRUARY 1966

PHOENIX GUIDANCE SECTION

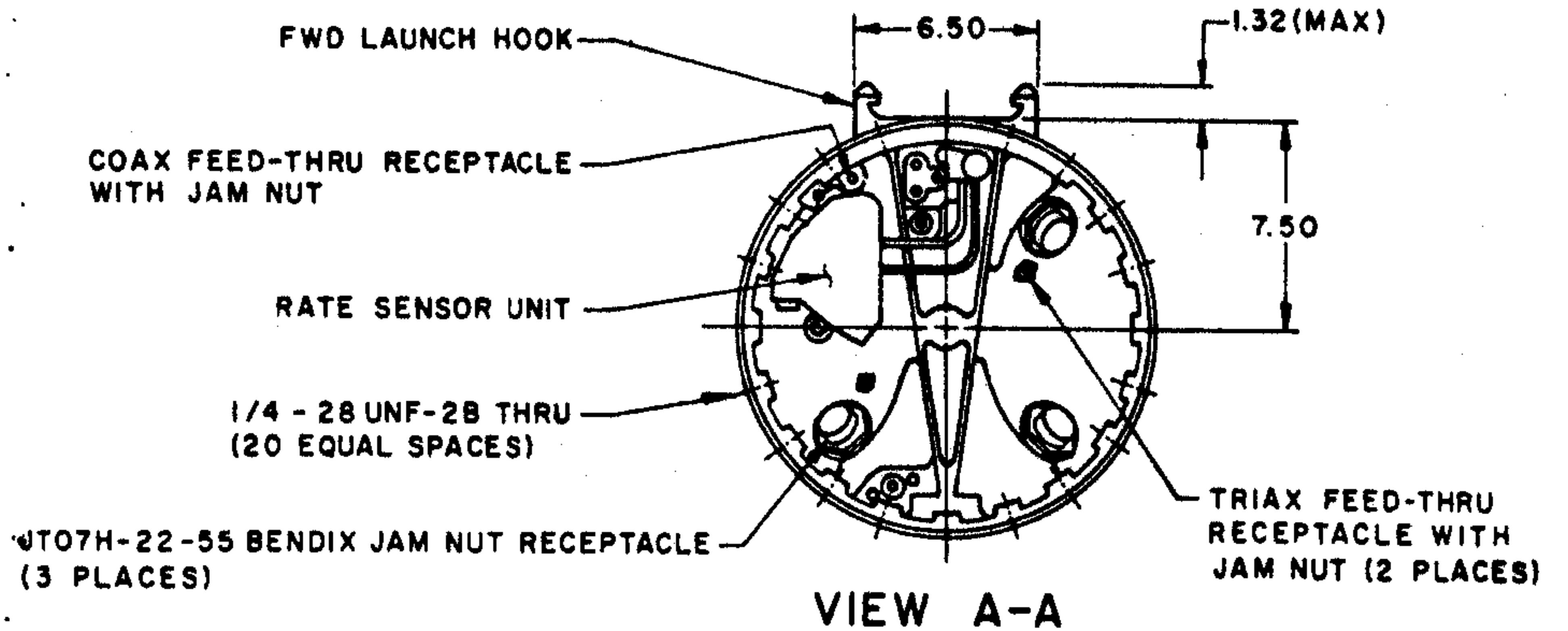
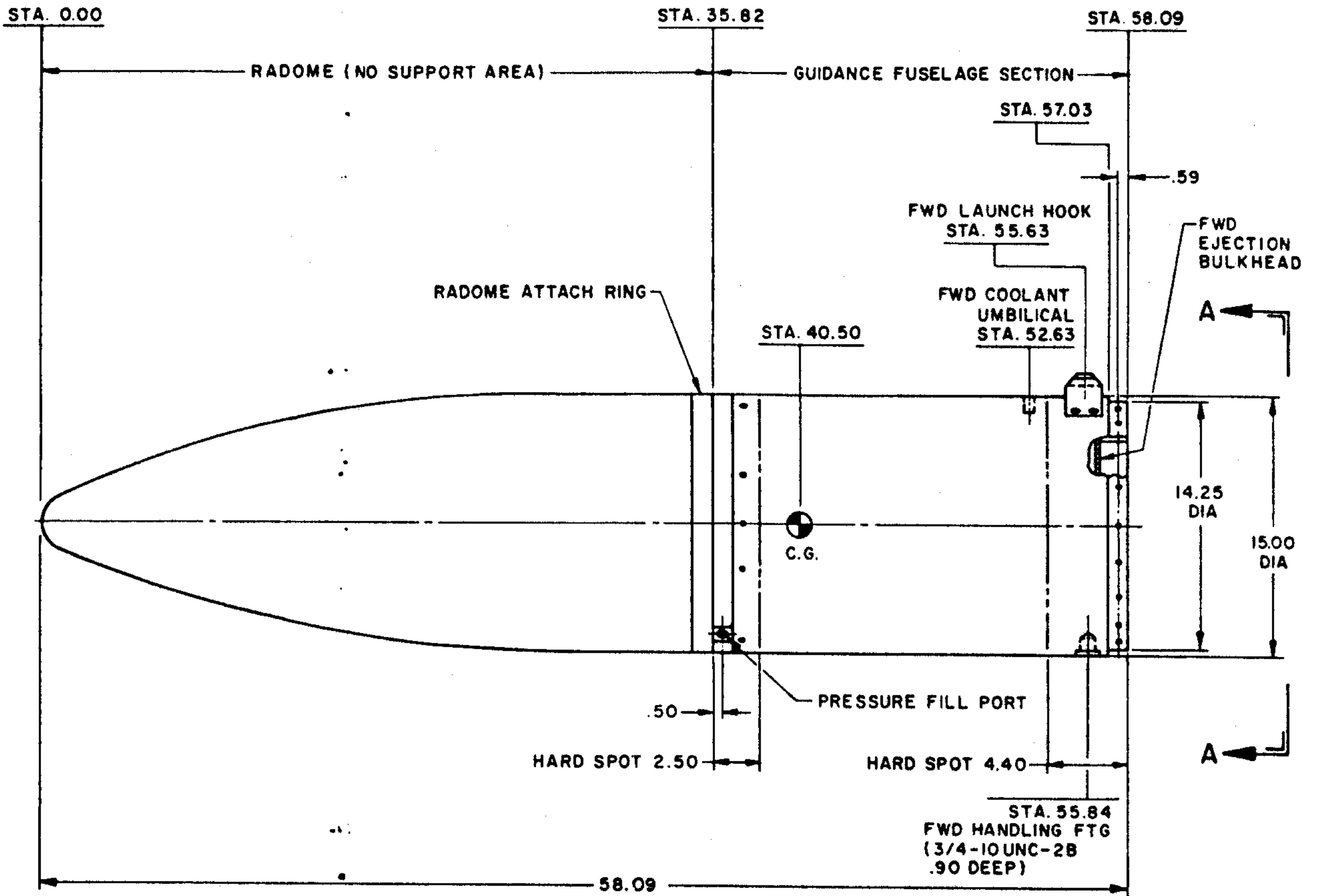

NOTES:

1. RADOME AND FUSELAGE SECTIONS ARE SEALED AND PRESSURIZED WITH DRY NITROGEN.
2. APPROXIMATE WEIGHT - 165.0 LBS

ORIGINAL DATA SOURCE

HUGHES AIRCRAFT CO.
REPORT NO. PMS 26-5/2173
DATED 6 JANUARY 1967

PHOENIX ARMAMENT SECTION

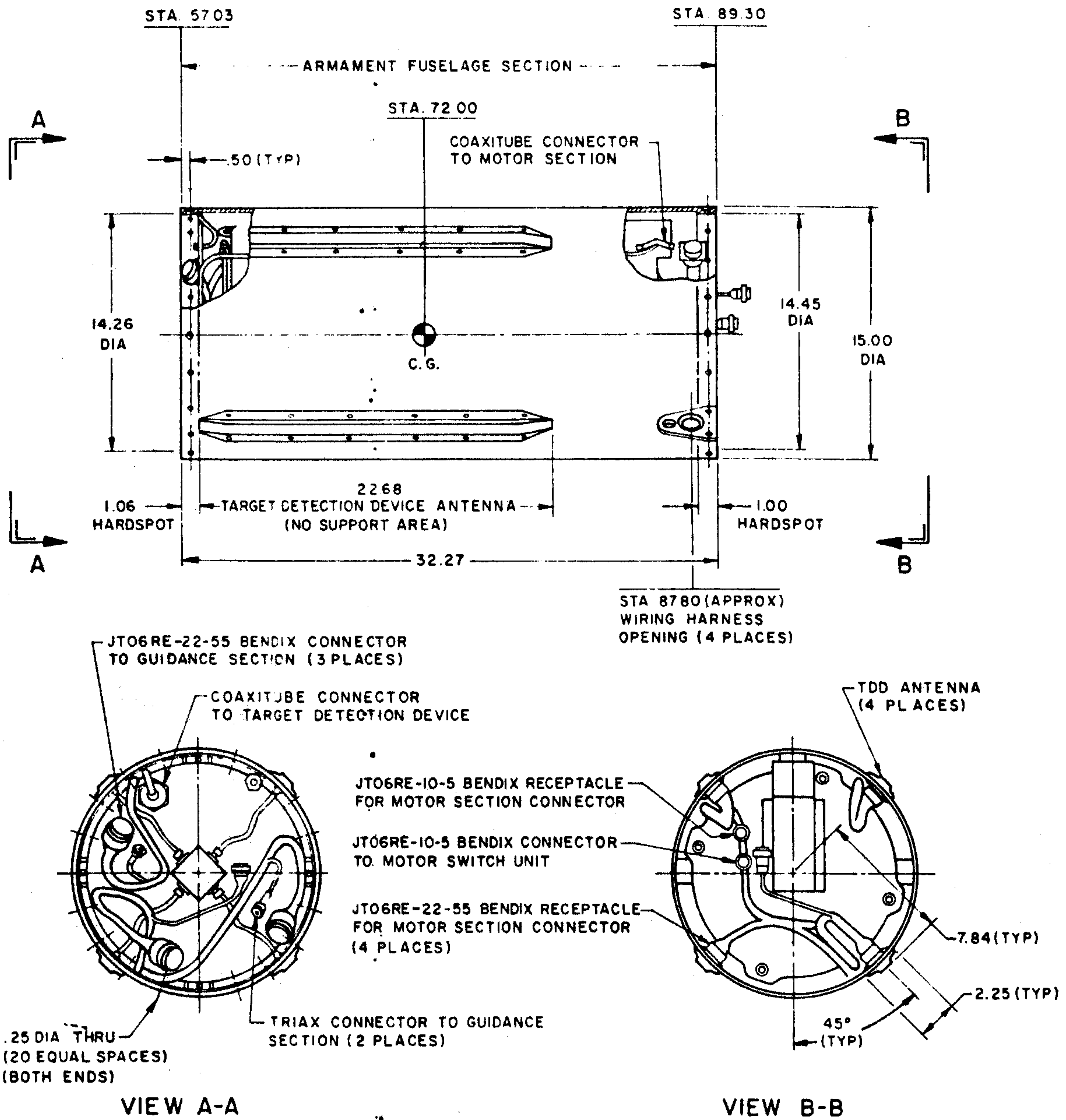

NOTE:

1. APPROXIMATE WEIGHT - 180.0 LBS

ORIGINAL DATA SOURCE

HUGHES AIRCRAFT CO.
 REPORT NO. PMS 26-5/2173
 DATED 6 JANUARY 1967

PHOENIX MOTOR SECTION

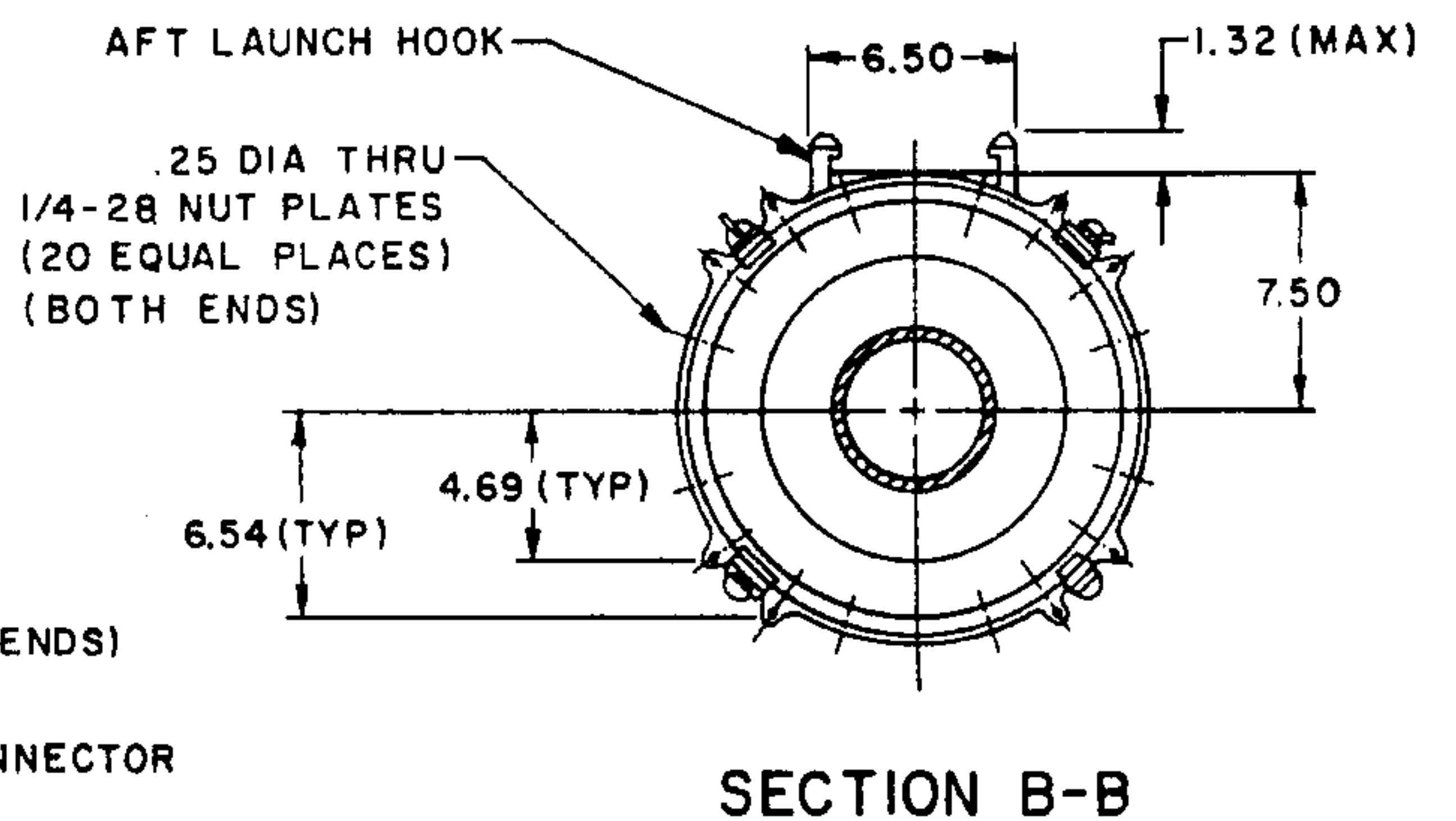
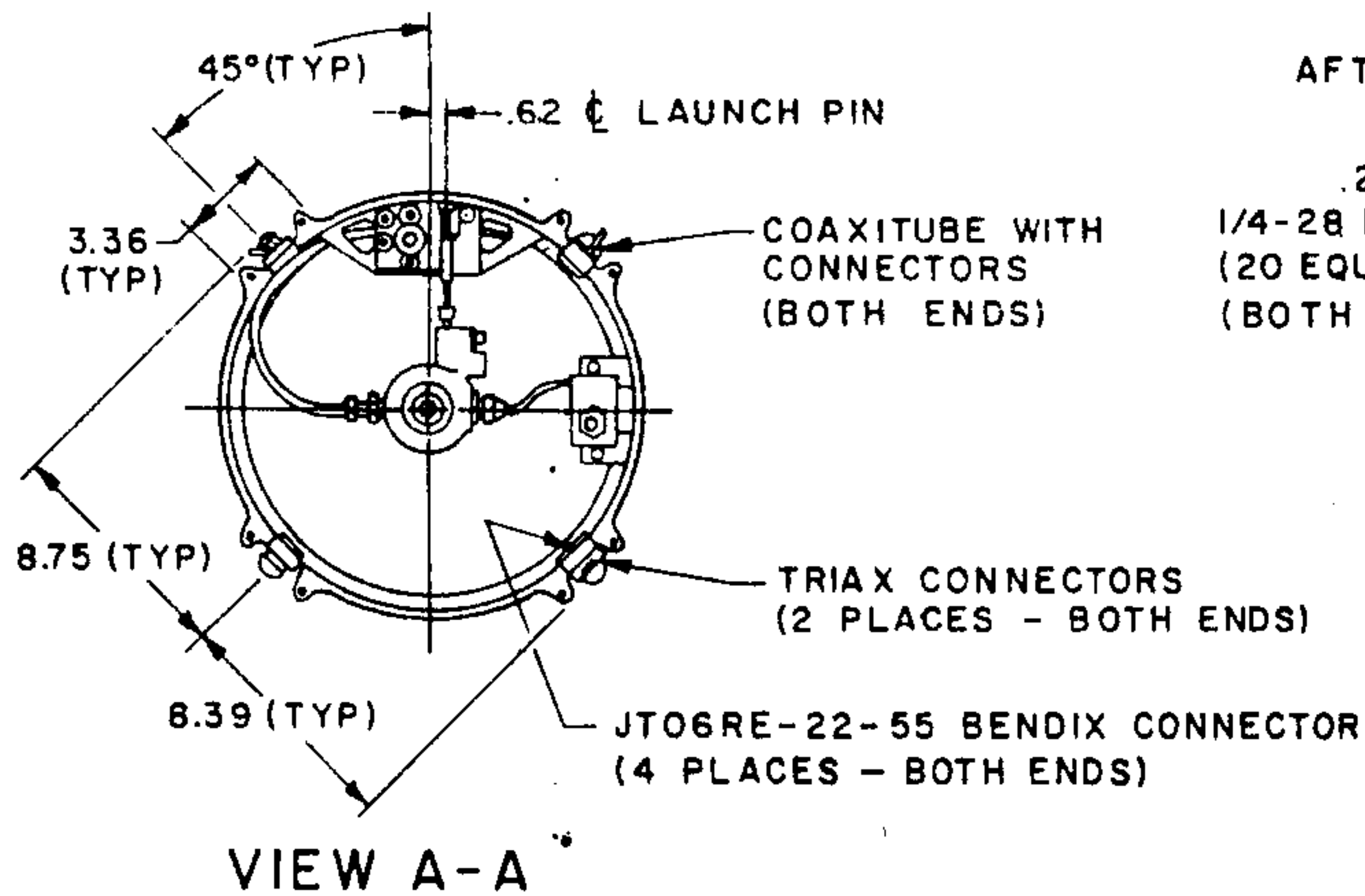
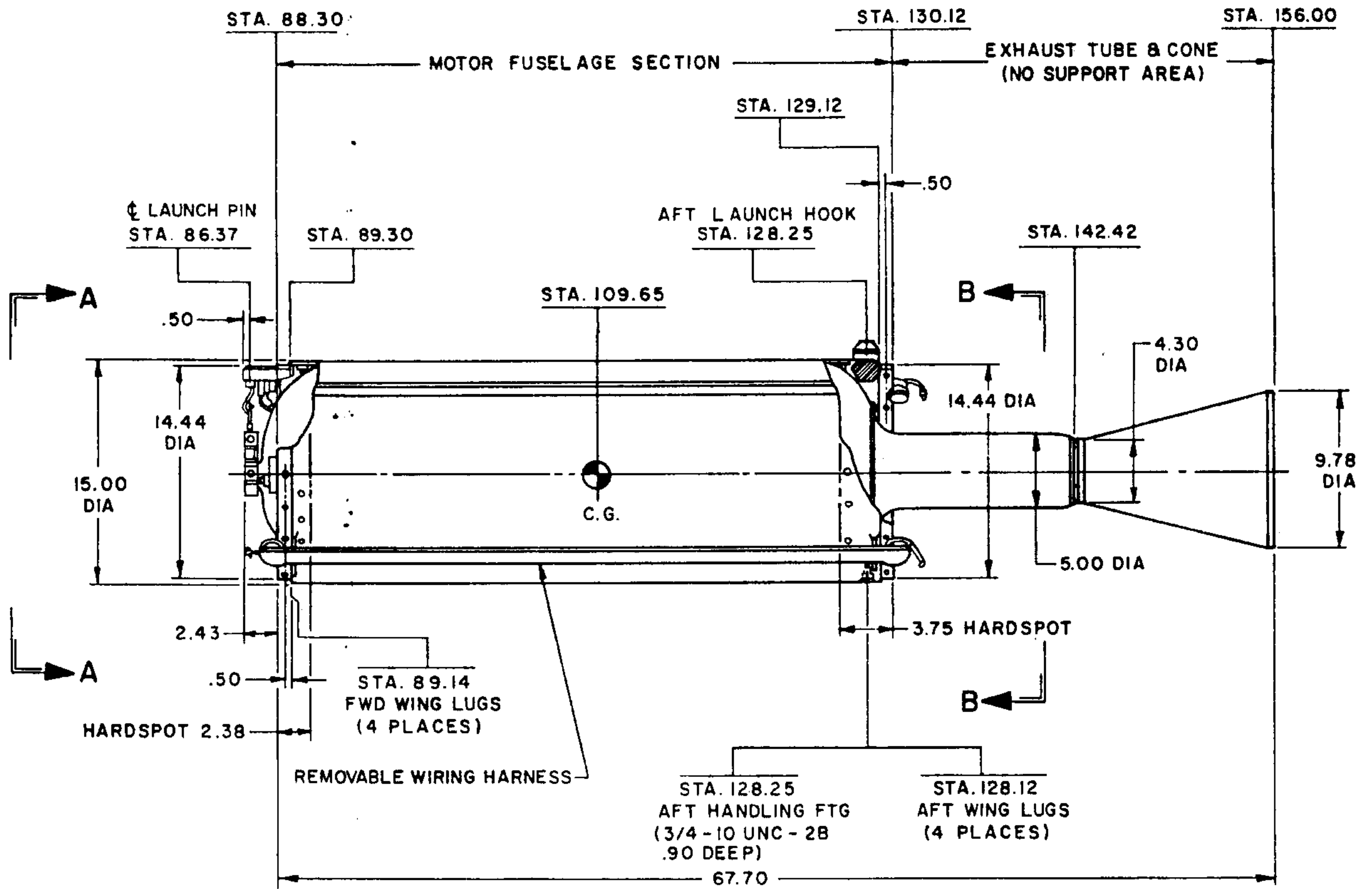

NOTE:

1. APPROXIMATE WEIGHT - 465.2 LBS

ORIGINAL DATA SOURCE

HUGHES AIRCRAFT CO.
 REPORT NO. PMS 26-5/2173
 DATED 6 JANUARY 1967

PHOENIX WING

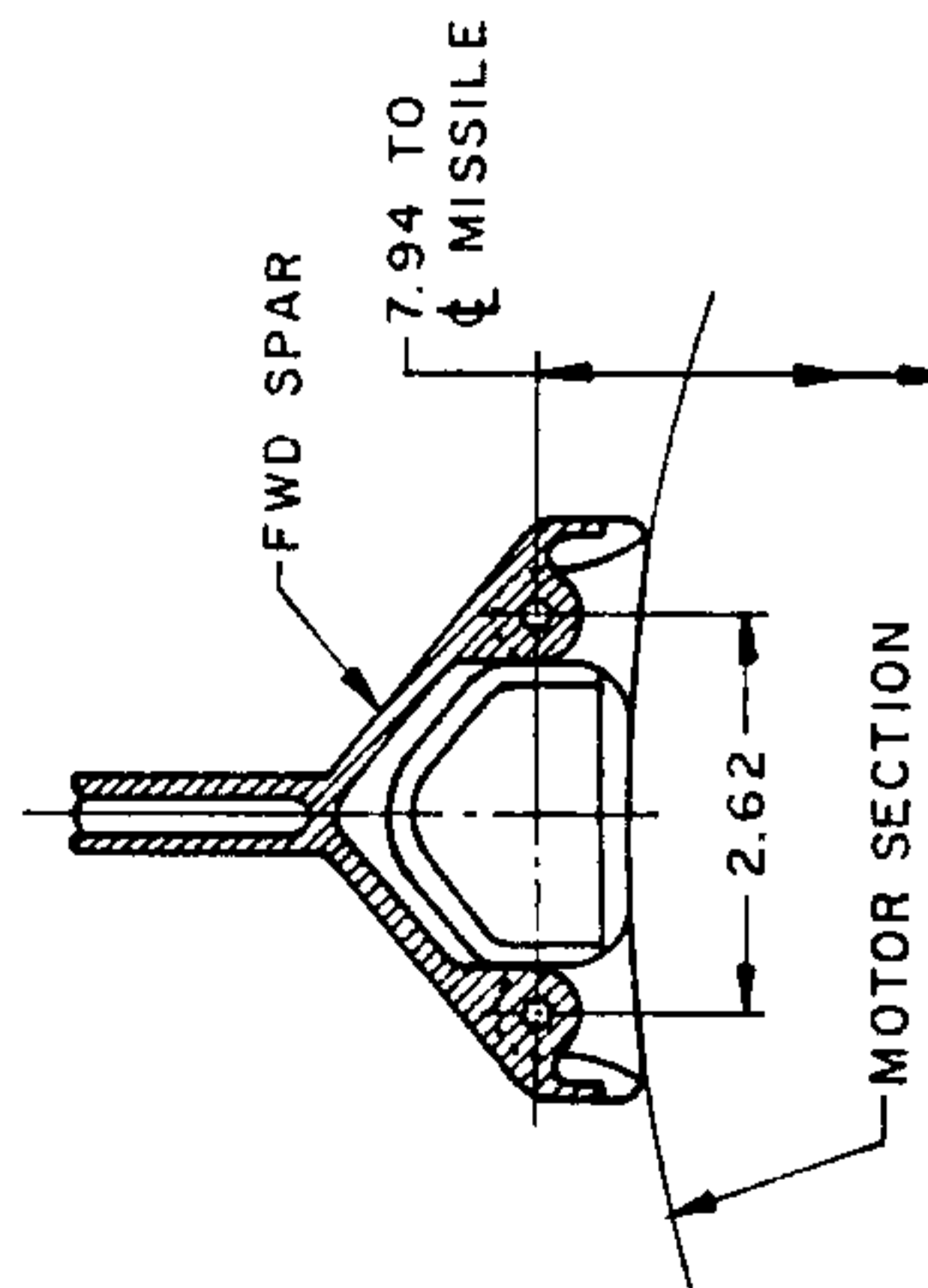
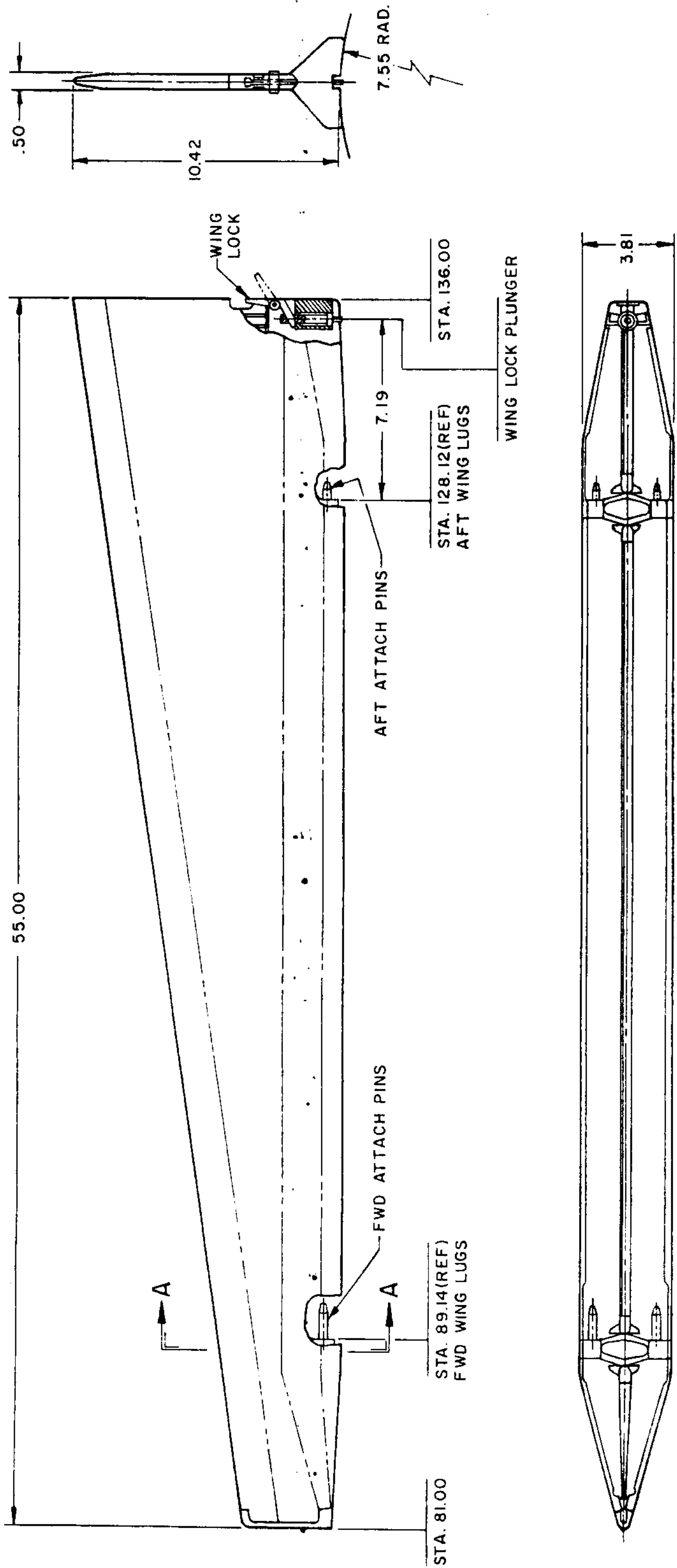

NOTES:

1. APPROXIMATE WEIGHT - 32.4 LBS PER SET
2. FOUR WINGS REQUIRED PER MISSILE.

ORIGINAL DATA SOURCE
 HUGHES AIRCRAFT CO.
 REPORT NO. PMS 77-7/2178
 DATED JANUARY 1967

ENLARGED SECTION A-A

PHOENIX CONTROL SURFACE

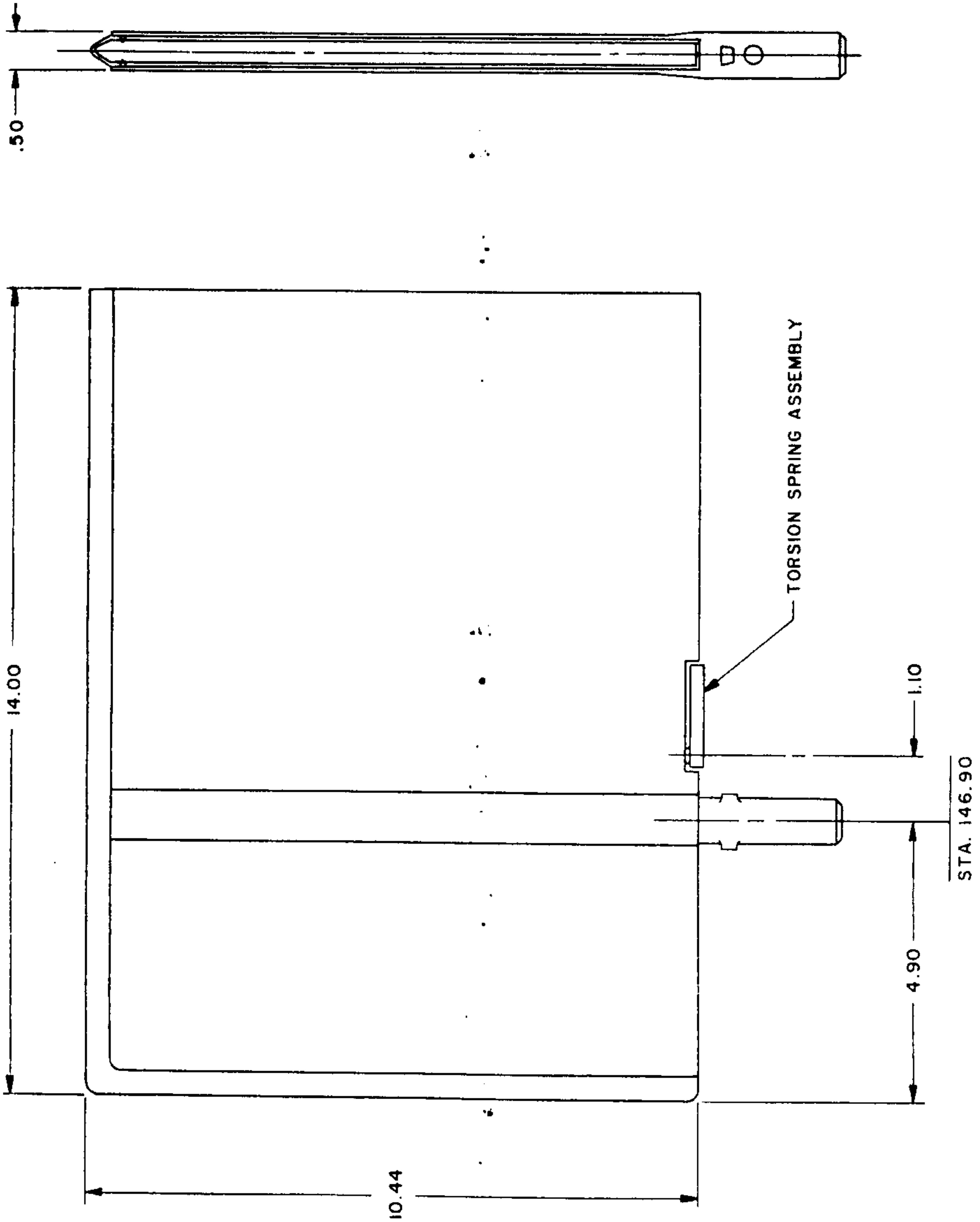

ORIGINAL DATA SOURCE

HUGHES AIRCRAFT CO.
REPORT NO. PMS 77-7/2178
DATED JANUARY 1967

NOTES:

1. APPROXIMATE WEIGHT - 14.9 LBS PER SET
2. FOUR CONTROL SURFACES REQUIRED PER MISSILE.

SHRIKE AGM-45A GENERAL ARRANGEMENT

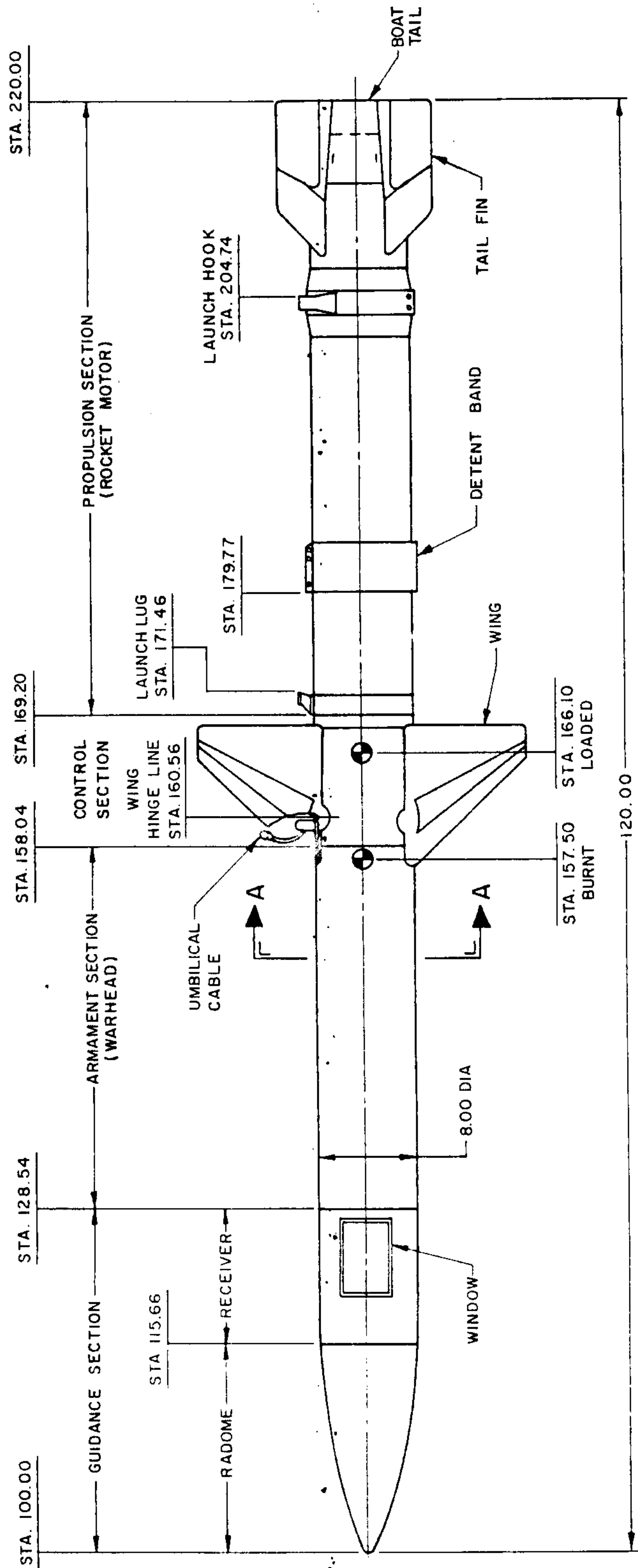

NOTES:

- MISSILE LAUNCHED FROM TYPE AERO 5A-1 OR LAU-34 LAUNCHERS.
- APPROXIMATE WEIGHT - 402.5 LBS. (MAX)

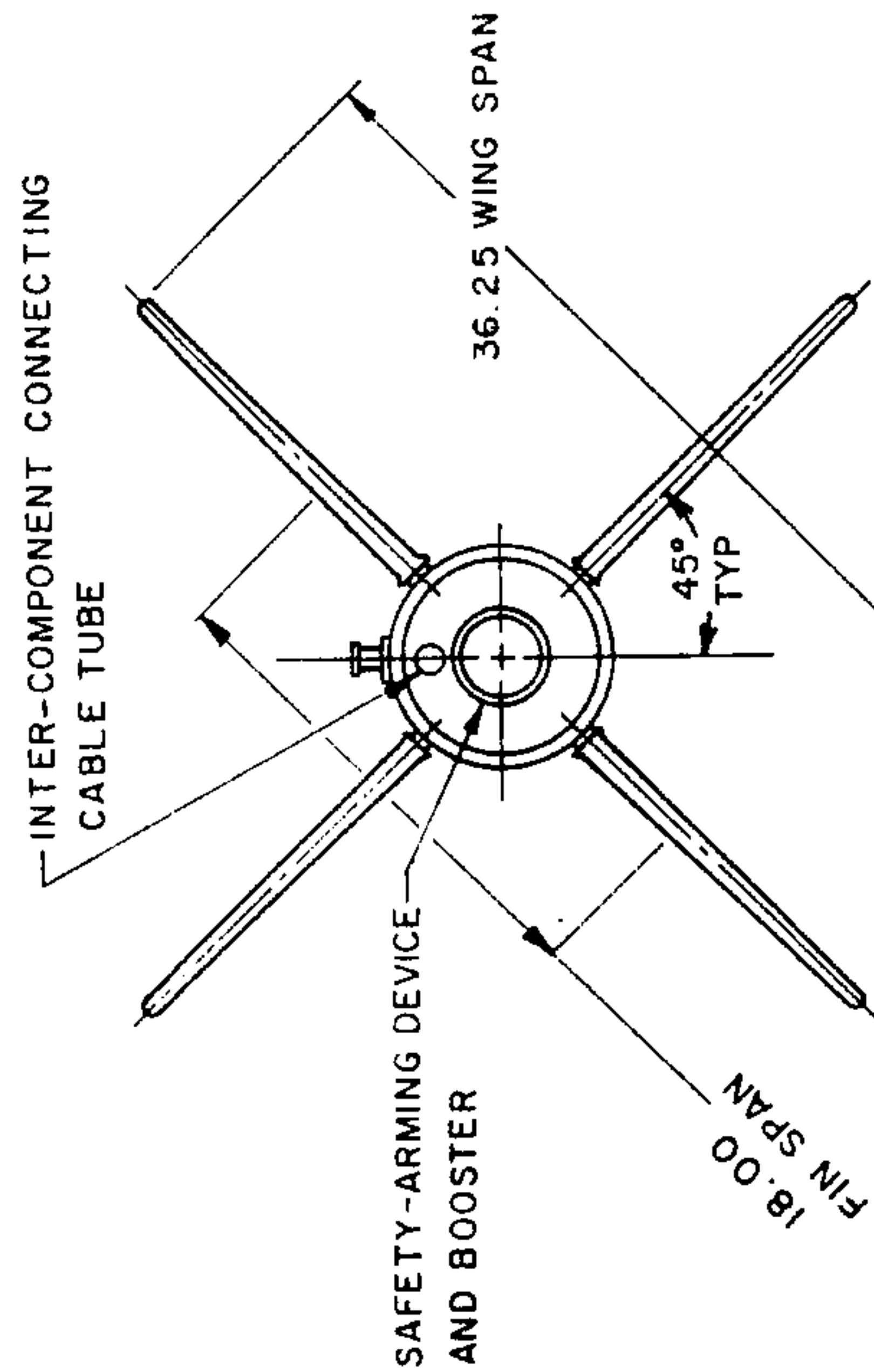

ORIGINAL DATA SOURCE
 BUWEPS DWG NO. 1570001
 DATED 28 JUNE 1964
 NAVWEPS OI-80MGA-2
 DATED 1 DECEMBER 1966

SHRIKE AGM-45A HARD SPOT LOCATIONS

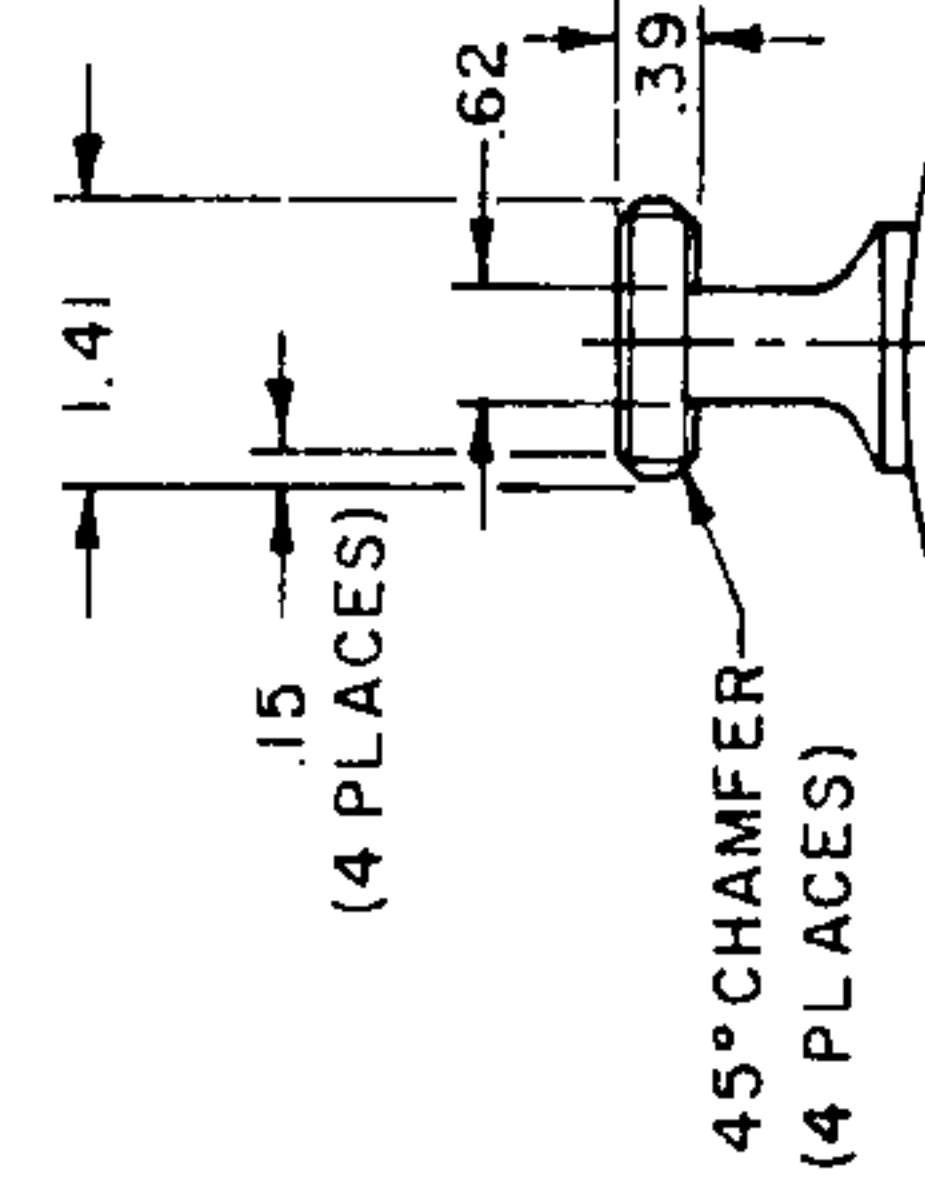
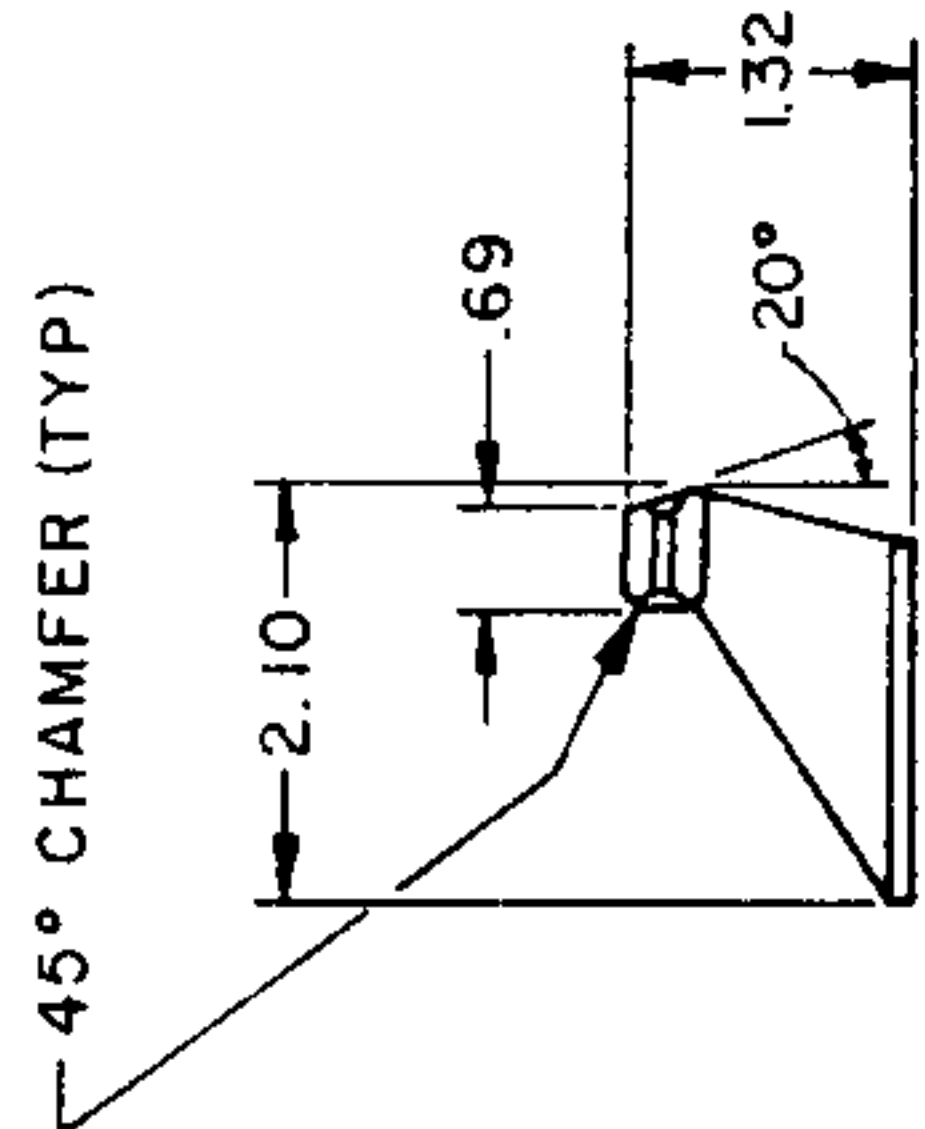
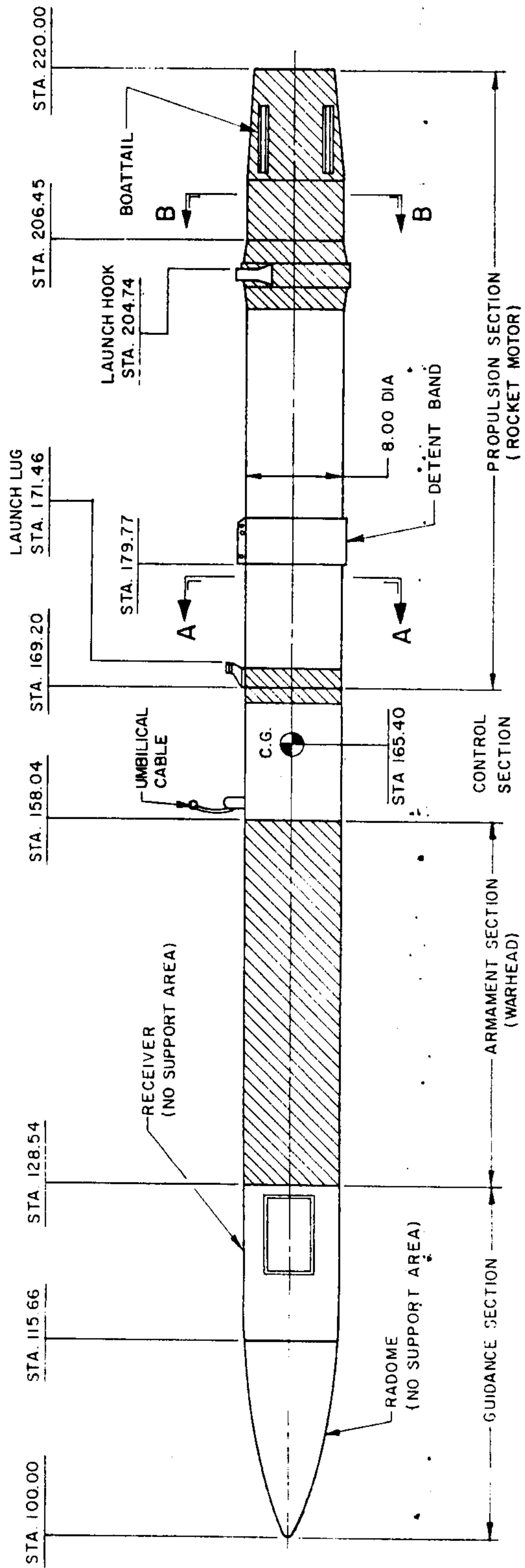

DETAIL C
LAUNCH LUG

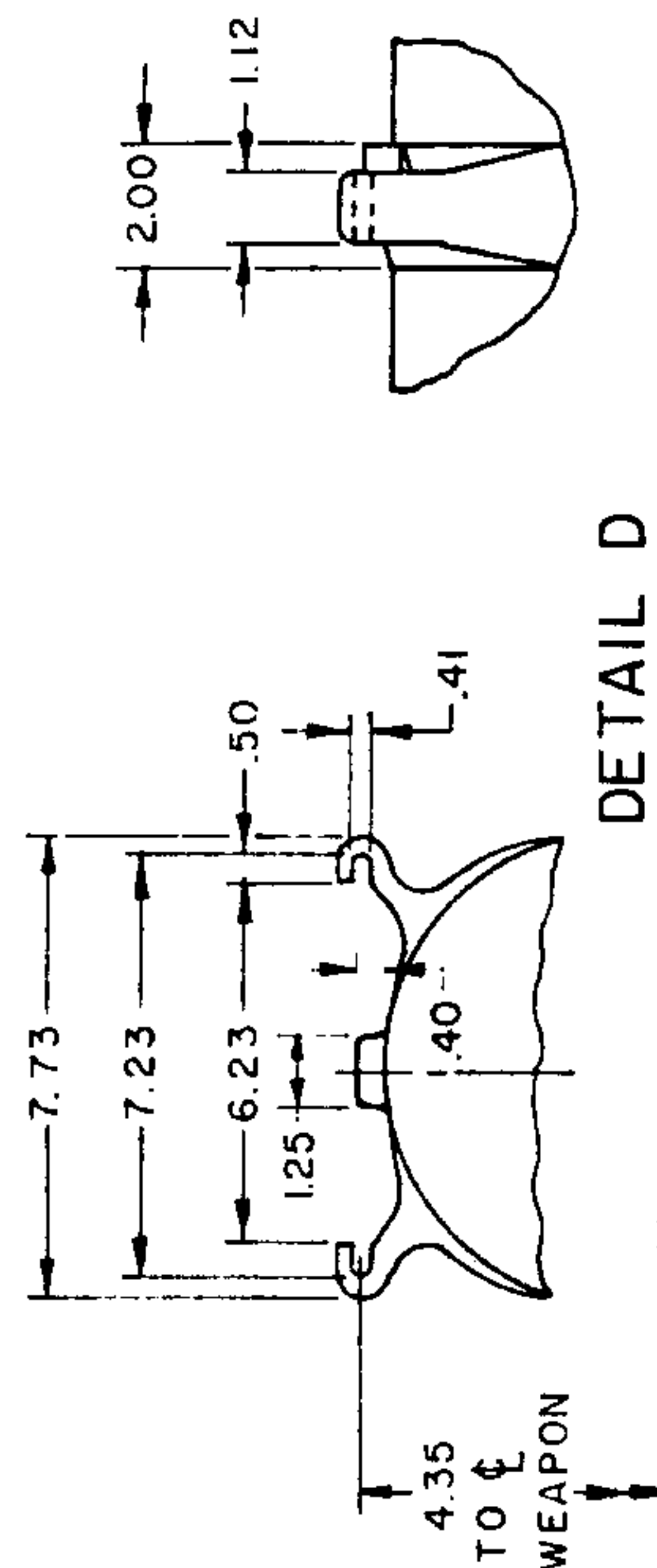

DETAIL D
LAUNCH HOOK

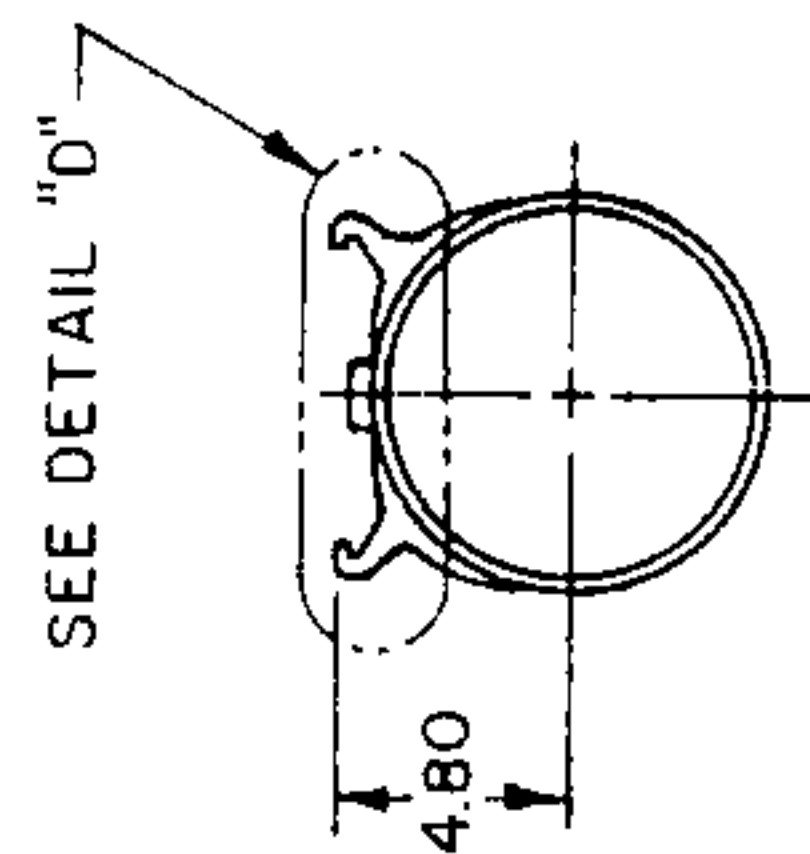

SECTION B-B

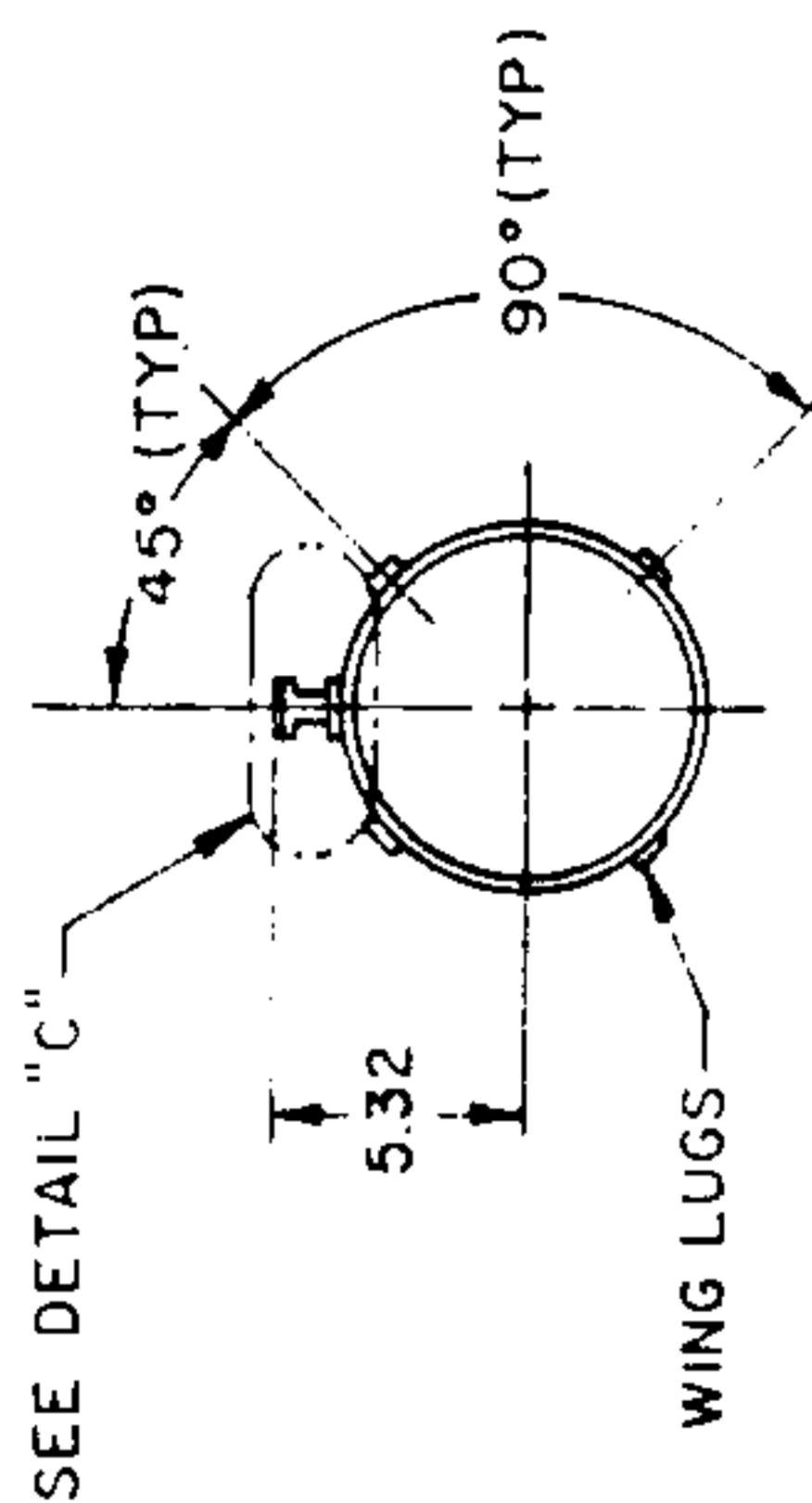

SECTION A-A

NOTES:

1. HARD SPOT LOCATIONS SHOWN ARE FOR AN ASSEMBLED SHRIKE AGM-45A-1, -1A, -2, -3 AND -4, LESS WINGS AND FINS.
2. ZZZZZZZ DENOTES HARD SPOT
3. APPROXIMATE WEIGHT - 383.2 LBS. (MAX) (LESS WINGS & FINS)

GUIDANCE SECTION MK 21 MODS

SHRIKE AGM-45A-1, 1A

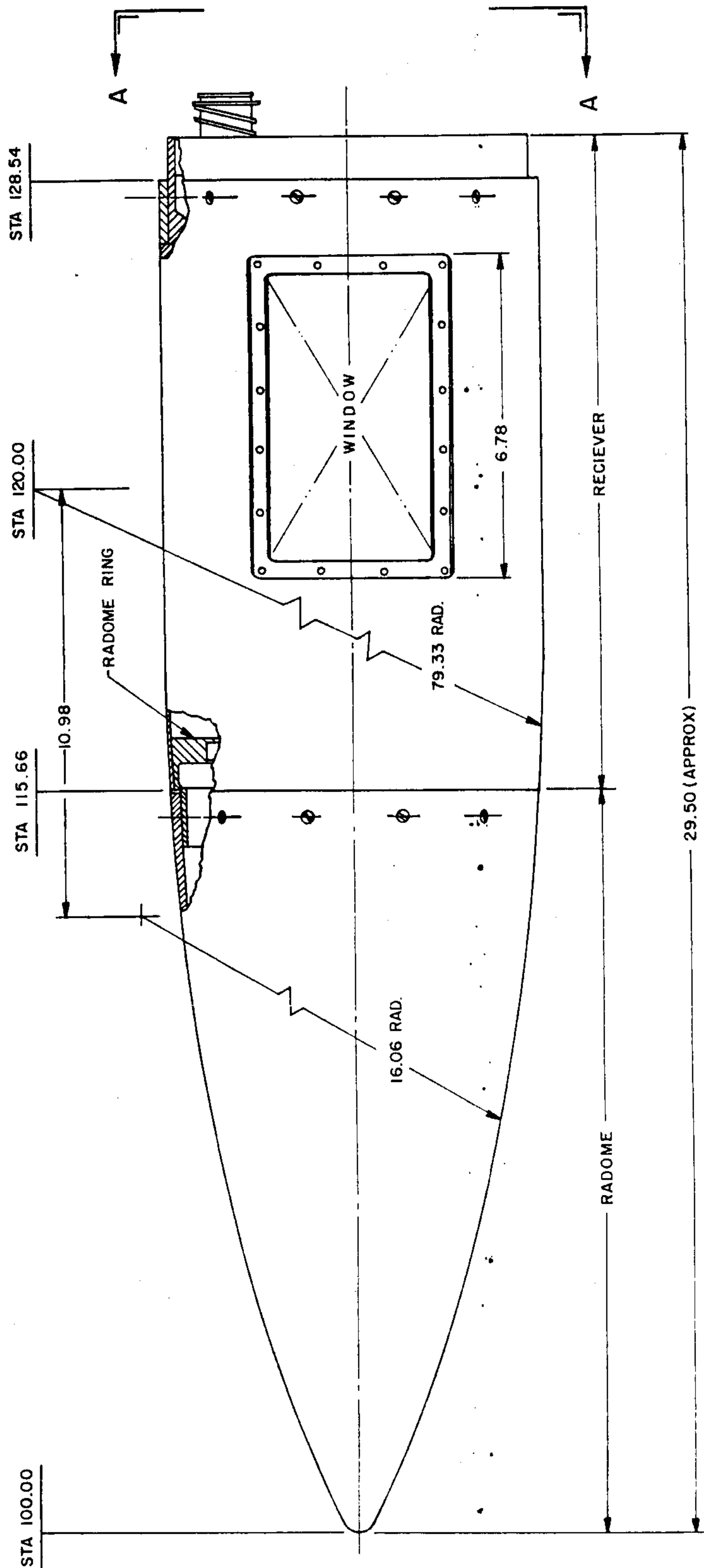

APPROXIMATE WEIGHT - 34.8 LBS

ORIGINAL DATA SOURCE
BUWEPS DWG NO. 1570152
DATED 27 JUNE 1964
BUWEPS DWG NO. 1570188
DATED 28 JULY 1964
NAVWEPS OI-80MGA-2
DATED 1 DECEMBER 1966

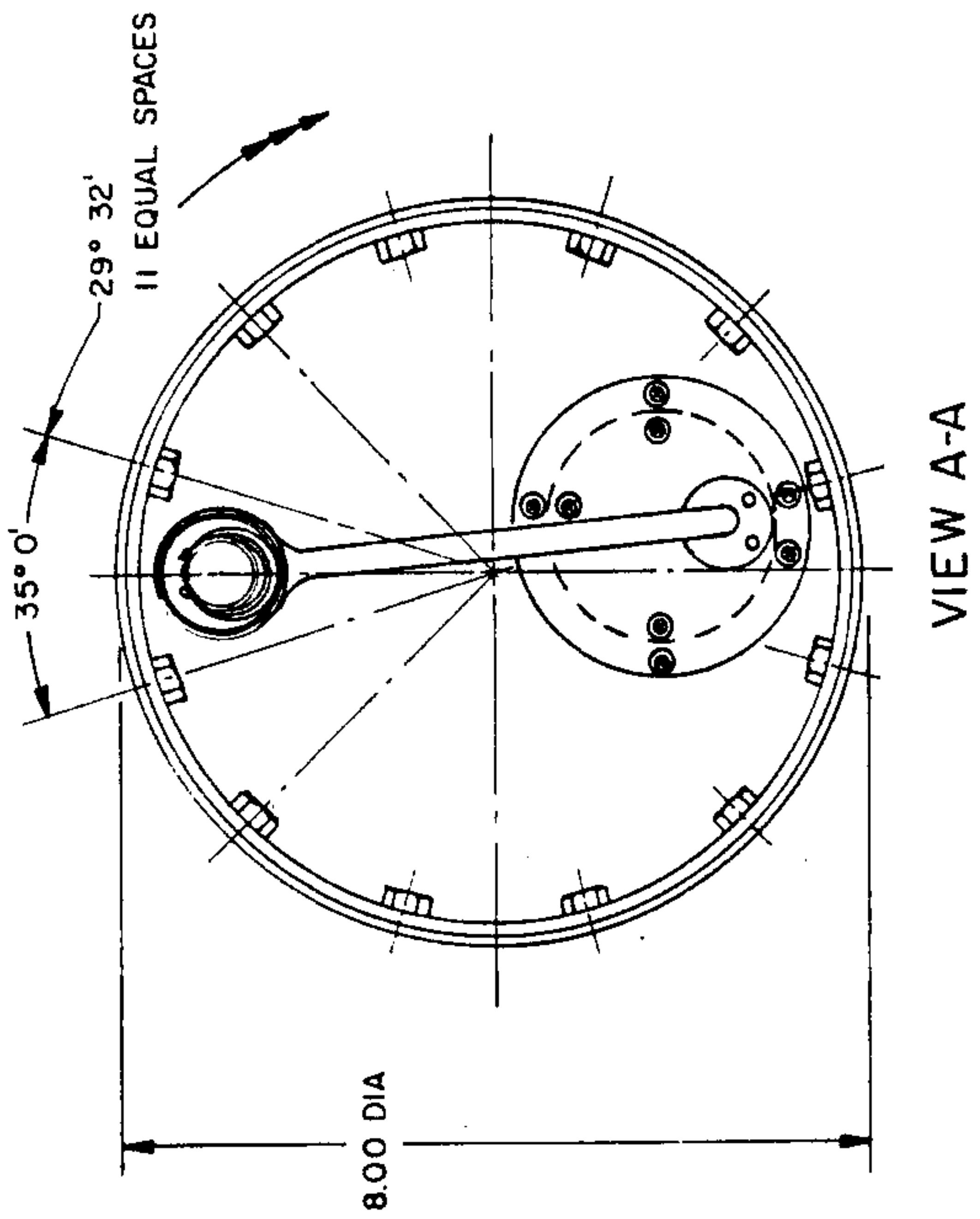

ARMAMENT SECTIONS MK 52, 68 & 69 MOD 0

SHRIKE AGM-45A

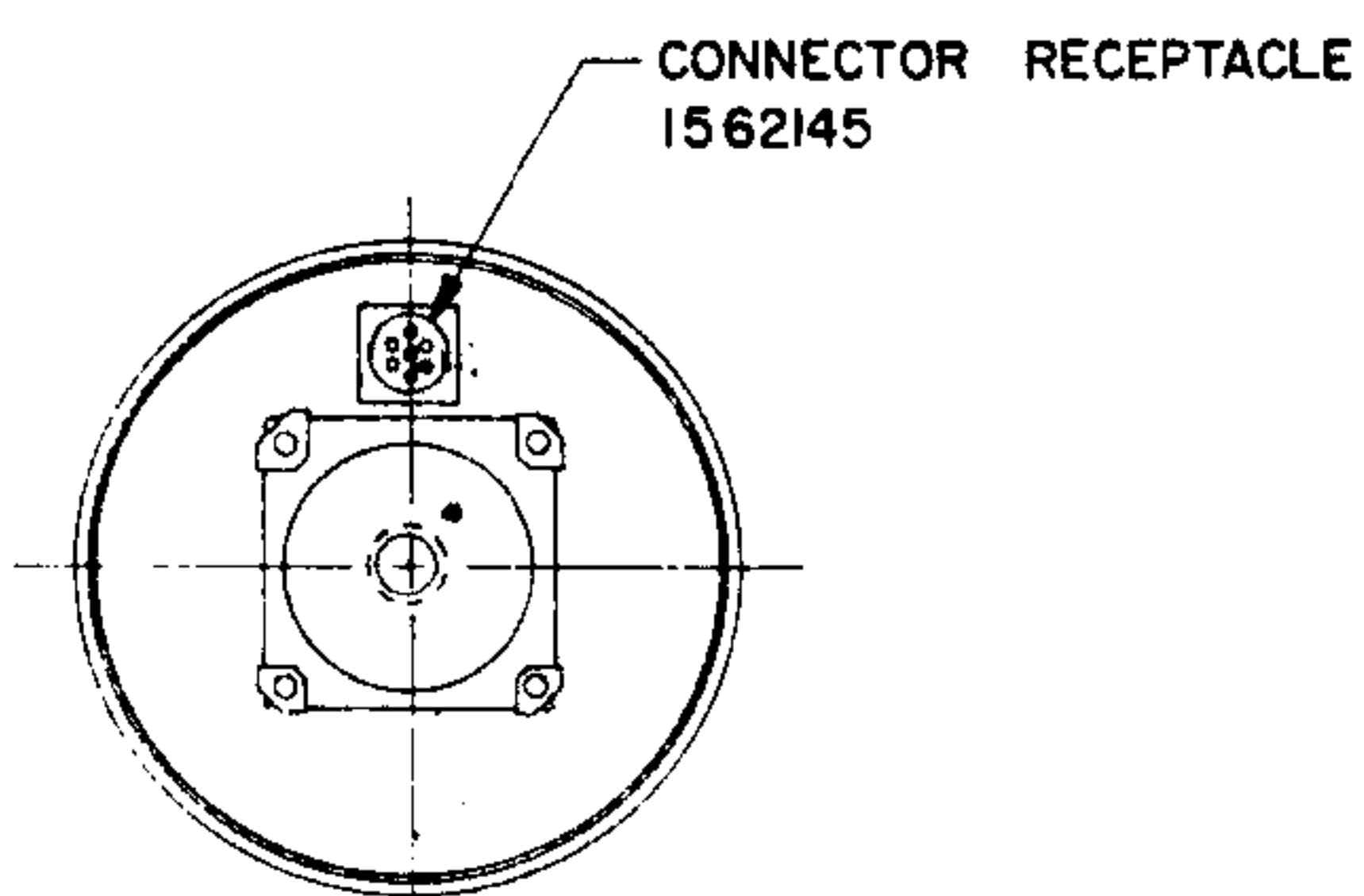
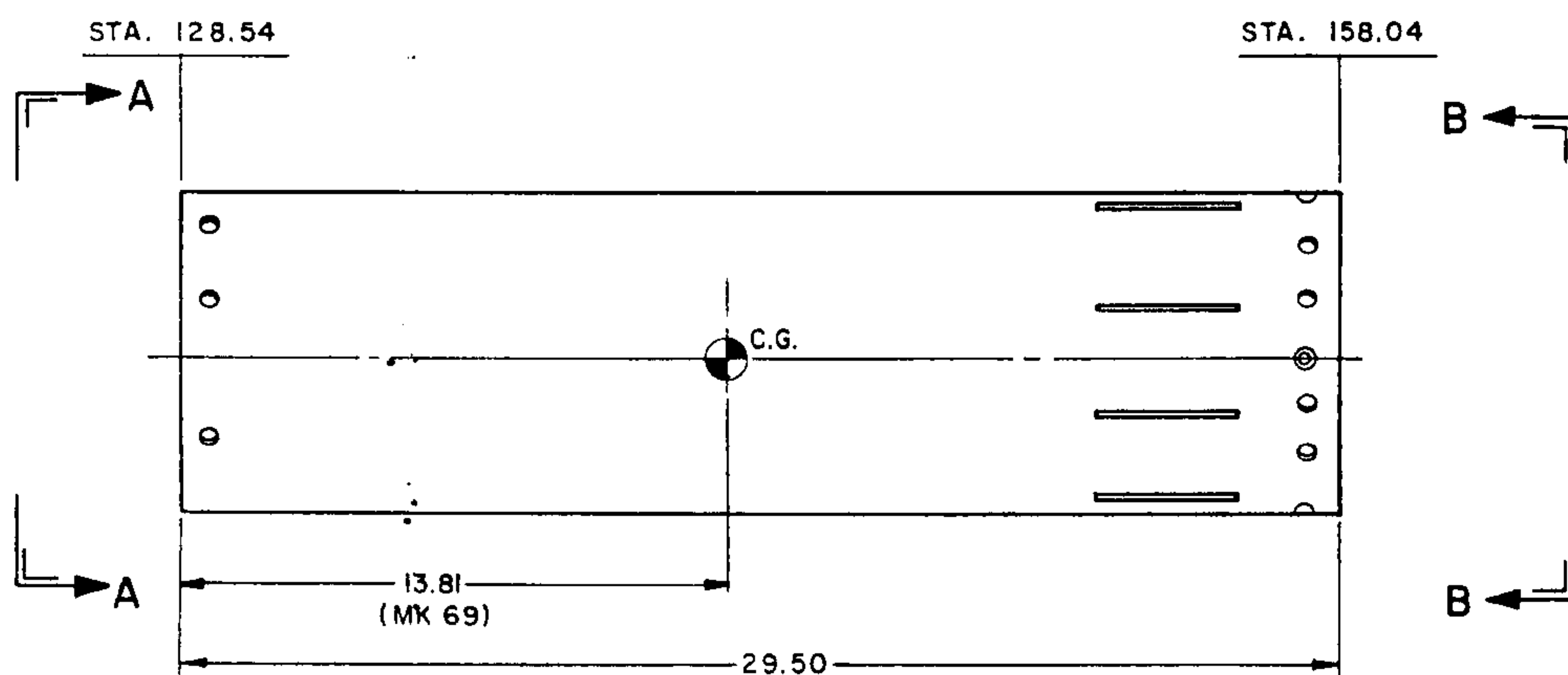

VIEW A-A

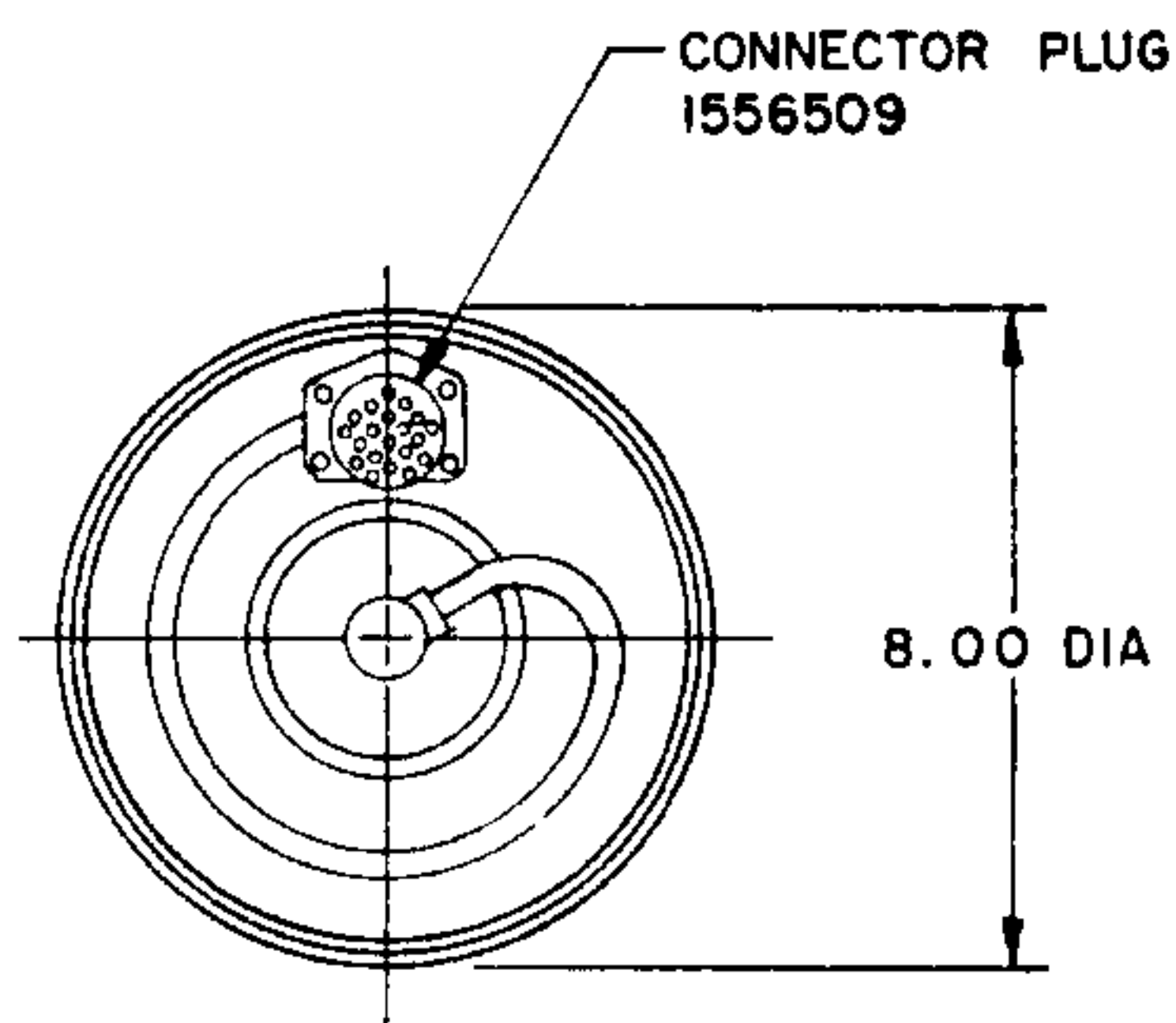

VIEW B-B

APPROXIMATE WEIGHT - 145.0 LBS

ORIGINAL DATA SOURCE
NAVORD DWG NO. 2581065 REV A
DATED 23 MARCH 1967
BUWEPS DWG. NO 1568640 REV E
DATED 25 MAY 1966
NAVWEPS OI-80MGA-2
DATED 1 DECEMBER 1966

CONTROL SECTION MK I MOD 2

SHRIKE AGM-45A

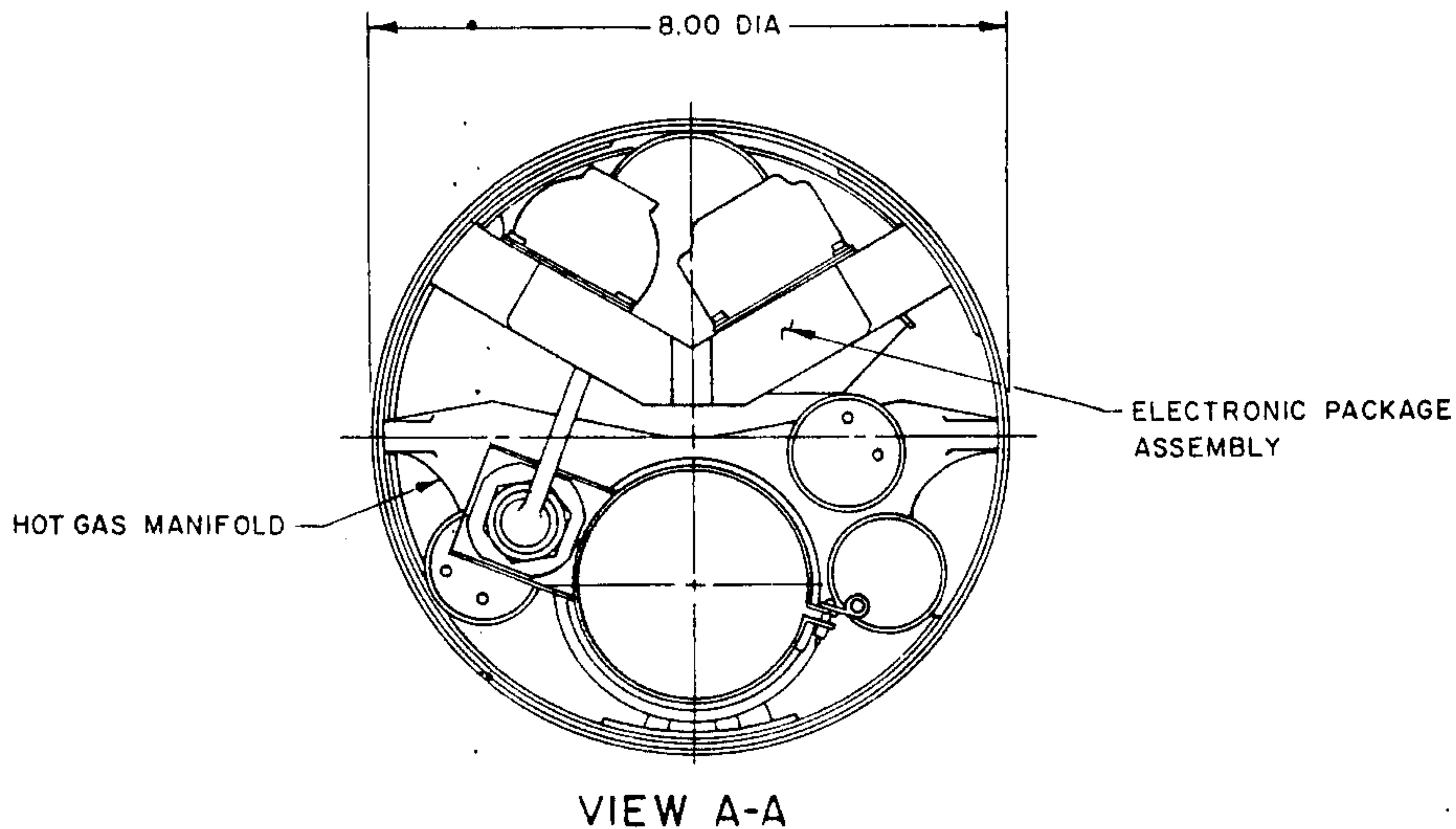
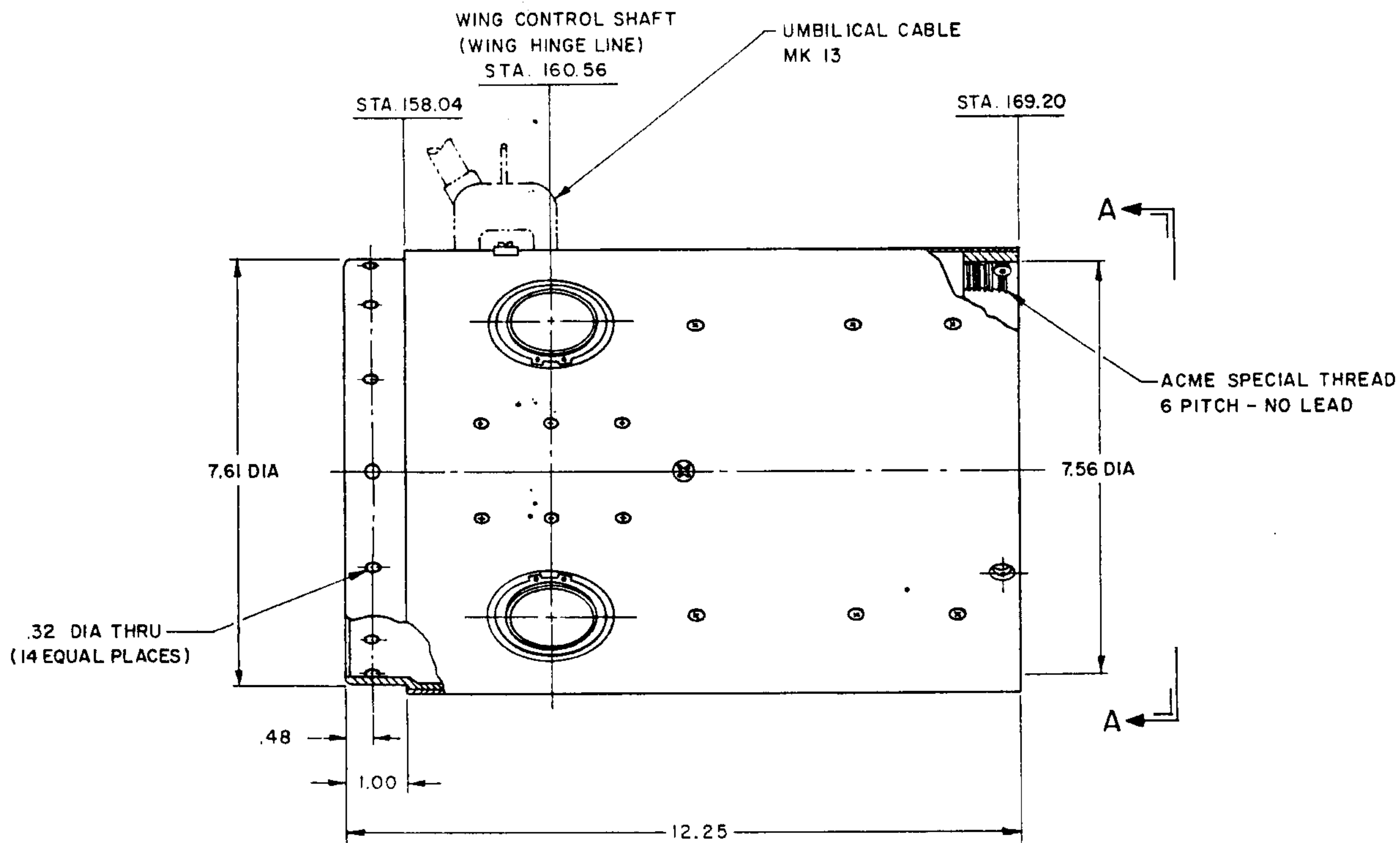

APPROXIMATE WEIGHT - 33.8 LBS.

ORIGINAL DATA SOURCE
BUWEPS DWG NO. 1570087 REV G
DATED 19 AUGUST 1965
NAVWEPS 01-80MGA-2
DATED 1 DECEMBER 1966

PROPULSION SECTION MK 39 MODS

SHRIKE AGM-45A

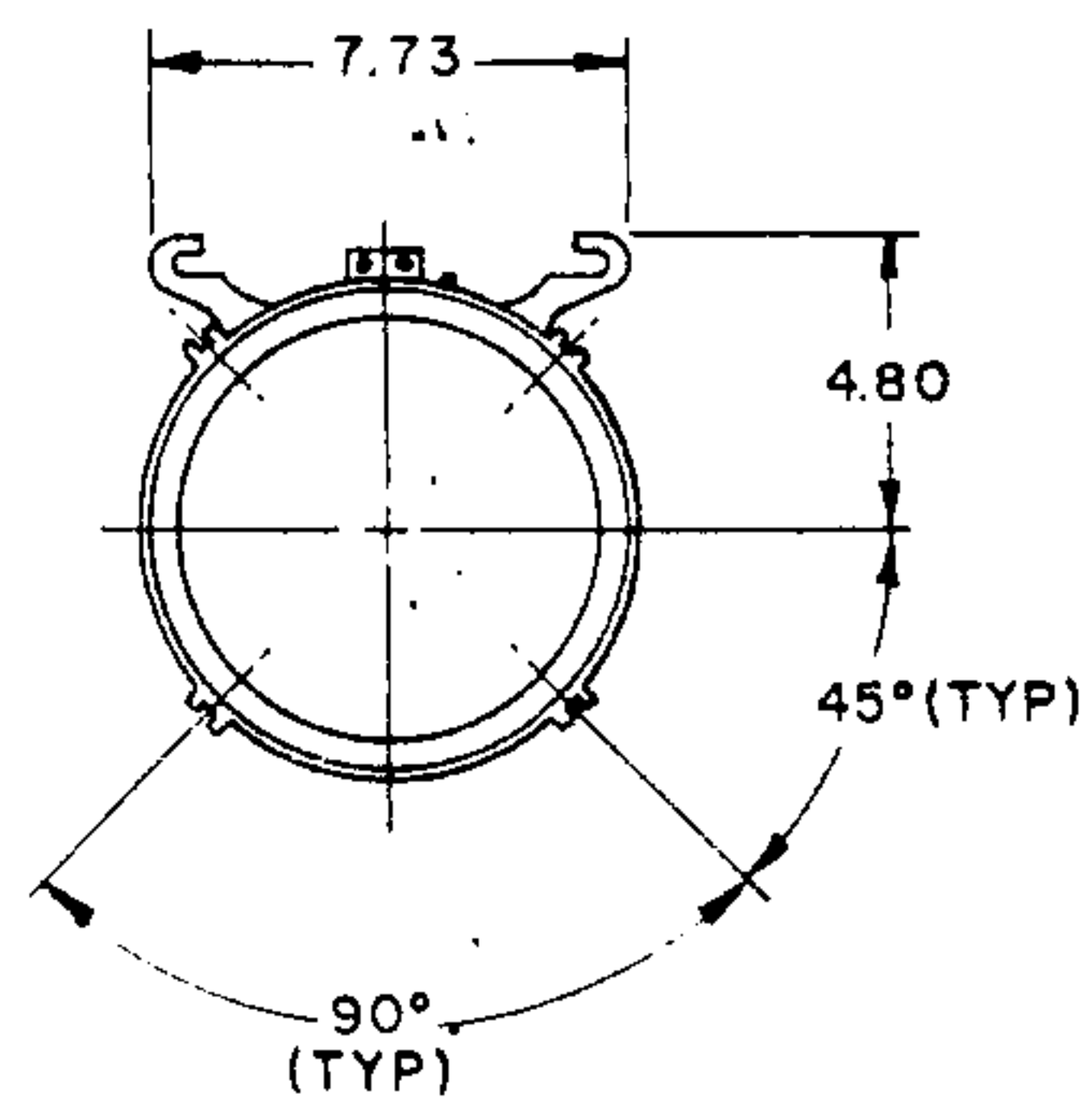
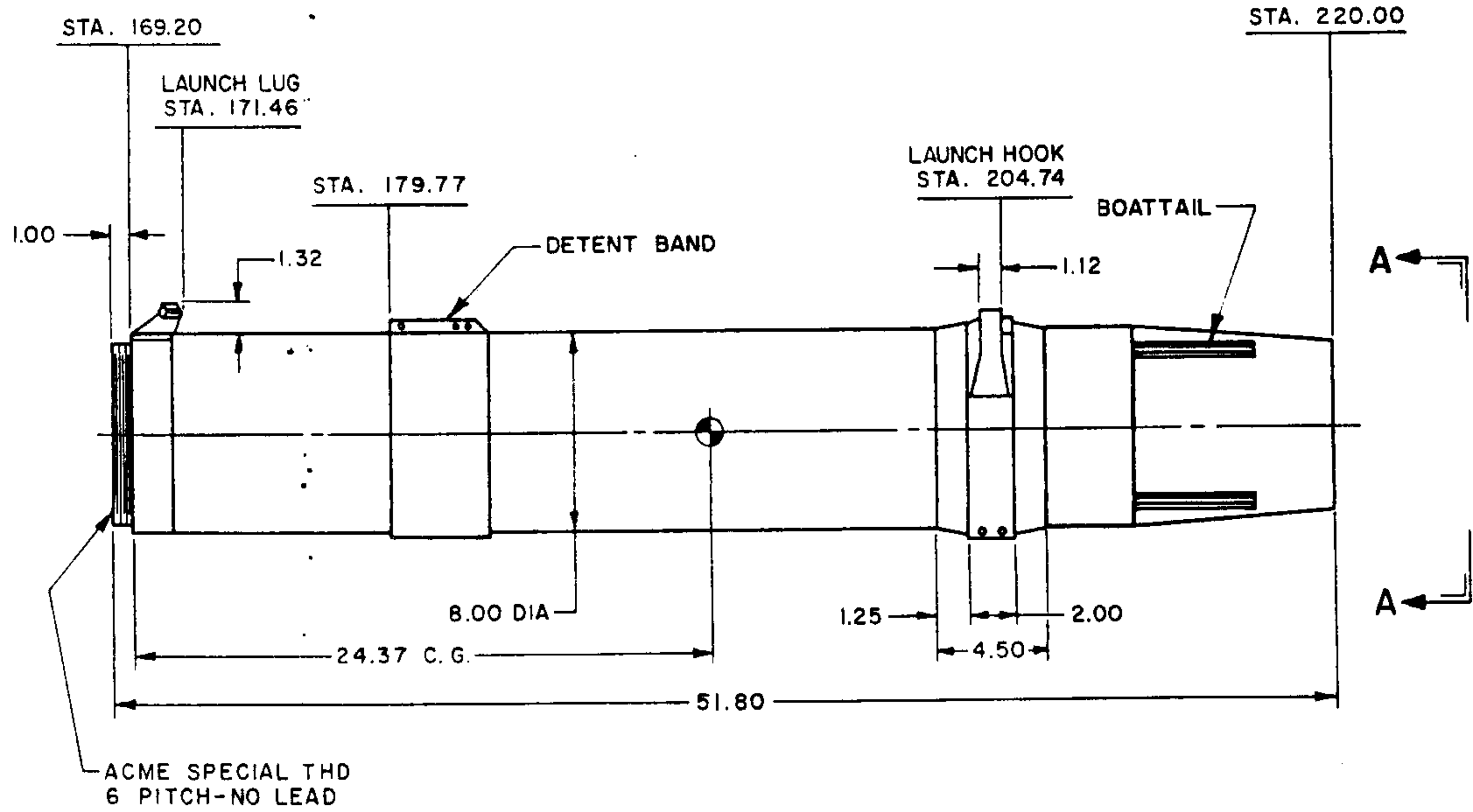

VIEW A-A

APPROXIMATE WEIGHT — 162.0 LBS.

ORIGINAL DATA SOURCE
ROCKETDYNE DWG. 802952
NAVWEP5 01-80MGA-2
DATED 1 DECEMBER 1966

WING ASSEMBLY MK 2 MOD 1

SHRIKE AGM - 45A

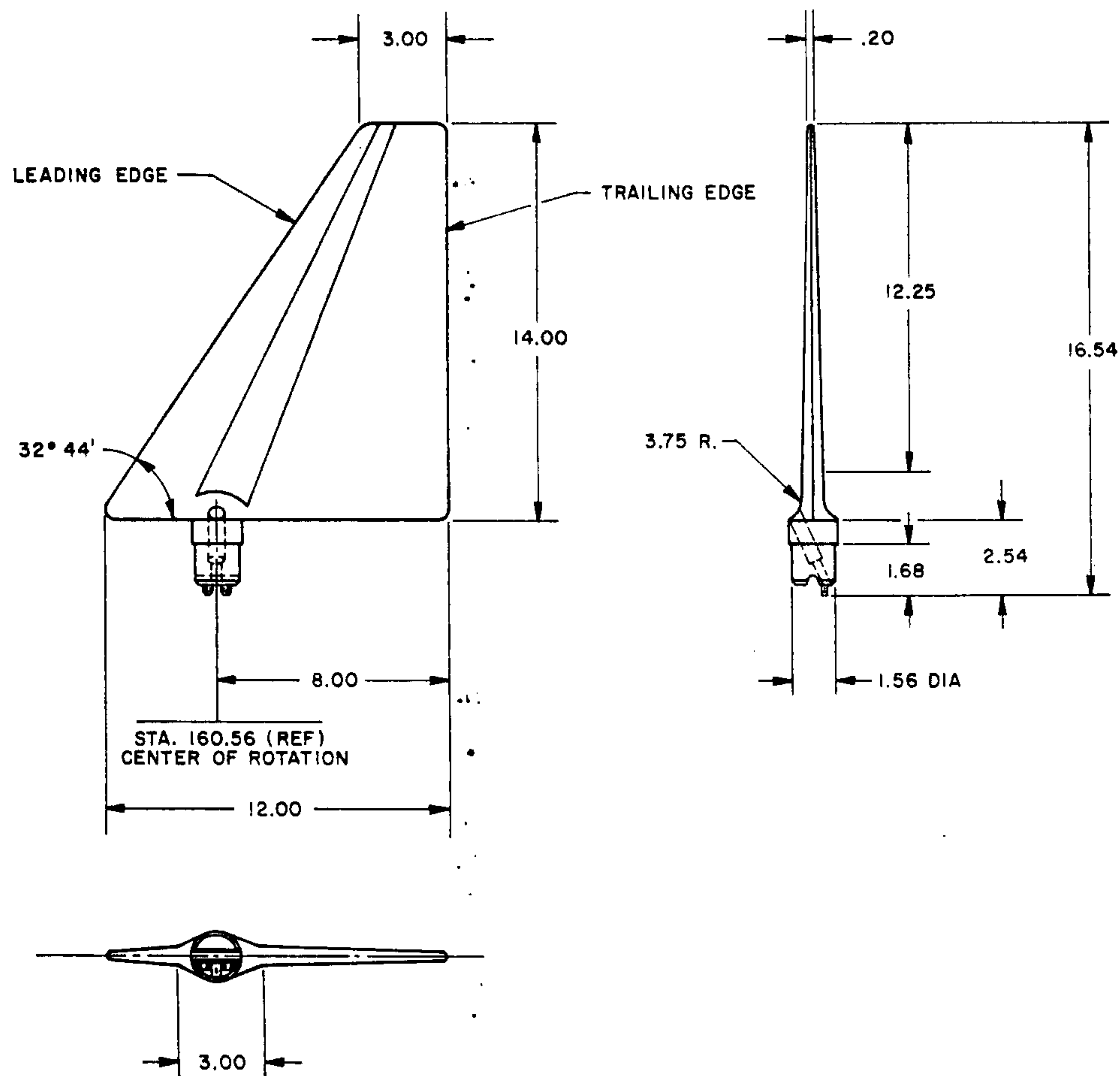

NOTES:

1. FOUR WINGS REQUIRED PER MISSILE.
2. APPROXIMATE WEIGHT - 3.4 LBS. EACH

ORIGINAL DATA SOURCE

BUWEPS DWG NO. 1570135 REV C
DATED 23 SEPTEMBER 1965

TAIL FIN ASSEMBLY MK 21 MOD 1

SHRIKE AGM - 45A

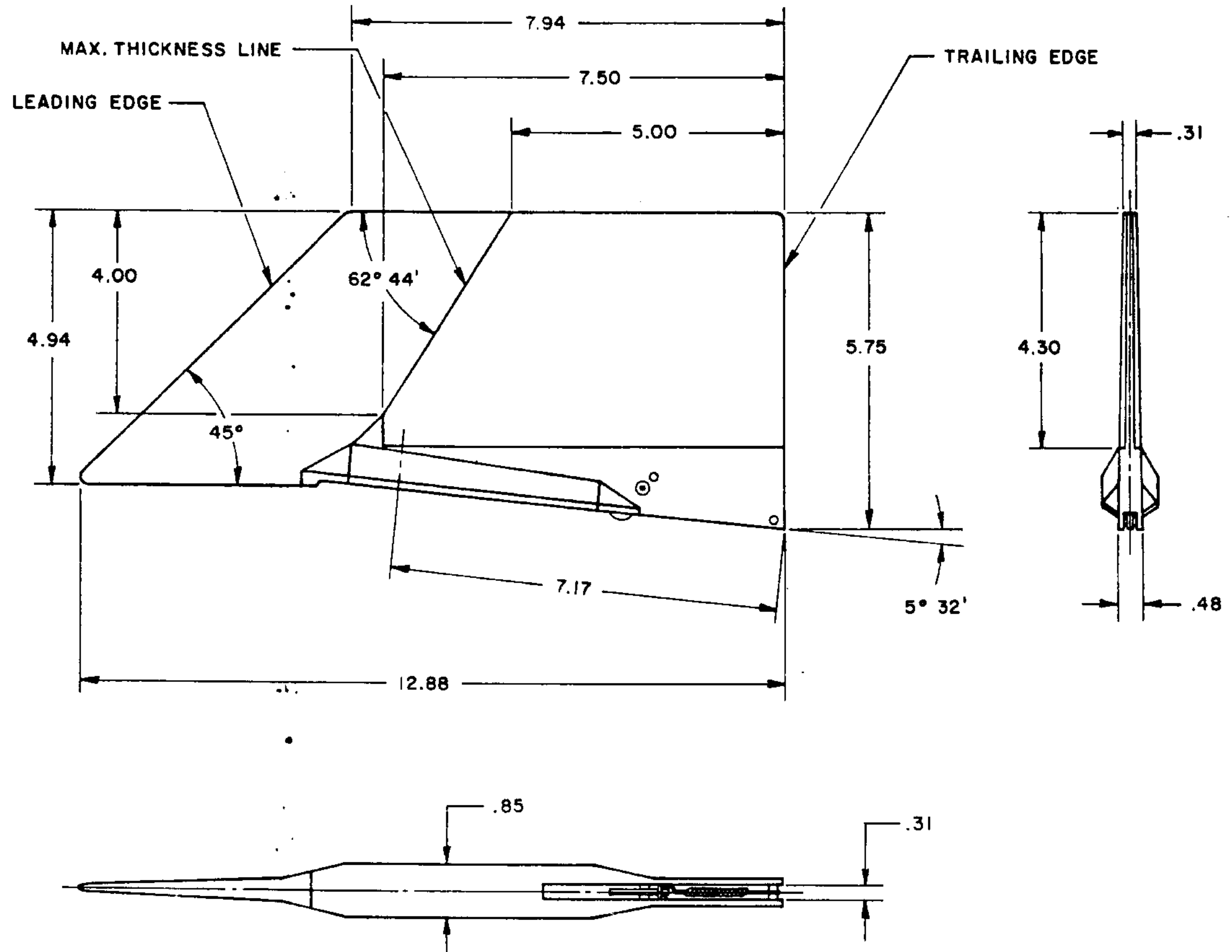

NOTES:

1. FOUR FINS REQUIRED PER MISSILE.
2. APPROXIMATE WEIGHT = 1.4 LBS. EACH

ORIGINAL DATA SOURCE

BUWPS DWG NO. 1570140 REV A
DATED 15 APRIL 1965
BUWPS DWG NO. 1570141 REV D
DATED 10 NOVEMBER 1965

CONDOR AGM-53A GENERAL ARRANGEMENT

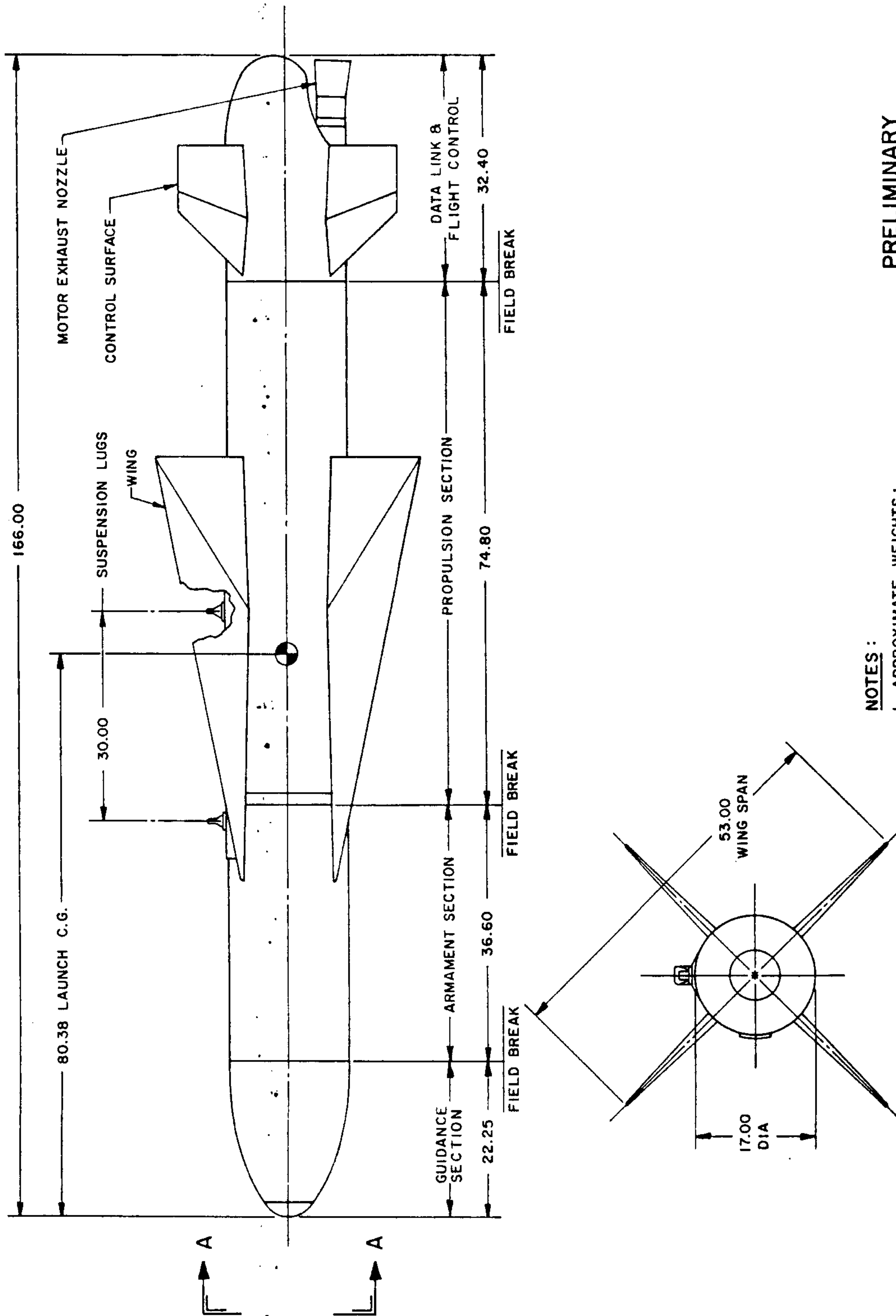

PRELIMINARY
 ORIGINAL DATA SOURCE
 NORTH AMERICAN REPORT
 NO. 66 H-897
 DATED 29 DECEMBER 1966

NOTES:
 1. APPROXIMATE WEIGHTS:
 LAUNCH 1885.0 LBS
 BURNOUT 1296.0 LBS
 2. MISSILE LAUNCHED FROM:
 AIRCRAFT A-6A
 PYLON RACK AERO 7A-R; MAU 9A/A

CONDOR AGM-53A HARD SPOT LOCATIONS

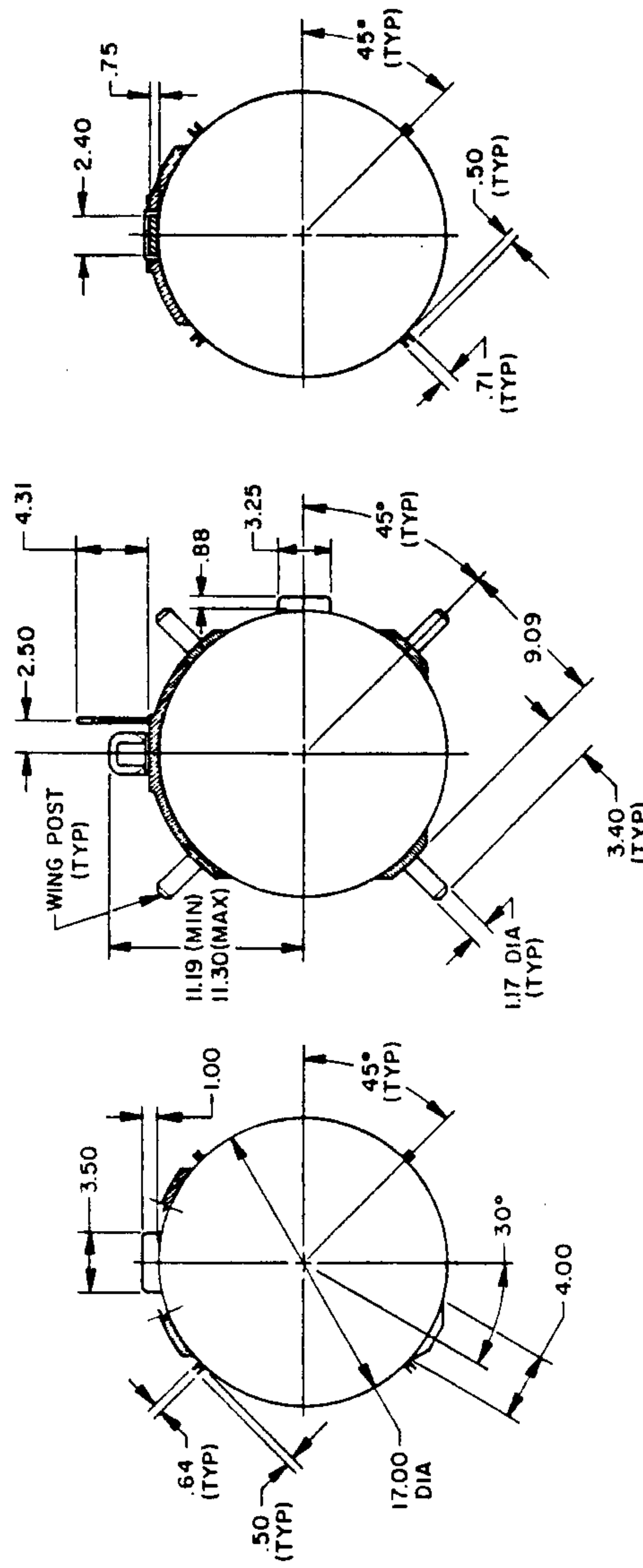
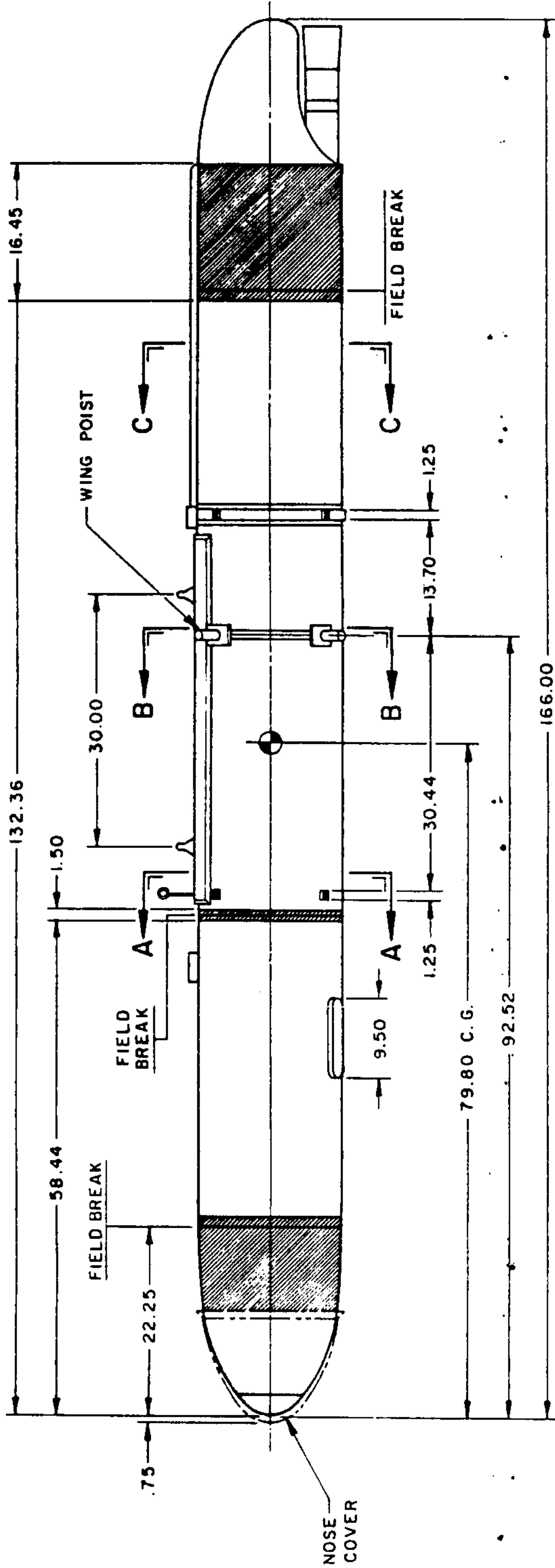

ENLARGED SECTION A-A

ENLARGED SECTION B-B

ENLARGED SECTION C-C

NOTES:

1. APPROXIMATE WEIGHT AS SHOWN - 1796.7 LBS
2. DENOTES HARD SPOT

PRELIMINARY
 ORIGINAL DATA SOURCE
 NORTH AMERICAN REPORT
 NO. ST192HC5001 REV C

AIRCRAFT POD GENERAL ARRANGEMENT

CONDOR AGM-53A

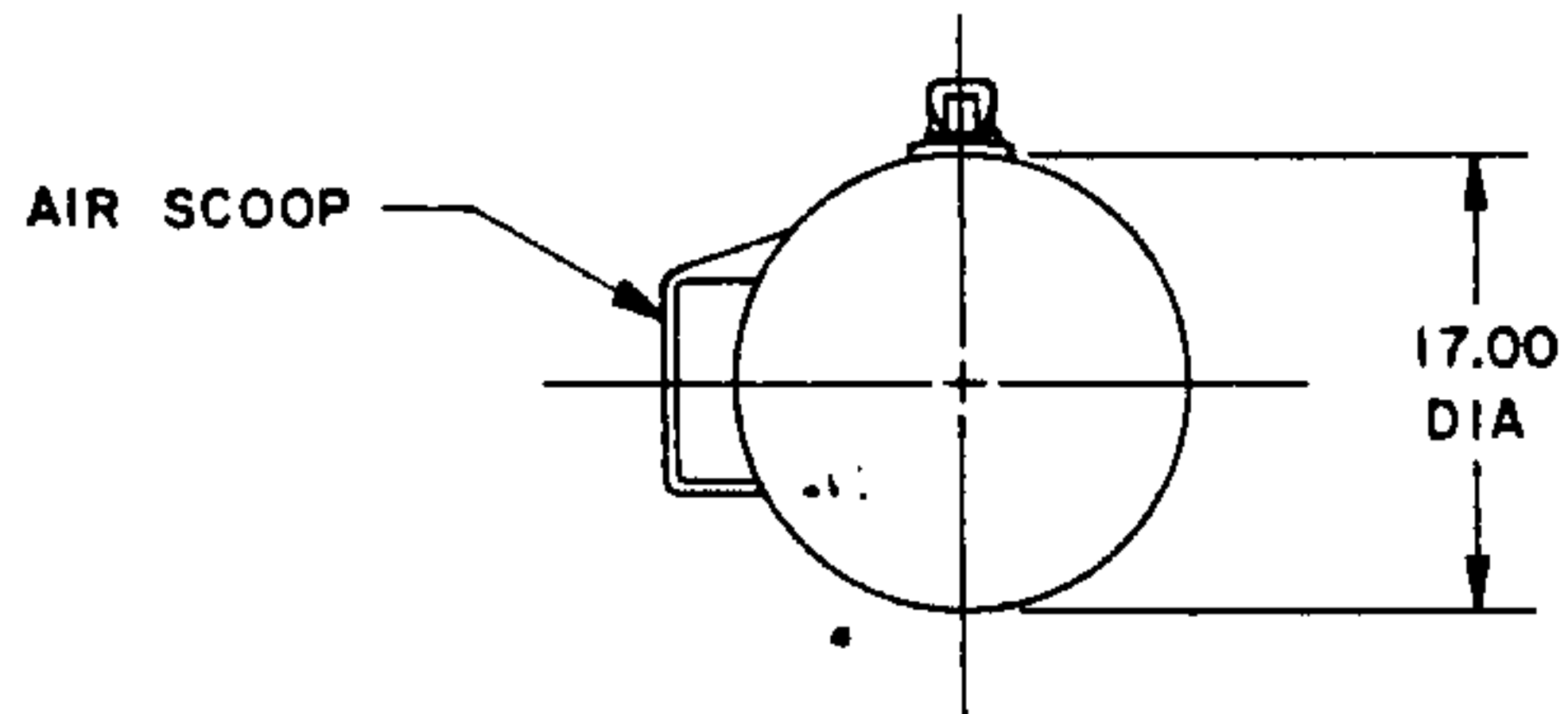
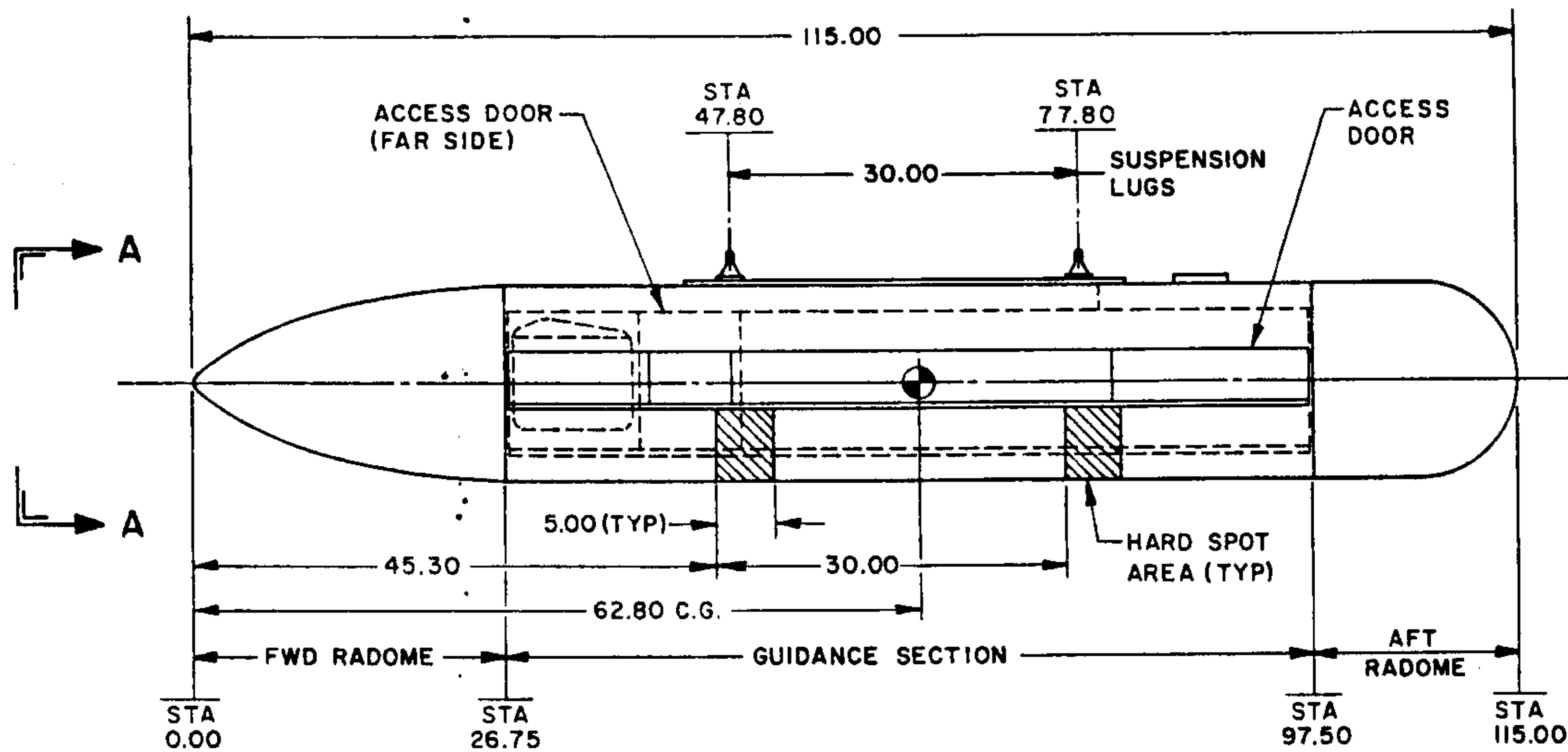

VIEW A-A

APPROXIMATE WEIGHT : 460.0 LBS (MAX)

PRELIMINARY

ORIGINAL DATA SOURCE
NORTH AMERICAN AVIATION
DWG NO. HZ017030
DATED 12 APRIL 1967
NORTH AMERICAN REPORT
NO. 66 H-897
DATED 29 DECEMBER 1966

CONDOR WING

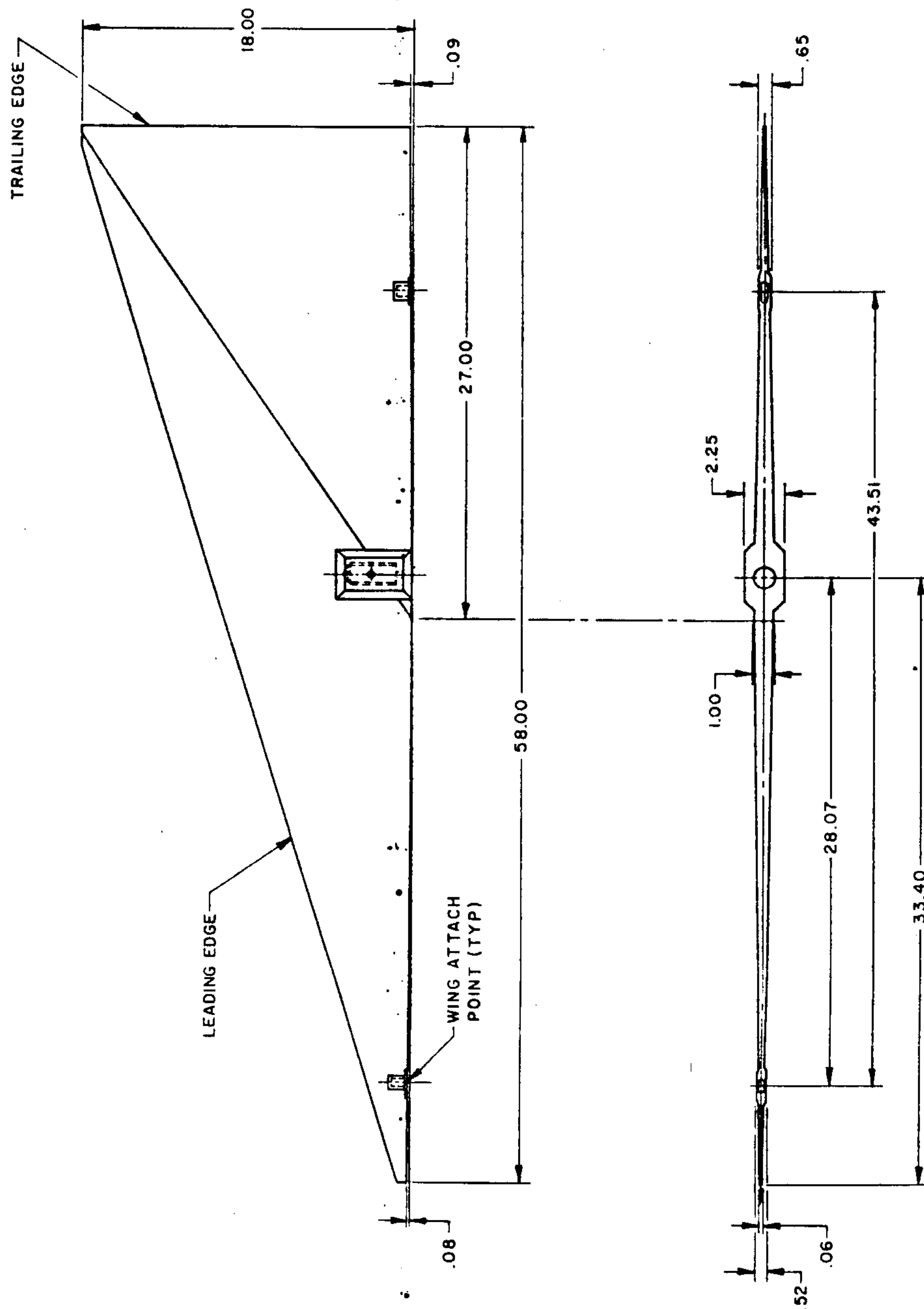

NOTE:

1. FOUR WINGS REQUIRED PER MISSILE.

PRELIMINARY

ORIGINAL DATA SOURCE
NORTH AMERICAN AVIATION
DWG NO. HZ015000 REV A
DATED 5 JUNE 1967

CONDOR CONTROL SURFACE

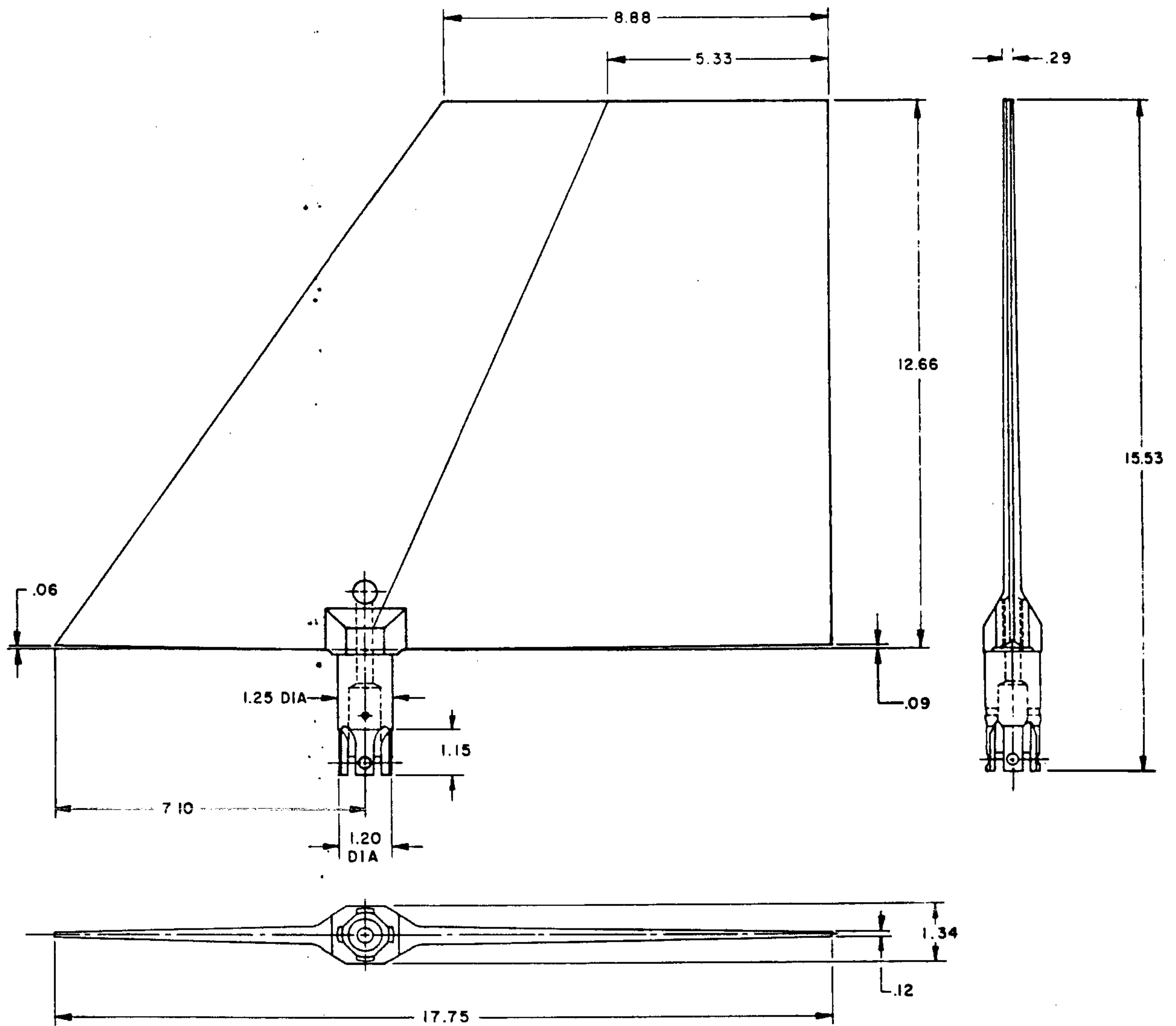

NOTE:
1. FOUR CONTROL SURFACES REQUIRED PER MISSILE.

PRELIMINARY

ORIGINAL DATA SOURCE
NORTH AMERICAN AVIATION
DWG NO. HZ016000

STANDARD ARM AGM-78A GENERAL ARRANGEMENT

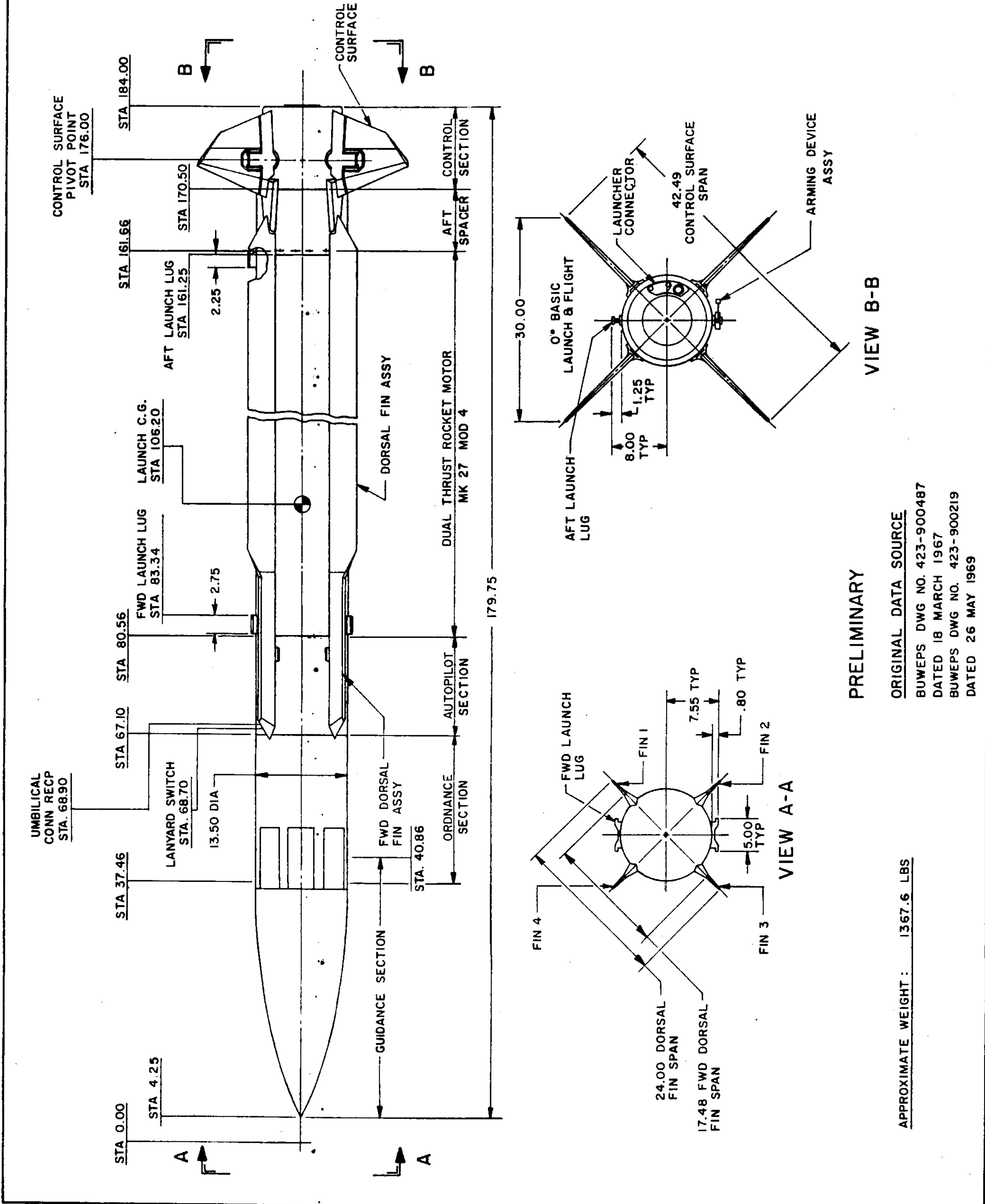

PRELIMINARY

ORIGINAL DATA SOURCE
 BUWEPS DWG NO. 423-900487
 DATED 18 MARCH 1967
 BUWEPS DWG NO. 423-900219
 DATED 26 MAY 1969

APPROXIMATE WEIGHT : 1367.6 LBS

STANDARD ARM HARD SPOT LOCATIONS

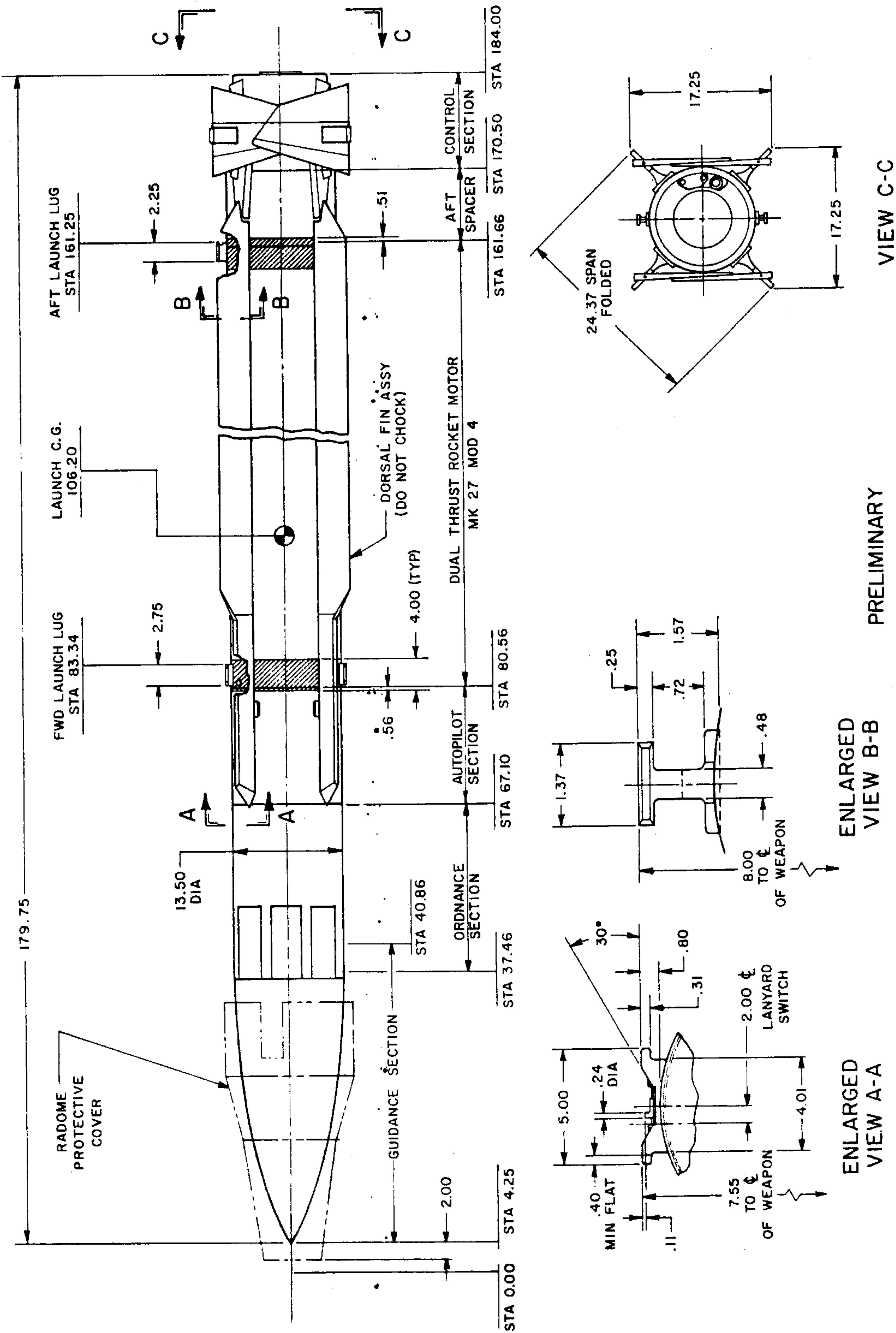

PRELIMINARY

ORIGINAL DATA SOURCE:
 BUWEPS DWG NO. 423-900487
 DATED 18 MARCH 1967
 NAVAIR REPORT 11-120-14
 DATED 16 FEBRUARY 1968
 BUWEPS DWG NO. 423-900219
 DATED 26 MAY 1969

NOTES:
 1. APPROXIMATE WEIGHT : 1367.6 LBS
 2. SYMBOL DENOTES HARD SPOT AREA.

STANDARD ARM MISSILE CONTAINER

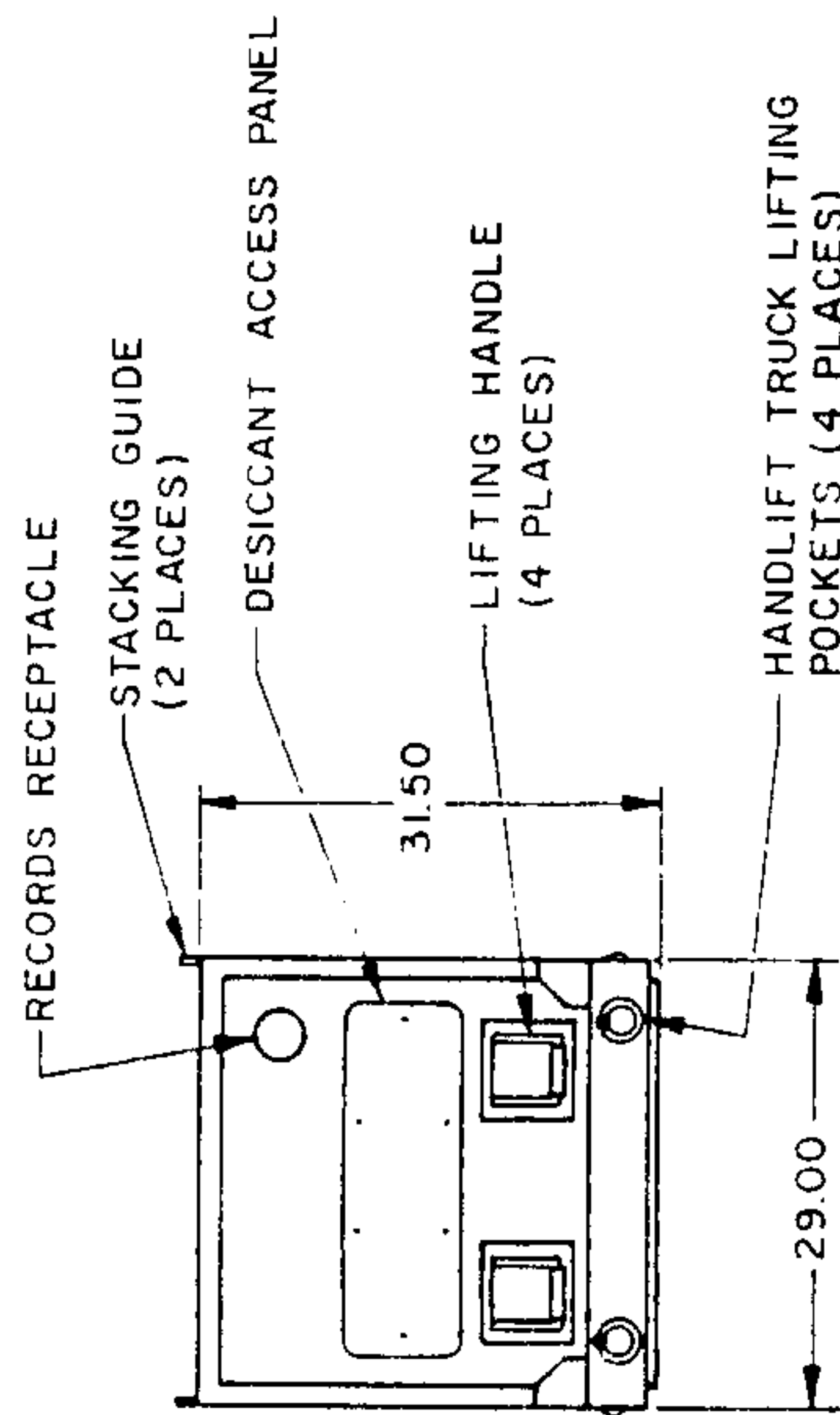
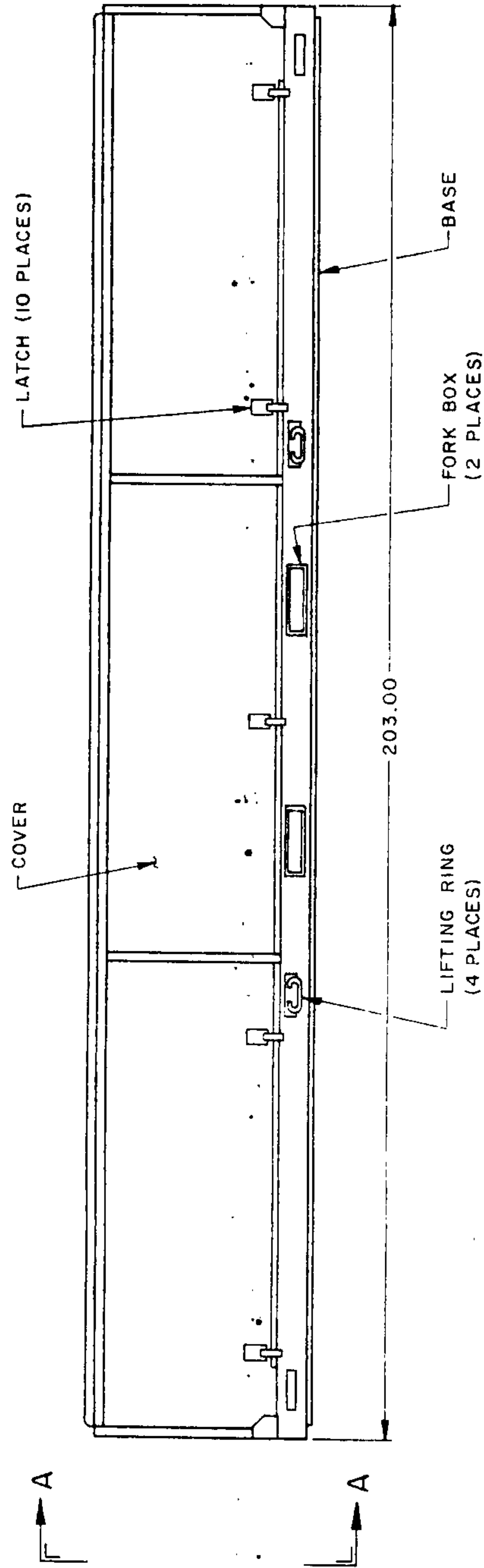

NOTES:

1. REUSABLE CRADLE SHOWN SHIPS & STOWS ONE ASSEMBLED STANDARD ARM MOD O, AGM-78A.
2. APPROXIMATE WEIGHTS:

CONTAINER EMPTY	-	700.0 LBS
MISSILE	-	1367.6 LBS
TOTAL	-	2067.6 LBS

PRELIMINARY

ORIGINAL DATA SOURCE
NAVAIR REPORT II-120-14
DATED 16 FEBRUARY 1968