

RECEIVED  
T. O. LIBRARY  
MAINT. INSP. SECTION

SECURITY INFORMATION—RESTRICTED

AN 01-250HDA-1

# PRELIMINARY FLIGHT HANDBOOK

USAF MODEL

# YH-21

HELICOPTER



PUBLISHED UNDER AUTHORITY OF THE SECRETARY OF THE AIR FORCE  
AND THE CHIEF OF THE BUREAU OF AERONAUTICS

NOTICE: This document contains information affecting the national defense of the United States within the meaning of the Espionage Laws, Title 18, U. S. C., Sections 793 and 794. The transmission or the revelation of its contents in any manner to an unauthorized person is prohibited by law.

RESTRICTED

**SECURITY INFORMATION—RESTRICTED**  
**AN 01-250HDA-1**

Reproduction for non-military use of the information or illustrations contained in this publication is not permitted without specific approval of the issuing service (BuAer or USAF). The policy for use of Classified Publications is established for the Air Force in AFR 205-1 and for the Navy in Navy Regulations, Article 1509.

**LIST OF REVISED PAGES ISSUED**

**INSERT LATEST REVISED PAGES. DESTROY SUPERSEDED PAGES.**

NOTE: The portion of the text affected by the current revision is indicated by a vertical line in the outer margins of the page.

\* The asterisk indicates pages revised, added or deleted by the current revision.

USAF

**ADDITIONAL COPIES OF THIS PUBLICATION MAY BE OBTAINED AS FOLLOWS:**

USAF ACTIVITIES.—In accordance with Technical Order No. 00-5-2.

NAVAL ACTIVITIES.—Use Publications and Forms Order Blank (NavAer 2126) and submit to the nearest publications supply point listed below: NAS, Alameda, Calif.; NAS, Jacksonville, Fla.; NAS, Norfolk, Va.; NAS, San Diego, Calif.; NAS, Seattle, Wash.; NASD, ASO, Guam; NASD, Philadelphia, Pa.

For listing of available publications see Naval Aeronautic Publications Index (NavAer 00-500).

# TABLE OF CONTENTS



<i>Section</i>	I	DESCRIPTION .....	1
	II	NORMAL PROCEDURES .....	25
	III	EMERGENCY PROCEDURES .....	37
	IV	DESCRIPTION & OPERATION OF AUXILIARY EQUIPMENT .....	45
	V	OPERATING LIMITATIONS .....	59
	VI	FLIGHT CHARACTERISTICS .....	65
	VII	SYSTEMS OPERATION .....	69
	VIII	CREW DUTIES .....	73
	IX	ALL WEATHER OPERATION .....	75
<i>Appendix</i>	I	OPERATING DATA .....	77
<i>Index</i>		.....	95



# important

**In order that you will gain the maximum benefits from this handbook it is imperative that you read these pages carefully.**

This handbook has been specifically designed and written with the best interests of YOU, the pilot, in mind. It is to your advantage to read this publication carefully, as it is intended to introduce you to the physical peculiarities of the YH-21 helicopter, and furthermore, thoroughly acquaint you with the operations and techniques required for its safe and efficient flight. Since the helicopter is vastly different from conventional aircraft, and since each model has its own peculiarities of operation and flight, the handbook applicable to the helicopter must be read and studied from cover to cover. Illustrations and text have been combined to present you with an attractive, easy reading, clear-cut publication.

It is the definite responsibility of the pilot and co-pilot to keep abreast with the latest changes that are available in the form of Immediate Attention Technical Orders. Each should check his local screening facilities to ascertain that Flight Handbook revisions and Immediate Attention Technical Orders are distributed promptly to qualified personnel. Each should familiarize himself with the following Technical Orders as they will help greatly in establishing the necessary pattern to follow:

- a. T.O. 00-5-2 outlines the procedure to be followed in obtaining necessary copies and revisions of the Flight Handbook.
- b. T.O. 00-3-1 describes the procedure to be followed in checking Flight Handbook requirements through with your Base Inspector.
- c. T.O. 01-250HDA (series for YH-21 and H-21A models). Ascertain that information pertaining to the above models is definitely scheduled for you on the Automatic Distribution List.

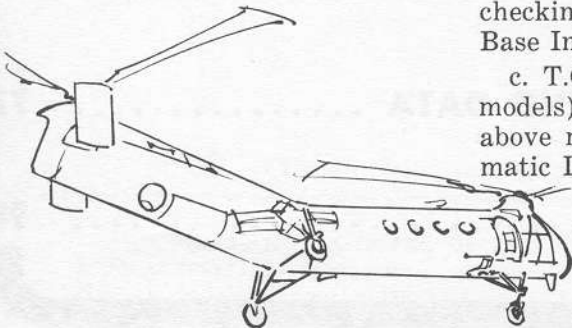

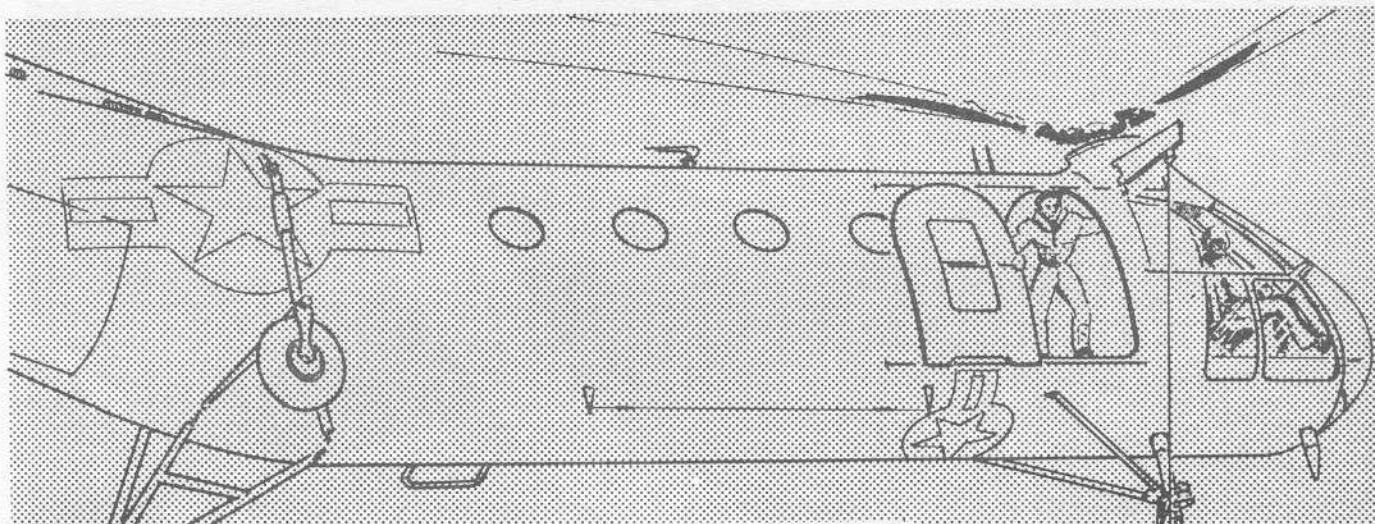

The handbook is divided into nine sections, an appendix and an index. The information to be found in each of these sections is as follows:

**SECTION I, DESCRIPTION**—Describes the helicopter and all its systems and controls which contribute to the physical act of flying the helicopter and the location of all items of emergency equipment.

**SECTION II, NORMAL PROCEDURES**—Contains the steps of procedure to be accomplished from the time the helicopter is approached by the flight crew until it is left parked on the ramp after accomplishing one complete non-tactical flight under normal conditions.

**SECTION III, EMERGENCY PROCEDURES**—Describes the procedure to be followed in meeting any emergency (except those in connection with auxiliary equipment) that could reasonably be expected to be encountered.

**SECTION IV, DESCRIPTION AND OPERATION OF AUXILIARY EQUIPMENT**—Includes the description, normal operation and emergency operation of all equipment not directly contributing to flight but which enables the helicopter to perform certain specialized functions.

**SECTION V, OPERATING LIMITATIONS**—Covers all important ground and flight limitations that must be observed during normal operation.

**SECTION VI, FLIGHT CHARACTERISTICS**—Describes the unique flight characteristics of the helicopter.

**SECTION VII, SYSTEMS OPERATION**—Describes operation of systems peculiar to this helicopter.

**SECTION VIII, CREW DUTIES**—Not required for this preliminary handbook.

**SECTION IX, ALL WEATHER OPERATION**—Describes precautions to be observed for this type of operation.

**APPENDIX I, OPERATING DATA**—Contains all operating data charts necessary for preflight and inflight mission planning and includes explanatory text on the use of the data presented.

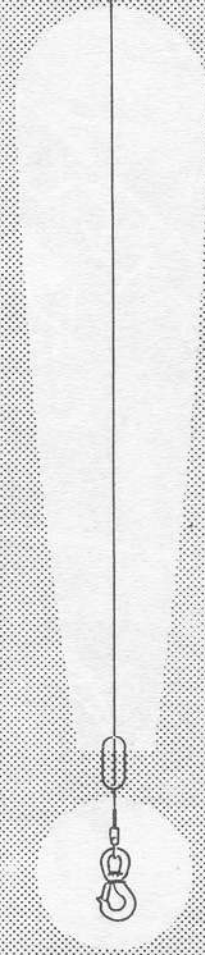



Figure 1-1. The Helicopter

# Section I DESCRIPTION

## THE HELICOPTER.

The model YH-21 (figure 1-1) is a 16-place, single engine, tandem rotored, rescue and utility helicopter manufactured by the Piasecki Helicopter Corporation. Power is supplied by a Wright R-1820-103 air-cooled radial engine, located within the fuselage aft of the cabin section. The engine simultaneously drives two three-bladed rotors, longitudinally disposed, through drive shafts and reduction transmissions. The rotor blades are constructed of wood on a steel spar and are plywood covered. The fuselage is of all-metal stressed skin construction. The cockpit incorporates side-by-side pilot seating with the pilot seat on the right. Dual flight controls are provided. The main entrance door is located on the center, left side of the fuselage. A rescue door and a swinging boom type rescue hoist are located on the forward, right side of the fuselage, immediately behind the pilot. The cabin can be fitted with troop seats and litters.

### DIMENSIONS.

The principal dimensions of the helicopter are as follows:

Length Overall	
Rotors Turning .....	86 ft 5 in.
Rotors in Phase and Static ....	75 ft 3 in.
Rotors Dephased .....	65 ft 10 in.
Blades Folded .....	52 ft 6 in.
Height Overall .....	
Width (Blades Folded) .....	14 ft 2 in.
Tread (Main Alighting Gear) ....	13 ft 6 in.

### GROSS WEIGHT.

Normal gross weight of the helicopter is approximately 11,000 pounds.

## ENGINE.

The helicopter is powered by a Wright R-1820-103 air-cooled radial engine, which is mounted within the fuselage, aft of the cabin (figure 1-2). Power is delivered to the rotors through drive shafts and reduction transmissions. The engine does not contain reduction gears. The speed of the drive shaft between engine and central transmission is the same as engine speed. An injection type carburetor supplies fuel to the engine. A single-stage, two-speed supercharger is installed for high altitude flight.

### THROTTLE.

The throttle is located on the pilot's collective pitch control lever (figure 1-3). Throttle control action is synchronized with the collective pitch control so that an rpm setting can be maintained automatically when the collective pitch is increased or decreased. The throttle may be operated independently by rotating the turnable (motorcycle) grip from right to left to increase rpm, or from left to right to decrease rpm.

### THROTTLE FRICTION LOCK.

The throttle friction lock (figure 1-4) is located just above the throttle control on the collective pitch lever. It is a friction type lock that will maintain a selected throttle position when locked. Rotate the knob from left to right to lock.

### MIXTURE CONTROL LEVER.

This control lever is located on the console to the left of the pilot (figure 1-3). Extreme forward position is RICH. Aft, to the first detent, is NORMAL and the extreme aft position is IDLE CUT-OFF. The NORMAL position is used for normal cruise, climb, hovering and when high blower is *not in use*. The RICH position should

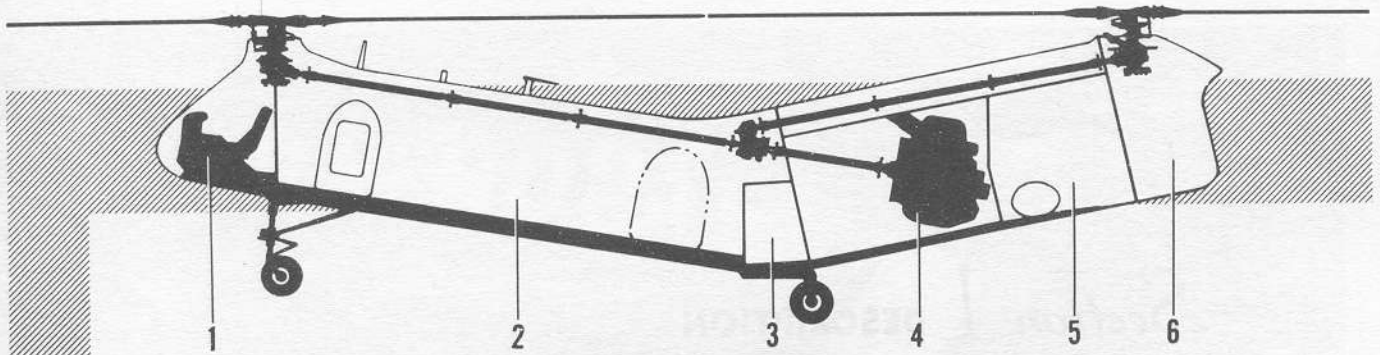

- 1 Pilots' Compartment
- 2 Cargo-Passenger Compartment
- 3 Fuel Cell Compartment
- 4 Engine Compartment
- 5 Engine Accessory Compartment
- 6 Tail Section

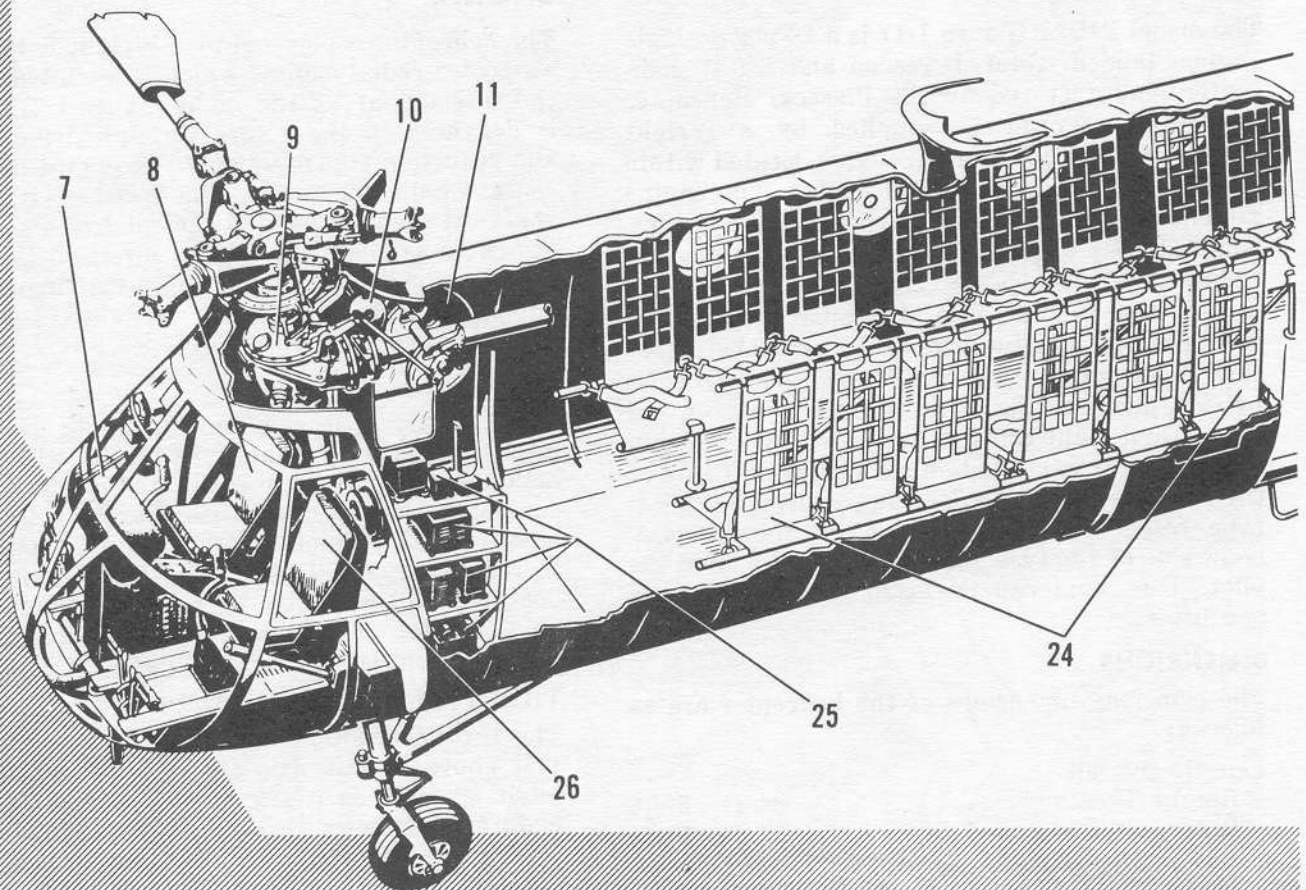
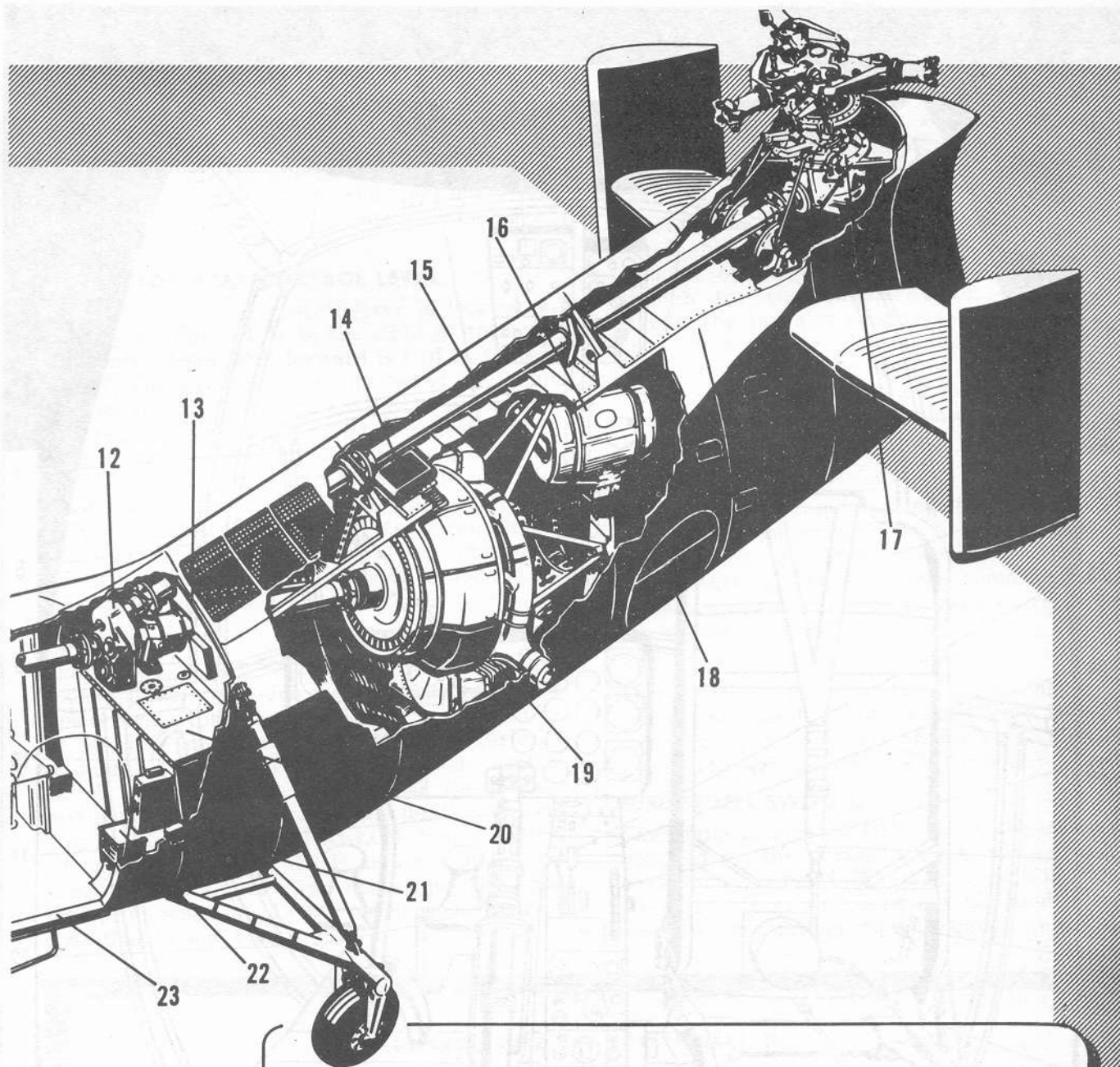

Figure 1-2. General Arrangement (Sheet 1 of 2)





- |    |                            |    |                           |
|----|----------------------------|----|---------------------------|
| 7  | Pilot's Instrument Console | 17 | Aft Transmission          |
| 8  | Pilot's Seat               | 18 | Engine Air Exit           |
| 9  | Forward Transmission       | 19 | Engine                    |
| 10 | Hydraulic Reservoir        | 20 | Fuel Cell                 |
| 11 | Forward Rescue Door        | 21 | External Power Receptacle |
| 12 | Central Transmission       | 22 | Battery                   |
| 13 | Firewall                   | 23 | Main Entrance Door        |
| 14 | Oil Cooler                 | 24 | Troop Seats               |
| 15 | Drive Shafting             | 25 | Radio Equipment           |
| 16 | Oil Tank                   | 26 | Co-Pilot's Seat           |

Figure 1-2. General Arrangement (Sheet 2 of 2)

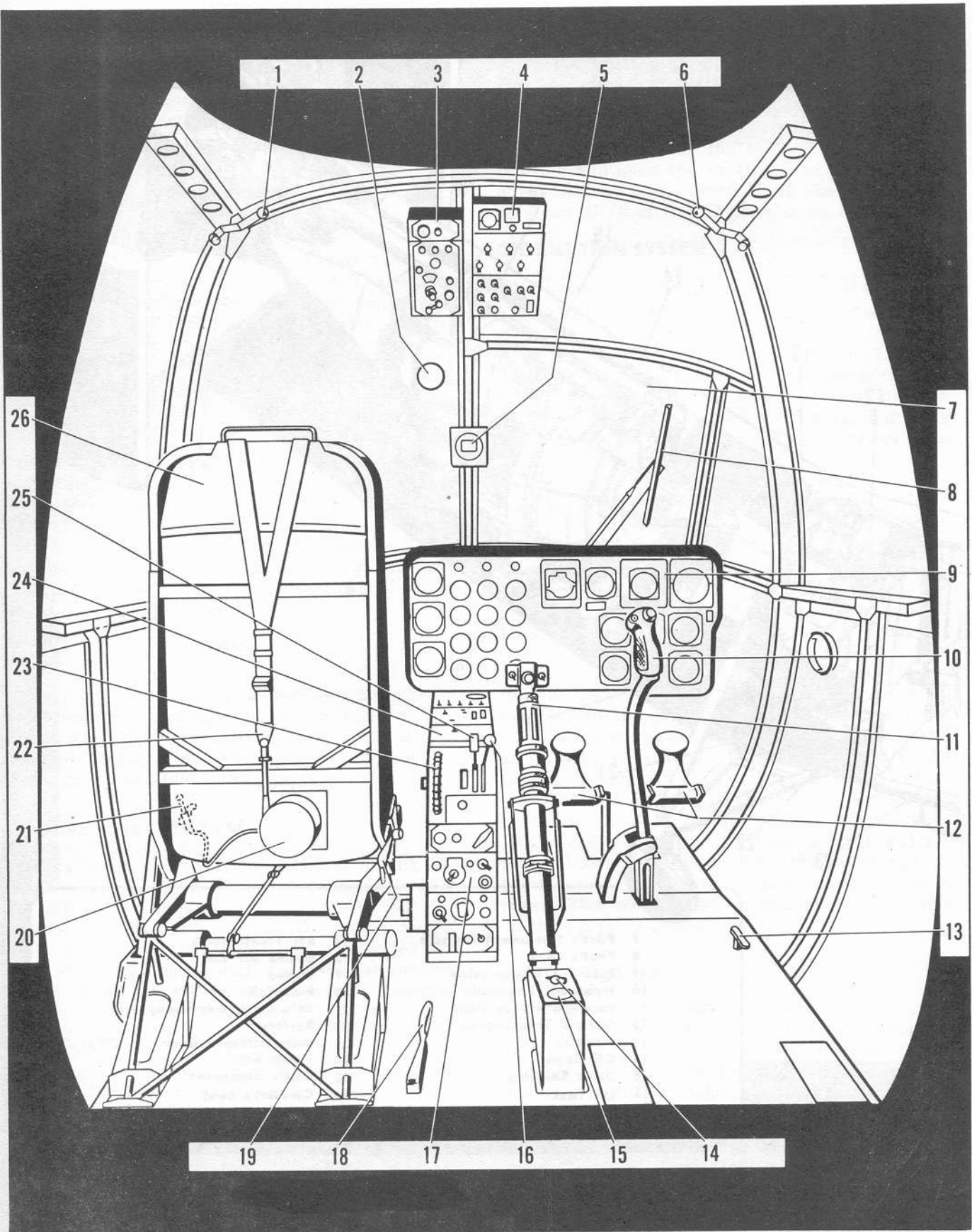

Figure 1-3. The Cockpit

be used for all ground operations, taxiing, take-offs, landings and on all occasions when high blower is in use. The mixture lever should be changed from the RICH position after the helicopter leaves the ground, and it should be moved from the NORMAL position to the RICH position while on the landing approach. IDLE CUT-OFF is used when stopping or shutting down the engine. There is no intermediate positioning of this lever.

#### CARBURETOR HEAT CONTROL LEVER.

The carburetor heat control lever is located on the console (figure 1-3) to the right of the mixture control lever. Full forward is COLD, full aft is HOT. The lever can be positioned at any point between the two limits to obtain the amount of heat required. When the carburetor heat control lever is placed in the COLD position, air is forced by the fan through the carburetor air duct located above the engine. When this control is positioned at HOT, heated air from the engine cylinders and exhaust shroud is channeled through the air duct into the carburetor air intake. Refer to figure 1-5 for air flow.

#### SUPERCHARGER.

The Wright R-1820-103 engine is equipped with a two-speed, gear-driven supercharger. The supercharger control at the engine is actuated by oil pressure and is controlled by an electrically actuated solenoid. The supercharger control switch (figure 1-4) is mounted on the console just below and to the left of the ignition switch. This is a two-position HIGH-LOW toggle switch, which when flipped to HIGH actuates the engine selector valve to the high blower position, and inversely, when on LOW, provides for engine operation in low blower.

#### ENGINE COOLING SYSTEM.

An engine air cooling system (figure 1-5) is necessary since ram air is not available during ground operations and hovering of the helicopter. The system consists of a fan, stator ring, cylinder head baffles and a cowling, plus the necessary air inlets and outlets. Air is drawn into the engine compartment through the inlet in the top of the fuselage just aft of the main cabin. The air is forced through the cowling around the engine cylinders by the engine-driven fan and expelled through the two circular outlets aft of the engine. The fan also acts as an engine flywheel when the rotors are disengaged. Two air outlet doors are installed to control the flow of air around the engine. These are manually operated on the ground. The pilot should check for adjustment before flight.

#### IGNITION SYSTEM.

This is a conventional dual magneto system with two spark plugs per cylinder. A vibrator provides high tension current to the right magneto for initial starting. The vibrator is connected to the engine starter circuit and provides current when the starter is energized.

#### IGNITION SWITCH.

This switch is located on the engine controls section of the console switch panel (figure 1-4). The switch positions are OFF, R for right magneto, L for left magneto, and BOTH for both magnetos.

#### FUEL PRIMER SWITCH.

The engine primer ON-OFF switch (figure 1-4) is installed on the engine controls section of the console switch panel. When the switch is held in the ON position, an electrically actuated solenoid energizes the primer pump, located on the rear

#### NOMENCLATURE KEY FOR FIGURE 1-3.

- |   |                                  |
|---|----------------------------------|
| 1 Co-Pilot's Window Jettison Handle                     | 14 Hydraulic Control Valve       |
| 2 Free-Air Thermometer                                  | 15 Hydraulic Control Valve Gage  |
| 3 Co-Pilot's Interphone and Radio Compass Control Panel | 16 Carburetor Heat Control Lever |
| 4 Overhead Switch Panel                                 | 17 Pilot's Radio Controls        |
| 5 Standby Compass                                       | 18 Nose Wheel Lock               |
| 6 Pilot's Window Jettison Handle                        | 19 Co-Pilot's Seat Adjustment    |
| 7 Windshield  | 20 Inertia Reel                  |
| 8 Windshield Wiper                                      | 21 Shoulder Harness Release      |
| 9 Instrument Panel                                      | 22 Co-Pilot's Shoulder Harness   |
| 10 Pilot's Cyclic Stick                                 | 23 Trim Control Wheel            |
| 11 Collective Pitch Control Lever                       | 24 Electrical Distribution Panel |
| 12 Directional Control Pedals                           | 25 Mixture Control Lever         |
| 13 Parking Brake Handle                                 | 26 Co-Pilot's Seat               |

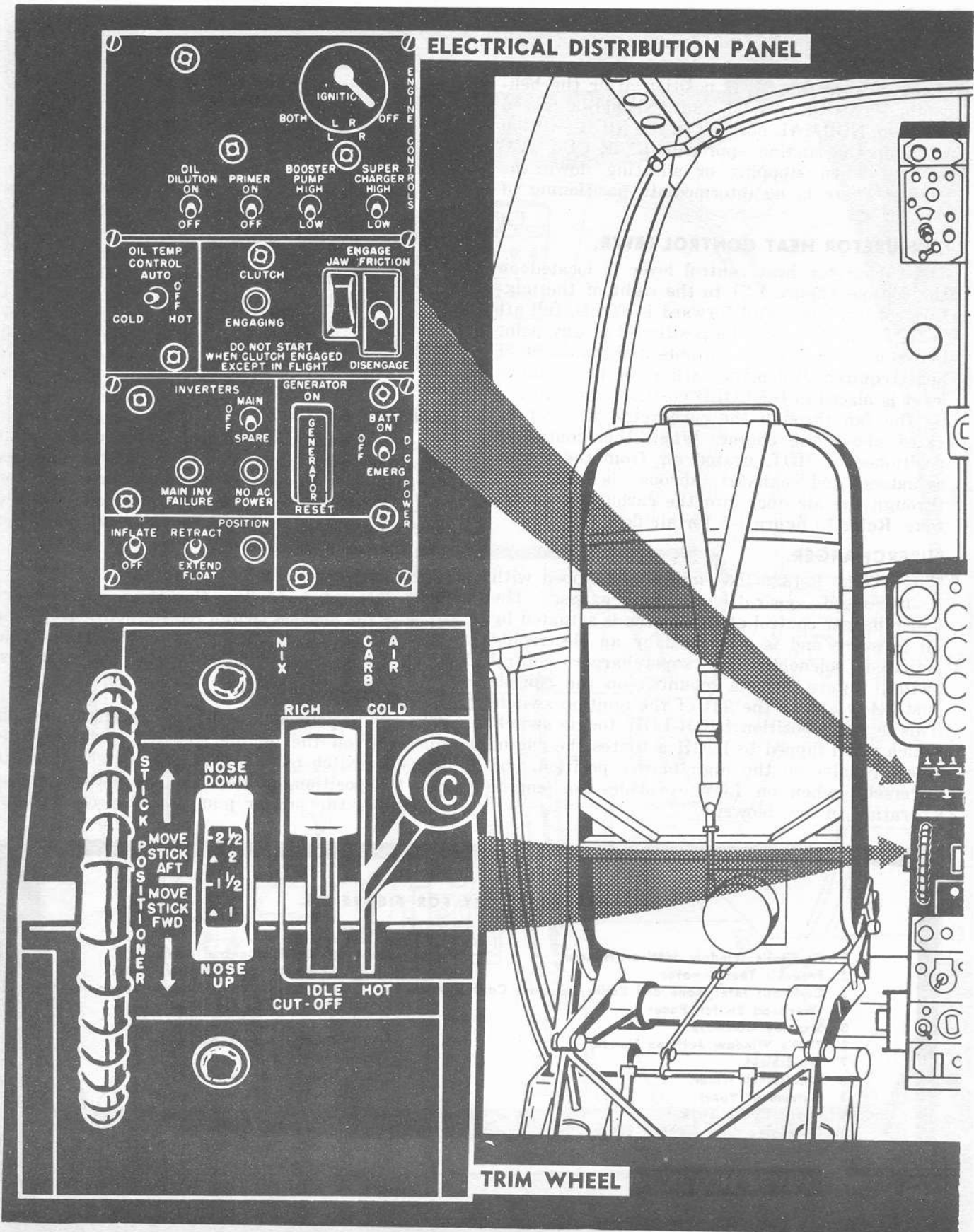

Figure 1-4. Pilot's Controls (Sheet 1 of 2)

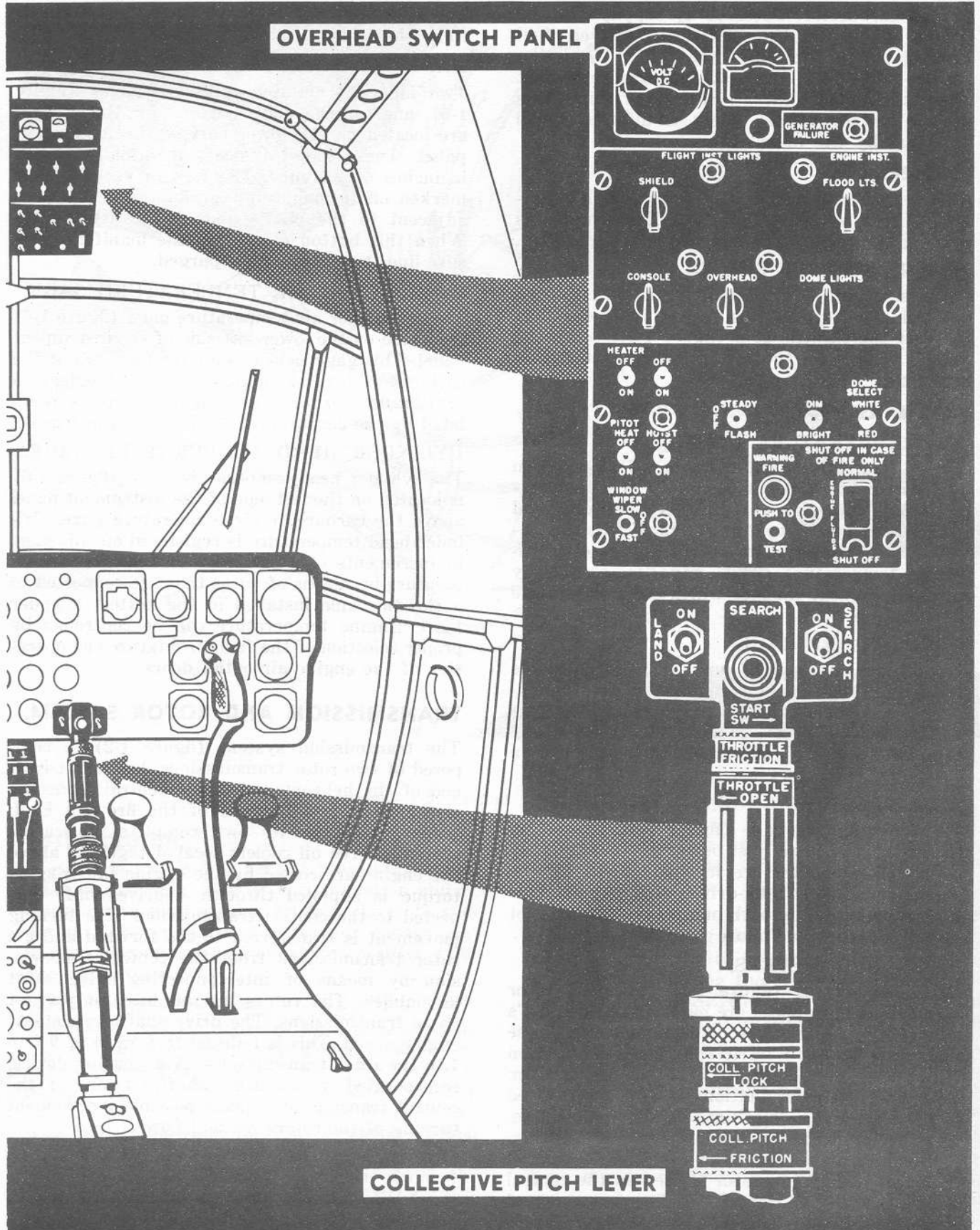

Figure 1-4. Pilot's Controls (Sheet 2 of 2)

of the carburetor. Pressure is supplied to the primer pump by the electrically driven fuel booster pump. Two lines are routed from the primer pump and outlet at the carburetor just above the impeller throat. Fuel sprayed into this section by the primer pump is diffused to all cylinders by the impeller.

#### STARTER.

The engine is provided with a 24 volt, d-c electric, direct cranking starter. The engine is cranked directly when the starter is energized.

#### ENGINE STARTER SWITCH.

This is a button type switch installed on the underside of the pilot's collective pitch lever, forward of the throttle grip (figure 1-4). When the switch is pressed, the direct cranking starter is energized.

#### ENGINE INSTRUMENTS.

##### OIL TEMPERATURE GAGE.

The oil temperature gage (figure 1-6), located on the instrument panel is connected to a temperature bulb in the oil system Y-drain, and registers engine oil heat on the face of the instrument dial in increments of 10 degrees of centigrade temperature. This gage is electrically actuated by heat changes which occur within the temperature bulb.

##### OIL PRESSURE GAGE.

The oil pressure gage (figure 1-6), located beside the engine oil temperature gage on the instrument panel, registers engine oil pressure in increments of 10 psi. Pressure is electrically transmitted to the gage from the transmitter in the engine accessory section.

##### FUEL PRESSURE GAGE.

The fuel pressure gage (figure 1-6), located on the instrument panel just below the fuel quantity gage, indicates fuel pressure put forth by the engine- and electrically-driven fuel pumps. This gage is connected to both pumps so that the pilot can be aware of a failure in either pump.

##### DUAL TACHOMETERS.

Dual tachometers (figure 1-6) indicating rotor speed and engine speed are mounted on the pilot's and co-pilot's side of the instrument panel. These dials have two concentric rpm scales marked on their faces in increments of hundreds of rpm. The inner scale graduations denote rotor speed and the outer scale markings signify engine rpm. The shorter of the two needles shown in the illustration indicates actual rotor rpm and is actuated by a tachometer generator located on the central transmission. The longer needle shows actual engine speed and is similarly energized by a tachometer generator located on the engine accessory section. Both tachometers are synchronized so

that both needles will line up when the rotors are fully engaged.

#### MANIFOLD PRESSURE GAGES.

Two identical manifold pressure gages (figure 1-6), one for the pilot and one for the co-pilot are located on the lower part of the instrument panel. These gages indicate manifold pressure in inches of mercury. The face of each gage is marked off in single unit graduations. A button adjacent to the pilot's gage is marked PUSH. When this button is pushed, the manifold pressure lines to the gage are purged.

#### CARBURETOR AIR TEMPERATURE GAGE.

The carburetor air temperature gage (figure 1-6) is located on the lower left side of the instrument panel. This gage indicates air temperature at the carburetor air intake in increments of five degrees centigrade. Carburetor air temperature is regulated by the carburetor heat lever on the console.

#### CYLINDER HEAD TEMPERATURE GAGE.

The cylinder head temperature gage (figure 1-6) is located on the left side of the instrument panel above the carburetor air temperature gage. Cylinder head temperature is registered on this gage in increments of 10 degrees of centigrade temperature by means of wires that are connected to a thermocouple installed in the hottest cylinder head. Engine temperature can be controlled by proper selection of the fuel-air mixture and operation of the engine air outlet doors.

#### TRANSMISSION AND ROTOR SYSTEM.

The transmission system (figure 1-2) is composed of two rotor transmissions, located at each end of the helicopter, and one central transmission located just forward of the firewall. Each transmission has its own complete lubrication system. Three oil coolers located together above the engine are cooled by the engine fan. Engine torque is supplied through a drive shaft connected to the central transmission. This turning movement is transferred to the forward and aft rotor transmissions from the central transmission by means of interconnecting drive shaft assemblies. The rotors are an integral part of these transmissions. The drive shafts operate at engine speed. This is reduced to a ratio of 9.7 to 1 in the rotor transmissions. A dephasing device, incorporated in the drive shaft forward of the central transmission makes possible independent turning of the rotors without power.

**CAUTION**

Rotors in dephased position will be noted by a red flag hung on the drive shaft near the central transmission.

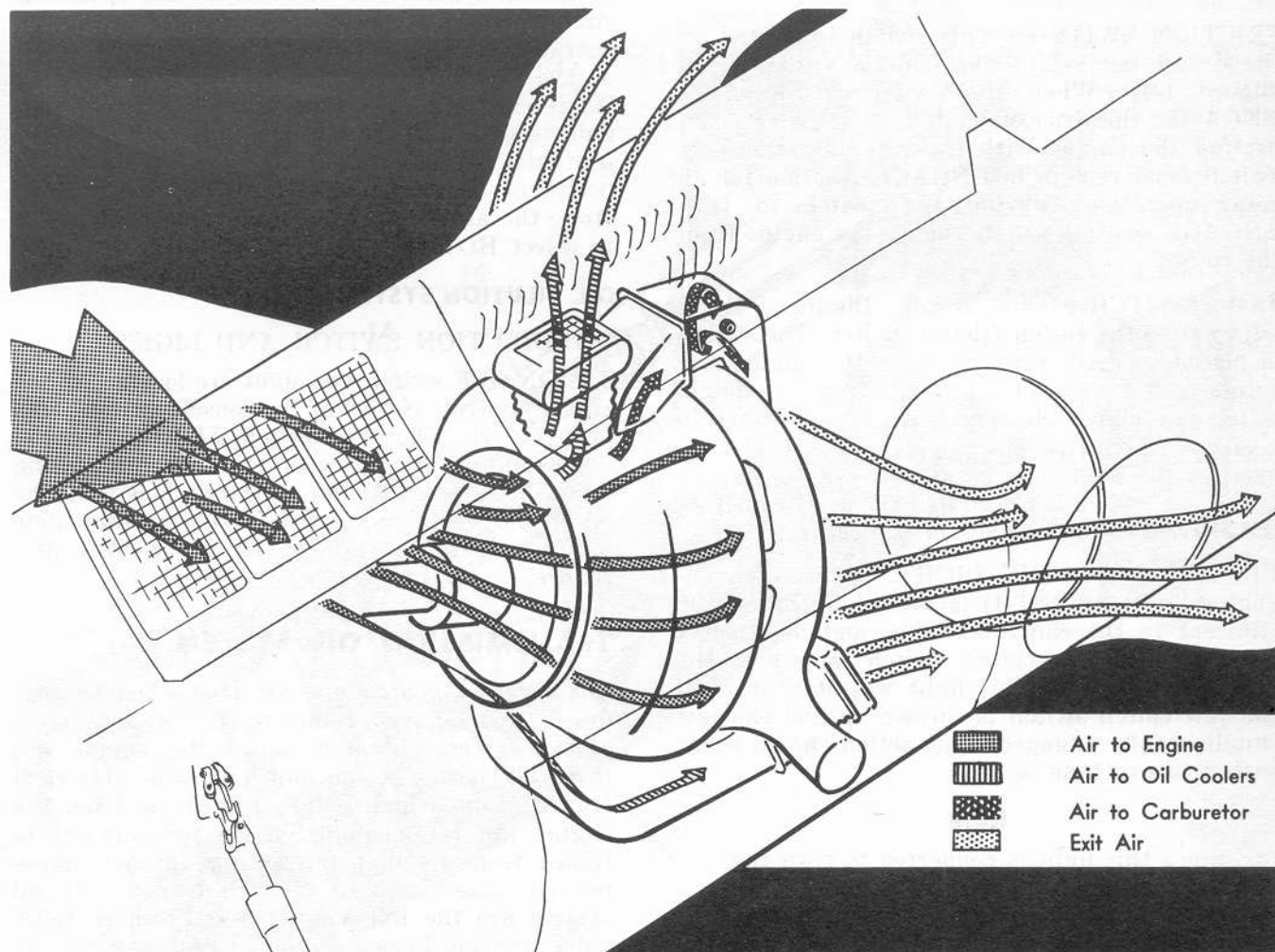

Figure 1-5. Engine Cooling System

**ROTOR CLUTCH.**

A clutch is installed as part of the central transmission assembly. This is a combination clutch, containing a multiple disc friction clutch to synchronize the engine and rotors for engagement and an overrunning jaw clutch for positive drive and autorotation.

**ROTOR CLUTCH OPERATIONAL FUNCTIONS.**

This clutch system provides for engine starting independently of rotor engagement. When the engine is operating smoothly the rotor system is engaged by the electrically actuated friction clutch. When the rotor rpm has synchronized with the engine rpm, the jaw clutch is engaged and the friction clutch disengaged simultaneously, thus supplying direct torque from the engine to the rotors. Refer to Section VII for this procedure. If, at any time, the rotor rpm should be greater than the engine speed (such as during autorotation or power failure) the jaw clutch will

overrun. When the engine speed is again increased to match the rotor speed the system will return to direct drive.

Stop the engine and rotors by increasing rotor speed then reducing the engine speed, thus permitting the jaw clutch to overrun. Disengage the jaw clutch by placing the friction switch, on the console, in the DISENGAGED position. Refer to Section VII for full information on this procedure.

When the helicopter is in autorotation, rotor rpm is maintained by the passage of air up through the blades. If overrunning clutch action were not possible, the rotors would stop when serious engine failure occurred. Since it is necessary that the engine be brought into direct drive at any time during a simulated autorotative descent, and since it may be desired to restart the engine during power-off descent (engine failure or stopping), overrunning clutch action for these flight conditions is mandatory.

**CLUTCH CONTROLS.**

**FRICTION SWITCH.** This switch is located on the center portion of the console switch panel (figure 1-4). When the switch is moved to ENGAGE, the friction clutch is actuated, connecting the engine with the rotor system. This switch must remain in ENGAGE position for all rotor operation. Moving the switch to DIS-ENGAGE position will disengage the engine from the rotors.

**JAW SWITCH.** This switch (figure 1-4) is adjacent to the clutch friction switch. The switch is placed in JAW position after the engine and rotors are synchronized with friction clutch. After jaw clutch engagement, the rotors are in positive drive with the engine and are free to overrun the engine as required for autorotation. If the jaw switch is placed in JAW position before the friction switch, no action will occur.

**CLUTCH ENGAGING LIGHT.** The clutch engaging light (figure 1-4) is located on the console adjacent to the clutch switches and illuminates when the friction clutch switch is put in the ENGAGE position. This light will stay on until the jaw clutch switch is thrown on and the jaw clutch is fully engaged. This action should occur within two to four seconds.

**Note**

Since this light is connected to both the central transmission oil pressure transmitter and the jaw clutch mechanism, it will not go out until the jaw clutch is fully engaged and the oil pressure has been stabilized to the proper point.

**ENGINE OIL SYSTEM.**

The engine oil system is composed of a tank assembly and oil cooler. The tank capacity is 19.5 US gallons with an expansion space of 6.8 US gallons. An internally contained hopper, which has a volume of 8.5 US gallons, is provided for quick warm-up, and to limit the required amount of oil dilution. Refer to Servicing Diagram (figure 1-13) for oil specification and grade.

**OIL COOLER.**

Engine oil is cooled during engine operation by passage through the oil cooler located on the lower section of the engine mount. When the oil is cold it is diverted around the cooler by a thermostatic bypass valve located in the cooler. When the oil is hot, it passes through the cooler where it is cooled by air from the engine fan.

**OIL COOLER DUCT SHUTTER.**

The shutter in the oil cooler duct is electrically actuated. The thermostat located in the Y-drain

of the oil system acts to energize the operating circuit. This installation is automatic in normal operation, but the pilot can also control it by use of the four-way OFF-AUTO-HOT-COLD switch located in the console switch panel if the sensing unit becomes inoperative. The switch in the HOT position will close the shutter and in the COLD position will open the shutter. The OFF position stops the automatic control and allows the pilot to select HOT or COLD position as desired.

**OIL DILUTION SYSTEM.****OIL DILUTION SWITCH AND LIGHT.**

The ON-OFF switch and light are located on the engine controls section of the console switch panel (figure 1-4). When the switch is placed ON, the engine oil is diluted with fuel. The indicating light shows when the diluting switch is ON. The oil should never be diluted for longer than nine minutes. Refer to Section IX for correct procedure.

**TRANSMISSION OIL SYSTEM.**

The forward, central and aft transmissions (figure 1-2) each have a complete and separate lubrication system. Located above the engine are three oil coolers in one unit, one cooler for each transmission, which obtain forced air from the engine fan for cooling. System pressure is obtained from an oil pump located in each transmission case. Included in each transmission oil system are the following items: Pressure relief valve, thermo bypass valve, two oil screens, and an oil temperature bulb. Mounted adjacent to the transmissions are pressure and temperature transmitters. Gages for these units are located on the left side of the instrument panel (figure 1-6). Pressure for the forward, central and aft transmission is registered on the outer row of gages, and temperature for these installations is transmitted to the gages immediately to the left of the pressure gages.

**FUEL SYSTEM.**

The fuel system (figure 1-7) consists of one fuel cell, centrally located in the helicopter, an engine-driven fuel pump, electric fuel booster pump, strainers, oil dilution solenoid, shut-off control and fuel quantity and fuel pressure gages. The system is suitable for aromatic fuels.

**FUEL SPECIFICATION AND GRADE.**

For fuel grade and specification refer to the Servicing Diagram (figure 1-13).

**FLUIDS SHUT-OFF SWITCH.**

A two-position fluids shut-off switch, located on the overhead switch panel (figure 1-4), provides



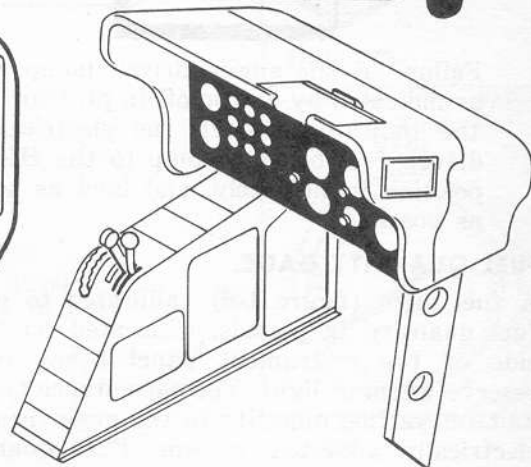
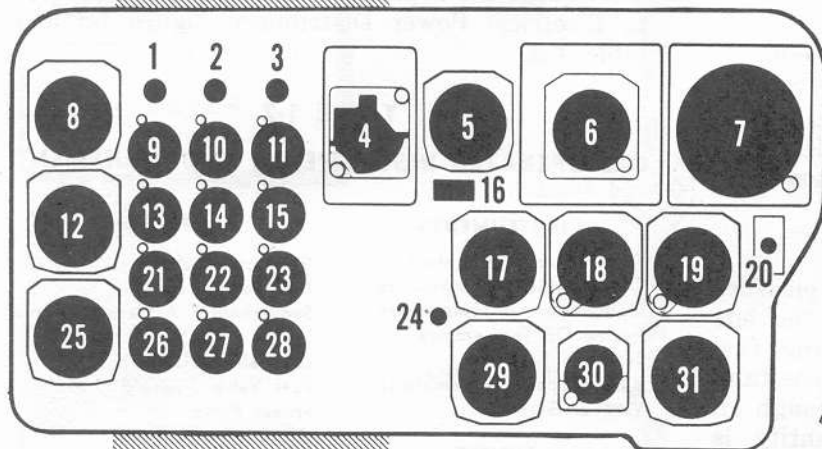
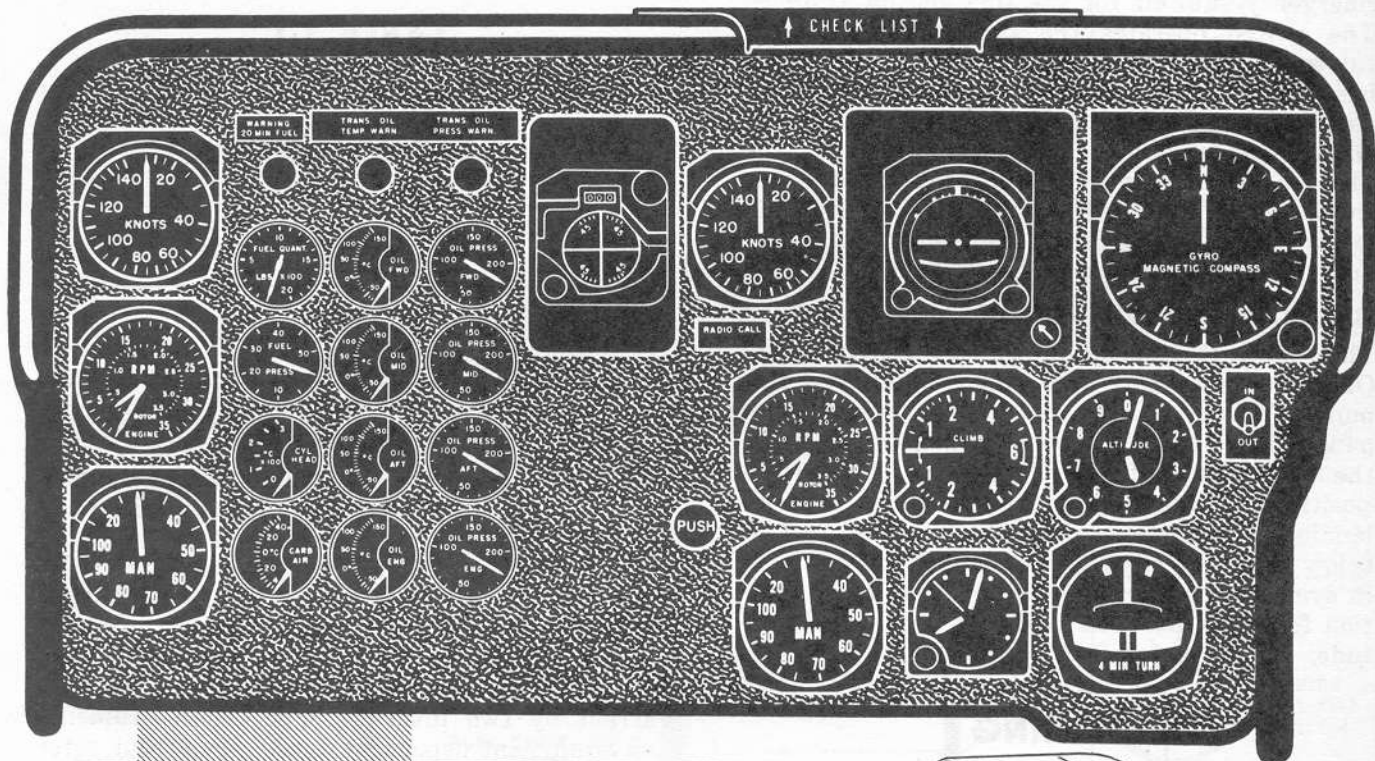

- |   |   |
|---|---|
| 1 Fuel Warning Light                              | 17 Pilot's Dual Tachometer                    |
| 2 Transmission Oil Temperature Warning Light      | 18 Rate of Climb Indicator                    |
| 3 Transmission Oil Pressure Warning Light         | 19 Altimeter                                  |
| 4 Course Indicator                                | 20 Compass Slaving Switch                     |
| 5 Pilot's Airspeed Indicator                      | 21 Cylinder Head Temperature Indicator        |
| 6 Vertical Gyro Indicator                         | 22 Aft Transmission Oil Temperature Indicator |
| 7 Gyro Magnetic Compass                           | 23 Aft Transmission Oil Pressure Indicator    |
| 8 Co-Pilot's Airspeed Indicator                   | 24 Purge Valve                                |
| 9 Fuel Quantity Indicator                         | 25 Co-Pilot's Manifold Pressure Gage          |
| 10 Forward Transmission Oil Temperature Indicator | 26 Carburetor Air Temperature Indicator       |
| 11 Forward Transmission Oil Pressure Indicator    | 27 Engine Oil Temperature Indicator           |
| 12 Co-Pilot's Dual Tachometer                     | 28 Engine Oil Pressure Indicator              |
| 13 Fuel Pressure Indicator                        | 29 Pilot's Manifold Pressure Gage             |
| 14 Central Transmission Oil Temperature Indicator | 30 Clock                                      |
| 15 Central Transmission Oil Pressure Indicator    | 31 Turn and Bank Indicator                    |
| 16 Radio Call Number                              |   |

Figure 1-6. Instrument Panel

emergency shut-off for the fuel and oil systems. The switch operates the two electric shut-off valves in the engine compartment. The switch has two positions, (NORMAL and SHUT-OFF) and it remains in the NORMAL position during all normal operation. Move the switch to the SHUT-OFF position *only* when the fire detector warning light (located next to the switch) is illuminated or when other such emergencies require that the fuel and oil be shut off.

#### FUEL BOOSTER PUMP SWITCH.

This is a three-position switch (HIGH-LOW-OFF) for operating the electrically-driven fuel pump. The switch is located on the console switch panel (figure 1-4). The pump is inoperative when the switch is in the OFF position. Use HIGH position for starting the engine, for take-off, landing, and for operating above 10,000 feet or below 1000 feet altitude. Use HIGH position also, in event of engine pump failure. Use LOW position for flight between 1000 and 10,000 feet altitude, and in autorotative descent.

### WARNING

Failure of the engine-driven pump will be indicated by a drop-off in pressure on the indicator. Switch the electrically-driven fuel booster pump to the HIGH position immediately, and land as soon as possible.

#### FUEL QUANTITY GAGE.

A fuel gage (figure 1-6) calibrated to measure fuel quantity in pounds, is located on the left side of the instrument panel below the fuel reserve warning light. The capacitance type tank unit relays fuel quantity to the gage through an electrically actuated system. Fuel quantity is then registered upon the dial in increments of 100 pounds.

#### FUEL QUANTITY GAGE TEST SWITCH.

This switch is installed on the engine controls section of the console switch panel (figure 1-4). When operated, the switch grounds one side of the bridge and causes the indicator pointer to rotate continuously counter clockwise. It is necessary to create a test condition just long enough to displace the pointer an observable amount. The pointer should return to its original position when the switch is released. Failure to do so indicates a malfunction in the system.

#### FUEL RESERVE WARNING LIGHT.

A red warning light above the fuel indicator will illuminate when 20 minutes of fuel remains in the tank. This period is based on a power setting of 2400 rpm and 33 inches Hg.

TABLE 1-1  
FUEL QUANTITY DATA  
U S GALLONS

TANK	USABLE FUEL	FULLY SERVICED	EXPANSION SPACE	TOTAL VOLUME
MAIN	302	304	10	314

#### ELECTRICAL POWER SUPPLY SYSTEM.

Power for operating the various units of electrical and electronic equipment is supplied by the 24 volt electrical system (figure 1-8) having a 400 ampere hour capacity. The generator, battery, or external power supply can be used independently or can be used collectively. The direct current system is converted to alternating current for the instruments requiring this type of current by two inverters. For the instruments and equipment dependent on direct current refer to Electrical Power Distribution figure 1-8 and table 1-2.

TABLE 1-2

#### D-C OPERATED INSTRUMENTS AND EQUIPMENT

INSTRUMENTS	ENGINE
Transmission Temperature	Generator Controls
Cylinder Head Temperature	Fuel Booster Pump
Carburetor Air Temperature	Supercharger Actuator Solenoid
Engine Oil Temperature	Starter
Turn and Bank	Oil Valve Solenoid
J-2 Compass (dynamotors)	Fuel Valve Solenoid
Vertical Gyro	Primer Pump
	Oil Dilution Solenoid
	Oil Cooler Shutter Actuator
LIGHTS	HEATING EQUIPMENT
Cockpit Flood Lights	Cabin Heater
Cabin Dome Lights	Heated Suit Outlets
Instrument Panel Lights	Heated Blanket Outlets
Warning Lights	Pitot Heat
C4A Lights	
Litter Lights	MISCELLANEOUS
Position Light	Windshield Wiper
Landing Light	Clutch Actuator
Search Light	Inverters
COMMUNICATIONS	Float Inflation and Retraction Control
AN/ARN-6 Radio Compass	Float Jettison Control
AN/ARN-14 Radio Navigation	Rescue Hoist Control Valve
AN/ARA-8A Homing Adapter	
AN/ARC-27 UHF Radio	
AN/ARC-3 VHF Radio	
USAF Combat Interphone	

#### BATTERY.

The battery is located on the floor, in front of the fuel cell, on the left side of the helicopter.

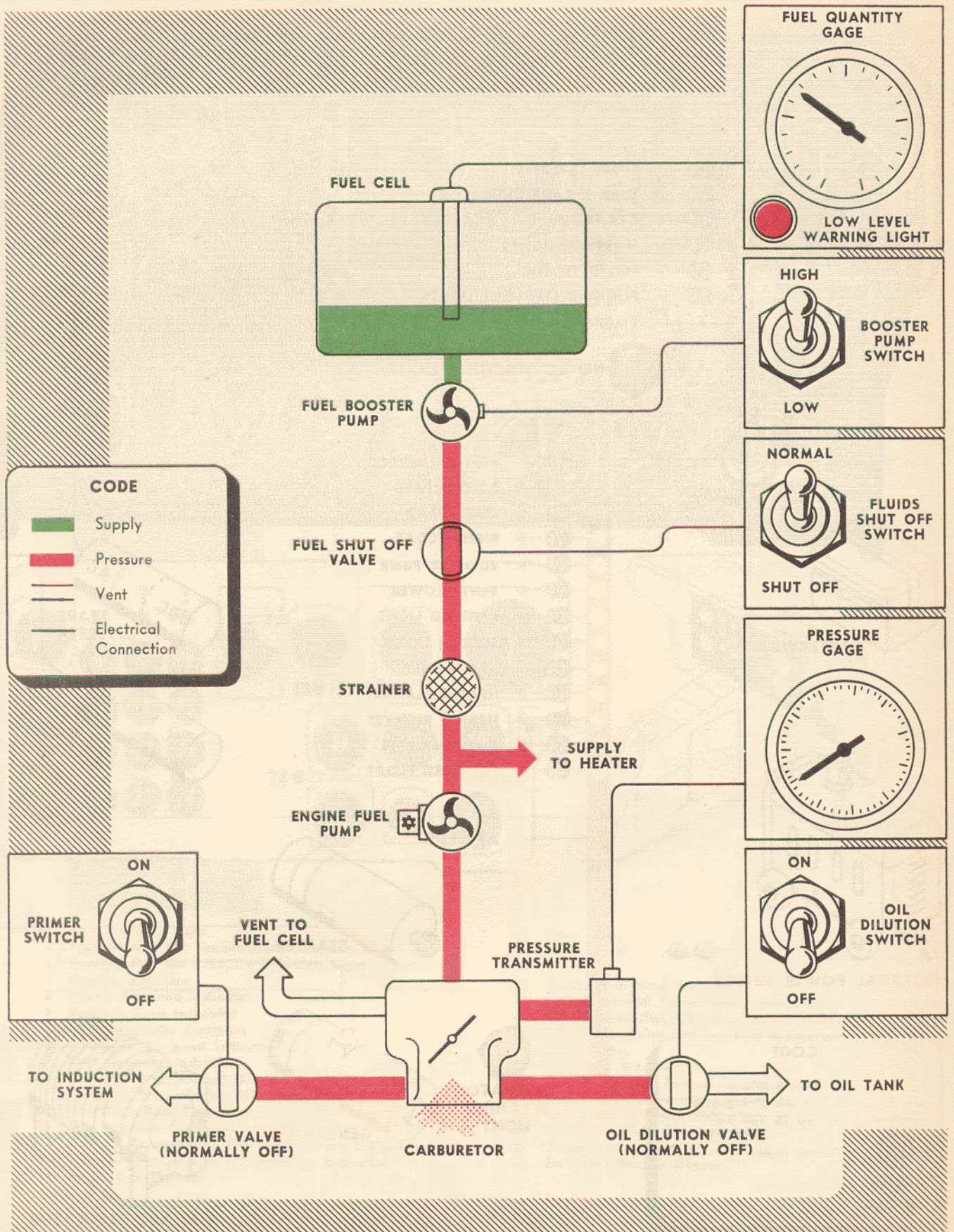

Figure 1-7. Fuel System Schematic Diagram

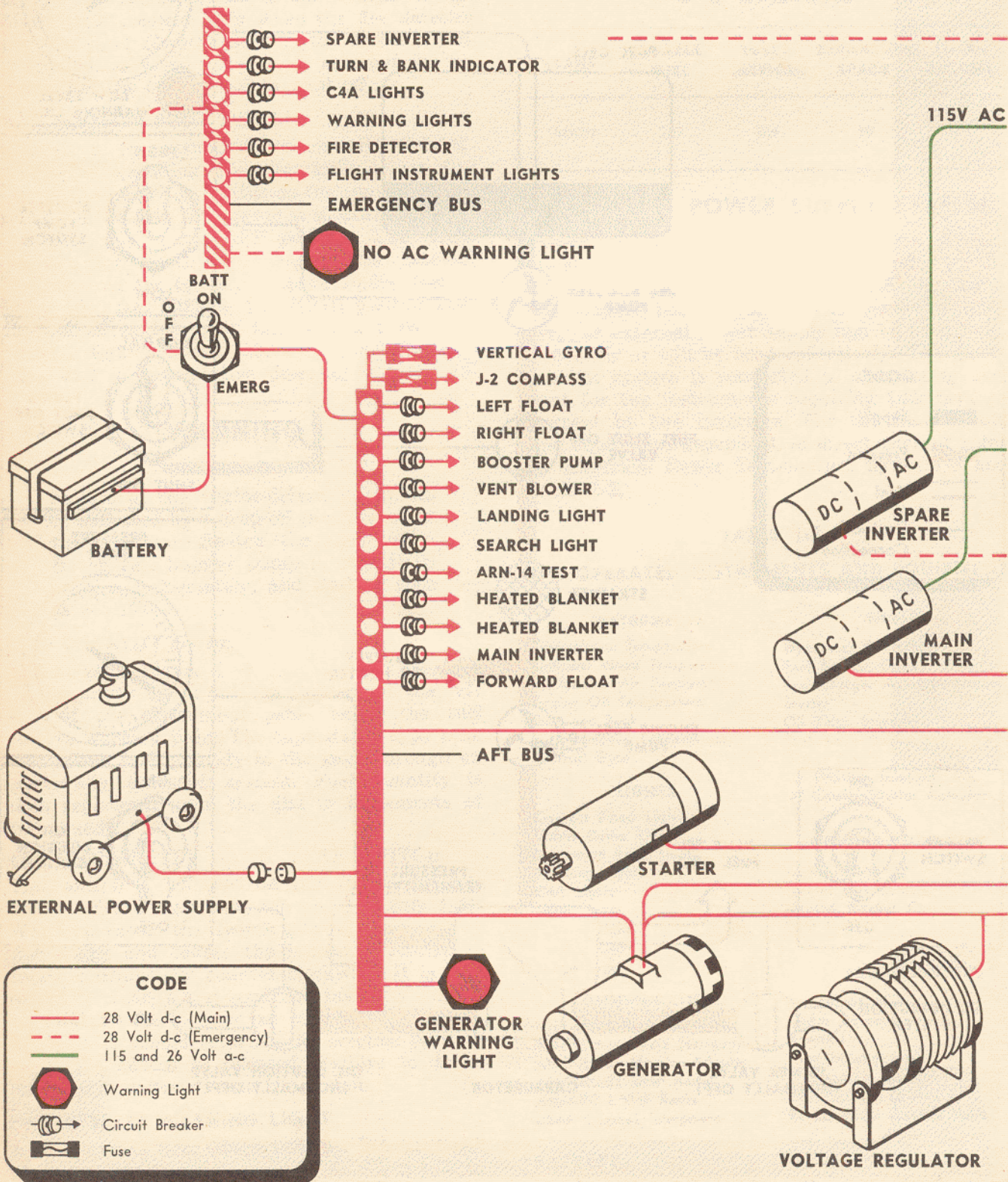

Figure 1-8. Electric Power Distribution (Sheet 1 of 2)

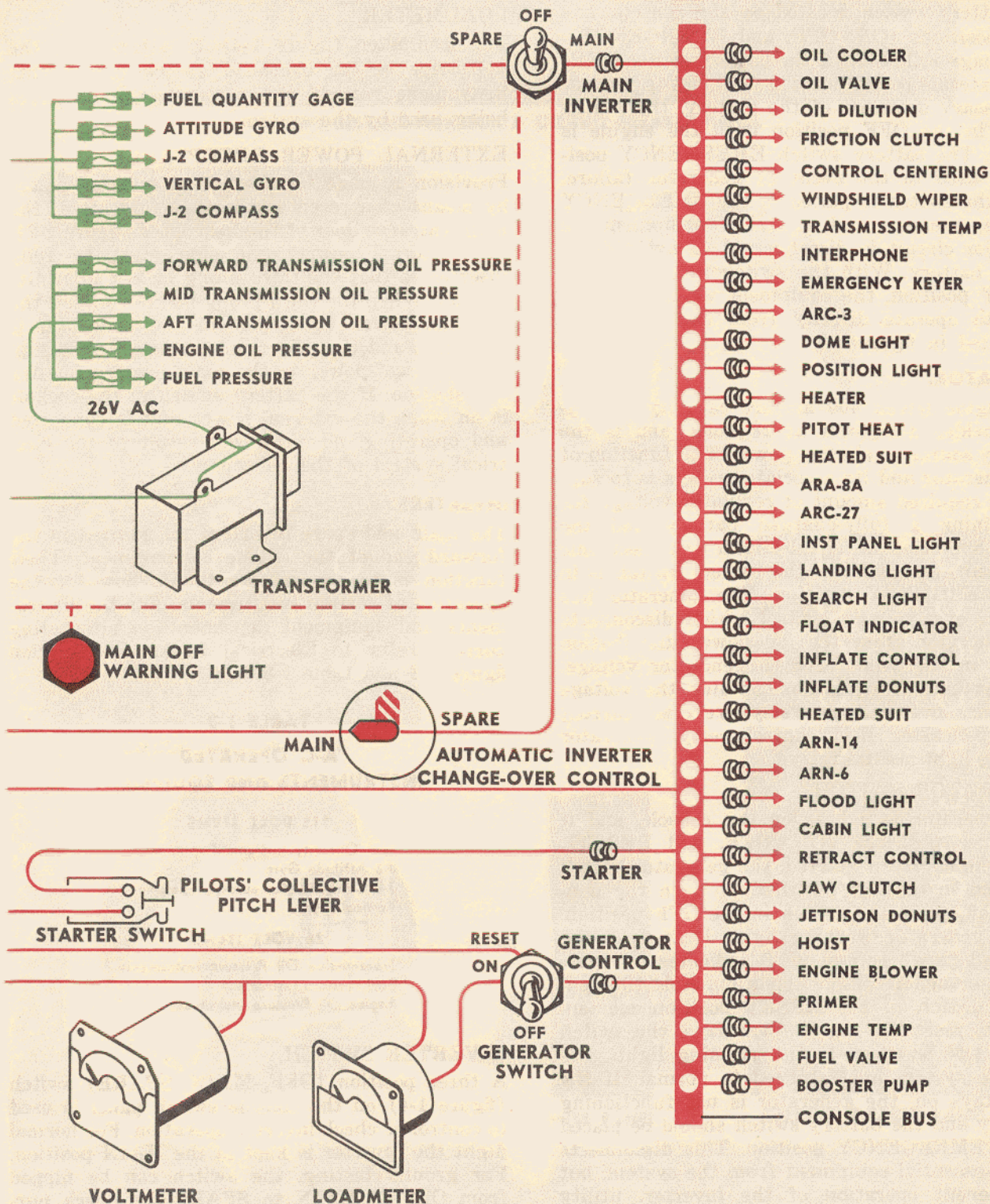

Figure 1-8. Electric Power Distribution (Sheet 2 of 2)

It has a potential of 24 volts and a 34 ampere hour capacity. Use of the battery for ground operation and starting of the engine should be avoided if an external source of power is available.

#### BATTERY SWITCH.

The battery switch, located on the console, has three positions (ON, OFF, and EMERGENCY). No damage will result if the battery switch is ON while external power is being used, but to prevent unnecessary drainage of the battery, the switch is left in the OFF position until the engine is started. The battery switch EMERGENCY position is used in the event of generator failure. When the switch is placed in the EMERGENCY position, non-essential electrical equipment on its major circuit is disconnected to avoid drain on the battery. With the switch in the EMERGENCY position, the equipment which will continue to operate directly from the battery is illustrated in figure 1-8.

#### GENERATOR.

The engine-driven 400 ampere capacity generator provides d-c power at 28 volts, and is the primary source of electric power. The function of the generator and its associated relays is to supply the required amount of regulated voltage for maintaining a fully-charged battery and the proper operation of all electrical and electronic equipment, except when the battery switch is in the EMERGENCY position. The generator has its own over-voltage control which disconnects the generator from the d-c power distribution system in the event of high generator voltage. This system of regulation contains the voltage regulator, over-voltage relay, reverse current relay, generator field control relay, generator warning light and its relay.

#### GENERATOR SWITCH.

The generator switch is on the console, and it has three positions (ON, OFF, and RESET). After the engine is started, the generator switch is placed in the ON position. To turn the generator off, place the switch in the OFF position. If the generator warning light, located on the overhead panel, comes on, it indicates an over-voltage or under-voltage condition. Hold the generator switch in the RESET position momentarily to reset the relays, then move the switch to the ON position. If the warning light goes out, the system has returned to normal. If the light stays on, the generator is not functioning properly and the battery switch should be placed in the EMERGENCY position. This disconnects all non-essential equipment from the system, but does permit operation of the inverter, utility lights, and the turn and bank indicator directly from the battery. Refer to table 1-2 and figure 1-8 for information on this circuit.

#### VOLTMETER.

The voltmeter is located in the upper left corner of the overhead switch panel (figure 1-4). Its purpose is to indicate voltage output of the generator.

#### LOADMETER.

The loadmeter (figure 1-4) is adjacent to the voltmeter in the overhead switch panel. This instrument records the percentage of amperes being used by the system.

#### EXTERNAL POWER RECEPTACLE.

Provision is made for the use of external power by means of a receptacle located just aft of the main entrance door of the helicopter (figure 1-2). The external power unit plug must be fully inserted so that the third prong makes a definite contact. When the third prong makes contact, the external power unit relay in the helicopter is energized and the power unit commences to supply electrical power to the main battery bus for distribution. If the battery switch in the cockpit is on when the external power unit is connected and operating, no harm will result to the electrical system of the helicopter.

#### INVERTERS.

The main and spare inverters are located in the forward end of the engine compartment. Their function is to convert d-c to a-c flow for the operation of certain instruments. For the instruments and equipment dependent on alternating current refer to Electrical Power Distribution figure 1-8 and table 1-3.

**TABLE 1-3**  
**A-C OPERATED**  
**INSTRUMENTS AND EQUIPMENT**

#### 115 VOLT ITEMS

Fuel Quantity Instrument  
J-8 Attitude Gyro  
J-2 Compass (for autosyn operation)  
Vertical Gyro

#### 26 VOLT ITEMS

Transmission Oil Pressure Instruments  
Fuel Pressure Instrument  
Engine Oil Pressure Instrument

#### INVERTER SWITCH.

A three position (OFF, MAIN, SPARE) switch (figure 1-4) on the console switch panel is used to control or check inverter operation. For normal flight the inverter is kept in the MAIN position. For ground testing, the switch can be flipped from OFF to MAIN to SPARE for check purposes. The switch can be put in the OFF position during flight in the event of failure of both inverters.

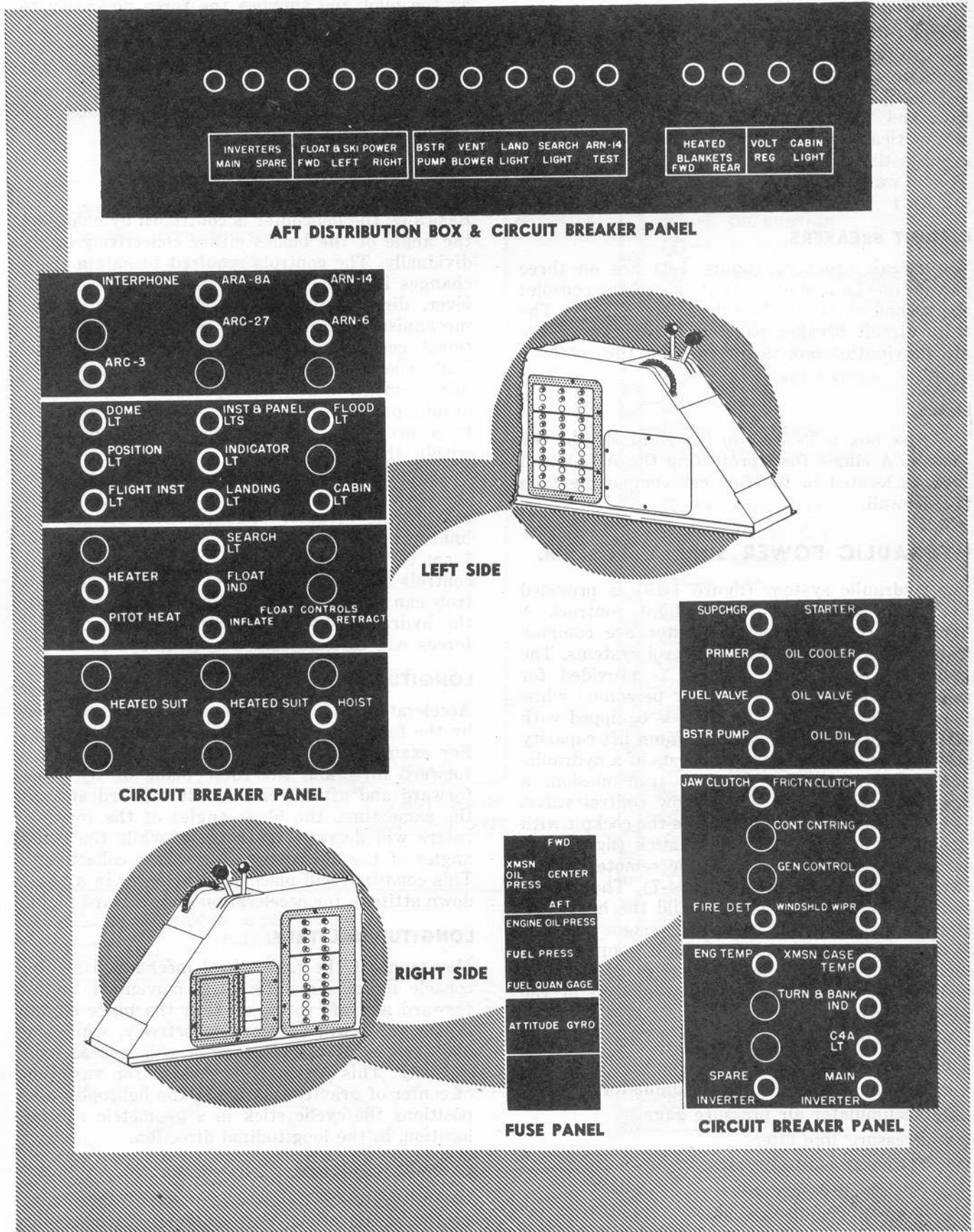

Figure 1-9. Fuse and Circuit Breaker Panels

**INVERTER LIGHTS.**

The inverter lights (figure 1-4) are located below the inverter switch on the console electrical distribution panel. If the main inverter fails, the MAIN INVERTER FAILURE light will illuminate and the inverter change-over control will automatically turn on the spare inverter. In the event both inverters are inoperative, the No a-c Power warning light will illuminate. (See figure 1-4.)

**CIRCUIT BREAKERS.**

The circuit breakers (figure 1-9) are on three panels; one located on the left side of the console; the second on the right side of the console. The third circuit breaker panel is located above the aft distribution box to the right of the entrance door.

**FUSES.**

The fuse box is located on the right side of the console. A single fuse, protecting the AN/ARC-3 radio is located in the fuel cell compartment on the firewall.

**HYDRAULIC POWER SUPPLY SYSTEM.**

The hydraulic system (figure 1-10) is provided for operating the hoist and flight controls. A hydraulic reservoir and line filter are common to both the hoist and flight control systems. The hydraulic rescue hoist system is provided for raising or lowering material or personnel while the helicopter hovers. The hoist is equipped with a 100 foot cable and has a maximum lift capacity of 450 pounds. This system consists of a hydraulic pump driven by the forward transmission, a pressure relief valve, and a flow control valve. The hoist may be controlled from the cockpit with the switch located on the cyclic stick (figure 1-4) or from the rescue door by a remote control switch mounted nearby (figure 4-7). The system can be manually controlled should the helicopter electrical system fail. The hoist system pressure is constant at 1250 psi. The flight controls system pressure is 1000 psi and varies as the controls are operated. This system consists of the following items:

- a. Pump (driven by the forward transmission).
- b. Pressure relief valve.
- c. Piston type hydraulic accumulator.
- d. Accumulator air pressure gage.
- e. Pressure line filter.
- f. Four-way shut-off valve.
- g. System pressure gage.
- h. Four hydraulic actuators.

The hydraulic flight control system senses the movement imparted to the cockpit flight controls

by the pilot and supplies the force necessary to move the various flight control assemblies. Should the hydraulic system fail, complete mechanical flight control of the helicopter can be maintained. The ON-OFF boost valve and hydraulic pressure gage are installed on the cockpit floor to the pilot's left.

**FLIGHT CONTROL SYSTEM.**

Basically, the helicopter is controlled by changing the angle of the blades either collectively or individually. The controls required to obtain these changes include the cyclic stick, collective pitch lever, directional pedals, and longitudinal trim mechanism. The collective pitch control, directional control and cyclic control are hydraulically operated to reduce the force necessary for displacement. When the system is on, the hydraulic pressure is 1000 psi, varying as the controls are displaced. The valves and passages within the four hydraulic actuators are so arranged that movement of the cockpit flight controls will direct fluid, under pressure, to either side of the actuator pistons. These pistons are linked to the lower flight controls and position them to transfer movement to the upper flight controls for the desired flight condition. The controls can be operated and flight maintained with the hydraulic system off. Stronger control stick forces will be necessary when the system is off.

**LONGITUDINAL CONTROL.**

Acceleration and forward or aft flight are gained by the fore and aft movement of the cyclic stick. For example, if the cyclic stick is displaced in a forward direction, the rotor plane of both the forward and aft rotors will tilt forward and, at the same time, the blade angles of the forward rotors will decrease collectively, while the blade angles of the aft rotor will increase collectively. This condition will place the helicopter in a nose-down attitude for acceleration and forward flight.

**LONGITUDINAL TRIM.**

Movement of the trim wheel mechanism on the console imposes a differential movement to the forward and aft rotors so that the blade angles of one rotor will decrease collectively, while the blade angles of the other rotor will increase collectively. This action compensates for variation of center of gravity location in the helicopter and positions the cyclic stick in a geometric neutral location, in the longitudinal direction.

**LATERAL CONTROL.**

Sideward flight is gained by the lateral movement of the cyclic stick. For example, if the cyclic stick is displaced to the right, the rotor plane of both the forward and aft rotors will tilt to the



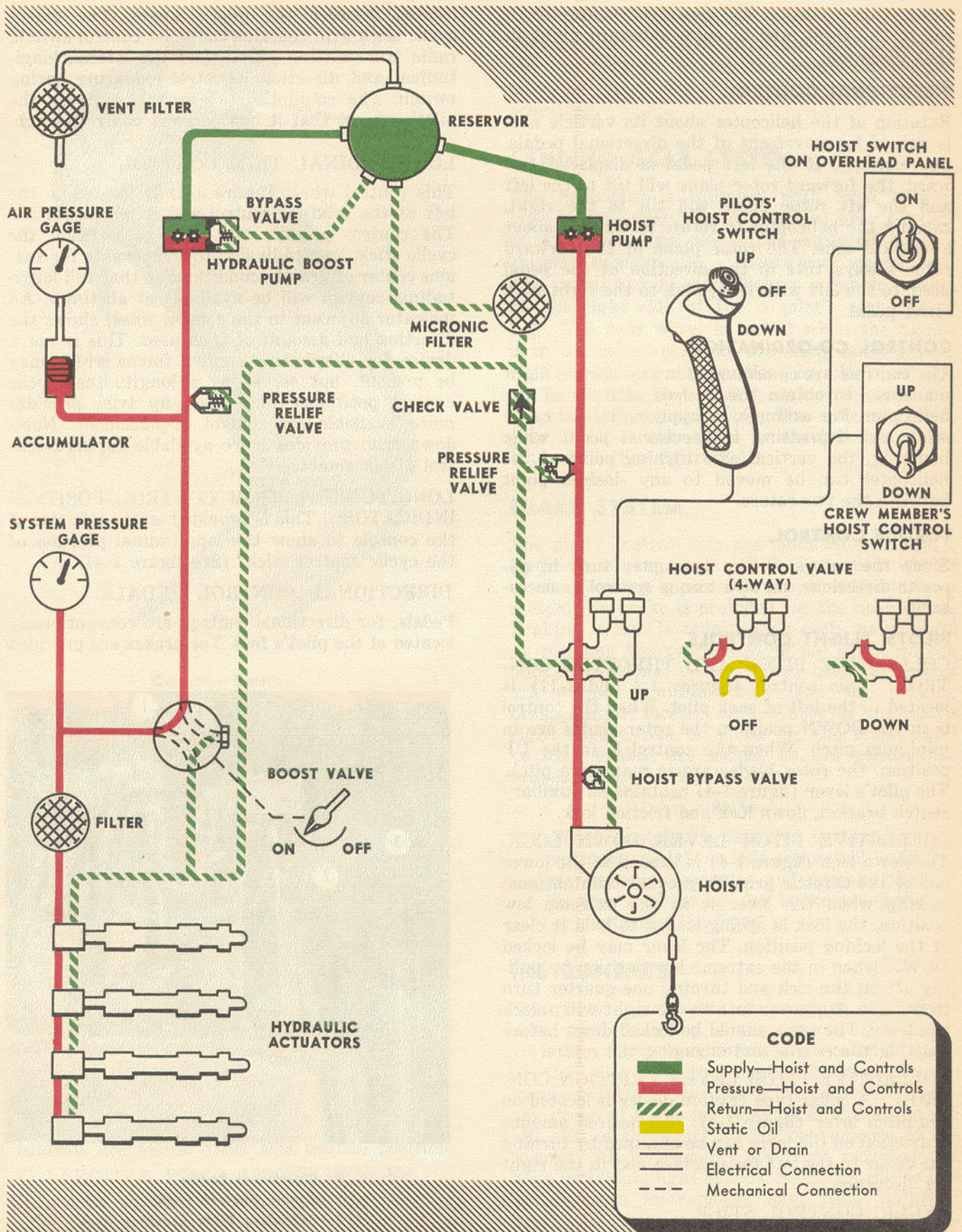

Figure 1-10. Hydraulic Systems Schematic Diagram

right. This condition will cause the helicopter to roll to the right, and to enter sideward flight in that direction.

### DIRECTIONAL CONTROL.

Rotation of the helicopter about its verticle axis is gained by movement of the directional pedals. For example, if the left pedal is displaced forward, the forward rotor plane will tilt to the left and the aft rotor plane will tilt to the right, causing the helicopter to rotate to the left about a vertical axis. The rotor plane of the forward rotor always tilts in the direction of the pedal used, to the left with left pedal, to the right with right pedal.

### CONTROL CO-ORDINATION.

The controls are co-ordinated in any normal flight maneuver to obtain the desired attitude of the helicopter. For example, by applying lateral cyclic stick and depressing a directional pedal while hovering, the vertical axis turning point of the helicopter can be moved to any desired point between the two rotors.

### TORQUE CONTROL.

Since the rotors of the helicopter turn in opposite directions, no anti-torque control is necessary.

### PILOTS' FLIGHT CONTROLS.

**COLLECTIVE PITCH AND THROTTLE CONTROL.** This control (figures 1-4 and 1-11) is located to the left of each pilot. When the control is in the DOWN position, the rotor blades are in minimum pitch. When the control is in the UP position, the rotor blades are in maximum pitch. The pilot's lever (figure 1-4) contains an auxiliary switch bracket, down lock and friction lock.

**COLLECTIVE PITCH LEVER DOWN LOCK.** The down lock (figure 1-4) is located at the lower end of the throttle grip. To prevent unintentional locking when the lever is in the extreme low position, the lock is spring-loaded to hold it clear of the locking position. The lever may be locked DOWN when in the extreme low position by pulling aft on the lock and turning one-quarter turn to the left. A quarter turn to the right will unlock the lever. The lever should be locked down before starting the engine and engaging the rotors.

**COLLECTIVE PITCH LEVER FRICTION CONTROL.** A collar type friction device is located on the pitch lever (figure 1-4). The desired amount of friction on the lever can be obtained by turning the collar to the left for increase and to the right for decrease.

### CYCLIC CONTROL STICK.

Lateral and longitudinal control is maintained with this stick (figure 1-12). It is conventionally

located between the pilot's knees. The pilot's cyclic stick grip contains the hoist control switch, radio transmitting switch and the lateral, longitudinal and directional control centering spring switch. The co-pilot's stick is the same as the pilot's except that it has no hoist control switch.

### LONGITUDINAL TRIM CONTROL.

This control wheel (figure 1-4) is located to the left of the mixture control and is labeled TRIM. The control permits the pilot to position the cyclic stick, longitudinally, to compensate for various center of gravity conditions so that full longitudinal control will be available at all times. An indicator adjacent to the control wheel shows the direction and amount of trim used. This is not a device for eliminating control forces which may be present, but serves as a longitudinal cyclic control positioner only. Nose-up trim provides more available aft control displacement. Nose-down trim provides more available forward control displacement.

**LONGITUDINAL TRIM CONTROL POSITION INDICATOR.** This is provided on the left side of the console to show the longitudinal position of the cyclic control stick. (See figure 1-4).

### DIRECTIONAL CONTROL PEDALS.

Pedals, for directional control, are conventionally located at the pilot's feet. Toe brakes are provided

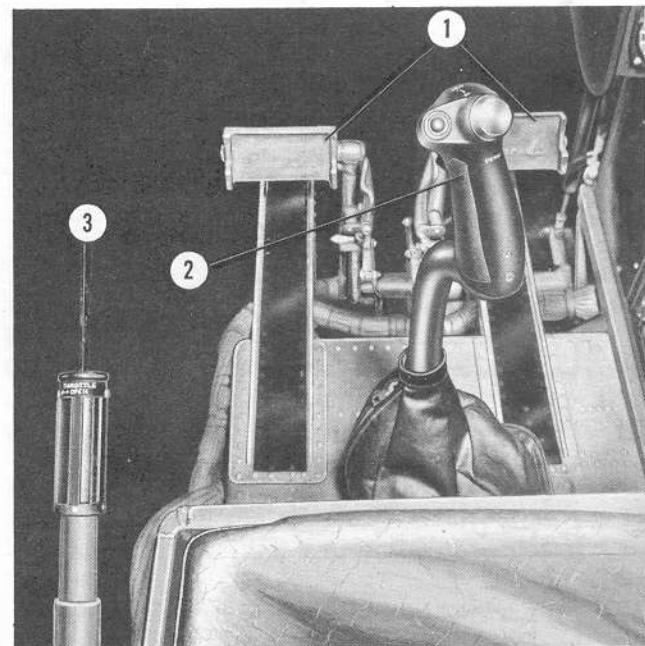

1 Directional Pedals  
2 Cyclic Control Stick  
3 Collective Pitch Lever

Figure 1-11. Co-Pilot's Flight Controls

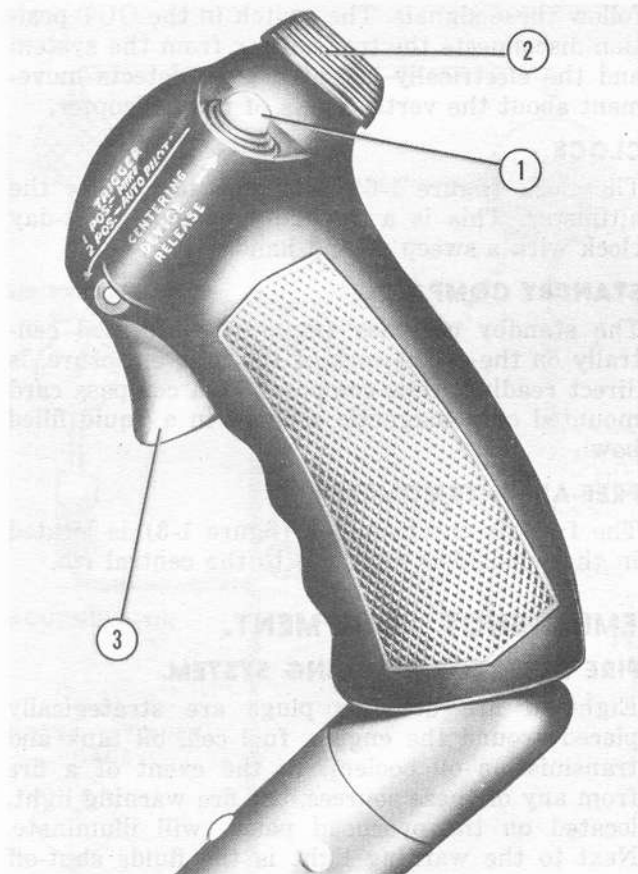

- 1 Centering Switch
- 2 Hoist Control Switch
- 3 Trigger Switch

**Figure 1-12. Pilot's Cyclic Stick**

on the upper portion of the pilot's pedals (figure 1-3). The co-pilot's pedals have no toe brakes. (See figure 1-11). The pedals can be adjusted to suit the individual pilot by releasing the lever on the pedal support.

#### FLIGHT CONTROL CENTERING SPRINGS SWITCH.

To relieve the pilot of control forces which may be present in steady flight, centering springs are installed on the longitudinal, lateral and directional control. The centering springs control switch is located on the cyclic stick (figure 1-12). The cyclic and directional forces may be neutralized in any position desired by first positioning the control, then pressing the centering spring switch. The neutralizing forces increase as the controls are moved from this neutral position.

#### COLLECTIVE PITCH LEVER BUNGEE.

A ground adjustable bungee for the collective pitch lever will cause the collective lever to balance when in cruising flight with hydraulic system inoperative.

#### LONGITUDINAL BUNGEE.

This bungee is ground adjustable and is used to aid the pilot in moving the longitudinal flight controls when the hydraulic system is not operating.

#### LANDING GEAR SYSTEM.

The helicopter is equipped with fixed tricycle type landing gear. The nose wheel gear consists of a swivel type oleo strut equipped with a shimmy damper and a mechanical swivel lock. The swivel lock is controlled by a handle located on the right side of the co-pilot's seat (figure 1-4). The nose wheel is locked when the handle is in the raised position. The main landing gear consists of three assemblies: an oleo (air and oil) strut, a welded V-strut and wheel fork, and a wheel and tire assembly. The nose and main gear shock struts should be checked for proper extension. (See figure 2-1.)

#### BRAKE SYSTEM.

The pilots' instruments are mounted on a single Hydraulic brakes are installed on the main wheels of the landing gear and are a self-contained system. No brake is provided for the nose wheel. Braking action is obtained on each main wheel by pressing the corresponding toe brake on the pilot's directional pedals. When both toe brakes are pressed simultaneously and the parking brake handle, located on the floor at the pilot's right (figure 1-3) is pulled up, the main wheel parking brakes are locked on. To release the brakes, push the handle down.

#### Note

When applying brakes for parking, do not pump pedals as this action will build up excessive pressure and damage the system by blowing the brake plungers or rupturing the lines.

#### INSTRUMENTS.

The pilots' instruments are mounted on a single panel located on top of the console. (See figure 1-6). The flight instruments are located in front of the pilot and the engine instruments are grouped in the center above the console. A primary group of flight instruments is located on the left side of the panel for the convenience of the co-pilot. All instruments are front mounted and have individual light shields. Since the engine and transmission instruments have been discussed previously, this text will cover only the remaining instruments with which the pilot should be familiar.

**AIRSPPEED INDICATORS.**

Two identical airspeed indicators (figure 1-6) are mounted on the instrument panel. One is located on the extreme upper left side and one is located in the upper central section of the panel. Pressure differences introduced into these instruments through the pitot static system cause them to register airspeed in knots.

**ALTIMETER.**

The altimeter (figure 1-6) is located centrally on the extreme right side of the instrument panel. This instrument registers height above sea level in thousands of feet, and is actuated by static air in the pitot static system.

**RATE OF CLIMB INDICATOR.**

The rate of climb indicator (figure 1-6) located in the instrument panel to the left of the altimeter registers ascent in feet per minute. This instrument is actuated by changing air density which is brought into the instrument through the pitot static system.

**WARNING**

As operation of the airspeed indicator, altimeter and rate of climb indicator are dependent upon the pitot static system, the pitot static head located below the nose enclosures should be covered during inactive periods to prevent moisture or dirt from entering the system.

**TURN AND BANK INDICATOR.**

The turn and bank indicator (figure 1-6) is located in the lower right corner of the instrument panel. This instrument is controlled by an electrically-actuated gyro.

**VERTICAL GYRO.**

The vertical gyro (figure 1-6) is located in the upper section of the instrument panel above the rate of climb indicator. This instrument, actuated by an electrically-driven gyro, provides the pilot with a visual indication of the attitude of the helicopter relative to the face of the earth.

**GYRO MAGNETIC COMPASS.**

The gyro magnetic compass (figure 1-6) is located in the extreme upper right-hand corner of the instrument panel. This unit may be used as a directional gyro or it may be "slaved" to the remote transmitter control unit by a two position IN-OUT switch located just below it. When the IN-OUT switch is in the IN position the remote transmitter is in operation. This picks up the lines of force from the earth's magnetic field, and transmits these signals to the gyro causing it to

follow these signals. The switch in the OUT position disconnects the transmitter from the system and the electrically actuated gyro detects movement about the vertical axis of the helicopter.

**CLOCK.**

The clock (figure 1-6) is located just below the altimeter. This is a manually wound, eight-day clock with a sweep second hand.

**STANDBY COMPASS.**

The standby compass (figure 1-3) located centrally on the framework of the nose enclosure, is direct reading. It is composed of a compass card mounted on a magnetic element in a liquid filled bowl.

**FREE-AIR THERMOMETER.**

The free-air thermometer (figure 1-3) is located in the windshield adjacent to the central rib.

**EMERGENCY EQUIPMENT.****FIRE DETECTOR WARNING SYSTEM.**

Eighteen fire detector plugs are strategically placed around the engine, fuel cell, oil tank and transmission oil coolers. In the event of a fire from any of these sources, the fire warning light, located on the overhead panel, will illuminate. Next to the warning light is the fluids shut-off switch with a NORMAL and a CUT OUT position. In the event of a fire, the switch is placed in the CUT OUT position, which will stop the flow of all fluids.

**FIRE EXTINGUISHERS.**

Two A-20 fire extinguishers (figure 3-3) are provided, one behind the pilot's seat, the other forward of the aft cabin bulkhead, on the right side. Each extinguisher is filled with one quart of bromochloromethane, referred to as CB, at 21°C (70°F). There is a gage indicating 300 pounds with a usable pressure above 150 pounds marked in green. Anytime the gage shows below 150 pounds it should be recharged.

CB should be handled in well ventilated spaces or outdoors. When used, either in flight or on the ground, the area should be well ventilated. If leakage of the extinguishers is suspected, this space should not be entered until it has been fully established that the vapors have dissipated. A halide detector will detect the presence of CB vapors.

**WARNING**

Do not breathe vapors. Do not swallow the liquid and do not permit the liquid to come in contact with the skin or clothing.

### FIRST AID.

If any person has breathed or swallowed CB, summon a physician at once. Induce vomiting if CB has been swallowed. Place the patient in fresh air, face downward, with the head slightly below the level of the lungs. Keep him warm. Give artificial respiration if breathing has stopped and use artificial inhalation and caffeine stimulants at the doctor's discretion. If CB has spilled on a person, remove the clothing and wash the affected parts of the body with soap and water.

### FIRST AID KITS.

One first aid kit is located behind and to the left of the co-pilot, on the cockpit bulkhead. Two others are located in the cabin, one on each side.

### LIFE RAFTS.

A six-man life raft can be stowed across from the entrance door, or across from the rescue door. The pilot's and co-pilot's seats can each contain a one-man life raft.

### EMERGENCY EXITS.

The entrance door, located at the left aft end of the cabin and the rescue door, forward and on the right side of the cabin, provide emergency exits from the helicopter (see figure 3-2). Both have emergency release handles and plexiglas knock-out panels. The pilot's and co-pilot's windows can be jettisoned by pulling the jettison handle which is located at the top of each window.

### DOORS AND WINDOWS.

#### WINDOWS.

The pilots' cockpit (figure 1-3) affords unrestricted vision and is made up of plexiglas panels supported on structural frames. A laminated glass panel located on the right side provides the pilot clearer vision and a scratch-proof surface for the windshield wiper. The sliding window panels located on each side of the cockpit provides emergency exits for the pilot and co-pilot. A window panel can be jettisoned by pulling the emergency handle (figure 3-2). This turns a cam assembly attached to the window tracks. The cam thrusts the track forward off its tapered mounting pins allowing the window to fall free. The windows are normally operated by depressing the trigger located at the forward lower corner of the window and by pulling back on the handle located above the trigger.

#### CABIN AND RESCUE DOORS.

The main cabin door (figure 1-2) is located at the center of the left side of the fuselage. The rescue door is located forward on the right side and just aft of the cockpit, and is open during rescue operations. Both doors contain plexiglas knock-

out panels for emergency escape. The doors are suspended from slotted tubular tracks bolted to the outside of the fuselage. The doors are on roller assemblies and may be secured in open or closed position. Either door may be jettisoned by pulling the emergency handle located at the right of both doors. The handle turns a cam assembly forcing the door tracks forward and off their attachments. This permits the entire door assembly to fall free.

### ENGINE HATCH DOORS.

There are two engine hatch doors (figure 1-2) located aft of the main landing gear on both lower sides of the fuselage.

## WARNING

Do not operate engine and engage clutch with the engine hatch doors removed since they are structural members and must be in place to help absorb the loads created by the turning rotors.

### AIR EXIT DOORS.

Two adjustable air exit doors (figure 1-2) are located on the lower side of the fuselage aft of the engine mount bulkhead. The doors are adjustable to vary the amount of air being expelled from the engine compartment. The doors may be moved independently from the outside of the helicopter by turning the internal wrenching nut located in the fuselage just aft of the door.

### SEATS.

#### PILOTS' SEATS.

The pilot and co-pilot seats (figure 1-3) are adjustable through five inches, vertically only. The adjustment control is located on the right aft side of each seat.

#### SAFETY BELTS.

Pilot and co-pilot seats have adjustable safety belts.

#### SHOULDER HARNESS INERTIA REEL.

The pilot and co-pilot seats each have a shoulder harness with an inertia reel, which allows freedom of movement when unlocked, and prevents the pilot from leaning forward when locked. A handle with LOCKED and RELEASED positioning is located beneath the left forward corner of each pilots' seat. (See figure 1-3.) A latch is provided for positive retention of the handle at either position of the quadrant. By pressing down on the top of the handle, the latch is released and the handle may then be moved freely from one position to the other. When the handle is in the RELEASED position, the reel harness cable will

extend to allow freedom of movement, however, the reel will automatically lock when an impact force of 2 to 3g is encountered. When the reel is locked in this manner it will stay locked until the handle is moved to the LOCKED position, and then returned to the RELEASED position. When the handle is in the LOCKED position, the harness cable is manually locked and the crew member is prevented from bending forward.

#### Note

The LOCKED position is used only when a crash landing is anticipated. This position provides an added safety precaution

over and above that of the automatic safety lock.

#### AUXILIARY EQUIPMENT.

The auxiliary equipment in the following list is described fully in Section IV.

- Heating and Defrosting System
- De-Icing System
- Ventilation System
- Communications Equipment
- Lighting System
- Rescue Hoist System
- Cargo and Troop Carrying Equipment
- Miscellaneous Equipment

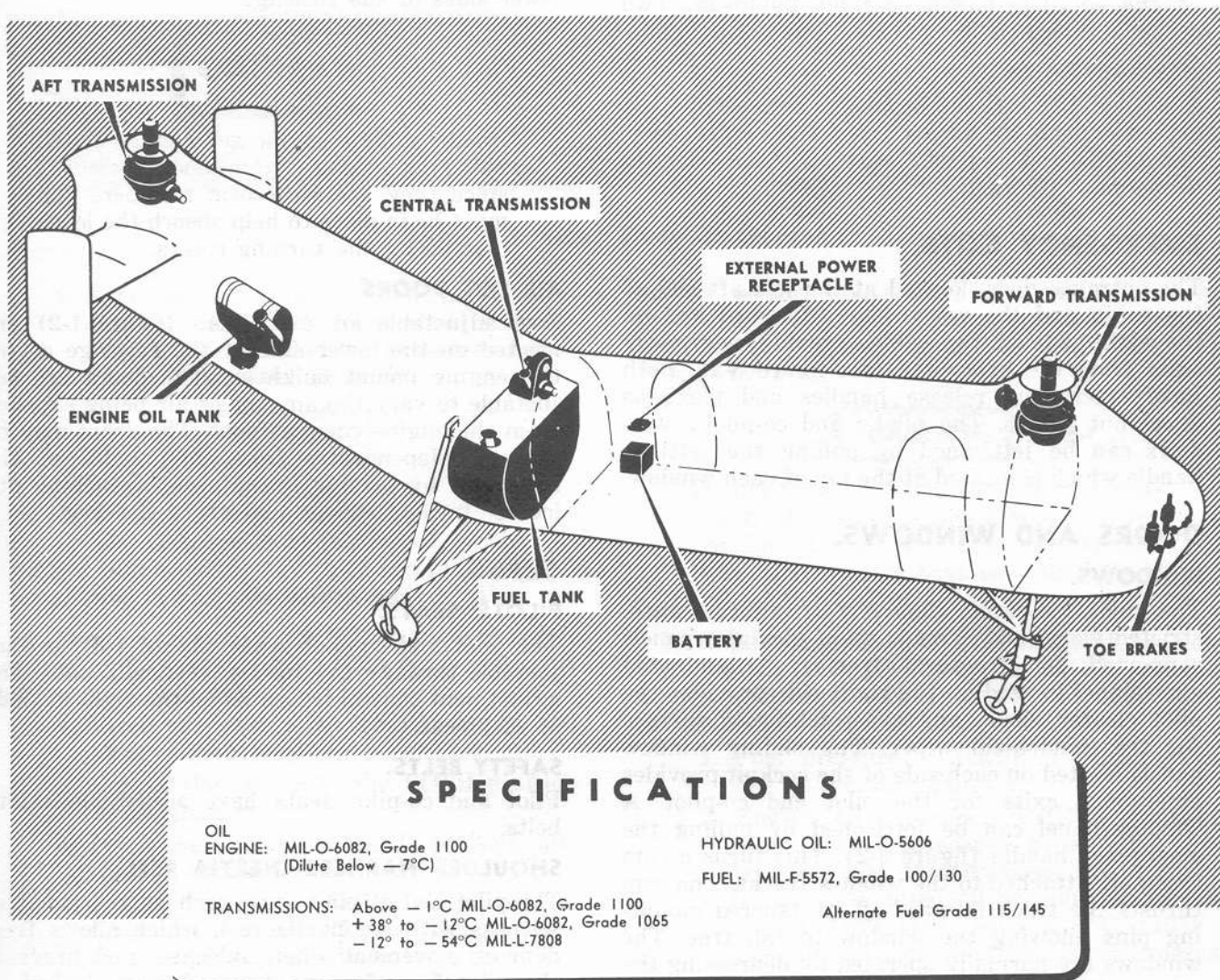

Figure 1-13. Servicing Diagram

## Section II NORMAL PROCEDURES

### STATUS OF THE HELICOPTER.

#### FLIGHT RESTRICTIONS.

Refer to Section V for flight limitations and restrictions imposed on the helicopter.

#### FLIGHT PLANNING.

All data necessary to fly an operational mission will be found in Appendix I. The Appendix includes information on airspeeds, power settings, and fuel consumption of the helicopter at various gross weights.

#### WEIGHT AND BALANCE.

- a. Refer to Handbook of Weight and Balance Data, AN 01-1B-40, for loading information.
- b. Check take-off and anticipated landing gross weight and balance.
- c. Refer to Appendix I to determine weight of fuel and oil, and other related factors incident to the mission to be performed.
- d. Check weight and balance clearance (Form F).
- e. For weight limitations information, refer to Section V.

#### Note

A balance computer is not required for this helicopter.

#### ENTRANCE TO THE HELICOPTER.

Entrance to the helicopter is gained through the sliding cabin doorway located centrally on the left side of the fuselage (figure 2-1). The door and latch are accessible from the ground. The cockpit is reached by proceeding forward through the cabin area (figure 1-2). Alternate entrance may be effected through the rescue door.

#### BEFORE EXTERIOR INSPECTION.

This check covers those items that would directly affect the safety of personnel making an exterior inspection. Check the following items:

- a. Ignition switch: OFF.
- b. Throttle: CLOSED.
- c. Mixture control lever: IDLE CUT-OFF.
- d. Fuel booster pump switch: OFF.
- e. Battery switch: OFF.
- f. Collective pitch lever: DOWN and LOCKED.
- g. Friction clutch switch: ENGAGE (as rotor parking brake).
- h. Parking brake lever: ON.
- i. Nose wheel: LOCKED.

#### EXTERIOR INSPECTION.

Consult USAF Form 1 for engineering status and make sure the helicopter has been properly serviced. See figure 2-1 for complete inspection to be performed by the pilot.

#### ON ENTERING THE HELICOPTER.

##### INTERIOR CHECK (ALL FLIGHTS).

Inspect interior of the helicopter to determine that there is no loose equipment lying about and see that all baggage and cargo is properly secured. Check cabin fire extinguisher for security, and gage for correct pressure.

##### PILOTS' COCKPIT CHECK.

This check must cover the following:

- a. Initial Check.
  1. Seat: ADJUST (to comfortable level).
  2. Safety belt and shoulder harness: FASTEN.
  3. Inertia reel: CHECK (operates freely).

**GENERAL INSPECTION**

- a. While approaching helicopter from a distance, view it critically for overall appearance. Ascertain that rotor covers are removed, blades phased and clear of obstructions.
- b. Check radio antennas and other protuberances for damage and positioning.

**RESCUE DOOR & RIGHT FORWARD FUSELAGE**

- a. Visually inspect rescue door from ground.
- b. Inspect plexiglas for cracks and cleanliness.
- c. Inspect skin for dents, wrinkles, loose or missing rivets.

**FORWARD ROTOR**

- a. Inspect rotor and blades for damage and security.

**NOSE SECTION**

- a. Pitot static and cockpit covers and rigging pins removed.
- b. Observe plexiglas beneath brake cylinders for fluid from leaks.
- c. Check wiper blades for presence of oil.
- d. Check air-oil shock strut for cleanliness and proper inflation (2-11/16 inches from gland nut to top of oleo).

**LEFT FORWARD FUSELAGE**

- a. Inspect skin for dents, wrinkles, loose or missing rivets.
- b. Inspect plexiglas for cracks and cleanliness.

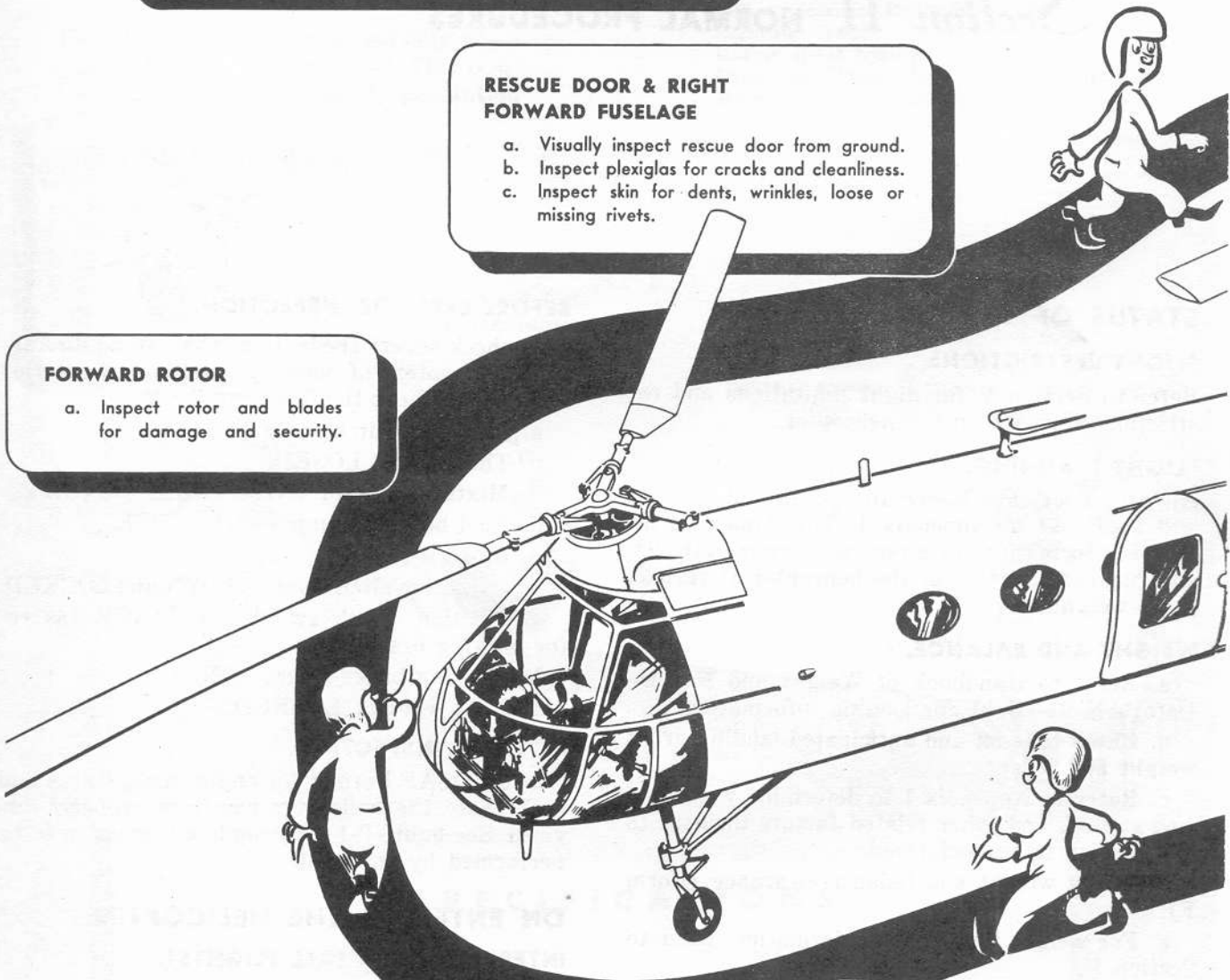

Figure 2-1. Exterior Inspection (Sheet 1 of 2)



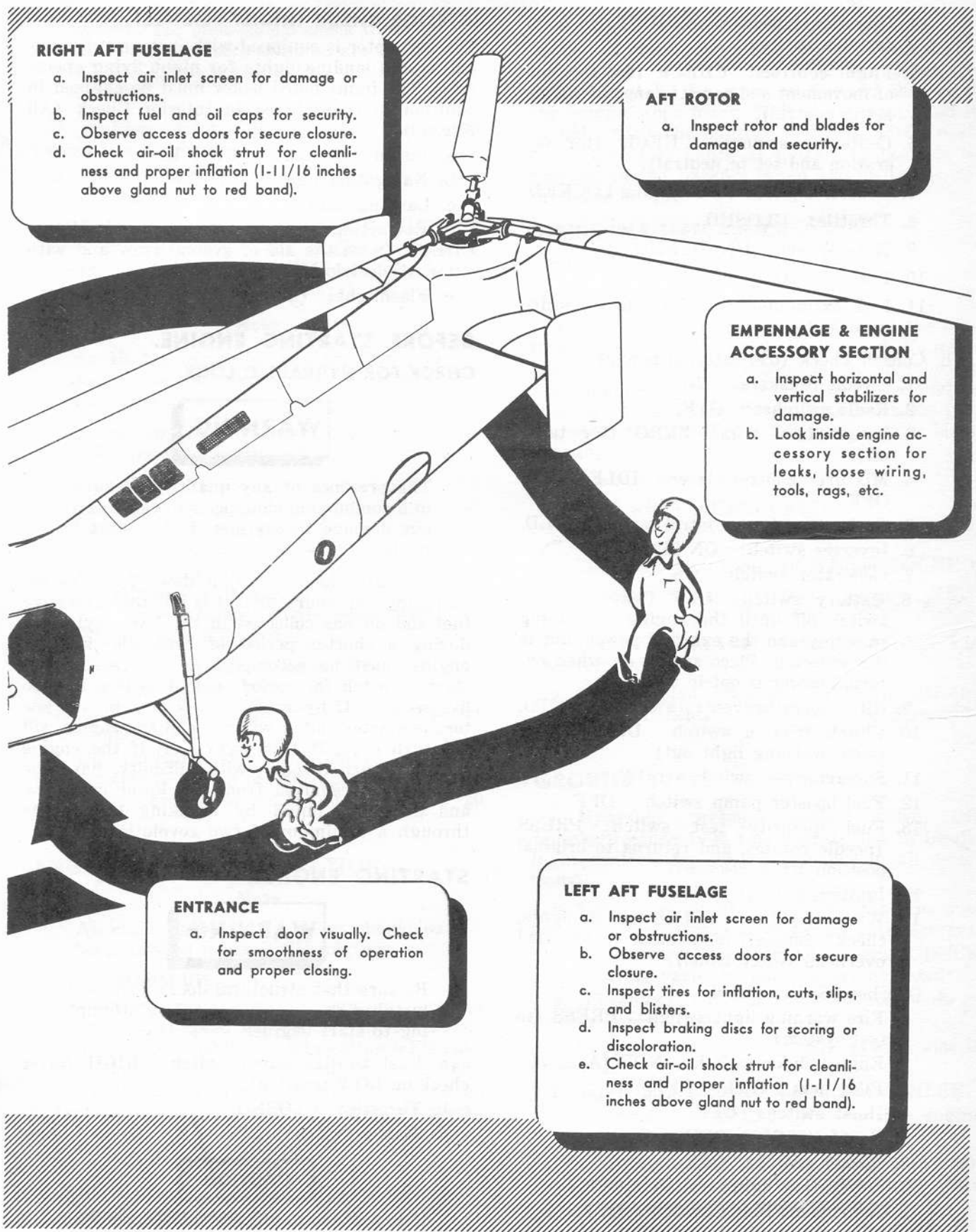

Figure 2-1. Exterior Inspection (Sheet 2 of 2)

4. Directional pedals: ADJUST (to comfortable position).
  5. Flight controls: CHECK (for freedom of movement and correct range of travel, set in neutral).
  6. Centering springs: CHECK (for operation and set in neutral).
  7. Collective pitch: DOWN and LOCKED.
  8. Throttle: CLOSED.
  9. Nose Wheel: UNLOCKED.
  10. Brakes: ON.
  11. Fire extinguishers: CHECK (pressure gage and security).
- b. Console check (use external power).
1. Circuit breakers: IN.
  2. Radio switches: OFF.
  3. Longitudinal trim: ZERO (for take-off).
  4. Mixture control lever: IDLE CUT-OFF.
  5. Carburetor heat control lever: COLD.
  6. Inverter switch: ON MAIN.
  7. Generator switch: ON.
  8. Battery switch: OFF (leave battery switch off until the engine is running smoothly and the external power unit is disconnected. Place switch on when external power is not in use).
  9. Oil temperature control switch: AUTO.
  10. Clutch friction switch: DISENGAGE (with warning light out).
  11. Supercharger switch: LOW.
  12. Fuel booster pump switch: OFF.
  13. Fuel quantity test switch: PRESS (needle rotates, and returns to original position when released).
  14. Ignition switch: OFF.
  15. Warning lights: PRESS (to test lights, check console, instrument panel and overhead switch panel).
- c. Overhead Switch Panel.
1. Fire warning light switch: PRESS (to test system).
  2. Engine fluids switch: NORMAL.
  3. Pitot heat switch: OFF.
  4. Hoist switch: OFF.
  5. Heater switch: OFF.
  6. Blower switch: OFF.
  7. Navigation lights switch: OFF.
  8. Instrument lights switch: OFF.
  9. Cockpit lights switch: OFF.
  10. Windshield wipers: CHECK.

**INTERIOR CHECK (NIGHT FLIGHTS).**

The helicopter is equipped with instrument, navigation and landing lights for night flying operations. The items noted below must be checked in addition to those listed in Interior Check (All Flights):

- a. Instrument lights: CHECK.
- b. Navigation lights: CHECK.
- c. Landing light: CHECK.
- d. Retracting and rotating search light: CHECK (with the aid of ground crew and with external electrical power connected).
- e. Flashlight: CHECK.

**BEFORE STARTING ENGINE.****CHECK FOR HYDRAULIC LOCK.****WARNING**

The presence of any quantity of liquid in a combustion chamber will cause serious damage to the engine if a start is made.

If the engine has been shut down for a period exceeding two hours, or if it is felt that excessive fuel and oil has collected in the lower cylinders during a shorter period of time, clearing the engine must be accomplished by pressing the starter switch for periods not exceeding four to five seconds. If hydraulic lock is present, the low torque starter clutch will slip and the engine will not turn over. If this occurs, or, if the engine seems to turn through with difficulty, have the spark plugs removed from the lower cylinders, and drain all liquid by cranking the engine through a minimum of two revolutions.

**STARTING ENGINE.****WARNING**

Be sure that structural doors have been installed and are secure before attempting to start engine.

- a. Fuel booster pump switch: HIGH (after checking LOW position).
- b. Throttle: CLOSED.
- c. Starter switch: ENGAGE.

**CAUTION**

It is possible to engage the starter with the clutch engaged in either friction or jaw with resultant damage to the rotor

system. The pilot should check to ascertain that the clutch switches are in DIS-ENGAGE before attempting to start the engine.

d. Ignition switch: BOTH (after engine has turned two revolutions).

e. Primer switch: ON (as necessary when engine is turning over).

f. Mixture control lever: IDLE CUT-OFF (Move to RICH when the engine is running smoothly on the prime. Continue to operate the prime intermittently as necessary).

#### Note

Should the engine fail to start within 30 seconds, let the starter cool for two minutes, then repeat the starting procedure.

For instructions on procedure in event of fire refer to Engine Fire, Section III.

g. Throttle: RESET (for 1200 rpm).

#### CAUTION

With the clutch disengaged, the throttle is extremely sensitive. If held open, it will cause excessive engine speed while the engine is still cold.

h. Manifold pressure gage line: PURGE (with engine at idling speed).

i. Battery switch: ON (when external power is disconnected).

j. Oil pressure and temperature: CHECK (stop engine if the oil pressure does not register within 10 seconds or reach 40 psi within 20 seconds).

### ENGINE GROUND OPERATION.

#### Note

All engine ground operations should be accomplished using RICH mixture.

#### ENGINE WARM-UP.

Warm up engine by operating between 1200 and 1400 rpm. This speed will provide smoothest operation of engine while the lubricating oil is cold. After the engine oil temperature rises 6°C (10°F) above the prestart temperature, the oil is then warm enough to make performance checks and take-off.

#### Note

If oil dilution has been used, check oil supply after thorough warm-up.

#### IGNITION SWITCH CHECK.

After engine warm-up and prior to engaging

rotors, check the ignition switch for proper connection of ground wire. Idle the engine on BOTH magnetos at approximately 1000 rpm. Turn the ignition switch OFF momentarily and observe if the engine stops firing. If it stops firing, and it should, return the ignition switch to BOTH position. Make this check as quickly as possible to prevent engine backfire when the switch is returned to BOTH.

#### ENGINE IDLE SPEED CHECK.

Idles at 1000 rpm with closed throttle.

#### STARTING ROTORS.

A qualified helicopter pilot should be at the controls when the rotors are to be engaged. No minimum warm-up of the engine is required before rotor engagement, however, the engine should be running smoothly and the helicopter headed into the wind. Refer to figure 2-2 for the rotor blade clearance.

a. Parking brake lever: ON.

b. Nose wheel: UNLOCKED.

c. Throttle: SET (1500 rpm).

d. Collective pitch lever: DOWN and LOCKED.

e. Cyclic stick and directional pedals: NEUTRAL.

f. Rotors: ENGAGE (refer to Section VII for procedure).

g. Transmission pressure: CHECK (if no pressure is indicated, shut down and determine cause).

#### GROUND TESTS.

a. Hydraulic pressure control valve: ON (check pressure 1000 psi. Operate the hydraulic flight controls for proper response in all directions).

b. Generator output: CHECK (that the output on voltmeter and load meter are satisfactory).

c. Carburetor heat control lever: CHECK (temperature varies as controls are actuated).

d. Oil cooler: CHECK (temperature varies as shutter is actuated).

e. Continue warm-up until 6°C (10°F) rise is observed.

f. Supercharger control operation: CHECK.

1. Throttle: ADVANCE (until engine speed reaches 1600 rpm).

2. Supercharger switch: HIGH (a momentary decrease in engine oil pressure indicates clutch engagement).

3. Collective pitch and throttle: INCREASE (to obtain 25 inches Hg manifold pressure and 2300 rpm).

Ground Clearances for Rotor Blades

- 18 FT 6 IN. AFT BLADES — CONED (FLIGHT)
- 16 FT 6 IN. FWD BLADES — CONED (FLIGHT)
- 16 FT 0 IN. AFT BLADES — LEVEL (IDLING)
- 14 FT 0 IN. FWD BLADES — LEVEL (IDLING)
- 13 FT 6 IN. AFT BLADES — STATIC DROOPED
- 11 FT 6 IN. FWD BLADES — STATIC DROOPED

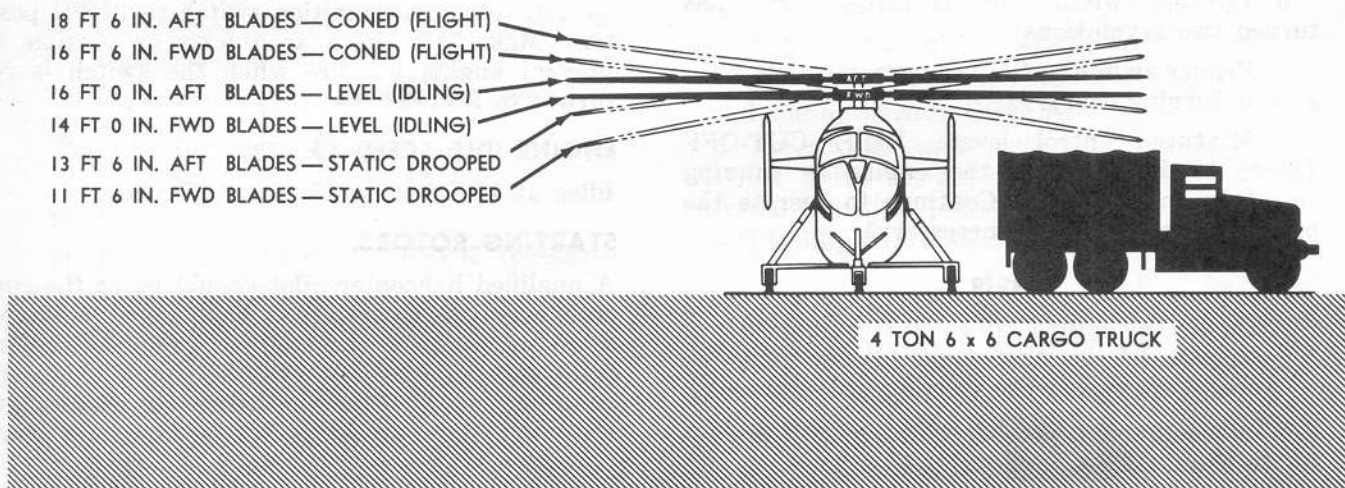

Figure 2-2. Rotor Blade Clearance

4. Supercharger switch: LOW (sudden decrease in manifold pressure and increase in rpm indicates that the two-speed mechanism is working properly).

**CAUTION**

Do not repeat the supercharger clutch shift check at less than five minute intervals. Extreme heat is created within the clutch during the shift and must be allowed to dissipate before another shift.

g. Ignition system: CHECK (with a power setting of 25 inches Hg at 2300 rpm, check the magnetos as follows):

1. Place the switch in the L position and observe rpm drop.
2. Return the switch to the BOTH position to stabilize rpm.
3. Place the switch in the R position and observe rpm drop.
4. Return the switch to BOTH position. A drop of 100 rpm or less when operating on one magneto is satisfactory, providing there is no engine roughness.

h. Transmission temperature: CHECK (with in limits, refer to Section V).

i. Transmission pressure: CHECK (within limits, refer to Section V).

j. Overrunning clutch: CHECK (for overrunning action of the jaw clutch after the ignition system check. With the engine at 2500 rpm and the blades in minimum pitch, close the throttle just enough to desynchronize (split) the tach-

ometer needles to indicate overrunning action. Synchronize engine and rotor speed and reduce both to the desired range for continuance of ground testing).

**CAUTION**

Do not take off if clutch does not overrun freely as autorotation would be impossible. If the clutch does not overrun, it is an indication that the clutch is in full friction and not jaw.

k. Engine accessories: CHECK (with the collective pitch lever DOWN and LOCKED and the engine operating between 1500 and 1800 rpm, make the following checks):

1. Fuel pressure: CHECK (within green line on pressure gage).
2. Engine oil pressure: CHECK (within green line on pressure gage. When extremely cold temperatures are encountered, a stabilized oil pressure of  $75 \pm 5$  psi at 1800 rpm, with a  $6^\circ\text{C}$  ( $10^\circ\text{F}$ ) rise in oil temperature is considered satisfactory).
3. Engine oil temperature: CHECK (high range of green line on temperature gage is desired; red line on gage is maximum; no minimum oil temperature required for take-off provided a rise of  $6^\circ\text{C}$  ( $10^\circ\text{F}$ ) above the pre-start temperature has occurred with stabilized pressure).
4. Cylinder head temperature: CHECK (no minimum required for take-off, providing

the engine will accelerate properly without backfire).

5. Carburetor air: CHECK (desired temperature).
6. Dual tachometer: CHECK (engine and rotor needles should coincide. Spread of the needles, unless clutch is overrunning, indicates a faulty instrument and should be checked before take-off).

l. Radio: ON (check squelch and sensitivity, controls checked for optimum operation. See Section IV).

m. Instruments: CHECK (respond correctly through various ranges of power and are free from undue fluctuation).

n. Compass: CHECK (readings are consistent with heading of helicopter).

o. Wheel chocks: REMOVED.

### TAXIING INSTRUCTIONS.

Thrust, to move forward, backward, or to turn is obtained from the rotor system. Use the cyclic stick for fore, aft, and lateral control; use the pedals for directional control. It is not necessary to use wheel brakes for control when taxiing, and it is not advisable to attempt to taxi over rough terrain. Under such conditions, it is much easier to fly the helicopter to the desired position.

### PROCEDURE.

a. With the nose wheel unlocked and the wheel brakes released, increase the collective pitch to obtain approximately 22 inches Hg, and an engine speed of 2300 rpm. Displace the cyclic stick forward to start taxiing the helicopter. Use pedals to control the direction of the helicopter.

b. Use throttle, pitch control, and displacement of the cyclic stick to control speed. Care should be taken to prevent the blades from hitting the droop stops. This can be recognized by a heavy thumping noise.

c. To slow or stop the helicopter, displace the cyclic stick rearward and, at the same time, increase collective pitch and rotor rpm. Here again, care should be taken to prevent the blades from hitting the droop stops. When the helicopter stops, return cyclic stick to neutral and reduce power. Brakes are normally used for slow-speed taxiing in conjunction with cyclic controls.

d. When taxiing or turning in strong crosswinds, caution must be used. Should a rolling-over tendency be noticed, the helicopter must be airborne immediately. The best practice is to keep the cyclic stick into the wind and maintain a high rotor rpm in order that take-off power may be applied more rapidly.

### PREFLIGHT HELICOPTER CHECK IMMEDIATELY PRIOR TO TAKE-OFF.

a. Nose wheel: LOCKED (for running take-off only).

b. Controls: CHECK (for freedom and correct movement).

c. Longitudinal trim wheel: SET (for take-off).

d. Gyros: PULL (caging knob to set horizon).

e. Altimeter: SET (adjust as required).

f. Hatches: CLOSED.

g. Cabin heater switch: AS DESIRED.

h. Fuel booster pump switch: HIGH.

i. Mixture control lever: RICH.

j. Crew: ALERTED (ready for take-off).

k. Shoulder harness: LOCKED.

l. Hydraulic pressure gage: CHECK (within prescribed limits).

m. Area: CHECK (clear for take-off).

n. Parking brake lever: OFF.

### TAKE-OFF.

#### THROTTLE AND COLLECTIVE PITCH OPERATION.

With the collective pitch lever in the minimum pitch position and unlocked, increase throttle until engine is operating at 2500 rpm. Increase collective pitch until the helicopter is airborne. If the throttle and collective pitch synchronization is not perfect, small adjustments of the throttle may be necessary to prevent changes in rpm as pitch is increased. Refer to the Appendix for information on take-off power settings for various conditions and gross weights.

#### Note

Check engine fuel and oil pressures, transmission pressures and temperatures while in hovering flight immediately after leaving the ground.

#### TAKE-OFF TO HOVERING POSITION.

Attention should be given to keeping the helicopter steady as it leaves the ground. If practical, take-off should be made with the helicopter headed into the wind. When a downwind take-off is made, there is a slight tendency for the helicopter to swing into the wind. When crosswind take-off is made, drift and weather-vaning tendencies will be more evident. When a downwind or crosswind take-off is made, attention must be given to correcting the above tendencies. As soon as the rotors begin to lift, increase the collective pitch steadily until the helicopter leaves the ground. This will minimize the possibility of the

occurrence of ground resonance (refer to Section VI for explanation).

### HOVERING.

The helicopter may be hovered with normal load.

#### Note

It is not desirable to hover, at zero airspeed, between 10 and 600 feet altitude. In the event of engine failure while at zero airspeed between 10 and 600 feet, exceptional technique will be necessary to avoid a hard landing.

### JUMP TAKE-OFF.

Jump take-offs with this helicopter are not recommended. There is sufficient power reserve and overload gross weight margin to execute a high speed emergency take-off using normal procedure.

### AFTER TAKE-OFF.

Decrease power when clear of immediate take-off obstacles, then proceed as follows:

a. Mixture control lever: NORMAL (refer to the Appendix for power settings).

#### Note

The NORMAL mixture position may be used as long as the cylinder head temperature can be maintained within the applicable limits and engine operation is normal.

b. Fuel booster pump switch: LOW.

c. Carburetor heat control lever: AS DESIRED.

### TRANSITION FROM HOVERING TO FLIGHT.

#### Note

In order to prevent the slight loss of altitude when moving off the "ground cushion" into forward or sideward flight, it may be necessary to increase the collective pitch slightly until transitional lift is attained.

### TRANSITION TO FORWARD FLIGHT.

Displace the cyclic control stick slightly forward. As the helicopter gains forward speed, and transitional lift is attained, neutralize the control stick or position it for climbing or cruising.

### TRANSITION TO BACKWARD FLIGHT.

The helicopter can be flown readily in rearward flight by displacing the control stick in the desired direction. Due to the impaired visibility, limit backward flight speed to 20 knots.

### CAUTION

Since the tip path of the aft rotor extends approximately 65 feet behind the pilot, it is mandatory that the pilot check the area thoroughly to be sure there are no obstructions before attempting rearward or sideward flight.

### TRANSITION TO SIDEWARD FLIGHT.

Sideward flight can be accomplished up to 40 knots without loss of control. Displace the cyclic stick toward the desired direction of flight.

### CLIMB AT NORMAL GROSS WEIGHT.

#### SETTINGS FOR BEST CLIMB.

The best rate of climb for sea level is achieved at approximately 60 knots, 260 rotor rpm and 41.5 inches Hg manifold pressure. For information incident to climb at other altitudes, refer to the Climb Chart in the Appendix.

#### CLIMB AND FORWARD SPEED.

Adjust collective pitch to maintain the required power setting. Regulate the forward speed with the cyclic stick and the rate of climb with the collective pitch lever.

#### FLAPS AND SHUTTERS.

The engine oil cooler shutter is automatically controlled. There is no automatic control of the engine air exit doors. These doors shall be adjusted or removed prior to take-off. Cylinder head temperature is not to exceed the limit red lined on the cylinder head temperature gage. If the temperature is increasing too rapidly, decrease the rate of climb and increase forward speed.

#### Note

In executing a climb after take-off, it is desirable to reach an altitude that will allow sufficient height for a safe landing in the event of engine failure.

### FLIGHT CHARACTERISTICS.

Refer to Section VI.

### SYSTEMS OPERATIONS.

Refer to Section VII.

### DESCENT.

#### POWER-ON DESCENT.

Accomplish power-on glides by reducing collective pitch for the desired rate of descent, being careful to maintain a safe rotor speed (green line on rotor tachometer indicator).

### POWER-OFF DESCENT.

#### PRACTICE AUTOROTATIVE DESCENTS.

Refer to Section III.

#### EMERGENCY AUTOROTATIVE DESCENT.

Refer to Section III.

#### VERTICAL DESCENT.

Vertical descent at zero airspeed may be accomplished. Vertical descent in autorotation is smoother than vertical descent with partial power. Refer to Section VI for Flight Characteristics during vertical descent.

#### PRE-TRAFFIC PATTERN CHECK.

Before entering the traffic pattern prior to landing, make the following check:

- a. Mixture control lever: RICH.
- b. Fuel booster pump switch: HIGH.
- c. Carburetor heat control lever: AS DESIRED.
- d. Hydraulic pressure gage: CHECK (within prescribed limits).
- e. Altimeter: ADJUST (as desired).
- f. Supercharger control switch: LOW.
- g. Rescue boom and cable: CHECK (secured).
- h. Crew and passengers: ALERTED (for landing).
- i. Nose wheel: LOCKED (for running landing).
- j. Parking brake lever: OFF.

#### TRAFFIC PATTERN CHECK.

a. After radio permission to land has been granted, observe that the landing area is cleared for the type of helicopter landing that is to be effected.

- b. Landing light: ON (if flying at night).
- c. Pilot and co-pilot windows: AS DESIRED.

#### APPROACH AND LANDING.

##### POWER-OFF LANDINGS.

###### Note

Two types of power-off landings may be accomplished. Refer to the Appendix for tabular data on Power-Off Landing Distances.

##### ROLL-ON LANDING WITH FORWARD SPEED.

Running landings between 20 and 40 knots IAS should be attempted only on smooth surfaced area with adequate space for a relatively long easy flare-out. Lock the nose wheel to prevent shimmy of the wheel when rolling at high speed.

The technique to accomplish this type of landing should be as follows: As the ground is approached (approximately 75 to 100 feet), bring the cyclic control stick rearward slowly, causing the flight path to flatten. A gradual reduction in airspeed will accompany this maneuver. At the same time, increase collective pitch gradually to reduce the rate of descent. By the time the helicopter has slowed down, between 20 and 40 knots IAS, the wheels should be on the ground and the landing effected. Bring the helicopter to a stop by continued application of rearward cyclic stick and toe brakes.

##### FLARED STALL TYPE LANDING.

The second type of landing may be accomplished on relatively rough terrain if necessary. To accomplish this type of landing, the technique to be used should be as follows:

As the ground is approached (approximately 75 to 100 feet), start a cyclic flare as in the first case. However, in this case, the flare should be more positive so that forward speed will be reduced to less than 10 knots at a point approximately 10 feet above the ground. In this case, accomplish the flare with cyclic stick only, maintaining maximum rotor speed as long as possible. As the helicopter arrives at the end of the flare, apply collective pitch rapidly, but smoothly. At the same time, bring the cyclic stick forward to prevent a "tail low" landing.

#### CAUTION

When recovery from a simulated emergency autorotative descent is conducted, apply power gradually and smoothly until rotor and engine speeds are synchronized. This will avoid shock loads caused by sudden synchronization.

##### APPROACH.

a. Airspeed: Reduce to zero gradually as ground is approached.

b. Angle of approach: Make approaches to landing areas long and low or nearly vertical as the terrain demands.

##### TRANSITION FROM APPROACH TO HOVERING.

a. Cyclic stick: Ease the cyclic control stick rearward until the helicopter slows down to the desired rate, then neutralize it.

b. Collective pitch lever: Decrease collective pitch to prevent climbing. The more abrupt the stop, the more decrease of collective pitch will be required.

c. Make the transition from approach to hovering at least 10 feet above the ground.

**DESCENT FROM HOVERING POSITION TO THE GROUND.**

- a. Collective pitch lever: Decrease slightly.
- b. Throttle: Maintain 2500 engine rpm.
- c. Allow the helicopter to become stabilized in hovering position before contacting the ground.
- d. As soon as the wheels are on the ground, decrease collective pitch.
- e. When landing is completed, close throttle.

**CROSSWIND AND DOWNWIND LANDINGS.**

Crosswind and downwind landings may be effected. Exercise care to prevent drift by applying cyclic control against the wind and increasing power if necessary. After touch down, continue to hold the cyclic stick slightly into the wind until rpm has decreased.

**GO-AROUND IF LANDING IS NOT COMPLETED.**

If excessive drift or swinging is evident as the helicopter touches down, apply power to lift the helicopter free of the ground, stabilize it by counteracting undesirable movement with cyclic control, increase forward speed and proceed with new landing.

**AFTER LANDING.**

- a. Collective pitch lever: AS DESIRED (for taxiing).
- b. Nose wheel: UNLOCK (for taxiing).

**POSTFLIGHT ENGINE CHECK.**

Postflight engine and transmission check is to be made daily after the last flight. All discrepancies noted must be entered in Form 1. Check items as follows:

- a. Transmission: CHECK (pressures and temperature within specified ranges).
- b. Ignition system: CHECK (accomplish as described in preflight engine check).
- c. Parking brake lever: ON.
- d. Throttle: 1800 engine rpm (reduce throttle rapidly to 1000 rpm).
- e. Friction clutch switch: DISENGAGE (while rotors are overrunning the jaw clutch).
- f. Idle mixture adjustment: CHECK (with the clutch disengaged).

**Note**

The mixture control lever may be adjusted through a 90-degree range in increments of 15 degrees. Full aft position is IDLE CUT-OFF and full forward position is RICH. While making the idle

mixture adjustment check, be certain that the cylinder head temperature is at least 150°C (302°F). If the temperature should be lower, engage rotors and operate the engine at 2300 rpm and 25 inches Hg for a short warm-up. Disengage rotors and continue idle check.

## 1. With Primer:

(a) Put mixture control lever in RICH position. Adjust throttle so that engine idles at 1000 rpm and lock the throttle in this position.

(b) Flick the primer switch momentarily and note any change in manifold pressure and rpm. A momentary decrease in manifold pressure accompanied by a corresponding increase in rpm indicates that the mixture is too lean. If the idling mixture is either correct (i.e., at best power) or too rich, a momentary decrease in rpm and increase in manifold pressure will occur when the primer is energized.

## 2. Without Primer:

(a) Recheck that cylinder head temperature is at least 150°C (302°F). Warm-up engine if necessary.

(b) With mixture control lever in RICH position, adjust throttle so engine will idle at 1000 rpm and lock the throttle in position.

(c) Move mixture control lever from RICH position to NORMAL position. No change in rpm or manifold pressure will be noted.

(b) To determine if mixture is too rich or at best power, proceed as follows: Slowly move the mixture control toward the IDLE CUT-OFF position until a change in rpm and manifold pressure is noted. A decrease in manifold pressure with an increase in rpm indicates that the mixture is too rich. If a decrease in rpm and an increase in manifold pressure occurs, then the mixture is at the desired best power setting.

**Note**

When making idle mixture check, both methods should be used.

- g. Ignition switch: CHECK (accomplish as described under Engine Ground Operation).

**CAUTION**

The ignition switch check and the idle mixture adjustment check must be made with the rotor blades disengaged.



h. Oil dilution: CHECK (when stopping the engine, and it is anticipated that the next start will be made in low temperatures, dilute the engine oil. Refer to oil dilution table, Section IX).

**CAUTION**

Do not dilute oil when oil temperature is above 50°C (122°F) as it will cause partial evaporation of fuel and result in improper dilution.

**STOPPING OF ENGINE AND ROTORS.**

- a. Mixture control lever: IDLE CUT-OFF (cylinder head temperature should be down to 150°C (302°F) before shut-down. Refer to Section VII).
- b. Ignition switch: OFF.
- c. Clutch friction switch: ENGAGE (when

rotors have slowed to 100 rpm or less. Refer to Section VII for procedure).

**BEFORE EXIT FROM THE HELICOPTER.**

**INTERIOR CHECK.**

- a. Friction clutch switch: ENGAGE.
- b. All switches: OFF.
- c. Radio switches: OFF.
- d. Parking brake lever: ON.
- e. Check the Form 1 and enter all discrepancies discovered in flight.
- f. Make an interior visual inspection of the helicopter.

**AFTER EXIT FROM THE HELICOPTER.**

Make an exterior walk-around inspection and enter all discrepancies in Form 1.



## Section III EMERGENCY PROCEDURES

### ENGINE FAILURE.

#### PARTIAL FAILURE.

If the engine is misfiring or causing an uneven power supply to the rotor system, autorotate to the nearest possible landing area to avoid damage to the rotor drive system. If there is a noticeable lack of power but the engine is operating smoothly, continue with partial power to the nearest suitable landing area. Be prepared for complete failure. Both of the above conditions may be accompanied by loss of altitude. No torque corrections are required due to the tandem configuration of this helicopter.

#### COMPLETE FAILURE AT TAKE-OFF, HOVERING, OR SLOW FLIGHT UNDER 15 FEET ALTITUDE.

Rapidly increase the collective pitch and keep the helicopter level. The inertia of the rotors will be sufficient to prevent an unreasonably hard landing.

#### COMPLETE FAILURE ABOVE 15 FEET ALTITUDE.

Instantly reduce the collective pitch to autorotative angles, turn into the wind if altitude permits, and obtain the best autorotative speed of 55 knots IAS. Perform emergency autorotative descent.

### EMERGENCY AUTOROTATIVE DESCENT.

Procedure for emergency autorotative descent is as follows:

Decrease collective pitch and establish airspeed between 50 and 60 knots. It is of the utmost importance that collective pitch be reduced immediately upon power failure in order that the rotor speed does not fall below the minimum safe limit (233 rpm). As rotor speed builds up, increase collective sufficiently to maintain desired rpm (250 to 270).

For autorotative descents from high altitudes, utilization of minimum rotor rpm (233 to 250) will give slower rate of descent. When below 1000 feet altitude, allow rotor rpm to build back up to desired limits (250-270) for proper ground cushioning effect. Refer to figure 3-1 for glide distances in autorotative flight.

When failure occurs at high forward speed, above 80 knots IAS, displace the cyclic stick rearward and effect a partial cyclic flare simultaneously with a decrease in collective pitch. This will maintain rotor speed and reduce the airspeed to the best autorotative speed. If this procedure is not followed, the rotor speed will be greatly reduced during the transition into autorotation. If power failure occurs at slow airspeeds, 0 to 30 knots IAS, use forward cyclic stick to maintain the helicopter in a level attitude and discourage a "tail down" tendency during the transition period. Once the collective pitch has been reduced to autorotative angles, allow the rotor speed to build up to desired steady autorotative speed. Vertical autorotation is possible, but it is preferable to maintain forward speed which greatly reduces the rate of descent. After establishing autorotative descent, proceed with landing as described under Power-Off Landing, Section II.

If no attempt is to be made to restart the engine, position the engine controls as follows:

- a. Mixture control lever: IDLE CUT-OFF.
- b. Ignition Switch: OFF.
- c. Fuel booster pump switch: OFF.

If low altitude prevents attempt to restart engine, and if landing conditions permit, make a normal power-off landing. After landing, examine helicopter to determine possible cause of failure. If there is no visible trouble, proceed to restart engine.

**AUTOROTATIVE GLIDE DISTANCES**

Figure 3-1. Glide Distance Chart

**ENGINE RESTART IN AUTOROTATION.**

If the situation warrants, and sufficient altitude permits, attempt to restart the engine. After establishing autorotative flight, use the following procedure:

- Set engine controls to proper positions for starting. Throttle back to "cracked" positions to prevent high engine surges and possible shock loads to the drive system.
- Mixture control lever: **RICH**.
- Fuel booster pump switch: **HIGH**.
- Starter switch: **ON**.
- After engine is started, proceed with normal recovery from autorotation.

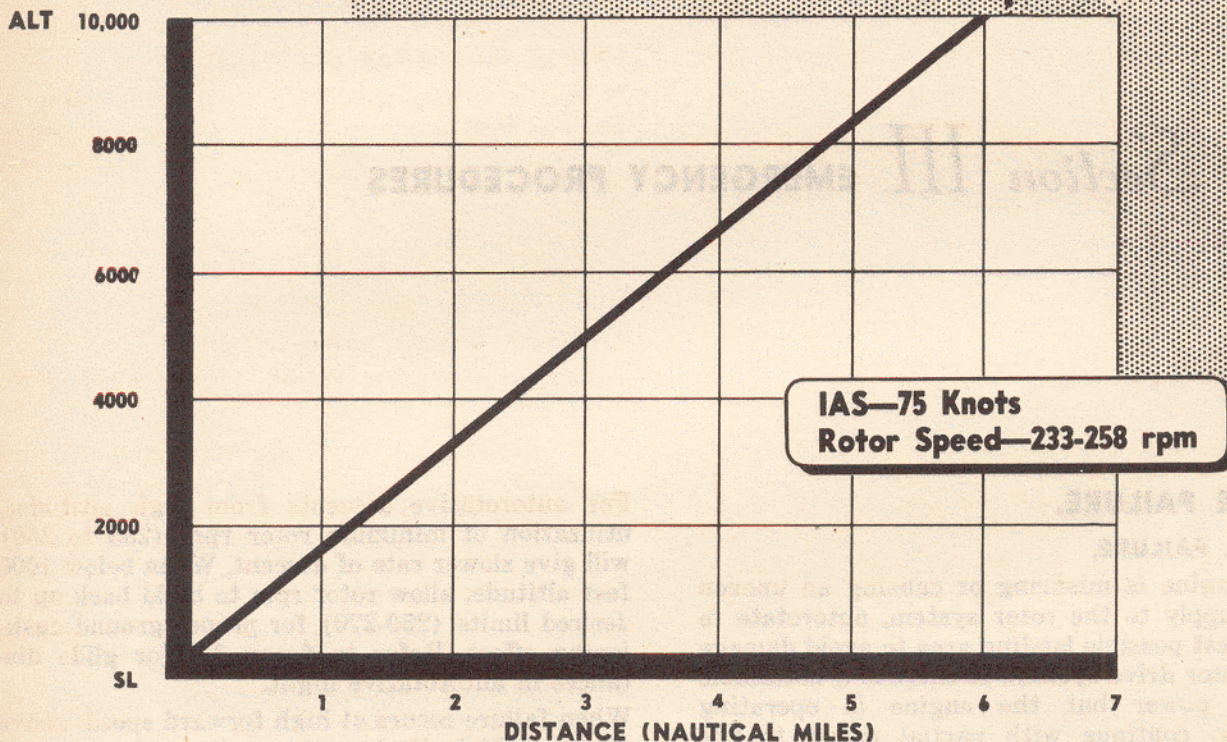
**WARNING**

When attempting to restart the engine in the air, do not disengage the clutch as time will not permit performance of the clutch engaging cycle.

**PRACTICE AUTOROTATIVE DESCENTS.**

Voluntary autorotative descents may be made by reducing the collective pitch approximately three

to four degrees. If making the reduction of collective pitch slowly, be sure to maintain safe rotor speed (green line on rotor tachometer). Clear the engine frequently during descent and set the engine controls as noted:

- Throttle: **SET** (to maintain a minimum of 1800 rpm).
- Mixture control lever: **RICH**.
- Carburetor heat control lever: **COLD** (if carburetor icing conditions exist or the weather is extremely cold, position the carburetor heat control lever to maintain a temperature of 25 to 35°C).

**CAUTION**

Do not let engine speed decrease below 1500 rpm during voluntary descent. This is to preclude possibility of the engine stopping due to low idling speed.

**RPM IN AUTOROTATION.**

The best collective pitch angle for autorotative descent is that angle which will maintain rotor rpm within the range of the tachometer green line, preferably staying close to the maximum

permissible rotor speed noted on the indicator. Rotor speed is affected by weight, altitude, and to a lesser degree by airspeed, and is controlled by the collective pitch. For minimum rate of descent, keep the helicopter between 50 and 60 knots IAS, maintaining desired rotor rpm. For maximum glide distance (figure 3-1) the best airspeed is 75 to 80 knots IAS.

### WARNING

Under no condition of flight should the rotor speed drop below 233 rpm. This low limit is only permissible during transition to autorotation and rotor speed should be increased to the desired range as rapidly as possible.

### TRANSMISSION FAILURE.

Trouble developing in the forward, central, or aft transmission can be identified by excessively high oil temperature or excessively high or low oil pressure, as indicated by the instruments and warning lights. Should these indicators warn of difficulty, land as soon as possible with minimum use of power, autorotating if practical. Should a warning occur while over water or unlandable terrain, attempt to reach the closest landable area at minimum altitude, 10 to 25 feet, and slow airspeed, 50 to 60 knots IAS. This will lessen the chance of injury to personnel or damage to the helicopter in event of complete failure. The decision to land or continue flight is left to the pilot.

#### Note

The use of minimum power will relieve the failing part and may considerably delay complete failure.

### DRIVE SYSTEM FAILURE.

Failure of the rotor drive system resulting in the severance of the interconnecting shafts between the transmissions should be considered as an extreme emergency condition. This type of failure will be noticeable by either a runaway engine or an unequal distribution of lift between the rotors. If at altitude sufficient for parachute descent (over 500 feet), make exit from the helicopter. (See figure 3-2 for emergency exits). If at low altitudes, immediately reduce the collective pitch to minimum pitch position, shut off engine, and autorotate to a landing.

### ROTOR BLADE FAILURE.

In the event of rotor blade failure, make immedi-

ate exit from the helicopter. Prior to bailout, shut off fluids emergency switch on the pilots' overhead switch panel.

### FIRE.

#### ENGINE FIRE WHEN STARTING.

If the engine catches fire when attempting to start, it is due to flooding from excessive priming. Use the following procedure to extinguish the fire:

- Make every attempt to complete the start.
- Starter switch: ENGAGE.
- Ignition switch: BOTH.
- Fuel booster pump switch: OFF.
- Mixture control lever: IDLE CUT-OFF.
- Throttle: OPEN.

This procedure will normally extinguish the fire. If the fire continues, use a fire extinguisher. For location of this item and other emergency equipment, refer to figure 3-3.

#### ENGINE FIRE DURING FLIGHT.

If engine catches fire during flight, proceed as follows:

- Collective pitch lever: Reduce to autorotative position.
- Throttle: CLOSED.
- Mixture control lever: IDLE CUT-OFF.
- Fluids shut-off switch: OFF.
- Ignition switch: OFF.
- Autorotate to landing, if below 500 feet altitude. Above 500 feet it is left to the pilot's discretion whether to bail out or autorotate to a landing. (See figure 3-2 for emergency exits.)

#### FUSELAGE FIRE.

Two fire extinguishers are provided to fight fires within the cockpit and cabin. One extinguisher is mounted behind the pilot's seat and one is mounted in the aft end of the cabin. If fire cannot be controlled, all personnel bail out if at sufficient altitude (500 feet). (See figure 3-2 for emergency exits.)

#### ELECTRICAL FIRE.

Electrical circuits are protected by circuit breakers and fuses so that any electrical fire will be isolated. If electrical fire occurs and cannot be controlled by the crew, turn battery and generator switches OFF and land as soon as possible.

#### Note

The two fire extinguishers provided in the cockpit and cabin are suitable for use in fighting electrical fires.

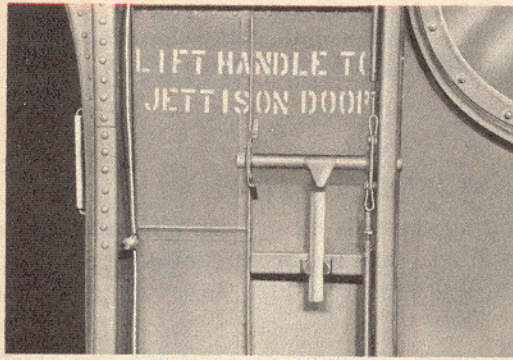

**1 CABIN DOOR:**  
Pull Handle to Jettison

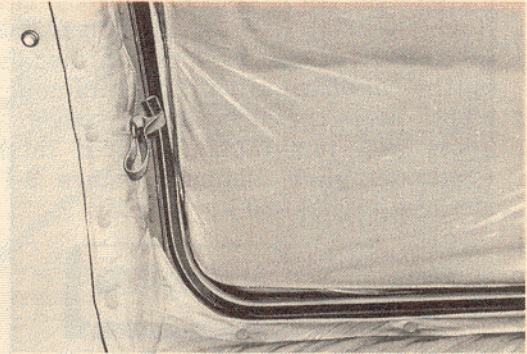

**2 OVERHEAD ESCAPE PANELS**  
Pull Tab, Push Out

**Warning:**

Do not remove overhead escape panels while in flight or when helicopter is on the ground with rotors turning.

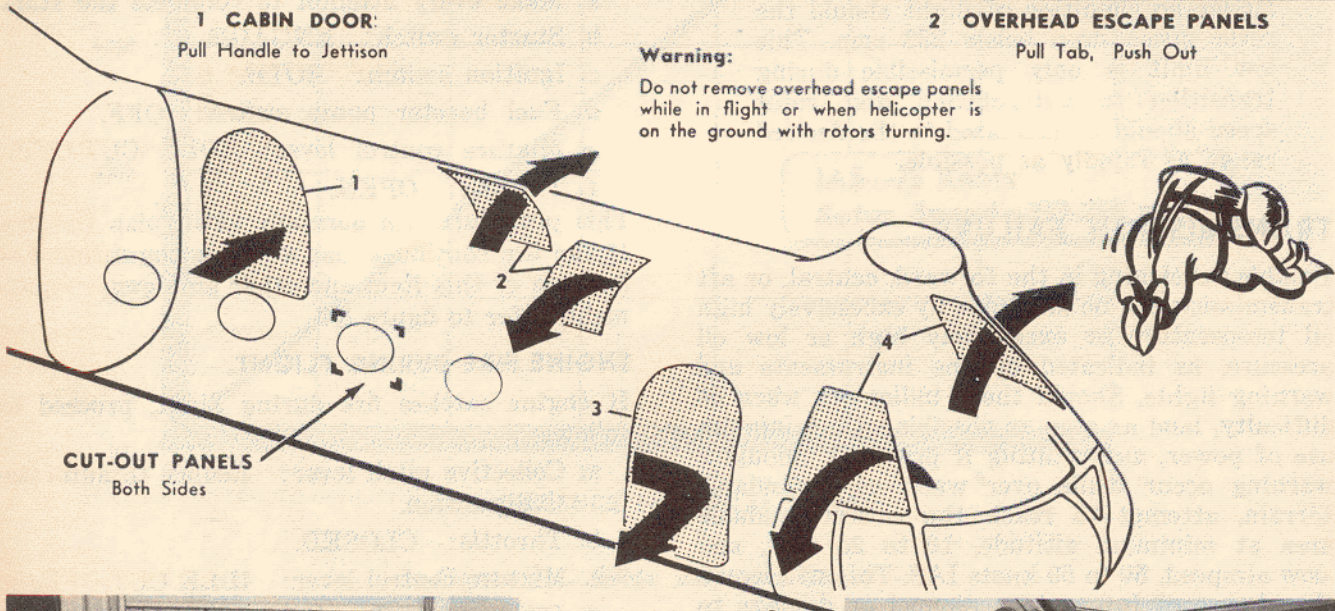

**CUT-OUT PANELS**  
Both Sides



**3 RESCUE DOOR**  
Pull Handle to Jettison

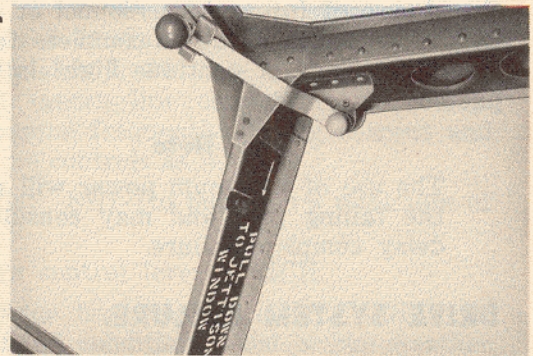
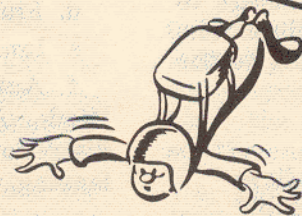

**4 PILOT'S & CO-PILOT'S WINDOWS**  
Pull Handle to Jettison

**Figure 3-2. Emergency Exits and Cut-Out Panels**

**SMOKE ELIMINATION.**

To be provided at a later date.

**LANDING EMERGENCIES (EXCEPT DITCHING).**

Landing emergencies in a helicopter may be construed broadly as that type of landing wherein the pilot feels that he can bring the helicopter

down without undue injury or danger to personnel or the helicopter rather than bailing out. Such emergencies would be partial failure of one of the helicopter's major components, fire, or damage by gunfire to rotor blades, fuselage or nose section. Conditions incident to the attempting of such a landing would be as follows:

- a. Seriousness of the emergency.
- b. Altitude of the helicopter.

- c. Terrain over which the helicopter is being flown.
- d. Weather conditions.
- e. Type and weight of load being carried.
- f. Pilot's opinion as to his available control of the helicopter for a reasonably safe landing.

**WITH OR WITHOUT POWER.**

During descent, accomplish as much of the following as time permits:

- a. Warn crew to prepare for an impact landing. Stand by to abandon the helicopter after landing and be ready to pull emergency equipment, fire extinguishers, etc.
- b. Lock shoulder harness.

**WARNING**

When the shoulder harness reel handle is in the LOCKED position, the cable is

manually locked and the crewmember is prevented from bending forward. The pilot should make a prior check to determine which controls he is able to reach with the harness locked.

- c. Unbuckle parachute harness.

d. Just prior to landing, execute an abrupt flare to cushion the impact, or if with power and time permits, a brief hover may be used.

e. Land, cut all switches, pilot and co-pilot jettison windows, crew jettison cabin door and rescue door.

**WARNING**

Windows and doors must be jettisoned at or near the point of touch down to eliminate the possibility of their fouling the rotor blades.

- f. Clear helicopter immediately.

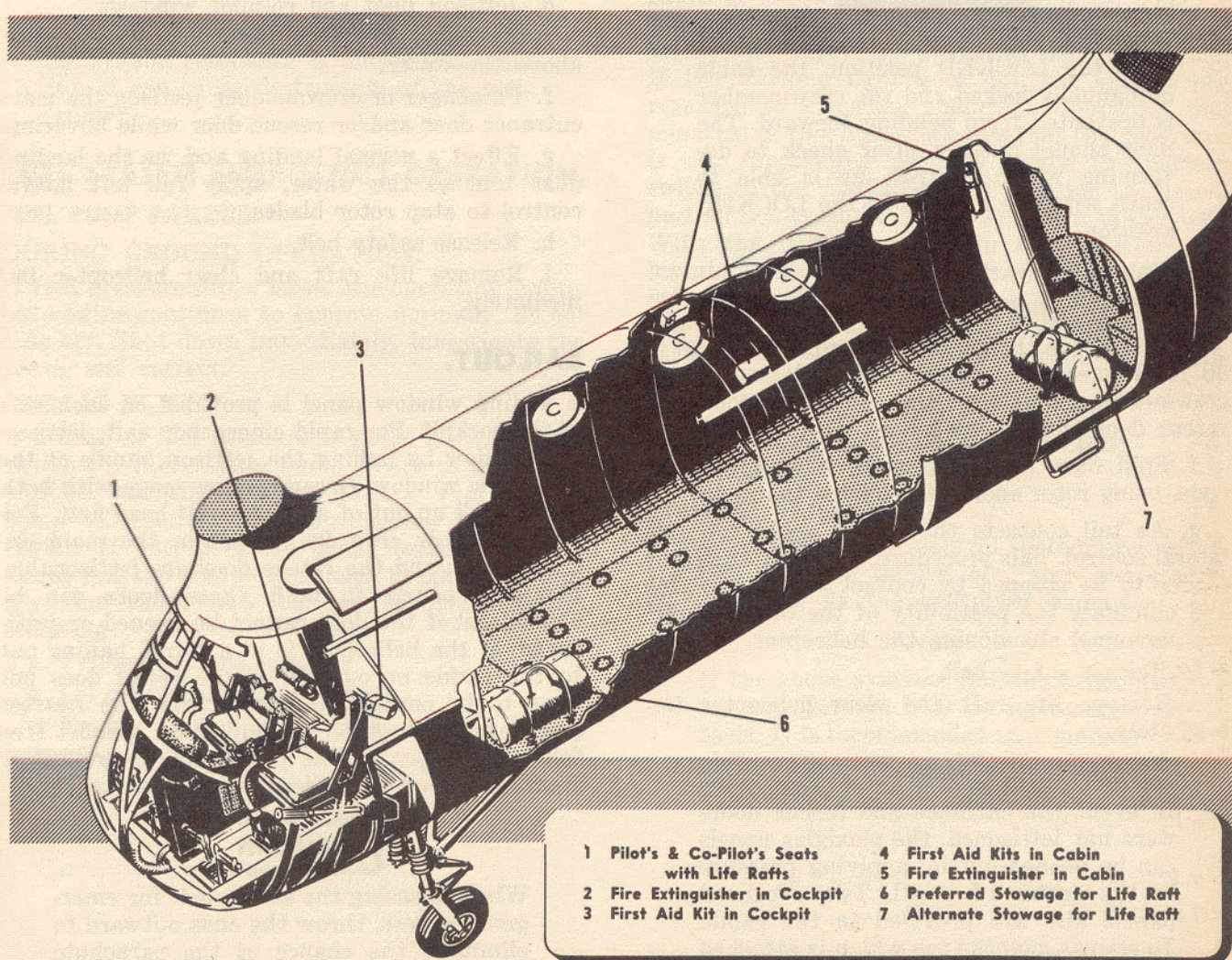

- |  |                                   |
|--|-----------------------------------|
| 1 Pilot's & Co-Pilot's Seats with Life Rafts | 4 First Aid Kits in Cabin         |
| 2 Fire Extinguisher in Cockpit               | 5 Fire Extinguisher in Cabin      |
| 3 First Aid Kit in Cockpit                   | 6 Preferred Stowage for Life Raft |
|  | 7 Alternate Stowage for Life Raft |

Figure 3-3. Emergency Equipment

**EMERGENCY ENTRANCE.**

Make emergency entrance through the same openings that are used for exit. Tabs are provided to pull the locking strip from the rubber grommet which surrounds each emergency exit panel. In case emergency entrance cannot be effected through the conventional openings, cut-out locations are painted on both sides of the fuselage as shown in figure 3-2.

**DITCHING.****WITHOUT POWER.**

Establish autorotative descent into the wind. During descent, accomplish as much of the following as time permits:

- a. Warn crew to prepare for ditching.
- b. Lock shoulder harness.

**WARNING**

When the shoulder harness reel handle is in the LOCKED position, the cable is manually locked and the crewmember is prevented from bending forward. The pilot should make a prior check to determine which controls he is able to reach with the harness in the LOCKED position.

- c. Unbuckle parachute harness.
- d. Jettison pilot and co-pilot windows.
- e. Just above the surface (approximately 20 to 30 feet) execute an abrupt flare. Passengers or crewmembers jettison main entrance door and rescue door at this point.
- f. Spill flare to a moderately "tail low" altitude, using rotor energy to cushion the impact.
- g. As tail contacts the water, apply full left lateral control. This procedure will cause the rotor blades to be stopped by contact with the water and eliminate the possibility of the blades injuring personnel abandoning the helicopter.
- h. Release safety belt.
- i. Remove life raft and clear helicopter immediately.

**Note**

In event the entrance and rescue doors were not jettisoned, the plexiglas panels can be pushed out by applying pressure to the center of panel. Two overhead panels also are provided in the cabin. To release, pull the tab which is attached to the filler strip in the grommet surrounding these panels. Push the panel

out. Never push these two overhead panels out while in flight or when on the ground with rotors turning.

**WITH POWER.**

During descent, accomplish as much of the following as time permits:

- a. Warn crew to prepare for ditching.
- b. Lock shoulder harness.

**WARNING**

When the shoulder harness reel handle is in the LOCKED position, the cable is manually locked and the crewmember is prevented from bending forward. The pilot should make a prior check to determine which controls he is able to reach with the harness locked.

- c. Unbuckle parachute harness.
- d. Jettison pilot and co-pilot windows.
- e. Establish hovering flight five to ten feet above the water.
- f. Passenger or crewmember jettison the main entrance door and/or rescue door while hovering.
- g. Effect a normal landing and, as the landing gear touches the water, apply full left lateral control to stop rotor blades.
- h. Release safety belt.
- i. Remove life raft and clear helicopter immediately.

**BAILOUT.**

A sliding window panel is provided on each side of the cockpit. For rapid emergency exit, jettison the window by pulling the jettison handle at the top of the window. Grasp window ledge with both hands, pull up out of seat and exit head first. For passengers or crew in the cabin, the main entrance door and the rescue door are jettisonable. Plexiglas panels in both these doors can be pushed out if the door cannot be opened or jettisoned. If the helicopter is in a spiral, bailing out to the inside or outside of the spiral does not have to be considered. Jump from the nearest emergency exit. After bailout, make a short free fall before opening the parachute to prevent it from fouling on the helicopter.

**CAUTION**

When releasing the safety belt for emergency egress, throw the ends outward to eliminate the chance of the parachute harness catching on the adjustment buckles of the shoulder harness.



## GROUND RESONANCE.

Ground resonance is a vibratory condition present in a helicopter while on the ground with its rotors turning. Refer to Ground Resonance, Section VI for description.

### RECOVERY.

Should ground resonance occur, the most positive and safest means of recovery is to apply enough power to become airborne immediately. If resonance is severe before take-off is accomplished, it may continue for two or three oscillations before dampening even after the helicopter is clear of the ground. When resonance has stopped, the flight may be continued or a new landing performed. If circumstances preclude the possibility of immediate take-off, the best corrective action is to cut collective pitch and rotor speed simultaneously.

## WARNING

If ground resonance is allowed to build up, it can cause destruction of the helicopter.

## FUEL SYSTEM EMERGENCY OPERATION.

### FUEL PUMP FAILURE.

#### DURING GROUND OPERATION.

If fuel pressure drops below the operating limits, but engine continues to operate normally, *do not take off*. Shut down immediately, investigate the cause, and correct.

#### DURING FLIGHT.

If a drop in fuel pressure is noted during flight, switch the fuel booster pump switch to the HIGH position immediately. The electric fuel booster pump will then supply the necessary fuel to the engine. If fuel pressure drops below operating limits, but the engine continues to operate normally, the cause may be one or more of the following:

- a. Primer solenoid leakage.
- b. Oil dilution solenoid leakage.
- c. Engine driven fuel pump bypass valve leakage.
- d. Clogged pressure line.

- e. Instrument failure.
- f. Line leakage.

Leakage in the fuel cell compartment may be detected by the presence of fumes in the cabin. Due to the location of the engine in the helicopter it is impossible to determine its seriousness. Effect a landing as soon as possible, and check to determine whether it is safe to continue the mission or if repairs must be made. Closely observe the fire warning light in the overhead switch panel during flight and while landing if trouble of this nature is suspected.

## ELECTRICAL SYSTEM EMERGENCY OPERATION.

### POWER FAILURE.

Electrical power failure during flight, due to an overvoltage or undervoltage condition, will be indicated by the illumination of the generator warning light located on the overhead switch panel. If the warning light illuminates, hold the generator switch in the RESET position, momentarily, then throw the switch to the ON position. If the warning light goes out, the system has returned to a normal condition. Continued illumination of this light indicates that the generator is not functioning properly. Place the battery switch in the EMERGENCY position to disconnect all non-essential equipment from the system. With the battery switch in this position, the inverter, utility lights and the turn and bank indicator will continue to operate. Refer to the schematic diagram, Electrical Power Distribution, Section I, for further information on this circuit.

## HYDRAULIC CONTROL SYSTEM EMERGENCY OPERATION.

### PRESSURE FAILURE.

If the hydraulic flight control system pressure is lost due to pump failure, etc., turn the control valve off and fly the helicopter manually.

#### Note

If the above systems fail, the helicopter can be operated only on an emergency basis. It is recommended that landing be made as soon as possible if such a failure occurs.

Faint, illegible text at the top of the page, possibly bleed-through from the reverse side.

ELECTRICAL SYSTEM EMERGENCY OPERATION

Main body of faint, illegible text in the left column, likely describing emergency procedures for the electrical system.

HYDRAULIC CONTROL SYSTEM EMERGENCY OPERATION

Main body of faint, illegible text in the left column, likely describing emergency procedures for the hydraulic control system.

Faint, illegible text in the right column, possibly bleed-through from the reverse side.

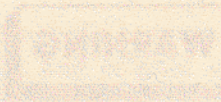

Faint, illegible text located below the 'WARNING' stamp.

ELECTRICAL SYSTEM EMERGENCY OPERATION

Main body of faint, illegible text in the right column, likely describing emergency procedures for the electrical system.

HYDRAULIC CONTROL SYSTEM EMERGENCY OPERATION

Main body of faint, illegible text in the right column, likely describing emergency procedures for the hydraulic control system.



## Section IV

Description and Operation of **AUXILIARY EQUIPMENT**

### HEATING AND VENTILATING SYSTEM.

#### DESCRIPTION.

##### HEATER AND BLOWER.

The helicopter recirculating air heater system (figure 4-1) is composed mainly of a combustion type burner with an output potential of 200,000 BTU an hour, an electrically powered blower, and ducting for the transfer of heated air from the unit to the cockpit and cabin area. The helicopter heating and ventilating unit is located forward of the rescue door on the right side of the cabin. Fuel for the combustion unit is supplied from the engine fuel system by means of the fuel booster pump. Refer to figure 4-1 and figure 1-7 for location of fuel transfer components. The heater switch and blower switch are located on the overhead switch panel (figure 1-4).

##### COCKPIT HEATING.

Ducts lead from the heater to the pilots' foot warmers and the windshield defrosters. The amount of heated air required for the foot warmers is metered through two anemostats (controllable air outlets). The PUSH-PULL manual control lever for the foot warmers is located on the co-pilot's side of the console. Full forward position closes the foot warmer outlet and full aft opens it. The lever may be positioned at any intermediate point. When closed, the entire output of the cockpit heat is sent through the defrosters for anti-icing or de-icing of the pilot's clear vision glass panel.

##### CABIN HEATING.

Ducts also go rearward, from the heater, along the cabin ceiling for cabin heating. The ducts also provide heat for transmissions and drive shaft bearings. This is explained in Ground

Heating for Engine in this section. The cabin has four anemostats (controllable air outlets) at evenly spaced intervals overhead in the cabin, that can be operated conveniently by the passengers. Refer to figure 4-1 for positioning of these cabin outlet heat controls.

##### VENTILATING.

The blower system can be used for forced circulation of air (at floor temperature) throughout the cockpit and cabin when outside air temperatures are high. To operate the ventilating system, place the blower switch ON and the heater switch OFF. The switches are located on the overhead switch panel (figure 1-4).

##### NORMAL OPERATION.

The heating system may be operated by either the pilot or the co-pilot, and can be started with or without the engine running. To operate, place the battery switch, fuel booster pump switch and heater switch in the ON positions. The heater switch energizes the blower motor and supplies current to the air pressure switch. Air pressure induced against the diaphragm of the air pressure switch, forces its contact against the point previously electrically energized by closing the heater switch. This automatically closes the circuit which opens the fuel solenoid at the firewall, fires the igniter, and also actuates the cycling solenoid in the fuel transfer line. The cycling solenoid is automatically controlled by the cycling thermal switch in the heater, thus regulating the amount of fuel supplied to the heater combustion unit. A portion of the air from the blower forced into the heater combustion chamber, mixed with the fuel, is ignited and, when burnt, is voided through the exhaust. The remaining air circulates around the combustion chamber, is heated, and is forced through the heat ducts.

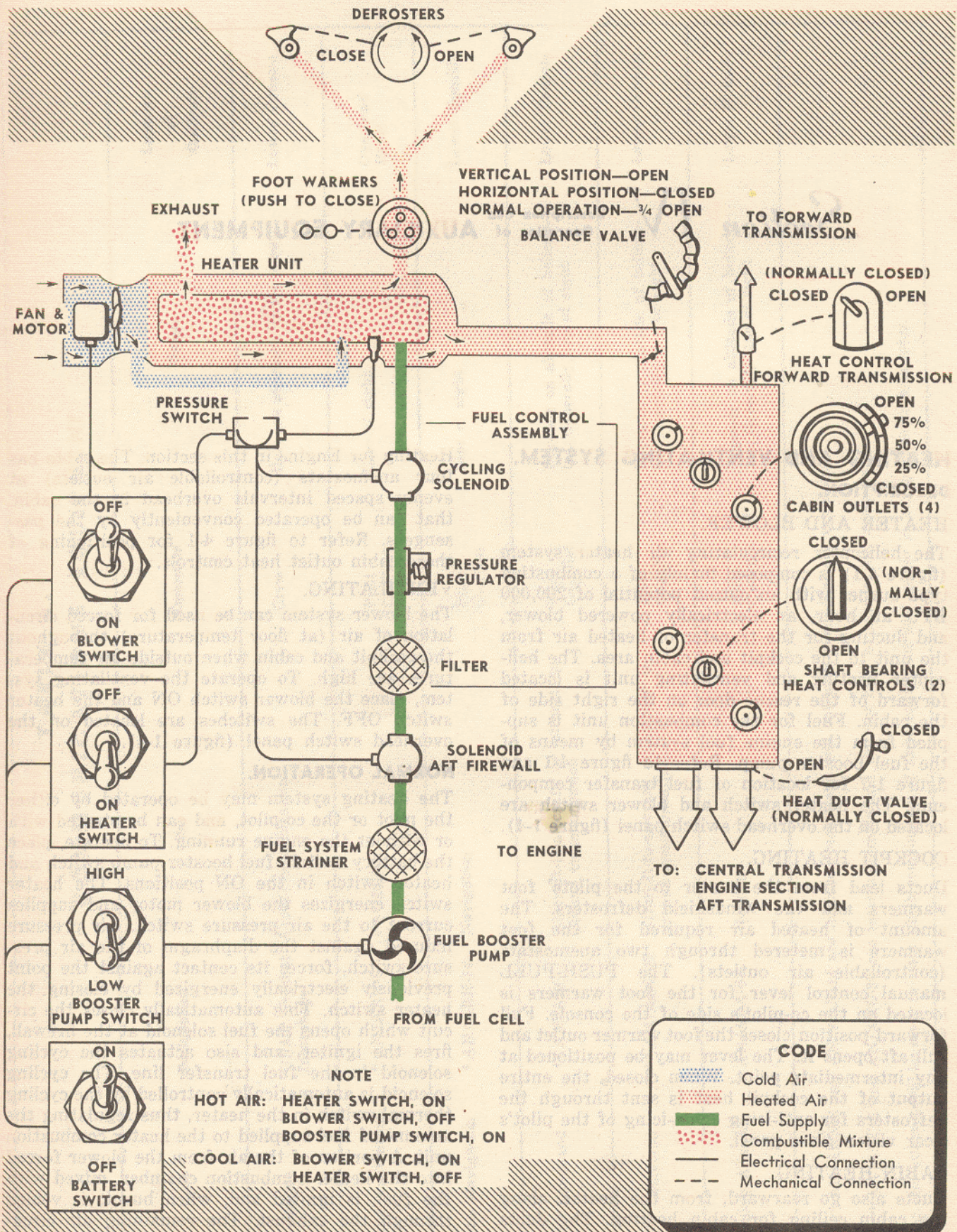

Figure 4.1. Heating and Ventilating System Schematic Diagram

**Note**

The heater should be turned off five minutes before stopping the helicopter engine. However, the fuel remaining in the combustion chamber will continue to burn until exhausted after the heater has been turned off, eliminating the danger of uncontrolled fumes being present in the helicopter.

**EMERGENCY OPERATION.**

The heater ignition unit has a reserve set of vibrator contacts for use in case the main contacts burn out or become fouled. The spare contacts can be put in operation by pulling out the push-pull switch on the bottom of the ignition unit.

**GROUND HEATING FOR ENGINE.**

**WITH AUXILIARY UNIT.**

An auxiliary ground heating unit for warming the engine compartment, drive shaft bearings, and gear cases will be used when available. These components can be warmed from  $-54^{\circ}\text{C}$  ( $-65^{\circ}\text{F}$ ) to  $+4^{\circ}\text{C}$  ( $+40^{\circ}\text{F}$ ) in 12 minutes. After the unit has been connected to the engine air outlet door, left side, check to see that the following has been done:

- a. Aft rotor head: COVERED.
- b. Engine air intake and transmission oil cooler: COVERED.
- c. Right hand engine air outlet door: CLOSED.
- d. Passage to aft transmission: OPEN.
- e. Cabin and rescue doors: CLOSED.
- f. Heat duct valves: OPENED.
- g. Firewall door around short shaft: OPEN.
- h. Cabin heat outlets: CLOSED.
- i. Shaft bearing heat control valves: OPENED.
- j. Forward transmission heat control valve: OPENED.
- k. Foot warmers and defrosters: CLOSED.
- l. Heater balance valve: CLOSED.

Start the auxiliary heating unit and allow it to operate until the engine and helicopter drive components have been sufficiently warmed for easy starting.

**Note**

The balance valve and other manual controls must be reset after using the auxiliary heating unit as shown in figure 4-1 for proper operation of the helicopter heating system.

**WITH HELICOPTER HEATING UNIT.**

The helicopter heater may be used for warming the engine and helicopter drive units if external power is available. The components can be warmed sufficiently for engine starting with the helicopter heater in approximately 35 minutes. Prior to starting the heating unit check to see the following has been done:

- a. Engine air outlet doors: CLOSED.
  - b. Aft rotor head, engine air intake and transmission oil cooler outlets: COVERED.
  - c. Passage to aft transmission and firewall doors around short shaft: OPENED.
  - d. Cabin and rescue doors: CLOSED.
  - e. Heat duct valves: OPENED.
  - f. Shaft bearing heat control valves: OPENED.
  - g. Forward transmission heat control valve: OPENED.
  - h. Cabin heat outlets: CLOSED.
  - i. Heater balance valve: OPENED.
  - j. Foot warmers and defrosters: CLOSED.
- Start the helicopter heating unit and allow it to operate until the engine and drive units have been warmed sufficiently for easy starting.

**SNAP VENTS.**

The passenger compartment windows and the cockpit windows have snap vents installed. These vents are adjustable and permit entrance of air as desired for comfort.

**ANTI-ICING AND DE-ICING SYSTEMS.**

**PITOT HEAT.**

To prevent ice accumulation in the pitot tube, located on the underside of the fuselage, a heating element is provided in the pitot head. Electricity is supplied to the heating element when the battery switch and pitot switch are placed ON.

**WARNING**

Do not operate for more than five minutes on the ground.

**TABLE 4-1**  
**COMMUNICATIONS EQUIPMENT**

Type	Designation	Use	Operator	Range	Location of Controls
Interphone	USAF Combat Interphone	Crew communication	Crew	Between members of the crew	Lower Console
Radio Navigation	* AN/ARN-6	Navigation	Pilot Co-Pilot	Line of sight	Overhead Panel
Radio Navigation	* AN/ARN-14	Navigation	Pilot Co-Pilot	Line of sight	Lower Console
VHF Command	** AN/ARC-3	Aircraft-to-aircraft or aircraft-to ground communication	Pilot Co-Pilot	Depends on altitude of helicopter. Generally line of sight	Lower Console
UHF Command	** AN/ARC-27	Aircraft-to-aircraft or aircraft-to ground communication	Pilot Co-Pilot	Depends on altitude of helicopter. Generally line of sight	Lower Console
Homing Adapter	AN/ARA-8A	Homing	Pilot Co-Pilot	Depends on altitude of helicopter. Generally line of sight	Lower Console

\* AN/ARN-6 and AN/ARN-14 are interchangeable and will not both be used at the same time.

\*\* AN/ARC-3 and AN/ARC-27 are interchangeable and will not both be used at the same time.

Note: No attempt will be made to state which combination of radio equipment will appear in any particular helicopter.

## COMMUNICATIONS EQUIPMENT.

The communications equipment (figure 4-2) consists of radio and interphone systems to provide communications between the helicopter and ground stations, between the helicopter and other aircraft, reception of automatic direction finder bearings, instrument landing system, automatic homing bearings, and interphone communication between members of the crew of the helicopter. The equipment listed in table I is available in four different combinations depending upon the mission of the helicopter. The various radio controls are located in the cockpit. The transmitters, receivers and amplifiers are located at the forward cabin bulkhead on the left side. Headset and microphone jack boxes are located at the pilot's, co-pilot's, rescue hoist operator's stations, and litter stations. A functional breakdown of the radio equipment is given in the following paragraphs.

### USAF COMBAT INTERPHONE.

The interphone system (figure 4-3) is conventional and provides interphone communication between all crew stations. The system is started when the helicopter battery switch is placed ON. The amplifier switch normally will be safetied ON. The control panel, located on the console, has facilities for the selection of interphone, VHF radio, or navigation radio. Both pilots' cyclic sticks have an ICS-Radio switch.

#### NORMAL OPERATION.

For interphone transmission, press the ICS (trigger switch) on the cyclic control stick.

#### Note

The trigger switch is held at the first detent for interphone operation and is positioned at the second detent for transmitting on the AN/ARC-3 or AN/ARC-27 radio units.

On the bulkhead behind the pilot and co-pilot are junction boxes for plugging in the pilot's and co-pilot's headsets. The rescue station and the litter station have junction boxes and a three position NORM-CALL-HOT selector switch. The HOT position is used when the rescue or litter attendant wishes to transmit without having to hold down the transmitting switch. See figure 4-4 for details.

### AN/ARN-6 RADIO COMPASS.

This navigation aid (figure 4-3) has four bands with frequencies ranging from 100 to 1750 kilocycles. The control box is located over the pilot's head. The control panel contains the following: OFF-COMP-ANT-LOOP function switch, tuning meter, LOOP L-R switch, light control, dial, band

switch, control switch, tuning crank, audio control, CW-VOICE switch and spare bulb.

#### NORMAL OPERATION.

The set is started by turning the OFF-COMP-ANT-LOOP switch to either the COMP or ANT position. The set is turned off by turning the switch to OFF. The radio compass indicator is located on the instrument panel.

### AN/ARN-14 VHF NAVIGATION RECEIVER.

The AN/ARN-14 (figure 4-3) is a navigation aid with frequencies from 108 to 135.9 megacycles. The control box, located on the lower console, has a TONE-PHASE-NAV-OFF switch, a frequency selector and a volume control.

#### NORMAL OPERATION.

To start the set, turn the TONE-PHASE-NAV-OFF switch to the TONE or PHASE position. To turn the set off, turn the switch to the OFF position.

### AN/ARC-3 VHF COMMAND TRANSMITTER AND RECEIVER.

The VHF radio has eight channels with frequencies from 100 to 156 megacycles. The control box is located on the lower console. (See figure 4-3.)

#### NORMAL OPERATION.

To receive, select the desired channel and push the ON-OFF switch to ON. Volume is controlled by the interphone control panel volume control. To turn the set off, push the ON-OFF switch to OFF. The small unmarked button to the left of the OFF button is for sending code messages. To transmit, select a channel and position the trigger switch on the cyclic control stick to the second detent.

#### Note

The trigger switch is held at the first detent for interphone operation and is positioned at the second detent for transmitting on the AN/ARC-3 or AN/ARC-27 radio units.

### AN/ARC-27 UHF TRANSMITTER AND RECEIVER.

The UHF radio has a frequency range of 225 to 399.9 megacycles. Provisions are made for the remote selection of 18 preset frequencies, or operation on guard frequency, by means of the first of two radio control panels located on the console. This control panel contains all the switches and controls for the remote operation of the equipment. The channel selector switch permits the selection of any one of the 18 preset frequencies. The four position switch provides the following functions:

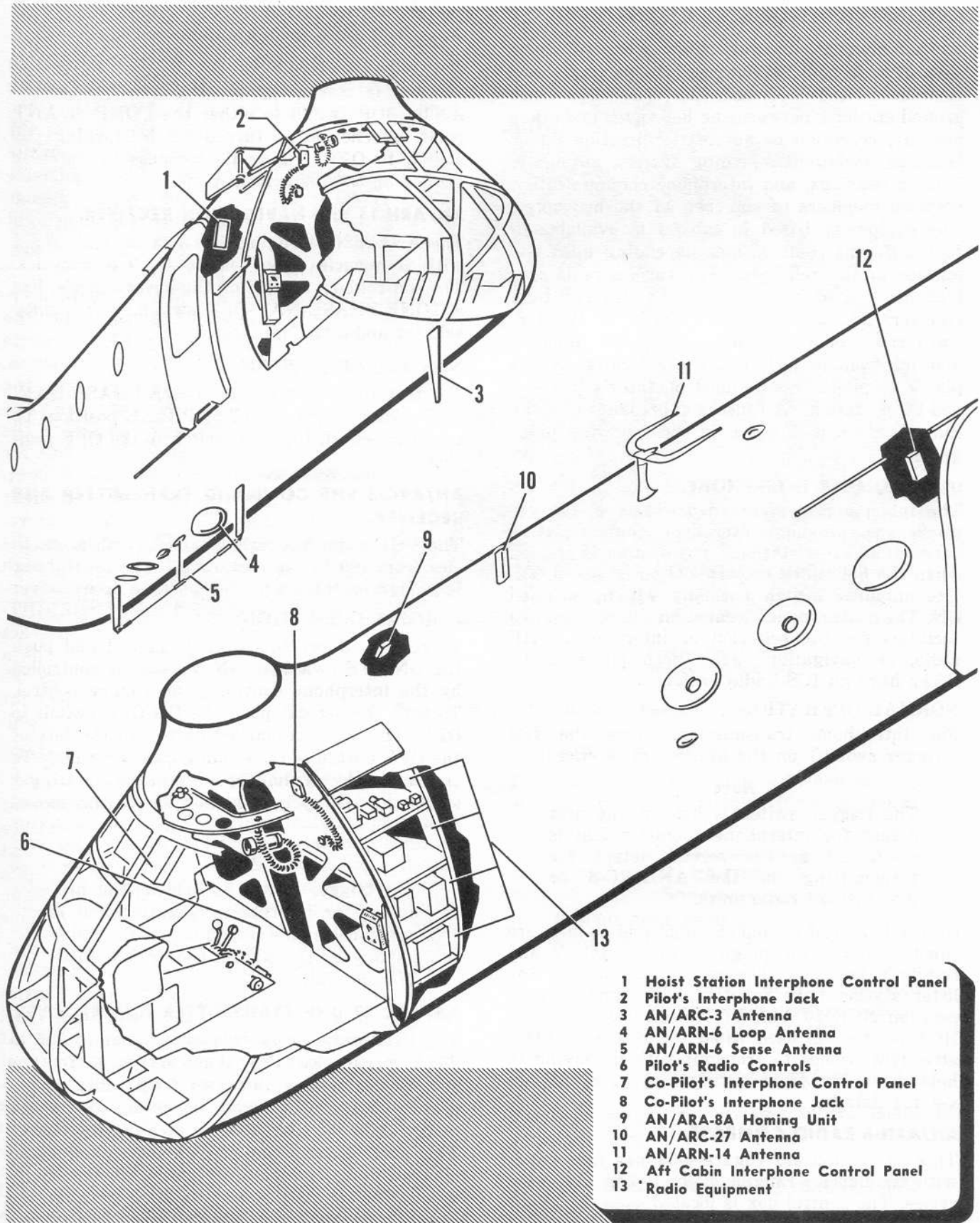

Figure 4-2. Location of Communication Equipment



<b>Switch Position</b>	<b>Function</b>
OFF	Transmitter-Receiver and ADF OFF
T/R + G REC	Transmitter on STANDBY Main Receiver ON ADF on STANDBY Guard Receiver ON
T/R	Transmitter on STANDBY Main Receiver ON ADF on STANDBY
ADF	Transmitter on STANDBY Guard receiver on STANDBY Main Receiver ON, ADF ON.

The other control panel contains switches marked power ON-OFF, TONE-VOICE and LOCAL-REMOTE. These switches control the operation of the transmitter-receiver. (See figure 4-3.)

**Note**

This equipment provides 1750 transmitting and receiving frequencies but only 18 are pretuned for communication use.

**NORMAL OPERATION.**

To start the set, turn the ON-OFF switch ON. Position the trigger switch on the cyclic control stick at the second detent to transmit.

**AN/ARA-8A HOMING ADAPTER.**

The adapter works with the VHF AN/ARC-3 command receiver in order for the pilot to be able to "home" on the station selected. A control panel for the adapter is located on the console with a HOMING-COMM-TRANS switch and a CW-MCW switch. (See figure 4-3.)

**NORMAL OPERATION.**

To use the homing device, turn on the VHF Command set and select a channel for homing. Place the HOMING-COMM-TRANS switch in the HOMING position, and place the CW-MCW switch in the CW position if the transmitting station is sending an unmodulated carrier. If the station is sending tone modulated signals, place the switch in MCW position. If it is necessary to turn the carrier of the VHF command set on continuously without the necessity of holding down the cyclic stick transmitting button, place the HOMING-COMM-TRANS switch in the TRANS position. To discontinue operation, place the switch in the COMM position.

**EMERGENCY OPERATION OF COMMUNICATIONS EQUIPMENT.**

There is no provision for emergency operation of the communications equipment. In the event of generator failure all equipment not absolutely essential to the operation of the helicopter should be turned off to conserve the battery.

**LIGHTING SYSTEM.**

**EXTERIOR LIGHTS.**

The exterior lights consist of the navigation lights and the landing lights. The navigation lights are: A red light on the left side of the fuselage, a green light on the right side of the fuselage, a yellow light on the tail, and two white lights, one on the top and one on the underside of the fuselage. On the bottom of the fuselage there is a fixed, and a controllable landing light (search light). (See figure 4-5.)

**NORMAL OPERATION.**

The position lights switch is located on the overhead switch panel. A type C-2 flasher flashes the side and tail lights alternating with the white lights, with the switch in the FLASHER position. With the switch in the STEADY position, the navigation lights burn steadily. There are two ON-OFF switches on the auxiliary bracket of the pilot's collective pitch lever (figure 1-4); one for the landing light and one for the search light. The landing light is fixed and shines straight down. The search light can be extended or retracted, stopped at any desired position in the arc and can be rotated either left or right through 360 degrees of travel. The search light is controlled by a four-position, UP-DOWN-RIGHT-LEFT switch, located on the auxiliary bracket between the two ON-OFF switches. There is a four-position, UP-DOWN-RIGHT-LEFT switch on the panel located by the cabin rescue door for the crew member to operate the search light. (See figure 4-4.)

**INTERIOR LIGHTS.**

The cockpit lighting consists of the instrument panel lights, cockpit dome light, and two utility flood lights. The panel lights have individual shields, and the utility instrument flood lights serve as a secondary instrument lighting system. The cabin lighting system consists of two dome lights.

**NORMAL OPERATION.**

**UTILITY LIGHTS.** Each utility light has a rheostat type ON-OFF switch as an integral part of its assembly. This switch, located on the aft part of the light, will regulate the intensity of the light from the OFF position to full power. A red button in the light housing, opposite the switch may be used for flashing the light. The red plastic cover may be left on, or removed from the main lens to produce the color light desired. The entire light can be removed from its mount and used as a hand light within the cockpit area. A lock screw on the barrel of the light, when loosened, allows adjustment of the beam.

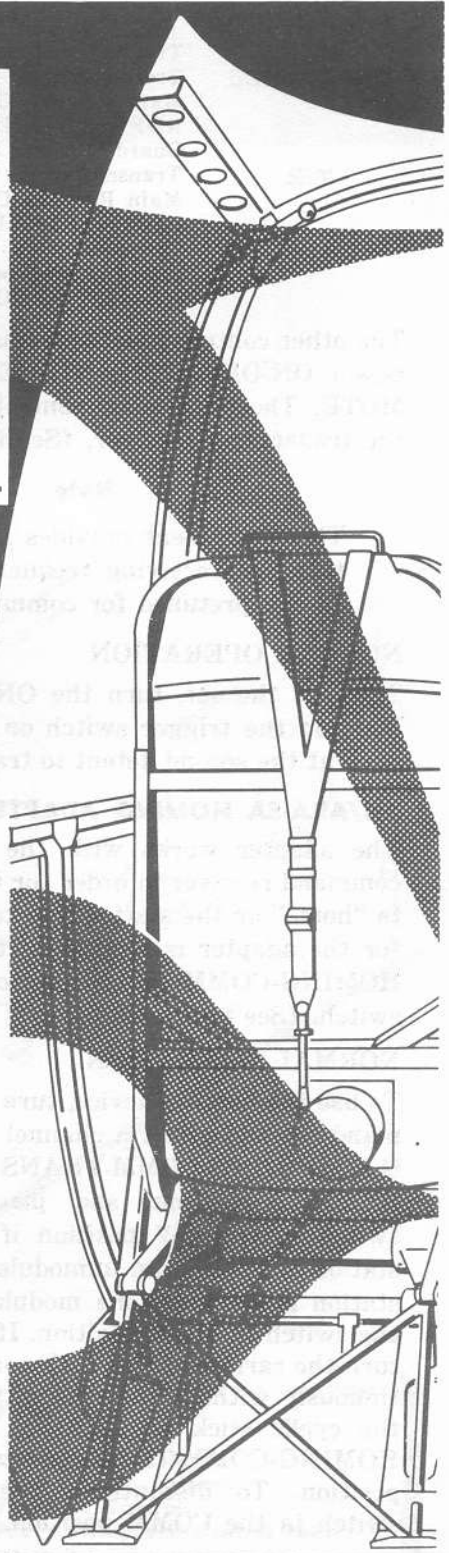
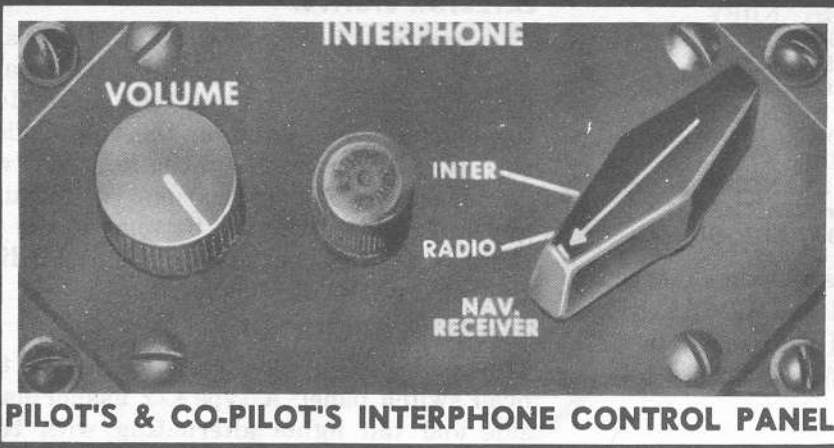

Figure 4-3. Pilot's and Co-Pilot's Radio Controls (Sheet 1 of 2)

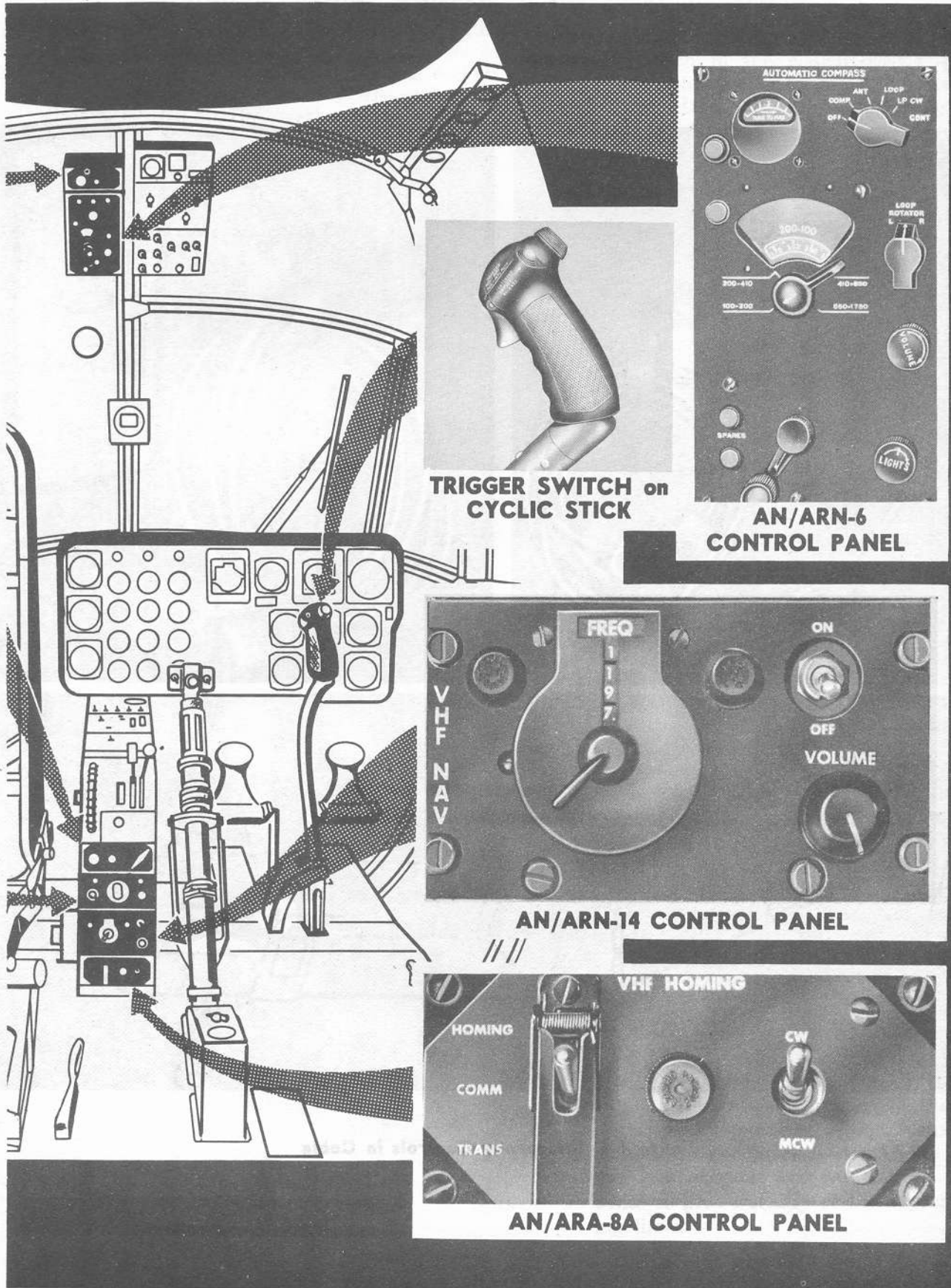

Figure 4-3. Pilot's and Co-Pilot's Radio Controls (Sheet 2 of 2)

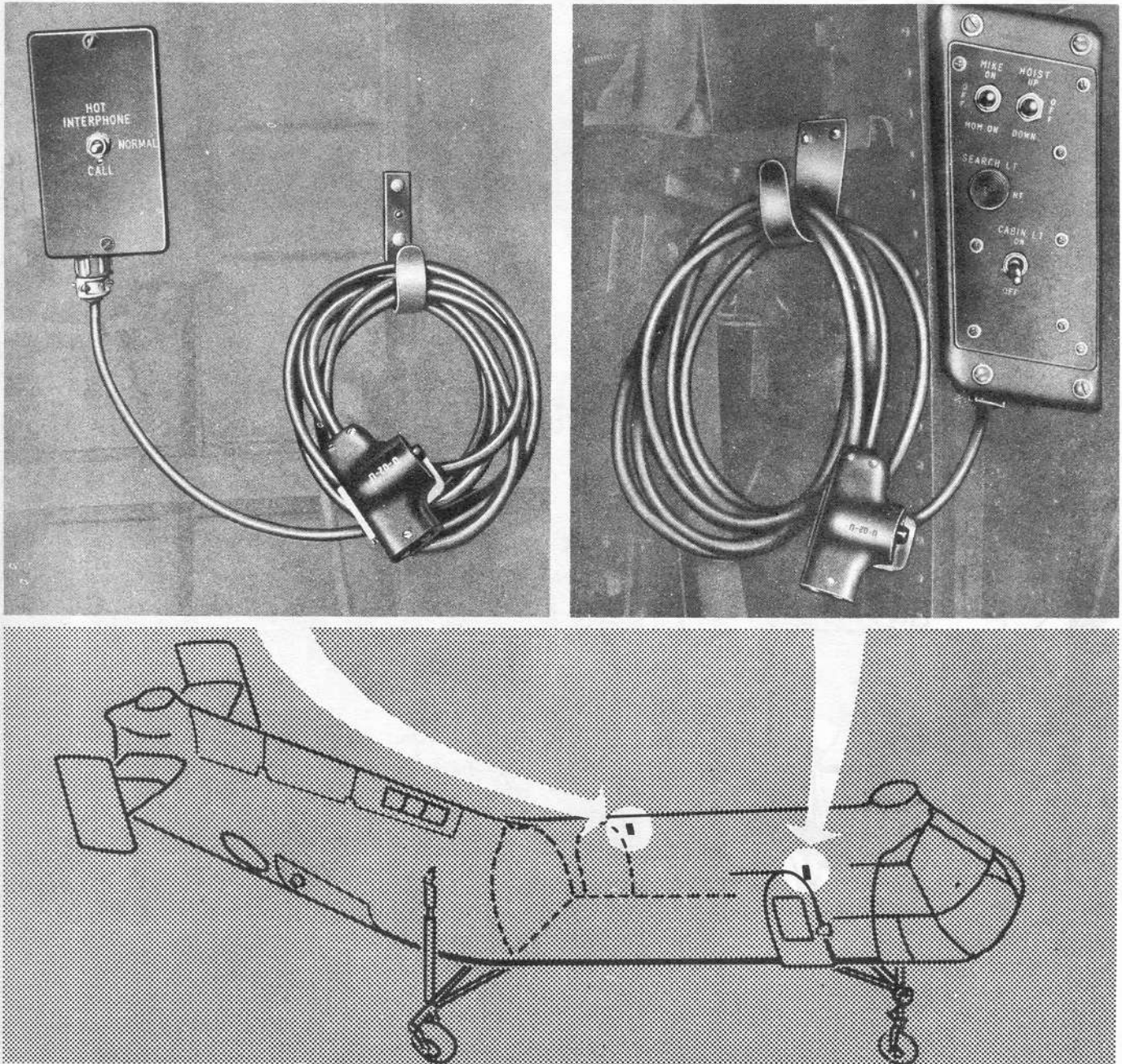

Figure 4-4. Interphone Controls in Cabin

LIGHTS—INSTRUMENT PANEL, CONSOLE, OVERHEAD SWITCH PANEL, COCKPIT DOME. The instrument panel lights, console lights, overhead switch panel lights and cockpit dome lights are controlled by rheostat type switches located in the overhead switch panel. (See figure 1-3.) The brightness of these lights may be increased by turning the switch pointer controlling the specific lighting circuit in a clockwise direction. The switch markings for these various circuits are as follows:

SWITCH MARKING	LIGHTS OPERATED
SHIELD	Flight instrument shield lights
FLOOD LIGHTS	Flight instrument and engine instrument bayonet lights
CONSOLE	Console lights
OVERHEAD	Overhead switch panel lights
DOME	Cockpit dome lights

A two-position RED-WHITE selector switch in the overhead switch panel permits a choice of a red or white dome light by the pilot.

CABIN LIGHTS. The forward and aft cabin dome lights are controlled by two ON-OFF switches. The switch for the forward dome light is just forward of the cargo door, and the switch for the aft dome light is just forward of the cabin door.

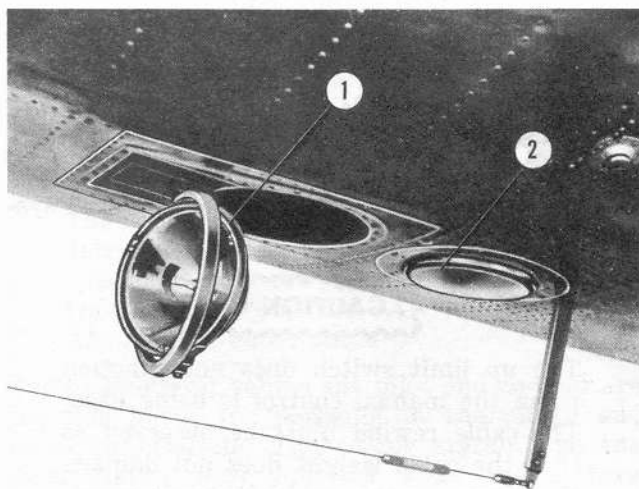

1 Controllable Search Light  
2 Landing Light

Figure 4-5. Landing Light and Controllable Search Light

### EMERGENCY OPERATION.

In the event of generator failure and with the battery switch in the EMERGENCY position, the utility lights and instrument lights will continue to function. All other interior lights will be disconnected.

### RESCUE HOIST EQUIPMENT.

A hydraulically operated rescue hoist is provided for raising and lowering personnel and material while the helicopter is in a hovering position. (See figure 4-6.) The hydraulic hoist system consists of a hydraulic pump mounted on the forward transmission, an electrically or manually operated four-way valve, a relief valve, and a flow control valve. The hoist equipment consists of a reversible hydraulic motor, an adjustable swinging boom and 100 feet of cable capable of lifting 450 pounds.

### CABLE BOOM WINCH, AND CABLE.

The winch is located on the floor, forward of the rescue door. The cable leads up from the winch, through the emergency cable cutter and out the swinging boom located forward and above the rescue door (figure 4-7). The boom can be locked in any of six positions. The forward position is opposite the pilot's lateral line of sight so that he can see the cable hanging below the helicopter. The most rearward position of the boom allows the cable to hang partially inside the helicopter due to the curvature of the side of the fuselage. Between the most forward and most aft positions of the boom, are four intermediate positions. A spring-lock handle, above the cable cutter, turns the boom to any desired position and incorporates a lock release on the handle. At the end of the cable is a swiveling safety hook, and above the hook is a weight which aids the pilot in judging the length of the cable paid out, and helps in placing the hook.



There is no down limit switch. Do not let out more than 100 feet of cable or it will start to rewind around the winch drum in a reverse direction, causing damage to the hoist system. The last five feet of cable are painted red and white to give warning of the approaching limit.

When the cable is raised as far as it will go, the weight will trip the up limit switch and stop the cable.

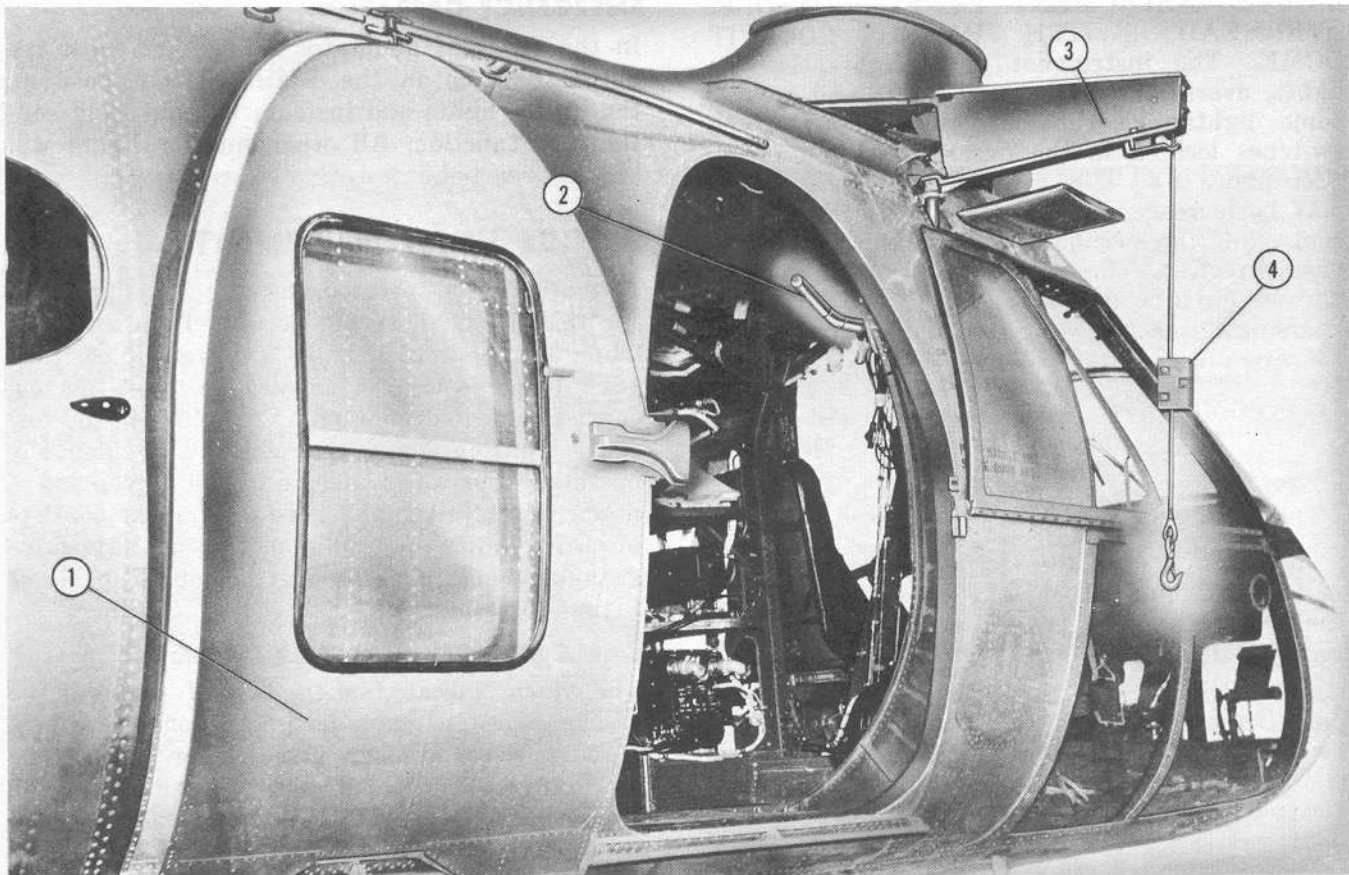

1 Rescue Door  
2 Boom Control Handle

3 Rescue Hoist Boom  
4 Rescue Hoist Cable

Figure 4-6. Rescue Hoist Cable and Boom

#### CABLE CUTTER.

A cable cutter (figure 4-7) is provided to shear the cable in the event that the cable hook becomes entangled or "snags" during a hoisting operation. The cable cutter is located forward of rescue door on the right side and consists of a handle attached to a small cylinder which rotates in a fitting through which the cable passes. If it becomes necessary to cut the cable, pull the cutter arm away from the side of the fuselage. This causes a shearing action and severs the cable.

#### NORMAL OPERATION.

The pilot can operate the hoist by placing the hoist switch on the overhead panel (figure 1-3) to the ON position and using the Up-Down switch on the cyclic stick. A crew member can operate the hoist with an electrical grip control, located by the rescue door.

#### Note

A safety harness is provided for an attendant operating the hoist at the rescue door. The harness allows freedom of movement, but will prevent the wearer from falling out the doorway.

#### EMERGENCY OPERATION.

The four-way valve (figure 4-7) can be operated manually by a crew member if the electrical system fails.

#### CAUTION

The up limit switch does not function when the manual control is being used. The cable rewind must be observed so that the cable weight does not damage the boom or the cable through excessive strain or sudden impact.

#### CARGO LOADING EQUIPMENT.

Tie-down rings are provided in the cabin for securing cargo.

#### TROOP AND CASUALTY CARRYING EQUIPMENT.

The helicopter has a capacity for carrying 14 fully equipped ground troops. Provisions are

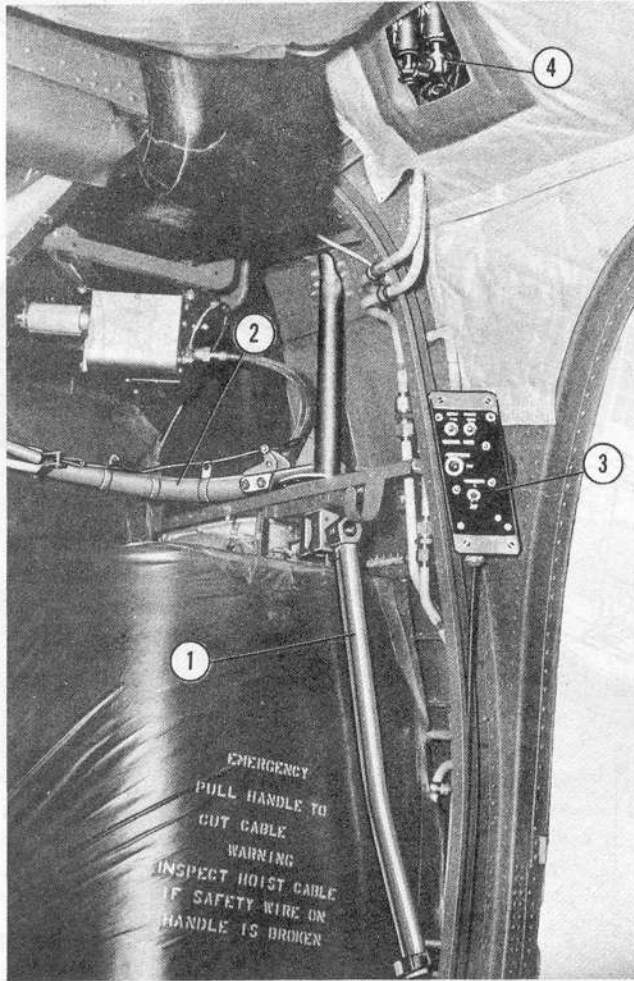

- 1 Cable Cutter
- 2 Boom Control Handle
- 3 Hoist Operator's Switch Panel
- 4 Four-Way Valve

**Figure 4-7. Rescue Hoist Controls and Cable Cutter**

made to carry up to 12 litters. Fittings for stokes litters are provided on the bottom positions of the tiers, but pole litters can also be used in the bottom positions as well as other positions.

**TROOP SEAT AND LITTER INSTALLATION.**

The helicopter cabin can be fitted with a combination of troop seat and litter installations. The troops seats are fitted with individual safety belts and shoulder harnesses. These can be adjusted to the individual but do not have inertia reels. The various combinations (figure 4-8) are as follows:

Capacity	Litter Tiers		Seats	
	(3-man)	(2-man)	(3-man)	(3-man)
14 men.....	0	1	1	4
14 men.....	1	1	1	3
14 men.....	2	1	1	2
14 men.....	3	1	1	1
12 men.....	4	0	0	0

**MISCELLANEOUS EQUIPMENT.**

**ELECTRICAL RECEPTACLES.**

**HEATED SUITS.**

Two receptacles are provided in the cockpit for heated suits, one each for the pilot and co-pilot. These are located on the bulkhead behind the pilot and co-pilot.

**HEATED BLANKETS.**

Receptacles, for plugging in electrically heated blankets, are located on the right side of the cabin. There are two receptacles, each having three sockets.

**COVERS.**

For the protection of the helicopter, covers are provided for the following parts: plastic nose, engine air intake, exhaust outlet, rotor blades, rotor hubs, and pitot tube.

**RELIEF TUBES.**

There are two relief tubes in the helicopter. One is located under the pilot's seat, the other is aft of the co-pilot's seat and can be made available to the passengers.

**DATA CASES.**

There are two data cases provided in the helicopter. One (Map Case) is located behind the co-pilot's seat. The other (Data Case) is located on the aft side of the radio shelf in the cabin.

**ANTI-GLARE CURTAIN.**

A fabric curtain which can be placed in the cockpit entrance is provided.

**BLACKOUT CURTAINS.**

Fabric blackout curtains are provided for all passenger compartment windows and the transparent panels in the entrance and rescue doors.

**TIE DOWN FITTINGS.**

Fittings are provided on the cabin floor and walls to secure litters, seats, and cargo.

**WINDSHIELD WIPER.**

One windshield wiper (figure 1-3) is provided on the right, or pilot's side of the windshield. The wiper is driven by an electric motor, located between the windshield and the console. The operating switch is located on the overhead switch panel and it has three positions, OFF, SLOW, and FAST.

**TROOP SEAT INSTALLATION**

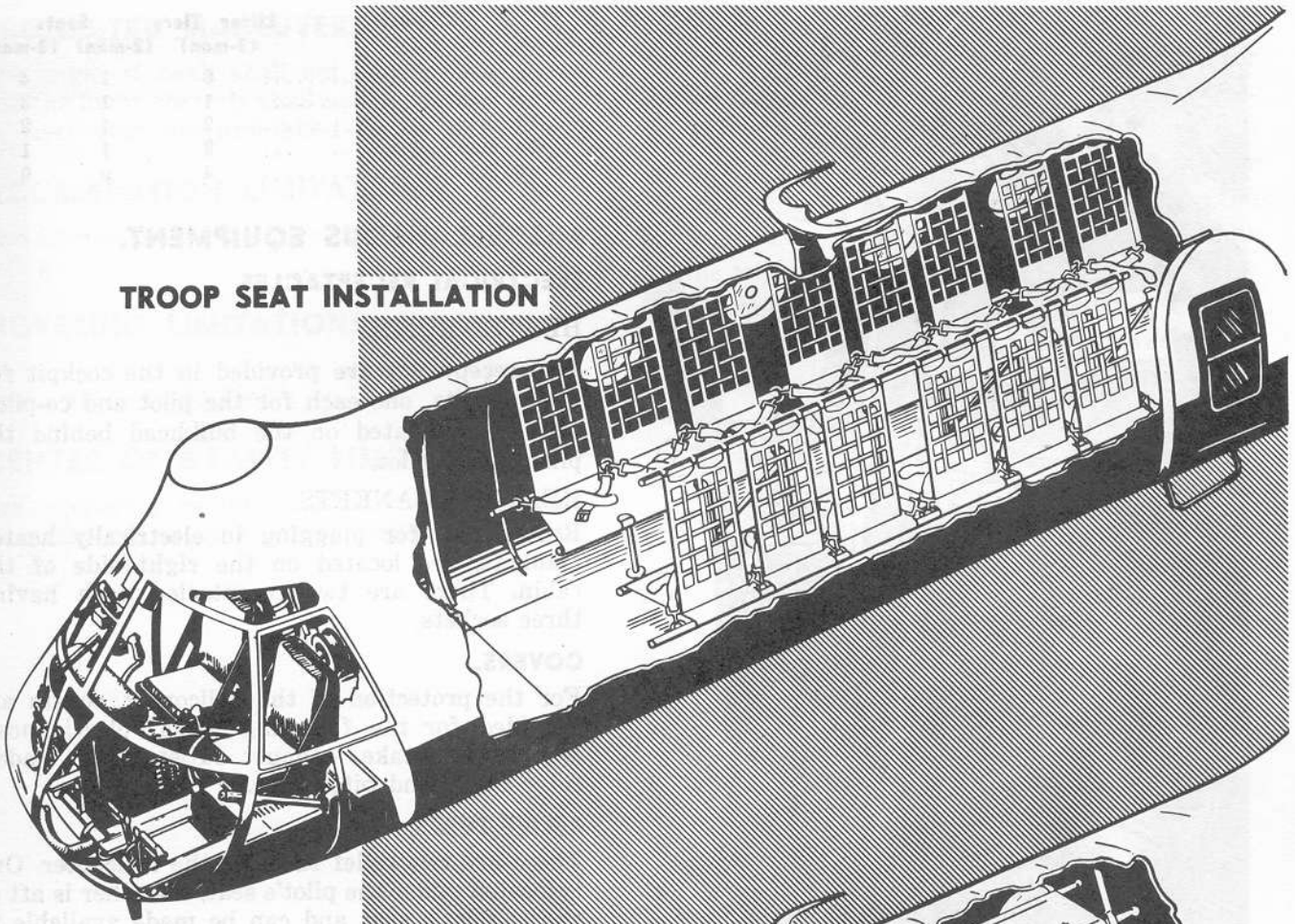

**LITTER INSTALLATION**

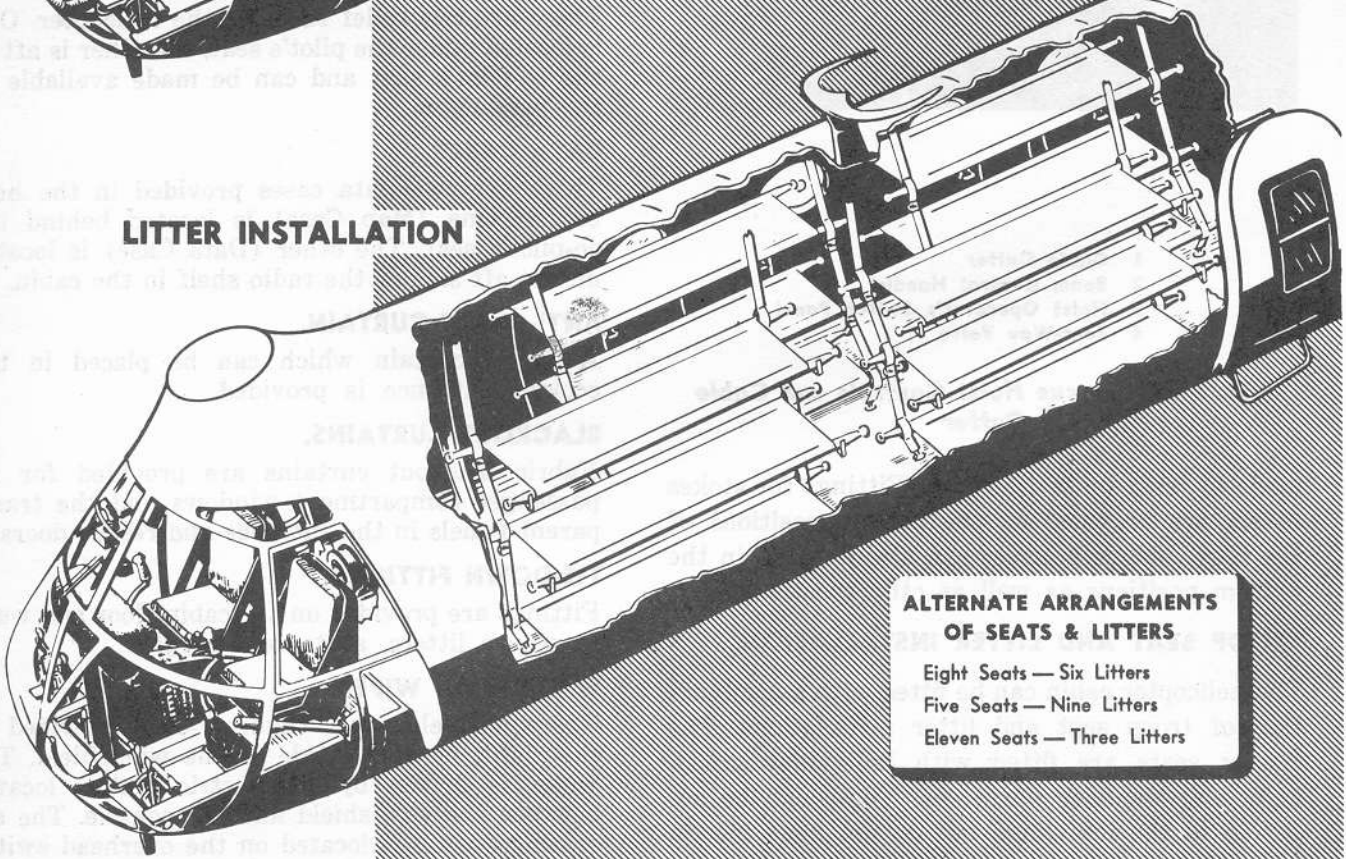

**ALTERNATE ARRANGEMENTS  
OF SEATS & LITTERS**  
Eight Seats — Six Litters  
Five Seats — Nine Litters  
Eleven Seats — Three Litters

Figure 4-8. Troop Seat and Litter Installation



## Section V OPERATING LIMITATIONS

### OPERATING LIMITATIONS.

The operating limitations of the helicopter discussed in this section are a result of extensive flight testing and experimentation. The limitations which are marked on the instruments, illustrated on the following pages, are not necessarily discussed in the text. Further explanation of the instrument markings, when necessary, is covered under the appropriate headings.

### MINIMUM CREW REQUIREMENTS.

The minimum crew required to fly the helicopter safely, under normal non-tactical conditions, is a pilot and a co-pilot. Additional crewmembers, as required to accomplish a specific mission, will be added at the discretion of the Commanding Officer.

### ENGINE LIMITATIONS.

Warm-up speed of the engine immediately after starting is 1200 rpm. Minimum idling speed is 1000 rpm. All other engine limitations are as shown in figures 5-1 and 5-2 and covered below.

#### CAUTION

Since the throttle is extremely sensitive with the clutch disengaged, care must be exercised to prevent overspeeding of the engine on starting as this can cause severe damage to engine components.

### MANIFOLD PRESSURE.

Normal manifold pressure for take-off in low blower at sea level is at the first red line on the manifold pressure gage. For emergency use, the engine may be operated at 46.5 inches Hg. There is no time limit on the use of take-off power of

this helicopter. Maximum manifold pressure in high blower is at the second red line on the manifold pressure gage.

#### Note

The engine is to be operated in low blower at all times for flights below 9000 feet. At altitudes above 9000 feet, operation in high blower is recommended.

### ROTOR LIMITATIONS.

The minimum rotor speed in powered flight is the low range marked on the tachometer indicator (green line). The maximum rotor speed in powered flight is the high range marked on the tachometer indicator (green line). The minimum for autorotative flight is 233 rpm. Maximum permissible rotor overspeed in autorotation is the red line on the tachometer indicator.

#### CAUTION

Rotor speeds below the minimum will result in blade coning beyond the safe limits. Rotor speeds in excess of the maximum limit will lower blade lift efficiency and cause excessive undesirable vibration.

### AIRSPEED LIMITATIONS.

Maximum indicated airspeed limit in level flight is 131 knots. Maximum diving speed is marked on the airspeed indicator (red line). The speed of the helicopter at any altitude shall not exceed the maximum speed attainable at that altitude in sustained level flight using normal rated power.

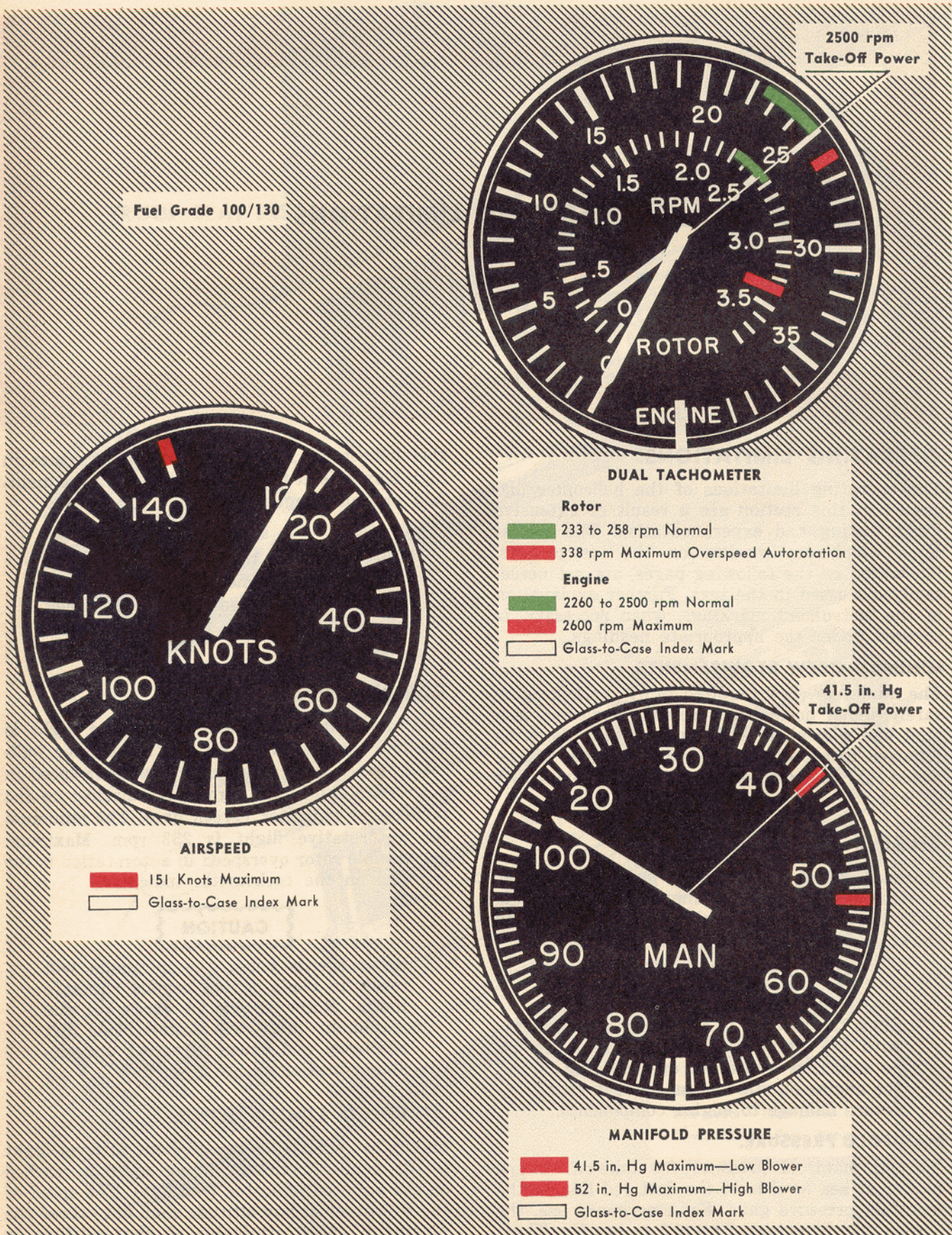
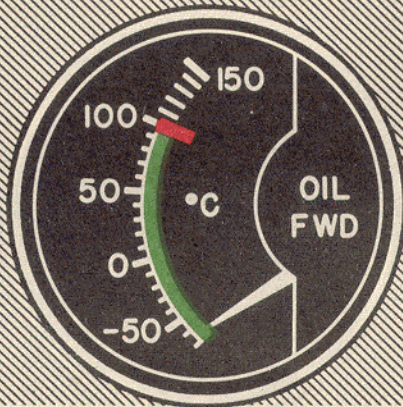

Figure 5-1. Flight Instrument Markings



**FORWARD  
TRANSMISSION OIL TEMPERATURE**

—70 to +95°C Normal  
+95°C Maximum



**FORWARD  
TRANSMISSION OIL PRESSURE**

20 psi Minimum  
20 to 85 psi Normal  
85 psi Maximum

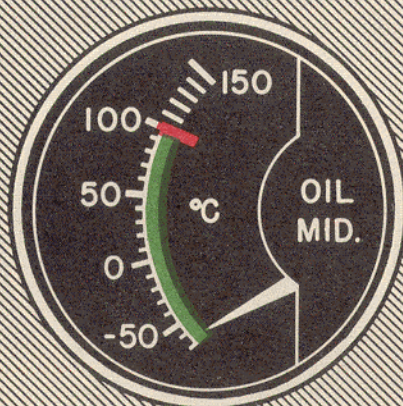

**CENTRAL  
TRANSMISSION OIL TEMPERATURE**

—70 to +95°C Normal  
+95°C Maximum

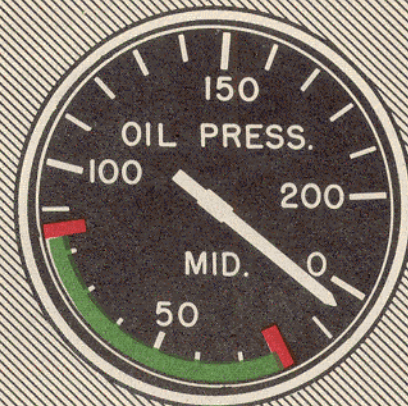

**CENTRAL  
TRANSMISSION OIL PRESSURE**

20 psi Minimum  
20 to 85 psi Normal  
85 psi Maximum

Figure 5-2. Engine and Transmission Instrument Markings (Sheet 1 of 3)

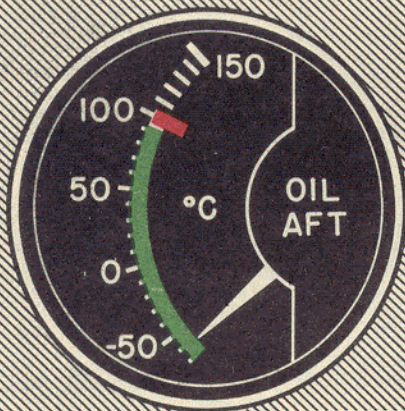

**AFT TRANSMISSION OIL TEMPERATURE**

- █ -70 to +95°C Normal
- █ +95°C Maximum

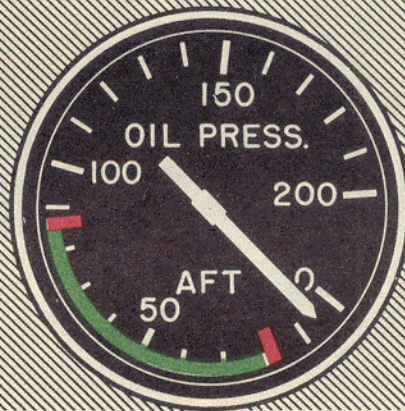

**AFT TRANSMISSION OIL PRESSURE**

- █ 20 psi Minimum
- █ 20 to 85 psi Normal
- █ 85 psi Maximum

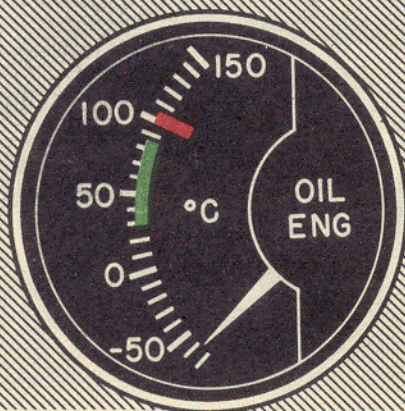

**ENGINE OIL TEMPERATURE**

- █ +30 to +85°C Normal
- █ +100°C Maximum

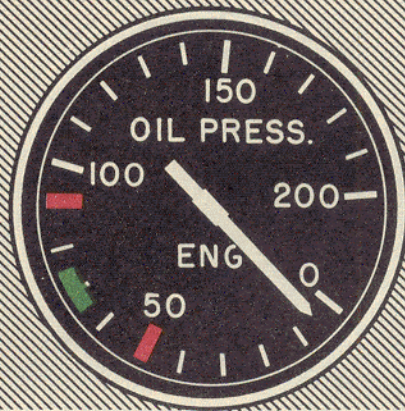

**ENGINE OIL PRESSURE**

- █ 50 psi Minimum
- █ 65 to 75 psi Desired
- █ 90 psi Maximum

Figure 5-2. Engine and Transmission Instrument Markings (Sheet 2 of 3)

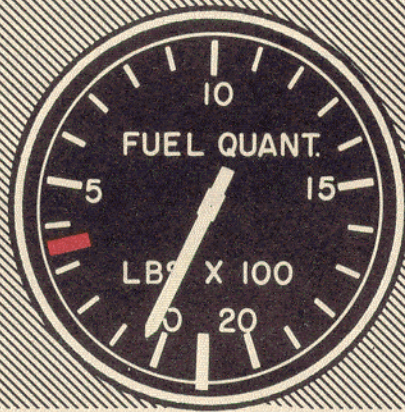

**FUEL QUANTITY**

Glass-to-Case Index Mark  
 360 Pounds

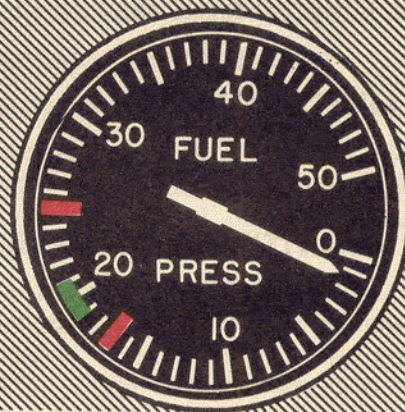

**FUEL PRESSURE**

17 psi Minimum  
 19 to 21 psi Desired  
 25 psi Maximum

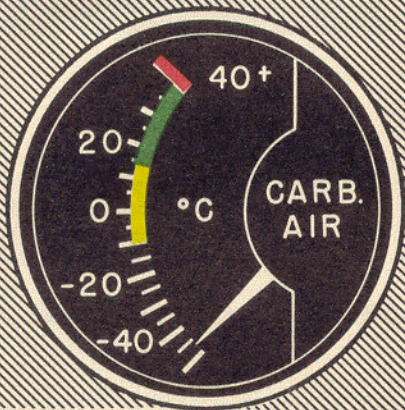

**CARBURETOR AIR TEMPERATURE**

-10 to +15°C Danger of Icing  
 +15 to +40°C Desired  
 +40°C Maximum

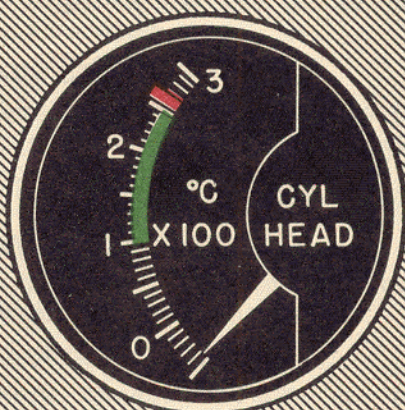

**CYLINDER HEAD TEMPERATURE**

+100 to +245°C Normal  
 +260°C Maximum

Figure 5-2. Engine and Transmission Instrument Markings (Sheet 3 of 3)

**PROHIBITED MANEUVERS.**

The angle of bank shall not exceed 30 degrees and the flight controls shall not be moved abruptly. Aerobatics are prohibited in the helicopter.

**ACCELERATION LIMITATIONS.**

The acceleration in the helicopter shall not exceed 2.75 g.

**HOVERING LIMITATIONS.**

Do not hover the helicopter at zero airspeed between 10 and 600 feet.

**CENTER OF GRAVITY LIMITATIONS.**

For temporary center of gravity changes, such as personnel moving about within the cabin,

displacement of the cyclic stick rearward from the normal hovering position will compensate for forward center of gravity stationing, and inversely, displacement of the cyclic stick forward will counteract an aft center of gravity shift. For permanent center of gravity changes, position the cyclic stick in hovering, or at 80 knots, by means of the trim control. (see Section II.) With a crew and normal load, the center of gravity is a point midway between the rotors; the forward limit is 31 inches forward of this point, and the aft limit is 12 inches aft of this point.

**WEIGHT LIMITATIONS.**

To be provided at a later date.

## Section VI FLIGHT CHARACTERISTICS

### GENERAL.

Normal flight for the helicopter is defined as follows:

- a. Taxiing, take-off, hovering, and landing.
- b. Cruising in a normal attitude.

### GROUND RESONANCE.

Ground resonance is a vibratory condition present in a helicopter while on the ground with its rotors turning. It cannot occur in the air. Resonance results when unbalanced forces in the rotor system cause the helicopter to rock on its landing gear at or near its natural frequency and the problem of its elimination is complicated by the fact that as lift is applied to the rotors, the natural frequency of the helicopter changes. The design of the helicopter is such that with all parts operating properly, the landing gear oleos and rotor blade lag dampers will, by energy dissipation, prevent the resonance from building up to dangerous proportions. Improper adjustment of the lag dampers, oleos and incorrect tire pressure are the major causes of ground resonance.

### FLIGHT CONDITIONS CAUSING GROUND RESONANCE.

It is possible to enter ground resonance when operating under the following conditions:

- a. Taxiing with a high power setting allowing the helicopter to be very light on the wheels.
- b. When operating at high power without forward motion but the helicopter very light on the wheels.
- c. The helicopter light on the wheels and rapidly oscillating the lateral cyclic control. Refer to Section III for recovery.

### WARNING

If ground resonance is allowed to build up, it will cause destruction of the helicopter.

### STALLS.

The helicopter is not subject to conventional stalls, however, rotor speed should be kept above the minimum to prevent excessive coning and stress of the rotor blades.

### BLADE STALL.

As the helicopter rotor moves into forward flight at a given rpm, it is clear that as the blade moves in the direction of flight (advancing blade) it experiences a velocity which is composed of its rotational velocity added to the forward speed. On the other hand, as it moves away from the direction of flight (retreating blade) it experiences a velocity lower than its rotational velocity by the amount of the forward speed component. Since the blade lift is proportional to the square of the velocity, the blade angle of attack must be varied cyclically (by feathering, or flapping, or both) to compensate for the variation in lift as the blade rotates.

As the helicopter gains forward speed, more and more increase in retreating blade angle is required to maintain the lift until the blade reaches its stalling angle and the resulting loss of lift, increase in drag and change in pitching moment cause a cyclical roughness described as "blade stall".

The advancing blade, however, in spite of operating at a lower and lower angle as forward speed increases, ultimately encounters a difficulty of its own. Since the velocities are added, the resultant speed at the blade tip begins to approach the speed of sound as rotor speed and forward speed increase and it may be expected that a similar cyclical roughness will finally develop, as described above under blade stall.

**Note**

Vibration from blade stall will not feed back to the controls with hydraulic boost system on, but will react on the directional pedals only with hydraulic boost system off.

Execution of one, or a combination of the following will overcome blade stall:

- a. Increase rotor rpm.
- b. Decrease airspeed.
- c. Reduce collective pitch.
- d. Decrease altitude (if possible).

**CAUTION**

Maneuvers will increase the tendency to stall, and must be avoided under the conditions described above.

**POWER SETTLING.****Note**

Power settling is not a common flight characteristic of this helicopter, but it will be discussed in this handbook to familiarize the pilot with it.

Under extremes of altitude and gross weight, combined with the condition of marginal power available, such as operating at hovering ceiling or service ceiling, level flight will be difficult, if not impossible, because of lack of power. Increase of forward speed or transition to sideward flight will rapidly overcome this condition.

**WARNING**

Recovery from power settling is necessarily accompanied by a loss of altitude, and conditions that might cause it should be avoided at low altitude.

**SPINS.**

The helicopter is not subject to conventional spins.

**FLIGHT CONTROLS.****TAXIING.**

If it is noted that the blades are hitting the droop stops (recognized by heavy thumping sound) while taxiing with lower power settings, increase the collective pitch, which will cause the blades to cone and clear the stops.

**HOVERING.**

Hovering into the wind will normally require displacement of the cyclic stick forward and slightly to the left, and displacement of the left directional pedal. Hovering crosswind will necessitate displacement of the cyclic stick into the wind, and, the directional pedal on the downwind side of the helicopter will have to be displaced to prevent weather-vaning. Downwind hovering will require cyclic stick rearward, and no weather-vaning tendency will be present as long as the aft end is directly into the wind.

**FORWARD FLIGHT.**

During the transition from hovering to forward flight or from forward flight to hovering, transitional vibration will be noticed in the low airspeed range. As airspeed increases, it will be necessary to increase the forward displacement of the cyclic stick and the right pedal.

**ROTOR RPM IN FLIGHT.**

For safe and efficient operation of the helicopter, adequate control of the rotors must be maintained. Recommended rotor speeds are dependent upon conditions of gross weight, altitude, forward speed, and proximity to the ground. In general, high gross weight, high altitude, high forward speed require high rpm for operation of the helicopter. However, lower rpm will provide optimum fuel economy.

**POWERED FLIGHT.**

In powered flight the rpm range is the green line range on the rotor tachometer.

**WARNING**

Do not operate at less than the low limit of the green line on the rotor tachometer in powered flight. Under no conditions of flight should the rotor speed exceed the rpm limit red lined on the tachometer. Allowing the rotor to drop below 233 rpm is permissible only during transition to autorotation.

**AUTOROTATION.**

The right pedal will be displaced forward during high speed autorotation. Maximum permissible



overspeed in autorotation is noted by the red line on the rotor tachometer.

#### HYDRAULIC FLIGHT CONTROLS.

The controls displacement is not affected by the hydraulic flight control system, however, with the system off, it is necessary to exert considerable pressure to move the controls thus making such flight for extended periods undesirable. (See Control Forces Check.)

#### CONTROL FORCES CHECK.

When the hydraulic control system is on, the pilot feels no forces in the collective and cyclic controls except from the centering springs. When the hydraulic system is off, greater forces will be present in the controls. In order to thoroughly familiarize the pilot with these forces and to make flying easier in the event of a hydraulic system failure, the following procedure is desirable and should be part of the daily procedure, if practical from an operational standpoint.

- a. Take off with the hydraulic control system off. (Collective pitch friction fully released.)
- b. Hover momentarily to determine the extent of the control forces. The lateral and longitudinal forces should be five to six pounds maximum, the collective pitch force about ten pounds maximum and the directional force fifteen to twenty pounds maximum.
- c. Enter cruising flight slowly so that any excessive forces can be detected. At 60 knots IAS, the forces should be the same as for hovering.
- d. Correct unbalanced forces by adjustment of the bungees.

#### LEVEL FLIGHT CHARACTERISTICS UNDER VARIOUS CONDITIONS.

At all operational altitudes the level flight characteristics of the helicopter are good. The helicopter is highly controllable and maneuverable at all speeds.

#### LEVEL FLIGHT CHARACTERISTICS WITH HYDRAULIC SYSTEM ON.

The characteristics of flight are good. However, during slow flight, a slight vibration will be noticed.

#### LEVEL FLIGHT CHARACTERISTICS WITH HYDRAULIC SYSTEM OFF.

As airspeed of the helicopter increases, the friction forces in the controls will increase, and the controls will be more difficult to move without hydraulic assistance. The controls will remain balanced, but directional forces increase so that

it is necessary to hold right pedal. Hovering flights and autorotative descents with the hydraulic system off are comparatively easy to control and maintain.

#### CRUISING AT NORMAL GROSS WEIGHT.

For sea level cruise use 27 inches Hg. manifold pressure and a rotor speed of 245 rpm. This will give an IAS of approximately 85 knots.

#### MANEUVERING FLIGHT.

During all operational maneuvers, the helicopter is completely stable and highly controllable. Excellent maneuvering qualities will be noticed in operations close to the ground.

#### DOWNWIND TURNS AT LOW ALTITUDES.

While the helicopter will not stall or spin, loss of airspeed will result in loss of transitional lift. When flying downwind at low altitude, the pilot tends to judge his speed by reference to the ground rather than by his true airspeed.

#### CAUTION

When downwind turns are made at low altitudes, the pilot should be certain to maintain airspeeds above 20 knots IAS, or be prepared to apply pitch and power at a rapid rate to prevent an unintentional landing.

#### DIVING.

The helicopter maintains good controllability to maximum allowable diving speed.

#### VERTICAL DESCENT.

Vertical descent at zero airspeed may be accomplished. During vertical descent with power, considerable vibration, similar to transitional vibration, will be present and the helicopter will be unsteady because it is settling through the rotor wash. However, full control can be maintained. Vertical descent in autorotation is smoother than vertical descent with partial power.

#### CAUTION

Vertical descents are not recommended. Due to lower rate of descent and better controllability at forward speeds of 50 to 60 knots IAS, it is more desirable to perform a power-on glide.



## Section VII SYSTEMS OPERATION

### ENGINE.

#### MIXTURE CONTROL.

After the engine is stopped, leave the mixture control lever in the IDLE CUT-OFF position until the next start. The mixture control lever in the NORMAL or RICH position will allow the fuel which is left in the carburetor after shut-down to drain out. When the carburetor is again placed in operation, the air that replaced the lost fuel is difficult to remove and will cause surging of the engine. The carburetor diaphragms will dry out and not function properly if the carburetor is drained.

#### CARBURETOR ICE.

##### IMPACT ICE.

Impact ice may be caused on the carburetor by snow or sleet. However, because of the carburetor installation on this helicopter, icing of this nature should be very infrequent.

##### THROTTLE ICE.

Throttle ice develops when moisture in the air becomes frozen at the carburetor butterfly valve. This condition results from the extreme cooling effect that takes place in the venturi section of the carburetor.

##### INTERNAL ICE.

Ice can be formed within the carburetor as a result of the rapid evaporation of fuel as it is sprayed into the air intake. This can occur even in warm weather under certain atmospheric conditions.

#### RESULTS OF CARBURETOR ICE.

Carburetor ice will affect engine performance as follows:

- a. Decrease in manifold pressure and power.
- b. Roughness in engine operation.

#### REMOVAL OF CARBURETOR ICE.

Carburetor ice may be removed by increasing carburetor heat or by operating the helicopter at an altitude where icing conditions do not prevail.

#### CAUTION

Avoid operating in the carburetor heat ranges that increase the tendency to carburetor icing.

#### BACKFIRING.

Backfiring of a cold engine after initial start can result from the following causes, any one of which upsets the fuel-air ratio entering the induction system:

- a. Overpriming.
- b. Underpriming.
- c. Engine speed above the prescribed idling rpm.
- d. Throttle pumping.

#### Note

Avoid conditions causing backfiring as it is harmful to the induction system, and can result in engine fire.

#### SPARK PLUG FOULING.

Residue will be built up on the spark plug electrode by use of improper fuel-air mixture or oil vapor leaking by the piston rings. This will render the spark plug inactive. This condition will be indicated by roughness in engine operation. This residue can be burned off the spark plug electrodes in some cases by operating the engine at

2300 rpm and 20 to 25 inches Hg. If the engine still continues to misfire the spark plugs must be removed and cleaned.

### CYLINDER HEAD TEMPERATURE.

The cylinder head temperature should never exceed the maximum indicated on the gage and if possible the engine should be operated within the optimum range shown on the dial. Cylinder head temperature may be lowered during climb by decreasing the rate of climb and increasing forward speed. Use of rich mixture and lower power settings will also produce a cooler operating range.

### DETONATION.

Detonation is caused in an engine by the extreme or a combination of extremes of the following:

- Cylinder head temperature.
- Manifold pressure.
- Spark advance.
- Carburetor air temperature.
- Lean mixture.

With the high cylinder head temperature that any one of these conditions produce, the induced fuel is pre-ignited, and explodes instead of burning evenly. This detonation can cause damage to the pistons and other engine components, as well as resulting in extreme loss of power. If detonation is experienced during flight, it can be counteracted as follows, dependent upon which operational factor the pilot feels is causing it:

- Decrease carburetor heat.
- Enrich mixture.
- Decrease manifold pressure and rpm.
- Change from climb to forward flight or from forward flight to long gliding flight to reduce cylinder head temperatures.

### PRIMING.

Priming supplies fuel to the engine induction system for starting. Pressure is supplied by the fuel booster pump to the primer pump, located on the rear of the carburetor. The primer pump is energized by an electrically actuated solenoid, controlled by the two-position, ON-OFF primer switch located on the console switch panel. Two lines are routed from this pump to the carburetor just above the impeller throat. Fuel sprayed into this section by the primer pump is diffused to all cylinders by the impeller. When the engine is running, priming is not required, as fuel is drawn into the induction system by the impeller. Priming this engine in warm or cold weather is accomplished by flicking the primer switch intermittently until the engine fires and runs smoothly.

## WARNING

Avoid priming a hot engine in warm weather as there is normally sufficient fuel remaining in the induction system from prior running. An added charge of fuel in this case could result in engine fire from backfiring.

### OVERPRIMING.

Overpriming is not desirable on engine starting as it produces the following bad effects:

- Makes engine starting difficult.
  - Increases danger of engine fire from back-firing.
  - Washes lubricating oil from the cylinder walls.
  - Causes hydraulic lock in extreme cases.
- Overpriming can be detected by the tendency of the engine to fire weakly and emit heavy black smoke from the exhaust. If overpriming has occurred, and the engine will not start, the pilot should cut the ignition switch immediately and return the mixture control lever to the IDLE CUT-OFF position. The engine should then be cranked through intermittently by pressing the starter button for periods not exceeding four to five seconds. This action should clear the engine of excess fuel. A new start may then be attempted with none or a minimum of priming.

### UNDERPRIMING.

Underpriming on engine start is not desirable as it develops engine backfiring conditions. Characteristics of underpriming are failure of the engine to start and white smoke from the exhaust system. If a start is made, the engine will run roughly with low power. If underpriming is prevalent, check to see that the fluids shut-off switch is ON, the mixture control lever is in the RICH position and the fuel booster pump switch is in the HIGH position. Check to ascertain that the fuel pump is delivering the minimum pressure required.

### HIGH RATIO BLOWER.

#### USE IN FLIGHT.

Use of the high blower is recommended for continuous flight operations at altitudes above 9000 feet. High blower should not be used below 9000 feet for the following reasons: The power required to operate the blower substantially reduces the power available for take-off, climb, etc. The additional adiabatic heating of the air when it passes thru the impeller at the high blower setting increases the temperature of the mixture which enters the combustion chamber and thus causes higher cylinder head temperatures. Maximum

BMEP of the engine can be obtained in low blower up to 9000 feet and therefore no advantage is gained by the use of high blower below this altitude.

**PROCEDURE FOR SHIFTING BLOWER.**

Shifting of the blower from the LOW ratio drive to the HIGH ratio drive should be accomplished as follows:

- a. Decrease the collective pitch and the throttle to obtain 2300 to 2400 engine rpm and a reduction of four inches in manifold pressure.

**CAUTION**

Do not shift to HIGH blower at engine speeds above 2400 rpm.

- b. Shift to high blower.
- c. Increase the engine rpm and the collective pitch to return the helicopter to the desired condition of flight.

**Note**

Care should be exercised to avoid blade tip stalling when slowing the engine down, as this condition causes undesirable vibration in the rotor system.

**TRANSMISSIONS.**

**TEMPERATURE.**

Transmission temperature: No minimum. The transmission oil will be warm enough for take-off by the time the engine is warmed up. Normal operating temperature of the transmissions is 65 to 75°C. (149 to 167°F). However, the operating temperatures vary with the outside temperature and it is permissible to operate at a stabilized temperature to the limit of the red line on the temperature gage.

**PRESSURE.**

Transmission oil pressure: The oil pressure of the forward, central and aft transmission will normally be observed at 55 to 65 psi. However, the pressure will vary with conditions and it is permissible to operate at a stabilized pressure within the range of the red lines on the pressure gage. It is permissible to take-off with excessive transmission pressure and the red warning light on, since the indicated pressure may exceed the maximum continuous operating pressure when the oil temperature is low and take-off rpm is applied. However, during flight the temperature and pressure must be checked for stabilization within the normal operating range. If stabilization is not obtained in 15 minutes, land immediately.

**WARNING**

If any of the transmission pressures or temperatures exceed or fall below the limits during flight (noted by illumination of respective warning lights on the instrument panel) the pilot should effect an immediate landing.

**CLUTCH ACTUATOR CHECK.**

The friction and jaw clutch switches should be placed on in proper sequence to check the actuator cycle. This test should be made twice by the pilot, while a crewmember watches the actuator arm from the left side of the central transmission. The arm is upright when both clutches are disengaged. It moves aft for friction clutch engage and down at 45 degrees for jaw clutch engage. This visual check will show that the actuator arm is working through its full range of travel and stopping at its designated points to minimize the possibility of damage to the helicopter resulting from actuator failure.

**ROTOR CLUTCH ENGAGEMENT.**

To engage the rotors, lift the guard from the friction clutch switch and place the switch in the FRICTION position. Lock switch in this position with the guard. Maintain 1500 rpm until rotor speed reaches approximately 100 rpm. The throttle may then be reduced until needles synchronize. *Only* when needles are synchronized may jaw clutch be engaged. Hold needles constant until jaw clutch is engaged. Light will go out when jaw clutch is fully engaged. Engine and rotors should synchronize within 10 to 15 seconds. Release the jaw clutch switch and allow it to return to the OFF position. The friction switch must remain in the FRICTION position until the clutch is to be disengaged.

**CAUTION**

Do not advance the jaw clutch switch to the JAW position before engine and rotor rpm have synchronized. Hold rpm of rotor and engine constant while engaging jaw clutch. Entering positive drive before synchronization or allowing either rpm to change while jaw clutch is being operated will bend rotor blades.

Disengage clutch immediately if oil pressures are not indicated in the forward, central, and aft transmissions within approximately two minutes. A red warning light on the instrument panel will light if the pressures are less than or more than the red line markings on the pressure gage. The

warning light may function during the warming up or idling periods due to reduced oil pressures at low rpm.

### STOPPING OF ROTORS.

#### FRICITION CLUTCH AS ROTOR BRAKE.

When the engine has stopped and the rotor speed has slowed to 100 rpm or less place the friction clutch switch in ENGAGE. This action should bring the rotors to a full stop within 30 seconds. Since the friction clutch also serves as a rotor parking brake it is left in the ENGAGE position when the helicopter is at rest.

**CAUTION**

The friction clutch switch must be OFF before starting the engine.

### FLIGHT CONTROLS.

#### TRIM.

##### OPERATING PROCEDURE.

- a. Set longitudinal trim to zero for take-off.

Hover crosswind to eliminate the necessity of holding the control forward or aft of neutral to correct for wind drift. Roll the trim wheel to bring the longitudinal stick indicator to HOVER position. (When the indicator is aft of HOVER position, nose-up trim will be required. When the indicator is forward of HOVER position, nose-down trim will be required.) When the longitudinal position of the cyclic stick is at HOVER position, it is actually 1-1/2 inches aft of the geometric center of travel. With this position obtained while in hovering, the required forward stick displacement will be available when recovering from an abrupt flare.

- b. Should the pilot fail to check the stick position or trim before take-off, or desires to make an additional check while in flight, he may stabilize at 80 knots IAS and make whatever trim changes are necessary to bring the indicator to the 80 knots position. Whether trimming is done in hovering or at 80 knots IAS, the indicator will be at the proper position when the remaining conditions of flight are entered.

*Section* VIII CREW DUTIES

There are not, at present, any crew duties warranting consideration beyond that already incorporated in the other sections of this handbook.





## *Section IX* ALL WEATHER OPERATION

### COLD WEATHER OPERATION

#### OIL DILUTION.

A momentary ON-OFF switch (figure 1-4), located in the console switch panel, energizes the solenoid which actuates the oil dilution valve. This switch is spring-loaded and will return to the OFF position when released. During oil dilution, the switch is held in the ON position for the prescribed period of time. Refer to the oil dilution table. The purpose of oil dilution is to allow fuel to mix with engine oil prior shut-down, to cut it or lower its viscosity, so that the engine will start, run and warm up within a relatively short time in cold weather.

#### OIL DILUTION PROCEDURE.

Oil dilution is accomplished as follows:

a. Operate the engine in as low an outside temperature as possible.

b. Idle the engine between 1000 and 1200 rpm or shut down until the cylinder head temperature has dropped to 150°C and old temperature is between 30 and 50°C.

#### Note

Oil temperature above 50°C will cause partial evaporation of the fuel, and give improper dilution.

c. With the engine still idling, and the fuel booster pump switch in the HIGH position, hold the oil dilution switch ON for the time specified in the oil dilution chart.

d. With the oil dilution switch ON, shut down the engine, and hold the dilution switch in the ON position until the engine stops.

#### OIL DILUTION TABLE

*Data on oil dilution to be provided when cold weather tests of this helicopter are completed.*



# Appendix I OPERATING DATA

## TABLE OF CONTENTS

Introduction .....	77	Landing Distance Power-On .....	86
Airspeed Correction .....	77	Landing Distance Power-Off .....	88
Sample Problem .....	79	Flight Operation Chart .....	90
Take-Off Chart .....	83	Maximum Endurance Chart .....	93
Climb Chart .....	84	Hovering Endurance Chart .....	94

### INTRODUCTION.

The charts and tables on the following pages are provided to assist the pilot in flight planning for the helicopter. The paragraphs which follow explain the function, method of use, and limitations for each chart. The emphasis on all charts has been toward conservatism since the number of variables makes accurate range predictions impossible.

### SYMBOLS AND DEFINITIONS.

The following is a list of symbols and abbreviations used in the charts and tables of this appendix:

alt	altitude
C	centigrade
deg	degree(s)
fpm	feet per minute
FT	full throttle
gal	gallons
gph	gallons per hour
IAS	indicated airspeed
in. Hg	inches of mercury
kts	knots
lb	pound(s)
lb/hr	pounds per hour
lb/gal	pounds per gallon
min	minute(s), minimum
mpg	miles per gallon
mph	miles per hour
naut	nautical
NORM	normal
OAT	outside air temperature
press.	pressure
SL	sea level
stat	statute
TAS	true airspeed

### AIRSPPEED CORRECTION.

Data on airspeed installation error to be provided at a later date, pending flight test calculations.

### FLIGHT CHARTS.

The values in these charts have been arranged so that they may be easily read. The gross weights columns provide data for all flyable weights. Altitudes have been presented in an order similar to their natural occurrence, that is, the lowest (sea level) altitude is at the bottom of the column. Centigrade temperature columns are headed by the highest number of degrees in a 20-degree bracket, therefore, always choose the temperature column identical to, or next higher than, the effective temperature used.

### TAKE-OFF DISTANCES—FEET.

Before using the chart (figure A-2) set altimeter to 29.92 and read pressure altitude. Determine the outside air temperature and gross weight of the helicopter. Locate the corresponding weight category on the chart. Opposite this weight and at the pressure altitude obtained from the altimeter, read across to the correct temperature column. This column will give the distance required for ground run and take-off to clear a 50-foot obstacle. For instance, at a pressure altitude of 8000 feet, with a gross weight of 10,799 pounds, and a temperature of +35°C (95°F) the chart indicates that a take-off distance of 490 feet with a 50 foot ground run is required.

## CLIMB CHART FOR NORMAL POWER.

This chart (figure A-3) gives the best indicated airspeed, rate of climb, elapsed time to climb, and fuel consumption for climbing. When using this chart it must be remembered that the temperature difference at start of climb up to desired altitude must be taken into consideration. The temperature differential factor to be used is  $-2^{\circ}\text{C}$  for each 1000 feet of altitude.

**EXAMPLE:** A climb from a pressure altitude of 2000 feet (OAT  $-3^{\circ}\text{C}$ ) to a pressure altitude of 10,000 feet, with a gross weight of 10,799 pounds is contemplated. Proper application of the values of temperature, airspeed, rate of climb, and fuel consumption from the chart will show that this can be accomplished between 61 and 65 knots in 5.7 minutes using 84 pounds of fuel. To obtain these results proceed as follows:

- Select the gross weight range category which, in this case, is 8500 to 11,500 pounds.
- Locate the pressure altitude of 2000 feet.
- Read across this line to the  $-5^{\circ}\text{C}$  temperature column to obtain 1.5 minutes (time to climb from sea level to 2000 feet).
- Apply  $-2^{\circ}\text{C}$  for every 1000 feet increase in altitude.
- Add the temperature difference between 2000 feet and 10,000 feet ( $-16^{\circ}\text{C}$ ) to the original temperature ( $-3^{\circ}\text{C}$ ).
- Select the next closest temperature range on the chart ( $-25^{\circ}\text{C}$ ).
- Under this corrected temperature, read down to the gross weight column of 8500 to 11,500 pounds previously chosen. Select the desired climb altitude of 10,000 feet.
- Under time column read 7.2 minutes. (Since both times to climb as given in steps c. and g. are from sea level, the time to climb from 2000 to 10,000 feet is the difference between the two, 7.2 minus 1.5 equals 5.7 minutes.)
- Select the actual airspeed at the closest practical range 61 to 65 knots.
- Note that the rate of climb value between 2000 feet and 10,000 feet is constant at 1380 feet per minute.
- Note that the fuel used is the difference between fuel used to 2000 feet and the fuel used to 10,000 feet, or 186 pounds minus 102 pounds which is 84 pounds of fuel.

## LANDING DISTANCE IN FEET—POWER-ON.

This chart (figure A-4) is given for determining the best approach speed and landing distance required for clearing a 50-foot obstacle with the resultant amount of ground roll. To illustrate this chart, a power-on landing with a gross weight of 10,799 pounds at a pressure altitude of 8000 feet, temperature  $+35^{\circ}\text{C}$ , can be made at 58 knots

with no ground roll. In this case, 90 feet is required to clear a 50-foot object.

LANDING DISTANCE IN FEET—  
POWER-OFF.

This chart (figure A-5) presents the distance in feet of cleared air space and/or surface suitable for safe landing of the helicopter without power (autorotative). The factors required to make use of the chart are:

- Degrees centigrade for point of landing.
- The pressure altitude in feet.
- Current gross weight.

**EXAMPLE:** Determine the distance in feet required to effect an autorotative landing with a gross weight of 10,799 pounds into a field 2000 feet above sea level. There are trees on the approach (downwind) side of the field, but none are over 50 feet high. The outside air temperature in the helicopter flying at 4000 feet was last noted as  $7^{\circ}\text{C}$ .

- Flying at 4000 feet using the standard lapse rate of  $2^{\circ}\text{C}$  per 1000 feet will provide a plus factor of  $4^{\circ}\text{C}$  which in turn would produce a temperature at 2000 feet of  $11^{\circ}\text{C}$ .
- Locate the  $15^{\circ}\text{C}$  column (the next higher temperature) on the chart.
- Select the 2000-foot pressure altitude line in this column.
- Best indicated approach speed is shown as 41 knots. Total distance necessary to clear an obstacle 50 feet high and effect a landing is 420 feet. This total distance includes a ground roll requirement of 190 feet.

## FLIGHT OPERATION INSTRUCTION CHART.

This chart (figure A-6) provides the pilot with performance data corresponding to the range that must be flown at any gross weight of the helicopter. The Flight Operation Chart consists of three sheets. The first sheet presents operational performance data at maximum continuous power setting. The second sheet presents operational performance data at an intermediate power setting. The third sheet presents operational performance data at power settings which will give the best possible ranges. For example, if a flight of 525 miles, at a gross weight of 10,799 pounds is contemplated at highest possible speed, the Maximum Continuous Chart is used. From this chart one may derive the following values:

- Fuel required: ..... 1800 pounds
- Mixture: ..... NORMAL
- Manifold pressure: ..... 25 inches Hg
- Engine rpm: ..... 2500
- Pressure altitude: ..... 6000 feet

**Note**

For an actual flight plan, the Sample Flight Plan Problem must be used.

**MAXIMUM ENDURANCE.**

This chart (figure A-7) indicates the maximum flight time that may be accomplished under given factors of gross weight, fuel and time. To use this chart, determine the gross weight of the helicopter and the fuel load. Locate the weight range on the chart which corresponds to the determined gross weight and select the fuel column which is equal to or less than the fuel load. Read down this column to the line containing the desired hours of endurance. Read left across this line to determine altitude, power settings, fuel consumption per hour and true airspeed required to obtain the desired endurance time. For instance, the helicopter is to be flown for four hours with a gross weight of 12,500 pounds and 1200 pounds of fuel available. Application of these values to the chart gives the following information:

- a. Airspeed ..... 66 knots
- b. Fuel consumption: ..... 295 lb/hr
- c. Mixture: ..... NORMAL
- d. Manifold pressure: ..... 26.5 inches Hg
- e. Engine rpm: ..... 2340
- f. Pressure altitude: ..... 2000 feet

**HOVERING ENDURANCE.**

This chart (figure A-8) indicates the maximum hovering time that can be expected with known factors of gross weight, fuel load, and pressure altitude. To use this chart, determine gross weight of the helicopter, fuel load, and desired altitude for hovering out of ground effect. Locate the weight range on the chart which corresponds to the determined gross weight, select the correct altitude line in this range and read across the line for power settings, fuel consumption per hour, and true airspeed. Continue reading across the selected altitude line to the fuel column which is equal to or less than the fuel load; the figure in this column will be the maximum hours of hovering endurance. To cite a specific example, the pilot desires to know how long the helicopter can be hovered with a gross weight of 12,500 pounds and a fuel load of 1200 pounds at 2000 feet pressure altitude. Reference to the chart under the appropriate value indicates that the maximum hovering time is 1.4 hours. Related values of engine rpm, manifold pressure, mixture, fuel consumption, and airspeed are also given.

**SAMPLE FLIGHT PLAN PROBLEM.**

Flight planning is resolved basically to an analysis of the mission to be performed, with the factors of gross weight, airspeed, distance, alti-

tude, temperature, and wind velocity considered to render the ultimate important result of fuel required for successful completion of the cruise.

**THE PROBLEM.**

Estimate the fuel required to fly 125 nautical miles from a point at sea level, rescue six survivors located at an altitude of 10,000 feet, and return to the base with a minimum of 10 per cent fuel load. Refer to figure A-1.

**GIVEN VALUES.**

- a. Outside air temperature at base °C .. +15
- b. Outbound tailwind, knots ..... 15
- c. Cruise altitude, feet ..... 6000
- d. Survivor weight, pounds per man .... 200

**CALCULATION.**

**Note**

In order to obtain the closest gross weight and fuel requirement for each flight pattern, it is necessary to work the problem in reverse of the actual flight plan.

**GROSS WEIGHT.** The initial gross weight of the helicopter is calculated before fuel is added and as shown below:

- a. Basic weight of YH-21 (including trapped fuel and engine oil) .....8117 pounds
  - b. Crew (2)..... 400 pounds
  - c. Survivors (200 lb each).....1200 pounds
  - d. Engine oil..... 64 pounds
  - e. Transmission oil..... 30 pounds
  - f. Litters (6)..... 150 pounds
  - g. Blankets (6)..... 42 pounds
  - h. Dressings and splints..... 33 pounds
  - i. First aid equipment..... 15 pounds
  - j. Rafts (2)..... 30 pounds
  - k. First aid kits (3)..... 3 pounds
  - l. Rescue hoist..... 45 pounds
- Total .....10,129 pounds

**RETURN CRUISE.** Fuel for return cruise is determined on the initial gross weight before fuel is added. Apply the following values to the Flight Operation Instruction Chart, Best Range Cruise Condition (figure A-6):

- a. Helicopter gross weight, pounds....10,129
- b. Pressure altitude, feet..... 6,000
- c. Inbound headwind, knots..... 15

At the corresponding power settings for the gross weight bracket of 8900 to 10,300 pounds and altitude of 6000 feet, previously selected, obtain:

- a. TAS. 103 knots.
- b. Fuel consumption. 305 lb/hr.

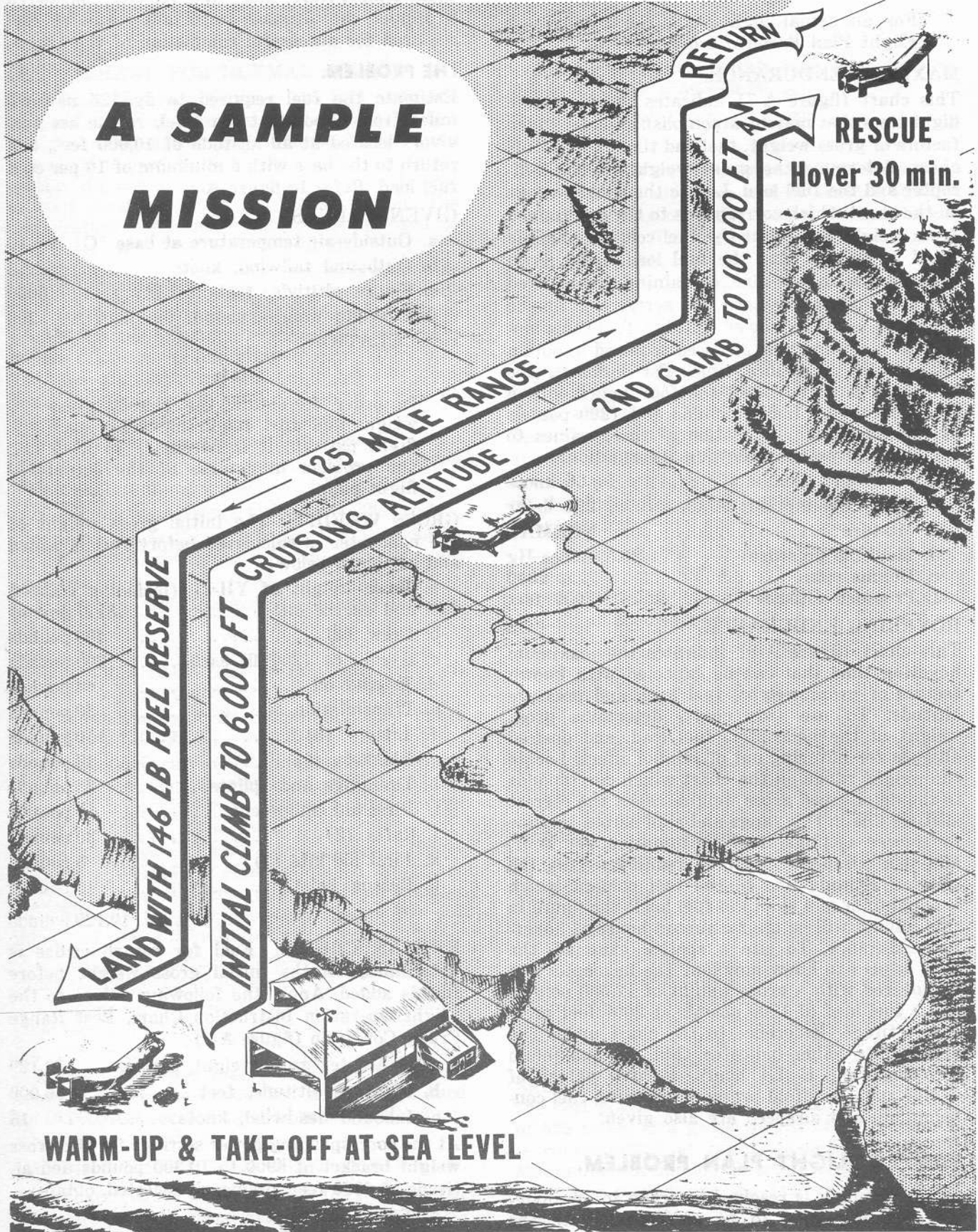

Figure A-1. Sample Mission

c. Subtract 15 knots from TAS of 103 knots, for inbound headwind.

d. Calculate the fuel required by using the proportion of  $\frac{125}{88} \times 305 = 433$  pounds of fuel for return cruise.

The new gross weight of helicopter, derived by adding the return cruise fuel to the initial gross weight is 10,562 pounds. Since this puts the helicopter gross weight in a new range, the return cruise fuel is recalculated to be 533 pounds. Hence, the weight of the helicopter before return cruise is 10,662 pounds.

RESCUE (HOVER). Hovering fuel consumption is determined on the basis of maximum weight during hovering, which in this case is the weight before return cruise (10,662 pounds). Apply the following values to the Hovering Endurance Chart (figure A-8):

- a. Gross weight of helicopter, pounds...10,662
- b. Time required for hover, five minutes per man, total minutes..... 30
- c. Pressure altitude, feet.....10,000

At a pressure altitude of 10,000 feet it is found that the fuel required to hover one hour is 756 pounds. Therefore, fuel required to hover one-half hour is 378 pounds.

SECOND CLIMB. The helicopter gross weight at the end of the climb is the gross weight at the beginning of the rescue, calculated as follows:

Gross weight before return cruise, pounds 10,662  
Plus weight of fuel for hover, pounds.... +378

Total pounds .....11,040  
Minus weight of survivors, pounds.....-1,200

Gross weight beginning of rescue, pounds 9,840  
Apply the following values to the Climb Chart (figure A-3):

- a. Helicopter gross weight, pounds.....9840
- b. Temperature at 6000 feet, °C..... +3
- c. Temperature at 10,000 feet, °C..... -5

The resultant variable in fuel to climb from 6000 feet to 10,000 feet is 48 pounds. This quantity added to the gross weight at the end of the second climb gives a resultant weight of 9888 pounds, helicopter gross weight at the beginning of the second climb.

OUTBOUND CRUISE. The helicopter gross weight at the finish of the outbound cruise is the same as that of the beginning of the second climb. By application of the following values to

the Flight Operation Instruction Chart, Best Range Cruise Condition (figure A-6), the resultant fuel consumption is 323 pounds:

- a. Helicopter gross weight, pounds.....9888
- b. Pressure altitude, feet.....6000
- c. Outbound tailwind, knots..... 15

It is then apparent that the helicopter gross weight at the beginning of the outbound cruise is 10,211 pounds, the sum of the outbound cruise fuel (323 pounds), plus the weight of the helicopter at the end of the outbound cruise (9888 pounds).

FIRST CLIMB (SEA LEVEL TO 6000 FEET). The helicopter gross weight at the end of the first climb is the same as its weight at the beginning of the outbound cruise (10,211 pounds). Apply the following values to the Climb Chart (figure A-3):

- a. Helicopter gross weight, pounds....10,211
- b. Temperature at 6000 feet..... +3°C
- c. Temperature at sea level..... +15°C

Hence, the variable between fuel at sea level (78 pounds) and the fuel used to climb to 6000 feet (138 pounds) is 60 pounds.

WARM-UP AND TAKE-OFF. The quantity of fuel allowed for warm-up and take-off is 78 pounds based on five minutes at normal rated power.

TOTAL MISSION FUEL.

- Fuel for warm-up and take-off, pounds.... 78
- Fuel for first climb, pounds..... 60
- Fuel for outbound cruise, pounds.....323
- Fuel for second climb, pounds..... 48
- Fuel for hover and rescue, pounds.....378
- Fuel for return cruise, pounds.....533

Mission fuel, pounds.....1420

$$\text{Total fuel} = \frac{1420 \text{ pounds}}{90\%} = 1577$$

Add reserve fuel to the original total landing weight: weight of 10,129 pounds plus 157 pounds equals 10,286 pounds. Since the total weight falls within the same weight bracket originally selected of 8900 to 10,300 pounds, it will not be necessary to re-estimate the problem. However, if the final landing weight plus the reserve fuel weight was greater than the originally selected weight bracket, the entire problem would have to be re-worked using the new weight (final landing weight plus reserve fuel weight).





# TAKE-OFF DISTANCES—FEET

FIRM DRY SOD

MODEL(S): YH-21

ENGINE(S): R-1820-103

GROSS WEIGHT	PRESS. ALT	TAKE-OFF SURFACE TEMPERATURE — Degrees Centigrade									
		-25°C		-5°C		15°C		35°C		55°C	
		GROUND RUN	CLEAR 50 ft	GROUND RUN	CLEAR 50 ft	GROUND RUN	CLEAR 50 ft	GROUND RUN	CLEAR 50 ft	GROUND RUN	CLEAR 50 ft
Pounds	Feet										
Minimum Gross to 8500	12000	0	0	0	0	0	0	0	0	0	0
	10000	0	0	0	0	0	0	0	0	0	0
	8000	0	0	0	0	0	0	0	0	0	0
	6000	0	0	0	0	0	0	0	0	0	0
	4000	0	0	0	0	0	0	0	0	0	0
	2000	0	0	0	0	0	0	0	0	0	0
	SL	0	0	0	0	0	0	0	0	0	0
8500 to 11500	12000	0	120	90	640	800	1720	3700	8300	--	--
	10000	0	0	0	110	70	580	690	1580	3200	6400
	8000	0	0	0	0	0	80	50	490	410	1270
	6000	0	0	0	0	0	0	0	50	20	360
	4000	0	0	0	0	0	0	0	0	0	30
	2000	0	0	0	0	0	0	0	0	0	0
	SL	0	0	0	0	0	0	0	0	0	0
11500 to 14500	12000	--	--	--	--	--	--	--	--	--	--
	10000	4200	6300	--	--	--	--	--	--	--	--
	8000	1340	2200	4400	6300	--	--	--	--	--	--
	6000	610	1270	1380	2270	3600	5600	--	--	--	--
	4000	200	700	570	1210	1300	2160	3150	5000	--	--
	2000	60	390	200	700	550	1180	1250	2100	2720	4100
	SL	0	160	60	400	190	680	530	1150	1180	2000

REMARKS: All figures in red are minimum distances increased by 15 percent until verified by flight test.

DATA AS OF: April 1952  
DATA BASIS: ESTIMATES - PHC REPORT NO. 22-A-09

FUEL GRADE: 100/130  
FUEL DENSITY: 6 lb/gal

Figure A-2. Take-Off Distance Chart

# CLIMB CHART FOR NORMAL POWER

MODEL(S): YH-21

ENGINE(S): R-1820-103

GROSS WEIGHT	PRESS. ALT	SEA LEVEL TEMPERATURE — Degrees Centigrade											
		-25 °C				-5 °C				+15 °C			
		BEST IAS	RATE OF CLIMB	FROM SL		BEST IAS	RATE OF CLIMB	FROM SL		BEST IAS	RATE OF CLIMB	FROM SL	
Pounds	Feet	Knots	Fpm	TIME	FUEL USED	Knots	Fpm	TIME	FUEL USED	Knots	Fpm	TIME	FUEL USED
				Min	Lb			Min	Lb			Min	Lb
Minimum Gross to 8500	20000	46	1100	9.9	228	38	100	12.0	258	--	--	--	--
	18000	56	1520	8.4	204	48	1140	8.8	210	38	400	10.4	234
	16000	57	1920	7.2	186	56	1550	7.3	186	48	1180	7.9	198
	14000	58	1985	6.2	168	58	1950	6.2	174	57	1575	6.4	174
	12000	58	2130	5.2	156	58	1960	5.2	156	57	1970	5.3	156
	10000	58	2470	4.3	144	58	2150	4.2	138	58	1960	4.3	144
	8000	58	2580	3.5	132	58	2470	3.3	126	58	2150	3.3	126
	6000	58	2440	2.7	120	58	2580	2.5	108	58	2475	2.4	108
	4000	57	2300	1.9	108	58	2450	1.7	102	58	2580	1.6	102
	2000	56	2150	1.0	90	57	2300	0.9	90	58	2440	0.8	90
SL	56	1980	0	78	56	2150	0	78	57	2300	0	78	
8500 to 11500	20000	--	--	--	--	--	--	--	--	--	--	--	--
	18000	--	--	--	--	--	--	--	--	--	--	--	--
	16000	33	200	15.8	318	--	--	--	--	--	--	--	--
	14000	43	700	11.3	246	34	200	14.1	288	--	--	--	--
	12000	56	960	8.9	210	44	700	9.6	222	35	290	11.8	258
	10000	63	1380	7.2	186	55	1020	7.3	186	44	720	7.8	198
	8000	63	1540	5.8	162	63	1400	5.6	162	56	1070	5.6	162
	6000	63	1460	4.5	144	63	1540	4.2	138	63	1410	4.1	138
	4000	63	1375	3.1	126	63	1460	2.9	120	63	1504	2.7	120
	2000	63	1280	1.6	102	63	1380	1.5	102	63	1460	1.4	102
SL	63	1200	0	78	63	1290	0	78	63	1370	0	78	
11500 to 14500	20000	--	--	--	--	--	--	--	--	--	--	--	--
	18000	--	--	--	--	--	--	--	--	--	--	--	--
	16000	--	--	--	--	--	--	--	--	--	--	--	--
	14000	--	--	--	--	--	--	--	--	--	--	--	--
	12000	--	--	--	--	--	--	--	--	--	--	--	--
	10000	39	100	19.3	366	--	--	--	--	--	--	--	--
	8000	51	520	12.8	270	39	130	15.9	318	--	--	--	--
	6000	63	620	9.3	216	51	520	9.7	222	39	140	12.6	270
	4000	70	660	6.2	174	63	620	6.2	174	52	530	6.6	180
	2000	70	670	3.2	126	70	660	3.1	126	63	620	3.2	126
SL	69	600	0	78	70	670	0	78	70	660	0	78	

**REMARKS:**

1. Maximum Engine Settings for Normal Power Climb:
  - a. Low Blower: MP of 39.5 inches Hg to 6000 feet  
Full throttle—6000 to 11600 feet
  - b. High Blower: MP of 43.5 inches Hg—11600 to 14750 feet  
Full throttle—14750 feet to ceiling.

2. Rapid decrease in rate of climb as service ceiling is approached is due largely to blade stall.
3. Fuel Used column includes warm-up and take-off allowance of 78 pounds (5 minutes at normal rated power).
4. Time column does not include time required for warm-up and take-off.

DATA AS OF: April 1952  
DATA BASIS: ESTIMATES - PHC REPORT NO. 22-A-09

FUEL GRADE: 100/130  
FUEL DENSITY: 6 lb/gal

Figure A-3. Climb Chart for Normal Power (Sheet 1 of 2)

# CLIMB CHART FOR NORMAL POWER

MODEL(S): YH-21

ENGINE(S): R-1820-103

GROSS WEIGHT	PRESS. ALT	SEA LEVEL TEMPERATURE — Degrees Centigrade											
		+35 °C				+55 °C				°C			
		BEST IAS	RATE OF CLIMB	FROM SL		BEST IAS	RATE OF CLIMB	FROM SL		BEST IAS	RATE OF CLIMB	FROM SL	
				TIME	FUEL USED			TIME	FUEL USED			TIME	FUEL USED
Pounds	Feet	Knots	Fpm	Min	Lb	Knots	Fpm	Min	Lb	Knots	Fpm	Min	Lb
Minimum Gross to 8500	16000	39	650	9.1	216	--	--	--	--				
	14000	50	1250	7.0	180	43	800	8.0	198				
	12000	56	1650	5.6	162	51	1300	6.1	174				
	10000	57	2000	4.5	144	57	1650	4.7	150				
	8000	58	1960	3.5	132	58	1980	3.6	132				
	6000	58	2200	2.5	114	58	1950	2.6	120				
	4000	58	2500	1.6	102	58	2240	1.6	102				
	2000	58	2570	0.8	90	58	2550	0.8	90				
	SL	58	2420	0	78	57	2540	0	78				
8500 to 11500	16000	--	--	--	--	--	--	--	--				
	14000	--	--	--	--	--	--	--	--				
	12000	--	--	--	--	--	--	--	--				
	10000	36	350	9.9	228	--	--	--	--				
	8000	46	750	6.3	174	38	470	8.0	198				
	6000	58	1120	4.2	144	49	770	4.8	150				
	4000	64	1440	2.6	120	59	1140	2.7	120				
	2000	64	1540	1.3	96	63	1480	1.3	96				
	SL	63	1450	0	78	63	1530	0	78				
11500 to 14500	16000	--	--	--	--	--	--	--	--				
	14000	--	--	--	--	--	--	--	--				
	12000	--	--	--	--	--	--	--	--				
	10000	--	--	--	--	--	--	--	--				
	8000	--	--	--	--	--	--	--	--				
	6000	--	--	--	--	--	--	--	--				
	4000	41	240	8.6	204	--	--	--	--				
	2000	52	540	3.5	132	43	310	4.7	150				
	SL	64	620	0	78	53	540	0	78				

REMARKS: See sheet 1.

DATA AS OF: April 1952  
DATA BASIS: ESTIMATES - PHC REPORT NO. 22-A-09

FUEL GRADE: 100/130  
FUEL DENSITY: 6 lb/gal

Figure A-3. Climb Chart for Normal Power (Sheet 2 of 2)

# LANDING DISTANCES—FEET

## POWER-ON

MODEL(S): YH-21

ENGINE(S): R-1820-103

GROSS WEIGHT	PRESS. ALT	LANDING SURFACE TEMPERATURE — Degrees Centigrade									
		-25 °C			-5 °C			+15 °C			
		BEST IAS APPROACH	GROUND ROLL	CLEAR 50 ft OBJECT	BEST IAS APPROACH	GROUND ROLL	CLEAR 50 ft OBJECT	BEST IAS APPROACH	GROUND ROLL	CLEAR 50 ft OBJECT	
Pounds	Feet	Knots		Knots			Knots				
Minimum Gross  to 8500											
	12000		59	0	0	58	0	0	58	0	0
	10000		59	0	0	58	0	0	58	0	0
	8000		59	0	0	58	0	0	58	0	0
	6000		58	0	0	58	0	0	58	0	0
	4000		57	0	0	58	0	0	58	0	0
	2000		57	0	0	57	0	0	58	0	0
	SL		56	0	0	57	0	0	57	0	0
8500  to 11500											
	12000		64	0	25	58	0	110	48	20	255
	10000		64	0	0	64	0	35	58	0	105
	8000		64	0	0	64	0	0	64	0	15
	6000		64	0	0	64	0	0	64	0	0
	4000		64	0	0	64	0	0	64	0	0
	2000		63	0	0	64	0	0	64	0	0
	SL		62	0	0	63	0	0	64	0	0
11500  to 14500											
	12000		--	--	--	--	--	--	--	--	--
	10000		50	115	365	--	--	--	--	--	--
	8000		65	40	275	51	115	365	--	--	--
	6000		70	0	220	65	45	280	52	105	360
	4000		70	0	185	70	0	220	66	40	275
	2000		70	0	160	70	0	185	70	0	220
	SL		70	0	145	70	0	160	70	0	185

- REMARKS:**
- Best IAS approach is speed for minimum rate of descent with rotor speed of 270 rpm.
  - Maximum power used during landing is military rated of 2600 engine rpm.
  - Distance to clear 50-foot obstacle is total amount of landing distance required. Ground roll is a part of the landing distance.
  - All figures in red are minimum distances increased by 15 percent until verified by flight test.

DATA AS OF: April 1952  
DATA BASIS: ESTIMATES - PHC REPORT NO. 22-A-09

FUEL GRADE: 100/130  
FUEL DENSITY: 6 lb/gal

Figure A-4. Power-On Landing Distance Chart (Sheet 1 of 2)

# LANDING DISTANCES—FEET

## POWER-ON

MODEL(S): YH-21

ENGINE(S): R-1820-103

GROSS WEIGHT	PRESS. ALT	LANDING SURFACE TEMPERATURE — Degrees Centigrade								
		+35 °C			+55 °C			°C		
		BEST IAS APPROACH	GROUND ROLL	CLEAR 50 ft OBJECT	BEST IAS APPROACH	GROUND ROLL	CLEAR 50 ft OBJECT	BEST IAS APPROACH	GROUND ROLL	CLEAR 50 ft OBJECT
Pounds	Feet	Knots			Knots			Knots		
Minimum Gross to 8500	12000	57	0	0	57	0	0			
	10000	58	0	0	57	0	0			
	8000	58	0	0	58	0	0			
	6000	58	0	0	58	0	0			
	4000	58	0	0	58	0	0			
	2000	58	0	0	58	0	0			
	SL	58	0	0	58	0	0			
8500 to 11500	12000	38	150	415	--	--	--			
	10000	48	10	230	38	140	410			
	8000	58	0	90	48	0	200			
	6000	64	0	15	58	0	70			
	4000	64	0	0	64	0	0			
	2000	64	0	0	64	0	0			
	SL	64	0	0	64	0	0			
11500 to 14500	12000	--	--	--	--	--	--			
	10000	--	--	--	--	--	--			
	8000	--	--	--	--	--	--			
	6000	--	--	--	--	--	--			
	4000	53	100	345	--	--	--			
	2000	67	35	265	55	95	340			
	SL	70	0	245	67	35	265			

REMARKS: See sheet 1.

DATA AS OF: April 1952

DATA BASIS: ESTIMATES - PHC REPORT NO. 22-A-09

FUEL GRADE: 100/130  
FUEL DENSITY: 6 lb/gal

Figure A-4. Power-On Landing Distance Chart (Sheet 2 of 2)

# LANDING DISTANCES—FEET

## POWER-OFF

MODEL(S): YH-21

ENGINE(S): R-1820-103

GROSS WEIGHT	PRESS. ALT	LANDING SURFACE TEMPERATURE — Degrees Centigrade								
		-25 °C			-5 °C			+15 °C		
		BEST IAS APPROACH	GROUND ROLL	CLEAR 50 ft OBJECT	BEST IAS APPROACH	GROUND ROLL	CLEAR 50 ft OBJECT	BEST IAS APPROACH	GROUND ROLL	CLEAR 50 ft OBJECT
Pounds	Feet	Knots		Knots			Knots			
Minimum Gross	12000	34	115	355	35	145	405	35	175	455
	10000	34	90	320	35	115	355	35	145	405
	8500	34	65	290	34	90	320	35	115	355
	6000	34	50	265	34	65	290	34	90	320
	4000	33	40	255	34	50	265	34	65	290
	2000	32	35	240	33	40	255	34	50	265
	SL	31	30	230	32	35	240	33	40	255
8500	12000	41	345	560	41	405	580	41	470	560
	10000	40	290	525	41	345	560	41	405	580
	8500	40	235	475	41	290	525	41	345	560
	6000	40	190	420	41	235	475	41	290	525
	4000	40	150	360	41	190	420	41	235	475
	2000	39	120	305	41	150	360	41	190	420
	SL	39	100	260	40	120	305	40	150	360
11500	12000	--	--	--	--	--	--	--	--	--
	10000	43	385	575	--	--	--	--	--	--
	8500	47	410	590	43	385	575	--	--	--
	6000	49	390	580	47	410	590	43	385	575
	4000	50	340	570	49	390	580	47	410	590
	2000	51	260	530	50	340	570	49	390	580
	SL	51	240	495	50	260	530	50	340	570

- REMARKS:**
- Best IAS approach is speed for steep glide angle with low rate of descent.
  - Rotor speed during approach is 270 rpm.
  - Distance to clear 50-foot obstacle is total amount of landing distance required. Ground roll is a part of total landing distance.

- All figures in red are minimum distances increased by 15 percent until verified by flight test.

DATA AS OF: April 1952  
DATA BASIS: ESTIMATES - PHC REPORT NO. 22-A-09

FUEL GRADE: 100/130  
FUEL DENSITY: 6 lb/gal

Figure A-5. Power-Off Landing Distance Chart (Sheet 1 of 2)

# LANDING DISTANCES—FEET

## POWER-OFF

MODEL(S): YH-21

ENGINE(S): R-1820-103

GROSS WEIGHT	PRESS. ALT	LANDING SURFACE TEMPERATURE — Degrees Centigrade								
		+35 °C			+55 °C			°C		
		BEST IAS APPROACH	GROUND ROLL	CLEAR 50 ft OBJECT	BEST IAS APPROACH	GROUND ROLL	CLEAR 50 ft OBJECT	BEST IAS APPROACH	GROUND ROLL	CLEAR 50 ft OBJECT
Pounds	Feet	Knots			Knots			Knots		
Minimum Gross  to 8500										
	12000		35	210	505	34	250	555		
	10000		35	175	455	34	210	505		
	8000		35	145	405	34	175	455		
	6000		35	115	355	34	145	405		
	4000		34	90	320	34	115	355		
	2000		33	65	290	34	90	310		
SL		33	50	265	33	65	290			
8500  to 11500										
	12000		--	--	--	--	--	--		
	10000		40	470	560	40	475	555		
	8000		41	405	580	41	470	560		
	6000		41	345	560	41	405	580		
	4000		41	290	525	41	345	560		
	2000		41	235	475	41	290	525		
SL		40	190	420	41	235	475			
11500  to 14500										
	12000		--	--	--	--	--	--		
	10000		--	--	--	--	--	--		
	8000		--	--	--	--	--	--		
	6000		--	--	--	--	--	--		
	4000		43	385	575	--	--	--		
	2000		47	410	590	43	385	575		
SL		49	390	580	47	410	590			

REMARKS: See sheet 1.

DATA AS OF: April 1952  
DATA BASIS: ESTIMATES - PHC REPORT NO. 22-A-09

FUEL GRADE: 100/130  
FUEL DENSITY: 6 lb/gal

Figure A-5. Power-Off Landing Distance Chart (Sheet 2 of 2)

<b>FLIGHT OPERATION INSTRUCTION CHART</b>													
MODEL(S): YH-21		ENGINE(S): R-1820-103		<b>STANDARD DAY</b>									
<b>CRUISE CONDITION — MAXIMUM CONTINUOUS</b>													
GROSS WEIGHT Pounds	POWER SETTINGS				PRESS. ALT Feet	RANGE — Nautical Air miles							
	ENGINE SPEED Rpm	MAN. PRESS. In. Hg	MIX-TURE	APPROXIMATE		1800 lb	1500 lb	1200 lb	900 lb	600 lb	300 lb		
				Total lb/hr								Speed/Knots	TAS
8900	2500	23.0	Norm	278	94	83	608	506	404	304	202	102	
to	2500	25.0	Norm	305	103	94	604	503	402	302	201	101	
10300	2500	27.5	Norm	361	111	105	555	462	370	277	185	93	
	2500	30.0	Norm	415	119	115	516	429	344	258	172	86	
	2500	33.0	Norm	568	125	125	397	330	264	199	132	66	
10300	2500	24.0	Norm	294	78	69	506	405	318	239	160	80	
to	2500	25.0	Norm	307	87	80	531	430	339	255	170	85	
11700	2500	27.0	Norm	337	96	91	521	427	339	255	170	85	
	2500	29.0	Norm	381	104	101	497	411	328	246	164	82	
	2500	31.0	Norm	445	112	112	441	374	302	226	151	76	
11700	2500	28.0	Norm	414	65	58	326	247	188	141	95	47	
to	2500	27.5	Norm	359	73	67	397	313	244	183	121	61	
13100	2500	27.5	Norm	346	81	76	440	356	280	210	140	70	
	2500	28.0	Norm	355	88	85	456	374	297	223	148	75	
	2500	30.0	Norm	384	96	96	452	376	301	226	150	76	
13100	2500	34.5	Norm	636	55	50	200	141	103	77	51	26	
to	2500	32.0	Norm	528	66	62	269	199	150	113	75	37	
14500	2500	30.0	Norm	424	70	68	331	257	199	149	100	50	
	2500	31.0	Norm	440	80	80	355	280	218	163	108	55	

**REMARKS:** 1. Range in Air miles given to show the speed at best mile per pound so that the best range can be obtained. Range values are calculated with zero wind.  
 2. Use Climb Chart for obtaining allowance for warm-up, take-off and climb.  
 3. Make allowance for wind and reserve fuel as required for Flight Plan.  
 4. Maximum continuous cruise condition is determined by blade stall rather than power limitations, therefore, power settings shown are less than normal rated.

**DATA AS OF:** April 1952  
**DATA BASIS:** ESTIMATES - PHC REPORT NO. 22-A-09  
**FUEL GRADE:** 100/130  
**FUEL DENSITY:** 6 lb/gal

Figure A-6. Flight Operation Instruction Chart (Sheet 1 of 3)



<b>FLIGHT OPERATION INSTRUCTION CHART</b>													
MODEL(S): YH-21		ENGINE(S): R-1820-103		<b>STANDARD DAY</b>									
<b>CRUISE CONDITION — INTERMEDIATE</b>													
GROSS WEIGHT	Pounds	POWER SETTINGS					PRESS. ALT	RANGE — Nautical Air miles					
		ENGINE SPEED	MAN. PRESS.	MIX-TURE	APPROXIMATE			1800 lb	1500 lb	1200 lb	900 lb	600 lb	300 lb
					Total	Speed/Knots							
Rpm	In. Hg		TAS	IAS	Feet								
8900	23.0	2500	278	94	83	8000	608	506	404	304	202	102	
to	25.0	2500	305	103	94	6000	604	503	402	302	201	101	
10300	26.5	2460	325	106	100	4000	586	489	391	293	195	98	
	29.0	2460	353	113	110	2000	576	480	384	287	192	96	
	31.0	2440	415	118	118	SL	512	427	342	256	171	85	
10300	24.0	2500	294	78	69	8000	506	405	318	239	160	80	
to	25.0	2500	307	87	80	6000	531	430	339	255	170	85	
11700	26.0	2475	321	91	86	4000	528	431	340	256	170	85	
	27.0	2455	331	96	93	2000	531	436	345	260	173	87	
	29.5	2430	374	103	103	SL	499	413	329	246	165	83	
11700	28.0	2500	414	65	58	8000	326	247	188	141	95	47	
to	27.5	2500	359	73	67	6000	397	313	244	183	121	61	
13100	27.5	2500	346	81	76	4000	440	356	280	210	140	70	
	28.0	2500	355	88	85	2000	456	374	297	223	148	75	
	29.5	2475	354	92	92	SL	473	392	310	233	155	78	
13100	34.5	2500	636	55	50	6000	200	141	103	77	51	26	
to	32.0	2500	528	66	62	4000	269	199	150	113	75	37	
14500	30.0	2500	424	70	68	2000	331	257	199	149	100	50	
	31.0	2500	440	80	80	SL	355	280	218	163	108	55	

REMARKS: See sheet 1 (Maximum Continuous).

DATA AS OF: April 1952  
 DATA BASIS: ESTIMATES — PHC REPORT NO. 22-A-09  
 FUEL GRADE: 100/130  
 FUEL DENSITY: 6 lb/gal

Figure A-6. Flight Operation Instruction Chart (Sheet 2 of 3)

# FLIGHT OPERATION INSTRUCTION CHART

MODEL(S): YH-21 ENGINE(S): R-1820-103

STANDARD DAY

## CRUISE CONDITION — BEST RANGE

GROSS WEIGHT Pounds	POWER SETTINGS					PRESS. ALT Feet	RANGE — Nautical Air miles											
	ENGINE SPEED Rpm	MAN. PRESS. In. Hg	MIX-TURE	APPROXIMATE			1800 lb	1500 lb	1200 lb	900 lb	600 lb	300 lb	Fuel	Fuel	Fuel	Fuel	Fuel	
				Total lb/hr	Speed/Knots													TAS
8900 to 10300	2500	23.0	Norm	278	94	83	608	506	404	304	202	102	8000					
	2500	25.0	Norm	305	103	94	604	503	402	302	201	101		6000				
	2400	24.5	Norm	279	96	91	616	513	411	308	205	102		4000				
10300 to 11700	2340	25.5	Norm	274	96	93	629	524	419	314	210	105	2000					
	2270	26.5	Norm	276	96	96	623	518	415	311	208	104		SL				
	2500	24.0	Norm	294	78	69	506	405	318	239	160	80		8000				
11700 to 13100	2500	25.0	Norm	307	87	79	531	430	339	255	170	85	6000					
	2430	25.3	Norm	292	86	81	547	445	352	264	176	88		4000				
	2390	25.5	Norm	285	86	83	562	457	361	271	181	90		2000				
13100 to 14500	2350	26.5	Norm	293	88	88	558	454	359	269	180	89	SL					
	2500	28.0	Norm	414	65	58	326	247	188	141	95	47		8000				
	2500	27.5	Norm	359	73	67	397	313	244	183	121	61		6000				
14500 to 15900	2500	27.5	Norm	346	81	76	440	356	280	210	140	70	4000					
	2460	27.5	Norm	332	83	81	468	377	298	224	149	75		2000				
	2450	28.5	Norm	328	87	87	491	401	318	239	159	80		SL				
15900 to 17300	2500	34.5	Norm	636	55	50	200	141	103	77	51	26	6000					
	2500	32.0	Norm	528	66	62	269	199	150	113	75	37		4000				
	2500	30.0	Norm	424	70	68	331	257	199	149	100	50		2000				
17300	2500	31.0	Norm	440	80	80	355	280	218	163	108	55	SL					

REMARKS: See sheet 1 (Maximum Continuous).

DATA AS OF: April 1952  
 DATA BASIS: ESTIMATES - PHC REPORT NO. 22-A-09  
 FUEL GRADE: 100/130  
 FUEL DENSITY: 6 lb/gal

Figure A-6. Flight Operation Instruction Chart (Sheet 3 of 3)

# MAXIMUM ENDURANCE STANDARD DAY

MODEL(S): YH-21

ENGINE(S): R-1820-103

GROSS WEIGHT	PRESS. ALT	POWER SETTINGS						ENDURANCE — Hours								
		Engine Speed	Man. Press.	Mixture	APPROXIMATE			1800 Pounds Fuel	1500 Pounds Fuel	1200 Pounds Fuel	900 Pounds Fuel	600 Pounds Fuel	300 Pounds Fuel	Pounds Fuel	Pounds Fuel	Pounds Fuel
					Total lb/hr	Speed/TAS	Speed/IAS									
Pounds	Feet	Rpm	In. Hg		lb/hr	TAS	IAS	Pounds Fuel	Pounds Fuel	Pounds Fuel	Pounds Fuel	Pounds Fuel	Pounds Fuel	Pounds Fuel	Pounds Fuel	Pounds Fuel
8900 to 10300	8000	2280	21.5	Norm	239	59	52	7.6	6.3	5.0	3.8	2.5	1.3			
	6000	2260	22.0	Norm	236	61	56	7.6	6.4	5.1	3.8	2.5	1.3			
	4000	2260	22.0	Norm	231	60	57	7.8	6.5	5.2	3.9	2.6	1.3			
	2000	2260	22.5	Norm	229	60	58	7.9	6.6	5.2	3.9	2.6	1.3			
	SL	2260	23.0	Norm	228	60	60	7.9	6.6	5.3	4.0	2.6	1.3			
10300 to 11700	8000	2420	23.5	Norm	283	66	58	6.6	5.4	4.2	3.2	2.1	1.1			
	6000	2320	23.5	Norm	270	62	57	6.9	5.6	4.5	3.3	2.2	1.1			
	4000	2300	24.0	Norm	257	65	61	7.1	5.8	4.7	3.5	2.3	1.2			
	2000	2260	24.5	Norm	254	65	63	7.3	5.9	4.7	3.5	2.4	1.2			
	SL	2260	25.0	Norm	250	62	62	7.4	6.0	4.8	3.6	2.4	1.2			
11700 to 13100	8000	2500	28.0	Norm	425	65	58	4.7	3.7	2.8	2.1	1.4	0.7			
	6000	2430	27.0	Norm	347	64	58	5.5	4.4	3.5	2.6	1.7	0.8			
	4000	2380	27.0	Norm	315	65	61	6.0	4.9	3.8	2.8	1.9	0.9			
	2000	2340	26.5	Norm	295	66	64	6.3	5.2	4.0	3.0	2.0	1.0			
	SL	2310	27.5	Norm	291	66	66	6.4	5.2	4.1	3.1	2.1	1.0			
13100 to 14500	6000	2500	34.5	Norm	645	55	50	3.3	2.4	1.8	1.4	0.9	0.4			
	4000	2500	32.0	Norm	515	66	62	4.0	3.0	2.3	1.7	1.1	0.6			
	2000	2490	30.0	Norm	418	69	67	4.7	3.6	2.9	2.1	1.4	0.7			
	SL	2420	31.0	Norm	425	68	68	4.7	3.6	2.8	2.1	1.4	0.7			

REMARKS:

DATA AS OF: April 1952  
DATA BASIS: ESTIMATES - PHC REPORT NO. 22-A-09

FUEL GRADE: 100/130  
FUEL DENSITY: 6 lb/gal

Figure A-7. Maximum Endurance Chart

# HOVERING ENDURANCE STANDARD DAY

MODEL(S): YH-21

ENGINE(S): R-1820-103

GROSS WEIGHT	PRESS. ALT	POWER SETTINGS						ENDURANCE — Hours								
		Engine Speed	Man. Press.	Mix-ture	APPROXIMATE			1800 Pounds Fuel	1500 Pounds Fuel	1200 Pounds Fuel	900 Pounds Fuel	600 Pounds Fuel	300 Pounds Fuel	Pounds Fuel	Pounds Fuel	Pounds Fuel
					Total lb/hr	Speed/Knots TAS	Speed/Knots IAS									
Pounds	Feet	Rpm	In. Hg													
8900	10000	2500	33.0	Norm	618	0	0	2.9	2.4	1.9	1.5	0.97	0.49			
	8000	2500	33.0	Norm	602	0	0	3.0	2.5	2.0	1.5	1.0	0.50			
to	6000	2500	33.0	Norm	583	0	0	3.1	2.6	2.1	1.5	1.0	0.51			
	4000	2500	33.5	Norm	573	0	0	3.1	2.6	2.1	1.6	1.0	0.52			
10300	2000	2500	33.5	Norm	565	0	0	3.2	2.7	2.1	1.6	1.1	0.53			
	SL	2500	34.0	Norm	553	0	0	3.3	2.7	2.2	1.6	1.1	0.54			
10300	10000	2500	FT	Norm	756	13	11	2.4	2.0	1.6	1.2	0.80	0.40			
	8000	2500	FT	Norm	756	10	9	2.4	2.0	1.6	1.2	0.80	0.40			
to	6000	2500	37.0	Norm	737	0	0	2.6	2.1	1.6	1.2	0.81	0.41			
	4000	2500	37.0	Norm	714	0	0	2.7	2.2	1.7	1.3	0.84	0.42			
11700	2000	2500	37.5	Norm	689	0	0	2.7	2.2	1.7	1.3	0.86	0.43			
	SL	2500	37.5	Norm	678	0	0	2.8	2.3	1.8	1.3	0.89	0.44			
11700	8000	2500	FT	Norm	756	25	22	2.4	2.0	1.6	1.2	0.80	0.40			
	6000	2500	39.5	Norm	823	12	11	2.2	1.8	1.4	1.1	0.73	0.36			
to	4000	2500	40.0	Norm	823	6	6	2.2	1.8	1.4	1.1	0.73	0.36			
	2000	2500	41.0	Norm	823	3	3	2.2	1.8	1.4	1.1	0.73	0.36			
13100	SL	2500	41.5	Norm	823	0	0	2.2	1.8	1.4	1.1	0.73	0.36			
13100	8000	2500	FT	Norm	756	48	42	2.4	2.0	1.6	1.2	0.80	0.40			
	6000	2500	39.5	Norm	823	26	24	2.2	1.8	1.4	1.1	0.73	0.36			
to	4000	2500	40.0	Norm	823	23	22	2.2	1.8	1.4	1.1	0.73	0.36			
	2000	2500	41.0	Norm	823	20	19	2.2	1.8	1.4	1.1	0.73	0.36			
14500	SL	2500	41.5	Norm	823	20	20	2.2	1.8	1.4	1.1	0.73	0.36			

REMARKS: 1. TAS - All values given are for headwinds required for hovering at each respective altitude and weight range.

DATA AS OF: April 1952  
DATA BASIS: ESTIMATES - PHC REPORT NO. 22-A-09

FUEL GRADE: 100/130  
FUEL DENSITY: 6 lb/gal

Figure A-8. Hovering Endurance Chart

# Index

<b>A</b>		Climb at Normal Gross Weight	32	Emergency Operation	43
Acceleration Limitations		Clock (See Instruments, Flight)		Fuses	18
(See Limitations)		Clutch Actuator Check	71	Receptacles	57
After Exit From the Helicopter	35	Clutch Controls	10	Emergency Autorotative	
After Landing	34	Clutch Engaging Light	10	Descents	33, 37
After Take-Off	32	Cockpit Heating	45	Emergency Entrance	42
Air Exit Doors		Collective Pitch		Emergency Equipment	
(See Doors and Windows)		and Throttle Control	20	First Aid Kit	23
Airspeed Indicators		Collective Pitch Bungee	21	Fire Extinguishers	22
(See Instruments, Flight)		Collective Pitch Lever Down		Life Rafts	23
Airspeed Limitations		Lock	20	Emergency Exits	23
(See Limitations)		Collective Pitch Lever Friction	20	Engine	1, 69
All Weather Operation	75	Control	20	Engine Cooling System	5
Altimeter		Communications Equipment		Engine Failure	
(See Instruments, Flight)		AN/ARN-6 Radio Compass	49	Partial Failure	37
Anti-Glare Curtain	57	AN/ARN-14 VHF Navigation Receiver	49	Complete Failure at Take-Off, Hovering, or Slow Flight Under 15 Feet Altitude	37
Anti-Icing and De-Icing Systems	47	AN/ARC-3 VHF Command Transmitter and Receiver	49	Complete Failure Above 15 Feet Altitude	37
Appendix	77	AN/ARC-27 UHF Transmitter and Receiver	49	Engine Ground Operation	29
Approach	33	AN/ARA-8A Homing Adapter	51	Engine Idle Speed Check	29
Approach and Landing	33	USAF Interphone	49	Engine Limitations	
Autorotation	66	Control Co-ordination	20	(See Limitations)	
Rpm in Autorotation	38	Control Forces Check	67	Engine Oil System	10
Auxiliary Equipment	24	Covers	57	Engine Restart in Autorotation	38
<b>B</b>		Crosswind and Downwind Landings	34	Engine Starter Switch	8
Backfiring	69	Cruising at Normal Gross Weight	67	Engine Warm-Up	29
Backward Flight	32	Cyclic Control Stick	20	Entrance to the Helicopter	25
Bail-Out	42	Cylinder Head Temperature	70	External Power Receptacle	16
Battery	12	Cylinder Head Temperature Gage (See Instruments, Engine)		Exterior Inspection	
Battery Switch	16	<b>D</b>		On Entering the Helicopter After Exit From the Helicopter	25
Before Exit from the Helicopter	35	Data Cases	57		35
Before Exterior Inspection	25	Descent		<b>F</b>	
Before Starting Engine	28	Emergency Autorotative	33, 37	Failures	
Blackout Curtains	57	From Hovering Position to Ground	34	Drive System	39
Blade Dephasing (See Rotor Blade Dephasing)		Power-On	32	Electrical System	43
Blade Stall (See Stalls)		Power-Off	33	Engine	37
Brake System	21	Practice Autorotative	33	Fuel Pump	43
<b>C</b>		Vertical	33, 67	Hydraulic Control System	43
Cabin Heating	45	Detonation	70	Rotor Blades	39
Cabin and Rescue Doors	23	Dimensions	1	Transmission	39
Cabin Lights (See Lighting System)		Directional Control Pedals	20	<b>Fire</b>	
Cable Boom Winch and Cable	55	Directional Gyro		During Flight	39
Cable Cutter	56	(See Instruments, Flight)		Electrical	39
Carburetor Air Temperature Gage (See Instruments, Engine)		Ditching		Engine (When Starting)	39
Carburetor Heat Control Lever	5	Without Power	42	Fuselage	39
Carburetor Ice		With Power	42	Fire Detector Warning System	22
Impact	69	Diving	67	Fire Extinguishers (See Emergency Equipment)	
Internal	69	Doors and Windows		First Aid Kits (See Emergency Equipment)	
Throttle	69	Air Exit	23	Flaps and Shutters	32
Results of	69	Cabin	23	Flight Characteristics	32
Removal of	69	Engine Hatch	23	Flight Controls	66, 72
Cargo Loading Equipment	56	Rescue	23	Flight Control System	
Centering Springs	21	Downwind Turns at Low Altitude	67	Directional Control	20
Center of Gravity Limitations (See Limitations)		<b>E</b>		Lateral Control	18
Check for Hydraulic Lock	28	Electrical Power Supply System		Flight Control Centering Springs	21
Circuit Breakers	18				
Climb and Forward Speed	32				

Longitudinal Bungee .....	21	Interior Check		Data Case .....	57
Longitudinal Control .....	18	On Entering Helicopter ....	25	Electrical Receptacles .....	57
Longitudinal Trim .....	18	Before Exit From the		Heated Blankets .....	57
Flight Crew (See Minimum		Helicopter .....	35	Heated Suits .....	57
Crew Requirements)		Interior Check (Night Flights)	28	Map Case .....	57
Flight Planning .....	25	Interior Lights (See		Pitot Heat .....	47
Flight Restrictions .....	25	Lighting System)		Relief Tube .....	57
Fluids Shut-Off Switch .....	10	Internal Ice (See Carburetor Ice)		Tie-Down Fittings .....	57
Forward Flight .....	66	Inverters		Windshield Wiper .....	57
Free Air Thermometer		Inverter Switch .....	16	Mixture Control Lever .....	1, 69
(See Instruments, Flight)		Inverter Lights .....	18		
Friction Clutch as Rotor Brake	72				
Fuel System		<b>J</b>			
Fuel Quantity Gage .....	12	Jaw Switch .....	10		
Specification and Grade ....	10			<b>O</b>	
Emergency Operation .....	43			Oil Dilution System	
Booster Pump .....	12	<b>L</b>		Switch and Light .....	10
Warning Light .....	12	Landings		Procedure for Dilution ....	75
Fuses .....	18	Crosswind and Downwind ..	34	Oil Cooler .....	10
		Flared Stall .....	33	Oil Cooler Duct Shutter .....	10
		Landing Emergencies		Overrunning Clutch Check ....	30
		(Except Ditching) .....	40	Operating Limitations	
		Power-Off .....	33	(See Limitations)	
		Roll-On .....	33		
		Landing Gear System .....	21	<b>P</b>	
		Lateral and Longitudinal Control		Pilots' Cockpit Check .....	25
		(See Flight Control		Pilots' Flight Controls	
		System)		Collective Pitch and Throttle	
		Level Flight Characteristics		Control .....	20
		Hydraulic System On .....	67	Control Position Indicator	
		Hydraulic System Off .....	67	(Longitudinal Trim) ....	20
		Life Rafts (See Emergency		Cyclic Control Stick .....	20
		Equipment)		Pilots' Seats (See Seats)	
		Lighting System		Pitot Heat .....	47
		Emergency Operation .....	55	Postflight Engine Check .....	34
		Exterior .....	51	Power-Off Descent and Landing	33
		Interior .....	51	Power Settling .....	66
		Inverter Lights .....	18	Practice Autorotative Descent	33, 88
		Landing .....	51	Preflight Engine Check	
		Fuel Reserve Warning .....	12	(See Ground Tests)	
		Generator Warning .....	16	Preflight Helicopter Check ....	31
		Fire Warning .....	22	Pre-Traffic Pattern Check ....	33
		Utility Lights .....	51	Priming	
		Limitations		Overpriming .....	70
		Airspeed .....	59	Underpriming .....	70
		Acceleration .....	64	Procedure For Shifting Blowers	71
		Center of Gravity .....	64	Prohibited Maneuvers .....	64
		Engine .....	59		
		Hovering .....	64		
		Manifold Pressure .....	59	<b>R</b>	
		Rotor .....	59	Radio Compass	
		Weight .....	64	(See Instruments, Flight)	
		Litter Installation		Radio Equipment	
		(See Troop Seats)		(See Communications)	
		Loadmeter .....	16	Rate of Climb	
		Longitudinal Bungee .....	21	(See Instruments, Flight)	
		Longitudinal Control (See		Relief Tube .....	57
		Flight Control System)		Rescue Hoist Equipment .....	55
		Longitudinal Trim (See		Roll-On Landings (See	
		Flight Control System)		Landings)	
				Rotor Blade Dephasing .....	8
		<b>M</b>		Rotor Clutch .....	9
		Maneuvering Flight .....	67	Rotor Clutch Operational	
		Manifold Pressure .....	59	Functions .....	9
		Manifold Pressure Gage .....	8	Rotor Clutch Engagement .....	71
		Minimum Crew Requirements ..	59	Rotor Drive System .....	8
		Miscellaneous Equipment		Rotor Rpm in Flight .....	66
		Anti-Glare Curtain .....	57		
		Blackout Curtains .....	57	<b>S</b>	
		Check List .....	57	Safety Belts .....	23
		Covers .....	57	Seats .....	23
				Settings for Best Climb .....	32

**SECURITY INFORMATION—RESTRICTED  
AN 01-250HDA-1**

**Index**

Shoulder Harness .....	23	Take-Off		Troop and Casualty Carrying	
Sideward Flight .....	32	Jump Take-Off .....	32	Equipment .....	56
Smoke Elimination .....	40	To Hovering Position .....	31	Troop Seat and Litter	
Spark Plug Fouling .....	69	Taxiing .....	66	Installation .....	57
Spins .....	66	Taxiing Instructions .....	31	Turns, Downwind at Low	
Stalls		Throttle .....	1	Altitude .....	67
Blade Stall .....	65	Throttle Friction Lock .....	1	Turn and Bank Indicator	
Starter .....	3	Throttle and Collective Pitch		(See Instruments, Flight)	
Starting Engine .....	28	Operation .....	31		
Starting Rotors .....	29	Throttle Ice (See Carburetor Ice)		<b>U</b>	
Status of the Helicopter .....	25	Tie-Down Fittings .....	57	Utility Lights	
Stopping of Engine and Rotors	35	Torque Control .....	20	(See Lighting System)	
Stopping of Rotors .....	72	Traffic Pattern Check .....	33		
Switches		Transmissions		<b>V</b>	
Battery .....	16	Temperature .....	71	Ventilating .....	45
Fluids Shut-Off .....	10	Pressure .....	71	Vents, Snap .....	47
Friction Clutch .....	10	Transmission and Rotor System	8	Vertical Descent .....	33, 67
Fuel Booster Pump .....	12	Transmission Instruments .....	10	Vertical Gyro	
Fuel Primer .....	5	Transmission Oil System .....	10	(See Instruments, Flight)	
Fuel Quantity Gage Test ...	12	Transition From Approach to		Voltmeter .....	16
Generator .....	16	Hovering .....	33		
Ignition .....	5	Transition From Hovering to		<b>W</b>	
Inverter .....	16	Flight .....	32	Weight and Balance .....	25
Jaw Clutch .....	10	Transition to Backward Flight	32	Weight Limitations .....	64
Oil Dilution .....	10	Transition to Forward Flight	32	Windows (See	
Supercharger .....	5	Transition to Sideward Flight	32	Doors and Windows)	
Systems Operations .....	32	Trim			
<b>T</b>		Operating Procedure .....	72		
Tachometer, Dual .....	8	Longitudinal Control .....	18		
		Longitudinal Control Position			
		Indicator .....	20		