

# Design Buy Build

Issue 51 2021

[www.designbuybuild.co.uk](http://www.designbuybuild.co.uk)

M A G A Z I N E

Self Builders



Property Developers



Architects



Interior Designers



## Tropical luxe in the bathroom

Create a serene and spa-like bathroom with the latest bathroom designs



## How to use dark carpets in any space

Contemporary palettes offer elegant and sophisticated alternatives



## Create your own garden bar

How you can create your own in time for Summer



# F.H. BRUNDLE

SERVING THE TRADE SINCE 1889

**ALUMINIUM FENCING SLATS TO CREATE A STUNNING PRIVACY FENCE.**

## MARANO<sup>®</sup>

Fully Modular Aluminium  
Fencing System



**Elements**



**Convex**



**Stripe**



**Single and double sided slats with textured and smooth surfaces. Available in Golden Oak, Anthracite Grey or Mill/Raw finish.**



**Breeze**

For a **FREE** sample pack or to request a catalogue:

**01708 25 35 09**  
**sales@brundle.com**  
**www.fhbrundle.co.uk**

**24/7 ONLINE ORDERING**

**COMPETITIVE PRICES**

**HUGE RANGE FROM STOCK**

**FREE DELIVERY OVER £150**

**TRADE COUNTER COLLECTION**

## ISSUE HIGHLIGHTS

- 08-13 Shutter House by Mobilia and State of Kin**  
An inspiring and forward thinking home designed for the modern family and furnished with some of the world's most renowned and decorated brands.
- 22-23 Trend Alert: Tropical luxe in the bathroom**  
Create a serene and spa-like bathroom with the latest bathroom designs, from Pelipal.
- 32-33 She House**  
The new residence which measures 600 sqm distributed on three levels including the terraces, is surrounded by compliant architecture and in line with a traditional vision.
- 36-37 How to use dark carpets in any space**  
Dark carpets have long been associated with dated room schemes, but today's contemporary palettes offer elegant and sophisticated alternatives that will complement an interior.
- 50 Light and dark - Oak Furnitureland's new cabinetry ranges**  
The UK's largest retailer of real hardwood furniture, Oak Furnitureland, has added two brand new cabinet ranges to its expanding portfolio.
- 54-56 Multifunctional style**  
Now more than ever we see the kitchen not just as the heart of the home, but also as an 'everything space', doubling up as an office, classroom, gym and even a bar.
- 62-63 Edgewood House**  
The dwelling is designed for a young Deaf family, where vision and touch are a primary means of spatial awareness and orientation.
- 76-77 New design additions to leven lighting range**  
The Leven Table Light and Leven Pendant Small are welcome additions to Tom Raffield's highly sought-after range.

## PRODUCTS & SERVICES

- 06-21** Editors Choice
- 22-25** Bathrooms
- 26-31** Doors, Windows & Fittings
- 32-33, 62-63** Architects Projects
- 34** Drainage & Plumbing
- 35-40** Floors & Flooring
- 41-45** Heating, Ventilation & Insulation
- 46-53** Interiors & Interior Design
- 54-61** Kitchens
- 64-71** Landscaping & External Works
- 72-77** Lighting
- 78-81** Safety, Security & Fire Protection

## COVER PHOTO



**08** Shutter House  
Jack Lovel

## Design Buy Build - [www.designbuybuild.co.uk](http://www.designbuybuild.co.uk)

**Editor in Chief**  
Antony Holter  
[antony@designbuybuild.co.uk](mailto:antony@designbuybuild.co.uk)  
01304 806 039

**Editor**  
Fiona Medows  
[fiona@designbuybuild.co.uk](mailto:fiona@designbuybuild.co.uk)  
01304 806 039

**Sales Director**  
Rebecca Charlesworth  
[rebecca@designbuybuild.co.uk](mailto:rebecca@designbuybuild.co.uk)  
01227 936 977

**Studio Designer**  
Sarah Johnson  
[sarah.johnson@mhmagazine.co.uk](mailto:sarah.johnson@mhmagazine.co.uk)

**Business Manager**  
Josh Holmes  
[josh@mhmagazine.co.uk](mailto:josh@mhmagazine.co.uk)

**Publishing Director**  
Martin Holmes  
[martin@mhmagazine.co.uk](mailto:martin@mhmagazine.co.uk)  
01304 806 039

**Editorial Assistant**  
Tom Moore  
[tom@designbuybuild.co.uk](mailto:tom@designbuybuild.co.uk)

**Digital Manager**  
Jamie Bullock  
[jamie@mhmagazine.co.uk](mailto:jamie@mhmagazine.co.uk)  
01227 936971



**Published by:**  
MH Media Global Ltd  
Office 15, Second Floor,  
Innovation House, Discovery Park,  
Ramsgate Road, Sandwich,  
Kent, CT13 9FD

Tel: 01304 806 039

© MH Media Global

# Diamik Glass the alternative and sustainable luxury surface

**Diamik Glass have created two environmentally friendly products Ecorok® and Decorok®, both products are made from recycling waste glass. Both are durable, strong, beautiful and have commendable environmental credentials. Years of development and trials have resulted in two products that offer a creditable alternative to imported, mined products.**

Ecorok® is perfect as worktops for kitchens, bathrooms and utility rooms. Made from a minimum of 85% recycled glass and the remainder a mixture of resin and pigment which makes them non-porous, scratch resistant, smooth to the touch and beautiful to the eye. As Ecorok® is non-porous it makes it highly resilient to stains and marks. Cleaning for the eco-warriors amongst us can be as simple as mild soapy water, but if you need to give it a deep clean you can use scouring pads and bleach sprays without damaging the surface.

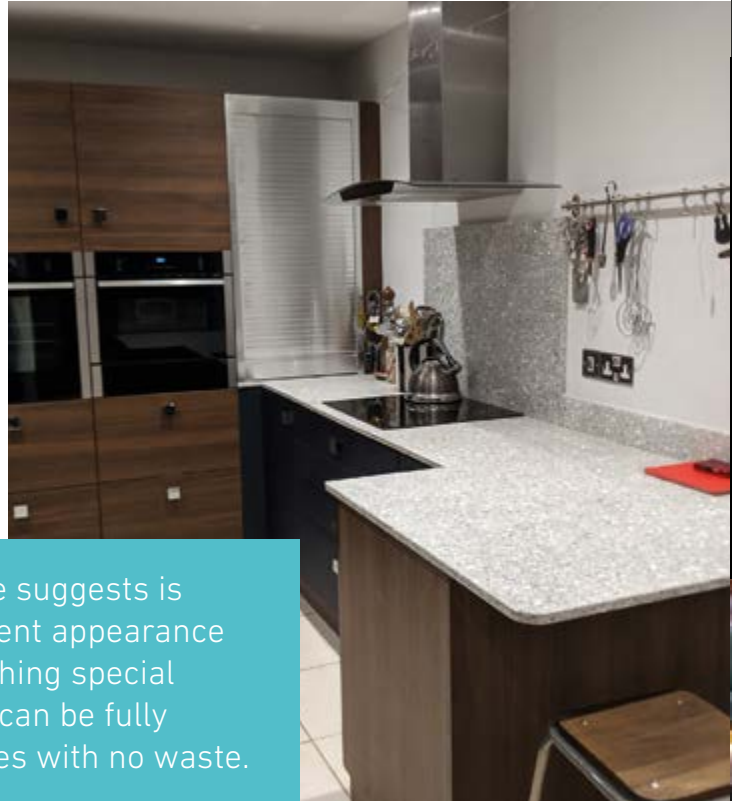

Decorok is made using 100% glass and as the name suggests is targeted as a more decorative material. Its translucent appearance featuring crushed glass design provides that something special in key environments. Just like Ecorok™ Decorok™ can be fully recycled at the end of its life to produce new surfaces with no waste.



Diamik harvests only local glass destined for landfill, then processes this waste, using craftsmanship into perfect sheet sizes for every customer. This is supported using modern technology to create these two innovative and versatile products. Their latest digital templating technology also allows for millimetre perfect measuring and cutting to create shapes – they even offer to video the procedure as a keep sake for the customer or to use as a promotional tool.

Diamik's products can now be found in all parts of the UK and Europe which is testament to how quickly people are moving towards a more sustainable future. Customers have been looking for something new, something fresh a new design with ecological street credibility. Ecorok comes in over fifty standard designs with new ones being created every month. The Diamik Bespoke option will create your very own unique special surface. The only limit is the customers imagination!



DIAMIK  
GLASS

**If you would like to find out more about these unique products contact Diamik Glass on 0113 249 7001**

**E: [info@diamik.co.uk](mailto:info@diamik.co.uk) or visit their website [www.diamikglass.co.uk](http://www.diamikglass.co.uk)**





DIAMIK  
ECOROK™

# Eco friendly, luxury surfaces

Our glass surfaces are manufactured using waste glass destined for landfill. A combination of craftsmanship and high-tech processes produce beautiful, hard wearing surfaces. Ecorok is scratch resistant, non porous and smooth to the touch making them easy to clean with just warm soapy water. We offer our customers a full service package including digital measuring, delivery and installation.



- ▶ Kitchen worktops
- ▶ Splashbacks
- ▶ Bathroom vanity units
- ▶ Wall panels
- ▶ Tiles - various sizes
- ▶ Bar tops
- ▶ Reception areas
- ▶ Serving stations
- ▶ Tea points
- ▶ Retails counters

We work with architects, designers and developers in addition to our rapidly expanding personal customer network. Our work can be found in homes and commercial buildings around the whole of the UK.

Our sustainable clients include, HMRC, Diageo, Kellogg's, Breeam, Dorrington PLC, Fortnum and Mason, Leeds Building Society, and MasterCard.

**ORDER SAMPLES  
ONLINE**

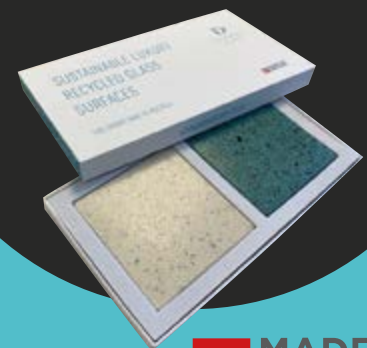

**MADE IN  
BRITAIN**

Get in touch if you would like to discuss how Ecorok™ recycled glass surfaces can help you to become more sustainable in the future.

**Diamik Glass on 0113 249 7001 email [info@diamik.co.uk](mailto:info@diamik.co.uk) [www.diamikglass.co.uk](http://www.diamikglass.co.uk)**

## Products that tell a story

Plastic waste saved from landfill since 1995 and turned into award-winning second life products.

Plaswood is the **durable** and **maintenance free** alternative to traditional materials.



Non Staining



Recyclable\*



Long Lasting



UV Stable\*\*



Maintenance Free



Durable



Weather Proof



Versatile



High Strength

🔄 Maintenance Free Planters



Edge Bench



Choose a product that stands the test of time. Plaswood provides a range of products and solutions, made from recycled plastic, that are maintenance and splinter free, rot and weather proof.

Begin your journey towards a maintenance free product, visit us at [www.plaswood.eco](http://www.plaswood.eco) or call us on +44 (0) 333 202 6800



Fencing



Decking



Boardwalks



Furniture



and more

Full range includes: Tables • Benches • Bins/Composters • Planters • Lumber Garden furniture • Edging • Decking • Fencing/Gates • Signage • Boardwalks



Chill Out Lounger Set



Photo credit: Jack Lovel



Photo credit: Jack Lovel

## MOBILIA AND STATE OF KIN JOIN FORCES TO FURNISH STATE OF KIN'S SHUTTER HOUSE PROJECT

Mobilia has teamed up with Perth based architectural and interior designer studio State Of Kin to furnish Shutter House, an inspiring and forward thinking home designed for the modern family and furnished with some of the world's most renowned and decorated brands; carefully hand picked to compliment the architectural beauty of the home.

Situated across from the iconic Lake Monger in Wembley, Western Australia the aptly named Shutter House is a concrete block that utilises the warmth of locally sourced timber to create a battened timber skin that wraps around the home, while a mechanical system allows the timber façade (Shutter) to open and close, creating a sense of enclosure and intimacy whilst still allowing unobstructed views to the adjacent lake.

The residence is spread over three levels. The ground floor consists of a four car garage, wine cellar and entry into a spectacular three storey void that connects all levels via a feature staircase. The timber entry and elevator shafts are flanked by crisp white porcelain wall lights by Michael Anastassiades which sit effortlessly within the playfulness of the architecture.

In addition to the skilful detailing of the balustrade, Patricia Urquiola's gem like Fordite rug by CC Tapis is a standout in the entrance bringing a joyful sense of scale and colour to the entry.

Inspired by the material of Fordite (a bi-product of the automotive industry) Urquiola has integrated a similar approach to sustainability in the creation of this rug collection, which coexists perfectly with its material surroundings.

Four bedrooms, three bathrooms, laundry and gallery are situated on the first floor, along with an intimate courtyard and balcony spaces adjoining each bedroom.

The master bedroom is fitted out with Patricia Urquiola's latest bed for Moroso and an extension of her Redondo collection inspired by 1960's American cars, the soft curves of their body work and their upholstered interiors.

The three bathrooms on this level are tied together by the clever use of graphic tiling, vibrant colour and the fascinating and magical Shimmer mirrors designed by Urquiola for Glas Italia, which throw dancing shadows of colour on the tiling behind.





Photo credit: Jack Lovel

"Four bedrooms, three bathrooms, laundry and gallery are situated on the first floor, along with an intimate courtyard and balcony spaces adjoining each bedroom."

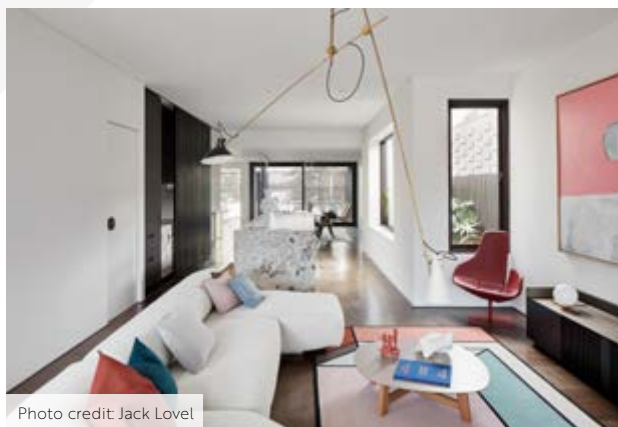

Photo credit: Jack Lovel

The monochromatic layering created by the nude Slinky Rug by CC Tapis and the vis a vis (face to face) Moroso Tender sofa, both designed by Patricia Urquiola, show the clever use of furniture and forms to define space in the gallery area; which divides the master bedroom from the other areas on the first floor.

The multi directional use of the sofa allows the user to face outward toward the light filled courtyard or reflect back at the artwork on the opposing wall when using the intermediate space as a place of reflection and pause (which also doubles as a void to ensure privacy for the master bedroom).

An open plan living, dining and kitchen space on the second floor affords panoramic views of Lake Monger, and connects to a terrace and pool area with a separate studio.

The sun filled front balcony, super architectural in its nature and providing an inner viewing to the timber battened operable shutters is graced by the welcoming relaxed vibe of Urquiola's Vimini collection by Kettal; that highlights a modern twist of traditional materials both elegant and warm.

The Vimini collection which was inspired by the Basket Chair by Danish designers Nanna Ditzel and Jørgen Ditzel from the 1950's, sits effortlessly with Urquiola's latest collection of furniture, the Roll Tables and Band Armchairs for Kettal, inspired by the honest exposure of materials, a perfect marriage to the balcony area.

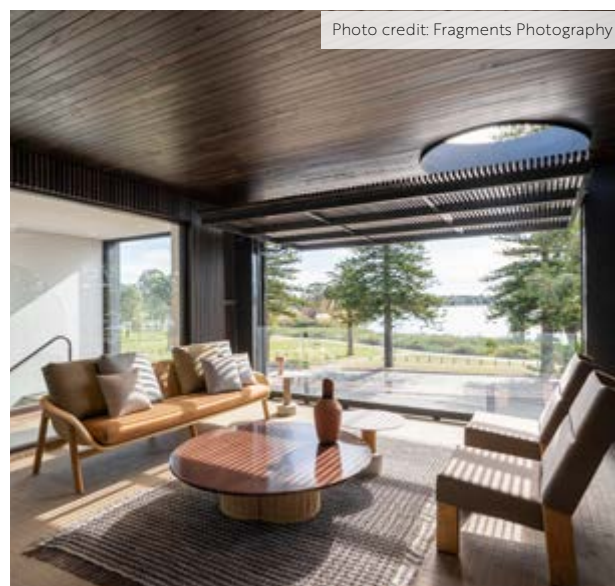

Photo credit: Fragments Photography

The warmth and colour from the outdoor area gently flows into the adjacent dining room which is defined by Golran’s impeccable Meteo Rug by Inga Sempé which houses the dark stained version of the Moroso Mathilda table and chairs, a stunning and vibrant entertaining area for the home owners.

The modern and versatile kitchen looks onto both the dining room and the perfectly executed main living area which is a gentle balance of form, colour and understated style and speaks back to the expression of the designers appreciation of Japanese architecture through the use of light and detail.

Mobilia’s Director Salvatore Fazzari says he was excited by the opportunity to work on Shutter House with the team at State Of Kin.

“We have always been big fans of the talented team at State Of Kin and when the opportunity presented itself to furnish Shutter House, we were very excited about what we could achieve with the furniture.

The architecture and hard interior finishes were so tastefully and perfectly executed that it was important to compliment those selections, as opposed to select furniture that would compete instead of enhance those pre made selections; which I felt we managed to achieve with the help of the State Of Kin Team.

The house is expressive and playful in nature but it also has an underlying sense of elegance and therefore the selections needed to be honest to that subtle balance which the State Of Kin team managed to create; a balanced that I feel we managed to emulate with the soft furnishings.”

Patrica Urquiola’s Moroso Gogan Sofa has been selected for the living space which takes its name from nature and in particular from Japanese stones rendered smooth over time. This sits perfectly with the Fjord armchair (one of the designer’s first and most iconic armchairs) and the blissful colour of the Visioni Rug that is centred by the VV Cinquanta Suspension Pendant by Italian architect Vittoriano Viganò, originally designed in 1951, and produced by Astep.





Photo credit: Jack Lovel

The outdoor terrace and pool area which are connected to the main living area are adorned with State Of Kin's recognisable curved deco references, richness and balance of colour and materiality which is best demonstrated with the tiling in the area, clear cut deco inspired reveals into the pool and the custom tiled curved bench seat; that has been coupled with Urquiola's Mesh Table and colourful Roll Chairs from Kettal.

This celebrated home, energetic and forward in its approach is testament to the wonderful work of this dynamic, young studio, State Of Kin and their partnership with Mobilia on this project has seen to the fact that the home and furniture selected is of the same high design standards of the interiors and architecture.

State Of Kin Co-Director Alessandra French explains "From the inception of this project we wanted to create a material palette championing raw, expressive materials and an enduring design statement for what has become our flagship project to date.

"We have a small studio which allows us to have a very close and collaborative approach between our architectural and interior departments, which is seen by the way the material finishes play off the architectural elements of this home.

The design vision was clear from the start and I feel we managed to materialise our initial vision for the project from an architectural and design perspective.

"The outdoor terrace and pool area which are connected to the main living area are adorned with State Of Kin's recognisable curved deco references."

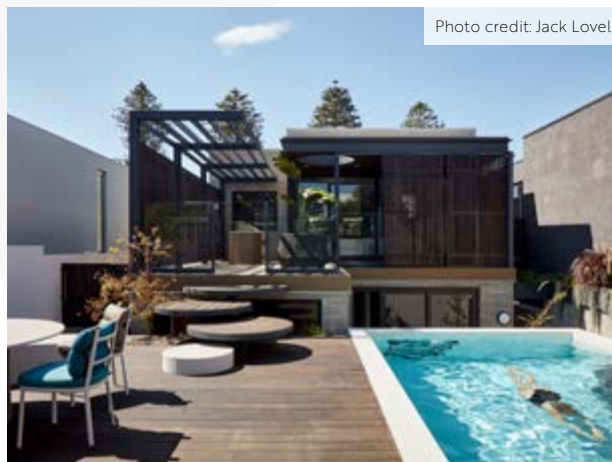

Photo credit: Jack Lovel

It was great to be able to use the work of some of our favourite contemporary designers like Patricia Urquiola, Michael Anastassiades and Inga Sempè and mix them with some of our favourite design masters like Gino Sarfatti and Vittoriano Viganò.

The furnishings became an important ingredient in the overall result and sit perfectly with our architecture and interior finishes. We were really fortunate to have been able to select from the world's best design brands giving rise to the opportunity to coordinate materiality and colour within the soft furnishings. This allowed us to complete the home to a standard that we had strived for from the start of this project."

Shutter House features an array of Mobilia's brands and work by a mixture of designers and brands including Patricia Urquiola (Kettal, CC Tapis, Moroso, Glas Italia), Inga Sempè (Golran), Studio Pepe (CC Tapis), Michael Anastassiades (Michael Anastassiades), Gino Sarfatti (Astep) and Vittoriano Viganò (Astep).

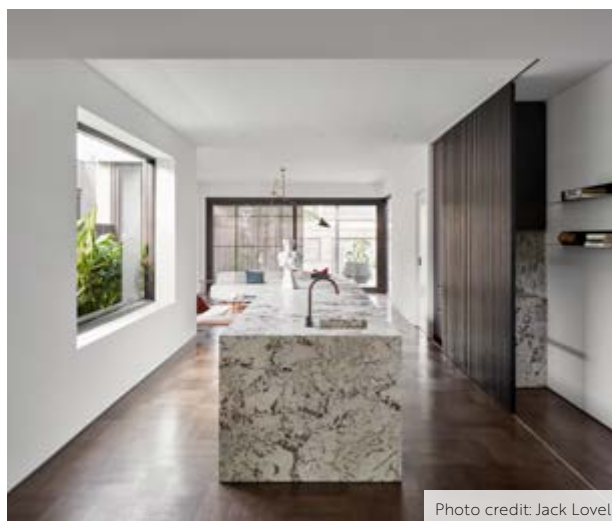

Photo credit: Jack Lovel



Photo credit: Jack Level



Photo credit: Jack Level

Mobilia's Director Salvatore Fazzari adds; "We have worked alongside the State Of Kin team on commercial projects before such as Pan Pacific Hotel's Uma Bar (Perth CBD), Stables Bar (Perth CBD), Bodyscape Yoga Studio (Nedlands) etc however this was the first time we worked on a residential project with them and from the outset I had every faith that they would execute this family home incredibly well due to their versatility and depth as a studio.

Good design to me is about an approach more so than the typology of a project, the projects location or the limitations that each project uniquely and evidently presents.

I feel the team at State Of Kin have really been able to showcase their flexibility and design maturity on this project and we were excited to see how well this project was embraced by their peers and our friends within the local design industry in Western Australia and abroad."



Photo credit: Jack Level

"Layering the second skin of timber battens to the openings of the building façade allows the residents to control and modify their experience of the home both internally and externally."

State Of Kin Co-Director Ara Salomone explains the architectural challenges of the project and how these challenges steered the designed of the home in a positive way:

"The site of the project was quite interesting from an architectural perspective, as a narrow, steeply sloping lot – it gave us some interesting parameters to work with.

We embedded the home into the slope, using the varied levels to create connection and interaction between floors, to encourage access to light and air in every space and create vignettes of interest throughout the home.

Layering the second skin of timber battens to the openings of the building façade allows the residents to control and modify their experience of the home both internally and externally. The mechanical opening movement of the shutters imbues the home with an almost animated quality and a sense of movement that is engaging. It is functional as a shading device and privacy screen but also adds a layering effect to the façade that emphasises visual depth and the movement of shadow and light from the streetfront.

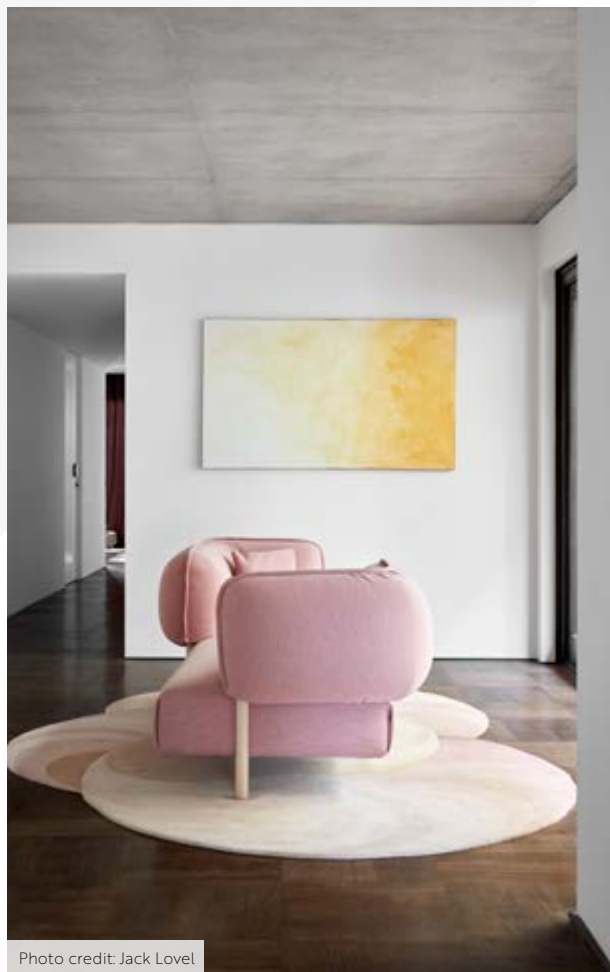

Photo credit: Jack Level



Photo credit: Jack Level

Spaces for rest and contemplation are separated from vibrant living spaces, they are smaller in scale and more intimate in ambience – yet each is connected to the exterior and allows flexibility in the ability to be open and airy, or private and tranquil. The outdoor and living spaces on the top floor are dynamic and bold, they are grand in scale but still welcoming, with clear visual connection to the outdoors from all points of view. These spaces are perfectly coordinated for entertaining, for energetic and lively gatherings."

➔ [mobilier.com.au](https://mobilier.com.au)

Photos by Fragments Photo = tags [@fragmentsphoto](#), [@stateofkin](#) [@mobilier\\_](#)

Photos by Jack Level = tags [@jack.level](#) [@stateofkin](#) [@mobilier\\_](#)

[@kettal](#)

## KETTAL FURNITURE

Band collection by Patricia Urquiola  
 Vimini collection by Patricia Urquiola  
 Roll collection by Patricia Urquiola  
 Vieques collection by Patricia Urquiola  
 Mesh collection by Patricia Urquiola  
 Rugs collection by Patricia Urquiola  
 Object Zigzag planters by Emiliana Design Studio

# TORC MAKE EVERYTHING BY HAND FROM THEIR STUDIO IN THE BRITISH ISLES



Working alongside a talented team of artisans this family run business really specializes in textures, scale and especially bespoke design. The design side of the business proving to be very popular with landscape architects and garden designers alike realizing just how much expertise this company has to offer with a wealth of experience in design and problem solving to bring to the table. Torc welcome the opportunity to be involved at the design stage and are happy to contribute ideas when requested. Frequently being commissioned to provide planter designs, outdoor furniture and paving as a one-off template for both commercial and residential spaces.

Launching their new contemporary shaped water bowl this month was a good example of how far they can go – the diameter of this little beauty can be offered up to 3m wide. Their green credentials are pretty impressive too.

[www.torc pots.com](http://www.torc pots.com)



# TORC:POTS



@torc\_pots



www.torc-pots.com

# 'OLD FARMHOUSE' BRICKS ADD RURAL STYLE TO NORFOLK HOME



The attractive waterside village of Upwell in rural West Norfolk is the picture-perfect location for a refreshingly modern take on the classic English farmhouse, developed by self-builder Andrew Yeoman, and authentically created with the help of Old Farmhouse bricks from Vandersanden.

Located in Orchard Gardens, this impressive, detached family home is fitted out to a high standard with a contemporary interior, sitting behind an evocative, farmhouse-style facade that resides easily within its village setting as well as the broader rural context of the surrounding area.

Andrew has a long history of working with Vandersanden through his day job as a builders' merchant account manager. He had supplied Vandersanden's Old Farmhouse bricks on many occasions and knew they would be ideal for this project with their winning combination of innovation and sustainability.

"I wanted the house to have a traditional farmhouse look despite being a new build," says Andy. "Based on my experience, I knew this particular Vandersanden brick had all the aesthetic ingredients I was looking for, and more. The Old Farmhouse bricks are 'tumbled' as part of the production process - which not only gives them an 'aged' look - but also makes them very forgiving on the joints when laying.

In fact, I was very impressed with how little waste there was from the brick. The sales and technical support from Vandersanden has been excellent throughout the project, helping to make sure everything went smoothly from the initial brick selection to delivery and construction."

Old Farmhouse is a multi-coloured brick with a strong base colour of red, which is muted by tones of brown, white, yellow and black and the brick's naturally creased structure. The result is a warm, textured and natural-looking finish to the facade. The bricks have been used in the construction of this two-storey, four bedroomed home as well as the garage which runs alongside part of the rear garden. The reclaimed look of the bricks complements the vintage clay pantiles on the roof, as well as 'setting off' the oak porch at the front, and feature windows to the rear of the property.

Vandersanden Old Farmhouse bricks are tumbled in a drum before final firing to achieve their appearance. The bricks collide with one another, resulting in broken corners and edges. By being simultaneously sprayed in mortar pulp, the surfaces of the bricks take on an additional weathered appearance.

The project was completed in June 2019.

▶ To learn more, visit [www.vandersanden.com](http://www.vandersanden.com)





Free design and sampling service

Packaging for furniture, DIY, window fashions and home accessories

Environmentally based credentials i.e. recyclable and biodegradable

# BELL PACKAGING

## 100% Recyclable Packaging for the 21st Century



DESIGNED & MANUFACTURED  
IN GREAT BRITAIN

### Biojet<sup>®</sup>

A new eco-friendly product packaging solution designed to keep our oceans cleaner.

As people seek better environmental packaging solutions, Bell Packaging is delighted to announce the introduction of this exciting new product designed to break down much quicker than other traditional materials. This means we can now offer a complete environmental range for new packaging projects in 2021.



[www.bellpackaging.com](http://www.bellpackaging.com)



+44 (0) 1582 459292

# THURSTON GROUP IS A FINALIST AT THE OFFSITE AWARDS FOR ITS SOCIAL HOUSING AND HEALTHCARE PROJECTS

Modular and portable building manufacturer, Thurston Group, has been shortlisted for two Offsite Awards. Their Tameside Hospital project is up for Healthcare Project of the Year, while their 'Meanwhile Housing' scheme for Be First London is up for Social Housing Project of the Year.

The Tameside and Glossop Integrated Care NHS Foundation Trust project saw Thurston's deliver a brand new modular ward for Tameside General Hospital within seven weeks to increase the hospital's critical care capacity during the pandemic. This project was critical to the hospital's ability to support their region with ventilated bedspace. A project that would normally take up to 20 weeks, Thurston's delivered the new ICU ward, extension and linkway within seven weeks.

Thurston Group delivered 92 modular homes on behalf of Jarram Falkus for Be First London on Cook Road, Dagenham. The local authority is under growing pressure to provide temporary housing for residents who are homeless or for those who are vulnerable and leaving care. Thurston's sustainable, accessible modular homes were the perfect solution for Be First and highlights the benefits offsite can offer.

Managing Director, Matthew Goff, said, "We're delighted to have been shortlisted and look forward to the event in September. Good luck to all of the other finalists! Being shortlisted for these awards reflects how our modular solution encapsulates all of the benefits of offsite construction while delivering against compliance, timeframe and budget."



Thurston Group can be reached on 0333 577 0883 or [sales@thurstongroup.co.uk](mailto:sales@thurstongroup.co.uk) | [www.thurstongroup.co.uk](http://www.thurstongroup.co.uk)

T: +44 (0) 1825 764 737  
F: +44 (0) 1825 768 330  
E: [info@appeng.co.uk](mailto:info@appeng.co.uk)  
[www.appeng.co.uk](http://www.appeng.co.uk)



**APPLICATIONS  
ENGINEERING LTD**

## FIRE SPRINKLER VALVE SET 1" TO 2"





## THINK DESIGN THINK HOMAPAL

Over the years, hardly any other material has proven its worth in interior design to the extent in which the laminate has done. Looks, feel and function are combined to get the interplay of elements into all-embracing spatial concepts in a way that couldn't be more natural

Above all, it has always been the genuine- metal coated laminates and magnetic boards that are associated with the HOMAPAL name. Yet behind the scenes in Herzberg, many more variations of this modern material are created and produced.

It provides architects, carpenters and joiners in furniture-making and interior designs with the basis for producing the last word in creative design - in doctors' surgeries, bars, hotels, clubs and restaurants, on cruise ships and in shop fitting.







[www.deralam.co.uk](http://www.deralam.co.uk)

Exclusive Distribution in the UK:

**Deralam Laminates Limited Head Office:**  
West Coast Park, Bradley Lane,  
Standish, Wigan WN6 0YR

**Southern Depot:**  
Units 10 + 10a, Foster Avenue,  
WoodSite Park, Dunstable  
Beds LU5 5TA

**Midlands Depot:**  
Crowcrofts Road, Newstead  
Industrial Estate, Trentham,  
Stoke-On-Trent, Staffordshire  
ST4 8JA

T 01257 478540 | F 01257 478550 | E [sales@deralam.co.uk](mailto:sales@deralam.co.uk)

All images provided by HOMAPALD



### Your FREE Ticket to the Latest Windows, Doors & Building Products

FIT Show - the UK's only dedicated B2B trade show for builders and installers involved in the window, door, glass & components industry - returns to the NEC from Sunday 26 - 28 September, 2021.

Over 40% of FIT Show's 200 exhibiting brands will be making their debuts at the event, including Rockdoor, Exlabesa, Solar Calibre, STORM Building Products, UK Doors Online, DAKO and GardenGate. Industry leaders like Hormann UK, Victorian Sliders, Ultraframe, SmartReady and Alutech Systems will be launching brand new products at FIT Show.

Expect a wide selection of products across features for timber, roofing, adhesives and sealants, garage doors, glass and outdoor living. There will be live demonstrations and a selection of exclusive FIT discounts and offers.

Register for the hottest FREE ticket in town today: [www.fitshow.co.uk](http://www.fitshow.co.uk)



### Screwshop

With over 35 years' experience specialising in screws, bolts and fixings for the DIY, hardware, building, joinery and furniture manufacturing sectors, Screwshop has evolved from its established sister company, NE Fasteners. Also proving a huge success with its online shop. Situated in Cradley Heath, West Midlands, it prides itself with offering expertise, competitive prices, imported bespoke products and off the shelf products with a nationwide next day delivery. Our versatile approach to providing a wide range of finishes, including zinc, electro brass, black chrome, satin chrome, bronze and nickel and packaging options, ensure that many buyers consider Screwshop to be a key and valued supplier.

We also offer builders metalwork, ironmongery, silicones, sealants and are specialists in kitting and coating. Go to our on line shop at [www.screwshop.co.uk](http://www.screwshop.co.uk) and enter July5 for a 5% discount, or message for one of our catalogues. If you can't find a certain product, get in touch and we'll try and source it for you. We will give you our best attention and prices at all times.

[www.screwshop.co.uk](http://www.screwshop.co.uk) | [sales@screwshop.co.uk](mailto:sales@screwshop.co.uk)



### Salamander Stoves

Our Hobbit stove has found its home in a wide range of applications over the last 12 years. Designed and assembled in Devon, our little stove is great for providing heat, cooking potential, and a focal point for your small space project. We originally designed the stove to fit gorgeous Victorian fire surrounds, as there were no stoves small enough to fit. Hence, we designed the Hobbit stove! The Hobbit enables you to retain your original period features, whilst incorporating an efficient, clean burning stove, rather than having an open fire.

The Hobbit stove is 80% efficient, ECO 2022 certificated, and it's also suitable for smoke controlled zones.

Visit our website for more information on quality cast iron small stoves.

[www.salamanderstoves.com](http://www.salamanderstoves.com)

Tel: 01626 363507 / 01626 333230

Email: [mark@salamanderstoves.com](mailto:mark@salamanderstoves.com) / [gillian@salamanderstoves.com](mailto:gillian@salamanderstoves.com)



- Quality factory reject Celotex insulation boards
- Thickness from 12mm to 250mm
- Standard size 1.2m x 2.4m
- Other sizes are also available
- Discount available for large orders
- Nationwide delivery subject to agreeing on delivery cost



### Collection from

Unit W, Stafford Park, Listion  
Sudbury, Suffolk, CO10 7HX

Culford Sawmill, Brandon Road  
Culford, Suffolk, IP28 6UE

Office: 01787 370 295 | Mobile: 07963 695 226 | [sales@economicinsulation.com](mailto:sales@economicinsulation.com)

[www.economicinsulation.com](http://www.economicinsulation.com)



# BESPOKE ROLLING LADDERS

Our rolling ladders are not just a simple access solution, but they are a key design feature in their own right. Often spotted in city centre cocktail bars as well as around other commercial and even domestic applications, our rolling ladders offer style and substance to even the trickiest of access solutions.

Over time we have revolutionised our rolling ladder system to enhance the look of our ladders in different environments. We don't only provide captive rolling systems but also offer a hook on ladder for ultimate simplicity.

Both our rolling and hook on ladders are hand crafted with sustainable handpicked timbers that are carefully selected, to allow us to use only the finest of timbers.

Our handcrafted rolling

ladders are available in Oak, Ash, Maple, Redwood and Walnut.

We've also recently designed a timber and stainless steel rolling ladder, which is perfect for modern spaces!

Customisable options on our rolling ladders are endless, don't forget our rolling ladders are hand crafted specifically for you. Choose from a range of tread inserts for additional security and for the perfect

finish we can paint, oil, lacquer or stain your rolling ladder for you, to protect the wood and match your decor.

If you are looking for a stylish access solution for your book shelf, mezzanine or any other application don't hesitate to get in touch.

**For working at height help and advice or for more rolling ladder options give us a call on 01204 590 232 or visit our website.**

# LADDERSTORE

- Working at Height Solutions -

Telephone: 01204 590 232

Email: [bespoke@ladderstore.com](mailto:bespoke@ladderstore.com)

Web: [www.ladderstore.com/rolling-ladders](http://www.ladderstore.com/rolling-ladders)

**See our website for our full range of rolling ladder options and configurations.**

# -BESPOKE ROLLING LADDERS-



Our rolling ladder systems are designed by engineers and created by craftsman.



**Stainless Steel  
Hook On Ladder  
With Timber Treads**



**Captive Rolling  
Ladder System With  
Handrail**



**Rolling Ladder With  
Stainless Steel & Timber  
Tread Inserts**

Telephone: 01204 590 232  
Email: [bespoke@ladderstore.com](mailto:bespoke@ladderstore.com)  
Web: [www.ladderstore.com/rolling-ladders](http://www.ladderstore.com/rolling-ladders)



# TREND ALERT: TROPICAL LUXE IN THE BATHROOM

Create a serene and spa-like bathroom with the latest bathroom designs, from Pelipal.

Bathrooms have long been practical spaces, but over the last year there has been a shift towards a new kind of bathroom. One that is an increasingly spa-like space to unwind and slow down at the end of a busy day. While you might think that bathrooms like these are limited to boutique hotels and luxurious resorts in Bali, you don't have to go abroad to enjoy your own tropical oasis.

Steven Jaques, Pelipal National Development Manager, InHouse says, "Creating a luxurious and spa-like bathroom is much easier than you might think. If you want to evoke the sense of relaxing at a beachside resort, combine volcanic blacks with natural wood, bright whites, and ocean blues. The key is to stick to natural colours, layer up textures, and be brave when it comes to application of blacks, greens and blues across a large surface area. Black is incredibly underused in the bathroom and yet it injects dramatic depth into any room and provides a stunning backdrop for subtle touches of colour."

## BACK TO BLACK

Black is elegant, timeless, and mysterious. When paired with natural textures and tropical houseplants you'd be forgiven for forgetting you're at home. Make a statement with striking dark graphite textured tiles, black cabinet fronts and solid oak counter tops.

## OCEAN INSPIRED

Ocean inspired cyan is already becoming a core interior design trend for 2021/22. Bright blue/green cyans are gentle, calming and reconnect us to open horizons. Transporting us to float in the ocean and be embraced by a vast, cloudless sky. Create an escapist haven by balancing bright blues and greens with earthy wooden surfaces and chrome details.

"Make a statement with striking dark graphite textured tiles, black cabinet fronts and solid oak counter tops."



**BLISSFULLY ORGANISED**

Keeping a bathroom clean and organised can feel like a never ending task. Make things easy for yourself by factoring in plenty of storage to your bathroom design. Keep your lotions and potions neatly tucked away and easy to access. If you're short on floorspace, maximise potential storage by opting for countertop washbasins to free up space beneath.

[www.pelipal.com](http://www.pelipal.com)

# TRAJAN NATURAL STONE



## From Inspiration to Installation, the versatility of stone.

**Natural stone, with its diverse properties is boundlessly versatile. Whether you are looking for classic traditional elegance or a chic and sophisticated contemporary look, there is a stone solution that will enhance your design.**

At Trajan Stone, our motto is "from inspiration to installation", and we think this exemplifies our service. Firstly, after understanding your design vision, we can help you choose the right material using our expertise to advise on colour, texture and suitability.



We will then source the stone direct from the best quarries around the world, drawing on our 27 years' experience.





Our team of highly skilled master stone masons will cut the stone to your precise specifications, using our state-of-the-art CNC machinery. Finally, our discreet and trusted craftsmen will fit it on site.

We are proud to have collaborated with many leading architects, interior designers, building contractors, surveyors, landscape designers and private clients. Attention to detail, quality of performance and integrity are the core of our company values, as is achieving fabulous results for our customers. The bespoke Arabescato marble vanity pictured above was designed by one of our clients and expertly crafted and installed by our master masons, and is just one example of how we can take your inspirations to the next level.



Be it a beautiful book-matched marble bathroom, a sweeping stone staircase, an elegant stone floor or even a private (or commercial) wellness spa, we are here to make your life easier.

We have even made a bespoke five-seater stone jacuzzi for a client before, so feel free to give us a challenge!

At Trajan Stone we pride ourselves at keeping up with all the latest products and design trends, so even if you need a Dekton kitchen work surface or a Neolith feature wall, we're always on hand to help.

[www.trajanstone.com](http://www.trajanstone.com)

---

# TOUCH

## IRONMONGERY LTD

[www.atouchofbrass.co.uk](http://www.atouchofbrass.co.uk)

210 Fulham Road, Chelsea London SW10 9PJ

---

## THE PERFECT TOUCH

---

### **Touch Ironmongery is one of London's leading Architectural Ironmongers Established in October 1982**

Originally called "A Touch of Brass", the firm changed their name in 2003 in reaction to slowly advancing market changes in architectural ironmongery which is no longer supplied solely in brass, and to also reflect the broader range of product and finishes that they sell.

In fact today, Touch can supply a wide range of finishes including Brass, Satin Brass, Polished Chrome, Polished Nickel, Satin Nickel, Copper, Bronze – solid and plated, BMA, Antique Brass, Black, Pewter, Ceramic, Leather, Stainless Steel, Satin Stainless Steel, Gun Metal, and the list keeps growing. Whatever finish you require, Touch can help you get the right look.

Touch occupy their recently refurbished showroom at 210 Fulham Road, Chelsea, where they display a vast range of their 5,000 products. With a customer base including Interior Designers, Builders and Individuals who are interested in the quality end of the Ironmongery market, Touch mainly supply to residential premises but hotel and office properties also contribute to their vast clientele.

The company also have a healthy export market to all corners of the world, namely the Middle East, Europe and the Americas. Touch's owner and founder, Bill Benham, has 38 years' experience in the ironmongery trade, as do his colleagues Jim Haselup and Alan Blanchard. Saleem Qureshi is the newest member of our team and has 10 years' experience, meaning their knowledge is unrivalled in this industry.

The range of products supplied by Touch date from circa 1640 French (Louise XIV) and cover all subsequent periods (Georgian, Edwardian & Victorian), art deco and contemporary pieces also make up the product ranges. In addition, Touch showcases the very best of British manufacturing; the best ranges are still produced in the Midlands by craftsmen in factories dating back 200 years or more.

Touch Ironmongery have recently become suppliers for **Designer Doorware (Australia)** who have beautiful products with a cutting edge design Metal, Wood and concrete. We also have the exclusive rights to sell the **Olaria (Barcelona)** range in the UK.

Olaria make all our bespoke products, they have incredible levels of workmanship. Touch also sell European manufactured goods which is considered to be of a very good quality and in recent years they have introduced some of the far eastern made products, albeit in a limited range but cost effective. With trends continuously evolving new innovative products are constantly under development. Touch understand that keeping up with the fashion-shifts is imperative in order to provide every customer with the best solution for their requirements.

Ironmongery can be a difficult and complicated aspect of a building project, as a result Touch aim to take this awkward aspect and make it user friendly and clear to understand by offering an on-site service where they carry out a detailed door by door, window by window, room by room Ironmongery schedule, highlighting all requirements and identifying any items that can be refurbished. Refurbishment is a large part of the business; Touch will undertake complete ironmongery refurbishment projects, and can restore old paint covered door furniture to their former glory, looking as new, at a fraction of the cost to replace.

**For more information about Touch Ironmongery or to arrange a  
showroom visit please call 0207 351 2255 or alternatively  
visit [www.atouchofbrass.co.uk](http://www.atouchofbrass.co.uk)**

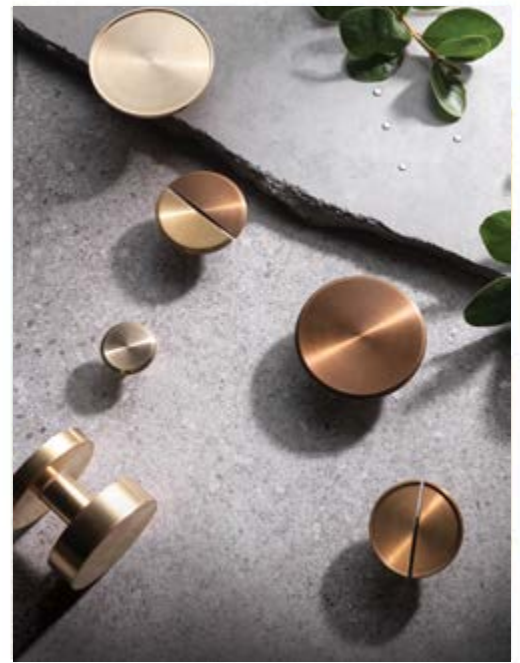

## BRITISH & EUROPEAN MANUFACTURERS SUPPLYING THE FINEST QUALITY IRONMONGERY

Touch combine traditional skills with modern manufacturing techniques to produce the most beautiful, quality fittings, built to stand the test of time.

As well as specialist bespoke items, Touch supply over 1000 products, available in 23 different finishes to furnish high end residential and commercial properties, royal palaces, government houses, historic castles and stately homes.

Olaria, available from Touch Ironmongery

[www.atouchofbrass.co.uk](http://www.atouchofbrass.co.uk) & [www.olariabarcelona.com](http://www.olariabarcelona.com)





# NEW PROJECT IMAGES OF A LUXURY RESIDENTIAL DEVELOPMENT

This stunning residential development in Dolphin Quay, Emsworth, consists of six housing units.

The two waterfront units were designed in a contemporary style and feature multiple Sieger aluminium glazing systems, including Sieger entrance doors, bifold doors, slim sliding doors and casement windows.



Located in a conservation area and surrounded by listed buildings, it was imperative for the buildings to work in harmony with the surrounding landscape and not disrupt the natural beauty.

Natural materials were specifically chosen for the external building finishes to reflect the industrial boatyard that the luxury apartments look out onto. This includes timber cladding, grey brick and a metal wraparound facade.

To maximise the waterfront views, Sieger's slim framed glazing systems were used all around the units. The aluminium frames were finished in a dark grey colour which enables them to blend in seamlessly with the exterior of the units.

Sieger uses marine grade polyester powder coating as standard, and the glazing for this project used pre-anodised frames that were finished with a polyester powder coating for maximum protection against the harsh marine air.



"To maximise the waterfront views, Sieger's slim framed glazing systems were used all around the units."



Theo Botha, the project manager on the job, said he was "ecstatic with the outcome. The interior spaces are flooded with natural light and the views of the quay are breathtaking".

All Sieger aluminium frames use specially engineered thermal break technology resulting in high thermal performance for our systems. Trickle vents can be incorporated into the head frame to ensure adequate ventilation throughout the property.

Sieger glazing systems are available from Sieger and available exclusively to IQ Glass in the UK.

[www.siegersystems.co.uk](http://www.siegersystems.co.uk)



### Building smarter homes with keyliteConnect®

UK based manufacturer of roof windows, Keylite Roof Windows (Keylite), has launched its new range of smart roof windows, blinds\* and technology, allowing homeowners to control daylight and ventilation in their home via smart devices.

With the keyliteConnect® app and keyliteConnect® hub, homeowners are able to monitor and engage with their smart app-enabled Electric and Solar Roof Windows and Blinds from anywhere in the world. This allows users to operate one or multiple applications at once, set pre-timed actions such as airing the building for a certain duration, or automatically lower blinds in the evening. To provide peace of mind for those days where you just can't predict the weather, the smart rain sensor will automatically close windows in the event of a downpour, even when homeowners are away.

**For more information on Keylite Roof Windows and its keyliteConnect® range, please visit [www.keyliterateofwindows.com/connect](http://www.keyliterateofwindows.com/connect), call 01283 200 158 or email [info@keyliteuk.com](mailto:info@keyliteuk.com).**

\*Not compatible with Manual or Solar Powered Keylite Blinds



### GARADOR LAUNCHES NEW SLATEGRAIN SECTIONAL GARAGE DOORS

Garador has introduced an exciting new surface finish, Slategrain, for its popular sectional garage door range. The new Slategrain surface finish imitates the fine grained and foliated surface texture of the naturally occurring rock, Slate.

Slategrain is available for Garador's Linear Medium and Linear Large door models and comes in two colours, Traffic White (RAL 9016) and Anthracite Grey (RAL 7016), for a clean, contemporary appearance.

Garador's sectional garage doors also offer many other advantages, including weather seals on all four sides of the door together with 42mm thick fully insulated door sections to reduce heat loss and potentially lower energy bills. The door's exceptional thermal performance is illustrated by a U-Value of 1.30 W/m²K.

Garador's sectional garage doors also lift vertically and run on tracks back into the garage, offering maximum drive-through width and height.

**Find out more about Garador garage doors by visiting [www.garador.co.uk](http://www.garador.co.uk) or calling 01935 443722**



### Steel steals the show at Hackney Church Brew Co's uber cool stunning home in the arches

A vibrant brewery in London, Hackney Church Brew Co [www.hackneychurchbrew.co](http://www.hackneychurchbrew.co), has been given the steel star treatment by Steel Window Services & Supplies [www.steelwindows.co.uk](http://www.steelwindows.co.uk), a member of the Steel Window Association [www.steel-window-association.co.uk](http://www.steel-window-association.co.uk).

Steel Window Service & Supplies' project entailed providing W20 arched, headed external screens, along with interior doors and screens. Over 80 man days, the company supplied and fitted the large entrance screens, two large external screens at the rear of the building, four internal WC doors and one internal double door set. The W20 suite features an industrial patina finish which offers a stunning urban aesthetic echoing the building's heritage whilst also reflecting the nature of this vibrant, fashionable district of London. Another innovative touch was the silicone fronted glazing which replicates perfectly the authentic look and feel of traditional steel windows.

**[www.steel-window-association.co.uk](http://www.steel-window-association.co.uk)  
020 3475 8049**

## GEORGE BARNSDALE

Est. 1884

Your job is to create something beautiful, and our job is to help you do it

Whether you are looking for solutions for a new build or a refurbishment, our timber windows and doors are expertly designed to meet the most demanding design and performance specifications whilst remaining sympathetic to the building's architecture and surroundings.



Visit [georgebarnsdale.co.uk/brochures](http://georgebarnsdale.co.uk/brochures) to download your copy of our latest brochure.

t. 01775 823000 e. [enquiries@georgebarnsdale.co.uk](mailto:enquiries@georgebarnsdale.co.uk) w. [georgebarnsdale.co.uk](http://georgebarnsdale.co.uk)    



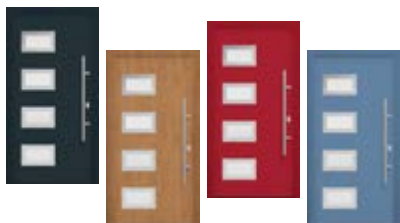

## GARADOR INTRODUCES NEW FGS 820 FRONT DOOR

Garador's FrontGuard front door range offers excellent security and thermal insulation, offering a great solution for all types of properties. Now Garador has added a new model to its extensive collection of front doors, the FrontGuard FGS 820.

This new door model is designed to minimise heat loss and incorporates four large windows to allow natural light to flow in through the doorway, which is ideal for hallways that are deprived of natural light. The windows are all triple glazed and the door leaf is 65mm thick, filled with dense polyurethane insulating foam. The door frame and seals have also been specifically designed to eliminate thermal bridges.

This FGS 820 also features 5-point locking and RC2 security equipment and comes in a selection of standard and custom door sizes up to 2250mm high.

Find out more about Garador's complete range of front entrance doors at [www.garador.co.uk](http://www.garador.co.uk) or call 01935 443722.



## Unique Windows London

As a family owned and run business we understand that attention to detail is vital to our long term success.

Here at Unique Windows London, we pride ourselves on our close family set up and the attitude it instils within us to always put our customer's satisfaction first by providing an intimate, bespoke and all round service that is of the highest quality.

Unique Windows London offers a wide choice in doors & windows in a range of modern and classic styles and finishes. Our doors & windows incorporate all the latest technology in design, from their energy efficiency to their styling and security features; all you have to do is pick out which looks best in your home!

020 8770 7397

[www.uniquewindowslondon.co.uk](http://www.uniquewindowslondon.co.uk)



## UltraSlim Contemporary Slide & Swing Glass Doors

Fully retractable double-glazed doors with ultra-slim 19mm aluminium side frames enable natural light to flow into your home and maximise your view. UltraSlim slide-and-pivot doors also have slim profiles for maximum access.

Edge-to-edge doors slide to the ends of the guide rails where each one opens 90 degrees to create a clear, wide opening space. Or doors can be spaced along the opening.

Exclusively made to order and installed directly by UK door technology designer-manufacturer SunSeeker Doors, UltraSlim costs a little more than standard bi folding doors but will enhance your home for years.

SunSeeker UltraSlim, launched almost ten years ago, is the market leader in its class, suitable as external doors. Frameless tempered glass doors are also available as room dividers or for commercial property.

Visit [www.sunseekerdoors.co.uk](http://www.sunseekerdoors.co.uk) or call direct on 01582 492 730

## MAKE LIGHT WORK (IN 'SOHO')



Photo courtesy of Nicola Hicks Design/Charlie Round-Turner/Lightfoot Windows (Kent)

Using natural light to define a space is a key element within a home's design - and should be a significant consideration for your home working environment; whether it's a home office, study, converted playroom, your bedroom, at the kitchen table or in a garden annex.

The hallmark of a Crittall window is the slender steel frame that is so much slimmer - and therefore

admits so much more light - than alternative window systems which require far larger profiles due to the basic differences in the frame material and their relative strengths.

For a new extension, combining outdoor space with an internal area under structural glazing, removing barriers so you have a level threshold, or creating a courtyard with stunning full-length glazing, are great ways to achieve impact and add value to your property.

Crittall Windows offer a complete service from start to finish via their Crittall Specialist Partners (CSPs). They give free, no obligation, quotes and a warranty covering windows, doors, glass and installation.

[www.crittall-windows.co.uk](http://www.crittall-windows.co.uk)  
t: 01376 530800  
e: [hq@crittall-windows.co.uk](mailto:hq@crittall-windows.co.uk)

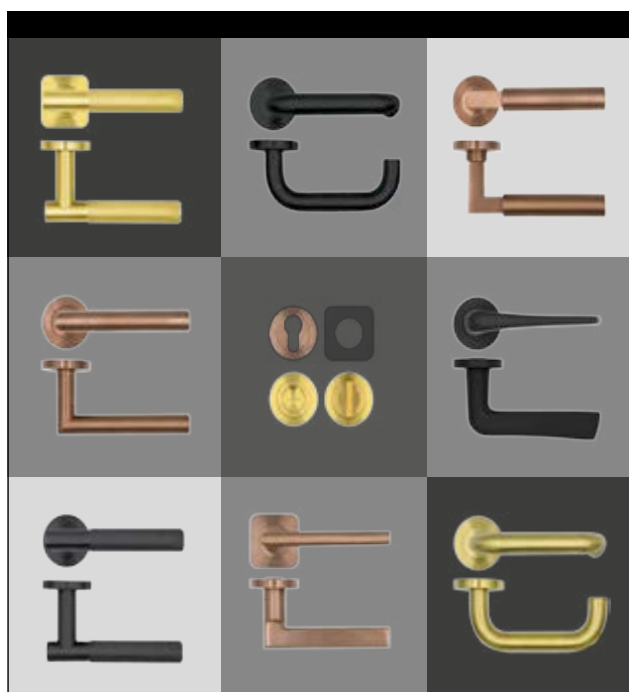

**ROSSO TECNICA**  
ACCIAIO CON STILE

ROSSO TECNICA is our new and exclusive range of European inspired designer levers. Manufactured from Grade 304 stainless steel and finished in a new selection of stunning hard-wearing finishes, these levers are the perfect accompaniment to the latest trends in interior fashion.



AS PART OF OUR ONGOING COMMITMENT TO REDUCE OUR IMPACT ON THE ENVIRONMENT, THE ROSSO TECNICA RANGE IS SUPPLIED WITHOUT ANY PLASTIC PACKAGING. NO POLY-BAGS ARE USED IN THIS RANGE.

T : +44 (0) 1228 672 900  
E : [sales@zoo-hardware.co.uk](mailto:sales@zoo-hardware.co.uk)  
W : [www.zoohardware.co.uk](http://www.zoohardware.co.uk)

Rosso Tecnica is part of Zoo Hardware Ltd. **ZOO**



# SHE HOUSE

The lot on which "She House" stands has a rectangular shape of 860 sqm on the Turin hills in a residential area, with a 270° view of the plain below.

The new residence which measures 600 sqm distributed on three levels including the terraces, is surrounded by compliant architecture and in line with a traditional vision. The client's request was to live in a house with a contemporary cut.



The project is broken down and reassembled making it unique among the architecture of the place.

The villa rests on a reinforced concrete volume and is spread over two floors above ground and a basement.

The house opens to the living areas on the south side and the bedroom area to the north and allows vertical connections stairs and the lift.

To access "She House" you go up a staircase covered in local stone that crosses the Japanese garden, also studied in every detail.

Upon entering the house, you are struck by the double-height living room and the glass walls that maintain a constant dialogue with the outside, creating changing scenery on the seasons.



"The villa rests on a reinforced concrete volume and is spread over two floors above ground and a basement."

In the living room we are greeted by an enveloping Standard sofa by Edra and a wood-burning fireplace. The furnishings in this room are the bench designed by Lissoni for Porro, the Cattelan coffee table, the Besana carpet and the Flos and Vibia lights. Here we find ourselves in the presence of a large window that reveals the communication stairs between the basement (service rooms, hobby room and garage) and the first floor.

Through the Velaria sliding door by Rimadesio you enter the dining / kitchen area (Arclinea furniture with Cea taps) and through the sliding windows (Sky frame) you have a total opening on the garden. The Rimadesio table, Bonaldo chairs, Flos and Foscarini lights complete the kitchen / dining room.

Venturing up the stairs made of metal by Cirifer, we reach the first floor, where there are rooms dedicated to relaxation and personal care.

Here there is a wellness area with sauna, services, directly connected to the terrace where there is a mini-pool with hydromassage.

Even the master bedroom, thanks to sliding windows (Sky frame), allows for a continuum with the Burma teak terrace.

The Flou bed, the walk- in closet by Rimadesio, the bathroom with Kartell toilet, the Casabath washbasin, the Fantini taps, the ceramic tiles in large DSG slabs, the resin floor (in the shower, cup, bidet areas) are a tribute to essential forms.



In the room we find a Kos Zucchetti bathtub with Fantini tap.

The curtains that screen the rooms are for Renson- Griesser exteriors and My Core interiors.

The bathrooms have furnitures Salvatori, Fantini, Geberit, Cielo, Hansgrohe, Duka.

Natural walnut floors cover all the rooms of the house with different laying on the ground floor and on the first floor.

All the doors are Rimadesio and Lualdi, the Olivari handles and the Ercos entrance door.

The rumpus room in the basement is furnished with a Meson's kitchen, a Roche Bobois sofa and Kartell chairs.

Pushing and divided elements, transparencies, emptied blocks open into the garden.

Glass blocks combined with wood finishes, local stone claddings, lightness and fluidity and very high technological levels characterize this architecture.



With over 30 years experience, we offer bespoke solutions for the domestic market across the South East. Feasibility can usually be determined with a site postcode.

COVID-19  
SAFE  
WORKING



**WATER SUPPLY & SOAKAWAY BOREHOLES & DRAINAGE SOLUTIONS**

Independent water supply for irrigation or consumption\*  
Soakaways, drainage fields and other drainage solutions.

\*subject to analysis and suitable filtration

**RENEWABLE HEATING**

Reduce heating bills by up to 50%

Groundwater can be used as a heat source for an Open-Loop Ground Source Heat Pump which could meet all hot water and heating needs.



**SEWAGE TREATMENT SYSTEMS**

Our bespoke systems are designed to meet the needs of individual clients and comply with strict discharge legislation.  
Servicing contracts are offered on all our installations.

enquiries@thehdgroup.co.uk | 01494 792000 | www.hdservicesltd.co.uk



SEWAGE TREATMENT  
ESTABLISHED 1987

THE MODERN 'ENVIRONMENTALLY FRIENDLY' ALTERNATIVE FOR SEPTIC TANKS AND CESSPOOLS WHERE 'MAINS DRAINAGE' IS NOT AVAILABLE

ECONOMICAL  
'ODOUR FREE'  
OPERATION

'T' RANGE  
BIODIGESTERS IN  
EIGHT SIZES 6 - 42  
PERSONS

RECOMMENDED  
FOR VARIABLE  
LOADINGS

WET GROUND ANCHORS



EXTENDED  
EMPTYING  
INTERVAL

CE MARK  
CLASS 'A'  
APPROVAL - USA

SIMPLE  
UNDERGROUND  
INSTALLATION

WIDE RANGE OF LARGER BIODIGESTERS ALSO AVAILABLE

**SIMPLY THE BEST!**

**BURNHAM ENVIRONMENTAL SERVICES LTD**

BURNHAM-ON-SEA, SOMERSET TA8 2HW

TEL: 01278 786104 EMAIL: SALES@BIODIGESTER.COM

WEBSITE: WWW.BIODIGESTER.COM



**Freephone: 0800 328 5492**

**Email: sales@allertonuk.com**

**Website: www.allertonuk.com**

**The Dependable Choice in Drainage**

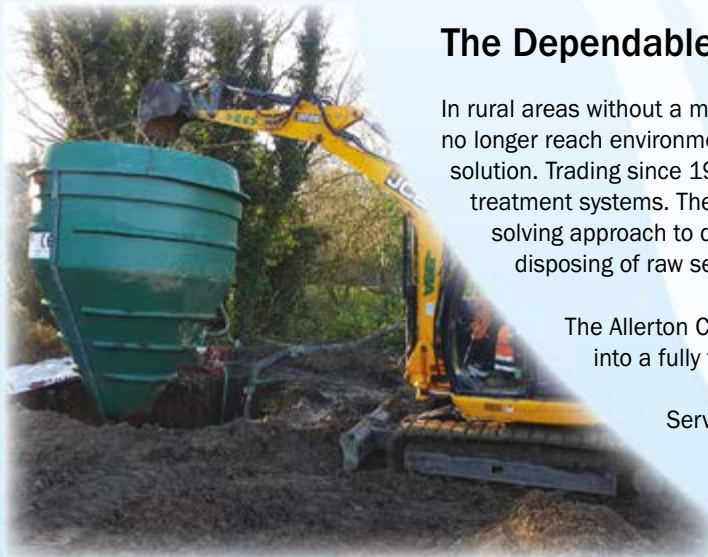

In rural areas without a mains drainage system, and where septic tanks will no longer reach environmental standards, Allerton can provide the ideal solution. Trading since 1974, Allerton are leading specialists in efficient treatment systems. They pride themselves on their individual, problem solving approach to dealing with alternative means of treating and disposing of raw sewage.

The Allerton ConSept converts your existing Septic Tank or Cesspit into a fully functioning Sewage Treatment Plant.

Servicing & Maintenance on a wide range of Sewage Treatment Plant and Pump Stations by BRITISH WATER ACCREDITED ENGINEERS.

The Diamond Sewage Treatment range is suitable for either individual homes or small population applications

When Gravity Drainage is not possible choose Allerton Pumping Stations for Sewage or Dirty Water



# Hardwood Flooring

*bespoke finished  
to complement  
your designs*



☎ 01462 486586

✉ [info@roversflooring.co.uk](mailto:info@roversflooring.co.uk)

🌐 [www.roversflooring.co.uk](http://www.roversflooring.co.uk)

33 Jubilee Trade Centre,  
Jubilee Road, Letchworth,  
Hertfordshire SG6 1SP

 **ROVER'S**  
F L O O R I N G  
PRODUCERS, IMPORTERS & DISTRIBUTERS



Bell Twist Damson, from £39.99 per sq m, Brintons



Abbotsford Heather Kilgour, from £69.99 per sq m, Brintons

# HOW TO USE DARK CARPETS IN ANY SPACE

Dark carpets have long been associated with dated room schemes, but today's contemporary palettes offer elegant and sophisticated alternatives that will complement an interior.

If you're unsure whether your home would benefit from a decadently dark carpet, heritage carpet company Brintons shares its expert advice on how to create a captivating interior through the use of dark colours and patterns.

Jodie Hatton, a Residential Designer at Brintons explains that "Similarly to how dark walls can transform a small room or a patterned wallpaper can bring interest to otherwise dull space, a patterned carpet is an inspired way to make a feature of a smaller room adding interest and character. However, it is important to choose the right patterned carpet depending on the size of the room. Patterns with a wider repeat don't always work in smaller spaces, as you don't get the full effect of the motif. The best options for dark, patterned carpets in smaller rooms are tighter floral repeats and tartans. In larger spaces, up-scaled, blowsy florals or sprawling abstract designs are most impactful."

## PLAY WITH PURPLE

Create a whole world of drama and impact in your living room with a deep purple carpet. The colour creates an energetic, cheerful atmosphere, making it ideal for lively, social spaces. The addition of dark flooring can add depth to a large space, and make it feel more intimate and cosy.

## SET THE TONE IN A DINING SPACE

If you're specifying a carpet for a dining space, not only is it best to opt for a dark or patterned option for practical benefits, but it's also worth sticking with a short pile that can be easily vacuumed. Warm tones such as earthy browns will set a calm and sophisticated backdrop in a formal dining space.



City Plaids Knightsbridge, from £69.99 per sq m, Brintons

"Patterns and dark colours are perfect for high-traffic areas like dining rooms where dust, food and dirt are repeatedly trodden into the carpet. In 2021, we need little moments of joy throughout the home, so dining room decoration should be equally as smile-inducing as your living room or bedroom. It is where you entertain guests, so why not make it special? We use an Axminster construction for our patterned carpets as this creates superior definition and creates a longer-lasting carpet," explains Hatton

### LET OTHER ACCESSORIES SHINE

A carpet in a dark neutral or pattern is great for anchoring a room and allowing other interior accessories to stand out. Hatton explains that "patterned flooring is a versatile option. At Brintons, we are seeing a resurgence in classic patterns and prints such as tartans and plaids, which create a warm, cosy feeling. To mix and match patterned carpets and plains in adjacent rooms ensure that you stick to a similar colour palette. For example, a soft, delicate pattern in silvers, greys and stones will naturally sit well against greys or beiges in a plain range –creating a seamless transition from both patterned to plain and room to room."

"Patterns with a wider repeat don't always work in smaller spaces, as you don't get the full effect of the motif."



Abbotsford Macinnes, from £69.99 per sq m, Brintons

### DARK COLOURS ARE A PRACTICAL CHOICE

A dark carpet is ideal for coping with high-traffic areas such as bedrooms and hallways. If you're struggling to find a wall colour that will adapt and grow with your interior scheme, maybe introducing colour on the floor is the answer. This way, you can stick to simple, timeless white walls and still ensure that the room is packed full of personality.

[www.brintons.co.uk](http://www.brintons.co.uk)



---

## WOOD FLOORING AND TILE COMPANY

Eden Clay have come a long way since beginning as two individuals set on serving local businesses and retail customers with products sourced from UK distributors. They now have a large team of talented individuals, import all their products direct from European manufacturers, produce all of their own wood flooring, and sell and install nationally for some of the countries most recognisable brands and personalities.

“It’s said that when starting a business “do what you know”. We built Eden Clay around the products we know inside out and centred it on service over sales. This is still at the heart of what we do, with our staff, showroom and website focused on the experience of finding the perfect tile and wood floor for your business or home.” Co founder Mark Bowring.

### Why Eden Clay?

Their wood flooring is hand finished in the UK providing their clients with a unique range of quality products including perfectly colour matched trims and accessories, and their tile collections include a number that are exclusive to them, with the majority imported directly from Italy.

However the aspect they are most proud of is their ability to equally and comprehensively service the commercial and domestic markets, offering both experiences tailored to their differing needs.

### Commercial

For Architects technical downloads and installation details specific to each product are available, as well as director lead technical support.

For Interior Designers detail is the key. Design is fundamental to Eden Clays product range and effort has been made to support current trends. Comprehensive samples are available to order or take away.

For Developers, being importers Eden Clay are able to offer a very competitive price point, especially considering the high quality of their products.

For Contractors site support and product training is available. This is supported by downloadable installation guides and video guides on request.

### Domestic

For home owners, Eden Clay understands the difficulties faced with selecting the right wood floor or tile. Both products are a permanent fixture in your home that helps determine its final aesthetic, so to help their clients make the right choice imagery of each product installed is available, and free samples and larger panels on request are provided.

With new products being added to their portfolio and website weekly, and the addition of a room visualiser app to come, Eden Clay are continually looking to improve their clients choices and experience.

Eden Clay has fast become a trusted brand for tiles and wood flooring.

**Designers, producers and curators  
of often unique and always  
wonderful tiles and wood floors.**

01277 624966 [info@edenclay.co.uk](mailto:info@edenclay.co.uk)

[www.edenclay.co.uk](http://www.edenclay.co.uk)



# EDEN CLAY

Wood Flooring  
and Tiles

01277 624966  
info@edenclay.co.uk  
www.edenclay.co.uk

THEFLOORINGSHOW.COM

  TheFlooringShow  FlooringShow

Image courtesy of Kellars



# REGISTER NOW

THEFLOORINGSHOW.COM

New Product Launches  
Demonstration Zones  
Design Trends



**THE FLOORING SHOW**  
19-21 SEPTEMBER 2021  
HCC, HARROGATE



## SOLUTION FIRES EXPANDS ITS TEAM AFTER A SUCCESSFUL LAUNCH YEAR

Solution Fires, a new generation of highly efficient, authentic, and stylish electric fires has announced the expansion of their management team after a successful first year of trading.

Joining the business is experienced Product Design Manager, Peter Gregory. Peter is an accomplished industrial designer and design manager with over 20 years' experience many of which were in the Electric Fire market with Glen Dimplex. Peter will be working closely with the Solution Fires Team to help develop existing and new Solution products whilst providing consumer insight and feedback, analysis of trends in the market and technical expertise.

Solution Fires, based in Bedfordshire, launched just over a year ago, and managed



Andy Hitchman, Managing Director and Peter Gregory, Product Design Manager, Solution Fires

to navigate through the pandemic with flying colours as people turned to home renovations, including the installation of media walls combining large flatscreen televisions and beautiful inset fireplaces, rather than holidays abroad.

➔ **For more information about Solution Fires visit: [solutionfires.co.uk](http://solutionfires.co.uk)**

## Beautiful Designer Ceiling Fans



Powerful - Stylish - Reliable - Silent



**THE HENLEY FAN COMPANY LTD**



**01256 636 509**  
**[www.henleyfan.com](http://www.henleyfan.com)**

**ehc**

the electric heating company



## No.1 Choice Electric Radiator Collection



**DSR Solaris Aluminium Convector Heater** with ceramic blocks. Four outputs available, 500, 1000, 1500 & 2000watts.

2 Year Controller & 5 Year Main Body Warranty

- Free APP
- Control your heating anywhere and anytime
- Adjust each room temperature separately
- Geolocation Feature
- Monitor electricity consumption.



**DSR Edge Traditional Column Convector Heater** with a large ceramic core. Four outputs available, 500, 1000, 1500 & 2000watts.

2 Year Controller & 10 Year Main Body Warranty



Contact us for a quote or more information

**01698 820533**

[www.electric-heatingcompany.co.uk](http://www.electric-heatingcompany.co.uk)

# SOLUTION FIRES - EXCELLENCE IN ELECTRIC



Solution Fires is a new generation of highly efficient, authentic and stylish electric fires. The focus of your living space, these fires have been designed and manufactured with optimal controllability of heat, light and sound as the critical elements.

Controllable from your handset, via Alexa or through the app on your smart phone or watch, you can customise your fireplace to suit your individual taste. No electric fire, currently on the market, has the level of product features or attention to detail that solution fires have as standard, supported by a high level of genuine customer service.

## TOP REASONS TO CHOOSE A SOLUTION LUXURY FIRE

- Ultra realistic, contoured flame effect technology
- 'One box solution' for front, corner or panoramic views
- Six preset illumination settings & one custom setting
- Nine independent flame colours with adjustable brightness\*
- Nine independent fuel bed colours with adjustable brightness\*
- Nine independent downlight colours with pulse effect\*
- High quality, hand decorated ceramic log fuel bed
- Crackling fire audio with volume control
- Customisable fuel bed set-up
- Fade in - ON, Fade out - OFF, flame effect feature
- Supplied with remote control as standard
- App control for most smart phones, tablets & watches
- Alexa voice control
- Optional Scene lighting LED kit available
- Optional Anti Reflective Glass available
- Thermostatically controlled with ultra-quiet fan heater
- Seven day, twice daily, program settings
- Fully ErP Compliant & low energy LED flame effect
- Plugs into a standard 13-amp 3 pin socket
- Optional 5 year warranty for added peace of mind

\*The above applies to the SLE75, 100, 150 & 200 fires

\*With use of Solution App

► For more information about our products, please visit: [www.solutionfires.co.uk](http://www.solutionfires.co.uk)

*A new generation of highly efficient, authentic and stylish electric fires and fireplaces.*

View the complete collection at  
[www.solutionfires.co.uk](http://www.solutionfires.co.uk)



Controllable from your handset, via Alexa or through the Solution App.

Fully customisable visual & audio settings to suit the consumers individual taste.

Ultra realistic, contoured ionic flame effect technology.

**solution**  
fires

# WARMUP UNDERFLOOR HEATING: PROVIDING SOLUTIONS FOR A SUSTAINABLE FUTURE



Underfloor heating is a cleaner, more efficient way to heat a home and is suitable for both new-build and renovation projects. Floor heaters require less energy to reach optimal comfort temperatures than traditional heating systems and with this increased energy-efficiency, you can expect lower long-term running costs. The 'invisible' nature of underfloor heating also facilitates complete freedom when designing your home, with no style interruptions caused by bulky radiators and exposed piping.

Warmup Underfloor Heating provides a bespoke floor-heating solution specifically designed and built to suit your requirements. With over 20 years of experience in heating homes, Warmup offer optimised electric and water underfloor heating systems to bring cost-savings, energy-efficiency and design freedom to your project.

## HYDRONIC UNDERFLOOR HEATING SYSTEMS

Hydronic Underfloor Heating, also known as Wet or Water Underfloor Heating, is a contemporary heating system that pumps heated water from a heat source through pipes within the floor construction. This heated water produces radiant warmth which heats up a room to a consistent, comfortable temperature from the floor up.

### KEY BENEFITS:

- Suitable for almost all floor finishes and room types
- Compatible with a variety of heat sources
- Perfect for new build and large-scale renovation projects
- Lower running costs

## REDUCING CO2 EMISSIONS: WARMUP PRO HYDRO

Warmup Pro Hydro is the world's first tool to instantly and automatically design bespoke underfloor heating systems, meaning real savings for installers and their customers by making correctly specified underfloor heating as quick and easy to buy as pre-packaged room kits.

In comparison to pre-packaged room kits, Warmup Pro Hydro uses up to 20% less pipe, because spacings are automatically optimised for the heat loss of the room. That is equivalent to saving an entire room's worth of pipe on a 100m<sup>2</sup> install. By automatically optimising the design of the system for the heat loss of the rooms, Warmup Pro Hydro can ensure enough heat output for the coldest days at lower flow temperatures. This allows the heat source to run at more efficient temperatures, saving up to 10% in energy use. In fact, for every 100 homes built with Warmup Pro Hydro systems instead of pre-packaged room kits, over 15 tons of CO<sub>2</sub> is saved each year.

Scan the QR code below to get a quote. Simply enter the details of your project and in a few clicks, we'll provide you with a comprehensive quote with full costings.

► Warmup Plc, 702 & 704 Tudor Estate, Abbey Road, London, NW10 7UW, United Kingdom

Website: [www.warmup.co.uk](http://www.warmup.co.uk)

Email: [uk@warmup.com](mailto:uk@warmup.com)

# Warmup



Get water underfloor heating quotes

in seconds that give the perfect temperature

required to heat your home.

## Only from Warmup Pro Hydro

- ✓ Full Quote in 18 seconds
- ✓ Instant Heat Loss Estimates
- ✓ Full Commissioning Log Included
- ✓ Up to 10% Reduction in Running Costs
- ✓ Up to 10% Reduction in Material Wastage

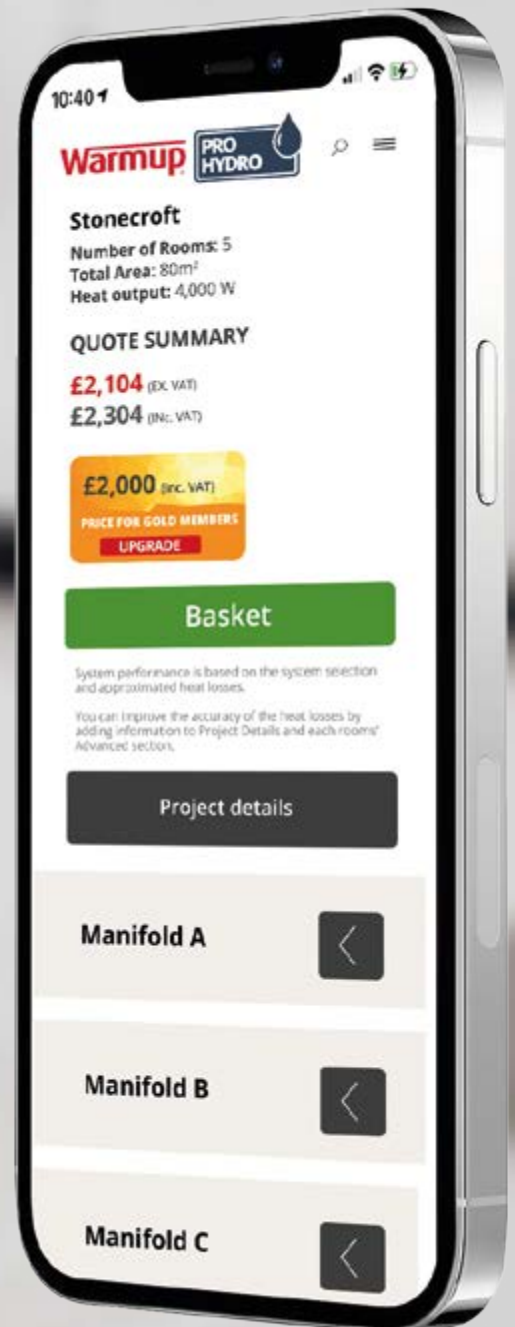

Scan to Get a Quote



# ELEGANT AND TIMELESS – AHMARRA’S ARTISAN PANEL DOOR COLLECTION

Ahmarra Door Solutions are one of the UK’s leading architectural door manufacturers covering all sectors including luxury residential, hotel, airport, education and commercial. They work closely with interior designers and architects to manufacture bespoke doorsets, and have developed sector specific ranges to aid design decisions and specification.



Their Artisan Panel Door Collection adds a touch of luxury to any home or business. The collection includes their most successful traditional and contemporary panel doors, which can be tailored to complement your interior design. Ahmarra offer full product certification, including ISO 9001, ISO 14001, FSC® and the Q-Mark Fire Door Manufacturers scheme.

All of their stunning Artisan doors are made to order, ensuring that your project is truly unique. You choose the style, the material and the finish, creating the perfect look with limitless options. Ahmarra also offer a colour matching service, so that doors can be made to match other elements of your design scheme. They can even supply extra components to complement the doors, including skirting boards, lining, architraves and ironmongery.

Ahmarra have supplied bespoke panel doors to many high-end properties including Magna Carta Park, a private residential estate in Surrey, Pentagon Apartments in Herefordshire and Arts House in Kensington, London.

Based in Hampshire, Ahmarra have been manufacturing doors for over 25 years. They are proud to fly the flag for British manufacturing and use traditional craftsmanship, cutting edge technology and the finest materials to guarantee exceptional standards. Ahmarra are also committed to sustainable working practices, and as such, use FSC® certified timber sourced from responsibly managed forests to manufacture their doors and frames.

Ahmarra’s core values are based on providing you with the highest quality of service, whilst making the entire process as simple and as practical as possible for you. Their experienced specifications team are always on hand to offer guidance and ensure Buildings Regulations are met. They also offer a Q-Mark certified fire door installation service.



➡ To learn more, visit; [www.ahmarra.co.uk](http://www.ahmarra.co.uk) or call 02392 389 076

# ARTISAN Panel Door Collection

Our Artisan doors grace some of the finest residences in the UK



- Bespoke doorsets designed to suit your unique project
- Available in a range of specialist stains, veneers and factory paint finishes
- Architectural ironmongery service available
- Dedicated specification team available to assist
- Certified Q-Mark fire door manufacturer and installer

**MADE IN BRITAIN**



FIRE  
RATING  
FD30 & FD60



ACOUSTIC  
RATING  
29, 30, 35 &  
40R.wdB

02392 389 076 | [www.ahmarra.co.uk](http://www.ahmarra.co.uk)

MADE TO ORDER BY  
**ahmarra**

# INSPIRED DESIGN TO ENHANCE YOUR WORLD – FOR LOVERS OF COLOUR, FINE MATERIALS AND A PASSION FOR ALL THAT’S CONTEMPORARY

**krib** LIFESTYLED™

Life evolves and so do home trends and peoples needs, at KRIB we like to think we are ahead of the curve in providing the most inspiring and unique furniture and homeware collections available – from emerging styles to timeless classics we offer luxury interior style at great prices backed by our exemplary customer service.

At KRIB you will discover ideas that can transform your space – fresh, functional pieces that make a statement, quirky items that say WOW or simple classics that exude style, you will soon see why KRIB is at the forefront of contemporary design.

Utilising both our in-house design & manufacturing and exclusive relationships with carefully selected designers and makers we are able to offer ever changing exclusive pieces, limited edition designs and unique collections to transform your home into somewhere that says it’s your personal style.



➡ [www.yourkrib.com](http://www.yourkrib.com) | Showroom: 0207502 8442 | Mobile: 07458 301790

## CHILDCARE INSTITUTIONS WITH SOUND DESIGN

The design of spaces for children is intriguing because of the permanent influence it can have on them. A new online theme by Danish acoustic panel manufacturer Troldekt explores through articles and expert interviews how good acoustics plays its part when designing these areas. Of course, other factors such as colour, shapes, robustness and finish also have an impact but so does sound. Children are noisy and active and the rooms they inhabit are typically large.

Careful design considerations are particularly important because a child’s environment moulds their perspectives for the future and the development of the mind and body. School, activity and childcare spaces all affect self-esteem, performance and friendships and help shape the individual into the adults they will become.

Studies such as Bronzaft and McCarthy (1975) have shown the effect noise has on wellbeing and learning - This is the reason why the products of specialist manufacturers like Troldekt are specified to solve the problems of noise and reverberated sounds.

If acoustic absorption is ineffective, discomfort and irritation will result from the reverberations. If it is designed well, the participant’s interest will increase, as many case studies for new and transformed buildings prove.

In an interview with Troldekt, the Danish education psychologist Mille Sylvest comments, “It’s very important to be aware of noise when designing facilities. Noise affects stress levels for both children and staff because nobody can endure spending long periods of time in a noisy environment. Lower energy levels, more sick leave and poorer learning outcomes are the direct results of noise.”

Specified throughout the UK and Europe, the benefits of 100% Troldekt natural wood wool panels include high sound absorption, high durability, natural breathability, low cost life cycle performance and sustainability.



This high performance is recognised by their Cradle to Cradle certification at Silver level. Available in various sizes and in four grades from extreme fine to coarse, the panels can be left untreated or painted in virtually any RAL colour.

➡ **Samples, case studies and technical information are easily sourced from tel 01978 664255 or visit [www.troldekt.co.uk](http://www.troldekt.co.uk).**

**More information around the theme of childcare institutions can be found on <https://www.troldekt.com/News/Themes/Child-care-institutions>**





**Few materials inspire the imagination in the way glass and mirror can. By augmenting the sense of space, light and even adding colour, these stunning options breathe an extra dimension of opulence into any design project.**

At MIRROR MANIA, we are experts in mirrors and decorative glass. We understand that designers, architects and renovation specialists are constantly striving to integrate new, creative features into their work. We also know it can be difficult to find a company offering unique and made-to-measure premium products.

MIRROR MANIA's products work in all kinds of residential and commercial projects, and for all eras and styles of architecture, whether a hyper-modern build or a listed building.

So, if you are looking for the perfect finishing touch for your project, call us to speak directly to our design team for advice or to interpret and create exactly what you have been looking for.

- An extensive range of beautiful hand-crafted mirrors
- Decorative glass for window or ceiling panels, or domes
- Unique products – no two will be exactly the same
- Inspiration to create feature details
- Designs tailored to your requirements, including colour matching and unusual shapes
- Reliability from design to delivery from a British company
- Tailor-made packaging with handmade timber crates and protective covering and edging.



**MM**  
**MIRROR MANIA**  
 Bespoke Mirrors & Glass Since 1985

**Tel:** 01493 304331  
**FB:** MirrorManiaDesignerMirrors  
**Twitter:** @MirrorManiaCoUk  
**Pinterest:** mirrormaniam  
**Instagram:** mirrormaniam  
**Web:** www.mirrormaniam.co.uk

# LIGHT AND DARK - OAK FURNITURELAND'S NEW CABINETRY RANGES



The UK's largest retailer of real hardwood furniture, Oak Furnitureland, has added two brand new cabinet ranges to its expanding portfolio.

Grove, is a deep dark grey range, almost black in some light. Solid hardwood all through, the deep grey finish is painted and glazed. The painted part is acacia, a hardwood that is ideal for painting, with its very smooth surface. The solid oak tops of the range have a natural finish. Grove is a versatile style that has longevity built

in. It can be styled in different ways, looking great in monochrome and earth-toned rooms, or being the perfect foil to colourful walls and accents.

By contrast, Willow has a smooth pale grey wash finish, and is made from solid oak throughout. For this new look, a lot of care has gone into getting the silvery grey finish right. It's a five stage process, with each layer needing to dry and be brushed down before the next. The finished surface lets the wood's knots of authenticity feature, and the natural patterns of the oak show through. This makes each piece of furniture unique. Gunmetal grey bar handles complement the grey glazed surface.

From beds to bookcases, wardrobes to dining tables, coffee tables and matching mirrors, the Willow and Grove ranges feature them all.

► For further information or to buy online go to [www.oakfurnitureland.co.uk](http://www.oakfurnitureland.co.uk). For inspiration, the latest news, and style advice follow @oak\_furniture\_land on Instagram or oakfurnitureland on Pinterest.



## PRODUCT SUMMARY

**Range name:** Grove

**Price:** From £179.99

**Link:** [www.oakfurnitureland.co.uk/range/grove-painted-natural/](http://www.oakfurnitureland.co.uk/range/grove-painted-natural/)

**Range name:** Willow

**Price:** From £179.99

**Link:** [www.oakfurnitureland.co.uk/range/willow-solid-oak/](http://www.oakfurnitureland.co.uk/range/willow-solid-oak/)



YOUR PERFECT PARTNER



any surface,  
any substrate  
and any volume  
**the only limit is  
your imagination.**

dp-limitless provides a limitless offer of surface finishes bonded with a high strength PUR glue line to the substrate of choice. Surfacing materials including Laminates, the full range of Senoplast Acrylics, Rehau Acrylics, Real Stone Veneer, Faux Leather, Natural Wood Veneer Laminate, Technical Surfaces and of course Unique, one off surface finishes.

There is no commitment to purchasing in bulk, the offer is deliverable from single sheets up to full load quantities – from stock.

Unique / Silver Mirror

Textured Surfaces / Diamantino

Faux Leather / Aliena Limette

Rehau Acrylics / Marmo Nero

Laminates / Brilliant Yellow

Senoplast / Denim

Technical / Tortona Natural Oak

Real Stone Veneer / Vienna

Natural Wood Veneer / Titanium Oak Groove Effect

**Contact us for more information.**

Century House, Premier Way, Lowfields Business Park,  
Elland, West Yorkshire, HX5 9HF

T: +44 (0) 1484 658341 E: [info@decorativepanels.co.uk](mailto:info@decorativepanels.co.uk)  
[www.decorativepanels.co.uk](http://www.decorativepanels.co.uk)



GAÏA

*by* LALIQUE



## MULTIFUNCTIONAL STYLE

After over a year of living with lockdowns, flexibility and work-life balance have become key for most of us.



Now more aware than ever of the need for multifunctional spaces for working, schooling, exercising and relaxing, we see the kitchen not just as the heart of the home, but also as an 'everything space', doubling up as an office, classroom, gym and even a bar. Finished just before the pandemic hit, this Arbor kitchen in South London has been a blessing for the homeowners, a family with young children. "We use it pretty much for everything - cooking, studying, reading, playing, dining and sometimes working", the owner confirms.

Previously four cramped rooms, including a garage, a laundry room, a dining room and the existing kitchen, the space was opened up to create a light-filled open-plan layout with easy access to the outdoors. On top of the homeowners' wish list was storage, so the Harvey Jones designer planned lots of cupboard space through dressers mounted on either end of the worktop that runs along the back wall and a pantry concealed behind panelled double doors. The central island also allows for pan drawers and a double cupboard, as well as bar seating, while a large wooden table for more formal dining is set a small distance apart from all the action.

"Finished just before the pandemic hit, this Arbor kitchen in South London has been a blessing for the homeowners, a family with young children."

Colour has been used expertly to offset the inky cabinetry, painted in 'Keep the Peace' by Valspar and the Calacatta Bluette marble worktops. Wooden flooring by Trunk and a concrete finish on the surround that encloses the gas fireplace on one side and an American-style fridge-freezer add texture and interest. It is not all elegant restraint though.



## PRODUCTS FEATURED

### Appliances:

Fridge: Fisher & Paykel, £1,640  
 Wine fridge: Fisher & Paykel, £1,120  
 Dishwasher: Fisher & Paykel, £985  
 Cooker: Fisher & Paykel, £1,080  
 Hob: Britannia, £785  
 Sink: Blaueo sublime sink, £320  
 Tap: Quooker tap fusion in Black

### Surfaces:

Worktops: Calacatta Bluette marble, supplied by Sidne4Life, £5,000 + VAT - (3 slabs used, cost includes installation)  
 Flooring: Trunk floor, £79 per sq m

### Furniture:

Table: Tiros by Barker & Stonehouse, £1,768  
 Chairs: Soho Home, £1,225 for 6  
 Island lamps: Soho Home, £99 each  
 Wall lamps: Julian Lighting, £300 for 3

### Paints:

Walls: Farrow & Ball in Velvet  
 Kitchen outside cabinets: Valspar in Keep the Peace and Farrow & Ball in Parma Grey  
 Inside cabinets: Farrow & Ball in Dutch Orange



The dark cabinetry opens to reveal a confident burst of Farrow & Ball's vibrant 'Dutch Orange'. "Applying bolder colours in unexpected places, such as the dresser interior and stools, changes the initial impression of the room and instantly adds depth to the aesthetic", explains Melissa Klink, Creative Director at Harvey Jones. "Strong colours are highly emotional but designing with them in a controlled manner ensures that they liven up the overall feel of the room instead of overpowering it. And there is the added benefit of being able to change the colour easily if you want a little refresh."

[www.harveyjones.com](http://www.harveyjones.com)

### Q&A WITH MELISSA KLINK, CREATIVE DIRECTOR AT HARVEY JONES:

**The images of this kitchen show the importance of the quality of finishes - the marble surfaces, the wooden floors, the concrete fireplace. Could you tell us more about the choices?**

We know how functional the kitchen space is to our everyday needs, and now more than ever we are occupying the room throughout the majority of our time, so you need to appreciate how the materials will react both initially and over a long period of time. It is important to take the variant qualities of each material into consideration - not just the colour, but durability, texture and finish too. Understanding how the materials allow light to travel throughout the space will also make a big difference to the overall sense of inspiration. Taking the time to select not just top-quality finishes, but selections that are unique to our personal style is paramount to creating a timeless finish.

**What do you think are the most important things to consider when designing a kitchen, and how does this project reflect these?**

The most important thing to consider when designing a kitchen is to make it work for you. You want to guarantee that immediate joy is carried through year after year. There are so many personal decisions to make when creating a kitchen space like this, so it is important to select a designer that you feel connected with - someone that will be dedicated to making sure all of your needs are met from both a practical and design perspective. Going with your gut will help to enhance the experience and provide you with a kitchen that is tailored to you and your life.



## PURE ELEGANCE INTRODUCING THE NEW ARTIC WHITE SURFACE FROM STARON

Staron is delighted to introduce a beautiful new colourway to its solid surface collection. Gleamingly white, featuring an ever-swirling pattern, Staron's latest shade, Arctic White, brings a sense of serenity to interiors.

Inspired by the great expanse of the Arctic, Staron's newest colour features a beautiful rippling ice-like pattern with light grey detailing used to create a soft marble-effect appearance.

A delicate aesthetic is combined with Staron's unique and robust structure to provide a material that's extremely durable and hardwearing. Perfect for use where hygiene is of utmost importance, Staron's waterproof, non-porous and join-free structure ensures an inhospitable environment for bacteria growth, making Staron one of the most hygienic surfaces in the world. A preferred choice for a variety of industries, Staron is ideal for use in the healthcare, hospitality, leisure and recreation sectors.



[www.staron.com](http://www.staron.com)

## OUTDOOR KITCHENS WITH LUNDHS REAL STONE



An increasingly popular choice for both residential and hospitality spaces, outdoor kitchens are a striking design feature. A 100% natural stone, Lundhs Real Stone is one of the most durable and resilient materials in the world and is the ideal choice for an outdoor kitchen worktop thanks to its many practical and aesthetic qualities.

Made from Larvikite, one of the most unique and strongest materials in the world, Lundhs Real Stone was crafted by nature 300 million years ago. Due to the stone's

natural properties and low porosity, the 100% natural stone will withstand even the harshest of climates. Not only does it not absorb water, but it is also resistant to stains, is easy to maintain and is able to deal with harsh temperature changes. Thanks to these practical and aesthetic qualities, Lundhs Real Stone is the perfect fit as a worktop for outdoor kitchens.

Lundhs works with a select network of distributors around the globe, with each product traceable from quarry to end product.

[www.lundhsrealstone.com/uk/](http://www.lundhsrealstone.com/uk/)

## Commodore Design - Bespoke As Standard



### Stylish Kitchens, Sell Homes

Heart of the home. Social space. The place where we feed the ones we love. Regardless of how you'd describe yours, the fact is great kitchens sell homes. And 'Commodore Design' kitchens sell homes even faster.

We design kitchens that homebuyers fall in love with. Our 50 years of contract kitchens experience and industry leading future trends analysis can help you predict fashion forward styles and must have features ahead of time. Thanks to us, the kitchens you specify now, will be bang on trend when your customers are ready to sign on the dotted line.

Whatever style, dimensions, materials and finish you're looking for, we can design to your brief and add the clever extra touches that will set your development apart.

Work with us and our wealth of consumer insights today, and you can be confident of kitchens that excite and delight your customers tomorrow.



[www.commodoredesign.com](http://www.commodoredesign.com)  
[hello@commodoredesign.com](mailto:hello@commodoredesign.com)



# DIAL UP THE COLOUR WHEEL – DIAL UP THE FEEL GOOD

## 2021/22 Kitchens Are Bursting With Bright Colour

Bright colours evoke a sense of vibrance, energy and positivity. With a growing interest in connecting to nature, health, wellbeing, and positive change, bright and cheerful tones are bursting into every area of the home. Could this be the end of the all white, all natural Instagram aesthetic? Well, times are a-changing and bold and saturated colours are going to see a huge renaissance over the coming months.

As society encounters new and difficult challenges over the next few years, there will be an increasing demand for organic yet bright and colourful tones that provide stability and optimism. This prediction is supported by a recent report from the Pantone Colour Institute containing ten colours that we should expect to see on the runway and in the home. The palette is bold, playful, fruity and fresh, offering a much needed burst of energy and joy.

### OCEAN BLUES

Verdigris sits comfortably between green and blue. With tones baring a striking resemblance to the Atlantic Ocean, it has the ability to give interiors an organic and earthy feel whilst remaining contemporary and bold. With wild swimming, rewilding, and outdoorsy lifestyles gaining increasing popularity, it won't be long before homes and interiors offer equally refreshing outlooks.

“Verdigris blues play on the luxury of escapism, offering a vision of tranquility and leisure” says Wayne Dance, Managing Director at InHouse Inspired Room Design. “Marine and teal hues are classic trans-seasonal colours that help the home feel warm and inviting all year round. Up the ante by matching your kitchen with co-ordinating cushions, tableware and furniture.”





## SAGE GREEN

A growing focus on personal wellbeing and environmental restoration will see soft green palettes extend far beyond the vegetable patch. Muted sage and mint greens offer a connection to the earthy and wild spaces around while creating a gentle and comforting atmosphere. If you love pastels but find candyfloss pink too girly, restorative greens are a fresh and trendy alternative.

Embrace nostalgia with a pastel green kitchen complete with terrazzo work surfaces. The antithesis of squeaky clean interiors and digital culture, pastels and terrazzo are bright, playful and full of texture.

## FOREST GREEN

Forest green continues to be a popular shade for those seeking to bring the outdoors in. Deep dark greens resonate with people and communities who reconnected with nature during the pandemic. After spending months upon months indoors for the most part, it makes sense that we are now yearning for a renewed sense of connection with the natural world.

"Times are a-changing and bold and saturated colours are going to see a huge renaissance over the coming months."

## LEMON YELLOW

After a challenging year of uncertainty, bright yellows offer a bold and uplifting boost of colour and positivity. As we emerge from a very drawn out hibernation, cheerful yellows provide a spark of light and an optimistic promise of better times ahead. An entirely yellow kitchen is a very brave move, so it may be worth combining a block of the bold sunshine shade with a soft, neutral tone for balance.

## RUBY RED

Last but certainly not least we have deep warm reds. Throughout history red has been used to symbolise power, prosperity and a hint of danger. In some cultures, the colour red is meant to bring you good fortune. Red is not commonly found in the kitchen, yet there is a huge opportunity to harness the deep crimson tones to create a confident and sophisticated space for entertaining guests.

Wayne Dance, Managing Director of InHouse Inspired Room Design, says, "If there's one thing this year has taught us about interiors, it has got to be the simple reminder that the home should be our individual sanctuary, designed in line with our own personal tastes and needs. Gone are the days of blindly following trends, so expect to see more playful and bold uses of colour throughout the house in 2021/22. Prepare to be unconventional."

[www.inhousetd.co.uk](http://www.inhousetd.co.uk)

## NEW THICKNESSES AND FINISHES TOP OFF THE ADVANTAGES OF CERALSIO CERAMIC



Giving even more choice and freedom of design in the kitchen and bathroom, Ceralsio ceramic surfaces from CRL Stone are now available in a greater variety of thicknesses and new finishes.

Responding to the trend for slim profiles and minimalism in contemporary kitchen design, Ceralsio is now available in a new 6mm thickness. Ideal for flooring and wall cladding, this presents opportunities for this most hard-wearing of materials to be used in a greater variety of ways, whether used as an eye-catching splashback to match or contrast with worktops or as an easy to clean and beautiful floor covering. Supplied in a slab format, this thickness is a cost-effective surface solution that also makes installation simple, particularly over large areas.

New additions to the Ceralsio collection include 11 new styles, all embracing current trends in interior design to offer consumers a luxurious surface that is also highly practical wherever the setting.

CRL Stone is working with leading brands to ensure the ready supply of Ceralsio, which is also now available in thicknesses of 12mm and 20mm, ideally suited for kitchen and bathroom countertops and particularly in high-traffic areas where durability is a must.

As well as being scratch and stain resistant, Ceralsio will also not fade from UV rays, so it can be used for outdoors as well as internally, and is perfect for surfaces that cross over between the two in the on-trend indoor outdoor kitchen.

**▶ For more information, brochures and free samples call CRL Stone on 01706 863 600 or visit [www.crlstone.co.uk](http://www.crlstone.co.uk)**



# ◆ BRYAN TURNER ◆

KITCHEN FURNITURE



*Cambridge  
design studio*

NOW OPEN

*Contemporary, traditional  
& truly bespoke living spaces*

Contact us to discuss how we can design your perfect room.

---

Design studio open Monday to Saturday 9:30–5pm  
De Freville House, High Green, Great Shelford, Cambridge CB22 5EG

**Cambridge** 01223 641050 | **Norfolk** 01953 601567

[enquiries@bryanturnerkitchens.com](mailto:enquiries@bryanturnerkitchens.com) | [bryanturnerkitchens.com](http://bryanturnerkitchens.com)





# EDGEWOOD HOUSE

**Terry & Terry Architecture**

The dwelling is designed for a young Deaf family, who desired an expanded open plan that incorporates Deaf-Space, creating ample transparency throughout the home, where vision and touch are a primary means of spatial awareness and orientation.

The project consists of transforming a 1950's existing Joseph Eichler home. Using a similar material palette, the design utilizes the primary floor plan and transforms the existing space by folding out the horizontal and vertical planes of the first story to form the second story. The new roof form creates a large central area and houses a second-floor bedroom wing. Elevating and shifting parts of the structure are used to support the second story and stairways.

The main living space is situated on the ground floor and offers expansive living spaces that extend into the landscape. Two existing bedrooms and office areas are reconfigured to become more transparent to the gardens. The second floor accommodates an extended family with two bedrooms, bathrooms, and sleeping porches.

Photovoltaic panels, solar water heating, and rain catchment systems are used to offset energy and water loads. Large overhangs provide sufficient shade during the warm months.

[terryandterryarchitecture.com](http://terryandterryarchitecture.com)

Photo credit: Bruce Damonte



"Photovoltaic panels, solar water heating, and rain catchment systems are used to offset energy and water loads."



## TECHNICAL SHEET

**Project name:** Edgewood House

**Architect:** Terry & Terry Architecture

**Location:** Palo Alto, California

**Plot:** 7,350 square feet (683 m<sup>2</sup>)

**Project Area:** 2,944 square feet (273 m<sup>2</sup>)

**Year:** 2020

**Design Team:** Alex Terry, Ivan Terry, Mike Start

**Structural Design:** Don David Double D Engineering

**Construction:** Maor Greenberg, Greenberg Construction

# PATIO AWNINGS: HOW TO DIFFERENTIATE BETWEEN A GOOD AND A GREAT AWNING



More versatile than other external shading systems including pergolas and canopies, retractable patio awnings are a quick, easy and affordable solution to transform any outdoor space. A good patio awning will ultimately provide shelter, block heat, diffuse light and protect against UV rays, however, a great awning will offer the user so much more.

Although an expert specification and professional installation are key, it's the attention to detail that makes a great awning. The use of quality fabrics, premium hardware finishes, British manufactured parts and app-controlled operation are just some of the elements that guarantee an awning will stand the test of time.

**FABRICS** All fabrics should be impregnated with a suitable coating such as TEXGard® which generates a self-clean effect, deterring dirt and water from the surface and preventing the growth of mould and algae. For maximum durability, the fabric should be woven from solution dyed acrylic fibres. Dimensionally stable, they will not stretch, warp or tear when under tension and as the dye is permeated right through to the core of the yarn, colours will stay true and will not fade over time.

Fabrics that are certified to UV standard 801 offer true protection levels against ultraviolet radiation, with more premium materials offering a minimum 95% UV block (the equivalent to SPF 40), guaranteeing protection to both the skin as well as any soft furnishings. To ensure a cooling effect, the fabric should be measured according to the heat and light that passes through it. Materials that filter 70% of solar heat can reduce interior room temperatures by more than 10°C, even on the hottest of days.

**FOLDING ARMS** The retractable folding arms on any patio awning must be able to withstand strong breezes and sudden gusts. Pressure die cast or drop forged joints on the elbows of folding arms offer the highest wind loading capabilities, with Beaufort 5 (24mph wind) as standard certification and Beaufort 6 (30mph) offering the highest wind resistance rating.

Springs should be tensioned via stainless steel cables (intertwined stranded cables won't tear or break) and looped around the elbow to ensure a crisp taut fabric at every position, allowing rainwater to run off the material. Fitting the springs and cables with sheathes will reduce friction and noise from the vibrations when it's windy, as well as result

in a clean and finished look. For optimum tension, arms with twin springs kept under tension via two steel cables is recommended, and four steel cables for deeper projections.

**HARDWARE** A full cassette casing design will not only provide a neat hideaway for the awning when retracted but also protect the fabric and operating mechanism from inclement weather. A flush-fitting cassette casing is the most visually appealing and will appear as an integral part of the façade.

Low maintenance, extruded aluminium is the metalwork of choice for awnings. It's lightweight, corrosion resistant and can be finished in hundreds of colours to match or contrast with the features of the property. QUALICOAT® standard powder coated aluminium creates the hardest finish, meaning it will withstand the harshest of weather conditions, including hail and snow, as well as knocks and bumps in busy environments.

**MOTORISATION** Radio technology is the operation method of choice for motorised awnings as it permits the user to extend and retract at just the touch of a button (on a hand-held remote). A secure rolling code and frequency is essential for no interference, whilst bi-directional technology allows the user to view and adjust the exact position of the awning via an app. Additional functions such as sun and wind sensors can also be changed electronically to suit specific requirements.

Integrated tubular motors built within the awning roller tube should have steel internal bearings for resilience and be of an appropriate size (torque) for the chosen awning. 17RPM (revolutions per minute) will guarantee smooth and steady operation and a consistent load, increasing the lifespan of the awning.

**INSTALLATION** The installation of an awning is equally as important as quality of the awning itself. Due to the considerable load that an awning exerts, the appropriate fixing method must be utilised to guarantee a secure and safe attachment. For the most common masonry (brickwork) façades, epoxy resin and stud provide a stress-free anchorage, while cantilever brackets offer the best solution on low single storeys.

For rain shower protection, awnings need to be mounted a set distance on the façade (determined by projection and leadrail height) allowing for a 14-degree (or greater) pitch, preventing water from 'pooling' on the fabric and ensuring it can run off smoothly.

Any additional finishing touches such as concealed fixing brackets, alu end caps, elbow covers on folding arms and colour co-ordinated stitching will ensure a quality installation that provides exemplary cover and fully transforms the client's outdoor space.

**Stuart Dantzic, Managing Director, Caribbean Blinds**

[www.cbsolarshading.co.uk](http://www.cbsolarshading.co.uk)





CARIBBEAN  
BLINDS UK LTD

# Sun. Shade. Shelter.



OUTDOOR LIVING POD™ - LOUVERED ROOF |

## ALL WEATHER | TERRACE COVERINGS

- Waterproof fabric or aluminium louvered roofs
- Effortless motorised remote control operation
- Wind resistant upto Beaufort 12 (hurricane force)\*
- Optional LED lighting & infra-red heating
- 5 year guarantee for peace of mind

Our **innovative retractable awnings and aluminium pergolas** provide flexible shade and shelter, allowing outdoor spaces to be enjoyed come sun, wind, rain or even snow\*. Proudly UK manufactured since 1987.



t 0344 800 1947  
e [info@cbsolarshading.co.uk](mailto:info@cbsolarshading.co.uk)  
w [cbsolarshading.co.uk/residential](http://cbsolarshading.co.uk/residential)

SHOWSITES IN | SUFFOLK | MIDDLESEX | SURREY

\*Wind resistance and snow load based on our louvered roof Outdoor Living Pods™



CUBA - PATIO AWNING |



# EXPERTS REVEAL HOW YOU CAN CREATE YOUR OWN GARDEN BAR IN TIME FOR SUMMER

Since the 17th of May, the rule of six has applied to indoor gatherings, meaning you can host up to 6 friends and family members, or two households indoors and up to 30 people outdoors in your garden...

...As a result, DIY bars are already proving to be popular with searches for garden bar ideas up 49% since March this year.<sup>[1]</sup>

Here's some top tips from outdoor building specialist, Lidget Compton, on how to create your own in time for summer.

## USE WEATHER RESISTANT PAINT

If your outdoor building is constructed of wood, a good quality weather resistant paint is a must. This will help protect against the elements, but also add a stylish look to the outside of the building.

To ensure a long-lasting finish, opt for a latex acrylic paint over standard vinyl acrylic as this will help prevent mould or peeling.

Experts also recommend choosing neutral tones as they are more likely to hide scratches and marks that can occur in outdoor spaces.

## INSTALL SUITABLE LIGHTING

Much like paint, lighting has the power to completely transform a room and set the mood, which is why it shouldn't be an afterthought when planning your at-home bar.

Installing LED lights that will not only be long lasting, water resistant and eco-friendly, but also open up the space can be a great addition to an outdoor building. LED lights also come in varying colours so you can create different moods or dependent on the time of day.

## INSULATE WALLS

It's important to be aware of three fundamental points when converting an outdoor building: regulating temperature, protecting fixtures and furniture, and reducing noise.

Experts recommend using insulation materials such as sheep's wool for your outdoor building as it not only has great thermal qualities but is also a breathable material.



## INSTALL CLEVER STORAGE

No bar is complete without a display of your favourite food and drinks, however, it's important to be conscious of the size of your building when planning your DIY bar.

Garages and sheds tend to be fairly small, so finding smart ways to create storage is key to a great space.

Installing high-rise, floating shelving which allow for plenty of storage yet cause minimal obstruction is the way to go. Materials, such as timber and pine are perfect for this as they're easy to cut and manipulate but strong enough to hold heavy bottles.

Utilising multi-use furniture is also a clever storage solution for small spaces. Hiding glasses or bottles within a seat or table means you can minimise clutter and keep your garden bar looking neat and tidy.

"It's important to be aware of three fundamental points when converting an outdoor building: regulating temperature, protecting fixtures and furniture, and reducing noise."



## ADD THE RIGHT FURNITURE

Even with insulation, outdoor buildings tend to be colder than your home due to lack of heating and the construction materials.

To help create warmth and regulate temperature within your at-home bar, it's a good idea to place insulating furniture, such as a sofa, a rug, cushions, or even a tapestry on the wall.

These can help recreate the comfy, yet stylish atmosphere found in bars and restaurants whilst adding warmth to the room.

[www.lidget.co.uk](http://www.lidget.co.uk)



## ALAMEDA GARDEN BUILDINGS | Beautiful Garden Rooms.

Choose from our current range or work with us to design your own building.  
 Our products are built to last. We only use top quality materials. All our buildings are fully insulated to give you year round enjoyment.  
 We strive to give you the best quality products for the most competitive price.  
 Manufactured and installed by Bedfordshire master craftsmen.

**Your Local Garden Building supplier.**

07784 358814 / 08454636634

info@alamedagardenbuildings.co.uk  
 www.alamedagardenbuildings.co.uk



## GARDEN ROOMS MADE BEAUTIFUL WITH STERLINGOSB ZERO



With more and more people working and studying at home, the need for extra space has grown enormously. Whether it's somewhere to make Zoom calls in peace, or to chill after a long day juggling home-schooling, or to get on your bike, a garden room has become a much-sought after addition to many homes.

This is good news for companies like H M Garden Rooms in Buckinghamshire. Having searched for garden offices for themselves, and finding a limited choice of well-priced, good quality options, Jordan Hickson and Jordan Marsh, both with over

20 years' experience in the construction industry, set up H M Garden Rooms. Using quality materials, they produce a range of built-to-last, aesthetically-pleasing garden buildings that their clients have put to a multitude of uses. H M Garden Rooms purchases SterlingOSB Zero from local builders' merchants Travis Perkins and Grant & Stone branches in the Home Counties, depending on the project location.

To find out more about Norbord's full range of carbon negative panel products visit the website and you can download a product guide and can even order free samples.

**For further information, call 01786 812 921 or visit [www.norbord.co.uk](http://www.norbord.co.uk)**



## The IRIS Louvered Roof Canopy

HOSPITALITY • ARCHITECTS  
 WEDDING VENUES • SPORTING CLUBS

Protect yourself and your customers against the sun, rain, wind or cold and enjoy. Our stylish aluminium louvered roof canopies can allow in the sun or close the blades for a waterproof roof. Converts your terrace into a more flexible outdoor space with remote controlled louvered roof.

**Louvered Roof Canopy:** When a great idea and a great product come together the result is a solution out of this world!

The Lanai IRIS outdoor rooms sit perfectly in this environment – the owners were looking for an outdoor space that can be used all year round.

- Glass doors
- Automatic Blinds
- Heaters
- Inside perimeter lighting

**For more information or a formal site survey please contact: 01223 915822 [www.Lanai-commercial.co.uk](http://www.Lanai-commercial.co.uk)**



## Stunning jetty finished with Osmo UK

After installing a jetty to provide safe access to his boat, a marine enthusiast was looking for a product that would protect the wooden decking from the elements whilst also enhancing its natural grain. Painter and decorator, Robert Moore of R.F.M Painting & Decorating Services was contracted for the project and Osmo UK Decking-Oil was chosen to provide a high-quality and professional finish. Designed to protect, maintain and enhance the wooden surface, Decking-Oil produces a smooth satin finish which is water and dirt resistant. The microporous finish consists of natural vegetable oils and waxes which allows the wood to breathe, reducing the risk of swelling and shrinkage over time. The professional nature of the finish means that it will not crack, flake, peel or blister providing the homeowner with peace of mind that his jetty will continue to look its best.

**For more information on the complete range of Osmo eco-friendly finishes, please visit [www.osmouk.com](http://www.osmouk.com)**



## Give your garden the edge on sustainability

become is taking the sustainability message to the great outdoors by launching a garden edging that is made from 100% recycled household plastic. Eco Edge is the latest addition to the become portfolio to meet soaring demand for all-things sustainable from consumers, businesses and public-sector organisations. Driven in part by the phenomenal impact of publicity from the likes of Blue Planet, Eco Edge is on trend, lending itself to promotional messages that will strike an immediate chord with ever-more eco-aware customers.

Eco Edge is stylish, strong and as easy to work with as wood, making it an ideal edging for virtually all types of gardens and landscaped public space. Unlike wood, however, it is rot-proof, and environment friendly, making it supremely cost-effective, flexible and long lasting. It suits the widest possible range of users and uses.

**[www.become.eco](http://www.become.eco) | 0333 202 6800  
 become@rpc-bpi.com**

# PLAYSMART UK: AN INNOVATOR IN SURFACING FOR PLAY, LEISURE, AND RECREATION



PlaySmart UK

PlaySmart UK has spent 20 years operating as the leading innovator in surfacing for play, leisure, and recreation. If you are planning a public, community or school play area, a landscaped space or even a roof top garden with a surfacing element then PlaySmart can support you. All solutions have been tested, where appropriate, to BS EN177 and BS EN 7188 and come with our no quibble guarantee.

We have a range like no other provider in the UK featuring a 100% sustainable solution in Corkeen. Produced with cork, a raw material of natural origin, reusable and recyclable the Corkeen system is the sustainable, ecological, and safe solution the world of play and landscaping has been waiting for. Corkeen can be installed into play areas, pathways and public spaces and can also achieve a Fall Height of up to 2.7m.

PlaySmart also offer a natural solution in Nordic Lawn Hybrid Grass. Nordic Lawn protects and stabilises natural grass and the open mesh structure allows the natural grass to grow through. This solution is safe, soft, easy to install with minimal ground preparation required. It is perfect for worn grassed areas, parks, public spaces or slopes. When combined with SmartPlay, our patented shock pad, Nordic Lawn achieves 2.7m high fall height in a play area.

More traditional surfacing solutions are also available from PlaySmart; Green Frog Artificial Grass, RubbaSmart EPDM, JungleMulch bonded mulch & EcoSmart grass mats. We also offer fire retardant grass mats in FireSmart which complies with BS7044.

➡ **For more information please visit our website [www.playsmartuk.co.uk](http://www.playsmartuk.co.uk) or contact us on [info@playsmartuk.co.uk](mailto:info@playsmartuk.co.uk) or 01564 742 811**

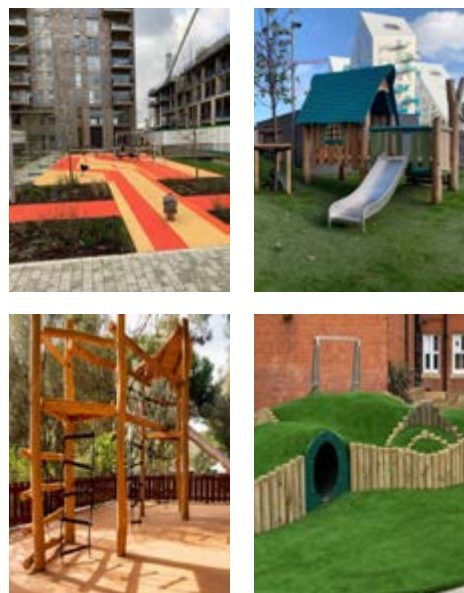

## Bringing life to outdoor spaces

- **BESPOKE SHADE SAILS**
- **RETRACTABLE SHADE SAILS**
- **METAL PERGOLAS**
- **ELECTRIC PATIO AWNINGS**
- **FABRIC ROOF CONSERVATOIRES**

**Sail Shades Direct specialize in bespoke solutions for your outdoor space, from domestic to commercial.**

Our production facility in Cornwall allows us to create truly inspirational projects for your outdoors. Our fully insured team will take care of everything from groundworks to bespoke metal works.

**We can offer a full range of products and accessories.**

**[www.sailshadesdirect.co.uk](http://www.sailshadesdirect.co.uk)**

Tel: **01752 816125** Email: **[jamie@sailshadesdirect.co.uk](mailto:jamie@sailshadesdirect.co.uk)**

Sail & Shade Systems Ltd, The Sail Loft, Ferry Street, TORPOINT PL11 2AX





# THE DECKING DEBATE: COMPOSITE VS TIMBER

Gardens and outdoor space have always been desirable assets for homeowners and this was amplified during the national restrictions.

Spending so much time at home throughout the pandemic led to a huge investment in home improvements, especially as people looked to utilise their gardens as an extra 'room' of the house.



Decking offers a year-round solution for outdoor living and al-fresco dining, it helps to create an increased sense of space for homeowners plus, it's ideal for entertaining family and friends.

Composite decking in particular, is an excellent choice for high traffic areas that are prone to spillages and stains, due to its durable and low maintenance properties. A capped layer to the decking also increases protection against fading and staining for an extra long life.

Composite is the fastest-growing timber decking alternative currently available on the market. Although traditional timber decking has been the preferred choice of many for years, it's a high maintenance product which requires annual painting and staining. Composite decking however is a simple, no fuss alternative due to its unique formula which produces a high quality finished product that does not rot, splinter or decay.

Many homeowners underestimate the maintenance that traditional timber decking needs or have not considered replacing an old timber substructure frame with composite decking boards that require far less upkeep.

Composite material combines the FSC® certified 100% hardwood flour (a waste product of hardwood production) and recycled plastic to produce a durable, natural-looking decking product that outperforms traditional treated timber. The wooden fibres and plastic shavings are combined with colour pigments before being heated and extruded.

The plastic content gives the boards a long lifespan without the need to treat or seal the decking, whilst the wood content enables the product to retain its natural look and feel. The finished product is 3D embossed with wood grain or contemporary linear grooves to ensure they look natural and engineered to ensure that it meets the requirements of DIY enthusiasts, landscapers and garden designers alike.



"Composite is the fastest-growing timber decking alternative currently available on the market."

A family of five from York recognised the benefits of installing composite decking and refurbished their tiny, unusable 60 metre back garden, creating a stunning outdoor living space. Mother of three, Sera Sekerci chose to lay Composite Prime's HD Deck 150 in stylish silver in her previously unusable back yard.

Sustainability was also key for Sera, who looked to create a visually appealing and low maintenance garden that was also kind to the environment. Each square metre of Composite Prime's decking contains the equivalent of more than 3,000 plastic bottle caps or 280 plastic bottles. In the last six years of operation the brand has saved the equivalent of 151 million plastic milk bottles from landfill.

Sera's refurbished outdoor area creates an illusion of space with minimal cost and very little maintenance. Her functional and attractive composite decking has transformed the visual appearance of her garden and maximised the space available.

Composite Prime manufactures a range of nine products, including cladding, decking and flooring, which are tested against the latest requirements to measure strength, impact resistance, weathering, extreme temperature cycles, UV resistance and water absorption.

➤ To find out more about Composite Prime visit [www.composite-prime.co.uk](http://www.composite-prime.co.uk)





Sleek Cone Pendant - 7 Inch - Copper £75.00  
Image supplied by: @renovation\_at\_5A

# LET IT GLOW WITH INDUSTVILLE'S SUSTAINABLE LIGHTING

Perhaps one positive to come out of the pandemic is that we have all had the chance to re-assess how we live and what we buy.

Consumers are more concerned over how their products are made, choosing more sustainable, natural and eco-friendly goods from companies they trust. Industville have always worked hard to ensure all of their products are built with sustainability in mind and that as a company they leave minimal impact on the world around them.

## A TRULY VERSATILE RANGE

Industville design and build a large collection of lighting for all rooms of the home and uniquely their core range is cleverly designed to coordinate beautifully with any of their other styles. For customers this means that if they want to purchase a new lighting product months or even years down the line, they won't need an entirely new light or suite of products, as any new Industville product will just fit right in. Marketa Rypacek, Managing Director at Industville Ltd

adds, "Here at Industville we are always striving to make our products as sustainable as possible. We use natural, raw metals, reducing the reliance on plastic and other chemicals. When it comes to packaging our products, we always use biodegradable bubble wrap as well as paper tape so that our packaging can be easily recycled."

This is also true of upcoming products and additions to the Industville range (keep your eyes peeled for new products to be launched in April) as the designers ensure everything works seamlessly together. This is helped in part by the fact that Industville only use three core materials for all of their lights; pewter, brass and copper. Keeping to this simple but effective formula not only ensures easy mixing and matching across the entire range, but also allows Industville to have comprehensive control over quality.



## AN ECO-FRIENDLY OUTLOOK

All of the products are handcrafted and made from natural and recycled materials such as pure brass and copper, something the company has always been proud of. Sustainable production methods are employed in the factory, where processes are regularly evaluated to see if they can be streamlined to become even more efficient. Marketa comments "Industville manage the whole manufacturing process to ensure the design and materials are in line with our ethos and values, regarding both sustainability and quality. We are very proud to have gained the ISO 9001:2015 certification which further demonstrates our ability to consistently provide products and services that meet customer and regulatory requirements."



Brooklyn 5 Wire Pendant shown in Brass £159.00  
Image supplied by @allangateswestwing

"Consumers are more concerned over how their products are made, choosing more sustainable, natural and eco-friendly goods from companies they trust."

## VALUING ARTISAN SKILLS

Industville work closely with artisans to develop their unique product range. By combining timeless design with traditional skills passed down through generations, each individual piece has its own character and story to tell. Industville strongly believe in the value of keeping these age-old techniques alive and the knowledge that comes with them. These amazing skills really help to set their products apart from others on the market. Marketa adds, "As an owner of an internationally recognised company, I have always believed it is vital to appreciate and value our people from employees through to suppliers. We often choose to work with independent businesses, social projects and co-operatives, to build strong relationships for the mutual success of everyone involved."



Bulkhead Outdoor & Bathroom Sconce Wall Light - 12 Inch in Gunmetal £79.00  
Image supplied by @theresa\_gromski



Lights left to right: Bulkhead Black Sconce Wall Light, 12 inch, £79.00, Bulkhead Cage Pendants, 11 inch in Gunmetal, £99.00 and Bulkhead Round Wall Lights, 8 inch in Gunmetal, £89.00



Sleek Edison Wall Light - Pewter £29.00  
Image supplied by @christianawilkinsinteriors

## SUMMER LOVIN'

With the roadmap to ease lockdown restrictions in place and the Summer months just around the corner, now is the perfect time to do all those garden renovation jobs and adding some carefully placed outdoor lights will ensure leisure time outside can be enjoyed for even longer. Perfect for setting the scene for alfresco dining, future garden parties or just a spot of evening relaxation with a good book, the right outdoor lighting will add extra hours and extra enjoyment to the time spent in the open air.



Brooklyn Outdoor & Bathroom Dome Wall Light - 8 Inch - Pewter & Copper £139.00 Image supplied by @nicbissekerphotography and @veryvictorianmerebrook



Orlando Wire Cage Wall Light - 4 Inch - Pewter £49.00  
Image supplied by: @iansandersontextile

Industville's outdoor lighting designs are the perfect mix of classic and contemporary so they work well with both modern and traditional properties. All designs are compatible with LED bulbs, which are not only energy efficient but also have incredibly long lives, making them the perfect sustainable choice. The bulbs themselves are also available in a variety of shapes and colours, giving even more choice to achieve the perfect look desired. Bright white may be chosen for areas needing practical lighting, whereas a warmer vintage style amber bulb may be preferred to create a softer atmospheric glow.

After selecting the style or styles of light needed for a space, the next thing to consider carefully is their positioning. As Marketa Rypacek comments, "Think about the direction of each light to ensure you are not exposing something you'd rather not draw attention to or creating too much glare. Exterior lighting will accentuate the architecture, colours and textures of your property for a home you can be proud of. Make sure you experiment with different positions before you decide on a final placement. You can use a large torch in varying placements to see where it is likely to provide light. For glow without glare, opt for downward facing wall-mounted lights that create a relaxing atmosphere that can be enjoyed by all."

**Industville | Tel: 020 7971 7871**  
[www.industville.co.uk](http://www.industville.co.uk)

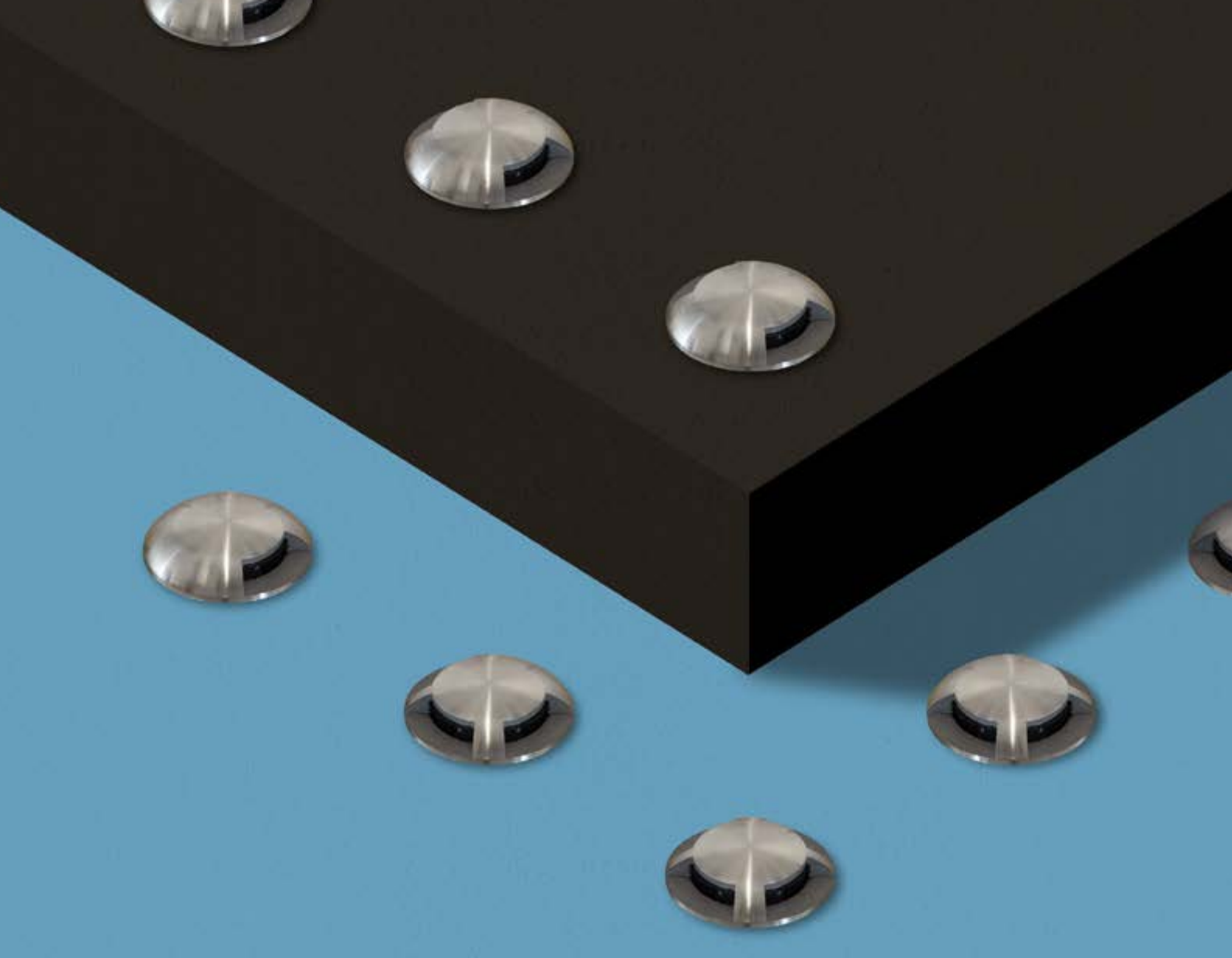

# MINI DOMED MARKER LIGHT

Available in five window options and three colour temperatures, this versatile marker light is perfect for low-glare and decorative illumination of pathways, decking and steps.

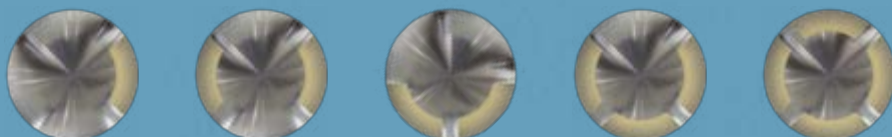

For our full product range visit [www.collingwoodlighting.com](http://www.collingwoodlighting.com) or call 01604 495 151

Mastering light together  
[collingwoodlighting.com](http://collingwoodlighting.com)



@collingwoodLED



/collingwoodlighting



collingwoodled



COLLINGWOOD  
LIGHTING



# NEW DESIGN ADDITIONS TO LEVEN LIGHTING RANGE

## Tom Raffield

The Leven Table Light and Leven Pendant Small are welcome additions to Tom Raffield's highly sought-after Leven Lighting Range. Both designs marry Scandinavian style with an Art Deco aesthetic to become minimalist, statement lighting pieces.

Experts in sustainable design, the Tom Raffield team skilfully handcraft each Leven Light from responsibly sourced FSC wood. Available in oak or walnut, the refined tiered drum aesthetic provides unique shapes and shadows, whilst showcasing structural beauty. Each Leven design appreciates the natural world and is an embodiment of how it can inspire daily life.

Radiating a warm glow throughout, the artisan designs expertly enhance interiors with ambient illumination, bringing any space to life.

### LEVEN TABLE LIGHT

Expertly radiating light in all directions, the Leven Table Light illuminates your space whilst projecting beautiful shapes and shadows across the surface on which it rests.

With a blend of Scandinavian and Art Deco aesthetics, use this wooden table light to brighten living spaces, bedrooms, and workspaces alike.

### LEVEN PENDANT SMALL

A smaller alternative to the Leven Pendant that lends the same layered luminescence to modern interiors. With a blend of Scandinavian and Art Deco aesthetics, use the wooden Leven Pendant Small in multiples to illuminate hallways, dining spaces and kitchens.

Perfect for creating your own clusters or bringing a soft spotlight effect to specific areas in your space.



The forward-thinking brand took a new perspective on nature, meaning the Leven Lighting Range is unlike anything Tom Raffield has ever created. Continuously seeking inspiration from the beauty of the natural world, whilst using innovative design principles to protect it, Raffield has produced a thoughtful and intriguing lighting range.

Inspired by the striking formations of smooth, sea-eroded cliff faces and ridged headlands that distinguish the north coast of Cornwall, the Leven Lighting Range effortlessly elevates space with its tiered drum aesthetic.

Strong, vertical lines characterised by a central plywood frame are what make the Leven Lighting Range so unique. Masters of their steam bending art, each piece handcrafted by the Tom Raffield team in their Cornish workshop, is guaranteed to last a lifetime. Every Tom Raffield heirloom is crafted to halt 'throwaway' culture, protecting the planet for future generations.

## ABOUT TOM RAFFIELD

Our purpose is to create new ways of living with our original, timeless objects that are inspired by the natural world that surrounds us here in Cornwall. Our artisan homeware designs are handcrafted by our skilled team to last a lifetime using traditional craft processes in sustainable and innovative ways. We aim to transform spaces and leave a lasting impact without having an impact on the very thing that drives us - nature. We are the antidote to over consumption and hope to inspire a like-minded conscious community, helping to create a world where people and nature thrive for future generations to enjoy.

Since discovering the traditional, age-old technique of steam bending wood whilst studying his degree in 3D Sustainability & Design, Tom has been on an incredible self-taught journey of developing and understanding the process to become one of the world leaders in his craft. Tom's fascination with the ecological technique allows him to create intricate curves and twists, mimicking organic shapes and celebrating the very thing that inspires him - nature.

"Each piece we create has been on an experimental journey - individual, organic and carefully considered. We source everything from sustainable woodlands and coupled with the low energy steam bending process, it is very ecological with little wastage,"

- Tom Raffield, Founder.

Handcrafted in their BREEAM Excellent studios in Cornwall, England, the range of contemporary lighting, furniture and accessories Tom Raffield creates is based on beauty, integrity and a desire to create unique, high specification objects that will be cherished by their owners for years to come.

## SUSTAINABILITY AT TOM RAFFIELD

His passion and skill are now shared with his talented team of craftspeople, together they create objects that symbolise nature, tell a story and will last a lifetime, all whilst protecting the natural world.

"The Leven Table Light and Leven Pendant Small are welcome additions to Tom Raffield's highly sought-after Leven Lighting Range."



Tom Raffield is one of a new generation of designers and makers, using his craft in innovative and contemporary ways. Leading the charge in sustainable design, he is driven to forge a path to excellence and cause as little environmental impact as possible along the way.

With the smallest ecological footprint possible, Tom Raffield forge a path to excellence, crafting the heirlooms of the future whilst protecting the natural world that inspires them.

01326 722725 | [www.tomraffield.com](http://www.tomraffield.com)  
 Twitter: @tomraffield | Facebook: @tomraffielldesign  
 Instagram: @tomraffield

## DISCOVER THE BENEFITS OF LOW-VOLTAGE, LED EMERGENCY LUMINAIRES AND EXIT SIGNS FROM ADVANCED



**Advanced's latest line of EasySafe low-voltage, LED emergency luminaires and exit signs offers higher performance and greater energy efficiency benefits than ever before.**

All EasySafe products are designed to work with LuxIntelligent, Advanced's emergency light testing system. Powered directly from the LuxIntelligent panel, Advanced's EasySafe devices require no local power supply. All devices are compatible with any existing LuxIntelligent luminaires and exit signs, enabling the easy installation of devices onto existing wiring to form a single, comprehensive intelligent emergency lighting system.

[www.luxintelligent.com](http://www.luxintelligent.com) | +44 (0)345 894 7000

The low-voltage lights offer quick and easy fitting and service, with a simple 'twist and click' installation onto a first-fix base. EasySafe has been designed to offer true scalability, with just one LuxIntelligent panel supporting up to 200 EasySafe devices alongside an additional 796 locally-powered devices.

Traditional fluorescent lighting consumes significantly more electricity than LED technology, while the typical lifespan of fluorescent lights is between 15 to 30 per cent shorter than that of identical LED solutions. This results in a greater number of bulb failures and replacements leading to higher overall maintenance costs. Switching to EasySafe's low-energy LED emergency lighting is quick, simple and will on average deliver 20% energy efficiency savings compared with fluorescent alternatives.

## MACS AUTOMATED BOLLARD SYSTEMS LTD

Nationwide supply of security bollards

[www.macs-bollards.com](http://www.macs-bollards.com)

Macs Automated Bollard Systems Ltd specialise in the nationwide supply of manual and automatic security bollards, automatic barriers, traffic calming and vehicle restriction solutions, and retractable power units.

With many years experience in the industry, and with customer satisfaction our number one goal, our team will thoroughly discuss and assess your specific needs, and work to deliver a solution to fit. We only work with manufacturers that we believe offer the most reliable and highest quality products, and we offer a full technical support and aftercare service, always having someone at the end of the phone or email when you need.

[www.macs-bollards.com](http://www.macs-bollards.com)  
tel: 0161 3206462  
e: [enquiries@macs-bollards.com](mailto:enquiries@macs-bollards.com)



**Protecting People  
and  
Places**



## Bull Products protects iconic Manchester Town Hall during extensive refurbishment project

Bull Products, a manufacturer of life-saving fire protection equipment, has installed its Cygnus 1 Wireless Alarm System to protect the scaffolding and renovations at Manchester Town Hall. The Grade 1, listed, heritage building is currently undergoing a four-year refurbishment project.

Current work to the extensive building includes replacing the heating, electrics, plumbing and ventilation access and, to carry this out, a huge amount of scaffolding was constructed around its large surface area. Due to its city centre location, scaffolding made the town hall an easy target for intruders, and contractor WysePower required an alarm system that would provide peace of mind and protection during the works and out of hours. The Cygnus Wireless Alarm System incorporates Scaff Alarm – a unique intruder detection system designed to deter attempted break-ins or access to higher levels of scaffolding.

[www.bullproducts.co.uk](http://www.bullproducts.co.uk)



## Home Security Systems from Securefast

It can be a full-time job ensuring the safety of your home, that's why the latest range of advanced home security products from Securefast are designed to offer surveillance for both the inside and outside of your home 24 hours a day 7 days a week. Utilising the free app software and the intelligent Wi-Fi configuration allows long distance signal transition, allowing the devices to be viewed from a mobile phone or tablet from anywhere in the world. A combination of the doorbell, internal and external cameras, can all be accessed by using the same app.

For more information on the Securefast home security range and other products in the Securefast range of safety, security and access control products please contact the sales team on 01704 502801..

[www.securefast.co.uk](http://www.securefast.co.uk)



## New all-in-one licence plate reader is the simple and Accessible solution for automatic vehicle identification

People and vehicle access control specialist Nortech is now offering Nedap's ANPR Lumo, an advanced licence plate camera for vehicle access control. The ANPR Lumo is an all-in-one licence plate camera, including embedded software, analyser and IR illuminator. With a range of action of 2 to 10 metres, the advanced camera ensures a smooth recognition of vehicles. Typical applications include vehicle access control, automatic toll collection, free flow applications at parking facilities or other situations in which it not desirable to issue RFID tags. If vehicles need to be granted access temporarily or incidentally, the licence plate camera is the perfect solution.

Further information is available from Nortech on 01633 485533 or by emailing [sales@nortechcontrol.com](mailto:sales@nortechcontrol.com) or by visiting the company's website at [www.nortechcontrol.com](http://www.nortechcontrol.com)

## ADVANCED'S EVACUATION ALERT SYSTEM CPD NOW RIBA APPROVED



Fire protection solutions manufacturer Advanced, has a new RIBA-approved course available to aid understanding of the BS 8629 Code of Practice and how its recommendations apply to architects and specifiers in planning building safety strategies.

'A Guide to Meeting BS 8629' is a continuing professional development course, approved by the FIA, the CPD Certification Service as well as RIBA and is suitable for all those wanting to gain a more in-depth understanding of the code of practice for the design, installation, commissioning and maintenance of evacuation alert systems for use by the

fire and rescue services in buildings containing flats.

Delivered online by the Advanced evacuation alert team – Ken Bullock, Business Development Manager and Shaun Scott, Applications Engineer for Evacuation Alert Systems – the one-hour session covers how BS 8629 applies to tall residential buildings – its scope and definitions, specifying products to meet the code of practice requirements, as well as identifying evacuation alert system components.

 +44 (0)345 894 7000  
[uk.advancedco.com](http://uk.advancedco.com)



 Advanced



## RELIABILITY FOR LIFE.

**EASY INSTALLATION FOR INCREASED OCCUPANT SAFETY**

BlazeMaster® Fire Protection Systems are lightweight, flexible and join together using a quick, one-step solvent cement process. When compared to metal systems, this enables building owners and contractors to save time, limit costs and avoid unnecessary tenant disruptions.

- ▶ [BLAZEMASTER.COM](http://BLAZEMASTER.COM)
- ▶ [WILL.ROBINSON@LUBRIZOL.COM](mailto:WILL.ROBINSON@LUBRIZOL.COM)
- ▶ +(44) 07710 372281 +(44) 07710 372281  
To speak with a piping systems consultant

**BlazeMaster®**  
FIRE PROTECTION SYSTEMS

©Lubrizol Advanced Materials, Inc. 2019, all rights reserved. All marks are property of Lubrizol Advanced Materials, a Berkshire Hathaway Company. 19-0204312



### BLAST RESISTANT LITTER BINS

Traditional litter bins make a terrorist job easy. This is because of fragmentation and the fact that this blast increases the level of injury to passers-by. Energetics Technology's Blast Resistant Litter Bins offer the solution. ETL Bins can be placed into your foyeys, walkways, stairways and outside spaces.

**Halo80:** Independently tested to stringent UK Standards, it has a high charge capability and it's designed to work even when the explosive device detonates near the side or the bottom of the unit.

**TC95:** 95ltr capacity, Blast disintegrating lid, all round lateral blast fragment mitigation, and bolt down mounting for extra safety.



### THREAT MITIGATION UNITS

A Threat Mitigation Unit is a blast protection box, on wheels, which can contain an explosives devise. Such a devise might have been placed in luggage or sent and delivered in a parcel. Anyone is susceptible to easy access from mail delivery, so these units offer a solution. We have various units but here are two of them.

**IU1170:** Designed to meet the demands of global couriers during cargo screening, it is ideal for any business receiving packages by courier or through the postal system.

**IU1105:** Provides safeguarding for small suspect packages, letter bombs, fireworks and explosive samples. Typical uses are in mailrooms, banks, embassies and police stations. Sliding internal box for easy loading and removal of suspect packages.



**Energetics Technology** design, manufacture and sell many blast protection products so call Samantha Bailey (01283 732339) [samantha.bailey@energetics-technology.com](mailto:samantha.bailey@energetics-technology.com) to discuss your requirements.

[www.energeticsblastprotection.co.uk](http://www.energeticsblastprotection.co.uk) or [www.energetics-technology.com](http://www.energetics-technology.com)

# UK CA

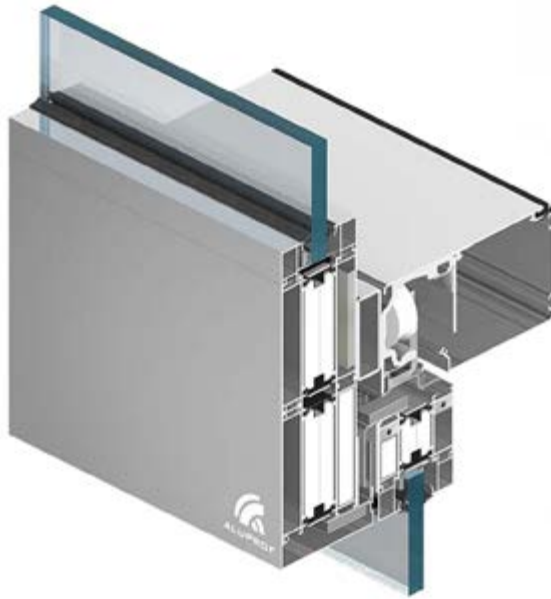

# THE MOVE TO UKCA MARKING OF EXTERNAL FIREDOORS

by Wojciech Brozyna - MD of Aluprof UK

Since Brexit the UK now sits outside the European Economic Area (EEA) and has a trade agreement which helps businesses trade without tariffs between the EEA and the UK. Despite the increased levels of paperwork required for such imports and exports, it is 'almost business as usual'.

Over the last few years conformity with legislation and standards present in Europe have been a prerequisite for producing and selling any goods within the EEA. This included products produced here, in the EEA or from overseas. Known as 'CE' marking, it is applicable equally to the manufacture and sale of a paper clip to more complex fire doors and fire screens. The 'CE mark' is a certification mark that is widely used throughout the EU.

Now the UK has launched its own conformity mark, the 'UKCA mark', this means that all products produced outside or inside the UK, for UK use, must carry the new UKCA mark. Fortunately, both conformity marks CE and UKCA, can be used this year, all products sold in the UK next year, 2022, must carry the UKCA mark.

In Northern Ireland, matters get a little more complicated as manufacturers have their own UK(NI) mark to comply with which must be used alongside the CE marking. Whilst Great Britain will accept the UK(NI)+CE marked products known as 'unfettered access', products manufactured in Northern Ireland only need to carry the CE mark if they are to be sold solely in the EEA. Part of the reason for the difference in

Northern Ireland is that whilst Northern Ireland sits within the EEA, from the 1st January 2021, it is now outside the EU Customs Union. It must be reiterated that for products manufactured and sold in Northern Ireland, they must always carry both the CE mark and the UK(NI).

The 'product' from the 'end fabricator' must be CE marked (accepted up to the end of 2021) and/or UKCA marked, this refers to all the parts that make up the final product from various suppliers such as the framing system, glazing and hardware. This must be declared in one document and on installation it is not possible to substitute any part. The product, such as supplied in a firescreen, including doors and glazing, is supplied to site complete in a fabricated form, glazing can be supplied separately on a stillage but must be supplied by the 'end fabricator'.

The door and sidescreens, or top-lights, must fall within a single overall frame, it is not possible to declare and UKCA mark a coupled door frame to a side screen or toplight. The company installing the product on-site may be another company who has sourced the product from an 'end fabricator'. It is the manufacture of the installed product that carries the responsibility for the UKCA marking by ensuring that the installer follows detailed installation instructions. The pressure is now on manufacturers to ensure that all their products are all reassessed through UK Approved Bodies before the end of this year if they are continuing to be sold in the UK and carry the UKCA mark.



"Now the UK has launched its own conformity mark, the 'UKCA mark', this means that all products produced outside or inside the UK, for UK use, must carry the new UKCA mark."



From the 1st November 2019 ALL external fire rated doorsets MUST carry conformity marking, CE and/or UKCA (from the being of 2021), to ensure conformity to both BS EN 14351-1:2006+A2:2016 - 'Windows and doors. Product standard, performance characteristics. Windows and external pedestrian doorsets.' and BS EN 16034:2014 - 'Pedestrian doorsets, industrial, commercial, garage doors and openable windows. Product standard, performance characteristics. Fire resisting and/or smoke control characteristics.'

The Standard, BS EN 16034 Pedestrian doorsets, industrial, commercial, garage doors and openable windows – Product standard, performance characteristics – Fire resisting and/or smoke control characteristics, cannot be used on its own for CE and/or UKCA (from the being of 2021) marking purposes as it must be used in conjunction with BS EN 14351-1. External Pedestrian Doorsets can include sidescreens as long as they are not coupled. The required characteristics are then raised on the DoP (Declaration of Performance) by the 'end fabricator' based on the ITT data supplied by the systems company and the fabricator's own CoCoP (Certificate of Constancy of Performance). A UK approved body then have to assess the fabricator to AVCP System Level 1 and only then can the UKCA mark be attached to the product. As a result of these imposed regulations, BS 476: Parts 20 & 22 can no longer be used as fire test evidence to CE and/or UKCA mark an external fire rated doorset.

Whilst BS EN 16034 was first published in October 2014, it didn't become a harmonised standard available for use as CE mark evidence until 1st November 2016. As with all new standards, there is a co-existence period in which current standards run alongside the new standard which lasted for three years ending on the 1st November 2019.

As for internal fire rated doorsets and screens we still wait for the BS EN 14351-2 'Product standard, performance characteristics. Internal pedestrian doorsets.' To be cited in the Official Journal of European Union (OJEU) which was

expected to be published in November/December 2019. This means that it is currently not possible to CE and/or UKCA mark internal fire rated doorsets and screens until the harmonisation of this standard occurs. Products can still be tested to achieve stated performance and covered by third party means such as Certifire.

As aluminium remains the most widely specified material for commercial windows, doors and curtain wall, it should come as no surprise that as a leading European systems company, Aluprof offer a comprehensive range of fire rated systems.

With an 86mm frame depth, the new glazed window and door system, MB-86EI can achieve class EI15, EW30, EI30, according to BS EN 13501-2:2016. Complete with polyamide thermal breaks, the door system is ideal for use in both external or internal applications. Doorsets can be manufactured with both fixed lights and opening, single or double doors, in a single outerframe to be UKCA marked, but it must be remembered that external coupled screen assemblies cannot be UKCA marked to BS EN 16034:2014.

Furthermore, in what is believed to be a first for the UK industry, a cap-less, fire rated curtain wall system is available and has been installed on a refurbishment development in Manchester. The project, known as 'The Core', is located at 24-30 Brown Street in the city centre and uses the 'MB-SR50N EI EFEKT' developed by Aluprof. A fire rating of EI60 was required on part of the new cap-less, curved glass facade on the top floor. Aluprof's new system, MB-SR50N EI EFEKT, enabled the architect to have a cap-less fire rated system whilst at the same time seamlessly blending in with areas which did not require a fire rating.

The Aluprof brochure entitled, 'Fire Rated and Smoke Exhaust Systems', explains in detail each product and rating. Aluprof systems offer some of the highest fire protection ratings in Europe, some reaching EI120 - that's two hours fire and smoke protection. Each system has been tested according to European industry standards with various specialist glasses and many are fully covered by the UK's 'Certifire' certificate of approval. With the emergence of the separate UKCA and UKNI marking it is advisable that you contact Aluprof for further technical advice when specifying for use in the UK and Northern Ireland.

Since setting up the Aluprof Office at the Business Design Centre in London, the company has rapidly grown their specification influence in the UK with their high performance architectural aluminium systems. Further expansion of the companies headquarters in Altrincham now provides specifiers with meeting facilities and an extensive showroom of commercial systems to view. With overseas growth across Europe spreading into the Middle East and firm roots already in the East of the USA, the company is becoming a global player in facade supply.

► **Further information is available on the companies website at [aluprof.co.uk](http://aluprof.co.uk) or direct from their UK office in Altrincham on 0161 941 4005.**



# CREATE A STANDOUT PROJECT WITH ETERNIT FIBRE CEMENT SLATES



Designing a project from top to bottom is no easy task, but one feature which can often be overlooked is the roof. The exterior of a building provides the perfect opportunity to make a lasting first impression and one way of achieving this is by using Eternit fibre cement slates.

Available in four slate options, Rivendale, Birkdale, Garsdale and Thrutone fibre cement slates have been designed to provide a range of options in terms of colour, texture and visual appearance, offering the opportunity to produce innovative and imaginative projects. Eternit's fibre cement slates also achieve a 'very good' rating under BES 6001 Responsible Sourcing providing extra credits under BREEM Schemes.

## ETERNIT RIVENDALE FIBRE CEMENT SLATES

Available in striking Blue-Black and Cromleigh Graphite, the Rivendale slates feature a finely detailed surface and dressed edge, combining the benefit of modern technology with the look of natural slate.

Ideal for use on projects where a natural look is sought, Rivendale fibre cement slates are perfect for homes where sustainability is key.

## ETERNIT BIRKDALE FIBRE CEMENT SLATE

Birkdale fibre cement slates can be used for pitch designs down to 20° in a moderate exposure location, offering the designer and contractor increasingly flexible design and installation options.

Featuring a smooth surface and dressed edges, the Birkdale range offers a traditional aesthetic creating the perfect look.

## ETERNIT GARSDALE FIBRE CEMENT SLATES

The Garsdale range features a detailed surface and square edges. Versatile and easy to install the Garsdale range is a favourite with both architects and contractors alike.

Available in a solid Blue Black colour, Garsdale is ideal for those looking to refresh a traditional home.

## ETERNIT THRUTONE FIBRE CEMENT SLATES

Finally, Thrutone slates feature a smooth surface and clean-cut edges for a sleek, aesthetically pleasing finish. With its low wastage and ease of installation, Thrutone slates are the ideal choice for new build and refurbishments. This range is available in six distinct colours and three shapes providing design flexibility.

Eternit fibre cement slates offer specifiers and designers the ideal solution for completing projects with ease.

► For further details about Eternit visit: [www.eternit.co.uk](http://www.eternit.co.uk)





# FIBRE CEMENT SLATES

The charm of a natural slate roof with all the economical, functional and environmentally friendly attributes of modern slate technology. Request a sample at [eternit.co.uk](http://eternit.co.uk)



**RIVENDALE** Finely detailed surface and dressed edges that reproduce the attractive appearance of natural slate

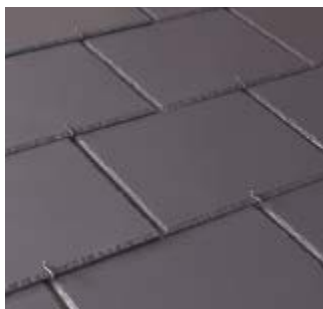

**BIRKDALE** Smooth surface and dressed edges offer a traditional and pleasing look



**GARSDALE** Detailed surface and square edge closely resembles natural slate



**THRUTONE** Smooth surface and square cut edges give a low profile slate at an economical price

**Eternit**

etex

# EASY Installation, FREE Illumination

Versatile & Bright Solar Lighting for Ultimate Efficiency



HALOPOST



SECURSOL



OLYMPIA



GUARDA



SOLLUX



PANAMA

In the current climate of isolation and distancing, our Pro Solar range provide a simple, D.I.Y-friendly alternative to mains powered lights, and in most cases, are equally as bright.

View Full Specifications & Full Product Range on Website

[www.lumenalights.com](http://www.lumenalights.com)



Next Working Day Delivery - High Stock Levels - Technical Advice

Tel: 01327 871161 Email: [sales@lumenalights.com](mailto:sales@lumenalights.com)



SOL-ICON