

T.O. GR1F-16CJ-1

---

# FLIGHT MANUAL

HAF SERIES AIRCRAFT

# F-16C/D

*BLOCKS 50 AND 52+*

LOCKHEED MARTIN CORPORATION

F33657-90-C-2002  
F42620-01-D-0058



Commanders are responsible for bringing this publication to the attention of all Air Force personnel cleared for operation of subject aircraft.

---

15 OCTOBER 2002

CHANGE 1      15 JUNE 2003

INSERT LATEST CHANGED PAGES. DESTROY SUPERSEDED PAGES.

**LIST OF EFFECTIVE PAGES (Cont)**

Page No.	*Change No.	Page No.	*Change No.	Page No.	*Change No.
1-114	0	1-169	0	1-224	0
1-115	0	1-170	0	1-225	0
1-116	0	1-171	0	1-226	0
1-117	0	1-172	0	2-1	0
1-118	0	1-173	0	2-2	0
1-119	0	1-174	0	2-3	0
1-120	0	1-175	0	2-4	0
1-121	0	1-176	0	2-5	1
1-122	0	1-177	0	2-6	0
1-123	0	1-178	0	2-7	0
1-124	0	1-179	0	2-8	0
1-125	0	1-180	0	2-9	0
1-126	0	1-181	0	2-10	0
1-127	1	1-182	0	2-11	0
1-128	0	1-183	0	2-12	1
1-129	0	1-184	0	2-13	1
1-130	0	1-185	0	2-14	0
1-131	0	1-186	0	2-15	0
1-132	0	1-187	0	2-16	0
1-133	0	1-188	0	2-17	1
1-134	0	1-189	0	2-18	0
1-135	0	1-190	0	2-19	0
1-136	0	1-191	0	2-20	0
1-137	0	1-192	0	2-21	0
1-138	0	1-193	1	2-22	0
1-139	1	1-194	1	2-23	1
1-140	0	1-195	1	2-24	0
1-141	0	1-196	0	2-25	0
1-142	0	1-197	1	2-26	1
1-143	0	1-198	0	2-27	0
1-144	0	1-199	0	2-28	0
1-145	0	1-200	0	2-29	0
1-146	0	1-201	0	2-30	1
1-147	0	1-202	0	2-31	0
1-148	0	1-203	0	2-32	0
1-149	0	1-204	0	2-33	0
1-150	0	1-205	0	2-34	1
1-151	0	1-206	0	2-35	1
1-152	0	1-207	0	2-36	0
1-153	0	1-208	0	2-37	0
1-154	0	1-209	0	2-38	1
1-155	0	1-210	0	2-39	0
1-156	0	1-211	0	2-40	0
1-157	0	1-212	0	2-41	0
1-158	0	1-213	0	2-42	0
1-159	0	1-214	0	3-1	0
1-160	0	1-215	0	3-2	0
1-161	0	1-216	0	3-3	0
1-162	0	1-217	0	3-4	0
1-163	0	1-218	0	3-5	0
1-164	0	1-219	0	3-6	0
1-165	0	1-220	0	3-7	0
1-166	0	1-221	0	3-8	0
1-167	0	1-222	0	3-9	1
1-168	0	1-223	1	3-10	0

\* Zero in this column indicates an original page.

INSERT LATEST CHANGED PAGES. DESTROY SUPERSEDED PAGES.

**LIST OF EFFECTIVE PAGES (Cont)**

Page No.	*Change No.	Page No.	*Change No.	Page No.	*Change No.
3-11	0	3-64	1	3-117	0
3-12	0	3-65	0	3-118	0
3-13	0	3-66	1	3-119	1
3-14	0	3-67	1	3-120	0
3-15	0	3-68	0	3-121	0
3-16	0	3-69	0	3-122	1
3-17	0	3-70	0	3-122.1 Added	1
3-18	0	3-71	1	3-122.2 Blank Added	1
3-19	0	3-72	0	3-123	0
3-20	0	3-73	0	3-124	0
3-21	0	3-74	0	3-125	0
3-22	0	3-75	0	3-126	0
3-23	0	3-76	0	3-127	0
3-24	0	3-77	0	3-128	0
3-25	0	3-78	0	3-129	0
3-26	1	3-79	0	3-130	0
3-27	0	3-80	1	3-131	0
3-28	0	3-81	1	3-132	0
3-29	0	3-82	1	3-133	0
3-30	0	3-83	0	3-134	0
3-31	0	3-84	1	3-135	0
3-32	0	3-84.1 Added	1	3-136	0
3-33	0	3-84.2 Blank Added	1	3-137	0
3-34	0	3-85	1	3-138	0
3-35	0	3-86	0	3-139	0
3-36	0	3-87	1	3-140	0
3-37	1	3-88	0	3-141	0
3-38	1	3-89	0	3-142	0
3-39	0	3-90	0	3-143	0
3-40	1	3-91	0	3-144	0
3-40.1 Added	1	3-92	0	3-145	0
3-40.2 Blank Added	1	3-93	0	3-146 Blank	0
3-41	1	3-94	0	4-1	0
3-42	0	3-95	0	4-2 Blank	0
3-43	0	3-96	1	5-1	0
3-44	1	3-97	1	5-2	1
3-45	0	3-98	1	5-3	0
3-46	0	3-99	1	5-4	0
3-47	0	3-100	0	5-5	0
3-48	0	3-101	1	5-6	0
3-49	1	3-102	1	5-7	0
3-50	1	3-103	1	5-8	0
3-51	0	3-104	0	5-9	0
3-52	0	3-105	1	5-10	0
3-53	0	3-106	1	5-11	0
3-54	0	3-107	1	5-12	0
3-55	0	3-108	0	5-13	1
3-56	0	3-109	0	5-14	0
3-57	0	3-110	0	5-15	1
3-58	0	3-111	1	5-16 Blank	0
3-59	0	3-112	1	6-1	0
3-60	1	3-113	1	6-2	0
3-61	0	3-114	0	6-3	0
3-62	0	3-115	0	6-4	0
3-63	0	3-116	0	6-5	0

\* Zero in this column indicates an original page.

INSERT LATEST CHANGED PAGES. DESTROY SUPERSEDED PAGES.

**LIST OF EFFECTIVE PAGES (Cont)**

Page No.	*Change No.	Page No.	*Change No.
6-6	0	8-37 Added	1
6-7	0	8-38 Blank Added	1
6-8	0	Glossary 1	1
6-9	0	Glossary 2	1
6-10	0	Glossary 3	1
6-11	0	Glossary 4	1
6-12	0	Glossary 5	0
6-13	0	Glossary 6 Blank	0
6-14	0		
6-15	0		
6-16	0		
7-1	0		
7-2	0		
7-3	0		
7-4	0		
7-5	0		
7-6	0		
7-7	0		
7-8	0		
8-1 Added	1		
8-2 Added	1		
8-3 Added	1		
8-4 Added	1		
8-5 Added	1		
8-6 Added	1		
8-7 Added	1		
8-8 Added	1		
8-9 Added	1		
8-10 Added	1		
8-11 Added	1		
8-12 Added	1		
8-13 Added	1		
8-14 Added	1		
8-15 Added	1		
8-16 Added	1		
8-17 Added	1		
8-18 Added	1		
8-19 Added	1		
8-20 Added	1		
8-21 Added	1		
8-22 Added	1		
8-23 Added	1		
8-24 Added	1		
8-25 Added	1		
8-26 Added	1		
8-27 Added	1		
8-28 Added	1		
8-29 Added	1		
8-30 Added	1		
8-31 Added	1		
8-32 Added	1		
8-33 Added	1		
8-34 Added	1		
8-35 Added	1		
8-36 Added	1		

\* Zero in this column indicates an original page.

**FLIGHT MANUALS, SAFETY SUPPLEMENT, AND  
OPERATIONAL SUPPLEMENT STATUS**

This supplement status page is based on information available as of 15 June 2003. It is not an official status page.

Flight Manual	Basic Date	Change No. and Date
T.O. GR1F-16CJ-1	15 Oct 2002	1 15 Jun 2003
Supplemental Flight Manuals	Basic Date	Change No. and Date
T.O. GR1F-16CJ-1-1	9 Jun 1997	7 15 Nov 2002
T.O. GR1F-16CJ-1-2	15 Feb 2000	5 15 Mar 2003
Flight Crew Checklist	Basic Date	Change No. and Date
T.O. GR1F-16CJ-1CL-1	15 Oct 2002	1 15 Jun 2003

**INCORPORATED SAFETY AND OPERATIONAL SUPPLEMENTS**

T.O. Number	Date	Short Title	Flight Manual Sections Affected
GR1F-16CJ-1SS-27	27 Nov 02	FLCS Failure That Results In Loss Of Pitch Control	III
GR1F-16CJ-1SS-29	29 Jan 03	Max Range Speeds and FO Pattern Altitudes	III
GR1F-16CJ-1S-31	30 Apr 03	Fuel Transfer Switch, Avionics Fault & ECM Lights, and EGI Align	II

**OUTSTANDING SAFETY AND OPERATIONAL SUPPLEMENTS**

T.O. Number	Date	Short Title	Flight Manual Sections Affected
None			

## TABLE OF CONTENTS

SECTION I	Description and Operation	1-1
SECTION II	Normal Procedures	2-1
SECTION III	Emergency Procedures	3-1
SECTION IV	Crew Duties	4-1
SECTION V	Operating Limitations	5-1
SECTION V	Operating Limitations (Stores)	T.O. GR1F-16CJ-1-2
SECTION VI	Flight Characteristics	6-1
SECTION VII	Adverse Weather Operation	7-1
SECTION VIII	Air Refueling Procedures	8-1
GLOSSARY	Standard and Nonstandard Abbreviations	Glossary 1
APPENDIX A	Performance Data - F100-PW-229	T.O. GR1F-16CJ-1-1
APPENDIX B	Performance Data - F110-GE-129	T.O. GR1F-16CJ-1-1
APPENDIX C	Performance Data - F100-PW-229/CFT	T.O. GR1F-16CJ-1-1

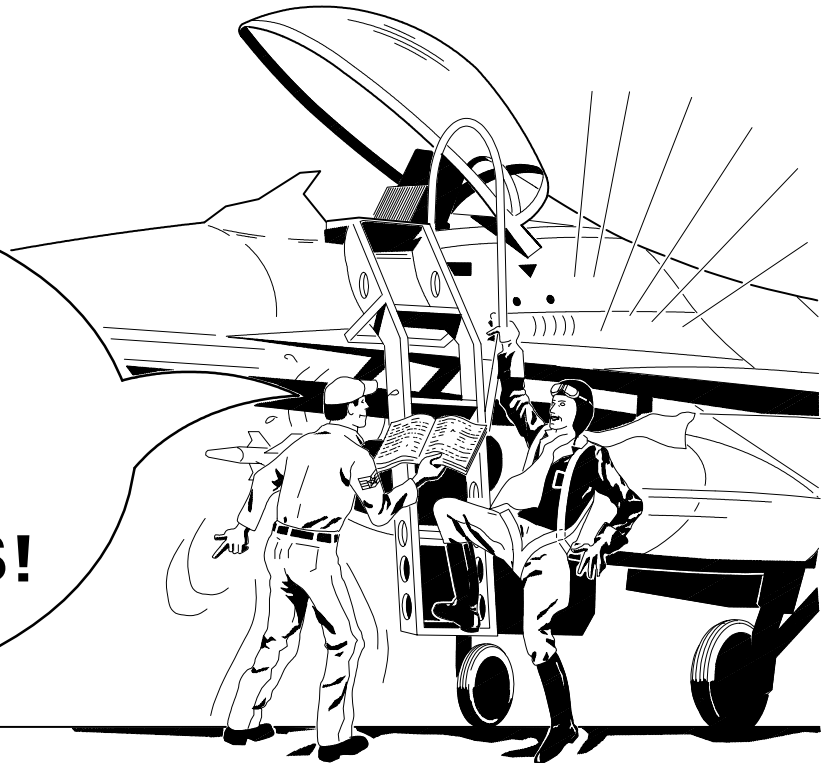
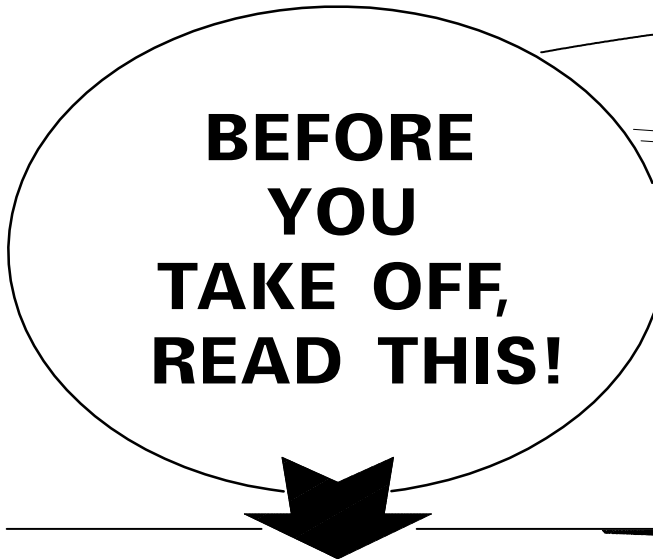

1F-16X-1-0002X ©

**SCOPE**

This manual contains the necessary information for safe and efficient operation of the aircraft. These instructions provide a general knowledge of the aircraft and its characteristics and specific normal and emergency operating procedures. Pilot experience is recognized; therefore, basic flight principles are avoided. Instructions in this manual are prepared to be understandable to the least experienced pilot who can be expected to operate the aircraft. This manual provides the best possible operating instructions under most conditions. Multiple emergencies, adverse weather, terrain, etc., may require modification of the procedures. This manual must be used with one or more of the following manuals to obtain information necessary for safe and efficient operation:

- T.O. GR1F-16CJ-1-1 Supplemental Flight Manual, F-16C/D Aircraft
- T.O. GR1F-16CJ-1-2 Supplemental Flight Manual, F-16C/D Aircraft
- T.O. GR1F-16CJ-5-2 Loading Data

- T.O. GR1F-16CJ-6CF-1 Acceptance and Functional Check Flight Procedures Manual, F-16C/D Aircraft
- T.O. GR1F-16CJ-34-1-1 Avionics and Nonnuclear Weapons Delivery Flight Manual
- T.O. GR1F-16CJ-34-1-2 Nonnuclear Weapons Ballistics
- T.O. 1-1C-1 Basic Flight Crew Air Refueling Procedures

**PERMISSIBLE OPERATIONS**

The flight manual takes a positive approach and normally states only what can be done. Unusual operations or configurations are prohibited unless specifically covered herein. Clearance must be obtained before any questionable operation which is not specifically permitted in this manual is attempted.

## HOW TO BE ASSURED OF HAVING LATEST DATA

Refer to T.O. GR0-1-71 for a listing of all current flight manuals, safety supplements, operational supplements, and checklists. Also, check the flight manual title page, the title block of each safety and operational supplement, and all status pages contained in the flight manual or attached to formal safety and operational supplements. Clear all discrepancies before flight.

## ARRANGEMENT

The manual is divided into eight sections and three supplemental appendices.

## ILLUSTRATIONS

Cockpit arrangement, cockpit console, and cockpit instrument panel illustrations display the delivered configuration plus the approved equipment modifications. For details of equipment modification, see the individual equipment illustration.

## SUPPLEMENT INFORMATION AND GUIDELINES

Supplements are safety or operational and are indicated -1SS or -1S, respectively. Supplements are issued as interim electronic messages or formal printed copies. All interim supplements are assigned odd numbers, such as -1SS-195. When an interim supplement is formalized, it is assigned the next following even number, such as -1SS-196. Formal supplements not preceded by an interim supplement are also assigned even numbers. If an interim supplement is not to be formalized, a statement cancelling the next assigned even supplement number is included in the REMARKS section of the interim supplement. If a formal supplement is not preceded by an interim supplement, a statement cancelling the previous odd supplement number is included on the status page of the formal supplement. Occasionally, a supplement has dual references in the instructions; this is because the supplement applies to the present and subsequent manual. Minor text/illustration changes or deletions are given as instructions in the supplement. When lengthy additions are required, the formal supplement provides one-sided insert page(s) to the flight manual and checklist. This supplement page(s) is attached to the original page(s). The original page(s) remains in the manual or checklist in case the supplement is rescinded and the page(s) is needed. Added page(s) (e.g., 3-48.1) are inserted in proper numerical sequence and may be printed on both sides.

## SAFETY SUPPLEMENTS

Information involving safety is promptly forwarded in a safety supplement. Urgent information is published in interim safety supplements and transmitted by electronic message. Formal supplements are mailed. The supplement title block and status page (published with formal supplements only) should be checked to determine the effect of the supplement on this manual and other outstanding supplements.

## OPERATIONAL SUPPLEMENTS

Information involving changes to operating procedures is forwarded by operational supplements. The procedure for handling operational supplements is the same as for safety supplements.

## CHECKLIST

The checklist contains itemized procedures without all of the amplification. Primary line items in the flight manual and checklist are identical.

## HOW TO GET PERSONAL COPIES

Each pilot is entitled to a personal copy of the flight manual, safety supplements, operational supplements, and a checklist. The required quantities should be ordered before needed to assure their timely receipt. Check with the publication distribution officer whose job is to fulfill T.O. requests. Country manuals and difference data are assigned a Country Standard T.O. (CSTO) number and indexed in the Security Assistance Program T.O. Index, T.O. GR0-1-71. Updates, stock, store, and issue of CSTO's are a contractor supported function. Insure a system is established at each base to deliver the publications to the pilots immediately upon receipt.

## FLIGHT MANUAL BINDERS

Looseleaf binders and sectionalized tabs are available for use with the manual. They are obtained through local purchase procedures and are listed in the USAF supply channels and may be ordered on the supply case through AFLC. Check with supply personnel for assistance in procuring these items.

## CHANGE SYMBOL

The change symbol, as illustrated by the black line in the margin of this paragraph, indicates changes made to the current issue.



## WARNINGS, CAUTIONS, AND NOTES

The following definitions apply to Warnings, Cautions, and Notes found throughout the manual:

### WARNING

Operating procedures, techniques, etc., which could result in personal injury or loss of life if not carefully followed.

### CAUTION

Operating procedures, techniques, etc., which could result in damage to equipment if not carefully followed.

### NOTE

An operating procedure, technique, etc., which is considered essential to emphasize.

## USE OF WORDS SHALL, WILL, SHOULD, AND MAY

The word shall or will is used to indicate a mandatory requirement. The word should is used to indicate a nonmandatory desired or preferred method of accomplishment. The word may is used to indicate an acceptable or suggested means of accomplishment.

## USE OF WORDS AS DESIRED AND AS REQUIRED

As desired allows pilot preference in switch/control positioning.

As required indicates those actions which vary based on mission requirements.

## AIRSPEED REFERENCES

All references to airspeed quoted in knots refer to indicated airspeed.

## PILOT'S RESPONSIBILITY – TO LET US KNOW

Every effort is made to keep the flight manual current. Review conferences with operating personnel and a constant review of safety investigation and flight test reports assure inclusion of the latest data in the manual. Comments, corrections, and questions

regarding this manual or any phase of the flight manual program are welcomed. These should be forwarded on AF Form 847 in accordance with AFI 11-215 through command headquarters to OO-ALC/YPVT, 6080 Gum Lane, Hill AFB, UT 84056-5825.

## PUBLICATION DATE

The date appearing on the title page represents the currency of material contained herein.

## AIRCRAFT AND COCKPIT DESIGNATION CODES

System and/or component effectivity for a particular aircraft version/cockpit is denoted by a letter code enclosed in a box located in the text or on an illustration. The symbols and designations are as follows:

No code – F-16C and F-16D aircraft

**C** F-16C aircraft

**D** F-16D aircraft

**DF** F-16D aircraft, forward cockpit

**DR** F-16D aircraft, rear cockpit

**PX II** Peace Xenia II aircraft

**PX III** Peace Xenia III aircraft

## ENGINE DESIGNATION CODES

System and/or component effectivity for a particular engine version is denoted by an engine code enclosed in a box located in the text or on an illustration. The symbols and designations are as follows:

No code – Either engine

**PW 229** F100-PW-229

**GE129** F110-GE-129

## BLOCK DESIGNATION CODES/SERIAL NUMBER/ TAIL NUMBER CROSS-REFERENCE

Because of differences in configuration between aircraft and to avoid repetitious use of aircraft serial numbers, a block effectivity system is used. The block effectivities reflect the aircraft block, the aircraft serial number, and the tail number. Attrited aircraft are removed from the listing. This system is used throughout the manual, both in text and illustrations.

**AIRCRAFT MODIFICATION/RETROFIT INFORMATION**

This list includes the applicable T.O./ECP effectivities. It is not an official status page. Refer to T.O. 0-1-4 for the complete listing of TCTO's. Throughout this manual, black TV screen symbols containing white numerals (2) are used to distinguish information related to aircraft which are modified by a specific

T.O./ECP. Information pertaining to modified aircraft is identified by an appropriate effectivity symbol. Information which is not identified by an effectivity symbol is considered common to all aircraft. Information pertaining only to unmodified aircraft has the appropriate effectivity symbol preceded by **LESS**. For example, **LESS 4** indicates that the information is only applicable to aircraft not modified by a specific T.O./ECP.

TV CODE/ T.O. NO.	SHORT TITLE	EFFECTIVITY	
		PRODUCTION	RETROFIT
<b>116</b> 1F-16-2121	Flight Control Computer Software Update (ECP 2269)	F-16C 93-1055, and on  F-16D NA	F-16C 93-1045 thru 93-1054  F-16D All
Summary:			
<ul style="list-style-type: none"> <li>• Retrofit authorized</li> <li>• Modification incorporates FLCS improvements, including improved reset capability for FLCC power up failures and elimination of lateral accelerometer failures during gun firing.</li> </ul>			
<b>125</b> 1F-16-2170	Modification of the Ejection Mode Selector Valve Console (ECP 2362)	F-16C NA  F-16D 99-1534, and on	F-16C NA  F-16D 93-1077 thru 93-1084
Summary:			
<ul style="list-style-type: none"> <li>• Retrofit authorized</li> <li>• Modification enlarges the hole in the console to allow the EJECTION MODE SEL handle to seat properly in the NORM position.</li> </ul>			
<b>129</b> XX1F-16-2077	Installation of Improved Antiskid Braking System (OCP H086) (ECP 2478)	F-16C 99-1500, and on  F-16D 99-1534, and on	F-16C 93-1045 thru 93-1076  F-16D 93-1077 thru 93-1084
Summary:			
<ul style="list-style-type: none"> <li>• Retrofit authorized</li> <li>• Modification incorporates an improved Brake Control/Anti-skid Assembly to replace the current Brake Control and Antiskid Control Boxes.</li> </ul>			
<b>163</b> NA	Flight Control Computer Software Update for CFT (ECP 2495)	F-16C 99-1500, and on  F-16D 99-1534, and on	NA
Summary:			
<ul style="list-style-type: none"> <li>• Retrofit NA</li> <li>• Modification incorporates flight control system software updates to provide increased roll rate capability in CAT III with CFT's and eliminate an existing prohibited maneuver.</li> </ul>			

TV CODE/ T.O. NO.	SHORT TITLE	EFFECTIVITY PRODUCTION	RETROFIT
173 TBD	AVIONICS FAULT caution/ECM lights CDEEU mod (ECP 2526)	F-16C 99-1507, and on F-16D 99-1541, and on	TBD

Summary:

- Retrofit TBD
- Modification to circuitry in the CDEEU which will allow the AVIONICS FAULT caution and ECM lights to illuminate in both cockpits of **PX III** **D** aircraft.

# Block Designation Codes/Serial Number/Tail Number Cross-Reference

<b>BLOCK 50</b>	93-1080/080 93-1081/081 93-1082/082 93-1083/083 93-1084/084	99-1533/533 01-8530/534 01-8531/535 01-8532/536 01-8533/537 01-8534/538 01-8535/539			
<b>C</b>					
<i>PX II</i>	<b>BLOCK 52+</b>	<b>D</b>			
93-1045/045 93-1046/046 93-1047/047 93-1048/048 93-1049/049 93-1050/050 93-1051/051 93-1052/052 93-1053/053 93-1054/054 93-1055/055 93-1056/056 93-1057/057 93-1058/058 93-1059/059 93-1060/060 93-1061/061 93-1062/062 93-1063/063 93-1064/064 93-1065/065 93-1066/066 93-1067/067 93-1068/068 93-1069/069 93-1070/070 93-1071/071 93-1072/072 93-1073/073 93-1074/074 93-1075/075 93-1076/076	Serial Numbers/ Tail Numbers	<i>PX III</i>			
	<b>C</b>				
	<i>PX III</i>				
	99-1500/500 99-1501/501 99-1502/502 99-1503/503 99-1504/504 99-1505/505 99-1506/506 99-1507/507 99-1508/508 99-1509/509 99-1510/510 99-1511/511 99-1512/512 99-1513/513 99-1514/514 99-1515/515 99-1516/516 99-1517/517 99-1518/518 99-1519/519 99-1520/520 99-1521/521 99-1522/522 99-1523/523 99-1524/524 99-1525/525 99-1526/526 99-1527/527 99-1528/528 99-1529/529 99-1530/530 99-1531/531 99-1532/532		99-1534/600 99-1535/601 99-1536/602 99-1537/603 99-1538/604 99-1539/605 99-1540/606 99-1541/607 99-1542/608 99-1543/609 99-1544/610 99-1545/611 99-1546/612 99-1547/613 99-1548/614 99-1549/615 01-8536/616 01-8537/617 01-8538/618 01-8539/619		
<b>D</b>					
<i>PX II</i>					
93-1077/077 93-1078/078 93-1079/079					

# F-16

## *Fighting Falcon*



C

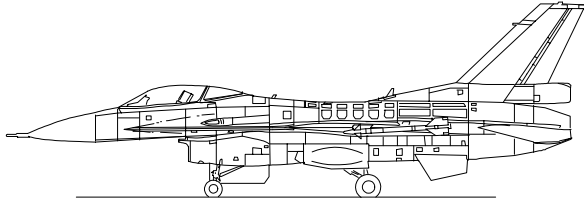

D

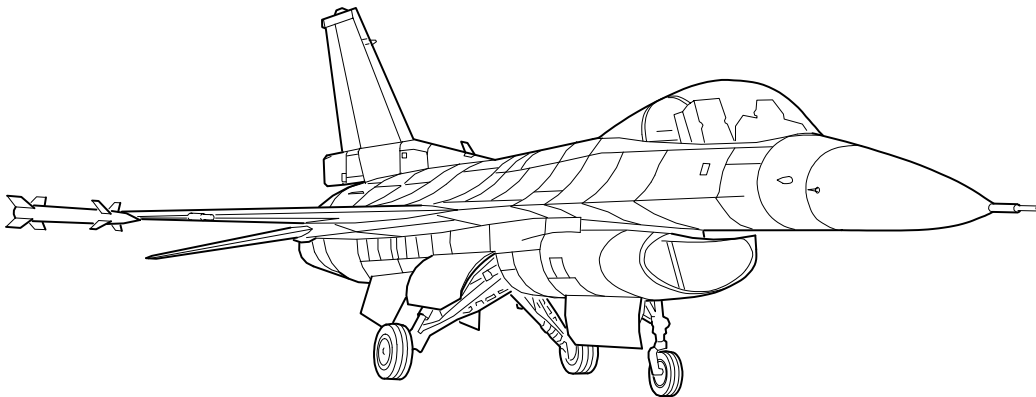
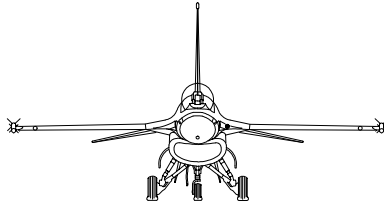
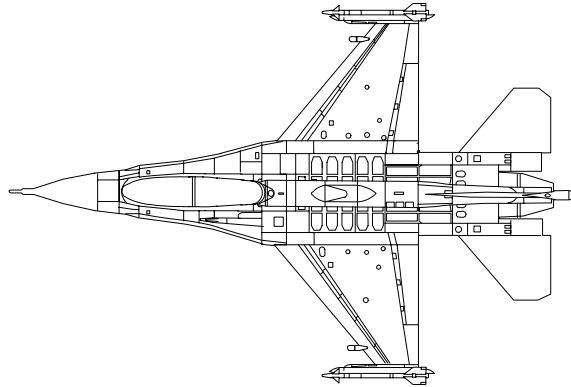
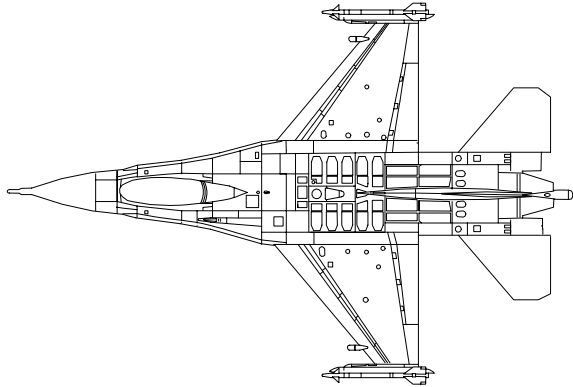
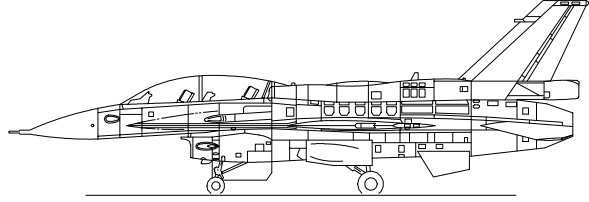

GR1F-16CJ-1-0003A37 ©

## SECTION I

### DESCRIPTION AND OPERATION

#### TABLE OF CONTENTS

The Aircraft .....	1-6	Jet Fuel Starter (JFS) <b>PW 229</b> .....	1-36
Aircraft General Data .....	1-7	ENG & JET START Control	
Aircraft General Arrangement .....	1-7	Panel <b>PW 229</b> .....	1-36
Aircraft Gross Weight (A/C GW) .....	1-7	JFS Switch <b>C DF PW 229</b> .....	1-36
Cockpit Arrangement .....	1-7	JFS RUN Light <b>C DF PW 229</b> .....	1-36
Engine <b>PW 229</b> .....	1-31	JFS Operation <b>PW 229</b> .....	1-37
Engine General Description <b>PW 229</b> .....	1-31	Engine Controls and	
Engine Fuel System <b>PW 229</b> .....	1-31	Indicators <b>PW 229</b> .....	1-37
Engine Control System <b>PW 229</b> .....	1-31	ENG CONT Switch <b>PW 229</b> .....	1-37
Main Fuel Control (MFC) <b>PW 229</b> .....	1-31	AB RESET Switch <b>C DF PW 229</b> .....	1-39
Afterburner (AB) Fuel		ENGINE FAULT Caution	
Control <b>PW 229</b> .....	1-31	Light <b>PW 229</b> .....	1-39
Digital Electronic Engine Control		Pilot Fault List Display	
(DEEC) <b>PW 229</b> .....	1-33	(PFLD) <b>PW 229</b> .....	1-39
Secondary Engine Control		SEC Caution Light <b>PW 229</b> .....	1-39
(SEC) <b>PW 229</b> .....	1-33	EEC Caution Light <b>PW 229</b> .....	1-39
Main Fuel Pump <b>PW 229</b> .....	1-33	BUC Caution Light <b>PW 229</b> .....	1-39
Afterburner (AB) Fuel		MAX POWER Switch <b>C DF PW 229</b> .....	1-39
Pump <b>PW 229</b> .....	1-33	RPM Indicator <b>PW 229</b> .....	1-39
Compressor Inlet Variable Vane		NOZ POS Indicator <b>PW 229</b> .....	1-39
(CIVV) Control <b>PW 229</b> .....	1-33	FTIT Indicator <b>PW 229</b> .....	1-39
Rear Compressor Variable Vanes		FUEL FLOW Indicator <b>PW 229</b> .....	1-39
(RCVV's) <b>PW 229</b> .....	1-33	OIL Pressure Indicator <b>PW 229</b> .....	1-39
Compressor Bleed Air <b>PW 229</b> .....	1-34	HYD/OIL PRESS Warning	
Pressurization and Dump		Light <b>PW 229</b> .....	1-39
Valve <b>PW 229</b> .....	1-34	ENGINE Warning Light <b>PW 229</b> .....	1-40
Exhaust Nozzle <b>PW 229</b> .....	1-34	Throttle <b>PW 229</b> .....	1-40
Convergent Exhaust Nozzle Control		Engine Operating	
(CENC) <b>PW 229</b> .....	1-34	Characteristics <b>PW 229</b> .....	1-40
Light-Off Detector (LOD) <b>PW 229</b> .....	1-34	Engine General <b>PW 229</b> .....	1-40
Engine Diagnostic Unit (EDU) <b>PW 229</b> .....	1-34	Ground Operations <b>PW 229</b> .....	1-40
Engine Oil System <b>PW 229</b> .....	1-34	Non-AB Operation in	
FUEL/OIL HOT Caution		Flight <b>PW 229</b> .....	1-40
Light <b>PW 229</b> .....	1-34	AB Operation in Flight <b>PW 229</b> .....	1-42
Engine Anti-Ice System <b>PW 229</b> .....	1-35	SEC Operation <b>PW 229</b> .....	1-42
Engine ANTI ICE Switch <b>PW 229</b> .....	1-35	Engine <b>GE129</b> .....	1-44
INLET ICING Caution		General Description <b>GE129</b> .....	1-44
Light <b>PW 229</b> .....	1-35	Engine Fuel/Control System <b>GE129</b> .....	1-44
Engine and Accessory Drive		Digital Electronic Control	
Gearboxes <b>PW 229</b> .....	1-35	(DEC) <b>GE129</b> .....	1-44
Engine Alternator <b>PW 229</b> .....	1-35	Afterburner Fuel Control	
Engine Ignition System <b>PW 229</b> .....	1-35	(AFC) <b>GE129</b> .....	1-44
		Main Engine Control (MEC) <b>GE129</b> .....	1-44
		Primary (PRI) Engine	
		Operation <b>GE129</b> .....	1-44

Hybrid (HYB) Engine			
Operation <b>GE129</b> .....	1-46	HYD/OIL PRESS Warning	
Secondary Engine Control (SEC)		Light <b>GE129</b> .....	1-53
Operation <b>GE129</b> .....	1-47	ENGINE Warning Light <b>GE129</b> .....	1-54
Engine Fuel Boost Pump <b>GE129</b> .....	1-47	Throttle <b>GE129</b> .....	1-54
Main Fuel Pump <b>GE129</b> .....	1-47	Engine Operating	
Afterburner (AB) Fuel		Characteristics <b>GE129</b> .....	1-54
Pump <b>GE129</b> .....	1-47	Ground Operations <b>GE129</b> .....	1-54
Inlet Guide Vanes (IGV's) <b>GE129</b> .....	1-47	Non-AB Operation in Flight <b>GE129</b> ....	1-54
Variable Stator Vanes		AB Operation <b>GE129</b> .....	1-56
(VSV's) <b>GE129</b> .....	1-47	Inlet Thump <b>GE129</b> .....	1-56
Compressor Bleed Air <b>GE129</b> .....	1-47	SEC Operation <b>GE129</b> .....	1-56
Exhaust Nozzle <b>GE129</b> .....	1-47	Fire and Overheat Detection System .....	1-58
AB Flame Detector <b>GE129</b> .....	1-48	FIRE & OHEAT DETECT Test	
Engine Monitoring System		Button <b>C DF</b> .....	1-58
(EMS) <b>GE129</b> .....	1-48	Fuel System .....	1-58
Engine Oil System <b>GE129</b> .....	1-48	Fuel Tank System .....	1-58
FUEL/OIL HOT Caution		Fuel Transfer System .....	1-58
Light <b>GE129</b> .....	1-48	Fuel Tank Vent and Pressurization	
Engine Anti-Ice System <b>GE129</b> .....	1-48	System .....	1-61
Engine ANTI ICE Switch <b>GE129</b> .....	1-49	Engine Fuel Supply System .....	1-61
INLET ICING Caution		Fuel Quantity Indicating System .....	1-74
Light <b>GE129</b> .....	1-49	Reservoir Fuel Level Sensing System ....	1-74
Engine and Accessory Drive		Fuel Low Caution Lights .....	1-74
Gearboxes <b>GE129</b> .....	1-49	HUD FUEL Low/Bingo Indication .....	1-74
Engine Alternator <b>GE129</b> .....	1-49	HUD TRP FUEL Warning .....	1-74
Engine Ignition System <b>GE129</b> .....	1-49	FUEL/OIL HOT Caution Light .....	1-77
Jet Fuel Starter (JFS) <b>GE129</b> .....	1-50	Fuel Tank Explosion Suppression	
ENG & JET START Control		System .....	1-77
Panel <b>GE129</b> .....	1-50	Refueling System .....	1-77
JFS Switch <b>C DF GE129</b> .....	1-50	Ground Refueling .....	1-77
JFS RUN Light <b>C DF GE129</b> .....	1-51	Air Refueling (AR) System .....	1-77
JFS Operation <b>GE129</b> .....	1-51	NWS A/R DISC MSL STEP	
Engine Controls and		Button .....	1-78
Indicators <b>GE129</b> .....	1-51	Air Refueling (AR) Status	
ENG CONT Switch <b>GE129</b> .....	1-51	Indicator .....	1-78
SEC Caution Light <b>GE129</b> .....	1-53	Environmental Control System (ECS) .....	1-78
EEC Caution Light <b>GE129</b> .....	1-53	Electrical Failures .....	1-78
BUC Caution Light <b>GE129</b> .....	1-53	Air-Conditioning .....	1-80
MAX POWER Switch <b>C DF GE129</b> ....	1-53	Pressurization .....	1-80
AB RESET Switch <b>C DF GE129</b> .....	1-53	AIR SOURCE Knob <b>C DF</b> .....	1-81
ENGINE FAULT Caution		TEMP Knob <b>C DF</b> .....	1-81
Light <b>GE129</b> .....	1-53	DEFOG Lever <b>C DF</b> .....	1-81
Pilot Fault List Display		EQUIP HOT Caution Light .....	1-82
(PFLD) <b>GE129</b> .....	1-53	Cockpit Pressure Altimeter <b>C DF</b> .....	1-82
RPM Indicator <b>GE129</b> .....	1-53	CABIN PRESS Caution Light .....	1-82
NOZ POS Indicator <b>GE129</b> .....	1-53	Anti-G System .....	1-82
FTIT Indicator <b>GE129</b> .....	1-53	Electrical System .....	1-82
FUEL FLOW Indicator <b>GE129</b> .....	1-53	Main AC Power System .....	1-82
OIL Pressure Indicator <b>GE129</b> .....	1-53	Overcurrent Sensing Contactors .....	1-83

Standby AC Power System .....	1-83	Wheel Brake System .....	1-110
Emergency AC Power System .....	1-83	Toe Brake System .....	1-110
DC Power System .....	1-83	Spin Down Braking System .....	1-111
FLCS Power Supply .....	1-83	Brakes Channel Switch <b>C</b> <b>DF</b> .....	1-111
External Power Provisions .....	1-86	Parking Brake <b>C</b> <b>DF</b> .....	1-111
Electrical System Controls and Indicators .....	1-86	Antiskid System .....	1-116
Electrical Power Distribution .....	1-86	ANTI-SKID Switch <b>C</b> <b>DF</b> .....	1-117
Electrical System Normal Operation .....	1-86	ANTI SKID Caution Light .....	1-117
Hydraulic System .....	1-98	Speedbrake System .....	1-117
HYD PRESS Indicators and Warning Light .....	1-98	SPD BRK Switch .....	1-117
HYD PRESS Indicators .....	1-98	SPEED BRAKE Position Indicator ....	1-117
HYD/OIL PRESS Warning Light .....	1-98	Drag Chute System .....	1-117
Emergency Power Unit (EPU) .....	1-98	DRAG CHUTE Switch .....	1-118
EPU Controls and Indicators .....	1-99	Arrestment System .....	1-118
EPU Ground Safety Switch .....	1-99	HOOK Switch .....	1-118
EPU Switch .....	1-99	HOOK Caution Light .....	1-118
EPU Run Light .....	1-99	Wing Flap System .....	1-118
HYDRAZN Light .....	1-99	Leading Edge Flaps (LEF's) .....	1-118
AIR Light .....	1-99	LE FLAPS Switch .....	1-118
EPU/GEN Test Switch .....	1-99	FLCS LEF LOCK PFL .....	1-118
EPU FUEL Quantity Indicator <b>C</b> <b>DF</b> .....	1-99	Trailing Edge Flaps (TEF's) (Flaperons) .....	1-120
Hydrazine Leak Detector .....	1-99	ALT FLAPS Switch .....	1-120
EPU Fired Indicator .....	1-102	Flight Control System (FLCS) .....	1-120
EPU Operation .....	1-102	Digital Backup (DBU) .....	1-120
Landing Gear (LG) System .....	1-104	FLCS Limiters .....	1-121
Main Landing Gear (MLG) .....	1-104	AOA/G Limiter .....	1-121
Nose Landing Gear (NLG) .....	1-104	Roll Rate Limiter .....	1-121
Landing Gear Controls and Indicators ...	1-104	Rudder Authority Limiter .....	1-121
Landing Gear Handle .....	1-104	Yaw Rate Limiter .....	1-121
Landing Gear Handle Down Permission Button .....	1-104	FLCS Gains .....	1-121
DN LOCK REL Button .....	1-104	Cruise Gains .....	1-127
ALT GEAR Handle .....	1-106	Takeoff and Landing Gains .....	1-127
LG Warning Horn .....	1-106	Standby Gains .....	1-127
HORN SILENCER Button .....	1-106	FLCS Data Recorder <b>C</b> <b>DF</b> .....	1-127
TO/LDG CONFIG Warning Light .....	1-106	Angle-of-Sideslip (AOS) Feedback Function .....	1-127
WHEELS Down Lights .....	1-106	Gun Compensation .....	1-127
Landing Gear Weight-on-Wheels (WOW) Switches .....	1-106	Flight Control System (FLCS) Controls .....	1-127
Landing Gear Operation .....	1-106	Stick .....	1-127
Nosewheel Steering (NWS) System .....	1-110	Rudder Pedals .....	1-130
NWS Controls and Indicators .....	1-110	MANUAL TRIM Panel .....	1-130
NWS A/R DISC MSL STEP Button ....	1-110	MANUAL PITCH Override (MPO) Switch .....	1-130
NWS Light .....	1-110	STORES CONFIG Switch <b>C</b> <b>DF</b> .....	1-130
NWS FAIL Caution Light .....	1-110	Low Speed Warning Tone .....	1-130
Nosewheel Steering (NWS) System <b>D</b> ....	1-110	FLT CONTROL Panel (FLCP) <b>C</b> <b>DF</b> ..	1-130



T.O. GR1F-16CJ-1

FLCS Warning, Caution, and Indicator		NVIS Switch <b>PX III</b> .....	1-155
Lights .....	1-130	Hands-On Blackout (HOBO)	
FLCS Warning Light .....	1-130	Switch <b>PX III</b> .....	1-157
DBU ON Warning Light .....	1-132	Utility Light .....	1-157
TO/LDG CONFIG Warning Light .....	1-132	Cockpit Spotlights .....	1-157
FLCS FAULT Caution Light .....	1-132	Escape System .....	1-157
Built-In Test (BIT) .....	1-135	Canopy .....	1-157
Pilot Fault List Display (PFLD) .....	1-135	Canopy Controls and Indicators .....	1-157
Trim .....	1-135	<b>MANUAL CANOPY CONTROL</b>	
Autopilot .....	1-135	Handcrank .....	1-157
Autopilot Operation .....	1-136	Canopy Handle <b>C</b> <b>DF</b> .....	1-157
ADV MODE Switch .....	1-136	Canopy Jettison .....	1-161
Stick Steering .....	1-136	Ejection Seat .....	1-161
AOA System .....	1-137	Ejection Handle .....	1-161
AOA Indicator .....	1-137	<b>SHOULDER HARNESS Knob</b> .....	1-161
AOA Indexer .....	1-138	<b>EMERGENCY MANUAL CHUTE</b>	
HUD AOA Display .....	1-138	Handle .....	1-161
Air Data System .....	1-138	Ejection Safety Lever .....	1-161
Air Data Probes .....	1-138	SEAT NOT ARMED Caution Light .....	1-161
AOA Transmitters .....	1-138	SEAT ADJ Switch .....	1-161
Total Temperature Probe .....	1-138	Shoulder Harness Straps/Parachute	
Static Pressure Ports .....	1-138	Risers .....	1-161
Probe Heat Monitor .....	1-138	Inertia Reel Straps .....	1-161
<b>PROBE HEAT Switch</b> .....	1-140	Lapbelt .....	1-161
Pneumatic Sensor Assembly (PSA) .....	1-140	Survival Kit .....	1-164
Central Air Data Computer (CADC) .....	1-140	<b>RADIO BEACON Switch</b> .....	1-164
CADC Caution Light .....	1-140	Emergency Oxygen .....	1-164
Warning, Caution, and Indicator Lights .....	1-140	Ejection Seat Operation .....	1-164
Voice Message System (VMS) .....	1-145	Ejection Mode Envelopes .....	1-164
<b>VOICE MESSAGE Switch</b> <b>C</b> <b>DF</b> .....	1-146	Ejection Sequence Times .....	1-164
<b>MASTER CAUTION Light</b> .....	1-146	Canopy Jettison/Seat Ejection .....	1-164
Pilot Fault List Display (PFLD) .....	1-146	Ejection Seat Performance .....	1-164
Caution Light Panel .....	1-147	Oxygen System <b>PX III</b> .....	1-173
<b>MAL &amp; IND LTS Test Button</b> .....	1-147	Onboard Oxygen Generating	
Lighting System .....	1-148	System (OBOGS) .....	1-173
Exterior Lighting .....	1-148	OBOGS Backup Oxygen	
Anticollision Strobe Light .....	1-148	Supply (BOS) .....	1-173
Position/Formation Lights .....	1-148	OBOGS Monitor .....	1-173
Air Refueling Lights .....	1-148	Emergency Oxygen Supply (EOS) .....	1-173
Vertical Tail-Mounted Floodlight .....	1-154	OBOGS Built-In-Tests (BIT's) .....	1-173
Landing and Taxi Lights .....	1-154	OBOGS Power-Up BIT .....	1-173
Interior Lighting .....	1-154	OBOGS Periodic BIT .....	1-173
<b>PRIMARY CONSOLES Knob</b> .....	1-155	OBOGS Manual BIT .....	1-173
<b>PRIMARY INST PNL Knob</b> .....	1-155	OBOGS Pneumatic BIT .....	1-174
<b>DATA ENTRY DISPLAY Knob</b> .....	1-155	Pressure Breathing for G (PBG) .....	1-174
<b>MAL &amp; IND LTS Switch</b> .....	1-155	Oxygen System Controls and	
<b>FLOOD INST PNL Knob</b> .....	1-155	Indicators .....	1-174
<b>FLOOD CONSOLES Knob</b> .....	1-155	Oxygen System Schematic .....	1-174

Oxygen System <b>PX II</b> .....	1-177	Antenna Locations .....	1-191
Liquid Oxygen System .....	1-177	Have Quick (HQ) System .....	1-191
Pressure Breathing for G (PBG) .....	1-177	Single Word of Day (WOD) .....	1-191
Oxygen System Controls and		Single WOD Transfer .....	1-191
Indicators .....	1-177	Multiple Word of Day (MWOD) .....	1-191
Oxygen Duration .....	1-177	Automatic MWOD Loading <b>PX III</b> .....	1-193
Emergency Oxygen System .....	1-177	Time-of-Day (TOD) Transmission .....	1-193
Oxygen System Schematic .....	1-177	Time-of-Day (TOD) Reception <b>PX III</b> ...	1-193
Communications, Navigation, and IFF		Time-of-Day (TOD) Reception <b>PX II</b> ...	1-193
(CNI) Equipment .....	1-182	Net Number .....	1-194
Upfront Controls .....	1-182	Antijamming (AJ) Mode Operation ....	1-194
DED/CNI Readouts .....	1-182	Have Quick (HQ) UHF Radio .....	1-194
CNI Readout/DED Page Summary ....	1-185	Operation of the UHF Radio on	
IFF Control Panel <b>C</b> <b>DF</b> <b>PX III</b> .....	1-185	Upfront Controls .....	1-194
C & I (Communications and IFF)		UHF Radio Backup Control Panel ....	1-196
Knob .....	1-186	Function Knob .....	1-196
IFF MASTER Knob .....	1-186	Mode Knob <b>PX II</b> .....	1-196
IFF M-4 CODE Switch .....	1-186	Mode Knob <b>PX III</b> .....	1-196
IFF MODE 4 REPLY Switch .....	1-186	CHAN Knob .....	1-197
IFF MODE 4 MONITOR Switch .....	1-186	Manual Frequency Knobs .....	1-197
IFF ENABLE Switch .....	1-187	A-3-2-T Knob <b>PX II</b> .....	1-197
IFF MODE 1/MODE 3 Selector		A-3-2 Knob <b>PX III</b> .....	1-197
Levers .....	1-187	VOL Knob .....	1-197
AUX COMM Panel <b>C</b> <b>DF</b> <b>PX II</b> .....	1-187	SQUELCH Switch .....	1-197
CNI (Communications, Navigation,		TONE Button <b>PX II</b> .....	1-197
and IFF) Knob .....	1-187	CHAN Display <b>PX III</b> .....	1-197
IFF MASTER Knob .....	1-187	Frequency/Status Display <b>PX III</b> .....	1-197
M-4 CODE Switch .....	1-187	STATUS Button <b>PX III</b> .....	1-198
IFF MODE 4 REPLY Switch .....	1-188	T-TONE Switch <b>PX III</b> .....	1-198
IFF MODE 4 MONITOR Switch .....	1-188	TEST DISPLAY Button <b>PX III</b> .....	1-198
TACAN Function Switch .....	1-188	ZERO Switch <b>PX III</b> .....	1-198
TACAN CHANNEL Selector Levers ...	1-188	FILL Connector <b>PX III</b> .....	1-198
AUDIO 1 Control Panel .....	1-188	VHF Radio .....	1-198
COMM 1 (UHF) Power Knob .....	1-188	Operation of the VHF Radio on	
COMM 1 (UHF) Mode Knob .....	1-188	Upfront Controls .....	1-198
COMM 2 (VHF) Power Knob .....	1-189	Zeroize Switch .....	1-199
COMM 2 (VHF) Mode Knob .....	1-189	Navigation Systems .....	1-199
SECURE VOICE Knob .....	1-189	Embedded Global Positioning and Inertial	
MSL Tone Knob .....	1-189	Navigation Set (EGI) <b>PX III</b> .....	1-199
TF Tone Knob .....	1-189	Global Positioning System (GPS) <b>PX II</b> ...	1-200
THREAT Tone Knob .....	1-189	Inertial Navigation Set (INS) <b>PX II</b> .....	1-200
AUDIO 2 Control Panel .....	1-190	Tactical Air Navigation (TACAN)	
ILS Power Knob .....	1-190	System .....	1-200
TACAN Power Knob .....	1-190	Operation of the TACAN on Upfront	
INTERCOM Knob .....	1-190	Controls .....	1-200
HOT MIC CIPHER Switch .....	1-190	Terrain Following Radar (TFR) System ....	1-200
ANT SEL Panel <b>C</b> <b>DF</b> .....	1-190	AIFF System .....	1-200
IFF ANT SEL Switch <b>C</b> <b>DF</b> .....	1-190	AIFF Transponder <b>PX II</b> .....	1-201
UHF ANT SEL Switch <b>C</b> <b>DF</b> .....	1-191	AIFF Transponder <b>PX III</b> .....	1-201
Communications System .....	1-191	Operation of the Transponder on	
		Upfront Controls <b>PX II</b> .....	1-201
		Operation of the Transponder on	
		Upfront Controls <b>PX III</b> .....	1-202

AIFF Interrogator ..... 1-203  
 Operation of the Interrogator on  
 Upfront Controls **PX II** ..... 1-204  
 Operation of the Interrogator on  
 Upfront Controls **PX III** ..... 1-204  
 AIFF Controls and Indicators ..... 1-204  
 IFF IDENT Button ..... 1-204  
 IFF (Mode 4) Caution Light ..... 1-204  
 UHF VHF IFF Transmit  
 Switch **PX II** ..... 1-204  
 Target Management Switch **PX III** ..... 1-205  
 Instrument Landing System (ILS) ..... 1-205  
 ILS Controls ..... 1-205  
 Operation of the ILS on Upfront  
 Controls ..... 1-206  
 MRK BCN Light ..... 1-206  
 INSTR MODE Select Panel ..... 1-206  
 INSTR HDG Knob **C** **DF** ..... 1-206  
 INSTR MODE Knob ..... 1-206  
 Navigation Aids and Display ..... 1-206  
 Instrument Modes ..... 1-206  
 Flight Instruments ..... 1-215  
 Altimeter ..... 1-215  
 Airspeed/Mach Indicator ..... 1-216  
 Standby Attitude Indicator (SAI) ..... 1-216  
 Vertical Velocity Indicator (VVI) ..... 1-216  
 Magnetic Compass ..... 1-216  
 Attitude Director Indicator (ADI) ..... 1-216  
 Horizontal Situation Indicator (HSI) ..... 1-216  
 Clock ..... 1-217  
 Crash Survivable Flight Data  
 Recorder (CSFDR) ..... 1-217  
 F-16D Aircraft ..... 1-219  
 Engine Controls **DR** ..... 1-219  
 Throttle **DR** ..... 1-219  
 ENG CONT Switch **DR** ..... 1-219  
 Fuel System ..... 1-219  
 Fuel Control Panel **DR** ..... 1-219  
 Speedbrake System ..... 1-219  
 SPD BRK Switch **DR** ..... 1-219  
 Drag Chute System ..... 1-219  
 DRAG CHUTE Switch **DR** ..... 1-219  
 Landing Gear (LG) System ..... 1-219  
 DN LOCK REL Button **DR** ..... 1-219  
 Flight Control System ..... 1-219  
 Stick Control Operation ..... 1-219  
 STICK CONTROL Switch **DF** ..... 1-220  
 Stick Indicator **DR** ..... 1-220  
 Stick OVRD Lights **D** ..... 1-220

Escape System **D** ..... 1-220  
 EJECTION MODE SEL Handle **DR** ... 1-220  
 Communications System ..... 1-221  
 INSTR Mode Select Panel **D** ..... 1-221  
 Flight Instruments **DR** ..... 1-221  
 Accelerometer **DR** ..... 1-221  
 Aft Station Interface Unit  
 (ASIU) **DR** **PX III** ..... 1-221  
 STICK CONTROL Switch **DR** **PX III** ... 1-221  
 ASIU Switch **DR** **PX III** ..... 1-222  
 Multifunction Display (MFD) **DR** ..... 1-222  
 Throttle and Stick Switches/Controls  
**DR** ..... 1-222  
 ARMT CONSENT Switch **DR** ..... 1-222  
 Aft Seat HUD Monitor (ASHM) **DR** ..... 1-222  
 Servicing Diagram ..... 1-222

## THE AIRCRAFT

The F-16C is a single-engine, single-seat, multirole tactical fighter with full air-to-air and air-to-surface combat capabilities. The F-16D is a two-seat (tandem) version and performs the secondary role of a trainer. The fuselage is characterized by a large bubble canopy, forebody strakes, and an underfuselage engine air inlet. The wing and tail surfaces are thin and feature moderate aft sweep. The wing has automatic leading edge flaps which enhance performance over a wide speed range. Flaperons are mounted on the trailing edge of the wing and combine the functions of flaps and ailerons. The horizontal tails have a small negative dihedral and provide pitch and roll control through symmetrical/differential deflection. The vertical tail, augmented by twin ventral fins, provides directional stability. All flight control surfaces are actuated hydraulically by two independent hydraulic systems and are directed by signals through a fly-by-wire system.

The fire control system includes a fire control radar with search and tracking capability; two multifunction displays (MFD's) for presentation of navigation, radar, weapons, and other information; and a head-up display (HUD). Upfront controls provide a central control point for fire control, communications, navigation, and IFF functions. A stores management system (SMS) presents a visual display on a selected MFD for inventory, control, and release of all stores. Basic armament includes a fuselage-mounted multibarrel 20 mm gun and an air-to-air missile on each wingtip. Additional stores of various types can be carried on pylons mounted under the wings and on the fuselage.

**AIRCRAFT GENERAL DATA**

Refer to figure 1-1. The aircraft approximate dimensions are:

- Span – including missile fins = 32 feet 10 inches
- Length – including nose probe = 49 feet 5.2 inches
- Height – top of vertical tail = 16 feet 10 inches
- Height – top of canopy = 9 feet 4 inches
- Tread = 7 feet 9 inches
- Wheelbase = 13 feet 2 inches

Refer to TURNING RADIUS AND GROUND CLEARANCE, Section II.

**AIRCRAFT GENERAL ARRANGEMENT**

Refer to figure 1-2 for general arrangement and overall view of the aircraft.

**AIRCRAFT GROSS WEIGHT (A/C GW)**

**☐** The GW of the aircraft including pilot, oil, two tip AIM-120 missiles, and a full load of 20 mm ammunition is approximately 21,000 pounds and with full internal JP-8 fuel 28,200 pounds.

**PX II ☐** The GW of the aircraft including pilot, oil, two tip AIM-120 missiles, and a full load of 20 mm ammunition is approximately 21,600 pounds and with full internal JP-8 fuel 27,500 pounds.

**PX III ☐** The GW of the aircraft including pilot, oil, two tip AIM-120 missiles, and a full load of 20 mm ammunition is approximately 21,900 pounds and with full internal JP-8 fuel 27,800 pounds.

**PX III** CFT's add approximately 900 pounds when empty and hold approximately 3000 pounds of JP-8 fuel.

These GW's are approximate and shall not be used for computing aircraft performance. For maximum GW limitations, refer to Section V, OPERATING LIMITATIONS. For detailed information, refer to T.O. GR1F-16CJ-1-1, Part I.

**COCKPIT ARRANGEMENT**

Refer to figure 1-3. The cockpit is conventional except for the seat, which is reclined 30 degrees, and the stick, which is mounted on the right console. The cockpit contains no circuit breakers.

# General Data

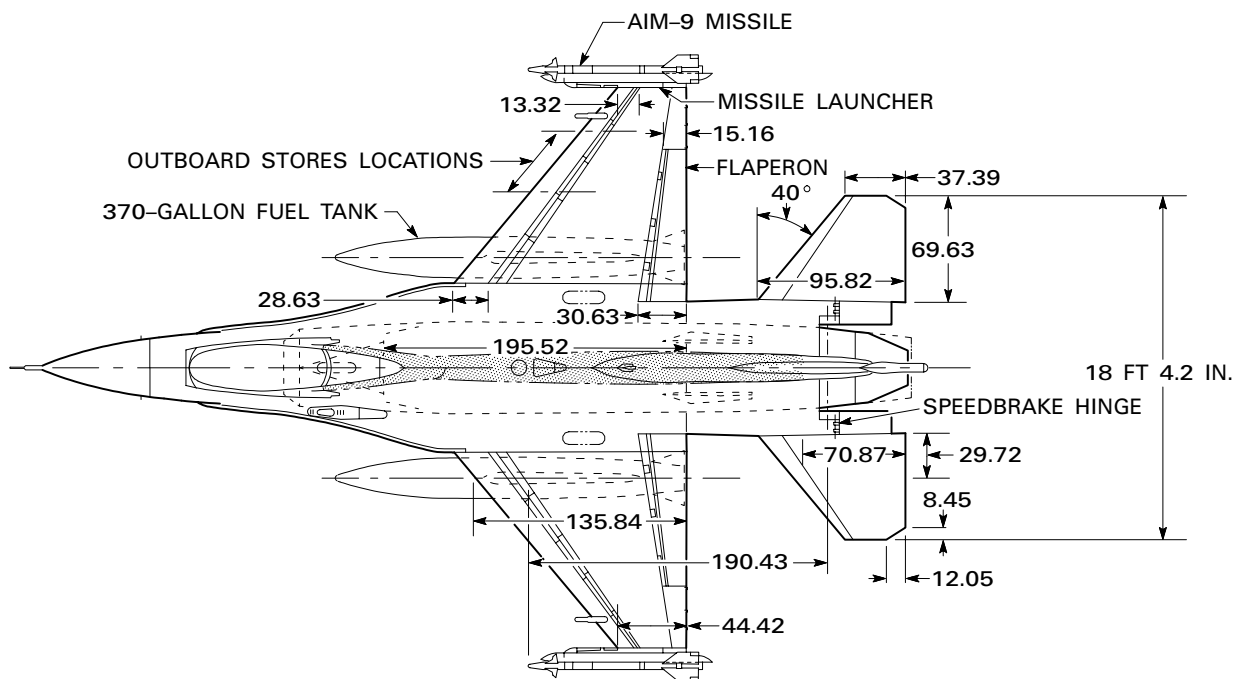

SHADED AREA REPRESENTS **PX III** **D** AIRCRAFT

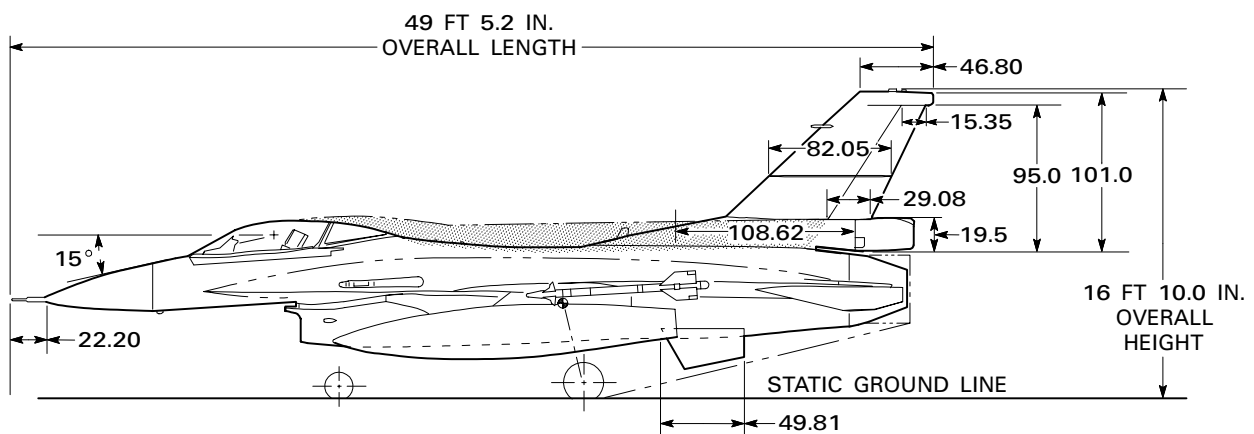

**NOTE:** Dimensions are in inches unless specified otherwise.

Figure 1-1. (Sheet 1)

<b>WINGS</b>		<b>VENTRAL FIN (EACH)</b>	
Area .....	300 Sq Ft	Area .....	8.03 Sq Ft
Span .....	30 Ft	Span .....	23.356 In. Theo (27.5 In. Actual)
Aspect Ratio .....	3.0	Aspect Ratio .....	0.472 (Theo)
Taper Ratio .....	0.2275	Taper Ratio .....	0.760 (Theo)
Sweep (LE) .....	40°	Sweep (LE) .....	30°
Dihedral .....	0°	Dihedral (Cant) .....	15° Outboard
Airfoil .....	NACA 64A204	Airfoil	
Incidence .....	0°	At Root .....	3.886% Modified Wedge
Twist		At Tip .....	Constant 0.03R
At BL 54.0 .....	0°		
At BL 180.0 .....	3°		
Flaperon Area .....	31.32 Sq Ft	<b>SPEEDBRAKES</b>	
LEF Area .....	36.71 Sq Ft	Area (4 Element Clamshell) ..	14.26 Sq Ft (3.565 Sq Ft Ea)
		<b>LANDING GEAR (LG)</b>	
<b>HORIZONTAL TAILS</b>		Main Gear (MLG)	
Area .....	63.70 Sq Ft	Tire Size .....	27.75 x 8.75-14.5 24 Ply
Aspect Ratio .....	2.114	Stroke .....	10.5 In.
Taper Ratio .....	0.390 (Theo)	Static Rolling Radius .....	11.9 In.
Sweep (LE) .....	40°	Nose Gear (NLG)	
Dihedral .....	-10°	Tire Size .....	17.9 x 6.7R8 22 Ply
Airfoil		Stroke .....	10.0 In.
At Root .....	6% Biconvex	Static Rolling Radius .....	7.5 In.
At Tip .....	3.5% Biconvex		
		<b>ENGINE</b>	
<b>VERTICAL TAIL</b>		F100-PW-229	
Area .....	54.75 Sq Ft	Thrust .....	29,000 Lb Class
Aspect Ratio .....	1.294	Engine Compressor	
Taper Ratio .....	0.437	Face Diameter .....	34.8 In.
Sweep (LE) .....	47.5°	Engine Length .....	208 In.
Airfoil		F110-GE-129	
At Root .....	5.3% Biconvex	Thrust .....	29,500 Lb Class
At Tip .....	3.0% Biconvex	Engine Compressor	
Rudder Area .....	11.65 Sq Ft	Face Diameter .....	35.8 In.
		Engine Length .....	183.76 In.

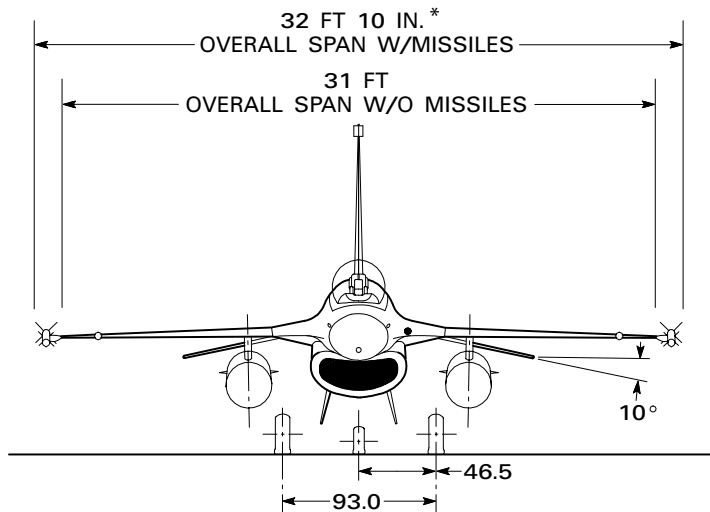

\* Add 3 inches for AIM-120 missiles

GR1F-16CJ-1-0004-2A37 ©

Figure 1-1. (Sheet 2)

# General Arrangement (Typical)

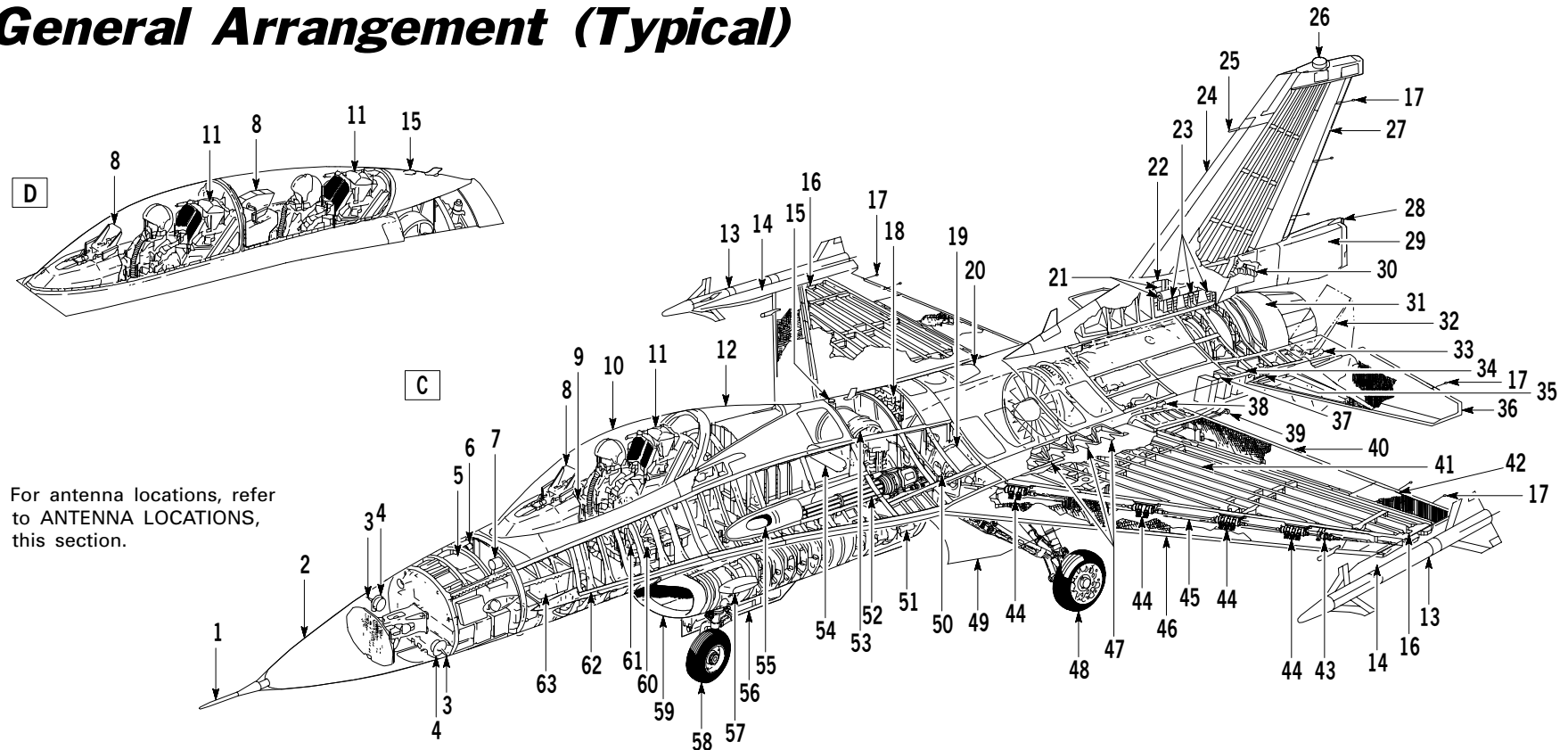

For antenna locations, refer to ANTENNA LOCATIONS, this section.

- |                                     |   |                               |                                 |
|-------------------------------------|---|-------------------------------|---------------------------------|
| 1. Air Data (Pitot) Probe           | 17. Static Discharger                       | 33. Speedbrake Actuator       | 49. MLG Door                    |
| 2. Nose Radome                      | 18. LEF Drive Unit                          | 34. Chaff/Flare Dispenser     | 50. LEF Angle Drive Gearbox     |
| 3. AOA Probe                        | 19. Hydraulic Reservoir                     | 35. Horizontal Tail ISA       | 51. Air-Conditioning Package    |
| 4. AOA Transmitter                  | 20. AR Slipway                              | 36. Horizontal Tail           | 52. M61A1 20MM Gun              |
| 5. Forward Electronic Equipment Bay | 21. FLCS Accumulators                       | 37. Formation Light           | 53. Ammunition Drum             |
| 6. Cockpit Pressure Regulator       | 22. Anticollision Strobe Light Power Supply | 38. Flaperon ISA              | 54. EPU Nitrogen Bottle         |
| 7. Cockpit Pressure Safety Valve    | 23. Vertical Tail Attachment Fittings       | 39. Hook                      | 55. Gun Port                    |
| 8. HUD/ASHM                         | 24. Vertical Tail                           | 40. Flaperon                  | 56. NLG Door                    |
| 9. Instrument Panel                 | 25. Vertical Tail-Mounted Floodlight        | 41. Wing Structural Box       | 57. Position Light              |
| 10. Canopy (Movable)                | 26. Anticollision Strobe Light              | 42. Fixed Trailing Edge Panel | 58. NLG                         |
| 11. Ejection Seat                   | 27. Rudder                                  | 43. Asymmetry Brake           | 59. Engine Air Inlet            |
| 12. Canopy (Fixed)                  | 28. Position Light                          | 44. LEF Rotary Actuator       | 60. Left Console                |
| 13. AIM-9 Missile                   | 29. Drag Chute Fairing                      | 45. LEF Torque Shaft          | 61. Throttle                    |
| 14. Missile Launcher                | 30. Rudder ISA                              | 46. LEF                       | 62. Strake                      |
| 15. AR and Formation Light          | 31. Turbofan Engine                         | 47. Wing Attachment Fittings  | 63. Lower Equipment Compartment |
| 16. Position/Formation Light        | 32. Speedbrake                              | 48. MLG                       |                                 |

GR1F-16CJ-1-0005X37 ©

Figure 1-2.

# Cockpit Arrangement **C** **DF** (Typical) **PX II**

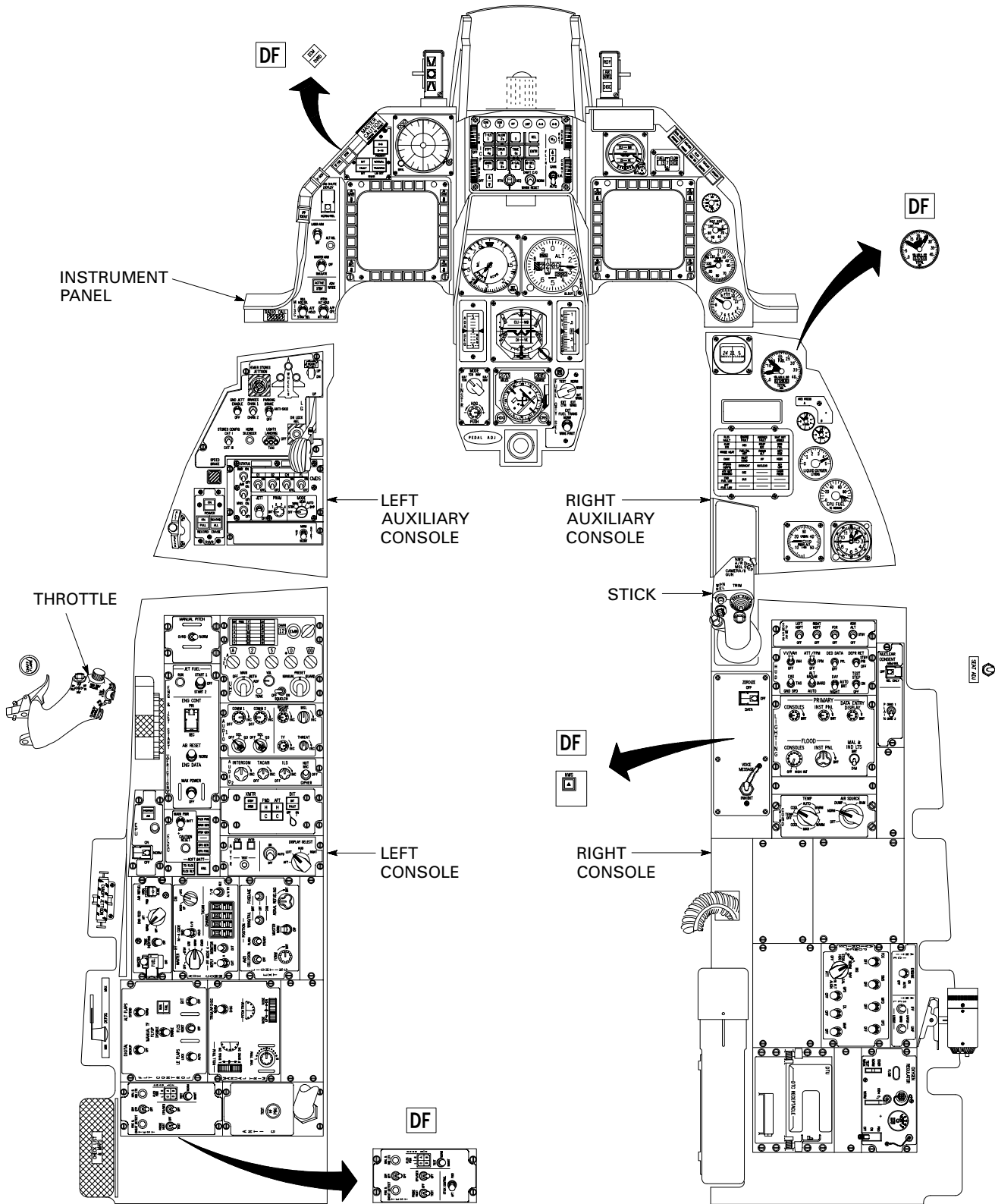

GR1F-16CJ-1-0006A37 ©

Figure 1-3. (Sheet 1)



# Cockpit Arrangement C DF (Typical) PX II

## LEFT CONSOLE

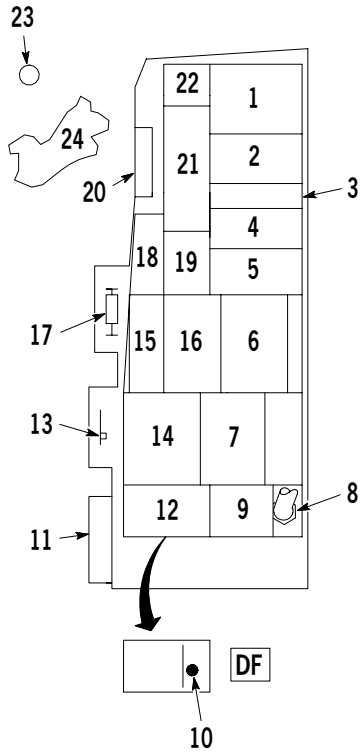

1. UHF Backup Control Panel
2. AUDIO 1 Control Panel
3. AUDIO 2 Control Panel
4. ECM Control Panel
5. AVTR Control Panel
6. EXT LIGHTING Control Panel
7. MANUAL TRIM Panel
8. G-Suit Hose Connection
9. ANTI G TEST Button
10. **DF** STICK CONTROL Switch
11. Stowage
12. TEST Switch Panel
13. DEFOG Lever
14. FLT CONTROL Panel
15. Fuel Control Panel
16. AUX COMM Panel
17. CANOPY JETTISON T-Handle
18. EPU Control Panel
19. ELEC Control Panel
20. Throttle FRICTION Control
21. ENG & JET START Control Panel
22. MANUAL PITCH Override Switch
23. CHAFF/FLARE Dispense Button
24. Throttle

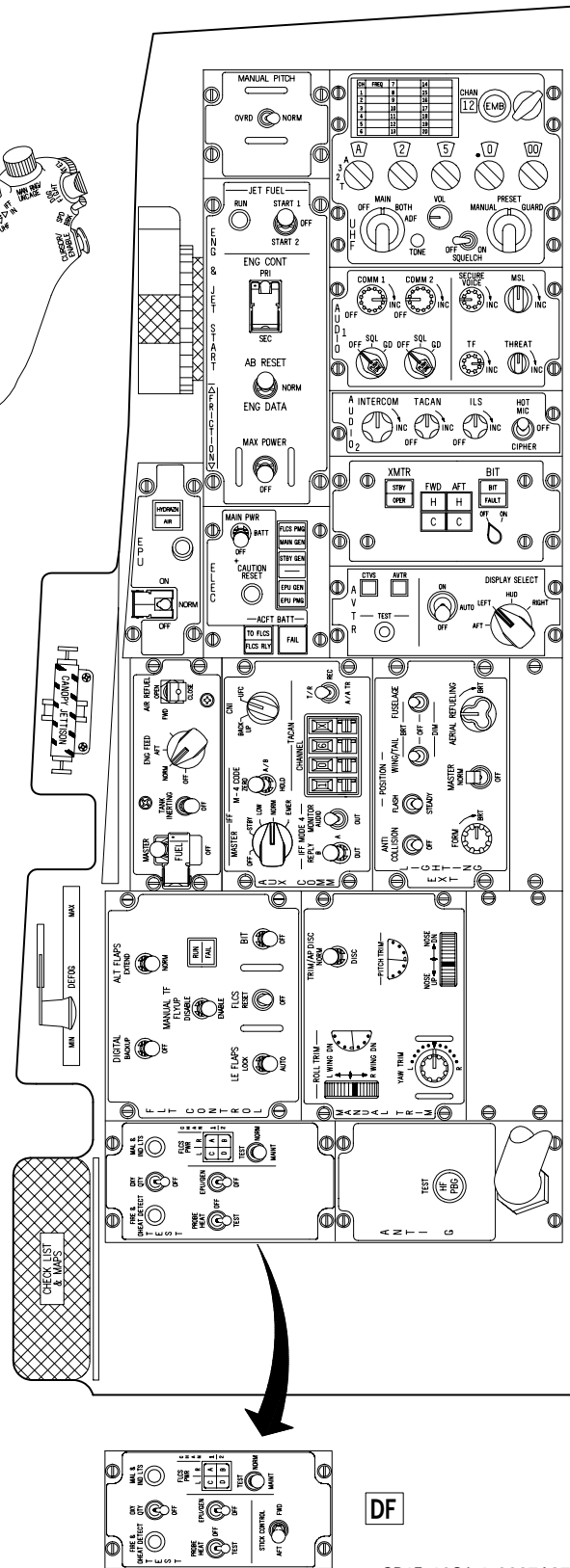
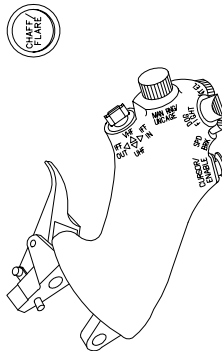

GR1F-16CJ-1-0007A37 ©

Figure 1-3. (Sheet 2)

# Cockpit Arrangement

**C DF (Typical) PX II**

## LEFT AUXILIARY CONSOLE

## RIGHT AUXILIARY CONSOLE

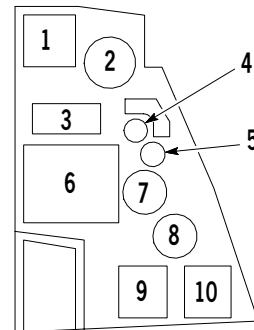
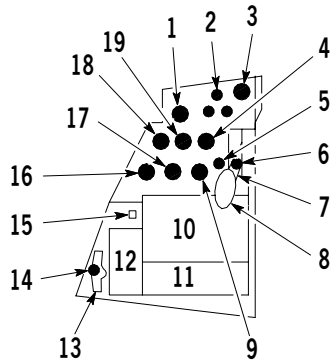
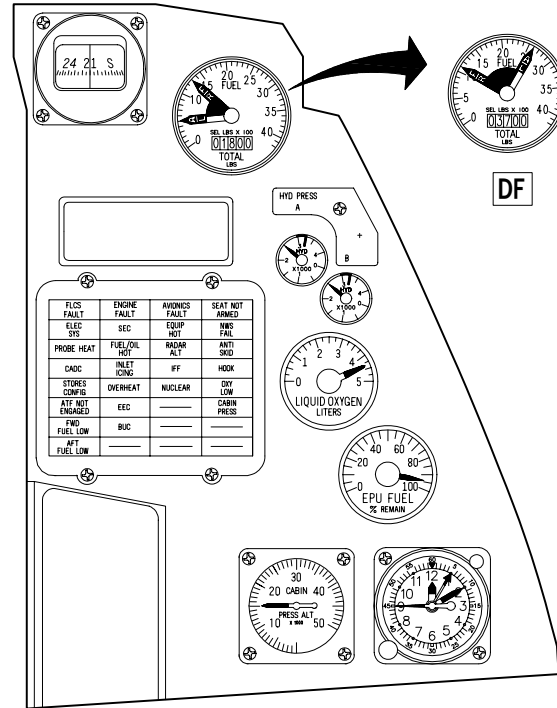
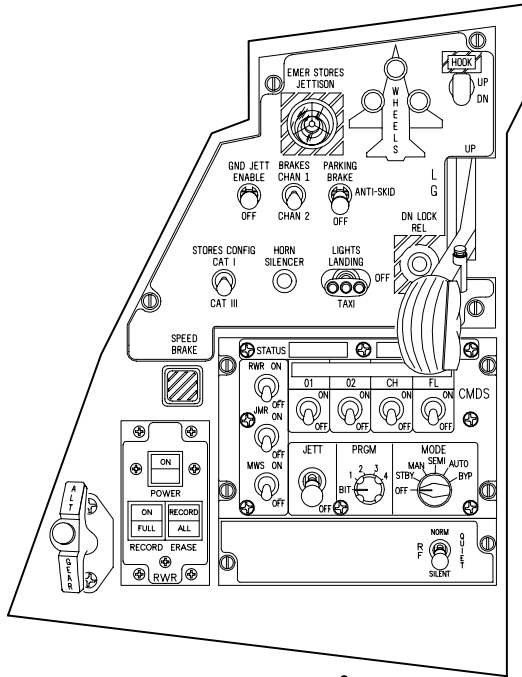

1. EMER STORES JETTISON Button (Covered)
2. WHEELS Down Lights (Green)
3. HOOK Switch (Lever Lock)
4. ANTI-SKID Switch
5. DN LOCK REL Button
6. LG Handle Down Permission Button
7. LG Handle
8. LG Handle Warning Light (Red)
9. LANDING TAXI LIGHTS Switch
10. CMDS Control Panel
11. RF Transmit Panel
12. RWR Aux Control Panel
13. ALT GEAR Handle
14. ALT GEAR Reset Button
15. SPEED BRAKE Position Indicator
16. STORES CONFIG Switch
17. HORN SILENCER Button
18. GND JETT ENABLE Switch (Lever Lock)
19. BRAKES Channel Switch

1. Magnetic Compass
2. FUEL Quantity Indicator
3. Pilot Fault List Display
4. System A HYD PRESS Indicator
5. System B HYD PRESS Indicator
6. Caution Light Panel
7. LIQUID OXYGEN Quantity Indicator
8. EPU FUEL Quantity Indicator
9. Cockpit Pressure Altimeter
10. Clock

Figure 1-3. (Sheet 3)

# Cockpit Arrangement C DF (Typical) PX II

## INSTRUMENT PANEL

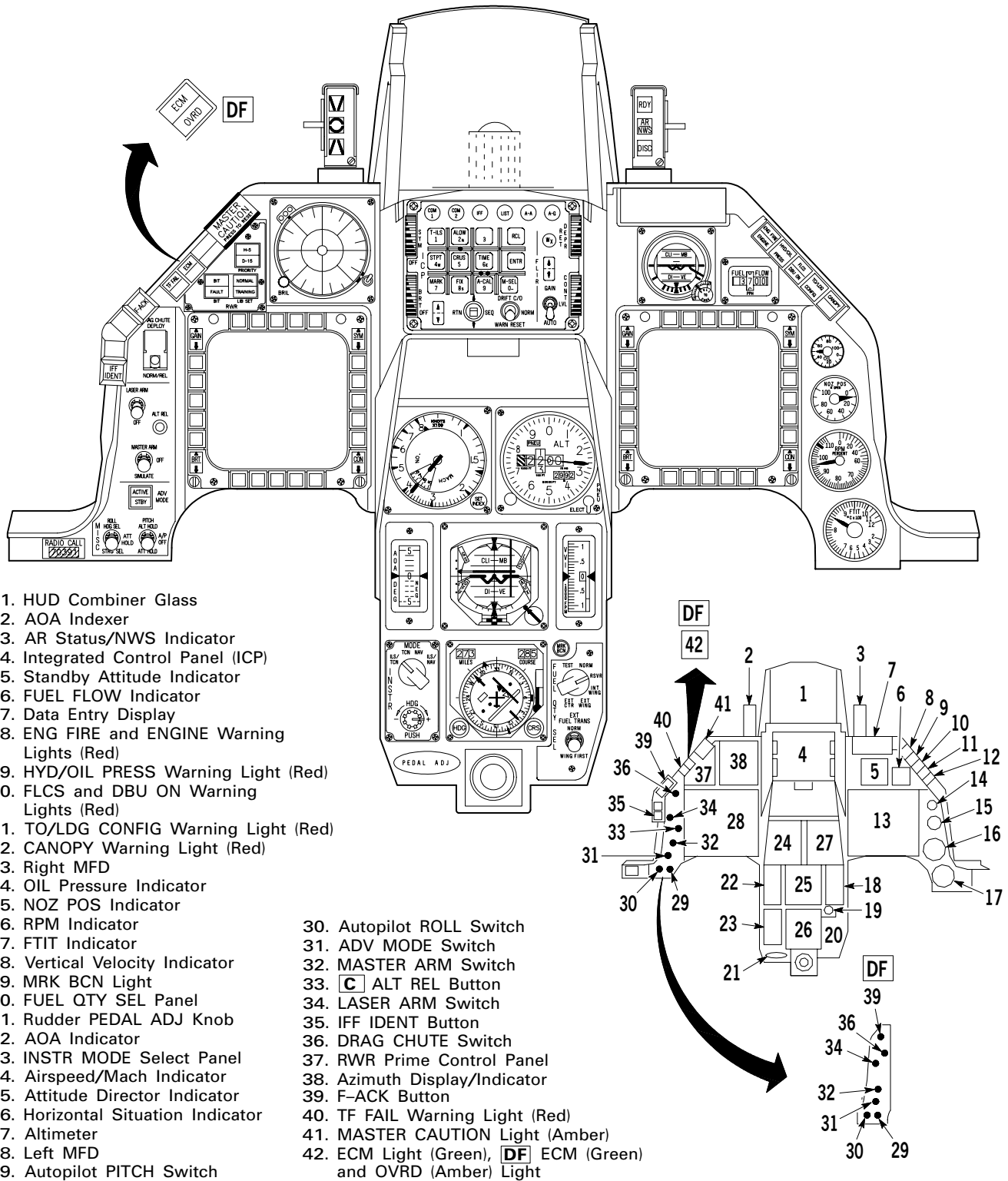

1. HUD Combiner Glass
2. AOA Indexer
3. AR Status/NWS Indicator
4. Integrated Control Panel (ICP)
5. Standby Attitude Indicator
6. FUEL FLOW Indicator
7. Data Entry Display
8. ENG FIRE and ENGINE Warning Lights (Red)
9. HYD/OIL PRESS Warning Light (Red)
10. FLCS and DBU ON Warning Lights (Red)
11. TO/LDG CONFIG Warning Light (Red)
12. CANOPY Warning Light (Red)
13. Right MFD
14. OIL Pressure Indicator
15. NOZ POS Indicator
16. RPM Indicator
17. FTIT Indicator
18. Vertical Velocity Indicator
19. MRK BCN Light
20. FUEL QTY SEL Panel
21. Rudder PEDAL ADJ Knob
22. AOA Indicator
23. INSTR MODE Select Panel
24. Airspeed/Mach Indicator
25. Attitude Director Indicator
26. Horizontal Situation Indicator
27. Altimeter
28. Left MFD
29. Autopilot PITCH Switch
30. Autopilot ROLL Switch
31. ADV MODE Switch
32. MASTER ARM Switch
33. ALT REL Button
34. LASER ARM Switch
35. IFF IDENT Button
36. DRAG CHUTE Switch
37. RWR Prime Control Panel
38. Azimuth Display/Indicator
39. F-ACK Button
40. TF FAIL Warning Light (Red)
41. MASTER CAUTION Light (Amber)
42. ECM Light (Green), DF ECM (Green) and OVRD (Amber) Light

GR1F-16CJ-1-0009A37 ©

Figure 1-3. (Sheet 4)

# Cockpit Arrangement C DF (Typical) PX II

## RIGHT CONSOLE

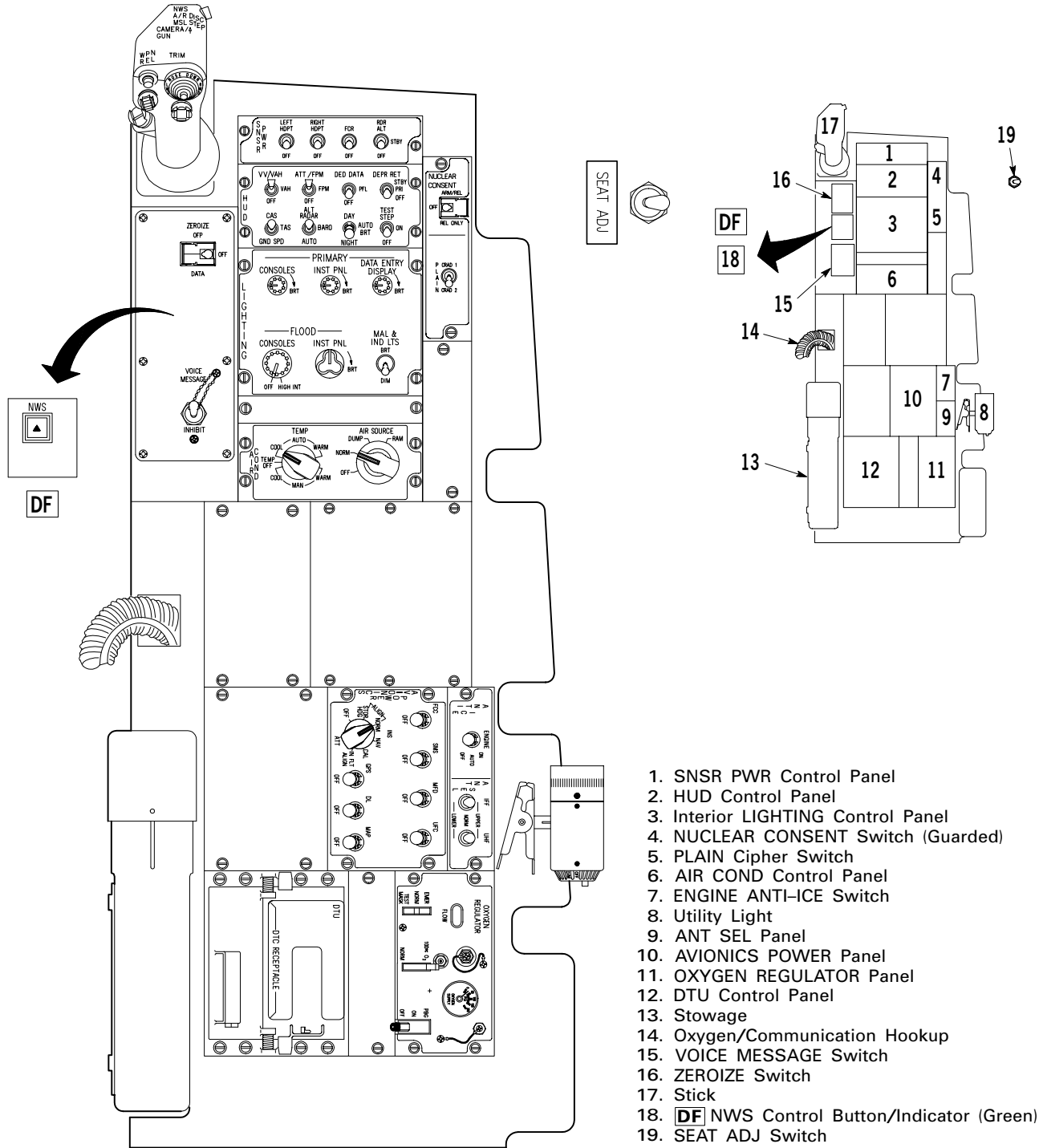

1. SNSR PWR Control Panel
2. HUD Control Panel
3. Interior LIGHTING Control Panel
4. NUCLEAR CONSENT Switch (Guarded)
5. PLAIN Cipher Switch
6. AIR COND Control Panel
7. ENGINE ANTI-ICE Switch
8. Utility Light
9. ANT SEL Panel
10. AVIONICS POWER Panel
11. OXYGEN REGULATOR Panel
12. DTU Control Panel
13. Stowage
14. Oxygen/Communication Hookup
15. VOICE MESSAGE Switch
16. ZEROIZE Switch
17. Stick
18. DF NWS Control Button/Indicator (Green)
19. SEAT ADJ Switch

Figure 1-3. (Sheet 5)

# Cockpit Arrangement DR (Typical) PX II

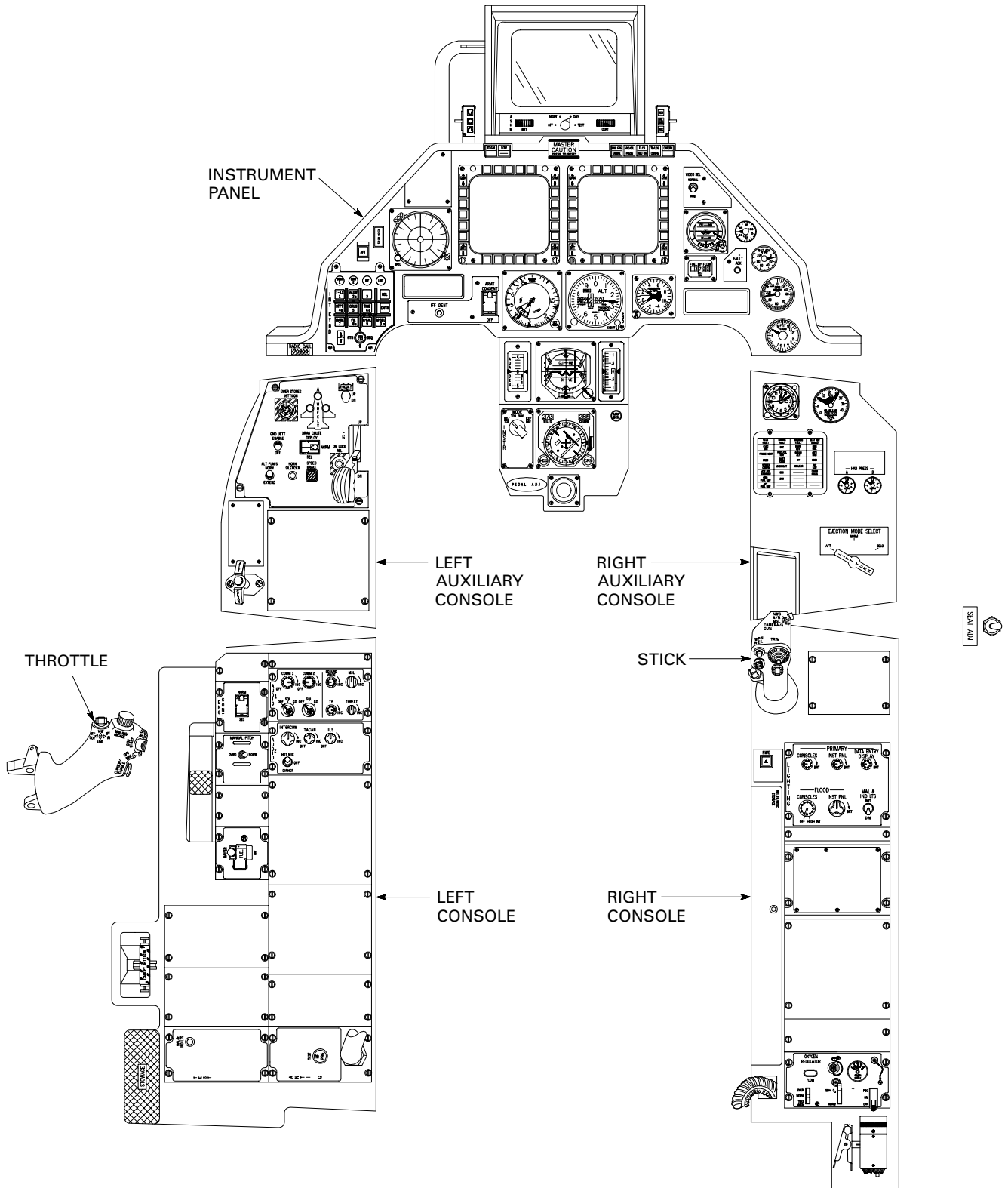

GR1F-16CJ-1-0011A37 ©

Figure 1-3. (Sheet 6)

# Cockpit Arrangement DR (Typical) PX II

## LEFT CONSOLE

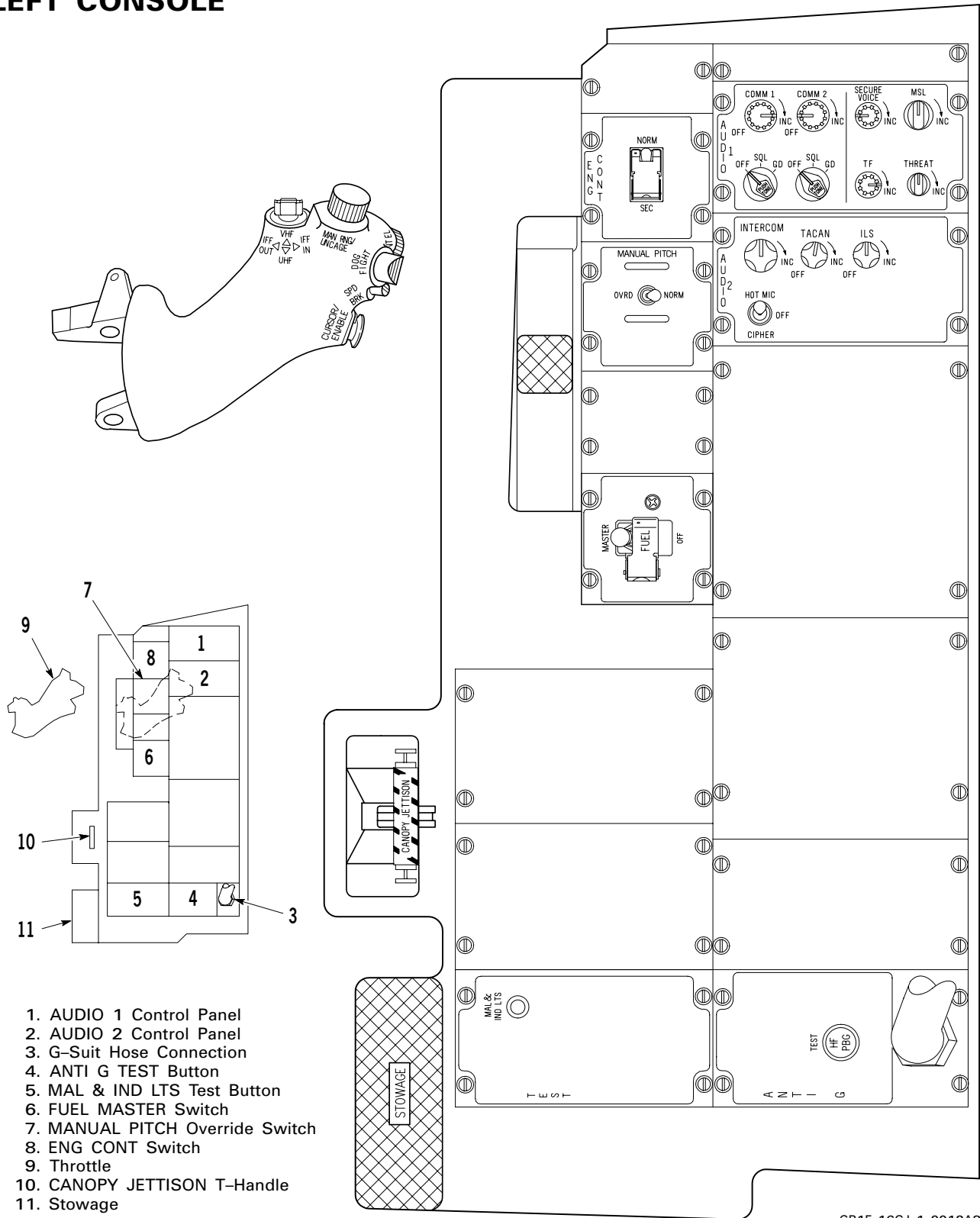

1. AUDIO 1 Control Panel
2. AUDIO 2 Control Panel
3. G-Suit Hose Connection
4. ANTI G TEST Button
5. MAL & IND LTS Test Button
6. FUEL MASTER Switch
7. MANUAL PITCH Override Switch
8. ENG CONT Switch
9. Throttle
10. CANOPY JETTISON T-Handle
11. Stowage

GR1F-16CJ-1-0012A37 ©

Figure 1-3. (Sheet 7)

# Cockpit Arrangement DR (Typical) PX II

## LEFT AUXILIARY CONSOLE

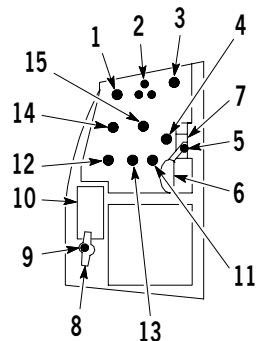
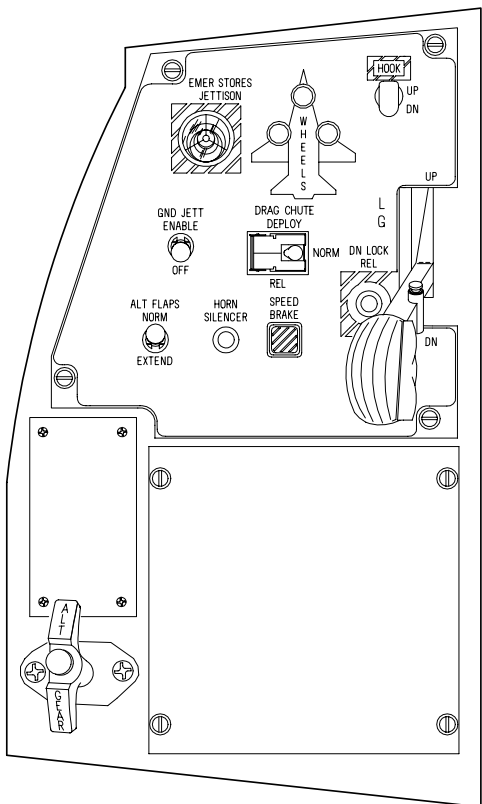

1. EMER STORES JETTISON Button (Covered)
2. WHEELS Down Lights (Green)
3. HOOK Switch (Lever Lock)
4. DN LOCK REL Button
5. LG Handle Down Permission Button
6. LG Handle Warning Light (Red)
7. LG Handle
8. ALT GEAR Handle
9. ALT GEAR Reset Button
10. Blank Panel
11. SPEED BRAKE Position Indicator
12. ALT FLAPS Switch (Lever Lock)
13. HORN SILENCER Button
14. GND JETT ENABLE Switch (Lever Lock)
15. DRAG CHUTE Switch

## RIGHT AUXILIARY CONSOLE

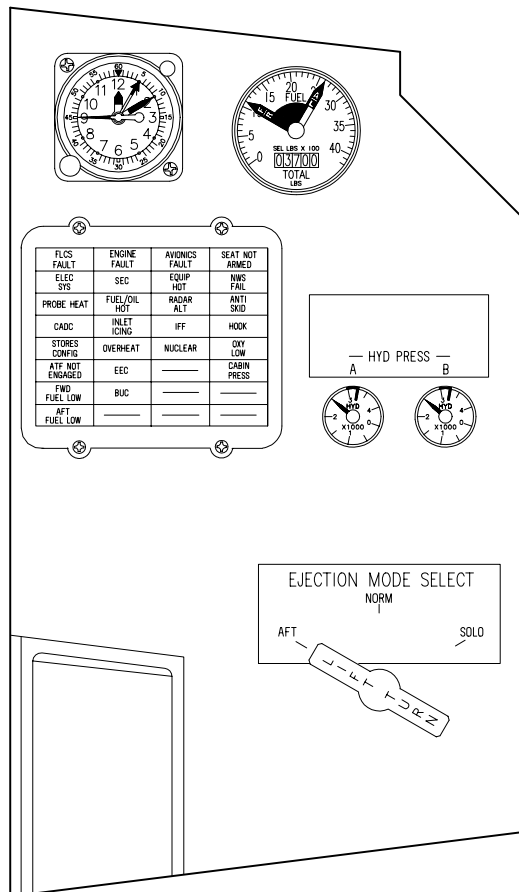

FLCS FAULT	ENGINE FAULT	AVIONICS FAULT	SEAT NOT ARMED
ELEC SYS	SEC	EQUIP HOT	WING FAIL
PROBE HEAT	FUEL/OIL HOT	RADAR ALT	ANTI SKID
CADC	INLET ICING	IFF	HOOK
STORES CORES	OVERHEAT	NUCLEAR	DRY LOW
ATF NOT ENGAGED	EEC		CABIN PRESS
FWD FUEL LOW	BUC		
AFT FUEL LOW			

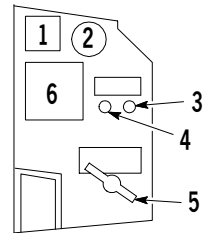

1. Clock
2. FUEL Quantity Indicator
3. System B HYD PRESS Indicator
4. System A HYD PRESS Indicator
5. EJECTION MODE SELECT Handle
6. Caution Light Panel

Figure 1-3. (Sheet 8)

# Cockpit Arrangement DR (Typical) PX II

## INSTRUMENT PANEL

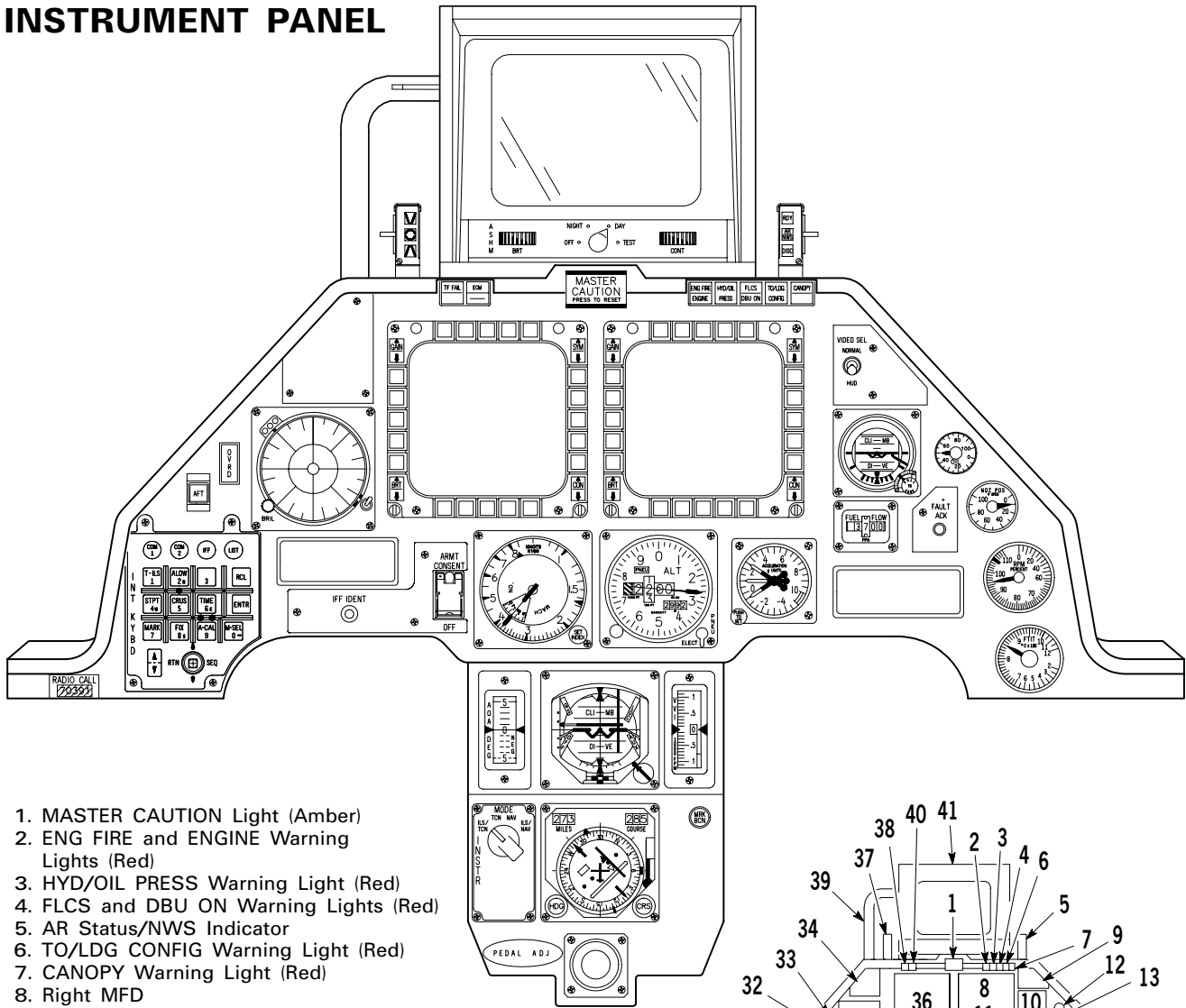

1. MASTER CAUTION Light (Amber)
2. ENG FIRE and ENGINE Warning Lights (Red)
3. HYD/OIL PRESS Warning Light (Red)
4. FLCS and DBU ON Warning Lights (Red)
5. AR Status/NWS Indicator
6. TO/LDG CONFIG Warning Light (Red)
7. CANOPY Warning Light (Red)
8. Right MFD
9. VIDEO SEL Switch
10. Standby Attitude Indicator
11. FUEL FLOW Indicator
12. OIL Pressure Indicator
13. FAULT ACK Button
14. NOZ POS Indicator
15. RPM Indicator
16. FTIT Indicator
17. Pilot Fault List Display
18. Accelerometer
19. Altimeter
20. Vertical Velocity Indicator
21. Attitude Director Indicator
22. MRK BCN Light
23. Rudder PEDAL ADJ Knob
24. INSTR MODE Select Panel
25. AOA Indicator
26. Airspeed/Mach Indicator
27. ARMT CONSENT Switch (Guarded)

29. IFF IDENT Button
30. Data Entry Display
31. Integrated Keyboard Panel (IKP)
32. Stick Indicator
33. OVRD Light (Amber)
34. Blank
35. Azimuth Display/Indicator
36. Left MFD
37. AOA Indexer
38. TF FAIL Warning Light (Red)
39. Handgrip
40. ECM Light (Green)
41. Aft Seat HUD Monitor

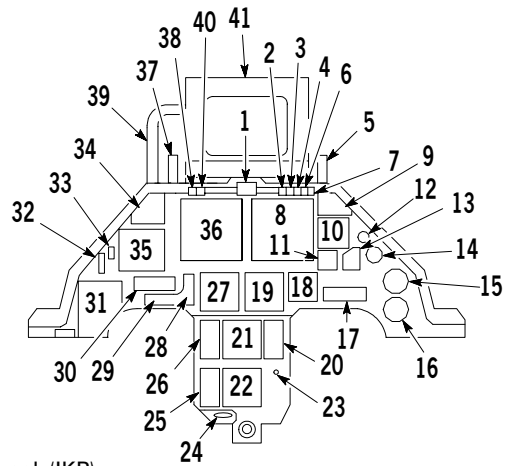

GR1F-16CJ-1-0014A37®

Figure 1-3. (Sheet 9)



# Cockpit Arrangement DR (Typical) PX II

## RIGHT CONSOLE

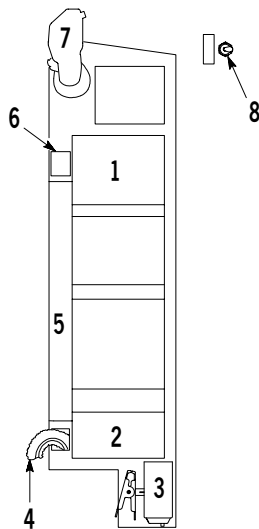

1. Interior LIGHTING Control Panel
2. OXYGEN REGULATOR Panel
3. Utility Light
4. Oxygen/Communications Hookup
5. Stowage
6. NWS Control Button/Indicator (Green)
7. Stick
8. SEAT ADJ Switch

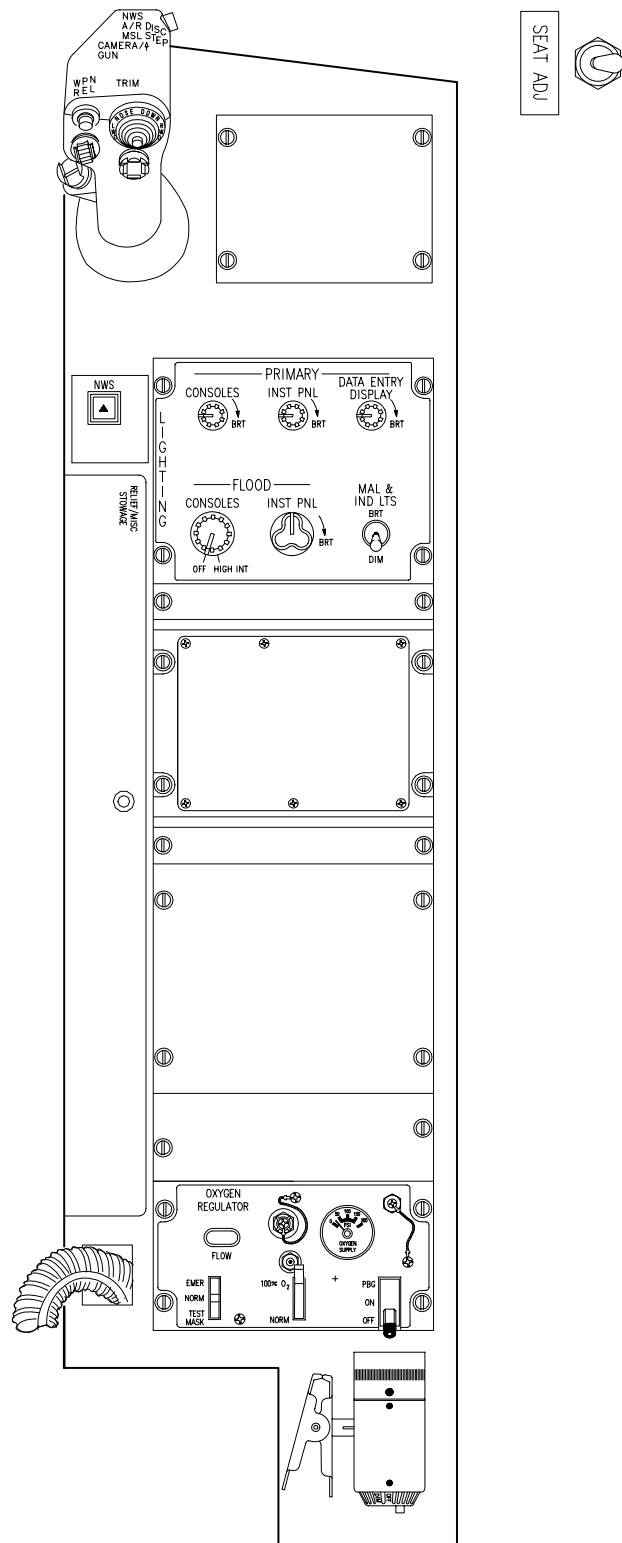

GR1F-16CJ-1-0015A37 ©

Figure 1-3. (Sheet 10)

# Cockpit Arrangement C DF (Typical) PX III

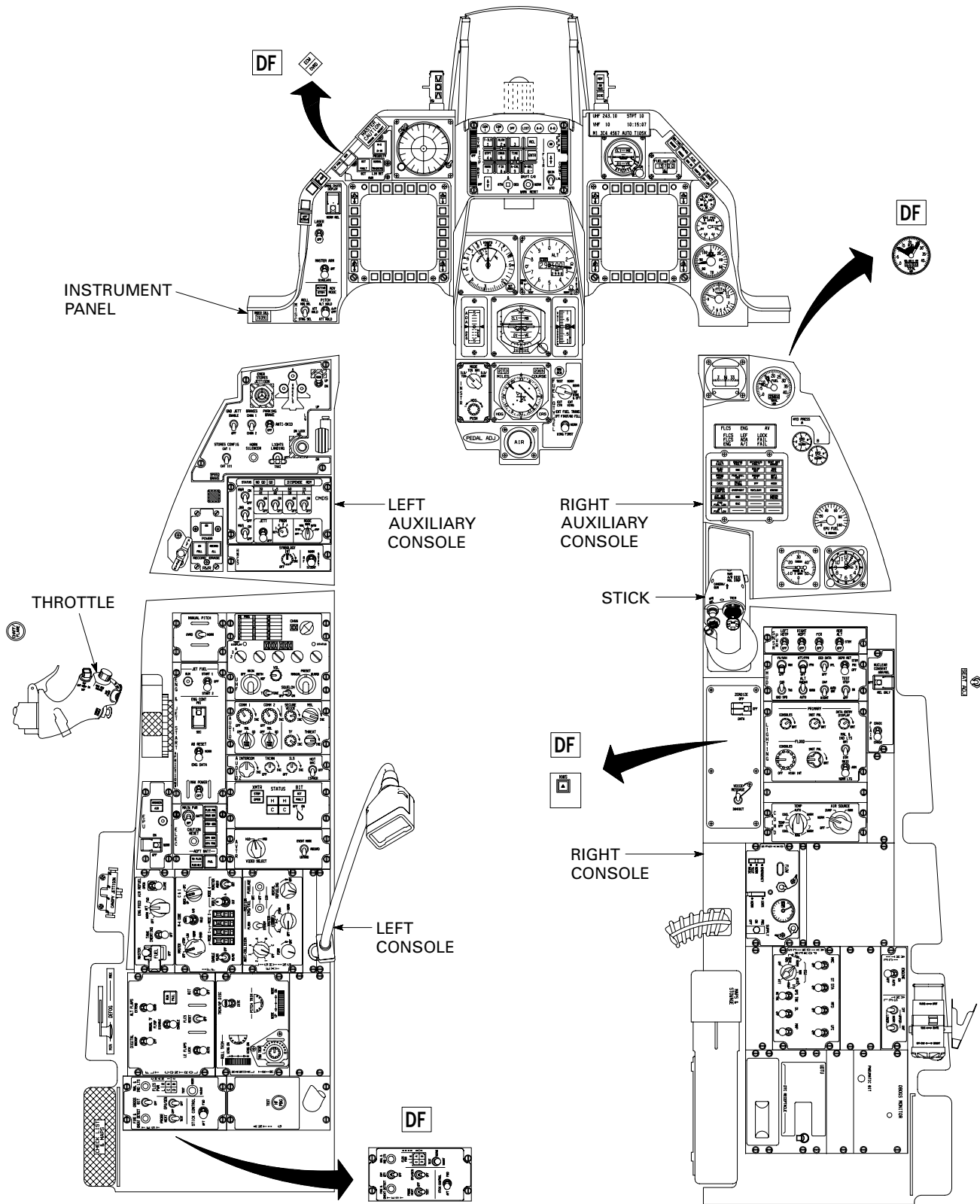

GR1F-16CJ-1-1006X37 ©

Figure 1-3. (Sheet 11)

# Cockpit Arrangement **C** **DF** (Typical) **PX III**

## LEFT CONSOLE

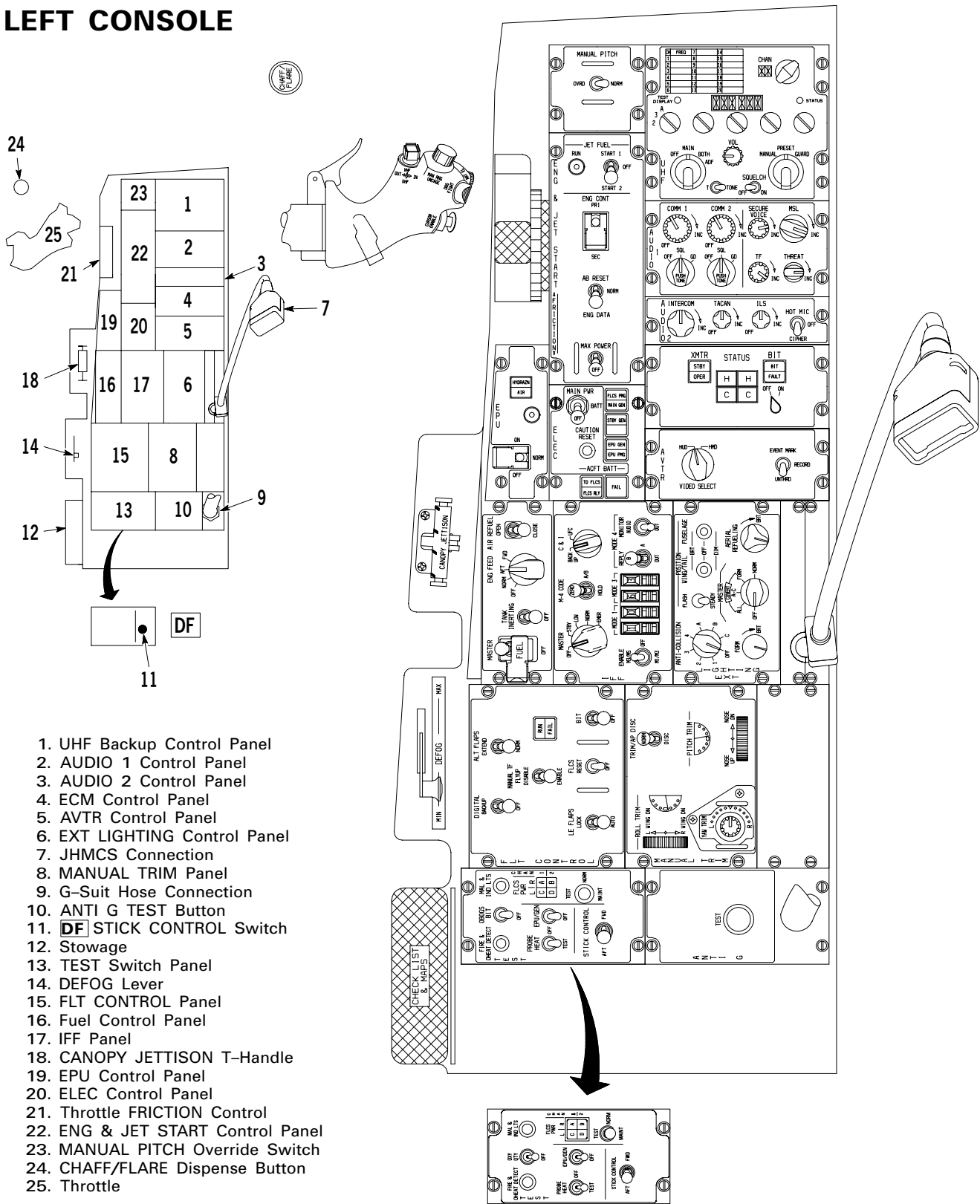

1. UHF Backup Control Panel
2. AUDIO 1 Control Panel
3. AUDIO 2 Control Panel
4. ECM Control Panel
5. AVTR Control Panel
6. EXT LIGHTING Control Panel
7. JHMCS Connection
8. MANUAL TRIM Panel
9. G-Suit Hose Connection
10. ANTI G TEST Button
11. **DF** STICK CONTROL Switch
12. Stowage
13. TEST Switch Panel
14. DEFOG Lever
15. FLT CONTROL Panel
16. Fuel Control Panel
17. IFF Panel
18. CANOPY JETTISON T-Handle
19. EPU Control Panel
20. ELEC Control Panel
21. Throttle FRICTION Control
22. ENG & JET START Control Panel
23. MANUAL PITCH Override Switch
24. CHAFF/FLARE Dispense Button
25. Throttle

GR1F-16CJ-1-1007X37 ©

Figure 1-3. (Sheet 12)

# Cockpit Arrangement C DF (Typical) PX III

## LEFT AUXILIARY CONSOLE

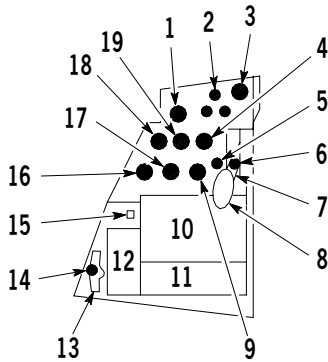
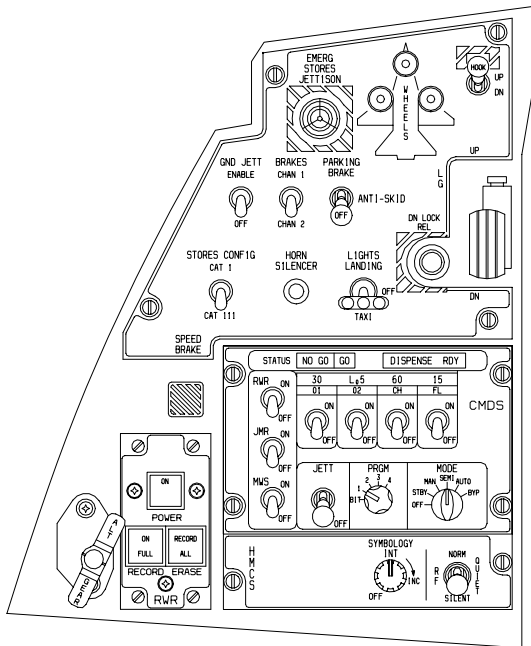

1. EMER STORES JETTISON Button (Covered)
2. WHEELS Down Lights (Green)
3. HOOK Switch (Lever Lock)
4. ANTI-SKID Switch
5. DN LOCK REL Button
6. LG Handle Down Permission Button
7. LG Handle
8. LG Handle Warning Light (Red)
9. LANDING TAXI LIGHTS Switch
10. CMDS Control Panel
11. HMCS Panel
12. RWR Aux Control Panel
13. ALT GEAR Handle
14. ALT GEAR Reset Button
15. SPEED BRAKE Position Indicator
16. STORES CONFIG Switch
17. HORN SILENCER Button
18. GND JETT ENABLE Switch (Lever Lock)
19. BRAKES Channel Switch

## RIGHT AUXILIARY CONSOLE

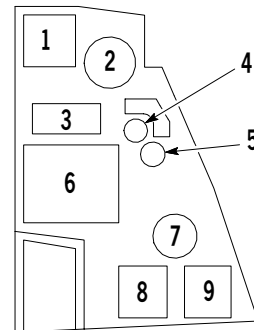
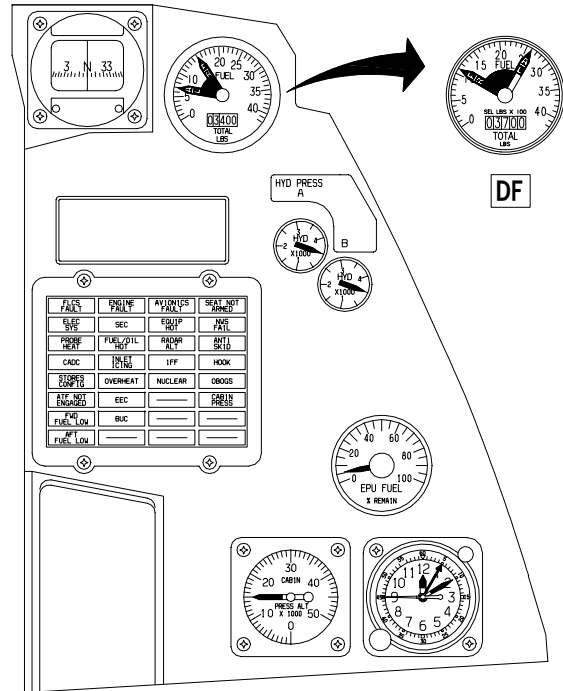

1. Magnetic Compass
2. FUEL Quantity Indicator
3. Pilot Fault List Display
4. System A HYD PRESS Indicator
5. System B HYD PRESS Indicator
6. Caution Light Panel
7. EPU FUEL Quantity Indicator
8. Cockpit Pressure Altimeter
9. Clock

Figure 1-3. (Sheet 13)

# Cockpit Arrangement C DF (Typical) PX III

## INSTRUMENT PANEL

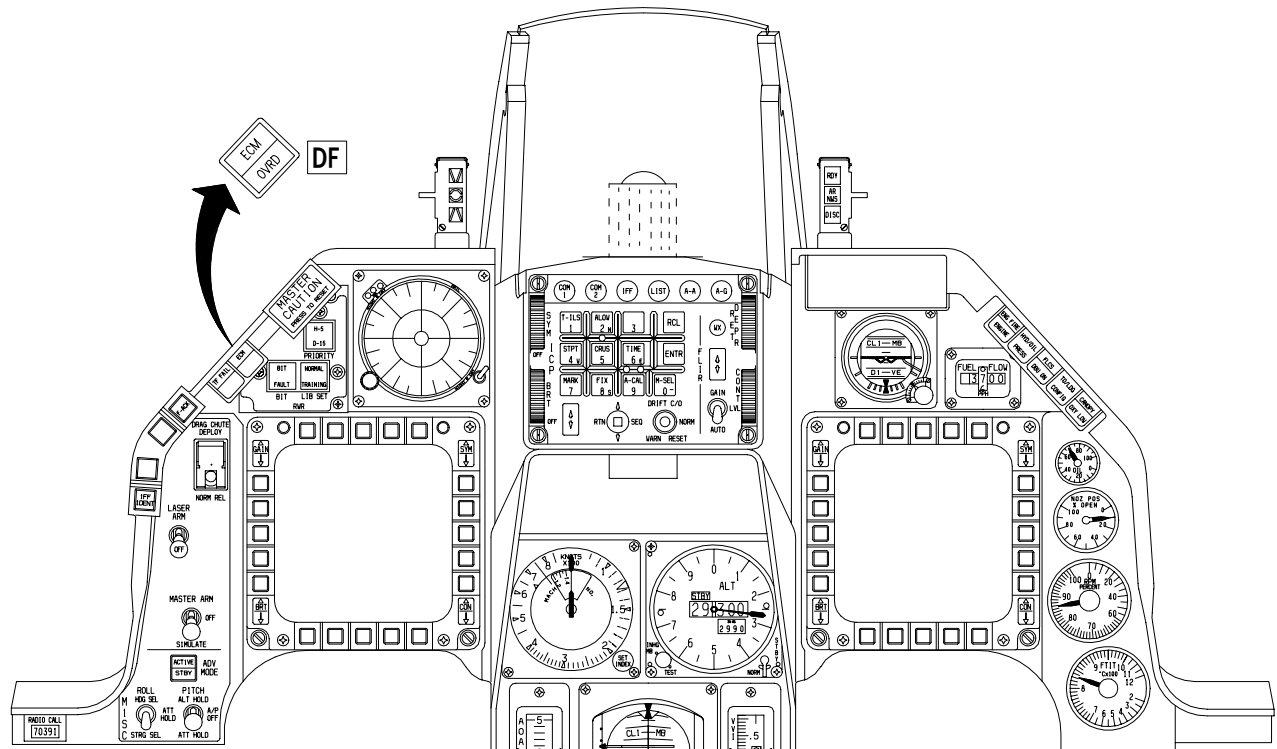

1. HUD Combiner Glass
2. AOA Indexer
3. AR Status/NWS Indicator
4. Integrated Control Panel (ICP)
5. Standby Attitude Indicator
6. FUEL FLOW Indicator
7. Data Entry Display
8. ENG FIRE and ENGINE Warning Lights (Red)
9. HYD/OIL PRESS Warning Light (Red)
10. FLCS and DBU ON Warning Lights (Red)
11. TO/LDG CONFIG Warning Light (Red)
12. CANOPY and OXY LOW Warning Lights (Red)
13. Right MFD
14. OIL Pressure Indicator
15. NOZ POS Indicator
16. RPM Indicator
17. FTIT Indicator
18. Vertical Velocity Indicator
19. MRK BCN Light
20. FUEL QTY SEL Panel
21. Rudder PEDAL ADJ Knob
22. AOA Indicator
23. INSTR MODE Select Panel
24. Airspeed/Mach Indicator
25. Attitude Director Indicator
26. Horizontal Situation Indicator
27. Altimeter
28. Left MFD
29. Autopilot PITCH Switch

30. Autopilot ROLL Switch
31. ADV MODE Switch
32. MASTER ARM Switch
33. LASER ARM Switch
34. IFF IDENT Button
35. DRAG CHUTE Switch
36. RWR Prime Control Panel
37. Azimuth Display/Indicator
38. F-ACK Button
39. TF FAIL Warning Light (Red)
40. MASTER CAUTION Light (Amber)
41. ECM Light (Green), DF ECM (Green) and OVRD (Amber) Light

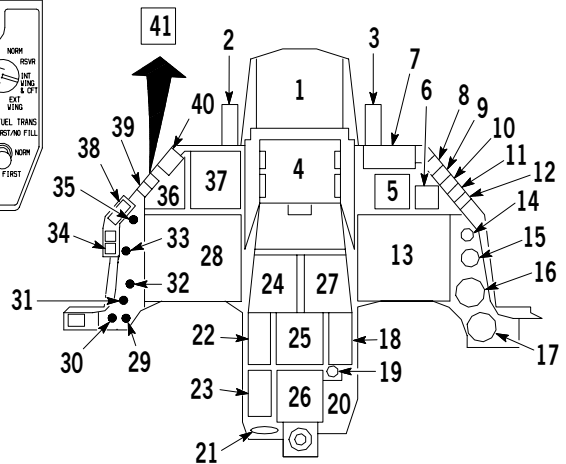

GR1F-16CJ-1-1009X37 ©

Figure 1-3. (Sheet 14)

# Cockpit Arrangement **C** **DF** (Typical) **PX III**

## RIGHT CONSOLE

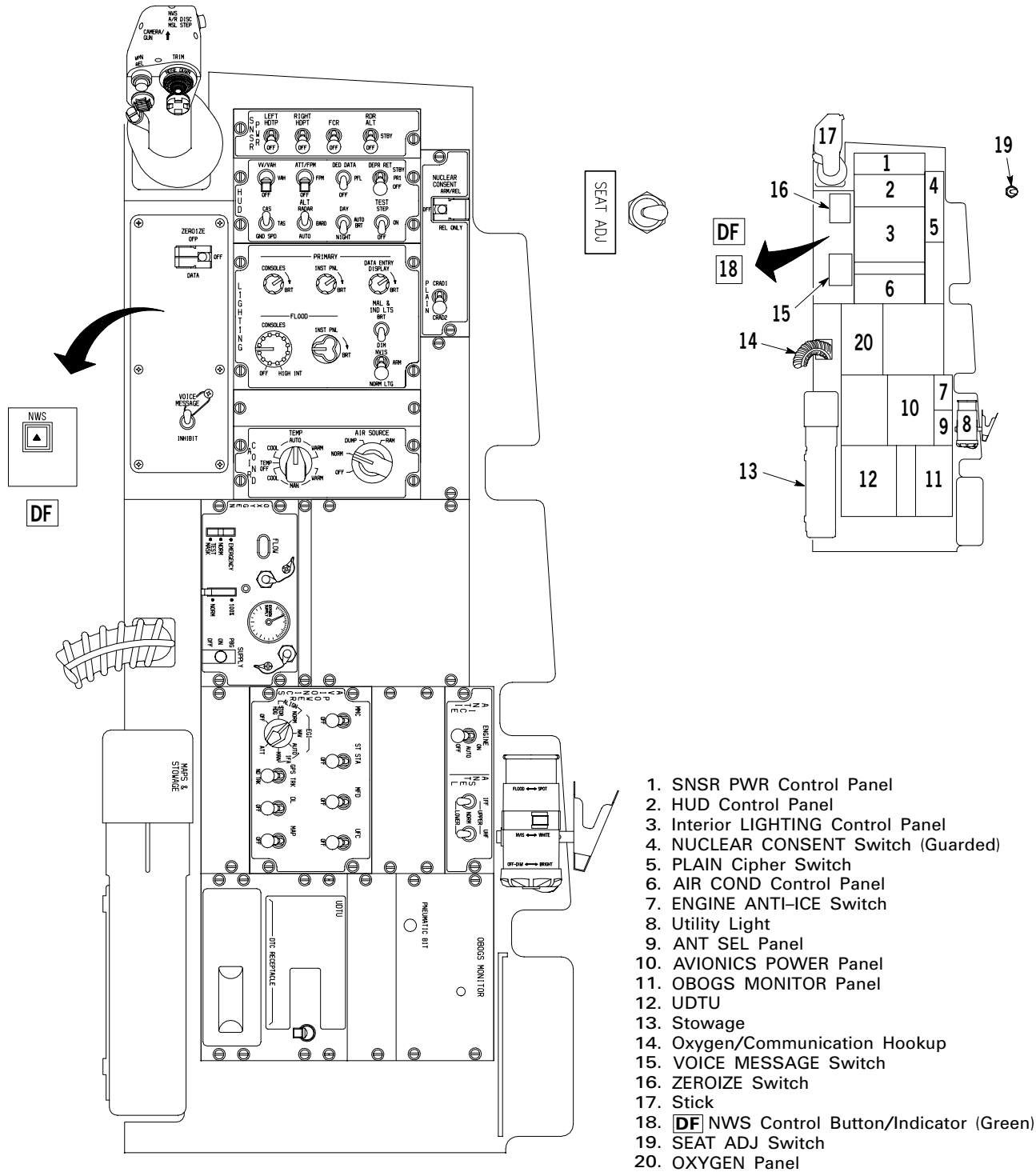
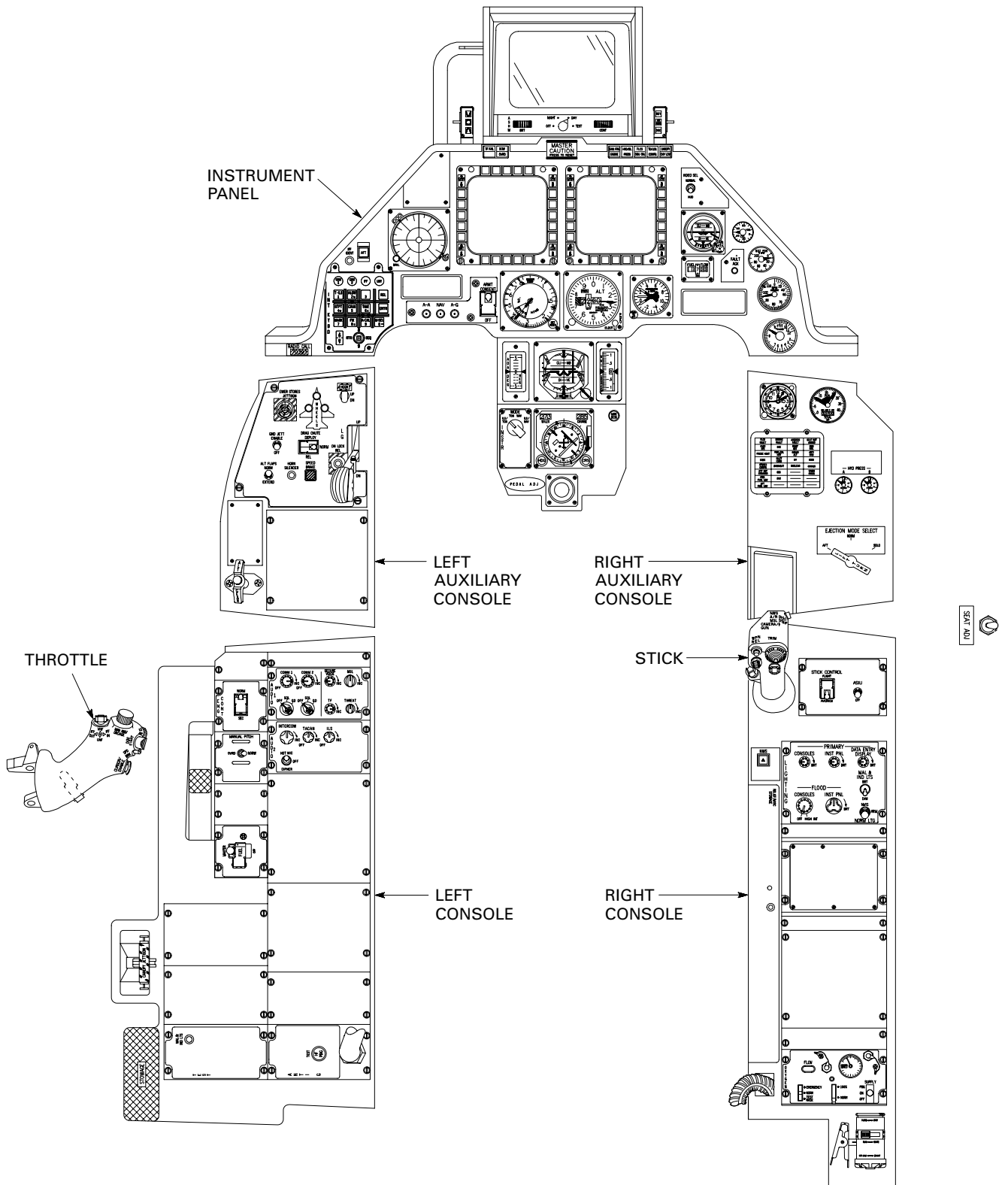

Figure 1-3. (Sheet 15)

# Cockpit Arrangement DR (Typical) PX III



GR1F-16CJ-1-1011X37 ©

Figure 1-3. (Sheet 16)

# Cockpit Arrangement DR (Typical) PX III

## LEFT CONSOLE

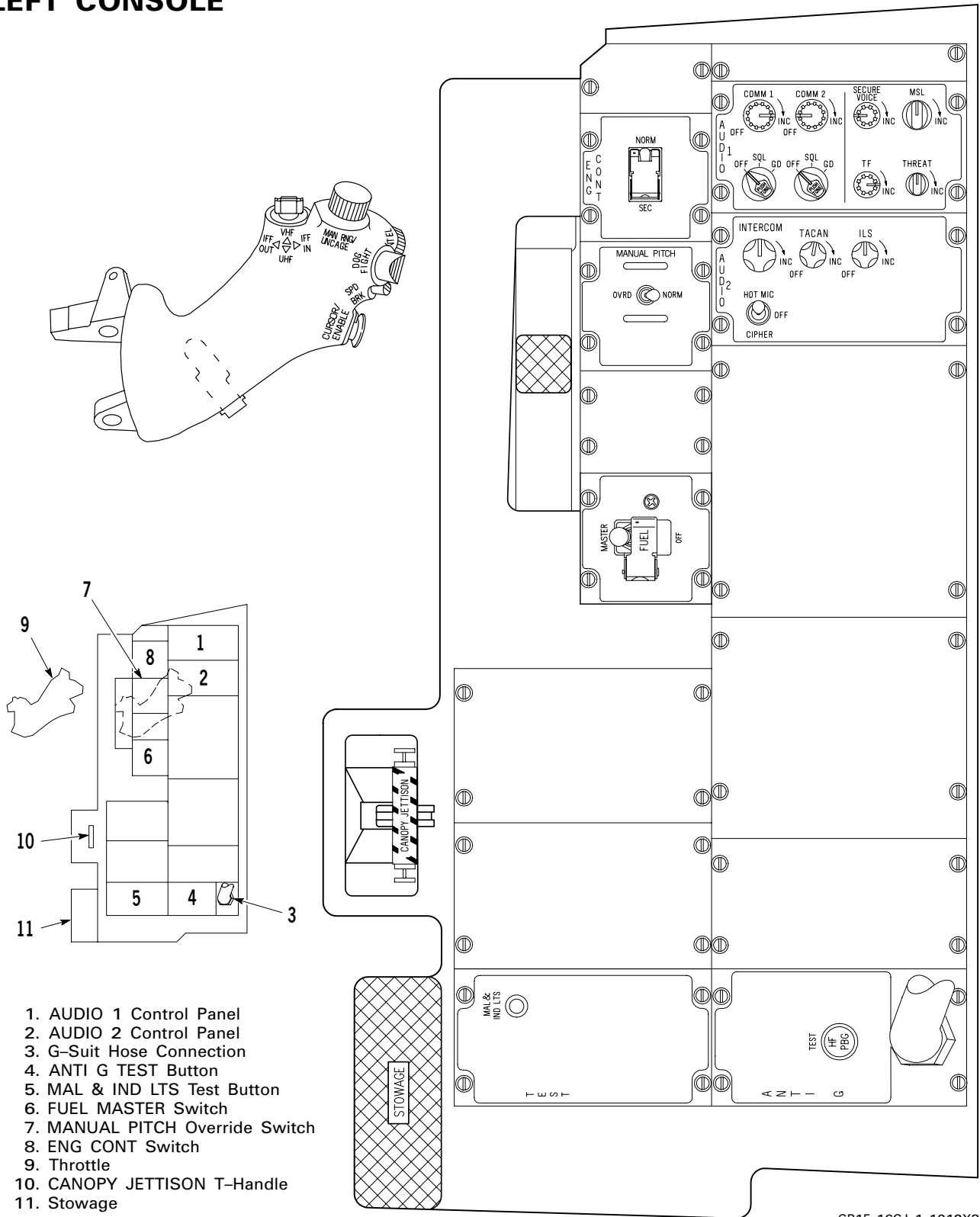

1. AUDIO 1 Control Panel
2. AUDIO 2 Control Panel
3. G-Suit Hose Connection
4. ANTI G TEST Button
5. MAL & IND LTS Test Button
6. FUEL MASTER Switch
7. MANUAL PITCH Override Switch
8. ENG CONT Switch
9. Throttle
10. CANOPY JETTISON T-Handle
11. Stowage

GR1F-16CJ-1-1012X37 ©

Figure 1-3. (Sheet 17)



# Cockpit Arrangement DR (Typical) PX III

## LEFT AUXILIARY CONSOLE

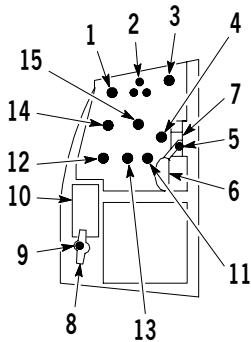
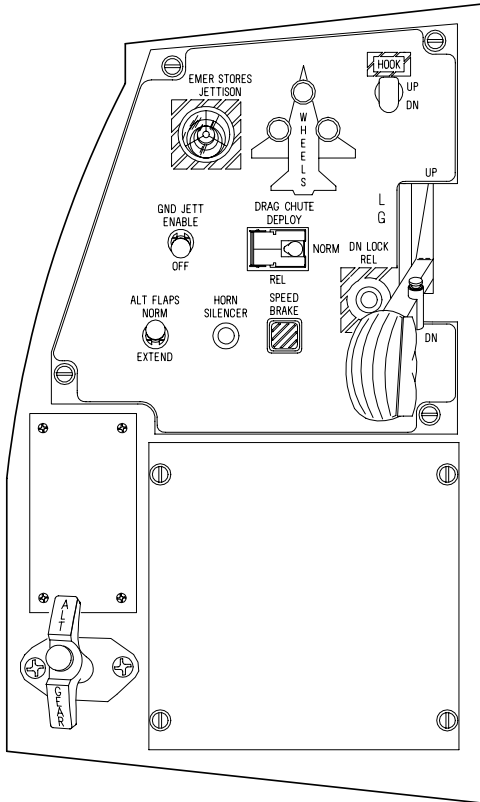

1. EMER STORES JETTISON Button (Covered)
2. WHEELS Down Lights (Green)
3. HOOK Switch (Lever Lock)
4. DN LOCK REL Button
5. LG Handle Down Permission Button
6. LG Handle Warning Light (Red)
7. LG Handle
8. ALT GEAR Handle
9. ALT GEAR Reset Button
10. Blank Panel
11. SPEED BRAKE Position Indicator
12. ALT FLAPS Switch (Lever Lock)
13. HORN SILENCER Button
14. GND JETT ENABLE Switch (Lever Lock)
15. DRAG CHUTE Switch

## RIGHT AUXILIARY CONSOLE

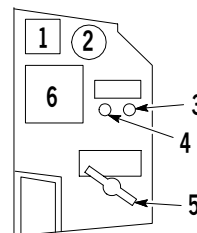
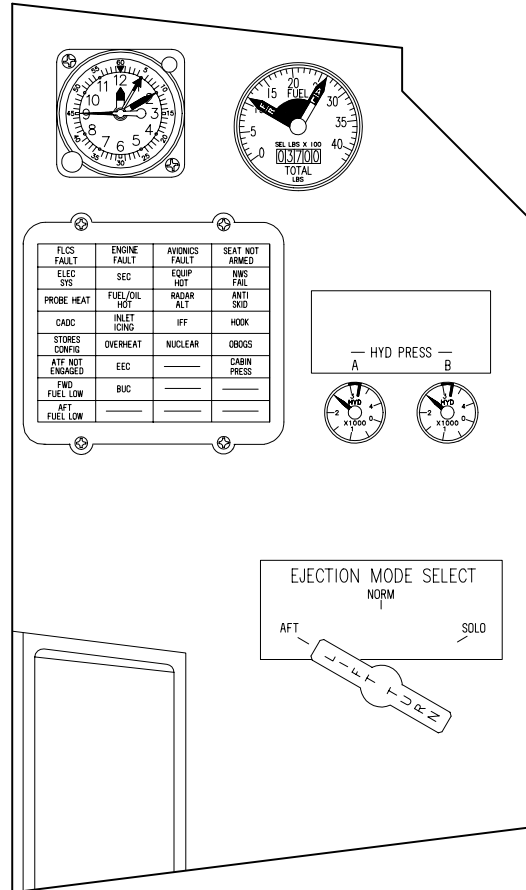

1. Clock
2. FUEL Quantity Indicator
3. System B HYD PRESS Indicator
4. System A HYD PRESS Indicator
5. EJECTION MODE SELECT Handle
6. Caution Light Panel

Figure 1-3. (Sheet 18)

# Cockpit Arrangement DR (Typical) PX III

## INSTRUMENT PANEL

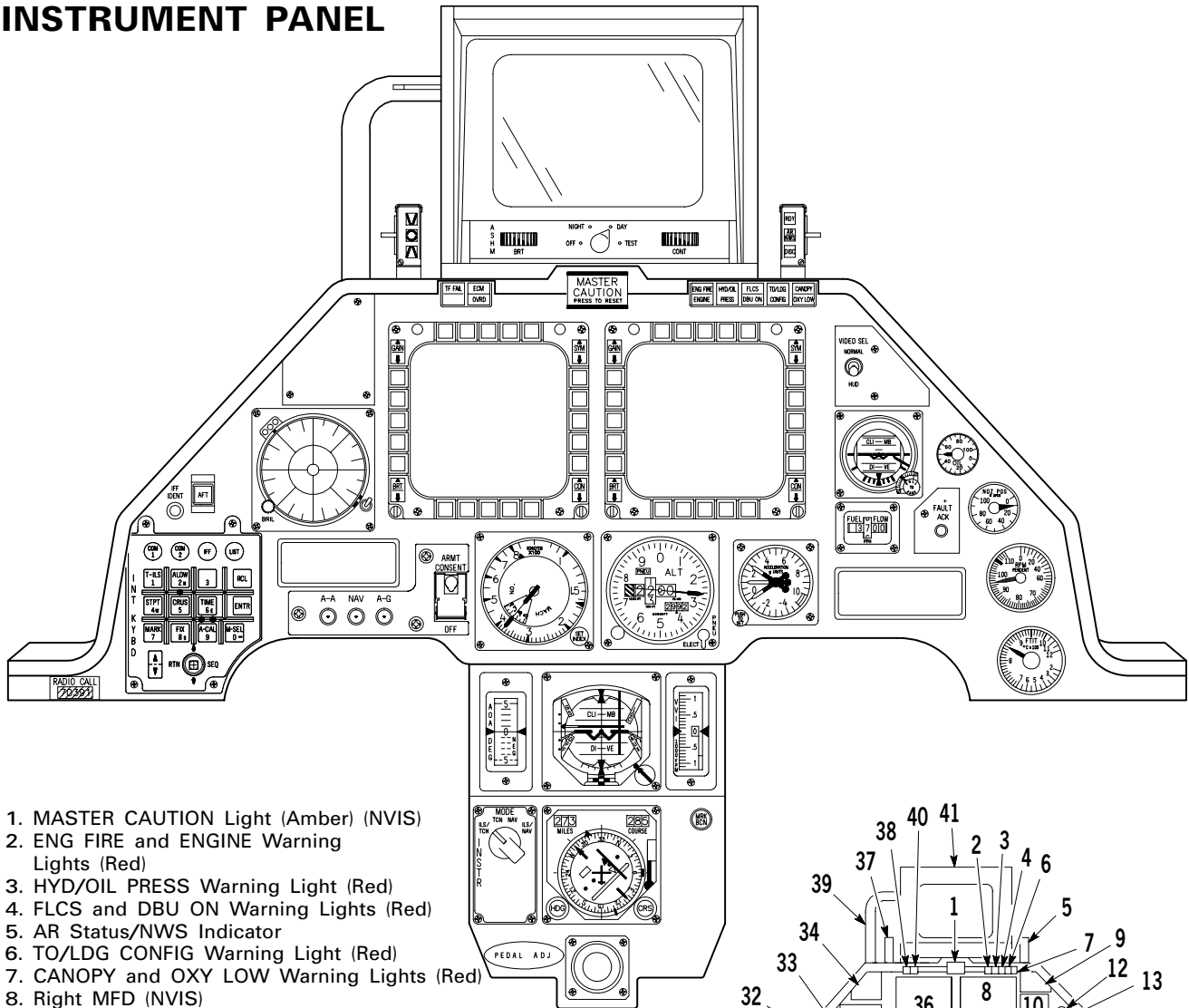

1. MASTER CAUTION Light (Amber) (NVIS)
2. ENG FIRE and ENGINE Warning Lights (Red)
3. HYD/OIL PRESS Warning Light (Red)
4. FLCS and DBU ON Warning Lights (Red)
5. AR Status/NWS Indicator
6. TO/LDG CONFIG Warning Light (Red)
7. CANOPY and OXY LOW Warning Lights (Red)
8. Right MFD (NVIS)
9. VIDEO SEL Switch
10. Standby Attitude Indicator
11. FUEL FLOW Indicator
12. OIL Pressure Indicator
13. FAULT ACK Button
14. NOZ POS Indicator
15. RPM Indicator
16. FTIT Indicator
17. Pilot Fault List Display
18. Accelerometer
19. Altimeter
20. Vertical Velocity Indicator
21. Attitude Director Indicator
22. Horizontal Situation Indicator
23. MRK BCN Light
24. Rudder PEDAL ADJ Knob
25. INSTR MODE Select Panel
26. AOA Indicator
27. Airspeed/Mach Indicator
28. ARMT CONSENT Switch (Guarded)

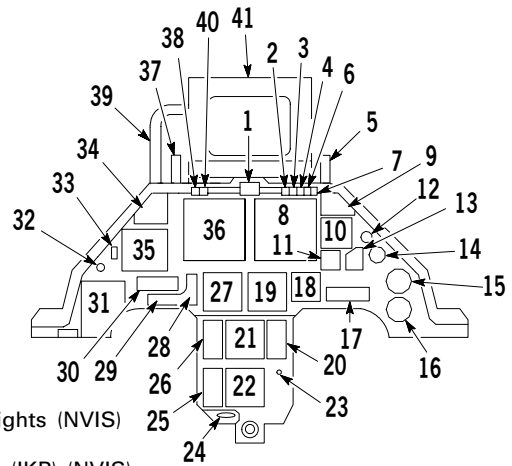

29. MASTER MODE Caution Lights (NVIS)
30. Data Entry Display
31. Integrated Keyboard Panel (IKP) (NVIS)
32. IFF IDENT Button
33. Stick Indicator
34. Blank
35. Azimuth Display/Indicator (NVIS)
36. Left MFD (NVIS)
37. AOA Indexer (NVIS)
38. TF FAIL Warning Light (Red)
39. Handgrip
40. ECM and OVRD Lights (Amber)
41. Aft Seat HUD Monitor (NVIS)

Figure 1-3. (Sheet 19)

# Cockpit Arrangement DR (Typical) PX III

## RIGHT CONSOLE

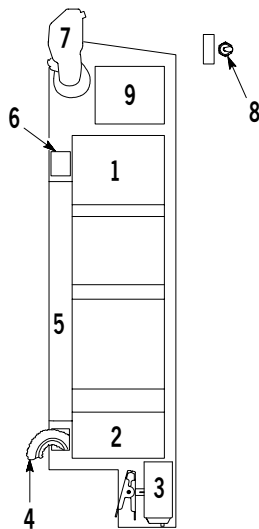

1. Interior LIGHTING Control Panel
2. OXYGEN REGULATOR Panel
3. Utility Light
4. Oxygen/Communications Hookup
5. Stowage
6. NWS Control Button/Indicator (Green)
7. Stick
8. SEAT ADJ Switch
9. STICK CONTROL/ASIU Panel

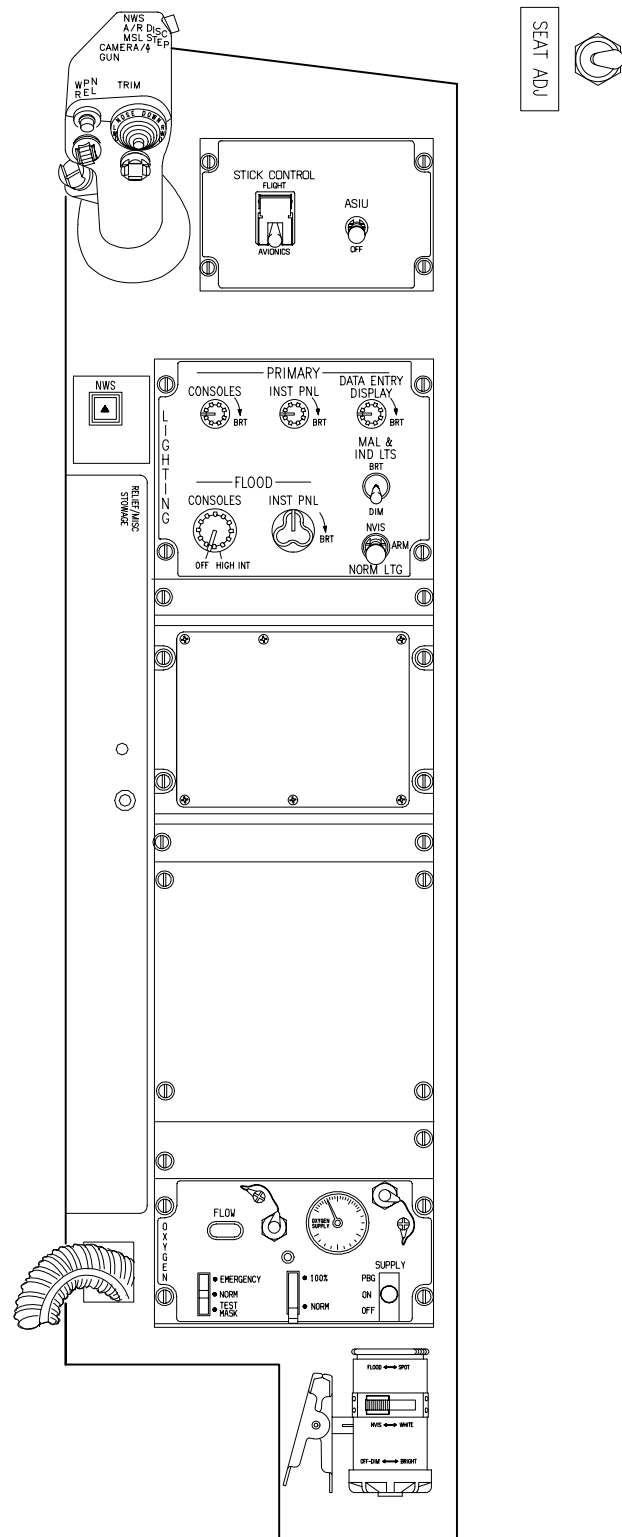

GR1F-16CJ-1-1015X37 ©

Figure 1-3. (Sheet 20)

## ENGINE PW 229

### ENGINE GENERAL DESCRIPTION PW 229

Refer to figure 1-4. The aircraft is powered by a single F100-PW-229 afterburning turbofan engine. Maximum thrust is approximately 29,000 pounds.

### ENGINE FUEL SYSTEM PW 229

Refer to figure 1-5. The engine fuel system delivers the required fuel to the engine for combustion and for use by the control system for scheduling the engine variable geometry.

### ENGINE CONTROL SYSTEM PW 229

The engine control system is composed of three major components: the main fuel control (MFC), the AB fuel control, and the digital electronic engine control (DEEC). The engine has two modes of operation: primary (PRI) and secondary (SEC).

### Main Fuel Control (MFC) PW 229

The MFC operates in both the PRI and SEC modes. During PRI control, the MFC receives throttle inputs, fuel from the main fuel pump, and electrical commands from the DEEC. It controls main ignition, start bleed strap position, main engine fuel flow, and rear compressor variable vane (RCVV) position. The MFC also provides actuation pressure to the compressor inlet variable vane (CIVV) control, the convergent exhaust nozzle control (CENC), and both the AB fuel control and AB pump controller.

In SEC, the MFC receives throttle inputs, fuel from the main fuel pump, and static pressure and total temperature signals from the fan inlet case. The MFC controls main engine fuel flow, start bleed strap position, RCVV's, and engine ignition.

### Afterburner (AB) Fuel Control PW 229

During primary operation, the AB fuel control receives fuel from the AB fuel pump and electrical commands from the DEEC. It provides AB ignition, AB segment sequencing, and fuel flow to the AB segments. During SEC control, AB fuel flow is inhibited.

## F100-PW-229 Engine

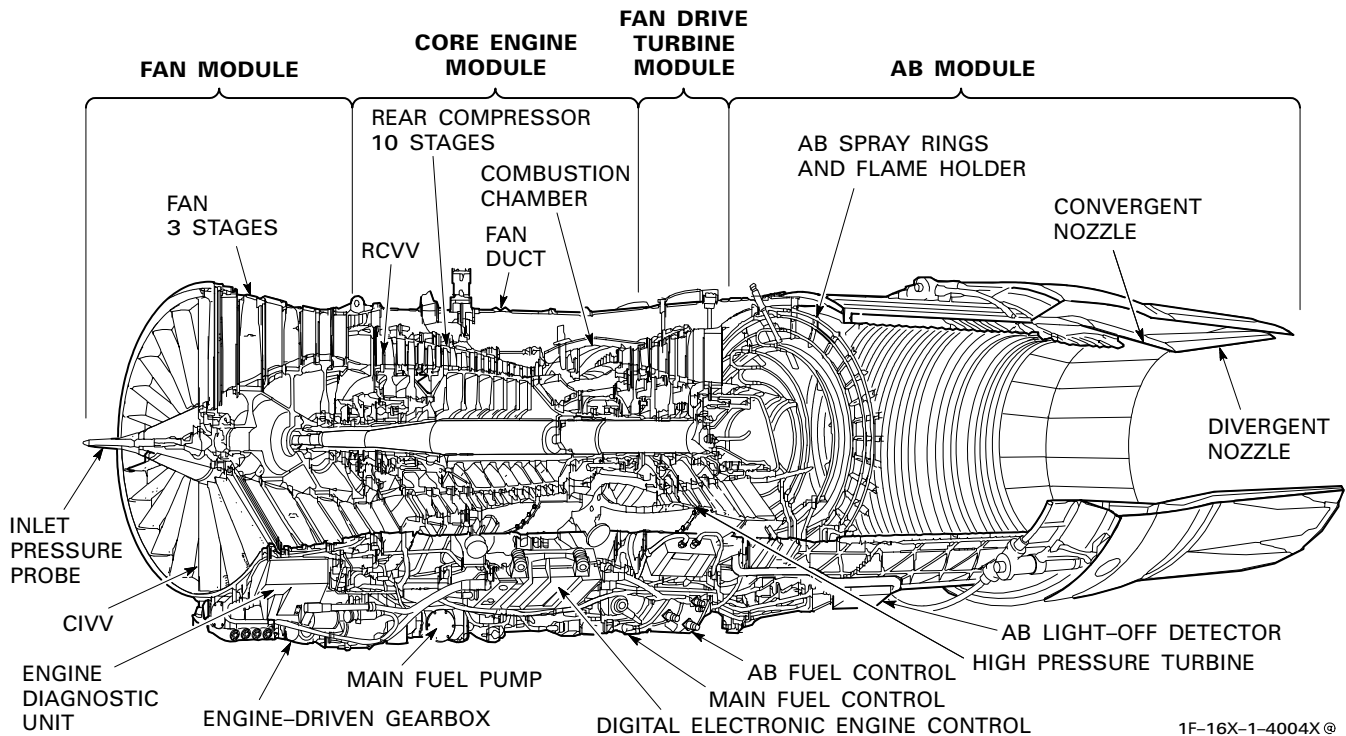

Figure 1-4.

# Engine Fuel/Control System Schematic (Typical)

ENGINE F100-PW-229

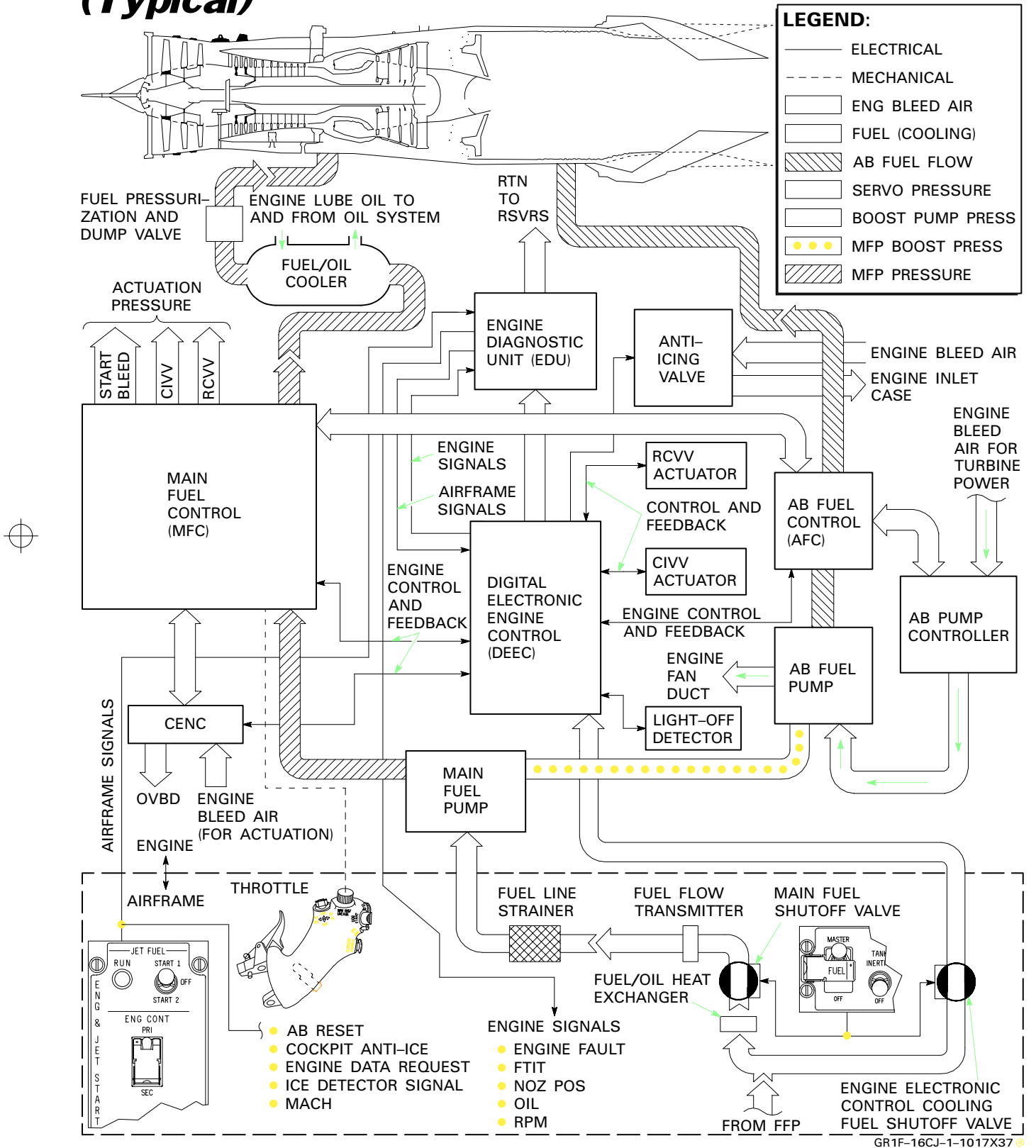

Figure 1-5.

**Digital Electronic Engine Control (DEEC) [PW 229](#)**

The DEEC is an engine-mounted, fuel-cooled, solid-state digital full authority computer.

Control functions provided by the DEEC during PRI operation are:

- Fuel flow scheduling.
- Fan speed control.
- Engine pressure ratio scheduling.
- Core compressor speed limiting.
- FTIT limiting.
- Minimum and maximum compressor discharge pressure limiting.
- Nozzle position control.
- RCVV scheduling.
- CIVV scheduling.
- Compressor start bleed system scheduling.
- AB segment sequencing and cancellation.
- Logic to detect and compensate for control system malfunctions.
- Logic to provide automatic transfer to SEC in the event of a critical PRI failure.

The DEEC closed-loop idle control schedules MFC fuel flow for three different idle levels. For functional description, refer to ENGINE OPERATING CHARACTERISTICS [PW 229](#), this section.

The DEEC limits minimum engine rpm throughout the flight envelope to maintain stable operation. At high altitude, low airspeed conditions, the DEEC protects against engine stalls. During transonic and supersonic conditions, the DEEC limits minimum idle rpm as a function of mach number (from CADC) to provide sufficient engine airflow.

To minimize the possibility of stalls during AB operation at high altitude and low airspeed, the DEEC commands termination of segment 11 AB. At extremely high altitude and low airspeed, the DEEC limits AB operation to eight AB segments. When a stall is sensed, the DEEC cancels the AB (if throttle is in AB range) and opens the nozzle until the stall clears. For subsequent AB operation, the throttle must be retarded below AB before AB can be reinitiated.

An engine overspeed or overtemperature condition causes the DEEC to automatically transfer to SEC and illuminate the SEC caution light.

The DEEC receives power directly from the engine alternator. In the event of an engine alternator or engine gearbox failure indicated by rapid decrease to zero rpm and illumination of the ENGINE warning light, the DEEC loses power and an automatic transfer to SEC occurs.

**Secondary Engine Control (SEC) [PW 229](#)**

The SEC is a hydromechanical system which provides engine control in the event of a DEEC malfunction. In SEC, the CIVV's move to a fixed (cambered) position, nozzle position is closed, the RCVV's are positioned by a hydromechanical control in the MFC, and AB operation is inhibited. SEC is selected manually with the ENG CONT switch or automatically by the DEEC. During SEC operation, the SEC caution light illuminates.

**Main Fuel Pump [PW 229](#)**

The gearbox-mounted main fuel pump provides pressurized fuel to the MFC and boosts pressure to the AB fuel pump.

**Afterburner (AB) Fuel Pump [PW 229](#)**

The AB fuel pump is driven by engine bleed air and provides pressurized fuel to the AB. The pump operates only during AB operation.

**Compressor Inlet Variable Vane (CIVV) Control [PW 229](#)**

The CIVV control positions the CIVV's using MFC fuel pressure in response to an electrical signal from the DEEC. In SEC, the CIVV's are in a fixed (cambered) position.

**Rear Compressor Variable Vanes (RCVV's) [PW 229](#)**

The first three stages of the rear compressor are equipped with variable geometry vanes. In PRI, RCVV's are controlled by the DEEC and are positioned using pressurized fuel from the main fuel pump. In SEC, the RCVV's are positioned by a hydromechanical control in the MFC as a direct function of throttle position.

### **Compressor Bleed Air** PW 229

Low-pressure bleed air is directed from the bleed strap into the fan duct to increase the compressor stall margin during starting. Pressurized fuel from the main fuel pump is used to drive the start bleed actuator. The bleed valve is scheduled as a function of engine rpm by the DEEC when starting in PRI and as a function of time and engine inlet pressure in SEC.

High-pressure bleed air is supplied to the EPU and engine nacelle ejectors. It is also used for engine inlet anti-icing, to drive the AB fuel pump, and to drive the CENC motor.

Either low-pressure or high-pressure air is provided to the ECS depending on engine bleed pressure levels.

### **Pressurization and Dump Valve** PW 229

A pressurization and dump valve is located in the engine fuel manifold line between the fuel/oil cooler and fuel nozzles. It provides a minimum fuel pressure for MFC operation at low rpm; the dump port is capped so that fuel is not drained from the engine fuel manifold when the throttle is retarded to OFF.

### **EXHAUST NOZZLE** PW 229

The exhaust nozzle is variable and consists of two sections. The divergent nozzle floats freely and moves in conjunction with the convergent nozzle. The convergent nozzle is controlled by the convergent exhaust nozzle control.

### **Convergent Exhaust Nozzle Control (CENC)** PW 229

The CENC is actuated by a high-pressure bleed air motor. The nozzle schedule is controlled by the DEEC as a function of throttle input to the MFC. In PRI with the LG handle down, the nozzle is greater than 80 percent open at IDLE (idle area reset). As the throttle is advanced, the nozzle closes. With the LG handle up, the nozzle is near minimum area except when approaching MIL or above. At MIL and above, the DEEC schedules the nozzle to control engine pressure ratio as a function of fan speed. When the throttle is advanced in the AB range, the DEEC schedules the nozzle open to compensate for increasing AB fuel flow. In SEC, the nozzle is positioned to approximately zero percent and AB operation is inhibited.

### **Light-Off Detector (LOD)** PW 229

The engine incorporates an AB LOD, which, when combined with the DEEC logic, provides AB no-light and blowout detection. When the LOD senses an AB no-light or blowout, the DEEC automatically terminates AB fuel flow. If the throttle is left in AB, the DEEC reattempts AB light-off up to three times. If these attempts are unsuccessful, the throttle must be retarded to MIL or below and then advanced into AB for further AB attempts.

### **ENGINE DIAGNOSTIC UNIT (EDU)** PW 229

The EDU operates in conjunction with the DEEC to automatically acquire and record diagnostic data whenever the engine is operating. In the event that the EDU detects one or more predetermined fault codes associated with abnormal operation it will automatically record approximately 4 seconds of engine data (3 seconds before the event and one second after the event). To manually acquire and record diagnostic data, place the AB RESET switch to ENG DATA. Four seconds of engine data is recorded (3 seconds prior to switch movement and one second after). The EDU can store one data set. The data recorded by the ENG DATA switch overwrites the automatically recorded data.

### **ENGINE OIL SYSTEM** PW 229

The engine is equipped with a self-contained oil system to lubricate the engine and gearbox. System pressure is nonregulated and varies with rpm and oil temperature, and altitude.

Below approximately 35,000 feet MSL, oil pressure should increase approximately 15 psi from IDLE to MIL. At very high altitudes (50,000 feet), the oil pressure increase is approximately 5 psi from IDLE to MIL. At all altitudes, however, a definite oil pressure increase should be evident when the rpm is increased. Refer to SERVICING DIAGRAM, this section for servicing/specifications information.

### **FUEL/OIL HOT Caution Light** PW 229

The FUEL/OIL HOT caution light is located on the caution light panel. The oil hot function of the light is inoperative.

**ENGINE ANTI-ICE SYSTEM** PW 229

The anti-ice system routes high-pressure bleed air to and through the fixed fan inlet guide vanes, the CIVV's, and the inlet pressure probe support cone to prevent ice formation. Additionally, the inlet pressure probe is continuously heated electrically to prevent ice formation. The system is controlled by the DEEC and a three-position ANTI ICE switch. The anti-ice system can be activated manually by placing the ANTI ICE switch to ON or automatically, if the ANTI ICE switch is in AUTO and a sensor located in the inlet senses the accumulation of ice. Activation can also occur if emergency dc bus No. 2 power is lost (unless inhibited by the DEEC).

The inlet strut is electrically heated to prevent ice buildup. This heater is also controlled by the ANTI ICE switch for manual or automatic operation.

The DEEC prevents anti-ice operation above 30,000 feet MSL and when engine inlet or bleed air temperatures are high. In addition, a DEEC malfunction may result in loss of bleed air for engine anti-icing.

**Engine ANTI ICE Switch** PW 229

The engine ANTI ICE switch is located on the right console.

Functions are:

- ON – The inlet strut electrical heater turns on and the engine anti-ice system is activated (if not inhibited by the DEEC). If ice accumulation is detected, the INLET ICING caution light illuminates. The caution light remains on for approximately 70 seconds (assuming that no additional ice accumulation occurs). If ice reaccumulates before the 70 second cycle expires, the caution light remains on and the cycle repeats until icing conditions no longer exist.
- AUTO – When an ice accumulation is detected, the INLET ICING caution light illuminates, the inlet strut electrical heater turns on, and the engine anti-ice system activates (unless inhibited by the DEEC). The caution light, inlet strut electrical heater, and engine anti-icing system remain on for approximately 70 seconds (assuming that no additional ice accumulation occurs). If ice reaccumulates before the 70 second cycle expires, the caution light, inlet strut electrical heater, and engine anti-icing system remain on and the cycle repeats until icing conditions no longer exist.

- OFF – Ice detector, engine anti-ice system, and inlet strut heater are off.

**INLET ICING Caution Light** PW 229

The INLET ICING caution light located on the caution light panel, illuminates when an ice accumulation is detected by the inlet ice detector or if a detection system failure occurs. The caution light remains on for approximately 70 seconds (assuming no additional ice accumulation). If more ice accumulates, the caution light may remain on for a longer period of time or may cycle off and then on again.

**ENGINE AND ACCESSORY DRIVE GEARBOXES** PW 229

Refer to figure 1-6. The engine gearbox drives the main fuel pump, the oil pump assembly, the engine alternator, and the PTO shaft, which powers the accessory drive gearbox (ADG).

The ADG powers the main generator through the constant-speed drive (CSD), hydraulic system A and B pumps, standby generator, and FLCS PMG. The JFS is also mounted on the ADG.

**ENGINE ALTERNATOR** PW 229

The engine alternator is driven by the engine gearbox and provides sole power for the DEEC, engine and AB ignition, inlet pressure probe heater, and the rpm signal to the RPM indicator.

**ENGINE IGNITION SYSTEM** PW 229

The ignition system is powered by the engine alternator and contains four igniter plugs (two for the engine and two for the AB). With the throttle at or above IDLE and engine rpm at 12 percent or above, engine ignition is continuous. When the throttle is moved into AB, AB ignition is activated by the DEEC for up to 3 seconds or until the LOD detects an AB light. In the event of an AB blowout or no-light condition with the throttle left in AB, AB ignition is automatically resequenced by the DEEC up to three additional times. For subsequent AB ignition, the throttle must be retarded to MIL or below and then returned to AB.



**JET FUEL STARTER (JFS) PW 229**

The JFS is a gas turbine which operates on aircraft fuel and drives the engine through the ADG. The JFS is connected by a clutch to the ADG and only provides torque when required to maintain engine rpm. If the ADG is not able to rotate (i.e., seized engine), the JFS runs, but the clutch prevents it from rotating the ADG. The JFS receives fuel at all times regardless of the FUEL MASTER switch position. The JFS is started by power from two brake/ JFS accumulators used either singly or together. The brake/JFS accumulators are charged automatically by hydraulic system B or manually by a hydraulic hand pump located in the left wheel well. Automatic recharging takes between 40 seconds (hot ambient conditions) and 60 seconds (cold ambient conditions). The JFS is used to start the engine on the ground and to assist in engine airstart. Refer to JET FUEL STARTER LIMITS, Section V.

**ENG & JET START CONTROL PANEL PW 229**

Refer to figure 1-7. The ENG & JET START control panel is located on the left console.

**JFS Switch C DF PW 229**

Functions are:

- OFF - Normal switch position. The JFS can be shut down at anytime by selecting OFF. The switch returns to OFF automatically during a normal ground start at 50 percent rpm.
- START 1 - Vents one of the brake/JFS accumulators to the hydraulic start motor.
- START 2 - Vents both brake/JFS accumulators to the hydraulic start motor.

**JFS RUN Light C DF PW 229**

The green JFS RUN light illuminates within 30 seconds after initiating JFS start to indicate that the JFS has attained governed speed.

# Engine and Accessory Drive Gearboxes

ENGINE F100-PW-229

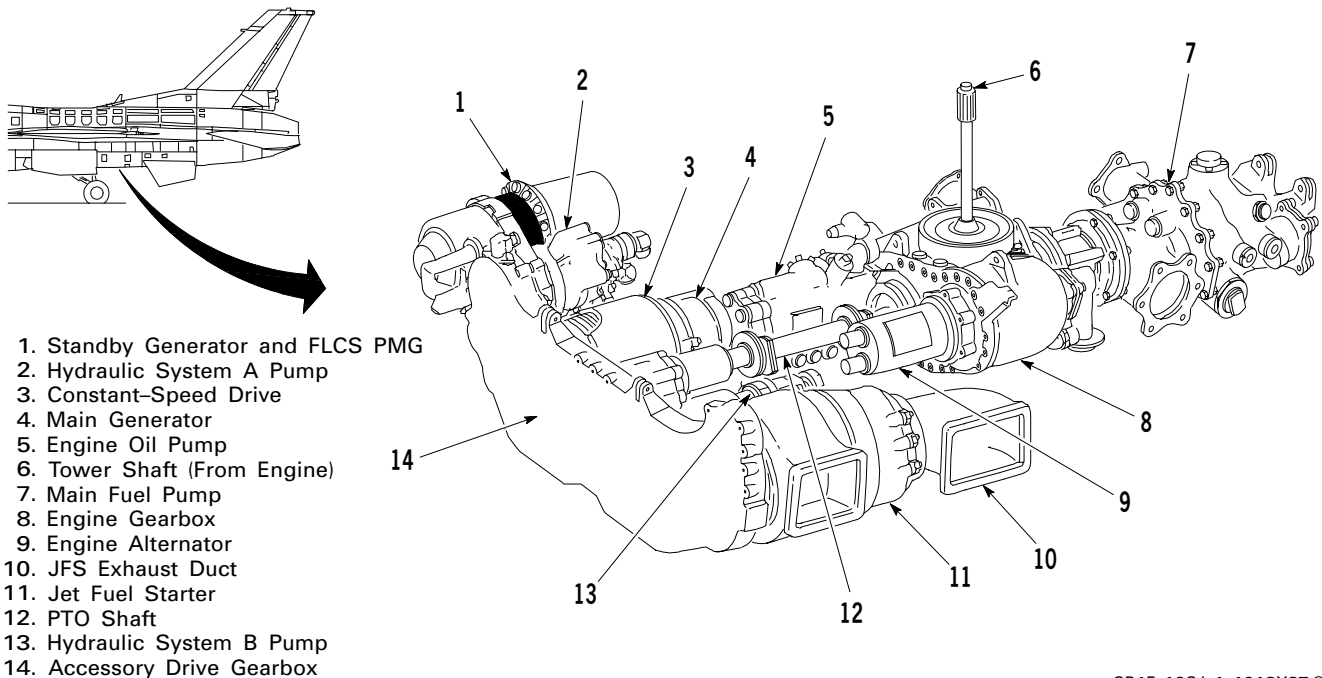

GR1F-16CJ-1-1018X37 ©

Figure 1-6.

**JFS Operation** PW 229

During a ground engine start, the brake/JFS accumulators begin to recharge after the engine accelerates through 12 percent rpm. As the engine accelerates through 50 percent rpm, a sensor causes the JFS to shut down automatically and the JFS RUN light goes off.

During in-flight operation, the brake/JFS accumulators begin to recharge (provided system B hydraulic pressure is available) when the JFS reaches 70 percent of governed speed (3-4 seconds before the JFS RUN light illuminates). If the JFS RUN light does not illuminate within 30 seconds or the JFS RUN light goes off once illuminated, the JFS START switch will not reengage and the JFS cannot be restarted until the JFS has spooled down. JFS spooldown takes approximately 17 seconds from full governed speed.

Once running, the JFS does not shut down until the JFS switch is manually positioned to OFF.

**ENGINE CONTROLS AND INDICATORS** PW 229

Refer to figure 1-8. The engine instruments are located on the right side of the instrument panel. Refer to ENGINE LIMITATIONS, Section V.

**ENG CONT Switch** PW 229

The ENG CONT switch (guarded out of SEC) is located on the left console. DR For ENG CONT switch differences, refer to F-16D AIRCRAFT, this section.

Functions are:

- C DF PRI - DEEC in operation (normal position).
- SEC - SEC operation. Transfer occurs when the switch is moved to the SEC position.

**ENG & JET START Control Panel (Typical)**

ENGINE F100-PW-229

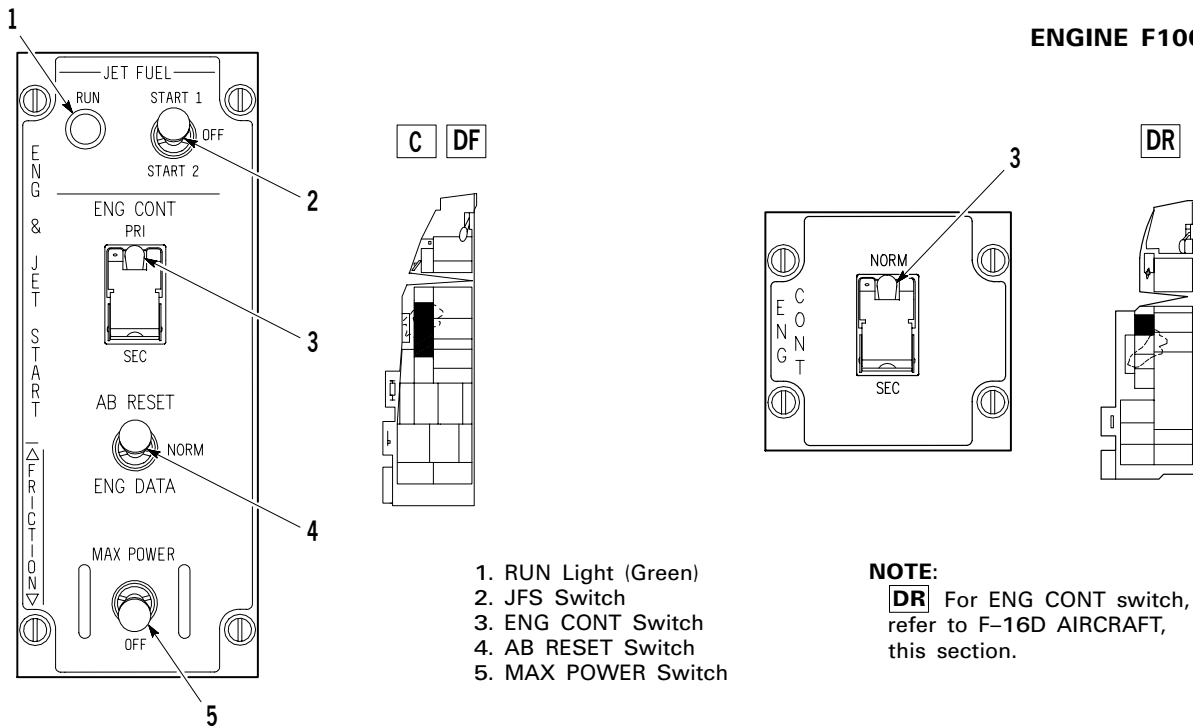

GR1F-16CJ-1-1019X37 @

Figure 1-7.

# Engine Controls and Indicators (Typical)

ENGINE F100-PW-229

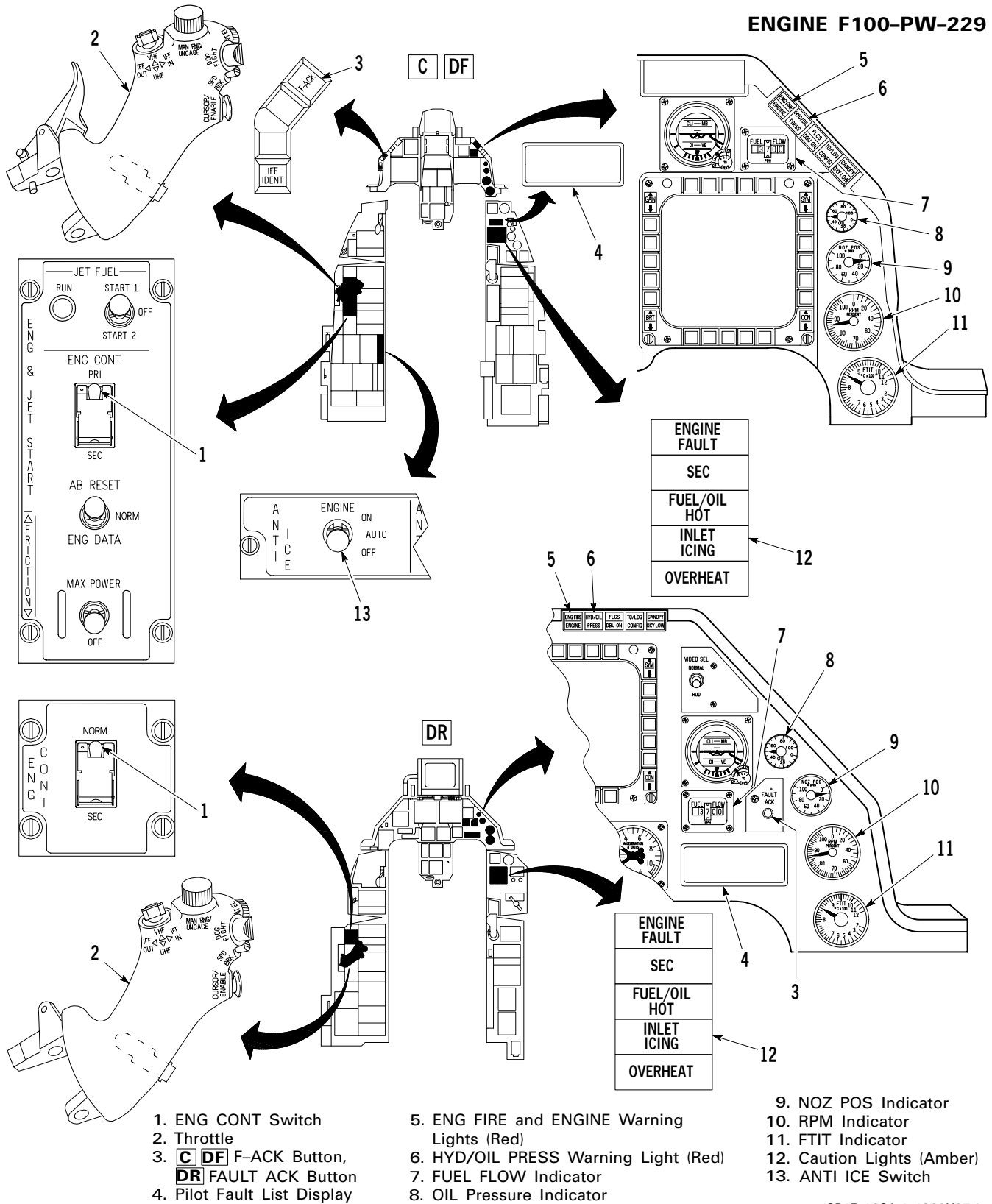

- 1. ENG CONT Switch
- 2. Throttle
- 3. **C DF** F-ACK Button, **DR** FAULT ACK Button
- 4. Pilot Fault List Display
- 5. ENG FIRE and ENGINE Warning Lights (Red)
- 6. HYD/OIL PRESS Warning Light (Red)
- 7. FUEL FLOW Indicator
- 8. OIL Pressure Indicator
- 9. NOZ POS Indicator
- 10. RPM Indicator
- 11. FTIT Indicator
- 12. Caution Lights (Amber)
- 13. ANTI ICE Switch

GR1F-16CJ-1-1020X37 ©

Figure 1-8.

**AB RESET Switch** C DF PW 229

The AB RESET switch, located on the left console, is a three-position toggle switch, spring-loaded to the center (NORM) position.

Functions are:

- AB RESET – This position is used to attempt to clear DEEC faults.
- NORM – Normal (deenergized) position.
- ENG DATA – This position may be used to record engine data in the EDU.

**ENGINE FAULT Caution Light** PW 229

The ENGINE FAULT caution light, located on the caution light panel, indicates that an engine PFL item was detected. The caution light goes off when the fault is acknowledged.

**Pilot Fault List Display (PFLD)** PW 229

The PFLD, located on the C DF right auxiliary console, DR instrument panel, displays engine PFL's. Refer to WARNING, CAUTION, AND INDICATOR LIGHTS, this section, for a description of the PFLD. Refer to PILOT FAULT LIST – ENGINE, Section III, for a description of engine PFL's.

**SEC Caution Light** PW 229

The SEC caution light, located on the caution light panel, indicates that the engine is operating in SEC or that main fuel pump pressure is low.

**EEC Caution Light** PW 229

The EEC caution light, located on the caution light panel, is deactivated.

**BUC Caution Light** PW 229

The BUC caution light, located on the caution light panel, is deactivated.

**MAX POWER Switch** C DF PW 229

The MAX POWER switch, located on the left console, is inoperative.

**RPM Indicator** PW 229

The RPM indicator has a pointer display and the rpm signal is supplied by the engine alternator. RPM is

expressed in percent from 0-100. The indicator is powered by battery bus No. 1.

**NOZ POS Indicator** PW 229

The NOZ POS indicator displays the position of the CENC exhaust nozzle drive shafts which are calibrated from 0 percent (closed) to 100 percent (fully open). The indicator accurately reflects exhaust nozzle position in PRI and SEC unless both drive shafts are failed. The indicator is powered by emergency ac bus No. 2.

**FTIT Indicator** PW 229

The FTIT indicator displays an average FTIT in degrees C. The indicator has a range of 200°-1200°C in major increments of 100°C and is powered by battery bus No. 1.

**FUEL FLOW Indicator** PW 229

The FUEL FLOW indicator is a digital indicator which displays the total fuel flow to the engine, including AB, in pph. The indicator has a range of 0-80,000 pph and is powered by emergency ac bus No. 1.

**OIL Pressure Indicator** PW 229

The OIL pressure indicator displays engine oil pressure from 0-100 psi and is powered by emergency ac bus No. 2.

**HYD/OIL PRESS Warning Light** PW 229

The HYD/OIL PRESS warning light, located on the edge of the right glareshield, serves as a monitor of engine oil pressure and hydraulic system pressure. For engine oil pressure, the warning light illuminates when oil pressure has been below approximately 10 psi for 30 seconds (time delay minimizes warning light illuminating during maneuvering). The light goes out when oil pressure exceeds approximately 20 psi. For hydraulic pressure, the warning light illuminates when either A or B system pressure decreases below 1000 psi. The light goes out when both system A and B pressures are above 1000 psi. During engine start, the light usually goes off before reaching idle rpm; however, acceptable operation is indicated if the warning light goes off before exceeding 70 percent rpm and remains off when the throttle is retarded to IDLE. The warning light is powered by battery bus No. 1.

**ENGINE Warning Light** PW 229

The ENGINE warning light, located on the edge of the right glareshield, illuminates when RPM and FTIT indicator signals indicate that an engine overtemperature or flameout has occurred. Illumination also occurs for an engine alternator failure and may occur as a result of an RPM or FTIT indicator failure. The warning light illuminates when the rpm decreases to subidle (below 55 percent) or approximately 2 seconds after FTIT indication exceeds 1100°C. The warning light goes off when the condition that turned it on is eliminated. The warning light is powered by battery bus No. 1.

**Throttle** PW 229

Refer to figure 1-9. The engine is controlled by a throttle mounted above the left console with detents at OFF, IDLE, MIL, and MAX AB. The throttle is mechanically connected to the MFC. The OFF position terminates engine ignition and fuel flow. The IDLE position commands minimum thrust and is used for all ground starts. From IDLE to MIL, the throttle controls the output of the engine. Forward of the MIL position, the throttle modulates the operation of the AB (through 11 segments) while maintaining constant basic engine operation.

C DF The throttle must be rotated outboard to allow advancement from OFF to IDLE and from MIL to AB. Retarding the throttle from AB to MIL automatically rotates the throttle. At IDLE, a cutoff release at the base of the throttle must be actuated to allow the throttle to be rotated outboard and retarded to OFF. DR For throttle differences, refer to F-16D AIR-CRAFT, this section.

A single white reflective stripe is located C DF on both the upper surface of the throttle foot and on the sidewall fairing, DR on both the lower throttle radius next to the console and on the panel outboard of the throttle radius. Alignment of the two stripes aids in identifying the IDLE position.

Six switches are located on the throttle. C DF A throttle friction control is located inboard at the base of the throttle. DR The throttles are mechanically linked together.

**ENGINE OPERATING CHARACTERISTICS** PW 229**Engine General** PW 229

Idle functions provided by the DEEC closed-loop idle control during PRI operation are:

- Ground idle – Provides the lowest level of idle thrust while maintaining adequate stall margin. The nozzle opens to greater than 80 percent and engine rpm is 65-77 percent. Ground idle is activated with the LG handle in DN and the throttle at or near IDLE.
- Flight idle – Flight idle provides in-flight idle thrust when the LG handle is in UP and the throttle is at or near IDLE. The nozzle is open to 0-20 percent and the thrust is approximately 700 pounds higher than ground idle.
- Transient idle – Transient idle rpm provides for rapid thrust response after rapidly retarding the throttle to IDLE and then advancing within 20 seconds.

At MIL, the DEEC controls fan speed and engine pressure ratio to maintain consistent thrust. RPM and FTIT vary as a function of flight conditions. Following engine ground start, whenever the LG handle is DN, and for 3 minutes after LG handle is placed UP, the DEEC may position the RCVV's more closed for increased stall margin. Positioning the RCVV's more closed results in up to 2 percent higher engine rpm at MIL and above. Three minutes after placing the LG handle UP, engine rpm may decrease up to 2 percent.

**Ground Operations** PW 229

Since the DEEC maintains constant idle thrust, rpm varies with temperature and pressure altitude (higher temperature or pressure altitude results in higher rpm).

**Non-AB Operation in Flight** PW 229

Regardless of temperature, NOZ POS indicator indication should not exceed 20 percent at MIL.

Engine operation is continually optimized as flight conditions change. This is evident by slight changes in the NOZ POS, RPM, and FTIT indicator indications.

Idle rpm is scheduled as a function of mach number (from CADC), altitude, temperature, throttle movement, and time. At altitudes below approximately 30,000 feet MSL, idle rpm is 70-80 percent. As altitude increases, idle rpm increases to provide the engine sufficient stall margin during throttle transients.

# Throttle (Typical)

ENGINE F100-PW-229

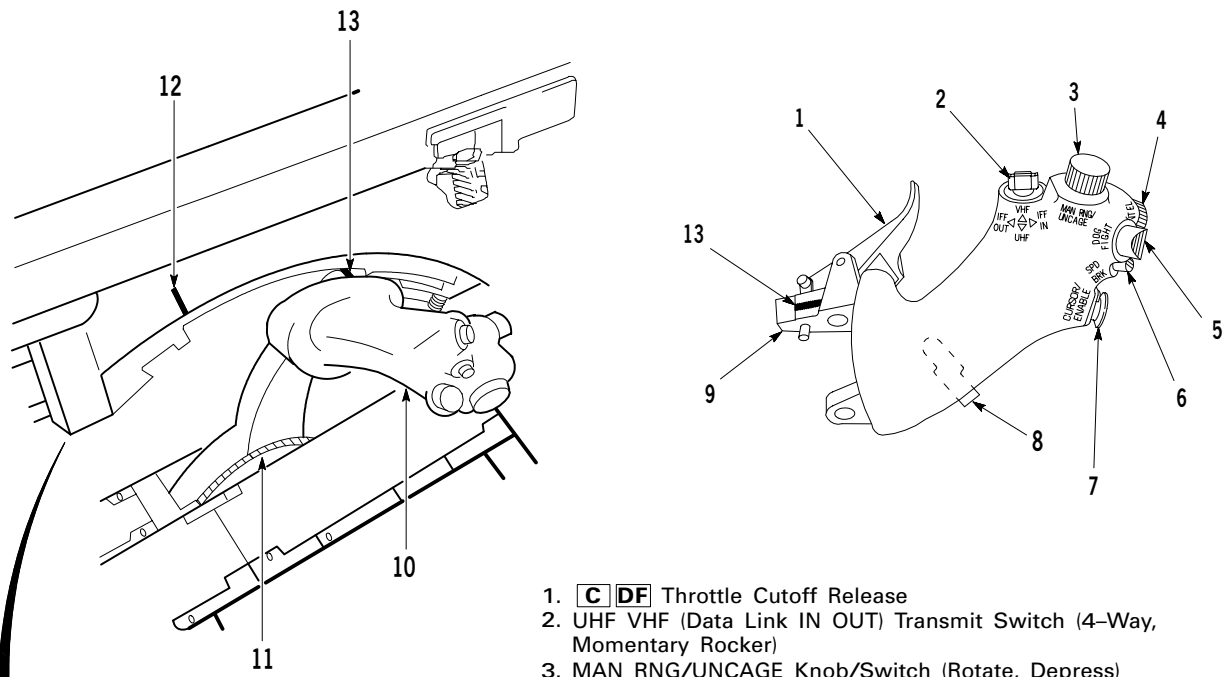

1. **C** **DF** Throttle Cutoff Release
2. UHF VHF (Data Link IN OUT) Transmit Switch (4-Way, Momentary Rocker)
3. MAN RNG/UNCAGE Knob/Switch (Rotate, Depress)
4. ANT ELEV Knob (Rotate, Center Detent)
5. DOG FIGHT Switch (3-Position, Slide)
6. SPD BRK Switch (3-Position, Aft Momentary)
7. RDR CURSOR/ENABLE Switch (Depress Multidirectional)
8. Hands-on Blackout (HOBO) Paddle Switch
9. Throttle Foot
10. Throttle
11. **C** **DF** Throttle Friction Control
12. **C** **DF** IDLE Stripe
13. **C** **DF** Throttle Stripe

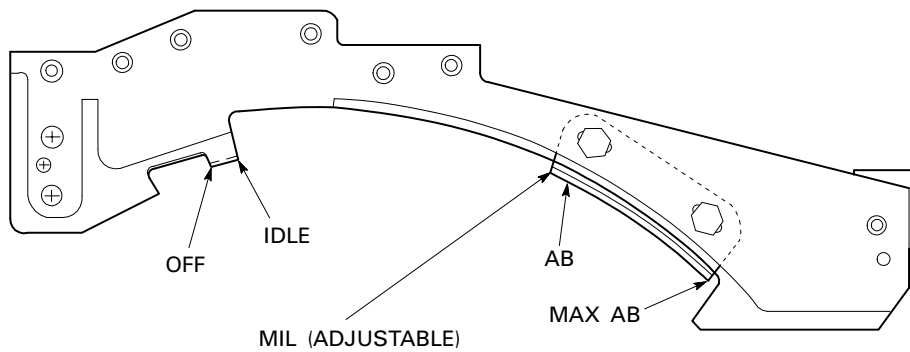

**NOTE:**

**DR** For throttle differences, refer to THROTTLE and F-16D AIRCRAFT, this section.

Figure 1-9.

At 1.4 mach and above, the minimum thrust level is MIL even though the throttle may be retarded below MIL. Typically, the minimum thrust level increases from idle to MIL between 0.98-1.4 mach. All of the minimum operating level features are deactivated during SEC operation.

After a rapid throttle movement to IDLE, engine rpm initially decreases to a level above flight idle (transient idle). Transient idle rpm provides for rapid thrust response if the throttle is advanced. If the throttle is not advanced within 20 seconds, engine rpm then slowly decreases to flight idle. As altitude increases, the difference between transient idle rpm and flight idle rpm decreases.

A low frequency engine vibration may be sensed in flight or on the ground primarily at or near idle, but may also occur at higher thrust settings. The vibration has no adverse effect on engine or aircraft structure and should disappear if engine rpm is either increased or decreased. Vibrations that change in intensity with throttle movement and are present across the throttle/rpm range may indicate a potential engine malfunction.

#### **AB Operation in Flight PW 229**

Refer to figure 1-10. The DEEC monitors AB operation and takes appropriate action to prevent engine stalls. In AB, the DEEC provides the following:

- **Fast acceleration capability:** The AB has no limitations. Near sea level, AB operation occurs immediately after AB is selected. At high altitude, a higher fan speed must be attained prior to AB operation. For example, during an IDLE-to-MAX AB throttle transient at low altitude, the AB lights immediately when AB is selected and sequencing begins just prior to attaining MIL thrust rpm.
- **AB segment sequencing limiting:** When AB is selected at extremely high altitudes and low airspeeds, the DEEC automatically schedules AB operation. As the airspeed increases or the altitude decreases, automatic AB sequencing takes place if the AB request is greater than the actual AB operation.

- **AB recycle capability:** The DEEC, in conjunction with the LOD, provides automatic AB recycle capability in the event of an AB blowout or no-light condition (if the throttle is left in AB). In that event, the DEEC automatically resets the control system to MIL, performs a control system check, and reattempts to light the AB up to three additional times before returning the engine to MIL. If the LOD is failed, the DEEC attempts one AB relight using a duct pressure signal to verify AB lightoff. No caution lights result from unsuccessful AB recycles. Additional AB attempts can be made by moving the throttle to MIL or below and then back into AB.

#### **SEC Operation PW 229**

The engine transfers to SEC when the ENG CONT switch is manually switched to SEC. To minimize rpm and thrust changes during manual transfers, the throttle should be placed to the midrange position. Transfer to SEC also occurs automatically if the DEEC senses a major engine control system malfunction or if loss of electrical power to the DEEC occurs.

When the engine transfers to SEC, the SEC caution light illuminates and AB operation is inhibited. RPM and FTIT may increase or decrease depending on flight conditions and on the engine malfunction.

If a transfer to SEC occurs while in AB, the nozzle closes and AB operation is automatically cancelled. If a transfer to SEC occurs during supersonic operation, the throttle should be maintained at MIL or above until the aircraft is subsonic.

While subsonic in SEC, throttle movement is unrestricted below 40,000 feet MSL. The throttle may be moved in the AB range; however, the AB is inhibited. Refer to ENGINE - OPERATIONAL ENVELOPE, Section V for transfer and throttle movement restrictions.

SEC provides 70-80 percent of normal MIL thrust. This level provides a measure of protection against exceeding engine operating limits and provides sufficient thrust for safe flight operations. SEC idle thrust is approximately twice that in PRI with a normal nozzle during landing approach and ground operations because the nozzle is closed.

# AB Envelope — Light-Off

ENGINE F100-PW-229

**NOTES:**

- Throttle movement is unrestricted throughout the aircraft flight envelope.
- Selecting AB above 45,000 feet MSL and less than 140 knots may result in delayed lights or recycles.
- Region 1 — Unlimited 11 segment AB operation.
- Region 2 — AB segments 1 through 10 available.
- Region 3 — AB segments 1 through 8 available.
- Region 4 — AB inhibited.

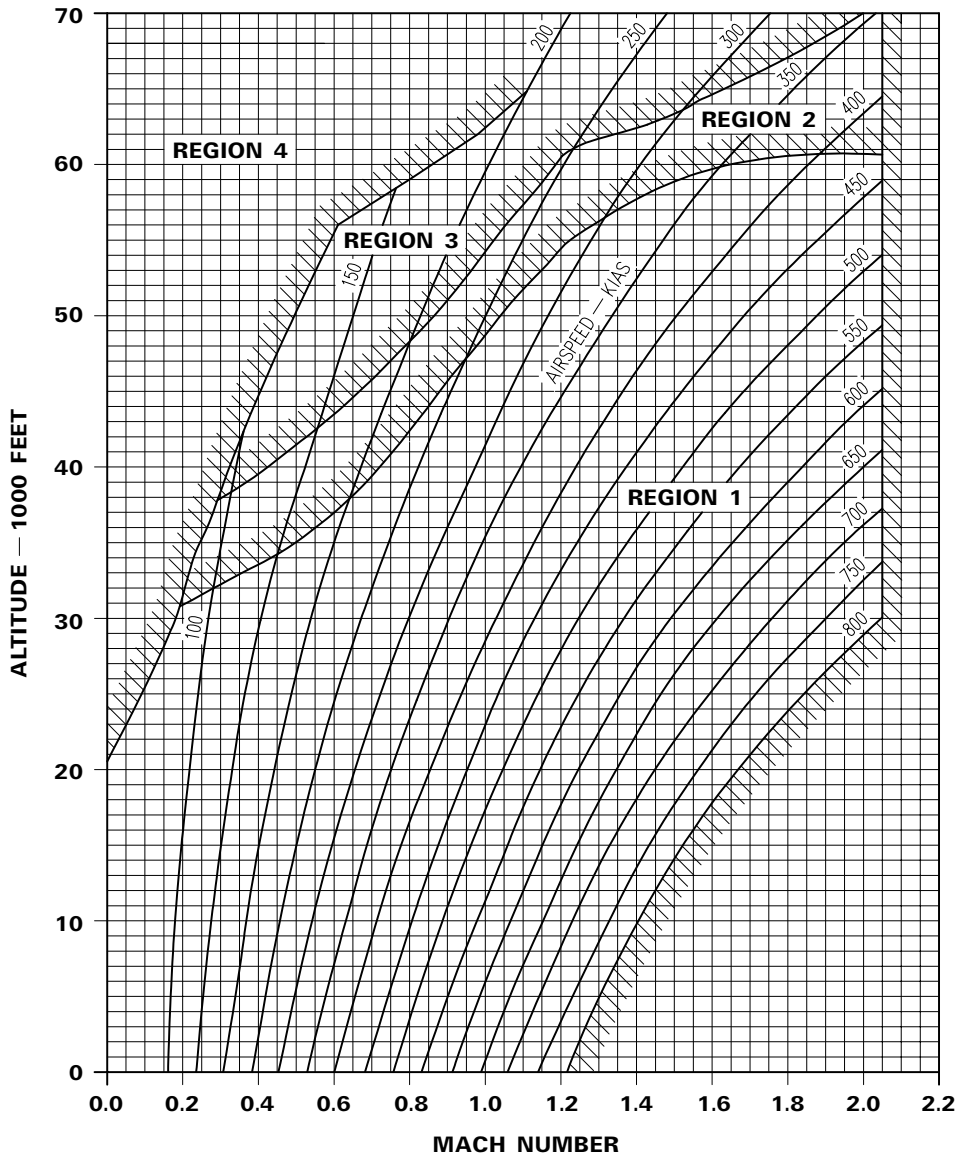

1F-16X-1-4006X®

Figure 1-10.



## ENGINE GE129

### GENERAL DESCRIPTION GE129

Refer to figure 1-11. The aircraft is powered by a single F110-GE-129 afterburning turbofan engine. Maximum thrust is approximately 29,500 pounds.

### ENGINE FUEL/CONTROL SYSTEM GE129

Refer to figure 1-12. The engine fuel/control system delivers the required fuel to the engine for combustion and for use by the control system for scheduling the engine variable geometry. The control system is primarily composed of three major components: the digital electronic control (DEC), the afterburner fuel control (AFC), and the main engine control (MEC). The engine has two pilot selectable modes of operation: primary (PRI) and secondary (SEC). In addition, there are two modes of operation between PRI and SEC which are not selectable by the pilot: hybrid VSV (HYB VSV) and hybrid (HYB).

### Digital Electronic Control (DEC) GE129

The DEC is the critical component of the primary (PRI) engine control. The DEC is an engine-mounted, fuel-cooled solid-state digital computer which controls both the main engine and the AB.

### Afterburner Fuel Control (AFC) GE129

The AFC is a fuel-operated electrohydraulic control which regulates fuel flow to the AB in conjunction with the DEC.

### Main Engine Control (MEC) GE129

The MEC is a fuel-operated hydromechanical control which provides various control functions in all control modes.

### Primary (PRI) Engine Operation GE129

PRI provides unrestricted engine operation throughout the entire flight envelope.

# F110-GE-129 Engine

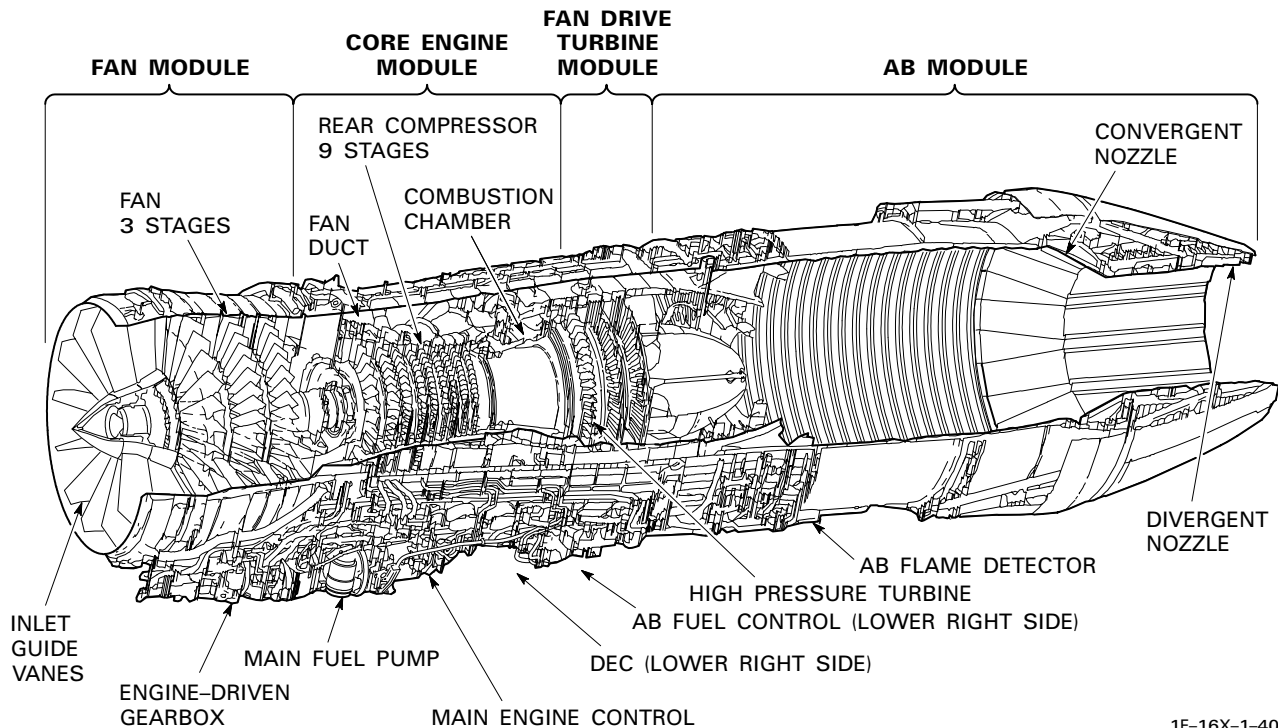

1F-16X-1-4005X@

Figure 1-11.

# Engine Fuel/Control System Schematic (Typical)

ENGINE F110-GE-129

**LEGEND:**

- ELECTRICAL
- - - MECHANICAL
- FUEL
- FUEL (COOLING)
- HYDRAULIC
- AB FUEL FLOW
- SERVO PRESSURE

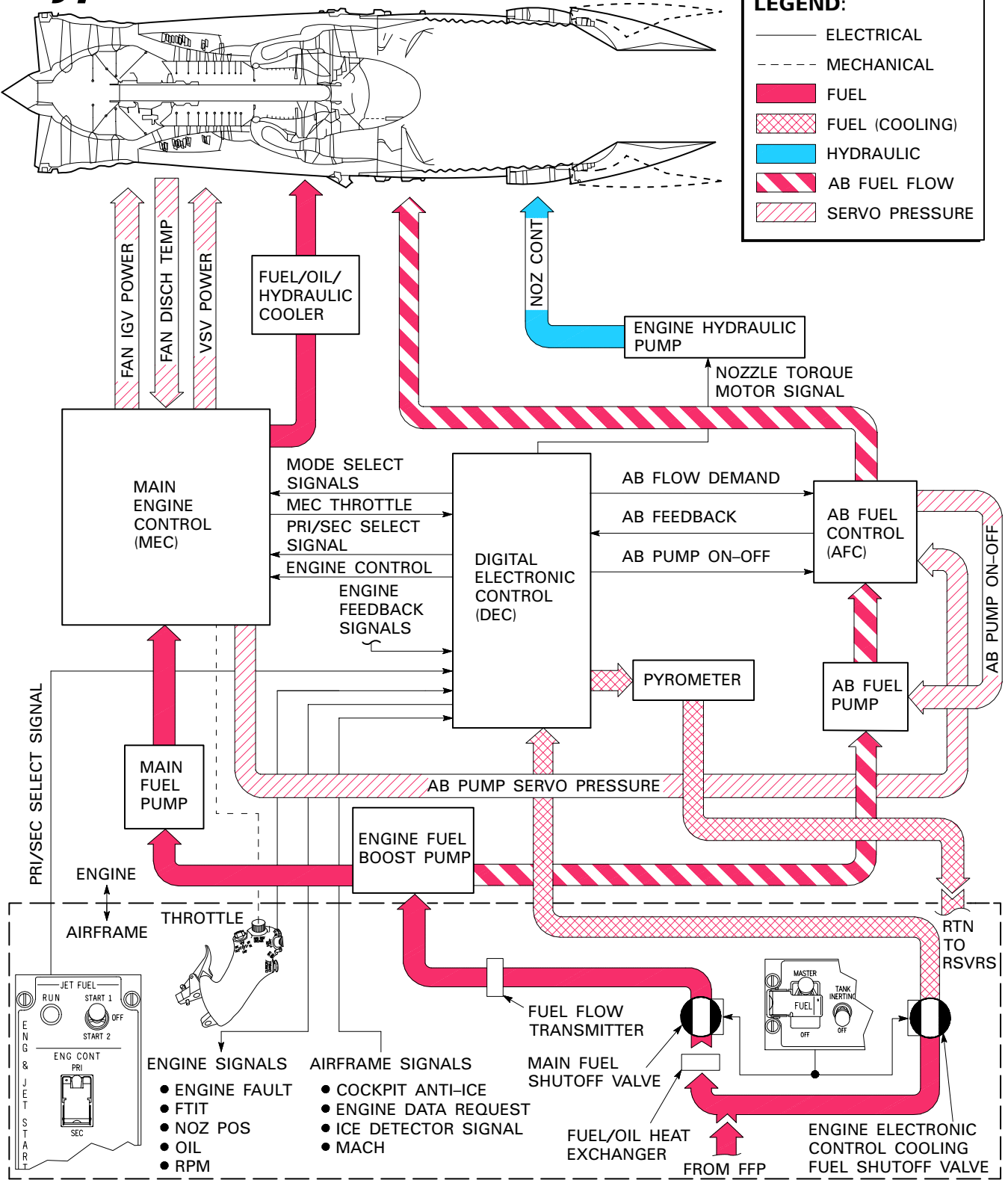

GR1F-16CJ-1-0017X37®

Figure 1-12.

## T.O. GR1F-16CJ-1

Control functions provided by the DEC during PRI operation are:

- Fan speed control.
- Core speed limiting.
- Acceleration and deceleration fuel flow scheduling.
- Turbine blade temperature limiting.
- AB fuel flow scheduling.
- Nozzle control to provide fan stall margin.
- Minimum and maximum compressor discharge pressure limiting.
- Scheduling of inlet guide vane (IGV) position.
- Resetting of the compressor variable stator vanes (VSV) for increased stall protection.
- Ignition logic for starting and automatic relight sequencing in both the engine and AB.
- Logic to automatically select HYB or HYB VSV or transfer to SEC for certain PRI failures.
- Compressor variable stator vane scheduling.

Control functions provided by the MEC during PRI operation are:

- Main engine fuel flow scheduling and metering.
- Engine overspeed protection (113 percent rpm overspeed fuel shutoff valve).
- Positive fuel cutoff.
- Compressor VSV scheduling (HYB VSV) for certain PRI failures.

When operating in PRI, main engine fuel flow is controlled by the DEC. The MEC fuel flow control feature is in standby mode.

The nozzle is controlled by signals from the DEC to the engine hydraulic pump which positions four nozzle actuators in order to maintain fan stall margin while providing the requested level of thrust.

Fan inlet guide vane (IGV) positioning is controlled by the DEC in accordance with the IGV schedule.

High energy and AB ignition are controlled by the DEC.

During transonic and supersonic flight, with the throttle retarded below MIL, the DEC limits minimum engine operation as a function of mach number from the central air data computer (CADC) to prevent inlet buzz and possible engine stall. When retarding the throttle to IDLE above 1.4 mach, rpm may decrease up to 15 percent from MIL rpm. RPM then decreases with mach number until approximately 1.1 mach, at which time the engine decelerates to normal flight idle rpm.

### **Hybrid (HYB) Engine Operation** GE129

HYB is activated when the DEC detects certain failures. In HYB, the MEC provides main engine fuel flow scheduling and VSV control.

Control functions by the DEC during HYB operation are:

- AB fuel flow scheduling.
- Nozzle control to provide fan stall margin.
- Scheduling of inlet guide vane (IGV) position.
- Logic to automatically transfer to SEC if HYB fails.

Control functions provided by the MEC during HYB operation are:

- Main engine fuel flow scheduling and metering.
- Compressor variable stator vane (VSV) scheduling.
- Engine overspeed protection (113 percent rpm overspeed fuel shutoff valve).
- Positive fuel cutoff.

During HYB operation:

- ENG HYB MODE PFL is displayed.
- Turbine blade temperature limiting is not provided.
- VSV reset is not active.
- Maximum fan speed is automatically limited.
- MIL thrust is 90-100 percent of that provided in PRI.
- Supersonic idle – Lockup is not active.

**Secondary Engine Control (SEC)****Operation** GE129

SEC is activated by either manually placing the ENG CONT switch to SEC or as a result of automatic transfer when the DEC detects certain failures. In SEC, the MEC provides fuel flow scheduling in addition to the functions it provides in PRI operation.

During SEC operation:

- The nozzle is closed.
- AB operation is inhibited (fuel and ignition).
- Turbine blade temperature limiting is not provided.
- High energy ignition is continuously energized.
- IGV's are in a fixed, fully closed position.
- VSV reset is not active.
- Maximum fan speed is automatically limited.
- SEC caution light is illuminated.
- In flight, MIL thrust is 70-95 percent of that provided at PRI MIL.
- Supersonic idle - Lockup is not active.
- Idle thrust is higher than that in PRI because the nozzle is closed.

**Engine Fuel Boost Pump** GE129

The gearbox-mounted engine fuel boost pump provides pressurized fuel to the main fuel pump and AB fuel pump.

**Main Fuel Pump** GE129

The gear-type main fuel pump receives pressurized fuel from the engine fuel boost pump. It provides additional pressure and supplies the fuel to the MEC.

**Afterburner (AB) Fuel Pump** GE129

The gearbox-mounted AB fuel pump receives fuel from the engine fuel boost pump. It provides additional pressure and supplies fuel to the AB fuel control.

**Inlet Guide Vanes (IGV's)** GE129

Each IGV is an airfoil which is divided into two sections. The forward portion of the inlet guide vane is fixed which provides structural support. The aft portion of the inlet guide vane is a variable angle flap which controls the angle at which air enters the fan. This both improves fan efficiency and increases the stall margin.

**Variable Stator Vanes (VSV's)** GE129

The compressor VSV system controls the angle of the core inlet guide vanes and the first three stages of core variable stator vanes. Positioning is a function of engine rpm. By varying the vane position, the system automatically changes the effective angle at which the airflow enters the compressor rotor blades, thereby maintaining satisfactory airflow and optimum compressor performance throughout the entire flight envelope. For increased stall protection, the VSV's are reset slightly closed from their normal position after a throttle snap to IDLE. The reset position is maintained for 2 minutes after which the VSV's return to their normal schedule, resulting in an rpm drop of approximately 2 percent.

**Compressor Bleed Air** GE129

Bleed air is extracted from two separate stages in the compressor for engine and airframe use. Low-pressure (fifth stage) air is used for turbine cooling and the engine anti-ice system. Air for airframe use is taken from both the low-and high-pressure (ninth stage) compressor sections. Low-pressure bleed air is used for the ECS unless the pressure is insufficient, in which case high-pressure bleed air is used. High-pressure bleed air is used for the nacelle ejectors and is also used to power the EPU.

**EXHAUST NOZZLE** GE129

The exhaust nozzle is a variable area convergent/divergent, semifloating type with mechanically linked primary and secondary flaps and seals. Nozzle area modulation is accomplished by four hydraulic actuators which provide synchronous actuation. The nozzle actuators are operated by the engine hydraulic pump using engine oil as hydraulic fluid, and respond to electrical inputs from the DEC.

The primary functions of the nozzle system are to maintain fan stall margin by varying the nozzle area and to control the engine thrust for optimum performance through the entire flight envelope.

## **AB FLAME DETECTOR** GE129

The AB flame detector provides AB light/no-light information to the DEC for use in AB sequencing and autorelight functions during PRI operation.

## **ENGINE MONITORING SYSTEM (EMS)** GE129

The EMS is operative in all engine control modes (PRI, SEC, HYB VSV, and HYB).

The EMS is designed to perform engine diagnostics and store engine fault data for postflight analysis. The EMS consists of two primary components: the digital electronic control (DEC) which is mounted on the engine and an engine monitoring system computer (EMSC) which is located in the leading edge flap drive bay in the forward fuselage section.

In all engine control modes the EMSC receives data from both the aircraft and the DEC to perform engine diagnostics and fault detection. Upon detection of a fault, the EMSC automatically stores approximately 8 seconds of engine data (6 seconds before and 2 seconds after the fault). If the fault is an engine pilot fault list (PFL) item, the ENGINE FAULT caution light illuminates.

Event data can also be manually stored at anytime by momentarily placing the AB RESET switch to ENG DATA. This function may be especially useful in event of unusual engine operation where EMS data was not automatically recorded. This action has no effect on data that was automatically recorded.

Data recorded by the EMS are parts life tracking data, engine performance trending data, and event data, including PFL's and MFL's. This data can be extracted from the EMS by maintenance personnel after flight.

During HYB VSV, HYB, and SEC modes, the EMSC continues the monitoring and reporting function for faults associated with the particular mode of operation.

## **ENGINE OIL SYSTEM** GE129

The engine is equipped with a self-contained, dry sump, full pressure lubrication system which provides filtered oil for lubricating and cooling the engine main shaft bearings, oil seals, gearboxes, and accessories. It also provides oil to the engine hydraulic pump for nozzle actuation. Engine oil level decreasing below approximately 40 percent of normal capacity for 15 seconds results in activation of an ENG LUBE LOW PFL. Refer to SERVICING DIAGRAM, this section for servicing/specifications information.

## **FUEL/OIL HOT Caution Light** GE129

The FUEL/OIL HOT caution light, located on the caution light panel, illuminates when the temperature of the oil becomes excessive (exceeds 300°F). The caution light also illuminates as a function of excessive fuel temperature. Refer to FUEL SYSTEM, this section.

## **ENGINE ANTI-ICE SYSTEM** GE129

The engine anti-ice system prevents the formation and accumulation of ice on the front frame struts, the forward centerbody, and the IGV flaps. Low-pressure bleed air is directed to a pressure regulating anti-icing valve. Valve actuation is accomplished either automatically (with the ANTI ICE switch in AUTO position) by an ice detector in the engine inlet or manually by the ANTI ICE switch. When the anti-icing valve is open, low-pressure bleed air enters the front frame at two separate locations. Bleed air is then distributed radially to each of the front frame struts, the IGV flaps, and the forward centerbody. Automatic activation also occurs if emergency dc bus No. 2 power is lost.

If engine anti-icing is either manually or automatically demanded while operating at idle rpm, engine rpm may increase as much as 3 percent when ambient temperature is below 30°F.

The inlet strut is electrically heated to prevent ice buildup. The heater is also controlled by the ANTI ICE switch for manual or automatic operation.

**Engine ANTI ICE Switch** GE129

The engine ANTI ICE switch is located on the right console.

Functions are:

- ON - The inlet strut electrical heater turns on and the engine anti-ice system is activated. If ice accumulation is detected, the INLET ICING caution light illuminates. The caution light remains on for approximately 70 seconds (assuming that no additional ice accumulation occurs). If ice reaccumulates before the 70-second cycle expires, the caution light remains on and the cycle repeats until icing conditions no longer exist.
- AUTO - When an ice accumulation is detected, the INLET ICING caution light illuminates, the inlet strut electrical heater turns on, and the engine anti-ice system activates. The caution light, inlet strut electrical heater, and engine anti-icing system remain on for approximately 70 seconds (assuming that no additional ice accumulation occurs). If ice reaccumulates before the 70-second cycle expires, the caution light, inlet strut electrical heater, and engine anti-icing system remain on and the cycle repeats until icing conditions no longer exist.
- OFF - Ice detector, engine anti-ice system, and inlet strut heater are off.

**INLET ICING Caution Light** GE129

The INLET ICING caution light, located on the caution light panel, illuminates when an ice accumulation is detected by the inlet ice detector or if a detection system failure occurs. The caution light remains on for approximately 70 seconds (assuming no additional ice accumulation). If more ice accumulates, the caution light may remain on for a longer period of time, or it may cycle off and then on again.

**ENGINE AND ACCESSORY DRIVE GEARBOXES** GE129

Refer to figure 1-13. The engine gearbox drives the main fuel pump, the engine fuel boost pump, the AB fuel pump, the engine/scavenge pump, the engine alternator, the engine hydraulic pump, the MEC, and the PTO shaft, which powers the accessory drive gearbox (ADG).

The ADG powers the main generator through the constant-speed drive (CSD), system A and B hydraulic pumps, standby generator, and FLCS PMG. The JFS is also mounted on the ADG.

**ENGINE ALTERNATOR** GE129

The engine alternator is driven by the engine gearbox and provides the rpm signal to the RPM indicator and power for high energy and AB ignition and the DEC.

**ENGINE IGNITION SYSTEM** GE129

The ignition system contains three igniter plugs (two for the engine and one for the AB). The engine igniters are controlled by engine rpm and operate completely independent of throttle position or throttle movement.

During engine start, high energy ignition, which is powered by the engine alternator, is automatically turned on at approximately 10 percent rpm and is automatically turned off at 59 percent rpm. The ignition system also provides an automatic relight feature which selects high energy ignition when the engine rpm deceleration rate exceeds 5 percent per second, or when the engine rpm goes below 59 percent.

A low energy ignition system is used as a backup to the high energy system. The low energy system is energized if the engine decelerates through approximately 55 percent rpm while airborne. The ignition system is powered by emergency ac bus No. 1.

AB ignition is powered by the engine alternator and provides energy to the AB spark igniter. AB ignition is automatically controlled by the DEC.

# Engine and Accessory Drive Gearboxes

ENGINE F110-GE-129

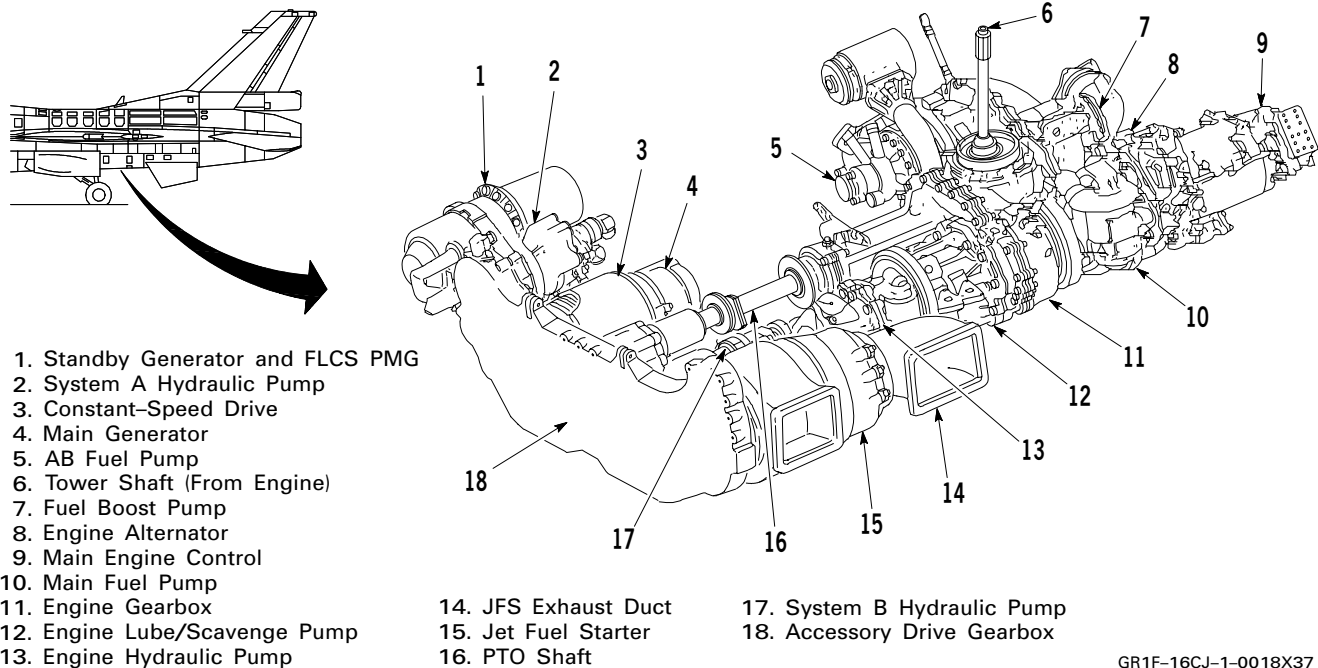

GR1F-16CJ-1-0018X37 ©

Figure 1-13.

## JET FUEL STARTER (JFS) GE129

The JFS is a gas turbine which operates on aircraft fuel and drives the engine through the ADG. The JFS is connected by a clutch to the ADG and only provides torque when required to maintain engine rpm. If the ADG is not able to rotate (i.e., seized engine), the JFS runs, but the clutch prevents it from rotating the ADG. The JFS receives fuel at all times regardless of the FUEL MASTER switch position. The JFS is started by power from two brake/JFS accumulators used either singly or together. The brake/JFS accumulators are charged automatically by hydraulic system B or manually by a hydraulic hand pump located in the left wheel well. Automatic recharging takes between 40 seconds (hot ambient conditions) and 60 seconds (cold ambient conditions). The JFS is used to start the engine on the ground and to assist in engine airstart. Refer to JET FUEL STARTER LIMITS, Section V.

## ENG & JET START CONTROL PANEL GE129

Refer to figure 1-14. The ENG & JET START control panel is located on the left console.

### JFS Switch C DF GE129

Functions are:

- OFF - Normal switch position. The JFS can be shut down at anytime by selecting OFF. The switch returns to OFF automatically during a normal ground start at approximately 55 percent rpm.
- START 1 - Vents one of the brake/JFS accumulators to the hydraulic start motor.
- START 2 - Vents both brake/JFS accumulators to the hydraulic start motor.

# ENG & JET START Control Panel (Typical)

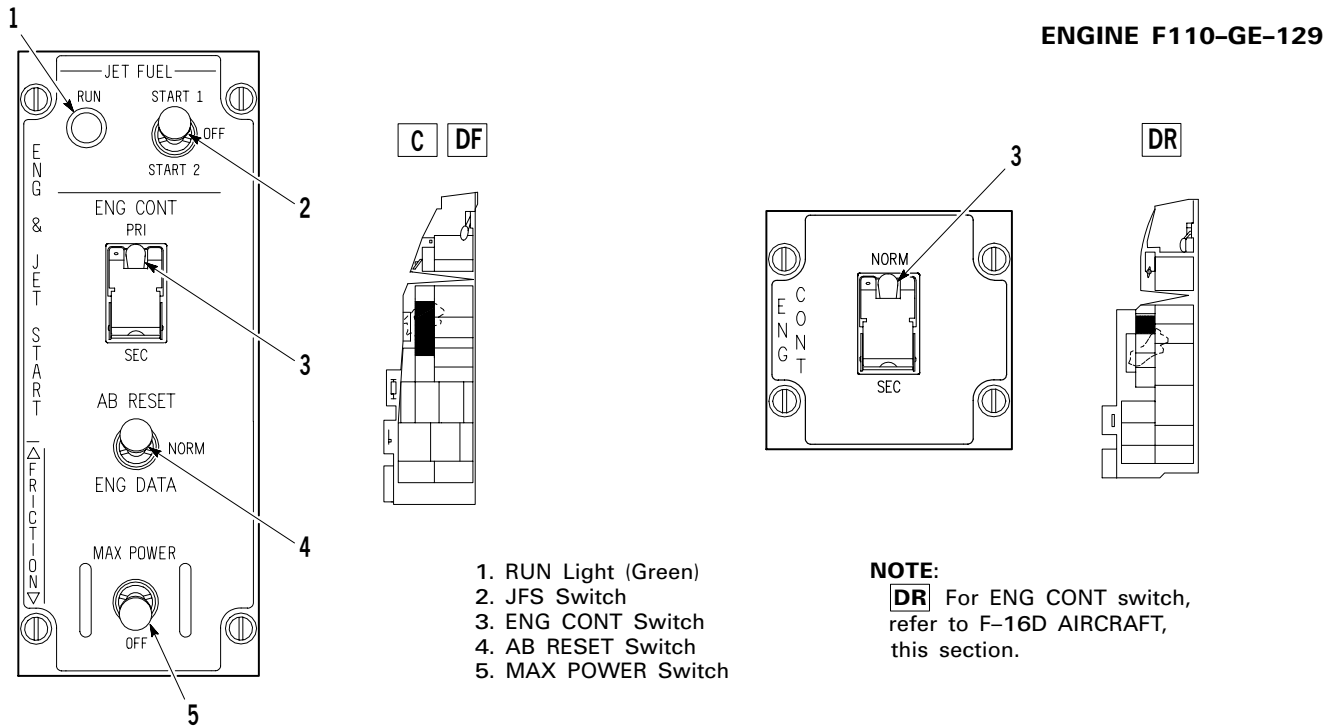

Figure 1-14.

## JFS RUN Light **C** **DF** **GE129**

The green JFS RUN light illuminates within 30 seconds after initiating JFS start to indicate that the JFS has attained governed speed.

## JFS Operation **GE129**

During a ground engine start, the brake/JFS accumulators begin to recharge after the engine accelerates through 12 percent rpm. As the engine accelerates through approximately 55 percent rpm, a sensor causes the JFS to shut down automatically and the JFS RUN light goes off.

During in-flight operation, the brake/JFS accumulators begin to recharge (provided system B hydraulic pressure is available) when the JFS reaches 70 percent of governed speed (3-4 seconds before the JFS RUN light illuminates). If the JFS RUN light does not illuminate within 30 seconds or the JFS RUN light goes off once illuminated, the JFS START switch will not reengage and the JFS cannot be restarted until

the JFS has spooled down. JFS spooldown takes approximately 17 seconds from full governed speed. Once running, the JFS does not shut down until the JFS switch is manually positioned to OFF.

## ENGINE CONTROLS AND INDICATORS **GE129**

Refer to figure 1-15. The engine instruments are located on the right side of the instrument panel. Refer to ENGINE LIMITATIONS, Section V.

## ENG CONT Switch **GE129**

The ENG CONT switch (guarded out of SEC) is located on the left console. **DR** For ENG CONT switch differences, refer to F-16D AIRCRAFT, this section.

Functions are:

- **C** **DF** PRI - PRI operation (normal position).
- SEC - SEC operation. Transfer occurs when the switch is moved to the SEC position.



# Engine Controls and Indicators (Typical)

ENGINE F110-GE-129

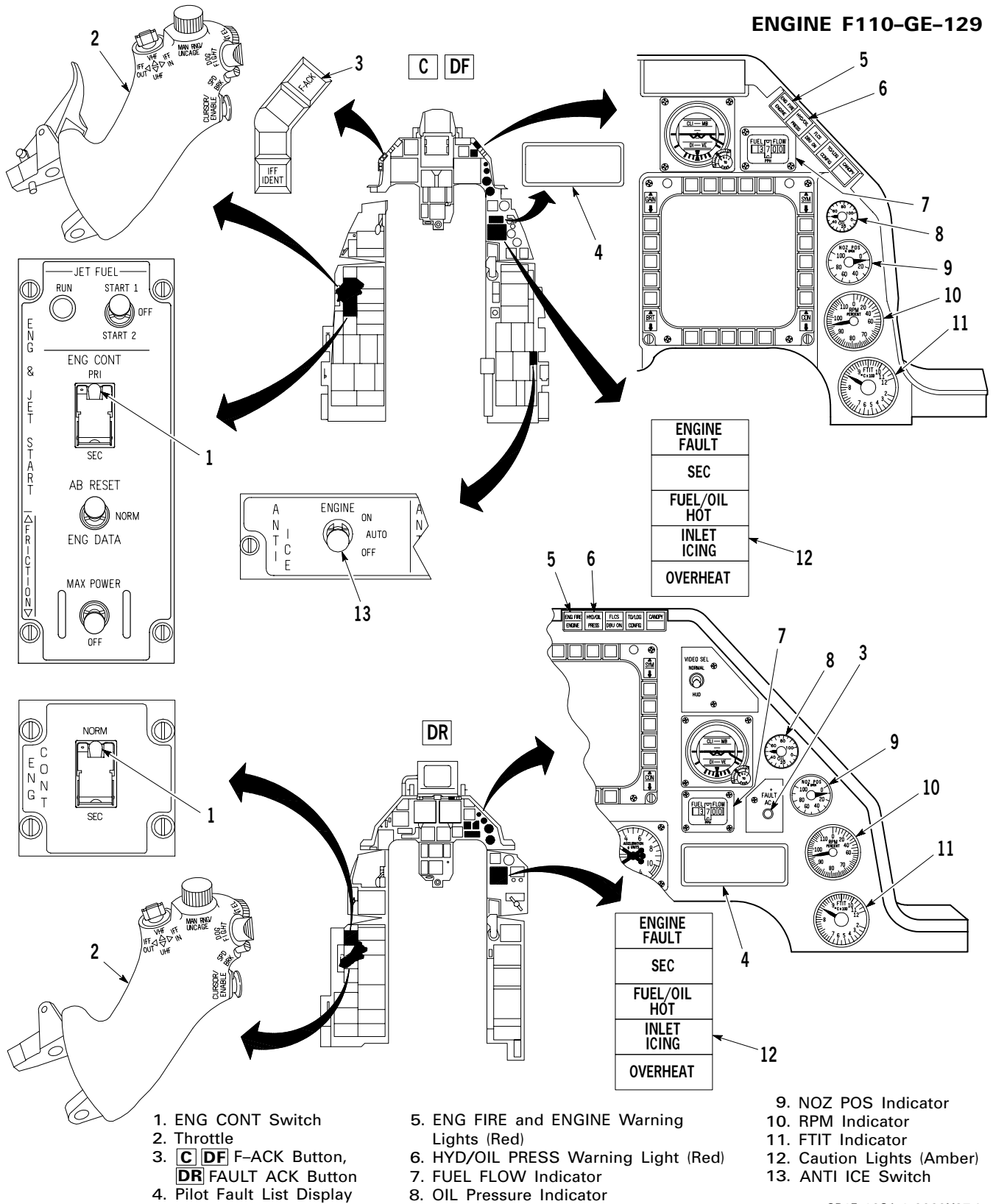

GR1F-16CJ-1-0020X37 ©

Figure 1-15.

**SEC Caution Light** [GE129]

The SEC caution light, located on the caution light panel, indicates that the engine is operating in SEC.

**EEC Caution Light** [GE129]

The EEC caution light, located on the caution light panel, is deactivated.

**BUC Caution Light** [GE129]

The BUC caution light, located on the caution light panel, is deactivated.

**MAX POWER Switch** [C] [DF] [GE129]

The MAX POWER switch, located on the left console, is inoperative.

**AB RESET Switch** [C] [DF] [GE129]

The AB RESET switch, located on the left console, is a three-position toggle switch, spring-loaded to center (NORM) position.

Functions are:

- AB RESET – Inoperative position.
- NORM – Normal (deenergized) position.
- ENG DATA – This position is used to record engine data in the EMSC. When ENG DATA is momentarily selected, ENG 066 MFL is generated and engine data is recorded for an 8-second period. Recorded data begins 6 seconds prior to selecting ENG DATA.

**ENGINE FAULT Caution Light** [GE129]

The ENGINE FAULT caution light, located on the caution light panel, indicates that an engine PFL item was detected. The caution light goes off when the fault is acknowledged.

**Pilot Fault List Display (PFLD)** [GE129]

The PFLD, located on the [C] [DF] right auxiliary console, [DR] instrument panel, displays engine PFL's. Refer to WARNING, CAUTION, AND INDICATOR LIGHTS, this section, for a description of the PFLD. Refer to PILOT FAULT LIST – ENGINE, Section III, for a description of engine PFL's.

**RPM Indicator** [GE129]

The RPM indicator has a pointer display expressed in percent rpm from 0-110. The rpm signal is supplied by the engine alternator. The indicator is powered by battery bus No. 1.

**NOZ POS Indicator** [GE129]

The NOZ POS indicator is a direct display of actual nozzle position ranging from 0 percent (closed) to 100 percent (full open). The indicator is powered by emergency ac bus No. 2.

**FTIT Indicator** [GE129]

The FTIT indicator displays exhaust gas temperature (EGT) in degrees C. The indicator has a range of 200°-1200°C in major increments of 100°C and is powered by battery bus No. 1.

**FUEL FLOW Indicator** [GE129]

The FUEL FLOW indicator is a digital indicator which displays the total fuel flow to the engine, including AB, in pph. The indicator has a range of 0-80,000 pph and is powered by emergency ac bus No. 1.

**OIL Pressure Indicator** [GE129]

The OIL pressure indicator displays engine oil pressure from 0-100 psi and is powered by emergency ac bus No. 2.

**HYD/OIL PRESS Warning Light** [GE129]

The HYD/OIL PRESS warning light, located on the edge of the right glareshield, serves as a monitor of engine oil pressure and hydraulic system pressure. For engine oil pressure, the warning light illuminates when oil pressure has been below approximately 10 psi for 30 seconds (time delay minimizes warning light illuminating during maneuvering). The light goes out when oil pressure exceeds approximately 20 psi. For hydraulic pressure, the warning light illuminates when either A or B system pressure decreases below 1000 psi. The light goes out when both system A and B pressures are above 1000 psi. During engine start, the warning light usually goes off before reaching idle rpm; however, acceptable operation is indicated if the warning light goes off before exceeding 70 percent rpm and remains off when the throttle is retarded to IDLE. The warning light is powered by battery bus No. 1.

**ENGINE Warning Light** GE129

The ENGINE warning light, located on the edge of the right glareshield, illuminates when RPM and FTIT indicator signals indicate that an engine overtemperature or flameout has occurred. Illumination also occurs for an engine alternator failure and may occur as a result of an RPM or FTIT indicator failure. The warning light illuminates when the rpm decreases to subidle (below 60 percent) or approximately 2 seconds after FTIT indication exceeds 1100°C. The warning light goes off when the condition that turned it on is eliminated. The warning light is powered by battery bus No. 1.

**Throttle** GE129

Refer to figure 1-16. The engine is controlled by a throttle mounted above the left console with detents at OFF, IDLE, MIL, and MAX AB. The OFF position inhibits fuel flow. The IDLE position commands minimum thrust and is used for all ground starts. From IDLE to MIL, the throttle controls the output of the engine. Forward of the MIL position, the throttle modulates the operation of the AB while maintaining constant basic engine operation.

C DF The throttle must be rotated outboard to allow advancement from OFF to IDLE and from MIL to AB. Retarding the throttle from AB to MIL automatically rotates the throttle. At IDLE, a cutoff release at the base of the throttle must be actuated to allow the throttle to be rotated outboard and retarded to OFF. DR For throttle differences, refer to F-16D AIRCRAFT, this section.

Both electrical and mechanical throttle positions are transmitted to the engine. The electrical input is used by the DEC as the primary throttle position signal to compute various engine operating values. The throttle is also mechanically connected to the engine via a cable to the MEC. This mechanical throttle position input is used for main fuel cutoff and during SEC and HYB operation. It also provides a backup electrical signal to the DEC during PRI operation.

A single white reflective stripe C DF is located on both the upper surface of the throttle foot and on the sidewall fairing, DR on both the lower throttle radius next to the console and on the panel outboard of the throttle radius. Alignment of the two stripes aids in identifying the IDLE position.

Six switches are located on the throttle. C DF A throttle friction control is located inboard at the base of the throttle. D The throttles are mechanically linked together.

**ENGINE OPERATING CHARACTERISTICS** GE129**Ground Operations** GE129

During engine start, the SEC caution light remains on until approximately 20 percent rpm. Since the DEC maintains constant idle thrust and minimum bleed air pressure, rpm varies with temperature and pressure altitude (higher temperature or pressure altitude results in higher rpm). While VSV reset is active, idle rpm is 2-3 percent higher than normal.

During cold weather operations below 30°F, the DEC logic, when either commanded manually or automatically, increases anti-ice bleed air pressure to improve system performance at idle rpm. Engine rpm may increase as much as 3 percent during anti-ice operations.

Engine vibration/rumble may be sensed in flight or on the ground while accelerating or decelerating the engine, when transferring to SEC, or when stabilized below MIL power in either PRI or SEC. The vibration/rumble at a stabilized rpm has no adverse effect on the engine or aircraft structure. The vibration/rumble should disappear when the throttle is advanced slightly (approximately 5 percent rpm increase). Vibration that persists or becomes appreciably more intense when the throttle is advanced may indicate a potential engine malfunction.

**Non-AB Operation in Flight** GE129

Regardless of temperature, stabilized NOZ POS indicator indications should not exceed 15 percent open in MIL.

Engine operation is continually optimized as flight conditions change. This is evident by slight changes in the NOZ POS, RPM, and FTIT indicator indications.

As altitude increases, idle rpm increases in order to maintain the required bleed air pressure for satisfactory ECS operation and stall margin for the engine. As a result, rpm and FTIT response during throttle movement between low throttle settings is significantly reduced.

# Throttle (Typical)

ENGINE F110-GE-129

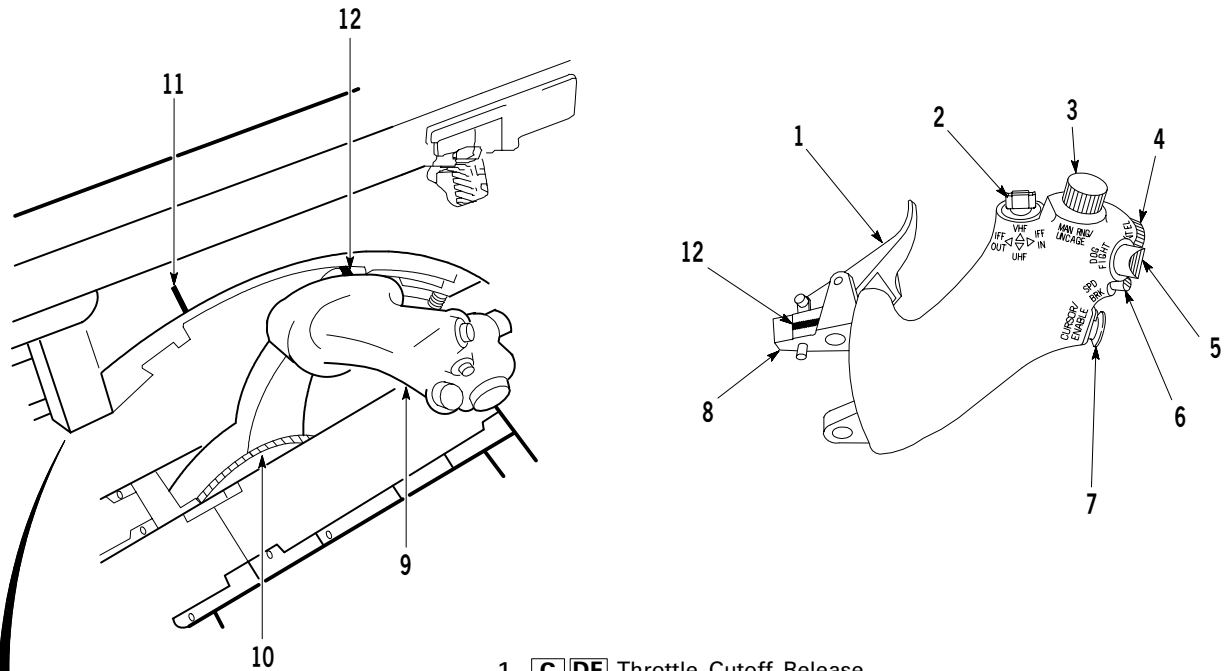

1. **C** **DF** Throttle Cutoff Release
2. UHF VHF IFF Transmit Switch (4-Way, Momentary Rocker)
3. MAN RNG/UNCAGE Knob/Switch (Rotate, Depress)
4. ANT ELEV Knob (Rotate, Center Detent)
5. DOG FIGHT Switch (3-Position, Slide)
6. SPD BRK Switch (3-Position, Aft Momentary)
7. RDR CURSOR/ENABLE Switch (Depress, Multidirectional)
8. Throttle Foot
9. Throttle
10. **C** **DF** Throttle Friction Control
11. **C** **DF** IDLE Stripe
12. **C** **DF** Throttle Stripe

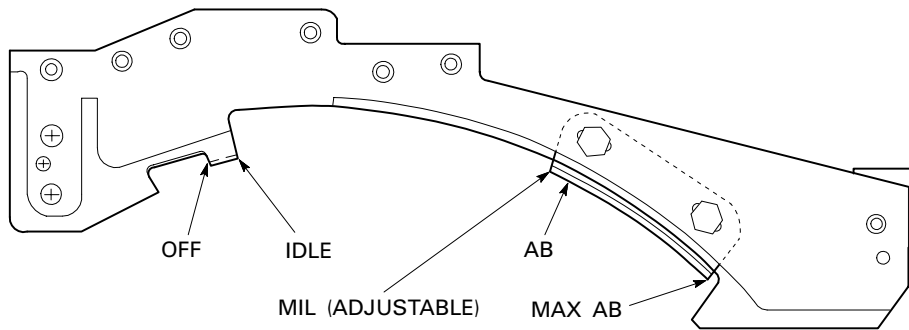

**NOTE:**

**DR** For throttle differences, refer to THROTTLE and F-16D AIRCRAFT, this section.

Figure 1-16.

## T.O. GR1F-16CJ-1

At 1.4 mach and greater, the minimum thrust level is near MIL even though the throttle may be retarded below MIL. Typically, the minimum thrust level decreases with mach number between 1.4-1.1 mach. At IDLE and while decelerating through 1.1 mach, the engine decelerates to normal in-flight idle thrust.

Reduced speed excursion (RSE) logic is activated during engine deceleration to idle speed above 0.6 mach. RSE results in a higher in-flight idle rpm offset by a greater nozzle opening than normal in-flight idle.

Idle thrust changes from in-flight idle to approach idle between 0.5-0.6 mach, resulting in an engine rpm change of approximately 10 percent. Slightly more time is required to accelerate the engine from approach idle thrust when airspeed is below 0.5 mach.

Idle thrust changes from approach idle to ground idle between 80-90 knots and results in reduced engine rpm of approximately 2 percent. This change occurs during the landing roll to achieve desired ground idle thrust levels for taxi.

While VSV reset is active, idle rpm is 2-3 percent higher than normal.

A high frequency vibration may be felt through the cockpit floor, ejection seat, and/or rudder pedals as a result of aircraft structural response to normal engine operation. The vibration is most noticeable with the aircraft in a clean configuration with reduced fuel loads at lower airspeeds when the engine is operating near MIL thrust or above. This vibration has no adverse effect on the engine or aircraft.

### **AB Operation** GE129

Refer to figure 1-17 for AB operational characteristics. During AB operation, FTIT, rpm, and oil pressure vary with altitude and airspeed. NOZ POS indications during minimum AB operation should be between 7-17 percent open and for MAX AB operation, between 40-70 percent open. The engine has a reduced AB region of operation (at high altitudes and low airspeeds) and commands a decrease in AB fuel flow to prevent AB instabilities. The NOZ POS indicator indicates approximately 30-50 percent open during this reduced AB operation.

When AB operation is first initiated, the exhaust nozzle preopens up to 10 percent more than MIL exhaust nozzle position to increase stall margin during AB light-off. Fuel flow and exhaust nozzle area are held at minimum AB levels until the flame detector determines that light-off (within 5 seconds (greater than 40°F) or 10 seconds (40°F or less) of AB selection) has occurred. Once AB light-off occurs, fuel flow and exhaust nozzle area increase to the requested AB level with a corresponding increase in thrust. If AB blowout occurs, the autorelight feature attempts to reinitiate AB without throttle movement. During AB operation at or above 45,000 feet, a mild AB rumble may be felt through the pilot seat. The rumble does not impact engine operation and should not be considered abnormal.

### **Inlet Thump** GE129

An inlet thump is an airflow-related phenomenon which may occur occasionally during PRI operation below 25,000 feet and below 500 knots when the throttle is retarded from MIL. The thump is the result of airflow changes within the aircraft inlet.

A thump can be heard or can be felt through the cockpit floor, ejection seat, and/or rudder pedals. The intensity can vary greatly, ranging from a barely perceptible sound or impulse to a louder and/or harder occurrence which may be quite noticeable. Thumps do not affect engine or aircraft operation.

### **SEC Operation** GE129

The engine can automatically transfer to SEC when a DEC failure occurs. It can manually be transferred to SEC by placing the ENG CONT switch to SEC. Transfer is indicated by the illumination of the SEC caution light; rpm may also initially decrease (up to 10 percent rpm) and then recover to a level slightly below that for PRI. When operating in SEC, the nozzle is closed.

Refer to ENGINE LIMITATIONS, Section V for throttle restrictions while operating in SEC. Movement of the throttle to MAX AB is permitted; however, since the AB is inhibited, maximum available thrust in SEC is attained at MIL. The thrust level at MIL during SEC operation is 70-95 percent of that available during PRI operation at the same throttle position. Idle thrust in SEC is higher than idle thrust in PRI because the exhaust nozzle is closed. VSV reset is not active in SEC.

# AB — Light-Off Characteristics

ENGINE F110-GE-129

**NOTES:**

- Regions 1 and 2 — Unrestricted throttle movement. AB blowouts should not occur.
- Region 1 — Normal AB light-offs are expected.
- Region 2 — No lights or delayed lights accompanied by nozzle fluctuations indicating recycling of AB initiation are possible.

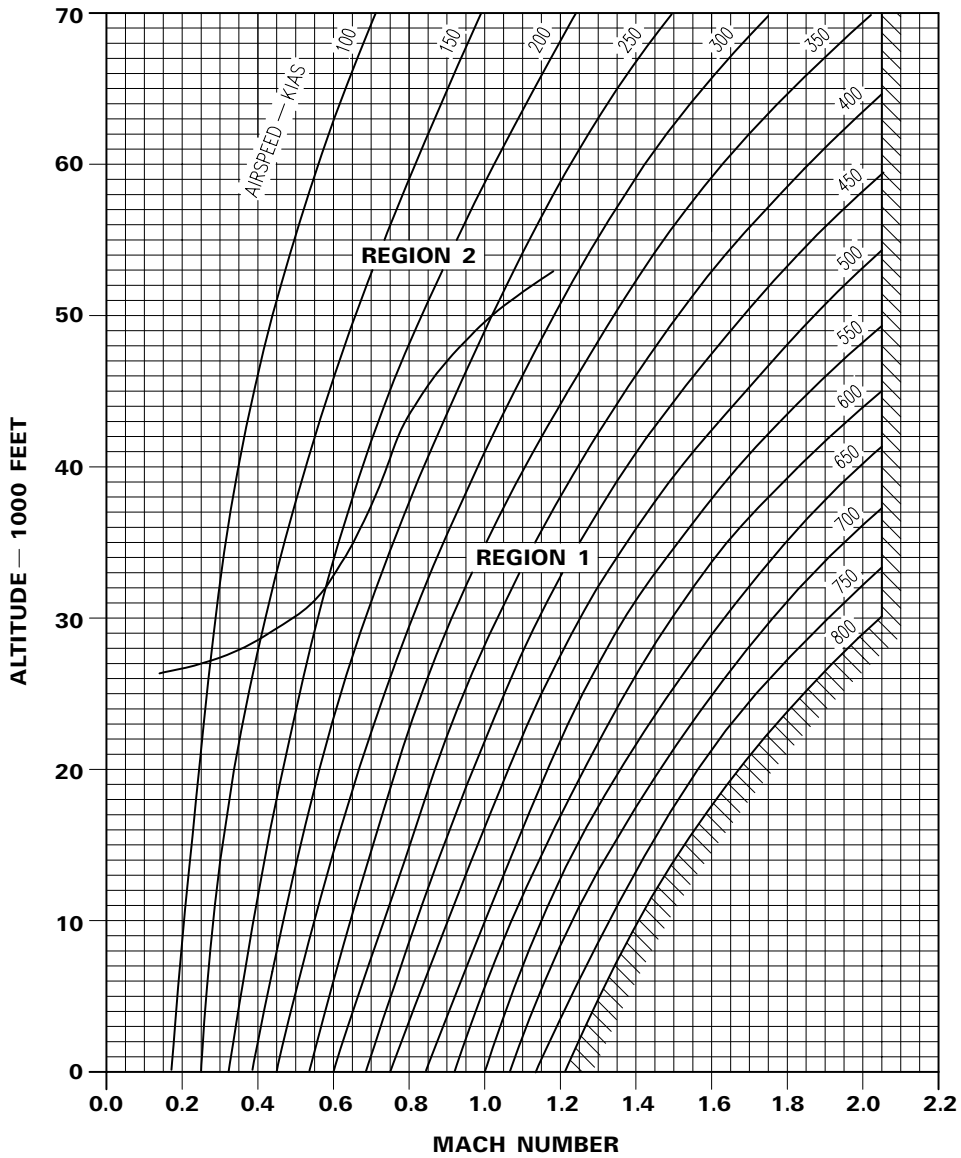

1F-16X-1-4007X@

Figure 1-17.

## FIRE AND OVERHEAT DETECTION SYSTEM

The fire and overheat detection system consists of two separate parallel loop sensing systems, one for fire and the other for overheat. The fire detection loops are routed through the engine compartment. The overheat detection loops are routed through the engine compartment, MLG wheel wells, ECS bay, and EPU bay. Activation of the overheat detection loops occurs approximately 100°C below the activation temperature of the fire detection loops. The fire warning signal causes the ENG FIRE warning light to illuminate. The overheat signal causes the OVERHEAT caution light to illuminate. When the temperature of the element drops below the critical temperatures, the signal ceases, allowing the ENG FIRE warning or the OVERHEAT caution light to go off. The detection circuit is powered by emergency ac bus No. 2 and battery bus No. 2.

### FIRE & OHEAT DETECT TEST BUTTON C DF

Refer to figure 1-18. The FIRE & OHEAT DETECT test button, located on the TEST switch panel, checks continuity of both systems and illuminates the ENG FIRE warning light and the OVERHEAT caution light and provides a CSFDR special event data save if depressed in flight.

## FUEL SYSTEM

Refer to figure 1-19 for a simplified system diagram and figures 1-20 and 1-21 for system schematics. The fuel system is divided into seven functional categories. These are the fuel tank system, fuel transfer system, fuel tank vent and pressurization system, engine fuel supply system, fuel quantity/fuel level sensing system, fuel tank explosion suppression system, and refueling/defueling system.

### FUEL TANK SYSTEM

Refer to figure 1-22 for tank locations and capacities. The aircraft has seven internal fuel tanks located in the fuselage and wings that are integral to the structure. There are provisions for carrying three external tanks on the wings and the centerline station PX III and for mounting two Conformal Fuel Tanks (CFT's) to the upper surface of the aircraft. CFT fuel is considered internal fuel. Five of the internal tanks are storage tanks: the left and right

## TEST Switch Panel

C DF (Typical)

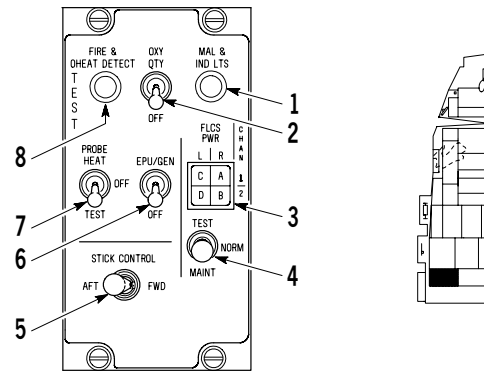

1. MAL & IND LTS Test Button
2. OXY QTY Indicator Test Switch
3. FLCS PWR Lights (Green)
4. FLCS PWR TEST Switch
5. DF STICK CONTROL Switch
6. EPU/GEN Test Switch
7. PROBE HEAT Switch
8. FIRE & OHEAT DETECT Test Button

GR1F-16CJ-1-0023X37 ©

Figure 1-18.

wing tanks, two forward fuselage tanks (F-1 and F-2), and the aft fuselage tank (A-1). The two internal reservoir tanks (forward and aft) supply fuel directly to the engine. D The F-1 fuel tank is reduced in size to allow room for the rear cockpit.

### FUEL TRANSFER SYSTEM

Fuel is transferred by two independent methods. The primary method provides a siphoning action through standpipes connecting the fuel tanks. Siphoning action depends on the absence of air in the bays receiving fuel. Air ejectors in each reservoir tank automatically expel air. In case of failure of the siphoning system, powered fuel pumps work continually to pump fuel from the internal tanks to the reservoirs. The powered transfer system also scavenges tanks to minimize unusable fuel by using electrically driven pumps and pumps powered by bleed fuel pressure from the engine manifold. Both methods operate simultaneously and independently to transfer fuel through the system.

# Fuel Tank System (Typical) PX II

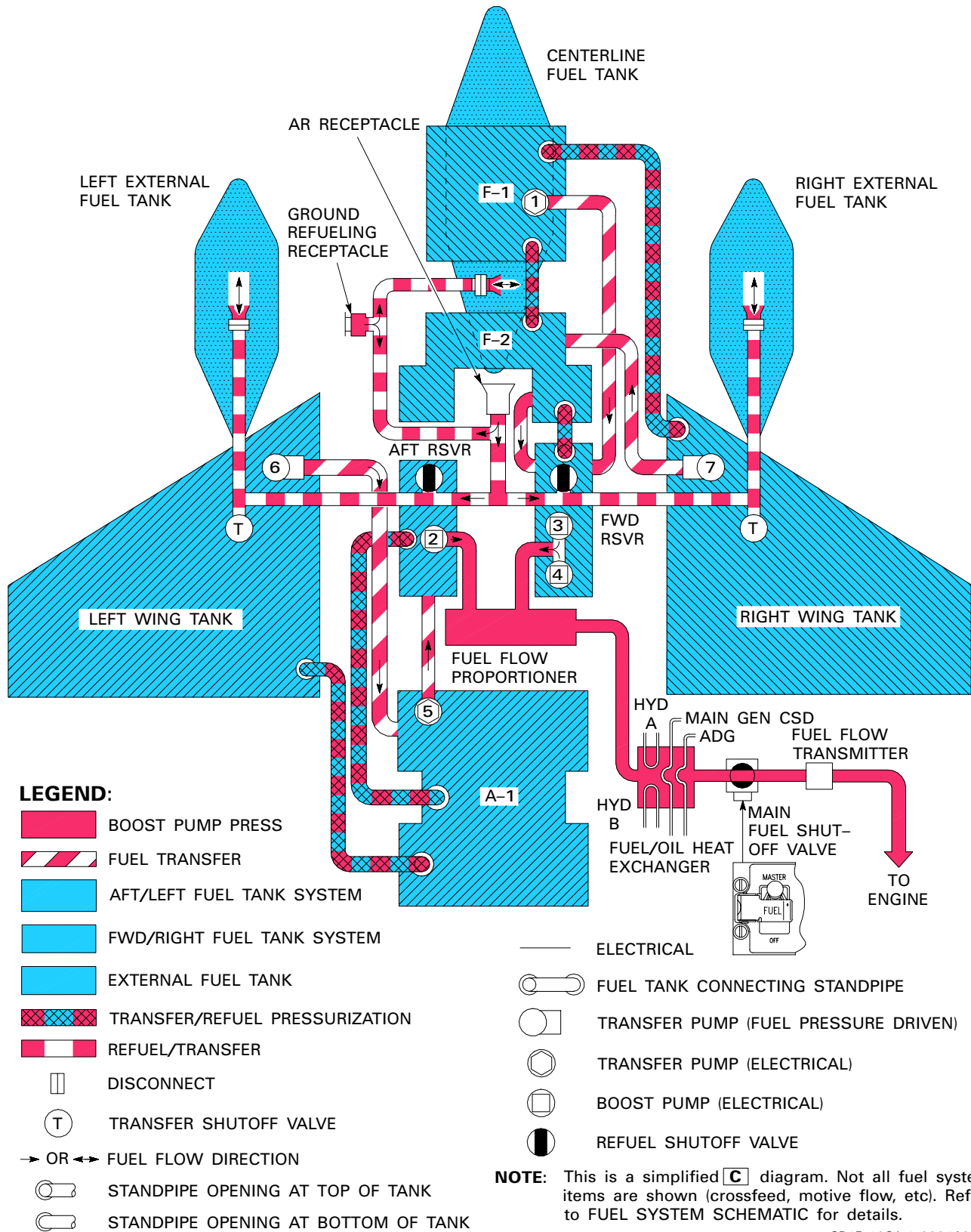

GR1F-16CJ-1-0024A37 ©

Figure 1-19. (Sheet 1)



# Fuel Tank System (Typical) PX III

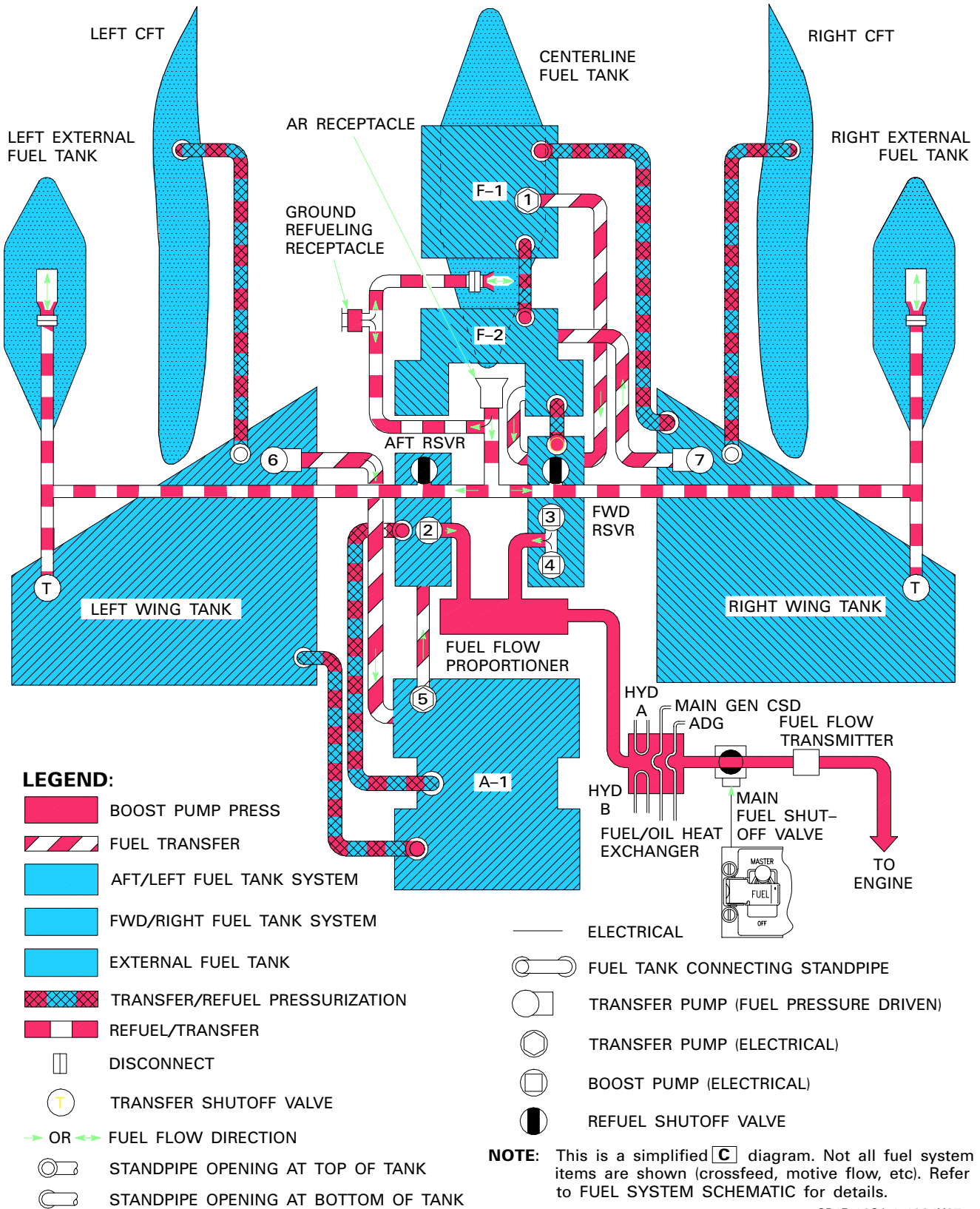

GR1F-16CJ-1-1024X37

Figure 1-19. (Sheet 2)

The transfer system is divided into two separate tank systems, the forward and the aft. The forward system consists of the right external tank (if installed), **PX III** right CFT (if installed), right internal wing tank, F-1, F-2, and the forward reservoir. The aft system consists of the left external tank (if installed), **PX III** left CFT (if installed), left internal wing tank, A-1, and the aft reservoir. If a centerline tank is installed, it is considered to be part of both forward and aft systems. The wing external tanks empty into the respective internal wing tanks. **PX III** The right CFT transfers into the right internal wing tank, and the left CFT transfers into the left internal wing tank.

Fuel flows from the internal wing tanks to the fuselage tanks and then to the forward and aft reservoirs. Fuel is pumped to the engine from the reservoirs. To automatically maintain the CG, fuel is transferred through the forward and aft systems simultaneously.

**PX III** The CFT fuel system gravity feeds fuel to the internal wing tanks. Primary fuel transfer is by siphon/air pressure transfer from the CFT to the internal wing. CFT's will empty prior to the internal wing tanks.

If external tanks are installed, air pressure transfers fuel to the internal wing tanks. If the EXT FUEL TRANS switch is in NORM, the sequence of fuel flow is from the centerline tank to the internal wing tanks. After the centerline tank empties, each external wing tank flows to its respective internal wing tank. The external tank fuel transfer valve in each internal wing tank shuts off fuel to prevent overfilling the internal tanks. If one of these valves fails, a float switch senses fuel and shuts off all external tank fuel transfer before fuel flows overboard. By placing the EXT FUEL TRANS switch to WING FIRST, the external wing tanks empty before the centerline tank, and the float switch does not prevent fuel from spilling overboard if a transfer valve fails.

**PX III** When using CFT's and external tanks, selection of the EXT FUEL TRANS switch to CFT FIRST/NO FILL will deplete the CFT's prior to the external tanks. After the CFT's deplete, the transfer sequence of the external tanks will be centerline first, followed by the external wing tanks. When using CFT's and external tanks, selection of the EXT FUEL TRANS switch to NORM or WING FIRST will allow air pressure transfer of fuel from the external tanks into the internal wing tanks, keeping the CFT's and the internal wing tanks full. The sequence of external tank transfer will be as described in the previous paragraph on external tank transfer. When external fuel has transferred, CFT fuel will begin to transfer.

The automatic forward fuel transfer system supplements the function of the FFP by preventing undesirable aft CG. The system operates only when the FUEL QTY SEL knob is in NORM and the total forward fuselage fuel quantity indication is less than 2800 (**D** 1500) pounds. In the **C**, forward fuel transfer starts when the forward heavy fuel differential drops below 300 pounds and stops when the forward heavy fuel differential reaches 450 pounds. In the **D**, forward fuel transfer starts when the aft heavy fuel differential exceeds 900 pounds and stops when the aft heavy fuel differential reaches 750 pounds. This system does not correct a forward fuel imbalance since it only transfers fuel from aft to forward.

For proper operation, the automatic forward fuel transfer system depends on a properly functioning fuel quantity indicating system. Fuel is transferred through a solenoid-operated trim valve powered from emergency dc bus No. 2. The automatic system is deactivated if electrical power is lost through failure, by moving the FUEL QTY SEL knob out of NORM, or during gravity feed conditions.

## FUEL TANK VENT AND PRESSURIZATION SYSTEM

The fuel tank vent and pressurization system supplies cooled pressurized air from the ECS to force fuel from the external tanks to the internal wing tanks and to power the air ejector pumps whenever the AIR SOURCE knob is in NORM or DUMP. It also prevents fuel in internal tanks from vaporizing at high altitude. An external tank vent and pressurization valve regulates pressure supplied to the external tanks.

If the combat schedule (reduced pressure) is activated by the TANK INERTING switch, Halon, if available, is mixed with air and the internal tank vent and pressurization valve controls the pressure.

If the AIR SOURCE knob is placed in OFF or RAM or if the ECS is inoperative, tank pressurization is not available and external fuel cannot be transferred.

With multiple generator failures, fuel tank pressurization continues and external fuel still transfers.

## ENGINE FUEL SUPPLY SYSTEM

Refer to figure 1-23 for fuel system controls and operation. When the ENG FEED knob is in NORM, boost pumps in the forward and aft reservoirs pump the fuel through the engine feedline to the fuel flow proportioner (FFP). In the FFP, twin constant-displacement pumps, powered by hydraulic system A, supply equal amounts of fuel from each reservoir to maintain CG. Two fuel lines with check valves can bypass the FFP in case it fails so that fuel flow will not be interrupted. After fuel flows through the FFP, a small amount of cooling fuel is routed to the **PW 229**

# Fuel System C (Typical) PX II

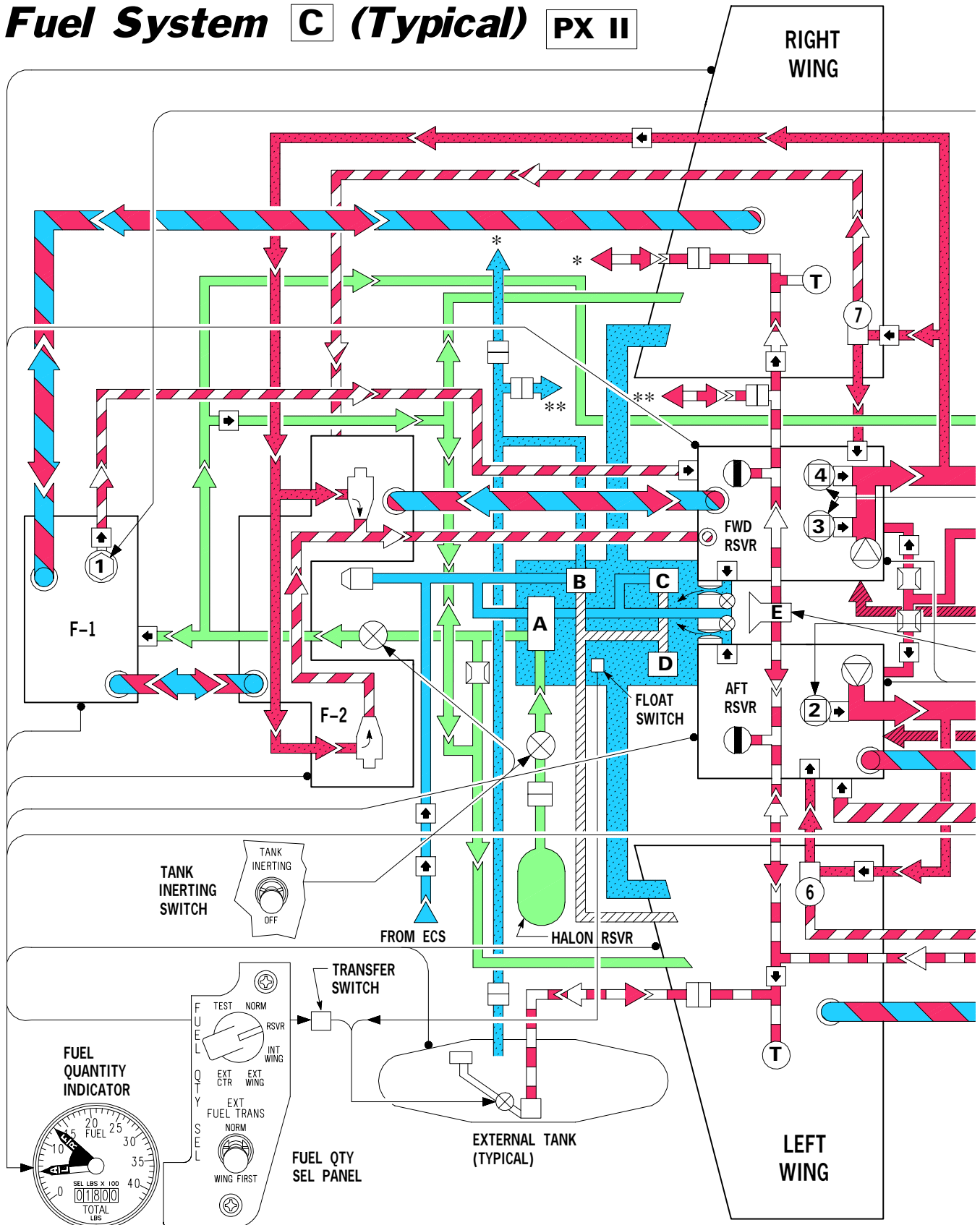

GR1F-16CJ-1-0026-1A37 ©

Figure 1-20. (Sheet 1)

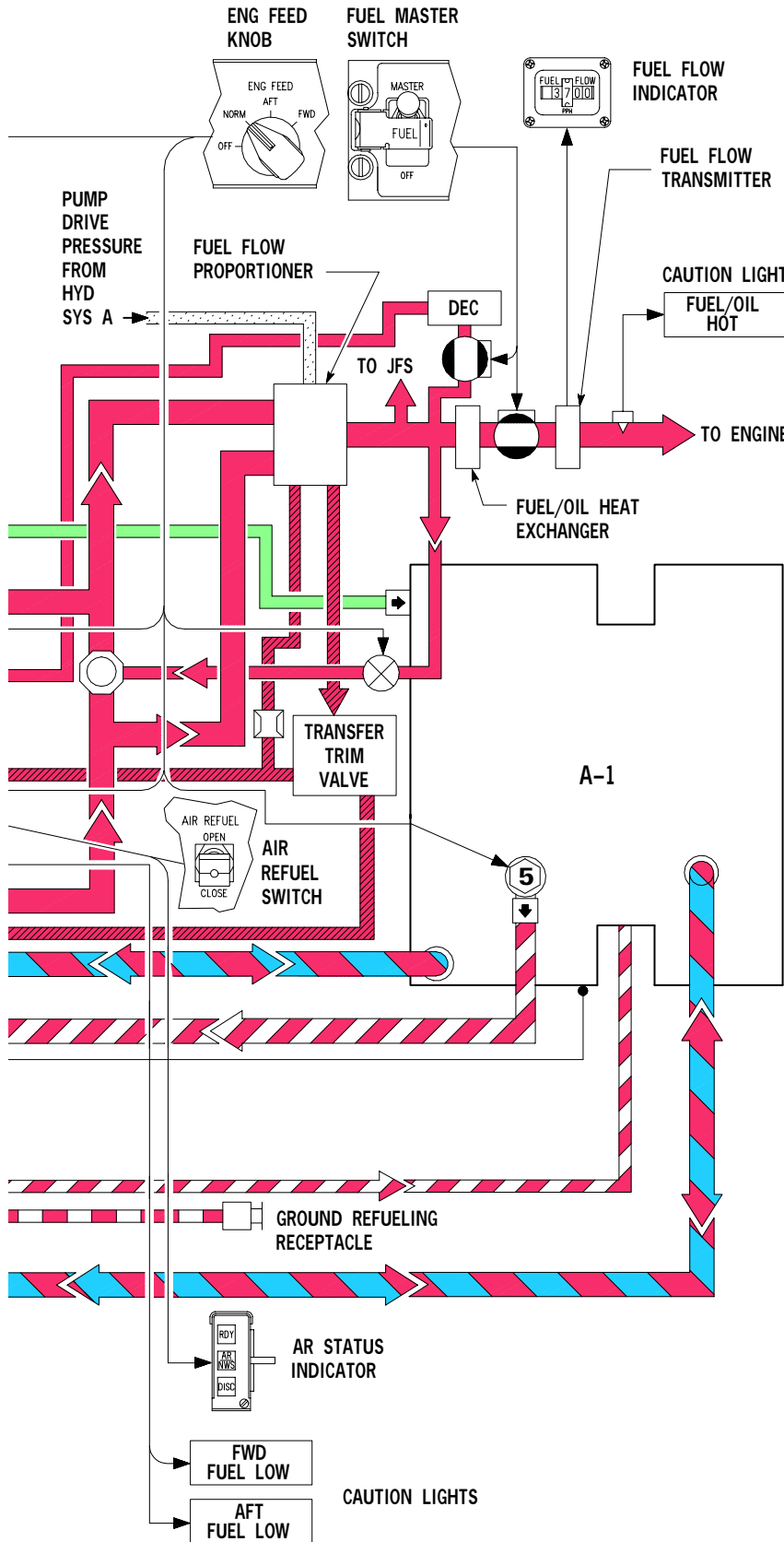

**LEGEND:**

- TRANSFER SHUTOFF VALVE
- TRANSFER PUMP (ELECTRICAL)
- BOOST PUMP (ELECTRICAL)
- REFUEL SHUTOFF VALVE
- SOLENOID VALVE
- CROSSFEED VALVE
- TRANSFER PUMP (FUEL PRESSURE DRIVEN)
- SUCTION FEED VALVE
- DISCONNECT
- GROUND COOLING RECEPTACLE
- FUEL EJECTOR PUMP
- ELECTRIC MOTOR OPERATED SHUTOFF VALVE
- ORIFICE
- CHECK VALVE
- TEMPERATURE SENSOR
- STANDPIPE OPENING AT TOP OF TANK
- STANDPIPE OPENING AT BOTTOM OF TANK
- FUEL TANK CONNECTING STANDPIPE
- \* TO RIGHT WING EXT TANK
- \*\* TO CENTERLINE TANK
- A** HALON/AIR MIXING VALVE
- B** EXT TANK VENT & PRESS VALVE
- C** INT TANK VENT & PRESS VALVE
- D** REMOTE SENSING PRESSURE RELIEF VALVE
- E** AR RECEPTACLE
- ELECTRICAL
- OVERBOARD VENT
- FUEL SUPPLY
- BOOST PUMP PRESSURE
- PUMP DRIVE PRESSURE
- TANK INERTING PRESSURE
- FUEL TRANSFER
- TRANSFER/REFUEL PRESSURIZATION
- TANK PRESSURIZATION
- REFUEL/TRANSFER
- ECS PRESSURIZATION SUPPLY
- TRANSFER BLEED

Figure 1-20. (Sheet 2)

# Fuel System C (Typical) PX III

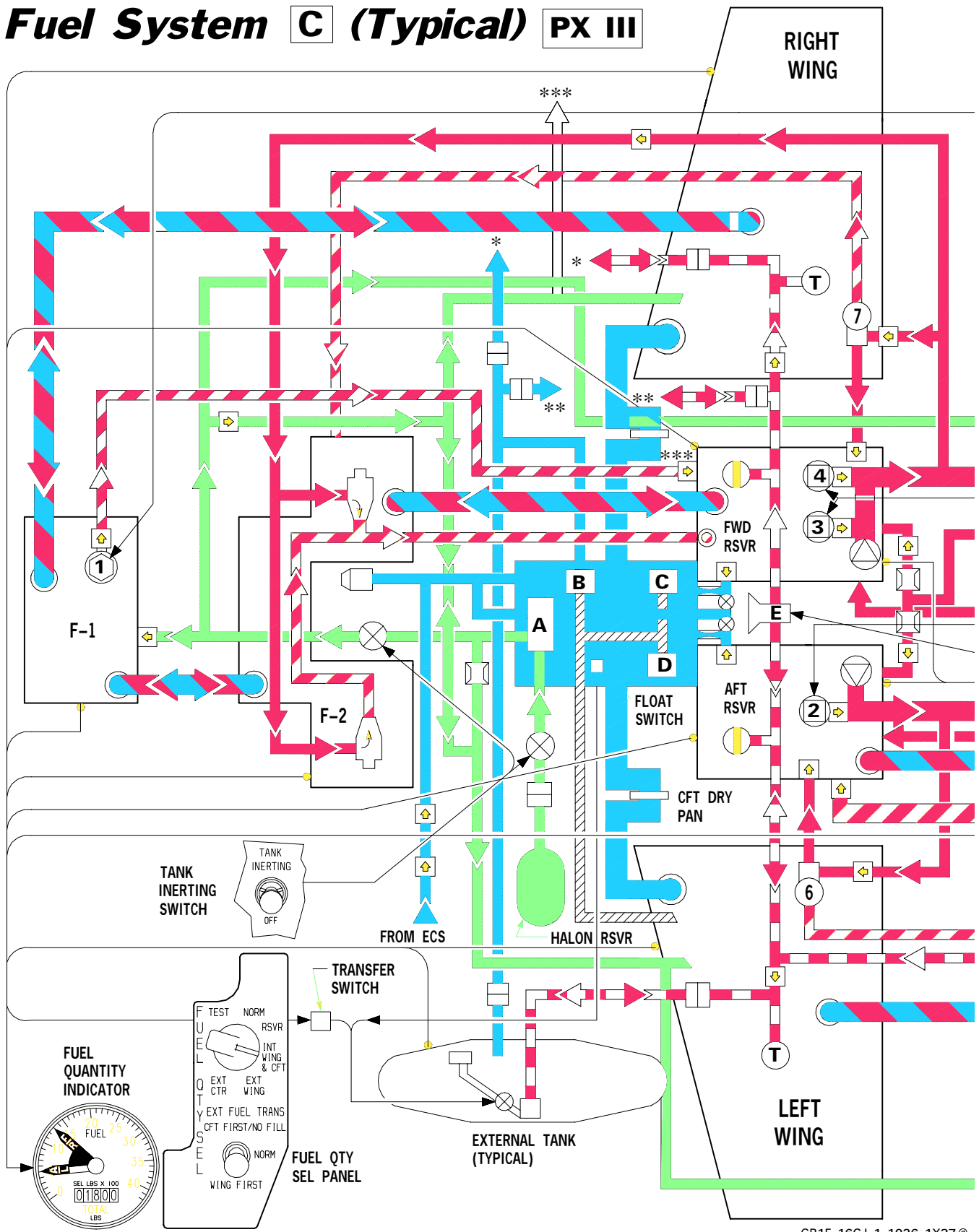

GR1F-16CJ-1-1026-1X37 ©

Figure 1-20. (Sheet 3)

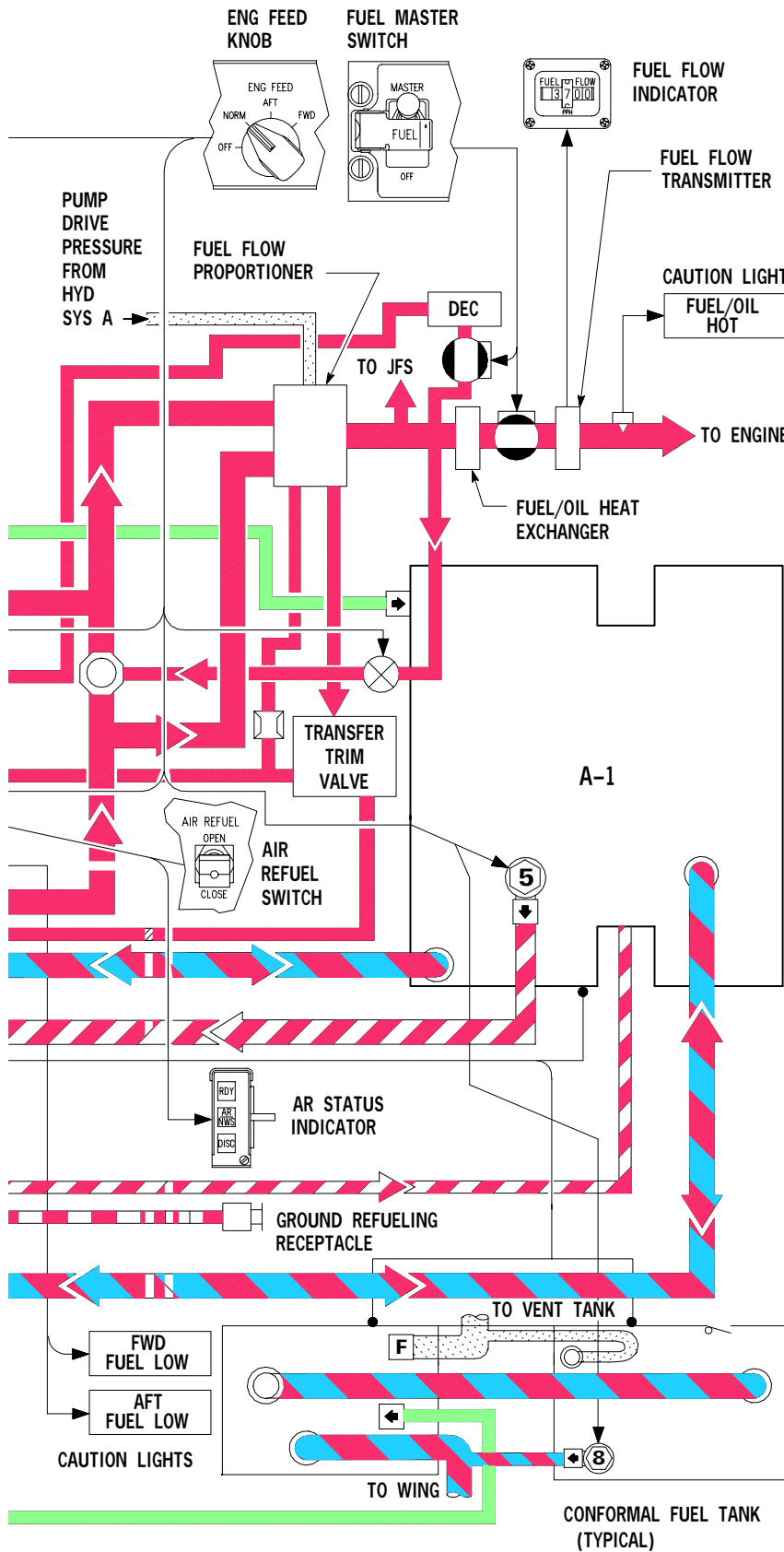

**LEGEND:**

- TRANSFER SHUTOFF VALVE
- TRANSFER PUMP (ELECTRICAL)
- BOOST PUMP (ELECTRICAL)
- REFUEL SHUTOFF VALVE
- SOLENOID VALVE
- CROSSFEED VALVE
- TRANSFER PUMP (FUEL PRESSURE DRIVEN)
- SUCTION FEED VALVE
- DISCONNECT
- GROUND COOLING RECEPTACLE
- FUEL EJECTOR PUMP
- ELECTRIC MOTOR OPERATED SHUTOFF VALVE
- ORIFICE
- CHECK VALVE
- TEMPERATURE SENSOR
- STANDPIPE OPENING AT TOP OF TANK
- STANDPIPE OPENING AT BOTTOM OF TANK
- FUEL TANK CONNECTING STANDPIPE
- \* TO RIGHT WING EXT TANK
- \*\* TO CENTERLINE TANK
- \*\*\* TO RIGHT CFT
- A HALON/AIR MIXING VALVE
- B EXT TANK VENT & PRESS VALVE
- C INT TANK VENT & PRESS VALVE
- D REMOTE SENSING PRESSURE RELIEF VALVE
- E AR RECEPTACLE
- F REMOTE SENSING PRESSURE RELIEF VALVE (CFT)
- ELECTRICAL
- OVERBOARD VENT
- FUEL SUPPLY
- BOOST PUMP PRESSURE
- PUMP DRIVE PRESSURE
- TANK INERTING PRESSURE
- FUEL TRANSFER
- TRANSFER/REFUEL PRESSURIZATION
- TANK PRESSURIZATION
- REFUEL/TRANSFER
- ECS PRESSURIZATION SUPPLY
- TRANSFER BLEED

GR1F-16CJ-1-1026-2X37 ©

Figure 1-20. (Sheet 4)

# Fuel System D (Typical) PX II

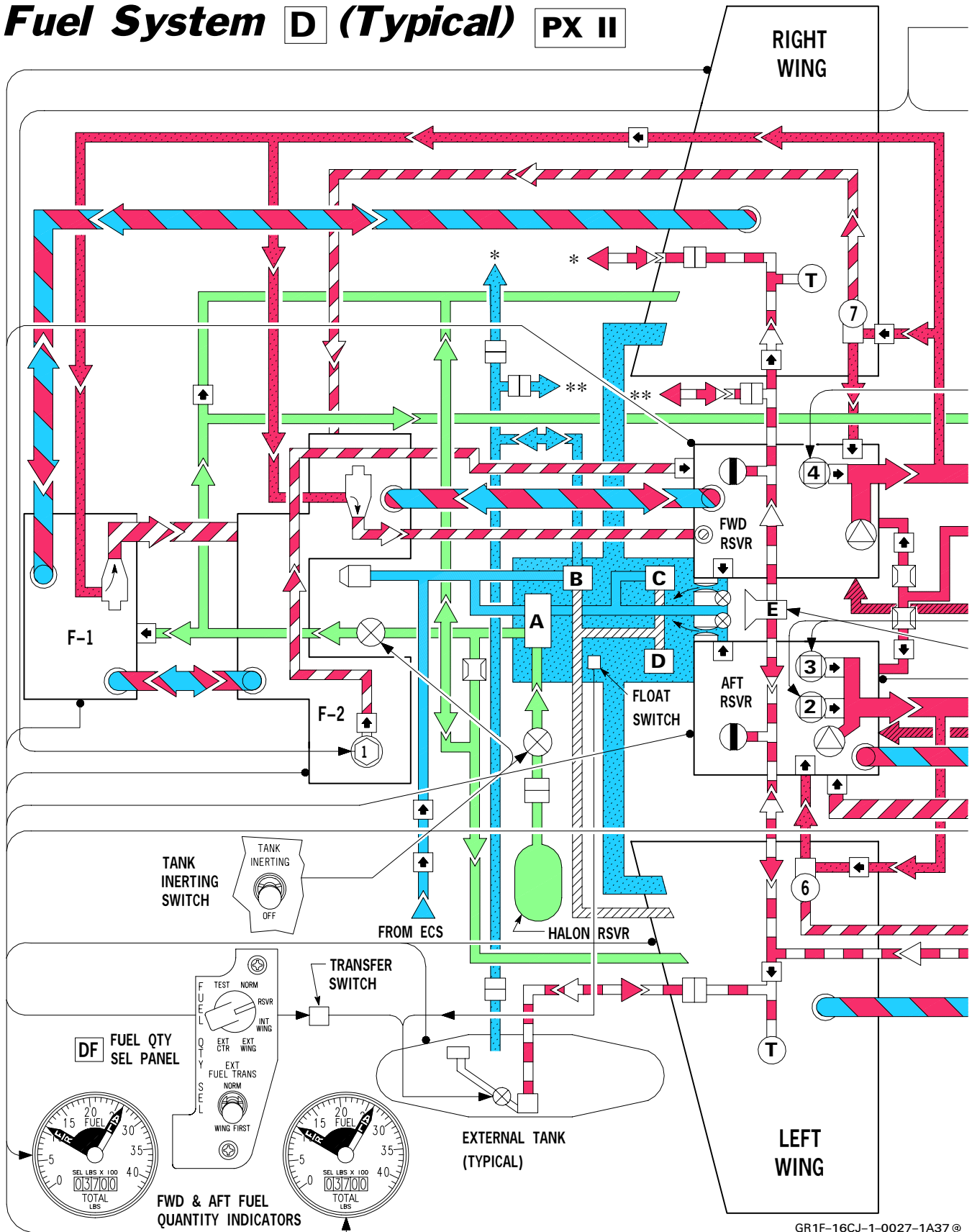

GR1F-16CJ-1-0027-1A37©

Figure 1-21. (Sheet 1)

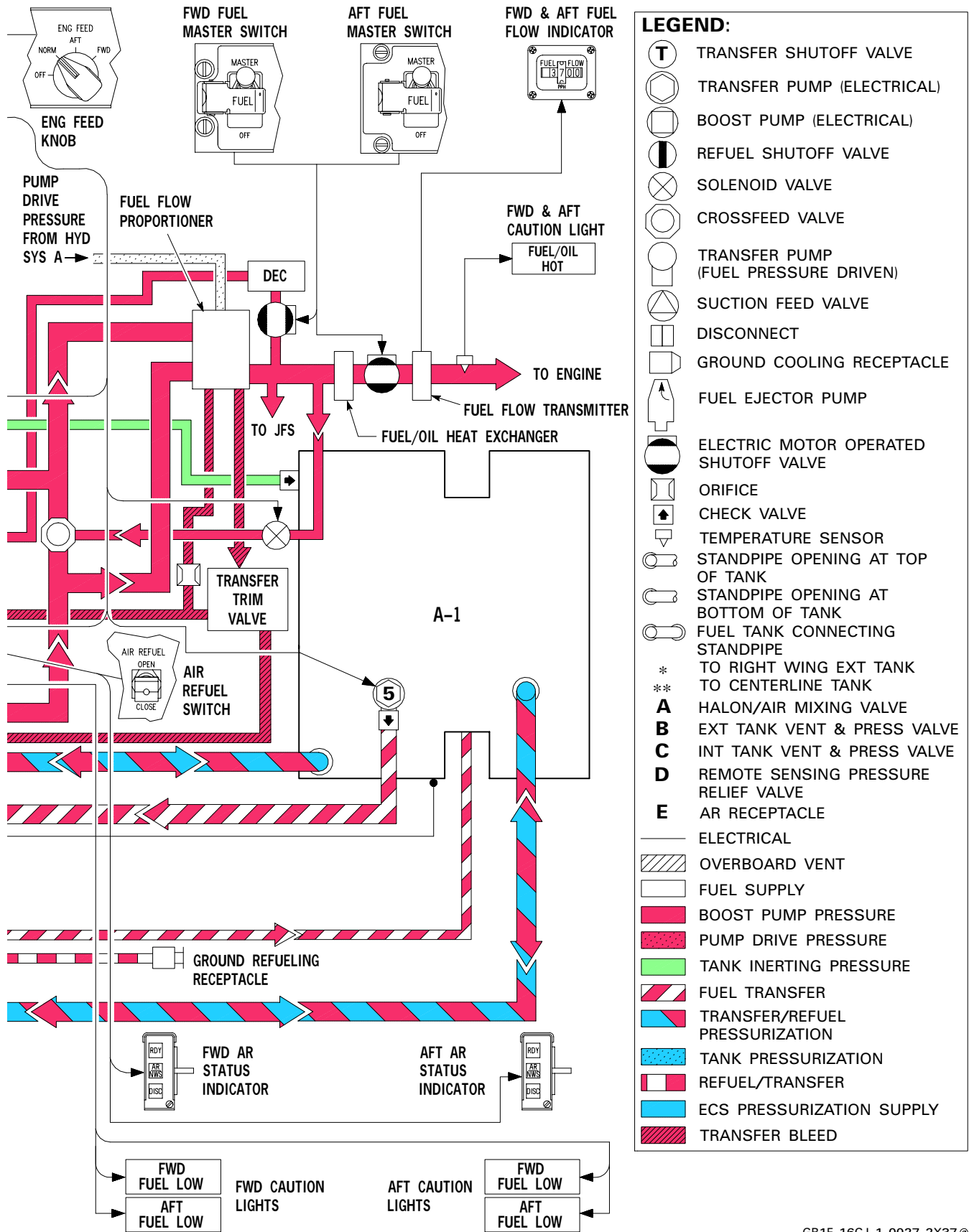

**LEGEND:**

	TRANSFER SHUTOFF VALVE
	TRANSFER PUMP (ELECTRICAL)
	BOOST PUMP (ELECTRICAL)
	REFUEL SHUTOFF VALVE
	SOLENOID VALVE
	CROSSFEED VALVE
	TRANSFER PUMP (FUEL PRESSURE DRIVEN)
	SUCTION FEED VALVE
	DISCONNECT
	GROUND COOLING RECEPTACLE
	FUEL EJECTOR PUMP
	ELECTRIC MOTOR OPERATED SHUTOFF VALVE
	ORIFICE
	CHECK VALVE
	TEMPERATURE SENSOR
	STANDPIPE OPENING AT TOP OF TANK
	STANDPIPE OPENING AT BOTTOM OF TANK
	FUEL TANK CONNECTING STANDPIPE
*	TO RIGHT WING EXT TANK
**	TO CENTERLINE TANK
<b>A</b>	HALON/AIR MIXING VALVE
<b>B</b>	EXT TANK VENT & PRESS VALVE
<b>C</b>	INT TANK VENT & PRESS VALVE
<b>D</b>	REMOTE SENSING PRESSURE RELIEF VALVE
<b>E</b>	AR RECEPTACLE
—	ELECTRICAL
	OVERBOARD VENT
	FUEL SUPPLY
	BOOST PUMP PRESSURE
	PUMP DRIVE PRESSURE
	TANK INERTING PRESSURE
	FUEL TRANSFER
	TRANSFER/REFUEL PRESSURIZATION
	TANK PRESSURIZATION
	REFUEL/TRANSFER
	ECS PRESSURIZATION SUPPLY
	TRANSFER BLEED

GR1F-16CJ-1-0027-2X37 ©

Figure 1-21. (Sheet 2)



# Fuel System D (Typical) PX III

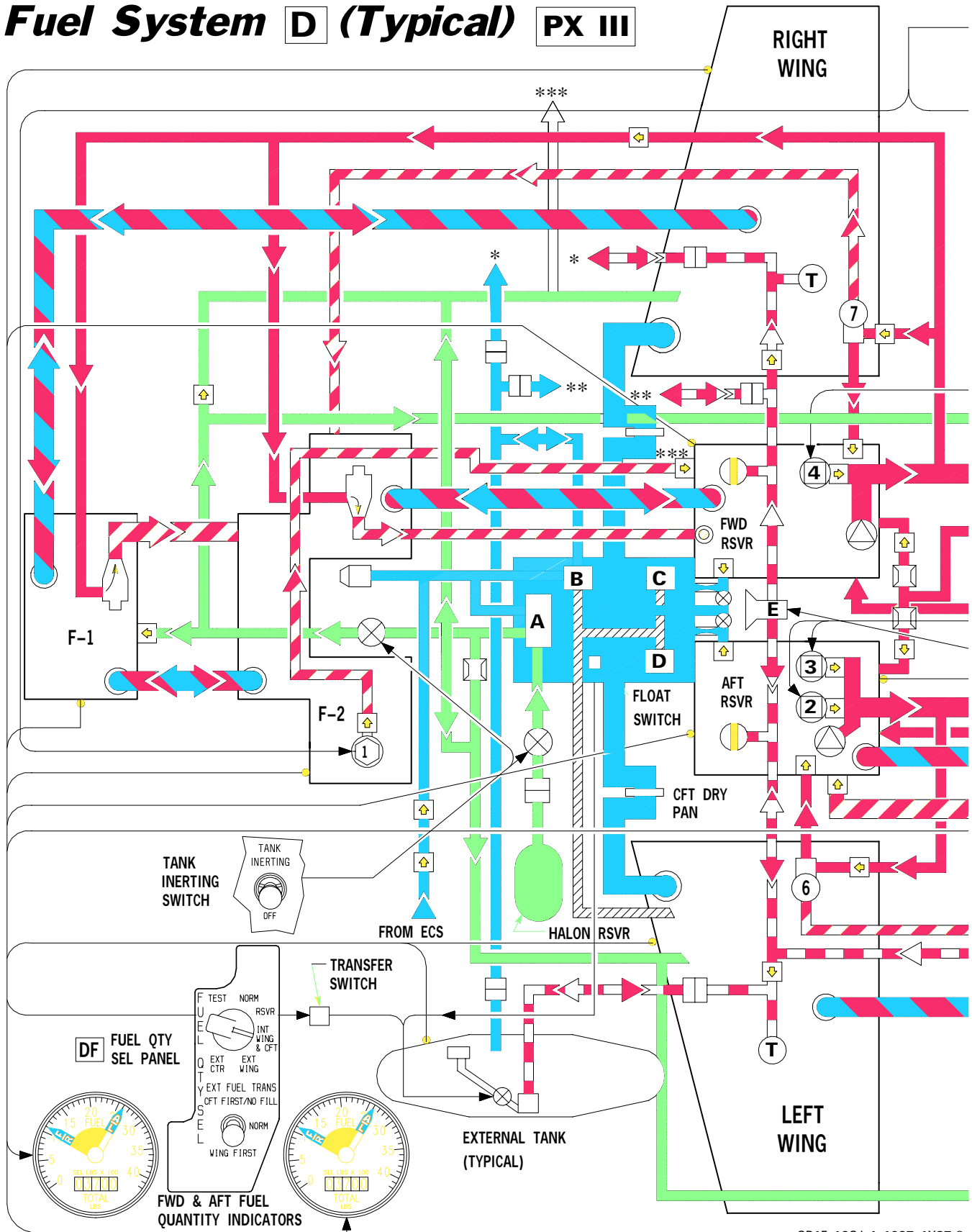

GR1F-16CJ-1-1027-1X37 ©

Figure 1-21. (Sheet 3)

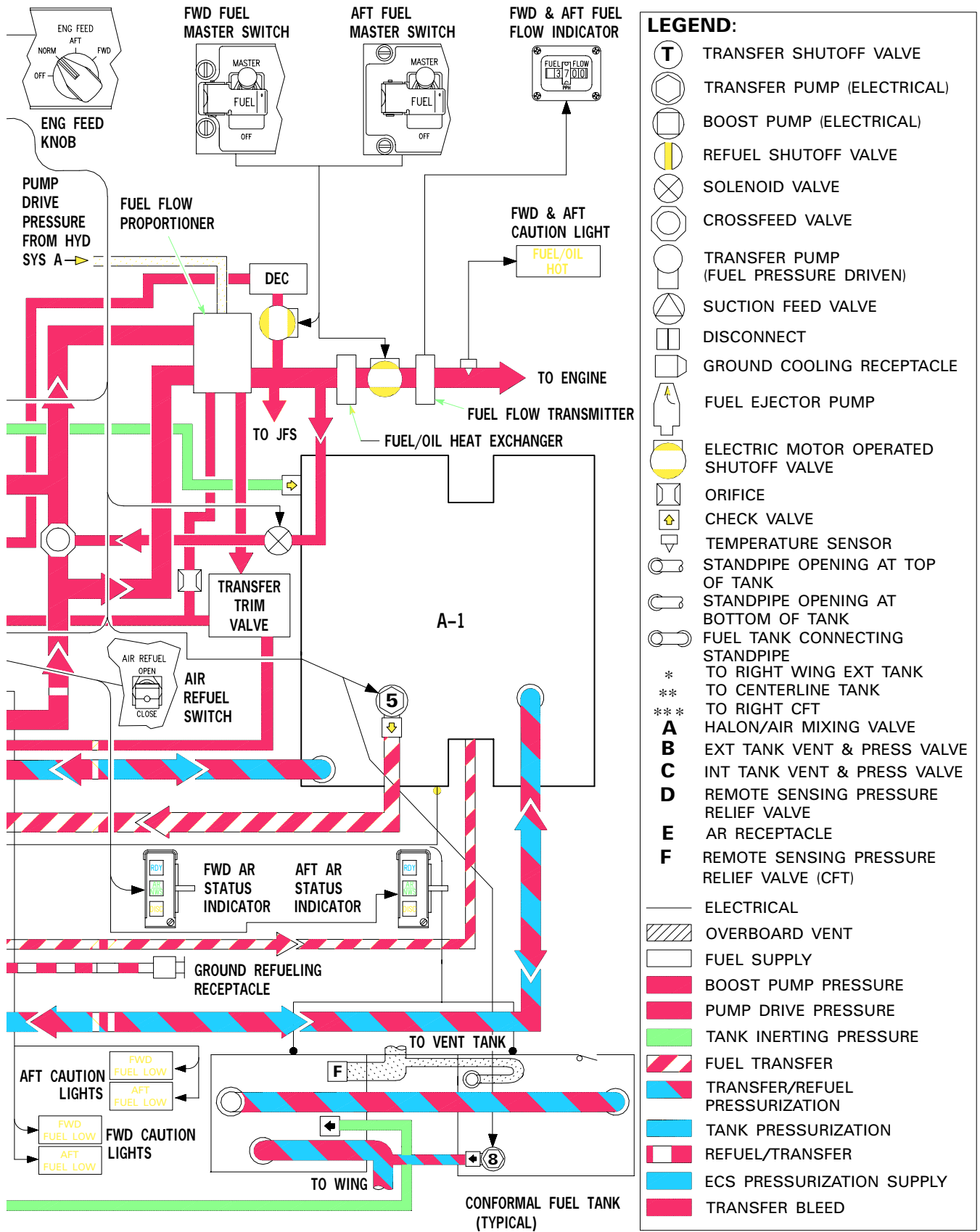

GR1F-16CJ-1-1027-2X37 ©

Figure 1-21. (Sheet 4)

# Fuel Quantity Indication and Tank Arrangement (Typical) **PX II**

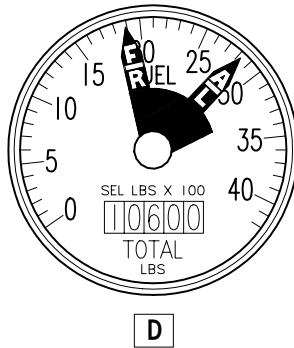
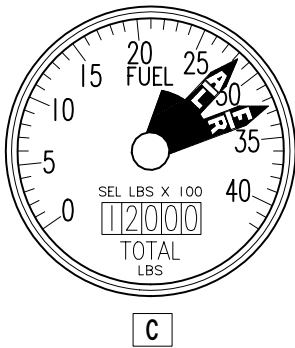

FUEL QUANTITY INDICATIONS (JP-8) WITH NORM SELECTED AND FULL INTERNAL TANKS WITH TWO FULL 370-GALLON EXTERNAL WING TANKS.

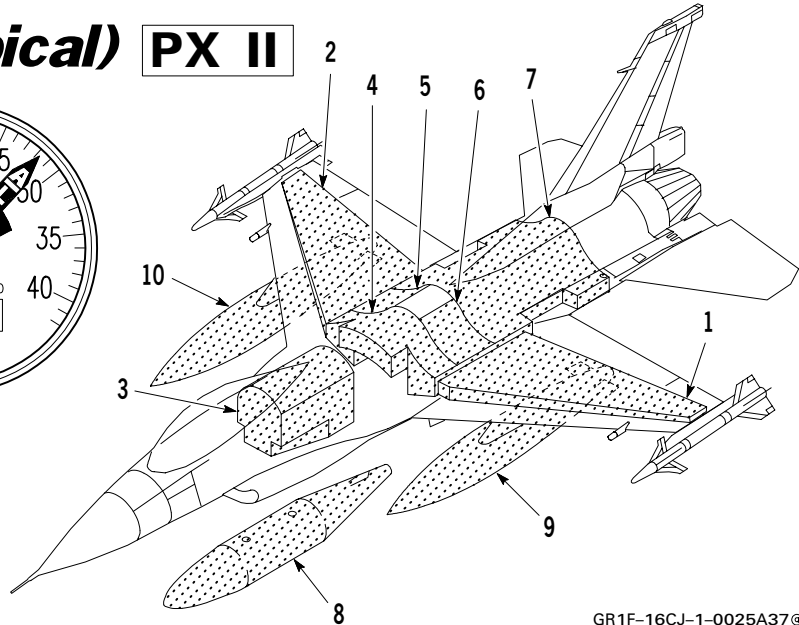

GR1F-16CJ-1-0025A37®

TANK LOCATION	FUEL QTY SEL KNOB SET-TINGS	POINTER	<b>C</b>		<b>D</b>	
			FUEL QTY (LB) JP-4	FUEL QTY (LB) JP-5/8	FUEL QTY (LB) JP-4	FUEL QTY (LB) JP-5/8
1. LEFT INTERNAL WING	INT WING	AL	525 ± 100	550 ± 100	525 ± 100	550 ± 100
2. RIGHT INTERNAL WING	INT WING	FR	525 ± 100	550 ± 100	525 ± 100	550 ± 100
3. F-1 FUSELAGE	} NORM	FR	3100 ± 100	3250 ± 100	1800 ± 100	1890 ± 100
4. F-2 FUSELAGE						
5. FWD RESERVOIR						
6. AFT RESERVOIR	} NORM	AL	2675 ± 100	2810 ± 100	2675 ± 100	2810 ± 100
7. A-1 FUSELAGE						
5. FWD RESERVOIR	RSVR	FR	460 ± 30	480 ± 30	460 ± 30	480 ± 30
6. AFT RESERVOIR	RSVR	AL	460 ± 30	480 ± 30	460 ± 30	480 ± 30
8. CENTERLINE	EXT CTR	FR	1800 ± 100	1890 ± 100	1800 ± 100	1890 ± 100
9. LEFT EXTERNAL WING 370/600	EXT WING	AL	2300/3750 ± 100	2420/3925 ± 100	2300/3750 ± 100	2420/3925 ± 100
10. RIGHT EXTERNAL WING 370/600	EXT WING	FR	2300/3750 ± 100	2420/3925 ± 100	2300/3750 ± 100	2420/3925 ± 100
TOTAL INTERNAL FUEL			6825 ± 300	7160 ± 300	5575 ± 300	5800 ± 300
TOTAL EXTERNAL FUEL (370/600)			6400/9300 ± 300	6730/9740 ± 300	6400/9300 ± 300	6730/9740 ± 300

**NOTES:**

1. Tolerances are due to indication errors with the variations in density resulting from temperatures, additives, etc.
2. The quantity of wing fuel varies depending upon aircraft attitude during refueling.
3. Usable fuel and indicated fuel quantities are approximately equal.
4. Indications are approximate and shall not be used for computing weight and balance data. Refer to T.O. GR1F-16CJ-1-1 for detailed information.

Figure 1-22. (Sheet 1)

# Fuel Quantity Indication and Tank Arrangement (Typical) PX III

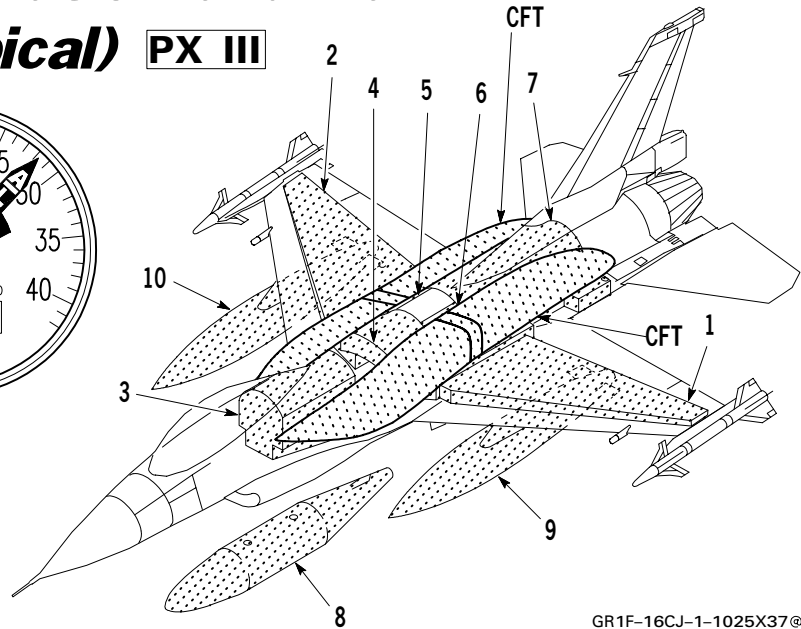
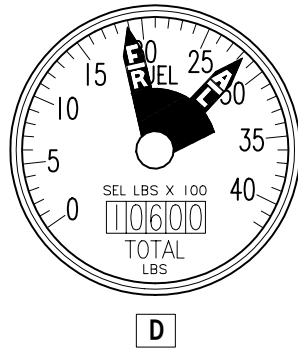
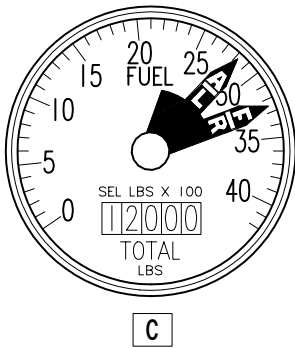

FUEL QUANTITY INDICATIONS (JP-8) WITH NORM SELECTED AND FULL INTERNAL TANKS WITH TWO FULL 370-GALLON EXTERNAL WING TANKS.

GR1F-16CJ-1-1025X37®

TANK LOCATION	FUEL QTY SEL KNOB SETTINGS	POINTER	C		D	
			FUEL QTY (LB) JP-4	FUEL QTY (LB) JP-5/8	FUEL QTY (LB) JP-4	FUEL QTY (LB) JP-5/8
1. LEFT INTERNAL WING/WITH CFT	INT WING & CFT	AL	525/1965 ± 100	550/2080 ± 100	525/1965 ± 100	550/2080 ± 100
2. RIGHT INTERNAL WING/WITH CFT	INT WING & CFT	FR	525/1965 ± 100	550/2080 ± 100	525/1965 ± 100	550/2080 ± 100
3. F-1 FUSELAGE	} NORM	FR	3100 ± 100	3250 ± 100	1800 ± 100	1890 ± 100
4. F-2 FUSELAGE						
5. FWD RESERVOIR						
6. AFT RESERVOIR	} NORM	AL	2675 ± 100	2810 ± 100	2675 ± 100	2810 ± 100
7. A-1 FUSELAGE						
5. FWD RESERVOIR	RSVR	FR	460 ± 30	480 ± 30	460 ± 30	480 ± 30
6. AFT RESERVOIR	RSVR	AL	460 ± 30	480 ± 30	460 ± 30	480 ± 30
8. CENTERLINE	EXT CTR	FR	1800 ± 100	1890 ± 100	1800 ± 100	1890 ± 100
9. LEFT EXTERNAL WING 370/600	EXT WING	AL	2300/3750 ± 100	2420/3925 ± 100	2300/3750 ± 100	2420/3925 ± 100
10. RIGHT EXTERNAL WING 370/600	EXT WING	FR	2300/3750 ± 100	2420/3925 ± 100	2300/3750 ± 100	2420/3925 ± 100
TOTAL INTERNAL FUEL (Without CFT's/With CFT's)			6825/9705 ± 300	7160/10220 ± 300	5525/8405 ± 300	5800/8860 ± 300
TOTAL EXTERNAL FUEL (370/600)			6400/9300 ± 300	6730/9740 ± 300	6400/9300 ± 300	6730/9740 ± 300

**NOTES:**

1. Tolerances are due to indication errors with the variations in density resulting from temperatures, additives, etc.
2. The quantity of wing fuel varies depending upon aircraft attitude during refueling.
3. Usable fuel and indicated fuel quantities are approximately equal.
4. Indications are approximate and shall not be used for computing weight and balance data. Refer to T.O. GR1F-16CJ-1-1 for detailed information.
5. Actual reservoir quantities are 23 pounds less than indicated because of provisions for CFT's.

Figure 1-22. (Sheet 2)

# Fuel Control Panel (Typical)

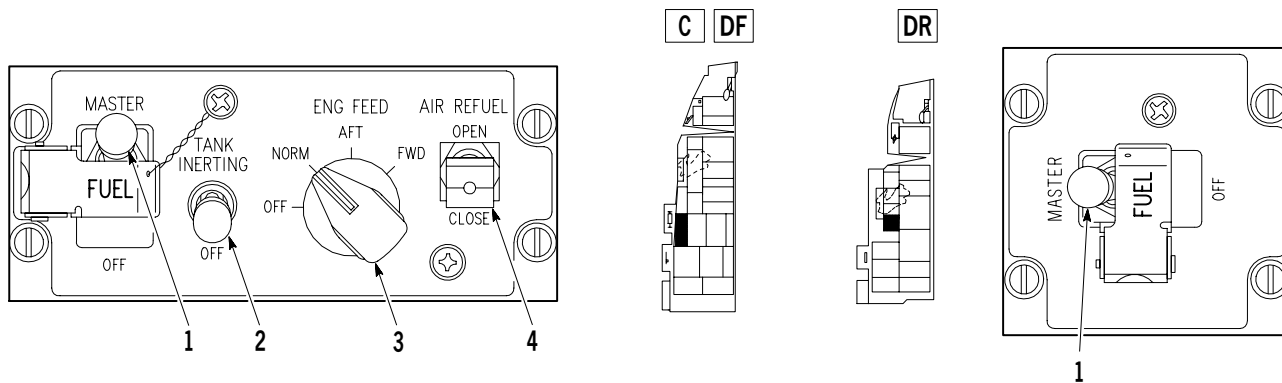

- 1. FUEL MASTER Switch
- 2. TANK INERTING Switch
- 3. ENG FEED Knob
- 4. AIR REFUEL Switch

GR1F-16CJ-1-0028X37©

CONTROL	POSITION	FUNCTION
1. FUEL MASTER Switch (lever lock)	MASTER (guarded)	Opens main fuel shutoff valve which then opens the engine electronic control cooling fuel shutoff valve
	OFF	Closes main fuel shutoff valve which then closes the engine electronic control cooling fuel shutoff valve
2. TANK INERTING Switch (lever lock to OFF)	TANK INERTING	Reduces internal tank pressurization. If Halon is available, allows <b>PX II</b> 20, <b>PX III</b> 30 seconds of initial Halon flow; thereafter, allows a small metered flow of Halon to the F-1, A-1, internal wing tanks, and <b>PX III</b> CFTs
	OFF	Stops Halon flow. Returns internal tank pressurization to normal schedule

Figure 1-23. (Sheet 1)

# Fuel Control Panel (Typical)

CONTROL	POSITION	FUNCTION
3. ENG FEED Knob	OFF	Deenergizes all electric-driven pumps. Engine supplied by FFP
	NORM	Energizes all pumps. CG maintained automatically
	AFT	Energizes pumps in aft tanks and opens cross-feed valve. Fuel is transferred from aft tanks to the engine and forward tanks. CG moves forward
	FWD	Energizes pumps in forward tanks and opens crossfeed valve. Fuel is transferred from forward tanks to the engine and aft tanks. CG moves aft
4. AIR REFUEL Switch	OPEN	Opens slipway door. Places FLCS in takeoff and landing gains when airspeed is below 400 knots
		Enables slipway light. Turns on AR floodlight and vertical tail-mounted fuselage floodlight
		Reduces internal tank pressurization, depressurizes external tanks, and allows the refuel valve in each reservoir to open when a centerline tank is installed and refuel pressure is applied
	CLOSE	Reverses the OPEN actions

Figure 1-23. (Sheet 2)

DEEC, **GE129** DEC and then returned to the reservoirs. The remainder of the fuel passes through a fuel/oil heat exchanger to cool hydraulic systems A and B, the main generator CSD, and the ADG. Then fuel flows through an electric main fuel shutoff valve which has a full travel time of 2-4 seconds and is controlled by the FUEL MASTER switch. (The JFS receives fuel at all times regardless of the FUEL MASTER switch position.) After passing through the main fuel shutoff valve, fuel passes through the fuel flow transmitter (which operates the FUEL FLOW indicator) to the engine.

### FUEL QUANTITY INDICATING SYSTEM

Refer to figure 1-24. The fuel quantity indicating system displays the amount and location of fuel remaining. The totalizer shows all fuel in the internal and external tanks in pounds. The AL and FR pointers show the fuel quantity in the tanks as selected by the FUEL QTY SEL knob. Erroneous fuel indications may occur during or immediately after maneuvering flight. The selected tanks should normally be the fuselage tanks (FUEL QTY SEL knob in NORM). The difference between the forward and aft tanks should remain essentially constant since the FFP maintains an equal flow of fuel. **PX III** With the FUEL QTY SEL knob in the INT WING & CFT position, the pointers show the combined total fuel in both tanks.

**C** Normally, the forward tank fuel quantity is 0-600 pounds greater than the aft tank quantity. **D** Normally, the aft tank fuel quantity is 700-1350 pounds greater than the forward fuel quantity. If these values are exceeded in either direction, a red portion of the AL pointer becomes visible. Fuel distribution can be changed by rotating the ENG FEED knob to the FWD or AFT position until the imbalance is corrected.

### RESERVOIR FUEL LEVEL SENSING SYSTEM

Fuel level sensors in the reservoir tanks are used to turn on/off the air ejectors and the fuel low caution lights. When a reservoir tank is not full, the air ejector in that tank is operating. The reservoir tank sensors, associated sensor circuitry, and fuel level sensing unit operate independently of the fuel quantity indicating system.

#### Fuel Low Caution Lights

The fuel low caution lights, located on the caution light panel, indicate either a low fuel quantity in the reservoir tanks or a reservoir fuel level sensing system malfunction. The caution lights function

independently of the fuel quantity indicating system. The FWD FUEL LOW caution light illuminates when fuel quantity in the forward reservoir drops below 400 (**D** 250) pounds. The AFT FUEL LOW caution light illuminates when aft reservoir fuel quantity drops below 250 (**D** 400) pounds. The caution lights are powered by emergency dc bus No. 1.

### HUD FUEL LOW/BINGO INDICATION

In addition to the fuel low caution lights, a fuel low condition may be indicated by the word FUEL in the HUD in conjunction with the home mode of the FCC or the previously entered bingo fuel value.

Bingo fuel warning is based either on fuselage fuel with the FUEL QTY SEL knob in NORM or on total fuel with the FUEL QTY SEL knob out of NORM.

With the FUEL QTY SEL knob in NORM, the bingo computation is based on the lesser of fuselage fuel weight or total fuel weight. That is, with the FUEL QTY SEL knob in NORM, bingo fuel warning will be triggered when either fuselage fuel or total fuel decreases below the bingo fuel value.

With the FUEL QTY SEL knob out of NORM, the warning will only be triggered when total fuel decreases below the bingo value. With trapped external fuel, this could lead to fuel starvation before the bingo warning is triggered.

The VMS provides a BINGO-BINGO message in the headset when the bingo fuel warning is activated with weight off wheels.

For a more detailed description of the home mode and the bingo fuel option, refer to T.O. GR1F-16CJ-34-1-1.

### HUD TRP FUEL WARNING

A trapped external fuel condition is indicated by flashing TRP FUEL and FUEL in the HUD. Five conditions must be met for a TRP FUEL warning to occur.

Conditions are:

- FUEL QTY SEL knob is in NORM.
- Aerial refueling has not occurred within previous 30-90 seconds.
- Fuselage fuel has been at least 500 pounds less than fuselage capacity for 30 seconds.
- Total fuel has been at least 500 pounds greater than fuselage fuel for 30 seconds.
- Fuel flow has been less than 18,000 pph for 30 seconds.

# Fuel Quantity Indicator and Select Panel (Typical)

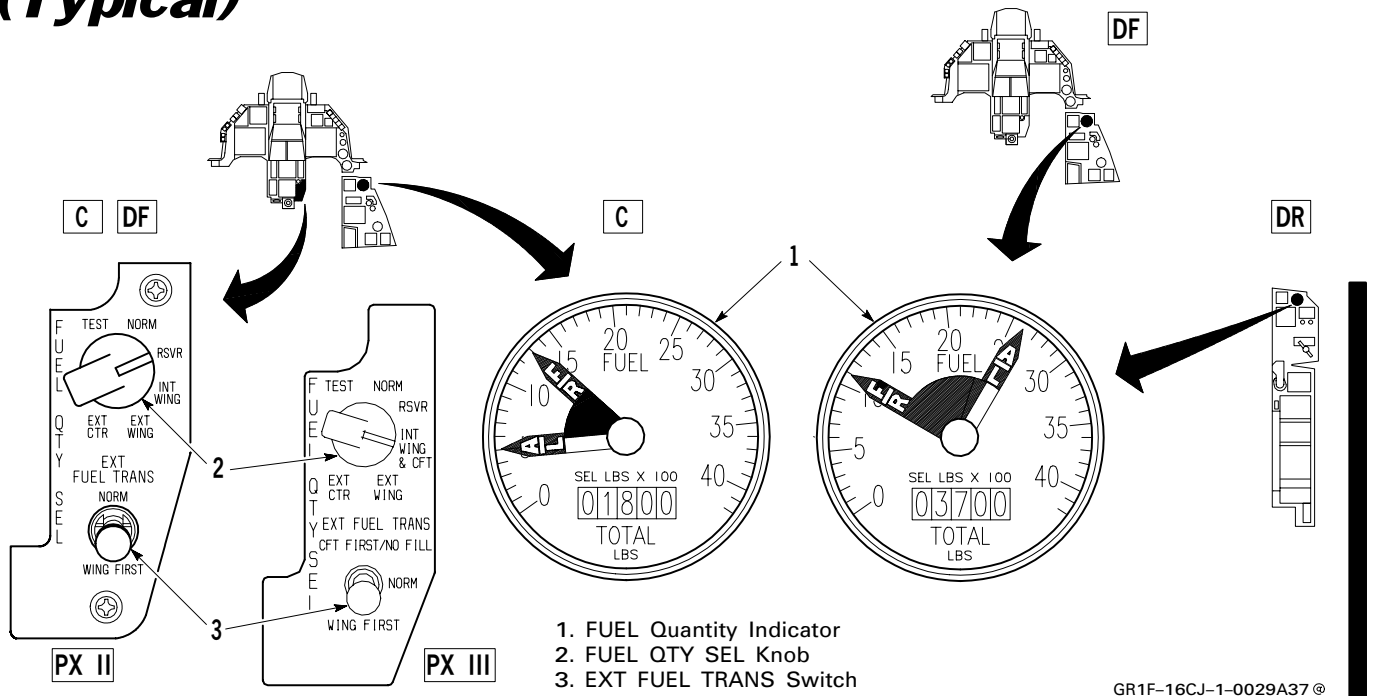

CONTROL/INDICATOR	POSITION	FUNCTION
1. FUEL Quantity Indicator	AL and FR pointers	Display fuel quantities as determined by the FUEL QTY SEL knob
	Totalizer	Displays total fuel in all fuel tanks (fuselage + wing + external). The totalizer and the fuel value displayed on the DED BIN-GO page should agree within 100 pounds of each other
	Red portion of AL pointer showing	Indicates fuel imbalance between forward and aft fuselage tanks
2. FUEL QTY SEL Knob	TEST	AL/FR pointers drive to 2000 (± 100) pounds
		Totalizer drives to 6000 (± 100) pounds
		Both fuel low caution lights illuminate
		<b>PX III</b> (with CFT's installed) CFT pumps operate and continue to operate for 30 seconds after switch is taken out of TEST position; CFT pump indicator lights illuminate (ground test panel)

Figure 1-24. (Sheet 1)



# Fuel Quantity Indicator and Select Panel (Typical)

CONTROL/INDICATOR	POSITION	FUNCTION
2. FUEL QTY SEL Knob (Cont)	NORM	AL pointer displays sum of fuel in the aft (left) reservoir and A-1 fuselage tanks
		FR pointer displays sum of fuel in the forward (right) reservoir and F-1, F-2 fuselage tanks
		Enables automatic forward fuel transfer system, trapped fuel warning, and bingo fuel computation based on fuselage fuel
	RSVR	AL/FR pointers display fuel in aft/forward reservoir tanks
	<b>PX II</b> INT WING	AL/FR pointers display fuel in left/right internal wing tanks
	<b>PX III</b> INT WING & CFT	AL pointer displays sum of fuel in the left CFT and left internal wing tank
		FR pointer displays sum of fuel in the right CFT and right internal wing tank
	EXT WING	AL/FR pointers display fuel in left/right external wing tanks
	EXT CTR	AL pointer drops to zero
FR pointer displays fuel in centerline tank		
3. EXT FUEL TRANS Switch	<b>PX III</b> CFT FIRST/NO FILL	On transfer, CFT's will transfer prior to external tanks. On refuel (ground or air), CFT's will not fill
	NORM	Centerline tank transfers first and then external wing tanks
	WING FIRST	External wing tanks transfer first and then centerline tank

Figure 1-24. (Sheet 2)

A false TRP FUEL warning may occur after the following:

- A fuel leak which exceeds the transfer rate of the external tank(s).
- Prolonged AB use if fuel flow to the engine exceeds the transfer rate from the external tank(s).
- Receiving a partial fuel load during air refueling with an external tank(s).

The TRP FUEL warning clears automatically after the condition is corrected; the FUEL mnemonic may be manually reset by placing the WARN RESET switch to WARN RESET.

### FUEL/OIL HOT CAUTION LIGHT

The FUEL/OIL HOT caution light, located on the caution light panel, illuminates when the temperature of fuel to the engine becomes excessive. **GE129** The caution light also comes on as a function of hot oil. Refer to ENGINE **GE129**, this section.

### FUEL TANK EXPLOSION SUPPRESSION SYSTEM

The fuel tank explosion suppression system places the fuel tank vent and pressurization system on a reduced pressure schedule and inerts the fuel vapors inside the tanks (if serviced with Halon). The system, intended for use only in combat or during emergencies, is controlled by the TANK INERTING switch on the fuel control panel. The system uses Halon as an inerting agent which prevents combustion when mixed with air. For the agent specification and reservoir location, refer to SERVICING DIAGRAM, this section. The Halon reservoir has a heater, controlled by a thermostatic switch, which assures sufficient operating pressure. The RMLG WOW switch prevents operation of the heater while the aircraft is on the ground.

When the TANK INERTING switch is placed to TANK INERTING, the fuselage tanks, internal wing tanks, **PX III** and CFT's (if present) are placed on a reduced pressure schedule and a valve at the Halon reservoir is opened. At each activation of the TANK INERTING switch, Halon (if available) is released into the F-1, A-1, internal wing tanks, **PX III** and CFT's (if present) for **PX II** 20, **PX III** 30 seconds for initial inerting. Thereafter, a continuous metered flow of Halon is mixed with the pressurization air to maintain the inert condition. The metered flow continues until the system is turned off or until the MAIN PWR switch is positioned to OFF.

Because of limited Halon supply, the system should be activated after the external tanks have emptied, but before half of the internal fuel is depleted. **PX III** Inerting may be selected at any CFT fuel state. Since the **PX II** 20, **PX III** 30 seconds of initial inerting occurs each time the TANK INERTING switch is placed to TANK INERTING, do not cycle the switch. The fuel tank explosion suppression system does not protect the external fuel tanks.

## REFUELING SYSTEM

### Ground Refueling

All external and internal fuel tanks can be pressure filled from a single-point ground refueling receptacle located on the lower left side of the fuselage just forward of the wing trailing edge. Electrical power is not required to refuel the aircraft unless fuel quantity is to be monitored or **PX III** CFT's are mounted and it is desired that they not be filled, in which case power must be applied and the EXT FUEL TRANS switch must be placed in the CFT FIRST/NO FILL position. Terminating refueling with partially filled tanks could result in fuel imbalance. When a partial fuel load is required, fuel distribution should be corrected prior to flight by selective operation of the fuel transfer pumps controlled by the ENG FEED knob.

### Air Refueling (AR) System

The AR system consists of a hydraulically actuated receptacle and slipway door, a signal amplifier, and the associated controls and indicators. Hydraulic system B provides pressure for operation of the door and latch mechanism. The receptacle is located on the top fuselage centerline aft of the canopy. When the slipway door is opened, a mechanical linkage retracts the aft end of the slipway door into the fuselage, forming a slipway into the receptacle.

When the AIR REFUEL switch is placed to OPEN, the external tanks are depressurized, external fuel does not transfer, and the FLCS is placed in takeoff and landing gains if airspeed is below 400 knots.

When closed, the slipway door is flush with the fuselage skin. The AR receptacle is equipped with four lights, two located on each side. An AR floodlight is located on the top fuselage centerline immediately aft of the canopy. A light on the upper leading edge of the vertical tail floods the AR receptacle area and the upper fuselage.

During AR operations, the AR boom enters the receptacle and is automatically latched in place by a hydraulic actuating mechanism. The HOT MIC switch allows intercom communications with compatible tankers through the AR boom. When the last refuel shutoff valve closes, a pressure switch automatically provides a signal to unlatch the boom from the receptacle. A disconnect signal can be manually initiated at anytime during AR by the receiver or by the tanker boom operator.

**D** Disconnect from the boom may occur before all tanks are full if the external fuel tank configuration consists of only a centerline fuel tank. Such a disconnect typically occurs when refueling with an initial internal fuel load of 4000 pounds or more and the centerline tank empty. At disconnect, the aircraft total fuel may be up to 1600 pounds less than full, with many occurrences resulting in approximately 1000 pounds less than full.

**PX III** When CFT's are present, the option to fill or prevent filling of the CFT's is available. By placing the EXT FUEL TRANS switch in CFT FIRST/NO FILL, the CFT's will not fill. If the EXT FUEL TRANS switch is in NORM or WING FIRST, the CFT's will fill.

Fuel venting from under the left wing can occur during AR, particularly when the aircraft is configured with external fuel tank(s). Terminating the AR operation in a partially filled condition could result in fuel imbalance. When a partial fuel load is required, fuel distribution should be monitored and corrected as required by use of the ENG FEED knob.

#### NWS A/R DISC MSL STEP BUTTON

The NWS A/R DISC MSL STEP button is located on the outboard side of the stick. The A/R DISC function of the switch is activated when the aircraft is airborne and the AIR REFUEL switch is positioned to OPEN. The button provides a means of manually disconnecting the AR boom. Depressing the switch causes the boom latching mechanism to unlatch and release the boom.

#### AIR REFUELING (AR) STATUS INDICATOR

The AR status indicator, located to the right of the HUD, contains three lights.

Functions are:

- RDY - Illuminates blue when the AR slipway door is open and the system is ready.
- AR/NWS - Illuminates green when the boom is latched in place.
- DISC - Illuminates amber when a disconnect occurs. After the disconnect, the system automatically recycles to ready, and the RDY light illuminates after a 3-second delay.

A lever for dimming the three lights is located on the right side of the unit.

## ENVIRONMENTAL CONTROL SYSTEM (ECS)

Refer to figure 1-25. The ECS combines air-conditioning and pressurization functions to provide temperature-controlled, pressure-regulated air for heating, cooling, ventilating, canopy defogging, cockpit pressurization, canopy sealing, g-suit pressurization, fuel tank pressurization, electronic equipment cooling, pressure breathing for g (PBG), and **PX III** OBOGS. Most of these functions are lost when the AIR SOURCE knob is placed to OFF or RAM. Refer to AIR SOURCE KNOB, this section.

Above 35,000 feet MSL, automatic changes in operation of the ECS may appear as short duration (approximately 15 seconds) losses of cockpit airflow alternating with normal cockpit airflow levels. These airflow changes are normal and are designed to prevent total ECS shutdowns.

## ELECTRICAL FAILURES

When the ECS loses electrical power, cabin temperature control and water separator anti-icing become inoperative. The cockpit receives cold air only. The water separator coalescer sock freezes at altitudes where there is enough moisture in the air (below 30,000 feet) and the built-in bypass valve opens allowing air to flow to the cockpit and avionics.

There is no interruption of bleed air flow due to a loss of electrical power. All pressurization functions (servo air, canopy seal, anti-g, PBG, and fuel tank pressurization) operate normally since the bleed air function continues to operate. **PX III** OBOGS also continues to receive ECS air; however, a problem that causes loss of power to the ECS may also cause a loss of power to OBOGS.

# Environmental Control System (Typical)

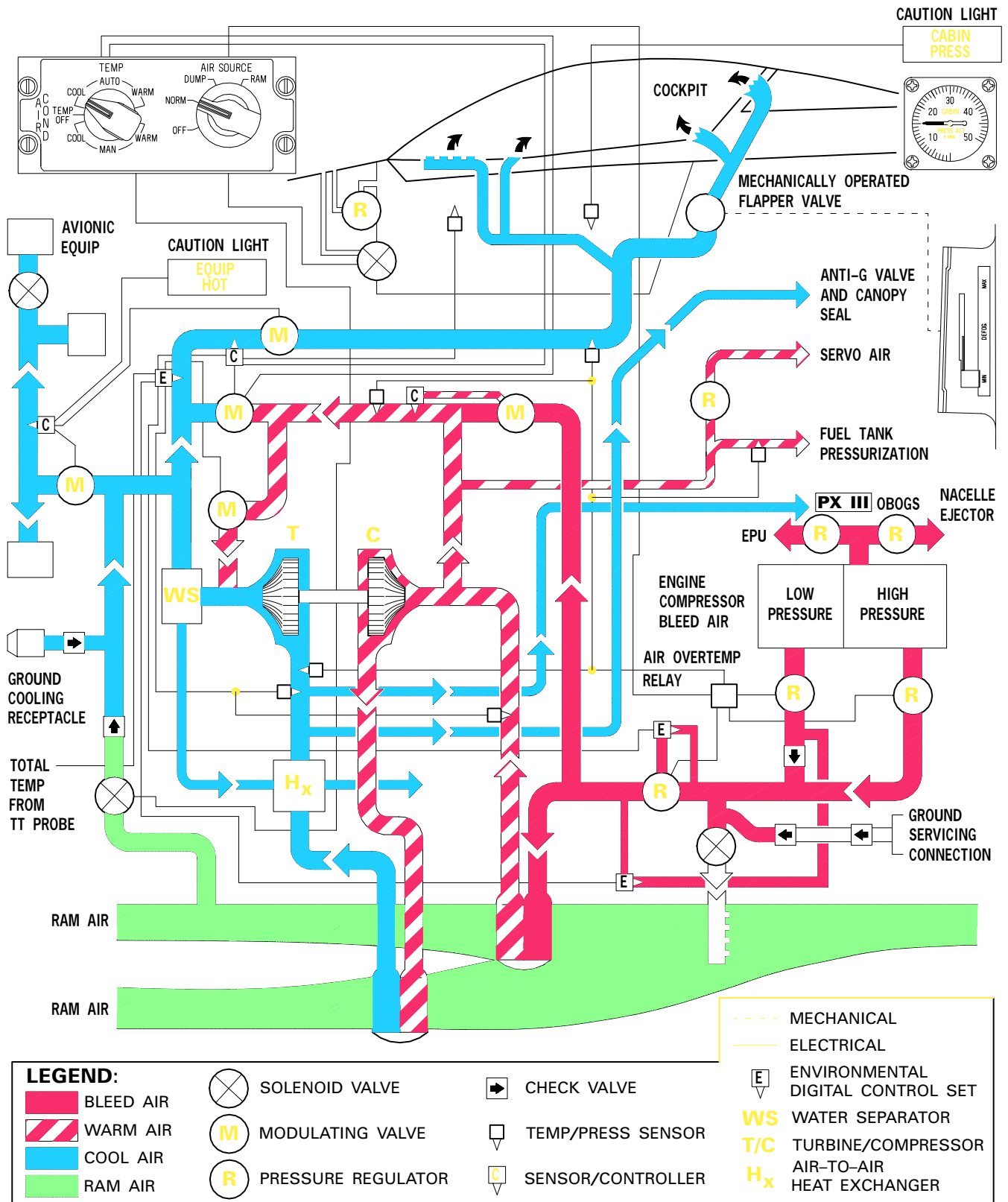

GR1F-16CJ-1-0030A37

Figure 1-25.

**AIR-CONDITIONING**

Engine bleed air is directed through a turbine compressor and air-to-air heat exchangers where it is cooled by ram air. The conditioned air is then used for the functions shown in figure 1-25.

A cockpit temperature controller receives signals from temperature sensors and from a manually operated control panel to automatically control the cockpit temperature. Conditioned air enters the cockpit on both sides, the top rear of the seat, through the angle vent on the instrument panel, and through the canopy defogger. In the event of an ECS malfunction, emergency ram air operation can be selected for ventilation and cooling.

A ground cooling cart can be connected to the ground cooling receptacle on the lower left side of the fuselage just above the nosewheel area to provide cooling air to the cockpit and avionic equipment.

**PRESSURIZATION**

Air pressure is provided by the pressurization system for control/operation of some of the ECS, canopy seal, g-suit, PBG, fuel tanks, radar and **PX III** OBOGS. Pressure in the cockpit is controlled automatically according to the schedule shown in figure 1-26. A cockpit pressure safety valve relieves pressure anytime the cockpit pressure exceeds ambient pressure by 5.4 psi.

The canopy seal is inflated/deflated with the mechanical locking/unlocking of the canopy.

# Cockpit Pressure Schedule

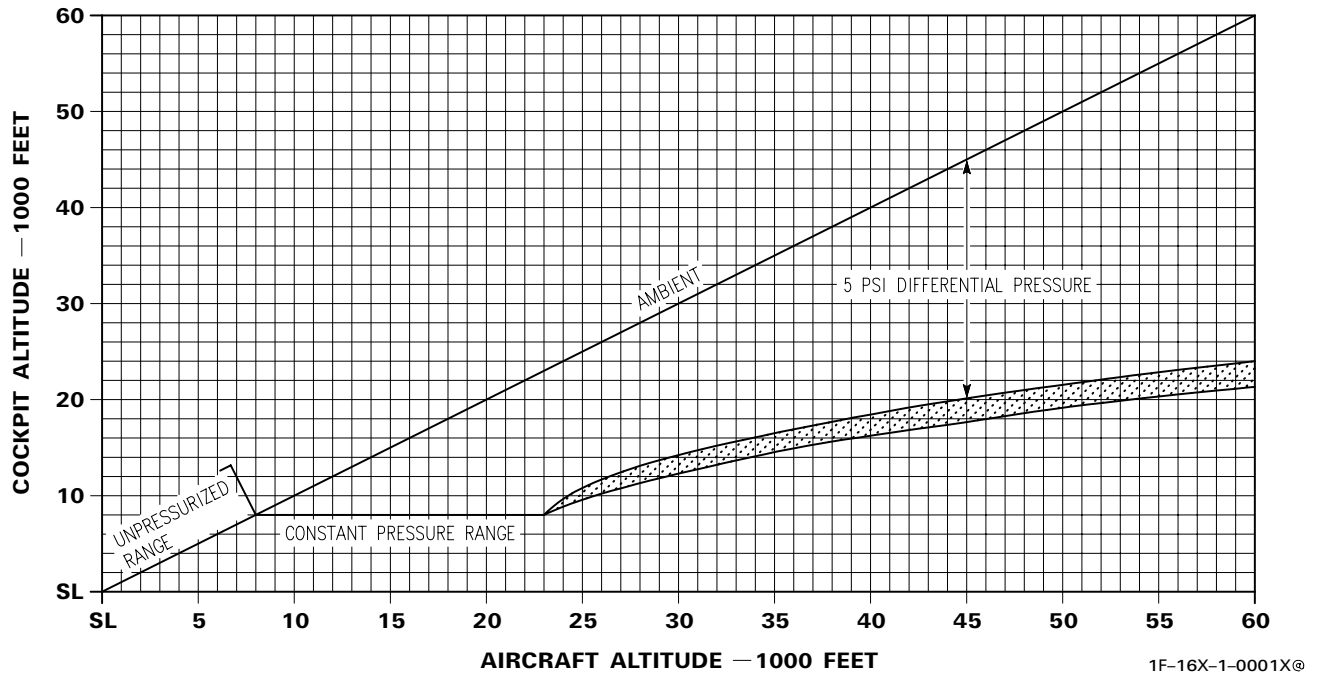

Figure 1-26.

**AIR SOURCE Knob** C DF

Refer to figure 1-27. The AIR SOURCE knob is located on the ECS panel.

Functions are:

- OFF - Engine bleed air valves close. All air-conditioning, cooling, and pressurizing functions shut off, including g-suit, PBG, canopy seal, fuel tank pressurization, and PX III OBOGS.
- NORM - Air-conditioning system set for automatic temperature and pressure regulation.
- DUMP - Cockpit pressure dump valve opens to atmospheric pressure. Cockpit pressure altitude increases if DUMP is selected above approximately 8000 feet MSL. Conditioned air ventilates cockpit and performs all other system functions.
- RAM - Engine bleed air valves close and the cockpit pressure dump valve opens to atmospheric pressure. Cockpit pressure altitude increases if RAM is selected above approximately 8000 feet MSL. All air-conditioning, cooling, and pressurizing functions shut off, including g-suit, PBG, canopy seal, fuel tank pressurization, and PX III OBOGS. The ram air valve opens to admit ram air to ventilate the cockpit and avionic equipment.

**TEMP Knob** C DF

Refer to figure 1-27. The TEMP knob is located on the ECS panel, only controls cockpit temperature.

Functions are:

- AUTO - Cockpit temperature is automatically maintained (50°-80°F) relative to the setting of the knob.
- MAN - The temperature control drives the air modulating valve to a set position. Cockpit temperature varies according to throttle setting, OAT, and cockpit heat load. If WARM is selected, the cockpit supply air temperature may exceed the maximum allowable limit of approximately 177°F. This causes the warm air valve to cycle on and off. This is a normal occurrence and can be stopped by selecting a cooler setting.
- TEMP OFF - Hot air mixing is shut off. Only air at approximately 35°F is delivered to cockpit.

Under extreme temperature conditions, system performance on the ground can be improved by advancing the throttle 1-3 percent above idle rpm.

Ground operation with the radar in OFF improves cockpit cooling and ground operation with the radar in STBY improves cockpit heating.

# Environmental Control System Control Panel C DF (Typical)

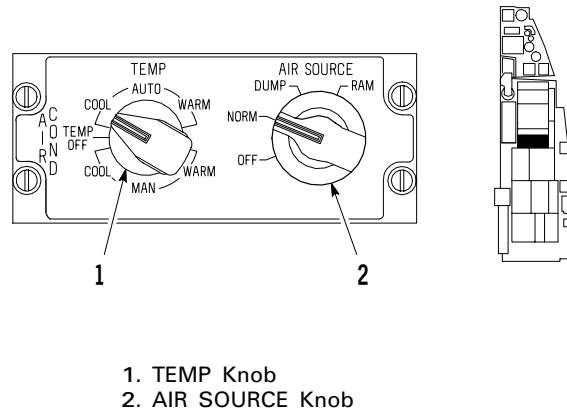

GR1F-16CJ-1-0032X37 ©

Figure 1-27.

**DEFOG Lever** C DF

Refer to figure 1-28. The DEFOG lever, located on the far aft portion of the left console, mechanically controls a flapper valve in the cockpit air supply line.

Functions are:

- MIN - Minimum airflow toward the canopy forward area and air vent in center pedestal; maximum airflow to outlets behind seat.
- MAX - Most of the cockpit air supply is diverted to the canopy forward area for defogging and to the air vent in the center pedestal. A partial opening of the center pedestal air outlet allows a more balanced defogging of the right and left sides of the canopy. When placed in the full forward (MAX) defog position and with the TEMP knob in AUTO, the lever activates a switch which shifts the cockpit air supply control to full warm. The full warm air supply automatically terminates 3 minutes after activation. The lever may be cycled to restart the full warm, 3-minute period.

Under extremely humid conditions or after initial engine start, fog may form at the cockpit air outlets as the cold air mixes with the moist cockpit atmosphere. This condition can be eliminated by selecting MAN and moving the TEMP knob toward WARM until the fog stops forming. In flight, while operating in AUTO, the most rapid method of eliminating air outlet fogging is by selecting the MAX position with the DEFOG lever. Fog may form on the interior surface of the canopy as a result of moisture in the cockpit air condensing on the cold surface. To warm the canopy surface above the dewpoint and permit the cockpit air to retain more moisture during cold weather operation, the DEFOG lever should be placed in a forward position and the TEMP knob positioned to MAN WARM.

### EQUIP HOT Caution Light

The EQUIP HOT caution light, located on the caution light panel, illuminates when the avionics equipment cooling air temperature/pressure is insufficient.

Degraded equipment performance and/or damage can result from overheating. Therefore, when the EQUIP HOT caution light illuminates, the electronic equipment should be turned off unless it is essential for flight. Illumination of the EQUIP HOT caution light automatically interrupts electrical power to the radar. Turning the radar to OFF in flight does not close the radar cooling air shutoff valve.

A short duration or intermittent EQUIP HOT caution light may occur when ground cooling air is disconnected.

### Cockpit Pressure Altimeter C DF

The cockpit pressure altimeter, located on the right auxiliary console outboard of the stick, is labeled CABIN PRESS ALT.

### CABIN PRESS Caution Light

The CABIN PRESS caution light, located on the caution light panel, illuminates when the cockpit pressure altitude is above 27,000 feet.

### ANTI-G SYSTEM

The anti-g system includes the ANTI-G panel/valve, the g-suit, and PBG equipment.

## Defog Control Panel

C DF (Typical)

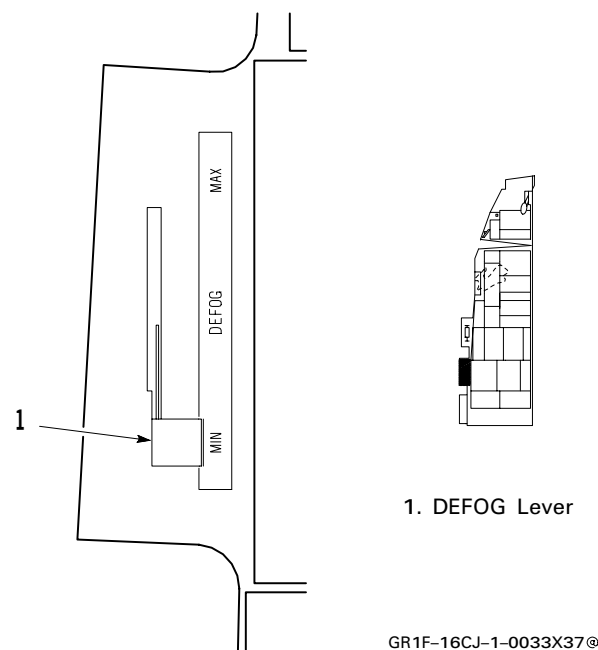

Figure 1-28.

The g-suit connector and TEST button are located on the ANTI-G panel at the aft end of the left console. The ECS delivers cooled bleed air to the g-suit and to the oxygen regulator as a control pressure for PBG. Airflow is proportional to the positive g forces sensed. If an ECS shutdown occurs, g-suit and PBG protection are not available.

The system can be manually tested by depressing the anti-g TEST button to inflate the g-suit and to check the PBG function. The system incorporates an automatic pressure relief valve.

## ELECTRICAL SYSTEM

Refer to figure 1-29. The electrical system consists of a main ac power system, a standby ac power system, an emergency ac power system, a dc power system, an FLCS power supply, and provisions for external ac power.

### MAIN AC POWER SYSTEM

AC power is normally supplied by a 60 kva main generator located on and driven by the ADG. The main generator supplies power to the overcurrent sensing contactors and nonessential, essential, and emergency ac buses.

## Overcurrent Sensing Contactors

The eight overcurrent sensing contactors protect certain ac buses; stations 3, 5, and 7; and inlet stations from overcurrent. The ELEC CAUTION RESET button on the ELEC control panel is used to reset a tripped overcurrent sensing contactor on nonessential ac bus No. 1 and the nacelle nonessential ac bus. The overcurrent sensing contactor may not remain reset if the fault persists.

The items with a nonresettable overcurrent sensing contactor are the radar ac bus; stations 3, 5, and 7; and left and right inlet stations.

## STANDBY AC POWER SYSTEM

The standby ac power system consists of the essential and emergency ac buses and is powered (if the main generator is inoperative) by a 10 kva standby generator which is located on and driven by the ADG. The standby generator has power available whenever the ADG is rotating and comes on line when the main generator is not supplying power, as long as the MAIN PWR switch is in MAIN PWR. The standby generator has an integral FLCS PMG which supplies power to the four FLCS branches. Refer to FLCS POWER SUPPLY, this section, for further discussion of the FLCS PMG.

## EMERGENCY AC POWER SYSTEM

If the main and standby generators fail, emergency ac power is supplied automatically by a **PX II** 5 kva, **PX III** 7 kva EPU generator driven by the EPU. The system supplies power to the emergency ac buses. The EPU generator has a PMG which supplies dc power through an ac to dc converter to the four FLCS branches. Refer to EMERGENCY POWER UNIT, this section, for further discussion of the EPU.

## DC POWER SYSTEM

DC power is supplied by ac to dc converters or by the aircraft battery. With the main generator operating, the ac to dc converters power emergency dc bus No. 1, battery bus No. 1, nonessential dc bus, nacelle dc bus, emergency dc bus No. 2, essential dc bus, and battery bus No. 2. With the standby generator operating, the ac to dc converters power emergency dc bus No. 1, battery bus No. 1, emergency dc bus No. 2, essential dc bus, and battery bus No. 2. With the EPU generator operating, the ac to dc converters power emergency dc bus No. 1, battery bus No. 1, emergency dc bus No. 2, and battery bus No. 2. With

the main, standby, or EPU generator operating, the aircraft battery is disconnected and charged by the battery charger/control assembly. If all generators fail, the aircraft battery is connected and powers battery bus No. 1 and battery bus No. 2. The battery buses are powered in all cases to provide a source of power to the FLCS power supply (if needed) and start power to the EPU.

## FLCS POWER SUPPLY

The primary FLCS power supply includes a dedicated FLCS PMG and two dual-channel converter regulators and four branch power supplies within the FLCC.

The FLCS PMG is the primary power source for the FLCS during normal operations. The FLCS PMG is integral with the standby generator and generates power whenever the ADG is rotating. The PMG has four outputs, one for each branch of the FLCS, and generates sufficient power to operate the FLCS at 40 percent rpm or greater.

Other FLCS power sources are the main generator, the standby generator, the EPU generator, the EPU PMG, and the aircraft battery.

Two converter/regulators, having two channels each, provide a separate channel for each branch of the FLCS. Both converter/regulators receive power from the FLCS PMG, the aircraft battery, and if the EPU is running, the EPU PMG. The branch A and B converter/regulator also receives power from emergency dc bus No. 1, and the branch C and D converter/regulator also receives power from emergency dc bus No. 2. Each converter/regulator channel converts ac power from the FLCS PMG to dc, selects the power source with the highest voltage (within limits), and provides dc power to the respective FLCC branch. Converter/regulator output voltages are regulated to prevent overvoltage to the FLCS. The converter/regulators also provide fault indications for display on the ELEC control panel and provide test indications to the TEST switch panel.

The aircraft battery can provide temporary emergency power to the FLCS. The length of time that the aircraft battery is able to power the FLCS is a function of the state of charge. The FLCS incorporates four latching relays which function to prevent depletion of the aircraft battery during ground maintenance. The relays prevent the FLCC from being connected to the aircraft battery until a JFS start is initiated.



# Electrical Power Distribution Diagram

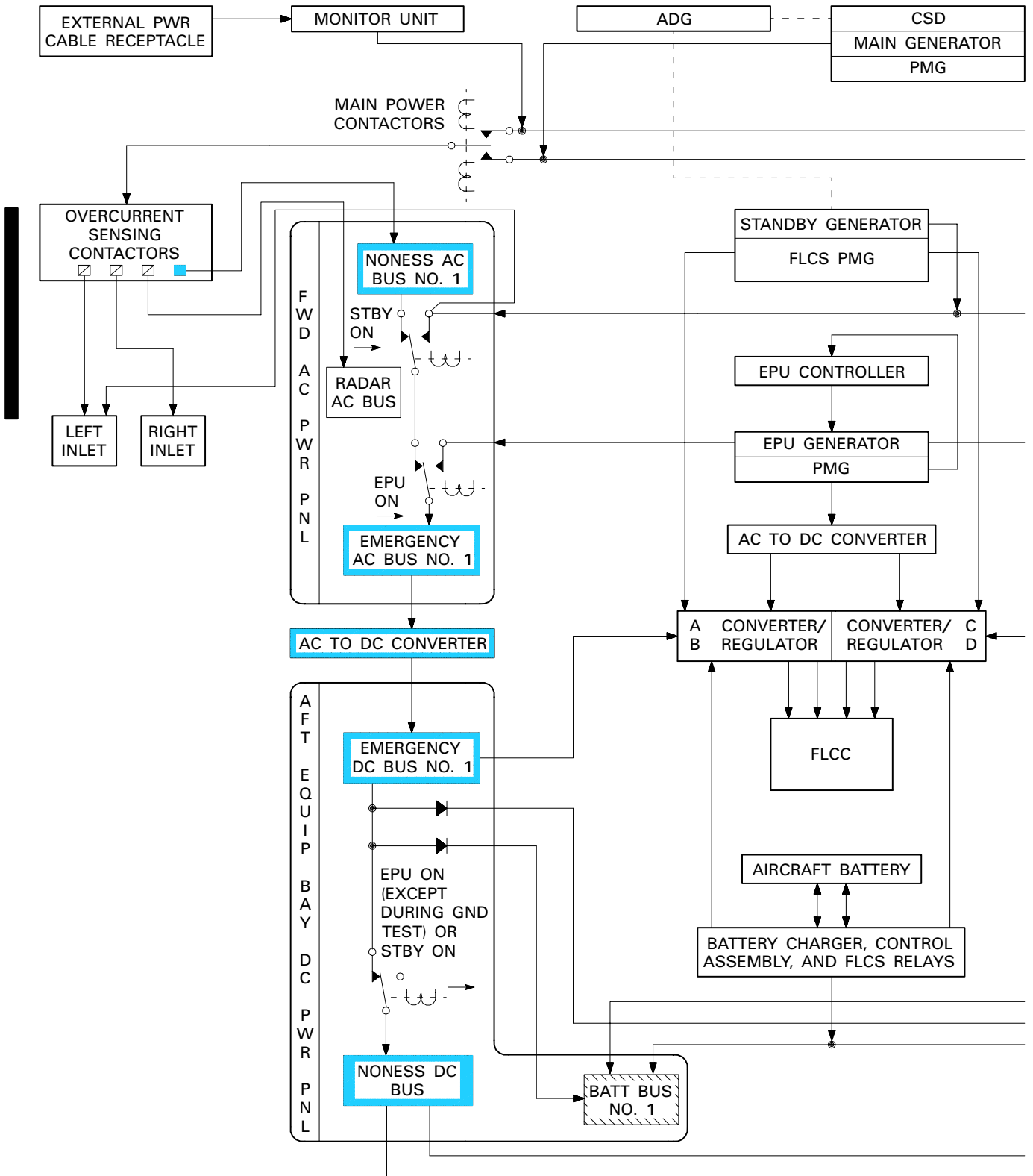

GR1F-16CJ-1-0034-1B37 ©

Figure 1-29. (Sheet 1)

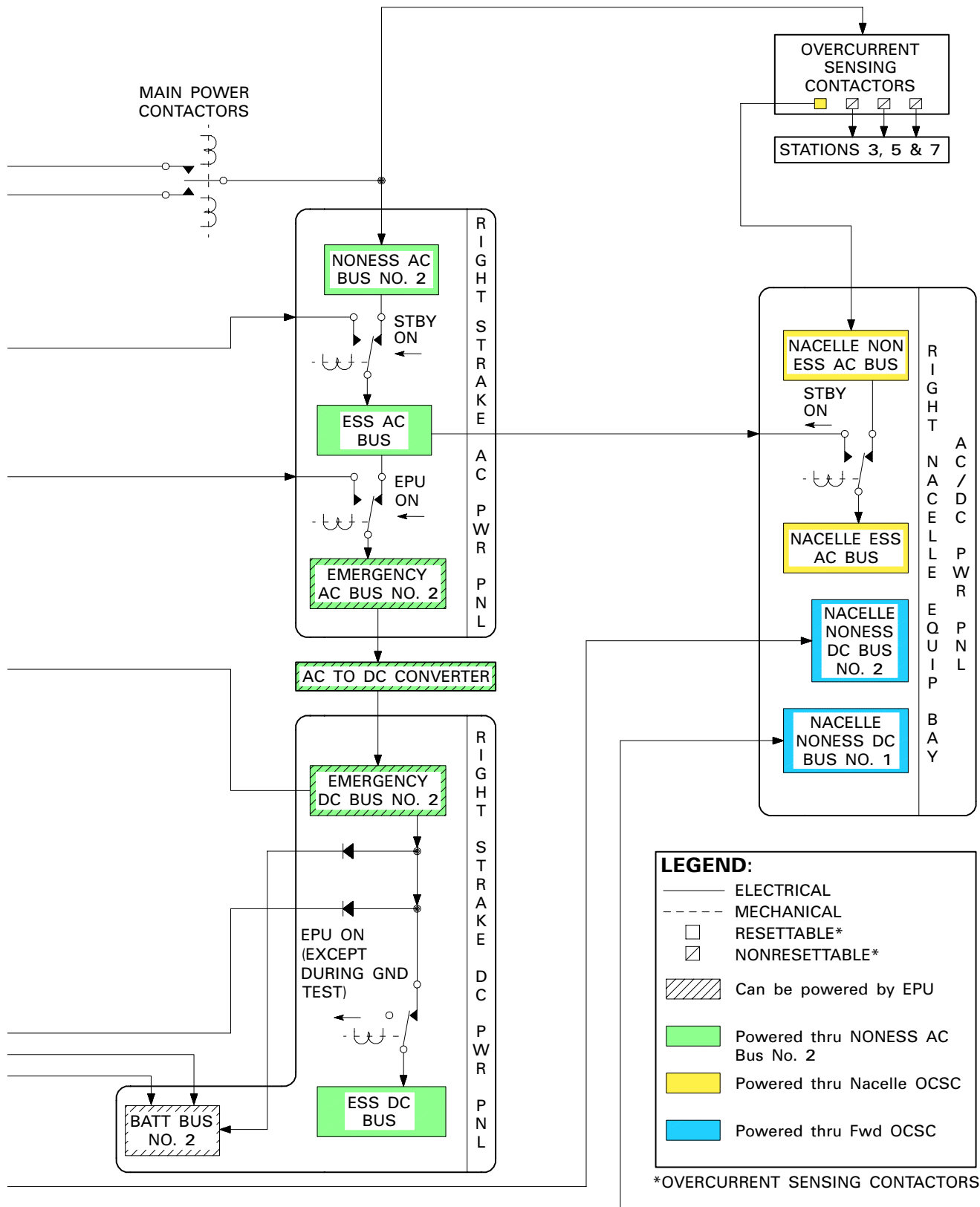

GR1F-16CJ-1-0034-2A37®

Figure 1-29. (Sheet 2)

## EXTERNAL POWER PROVISIONS

The external power provisions include a standard external power cable receptacle and a monitor unit which is part of the airframe. The monitor unit allows external power to be connected to the aircraft buses if the phasing, voltage, and frequency of the external power are correct. When connected, the external power provides the same power as the main generator.

## ELECTRICAL SYSTEM CONTROLS AND INDICATORS

Refer to figure 1-30.

## ELECTRICAL POWER DISTRIBUTION

Refer to figures 1-31 and 1-32.

## ELECTRICAL SYSTEM NORMAL OPERATION

Prior to engine start, the MAIN PWR switch is placed to BATT to permit a check of the aircraft battery. The ELEC SYS, MAIN GEN, STBY GEN, and FLCS RLY lights come on. The FLCS RLY light illuminates because the four FLCS relays are open and the FLCC is not connected to the aircraft battery. The FLCS PMG light is not illuminated since it requires FLCS power. The ACFT BATT TO FLCS light does not illuminate since the FLCS relays are open. With the FLCS PWR TEST switch held in TEST, the FLCS relays close but do not latch. The FLCS PMG and the ACFT BATT TO FLCS lights illuminate and the FLCS RLY light goes off. The FLCS PWR lights on the TEST switch panel illuminate, indicating that the power output of the FLCC is good.

With the FLCS PWR TEST switch in NORM and the MAIN PWR switch positioned from BATT to MAIN PWR, the lights do not change. If external power is connected, the MAIN GEN light goes off.

If the FLCS PWR TEST switch is placed to TEST with the MAIN PWR switch in MAIN PWR, the FLCS relays are latched closed. The FLCS RLY light remains off when the FLCS PWR TEST switch is returned to NORM. The aircraft battery is now powering the FLCC and depletes more rapidly. To eliminate the increased battery load, cycle the MAIN PWR switch to BATT and back to MAIN PWR to open the FLCS relays (FLCS RLY light illuminates).

When the JFS switch is moved to either start position, the FLCS PMG light (and ACFT BATT TO FLCS light if engine is started on battery power) illuminates and the FLCS RLY light goes off, indicating that the FLCS relays have closed.

During engine start, the FLCS PMG light (and ACFT BATT TO FLCS light if engine is started on battery power) goes off at approximately PW 229 40, GE129 44 percent engine rpm. The STBY GEN light goes off at approximately PW 229 55, GE129 60 percent engine rpm; the MAIN GEN light goes off approximately 10 seconds later if both generators are operating normally. External power, if used, is disconnected from the aircraft buses when the main generator comes on line.

Anytime after selecting MAIN PWR, including in flight, the FLCS PWR TEST switch may be held momentarily in TEST to check FLCC power output. During the EPU test, the FLCS PWR lights come on to indicate that EPU PMG power is available to the FLCS.

During engine shutdown, the ELEC SYS caution light and FLCS PMG, MAIN GEN, and STBY GEN lights come on as the engine spools down. The ACFT BATT TO FLCS light also illuminates.

# Electrical System Controls and Indicators

**C DF (Typical)**

- 1. MAIN PWR Switch
- 2. FLCS PMG Indicator Light
- 3. MAIN GEN Indicator Light
- 4. STBY GEN Indicator Light
- 5. EPU GEN Indicator Light
- 6. EPU PMG Indicator Light
- 7. ACFT BATT Indicator Lights
- 8. ELEC SYS Caution Light
- 9. ELEC CAUTION RESET Button
- 10. FLCS PWR TEST Switch
- 11. FLCS PWR Indicator Lights

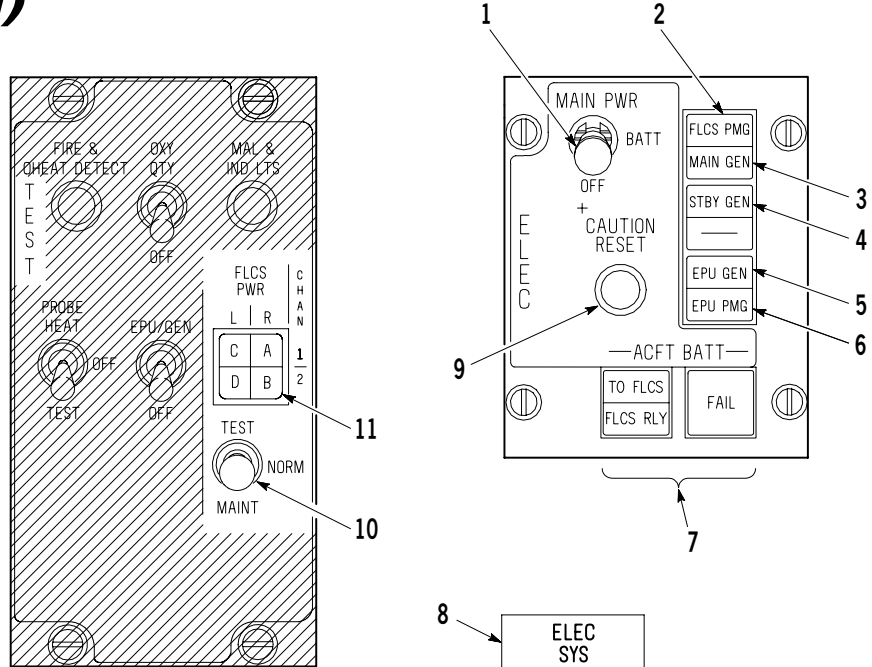

GR1F-16CJ-1-0035X37©

CONTROL/INDICATOR	POSITION/INDICATION	FUNCTION
1. MAIN PWR Switch  <b>NOTE:</b> During ground operation, if the MAIN PWR switch is moved from MAIN PWR to OFF without a delay of 1 second in BATT, the EPU does not activate and electrical power for braking, NWS, hook, and radios is lost.	MAIN PWR	Connects external power or the main generator to the electrical system and enables standby generator. Determines function of FLCS PWR TEST switch. If ac power is not available, connects aircraft battery to the battery buses
	BATT	Connects aircraft battery to the battery buses, disconnects main generator or external power, resets main generator, disables standby generator, and determines function of FLCS PWR TEST switch
	OFF	In flight - disconnects main generator from electrical system and disables standby generator  On ground - disconnects main generator or external power from aircraft electrical system and disables standby generator. Disconnects the aircraft battery from the battery buses. Canopy operation is available after engine shutdown

Figure 1-30. (Sheet 1)

# Electrical System Controls and Indicators

## C DF (Typical)

CONTROL/INDICATOR	POSITION/INDICATION	FUNCTION
2. FLCS PMG Indicator Light	FLCS PMG (amber)	In flight - None of the FLCS branches are receiving power from the FLCS PMG
		On ground - FLCS PMG power is not available at one or more FLCS branches. Light is delayed 60 seconds after initial NLG WOW
3. MAIN GEN Indicator Light	MAIN GEN (amber)	Indicates external power or main generator not connected to one or both nonessential ac buses
4. STBY GEN Indicator Light	STBY GEN (amber)	Indicates standby generator power is not available
5. EPU GEN Indicator Light	EPU GEN (amber)	Indicates the EPU has been commanded on but the EPU generator is not providing power to both emergency ac buses. The light does not function with the EPU switch in OFF (WOW) and the engine running
6. EPU PMG Indicator Light	EPU PMG (amber)	Indicates the EPU has been commanded on but EPU PMG power is not available to all branches of the FLCS
7. ACFT BATT Indicator Lights	FAIL (amber)	In flight - indicates aircraft battery failure (20V or less)
		On ground - indicates aircraft battery or battery charger failure. Light is delayed 60 seconds after MLG WOW
	TO FLCS (amber)	In flight - indicates battery bus power is going to one or more FLCS branches and voltage is 25V or less
		On ground - indicates battery bus power is going to one or more FLCS branches
FLCS RLY (amber)	Indicates that voltage on one or more of the four FLCC branches connected to the aircraft battery is inadequate (below 20V) or that one or more FLCC branches are not connected to the battery	

Figure 1-30. (Sheet 2)

# Electrical System Controls and Indicators

## C DF (Typical)

CONTROL/INDICATOR	POSITION/INDICATION	FUNCTION	
8. ELEC SYS Caution Light	ELEC SYS (amber)	Illuminates in conjunction with any of the above lights	
9. ELEC CAUTION RESET Button	Push	Resets resettable overcurrent protection units and ELEC SYS caution light and clears MASTER CAUTION light for future indications. Resets main and standby generators	
10. FLCS PWR TEST Switch	TEST	When MAIN PWR switch is in:	
		MAIN PWR	BATT
		Tests FLCC power output	Tests FLCC power output on aircraft battery
	NORM	Normal position. Tests EPU PMG power availability during EPU/GEN test on ground	NA
	MAINT	For maintenance use on the ground. Inoperative in flight	
11. FLCS PWR Indicator Lights	A, B, C, and D (green)	Illuminate to indicate proper power output of FLCC during FLCS power tests	

Figure 1-30. (Sheet 3)

# AC Power Distribution Diagram PX II

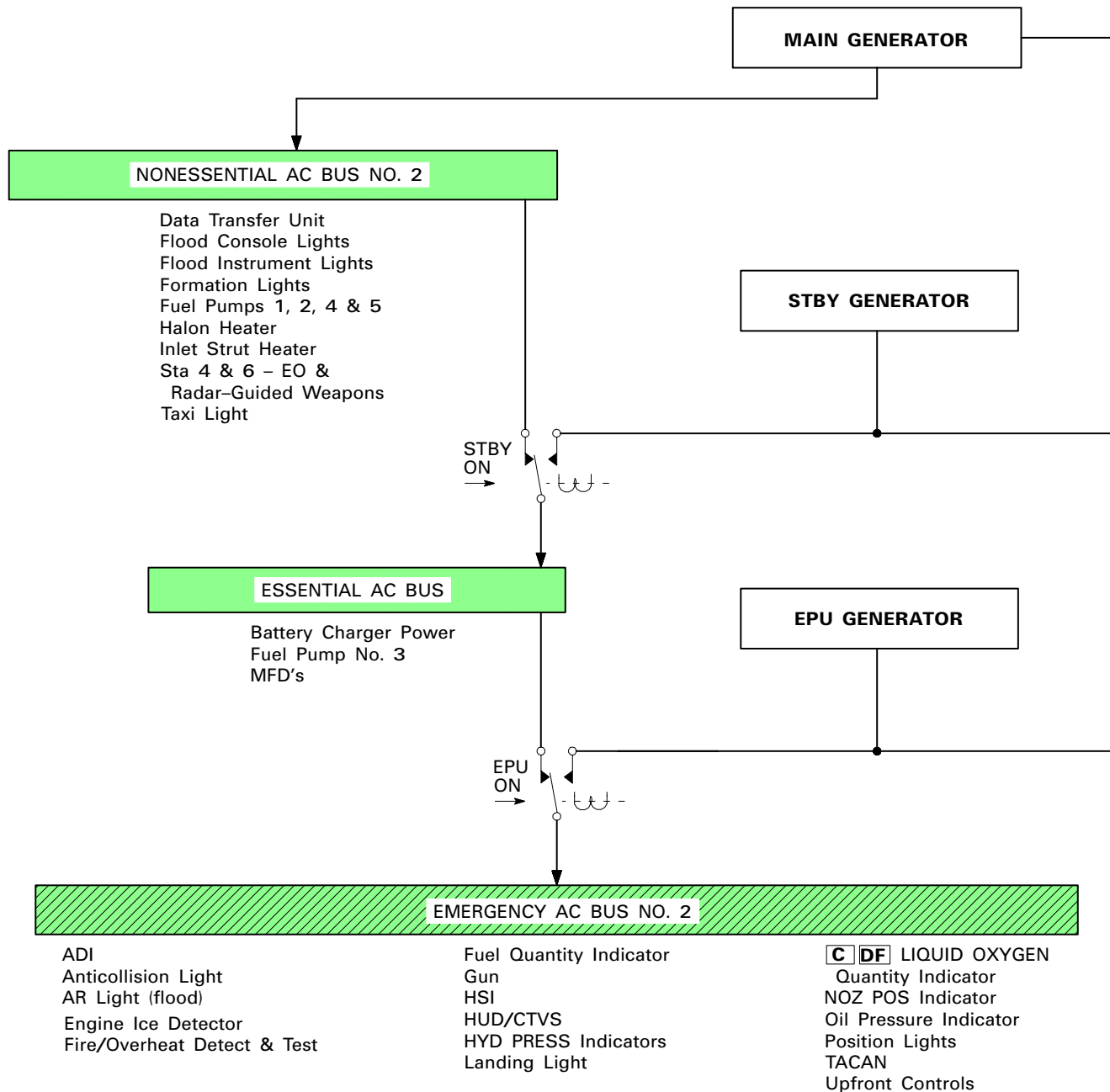

GR1F-16CJ-1-1154-1A37 ©

Figure 1-31. (Sheet 1)

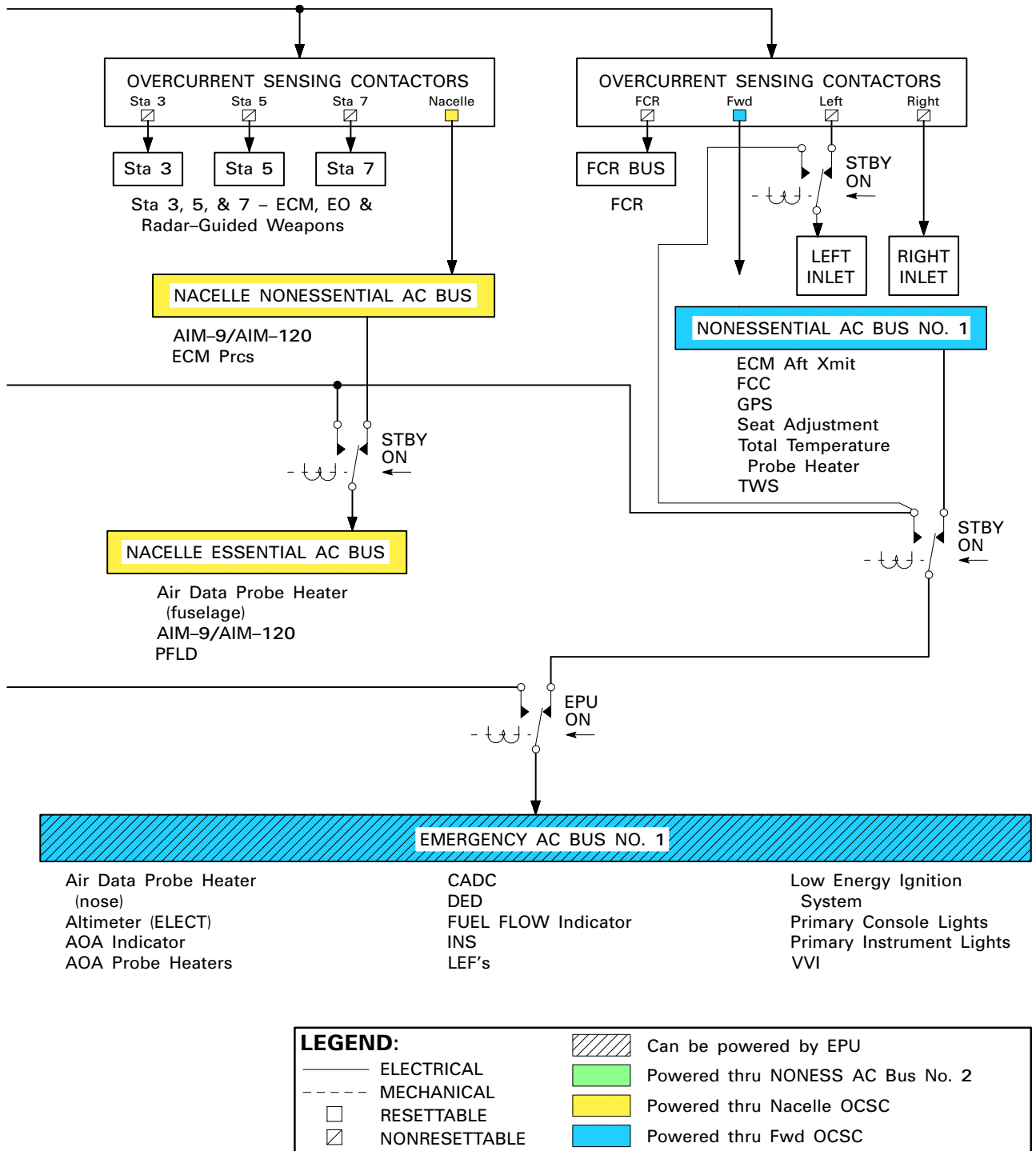

GR1F-16CJ-1-1154-2A37 ©

Figure 1-31. (Sheet 2)



# DC Power Distribution Diagram PX II

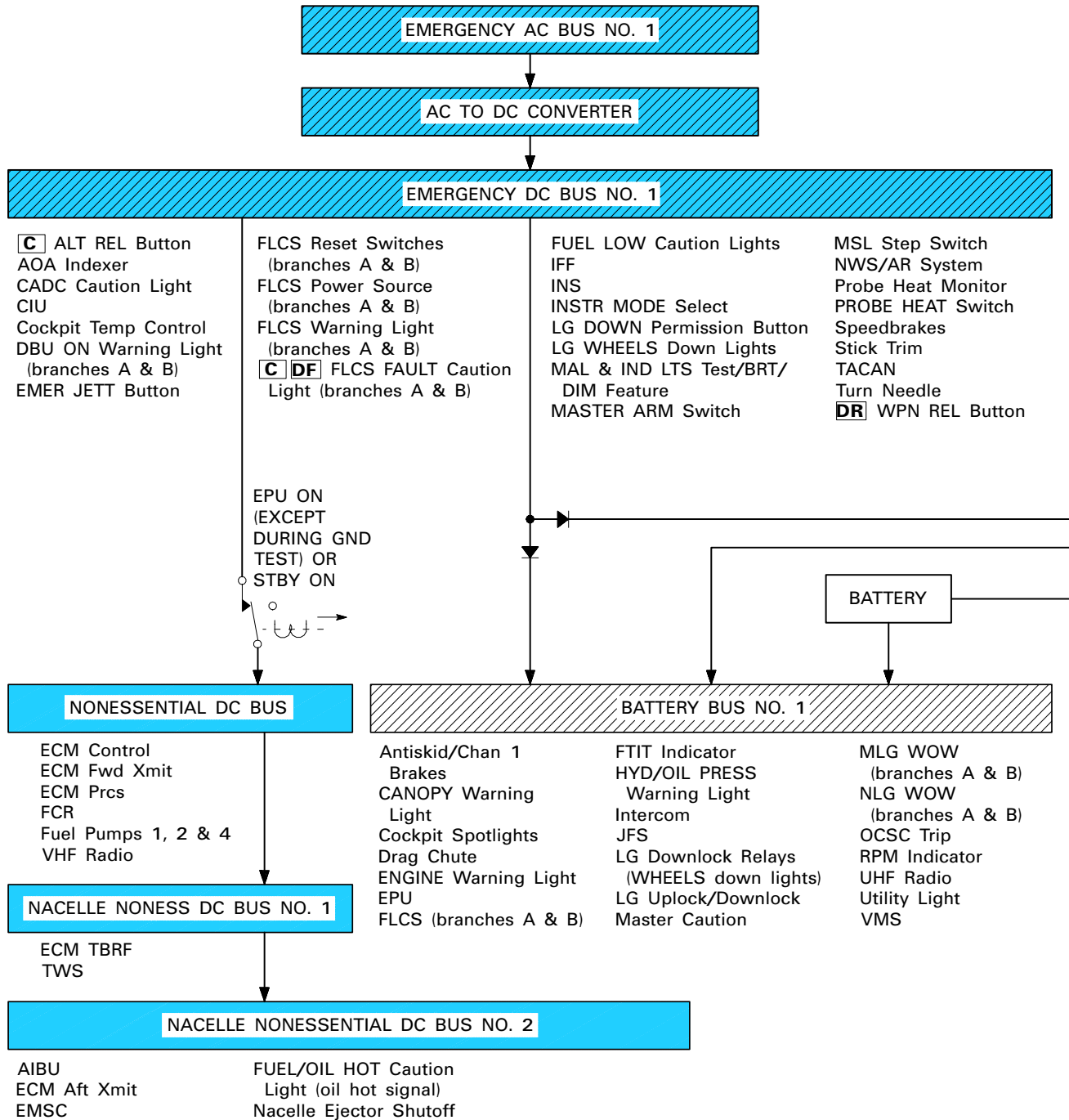

GR1F-16CJ-1-1155-1A37 ©

Figure 1-31. (Sheet 3)

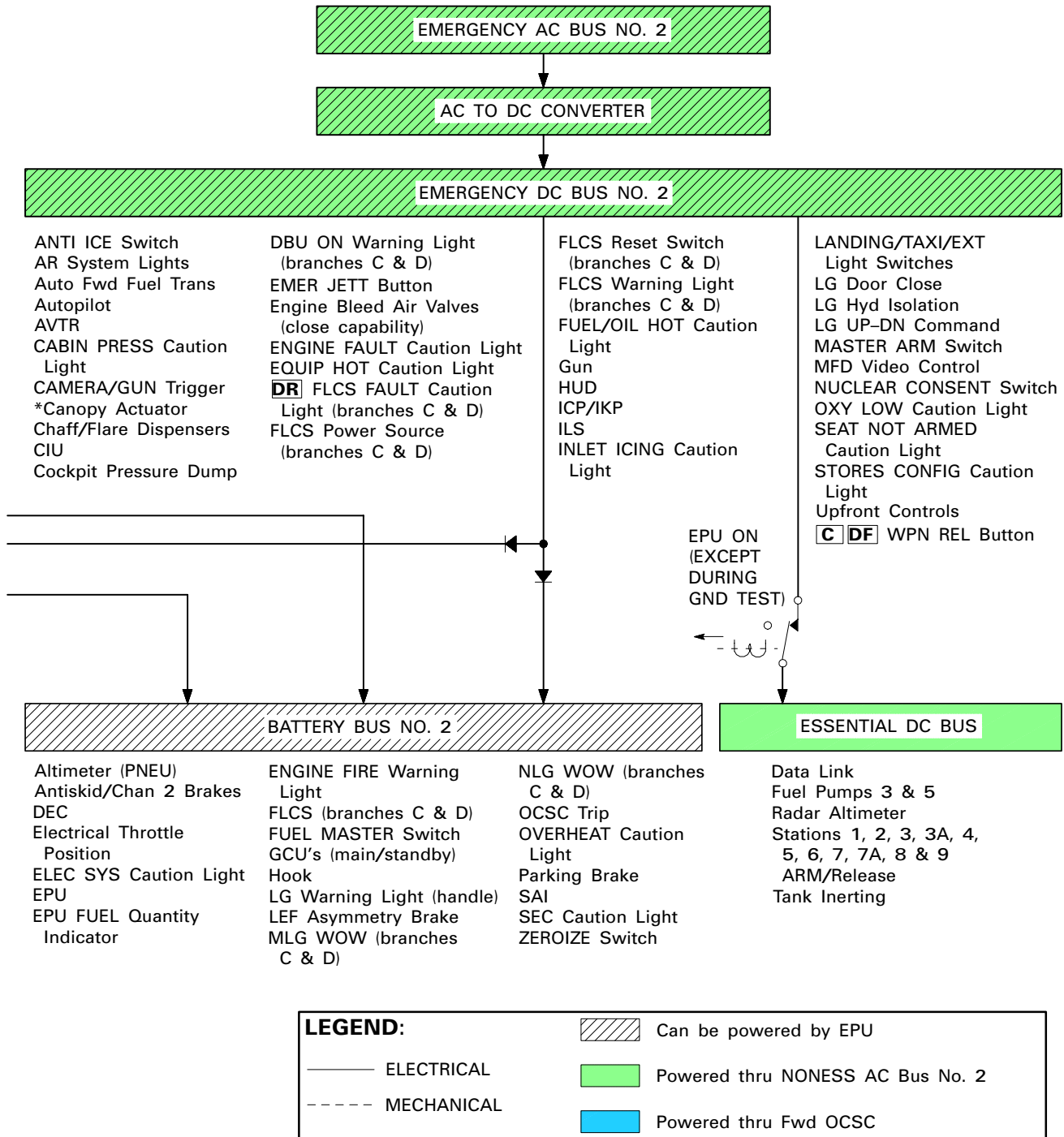

\* Power available from the battery bus box with MAIN PWR switch OFF.

Figure 1-31. (Sheet 4)

# AC Power Distribution Diagram PX III

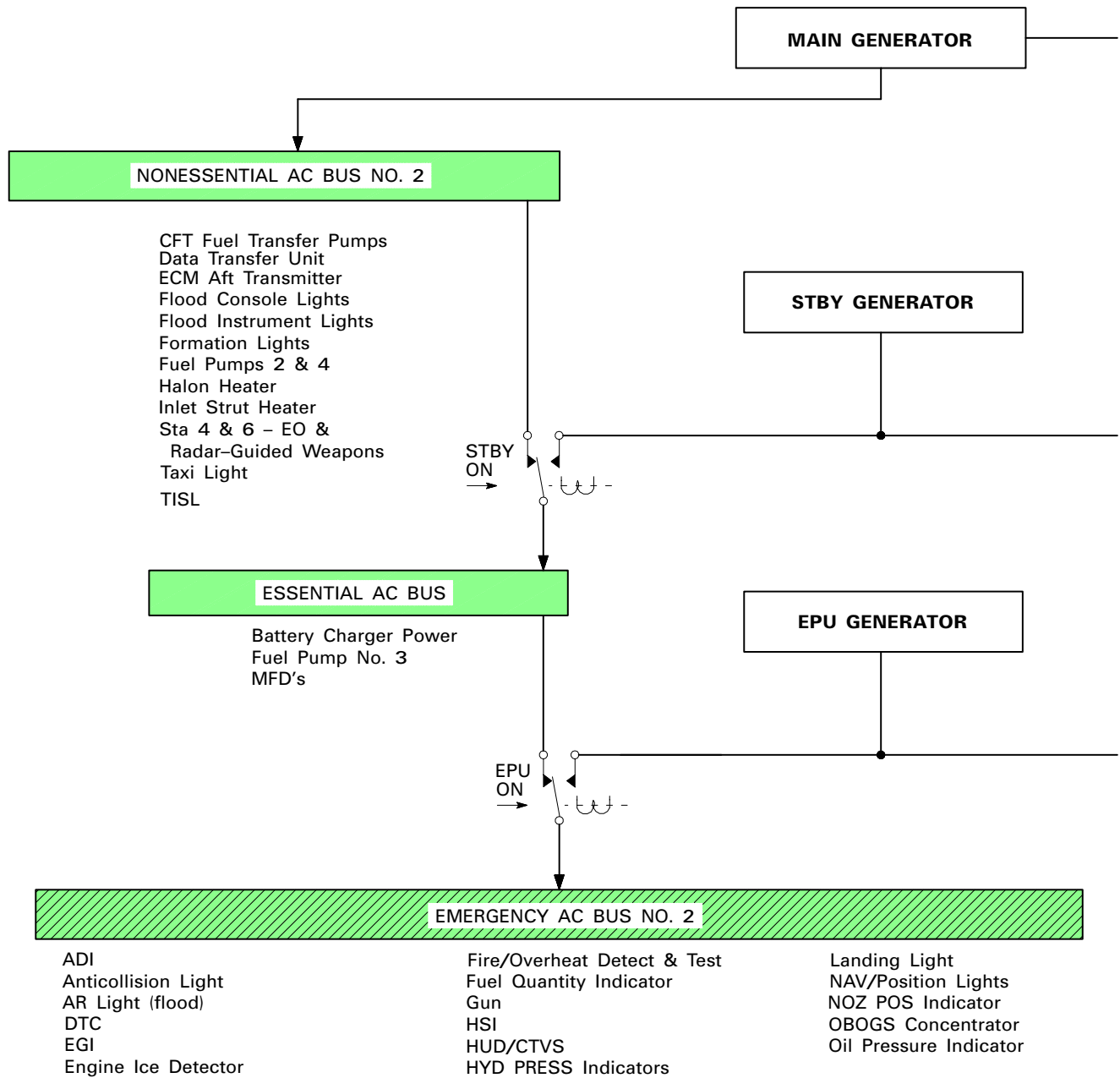

GR1F-16CJ-1-2154-1X37 ©

Figure 1-32. (Sheet 1)

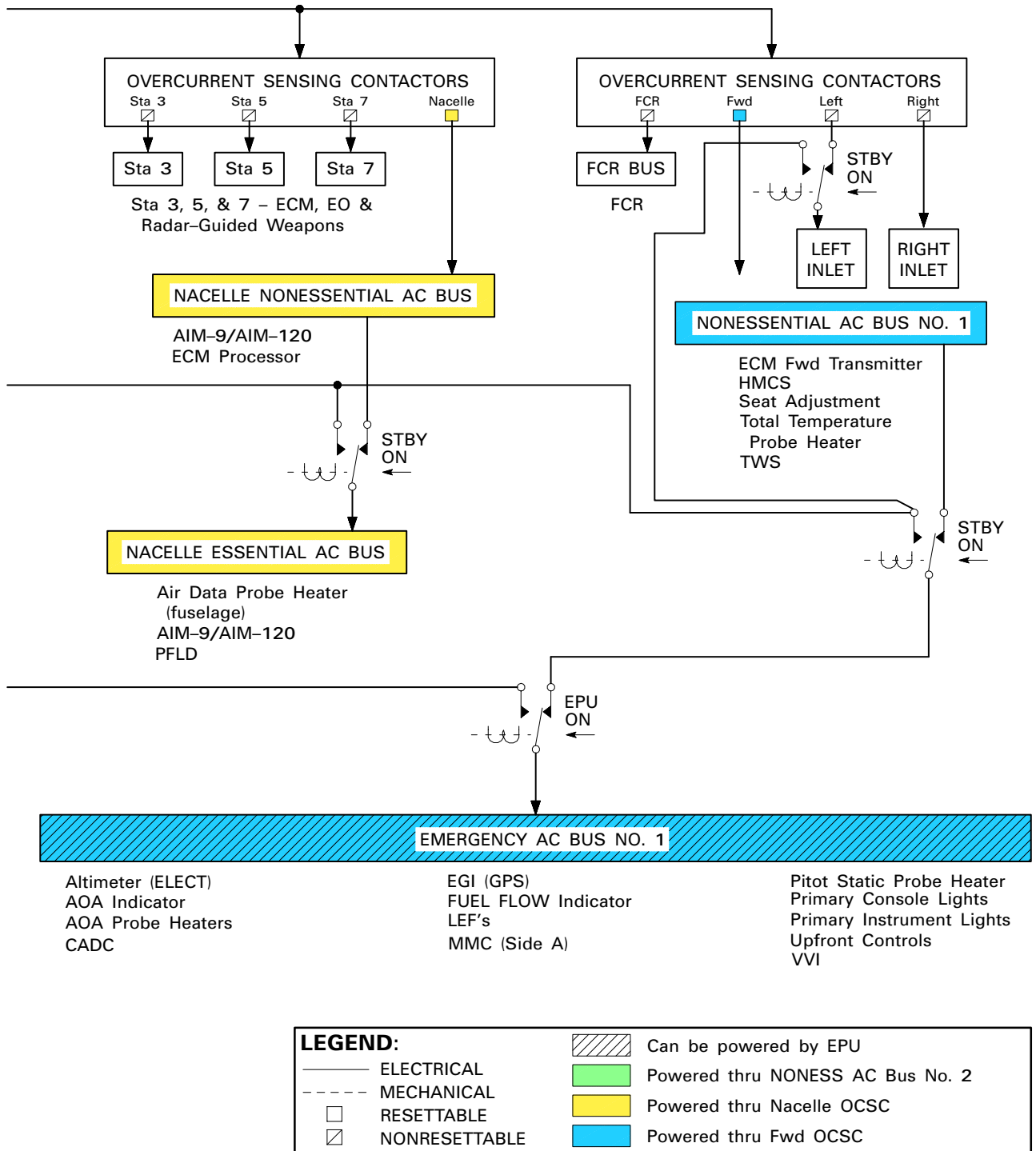

GR1F-16CJ-1-2154-2X37 ©

Figure 1-32. (Sheet 2)

# DC Power Distribution Diagram PX III

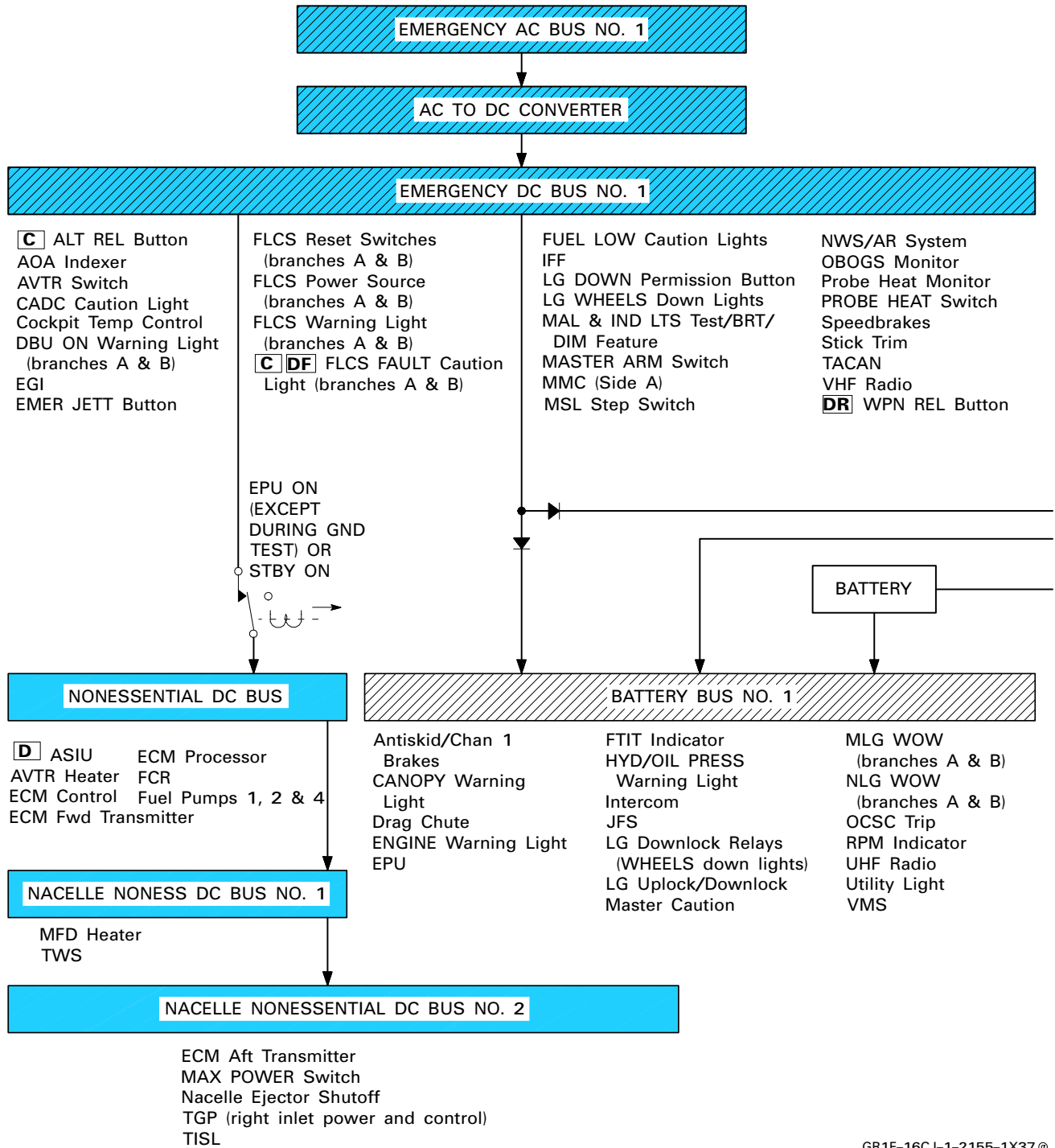

GR1F-16CJ-1-2155-1X37 ©

Figure 1-32. (Sheet 3)

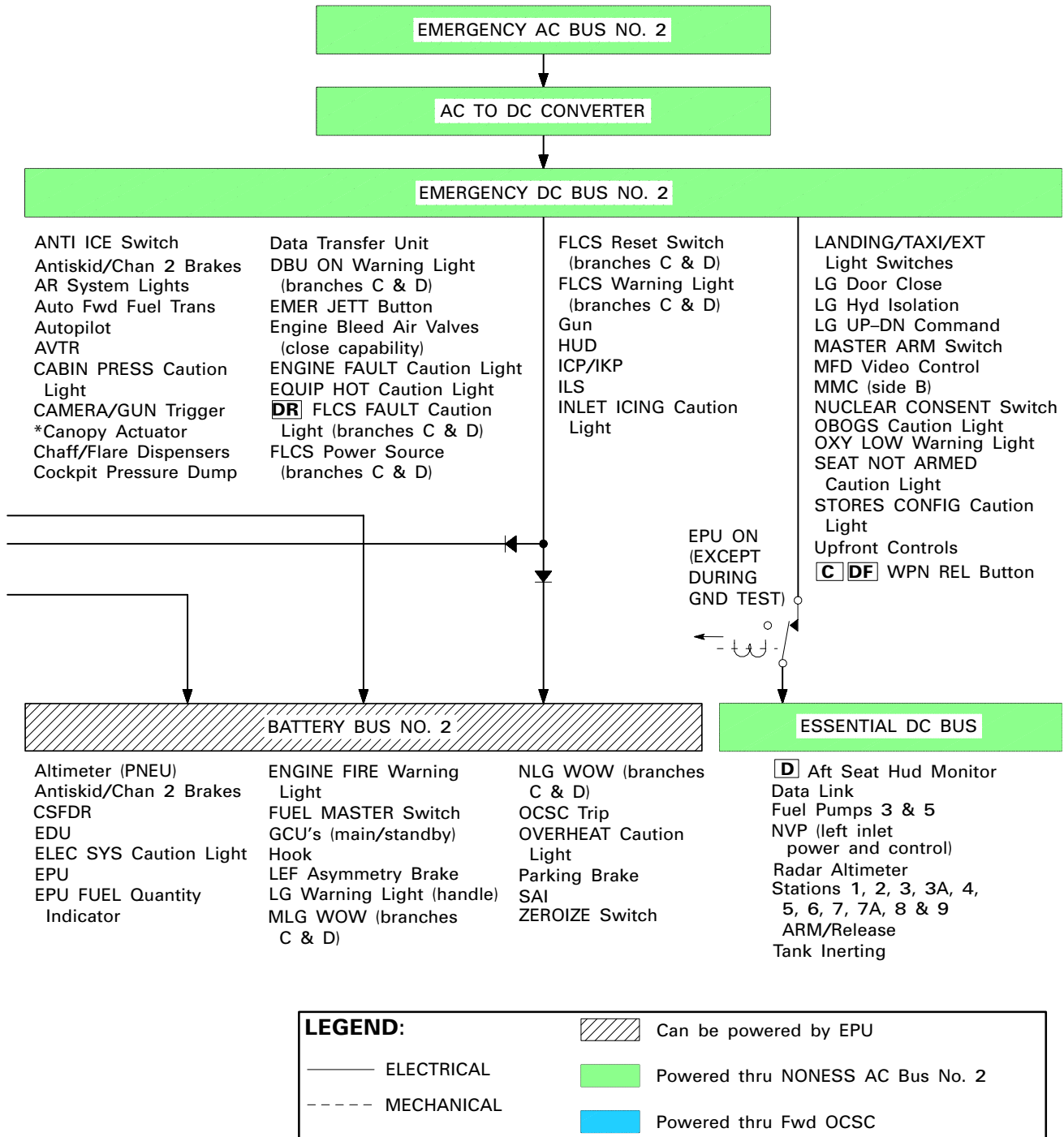

\* Power available from the battery bus box with MAIN PWR switch OFF.

Figure 1-32. (Sheet 4)

## HYDRAULIC SYSTEM

Refer to figure 1-33. Hydraulic pressure is supplied by 3000 psi hydraulic systems designated as systems A and B. The systems are powered by two independent engine-driven pumps located on the ADG. Each system has a reservoir to store hydraulic fluid. The reservoirs are pressurized by their respective hydraulic system to insure positive pressure at the pump. For hydraulic system cooling, refer to ENGINE FUEL SUPPLY SYSTEM, this section.

Both systems operate simultaneously to supply hydraulic power for the primary flight controls and LEF's. If one of the systems should fail, the remaining system provides sufficient hydraulic pressure; however, the maximum actuation rate of the FLCS is reduced. System A also supplies power to the FFP and the speedbrakes. All remaining utility functions, consisting of the gun and gun purge door, AR system, LG, brakes, and NWS, are supplied by system B. System B also charges the brake/JFS accumulators (which provide start power for the JFS and backup pressure for the brakes), provided the engine is rotating at a minimum of 12 percent rpm. System B takes between 40 seconds (hot ambient conditions) and 60 seconds (cold ambient conditions) to recharge the brake/JFS accumulators.

The LG can be extended pneumatically in the event of hydraulic system B failure. Should both hydraulic systems fail, a third hydraulic pump located on the EPU automatically provides hydraulic pressure to system A. Refer to EMERGENCY POWER UNIT (EPU), this section, for a further discussion of the EPU.

Each hydraulic system has an FLCS accumulator which is isolated from the main system by check valves. These FLCS accumulators serve a dual function. If demand exceeds the pump maximum flow rate during rapid control surface movement, the FLCS accumulators provide additional hydraulic pressure. Also, if both hydraulic systems fail, the FLCS accumulators provide adequate hydraulic pressure to the flight controls while the EPU comes up to speed. Refer to SERVICING DIAGRAM, this section, for servicing/specifications information.

## HYD PRESS INDICATORS AND WARNING LIGHT

Refer to figure 1-34.

### HYD PRESS Indicators

The HYD PRESS indicators, one for system A and one for system B, are located on the right auxiliary console. The indicators are powered by emergency ac bus No. 2.

### HYD/OIL PRESS Warning Light

A HYD/OIL PRESS warning light, located on the right glareshield, comes on when hydraulic system A or B pressure drops below 1000 psi or when engine oil pressure drops below 10 ( $\pm 2$ ) psi. For the oil pressure function only, there is a 30-second time delay in the light circuit to minimize transient lights during negative g maneuvers. The light is powered by battery bus No. 1.

## EMERGENCY POWER UNIT (EPU)

Refer to figure 1-35. The EPU is a self-contained system which simultaneously provides emergency hydraulic pressure to system A and emergency electrical power. The EPU automatically activates when both main and standby generators fail or when both hydraulic system pressures fall below 1000 psi. The EPU may be operated manually regardless of failure conditions.

The EPU requires dc power from either battery bus No. 1 or No. 2 for automatic or manual activation. When the EPU is operating, the emergency ac and dc buses are powered by the EPU generator. To reduce electrical loads, the nonessential and essential dc buses are unpowered whenever the EPU is operating (except when activated for ground test using the EPU/GEN test switch).

When operating, the EPU augments hydraulic system A as required. If the normal system A hydraulic pump fails, the EPU is the only source of system A pressure.

The EPU uses engine bleed air and/or hydrazine to operate. Normally, engine bleed air is used to maintain operating speed. When bleed air is insufficient, hydrazine augmentation automatically occurs. Hydrazine is always used when the EPU is commanded to start except when activated during ground test using the EPU/GEN test switch.

On system command, hydrazine is forced by nitrogen pressure into a decomposition chamber. The gaseous products of the reaction spin the turbine/gearbox which then powers the EPU generator and hydraulic pump. Hydrazine exhaust is vented overboard on the lower inboard side of the right strake and consists primarily of nitrogen, hydrogen, ammonia, and water. The temperature of exhaust gases can reach 1600°F and will ignite in the presence of a flame. The exhaust gases have an ammonia odor, are irritating to the nose and eyes, and should be avoided to the maximum extent possible.

## EPU CONTROLS AND INDICATORS

Refer to figure 1-36.

### EPU Ground Safety Switch

The ground safety switch, located on the right side of the engine inlet, is used to disable the EPU on the ground. With the EPU safety pin installed, the EPU does not operate.

### EPU Switch

The EPU switch, located on the EPU control panel, is a three-position toggle switch.

Functions are:

- OFF
  - Prevents or terminates EPU operation on the ground (WOW).
  - Does not prevent or terminate EPU operation in flight for main and standby generator failures if switch was cycled or placed to NORM at anytime since takeoff (since WOW).
  - Prevents EPU operation in flight if switch has remained in the OFF position since takeoff (since WOW).
  - Terminates EPU operation in flight except during main and standby generator failures.
- NORM - The system is armed for automatic operation except during engine shutdown on the ground. With WOW and throttle in OFF, the EPU does not activate when the main and standby generators drop off line.
- ON - Commands EPU to run regardless of failure conditions. Operation will cease when switch is positioned to OFF except for main and standby generator failures in flight.

The switch has a split guard; the top half can be raised to move the switch to ON, and the bottom half can be raised to move the switch to OFF. When both sections of the guard are down, the switch is retained in the NORM position.

### EPU Run Light

The EPU run light, located on the EPU control panel, illuminates when the EPU turbine speed is within the proper range and the EPU-driven hydraulic pump discharge pressure is above 2000 psi.

### HYDRAZN Light

The HYDRAZN light, located on the EPU control panel, illuminates when the EPU is commanding hydrazine for operation (whether hydrazine is available or not) or if a primary speed control failure has occurred.

### AIR Light

The AIR light, located on the EPU control panel, illuminates whenever the EPU has been commanded to run with the EPU safety pin removed. It remains on even when the EPU is augmented by hydrazine.

### EPU/GEN Test Switch

The EPU/GEN test switch, located on the TEST switch panel, has positions of OFF and EPU/GEN. The switch is spring-loaded to the OFF position. It provides a means to test the EPU generator and EPU PMG output to FLCS on the ground without using hydrazine.

### EPU FUEL Quantity Indicator

Refer to figure 1-3. The EPU FUEL quantity indicator, located on the right auxiliary console, is graduated 0-100 and indicates the percent of hydrazine remaining. The indicator is powered by battery bus No. 2.

### Hydrazine Leak Detector

The hydrazine leak detector is a silicone base, mustard yellow disc visible through access door 3208. The viewing area is black on one half to provide contrast with the mustard yellow disc. The mustard yellow turns purple/black in the presence of hydrazine and/or its vapors, indicating a leak in the EPU and/or fuel tank system.



# Hydraulic Power Supply (Typical)

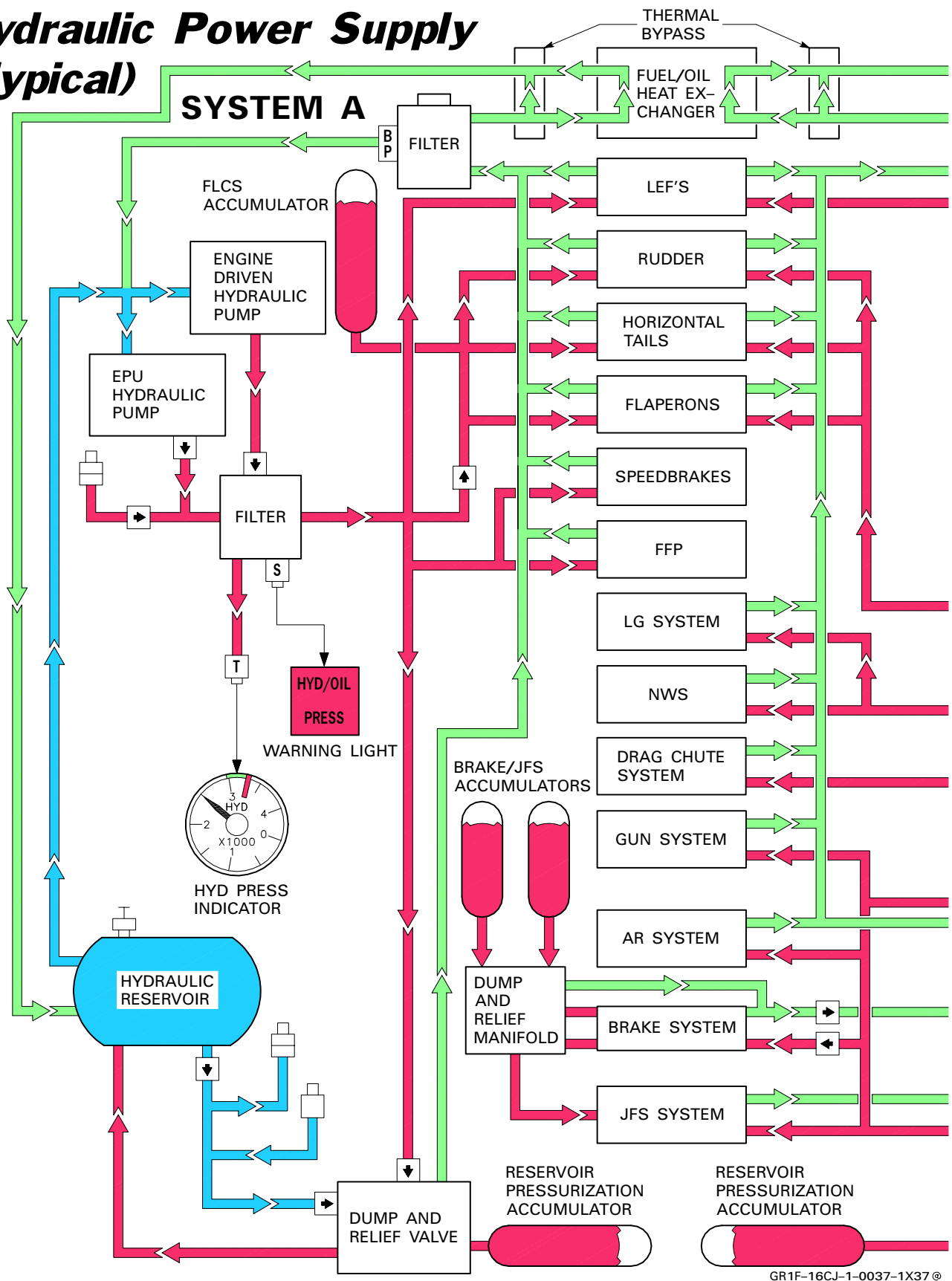

GR1F-16CJ-1-0037-1X37 ©

Figure 1-33. (Sheet 1)

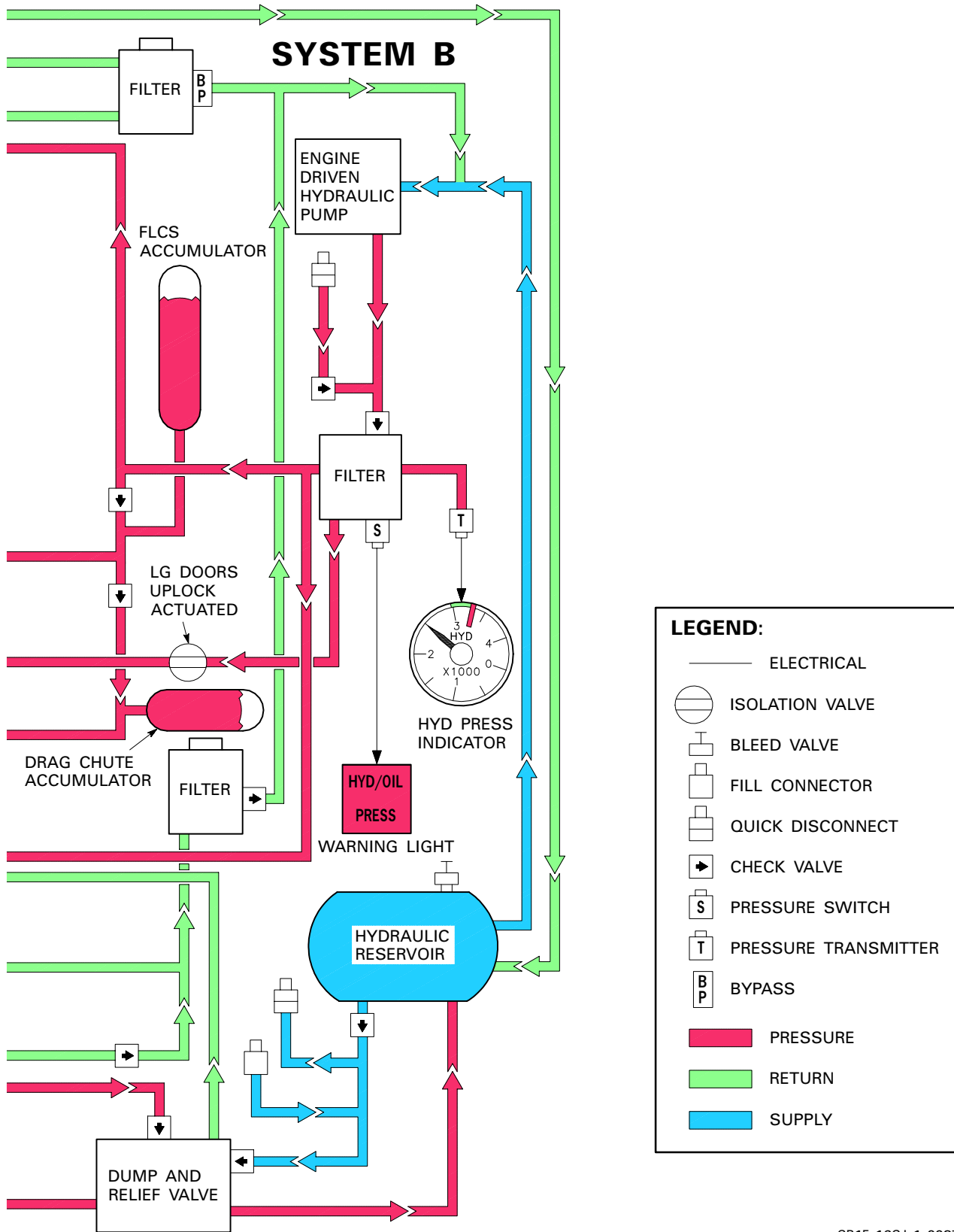

GR1F-16CJ-1-0037-2X37 ©

Figure 1-33. (Sheet 2)

# HYD PRESS Indicators and Warning Light (Typical)

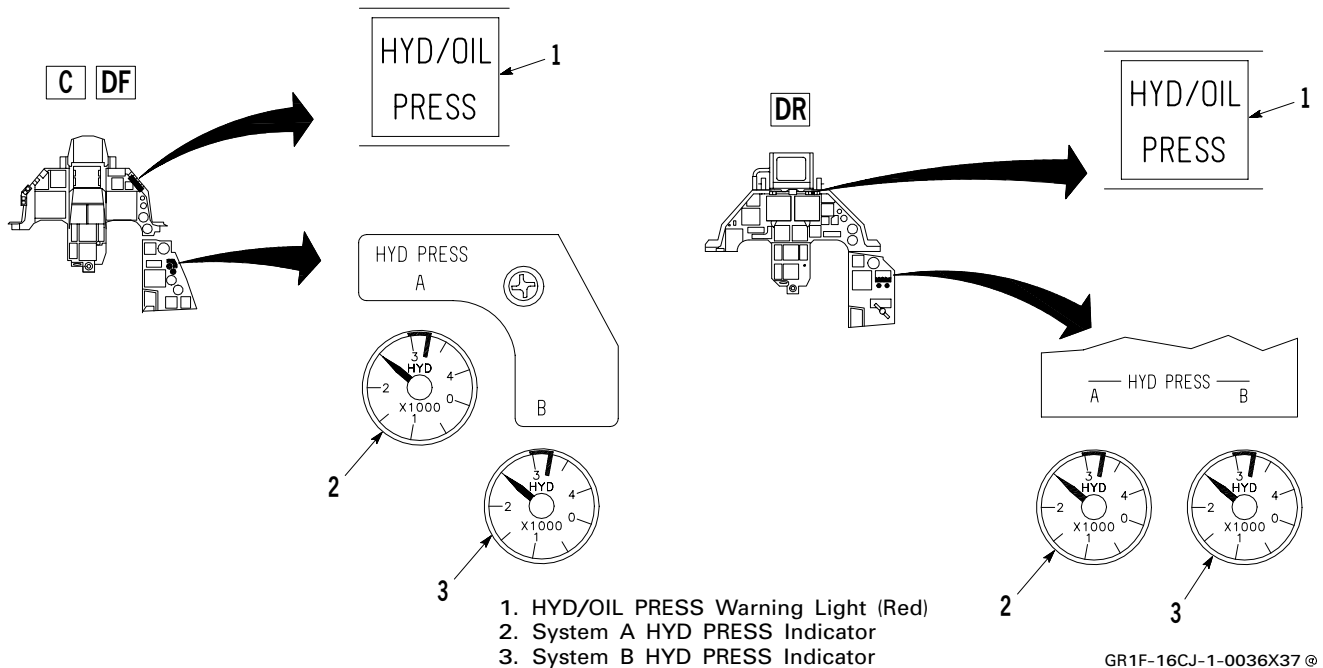

Figure 1-34.

## EPU Fired Indicator

The EPU fired indicator is located next to the EPU ground safety switch on the right side of the engine inlet. Normally, the indicator displays a gray and black disc. If the EPU has been activated, the indicator displays six equally spaced black and white triangles.

## EPU OPERATION

The EPU is designed to operate automatically for main and standby generator failure, dual hydraulic system failure, PTO shaft or ADG failure, and engine flameout or if the engine is shut down in flight. The EPU can also be activated manually. After receiving any start command, the EPU requires approximately 2 seconds to come up to speed.

EPU startup may not be audible. Once operating, however, the EPU may be heard but does not sound the same as during the EPU ground check. A lack of sound during EPU startup does not indicate lack of EPU operation which must be confirmed by monitoring the EPU run light. EPU rpm is controlled by three speed controls. The primary and secondary speed controls are based on EPU rpm. The tertiary speed control is based on EPU PMG frequency.

When the EPU is operating, engine thrust settings should be maintained to prevent using hydrazine. This normally requires a minimum of **PW 229** 75-80, **GE129** 82-90 percent rpm depending on pressure altitude.

If the engine fails, hydrazine alone is used to power the EPU. With hydrazine only, operating time of the system is approximately 10 minutes under normal load requirements. Increased flight control movement reduces this operating time. When the EPU is the sole source of hydraulic power, EPU loss results in loss of aircraft control.

# Emergency Power Unit Schematic (Typical)

**NOTE:**

Shown in augment mode with main and standby generators failed.

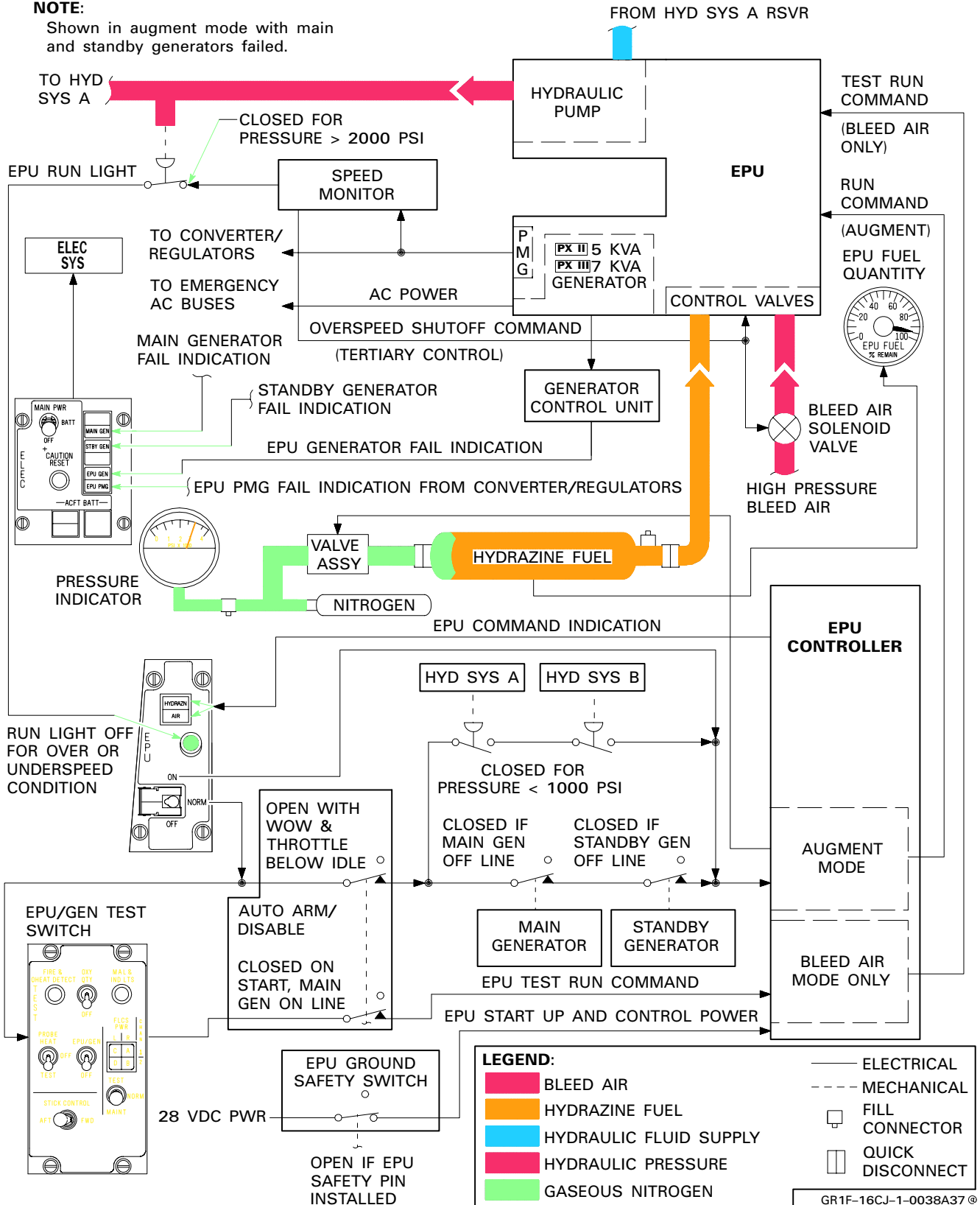
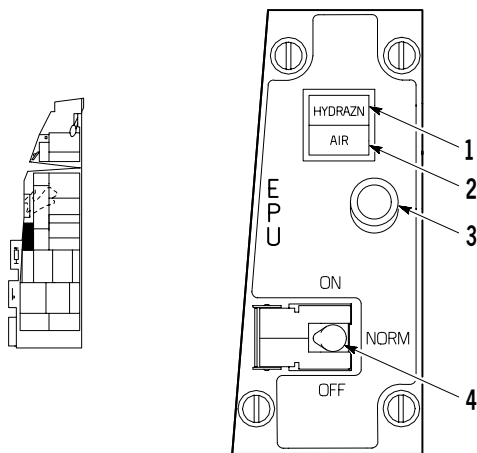

Figure 1-35.

# EPU Control Panel

**C DF (Typical)**



1. HYDRAZIN Light (Amber)
2. AIR Light (Amber)
3. EPU Run Light (Green)
4. EPU Switch

GR1F-16CJ-1-0039X37®

Figure 1-36.

## LANDING GEAR (LG) SYSTEM

The LG system is normally operated by hydraulic system B. The NLG is extended and retracted by hydraulic pressure. The MLG's are retracted hydraulically but are extended by free-fall assisted by airloads. All the LG doors are hydraulically activated with electrical sequencing during retraction and mechanical sequencing during extension. If hydraulic system B fails, the LG may be extended pneumatically.

### MAIN LANDING GEAR (MLG)

The two MLG's are independent of each other and retract forward with a mechanical wheel twist into two separate wheel wells. Each MLG wheel is equipped with three fusible (thermal pressure relief) plugs.

### NOSE LANDING GEAR (NLG)

The NLG retracts aft with a 90-degree mechanical wheel twist into the wheel well. A torque arm quick-disconnect is provided so that the nosewheel can be turned beyond the steerable range for towing.

## LANDING GEAR CONTROLS AND INDICATORS

Refer to figure 1-37. The LG control panel is located on the left auxiliary console.

### Landing Gear Handle

The LG handle, located on the LG control panel has a wheel-shaped grip. Movement of the handle operates electrical switches (powered by emergency dc bus No. 2) to command LG retraction or extension. A warning light in the LG handle, powered by battery bus No. 2 illuminates when the LG and doors are in transit or have failed to lock in the commanded position. The warning light also illuminates when all LG's are not down and locked, airspeed is less than 190 knots, altitude is less than 10,000 feet, and rate of descent is greater than 250 feet per minute. The handle is locked in the DN position when the aircraft is on the ground (weight on wheels). In flight, a signal from the left MLG WOW switch automatically activates a solenoid which unlocks the handle, allowing movement to the UP position. The handle is locked in the UP position to prevent LG extension during high g maneuvers.

### Landing Gear Handle Down Permission Button

The LG handle down permission button, located on the LG handle, unlocks the handle electrically to permit movement to the DN position. The button energizes an electrical solenoid which releases the spring-actuated handle lock. The button must be depressed before downward force is applied to the LG handle. The electrical solenoid may not unlock the handle while any appreciable downward force is applied.

### DN LOCK REL Button

**C DF** The DN LOCK REL button, located on the LG control panel, when depressed, mechanically unlocks the spring-actuated handle lock if the electrical solenoid should fail or not be powered. It overrides all electrical LG control signals. Depressing this button and raising the LG handle on the ground retracts the LG. The downlock release button may not unlock the LG handle while any appreciable downward force is applied. **DR** For DN LOCK REL button differences, refer to F-16D AIRCRAFT, this section.

# Landing Gear Control Panel (Typical)

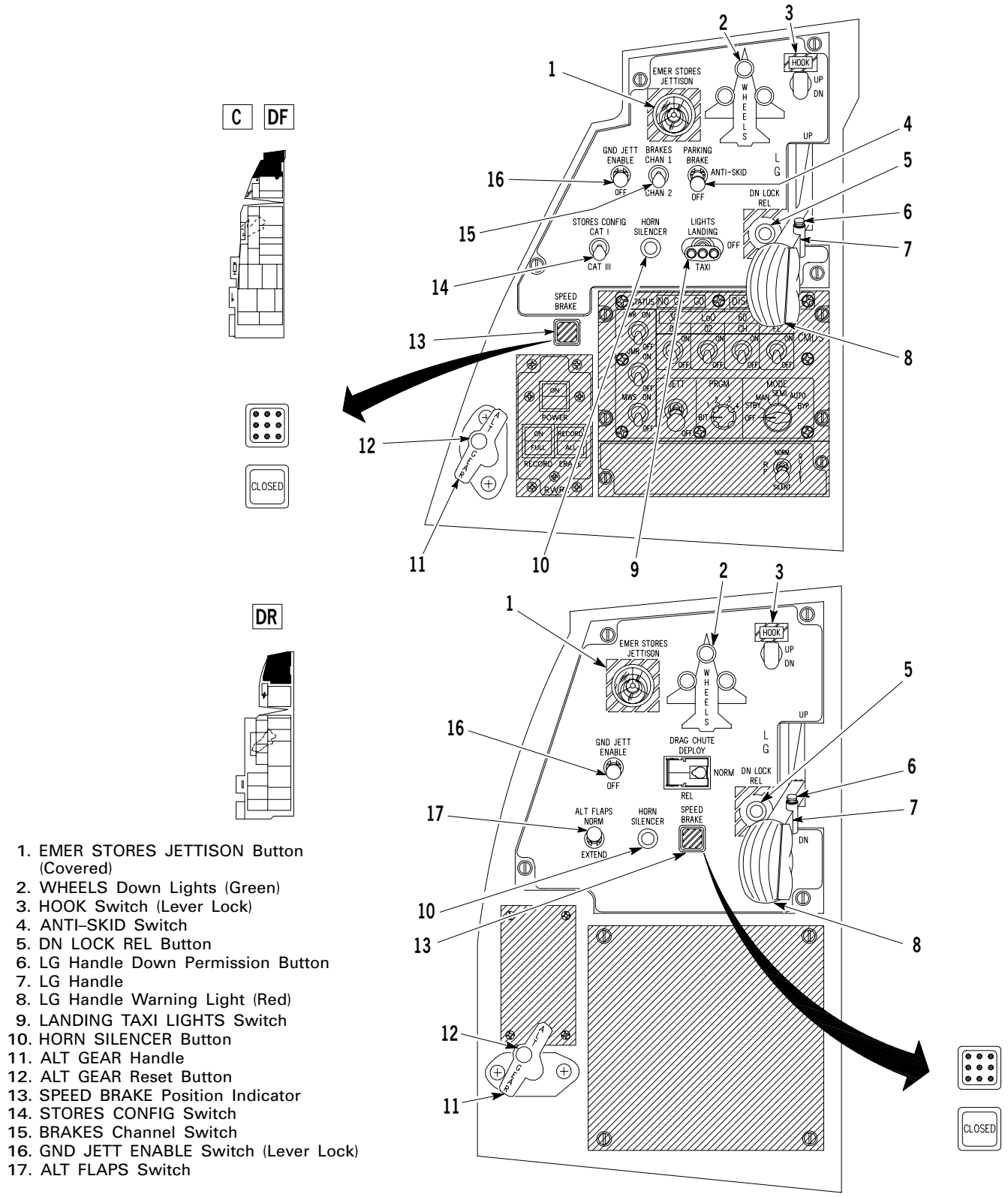

- 1. EMER STORES JETTISON Button (Covered)
- 2. WHEELS Down Lights (Green)
- 3. HOOK Switch (Lever Lock)
- 4. ANTI-SKID Switch
- 5. DN LOCK REL Button
- 6. LG Handle Down Permission Button
- 7. LG Handle
- 8. LG Handle Warning Light (Red)
- 9. LANDING TAXI LIGHTS Switch
- 10. HORN SILENCER Button
- 11. ALT GEAR Handle
- 12. ALT GEAR Reset Button
- 13. SPEED BRAKE Position Indicator
- 14. STORES CONFIG Switch
- 15. BRAKES Channel Switch
- 16. GND JETT ENABLE Switch (Lever Lock)
- 17. ALT FLAPS Switch

GR1F-16CJ-1-0040A37 ©

Figure 1-37.

### ALT GEAR Handle

The ALT GEAR handle, located just outboard of and below the LG control panel, is used to extend the LG if normal extension is not possible. Pulling the ALT GEAR handle supplies pneumatic pressure to open all LG doors, extend the NLG, and shut off the LG selector hydraulic valve. The LG/hook emergency pneumatic bottle is also used to lower the hook and contains sufficient pneumatic pressure for one LG extension and to hold the hook down. The bottle cannot be recharged in flight. Since pneumatic pressure is reduced by expansion as the actuators extend, less than the normal extending force is available.

An LG reset button, located on the ALT GEAR handle, provides a means of retracting the LG after an alternate extension if system B hydraulic pressure is available.

### LG Warning Horn

The LG warning horn is an intermittent fixed volume signal which sounds in the headset when the NLG or MLG is not down and locked and all the following conditions exist:

- Airspeed is below 190 knots.
- Pressure altitude is less than 10,000 feet.
- Rate of descent is greater than 250 fpm.

### HORN SILENCER Button

The HORN SILENCER button is located on the LG control panel. Depressing the button silences the LG warning horn. If the warning condition is eliminated, the horn resets. If it is not eliminated, subsequent LG audio warnings do not occur.

### TO/LDG CONFIG Warning Light

The TO/LDG CONFIG warning light, located on the right glareshield, illuminates in flight whenever pressure altitude is less than 10,000 feet, airspeed is less than 190 knots, rate of descent is greater than 250 fpm, and either of the following conditions exists:

- TEF's not full down.
- NLG or either MLG not down and locked (accompanied by LG warning horn).

The TO/LDG CONFIG warning light illuminates on the ground if TEF's are not full down.

With TEF's full down, rapid reversals of roll command inputs may cause the TO/LDG CONFIG warning light to momentarily illuminate if the altitude, airspeed, and rate of descent conditions outlined above are met or WOW.

### WHEELS Down Lights

The three green WHEELS down lights, located on the LG control panel, are arranged on the silhouette of the aircraft. When any LG is down, its respective light is on. A safe up and locked LG condition is indicated when all three of the lights and the LG handle warning light are off. The lights are powered by battery bus No. 1 (to energize downlock relays) and emergency dc bus No. 1 (to illuminate lights).

### Landing Gear Weight-on-Wheels (WOW) Switches

The LG WOW switches, located on both MLG's and on the NLG, operate as a function of LG strut extension to allow or terminate various system functions.

Refer to figure 1-38 for a list of systems affected by the WOW switches and symptoms of WOW switch failure.

### LANDING GEAR OPERATION

Movement of the LG handle to the UP position causes the following events:

- LG handle warning light illuminates.
- LG unlocks and retracts.
- Three WHEELS down lights go off.
- MLG wheel spin is stopped.
- LG doors close and lock.
- LG handle warning light goes off.
- Hydraulic pressure removed from LG.
- FLCS switches to cruise gains.
- TEF's retract to streamlined position.
- Electrical power is removed from brake channel 1.

Movement of the LG handle to the DN position causes the following events:

- LG handle warning light illuminates.
- LG doors and LG unlock, extend, and lock into place.
- Three WHEELS down lights illuminate.
- LG handle warning light goes off.
- TEF's extend.
- FLCS switches to takeoff and landing gains.
- **PW 229** LG DN nozzle scheduling is activated.
- Speedbrakes close to 43 degrees if not overridden.
- Electrical power is supplied to brake channel 1.

# LG WOW Switch

## RIGHT MLG — SYSTEMS

Aircraft Battery	FCR	
Air Data Probe	FLCC	
Altimeter (ELECT)	LG Warning	
AOA Probes	Pitot Probe	
Brakes/Antiskid	Probe Heat Monitor	
ECS	SMS	
Engine Controls		
EPU	<input type="checkbox"/> VMS	
Fails to Ground Position in Flight		
<p>FCR does not transmit</p> <p>Stores cannot be emergency jettisoned with LG down unless GND JETT ENABLE switch is in ENABLE</p> <p><input type="checkbox"/> VMS is inoperative</p> <p>Brakes can be applied before touchdown if toe brakes are depressed</p> <p>ANTI-SKID switch holds in PARKING BRAKE with throttle in OFF to IDLE range</p> <p>With simultaneous failure of left and right MLG WOW switches, ACFT BATT FAIL light indicates aircraft battery failure (voltage 20V or less) or battery charger failure</p> <p><input type="checkbox"/> LG and low speed warning tones are inoperative</p> <p>Probe heat monitor is inoperative unless TEST or PROBE HEAT is selected</p>	Fails to In-Flight Position on Ground	
	<p>FCR transmits</p> <p>Stores can be emergency jettisoned with GND JETT ENABLE switch in OFF</p> <p><input type="checkbox"/> VMS is operative unless INHIBIT is selected</p> <p>With simultaneous failure of left and right MLG WOW switches and ANTI-SKID switch in ANTI-SKID, toe brakes are inoperative when groundspeed is less than 20 knots</p> <p>With simultaneous failure of left and right MLG WOW switches, ANTI-SKID switch must be held in PARKING BRAKE to operate parking brake</p> <p>ACFT BATT FAIL light indicates aircraft battery failure only</p> <p>EPU is commanded on during engine shutdown; operation cannot be terminated with the EPU switch</p> <p>Probe heat monitor is operative</p> <p>All probe heaters except total temperature are on</p> <p>FLCS BIT cannot be initiated</p>	

Figure 1-38. (Sheet 1)



# LG WOW Switch

## LEFT MLG — SYSTEMS

<p>Aircraft Battery AOA Probe (right) Brakes/Antiskid Chaff/Flare Dispenser EPU FLCC</p>	<p>Ground Test Panel (fuel pump lights) JFS Ground Cutout LG Handle LG Warning Total Temperature Probe <input type="checkbox"/> VMS</p>
<p><b>Fails to Ground Position in Flight</b></p>	<p><b>Fails to In-Flight Position on Ground</b></p>
<p>Chaff/flare dispenser is inoperative</p> <p>JFS shuts down automatically during engine start</p> <p>LG UP position cannot be selected unless DN LOCK REL button is depressed</p> <p>TO/LDG CONFIG warning light is on with TEF's not down</p> <p>Total temperature probe heater is inoperative</p> <p><input type="checkbox"/> VMS is inoperative</p> <p>Brakes can be applied before touchdown if toe brakes are depressed</p> <p>ANTI-SKID switch holds in PARKING BRAKE with throttle in OFF to IDLE range</p> <p>With simultaneous failure of right and left MLG WOW switches, ACFT BATT FAIL light indicates aircraft battery failure (voltage 20V or less) or battery charger failure</p> <p><input type="checkbox"/> LG and low speed warning tones are inoperative</p>	<p>Chaff/flare dispenser is operative</p> <p>AOA probe heater (right) is on</p> <p>JFS does not shut down automatically during engine start</p> <p>LG UP position can be selected without DN LOCK REL button depressed</p> <p>TO/LDG CONFIG warning light is off with TEF's up</p> <p>Total temperature probe heater is on</p> <p><input type="checkbox"/> VMS is operative unless INHIBIT is selected</p> <p>With simultaneous failure of right and left MLG WOW switches and ANTI-SKID switch in ANTI-SKID, toe brakes are inoperative when groundspeed is less than 20 knots</p> <p>With simultaneous failure of right and left MLG WOW switches, ANTI-SKID switch must be held in PARKING BRAKE to operate parking brake</p> <p>Fuel pump lights on external ground test panel are inoperative</p> <p>ACFT BATT FAIL light indicates aircraft battery failure only</p> <p>EPU is commanded on during engine shutdown; operation cannot be terminated with the EPU switch</p> <p>FLCS BIT cannot be initiated</p>

Figure 1-38. (Sheet 2)

# LG WOW Switch

## NLG — SYSTEMS

Air Data Probe	FLCS Power
AOA Probe (Left)	<input type="checkbox"/> NWS
<input type="checkbox"/> AR	Pitot Probe
FLCP	Speedbrakes
<b>Fails to Ground Position in Flight</b>	<b>Fails to In-Flight Position on Ground</b>
<p>AOA indicator displays zero degrees</p> <p><input type="checkbox"/> A/R DISC button is inoperative</p> <p>NWS can be engaged and follows rudder inputs with NLG down</p> <p>Speedbrakes are not limited to 43 degrees with right MLG down and locked</p> <p>ACFT BATT TO FLCS light indicates aircraft battery is supplying power to one or more FLCS branches</p> <p>FLCS PMG light indicates FLCS PMG power is not available at one or more FLCS branches</p>	<p>Air data, pitot, and left AOA probe heaters are on</p> <p><input type="checkbox"/> A/R DISC button is operative</p> <p>FLCS fails BIT</p> <p>NWS is inoperative</p> <p>Speedbrakes do not remain open more than 43 degrees</p> <p>ACFT BATT TO FLCS light indicates aircraft battery is supplying power to one or more FLCS branches (bus voltage 25 vdc or less)</p> <p>FLCS PMG light indicates the FLCS PMG is not supplying power to any FLCS branches</p>

Figure 1-38. (Sheet 3)

## NOSEWHEEL STEERING (NWS) SYSTEM

The NWS is electrically controlled using dc bus No. 1 power and is hydraulically operated using system B pressure. Steering signals are provided through the rudder pedals. Should NWS be engaged with the rudder pedals displaced, the nosewheel drives to the rudder pedal commanded position. NWS is limited to 32 degrees in each direction; however, turn radius can be reduced by using inside brake. NWS is automatically disengaged when the NLG strut is extended. NWS is not available following an alternate LG extension and may not be available anytime the nosewheel WHEELS down light is not illuminated.

### NWS CONTROLS AND INDICATORS

Refer to figure 1-3.

#### NWS A/R DISC MSL STEP Button

The NWS A/R DISC MSL STEP button, located on the outboard side of the stick, is used to engage or disengage NWS when the aircraft is on the ground. Once depressed, NWS is engaged and the button may be released. If the button is held depressed, continuous NWS is provided.

#### NWS Light

The NWS light, the center element of the AR/NWS status indicator located on the top of the glareshield, illuminates green when NWS is engaged. NWS does not operate even though the NWS light is illuminated when the NWS FAIL caution light is on or when system B hydraulic pressure is unavailable. On the ground, NWS continues to operate with the AIR REFUEL switch in OPEN even though the NWS light is off.

#### NWS FAIL Caution Light

The NWS FAIL caution light, located on the caution light panel, illuminates when a failure in the NWS system has caused electrical power to be switched off.

### NOSEWHEEL STEERING (NWS) SYSTEM D

Either cockpit can control the NWS. Control is accomplished by means of an NWS control button/indicator located in both cockpits just aft of the stick. Depressing the button/indicator transfers control of the NWS; the indicator illuminates green in the cockpit which has control. Control then remains in that cockpit even if the engine is shut down and/or electrical power is removed. NWS can only be

engaged and operated from the cockpit which has control. When NWS is selected, the NWS light illuminates green in both cockpits. The aft stick-paddle switch allows immediate override of the forward cockpit if the STICK CONTROL switch on the TEST switch panel is in AFT; the NWS control button/indicator in the aft cockpit and OVRD light illuminates. The front cockpit paddle switch cannot override the aft cockpit regardless of the position of the STICK CONTROL switch. With the AIR REFUEL switch in OPEN, NWS can be engaged or disengaged from either cockpit without using the paddle switch regardless of which cockpit has control.

## WHEEL BRAKE SYSTEM

Each MLG wheel is equipped with a hydraulically powered multiple disc brake. The brakes are electrically controlled by conventional toe brake pedals. The amount of braking gradually increases as pedal pressure is applied. A parking brake is also provided. An antiskid system protects against blown tires and is only available when using toe brakes.

D Brakes may be applied singly or simultaneously from the forward or rear cockpits. The brake signals from both cockpits are additive so that the total signal to the brakes is the sum of the pedal forces from both cockpits.

Brake hydraulic power is supplied by system B. If system B fails or the engine is operating at less than 12 percent rpm, the toe brakes and parking brake are available until the brake/JFS accumulators deplete. Continuous use of the toe brakes, even with the parking brake set, depletes accumulator fluid and causes loss of all braking capability after approximately 75 seconds (brake/JFS accumulators initially fully charged). When holding the aircraft stationary, use of the parking brake is preferred since brake/JFS accumulator fluid is not depleted.

### TOE BRAKE SYSTEM

Refer to figures 1-39 and 1-40. The toe brakes use electrical power from the FLCC and CHAN 1 and CHAN 2 dc power sources. The brake pedals require FLCC power to operate. The pedal signals are supplied to the 129 brake control/anti-skid assembly **LESS** 129 brake control box which, in turn, uses both CHAN 1 and CHAN 2 dc power sources to operate valves for controlling hydraulic pressure to the brakes. CHAN 1 and CHAN 2 are powered by battery buses No. 1 and No. 2, respectively. PX III In addition, there is an alternate power source for CHAN 2 on emergency dc bus No. 2.

# Toe Brake System

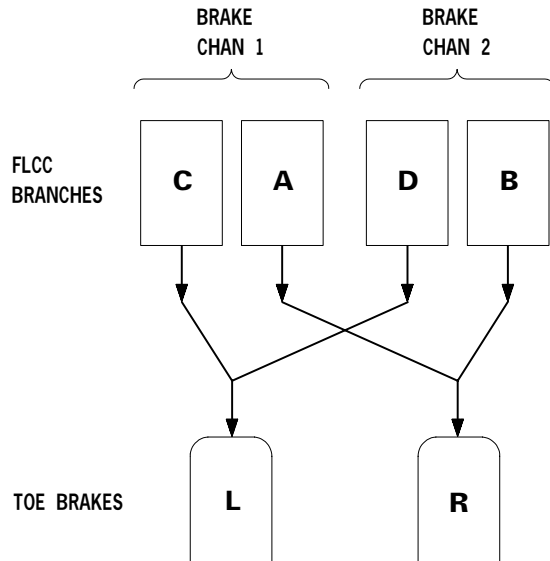

1F-16X-1-0026X®

Figure 1-39.

The electrical power sources are grouped to provide two redundant channels. Channel 1 uses FLCC branches A and C and CHAN 1 dc power. Channel 2 uses FLCC branches B and D and CHAN 2 dc power. If one FLCC branch fails, one toe brake in either CHAN 1 or CHAN 2 is inoperative.

An inoperable FLCC branch may illuminate the FLCS FAULT caution light and generate a BRK PWR DEGR PFL. FLCS PWR lights on the TEST switch panel should be used to determine the proper BRAKES channel switch position.

After engine shutdown (main and standby generators and FLCS PMG not operating), the brakes remain powered as long as the MAIN PWR switch is not moved out of MAIN PWR. If the MAIN PWR switch is moved to BATT, the FLCS relays open and the FLCC is no longer powered by the aircraft battery. Therefore, the toe brakes are inoperative.

Regardless of which channel is selected, hydraulic pressure to three of the six pistons in each brake is controlled by electrical power from one dc power source and pressure to the other three pistons of each brake is controlled by electrical power from another dc power source. A loss of one dc power source when CHAN 1 is selected results in degraded brake operation (only one-half of the pistons are powered and significantly more brake pedal force than normal is required to stop). Due to redundancy features, selecting CHAN 2 may restore full braking. If all dc power sources fail or if all FLCC branches are off, the toe brakes are totally inoperative.

Channels 1 and 2 use separate redundant circuit elements for controlling the brakes and operate the same except that when CHAN 1 is selected, both dc power sources are switched off when the LG handle is up. With CHAN 1 selected, the brakes only operate with the LG handle down; with CHAN 2 selected, the brakes are operable with the LG handle either up or down. If the LG handle is stuck in the UP position, CHAN 2 must be selected to achieve braking.

## SPIN DOWN BRAKING SYSTEM

The spin down braking system provides hydraulic brake pressure to stop MLG wheel spin during LG retraction. The hydraulic pressure is relieved when the LG is up and locked.

## BRAKES CHANNEL SWITCH

The BRAKES channel switch, located on the LG control panel, has positions of CHAN 1 and CHAN 2 and allows wheel brake system switching. CHAN 1 is the normal position.

## PARKING BRAKE

The parking brake is activated by the ANTI-SKID switch located on the LG control panel, and supplies full, unmetered pressure to three of the six pistons in each brake. The parking brake holds the aircraft stationary without the use of toe brakes. It can also be used for emergency braking if the toe brakes are inoperative. The parking brake is powered by battery bus No. 2 and system B hydraulics or one brake/JFS accumulator (the brake/JFS accumulator which is not used for START 1).

# Wheel Brake Schematic (Typical) 129

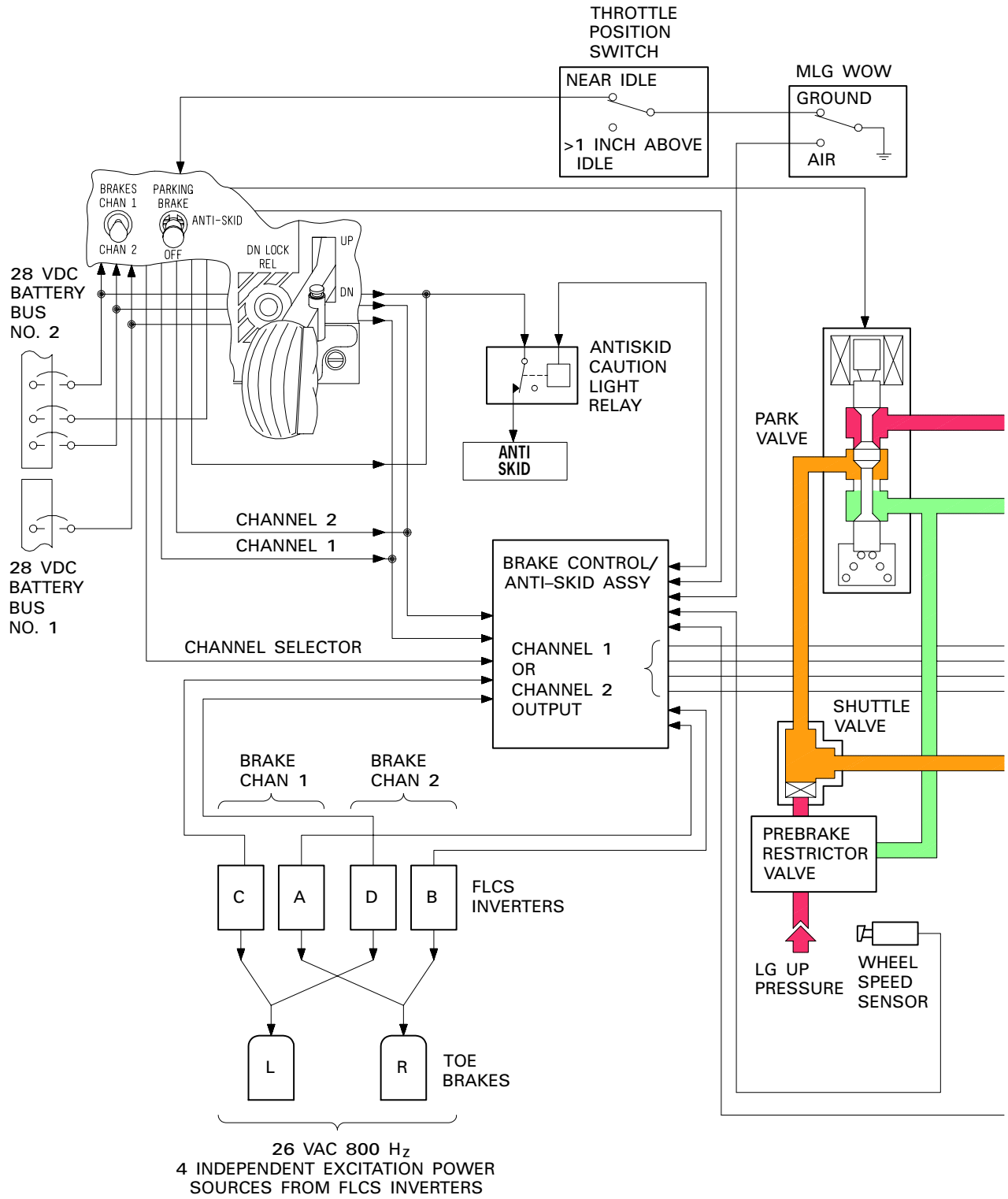
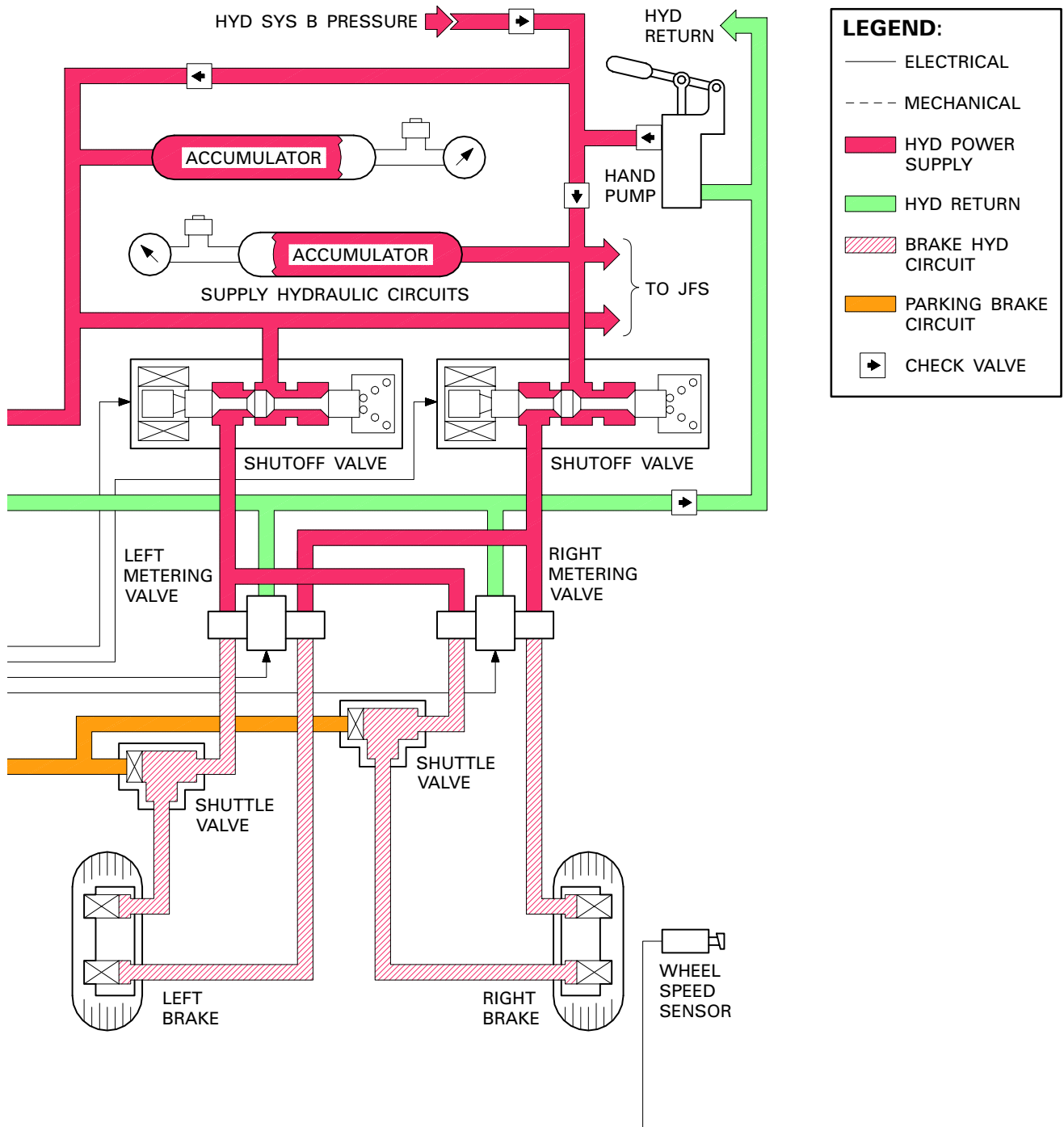

Figure 1-40. (Sheet 1)



GR1F-16CJ-1-1042-2X37 ©

Figure 1-40. (Sheet 2)

# Wheel Brake Schematic (Typical) LESS 129

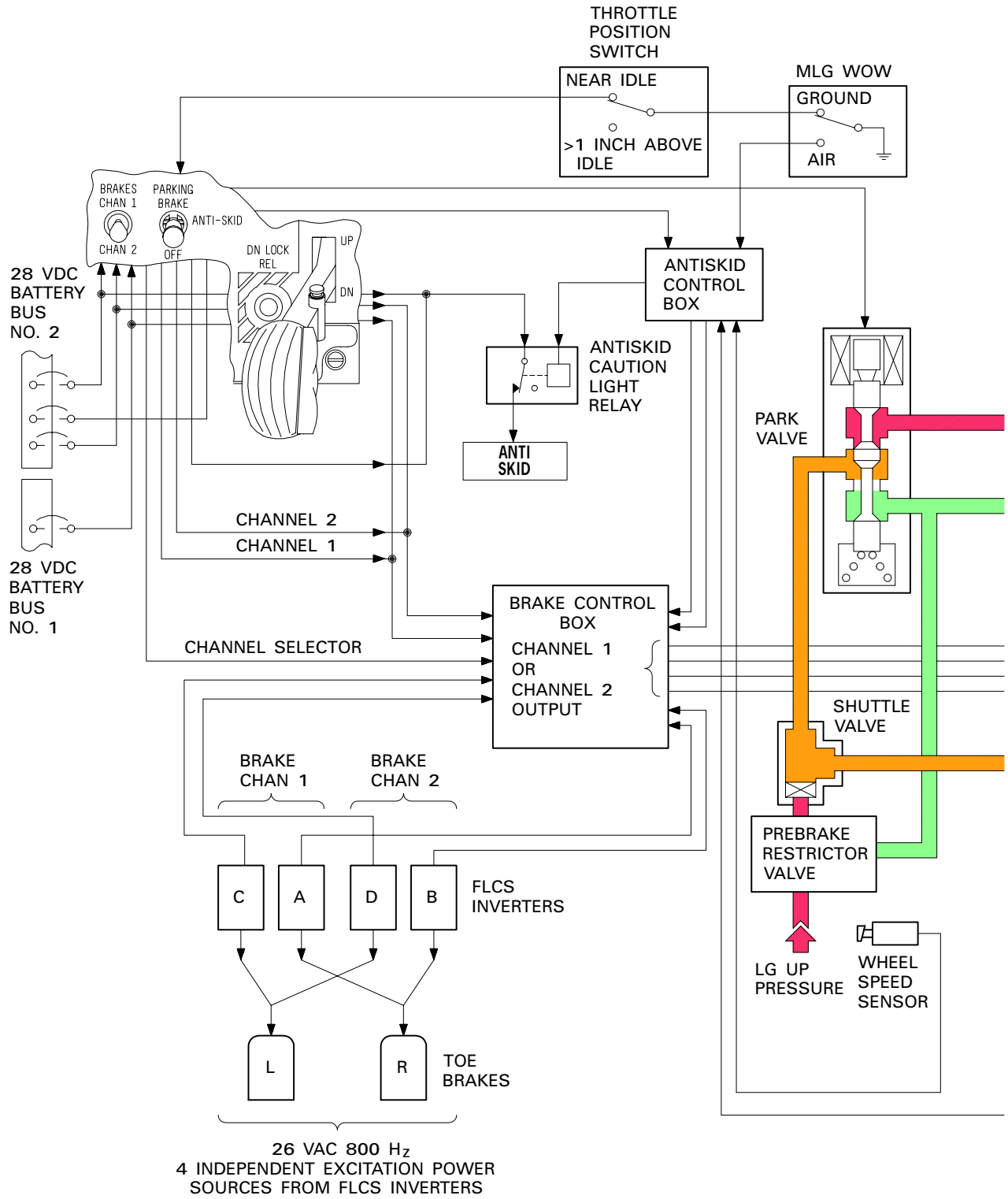
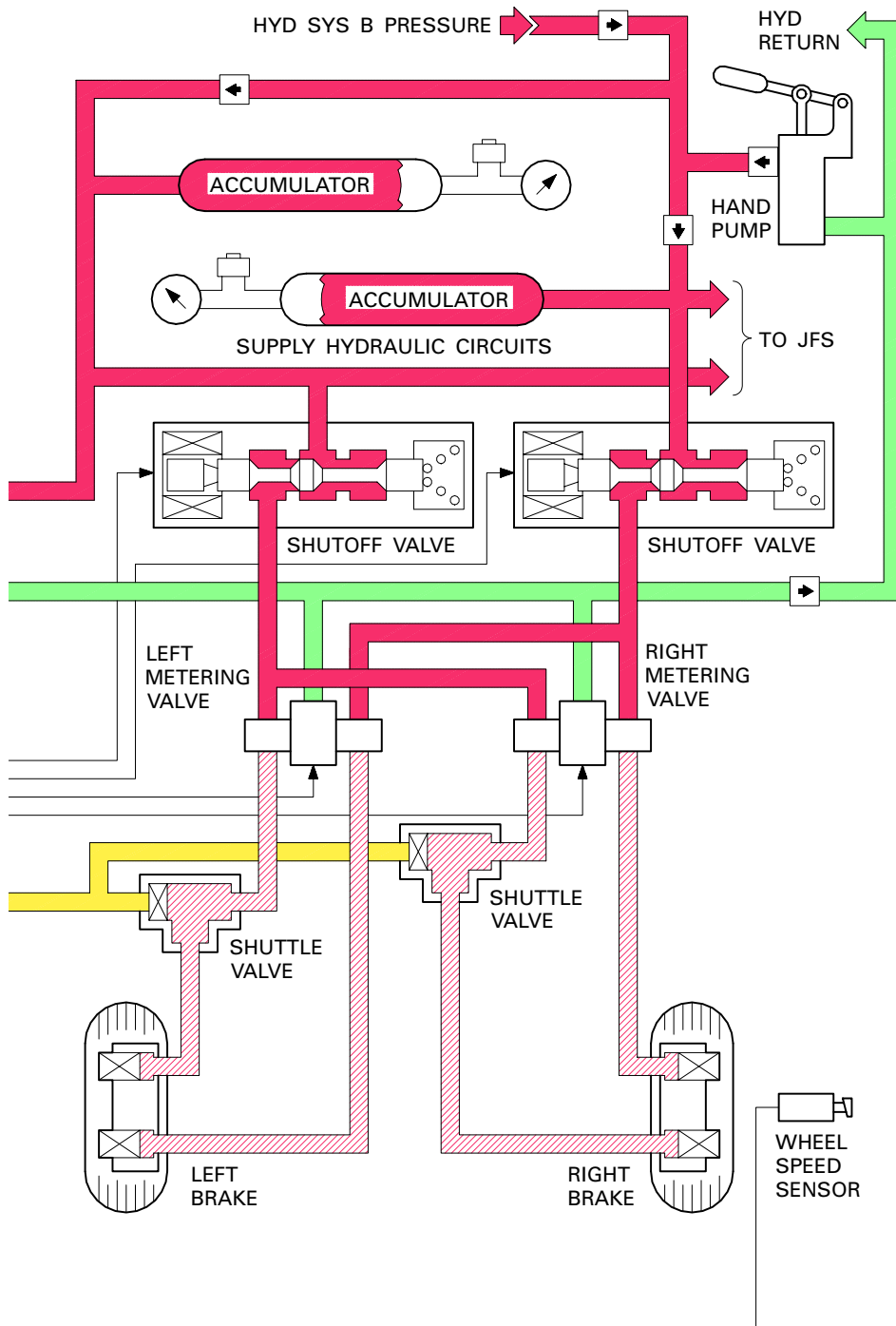

Figure 1-40. (Sheet 3)



**LEGEND:**

- ELECTRICAL
- - - MECHANICAL
- HYD POWER SUPPLY
- HYD RETURN
- ▨ BRAKE HYD CIRCUIT
- PARKING BRAKE CIRCUIT
- ▣ CHECK VALVE

GR1F-16CJ-1-0042-2X37 ©

Figure 1-40. (Sheet 4)



**ANTISKID SYSTEM**

The antiskid system is available in either brake channel anytime the toe brakes are powered.

**129** The antiskid system will deliver a corresponding deceleration rate to a given pedal deflection. The deceleration skid control will dampen brake pedal inputs to the brakes resulting in a smoother, more efficient stop than with previous antiskid systems. To optimize braking performance and reduce wear on aircraft brakes and tires, smoothly apply brakes in a single application.

Functions are:

- Touchdown skid control – Prevents brake application prior to wheel spinup even if brake pedals are fully depressed.
- **129** Deceleration skid control – Active when either brake pedal deflection is less than 85 percent of maximum and runway surface can provide the requested deceleration.
- **129** Maximum performance skid control – Active when both brake pedal deflections are equal to or greater than 85 percent or runway surface cannot provide requested deceleration.
- **129** Antiskid failure detection – Detects a failure affecting braking or in a system component.
- **LESS 129** Proportional skid control – Prevents skidding due to overbraking at 5 knots groundspeed or greater.
- **LESS 129** Locked wheel skid control – Backs up the proportional skid control and operates at 20 knots groundspeed and greater.
- **LESS 129** Antiskid failure detection – Detects an antiskid system malfunction.

**129** If a failure affecting braking performance is detected while the aircraft is moving above 5 knots groundspeed, the ANTI SKID caution light illuminates. In most cases this represents the loss of a wheel speed sensor signal, and the system switches to an alternate braking mode. In this mode, if differential braking is applied (15 percent or greater difference between pedals), both brakes alternate between pedal pressure as metered and no pressure. Braking effectiveness is reduced by 50 percent or greater. If brake pedals are within 15 percent, the system uses the information from the remaining good wheel speed sensor and stopping distance is increased by approximately 25 percent on both wet and dry runways.

**129** The alternate mode continues until the BRAKES channel switch is switched to CHAN 2 and the ANTI-SKID switch is placed to OFF. The ANTI SKID caution light remains on and braking is manual. The brakes then can be locked by applying too much pedal pressure, which may result in blown tires.

**129** The antiskid system incorporates a hydroplaning protection function which prevents brake application until the wheels have spun up, even if WOW has occurred before spinup.

**129** Full antiskid function becomes active at 12 knots groundspeed when accelerating and is available to below 5 knots when decelerating. Maximum braking below 12 knots groundspeed may result in tire flat spotting.

**LESS 129** If a failure is detected, the ANTI SKID caution light illuminates and the brake system automatically switches to pulsating pressure (constant frequency pulsating on-off pressure). In this mode, braking effectiveness is reduced approximately 50 percent; however, in most cases, braking effectiveness is as good as can be obtained with ANTI-SKID switch in OFF while avoiding wheel lockup and its associated risk of control difficulty. Short field landing distances are increased approximately 60 percent for dry runway and 25 percent for wet runway from those normally computed. The amount of pulsating braking is dependent on the toe pressure applied. Pulsating braking continues until the ANTI-SKID switch is placed to OFF. At that time, the ANTI SKID caution light remains on, and the brake system reverts to manual control. The brakes then can be locked by applying too much pedal pressure, which may result in blown tires.

**LESS 129** The antiskid system does not provide skid or locked wheel protection if MLG wheels are not spinning due to hydroplaning. If WOW occurs prior to spinup of at least one MLG wheel, wheel brakes become operative without antiskid protection.

**LESS 129** Antiskid protection and failure detection are intentionally diminished as speed decreases below 20 knots to allow a complete stop without continuous brake release or an ANTI SKID caution light. Consequently, maintaining maximum toe pressure while the aircraft comes to a complete stop may cause wheel lockup during the last 5-10 feet before stopping with resultant tire flat spotting. A dragging brake not correctly releasing in response to antiskid signals may also cause wheel lockup without an illuminated ANTI SKID caution light at speeds below 20 knots. Avoid maximum braking at speeds below 20 knots whenever possible to prevent tire flat spotting and possible blowout.

**ANTI-SKID Switch** **C** **DF**

The ANTI-SKID switch, located on the LG control panel, is not lever-locked in the ANTI-SKID position and can be bumped to OFF.

Functions are:

- **PARKING BRAKE** – Full unmetred brake pressure is applied with the throttle in the OFF to IDLE range and WOW. Advancing the throttle more than 1 inch beyond IDLE automatically returns the switch to ANTI-SKID which releases the parking brake.
- **ANTI-SKID** – Antiskid protection is available.
- **(129) OFF** – Parking brake feature is deactivated and antiskid functions are as follows:
  - With **BRAKES** channel switch in **CHAN 1** – Touchdown skid control is not available, but deceleration and maximum performance skid control remain active.
  - With **BRAKES** channel switch in **CHAN 2** – All antiskid functions are deactivated.
- **LESS (129) OFF** – Antiskid and parking brake features are deactivated.

**ANTI SKID Caution Light**

**(129)** The ANTI SKID caution light, located on the caution light panel, illuminates at groundspeeds above 5 knots when a malfunction affecting braking performance is detected. If a system malfunction not affecting braking performance (e.g. loss of redundancy) is detected, the light illuminates when groundspeed is below 5 knots. The caution light is not latched and will extinguish above 5 knots if a failure that does not affect braking performance is present.

**(129)** The ANTI SKID caution light illuminates when power is applied to the brake control/antiskid assembly and goes off when power-up BIT has been successfully completed (approximately 1/2 second later). This brief illumination of the ANTI SKID caution light may be observed when power is first applied or after the LG handle is placed down with the **BRAKES** channel switch in **CHAN 1**.

**LESS (129)** The ANTI SKID caution light, located on the caution light panel, illuminates when a malfunction occurs with the ANTI-SKID switch in ANTI-SKID.

The ANTI SKID caution light illuminates when the LG handle is down and the switch is in OFF.

**SPEEDBRAKE SYSTEM**

The speedbrake system consists of two pairs of clamshell surfaces located on each side of the engine nozzle and inboard of the horizontal tail and is powered by hydraulic system A. The speedbrakes open to 60 degrees with the right MLG not down and locked. With the right MLG down and locked, speedbrake opening is limited to 43 degrees to prevent the lower surfaces from striking the runway during landing. This limit can be overridden by holding the SPD BRK switch in the open (aft) position. When the NLG strut compresses on landing, the speedbrakes can be fully opened and remain fully open without holding the SPD BRK switch.

**SPD BRK Switch**

**C** **DF** The SPD BRK switch, located on the throttle, is a thumb-activated, three-position slide switch. The open (aft) position is spring-loaded to off (center) and allows the speedbrakes to be incrementally opened. The closed (forward) position has a detent, allowing a single motion to close the speedbrakes. To prevent possible creeping, the switch should be left in the closed position. **DR** For SPD BRK switch differences, refer to F-16D AIRCRAFT, this section.

**D** The speedbrake switches are connected in parallel and function so that either can override the other by holding in the open position. If one switch is in the closed position, the speedbrakes close when the other is released from the open position.

**SPEED BRAKE Position Indicator**

A three-position SPEED BRAKE indicator is located on the LG control panel.

Positions are:

- **CLOSED** – Both speedbrakes closed.
- **Speedbrake symbol** – Speedbrakes not closed.
- **Diagonals** – Electrical power removed from the indicator. Diagonals also appear momentarily during switching.

**DRAG CHUTE SYSTEM**

A drag chute is provided to minimize stopping distance. Drag chute deployment is obtained when hydraulic system B pressure is routed to the drag chute actuator by placing the DRAG CHUTE switch to DEPLOY. Drag chute accumulator pressure is available in case of hydraulic system B failure.

## T.O. GR1F-16CJ-1

Extension of the actuator closes a set of jaws onto the parachute D-ring and pulls the ripcord that releases a spring-loaded pilot chute. The pilot chute functions to pull the main canopy from deployment bag located in an aerodynamic fairing below the rudder. Deployment below 90 knots may result in improper deployment and damage to the drag chute.

The drag chute system has safety provisions for accidental deployments, both commanded and uncommanded:

- Above 190 knots, the mechanical fuse section on the D-ring fails and releases the chute.
- A deployed drag chute (or some residue thereof) resulting from placing the DRAG CHUTE switch to DEPLOY can be released by moving the switch to **C** **DF** NORM/REL or **DR** REL at any airspeed.
- If the drag chute is deployed uncommanded (i.e., ripcord failure) and airspeed is above 60 knots, the D-ring pulls out of the jaw mechanism.

### DRAG CHUTE Switch

Refer to figure 1-41. **C** **DF** The DRAG CHUTE switch, located on the MISC panel, is a two-position guarded switch used to deploy and release the drag chute. The switch is powered by battery bus No. 1. **DR** For DRAG CHUTE switch differences, refer to F-16D AIR-CRAFT, this section.

## ARRESTMENT SYSTEM

The hook is electrically controlled and pneumatically operated. Pneumatic pressure is supplied by the LG/hook emergency pneumatic bottle which contains sufficient pressure to lower the LG and hook.

When extended, pneumatic pressure holds the hook on the runway. When subsequently retracted, the hook rises enough to allow the cable to drop off the hook or to be disengaged. The hook is spring-loaded partially up to allow taxiing over a cable. The hook must be raised manually to reset it to the stowed position.

### HOOK Switch

The HOOK switch, located on the LG control panel, is lever-locked in the UP or DN position. Positioning the switch to DN causes the hook to extend. Returning the switch to UP partially retracts the hook, allowing for cable disengagement and for taxi

over the cable. **D** Either HOOK switch may be used to extend the hook. Both switches must be positioned to UP to raise the hook.

### HOOK Caution Light

The HOOK caution light, located on the caution light panel, illuminates anytime the hook is not up and locked.

## WING FLAP SYSTEM

### LEADING EDGE FLAPS (LEF'S)

The LEF's consist of a spanwise flap on each wing leading edge controlled as a function of mach number, AOA, and altitude by command signals from the FLCC.

An asymmetry sensing and braking mechanism prevents LEF asymmetry. If an asymmetry is sensed, the LEF's lock, FLCS LEF LOCK PFL is displayed, and the FLCS warning light illuminates.

The LEF's are automatically programmed when the LE FLAPS switch is in AUTO.

Exceptions are:

- When weight is on both MLG (the LEF's are 2 degrees up).
- When the throttle is at IDLE and MLG wheel speed is greater than 60 knots groundspeed (the LEF's are 2 degrees up).
- LEF asymmetry brakes are locked.
- When the FLCS is operating on standby gains. Refer to STANDBY GAINS, this section.

### LE FLAPS Switch

The LE FLAPS switch is covered as a part of the FLT CONTROL panel.

### FLCS LEF LOCK PFL

The FLCS LEF LOCK PFL is activated by malfunctions in the flap drive unit or flap commands. The FLCS LEF LOCK PFL is also activated if the LEF's are manually locked or the asymmetry brakes are activated. The FLCS warning light illuminates when the FLCS LEF LOCK PFL occurs.

# Drag Chute Controls (Typical)

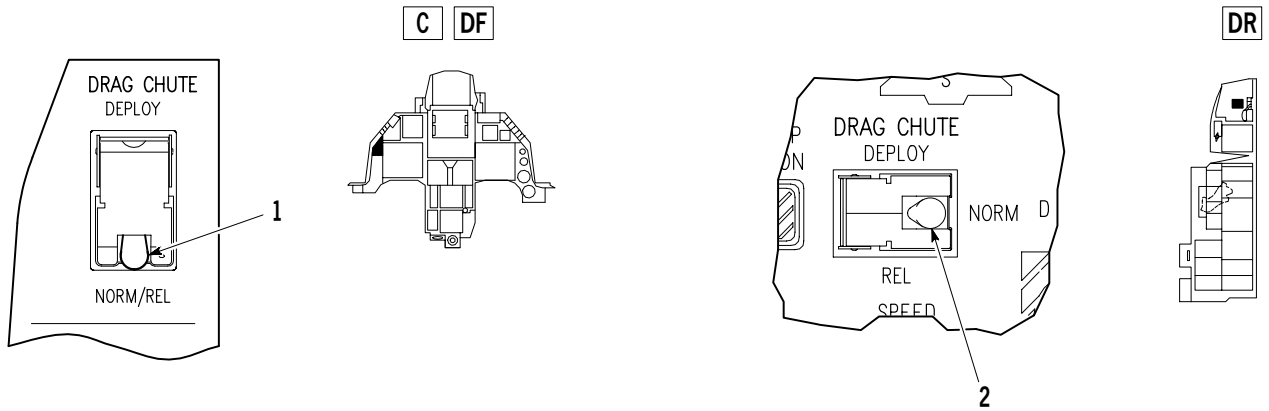

1. **C** **DF** DRAG CHUTE Switch
2. **DR** DRAG CHUTE Switch

**NOTE:**  
**DR** For DRAG CHUTE switch, refer to F-16D AIRCRAFT, this section.

GR1F-16CJ-1-0043X37®

SWITCH POSITION	FUNCTION
NORM	Chute stowed
	Attachment jaws at midrange
DEPLOY	Hydraulic actuator extends
	Ripcord pulled to release spring-loaded pilot chute
	Attachment jaws close on D-ring
REL	Hydraulic actuator retracts for 2 seconds, releasing the D-ring from the attachment jaws and then returns to midrange

Figure 1-41.

## TRAILING EDGE FLAPS (TEF'S) (FLAPERONS)

The flaperons are located on the wing trailing edge and function as ailerons and TEF's. The flaperons have a maximum command deflection of 20 degrees down and 23 degrees up. When acting as flaps, the deflection is downward; when acting as ailerons, the deflection is up or down, as commanded. Both functions are operable whenever the FLCS is powered. The TEF's are controlled as a function of the LG handle position, the ALT FLAPS switch, airspeed, and mach number. Positioning the LG handle to DN or the ALT FLAPS switch to EXTEND causes the TEF's to deflect downward. At all airspeeds below 240 knots, the TEF's position is 20 degrees down. Above 240 knots, the TEF's reduce deflection as a function of airspeed until nearly/fully retracted at 370 knots.

### ALT FLAPS Switch

The ALT FLAPS switch is located **[C]** **[DF]** on the FLCP, **[DR]** on the LG control panel. With the switch in NORM, the TEF's are controlled by the LG handle and airspeed. Placing the switch to EXTEND lowers the TEF's only, depending on airspeed. The ALT FLAPS switch does not affect the operation of the LEF's unless the FLCS is operating on standby gains. Refer to STANDBY GAINS, this section.

## FLIGHT CONTROL SYSTEM (FLCS)

Refer to figure 1-42 for FLCS functional schematic and figure 1-43 for FLCS pitch, roll, and yaw schematic. The FLCS is a digital four-channel, fly-by-wire system which hydraulically positions control surfaces. Electrical signals are generated through a stick, rudder pedals, and a MANUAL TRIM panel. A main component of the FLCS is the flight control computer (FLCC). Redundancy is provided in electronic branches, hydraulic systems, power supplies, and sensor systems. A FLT CONTROL panel (FLCP) provides a BIT RUN FAIL light and controls.

Command signals to the FLCC are initiated by applying force to the stick and rudder pedals. These signals are processed by the FLCC along with signals from the AOA sensors, air data system, flight control rate gyros, accelerometers, and INS. The processed signals are transmitted to the ISA's of the horizontal tails, flaperons, and rudder which are positioned to give the commanded response.

Pitch motion is controlled by symmetrical movement of the horizontal tails. Roll motion is controlled by differential movement of the flaperons and horizontal tails. Yaw motion is controlled by the rudder. Roll

coordination is provided by an ARI. The ARI function is not available whenever MLG wheel speed exceeds 60 knots or if AOA exceeds 35 degrees. After takeoff, ARI is activated within 2 seconds after the LG handle is raised (spin down braking system). If the LG handle remains down, 10-20 seconds are required for the MLG wheels to spin down and activate ARI.

### Digital Backup (DBU)

DBU provides a software backup in the event of software problems in the primary program. The DBU is a reduced set of control laws which automatically engages when software problems in the FLCC force a majority of the branches into a failed state. DBU can only be disengaged by use of the DIGITAL BACKUP switch.

DBU operation does not significantly impact aircraft handling qualities during normal cruise operation or landing.

During DBU operation:

- The AOS feedback function is inoperative.
- Autopilot, terrain following, and stick steering are inoperative.
- Gun compensation is not provided.
- With the LG handle in DN, the TEF's are positioned to 20 degrees down. With the LG handle in UP and the ALT FLAPS in EXTEND, the TEF's are positioned to 20 degrees down if airspeed is less than 290 knots.
- There is no roll rate input to the AOA limiter. Maximum roll rate command is a constant 167 degrees per second.
- STORES CONFIG switch is inoperative.
- Stick commands are essentially CAT III limited. Rudder pedal commands are essentially CAT I limited.
- Dual air data failures are not recognized in DBU. Standby gains are not engaged. If the LG handle is in UP, midvalue air data is always selected. If the LG handle is in DN, gains are fixed at normal landing values.
- Pitch trim centering at wheel spin-up is inoperative.
- AOA indications do not set to zero and random AOA indications are possible in gusty wind conditions with NLG WOW.

- **D** The STICK CONTROL switch and the override feature of the paddle switch are inoperative. If MPO is activated, it cannot be overridden in the other cockpit.
- LEF scheduling is simplified and optimized for a cruise condition at approximately 20,000 feet MSL.
- LEF are not commanded to 2 degrees up when MLG wheel speed is greater than 60 knots and the throttle is IDLE or if MLG WOW.
- DBU does not support communication on the MUX bus, so failures while in DBU are not reported.

## FLCS LIMITERS

Refer to figure 1-44 for limiter values. FLCS limiters are provided in all three axes to help prevent departures/spins.

### AOA/G Limiter

Refer to figure 1-45. In cruise gains, the AOA/g limiter reduces the positive g available as a function of AOA. The negative g available is a function of airspeed. Below 15 degrees AOA, the maximum positive g available is +9g. As AOA increases, the maximum allowable positive g decreases. The positive g limit and maximum AOA depend on the position of the STORES CONFIG switch. In CAT I, positive g decreases to a value of 1g at 25 degrees AOA. Maximum commanded AOA is approximately 25.5 degrees. In CAT III, maximum AOA varies from approximately 16-18 degrees as a function of GW and g.

The negative g available above approximately 250 knots is -3g. Below 250 knots, the available negative g varies between -3g and zero g as a function of airspeed, altitude, and AOA.

In takeoff and landing gains, the STORES CONFIG switch has no effect on limiting or gains. Maximum positive g is a function of airspeed and AOA. The negative g command limit is not a function of airspeed. It is a fixed limit. The maximum AOA for 1g is approximately 21 degrees.

In inverted or upright departures, the AOA/g limiter will override stick pitch commands if the MPO is not engaged. The MPO can always override the negative g function of the limiter. It can also override the AOA function of the limiter when the AOA exceeds 35 degrees. Refer to MPO, this section.

## Roll Rate Limiter

In cruise gains, the roll rate limiter reduces available roll rate authority to help prevent roll coupled departures. This authority is reduced as airspeed decreases, AOA increases, or trailing edge down horizontal tail deflection increases. Roll authority is further reduced for large total rudder commands. In takeoff and landing gains, roll rate limiting is available but is a fixed value independent of AOA, airspeed, or horizontal tail position.

## Rudder Authority Limiter

In cruise gains, the rudder authority limiter reduces the pedal commanded rudder deflection as a function of AOA, roll rate, and STORES CONFIG switch position for departure protection. However, ARI authority, stability augmentation, and trim authority are not reduced. In takeoff and landing gains, category I rudder authority limiting is provided.

## Yaw Rate Limiter

When AOA exceeds 35 degrees, the yaw rate limiter overrides pilot roll and rudder commands and provides flaperon with and rudder against the yaw rate until AOA is below 32 degrees to enhance spin resistance. The yaw rate limiter provides no protection against yaw departures in the normal flying range (-5 to 25 degrees AOA).

When AOA decreases below -5 degrees and airspeed is less than 170 knots, the yaw rate limiter engages but does not affect pilot roll and rudder commands. Pilot roll and rudder commands are inhibited during inverted departures only when the MPO is engaged. The yaw rate limiter provides rudder against the yaw rate until AOA is above -5 degrees to enhance spin resistance.

Automatic yaw rate limiting to enhance spin resistance is independent of the angle-of-sideslip feedback function; thus, limiting is available even if the FLCS AOS FAIL PFL is present.

## FLCS GAINS

During normal operation, the FLCS receives inputs (gains) from the ADC and provides relatively constant aircraft response for a given stick input, regardless of altitude or airspeed. This response varies slightly depending on configuration. In the event of a dual air data failure, the FLCS switches to standby (fixed) gains.

# FLCS Functional Schematic (Typical)

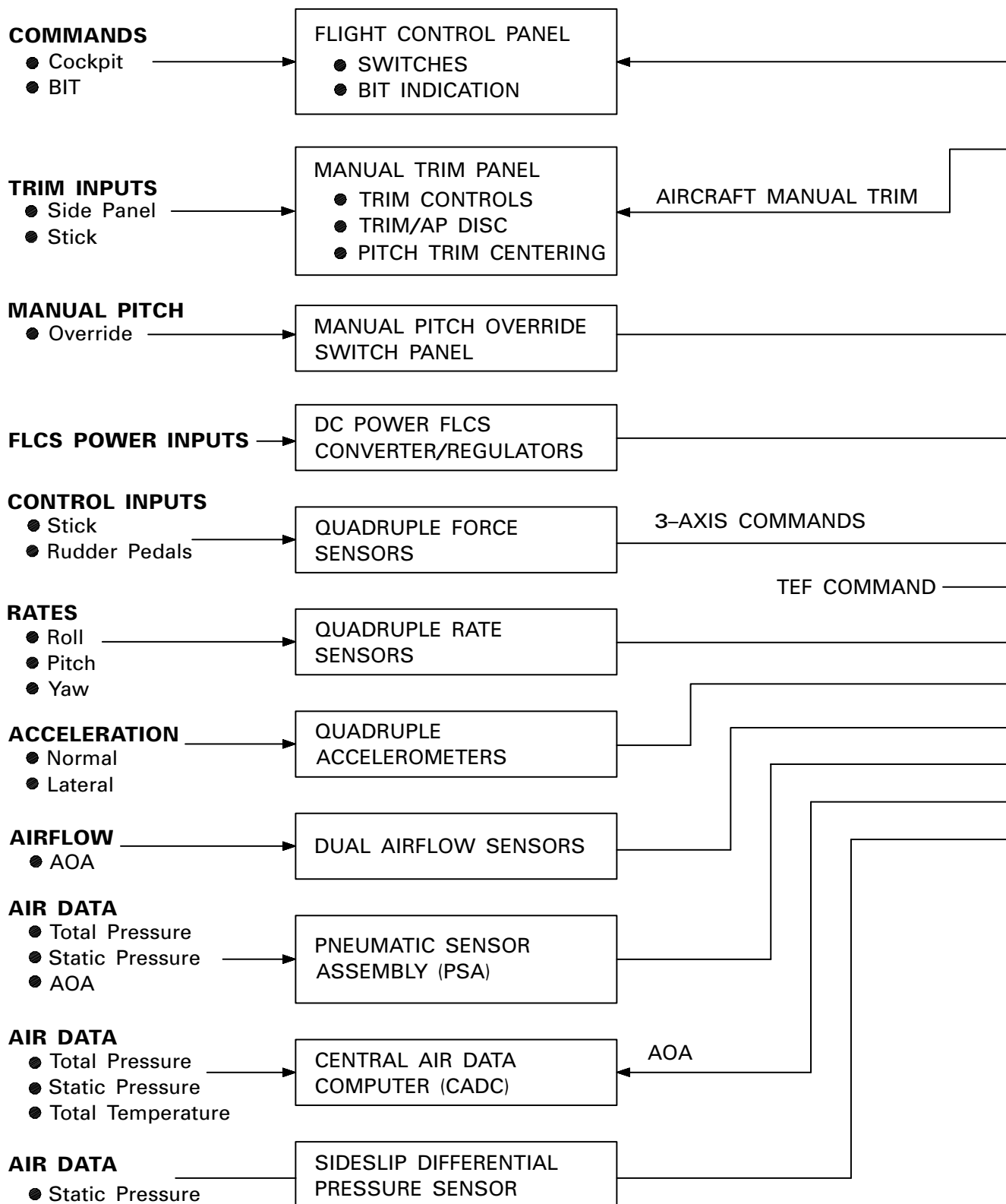

GR1F-16CJ-1-0044-1X37 ©

Figure 1-42. (Sheet 1)

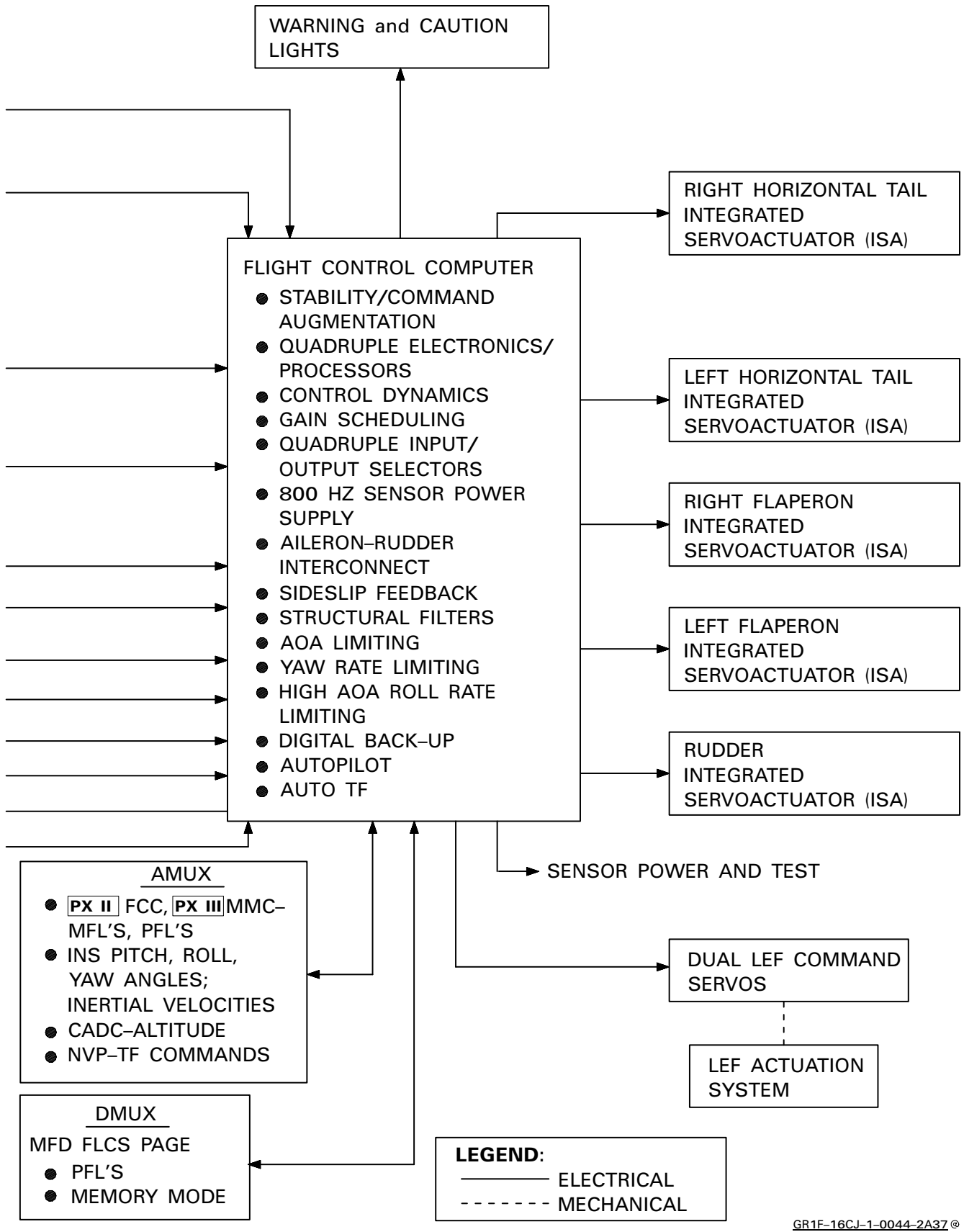

GR1F-16CJ-1-0044-2A37®

Figure 1-42. (Sheet 2)



# FLCS Pitch, Roll & Yaw Schematic (Typical)

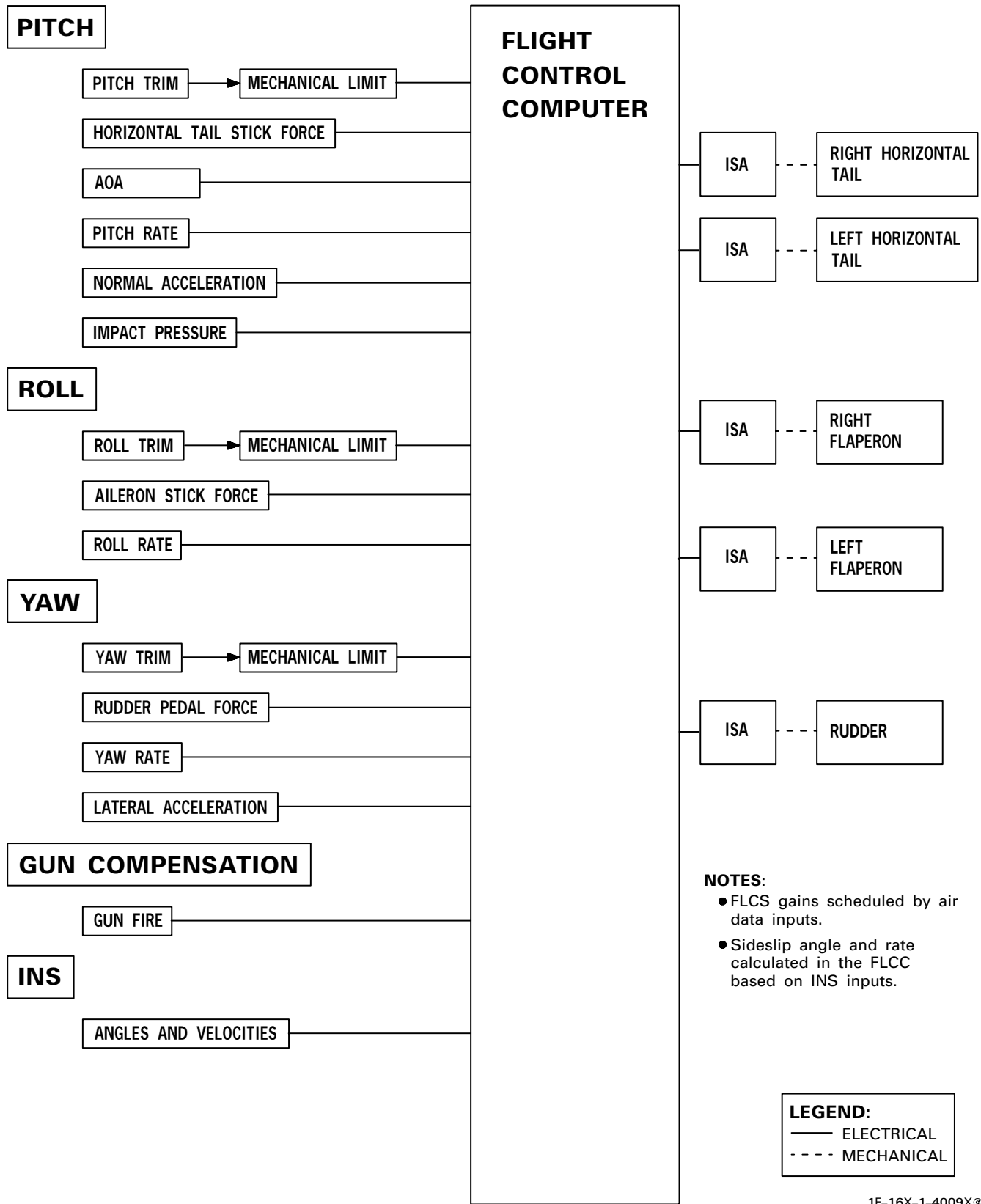

1F-16X-1-4009X®

Figure 1-43.

# FLCS Limiter Functions

	PITCH AXIS	ROLL AXIS	YAW AXIS
CAT I	Maximum AOA=25°	Maximum roll rate command decreases with: <ul style="list-style-type: none"> <li>• AOA above 15°</li> <li>• Airspeed less than 250 knots</li> <li>• Horizontal tail deflection more than 5° trailing edge down</li> <li>• Total rudder command (from pilot and FLCS) exceeding 20°</li> <li>• Combination of horizontal tail greater than 15° trailing edge down and AOA above 22°</li> </ul>	Maximum deflection (pedal command) reduced for: <ul style="list-style-type: none"> <li>• AOA&gt;14° (zero roll rate)</li> <li>• Roll rate&gt;20°/sec</li> </ul> <b>NOTE:</b> Zero rudder authority available at 26° AOA
	g command system until 15° AOA		
	g/AOA command system above 15° AOA		
CAT III	Maximum AOA=16°-18° (depending on GW)	Maximum roll rate command reduced by approximately 40 percent of CAT I authority. Additional decreases as function of AOA, airspeed, horizontal tail position, and total rudder command	Maximum deflection (pedal command) reduced for: <ul style="list-style-type: none"> <li>• AOA&gt;3° (zero roll rate)</li> <li>• Roll rate&gt;20°/sec</li> </ul> <b>NOTE:</b> Zero rudder authority available at 15° AOA
	g command system until 7° AOA at 100 knots to 15° AOA at 420 knots and above		
	g/AOA command system above these values		
NOTES	<ol style="list-style-type: none"> <li>1. In takeoff/landing gains, the FLCS operates as a pitch rate command system until 10° AOA and a pitch rate/AOA command system above 10° AOA</li> <li>2. +9g available until 15° AOA. Maximum g decreases as a function of AOA and airspeed</li> </ol>	<ol style="list-style-type: none"> <li>1. In takeoff/landing gains, maximum roll rate is fixed at approximately one-half the maximum roll rate available in cruise gains, regardless of AOA, airspeed, or horizontal tail deflection</li> <li>2. Above 35° AOA, the yaw rate limiter cuts out stick roll commands and provides roll axis antispin control inputs</li> </ol>	<ol style="list-style-type: none"> <li>1. Above 35° AOA, the yaw rate limiter provides yaw axis antispin control inputs</li> <li>2. Below -5° AOA and less than 170 knots, the yaw rate limiter provides antispin rudder inputs; pilot roll and rudder commands are cut out only when MPO is engaged</li> <li>3. Maximum deflection (30°) always available thru ARI and stability augmentation</li> </ol>

Figure 1-44.

# AOA/G Limiter Function (Cruise Gains)

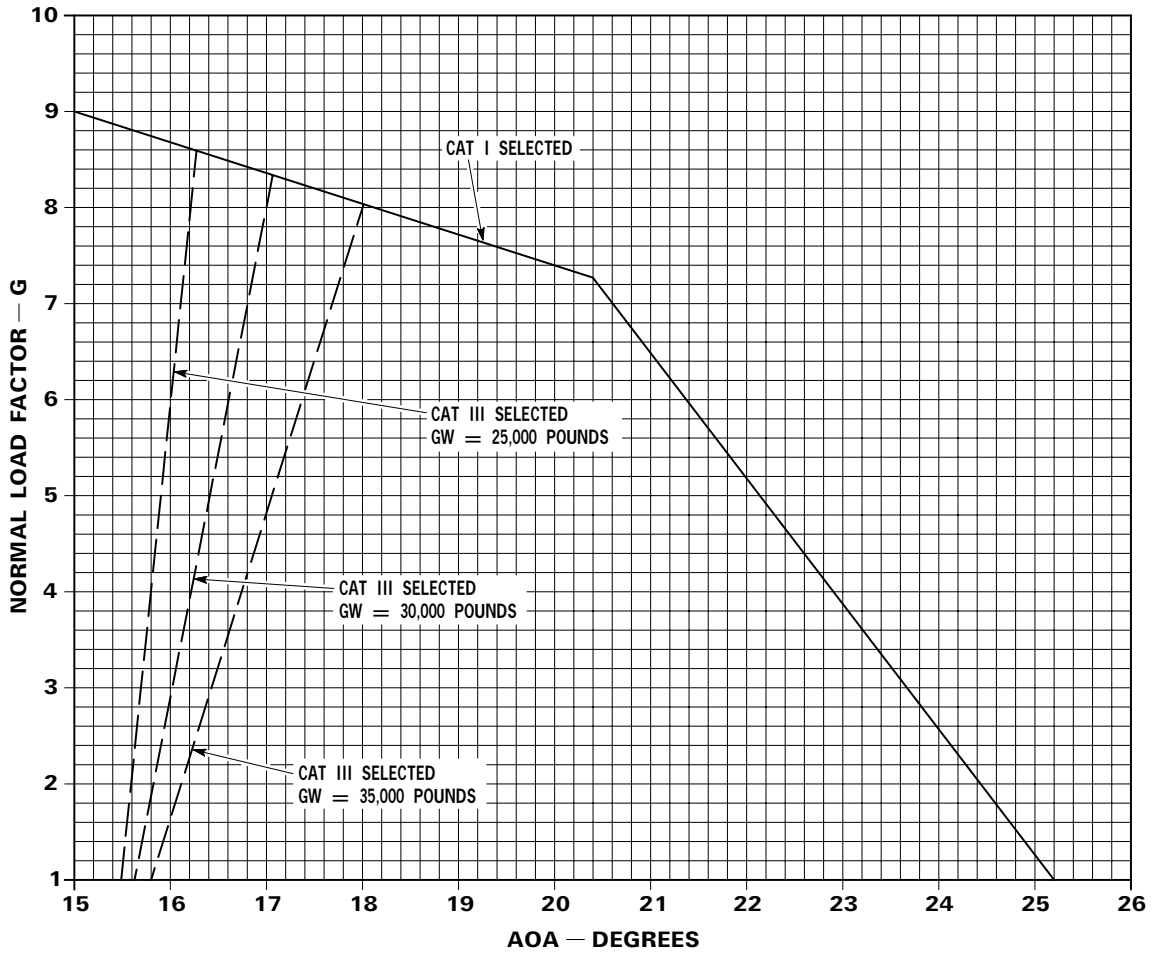

1F-16X-1-0010X®

Figure 1-45.

## Cruise Gains

The FLCS is in cruise gains with the LG handle in UP, the ALT FLAPS switch either in NORM or in EXTEND above 400 knots, and the AIR REFUEL switch either in CLOSE or in OPEN above 400 knots. At low AOA, the pitch axis of the FLCS is a g command system. As AOA increases, the FLCS switches to a blended g and AOA system to provide a warning of high AOA/low airspeed. Roll rate limiting is available and maximum roll rate decreases as a function of low airspeed, high AOA, and horizontal tail position.

## Takeoff and Landing Gains

The FLCS is in takeoff and landing gains with the LG handle in DN, the ALT FLAPS switch in EXTEND (below 400 knots), or the AIR REFUEL switch in OPEN (below 400 knots). In takeoff and landing gains, the FLCS pitch axis operates as a pitch rate command system until 10 degrees AOA and a blended pitch rate and AOA command system above 10 degrees AOA. Roll rate limiting is available but is a fixed value independent of AOA, airspeed, or horizontal tail position.

## Standby Gains

In standby gains, control response is tailored for a fixed altitude (sea level, standard day) and airspeed (LG handle in UP, approximately 600 knots; LG handle in DN, approximately 230 knots). The FLCS warning light and FLCS FAULT caution light illuminate.

When operating on standby gains, the LEF's are at zero degrees with the LG handle in UP and the ALT FLAPS switch in NORM. The LEF's deflect 15 degrees down with the LG handle in DN or the ALT FLAPS switch in EXTEND. The operation of the TEF's is not affected in standby gains.

A standby gains condition can be reset in flight, back to the first failure condition, by using the FLCS RESET switch. The original air data system failure is latched upon occurrence of the second failure and does not reset. If reset is successful, the FLCS warning light goes off.

## FLCS DATA RECORDER C DF

The FLCS data recorder is attached to the ejection seat and departs the aircraft on ejection. It retains the same information as the FLCC including FLCS failure data, airspeed, altitude, true heading and elapsed time from takeoff.

## ANGLE-OF-SIDESLIP (AOS) FEEDBACK FUNCTION

The angle-of-sideslip feedback function provides improved departure prevention by using AOS and AOS rate feedback to position the rudder. AOS and AOS rate are calculated in the FLCC using INS data. The calculated AOS is also monitored in the FLCC by comparing it to an AOS derived from differential pressure sensor signals. This monitoring detects one of two possible failures:

- AOS derived from INS is erroneous.
- AOS derived from differential pressure sensor is erroneous.

Either failure deactivates the AOS feedback function and activates the FLCS FAULT caution light and the FLCS AOS FAIL PFL.

The AOS feedback function is active when all of the following conditions are met:

- Airspeed is less than 350 knots.
- AOA is greater than 10 degrees.
- AOS exceeds 2 degrees.
- AOS monitoring has not detected a failure.
- DBU is not engaged.
- MPO switch is in NORM.
- The FLCS is in cruise gains.
- Terrain following is not engaged.

## GUN COMPENSATION

The FLCS automatically compensates for the off-center gun and the aerodynamic effects of gun gas emissions during firing by moving the flaperons and rudder. Gun compensation is optimized for 0.7-0.9 mach range; therefore, all excursions may not be eliminated. For example, gunfiring at low mach may result in nose left excursions while nose right excursions are likely at higher mach. Failure monitoring of gun compensation circuits is not provided and there are no caution light indications for incorrect compensation.

## FLIGHT CONTROL SYSTEM (FLCS) CONTROLS

### Stick

Refer to figure 1-46. The stick is a force-sensing unit which contains transducers in both pitch and roll axes, moves approximately 1/4 inch in both axes, and is rotated slightly cw.

# Stick (Typical)

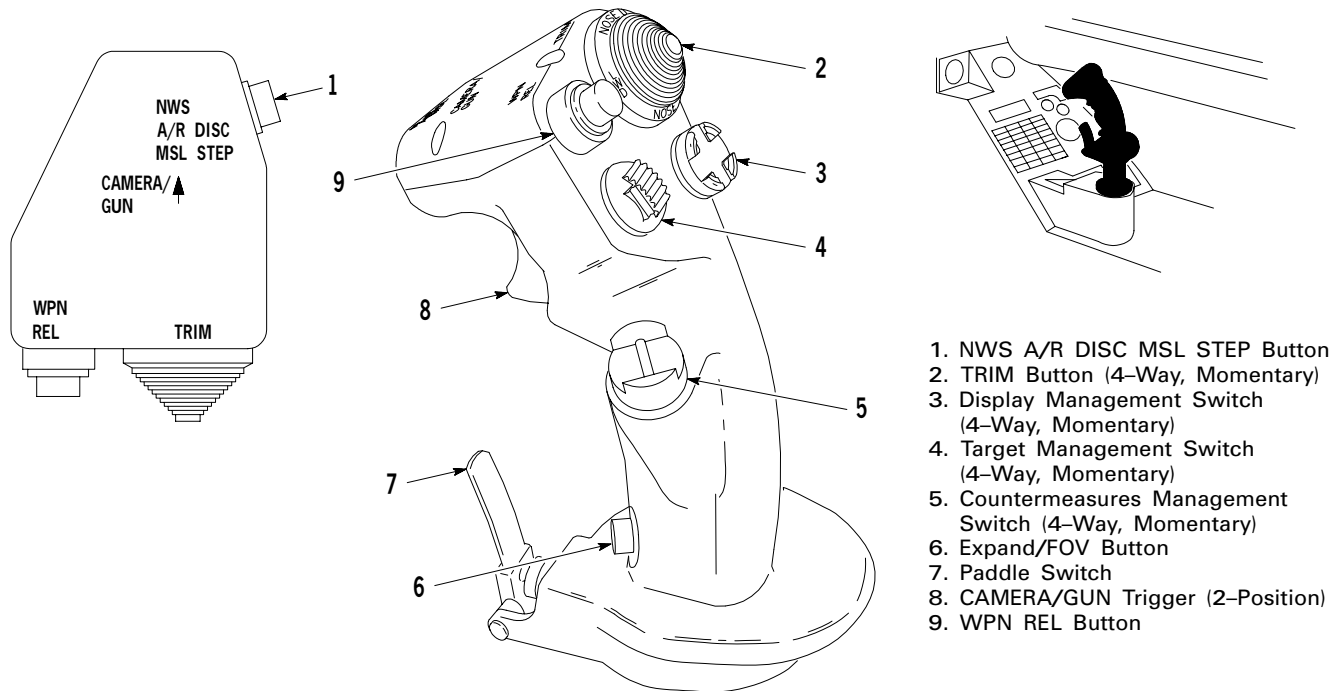

GR1F-16CJ-1-0047X37 ©

CONTROL	POSITION	FUNCTION
1. NWS A/R DISC MSL STEP Button	(NWS) Depress (on ground)	Activates NWS
	Depress (2nd time)	Deactivates NWS
	(A/R DISC) Depress (in flight)	Disconnects boom latching. AIR REFUEL switch must be in OPEN position
	(MSL STEP) Depress (in flight)	Activates missile step function. Refer to T.O. GR1F-16CJ-34-1-1
2. TRIM Button (NOSE DOWN) (4-way, momentary) (NOSE UP) (LWD) (RWD)	Fwd	Trims nosedown
	Aft	Trims noseup
	Left	Trims left wing down
	Right	Trims right wing down

Figure 1-46. (Sheet 1)

# Stick (Typical)

CONTROL	POSITION	FUNCTION
3. Display Management Switch (4-way, momentary)	Up	Refer to T.O. GR1F-16CJ-34-1-1 for a detailed description of switch functions
	Down	
	Left	
	Right	
4. Target Management Switch (4-way, momentary)	Up	
	Down	
	Left	
	Right	
5. Countermeasures Management Switch (4-way, momentary)	Fwd	
	Aft	
	Left	
	Right	
6. Expand/FOV Button	Depress	Successive depressions sequence through the available field-of-view (FOV) selections for the sensor/system mode being displayed on the DOI
7. Paddle Switch	Depress	Interrupts the autopilot while switch is depressed. Terminates ATF fly-up. If in ATF, reverts to manual TF while depressed. Resets SWIM monitors when released
		<b>D</b> For stick override function, refer to F-16D AIRCRAFT, this section
8. CAMERA/GUN Trigger (2-position)	Squeeze trigger to detent	Starts operation of AVTR/CTVS with AUTO selected on AVTR power switch and provides consent for laser fire (if selected and armed)
	Squeeze trigger past detent	Fires gun (if selected and armed), AVTR/CTVS operation continues, and consent for laser fire continues (camera operation continues for 30 seconds after trigger is released)
9. WPN REL Button	Depress	Signals consent to <b>PX II</b> FCC or SMS, <b>PX III</b> MMC to initiate weapon release and operates HUD camera for 30 seconds when in AUTO

Figure 1-46. (Sheet 2)

## T.O. GR1F-16CJ-1

Maximum noseup and nosedown pitch commands are generated by 25 and 16 pounds of input, respectively. Roll commands are generated by a maximum of 17 pounds in cruise gains and by 12 pounds in takeoff and landing gains. When using the switches/buttons on the stick, inadvertent commands to the FLCS are possible.

The wristrest and armrest assemblies which may be used in conjunction with the stick are located on the right side wall aft of the stick.

### Rudder Pedals

The rudder pedals are force-sensing units containing transducers. Force on the applicable rudder pedal produces electrical yaw command signals.

The rudder pedals are also used to generate brake and NWS signals. Rudder pedal feel is provided by mechanical springs.

### MANUAL TRIM Panel

Refer to figure 1-47. The MANUAL TRIM panel, located on the left console, contains trim controls and indicators.

### MANUAL PITCH Override (MPO) Switch

Refer to figure 1-48. The MPO switch, located on the left console, has two positions, NORM and OVRD, and is spring-loaded to the NORM position. This switch is used during a deep stall condition to enable manual control of the horizontal tails. Positioning and holding the switch to OVRD overrides the negative g limiter. If AOA exceeds 35 degrees, the OVRD position overrides the AOA/g limiter and allows pitch commands.

### STORES CONFIG Switch

Refer to figure 1-49. The STORES CONFIG switch, located on the LG control panel, has two positions, CAT I and CAT III. The CAT III position shall be selected when the aircraft is configured with a category III loading.

AOA limiting is provided. Refer to FLCS LIMITERS, this section, for a description of categories I and III AOA limiter.

### Low Speed Warning Tone

Refer to figure 1-50. A low speed warning tone (steady) sounds in the headset when one of the following conditions exists:

- AOA is 15 degrees or greater with LG handle down or ALT FLAPS switch in EXTEND.
- Combined airspeed and pitch angle fall on a point within the tone on area with LG handle up and ALT FLAPS switch in NORM.
- When the TFR is operating and airspeed drops below 300 knots (KCAS or groundspeed).

The low speed warning tone has priority over the LG warning horn. Depressing the HORN SILENCER button silences the low speed warning tone.

The low speed warning tone is reactivated only after the original warning condition is eliminated. The MAL & IND LTS test button does not test the low speed warning tone.

### FLT CONTROL Panel (FLCP)

Refer to figure 1-51. The FLCP, located on the left console, contains indicators and controls related to flight control functions.

### FLCS WARNING, CAUTION, AND INDICATOR LIGHTS

The instrument panel, caution panel, PFLD, FLCP, ELEC control panel, TEST switch panel, and avionic system contain warning, caution, and indicator lights related to the FLCS. The FLCS is interfaced to the avionic system via the multiplex (MUX) bus to provide PFL and MFL reporting.

### FLCS Warning Light

The FLCS warning light, located on the right glareshield, illuminates to indicate a dual malfunction in the FLCC electronics, including the processors, power supplies, input commands or sensors, AOA, or air data inputs. The FLCS warning light also illuminates if the LEF's are locked or BIT fails. The FLCS warning light remains illuminated until FLCS reset action is successful in clearing the failure. If an active warning fault exists and a subsequent warning level malfunction occurs, the FLCS warning light goes off momentarily to retrigger HUD WARN and voice warning.

More specific system failure information can be obtained from the PFLD.

# MANUAL TRIM Panel **C** **DF** (Typical)

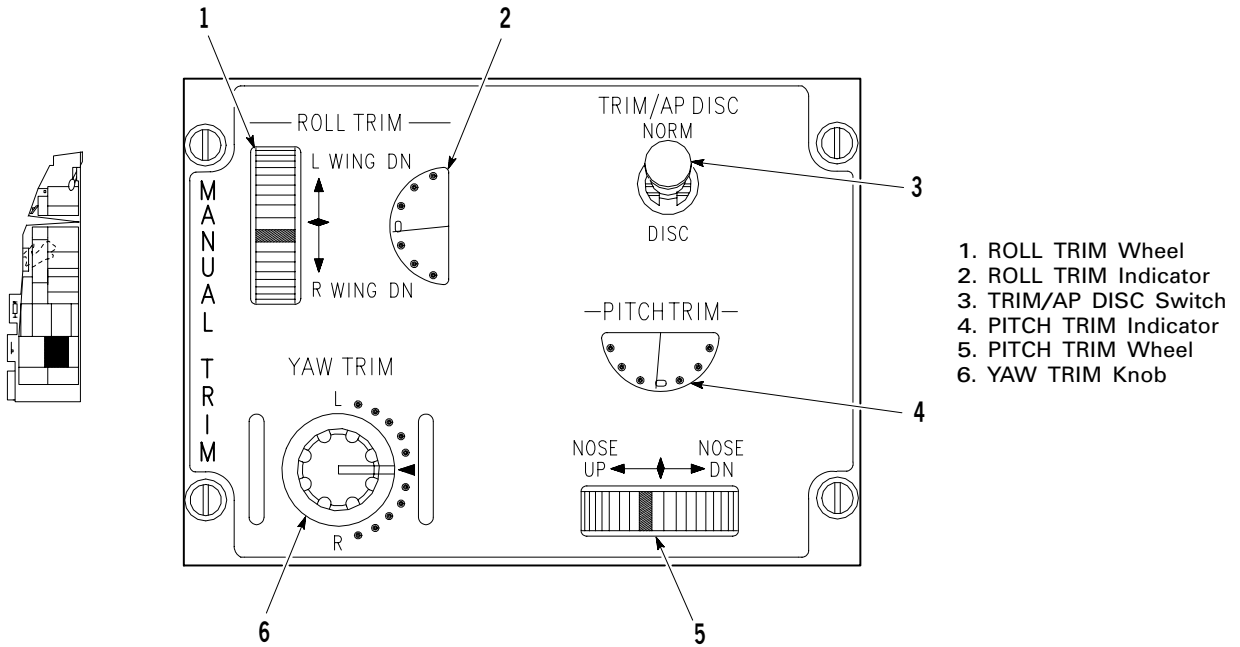

GR1F-16CJ-1-0048X37 ©

CONTROL	POSITION	FUNCTION
1. ROLL TRIM Wheel	L WING DN rotation	Trims left wing down
	R WING DN rotation	Trims right wing down
2. ROLL TRIM Indicator	Visual	Indicates roll trim
3. TRIM/AP DISC Switch	NORM	Energizes stick TRIM button. Permits autopilot engagement
	DISC	Deenergizes stick TRIM button, prevents autopilot engagement and ATF/autopilot blending, and deactivates trim motors (manual trim wheels still operative)
4. PITCH TRIM Indicator	Visual	Indicates pitch trim
5. PITCH TRIM Wheel	NOSE UP rotation	Trims noseup
	NOSE DN rotation	Trims nosedown
6. YAW TRIM Knob	CCW rotation	Trims nose left
	CW rotation	Trims nose right

Figure 1-47.



# Manual Pitch Over-ride Switch (Typical)

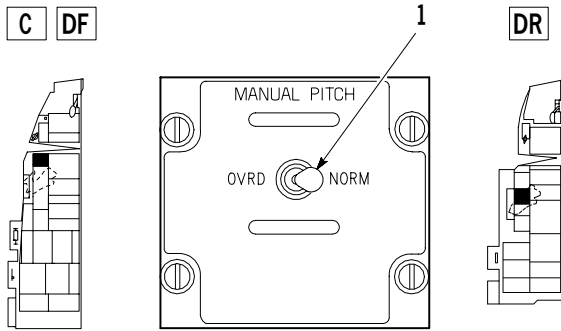

1. MPO Switch

GR1F-16CJ-1-0049X37 ©

Figure 1-48.

# STORES CONFIG Switch C DF (Typical)

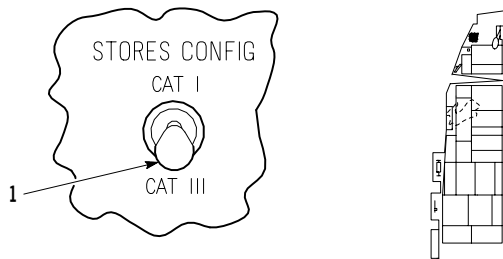

1. STORES CONFIG Switch

GR1F-16CJ-1-0050X37 ©

Figure 1-49.

# Low Speed Warning Tone Schedule

**NOTES:**

- LG handle in UP and ALT FLAPS switch in NORM.
- Dashed lines indicate airspeed tolerances for low speed warning tone activation.

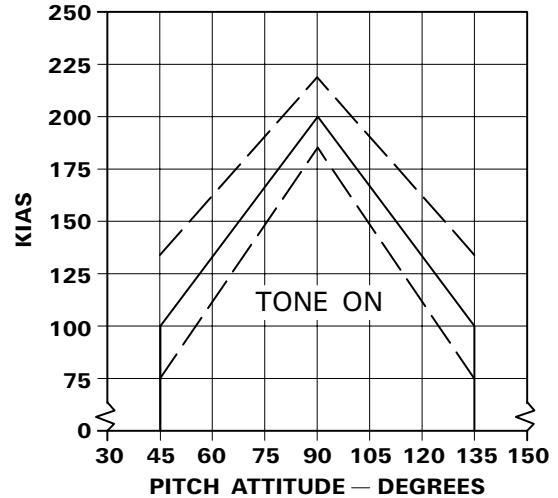

1F-16X-1-0022X ©

Figure 1-50.

## DBU ON Warning Light

The DBU ON warning light, located on the right glareshield, illuminates to indicate the FLCC has automatically switched to DBU or if the DIGITAL BACKUP switch is manually positioned to DIGITAL BACKUP.

## TO/LDG CONFIG Warning Light

Refer to LANDING GEAR SYSTEM, this section.

## FLCS FAULT Caution Light

The FLCS FAULT caution light, located on the caution light panel, illuminates when the FLCC reports a caution level PFL item which requires pilot action. The caution light goes off either when the fault is acknowledged or when FLCS reset action is successful in clearing the failure.

If the FLCS FAULT caution light is illuminated and a subsequent malfunction occurs, the caution light goes off momentarily to activate the MASTER CAUTION light and retrigger voice caution.

More specific system failure information can be obtained from the PFLD.

# FLT CONTROL Panel C DF (Typical)

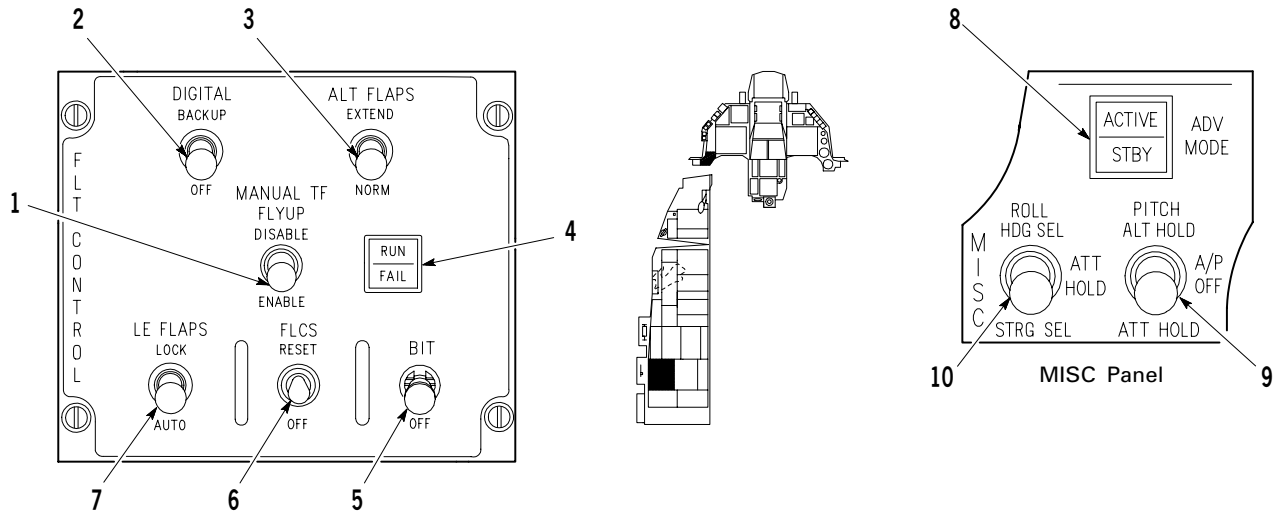

- 1. MANUAL TF FLYUP Switch
- 2. DIGITAL BACKUP Switch
- 3. ALT FLAPS Switch
- 4. RUN FAIL Light
- 5. BIT Switch
- 6. FLCS RESET Switch
- 7. LE FLAPS Switch
- 8. ADV MODE Switch
- 9. Autopilot PITCH Switch
- 10. Autopilot ROLL Switch

GR1F-16CJ-1-0052X37®

CONTROL/INDICATOR	POSITION/INDICATION	FUNCTION
1. MANUAL TF FLYUP Switch (lever lock)	DISABLE	Fly-up protection not available in manual TF
	ENABLE	Fly-up protection available in manual TF for TF or SWIM detected failure
2. DIGITAL BACKUP Switch (lever lock)	BACKUP	Selects backup software program within the FLCC
	OFF	Normal position
3. ALT FLAPS Switch (lever lock)	NORM	TEF operation controlled by LG handle
	EXTEND	TEF's extend regardless of LG handle positions
4. RUN/FAIL Lights	RUN (green)	Indicates FLCS BIT is running
	FAIL (red)	Indicates a failure during the FLCS BIT
5. BIT Switch (solenoid held in BIT and lever-locked to OFF)	OFF	Normal position
	BIT	Commands BIT if weight is on main LG and wheel speed is less than 28 knots groundspeed

Figure 1-51. (Sheet 1)

# FLT CONTROL Panel C DF (Typical)

CONTROL/INDICATOR	POSITION/INDICATION	FUNCTION
6. FLCS RESET Switch (spring-loaded to OFF)	OFF	Normal position
	RESET	Momentary position which performs servo or electronic reset of FLCS system failures. Resets FLCS warning light, CADC, FLCS FAULT, and MASTER CAUTION lights and clears PFL's if fault is cleared
7. LE FLAPS Switch (lever lock)	AUTO	LEF's are automatically controlled as a function of mach, altitude, and AOA
	LOCK	Manually locks the LEF's in position and illuminates the FLCS warning light and FLCS LEF LOCK PFL
8. ADV MODE Switch	—	Depressing switch illuminates ATF NOT ENGAGED caution light if NVP or FLCS cannot support ATF
	ACTIVE (green)	Depressing switch illuminates ACTIVE light and selects ATF if TFR is in operate mode
	STBY (amber)	Illuminates when ATF/autopilot blended mode is in use or the paddle switch is depressed in ATF. STBY light indicates that ATF is ready to take over if the paddle switch is released or if higher terrain requires it
9. Autopilot PITCH Switch	ALT HOLD	Engages pitch and roll axes of autopilot. Autopilot maintains constant altitude as determined by CADC; roll mode is determined by ROLL switch
	A/P OFF	Disengages pitch and roll axes of autopilot
	ATT HOLD	Engages pitch and roll axes of autopilot. Autopilot maintains constant pitch attitude as determined by INS; roll mode is determined by ROLL switch
10. Autopilot ROLL Switch  <b>NOTE:</b>  Autopilot roll modes are functional when the PITCH switch is out of A/P OFF.	HDG SEL	Autopilot turns the aircraft to capture and maintain the heading selected by the heading reference marker on the HSI
	ATT HOLD	Autopilot maintains roll attitude as determined by the INS
	STRG SEL	Autopilot steers aircraft to the selected steer-point

Figure 1-51. (Sheet 2)

### Built-In Test (BIT)

The BIT switch, located on the FLCP, is a two-position switch which is lever-locked in OFF and solenoid held in BIT. When engaged (green RUN light illuminates), the BIT runs for approximately 45 seconds. A failure during the BIT sequence or a BIT interlock failure terminates BIT, returns the switch to OFF, illuminates the red FAIL light and the FLCS warning light, and sends an FLCS BIT FAIL PFL message. BIT failures are nonresettable and the red FAIL light does not go off until a subsequent BIT is successfully completed. A BIT detected bus communication failure results in illumination of the FLCS FAULT caution light and an FLCS MUX DEGR PFL. An FLCS reset extinguishes the caution light but the PFL remains.

Successful completion of BIT is indicated by the BIT switch automatically returning to OFF, the green RUN light going off, no FLCS BIT FAIL PFL, and a BIT PASS message on the FLCS page of the MFD.

### Pilot Fault List Display (PFLD)

The PFLD, located on the **C** **DF** right auxiliary console, **DR** instrument panel, displays FLCS PFL's. Refer to WARNING, CAUTION, AND INDICATOR LIGHTS, this section, for a description of the PFLD. Refer to PILOT FAULT LIST - FLCS, Section III, for a description of FLCS PFL's.

### TRIM

Pitch trim inputs may be initiated from either the TRIM button on the stick or the PITCH TRIM wheel on the MANUAL TRIM panel. In cruise gains, pitch trim inputs are g command signals identical in function to normal stick pitch commands. In takeoff and landing gains, the FLCS operates as a pitch rate command system until 10 degrees AOA and a pitch rate and AOA command system above 10 degrees AOA.

With both main wheel speeds at 60 knots groundspeed or greater, pitch trim automatically centers.

Roll trim inputs can be initiated from either the TRIM button on the stick or the ROLL TRIM wheel on the MANUAL TRIM panel. For asymmetric configurations or rudder mistrim, roll retrimming may be required as flight conditions change. Roll trim inputs also command proportional rudder deflection through the ARI function.

Rudder trim is initiated from the YAW TRIM knob on the MANUAL TRIM panel only. For asymmetric configurations or roll mistrim, rudder retrimming may be required as flight conditions change.

### AUTOPILOT

The autopilot provides attitude hold, heading select, and steering select in the roll axis and attitude hold and altitude hold in the pitch axis. These modes are controlled by PITCH and ROLL switches on the MISC panel. The TRIM/AP DISC switch on the MANUAL TRIM panel disengages the autopilot. The paddle switch on the stick interrupts autopilot operation while the switch is held depressed.

The PITCH switch is a three-position switch which is solenoid held in an engaged position and goes to the A/P OFF position if any of the following conditions exist.

Conditions are:

- AIR REFUEL switch - OPEN.
- ALT FLAPS switch - EXTEND (below 400 knots). ■
- A/P FAIL PFL occurs.
- AOA greater than 15 degrees.
- DBU - Engaged.
- LG handle - DN.
- Low speed warning tone sounds.
- MPO switch - OVRD.
- STBY GAIN PFL occurs.
- TRIM/AP DISC switch - DISC.

Movement of the PITCH switch out of A/P OFF engages both the pitch and roll autopilot modes selected.

The ROLL switch is a three-position switch which enables one of the three roll autopilot modes whenever a pitch autopilot mode is selected.

## AUTOPILOT OPERATION

The autopilot is fully engaged when the PITCH switch is not in A/P OFF. Autopilot options are selected by positioning the PITCH switch (ALT HOLD, A/P OFF, or ATT HOLD) and the ROLL switch (HDG SEL, ATT HOLD, or STRG SEL). Stick trim is inoperative with the autopilot engaged. The manual trim is operable and may be used while the autopilot is engaged. However, due to the limited authority of the autopilot, engagement of any mode in other than a trimmed flight condition degrades autopilot performance.

The autopilot loop in the FLCC receives inputs from the INS and CADC by means of the AMUX bus. A lack of data, inaccurate data, or degradation/failure of the AMUX disconnects the autopilot and activates the FLCS FAULT caution light and the FLCS A/P FAIL PFL message. The sensor information used by the autopilot does not include the redundancy of the FLCS so its use must be closely monitored at low altitude or in close formation. If AOA is greater than 15 degrees, the autopilot will disconnect and the FLCS FAULT caution light and the FLCS A/P FAIL PFL message will activate.

Additionally, the FLCC monitors autopilot operation for a failure to maintain the selected mode and for prolonged engagement outside of autopilot attitude limits with no stick inputs. Detection of a failure results in activation of the FLCS FAULT caution light and the FLCS A/P DEGR PFL message.

Positioning the PITCH switch to ALT HOLD enables the FLCS to use CADC information to generate commands to the horizontal tails which result in the aircraft maintaining a constant altitude. The FLCS limits the pitch command to +0.5g to +2g. Engagement of altitude hold at rates of climb or dive less than 2000 fpm selects an altitude within the pitch command g limits. Engagement above rates of 2000 fpm causes no unsafe maneuvers; however, the engaged altitude may not be captured. Control accuracy of  $\pm 100$  feet is provided to 40,000 feet pressure altitude for normal cruise conditions. The altitude reference may be changed by depressing the paddle switch, changing altitude, and releasing the paddle switch. ALT HOLD in the transonic region may be erratic.

Positioning the PITCH switch to ATT HOLD allows an attitude signal from the INU to be used to maintain the selected pitch attitude. This mode does not function if pitch angle exceeds  $\pm 60$  degrees; however, the PITCH switch remains engaged.

Positioning the ROLL switch to HDG SEL allows the FLCS to use a signal from the HSI to maintain the heading set on the HSI. Adjusting the HSI heading reference marker to the aircraft heading prior to engagement maintains the existing aircraft heading; otherwise, when the autopilot is engaged with the ROLL switch in HDG SEL, the aircraft turns to capture the heading indicated by the heading reference marker on the HSI. The roll command does not exceed a 30-degree bank angle or a 20-degree/second roll rate. This mode does not function if bank angle exceeds  $\pm 60$  degrees; however, the ROLL switch remains engaged.

Positioning the ROLL switch to ATT HOLD allows the FLCS to use an attitude signal from the INU to maintain the aircraft at selected roll attitude. This mode does not function if bank angle exceeds  $\pm 60$  degrees.

Positioning the ROLL switch to STRG SEL allows the autopilot to steer the aircraft to the selected steerpoint using roll commands. The roll command does not exceed a 30-degree bank angle or a 20-degree/second roll rate. This mode does not function if bank angle exceeds  $\pm 60$  degrees; however, the ROLL switch remains engaged.

## ADV MODE Switch

ADV MODE switch is a two-function switch. The ACTIVE light, which is located on the top half of the ADV MODE switch, illuminates whenever ATF is engaged. Depression of the ADV MODE switch when the NVP is in an operate mode engages ATF. The STBY light, which is located on the bottom half of the ADV MODE switch, illuminates when PITCH autopilot is engaged and the NVP is in an operate mode. This configuration engages the TF/PITCH autopilot blending mode; depression of the ADV MODE switch at this point deselects the blending mode and illuminates the ACTIVE light (ATF). The STBY light also illuminates from the ATF mode if the paddle switch is depressed, indicating that ATF is ready to assume control (when paddle switch is released).

## STICK STEERING

Stick steering is operable only with the pitch and roll attitude hold modes. Stick steering operation is accomplished by applying force to the stick. With ATT HOLD selected, a force applied in the appropriate axis large enough to activate stick steering causes the autopilot to drop the selected reference and the system accepts manual inputs from the stick.

## AOA SYSTEM

The system consists of two AOA transmitters located on each side of the nose radome, AOA ports on the fuselage-mounted air data probe, a PSA, an AOA correction device in the CADC, an AOA indexer, and a vertical scale AOA indicator. In flight, the airflow direction is sensed by the conical AOA probes and the AOA ports of the fuselage-mounted air data probe. The AOA signals from all three sources are sent to the input selector/monitor of each of the four FLCC branches.

The AOA indicator, AOA indexer, and HUD AOA bracket display the correct AOA until NLG WOW. Therefore, accurate AOA indication is available throughout two-point aerodynamic braking. When NLG WOW occurs, all AOA indications are based on zero degrees.







The first AOA input signal or sensing failure is indicated by the FLCS FAULT caution light and the PFL message FLCS AOA FAIL on the PFLD and the FLCS MFD page. A second failure is indicated by the FLCS warning light and the FLCS AOA WARN PFL message on the PFLD. When a first AOA failure is identified, the failed input is set to 11 degrees AOA. If a second AOA failure subsequently occurs, the 11-degree signal existing in the first failed branch prevents hardover AOA inputs and may provide AOA information for landing.

During DBU operation, AOA failures are not reported and a first AOA failure is not set to 11 degrees.

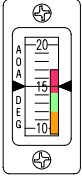
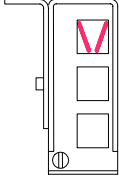
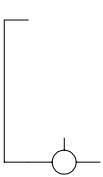
### AOA Indicator

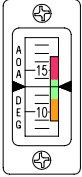
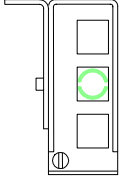
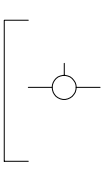
Refer to figure 1-52. The AOA indicator, located on the instrument panel, displays actual AOA in degrees. The indicator has a vertically moving tape display indicating an operating range of -5 to approximately +32 degrees. The tape is color coded from 9-17 degrees to coincide with the color-coded symbols on the AOA indexer.

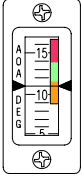
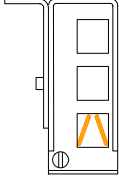
## AOA Displays

INDICATOR	INDEXER	HUD DISPLAY	ATTITUDE
 <p>15</p>			 <p>HIGH AOA</p> <p>SLOW</p>
 <p>13</p>			 <p>OPTIMUM AOA</p> <p>ON SPEED</p>
 <p>11</p>			 <p>LOW AOA</p> <p>FAST</p>

GR1F-16CJ-1-0053X37 ©

Figure 1-52.

### **AOA Indexer**

Refer to figure 1-52. The AOA indexer, located on the top left side of the glareshield, consists of three color-coded symbols arranged vertically. The indexer provides a visual head-up indication of aircraft AOA by illuminating the symbols individually or in combinations as shown. The indexer lights display AOA correction (based on approximately 13 degrees AOA). This correction may be used during landing approaches as visual direction toward optimum landing AOA. The AOA indexer operates continuously with the LG handle up or down.

A dimming lever, located on the left side of the indexer, controls the intensity of the lighted symbols.

The indexer lights are tested by activation of the MAL & IND LTS switch on the TEST switch panel. The test should be performed with the dimming lever in the bright position.

### **HUD AOA Display**

Refer to figure 1-52. The HUD AOA bracket and flightpath marker provide a visual head-up indication of aircraft AOA. The flightpath marker aligned with the top of the bracket indicates 11 degrees AOA. The flightpath marker centered on the bracket indicates 13 degrees AOA. The flightpath marker aligned with the bottom of bracket indicates 15 degrees AOA. The HUD AOA display is only available with the NLG lowered.

## **AIR DATA SYSTEM**

Refer to figure 1-53. The air data system uses probes and sensors to obtain static and total air pressures, AOA, sideslip, and air temperature inputs. These air data parameters are processed and supplied to various systems.

Proper AOA transmitter and fuselage air data probe operation is essential for safe flight operation. Interference from foreign objects (especially ice, internal or external) or improperly installed AOA transmitters can result in erroneous AOA data at weight off wheels. Reporting of false high AOA concurrently from two sources can cause the FLCC to command full nose down pitch which is impossible for the pilot to stop. Ground use of probe covers protects the system from foreign objects and moisture intrusion. Ice on/in the probes is eliminated by using probe heat prior to takeoff.

### **Air Data Probes**

Two air data probes provide data inputs to the air data system. One air data probe (pitot probe) is mounted on the nose and provides a dual source of static and total pressure. The other air data probe is mounted on the forward right side of the fuselage and provides a source of AOA, sideslip, static pressure, and total pressure.

### **AOA Transmitters**

The AOA transmitters are mounted on each side of the radome and each provides sensor data to the FLCS proportional to local AOA. The probe of the transmitter protrudes through the radome to align with the airstream.

### **Total Temperature Probe**

The total temperature probe provides the CADC with an analog signal which is required for true airspeed and air density computation. The probe is located on the underside of the right forebody strake.

### **Static Pressure Ports**

Two flush-mounted static pressure ports used for measuring sideslip are located on the fuselage left and right sides aft of the forward equipment bay doors. These two ports provide inputs to a differential pressure sensor for angle-of-sideslip measurement. The measurement is also used to compensate the third AOA source error and to verify the AOS derived from the INS.

### **Probe Heat Monitor**

The probe heat monitor monitors current flow to the pitot, fuselage air data, and AOA probes (total temperature probe current is not monitored). If the current flow decreases below a certain value, the monitor illuminates the PROBE HEAT caution light. The monitor operates anytime the aircraft is airborne, regardless of the PROBE HEAT switch position.

# Air Data System Schematic (Typical)

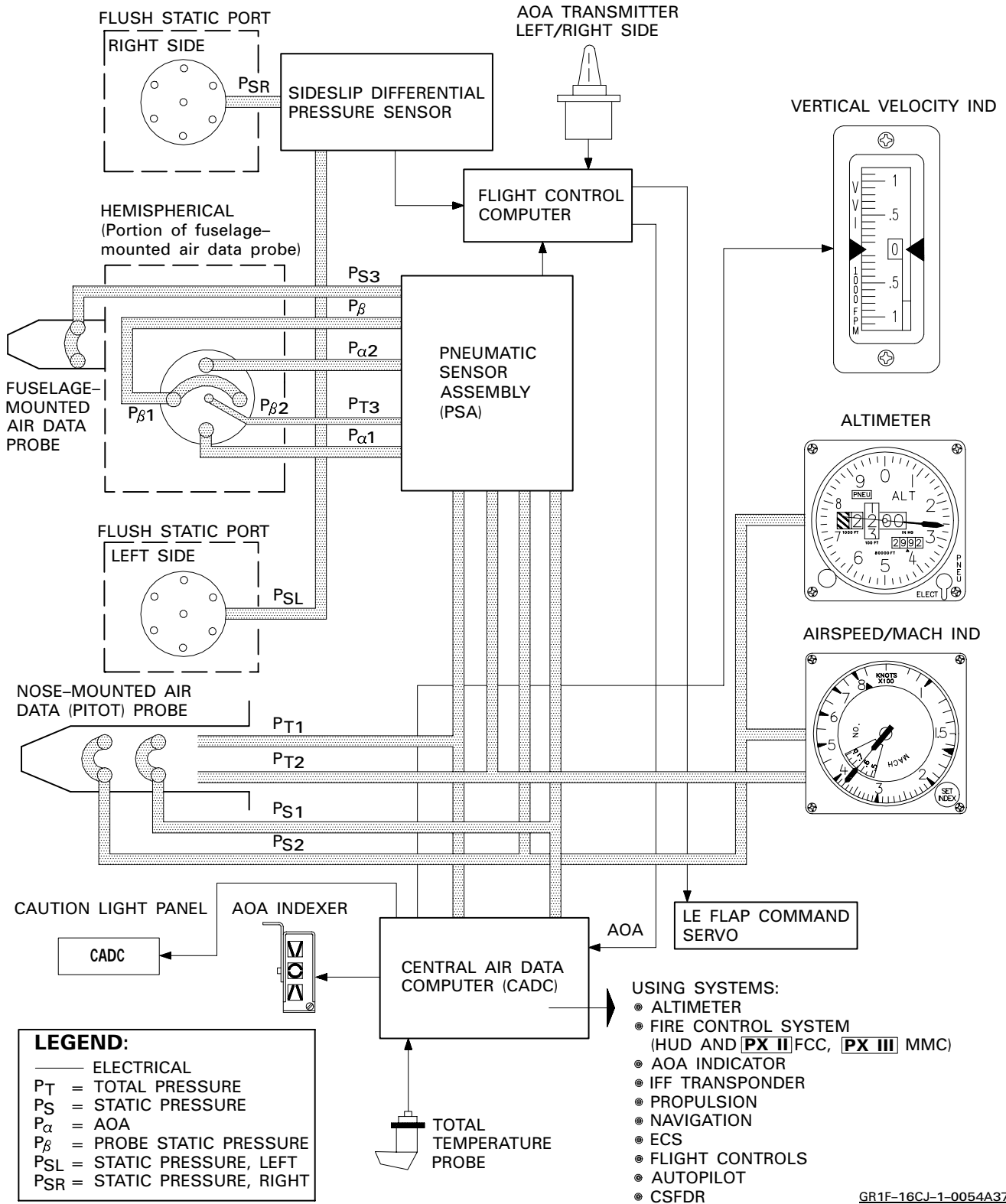

Figure 1-53.



### **PROBE HEAT Switch**

The PROBE HEAT switch is located on the TEST switch panel. The pitot, fuselage air data, AOA, and the total temperature probe heaters are on anytime the aircraft is airborne, regardless of the PROBE HEAT switch position.

Functions are:

- PROBE HEAT – On the ground, this position energizes the pitot, fuselage air data, AOA, and the total temperature probe heaters and the probe heat monitor.
- OFF – On the ground, circuits deenergized.
- TEST – On the ground and in flight, this position performs a functional test of the probe heat monitoring system. The PROBE HEAT caution light flashes 3-5 times per second. If the caution light does not illuminate or if it illuminates but does not flash, the probe heat monitoring system is inoperative. The test feature does not verify proper operation of probe heaters.

### **PNEUMATIC SENSOR ASSEMBLY (PSA)**

The PSA converts pneumatic inputs from the nose air data probe and the fuselage air data probe into electrical signals. The PSA supplies static and impact pressure signals and single AOA signals to the input selector/monitor of each branch of the FLCC. A ratio of impact to static pressure is generated within the FLCC and used with AOA and static pressure to schedule the LEF's and for gain scheduling. The input selector/monitors also are capable of detecting single and dual malfunctions of the air data sensor signals. Single static or impact pressure failures illuminate the FLCS FAULT caution light and the FLCS ADC FAIL PFL on the PFLD and MFD. A dual malfunction of static or impact pressure signals results in the following:

- Illumination of the FLCS warning light, continued illumination of the FLCS FAULT caution light, and the FLCS ADC FAIL (for first failure) and STBY GAINS PFL messages.
- Activation of FLCS standby gains. Refer to STANDBY GAINS, this section.

Pitot probe tip icing results in erroneously low airspeed indications, illumination of the FLCS FAULT caution light with an FLCS ADC FAIL PFL message, and flight control gains scheduled for low airspeed conditions.

### **CENTRAL AIR DATA COMPUTER (CADC)**

Refer to figure 1-54 for a signal flow diagram showing the systems interacting with the CADC. The CADC receives total and static pressures, AOA, and total temperature inputs, converts the inputs into digital data, and then transmits the data to the using systems. The CADC has continuous BIT and initiated BIT features; initiated BIT is run during the FLCS BIT.

### **CADC Caution Light**

The CADC caution light, located on the caution light panel, illuminates whenever a malfunction in the CADC is detected. If there is a mach signal failure from the CADC, the ENGINE FAULT caution light also illuminates and the ENG MACH FAIL PFL is displayed on the PFLD. A CADC malfunction may result in an FLCS AOS FAIL PFL and deactivation of the AOS feedback function.

## **WARNING, CAUTION, AND INDICATOR LIGHTS**

Refer to figure 1-55. Warning, caution, and indicator lights are used throughout the cockpit to call attention to a condition or to allow an item to be easily read. Red warning lights and the amber MASTER CAUTION light are all located on the edge of the glareshield. All of the lights, except the MASTER CAUTION light, are described under their respective systems.

The warning and caution lights (except MASTER CAUTION) are not press-to-test or press-to-reset lights. Pressing these lights releases them from their modules and deactivates them. To reengage a released light, pull it out slightly and then press to reengage the module.

# CADC and Interfacing Systems

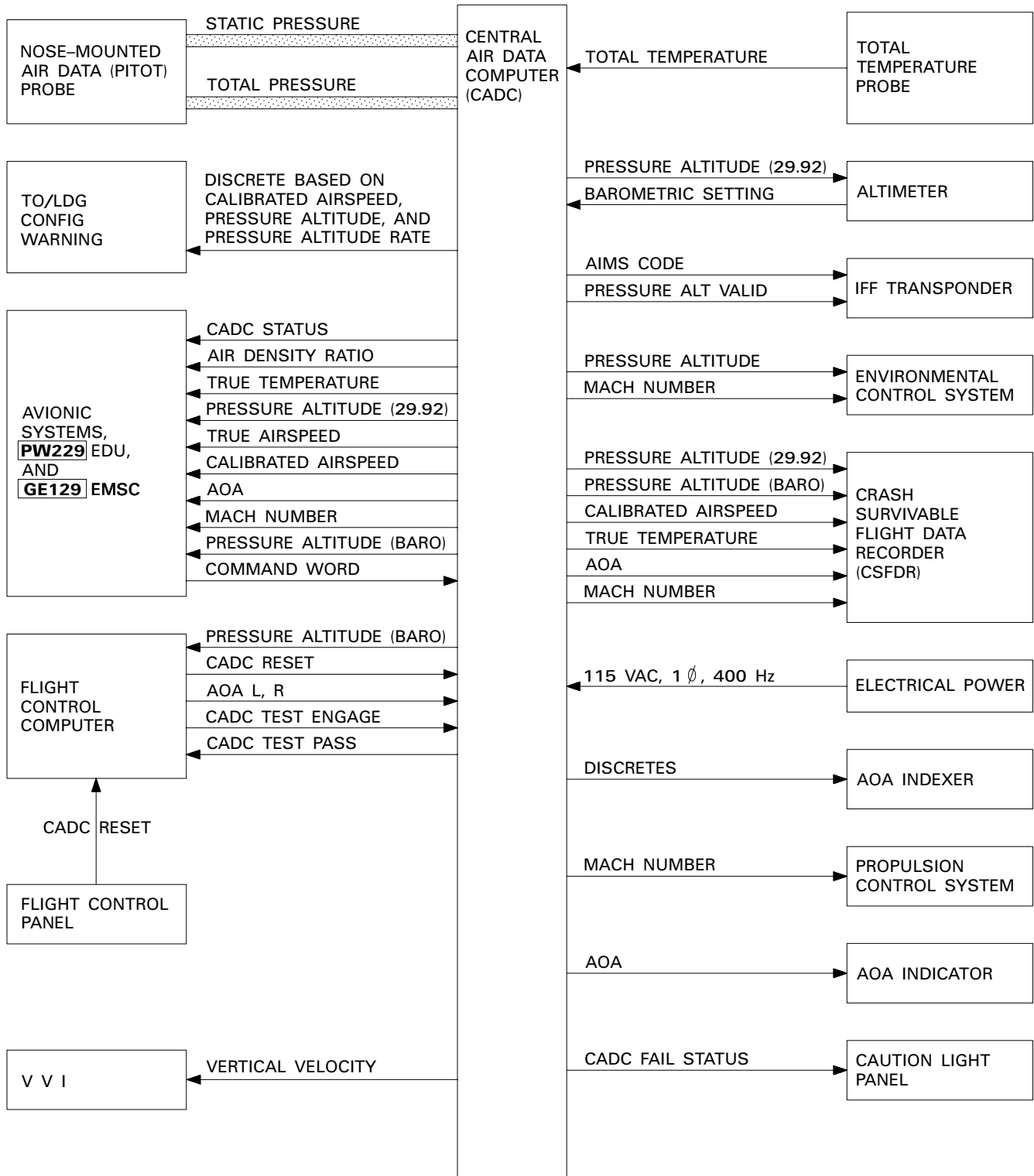

GR1F-16CJ-1-0055A37 ©

Figure 1-54.

# Warning, Caution, and Indicator Lights C DF (Typical)

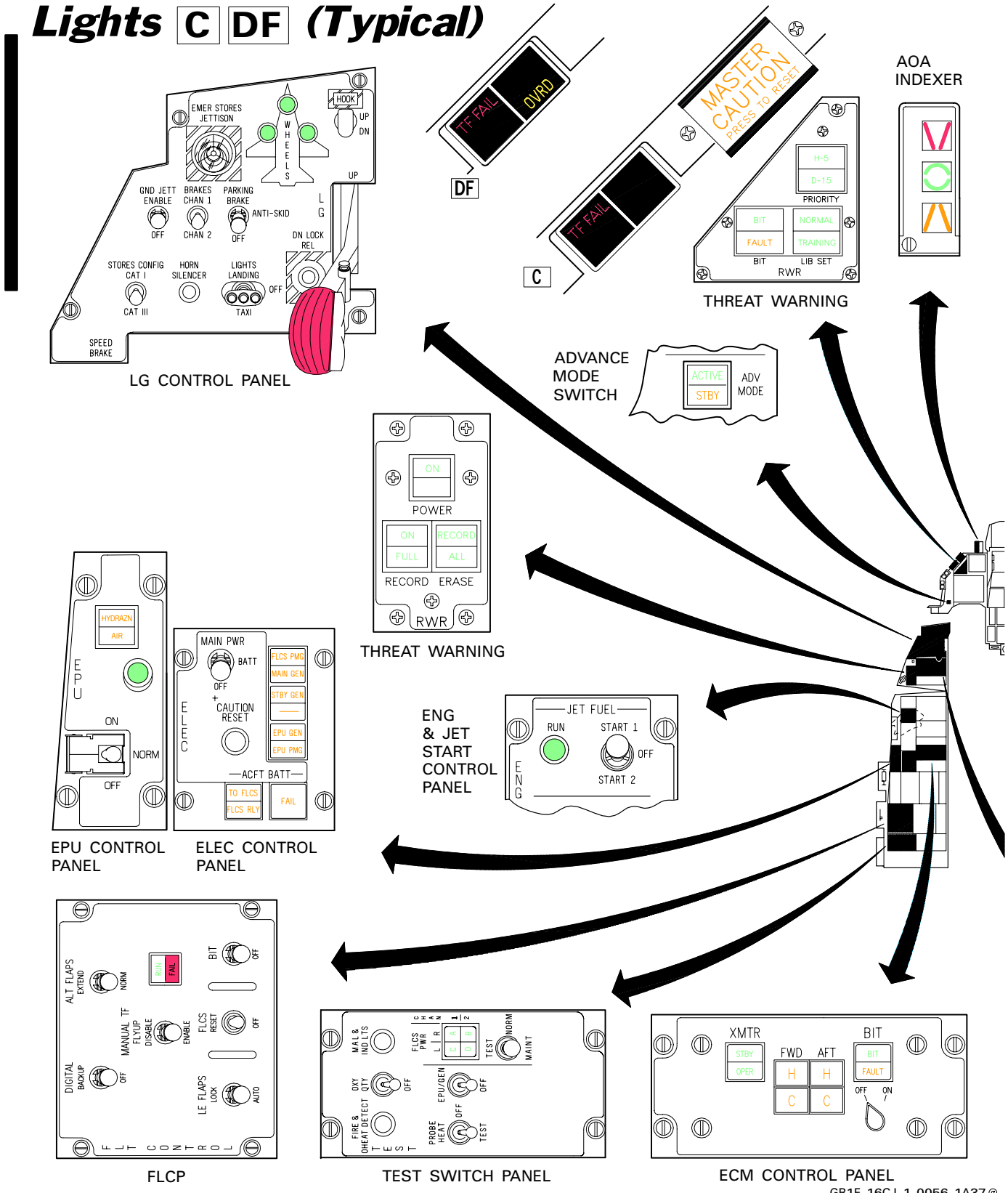

GR1F-16CJ-1-0056-1A37 ©

Figure 1-55. (Sheet 1)

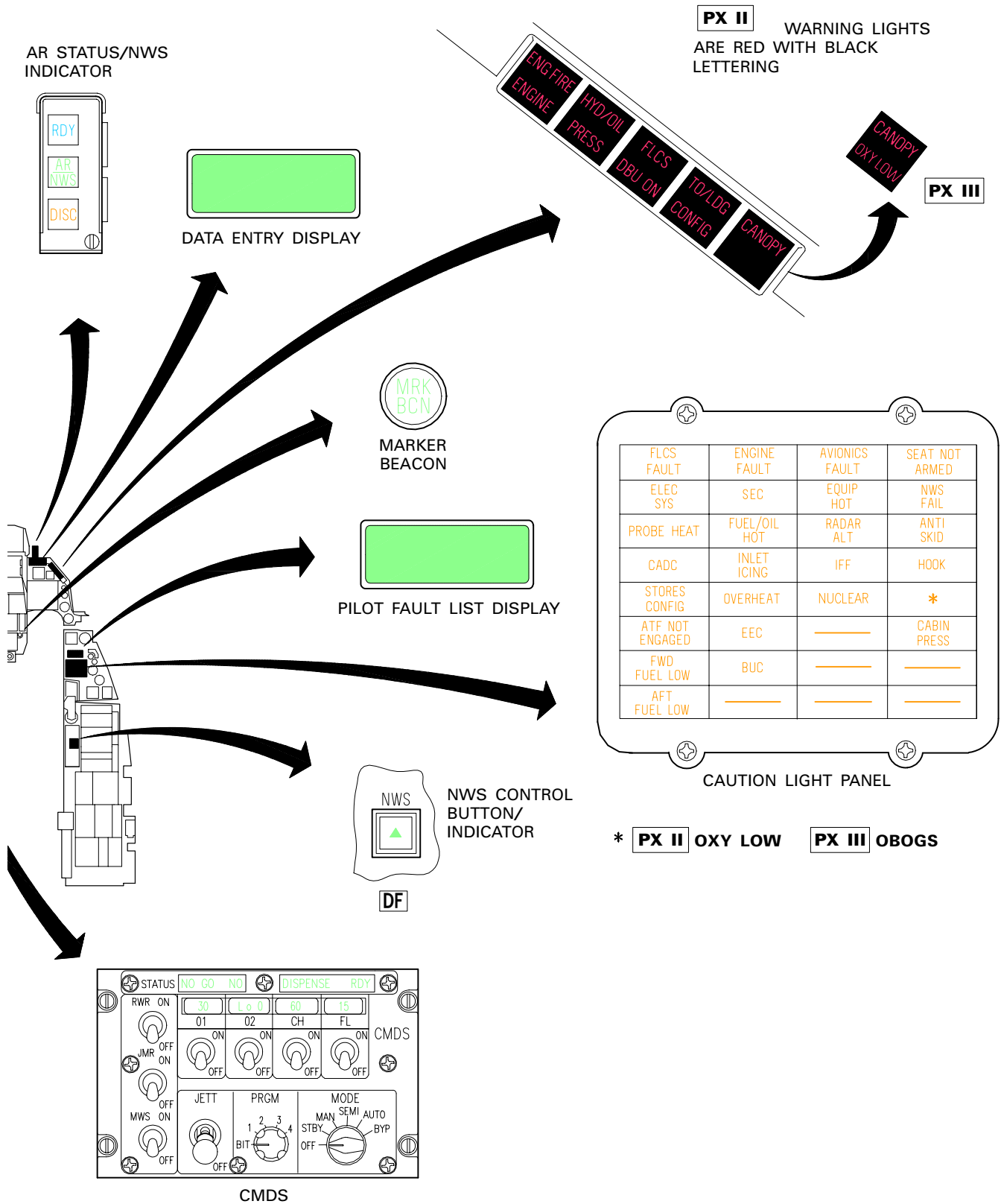
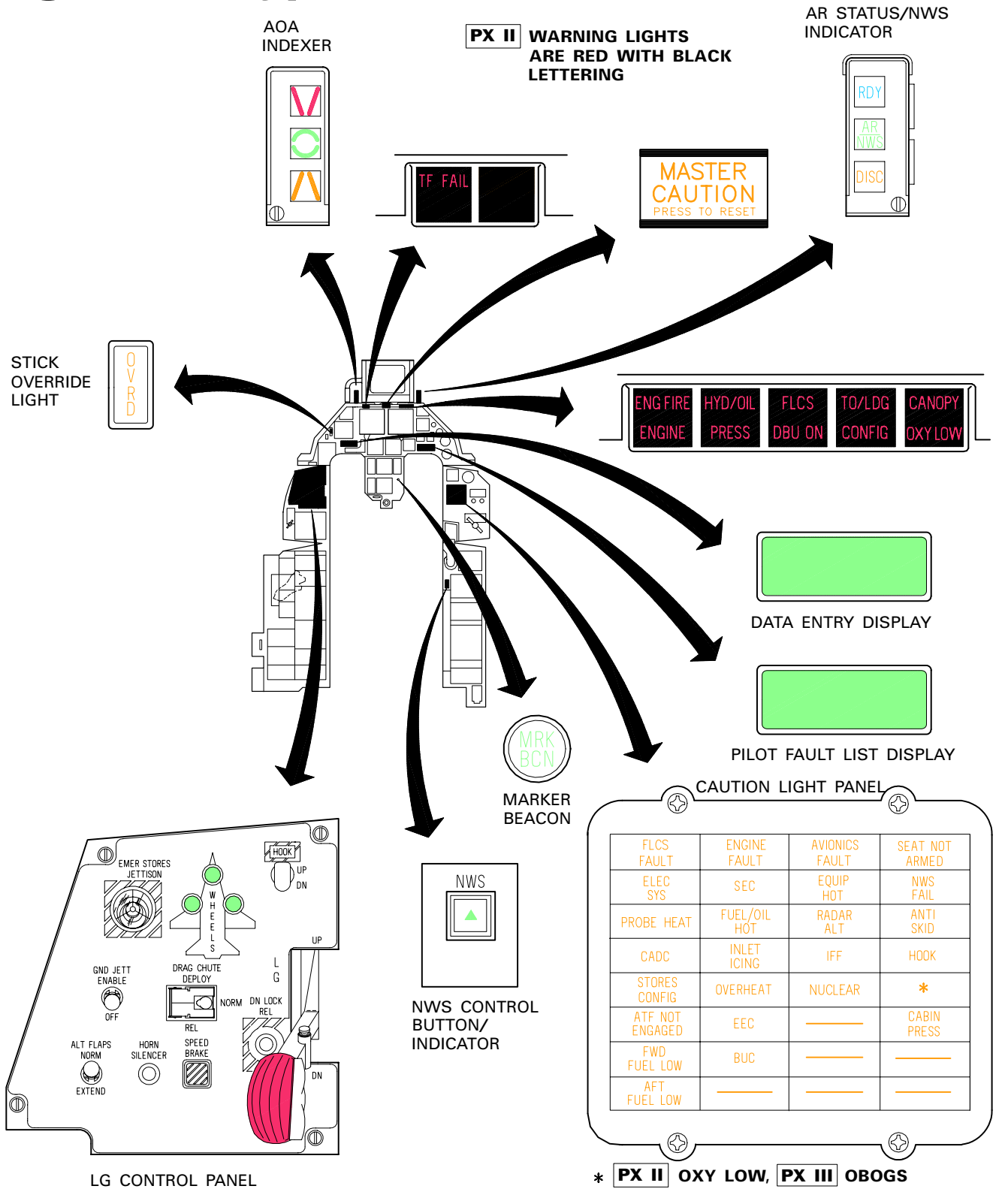

Figure 1-55. (Sheet 2)

# Warning, Caution, and Indicator Lights DR (Typical)



GR1F-16CJ-1-0057A37 ©

Figure 1-55. (Sheet 3)

**VOICE MESSAGE SYSTEM (VMS)**

The VMS provides a warning message, a caution message, or discrete messages. The fixed volume voice message does not blank other audio and, therefore, may not be heard.

The warning message (WARNING-WARNING pause WARNING-WARNING) is automatically activated 1.5 seconds after illumination of any glareshield-mounted warning light.

The caution message (CAUTION-CAUTION) is automatically activated 7 seconds after the illumination of any light on the caution light panel except the IFF caution light. If the MASTER CAUTION light is reset immediately after its illumination, the caution message does not occur.

The warning/caution messages are reset for subsequent activation by:

- Resetting the WARN RESET on the ICP for voice warning.
- Resetting the MASTER CAUTION for voice caution.
- Eliminating the condition that originally activated the lights and messages.

Discrete voice messages are provided when certain conditions occur.

Messages are:

- ALTITUDE-ALTITUDE - Advises that:
  - Descent is occurring after takeoff.
  - Radar altitude is below the entered radar ALOW value.
  - Barometric altitude is below the entered MSL ALOW value.

Refer to T.O. GR1F-16CJ-34-1-1 for a detailed description.

- BINGO-BINGO - Advises that the bingo fuel warning has been activated. Refer to T.O. GR1F-16CJ-34-1-1 for a detailed description.
- IFF - Not operable in flight (message is heard during ground test).
- JAMMER - Active if REQJAM option is turned on via the DED CMDS BINGO page. Advises that a threat should be jammed and pilot consent is required.

- LOCK-LOCK - Advises that radar has locked on to target. Refer to T.O. GR1F-16CJ-34-1-1 for a detailed description.
- PULLUP-PULLUP-PULLUP-PULLUP:
  - In ATF or in manual TF (fly-up enabled), advises that an automatic fly-up has been initiated.
  - In manual TF (fly-up disabled), advises that TF failure, SWIM-detected failure, g-limit warning, or obstacle warning has occurred.
  - Advises that GAAF was activated **PX III** or that DTS ground proximity warning was activated.
- COUNTER - Active in semiautomatic mode only if REQCTR option is turned on via the DED CMDS BINGO page. Advises that a dispense command should be initiated.
- CHAFF-FLARE - Active if FDBK option is turned on via the DED CMDS BINGO page. Advises that CMDS has initiated a dispense program.
- LOW - Active if BINGO option is turned on via the DED CMDS BINGO page. Advises that expendable low quantity exists.
- OUT - Active if BINGO option is turned on via the DED CMDS BINGO page. Advises that expendable type is completely spent.
- **PX III** DATA - Advises that IDM received data link target information.
- LOCK - Not operable in flight (message is heard during ground test).

All voice messages have priority over the low speed warning tone and LG warning horn. Voice messages are also prioritized.

Priority sequence is:

- PULLUP.
- ALTITUDE.
- WARNING.
- JAMMER.
- COUNTER.
- CHAFF-FLARE.
- LOW.
- OUT.
- LOCK.

- CAUTION.
- BINGO.
- DATA.
- IFF.

The VMS does not function with WOW. However, it can be tested by pressing the MAL & IND LTS test button on the TEST switch panel. During test, each word is heard one time. The VMS is powered by battery bus No. 1.

### VOICE MESSAGE Switch **C** **DF**

Refer to figure 1-3. The VOICE MESSAGE switch, located aft of the stick, is a two-position switch. Positions are marked VOICE MESSAGE and INHIBIT. During normal operation, the switch is safety-wired in VOICE MESSAGE. Placing the switch to INHIBIT disables all voice messages. INHIBIT should only be used to clear a voice message which repeats abnormally. Placing the switch back to VOICE MESSAGE enables normal operation.

### MASTER CAUTION LIGHT

The MASTER CAUTION light, located on the **C** **DF** left upper edge, **DR** center of the glareshield, illuminates shortly after an individual light on the caution light panel illuminates (except the IFF caution light) to indicate a malfunction or specific condition exists.

The MASTER CAUTION light does not illuminate in conjunction with the warning lights. The MASTER CAUTION light may be reset by depressing the face of the light unless it is illuminated by the ELEC SYS caution light. For FLCS FAULT, ENGINE FAULT, and AVIONICS FAULT caution lights, the MASTER CAUTION light may also be reset by depressing the **C** **DF** F-ACK, **DR** FAULT ACK button. The light should be reset as soon as feasible so that other caution lights can be monitored should additional malfunctions or specific conditions occur. Unless it is reset, the MASTER CAUTION light remains illuminated as long as the individual caution light is illuminated. **DR** The MASTER CAUTION light is a repeater and cannot be reset individually.

### PILOT FAULT LIST DISPLAY (PFLD)

Refer to figure 1-56. The PFLD, located on the **C** **DF** right auxiliary console, **DR** instrument panel, displays engine, avionics, and FLCS PFL's. In addition, a status line displays a system code to identify the system associated with an active fault(s).

Two types of PFL's are displayed: warning level and caution level. Warning level PFL's are associated with the FLCS (TFR system PFL's are considered to be associated with the FLCS) and are distinguished from caution level PFL's by a warning indicator which brackets the PFL message. When an FLCS warning level PFL occurs, the PFL message and FLCS code are displayed on the PFLD, the FLCS warning light illuminates, a flashing WARN is displayed in the HUD, and the voice warning message is activated. Caution level PFL's are associated with the FLCS, engine, and avionic system. When a caution level PFL occurs, the PFL message and system code are displayed on the PFLD, the appropriate system fault caution panel light illuminates, the MASTER CAUTION light illuminates, and the voice caution message is activated.

If multiple PFL's occur, they are displayed in the following priority order:

- FLCS warning level PFL's.
- FLCS caution level PFL's.
- Engine PFL's.
- Avionic PFL's.

Each page of the PFLD displays up to three PFL's. Additional pages are indicated by an arrow at each end of the bottom PFL and are accessed by depressing the **C** **DF** F-ACK, **DR** FAULT ACK button. Page numbers are also displayed when more than three PFL's are listed.

PFL's are acknowledged and recalled by depressing the **C** **DF** F-ACK, **DR** FAULT ACK button. Acknowledging a caution level PFL clears it from the PFLD and extinguishes the associated caution panel light and MASTER CAUTION light (if not previously reset). Acknowledging an FLCS warning level PFL clears it from the PFLD; however, the FLCS warning light remains on. Subsequent depressions of the **C** **DF** F-ACK, **DR** FAULT ACK button perform fault recalls. At the time of a fault recall, PFL's that are no longer being reported as a failure within the originating system are not displayed and are cleared from memory. The system code (FLCS, ENG, and/or AV) provides a real time indication of the presence of active fault(s). If the code is displayed, there is at least one active PFL within the reported category. If no system codes are displayed, there are no active PFL's.

# Pilot Fault List Display (Typical)

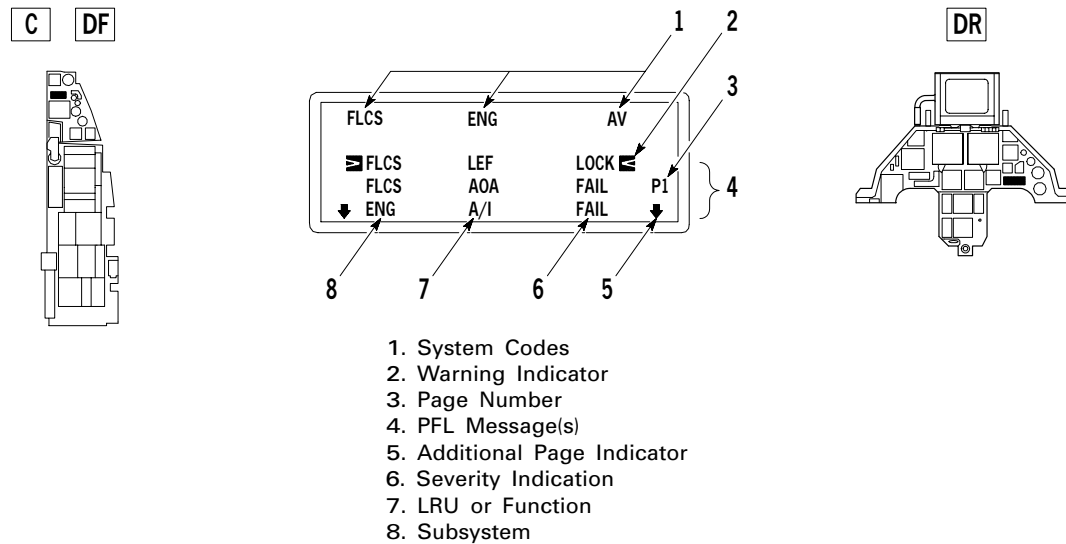

GR1F-16CJ-1-0058X37 ©

Figure 1-56.

Eliminating a FLCS failure condition by corrective action (e.g., FLCS reset) prior to fault acknowledgment removes all FLCS failure indications. For engine and avionic failure conditions and for FLCS failure conditions after fault acknowledgment, elimination of the failure condition will automatically remove/clear the system codes but not the PFL messages. Fault acknowledgment (if not previously accomplished) and fault recall are required to remove the PFL message(s).

The PFLD blanks if the upfront controls fail. Refer to T.O. GR1F-16CJ-34-1-1 for additional PFLD information. The PFLD is powered by the nacelle essential ac bus.

## CAUTION LIGHT PANEL

The caution light panel is located on the right auxiliary console.

The ELEC SYS caution light must be reset at the ELEC control panel with the ELEC CAUTION RESET button. The light may appear nonresettable in situations where the ELEC SYS caution light is rapidly flashing or cycling on and off.

The following caution lights may be reset with the **C** **DF** F-ACK **DR** FAULT ACK button:

- FLCS FAULT.
- ENGINE FAULT.
- AVIONICS FAULT.

## MAL & IND LTS Test Button

The MAL & IND LTS test button, located on the TEST switch panel, operates relays which test the illumination of all warning, caution, and indicator lights, the LG warning horn, and voice messages.



# LIGHTING SYSTEM

## EXTERIOR LIGHTING

Refer to figure 1-57, 1-58, and 1-59. All of the exterior lights except the landing/taxi lights are controlled from the EXT LIGHTING control panel.

### Anticollision Strobe Light

The anticollision strobe light is masked to minimize projections in the cockpit.

**PX III** The anticollision light has a strobe (visible to the unaided eye) as well as an infrared emitter (covert, visible to night vision devices but invisible to the unaided eye). The strobe is disabled and the IR emitter enabled with the MASTER knob in COVERT ALL or COVERT A-C. The anticollision light can flash seven selectable patterns in each of four power supply switch settings (figure 1-59).

### Position/Formation Lights

Refer to figure 1-60.

**PX III** The position/formation lights have NVIS friendly visible color lights as well as covert IR emitters. The visible lights are disabled and the covert lights enabled with the MASTER knob in COVERT ALL or COVERT FORM. The lower formation light and the lower wingtip lights do not have IR emitters and are disabled with the MASTER knob in COVERT ALL or COVERT FORM.

### Air Refueling Lights

The AR floodlight shares the housing of the top fuselage formation light. The light is directed aft to flood the receptacle, fuselage, wing, and empennage. The AR floodlight is not NVIS friendly. The AR slipway contains embedded lights on each side of the slipway. These lights are enabled when the AIR REFUEL switch is in OPEN. The intensity of these lights is controlled by the AERIAL REFUELING knob. These lights are not NVIS friendly.

## EXT LIGHTING Control Panel **C** **DF** (Typical) **PX II**

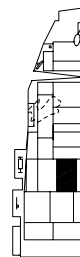
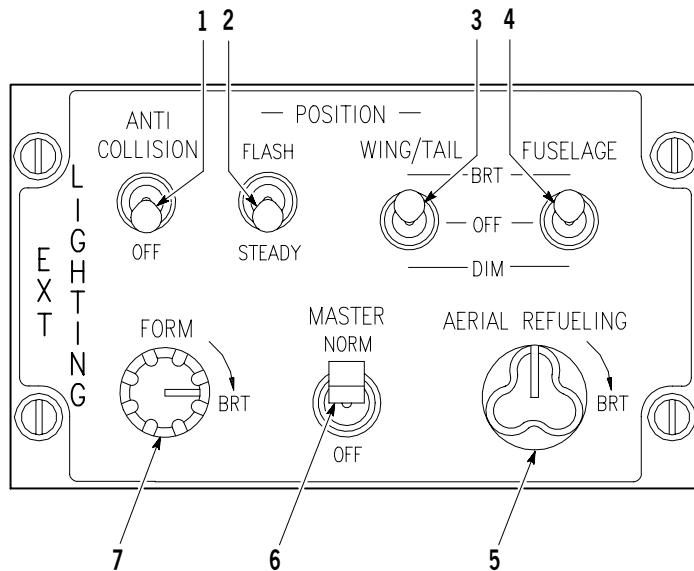

1. ANTICOLLISION Switch
2. FLASH STEADY Switch
3. WING/TAIL Switch
4. FUSELAGE Switch
5. AERIAL REFUELING Knob
6. MASTER Switch
7. FORM Knob

GR1F-16CJ-1-0059A37 ©

Figure 1-57. (Sheet 1)

# EXT LIGHTING Control Panel **C** **DF**

## (Typical) **PX II**

CONTROL	POSITION	FUNCTION
1. ANTICOLLISION Switch	ANTICOLLISION	Turns on the white anticollision strobe (flash) light on top of vertical tail
	OFF	Turns off the anticollision strobe light
2. FLASH STEADY Switch	FLASH	Causes the lights controlled by WING/TAIL switch to flash when turned on
	STEADY	Causes the lights controlled by WING/TAIL switch to light steady when turned on
3. WING/TAIL Switch	BRT	Turns on the red and green wingtip and inlet lights and white light at trailing edge of vertical tail bright
	OFF	Turns off the white light at trailing edge of vertical tail and the inlet lights. Allows the red and green wingtip lights to be controlled by the FORM knob
	DIM	Turns on the red and green wingtip lights dim. Turns on the red and green inlet lights and the white light at the trailing edge of the vertical tail dim
4. FUSELAGE Switch	BRT	Turns on the white floodlights at the base of the vertical tail bright
	OFF	Turns off the white floodlights
	DIM	Turns on the white floodlights dim
5. AERIAL REFUELING Knob	Variable from off to BRT	Varies the AR slipway lights from off to bright if AIR REFUEL switch is in OPEN
6. MASTER Switch	NORM	Enables all exterior lights except landing and taxi lights
	OFF	Disables all exterior lights except landing and taxi lights
7. FORM Knob	Variable from off to BRT	Varies the white formation lights on top and bottom of fuselage and, when the WING/TAIL switch is OFF, varies the red and green wingtip lights from off to bright

Figure 1-57. (Sheet 2)

# EXT LIGHTING Control Panel C DF (Typical) PX III

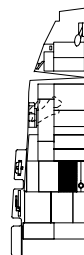
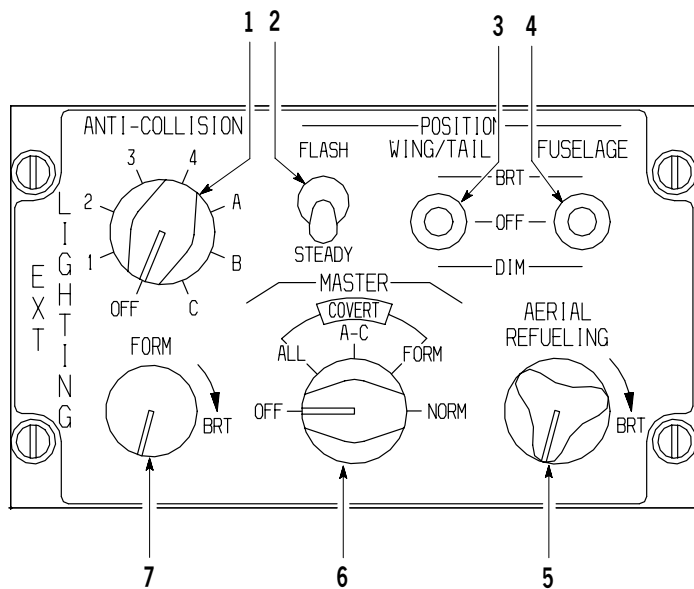

1. ANTI-COLLISION Knob
2. FLASH STEADY Switch
3. WING/TAIL Switch
4. FUSELAGE Switch
5. AERIAL REFUELING Knob
6. MASTER Knob
7. FORM Knob

GR1F-16CJ-1-1059X37 ©

CONTROL	POSITION	6. MASTER Knob			
		COVERT ALL	COVERT A-C	COVERT FORM	NORM
1. ANTI-COLLISION Knob	1, 2, 3, 4, A, B, & C	Flashes set pattern (covert strobe)	Flashes set pattern (covert strobe)	Flashes set pattern (visible strobe)	Flashes set pattern (visible strobe)
	OFF	Off	Off	Off	Off
2. FLASH STEADY Switch	FLASH	All lights flash covert	All lights except the fuselage lights flash	All lights flash covert	All lights except the fuselage lights flash
	STEADY	All lights are covert steady	All lights steady	All lights are covert steady	All lights steady
3. WING/TAIL Switch	BRT	Upper wingtip, intake, upper formation, and tail lights on covert bright (lower wingtip and lower formation lights off)	Wing tip, intake, and tail lights on visible bright	Upper wingtip, intake, upper formation, and tail lights on covert bright (lower wingtip and lower formation lights off)	Wing tip, intake, and tail lights on visible bright

Figure 1-58. (Sheet 1)

# EXT LIGHTING Control Panel **C** **DF**

## (Typical) **PX III**

CONTROL	POSITION	6. MASTER Knob			
		COVERT ALL	COVERT A-C	COVERT FORM	NORM
3. WING/ TAIL Switch (Cont)	OFF	Wing tip, intake and tail lights off. Upper formation light covert bright	Intake and tail lights off. Wingtip lights controlled by FORM knob	Wing tip, intake and tail lights off. Upper formation light covert bright	Intake and tail lights off. Wingtip lights controlled by FORM knob
	DIM	Upper wingtip, intake, tail lights on covert dim. Upper formation light covert bright. (lower wingtip and formation lights off)	Wingtip, intake, and tail lights on visible dim	Upper wingtip, intake, tail lights on covert dim. Upper formation light covert bright. (lower wingtip and formation lights off)	Wingtip, intake, and tail lights on visible dim
4. FUSE- LAGE Switch	BRT	Fuselage lights covert bright	Fuselage lights visible bright	Fuselage lights covert bright	Fuselage lights visible bright
	OFF	Fuselage lights off	Fuselage lights off	Fuselage lights off	Fuselage lights off
	DIM	Fuselage lights covert dim	Fuselage lights visible dim	Fuselage lights covert dim	Fuselage lights visible dim
5. AERIAL REFUEL- ING Knob		Variable from off to bright	Variable from off to bright	Variable from off to bright	Variable from off to bright
7. FORM Knob		No effect	Controls formation lights (and wingtip lights when WING/TAIL switch is in OFF) variable from off to bright	No effect	Controls formation lights (and wingtip lights when WING/TAIL switch is in OFF) variable from off to bright

Figure 1-58. (Sheet 2)

# Anticollision Light Flash Patterns PX III

**NOTE:**

Power supply settings are preset by maintenance personnel.

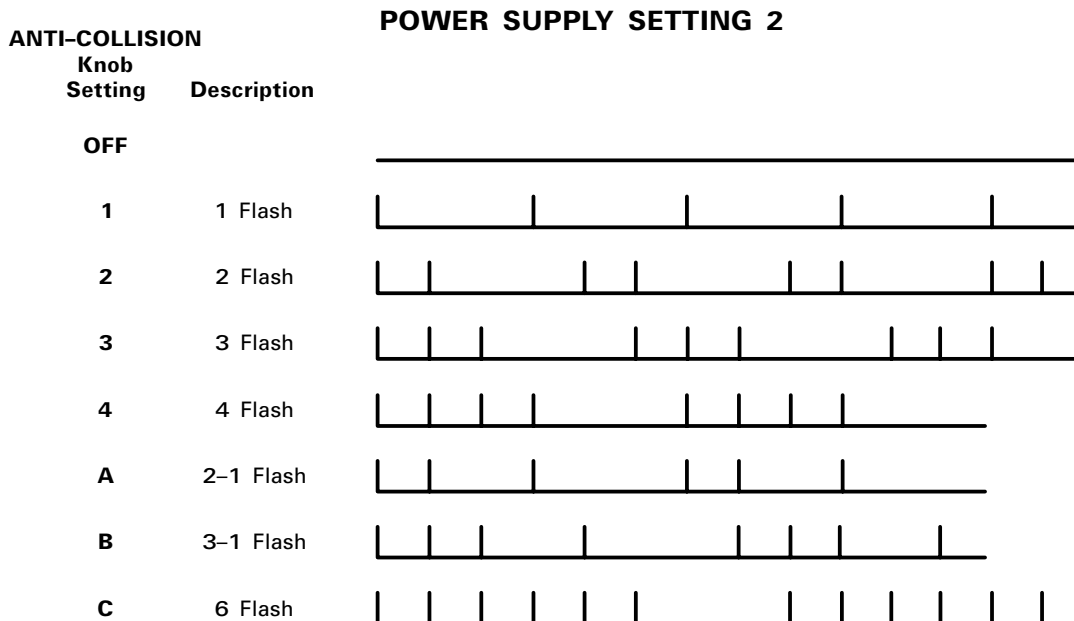
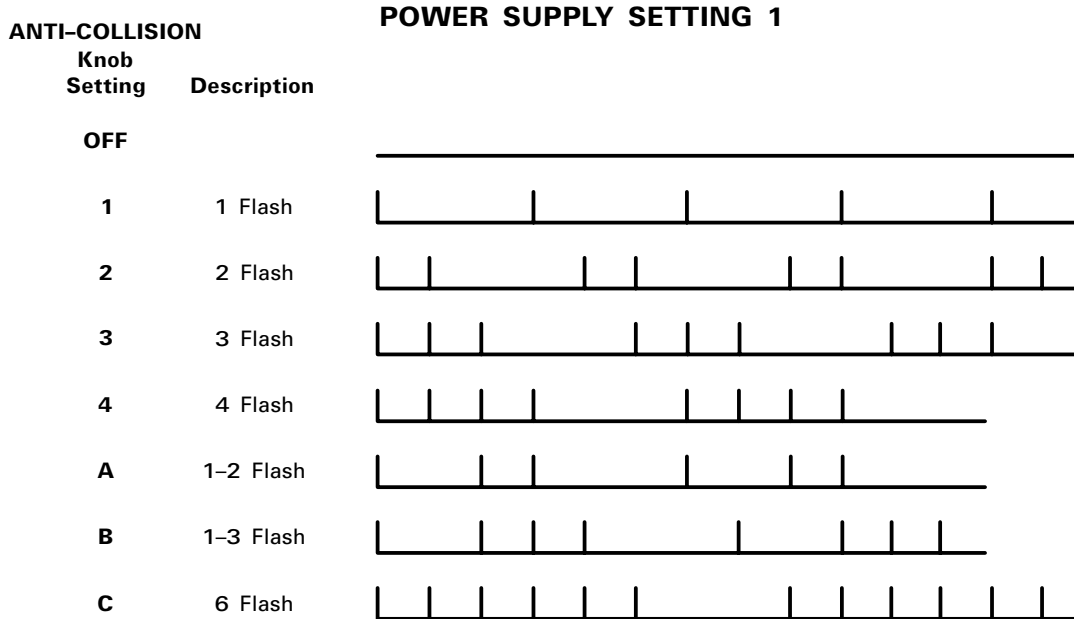

GR1F-16CJ-2066X37 ©

Figure 1-59. (Sheet 1)

# Anticollision Light Flash Patterns PX III

**NOTE:**  
Power supply settings are preset by maintenance personnel.

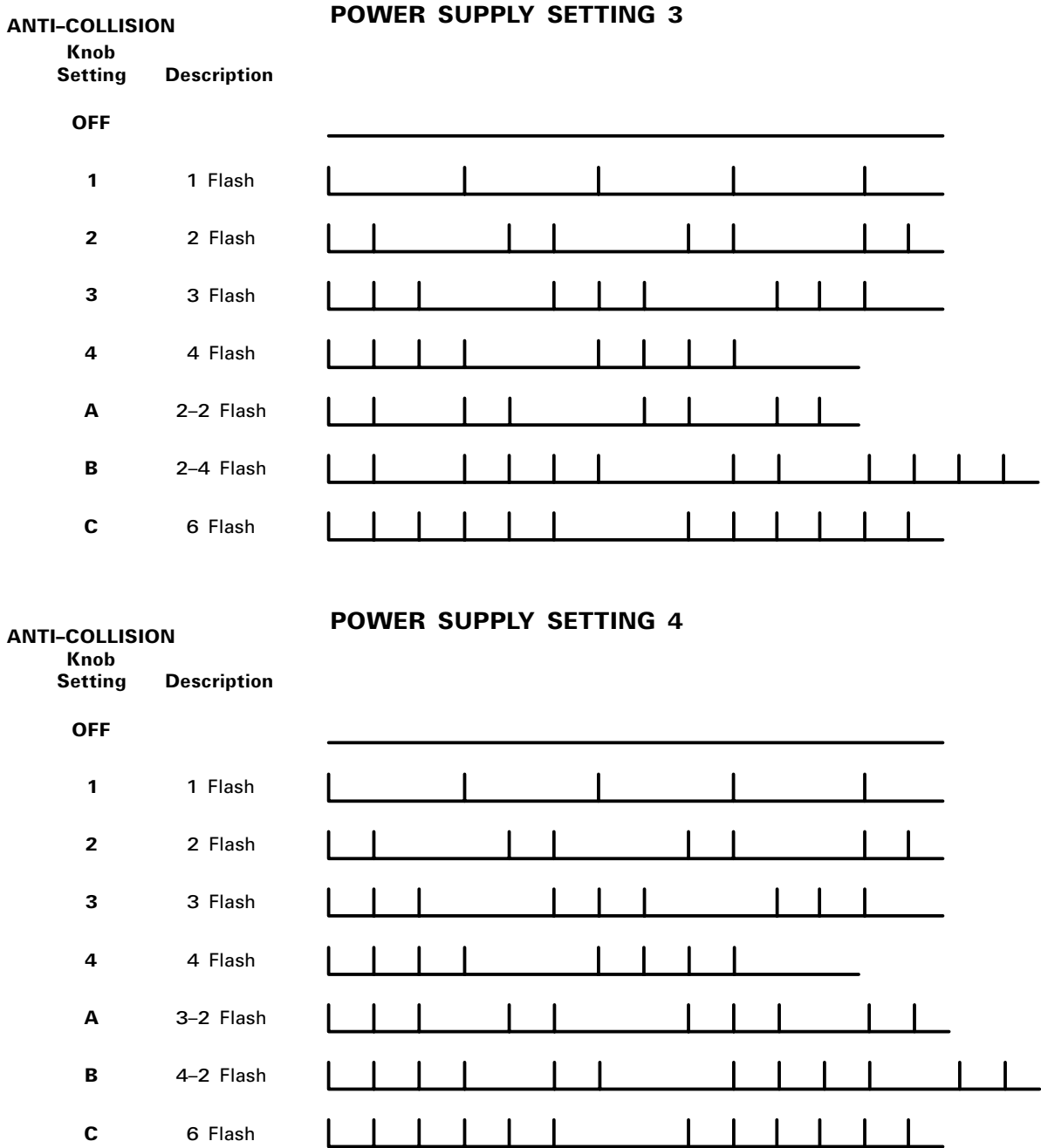

GR1F-16CJ-1-2067X37®

Figure 1-59. (Sheet 2)

## Exterior Lighting (Typical)

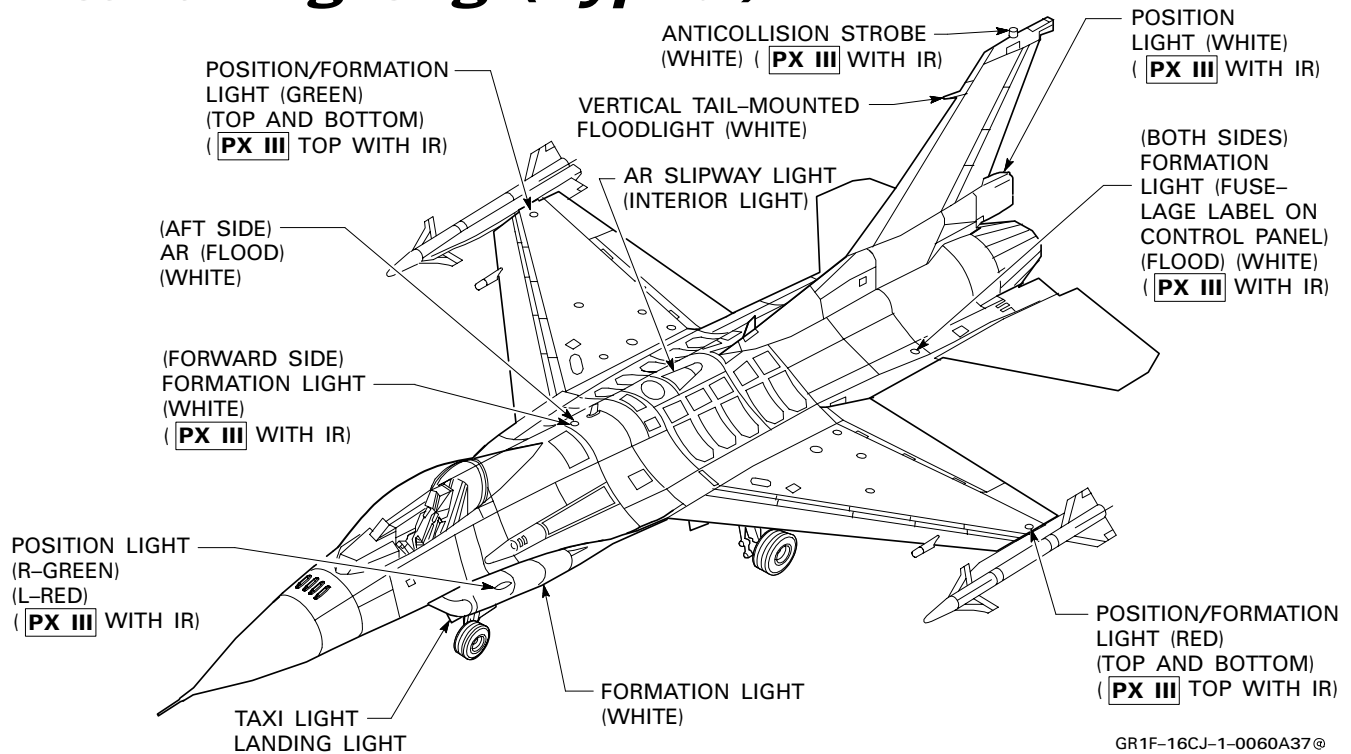

Figure 1-60.

### Vertical Tail-Mounted Floodlight

A white light is mounted on the upper leading edge of the vertical tail and is directed forward to flood the AR receptacle and upper fuselage. The light illuminates by the OPEN position of the AIR REFUEL switch. The floodlight is not NVIS friendly.

### Landing and Taxi Lights

A white landing and taxi light assembly is located on the NLG door. The landing light is angled to illuminate the landing area. The lights are turned on by the three-position LANDING TAXI lights switch located on the LG control panel. The switch has positions of LANDING, OFF, and TAXI. The light goes off during LG retraction if the switch is left in either the LANDING or TAXI position. The landing and taxi lights are not NVIS friendly.

### INTERIOR LIGHTING

Refer to figure 1-61. The interior LIGHTING control panel, located on the right console, contains the power

and intensity controls for the primary (console and instrument) and secondary (flood) lighting systems for the cockpit, PX III and NVIS (night vision imaging system). The HIGH INT position of the FLOOD CONSOLES knob provides thunderstorm lighting. PX III In addition, NVIS operation is provided which turns off most primary and secondary lights and sets the warning, caution, and advisory lights to dim.

PX III The interior lighting system, with the exception of the utility light, functions normally except all lighting is NVIS green. Internal instrument lighting has been disabled and replaced with post and bezel NVIS friendly lighting. Secondary lighting has been equipped with NVIS green filters to eliminate IR light. Caution and warning lights have filters which limit IR emissions to be compatible with night vision goggles. All interior lighting (except for one position on the utility light) is NVIS friendly and invisible through the night vision goggles. Cockpit instruments must be viewed beneath the goggles.

**PX III** When NVIS operation is de-selected, all light control panel functions are returned to normal operation. All console, instrument, and flood lights are illuminated to current settings. All warning, caution, and advisory lights return to bright only if the PRIMARY INST knob is in HIGH INT or OFF.

### PRIMARY CONSOLES Knob

The PRIMARY CONSOLES knob has a cw arrow pointing toward BRT. Rotating the knob cw varies the intensity of the primary console and left auxiliary console lighting from dim to bright. **PX III** During NVIS operation, this lighting is off and rotating the knob has no effect on lighting intensity.

### PRIMARY INST PNL Knob

The PRIMARY INST PNL knob has a cw arrow pointing toward BRT. Rotating the knob cw varies the intensity of the forward instrument panel and right auxiliary console lighting from off to bright. **PX III** During NVIS operation, rotating the knob cw varies the intensity of the **C** **DF** ICP, **DR** IKP.

### DATA ENTRY DISPLAY Knob

The DATA ENTRY DISPLAY knob has a cw arrow pointing toward BRT. The knob controls the lighting of the DED and PFLD from dim to bright.

### MAL & IND LTS Switch

The MAL & IND LTS switch has positions of BRT and DIM and a spring-loaded unmarked center position. If the PRIMARY INST PNL knob is on, momentary activation of the switch to DIM places the lighting system to the dim condition. The system automatically returns to the BRT condition if the FLOOD CONSOLES knob is turned past the detent to HIGH INT, if the PRIMARY INST PNL knob is turned off, or if emergency dc power is lost. The BRT condition can be manually selected anytime. The switch controls the light intensity of all the warning, caution, and indicator lights except the following individually dimmed lights:

- AOA indexer.
- AR/NWS indexer.
- DED.
- ECM control panel.
- MFD's.
- PFLD.
- TWS indicators.

**PX III** When the NVIS switch is in ARM, all lights controlled by the MAL & IND LTS switch are automatically set and locked to the dim setting and the MAL & IND LTS switch is inoperative.

### FLOOD INST PNL Knob

The FLOOD INST PNL knob has a cw arrow pointing toward BRT. Rotating the knob cw varies the floodlights intensity from off to bright. **PX III** During NVIS operation, the floodlights are off and rotating the knob has no effect on lighting intensity.

### FLOOD CONSOLES Knob

The FLOOD CONSOLES knob rotates from OFF to HIGH INT. Rotating the knob cw varies the console floodlights intensity from off to bright. If rotated to HIGH INT, the MAL & IND LTS and instrument panel floodlights automatically go to bright and the alphanumeric displays controlled by the DATA ENTRY DISPLAY knob go to the highest intensity level. CCW rotation past a certain point restores the alphanumeric displays to the intensity level set by the DATA ENTRY DISPLAY knob, but the MAL & IND LTS switch must be manually reset to DIM, if dim is desired. **PX III** During NVIS operation, the console floodlights are off and rotating the knob has no effect on lighting intensity.

### NVIS Switch **PX III**

The NVIS switch has three positions: NORM LTG, ARM, and NVIS. The ARM position is a lever locked position. The NVIS position is spring loaded and the switch returns to the ARM position when released.

Functions are:

- NORM LTG:
  - All cockpit lighting functions normally.
  - Blackout function disabled.
- ARM:
  - Blackout function enabled (not activated).
  - Caution/warning/advisory lights function in the dim mode.
  - High intensity flood lighting disabled.
  - Reduces the MFD brightness level when above a preset level.
  - De-energizes the MFD non-NVIS compatible backlighting.
- NVIS:
  - Activates/de-activates blackout function.



# Interior LIGHTING Control Panel (Typical)

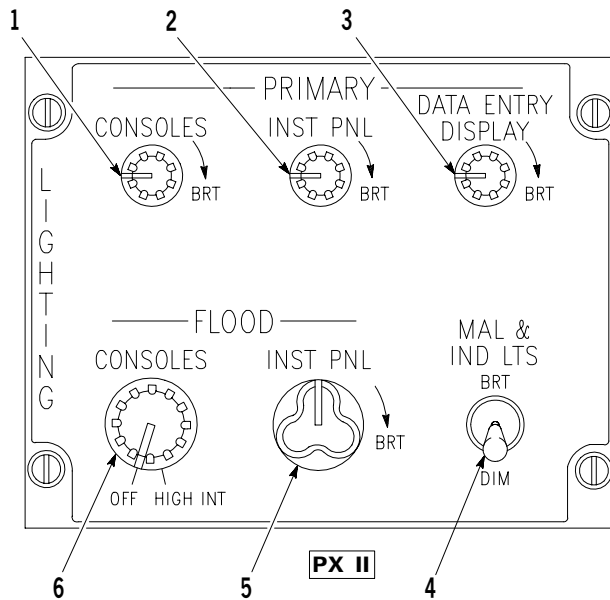

DR

C DF

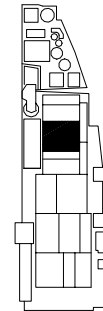
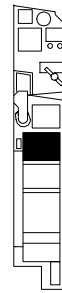

1. PRIMARY CONSOLES Knob
2. PRIMARY INST PNL Knob
3. DATA ENTRY DISPLAY Knob
4. MAL & IND LTS Intensity Switch
5. FLOOD INST PNL Knob
6. FLOOD CONSOLES Knob
7. NVIS Switch
8. Hands-on Blackout (HOB) Paddle Switch

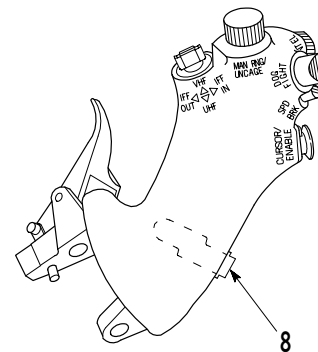
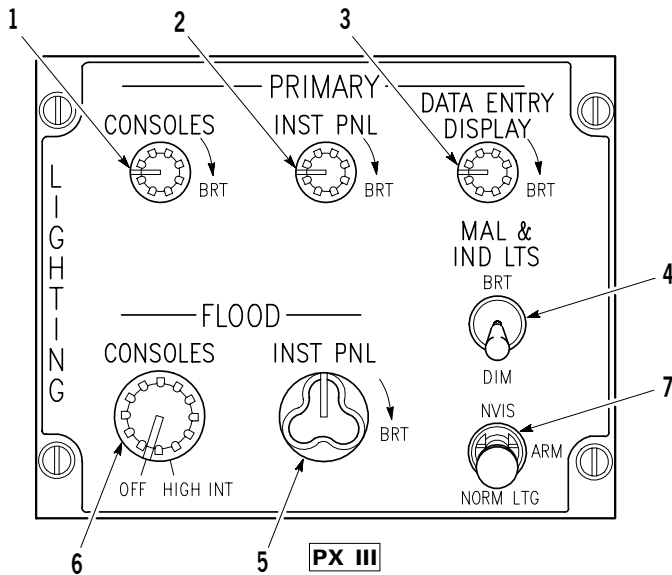

Figure 1-61.

When the blackout function is activated, most of the non-NVIS compatible light sources in the cockpit are turned off. These include primary flight instruments, engine instruments, and hydraulic gauges. For a complete list of the non-NVIS compatible lights which are not turned off by the blackout function, refer to GR1F-16CJ-34-1-1.

### Hands-On Blackout (HOBO) Switch **PX III**

The HOBO paddle switch, located on the throttle, activates/de-activates the blackout function when the NVIS switch is in ARM.

### Utility Light

Refer to figure 1-62. The utility light, located on the right console, includes **PX II** three, **PX III** four controls: a pushbutton switch to allow momentary operation at the highest intensity level, an OFF DIM BRT rotary knob to allow continuous operation at any desired intensity level, **PX III** an NVIS WHITE selector for NVIS (green) or normal (white) operation, and a lens housing which, when rotated, adjusts the beam from flood to spot. To release the light from its stowed position, lower the knurled collar at the base of the light and it will pop free. The light can be locked back into position by placing the body of the light parallel to the sidewall fairing and pushing down firmly on the light assembly. With the canopy closed, the utility light may be attached to an adjustable sliding holder located on the right body positioning handle (towel rack). The light is powered by battery bus No. 1.

### Cockpit Spotlights

Refer to figure 1-62. The cockpit spotlights are located under the upper left and right glareshields. In the stowed position (horizontal, facing forward), the spotlight is off. The spotlight is turned on by pulling the spotlight barrel downward. Illumination intensity is controlled by turning the knurled barrel (dimmer). To turn the spotlight off, return it to the stowed position. Overrotation of the knurled barrel may cause breakage of the bulb or rheostat. The lights are powered by battery bus No. 1.

## ESCAPE SYSTEM

### CANOPY

The canopy is a two-piece, plastic, bubble-type, transparent enclosure. The forward part is a single-piece windshield-canopy transparency, which is

hinged at the aft end and is unlatched, opened, or closed/latched by an electrically operated actuator with a manual backup. **C** A smaller fixed transparency fits to the fuselage aft of the seat. The canopy may be jettisoned by internal controls for in-flight or ground escape and by external controls for ground rescue. An inflatable pressurization seal on the cockpit sill mates with the edge of the movable canopy. A noninflatable rubber seal on the canopy prevents the entry of water when the cockpit is not pressurized.

The canopy provides some bird strike protection. Bird strikes on centerline at approximately eye level may produce enough canopy deflection to shatter the HUD combiner glass and cause rearward propagation of a deflection wave. Deflection of the canopy in the area of the pilot's helmet has been observed to be 1 to 2 inches during bird strike tests that were considered successful. Successful completion of canopy bird strike testing (4 pound bird at 350 or 550 knots, depending on canopy) requires that the canopy not deflect more than 2 1/4 inches in the area of the pilot's helmet. This may be a consideration for adjusting seat height, especially while flying at lower altitudes with helmet-mounted equipment. Impacts off center may not shatter the HUD glass. High energy bird strikes may cause canopy penetration or larger deflection waves.

### CANOPY CONTROLS AND INDICATORS

Refer to figure 1-63.

#### MANUAL CANOPY CONTROL Handcrank

**C** **DF** An internal MANUAL CANOPY CONTROL handcrank manually performs the same function as the canopy switch. Due to the strength required to open the canopy with the handcrank, the method should be considered a last resort.

An external flush-mounted CANOPY handcrank receptacle just opposite the inside manual drive is used for ground crew manual operation of the canopy.

#### Canopy Handle **C** **DF**

The canopy handle, located on the canopy sill just forward of the throttle, hinges down to cover and protect the internal canopy switch. The handle also functions to inflate/deflate the canopy pressure seal, to turn the CANOPY warning light off/on, and to mechanically prevent the canopy actuator from unlatching. The canopy handle should be in the up (unlock) position prior to lowering the canopy.

# Utility Light and Spotlights (Typical)

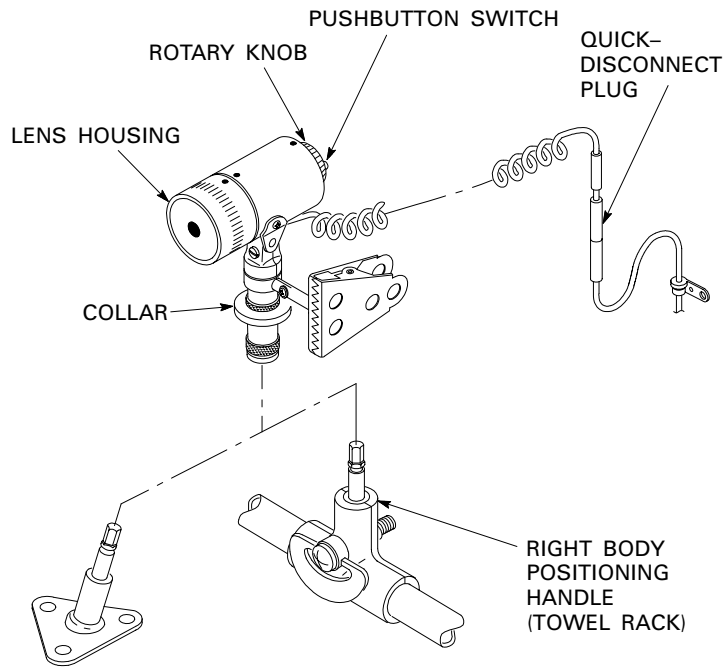

PX II

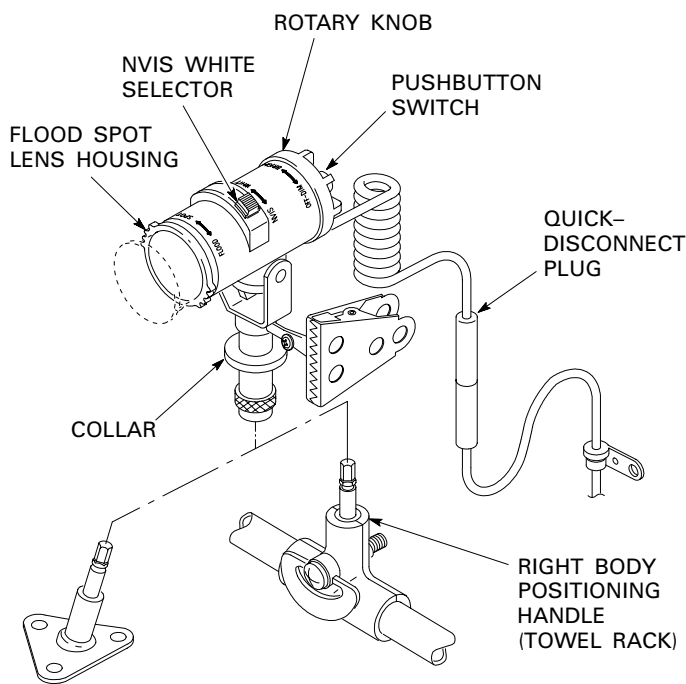

PX III

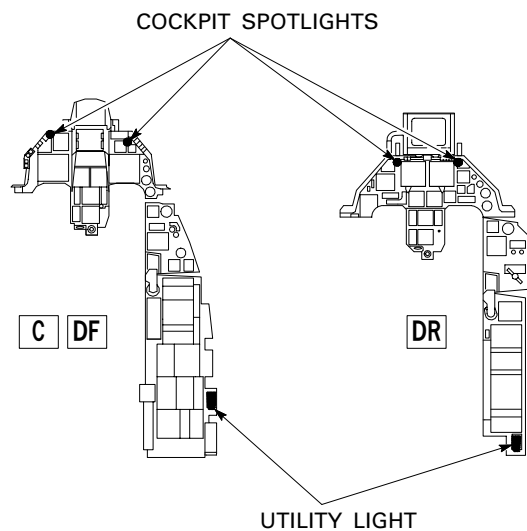
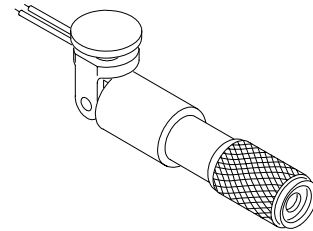
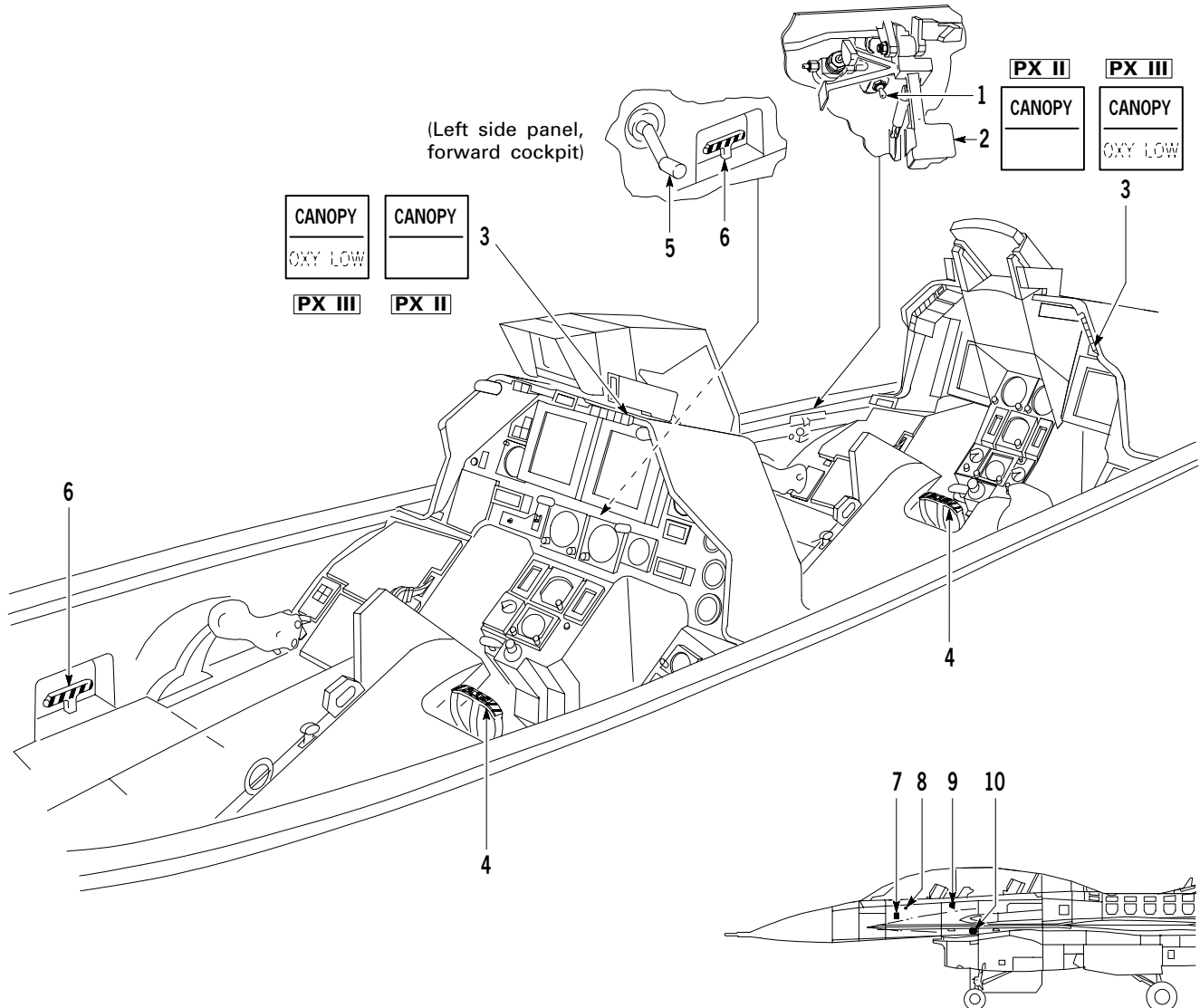

Figure 1-62.

# Canopy Controls and Indicators (Typical)

## NOTE:

If the internal canopy switch is in the up position, the canopy cannot be closed using the external canopy switch.



1. **C** **DF** Canopy Switch (internal) (spring-loaded to center from down position)
2. **C** **DF** Canopy Handle (shown in unlocked position)
3. CANOPY Warning Light (Red)
4. Ejection Handle (PULL TO EJECT)
5. **C** **DF** MANUAL CANOPY CONTROL Handcrank
6. CANOPY JETTISON T-Handle
7. Canopy Jettison D-Handle (each side of fuselage)
8. Canopy Lock Access Plug (external)
9. CANOPY Handcrank Receptacle (external)
10. Canopy Switch (external) (spring-loaded to center)

GR1F-16CJ-1-0063A37®

Figure 1-63. (Sheet 1)

# Canopy Controls and Indicators (Typical)

CONTROL/INDICATOR	POSITION/INDICATION	FUNCTION
1. <input type="checkbox"/> <input type="checkbox"/> Canopy Switch (internal) (spring-loaded to center from down position)	Up	Opens canopy
	Center	Stops canopy motion
	Down	Closes and latches canopy
2. <input type="checkbox"/> <input type="checkbox"/> Canopy Handle	Up	Unlocks canopy
	Down	Locks canopy
3. CANOPY Warning Light (red)	Off	Canopy locked
	On	Canopy unlocked
4. Ejection Handle (PULL TO EJECT)	Pull	Jettisons canopy and ejects seat
5. <input type="checkbox"/> <input type="checkbox"/> MANUAL CANOPY CONTROL Handcrank	Rotate ccw	Opens canopy
	Rotate cw	Closes and latches canopy
6. CANOPY JETTISON T-Handle	Pull (depress either button)	Jettisons canopy independent of seat ejection
7. Canopy Jettison D-Handle (each side of fuselage)	Pull (approximately 6 feet) (either handle)	Jettisons canopy independent of seat ejection
8. Canopy Lock Access Plug (external)	Remove access plug	Access to unlock internal canopy handle
		Refer to EMERGENCY ENTRANCE AND CREW RESCUE, Section III
9. CANOPY Handcrank Receptacle (external)	Rotate cw	Opens canopy
	Rotate ccw	Closes and latches canopy
10. Canopy Switch (external) (spring-loaded to center position)	<input type="checkbox"/> Up	Opens canopy
	<input type="checkbox"/> Aft	
	Center	Stops canopy motion
	<input type="checkbox"/> Down	Closes and latches canopy
	<input type="checkbox"/> Fwd	

Figure 1-63. (Sheet 2)

## CANOPY JETTISON

Pulling the external canopy jettison D-handle, located on either side of the fuselage, initiates the canopy jettison sequence independent of seat ejection.

Depressing the button, located on either side of the internal CANOPY JETTISON T-handle, and pulling the T-handle initiates the canopy jettison sequence independent of seat ejection.

Pulling the ejection handle (PULL TO EJECT), located on the front of the ejection seat, initiates the canopy jettison sequence followed by the seat ejection sequence.

## EJECTION SEAT

Refer to figure 1-64. The ACES II ejection seat is a fully automatic emergency escape system. One of three ejection modes is automatically selected. Mode 1 is a low airspeed, low altitude mode during which the recovery parachute assembly is deployed almost immediately after the ejection seat departs the aircraft. Mode 2 is an intermediate airspeed, low altitude mode during which a drogue chute is first deployed to slow the ejection seat followed by the deployment of the recovery parachute assembly. Mode 3 is a high airspeed/high altitude mode in which the sequence of events is the same as mode 2, except that automatic pilot/seat separation and deployment of the recovery parachute assembly are delayed until safe airspeed and altitude are reached. Controls are provided to adjust seat height and lock shoulder harness.

### Ejection Handle

The ejection handle (PULL TO EJECT) is sized for one-handed or two-handed operation and requires a pull of 40-50 pounds to activate. The handle remains attached to the seat by a wire cable after activation.

### SHOULDER HARNESS Knob

The SHOULDER HARNESS knob unlocks the inertia reel when in the aft position and locks it when in the forward position. If high longitudinal deceleration force or high shoulder harness strap payout velocities are encountered, the inertia reel automatically locks.

### EMERGENCY MANUAL CHUTE Handle

The EMERGENCY MANUAL CHUTE handle is locked while the ejection seat is in the aircraft. After

ejection, the handle provides a backup to the automatic pilot/seat separation and recovery parachute deployment system. The handle must be pulled approximately 6 inches. The first 2 inches of pull ballistically deploys the recovery parachute assembly; however, the seat will still be attached by the lapbelt and the inertia reel straps, and the survival kit under the latched seat pan lid. Continued pull releases the lapbelt and inertia reel straps and unlatches the seat pan lid.

### Ejection Safety Lever

The ejection safety lever mechanically safeties (in the up/vertical position) or arms (in the down/horizontal position) the seat ejection handle.

### SEAT NOT ARMED Caution Light

The SEAT NOT ARMED caution light, located on the caution light panel, illuminates when the ejection safety lever is in the up (vertical) position.  The caution lights illuminate independently of each other.

### SEAT ADJ Switch

Refer to figure 1-3. The SEAT ADJ switch is located on the right cockpit sidewall outboard of the stick. Center position is spring-loaded off. The up position raises the seat, while the down position lowers the seat. The seat adjustment motor is protected by a thermal relay which interrupts electrical power when overheated. After a 1-minute cooling period, the motor should operate normally. The motor is powered by nonessential ac bus No. 1.

### Shoulder Harness Straps/Parachute Risers

The upper torso restraints consist of shoulder harness straps which also act as parachute risers. The inertia reel straps are attached to the parachute risers.

### Inertia Reel Straps

The inertia reel straps may be manually released after ejection by pulling the EMERGENCY MANUAL CHUTE handle approximately 6 inches.

### Lapbelt

The lower torso restraint is the lapbelt. The lapbelt may be released after ejection by pulling the EMERGENCY MANUAL CHUTE handle approximately 6 inches.

# Ejection Seat Controls and Indicators (Typical)

(FLIP-UP PITOTS)

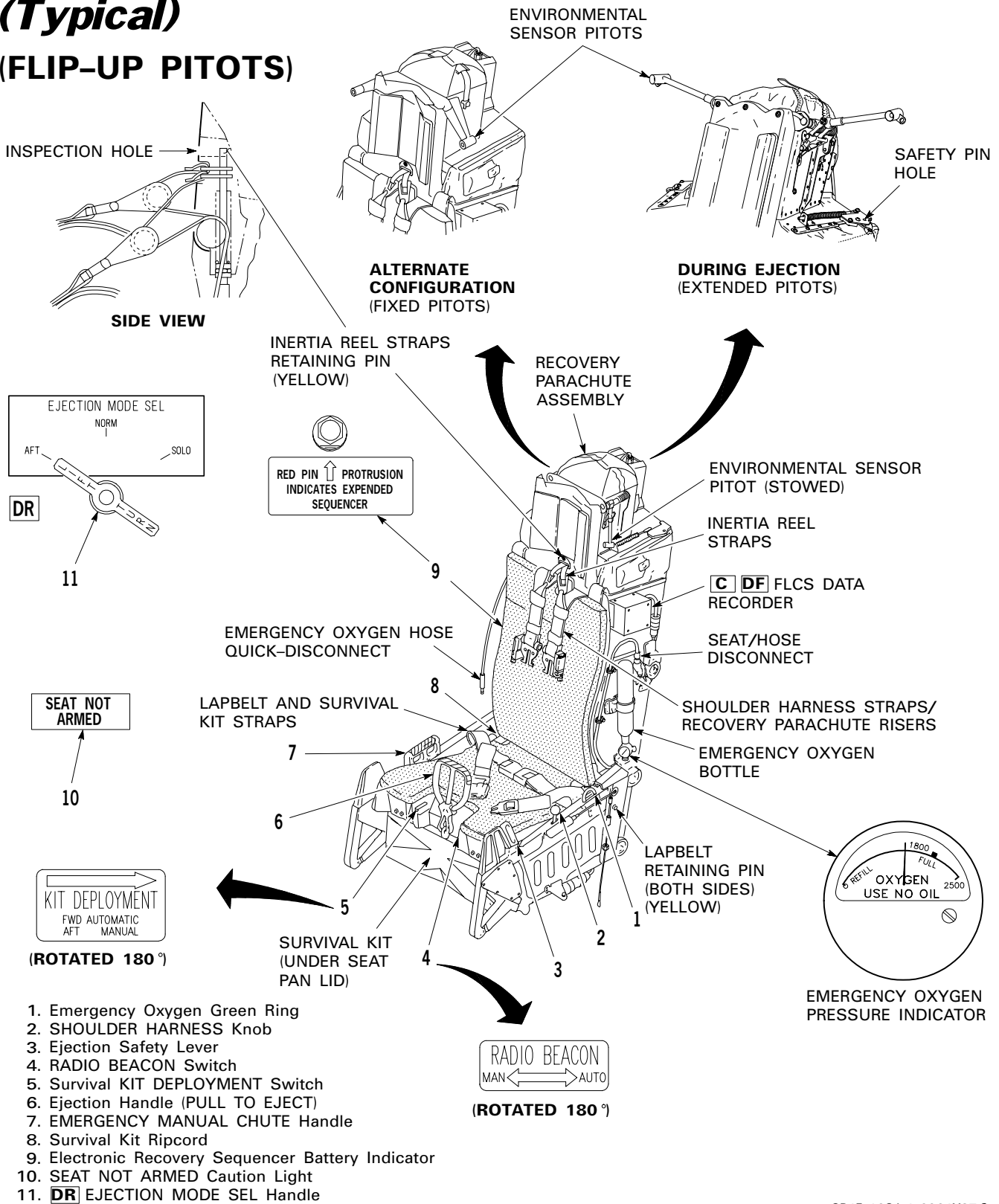

GR1F-16CJ-1-0064X37 ©

Figure 1-64. (Sheet 1)

# Ejection Seat Controls and Indicators (Typical)

CONTROL/INDICATOR	POSITION/INDICATION	FUNCTION
1. Emergency Oxygen Green Ring	Pull	Activates emergency oxygen
2. SHOULDER HARNESS Knob	UNLOCKED (aft)	Unlocks inertia reel and allows free movement of shoulder harness
	LOCKED (forward)	Locks inertia reel and prevents forward movement of shoulder harness
3. Ejection Safety Lever	Up	Prevents pulling of ejection handle
	Down	Allows ejection handle to be pulled
4. RADIO BEACON Switch	MAN (green dot visible)	Selects manual mode
	AUTO (red dot visible)	Selects automatic mode
5. Survival KIT DEPLOYMENT Switch	A (forward)	Selects automatic mode
	M (aft)	Selects manual mode
6. Ejection Handle (PULL TO EJECT)	Pull	Jettisons canopy and ejects seat
7. EMERGENCY MANUAL CHUTE Handle	Pull	After ejection - ballistically deploys the recovery parachute assembly and releases lapbelt and inertia reel straps and unlatches the seat pan lid
8. Survival Kit Ripcord	Pull	Deploys survival kit
9. Electronic Recovery Sequencer Battery Indicator	White	Sequencer thermal batteries not activated - operational
	Red	Sequencer thermal batteries activated - not operational
10. SEAT NOT ARMED Caution Light (amber)	On	Ejection safety lever up
	Off	Ejection safety lever down
11. <b>DR</b> EJECTION MODE SEL Handle (LIFT TURN)	AFT/NORM/SOLO	Selects ejection mode
		Refer to F-16D AIRCRAFT, this section

Figure 1-64. (Sheet 2)



### **Survival Kit**

The survival kit is stowed under the seat pan lid. The KIT DEPLOYMENT switch has a manual (aft) or automatic (forward) position which selects the mode of postjection survival kit deployment. Pulling the kit ripcord handle deploys the kit which remains attached by a 25-foot lanyard.

### **RADIO BEACON Switch**

The RADIO BEACON switch allows the pilot to select AUTO or MAN. In AUTO (red dot visible), the beacon activates after pilot/seat separation. In MAN (green dot visible), the beacon does not activate. The beacon may be activated when on the ground if the RADIO BEACON switch is placed to AUTO or it can be removed and manually operated as desired. The beacon transmits on 243.0 MHz.

### **Emergency Oxygen**

Emergency oxygen supply is automatically activated during ejection or may be manually activated by pulling the emergency oxygen green ring.

### **EJECTION SEAT OPERATION**

Seat ejection is initiated by pulling the ejection handle (PULL TO EJECT). This action retracts the shoulder harness straps and locks the inertia reel, fires the initiators for canopy jettison, and ignites two canopy removal rockets. As the canopy leaves the aircraft, lanyards fire two seat ejection initiators.

A rocket catapult propels the seat from the cockpit exposing the seat environmental sensor pitots and activating the emergency oxygen. The recovery sequencer selects the correct ejection mode, ignites the stabilization package (STAPAC) rocket and the trajectory divergence rocket, and (if in mode 2 or 3) initiates the drogue gun.

If the automatic pilot/seat separation and recovery parachute deployment system fails, pulling the EMERGENCY MANUAL CHUTE handle approximately 6 inches ballistically deploys the recovery parachute assembly and releases the lapbelt and inertia reel straps and unlatches the seat pan lid.

The liferaft, survival kit, and radio beacon antenna are deployed following pilot/seat separation when the survival KIT DEPLOYMENT switch is in AUTO. If the parachute is equipped with SEAWARS, the parachute risers are automatically released within 2 seconds after entering saltwater.

Seat ejection also automatically performs an escape zeroize operation by purging coded electronic information associated with the following equipment:

- DTC.
- **PX II** FCC.
- **PX III** MMC.
- **PX III** EGI.
- **PX II** GPS.
- AIFF mode 4.
- **PX III** IDM.
- MFDS.
- TWS.

### **EJECTION MODE ENVELOPES**

Refer to figure 1-65.

### **EJECTION SEQUENCE TIMES**

Refer to figure 1-66.

### **CANOPY JETTISON/SEAT EJECTION**

Refer to figure 1-67.

### **EJECTION SEAT PERFORMANCE**

Refer to figure 1-68.

# Ejection Mode Envelopes

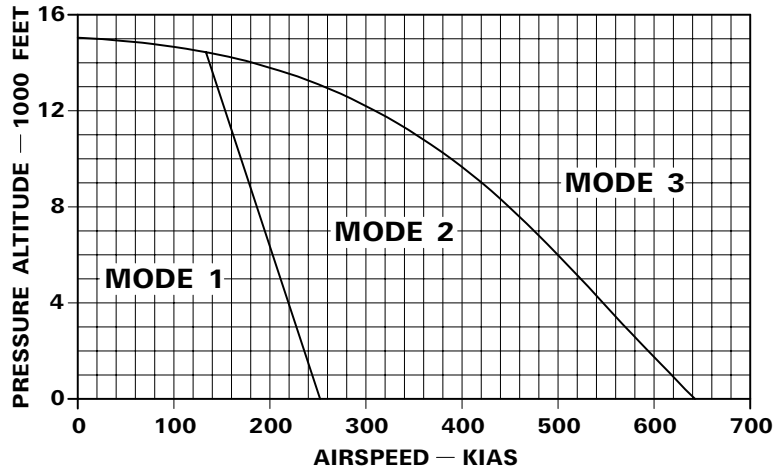

1F-16X-1-0011X®

Figure 1-65.

# Ejection Sequence Times

NOTE:	EVENT	TIME (SECONDS)	
		Mode 1	Mode 2
<ul style="list-style-type: none"> <li>In mode 3, events after drogue deployment are delayed until within mode 2 envelope. Recovery parachute deploys 1 second after entering mode 2 envelope.</li> <li><b>D</b> Times in the aft/forward sequence increase to include a 0.33-second delay for the rear seat and a 0.73-second delay for the forward seat. In SOLO, the forward seat is delayed 0.33 second.</li> <li>Canopy jettison time varies from 0.75 second at 0 KIAS to 0.13 second at 600 KIAS. Ejection begins when canopy jettison initiates seat lanyards.</li> </ul>	1. Catapult Initiation	0.0	0.0
	2. Drogue Gun Fired	NA	0.17
	3. Drogue Chute Inflated	NA	0.38
	4. Parachute Fired	0.20	1.17
	5. Seat/Drogue Separation	NA	1.32
	6. Pilot/Seat Separation	0.45	1.42
	7. Recovery Parachute Inflated	1.80	2.80
	8. Survival Kit Deployed	5.50	6.30

Figure 1-66.

# Canopy Jettison/Seat Ejection

## MODE 1

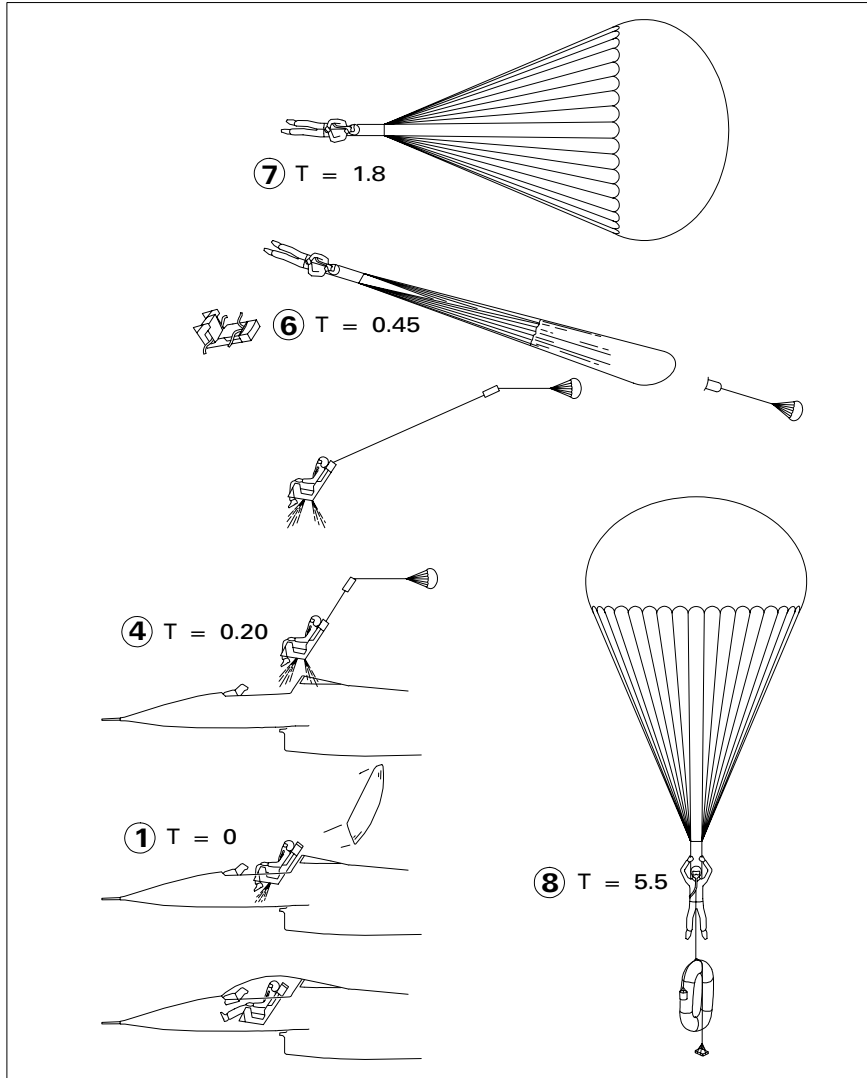

## MODE 2

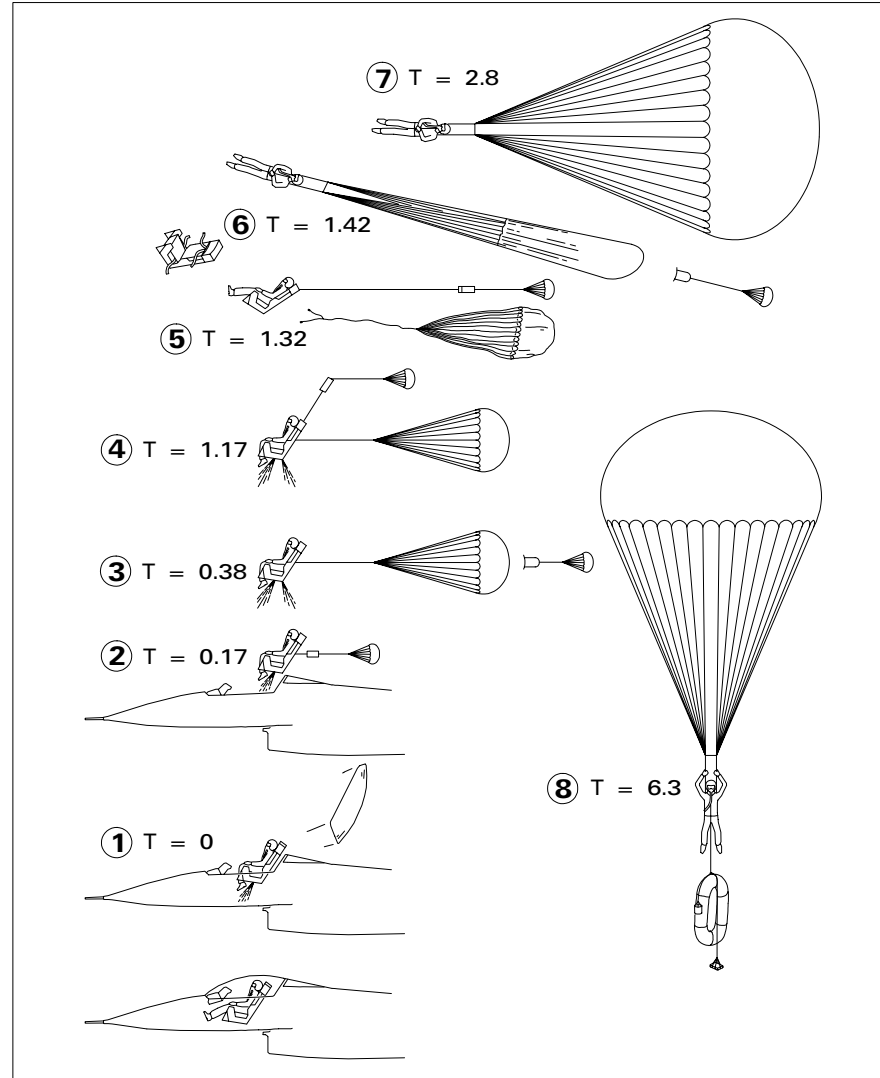

1F-16X-1-0012X®

Figure 1-67.

# Ejection Seat Performance C

## MINIMUM EJECTION ALTITUDE vs DIVE ANGLE AND SPEED

**NOTES:**

- ZERO PILOT REACTION TIME
- SEA LEVEL
- WINGS LEVEL
- 95th PERCENTILE PILOT

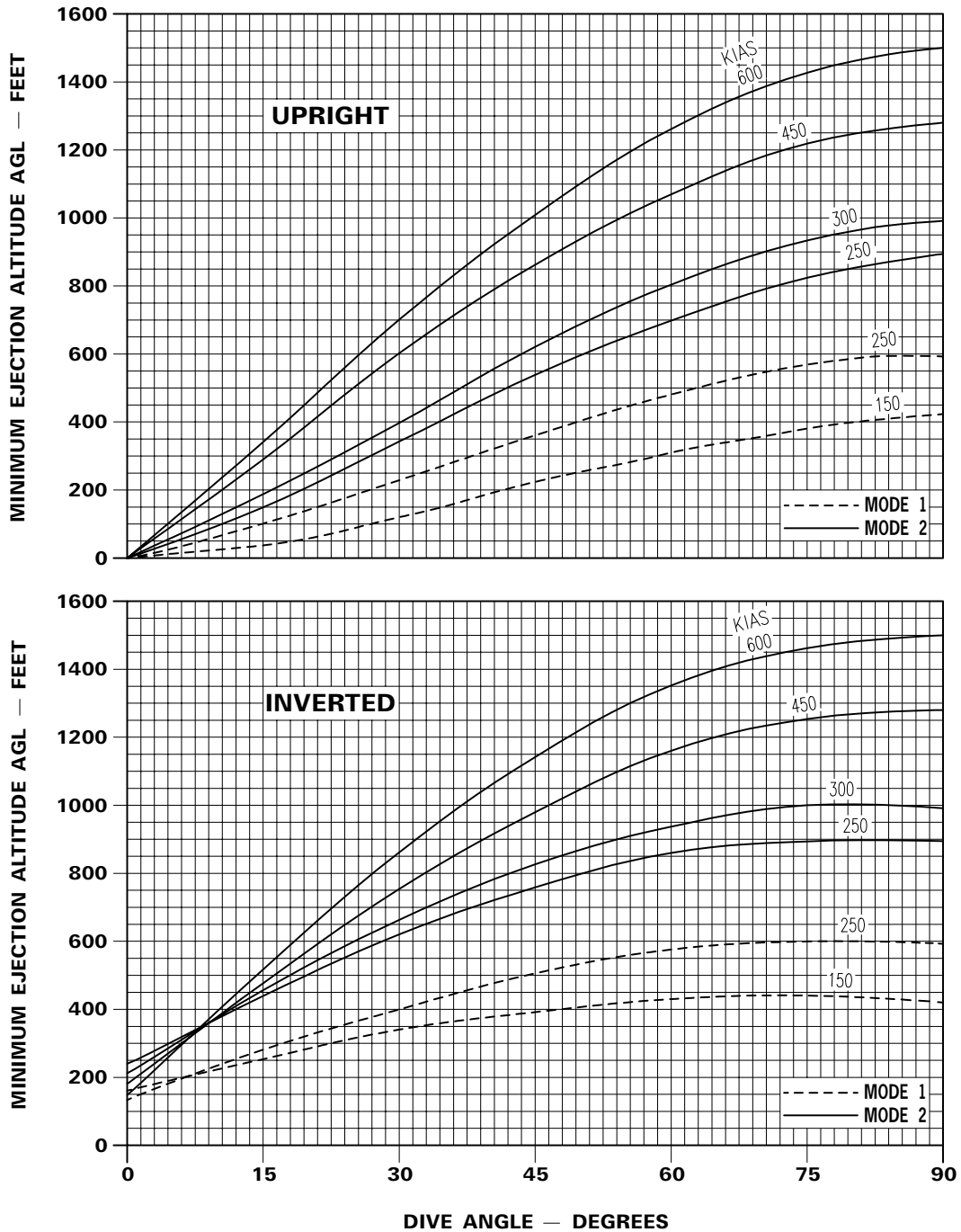

1F-16X-1-2002X ©

Figure 1-68. (Sheet 1)

# Ejection Seat Performance C

## MINIMUM EJECTION ALTITUDE vs SINK RATE AND SPEED

**NOTES:**

- ZERO PILOT REACTION TIME
- WINGS LEVEL

- SEA LEVEL
- 95th PERCENTILE PILOT

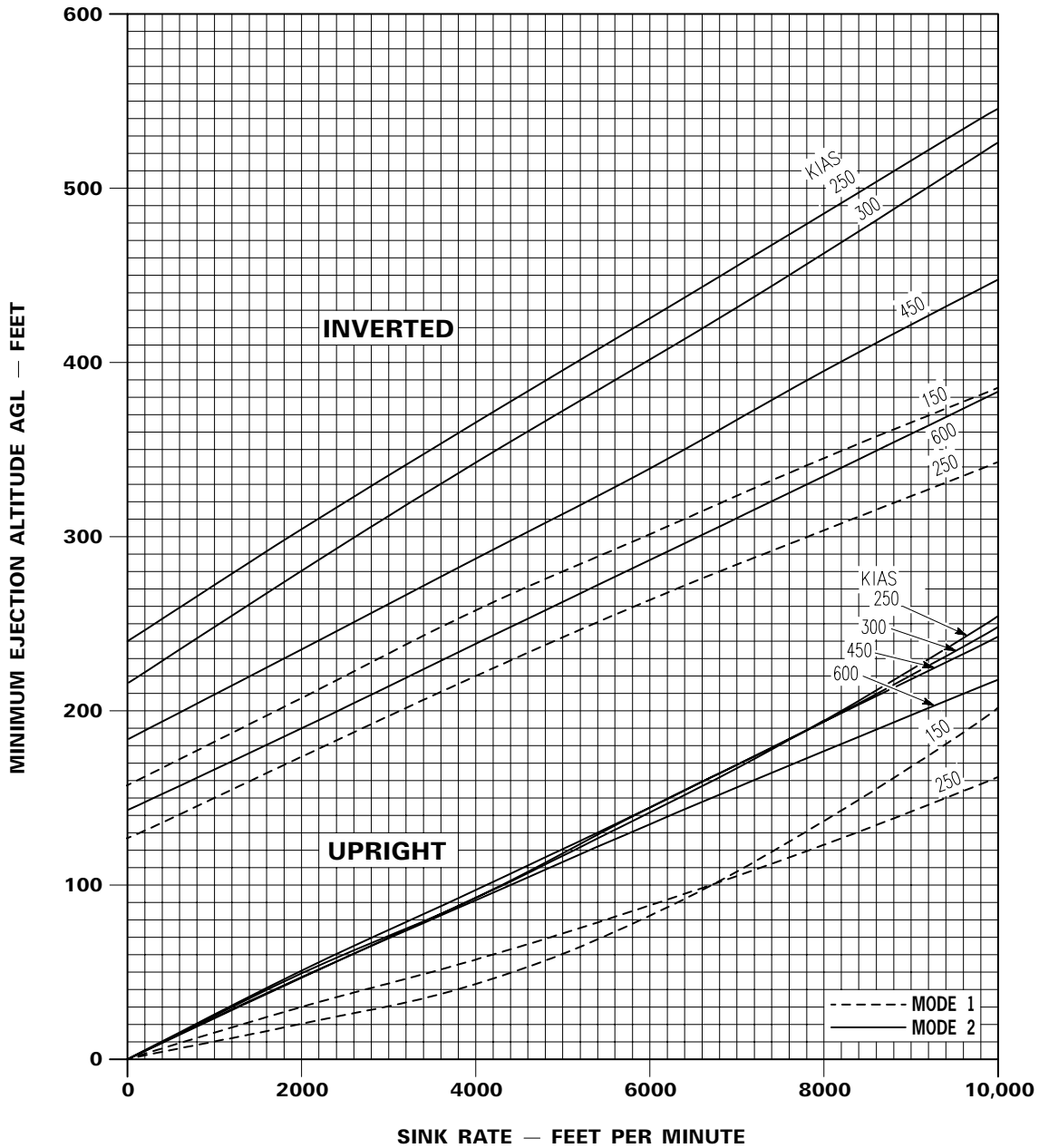

1F-16X-1-2003X ©

Figure 1-68. (Sheet 2)

# Ejection Seat Performance C

## MINIMUM EJECTION ALTITUDE vs SPEED, DIVE ANGLE, AND BANK ANGLE

- NOTES:
- ZERO PILOT REACTION TIME
  - SEA LEVEL
  - 95th PERCENTILE PILOT

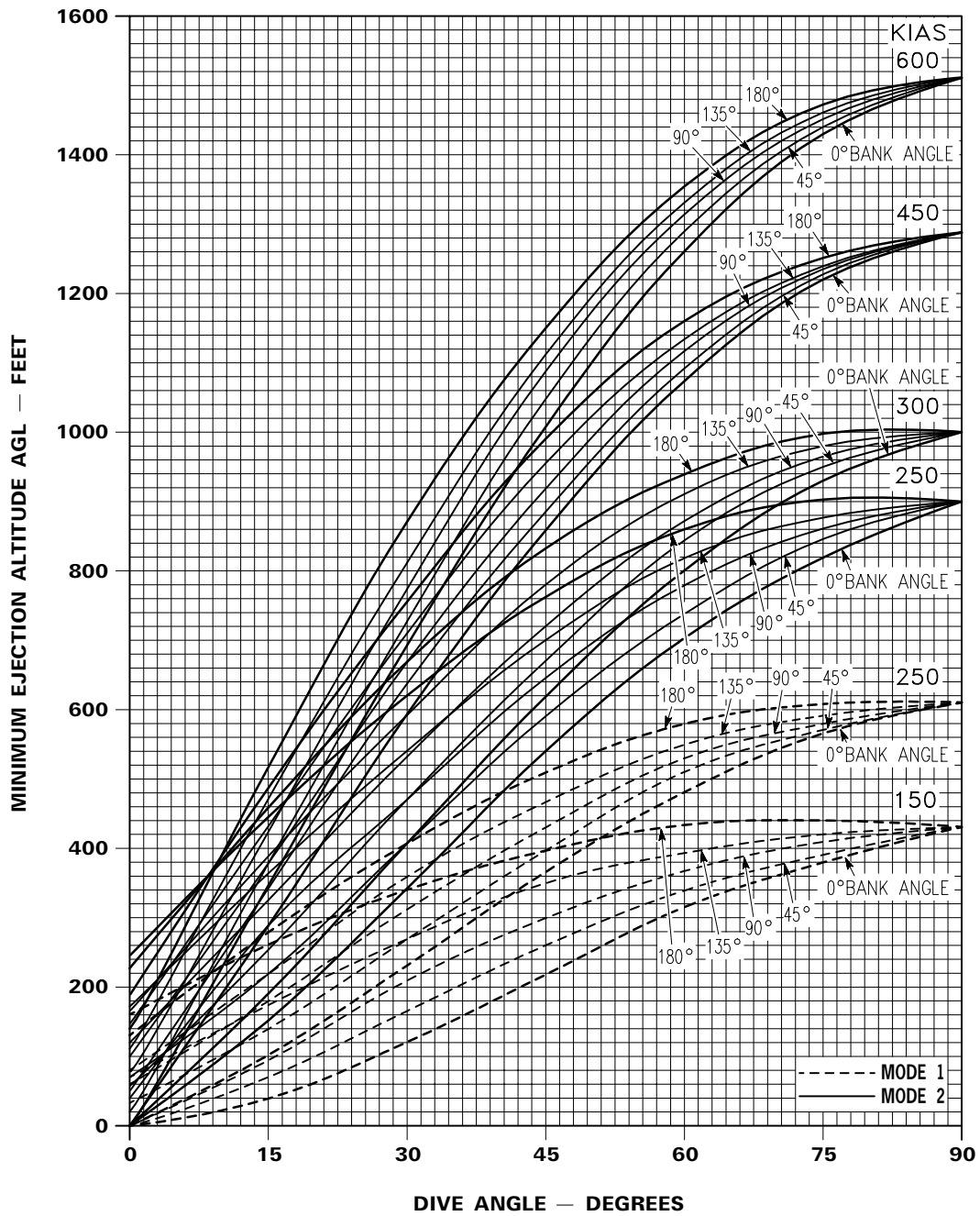

1F-16X-1-2004X ©

Figure 1-68. (Sheet 3)

# Ejection Seat Performance D

## MINIMUM EJECTION ALTITUDE vs DIVE ANGLE AND SPEED

**NOTES:**

- ZERO PILOT REACTION TIME
- WINGS LEVEL
- SEA LEVEL
- FORWARD SEAT DURING DUAL, SEQUENCED EJECTION
- 95th PERCENTILE PILOT

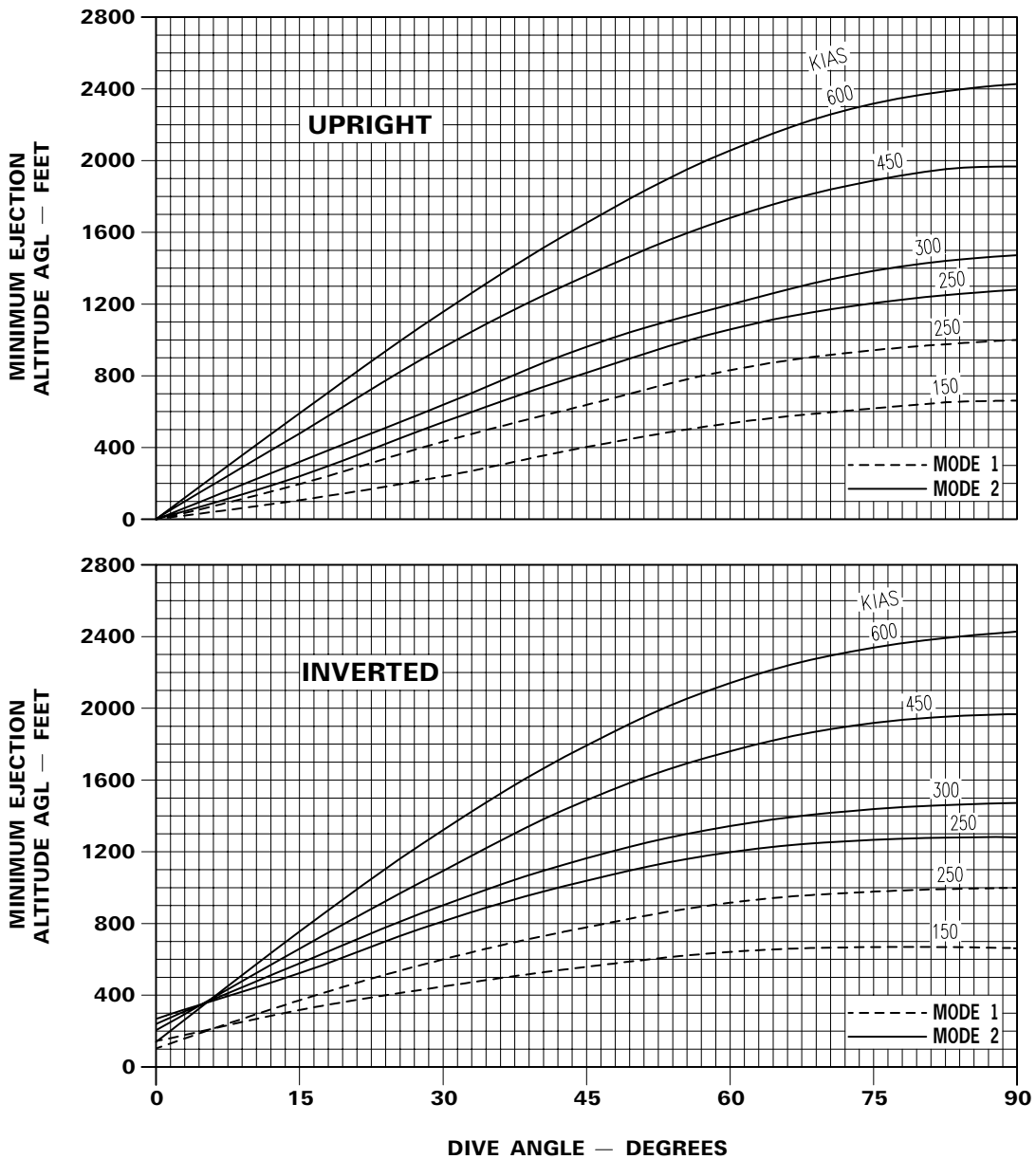

1F-16X-1-2005X ©

Figure 1-68. (Sheet 4)

# Ejection Seat Performance D

## MINIMUM EJECTION ALTITUDE vs SINK RATE AND SPEED

**NOTES:**

- ZERO PILOT REACTION TIME
- WINGS LEVEL
- SEA LEVEL
- FORWARD SEAT DURING DUAL, SEQUENCED EJECTION
- 95th PERCENTILE PILOT

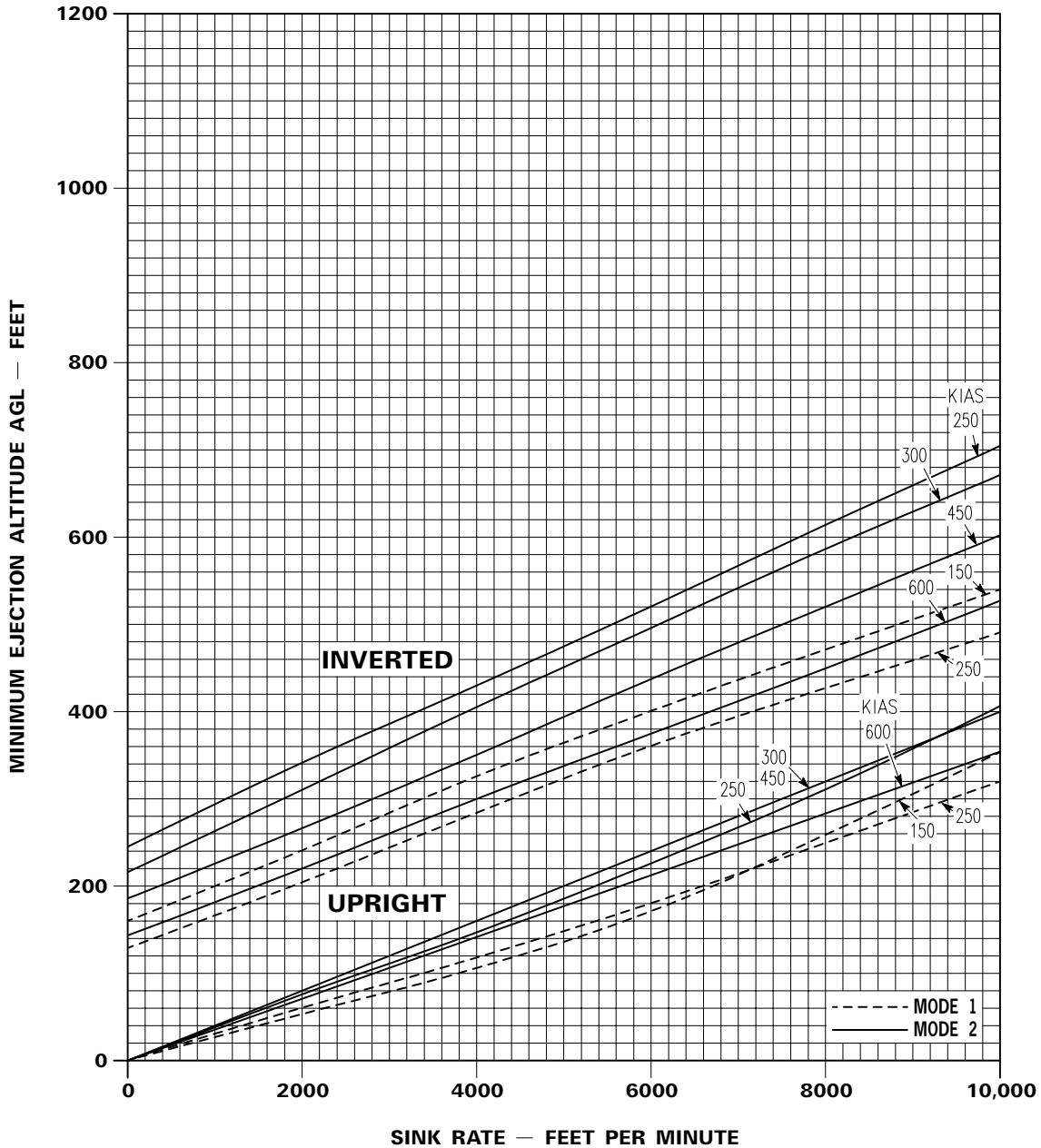

1F-16X-1-2006X ©

Figure 1-68. (Sheet 5)



# Ejection Seat Performance D

## MINIMUM EJECTION ALTITUDE vs SPEED, DIVE ANGLE, AND BANK ANGLE

**NOTES:**

- ZERO PILOT REACTION TIME
- SEA LEVEL
- FORWARD SEAT DURING DUAL, SEQUENCED EJECTION
- 95th PERCENTILE PILOT

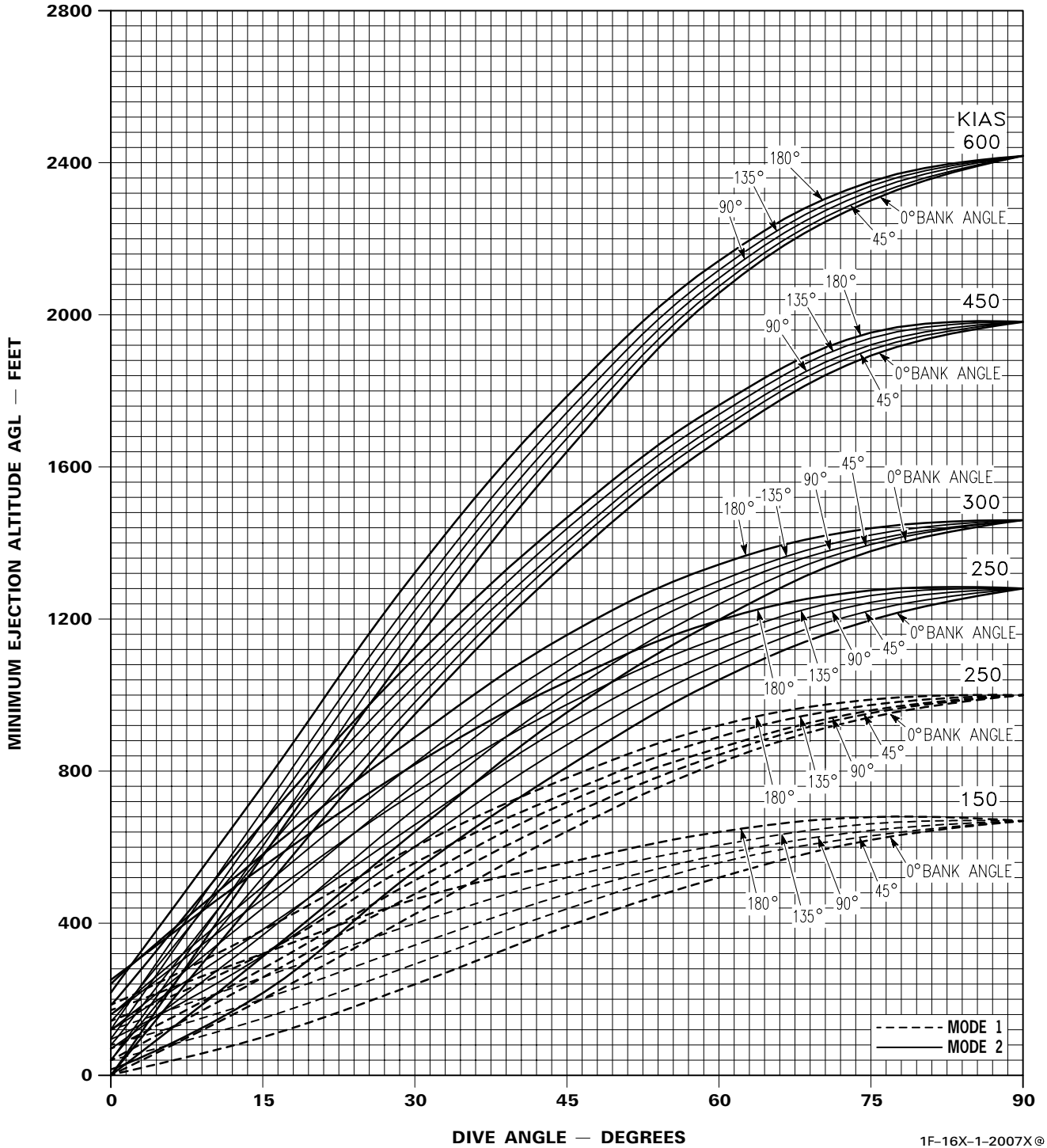

1F-16X-1-2007X®

Figure 1-68. (Sheet 6)

## OXYGEN SYSTEM **PX III**

The oxygen system consists of an onboard oxygen generating system (OBOGS), a backup oxygen supply (BOS), and a regulated 50 cubic inch emergency oxygen supply (EOS) bottle.

### **ONBOARD OXYGEN GENERATING SYSTEM (OBOGS)**

The OBOGS is a molecular sieve/concentrator that uses an adsorption filtering process to remove nitrogen from the ECS supplied bleed air and provide oxygen rich breathing gas. The system is capable of producing 95 percent oxygen with the balance being argon and other inert gases. For normal operation the concentrator provides oxygen to a compatible diluter demand breathing regulator. The system pressure to the regulator can be read on a pressure gage located on the face of the regulator. The normal operating pressure range is 25-40 psi.

### **OBOGS BACKUP OXYGEN SUPPLY (BOS)**

If the OBOGS is not producing oxygen due to loss of ECS input air to the concentrator, concentrator failure, or loss of power to the concentrator, the system will revert to stored oxygen in the sieve filled plenum, called the backup oxygen supply (BOS). The BOS will last for a period of 3 to 5 minutes depending on altitude and breathing rate. Resupplying a depleted BOS requires up to 10 minutes. After the BOS has been expended and system pressure falls below 5 psi, the OXY LOW warning light, located on the right glare shield, illuminates.

### **OBOGS MONITOR**

The OBOGS is monitored by an oxygen monitor with built-in-test (BIT) circuitry. The oxygen monitor samples oxygen for the correct oxygen concentration at a particular altitude from 10,000 to 50,000 feet. The OBOGS monitor provides a signal to turn on the OXY LOW warning light if the partial pressure of oxygen (PPO<sub>2</sub>) from the concentrator drops below a preset alarm range or if BIT detects an internal monitor fault. The monitor provides low oxygen partial pressure warning at either of two thresholds based on the position of the diluter lever located on the regulator. Low PPO<sub>2</sub> can be caused by a concentrator malfunction or a clogged input filter on the concentrator.

### **EMERGENCY OXYGEN SUPPLY (EOS)**

The emergency oxygen supply (EOS) consists of a high-pressure bottle mounted on the left side of the ejection seat. The EOS is a regulated oxygen supply that will last for 8 to 12 minutes depending on altitude and breathing rate. The hose is routed to the right side of the seat. The system is activated:

- Automatically upon ejection.
- Manually by pulling the emergency oxygen green ring located on the left aft side of the seat.

A gauge on the EOS indicates the stored oxygen pressure.

### **OBOGS BUILT-IN-TESTS (BIT's)**

The OBOGS monitor has four BIT programs: power-up BIT, periodic BIT, manual BIT, and pneumatic BIT. All BIT programs are for testing the monitor's circuitry only.

#### **OBOGS Power-Up BIT**

Power-up BIT is performed automatically upon power-up during engine start. The power-up BIT includes a two minute warmup period during which the OXY LOW warning light is inhibited. The OXY LOW warning light illuminates at the end of the power-up BIT if a monitor failure is detected.

#### **OBOGS Periodic BIT**

Periodic BIT is performed automatically during normal operations. If a monitor fault is detected, the OXY LOW warning light will illuminate.

#### **OBOGS Manual BIT**

Manual BIT is activated by momentarily positioning the OBOGS BIT switch, located on the TEST panel, to BIT. This can be accomplished to perform a monitor check or to determine the cause of an OXY LOW warning light.

Selecting BIT causes the OXY LOW warning light to illuminate for ten seconds. If no faults are detected, the warning light will go off. If a monitor fault is detected, the OXY LOW warning light will remain on with a continuous indication as long as the fault condition exists.

If the OBOGS BIT switch is positioned to BIT while the OXY LOW warning light is on, the warning light will remain on steady if the problem is due to a low PPO<sub>2</sub> condition or low regulator pressure. It will flash one second on and one second off if a monitor fault was detected. If a monitor fault exists, subsequent positioning of the OBOGS BIT switch to BIT will toggle the warning light from flashing to continuous.

**OBOGS Pneumatic BIT**

Pneumatic bit is a maintenance function.

**PRESSURE BREATHING FOR G (PBG)**

The PBG mode of the oxygen regulator provides pressure breathing above 4g's to enhance g tolerance

and reduce fatigue. Air pressure from the anti-g valve is used by the oxygen regulator to control the amount of pressurization supplied to the oxygen mask, helmet, and vest. A malfunction in the OBOGS system can result in a degradation in PBG system performance.

**OXYGEN SYSTEM CONTROLS AND INDICATORS**

Refer to figure 1-69 for a description of the oxygen system controls and indicators.

**OXYGEN SYSTEM SCHEMATIC**

Refer to figure 1-70.

**Oxygen System Controls and Indicators (Typical) PX III**

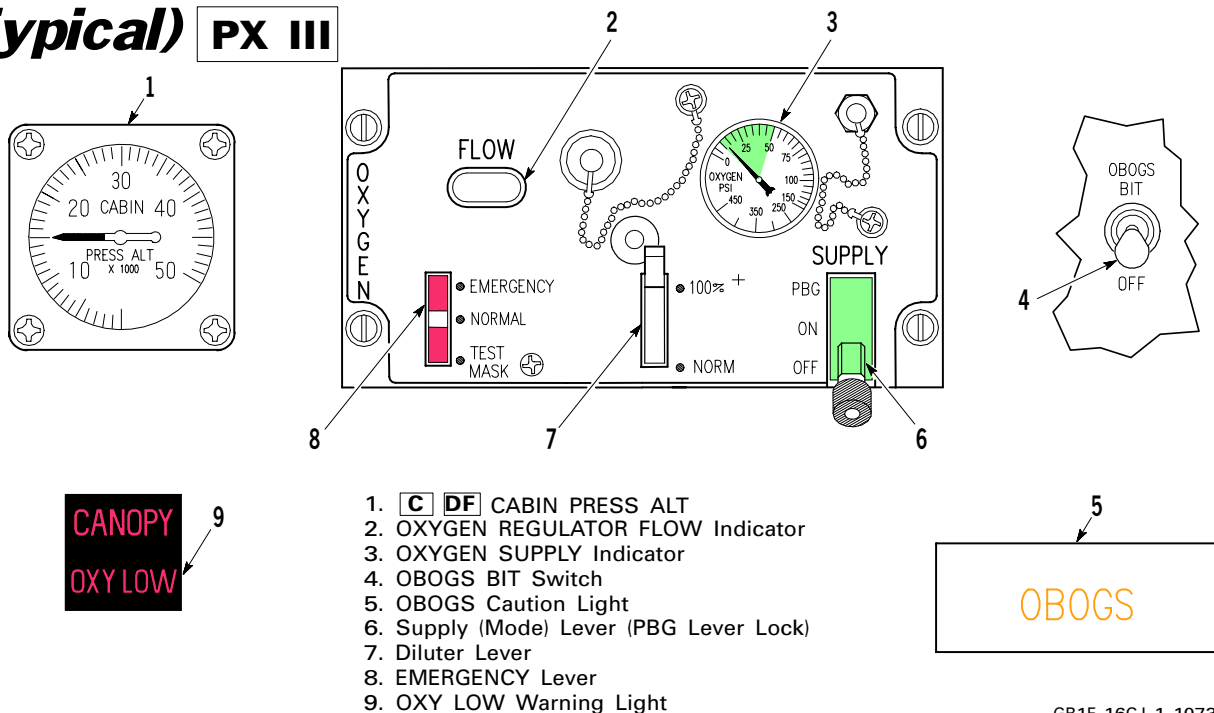

1. **C DF** CABIN PRESS ALT
2. OXYGEN REGULATOR FLOW Indicator
3. OXYGEN SUPPLY Indicator
4. OBOGS BIT Switch
5. OBOGS Caution Light
6. Supply (Mode) Lever (PBG Lever Lock)
7. Diluter Lever
8. EMERGENCY Lever
9. OXY LOW Warning Light

Figure 1-69. (Sheet 1)

# Oxygen System Controls and Indicators

## PX III (Typical)

CONTROL/INDICATOR	POSITION/INDICATION	FUNCTION
1. <input checked="" type="checkbox"/> <input checked="" type="checkbox"/> CABIN PRESS ALT	0-50,000 feet	Indicates cockpit altitude
2. OXYGEN Regulator FLOW Indicator	White	Indicates oxygen flow
	Black	Indicates no oxygen flow
3. OXYGEN SUPPLY Indicator	Oxygen pressure (psi)	Indicates gaseous oxygen pressure at regulator in psi
4. OBOGS BIT Switch	BIT	Initiates OBOGS manual BIT
5. OBOGS Caution Light (amber)	On	Indicates that ECS air pressure has dropped below 10 psi
6. SUPPLY (Mode) Lever	PBG (lever lock)	Provides oxygen supply to mask, helmet bladder, and vest. Pressure breathing as a function of g is available
	ON	Provides oxygen supply to mask, helmet bladder, and vest. Pressure breathing as a function of g is not available
	OFF	Turns off oxygen supply
7. Diluter Lever	NORM	Provides regulated mixture of cockpit air and oxygen as determined by cockpit altitude
	100%	Provides maximum amount of oxygen
8. EMERGENCY Lever	NORM	Provides normal operation. Positive pressure is provided if cockpit altitude exceeds 28,000-32,000 feet
	EMERGENCY	Provides maximum amount of oxygen under positive pressure. This position is used by the pilot to test for leaks
	TEST MASK	Provides maximum amount of oxygen under positive pressure. This position is used for testing by life support maintenance
9. OXY LOW Warning Light (red)	On	Indicates that partial pressure of oxygen (PPO <sub>2</sub> ) is low, the presence of a BIT detected monitor fault, or that regulator pressure has dropped below 5 psi

Figure 1-69. (Sheet 2)

# Oxygen System Schematic (Typical) PX III

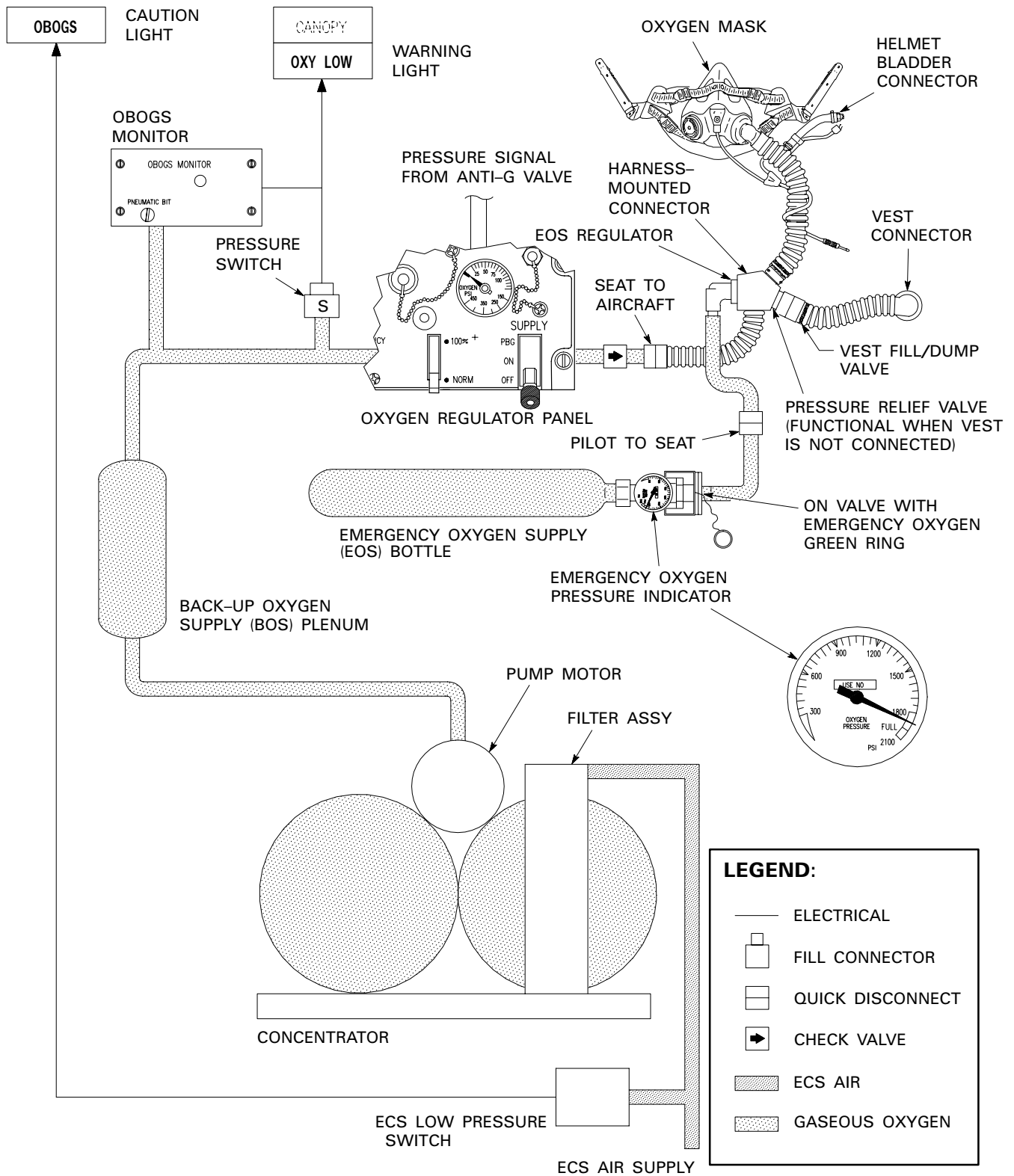

GR1F-16CJ-1-1074X37 ©

Figure 1-70.

## OXYGEN SYSTEM PX II

The oxygen system consists of a liquid system and an emergency gaseous system.

### LIQUID OXYGEN SYSTEM

A 5-liter liquid oxygen system provides breathing oxygen to a diluter demand oxygen regulator. The regulator provides for selection of normal diluted oxygen and 100 percent oxygen and selection of PBG. Quick-disconnects are used to expedite egressing the aircraft on the ground. Oxygen duration varies depending upon altitude, regulator settings, and usage.

### Pressure Breathing for G (PBG)

The PBG mode of the oxygen regulator provides pressure breathing above 4g's to enhance g tolerance and reduce pilot fatigue. ECS air used to inflate the g-suit is also used by the oxygen regulator to control the amount of pressurization supplied to the oxygen mask, helmet, and vest.

### Oxygen System Controls and Indicators

Refer to figure 1-71 for description of the oxygen system controls and indicators.

### Oxygen Duration

Refer to figure 1-72.

### EMERGENCY OXYGEN SYSTEM

The emergency oxygen system consists of a high-pressure bottle with a flow controller mounted on the left side of the ejection seat. The hose is routed to the right side of the seat. The system is activated:

- Automatically upon ejection.
- Manually by pulling the emergency oxygen green ring located on the left aft side of the seat.

### OXYGEN SYSTEM SCHEMATIC

Refer to figure 1-73.

## Oxygen System Controls and Indicators (Typical) PX II

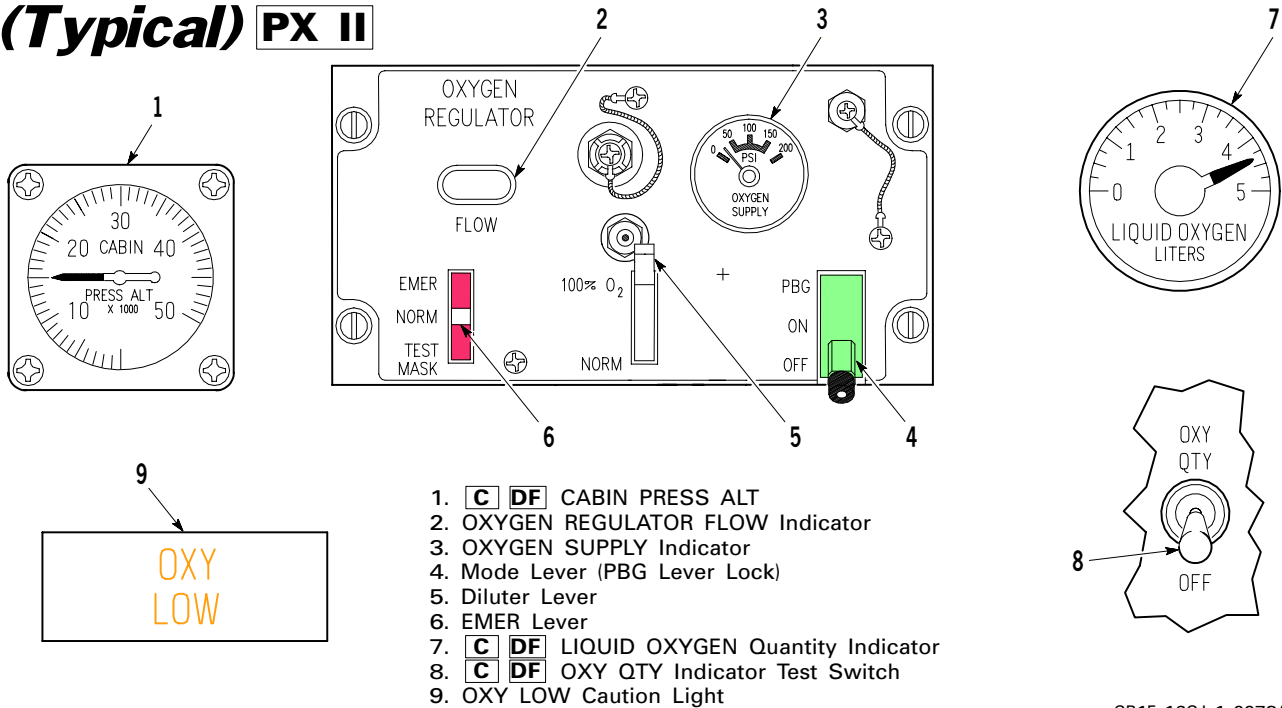

GR1F-16CJ-1-0073A37 ©

Figure 1-71. (Sheet 1)

# Oxygen System Controls and Indicators

## (Typical) PX II

CONTROL/INDICATOR	POSITION/INDICATION	FUNCTION
1. <input type="checkbox"/> <input checked="" type="checkbox"/> CABIN PRESS ALT	0-50,000 feet	Indicates cockpit pressure altitude
2. OXYGEN REGULATOR FLOW Indicator	White	Indicates oxygen flow
	Black	Indicates no oxygen flow
3. OXYGEN SUPPLY Indicator	Oxygen pressure (psi)	Indicates gaseous oxygen pressure at regulator in psi
4. Mode Lever	PBG (lever lock)	Provides oxygen supply to mask, helmet bladder, and vest. Pressure breathing as a function of g is available
	ON	Provides oxygen supply to mask, helmet bladder, and vest. Pressure breathing as a function of g is not available
	OFF	Turns off oxygen supply
5. Diluter Lever	NORM	Provides regulated mixture of cockpit air and oxygen as determined by cockpit pressure altitude
	100% O <sub>2</sub>	Provides regulated 100 percent oxygen
6. EMER Lever	NORM	Provides normal operation. Positive pressure is provided if cabin pressure altitude exceeds 28,000-32,000 feet
	EMER	Provides 100 percent oxygen under positive pressure. This position is used by the pilot to test for leaks
	TEST MASK	Provides 100 percent oxygen under positive pressure. This position is used for testing by life support maintenance

Figure 1-71. (Sheet 2)

# Oxygen System Controls and Indicators (Typical) **PX II**

CONTROL/INDICATOR	POSITION/INDICATION	FUNCTION
7. <b>C</b> <b>DF</b> LIQUID OXYGEN Quantity Indicator	0-5 liters	Indicates quantity of liquid oxygen
8. <b>C</b> <b>DF</b> OXY QTY Indicator Test Switch	OXY QTY	Drives pointer ccw toward 0. As pointer passes 0.5 liter, OXY LOW caution light comes on. Light goes off after the switch is released and the pointer passes 0.5 liter
9. OXY LOW Caution Light (amber)	On	Indicates oxygen quantity is less than 0.5 liter or system pressure below 42 psi

Figure 1-71. (Sheet 3)



# Oxygen Duration **PX II**

OXYGEN DURATION (HOURS)						
COCKPIT PRESSURE ALTITUDE (FEET)	DILUTER LEVER (POSITION)	INDICATED QUANTITY (LITERS)				
		5	4	3	2	1
<b>35,000 AND UP</b>	100%	30.94	24.75	18.56	12.37	6.19
	NORM	30.94	24.75	18.56	12.37	6.19
<b>30,000</b>	100%	22.63	18.11	13.58	9.05	4.53
	NORM	23.00	18.40	13.80	9.20	4.60
<b>25,000</b>	100%	17.48	13.98	10.49	6.99	3.50
	NORM	21.72	17.37	13.03	8.69	4.34
<b>20,000</b>	100%	13.19	10.55	7.91	5.28	2.64
	NORM	24.43	19.55	14.66	9.77	4.89
<b>15,000</b>	100%	10.62	8.49	6.37	4.25	2.12
	NORM	29.86	23.89	17.92	11.94	5.97
<b>10,000</b>	100%	8.53	6.83	5.12	3.41	1.71
	NORM	29.86	23.89	17.92	11.94	5.97

**NOTES:**

1. Oxygen duration increases as cockpit pressure altitude increases because there is less ambient pressure acting upon the lungs. Therefore, a smaller quantity of oxygen at altitude expands the lungs to the same size that they were at sea level.
2. With two people, decrease NORM/100% oxygen duration by 50 percent.
3. Use of PBG may reduce the listed available oxygen times.

*Figure 1-72.*

# Oxygen System Schematic (Typical) PX II

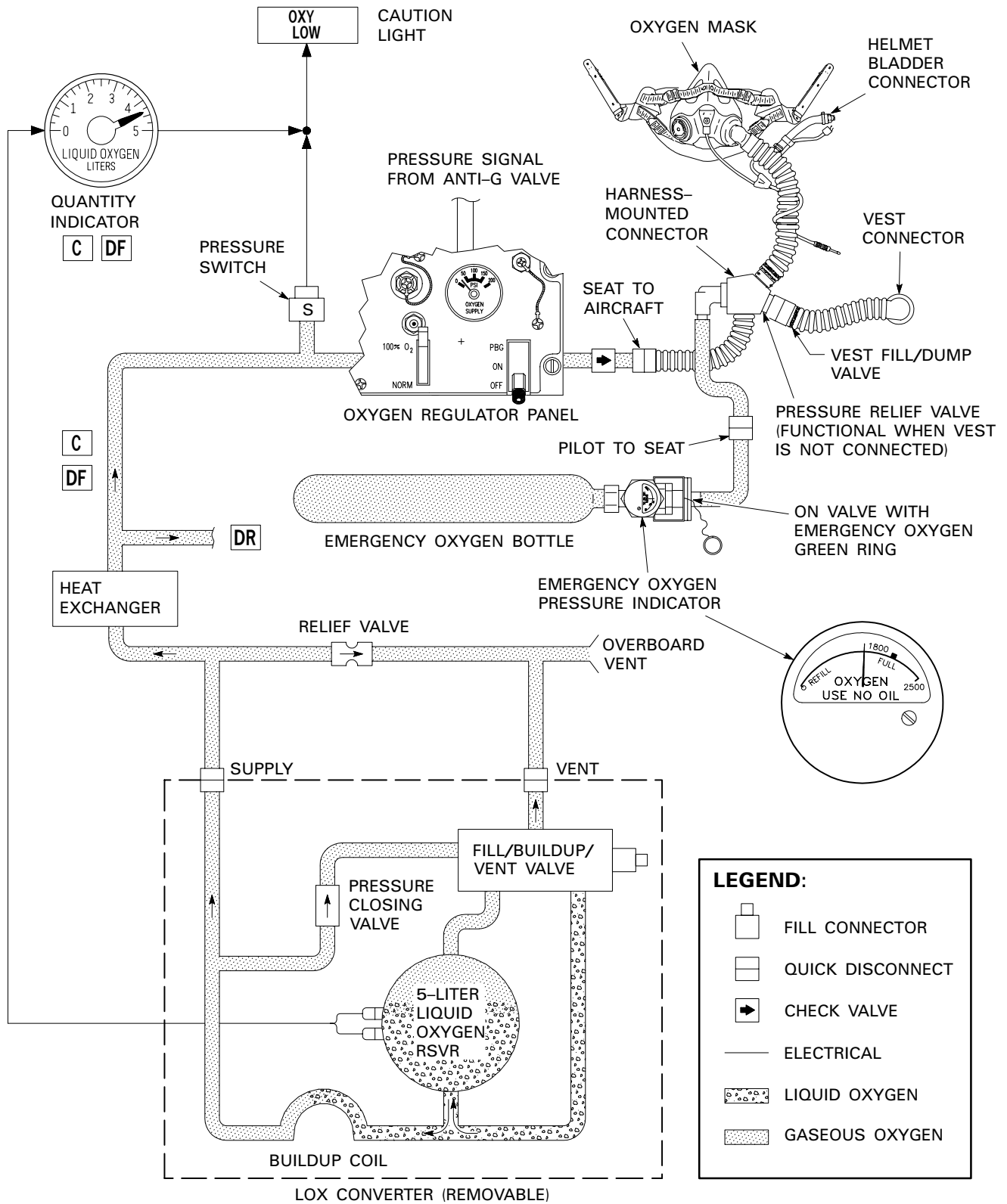

GR1F-16CJ-1-0074A37 ©

Figure 1-73.

# COMMUNICATIONS, NAVIGATION, AND IFF (CNI) EQUIPMENT

Cockpit controls for CNI equipment are divided between control units on the consoles and the upfront controls located on the instrument panel. Controls for less frequently used functions, such as power and audio volume, and essential functions, such as communications backup and guard, are located on console panels. Controls for frequently used functions of CNI are located on the upfront controls to permit head-up control during flight.

## UPFRONT CONTROLS

Refer to figure 1-74. The upfront controls provide a simplified, centralized, head-up means of controlling the most frequently used functions of the communications system, navigation systems, and IFF. The upfront control set consists of the data entry display (DED), [C] [DF] the integrated control panel (ICP), and

[DR] the integrated keyboard panel (IKP). The upfront controls are powered by emergency dc bus No.2 and emergency ac bus No. 2. Refer to F-16D AIRCRAFT, this section, for supplementary [D] information.

## DED/CNI READOUTS

Refer to figure 1-74, 1-75, and 1-76. The DED is an integral part of the upfront controls and provides a visual display of the switch actions made via upfront controls. The primary readouts of communication, navigation, and IFF systems are included in the page selections available for display on the DED. Channel, frequency, mode, and code selections of UHF, VHF, TACAN, ILS and IFF are presented when the appropriate page is selected. Present position and steerpoint data may be selected for display on the DED.

Displays for UHF, TACAN, and IFF show the word BACKUP when the [PX II] CNI, [PX III] C & I knob is in BACKUP. The word GUARD appears on UHF and VHF pages when guard is selected.

## Upfront Controls (Typical)

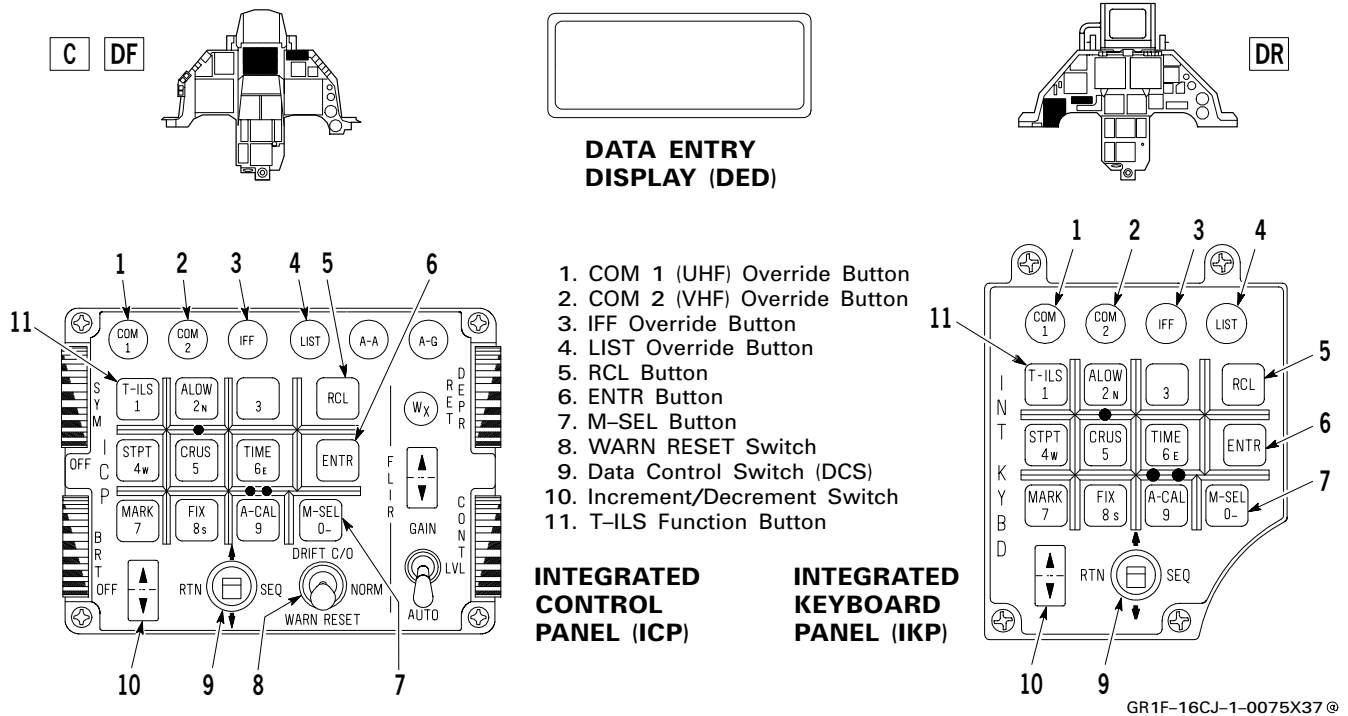
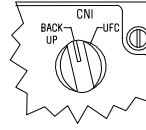
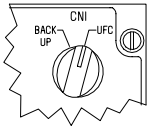

Figure 1-74.

# CNI Readout/DED Page Summary PX II



Normal Display Pages (Upfront Control)

Backup or Guard Pages (Typical)

UHF ↕10	STPT 5
VHF 12	10 : 32 : 47
M1 34CS 4567	STBY T123X

DISPLAYED ON INITIAL POWER-UP

UHF	STPT ↕ 5
BUP	
VHF 12	10 : 32 : 47
GRD	
M	BUP

CNI PAGE

UHF	MAIN
10	235.00
PRE 10 ↕	TOD
226.00	NB



UHF ON
BACKUP
10 235.00

UHF PAGE

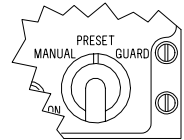

All 3 Positions Function

HQ-TNG	TNET
002	12
PRE 12 ↕	TOD
123	



HAVE QUICK PAGE

VHF ON
12
PRE 12 ↕
126.00
135.00
NB



VHF ON
AM
GUARD

VHF PAGE

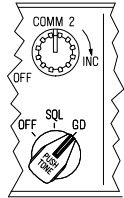

TCN T/R	ILS ON
CHAN 24	CMD STRG
BAND X (0)	FRO 106.10
CRS 10°	



TCN ON	ILS ON
BACKUP	CMD STRG
FRO	106.10
CRS	205°

TCN/ILS PAGE

IFF ON	MAN
M1 25	MC (5)
M2 1432	M4 A(6)
M3 2365	OUT (7) MS (8)



IFF ON
BACKUP

MAN PAGE

ALL IFF MODES

IFF ON	AUTO	POS 1 ↕
M1	MC (5)	
M2	M4	NOF04
M3		MS (8)



POS PAGE

IFF ON	AUTO	TIM 2 ↕
M1 21	MC (5)	
M2	M4 A(6)	01:36
M3 1234		MS

TIM PAGE

GR1F-16CJ-1-0076A37 ©

Figure 1-75.

# CNI Readout/DED Page Summary PX III

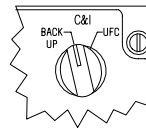
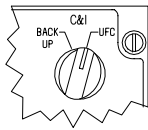

Normal Display Pages (Upfront Control)

Backup or Guard Pages (Typical)

UHF ↕ 10	STPT 5
VHF 12	10 : 32 : 47
M1 34CS 4567	STBY T123X

DISPLAYED ON INITIAL POWER-UP

UHF	STPT ↕ 5
BUP	
VHF 12	10 : 32 : 47
GRD	
M	BUP

CNI PAGE

UHF	BOTH
10	
PRE 10 ↕	235.00
226.00	TOD
	NB



UHF ON
BACKUP
10 235.00

UHF PAGE

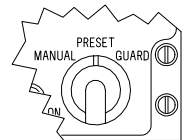

All 3 Positions Function

HQ-TNG	BOTH
002 TNET	
PRE 11 ↕	12
003	TOD



HAVE QUICK PAGE

VHF ON	
12	
PRE 12 ↕	135.00
126.00	NB



VHF ON
AM GUARD

VHF PAGE

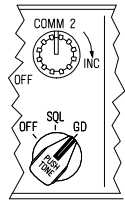

TCN T/R	ILS ON
CHAN 24	CMD STRG
BAND X (0)	FRO 106.10
CRS 10°	



TCN ON	ILS ON
BACKUP	CMD STRG
FRO	106.10
CRS	205°

TCN/ILS PAGE

IFF ON	MAN
M1 25	M4 A(6)
M2 1432	MC (5)
M3 2365	AUD (7) MS (8)



IFF ON
BACKUP

MAN PAGE

ALL IFF MODES

IFF ON	AUTO	POS 1 ↕
M1	M4	NOF04
M2	MC (5)	MS (8)
M3		

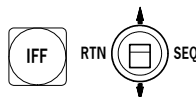

POS PAGE

IFF ON	AUTO	TIM 4 ↕
M1 21	M4 B(6)	01:36
M2	MC	MS
M3 1234		

TIM PAGE

Figure 1-76.

The current state of CNI operation is shown on the DED and is automatically displayed on initial power up of the upfront controls or may be selected by positioning the data control switch (DCS) to RTN momentarily.

### CNI Readout/DED Page Summary

The CNI page displays data concerning the UHF (COM 1), VHF (COM 2), steerpoints, IFF, system time, and TACAN. The CNI page displays its data on five lines.

The first line displays information concerning the UHF radio mode, preset channel or manual frequency, and current steerpoint number. The label at the far left indicates the radio mode (either UHF or HQ). UHF is displayed when the normal mode is selected; HQ is displayed when the AJ mode is selected. The UHF/HQ label is highlighted when the UHF VHF IFF transmit switch is keyed to UHF. Adjacent to the mode label is the preset UHF channel, if one is selected. If a preset channel is not selected, this area contains the manual frequency. The right side of the first line displays navigation information. If a steerpoint is selected, STPT is displayed. If an initial point is selected, IP is displayed. Adjacent to the steerpoint label is the number of the current steerpoint. Line one displays UHF (normal mode), the selected preset UHF channel (10), and the selected steerpoint (STPT 5).

The left side of the second line displays the status of the UHF radio and default value indication. During normal operation, this area is blank. OFF, BUP, and GRD are other indications of UHF radio status. OFF is displayed when the power is turned off with the COMM 1 power knob. When BACKUP or GUARD is selected, BUP or GRD is displayed. The middle area of line two is blank during normal operation. If the upfront controls memory is lost, the upfront controls revert to default values and DFLT is displayed in the middle of line two. DFLT is displayed if UFC memory is lost and the UFC automatically uses default values. The right side of the second line can display wind direction and velocity. When the SEQ position of the DCS is activated, wind direction (referenced to magnetic north) and velocity, in knots, is displayed. When the SEQ position of the DCS is again activated, wind data is blanked. If wind data is displayed when the CNI page is exited, wind data is displayed when the CNI page is reentered. Wind data is not displayed upon UFC power-up.

The third line displays VHF (COM 2) function, preset channel or manual frequency, and system time. The left side of line three always displays the radio mode label VHF. When the UHF VHF IFF transmit switch is keyed to VHF, the VHF label is

highlighted. Adjacent to the VHF label is the active preset channel or manual frequency number. The right side of line three shows VHF, active preset VHF channel (12), and system time.

The fourth line displays the status of the VHF radio. A blank area indicates normal operation. OFF indicates that the power is off, and GRD indicates that GUARD has been selected. The CNI readout/DED page summary displays blank for normal operation. The right side of the fourth line also displays hack time anytime the stopwatch is activated.

The fifth line displays IFF and TACAN information. The area at the far left displays IFF modes selected. M, which stands for mode, is always displayed; 1, 2, 3/A, 4, C, and S are displayed when the corresponding mode is selected. When a mode 4 reply is issued, the 4 is highlighted. The next area of line five displays the four-digit code associated with IFF mode 3/A. The next area displays IFF status. During normal operation, this area is blank. OFF, STBY, BUP, and AUTO are other indications of IFF status. OFF is displayed when the power is turned off with the IFF MASTER knob. When STANDBY or BACKUP is selected, STBY or BUP is displayed. AUTO is displayed when the automatic transponder switching function of IFF is selected. The right side displays TACAN channel number and band. TACAN channel number and band are not displayed when TACAN radio is off or in backup. The CNI readout/DED page summary displays IFF modes 1, 3/A, 4, C, and S selected, 4567 (mode 3/A code), AUTO (automatic transponder switching function), T123 (TACAN channel number), and X (TACAN band).

To change preset channels or steerpoint numbers, the up/down triangles must be next to the item to be changed. When the DCS is positioned up or down, the up/down triangles move between the steerpoint and the UHF and VHF preset channels. With the up/down triangles next to the desired item, the steerpoint/channel can be changed by depressing the increment/decrement switch until the desired steerpoint or channel is selected. If a manual frequency is selected, the triangles are displayed but are not functional. The up/down triangles are displayed at the steerpoint number during initial upfront control power-up. UHF, VHF, IFF, TACAN, and ILS detailed operation using the upfront controls is described under their respective system.

### IFF CONTROL PANEL

Refer to figure 1-77. The IFF control panel, located on the left console, provides backup control of essential CNI functions and some primary functions of IFF.

# IFF Control Panel

**C DF (Typical)**

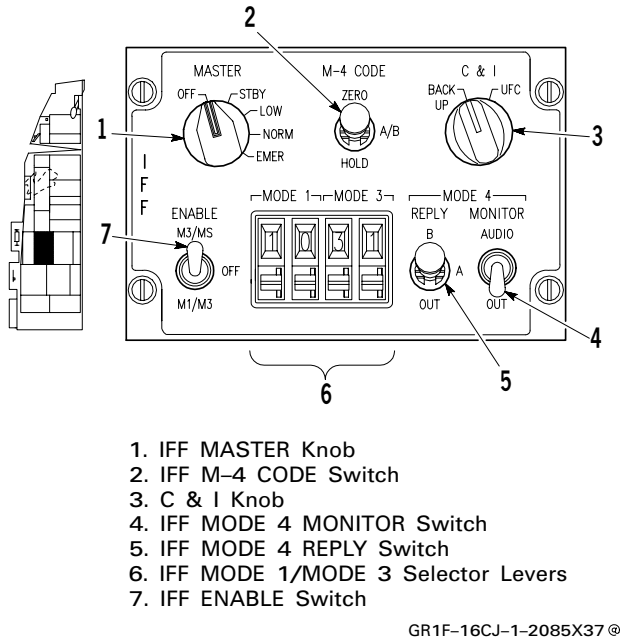

1. IFF MASTER Knob
2. IFF M-4 CODE Switch
3. C & I Knob
4. IFF MODE 4 MONITOR Switch
5. IFF MODE 4 REPLY Switch
6. IFF MODE 1/MODE 3 Selector Levers
7. IFF ENABLE Switch

GR1F-16CJ-1-2085X37 ©

Figure 1-77.

## C & I (Communications and IFF) Knob

Functions are:

- **BACKUP** – In the event of failure of the upfront controls, the BACKUP position provides for alternate operation of the UHF and IFF. BACKUP may be selected, when desired, even when upfront controls are functioning.
- **UFC** – Provides for normal control of communications, navigation, and IFF primarily via upfront controls. Refer to UPFRONT CONTROLS, this section.

## IFF MASTER Knob

The IFF MASTER knob functions with the C & I knob in BACKUP or UFC.

Functions are:

- **OFF** – Removes power from the IFF equipment and zeroizes mode 4 settings unless HOLD function has been used. The knob must be lifted to position to or from OFF.
- **STBY** – The equipment is turned on and warmed up but does not transmit.

- **LOW** – Same as NORM.
- **NORM** – Full range recognition and reply occur.
- **EMER** – The knob must be lifted to position to EMER. When so positioned, an emergency-indicating pulse group is transmitted each time a mode 1, 2, or 3/A interrogation is recognized. IFF replies to mode S interrogations with an alert consideration.

## IFF M-4 CODE Switch

The IFF M-4 CODE switch has three positions. It is spring-loaded to center (A/B) from HOLD and is lever locked in ZERO position.

Functions are:

- **ZERO** – Zeroizes mode 4 settings whenever IFF MASTER knob is not OFF.
- **A/B** – A/B position permits code selection via upfront controls or via IFF MODE 4 REPLY switch when C & I knob is in BACKUP.
- **HOLD** – Both code settings can be retained after flight by placing the IFF M-4 CODE switch to HOLD momentarily prior to placing the IFF MASTER knob to OFF or removing power.

## IFF MODE 4 REPLY Switch

The IFF MODE 4 REPLY switch has three positions and is used when the C & I knob is in BACKUP.

Functions are:

- **OUT** – Mode 4 operation is disabled.
- **A** – Enables mode 4 and selects the preset code for A.
- **B** – Enables mode 4 and selects the preset code for B.

## IFF MODE 4 MONITOR Switch

The IFF MODE 4 MONITOR switch permits audio monitor of mode 4 replies when the C & I knob is in BACKUP.

Functions are:

- **AUDIO** – Monitoring of mode 4 interrogations is provided by an audio tone on the intercom. An audio tone of 0 to 1000 Hz is generated when the transponder is not replying to valid mode 4 interrogations. The frequency of the tone depends on the number of interrogations received; i.e., the higher the number of interrogations, the higher the frequency.
- **OUT** – Disables audio monitor from intercom.

## IFF ENABLE Switch

The IFF ENABLE switch permits mode selection in BACKUP.

Functions are:

- M3/MS – Modes 3/A and S enabled in backup.
- OFF – Modes 1, 3/A, 4 and S disabled in backup.
- M1/M3 – Modes 1 and 3/A enabled in backup.

## IFF MODE 1/MODE 3 Selector Levers

The MODE 1 code selector levers are incremented/decremented to select the two-digit code displayed in the readout windows. The two left-most windows display the mode 1 code digits when the C & I knob is in BACKUP.

The Mode 3/A code selector levers are incremented/decremented to select the two-digit code displayed in the readout windows. The two right-most windows display the two most significant mode 3/A backup code digits when the C & I knob is in BACKUP. The two least significant digits are always set to zero. For example, if the windows are set to 77, the transmitted mode 3/A code is 7700.

## AUX COMM PANEL C DF PX II

Refer to figure 1-78. The AUX COMM panel, located on the left console, provides backup control of essential CNI functions and some primary functions of IFF.

### CNI (Communications, Navigation, and IFF) Knob

Functions are:

- BACKUP – In the event of failure of the upfront controls, the BACKUP position provides for alternate operation of the UHF, TACAN, and IFF (mode 4 and EMER functions only). BACKUP may be selected, when desired, even when upfront controls are functioning.
- UFC – Provides for normal control of communications, navigation, and IFF primarily via upfront controls. Refer to UPFRONT CONTROLS, this section.

# AUX COMM Panel

## C DF (Typical)

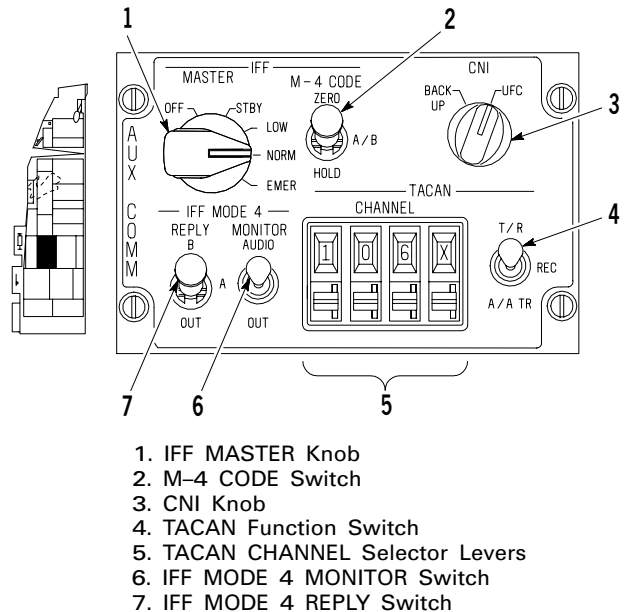

GR1F-16CJ-1-0077X37 ©

Figure 1-78.

### IFF MASTER Knob

The IFF MASTER knob functions with the CNI knob in BACKUP or UFC.

Functions are:

- OFF – Removes power from the IFF equipment and zeroizes mode 4 settings unless HOLD function has been used. The knob must be pulled outward to position to OFF from STBY.
- STBY – The equipment is turned on and warmed up but does not transmit.
- LOW or NORM – Full range recognition and reply occur. Transmitted power from the IFF system is the same for both the LOW and NORM positions.
- EMER – The knob must be pulled outward to position to EMER. When so positioned, an emergency-indicating pulse group is transmitted each time a mode 1, 2, 3/A, or S interrogation is recognized.

### M-4 CODE Switch

The M-4 CODE switch has three positions. It is spring-loaded to center (A/B) from HOLD and is lever locked in ZERO position.



## T.O. GR1F-16CJ-1

Functions are:

- ZERO – Zeroizes mode 4 settings whenever IFF MASTER knob is not OFF.
- A/B – A/B position permits code selection via upfront controls or via mode 4 REPLY switch when in BACKUP.
- HOLD – Both code settings can be retained after flight by placing the M-4 CODE switch to HOLD momentarily prior to placing the IFF MASTER knob to OFF or removing power.

### IFF MODE 4 REPLY Switch

The IFF MODE 4 REPLY switch has three positions and is used when the CNI knob is in BACKUP position.

Functions are:

- OUT – Mode 4 operation is disabled.
- A – Enables mode 4 and selects the preset code for A.
- B – Enables mode 4 and selects the preset code for B.

### IFF MODE 4 MONITOR Switch

The IFF MODE 4 MONITOR switch permits audio monitor of mode 4 replies when in BACKUP.

Functions are:

- AUDIO – Monitoring of mode 4 interrogations and replies is provided by an audio tone on the intercom. An audio tone of 0 to 1000 Hz is generated when the transponder is not replying to valid mode 4 interrogations. The frequency of the tone depends on the number of interrogations received; i.e., the higher the number of interrogations, the higher the frequency.
- OUT – Removes audio monitor from intercom.

### TACAN Function Switch

The TACAN function switch provides control of TACAN functions when the CNI knob is in BACKUP position.

Functions are:

- T/R – Transmit/receive mode. Same as REC and in addition, interrogates the TACAN ground station for DME information; distance (nm) is displayed in the HSI range indicator (MILES).

- REC – Receive mode. The system receives signals which result in a bearing and course deviation display on the HSI and audio in the headset. TACAN range indicator (MILES) on HSI is shuttered.
- A/A TR – Air-to-air transmit-receive mode. TACAN system interrogates and receives signals from aircraft having air-to-air capability, providing slant range (nm) distance between aircraft operating 63 TACAN channels apart. (KC-10A also provides bearing information.) Up to five aircraft can determine distance from a sixth lead aircraft.

### TACAN CHANNEL Selector Levers

Four TACAN CHANNEL selector levers and readout windows are provided for TACAN operation when the CNI knob is in BACKUP. The TACAN channel is set into the first three windows. The fourth window is used to select X or Y band.

### AUDIO 1 CONTROL PANEL

Refer to figure 1-79. The AUDIO 1 control panel provides control of less frequently used functions of the communications system. Except as noted, controls are active regardless of the position of the CNI knob.

### COMM 1 (UHF) Power Knob

The COMM 1 power knob has an OFF position and a cw arrow pointing to INC. The OFF position removes power from the UHF radio. Rotating the knob cw applies power and increases UHF audio volume.

### COMM 1 (UHF) Mode Knob

The COMM 1 mode knob has three positions and may be depressed in any of the three positions. Depressing the knob interrupts reception and transmits a tone signal and TOD for HQ on the selected frequency.

Functions are:

- OFF – Disables squelch circuit to permit reception of a weak signal.
- SQL – Enables squelch circuit to help reduce background noise in a normal operation.
- GD – The main receiver and transmitter are automatically tuned to the guard frequency and the guard receiver is disabled. GD position is not functional with CNI knob in BACKUP.

# Audio Control Panels (Typical)

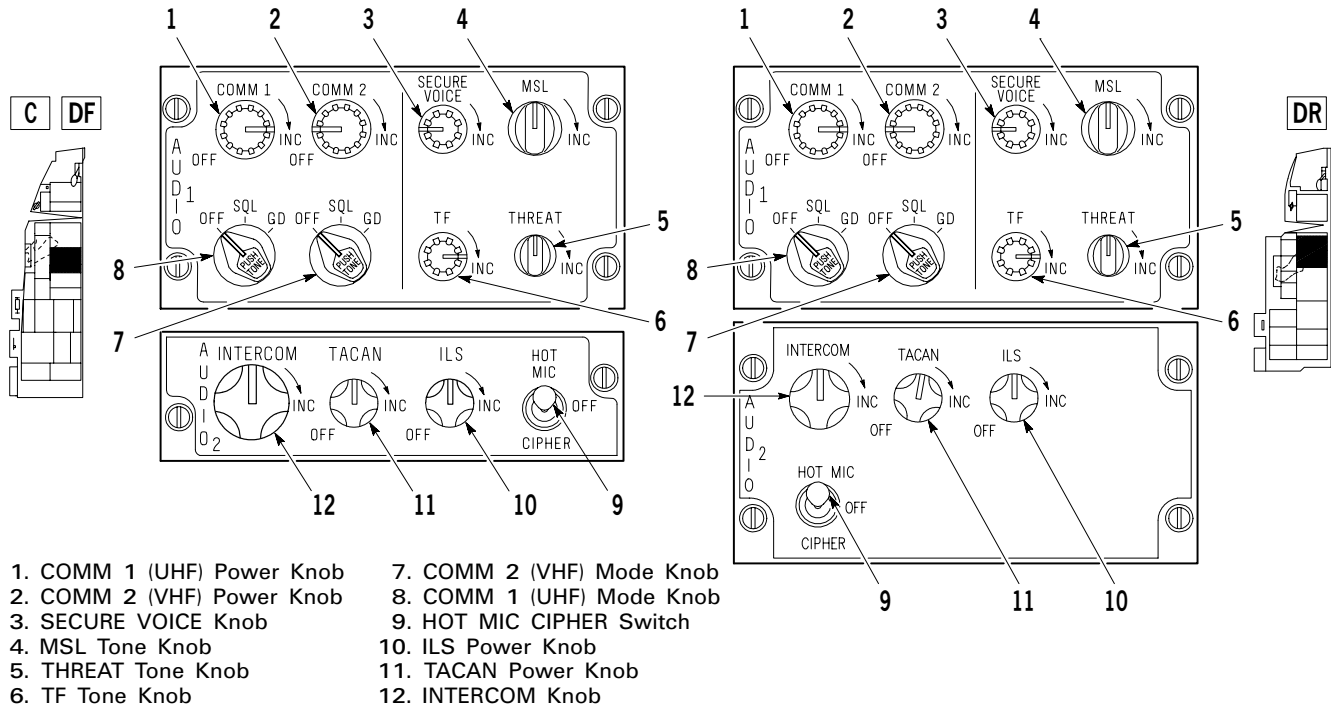

GR1F-16CJ-1-0078X37 ©

Figure 1-79.

## COMM 2 (VHF) Power Knob

The COMM 2 power knob has an OFF position and a cw arrow pointing to INC. The OFF position removes power from the VHF radio. Rotating the knob cw applies power and increases VHF audio volume.

## COMM 2 (VHF) Mode Knob

The COMM 2 mode knob has three positions and may be depressed to transmit a VHF tone in any of the three positions. The COMM 2 mode knob may not function during certain failures of the upfront controls.

Functions are:

- OFF - Disables squelch circuit to permit reception of a weak signal.
- SQL - Enables squelch circuit to help reduce background noise in normal operation.

- GD - The main receiver and transmitter are automatically tuned to the guard frequency.

## SECURE VOICE Knob

The SECURE VOICE knob is inoperative.

## MSL Tone Knob

The MSL tone knob has a cw arrow pointing to INC. Rotating the knob cw increases the volume of the tone from the AIM-9 missile being monitored.

## TF Tone Knob

The TF tone knob is not functional.

## THREAT Tone Knob

The THREAT tone knob has a cw arrow pointing to INC. CW rotation increases the volume of the TWS composite tone.

### AUDIO 2 CONTROL PANEL

Refer to figure 1-79. The AUDIO 2 control panel provides control of less frequently used functions of the communications system. Except as noted, controls are active regardless of the position of the CNI knob.

#### ILS Power Knob

The ILS power knob has an OFF position and a cw arrow pointing to INC. The OFF position removes power from the ILS receiver. Rotating the knob cw applies power and increases the volume of the localizer identification signal. The ILS may not function during certain failures of the upfront controls.

#### TACAN Power Knob

The TACAN power knob has an OFF position and a cw arrow pointing to INC. The OFF position removes power from the TACAN receiver. Rotating the knob cw applies power and increases volume of the TACAN station identification signal.

#### INTERCOM Knob

The INTERCOM knob has a cw arrow pointing to INC. Rotating the knob increases the volume of the signals available to the intercom set.

The intercom provides the following functions:

- Monitoring and volume control of voice communication between pilot and ground crew or between pilot and tanker boom operator, monitoring and volume control of AIM-9 missile tone, TWS composite audio tone, and TWS missile launch tone.
- Monitoring of systems individually volume controlled from the audio control panels.
- Monitoring of fixed volume warning tones (LG and low speed warning tone, TWS missile launch tone, and IFF mode 4 audio monitor) and voice messages.

#### HOT MIC CIPHER Switch

The HOT MIC CIPHER switch is a three-position switch.

Functions are:

- HOT MIC - Activates communication between pilot and tanker boom operator or ground crew. Activation of UHF VHF IFF transmit switch on the throttle will override this function.

- OFF - Deactivates HOT MIC and CIPHER functions.

- CIPHER - Momentary position which limits UHF and VHF reception to secure voice only. CIPHER is functional only when operating in secure voice mode.

### ANT SEL PANEL C DF

Refer to figure 1-80. The ANT SEL panel allows selection of various antennas for optimum transmission and reception of IFF and UHF signals.

#### IFF ANT SEL Switch C DF

The IFF ANT SEL switch is a three-position switch.

Functions are:

- UPPER - Upper antenna is used to receive and reply to interrogation signals.
- NORM - The system selects the antenna which is receiving the best signal.
- LOWER - Lower antenna is used to receive and reply to interrogation signals.

## ANT SEL Panel C DF (Typical)

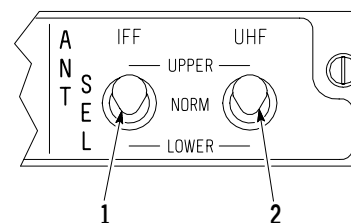
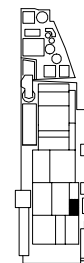

1. IFF ANT SEL Switch
2. UHF ANT SEL Switch

GR1F-16CJ-1-0079X37 ©

Figure 1-80.

**UHF ANT SEL Switch** **C** **DF**

The UHF ANT SEL switch is a three-position switch.

Functions are:

- **UPPER** – Upper antenna is used to receive and transmit signals.
- **NORM** – The antennas cycle between upper and lower to provide omnidirectional antenna pattern.
- **LOWER** – Lower antenna is used to receive and transmit signals.

**COMMUNICATIONS SYSTEM**

The aircraft communications system consists of a **HAVE QUICK UHF** radio, a VHF radio, and an intercom set. Communications are controlled by the upfront controls, two audio control panels, a UHF radio backup control panel, and a **PX II** AUX COMM panel, **PX III** IFF control panel.

**ANTENNA LOCATIONS**

Refer to figure 1-81.

**HAVE QUICK (HQ) SYSTEM**

The HQ system provides normal and antijamming, air-to-air, and air-to-ground UHF communication capability. The usual operating mode for an HQ UHF radio is in the normal mode where the radio uses 1 of 7000 channels. The antijamming (AJ) mode uses a frequency hopping scheme to change the channel or frequency many times per second. Because the particular frequency used at any instant depends on the precise time of day (TOD), both participating HQ UHF radios must have clocks which are synchronized. In addition, the HQ UHF radio uses word of day (WOD) and net number in the AJ mode.

**Single Word of Day (WOD)**

The WOD entry is normally entered before flight, but it is possible to enter it in flight. WOD is entered by using the six preset channels 15-20. The WOD elements are entered with the manual frequency knobs and the PRESET button. For a new WOD entry, start at preset channel 15 and enter an element using the same method as in entering preset frequencies in the normal mode. Progressively select the next higher preset channel (16-20) and continue to enter WOD elements into preset memory. A short tone is heard when the PRESET button is depressed

for channel 20. This tone indicates that the WOD element for channel 20 was accepted and transferred to the radio. The WOD is stored in the nonvolatile preset channel memory until a WOD transfer occurs. This procedure overwrites preset channels 15-20.

**Single WOD Transfer**

The WOD must be transferred from the nonvolatile preset channel memory to the volatile WOD memory for HQ operation. Progressively select the next lower channel (19-15) until a double beep is heard at channel 15. A double beep indicates that all WOD elements have been transferred to the volatile memory.

When the HQ radio is off, the WOD data is not lost, but is stored in nonvolatile preset memory. When the radio is initially turned on, the WOD must be transferred to the volatile memory. To transfer WOD data to the volatile memory, select preset mode and repeat the steps described above.

**PX III** Single WOD transfer is done automatically at power up if the single WOD method was used for loading.

**Multiple Word of Day (MWOD)**

MWOD capability allows for up to six WOD's and dates to be stored at one time into nonvolatile MWOD memory. If the radio is turned off or power is lost after entry of MWOD and date codes, the data is not lost; therefore, the information remains intact until manually changed. The six most recent WOD's are retained. If a WOD with a duplicate date is entered, the new entry takes precedence. After the MWOD information is entered, the operational date must be entered so the radio can select the proper WOD. If power is lost, the operational date is lost and must be reentered. However, if a TOD is received, the operational date is automatically entered as part of the TOD message. To access MWOD load, select preset mode, enter 220.025 in channel 20, and depress **PX II** PRESET, **PX III** LOAD (M-LOAD is displayed) button. Next, select manual mode and load word of day elements in channels 20-15 by **PX II** depressing the TONE button, **PX III** positioning the T-TONE switch to TONE. After each entry is made, a tone is heard. After the first WOD is entered, the corresponding date code is entered by selecting channel 14. The date code is represented by the format 3AB.000, where AB equals the day of the month; e.g., 315.000 indicates the 15th of the month. Press the **PX II** TONE button, **PX III** T-TONE switch to complete the date entry.

# Antenna Locations (Typical)

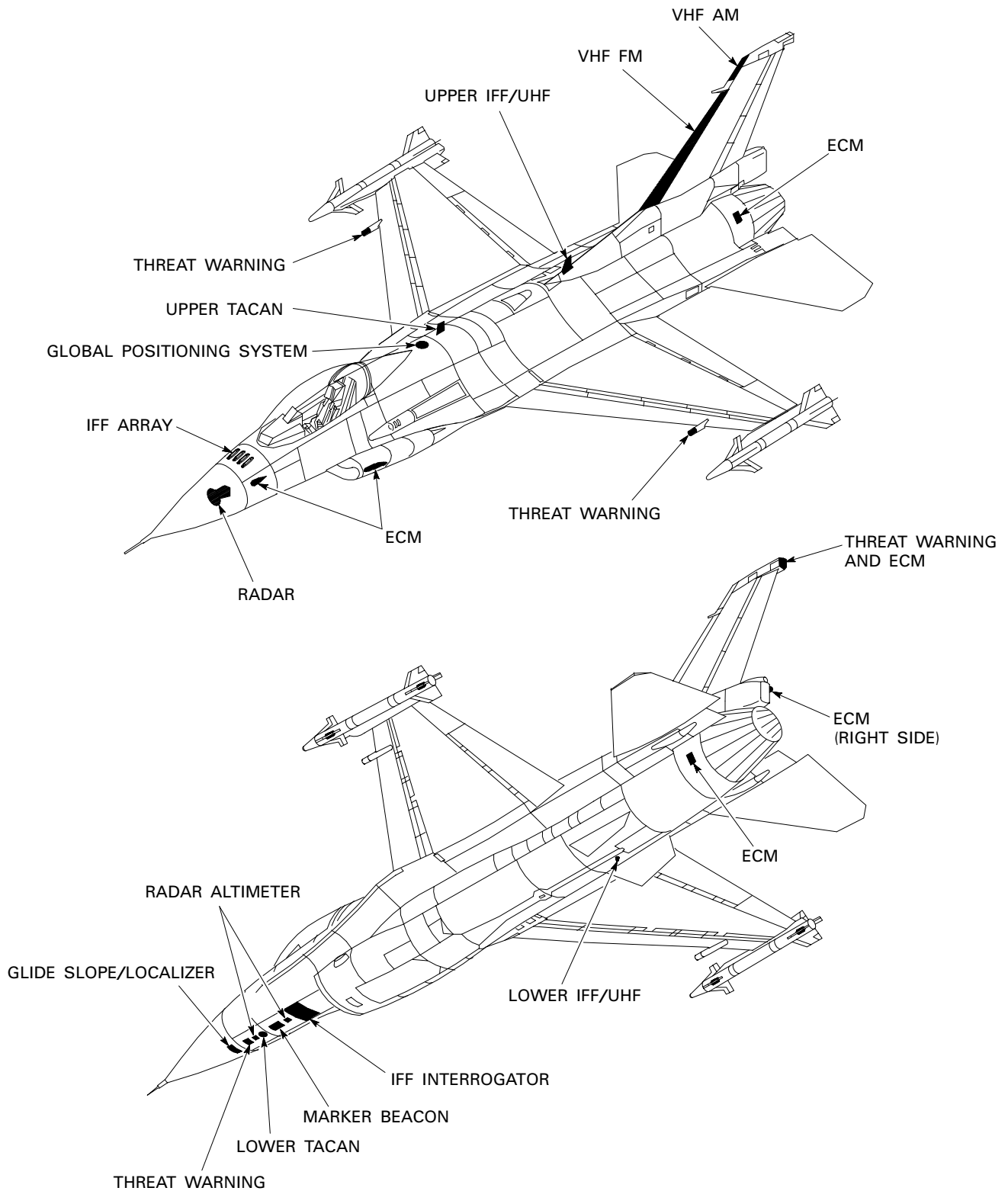

GR1F-16CJ-1-0080A37 ©

Figure 1-81.

A double beep indicates the date code has been entered. When using MWOD, the current date must be set into channel 1 prior to receiving TOD or the current date must be part of the received TOD message. Without date information, the radio cannot select the current WOD, and a steady tone results when entering AJ mode. After entering WOD(s) and/or setting operational date, select 220.00, preset channel 20, and depress PRESET button to enter the verify/operate mode. The UHF radio is inoperative when in any mode other than verify/operate. MWOD capability can be determined by selecting 220.000, channel 20 preset mode, and pressing the **PX II** PRESET, **PX III** LOAD (M-LOAD is displayed) button. Select channel 19; if one or two beeps are heard, the radio is not equipped with MWOD capability. If no beep is heard, the radio has MWOD capability. Verify a WOD for a particular date is loaded by selecting channel 20, manual mode, and by selecting the date to be verified with the manual frequency knobs. Select CHAN 19, then CHAN 20. A single beep signifies that a WOD for that date is present. The single WOD entry procedure remains valid for radios that are equipped for MWOD operation. Preset channel 20 is reserved for MWOD mode selection.

#### **Automatic MWOD Loading **PX III****

The HAVE QUICK II PHASE 2 radio allows automatic MWOD loading with a KYK-13/TSEC fill device. Insure radio power is on. Lift access door to reveal FILL connector and insure mode switch on fill device is in OFF position. Install fill device in FILL connector and place mode switch on fill device to ON. Frequency/status display displays FILL. Select desired channel on fill device and depress LOAD button. A series of beeps is heard and the frequency/status display displays WOD OK if WOD is valid and successfully received. If WOD is invalid or unsuccessfully received, the frequency/status display displays BAD. If BAD is displayed, the fill device must be disconnected and reloaded and the loading procedure must be repeated. If WOD OK is displayed, repeat the loading procedure for subsequent channels.

Insure WOD OK is displayed after each WOD is loaded. The CHAN display displays CHAN 1. Operational date may be loaded by positioning the frequency switches to OP DATE and setting the T-TONE switch to TONE. After all WOD's are loaded, place mode switch on fill device to OFF and disconnect FILL connector. Close access door. Radio returns to previous mode and the frequency/status display displays previous settings.

#### **Time-of-Day (TOD) Transmission**

The TOD entry is normally entered before flight, but it is possible to enter it in flight. It is possible to transmit timing information in both normal and AJ modes by momentarily pressing the **PX II** TONE button, **PX III** T-TONE switch. In the normal mode, a complete TOD message is transmitted, while in the AJ mode, only an abbreviated time update is transmitted. A time transmission allows a time update if one radio has drifted out of synchronization.

#### **Time-of-Day (TOD) Reception **PX III****

The HAVE QUICK radio accepts the first TOD that is received after power up. When the EGI is first powered on, the EGI TOD signal will likely not be synchronized with the GPS constellation universal time coordinated (UTC) time since 30-45 seconds are typically required for satellite acquisition. To insure that the HAVE QUICK radio is using a synchronized UTC TOD, another TOD should be manually received after an adequate GPS track has been achieved. The best indication of an adequate GPS track is to access the NAV STATUS DED page (LIST 4) and verify the horizontal accuracy status. A GPS HIGH estimated horizontal accuracy status (or 300 feet if selected accuracy display format is in feet) should insure that the EGI TOD signal is synchronized with UTC time. Alternatively, verify that four satellites are being tracked by the EGI by confirming that a 4 is displayed for EGI miscellaneous parameter (EGIM) 200.

#### **Time-of-Day (TOD) Reception **PX II****

Reception is possible in both normal and AJ modes. The radio automatically accepts the first TOD message received after the radio is turned on. Subsequent messages are ignored unless the T position is selected with the A-3-2-T knob. The radio then accepts the next TOD update in either normal or AJ mode, provided the TOD update arrives within 1 minute of the time the T position has been selected. To receive time in the normal mode, position the A-3-2-T knob to T and return to a normal channel in either manual or preset mode. To receive a time update in AJ mode, rotate the A-3-2-T knob to the T position and then back to the A position. A TOD update (time tick) can now be received on the selected AJ net for 1 minute.

## Net Number

After TOD and WOD are entered, any valid AJ net number can be selected by using the manual frequency knobs.

## Antijamming (AJ) Mode Operation

An intermittent tone is heard in the headset if an invalid AJ net is selected. A steady tone is heard if TOD was not received or if a WOD for the current date was not entered.

In the AJ mode, the radio can receive and process two simultaneous transmissions on the same net. Conferencing is controlled by the WOD loaded in channel 19. If the WOD in channel 19 ends with 00 or 50, conferencing is possible. If the WOD in channel 19 ends with 25 or 75, conferencing is disabled.

If the function knob is set to BOTH and guard channel jamming is encountered, switching the function knob to MAIN negates the jamming.

## HAVE QUICK (HQ) UHF RADIO

The UHF radio provides line-of-sight communications. UHF transmissions are made by holding the UHF VHF IFF transmit switch on the throttle to the UHF position. Frequencies range from 225.000-399.975 MHz. The guard receiver monitors the guard frequency of 243.0 MHz. Power, volume, squelch, guard, and tone controls are located on AUDIO 1 control panel. HAVE QUICK mode selection and other UHF functions are controlled by the upfront controls.

Twenty or 19 channels may be preset using upfront or backup controls, respectively. The UHF radio is powered by battery bus No. 1 and requires power from emergency ac bus No. 2 and emergency dc bus No. 2 for operation on upfront control.

## Operation of the UHF Radio on Upfront Controls

To change UHF preset channels on the CNI page, refer to CNI READOUT/DED PAGE SUMMARY, this section.

The UHF page is selected by depressing the COM 1 override button on the upfront controls.

Functions available on the UHF page are:

- Changing preset channels and manual frequencies.
- Changing between MAIN and BOTH functions.
- Channelizing frequencies.
- Changing bandwidth.
- Updating TOD and selecting AJ mode. ■

The UHF page displays its data on five lines. The first line contains information about the radio mode and transmission status. The radio mode displays UHF-TOD for normal operation; HQ-TOD is displayed when the AJ mode is selected. Either label is highlighted when the radio is keyed. The transmission status is displayed as OFF, MAIN, or BOTH. OFF is displayed when power is turned off with the COMM 1 power knob.

**PX III** Following UFC power cycles with weight-on-wheels, BOTH is automatically displayed; when airborne, the previously selected mode (MAIN or BOTH) is retained.

MAIN is displayed when transmissions are received only on the main UHF receiver; BOTH is displayed when transmissions are received on both the main and guard receivers. The second line displays the active frequency or preset channel number. Line three displays the data entry scratchpad. The fourth line displays the label PRE and a preset channel number, increment and decrement symbols, and the label TOD. ■

Line five displays the frequency associated with the preset channel and selected bandwidth, which is displayed as either narrow band (NB) or wide band (WB). **PX III** At UFC power up and weight-on-wheels, NB is automatically selected. **PX III** The CNI readout/DED page summary shows the radio mode UHF, transmission status (BOTH), active preset channel number (10), the scratchpad frequency (\*235.00\*), a preset channel (PRE 10), and label (TOD), the frequency associated with the preset number in line four (226.00), and radio bandwidth (NB). **PX II** The CNI readout/DED page summary shows the radio mode (UHF-TOD), transmission status (MAIN), active preset channel number (10), the scratchpad frequency (\*235.00\*), a preset channel (PRE 10), the frequency associated with the preset channel in line four (226.00), and radio bandwidth (NB). ■

Changes on the UHF page are made by the use of asterisks and the keyboard, the increment/decrement switch, or the SEQ position of the DCS, depending on the nature of the change. Asterisks (\*235.00\*) are moved by up/down movement of the DCS through the following locations: scratchpad, TOD, bandwidth (UHF mode only), radio mode, preset channel, preset channel frequency designation, and back to the scratchpad. Information enclosed by the asterisks may be changed. With asterisks properly positioned, the radio mode and bandwidth are changed by depressing any ICP/IKP key (1-9). Channels/frequencies are changed by placing the asterisks over the scratchpad, keying in the desired channel/frequency, and then depressing the ENTR button. If one or two digits are entered, a preset channel is selected; if three to five digits are entered, a frequency is selected. Extra numbers over five digits are ignored. When the ENTR button is depressed, the channel/frequency changes and the DED reverts to the overridden page. (If the COM 1 override button is depressed and the ENTR button is depressed without keying new digits in the scratchpad, the channel or frequency that was previously in the scratchpad is selected.) The preset channel is changed by using either the increment/decrement switch (note the up/down triangles next to the preset channel number) or by use of the asterisks and keyboard as previously described. As the preset channel is changed, its associated frequency also changes. Changing between MAIN and BOTH functions can only be accomplished by positioning the DCS to SEQ. This action can be accomplished independently of asterisk position. For HAVE QUICK selection, enter 0 in the scratchpad.

HAVE QUICK primary page displays data on five lines. The first line displays HQ radio mode with submode characters (HQ-TNG or HQ-CBT). **PX III** The receiver mode (BOTH, MAIN) is displayed on the first line and can be changed by positioning the DCS to SEQ. **PX II** The net types for training submode are displayed TNET or FMT; combat submode net types are A/B, NATO, or NNTO. Line two displays **PX III** the active net number/preset and the net type, **PX II** the active net number/preset. When using combat HAVE QUICK frequencies, the first three digits indicate the HAVE QUICK net number. The last two digits indicate the combat submode where 00 corresponds to A/B, 25 to NATO, and 50 to NNTO. For example, A32.425 is combat net 324, submode NATO.

Line three displays data entry scratchpad, where new active net numbers or preset numbers are keyed in and entered. Changing the active preset via the scratchpad also sets the preset number to the same value. Line four displays PRE mnemonic, preset channel number and TOD label. The system supports entry/storage of 20 net numbers in preset locations. The fifth line displays the preset net number. Asterisks are moved by up/down movement of the DCS through the following locations: scratchpad, TOD, HQ submode, preset channel number, preset net, and back to the scratchpad.

Special considerations should be given in instances where the features of the HAVE QUICK radio are used. The HAVE QUICK radio operates in two modes: UHF, for the normal mode using a single UHF frequency, and HQ, for the AJ mode using pseudorandom frequency-hopping techniques. Before the AJ mode can be used a WOD must be loaded, a TOD must be received, and a valid net must be selected. The radio automatically accepts the first TOD message received after the radio is turned on.

After the initial TOD is received an updated TOD can be received by placing the asterisks around the TOD label on the UHF page and then depressing the ENTR or M-SEL button. The asterisks autostep back to the scratchpad and TOD is highlighted. A TOD update must be received within 1 minute of depressing the ENTR or M-SEL button. TOD label dehighlights after 1 minute or when a scratchpad operation is performed. If the TOD label is highlighted when an UFC power cycle or an autorestart occurs TOD label is dehighlighted upon power up. If the TOD label is highlighted and the COM 1 HQ page is exited (for a reason other than a scratchpad autoexit operation), the TOD label remains highlighted on the COM 1 HQ page (if the page is reentered before the 1 minute time delay has timed out). After the TOD update and with proper WOD entries on the UHF backup control panel, the AJ mode is accessed by entering zero on the scratchpad which gives the ability to switch between HQ and UHF modes. There is no autoexit when zero is entered on the scratchpad. When HQ is selected, the bandwidth window is blanked from the page. Nets, consisting of three digits, are entered and changed just as operating frequencies and can be preentered in preset locations.



### UHF Radio Backup Control Panel

Refer to figure 1-82. The UHF radio backup control panel, located on the left console, controls the UHF radio, when required, by positioning the **PX II** CNI knob to BACKUP (AUX COMM panel), **PX III** C & I knob to BACKUP (IFF control panel). When BACKUP is selected, the controls on the UHF radio backup control panel have the following functions:

#### Function Knob

Functions are:

- OFF – Power off.
- MAIN – With COMM 1 power switch on, UHF radio operates on selected frequency.
- BOTH – Normal operation plus receiving on guard frequency.
- ADF – Not operational.

#### Mode Knob **PX II**

Functions are:

- MANUAL – UHF frequency is selected by manually setting the five frequency knobs.
- PRESET – UHF frequency is determined by the CHAN knob.
- GUARD – The main receiver and transmitter are automatically tuned to the guard frequency and the guard receiver is disabled.

#### Mode Knob **PX III**

Functions are:

- MNL – UHF frequency is selected by manually setting the five frequency knobs.
- PRESET – UHF frequency is determined by the CHAN knob.
- GRD – The main receiver and transmitter are automatically tuned to the guard frequency and the guard receiver is disabled.

## UHF Radio Backup Control Panel **C** **DF** (Typical)

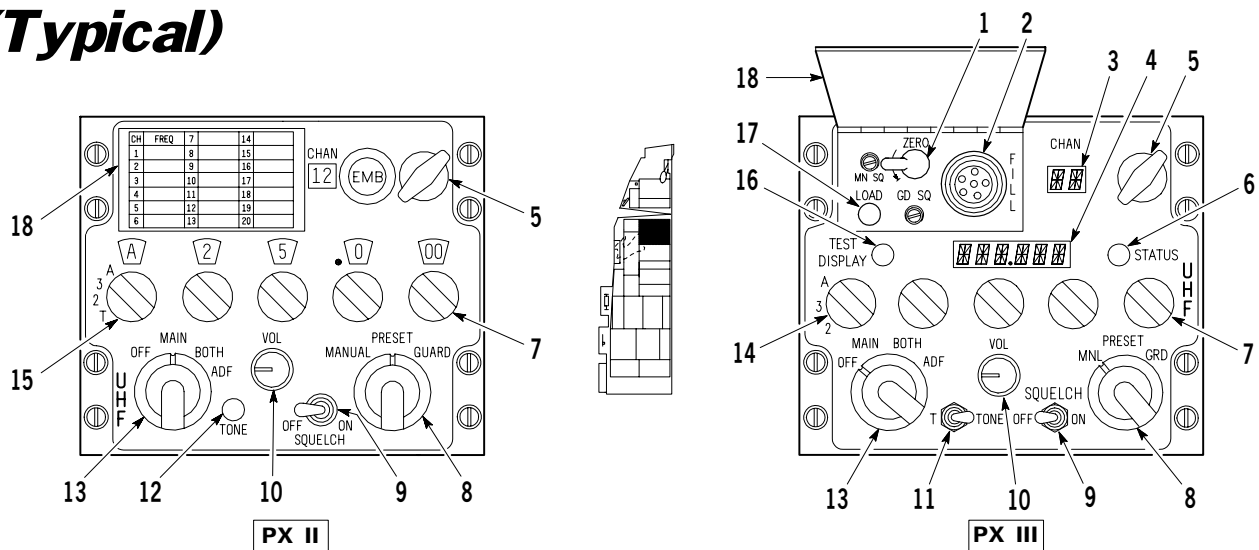

- |                             |                           |
|-----------------------------|---------------------------|
| 1. ZERO Switch              | 7. Manual Frequency Knobs |
| 2. FILL Connector           | 8. Mode Knob              |
| 3. CHAN Display             | 9. SQUELCH Switch         |
| 4. Frequency/Status Display | 10. VOL Knob (Inactive)   |
| 5. CHAN Knob                | 11. T-TONE Switch         |
| 6. STATUS Button            | 12. TONE Button           |

- |   |
|---|
| 13. Function Knob                       |
| 14. A-3-2 Knob                          |
| 15. A-3-2-T Knob                        |
| 16. TEST DISPLAY Button                 |
| 17. LOAD Button                         |
| 18. Preset Channel Card and Access Door |

GR1F-16CJ-1-0081A37®

Figure 1-82.

## CHAN Knob

The CHAN knob permits the selection of 1 of 19 (MWOD) or 14 (single WOD) preset frequencies (channels 1-19) with the mode knob at PRESET and the **PX II** A-3-2-T, **PX III** A-3-2 knob in either 2 or 3. Preset channels used for WOD storage cannot be used as preset channels for normal radio operation. Frequencies set for each channel can be manually written on a channel frequency card located on the access door. Preset channel frequencies are set (or changed) as follows:

- Function knob – MAIN or BOTH.
- Mode knob – PRESET.
- Manual frequency knobs – Set to desired frequency.
- CHAN knob – Set to desired channel.
- Lift access door.
- Depress **PX II** PRESET, **PX III** LOAD button under access door.

## Manual Frequency Knobs

The five manual frequency knobs allow manual selection of frequencies in steps of 0.025 MHz from 225.000-399.975 MHz.

### A-3-2-T Knob **PX II**

Functions are:

- A – Selects AJ mode.
- 3 – Allows manual selection of frequencies.
- 2 – Allows manual selection of frequencies.
- T – Momentary position which enables the radio to accept a new TOD for up to 1 minute after selection. Also used in conjunction with the TONE button for emergency startup of the TOD clock when TOD is not available from external sources.

### A-3-2 Knob **PX III**

Functions are:

- A – Selects AJ mode.
- 3 – Allows manual selection of frequencies.
- 2 – Allows manual selection of frequencies.

## VOL Knob

The VOL knob is nonfunctional. Volume can only be controlled by the COMM 1 (UHF) power knob.

## SQUELCH Switch

Functions are:

- ON – Enables squelch circuit which helps to eliminate background noise in normal reception. ■
- OFF – Disables squelch circuit to permit reception of a weak signal.

### TONE Button **PX II**

Depressing the TONE button in normal or AJ mode interrupts reception and transmits a tone signal and TOD for HQ on the selected frequency. Simultaneously pressing the TONE button in conjunction with the A-3-2-T knob in T position starts the emergency startup of the TOD clock. Pressing the TONE button with channels 1, 14, 15-20 selected in manual mode enters MWOD data when in load mode. Pressing the TONE button in erase mode erases all MWOD data.

### CHAN Display **PX III**

The CHAN display displays selected channel number when mode knob is positioned to PRESET. If in M-LOAD or FMT.CNG operating mode, the selected memory location is displayed. Display is blank when the mode knob is positioned to MANUAL or GUARD.

### Frequency/Status Display **PX III**

The frequency/status display displays several conditions of radio operation. Four programming modes control AJ operation. These modes are VER/OP, M-LOAD, ERASE, and FMT.CHG. These modes are accessed by placing the CHAN knob to 20, rotating the mode knob to PRESET, and keying in the appropriate frequency for the applicable mode. Frequencies are 220.000 for VER/OP, 220.025 for M-LOAD, 220.050 for ERASE, and 220.075 for FMT.CHG. VER/OP is displayed when the STATUS button is depressed. M-LOAD is displayed when MWOD's are loaded manually. ERASE is displayed when WOD's are erased by depressing the TONE button or by selecting 0. FMT.CHG is displayed when frequency management training net frequencies are changed by selecting a channel with the mode knob and changing frequencies with the manual frequency knobs.

Other displays are:

- FILL – A fill device is connected to the FILL connector to load MWOD's.

- BAD – A WOD was unsuccessfully received.
- WOD OK – A correct WOD has been successfully received.

#### **STATUS Button** PX III

When the STATUS button is depressed, selected preset channels and manual frequencies may be verified on proper displays.

#### **T-TONE Switch** PX III

Functions are:

- T – Momentary position which enables the radio to accept a new TOD for up to 1 minute after selection. Also used in conjunction with the TEST DISPLAY button for emergency startup of the TOD clock when TOD is not available from external sources.
- TONE – In normal or AJ mode, the TONE position interrupts reception and transmits a tone signal and TOD for HQ on the selected frequency. Selecting TONE with channels 1, 14, 15-20 selected in manual mode enters MWOD data when in LOAD mode. Selecting TONE when in ERASE mode erases all MWOD data.

#### **TEST DISPLAY Button** PX III

Depressing the TEST DISPLAY button illuminates all segments of the frequency/status display and the CHAN display for a functional test.

#### **ZERO Switch** PX III

Depressing the ZERO switch erases all MWOD data regardless of radio switch/knob positions or radio operating mode.

#### **FILL Connector** PX III

The FILL connector connects fill device to the radio. The FILL connector allows automatic MWOD loading.

### **VHF RADIO**

The VHF radio provides line-of-sight voice communication. VHF transmissions are made by holding the UHF VHF IFF transmit switch on the throttle to the VHF position. Transmission and reception are available for AM from 116.000-151.975 MHz and for FM from 30.000-87.975 MHz. Only reception is available from 108.000-115.975 MHz. Twenty channels may be preset. Operation may be either on narrow band or wide band. Narrow band is used for

all normal operations. Power, volume, squelch, guard, and tone controls for the VHF radio are located on the AUDIO 1 control panel. Other VHF radio functions are controlled by the upfront controls. There are no backup controls. In the event of certain failures of the upfront controls, the VHF radio may remain on the last frequency set prior to the failure. The VHF radio is powered by PX III emergency dc bus no. 1, PX II the nonessential dc bus.

#### **Operation of the VHF Radio on Upfront Controls**

To change VHF preset channels on the CNI page, refer to CNI READOUT/DED PAGE SUMMARY, this section.

The VHF page is selected by depressing the COM 2 override button on the upfront controls. Functions available on the VHF page are:

- Changing preset channels and manual frequencies.
- Channelizing frequencies.
- Changing bandwidth.

The VHF page displays its data on five lines. The first line displays information about secure voice, the VHF radio mode and status. The radio mode always displays VHF for normal operation. The radio status is displayed as ON or OFF; however, the ON and OFF functions can only be controlled via the AUDIO 1 control panel. The second line displays active frequency or preset channel. Line three displays the data entry scratchpad, which is a five-digit area highlighted by two asterisks. The scratchpad is used to change either channels or manual or active frequencies, and it displays the channel/frequency not currently being used. When the VHF page is first selected, the scratchpad is displayed in one of two ways: (1) If the radio is operating on manual frequency, the scratchpad displays preset channel entry. (2) If the radio is operating on preset channels, the scratchpad displays manual or active frequency entry. The fourth line contains the label PRE and a preset channel number. The label PRE is highlighted when the radio is tuned to a preset channel. Line five displays the frequency associated with the preset channel. The fifth line also shows the selected bandwidth, which is displayed as either narrow band (NB) or wide band (WB). The CNI readout/DED page summary displays the radio mode (VHF), radio power status (ON), active preset channel number (12), the scratchpad frequency (\*135.00\*), a preset channel (PRE 12), the frequency associated with the preset channel in line four (126.00), and bandwidth (NB).

Changes on the VHF page are made by use of the asterisks and the keyboard or the increment/decrement switch, depending on the change. Asterisks (\*135.00\*) are moved by up/down movement of the DCS through the following locations: scratchpad, bandwidth, manual frequency, preset channel number, preset channel frequency designation, and back to the scratchpad. Information enclosed with asterisks may be changed as described under OPERATION OF THE UHF RADIO ON UPFRONT CONTROLS, this section. The preset channel may be changed by using either the increment/decrement switch (note the up/down triangles next to the preset channel number) or by use of the asterisks and the keyboard.

When operating on guard frequency, AM or FM selections are available on the VHF page. To switch from AM to FM or FM to AM, depress any ICP/IKP key (1-9).

## ZEROIZE SWITCH

Refer to figure 1-3. The ZEROIZE switch is a guarded three-position toggle switch.

When positioned to OFP, coded electronic information associated with the following equipment is purged:

- DTC.
- **PX II** FCC.
- **PX III** MMC.
- GPS.
- AIFF mode 4.
- **PX III** IDM.
- PDG.
- RWR.

When positioned to DATA, coded electronic information associated with the following equipment is purged:

- DTC.
- GPS.
- AIFF mode 4.
- **PX III** MMC.
- **PX III** IDM.

Seat ejection also automatically performs an escape zeroize operation; refer to EJECTION SEAT OPERATION, this section.

## NAVIGATION SYSTEMS

### EMBEDDED GLOBAL POSITIONING AND INERTIAL NAVIGATION SET (EGI) **PX III**

The EGI is the prime sensor for aircraft velocity, attitude, heading, position, and is a source of navigation information. The EGI consists of an embedded GPS receiver (EGR) and ring laser gyro inertial navigation unit.

The EGR is a 12 channel receiver for all-in-view tracking. The EGI provides GPS-only and free inertial navigation solutions.

The EGI, in conjunction with the UFC, CADC, and MMC, provides:

- Acceleration.
- Velocity.
- Position.
- Attitude.
- Magnetic and true heading.
- Altitude.
- Angular rates.
- Universal time coordinated (UTC) and time tags.
- Instantaneous and maximum g data for display in the HUD.

The EGI generates signals which drive the aircraft attitude direction indicator (ADI) and horizontal situation indicator (HSI).

For a detailed system description, refer to T.O. GR1F-16CJ-34-1-1.

## **GLOBAL POSITIONING SYSTEM (GPS) PX II**

The GPS receives signals from orbiting satellites to determine accurate aircraft position, velocity, and time information. The FCC uses this data to reduce inertial navigation errors and enable accurate weapon delivery solutions. GPS data can also be used for in-flight alignment of the INS. The FLCS uses GPS data for SWIM during TF. GPS data is also used in HAVE QUICK time-of-day updates.

Refer to T.O. GR1F-16CJ-34-1-1 for a detailed description of GPS.

## **INERTIAL NAVIGATION SET (INS) PX II**

The INS is a prime sensor for aircraft velocity, attitude, and heading and is a source of navigation information.

The INS, in conjunction with the upfront controls, GPS, CADC, and FCC provides:

- Present position with update and storage capability.
- Current winds.
- Groundspeed and drift angle.
- Great circle course computation with steering provided to 30 points.
- Instantaneous and maximum g data for display in the HUD.

For a detailed system description, refer to T.O. GR1F-16CJ-34-1-1.

## **TACTICAL AIR NAVIGATION (TACAN) SYSTEM**

The TACAN system provides continuous bearing and distance information from any selected TACAN station within a line-of-sight distance up to approximately 390 miles, depending upon terrain and aircraft altitude. Only distance information is presented when a DME navigational aid is selected. There are 252 channels available for selection. Two antennas, one on top and one on the bottom of the fuselage, provide omnidirectional coverage regardless of aircraft attitude. The TACAN bearing, selected course, range, and course deviation information are displayed on the HSI as determined by HSI and INSTR MODE knob settings.

## **Operation of the TACAN on Upfront Controls**

The TACAN is controlled by the upfront controls when the TACAN power knob on the AUDIO 2 control panel is placed to on (cw) and the PX II CNI, PX III C & I knob is in UFC. The TCN/ILS page is selected by verifying the CNI page is displayed on the DED and then depressing the T-ILS function button on the upfront controls. The DED displays information about three TACAN items: operating mode, channel number, and band. The operating mode is displayed (REC, T/R, or A/A TR) and may be changed by positioning the DCS to SEQ until the desired mode is displayed. Channel (1-126) and band (X or Y) may be changed within the scratchpad with the keyboard.

Channels are selected by keying in the desired number on the scratchpad and then depressing the ENTR button. Asterisks remain about the scratchpad after channel change. TACAN band is selected by keying zero in the scratchpad and then depressing the ENTR button. The asterisks remain about the scratchpad after band change.

## **TERRAIN FOLLOWING RADAR (TFR) SYSTEM**

The TFR system provides manual TF and ATF capability. In manual TF, the NVP provides pitch steering cues via the HUD. In ATF, climb/dive commands are calculated in the NVP and sent to the FLCS to maintain a selectable clearance above the terrain.

Refer to T.O. GR1F-16CJ-34-1-1 for expanded TFR system description, operating procedures, and operating limitations.

## **AIFF SYSTEM**

The AIFF system provides selective identification feature (SIF), automatic altitude reporting, and encrypted mode 4 IFF. Normal operation is possible in any of six modes:

- Mode 1 – Security identity.
- Mode 2 – Personal identity.
- Mode 3/A – Traffic identity.
- Mode 4 – Encrypted identity.
- Mode C – Altitude reporting.
- Mode S – PX II Data Link (Surveillance mode), PX III Air traffic control data link (includes mode 3/A and C functions).

**AIFF TRANSPONDER [PX II]**

The transponder only transmits coded replies to correctly coded interrogations. Backup control is provided for mode 4 and EMER functions. Refer to AUX COMM PANEL, this section, for functions of IFF MASTER knob and mode 4 backup controls. In the event of certain failures of upfront controls, IFF modes 1 and 3/A may continue to reply on the last codes selected prior to failure.

Modes 2 and C, if selected prior to failure, may continue to reply. However, when the CNI knob is placed in BACKUP, modes 1, 2, 3/A, C, and S are disabled except when the IFF MASTER knob is in EMER. Mode C provides altitude information from the CADC in 100-foot increments. The AIFF transponder also provides for selection of manual or automatic operation. If the automatic function is selected, IFF operation can be programmed to:

- Turn modes on or off when a certain position is reached.
- Change codes when a specific time is reached.
- Turn modes on or off when a certain position is reached and changes codes when specific time is reached.

If the automatic position switching mode is selected, two mode groups are available. Mode groups contain selection status and position criteria that determine where a selected group becomes active. Mode groups are designated 1 or 2. Mode groups may be preprogrammed via the DTE or manually.

If the automatic time switching mode is selected, six code groups for IFF modes 1, 3/A, 4, and S are available. Code groups (1-6) designate the codes for the four IFF modes and a time when the selected code group becomes active. Code groups may be preprogrammed via the DTE or manually.

**■ AIFF TRANSPONDER [PX III]**

The transponder only transmits coded replies to correctly coded interrogations. Backup control is provided for modes 1, 3/A, S, and 4 and EMER functions. Refer to IFF CONTROL PANEL, this section, for functions of IFF MASTER knob and modes 1, 3/A, S, and 4 backup controls. In the event of certain failures of upfront controls, IFF modes 1, 2, and 3/A may continue to reply on the last codes selected, if modes are selected prior to failure. Mode

C, if selected prior to failure, may continue to reply. When the C&I knob is placed in BACKUP, modes 2 and C are disabled. Modes 1, 3/A, 4, and S can be enabled via switches on the IFF control panel. When the C&I knob is placed in UFC, all modes are automatically enabled. Mode C provides altitude information from the CADC in 100-foot increments.

The AIFF transponder also provides for selection of manual or automatic operation. If the automatic function is selected, IFF operation can be programmed to:

- Turn modes on or off when a certain position is reached.
- Change codes when a specific time is reached.
- Turn modes on or off when a certain position is reached and change codes when a specific time is reached.

IFF modes may be selected and programmed for use in groups. Mode groups contain selection status and position criteria that determine where a selected group becomes active. Mode groups are designated 1 or 2. Mode groups may be preprogrammed via the DTE or manually by placing the DED asterisks around the scratchpad and entering the desired data using the ICP/IKP keys.

If the automatic time switching mode is selected, six code groups for IFF modes 1, 3/A, and 4 are available. Code groups (1-6) designate the codes for the three IFF modes and a time when the selected code group becomes active. Code groups may be preprogrammed via the DTE or manually by placing the DED asterisks around the scratchpad and entering the desired data using the ICP/IKP keys.

**Operation of the Transponder on Upfront Controls [PX II]**

When the IFF MASTER knob, located on the AUX COMM panel, is placed to LOW or NORM and the CNI knob is in UFC, the AIFF transponder is controlled by the upfront controls. The IFF page is selected by depressing the IFF override button on the upfront controls. The IFF page displayed depends on the mode/code switching function last selected; i.e., the MAN page is displayed if manual function was last selected. IFF pages are accessed by placing the DCS to SEQ. Information is displayed on the IFF pages in four lines (lines one, three, four, and five). Refer to CNI READOUT/DED PAGE SUMMARY, this section.

## T.O. GR1F-16CJ-1

The first line displays IFF and power status (OFF, STBY, or ON). The next area displays MAN for manual IFF operation or AUTO for automatic IFF operation. If POS page is selected, the label POS is displayed in the next area of line one. The next area displays the selected mode group (1 or 2). The area at the far right displays two items: the label TIM is displayed if TIM is selected; the selected code group (1-6) for the IFF modes 1, 3/A, 4 and S is displayed next to the TIM label.

Line three displays four items. M1 is displayed at the far left. Displayed with the M1 label is the two-digit mode 1 code. The next area displays the MC label and a 5. MC represents IFF mode C, and it is highlighted when mode C is selected (MAN and POS only). The 5 represents the ICP/IKP key that provides selection of mode C if the ICP/IKP key is entered by the scratchpad. The area at the far right displays the scratchpad, which is displayed only when values are being keyed in. The scratchpad provides on/off control for each of the six IFF modes, code control for modes 1, 2, 3/A, 4 and S, and monitoring control for mode 4.

Line four displays five items. The first area at the left displays the M2 label, representing mode 2, and enterable mode 2 code (MAN only). The second area displays M4 and an A or a B. M4 represents mode 4. A or B indicates the two mode 4 codes. The third area displays a 6, which represents the ICP/IKP key that alternates selection of the mode 4 code (A or B). The fourth area displays the criteria used for position switching or time switching. This area displays a direction (N, S, E, or W), the fixed label OF, and a destination number (1-25) (POS only) or a time (HH:MM) (TIM only).

Line five displays data concerning IFF modes 3/A and 4 (MAN only) and S. The first area displays the label M3 and the enterable four-digit mode 3/A code. The second area displays mode 4 monitoring modes (OUT, LIT, AUTO). The third area displays a 7, which represents the ICP key that rotates selection of mode 4 monitoring (MAN only). The fourth area displays the label MS and an 8, which represents the ICP key that rotates selection of mode S.

IFF manual mode switching is accomplished by verifying the IFF MAN page. With asterisks positioned about the scratchpad, depress appropriate ICP/IKP key and depress ENTR. ICP/IKP keys represent the following: 0, 8, and 9 are invalid (scratchpad flashes); 1 for mode 1 selection; 2 for mode 2; 3 for mode 3/A; 4 for mode 4; 5 for mode C; 6 for mode 4 A/B code; 7 for mode 4 monitoring (OUT,

LIT, or AUD); 8 for mode S selection; two digits (mode 1 code); 2 plus four digits (mode 2 code); three or four digits (mode 3/A code).

IFF automatic switching is accomplished on the IFF AUTO pages. IFF AUTO pages are accessed by placing DCS to SEQ. To select AUTO POS or AUTO TIM switching functions, position asterisks about the POS and/or the TIM labels and depress the M-SEL button. If AUTO POS switching function is selected, only position and mode criteria is displayed. Labels (6) (mode 4 codes) and (7) (mode 4 audio monitor function) are removed and mode 4 A/B codes are not modifiable. The scratchpad is reduced to one digit (mode numbers only). The mode group number is displayed on the page and is highlighted when that mode group is active. The DCS provides access to the different mode groups by positioning the switch to INC or DEC. Sequencing to a different mode group does not affect the active squawks.

If AUTO TIM switching function is selected, only time and code criteria is displayed. Labels (5) (mode C is not modifiable from this page) and (7) (mode 4 audio monitor), and (8) (mode S) are removed. Mode 2 codes are not displayed (only modifiable from the IFF MAN page). The code group number is displayed on the page and is highlighted when that code group is active. The DCS provides access to the different code groups by positioning the switch to INC or DEC. Sequencing to a different code group does not affect the active squawks.

If the FCC fails, only IFF manual mode is available.

### **Operation of the Transponder on Upfront Controls** PX III

Refer to figure 1-77. When the IFF MASTER knob, located on the IFF control panel, is placed to LOW or NORM and the C&I knob is in UFC, the AIFF transponder is controlled by the upfront controls. The IFF page is selected by depressing the IFF override button on the upfront controls. Information is displayed on the IFF pages in five lines.

The first line displays IFF and power status (OFF, STBY, DEGR, or ON). The next area displays MAN for manual IFF operation or AUTO for automatic IFF operation. The third area displays POS for position switching and a two state mode group or TIM for time switching and a six state Code group.

Line two is blank.

Line three displays four items. The first area at the left displays M1 and the enterable mode 1 code (MAN and TIM pages only). The second area displays M4 and an A or a B (MAN and TIM pages only). M4 indicates that mode 4 is selected. A or B indicates the two mode 4 codes. The third area displays a 6, which represents the ICP/IKP key that alternates selection of the mode 4 code (A or B). The area at the far right displays the scratchpad, which is displayed only when values are being keyed in, provides on/off for each of the six IFF modes, code control for modes 1, 2, 3/A, and 4, and monitoring control for mode 4.

Line four displays five items. The first area at the left displays M2 and the enterable mode 2 code (MAN page only). The next area displays MC and 5. MC represents IFF mode C, and it is highlighted when mode C is selected (MAN and POS pages only). The 5 represents the ICP/IKP key that provides selection of mode C via the scratchpad. The fourth area displays the criteria used for position switching. This area displays a direction (N, S, E, or W), the fixed label OF, and a destination number (1-25) (POS page only).

Line five displays five items. The first area displays M3 and the enterable mode 3/A code (MAN and TIM pages only). The second area displays mode 4 monitoring modes (MAN page only). The third area displays a 7, which represents the ICP/IKP key that rotates selection of mode 4 monitoring. The fourth area displays MS. The fifth area displays an 8, which represents the ICP/IKP key that provides selection of mode S via the scratchpad.

The initial IFF page display is always MAN. IFF pages are accessed by placing the DCS to SEQ. IFF manual mode switching is accomplished by verifying the IFF MAN page is selected. With asterisks positioned about the scratchpad, depress appropriate

ICP/IKP key and depress ENTR. ICP/IKP keys represent the following: 0 and 9 are invalid (scratchpad flashes); 1 for mode 1 selection; 2 for mode 2; 3 for mode 3/A; 4 for mode 4; 5 for mode C; 6 for mode 4 A/B code; 7 for mode 4 monitoring (OUT, LIT, or AUD); 8 for mode S selection; any two digits (mode 1 code); three or four digits (mode 3/A code); 2 followed by 4 digits (mode 2 code). IFF automatic switching is accomplished on the POS and TIM pages. These pages are accessed by placing DCS to SEQ. To select AUTO POS or AUTO TIM switching functions, place DCS to SEQ to display the POS and TIM pages.

If AUTO POS switching function is selected, only position and mode criteria are displayed.

The scratchpad is reduced to one digit (mode numbers only). The active mode group is displayed on the page and is highlighted when that code is active. The DCS provides access to the different mode groups by positioning the switch to INC or DEC. Sequencing to a different mode group does not affect the active squawks. If AUTO TIM switching function is selected, only time and code criteria are displayed. The active code group is displayed on the page and is highlighted when that code is active. The DCS provides access to the different code groups by positioning the switch to INC or DEC. Sequencing to a different code group does not affect the active squawks.

## AIFF INTERROGATOR

The interrogator provides selective interrogation of IFF systems along a line-of-sight (LOS) or within a specific scan area. For a specific scan area, the interrogator may be selectively coupled or decoupled with the FCR. Refer to T.O. GR1F-16CJ-34-1-1 for details.

Location and classification of a particular IFF system as a friend or unknown is possible by comparison SIF codes. During interrogation, the interrogator is commanded to the modes 1, 2, 3/A, 4 (A or B) code, **PX II** and C as programmed via the DTE or manually entered using the scratchpad. The mode 4 (A/B) interrogator code is independent of the mode 4 (A or B) transponder code as displayed on the CNI interrogator (INTG) page.

Control of the interrogator is accomplished via the **PX II** AUX COMM, **PX III** IFF control panel, **PX II** the MISC panel, the **PX II** UHF VHF IFF transmit, **PX III** target management switch, the INTG page, and the MFDS FCR display. Interrogation of other IFF systems is possible when in any one of **PX II** five, **PX III** four modes:

- Mode 1 – Security identity.
- Mode 2 – Personal identity.
- Mode 3/A – Traffic identity.
- Mode 4 – Encrypted identity.
- **PX II** Mode C – Altitude reporting.



**Operation of the Interrogator on Upfront Controls PX II**

Selecting the INTG page displays and commands the interrogator to the same mode 1, 2, 3/A, and 4 (A/B) codes as the transponder mode 1, 2, 3/A, and 4 (A/B) codes. The interrogator continues to use the same codes until modified via the scratchpad. The scratchpad is displayed only when data is keyed in and provides on/off control for each of the five IFF modes and enterable code control for modes 1, 2, 3/A, and 4. After modification, the interrogator operates independently of the transponder mode codes. The interrogator is commanded back to the current transponder mode 1, 2, 3/A, and 4 (A/B) codes via the scratchpad or by entering the ICP/IKP 7 key via the scratchpad. The INTG page displays its data on four lines (lines one, three, four, and five).

The first line displays INTG and the interrogator power status (ON/OFF) The next area displays the coupled (CPL) or decoupled (DCPL) status with the FCR. The area on the right displays the current selected steerpoint. For CPL and DCPL detailed description, refer to T.O. GR1F-16CJ-34-1-1.

The third line displays M1 and enterable mode 1 interrogation code, MC and 5, and the scratchpad. The 5 represents the ICP/IKP key that provides mode C interrogation when entered by the scratchpad.

The fourth line displays M2 and enterable mode 2 interrogation code, M4 and selectable mode 4 A/B code and 6. The 6 represents the ICP/IKP key that provides selection of mode 4 A/B interrogation when entered by the scratchpad.

The fifth line displays M3, mode 3/A interrogation code, RST, and 7. The 7 represents the ICP/IKP key that resets the interrogator modes and codes to match the active transponder modes and codes when entered by the scratchpad.

**Operation of the Interrogator on Upfront Controls PX III**

Selecting either the SCAN INTG page or the LOS INTG page displays the corresponding interrogator mode 1, 2, 3/A, and 4 (A/B) codes. After a DTU load for IFF codes, the SCAN and LOS interrogator mode 1, 2, 3/A, and 4 (A/B) codes are the same as the transponder mode 1, 2, 3/A, and 4 (A/B) codes. Modes and codes selected for SCAN are independent of the modes and codes selected for LOS. The interrogator continues to use the same codes until modified via the scratchpad. For a detailed description, refer to T.O. GR1F-16CJ-34-1-1.

**AIFF CONTROLS AND INDICATORS**

**IFF IDENT Button**

Refer to figure 1-83. The IFF IDENT button, located on the instrument panel, provides the primary method of initiating the identification of position (I/P) function of the IFF system. Pushing the button momentarily causes the I/P timer to energize for 15-30 seconds. If a PX II mode 1, 2, 3/A, or S, PX III mode 3/A interrogation is recognized within this 15-30 second period, I/P replies are made.

**IFF (Mode 4) Caution Light**

The IFF (mode 4) caution light, located on the caution light panel, indicates that the IFF system was interrogated on mode 4 and is unable to respond because the mode 4 codes (A and B) are zeroized or not coded, mode 4 is not enabled, or the RF switch is in QUIET or SILENT.

**UHF VHF IFF Transmit Switch PX II**

The UHF VHF IFF transmit switch, located on the throttle, provides control of the area for interrogation (LOS or scan). For a detailed description, refer to T.O. GR1F-16CJ-34-1-1.

**IFF IDENT Button (Typical)**

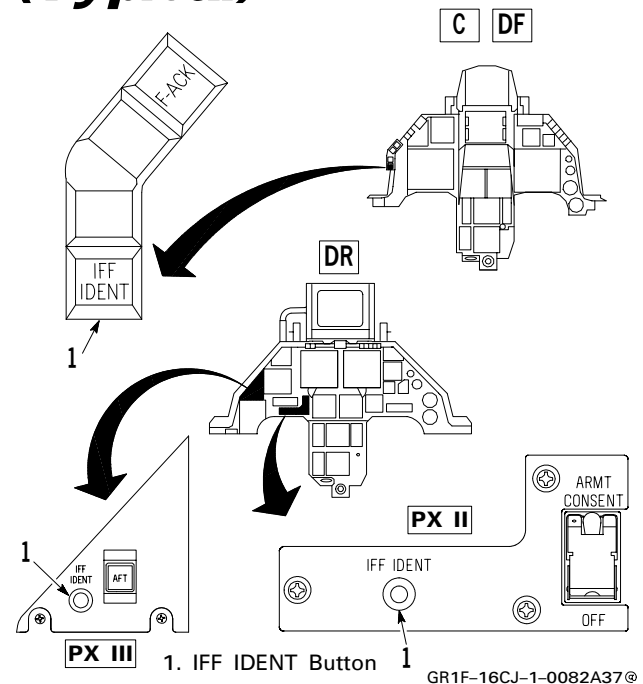

Figure 1-83.

## ■ Target Management Switch **PX III**

The target management switch, located on the stick, provides control of the area for interrogation (LOS or scan). For a detailed description, refer to T.O. GR1F-16CJ-34-1-1.

## INSTRUMENT LANDING SYSTEM (ILS)

The ILS provides precision approaches to runways equipped with localizer, glide slope, and marker beacon equipment. Localizer identification signals are supplied to the headset for station identification. The glide slope and localizer receivers supply glide slope and localizer deviation data to the deviation bars on the ADI and HUD; the HSI also displays course or localizer deviation data. Two warning flags, designated LOC and GS, appear on the ADI when deviation data is invalid. A course deviation warning flag appears on the HSI if localizer deviation data is invalid. HUD symbology consists of localizer and glide slope deviation bars. Dashed deviation bars indicate invalid data. Deviation bars are roll stabilized with tic marks positioned at the one-dot and two-dot deflections.

The symbology automatically displayed on the HUD with ILS selected is the same as LG down with the following exceptions:

- The great circle steering symbol is replaced by the ILS deviation bars.
- The lower HUD windows, except distance-to-destination, are not blanked unless the NLG is lowered and inertial velocity exceeds 80 knots.
- The HUD altitude scale does not change from 100-foot increments to 20-foot increments until NLG is lowered.
- AOA bracket is not displayed until NLG is lowered.

The flight director displays command steering data on the HUD when selected on the upfront controls. Command steering symbology consists of a circle, a tic mark positioned at the top of the circle, and a reference mark/caret positioned at the heading/ground track scale. The flight director circle is referenced to the FPM and appears when localizer data is valid. Proper use of the flight director requires that the localizer be intercepted from a heading no more than 45 degrees from the localizer course using bank angles of 30 degrees or less. When the aircraft is within two dots deflection of the localizer deviation bar, the flight director commands a turn to roll out on the localizer course. The tic mark appears on the flight director circle when glide slope deviation nears center, indicating that pitch steering data is valid. The glide slope should be intercepted from a position that is wings level and on the localizer course. If the pitch steering becomes invalid, the symbol X appears over the tic mark. The reference caret indicates the heading required to maintain the course selected on the DED (magnetic heading scale displayed) or ground track error relative to the course selected (magnetic ground track scale displayed). The course value may be changed only by entering the new value through the DED.

The ILS flight director is designed to intercept the glide slope from below while in approximately level flight. If the aircraft approaches the glide slope from above, there is no pitch steering data. The flight director symbol remains on the horizon, displaying bank steering data, and the symbol X appears over the tic mark, indicating that pitch steering data is invalid. Valid pitch steering is provided after the glidepath is intercepted.

The marker beacon receiver operates on a fixed frequency of 75 MHz. Refer to MRK BCN LIGHT, this section.

### ILS Controls

The ILS power knob, located on the AUDIO 2 panel, controls ILS power and audio volume. The ILS presentation on the HSI and ADI is controlled by the CRS set knob (HSI) and INSTR MODE knob. All other control functions are selected by the upfront controls. There are no backup controls. In the event of certain upfront control failures, the ILS may remain on the last frequency selected prior to failure.

### Operation of the ILS on Upfront Controls

The ILS is controlled by the upfront controls when the ILS power knob on the AUDIO 2 control panel is placed to on (cw). The ILS page is selected by verifying the CNI page is displayed on the DED and then depressing the T-ILS function button. Commanded (OFF or ON) ILS status and three changeable items appear: the ILS frequency, the localizer course for the ILS flight director cues on the HUD, and the selection of the flight director (CMD STRG). The asterisks initialize over the scratchpad when the TCN/ILS page is selected. The ILS frequency is changed by insuring that the asterisks are over the scratchpad, keying in the desired frequency, and then depressing the ENTR button. The asterisks then automatically step to the ILS course for course entry. The flight director is selected/deselected by positioning the asterisks about the CMD STRG label and depressing the M-SEL button. (The flight director is automatically selected at ILS power up.) Positioning the INSTR MODE knob to one of the ILS positions is required before ILS deviation data (localizer and glide slope) can be displayed on the HSI, HUD, and ADI.

Three steps are required before the ILS flight director (command steering) HUD cues are usable: the localizer course is displayed on the DED, the flight director is mode-selected on the upfront controls, and an ILS mode is selected with the INSTR MODE knob.

The course setting on the HSI is not connected to the flight director in the HUD. For consistent ILS displays, the inbound localizer course should be set on both the DED and the HSI.

### MRK BCN Light

Refer to figure 1-3. The MRK BCN light is located on the instrument panel. When the aircraft is over a marker beacon facility, the light illuminates green and blinks according to the code of the marker beacon.

## INSTR MODE SELECT PANEL

Refer to figure 1-84. The INSTR MODE select panel, located on the instrument panel, provides for the selection of the displays on the HSI and the ADI.

### INSTR HDG Knob **C** **DF**

Refer to figure 1-84. The INSTR HDG knob, located on the INSTR MODE select panel, has arrows pointing in cw and ccw directions. The knob is pushed and turned to set the INS heading to a known magnetic heading in the event of an INS failure (indicated by the AUX warning flag on the ADI).

### INSTR MODE Knob

Refer to figure 1-85 for functions and details of the INSTR MODE knob, located on the INSTR MODE select panel. Refer to figure 1-86 for details of the ADI and HSI in the instrument modes.

### Navigation Aids and Display

Refer to figure 1-85.

### Instrument Modes

Refer to figure 1-86.

## INSTR MODE Select Panel (Typical)

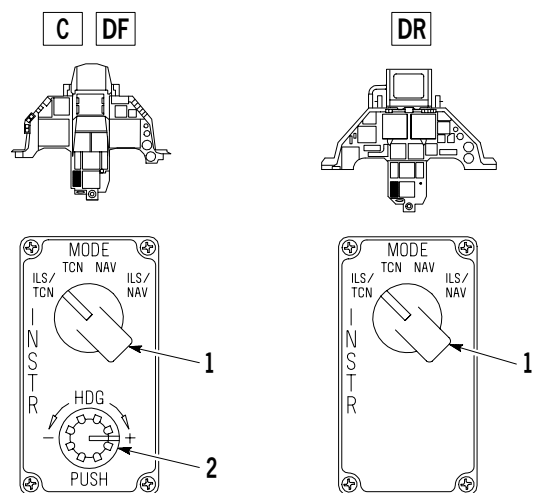

1. INSTR MODE Knob
2. INSTR HDG Knob

GR1F-16CJ-1-0083X37©

Figure 1-84.

# Navigation Aids and Display (Typical)

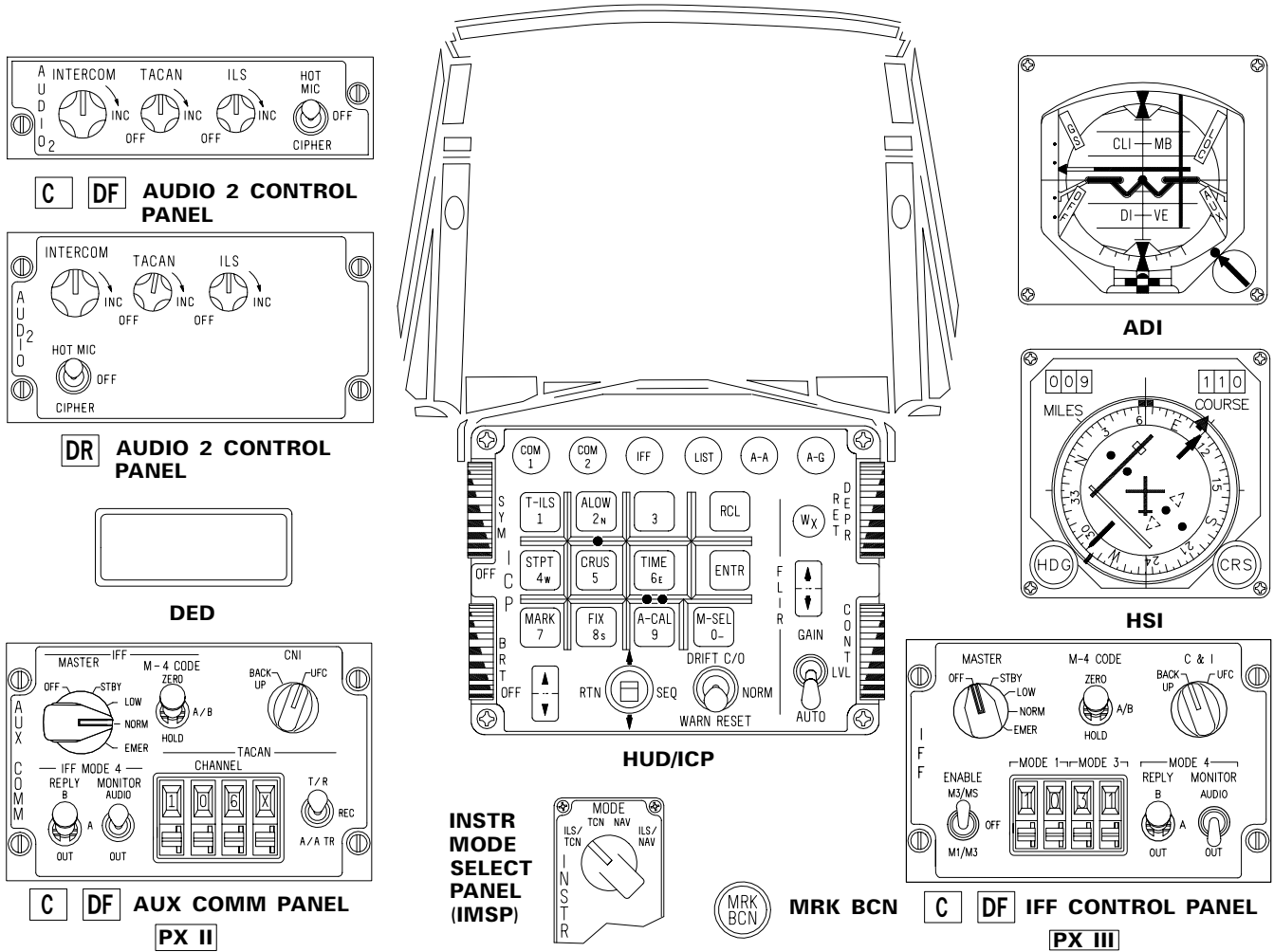

IMSP	HSI				ADI			
INSTRUMENT MODE SELECTED	RANGE INDICATOR	COURSE ARROW & COURSE SELECTED	COURSE DEVIATION INDICATOR	TO — FROM INDICATOR	BEARING POINTER	ATTITUDE SPHERE	LOCALIZER DEVIATION BAR	GLIDE SLOPE DEVIATION BAR
ILS/TCN	RANGE TO TACAN STATION OR DME NAV AID	MANUALLY SELECTED LOCALIZER COURSE	LOCALIZER DEVIATION	OUT OF VIEW	BEARING TO TACAN STATION	EGI/INS ROLL AND PITCH ATTITUDE	LOCALIZER DEVIATION	GLIDE SLOPE DEVIATION
TCN		MANUALLY SELECTED COURSE	DEVIATION FROM SELECTED COURSE	IN VIEW			OUT OF VIEW	OUT OF VIEW
NAV	RANGE TO EGI/INS DESTINATION	MANUALLY SELECTED LOCALIZER COURSE	LOCALIZER DEVIATION	OUT OF VIEW	BEARING TO EGI/INS DESTINATION		LOCALIZER DEVIATION	GLIDE SLOPE DEVIATION
ILS/NAV		MANUALLY SELECTED LOCALIZER COURSE	LOCALIZER DEVIATION	OUT OF VIEW	BEARING TO EGI/INS DESTINATION		LOCALIZER DEVIATION	GLIDE SLOPE DEVIATION

GR1F-16CJ-1-0084A37®

Figure 1-85.

# Instrument Modes (Typical)

## TCN

**NOTE:**

The TCN mode has no effect on HUD symbology.

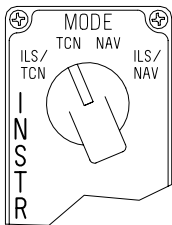

**INSTR MODE SELECT PANEL (IMSP)**

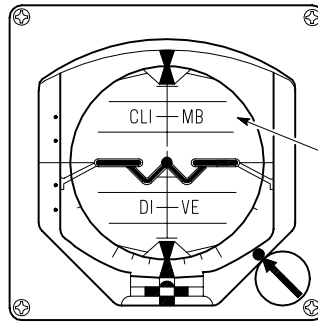

INS/EGI PITCH AND ROLL ATTITUDE

**ADI**

EGI/INS MAGNETIC HEADING      HEADING REFERENCE MARKER

RANGE TO TACAN STATION OR DME NAV AID  
 TACAN COURSE SIGNAL UNRELIABLE  
 DEVIATION FROM SELECTED COURSE

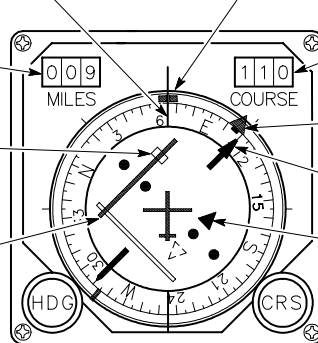

MANUALLY SELECTED COURSE  
 BEARING TO TACAN STATION  
 MANUALLY SELECTED COURSE  
 TO-FROM INDICATOR

**HSI**

## NAV

**NOTE:**

The NAV mode has no effect on HUD symbology.

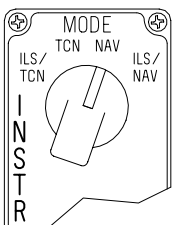

**INSTR MODE SELECT PANEL (IMSP)**

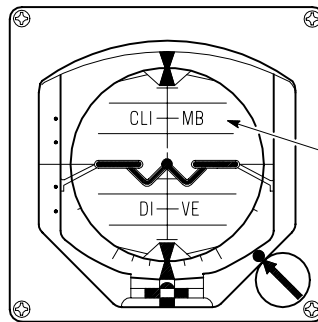

EGI/INS PITCH AND ROLL ATTITUDE

**ADI**

EGI/INS MAGNETIC HEADING      HEADING REFERENCE MARKER

RANGE TO INS/EGI DESTINATION  
 EGI/INS MAGNETIC HEADING SIGNAL UNRELIABLE  
 DEVIATION FROM SELECTED COURSE

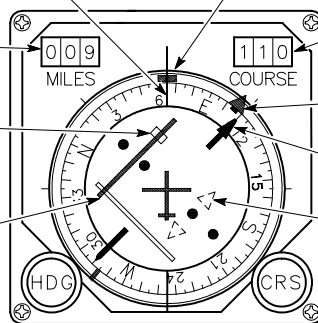

MANUALLY SELECTED COURSE  
 BEARING TO INS/EGI DESTINATION  
 MANUALLY SELECTED COURSE  
 TO-FROM INDICATOR (OUT OF VIEW)

**HSI**

Figure 1-86. (Sheet 1)

# Instrument Modes (Typical) PX II

## ILS/TCN

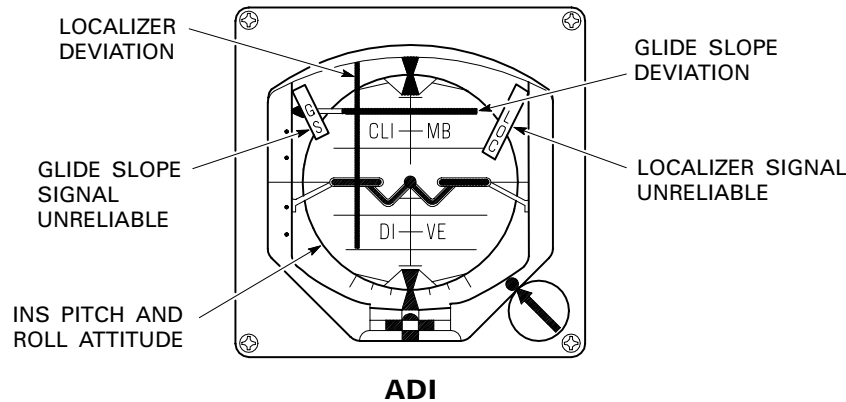
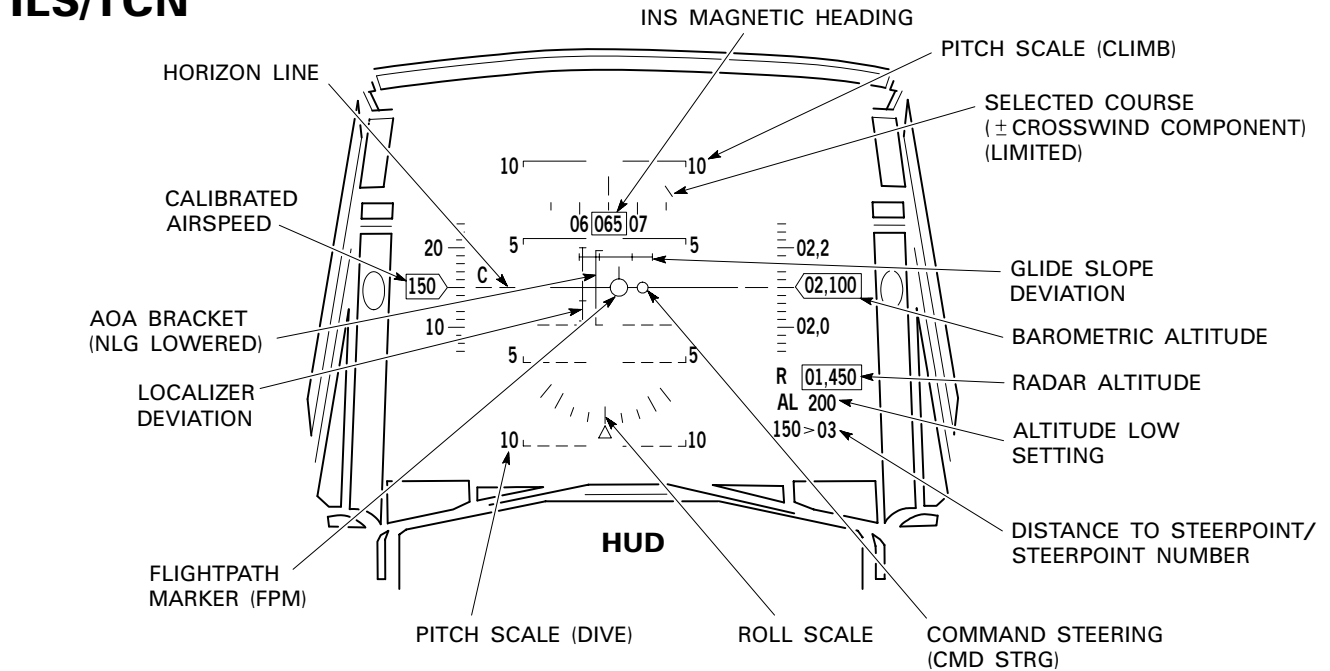

**NOTES:**

1. Glide slope and localizer bars indicate deviation only, not steering.
2. Command steering is referenced to the localizer course displayed on the DED.

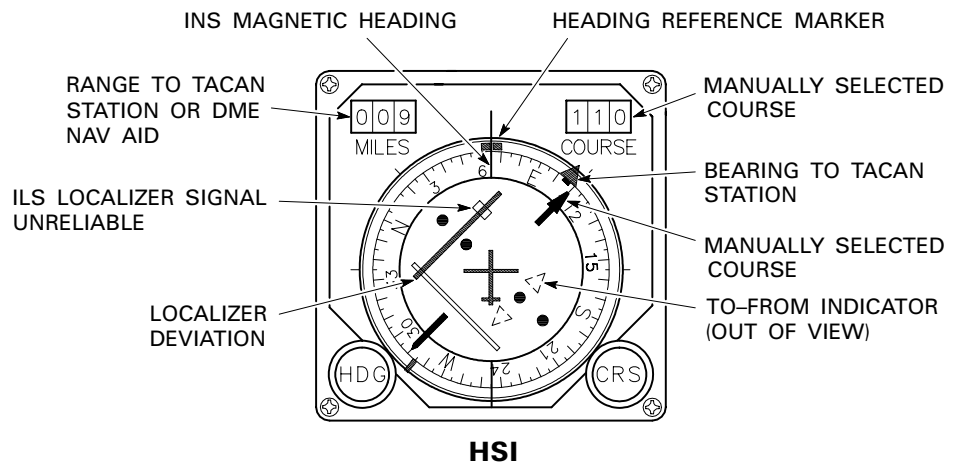
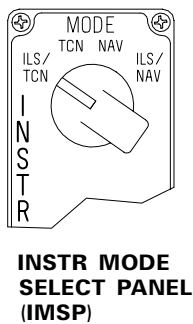

GR1F-16CJ-1-0086A37 ©

Figure 1-86. (Sheet 2)

# Instrument Modes (Typical) PX III

## ILS/TCN

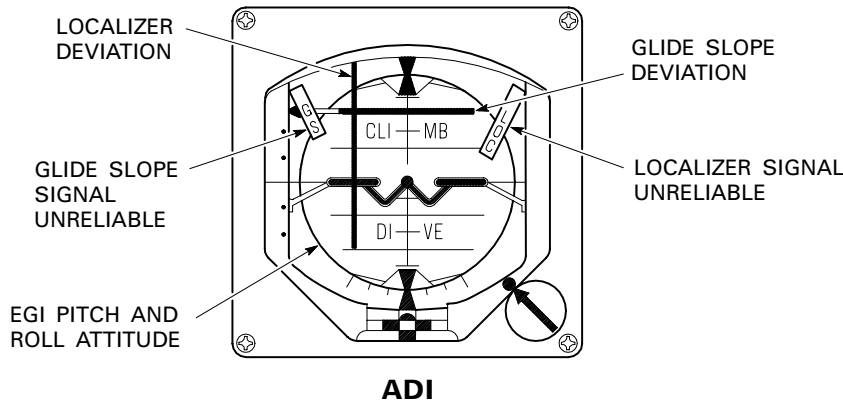
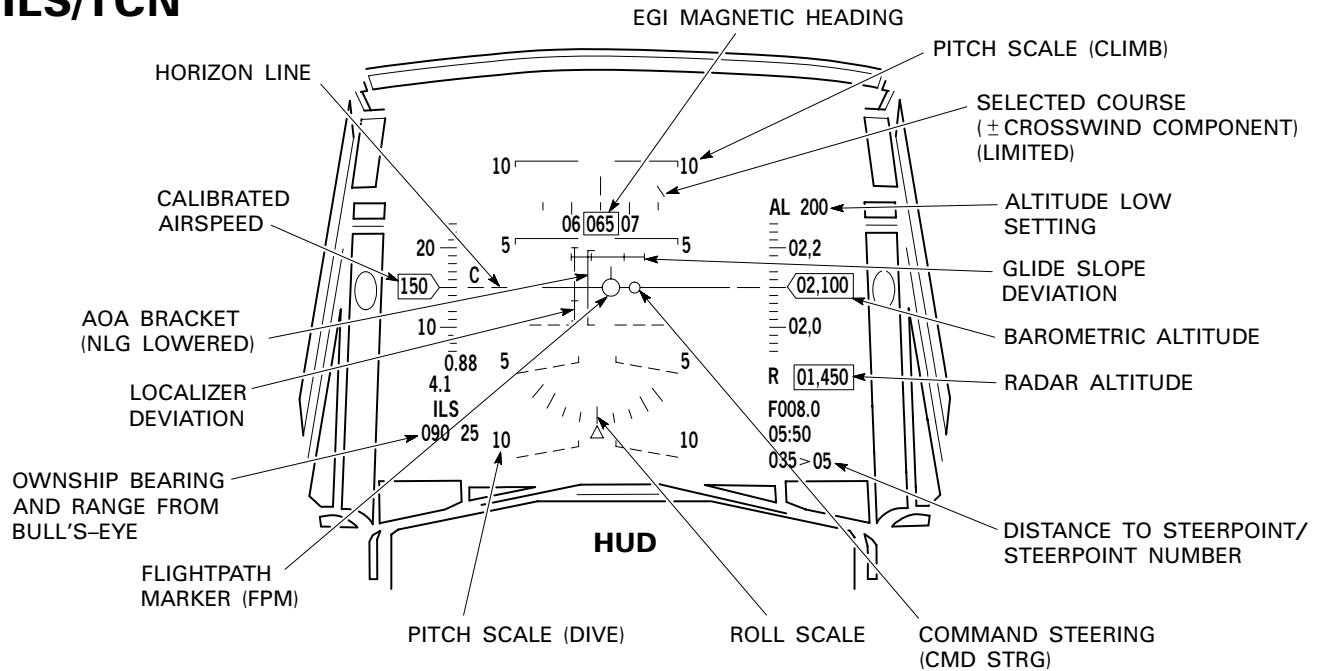

**NOTES:**

1. Glide slope and localizer bars indicate deviation only, not steering.
2. Command steering is referenced to the localizer course displayed on the DED.

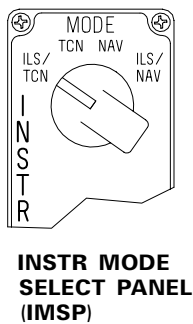
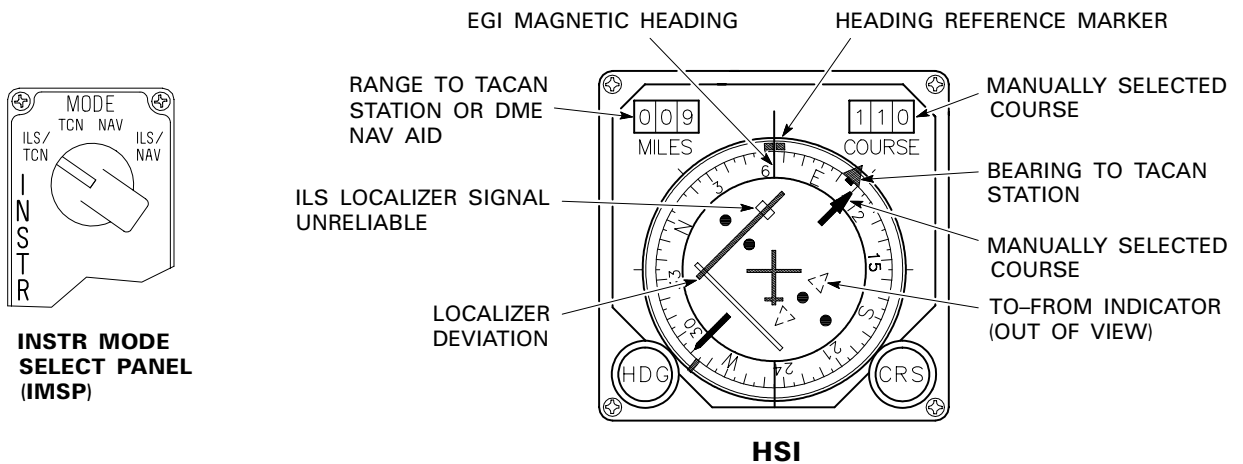

**INSTR MODE SELECT PANEL (IMSP)**

Figure 1-86. (Sheet 3)

# Instrument Modes (Typical) **PX II**

## ILS/NAV

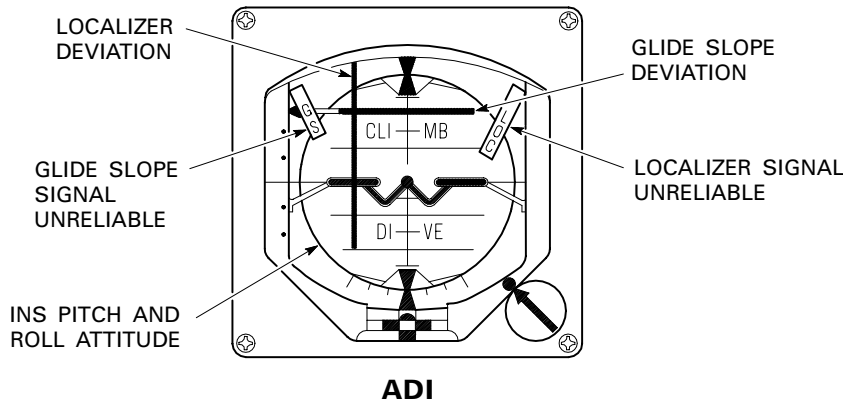
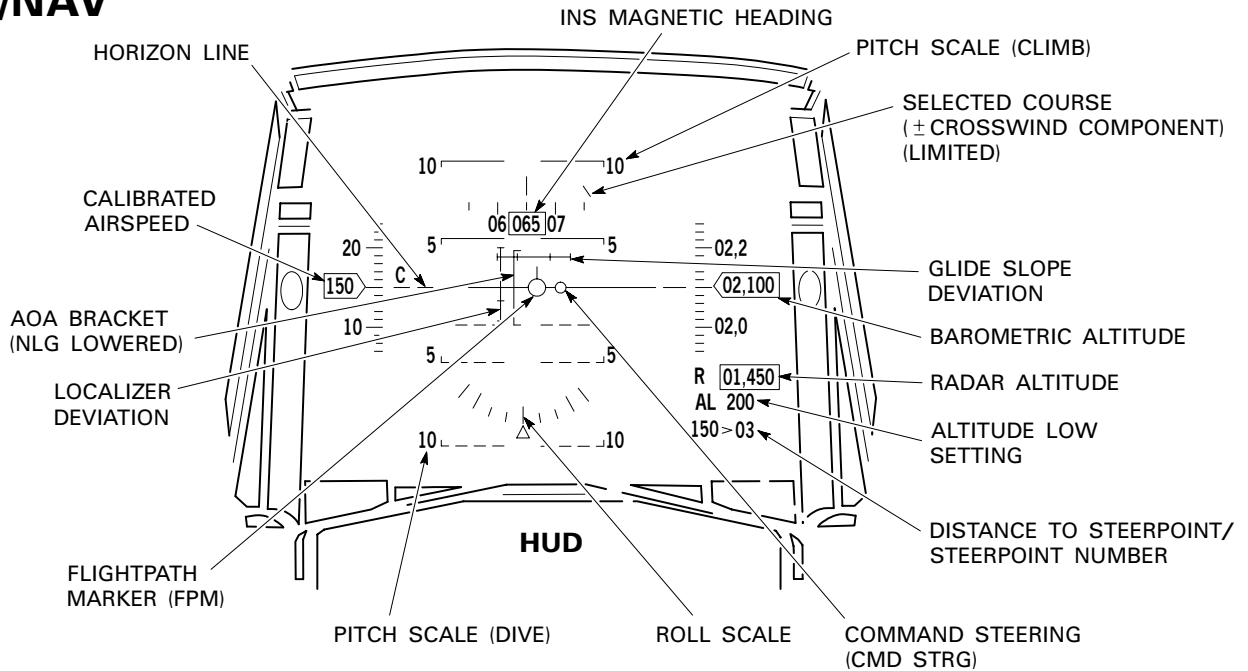

**NOTES:**

1. Glide slope and localizer bars indicate deviation only, not steering.
2. Command steering is referenced to the localizer course displayed on the DED.

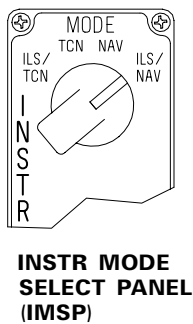
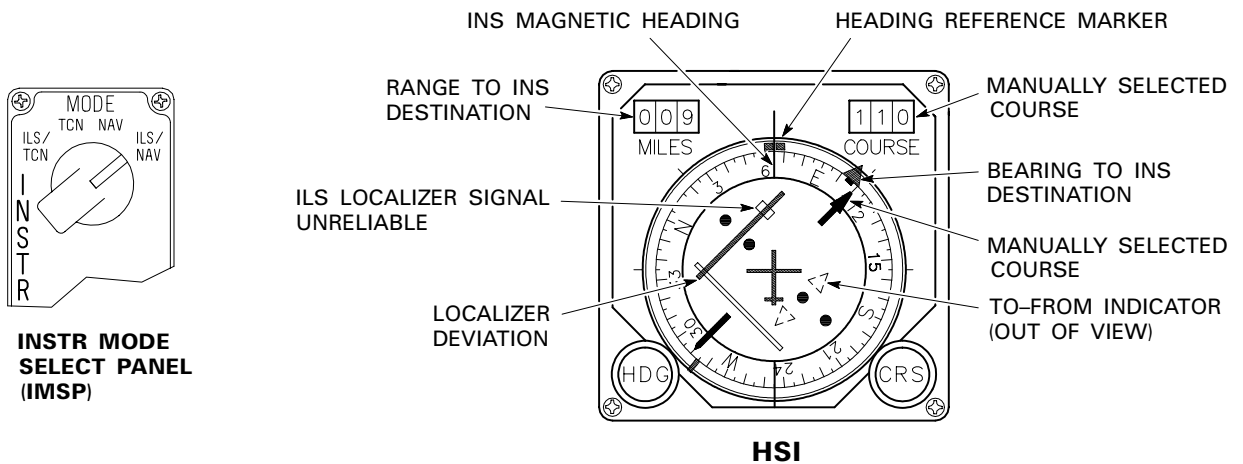

GR1F-16CJ-1-0087A37 ©

Figure 1-86. (Sheet 4)



# Instrument Modes (Typical) PX III

## ILS/NAV

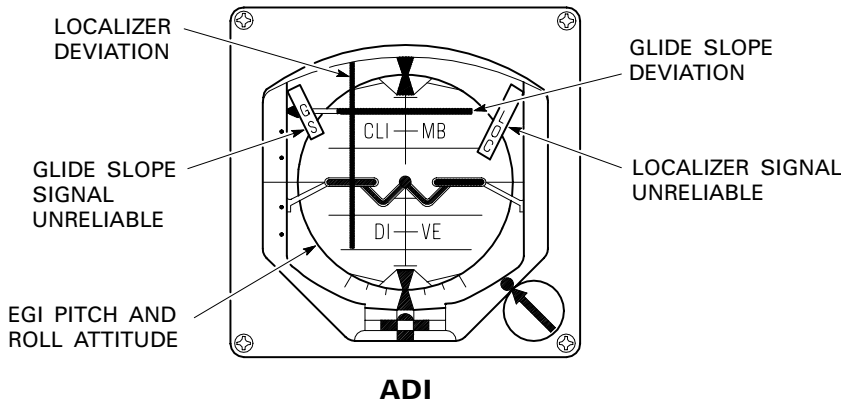
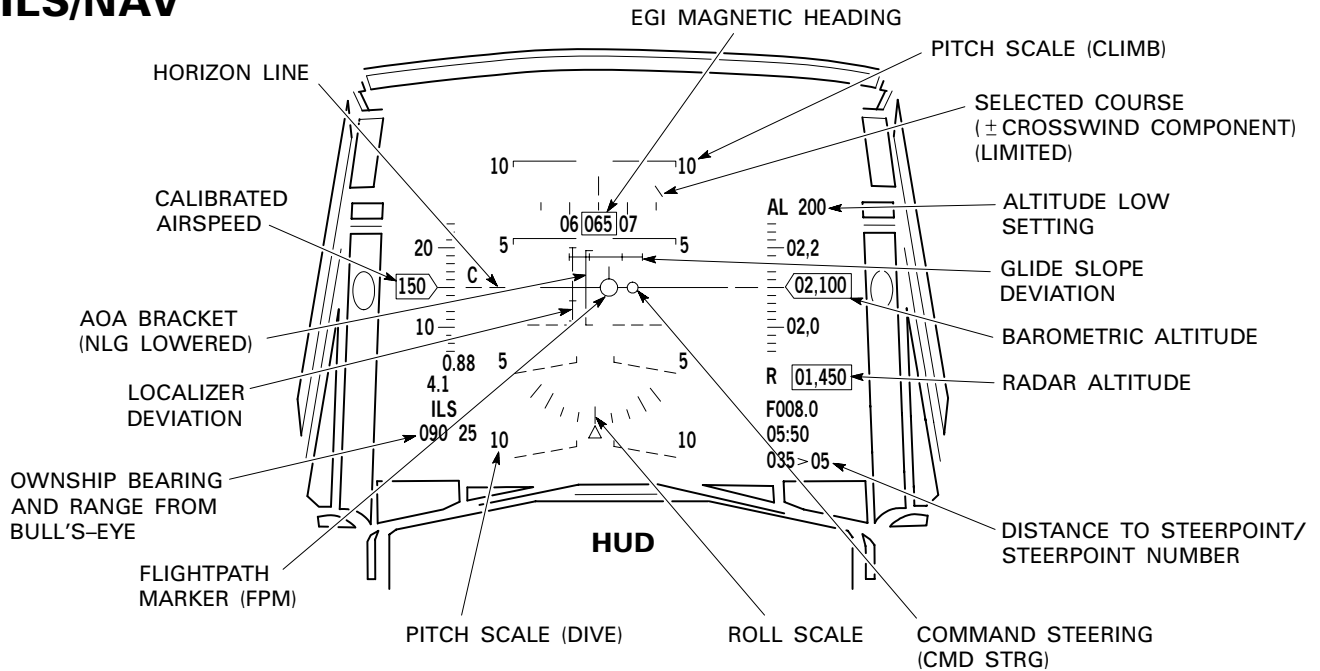

**NOTES:**

1. Glide slope and localizer bars indicate deviation only, not steering.
2. Command steering is referenced to the localizer course displayed on the DED.

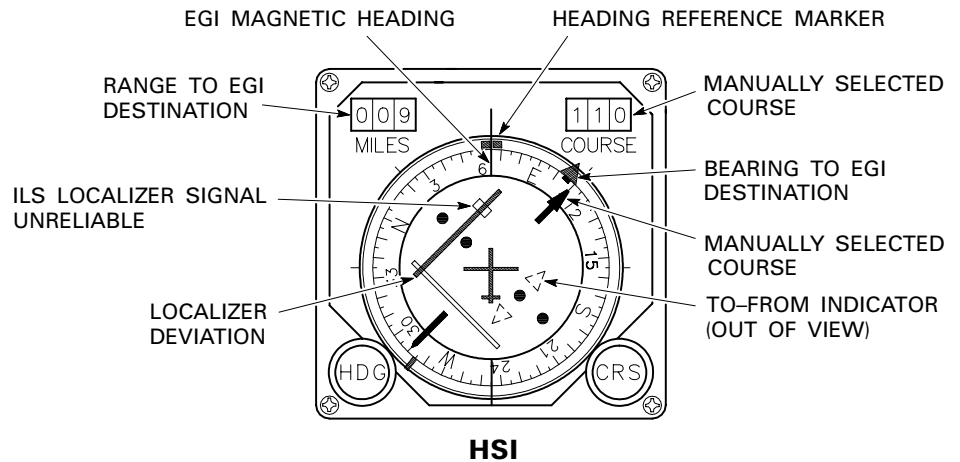
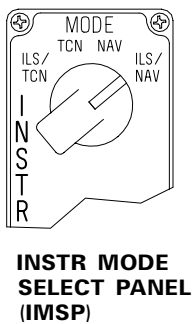

GR1F-16CJ-1-1087X37 ©

Figure 1-86. (Sheet 5)

# Instrument Modes (Typical)

## ILS HUD DISPLAYS

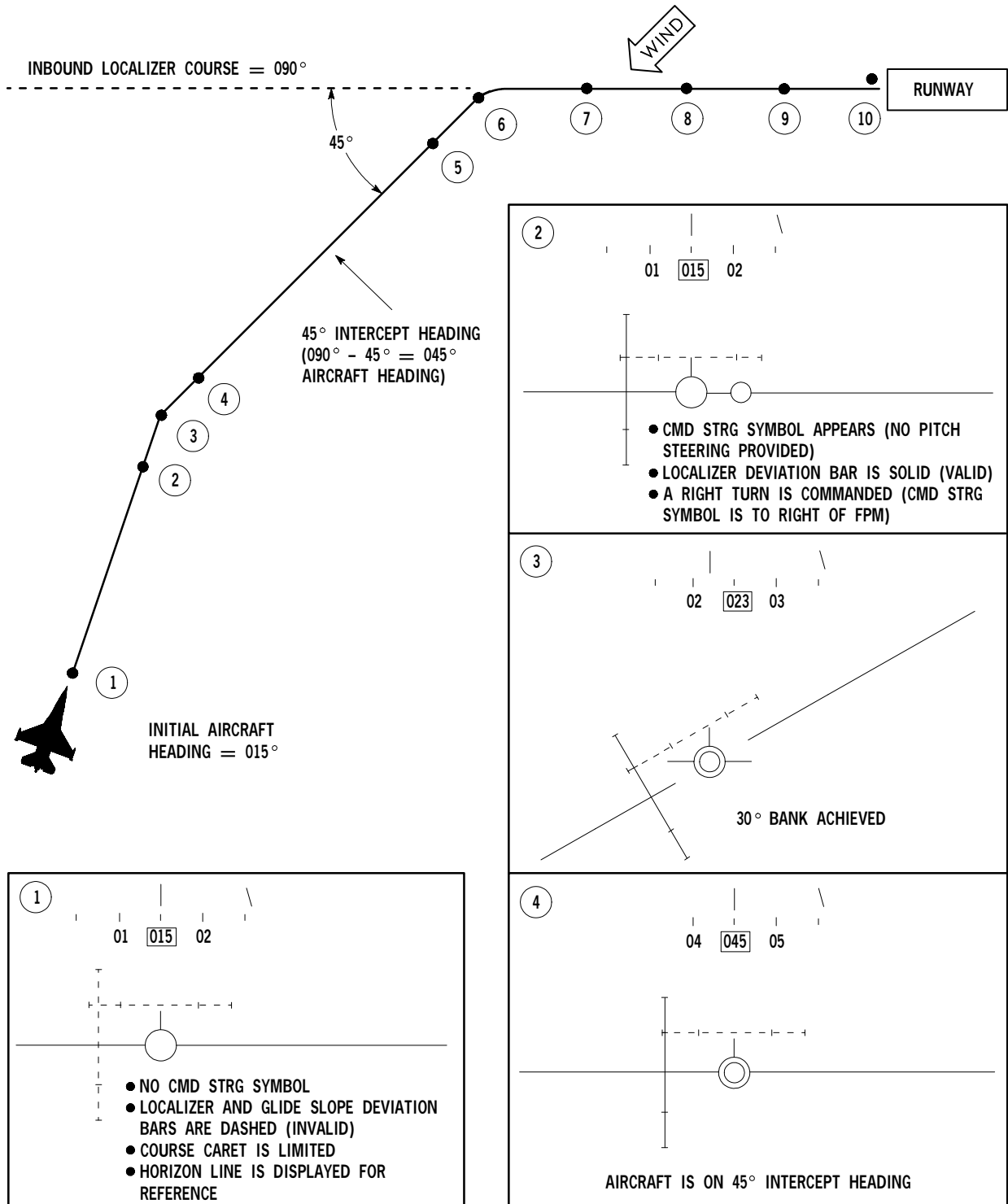

GR1F-16CJ-1-0088X37©

Figure 1-86. (Sheet 6)

# Instrument Modes (Typical)

## ILS HUD DISPLAYS

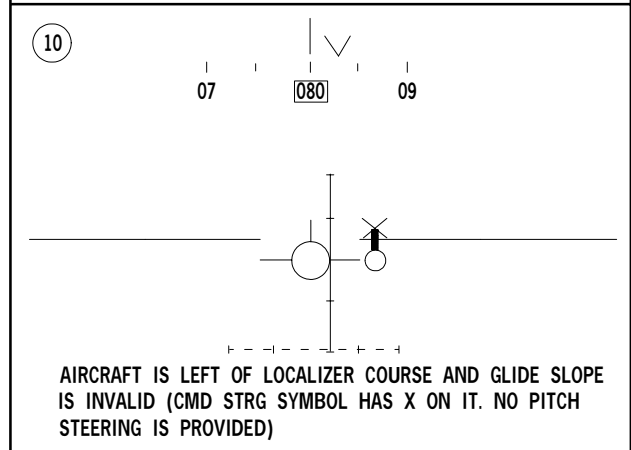
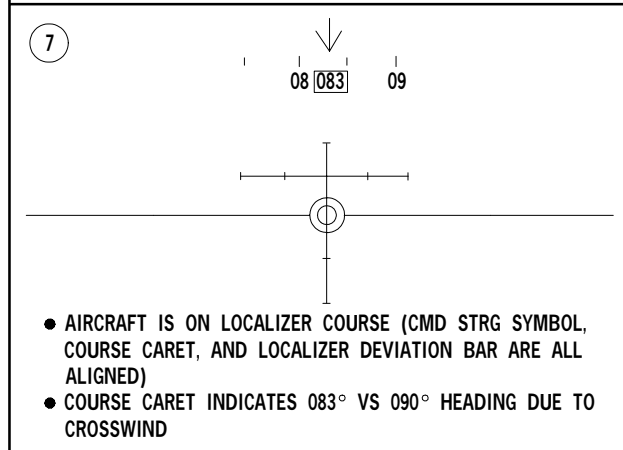
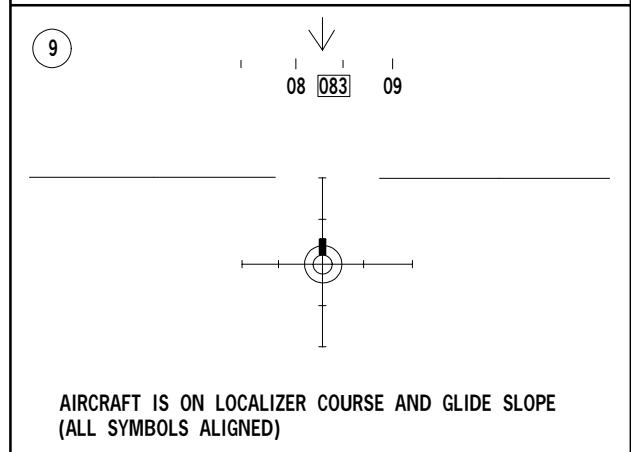
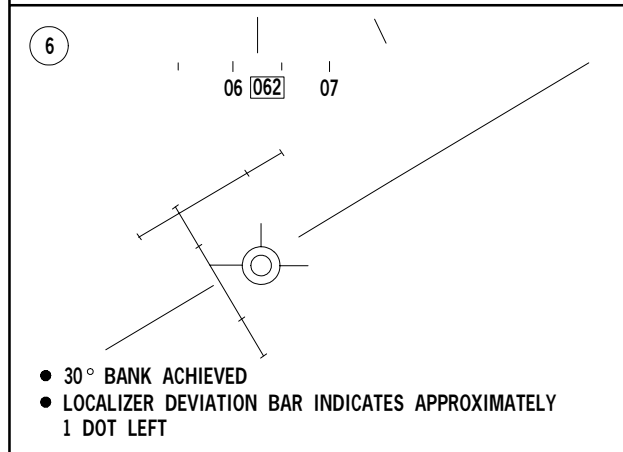
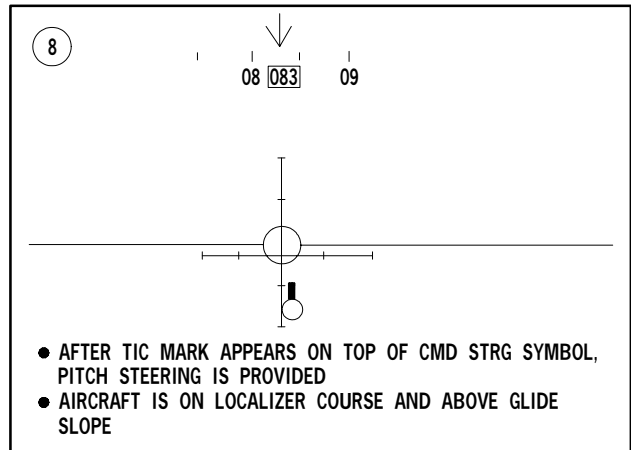
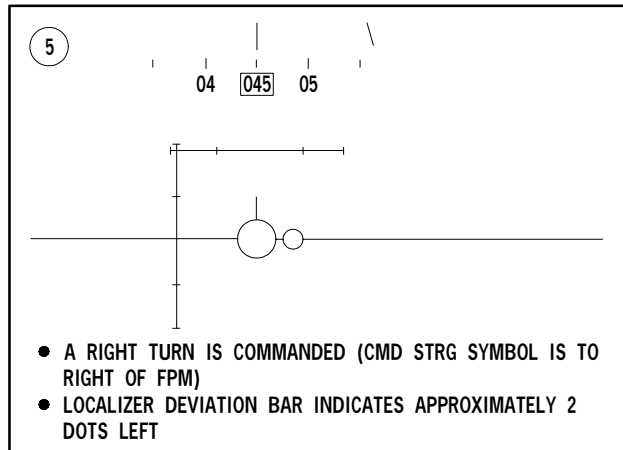

Figure 1-86. (Sheet 7)

## FLIGHT INSTRUMENTS

Refer to figure 1-87. The flight instruments are located on the instrument panel. The instruments listed below are common and are not illustrated in detail.

- Airspeed/Mach Indicator.
- Clock.
- Magnetic Compass.
- Servo-Pneumatic Altimeter.
- Standby Attitude Indicator.
- Vertical Velocity Indicator.

### ALTIMETER

The servo-pneumatic altimeter is a dual mode pressure altitude indicator with a range of -1000 to

+80,000 feet. The operating mode is manually selected by the mode lever located at the lower right corner of the instrument. In the **ELECT** (primary) operating mode, the altimeter is electrically driven by the CADC. In the **PNEU** (secondary) operating mode, the altimeter is pneumatically operated by static pressure supplied by the pitot-static system. Should the CADC or altimeter servo malfunction, the altimeter automatically reverts to the pneumatic mode and the PNEU flag appears on the face of the altimeter. The PNEU flag may also appear when accelerating or decelerating through the transonic region or while performing high g maneuvers.

The barometric setting knob, located at the lower left corner of the instrument, is used to set the desired altimeter setting. **C** **DF** The barometric setting of the altimeter is electrically transmitted to the CADC as a manual input correction for the pressure altitude display on the HUD. The barometric setting is shown in inches of mercury (Hg).

## Flight Instruments (Typical)

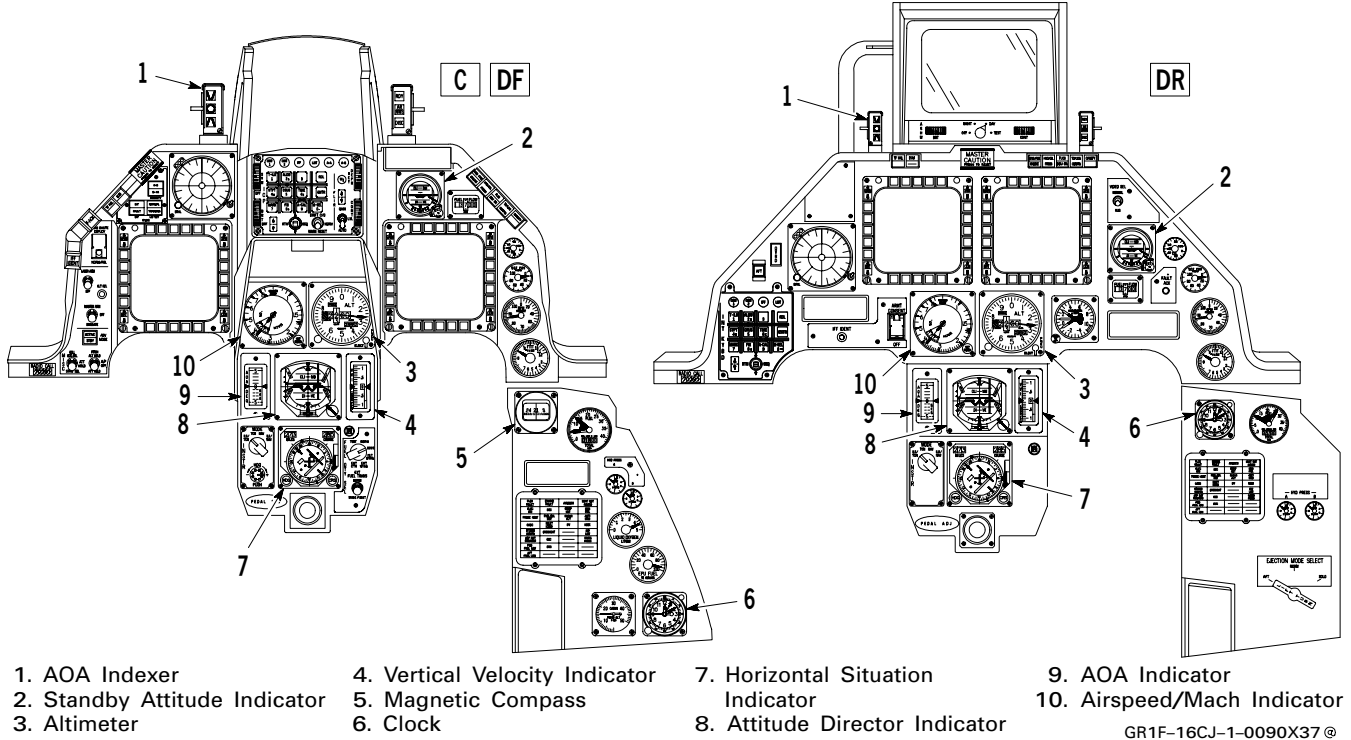

Figure 1-87.

**AIRSPPEED/MACH INDICATOR**

The airspeed/mach indicator is pneumatically operated by total and static pressure supplied by the pitot-static system. The indicator displays indicated airspeed and mach number. Indicated airspeed is displayed by a moving airspeed/mach pointer against a fixed airspeed scale. Mach number, which is read against the airspeed/mach pointer, is displayed by a rotating mach scale. The range of the indicator is from 80-850 knots and from 0.5-2.2 mach.

The maximum allowable airspeed pointer indicates 800 knots at sea level. Higher airspeeds are indicated as altitude is increased. This indication is not a valid maximum allowable airspeed cue; it should be disregarded. Refer to MAXIMUM AIRSPEED OPERATING LIMITATIONS, Section V.

The SET INDEX knob is used to set the airspeed reference index.

**STANDBY ATTITUDE INDICATOR (SAI)**

The SAI is a self-contained, electrically powered vertical gyroscope that mechanically positions the attitude sphere of the indicator to display aircraft pitch and roll attitudes. Manual caging of the gyroscope is accomplished by pulling the PULL TO CAGE knob at the lower right corner of the indicator. The knob is held out until the sphere is caged to zero pitch and roll indication and then released. Adjustment of the miniature aircraft reference symbol is accomplished by rotation of the PULL TO CAGE knob.

Since the SAI is mounted in the instrument panel at an angle, it indicates a pitch angle of 4 degrees less than the ADI when pitch trim knobs on both indicators are set at the pitch trim index. If caging is required, the aircraft should be flown wings level, constant altitude, and at an AOA of approximately +4 degrees. When caged on the ground, allow 2 minutes prior to taxi.

An OFF warning flag appears whenever electrical power is lost or whenever the PULL TO CAGE knob is pulled. After power loss, the indicator continues to provide usable attitude information for approximately 9 minutes. The gyroscope of the indicator is unrestricted in roll but is limited to approximately  $\pm 85$  degrees in pitch.

The indicator can develop errors during aerobatic maneuvering, primarily when pitch is near 90 degrees. If these errors exceed 7 degrees after returning to level flight, erection is cut off. If this occurs, the gyro does not automatically erect and must be manually caged to eliminate the error. The indicator is powered by battery bus No. 2.

**VERTICAL VELOCITY INDICATOR (VVI)**

The VVI displays rate of climb/descent information provided by the CADC. The indicator has a vertically moving tape display with a range of 6000 fpm climb or dive. The VVI is powered by emergency ac bus No. 1.

**MAGNETIC COMPASS**

The magnetic compass is a self-contained indicator which shows the heading of the aircraft with respect to magnetic north. Adjustable compensating magnets in the compass provide the means for cancelling magnetic disturbances originating within the aircraft. A deviation correction card for the compass is located immediately below and aft of the compass.

**ATTITUDE DIRECTOR INDICATOR (ADI)**

Refer to figure 1-88. The ADI displays pitch and roll attitude information supplied by the EGI/INS. The ADI is not limited in pitch or roll and displays any aircraft attitude accurately. In certain modes of operation, the indicator displays ILS glide slope and localizer deviation information. The instrument displays turn rate which is presented in standard turn needle format. The turn rate needle is driven by the rate gyroscope transmitter which senses the aircraft turn rate and displaces one needle width in response to a 1-1/2-degree/second turn rate. The slip indicator (ball) is a self-contained item. The pitch trim knob is used to adjust the attitude sphere to the desired pitch attitude in reference to the miniature aircraft.

The OFF warning flag may indicate failure of either the EGI/INS or the ADI. A momentary OFF and/or AUX flag, even with proper attitude being displayed, may indicate impending failure of the ADI or EGI/INS data to the ADI. The GS warning flag indicates that the glide slope deviation bar is unreliable. The LOC warning flag indicates that the localizer signal is unreliable. The AUX warning flag signifies that the EGI/INS has failed or is operating in a less precise attitude condition and that HSI heading must be set to a known heading by the **C** **DF** INSTR HDG knob on the INSTR MODE select panel.

**HORIZONTAL SITUATION INDICATOR (HSI)**

Refer to figure 1-89. The HSI displays horizontal or plan view of the aircraft with respect to the navigation situation. The miniature aircraft symbol in the center of the HSI is fixed and comparable to an aircraft superimposed on a compass rose. The face of the HSI is a compass card driven by the EGI/INS so that aircraft magnetic heading is always read at the upper lubber line.

The HDG set knob provides the means for rotating the heading reference marker to the desired heading. Once set, the heading reference marker rotates with the compass card. The heading reference marker provides a reference to the heading select mode of the autopilot.

The CRS set knob provides the means for selecting any one of 360 courses. To select a desired course, rotate the head of the course arrow to the desired course on the compass card and check the course selector window for the precise setting. Once set, the course arrow rotates with the compass card.

**PX III** The EGI does not use slaved variation for course display for TACAN, VORTAC, and VOR points retrieved from the database. Rather, the magnetic variation at the aircraft present position is used for course computation and display.

**PX III** Except for UTM's and markpoints (steerpoints 21-30), each steerpoint can have an associated CDI deflection. The selected deflection scales the HSI for course deviation as represented by a two-dot deflection of the CDI. From the STPT L/L or DEST DIR pages, DCS SEQ can be used to display a DED page to program these functions. Two options for CDI lateral deflection are available: 4 NMI (default) or 3 DEG. The 3-degree selection will be displayed in the lower left corner of the HUD as ANG. UTM's and markpoints always use 4 nm scaling.

The bearing pointer provides bearing information to TACAN station or EGI/INS destination. Refer to NAVIGATION AIDS AND DISPLAY, this section.

The range indicator provides a readout of distance in nm to a TACAN station, DME navigational aid, or EGI/INS destination. Loss of TACAN or DME signal or an unreliable signal causes a warning flag to cover the range indication window when ILS/TCN or TCN is selected. When NAV or ILS/NAV is selected, an EGI/INS failure causes the warning flag to cover the range indication window. Loss of power to the HSI causes the OFF warning flag to come into view.

### CLOCK

The clock, located on the right auxiliary console, is an 8-day, manually wound clock with provisions for an elapsed time indication up to 60 minutes.

## CRASH SURVIVABLE FLIGHT DATA RECORDER (CSFDR)

The aircraft contains a CSFDR system that stores engine usage data, aircraft service life data, avionics health and diagnostic data, and mishap investigation data. The CSFDR system consists of two units

containing stored flight data: the Signal Acquisition Unit (SAU) and the Crash Survivable Memory Unit (CSMU). The mishap investigation data, or Type 1 data, is stored in the CSMU. Service life data (Types 2 and 3 data), engine usage data (Type 4 data), and avionics health and diagnostic data (Type 5 data) are stored in the SAU. The SAU is not crash hardened. Service life and engine usage data is stored for approximately the last seven flights. Type 5 data is available for the last two or three flights. Mishap investigation data storage is limited to the last approximately 60 minutes of flight time; however, there are automatic special event provisions in flight that protect an approximate 30 seconds worth of data from overwrite until the next flight. If desired, a manual special event data save can be accomplished by depressing the FIRE & OHEAT DETECT test button for 1 second. Saved data covers at least the 15 seconds prior to and after button depression. A total of ten special events (automatic and manual) may be saved in Type 1 data. There is no limit to the number of special events that can be stored in Type 5 data. The occurrence of a special event also generates an MFL.

Special events are:

- Acceleration (NZ) greater than 9.5g or less than -3.5g.
- AOA greater than 29 degrees or less than or equal to -5 degrees.
- Canopy unlocked in flight.
- Engine data save.
- Engine overspeed.
- Engine overtemperature.
- Engine stagnation.
- Engine subidle.
- Engine transfer to SEC.
- EPU overspeed.
- FLCS reset.
- FLCS warning light.
- LEF's locked by asymmetry brakes.
- Main fuel shutoff valve not fully open.
- Main generator off line.
- OVERHEAT caution light.
- Throttle in OFF in flight.

# Attitude Director Indicator (ADI) (Typical)

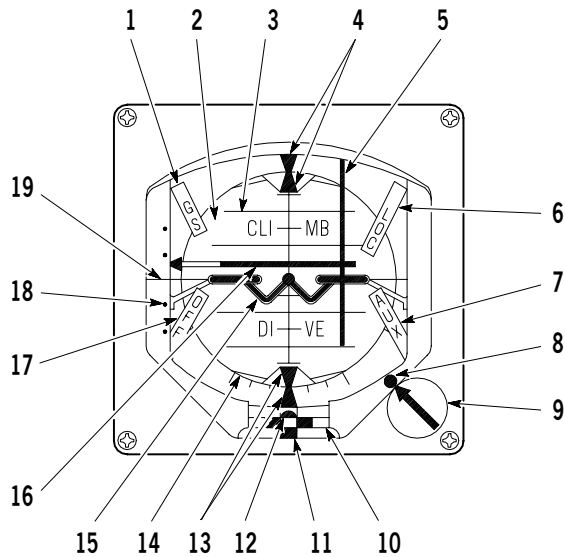

1. GS Warning Flag — Glide Slope Unreliable
2. Attitude Sphere
3. Pitch Scale
4. Upper Bank Index Pointer
5. Localizer Deviation Bar
6. LOC Warning Flag — Localizer Signal Unreliable
7. AUX Warning Flag — INS/EGI Navigation and Heading Unavailable
8. Pitch Trim Index
9. Pitch Trim Knob
10. Rate-of-Turn Scale
11. Rate-of-Turn Needle
12. Slip Indicator (Ball)
13. Lower Bank Index Pointer
14. Lower Bank Scale
15. Miniature Aircraft Symbol
16. Glide Slope Deviation Bar and Pointer
17. OFF Warning Flag — Attitude Sphere/INS/EGI Unreliable
18. Glide Slope Deviation Scale
19. Horizon Line

1F-16X-1-0013X®

Figure 1-88.

# Horizontal Situation Indicator (HSI) (Typical)

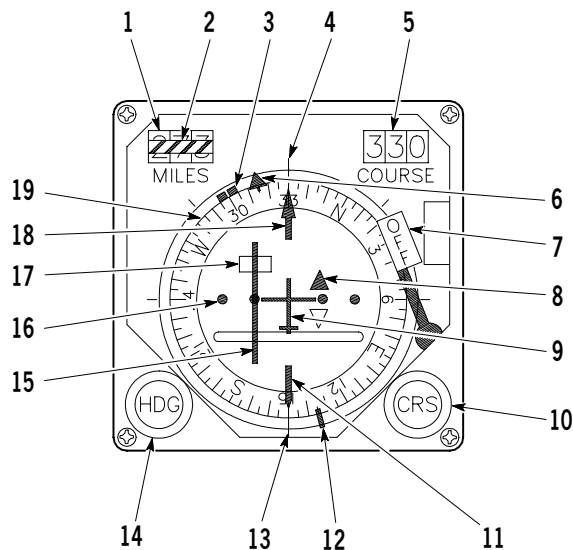

1. Range Indicator
2. Warning Flag — Range Indicator
3. Heading Reference Marker
4. Upper Lubber Line
5. Course Selector Window
6. Bearing Pointer
7. OFF Warning Flag — HSI Power
8. TO-FROM Indicator
9. Miniature Aircraft Symbol
10. CRS Set Knob
11. Course Arrow — Tail
12. Bearing Pointer — Tail
13. Lower Lubber Line
14. HDG Set Knob
15. Course Deviation Indicator
16. Course Deviation Scale
17. Warning Flag — Course Deviation
18. Course Arrow
19. Compass Card

1F-16X-1-0014X®

Figure 1-89.

## F-16D AIRCRAFT

Only those items which are different, significant, or unique to the forward or rear cockpit are discussed in the following paragraphs.

### ENGINE CONTROLS **DR**

Only a throttle, ENG CONT switch, and FUEL MASTER switch are provided.

#### Throttle **DR**

The throttle is limited in certain functions:

- Cannot be advanced from OFF to IDLE.
- Cannot be advanced from MIL to AB.
- Cannot be retarded from IDLE to OFF.
- Does not have a throttle friction control.

#### ENG CONT Switch **DR**

Refer to figure 1-3. The ENG CONT switch, located on the left console, is a two-position switch.

Functions are:

- SEC – Manually selects SEC (SEC caution light illuminates) regardless of forward cockpit ENG CONT switch position.
- NORM – (Guarded position) Returns control to forward cockpit switch position.

### FUEL SYSTEM

#### Fuel Control Panel **DR**

Refer to figure 1-23. The fuel control panel, located on the left console, contains a guarded FUEL MASTER switch. The FUEL MASTER switches in both cockpits must be in the MASTER (on) position to permit fuel flow to the engine. Either switch when positioned to OFF shuts off all fuel flow to the engine.

### SPEEDBRAKE SYSTEM

#### SPD BRK Switch **DR**

Refer to figure 1-16. The SPD BRK switch is spring-loaded to the off (center) position and must be held in either the open (aft) position or close (forward) position.

### DRAG CHUTE SYSTEM

#### DRAG CHUTE Switch **DR**

Refer to figure 1-41. The DRAG CHUTE switch, located on the LG control panel, is a three-position guarded switch used to deploy and release the drag chute. Manually holding the DRAG CHUTE switch in REL prevents drag chute deployment when the **DF** switch is placed to DEPLOY.

Manually holding the DRAG CHUTE switch in REL after **DF** drag chute deployment (switch remaining in DEPLOY) allows the deployed drag chute to release if airspeed is above 60 knots.

Manually holding the DRAG CHUTE switch in DEPLOY prevents drag chute release when the **DF** switch is moved from DEPLOY to NORM/REL.

### LANDING GEAR (LG) SYSTEM

**DR** All LG functions are duplicated except that the BRAKES channel, ANTI-SKID, and LANDING TAXI LIGHTS switches are not present. In addition, the DN LOCK REL button function is different.

#### DN LOCK REL Button **DR**

Refer to figure 1-37. The DN LOCK REL button, located on the LG control panel, when depressed, unlocks the LG handle electrically to allow movement to UP in case the left MLG WOW switch has failed to the ground position. The DN LOCK REL button has no mechanical unlock function.

### FLIGHT CONTROL SYSTEM

Simultaneous inputs to the forward and aft sticks (or rudder pedals) are added together to position the flight control surfaces accordingly. Unintentional right roll inputs can occur as a result of leg/knee interference with the stick.

**DR** The flight controls are abbreviated and contain only the stick, rudder pedals, and warning, caution, and status lights. The FLCP and MANUAL TRIM panels are not available.

### STICK CONTROL OPERATION

With the STICK CONTROL switch in FWD, the stick indicator displays the word FWD. Depressing the forward cockpit paddle switch locks out the rear cockpit stick, rudder, and MPO commands. The OVRD light in both cockpits illuminates indicating override is activated. Depressing the rear cockpit paddle switch has no effect on the forward cockpit controls.



With the STICK CONTROL switch in AFT, the stick indicator displays the word AFT. Depressing the rear cockpit paddle switch, **PX III** with the ASIU switch OFF or the ASIU STICK CONT switch in FLIGHT, locks out the forward cockpit stick, rudder, and MPO commands and transfers control of NWS to the rear cockpit. The OVRD light in both cockpits illuminates, indicating override is activated. Depressing the forward cockpit paddle switch has no effect on the rear cockpit controls.

**STICK CONTROL Switch **DF****

Refer to figure 1-18. The STICK CONTROL switch is located on the TEST switch panel.

Functions are:

- FWD – The aft cockpit flight control functions are locked out as long as the paddle switch is held depressed.
- AFT – The forward cockpit flight control functions are locked out, and NWS control is transferred to the rear cockpit as long as the paddle switch is held depressed.

**Stick Indicator **DR****

Refer to figure 1-90. A three-position stick indicator, located on the instrument panel, indicates the position of the STICK CONTROL switch by displaying the word AFT or FWD as applicable. Diagonal stripes appear when power is removed or appear momentarily during switching.

**Stick OVRD Lights **D****

Refer to figure 1-90. The stick OVRD lights, located on the forward and rear cockpit instrument panels, illuminate when the paddle switch is used to take control.

**ESCAPE SYSTEM **D****

**EJECTION MODE SEL Handle **DR****

Refer to figure 1-55. The EJECTION MODE SEL handle is located on the right auxiliary console.

Functions are:

- NORM
  - Activation of ejection system from rear cockpit results in canopy jettison, then a .33-second delay followed by only rear seat being ejected. Activation of ejection system from forward cockpit following rear seat ejection results in forward seat ejection.
  - Activation of ejection system from forward cockpit results in canopy jettison, a .33-second delay, aft seat ejection, and a .4-second delay followed by forward seat ejection.
- AFT – Activation of ejection system from either cockpit results in canopy jettison, a .33-second delay, aft seat ejection, and a .4-second delay followed by forward seat ejection.
- SOLO – Activation of ejection system from forward cockpit results in canopy jettison, then a .33-second delay followed by only forward seat being ejected. Activation of ejection system from aft cockpit results in canopy jettison, then a .33-second delay followed by only aft seat being ejected. Simultaneous activation from forward and aft cockpits results in unsequenced ejections.

**Stick Indicator and OVRD Light **D** (Typical)**

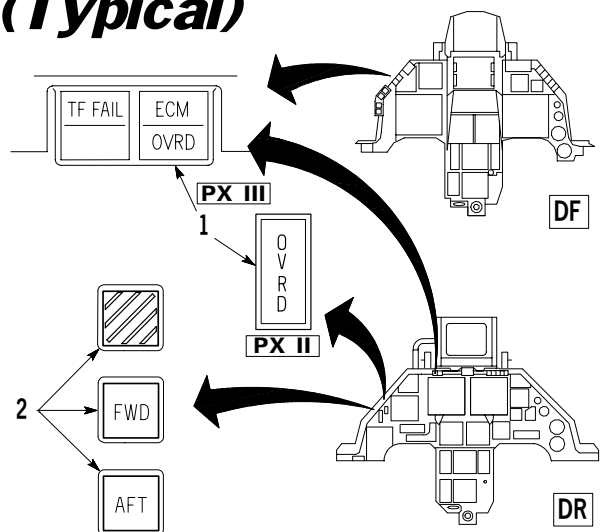

- 1. OVRD Light (Amber)
- 2. Stick Indicator

GR1F-16CJ-1-0093A37 ©

Figure 1-90.

## COMMUNICATIONS SYSTEM

Refer to figure 1-79. Identical audio control panels, with fully active switches, are located in both cockpits. The UHF, VHF, TACAN, and ILS can be enabled from either cockpit with the audio control panels but must be turned off in both cockpits to deactivate the equipment. Squelch functions only if squelch is enabled in both cockpits. Control of other functions is determined by the position of the **DF** **PX II** CNI, **PX III** C & I knob.

Functions are:

- **UFC** - Switches on the upfront controls are fully active in **DF** and **DR**. Control inputs can be made from either or both cockpits; however, only one variable (e.g., UHF frequency) can be selected or changed at one time. Only one DED, presented in both cockpits, can be selected at a time.
- **BACKUP** - **DR** No control is available for mode, code, channel, or frequency of the UHF, TACAN, or IFF. Audio control panels are not affected.

## INSTR MODE SELECT PANEL **D**

Refer to figure 1-84. If the INSTR MODE knob is in the same position in both cockpits, the rear cockpit HSI course slaves to that selected in the front cockpit. **DR** The INSTR MODE select panel does not have an INSTR HDG knob.

## FLIGHT INSTRUMENTS **DR**

An accelerometer is installed and the altimeter barometric pressure set knob is not connected to the CADC.

### Accelerometer **DR**

Refer to figure 1-91. The accelerometer is self-contained and mechanically indicates acceleration acting along the vertical axis of the aircraft. The accelerometer is graduated in g units and has three indicating pointers. The main pointer displays instantaneous changes in acceleration. The positive and negative auxiliary pointers indicate the maximum positive and negative acceleration experienced. The auxiliary pointers retain their highest readings until the PUSH TO SET knob is depressed.

## AFT STATION INTERFACE UNIT (ASIU) **DR** **PX III**

Refer to figure 1-92. The ASIU allows the aft stick to perform either regular flight control functions or expanded avionic functions. The ASIU panel is located on the right console, to the right of the aft stick. When activated, the ASIU converts aft station

stick and hands-on control inputs from analog signals to digital signals for transmission to the SMS and selected stores. Refer to figure 1-79.1 for hands-on controls located on the throttle and stick.

The switches on the ASIU panel have the following functions:

### STICK CONTROL Switch **DR** **PX III**

The STICK CONTROL switch is a two-position guarded switch. The switch positions are marked FLIGHT and AVIONICS.

Functions are:

- **FLIGHT** - Allows normal flight functions for aft stick and hands-on controls when the ASIU switch is in ASIU and the **DF** STICK CONTROL switch is in FWD.
- **AVIONICS** - Allows expanded avionic functions for aft stick and hands-on controls when the ASIU switch is in ASIU and the **DF** STICK CONTROL switch is in FWD. Allows normal flight operations for aft stick and hands-on controls when ASIU switch is in OFF.

## Accelerometer **DR** (Typical)

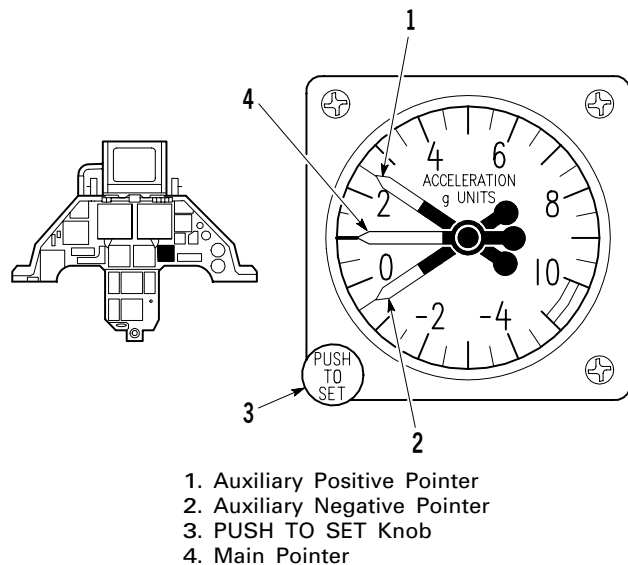

GR1F-16CJ-1-0094X37®

Figure 1-91.

# ASIU Panel **DR** **PX III**

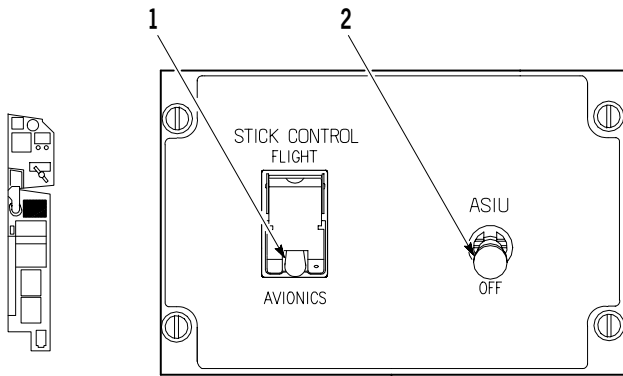

1. STICK CONTROL Switch  
2. ASIU Switch

GR1F-16CJ-1-1097X37 ©

Figure 1-92.

## ASIU Switch **DR** **PX III**

The ASIU switch is a two-position lever lock switch.

Functions are:

- ASIU - Power on.
- OFF - Power off.

For a detailed system description, refer to T.O. GR1F-16CJ-34-1-1.

## MULTIFUNCTION DISPLAY (MFD) **DR**

Refer to figure 1-3. The HUD CTVS video can be displayed on the right MFD by placing the VIDEO SEL switch to HUD.

## THROTTLE AND STICK SWITCHES/CONTROLS **DR**

Refer to figures 1-93 and 1-94 for the switches/controls located on the throttle and stick.

## ARMT CONSENT SWITCH **DR**

Refer to figure 1-3. The ARMT CONSENT switch, located on the instrument panel, is guarded in the

ARMT CONSENT position. The switch is in series with the MASTER ARM switch in the forward cockpit and must be in the ARMT CONSENT position to enable the normal release of any store.

## AFT SEAT HUD MONITOR (ASHM) **DR**

Refer to figure 1-95. The HUD CTVS video can be displayed on the ASHM or on the right MFD, depending on the position of the VIDEO SEL switch.

## SERVICING DIAGRAM

Refer to figure 1-96 for servicing/specifications information.

# Throttle and Stick Switches/Controls

## **DR** **PX II**

SWITCH/CONTROL	STATUS
<b>THROTTLE</b>	
DOG FIGHT/Missile Override	Inactive/Inactive
SPD BRK	Active
*RDR CURSOR/ENABLE	Active/Active
*ANT ELEV	Active
*MAN RNG/UNCAGE	Active/Active
UHF/VHF/IFF	Active/Active/Inactive
<b>STICK</b>	
TRIM	Active
CAMERA/GUN	Active/Inactive
WPN REL	Active
*Target Management	Active
*Display Management	Active
NWS A/R DISC	Active/Active
MSL STEP	Active
Paddle	Active
Expand/FOV	Active
Countermeasures Management	Inactive

\* Control gained by first upward activation of display management switch.

Figure 1-93.

# Throttle and Stick Switches/Controls

**DR PX III**

SWITCH/CONTROL	STATUS	
	ASIU POWER ON	ASIU POWER OFF
<b>THROTTLE</b> DOG FIGHT/Missile Override SPD BRK RDR CURSOR/ENABLE ANT ELEV MAN RNG/UNCAGE Transmit (UHF/VHF/IFF)	Inactive/Inactive Active Active/Active Active Active/Active Active/Active/Active/Inactive	Inactive/Inactive Active Inactive/Inactive Active Inactive/Inactive Active/Active/Active/Inactive
<b>STICK</b> TRIM CAMERA/GUN WPN REL Target Management Display Management NWS A/R DISC MSL STEP Paddle Expand/FOV Countermeasures Management	Active Active/Inactive Active Active Active Active/Active Active Active Active Inactive	Active Active/Inactive Active Inactive Inactive Active/Active Inactive Active Inactive Active (aft CMS FWD only)/Inactive

## NOTES:

- Switch/control functions vary depending on selection of FLIGHT or AVIONICS on the ASIU panel.
- Refer to T.O. GR1F-16CJ-34-1-1.

Figure 1-94.

# Aft Seat HUD Monitor DR

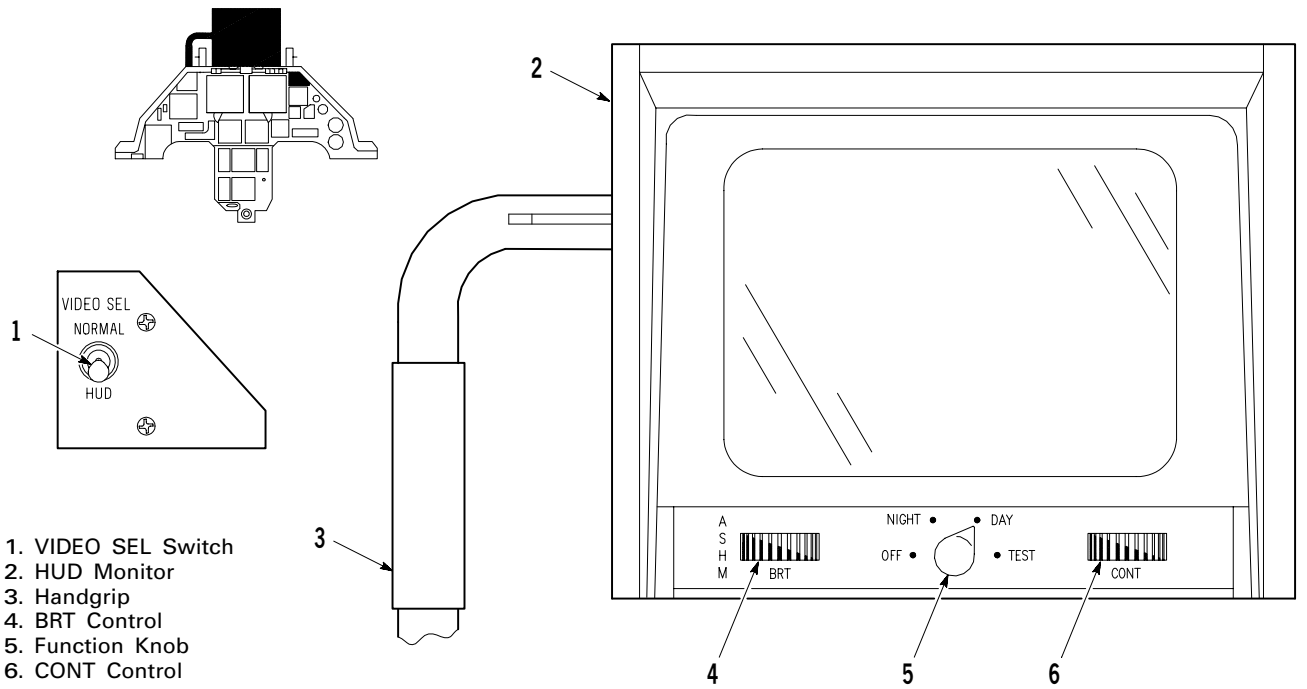
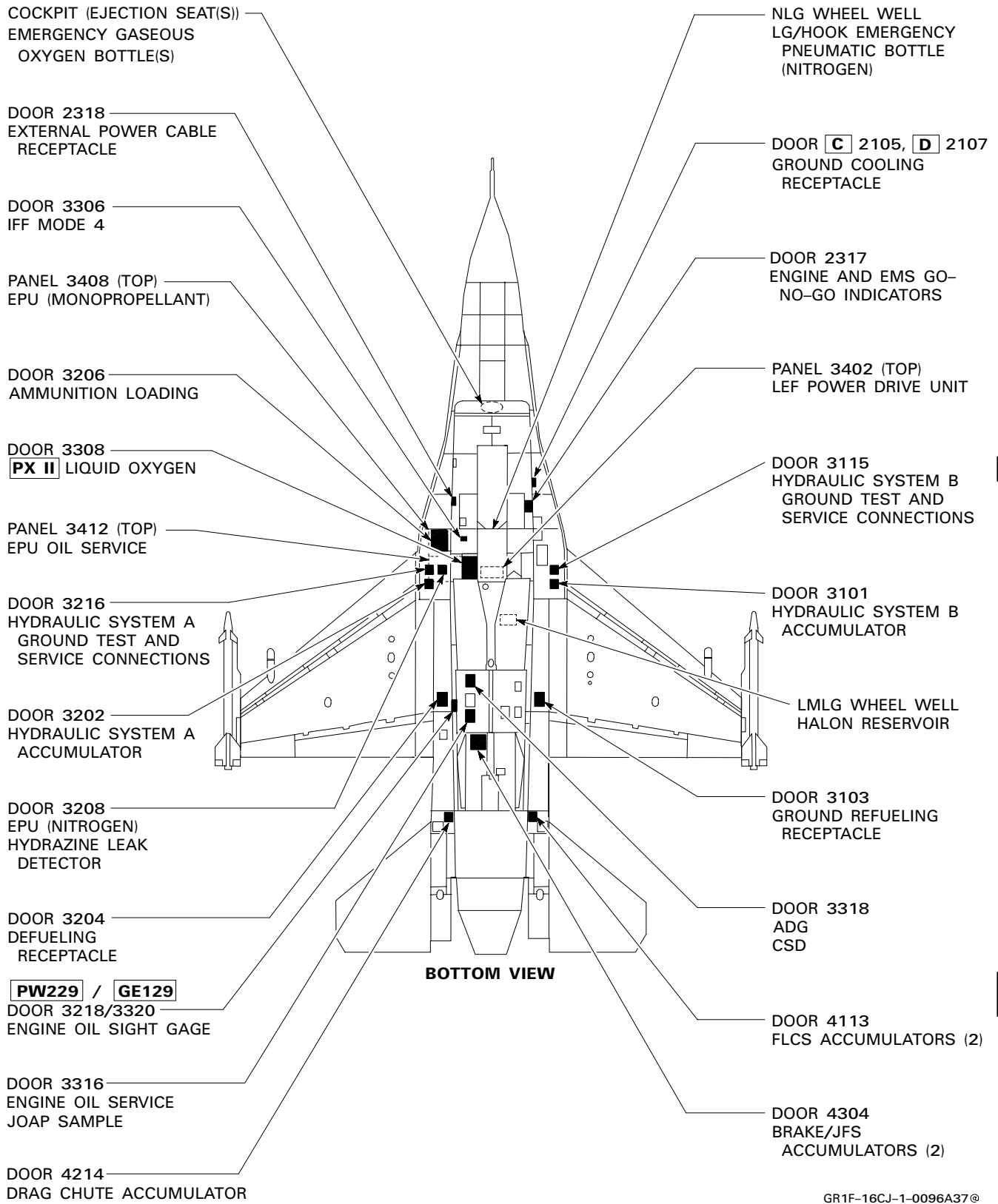

Figure 1-95.

# Servicing Diagram (Typical)



GR1F-16CJ-1-0096A37@

Figure 1-96. (Sheet 1)

# Servicing Diagram (Typical)

SERVICEABLE ITEM		SPECIFICATIONS	
		USAF	NATO
FUEL	ENGINE/JFS	MIL-T-5624, JP-4 MIL-T-5624, JP-5 MIL-T-83133, JP-8 JET A, B (COMMERCIAL) JET A-1 (COMMERCIAL)	F-40 F-43 OR F-44 F-34 NONE F-35
OIL	PW229 ENGINE *	MIL-L-7808J OR LATER	0-148
	GE129 ENGINE *	MIL-L-7808	
	ADG/CSD/EPU	MIL-L-7808	0-148
HYDRAULIC FLUID	HYDRAULIC SYSTEMS A AND B	MIL-H-5606 MIL-H-83282	H-515 H-537
OXYGEN	GASEOUS	MIL-O-27210, TYPE I	NONE
	PX II LIQUID	MIL-O-27210, TYPE II	
EXTERNAL ELECTRICAL POWER	115 (±15) VAC, 400 (±30) HZ	A/M32A-60A	NONE
NITROGEN	GASEOUS	BB-N-441A, TYPE I, GRADE B	NONE
FUEL TANK INERTING AGENT (OPTIONAL)	LIQUID	HALON 1301	NONE
MONOPROPELLANT (EPU)	LIQUID	HYDRAZINE (70% N <sub>2</sub> H <sub>4</sub> , 30% H <sub>2</sub> O)	NONE

\*IF NECESSARY, ENGINE LUBRICATING OILS MIL-L-7808 (NATO CODE 0-148) AND MIL-L-23699 (NATO CODE 0-156) MAY BE MIXED. AT THE FIRST OPPORTUNITY THEREAFTER, THE OIL SHALL BE DRAINED AND FLUSHED, AND THE ENGINE SERVICED WITH THE PROPER LUBRICATING OIL AS SPECIFIED IN THE APPLICABLE ENGINE TECHNICAL ORDERS.

Figure 1-96. (Sheet 2)

## SECTION II

## NORMAL PROCEDURES

## TABLE OF CONTENTS

TABLE OF CONTENTS	Page		Page
Introduction .....	2-1	Prior to Hot Refueling .....	2-31
Flight Planning .....	2-1	During Hot Refueling .....	2-32
Takeoff and Landing Data Card .....	2-1	Hot Refueling Complete .....	2-32
Cockpit Designation Code .....	2-1	Quick Turnaround .....	2-32
Weight and Balance .....	2-1	Prior to Engine Shutdown .....	2-32
Preflight Check .....	2-2	Special Procedures .....	2-32
Exterior Inspection .....	2-2	EPU Hydrazine Support at Non-F-16	
Cockpit Access .....	2-2	Bases .....	2-32
Before Entering Cockpit .....	2-2	Supplemental Procedures .....	2-32
Cockpit Interior Check .....	2-3	ILS Procedures .....	2-32
Left Console .....	2-4	Exterior Inspection .....	2-32
Left Auxiliary Console .....	2-5	Danger Areas .....	2-32
Instrument Panel .....	2-5	Turning Radius and Ground Clearance ....	2-32
Right Auxiliary Console .....	2-5	G-Suit Hose Routing .....	2-32
Right Console .....	2-6	Strange Field Procedures .....	2-32
After Cockpit Check Is			
Complete - Verify .....	2-6		
Before Starting Engine .....	2-7		
Starting Engine <b>PW 229</b> .....	2-8		
Starting Engine <b>GE129</b> .....	2-10		
After Engine Start .....	2-11		
Before Taxi .....	2-17		
Taxi .....	2-18		
Before Takeoff .....	2-18		
Takeoff .....	2-20		
Normal Takeoff .....	2-20		
Takeoff With Asymmetric Stores .....	2-22		
Climb .....	2-22		
Climb/In-Flight/Operational Checks .....	2-22		
Air Refueling Procedures .....	2-23		
Descent/Before Landing .....	2-23		
Landing .....	2-23		
Normal Landing .....	2-23		
Short Field Landing (Dry Runway) .....	2-26		
Crosswind Landing .....	2-26		
Touch-and-Go Landing .....	2-27		
After Landing .....	2-27		
Prior to Engine Shutdown .....	2-28		
Engine Shutdown .....	2-29		
Scramble .....	2-30		
Preflight .....	2-30		
Aircraft On Quick Response Status .....	2-30		
Hot Refueling .....	2-31		
Hot Refueling Precautions .....	2-31		
Prior to Hot Pit Entry .....	2-31		

## INTRODUCTION

This section provides the actions required for normal operation of the aircraft. Amplification is included only when special considerations or techniques should be observed. A complete knowledge of Section III, EMERGENCY PROCEDURES, and Section V, OPERATING LIMITATIONS, is required prior to flight.

## FLIGHT PLANNING

Refer to T.O. GR1F-16CJ-1-1.

## TAKEOFF AND LANDING DATA CARD

A takeoff and landing data card is provided in the Flight Crew Checklist for recording computed data.

## COCKPIT DESIGNATION CODE

An asterisk (\*) preceding steps is used to highlight procedures for **D** aircraft which apply to both cockpits.

## WEIGHT AND BALANCE

For maximum GW limitations, refer to Section V, OPERATING LIMITATIONS. For weight and balance information, refer to the individual aircraft Form F (DD Form 365-4) and the Weight and Balance Handbook.



## PREFLIGHT CHECK

Check AFTO Form 781 for aircraft release and stores status.

### EXTERIOR INSPECTION

Refer to figure 2-4 for normal preflight inspection.

### COCKPIT ACCESS

Refer to figure 2-1.

1. Canopy - Open by positioning external canopy switch to the up position.

#### WARNING

If winds exceed 30 knots, open the canopy only as far as needed to enter/exit the cockpit. Decreasing the canopy angle reduces the possibility that the canopy can be blown past full open.

2. Ladder - Position on cockpit sill.

#### CAUTION

**C** A failure of the canopy actuator could allow the canopy to fall during transit. Do not position the ladder until the canopy motion has stopped.

#### NOTE

**D** Cockpit access is gained by the use of two entrance ladders or moving one ladder as required.

### BEFORE ENTERING COCKPIT

- \*1. Ejection seat - Check.
  - Ejection safety lever - Safe (up).
  - Safety pins (2) - Removed (ejection safety lever and EMERGENCY MANUAL CHUTE handle).

## Cockpit Access (Typical)

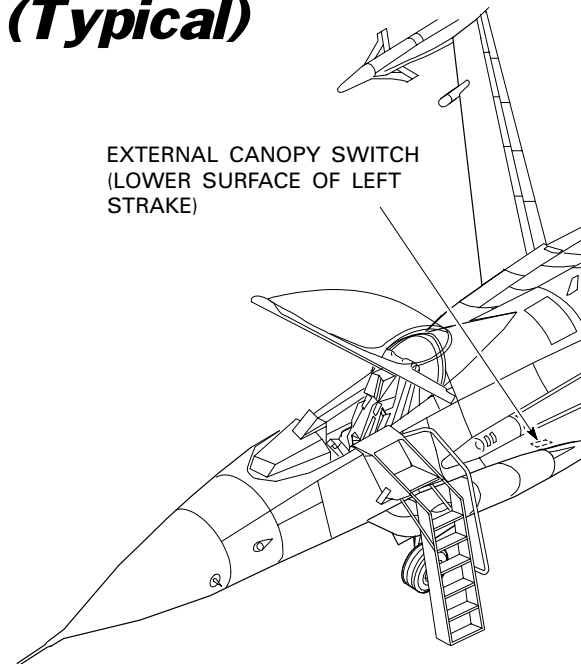

1F-16X-1-1045A ©

Figure 2-1.

- Survival KIT DEPLOYMENT switch - As desired.

#### WARNING

A Parachute Landing Fall (PLF) with the survival kit not deployed may result in injury.

- RADIO BEACON - As desired.
- Emergency oxygen bottle - 1800 psi minimum.
- Quick-disconnect (left side) - Connected.
- Recovery parachute - Free from damage and grease.
- Inertia reel straps retaining pin (yellow) - Visible in circular inspection hole.
- Parachute risers and SEAWARS - Free from damage and grease.



Rapidly pulling on the shoulder harness to check the locking mechanism may cause damage to the locking mechanism.

- Lanyards from canopy to seat – Check.
  - Emergency oxygen hose quick-disconnect – Connected.
  - Environmental sensor pitot tubes – Clear of obstructions and if flip-up pitot tubes are installed, safety pins (2) removed.
  - Quick-disconnect (right side) – Connected.
  - Electronic recovery sequencer battery indicator – White indication.
  - CANOPY JETTISON T-handle – Secure, safety pin removed.
  - Lapbelt retaining pins (yellow) – Protruding, both sides.
  - Lapbelts – Secure. (Pull up and forward, both sides.)
  - Survival kit straps – Secure. (Pull up and aft, both sides.)
2. MAIN PWR switch – OFF.

**DR** For solo flight:

3. Ejection seat – Safe, straps secure, pins removed.
4. CANOPY JETTISON T-handle – Secure, safety pin removed.
5. SPD BRK switch – Center.
6. FUEL MASTER switch – MASTER (guard down).
7. ENG CONT switch – NORM (guard down).

8. Audio panels – Set:
  - COMM 1 mode knob – SQL.
  - COMM 2 mode knob – SQL.
  - All other knobs – CCW.
9. ALT GEAR handle – In.
10. ALT FLAPS switch – NORM.
11. GND JETT ENABLE switch – OFF.
12. DRAG CHUTE Switch – NORM.
13. HOOK switch – UP.
14. ARMT CONSENT switch – ARMT CONSENT (guard down).
15. EJECTION MODE SEL handle – SOLO.
16. Interior LIGHTING control panel – All knobs off.
17. OXYGEN REGULATOR – OFF and 100%.
18. Utility light – OFF and secured.

### COCKPIT INTERIOR CHECK

The checklist steps are not arranged in a mandatory order.

- \*1. Loose or foreign objects – Check.  
A thorough cockpit interior preflight check shall be accomplished prior to each flight with emphasis on loose or foreign objects that might cause injury to personnel or damage to the aircraft.
- \*2. Harness and personal equipment – Fasten.  
Attach the parachute risers to the harness. Attach and adjust survival kit straps. Secure and adjust the lapbelt. After fastening lapbelt, hold right side of lapbelt buckle stationary and shake and push left side. Also insure that latching mechanism has reset back to its original position and is flush with buckle to insure a positive lock. Connect oxygen hose, g-suit hose, vest hose, and communication leads. Check operation of the shoulder harness locking mechanism.

**WARNING**

- A partially locked lapbelt may open during maneuvering flight or ejection sequence.
- Unobserved g-suit hose or vest hose disconnects can contribute to gray/blackout or loss of consciousness.
- Failure to adjust survival kit straps to achieve a snug fit between the pilot and seat pan lid may result in injury during ejection.
- Failure to adequately secure and tighten lapbelt may result in inability to reach and operate the MPO switch during out-of-control situations.

**CAUTION**

Do not adjust seat height with survival kit straps or lapbelt disconnected as damage to the ejection seat or stick may occur.

**NOTE**

- Refer to figure 2-11. The recommended routing of the g-suit hose is directly under the torso harness and aft of the survival kit strap to reduce the possibility of a g-suit hose disconnect. G-suit hose routing must provide sufficient slack to allow for maximum mobility since in-flight reconnect is extremely difficult.
- Excess g-suit hose must be properly routed to prevent MANUAL TRIM panel interference during flight.
- **DR** Incorrectly routed or unsecured g-suit hose may result in throttle interference or disconnected g-suit hose.

- \*3. Rudder pedals - Adjust.  
Adjust rudder pedals so that legs are flat on the seat cushion to prevent the right leg from hitting stick or injury during ejection.

**Left Console**

1. PROBE HEAT switch - OFF.
2. **DF** STICK CONTROL switch - As briefed when **DR** occupied; FWD for solo flight.

3. FLCS PWR TEST switch - NORM.
4. DEFOG lever - Midrange.
5. DIGITAL BACKUP switch - OFF.
- \*6. ALT FLAPS switch - NORM.
7. MANUAL TF FLY UP switch - ENABLE. ■
8. LE FLAPS switch - AUTO.
9. BIT switch - OFF.
10. TRIM/AP DISC switch - NORM.
11. ROLL, YAW, and PITCH TRIM - Center.
- \*12. FUEL MASTER switch - MASTER (guard down and **C** **DF** safety-wired).
13. TANK INERTING switch - OFF.
14. ENG FEED knob - NORM.
15. AIR REFUEL switch - CLOSE.
16. IFF MASTER knob - STBY.
17. **PX II** CNI, **PX III** C & I knob - BACKUP. ■
- \*18. TACAN - As desired.
19. EXT LIGHTING control panel - As required.

**CAUTION**

**PX III** If ground operation of the anticollision strobe light is anticipated to be longer than 2 hours, the ANTI-COLLISION knob should be set in position 1 to avoid overheating the power supply and strobe.

20. MASTER light switch - NORM.
21. EPU switch - NORM (guard down).
22. MAIN PWR switch - OFF.
23. AVTR power switch - OFF.
24. AVTR **PX II** DISPLAY, **PX III** VIDEO SELECT knob - HUD. ■
25. ECM power - Off.
- \*26. COMM 1 power knob - CW.
- \*27. COMM 1 mode knob - SQL.

- \*28. COMM 2 power knob – CW.
- \*29. COMM 2 mode knob – SQL.
- \*30. TACAN power knob – CW.
- 31. **[C]** **[DF]** AB RESET switch – NORM.
- 32. **[C]** **[DF]** ENG CONT switch – PRI (guard down).
- 33. **[DR]** ENG CONT switch – NORM (guard down).
- 34. JFS switch – OFF.
- 35. UHF radio backup control panel:
  - a. Function knob – BOTH.
  - b. Frequency – As desired.
- 36. Throttle – Verify freedom of motion, then OFF.
- \*37. SPD BRK switch – Forward.
- \*38. DOG FIGHT switch – Center.
- 4. **[DR]** ARMT CONSENT switch – ARMT CONSENT (guard down).
- 5. LASER ARM switch – OFF.
- \*6. DRAG CHUTE switch – NORM.
- \*7. HUD/ASHM – Set.
- \*8. Altimeter – Set.
- 9. FUEL QTY SEL knob – NORM.
- 10. EXT FUEL TRANS switch – NORM.

#### NOTE

- If a wing transfer valve fails and WING FIRST is selected, fuel flows onto the ground from the overboard vent line under the left wing (outboard of the fuel pylon). Selecting NORM should stop the fuel spillage.

#### Left Auxiliary Console

- \*1. ALT GEAR handle – In.
- 2. CMDS switches (9) – OFF.
- 3. RF switch – NORM.
- 4. **[PX III]** SYMBOLOGY power knob – Off.
- 5. STORES CONFIG switch – As required.
- 6. LANDING TAXI LIGHTS switch – OFF.
- \*7. LG handle – DN.
- \*8. GND JETT ENABLE switch – OFF.
- 9. BRAKES channel switch – CHAN 1.
- 10. ANTI-SKID switch – ANTI-SKID.
- \*11. EMER STORES JETTISON button – Cover intact.
- \*12. HOOK switch – UP.

#### Instrument Panel

- 1. ROLL switch – ATT HOLD.
- 2. PITCH switch – A/P OFF.
- 3. MASTER ARM switch – OFF.

- **[PX III]** If CFT's are installed and an external tank transfer valve fails to close when the tank is empty and WING FIRST or NORM is selected, fuel is trapped in the CFT and some trapped fuel may vent overboard. Selecting CFT FIRST/NO FILL should prevent trapped/vented CFT fuel.

- \*11. INSTR MODE knob – As desired.

#### Right Auxiliary Console

- \*1. Clock – Set.
- 2. **[DR]** EJECTION MODE SEL handle – **[125]** NORM or AFT (as briefed), **LESS [125] AFT**.

#### WARNING

- SOLO position should not be selected with the rear seat occupied.
- **[DR]** Ejection initiated with the EJECTION MODE SEL handle in NORM may incapacitate the **[DF]** pilot at airspeeds greater than 180 knots. Use of the NORM position is therefore not recommended.

**Right Console**

**NOTE**

**PX III** Oxygen regulator pressure decreases slowly when OBOGS is not operating and may indicate low prior to engine start.

1. SNSR PWR switches (4) – OFF.
2. HUD control panel – Set.
3. NUCLEAR CONSENT switch – OFF (guard down).
4. ZEROIZE switch – OFF.
- \*5. Wristrest and armrest – As desired.
- \*6. Interior LIGHTING control panel – As desired.
7. **C DF** VOICE MESSAGE switch – VOICE MESSAGE.  
If safety wire is broken, notify maintenance.
8. TEMP knob – AUTO.
9. AIR SOURCE knob – NORM.



If AIR SOURCE knob is in OFF or RAM, electronic equipment may be damaged.

10. AVIONICS POWER switches (8) – OFF.
11. ANTI ICE switch – AUTO/ON.



If engine anti-ice is on or has been on, heat in the inlet strut may be sufficient to cause injury if touched.



If there is visible moisture and ambient temperature is 45°F (7°C) or less, place the ANTI ICE switch to ON.

12. IFF ANT SEL switch – NORM.
13. UHF ANT SEL switch – NORM.

- \*14. **PX II** Oxygen system – Check:
  - Pressure – Check 50-120 psi.
  - Mode lever – PBG/ON (as required).
  - Diluter lever – NORM.
  - EMER lever – NORM.
  - FLOW indicator – Check.
  - EMER lever – EMER.  
Check for positive oxygen pressure and mask and hose/connector leakage.
  - EMER lever – NORM.

**AFTER COCKPIT CHECK IS COMPLETE – VERIFY**

The following items are those important switches that, if not correctly positioned, could cause a safety hazard and/or improperly operated systems during engine start.

- \*1. FUEL MASTER switch – MASTER (guard down and **C DF** safety-wired).
2. ENG FEED knob – NORM.
3. EPU switch – NORM (guard down).
4. **C DF** ENG CONT switch – PRI (guard down).
5. **DR** ENG CONT switch – NORM (guard down).
- \*6. Throttle – OFF.
- \*7. LG handle – DN.



Insure that the LG handle is confirmed fully down. The LG handle can be in an intermediate position allowing LG extension and/or safe indications; however, the LG handle is not locked and LG retraction could occur during subsequent ground operations.

- \*8. HOOK switch – UP.



**D** If either HOOK switch is in DN, the hook extends when aircraft battery power is applied.

9. MASTER ARM switch – OFF.

10. AIR SOURCE knob - NORM.
- \*11. Loose or foreign objects - Check.

**WARNING**

Loose or foreign objects in the cockpit can cause entanglement or obstruction with critical controls (e.g., ejection handle, stick, rudder pedals, throttle, canopy handle, etc.).

## BEFORE STARTING ENGINE

1. MAIN PWR switch - BATT.

**CAUTION**

To prevent possible depletion of battery power, do not allow MAIN PWR switch to remain in BATT or MAIN PWR for more than 5 minutes without engine running or external power applied.

**NOTE**

- A JFS RUN light flashing once per second indicates a non-critical failure in the JFS system. If the JFS operates normally for engine start, the mission may be continued. Notify maintenance after flight.
- A JFS RUN light flashing twice per second indicates a critical failure in the JFS system. The JFS will not operate. Place the MAIN PWR switch to OFF and notify maintenance.

- Verify FLCS RLY light on.

**NOTE**

- Toe brakes are not available when the FLCS RLY light is on and the aircraft battery is the only operating power source.

- **PX III** Labored breathing through the oxygen mask before engine start is possible with the diluter lever in NORM. It is not possible to breathe through the oxygen mask before engine start with the diluter lever in 100%.

2. FLCS PWR TEST switch - TEST and hold.  
Activation of the FLCS PWR TEST switch with the MAIN PWR switch in BATT closes FLCS relays and allows verification of power output of the FLCC with the aircraft battery as the power source.

- Verify lights on:

- ACFT BATT TO FLCS.
- FLCS PMG.
- FLCS PWR (4).

- Verify FLCS RLY light off.

3. FLCS PWR TEST switch - Release.

4. MAIN PWR switch - MAIN PWR.

- Verify lights on:

- ELEC SYS.
- HYD/OIL PRESS.
- FLCS RLY.
- SEC.
- ENGINE.

**CAUTION**

Do not apply external electrical power for more than 30 minutes without cooling air; longer operation may damage electronic components which cannot be turned off. Prior to applying external power without cooling air, insure that all avionic equipment is off; UHF radio operation on backup control is permissible.

**NOTE**

If FLCS RLY light is off, cycle MAIN PWR switch to BATT and back to MAIN PWR to open FLCS relays.

5. EPU GEN and EPU PMG lights - Confirm off.

**WARNING**

If either light is illuminated, turn the MAIN PWR switch to OFF. Insure that the EPU safety pin remains installed and notify maintenance. (The EPU will activate using hydrazine if the EPU safety pin is removed.)

6. Communications - Established.
7. Canopy - As desired.

**WARNING**

Ⓢ A failure of the canopy actuator could allow the canopy to fall during transit. Keep hands and arms out of the path of canopy travel during opening or closing.

**CAUTION**

- To prevent possible engine damage, stow or secure loose cockpit items prior to engine start with the canopy not closed.
- Ⓢ Ⓞ When lowering or raising the canopy handle, insure that the canopy switch is not bumped to the up (open) position before handle is completely locked or unlocked. If this occurs, hold the switch in the down (close) position as soon as possible to relieve the jammed condition and prevent canopy actuator motor burnout. If required, manually crank canopy toward the closed position to relieve the jammed condition. If possible, place MAIN PWR switch to OFF and have the aircraft battery disconnected by the ground crew. This action removes power from the canopy actuator.

8. Chocks in place, fireguard posted, and intake and other danger areas clear (ground crew).

**STARTING ENGINE** PW 229

Refer to figure 2-8 for danger areas. Moving the JFS switch to either start position closes the FLCS relays. The FLCS RLY light goes off; the FLCS PMG light (and ACFT BATT TO FLCS light if engine is started on battery power) illuminates. Toe brakes also become functional (if engine is started on battery power).

The JFS RUN light comes on within 30 seconds; after the JFS RUN light illuminates, engine rpm starts to increase smoothly. At approximately 15 percent rpm, the hydraulic and fuel pressures increase. The SEC caution light goes off by approximately 18 percent rpm. The throttle should be advanced to IDLE after engine rpm reaches 20 percent. Immediately after advancing the throttle to IDLE, the SEC caution light illuminates for about 3 seconds to indicate automatic DEEC/SEC ground self-test. Engine light-off occurs within 20 seconds after throttle advance and is indicated by airframe vibration and an increase in rpm followed by an increase in FTIT. Without external power connected, only the RPM and FTIT indicators function until the standby generator is on line.

At approximately 50 percent rpm, the JFS automatically shuts down. At approximately 55 percent rpm, the standby generator comes on line, the ENGINE warning light goes off, and the OXY LOW warning light illuminates for approximately one second. To insure the emergency buses are being powered by the standby generator, check for illumination of the SEAT NOT ARMED caution light and three green WHEELS down lights prior to the main generator coming on line. Five to ten seconds after the the standby generator comes on line, the main generator comes on line, and the standby generator goes off line.

FTIT increases smoothly at a moderate rate and normally peaks at less than 625°C.

1. JFS switch - START 2.
2. SEC caution light - Check off.

3. Throttle - Advance to IDLE at 20 percent rpm minimum.



If the FUEL MASTER switch is discovered in OFF during start (i.e., after the throttle is moved to IDLE), discontinue the start. Positioning the FUEL MASTER switch to MASTER with the throttle out of OFF may cause a hot start or tailpipe fire.

#### NOTE

- If the HYD/OIL PRESS warning light goes off and stays off prior to approximately 25 percent rpm, suspect failure of the engine oil pressure sensor and abort the aircraft. This check is not valid if less than 30 seconds elapse from movement of the MAIN PWR switch out of OFF until both hydraulic pressures are above 1000 psi (i.e., low oil pressure time delay has not expired; in which case, the HYD/OIL PRESS warning light goes off when hydraulic pressures exceed 1000 psi, but may reilluminate if the 30-second time delay expires while oil pressure is still low.
- If the main and/or standby generator fails to come on, do not attempt reset. Although the generator(s) may reset, a problem may still exist. Notify maintenance.
- The SEC caution light illuminates immediately after throttle advance for about 3 seconds indicating automatic DEEC/SEC ground self-test.
- If the FLCS RLY light remains on with the JFS switch in either start position, one or more FLCS relays did not latch closed. Latching may occur when the standby or main generator comes on line. If the FLCS RLY light goes off when either generator comes on line, notify maintenance of the occurrence after flight. If the FLCS RLY light remains on after the main generator is on line, notify maintenance.

- If an engine restart is desired shortly after engine shutdown, motor the engine with the JFS for a minimum of 1 minute or a maximum of 4 minutes before throttle advancement to insure the FTIT drops below 200°C. Initiating a start with the FTIT above 200°C may result in a DEEC FTIT limited hung start.

4. ENGINE warning light - Off (approximately 55 percent rpm).

\*Engine at idle and check:

5. JFS switch - Confirm OFF.



If JFS switch does not automatically return to OFF, turn JFS off. Notify maintenance after flight.

6. HYD/OIL PRESS warning light - Off.  
The HYD/OIL PRESS warning light may not go off until rpm is increased to 70 percent. If the warning light comes on again at idle, notify maintenance.
7. FUEL FLOW - 500-1500 pph.
8. OIL pressure - 15 psi (minimum).
9. NOZ POS - Greater than 80 percent.
10. RPM - 65-77 percent.
11. FTIT - 625°C or less.
12. HYD PRESS A & B - 2850-3250 psi.
13. Six fuel pump lights (ground crew) - On.

#### NOTE

FFP light may blink at idle rpm.



14. Main fuel shutoff valve (ground crew) – Check.

**WARNING**

Do not make stick inputs while ground crew is in proximity of control surface.

15. JFS doors (ground crew) – Verify closed.
16. Throttle cutoff release – Check.  
Verify that the cutoff release does not remain in the actuated position by attempting to retard the throttle to OFF without depressing the cutoff release. If throttle moves to OFF, remain in OFF and notify maintenance.

**NOTE**

Failure to perform this check after engine start can result in an undetected stuck throttle cutoff release, which may lead to an unintentional engine shutdown.

**STARTING ENGINE** GE129

Refer to figure 2-8 for danger areas. Moving the JFS switch to either start position closes the FLCS relays. The FLCS RLY light goes off; the FLCS PMG light (and ACFT BATT TO FLCS light if engine is started on battery power) illuminates. Toe brakes also become functional (if engine is started on battery power).

The JFS RUN light comes on within 30 seconds; after the JFS RUN light illuminates, engine rpm starts to increase smoothly. The throttle should be advanced to IDLE after engine rpm reaches either 20 percent rpm (ambient temperature less than 90°F) or maximum motoring rpm (ambient temperature 90°F or greater). Engine light-off occurs within 10 seconds after throttle advance and is indicated by an airframe vibration and an increase in rpm followed by an increase in FTIT. Without external power connected, only the RPM and FTIT indicators function until the standby generator is on line.

The SEC caution light goes off at 20 percent rpm. At approximately 55 percent rpm, the JFS automatically shuts down. At approximately 60 percent rpm, the standby generator comes on line and the ENGINE warning light goes off. To insure the emergency buses are being powered by the standby generator, check for illumination of the SEAT NOT ARMED caution light and three green WHEELS

down lights prior to the main generator coming on line. Five to ten seconds after the standby generator comes on line, the main generator comes on line and the standby generator goes off line.

FTIT increases smoothly at a rapid rate.

1. JFS switch – START 2.

**NOTE**

Abnormal rpm indications (i.e. instantaneous jumps) may indicate alternator failure and not rpm indicator malfunction. Abort the aircraft and notify maintenance.

2. Throttle – Advance to IDLE at either 20 percent rpm minimum (ambient temperature less than 90°F) or maximum motoring rpm (ambient temperature 90°F or greater).

**CAUTION**

If the FUEL MASTER switch is discovered in OFF during engine start (i.e., after the throttle is moved to IDLE), discontinue the start. Positioning the FUEL MASTER switch to MASTER with the throttle out of OFF may cause a hot start or tailpipe fire.

**NOTE**

- If the HYD/OIL PRESS warning light goes off and stays off prior to approximately 15 percent rpm, suspect failure of the engine oil pressure sensor and abort the aircraft. This check is not valid if less than 30 seconds elapse from movement of the MAIN PWR switch out of OFF until both hydraulic pressures are above 1000 psi (i.e., low oil pressure time delay has not expired; in which case, the HYD/OIL PRESS warning light goes off when hydraulic pressures exceed 1000 psi, but may reilluminate if the 30-second time delay expires while oil pressure is still low).
- If the main and/or standby generator fails to come on, do not attempt reset. Although the generator(s) may reset, a problem may still exist. Notify maintenance.

**NOTE**

If the FLCS RLY light remains on with the JFS switch in either start position, one or more FLCS relays did not latch closed. Latching may occur when the standby or main generator comes on line. If the FLCS RLY light goes off when either generator comes on line, notify maintenance of the occurrence after flight. If the FLCS RLY light remains on after the main generator is on line, notify maintenance.

3. SEC caution light - Off.
4. ENGINE warning light - Off (approximately 60 percent rpm).

**NOTE**

In hot day conditions (temperature greater than 90°F (32°C)) the ENGINE warning light may not go off until idle speed is obtained (greater than 70 percent rpm).

\*Engine at idle and check:

5. JFS switch - Confirm OFF.



If JFS switch does not automatically return to OFF, turn JFS off. Notify maintenance after flight.

6. HYD/OIL PRESS warning light - Off.  
The HYD/OIL PRESS warning light may not go off until rpm is increased to 70 percent. If the warning light comes on again at idle, notify maintenance.
7. FUEL FLOW - 700-1700 pph.
8. OIL pressure - 15 psi (minimum).
9. NOZ POS - Greater than 94 percent.
10. RPM - 62-80 percent.
11. FTIT - 650°C or less.
12. HYD PRESS A & B - 2850-3250 psi.
13. Six fuel pump lights (ground crew) - On.

**NOTE**

FFP light may blink at idle rpm.

14. Main fuel shutoff valve (ground crew) - Check.

**WARNING**

Do not make stick inputs while ground crew is in proximity of control surface.

15. JFS doors (ground crew) - Verify closed.
16. Throttle cutoff release - Check.  
Verify that the cutoff release does not remain in the actuated position by attempting to retard the throttle to OFF without depressing the cutoff release. If throttle moves to OFF, remain in OFF and notify maintenance.

**NOTE**

- Failure to perform this check after engine start can result in an undetected stuck throttle cutoff release, which may lead to an unintentional engine shutdown.
- Engine vibration/rumble may be sensed on the ground while accelerating or decelerating the engine, when transferring to SEC, or when stabilized at idle in either PRI or SEC. This vibration/rumble has no adverse effect on the engine or aircraft structure. The vibration/rumble should disappear when the throttle is advanced slightly (approximately 5 percent rpm increase).

**AFTER ENGINE START**

1. TEST switch panel - Check:
  - a. PROBE HEAT switch - PROBE HEAT.  
PROBE HEAT caution light off. If the caution light illuminates, one or more probe heaters are inoperative or a monitoring system failure has occurred.
  - b. PROBE HEAT switch - TEST.  
PROBE HEAT caution light flashes 3-5 times per second. If the caution light does not illuminate or if it illuminates but does not flash, the probe heat monitoring system is inoperative.
  - c. PROBE HEAT switch - OFF.
  - d. FIRE & OHEAT DETECT button - Test.

- e. **PX II** OXY QTY test switch - Test and check.
- f. MAL & IND LTS button - Test.

**NOTE**

- Proper VMS operation is verified by the presence of each word in priority sequence (i.e., PULLUP, ALTITUDE, WARNING, etc.). A brief LG warning horn is also heard prior to the WARNING and CAUTION words.
- **D** Only the LG warning horn and the warning and caution voice messages are heard when MAL & IND LTS test is initiated from the rear cockpit.
- **LESS 173 PX III D** The circuitry powering the AVIONICS FAULT caution lights and ECM lights is not capable of turning on both the **DF** and the **DR** lights except during MAL & IND LTS test. As a result, the only time these lights illuminate in either cockpit is during MAL & IND LTS test. For avionics faults, failure of the AVIONICS FAULT caution lights to come on also prevents illumination of the MASTER CAUTION light and operation of the voice caution message. Faults will still be displayed on the PFLD. The interim solution is removal of the light bulbs from the **DR** AVIONICS FAULT caution light and **DR** ECM light. This solution enables operation of the **DF** AVIONICS FAULT caution light, **DF** ECM light, both MASTER CAUTION lights, and the voice caution message after a fault occurs. The **DR** AVIONICS FAULT caution light and **DR** ECM light should not illuminate during MAL & IND LTS test if the bulbs have been removed. If the **DR** AVIONICS FAULT caution light or **DR** ECM light illuminates during MAL & IND LTS test, contact maintenance.

- 2. **PX II** AVIONICS POWER panel - Set:
  - a. FCC switch - FCC.
  - b. SMS switch - SMS.
  - c. MFD switch - MFD.
  - d. UFC switch - UFC.
  - e. GPS switch - GPS.

- 3. **PX III** AVIONICS POWER panel - Set:
  - a. MMC switch - MMC.
  - b. ST STA switch - ST STA.
  - c. MFD switch - MFD.
  - d. UFC switch - UFC.
  - e. GPS TRK switch - GPS TRK.
- 4. EGI/INS - Align (**PX III** after display visible on the DED).

**NOTE**

- **PX III** If GPS is unavailable, failure to enter alignment coordinates flags the alignment as degraded (NAV RDY light does not flash).
- **PX II** Entry of alignment coordinates is required even if internal coordinates are exactly equal to parking spot location.
- Failure to enter alignment coordinates flags the alignment as degraded (NAV RDY light does not flash).
- 5. SNSR PWR panel:
  - a. LEFT HDPT switch - OFF, unless required.

**WARNING**

Select OFF unless TFR/FLIR operation is planned. With LEFT HDPT power on and the TFR in OFF/STBY, a failure in the WX mode circuitry can cause the TFR to operate in the WX mode. An unexpected fly-up may subsequently occur.

- b. RIGHT HDPT switch - As required.
- c. FCR switch - FCR.

**CAUTION**

In environments of high humidity, delay turning the FCR on for approximately 4 minutes. This action precludes damage to FCR caused by moisture in the ECS immediately after engine start.

- d. RDR ALT switch - RDR ALT.

- \*6. HUD/ASHM – As desired.
7. **PX II** CNI, **PX III** C & I knob – UFC.

**NOTE**

If UFC battery failure occurs, UHF/VHF preset frequencies in the UFC revert to default values until entered manually or by the DTC.

8. MFL – Clear.

**NOTE**

Multiple nonresettable FLCS MFL's may occur during engine start and may be accompanied by a lack of control surface response to stick/rudder commands. These MFL's can occur if aircraft battery voltage is low or if a switching problem occurs when the JFS switch is moved out of OFF. If multiple FLCS MFL's remain after a FLCS reset:

**116** Perform the following:

- DBU switch – BACKUP, then OFF. Cycling the DBU switch with WOW reinitializes the FLCC and inhibits FLCS MFL reporting for 20 seconds.

If FLCS MFL's clear and do not recur after 20 seconds, maintenance action is not required.

**LESS 116** Perform the following:

- DBU switch – BACKUP, then OFF.
- FLCS RESET switch – RESET.

If FLCS MFL's clear, maintenance action is not required.

If FLCS MFL's remain:

- FLCS BIT – Initiate and monitor.

If FLCS MFL's remain:

- Engine – Shut down, then restart to cycle power to the FLCC.

If FLCS MFL's clear following FLCS BIT or engine restart, notify maintenance of the occurrence after flight.

9. **PW 229** SEC – Check after the engine has run at idle for at least 30 seconds. May be delayed until the BEFORE TAKEOFF check.

- Throttle – IDLE.

- ENG CONT switch – SEC.
  - NOZ POS – Less than 5 percent.
  - SEC caution light – On.
  - Throttle – Verify engine response to throttle movement, then IDLE.
- ENG CONT switch – **C** **DF** PRI, **DR** NORM.
  - NOZ POS – Greater than 80 percent.
  - SEC caution light – Off.

10. **GE129** SEC – Check. May be delayed until the BEFORE TAKEOFF check.

- ENG CONT switch – SEC.
  - SEC caution light – On.
  - RPM – Stabilized.
    - RPM may drop up to 10 percent from PRI value before stabilizing. Stabilized SEC idle rpm may be up to 5 percent lower than that in PRI.
  - Throttle – Snap to MIL and then snap to IDLE when rpm reaches 85 percent. Check for normal indications and smooth operation.
  - NOZ POS – 10 percent or less within 30 seconds after selecting SEC.
- ENG CONT switch – **C** **DF** PRI, **DR** NORM.
  - SEC caution light – Off.
  - NOZ POS – Greater than 94 percent.

11. Flight controls – Cycle.

**NOTE**

To assist in warming the hydraulic fluid and removing air from the hydraulic system, maximum stick and rudder pedal inputs should be made prior to running FLCS BIT.

12. FLCS BIT – Initiate and monitor. Position BIT switch to BIT. The RUN light on FLCP illuminates. At successful completion of BIT (approximately 45 seconds), the RUN light goes off, the BIT switch returns to OFF, and the FAIL light and FLCS warning light remain off. A BIT pass message appears on the FLCS MFD page.

**NOTE**

- If the FLCS BIT reports a failure through the FLCS warning light and the FAIL light on the FLCP, the failure cannot be reset. The BIT must be reinitiated. In this case, the RUN light and the FAIL light are simultaneously illuminated for the first steps of the BIT, after which the FAIL light goes off unless BIT detects a subsequent failure.
- If the **PX II** FCC, **PX III** MMC is not turned on prior to FLCS BIT, an FLCS MUX DEGR message appears on the PFLD.
- Entering system altitude during FLCS BIT results in an incorrect system altitude.
- During FLCS BIT, the ECS air ejectors are turned off. This results in higher ECS component temperatures and may cause fumes in the cockpit that could be described as metallic odors. This situation is normal and does not require maintenance action.
- **PW 229** During FLCS BIT, the CADC provides a mach signal to the engine that results in an rpm increase of approximately 2 percent.

13. ECM panel - As required.

14. SPD BRK switch - Cycle.

\*15. WHEELS down lights - Three green.

\*16. SAI - Set.

17. FUEL QTY SEL knob - Check.

The following values are based on JP-4 or JP-5/8:

- TEST - FR, AL pointers indicate 2000 ( $\pm 100$ ) pounds and totalizer indicates 6000 ( $\pm 100$ ) pounds. FWD and AFT FUEL LOW caution lights illuminate. **PX III** If CFT's are installed, CFT pumps operate and shut down 30 seconds after switch is moved out of TEST (if INT WING & CFT fuel quantity is less than 1425/1500 pounds).
- NORM - AL pointer indicates approximately 2675/2810 pounds. FR pointer indicates approximately 3100/3250 (**D**) 1800/1890) pounds.

- RSVR - Each reservoir indicates approximately 460/480 pounds.
- **PX II** INT WING - Each wing indicates approximately 525/550 pounds.
- **PX III** INT WING & CFT - If CFT's are not installed (or installed and not filled), each wing indicates approximately 525/550 pounds. If CFT's are filled, each pointer indicates approximately 2000/2100 pounds.
- EXT WING - Each external wing tank indicates approximately 2300/2420 pounds (370-gallon fuel tank) or 3750/3925 pounds (600-gallon tank) (for full tanks).
- EXT CTR - FR pointer indicates approximately 1800/1890 pounds (for full tank). AL pointer drops to zero.

**NOTE**

The sum of the individual fuel tanks and the totalizer should agree within  $\pm 100$  pounds with only internal fuel or  $\pm 300$  pounds with external fuel.

- FUEL QTY SEL knob - As desired.

18. EPU FUEL quantity - 95-102 percent.

19. Avionics - Program as required and verify (manual or data transfer cartridge).

- SMS.



When AIM-9's are loaded, the **PX II** SMS, **PX III** ST STA switch must be maintained in the **PX II** SMS, **PX III** ST STA position while taxiing or airborne. If recycling of the **PX II** SMS, **PX III** ST STA switch is required, power should not be off longer than 8 seconds at any one time.

- Communications.
- Steerpoints.
- Profile data (including bingo fuel).
- MFD master mode data.

\*20. MFD's – As desired.

21. VHF radio – As desired.

After FLCS BIT completed:

\*22. DBU – Check.

- a. DIGITAL BACKUP switch – BACKUP.  
Verify that DBU ON warning light illuminates.

**NOTE**

The AOA indicator displays the middle AOA value selected. The indication may change in gusty wind conditions.

- b. Operate controls – All surfaces respond normally.
- c. DIGITAL BACKUP switch – OFF.  
Verify that DBU ON warning light goes off.

23. Trim – Check.

- TRIM/AP DISC switch – DISC.
- Stick TRIM button – Activate in roll and pitch.
  - No control surface motion.
  - No TRIM wheel or indicator motion.
- TRIM/AP DISC switch – NORM.
- Stick TRIM button – Check and center.
  - Control surface motion.
  - TRIM wheel and indicator motion.
- Rudder trim check.
  - YAW TRIM knob – Check and center.

\*24.  FLCS override – Check.

- STICK CONTROL – Selected cockpit.
- Stick indicator – As selected.
- Selected cockpit paddle switch – Depress.

- OVRD lights – On (both cockpits).

- Selected cockpit stick – Operative.

- Other cockpit stick – Inoperative.

\*25. MPO – Check.

- Stick – Full forward and hold; note horizontal tail deflection.

- MPO switch – OVRD and hold.

- Confirm that horizontal tail trailing edges move farther down.

- Stick and MPO switch – Release.

- Confirm that the horizontal tail returns to its original position.

\*26. Operate controls – All surfaces respond normally; no FLCS lights on.

\*27. AR system (if required) – Check.

- AIR REFUEL switch – OPEN, RDY light on, DISC light off.

**NOTE**

If both the RDY and DISC lights are on, then one or more relays are failed. This condition must be corrected prior to AR.

- A/R DISC button – Depressed. DISC light on, RDY light off; 3 seconds later, RDY light on, DISC light off.

- AIR REFUEL switch – CLOSE, RDY light off.

\*28. Brakes – Check both channels; then return to CHAN 1.

- One brake pedal – Depress.

- Confirm (ground crew) – Brake activates.

- Opposite brake pedal – Depress.

- Confirm (ground crew) – Initial brake does not activate.

- Repeat above steps for opposite brake.

T.O. GR1F-16CJ-1

29. Anti-ice – Check.

**PW 229** Perform the following:

- Insure that the engine has been stabilized at idle rpm for at least 1 minute with ANTI ICE switch ON.
- ANTI ICE switch – OFF.
  - Monitor FTIT when the ANTI ICE switch is moved to OFF. If FTIT does not decrease by at least 10°C within 15 seconds, abort the aircraft.
- ANTI ICE switch – AUTO or ON as required.

**GE129** Perform the following:

- Insure that the engine is stabilized at idle rpm.
- ANTI ICE switch – OFF, then ON for 45 seconds.
- If ENG A/I FAIL PFL occurs:
  - Stabilize engine at 80 percent rpm.
  - ANTI ICE switch – OFF for 15 seconds, then note FTIT.
  - ANTI ICE switch – ON while monitoring FTIT.
  - If FTIT fails to increase a minimum of 10°C within 30 seconds, abort the aircraft if flight may encounter areas of known or suspected icing conditions.
- ANTI ICE switch – AUTO/ON.

30. EPU GEN and EPU PMG lights – Confirm off. If either light is illuminated, cycle the EPU switch to OFF, then back to NORM. If either light stays on, abort the aircraft.

31. EPU switch – OFF.

**NOTE**

To prevent inadvertently selecting ON, lift only the aft section of the split guard.

32. Ground safety pins (ground crew) – Remove.

33. EPU switch – NORM.

34. Intercom (ground crew) – Disconnect.

35. Avionic BIT's – As desired.

- TACAN preflight check – Complete.
  - TACAN power knob – CW. (Allow 90 seconds for warmup.)
  - HSI CRS knob – Set COURSE 180.
  - INSTR MODE knob – TCN.
  - Select TACAN BIT on MFD test page.
  - HSI range and course warning flags – In view.
  - HSI bearing pointer may temporarily slew to 270 degrees.
  - HSI range and course warning flags – Out of view.
  - HSI range indicator – Indicates 000 ( $\pm 0.5$ ) nm.
  - HSI bearing pointer – Indicates 180 ( $\pm 3$ ) degrees.
  - HSI CDI – Center within  $\pm 1/2$  dot.
  - HSI TO-FROM indicator – TO.

36. **C DF** Seat – Adjust to design eye.

37. **PX III** OBOGS – Check (at least 2 minutes after engine start).

- OBOGS BIT switch – BIT.
- Verify that OXY LOW warning light illuminates for 10 seconds, then goes off.
- Pressure – Check 25-40 psi.
- Mode lever – PBG/ON (as required).
- Diluter lever – NORM.
- EMERGENCY lever – NORM.
- FLOW indicator – Check.
- EMERGENCY lever – EMERGENCY.
  - Check for positive pressure and mask and hose/connector leakage.
- EMERGENCY lever – NORM.

## BEFORE TAXI

1. Canopy - Close and lock.  
The canopy may be partially opened for taxiing if required for increased visibility.
2. HAVE QUICK radio - Set and check (if required).

### NOTE

**PX III** The HAVE QUICK radio accepts the first TOD signal that is received after power up. When the EGI is first powered on, the first EGI TOD signal will likely not be synchronized with the GPS constellation universal time coordinated (UTC) time since 30-45 seconds are typically required for satellite acquisition. To insure that the HAVE QUICK radio is using a synchronized UTC TOD, another TOD should be manually received after an adequate GPS track has been achieved. The best indication of an adequate GPS track is to access the NAV STATUS DED page (LIST 4) and verify the horizontal accuracy status. A GPS HIGH estimated horizontal accuracy status (or less than 300 feet if the selected accuracy display format is in feet) should ensure that the EGI TOD signal is synchronized with UTC time. Alternatively, verify that 4 satellites are being tracked by the EGI by confirming that a 4 is displayed for EGI Miscellaneous Parameter (EGIM) 200.

### Upfront controls:

- Select the UHF page on DED by depressing the COM 1 override button.
- **PX II** CNI, **PX III** C & I knob - BACKUP.
- Mode knob - PRESET.
- After the MWOD and current date (if required) are entered, select channel 20, manually set 220.000 MHz, and depress the PRESET button (failure to do this renders the UHF radio inoperative).

- **PX II** CNI, **PX III** C & I knob - UFC.
- Update the TOD by positioning the DED asterisks around the TOD label on either the UHF or HAVE QUICK pages and then depressing the ENTR or M-SEL button. Request a TOD transmission from another user. In either mode, the transmission must be received within 1 minute of depressing the ENTR or M-SEL button.
- Operating mode - UHF (normal) or HQ (AJ).
- Transmission status - MAIN or BOTH.
- Select an AJ net number with the manual frequency knob.
- Bandwidth - NB or WB.

### Backup controls:

- **PX II** CNI, **PX III** C & I knob - BACKUP.
- Function knob - MAIN or BOTH.
- Mode knob - PRESET.
- After the MWOD and current date are entered, select channel 20, manually set 220.000 MHz, and depress the PRESET button (failure to do this renders the UHF radio inoperative).
- Enter the TOD by requesting a TOD transmission. To receive TOD update for the normal mode (UHF-TOD), position the **PX II** A-3-2-T knob, **PX III** T-TONE switch to T and then return to a normal channel in either manual frequency or preset channel mode. To receive TOD update for the AJ mode (HQ-TOD), **PX II** rotate the A-3-2-T knob to T and then back to A, **PX III** place T-TONE switch to T. A TOD abbreviated time update can be received on the selected AJ net on which the TOD is being transmitted. In either mode, the transmission must be received within 1 minute of selecting T.
- Select an AJ net number with the manual frequency knobs.
- **PX II** A-3-2-T, **PX III** A-3-2 knob - A.



- \*3. Altimeter and altitude indications - Set and check.

Check that the altimeter readings in ELECT and PNEU are  $\pm 75$  feet of a known elevation and are  $\times \pm 75$  feet of one another. Also check that the ELECT mode altimeter reading is  $\times \pm 75$  feet of the altitude displayed in the HUD.

- 4. Exterior lights - As required.
- 5. **PX II** INS, **PX III** EGI knob - NAV.

**WARNING**

ATF or manual TF is prohibited following any INS/EGI alignment other than a full performance NORM gyrocompass ground alignment with flashing RDY/ALIGN displayed.

- 6. Chocks (ground crew) - Remove.

**WARNING**

If the aircraft has flown in the past 2 hours, do not use the parking brake except for an emergency. (Does not apply if drag chute was used.) Parking brake use may cause residual heat damage to brakes and may increase the probability of a subsequent brake fire.

**TAXI**

Refer to figure 2-6 for turning radius and ground clearance.

- \*1. Brakes and NWS - Check.

**CAUTION**

- To minimize heat buildup in the brake assemblies, do not ride the brakes to control taxi speed. Use one firm application of the toe brakes to slow the aircraft.
- Hydraulic fluid ignites at relatively low temperatures. If advised of a hydraulic leak around the brakes, request firefighting equipment and do not taxi.

**NOTE**

Constant rudder pedal pressure should not be required to maintain a straight ground track during taxi (based on level surface and no asymmetries or crosswind).

- \*2. Heading - Check.
- \*3. Flight instruments - Check for proper operation.

**BEFORE TAKEOFF**

- \*1. ALT FLAPS switch - NORM.
- 2. MANUAL TF FLYUP switch - ENABLE.
- 3. Trim - Check pitch and yaw trim centered and roll trim as required.

**WARNING**

Failure to center yaw trim may result in severe control difficulties during takeoff.

- 4. **C DF** ENG CONT switch - PRI (guard down).
- 5. **DR** ENG CONT switch - NORM (guard down).
- 6. Speedbrakes - Closed.
- 7. Canopy - Close, lock, light off.
- 8. IFF - Set and check.
- 9. External tanks (if installed) - Verify feeding. If three tanks are installed, verify that the centerline tank is feeding. This action checks that pressurization is available to all tanks.
- 10. FUEL QTY SEL knob - NORM.

**NOTE**

The FUEL QTY SEL knob must be in NORM for operation of the automatic forward fuel transfer system, trapped fuel warning, and for the BINGO fuel warning computation to be based on fuselage fuel.

- 11. STORES CONFIG switch - As required.

- \*12. GND JETT ENABLE switch – As required.

**NOTE**

Selecting ENABLE starts the DWAT 3-minute timer.

- \*13. Harness, leads, and anti-g system – Check.

- OXYGEN mode lever – PBG.
- Anti-g system – Test.  
Depress TEST button to check that g-suit inflates, comfort zippers are closed and remain closed, and hose remains connected and that pressure is supplied to mask, helmet bladder, and vest.

**WARNING**

Delayed or slow inflation of the g-suit could indicate impending anti-g system failure. Complete loss of g-protection could occur with no warning.

- OXYGEN mode lever – As required.

**WARNING**

- Failure to select PBG when PBG operation is desired can contribute to gray/blackout or loss of consciousness.
- Placing the OXYGEN mode lever to PBG without wearing the CRU-94/P harness-mounted connector can expose the pilot to injury producing levels of oxygen pressure should a failure occur within the oxygen regulator.

14. EPU – Check:

**NOTE**

- EPU may be checked anytime after engine start.
  - EPU safety pin (ground crew) – Check removed.
  - OXYGEN – 100%.
  - Engine rpm – Increase **PW 229** 5 percent, **GE129** 10 percent above normal idle.



Attempting EPU/GEN TEST at idle rpm results in abnormally low EPU run speed. Low EPU speed may cause electrical bus cycling and possible damage to electrical equipment. Indications may include blinking EPU GEN light or audible clicking of electrical contactors as the bus cycles. If electrical bus cycling is experienced, abort the aircraft and do not taxi.

- EPU/GEN TEST switch – EPU/GEN and hold. Check lights:
  - EPU AIR light – On.
  - EPU GEN and EPU PMG lights – Off (may come on momentarily at start of test).
  - FLCS PWR lights – On.
  - EPU run light – On for a minimum of 5 seconds.

**NOTE**

If EPU run light does not come on within 10 seconds after EPU/GEN is selected, release EPU/GEN TEST switch, advance the throttle to idle rpm plus **PW 229** 10 percent (85 percent rpm maximum), **GE129** 15 percent (90 percent rpm maximum), and reselect EPU/GEN. If the EPU run light does not illuminate within 10 seconds or if it cycles on and off, abort the aircraft.

- EPU/GEN TEST switch – OFF.
- Throttle – IDLE.
- Voltage transients may cause fault light indications. Reset CADC, AVIONICS FAULT and **PW 229** ENGINE FAULT caution lights as necessary and check MSL ALLOW value. A power cycle of individual systems may also be required if MFL's occur and remain after the MFD TEST page is cleared.
- OXYGEN – NORMAL.
- EPU exhaust (ground crew) – Check for no airflow.

**WARNING**

- Airflow is indicative of a failed high-pressure bleed valve which could result in an EPU overspeed in flight. If airflow is detected, abort the aircraft.
- If required to shut down and restart the engine after completing the EPU check or if the EPU safety pin is reinstalled for any reason, the EPU check must be reaccomplished prior to flight to insure proper EPU operation and closure of the high-pressure bleed valve.

15. FLIR – As required.
16. TFR – As required.
17. PROBE HEAT switch – PROBE HEAT.

Turn probe heat on at least 2 minutes prior to takeoff anytime icing of probes is possible. When probe icing is not suspected, delay selection of probe heat as long as possible prior to takeoff.

**WARNING**

- Probe internal icing must be suspected anytime the aircraft has been exposed to near or below freezing conditions on the ground. Internal icing may be difficult to see and may remain present even when current conditions do not appear conducive to ice formation.
- AOA probes may become hot enough to shut off probe heaters and cause illumination of the PROBE HEAT caution light. Refer to CAUTION LIGHT ANALYSIS, Section III, to determine if the shutdown was due to overheat or system failure.
- If probe heat is on or has been on, heat in probes may be sufficient to cause injury if touched.

- \*18. Ejection safety lever – Arm (down).
- \*19. Flight controls – Cycle.
- \*20. OIL pressure – Check psi.
- \*21. **PX III** ALLOW MSL FLOOR Data – Check.

**NOTE**

**PX III** MSL FLOOR value of 0 feet may indicate a MMC autorestart occurred, and mission planning data has been lost.

- \*22. All warning and caution lights – Check.
23. Adjustable sliding holder (when utility light is not in use) – **C** **DF** Full forward, rotated cw, and secured.

**WARNING**

Failure to properly secure utility light and adjustable sliding holder can result in stick interference.

24. TGP – Stow.

**TAKEOFF****NORMAL TAKEOFF**

Refer to figure 2-2. When ready for takeoff:

- Advance throttle to approximately **PW 229** 85, **GE129** 90 percent rpm.
- Verify parking brake disengaged.
- Check engine instruments for normal indications.
- Release brakes prior to exceeding **PW 229** 85, **GE129** 90 percent rpm.
- Advance throttle to desired thrust.

**NOTE**

An engine runup check is not required if conditions require a rolling takeoff.

Maximum FTIT and rpm vary with temperature and pressure altitude but stabilize in 5-15 seconds.

Normal engine operation during an MIL takeoff is indicated by a exhaust nozzle position of:

- **PW 229** 20 percent or less.
- **GE129** 15 percent or less after 5 seconds at MIL.

Normal engine operation during an AB takeoff is indicated by:

- **PW 229** The nozzle beginning to open within 5 seconds after selecting AB.

- **GE129** The nozzle preopening up to 10 percent more than MIL nozzle position when AB is first selected. AB light-off should occur within 5 seconds (greater than 40°F) or 10 seconds (40°F or less) after AB selection and is indicated by increasing fuel flow and nozzle position.

#### NOTE

Spacing of less than 15 seconds between aircraft when AB is used by preceding aircraft increases the probability of an AB blowout or no light due to hot gas ingestion.

When airspeed is approximately 10 knots below computed takeoff speed for non-AB or 15 knots for AB, initiate rotation to establish takeoff attitude (8-12 degrees). Do not apply aft stick at airspeed lower than 10-15 knots below computed takeoff speed. Early rotation can lead to overrotation, skipping, wallowing due to early lift-off, and increased takeoff distance.

As aircraft lifts off, LEF's extend downward. Retract LG when safely airborne. Insure LG is up and locked before exceeding 300 knots. TEF's retract when the LG handle is raised.



- Since LG and TEF retraction occurs simultaneously, LG retraction should not be rushed after takeoff. The reduction in lift may cause the aircraft to descend and contact the runway.
- Due to low aft stick forces required for takeoff, use caution to avoid early rotation.
- If any FLCS PFL occurs during takeoff, a WOW switch problem may be indicated. If the fault clears, the mission may be continued. Notify maintenance of the occurrence after the flight.
- Insure that the LG handle is placed fully up. The handle can stop in an intermediate position which retracts the LG; however, the handle is not locked and may lower under high g conditions.

## Normal Takeoff (Typical)

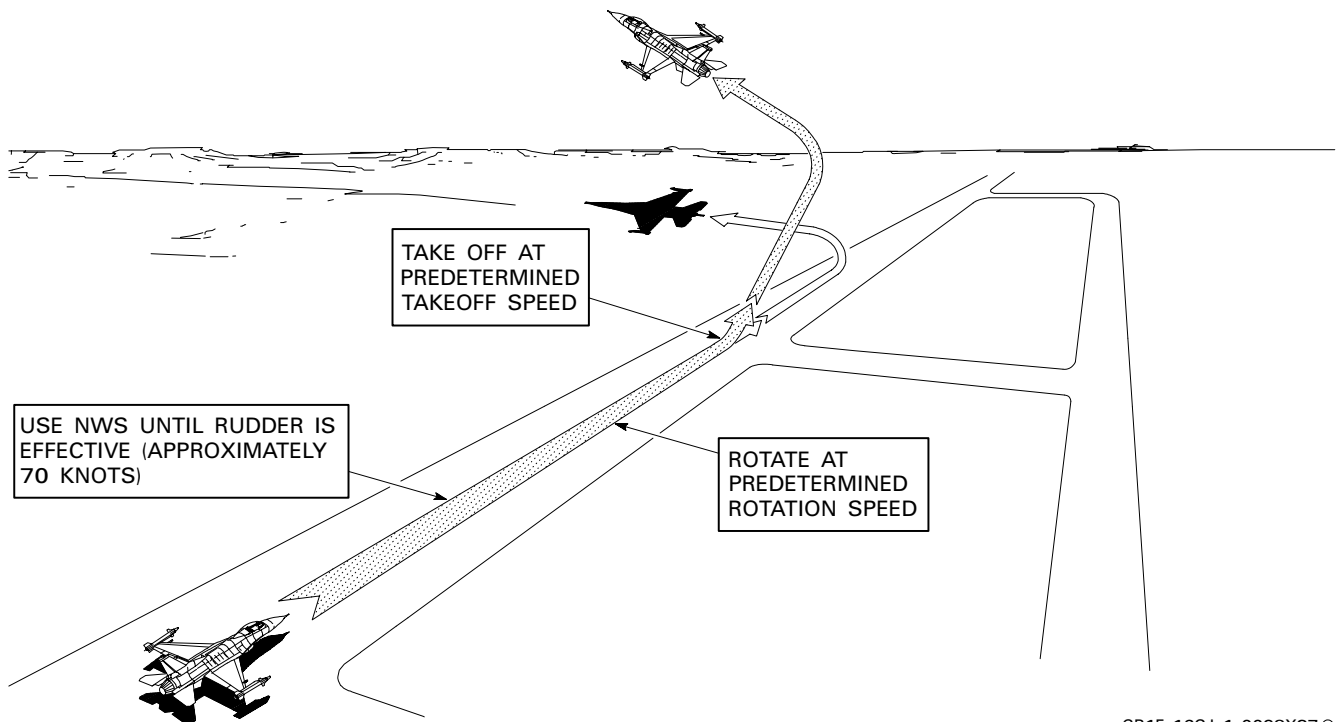

GR1F-16CJ-1-0098X37@

Figure 2-2.

## TAKEOFF WITH ASYMMETRIC STORES

Roll trim should be set prior to takeoff with asymmetric stores to prevent wing drop. The amount of roll trim required for various asymmetric store weights is shown in T.O. GR1F-16CJ-1-1, Part 2.

### NOTE

It is possible to exceed the roll trim authority of the aircraft for an onspeed takeoff with a net asymmetric (rolling) moment less than aircraft takeoff limits. Refer to ASYMMETRIC STORES LOADING, Section V.

When ARI activates after takeoff, roll trim for asymmetric stores causes a rudder input that can cause aircraft yaw away from the wing with the asymmetric store. This yaw is easily controllable by pilot rudder inputs.

## CLIMB

The climb schedules are defined by airspeed/mach number or mach number only. When airspeed/mach number is shown, climb at the scheduled airspeed to the scheduled mach number, then maintain the mach number to the desired altitude. When starting a climb at an altitude above the airspeed/mach transition point, climb at the scheduled mach number.

The recommended MIL climb schedule to optimum cruise altitude is tabulated versus drag index in T.O. GR1F-16CJ-1-1, Part 3. For MIL, the schedule provides optimum range performance. The recommended MIL climb schedules to altitudes other than optimum cruise altitude are shown in T.O. GR1F-16CJ-1-1 and T.O. GR1F-16CJ-1CL-1.

The recommended MAX AB climb schedule is tabulated versus drag index in T.O. GR1F-16CJ-1-1, Part 3. The MAX AB climb schedule provides minimum time to climb performance.

## CLIMB/IN-FLIGHT/OPERATIONAL CHECKS

At frequent intervals, check the aircraft systems, engine instruments, cockpit pressure, and oxygen flow indicator and system operation. Monitor fuel in each internal and external tank to verify that fuel is transferring properly by rotating the FUEL QTY SEL knob and checking that the sum of the pointers and totalizer agree and that fuel distribution is correct.

### WARNING

Maximum fuel transfer rate is 18,000 pph from the 300-gallon fuel tank or 30,000 pph from the 370/600-gallon fuel tanks. Maintaining fuel flow above these values while the external tank(s) is feeding results in a decrease of internal fuel. Prolonged operation under these conditions may result in the rapid depletion of fuselage fuel and render fuel transfer by siphoning action inoperative. Without siphoning action, fuel transfer to the fuselage tanks is provided by the wing turbine pumps at a maximum rate of 6000 pph. A fuel flow rate greater than 6000 pph continues to deplete fuselage fuel. Under these conditions, the external fuel tank(s) may appear slow to feed and a fuel imbalance may result. Prolonged AB operation in a three tank configuration may result in engine flameout prior to depletion of external fuel.

1. Fuel - Check quantity/transfer/balance.
2. FUEL QTY SEL knob - NORM.

### NOTE

The FUEL QTY SEL knob must be in NORM for operation of the automatic forward fuel transfer system, trapped fuel warning, and for the BINGO fuel warning computation to be based on fuselage fuel.

3. Oxygen system – Check.
4. Cockpit pressurization – Check.

### WARNING

The CABIN PRESS caution light does not illuminate until cockpit pressure altitude is above 27,000 feet. At ambient altitudes where hypoxia is possible, do not remove the oxygen mask without first checking cockpit pressure altitude.

5. Engine instruments – Check.

## AIR REFUELING PROCEDURES

Refer to T.O. 1-1C-1 for general AR procedures and to AIR REFUELING PROCEDURES, Section VIII for specific AR procedures.

## DESCENT/BEFORE LANDING

1. Fuel – Check quantity/transfer/balance.
2. Final approach airspeed – Compute.
3. DEFOG lever/cockpit heat – As required.
4. Landing light – On.
- \*5. Altimeter and altitude indications – Check altimeter setting, ELECT versus PNEU mode altimeter readings, and ELECT mode altitude versus altitude displayed in HUD.

For subsonic flight below 20,000 feet MSL with vertical velocity less than 500 fpm, the difference between ELECT and PNEU mode altitudes should not exceed 270 feet and the difference between the ELECT mode altitude and the altitude displayed in the HUD should not exceed 75 feet.

### WARNING

- An erroneous ELECT mode altitude can be displayed without a CADC caution light or a transfer to PNEU mode.
- An erroneous altitude can be displayed in the HUD without a CADC caution light.

- \*6. Attitude references – Check ADI/HUD/SAI.
7. ANTI ICE switch – As required.
8. TGP – Stow.

## LANDING

### NORMAL LANDING

Refer to figure 2-3. Fly initial at 300 knots. At the break, retard throttle and open speedbrakes as required. On downwind leg, when airspeed is below 300 knots, lower the LG. During base turn, recheck the LG down and slow to computed final approach airspeed to arrive on final at 11 or 13 degrees AOA. Check speedbrakes open and maintain computed final approach airspeed/AOA on final. Rate of descent decreases slightly when entering ground effect. Reduce thrust gradually to continue the descent while applying back stick to reduce sink rate to the minimum practical. Thrust can be reduced sooner during an 11-degree approach than during a 13-degree approach. In either case, maintain a maximum of 13 degrees AOA while reducing sink rate to the minimum practical.

### WARNING

- Physically confirm that the LG handle is fully down. The LG handle may visually appear to be down when in an intermediate position. An intermediate position may allow LG extension and/or safe indications; however, the LG handle is not locked and LG retraction could occur during subsequent in-flight or ground operations.
- Failure of the ANTI-SKID switch can allow it to be bumped/placed towards PARKING BRAKE while airborne. A very small movement out of ANTI-SKID is sufficient to engage the parking brake. Landing with the parking brake engaged will result in main tire failures upon touchdown.



- Failure to depress the LG handle down permission button prior to attempting to lower the LG may result in damage to the electrical solenoid.
- Failure to reduce sink rate, particularly at heavier GW's, may cause a firm landing and structural damage or failure of the LG.
- **D** Use of the paddle switch may cause pitch and/or roll transients as control is switched from one cockpit to the other.
- Avoid landing directly on approach-end arresting cable to prevent possible cable strike damage to nozzle, speedbrakes, and ventral fins.
- Horizontal tail contact with the runway is possible if a large roll input is made at or near touchdown.
- Deploying the drag chute above 170 knots may result in loss of the chute canopy.
- Drag chute deployment below 90 knots may result in improper deployment and damage to the chute.

#### NOTE

- The HUD AOA bracket and AOA indicator display the correct AOA until NLG WOW. Therefore, these indications are valid references for aircraft attitude throughout two-point aerodynamic braking. After NLG WOW, the AOA indicator displays zero.
- The LG warning horn and the TO/LDG CONFIG warning light are inhibited at approach airspeed above 190 ( $\pm 4$ ) knots.
- Aft CG approaches may be characterized by increased pitch sensitivity which will be most noticeable upon entering ground effect.

Deploy the drag chute (if desired) immediately after touchdown. The nose may pitch up or down when the chute is deployed, but the motion is easily controlled.

#### NOTE

- To deploy the drag chute after touchdown, lift the guard and switch in one single motion with the side of the index finger.
- When deploying the drag chute in a two-point aerodynamic braking attitude, the drag chute may contact the runway.

Use two-point aerodynamic braking until approximately 100 knots; then fly the nosewheel to runway. Maximum effective two-point aerodynamic braking is achieved at 13 degrees AOA. An AOA less than 11 degrees results in significantly reduced two-point aerodynamic braking. Although two-point aerodynamic braking is effective as low as 80 knots, runway length and condition should be used to determine when, after decelerating to 100 knots, to lower the nose to the three-point attitude.



- Do not touch down with brake pedals depressed. A failure in either the touchdown protection circuitry or an MLG WOW switch can result in locked wheels and blown MLG tires.
- Use a maximum of 13 degrees AOA for two-point aerodynamic braking. Nozzle, speedbrakes, and ventral fins may contact runway if 15-degree pitch angle is exceeded.
- During two-point aerodynamic braking, the speedbrakes (43 degrees or greater open) may contact the cable.
- During the landing phase, large/rapid roll control inputs in reaction to turbulence or wake vortices will cause temporary retraction of one and sometimes both flaperons. This retraction will decrease lift and may induce a sink rate beyond the structural limit of the landing gear. During rapid reversal of roll inputs, both flaperons might move up to a position that will illuminate the TO/LDG CONFIG warning light. Display of ISA FAIL PFL's is also possible. Be prepared to initiate a go-around if wake turbulence is encountered.

# Normal Landing Pattern (Typical)

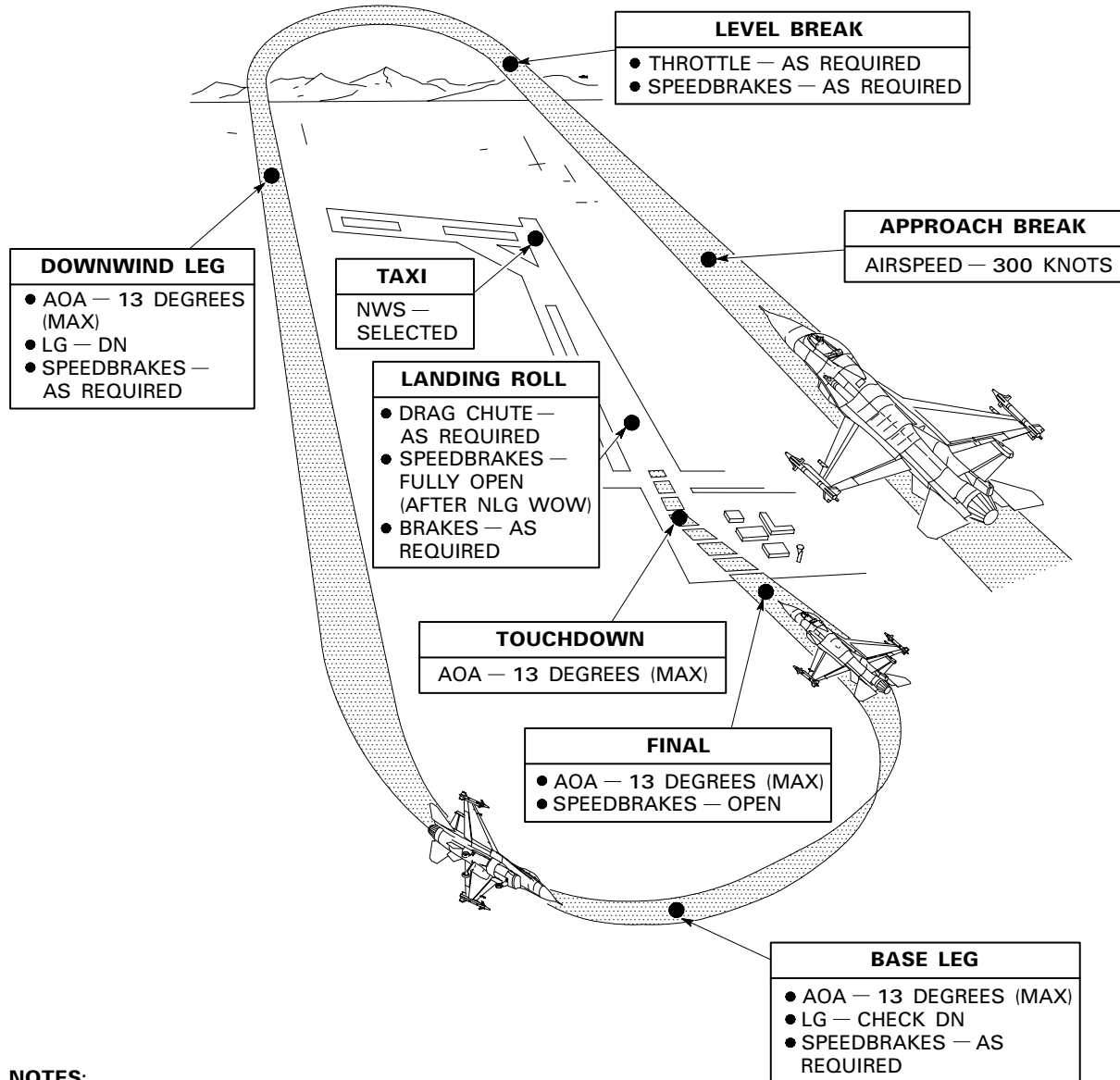

## NOTES:

- FINAL APPROACH AIRSPEED/13 DEGREES AOA CROSS-CHECK.
  - **C** PW229 135 GE129 136 KNOTS + 4 KNOTS PER 1000 POUNDS OF FUEL/STORE WEIGHTS. ADD 8 KNOTS FOR 11 DEGREES AOA APPROACH.
  - **D** PW229 137 GE129 138 KNOTS + 4 KNOTS PER 1000 POUNDS OF FUEL/STORE WEIGHTS. ADD 8 KNOTS FOR 11 DEGREES AOA APPROACH.
- THE PRECEDING BASELINE AIRSPEEDS ARE BASED ON THE BASIC OPERATING WEIGHT FROM T.O. GR1F-16CJ-1-1 PLUS FULL AMMO. ACTUAL FINAL APPROACH AIRSPEED AT 11/13 DEGREES AOA MAY DIFFER BY +/-5 KNOTS DUE TO VARIATIONS IN AIRCRAFT CG.

GR1F-16CJ-1-0099A37®

Figure 2-3.



After the nosewheel is on the runway, open the speedbrakes fully and maintain full aft stick for maximum three-point aerodynamic braking and wheel braking effectiveness.

**CAUTION**

- Crossing an arresting cable in a three-point attitude above 90 knots groundspeed with a centerline store may cause cable strike.
- Do not move SPD BRK switch to open until the nosewheel is on runway as speedbrakes may contact runway.
- Until WOW, forward stick pressure in excess of approximately 2 pounds results in full trailing edge down deflection of the horizontal tails. This horizontal tail deflection reduces wheel braking effectiveness. At high speeds in the three-point attitude, forward stick results in excessive loads on the NLG which can lead to nose tire failure and possibly cause structural failure of the NLG.

Smoothly apply moderate to heavy braking to decelerate to taxi speed. Using less than moderate braking increases the likelihood of a hot brake(s). NWS should not be engaged above taxi speed unless required to prevent departure from prepared runway surface.

**WARNING**

NWS malfunctions at any speed may cause an abrupt turn, tire skidding or blowout, aircraft tipping, and/or departure from the prepared surface.

**SHORT FIELD LANDING (DRY RUNWAY)**

**NOTE**

The following procedures should be used anytime stopping distance is critical, whether due to a long, fast, heavy weight, or short field landing.

When stopping distance is critical, a normal approach should be made. Select IDLE at or slightly before touchdown. Touch down as near as possible to the end of the runway at 13 degrees AOA. Deploy the drag chute immediately after touchdown. Two-point aerodynamic and wheel braking should be used with the nose held up at 13 degrees AOA until the nose falls. Pitch must be held at 13 degrees AOA if two-point aerodynamic braking is to be effective. Maximum effort braking is achieved by using the wheel brakes in conjunction with two-point aerodynamic braking. When the wheel brakes become effective, the nose automatically lowers. This occurs soon after brakes are applied. After the nosewheel is on the runway, maintain full aft stick, open the speedbrakes fully, and use maximum wheel braking (antiskid on).

For landing on icy/wet runways, refer to LANDING IN ICY OR WET CONDITIONS, Section VII.

**CROSSWIND LANDING**

The recommended technique for landing in a crosswind is to use a wing level crab through touchdown. At touchdown, the ARI switches out. Undesirable yaw transients may occur if roll control is being applied at this time. After touchdown, perform two-point aerodynamic braking using the rudder to maintain aircraft track down the runway and flaperon to prevent wing rise. In crosswinds, the aircraft may drift downwind due to side loads imposed by the crosswinds or travel upwind due to insufficient directional control inputs/availability. As the airspeed decreases, increasing amounts of rudder are required to maintain track. Maintain two-point aerodynamic braking until approximately 100 knots or until roll or directional control becomes a problem. As the pitch attitude decreases, the nose tends to align itself with the ground track.

Aft stick and fully opened speedbrakes reduce stopping distance. Apply brakes after nosewheel is on the runway; however, if stopping distance is a factor, refer to SHORT FIELD LANDING, this section. With all LG on the runway, maintain directional control with rudder, differential braking, and NWS if required.

During landing rollout, the main concerns are wing rise (roll control), weathervaning (directional control), and downwind drift. Wing rise is controlled by flaperon into the crosswind. Excessive flaperon deflection degrades directional control. Use rudder and differential braking to control ground track, especially on wet or icy runways. Engage NWS if required to maintain directional control and to prevent departure from the runway. Excessive differential braking may result in a hot brake condition. High rudder pedal force may result in a yaw transient when NWS is engaged. NLG strut compression is required to engage NWS but sustained forward stick may result in full horizontal tail deflection which decreases weight on the MLG and thus reduces wheel braking effectiveness. NWS engagement may be required with the drag chute deployed to control increased weathervaning tendencies. However, the nose up pull of the drag chute may prevent early NWS engagement.

### **WARNING**

Be prepared to release the drag chute during the landing rollout if directional control or downwind drifting becomes a problem.

### **NOTE**

Deploying the drag chute during two-point aerodynamic braking with a crosswind may complicate aircraft control.

### **TOUCH-AND-GO LANDING**

Perform a normal approach and landing. After touchdown, maintain landing attitude, advance the throttle, close the speedbrakes, and perform a normal takeoff.

## **AFTER LANDING**

### **WARNING**

Do not use parking brake. Use only chocks, if available, or minimum possible toe brakes pressure to hold the aircraft stationary. Parking brake use may cause residual heat damage to brakes and may increase the probability of a subsequent brake fire.

### **NOTE**

- Avoid heavy braking below 20 knots at light GW's. Heavy braking during these conditions may cause both MLG WOW switches to momentarily go to the air position, which causes the anti-skid system to deactivate the toe brakes. The WOW switches return to the ground position after 1-1.5 seconds, restoring braking capability. If heavy braking resumes, the cycle may be repeated.
  - ☐ NWS disengagements are possible when taxiing with CG near the in-flight aft limit.
1. DRAG CHUTE switch - NORM/REL as required.

### **NOTE**

Turn aircraft into the wind prior to releasing drag chute.

2. PROBE HEAT switch - OFF.

### **WARNING**

If probe heat is on or has been on, heat in probes may be sufficient to cause injury if touched.



Prolonged ground operation of probe heat may cause failure of AOA probe heaters.

3. ECM power – Off.
4. Speedbrakes – Close.
- \*5. Ejection safety lever – Safe (up).
6. IFF MASTER knob – STBY.
7. IFF M-4 CODE switch – HOLD.
8. LANDING TAXI lights – As required.
9. ZEROIZE switch – As required.

#### NOTE

- If any FLCS single failures occurred while airborne, they are reported in the PFL 2 minutes after WOW. The FLCS FAULT caution light also illuminates.
  - If an FLCS SNGL FAIL PFL occurs and FLCS 049 and 070 MFL's are the only MFL's present on the MFD test page, perform up to three additional FLCS BIT's and MFL clear actions. If these FLCS MFL's clear, no writeup is required. If these FLCS MFL's do not clear, inform maintenance.
10. Canopy handle – Up.
- #### NOTE
- Unlock the canopy to insure that the canopy seal is deflated before the canopy is opened.
  - If the canopy handle is placed to up within 2 minutes of WOW, an FDR 024 MFL is generated.
11. Armament switches – Off, safe, or normal.

## PRIOR TO ENGINE SHUTDOWN

#### NOTE

If a flight control related problem was experienced during the flight, coordinate with maintenance to determine if the contents of the FLCC fault history table are desired before shutdown of FLCS power.

1. EPU safety pin (ground crew) – In.

#### NOTE

Installation of the EPU safety pin should be delayed until after engine shutdown under the following conditions:

- The ground crew recovering the aircraft is not familiar with F-16 danger areas.
- The aircraft is being recovered by emergency response personnel (landing with activated EPU, hot brakes, etc.).

Place the EPU switch to OFF prior to engine shutdown if the EPU safety pin is not installed.

2. EGI/INS – Check.
  - Steerpoint of current location – Select.
  - Miscellaneous data – Record.
    - EGI or INS locations 19 (RER), 20 (CEP), 62 (align events), 64 (NAV events), 66 (VX), and 67 (VY) – Record.

#### NOTE

EGI or INS radial error rate (RER) greater than 3 nm/hour or either velocity (VX or VY) greater than 5 fps is considered out of tolerance.

3. MFL – Record (as required).
4. AVTR power switch – **PX II** OFF, **PX III** UNTHRD.

#### NOTE

Place the AVTR power switch to OFF at least 15 seconds prior to engine shutdown to allow the tape to unthread.

5. **PX II** CNI, **PX III** C & I knob – BACKUP.
6. **PX II** INS, **PX III** EGI knob – OFF.

**NOTE**

- **PX II** Turn INS off at least 10 seconds prior to engine shutdown to insure that the INU has adequate time to complete its shutdown sequence.
  - **PX III** Turn EGI off at least 20 seconds prior to engine shutdown to insure that the INU has adequate time to complete its shutdown sequence.
7. Avionics – OFF:
    - HUD thumbwheels.
    - SNSR PWR switches.
    - AVIONICS POWER switches.

**ENGINE SHUTDOWN****WARNING**

A postshutdown engine tailpipe fire is possible. Ignition may be indicated by a mild bang, followed by smoke, fumes, or a small fire in the combustion/turbine area. Potentially hazardous inlet and exhaust areas should be avoided within **PW 229** 10, **GE129** 5 minutes after engine shutdown. This phenomenon does not cause damage to the engine or aircraft. If a postshutdown fire occurs, the engine may be motored with the JFS for approximately 1 minute to extinguish the fire. If motoring the JFS is not possible, the fire extinguishes on its own within a few minutes.

1. Throttle – OFF.
2. JFS RUN light – Check.  
Notify maintenance if the JFS RUN light is flashing after the throttle is placed to OFF.

After main generator drops off line:

3. EPU GEN and EPU PMG lights – Confirm off.

**WARNING**

If either light is illuminated, turn the MAIN PWR switch to OFF. Insure that the EPU safety pin remains installed and notify maintenance.

4. MAIN PWR switch – OFF.

**NOTE**

**GE129** Delay placing MAIN PWR switch to OFF until after engine rpm decreases through 20 percent. This delay should allow the exhaust nozzle to remain open and makes it easier for maintenance to accomplish the post-flight inspection.

5. Oxygen hose, survival kit straps, lapbelt, g-suit hose, and vest hose – Disconnect, stow.
  - Stow oxygen connector in bracket on right sidewall. Insure oxygen hose does not protrude beyond console edge.
  - Stow lapbelt and survival kit straps on seat cushion.
  - Use both hands to disconnect g-suit hose to avoid excessive force on the hose-to-console connection.

**CAUTION**

- One-handed or brute force disconnects of the g-suit connection will cause internal damage to the hose at the hose-to-console connection.
  - Failure to properly stow lapbelt, survival kit straps, oxygen connector, g-suit hose, and oxygen hose may cause damage to consoles and to the ejection seat during seat adjustment.
6. OXYGEN REGULATOR – OFF and 100%.



- Failure to position the oxygen regulator to OFF and 100% may result in particulate contamination of the regulator and subsequent damage.
- To avoid damage to the oxygen regulator, do not pull the knob on the end of the mode lever when moving the mode lever from ON to OFF.

7. Canopy - Open.



- If winds exceed 30 knots, open the canopy only as far as needed to enter/exit the cockpit. Decreasing the canopy angle reduces the possibility that the canopy can be blown past full open.
- ☐ A failure of the canopy actuator could allow the canopy to fall during transit. Keep hands and arms out of the path of canopy travel during opening or closing.

**NOTE**

If the internal canopy switch is left in the up position, the canopy automatically opens if closed from the outside.

**SCRAMBLE**

**PREFLIGHT**

Perform the following preflight inspections prior to placing the aircraft on quick response status:

1. EXTERIOR INSPECTION.
2. BEFORE ENTERING COCKPIT.
3. COCKPIT INTERIOR CHECK.
4. BEFORE STARTING ENGINE.
5. STARTING ENGINE.
6. AFTER ENGINE START (include EPU check but do not remove MLG ground safety pins).

7. Aircraft cocked for scramble - Per local policies and directives.

**AIRCRAFT ON QUICK RESPONSE STATUS**

If the above actions were not completed prior to scramble, normal preflight procedures should be used.

1. FLCS power - Check.  
With MAIN PWR switch in BATT, verify that FLCS power is good (FLCS PWR lights) with the aircraft battery.
2. MAIN PWR switch - MAIN PWR.
3. Engine - Start.
4. Canopy - Close and lock.
5. Instruments - Check.
6. SNSR PWR switches - As required.
7. AVIONICS POWER switches - As required.
8. **PX II** INS, **PX III** EGI knob - STOR HDG.

**NOTE**

Prior to aligning the INS/EGI using a stored heading alignment, accomplish a normal alignment, except turn the **PX II** INS, **PX III** EGI knob to OFF from NORM (prior to power being removed), and do not move the aircraft.

9. FLCS BIT - Accomplish.
10. MFD's - As desired.
11. SMS - As desired.
- \*12. HUD/ASHM - As required.
13. **PX II** INS, **PX III** EGI knob - NAV.



A full performance NORM gyrocompass ground alignment, or **PX II** extended interrupted alignment (EIA) with flashing RDY/ALIGN display should be performed prior to flying any terrain following mission. If degraded alignment occurs, terrain following is prohibited.

**NOTE**

- When positioning the **PX II** INS, **PX III** EGI knob from STOR HDG to NAV, do not hesitate in NORM or the alignment will be lost.
  - If time permits, the **PX II** INS, **PX III** EGI knob can be moved to NORM at any time for a normal alignment.
14. EPU GEN and EPU PMG lights - Confirm off.  
If either light is illuminated, cycle the EPU switch to OFF, then back to NORM. If either light stays on, abort the aircraft.

**WARNING**

If either light is illuminated, the EPU activates using hydrazine when the EPU safety pin is removed.

15. EPU - Check (if EPU safety pin was installed since last EPU check).

**WARNING**

If the EPU safety pin is reinstalled for any reason, the EPU check must be reaccomplished prior to flight to insure proper EPU operation.

16. Chocks and safety pins (ground crew) - Remove.
- \*17. Brakes and NWS - Check.
- \*18. Ejection safety lever - Armed (down).
- \*19. Flight control surfaces - Cycle.
20. IFF - As required.

**HOT REFUELING****HOT REFUELING PRECAUTIONS**

Perform dearming prior to entry to the hot refueling pit. If suspected hot brakes or other unsafe condition exists, do not enter refueling area. Follow ground crew directions into the refueling area and establish communications with the ground crew. If a malfunction is suspected, stop refueling.

Hot refueling is prohibited with an activated EPU, hung ordnance, hot brakes, or fuel leakage in vicinity of AR receptacle during AR. Safety pins for stores and gun must be installed. In the refueling area, use minimum thrust for taxiing.

**PRIOR TO HOT PIT ENTRY**

1. AFTER LANDING checks - Complete.
2. AIR REFUEL switch - OPEN; RDY light on.

**NOTE**

- **D** With the AR switch in OPEN, NWS can be engaged or disengaged from either cockpit regardless of the position of the STICK CONTROL switch and without using the paddle switch.
  - With the AR switch in OPEN, the AR/NWS light remains off whenever NWS is engaged.
- \*3. TACAN power knob - OFF.
- \*4. GND JETT ENABLE switch - OFF.

**PRIOR TO HOT REFUELING**

Perform the following actions prior to refueling:

1. EPU safety pin (ground crew) - Installed.
- \*2. Personal equipment leads (except oxygen and communication) - As desired.
3. Canopy - As desired.

**CAUTION**

Insure all cockpit items are secure prior to opening the canopy. With the canopy open, the engine is susceptible to FOD from loose cockpit items.

4. Brake and tire inspection (ground crew) - Complete.
5. Intercom with refueling supervisor - Established.

## DURING HOT REFUELING

- \*1. Be alert for visual or voice signals from refueling supervisor.
- \*2. Terminate refueling if intercom contact is lost – Visual signal.
- \*3. Ground control radio frequency – Monitor.
- \*4. Insure hands are visible to ground crew.

## HOT REFUELING COMPLETE

1. AIR REFUEL switch – CLOSE.
2. EPU GEN and EPU PMG lights – Confirm off.
3. EPU switch – OFF.
4. EPU safety pin (ground crew) – Removed.
5. EPU switch – NORM.
6. Intercom (refueling supervisor) – Disconnect.
7. Taxi clear of refueling area and configure aircraft as required.

## QUICK TURNAROUND

### PRIOR TO ENGINE SHUTDOWN

1. AFTER LANDING checks – Complete.
2. PRIOR TO ENGINE SHUTDOWN checks – Complete.
3. Communication with ground crew – Establish (if required).
4. ENGINE SHUTDOWN checks – Complete.
5. Aircraft setup – IAW local procedures.

## SPECIAL PROCEDURES

### EPU HYDRAZINE SUPPORT AT NON-F-16 BASES

At non-F-16 bases, the pilot is responsible for the aircraft. Response actions shall be limited to identification of a hydrazine or EPU problem, isolation, containment, and minimal dilution with water (1 part water to 1 part hydrazine). No major neutralization, maintenance, or hydrazine servicing capability is planned for transient bases. If a

hydrazine leak or EPU incident occurs on a base where no disaster response force or bioenvironmental support is available, the pilot must insure that the aircraft is isolated and the leak contained. Refer to ACTIVATED EPU/HYDRAZINE LEAK, Section III.

## SUPPLEMENTAL PROCEDURES

### ILS PROCEDURES

1. DED – Verify CNI display.
2. T-ILS button – Depress and release.
3. ILS frequency – Key in and ENTR.
4. DCS – Position asterisks about selectable items:
  - Key in and enter inbound localizer course. The inbound localizer course must be entered to obtain correct command steering.
  - Depress M-SEL button to deselect/select command steering; verify CMD STRG is highlighted, if selected.
5. HSI – Set inbound localizer course.
6. INSTR MODE knob – ILS/TCN or ILS/NAV. Verify proper indications/symbology on ADI, HSI, and HUD.

### EXTERIOR INSPECTION

Refer to figure 2-4 for normal preflight inspection.

### DANGER AREAS

Refer to figures 2-8 and 2-9.

## TURNING RADIUS AND GROUND CLEARANCE

Refer to figure 2-10.

### G-SUIT HOSE ROUTING

Refer to figure 2-11 for the recommended g-suit hose routing.

## STRANGE FIELD PROCEDURES

Refer to Air Force/Command Guidance.

# Exterior Inspection (Typical)

NOTE: Check aircraft for loose doors and fasteners, cracks, dents, leaks, and other discrepancies.

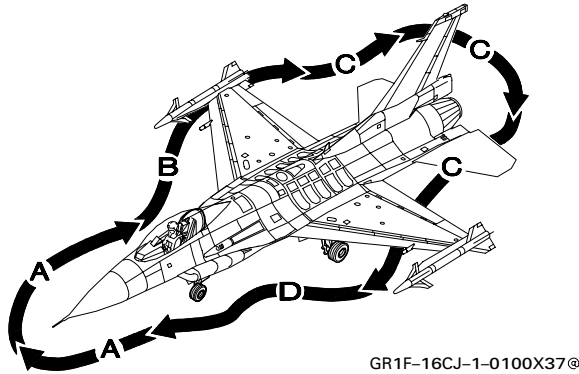

## NOSE - A

1. FORWARD FUSELAGE:
  - A. EXTERNAL CANOPY JETTISON D-HANDLES (2) - ACCESS DOORS CLOSED.
  - B. PITOT-STATIC PROBES (2) - COVERS REMOVED.
  - C. AOA PROBES (2) - COVERS REMOVED; SLOTS CLEAR; FREEDOM OF MOVEMENT CHECKED; ALIGNMENT CHECKED (ROTATE PROBES FULLY TOWARD FRONT OF AIRCRAFT (CCW ON THE LEFT; CW ON THE RIGHT) AND VERIFY BOTTOM SLOTS SLIGHTLY AFT OF 6 O'CLOCK AND TOP SLOTS FORWARD); SET IN NEUTRAL POSITION (BOTTOM SLOT AT 4 O'CLOCK ON THE RIGHT SIDE AND 8 O'CLOCK ON THE LEFT SIDE).
  - D. STATIC PORTS (2) - CONDITION.
  - E. RADOME - SECURE.
  - F. ENGINE INLET DUCT - CLEAR.
  - G. PODS AND PYLONS - SECURE (PREFLIGHT IAW T.O. GR1F-16CJ-34-1-1CL-1).
  - H. EPU FIRED INDICATOR - CHECK.
  - I. ECS RAM INLET DUCTS - CLEAR.

## CENTER FUSELAGE & RIGHT WING - B

1. RIGHT MLG:
  - A. TIRE, WHEEL, AND STRUT - CONDITION.
  - B. UPLOCK ROLLER - CHECK.
  - C. DOOR AND LINKAGE - SECURE.
  - D. LG SAFETY PIN - INSTALLED.
2. RIGHT WING:
  - A. HYDRAZINE LEAK DETECTOR - CHECK.
  - B. EPU NITROGEN BOTTLE - CHARGED (REFER TO FIGURE 2-6).
  - C. EPU OIL LEVEL - CHECK.
  - D. HYD SYS A QTY AND ACCUMULATOR - CHECK.
  - E. GUN-RNDS COUNTER AND RNDS LIMIT - SET.

- F. EPU EXHAUST PORT - CONDITION.
- G. LEF - CONDITION.
- H. STORES AND PYLONS - SECURE (PREFLIGHT IAW T.O. GR1F-16CJ-34-1-1CL-1).
- I. NAV AND FORM LIGHTS - CONDITION.
- J. FLAPERON - CONDITION.

## AFT FUSELAGE - C

1. TAIL:
  - A. ADG - CHECK.
  - B. CSD OIL LEVEL - CHECK.
  - C. BRAKE/JFS ACCUMULATORS - CHARGED (REFER TO FIGURE 2-5).
  - D. HOOK - CONDITION AND PIN FREE TO MOVE.
  - E. DRAG CHUTE ACCUMULATOR - CHARGED.
  - F. VENTRAL FINS, SPEEDBRAKES, HORIZONTAL TAILS, AND RUDDER - CONDITION.
  - G. DRAG CHUTE HOUSING - CONDITION.
  - H. ENGINE EXHAUST AREA - CONDITION.
  - I. NAV AND FORM LIGHTS - CONDITION.
  - J. VERTICAL TAIL LIGHT - CONDITION.
  - K. FLCs ACCUMULATORS - CHARGED (REFER TO FIGURE 2-7).
  - L. JFS DOORS - CLOSED.

## LEFT WING & CENTER FUSELAGE - D

1. LEFT WING:
  - A. FLAPERON - CONDITION.
  - B. NAV AND FORM LIGHTS - CONDITION.
  - C. STORES AND PYLONS - SECURE (PREFLIGHT IAW T.O. GR1F-16CJ-34-1-1CL-1).
  - D. LEF - CONDITION.
  - E. FUEL VENT OUTLET - CLEAR.
  - F. HYD SYS B QTY AND ACCUMULATOR - CHECK.
2. LEFT MLG:
  - A. TIRE, WHEEL, AND STRUT - CONDITION.
  - B. UPLOCK ROLLER - CHECK.
  - C. DOOR AND LINKAGE - SECURE.
  - D. LG SAFETY PIN - INSTALLED.
  - E. LG PIN CONTAINER - CHECK CONDITION.
3. FUSELAGE:
  - A. GUN PORT - CONDITION.
  - B. IFF - CHECK.
  - C. AVTR - CHECK.
  - D. DOOR 2317, ENGINE AND EMS GO-NO-GO INDICATORS - CHECK.
4. UNDERSIDE:
  - A. NLG TIRE, WHEEL, AND STRUT - CONDITION.
  - B. NLG TORQUE ARMS - CONNECTED, PIN SECURE AND SAFETIED.
  - C. NLG DOOR AND LINKAGE - SECURE.
  - D. LANDING AND TAXI LIGHTS - CONDITION.
  - E. LG/HOOK EMERGENCY PNEUMATIC BOTTLE PRESSURE - WITHIN PLACARD LIMITS (REFER TO FIGURE 2-6).

Figure 2-4.



## **Brake/JFS Accumulators Pneumatic Servicing**

TEMPERATURE °F	PRESSURE PSIG
-44 to -36	1475-1625
-35 to -27	1525-1675
-26 to -18	1575-1725
-17 to -9	1625-1775
-8 to -1	1675-1825
0 to 8	1725-1875
9 to 17	1775-1925
18 to 26	1825-1975
27 to 35	1875-2025
36 to 44	1925-2075
45 to 53	1975-2125
54 to 62	2025-2175
63 to 71	2075-2225
72 to 80	2125-2275
81 to 89	2175-2325
90 to 98	2225-2375
99 to 107	2275-2425
108 to 116	2325-2475
117 to 125	2375-2525
126 to 135	2425-2575

Figure 2-5.

## **EPU Nitrogen & Alternate LG/Hook Bottles Pneumatic Servicing**

TEMPERATURE °F	PRESSURE PSIG
100 and higher	3250-3500
50 to 100	2850-3250
10 to 50	2500-2850
-60 to +10	2000-2500

Figure 2-6.

## **Drag Chute/FLCS Accumulators Pneumatic Servicing**

TEMPERATURE °F	PRESSURE PSIG
100 and higher	1300-1400
50 to 100	1200-1300
10 to 50	1100-1200
-60 to +10	950-1100

Figure 2-7.

# Danger Areas

ENGINE F110-GE-129

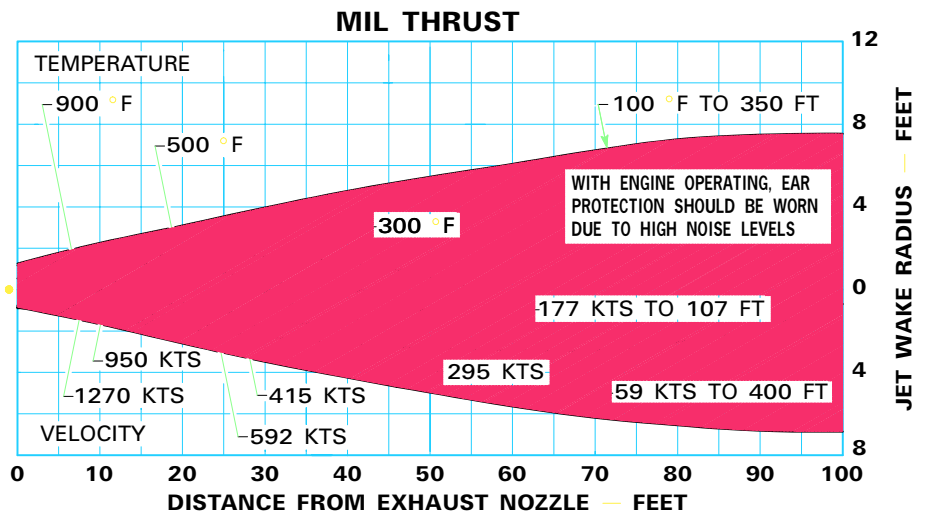
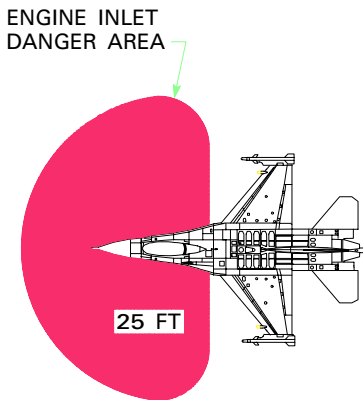
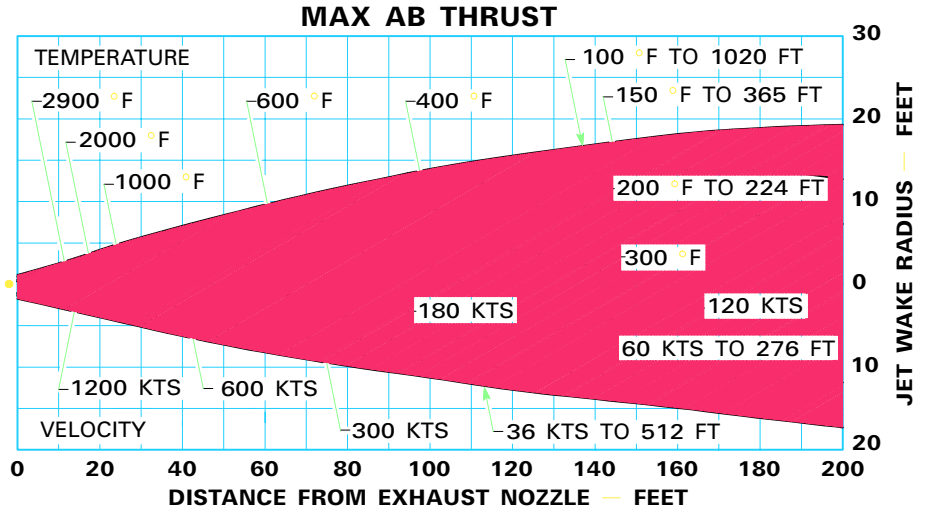
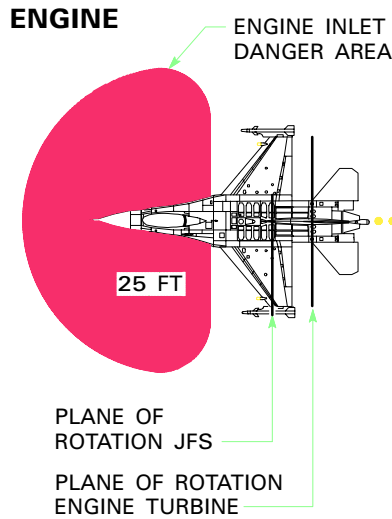

## TIRES

WITH HOT BRAKES, AVOID INFLATED MLG TIRE SIDE AREA WITHIN 300 FEET FOR 45 MINUTES AFTER AIRCRAFT HAS STOPPED. IF REQUIRED, APPROACH FROM THE FRONT OR REAR FOR FIREFIGHTING PURPOSES ONLY.

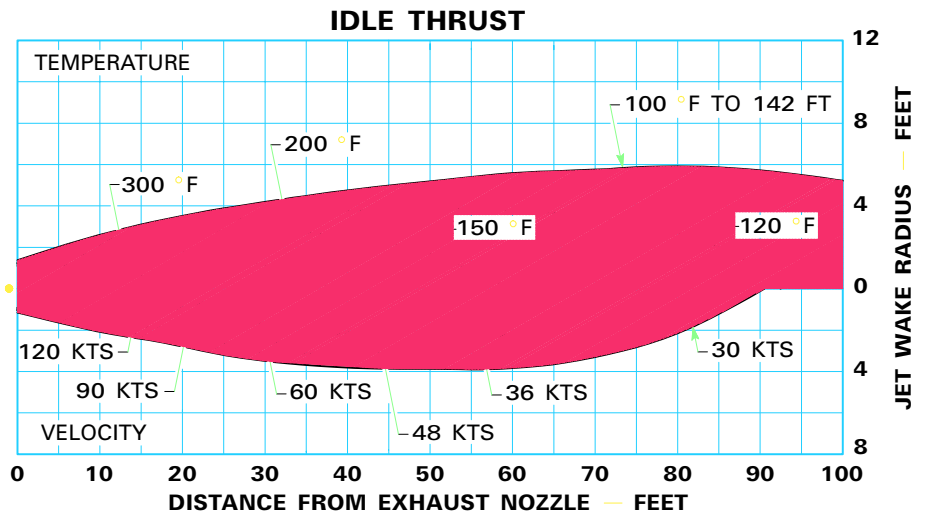
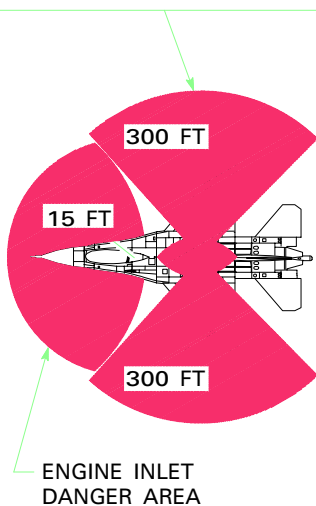

GR1F-16CJ-1-0101A37

Figure 2-8. (Sheet 1)

# Danger Areas

ENGINE F110-GE-129

## RADIATION AND TEMPERATURE

**NOTES:**

- Distance from radar disc to forward tip of radome = 5 feet.
- ECM radiation is in a fan pattern fore and aft.

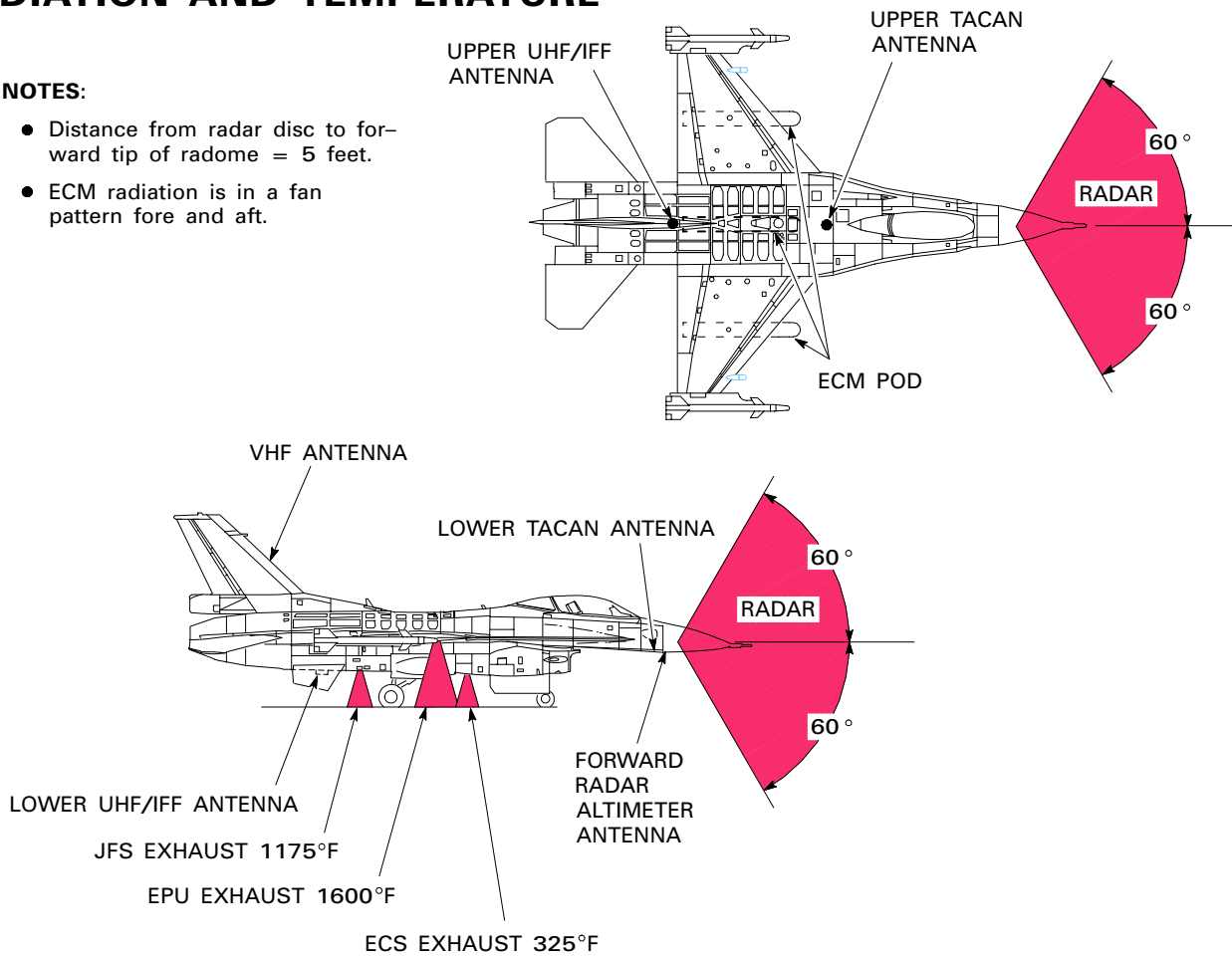

OPERATING TRANSMITTERS	MINIMUM SAFE DISTANCE FROM ANTENNAS IN FEET		
	VOLATILE FLUIDS	PERSONNEL	EED
UPPER AND LOWER UHF/IFF	—	1	—
UPPER AND LOWER TACAN	—	1	—
VHF	—	1	—
RADAR ALTIMETER	—	1	—
FIRE CONTROL RADAR	30	120	120
INTERNAL ECM	21	1.5	4
AN/ALQ-119	—	6	6
AN/ALQ-131	—	15	15
AN/ALQ-176	—	6	6
AN/ALQ-184	—	31	6
AN/ALQ-188	—	6	6
QRC-80-01	—	6	6

GR1F-16CJ-1-0102X37 ©

Figure 2-8. (Sheet 2)

# Danger Areas

## HAZARDOUS NOISE LEVEL AREAS

ENGINE F110-GE-129

MAX AB THRUST (ESTIMATED)

MIL THRUST (ESTIMATED)

**NOTE:**  
Noise levels are symmetrical and may be altered by surrounding obstacles.

LIMIT 5 MINUTES PER DAY WITH EAR PROTECTION

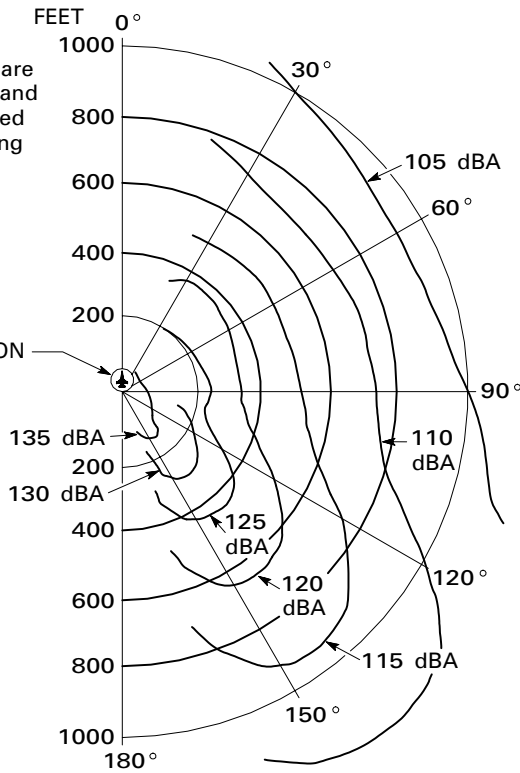

LIMIT 15 MINUTES PER DAY WITH EAR PROTECTION

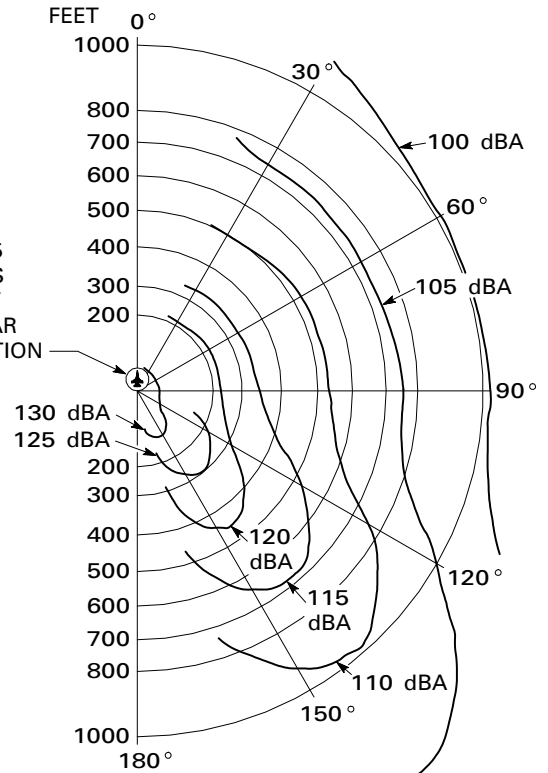

IDLE THRUST

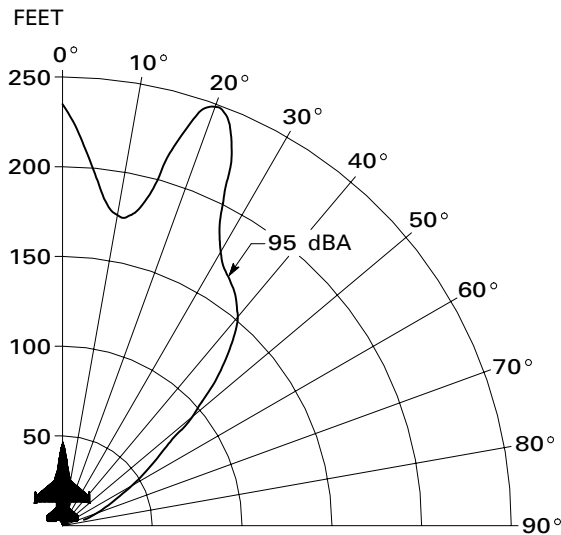

NOISE EXPOSURE LIMITS

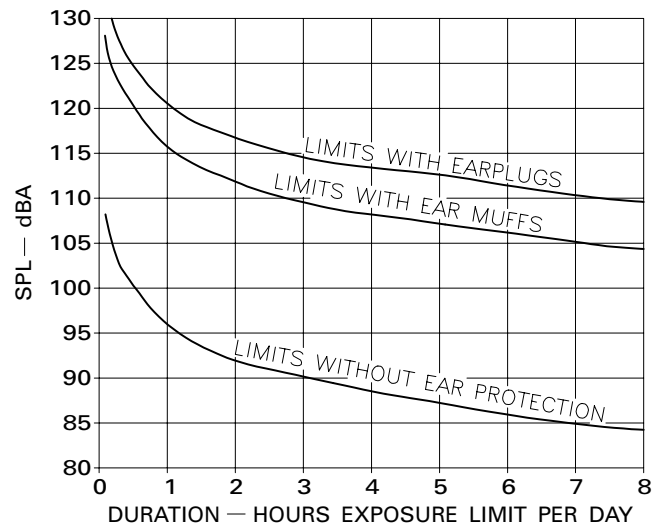

**NOTES:**

- Attenuation factors and exposure limits are for typical ear muffs and earplugs.
- SPL — Sound pressure level.
- dBA — Adjusted (human ear response) decibels.

1F-16X-1-4031X®

Figure 2-8. (Sheet 3)

# Danger Areas

ENGINE F100-PW-229

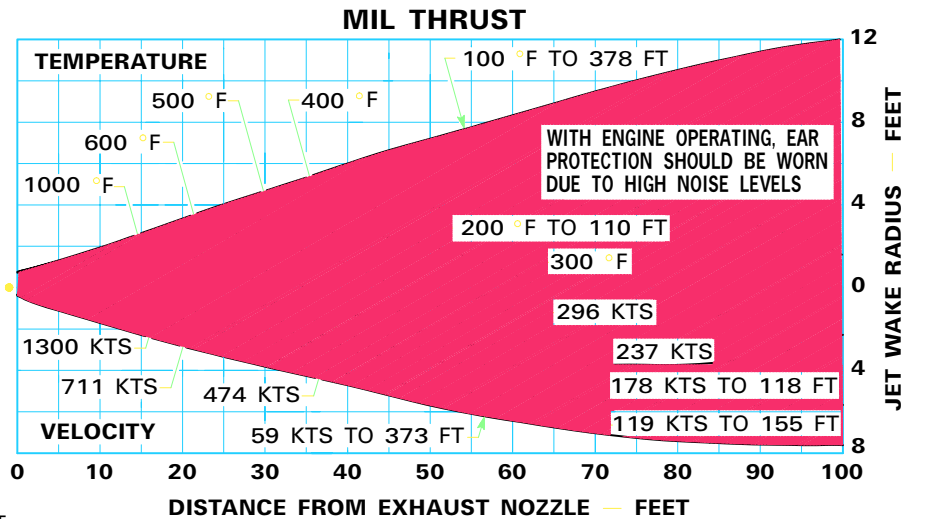
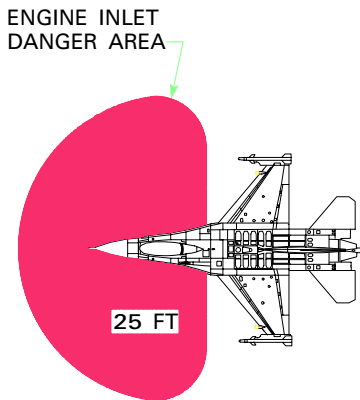
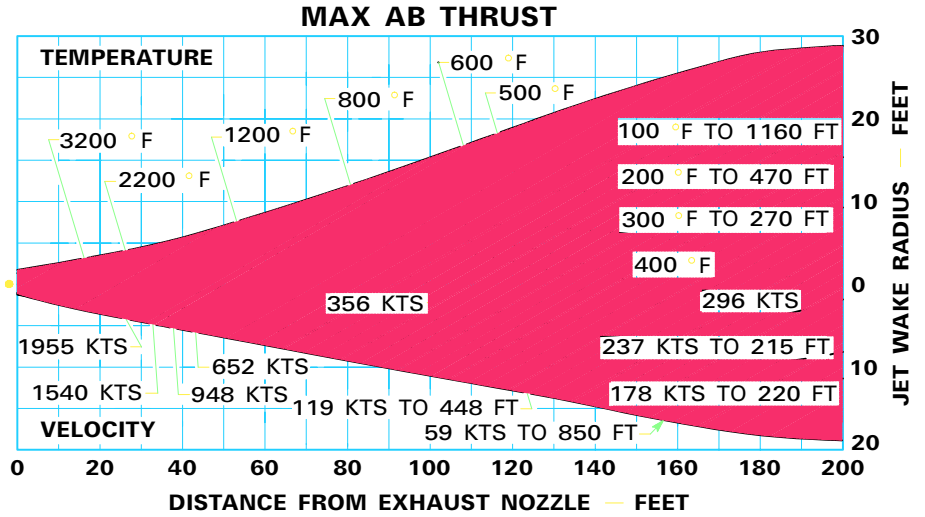
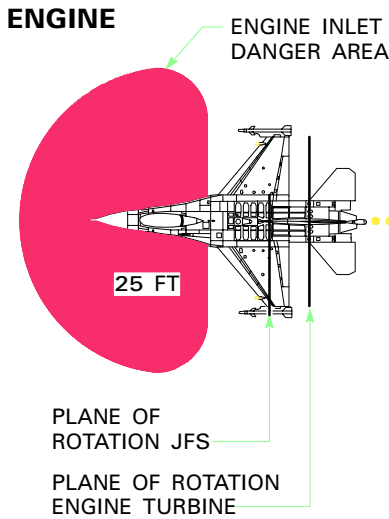

**TIRES**  
 WITH HOT BRAKES, AVOID INFLATED MLG TIRE SIDE AREA WITHIN 300 FEET FOR 45 MINUTES AFTER AIRCRAFT HAS STOPPED. IF REQUIRED, APPROACH FROM THE FRONT OR REAR FOR FIREFIGHTING PURPOSES ONLY.

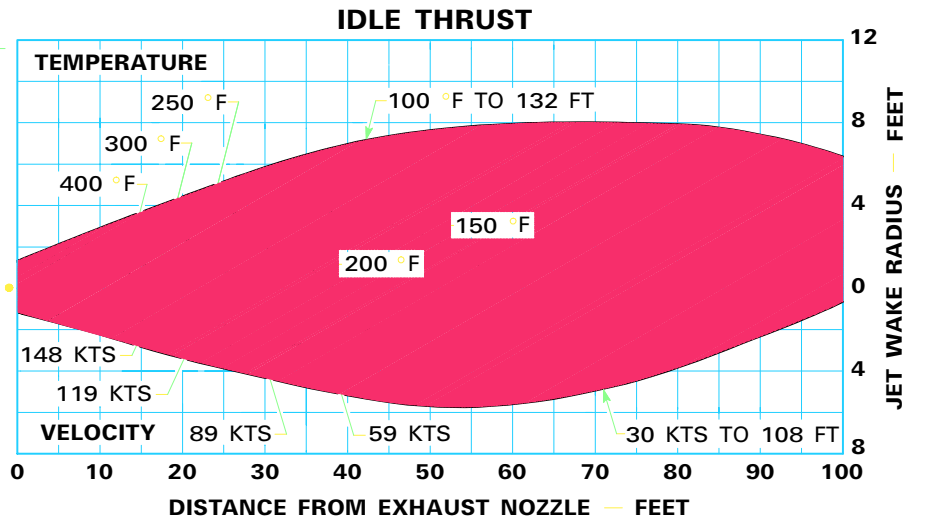
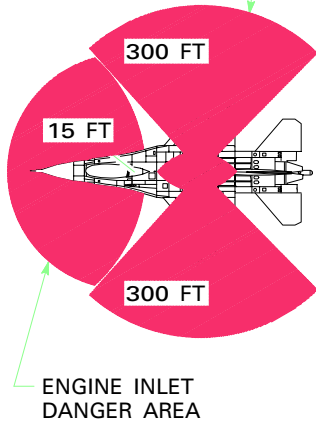

GR1F-16CJ-1-1101A37 ©

Figure 2-9. (Sheet 1)

# Danger Areas

ENGINE F100-PW-229

## RADIATION AND TEMPERATURE

**NOTES:**

- Distance from radar disc to forward tip of radome = 5 feet.
- ECM radiation is in a fan pattern fore and aft.

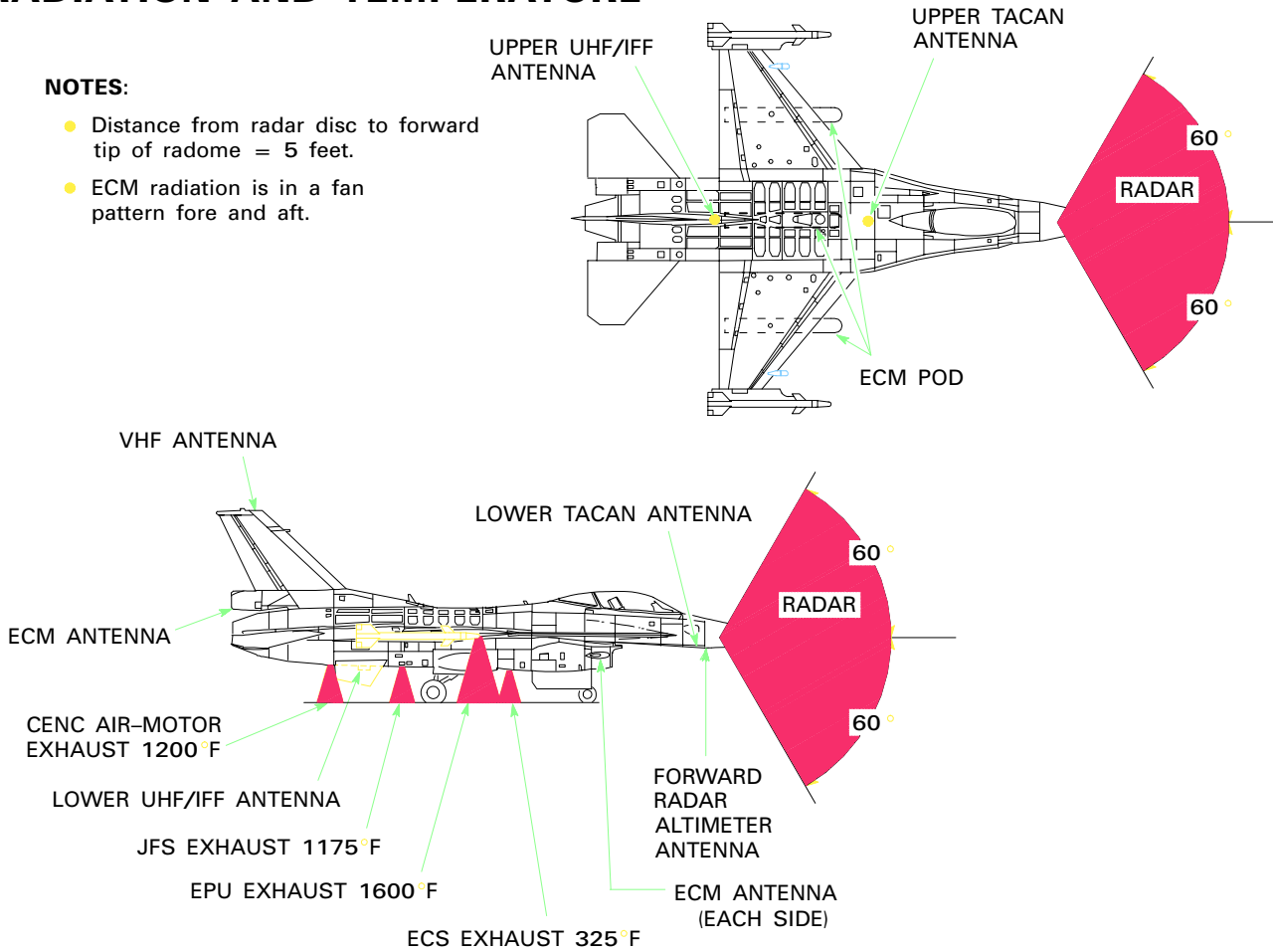

OPERATING TRANSMITTERS	MINIMUM SAFE DISTANCE FROM ANTENNAS IN FEET		
	VOLATILE FLUIDS	PERSONNEL	EED
UPPER AND LOWER UHF/IFF	—	1	—
UPPER AND LOWER TACAN	—	1	—
VHF	—	1	—
RADAR ALTIMETER	—	1	—
FIRE CONTROL RADAR	30	120	120
INTERNAL ECM	21	1.5	4
AN/ALQ-119	—	6	6
AN/ALQ-131	—	15	15
AN/ALQ-176	—	6	6
AN/ALQ-184	—	31	6
AN/ALQ-188	—	6	6
QRC-80-01	—	6	6

GR1F-16CJ-1-1102X37

Figure 2-9. (Sheet 2)

# Danger Areas

## HAZARDOUS NOISE LEVEL AREAS

ENGINE F100-PW-229

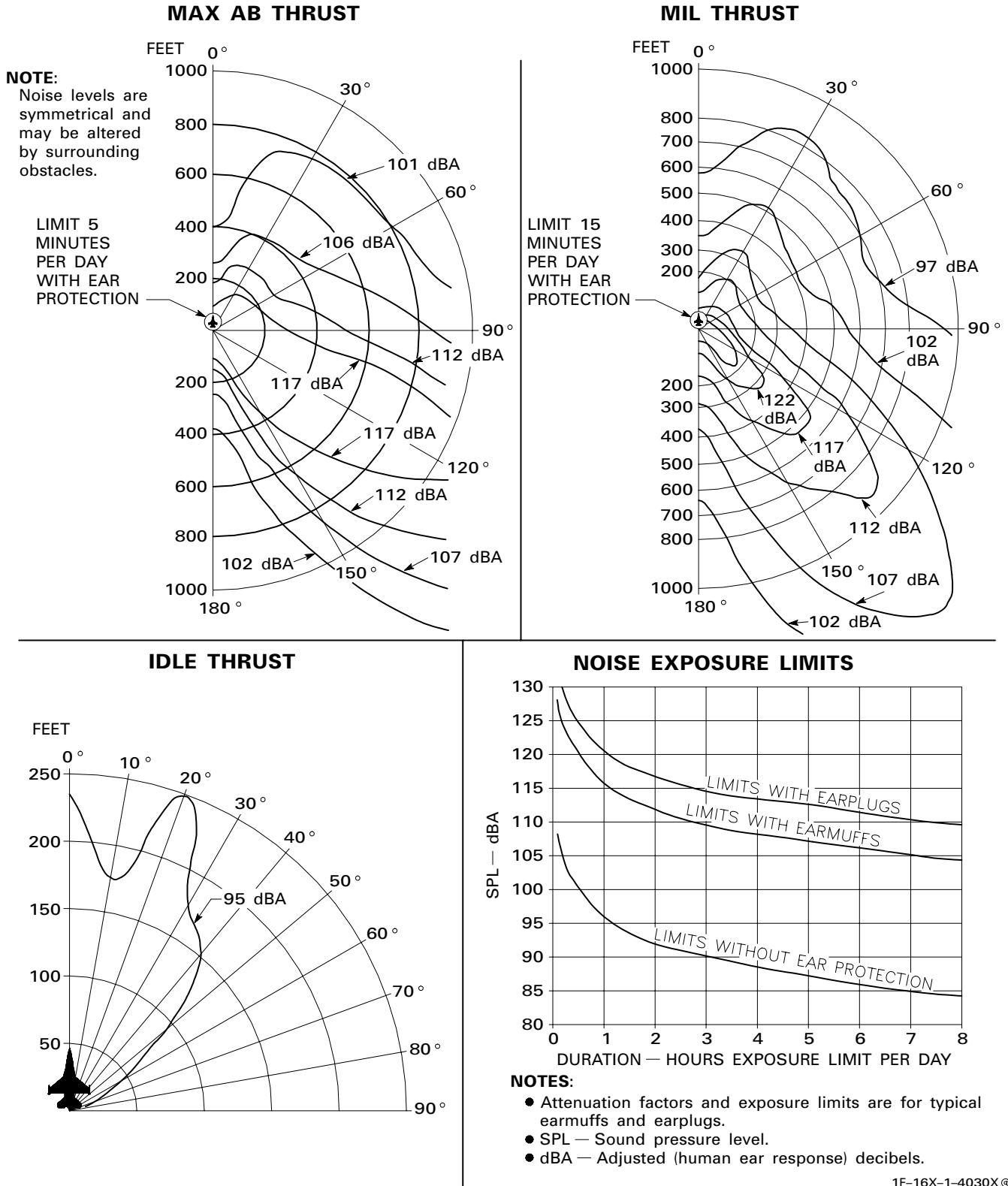
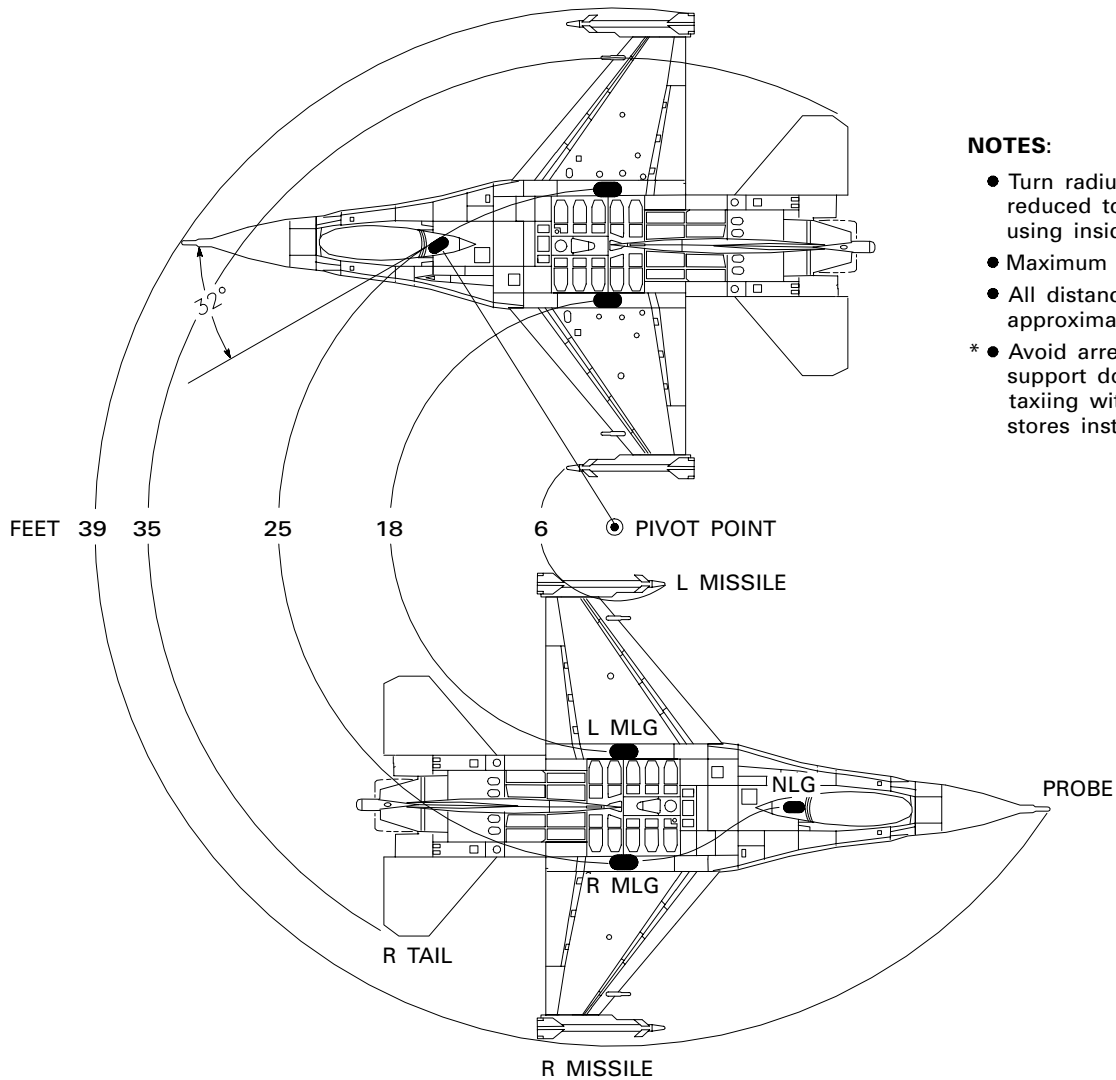

Figure 2-9. (Sheet 3)

# Turning Radius and Ground Clearance



**NOTES:**

- Turn radius can be reduced to 38 feet by using inside brake.
- Maximum NWS deflection.
- All distances are approximate.
- \* ● Avoid arresting cable support donuts when taxiing with centerline stores installed.

**WARNING**

With large asymmetries, reduce taxi speed, avoid sharp turns and, when possible, turn toward heavy wing to prevent possible tipping.

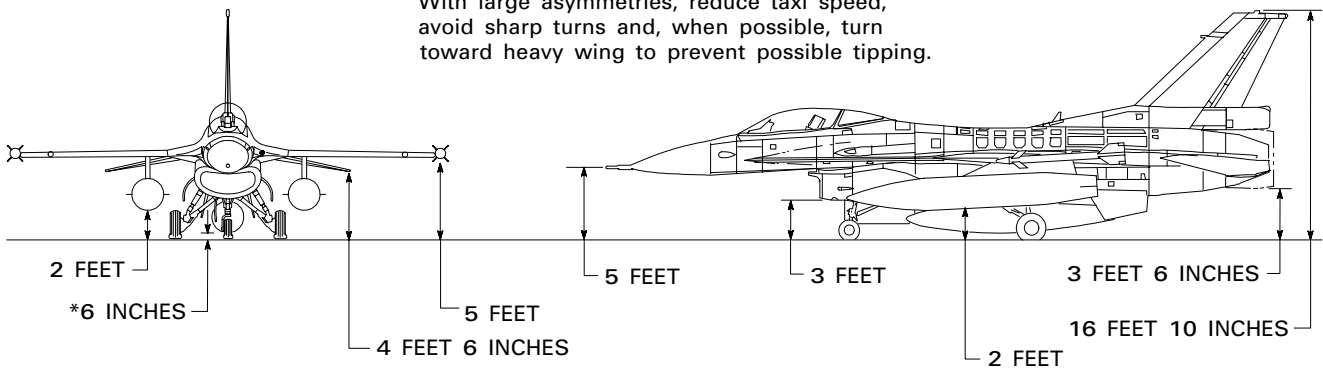

GR1F-16CJ-1-0104X37 ©

Figure 2-10.



# G-Suit Hose Routing (Typical)

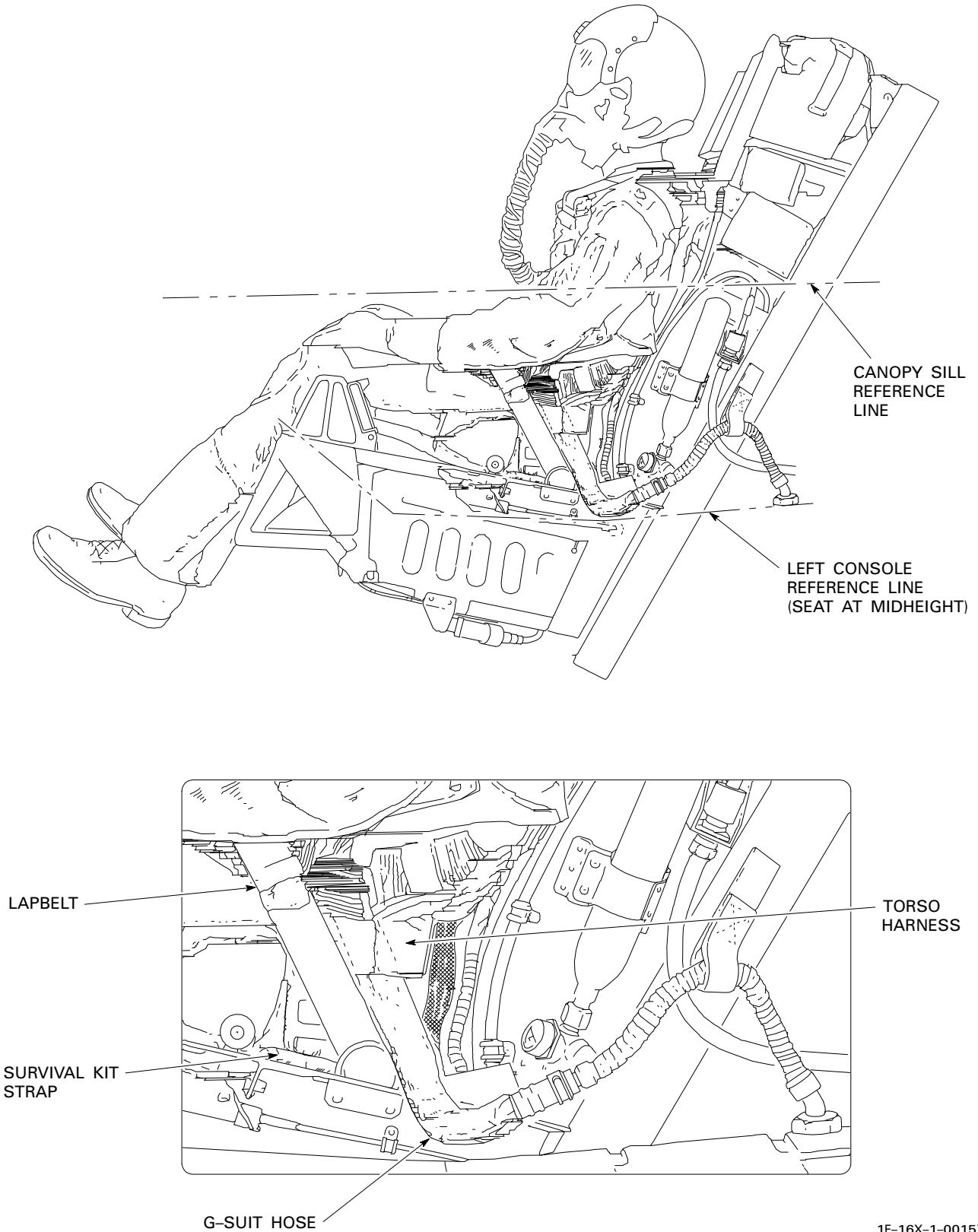

1F-16X-1-0015X ©

Figure 2-11.

## SECTION III

### EMERGENCY PROCEDURES

TABLE OF CONTENTS	Page		Page
INTRODUCTION .....	3-3	IN-FLIGHT EMERGENCIES .....	3-38
WARNING AND CAUTION LIGHT AND PILOT FAULT LIST ANALYSIS .....	3-4	CANOPY Warning Light On .....	3-38
FORMAT .....	3-4	Canopy Loss/Penetration in Flight .....	3-38
GROUND EMERGENCIES .....	3-26	Drag Chute Deployed in Flight .....	3-38
Fire/Overheat/Fuel Leak (Ground) .....	3-26	Cockpit Pressure/Temperature Malfunction .....	3-39
Hot Start (Ground) .....	3-26	EQUIP HOT Caution Light .....	3-40
Hung Start/No Start <b>PW 229</b> .....	3-26	Ejection .....	3-40
Hung Start/No Start <b>GE129</b> .....	3-26	Ejection (Immediate) .....	3-41
Engine Autoacceleration (Ground) .....	3-26	Ejection (Time Permitting) .....	3-41
Antiskid Malfunction (Ground) .....	3-26	Failure of Canopy To Separate .....	3-41
Brake Failure .....	3-27	Ejection Seat Failure .....	3-43
Hot Brakes .....	3-28	Ditching .....	3-43
Main Generator Failure (Ground) .....	3-29	Electrical System Failures .....	3-43
Main and Standby Generator Failure (Ground) .....	3-29	FLCS PMG Failure .....	3-43
Emergency Entrance and Crew Rescue ....	3-29	Single Generator Failures (in Flight) .....	3-43
Emergency Ground Jettison .....	3-29	Main and Standby Generator Failure (in Flight) .....	3-44
Ground Egress .....	3-29	Main, Standby, and EPU Generator Failure .....	3-45
Hot Refueling Emergency .....	3-32	EPU Malfunctions .....	3-47
Activated EPU/Hydrazine Leak .....	3-32	Uncommanded EPU Operation .....	3-47
NWS Failure/Hardover .....	3-32	Abnormal EPU Operation .....	3-48
TAKEOFF EMERGENCIES .....	3-33	FLCS RLY Light .....	3-49
Delayed Rotation .....	3-33	Partial Electrical Power Loss .....	3-49
Abort .....	3-33	Aircraft Battery Failure .....	3-50
Engine Malfunction on Takeoff .....	3-34	Emergency Power Distribution .....	3-51
Engine Failure on Takeoff .....	3-34	Engine Malfunctions <b>PW 229</b> .....	3-61
AB Malfunction on Takeoff .....	3-35	Engine Fire <b>PW 229</b> .....	3-61
Low Thrust on Takeoff or at Low Altitude (Non-AB) <b>PW 229</b> .....	3-35	OVERHEAT Caution Light <b>PW 229</b> ....	3-62
Low Thrust on Takeoff or at Low Altitude (Non-AB) <b>GE129</b> .....	3-36	Engine Vibrations <b>PW 229</b> .....	3-63
Engine Fire on Takeoff .....	3-36	Oil System Malfunction <b>PW 229</b> .....	3-63
LG Fails To Retract .....	3-36	ENGINE FAULT Caution Light <b>PW 229</b> .....	3-64
LG Handle Will Not Raise .....	3-36	SEC Caution Light <b>PW 229</b> .....	3-64
Blown Tire on Takeoff .....	3-37	FTIT Indicator Failure <b>PW 229</b> .....	3-65
		Zero RPM/Erroneous RPM Indication <b>PW 229</b> .....	3-65
		Abnormal Engine Response <b>PW 229</b> ....	3-65
		Nozzle Failure <b>PW 229</b> .....	3-67
		AB Blowout/Failure To Light <b>PW 229</b> .....	3-68

T.O. GR1F-16CJ-1

Engine Stalls <b>PW 229</b> .....	3-68	Flameout Landing .....	3-98
AB-Associated Engine		Overhead Approach .....	3-99
Stalls <b>PW 229</b> .....	3-69	Straight-In Approach .....	3-100
Non-AB Engine Stalls <b>PW 229</b> .....	3-69	IMC Penetration .....	3-100
Engine Stall Recovery <b>PW 229</b> .....	3-69	Landing Phase .....	3-105
Inlet Buzz <b>PW 229</b> .....	3-70	After Touchdown .....	3-105
Engine Failure or Flameout <b>PW 229</b> .....	3-70	Flameout Landing Procedures .....	3-105
Tower Shaft Failure <b>PW 229</b> .....	3-70	Jettison .....	3-107
Low Altitude Engine Failure or		Selective Jettison .....	3-107
Flameout <b>PW 229</b> .....	3-71	Emergency Jettison .....	3-108
Airstarts <b>PW 229</b> .....	3-71	FLCS Failures .....	3-108
High Altitude Airstart		Air Data Malfunctions .....	3-108
Considerations <b>PW 229</b> .....	3-78	AOA Malfunction .....	3-109
Low Altitude Airstart		CADC Malfunction .....	3-110
Considerations <b>PW 229</b> .....	3-79	Servo Malfunction .....	3-110
Airstart Procedures <b>PW 229</b> .....	3-79	FLCS Electronic Malfunctions .....	3-110
Engine Malfunctions <b>GE129</b> .....	3-81	FLCS Single Electronic Failure .....	3-111
Engine Fire <b>GE129</b> .....	3-81	FLCS Dual Electronic Failure .....	3-111
OVERHEAT Caution Light <b>GE129</b> ....	3-82	FLCS Temperature Malfunction .....	3-112
Oil System Malfunction <b>GE129</b> .....	3-83	Autopilot Malfunctions .....	3-112
ENGINE FAULT Caution		DBU ON Warning Light .....	3-113
Light <b>GE129</b> .....	3-84	TF FAIL Warning Light .....	3-113
SEC Caution Light <b>GE129</b> .....	3-84	LEF Malfunction (Symmetric) .....	3-114
FTIT Indicator Failure <b>GE129</b> .....	3-85	LEF Malfunction (Asymmetric) .....	3-115
Zero RPM/Erroneous RPM		Trim Malfunction .....	3-116
Indication <b>GE129</b> .....	3-85	Stick Interference .....	3-116
Abnormal Engine Response <b>GE129</b> ....	3-86	Fuel Malfunctions .....	3-117
AB Blowout/Failure To		Fuel Management System PFL .....	3-117
Light <b>GE129</b> .....	3-87	Fuel Leak .....	3-117
Engine Stalls <b>GE129</b> .....	3-88	Fuel Low .....	3-118
AB-Associated Engine Stalls <b>GE129</b> ...	3-88	Hot Fuel/Oil or Gravity Feed .....	3-118
Non-AB Engine Stalls <b>GE129</b> .....	3-88	Fuel Imbalance .....	3-119
Engine Stall Recovery <b>GE129</b> .....	3-89	Trapped External Fuel .....	3-121
Inlet Buzz <b>GE129</b> .....	3-89	Trapped CFT Fuel <b>PX III</b> .....	3-122
Bird Strike <b>GE129</b> .....	3-89	Hydraulic Malfunctions .....	3-123
Engine Overspeed <b>GE129</b> .....	3-89	Single Hydraulic Failure .....	3-123
Engine Failure or Flameout <b>GE129</b> .....	3-89	System A Failure .....	3-123
Tower Shaft Failure <b>GE129</b> .....	3-90	System B Failure .....	3-123
Low Altitude Engine Failure or		Dual Hydraulic Failure .....	3-124
Flameout <b>GE129</b> .....	3-90	System B and Generator Failure	
Airstarts <b>GE129</b> .....	3-90	(PTO Shaft) .....	3-125
High Altitude Airstart		EGI Failure <b>PX III</b> .....	3-126
Considerations <b>GE129</b> .....	3-95	INS Failures <b>PX II</b> .....	3-127
Low Altitude Airstart		Total INS Failure <b>PX II</b> .....	3-128
Considerations <b>GE129</b> .....	3-96	Out-of-Control Recovery .....	3-128
Airstart Procedures <b>GE129</b> .....	3-96	Oxygen Malfunction <b>PX II</b> .....	3-130
		OBOGS Malfunction <b>PX III</b> .....	3-131
		PBG Malfunction .....	3-131
		Smoke or Fumes .....	3-131

LANDING EMERGENCIES .....	3-132
Straight-in Landing .....	3-132
Simulated Flameout (SFO) Landing .....	3-132
Controllability Check .....	3-133
Cable Arrestment .....	3-134
Net Arrestment .....	3-135
Landing With A Blown Tire .....	3-135
Landing With A Blown Main Gear Tire .....	3-136
Landing With A Blown Nose Gear Tire .....	3-136
LG Extension Malfunctions .....	3-137
LG Handle Will Not Lower .....	3-137
LG Fails To Extend .....	3-138
Alternate LG Extension .....	3-139
Landing With LG Unsafe/Up .....	3-140
Antiskid Malfunction (Landing) .....	3-140
Asymmetric Stores (Landing) .....	3-141
NLG WOW Switch Failure .....	3-145
Drag Chute Failure .....	3-145

## INTRODUCTION

This section covers the operation of the aircraft during emergency/abnormal conditions. It includes a discussion of problem indications and corrective actions as well as procedural steps when applicable. Adherence to these guidelines insures maximum safety for the pilot and/or aircraft. The situations covered are representative of the most probable malfunctions. However, multiple emergencies, adverse weather, or other factors may require modification of the recommended procedures. Only those steps required to correct or manage the problem should be accomplished. When dealing with emergency/abnormal conditions, it is essential to determine the most correct course of action by using sound judgment and a full understanding of the applicable system(s). When practical, other concerned agencies (i.e., flight lead, tower, etc.) should be advised of the problem and intended course of action.

When a voice WARNING or CAUTION message is heard, check cockpit indications; then refer to the appropriate emergency procedure for corrective action.

When structural damage or any other failure that may adversely affect aircraft handling characteristics is known or suspected, a controllability check should be performed.

Certain steps (e.g., MASTER CAUTION reset, ELEC CAUTION reset) are intentionally omitted from the numbered procedures. Pilots are expected to perform these actions without prompting, when warranted.

Three basic rules, which apply to all emergencies, are established:

1. MAINTAIN AIRCRAFT CONTROL.
2. ANALYZE THE SITUATION AND TAKE PROPER ACTION.
3. LAND AS THE SITUATION DICTATES.

The following information provides general landing guidance:

### Land As Soon As Possible

An emergency will be declared. A landing should be accomplished at the nearest suitable airfield considering the severity of the emergency, weather conditions, airfield facilities, lighting, aircraft GW, and command guidance.

### Land As Soon As Practical

Emergency conditions are less urgent and, although the flight is to be terminated, the degree of the emergency is such that an immediate landing at the nearest suitable airfield may not be necessary.

## WARNING

- The canopy should remain closed during all emergencies that could result in a crash or fire such as crash landings, aborted takeoffs, and arrestments. The protection the canopy affords far outweighs the isolated risk of entrapment due to a canopy malfunction or overturn.
- Ejection is preferable to sliding into an arrestment cable with the NLG collapsed. The cable may slide up over the nose with unpredictable and potentially dangerous consequences to anyone in the cockpit(s).

**WARNING**

- If it appears that the aircraft will depart a prepared surface above normal taxi speed during an aborted take-off or a landing and go-around is not possible, eject since breakup of cockpit structure may occur. Retracting the LG to prevent departure from a prepared surface is not recommended since the MLG will probably not retract symmetrically.
- If remaining with an aircraft that will depart a prepared surface, shut down the engine, if feasible. This action reduces the potential for fire, reduces engine damage, and permits EPU turnoff if an MLG WOW signal is lost.

**WARNING AND CAUTION LIGHT AND PILOT FAULT LIST ANALYSIS**

Refer to figures 3-1, 3-2, and 3-3 for analysis and amplification of warning and caution light and Pilot

Fault List procedures. Fault trees show interrelationships with examples of problem events and corrective action.

**FORMAT**

The format of Emergency Procedures differs slightly between the Checklist and the Flight Manual. Procedures in the Checklist have been grouped by malfunction category (engine, electrical, etc.) to provide maximum in-flight utility. In the Flight Manual, procedures are listed by the phase of flight in which the emergency may occur. In the Checklist, some procedures are split into two independent side-by-side series of steps and are separated by a straight line; in the Flight Manual, these side-by-side steps appear in a continuous column and can be identified by repeat numbering of steps following conditional statements beginning with the word if. Amplification following procedural steps in the Flight Manual is repeated in the Checklist under the heading Inoperative Equipment, Other Indications, or Other Considerations. A thorough review of the layout and content of the Checklist and Flight Manual is recommended prior to in-flight use.

# Warning Light Analysis

WARNING LIGHT	CAUSE	CORRECTIVE ACTION/REMARKS
<div style="border: 1px solid black; padding: 2px; width: fit-content;">ENG FIRE</div> <div style="border: 1px solid black; padding: 2px; width: fit-content; margin-top: 2px;">ENGINE</div>	Engine compartment fire	Refer to ENGINE FIRE

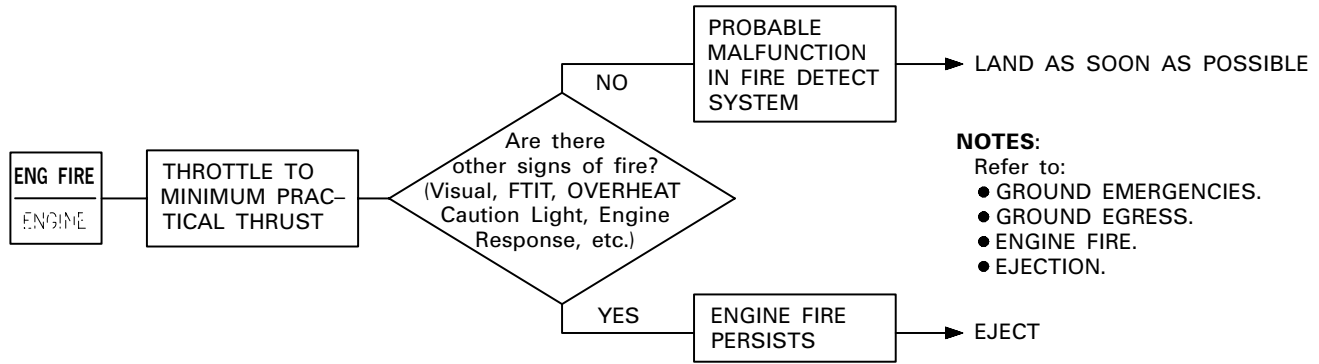

WARNING LIGHT	CAUSE	CORRECTIVE ACTION/REMARKS
<div style="border: 1px solid black; padding: 2px; width: fit-content;">TO/LDG</div> <div style="border: 1px solid black; padding: 2px; width: fit-content; margin-top: 2px;">CONFIG</div>	Aircraft configuration wrong for takeoff or landing  Any of the following: 1. LG not down and locked 2. TEF's not fully down	<b>A.</b> For in-flight LG problems, refer to LANDING EMERGENCIES  <b>B.</b> If TEF's do not extend, execute landing using normal AOA (approximately 20 knots faster than normal)

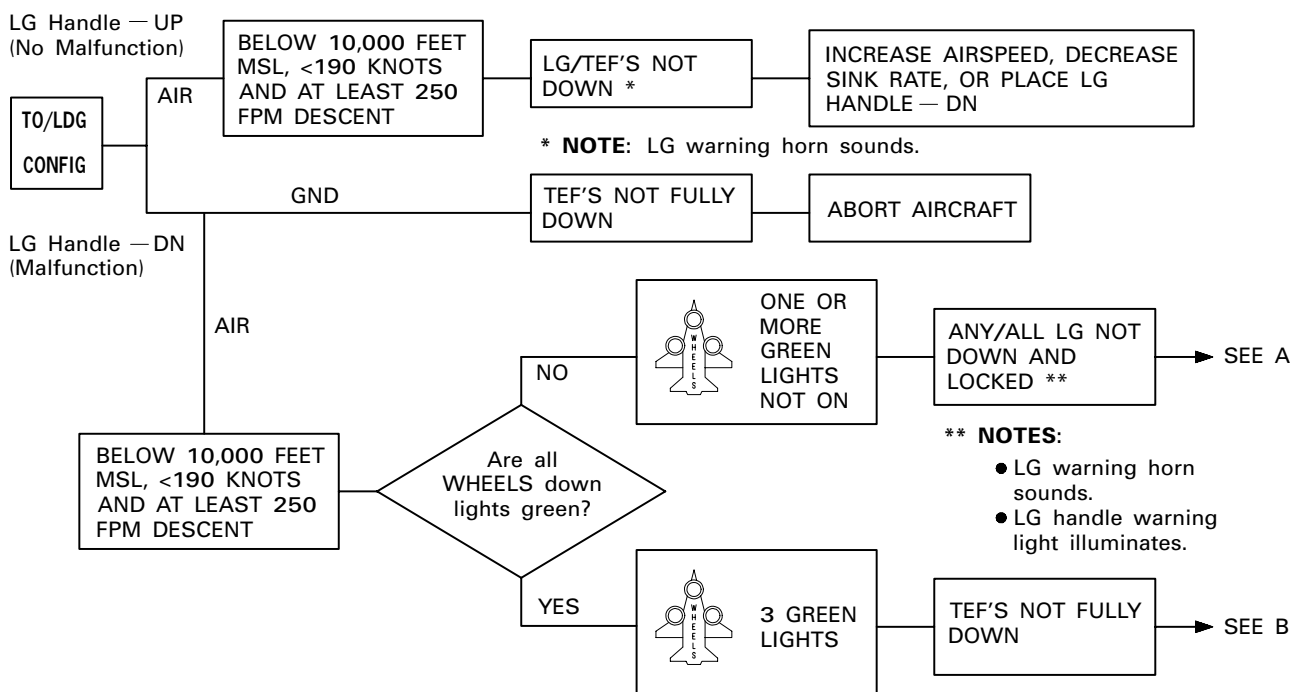

GR1F-16CJ-1-0106X37 ©

Figure 3-1. (Sheet 1)

# Warning Light Analysis PW229

WARNING LIGHT	CAUSE	CORRECTIVE ACTION/REMARKS
<div style="border: 1px solid black; padding: 5px; width: fit-content; margin: 0 auto;">                     HYD/OIL PRESS                 </div>	Low pressure in one or both hydraulic systems, low engine oil pressure, or low oil pressure switch failure	Check pressure indicators to determine system and condition  Refer to: <ul style="list-style-type: none"> <li>● OIL SYSTEM MALFUNCTION</li> <li>● HYDRAULIC MALFUNCTIONS</li> </ul>

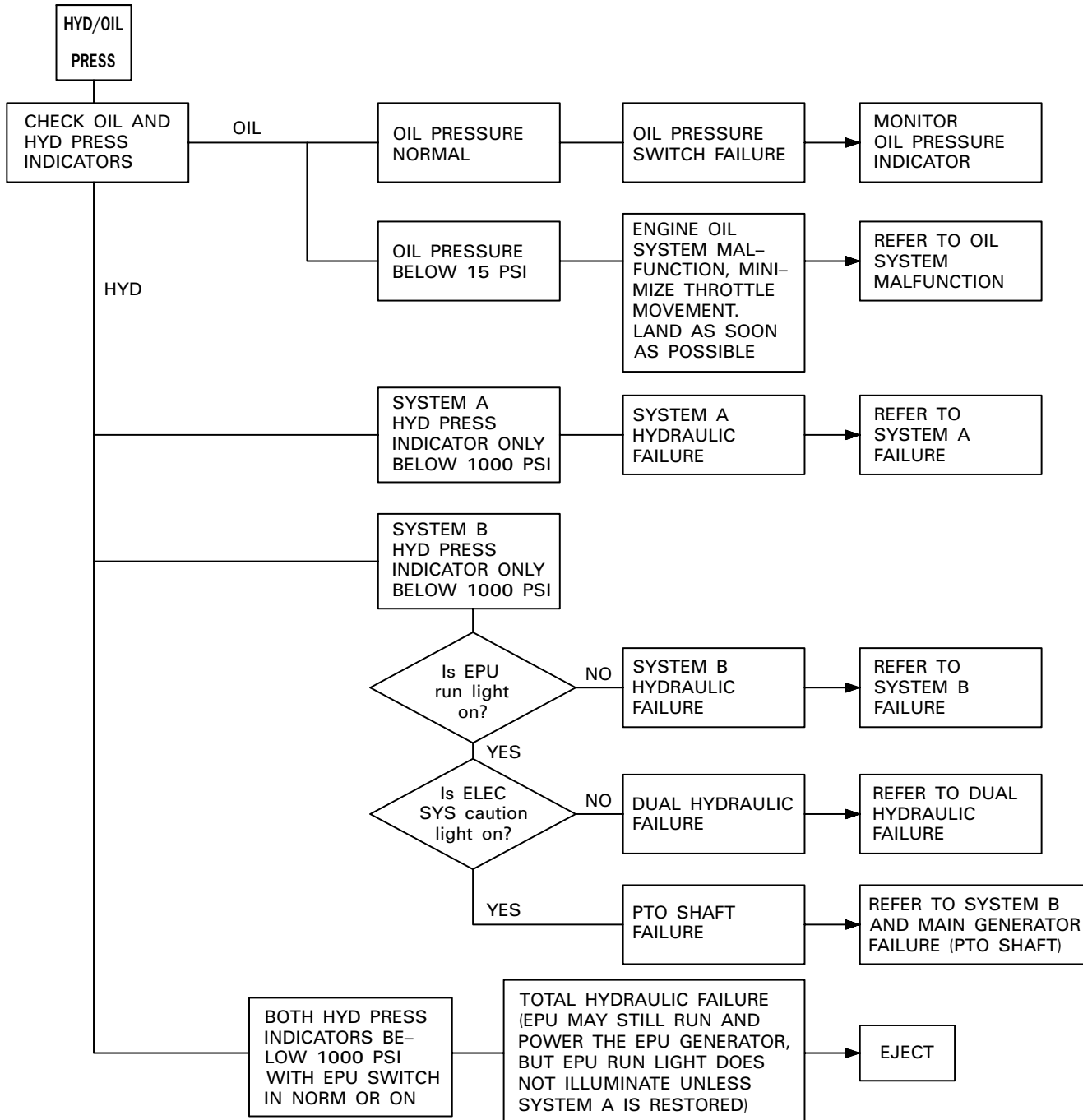

GR1F-16CJ-1-1107X37 ©

Figure 3-1. (Sheet 2)

# Warning Light Analysis **GE129**

WARNING LIGHT	CAUSE	CORRECTIVE ACTION/REMARKS
HYD/OIL PRESS	Low pressure in one or both hydraulic systems, low engine oil pressure, or low oil pressure switch failure	Check pressure indicators to determine system and condition
		Refer to: <ul style="list-style-type: none"> <li>● OIL SYSTEM MALFUNCTION</li> <li>● HYDRAULIC MALFUNCTIONS</li> </ul>

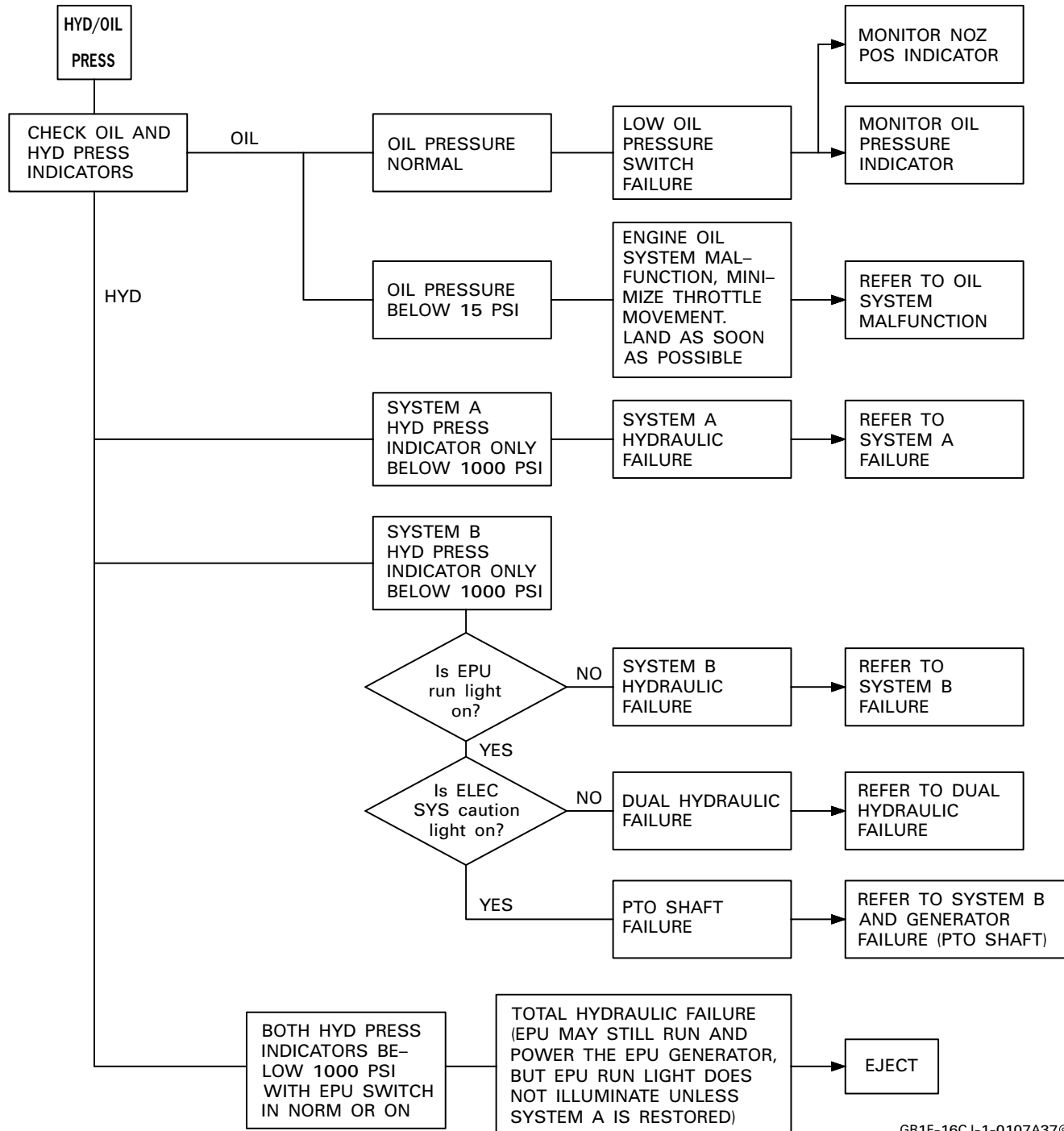

GR1F-16CJ-1-0107A37®

Figure 3-1. (Sheet 3)



# Warning Light Analysis

WARNING LIGHT	CAUSE	CORRECTIVE ACTION/REMARKS
	Canopy hooks or lock not secure	<b>A.</b> <ul style="list-style-type: none"> <li>• Push handle down farther into locked (outboard) position or if on the ground, inform maintenance</li> <li>• Refer to CANOPY LOSS/PENETRATION IN FLIGHT</li> </ul>

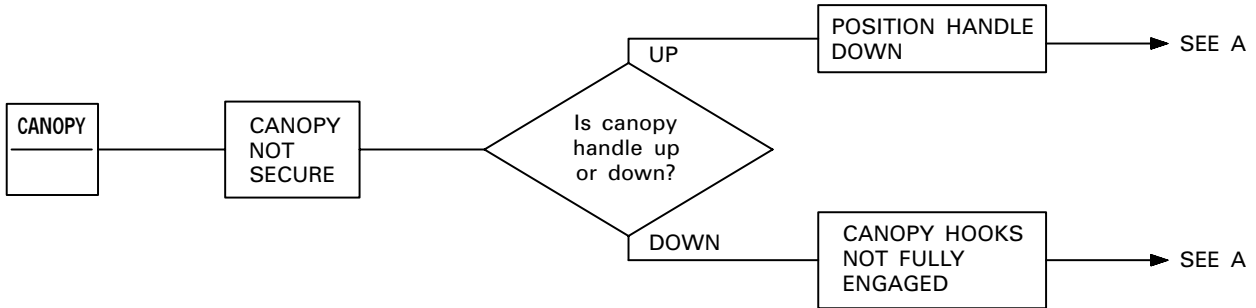

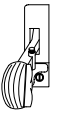
WARNING LIGHT	CAUSE	CORRECTIVE ACTION/REMARKS
	LG or LG door not in position commanded by LG handle	<b>A.</b> Refer to LG FAILS TO RETRACT <b>B.</b> Refer to LG FAILS TO EXTEND

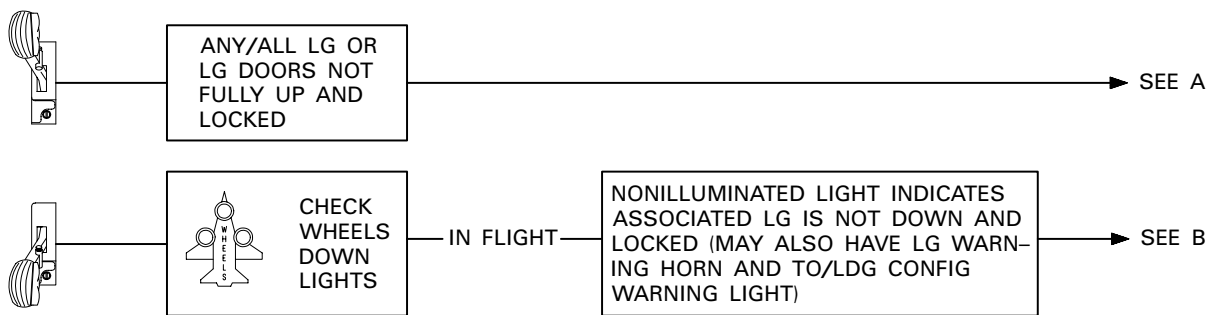

Figure 3-1. (Sheet 4)

# Warning Light Analysis





WARNING LIGHT	CAUSE	CORRECTIVE ACTION/REMARKS
	TF system failure	Climb to a safe altitude. Refer to TF FAIL WARNING LIGHT
	One or more malfunctions	Note PFL(s) displayed and refer to PILOT FAULT LIST – FLCS
	FLCC operating with backup software program	Refer to DBU ON WARNING LIGHT
	Partial pressure oxygen low	Refer to OBOGS MALFUNCTION  , this section
	BIT has detected a fault	
	Regulator pressure below 5 psi	
Flashing WARN symbol 	One or more red glareshield warning lights illuminated	Check for specific illuminated warning light  Reset by toggling WARN RESET switch on ICP
Flashing TRP FUEL and FUEL warning symbols 	A trapped external fuel condition is detected	Reset FUEL by toggling WARN RESET switch on ICP
		Check fuel tank quantities and refer to TRAPPED EXTERNAL FUEL

Figure 3-1. (Sheet 5)

# Warning Light Analysis PW229

WARNING LIGHT	CAUSE	CORRECTIVE ACTION/REMARKS
<div style="border: 1px solid black; padding: 2px; display: inline-block; text-align: center;">                     ENG FIRE ENGINE                 </div> Check rpm and FTIT indications	Engine flameout	<b>A.</b> Place throttle to OFF and initiate airstart. Refer to AIRSTARTS
	Engine alternator failure	<b>B.</b> Refer to ZERO RPM
	Engine overtemperature	<b>C.</b> Land as soon as possible
	Engine warning system failure or RPM/FTIT indicator failure	<b>D.</b> Land as soon as practical

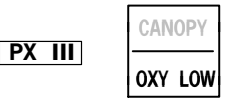

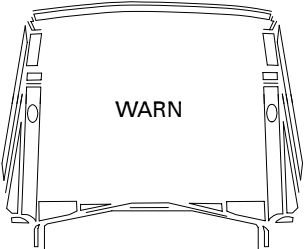
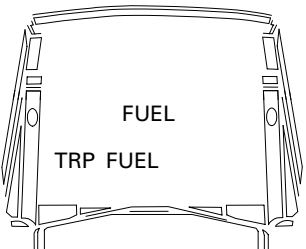
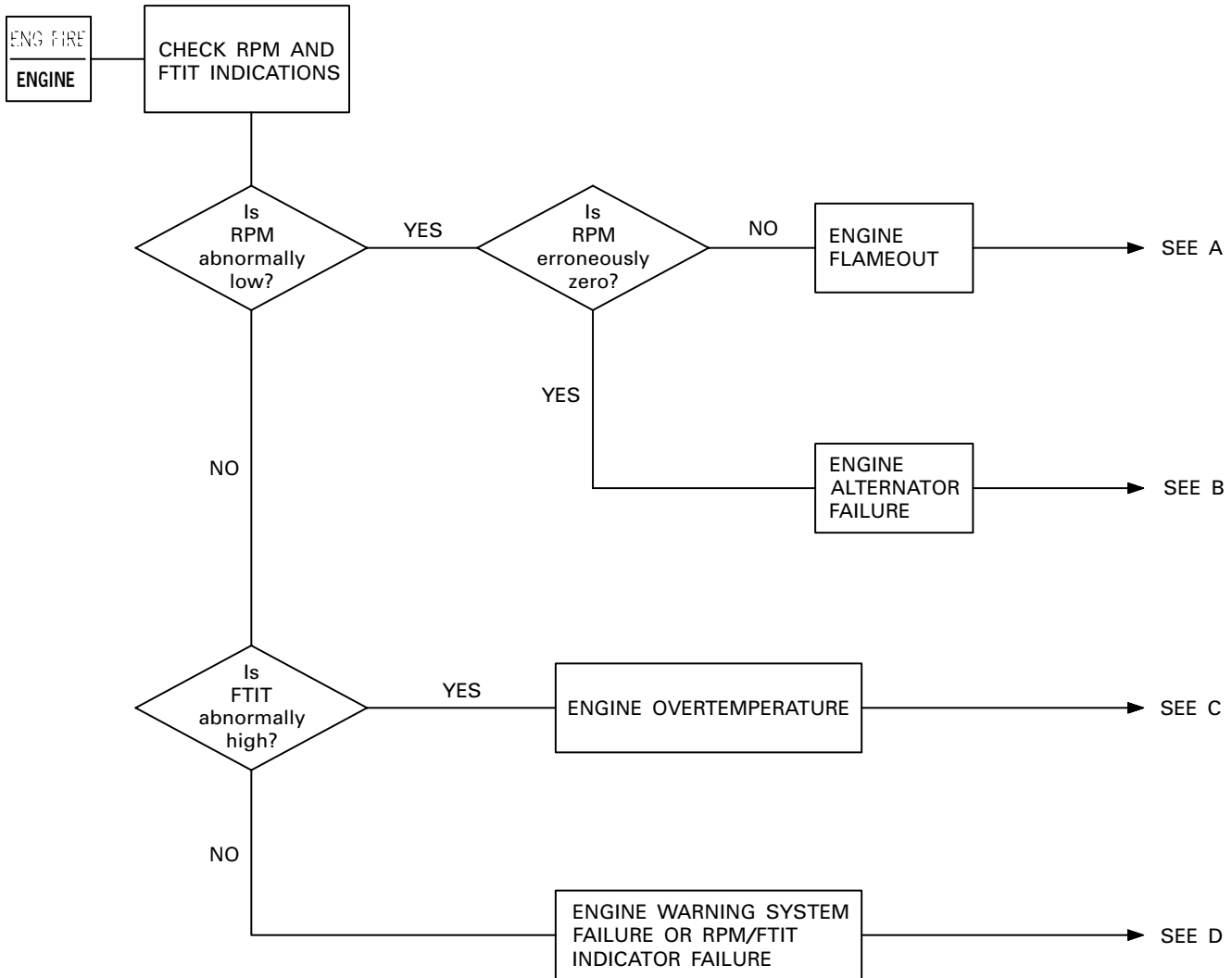
GR1F-16CJ-1-1109X37 ©

Figure 3-1. (Sheet 6)

# Warning Light Analysis GE129

WARNING LIGHT	CAUSE	CORRECTIVE ACTION/REMARKS
<div style="border: 1px solid black; padding: 2px; display: inline-block; text-align: center;">                     ENG FIRE ENGINE                 </div> Check rpm and FTIT indications	Engine flameout	<b>A.</b> Place throttle to OFF and initiate airstart. Refer to AIRSTARTS
	Engine alternator failure	<b>B.</b> Refer to ZERO RPM
	Engine overtemperature	<b>C.</b> Land as soon as possible
	Engine warning system failure or RPM/FTIT indicator failure	<b>D.</b> Land as soon as practical

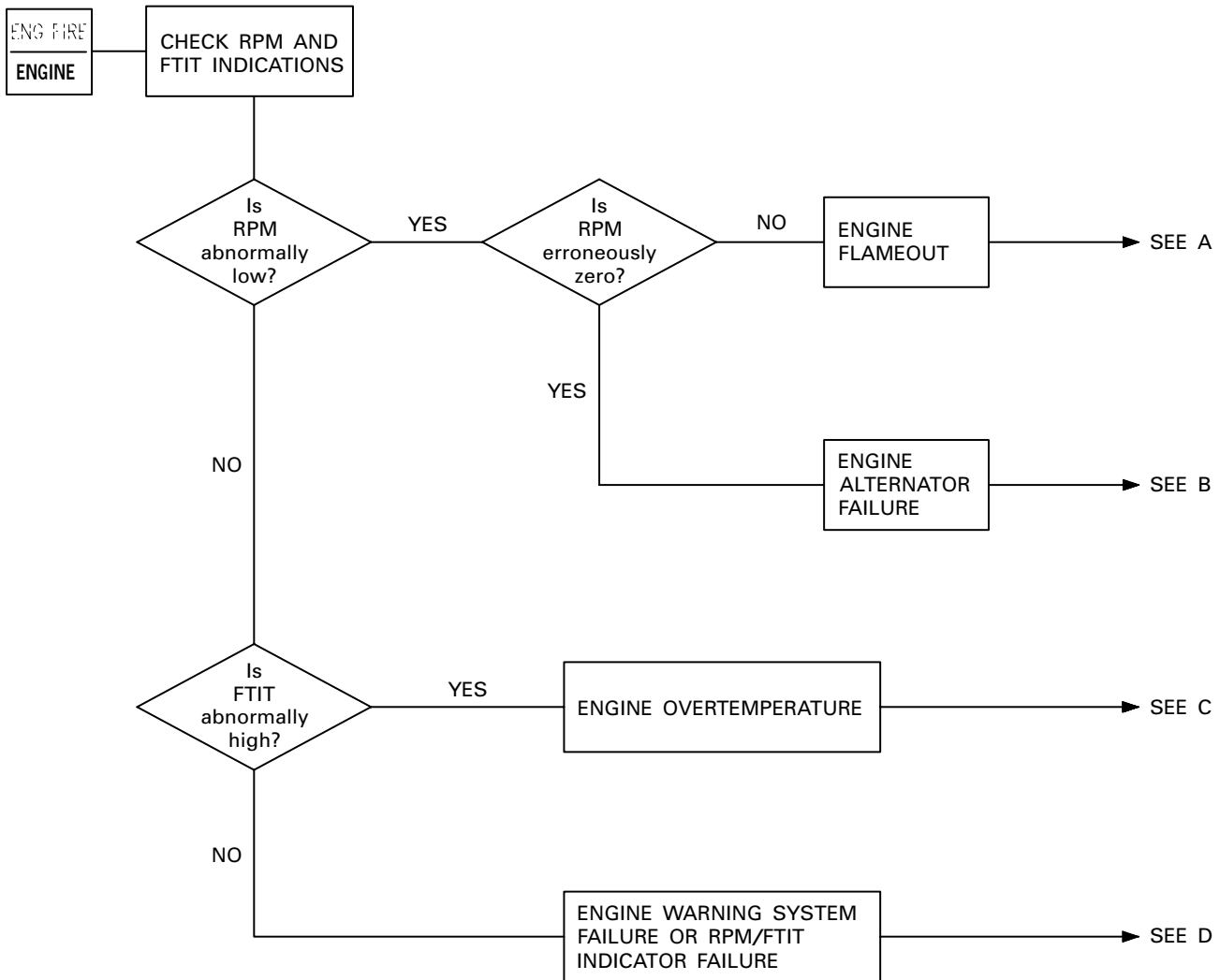

GR1F-16CJ-1-0109A37 ©

Figure 3-1. (Sheet 7)

# Caution Light Analysis

CAUTION LIGHT	CAUSE	CORRECTIVE ACTION/REMARKS
	One or more caution lights on	Check for specific caution light on caution light panel
	<p><b>NOTE</b></p> <p>The MASTER CAUTION light does not illuminate for the IFF caution light.</p>	<p>Reset MASTER CAUTION light</p> <p><b>NOTE</b></p> <p>The MASTER CAUTION light does not reset when the ELEC SYS caution light is illuminated. The ELEC CAUTION RESET button must be depressed or the electrical malfunction cleared to extinguish ELEC SYS and MASTER CAUTION lights.</p>

FLCS FAULT	ENGINE FAULT	AVIONICS FAULT	SEAT NOT ARMED
ELEC SYS	SEC	EQUIP HOT	NWS FAIL
PROBE HEAT	FUEL/OIL HOT	RADAR ALT	ANTI SKID
CADC	INLET ICING	IFF	HOOK
STORES CONFIG	OVERHEAT	NUCLEAR	OXY LOW
ATF NOT ENGAGED	EEC	_____	CABIN PRESS
FWD FUEL LOW	BUC	_____	_____
AFT FUEL LOW	_____	_____	_____

**PX II**

FLCS FAULT	ENGINE FAULT	AVIONICS FAULT	SEAT NOT ARMED
ELEC SYS	SEC	EQUIP HOT	NWS FAIL
PROBE HEAT	FUEL/OIL HOT	RADAR ALT	ANTI SKID
CADC	INLET ICING	IFF	HOOK
STORES CONFIG	OVERHEAT	NUCLEAR	OBOGS
ATF NOT ENGAGED	EEC	_____	CABIN PRESS
FWD FUEL LOW	BUC	_____	_____
AFT FUEL LOW	_____	_____	_____

**PX III**

Figure 3-2. (Sheet 1)

# Caution Light Analysis

CAUTION LIGHT	CAUSE	CORRECTIVE ACTION/REMARKS
CADC	Malfunction of CADC or input(s) to it	<b>A.</b> Refer to CADC MALFUNCTION
CADC      ENGINE FAULT	Loss of valid mach data to engine	<b>B.</b> Refer to CADC MALFUNCTION

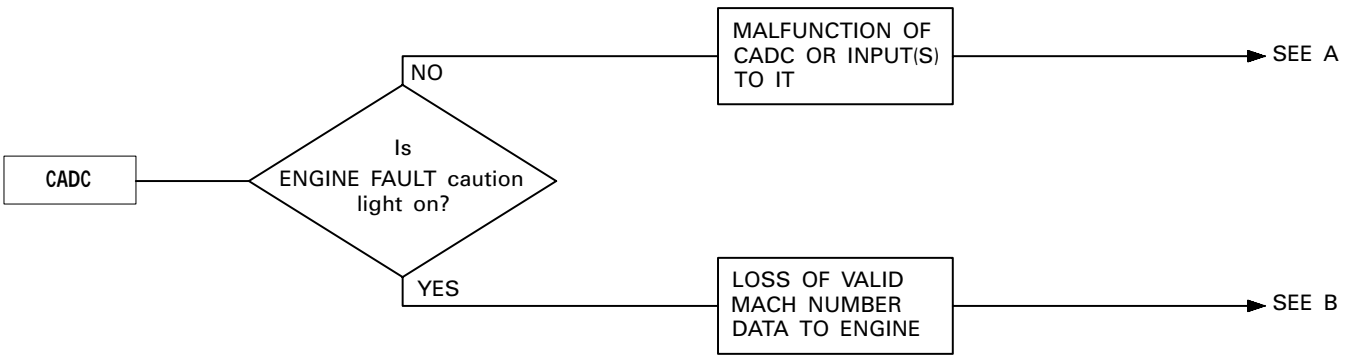

Figure 3-2. (Sheet 2)

# Caution Light Analysis

CAUTION LIGHT	CAUSE	CORRECTIVE ACTION/REMARKS
<div style="border: 1px solid black; padding: 2px; display: inline-block;">ELEC SYS</div>	Failure(s) of electrical system	*Check ELEC control panel for illuminated light(s) and depress ELEC CAUTION RESET button
FLCS PMG light (in flight)	Failure of FLCS PMG	A. Refer to FLCS PMG FAILURE
STBY GEN light	Failure of standby generator	B. Refer to SINGLE GENERATOR FAILURES
MAIN GEN light	Failure of main generator	C. Refer to SINGLE GENERATOR FAILURES
STBY GEN and FLCS PMG lights	Failure of standby generator and FLCS PMG	D. Refer to SINGLE GENERATOR FAILURES
MAIN GEN, STBY GEN, EPU run, EPU AIR, and (possibly) EPU HYDRAZN lights	Failure of main and standby generators	E. Refer to MAIN AND STANDBY GENERATOR FAILURE
MAIN GEN, STBY GEN, EPU GEN, and EPU PMG lights on. EPU run light off	Failure of main, standby, and EPU generators	F. Refer to MAIN, STANDBY, AND EPU GENERATOR FAILURE
MAIN GEN, STBY GEN, EPU GEN, EPU PMG, FLCS PMG, and ACFT BATT TO FLCS and/or FLCS BATT lights on. EPU run light off	Failure of all generators	G. Refer to MAIN, STANDBY, AND EPU GENERATOR FAILURE
*ACFT BATT FAIL light or ACFT BATT FAIL and FLCS RLY lights	Failure of aircraft battery or battery charging system	H. Refer to AIRCRAFT BATTERY FAILURE
FLCS RLY light	Voltage on one or more of the four FLCC branches connected to the aircraft battery is inadequate (below 20V)	I. Refer to FLCS RLY LIGHT

**NOTE:**

\*During ground operations after engine start, the ACFT BATT FAIL light (and possibly ELEC SYS caution light) may flicker on then off (duration of illumination is not long enough to activate the MASTER CAUTION light). This flickering is the result of a nuisance problem that does not require corrective action by maintenance and it should not occur in flight.

Figure 3-2. (Sheet 3)

# Caution Light Analysis

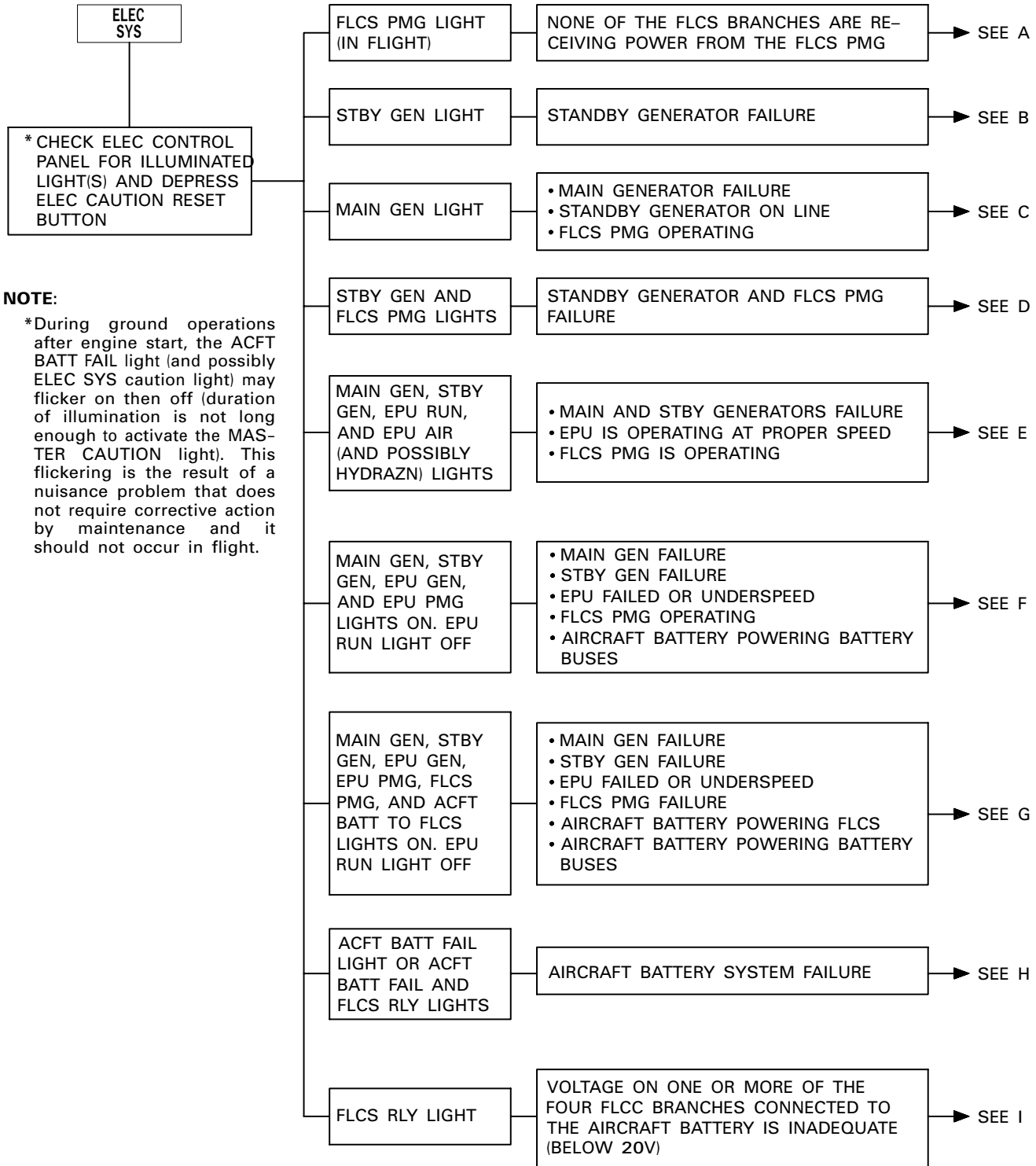

**NOTE:**

\*During ground operations after engine start, the ACFT BATT FAIL light (and possibly ELEC SYS caution light) may flicker on then off (duration of illumination is not long enough to activate the MASTER CAUTION light). This flickering is the result of a nuisance problem that does not require corrective action by maintenance and it should not occur in flight.

GR1F-16CJ-1-0111X37 ©

Figure 3-2. (Sheet 4)



# Caution Light Analysis

CAUTION LIGHT	CAUSE	CORRECTIVE ACTION/REMARKS
AVIONICS FAULT	Avionic fault(s) detected or MUX communication with FLCS or engine lost	Note PFL(s) displayed on PFLD. Depress <b>C</b> <b>DF</b> F-ACK, <b>DR</b> FAULT ACK button to acknowledge fault(s) and reset AVIONICS FAULT caution light. Perform fault recall(s) to determine if the failure condition still exists
SEAT NOT ARMED	Ejection safety lever up (system safe)	When desired, rotate ejection safety lever down (armed)
HOOK	Hook not up and locked	Normal landing, touchdown beyond approach end arresting gear
NWS FAIL	NWS system failure or loss of NWS electrical power	Normal landing, NWS is not available. Refer to NWS FAILURE/HARDOVER  NOTES: 1. Does not illuminate for NWS failure due to hydraulic system B failure or NLG strut overextension. 2. Possible indication that AR door cannot be opened or closed.
EEC	Not used	None
BUC	Not used	None
FLCS FAULT	FLCS fault(s) detected	Note PFL(s) displayed and refer to PILOT FAULT LIST – FLCS
<b>PW229</b> FUEL/OIL HOT	Temperature of fuel to engine excessive. Oil hot function is inoperative	Refer to HOT FUEL/OIL OR GRAVITY FEED
<b>GE129</b> FUEL/OIL HOT	Temperature of fuel to engine excessive or engine oil temperature excessive	Refer to HOT FUEL/OIL OR GRAVITY FEED
FWD FUEL LOW	Forward reservoir contains: <b>C</b> Less than 400 pounds fuel <b>D</b> Less than 250 pounds fuel	Refer to FUEL LOW
AFT FUEL LOW	Aft reservoir contains: <b>C</b> Less than 250 pounds fuel <b>D</b> Less than 400 pounds fuel	Refer to FUEL LOW
IFF	MODE 4 REPLY sw in OUT (backup mode only); zeroized or not coded; correct code not selected (A or B); code does not match code interrogation; or mode 4 inoperative; or RF sw in QUIET or SILENT	Advisory

Figure 3-2. (Sheet 5)

## Caution Light Analysis

CAUTION LIGHT	CAUSE	CORRECTIVE ACTION/REMARKS
INLET ICING	Ice accumulation detected or system malfunction	If in area of known or suspected icing conditions, position engine ANTI ICE switch to ON
NUCLEAR	Malfunction in nuclear control circuitry	Advisory
SEC	<b>PW229</b> Engine operating in SEC or main fuel pump pressure is low	Refer to SEC CAUTION LIGHT
	<b>GE129</b> Engine operating in SEC	Refer to SEC CAUTION LIGHT
ENGINE FAULT	Engine fault(s) detected	Refer to ENGINE FAULT CAUTION LIGHT
STORES CONFIG	STORES CONFIG switch is in incorrect position or loading category in SMS software disagrees with actual GP/STORE/LINE loading category	Verify STORES CONFIG switch is in proper position for aircraft loading category. Refer to T.O. GR1F-16CJ-1-2
PROBE HEAT	Ground: Probe heater failure, monitoring system failure, or one/both AOA probe heaters have shut off to prevent overheat	Ground: Place PROBE HEAT switch to OFF for 1 minute (caution light goes off when OFF is selected); then reselect PROBE HEAT. If caution light comes on simultaneously with reselection of PROBE HEAT, a probe heater or monitoring system failure has occurred. If caution light does not come on when PROBE HEAT is reselected, one/both AOA probe heaters were shut off to prevent overheat
	In flight: Probe heater(s) or monitoring system failure	In flight: Place PROBE HEAT switch to PROBE HEAT, if required, and avoid areas of known or suspected icing conditions

Figure 3-2. (Sheet 6)

# Caution Light Analysis

CAUTION LIGHT	CAUSE	CORRECTIVE ACTION/REMARKS
CABIN PRESS	Cockpit pressure altitude above 27,000 feet	A. Refer to COCKPIT PRESSURE/TEMPERATURE MALFUNCTION

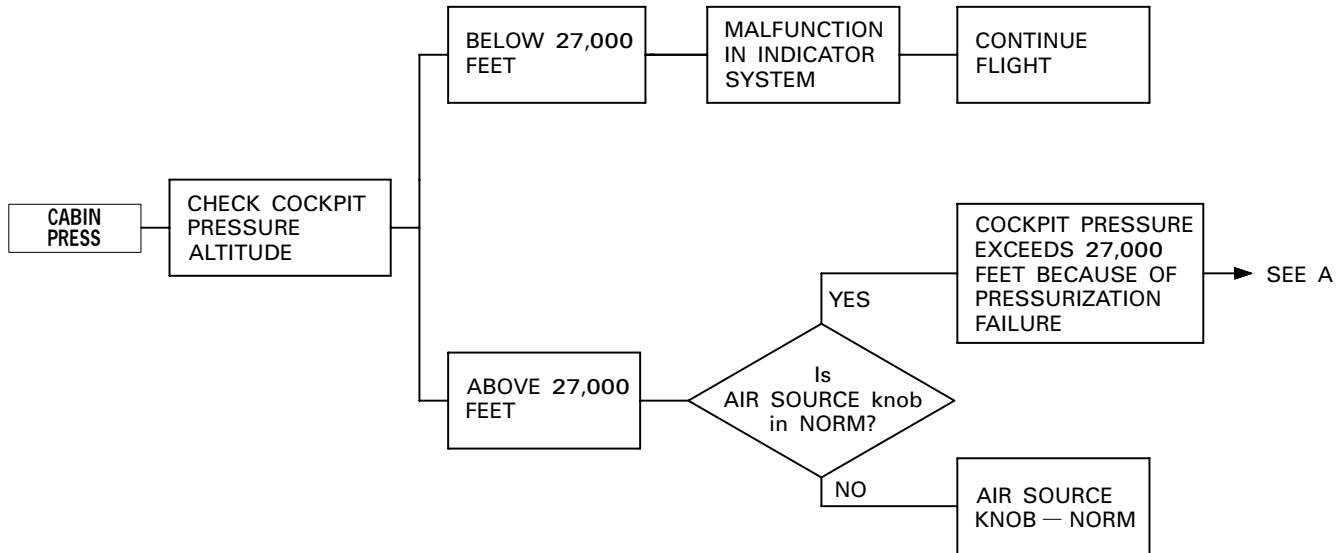

CAUTION LIGHT	CAUSE	CORRECTIVE ACTION/REMARKS
EQUIP HOT	Avionic equipment cooling air temperature/pressure insufficient	A. Refer to EQUIP HOT CAUTION LIGHT

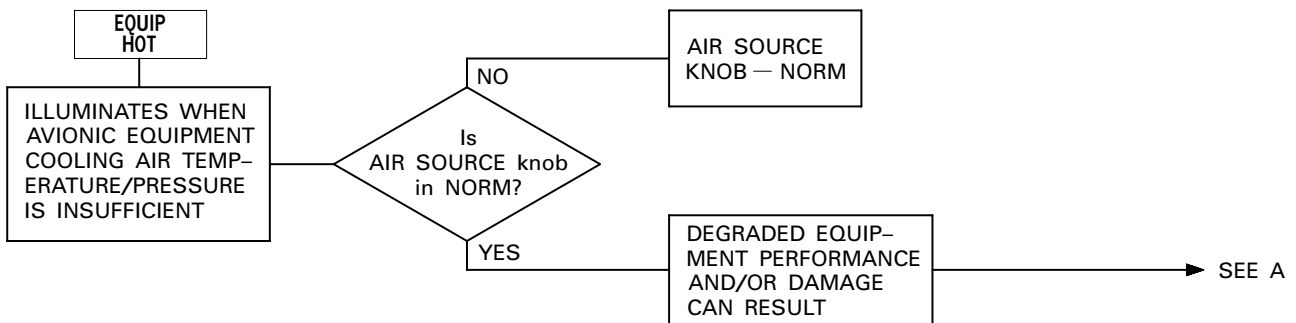

GR1F-16CJ-1-0112X37 ©

Figure 3-2. (Sheet 7)

# Caution Light Analysis

CAUTION LIGHT	CAUSE	CORRECTIVE ACTION/REMARKS
OVERHEAT	Overheat condition in engine compartment, ECS or EPU bays, or MLG wheel wells	A. Refer to OVERHEAT CAUTION LIGHT

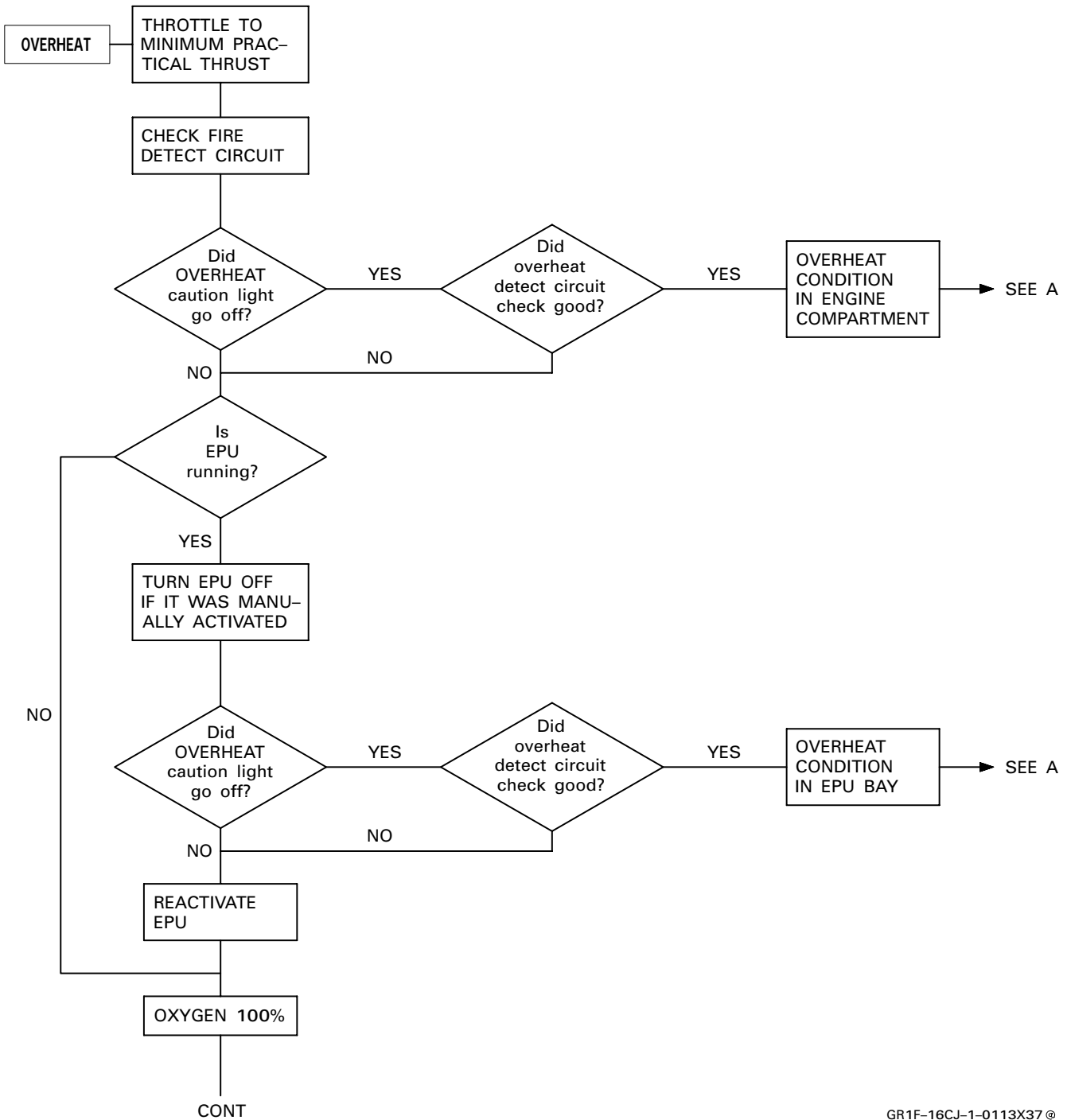

GR1F-16CJ-1-0113X37 ©

Figure 3-2. (Sheet 8)

# Caution Light Analysis

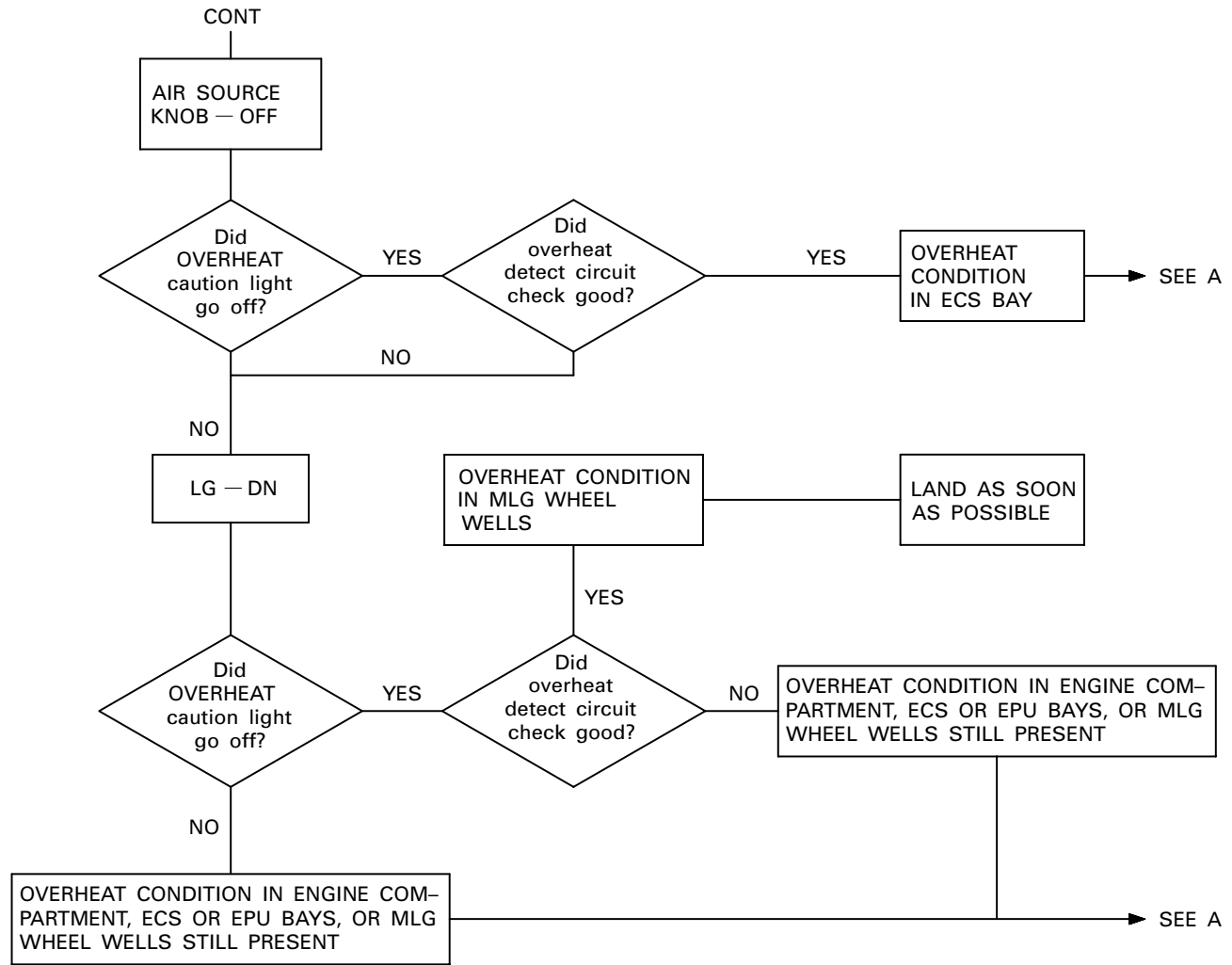

CAUTION LIGHT	CAUSE	CORRECTIVE ACTION/REMARKS
ANTI SKID	ANTI-SKID switch OFF or system malfunction	A. Refer to ANTISKID MALFUNCTION

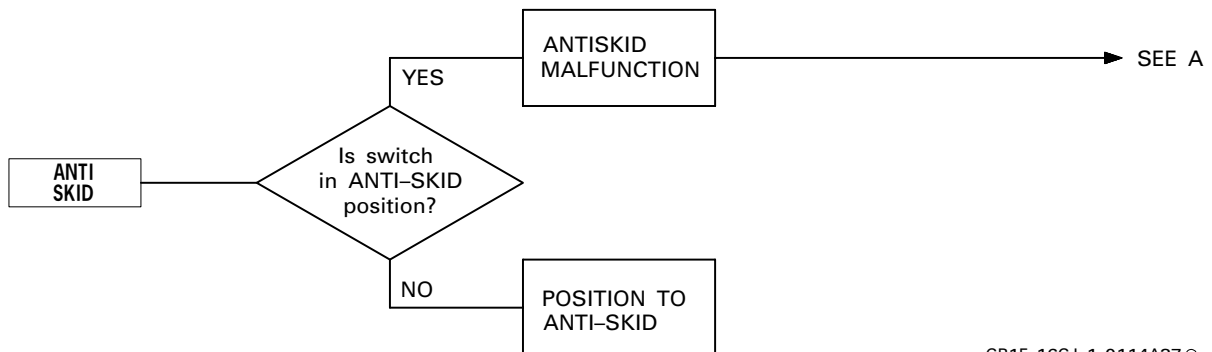

GR1F-16CJ-1-0114A37 ©

Figure 3-2. (Sheet 9)

# Caution Light Analysis

CAUTION LIGHT	CAUSE	CORRECTIVE ACTION/REMARKS
ATF NOT ENGAGED	NVP or FLCS cannot support ATF	If in ATF, climb to a safe altitude and verify: <ul style="list-style-type: none"> <li>● AIR REFUEL switch CLOSE</li> <li>● ALT FLAPS switch NORM</li> <li>● TRIM/AP DISC switch NORM</li> <li>● No CADC failures</li> </ul> <p><b>NOTE</b></p> Deselect ATF until the cause of the caution light illumination can be determined.
RADAR ALT	Malfunction of radar altimeter	Move RDR ALT switch to OFF
PX II OXY LOW	Oxygen pressure is below 42 psi or quantity is below 0.5 liter	<b>A.</b> Descend to 10,000 feet cockpit pressure altitude. Activate emergency oxygen if required
PX III OBOGS	The ECS air supply for OBOGS has dropped below 10 psi	Oxygen production stops. BOS provides oxygen for 3-5 minutes. Expect OXY LOW warning light if regulator pressure drops below 5 psi. Attempt to increase ECS air pressure by increasing throttle setting, increasing airspeed, and/or decreasing altitude <p><b>NOTE</b></p> The OBOGS caution light may illuminate as a result of ECS cycling or temporary ECS shutdown. This is normal as long as the OXY LOW warning light does not illuminate.

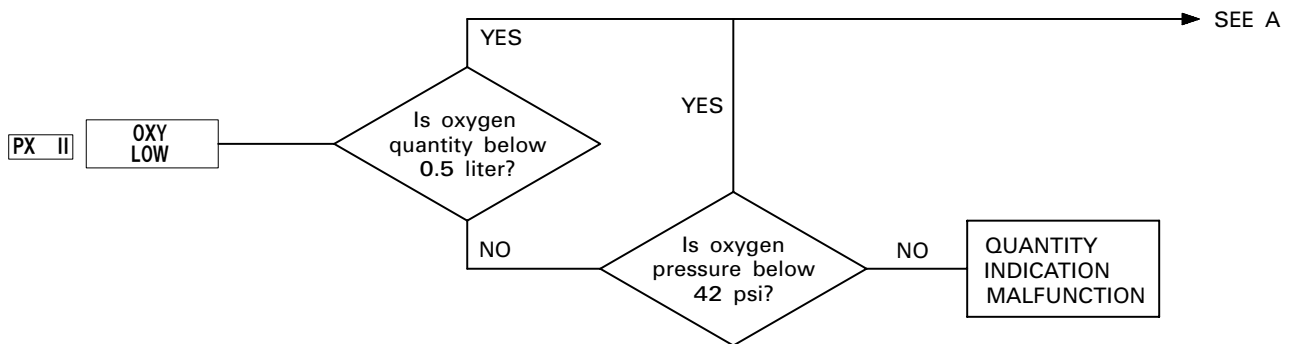

GR1F-16CJ-1-0115A37 ©

Figure 3-2. (Sheet 10)

# Pilot Fault List – Engine PW 229

FAULT	CAUSE	CORRECTIVE ACTION/REMARKS
ENG A/B FAIL and ENG THST LOW	Engine hardware deterioration/detected performance loss	Reduce engine rpm to 85% or less, unless required to sustain flight. High thrust levels may result in further deterioration/performance loss. Land as soon as possible
ENG A/I TEMP	Anti-ice valve failed open and/or bleed air temperature greater than 850°F	Reduce throttle setting to midrange unless required to sustain flight. Operating the engine above midrange with anti-ice system failed on may result in engine stall. Land as soon as practical
ENG A/I FAIL	Engine anti-ice valve failed in closed position	Avoid areas of known or suspected icing conditions
ENG MACH FAIL	The CADC supplied mach number to the DEEC is no longer available	Supersonic stall protection is inoperative. Do not retard throttle below MIL while supersonic. If CADC caution light is also on, refer to CADC MALFUNCTION, this section
ENG A/B FAIL	AB system failure detected	AB RESET switch – AB RESET. Land as soon as practical if fault does not clear. AB operation is partially or fully inhibited
ENG THST LOW	Loss of redundant FTIT signals received by DEEC DEEC has detected a failed open or missing nozzle	MIL rpm is reduced 7 percent by DEEC. Land as soon as practical If a failed open or missing nozzle is suspected, refer to NOZZLE FAILURE, this section
ENG BUS FAIL	Communication lost between EDU and MUX bus	Illuminates AVIONICS FAULT caution light. A subsequent engine fault causes a nonresettable ENGINE FAULT caution light and is not displayed on the PFLD
ENG PFL DGRD	Communication lost between EDU and DEEC	Do not retard throttle below MIL while supersonic. Only ENG A/I TEMP PFL can subsequently be displayed

**NOTE:**

A short duration fault condition may cause display of a PFL without illumination of the ENGINE FAULT caution light.

*Figure 3-3. (Sheet 1)*

## Pilot Fault List – Engine GE129

FAULT	CAUSE	CORRECTIVE ACTION/REMARKS
ENG LUBE LOW	Oil quantity below preset limit	Refer to OIL SYSTEM MALFUNCTION, this section
ENG A/I FAIL	Engine anti-ice valve failed in closed position or indication malfunction	Avoid areas of known or suspected icing conditions
ENG MACH FAIL	The CADC supplied mach number to the DEC is no longer available	Supersonic stall protection is inoperative. Do not retard throttle below MIL while supersonic. If CADC caution light is also on, refer to CADC MALFUNCTION, this section
ENG BUS FAIL	Communication between engine and MUX bus lost	Illuminates AVIONICS FAULT caution light. Other engine PFL's cannot be displayed
ENG A/B FAIL	AB system failure detected	Land as soon as practical if fault does not clear. AB operation inhibited. If nozzle remains closed at idle below 0.5 mach, refer to ABNORMAL ENGINE RESPONSE, this section
ENG EMS FAIL	<ul style="list-style-type: none"> <li>• Data transmission from DEC lost</li> <li>• BIT/self-test received from DEC indicates a failure</li> <li>• EMSC BIT/self-test detects a failure</li> </ul>	Other PFL's either cannot be displayed or, if displayed, are not reliable
ENG HYB MODE	A PRI fuel flow scheduling problem was detected	Supersonic stall protection is inoperative. Do not retard throttle below MIL while supersonic. Check engine response to throttle movement when subsonic. If engine responds normally, land as soon as practical. If engine does not respond normally, refer to ABNORMAL ENGINE RESPONSE, this section

**NOTE:**

A short duration fault condition may cause display of a PFL without illumination of the ENGINE FAULT caution light.

Figure 3-3. (Sheet 2)



# Pilot Fault List – FLCS

(FLCS warning light illuminated)

FAULT	CAUSE	CORRECTIVE ACTION/REMARKS
FLCS AOA WARN	Dual AOA failure	Refer to AOA MALFUNCTIONS
FLCS DUAL FAIL	Dual electronic, sensor, or power failure in one or more axes	Refer to FLCS DUAL ELECTRONIC FAILURE
FLCS LEF LOCK	LEF's are locked due to multiple failures, LE FLAPS switch position, or asymmetry	Refer to LEF MALFUNCTIONS
STBY GAIN	Dual air data failure	Refer to AIR DATA MALFUNCTIONS
FLCS BIT FAIL	FLCS BIT has detected a failure	Perform a second FLCS BIT. If fault does not clear, notify maintenance. Fault only occurs on ground

(TF FAIL warning light illuminated)

FAULT	CAUSE	CORRECTIVE ACTION/REMARKS
SWIM NVP FAIL	NVP data bad, AMUX wraparound failure, NVP self-mode failure, or cyclic test problem monitor failure	Refer to TF FAIL WARNING LIGHT
SWIM RALT FAIL	SDC monitor failure or CARA data bad	
SWIM SCP FAIL	Below set clearance failure	
SWIM ATTD FAIL	INS attitude estimator failure	
SWIM ATF FAIL	NVP ATF select failure	
SWIM VEL FAIL	GPS/INS failure	

Figure 3-3. (Sheet 3)

# Pilot Fault List – FLCS

(FLCS FAULT caution light illuminated for all except FLCS BUS FAIL)

FAULT	CAUSE	CORRECTIVE ACTION/REMARKS
FLCS ADC FAIL	First failure of triplex air data input signal	Refer to AIR DATA MALFUNCTIONS
FLCS AOA FAIL	First failure of triplex AOA input signal	Refer to AOA MALFUNCTIONS
FLCS AOS FAIL	AOS feedback function is inoperative due to failure	Perform FLCS reset to attempt to clear fault; fault cannot be reset if INS or CADC is failed If fault does not clear, the autopilot cannot be engaged. Position the STORES CONFIG switch to CAT III if the aircraft is configured with a ③ GP/STORE/LINE loading. Refer to T.O. GR1F-16CJ-1-2 *
FLCS FLUP OFF	MANUAL TF FLYUP switch moved to DISABLE  FLCS BIT detects MANUAL TF FLYUP switch in DISABLE	Position the MANUAL TF FLYUP switch as required. A FLCS reset extinguishes FLCS FAULT caution light  Position MANUAL TF FLYUP switch to ENABLE. Rerun FLCS BIT
FLCS A/P DEGR	Autopilot operating outside of attitude limits or unable to hold commanded mode	Refer to AUTOPILOT MALFUNCTIONS
FLCS A/P FAIL	Autopilot has disconnected or cannot be engaged due to loss of needed data	Refer to AUTOPILOT MALFUNCTIONS
FLCS BUS FAIL	Communication lost between FLCC and MUX bus	Illuminates AVIONICS FAULT caution light. Other FLCS PFL's may not be displayed on the PFLD. Refer to FLCS page on MFD for FLCS PFL's
BRK PWR DEGR	Power supply failure detected in one or more branches	Refer to FLCS SINGLE ELECTRONIC FAILURE
FLCS CCM FAIL	Erroneous output command detected by CCM	Refer to FLCS SINGLE ELECTRONIC FAILURE
FLCS HOT TEMP	FLCC sensors detect two branches in excess of 75°C	Refer to FLCS TEMPERATURE MALFUNCTIONS
ISA ALL FAIL	Two or more ISA's have reported a first servo valve failure	Refer to SERVO MALFUNCTIONS
ISA LHT FAIL ISA RHT FAIL ISA LF FAIL ISA RF FAIL ISA RUD FAIL	Indicated ISA has reported a first servo valve failure	Refer to SERVO MALFUNCTIONS
FLCS SNGL FAIL	Indicates single electronic or sensor failure in one or more axes	Notify maintenance. Fault only occurs on ground
FLCS MUX DEGR	BIT detected degradation of FLCC MUX interface	FLCS reset will not clear fault. Perform a second FLCS BIT. If fault does not clear and no other faults are reported, the system redundancy is adequate for flight. Notify maintenance after flight. Fault only occurs on ground

**NOTE:**

\*The potential for a departure from controlled flight is significantly increased if the AOS feedback function is inoperative and maneuvering with ③ GP/STORE/LINE loadings occurs with the STORES CONFIG switch in CAT I.

Figure 3-3. (Sheet 4)

## GROUND EMERGENCIES

### FIRE/OVERHEAT/FUEL LEAK (GROUND)

An engine or JFS fire/overheat can be detected by flames, smoke, explosion, signal from ground crew, or radio call. FTIT may exceed **PW 229** 800°C, **GE129** 935°C and, if ac power is available, ENG FIRE warning or OVERHEAT caution light may illuminate.

1. Throttle - OFF.
2. JFS switch - OFF.
3. FUEL MASTER switch - OFF.
4. ENG FEED knob - OFF (if external power applied).

If fire continues:

5. Abandon aircraft.

### HOT START (GROUND)

**PW 229** Hot start - FTIT over 800°C. During engine start, if the FTIT increases at an abnormally rapid rate through 750°C, a hot start can be anticipated.

**GE129** Hot start - FTIT over 935°C. During engine start, if the FTIT increases through 750°C while engine rpm is less than 40 percent, a hot start can be anticipated.

1. Throttle - OFF.
2. FTIT indicator - Monitor.

If FTIT remains above 500°C:

3. JFS switch - START 2.  
Motor engine with JFS until FTIT reaches 200°C or for four minutes (JFS ground operating limit), whichever occurs first.

### HUNG START/NO START **PW 229**

Hung start - RPM has stopped increasing below IDLE and FTIT is stabilized at less than 800°C.

No start - Light-off does not occur within 20 seconds.

1. Throttle - OFF. Notify maintenance.

### HUNG START/NO START **GE129**

Hung start - RPM has stopped increasing below IDLE and FTIT is stabilized at less than 935°C.

No start - Light-off does not occur within 10 seconds.

1. Throttle - OFF. Notify maintenance.

## ENGINE AUTOACCELERATION (GROUND)

If the engine autoaccelerates on the ground, primary consideration should be given to shutting the engine down as quickly as possible. With engine shut down, only the brake/JFS accumulators are available to supply hydraulic pressure for braking. Stop the aircraft by making one steady brake application. When the aircraft is fully stopped, have chocks installed or engage parking brake. Leave the battery on until chocks are installed.

1. Throttle - OFF.
2. FUEL MASTER switch - OFF.

## ANTISKID MALFUNCTION (GROUND)

**129** If a failure affecting braking performance is detected while the aircraft is moving above 5 knots, the ANTI SKID caution light illuminates. In most cases this represents the loss of a wheel speed sensor signal, and the system switches to an alternate braking mode. In this mode, if differential braking is applied (15 percent or greater difference between pedals), both brakes oscillate between pressure as metered and no pressure. Braking effectiveness is reduced by 50 percent or greater. If brake pedals are within 15 percent, the system uses the information from the remaining good wheel speed sensor and stopping distance is increased by approximately 25 percent on both wet and dry runways. An ANTI SKID caution light which only illuminates below 5 knots indicates a malfunction that does not affect braking performance. Normal braking and antiskid are available; however, system redundancy may have been lost.

**129** Below 20 knots ground speed the alternate braking mode is less effective. Place BRAKES channel switch to CHAN 2 and ANTI-SKID switch to OFF. Braking will be manual.

**LESS 129** In case of an antiskid failure, the ANTI SKID caution light illuminates and the brake system automatically switches to pulsating pressure. In this mode, braking effectiveness is reduced approximately 50 percent; however, in most cases, braking effectiveness is as good as can be obtained with ANTI-SKID switch in OFF while avoiding wheel lockup and its associated risk of control difficulty. Short field landing distances are increased approximately 60 percent for dry runway and 25 percent for wet runway from those normally computed.

If the ANTI SKID caution light illuminates (with the ANTI-SKID switch in ANTI-SKID):

1. DRAG CHUTE switch - DEPLOY (if required).
2. Brakes - Apply as needed.

#### NOTE

- **(129)** Use of maximum symmetric pedal pressure provides the best stopping performance. Differential brake only when essential for directional control. If the ANTI SKID caution light illuminated above 5 knots groundspeed, the aircraft may oscillate due to pulsating brake pressure (if 15 percent or greater differential pedal pressure is applied). Changing brake channels may restore normal braking.
- **LESS (129)** Maximum pedal pressure is required to obtain approximately 50 percent of normal braking force. If less than maximum pedal pressure is used, braking is extremely degraded. The aircraft will oscillate due to pulsating brake pressure. Changing brake channels will not restore normal braking since the same antiskid signal is used in both brake channels.

3. NWS - Engage (if required).

If manual braking is desired or after aircraft is stopped:

4. **(129)** BRAKES channel switch - CHAN 2.
5. ANTI-SKID switch - OFF.



No antiskid protection is available with the ANTI-SKID switch in OFF **(129)** and BRAKES channel switch in CHAN 2. Brakes should be applied with caution to avoid wheel lockup and blown tires.

#### NOTE

**LESS (129)** Below normal taxi speed, pulsating braking is only marginally effective. Stopping distance may be shortened with antiskid off.

## BRAKE FAILURE

Malfunctions in systems which affect normal braking are described in the emergency procedure which addresses each specific system. One of the brake failure modes is the loss of one brake circuit. With this failure, both brakes are still available; however, significantly more pedal force than normal is required to achieve a specific braking effectiveness.

Another failure mode is loss of brakes on one or both MLG. Changing brake channels may return the system to normal operation. Turning the ANTI-SKID switch to OFF **(129)** and confirming BRAKES channel switch in CHAN 2 may also restore braking; however, the system reverts to manual control and antiskid protection is lost. (Status of the power source for toe brake transducers can be determined by testing the FLCS PWR lights on the TEST switch panel.) Release brake pedal pressure before changing channels or turning off the ANTI-SKID switch to avoid immediate brake lockup if braking returns. When moving the ANTI-SKID switch, be very careful not to select the PARKING BRAKE unless that is what is intended. If directional control is a problem (such as with one brake inoperative on landing roll), do not hesitate to use NWS. If conditions permit, consider a go-around if the brakes are found to be inoperative on landing. Lower hook if a cable is available. If normal brakes cannot be restored, do not hesitate to use the parking brake if a cable is not available. The lower the groundspeed, the less chance there is for aircraft damage when using the parking brake. If the aircraft is accelerating, use the parking brake early. It may be possible to cycle the parking brake on and off and stop the aircraft; however, regardless of technique, use of the parking brake may result in blown tires.

Another failure mode is a hydraulic leak in the brake itself, which might not be apparent until after two-point aerodynamic braking. In this case, if a cable is not available, the aircraft should be stopped using the good brake and NWS for directional control. Once the aircraft is stopped, do not engage the parking brake; use continuous pedal pressure on the good brake only. Failure to do so could deplete the hydraulic system and result in total brake failure prior to chock installation.

Accomplish as many steps as required:

#### NOTE

If conditions permit, consider a go-around if the brakes are found to be inoperative on landing. An approach-end cable arrestment is recommended.

T.O. GR1F-16CJ-1

1. BRAKES channel switch – Change channels.



Release brakes prior to changing brake channels or turning antiskid off.

2. **129** BRAKES channel switch – CHAN 2.
3. ANTI-SKID switch – OFF.



Release brakes prior to changing brake channels or turning antiskid off.

4. NWS – Engage (if required).
5. HOOK switch – DN.

If arresting cable is not available or if at low groundspeed:

6. ANTI-SKID switch – Intermittent PARKING BRAKE, then ANTI-SKID.



If in a congested area, use the parking brake immediately to stop.

### HOT BRAKES

The pilot has the responsibility to determine when a hot brake condition exists. The pilot evaluates the situation by analyzing the variables that influence brake temperature: GW, pressure altitude, OAT, speed at brake application, etc. Refer to T.O. GR1F-16CJ-1-1, PART 2, BRAKE ENERGY LIMITS – MAXIMUM EFFORT BRAKING. Observations by ground crewmembers should also be used as certain malfunctions that result in overheated brakes, such as dragging brakes, may not be readily apparent to the pilot. Perform hot brake procedures anytime hot brakes are suspected.

It is impossible for the ground crew to avoid the hot brake and engine intake danger areas while pinning the EPU or chocking the aircraft. Therefore, if conditions permit, the aircraft should be shut down without pinning the EPU or chocking the wheels.

Release brake pressure as soon as possible to minimize heat transfer between the brake surfaces and the wheel. This action also relieves hydraulic pressure to the brakes, which if leaking, could feed a hydraulic fire.

Perform the following after any event that may result in hot brakes:

1. Request firefighting equipment and proceed directly to the designated hot brake area or nearest area clear of other aircraft and personnel.



- If a hot brake condition is a result of a dragging brake, taxiing the aircraft worsens the condition.
- Any leaking hydraulic fluid may be ignited by hot wheel and brake surfaces.
- Wheel fusible plugs may relieve tire pressure at anytime during the 15 minutes after brake application.
- With hot brakes, avoid inflated MLG tire side area within 300 feet for 45 minutes after aircraft has stopped. If required, approach from the front or rear for firefighting purposes only.

When in the hot brake area:

2. Align aircraft with nose into wind if possible.



- Do not use the parking brake.
- If battery power is not available, toe brakes will be inoperative after engine shutdown.
- Do not turn MAIN PWR switch to OFF until the nosewheel is chocked.
- Attempt to park in a level area to minimize risk of aircraft rolling if the brakes should fail after shutdown.



Use only minimum possible toe brake pressure to hold aircraft stationary until engine is shut down and nose wheel is chocked.

3. EPU switch – OFF.
4. Throttle – OFF.

5. Nose wheel - Chocked.
6. MAIN PWR switch - OFF.
7. Exit toward the front of the aircraft.

If a brake fire occurs:

8. Go to GROUND EGRESS, this section.

#### MAIN GENERATOR FAILURE (GROUND)

If the main generator fails on the ground, the standby generator provides power for full normal braking (both channels) and NWS. Abort the aircraft. Taxiing is permissible.

#### MAIN AND STANDBY GENERATOR FAILURE (GROUND)

If the main and standby generators fail on the ground, the FLCS PMG and aircraft battery provide power for full normal braking (both channels). The EPU should activate and provide power for NWS.

Stop and engage the parking brake prior to attempting to reset the generators.

If main or standby generator resets and further taxiing is required, brakes should be checked carefully. Allow the aircraft to begin rolling slowly and check for normal braking. If normal braking is inoperative, immediately engage the parking brake.

If MAIN GEN and STBY GEN lights illuminate:

1. Stop the aircraft.  
Turn EPU on, if required, to obtain NWS.
2. ANTI-SKID switch - PARKING BRAKE.
3. OXYGEN - 100%.
4. EPU switch - OFF.



If chocks are not installed, be prepared to immediately engage the parking brake if it disengages when the EPU is shut off.

If further taxiing is required:

5. ELEC CAUTION RESET button - Depress.  
Toe brakes and parking brake are available with or without the EPU as long as the MAIN PWR switch is not moved to OFF.



If main or standby generator cannot be reset, NWS is inoperative unless the EPU is activated.

6. Refer to ACTIVATED EPU/HYDRAZINE LEAK, this section.

#### EMERGENCY ENTRANCE AND CREW RESCUE

Refer to figure 3-4 for emergency entrance and crew rescue procedures.

#### EMERGENCY GROUND JETTISON

Ground jettison of the 300-gallon, 370-gallon, or 600-gallon fuel tank(s) results in the tank(s) striking the ground before the pylon aft pivots release. The tank(s) will probably rotate horizontally and may strike the LG. Use EMER STORES JETTISON on the ground only as a last resort. Refer to EMERGENCY JETTISON, this section.

#### GROUND EGRESS

The order of accomplishment of ground egress steps depends on the nature of the emergency. For quickest ground egress (without jettisoning the canopy), place the canopy switch up and then prepare for exit while the canopy is opening. However, if fire or danger of explosion exists, accomplish steps necessary for egress prior to opening canopy to retain maximum protection until ready for exit. Disconnect parachute risers, lapbelt, survival kit, and g-suit. Oxygen and communication leads are quick-disconnect. If required, the canopy can be jettisoned even after it has been partially or fully opened. If the canopy is restrained by debris or jammed by crash damage, attempted jettison may result in a portion of the canopy rocket exhaust entering the cockpit. This exhaust may present a heat and blast hazard in the cockpit; toxic gases are present and 100 percent oxygen should be used.

1. Throttle - OFF.
2. Ejection safety lever - Safe (up).
3. Harness and personal equipment - Release.
4. EPU switch - OFF (time permitting).



Exit over the left side (conditions permitting) to avoid EPU exhaust gases.

# Emergency Entrance and Crew Rescue (Typical)

## NORMAL

- 1.** If time and conditions permit:
  - a. Insert a 1/4-inch drive socket wrench/speed handle into canopy handle lock access plug and rotate ccw to remove plug.
  - b. Insert an 8-inch or longer piece of number 25 drill rod (or 1/8-inch rod) into opening and push inboard to unlock canopy handle.
  - c. Position external CANOPY switch to UP.

## CAUTION

Positioning the external CANOPY switch to UP prior to unlocking the canopy will overheat the canopy actuator motor or pop the circuit breaker.

- d. If canopy is still not open, insert 1/4-inch drive socket wrench/speed handle into the external canopy handcrank receptacle and rotate cw (approximately **C** 52 or **D** 87 revolutions required to fully open canopy).

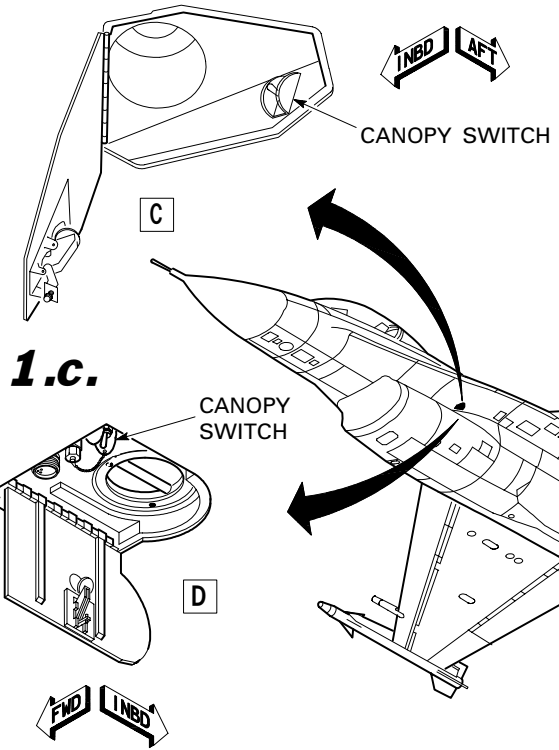

## EMERGENCY

- 2.** Open the canopy emergency release door and extend the canopy jettison D-handle to full length of cable (approximately 6 feet). When the cable tightens, pull handle hard to jettison the canopy.

## WARNING

The canopy jettisons upward and back toward the vertical tail with great force. Stand to the side and slightly aft of canopy to full length of the cable to avoid canopy rocket blast.

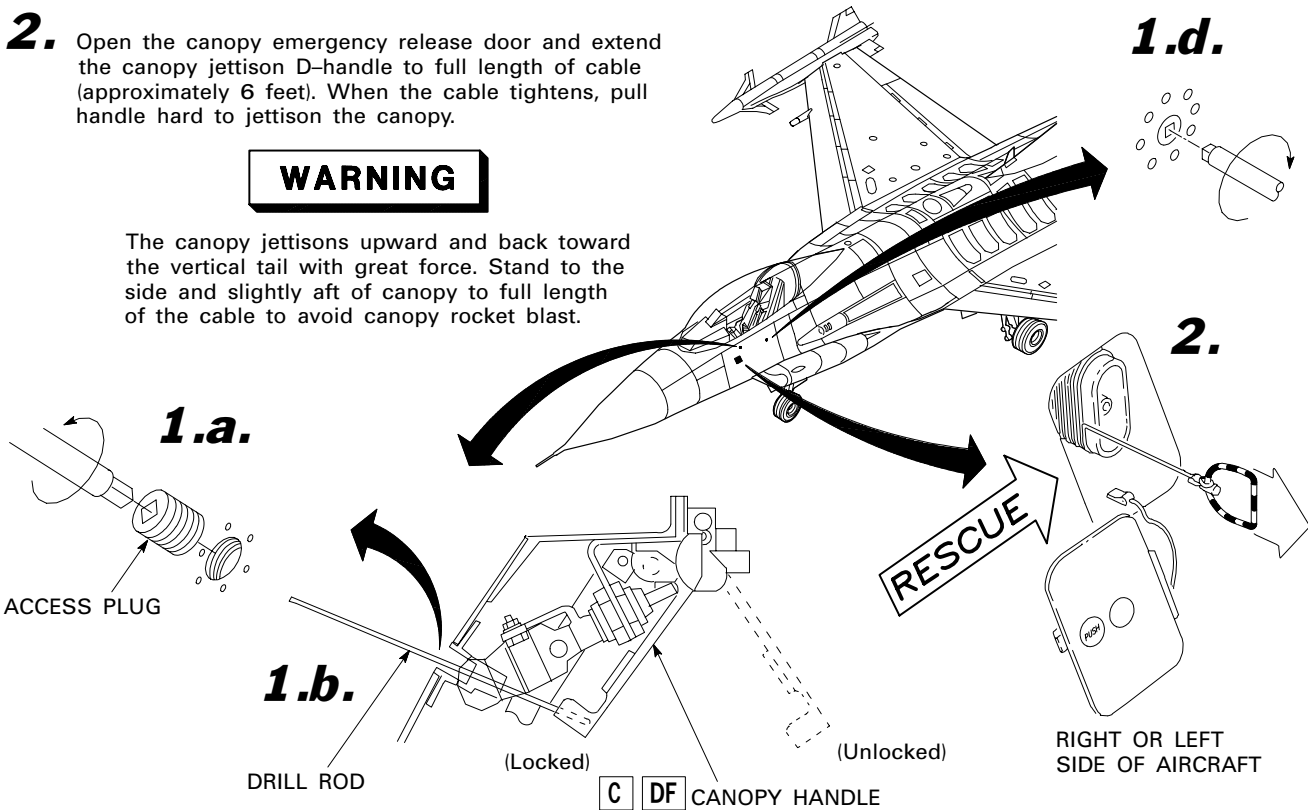

1F-16X-1-0027X©

Figure 3-4. (Sheet 1)

# Emergency Entrance and Crew Rescue (Typical)

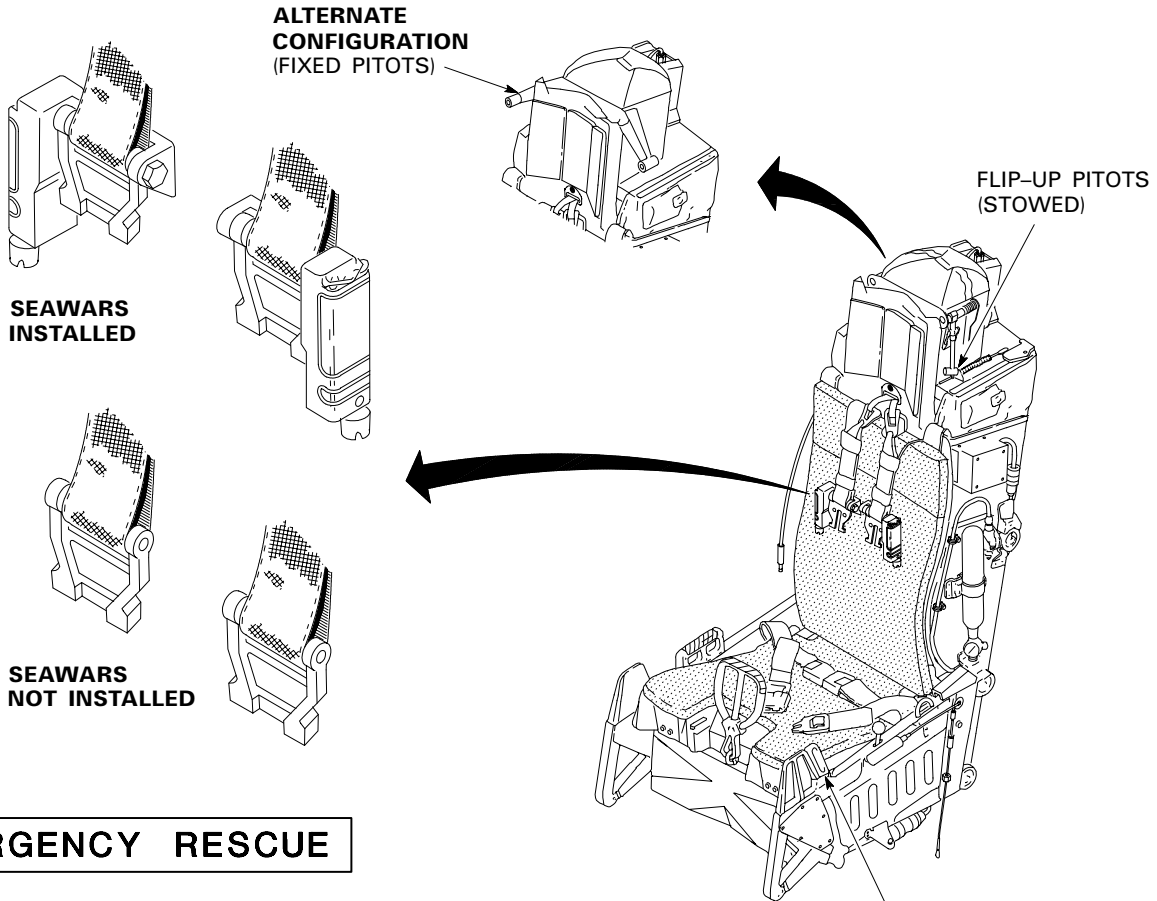

## EMERGENCY RESCUE

3. Rotate ejection safety lever located on left of seat to full up (vertical) position.

### WARNING

To prevent possible seat ejection during rescue, rotate ejection safety lever located on left of seat to full up (vertical) position.

4. Disconnect crewmember from lapbelt, g-suit hose, survival kit straps, and parachute risers.

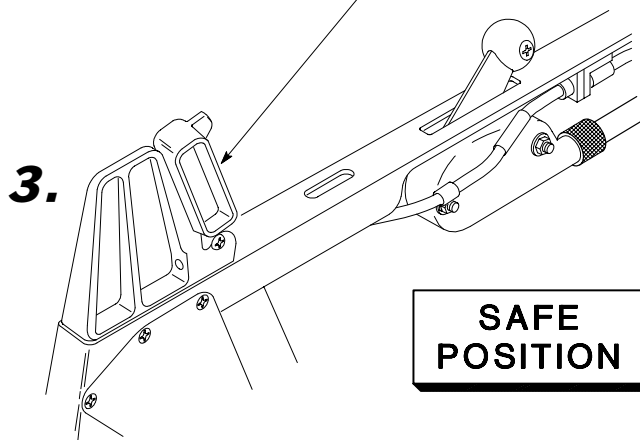

GR1F-16CJ-1-0117X37 ©

Figure 3-4. (Sheet 2)



5. Canopy - Open.

**WARNING**

- **D** Consider canopy jettison so rear seat occupant can egress more rapidly.
- Opening the canopy with the MANUAL CANOPY CONTROL hand-crank is extremely difficult. If immediate egress is required, the canopy should be jettisoned rather than opened with the handcrank.

If canopy does not raise:

6. OXYGEN - 100%.

**WARNING**

- If jettison is unsuccessful, heat, blast, and toxic gas from the rockets may enter the cockpit.
- To prevent the flow of oxygen into the cockpit after the oxygen hose is disconnected, do not select EMER.

7. Canopy - Jettison.

**WARNING**

Pulling the CANOPY JETTISON T-handle other than straight out may cause the handle to jam.

**HOT REFUELING EMERGENCY**

In the event of a fire or fuel leak/spill while refueling in hot pit area, refer to FIRE/OVERHEAT/FUEL LEAK (GROUND), this section. In the event of fire in the area of refueling operation (other than in the hot pit area), have the refueling operation discontinued and taxi clear.

**ACTIVATED EPU/HYDRAZINE LEAK**

If landing with an activated EPU or a hydrazine leak is detected while the engine is running:

Inform landing base of hydrazine leak or EPU operation and request bioenvironmental services support.

**WARNING**

Treat any leak as a hydrazine leak until investigation proves otherwise.

1. OXYGEN - 100%.

When on the ground:

2. AIR SOURCE knob - OFF (if required).  
Consider turning the ECS off to prevent the possibility of hydrazine fumes or EPU exhaust gases entering the cockpit.

**CAUTION**

- If AIR SOURCE knob is placed to OFF, also turn off nonessential avionic equipment as electronic equipment may be damaged.
  - **PX III** If AIR SOURCE knob is placed to OFF, OBOGS caution light will illuminate. If OXY LOW warning light illuminates before ground crew arrives with oxygen bottle, activate EOS.
3. Taxi to designated isolated parking area (if required) and park aircraft with left wing into wind if possible.
  4. Insure all nonessential personnel are clear.
  5. EPU switch - OFF.
  6. Shut down the engine (after left main wheel is chocked).

**NOTE**

To prevent sitting in a sealed cockpit (hot) without ECS, consider waiting for ground crew to arrive with ladder and oxygen bottle prior to shutting down the engine.

**NWS FAILURE/HARDOVER**

NWS failure may be detected by the NWS FAIL caution light or uncommanded NWS inputs with no caution light. If NWS FAIL caution light is on, do not engage NWS. If the NLG strut is overextended, the NWS cannot engage. If the NLG strut overextends after NWS engagement, NWS becomes disengaged and the AR/NWS light goes off.

**WARNING**

NWS malfunctions at any speed may cause an abrupt turn, tire skidding or blowout, aircraft tipping, and/or departure from the prepared surface.

1. NWS - Disengage.
2. AR/NWS light - Verify off.
3. Rudder and brakes - As required.

**TAKEOFF EMERGENCIES****DELAYED ROTATION**

Several factors can cause the airspeed at which rotation occurs to be greater than that determined from T.O. GR1F-16CJ-1-1. As the weight of external stores carried increases, more nose down moment must be overcome to rotate for takeoff. Another factor is the application of roll stick force in addition to aft stick force. Applying a roll input reduces the maximum trailing edge up position for one horizontal tail and increased airspeed may be required to compensate. The last and most significant factor is improper servicing of the nose gear strut. Improper servicing may not be detectable during preflight inspection and may cause rotation speed to increase by up to 15 knots. All of these factors combined may add up to 25 knots to the computed airspeed for rotation. If pre-takeoff flight control checks were normal and the engine is operating normally (acceleration check normal), the aircraft will rotate above computed rotation speed. Therefore, takeoff should not be aborted due to delayed rotation until at least takeoff speed is attained. Notify maintenance after flight if a significantly delayed rotation occurred.

**ABORT**

The decision to abort or continue takeoff depends on many factors. Considerations should include, but not be limited to, the following:

- Runway factors: Runway remaining, surface condition (wet, dry, etc.), type and/or number of barriers/cables available, obstructions alongside or at the departure end, wind direction and velocity, and weather and visibility.

- Aircraft factors: GW, stores, nature of the emergency, speed at decision point, and importance of becoming airborne.
- Stopping factors: Maximum antiskid braking, speedbrakes, aerodynamic braking, hook, and drag chute.

**WARNING**

Aborting takeoff at high speed with a blown tire may be more dangerous than continuing takeoff. For heavy GW takeoffs, an abort at high speed with a blown tire is extremely dangerous because braking and directional control are impaired.

**CAUTION**

- At high speed (prior to WOW), forward stick pressure in excess of approximately 2 pounds results in full trailing edge down deflection of the horizontal tails. This causes excessive loads on the NLG which can lead to nose tire failure and possible structural failure of the NLG.
- Failure to use full antiskid braking or applying brakes with engine above idle thrust significantly increases the wheel brake temperature and probability of a wheel brake fire.

Normally, with the short takeoff distances of the aircraft, abort is not a problem unless directional control is a factor (e.g., blown tire). An early decision to abort provides the most favorable circumstances. If there is any doubt about the ability to stop on the runway, lower the hook.

Consider aborting after becoming airborne only when sufficient runway is available and flight to a key position is not possible.

Aborts above 100 KCAS require diligent adherence to the procedures in this section for the abort to be successful. If aborting after rotation, retard throttle to IDLE and maintain two-point attitude while applying maximum wheel braking (maximum pedal pressure (antiskid on) consistent with maintaining directional control). When wheel brakes become effective, the nose automatically lowers. After the nosewheel is on the runway, use maximum effort braking (full aft stick, full open speedbrakes, and maximum wheel braking). If aborting before rotation, retard throttle to IDLE, maintain three-point attitude and apply maximum effort braking if stopping distance is critical. NWS should be engaged if directional control is a problem.

Consider following hot brake procedures after any abort. Taxiing after an abort will further increase brake temperature.

**WARNING**

- When braking absorbs a high amount of energy, do not shut down engine until firefighting equipment is available and do not use the parking brake.
  - Hot wheels and brakes may ignite leaking hydraulic fluid. Wheel fusible plugs may relieve tire pressure within 15 minutes after stop.
1. Throttle - IDLE.

**WARNING**

When the throttle is retarded to IDLE from MAX AB, the thrust and rpm decay to idle can take up to 2-4 seconds. Do not mistake high thrust/rpm for failure of the engine to respond to the idle command. Engine shutdown from MAX AB may result in a tailpipe fire.

2. DRAG CHUTE switch - DEPLOY (if required).
  3. Wheel brakes - Apply (as required).
  4. HOOK switch - DN (if required).
- The hook should be lowered at least 1500 feet from the cable to allow adequate time for hook to stabilize and for full holddown force to be developed by the hook actuator.
  - Refer to CABLE ARRESTMENT, this section.

**WARNING**

The hook may miss the cable if the aircraft is not slow enough to compress the MLG struts sufficiently to make WOW or if forward stick pressure is held.

If on fire:

5. Throttle - OFF.

**NOTE**

With engine shut down, NWS is lost and EPU does not activate automatically. After hydraulic pressure drops, braking is available using the brake/JFS accumulators only. Stop straight ahead and engage parking brake.

6. FUEL MASTER switch - OFF.

**ENGINE MALFUNCTION ON TAKEOFF**

An engine malfunction on takeoff presents a demanding situation where critical actions must be accomplished quickly with little time for analysis. If takeoff is continued, a straight ahead climb is generally preferred over an immediate turn to low key. This action provides more favorable ejection parameters and an increase in analysis time. If necessary, use only shallow turns to avoid aggravating the situation. Jettison stores if required to reduce GW.

**ENGINE FAILURE ON TAKEOFF**

Engine failure shortly after lift-off may not permit time for analysis or corrective action. The primary concern should be to trade any excess airspeed for altitude and to eject prior to allowing a sink rate to develop. Jettisoning stores may aid in gaining altitude but must not delay the ejection decision. If the failure occurs later in the takeoff phase, time may be available for analysis or corrective action.

If conditions permit:

1. Abort.

If conditions do not permit an abort:

1. Zoom.
2. Stores - Jettison (if possible).
3. Eject.

**AB MALFUNCTION ON TAKEOFF**

An AB malfunction can be detected by a thrust loss and nozzle closure or failure of AB to light within allowed time or stalls accompanied by a loud bang or pop. An AB failure (other than a slow/no light) may indicate other engine problems. If possible, abort the takeoff. If takeoff is continued, the throttle should be retarded to MIL. If normal thrust is not available in MIL, refer to LOW THRUST ON TAKEOFF OR AT LOW ALTITUDE (NON-AB), this section. AB operation should not be reattempted unless required to sustain flight.

If decision is made to stop:

1. Abort.

If takeoff is continued:

1. Throttle - MIL.
2. Stores - Jettison (if required).

**LOW THRUST ON TAKEOFF OR AT LOW ALTITUDE (NON-AB) PW 229**

Low altitude, for engine malfunction purposes, is generally defined as 10,000 feet AGL or below.

Low thrust can be the result of DEEC-related failures; a failed open, damaged or missing nozzle; or an engine rpm rollback. A failed open, damaged or missing nozzle may result in significant thrust loss and the inability to take off or maintain level flight. For description of failed open, damaged or missing nozzle, refer to NOZZLE FAILURE PW 229, this section. Low thrust can also be the result of the start bleed strap failing to close during the normal start cycle.

If low thrust occurs during takeoff and conditions permit, the takeoff should be aborted. If the takeoff must be continued or in any critical phase of flight and MIL thrust is not sufficient, AB should be used. An excessively open nozzle may reduce the chance for successful AB light. If the AB does not light (allow the DEEC to automatically resequence the AB if conditions permit), place the ENG CONT switch to SEC.

If an automatic transfer to SEC occurs or SEC is selected manually, resulting thrust is 70-80 percent of normal MIL thrust with no AB capability. If thrust is still low, consider jettisoning stores.

If on takeoff and the decision is made to stop:

1. Abort.

If takeoff is continued and/or thrust is insufficient:

1. Throttle - AB.  
The chances for a successful AB light with the nozzle open more than 30 percent are reduced.

If thrust is still insufficient or AB does not light:

2. ENG CONT switch - SEC.

**WARNING**

With nozzle loss, catastrophic engine failure and fire are probable with prolonged high power settings above 850°C FTIT while in SEC.

**NOTE**

In a partial thrust situation, thrust available may increase as altitude decreases. 250 knots approximates the airspeed at which thrust required for level flight is the lowest.

3. Stores - Jettison (if required).

If nozzle is failed open, damaged, or missing:

4. Airspeed - Climb to arrive at 250 knots or descend at 250 knots to obtain level flight above minimum recommended ejection altitude or minimum safe altitude, whichever is appropriate.

**NOTE**

- With a missing nozzle, level flight may not be attainable above 5000 feet MSL.
- If descent is required, maintain 250 knots with throttle set at 850°C FTIT.

If level flight cannot be maintained by 1000 feet above minimum recommended ejection altitude or minimum safe altitude, whichever is appropriate:

5. Throttle - As required to maintain 250 knots in level flight.

**CAUTION**

If airspeed drops below 250 knots, trade altitude to reacquire 250 knots. Do not descend below minimum recommended ejection altitude or minimum safe altitude, whichever is appropriate.

T.O. GR1F-16CJ-1

6. Land as soon as possible. Plan a flameout landing. Refer to FLAMEOUT LANDING, this section.

**LOW THRUST ON TAKEOFF OR AT LOW ALTITUDE (NON-AB) [GE129]**

Low altitude, for engine malfunction purposes, is generally defined as 10,000 feet AGL or below.

Low thrust can be the result of DEC-related failures, the nozzle failing, or an rpm rollback. These situations may result in significant thrust loss and the inability to take off or maintain level flight. If low thrust occurs during takeoff and conditions permit, the takeoff should be aborted.

If the takeoff must be continued or in any critical phase of flight, when MIL thrust is insufficient, AB should be used. An automatic transfer to HYB or SEC may occur resulting in less than MIL thrust with no AB capability (SEC). An excessively open nozzle may reduce the chance for a successful AB light. If the AB does not light, the ENG CONT switch should be placed to SEC.

If an automatic transfer to SEC occurs or SEC is selected manually, resulting thrust is 70-95percent of normal MIL thrust with no AB capability. If thrust is still low, consider jettisoning stores.

If on takeoff and the decision is made to stop:

1. Abort.

If takeoff is continued and/or thrust is insufficient:

1. Throttle - AB.  
The chances for a successful AB light with the nozzle open more than 30 percent are reduced.

If thrust is still insufficient or AB does not light:

2. ENG CONT switch - SEC.

**NOTE**

In a partial thrust situation, thrust available may increase as altitude decreases. 250 knots approximates the airspeed at which thrust required for level flight is the lowest.

3. Stores - Jettison (if required).

**ENGINE FIRE ON TAKEOFF**

An engine fire may be indicated by the ENG FIRE warning and/or OVERHEAT caution lights, high FTIT, smoke, or fumes. Refer to ENGINE FIRE, this section.

**LG FAILS TO RETRACT**

If the LG handle warning light remains on after the LG handle is placed to UP, the LG or LG doors are not fully up and locked.

1. Airspeed - 300 knots maximum.
2. LG handle - DN. (Use DN LOCK REL button if required.)

**WARNING**

If LG handle does not lower, select BRAKES CHAN 2 and position ALT FLAPS switch to EXTEND. [PW 229] Nozzle remains closed, resulting in higher than normal landing thrust.

If LG comes down normally:

3. GW - Reduce prior to landing.

If LG does not indicate down:

**CAUTION**

Do not cycle LG handle. Damage to LG or LG doors may result.

4. Go to ALTERNATE LG EXTENSION, this section.

**LG HANDLE WILL NOT RAISE**

If the left MLG WOW switch fails to the ground position, the LG handle does not move out of the DN position. In addition, the TO/LDG CONFIG warning light and touchdown skid control system are affected. The LG handle may be raised by first depressing the LG handle downlock release button.

If conditions permit:

1. Airspeed - 300 knots maximum.
2. GW - Reduce prior to landing.

If LG must be raised:

1. LG handle DN LOCK REL button - Depress.
2. LG handle - UP.  
TO/LDG CONFIG light is on if left MLG WOW switch has failed.

When desired:

3. LG handle - DN. (Use DN LOCK REL button if required.)

### WARNING

If LG handle does not lower, select BRAKES CHAN 2 and position ALT FLAPS switch to EXTEND. **PW 229** Nozzle remains closed, resulting in higher than normal landing thrust.

After touchdown:

4. Brakes - Apply after wheels spin up.

### CAUTION

Touchdown antiskid protection may not be available. Landing with feet on the brake pedals may result in blown tire(s).

### BLOWN TIRE ON TAKEOFF

Tire failure on takeoff is difficult to recognize and may not be noticed in the cockpit.

Possible indications of a NLG tire failure include a loud explosion, slight deceleration, vibrations, flying debris, and at night, a flash or flame. These characteristics can be mistaken for an engine stall. Rubber debris may cause damage to the engine, NWS wiring harness, WOW switch assembly and/or gear position sensor wiring. NWS may not be available even though the AR/NWS light is on and the NWS FAIL light is off.

### WARNING

Aborting takeoff at high speed with a blown tire may be more dangerous than continuing takeoff. For heavy weight takeoffs, an abort at high speed with a blown tire is extremely dangerous because braking and directional control are impaired.

### NOTE

The decision to take off or abort depends on the speed at the time of the failure, GW, stopping distance required, and arresting gear availability.

If takeoff is continued, do not retract the LG, reduce GW if practical, and prepare to land as soon as practical.

Directional control during stopping is the primary concern when aborting with a blown tire. Heavy GW and high speed aborts place greater demands on the brakes and tires. This may cause damage to the NWS, wheels, and struts which may result in loss of directional control. In addition, heavy differential braking may result in MLG tire failure.

If aborting with a blown MLG tire, leave antiskid on to minimize possibility of skidding the good tire. If the wheel with the blown tire does not turn, the antiskid switches to the **(129)** alternate braking mode, **LESS (129)** pulsating antiskid mode. Use roll control to relieve pressure on the blown tire and NWS to maintain directional control.

If aborting with a blown NLG tire, hold the nosewheel off the runway (if able) and use two-point aerodynamic braking until control effectiveness begins to decay. Lower the nosewheel to the runway and immediately engage NWS, if available, to maintain directional control. Use aft stick to reduce load on the NLG after brakes are applied. If NWS is not available, the aircraft tends to drift right. Attempt to move to the left side of the runway before rudder effectiveness is lost and maintain directional control with rudder and differential braking. Stop short of the departure-end arresting cable if possible. The small nosewheel rolling radius with the tire missing may allow the cable to pass over top of the nosewheel and cause NLG collapse.

A NLG tire failure accompanied by complete tire separation from the wheel may cause reverse castering. The conditions for this to occur are the NWS disengaged or inoperative; the nose wheel rim rolling on a deformable surface (i.e. asphalt); and lateral force applied to the nose wheel from either a rudder input or differential braking. If reverse castering occurs the nose wheel will turn in the opposite direction of rudder and brake inputs making it extremely difficult to maintain directional control.

**WARNING**

If a blown NLG tire occurred and NWS is not available, it may not be possible to prevent departure from the runway. A reverse castering effect may occur in which the nosewheel moves opposite to the rudder or differential braking input.

**CAUTION**

With a blown tire, avoid centerline lights as they may cause wheel damage and subsequent loss of directional control. Failure to use full aft stick with a blown NLG tire may lead to wheel failure and directional control problems.

Stop straight ahead and shut down the engine as soon as firefighting equipment is available. Do not attempt to taxi unless an emergency situation exists.

If takeoff is not feasible:

1. Abort.

If takeoff is continued:

1. LG - Do not retract.
2. Airspeed - 300 knots maximum.
3. Refer to LANDING WITH A BLOWN TIRE, this section.

**IN-FLIGHT EMERGENCIES**

When preparing to activate backup systems which rely on stored nitrogen pressure to function, consider the potential for time-related failures and do not activate the system earlier than required. For example, the hydrazine mode of the EPU requires nitrogen pressure to force hydrazine to the EPU. If a nitrogen leak exists, turning the EPU on early could lead to an inability of the EPU to function on hydrazine. Similarly, alternate LG and hook extension use stored nitrogen pressure. If alternate LG extension is used early and a nitrogen leak exists, hydraulic system B could subsequently fail. Such a leak could also result in insufficient pressure to maintain proper hook holddown force. Since nitrogen leaks are not apparent prior to system activation, consider their potential existence and activate the backup system when needed, but not excessively early.

**CANOPY WARNING LIGHT ON**

If CANOPY warning light illuminates:

1. Canopy handle - Push outboard.

If CANOPY warning light remains on:

2. Go to CANOPY LOSS/PENETRATION IN FLIGHT, this section.

**CANOPY LOSS/PENETRATION IN FLIGHT**

Canopy loss/penetration in flight results in disorientation and may result in structural damage caused by the canopy striking the aircraft. Due to the possibility of severe disorientation, vision loss, injury, or incapacitation at high airspeed, immediate ejection may be the only option. Slow to 180 knots or less and check for controllability. Wind blasts up to 180 knots can be coped with by leaning forward and down behind the glareshield and HUD.

**WARNING**

- Arms must be kept close to the body to avoid letting wind blast pull arms out of the cockpit.
- HUD glass disintegration can be expected following a medium to high energy bird strike with or without canopy penetration.

Wind buffet increases slightly with increased AOA. Therefore, if fuel is not critical, TEF's should be extended using the ALT FLAPS switch or by placing the LG handle to DN.

1. Airspeed - 180 knots maximum.
2. Seat - Full down.
3. ALT FLAPS switch - EXTEND.
4. Land as soon as possible.

**DRAG CHUTE DEPLOYED IN FLIGHT**

If the drag chute is deployed in flight below 190 knots:

**NOTE**

If the drag chute is deployed below approximately 190 knots, it does not break away from the aircraft.

1. DRAG CHUTE switch - REL.

If the drag chute does not release:

2. Throttle - MAX AB.

**COCKPIT PRESSURE/TEMPERATURE MALFUNCTION**

Loss of cockpit pressurization could be caused by canopy seal, air-conditioning system, or cockpit pressure regulator safety valve malfunctions or ECS shutdown or failure.

Certain ECS equipment malfunctions result in temporary shutdown of the ECS. These shutdowns are more prevalent at high altitude during low speed flight with high engine thrust settings. An ECS shutdown is characterized by an oily, smokey smell, followed by loss of cockpit noise and airflow and gradual loss of pressurization. These temporary shutdowns typically last from 20-45 seconds or, on occasion, up to 2 minutes. The EQUIP HOT caution light may illuminate if the shutdown lasts longer than 20 seconds.

**WARNING**

- With the ECS shut down or the AIR SOURCE knob in OFF or RAM, the g-suit does not inflate and PBG is disabled.
- **PX III** With the ECS shut down or the AIR SOURCE knob in OFF or RAM, OBOGS is inoperative. Activate EOS if OXY LOW warning light illuminates above 10,000 feet cockpit altitude.

Short duration (approximately 15 seconds) losses of cockpit airflow when operating above 35,000 feet MSL should not be confused with an ECS shutdown. These are the result of an automatic ECS cutback which is designed to prevent total system shutdown.

**NOTE**

**PX III** The OBOGS caution light may illuminate as a result of ECS cycling or temporary ECS shutdown. This is normal as long as the OXY LOW warning light does not illuminate.

Most AUTO position temperature failures can be corrected by use of the MAN position.

If cockpit pressure altitude exceeds 27,000 feet, the CABIN PRESS caution light illuminates.

If the cockpit temperature is excessive and does not respond to AUTO or MAN temperature commands or cockpit pressure is lost, proceed as follows:

1. OXYGEN - 100%
2. Altitude - 25,000 feet maximum.
3. Airspeed - 500 knots maximum.
4. AIR SOURCE knob - OFF (10-15 seconds), then NORM.

**PX III** The OBOGS caution light illuminates while AIR SOURCE knob is in OFF.

If cockpit pressure is not regained but all other systems dependent on the ECS are operational:

- 5 Flight may be continued below 25,000 feet.

If ECS has failed or cockpit temperature control is not regained:

- 5 AIR SOURCE knob - OFF.

**WARNING**

**PX III** If AIR SOURCE knob is placed to OFF or RAM, OBOGS is inoperative. Activate EOS if OXY LOW warning light illuminates above 10,000 feet cockpit altitude.

6. AIR SOURCE knob - RAM (after cockpit is depressurized).

**WARNING**

**PX III** If AIR SOURCE knob is placed to OFF or RAM, OBOGS is inoperative. Activate EOS if OXY LOW warning light illuminates above 10,000 feet cockpit altitude.

**NOTE**

External fuel cannot be transferred in OFF or RAM. Consider jettisoning tank(s) to decrease drag if range is critical and ECS cannot be turned on for short periods of time to transfer fuel.



- 7. Nonessential electrical equipment – Off.

**NOTE**

If in VMC and the ADI and HSI are not required for flight, the EGI/INS should be considered nonessential.

- 8. Land as soon as practical.
- 9. Check for failed emergency dc bus(es). Refer to EMERGENCY POWER DISTRIBUTION, this section.

**EQUIP HOT CAUTION LIGHT**

If EQUIP HOT caution light illuminates:

**NOTE**

- Certain ECS equipment malfunctions result in temporary shutdown of the ECS and illumination of the EQUIP HOT caution light.
  - An ECS shutdown and EQUIP HOT caution light illumination for up to 2 minutes can occur either during extended LG down flight between sea level and 7000 feet MSL or during operation above a line from 42,000 feet MSL at 0.2 mach to 50,000 feet MSL at 0.95 mach. These ECS shutdowns are normal, but may still require additional action if the EQUIP HOT light remains on for more than 1 minute.
  - If cockpit temperature is excessive, refer to COCKPIT PRESSURE/TEMPERATURE MALFUNCTION, this section.
1. AIR SOURCE knob – Confirm in NORM if smoke or fumes are not present.
  2. Throttle – 80 percent rpm minimum (in flight).

If EQUIP HOT caution light remains on after 1 minute:

- 3. Nonessential avionics – Off.

**NOTE**

If in VMC and the ADI and HSI are not required for flight, the EGI/INS should be considered nonessential.

- 4. Land as soon as practical.

**EJECTION**

Refer to figure 3-4.1. Ejection should be accomplished at the lowest practical airspeed.

**WARNING**

- The minimum altitude obtained from EJECTION SEAT PERFORMANCE charts, Section I, does not include any allowance for pilot decision making, changing flight conditions, or hand movement from the stick and/or throttle to the ejection handle. Therefore, minimum altitude for ejection decision could be significantly higher.
- When in a spin/deep stall or other uncontrolled flight, eject at least 6000 feet AGL whenever possible. This is the minimum altitude to initiate ejection with minimal risk of injury under the most adverse conditions. The decision to eject must have been made prior to this altitude. Delaying ejection below this altitude may result in serious injury or death.
- Under controlled flight conditions, eject at least 2000 feet AGL whenever possible. If below 2000 feet AGL, attempt to gain altitude if airspeed permits. Do not delay ejection below 2000 feet AGL for any reason which may commit you to unsafe ejection.
- Failure to monitor sink rate and height above terrain while performing an airstart or applying low thrust recovery procedures can result in an ejection outside the ejection seat performance envelope.

# F-16 ACES II Ejection Injury Risk Chart

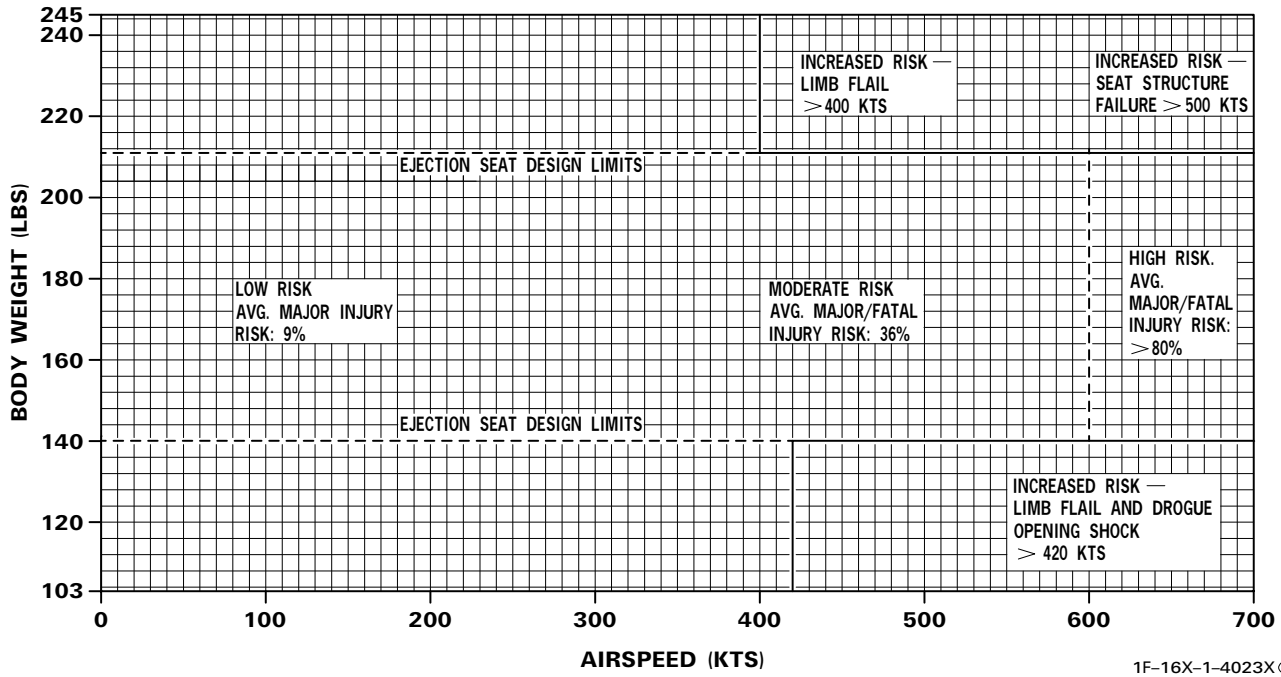

1F-16X-1-4023X ©

Figure 3-4.1

**WARNING**

- The ACES II ejection seat was designed for body weights in the 140 to 211 pound range. There are additional ejection injury risks associated with body weights outside this range.
- For body weights less than 140 pounds, limb flailing, less seat stability, and more severe drogue chute opening shock (ejection modes 2 and 3) are concerns. The risk of injury associated with limb flailing and drogue chute opening shock increases for ejection above 420 knots. This injury risk also increases as body weight decreases below 140 pounds.
- For body weights greater than 211 pounds, limb flailing, seat structural failure, and parachute landings are concerns. The risk of injury from limb flailing is high for ejection above 400 knots. The seat leg braces frequently deform during ejections above 500 knots; this deformation has led to seat side panel failures (and unsuccessful ejections) during 600 knot ejection tests. The risk of injury during parachute landing is three times the average. These injury risks also increase as body weight increases above 211 pounds.
- Wind blast exerts medium force on the body up to 400 knots, severe forces causing flailing and skin injuries between 400-600 knots, and excessive force above 600 knots.
- During high altitude ejections (mode 3), automatic pilot/seat separation and recovery parachute deployment occur between 16,000-14,500 feet MSL. If high terrain is a factor, manual seat separation procedures must be used to bypass the automatic sequence.

To eject, grasp ejection handle using a two-handed grip with thumb and at least two fingers of each hand. Pull up on handle and continue holding until pilot/seat separation. The ejection handle does not separate from the seat.

Refer to figure 3-5 for manual seat separation and manual survival equipment deployment.

**Ejection (Immediate)**

1. Ejection handle - Pull.

**Ejection (Time Permitting)**

If time permits, descend to avoid the hazards of high altitude ejection. Stow all loose equipment and direct the aircraft away from populated areas. Sit with head against headrest, buttocks against back of seat, and feet on rudder pedals.

1. IFF MASTER knob - EMER.
2. Loose equipment and checklist - Stow.
3. Lapbelt and helmet chin strap - Tighten.
4. Night vision devices - Remove (if appropriate).

**WARNING**

Failure to remove night vision goggles (NVG) prior to ejection may cause serious injury. If unable to remove NVG, a proper ejection body position (head back against the seat headrest) reduces the chance of injury from the NVG.

5. Visor - Down.
6. Throttle - IDLE.  
Slow to lowest practical airspeed.
7. Assume ejection position.
8. Ejection handle - Pull.

**Failure of Canopy To Separate**

If canopy fails to separate, remain in position for ejection while keeping arms inboard and perform the following:

**WARNING**

If canopy is jettisoned or manually released/opened after pulling the ejection handle, the ejection seat functions immediately after canopy separation. Be prepared to immediately put arm back in ejection position when the canopy starts to separate.

1. Canopy - Open normally.
2. Canopy - Jettison.

# Manual Survival Equipment Deployment/ Manual Seat Separation

## SURVIVAL EQUIPMENT (TYPICAL)

- A. IF EMERGENCY OXYGEN FAILS TO ACTIVATE AUTOMATICALLY UPON EJECTION, PULL THE EMERGENCY OXYGEN GREEN RING LOCATED NEAR THE LEFT HIP.
- B. AFTER RECOVERY PARACHUTE ASSEMBLY DEPLOYMENT, RAISE VISOR AND DISCARD OXYGEN MASK. IF SURVIVAL KIT DOES NOT DEPLOY AUTOMATICALLY, GRASP KIT RIPCORD HANDLE WITH RIGHT HAND AND PULL. KIT RIPCORD HANDLE IS LOCATED NEAR RIGHT HIP.
- C. LIFERAFT INFLATION IS INITIATED WHEN THE DROP LINE/LANYARD IS FULLY EXTENDED AFTER SURVIVAL KIT DEPLOYMENT. CHECK LIFERAFT AND IF NOT INFLATED, SNATCH PULL DROP LINE/LANYARD TO INFLATE.

### NOTE

If the survival kit is deployed after landing in water, a snatch pull on the drop line/lanyard (near CO<sub>2</sub> bottle) is required to inflate the liferaft.

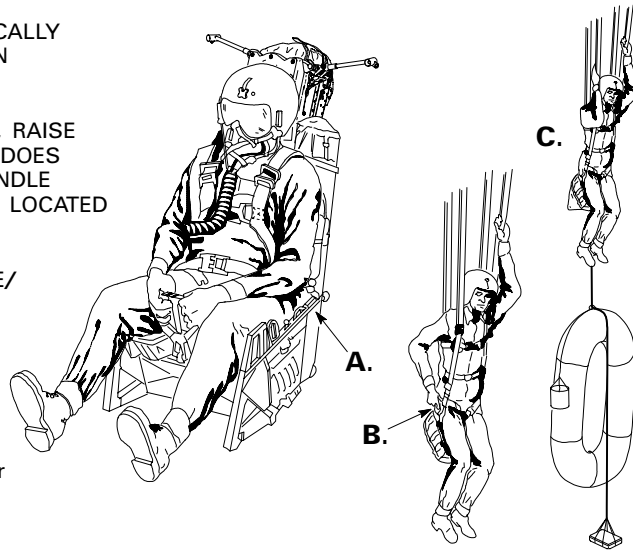

## MANUAL SEAT SEPARATION

TO PERFORM MANUAL SEAT SEPARATION AND DEPLOY THE RECOVERY PARACHUTE ASSEMBLY, PULL THE EMERGENCY MANUAL CHUTE HANDLE.

### WARNING

- After ejection, the EMERGENCY MANUAL CHUTE handle should only be used if the automatic sequence has failed or if high terrain is a factor. Pilot/seat separation in modes 1 and 2 should occur rapidly after pulling the ejection handle. If the pilot has time to realize seat separation has not taken place, a failure has probably occurred and manual seat separation should be performed. In mode 3, pilot/seat separation occurs between 16,000–14,500 feet MSL. If automatic pilot/seat separation does not occur in this altitude range or if high terrain is a factor, manual seat separation must be performed.
- Failure to fully pull the EMERGENCY MANUAL CHUTE handle may result in ballistically deploying the recovery parachute assembly without releasing the lapbelt and inertia reel straps and unlatching the seat pan lid.
- Do not attempt to open the lapbelt. If the lapbelt is opened, the seat will partially fall away, but the parachute risers remain attached to the inertia reel straps. The only way to separate from the seat is to pull the EMERGENCY MANUAL CHUTE handle at least 6 inches.



1F-16X-1-2023X ©

Figure 3-5.

**WARNING**

Pulling the CANOPY JETTISON T-handle other than straight out may cause the handle to jam.

3. MANUAL CANOPY CONTROL handcrank - Push in and rotate ccw.

**WARNING**

Use of the CANOPY JETTISON T-handle or MANUAL CANOPY CONTROL handcrank may result in serious injury. To minimize chances of injury, immediately release the handle when the canopy starts to separate.

**Ejection Seat Failure**

If the ejection seat fails to function after the ejection handle is pulled and the canopy has separated from the aircraft, there are no provisions designed into the escape system for manual bailout.

**DITCHING**

Ditch the aircraft only as a last resort. All attempts to eject should be accomplished prior to ditching.

**ELECTRICAL SYSTEM FAILURES**

Electrical system failures are indicated by illumination of the ELEC SYS caution light and one or more ELEC control panel lights (in any combination). After accomplishing the appropriate emergency procedures, refer to EMERGENCY POWER DISTRIBUTION, this section, to determine inoperative equipment for any remaining ELEC control panel lights.

**FLCS PMG Failure**

If all four branches of the FLCS PMG fail in flight, the FLCS PMG light illuminates. The converter/regulator automatically selects the power source with the highest voltage from the available alternate sources. Other FLCS power sources are the main generator, the standby generator, the EPU generator, the EPU PMG, and the aircraft battery.

If FLCS PMG light illuminates:

1. Land as soon as practical.

**Single Generator Failures (in Flight)**

A single generator failure is indicated by illumination of either the MAIN GEN or STBY GEN light. A mechanical failure which affects the standby generator may also affect the FLCS PMG causing illumination of both the STBY GEN and FLCS PMG lights. Actions required in this circumstance are the same as those for illumination of the MAIN GEN or STBY GEN light; thus, this failure is also categorized as a single generator failure.

Illumination of the MAIN GEN light indicates that one or both nonessential ac buses are not being powered by the main generator. The light may illuminate if the main generator fails, if a main power contactor trips off one or both nonessential ac buses, or if a shorting failure of an overcurrent sensing contactor (OCSC) or other wiring/equipment occurs. Refer to PARTIAL ELECTRICAL POWER LOSS, this section, for discussion of OCSC failures. In all cases, the standby generator should automatically come on line to power the essential and emergency buses which are not being powered by the main generator. The nonessential dc bus is not powered. The main generator may be reset by depressing the ELEC CAUTION RESET button or cycling the MAIN PWR switch; however, moving the switch out of MAIN PWR removes standby generator power and causes the EPU to activate. A reset attempt should not be made if the MAIN GEN light was preceded by a 2-3 second loss of power to the HUD, MFD's, and other cockpit equipment. Refer to EMERGENCY POWER DISTRIBUTION, this section, for a list of inoperative equipment if the main generator is/does not reset.

Illumination of the STBY GEN light indicates that standby generator power is not available for the essential and emergency buses. The STBY GEN light illuminates for standby generator system failure or for failure of the essential bus relay(s). No bus loses power if the STBY GEN light illuminates when the main generator is still on line. The standby generator may only be reset by depressing the ELEC CAUTION RESET button.

Illumination of both STBY GEN and FLCS PMG lights indicates that standby generator and FLCS PMG power is not available. If the main generator is on line, no buses lose power and the EPU does not automatically activate.

**CAUTION**

Illumination of the MAIN GEN light after a 2-3 second loss of power to the HUD, MFD's, and other cockpit instruments indicates shorting failure of an OCSC or other wiring/equipment.

**NOTE**

- **PX II** The VHF radio is not powered when the main generator is off line.
- With standby generator failure and the MAL & IND LTS switch in DIM, the ELEC SYS caution light may not appear to illuminate when the MASTER CAUTION and STBY GEN lights illuminate.

If MAIN GEN light illuminated after a 2-3 second loss of the HUD and MFD's was observed:

1. Land as soon as practical.

If MAIN GEN light illuminated and a 2-3 second loss of the HUD and MFD's was not observed, or if STBY GEN or STBY GEN and FLCS PMG lights illuminate:

1. ELEC CAUTION RESET button - Depress.  
This action may reset the main or standby generator. Cycling the MAIN PWR switch may also reset the main generator; however, this action momentarily removes standby generator power and activates the EPU.
2. Land as soon as practical.

**Main and Standby Generator Failure (in Flight)**

Illumination of the MAIN GEN and STBY GEN lights indicates that power is lost from at least one nonessential ac bus and that the standby generator also failed. The EPU should start automatically at the time of the second failure as indicated by the EPU AIR and EPU run lights. Additional lights, such as HYDRAZN, AVIONICS FAULT, and ENGINE FAULT, may also illuminate. If both generators fail, power to all essential and non-essential buses (ac and dc) is lost. Refer to EMERGENCY POWER DISTRIBUTION, this section, for list of inoperative equipment. The EPU generator powers the emergency ac and dc buses and both battery buses. Depressing the ELEC CAUTION RESET button may reset the main and/or standby generator.

**NOTE**

**PX II** The VHF radio is not powered when the EPU is running or the main generator is off line.

If MAIN GEN and STBY GEN lights illuminate:

1. EPU switch - ON (if EPU run light is off).
2. ELEC CAUTION RESET button - Depress.  
This action may reset the main and/or standby generator. The MAIN PWR switch may also be cycled to reset the main generator.

If MAIN GEN or STBY GEN light goes off:

3. EPU switch - OFF, then NORM.
4. ADI - Check for presence of OFF and/or AUX warning flags.  
If warning flag(s) is in view, refer to EGI FAILURE/TOTAL INS FAILURE, this section.

**WARNING**

**PX II** If only AUX flag is in view, pitch and roll attitude information is likely to be erroneous due to INS autorestart in the attitude mode when other than straight and level, unaccelerated flight conditions existed.

5. Land as soon as practical.
6. Refer to ACTIVATED EPU/HYDRAZINE LEAK, this section.

If MAIN GEN and STBY GEN lights remain on:

3. ADI - Check for presence of OFF and/or AUX warning flags.  
If warning flag(s) is in view, refer to EGI FAILURE/TOTAL INS FAILURE, this section.

**WARNING**

**PX II** If only AUX flag is in view, pitch and roll attitude information is likely to be erroneous due to INS autorestart in the attitude mode when other than straight and level, unaccelerated flight conditions existed.

4. Land as soon as possible.
5. Refer to ACTIVATED EPU/HYDRAZINE LEAK, this section.
6. If hydrazine depletes or EPU run light goes off at low thrust - Go to ABNORMAL EPU OPERATION, this section.

After landing and aircraft is stopped:

7. Chocks - Installed (or parking brake engaged).
8. EPU switch - OFF.



If chocks are not installed, be prepared to immediately engage the parking brake if it disengages when the EPU is shut off.

9. MAIN PWR switch - MAIN PWR (until chocks are installed).

#### Main, Standby, and EPU Generator Failure

A main, standby, and EPU generator failure is indicated by illumination of the MAIN GEN and STBY GEN lights without an EPU run light. Other indications include loss of all avionics, ADI OFF and AUX warning flags, and uncontrollable cold airflow into the cockpit or reduced airflow to the cockpit if the water separator coalescer freezes up, and **PX III** loss of OBOGS. The caution lights which illuminate for a failure of just the main and standby generators (e.g., AVIONICS FAULT, ENGINE FAULT) do not illuminate. Refer to EMERGENCY POWER DISTRIBUTION, this section, for a list of inoperative equipment. The primary concerns during multiple generator failures are maintaining power to the FLCS and maintaining/regaining power to the emergency buses.

#### WARNING

**PX III** With a main, standby, and EPU generator failure, OBOGS and the OXY LOW warning light are inoperative. Activate EOS if above 10,000 feet cockpit altitude.

The EPU generator may be inoperative for several reasons, two of which may be remedied from the cockpit. If the EPU AIR light is off, the EPU may not have received an automatic start command; manually turning the EPU on may correct this failure. If the EPU GEN, EPU AIR, and HYDRAZIN lights are illuminated but the EPU run light is off, the EPU may be underspeeding. If the EPU PMG light is on or blinking, EPU speed is very slow. The underspeed could be caused by failure of hydrazine to power the EPU in conjunction with a low thrust setting and may be corrected by advancing the throttle. If the EPU generator operates, refer to MAIN AND STANDBY GENERATOR FAILURE (IN FLIGHT), this section.

If the EPU generator is still inoperative and the main and standby generators do not reset, power cannot be restored to the emergency buses. The aircraft battery supplies power to battery buses No. 1 and No. 2. As long as the ACFT BATT TO FLCS light remains off, the EPU PMG and/or FLCS PMG is supplying adequate FLCS power. The primary concern is aircraft battery life for communications, brakes, and hook. UHF communications are available on the frequency in use at power loss with UFC selected. BACKUP must be selected if a frequency change is desired.

If the FLCS PMG light illuminates when the MAIN GEN, STBY GEN, and EPU GEN lights are on, there are two possible sources of FLCS power (EPU PMG and aircraft battery). If the EPU PMG and ACFT BATT TO FLCS lights are off, the EPU PMG is supplying power to the FLCS whether the EPU run light is on or off.

If the ACFT BATT TO FLCS light is on, the aircraft battery is supplying power to the FLCS. The aircraft battery supplies power for FLCS operation for 3-14 minutes (depending on state of battery charge) after total generator failure. As the aircraft battery depletes, the flight controls either become unresponsive or uncommanded maneuvers occur.

#### WARNING

Imminent loss of electrical power to the FLCS is indicated by increasingly degraded flight control response and uncommanded motions. Total loss of FLCS power results in a pitching motion and complete loss of control. At high airspeeds, the pitching motion could be excessive and interfere with the ability to eject.

**NOTE**

If total loss of FLCS power occurs in the landing configuration and near final approach airspeed, the pitching motion is gradual and in the noseup direction for all configurations.

The ACFT BATT FAIL light indicates battery voltage less than 20 volts. Brake operation is doubtful during total generator failure with the ACFT BATT FAIL light on. As aircraft battery voltage continues to decrease, the capability to operate the brakes, lower the hook, and deploy the drag chute is lost. Lower the hook early since significantly higher battery voltage is required to lower the hook than is required to keep it fully extended. Once lowered, the hook remains full down well past the point at which the brakes are lost. An approach-end arrestment is recommended, if conditions permit, because it is difficult to ascertain brake operation. Relative intensity of the warning and caution lights is not a positive indication of battery voltage level.

If MAIN GEN, STBY GEN, and EPU GEN lights illuminate:

**WARNING**

**PX III** With a main, standby, and EPU generator failure, OBOGS and the OXY LOW warning light are inoperative. Activate EOS if above 10,000 feet cockpit altitude.

**NOTE**

**PX II** The VHF radio is not powered when the EPU is running or the main generator is off line.

1. AOA - 12 degrees maximum (200 knots minimum).

**WARNING**

LEF's are inoperative and departure susceptibility may be increased. Near 1g flight, 200 knots should keep AOA less than 12 degrees. Limit rolling maneuvers to a maximum bank angle change of 90 degrees and avoid rapid roll rates.

2. EPU switch - ON (if EPU run light is off).

3. Climb if necessary.
4. Throttle - As required to extinguish the HYDRAZN light.

If EPU GEN light goes off:

5. Go to MAIN AND STANDBY GENERATOR FAILURE (IN FLIGHT), this section.

If EPU GEN light is still on:

6. ELEC CAUTION RESET button - Depress. This action may reset the main and/or standby generator.

If both MAIN GEN and STBY GEN lights remain on:

7. MAIN PWR switch - BATT, then MAIN PWR. This action may reset the main generator.

If either MAIN GEN or STBY GEN light goes off:

8. EPU switch - OFF, then NORM.
9. Land as soon as possible.
10. Refer to ACTIVATED EPU/HYDRAZINE LEAK, this section.

If MAIN GEN, STBY GEN, and EPU GEN lights all remain on or all come on again:

**WARNING**

- Plan to land within 30 minutes to insure adequate electrical power for communications, brakes, hook, and drag chute.
- If the FLCS PMG and EPU PMG lights are on in combination with the ACFT BATT TO FLCS light, the aircraft battery is powering the FLCS. With the aircraft battery powering the FLCS in addition to the battery buses, approximately 3-14 minutes flight time is available.
- When the FLCS is powered by the aircraft battery, remain alert for degraded flight controls. At the first indication of degraded response, reduce airspeed and climb to safe ejection altitude. Eject prior to complete loss of control.

8. HOOK switch - DN.
9. **PX II** CNI, **PX III** C & I knob - BACKUP.
10. Minimize UHF transmissions.



If conditions permit:

11. Land as soon as possible.  
Fly airspeed for 11 degrees AOA approach using fuel state when power was lost.
12. LG handle - DN. (Use DN LOCK REL button.)

### WARNING

If LG handle does not lower, select BRAKES CHAN 2 and position ALT FLAPS switch to EXTEND. **PW 229** Nozzle remains closed resulting in higher than normal landing thrust.

13. ALT GEAR handle - Pull (190 knots maximum).
  - Alternate LG extension can be used up to 300 knots; however, the NLG may not fully extend until 190 knots. Time above 190 knots should be minimized in case there is a leak in the pneumatic lines.
  - WHEELS down lights and TO/LDG CONFIG warning light function are inoperative. Monitor LG handle warning light to verify that LG is down.

### CAUTION

- NWS is not available following alternate LG extension.
  - Do not depress the ALT GEAR reset button while pulling the ALT GEAR handle. This action may preclude successful LG extension.
  - Pulling the ALT GEAR handle with normal system B hydraulic pressure may result in system B hydraulic failure within 15 minutes.
14. Consider an approach-end arrestment, if conditions permit. (Refer to CABLE ARRESTMENT, this section.)
  15. Refer to ACTIVATED EPU/HYDRAZINE LEAK, this section.

After landing:

16. Stop straight ahead and have chocks installed (or engage parking brake).
17. MAIN PWR switch - MAIN PWR (until chocks are installed).

## EPU Malfunctions

### UNCOMMANDED EPU OPERATION

Failures can occur which allow engine bleed air to spin the EPU turbine even though the EPU has not been commanded on. This may not be apparent if the thrust level and amount of bleed air are such that the EPU is turning above or below the speed range which turns on the EPU run light. During uncommanded EPU operation on bleed air, EPU speed varies directly with throttle position. High thrust settings are likely to result in EPU failure.

The EPU may also activate for reasons not apparent to the pilot. Although this is not an EPU malfunction, it may be interpreted as uncommanded EPU operation.

If uncommanded EPU operation on bleed air is suspected:

#### NOTE

The nonessential dc buses and essential dc bus may lose power. If so, this results in loss of power to fuel boost and transfer pumps, **PX II** VHF radio, CARA, ECM, and FCR and power for normal weapon arming/release including selective jettison.

1. Throttle - Minimum practical thrust.
2. Stores - Jettison (if required).  
Only if required to maintain low thrust.
3. Land as soon as possible.

If EPU is running with normal indications:

#### NOTE

- The nonessential dc buses and essential dc bus lose power. This results in loss of power to fuel boost and transfer pumps, **PX II** VHF radio, CARA, ECM, and FCR and power for normal weapon arming/release including selective jettison.
  - If the affected systems are required for the safe recovery of the aircraft, consider delaying/terminating EPU operation until the systems are no longer required.
4. EPU - Leave running.
  5. Land as soon as possible.
  6. Refer to ACTIVATED EPU/HYDRAZINE LEAK, this section.

**ABNORMAL EPU OPERATION**

Abnormal EPU operation after a normal start command is indicated by one or more of the following: EPU run light flashes, indicating EPU operation in tertiary speed control mode; EPU run light does not come on or goes off after initial illumination, indicating sustained underspeed or overspeed operation; EPU HYDRAZN light does not go off or EPU fuel quantity continues to deplete when the throttle is advanced to assure adequate bleed air, indicating an EPU bleed air or fuel control system problem.

When tertiary speed control is functioning, the EPU run light alternately cycles on and off (one to three times per second) as a function of EPU speed fluctuating between the normal and slightly above normal speed ranges. The MASTER CAUTION and the EPU HYDRAZN lights may illuminate. Hydrazine use occurs regardless of available engine bleed air. The hydrazine supply depletes in approximately 10 minutes. After hydrazine depletion, the EPU continues to operate with available bleed air on tertiary speed control.

If tertiary speed control cannot control EPU speed (constant overspeed), total EPU failure is imminent. Excessive voltage generated by the EPU generator or its PMG is regulated by the converter/regulators before going to the FLCC. Other electrical and avionic equipment may be damaged by the overvoltage condition. When EPU failure occurs, FLCS power is provided by the FLCS PMG, main generator, standby generator, or the aircraft battery (whichever has the higher voltage).

Under some failure conditions, hydrazine may not be available to the EPU or it may continue to deplete even with adequate bleed air. If a hydrazine malfunction or depletion occurs, landing must be accomplished using an engine thrust setting sufficient to maintain an adequate bleed air supply to the EPU. Failure to maintain minimum engine rpm can result in hydraulic pressure fluctuations or electrical bus cycling. Advance throttle as required to maintain adequate bleed air supply. (If the EPU is the sole source of hydraulic pressure, the throttle should be set so as to keep the EPU run light on during mild flight control inputs.) This action may result in a thrust level that is higher than required for a normal straight-in approach. Fully open speedbrakes or a shallower than normal approach may be required. A straight-in approach followed by an approach-end arrestment is recommended.

If EPU was turned on for an ACFT BATT FAIL or an FLCS RLY light:

1. EPU switch - OFF, then NORM.
2. Land as soon as possible.
3. Refer to ACTIVATED EPU/HYDRAZINE LEAK, this section.

If EPU was activated for other reasons:

1. Throttle - As required (PW 229 75-80, GE129 82-90 percent rpm).  
Keep thrust high enough to assure adequate bleed air if EPU fuel usage continues above PW 229 80, GE129 90 percent rpm or if EPU run light is flashing. If EPU fuel is depleted or if EPU run light goes off at low thrust, set throttle to keep EPU run light on.
2. EPU FUEL quantity - Monitor.
3. Land as soon as possible.  
Make an approach-end arrestment, if practical, if EPU fuel depletes before landing or if EPU run light goes off at low thrust settings. Refer to CABLE ARRESTMENT, this section.

**WARNING**

If PTO shaft or both hydraulic systems are failed, underspeed of the EPU results in loss of control. Do not retard throttle completely to IDLE until after touchdown.

**CAUTION**

If EPU underspeeds, electrical bus cycling may affect brake operation. For a missed engagement, attempt CHAN 1 then CHAN 2 brakes. If no braking is available, consider going around for another engagement or making a departure-end arrestment. The parking brake still operates.

4. Refer to ACTIVATED EPU/HYDRAZINE LEAK, this section.

**FLCS RLY Light**

Illumination of the FLCS RLY light indicates that voltage on one or more of the four FLCC branches connected to the aircraft battery is inadequate (below 20V). Therefore, should main generator, standby generator, and FLCS PMG power be lost (engine shutdown, PTO shaft failure, ADG failure), power would not be available to one or more FLCS branches until the EPU is on line. The EPU must be turned on if the FLCS RLY light cannot be extinguished.

1. FLCS PWR TEST switch - TEST, momentarily.

If FLCS RLY light goes off:

2. Land as soon as practical.

If FLCS RLY light remains on:

2. EPU switch - ON.

**NOTE**

- The nonessential dc buses and essential dc bus lose power. This results in loss of power to fuel boost and transfer pumps, **PX II** VHF radio, CARA, ECM, and FCR and power for normal weapon arming/release including selective jettison.
  - If the affected systems are required for the safe recovery of the aircraft, consider delaying/terminating EPU operation until the systems are no longer required.
3. Land as soon as practical.
  4. Refer to ACTIVATED EPU/HYDRAZINE LEAK, this section.

If EPU runs abnormally:

3. EPU switch - OFF, then NORM.
4. Land as soon as possible.

**Partial Electrical Power Loss**

Loss of power to several systems or indicators without any indications on the ELEC control panel may be the result of wire harness chafing or the loss of power to

one or more ac or dc buses. Refer to EMERGENCY POWER DISTRIBUTION, this section, to determine affected buses and equipment. If one item on a bus is powered, then that bus should be considered powered. Wire harness chafing can affect numerous items on more than one bus without causing loss of power to a bus.

A failed overcurrent sensing contactor (OCSC) may be the cause of the partial power loss. If the OCSC failure involves electrical shorting, power from the main generator is degraded while the short is present. An obvious effect of this degraded power is loss of the HUD and MFD's. If the short quickly burns itself open, only the system(s) which receives power through the failed OCSC is lost. Power to the nonessential ac No. 1, emergency ac No. 1, emergency dc No. 1, and nonessential dc buses goes through one OCSC. Failure of this OCSC results in a loss of power to many items, including the FCR, CADC, stick trim, TACAN, VHF radio, DED, FUEL FLOW indicator, primary instrument and console lights, VVI, AOA indicator, and **PX II** FCC. **PX III** The MMC enters a degraded mode that includes loss of the HUD. Failure effects for the other OCSC's are limited to individual store stations, the FCR, or the nacelle ac buses. If the short persists for 2-3 seconds, the main generator goes off line and power is removed from all eight overcurrent sensing contactors. The standby generator should automatically come on line to power the essential, emergency, and battery buses. Refer to SINGLE GENERATOR FAILURES (IN FLIGHT), this section if the MAIN GEN FAIL light is on.

OCSC's can also fail open without electrical shorting. These failures do not result in degraded power from the main generator but do cause loss of power to the buses/items protected by the OCSC.

The ELEC CAUTION RESET button can be used to reset a failed open OCSC; however, the OCSC may not remain reset if the fault persists.

The buses with a resettable overcurrent sensing contactor are nonessential ac bus No. 1 and the nacelle nonessential ac bus.

The items with a nonresettable overcurrent sensing contactor are the radar ac bus; stations 3, 5, and 7; and left and right inlet stations.

1. ELEC CAUTION RESET button - Depress.  
The failed open OCSC may reset.

If power is restored:

2. Land as soon as practical.

If power is not restored:

2. Determine the power status of electrical buses. Refer to EMERGENCY POWER DISTRIBUTION, this section, to determine the power status of individual buses. If one item on a bus is powered, then that bus should be considered powered.

**NOTE**

Determining the status of the battery buses is critical for a safe recovery of the aircraft.

If one or both emergency ac buses are not powered:

3. EPU switch - ON.

**NOTE**

- The nonessential dc buses and essential dc bus lose power. This results in loss of power to fuel boost and transfer pumps, **PX II** VHF radio, CARA, ECM, and FCR and power for normal weapon arming/release including selective jet-tison.
- If the affected systems are required for the safe recovery of the aircraft, consider delaying/terminating EPU operation until the systems are no longer required.

If the battery buses **PX III** and emergency dc bus No. 2 are not powered,:

4. Consider a net arrestment, refer to NET ARRESTMENT, this section.

If net arrestment is not available:

5. Consider a gear up landing, refer to LANDING WITH LG UNSAFE/UP, this section.  
If power to the battery buses is lost after the landing gear has been extended, the landing gear cannot be raised.
6. Refer to EMERGENCY POWER DISTRIBUTION, this section.
7. Land as soon as possible.

If EPU was activated:

8. Refer to ACTIVATED EPU/HYDRAZINE LEAK, this section.

**Aircraft Battery Failure**

Aircraft battery system failure is indicated by the ELEC SYS and ACFT BATT FAIL lights. The FLCS RLY light also illuminates if the failure involves low battery voltage. If the battery fails and both main and standby generators subsequently drop off line, power is not available to activate the EPU. If the battery fails and subsequent loss of main generator, standby generator, and FLCS PMG power occurs (e.g., engine shutdown, PTO shaft failure, ADG failure), power is not available to activate the EPU or control the aircraft. Thus, it is necessary to turn the EPU on after battery failure is indicated. The ACFT BATT FAIL light illuminates only for low battery voltage while in flight (approximately 20 volts). If a battery charger failure occurs in flight and is still present after landing, the ACFT BATT FAIL light illuminates 60 seconds after WOW.



If the aircraft battery fails (and EPU is off), do not taxi except to clear runway. Subsequent loss of the main and standby generators results in loss of all braking, NWS, hook, radios, and drag chute.

1. EPU switch - ON.

**NOTE**

- The nonessential dc buses and essential dc bus lose power. This results in loss of power to fuel boost and transfer pumps, **PX II** VHF radio, CARA, ECM, and FCR and power for normal weapon arming/release including selective jet-tison.
- If the affected systems are required for the safe recovery of the aircraft, consider delaying/terminating EPU operation until the systems are no longer required.
- If both radios become inoperative after an aircraft battery failure indication, refer to PARTIAL ELECTRICAL POWER LOSS, this section.
- The ACFT BATT FAIL light may subsequently extinguish. This should not be interpreted to mean that the battery has recharged. It may indicate that the battery voltage is so low that the light cannot remain illuminated.

2. Land as soon as practical.
3. Refer to ACTIVATED EPU/HYDRAZINE LEAK, this section.

If EPU runs abnormally:

4. EPU switch - OFF, then NORM.
5. Land as soon as possible.

6. Refer to ACTIVATED EPU/HYDRAZINE LEAK, this section.

Prior to shutdown:

7. Loose items - Secure.
8. Canopy - Open.

**Emergency Power Distribution**

Refer to figure 3-6.

# Emergency Power Distribution

## MAIN GENERATOR FAILED

SYSTEM	INOPERATIVE EQUIPMENT	BUS ASSIGNMENT			
		NONESS AC		NACELLE NONESS DC	
		NO. 1	NO. 2	NO. 1	NO. 2
ENGINE	<input checked="" type="checkbox"/> <b>GE129</b> EMSC				X
NAV/COMM	<input checked="" type="checkbox"/> <b>PX II</b> VHF Radio			*	
FUEL	Pumps 1, 2, 4 & 5		X	*	
	<input checked="" type="checkbox"/> <b>PX III</b> CFT Pumps		X		
	<input checked="" type="checkbox"/> <b>GE129</b> FUEL/OIL HOT Caution Light (oil hot signal)				X
STORES MGT	AIM-120	***			
	Stations 3, 5 & 7 - EO, Radar-Guided Weapons, ECM Pods	**			
	Stations 4 & 6 - EO, Radar-Guided Weapons		X		
AVIONICS	DTU		X		
	<input checked="" type="checkbox"/> <b>PX II</b> FCC	X			
	FCR	Radar		*	
	<input checked="" type="checkbox"/> <b>PX II</b> GPS	X			
	TWS	X		X	
LIGHTS	Flood Console		X		
	Flood Instrument		X		
	Formation		X		
	Taxi		X		
OTHER	<input checked="" type="checkbox"/> <b>PX III</b> <input checked="" type="checkbox"/> <b>D</b> ASIU			*	
	ECM Control			*	
	Halon Heater		X		
	<input checked="" type="checkbox"/> <b>PX III</b> HMCS	X			
	Inlet Strut Heater		X		
	<input checked="" type="checkbox"/> <b>PX II</b> INS Heater	X			
	Nacelle Ejector Shutoff				X
	Seat Adjustment	X			
Total Temperature Probe Heater	X				

**NOTE:**

Equipment on nonessential ac bus No. 1 or nonessential ac bus No. 2 may be functional with MAIN GEN light on (bus contactor failure).

\* Aft equipment bay nonessential dc bus.

\*\* Overcurrent sensing contactors.

\*\*\* Nacelle nonessential ac bus.

Figure 3-6. (Sheet 1)

# Emergency Power Distribution

## MAIN AND STANDBY GENERATORS FAILED

(All equipment from sheet 1 plus the following:)

SYSTEM	INOPERATIVE EQUIPMENT	BUS ASSIGNMENT	
		ESS AC	ESS DC
FUEL	Pump 3	X	X
	Tank Inerting		X
STORES MGT	AIM-9	*	
	Arm and Release Power - Stations 1 Thru 9		X
AVIONICS	Radar Altimeter		X
	MFD's	X	
	PFLD	*	
OTHER	Air Data Probe Heater (fuselage)	*	
	<input type="checkbox"/> PX III <input type="checkbox"/> D ASHM		X
	Battery Charger	X	
	<input type="checkbox"/> PX III Data Link		X
<b>NOTE:</b> Equipment on this sheet may operate if MAIN GEN light was caused by bus contactor failure at nonessential bus No. 1.			

\*Nacelle essential ac bus.

Figure 3-6. (Sheet 2)

# Emergency Power Distribution

## MAIN, STANDBY, AND EPU GENERATORS FAILED

(All equipment from sheets 1 and 2 plus the following:)

SYSTEM	INOPERATIVE EQUIPMENT	BUS ASSIGNMENT			
		EMER AC		EMER DC	
		NO. 1	NO. 2	NO. 1	NO. 2
ENGINE	Engine ANTI ICE Switch				X
	ENGINE FAULT Caution Light				X
	Engine Ice Detector		X		
	Fire/Overheat Detect and Test		X		
	HYD PRESS Indicators		X		
	<b>GE129</b> Low Energy Ignition Power	X			
	NOZ POS Indicator		X		
	OIL Pressure Indicator		X		
FLIGHT INSTRUMENT	ADI		X		
	Altimeter (ELECT)	X			
	AOA Indexer			X	
	AOA Indicator	X			
	HSI		X		
	Turn Needle			X	
	INSTR MODE Select Switch			X	
FUEL	VVI	X			
	Automatic Forward Fuel Transfer				X
	FUEL FLOW Indicator	X			
	FUEL LOW Caution Lights			X	
FLIGHT CONTROLS	FUEL Quantity Indicator		X		
	Autopilot				X
	DBU ON Warning Light (branches A & B)			X	
	DBU ON Warning Light (branches C & D)				X
	<b>C</b> <b>DF</b> FLCS FAULT Caution Light (branches A & B)			X	
	<b>DR</b> FLCS FAULT Caution Light (branches C & D)				X
	FLCS RESET Switch (branches A & B)			X	
	FLCS RESET Switch (branches C & D)				X
	FLCS Power Source (branches A & B)			X	
	FLCS Power Source (branches C & D)				X
	FLCS Warning Light (branches A & B)			X	
FLCS Warning Light (branches C & D)				X	

Figure 3-6. (Sheet 3)



# Emergency Power Distribution

## MAIN, STANDBY, AND EPU GENERATORS FAILED – CONT

(All equipment from sheets 1, 2, and 3 plus the following:)

SYSTEM	INOPERATIVE EQUIPMENT	BUS ASSIGNMENT			
		EMER AC		EMER DC	
		NO. 1	NO. 2	NO. 1	NO. 2
FLIGHT CONTROLS (cont)	LEF's	X			
	Speedbrakes			X	
	Stick Trim			X	
NAV/COMM	<input type="checkbox"/> PX III EGI			X	
	IFF			X	
	<input type="checkbox"/> PX II INS	X		X	
	ILS				X
	TACAN		X	X	
	<input type="checkbox"/> PX III VHF Radio			X	
STORES MGT	<input type="checkbox"/> ALT REL Button			X	
	CIU*			X	X
	Chaff Dispenser				X
	Gun		X		X
	EMER JETT Button*			X	X
	MASTER ARM Switch			X	
	MSL STEP Switch			X	
	NUCLEAR CONSENT Switch				X
	STORES CONFIG Caution Light				X
	<input type="checkbox"/> DF WPN REL Button				X
<input type="checkbox"/> DR WPN REL Button			X		
AVIONICS	CADC	X			
	CADC Caution Light			X	
	HUD				X
	HUD/CTVS		X		
	ICP/IKP				X
	MFD Video Control				X
	<input type="checkbox"/> PX III MMC*	X	X	X	X
	Upfront Controls		X		X

\*Indicates redundancy.

Figure 3-6. (Sheet 4)

# Emergency Power Distribution

## MAIN, STANDBY, AND EPU GENERATORS FAILED – CONT

(All equipment from sheets 1, 2, 3, and 4 plus the following)

SYSTEM	INOPERATIVE EQUIPMENT	BUS ASSIGNMENT			
		EMER AC		EMER DC	
		NO. 1	NO. 2	NO. 1	NO. 2
LIGHTS	ANTICOLLISION Strobe		X		
	AR (flood)		X		
	AR (slipway)				X
	Landing		X		
	LANDING/TAXI/External Switches				X
	MAL & IND LTS TEST/BRT DIM			X	
	POSITION		X		
	PRIMARY CONSOLES	X			
	PRIMARY INST PNL	X			
LG/NWS/ BRAKES	LG Hydraulic Isolation				X
	LG Sequence (doors)				X
	LG UP-DN Command				X
	NWS			X	
	WHEELS Down Lights			X	
OTHER	Air Data Probe Heater (nose)	X			
	AOA Probe Heaters	X			
	AR System			X	
	AVTR/CTVS				X
	CABIN PRESS Caution Light				X
	CAMERA/GUN Trigger				X
	Cockpit Pressure Dump Capability				X
	Cockpit Temperature Control			X	
	Engine Bleed Air Valves (close capability)				X
	EQUIP HOT Caution Light				X
	INLET ICING Caution Light				X
	<input type="checkbox"/> PX <input type="checkbox"/> II <input type="checkbox"/> C <input type="checkbox"/> DF LIQUID OXYGEN Quantity Indicator			X	

Figure 3-6. (Sheet 5)

# Emergency Power Distribution

## MAIN, STANDBY, AND EPU GENERATORS FAILED – CONT

(All equipment from sheets 1, 2, 3, 4, and 5 plus the following)

SYSTEM	INOPERATIVE EQUIPMENT	BUS ASSIGNMENT			
		EMER AC		EMER DC	
		NO. 1	NO. 2	NO. 1	NO. 2
OTHER - continued	<b>PX II</b> OXY LOW Caution Light				X
	<b>PX III</b> OXY LOW Warning Light				X
	<b>PX III</b> OBOGS Caution Light				X
	<b>PX III</b> OBOGS Concentrator		X		
	<b>PX III</b> OBOGS Monitor			X	
	Probe Heat Monitor			X	
	PROBE HEAT Switch			X	
	SEAT NOT ARMED Caution Light				X

Figure 3-6. (Sheet 6)

# Emergency Power Distribution

## OPERATING EQUIPMENT – MAIN, STANDBY, AND EPU GENERATORS FAILED

SYSTEM	OPERATING EQUIPMENT	BUS ASSIGNMENT	
		BATTERY NO. 1	BATTERY NO. 2
ENGINE	<b>PW229</b> EDU		X
	<b>GE129</b> Electrical Throttle Position		X
	PRI (no supersonic stall protection)*		
	PRI/SEC Transfer Circuit*		
INSTRUMENTS	Airspeed/Mach Indicator*		
	Altimeter (PNEU)*		
	FTIT Indicator	X	
	RPM Indicator	X	
	SAI		X
FUEL	External Fuel Transfer*		
	FUEL MASTER Switch		X
	FFP*		
FLIGHT CONTROLS	Functional (except LEF's, speedbrakes, autopilot, and stick trim)*		
NAV/COMM	Intercom	X	
	Magnetic Compass*		
	UHF Radio	X	
LIGHTS	Spotlights	X	
	Utility Light	X	
LG/NWS/ BRAKES	Alternate LG Extension*		
	Antiskid/Channel 1 Brakes	X	
	Antiskid/Channel 2 Brakes		X
	LG Uplock/Downlock	X	
	MLG WOW (branches A & B)	X	
	MLG WOW (branches C & D)		X
	NLG WOW (branches A & B)	X	
	NLG WOW (branches C & D)		X
Parking Brake		X	

\*Indicates items that do not require power through the battery buses.

Figure 3-6. (Sheet 7)

# Emergency Power Distribution

OPERATING EQUIPMENT – MAIN, STANDBY, AND EPU GENERATORS  
FAILED – CONT

SYSTEM	OPERATING EQUIPMENT	BUS ASSIGNMENT	
		BATTERY NO. 1	BATTERY NO. 2
WARNING LIGHTS	CANOPY	X	
	ENGINE	X	
	HYD/OIL PRESS	X	
	LG Warning (handle)		X
CAUTION LIGHTS	ANTI SKID		X
	ELEC SYS		X
	HOOK		X
	MASTER CAUTION	X	
	SEC		X
OTHER	Canopy Activation*		
	Drag Chute	X	
	EPU	X	X
	Hook		X
	JFS	X	
	MAIN PWR Switch		X
	VMS	X	

\*Indicates items that do not require power through the battery buses.

Figure 3-6. (Sheet 8)

# Emergency Power Distribution

## PARTIAL ELECTRICAL POWER LOSS

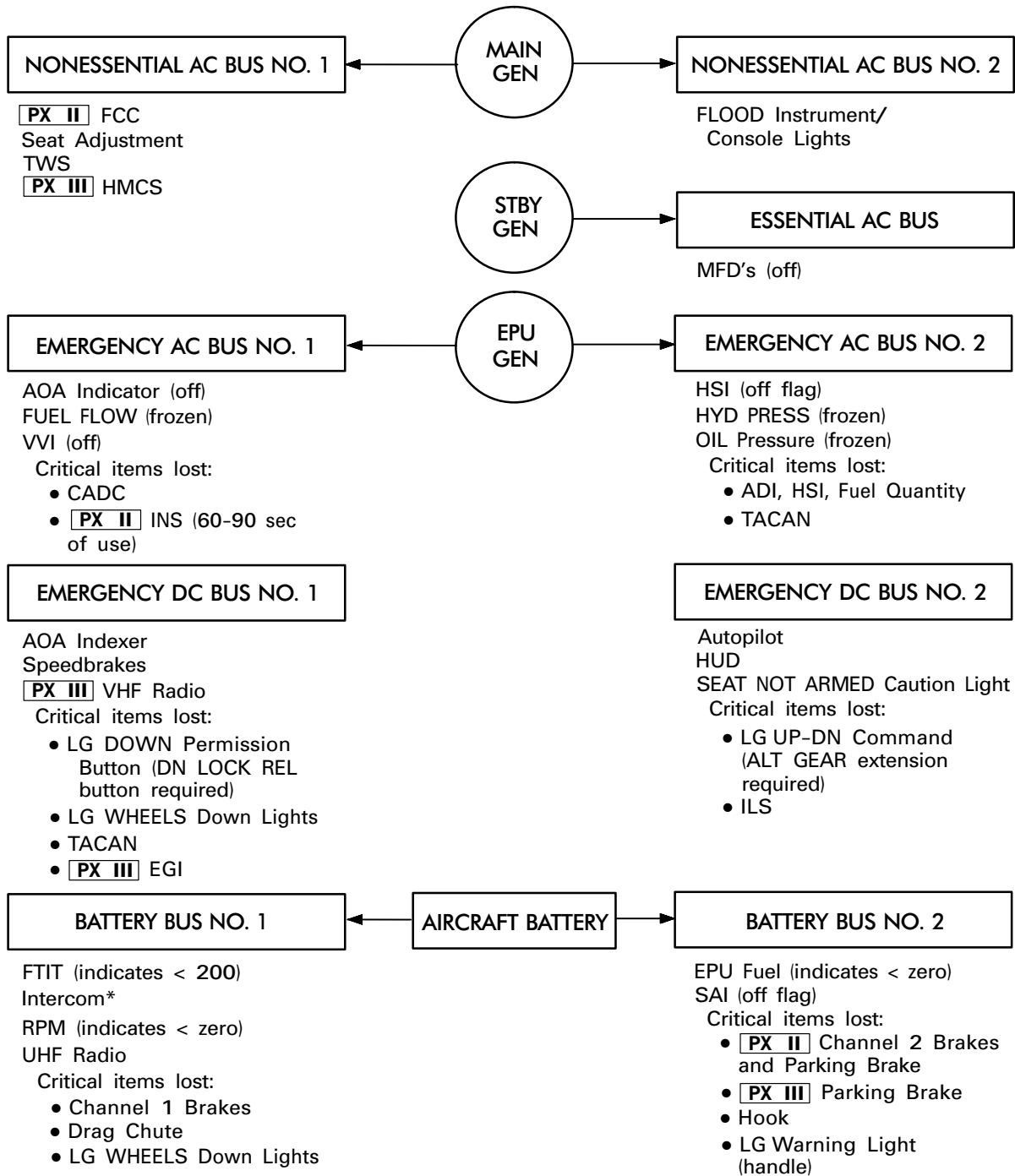

\*VHF radio is also inoperative because the ability to key either radio is lost.

Figure 3-6. (Sheet 9)

## ENGINE MALFUNCTIONS **PW 229**

The EDU compares expected versus actual engine operation. The purpose of the EDU MFL is to provide maintenance personnel with an early indication of an engine condition which requires correction. No action is required for an engine MFL at anytime during a flight.

Low altitude, for engine malfunction purposes, is generally defined as 10,000 feet AGL or below. If an engine malfunction is suspected, the initial reaction should be to trade excess airspeed for altitude. Unless a suitable airfield is within gliding distance, turns should be avoided as they decrease the amount of time/altitude available to successfully recover engine performance or prepare for ejection. Optimizing the exchange of airspeed for altitude must be a priority action for any engine malfunction. Above 350 knots, more time is available by performing a zoom climb using a 3g pullup to 30-degree climb until approaching the desired airspeed (use approximately 50 knots lead point) and then initiating a zero-g pushover. Below 350 knots and above the minimum recommended ejection altitude, more time is available by performing a constant altitude deceleration to the desired airspeed. If below the minimum recommended ejection altitude and below 350 knots, primary concern should be to trade excess airspeed for altitude in preparation for ejection. If appropriate, jettison stores as soon as possible.

### **WARNING**

With engine failure or flameout, OBOGS is inoperative. Activate EOS if OXY LOW warning light illuminates above 10,000 feet cockpit altitude.

For any situation where automatic activation of the EPU is relied upon, verify that the EPU run light is on to insure that the EPU has started. If the EPU run light is off, position the EPU switch to ON.

Idle thrust in SEC during ground operation is approximately twice that in PRI. After landing in SEC, consider minimizing taxi distance and consider following HOT BRAKES procedures, this section.

### **Engine Fire **PW 229****

Generally, the first indication of fire in the engine compartment is the ENG FIRE warning light. Abnormal fuel indications (quantity/flow) may also be present. FTIT probably will not be higher than normal. Explosions, vibrations, or engine instrument fluctuations are usually indicative of a serious engine problem; engine failure may be imminent. Immediate action

should be taken to reduce thrust to the minimum practical level after attaining safe ejection parameters. If within gliding distance of a suitable runway, consider shutting the engine down. Sufficient time should exist to analyze the situation and make an ejection versus land decision. The ejection decision should be based on visual and/or cockpit indications that the fire is persisting. Cockpit indications include continued illumination of the ENG FIRE warning light and subsequent FLCS malfunctions/degraded flight controls or subsequent loss of either hydraulic system.

Fires can also occur in the exhaust nozzle area when using AB. These fires are the result of portions of the nozzle failing which allows the AB plume to burn through the nozzle. Ventilation should inhibit forward movement of the fire into and through the engine bay. Since these fires are aft of the detection circuit, the ENG FIRE warning light will not illuminate. Additionally, the nozzle position indications are normal, and there are no vibrations or instrument fluctuations. In most cases, these AB-related nozzle fires are detected by someone outside the aircraft (wingman, tower, etc.). When operating in AB and a fire is reported at the rear of the aircraft, retard throttle below AB immediately. This action should extinguish a nozzle fire within approximately 30-45 seconds and minimize damage to the aircraft skin, speedbrakes, nozzle, and flight controls; however, nozzle damage may result in a noticeable thrust loss.

A failure that causes an oil leak may also result in an oil-fed fire in the AB section. The fire may continue for several minutes after the engine fails or is shut down (until the oil supply is exhausted). Since the fire is likely to be contained within the engine, the ENG FIRE warning light does not illuminate.

If on takeoff and conditions permit:

1. Abort.

If takeoff is continued:

1. Climb.  
Maintain takeoff thrust until minimum recommended ejection altitude is attained and then throttle to minimum practical.
2. Stores - Jettison (if required).

At a safe altitude:

3. Throttle - Minimum practical.  
If fire occurred in AB, ENG FIRE warning light may not illuminate. Fire should extinguish after throttle is retarded; however, nozzle damage may result in lower than normal thrust.

T.O. GR1F-16CJ-1

If ENG FIRE warning light goes off:

4. FIRE & OHEAT DETECT button - Depress.  
Determine if fire detection circuit is functional.

If fire persists:

5. Eject.

If fire indications cease:

5. Land as soon as possible.

#### **OVERHEAT Caution Light PW 229**

Detection of an overheat condition in the engine compartment, ECS bay, MLG wheel wells, or EPU bay illuminates the OVERHEAT caution light. Accomplish as many of the following as required to extinguish the light. If the light goes off, verify the integrity of the detection circuit by depressing the FIRE & OHEAT DETECT button and land as soon as possible.

If OVERHEAT caution light illuminates:

1. Throttle - Minimum practical.
2. FIRE & OHEAT DETECT button - Depress.  
Determine if fire detection circuit is functional.

If OVERHEAT caution light remains on (or detect circuit checks bad) and EPU is running:

3. EPU switch - OFF (if feasible).  
If the EPU was manually turned on, consider turning it off to determine if it is the source of the overheat condition. If the OVERHEAT caution light remains on, the EPU should be turned back on.

If OVERHEAT caution light remains on (or detect circuit checks bad):

4. OXYGEN - 100%.
5. AIR SOURCE knob - OFF.  
External fuel cannot be transferred in OFF or RAM. Consider jettisoning tanks to decrease drag if range is critical and the ECS cannot be turned on for short periods of time to transfer fuel.

#### **WARNING**

- With the ECS shut down or the AIR SOURCE knob in OFF or RAM, the g-suit does not inflate and PBG is disabled.
  - With the AIR SOURCE knob in OFF or RAM, OBOGS is inoperative. Activate EOS if OXY LOW warning light illuminates above 10,000 feet cockpit altitude.
6. Descend to below 25,000 feet and reduce air-speed to below 500 knots.

When airspeed is reduced and cockpit is depressurized:

7. AIR SOURCE knob - RAM (below 25,000 feet).  
External fuel cannot be transferred in OFF or RAM. Consider jettisoning tanks to decrease drag if range is critical and the ECS cannot be turned on for short periods of time to transfer fuel.

#### **WARNING**

- With the ECS shut down or the AIR SOURCE knob in OFF or RAM, the g-suit does not inflate and PBG is disabled.
  - With the AIR SOURCE knob in OFF or RAM, OBOGS is inoperative. Activate EOS if OXY LOW warning light illuminates above 10,000 feet cockpit altitude.
8. Nonessential electrical equipment - Off.

#### **NOTE**

If in VMC and the ADI and HSI are not required for flight, the EGI should be considered nonessential.

If OVERHEAT caution light still remains on (or detect circuit checks bad):

9. TANK INERTING switch - TANK INERTING even if Halon is not available.
10. LG handle - DN (300 knots/0.65 mach maximum). (Use DN LOCK REL button if required.)



**WARNING**

If LG handle does not lower, select BRAKES CHAN 2 and position ALT FLAPS switch to EXTEND. Nozzle remains closed, resulting in higher than normal landing thrust.

11. Land as soon as possible.

**Engine Vibrations PW 229**

Some engines exhibit low frequency vibrations which are non-damaging to both the airframe and engine. The vibrations should disappear if engine rpm is either increased or decreased.

Vibrations that change in intensity with throttle movement and are present across the throttle/rpm range may indicate a potential engine malfunction.

If vibrations persist:

1. Throttle - Minimum practical.
2. Land as soon as possible.

**Oil System Malfunction PW 229**

An oil system malfunction is characterized by a pressure (including fluctuations) below 15 psi at IDLE or 30 psi at MIL, a pressure above 95 psi at any thrust setting, pressure fluctuations greater than  $\pm 5$  psi at IDLE or  $\pm 10$  psi above IDLE, or by a lack of oil pressure rise when the throttle is advanced. The OIL pressure indicator can be used as an early indication of oil loss. An indication of excessive oil loss is the lack of oil pressure rise when the throttle is advanced in the IDLE to MIL range. These conditions may not occur until approximately one-half the usable oil is lost. The HYD/OIL PRESS warning light may not illuminate until most of the usable oil is lost. At the first indication of an oil system malfunction, take immediate action to land as soon as possible.

Climbing to a higher altitude allows higher cruise airspeed and increases glide range. However, if the oil malfunction is caused by an internal engine oil leak, the rate of oil loss is decreased at low altitude and throttle settings. Usually it is advisable to climb to a reasonable cruise altitude. Once at altitude, retard throttle to approximately 80 percent rpm and do not move the throttle unless absolutely required. With

zero oil pressure, any throttle movement may cause the engine to seize. Minimize maneuvering g to minimize loads. Plan an approach which allows a flameout landing from any position should engine seize. Refer to SIMULATED FLAMEOUT (SFO) LANDING and FLAMEOUT LANDING, this section.

The EPU should be manually activated; otherwise, if the EPU does not start automatically when the engine seizes, the short time remaining before loss of control may be inadequate for recognition of the EPU failure and corrective action. Monitor hydrazine use after activating the EPU. If consumption rate is too high, cycle EPU switch to OFF, then NORM to conserve hydrazine. Be prepared to place the EPU switch back to ON if the engine seizes.

If an oil pressure malfunction is suspected:

1. Attain desired cruise altitude.  
The rate of oil loss is decreased at low altitudes and low throttle settings.
2. Stores - Jettison (if required).
3. Throttle - Approximately 80 percent rpm.
4. EPU switch - ON.  
Monitor hydrazine use. If consumption rate is too high, cycle EPU switch to OFF, then NORM to conserve hydrazine. Be prepared to place EPU switch back to ON if the engine seizes.
5. Throttle - Do not move until landing is assured.

**CAUTION**

- Throttle movement/rpm change may cause engine seizure.
  - Do not start the JFS if engine seizure has occurred or is anticipated. Starting the JFS may result in no brake/JFS accumulator pressure for the brakes.
6. Land as soon as possible.  
Plan to fly an SFO. Refer to SIMULATED FLAMEOUT (SFO) LANDING and FLAMEOUT LANDING, this section.
  7. Refer to ACTIVATED EPU/HYDRAZINE LEAK, this section.

**ENGINE FAULT Caution Light PW 229**

Illumination of the ENGINE FAULT caution light indicates that an engine PFL item was detected.

If ENGINE FAULT caution light illuminates:

1. PFLD – Note PFL(s) displayed.

**NOTE**

If ENG BUS FAIL PFL is displayed or has been displayed, MUX communication with the EDU is no longer possible. Subsequently, if an engine PFL occurs, the ENGINE FAULT caution light illuminates but cannot be reset and that PFL cannot be displayed on the PFLD.

2. **C DF** F-ACK, **DR** FAULT ACK button – Depress to acknowledge fault.

If ENGINE FAULT caution light does not reset when the fault is acknowledged:

3. Throttle – 85 percent rpm or less.
4. Land as soon as possible.

If ENGINE FAULT caution light resets when the fault is acknowledged:

3. Refer to PILOT FAULT LIST – ENGINE, this section.
4. **C DF** AB RESET switch – AB RESET, then NORM.  
This action resets the DEEC and may clear the failure condition.
5. **C DF** F-ACK, **DR** FAULT ACK button – Depress to perform fault recall.  
The failure condition no longer exists if the PFL is not present during the fault recall.

**SEC Caution Light PW 229**

Illumination of the SEC caution light indicates that the engine is operating in SEC. If the ENG CONT switch is in **C DF** PRI, **DR** NORM and the SEC caution light is on, an automatic transfer to SEC has occurred. The transfer may be due to a DEEC malfunction, the DEEC sensing the loss of a critical input signal to the DEEC, or loss of power to the DEEC (engine alternator failure).

**NOTE**

- Compressor stalls may result from throttle movement in SEC above 40,000 feet MSL.
- Transfers from SEC to PRI above 40,000 feet MSL may result in stalls.

Automatic transfers to SEC after an engine alternator failure may also cause engine stalls. The combination of stalls and an erroneously low rpm indication may be incorrectly interpreted as a nonrecoverable stall. Confirm that a nonrecoverable stall actually exists before shutting down the engine.

If the SEC caution light illuminates while supersonic, do not retard throttle below MIL until subsonic. During landing in SEC, idle thrust is approximately twice that in PRI with a normal nozzle because the nozzle is closed.

**NOTE**

The ENG CONT switch should not be returned to **C DF** PRI, **DR** NORM after landing in an attempt to open the nozzle and decrease thrust.

If SEC caution light illuminates while supersonic:

1. Throttle – Do not retard below MIL until subsonic.



Retarding the throttle below MIL while supersonic may induce inlet buzz which produces severe cockpit vibration and probable engine stalls.

When subsonic or if SEC caution light illuminates while subsonic:

2. Throttle – Verify engine responds normally to throttle movement from IDLE to MIL; set as required.  
AB operation is inhibited. Above 40,000 feet MSL, minimize throttle movement.



If the rpm indication is also zero or erroneously low, the engine alternator may have failed. If the engine is shut down, an airstart may not be possible.

3. ENG CONT switch - SEC.
4. Land as soon as practical.  
During landing in SEC, idle thrust is approximately twice that in PRI with a normal nozzle.

If engine is operating abnormally in SEC:

5. Refer to ABNORMAL ENGINE RESPONSE **PW 229**, this section.

#### **FTIT Indicator Failure **PW 229****

Certain failures of the FTIT indicator can cause erroneous indications above 1100°C and illumination of the ENGINE warning light. If all other engine indications are normal and the engine responds normally to throttle movement, the engine should not be shut down. Routine missions should not be continued since FTIT cannot be monitored.

#### **Zero RPM/Erroneous RPM Indication **PW 229****

If the RPM indicator displays a zero or erroneous indication while other engine instruments indicate normal operation, the cause is loss of power to the indicator or indicator failure. Loss of power to the indicator causes the ENGINE warning light to illuminate. RPM indicator failure may not cause ENGINE warning light illumination.

### **WARNING**

Assume engine alternator is inoperative or malfunctioning. If the engine is shut down, an airstart may not be possible.

If the RPM indicator displays a zero or erroneously low indication accompanied by an automatic transfer to SEC (SEC caution light illuminated), the engine alternator may have failed. Since rpm cannot be monitored, routine missions should not be continued.

If SEC caution light is illuminated:

1. Go to SEC CAUTION LIGHT **PW 229**, this section.

If SEC caution light is not illuminated:

1. Land as soon as practical.

#### **Abnormal Engine Response **PW 229****

Refer to LOW THRUST ON TAKEOFF OR AT LOW ALTITUDE (NON-AB) **PW 229**, this section, if appropriate.

Abnormal engine response is varied and generally indicated by abnormal thrust in relation to throttle position, engine oscillations (either continuous, momentary, or recurring), a complete lack of engine response to throttle movement, autoacceleration/deceleration, exhaust nozzle failure, or insufficient thrust. The DEEC detects and automatically attempts to take corrective action for engine malfunctions. This action may result in partially or totally inhibited AB operation or in engine control being transferred to SEC. The action taken by the DEEC may be indicated by illumination of either or both the ENGINE FAULT and SEC caution lights.

If thrust is too low to sustain level flight, turn immediately toward the nearest suitable runway and establish 250 knots airspeed. Consider jettisoning stores to increase flying time available to complete actions designed to restore usable thrust and improve range in the event those actions are unsuccessful.

#### **NOTE**

In a partial thrust situation, thrust available may increase as altitude decreases. 250 knots approximates the airspeed at which thrust required for level flight is the lowest.

A throttle linkage problem should be suspected if throttle movements in both PRI and SEC produce either no rpm change or an rpm increase but no rpm decrease. In either case, the OFF position does not shut down the engine. If the throttle is stuck and thrust is suitable for sustained flight, attempts to free the throttle should be delayed until within gliding distance of a suitable landing field. If throttle is stuck in AB, placing the ENG CONT switch to SEC terminates AB and provides SEC MIL thrust. If throttle is stuck or otherwise prevented from normal movement, control might be regained by depressing the cutoff release, rotating the throttle outboard, and applying necessary force.

The engine may roll back, which prevents the engine from reaching normal rpm and FTIT levels when the throttle is advanced. This rollback is generally caused by the DEEC sensing an out-of-limits condition and may not be accompanied by a SEC caution light. For this situation or any abnormal engine response below AB, follow the procedures of this section until the situation is corrected.

If thrust is too high to permit a safe landing, use excess thrust to climb and maneuver toward the nearest suitable airfield. Once high key for a flameout landing is assured, follow procedures as outlined in FLAMEOUT LANDING, this section. Activate the JFS and EPU and then shut down the engine as soon as landing is assured (normally high key) by placing the throttle to OFF or, if necessary, by placing the FUEL MASTER switch to OFF.

If the decision is made to manually select SEC while subsonic below 40,000 feet MSL, set the throttle to midrange or above before positioning the ENG CONT switch to SEC.

**WARNING**

- Failure to monitor sink rate and height above terrain while applying low thrust recovery procedures can result in ejection outside ejection seat performance envelope.
- If the throttle is stuck and thrust is suitable for sustained flight, attempts to free the throttle should be delayed until within gliding distance of a suitable landing field.
- Jettison stores when necessary to increase flying time available to accomplish actions designed to restore thrust.

**NOTE**

- Transfer to SEC removes stall recovery logic. If SEC is selected while the engine is stalling, a stagnation may occur.
- The ENG CONT switch should not be returned to **C** **DF** PRI, **DR** NORM after landing in an attempt to open the nozzle and decrease thrust.

If in AB or supersonic:

1. Throttle - MIL.

**CAUTION**

Retarding the throttle below MIL while supersonic may induce inlet buzz which produces severe cockpit vibration and probable engine stalls.

If thrust is low and nozzle is suspected to be failed open, damaged, or missing:

2. Refer to NOZZLE FAILURE **PW 229**, this section.

If problem still exists:

3. **C** **DF** AB RESET switch - AB RESET, then NORM.
4. Airspeed - 250 knots (if thrust is too low to sustain level flight).

If problem still exists:

5. Throttle - IDLE.
6. ANTI ICE switch - OFF.  
Stalls may be caused by the anti-ice valve failing to close at high throttle settings (above midrange).
7. Throttle - Slowly advance to minimum practical. Attempts to establish a minimum practical throttle setting that provides sufficient thrust may result in repeated stalls that clear when the throttle is retarded. Note stalled RPM/throttle position and attempt to establish a lower throttle setting that provides sufficient thrust.

If current thrust will allow a safe landing:

8. Land as soon as possible.

If suitable thrust cannot be attained or thrust is too high to permit a safe landing:

8. Throttle - Midrange.
9. ENG CONT switch - SEC.  
Transfer to SEC while supersonic should be accomplished with the throttle at MIL; if the throttle can not be retarded to MIL, transfer to SEC is permissible with the throttle in AB. Subsonic transfers to SEC below 40,000 feet MSL should be accomplished with the throttle at midrange or above.
10. Throttle - Minimum practical.

If current SEC thrust will allow a safe landing:

11. Land as soon as practical.  
During landing in SEC, idle thrust is approximately twice that in PRI.

**CAUTION**

An SFO is not recommended if engine is operating satisfactorily in SEC.

When landing is assured:

12. Throttle - Verify engine responds normally to throttle movement from IDLE to MIL; set as required.

If suitable thrust cannot be attained:

11. ENG CONT switch - **C** **DF** PRI, **DR** NORM.
12. Throttle - AB (if required to sustain level flight).
13. Land as soon as possible.

If thrust is too high to permit a safe landing:

#### NOTE

If throttle is stuck, control might be regained by depressing the cutoff release, rotating the throttle outboard, and applying necessary force.

11. Plan a flameout landing. Refer to FLAMEOUT LANDING, this section.

#### WARNING

Do not start the JFS if engine seizure has occurred or is anticipated or if engine failure is a result of fuel starvation. Starting the JFS may result in no brake/JFS accumulator pressure for the brakes.

When prepared to land (normally high key):

#### WARNING

Delaying engine shutdown can result in a long, fast landing. Wheel braking is less effective due to lack of WOW and there is an increased probability of a missed cable engagement.

12. Throttle - OFF.  
If throttle is stuck or engine does not respond, shut down the engine with the FUEL MASTER switch. At MIL, the engine flames out in approximately 6 seconds. At IDLE, the engine flames out in approximately 45 seconds.

13. Hook switch - DN (if required).

#### WARNING

The hook may miss the cable if the aircraft is not slow enough to compress the MLG struts sufficiently to make WOW or if forward stick pressure is held.

#### Nozzle Failure **PW 229**

Exhaust nozzle malfunctions and nozzle control system malfunctions can result in the nozzle being too far open or too far closed. These malfunctions can result in loss of AB capability, engine stalls, or low thrust. Separation of the nozzle assembly from the engine is also possible and results in low thrust. The ENG THST LOW PFL is displayed for failed open/missing nozzle events.

A failed closed nozzle results in normal thrust below AB and stalls when AB is attempted.

Low or insufficient thrust can be caused by a failed open, damaged, or missing nozzle or a nozzle control system malfunction. If thrust is too low to sustain level flight, turn immediately toward the nearest suitable runway and establish 250 knots. With a missing nozzle, level flight may not be possible above 8000 feet MSL.

Thrust available should increase as altitude decreases. The airspeed at which thrust required for level flight is the lowest is approximately 250 knots.

Indications of a nozzle loss are as follows:

- An initial loud bang or pop, similar to a compressor stall, but rpm is stable above 60 percent; in PRI MIL, engine rpm is approximately 5 percent lower than normal and FTIT is approximately 250°C lower than normal; fuel flow is lower than normal; the nozzle is likely indicated in the full closed position; and thrust is decreased. Malfunctions of the exhaust nozzle control system may have symptoms similar to a missing nozzle, but the nozzle may indicate full open since the nozzle actuation system is intact.
- Presence of the ENG THST LOW PFL indicates that the DEEC has detected the malfunction and has activated logic to increase the thrust available in PRI. AB is inhibited. Remain in PRI if possible, as it should provide a sufficient level of thrust while also maintaining safe engine operation.

- If level flight cannot be attained by 1000 feet above minimum safe ejection altitude or minimum safe altitude with the ENG CONT switch in PRI, select SEC. Set the throttle as required to maintain 250 knots. Continuous operation above 850°C in SEC is likely to result in catastrophic engine failure and fire in as little as 5 minutes.

If thrust is low and a failed open, damaged, or missing nozzle is suspected:

1. Throttle - MIL or below.
2. Stores - Jettison (if required).
3. Airspeed - 250 knots.

If thrust is sufficient to reach a suitable landing field:

4. Land as soon as possible. Plan a flameout landing. Refer to FLAMEOUT LANDING, this section.

If unable to reach a suitable landing field and level flight cannot be maintained by 1000 feet above minimum recommended ejection altitude or minimum safe altitude, whichever is appropriate:

5. ENG CONT switch - SEC.

#### NOTE

SEC should only be selected when it becomes apparent that sufficient thrust cannot be achieved in PRI. SEC eliminates the additional thrust and the engine protection benefits provided by the DEEC in PRI. The nozzle loss logic holds the engine in PRI for these reasons.

6. Throttle - As required to maintain 250 knots in level flight above minimum recommended ejection altitude or minimum safe altitude, whichever is appropriate.

#### WARNING

With nozzle loss, catastrophic engine failure and fire are probable with prolonged high power settings above 850°C FTIT while in SEC.



If airspeed drops below 250 knots, trade altitude to reacquire 250 knots. Do not descend below minimum recommended ejection altitude or minimum safe altitude, whichever is appropriate.

7. Land as soon as possible. Plan a flameout landing. Refer to FLAMEOUT LANDING, this section.

#### AB Blowout/Failure To Light **PW 229**

An AB blowout is indicated by the nozzle opening then closing after the throttle is advanced to AB. If an AB blowout occurs and the throttle is left in AB, the DEEC automatically recycles the AB up to three additional times (each cycle indicated by the nozzle opening and closing). An AB no-light is indicated by the nozzle failing to start open within 5 seconds of advancing the throttle to AB (nozzle remains closed or shows minimal movement). If an AB no light occurs and the throttle is left in AB, the DEEC automatically attempts to relight the AB up to 3 times. The initial attempt and 3 subsequent no lights could take up to 20 seconds. A combination of no lights and blowout recycles could take longer. If further AB attempts are required and the DEEC has completed all recycle attempts, then the throttle must be retarded to MIL or below and advanced to AB.

If the AB blowout/failure to light was not accompanied by an ENGINE FAULT caution light, flight may be continued. If an ENGINE FAULT caution light also occurred, refer to ENGINE FAULT CAUTION LIGHT **PW 229**, this section.

#### ENGINE STALLS **PW 229**

The three primary causes of a stall are inlet flow distortion, AB instabilities, and hardware malfunctions. During normal aircraft operation, inlet flow distortion severe enough to cause an engine stall is not expected. However, under some departure conditions, inlet flow distortion may induce engine stalls. Hardware-associated stalls may result from a failed nozzle, control system malfunctions, anti-ice system failed on, or FOD.

Stalls may be caused by an anti-ice valve failed in the open position at high thrust settings (throttle above midrange). The engine should be operable with this condition by limiting throttle position to midrange or below. If flight conditions permit, place the ANTI ICE switch to OFF.

The first indication of an engine stall at high thrust settings may be a loud bang or pop. At lower thrust settings, the first indication may be loss of thrust, lack of throttle response, or decreasing engine rpm. When a stall is sensed, the DEEC cancels the AB (if throttle is in AB range), opens the nozzle, and decreases fuel flow until the stall clears. FTIT and NOZ POS may fluctuate in response to the stall recovery signal. If the engine auto transfers to SEC, automatic stall recovery and overtemp protection are not available. A malfunction such as engine internal damage or primary control system failure could result in a stall, an automatic SEC transfer, and possible FTIT overtemp. Throttle reduction is appropriate as a first response to clear any engine stall.

If the engine stalls at low altitude, an immediate climb should be initiated, and stores jettison should be considered. Retarding the throttle may clear the stall. During a high thrust stall that is self recovering, there will be an immediate thrust loss. In PRI, the DEEC gradually restores thrust to the original level. If engine response at low altitude is not sufficient to maintain or gain altitude and a suitable landing field is not available, ejection may be required.

If a stall occurs at MIL or below, retarding the throttle may clear the stall. Further throttle movement should be limited to midrange or below.

#### **AB-Associated Engine Stalls** [PW 229](#)

AB-associated stalls are normally accompanied by a loud bang or pop and a series of fireballs from the engine exhaust and occasionally the engine inlet. This is followed by an erratic flame from the engine exhaust if the stall is nonrecoverable. These characteristics could be mistaken for an aircraft fire. Whenever a stall occurs while operating in AB, the DEEC automatically cancels AB and activates stall recovery. This may be accompanied by a nozzle swing to full open for a few seconds and an associated temporary reduction of thrust. The throttle should be snapped out of AB to MIL. This action usually clears the stall and restores normal operation; however, stalls may continue at MIL and can be severe. They may be characterized by bangs or pops of low intensity or engine vibrations severe enough to preclude reading engine instruments. Refer to NON-AB ENGINE STALLS [PW 229](#), this section.

#### **Non-AB Engine Stalls** [PW 229](#)

Non-AB stalls may occur if the engine is malfunctioning, particularly during throttle transients near IDLE. Non-AB stalls are often a symptom of a serious engine problem. Non-AB stalls may be inaudible; the first indication may be a lack of throttle response which may be difficult to differentiate from abnormal

engine response. However, non-AB stalls can also be severe. They may be characterized by bangs, pops, low intensity or severe engine rumble or vibration. A momentary nozzle swing to near full open may occur, causing a temporary reduction in thrust, as the DEEC activates stall recovery. An erratic orange-yellow flame from the engine exhaust may be present. This exhaust flame should not be mistaken for an engine fire. If the stall is confirmed, the throttle should be immediately retarded to IDLE which may clear the stall. Further throttle movement should be limited to midrange or below.

### **WARNING**

Prolonged engine operation with FTIT in excess of 1000°C can result in significant engine damage and may cause a nonrecoverable engine failure.

#### **Engine Stall Recovery** [PW 229](#)

If an AB stall(s) occurs:

1. Throttle - Snap to MIL.

If AB stalls do not clear or stall(s) occurs below AB:

#### **NOTE**

Non-AB stalls may be inaudible.

2. Throttle - IDLE.
3. ANTI ICE switch - OFF when conditions permit.

#### **NOTE**

Stalls may be caused by anti-ice valve failing to close at high thrust setting (throttle above midrange).

If stalls continue at idle and engine rpm is less than 60 percent with no rpm response to throttle movement:

4. Throttle - OFF. Initiate airstart. Refer to AIR-START PROCEDURES [PW 229](#), this section.

### **WARNING**

Shutting down the engine with an engine alternator failure (indicated by zero or erroneously low rpm, illuminated SEC caution light, illuminated ENGINE warning light, and normal thrust) results in no ignition for an airstart.

## T.O. GR1F-16CJ-1

If non-AB stall(s) clears:

5. Throttle - Midrange or below.  
If a non-AB stall clears, maintain throttle at midrange or below unless required to sustain flight.
6. Land as soon as possible.

If AB stall(s) clears:

2. Throttle - As required.  
If an AB stall clears, the engine is safe to operate in the IDLE to MIL range, provided no other abnormal indication is observed. Attempt further AB operation only if needed to sustain flight.

### **INLET BUZZ** PW 229

Inlet buzz occurs at supersonic airspeeds if the engine control system fails to maintain adequate engine rpm when the throttle is retarded below MIL. Inlet buzz causes moderate to severe vibration within the cockpit and probably results in multiple engine stalls.

If inlet buzz occurs, do not move the throttle until subsonic. Decrease airspeed to subsonic as quickly as possible by opening the speedbrakes and increasing g. If engine stalls occur and persist, the throttle should be retarded to IDLE when subsonic. If the stalls do not clear, the engine must be shut down and restarted.

### **ENGINE FAILURE OR FLAMEOUT** PW 229

Engine failures can result in rpm decrease with no abnormal vibration or sound (flameout), rpm decrease with abnormal vibration and/or stalls, or stable rpm with abnormal vibration and/or low thrust.

If the engine flames out, fuel starvation or mechanical failure has occurred. A flameout is indicated by decrease in FTIT and engine rpm decaying below approximately 60 percent. Loss of thrust and lack of response to throttle movement confirm the flameout. The ENGINE warning light illuminates when engine rpm is below 55 percent. Additionally, the MAIN GEN and STBY GEN lights illuminate below 45 percent rpm and the EPU should start running. Do not mistake a loss of ECS noise as an engine flameout.

If the reservoir tanks do not contain fuel, an airstart is impossible. If fuel starvation was due to a temporary lack of fuel, restart should be possible. If fuel quantities appear normal, the flameout may have been caused by fuel contamination. In this case, placing the throttle to OFF may clear the contaminated fuel and allow an airstart.

Main fuel pump failure or tower shaft geartrain failure also causes flameout. Both present similar symptoms: an abrupt decrease of indicated fuel flow to less than 500 pph; loss of main generator, standby generator, and FLCS PMG and EPU activation; no throttle response; and illumination of the SEC caution light even though the ENG CONT switch is in **C** **DF** PRI, **DR** NORM.

If only the main fuel pump has failed, the rpm indication reflects a gradual spooldown. The JFS can be started and the engine can be motored at approximately 25 percent rpm. If the SEC caution light remains on (with ENG CONT switch in **C** **DF** PRI, **DR** NORM and engine rpm at 12 percent or above), the engine probably cannot be restarted; therefore, place primary emphasis on a flameout landing while continuing airstart attempts. If unable to make a flameout landing, refer to EJECTION, this section.

### **Tower Shaft Failure** PW 229

Failure of the engine tower shaft or its associated geartrain results in loss of all rotation to the engine gearbox and the ADG. Loss of rotation to the engine gearbox renders the engine alternator, main fuel pump, and oil pump inoperative resulting in a zero rpm indication, zero oil pressure, illumination of the ENGINE warning and SEC caution lights, and engine flameout due to fuel starvation. The initial symptoms are similar to main fuel pump failure; however, the primary difference is that the rpm and oil pressure indications drop immediately to zero with a tower shaft failure since the engine alternator is not being driven. Additional symptoms caused by loss of rotation to the ADG include loss of hydraulic systems A and B, main and standby generators, and FLCS PMG and subsequent activation of the EPU. It may be possible to regain engine operation using the JFS and performing an SEC airstart. The JFS drives the ADG and the engine gearbox (through the PTO shaft), restoring rotation to both hydraulic pumps, FLCS PMG (at a reduced output), main fuel pump (SEC caution light goes off in PRI until SEC is selected), engine alternator (cockpit rpm signal, DEEC power, and engine ignition), and oil pump (oil pressure increases). Without the load of the engine, the JFS produces an rpm indication fluctuating between 30-50 percent which is the speed of the engine alternator, not the actual engine rpm. This rpm may be high enough to restore standby generator power; however, main generator power may cycle on and off line with the rpm fluctuations. If the ENG CONT switch is still in **C** **DF** PRI, **DR** NORM, the SEC caution light goes off when fuel pump pressure is restored; however, a PRI airstart is not possible since



the rpm signal to the DEEC is in error. Perform an SEC airstart. Since the JFS is not preserving rpm, maintain 250 knots minimum during the airstart attempt, which should assure adequate actual engine rpm for the airstart.

#### Low Altitude Engine Failure or Flameout **PW 229**

Refer to figures 3-7 and 3-8. Initial reaction to any malfunction at low altitude should be to trade excess airspeed for altitude. Higher altitude translates directly to either additional time to achieve an airstart or to additional glide range to reach a suitable landing field. At low airspeed, the climb may be only enough to insure a safe ejection altitude. Above 350 knots, more time is available by a zoom climb using a 3g pullup to 30-degree climb approaching the desired airspeed (use approximately 50 knots lead point) and then initiating a zero g pushover. Below 350 knots and above the minimum recommended ejection altitude, more time is available by performing a constant altitude deceleration to the desired airspeed. If below the minimum recommended ejection altitude and below 350 knots, primary concern should be to trade excess airspeed for altitude in preparation for ejection.

If required, jettison stores as soon as possible to aid in gaining or maintaining altitude and maneuver toward a suitable landing field, if available. If the zoom results in an altitude below 4000 feet AGL, there will probably be insufficient time to achieve an airstart prior to minimum recommended ejection altitude. In that case, primary consideration should be given to preparing for ejection; do not delay ejection below 2000 feet AGL. If the zoom results in an altitude between 4000-10,000 feet AGL, there is probably time for one airstart attempt prior to minimum recommended ejection altitude. This attempt shall be performed in the control mode selected by the DEEC.

If low altitude engine failure or flameout occurs:

1. Zoom.
2. Stores - Jettison (if required).  
If stores jettison is attempted after main and standby generators drop off line but before EPU generator powers the SMS (approximately 5 seconds delay), stores will not jettison.

#### NOTE

Visually confirm the stores have jettisoned and jettison again if required.

3. Perform airstart (if altitude permits). Refer to AIRSTART PROCEDURES **PW 229**, this section.

#### WARNING

Below 4000 feet AGL, there may be insufficient time to perform an airstart prior to minimum recommended ejection altitude.

#### AIRSTARTS **PW 229**

Refer to figure 3-9. Factors such as altitude, airspeed, weather, etc., must be considered in determining whether to try an airstart, accomplish a flameout landing, or eject. Jettisoning of stores reduces altitude loss during an airstart and improves glide ratio during a flameout landing.

Oil pressure is directly related to rpm. Do not confuse a low oil pressure indication due to windmilling rpm as an oil system malfunction.

If the engine seized due to an oil system malfunction or flamed out due to total fuel starvation or mechanical failure, either a flameout landing or ejection is required.

The most likely reason to perform an airstart is that the engine has shut down due to a PRI system failure or hardware failure or to clear a stall. The DEEC assesses any faults or internal failures and automatically transfers to SEC, if required. The first airstart attempt should be made in the engine control mode selected by the DEEC except when a tower shaft failure is suspected it shall be performed in SEC. Procedures for SEC and PRI airstarts are identical except for ENG CONT switch position and JFS assist minimum airspeed requirements.

There are two airstart options available. One option is a spooldown airstart, for which the throttle is advanced from OFF to midrange as rpm is decreasing. There is no specific envelope within which a spooldown airstart should be initiated, but once the decision to perform an airstart is made, airspeed should be adjusted to maintain 250-400 knots/0.9 mach. The secondary option is a JFS-assisted airstart which differs from a spooldown airstart in that once the JFS RUN light is on and PRI mode is confirmed, airspeed can be reduced to achieve maximum range or maximum endurance ( **C** 200 or 170, **D** 205 or 175 knots respectively, plus 5 knots per 1000 pounds of fuel/store weights and plus 5 knots if CFT's are installed). The minimum airspeed for PRI JFS-assisted airstarts is 170 knots. The minimum airspeed for all SEC airstarts, including JFS assisted, is 250 knots.

# Low Altitude Zoom Capability

DATA BASIS ESTIMATED

ENGINE F100-PW-229

### CONFIGURATION:

- GW = 23,000-25,000 LB
- DI = 0-50
- LG - UP

### CONDITIONS:

- WINDMILLING OR SEIZED ENGINE
- 30-DEGREE CLIMB MAINTAINED TO 170/250 KIAS

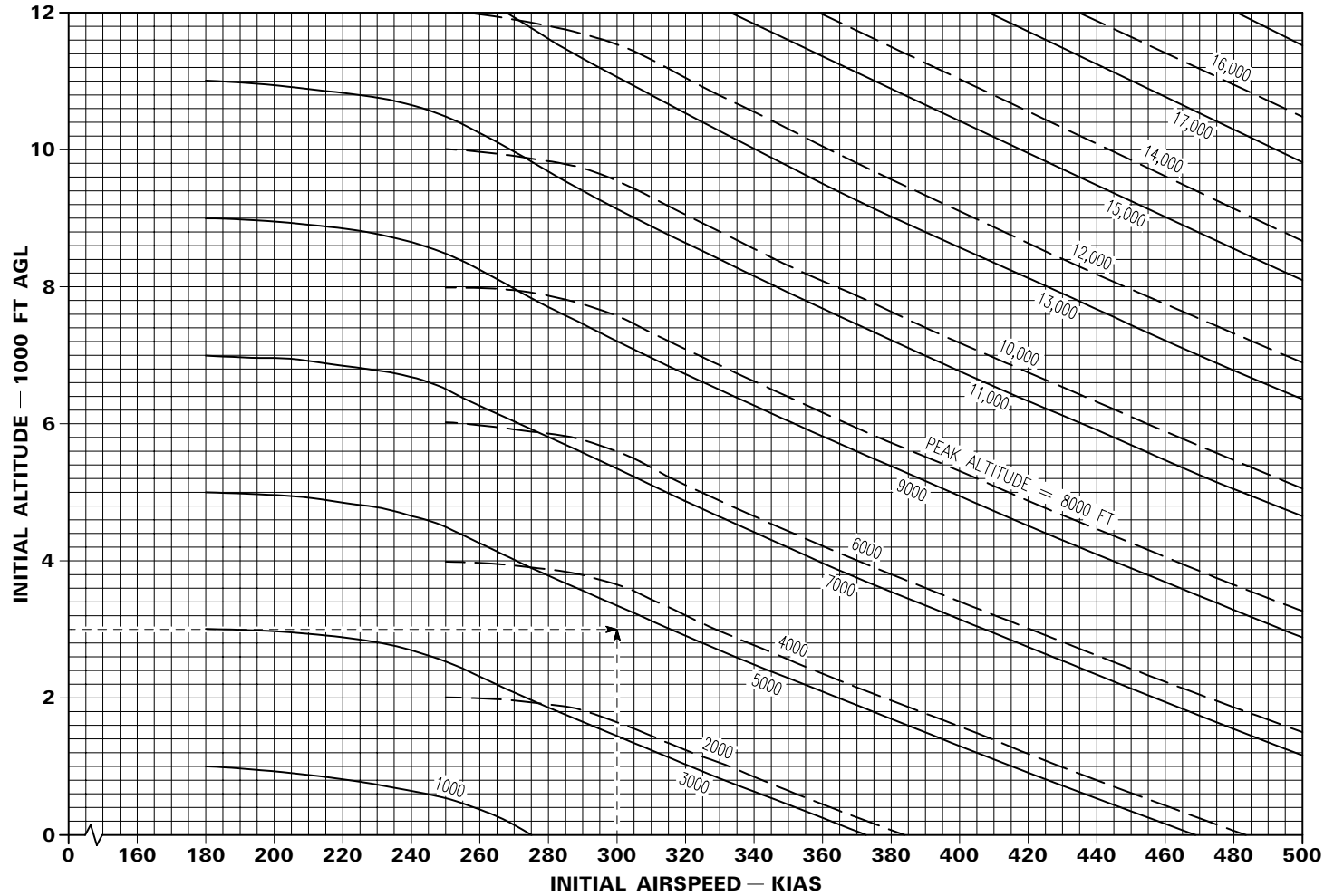

1F-16X-1-4028X ©

Figure 3-7.

# Low Altitude Airstart Capability

DATA BASIS ESTIMATED

ENGINE F100-PW-229

## CONFIGURATION:

- GW = 23,000-25,000 LB
- DI = 0-50
- LG — UP

## CONDITIONS:

- 30° DIVE TO DESCENT KIAS OR 3G PULLUP TO 30° ZOOM CLIMB TO 30° ZOOM CLIMB INITIATED FROM THE AIRSPEED/ALTITUDE EXISTING AT FIRST RECOGNITION OF ENGINE FAILURE (60 PERCENT RPM)
- AIRSTART INITIATED AT START OF DIVE OR ZOOM

- 60 SECONDS ASSUMED AFTER THROTTLE ADVANCE TO ACHIEVE USABLE THRUST
- DESCENT AIRSPEED IS 250 KIAS (JFS RUN LIGHT ON)

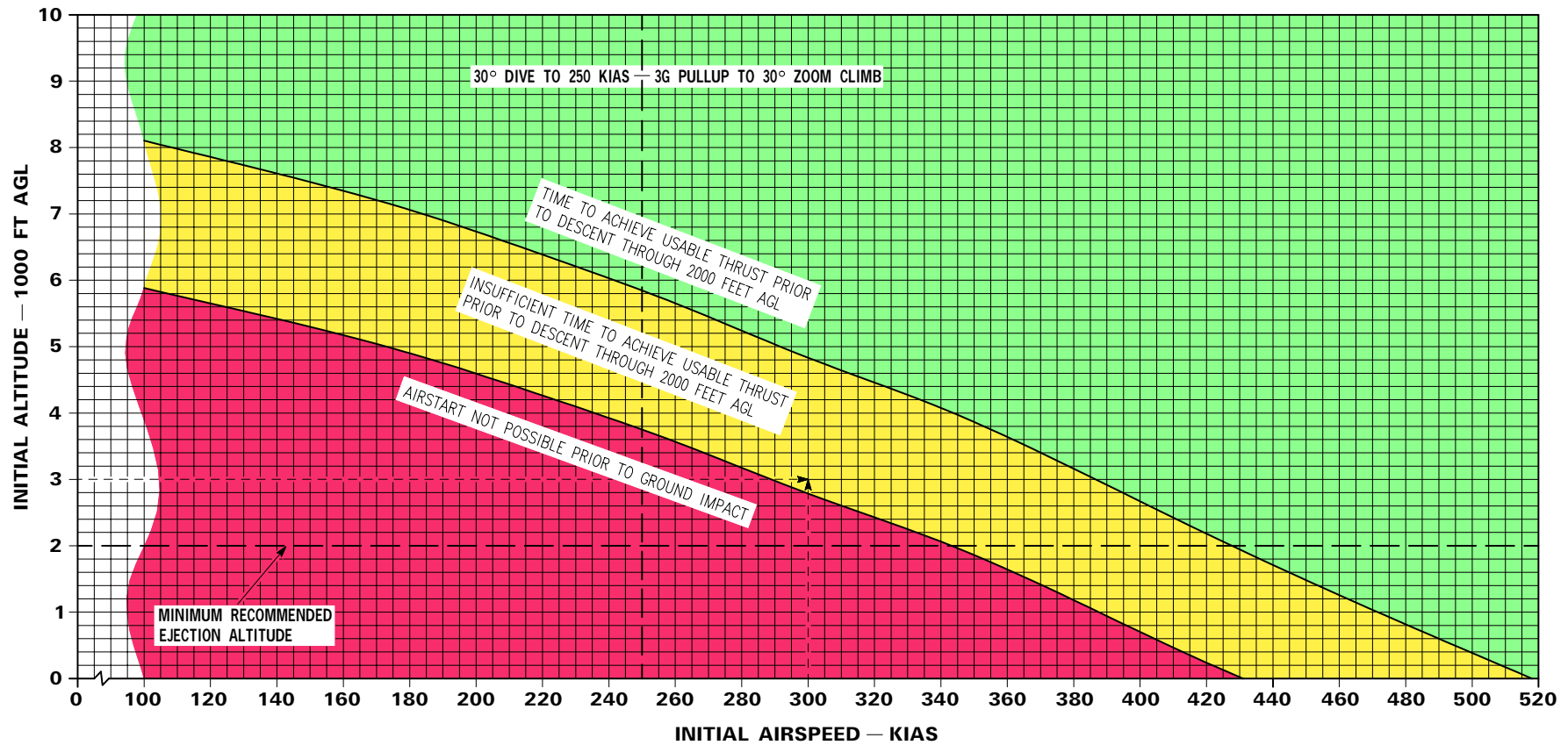

GR1F-16CJ-1-1120X37®

Figure 3-8.

# Engine RPM and FTIT Response During Spooldown and Airstart

ENGINE F100-PW-229

**CONDITIONS:**

- DRAG INDEX = 0
- KIAS = 250
- GW = 20,000 LB
- NO WIND

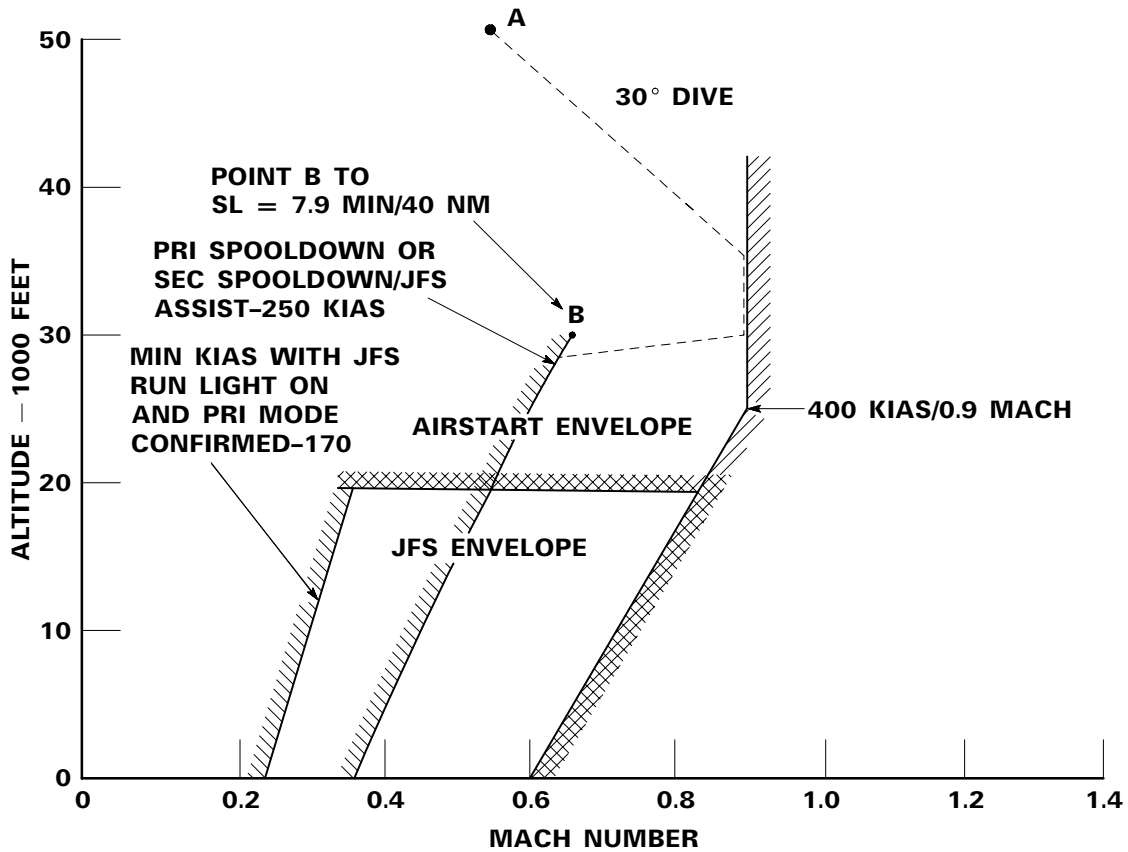

**OPTIMUM FLIGHT PATH DURING AN AIRSTART (TYPICAL)**

Engine out descent flight path maintains the aircraft in the required airstart envelope. A 30-degree dive to 400 KIAS/0.9 mach is used to quickly reduce altitude to below 30,000 feet where airspeed can be reduced to 250 KIAS (Point A to B).

1F-16X-1-1039A ©

Figure 3-9. (Sheet 1)

# Engine RPM and FTIT Response During Spooldown and Airstart

ENGINE F100-PW-229

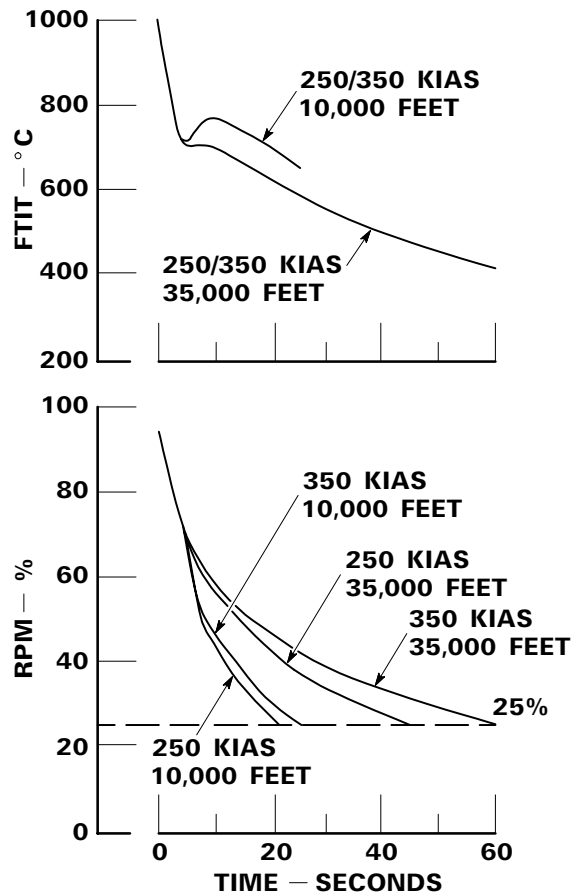

## RATE OF ENGINE RPM AND FTIT DECAY AS A FUNCTION OF ALTITUDE AND AIRSPEED

At low altitude, regardless of airspeed, the spooldown rate is rapid. Spooldown rate is slower at higher altitudes as airspeed is increased.

1F-16X-1-1040X®

Figure 3-9. (Sheet 2)

# Engine RPM and FTIT Response During Spooldown and Airstart

ENGINE F100-PW-229

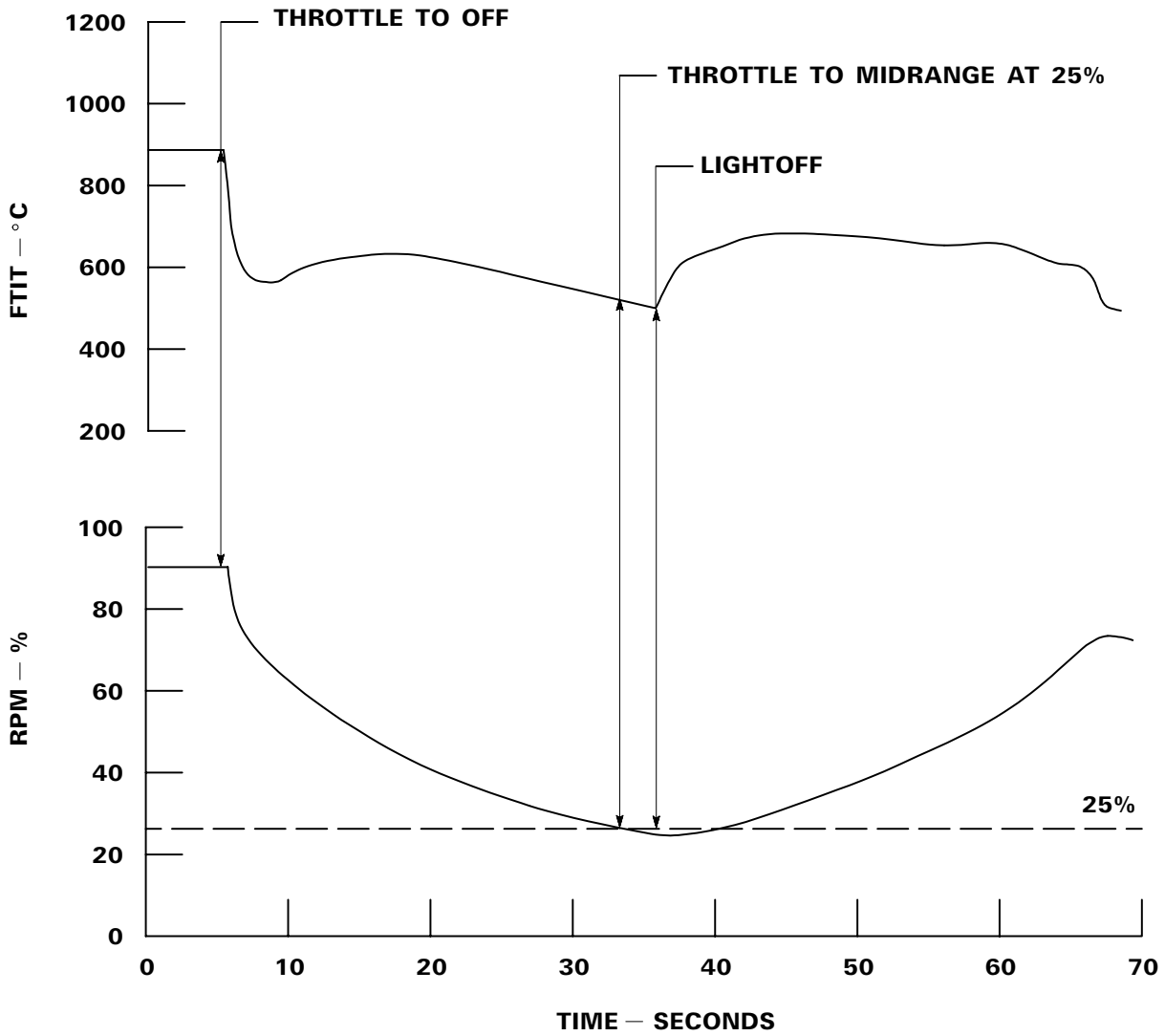

**NORMAL 25 PERCENT SPOOLDOWN AIRSTART ENGINE RPM AND FTIT TIME TRACES FOR 250 KIAS/20,000 FEET**

Light-off normally occurs within 5 seconds after the throttle is advanced to midrange. However, engine rpm and FTIT turnaround are slow, making light-off subtle or difficult to detect. Engine rpm stabilizes momentarily after light-off and FTIT may increase, stabilize, or decrease as the engine rpm increases.

1F-16X-1-1041X®

Figure 3-9. (Sheet 3)

# Engine RPM and FTIT Response During Spooldown and Airstart

ENGINE F100-PW-229

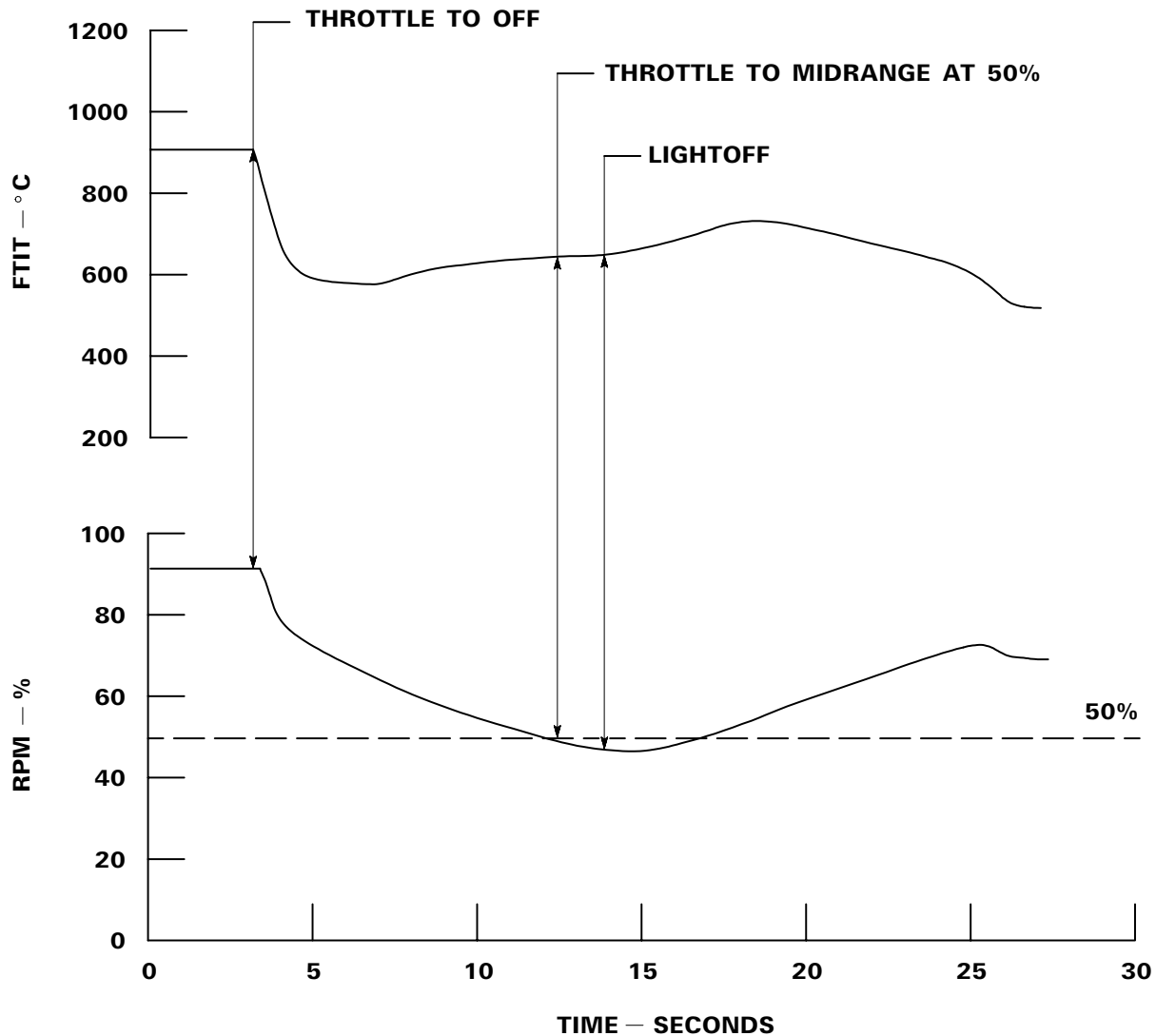

## NORMAL 50 PERCENT SPOOLDOWN AIRSTART ENGINE RPM AND FTIT TIME TRACES FOR 250 KIAS/20,000 FEET

Light-off normally occurs within 5 seconds after the throttle is advanced to midrange. However, engine rpm and FTIT turnaround are slow, making light-off subtle or difficult to detect. Engine rpm stabilizes momentarily after light-off and FTIT may increase, stabilize, or decrease as the engine rpm increases.

1F-16X-1-1042X®

Figure 3-9. (Sheet 4)

**NOTE**

- In most cases, the JFS will engage and begin to arrest rpm spooldown rate at approximately 30 percent. Engine rpm should stabilize on the JFS at a minimum of 22 percent.
- PRI operation is confirmed by SEC caution light not illuminated.

There are critical requirements which apply to any airstart attempt. The most important is engine rpm. High engine rpm provides the best chance of a successful restart. Therefore, do not delay the initiation of an airstart in an attempt to reach a particular flight condition. Initiate an airstart as soon as it becomes apparent that engine rpm has decayed below in-flight idle (approximately 60 percent rpm). Illumination of the ENGINE warning light, engine instrument indications, and no response to throttle movement can help confirm a flameout. The best conditions for an airstart are at 30,000 feet MSL or below, 250 knots or more, and high rpm. In general, the success of an airstart is increased with higher engine rpm, lower altitude, and higher airspeed.

The throttle should always be advanced to midrange before 25 percent rpm regardless of FTIT, altitude, airspeed, JFS assistance, or engine control mode to prevent rpm decreasing below 12 percent. If rpm decreases below 12 percent, fuel flow from the main fuel pump and ignition power from the engine alternator are lost allowing a further decrease in rpm. As much as 350 knots or more is required to prevent rpm from decreasing below 12 percent. If rpm is allowed to decrease to near zero, 400 knots or more may be required to regain 12 percent. This requires a great amount of altitude which may not be available. If rpm decreases to zero, a seized rotor may occur, due to temporary engine thermal conditions, after which it will not rotate even with high airspeeds or by engaging the JFS. In general, rpm decay rate can be decreased by increasing airspeed; however, below 30,000 feet MSL, higher airspeeds do not significantly affect the rpm decay. Therefore, maintain 250 knots below 30,000 feet MSL for spooldown airstarts. This airspeed does not maintain rpm above 12 percent; however, it does the best tradeoff between the rate of rpm spooldown and loss of altitude.

Stabilizing or increasing rpm is normally the first indication of an engine light-off. Light-off normally occurs within 5 seconds after advancing the throttle.

However, rpm turnaround is slow, making light-off subtle and difficult to detect. FTIT response is slow and may reverse trend one or more times during the start sequence. Neither condition should be confused with a hung start.

DEEC overtemperature protection logic attempts to limit FTIT to 870°C, which may result in decreasing, hung, or slowly increasing engine rpm. If a hung start occurs (stabilized FTIT 870°C or less, rpm stabilized below 60 percent), increase airspeed to a maximum of 400 knots/0.9 mach if altitude allows. If hung start continues or there is no throttle response, reinitiate the airstart with the ENG CONT switch in SEC when below 30,000 feet MSL.

During an SEC start, 45-60 seconds is required for engine light-off and acceleration to midrange from the time the throttle is advanced from OFF.

If a SEC airstart is initiated at high RPM (above 40 percent), as much as 30 seconds following throttle advancement may be required for RPM to stabilize or begin to increase, indicating a successful light. This slow engine response should not be confused with a no-light response in which case RPM would continue to decrease.

SEC airstarts initiated at lower RPM show positive RPM turnaround within 15 seconds of placing throttle to midrange. RPM continuing to decrease after 15 seconds from throttle advancement or stabilizing at a minimum of 22 percent with the JFS RUN light on, indicates a no-light has occurred.

**High Altitude Airstart Considerations** **PW 229**

Refer to figure 3-9. At 30,000 feet MSL and above, the airstart (PRI or SEC) should be initiated by retarding the throttle to OFF then advancing to midrange as soon as possible regardless of FTIT or airspeed. Always advance the throttle to midrange by 25 percent engine rpm. Dive to obtain 400 knots/0.9 mach to minimize rpm spooldown rate and quickly decrease altitude to less than 30,000 feet MSL. If light-off indications are not noted within 20 seconds in PRI or 30 seconds in SEC after advancing the throttle, or if FTIT exceeds 870°C, retard the throttle to OFF and reinitiate the airstart with the ENG CONT switch in **C** **DF** PRI, **DR** NORM, regardless of which control mode the engine is presently in. If a hung start occurs (rpm stable with FTIT stable at 870°C or less), keep the throttle at midrange until below 30,000 MSL then reinitiate the airstart with the ENG CONT switch in SEC.



At high altitudes, the dive should be at approximately 30 degrees to gain or maintain 250 knots below 30,000 feet. Once established, approximately 5-10 degrees of dive should maintain airspeed. Note that airspeed should not be reduced to less than 250 knots until the JFS RUN light is on, and PRI mode is confirmed. Unless an airstart is obviously impossible (total lack of fuel, engine seizure, etc.), do not become tempted to establish a maximum range or maximum endurance glide. The first consideration should be an immediate spooldown airstart attempt even if the engine failed for no apparent reason. If airstart airspeed is not maintained, rpm decreases at a faster rate. The only airstart option available is then a JFS-assisted airstart. Time constraints due to EPU fuel consumption must be considered. A maximum range or maximum endurance glide from above approximately 35,000 feet may exhaust EPU fuel prior to landing. (Refer to T.O. GR1F-16CJ-1-1, figure A6-3.)

The reason for most airstart failures above 30,000 feet MSL is the engine inability to light off and not due to the DEEC's inability to control the start. Therefore, all second airstart attempts above 30,000 feet MSL should be made with the ENG CONT switch in **C** **DF** PRI, **DR** NORM. The engine does not have a light-off problem below 30,000 feet; therefore, all second airstart attempts below 30,000 feet MSL should be made with the ENG CONT switch in SEC.

When below 20,000 feet MSL, select JFS START 2. Activating the JFS above 20,000 feet is prohibited since successful JFS start/motoring of engine is unlikely and the brake/JFS accumulators will be depleted. If the JFS RUN light is on and PRI mode is confirmed, airspeed may be reduced to achieve maximum range or maximum endurance. If the JFS RUN light is on and SEC mode is confirmed, maintain 250 knots minimum. With the JFS running, EPU fuel consumption is also reduced.

#### **Low Altitude Airstart Considerations** **PW 229**

Due to the limited time available and the rapid rpm spooldown rate at low altitude, some additional considerations are required. Below approximately 10,000 feet MSL, rpm decreases rapidly regardless of airspeed and remains between 50-25 percent for only 5-10 seconds; therefore, rpm should be closely monitored. Advance the throttle to initiate the airstart before rpm goes below 25 percent regardless of FTIT indication. This action should insure that light-off occurs prior to 12 percent rpm. Start the JFS immediately after advancing the throttle (if airspeed is below 400 knots).

Following a zoom climb, plan to arrive at 250 knots. Airspeed may be reduced to achieve maximum range or maximum endurance (200 or 170 knots, respectively) only if PRI mode is confirmed and the JFS RUN light is on. If SEC mode is confirmed or tower shaft failure is suspected, maintain 250 knots minimum. If a higher airspeed is maintained or an attempt is made to gain airspeed to delay the rpm decay, available time may be reduced to the point that an airstart is not possible. During any low altitude airstart attempt, constantly evaluate altitude above the ground relative to airstart success. Do not delay ejection below 2000 feet AGL unless the engine is producing thrust capable of maintaining level flight or safely controlling the sink rate or unless a flameout landing can be accomplished.

#### **Airstart Procedures** **PW 229**

To perform an airstart, retard throttle to OFF, then advance throttle to midrange.

#### **NOTE**

If the throttle is retarded to OFF to clear a stall, it should be maintained in OFF for a few seconds to allow the stall to clear.

Start the JFS below 20,000 feet MSL and below 400 knots immediately after the throttle is advanced to midrange to initiate the spooldown airstart.

If the JFS stops running or fails to run within 30 seconds, do not reattempt a JFS start until the brake/JFS accumulators have time to recharge. Allow 1 minute of engine rotation (either windmilling or JFS assisted) at 12 percent rpm or above to insure that the brake/JFS accumulators are fully recharged. Recharging begins 3-4 seconds before the JFS RUN light illuminates or 30 seconds after selecting a start position (in the event of a JFS failure to run). Recharging begins regardless of JFS switch position.

In the event of a JFS shutdown, the JFS switch does not relatch in either start position while the JFS is spooling down. Spooldown from full governed speed takes approximately 17 seconds. The JFS switch must be cycled to OFF and then to START 2 to reinitiate a JFS start. It is possible to complete the spooldown before the brake/JFS accumulators are recharged if the JFS ran for only a short time.

When the airstart is completed, turn the JFS off (if tower shaft failure is not suspected). Reset the main generator using the ELEC CAUTION RESET button and verify MAIN GEN and STBY GEN lights are off. Cycle the EPU switch to OFF, then back to NORM.

**WARNING**

With engine failure or flameout, OBOGS is inoperative. Activate EOS if OXY LOW warning light illuminates above 10,000 feet cockpit altitude.

To accomplish an airstart:

1. Throttle - OFF, then midrange.

**NOTE**

FTIT will decrease rapidly when throttle is OFF.

2. Airspeed - As required.  
Above 30,000 feet MSL, dive at 400 knots/0.9 mach. Below 30,000 feet MSL, establish approximately 250 knots. When below 20,000 feet MSL with the JFS RUN light on and PRI mode confirmed, airspeed can be reduced to achieve maximum range or maximum endurance (☐ 200 or 170, ☐ 205 or 175 knots, respectively, plus 5 knots per 1000 pounds of fuel/store weights and plus 5 knots if CFT's are installed).

**NOTE**

If maximum gliding range is not a factor, consider maintaining 250 knots above 10,000 feet AGL to reduce rpm spooldown rate (in case of JFS failure). Below 10,000 feet AGL with the JFS RUN light on and PRI mode confirmed, maintain maximum range or maximum endurance airspeed.

3. JFS switch - START 2 below 20,000 feet MSL and below 400 knots.

**NOTE**

- If the JFS switch is erroneously placed to START 1, leave it there.
- If the JFS RUN light does not illuminate or goes off once illuminated, place the JFS switch to OFF and reattempt START 2 when the brake/JFS accumulators are recharged. The JFS switch does not relatch in either start position while the JFS is spooling down.

4. Stores - Jettison (if required).  
If stores jettison is attempted after main generator drops off line but before EPU generator powers the SMS (approximately 5 seconds delay), stores will not jettison.

**NOTE**

Visually confirm the stores have jettisoned and jettison again if required.

If a no light, hot start, or stall occurs:

5. Throttle - OFF.
6. ENG CONT switch - SEC if below 30,000 feet MSL (250 knots minimum).

**NOTE**

- Place the ENG CONT switch to SEC prior to placing the throttle to midrange, otherwise a start anomaly may result.
- The proximity of the ENG CONT switch to the JFS switch makes the JFS switch susceptible to being bumped to OFF when selecting SEC.

7. Throttle - Midrange.

If a hung start occurs:

8. Airspeed - Increase (maximum of 400 knots/0.9 mach).

If hung start continues or there is no throttle response:

9. Throttle - OFF when below 30,000 feet MSL.
10. ENG CONT switch - SEC (250 knots minimum).

**NOTE**

- Place the ENG CONT switch to SEC prior to placing the throttle to midrange, otherwise a start anomaly may result.
- The proximity of the ENG CONT switch to the JFS switch makes the JFS switch susceptible to being bumped to OFF when selecting SEC.

11. Throttle - Midrange.

If engine does not respond normally after airstart is completed:

12. Refer to FLAMEOUT LANDING, this section.

If engine responds normally:



Do not turn JFS or EPU off if indicated rpm is below 60 percent with adequate thrust (e.g., tower shaft failure).

12. JFS switch - OFF.
13. ELEC CAUTION RESET button - Depress.  
Verify MAIN GEN and STBY GEN lights are off.
14. EPU switch - OFF, then NORM.
15. ADI - Check for presence of OFF and/or AUX warning flags.  
If warning flag(s) is in view, refer to EGI FAILURE, this section.
16. Throttle - As required.

#### NOTE

If the SEC caution light is on, refer to SEC CAUTION LIGHT, this section.

17. Land as soon as possible.
18. Refer to ACTIVATED EPU/HYDRAZINE LEAK, this section.

#### ENGINE MALFUNCTIONS GE129

The EMS compares expected versus actual engine operation. The purpose of the EMS MFL is to provide maintenance personnel with an early indication of an engine condition which requires correction. No action is required for an engine MFL at anytime during a flight.

Low altitude, for engine malfunction purposes, is generally defined as 10,000 feet AGL or below. If an engine malfunction is suspected, the initial reaction should be to trade excess airspeed for altitude. Unless a suitable airfield is within gliding distance, turns should be avoided as they decrease the amount of time/altitude available to successfully recover engine performance or prepare for ejection. Optimizing the exchange of airspeed for altitude must be a priority action for any engine malfunction. Above 310 knots, more time is available by performing a zoom climb using a 3g pullup to 30-degree climb until approaching the desired airspeed (use approximately 50 knots lead point) and then initiating a zero-g pushover. Below 310 knots and above the minimum

recommended ejection altitude, more time is available by performing a constant altitude deceleration to the desired airspeed. If below the minimum recommended ejection altitude and below 310 knots, primary concern should be to trade excess airspeed for altitude in preparation for ejection. If appropriate, jettison stores as soon as possible.

For any situation where automatic activation of the EPU is relied upon, verify that the EPU run light is on to insure that the EPU has started. If the EPU run light is off, position the EPU switch to ON.

SEC is a highly reliable backup engine operating mode. However, in certain circumstances the engine may malfunction in SEC following an auto transfer, or continue to malfunction in SEC following a manual transfer. Returning to PRI may result in proper engine response, due to either the resetting of internal hydromechanical control pressures or to the resetting of digital engine control logic.

Idle thrust in SEC during ground operation is approximately twice that in PRI. After landing in SEC, consider minimizing taxi distance and consider following HOT BRAKES procedures, this section.

#### Engine Fire GE129

Generally, the first indication of fire in the engine compartment is the ENG FIRE warning light. Abnormal fuel indications (quantity/flow) may also be present. FTIT probably will not be higher than normal. Explosions, vibrations, or engine instrument fluctuations are usually indicative of a serious engine problem; engine failure may be imminent. Immediate action should be taken to reduce thrust to the minimum practical level after attaining safe ejection parameters. If within gliding distance of a suitable runway, consider shutting the engine down. Sufficient time should exist to analyze the situation and make an ejection versus land decision. The ejection decision should be based on visual and/or cockpit indications that the fire is persisting. Cockpit indications include continued illumination of the ENG FIRE warning light and subsequent FLCS malfunctions/degraded flight controls or subsequent loss of either hydraulic system.

Fires can also occur in the nozzle area when using AB. These fires are the result of portions of the nozzle failing which allows the AB plume to burn through the nozzle. Ventilation should inhibit forward movement of the fire into and through the engine bay. Since these fires are aft of the detection circuit, the ENG FIRE warning light will not illuminate. Additionally, the nozzle position indications are normal, and there are no vibrations or instrument fluctuations. In most cases, these AB-related nozzle

T.O. GR1F-16CJ-1

fires are detected by someone outside the aircraft (wingman, tower, etc.). When operating in AB and a fire is reported at the rear of the aircraft, retard throttle below AB immediately. This action should extinguish a nozzle fire within approximately 30-45 seconds and minimize damage to the aircraft skin, speedbrakes, nozzle, and flight controls; however, nozzle damage may result in a noticeable thrust loss.

If on takeoff and the conditions permit:

1. Abort.

If takeoff is continued:

1. Climb.  
Maintain takeoff thrust until minimum recommended ejection altitude is attained and then throttle to minimum practical.
2. Stores - Jettison (if required).

At a safe altitude:

3. Throttle - Minimum practical.  
If fire occurred in AB, ENG FIRE warning light may not illuminate. Fire should extinguish after throttle is retarded; however, nozzle damage may result in lower than normal thrust.

If ENG FIRE warning light goes off:

4. FIRE & OHEAT DETECT button - Depress.  
Determine if fire detection circuit is functional.

If fire persists:

5. Eject.

If fire indications cease:

5. Land as soon as possible.

**OVERHEAT Caution Light** GE129

Detection of an overheat condition in the engine compartment, ECS bay, MLG wheel wells, or EPU bay illuminates the OVERHEAT caution light. Accomplish as many of the following as required to extinguish the light. If the light goes off, verify the integrity of the detection circuit by depressing the FIRE & OHEAT DETECT button and land as soon as possible.

If OVERHEAT caution light illuminates:

1. Throttle - Minimum practical.

2. FIRE & OHEAT DETECT button - Depress.  
Determine if fire detection circuit is functional.

If OVERHEAT caution light remains on (or detect circuit checks bad) and EPU is running:

3. EPU switch - OFF (if feasible).  
If the EPU was manually turned on, consider turning it off to determine if it is the source of the overheat condition. If the OVERHEAT caution light remains on, the EPU should be turned back on.

If OVERHEAT caution light remains on (or detect circuit checks bad):

4. OXYGEN - 100%.
5. AIR SOURCE knob - OFF.  
External fuel cannot be transferred in OFF or RAM. Consider jettisoning tanks to decrease drag if range is critical and the ECS cannot be turned on for short periods of time to transfer fuel.

**WARNING**

With the ECS shut down or the AIR SOURCE knob in OFF or RAM, the g-suit does not inflate and PBG is disabled.

6. Descend to below 25,000 feet and reduce airspeed to below 500 knots.

When airspeed is reduced and cockpit is depressurized:

7. AIR SOURCE knob - RAM (below 25,000 feet).  
External fuel cannot be transferred in OFF or RAM. Consider jettisoning tanks to decrease drag if range is critical and the ECS cannot be turned on for short periods of time to transfer fuel.

**WARNING**

With the ECS shut down or the AIR SOURCE knob in OFF or RAM, the g-suit does not inflate and PBG is disabled.

8. Nonessential electrical equipment - Off.

**NOTE**

If in VMC and the ADI and HSI are not required for flight, the INS should be considered nonessential.

If OVERHEAT caution light still remains on (or detect circuit checks bad):

9. TANK INERTING switch - TANK INERTING even if Halon is not available.
10. LG handle - DN (300 knots/0.65 mach maximum). (Use DN LOCK REL button if required.)

### WARNING

If LG handle does not lower, select BRAKES CHAN 2 and position ALT FLAPS switch to EXTEND.

11. Land as soon as possible.

### Oil System Malfunction GE129

An oil system malfunction may be indicated by the EMS, the OIL pressure indicator, the NOZ POS indicator, and the HYD/OIL PRESS warning light.

An oil system malfunction is characterized by a pressure (including fluctuations) below 15 psi at IDLE or 25 psi at MIL, pressure above 65 psi at any throttle setting, pressure fluctuations greater than  $\pm 5$  psi, or continuous presence of the ENG LUBE LOW PFL.

Engine oil level decreasing below approximately 40 percent of normal capacity for 15 seconds results in activation of an ENG LUBE LOW PFL. Further oil level decrease may cause the exhaust nozzle to fail to an aerodynamically balanced position and there may be a decrease in thrust and a larger than normal NOZ POS indication. The HYD/OIL PRESS warning light may not illuminate until most of the usable oil is lost.

### NOTE

An ENG LUBE LOW PFL can occur as the result of sustained longitudinal acceleration during takeoff or during other maneuvering.

High airspeeds (especially at low altitude), high throttle settings, and/or throttle movements are undesirable when oil pressure is abnormally low.

Initial reaction to an oil system malfunction at low altitude should be to gain altitude and, if oil pressure is low, reduce airspeed. If oil pressure is 10 psi or above, consider using MIL or AB thrust to quickly attain desired cruise altitude. If oil pressure is below 10 psi, increase altitude and reduce airspeed by

performing a fixed throttle climb. If the altitude gained is insufficient for a safe cruise, a slow throttle advance followed by a slow throttle reduction, when at a sufficient cruise altitude, may be performed. Do not make subsequent throttle movements unless required to sustain flight.

Anticipate engine seizure approximately 5 minutes after oil pressure drops below 10 psi. Use minimal throttle movement and reduced thrust settings to maximize time. Minimize maneuvering g to minimize loads. Plan an approach which allows a flameout landing from any position should engine seize. Refer to SIMULATED FLAMEOUT (SFO) LANDING and FLAMEOUT LANDING, this section.

The EPU should be manually activated if engine seizure is anticipated (i.e., oil pressure decreases below 10 psi); otherwise, if the EPU does not start automatically when the engine seizes, the short time remaining before loss of control may be inadequate for recognition of the EPU failure and corrective action. Monitor hydrazine use after activating the EPU. If consumption rate is too high, cycle EPU switch to OFF, then NORM to conserve hydrazine. Be prepared to place the EPU switch back to ON if the engine seizes.

If an oil system malfunction is suspected:

1. Range - Maximize.
  - If oil pressure is 10 psi or above and the nearest suitable airfield is not within gliding distance, consider using MIL or AB thrust to quickly gain altitude and/or decrease distance to the nearest suitable airfield. If oil pressure is below 10 psi, attain desired cruise conditions using minimum throttle movement and then slowly retard to the minimum setting required.

### CAUTION

- When oil pressure is below 10 psi, throttle movement, high throttle settings, or high airspeeds may accelerate or cause engine seizure.
  - Do not start the JFS if engine seizure has occurred or is anticipated. Starting the JFS may result in no brake/JFS accumulator pressure for the brakes.
2. Plan to land at the nearest suitable airfield.
 

If oil pressure is low (with or without an ENG LUBE LOW PFL):
  3. Stores - Jettison (if required).

T.O. GR1F-16CJ-1

4. EPU switch - ON, if oil pressure decreases below 10 psi.  
Monitor hydrazine use. If consumption rate is too high, cycle EPU switch to OFF, then NORM to conserve hydrazine. Be prepared to place EPU switch back to ON if the engine seizes.

5. Land as soon as possible.  
Plan to fly an SFO. Refer to SIMULATED FLAMEOUT (SFO) LANDING and FLAMEOUT LANDING, this section.

6. Refer to ACTIVATED EPU/HYDRAZINE LEAK, this section.

If oil pressure is fluctuating or high (without an ENG LUBE LOW PFL):

3. Land as soon as practical at the nearest suitable airfield.

If oil pressure is normal and ENG LUBE LOW PFL occurred:

3. **C DF** F-ACK, **DR** FAULT ACK button - Depress to acknowledge fault.

4. Turn toward the nearest suitable airfield.

5. Maintain straight, level, and unaccelerated flight for 15 seconds.

6. **C DF** F-ACK, **DR** FAULT ACK button - Depress for fault recall.

Presence of an ENG LUBE LOW PFL after 15 seconds of straight, level, and unaccelerated flight is a valid indication of low oil quantity.

If ENG LUBE LOW PFL was not present during fault recall:

7. Land as soon as practical at the nearest suitable airfield.

If ENG LUBE LOW PFL was present during fault recall or recurs after fault recall:

8. Stores - Jettison (if required).

9. EPU switch - ON, if oil pressure decreases below 10 psi.

Monitor hydrazine use. If consumption rate is too high, cycle EPU switch to OFF, then NORM to conserve hydrazine. Be prepared to place EPU switch back to ON if the engine seizes.

10. Land as soon as possible.  
Plan to fly an SFO. Refer to SIMULATED FLAMEOUT (SFO) LANDING and FLAMEOUT LANDING, this section.

11. Refer to ACTIVATED EPU/HYDRAZINE LEAK, this section.

**ENGINE FAULT Caution Light GE129**

Illumination of the ENGINE FAULT caution light indicates that an engine PFL item was detected.

If ENGINE FAULT caution light illuminates:

1. PFLD - Note PFL(s) displayed.

2. **C DF** F-ACK, **DR** FAULT ACK button - Depress to acknowledge fault.

3. Refer to PILOT FAULT LIST - ENGINE, this section.

4. **C DF** F-ACK, **DR** FAULT ACK button - Depress to perform fault recall.

The failure condition no longer exists if the PFL is not present during the fault recall.

**SEC Caution Light GE129**

Illumination of the SEC caution light indicates that the engine is operating in SEC. If the ENG CONT switch is in **C DF** PRI, **DR** NORM and the SEC caution light illuminates, an automatic transfer to SEC has likely occurred. Normal SEC operation is characterized by the SEC caution light, a fixed closed exhaust nozzle, and AB unavailable. The ENG CONT switch does not have to be positioned to SEC.

**NOTE**

If the rpm indication is also zero, the engine alternator has failed.

There are no throttle restrictions while operating subsonic in SEC. If supersonic when transfer to SEC occurs, the throttle must remain at MIL or above until subsonic.

The thrust level at MIL, while operating in SEC, is 70-95 percent of that provided (for the same throttle position and flight condition) in PRI. During landing in SEC, idle thrust is approximately twice that in PRI with a normal nozzle because the nozzle is closed.

A throttle cable internal failure or a throttle linkage disconnect results in an automatic transfer to SEC; however, control of the engine with a failed throttle cable or linkage disconnect is not possible in SEC. In SEC, a throttle cable internal failure is characterized by a possible rpm increase but no decrease with throttle movements; a linkage disconnect results in no response to throttle movements. In this situation, control of the engine at idle and above can be regained in PRI by cycling the ENG CONT switch to SEC, then back to **C** **DF** PRI, **DR** NORM. The engine logic for this failure is such that the engine remains in PRI after cycling the ENG CONT switch. After landing, shutdown of the engine must be accomplished either with the FUEL MASTER switch or maintenance personnel action to position the MEC throttle input shaft to off.

If SEC caution light illuminates when supersonic:

1. Throttle - Do not retard below MIL until subsonic.



Retarding throttle below MIL while supersonic may induce inlet buzz which produces severe cockpit vibration and probable engine stalls.

When subsonic or if SEC caution light illuminates when subsonic:

2. Throttle - Verify engine responds normally to throttle movement from IDLE to MIL; set as desired.  
AB operation is inhibited and exhaust nozzle is closed.

If the engine is operating normally in SEC:

3. ENG CONT switch - Do not cycle.  
The switch may remain in PRI or may be placed to SEC. If the switch is placed to SEC, do not place switch back to PRI.

### **WARNING**

Cycling the ENG CONT switch in an attempt to regain PRI may result in reoccurrence of the original malfunction or a more severe condition.

4. Land as soon as practical.  
During landing in SEC, idle thrust is approximately twice that in PRI with a normal nozzle.

If the engine is operating abnormally in SEC:

**WARNING**

Failure to monitor sink rate and height above terrain while applying low thrust recovery procedures can result in ejection outside ejection seat performance envelope.

3. ENG CONT switch - Position to SEC, then back to **C** **DF** PRI, **DR** NORM.
4. Airspeed - 250 knots (If thrust is too low to sustain level flight).
5. Land as soon as possible.

**NOTE**

A broken throttle cable or throttle linkage disconnect causes a transfer to SEC and abnormal engine response in SEC. Reselecting PRI restores normal engine operation for flight; however, engine shutdown after flight requires either use of the FUEL MASTER switch or maintenance personnel action to position the MEC throttle input shaft to off.

If thrust is too high to permit a safe landing:

**NOTE**

If throttle is stuck, control might be regained by depressing the cutoff release, rotating the throttle outboard, and applying necessary force.

6. Plan a flameout landing. Refer to FLAMEOUT LANDING, this section.

**WARNING**

Do not start the JFS if engine seizure has occurred or is anticipated or if engine failure is a result of fuel starvation. Starting the JFS may result in no brake/JFS accumulator pressure for the brakes.

When landing is assured (normally high key):

**WARNING**

Delaying engine shutdown can result in a long, fast landing. Wheel braking is less effective due to lack of WOW and there is an increased probability of a missed cable engagement.

7. Throttle - OFF.  
If throttle is stuck or engine does not respond, shut down the engine with the FUEL MASTER switch. At MIL, the engine flames out in approximately 6 seconds. At IDLE, the engine flames out in approximately 45 seconds.
8. HOOK switch - DN (if required).

**WARNING**

The hook may miss the cable if the aircraft is not slow enough to compress the MLG struts sufficiently to make WOW or if forward stick pressure is held.

**FTIT Indicator Failure** **GE129**

The engine does not use FTIT as a control parameter. However, routine missions should not be continued since FTIT cannot be monitored.

**Zero RPM/Erroneous RPM Indication** **GE129**

If the RPM indicator fails to zero or displays erroneous RPM indication, it indicates either a malfunction within the indicator itself or within the engine alternator. Total alternator failure also causes an automatic transfer to SEC. The ENGINE warning light also illuminates for engine alternator or RPM indicator failure. Engine transfer to SEC due to certain partial or total alternator failures, results in loss of most engine fault reporting. Partial alternator failure may not result in automatic transfer to SEC. If the engine does not transfer to SEC, fault reporting continues. Partial alternator failure may also result in transfer to hybrid operation with AB operation inhibited. In this case, ENG HYB MODE and ENG A/B FAIL PFL's occur. Routine missions should not be continued without a functional RPM indicator.



If SEC caution light is illuminated:

1. Go to SEC CAUTION LIGHT, this section.

If SEC caution light is not illuminated:

1. Land as soon as practical.

**Abnormal Engine Response** GE129

Refer to LOW THRUST ON TAKEOFF OR AT LOW ALTITUDE (NON-AB) GE129, this section, if appropriate.

If thrust is too low to sustain level flight, turn immediately toward the nearest suitable runway and establish 250 knots airspeed. Consider jettisoning stores to increase flying time available to complete actions designed to restore usable thrust and improve range in the event those actions are unsuccessful.

**NOTE**

In a partial thrust situation, thrust available may increase as altitude decreases. 250 knots approximates the airspeed at which thrust required for level flight is the lowest.

Abnormal engine response is varied and generally indicated by abnormal thrust in relation to throttle position, engine oscillations (either continuous, momentary, or recurring), a complete lack of engine response to throttle movement, autoacceleration/deceleration, exhaust nozzle failure, or insufficient thrust. A PRI malfunction can cause these abnormal engine responses as well as overtemperature or overspeed indications. During AB operation, if engine anomalies occur in region 1, the throttle should be moved out of the AB range and AB should not be selected again for the remainder of the flight.

Exhaust nozzle control or oil system malfunctions can result in the nozzle being too far open, too far closed, or unstable. Insufficient thrust may result if the nozzle is more open than normal. SEC should be selected and, if the nozzle goes fully closed, engine operation should be continued in SEC. If the nozzle does not close in SEC, the ENG CONT switch should be moved back to C DF PRI, DR NORM as more thrust results and AB light-off may be attainable at lower altitudes. AB should only be used when required to sustain flight.

If the exhaust nozzle is positioned more closed than normal, thrust is adequate, but engine stall may occur if AB is selected. Automatic transfer to SEC should occur for most exhaust nozzle malfunctions.

**NOTE**

Certain PRI malfunctions may not result in an autotransfer to SEC. If the engine operates abnormally, do not rely upon an autotransfer to SEC. Timely selection of SEC may preclude further engine problems.

If thrust is still insufficient to make a safe landing after selecting SEC or abnormal engine response is still present, reattempt PRI.

If the throttle is stuck and thrust is suitable for sustained flight, attempts to free the throttle should be delayed until within gliding distance of a suitable landing field. If throttle is stuck in AB, placing the ENG CONT switch to SEC terminates AB and provides SEC MIL thrust. If throttle is stuck or otherwise prevented from normal movement, control might be regained by depressing the cutoff release, rotating the throttle outboard, and applying necessary force.

If thrust is too high to permit a safe landing, use excess thrust to climb and maneuver toward the nearest suitable airfield. Once high key for a flameout landing is assured, follow procedures as outlined in FLAMEOUT LANDING, this section. Activate the JFS and EPU and then shut down the engine as soon as landing is assured (normally high key) by placing the throttle to OFF or, if necessary, by placing the FUEL MASTER switch to OFF.

If abnormal engine response occurs:

**WARNING**

- Failure to monitor sink rate and height above terrain while applying low thrust recovery procedures can result in an ejection outside ejection seat performance envelope.
- If the throttle is stuck and thrust is suitable for sustained flight, attempts to free the throttle should be delayed until within gliding distance of a suitable landing field.

**CAUTION**

Idle PRI thrust with nozzle closed is approximately 50 percent greater than idle SEC thrust.

If in AB or if supersonic:

1. Throttle - Retard to MIL.



Retarding throttle below MIL while supersonic may induce inlet buzz which produces severe cockpit vibration and probable engine stalls.

If subsonic or problem still exists:

2. ENG CONT switch - SEC.

#### NOTE

Transfer to SEC may be accomplished while supersonic if the throttle remains at MIL.

3. Airspeed - 250 knots (if thrust is too low to sustain level flight).
4. Throttle - Verify engine responds normally to throttle movement from IDLE to MIL; set as desired.  
AB operation is inhibited and exhaust nozzle is closed.

If a safe landing can be made with the current thrust:

5. Land as soon as practical.  
During landing in SEC, idle thrust is higher than normal.

If thrust is insufficient to make a safe landing or abnormal engine response is still present:

5. ENG CONT switch - **C** **DF** PRI, **DR** NORM.

#### NOTE

If the exhaust nozzle is failed open, additional thrust to sustain flight may be attained by selecting AB at low altitudes.

6. Land as soon as possible.

If thrust is too high to permit a safe landing:

#### NOTE

If throttle is stuck, control might be regained by depressing the cutoff release, rotating the throttle outboard, and applying necessary force.

5. Plan a flameout landing. Refer to FLAMEOUT LANDING, this section.

#### WARNING

Do not start the JFS if engine seizure has occurred or is anticipated or if engine failure is a result of fuel starvation. Starting the JFS may result in no brake/JFS accumulator pressure for the brakes.

When landing is assured (normally high key):

#### WARNING

Delaying engine shutdown can result in a long, fast landing. Wheel braking is less effective due to lack of WOW and there is an increased probability of a missed cable engagement.

6. Throttle - OFF.  
If throttle is stuck or engine does not respond, shut down the engine with the FUEL MASTER switch. At MIL, the engine flames out in approximately 6 seconds. At IDLE, the engine flames out in approximately 45 seconds.
7. HOOK switch - DN (if required).

#### WARNING

The hook may miss the cable if the aircraft is not slow enough to compress the MLG struts sufficiently to make WOW or if forward stick pressure is held.

#### AB Blowout/Failure To Light **GE129**

AB blowouts are characterized by a thrust loss, a fuel flow decrease, and nozzle closure. The DEC attempts to relight the AB as long as the throttle remains in AB.

Refer to Figure 1-17. If AB is selected in region 1 and fails to light within 10 seconds or if the AB blows out in any region, retard throttle out of AB. AB operation should not be reattempted for the remainder of the flight.

AB operation in region 2 may include AB no lights or delayed lights if unfavorable AB light-off conditions exist. If these are encountered, the throttle may be left in AB. If the throttle is retarded, an AB light may be attempted.

### **ENGINE STALLS** [GE129]

The three primary causes of a stall are inlet flow distortion, AB instabilities, and hardware malfunctions. During normal aircraft operation, inlet flow distortion severe enough to cause engine stall is not expected. However, under some departure conditions, inlet flow distortion may induce engine stalls. Hardware-associated stalls may result from a failed nozzle, control system malfunctions, or FOD.

The first indication of a stall at high thrust settings may be a loud bang or pop. At lower thrust settings, the first indication may be loss of thrust, lack of throttle response, or decreasing rpm. The throttle should be retarded at the first indication of a stall. Engine stalls are divided into two types: AB-associated engine stalls and non-AB engine stalls.

#### **AB-Associated Engine Stalls** [GE129]

Types of AB-associated engine stalls are:

- AB initiation – Stall at AB light-off.
- AB sequencing – Stall during AB sequencing as the AB fuel flow increases with the throttle in AB.
- AB cancellation – Stall during throttle retard from AB.
- AB blowout/relight – Stall occurs during relight after a blowout in stabilized AB. May be preceded by AB rumble.

AB-associated engine stalls are normally accompanied by a loud bang or pop and a possible fireball from the engine exhaust and occasionally the engine inlet. These characteristics could be mistaken for an aircraft fire. Whenever a stall occurs while operating in AB, the throttle should be snapped out of AB to MIL. This usually clears the stall and restores normal operation. The stalls may continue at MIL and are characterized by bangs or pops of lower intensity than AB stalls. If stall condition persists, refer to NON-AB ENGINE STALLS [GE129], this section.



If an AB-associated engine stall occurs below 30,000 feet MSL or while supersonic, IGV system damage may occur. Throttle movements after the stall clears should not be rapid.

FTIT fluctuation and decreasing rpm will probably accompany stalls. The throttle should be retarded to IDLE if the stall continues for a few seconds. The engine may continue to stall at IDLE but may not be audible, particularly at high altitudes. The engine instruments should be monitored for indications of stall. FTIT may rise while rpm decreases.

If the engine stalls at low altitude, an immediate climb should be initiated. Retarding the throttle to MIL may clear the stall. If engine response at low altitude is not sufficient to maintain or gain altitude and a suitable field is not immediately available, ejection may be required.

#### **Non-AB Engine Stalls** [GE129]

Non-AB engine stalls may occur if the control system is malfunctioning, particularly during throttle transients. Non-AB engine stalls are often a symptom of a serious engine problem. Non-AB engine stalls may be inaudible; the first indication may be a lack of engine response to throttle movement which may be difficult to differentiate from abnormal engine response. However, non-AB engine stalls may be characterized by bangs, pops, low intensity engine rumble or vibration, and/or erratic orange-yellow flame from the engine exhaust.

This exhaust flame could be mistaken for an engine fire. FTIT fluctuation and decreasing rpm will probably accompany stalls. If a stall is confirmed, the throttle should be immediately retarded to IDLE. The engine may continue to stall at IDLE but the stall may not be audible, particularly at high altitudes. The engine instruments should be monitored for indications of stall. FTIT may increase while rpm decreases. If the stall continues, place ENG CONT switch to SEC. If the engine recovers, throttle movements should be minimized and made slowly until landing is assured.

If stall continues, initiate airstart. Refer to AIRSTARTS [GE129], this section. When trying to clear a stall with an airstart, the throttle should be maintained in OFF for a few seconds to allow the stall to clear. If the stall continues after the airstart, the engine may have a serious hardware problem. The focus should shift to using available thrust to land at the nearest divert field.

**WARNING**

Prolonged engine operation with FTIT in excess of 980°C can result in significant engine damage and may cause a nonrecoverable engine failure.

**Engine Stall Recovery** GE129

If an AB stall(s) occurs:

1. Throttle - Snap to MIL.

If AB stalls do not clear or stall(s) occurs below AB:

**NOTE**

Non-AB stalls may be inaudible.

2. Throttle - IDLE.

If stalls continue:

3. ENG CONT switch - SEC.

If stalls continue:

4. Throttle - OFF for a few seconds, then initiate airstart. Refer to AIRSTART PROCEDURES GE129, this section.

**NOTE**

For serious hardware problems, the engine may operate normally at idle rpm but exhibit stall/vibration conditions at thrust settings above idle rpm. Attempting additional airstarts will not clear the condition. Use the highest thrust setting below the stall/vibration condition to sustain flight.

If stall(s) clears:

5. Throttle - MIL or below. Minimize throttle movements and make necessary movements slowly.

**NOTE**

If stall(s) occurred in AB at 30,000 feet MSL or above and while subsonic, the engine is safe to operate in the IDLE to MIL range provided no other abnormal engine indications are observed.

If stall(s) occurred at MIL or below, or in AB below 30,000 feet MSL or while supersonic:

6. Land as soon as possible.

**INLET BUZZ** GE129

Inlet buzz occurs at supersonic airspeeds if an engine control system failure or a CADC mach signal failure results in insufficient airflow or if the throttle is retarded below MIL while operating in HYB or SEC. Inlet buzz causes moderate to severe vibration within the cockpit and may result in multiple engine stalls.

If inlet buzz occurs, do not move the throttle until subsonic. Decrease airspeed to subsonic as quickly as possible by opening the speedbrakes and increasing g. If engine stalls occur and persist, the throttle should be retarded to IDLE when subsonic. If the stalls do not clear, retard the throttle to OFF for a few seconds, then advance to midrange. Refer to AIRSTART PROCEDURES GE129, this section.

**BIRD STRIKE** GE129

In the event of a bird strike or suspected bird strike, AB should be used only if absolutely necessary. It is possible to lodge bird remains in the AB system such that liner damage and subsequent duct burn-through occurs if AB is used. There is no concern of liner damage during any non-AB operation. Refer to ABNORMAL ENGINE RESPONSE GE129, this section, if appropriate.

**ENGINE OVERSPEED** GE129

An overspeed occurs when engine rpm exceeds 109.5 percent. If an overspeed condition occurs, an MFL is recorded and the engine control attempts to reduce rpm below maximum limit. However, if the DEC malfunctions and engine rpm reaches 113 percent, the overspeed protection in the MEC closes the overspeed fuel shutoff valve resulting in a flameout. To restore fuel, retard the throttle to OFF then advance to midrange. Refer to AIRSTART PROCEDURES GE129, this section.

**ENGINE FAILURE OR FLAMEOUT** GE129

If the engine flames out, fuel starvation or mechanical failure has occurred.

A flameout is indicated by a decrease in FTIT and engine rpm decaying below in-flight idle (approximately 70 percent rpm). Loss of thrust and lack of response to throttle movement confirm the flameout.

The ENGINE warning light illuminates when engine rpm is below 60 percent. Additionally, the MAIN GEN and STBY GEN lights illuminate below 50 percent rpm and the EPU should start running. Do not mistake a loss of ECS noise as an engine flameout.

A flameout indicates an engine control failure, fuel starvation, fuel system malfunction, or fuel cutoff due to engine overspeed protection. If the engine flames out, two features may instantly restart the engine. There is an autorelight feature and the capability to automatically transfer to SEC if certain faults are detected in PRI. If these features work, the restart may take place instantly and the flameout may not be noticeable (except for the illumination of the SEC caution light). In this situation, remain in SEC. (Refer to SEC CAUTION LIGHT, this section.)

If the flameout progresses to the point that it is noticeable, retard the throttle to OFF, then advance to midrange. Refer to AIRSTART PROCEDURES [GE129], this section.

**Tower Shaft Failure [GE129]**

Failure of the engine tower shaft or its associated geartrain results in engine flameout due to fuel starvation. A restart is not possible; primary emphasis should be on a flameout landing. If unable to make a flameout landing, refer to EJECTION (TIME PERMITTING), this section. Because tower shaft failure results in the loss of rotation to the engine-driven gearbox and ADG, the initial symptoms are similar to main fuel pump failure. The primary differences are that the rpm indication drops immediately to zero and ENGINE warning light and the SEC caution light illuminate since the engine alternator is no longer providing power to the DEC.

The JFS should be started immediately upon entering the JFS envelope to conserve EPU fuel. The JFS drives the ADG and the engine gearbox which restores rotation to both hydraulic pumps and provides a reduced FLCS PMG output. Depending on JFS performance and load, rpm may even be high enough to restore standby generator power; however, main generator power may cycle on and off. Without the load of the engine, the JFS produces a 30-55 percent rpm indication, which is the speed of the engine gearbox and not the actual engine rpm. The true engine rpm is unknown.

**Low Altitude Engine Failure or Flameout [GE129]**

Refer to figures 3-10 and 3-11. Initial reaction to any malfunction at low altitude should be to trade excess airspeed for altitude. Higher altitude translates directly to either additional time to achieve an

airstart or to additional glide range to reach a suitable landing field. Above 310 knots, more time is available by performing a zoom climb using a 3g pullup to 30-degree climb until approaching the desired airspeed (use approximately 50 knots lead point) and then initiating a zero-g pushover. Below 310 knots, more time is available by performing a constant altitude deceleration to the desired airspeed; if required, climb to achieve minimum recommended ejection altitude.

If the zoom results in an altitude below 4000 feet AGL, there may be insufficient time to achieve an airstart prior to reaching minimum recommended ejection altitude. In that case, primary consideration should be given to preparing for ejection; do not delay ejection below 2000 feet AGL.

If low altitude engine failure or flameout occurs:

1. Zoom.
2. Stores - Jettison (if required).  
If stores jettison is attempted after main and standby generators drop off line but before EPU generator powers the SMS (approximately 5 seconds delay), stores will not jettison.
3. Perform airstart (if altitude permits). Refer to AIRSTART PROCEDURES, this section.

**NOTE**

Visually confirm the stores have jettisoned and jettison again if required.

**WARNING**

Below 4000 feet AGL, there may be insufficient time to perform an airstart prior to minimum recommended ejection altitude.

**AIRSTARTS [GE129]**

Refer to figure 3-12. Airstarting the engine does not require exact airspeeds or rpm ranges, but there are key events in the airstart sequence that must be performed in a timely manner in order to have the best chance for an airstart. The key events are initiating the airstart while engine rpm is still high, selecting SEC if there is no light-off prior to rpm decaying below 50 percent in PRI (or immediately when below 10,000 feet AGL), and preserving engine rpm prior to light-off.

# Low Altitude Zoom Capability

DATA BASIS ESTIMATED

ENGINE F110-GE-129

## CONFIGURATION:

- GW = 23,000-25,000 LB
- DI = 0-50
- LG - UP

## CONDITIONS:

- WINDMILLING OR SEIZED ENGINE
- 30-DEGREE CLIMB MAINTAINED TO 170/250 KIAS

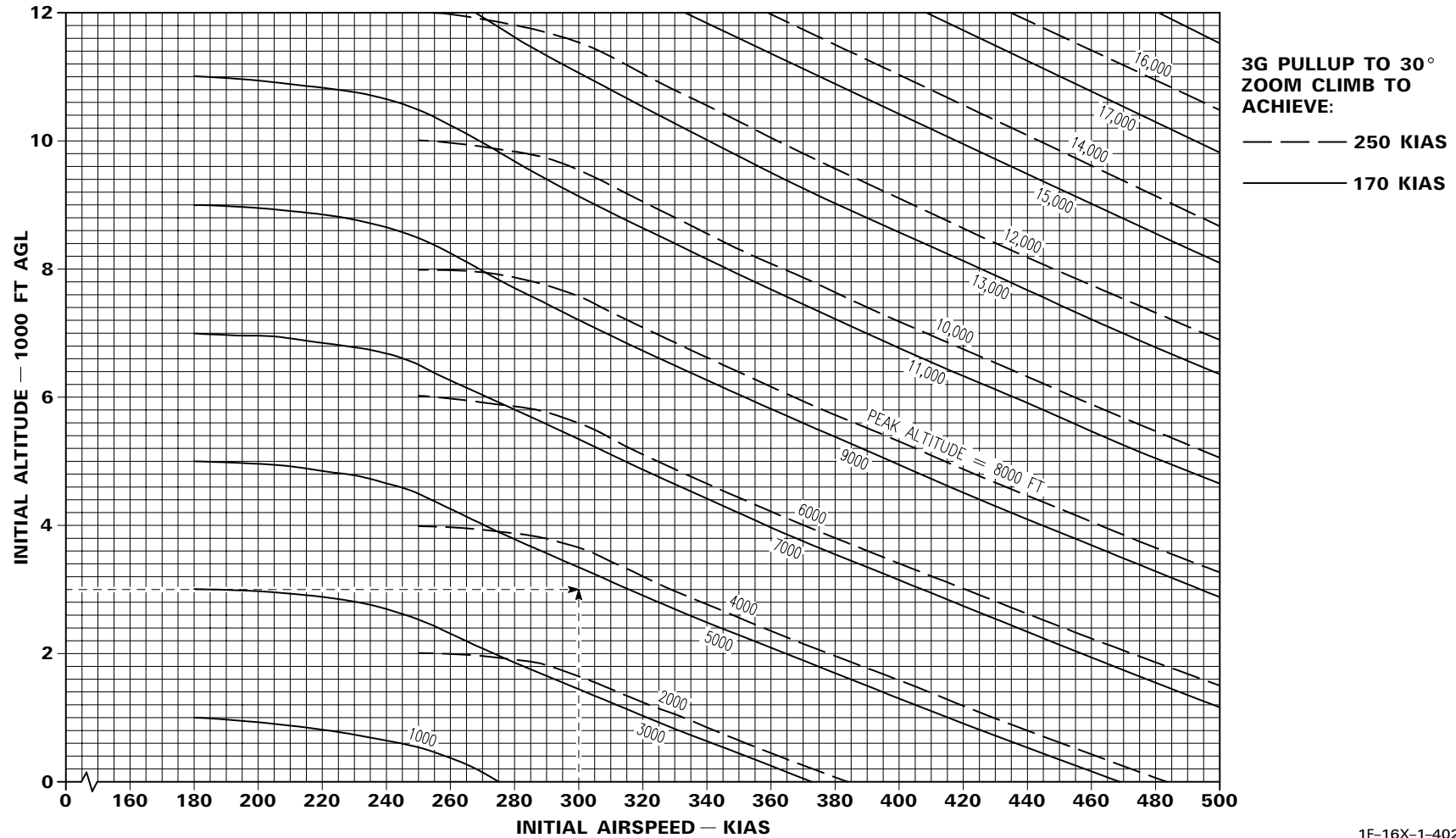

1F-16X-1-4025X ©

Figure 3-10.

# Low Altitude Airstart Capability

DATA BASIS ESTIMATED

ENGINE F110-GE-129

**CONFIGURATION:**

- GW = 23,000-25,000 LB
- DI = 0-50
- LG - UP

**CONDITIONS:**

- 30° DIVE TO DESCENT KIAS OR 3G PULLUP TO 30° ZOOM CLIMB INITIATED FROM THE AIRSPEED/ALTITUDE EXISTING AT FIRST RECOGNITION OF ENGINE FAILURE
- AIRSTART INITIATED AT START OF DIVE OR ZOOM BY CYCLING THROTTLE TO OFF AND THEN MIDRANGE

- 45 SECONDS ASSUMED AFTER THROTTLE ADVANCE TO ACHIEVE USABLE THRUST (ASSUMES AIRSTART INITIATION AT 25 PERCENT RPM)
- DESCENT AIRSPEED IS 170 KIAS (SEC) (JFS RUN LIGHT ON)

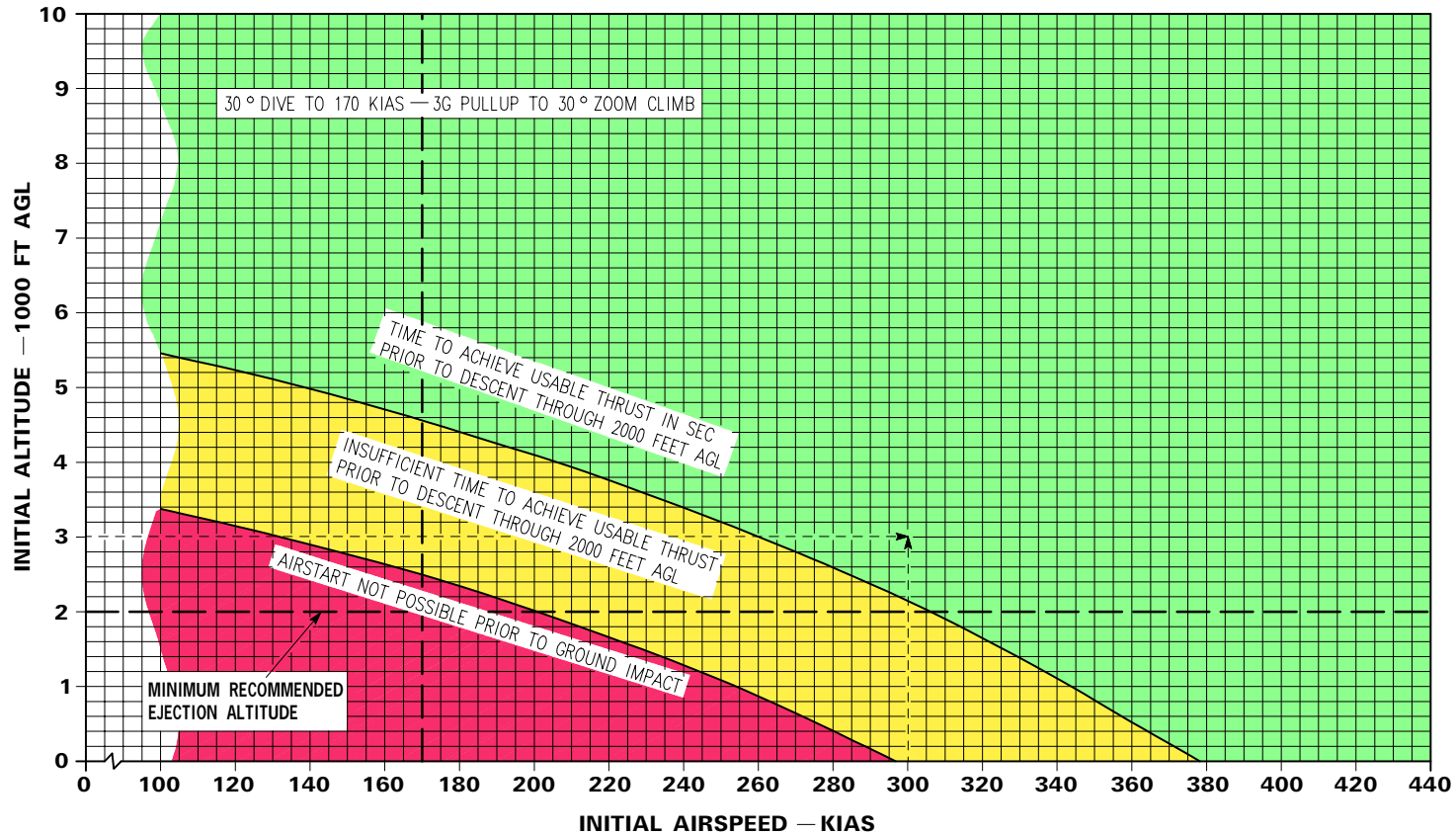

GR1F-16CJ-1-0120A37 ©

Figure 3-11.

# Engine RPM and FTIT Response During Spooldown and Airstart

ENGINE F110-GE-129

**CONDITIONS:**

- DRAG INDEX = 0
- GW = 26,000 LB
- KIAS = 250
- NO WIND

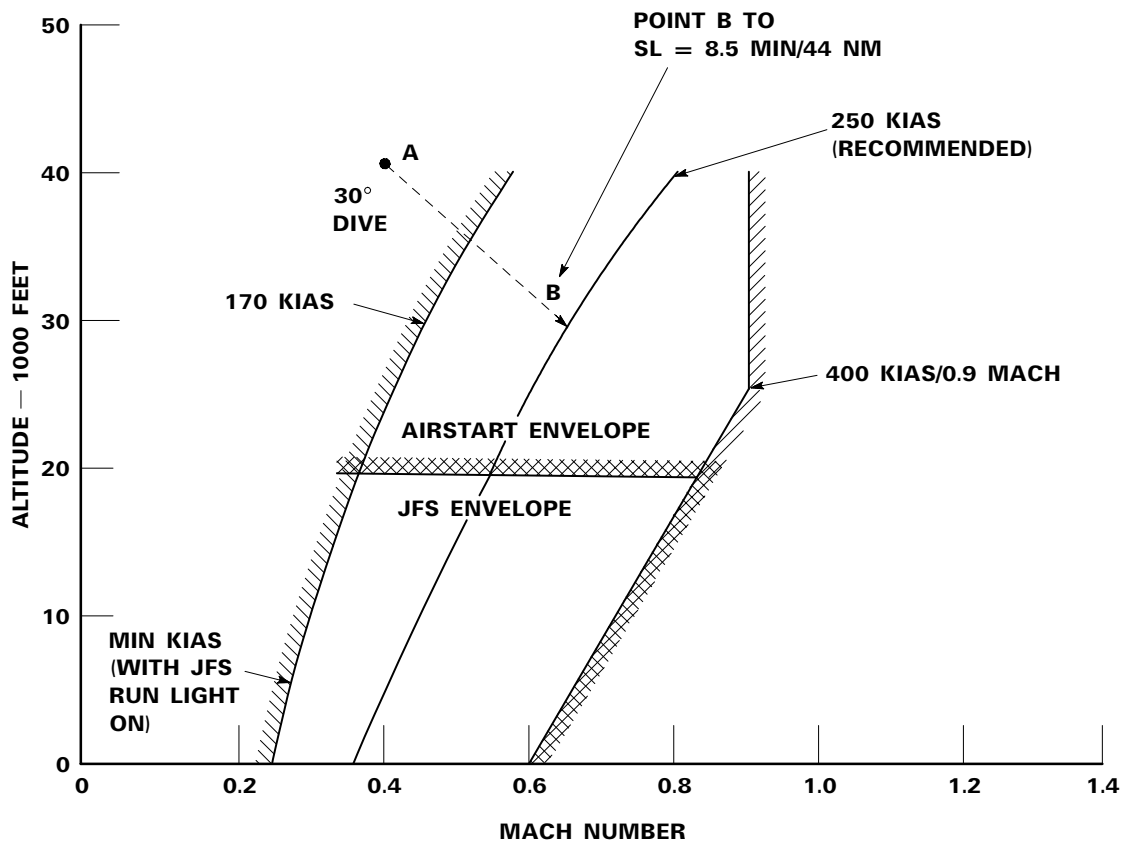
**OPTIMUM FLIGHT PATH DURING AN AIRSTART (TYPICAL)**

Engine out descent flight path maintains the aircraft in the required airstart envelope. A 30-degree dive to descent KIAS is used to approach the airstart envelope (Point A to B).

Airstart is enhanced by increased airspeed, altitudes below 30,000 feet, and light-off at highest possible engine rpm.

1F-16X-1-4024-1A ©

Figure 3-12. (Sheet 1)



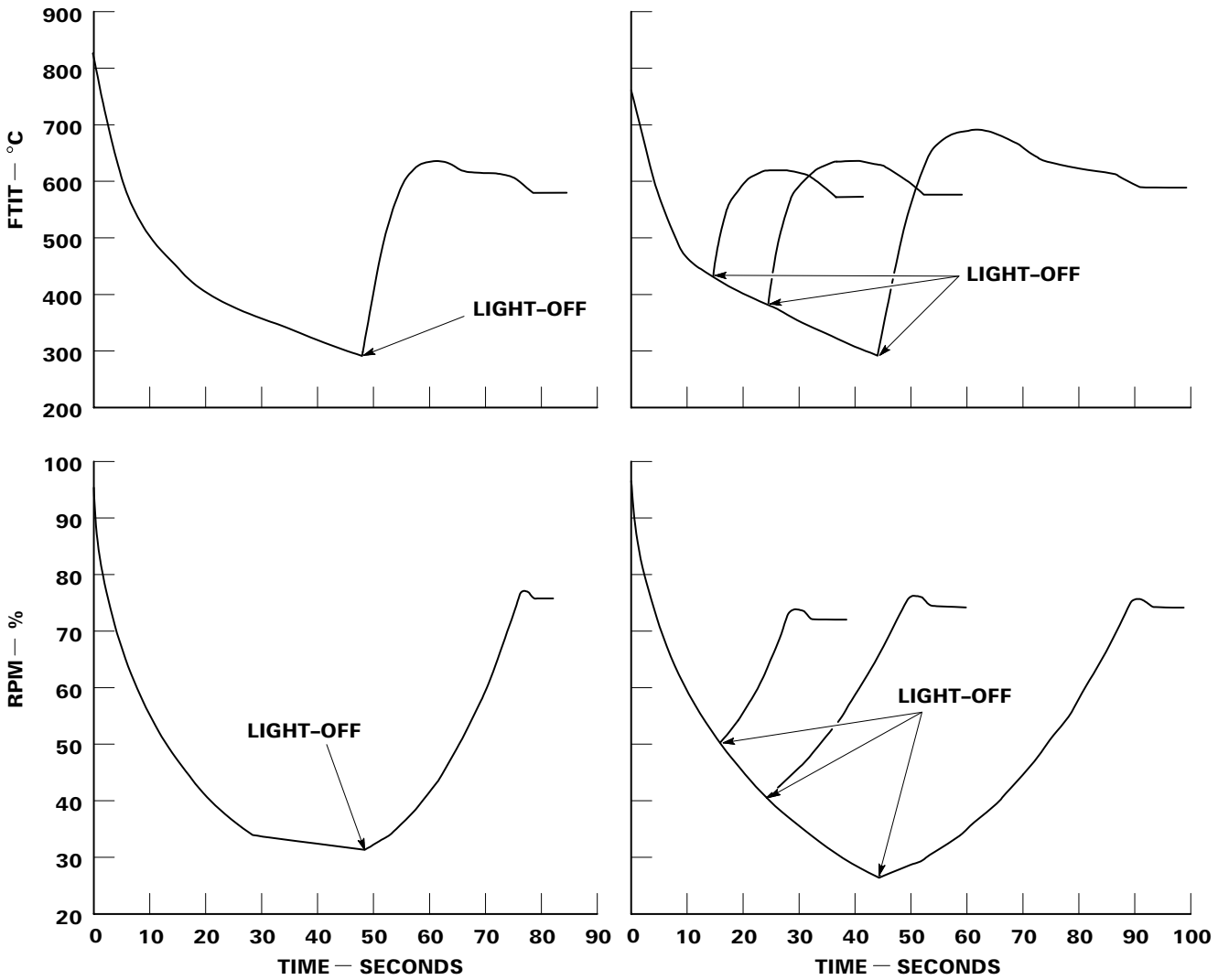

**RATE OF ENGINE RPM AND FTIT DECAY AND RECOVERY FOR JFS-ASSISTED AIRSTART AT 20,000 FEET.**

Following the rapid FTIT rise and peak after light-off, FTIT slowly decreases approximately 50°C.

Airstarts initiated between 25-50 percent engine rpm are slow to light-off and may take up to 90 seconds to regain usable thrust.

**RATE OF ENGINE RPM AND FTIT DECAY AND RECOVERY FOR SPOOLDOWN AIRSTARTS AT 25,000 FEET.**

Following the rapid FTIT rise and peak after light-off, FTIT slowly decreases approximately 50°C.

Airstarts initiated between 25-50 percent engine rpm are slow to light-off and may take up to 90 seconds to regain usable thrust.

1F-16X-1-4024-2X ©

Figure 3-12. (Sheet 2)

Oil pressure is directly related to rpm. Do not confuse a low oil pressure indication due to windmilling rpm as an oil system malfunction.

Factors such as altitude, airspeed, weather, etc., must be considered in determining whether to try an airstart, to accomplish a flameout landing, or to eject. Jettisoning stores reduces altitude loss during an airstart and improves glide ratio during flameout landing. If gliding distance is not a factor, maintain 250 knots or more in order to reduce rpm rate of decay until the JFS can be started. The engine can be airstarted with airspeeds from 170-400 knots/0.9 mach; however, 250 knots provides the best tradeoff of altitude loss, range, and airflow for the engine.

In flight, the throttle must be retarded to OFF then back to the operating range for only four reasons: to reset the overspeed protection logic, to clear a stall, to begin the airstart procedure, or to terminate a hot/hung start. Exact throttle position is not important for an airstart, so any position between IDLE and MAX AB is acceptable; however, the midrange position is preferred because of possible throttle misgearing at IDLE or possible engine overspeed shutdown at MIL or above.

Once the throttle is retarded to OFF and then back to the normal operating range, do not retard the throttle to OFF again during the airstart unless a hot/hung start occurs. Unnecessarily retarding the throttle to OFF terminates any start attempt which may be in progress.

A successful restart depends on many variables: cause of flameout, type of fuel, altitude, airspeed, and engine rpm when the airstart is attempted. High engine rpm is the most important variable and provides the best chance of a successful restart. Therefore, do not delay the initiation of an airstart in an attempt to reach a particular flight condition. Initiate the airstart as soon as it becomes apparent that engine rpm has decayed below in-flight idle (approximately 70 percent rpm) or illumination of the ENGINE warning light, engine instrument indications, and no response to throttle movement confirm a flameout. The best conditions for airstart are below 30,000 feet MSL, at 250 knots or more, and with high engine rpm.

At medium and high altitudes, the airstart attempt should be started in the engine control mode selected by the DEC. The DEC contains diagnostic logic designed to identify PRI engine control failures and may automatically transfer to SEC. If there is no indication of a light-off before rpm decays below 50 percent, place ENG CONT switch to SEC (even if the SEC caution light is on) and continue the airstart attempt. At low altitude (below 10,000 feet AGL), SEC should be selected as soon as possible after initiating the airstart.

Of equal importance to selecting SEC when required is preserving engine rpm. The JFS should be started as soon as the aircraft is in the JFS envelope. The advantage of using the JFS to assist the airstart is that once the JFS RUN light is on, airspeed can be reduced. Under normal conditions the JFS will motor the engine at a minimum of 25 percent.

An airstart can be rapid if light-off occurs above 60 percent rpm. Airstarts initiated between 50-25 percent engine rpm are slow to light off and may take up to 90 seconds to regain usable thrust. If altitude is available, increasing airspeed can assist engine acceleration and decrease the time to regain usable thrust once a light-off is achieved. As long as engine rpm continues to increase, this condition should not be considered as a hung/no start. Spooldown airstarts initiated below 25 percent rpm have been successful during flight tests, but spool up to usable thrust may take more time than is available. Keep engine rpm at 25 percent or above during spooldown airstarts, if possible.

Following the rapid FTIT rise and peak of a light-off, FTIT slowly decreases approximately 50°C. Therefore, do not confuse a drop in FTIT as an unsuccessful airstart unless accompanied by decreasing rpm as well.

#### **High Altitude Airstart Considerations** GE129

As altitude is increased above 30,000 feet MSL, the probability of a successful airstart can be improved by attempting the airstart as soon as possible (before rpm decays below approximately 50 percent) and by quickly descending to altitudes below 30,000 feet MSL after the airstart is initiated. Airspeeds above 250 knots (400 knots/0.9 mach maximum) should be considered as a means to reduce altitude and increase the probability of a successful airstart. Spooldown airstarts can be achieved with rpm as low as 25 percent, but not at all airspeeds and altitudes.

## T.O. GR1F-16CJ-1

At high altitudes, dive as required to maintain speed in the 250-400 knot/0.9 mach range. Unless an airstart is obviously impossible (total lack of fuel, tower shaft failure, engine seizure, etc.), do not become tempted to establish a maximum range or maximum endurance glide. The first consideration should be an immediate spooldown airstart attempt even if the engine fails for no apparent reason. If a spooldown airstart is not successful before reaching 20,000 feet MSL, a JFS-assisted airstart should be attempted. When below 20,000 feet MSL, turn JFS on. Activating the JFS above 20,000 feet MSL is prohibited since successful JFS start/motoring of engine is unlikely and the brake/JFS accumulators will be depleted. If the JFS RUN light is on, airspeed may be reduced to achieve maximum range or maximum endurance (C 200 or 170, D 205 or 175 knots, respectively, plus 5 knots per 1000 pounds of fuel/store weights). Time constraints due to EPU fuel consumption must also be considered. A maximum range or maximum endurance glide from above approximately 35,000 feet MSL may exhaust EPU fuel prior to landing. (Refer to T.O. GR1F-16CJ-1-1, figure B6-3.) With the JFS running, EPU fuel consumption is also reduced.

### Low Altitude Airstart Considerations GE129

Initiate the airstart as soon as possible. After initiating a zoom climb and jettisoning stores (if required), retard the throttle to OFF then advance the throttle to the normal operating range. Place the ENG CONT switch to SEC and turn on the JFS (START 2) to assist the airstart.

Following a zoom climb, plan to arrive at 250 knots until the JFS RUN light is on; airspeed may then be reduced to achieve maximum range or maximum endurance (C 200 or 170, D 205 or 175 knots, respectively, plus 5 knots per 1000 pounds of fuel/store weights). If a higher airspeed is maintained or an attempt is made to gain airspeed to delay the rpm decay, available time may be reduced to the point that an airstart is not possible.

During any low altitude airstart attempt, constantly evaluate altitude above the ground relative to airstart success. Do not delay ejection below 2000 feet AGL unless the engine is producing thrust capable of maintaining level flight or safely controlling the sink rate or unless a flameout landing can be accomplished.

### Airstart Procedures GE129

To begin the airstart sequence, retard the throttle to OFF; then immediately advance the throttle back into the normal operating range, preferably midrange.

## NOTE

If the throttle is retarded to OFF to clear a stall, it should be maintained in OFF for a few seconds to allow the stall to clear.

After throttle advance, monitor for signs of a light-off before rpm decays below 50 percent (characterized by a rapid rise in FTIT accompanied by a slow increase in rpm). If rpm and FTIT continue to decay after rpm drops below 50 percent, place the ENG CONT switch to SEC (even if the SEC caution light is illuminated).

If a hot/hung start occurs, retard the throttle to OFF and allow the FTIT to drop to below 700°C before advancing the throttle. Increasing the airspeed (maximum of 400 knots/0.9 mach) should help the next airstart to be cooler. If the condition persists, retard the throttle to OFF, place the ENG CONT switch to SEC, and allow the FTIT to decrease below 700°C before advancing the throttle.

After entering the JFS envelope, start the JFS to assist in preserving rpm. With the JFS RUN light on, airspeed may be reduced to achieve maximum range/endurance.

If the JFS stops running or fails to run within 30 seconds, do not reattempt a JFS start until the brake/JFS accumulators have had time to recharge. Allow 1 minute of engine rotation (either windmilling or JFS-assisted) at 12 percent rpm or above to insure that the brake/JFS accumulators are fully recharged. Recharging begins 3-4 seconds before the JFS RUN light illuminates or 30 seconds after selecting a start position (in the event of a JFS failure to run). Recharging occurs regardless of JFS switch position.

In the event of a JFS shutdown, the JFS switch does not relatch in either start position while the JFS is spooling down. Spooldown from full governed speed takes approximately 17 seconds. The JFS switch must be cycled to OFF and then START 2 to reinitiate a JFS start. It is possible to complete the spooldown before the brake/JFS accumulators are recharged if the JFS ran for only a short time.

It is possible the engine may not respond properly to throttle movement following an otherwise successful airstart. If this occurs or if thrust is insufficient to ensure a safe landing, switch to SEC, or if already in SEC, switch to PRI.

When the airstart is completed and usable thrust is regained, turn the JFS off. Reset the main generator using the ELEC CAUTION RESET button and verify MAIN GEN and STBY GEN lights are off. Cycle the EPU switch to OFF and then back to NORM.

**NOTE**

The VHF radio is not powered when the EPU is running.

To accomplish an airstart:

1. Throttle - OFF, then midrange.



- FTIT should decrease rapidly when throttle is OFF. If FTIT does not decrease rapidly, verify that the throttle is OFF.
- Do not mistake a rapid initial FTIT rise during an airstart as an indication of a hot start. Typically, airstarts are characterized by rapidly increasing FTIT with a slow increase in rpm.

If a relight does not occur before rpm decays below 50 percent or if below 10,000 feet AGL:

2. ENG CONT switch - SEC (even if SEC caution light is on).
3. Airspeed - Attain approximately 250 knots or establish maximum range or endurance airspeed (☐ 200 or 170, ☐ 205 or 175 knots, respectively, plus 5 knots per 1000 pounds of fuel/store weights) with JFS RUN light on.  
Above 30,000 feet MSL, airspeeds in the 250-400 knot/0.9 mach range should be considered to reduce altitude and increase the probability of a successful airstart.

**NOTE**

If maximum gliding range is not a factor, consider maintaining 250 knots or more above 10,000 feet AGL to provide best restart conditions (in case of JFS failure). Below 10,000 feet AGL with the JFS RUN light on, maintain maximum range or maximum endurance airspeed.

4. JFS switch - START 2 below 20,000 feet MSL and below 400 knots.

**NOTE**

- If the JFS switch is erroneously placed to START 1, leave it there.
  - If the JFS RUN light does not illuminate or goes off once illuminated, place the JFS switch to OFF and reattempt START 2 when the brake/JFS accumulators are recharged. The JFS switch does not relatch in either start position while the JFS is spooling down.
5. Stores - Jettison (if required).  
If stores jettison is attempted after main generator drops off line but before EPU generator powers the SMS (approximately 5 seconds delay), stores will not jettison.

**NOTE**

Visually confirm the stores have jettisoned and jettison again if required.

If engine rpm rolls back or hangs below in-flight idle (approximately 70 percent) and FTIT exceeds 935°C:

6. Throttle - OFF, then midrange.  
Allow FTIT to drop below 700°C before advancing the throttle.
7. Airspeed - Increase (400 knots/0.9 mach maximum).

If hung start/hot start persists:

8. Throttle - OFF.
9. ENG CONT switch - SEC, if in PRI; PRI, if in SEC.

**NOTE**

- In certain circumstances, the engine may malfunction in SEC. Returning to PRI may result in attaining usable thrust.
  - The proximity of the ENG CONT switch to the JFS switch makes the JFS switch susceptible to being bumped to OFF when selecting SEC.
10. Throttle - Midrange.  
Allow FTIT to drop below 700°C before advancing the throttle.

## T.O. GR1F-16CJ-1

If engine does not respond normally after airstart is completed:

11. ENG CONT switch - SEC.
12. Airspeed - 250 knots (if thrust is too low to sustain level flight).
13. Throttle - Verify engine responds to throttle movement; set as desired.

If engine does not respond normally after an airstart is complete in SEC, if thrust is still insufficient to make a safe landing, or abnormal engine response is still present:

14. ENG CONT switch - **C** **DF** PRI, **DR** NORM.
15. Refer to FLAMEOUT LANDING, this section.

If engine responds normally:

16. JFS switch - OFF.
17. ELEC CAUTION RESET button - Depress.  
Verify MAIN GEN and STBY GEN lights are off.
18. EPU switch - OFF, then NORM.
19. ADI - Check for presence of OFF and/or AUX warning flags.  
If warning flag(s) is in view, refer to TOTAL INS FAILURE, this section.

### WARNING

If only AUX flag is in view, pitch and roll attitude information is likely to be erroneous due to INS autorestart in the attitude mode when other than straight and level, unaccelerated flight conditions existed.

20. Land as soon as possible.
21. Refer to ACTIVATED EPU/HYDRAZINE LEAK, this section.

### FLAMEOUT LANDING

The decision to eject or make a flameout landing rests with the pilot. Considerations for attempting a flameout landing must include:

- Nature of the emergency.
- Weather conditions.
- Day or night.

- Proximity of a suitable landing runway.
- Proficiency in performing simulated flameout (SFO) landings.

Due to the capabilities of the ejection seat, the entire approach is within the ejection envelope; however, ejection should not be delayed in an attempt to salvage a questionable approach. When performing a flameout landing, the aircraft can safely stop (dry runway without arresting gear) in approximately twice the computed ground roll distance (8000-foot minimum runway length recommended), assuming a touchdown no more than 1/3 of the way down the runway at 11-13 degrees AOA.

To perform a flameout landing, turn immediately toward the desired runway. Jettison stores and establish maximum range airspeed. Maximum range airspeed may be less than the minimum airstart airspeed. If range to the desired runway is critical, the decision to attempt an airstart or a flameout landing rests with the pilot.

### NOTE

- During an airstart attempt, do not slow below the minimum airstart airspeed.
- If the engine is still running, but thrust is insufficient to sustain level flight, treat it as a flameout situation.

Maximum range airspeed varies only with GW and is not affected by drag index. Maximum range airspeed is **C** 200 knots for a GW of 20,000 pounds, **D** 205 knots for a GW of 21,000 pounds, and increases 5 knots per 1000 pounds of additional GW. For most circumstances, sufficient accuracy is obtained by adding 5 knots per 1000 pounds of fuel/store weights **PX III** and by adding 5 knots if CFT's are installed.

### NOTE

- This formula is based on the average aircraft operating weight. Refer to T.O. GR1F-16CJ-1-1, PART 1, DRAG INDEXES AND WEIGHTS - BASIC AIRCRAFT. If range to desired runway is critical, maximum range airspeed may be calculated using actual GW in excess of **C** 20,000 pounds, **D** 21,000 pounds.
- For a 10,000-foot descent (LG up), each 10 knots above or below maximum range airspeed decreases glide range up to 1/4 nm.

The maximum range airspeed equates to approximately 7 degrees AOA (any GW or drag index) and provides a glide ratio of approximately 7 nm per 5000 feet AGL (a no wind condition). Retaining stores or flying into a headwind decreases glide range significantly.

The EPU should be on and, if aircraft fuel is available, the JFS should be started using START 2 when below 20,000 feet MSL and below 400 knots unless the engine is either seized or anticipated to seize. The EPU should provide a minimum operation of 10 minutes (HYDRAZN light on) with normal flight control demands before EPU fuel depletion. Operating time can be extended to as much as 15 minutes if the JFS is running and flight control inputs are minimized.

If expected time to landing exceeds expected EPU operating time and excess energy is available, a steeper/faster descent may be flown. The JFS also provides hydraulic pressure for normal braking and NWS after landing.

When bleed air is no longer available to operate the EPU, confirm that the EPU is operating on hydrazine (EPU run and HYDRAZN lights on) since the JFS alone does not provide adequate hydraulic pressure to land the aircraft. If the EPU is inoperative, maneuver the aircraft as necessary on JFS-assisted hydraulic pressure to a more favorable ejection envelope and initiate ejection.

There are two basic types of flameout landing patterns: the overhead approach (figure 3-10) or the straight-in approach (figure 3-11). The overhead approach is preferred as it affords the most opportunities to properly manage available energy while providing the best visual cues for pattern corrections. The overhead approach may be entered at any position, provided the proper altitude for that point in the pattern can be obtained. The main concern is to reach high key, low key, or base key at or above the recommended minimum key altitudes. A straight-in approach is an alternate approach when the overhead approach cannot be attained. For both approaches, the initial aimpoint should be approximately 1/3 of the way down the runway.

### Overhead Approach

Refer to figure 3-13. Plan to arrive over the landing runway (high key) at 7000-10,000 feet AGL. The high key position may be approached from any direction.

The recommended key altitudes are based on flying a 360-degree descending turn from high key with the LG down. The altitudes vary with GW and with additional drag due to stores. The recommended high key altitude is **C** 7000, **D** 7500 feet AGL plus 500 feet per 1000 pounds of fuel/store weights **PX III** and plus 500 feet if CFT's are installed. The recommended low key altitude is **C** 3000, **D** 3250 feet AGL plus 250 feet per 1000 pounds of fuel/store weights **PX III** and plus 250 feet if CFT's are installed. These formulas include compensation for stores drag effects; thus, no additional correction is required.

If altitude will be significantly higher at high key, some form of altitude dissipating maneuver such as a dive, gentle S-turns, or a 360-degree descending turn should be used. Speedbrakes also may be used to lose excess altitude. However, if the speedbrakes are not closed when a satisfactory flightpath is reached, the added drag may preclude a successful flameout approach.

After departing high key, all attention should be directed toward a successful landing. If actual altitude at high key was below the recommended altitude, fly maximum range airspeed with the LG up until a satisfactory flightpath is reached and then lower the LG. Optimum LG down airspeed is 10 knots less than maximum range (LG up) airspeed. Minimum LG down airspeed is 20 knots less than maximum range (LG up) airspeed and provides sufficient maneuverability to arrest the high sink rate associated with a flameout approach. Optimum angle of bank is 50 degrees with the LG up and 55 degrees with the LG down. Bank angles more than 10 degrees above/below optimum result in a significant increase in altitude loss per degree of turn and may preclude a successful flameout approach.

### NOTE

- Delaying LG extension until low key allows successful completion of the overhead approach from as low as 1500 feet below the recommended high key altitude.
- Altitude loss for a 360-degree descending turn with the LG down increases up to 500 feet for every 10 knots above optimum LG down airspeed.
- Altitude loss for a 360-degree descending turn with the LG down increases up to 500 feet for each 5 degrees above/below the optimum bank angle.

The ground track of a flameout/SFO overhead approach is approximately the same as that of a normal overhead approach except the final approach is approximately 3/4 nm long. Avoid rapid flight control inputs which use excessive EPU fuel and may exceed the emergency hydraulic pump capability.

**WARNING**

If EPU fuel quantity is below 25 percent at high key (20 percent with the JFS running), a flameout landing should not be attempted since adequate hydraulic pressure may not be available through the landing.

**Straight-In Approach**

Refer to figure 3-14. If one of the overhead approach key positions cannot be reached, a straight-in approach may be flown. The clean glide at maximum range airspeed should be continued until the initial aimpoint is 11-17 degrees below the horizon; then the LG should be lowered. Seventeen degrees is below the forward field of view. A good visual reference for 15 degrees is when the initial aimpoint is at the bottom of the HUD (just above the radome). Optimum LG down airspeed is 10 knots less than maximum range (LG up) airspeed. Minimum LG down airspeed is 20 knots less than maximum range (LG up) airspeed and provides sufficient maneuverability to arrest the high sink rate associated with a flameout approach.

**NOTE**

For a 10,000-foot descent (LG down), each 10 knots above optimum LG down airspeed decreases glide range up to 1/2 nm.

**IMC Penetration**

Should IMC be encountered during a flameout approach to the intended runway and no alternate runway is available, an alternate descent/penetration may be flown which should allow maneuvering airspeed after penetrating the undercast.

**WARNING**

IMC penetration should not be attempted unless present position is known and navigation can be performed throughout the descent, and high terrain or other hazards are not a factor.

The stores should be jettisoned and the aircraft glided at maximum range airspeed until a 1:1 ratio between altitude in thousands of feet and range to the runway (e.g., 20,000 feet AGL at 20 nm, 15,000 feet AGL at 15 nm, etc.) is attained. The descent angle should then be increased and airspeed allowed to increase to maintain the 1:1 ratio. This equates to a 9-10 degree descent angle. This 1:1 glide ratio must be maintained until sufficient airspeed is attained to maneuver after penetrating the undercast.

**NOTE**

A 90 degree level turn at 50 degrees bank angle with the LG and speedbrakes retracted will dissipate 65-85 knots. A 180 degree turn will dissipate 145-250 knots. Airspeed dissipation increases with increasing GW and DI. A glide angle at a 1:1 ratio begun from maximum range airspeed will result in an airspeed of 260-320 knots after a 10,000-foot descent. Higher airspeed at the start of the glide, additional descent altitude, heavier gross weight, or lower drag index will result in higher airspeed at the completion of the glide.

At 3000 feet AGL, the aircraft should be 3 nm from the touchdown point. If the runway is not in sight by base key altitude, the aircraft may be zoomed for a controlled ejection. When VMC is attained and the runway is in sight, the aircraft should be glided to an attainable key position for an overhead approach or to a straight-in approach and the LG should be lowered. Excess airspeed above optimum LG down airspeed not required to maneuver to the flameout landing approach should be dissipated by use of speedbrakes or early LG extension.

# Flameout Landing Pattern (Typical)

## (OVERHEAD APPROACH)

### NOTES:

- Jettison stores (if required).
- Maximum range (LG up) airspeed is **C** 200, **D** 205 knots. Optimum airspeed (LG down) is **C** 190, **D** 195 knots. Minimum LG down airspeed is **C** 180, **D** 185 knots. Increase airspeeds by 5 knots per 1000 pounds of fuel/store weights **PX III** and an additional 5 knots if CFT's are installed.
- Maximum range (LG up) airspeed equates to approximately 7 degrees AOA (any GW or drag index) and provides a glide ratio of approximately 7 nm per 5000 feet AGL. If stores are retained, glide ratio decreases.
- Altitudes:
  - High Key — 7000–10,000 feet AGL  
Recommended altitude is **C** 7000, **D** 7500 feet AGL plus 500 feet per 1000 pounds of fuel/store weights **PX III** and 500 feet if CFT's are installed.
  - Low Key — 3000–5000 feet AGL  
Recommended altitude is **C** 3000, **D** 3250 feet AGL plus 250 feet per 1000 pounds of fuel/store weights **PX III** and 250 feet if CFT's are installed.
  - Base Key — 2000 feet AGL minimum
- Optimum bank angles are 50 degrees (LG up) and 55 degrees (LG down) for least altitude lost per degree of turn.

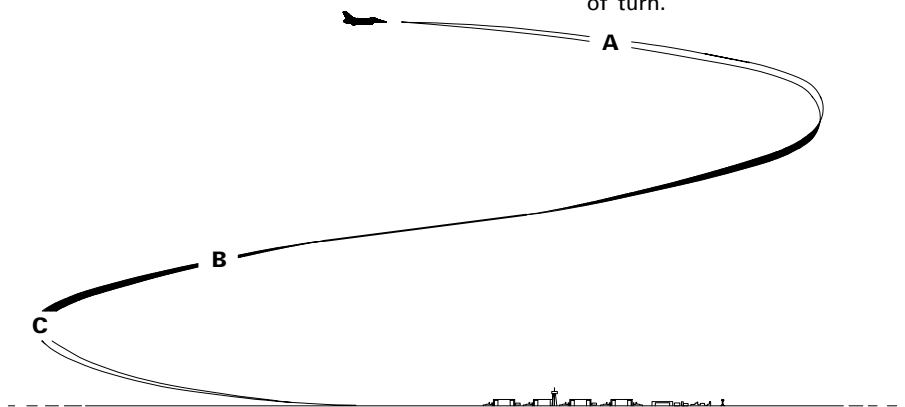

- HIGH KEY** — Above a point approximately 1/3 of the way down the runway
- LOW KEY** — Abeam point of rollout on final
- BASE KEY** — Midpoint of turn from downwind to final

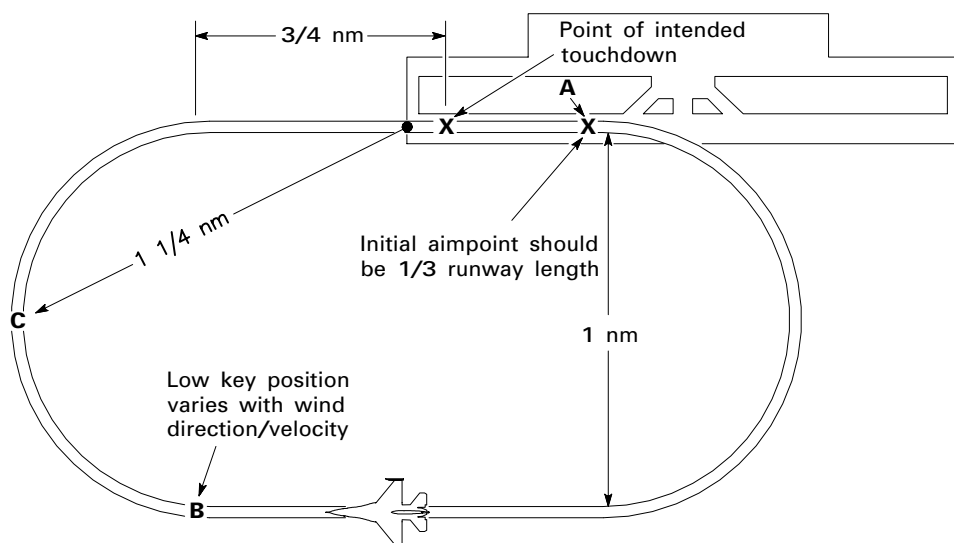

GR1F-16CJ-1-0123X37©

Figure 3-13. (Sheet 1)



# Flameout Landing Pattern (Typical)

## (OVERHEAD APPROACH)

**NOTES:**

6. **PX II** With FCC off, HUD continues to compute flightpath marker and to position scales for use during flameout approach.
7. Frost or condensation on the canopy could restrict visibility during flameout approach. Place AIR SOURCE knob to RAM and place DEFOG lever forward below 25,000 feet MSL.
8. Time constraints due to EPU fuel consumption must be considered as well as distance to be covered. To estimate required EPU fuel for a nonstandard approach, use 15 percent per minute as a basis for computation.
9. Starting JFS reduces load on EPU, conserves EPU fuel, and partially restores hydraulic system B.
10. If alternate LG extension is used, the NLG may not indicate down until airspeed is reduced below 190 knots.

**WARNING**

- The JFS alone does not provide adequate hydraulic pressure to land the aircraft.
- Do not allow airspeed to decrease below minimum LG down airspeed.
- Eject if it becomes obvious that a safe landing cannot be made. Ejection can be accomplished at any point in the pattern; however, do not delay ejection below 2000 feet AGL in an attempt to salvage a questionable approach.

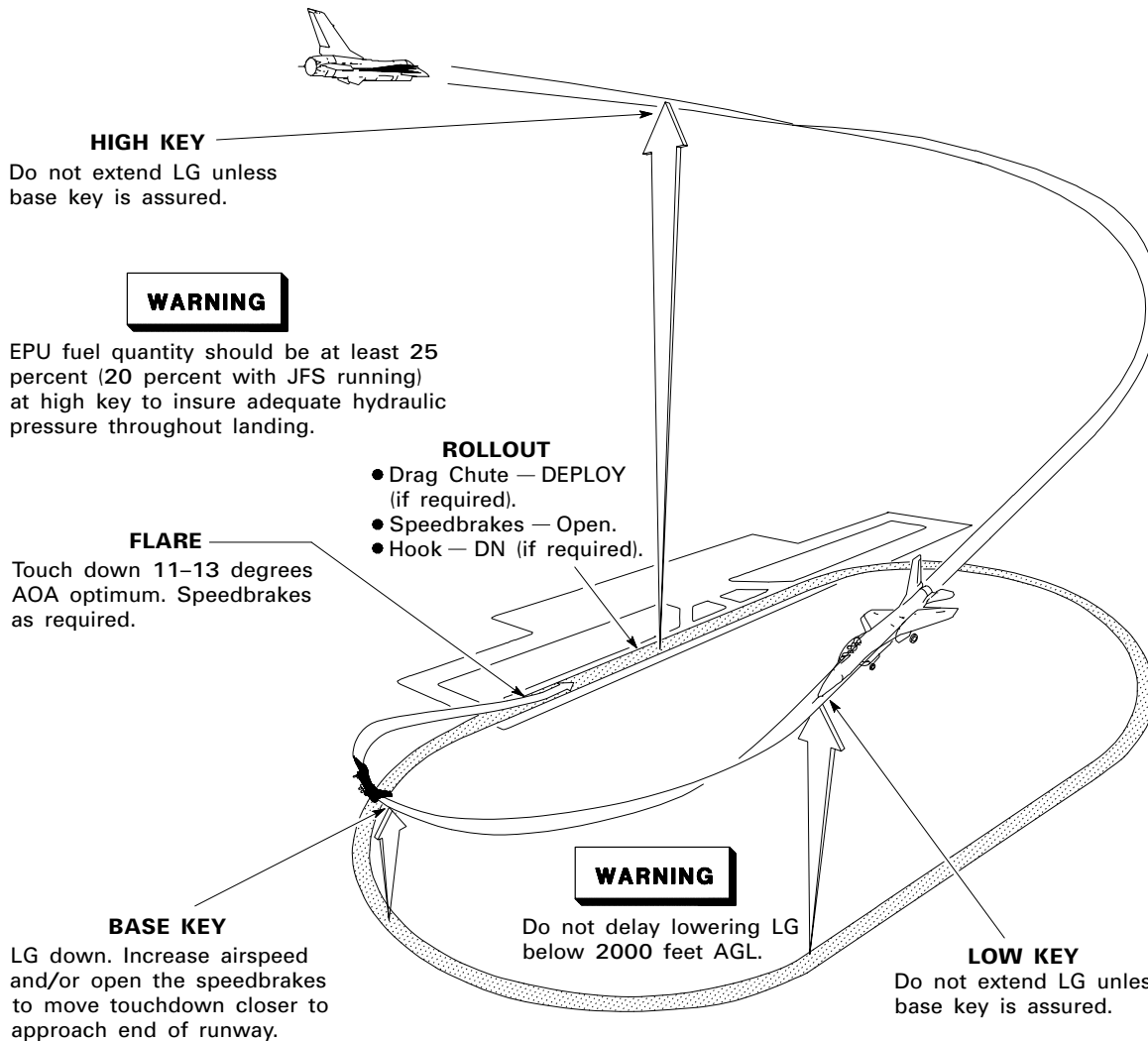

GR1F-16CJ-1-0124A37®

Figure 3-13. (Sheet 2)

# Flameout Landing Pattern (Typical)

## (STRAIGHT-IN APPROACH)

### NOTES:

1. Jettison stores (if required).
2. Maximum range (LG up) airspeed is **C** 200, **D** 205 knots. Optimum airspeed (LG down) is **C** 190, **D** 195 knots. Minimum LG down airspeed is **C** 180, **D** 185 knots. Increase airspeeds by 5 knots per 1000 pounds of fuel/store weights **PX III** and an additional 5 knots if CFT's are installed.
3. Maximum range (LG up) airspeed equates to approximately 7 degrees AOA (any GW or drag index) and provides a glide ratio of approximately 7 nm for each 5000 feet AGL. If stores are retained, glide ratio decreases.
4. Minimum altitudes are based on an LG up glide at maximum range airspeed to 2000 feet AGL followed by an LG down glide at optimum LG down airspeed to the runway for a drag index of 100.
5. After lowering LG, glide range decreases by approximately 30 percent. Airspeed greater than optimum LG down airspeed significantly increases energy loss rate and decreases glide range.
6. **PX II** With FCC off, HUD continues to compute flightpath marker and to position scales for use during flameout approach.
7. Frost or condensation on the canopy could restrict visibility during flameout approach. Place AIR SOURCE knob to RAM and place DEFOG lever forward below 25,000 feet MSL.
8. Time constraints due to EPU fuel consumption must be considered as well as distance to be covered. To estimate required EPU fuel for a nonstandard approach, use 15 percent per minute as a basis for computation.
9. Starting JFS reduces load on EPU, conserves EPU fuel, and partially restores hydraulic system B.
10. If alternate LG extension is used, the NLG may not indicate down until airspeed is reduced below 190 knots.

### ROLLOUT

- Drag Chute — DEPLOY (if required).
- Speedbrakes — Open.
- Hook — DN (if required).

### FLARE

Touch down 11–13 degrees AOA optimum. Speedbrakes as required.

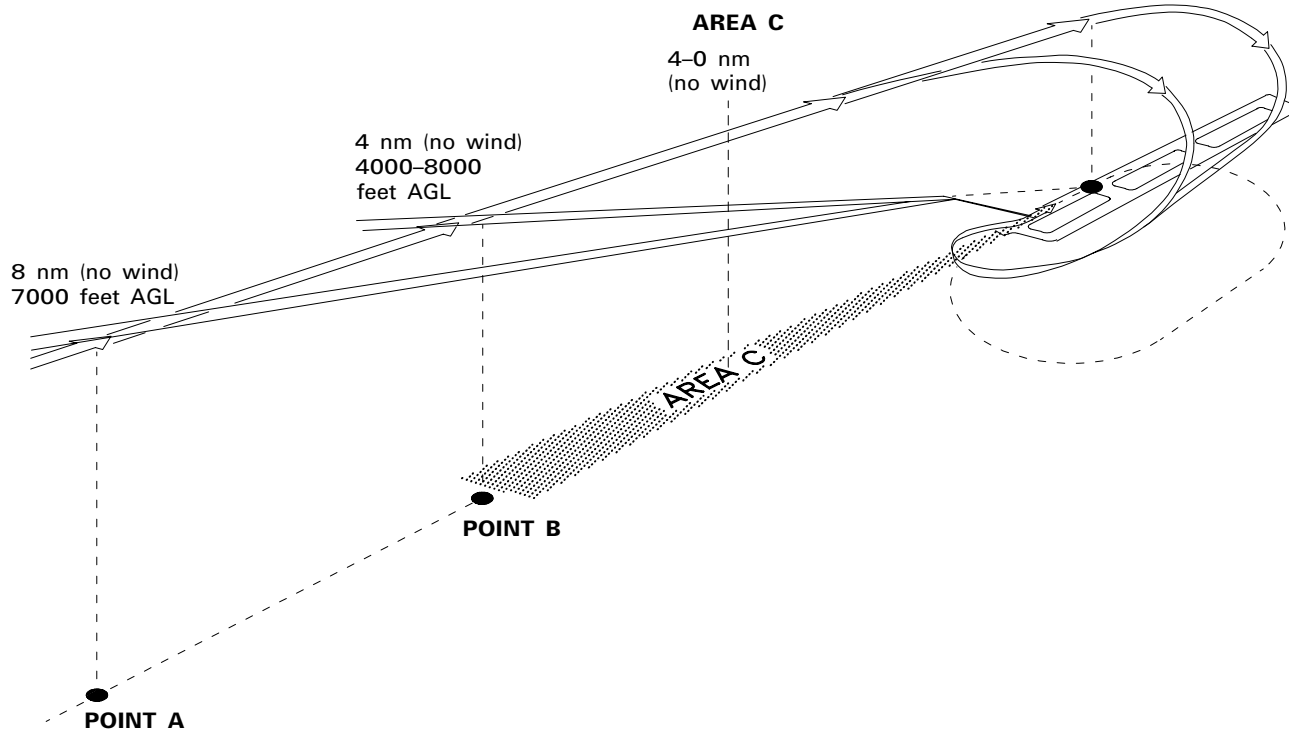

GR1F-16CJ-1-0125A37 ©

Figure 3-14. (Sheet 1)

# Flameout Landing Pattern (Typical)

## (STRAIGHT-IN APPROACH)

**WARNING**

- Do not allow airspeed to decrease below minimum LG down airspeed.
- If the aimpoint on the runway moves up in the field of view while maintaining maximum range (LG up) airspeed, the runway probably cannot be reached. This path corresponds to a glide angle of about 7 degrees between the horizon and the aimpoint.
- The JFS alone does not provide adequate hydraulic pressure to land the aircraft.
- EPU fuel quantity (points A, B<sub>1</sub>, and B<sub>2</sub>) should be sufficient to insure adequate hydraulic pressure through landing.
- Eject if it becomes obvious that a safe landing cannot be made. Ejection can be accomplished at any point in the approach; however, do not delay ejection below 2000 feet AGL in an attempt to salvage a questionable approach.

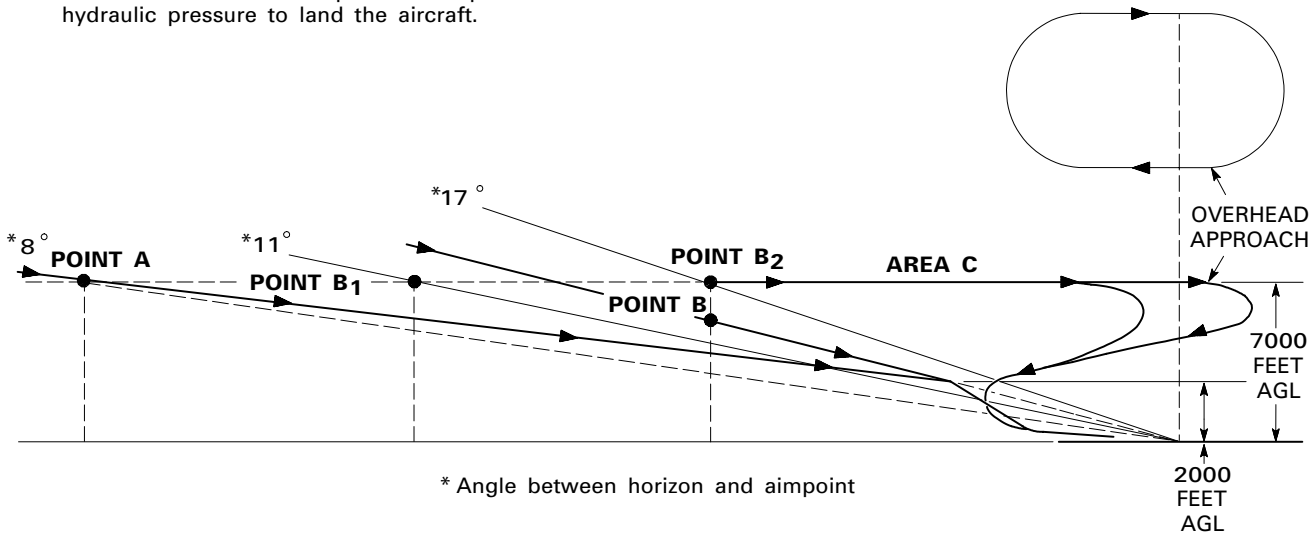

**POINT A**

8 nm (no wind), 7000 feet AGL, continue glide until initial aimpoint is 11–17 degrees below horizon. Then lower LG and establish optimum LG down airspeed. As a guide, no wind minimum EPU fuel is 45 percent (40 percent with JFS running).

**POINT B**

4 nm (no wind), 4000–8000 feet AGL, airspeed and LG as required. As a guide, no wind minimum EPU fuel is:

**POINT B<sub>1</sub>**

6 nm — 35 percent (30 percent with JFS running).

**POINT B<sub>2</sub>**

4 nm — 25 percent (20 percent with JFS running).

**AREA C**

4 – 0 nm (no wind), initial aimpoint is more than 17 degrees below horizon (under nose of aircraft and not visible). Normal straight-in approach is not feasible.

Options are:

- Delay LG lowering. Plan an overhead approach from a high key altitude but below the normal recommended altitude.
- Delay LG lowering. Plan a modified flightpath to low key.
- Lower LG, open speedbrakes, and dive and maneuver aircraft to intercept a point on the normal straight-in glidepath.

**WARNING**

Do not delay lowering LG below 2000 feet AGL.

GR1F-16CJ-1-0126X37®

Figure 3-14. (Sheet 2)

## Landing Phase

The LG should be lowered no later than 2000 feet AGL to allow adequate time for alternate LG extension. Establish a glidepath to achieve the initial aimpoint while maintaining optimum LG down airspeed. Once wings level on final approach, be aware of the tendency to slow below minimum LG down airspeed.

### WARNING

Do not attempt to stretch a glide by allowing the airspeed to decrease below minimum LG down airspeed. A slower airspeed decreases the maneuverability available to arrest the high sink rate associated with the flameout approach and may preclude a successful flameout landing.

Once landing is assured, the recommended procedure is to shift the aimpoint from 1/3 of the way down the runway to a position short of the intended touchdown point. Speedbrakes may be used to help control airspeed. The higher the airspeed, the shorter the aimpoint should be to allow for additional float (from flare to touchdown). The aircraft is easiest to control in the flare if the flare is begun between optimum and minimum LG down airspeeds. The point at which the flare is begun depends upon airspeed, sink rate, and glide angle. The flare should be started high enough to allow a smooth gradual reduction in glide angle but not so high as to run out of airspeed prior to touchdown. Under a no wind condition, the aircraft floats 3000-4000 feet after beginning the flare, if the flare is begun at the optimum LG down airspeed. Once the sink rate is arrested, attempt to slow to a normal touchdown airspeed and AOA. If excess airspeed exists after arresting the sink rate, the best method to slow the aircraft is to stay airborne until normal touchdown airspeed is reached.

## After Touchdown

After touchdown from a flameout landing, use a normal or short field stopping technique as required by the stopping distance available. If the JFS and EPU are running, normal braking and NWS are available (NWS is inoperative if the LG was lowered with the alternate LG system). If the JFS is not running, only the brake/JFS accumulators are available to supply hydraulic pressure for braking. Stop the aircraft by making one steady brake application just short of antiskid cycling. If there is any doubt about stopping on the remaining runway, lower the hook. When the aircraft is fully stopped,

have chocks installed or engage parking brake. Leave the battery on line until chocks are installed. If JFS START 2 was attempted but was unsuccessful, no braking is available for stopping or directional control unless the brake/JFS accumulators are recharged. Use flaperons and rudder as required to maintain directional control. As the aircraft slows below 70 knots, directional control is reduced and the aircraft may drift right.

## Flameout Landing Procedures

If the engine has flamed out or if flameout is imminent, turn toward a suitable runway and accomplish either an overhead approach or a straight-in approach, as appropriate.

- Altitudes (overhead approach):
  - High key – 7000-10,000 feet AGL.  
Recommended altitude is **C** 7000, **D** 7500 feet AGL plus 500 feet per 1000 pounds of fuel/store weights **PX III** and plus 500 feet if CFT's are installed.
  - Low key – 3000-5000 feet AGL.  
Recommended altitude is **C** 3000, **D** 3250 feet AGL plus 250 feet per 1000 pounds of fuel/store weights **PX III** and plus 250 feet if CFT's are installed.
  - Base key – 2000 feet AGL minimum.
- Altitudes (straight-in approach):
  - 8 nm – 7000 feet AGL minimum.  
The minimum altitude is based on an LG up glide at maximum range airspeed to 2000 feet AGL followed by an LG down glide at optimum LG down airspeed to the runway for a drag index of 100. A lower drag index slightly reduces the minimum altitude required. A higher drag index slightly increases the minimum altitude required.
  - 4 nm – 4000-8000 feet AGL.  
Delay lowering the LG until the initial aimpoint is 11-17 degrees below the horizon.

### WARNING

Eject if a safe landing cannot be made. Ejection can be accomplished at any point in the pattern but do not delay ejection below 2000 feet AGL in an attempt to salvage a questionable approach.

T.O. GR1F-16CJ-1

1. Stores - Jettison (if required).
2. Airspeed - **C** 200, **D** 205 knots.  
Increase airspeed 5 knots per 1000 pounds of fuel/store weights **PX III** and plus 5 knots if CFT's are installed. This airspeed equates to approximately 7 degrees AOA.

**NOTE**

During an airstart attempt, do not slow below the minimum airstart airspeed.

3. EPU switch - ON.

**NOTE**

**PX II** The VHF radio is not powered by the EPU.

4. JFS switch - START 2 below 20,000 feet MSL and below 400 knots.

**WARNING**

- EPU fuel quantity should be at least 25 percent (20 percent with JFS running) at high key for an overhead approach or 45 percent (40 percent with JFS running) at 8 nm for a straight-in approach to insure adequate hydraulic pressure through landing.
- The JFS alone does not provide adequate hydraulic pressure to land the aircraft.
- Do not start the JFS if engine seizure has occurred or is anticipated or if engine failure is a result of fuel starvation. Starting the JFS may result in no brake/JFS accumulator pressure for the brakes.

**NOTE**

- If engine is not operating, consider placing the FUEL MASTER switch to OFF if a fuel leak exists. This action may conserve fuel for the JFS.
- If the JFS is erroneously placed to START 1, leave it there.
- If the JFS RUN light does not illuminate or goes off once illuminated, place the JFS switch to OFF and reattempt START 2 when the brake/

JFS accumulators are recharged. The JFS switch does not relatch in either start position while the JFS is spooling down.

5. AIR SOURCE knob - RAM (below 25,000 feet MSL).
6. DEFOG lever - Forward.
7. LG handle - DN. (Use DN LOCK REL button if required.)

**WARNING**

- Do not delay lowering LG below 2000 feet AGL.
- If LG handle does not lower, select BRAKES CHAN 2 and position ALT FLAPS switch to EXTEND. **PW 229** Nozzle remains closed, resulting in higher than normal landing thrust.
- 8. ALT GEAR handle - Pull (if required) (190 knots maximum, if practical).  
Alternate LG extension can be used up to 300 knots; however, the NLG may not fully extend until 190 knots. Time above 190 knots should be minimized in case there is a leak in the pneumatic lines.

**CAUTION**

- NWS is not available following alternate LG extension.
- Do not depress the ALT GEAR reset button while pulling the ALT GEAR handle. This action may preclude successful LG extension.
- 9. Airspeed - **C** 190, **D** 195 knots optimum in pattern.  
Increase airspeed 5 knots per 1000 pounds of fuel/store weights **PX III** and plus 5 knots if CFT's are installed.

**WARNING**

Do not allow airspeed to decrease below **C** 180, **D** 185 knots plus 5 knots per 1000 pounds of fuel/store weights **PX III** and plus 5 knots if CFT's are installed.

After touchdown:

10. DRAG CHUTE switch - DEPLOY (if required).
11. HOOK switch - DN (if required).

If brake/JFS accumulator braking is used:

12. Stop straight ahead and engage parking brake.



- Brakes should be applied in a single, moderate, and steady application without cycling the antiskid.
  - Brake pedal deflection of 1/16 inch activates the brakes and bleeds the brake/JFS accumulators. To avoid brake activation and loss of accumulator fluid, do not rest feet on the brake pedals.
  - Do not attempt to taxi clear of the runway. Loss of brake/JFS accumulator pressure results in the inability to stop or steer the aircraft.
13. Refer to ACTIVATED EPU/HYDRAZINE LEAK, this section.

## JETTISON

### Selective Jettison

Selective jettison is used to release selected store(s) (except air-to-air missiles) or suspension equipment in an unarmed or unguided condition.

1. GND JETT ENABLE switch - ENABLE (if LG is down).
2. MASTER ARM switch - MASTER ARM.
3. **DR** ARMT CONSENT switch - On.
4. **PX II** SMS switch - SMS.
5. **PX III** ST STA switch - ST STA.
6. DOG FIGHT switch - Center.
7. MFD - SMS format.
  - D** Store and station selections can be made from either cockpit.
8. S-J OSB (MFD) - Depress.

9. S-J PAGE (MFD) - Select stores desired for jettison.



- Jettison of an inboard shoulder-mounted store from a TER at station 4 or 6 with the MLG down may result in LG and store(s) collision. To avoid this, select RACK for jettison instead of WPN.
- Jettison of external wing fuel tanks with stores/suspension equipment at stations 3 and/or 7 with MLG down may result in LG and external wing fuel tank collision.
- Failure to load the actual stores configuration into SMS inventory could cause damage to the aircraft by inhibiting the selective jettison release time delay used to insure safe 370/600-gallon fuel tank separation when a store is present at station 3 or 7.
- Selective jettison airspeed/mach limits in T.O. GR1F-16CJ-1-2 are only valid for:
  - Selective jettison of one store type at a time.
  - Selective jettison from nonadjacent stations.

If simultaneous selective jettison of either more than one store type or from adjacent stations is required, adhere to emergency jettison airspeed/mach limits.

### NOTE

- Weapon(s) and/or rack(s) to be jettisoned is highlighted.
  - When 300-gallon and 370/600-gallon fuel tanks are carried simultaneously, the 300-gallon fuel tank must be separated prior to the 370/600-gallon fuel tanks.
10. WPN REL or **PX II** **C** ALT REL button - Depress.

### NOTE

When jettisoning tanks from stations 4 and 6, hold release button depressed for 1 second.

**Emergency Jettison**

Emergency jettison is a one-step operation which clears all expendable stores and racks except air-to-air missiles. All weapons are released in an unarmed or unguided condition. **PX II** If the SMS is off, depressing the EMER STORES JETTISON button supplies electrical power to the SMS. In addition, while the button is depressed, the SMS enters the E-J mode. When the button is released, the avionic system returns to the previous operating mode. Emergency jettison is not available unless the main, standby, or EPU generator is operating. **PX III** Emergency jettison may not be available if an MMC FAIL PFL message is present. In this case, emergency jettison can be restored by placing the MMC switch to OFF.

**PX III** If the MMC is off, depressing EMER STORES JETTISON button supplies electrical power to the MMC and RIU's. In addition, while the button is depressed, the MMC enters the E-J mode.

1. GND JETT ENABLE switch - ENABLE (if required).  
Use EMER STORES JETTISON on the ground only as a last resort.
2. EMER STORES JETTISON button - Depress (1 second).

**WARNING**

**PX III** Emergency jettison is not available if an MMC FAIL PFL message is present. Emergency jettison can be restored by placing the MMC switch to OFF.

**NOTE**

If the initial actuation of the EMER STORES JETTISON button fails to jettison all aircraft stores, subsequent attempts may successfully release the remaining stores.

**FLCS FAILURES**

Significant FLCS failures, except for reversion to DBU, cause one or more PFL's to be displayed. Warning level failures also trigger the FLCS warning light; this light goes off only if the failure

resets. Caution level failures (except FLCS BUS FAIL) also trigger the FLCS FAULT caution light; this light goes off if the failure resets or when the fault is acknowledged. Refer to PILOT FAULT LIST - FLCS, this section, for PFL list.

The FLCS emergency procedures are based on the following recommended sequence of pilot actions:

- Note PFL(s) displayed.
- Acknowledge fault.
- Refer to PILOT FAULT LIST - FLCS, this section.
- Refer to appropriate FLCS emergency procedure.
- Perform FLCS reset, if so directed in the emergency procedure.
- Perform fault recall.

Certain MUX bus communication failures may result in the inability to display FLCS PFL's on the PFLD. If this occurs, PFL's may be observed on the FLCS page of the MFD.

Manual selection of DBU to attempt correction of a perceived FLCS failure is not recommended.

**WARNING**

Do not select DBU if the FLCS warning light is on since doing so allows failed signals which were previously voted out to be used.

**Air Data Malfunctions**

A single failure in the air data system (static/impact pressure) is indicated by the FLCS FAULT caution light and an FLCS ADC FAIL PFL. No degradation of aircraft performance should be noticed.

Contamination of the pitot probe can cause blockage of the passage which provides total pressure signals. This causes erroneously low airspeed indications in the HUD and on the airspeed/mach indicator with an FLCS ADC FAIL PFL at approximately 300 knots. An erroneously low airspeed value is used for FLCS gain scheduling which may result in pitch oscillations.

If erroneously low airspeed indications are present both in the HUD and on the airspeed/mach indicator during takeoff, consider aborting. If takeoff is continued, maintain airspeed below 210 knots (Cat I) or 275 knots (Cat III) (use INS groundspeed or wingman indications to determine airspeed) and land as soon as practical. Pitch oscillations may be experienced at higher speeds. If oscillations are encountered, minimize stick commands and slow to less than 210 knots (Cat I) 275 knots (Cat III).

A dual failure of static or impact pressure systems is indicated by the FLCS warning light and a STBY GAIN PFL. The FLCS ADC FAIL PFL is still present since the first failure is still active. In standby gains, the FLCS has transitioned to a fixed set of control gains which are optimized for sea level and 600 knots (LG handle in UP) and sea level and 230 knots (LG handle in DN). The LEF's are at zero degrees with the LG handle up and ALT FLAPS switch in NORM, and are at 15 degrees down with the LG handle down or the ALT FLAPS switch in EXTEND.

An FLCS reset can always be attempted for a first air data failure. If the first air data failure does not reset, and a second failure occurs (engaging standby gains), the first failure is latched and will not reset. However, the second failure is allowed to be reset and standby gains can be exited if the reset is successful.

Flying qualities in standby gains are degraded. Airspeed should be maintained subsonic and less than 650 knots. AOA should be maintained less than 12 degrees. Since the gains are optimized for 600 knots at sea level, airspeed should be maintained greater than 240 knots until the LG is lowered.

If FLCS ADC FAIL PFL occurs:

If BRK PWR DEGR PFL is also present, refer to FLCS SINGLE ELECTRONIC FAILURE, this section.

1. Establish 1g flight.
2. FLCS RESET switch - RESET.

If failure indications go off:

3. Continue normal operation.

If failure indications remain on:

3. Land as soon as practical.

If STBY GAIN PFL occurs:

1. Establish 1g flight with maximum of 12 degrees AOA.  
Airspeed 240-650 knots with LG up.
2. FLCS RESET switch - RESET.
3. Land as soon as practical.  
Do not slow below 240 knots with LG up if STBY GAIN PFL is still present.

### AOA Malfunction

A single failure in the AOA system is indicated by illumination of the FLCS FAULT caution light and an FLCS AOA FAIL PFL. No degradation in aircraft handling characteristics should be encountered. The first AOA failure signal defaults to 11 degrees to prevent hardover commands if two AOA inputs fail at the upper AOA limit.

A dual AOA failure illuminates the FLCS warning light and triggers an FLCS AOA WARN PFL. The FLCS system code and FLCS AOA FAIL PFL are still present since the first failure is still active. With a dual AOA failure, the FLCC selects the mid AOA value among the remaining good signal, 11 degrees, and the failed signal. Aircraft handling characteristics may be degraded somewhat in the cruise configuration, but should be adequate for landing since the first AOA failure defaulted to 11 degrees.

FLCS RESET may be attempted for any AOA failure. If the first failure does not reset and a second failure occurs, the first failure is latched and cannot be reset.

If FLCS AOA FAIL PFL occurs:

If BRK PWR DEGR PFL is also present, refer to FLCS SINGLE ELECTRONIC FAILURE, this section.

1. Establish 1g flight.
2. FLCS RESET switch - RESET.

If failure indications go off:

3. Continue normal operation.

If failure indications remain on:

3. Land as soon as practical.  
Do not exceed 11 degrees AOA during approach, landing, or two-point aerodynamic braking.

If FLCS AOA WARN PFL occurs:

1. Establish 1g flight.



T.O. GR1F-16CJ-1

2. FLCS RESET switch - RESET.

If FLCS warning light goes off:

3. Land as soon as practical.  
Do not exceed 11 degrees AOA during approach, landing, or two-point aerodynamic braking.

If FLCS warning light remains on:

3. Land as soon as possible.  
Do not exceed 11 degrees AOA during approach, landing, or two-point aerodynamic braking.

### CADC Malfunction

A failure of any of the CADC electrical inputs (AOA, total temperature, altimeter barometric reference, etc.) or a detected failure internal to the CADC causes illumination of the CADC caution light. If the CADC caution light does not reset, systems dependent on CADC information should be checked for proper operation.



Retarding the throttle below MIL while supersonic may induce inlet buzz which produces severe cockpit vibration and probable engine stalls.

### NOTE

If a CADC malfunction occurs, the FLCC AOS feedback function may deactivate.

If CADC caution light illuminates:

1. FLCS RESET switch - RESET.

If CADC caution light goes off:

2. Check for an ENG MACH FAIL PFL.

If ENG MACH FAIL PFL is still present:

3. Continue flight and observe throttle limitation, if supersonic. Refer to PILOT FAULT LIST - ENGINE, this section.

If CADC caution light remains on:

2. AOA - Cross-check with airspeed.  
Use AOA indications with caution.

3. Land as soon as practical.  
Final approach airspeeds:

- **C** PW 229 135, GE129 136 knots

- **D** PW 229 137, GE129 138 knots

- Add 4 knots/1000 pounds of fuel/store weights equates to 13 degrees AOA (add 8 knots for 11 degrees AOA).

### Servo Malfunction

An initial servo malfunction results in illumination of the FLCS FAULT caution light and an ISA LHT/RHT/LF/RF/RUD FAIL PFL for the applicable ISA. A failure of the second servo in the same ISA results in a repeat of the PFL. Multiple servo malfunctions involving more than one ISA cause an ISA ALL FAIL PFL. Servo failures are reset by placing the FLCS RESET switch to RESET. No degradation in flying qualities is expected if the servo does not reset.

Hydraulic failures or momentary drops in hydraulic pressure (e.g., wake turbulence encounter, air in hydraulic system) also illuminate the FLCS FAULT caution light and cause an ISA ALL FAIL PFL.

1. Airspeed - 400 knots maximum (subsonic).

If hydraulic failure is confirmed:

2. Go to SINGLE/DUAL HYDRAULIC FAILURE, this section.

If hydraulic pressures are normal:

3. FLCS RESET switch - RESET.

If failure indications go off:

4. Continue normal operation.

If failure indications remain on:

4. Land as soon as practical.

### FLCS Electronic Malfunctions

Only two single electronic failures are reported in flight. These are a branch power supply failure (BRK PWR DEGR PFL) and a coil current monitor (CCM) detected failure (FLCS CCM FAIL PFL). All other single electronic failures (rate gyro and accelerometer failures, stick sensor failures, single axis failures, and single branch failures) are reported 2 minutes after WOW as an FLCS SNGL FAIL PFL. A momentary, mild transient might be felt when a single electronic failure occurs. Even though display of a single failure is not always provided in flight, a single FLCS failure can be reset.

If a branch fails due to a branch power supply problem, BRK PWR DEGR PFL is displayed. If power fails in branch A, B, or C, then one AOA and one air data input are also failed. This condition is displayed by FLCS AOA FAIL and FLCS ADC FAIL PFL's in addition to the BRK PWR DEGR PFL. A single branch power supply failure may also cause FLCS dual fail indications if the ADV MODE switch is not in the depressed position. This dual failure can be reset as long as the ADV MODE switch is in the depressed position prior to reset. Anytime BRK PWR DEGR occurs, FLCS power supply status should be checked by placing the FLCS PWR TEST switch to the TEST position. If any one of the four FLCS PWR indicator lights does not illuminate, then that branch is not powered and the indicated toe brake in the indicated channel is inoperative.

If the CCM detects an erroneous output command from one of the three servo amplifiers which drive the three ISA servo valves, a backup servo amplifier is energized. FLCS CCM FAIL PFL is then displayed. An FLCS reset may bring the tripped amplifier back on line.

If a dual electronic failure occurs (i.e., two pitch rate gyros, two roll stick sensors, or two power supplies), the FLCS warning light illuminates and an FLCS DUAL FAIL PFL occurs. A reset of a dual failure may be attempted. However, reset is only possible back to the single failure condition, since the single failure is latched if it still existed at the time of the second failure. Branch power status should again be checked with the FLCS PWR TEST switch.

There is a remote possibility that a series of FLCS failures during maneuvering on the CAT I/III AOA limiter can result in centering of and lack of response from one or both horizontal tails. The series of failures starts with a FLCS CCM FAIL PFL and can quickly progress to ISA FAIL PFL's and a FLCS dual failure. Centering of and loss of horizontal tail response only occurs in conjunction with FLCS dual electronic fail indications. This should not be confused with a loss of control associated with a departure from controlled flight. If the aircraft suddenly becomes non-responsive in pitch and FLCS DUAL FAIL indications are present, perform a FLCS reset.

It is possible to receive FLCS dual fail indications following a single failure of the ADV MODE switch when attempting/during ATF operations. The dual-redundant switch has two outputs, each of which are split for use by the four-channel FLCS. If one side of the switch fails, the FLCS warning light illuminates and an FLCS DUAL FAIL PFL occurs. This dual failure can be reset as long as the ADV MODE switch is disengaged prior to reset.

**LESS 116** Vibrations associated with gun firing may cause either a single failure or a dual failure of a

FLCS accelerometer to be declared. These failure declarations occur during gun firing because the four outputs of the accelerometer do not always compare within present software tolerances.

#### FLCS SINGLE ELECTRONIC FAILURE

If BRK PWR DEGR or FLCS CCM FAIL PFL occurs:

1. Establish 1g flight and airspeed less than 400 knots (subsonic).
2. FLCS RESET switch - RESET.

If failure indications go off:

3. Continue normal operation.

If failure indications remain on:

3. FLCS PWR TEST switch - TEST.  
Observe FLCS PWR lights and determine brake and brake channel affected. If branch A, B, or C FLCS PWR light fails to illuminate, use a maximum of 11 degrees AOA for approach, landing, and two-point aerodynamic braking.
4. BRAKES channel switch - Change channels (if required).
5. Land as soon as practical.

#### FLCS DUAL ELECTRONIC FAILURE

If FLCS DUAL FAIL PFL occurs:

1. Establish 1g flight and airspeed less than 400 knots (subsonic).
2. ADV MODE switch - Depress.  
The ATF NOT ENGAGED caution light may illuminate shortly after depressing the ADV MODE switch.
3. FLCS RESET switch - RESET.  
Reset may clear the FLCS warning light; however, the single failure is still present.

If FLCS warning light goes off and no FLCS PFL's are present:

4. Continue normal operation, but do not use ADV MODE switch.

If FLCS warning light goes off and an FLCS PFL is still present:

4. FLCS PWR TEST switch - TEST.  
Observe FLCS PWR lights and determine brake and brake channel affected. If branch A, B, or C FLCS PWR light fails to illuminate, use a maximum of 11 degrees AOA for approach, landing, and two-point aerodynamic braking.

## T.O. GR1F-16CJ-1

5. BRAKES channel switch - Change channels (if required).

6. Land as soon as practical.

If FLCS warning light remains on:

4. FLCS PWR TEST switch - TEST.  
Observe FLCS PWR lights and determine brake and brake channel affected. If branch A, B, or C FLCS PWR light fails to illuminate, use a maximum of 11 degrees AOA for approach, landing, and two-point aerodynamic braking.

5. BRAKES channel switch - Change channels (if required).

6. Land as soon as possible.

### NOTE

- No significant flying qualities degradation should occur; however, with an FLCS dual failure, the FLCS has no redundancy.
- Two minutes after WOW, the FLCS FAULT caution light illuminates and an FLCS SNGL FAIL PFL occurs.

### FLCS Temperature Malfunction

If sensors in any two branches of the FLCC detect temperatures in excess of 75°C, the FLCS FAULT caution light illuminates and the FLCS HOT TEMP PFL is displayed.

If an FLCS HOT TEMP PFL occurs:

1. Airspeed - 400 knots maximum (subsonic).
2. Altitude - 25,000 feet MSL maximum.  
If possible, descend below 15,000 feet MSL.
3. AIR SOURCE knob - RAM.

### WARNING

- With the ECS shut down or the AIR SOURCE knob in OFF or RAM, the g-suit does not inflate and PBG is disabled.
- **PX III** If AIR SOURCE knob is placed to OFF or RAM, OBOGS is inoperative. Activate EOS if OXY LOW warning light illuminates above 10,000 feet cockpit altitude.

### NOTE

External fuel cannot be transferred in OFF or RAM. Consider jettisoning tanks to decrease drag if range is critical and ECS cannot be turned on for short periods of time to transfer fuel.

If failure indications go off:

It may take up to 15 minutes for ram-air cooling to extinguish the light.

4. Land as soon as practical.

If failure indications remain on:

5. Land as soon as possible.

### Autopilot Malfunctions

If the autopilot fails to receive needed data or AOA exceeds 15 degrees, the FLCS FAULT caution light illuminates, the FLCS A/P FAIL PFL is displayed, and the autopilot automatically disengages. If engagement is attempted with a failure or degradation, or AOA above 15 degrees the autopilot does not engage and FLCS A/P FAIL PFL occurs. If ATF is engaged or if engagement is attempted, this failure also causes the ATF NOT ENGAGED caution light to illuminate.

If FLCS A/P FAIL PFL occurs:

1. Establish 1g flight.  
Below 15 degrees AOA.
2. FLCS RESET switch - RESET.

If PFL clears:

3. Continue normal operation.

If PFL remains, autopilot cannot be engaged.

The FLCS FAULT caution light and the FLCS A/P DEGR PFL are displayed during non-TF operations if the autopilot is engaged but is not providing the selected function.

The PFL occurs under the following conditions:

- Attitude hold modes - After 12 seconds of operation outside of attitude limits with no stick input.
- Roll attitude hold mode - After 12 seconds of operation with the autopilot roll command at its maximum authority.

- Pitch attitude and altitude hold modes – After 5 seconds of operation with the autopilot pitch command at its maximum authority, no stick inputs, and aircraft not correcting back to referenced altitude/attitude.

If FLCS A/P DEGR PFL occurs:

1. Maneuver aircraft into autopilot envelope.
2. FLCS RESET switch – RESET.

If PFL clears:

3. Continue normal operation.

If PFL remains:

3. Disengage autopilot.

### DBU ON Warning Light

DBU is entered automatically by detection of a primary software fault. Such a fault is assumed to exist if power is lost in three branches, if three processors fail, or if a three-branch combination of power and processor failures occur. If automatic DBU engagement occurs, toe brake operation may be affected.

Due to the simplicity of the DBU, fault tolerance is reduced and detailed FLCS failure information is not provided. DBU is intended as a backup mode that provides a transition to cruise flight and a return to base capability in the event that a software fault has been encountered within the FLCC.

To transfer back to primary mode after an automatic transfer to DBU, the DIGITAL BACKUP switch must be cycled to BACKUP and then back to OFF. Pitch transients are possible due to horizontal tail position changes when the DIGITAL BACKUP switch is cycled back to OFF. These transients can be minimized by stabilizing at 1g prior to reselecting OFF. If ATF was engaged prior to automatic DBU engagement, a 3g incremental nonroll-to-wings level fly-up is present. Depressing the paddle switch interrupts the fly-up command. Placing the DIGITAL BACKUP switch to BACKUP cancels the fly-up command.

If DBU ON warning light illuminates:

1. Establish 1g flight.  
Do not use abrupt control inputs or make rudder inputs during rolls.
2. Airspeed – 500 knots/0.9 mach maximum.  
If possible, slow to 300 knots.

3. DIGITAL BACKUP switch – Cycle to BACKUP, then back to OFF.

If DBU ON warning light goes off:

Verify that DBU is no longer present on the FLCS page of the MFD.

4. FLCS RESET switch – RESET (if required).
5. Land as soon as practical.  
Do not exceed 500 knots/0.9 mach.

If DBU ON warning light remains on:

4. DIGITAL BACKUP switch – BACKUP.
5. Airspeed – 500 knots/0.9 mach maximum.  
If possible, slow to 300 knots. Avoid abrupt control inputs. Restrict bank angle changes to less than 90 degrees.
6. Controllability – Check.  
Lower LG at safe altitude and check handling qualities at 11-13 degrees AOA. A mild noseup transient of approximately 2 degrees occurs if LG is lowered below 200 knots.
7. FLCS PWR TEST switch – TEST.  
Observe FLCS PWR lights and determine status of toe brakes. If branch A, B, or C FLCS PWR light fails to illuminate, use a maximum of 11 degrees AOA for approach, landing, and two-point aerodynamic braking.
8. BRAKES channel switch – Change channels (if required).
9. Land as soon as possible.  
Plan a straight-in approach.

### TF FAIL Warning Light

The TF FAIL warning light illuminates when a TF malfunction is detected by the NVP or when SWIM failures are detected by the FLCS.

If TF FAIL warning light illuminates:

1. Altitude – As required.  
Climb to minimum enroute altitude (MEA) or depart low altitude environment, if required.
2. Paddle switch – Depress (if required).  
This action interrupts the fly-up in ATF or manual TF (if enabled).
3. PFLD – Check.  
If a SWIM PFL is displayed, the TF malfunction was detected by one or more SWIM monitors.
4. CARA, EGI/INS, and **PX II** FCC, **PX III** MMC – Check for proper operation.

T.O. GR1F-16CJ-1

If SWIM ATF FAIL, SWIM NVP FAIL, SWIM RALT FAIL, or SWIM SCP FAIL PFL is displayed:

5. Paddle switch - Release.

**NOTE**

If the malfunction was detected by SWIM and this malfunction is no longer present, releasing the paddle switch resets the SWIM monitors, cancels the fly-up, and extinguishes the TF FAIL warning light.

If SWIM ATF FAIL, SWIM NVP FAIL, SWIM RALT FAIL, or SWIM SCP FAIL PFL does not clear or recurs:

6. Discontinue TF operations.

If SWIM ATTD FAIL or SWIM VEL FAIL PFL is displayed:

5. Paddle switch - Release.
6. Discontinue TF operations.

**WARNING**

Further TF operations should not be attempted after the occurrence of a SWIM ATTD FAIL or SWIM VEL FAIL PFL.

If no SWIM PFL was present (NVP malfunction):

5. Paddle switch - Release.
6. Perform TFR BIT.

If NVP malfunction still exists:

7. Discontinue TF operations.

**LEF Malfunction (Symmetric)**

A symmetric LEF malfunction may be indicated by an FLCS warning light and an FLCS LEF LOCK PFL. These indicate that one or both of the LEF branches have malfunctioned, that the asymmetry brakes have been activated, or that the LEF have been manually locked.

LEF's will stop and remain fixed in position when an FLCS LEF LOCK PFL occurs. LEF should remain symmetrical (within 10 degrees).

Certain LEF malfunctions do not activate the FLCS LEF LOCK PFL. The presence of higher than normal buffet levels during maneuvering flight and reduced directional stability in the high AOA region are indications that the LEF have failed to schedule properly.

If an FLCS LEF LOCK PFL occurs or a malfunction is suspected (without an FLCS LEF LOCK PFL):

1. AOA - 12 degrees maximum.

**WARNING**

Exceeding 12 degrees AOA reduces departure resistance. Limit rolling maneuvers to a maximum bank angle change of 90 degrees and avoid rapid roll rates.

2. FLCS RESET switch - RESET.

If FLCS warning light resets:

3. Continue flight.

If the FLCS warning light does not reset or a malfunction is suspected (without an FLCS LEF LOCK PFL):

4. Airspeed - Decelerate to subsonic flight if supersonic.
5. LE FLAPS switch - LOCK (after LG is down). Lock LEF's in landing configuration at final approach airspeed at a safe altitude. This makes final approach and landing as normal as possible and protects against uncommanded LEF excursions close to the ground.
6. Land as soon as practical.

With the LEF at or near full up, there are no unique control inputs required. A small increase in airspeed may be noted compared to a normal landing approach at 11 degrees AOA. With the LEF at or near full down, the aircraft may tend to float in ground effect and a slight forward stick force may be required.

During engine shutdown:

7. MAIN PWR switch - Do not place to OFF until engine rpm has reached zero.

**CAUTION**

Placing MAIN PWR switch to OFF before hydraulic pressure is lost may cause damage to two LEF shafts.

**LEF Malfunction (Asymmetric)**

The most likely cause of asymmetric LEF's is a mechanical disconnect in one of the LEF drive trains accompanied by a failure of the asymmetry brake. This failure may not activate the FLCS LEF LOCK PFL or illuminate the FLCS warning light. The first indication of an asymmetry is an uncommanded roll. The failed LEF may be as much as 90 degrees up or down. Adequate roll control is available below 10 degrees AOA at subsonic speeds. Use lateral stick for roll control. Use roll trim to reduce lateral stick force as required. Do not attempt to achieve coordinated flight. Avoid using rudder except to reduce sideslip when stores are jettisoned or to aid in maintaining desired ground track during the final part of landing approach. Do not use rudder trim. If the yaw is away from the failed LEF (i.e., nose left yaw with right LEF failed up), rudder inputs to reduce resulting sideslip actually aggravate the situation by increasing roll control requirements. Accepting some sideslip reduces roll control requirements. To prevent excessive sideslip, maintain AOA as low as practical. Banked flight reduces the amount of heading change due to sideslip-induced heading drift. Lock the good LEF as close to symmetrical as possible to aid in roll control and to prevent transients caused by automatic scheduling. Monitor fuel consumption since significantly higher thrust is required to compensate for the increased drag.

Selectively jettison stores to reduce asymmetry and sideslip and reduce fuel weight as necessary to reduce approach speed. Perform a controllability check. The aircraft tends to roll into the wing with the least lift (i.e., the heavy wing). If the LEF is failed up, lift on that wing is less. If the LEF is failed down, lift on that wing is more or less depending on the failed LEF position and the position at which the other LEF is locked. If there is a significant crosswind, diminish crosswind effects, if possible, by landing with the heavy wing upwind.

Fly a shallow, straight-in approach at approximately 8 degrees AOA (fly no lower than 6 degrees AOA) with minimum roundout for touchdown. Immediately prior to touchdown, use rudder as required to align the aircraft with the runway. Reduce the rate of descent somewhat prior to touchdown, as required, but do not flare or raise the nose above 10 degrees AOA because available roll control is reduced and

heading drift will increase as AOA increases. Lower the nose immediately after touchdown. Directional control should not be a problem.

If LEF asymmetry occurs:

1. AOA - 6-10 degrees.

**WARNING**

- Exceeding 10 degrees AOA may result in insufficient roll authority. Limit rolling maneuvers to gentle roll in with a maximum bank angle of 30 degrees.
  - Flying a fast approach (lower than 6 degrees AOA) presents additional control difficulties caused by a change in the path of the disturbed airflow coming off the failed LEF.
2. Lateral stick/roll trim - As required.

**WARNING**

Minimize rudder inputs. Use rudder as required to reduce sideslip when jettisoning stores or to aid in maintaining desired ground track during the final part of landing approach. Do not use rudder trim.

3. LE FLAPS switch - LOCK.  
Lock operating LEF as near symmetrical as possible.
4. Stores - Jettison (if required).  
Consider selective jettison of stores from the heavy wing as a means to reduce roll control requirements. Refer to SELECTIVE JETTISON, this section.
5. Fuel weight - Reduce (if feasible/required).

**CAUTION**

Reduce fuel weight if fatigue is not a factor. Fuel flow is significantly higher with an LEF failed full up or down and must be considered during recovery.

6. Controllability - Check.  
Lower LG at a safe altitude and check handling qualities at 6-8 degrees AOA.
7. Land as soon as practical.

**WARNING**

- Prior to landing with a significant asymmetric LEF condition, consider aircraft configuration, pilot experience level, pilot arm fatigue, airfield facilities, weather, winds, and light conditions (day/night). If conditions are not favorable, a controlled ejection is recommended.
- If crosswind component is greater than 10 knots, choose a runway, if possible, which allows landing with the heavy wing upwind. Fly a shallow, straight-in approach at approximately 8 degrees AOA (fly no lower than 6 degrees AOA) with minimum roundout for touchdown. Use rudder, as required, to align aircraft with the runway immediately prior to touchdown.

8. Stick - Lower the nose immediately after touchdown.

**CAUTION**

Until WOW, forward stick pressure in excess of approximately 2 pounds results in full trailing edge down deflection of the horizontal tails with reduced directional control and wheel braking effectiveness.

If departure-end arrestment is required:

9. HOOK switch - DN.

**Trim Malfunction**

Trim malfunction is detected by an increase in stick pressure required to maintain the desired attitude or by a lack of response to stick trim inputs.

1. TRIM/AP DISC switch - DISC, then NORM.

If normal operation is not restored:

2. TRIM/AP DISC switch - DISC.  
Autopilot cannot be engaged.
3. ROLL and PITCH TRIM wheels - As required.

**Stick Interference**

**WARNING**

Prior to any ejection seat movement, clear the area around the stick.

Stick interference can occur at anytime for a number of reasons. Known hazards include intentional or unintentional input by the passenger/pilot not in control, the utility light/adjustable sliding holder, or the right lapbelt buckle.

Contact between the right leg/knee and the stick can result in an unintentional right roll command. The resulting right roll may be perceived as a flight control problem especially in the **D** aircraft when a passenger/pilot not in control unknowingly interferes with the stick. The probability of interference is increased with feet on the floor versus feet on the rudder pedals, bulky personal equipment, or g-suit inflation.

**WARNING**

**D** The passenger/pilot not in control must take care not to interfere with the stick as a result of leg/knee movement or g-suit inflation. If stick interference is suspected, the pilot in control should depress the paddle switch to eliminate undesired inputs.

Contact between the utility light/adjustable sliding holder and the stick can result in unintentional stick commands. Unintentional stick commands may be perceived as a flight control problem. If uncommanded stick inputs are encountered, check for interference between the stick and utility light/adjustable sliding holder.

**WARNING**

Failure to properly secure utility light/adjustable sliding holder can result in stick interference. The adjustable sliding holder may become loose and come in contact with the stick. **D** If stick interference is confirmed, undesired inputs may be eliminated by placing the STICK CONTROL switch to the appropriate position and depressing the paddle switch.

If the seat is moved after an object (especially the right lapbelt buckle) becomes lodged between the seat and stick, unintended stick inputs can occur. Reversing the direction of the initial seat movement should correct the situation.

### WARNING

- The lapbelt should remain fastened at all times. If the lapbelt is opened in flight, caution must be taken to insure the right lapbelt buckle does not become lodged between the ejection seat and stick.
- Do not move the seat with the lapbelt disconnected.

## FUEL MALFUNCTIONS

### Fuel Management System PFL

An FMS FAIL PFL indicates that the fuel reference voltage supplied to the **PX II** FCC, **PX III** MMC is out of tolerance. Fuel system effects associated with the PFL range from degraded FCC fuel computations (e.g., BINGO fuel) to degradation/failure of the fuel quantity indicating system. If an FMS FAIL PFL occurs, monitor the FUEL quantity indicator for proper operation.

### Fuel Leak

A fuel leak may first be noticed by visual means, fuel imbalance, an unexpected FWD or AFT FUEL LOW caution light, or an unusually high fuel flow indication. Monitor the totalizer to determine whether or not a leak exists.

If a fuel leak is suspected (indicated by abnormally high fuel flow, by totalizer decreasing at abnormal rate, or by visual means):

1. Range - Maximize.  
If a suitable landing field is not within gliding distance, consider increasing airspeed and altitude (without the use of AB) to maximize range by using fuel which would otherwise be lost.

### WARNING

Avoid negative g flight when either reservoir is not full.

If fuel flow is abnormally high:

2. ENG FEED knob - OFF.  
Leak is in the engine feed line or engine components.
3. Land as soon as possible.  
Consider stores jettison if range is critical. Consider an SFO. Refer to SIMULATED FLAMEOUT (SFO) LANDING, this section.

If fuel flow is normal:

2. ENG FEED knob - NORM.  
A NVP TFR FAIL PFL and a fly-up can occur when NORM is reselected while operating in TFR.

If leak is from the forward system:

3. FUEL QTY SEL knob - Out of NORM.  
This action stops automatic forward fuel transfer.

If external tanks contain fuel:

4. TANK INERTING switch - TANK INERTING to reduce internal tank pressurization.

If external tanks are not installed or when they are empty:

5. AIR REFUEL switch - OPEN.
6. Land as soon as possible.  
Consider stores jettison if range is critical.

If aft fuel imbalance exists (aft CG):

7. AOA - 15 degrees maximum.

### WARNING

Aft fuel heavy (red portion of AL pointer showing) results in increased susceptibility to departure and deep stall conditions. Limit AOA and avoid maximum command rolling maneuvers.

### CAUTION

If two-point aerodynamic braking is used with an aft CG, pitch overshoots may occur and the nozzle, speedbrakes, and ventral fins may contact the runway.



**Fuel Low**

A fuel low caution light may be caused by a fuel leak, trapped external fuel, **PX III** trapped CFT fuel, a fuel imbalance between the forward and aft systems, prolonged AB operation, or a fuel sensing problem.

The FWD FUEL LOW and AFT FUEL LOW caution lights indicate either a reservoir fuel level sensing system malfunction or that reservoir tank quantities are less than:

<b>C</b>	<b>D</b>
FWD 400 pounds	FWD 250 pounds
AFT 250 pounds	AFT 400 pounds

If FWD FUEL LOW and/or AFT FUEL LOW caution light illuminates:

1. Fuel flow - Reduce to the minimum required to sustain flight below 6000 pph.

**WARNING**

Limit fuel flow to the minimum required to sustain flight while the cause of the fuel low light(s) is determined. Avoid negative g flight when either reservoir is not full.

2. ENG FEED knob - NORM.  
A NVP TFR FAIL PFL and a fly-up can occur when NORM is reselected while operating in TFR.
3. FUEL QTY SEL knob - RSVR.  
Leave FUEL QTY SEL knob out of NORM if FUEL quantity indicator displays erroneous information.

If either or both reservoir tanks are low:

**NOTE**

Fuel flow indications may fluctuate with either reservoir empty.

4. Land as soon as possible.  
Consider an SFO. Refer to SIMULATED FLAMEOUT (SFO) LANDING, this section.

If a fuel leak is suspected (indicated by abnormally high fuel flow, by totalizer decreasing at abnormal rate, or by visual means):

5. Go to FUEL LEAK, this section.

If external fuel has not transferred:

6. Go to TRAPPED EXTERNAL FUEL, this section.

**PX III** If CFT fuel has not completely transferred:

7. Go to TRAPPED CFT FUEL, this section.

If forward and aft fuselage fuel is not properly balanced:

8. Go to FUEL IMBALANCE, this section.

If fuel is properly balanced:

**NOTE**

A fuel line between the reservoir and FFP may be ruptured, causing fuel to cycle between tanks in the same system.

9. Land as soon as possible.

If reservoir tanks indicate full:

4. FUEL QTY SEL knob - TEST.

If AL and/or FR pointers test bad, or FUEL quantity indicator is inoperative:

5. Land as soon as possible.  
Consider an SFO. Refer to SIMULATED FLAMEOUT (SFO) LANDING, this section.

If AL and FR pointers test good:

6. Individual fuel quantities - Check and compare with totalizer.  
Monitor reservoir tanks to insure they are maintained full.
7. Land as soon as practical.

**Hot Fuel/Oil or Gravity Feed**

Gravity feed from the reservoirs to the engine occurs after loss of the main and standby generators and failure of either hydraulic system A or the FFP. Failure of the FFP may be detected by improper fuel balance. Fuel continues to be transferred to both reservoirs by siphoning action. Fuel distribution cannot be manually or automatically controlled during gravity feed. Minimize aircraft maneuvering for duration of flight. Due to the ingestion of air into the engine fuel system, engine flameout may occur when either reservoir tank empties. If the standby generator is operating, one boost pump continues to transfer fuel from the **C** forward, **D** aft reservoir to the FFP.

Hot fuel, as indicated by the FUEL/OIL HOT caution light, may result from high speed flight or fuel system/heat exchanger malfunctions. Excess fuel temperatures may result in engine malfunctions. Engine flameout may occur at low flow rates associated with the landing pattern due to hot fuel. Fuel flow above 4000 pph minimizes fuel temperature rise.

**GE129** Hot engine oil, as indicated by the FUEL/OIL HOT caution light, may also result from high speed flight or fuel/oil heat exchanger malfunctions. Sustained engine operation with excessive oil temperature may result in engine damage and/or failure.

If FUEL/OIL HOT caution light illuminates or gravity feed situation exists:

### WARNING

- Engine flameout may occur at low fuel flow rates when in a hot fuel situation.
- Engine flameout may occur when either reservoir tank empties if a gravity feed condition exists.

1. AIR REFUEL switch – Check CLOSE.
2. TANK INERTING switch – Check OFF.
3. Altitude – 10,000 feet maximum (if practical). Minimize aircraft maneuvering for duration of flight.
4. Fuel flow – 4000 pph minimum until landing is assured when in a hot fuel situation.

If FUEL/OIL HOT caution light goes off:

5. Land as soon as practical.

If FUEL/OIL HOT caution light remains on or gravity feed situation exists:

5. Land as soon as possible.  
Consider an SFO. Refer to SIMULATED FLAMEOUT (SFO) LANDING, this section.

### Fuel Imbalance

Refer to figure 3-15. A fuel imbalance when not carrying an external fuel tank(s) indicates a system malfunction. A fuel imbalance when carrying an external fuel tank(s) may be the result of normal system operating tolerances.

## Fuel Imbalance Indications

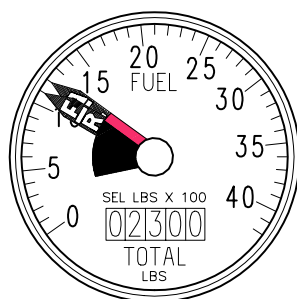

C

### FUEL IMBALANCE WARNING (AFT CG)

Fuel imbalance warning (red portion of AL pointer) shows when forward fuselage fuel (FR) indication is less than aft fuselage fuel (AL) indication.

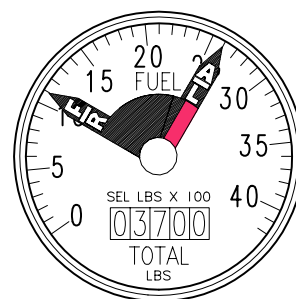

D

### FUEL IMBALANCE WARNING (AFT CG)

Fuel imbalance warning (red portion of AL pointer) shows when forward fuselage fuel (FR) indication is more than 1350 pounds less than aft fuselage fuel (AL) indication.

GR1F-16CJ-1-0127X37 ©

Figure 3-15.

**NOTE**

- Any correction required per total fuel quantity usage with internal fuel only indicates a system malfunction.
- More than one correction per total fuel quantity usage with either a 300-gallon fuel tank or two 370-gallon fuel tanks indicates a system malfunction.
- More than two corrections per total fuel quantity usage with either a 300-gallon fuel tank and two 370-gallon fuel tanks or two 600-gallon fuel tanks indicate a system malfunction.
- More than three corrections per total fuel quantity usage with a 300-gallon fuel tank and two 600-gallon fuel tanks indicate a system malfunction.
- **PX III** Placing the ENG FEED knob to either FWD or AFT during external tank fuel transfer may cause some fuel to enter empty CFT's.

A fuel imbalance is indicated by the red portion of the AL pointer. This may be caused by an FFP malfunction, fuel leak, uneven or partial refueling (either ground or AR), or a malfunction of the automatic forward fuel transfer system. A fuel imbalance may also occur as a result of a main generator failure and an inoperative FFP (FFP malfunction or system A hydraulic failure). In this case, boost pump No. 3 still transfers fuel from the **C** forward, **D** aft reservoir to the engine, creating the imbalance.

An unexpected FWD or AFT FUEL LOW caution light may also be an indication of fuel imbalance; however, verify that forward fuselage fuel and aft fuselage fuel (as indicated by AL and FR pointers with FUEL QTY SEL knob in NORM) are not properly balanced and that a leak does not exist before selecting FWD or AFT ENG FEED.

If fuel imbalance is indicated by AL and FR pointers with FUEL QTY SEL knob in NORM:

1. Fuel flow - Reduce to the minimum required to sustain flight below 6000 pph.

**WARNING**

Limit fuel flow to the minimum required to sustain flight while the cause is determined. Avoid negative g flight when either reservoir is not full.

If aft fuel imbalance exists (aft CG):

2. AOA - 15 degrees maximum.

**WARNING**

Aft fuel heavy (red portion of AL pointer showing) results in increased susceptibility to departure and deep stall conditions. Limit AOA and avoid maximum command rolling maneuvers.

If a fuel leak is suspected (indicated by abnormally high fuel flow, by totalizer decreasing at abnormal rate, or by visual means):

3. Go to FUEL LEAK, this section.

If a fuel leak is not suspected:

4. Fuel quantities - Check.  
Use the FUEL QTY SEL knob to determine if a trapped fuel condition exists. Refer to TRAPPED EXTERNAL FUEL, this section, if required.
5. ENG FEED knob - FWD or AFT.  
Use only to correct a forward and aft fuselage fuel imbalance and not to correct imbalances between reservoirs. Do not exceed 25,000 pph fuel flow while balancing fuel.

If imbalance is not corrected:

6. Land as soon as practical.

**CAUTION**

If two-point aerodynamic braking is used with an aft CG, pitch overshoots may occur and the nozzle, speedbrakes, and ventral fins may contact the runway.

If proper distribution is attained:

6. ENG FEED knob - NORM.  
A NVP TFR FAIL PFL and a fly-up can occur when NORM is reselected while operating in TFR.
7. Fuel balance - Monitor.

**Trapped External Fuel****WARNING**

- A TRP FUEL indication in the HUD may be a symptom of an external fuel leak. If a fuel leak is suspected (indicated by abnormally high fuel flow, by totalizer decreasing at abnormal rate, or by visual means), refer to FUEL LEAK, this section.
- With trapped external fuel, the totalizer does not indicate total usable fuel. Usable fuel is the totalizer quantity less the external fuel quantity.

**NOTE**

**PX III** If either INT WING & CFT indication is greater than 700 pounds and an external tank is empty, go to TRAPPED CFT FUEL, this section.

Certain malfunctions can cause fuel to be trapped in the external tank(s). The tank(s) in which fuel is trapped can be detected by a periodic check of external tank fuel quantities.

Accomplish steps 1 through 8 and 9 (if required) without delay:

**NOTE**

Repeating or undoing any steps may delay transfer.

1. Fuel flow - Minimize.
2. AIR REFUEL switch - Confirm in CLOSE.
3. AIR SOURCE knob - Confirm in NORM or DUMP.
4. TEMP knob - MAN and adjust for comfort. This action usually increases ECS air pressure for external fuel transfer.
5. TANK INERTING switch - TANK INERTING to reduce internal tank pressurization.
6. EXT FUEL TRANS switch - WING FIRST.

**NOTE**

Selecting WING FIRST bypasses electrical components that, if malfunctioning, can prevent fuel transfer from

external wing tanks, the centerline tank, or all three external tanks. With a three tank configuration, the first indication that the centerline tank is feeding is after the external wing tanks are emptied.

7. ENG FEED knob - NORM.  
A NVP TFR FAIL PFL and a fly-up can occur when NORM is reselected while operating in TFR.
8. Stick - Pulse aircraft in pitch several times by applying differential g forces of approximately  $\pm 2g$ .

If the AIR REFUEL switch was initially found in CLOSE (step 2), perform step 9. If the AIR REFUEL switch was initially found in OPEN (step 2), omit step 9.

9. AIR REFUEL switch - OPEN (1 second), then CLOSE.  
Open or close AR door at or below 400 knots/0.85 mach.
10. External tank fuel quantity - Monitor.  
The time required to observe fuel transfer if the malfunction is corrected can vary from 1-3 minutes (for a full centerline tank) to 10-12 minutes (for three external tanks with 500 pounds fuel in each) if reservoir tanks are full (i.e., both air ejectors are off).

**WARNING**

If a trapped external fuel condition is not discovered until either reservoir tank is less than full or a fuel low light is on, sufficient fuel transfer from the external tank(s) may not occur even if the malfunction is corrected. Consider fuselage fuel to be the only usable fuel.

**NOTE**

If trapped external fuel occurs after air refueling and completion of checklist steps did not correct the malfunction, consider descending well below the freezing level to unfreeze the external pressurization and vent valve. Cycling the AR door at lower altitude may restore normal operation.

11. Stores - Jettison (if required).

**Trapped CFT Fuel** **PX III**

**WARNING**

- With trapped CFT fuel, the totalizer does not indicate total usable fuel. Until fuel transfer can be established, fuselage fuel is the only available usable fuel.
- If a trapped CFT fuel condition is not discovered until either reservoir tank is less than full or a fuel low light is on, sufficient fuel transfer from the CFT may not occur even if the malfunction is corrected. Consider fuselage fuel to be the only usable fuel.

If an external tank transfer valve does not close when the tank empties, air pressure is routed to the CFT. This air may completely trap CFT fuel or may cause as much as 800 pounds per side of CFT fuel to vent overboard and trap the remaining CFT fuel.

Typically a centerline tank transfer valve failure will affect both left and right CFT's and an external wing tank transfer valve failure will affect the CFT on the same side. A centerline tank failure may trap fuel in both CFT's and both external wing tanks; in this condition, the CFT fuel must be transferred before the external wing tank fuel can be transferred.

1. Fuel flow - Minimize.
2. EXT FUEL TRANS switch - CFT FIRST / NO FILL.
3. FUEL QTY SEL knob - Check all positions. If INT WING & CFT quantity remains greater than 700 pounds and fuselage fuel is decreasing and an external tank is empty, fuel is trapped in the CFT.

If FWD FUEL LOW and/or AFT FUEL LOW caution light is on:

4. Stores - Retain any external tank containing fuel; jettison any empty external tank and other stores. Refer to JETTISON, this section.
5. AIR REFUEL switch - OPEN for 1 minute then CLOSE.  
Open or close AR door at or below 400 knots/0.85 mach.

**NOTE**

Opening the AR door for 1 minute vents pressure that may prevent transfer of CFT fuel.

If FWD FUEL LOW and AFT FUEL LOW caution lights are off:

4. AIR REFUEL switch - OPEN.  
Open or close AR door at or below 400 knots/0.85 mach.

**NOTE**

Opening the AR door depressurizes external tanks and removes the cause of trapped CFT fuel. It may take from 1 minute (centerline tank) to 4 minutes (centerline tank and two 600-gallon fuel tanks) for external tank air pressure to decrease to zero. With the air source removed, CFT fuel can be transferred. The wing turbine pump capability limits the transfer rate of CFT fuel from the internal wings to the fuselage.

5. Fuel quantities - Monitor.  
The time required to observe fuel transfer can vary from 10-25 minutes after AR door is opened. Because CFT fuel is combined with internal wing fuel, the INT WING & CFT quantity will not immediately decrease. As fuel transfers, the INT WING & CFT quantity indication may be very erratic with jumps of 200 pounds. CFT fuel transfer is best determined by observing a reduction in fuselage fuel usage or an increase in fuselage fuel.

**NOTE**

If no fuel transfer is apparent after 10 minutes with AR door open, consider descending. A descent of 1/3 of the altitude available may speed up the process by increasing air pressure behind the CFT fuel.

When each INT WING & CFT quantity is less than 200 pounds:

6. AIR REFUEL switch - CLOSE.

**NOTE**

Closing the AR door repressurizes the external tank(s). Repressurization may be slow because of the failed external tank and may not be sufficient to obtain normal external tank transfer rate. With EXT TANK TRANS switch in CFT FIRST/NO FILL, the CFT's will remain empty.

If fuselage fuel is not sufficient to recover the aircraft:

**NOTE**

Jettison of the failed empty external tank will immediately remove the source of air trapping the CFT fuel. Jettison does not improve the fuel transfer rate. However, once the failed

tank is removed, the AR door can be closed so that the fuel system pressure will increase and improve the CFT transfer rate. Fuel in any remaining external tank(s) may also transfer to fill the internal wing.

7. Jettison empty external tank(s).
8. AIR REFUEL switch - CLOSE.

## HYDRAULIC MALFUNCTIONS

A hydraulic system failure is indicated by illumination of the HYD/OIL PRESS warning light, FLCS FAULT caution light, and ISA ALL FAIL PFL. The HYD/OIL PRESS warning light illuminates whenever either hydraulic system pressure drops below 1000 psi. The ISA ALL FAIL PFL may occur prior to the HYD/OIL PRESS warning light.

With system B hydraulic failure, perform alternate LG extension with the LG handle up. This action reduces the possibility of failing to unlock a LG door actuator or the NLG extend/retract actuator due to low or fluctuating system B hydraulic pressure.

### Single Hydraulic Failure

#### WARNING

If hydraulic failure is due to structural damage (e.g., battle damage, midair collision, bird strike, fire, or hard landing), the other system may be damaged and failure can occur with little warning. The HYD PRESS indicator may show normal pressure until system fluid is depleted.

#### SYSTEM A FAILURE

The FLCS ISA's are operating in the nonredundant mode and the speedbrakes and FFP are inoperative.

1. Land as soon as practical.  
Make smooth control inputs and plan to fly a straight-in approach.
2. System B HYD PRESS indicator - Monitor.
3. Fuel balance - Monitor.  
Fuel distribution must be controlled manually.

#### SYSTEM B FAILURE

#### NOTE

EPU RUN light on may indicate a dual hydraulic or PTO shaft failure.

The FLCS ISA's are operating in the nonredundant mode and normal braking, NWS, AR door operation, gun operation, and normal LG extension are lost. Low hydraulic pressure may cause one or more LG actuators to remain locked in the LG up position. LG extension should be attempted in sufficient time to

prepare for possible LG up landing. Drag chute operation is normal using drag chute accumulator pressure. Braking is available using brake/JFS accumulator pressure. The fully charged brake/JFS accumulators contain sufficient fluid for at least 75 seconds of continuous brake application. Use aerodynamic braking to the maximum extent possible. A single moderate and steady brake application without cycling the antiskid should then be applied. After stopping, engage the parking brake. If there is reason to believe that the brake/JFS accumulators are depleted or that directional control may be a problem, an approach-end arrestment should be considered.

1. Land as soon as practical.  
Make smooth control inputs and plan to fly a straight-in approach.
2. ALT GEAR handle - Pull (190 knots maximum, if practical).  
Alternate LG extension can be used up to 300 knots; however, the NLG may not fully extend until 190 knots. Time above 190 knots should be minimized in case there is a leak in the pneumatic lines.

#### CAUTION

- NWS is not available following alternate LG extension.
  - Do not depress the ALT GEAR reset button while pulling the ALT GEAR handle. This action may preclude successful LG extension.
3. LG handle - DN. (Use DN LOCK REL button if required.)

#### WARNING

If LG handle does not lower, select BRAKES CHAN 2 and position ALT FLAPS switch to EXTEND. **PW 229** Nozzle remains closed resulting in higher than normal landing thrust.

4. HOOK switch - DN (if required).  
Braking is available using brake/JFS accumulators only. To avoid brake activation and loss of brake/JFS accumulator pressure, do not rest feet on brake pedals. If the brake/JFS accumulators are depleted or if directional control may be a problem, consider an approach-end arrestment. Refer to CABLE ARRESTMENT, this section.

After landing:

- 5. Stop straight ahead and engage parking brake.

**CAUTION**

- Brakes should be applied in a single, moderate, and steady application without cycling the antiskid.
- Brake pedal deflection of 1/16 inch activates the brakes and bleeds the brake/JFS accumulators. To avoid brake activation and loss of brake/JFS accumulator pressure, do not rest feet on brake pedals.
- Do not attempt to taxi clear of the runway. Loss of brake/JFS accumulator pressure results in the inability to stop or steer the aircraft.

**Dual Hydraulic Failure**

A dual hydraulic system failure can be detected by sluggishness or lack of response to flight control inputs, decreasing pressure readings on both HYD PRESS indicators, and associated warning and caution lights. The EPU automatically provides hydraulic pressure for system A when pressure of both hydraulic systems drops below 1000 psi. The systems affected by dual hydraulic system failure after the EPU is running are the same as those affected by system B failure. Refer to SYSTEM B FAILURE, this section.

- 1. EPU switch - ON (if EPU run light is off).
- 2. System A HYD PRESS indicator - Check pressure increasing.

If hydraulic pressure does not increase or control response is lost:

- 3. Eject.

If system A hydraulic pressure is restored:

- 3. EPU run light - Check light on at idle thrust.

**NOTE**

Before landing, confirm that the EPU operates (EPU run light is on) with the throttle in IDLE. If the EPU run light goes off, refer to ABNORMAL EPU OPERATION, this section.

- 4. Land as soon as possible. Make smooth control inputs and plan to fly a straight-in approach.
- 5. ALT GEAR handle - Pull (190 knots maximum, if practical). Alternate LG extension can be used up to 300 knots; however, the NLG may not fully extend until 190 knots. Time above 190 knots should be minimized in case there is a leak in the pneumatic lines.

**CAUTION**

- NWS is not available following alternate LG extension.
- Do not depress the ALT GEAR reset button while pulling the ALT GEAR handle. This action may preclude successful LG extension.
- 6. LG handle - DN. (Use DN LOCK REL button if required.)

**WARNING**

If LG handle does not lower, select BRAKES CHAN 2 and position ALT FLAPS switch to EXTEND. **PW 229** Nozzle remains closed resulting in higher than normal landing thrust.

- 7. HOOK switch - DN (if required). Braking is available using brake/JFS accumulators only. To avoid brake activation and loss of brake/JFS accumulator pressure, do not rest feet on brake pedals. If the brake/JFS accumulators are depleted or if directional control may be a problem, consider an approach-end arrestment. Refer to CABLE ARRESTMENT, this section.

After landing:

- 8. Stop straight ahead and engage parking brake.



**CAUTION**

- Brakes should be applied in a single, moderate, and steady application without cycling the antiskid.
  - Brake pedal deflection of 1/16 inch activates the brakes and bleeds the brake/JFS accumulators. To avoid brake activation and loss of brake/JFS accumulator pressure, do not rest feet on brake pedals.
  - Do not attempt to taxi clear of the runway. Loss of brake/JFS accumulator pressure results in the inability to stop or steer the aircraft.
9. Refer to ACTIVATED EPU/HYDRAZINE LEAK, this section.

**System B and Generator Failure (PTO Shaft)**

A PTO shaft failure is indicated by failure of hydraulic system B, the main and standby generators, and the FLCS PMG. The EPU should start automatically to provide emergency hydraulic and electrical power. After accomplishing the appropriate emergency procedures, refer to EMERGENCY POWER DISTRIBUTION, this section, to determine inoperative equipment.

**NOTE**

**PX II** The VHF radio is not powered when the EPU is running or the main generator is off line.

1. EPU switch - ON (if EPU run light is off).  
If EPU run light is off and control response is lost:
2. Eject.  
If EPU run light is on:
3. Throttle - As required.

**CAUTION**

Stall protection may be lost. Do not retard throttle below MIL until subsonic.

4. ADI - Check for presence of OFF and/or AUX warning flags.  
If warning flag(s) is in view, refer to EGI FAILURE/TOTAL INS FAILURE, this section.

**WARNING**

**PX II** If only AUX flag is in view, pitch and roll attitude information is likely to be erroneous due to INS autorestart in the attitude mode when other than straight and level, unaccelerated flight conditions existed.

5. Fuel balance - Monitor.
6. EPU run light - Check light on at idle thrust.

**NOTE**

Before landing, confirm that the EPU operates (EPU run light is on) with the throttle in IDLE. If the EPU run light goes off, refer to ABNORMAL EPU OPERATION, this section.

7. Land as soon as possible.  
Make smooth control inputs and plan to fly a straight-in approach.
8. ALT GEAR handle - Pull (190 knots maximum, if practical).  
Alternate LG extension can be used up to 300 knots; however, the NLG may not fully extend until 190 knots. Time above 190 knots should be minimized in case there is a leak in the pneumatic lines.

**CAUTION**

- NWS is not available following alternate LG extension.
  - Do not depress the ALT GEAR reset button while pulling the ALT GEAR handle. This action may preclude successful LG extension.
9. LG handle - DN. (Use DN LOCK REL button if required.)

**WARNING**

If LG handle does not lower, select BRAKES CHAN 2 and position ALT FLAPS switch to EXTEND. **PW 229** Nozzle remains closed, resulting in higher than normal landing thrust.

10. HOOK switch - DN (if required).  
Braking is available using brake/JFS accumulators only. To avoid brake activation and loss of brake/JFS accumulator pressure, do not rest feet on brake pedals. If the brake/JFS accumulators are depleted or if directional control may be a problem, consider an approach-end arrestment. Refer to CABLE ARRESTMENT, this section.

After landing:

11. Stop straight ahead and engage parking brake.

**CAUTION**

- Brakes should be applied in a single, moderate, and steady application without cycling the antiskid.
  - Brake pedal deflection of 1/16 inch activates the brake/JFS accumulators. To avoid brake activation and loss of accumulator fluid, do not rest feet on the brake pedals.
  - Do not attempt to taxi clear of the runway. Loss of brake/JFS accumulator pressure results in the inability to stop or steer the aircraft.
12. EPU switch - OFF.
13. Refer to ACTIVATED EPU/HYDRAZINE LEAK, this section.

**EGI FAILURE PX III**

Most EGI failures are apparent and affect flight operations significantly.

**WARNING**

It is possible for the displayed ADI and/or HUD attitude to be in error with no ADI OFF or AUX warning flags in view and without an EGI or HUD MFL/PFL. Displayed HSI and/or HUD headings may also be in error with no HSI OFF or ADI AUX warning flags in view and without an EGI or HUD MFL/PFL. Momentary warning flags may indicate impending failure. To detect these failures and maintain proper flight orientation, basic and backup instruments must be cross-checked.

If the autopilot is engaged when an EGI failure occurs or during an in-flight alignment (IFA) or attitude alignment (ATT), uncommanded pitch and roll flight control inputs may occur.

**WARNING**

The autopilot does not automatically disengage with EGI failures. Failure to manually disconnect the autopilot may result in an unusual aircraft attitude and disorientation.

The most likely cause of an EGI failure is loss of primary and backup power to the EGI, causing a shutdown. The EGI may also fail or shutdown due to internal failures. The primary indication of an EGI failure is the loss of attitude information (OFF and AUX flags may be displayed on the ADI) and HSI data. With ADI OFF and AUX flags displayed or during an HSI failure, EGI MFL/PFL's may be displayed.

**NOTE**

The EGI may continue to provide useful attitude and navigation data with the occurrence of EGI MFL/PFL's. If the ADI OFF and AUX flags are not displayed and data on the ADI and HSI can be confirmed as valid, selection of IFA or ATT will result in loss of the existing attitude and navigation data and the fault condition may prevent successful completion of the alignment.

The emergency procedures for an EGI failure with ADI OFF and AUX flags in view require either an in-flight or an ATT alignment. An in-flight alignment is preferred as it will provide complete navigation capability (heading, attitude, steerpoint steering). In addition, an in-flight alignment uses GPS information and aircraft movement to derive an attitude referenced to the horizon.

The attitude information derived from an ATT alignment is based on the aircraft attitude that existed when the ATT alignment was accomplished.

The ATT alignment can provide attitude information in approximately 10 seconds whereas an in-flight alignment requires approximately 1 minute to obtain attitude information.

There are two in-flight alignment selections – AUTO IFA and MAN IFA. AUTO IFA is a GPS-based alignment internal to the EGI. MAN IFA is a master navigation filter based alignment that can use GPS data or manual fix taking if GPS is unavailable. The four options (listed from best to worst performance) are AUTO IFA, MAN IFA (with GPS), MAN IFA (with fix taking), and ATT. Refer to T.O. GR1F-16CJ-34-1-1 for more detailed in-flight alignment procedures.

If ADI OFF and AUX flags are in view or attitude is erroneous:

1. EGI knob – OFF for 10 seconds.
2. Attitude – Establish straight, level, and unaccelerated flight.
3. EGI knob – AUTO IFA.
4. Attitude – Maintain straight, level, and unaccelerated flight until ALIGN replaces STBY in the HUD and ADI AUX flag is out of view.
5. In-flight alignment – Accomplish.

#### NOTE

Constant altitude ( $\pm 200$  feet) coordinated turns (bank angle less than 45 degrees) to change heading by 45 to 90 degrees and holding the heading for 1 minute will assist completion of the alignment.

6. EGI knob – NAV after Max-g replaces ALIGN in the HUD and RDY is removed from the DED EGI page.
7. ADI, HUD, and HSI – Verify accuracy of attitude and navigation data.

If the AUTO IFA fails to complete after 10 minutes, consider attempting a MAN IFA with GPS or with fix taking:

8. EGI knob – OFF for 10 seconds.
9. Attitude – Establish straight, level, and unaccelerated flight.
10. EGI knob – MAN IFA.

11. Enter best available magnetic heading on the DED MAN INFLT ALIGN page.
12. Attitude – Maintain straight, level, and unaccelerated flight until ALIGN replaces STBY in the HUD and ADI AUX flag is out of view.
13. In-flight alignment – Accomplish.

#### NOTE

- Fix taking procedures may be required as indicated on the DED MAN INFLT ALIGN page.
  - Constant altitude ( $\pm 200$  feet) coordinated turns (bank angle less than 45 degrees) to change heading by 45 to 90 degrees and holding the heading for 1 minute will assist completion of the alignment.
14. EGI knob – NAV after Max-g replaces ALIGN in the HUD and RDY is removed from the DED EGI page.
  15. ADI, HUD, and HSI – Verify accuracy of attitude and navigation data.

If the MAN IFA fails to complete after 10 minutes, the attitude mode should be attempted:

16. EGI knob – OFF for 10 seconds.
17. Attitude – Establish straight, level, and unaccelerated flight.
18. EGI knob – ATT.
19. Attitude – Maintain straight, level, and unaccelerated flight until ADI OFF warning flag goes out of view after approximately 10 seconds.
20. ADI and HUD – Verify attitude information is correct.
21.   INSTR HDG knob – Slew HSI to match best available magnetic heading.

#### INS FAILURES PX II

Most INS failures are apparent and affect flight operations significantly.

An FLCS A/P FAIL PFL occurs if the autopilot is engaged during an in-flight alignment. The PFL can be cleared after a full alignment is achieved by doing an FLCS reset.

**Total INS Failure PX II**

A total INS failure is normally indicated by the INS BUS FAIL PFL. The ADI freezes with OFF and AUX warning flags in view; the HSI compass card and bearing pointer freeze; the HUD pitch ladder, heading scale, roll scale, and FPM also blank; magnetic heading is displayed only on the magnetic compass; the FLCC AOS feedback function is deactivated; and attitude reference is available only on the SAI. When the INSTR MODE knob is in TCN the HSI course deviation indicator, RANGE indicator, and TO-FROM indicator are operative, and the capability to fly an inbound (or outbound) radial to (or from) a TACAN station is available.

**WARNING**

It is possible for the displayed ADI and/or HUD attitude to be in error with no ADI OFF or AUX warning flags in view and without an INS or HUD PFL. Displayed HSI and/or HUD headings may also be in error with no HSI OFF or ADI AUX warning flags in view and without an INS or HUD PFL. Momentary warning flags may indicate impending failure. To detect these failures and maintain proper flight orientation, basic and backup instruments must be cross-checked. Refer to T.O. GR1F-16CJ-34-1-1 for more detailed in-flight alignment procedures.

1. INS knob - OFF for 10 seconds.
2. Attitude - Straight, level, and unaccelerated.
3. INS knob - IN FLT ALIGN.
4. Magnetic heading - Enter.
5. Attitude - Straight, level, and unaccelerated until ADI OFF warning flag goes out of view after approximately 10 seconds.
6. Auto or manual in-flight alignment - Accomplish.

Minimum performance is available with return of the HUD FPM; return of MAX G indicates full performance. INS knob can remain in IN FLT ALIGN to insure the highest performance by continuing the INS updating process.

**NOTE**

Limit vertical maneuvering until the FPM is displayed on the HUD. Failure to do so could delay or prevent completion of the in-flight alignment.

If ADI OFF and/or AUX warning flag remains in view, alignment is not possible and the attitude mode should be attempted:

7. INS knob - OFF for 15 seconds.
8. INS knob - ATT.
9. Attitude - Straight, level, and unaccelerated until ADI OFF warning flag goes out of view after approximately 10 seconds.
10. ADI and HUD- Verify attitude information correct.
11. C DF INSTR HDG knob - Slew HSI to match best available magnetic heading.

**OUT-OF-CONTROL RECOVERY**

Refer to OUT-OF-CONTROL CHARACTERISTICS, Section VI, for a detailed discussion of flight characteristics and indications during departures, deep stalls, spins, and recoveries.

In order to prevent a departure, immediately initiate recovery after the low speed warning tone comes on. Prompt recovery is even more critical with heavyweight loadings or during hard maneuvering since the airspeed bleedoff is more rapid. Additionally, a yaw departure may be prevented if controls are promptly neutralized following an uncommanded nose slice or roll hesitation.

In order to minimize time and altitude loss following a departure, immediately release the stick and rudder controls. The aircraft should be allowed the opportunity to self-recover. Self-recoveries usually occur within the first two postdeparture pitch oscillations, and may take up to 10-20 seconds. Recovery is indicated by the nose dropping and the AOA remaining below 25 degrees. Fly the aircraft at a low AOA until airspeed reaches 200 knots or more (if altitude permits) and recover from the resulting dive. If the departure does not result in self-recovery, then the aircraft is in a deep stall or spin.

PW 229 Departures at high altitude may result in an engine stall. If in AB during an out-of-control situation, retard the throttle to MIL. If at MIL or below, do not move the throttle. Do not advance the throttle until beginning the dive recovery.

**GE129** Departures at high altitude may result in an engine stall. Prolonged negative g flight at a high engine thrust level may result in an engine bearing failure. Retard the throttle to IDLE. Do not advance the throttle until beginning the dive recovery.

Upright deep stalls may be very stable with little or no pitch motions or may be very oscillatory with large pitch, roll, and yaw motions. Generally, a clean configuration results in a deep stall with a near wings-level pitching motion.

During upright deep stalls with a centerline store, particularly a 300-gallon fuel tank, the aircraft tends to roll and yaw right while pitching up, and roll and yaw left while pitching down. During deep stalls with 370-gallon fuel tanks, the aircraft nose motion appears triangular. This motion is characterized by a roll and yaw right while pitching up, followed by a pitch down, a hesitation, and yaw to the left.

In an upright deep stall or spin, the yaw rate limiter automatically provides antispin controls and the rudder authority limiter prevents pilot yaw commands. The yaw rate limiter is effective in preventing spins with almost all CAT I loadings. However, following a yaw departure above 25,000 feet, aircraft with CAT I loadings that have all the following characteristics may spin:

- Centerline store.
- Inlet mounted pod(s).
- Lateral asymmetry greater than 300 pounds at stations 1, 2, or 3.

Upright spins following a yaw departure can be disorienting. The initial portion of the spin is characterized by highly oscillatory motions and a high yaw rate (70 to 100 degrees per second). Initially, the aircraft spins roughly around the aircraft's flight path at departure. As the spin continues, the rotation axis eventually becomes vertical. Very noticeable forward g (eyeballs out) and sideforces are present.

In a spin, the yaw rate must be allowed to subside before the aircraft can be recovered. This may require 20 to 30 seconds. Pitch, roll, and yaw oscillations associated with a deep stall should not be confused with the continuous yaw rotation of a spin. When the yaw rotation subsides, the aircraft will either recover or will settle into an upright deep stall.

In an inverted deep stall or spin, the yaw rate limiter automatically provides rudder against the yaw rate. Roll and rudder commands should be avoided. Pilot roll and rudder commands are inhibited when MPO is engaged.

The aircraft must be rocked out of a deep stall with the MPO switch held in OVRD until recovery is complete. The MPO switch allows the pilot to use the horizontal tail surfaces to reinforce pitch oscillations until the pitch rates are sufficient for recovery. When sufficient nosedown pitch rate is generated to reduce the AOA below the deep stall AOA, the aircraft will recover.

The MPO switch must remain in the OVRD position during pitch rocking. If the MPO switch is released, the horizontal tails reposition to reduce AOA and may negate any pitch oscillations. Additionally, if the MPO switch is positioned to OVRD without any stick commands, the horizontal tails streamline and prevent recovery.

In an upright deep stall, begin pitch rocking in-phase with nose movement; i.e., if the nose is pitching up, pull back on the stick. Maintain aft stick until the maximum pitch attitude is reached, which is indicated by the nose stopping and reversing direction, and then push full forward on the stick to generate a nosedown pitch rate. If the nosedown pitch rate is high enough to break the deep stall, the aircraft will recover.

During some upright deep stalls, the aircraft may be stable with essentially no pitching motion. In these cases, pull full aft stick (away from the ground) and monitor nose movement. If nose movement occurs, continue stick cycling in-phase. If nose movement is not apparent after 3-4 seconds, then push full forward on the stick to generate a nosedown pitch rate. This nosedown pitch rate may be sufficient to reduce AOA below the deep stall AOA and recover the aircraft. If the nose does not continue down but reverses and starts up, pull back on the stick and continue to reinforce these pitch cycles. Proper pitch rocking is accomplished by allowing the nose to lead stick motion; i.e., when nose movement reverses, the stick should be reversed. When sufficient nosedown pitch rate is generated to reduce the AOA below the deep stall AOA, the aircraft will recover.

During upright deep stalls that are not stable, roll and yaw motions make it more difficult to determine proper recovery inputs; however, pitch attitude is still the best indication available. This pitch attitude is determined by the nose position with respect to the horizon. If unable to determine pitch motions with outside references, the ADI may be useful.

With proper stick cycling, the magnitude of the pitch oscillations progressively increases until large enough for recovery. Rapid fore and aft cycling of the stick or cycling out of phase with the pitching motion of the aircraft will not be effective and may prevent recovery. Pitch inputs must be abrupt and maximum command. Pitch inputs that are smooth or less than

maximum command do not generate pitch rate as effectively, and may prevent recovery. Normally, only one or two correctly applied cycles are required to break a deep stall; however, the presence of stores, particularly a 300-gallon fuel tank or 370-gallon fuel tanks, may necessitate five or more properly executed stick cycles for recovery. Altitude loss is approximately 1000-1500 feet per pitch rock cycle.

If inverted, the same pitch rocking procedures apply except if no pitch motion is apparent, the first stick command should be full forward (away from the ground). Inverted deep stalls are generally stable, regardless of the stores configuration. Yaw oscillations may be noticed, but do not affect recovery.

If the pitch rate is still high as the aircraft recovers, there may be a tendency for the aircraft to continue pitching through to a deep stall in the other direction. Attempt to stop the nose in a near vertical dive by tracking a spot on the ground. If the aircraft does transition to an opposite AOA deep stall, it may be very disorienting; however, pitch oscillations are generally high and recovery should be rapid with a few properly executed stick cycles. Recovery is confirmed by the nose remaining down and the AOA remaining in the normal range. As the airspeed increases above 200 knots, release the MPO switch, maintain neutral roll and yaw commands, and apply pitch commands as required to recover from the resulting dive using MIL/AB thrust.

**WARNING**

- Recovery from a deep stall condition will present a low airspeed situation in which the aircraft may require more than 6000 feet of altitude to attain level flight.
- If recovery (pitch rate stopped, AOA within -5 to +25 degrees, and airspeed 200 knots or greater) is not apparent by 6000 feet AGL, eject.

The engine may stall when out of control. Also, FLCS failure indications may occur. Ignore these indications and concentrate on recovery.

In the event of a departure from controlled flight, accomplish as much of the following as required to effect a recovery:

1. Controls - Release.
2. Throttle - **GE129** IDLE, **PW 229** MIL if in AB. **PW 229** If other than AB, do not move the throttle.

If still out of control:

Positive g, AOA indicator pegged at 32 degrees (upright deep stall) or negative g, AOA indicator pegged at -5 degrees (inverted deep stall).

3. MPO switch - OVRD and hold. Maintain firm pressure.

**WARNING**

- The MPO switch must be held in the OVRD position until the deep stall is positively broken as evidenced by the pitch rate stopping, AOA in the normal range (-5 to +25 degrees), and airspeed increasing above 200 knots. Early release of the MPO switch may delay recovery.
- Failure to adequately secure and tighten lapbelt may result in inability to reach and operate the MPO switch during out-of-control situations.

4. Stick - Cycle in-phase.

**WARNING**

Pitch rocking with a high sustained yaw rate may prevent recovery. Delay stick inputs until yaw rotation stops or is minimized. Pitch, roll, and yaw oscillations associated with a deep stall should not be confused with the continuous yaw rotation associated with a spin.

**OXYGEN MALFUNCTION **PX II****

The OXY LOW caution light indicates oxygen quantity below 0.5 liter or pressure below 42 psi.

If OXY LOW caution light illuminates:

1. Cockpit pressure altitude - 10,000 feet maximum.

If unable to descend immediately:

2. Emergency oxygen - Activate.
3. Oxygen hose - Disconnect.

## ■ OBOGS MALFUNCTION **PX III**

An OBOGS malfunction may be indicated by either an OXY LOW warning light or difficulty in breathing through the oxygen mask. An OXY LOW warning light is activated by low partial pressure of oxygen (PPO<sub>2</sub>), regulator pressure falling below 5 psi, or a monitor failure. Difficulty in breathing through the mask may indicate an OBOGS malfunction combined with a failure in the warning light circuit. If difficulty in breathing through the mask occurs, activate EOS if above 10,000 feet cockpit altitude, descend, and land as soon as practical.

If OXY LOW warning light illuminates:

1. OXYGEN regulator pressure and cockpit altitude - Check.

If pressure is less than 5 psi and cockpit altitude is above 10,000 feet, or if pressure is greater than 5 psi and cockpit altitude is above 25,000 feet:

2. EOS - Activate.
3. Altitude - Descend to cockpit altitude below 10,000 feet.
4. Land as soon as practical.

If pressure is less than 5 psi and cockpit altitude is below 10,000 feet:

2. Land as soon as practical.  
Do not exceed cockpit altitude of 10,000 feet.

If pressure is greater than 5 psi and cockpit altitude is below 25,000 feet:

2. Diluter lever - 100%.

If OXY LOW warning light goes off within 10 seconds: Partial pressure of oxygen is sufficient for operation in 100% but is not sufficient for operation in NORM.

3. Continue mission with diluter lever in 100%.

If OXY LOW warning light remains on or diluter lever was in 100% when light illuminated:

4. OBOGS BIT switch - BIT.

If OXY LOW warning light remains on steady: Partial pressure of oxygen is not sufficient.

5. EOS - Activate if cockpit altitude is above 10,000 feet.

6. Altitude - Descend to cockpit altitude below 10,000 feet.

7. Land as soon as practical.

If OXY LOW warning light begins flashing when BIT is selected:

OBOGS monitor has failed.

5. OBOGS BIT switch - BIT.  
Returns OXY LOW warning light to steady.
6. Altitude - Descend to cockpit altitude below 10,000 feet.
7. Land as soon as practical.

## PBG MALFUNCTION

A malfunction of the oxygen regulator while in PBG may cause excessive pressure or failure of pressure to decrease when g is reduced.

If excessive pressure is experienced or high pressure continues after g is reduced:

1. OXYGEN mode lever - ON.

If pressure is not relieved:

2. Oxygen hose - Disconnect.
3. Cockpit pressure altitude - 10,000 feet maximum.

If unable to descend immediately:

4. Emergency oxygen - Activate.
5. Land as soon as practical.

## SMOKE OR FUMES

All unidentified odors will be considered toxic. Do not take off when unidentified odors are present. Do not confuse ECS condensation for smoke.

If smoke or fumes are detected:

1. OXYGEN REGULATOR - Check ON, 100%, and EMER.

## NOTE

The emergency oxygen bottle is not recommended for use in the smoke and fumes environment unless aircraft oxygen supply contamination is suspected. Activation of the emergency oxygen bottle does not prevent cockpit smoke or fumes from entering the oxygen mask.

## T.O. GR1F-16CJ-1

- Altitude – 25,000 feet maximum.
- Airspeed – 500 knots maximum.
- AIR SOURCE knob – RAM.  
External fuel cannot be transferred in OFF or RAM. Consider jettisoning tank(s) to decrease drag if range is critical and the ECS cannot be turned on for short periods of time to transfer fuel.

### **WARNING**

**PX III** If AIR SOURCE knob is placed to OFF or RAM, OBOGS is inoperative. Activate EOS if OXY LOW warning light illuminates above 10,000 feet cockpit altitude.

- Nonessential electrical equipment – Off.

### **NOTE**

If in VMC and the ADI and HSI are not required for flight, the EGI/INS should be considered nonessential.

- Determine cause of smoke or fumes and correct (if possible).

### **NOTE**

- Smoke in the cockpit may be indicative of an engine oil system malfunction. If possible, retard throttle to lowest setting possible to sustain flight and monitor the OIL pressure indicator. Refer to OIL SYSTEM MALFUNCTION, this section, if appropriate.
- Any odor that smells of burning flesh may be indicative of bird ingestion into the engine. Monitor engine instruments for signs of abnormal operation.

- Land as soon as possible.

If cockpit visibility precludes safe operation:

- Airspeed – 180 knots maximum.
- Seat – Full down.
- ALT FLAPS switch – EXTEND.
- Canopy – Jettison.

## LANDING EMERGENCIES

Generally, the type of pattern flown in an emergency is either an SFO or straight-in approach and depends on several factors:

- Nature of the emergency.
- Weather conditions.
- Day or night.
- Proximity of a suitable landing runway.
- Fuel status.

### STRAIGHT-IN LANDING

A straight-in landing is recommended for emergencies which dictate minimum maneuvering inputs such as hydraulic, flight control, or electrical problems or situations which result in a relatively high thrust level being maintained to touchdown such as a stuck or closed nozzle or when the engine is operating satisfactorily in SEC. A controllability check should be accomplished prior to commencing the approach if minimum flying airspeeds or control difficulties are experienced or are anticipated.

### **NOTE**

When landing in SEC, an increased ground roll distance is required due to higher idle thrust.

### SIMULATED FLAMEOUT (SFO) LANDING

Anytime engine failure is anticipated (abnormal engine response, oil system failures, low fuel, etc.), an SFO landing should be performed. At or just prior to high key, turn the EPU on, and if engine seizure is not anticipated, turn the JFS on and verify their operation (EPU run and JFS RUN lights on). If the engine is still running at touchdown, the JFS shuts down at WOW.

Fly the SFO pattern and landing in accordance with the procedures for FLAMEOUT LANDING, this section. If the engine fails, this action provides sufficient energy to safely land the aircraft or to zoom and eject if a safe landing cannot be made.



An SFO landing is not recommended when landing with the engine operating satisfactorily in SEC. The higher level of idle thrust may result in a long and fast landing and difficulty stopping the aircraft.

To simulate an engine out glide with the LG up, use idle thrust and 30 degrees speedbrakes. From the front cockpit, this equates to the intersection of the top of the speedbrakes and a line drawn from the tip of the horizontal tail to the top of the vertical tail root fairing. To simulate an engine out glide with the LG down, use idle thrust and 20 degrees speedbrakes. From the front cockpit, this equates to the intersection of the top of speedbrakes and a line drawn from the tip of the horizontal tail to the base of the vertical tail root fairing. The additional drag produced during an engine-out condition is equivalent to retaining stores with a drag index of 170 with the LG up or 70 with the LG down. If stores are retained, adjust speedbrake deflection accordingly. If the engine fails, close speedbrakes and jettison stores.

When flying an SFO approach with the engine operating at a higher thrust level than normal idle, control descent rate and airspeed with the speedbrakes rather than adjust the ground track. If thrust is excessively high or if landing on a runway where stopping distance may be critical, the procedures for ABNORMAL ENGINE RESPONSE, this section, should be considered.

### **WARNING**

On runways with less than 8000 feet and without arresting gear or drag chute, there may be insufficient distance to safely stop the aircraft.

After touchdown from an SFO landing, use a normal or short field stopping technique as required by the stopping distance available. Extend the hook if required. If the engine rpm is greater than normal with the throttle in IDLE or some other malfunction requires excessive braking action to maintain a safe taxi speed, the brakes may absorb a high amount of energy in a short period of time. If required, refer to HOT BRAKES, this section.

### **CONTROLLABILITY CHECK**

When structural damage or any other failure that may adversely affect aircraft handling characteristics is known or suspected, a controllability check should be performed.

The following items should be accomplished:

1. Attain safe altitude.

### **NOTE**

In the event that structural damage of unknown extent is encountered or if continued control of the aircraft is in doubt, consider accomplishing applicable steps of EJECTION (TIME PERMITTING), this section, prior to proceeding with CONTROLLABILITY CHECK.

2. GW - Reduce (as required).
3. LE FLAPS switch - LOCK (if required).  
If LEF damage is observed, consider locking LEF's.
4. Determine optimum configuration available for landing.

### **WARNING**

If a condition which might cause asymmetric TEF extension exists, consider alternate LG extension with the LG handle in UP to preclude TEF extension. If the LG handle remains up:

- Final approach airspeed is 20 knots higher than normal.
- The TO/LDG CONFIG warning light may illuminate.
- **PW 229** Nozzle remains closed, resulting in higher than normal landing thrust.
- NWS is inoperative.
- BRAKES CHAN 2 must be selected.
- FLCS remains in cruise gains. Consider positioning AIR RE-FUEL switch to OPEN to obtain takeoff and landing gains.
- The LG handle warning light remains on to indicate the position of the gear handle is not in agreement with the actual gear position.

T.O. GR1F-16CJ-1

5. Stores - Selectively jettison (if required). Refer to SELECTIVE JETTISON, this section.
6. Slow only to that AOA/airspeed which allows acceptable handling qualities.

**WARNING**

If the aircraft is not controllable down to a reasonable landing speed (given consideration to weather, runway condition, facilities, pilot experience, pilot arm fatigue, etc.), an ejection is recommended.

**CABLE ARRESTMENT**

Refer to figure 5-5 for hook engagement limits. If there is any doubt about stopping on the remaining runway, lower the hook. Engage the cable as close to center as possible, nosewheel on the runway with brakes off and aircraft aligned with the runway. Place the HOOK switch to DN at least 1500 feet before reaching the desired arresting cable and reduce speed as much as possible; however, if brakes and NWS are inoperative, use flaperons and rudder as required to maintain directional control. As the aircraft slows to below 70 knots, directional control is reduced and the aircraft drifts right.

For most approach-end arrestments, touchdown should be at least 500 feet in front of the cable to allow sufficient time to lower the nosewheel to the runway prior to engagement. For an approach-end arrestment with one MLG up or damaged as described in LANDING WITH LG UNSAFE/UP, this section, maintain landing attitude after touchdown and prior to engagement. Immediately after touchdown, retard throttle to IDLE.

After engagement, rollback should be controlled by the throttle. For cable disengagement, place HOOK switch to UP and use approximately 10-15 percent increase in rpm to allow a rollback disengagement.

**WARNING**

- Cable arrestment at speeds greater than emergency arrestment speed, with offcenter distances greater than 35 feet, or with the nosewheel in the air could result in structural failure of the NLG, hook, and/or hook backup structure.

- The hook may miss the cable if the aircraft is not slow enough to compress the MLG struts sufficiently to make WOW or if forward stick pressure is held.
- To prevent hook bounce and possible missed engagement, avoid runway centerline lighting.

**NOTE**

- Under certain conditions, arrestment may produce a bouncing motion which is readily apparent.
  - Offcenter engagement results in aircraft yaw motions during cable runout.
  - Up to 5 seconds (after activation) are required to fully raise the BAK-14 cable.
1. GW - Reduce (as required).
  2. HOOK switch - DN.
    - Approach-end arrestment: Touch down at least 500 feet in front of the cable.
    - Departure-end arrestment: HOOK switch to DN at least 1500 feet before reaching the cable.
  3. SHOULDER HARNESS knob - LOCKED.
  4. Consider options available if a missed engagement occurs.

Prior to cable engagement:

5. Throttle - IDLE.
6. NWS - Engage (if required).
7. Engage cable as close to center as possible; nosewheel on the runway (if required) and brakes off.

**WARNING**

Using forward stick pressure to keep an abnormally fast aircraft on the runway for cable engagement will probably result in a missed engagement or failure of the nose tire/NLG.

**CAUTION**

Do not use brakes while the cable is stretched or while being pulled backward. This action can result in aircraft tipping backward. Control rollback with the throttle.

**NET ARRESTMENT**

Refer to NET ARRESTMENT LIMITATIONS, section 5. Engaging a net barrier requires minimal pilot action as there is no hook to lower and little roll back after the aircraft's forward motion stops.

1. SHOULDER HARNESS knob - LOCKED.
2. Brakes - Release prior to engagement.
3. Throttle - Off prior to engagement.
4. Engage net perpendicular, preferably in the center portion of the runway.

**WARNING**

The canopy should be retained throughout the engagement to provide pilot protection. Barrier netting will not prevent subsequent canopy opening/jettison.

**CAUTION**

Engage net perpendicular to preclude aircraft rotating sideways during the arrestment. Avoid steering back toward the center of the runway just prior to engagement as this could result in a non-perpendicular engagement. Nosewheel steering is not required; however, if engaged, it may be left engaged. The throttle should be retarded to off prior to engagement to reduce the possibility of foreign object damage.

**LANDING WITH A BLOWN TIRE**

When landing with a blown MLG tire, the landing gear may collapse during landing roll if portions of the tire remain and cause a wheel imbalance condition. To avoid possible directional control

problems associated with landing gear collapse, an approach-end arrestment is preferred over a normal approach and landing. To reduce the possibility of damage, the lowest practical landing GW and airspeed should be attained. Jettison stores if possible. Retain empty external fuel tanks. Stores/suspension equipment at stations 3 and/or 7 may cause external fuel tanks at stations 4 and 6 to move inboard when jettisoned. If an approach-end arrestment is not available and a normal approach and landing is flown, leave the anti-skid system on to minimize the possibility of skidding on the good tire. If the wheel with the blown tire does not turn after landing, the antiskid system switches to the **(129)** alternate braking mode, **LESS (129)** pulsating antiskid mode. Use roll control to relieve pressure on the blown tire and NWS to maintain directional control.

**CAUTION**

With a blown tire, avoid centerline lights as they may cause wheel damage and subsequent loss of directional control.

Stop straight ahead and shut down the engine as soon as firefighting equipment is available. Do not attempt to taxi unless an emergency situation exists.

If the blown tire is on the NLG, directional control may be a problem due to a reverse castering effect. An approach-end arrestment with the nosewheel off the runway is recommended. Depending on GW and speed at the time of engagement, type of cable engaged, and height of nosewheel above the runway, it is possible for NLG strut failure and/or inlet structural damage to occur. To reduce the possibility of such damage, the lowest practical landing GW and airspeed should be attained. Jettison stores if possible. Retain empty external fuel tanks. Stores/suspension equipment at stations 3 and/or 7 may cause external fuel tanks at stations 4 and 6 to move inboard when jettisoned. Landing should be made with the remaining internal fuel in the aft system. After touchdown from a 13 degree AOA approach, pitch attitude should be reduced to approximately 5 degrees prior to cable engagement. The HUD gun borecross can be used to determine pitch attitude. During the arrestment, the aircraft is likely to turn slightly right before stopping.

If an approach-end arrestment is not available, refer to procedures for aborting with a blown nose tire in BLOWN TIRE ON TAKEOFF, this section, or consider an all LG up landing (refer to LANDING WITH LG UNSAFE/UP, this section).

### Landing With A Blown Main Gear Tire

Prior to landing:

1. Stores – Jettison. Refer to JETTISON, this section.  
Retain empty external fuel tanks.
2. GW – Reduce (if practical).
3. TANK INERTING switch – TANK INERTING even if Halon is not available.
4. AIR REFUEL switch – OPEN, if external fuel tank(s) is installed.

#### **WARNING**

Failure to depressurize external fuel tank(s) significantly increases the probability of tank explosion and fire if the aircraft departs the runway.

#### **NOTE**

Delay placing the AIR REFUEL switch to OPEN until all external tanks are empty.

5. ANTI-SKID switch – ANTI-SKID.  
Use of antiskid minimizes skidding on good tire during braking.
6. HOOK switch – DN.  
An approach-end arrestment is recommended. Refer to CABLE ARRESTMENT, this section.
7. Final approach AOA – 13 degrees.

If a missed approach-end cable arrestment occurs or no approach-end cable is available:

#### **NOTE**

If no approach-end cable is available, land on the side of runway away from the blown tire.

8. NWS – Engage (if required).  
The NWS light does not illuminate when NWS is engaged if the AIR REFUEL switch is in OPEN.
9. Brake – As desired on good tire.

### Landing With A Blown Nose Gear Tire

Prior to landing:

1. Stores – Jettison. Refer to JETTISON, this section.  
Retain empty external fuel tanks.
2. GW – Reduce (if practical).  
Plan to land with approximately 1500 pounds of fuel on board.
3. Fuel distribution – All fuel in aft tank system (if practical).  
At 3000 pounds fuel remaining, place ENG FEED knob to FWD. When forward reservoir is empty, place ENG FEED knob to NORM. (Emptying forward tank system takes approximately **C** 15 minutes, **D** 9 minutes if fuel flow is 4000 pph. When forward tank system empties, the fuel in aft tank system is approximately **C** 2000 pounds, **D** 2400 pounds.)
4. TANK INERTING switch – TANK INERTING even if Halon is not available.
5. AIR REFUEL switch – OPEN, if external fuel tank(s) is installed.

#### **WARNING**

Failure to depressurize external fuel tank(s) significantly increases the probability of tank explosion and fire if the nose gear collapses during the arrestment.

6. HOOK switch – DN.  
An approach-end cable arrestment with the nosewheel off the runway is recommended. Refer to CABLE ARRESTMENT, this section.
7. Final approach AOA – 13 degrees.

After touchdown:

8. Stick – Lower nose to approximately 5 degrees pitch attitude for arrestment.

After cable engagement:

9. Stick – Apply aft stick after nose starts down to reduce load on the NLG.

If a missed cable engagement occurs:

10. Maintain pitch attitude and go around.

**WARNING**

With a blown NLG tire and loss of NWS, it may not be possible to prevent departure from the runway. A reverse castering effect may occur in which the nosewheel moves opposite to the rudder or differential braking input.

**NOTE**

The maximum allowable fuel flow with one reservoir empty is 25,000 pph.

**LG EXTENSION MALFUNCTIONS**

Malfunctions in extending the LG are normally indicated by failure of the LG handle to lower or by failure of one or more LG's to extend accompanied by lack of the corresponding WHEELS down lights and continuous illumination of the LG handle warning light. Refer to LG FAILS TO EXTEND, this section.

Mechanical failures can have varying causes. Failure of an LG component usually affects only one LG and cannot be corrected in flight. Abnormally high moisture content in the hydraulic fluid can cause more than one LG to fail to extend after prolonged operation at low ambient temperatures. This situation can usually be corrected after several cycles of the LG handle at low altitude.

Abnormal indications after the LG handle is lowered can also be caused by electrically related malfunctions (i.e., electrical shorts, electrical component failures, or cannon plug problems). The malfunction may result in an indication problem or an actual failure of one or more LG to extend. A visual confirmation of the LG position should be obtained if possible before any action is taken.

A common failure mode is electrical shorting within a downlock switch caused by moisture intrusion. This shorting typically occurs after the LG handle is lowered and results in opening of the LG uplock/downlock circuit breaker. Opening of this circuit breaker causes all WHEELS down lights to remain off. The light in the handle may go off normally or it may remain on if the shorting has also adversely affected the warning light circuit. Another result of this circuit breaker opening is that the LG will go into hydraulic isolation immediately after the LG handle is raised and the LG won't retract. Other effects associated with an open LG uplock/downlock circuit breaker are as follows:

- No AOA bracket in the HUD.

- Speedbrakes are not limited to 43 degrees.
- Landing/taxi light is inoperative.
- NWS is inoperative.

An indication failure may be distinguished from an actual extension malfunction by the WHEELS down lights and the LG handle warning light. The WHEELS down lights and the LG handle warning light have separate power sources and circuitry. Thus, if either circuit operates correctly, the LG should be down and locked even though the other circuit may indicate a problem. If possible, cycle the LG to reattempt extension while watching the WHEELS down lights and the LG handle warning light.

Because of the number of possible malfunctions, specific procedures for every situation are not feasible. If time and conditions permit, ground supervisory and technical assistance should be requested. Evaluate available options prior to using the ALT GEAR handle. Other options may include an LG up landing, diverting to a more suitable landing field, landing where the hazards of departing the prepared surface are minimal, or using a cable arrestment.

**LG Handle Will Not Lower**

If the LG handle cannot be moved to the DN position after depressing the LG handle down permission button, the electrical circuitry or solenoid has probably failed. **[C]** **[DF]** The DN LOCK REL button mechanically permits the LG handle to be moved to the DN position. If the LG handle cannot be moved to the DN position due to a mechanical failure, CHAN 1 brakes are inoperative and TEF's must be extended using the ALT FLAPS switch **[PW 229]** and the nozzle remains closed. With the nozzle closed, idle thrust is approximately 400 pounds greater than normal.

If LG handle cannot be lowered normally:

1. DN LOCK REL button - Depress and lower LG handle.

If LG handle still cannot be lowered:

2. ALT FLAPS switch - EXTEND.
3. BRAKES channel switch - CHAN 2.
4. Go to ALTERNATE LG EXTENSION, this section.

**[PW 229]** Nozzle remains closed, resulting in higher than normal landing thrust.

**NOTE**

After a successful alternate gear extension with the landing gear handle still up, the LG handle warning light remains on to indicate the position of the gear handle is not in agreement with the actual gear position.

**LG Fails To Extend**

**NOTE**

If alternate LG extension was performed and one or more LG indicate unsafe, refer to ALTERNATE LG EXTENSION, this section.

If one or more LG fail to extend, the LG handle may be cycled multiple times to attempt to extend the LG if no structural/battle damage exists and if normal hydraulic pressure exists. Multiple cycle attempts may release the locking pawls and result in normal gear extension if the failure to extend was caused by failure of the uplocks to release.



If the LG previously failed to retract, do not cycle the LG handle. Damage to the LG or LG doors may preclude successful extension.

If cycling of the LG handle fails to correct the situation, use of the alternate extension system must be considered.

If possible, get a visual confirmation of LG position. If the NLG WHEELS down light is off, confirmation of the NLG position can be made by checking landing/taxi light operation. Illumination of either light confirms that the NLG is down. With the NLG WHEELS down light off, NWS may be inoperative (without a NWS FAIL caution light).

If one or more LG indicate unsafe:



If at anytime, an LG intermittently indicates unsafe (i.e. WHEELS down light off and LG handle warning light on), the overcenter lock on the LG drag

brace assembly may not be functioning properly. The LG may appear down, but the LG may collapse during landing. Plan on using the LG unsafe/up procedures even if the LG eventually indicates normal. Refer to LANDING WITH LG UNSAFE/UP, this section.



If the LG previously failed to retract, do not cycle the LG handle. Damage to the LG or LG doors may preclude successful extension.

**NOTE**

If the NLG WHEELS down light is off, confirmation of the NLG position can be made by checking landing/taxi light operation. Illumination of either light confirms that the NLG is down. With the NLG WHEELS down light off, NWS may be inoperative (without a NWS FAIL caution light).

1. LG handle - Cycle and monitor LG handle warning light and WHEELS down lights.

If LG handle warning light came on when the LG handle was lowered, then went off, and tests good or if WHEELS down lights operated normally:

2. Speedbrakes - Verify opening is less than 43 degrees.  
From the front cockpit, the top of the speedbrakes should be slightly above a line drawn from the tip of the horizontal tail to the top of the vertical tail root fairing.



If RMLG WHEELS down light is off, speedbrakes may not be limited to 43 degrees.

3. Land normally.

If LG handle warning light did not illuminate or remained illuminated after LG handle was lowered and if one or more WHEELS down lights did not illuminate:

4. Go to ALTERNATE LG EXTENSION, this section.

### Alternate LG Extension

Alternate LG extension should be accomplished at the lowest practical airspeed below 190 knots. The NLG may not indicate down until airspeed is reduced below 190 knots. NWS is inoperative after alternate LG extension even if system B hydraulic pressure is available.

1. LG handle - DN. (Use DN LOCK REL, if required.)

#### WARNING

- Do not delay lowering LG below 2000 feet AGL.
  - If LG handle does not lower, select BRAKES CHAN 2 and position ALT FLAPS switch to EXTEND. **PW 229** Nozzle remains closed, resulting in higher than normal landing thrust.
2. ALT GEAR handle - Pull (if required). (190 knots maximum, if practical).
    - Alternate LG extension can be used up to 300 knots; however, the NLG may not fully extend until 190 knots. Time above 190 knots should be minimized in case there is a leak in the pneumatic lines.
    - If an unsafe MLG indication exists and both MLG are out of the wheel wells, pulling the ALT GEAR handle is not recommended.

#### CAUTION

- NWS is not available following alternate LG extension.
- Do not depress the ALT GEAR reset button while pulling the ALT GEAR handle. This action may preclude successful LG extension.
- Pulling the ALT GEAR handle with normal system B hydraulic pressure, e.g., NLG fails to extend, may result in hydraulic system B failure within 15 minutes.

If LG indicates safe:

3. Land normally.
 

If possible, get visual confirmation of LG position. If all WHEELS down lights were initially off with the LG handle down and use of the hook may be required after touchdown, verify before landing that the hook extends.
4. Stop straight ahead on the runway.

#### CAUTION

- NWS is not available following alternate LG extension.
- If the LG was alternately extended due to failure of system B, only brake/JFS accumulator braking is available and after stopping, the parking brake should be engaged until chocks are installed.

If LG indicates unsafe:

3. Stick - Apply alternating g forces (-1.0 to +3.0 g) to free LG.
 

Up to 300 knots may be required to provide sufficient g force.

If LG indicates safe:

4. Land normally.
 

If possible, get visual confirmation of LG position.
5. Stop straight ahead on the runway.

#### CAUTION

If the LG was alternately extended due to failure of system B, only brake/JFS accumulator braking is available and after stopping the parking brake should be engaged until chocks are installed.

If LG still indicates unsafe:

4. Speedbrakes - Verify opening is less than 43 degrees.
 

From the front cockpit, the top of the speedbrakes should be slightly above a line drawn from the tip of the horizontal tail to the top of the vertical tail root fairing.

**CAUTION**

If RMLG WHEELS down light is off, speedbrakes may not be limited to 43 degrees.

5. Go to LANDING WITH LG UNSAFE/UP, this section.

**Landing With LG Unsafe/Up**

Prior to landing with any of the LG unsafe or up, consider the following:

- Airfield facilities.
- Hook engagement limits.
- Crosswind component.
- Runway and overrun conditions.

If conditions are not favorable:

1. Refer to EJECTION (TIME PERMITTING), this section.

To accomplish the landing:

1. Retain empty fuel tanks and racks.

**WARNING**

If time permits, delay landing until external fuel tanks are empty. If an immediate landing is required, jettison all external fuel tanks.

2. Armament - Jettison.
3. GW - Reduce.
4. TANK INERTING switch - TANK INERTING even if Halon is not available.
5. AIR REFUEL switch - OPEN.

**WARNING**

Failure to depressurize external fuel tanks significantly increases the probability of tank explosion and fire.

**NOTE**

Delay placing the AIR REFUEL switch to OPEN until all external fuel tanks are empty.

6. FCR - OFF.
7. **PX II** SMS **PX III** ST STA/HDPT/ECM power - Off.
8. SHOULDER HARNESS knob - LOCKED.
9. Refer to figure 3-16.

**NOTE**

If either MLG is not extended, EPU operation cannot be terminated with the EPU switch after engine shut-down.

**ANTISKID MALFUNCTION (LANDING)**

Illumination of the ANTI SKID caution light when the LG handle is lowered indicates one of the following:

- **129** Loss of power to one of the two brake channels or from the ANTI-SKID switch.
- **129** Built in Test (BIT) detected malfunction of one of the two brake channels.
- **LESS 129** Failure in the antiskid system (pulsating brake pressure mode activated).
- **LESS 129** Loss of electrical power to the CHAN 1 brake and antiskid control circuits.

**129** Cycling the ANTI-SKID switch to OFF and back to ANTI-SKID will not extinguish the ANTI SKID caution light. Touchdown skid control protection may not be available, so do not apply brakes before touchdown.

**129** If the ANTI SKID light extinguishes on wheel spin up, antiskid protection is available and one of the two brake control channels is fully functional. Normal braking may be used. If the light does not extinguish on wheel spinup, or first illuminates on wheel spinup, braking may be in the alternate braking mode, detectable by a pulsing sensation when differential braking is applied. In the alternate braking mode, symmetric braking will give the best stopping performance.



**LESS 129** Changing to CHAN 2 brakes may extinguish the ANTI SKID caution light and provide normal antiskid and braking functions. If the failure was in the antiskid system, cycling the ANTI-SKID switch may correct the problem. If the ANTI SKID caution light remains on, antiskid protection is not available and degraded (i.e. pulsating) or inoperative braking should be expected.

If the ANTI SKID caution light illuminates (with the ANTI-SKID switch in ANTI-SKID) when the LG handle is lowered:

1. BRAKES channel switch - CHAN 2.

**129** If the ANTI SKID caution light remains on:

2. Refer to ANTISKID MALFUNCTION (GROUND), this section.

**LESS 129** If the ANTI SKID caution light remains on:

2. ANTI-SKID switch - OFF, then back to ANTI-SKID.

If the ANTI SKID caution light remains on, expect pulsating or inoperative braking and no antiskid protection during landing:

3. Refer to ANTISKID MALFUNCTION (GROUND), this section.

### ASYMMETRIC STORES (LANDING)

Refer to figure 3-17 for computation of asymmetric moment. A modified approach is required if the net asymmetry exceeds 10,000 foot-pounds. Successful landings have been demonstrated with asymmetries as large as 25,020 foot-pounds. If the net asymmetry exceeds 25,020 foot-pounds, stores should be selectively jettisoned from the heavy wing to reduce the asymmetry. The decision to land with large asymmetries should consider such factors as weather conditions, runway length/width, surface conditions (RCR), arresting gear availability, crosswind component/gusts, and pilot experience. Avoid abrupt control inputs. Limit maximum bank angle changes to 90 degrees and do not exceed 10 degrees AOA until the net asymmetry can be determined. A controllability check should be performed with the LG down to determine handling qualities and the feasibility of landing. During the controllability check, determine maximum maneu-

vering AOA by slowly increasing AOA until roll authority is insufficient to maintain wings level. Do not exceed 12 degrees AOA during this check. If loss of roll authority is experienced, the maximum maneuvering AOA is 2 degrees below that at which roll authority was lost or 10 degrees AOA, whichever is less. If landing is feasible, plan to fly a shallow, power-on, straight-in approach. Use roll trim and lateral stick as required. Full roll trim may not be enough to compensate for large asymmetries. Trim rudder into the heavy wing up to a maximum of two dots. This decreases bank angle and permits a low bank angle, low sideslip approach, minimizing pilot induced lateral oscillations. This action increases the roll trim necessary to hold up the heavy wing.

Fly a shallow, power-on, straight-in approach and reduce bank angle to wings level on short final. Do not exceed the maximum maneuvering AOA, as determined during the controllability check, on final approach or during the flare/touchdown. Two-point aerodynamic braking should be performed at 10-11 degrees AOA until approximately 120 knots. The nose should then be lowered to the runway and maximum effort antiskid braking should be used. At no time should 11 degrees AOA be exceeded while on the runway. When the ARI switches out with wheel spin-up, large rudder changes can occur which cause yaw into the heavy wing. When landing with no crosswind, this yaw helps align the aircraft with the runway. With crosswind components greater than 10 knots (5 knots if the net asymmetry exceeds 20,000 foot-pounds), land with the heavy wing into the crosswind even if this results in landing downwind. Failure to do so may result in inadequate roll control.

1. Compare weights on mirror stations (4 and 6, 3 and 7, etc.). Include wingtip AIM-120's; exclude wingtip AIM-9's since their weight is offset by the lift they generate.
2. Determine asymmetric moment for each set of stations. Enter with weight difference at bottom of chart, proceed vertically to the appropriate line, and proceed horizontally left to read the asymmetric moment.
3. Add or subtract each asymmetric moment to determine net asymmetry.

# LG Unsafe/Up Landing

CONFIGURATION	APPROACH-END ARRESTMENT	
	AVAILABLE	UNAVAILABLE
<p>ALL LG INDICATE UNSAFE BUT APPEAR NORMAL</p> 	<ol style="list-style-type: none"> <li>10. HOOK – DOWN.</li> <li>11. APPROACH-END CABLE – ENGAGE.</li> </ol>	<ol style="list-style-type: none"> <li>10. LAND NORMALLY.</li> </ol>
<p>ALL LG UP</p> 	<p>ARRESTMENT NOT RECOMMENDED. USE APPROACH-END ARRESTMENT UNAVAILABLE PROCEDURE.</p>	<ol style="list-style-type: none"> <li>10. EPU – ON.</li> <li>11. ALT FLAPS – EXTEND.</li> <li>12. LOW ANGLE APPROACH AT 13° AOA.</li> <li>13. THROTTLE – OFF IMMEDIATELY PRIOR TO TOUCHDOWN.</li> </ol>
<p>BOTH MLG UP OR UNSAFE</p> 	<ol style="list-style-type: none"> <li>10. ALT GEAR HANDLE – IN.</li> <li>11. WAIT 5 SECONDS.</li> <li>12. LG HANDLE – UP.</li> <li>13. ALT GEAR RESET BUTTON – DEPRESS (2 SECONDS).</li> <li>14. USE ALL LG UP PROCEDURE.</li> <li>15. IF NLG DOES NOT RETRACT:                             <ol style="list-style-type: none"> <li>a. HOOK – DOWN.</li> <li>b. LOW ANGLE APPROACH AT 11° AOA.</li> <li>c. ATTEMPT A FLY-IN ENGAGEMENT.</li> <li>d. THROTTLE – OFF AFTER ENGAGEMENT.</li> </ol> </li> </ol> <div style="border: 1px solid black; padding: 5px; text-align: center; margin: 10px 0;"><b>WARNING</b></div> <p>IF THE ENGAGEMENT IS MISSED, MAINTAIN WINGS LEVEL AND GO AROUND. IF A GO-AROUND IS NOT ACCOMPLISHED, THE AIRCRAFT MAY GROUND LOOP.</p>	<ol style="list-style-type: none"> <li>10. ALT GEAR HANDLE – IN.</li> <li>11. WAIT 5 SECONDS.</li> <li>12. LG HANDLE – UP.</li> <li>13. ALT GEAR RESET BUTTON – DEPRESS (2 SECONDS).</li> <li>14. USE ALL LG UP PROCEDURE.</li> <li>15. IF NLG DOES NOT RETRACT:                             <ol style="list-style-type: none"> <li>a. CONSIDER LANDING FROM A LOW ANGLE APPROACH AT 13° AOA IF WING FUEL TANKS ARE CARRIED.</li> <li>b. RECOMMEND EJECTION IF WING FUEL TANKS ARE NOT CARRIED OR IF CONDITIONS ARE NOT CONSIDERED FAVORABLE FOR AN ATTEMPTED LANDING WITH WING FUEL TANKS.</li> </ol> </li> </ol>
<p>NLG UP OR UNSAFE</p> 	<p>ARRESTMENT NOT RECOMMENDED. USE APPROACH-END ARRESTMENT UNAVAILABLE PROCEDURE.</p>	<ol style="list-style-type: none"> <li>10. EPU – ON.</li> <li>11. LOW ANGLE APPROACH AT 13° AOA.</li> <li>12. THROTTLE – OFF AFTER TOUCHDOWN.</li> <li>13. LOWER NOSE TO RUNWAY BEFORE CONTROL EFFECTIVENESS BEGINS TO DECAY.</li> <li>14. EPU – OFF AFTER STOP.</li> </ol>

Figure 3-16. (Sheet 1)

# LG Unsafe/Up Landing

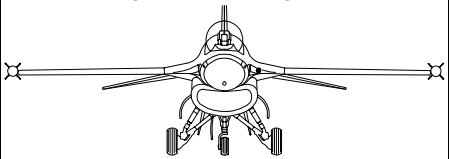
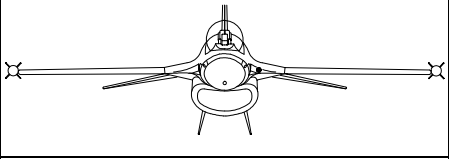
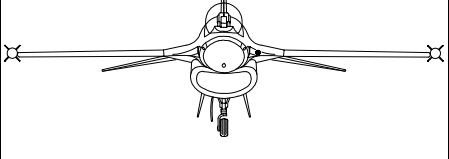
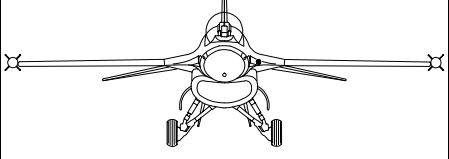

CONFIGURATION	APPROACH-END ARRESTMENT	
	AVAILABLE	UNAVAILABLE
ONE MLG AND NLG UP OR UNSAFE 	ARRESTMENT NOT RECOMMENDED. USE APPROACH-END ARRESTMENT UNAVAILABLE PROCEDURE.	<ol style="list-style-type: none"> <li>10. ALT GEAR HANDLE – IN.</li> <li>11. WAIT 5 SECONDS.</li> <li>12. LG HANDLE – UP.</li> <li>13. ALT GEAR RESET BUTTON – DEPRESS (2 SECONDS).</li> <li>14. USE ALL LG UP PROCEDURE.</li> <li>15. IF LG DOES NOT RETRACT:               <ol style="list-style-type: none"> <li>a. CONSIDER LANDING FROM A LOW ANGLE APPROACH AT 13° AOA IF EXTERNAL FUEL TANK(S) IS CARRIED.</li> </ol> </li> </ol> <p style="text-align: center;"><b>NOTE</b></p> <p>LAND ON THE SIDE OF THE RUNWAY AWAY FROM THE UNSAFE MLG.</p> <ol style="list-style-type: none"> <li>b. RECOMMEND EJECTION IF EXTERNAL FUEL TANK(S) IS NOT CARRIED OR IF CONDITIONS ARE NOT CONSIDERED FAVORABLE FOR AN ATTEMPTED LANDING WITH EXTERNAL FUEL TANK(S).</li> </ol>
ONE MLG INDICATES UNSAFE BUT APPEARS NORMAL 	<ol style="list-style-type: none"> <li>10. HOOK – DOWN.</li> <li>11. LOW ANGLE APPROACH AT 11° AOA.</li> <li>12. AFTER TOUCHDOWN, USE ROLL CONTROL, IF NECESSARY, TO HOLD WING UP. IF ROLL CONTROL IS NEEDED TO HOLD WING UP, MAINTAIN LANDING ATTITUDE FOR ENGAGEMENT. IF ROLL CONTROL IS NOT NEEDED TO HOLD WING UP, LOWER NOSE FOR ARRESTMENT.</li> <li>13. THROTTLE – OFF AFTER ENGAGEMENT.</li> </ol> <p style="text-align: center;"><b>WARNING</b></p> <p>IF THE ENGAGEMENT IS MISSED AND ROLL CONTROL WAS NECESSARY TO HOLD WING UP, MAINTAIN WINGS LEVEL AND GO AROUND. IF A GO-AROUND IS NOT ACCOMPLISHED, THE AIRCRAFT MAY GROUND LOOP.</p>	
ONE MLG UP 	<ol style="list-style-type: none"> <li>10. ALT GEAR HANDLE – IN.</li> <li>11. WAIT 5 SECONDS.</li> <li>12. LG HANDLE – UP.</li> <li>13. ALT GEAR RESET BUTTON – DEPRESS (2 SECONDS).</li> <li>14. USE ALL LG UP PROCEDURE.</li> <li>15. IF LG DOES NOT RETRACT:               <ol style="list-style-type: none"> <li>a. HOOK – DOWN.</li> <li>b. LOW ANGLE APPROACH AT 11° AOA.</li> <li>c. AFTER TOUCHDOWN, USE ROLL CONTROL TO HOLD WING UP AND MAINTAIN LANDING ATTITUDE FOR ENGAGEMENT.</li> <li>d. THROTTLE – OFF AFTER ENGAGEMENT.</li> </ol> </li> </ol> <p style="text-align: center;"><b>WARNING</b></p> <p>IF THE ENGAGEMENT IS MISSED, MAINTAIN WINGS LEVEL AND GO AROUND. IF A GO-AROUND IS NOT ACCOMPLISHED, THE AIRCRAFT MAY GROUND LOOP.</p>	

Figure 3-16. (Sheet 2)

# Asymmetric Moment

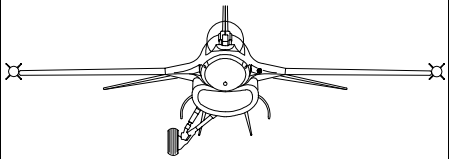
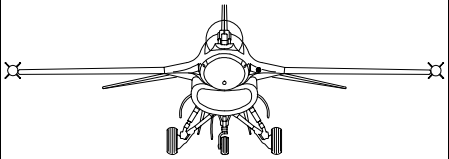

GR1F-16CJ-1-0128X37®

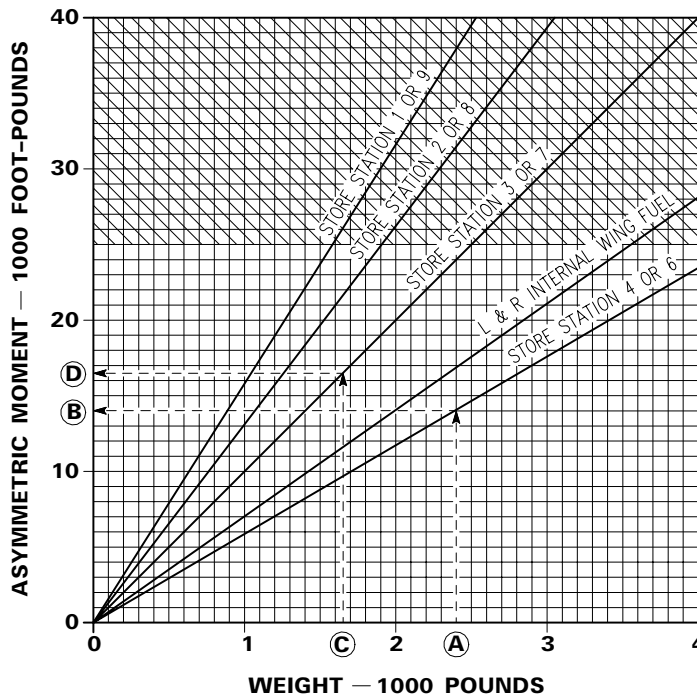
Figure 3-17.

**SAMPLE PROBLEM 1:**

- Full 370-gallon fuel tank on station 4; empty fuel tank on station 6.
- Three MK 82 (SNAKEYE) bombs on station 3, station 7 empty.

- A. Station 4/6 weight difference = 2405 pounds
- B. Asymmetric moment = 14,000 foot-pounds
- C. Station 3/7 weight difference = 1650 pounds
- D. Asymmetric moment = 16,500 foot-pounds
- E. Net asymmetry (B+D) = 30,500 foot-pounds

**SAMPLE PROBLEM 2:**

- Full 370-gallon fuel tank on station 6; empty fuel tank on station 4.

- Three MK 82 (SNAKEYE) bombs on station 3; station 7 empty.

Follow same procedures (A through D) as above; however, since the asymmetric moments are on the opposite wing, the moments are subtracted rather than added.

- E. Net asymmetry (B-D) = 2500 foot-pounds
- 1. AOA - 10 degrees maximum.

**WARNING**

Large asymmetric loads severely limit lateral control when rolling away from the heavy wing. Until determining net asymmetry, limit maximum bank angle change to 90 degrees, avoid abrupt control inputs, and do not exceed 10 degrees AOA.

- 2. Determine net asymmetry. Refer to figure 3-17.

If asymmetry is greater than 25,020 foot-pounds:

3. Stores - Jettison (as required).  
Selectively jettison stores from the heavy wing to obtain a net asymmetry less than 25,020 foot-pounds. Refer to SELECTIVE JETTISON, this section.

If asymmetry is greater than 10,000 foot-pounds:

4. Controllability - Check.
  - Lower LG at a safe altitude and check handling qualities until roll authority is insufficient or up to 12 degrees AOA maximum.
  - Maximum maneuvering AOA for approach and landing is 10 degrees AOA or 2 degrees less than the AOA at which roll authority is insufficient to maintain wings level, whichever is less.

If landing is feasible:

### WARNING

The decision to land with a large asymmetry should consider such factors as weather conditions, runway length/width and surface conditions (RCR), arresting gear availability, crosswind component/gusts, and pilot experience.

5. Fly a shallow, power-on, straight-in approach.

### WARNING

- With crosswind component greater than 10 knots (5 knots if the net asymmetry exceeds 20,000 foot-pounds), land with heavy wing into the crosswind even if this results in landing downwind. Failure to do so may result in inadequate roll control.
  - Do not exceed the maximum AOA, as determined during the controllability check, during final approach, flare, touchdown, or two-point aerodynamic braking.
6. Roll trim and lateral stick - As required.

7. Rudder trim - Trim into the heavy wing (if required).

If landing is not feasible:

5. Go to EJECTION (TIME PERMITTING), this section.

If asymmetry is less than 10,000 foot-pounds:

4. Land normally.

### NLG WOW SWITCH FAILURE

If the NLG WOW switch fails to the ground position, the A/R DISC function on the stick is inoperative, the speedbrakes are not limited to 43 degrees with the right MLG down, NWS can be engaged in flight, and AOA indications are approximately 0 degrees.

1. NWS - Engage.

If AR/NWS light comes on:

2. NWS - Disengage.
3. AR/NWS light - Off.

### NOTE

Insure that AR/NWS light is off prior to landing so that the NWS does not follow rudder commands when the nosewheel is lowered to the runway.

4. Speedbrakes - Close to less than 43 degrees.  
From the front cockpit, the top of the speedbrakes should be slightly above a line drawn from the tip of the horizontal tail to the top of the vertical tail root fairing.

### CAUTION

Visually confirm speedbrake opening is limited to 43 degrees to prevent the lower surfaces from striking the runway during landing.

### DRAG CHUTE FAILURE

If decision is made to go-around:

1. Drag chute - Release.
2. Throttle - MAX AB.

**SECTION IV**  
**CREW DUTIES**

(Not Applicable)

## SECTION V

### OPERATING LIMITATIONS

TABLE OF CONTENTS	Page
Introduction .....	5-1
Instrument Markings .....	5-1
Engine Limitations .....	5-1
Fuels .....	5-1
System Restrictions .....	5-2
Terrain Following Radar .....	5-2
Jet Fuel Starter Limits .....	5-2
Tire Speed Limit .....	5-2
Brake Energy Limits .....	5-2
Fuel System Limitations .....	5-2
One Reservoir Empty .....	5-2
Negative G Flight .....	5-2
Airspeed Limitations .....	5-2
System Airspeed Limitations .....	5-2
Maximum Airspeed Operating Limitations .....	5-2
Low Airspeed Operating Limitations .....	5-3
Prohibited Maneuvers .....	5-3
Gross Weight Limitations .....	5-3
Center-of-Gravity Limitations .....	5-3
Acceleration Limitations .....	5-3
AOA and Rolling Limitations .....	5-4
Stores Limitations .....	5-4
Asymmetric Stores Loading .....	5-4
Miscellaneous Limitations .....	5-5
Net Arrestment Limitations .....	5-5
Crosswind Limits .....	5-5

### INTRODUCTION

The aircraft and system limitations that must be observed during normal operations are presented in this section and T.O. GR1F-16CJ-1-2. Those limitations that are characteristic of a special phase of operations such as emergency procedures, etc., are not covered in this section.

### INSTRUMENT MARKINGS

Refer to figure 5-1 for location and range of the markings.

### ENGINE LIMITATIONS

Refer to figure 5-2 for Engine Limitations and figure 5-3 for Engine – Operational Envelope.

### FUELS

JP-4, JP-5, JP-8; NATO F-34, F-35, F-40, F-43, and F-44; and commercial JET A, JET A-1, and JET B are approved fuels. Except for freeze point and possible icing and corrosion inhibitor differences, JP-4, NATO F-40, and JET B are equivalent and the same operating limitations apply.

Operating and throttle movement limitations for fuels other than JP-4, NATO F-40, and JET B, are the same as for JP-4, NATO F-40, and JET B except: Ground starts with temperature below -4°F (-20°C) may produce more smoke and require a longer time for engine light-off. Ground starts should not be attempted with fuel temperature below -40°F (-40°C) except JET A which is -35°F (-37°C). Airstart light-off times also may be slightly longer.

#### NOTE

**PW 229** Changing operations from JP-4, NATO F-40, or JET B may result in an increase in the number of AB recycles.

**PW 229** Fuels with very high flash points (JP-5, NATO F-43, and NATO F-44) may leave visible signature on AB cancellation at high altitude.

Approved fuels may be intermixed in any proportion during ground or AR operations. No change in engine operating limitations is required.

Due to fuel freeze points, non JP-4 or NATO F-40 fuel in external tanks may not transfer after sustained operation (5 minutes or longer) below 275 knots from 25,000-30,000 feet or below 0.72 mach from 30,000-42,000 feet (all non JP-4 or NATO F-40 fuels except JET A) or below 300 knots from 25,000-30,000 feet or below 0.83 mach from 30,000-42,000 feet (JET A).

NATO F-34, NATO F-40, and NATO F-44 may not contain corrosion inhibitor and NATO F-35, NATO F-43, JET A, JET A-1, and JET B may not contain icing or corrosion inhibitors. Restrict operation without icing inhibitor to one flight. Restrict engine operation without corrosion inhibitor to 10 consecutive hours.

Certain fuels are heavier; refer to FUEL QUANTITY INDICATION AND TANK ARRANGEMENT, Section I.

## SYSTEM RESTRICTIONS

### TERRAIN FOLLOWING RADAR

Refer to TF DISPLAYS AND OPERATION, T.O. GR1F-16CJ-34-1-1.

### JET FUEL STARTER LIMITS

Refer to figure 5-4.

### TIRE SPEED LIMIT

The MLG tires are certified for use to 225 knots groundspeed. The NLG tire is certified for use to **PX II** 217, **PX III** 235 knots groundspeed.

### BRAKE ENERGY LIMITS

Refer to T.O. GR1F-16CJ-1-1, Part 2 for brake energy limits for maximum effort braking, taxi, aborted takeoff, landing, and the effect on turnaround capability. The actual energy per brake may differ considerably from the value found in Part 2. This is caused by unequal energy distribution between the brakes or residual heat from previous braking. Maximum brake application speed is the maximum speed from which the aircraft can be stopped using maximum braking. This speed is based on the capability of each brake to absorb a maximum of 23.5 million foot-pounds of energy. (Refer to T.O. GR1F-16CJ-1-1, Part 2 ABORTED TAKEOFF MAXIMUM BRAKE APPLICATION SPEED.)

### CAUTION

- Initiating maximum effort braking above maximum brake application speed may result in loss of braking before the aircraft is stopped.
- Danger zone procedures should be followed for any event which requires excessive braking.
- If brake energy absorption is in the danger zone, wheel fusible plugs release tire pressure within 3-15 minutes after the stop.

## FUEL SYSTEM LIMITATIONS

### One Reservoir Empty

The maximum allowable fuel flow with one reservoir empty is 25,000 pph.

### Negative G Flight

Negative g flight with both reservoir tanks full is limited to:

- AB thrust - 10 seconds.
- MIL thrust or below - 30 seconds.

### NOTE

Negative g flight should be avoided when a low fuel condition exists (forward or aft reservoir not full) or ENG FEED knob out of NORM.

## AIRSPEED LIMITATIONS

### WARNING

Maximum airspeed operating limitations may be easily exceeded in level flight due to the improved performance engine excess thrust capabilities.

### SYSTEM AIRSPEED LIMITATIONS

Refer to figures 5-3, 5-5, and 5-6.

### MAXIMUM AIRSPEED OPERATING LIMITATIONS

Refer to figure 5-3. Maximum operating airspeed is 800 knots from sea level to 30,000 feet MSL. Above 30,000 feet MSL, the aircraft is limited to 2.05 mach.

Refer to figure 5-6 and T.O. GR1F-16CJ-1-2. Maximum operating airspeed/mach may be reduced as a result of system restrictions or stores limitations.



## LOW AIRSPEED OPERATING LIMITATIONS

Recovery should be initiated no later than activation of the low speed warning tone.

### WARNING

For CAT I configurations with drag indices greater than 120, delaying recovery until activation of the low speed warning tone may result in departure regardless of recovery technique. Rapid airspeed decay may reduce control authority to the point that recovery inputs have no effect. Low thrust settings, external fuel tanks, or inlet pods increase the possibility of a departure.

To avoid departures due to roll coupling, do not operate with category III loadings below 200 knots except for takeoff and landing.

### WARNING

Departures from controlled flight with asymmetric category III loadings may result in fast, flat (possibly nonrecoverable) spins.

## PROHIBITED MANEUVERS

The following maneuvers are prohibited:

- Intentional departures and spins with any of the following:
  - Symmetric category I loading with suspension equipment or missiles at station 3, 4, 6, or 7.
  - Asymmetric category I loading.
  - Category III loading.
  - Altitude below 30,000 feet AGL.
  - CG aft of aft limit for the configuration being flown.
  - Lateral fuel (internal and external) imbalance greater than 200 pounds.
- Repeated maximum rudder reversals.

- Consecutive 360-degree maximum command rolls.
- Maximum command rolling maneuvers above 1.8 mach and either above 3g or below 35,000 feet MSL.
- Rudder rolls or rudder-assisted rolls of more than 90 degrees of bank angle change with any store on station 3, 4, 6, or 7.
- With LG and/or TEF's down:
  - Flight above 15 degrees AOA with stores at station 3, 4, 6, or 7.
  - Maximum command rolls of more than 90 degrees of bank angle change.
- Abrupt roll reversals above 550 knots and below 20,000 feet MSL with the STORES CONFIG switch in CAT I.
- PX III** With CFT's installed, abrupt roll reversals above 500 knots with the STORES CONFIG switch in CAT I.
- LESS 163** Rapid rudder release or reversal above 300 knots/0.6 mach.
- LESS 163 PX III** Flight with CFT's installed and CAT III configurations.

## GROSS WEIGHT LIMITATIONS

The maximum allowable GW for ground handling, taxi, takeoff, in-flight, and landing is 48,000 pounds.

## CENTER-OF-GRAVITY LIMITATIONS

Refer to T.O. GR1F-16CJ-5-2.

Generally, the aircraft is within CG limits when the red portion of the AL pointer is not visible (FUEL QTY SEL knob in NORM).

## ACCELERATION LIMITATIONS

Acceleration limitations are contained in figure 5-7 this section, and T.O. GR1F-16CJ-1-2, figures 5-9 and 5-10.

Load factor limits should not be intentionally exceeded. Notify maintenance of a possible over-g if symmetric maneuvering on the g limiter results in a load factor greater than or equal to 9.5g/-3.2g or if symmetric non-g limiter maneuvering or asymmetric

maneuvering exceeds a positive or negative g limit specified in this section. Provide details of the occurrence (maximum g indication, airspeed, altitude, description of maneuver, fuel weight and distribution, etc.) and HUD videotape if it is available.

**NOTE**

- SYM G limits apply to maneuvers resulting from less than abrupt roll stick inputs and in which roll rate does not exceed 20 degrees/second. ROLL G limits apply to maneuvers resulting from abrupt roll stick inputs or maneuvers in which roll rate exceeds 20 degrees/second.
- A false maximum g indication may be displayed in the HUD due to INU vibration while the aircraft is at maximum g. G indications above 10 (e.g., 0.2 for 10.2g) have been observed.
- **DR** Due to the location of the accelerometer, it should not be used to determine maximum g force.
- For evaluating a possible over-g, determine the allowable CARRIAGE MAX ACCEL G for the actual store configuration at the time of the occurrence. Use of T.O. GR1F-16CJ-1-2, figure 5-9,  $N_z$ W curves (if applicable) is permitted.
- G's experienced during a wingtip vortex/wake turbulence encounter should be considered as asymmetrical when determining if a g limit has been exceeded.

**AOA AND ROLLING LIMITATIONS**

Refer to figure 5-8. With heavy wing loadings, it may be necessary to cancel the roll command up to 90 degrees early to avoid exceeding the maximum bank angle limit. Except for emergency conditions, do not fly category III loadings with the STORES CONFIG switch in CAT I.

**WARNING**

- Category III loadings are not protected from AOA or roll-induced departures with the STORES CONFIG switch in CAT I.

- Damage to or failure of wing internal structure can occur if rolling maneuvers are performed with the STORES CONFIG switch in CAT I while carrying a category III loading.

An asymmetric loading is any asymmetry that requires roll and/or yaw trim. Refer to ASYMMETRIC LOADINGS, Section VI.

Nose slice and yaw departure may occur during maximum command rolls on the CAT I AOA limiter at high altitude when carrying a centerline tank. Refer to YAW DEPARTURE, Section VI.

**WARNING**

- If the aircraft CG is near the aft limit, departure may occur while performing low airspeed, high AOA, maximum command rolling maneuvers with either of the following:
  - Asymmetric category I missile loadings (station 2, 3, 7, or 8).
  - Speedbrakes opened.
- The indicated bank angle change limit is particularly critical for category I loadings with 370-gallon fuel tanks plus suspension equipment on stations 3 and 7. Care is required with these loadings to check the roll so as not to exceed the indicated bank angle change limit.

**STORES LIMITATIONS**

Refer to T.O. GR1F-16CJ-1-2, figure 5-10 for authorized stores loading configurations and related limitations.

**ASYMMETRIC STORES LOADING**

Refer to figure 3-17 for computation of asymmetric moment. The maximum allowable asymmetric (rolling) moment for ground handling, taxi, takeoff, inflight, and landing is 25,020 foot-pounds.

Takeoff is prohibited when the roll trim necessary to compensate for an asymmetric loading exceeds the maximum roll trim available. Refer to T.O. GR1F-16CJ-1-1, PART 2.

## MISCELLANEOUS LIMITATIONS

### NET ARRESTMENT LIMITATIONS

Refer to figure 5-5 for cable/net arrestment limits. 61QSII/BAK-15 multi-element net barrier systems have the following designations: 24A, 30F, 40A, HP, and MEN. Any net barrier system with these designations, e.g., 61QSII/HP30 or MK-6/MEN, is compatible with the aircraft.

The 61QSII/BAK-15 arresting system consists of two major components - an energy absorber and an engagement device. The engagement device is the net which is attached to the energy absorber. These absorbers include heavy chains as used with the

MA-1A system, friction brake systems such as the BAK-9 and -12, and water twisters as used in BAK-13 systems. Because of the variety of energy absorbers in use, it is not possible to establish one maximum engagement speed for the aircraft. In each case, the maximum engagement speed is determined by the capabilities of the energy absorption system attached to the net. For example, the HP30 is an all nylon, three element net. It incorporates all the latest technology and, coupled with a 1200-foot runout BAK -12, should provide a 35,000-pound F-16 with 190-knot arrestment capability.

### CROSSWIND LIMITS

Refer to T.O. GR1F-16CJ-1-1, Part 2 for crosswind limits for takeoff and landing.

# Instrument Markings

## ENGINE F100-PW-229

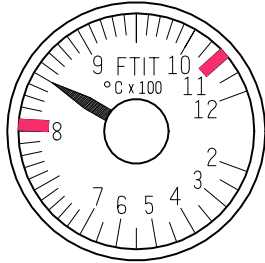

- 800 °C GROUND ENGINE START
- 1070 °C MAXIMUM STEADY STATE

**FTIT**

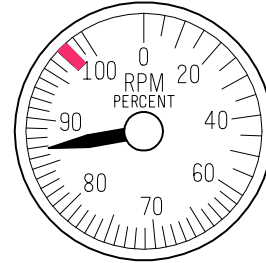

- 97% MAXIMUM STEADY STATE

**RPM**

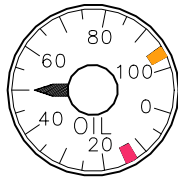

- 15 PSI MINIMUM
- 95 PSI MAXIMUM

**OIL PRESSURE**

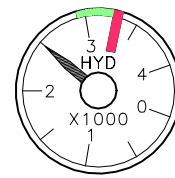

- 2850-3250 PSI NORMAL
- 3250 PSI MAXIMUM



**HYDRAULIC PRESSURE**

Figure 5-1. (Sheet 1)

# Instrument Markings

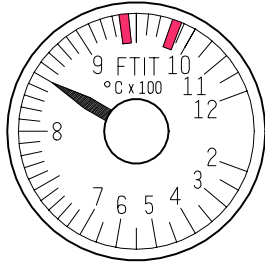
## ENGINE F110-GE-129



-  935°C ENGINE START
-  980°C MAXIMUM

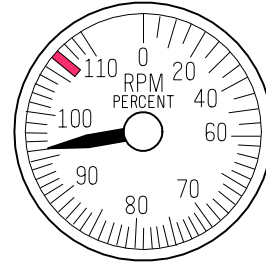

**FTIT**



-  108% MAXIMUM

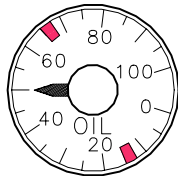

**RPM**

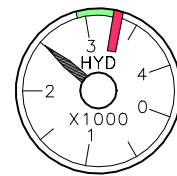

-  15 PSI MINIMUM
-  65 PSI MAXIMUM

**OIL PRESSURE**



-  2850-3250 PSI NORMAL
-  3250 PSI MAXIMUM

**HYDRAULIC PRESSURE**

Figure 5-1. (Sheet 2)

# Engine Limitations

## ENGINE F100-PW-229

### GROUND

CONDITION	FTIT °C	RPM %	OIL PSI	REMARKS
START	800	-	-	During cold start, oil pressure may be 100 psi for up to 1 minute
IDLE	625	-	15 (min)	Maximum FTIT in SEC is 650°C
MIL/AB	1070	97	30-95	At MIL and above, oil pressure must increase 15 psi minimum above IDLE oil pressure. Use transient rpm limit for takeoff
TRANSIENT	1090	98	30-95	Time above 1070° is limited to 10 seconds
FLUCTUA- TION	± 10	± 1	± 5 IDLE	Must remain within steady-state limits. In-phase fluctuations of more than one instrument or fluctuations accompanied by thrust surges indicate engine control problems. Nozzle fluctuations limited to ± 2% at and above MIL. Fluctuations not permitted below MIL
			± 10 above IDLE	

### IN FLIGHT

CONDITION	FTIT °C	RPM %	OIL PSI	REMARKS
AIRSTART	870	-	-	-
IDLE	-	-	15 (min)	-
MIL/AB	1070	97	30-95	Oil pressure must increase as rpm increases. Use transient rpm limit with LG handle DN and for 3 minutes after LG handle is placed UP
TRANSIENT	1090	98	30-95	Time above 1070° is limited to 10 seconds
FLUCTUA- TION	± 10	± 1	± 5 IDLE	Same as ground operation. Zero oil pressure is allowable for periods up to 1 minute during flight at less than +1g
			± 10 above IDLE	

Figure 5-2. (Sheet 1)

# Engine Limitations

## ENGINE F110-GE-129

### GROUND

CONDITION	F <sup>T</sup> TIT °C	RPM %	OIL PSI	REMARKS
START	935	-	-	During cold start, oil pressure may be 100 psi for up to 2 minutes
IDLE	650	-	15 (min)	-
MIL/AB	980	108	25-65	At MIL and above, oil pressure must increase 10 PSI minimum above IDLE oil pressure
TRANSIENT	980	109	25-65	-
FLUCTUATION	± 10	± 1	± 5	Must remain within steady-state limits. Nozzle fluctuations limited to ± 2

### IN FLIGHT

CONDITION	F <sup>T</sup> TIT °C	RPM %	OIL PSI	REMARKS
AIRSTART	935	-	-	-
IDLE	-	-	15 (min)	-
MIL/AB	980	108	25-65	Oil pressure must increase as rpm increases
TRANSIENT	980	109	25-65	-
FLUCTUATION	± 10	± 1	± 5	Must remain within steady-state limits. Zero oil pressure is allowable for periods up to 1 minute during flight at less than +1g

Figure 5-2. (Sheet 2)

# Engine — Operational Envelope

ENGINE F100-PW-229

**NOTES:**

- Transfers from SEC to PRI should be performed below 40,000 feet MSL and subsonic with the throttle at MIL or below.
- Maximum operating airspeed is 800 knots from sea level to 30,000 feet MSL. Above 30,000 feet MSL, the aircraft is limited to 2.05 mach.

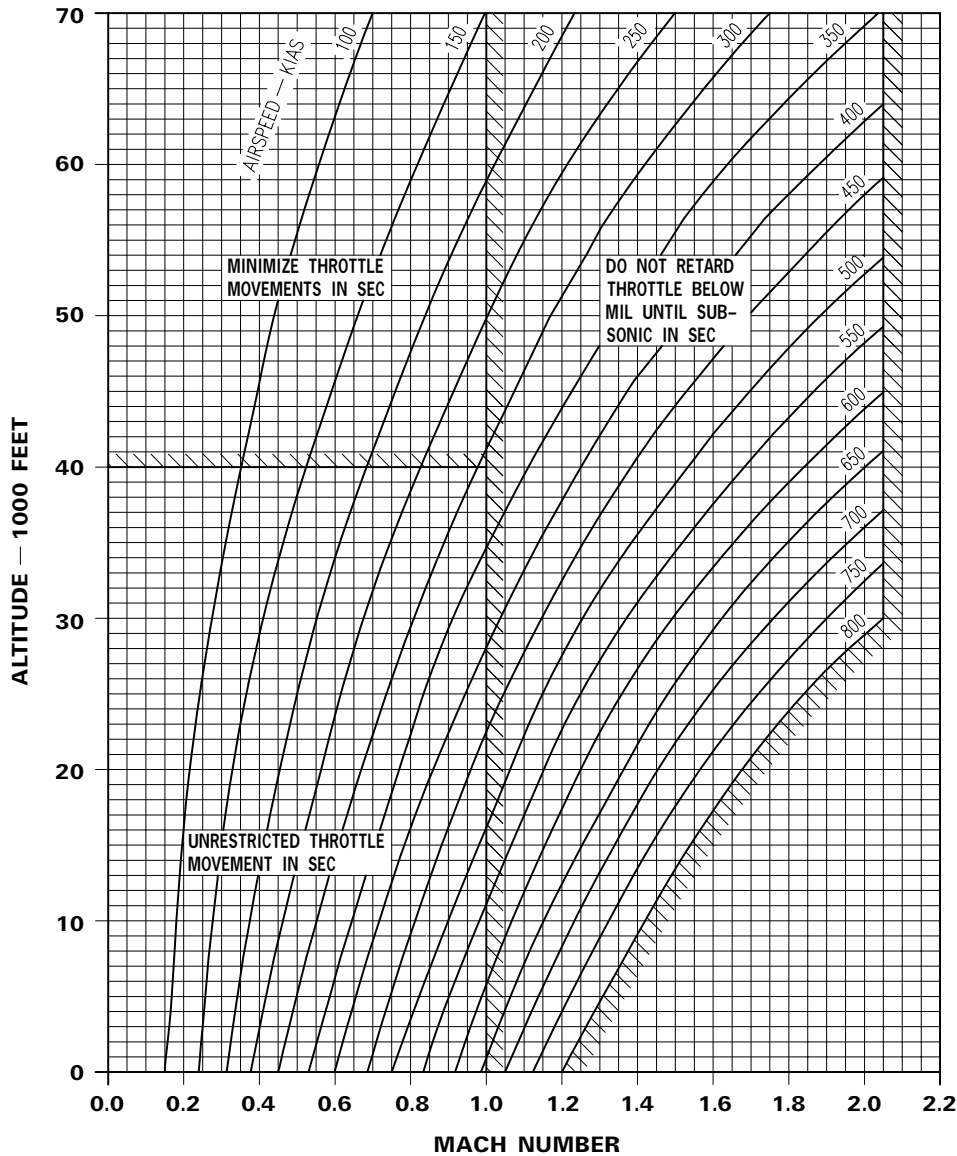

1F-16X-1-4018X©

Figure 5-3. (Sheet 1)



# Engine — Operational Envelope

ENGINE F110-GE-129

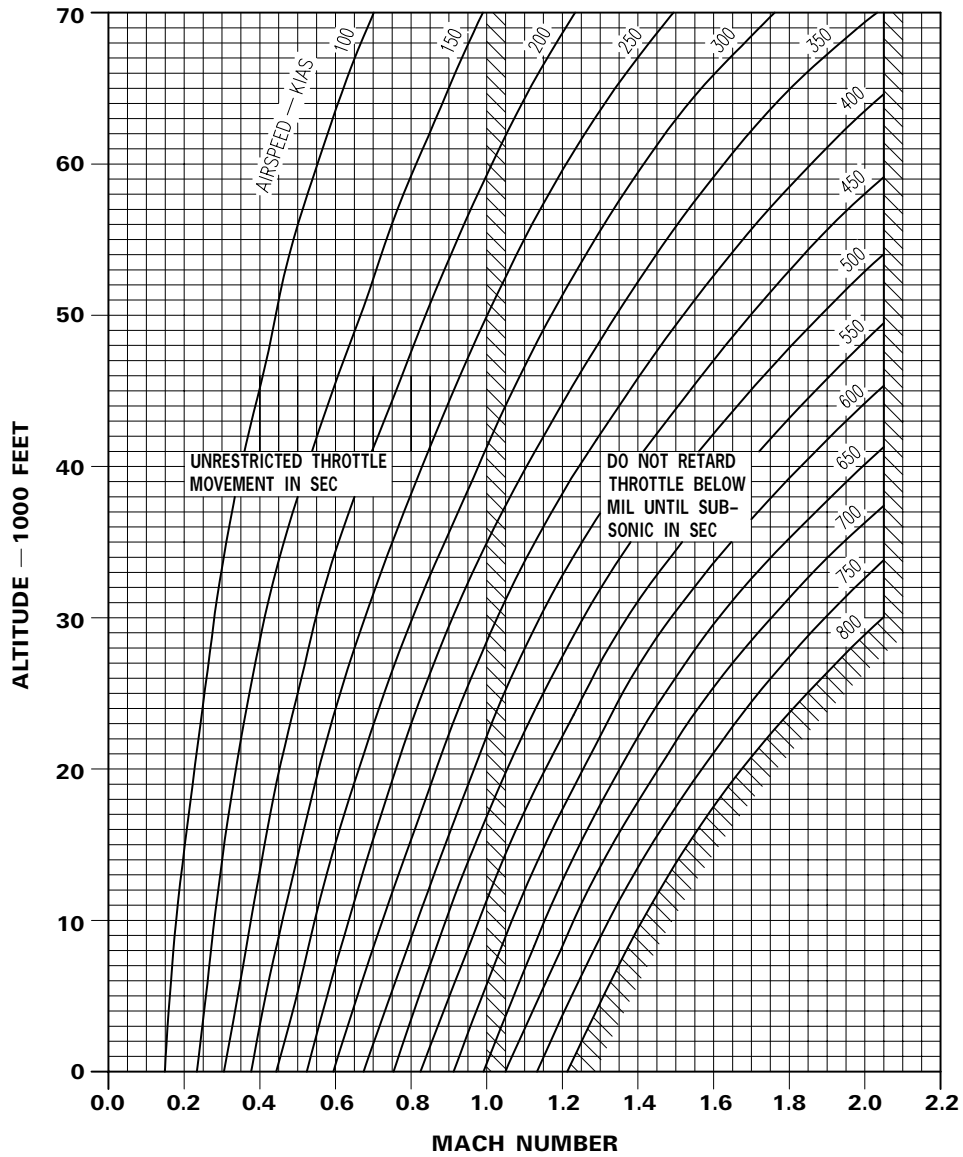

Figure 5-3. (Sheet 2)

# Jet Fuel Starter Limits

CONDITION	LIMITS
Normal Ground Operation	* Continuous motoring of the engine shall not exceed 4 minutes. After 4 minutes of continuous motoring, a normal engine start may be initiated after 5 minutes of cooling
	A minimum wait of 1 minute is required after each JFS start attempt to allow fuel drainage from the JFS
Hot Start of Engine	Motor until FTIT is below 200°C
Airstart/In Flight	Below 20,000 feet MSL and 400 knots. 3-minute maximum run time when the engine is operating satisfactorily above 60 percent rpm; otherwise, unlimited

\* Motoring is defined as JFS rotating the engine **PW229** at 22 percent rpm, **GE129** 25 percent rpm minimum with the throttle in OFF.

**NOTES:**

- OAT between 20°F (-6°C) and 100°F (38°C). A minimum brake/JFS accumulator pressure of 3000 psi is required for START 1 and 2800 psi is required for START 2.
- OAT between -25°F (-32°C) and 20°F (-6°C) or OAT above 100°F (38°C). START 2 and a minimum brake/JFS accumulator pressure of 2800 psi are required.
- OAT below -25°F (-32°C). START 2 and a minimum brake/JFS accumulator pressure of 3200 psi are required.
- If one brake JFS accumulator is depleted, verify a minimum pressure of 3000 psi in the remaining brake/JFS accumulator before attempting START 2.

Figure 5-4.

# Cable/Net Arrestment Limits

## Compatible Cable Systems With Established Aircraft Limits

BAK-6  
 BAK-9  
 BAK-12 (Standard, Extended, and Dual)  
 BAK-13 (Navy designation is E-28)  
 BAK-14  
 BAK-15 (NI) (Net barrier with cable for hook)  
 MAAS  
 \*44B-2L

### ROUTINE ARRESTMENT

A planned event. Operational conditions are such that each landing requires arrestment. Such operational conditions include operating from highways or from runways that are too short for normal landings. The standard factor of safety is used to determine the maximum engagement speed.

- **PX II** LIMITS - 150 knots for GW less than/equal to 42,300 pounds, 130 knots for GW greater than 42,300 pounds, (\*156 knots).
- **PX III** LIMITS - 146 knots (\*160 knots).

### EMERGENCY ARRESTMENT

An unplanned event. A reduced factor of safety is accepted and the corresponding maximum engagement speed is slightly higher than for a routine arrestment. With a ground level ejection capability, a reduced factor of safety for the arrestment is possible since the pilot can still eject if the arrestment fails.

- **PX II** LIMITS - 160 knots for GW less than/equal to 42,300 pounds, 140 knots for GW greater than 42,300 pounds, (\*171 knots).
- **PX III** LIMITS - 160 knots (\*174 knots).

## Compatible Cable Systems Without Established Aircraft Limits



Use of arresting systems without established aircraft limits may result in failure of the hook, hook backup structure, or nose landing gear.

BLISS 500S-6  
 TAGS BLISS 500S-6B Transportable  
 44B-3H/SP/WR  
 MAGS 44B-3H/SP/WR Mobile  
 RHAG MK-1  
 RHAG MK-2  
 PUAG  
 PAAG  
 P-IV/BAK-12 Portable

Figure 5-5. (Sheet 1)

# Cable/Net Arrestment Limits

## Compatible Strut Engagement/Cable Systems Without Established Aircraft Limits



Use of arresting systems without established aircraft limits may result in failure of the hook, hook backup structure, or nose landing gear.

MA-1A Modified  
MA-1A/E-5  
MA-1A/BAK-9  
MA-1A/BAK-12

### NOTE

Attempting to engage an unmodified (non-hook capable) MA-1A will most likely be unsuccessful.

## Compatible Net Barrier Systems

BAK-15  
SAFE-BAR (Safeland Barrier)

### Stanchions

61QSII  
61QSIIM  
MK-6

### NOTE

The above stanchions can be rigged with the following nets: HP30, HP40, MEN241, MEN301, 24, 30, or 40. In addition, they will be associated with the following energy absorbers: Chain (E-5), BAK-9, BAK-12, BAK-13, 34B, 44B, 500S, BEFAB 6:3, BEFAB 21:2, and BEFAB 24:4.

### Other Net Systems

ARZ-30/-40  
BEFAB 21:2/MK VI-1 stanchion  
BEFAB 6:3/MK VI-1 stanchion  
MK-12A  
RAF TYPE A  
RAF TYPE B

Figure 5-5. (Sheet 2)

# Airspeed Limitations (Systems)

SYSTEM OR CONDITION	KIAS/MACH
Canopy Open or in Transit	70 (includes ground wind velocity)
LG Extended or in Transit	300/0.65, whichever is less
AR Door Opening/Closing	400/0.85, whichever is less
AR Door Open	400/0.95, whichever is less
Flight in Severe Turbulence (+3g)	500
Drag Chute Deployment	170

Figure 5-6.

# Acceleration Limitations

CONFIGURATION	LOAD FACTOR (g)	
	SYMMETRIC	ASYMMETRIC
TAKEOFF	+4.0, 0.0	+2.0, 0.0
LANDING		
LG RETRACTION*	+2.0, 0.0	+2.0, 0.0
LG EXTENSION		

\* If the LG handle is raised near 2 g's approaching 300 knots, actuator power may be insufficient to completely retract the LG until g is reduced.

Figure 5-7.

# AOA and Rolling Limitations

LOADING CATEGORY	STORES CONFIG SWITCH	MAX AOA	MAX BANK ANGLE CHANGE FOR MAX ROLL MANEUVER
I	I	LIMITER	360°
III	III	LIMITER	360°

**NOTES:**

- Determine loading category from the appropriate line in T.O. GR1F-16CJ-1-2, figure 5-10, Stores Limitations.
- The roll command should be released in sufficient time to avoid overshooting the indicated bank angle change limits.

Figure 5-8.

## SECTION VI

### FLIGHT CHARACTERISTICS

#### TABLE OF CONTENTS

Introduction .....	6-1
Flight Control System .....	6-1
FLCS Limiters .....	6-1
Leading Edge Flaps .....	6-1
Speedbrakes .....	6-2
Autopilot .....	6-2
Trim .....	6-2
Normal Flight Characteristics .....	6-3
Category I Loadings .....	6-3
Category III Loadings .....	6-3
Conformal Fuel Tanks <b>PX III</b> .....	6-3
Flight With LG Down .....	6-3
Landing Configuration .....	6-4
Factors Affecting Flying Characteristics .....	6-4
Center-of-Gravity Considerations .....	6-5
Effect of Thrust .....	6-5
Effect of Low Airspeed Maneuvering .....	6-5
High Pitch, Low Airspeed .....	6-6
Flight With Stores .....	6-6
Limit Cycle Oscillation and Aeroservoelastic Oscillation .....	6-7
Asymmetric Loadings .....	6-7
Store Separation .....	6-8
Out-of-Control Characteristics .....	6-8
Yaw Departure .....	6-8
Pitch Departure .....	6-9
Deep Stall .....	6-10
Spin .....	6-10
Recoveries .....	6-11
Self-Recovery .....	6-11
Deep Stall Recovery .....	6-11
Spin Recovery .....	6-12
Engine Operation During Departures/ Out-of-Control .....	6-13
Degraded Flight Controls .....	6-13
FLCS DBU .....	6-13
Leading Edge Flaps Locked (Symmetric) .....	6-13
Standby Gains .....	6-13
One Hydraulic System .....	6-13
Speedbrakes .....	6-13
Aircraft Damage .....	6-14
Horizontal Tail .....	6-14
Flaperon .....	6-14
Rudder and Ventral Fins .....	6-14

Leading Edge Flaps .....	6-14
Wing .....	6-14
Radome .....	6-14
Dive Recovery .....	6-15

#### INTRODUCTION

Information presented in this section reflects the flight characteristics with category I and III loadings. Refer to AOA AND ROLLING LIMITATIONS, Section V, for information regarding specific categories.

#### FLIGHT CONTROL SYSTEM

The FLCS is a four-channel fly-by-wire system. The FLCC combines pilot commands along with aircraft motion and flight conditions to command position of the flight control surfaces. Artificial stability provided by the FLCS allows for relaxed static stability which increases performance and maneuverability by reducing trim drag and increasing maximum lift. Refer to FLIGHT CONTROL SYSTEM, Section I.

#### FLCS LIMITERS

FLCS limiters may be defeated if maneuvering limits are not strictly observed. Departure may result from maximum maneuvering combined with maximum permissible aft CG. The most critical maneuvers are maximum command rolls coupled with either maximum aft stick or exceeding the maximum bank angle change limits.

The AOA/g limiter depends on the horizontal tails to control g and AOA. If the airspeed decreases until there is not enough airflow over the tails to provide this control, the limiter is defeated and a departure or deep stall may result. This condition may occur in a nose-high, decreasing speed maneuver. Refer to LOW AIRSPEED OPERATING LIMITATIONS, Section V.

#### LEADING EDGE FLAPS

The LEF system is designed to optimize wing airflow. It also provides special functions in the takeoff and landing configurations.

At subsonic speeds, the LEF's move from 2 degrees up to 25 degrees down as a function of mach number, AOA, and altitude. This automatic operation significantly reduces buffet and drag and improves high AOA directional stability. If the LEF's fail to schedule properly during maneuvering flight, higher than normal buffet levels occur and, in the high AOA region, reduced directional and longitudinal stability may also be noted. At supersonic speeds, the LEF's are scheduled to minimize drag.

## **SPEEDBRAKES**

The speedbrakes provide deceleration over the entire flight envelope. There are no trim changes associated with speedbrake operation and induced buffet is negligible. A yaw oscillation may occur at approximately 1.4 mach with speedbrakes opened. The oscillation is neutrally damped and no action is required. The oscillation may be eliminated by either closing the speedbrakes, reducing mach, or increasing the g level.

## **AUTOPILOT**

With the HDG SEL and ALT HOLD modes engaged, the aircraft turns, climbs, or dives within the limits of the autopilot to capture the heading reference and the altitude reference regardless of aircraft attitude. This autopilot-commanded flight may eventually return the aircraft to a preselected heading and altitude if airspeed and altitude permit.

If the ALT HOLD remains engaged as airspeed transits 1.0 mach, a mild pitch transient may occur and can be eliminated by depressing the paddle switch until the altimeter has stabilized.

Use of pitch altitude or attitude hold during decelerating flight can produce either autopilot disengagement and the FLCs A/P FAIL PFL or descent from the referenced altitude if AOA increases above certain values. In CAT I, the autopilot disengages and the FLCs A/P FAIL PFL occurs when 15 degrees AOA is exceeded. In CAT III, the aircraft starts descending from the referenced altitude at approximately 8-10 degrees AOA. If the descent is not corrected within 5 seconds, the FLCs A/P DEGR PFL occurs.



Since the autopilot command is additive to stick commands, use of ALT HOLD in conjunction with high g maneuvering may result in aircraft over-g.

## **TRIM**

The aircraft can be trimmed about all three axes. With pitch trim centered in cruise gains and no input to the stick, the aircraft attempts to maintain 1g flight regardless of flight condition unless AOA exceeds 15 degrees. Full noseup/full nosedown trim corresponds to +3.4g or -1.4g in cruise gains.

## **NOTE**

Airspeed must be closely monitored because there is little aerodynamic indication of large changes in airspeed. Cues which normally indicate airspeed changes, such as stick movement or trim changes, are absent.

Above 15 degrees, the FLCs commands an increasing nosedown pitch attitude as a warning of decreasing airspeed. A specific force applied to the stick commands a specific g increment from the trim condition. Moving the PITCH TRIM wheel changes the hands-off trim condition.

In takeoff and landing gains, zero pitch trim commands zero pitch rate until 10 degrees AOA. A slight amount of noseup trim is required to zero stick forces during an 11-13 degree AOA approach.

When properly trimmed and no input is applied to the stick, the aircraft attempts to maintain zero roll rate. Moving the ROLL TRIM wheel changes the hands-off trim condition. Maximum roll trim authority is approximately one-fifth of maximum stick command of cruise gains. However, precise trimming is difficult using the stick TRIM button. Roll trim requirements may change with stores, particularly at supersonic speeds. For asymmetric configurations (asymmetrical stores or rudder mistrim), roll retrimming may be required as flight conditions change. Roll trim inputs also command rudder deflection through the ARI. The ARI switches out with wheel spinup upon landing. Likewise, the ARI switches in following takeoff as the wheels spin down. This switching may cause abrupt rudder inputs to occur if roll (due to asymmetries or crosswind) is being input via the stick or trim.

Rudder trim inputs command rudder deflection. Rudder trim is required with asymmetrical configurations and frequently during supersonic flight, especially with stores. Maximum trim authority is 12 degrees.

## NORMAL FLIGHT CHARACTERISTICS

### WARNING

The capability of the aircraft to rapidly attain and sustain high g levels, which may cause g-induced loss of consciousness, should be considered during heavy maneuvering.

The FLCS provides constant response for specific inputs regardless of flight conditions. Commanded pitch responses are in g increments per stick force for AOA below 15 degrees. Above 15 degrees AOA, stick force increases as a cue of increasing AOA.

Conventional cues such as aircraft buffeting forces are not always present as AOA and g limits are approached. The commanded lateral response is roll rate per stick force. Rudder position is commanded by rudder pedal force.

The ARI provides coordinated rudder commands and reduces sideslip during rolling maneuvers. Additional pilot rudder commands do not improve roll performance but do increase departure susceptibility. When ARI is not available during takeoff and landing (MLG wheel speed above 60 knots), pilot rudder commands may be required to provide coordinated flight and to control yaw.

### WARNING

Rolling g limits are not protected by the FLCS and must be observed.

### CATEGORY I LOADINGS

The FLCS minimizes the possibility of departures or spins. Roll rate inputs command flaperons and horizontal tails for roll power to provide a relatively constant roll response.

Maximum command 360-degree rolls at subsonic speeds may cause a slight g reduction on termination. At supersonic speeds, maximum roll rates may cause a slight increase in g. At high AOA and low airspeed conditions, roll performance is reduced by the FLCS to minimize pitch/roll coupling. Aft CG's, open speedbrakes, asymmetric missiles, or centerline stores decrease departure resistance.

### CATEGORY III LOADINGS

Aircraft response with most category III loadings remains similar to that of the clean aircraft; however, large stores significantly increase total aircraft drag and reduce performance. Light buffeting may occur during level flight at approximately 0.92 mach. In addition, surging may occur near the store limit airspeed, especially at low altitude. Neither condition requires specific action.

With STORES CONFIG switch in CAT III, the AOA/g limiter provides departure resistance for all category loadings. Except for the requirement to avoid structural overstress, pilot workload is reduced to a level comparable to that with category I loadings.

### CONFORMAL FUEL TANKS PX III

In general, the presence of CFT's only minimally affects flight characteristics. One item of significance is a reduction in directional stability which manifests itself as higher angles of sideslip during lateral-directional maneuvering. Directional "looseness" may be evident during tasks such as tracking and aerial refueling.

**LESS 163** Significantly higher angles of sideslip can be generated with pilot rudder input. Rudder should be used only as required. Avoid abrupt and/or large inputs.

### WARNING

**LESS 163** Maximum command and/or abrupt pilot rudder inputs can result in departure or structural overload when CFT's are installed.

### FLIGHT WITH LG DOWN

With the LG handle down, LG and TEF's are extended and the FLCS operates in takeoff and landing gains. Normally, this mode of flight is limited to takeoff, approach, and landing; however, circumstances can arise which require flight for an extended distance with the LG down. If so, the LG should be left pinned but the streamers should be removed to prevent damage.



With the LG pins installed, it is preferable to raise the LG handle once airborne. This action retracts the TEF's and significantly reduces drag and the FLCS switches to cruise gains. For cruise with only the LG down, the best airspeed is 230-250 knots. A clean aircraft can be flown at 25,000-30,000 feet with the LG down and TEF's up and fuel flow is 3000-3400 pph. If the LG handle is left down, the TEF's remain down and the best cruise altitude is less than 20,000 feet with significantly higher fuel flows.

## LANDING CONFIGURATION

Two distinct techniques may be used when landing. One technique is to trim for approximately 11 degrees AOA and to fly that airspeed throughout the final approach. Attitude/glidepath is controlled by the stick, and airspeed/AOA is controlled by the throttle. This technique allows better pitch control, better over-the-nose visibility, and a more stable HUD presentation. In gusty wind conditions, the aircraft wallows less, and during the flare, the sink rate is easier to control. The aircraft floats approximately 800-1200 feet from flare initiation to touchdown. Another technique is to trim for 13 degrees AOA and to fly that airspeed throughout the final approach. The throttle is used primarily to control glidepath, and the stick controls airspeed through control of AOA and direction through bank angle. This type of approach primarily allows better control of touchdown point and more efficient energy dissipation; however, since the aircraft is already at 13 degrees AOA, the flare is more difficult, and care must be exercised to avoid scraping the speedbrakes or landing firm. The aircraft floats approximately 500-700 feet from flare initiation to touchdown.

Regardless of the technique used, establish computed final approach airspeed for the desired AOA early on final and trim the aircraft. Airspeed changes result in pitch changes, which may require retrimming and make glidepath control more difficult. **[PW 229]** Small throttle adjustments may be required as the DEEC retrimms the engine.

On short final, avoid premature or large thrust reductions which may cause increased sink rates and a hard landing. Use thrust rather than back stick to control undesirable sink rates. Increased back stick may result in a tail strike in this situation. AOA decreases slightly as the aircraft enters ground effect.

All normal landings should be made with speedbrakes opened to the 43-degree position to avoid a floating tendency when entering ground effect. A touchdown at the desired point at 13 degrees AOA can be achieved when flying final at either 11 or 13 degrees AOA by adjusting the initial aimpoint.

Increased control inputs to achieve normal aircraft response as airspeed decreases are unnecessary. Control inputs should be kept small to avoid overcontrol.

Due to the aircraft light wing loading and the floating tendency associated with ground effect, wake turbulence on final approach and during touchdown presents a significant hazard. Increased spacing between landing aircraft should be used when there is little or no effective crosswind. Exercise caution and be ready to initiate a go-around when wake turbulence is encountered. An early go-around decision may help avoid the need for a large roll control input. Such an input retracts a flaperon, causing decreased lift and possibly a sink rate as well as a roll. A large roll input at slow airspeed also causes a large horizontal tail split. A horizontal tail surface could contact the runway while trying to counter wake turbulence effects during touchdown.

If pitch trim is used during the turn to final, forward stick/trim will be required upon rollout on final approach to counter noseup motion. Floating tendencies following a high flare or aircraft bounce may be increased. Slight forward stick force may be required to prevent a long or slow landing. Stick force per degree AOA change is reduced and should not be relied upon as a slow speed cue.

## FACTORS AFFECTING FLYING CHARACTERISTICS

### NOTE

Pitch sensitivity and pilot induced oscillations (a maximum of  $\pm 0.5g$ ) may occur above 0.80 mach when flying with 600-gallon fuel tanks. This behavior can be minimized by avoiding large pitch-stick inputs and rapid pitch-stick reversal. If this behavior becomes objectionable, reduce airspeed and pitch-stick inputs.

**NOTE**

- Momentary uncommanded pitch changes (a maximum increase of 1g) and/or bank angle changes (a maximum increase of 15 degrees) may occur above 0.85 mach when flying with 600-gallon fuel tanks. This behavior is known to occur with loaded TER racks but may occur with other store loadings. Avoid overresponding to the changes and use smooth stick input to minimize pilot induced oscillations. Airspeed should be reduced if this behavior becomes objectionable. If flying within normal load factor carriage (MAX ACCEL G) limits defined in T.O. GR1F-16CJ-1-2, STORES LIMITATIONS, an incremental 1g uncommanded pitch change will not exceed structural limits.
- A mild pitch oscillation (a maximum of  $\pm 0.15g$  at 3 cycles per second) may occur at 0.75-0.90 mach while in cruise gains or at 330-400 knots while in takeoff and landing gains. The oscillation is caused by the normal response of the aircraft and FLCS and does not cause a significant tracking problem.
- Momentary roll hesitations may occur when commanding low to moderate roll rates (generally less than 100 degrees per second) when airspeed is above 350 knots, and altitude is 20,000 feet or less. This behavior is most noticeable when flying without stores.
- A short duration (less than 3 seconds) series of rapid wing rocks (less than 10 degrees of bank angle change) may occur when terminating a high roll rate maneuver at airspeeds above 400 knots. This behavior is most noticeable when flying without stores.
- Minor AOA oscillations (less than  $\pm 2$  degrees) may be noticed during elevated-g maneuvering on or near the AOA/g limiter with certain loadings. This behavior is most noticeable between 250 and 350 knots when flying above 25,000 feet MSL.

- Momentary roll hesitations may occur during elevated-g maneuvering on or near the AOA/g limiter with certain loadings. This behavior is most noticeable between 250 and 350 knots when flying above 25,000 feet MSL.

**CENTER-OF-GRAVITY CONSIDERATIONS**

Monitoring the forward and aft fuel distribution provides an indication of the aircraft CG.

As CG moves aft, higher pitch rates are obtainable and susceptibility to departure and deep stall increases.

**NOTE**

- **C** The most aft CG occurs with approximately 2000 pounds of internal fuel remaining.
- **D** With external fuel tanks, the most aft CG occurs when the external fuel tanks have just emptied.

**EFFECT OF THRUST**

Thrust changes result in little or no change in aircraft trim or stability at all operational load factors and for all store loadings.

**EFFECT OF LOW AIRSPEED MANEUVERING**

Departures are possible at low airspeeds and low pitch angles if large, simultaneous pitch and roll inputs are made.

The FLCS requires adequate airflow over the control surfaces to be effective, which means that airspeed is a critical factor in departure susceptibility during maneuvering. Low airspeeds should, therefore, be avoided during maximum performance maneuvering.

**WARNING**

- FLCS limiters can be defeated at low airspeeds (below 200 knots in a CAT I configuration) during maximum pitch and roll commands initiated from below limiter AOA's.
- The aircraft can be departed (from parameters outside the tone on area of figure 1-42) with no low airspeed warning tone present, if abrupt or uncoordinated FLCS commands are made.

## HIGH PITCH, LOW AIRSPEED

The low airspeed warning tone sounds to aid in recognizing that critical high pitch, low airspeed flight conditions are reached.

### **WARNING**

Proper assessment of flight path angle (not pitch angle) is key to determining the nearest horizon and performing a proper recovery. Differences between flight path and pitch angle of up to 25 degrees, combined with the visual illusion caused by a reclined seat can lead to an incorrect decision to continue the maneuver through the vertical. The risk of a departure/deep stall in this instance is very high.

Avoiding a departure under these conditions requires specific control techniques. To recover, first release aft stick pressure. This action unloads the aircraft and reduces AOA so that the flightpath more closely coincides with the longitudinal axis of the aircraft. Smoothly roll inverted to the nearest horizon. After the roll, smoothly apply the aft stick pressure required to keep the nose moving toward the horizon. As airspeed continues to decrease during the recovery, more aft stick pressure may be required to keep the nose moving. Continue to smoothly increase aft stick pressure up to the AOA/g limiter. If full aft stick is inadvertently released, do not reapply it unless required to keep the nose moving.

### **WARNING**

Avoid large, simultaneous pitch and roll commands to preclude a roll-coupled departure. Small lateral commands can be made as required to maintain wings level, inverted flight. Do not abruptly apply aft stick pressure at anytime during the recovery. Rapid aft stick pressure will generate excessive AOA, overshooting the AOA limiter and causing departure.

During a recovery where full aft stick is required, nose movement toward the horizon may slow down markedly as the AOA/g limiter tries to limit AOA. As long as the nose continues to move, no further action is required. If the nose of the aircraft does not continue to move toward the horizon, the aircraft has departed, and out-of-control recovery procedures should be initiated.

After attaining a nosedown attitude with airspeed increasing, continue to avoid abrupt commands. The aircraft may either be unloaded and rolled upright or a split-s recovery can be made at airspeed above 200 knots, altitude permitting, before continuing to maneuver. The split-s recovery is the simplest way to recover the aircraft. However, if altitude is a factor, allow airspeed to increase to a minimum of 150 knots, unload the aircraft to less than 1g, smoothly roll upright, and recover to level flight.

## FLIGHT WITH STORES

The major effects of stores are increased weight and inertia. A reduction in aircraft response and damping should be expected as GW increases, particularly when stores are carried. Stores generally reduce longitudinal and directional stability and increase inertial effects so that the pilot must anticipate initiation and termination of maneuvers based on the loadings. High roll and pitch rates are attainable with full force application of the stick. Avoid abrupt control commands which may cause AOA overshoots in excess of the limitations specified in Section V and T.O. GR1F-16CJ-1-2.

Bank angle change limits must not be exceeded. During rolling maneuvers with category III loadings, the roll rate must be stopped prior to 360-degree bank angle change. Removing the roll input is not always sufficient (opposite stick may be required). Refer to STORES LIMITATIONS, T.O. GR1F-16CJ-1-2, for carriage limits.

Certain store loadings may exhibit decreased yaw/roll damping in supersonic flight and result in mild yawing oscillations. Neutral and divergent yaw and roll oscillations may occur during sideslip maneuvers at supersonic airspeed. These oscillations are aggravated when large stores are carried. Excessive vertical tail loads may be generated if oscillations become sufficiently large. If oscillations are encountered during rudder commands, release the rudder input. Additionally, buffeting may occur in transonic flight with certain store loadings.

### **NOTE**

A mild airframe vibration may be experienced while supersonic when carrying a centerline store.

## LIMIT CYCLE OSCILLATION AND AEROSERVO-ELASTIC OSCILLATION

A limited amplitude constant frequency oscillation (commonly referred to as limit cycle oscillation or LCO) may occur with certain stores loadings. The LCO (typically 5-10 cycles per second) may occur in level flight or during elevated g maneuvers. The LCO may appear as buffeting or turbulence similar to that experienced during normal transonic buffet, but the buffeting is a constant frequency, lateral acceleration from side-to-side or, in some cases, vertical accelerations up and down. The magnitude generally increases with increasing airspeed and/or load factor. Other cues of LCO include significant vertical movement of the forward area of wing stores, especially wingtip launchers and missiles; this motion is typically up and down, but may also follow a circular pattern. In addition, cockpit instruments may become difficult to read as the LCO amplitude increases from moderate to severe. Within published carriage limits, LCO is not detrimental to the aircraft. LCO susceptible loadings include air-to-surface and air-to-air loadings and associated downloadings. If LCO is encountered and is uncomfortable or distracting, reduce airspeed and/or load factor. Refer to STORES LIMITATIONS, T.O. GR1F-16CJ-1-2, for carriage limits.

An aeroservoelastic (ASE) oscillation is similar to LCO. Wing and store oscillation and cockpit vibration may be indistinguishable from those caused by LCO. However, ASE oscillation is driven by the FLCS, resulting in key differences. ASE oscillation (typically at 4-5 cycles per second) is most likely to occur within a narrow range between 0.9 and 0.95 mach. The magnitude is strongly dependent on mach, but not strongly dependent on load factor, and increases in severity as altitude decreases. ASE oscillation will probably occur when carrying wingtip AIM-120 missiles. The presence of stores at stations 3 and/or 7 may dampen the oscillation. Within published carriage limits, ASE oscillation is not detrimental to the aircraft. If ASE oscillation is encountered and is uncomfortable or distracting, change airspeed by at least 0.05 mach.

### NOTE

LCO and ASE oscillation may be indistinguishable to the pilot. Either may produce severe oscillation at the most critical flight condition. While not detrimental to the aircraft within published carriage limits, the motions may be extremely uncomfortable or

impact mission accomplishment. The most effective way to reduce LCO or ASE is to reduce airspeed.

## ASYMMETRIC LOADINGS

If roll trim is used to hold up a heavy wing, the ARI adds rudder in the direction of the roll trim, causing a yaw away from the heavy wing. If roll trim is used for takeoff, yaw occurs when the wheel speed drops below 60 knots groundspeed after takeoff, activating the ARI. This yaw is easily controllable by rudder commands. Yaw and roll trim requirements change for different flight conditions.

Asymmetric loads increase departure and spin susceptibility. Roll commands/trim away from the heavy wing is required to maintain the desired roll attitude. Increasing g requires additional roll commands/trim. Therefore, aft stick commands result in increased roll requirements which, in turn, produce yaw away from the heavy wing due to ARI action.

## WARNING

- With certain asymmetric category III loadings (2000 pounds or greater on station 3 or 7 with stores on stations 4, 6, and/or 5), rapid or abrupt aft stick commands may result in sudden nose slicing departures.
- Departure with an asymmetric category III loading may result in a fast, flat (possibly nonrecoverable) spin.

### NOTE

Left-wing heavy asymmetries are more susceptible to departure.

During TF, commanded fly-ups with asymmetric loads result in a slower roll to wings level away from the heavy wing. Stick inputs to assist the roll to wings level may be required as described in T.O. GR1F-16CJ-34-1-1

At high airspeeds, asymmetric loads exhibit some unusual flight characteristics. Frequent trim reversals may occur during supersonic acceleration. At airspeeds greater than 700 knots, yaw oscillation may occur with significant lateral accelerations.

Over 750 knots, a high frequency directional shaking may occur with loadings such as the ECM pod.

## STORE SEPARATION

Symmetrical store releases and wingtip AIM-9 missile launches can be accomplished with no unusual aircraft responses. Separation of the 300-gallon fuel tank produces negative g on the aircraft. The magnitude of this response depends on the amount of fuel remaining in the tank and the mach number at release. Separating a full centerline fuel tank at supersonic speeds produces the worst response (up to  $-1.5g$ ).

Separation of 370-gallon fuel tanks produces a minimal aircraft response. Separation of a single 370-gallon fuel tank will initially produce aircraft positive g response and roll away from the separated tank (up to  $+1g$  and 15 degrees of bank).

## OUT-OF-CONTROL CHARACTERISTICS

A departure is a loss of aircraft control that is characterized primarily by uncommanded aircraft motions or failure of the aircraft to respond to control commands. In a pitch departure, the AOA increases beyond the normal controllable range. In a yaw departure, the sideslip angle increases beyond the normal controllable range first, although a pitch departure may immediately follow. The automatic features of the FLCS normally prevent departures. However, departures may occur when Section V limits are exceeded or in certain circumstances when the FLCS provides only marginal protection.

With a lateral asymmetry in excess of 300 pounds (including wing tip missile and internal/external fuel), abrupt maneuvering on or near the CAT I AOA limiter can result in a departure if the aircraft is configured with any of the following:

- 300-gallon fuel tank.
- 370-gallon fuel tanks.
- Inlet mounted pod(s).
- Combination of a centerline store plus stores (or suspension equipment) at stations 3 and/or 7.

With these loadings, maneuvering at high altitude (above 25,000 feet) increases the probability of a yaw departure. Even moderate control commands may cause aircraft with some CAT I loadings to depart above 25,000 feet.

Abrupt maneuvering on or near the CAT I AOA limiter at slow airspeeds (less than 200 knots) may result in a departure.

## YAW DEPARTURE

A yaw departure occurs when sideslip increases beyond the normal controllable range (i.e., beyond about 15 degrees). The primary indication of most yaw departures is an abrupt nose slice. The aircraft then fails to respond properly to pilot commands and exhibits uncommanded motions. AOA is in the normal range ( $-5$  to  $+25$  degrees) during the initial phase of the nose slice. Immediately following a yaw departure, a pitch departure usually occurs resulting in AOA indication of  $-5$  or  $+32$ .

It is possible for the sideslip to briefly exceed the normal controllable range without the aircraft experiencing uncommanded motions. In this situation, the pilot's only indication of a departure may be noticeable sideforces. These brief departures typically self-recover within 5 seconds.

A yaw departure may occur while maneuvering on or near the CAT I AOA limiter in the 0.80 to 0.95 mach range, especially at high altitude (above 25,000 feet). Maneuvering at high altitude is more critical than low altitude because mach effects reduce directional stability. These yaw departures usually result from maximum command left rolls; but they may also occur during symmetric maneuvering.

The possibility of a yaw departure is increased whenever the aircraft is configured with stores or suspension equipment, especially a centerline store. In general, the possibility of departure increases as the number, weight, and size of such equipment or stores increases. Susceptibility to a yaw departure increases significantly with lateral asymmetry, with left-wing-heavy loadings being more likely to depart than right-wing-heavy loadings. In addition, a heavier GW aircraft is generally more likely to experience yaw departures. CAT I loadings most susceptible to yaw departures have one or more of the following characteristics:

- Centerline store.
- Inlet mounted pod(s).
- Lateral asymmetry greater than 300 pounds at stations 1, 2, or 3.

Yaw departures can be minimized by avoiding abrupt maneuvers in the 0.80 to 0.95 mach range with a centerline store, especially above 25,000 feet. Either unload the aircraft prior to making roll commands or command only minimum required roll rate when operating near the CAT I AOA limiter. With centerline store loadings having lateral asymmetries greater than 300 pounds and inlet mounted pod(s), avoid abrupt aft stick commands above 25,000 feet.

**WARNING**

The probability of a yaw departure significantly increases above 25,000 feet for CAT I loadings having a centerline store, a lateral asymmetry greater than 300 pounds, and inlet mounted pod(s). With these loadings, moderate, full-aft-stick inputs at 35,000 feet and 300 knots have caused yaw departures and spins.

A yaw departure may also occur with large air-to-surface lateral asymmetries with the STORES CONFIG switch in the CAT III position. These departures can be avoided if abrupt control commands are not used with lateral asymmetries in excess of 1500 pounds at station 3 (or equivalent).

A yaw departure results in one of the following:

- A self-recovery. The self-recovery may occur quickly (within approximately 5 seconds). If a pitch departure follows the yaw departure, the self-recovery may require 10-20 seconds. Random and possibly abrupt pitch, roll, and yaw rates may occur.
- A deep stall.
- An upright spin.

**PITCH DEPARTURE**

A pitch departure occurs when the AOA exceeds the AOA/g limiter. A pitch departure is classified either as upright if the AOA is positive or as inverted if the AOA is negative. Although the AOA indicator displays a maximum of 32 degrees and a minimum of -5 degrees, the actual AOA during a departure will exceed these values. In highly oscillatory departures, the AOA indicator may momentarily indicate an AOA below 32 degrees. Airspeed indications are erroneous and generally oscillate between the minimum value and approximately 150 knots.

An upright pitch departure occurs when the AOA exceeds the positive AOA/g limiter. Above 25 degrees AOA, both horizontal tails are commanded to full trailing edge down by the pitch axis of the FLCS to try to reduce the AOA. If AOA exceeds 35 degrees, the yaw rate limiter provides antispin commands to the rudder, flaperons, and horizontal tails. Pilot roll and rudder commands are inhibited and pitch stick commands are ineffective without use of the MPO switch.

An inverted pitch departure occurs at negative AOA when the AOA significantly exceeds the negative g limiter. During the departure, the pitch axis of the

FLCS commands the horizontal tails to full trailing edge up to try to return AOA to the normal range. Pitch stick commands are ineffective without use of the MPO switch.

If AOA is below -5 degrees and airspeed is less than 170 knots, the yaw rate limiter provides antispin commands to the rudder. During an inverted departure, roll and rudder commands should be avoided. Pilot roll and rudder commands are inhibited when the MPO switch is engaged.

An upright or inverted pitch departure can occur when the aircraft is flown to airspeeds below that indicated by the low speed warning tone. Inverted pitch departures usually result from inverted flight at high pitch attitudes and low airspeeds, such as those often encountered by going over the top at too slow an airspeed. An upright or inverted pitch departure may also occur at any pitch attitude if abrupt stick commands are made at airspeeds below 200 knots. Simultaneous abrupt roll and aft stick commands are especially likely to cause an upright pitch departure. However, the aircraft can be safely flown to the AOA/g and roll limiters below 200 knots with smooth commands.

An upright pitch departure may also result from a yaw departure. In addition, recovery from an inverted pitch departure may cause the aircraft to pendulum into an upright departure and vice versa.

The likelihood of a pitch departure increases if the aircraft is configured with stores (especially 370-gallon fuel tanks), if the speedbrakes are opened, or if the CG is near the aft limit.

Pitch departure characteristics are strongly influenced by the airspeed and aircraft rates present at departure. A low airspeed departure (below 200 knots) may have relatively benign uncommanded pitch, roll, and yaw motions. Higher airspeed departures are usually very dramatic with large uncommanded pitch, roll, and yaw motions which may persist for 10 seconds or more.

It is possible for the AOA to briefly exceed the AOA/g limiter without the aircraft experiencing uncommanded motions. In this situation, the pilot's only indication of a departure may be a failure of the aircraft to respond to control commands. These brief departures typically self-recover within 5 seconds.

A pitch departure results in one of the following:

- A self-recovery which occurs within 5-20 seconds. Random and possibly abrupt pitch, roll, and yaw rates may occur.
- A deep stall.
- A spin.

**DEEP STALL**

If the aircraft does not self-recover following a departure, a deep stall may have developed. A deep stall is an out-of-control flight condition in which the aircraft stabilizes at an AOA of approximately 60 degrees (upright) or -60 degrees (inverted) with low yaw rates. The FLCS attempts to return AOA to the normal range by commanding full horizontal tail deflection. However, the full horizontal tail deflection is insufficient to return AOA to the controllable range. The aircraft has entered a deep stall if the AOA remains outside the controllable range. In a deep stall the AOA indicator will be pegged at 32 or -5 degrees. Recovery to controlled flight requires that the pilot pitch rock the aircraft with the MPO switch in OVRD. The MPO switch allows the pilot to override the FLCS and to manually control the horizontal tails.

Airspeed indications are erroneous in a deep stall and fluctuate between 0-150 knots. Altimeter indications should be considered reliable; however, aircraft oscillations may cause momentary stabilized or even slightly increased altitude indications. Sink rate in a deep stall is usually between 10,000 and 15,000 feet per minute. The normal load factor is approximately 1g or -1g for upright and inverted deep stalls, respectively.

Upright deep stalls may be very stable with little or no pitch, roll, and yaw motions or may be very oscillatory with large pitch, roll, and yaw motions. Generally, a clean configuration results in a deep stall with a near wings-level pitching motion. If stores are being carried, especially a 300-gallon fuel tank or 370-gallon fuel tanks, the deep stall may be very oscillatory, masking the pitch motions.

In an upright deep stall, the nose of the aircraft usually oscillates  $\pm 15$  degrees about a slightly nose-low pitch attitude. Pitch oscillations may be as high as  $\pm 40$  degrees and normally reverse direction approximately every 3 seconds. Roll reversals up to  $\pm 90$  degrees from wings level may occur and the yaw rate tends to cyclically reverse back and forth and may be as high as 40 degrees per second. A slow net heading change, usually to the left, may occur.

Inverted deep stalls may be either stable or highly oscillatory in pitch, depending upon the CG. If there is little or no pitch motion, the nose is slightly above the horizon and the wings are generally level. If the deep stall is oscillatory in pitch, the nose may oscillate above and below the horizon by as much as  $\pm 20$  degrees. Yaw and roll oscillations in an inverted deep stall are normally smaller than those during an upright deep stall.

The aircraft is most likely to stabilize in a deep stall if it does not self-recover within two postdeparture pitch oscillations. The likelihood of a deep stall occurring after a departure is also dependent upon the aircraft CG and configuration. An inverted deep stall can occur at a more forward CG than an upright one. The likelihood of a deep stall developing after a departure increases as the CG moves farther aft and if stores (especially 370-gallon fuel tanks) are loaded.

**SPIN**

A spin is a deep stall with a significant sustained yaw rate in one direction (greater than 30 degrees per second). The pitch, roll, and yaw oscillations associated with a deep stall should not be confused with the continuous yaw rotation associated with a spin. AOA, airspeed indications, and altitude loss are similar to those during deep stalls. Spins can be either upright or inverted, although inverted spins are much less likely to occur than upright spins.

The yaw rate limiter is effective in preventing an upright spin with most CAT I loadings. However, following a yaw departure above 25,000 feet, aircraft with CAT I loadings that have all the following characteristics may spin:

- Centerline store.
- Inlet mounted pod(s).
- Lateral asymmetry greater than 300 pounds at stations 1, 2, or 3.

Upright spins following a yaw departure can be disorienting. The initial portion of the spin is characterized by highly oscillatory pitch and roll motions and a high yaw rate (70 to 100 degrees per second). Initially, the aircraft spins roughly around the aircraft's flight path at departure. As the spin continues, the rotation axis eventually becomes vertical. Very noticeable forward g (eyeballs out) and sideforces are present.

Yaw rate usually decreases to near zero within 10 to 25 seconds. The g forces decrease noticeably as yaw rate decreases, which may give the sensation that yaw rate is lower than it actually is. Use outside references to determine when the yaw rate has stopped. A recovery may occur after yaw rate has decreased to near zero. If recovery does not occur, the aircraft has settled into a deep stall and pitch rocking must be used to recover the aircraft to controlled flight. However, because pitch rocking is less effective when a yaw rate is present, pitch rocking should not begin until yaw rotation stops or is minimized (if altitude permits).

A spin may also occur following any departure with a CAT III loading that has a large lateral asymmetry from air-to-surface stores. These spins may be fast, flat, and possibly unrecoverable.

An inverted spin can be caused by pilot rudder and roll commands if they are not released following an inverted departure.

The yaw rate limiter is effective in preventing an inverted spin with all CAT I loadings. However, large lateral asymmetries from air-to-surface stores on CAT III loadings may overpower the yaw rate limiter and cause unrecoverable inverted spins.

## RECOVERIES

### Self-Recovery

Recovery from most departures is automatic, requiring only release of the controls. Once the controls are released, self-recoveries usually occur within the first two postdeparture pitch oscillations (10-20 seconds). Recovery is characterized by the nose pitching down to a steep dive angle, increasing airspeed, and AOA and sideslip returning to the normal range. Some postdeparture yaw and roll oscillations may be evident, particularly if the departure was in yaw. To prevent departure reentry, the airspeed should be allowed to increase to 200 knots prior to dive recovery. Flight control failure indications may be present after recovery from any departure.

### Deep Stall Recovery

The aircraft should be allowed the opportunity to self-recover if altitude permits. Initiating pitch rocking too soon should be avoided because it can aggravate postdeparture roll and yaw motions, which can significantly lengthen recovery time.

If recovery is not apparent after two postdeparture pitch oscillations (10-20 seconds) or if altitude is a factor, the aircraft must be rocked out of a deep stall. To pitch rock the aircraft, the MPO switch must be firmly held in OVRD until recovery is complete. Recognize any pitching motions and begin stick cycling in-phase with these motions. If no pitch motions are apparent, an abrupt maximum command stick input to pitch the nose away from the ground (full aft stick for an upright deep stall, full forward for an inverted deep stall) will reverse the horizontal tail deflection and should generate a noticeable pitch rate. The best indicator for timing stick cycles is the nose position relative to the horizon, or if no outside references are available, the ADI may be useful. In an upright deep stall, an aft stick command increases

the AOA and pitch angle. When the nose reaches its highest point and reverses direction, a full forward stick command reinforces the nosedown pitch rate. One complete pitch rocking cycle takes approximately 6 seconds, during which time the aircraft descends 1000 to 1500 feet.

If the nosedown pitch rate is large enough, the upright deep stall is broken and AOA returns to the normal range (below +25 degrees). If the nosedown pitch rate is insufficient, the nose stops its downward motion and either begins to rise or stabilizes. Promptly reapply the full aft stick command when the nose reverses or after 2-3 seconds if reversal is not apparent. Holding full forward stick more than 2-3 seconds with the nose stabilized can generate a rapid yaw rate and delay recovery. If the aircraft has not recovered after 2-3 seconds or if a yaw rate develops, reapply full aft stick and complete another in-phase pitch rocking cycle.

Just prior to breaking the deep stall, the nosedown pitch rate may decrease or even stop. Unless the nose either definitely starts back up or stabilizes for longer than 2-3 seconds, another pitchup cycle should not be started. On the pitchdown cycle, the stick should be held full forward (upright) or aft (inverted) while the nose hesitates as the stall breaks. Following a short hesitation (less than 2-3 seconds), the nose continues down to near vertical. There is frequently a distinct, low magnitude airframe shudder which occurs as the stall is breaking. This shudder is a favorable indication that recovery is occurring.

Once the deep stall is broken, aggressive pilot commands are usually required to stop the pitch rate in a steep dive. If possible, find and track a feature on the ground. Maintain firm pressure on the MPO switch until airspeed reaches 200 knots. If a transition to an opposite AOA deep stall does occur, reinforce the already present pitch motion with the MPO still engaged and recovery should be rapid. Transitions during upright deep stall recoveries are most likely to occur with 370-gallon fuel tank configurations.

Recovery to controlled flight is recognized by a steep pitch attitude (usually within 30 degrees of vertical), pitch rate stopping, and AOA in the normal range (-5 to +25 degrees). As airspeed increases above 200 knots, release the MPO switch, maintain neutral roll and yaw commands, and recover from the resulting dive.

Stick commands during pitch rocking should be abrupt and full command, and should reverse after pitch motion reverses. Stick commands that are not abrupt and full command may not be effective. Rapid fore and aft cycling of the stick out of phase with the aircraft motion is also not effective.



The number of pitch rocking cycles required for recovery from an upright deep stall is dependent on aircraft configuration. Generally, recovery occurs in one or two pitch rocking cycles. However, configurations with a centerline store (particularly a 300-gallon fuel tank) or with 370-gallon fuel tanks may require more pitch rocking cycles for recovery. These loadings usually have more oscillatory deep stalls, and the roll and yaw motions make it more difficult to determine proper stick cycling. Pitch attitude is still the best indication for proper stick cycling.

During upright deep stalls with a centerline store, particularly a 300-gallon fuel tank, the aircraft tends to roll and yaw right while pitching up, and roll and yaw left while pitching down. During deep stalls with 370-gallon fuel tanks, the aircraft nose motion appears triangular. This motion is characterized by a roll and yaw right while pitching up, followed by a pitch down, a hesitation, and a yaw to the left. These alternating yaw oscillations should not be confused with a sustained yaw rotation in one direction indicating the aircraft is in a spin.

An inverted deep stall recovery is similar to an upright recovery. In an inverted deep stall, the yaw rate limiter automatically provides rudder against the yaw rate. Pilot roll and rudder commands should be avoided. Pilot roll and rudder commands are inhibited when the MPO switch is in OVRD. Yaw oscillations may be noticed but do not affect recovery.

To recover from an inverted deep stall, position the MPO switch to OVRD and begin stick cycling in-phase with pitch motions. If no pitch motions are apparent, make the first pitch input away from the ground by pushing full forward and monitor pitch motion. One or two pitch rocking cycles are usually sufficient to recover from an inverted deep stall.

During recovery from an inverted deep stall, a transition to an upright deep stall is likely to occur if large pitch motions are present during inverted pitch rocking and the MPO switch is released too early. Early release of the MPO switch reduces the horizontal tail authority available and delays recovery. The MPO switch must be held in the OVRD position until the deep stall is positively broken as evidenced by the pitch rate stopping, AOA in normal range (-5 to +25 degrees), and a steep pitch attitude (usually within 30 degrees of the vertical). As airspeed increases above 200 knots, release the MPO switch, maintain neutral roll and yaw commands, and recover from the resulting dive.

## NOTE

**GE129** The aircraft has demonstrated a strong tendency to transition to an upright deep stall during recovery from an inverted deep stall. Aggressive pilot commands (full forward stick) are required as the nose pitches down to the vertical during recovery to preclude a transition.

## Spin Recovery

To recover from a spin, yaw rate must be stopped or minimized before the aircraft can be recovered. Due to large noseup moments caused by the inertial properties of the aircraft and decreased horizontal tail pitch effectiveness with sideslip, attempts to pitch rock out of a spin are usually not effective. Pitch rocking during a spin is also likely to aggravate roll and yaw oscillations, which make recovery more difficult.

The large forward g (eyeballs out) and sideforces present during the initial portion of an upright spin decrease noticeably as yaw rate decreases, which may give the sensation that yaw rate is lower than it actually is. Use outside references to determine when the yaw rotation has stopped. Pitch rocking should not begin until the yaw rotation stops or is minimized. Pitch rocking with a steady yaw rate greater than 30 degrees per second may prevent recovery.

Waiting for yaw rotation to stop or minimize may require from 20 to 30 seconds. When the yaw rotation stops or is minimized, the aircraft will either self-recover or will settle into an upright deep stall. If recovery is not apparent after yaw rate has stopped or is minimized, perform the appropriate recovery procedures described in the Deep Stall Recovery section.

Pitch, roll, and yaw oscillations associated with a deep stall should not be confused with the continuous yaw rotation associated with a spin. Once the continuous yaw rotation of a spin has been arrested and pitch rocking has begun, pitch rocking should continue until a recovery is achieved.

Upright spins with CAT III loadings that have large lateral asymmetries from air-to-surface stores may be fast, flat, and possibly unrecoverable. There is an option to jettison an asymmetric store as a last ditch effort in case of a fast, flat spin. However, aircraft-store collision may occur.

Inverted spins with CAT I loadings are effectively prevented by the yaw rate limiter. The yaw rate limiter automatically provides rudder against the yaw rate. Pilot roll and rudder commands should be avoided.

If recovery is not apparent after yaw rate has stopped or is minimized in an inverted spin, the aircraft has settled into an inverted deep stall. Perform the inverted deep stall recovery procedures.

## **ENGINE OPERATION DURING DEPARTURES/OUT-OF-CONTROL**

**PW 229** Departures at high altitude may result in an engine stall. If in AB during an out-of-control situation, retard the throttle to MIL. If at MIL or below, do not move the throttle. Do not advance the throttle until beginning the dive recovery.

**GE129** Departures at high altitude may result in an engine stall. Prolonged negative g flight at a high engine thrust level may result in an engine bearing failure. Retard the throttle to IDLE after a departure. Do not advance the throttle until beginning the dive recovery.

If the engine stalls during a departure or out-of-control situation, refer to ENGINE STALLS, Section III, after recovery is complete. The engine should be left running during an out-of-control situation to insure adequate hydraulic pressure to flight control surfaces for recovery. Recover from the out-of-control condition; then concentrate on the engine. If the engine does not recover, it must be shut down and restarted.

## **DEGRADED FLIGHT CONTROLS**

### **FLCS DBU**

Flight characteristics for cruise and landing are not significantly affected by operation in DBU. Although airspeed should be maintained below 500 knots/0.9 mach while in DBU, transitions to DBU at higher airspeeds do not produce adverse handling characteristics. Minimal pitch transients occur if transition to DBU occurs at 1g. At higher g levels, transition to DBU is accompanied by an initial reduction in g. If the aft stick input is continued, g level again increases, but may be less than that which was available prior to the transition. The STORES CONFIG switch is inoperative in DBU and AOA/g force available is similar to that in CAT III.

If LG are lowered below 200 knots, a mild noseup transient of approximately 2 degrees occurs. A similar nosedown movement occurs if LG is raised below 200 knots.

If an automatic transition to DBU occurs when in auto TF, the FLCS initiates a 3g incremental no roll

to wings level fly up. This fly up can be interrupted using the paddle switch. All ATF indications are turned off (active light, TF FAIL warning light, ATF NOT ENGAGED caution light, and autopilot PITCH switch). HUD TF symbology is also removed.

### **LEADING EDGE FLAPS LOCKED (SYMMETRIC)**

Flight characteristics for landing and low AOA maneuvering are not significantly affected by locked LEF's. At high airspeeds, LEF's locked down cause increased buffet. At high AOA, LEF's locked up reduce stability, increase departure susceptibility significantly, and cause increased buffet. Above 16-18 degrees AOA, an abrupt yaw departure may occur, producing an uncommanded roll with little or no forewarning. Do not exceed 12 degrees AOA with the LEF's inoperative. Locked down LEF's significantly reduce cruise range. During landing, floating may also be noticeable if LEF's are locked at or near full down. The aircraft may float, sink rate may decrease, and a slight forward stick pressure may be needed to fly through the ground effect.

### **STANDBY GAINS**

When operating on standby gains, aircraft response is normal at low AOA. Because the LEF's are at zero degrees (LG handle in UP and ALT FLAPS switch in NORM) with a dual air data failure, buffet and departure susceptibility will be increased at higher AOA (above 18 degrees). At flight conditions higher/slower than the fixed gain conditions, aircraft response is more sluggish requiring larger control commands for a given response. Landing the aircraft should present no special problems.

### **ONE HYDRAULIC SYSTEM**

Flight characteristics with one hydraulic system should be normal unless extremely large, rapid control surface deflections are commanded. Under these conditions, the hydraulic flow rate from the one system may be inadequate which slows down control surface movement rates and possibly causes sluggish aircraft response.

### **SPEEDBRAKES**

Speedbrakes may stick fully open or open asymmetrically. If a yawing moment is noted when the speedbrakes are opened, close the speedbrakes. If the speedbrakes fail to close, a significant increase in drag results. Fully opened speedbrakes significantly reduce cruise range.

## AIRCRAFT DAMAGE

Procedures for recovery of an aircraft with damage will depend on the type and extent of the damage. The following paragraphs provide general information based on analysis of past mishaps.

### HORIZONTAL TAIL

Loss or partial loss of one horizontal tail surface will not result in an uncontrollable aircraft except for certain combinations of flight conditions (mach greater than 0.80 and altitude less than 15,000 feet), aircraft loading (heavy CAT III), and CG at or near the aft limit. Avoid abrupt maneuvering and maintain airspeed between 200 and 300 knots until landing approach. Place the STORES CONFIG switch to CAT III if in CAT I. Some roll stick or roll trim may be required to maintain wings level. Use a maximum of 11 degrees AOA during final approach. After touchdown, lower nose to runway as soon as practical.

### FLAPERON

Separation of a flaperon from the wing (flaperon still attached to the ISA in the fuselage) causes the outboard end of the flaperon surface to rotate upwards, towards the fuselage. This may be accompanied by a roll transient. Adequate roll stick authority should be available to counter the effect and maintain control. With a flaperon surface separated from one wing, landing should be made without extending the TEF on the other wing (use alternate landing gear extension, leave LG handle UP, and select brakes CHAN 2). Hydraulic system pressures should also be monitored. Upward rotation of a separated-from-the-wing flaperon surface has caused ISA movement that resulted in a leakage failure of hydraulic system A.

### RUDDER AND VENTRAL FINS

Loss or partial loss of the rudder or a ventral fin will not result in controllability problems unless the aircraft is above 1.5 mach. If loss or partial loss of the rudder or a ventral fin occurs, avoid abrupt maneuvering and reduce speed to subsonic, if supersonic. Place the STORES CONFIG switch to CAT III if in CAT I. During landing with loss or partial loss of the rudder, lower the nose to the runway as soon as practical so that NWS can be used as required for directional control.

### LEADING EDGE FLAPS

Damage to the LEF's may result in locked LEF's. If the LEF's have not automatically locked, they should be manually locked. Refer to Leading Edge Flaps Locked (Symmetric), this section for a discussion of flight characteristics.

### WING

Loss of a portion of the wing produces a rolling motion towards the damaged wing. The capability to stop this roll depends on airspeed, g, and the amount of wing surface lost. Higher airspeeds (above 250 knots) and low g (less than 2) are essential for maximizing the amount of roll control authority available. If the aircraft is in a dive when a portion of the wing surface is lost, apply roll stick force to stabilize the aircraft in roll before applying g to recover from the dive (altitude permitting). Use the lowest g level practical to recover from the dive. As g is increased, additional roll stick force is required to maintain wings level. Depending on the amount of wing surface lost, the minimum speed to maintain adequate roll control could be well above 200 knots.

### RADOME

Loss of the radome results in loss of two air data sources (pitot probe) and two AOA sources (AOA transmitters); however, loss of the radome does not necessarily cause the aircraft to be uncontrollable. FOD to the engine and other damage to the aircraft may also occur as the radome departs.

Loss of two air data sources will affect handling qualities. If the two airspeed sources from the pitot probe go to erroneously low values at the same time, the remaining good source from the fuselage air data probe will be considered failed (i.e. a single failure). In this case the FLCS will not switch to standby gains. Gain scheduling will be based on the erroneously low airspeed; thus, the aircraft will become increasingly pitch sensitive as airspeed is increased. If the two airspeed sources are lost in a manner that the FLCS recognizes as two failures, then the FLCS reverts to standby gains. In standby gains, the opposite problem occurs. With the landing gear up at slow speeds, the aircraft will be sluggish compared to handling qualities prior to the radome loss. It may seem as though the aircraft isn't responding to stick inputs if sufficient response time is not allowed.

Loss of two AOA sources may not be detected as a dual failure. The end result to the FLCS is an AOA in the range of 11 - 13.6 degrees (i.e. no AOA limiter).

If the radome is lost, attempt to attain 1 g level flight at 275 – 300 knots and place the landing gear handle down. Airspeed and AOA indications won't be accurate. Use a chase aircraft to help establish speed and keep AOA below 12 degrees. Assess the situation by determining what failures are being annunciated and perform a controllability check.

## DIVE RECOVERY

Refer to figure 6-1. Dive recovery capability is given as altitude lost during pullout and is a function of pullout load factor, dive angle, true airspeed, and FLCS limiting. Plots to convert indicated airspeed or mach number into true airspeed are provided on the chart. Dive recovery during constant load factor pullout may be on the AOA limiter prior to recovery, under certain initial conditions, as airspeed is reduced. Dive recovery capability at constant load factor is nearly independent of store drag. The dive recovery chart is applicable to GW's between 20,000- 30,000 pounds. The dive recovery chart becomes increasingly conservative for GW's less than 25,000 pounds and decreasingly conservative for GW's greater than 25,000 pounds. Increase altitude lost during full aft stick pullout by 4 percent for each 1000 pounds in excess of 25,000 pounds GW if initial dive angle is  $\geq 45$  degrees and initial airspeed is less than 500 knots.

For a constant g pullout, use the greater of constant g or limiter pullout altitude lost.

### NOTE

The dive recovery chart is based on an idle thrust, wings level, speedbrakes fully open recovery. However, if airspeed is below 350 knots, altitude loss is minimized by selecting/maintaining MIL/AB thrust and closing speedbrakes. If airspeed is 350 knots or above, selecting/maintaining idle thrust and opening speedbrakes minimize altitude loss. In either case, best dive recovery performance is obtained by making an ADI referenced wings level pull.

### SAMPLE PROBLEM:

- GW = 25,000 pounds
- A. KIAS = 300
- B. Initial altitude = 15,000 feet
- C. Temperature = 0°C
- D. KTAS = 381
- E. Mach number = 0.59
- F. Dive angle = 60 degrees
- G. Category/KIAS = CAT I/300
- H. Altitude lost during limiter pullout = 2130 feet
- I. Altitude lost during limiter pullout = 2130 feet
- J. Maximum pullout load factor available = 5.8g
- K. Pullout load factor = 3g
- L. Altitude lost during 3g pullout = 4150 feet

# Dive Recovery

DATA BASIS ESTIMATED

**CONDITIONS:**

- IDLE THRUST
- NO DELAY BEFORE PULLUP INITIATION
- WINGS LEVEL
- MAXIMUM G ONSET RATE
- FULL SPEEDBRAKES

**NOTES:**

1. Applicable for CAT I or CAT III limiter.
2. Increase altitude lost during limiter pullout by 4 percent for each 1000 pounds in excess of 25,000 pounds GW if initial dive angle is  $\geq 45$  degrees and initial KIAS is less than 500.

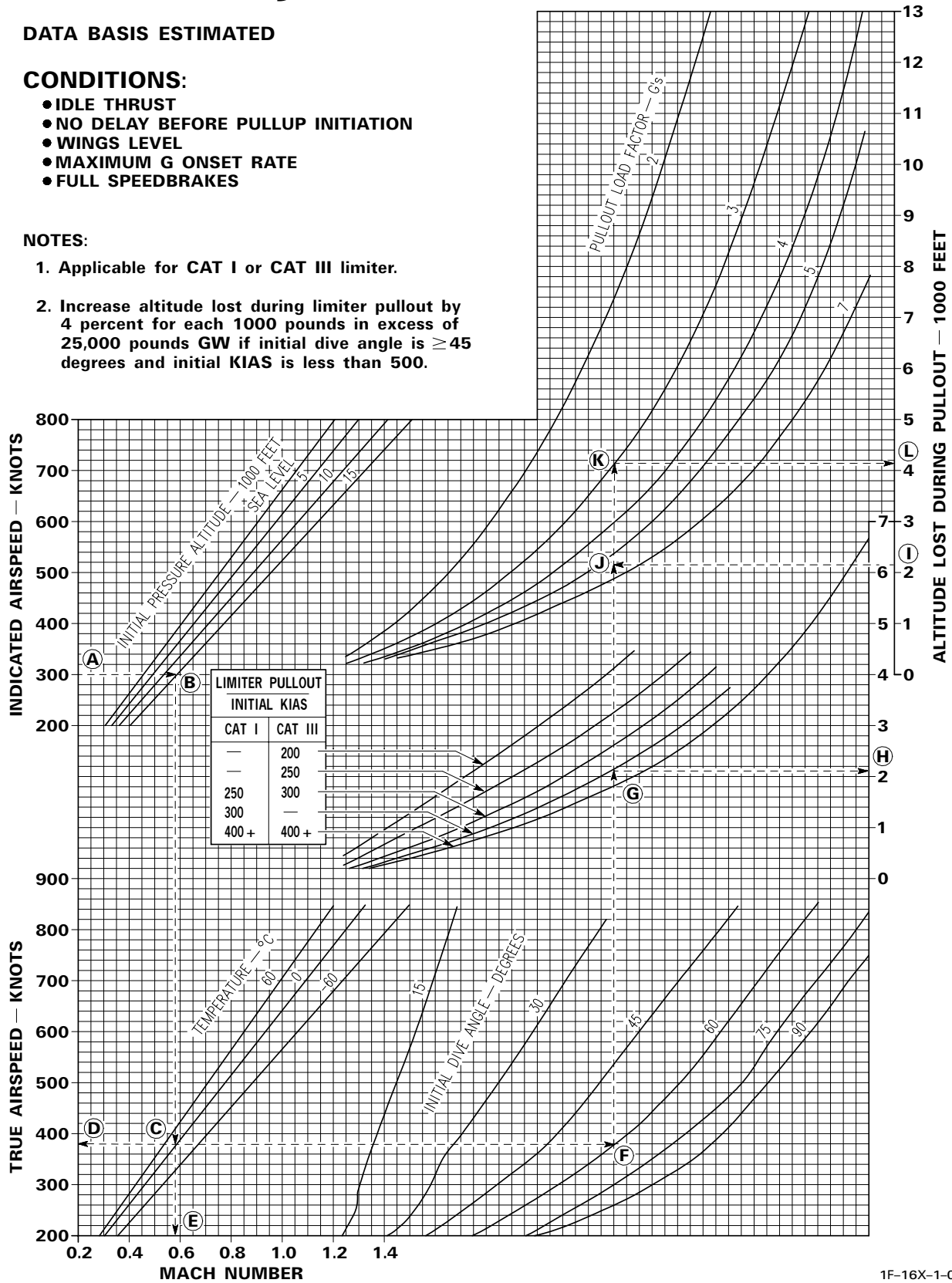

1F-16X-1-0021X©

Figure 6-1.

## SECTION VII

### ADVERSE WEATHER OPERATION

#### TABLE OF CONTENTS

Introduction .....	7-1
Instrument Flight Procedures .....	7-1
Holding .....	7-2
Penetration .....	7-2
Instrument Pattern/Approaches .....	7-2
Missed Approach .....	7-2
Turbulence and Thunderstorms .....	7-2
Cold Weather Operation .....	7-5
Before Entering Cockpit .....	7-5
Before Starting Engine .....	7-5
Starting Engine .....	7-5
After Engine Start .....	7-5
Taxi .....	7-6
Takeoff .....	7-6
In Flight .....	7-6
Landing in Icy or Wet Conditions .....	7-6
Hot Weather and Desert Ground	
Operation .....	7-7
Volcanic Ash Operation .....	7-7
Ground Operations .....	7-7
In-Flight Operations .....	7-8

#### INTRODUCTION

This section contains information and procedures that affect operation of the aircraft in adverse weather and climatic conditions and which differ from the normal procedures in Section II.

#### INSTRUMENT FLIGHT PROCEDURES

**PX II** The HUD may be used as a reference for instrument flight. **PX III** The HUD may be used as a primary reference for instrument flight. Frequent cross-checks with other instruments will be performed to maintain proper flight orientation and detect failures that are not directly communicated to the pilot.

#### WARNING

- **PX III** The EGI is not certified to provide instrument approach flight path guidance.

- The HUD should not be used as the sole reference for instrument flight due to the lack of adequate failure warning but should be cross-checked with the primary/basic instruments.

- **PX III** The displays generated for the JHMCS helmet are not approved for use as a reference during instrument meteorological conditions (IMC) or for course guidance during landing.

- A delayed selection of ILS/TCN or ILS/NAV until the aircraft is nearly on the ILS glide slope may cause the flight director circle to be positioned incorrectly (full up or full down) for up to 90 seconds. If the flight director circle is positioned incorrectly when an ILS mode is selected, move the INSTR MODE knob to TCN or NAV, then back to the desired ILS mode. This action enables the flight director to operate properly.

- It is possible for the displayed ADI and/or HUD attitude to be in error with no ADI OFF or AUX warning flags in view and without an INS or HUD PFL. Displayed HSI and/or HUD headings may also be in error with no HSI OFF or ADI AUX warning flags in view and without an INS or HUD PFL. Momentary warning flags may indicate impending failure. To detect these failures and maintain proper flight orientation, basic and backup instruments shall be cross-checked.

- **PX III** It is possible for the MMC to position the ILS glideslope bar full down without being dashed even though the ILS glideslope signal may be valid. Care must be taken during precision approaches to cross check ILS information on the ADI if the HUD glideslope bar drives full down and is not dashed.

**WARNING**

- **PX II** With certain failures of the INS with ILS selected, a fixed aircraft reference symbol is displayed at zero degrees azimuth, 11 degrees below the boresight symbol. This symbol is for ILS deviation reference in conjunction with the horizontal and vertical deviation bars. The aircraft reference symbol should not be used for attitude reference.
- Avoid touching the canopy transparency, canopy frame or placing arms on the canopy body positioning handles during IMC. Contact may produce severe shock as a result of static discharge.

**NOTE**

- When rotating the HSI course setting from an eight-unit digit to a nine-unit digit (e.g., 018 to 019), the tens digit may rotate prematurely causing a 10-degree reading error (e.g., 029). Cross-check counter setting with course arrow reading to insure proper course setting.
- Electrical transients (particularly during the EPU check) may cause the INS to revert to use of the last manually entered magnetic variation. Under these conditions, the accuracy of heading information displayed on the HSI and HUD depends upon the manual magnetic variation value entered. If magnetic heading error is suspected, confirm that automagnetic variation is in use or that the correct local magnetic variation is entered.
- **PX III** The EGI does not use navigational aid assigned variation to compute course display for TACAN, VORTAC, VOR, or VOR-DME points retrieved from the database. Rather, the magnetic variation at the aircraft present position is used for course computation and display.

**HOLDING**

Holding airspeed is 200-250 knots (maximum endurance airspeed recommended).

**PENETRATION**

Penetrations are normally flown at 300 knots, speedbrakes as required, and throttle at IDLE.

**INSTRUMENT PATTERN/APPROACHES**

Refer to figure 7-1 for a typical TACAN holding, penetration, and approach. Refer to figure 7-2 for a typical GCA. Instrument patterns are normally flown at 200-250 knots clean. Approaching final, lower the LG, slow the aircraft, and fly final approach at 13 degrees AOA maximum.

**MISSED APPROACH**

Advance throttle as required, close speedbrakes, and retract LG after a positive climb is established. Adjust throttle to maintain between 200-250 knots. Pitch transients resulting from LG and TEF changes are mild and require minimum control compensation.

**TURBULENCE AND THUNDERSTORMS**

Avoid flight in turbulent air, hailstorms, and thunderstorms. There is a high probability of damage to airframe and components from impact ice, hail, and lightning. Thunderstorm penetration airspeed is 300 knots or optimum cruise airspeed, whichever is lower. At high airspeeds, personal discomfort and structural stress are greater. At slower airspeeds, controllability is reduced and inlet airflow distortion due to turbulence may cause compressor stall and/or engine stagnation.

The GM mode of the radar can be used as an aid in navigation between or around storm cells. Refer to T.O. GR1F-16CJ-34-1-1 for expanded information. If entry into adverse weather cannot be avoided, the following procedures should be used:

1. PROBE HEAT switch - Check PROBE HEAT.
2. FLOOD CONSOLES knob - HIGH INT.
3. ANTI ICE switch - ON.
4. Airspeed - 300 knots or optimum cruise, whichever is lower.

**NOTE**

Severe turbulence causes variations in airspeed and altitude. Do not change throttle setting except for extreme airspeed variations.

# TACAN Holding, Penetration, and Approach (Typical)

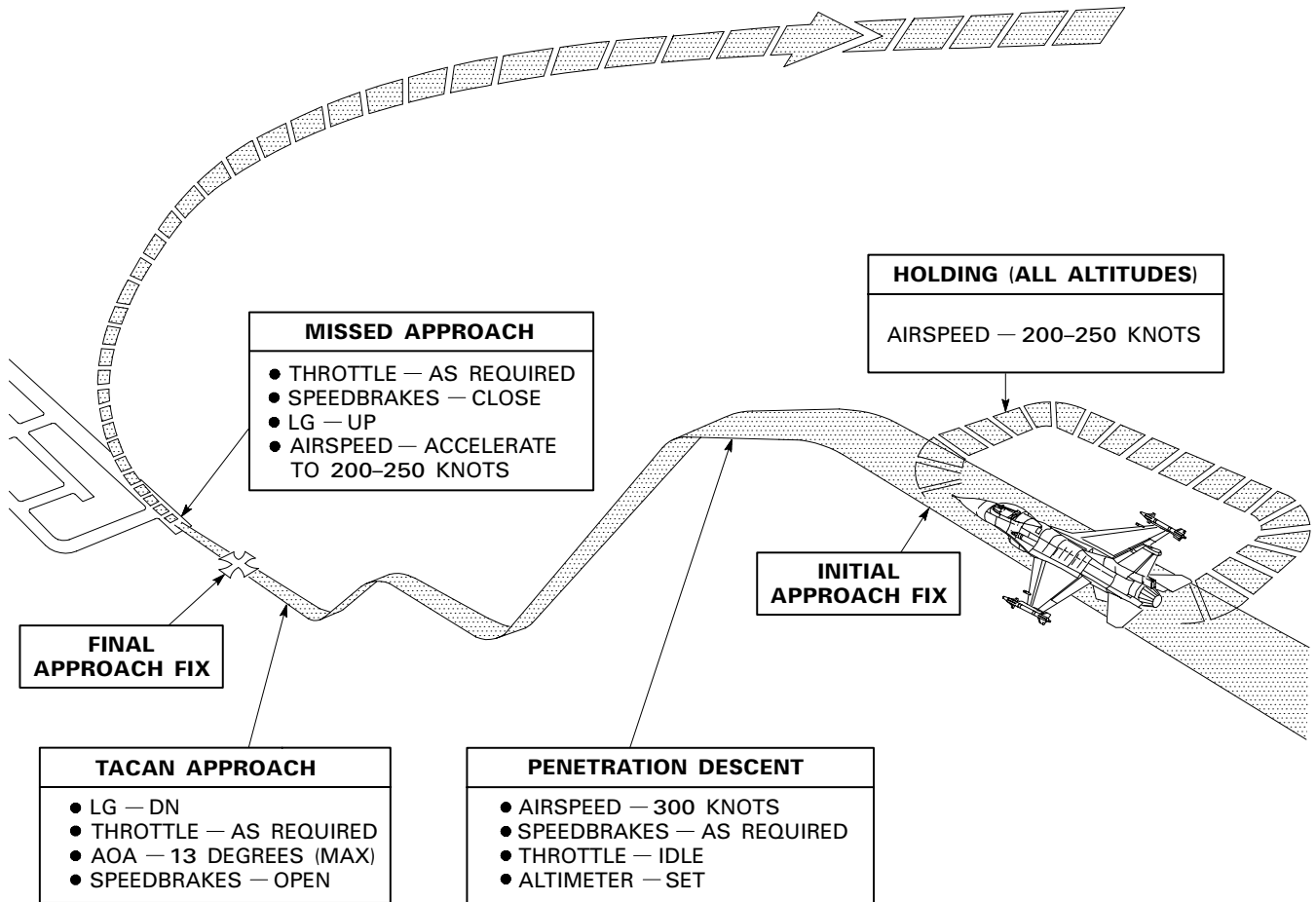

**NOTE:**

A typical straight-in penetration and approach require approximately 400 pounds of fuel for a drag index of 0 and 600 pounds of fuel for a drag index of 200.

Figure 7-1.



# GCA (Typical)

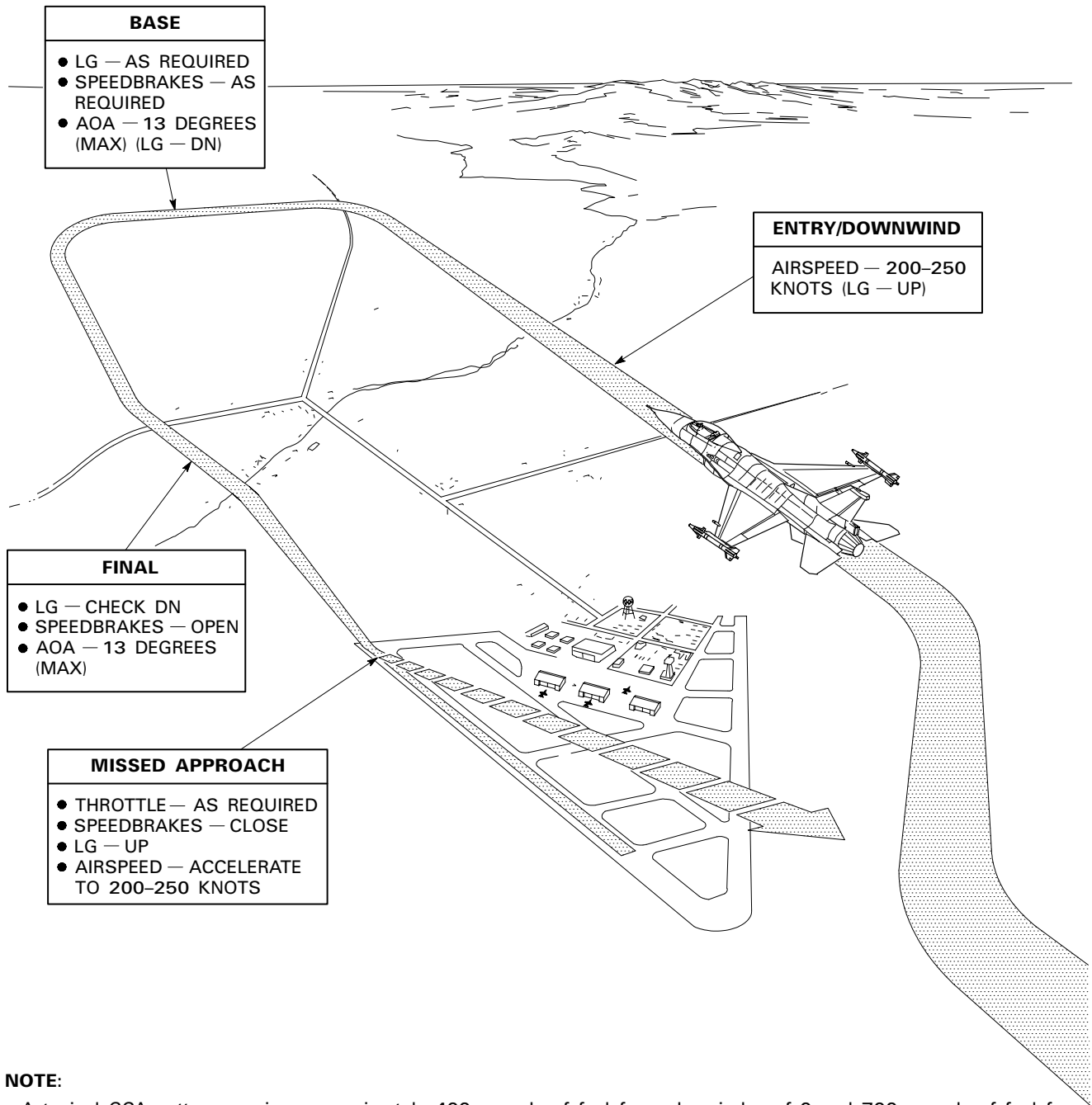

**NOTE:**

A typical GCA pattern requires approximately 400 pounds of fuel for a drag index of 0 and 700 pounds of fuel for a drag index of 200.

Figure 7-2.

**NOTE**

- An extremely loud screeching noise may be heard in the headset while flying in cirrus clouds or in the vicinity of thunderstorms. The noise may be eliminated by turning the UHF or VHF radio off, by turning the volume(s) down, or by changing UHF antenna positions.
- When flying in heavy rain, water tends to be aerodynamically held on the forward portion of the canopy. At higher airspeeds, this condition may obscure visibility as much as 30 degrees back on each side of the canopy. On final approach, the water is generally confined to the position of the canopy immediately in front of the HUD. It may be necessary to look out the sides of the canopy to acquire the runway and to flare and land the aircraft.

**COLD WEATHER OPERATION**

Engine operation under the following conditions may result in engine damage due to icing:

- Ambient temperatures between 20°F (-7°C) and 45°F (7°C) with precipitation (rain, fog, sleet, or snow).
- Dewpoint within 9°F (5°C) of ambient temperatures between 25°F (-4°C) and 45°F (7°C).
- Ambient temperature below 45°F (7°C) with standing water or a mixture of water with ice or snow within the immediate proximity of the engine inlet.

**BEFORE ENTERING COCKPIT**

All accumulated ice and snow must be removed from the aircraft before flight is attempted. Insure that water does not accumulate on control surfaces or other critical areas where refreezing may cause damage or binding.



Do not permit ice to be chipped or scraped away.

**BEFORE STARTING ENGINE**

Extreme cold temperature may require cockpit preheating to ease operation of rotary-type switches. **[D]** The canopy may not latch on battery power alone. Start the engine with the canopy closed as much as possible.

If there is visible moisture and ambient temperature is 45°F (7°C) or less, place the ANTI ICE switch to ON. This reduces ice buildup on the engine front face, eliminates ice on the heated inlet strut, and reduces the possibility of ice ingestion.

**STARTING ENGINE**

If the aircraft is serviced with MIL-H-5606 hydraulic fluid and the aircraft has cold soaked for more than 1 hour at temperatures below -40°F (-40°C), do not start the JFS until ambient temperature increases to above -40°F (-40°C) for at least 2 hours or until the engine bay is preheated. For temperatures above -40°F (-40°C), refer to JET FUEL STARTER LIMITS, Section V.

If the aircraft is serviced with MIL-H-83282 hydraulic fluid and the aircraft has cold soaked for more than 1 hour at temperatures below -20°F (-29°C), do not start the JFS until ambient temperature increases above -20°F (-29°C) for at least 2 hours or until the engine bay is preheated. For temperatures above -20°F (-29°C), refer to JET FUEL STARTER LIMITS, Section V.

During cold start, oil pressure may be 100 psi for up to **[PW 229]** 1 minute, **[GE129]** 2 minutes.

**AFTER ENGINE START**

EPU fuel quantity can indicate as low as 90 percent at temperatures below 40°F (4°C).

For rapid cockpit warming, position the TEMP knob to the desired MAN WARM range. Position the RADAR to off and the DEFOG lever as required to clear fogging. After the cockpit reaches a comfortable temperature, select a setting within the AUTO range. If the engine was started with the canopy unlatched, wait approximately 10 minutes to warm the canopy before fully closing it.

If probe icing is evident or suspected, turn the PROBE HEAT switch to PROBE HEAT at least 2 minutes prior to accomplishing the FLCS BIT.

**WARNING**

If probe heat is on or has been on, heat in probes may be sufficient to cause injury if touched.

**CAUTION**

If the aircraft has cold soaked at temperatures below  $-20^{\circ}\text{F}$  ( $-29^{\circ}\text{C}$ ), repeated brake applications (25-30) may be required before the brakes work effectively.

**TAXI**

To avoid brake icing, do not taxi in deep water, slush, or deep snow. When taxiing on ice or hard packed snow, NWS may not be completely effective. Use a combination of NWS and differential braking to maintain directional control. Taxi at a safe speed considering surface condition, GW, slope, and thrust. If the aircraft has cold soaked at temperatures below  $-20^{\circ}\text{F}$  ( $-29^{\circ}\text{C}$ ), the NWS may initially be sluggish, but controllable.

**WARNING**

Probe internal icing must be suspected anytime the aircraft has been exposed to near or below freezing conditions on the ground. Internal icing may be difficult to see and may remain present even when current conditions do not appear conducive to ice formation. Turn probe heat on at least 2 minutes prior to takeoff anytime icing of probes is possible.

**CAUTION**

If unable to control taxi speed or direction, immediately shut down the engine.

**NOTE**

After cold soaking at temperatures below  $0^{\circ}\text{F}$  ( $-18^{\circ}\text{C}$ ), be alert for flat MLG struts.

**TAKEOFF**

If the aircraft has cold soaked at temperatures below  $-20^{\circ}\text{F}$  ( $-29^{\circ}\text{C}$ ), LG retraction times may be significantly increased. In addition, the nose gear door may fail to close. If the nose gear door can be visually confirmed as the only LG component that has failed to retract/close, then up to two extend/retract cycles can be made in an attempt to achieve a normal LG up condition. Observe LG extended or in transit limitations, Section V.

**IN FLIGHT**

Flight in areas of icing should be avoided whenever possible. If icing conditions are anticipated or cannot be avoided, turn ANTI ICE switch to ON and PROBE HEAT switch to PROBE HEAT. Frequently check the aircraft leading edges for indication of ice buildup. Make all throttle movements slower than normal when in potential icing conditions to reduce possibility of engine stalls and/or stagnation. Consider diverting to an alternate field if required to avoid icing conditions.

**LANDING IN ICY OR WET CONDITIONS**

Icy or wet runway conditions may pose severe problems in directional control and braking effectiveness due to hydroplaning. Although possible, total hydroplaning is not expected below 130 knots groundspeed. Partial hydroplaning can occur to varying degrees below 130 knots. Once hydroplaning occurs, it can continue to speeds well below the onset speed. Wheel spinup must occur to permit normal antiskid braking. Hydroplaning can prevent wheel spinup and can occur on runways which only appear damp if heavy braking is applied at high speeds. Hydroplaning tendency increases with water depth and with smooth runway surfaces such as rubber deposits or paint stripes.

**LESS 129** Approach and touchdown are the same as for a short field landing on a dry runway. Immediately after touchdown, make a deliberate effort to be sure brakes are not applied while using the rudder. Deploy the drag chute (if required) immediately after touchdown. Use two-point aerodynamic braking until approximately 100 knots; then fly the nosewheel to the runway. Maximum effective two-point aerodynamic braking is achieved at 13 degrees AOA. After the nosewheel is on the runway, open the speedbrakes fully and maintain full aft stick for maximum three-point aerodynamic braking and wheel braking effectiveness. Test for braking effectiveness before using full

continuous braking by momentarily depressing pedals, fully releasing pedals for at least one-half second, and then depressing pedals again. This technique gives the wheels a better opportunity to spin up if hydroplaning conditions exist. If braking effectiveness is not felt, continue to pump brakes as speed decreases, making sure pedals are momentarily fully released between applications. Use continuous braking after braking effectiveness is felt. As speed decreases, the antiskid system will increase deceleration accordingly.

**LESS 129** When stopping distance is critical, wheel braking should be initiated when below 100 knots. Wheel braking effectiveness at high speeds is very low compared to two-point aerodynamic braking effectiveness. Low deceleration at high speed may be mistakenly interpreted as a brake or antiskid failure. If braking effectiveness or anti-skid cycling is not perceived, release brakes momentarily and then reapply brakes. When the wheel brakes become effective, the nose will automatically lower. After the nosewheel is on the runway, maintain full aft stick, open the speedbrakes fully, and use continuous maximum braking. Do not hesitate to lower the hook, if required.

**LESS 129** If crosswinds preclude maintaining two-point aerodynamic braking, test for braking effectiveness as previously discussed before using full continuous braking. Continue to pump the brakes until braking effectiveness is felt and speed is below 100 knots.

**129** Approach and touchdown are the same as for a short field landing on a dry runway. Immediately after touchdown, make a deliberate effort to be sure brakes are not applied while using the rudder. Use two-point aerodynamic braking until approximately 100 knots; then fly the nosewheel to the runway. Maximum effective two-point aerodynamic braking is achieved at 13 degrees AOA. After the nosewheel is on the runway, open the speedbrakes fully and maintain full aft stick for maximum three-point aerodynamic braking and wheel braking effectiveness. When wheel brakes are used, they should be continuously applied.

**129** When stopping distance is critical, continuous maximum wheel braking should be initiated in the two-point attitude. Wheel braking effectiveness at high speeds is very low compared to two-point aerodynamic braking effectiveness. Low deceleration at high speed may be mistakenly interpreted as a brake or anti-skid failure. When the wheel brakes become effective, the nose will automatically lower. Do not hesitate to lower the hook, if required.



- **LESS 129** Continuous wheel braking above 100 knots is not recommended. Hydroplaning may prevent spinup of both MLG wheels and wheel brakes may become operative without anti-skid protection. Locked wheels and subsequent blown tires can occur.
- Rubber deposits on the last 2000 feet of a wet runway make directional control a difficult problem even at very low speeds. Braking should be started in sufficient time to avoid excessive braking on the last portion of the runway.

## HOT WEATHER AND DESERT GROUND OPERATION

Hot weather and desert ground operation requires that added precautions be taken against damage from dust, sand, and high temperatures. Particular attention should be given to those components and systems (engine, fuel, oil, hydraulic, pitot-static, etc.) which are susceptible to contamination, malfunction, or damage from sand and dust. Inspect the pistons on the LG and have them cleaned as required. Check the engine inlet duct for sand accumulation. During conditions of blowing sand and dust, the canopy should be closed and sealed and all protective covers installed when the aircraft is not in use.

In hot, humid conditions, fogging of the exterior canopy surface after flight may reduce visibility to the point where the canopy must be opened prior to taxiing. Stow all equipment prior to opening the canopy.

## VOLCANIC ASH OPERATION

### GROUND OPERATIONS

Modified ground operations on an airfield which has experienced volcanic ash fallout are required even after cleanup is complete.

## T.O. GR1F-16CJ-1

For preflight, carefully inspect the following areas for volcanic dust:

- ECS ram inlet ducts.
- Engine inlet.
- LG strut chrome surface.
- Pitot tube, air data probes, and AOA probes.
- Static ports.

After engine start, keep ground operation time and thrust to a minimum and run air-conditioning at full cold setting, if practical. Do not use anti-ice unless required.

Taxi at a safe speed considering surface conditions, GW, slope, and thrust. As volcanic ash, especially when wet, reduces RCR, perform a rolling takeoff, if possible.

Consider increasing the interval between takeoffs to allow clouds of suspended volcanic ash to clear.

After landing, consider shutting down the engine and have aircraft towed to the parking area.

Use RCR of 18 for dry volcanic ash and 10 for wet volcanic ash if actual RCR value is unknown.

### IN-FLIGHT OPERATIONS

Flight in a volcanic ash environment is extremely hazardous. Airborne radar does not detect ash clouds which visually are easily mistaken for normal clouds.

Some indications of volcanic ash cloud penetration are:

- Acrid odor.
- Canopy opaquing.
- Engine exhaust torching.
- Engine surges/malfunctions.
- Erroneous airspeed indications/fluctuations.
- FTIT rise.
- Saint Elmo's fire.
- Volcanic ash entering cockpit.

Upon detecting volcanic ash cloud penetration, reduce thrust and maintain minimum thrust required to sustain flight, exit the volcanic ash environment, and land as soon as practical. Do not use anti-ice unless required.

**PW 229** Engine operation above 80 percent rpm while ingesting volcanic ash may cause buildup of melted ash on turbine hardware and possible engine stalls. If possible, keep rpm at 80 percent or less until clear of volcanic ash.

## SECTION VIII

## AIR REFUELING PROCEDURES

TABLE OF CONTENTS		Page		Page
Introduction .....	8-2		Point Parallel Rendezvous .....	8-22
General .....	8-2		Point Parallel Rendezvous With	
Control of Tanker/Receiver Forces .....	8-2		Tanker Escort .....	8-23
Wingman Receiver Responsibilities .....	8-2		Receiver Turn-On Rendezvous .....	8-24
Airspeeds and Altitudes .....	8-2		Rendezvous Overrun .....	8-24
Fuel Reserve Requirements .....	8-2		Enroute Rendezvous .....	8-24
Weather .....	8-2		Departure and Climb .....	8-24
Refueling Transfer Rate .....	8-2		Enroute Rendezvous Procedures ....	8-24
Communications .....	8-2		Alternate Rendezvous Procedures ....	8-26
Oral Communications .....	8-3		Emission Option 3 .....	8-27
Visual Signals .....	8-6		Missed Rendezvous Procedures .....	8-27
Hot Armament Procedures .....	8-6		Special Air Refueling Procedures .....	8-27
Lighting .....	8-6		Refueling Sequence .....	8-27
Receiver Director Lights KC-135 .....	8-11		Fingertip Formation .....	8-27
Receiver Director Lights			Echelon Formation (VMC Only) ....	8-27
KC-10/KDC-10 .....	8-11		Fuel Management .....	8-28
Navigation and Position Reporting .....	8-11		Precontact .....	8-28
Post Air Refueling .....	8-12		Boom and Receptacle Procedures .....	8-28
Flying Safety .....	8-12		Disconnect KC-135 .....	8-29
Boom Envelope Limits .....	8-12		Disconnect KC-10/KDC-10 .....	8-29
Air Refueling Procedures .....	8-17		Quick Flow Air Refueling	
Departure/Enroute Procedures .....	8-17		Procedures .....	8-29
Cell Leader Responsibility .....	8-17		Toboggan .....	8-31
Buddy Departure .....	8-17		Weather Abort Procedures .....	8-31
Taxi .....	8-17		Afterburner Air Refueling .....	8-31
Line-Up .....	8-17		Separation/Termination Procedures ...	8-31
Takeoff .....	8-17		Separation From a Single Tanker ...	8-31
Aborts During Takeoff .....	8-17		Cruise Cell Termination (VMC) ....	8-31
Element Join-Up and Climb .....	8-17		Cruise Cell Termination (IMC) ....	8-31
Element Cruise Formation .....	8-18		Cell Termination at Terminal	
Force Extension Procedures .....	8-18		Approach Fix .....	8-31
VMC Procedures .....	8-19		Element Penetration .....	8-32
IMC or Night Procedures .....	8-19		Receiver Radar Rejoin Procedures	
Post Refueling Procedures .....	8-19		(IMC) .....	8-32
Lost Wingman Procedures .....	8-19		Normal Air Refueling Procedures .....	8-34
Abort Procedures .....	8-20		Armament Safety Check .....	8-34
Rendezvous Procedures .....	8-20		Precontact .....	8-34
Altimeter Settings .....	8-20		Contact .....	8-34
Rendezvous Altitude Block .....	8-20		Disconnect .....	8-34
Track .....	8-21		Post Air Refueling .....	8-34
Tanker Rendezvous Equipment .....	8-21		Emergency Air Refueling Procedures ...	8-35
Receiver Formation During			Breakaway Procedures .....	8-35
Rendezvous .....	8-21		System Malfunctions .....	8-35
Early Arrival .....	8-22		Slipway Door Will Not Open .....	8-35
Tanker Identification .....	8-22		Slipway Door Will Not Close .....	8-35
			Inoperative Boom/Receptacle	
			Latching .....	8-36
			KC-10/KDC-10 Boom FLCS Failure ...	8-36
			Brute Force Disconnect .....	8-36
			Inadvertent Disconnect .....	8-36
			Controlled Tension Disconnect .....	8-36

## INTRODUCTION

This section contains information and procedures for F-16 air refueling with KC-135 and KC-10/KDC-10 aircraft. For basic flight crew air refueling procedures, refer to T.O. 1-1C-1.

## GENERAL

This section reflects Emission Option 2 procedures unless noted within the text. Inflight situations and sound judgement may dictate discontinuing communications procedures outlined for Emission Option 2.

Both tanker and receiver crew must be thoroughly familiar with all aspects of the refueling in order to adequately plan the mission. Planners will coordinate and crews will be thoroughly familiar with mission requirements as prescribed in the appropriate command directives.

The air refueling operation requires precise and detailed planning to insure success. Each receiver unit will maintain a file of T.O. 1-1C-1 along with this manual.

### CONTROL OF TANKER/RECEIVER FORCES

An airborne tanker force commander and alternate commanders, as required by the mission, will be designated for each air refueling area. During operational missions, the tanker commander is in command of the air refueling operation from the period subsequent to positive radio contact between the tanker cell leader and the receiver leader during rendezvous until the end of the refueling or termination of route cell formation, as applicable. The airborne tanker force commander will coordinate with the receiver force commander to insure successful mission completion.

### WINGMAN RECEIVER RESPONSIBILITIES

To assist the cell leader in insuring the safety and integrity of the flight, the wingman receiver will:

- Keep the leader in visual or electronic contact at all times.
- Maintain briefed position at all times.
- Anticipate corrections/changes and plan accordingly.
- Monitor all aspects of formation operations and advise the cell leader if an unsafe condition is noted.

### AIRSPEDS AND ALTITUDES

Cruise and air refueling KCAS is 310 knots at 30,000 feet unless specifically directed otherwise. Lower

altitudes may be required for abnormally high free air temperatures. The controlling agency directing the mission will be responsible for obtaining enroute and air refueling altitude clearance for training and operational missions.

### FUEL RESERVE REQUIREMENTS

For deployment operations, the last receiver in the cell will depart the penetration fix at the abort or destination base with a minimum of 30 minutes of fuel remaining, computed in accordance with command guidance.

### WEATHER

Weather minimums are prescribed by command guidance. Buddy departure minimums are 1500 feet and 3 NM for day and 2500 feet and 3 NM for night takeoffs.

Rendezvous and air refueling will not be attempted when inflight visibility is deemed insufficient for safe air refueling operations; however, the aircraft may close to the lock-on limits of the radar provided that the required altitude separation is maintained until visual contact has been established. Without lock-on capability, minimum visibility for rendezvous is 1 NM.

### REFUELING TRANSFER RATE

The air refueling transfer rate averages 2,000 pounds per minute with two tanker A/R pumps operating with a KC-135 and 3,000 pounds per minute with a KC-10/KDC-10.

### COMMUNICATIONS



Except during an emergency fuel situation, air refueling operations will not be conducted when radio communication capability is lost between tanker and receivers. If radio communications are lost, or unreadable between the boom operator and receiver pilot, contacts will not be attempted.

Emission Option 2 will be used as the normal rendezvous and air refueling procedures. Emission Option 2, 3, or 4 procedures do not preclude verbal communications for safety of flight situations or to insure mission success. Boom interphone should be used when compatible.

Communications procedures and plans for rendezvous and air refueling as outlined in pertinent command directives will apply. Deviations must be specifically authorized by the appropriate command headquarters.

Unless directed otherwise, communication capability between tankers and receivers will be maintained during all normal rendezvous and air refueling operations. Voice transmissions, however, will be held to an absolute minimum during rendezvous and air refueling to be in accordance with the Emission Option being used.

A "Talk-Through-The-Boom" interphone system is available after contact when air refueling with all KC-135 tankers if hot mic is selected.

KC-10/KDC-10 aircraft are equipped with UHF, HF, and VHF radios and a boom interphone system.

All crewmembers must be thoroughly familiar with all required oral, visual, and electronic means of communications. Strict radio discipline must be adhered to at all times. All calls will be prefaced with individual call signs. Tankers will begin monitoring designated frequencies and will have the Radar Rendezvous Beacon operating at least 30 minutes prior to the rendezvous control time. The A/A TACAN will be tuned to the appropriate channel 15 minutes prior to the rendezvous control time unless it is required for navigational purposes. Receivers will call 15 minutes prior to the air refueling control time, advising the tanker(s) of call signs, any changes in ETA (minutes early or late) or altitude, and hot armament check (if required).

#### NOTE

- If tankers and receivers are in contact with a common facility providing rendezvous assistance, radio contact between the tanker and receivers may be delayed to accomplish the rendezvous.
- During enroute rendezvous, all A/R equipment operations, interplane communications, and timing should be based on the RZ time. For example, the A/A TACAN should be tuned to the appropriate channel 15 minutes prior to the RZIP unless it is required for navigational purposes.

The tanker will advise the receiver(s) of their call sign, air refueling altitude and, if applicable, any change in tanker timing that would affect the rendezvous (in minutes early or late).

Tanker(s) and/or receiver(s) will make an additional radio call confirming level at the proper rendezvous altitude if they are not at the proper rendezvous altitude when the 15 minute prior to the rendezvous control time call is made.

#### NOTE

Tankers and receivers will include altimeter setting with appropriate altitude calls if other than 29.92 is used. For example, "RENO 01, ONE TWO THOUSAND FEET, ALTIMETER SETTING THREE ZERO ZERO FOUR, ON TIME." If EMCON 3 or 4, altimeter setting must be prebriefed.

For all rendezvous and air refueling operations, tankers and receivers will normally use their individual flight call signs unless directed otherwise in operational plans. When assured no other co-unit formation will be in range of or using the frequency, and/or a discrete tactical frequency has been assigned to the formation, flight call signs may be abbreviated for clarity and brevity; for example, "RENO FLIGHT...GO ECHELON" (acknowledge) "TWO" "THREE."

Mandatory calls for the receivers are as follows:

- Initial radio call 15 minutes prior to the rendezvous control time.
- Notify the tanker when established on the proper rendezvous altitude, if not at the proper rendezvous altitude at the 15 minute prior to the ARCT call.
- Precontact call (required by Flight Leader only).

#### Oral Communications

#### NOTE

- With the exception of the breakaway calls, crewmembers may shorten individual flight call signs using only the number. Example: "Tank 11" would be "11."
- Normally, the receiver leader will proceed to the precontact position. When the leader has completed refueling, subsequent receivers will move from the observation position as precoordinated.

The communications requirements should be established prior to the flight. For different EMCON levels, refer to figure 8-1 for Emission Option Communications and figure 8-2 for Emission Option Emitters.



# Emission Option Communications

ITEM	ACTION	EMISSION OPTION			
		1	2	3	4
1.	Radios Set 30 Minutes Prior to ARCT (if dual radio capable)	X	X	*	**
2.	15 Minute Call	X	X		
3.	A/A TACAN Set 15 Minutes Prior to ARCT	X	X	***	
4.	Beacon Positive Identification (if applicable)	X			
5.	ADF Check (if applicable)	X			
6.	Halfway Through Turn Call (Tanker)	X			
7.	Mandatory Boom Operator Calls				
	a. Precontact Call	X	X		
	b. Clear Receiver to Contact	X			
	c. Acknowledge Contact/Disconnect	X			
	d. Verbal Corrections	X			
	e. Advise Receiver(s) to Return to Precontact for checklist or equipment considerations	X			
8.	Mandatory Receiver Calls After 15 Minute Call				
	a. Visual Contact Established/Lost to Include Overrun	X			
	b. Precontact Call	X	X		
	c. When Contact or Disconnect is Made	X			
	d. Verbally notify Boom Operator prior to Manual/ Emergency Boom Latching Procedures	X	X		
9.	Post Air Refueling Report	X	X		
10.	1 Mile Closure Call (Receiver)	X			

\* Radio silent. Use of other emitters is authorized unless prohibited by Supported Operations Plans.

\*\* No emissions (UHF, VHF, TACAN, FCR/Radar, AIFF/IFF, exterior lighting, etc.) unless authorized by Air Tasking Order, Rules of Engagement, Operations Plans, Safe Passage procedures, or other mission directives.

\*\*\* Point parallel rendezvous only.

**NOTE:**

Variations may be indicated by, "EMCON 2. Item 7a/8b COMM N/A." This would mean normal Emission Option 2 procedures, except the precontact call would be deleted.

Figure 8-1.

# Emission Option Emitters

ITEM	EQUIPMENT	EMISSION OPTION			
		1	2	3	4
1.	FCR/Radar	On	On	As required	Off
2.	CARA/Radar Altimeter	On	On	As required	Off
3.	TACAN/DME	On	On	As required	Off
4.	AIFF/IFF	On	On	As required	Off
5.	UHF/VHF Radio	On	On	Monitor	Monitor
6.	Exterior Lighting	On	On	As required	Off

**NOTE:**

Variations may be indicated by, "EMCON 3. Item 1 Emitters Off." This would mean normal Emission Option 3 procedures, except the FCR would be off.

*Figure 8-2.*

Normally, boom visual signals will be used exclusively; however, if required or requested by the receiver, the boom operator will begin communications when the receiver reaches approximately 50 feet from the contact position. Direction, if required, will precede distance for receiver to move and will be given until the receiver reaches the contact position. Example: "Forward 50," "Up 4," "Back 2." When contact is established, the tanker will state, "(Tanker call sign), contact."

For Emission Option 1 and 2, the boom operator will make a precontact audio check with receiver(s) and the receiver(s) will acknowledge. Example: Tanker will say, "25/57." The receiver will reply, "25."

During receiver pilot demonstration of air refueling envelope limits, the boom operator will state boom limit and give the boom position for the limit being demonstrated in increments of 2.

When the tanker is required to use manual operation, without disconnect capability, the boom operator will state: "(Receiver call sign), the following contacts will be made in tanker manual operation. Receiver air refueling system will remain in normal and receiver pilot must initiate all disconnects. (Tanker call sign), ready." Receiver pilot acknowledges by stating, "(Receiver call sign), ready."

### Visual Signals

Refer to figure 8-3. Radio silent air refueling can be conducted by use of visual signals provided the following precautions and procedures are observed:

- The method, time and place of rendezvous, and amount of fuel to be transferred must be covered in the briefing of each crew.
- The tanker will use the receiver director lights (red only) to aid in positioning the receiver. A steady red light indicates a large correction and a flashing red light indicates a small correction in the direction indicated.
- If the need for an emergency breakaway occurs during radio silent air refueling, oral breakaway procedures and the visual signal in figure 8-3 will be used.

### Hot Armament Procedures

Prior to rendezvous with the tanker for air refueling, receiver aircraft carrying forward firing ordnance will conduct an Armament Safety Check in accordance with NORMAL AIR REFUELING

PROCEDURES, this section. When radio silence is mandatory, the receiver leader will conduct a visual challenge with each member of his flight by pointing his index finger straight forward and thumb upward (simulating a pistol). Each member of the flight will complete the safety check and respond to the leader by raising his hand and showing a circle formed by his index finger and thumb. To reduce the possibility of inadvertent firing, receivers will not reposition any electrical switches while behind a tanker unless those switch changes are required for air refueling operations or aircraft control.

### LIGHTING

Refer to figure 8-4. While approaching the precontact or contact position, the receiver pilot can adjust exterior lighting as required by the boom operator.

#### NOTE

Visual contact for night air refueling can be aided by requesting the tanker to flash his landing lights prior to and/or during the tanker turn.

On single KC-135 tankers performing a rendezvous both upper and lower strobes will display red.

#### NOTE

If the spare is used during the air refueling, the appropriate color code will be displayed until the receiver is in the precontact position. To further aid in identification, tanker position lights will be placed on BRIGHT and FLASHING for numbers 1, 3, and 5. Position lights for numbers 2 and 4 will be BRIGHT and STEADY. Position lights will be set prior to takeoff. After the receiver has established visual contact and has closed to 1/2 NM in trail, tankers will turn position lights to STEADY and DIM and turn strobe light OFF. When any aircraft will be flying visual wing formation on the tanker, the tanker will also turn off the strobe light. In this case, the last (outside) receiver aircraft with each tanker will have anticollision lights ON. When fighter receivers reach the observation position, tankers will turn underwing, underbody, and nacelle illuminating lights to DIM. Exterior lights will then be adjusted as requested by the receiver pilot.

# Visual Signals

SIGNAL	INDICATION	
	BOOM AIR REFUELING	PROBE & DROGUE REFUELING
1. Boom in Trail		
A. Extended 10 feet	*Ready for Contact	
B. Fully extended	1. Tanker Manual Operation without Tanker Disconnect Capability 2. Acknowledge Receiver's Manual Boom Latching Signal	
C. Fully retracted	Offload Complete	
2. Boom Stowed		
A. Fully retracted	Tanker Air Refueling System Inoperative	
B. Extended 5 feet	System Malfunction, Tanker and Receiver Check Air Refueling Systems	
3. Flashing Receiver Director Lights/Tanker Lower Rotating Beacon ON	BREAKAWAY	
4. **Receiver Director Lights Going OUT During Contact	Tanker Request for Disconnect, Receiver return to Precontact Position	
5. Receiver Closing and Opening Receptacle Door when in Precontact Position	1. Manual Boom Latching 2. Acknowledge Tanker's Manual Operation without Tanker Disconnect Capability Signal	
6. ***Steady Light from Receiver or rocking of wings	Emergency Fuel Shortage Exists	
7. Flashing light from receiver cockpit area	Initiate toboggan maneuver	

Figure 8-3. (Sheet 1)

# Visual Signals (Cont)

SIGNAL	INDICATION	
	BOOM AIR REFUELING	PROBE & DROGUE REFUELING
8. (a). (DAY): Same receiver returns to precontact with receptacle door open. Pilot signals closed fist, thumb to mouth, plus hand signaling number ****(NIGHT): Same receiver returns to precontact with receptacle door open, ready for contact	Additional fuel required EMCON 2-4	
(b). (DAY): Same receiver returns to precontact, ready for contact. Pilot signals closed fist plus hand signaling number ****(NIGHT): Same receiver returns to precontact, ready for contact		Additional fuel required EMCON 2-4

\*Receiver(s) in the observation position will move to the precontact position in their briefed sequence only after insuring that the boom is in the ready for contact position and the preceding receiver has cleared the tanker. The receiver will stabilize in the precontact position, then move to the contact position. The boom operator will not give the ready for contact signal until the preceding receiver has cleared the tanker.

\*\*The receiver(s) will advise the tanker of any pilot director light malfunctions/deficiencies.

\*\*\* If fuel shortage occurs at times other than scheduled air refueling, the receiver should be positioned so the signal may be seen from the tanker cockpit.

\*\*\*\* Additional fuel offloaded will be 5000 pounds for large receiver aircraft, or 2000 pounds for small receiver aircraft, on each subsequent contact.

Figure 8-3. (Sheet 2)

# Exterior Lighting (KC-135)

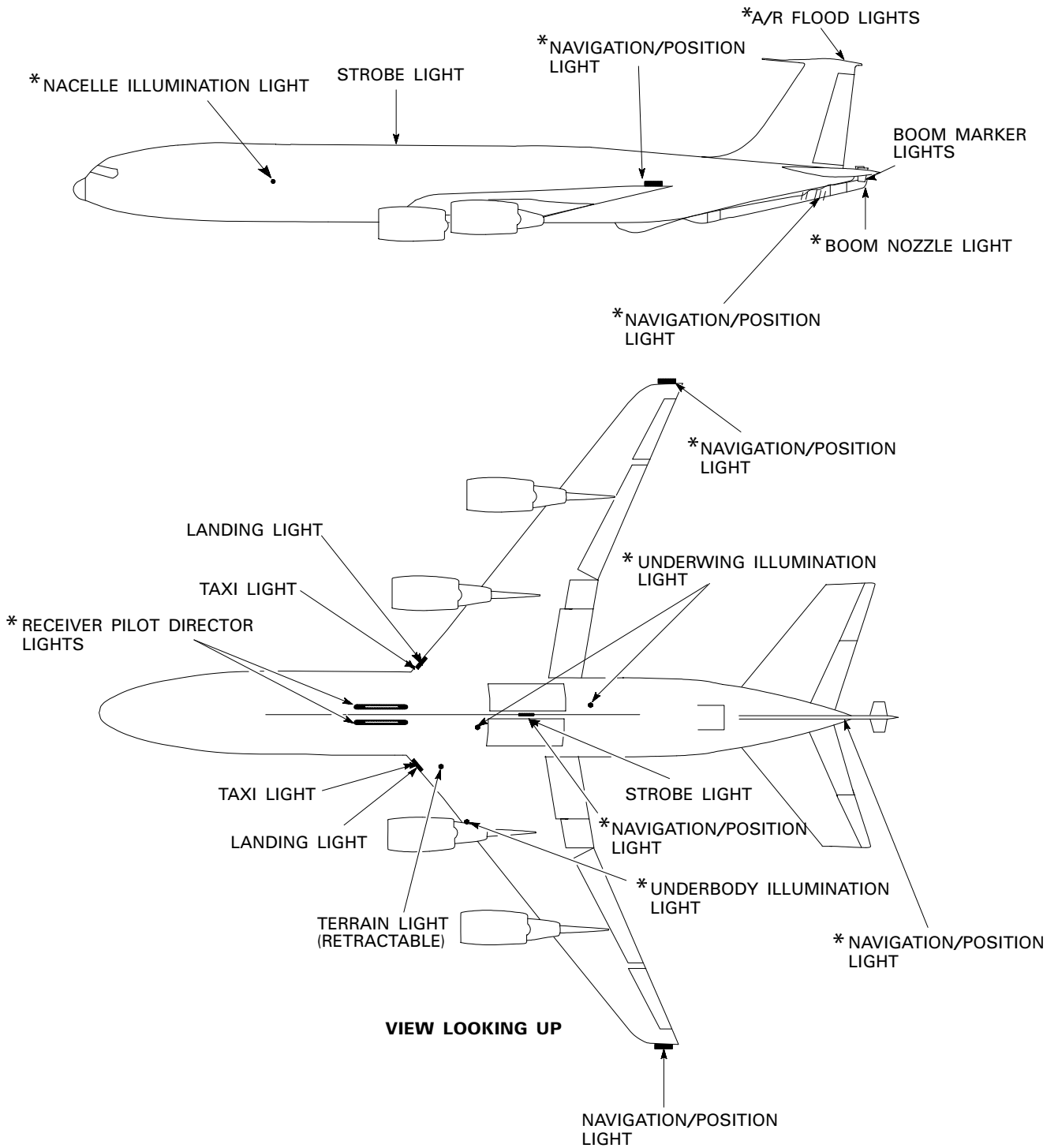

\* DESIGNATES ADJUSTABLE LIGHTING

1F-16X-1-8004X ©

Figure 8-4. (Sheet 1)

# Exterior Lighting (KC-10/KDC-10)

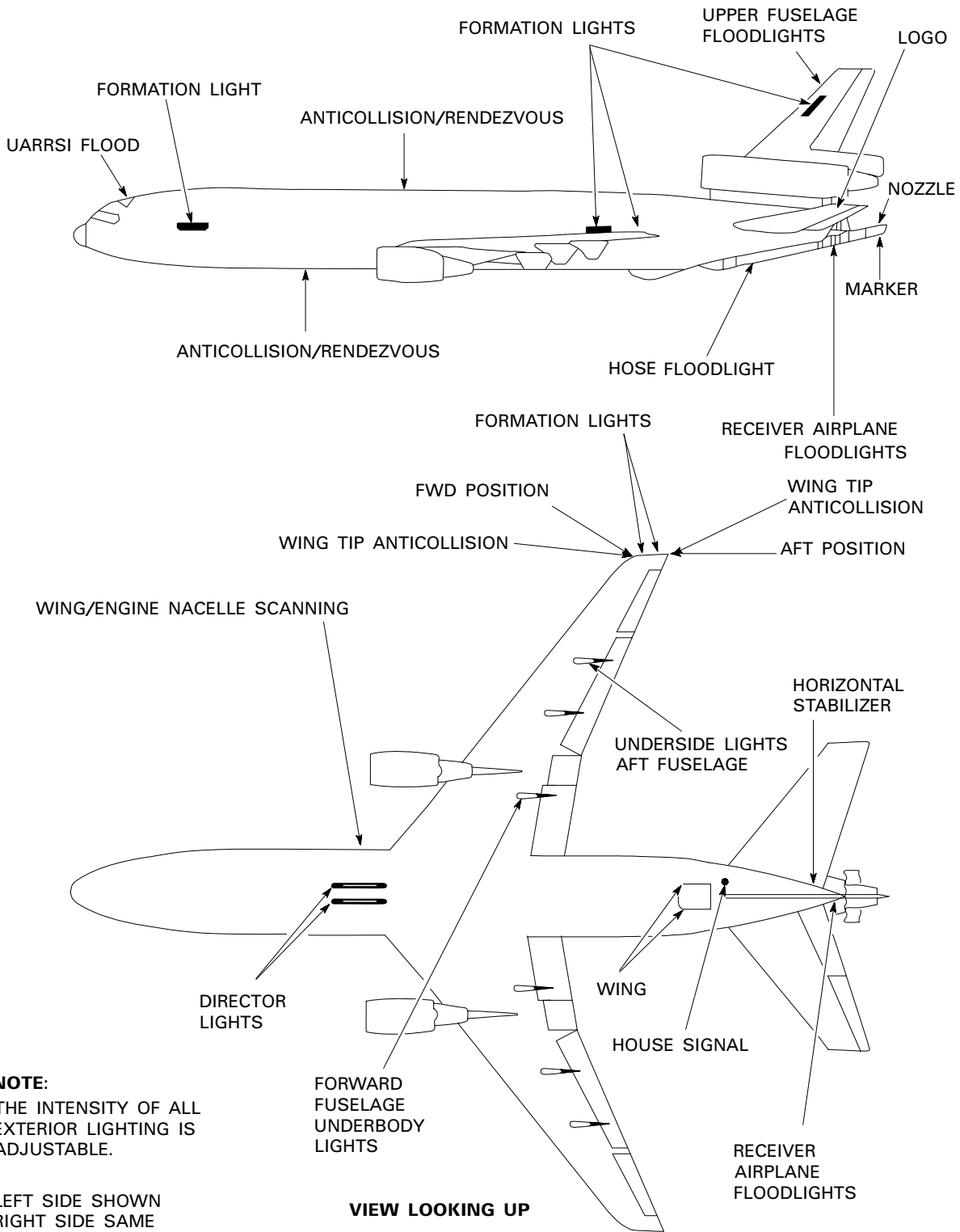

1F-16X-1-8003X ©

Figure 8-4. (Sheet 2)

KC-135 aircraft in cell formation will set their strobe lights according to their position in the refueling cell. Their lighting is as follows:

- Tanker Number 1  
Upper and Lower Lights - RED
- Tanker Number 2  
Upper and Lower Lights - WHITE
- Tanker Number 3  
Upper Lights - RED  
Lower Lights - WHITE
- Tanker Number 4  
Upper Lights - WHITE  
Lower Lights - RED

### Receiver Director Lights KC-135

Refer to figure 8-5. The receiver director lights do not give true vertical and horizontal information. The up and down lights change because of angular movement of the boom and the fore-and-aft lights change because of in-and-out movements of the boom. The axis of the director lights system is inclined at a 30 degree angle to the fuselage. This angle causes an interaction in both lights when a true vertical or horizontal movement is made by the receiver. For example, flying straight forward while in contact will cause the boom to compress and also increase its angle with the tanker fuselage. The lights will show that the aircraft is flying forward and down. If a true up movement is made, the boom will both compress and lessen its angle with the tanker fuselage and the director lights will indicate that an up and forward movement has been made. Small fore and aft corrections can be made with little or no power change by moving vertically.

Receiver director lights are on the bottom of the fuselage directly aft of the nose landing gear. They consist of two rows of lights: the left row for elevation and the right row for telescoping. The elevation lights consist of five colored panels with a green stripe, green and red colors, and two illuminated letters, D and U, for down and up respectively. The colored panels are illuminated by lights that are controlled by boom elevation during contact. There is an illuminated white panel between each panel to serve as a reference. The letters A, for aft, and F, for forward, augment the colored panels on the telescope side. The receiver pilot director lights will remain illuminated and follow boom movements in both the contact made and disconnect conditions. There are no lights for azimuth position. A fluorescent yellow strip on the bottom center of the tanker fuselage may be

used as centerline reference by the pilot. The triangular-shaped panels are for elevation and the rectangular-shaped panels are for forward and back movement.

### Receiver Director Lights KC-10/KDC-10

Refer to figure 8-5. The receiver director lights consist of two rows of lights located forward of the wing root. Relative elevation position is provided by the left row and the right row provides telescoping position. The elevation row contains one striped green, two amber and two red triangular panels, and two white letters: U at the forward end for UP, and D at the aft end for DOWN. The colored panels and letters are dimly illuminated by background lights. The telescoping row contains one striped green, two amber, two red, and four white rectangular panels, and two white letters: A at the forward end for AFT, and F at the aft end for FORWARD. The colored panels are not background lighted; however, the letter at each end of the row is dimly illuminated. Separation is provided by the white panels. The pilot director lights are adjusted by the boom operator to the size air refueling envelope for each receiver and provide guidance during contact.

To provide more response time, the appropriate panel and letter are illuminated in anticipation of receiver movement. The director lights provide commands based on both receiver position and rate of movement. Figure 8-5 shows the lights with no receiver motion. With rapid motions of the receiver, the lights can show a correction required even though the receiver is in the center of the envelope. The red panel and letter at the ends of each row can be illuminated by the boom operator to aid the receiver in attaining the contact position.

### NAVIGATION AND POSITION REPORTING

When rendezvous is complete, tankers will be responsible for all navigation, weather avoidance and position reporting. The tanker pilot will, once each hour, advise the receiver pilots of the cell geographic position, heading, and distance and ETE to the next checkpoint or destinations applicable. If the receiver pilot has not completed his onload upon reaching his geographic air refueling abort point, the tanker pilot will so advise.

#### NOTE

During refueling operations conducted within a pre-planned orbit pattern, the tanker is not required to provide the above information unless requested by the receiver leader.



### Post Air Refueling

Upon completion of air refueling, the tanker will normally climb to the top and the receiver(s) will descend to the bottom of the air refueling block. The receivers should maneuver to the prescribed formation position while awaiting post air refueling report and further clearance. The tanker will give post air refueling information to the receiver as required. The receiver will advise the tanker of any pilot director light malfunctions/deficiencies, e.g., lights intermittent, inoperative, dim, dirty, etc. Upon termination of air refueling, all exterior lights will be as directed.

#### **WARNING**

Receiver will insure a safe clearance from the tanker(s) as they proceed on their assigned missions. Receiver(s) required to accelerate past the tanker(s) and climb on the refueling heading will maneuver either left or right (a minimum of 1 NM) of track to preclude climbing directly in front of the tanker(s) remaining receiver(s). Aircraft flying through departing receivers' jet wash may experience damage to the aircraft and injury to personnel.

## FLYING SAFETY

### BOOM ENVELOPE LIMITS

Refer to figure 8-6. The refueling envelope is limited by the refueling receptacle location. As long as the receiver is positioned within these limits, contact can be maintained despite rolling, yawing, or pitching.



- Approaching boom limits at a relatively high velocity can cause structural damage as a result of an inability to disconnect due to binding of the boom nozzle.
- Due to the restricted refueling envelope, boom limit switch protection is not provided in up elevation.

#### **NOTE**

The boom operator will disconnect at 25 degrees elevation (upper envelope limit). In this position, a green DOWN arrow will be illuminated.

# RECEIVER DIRECTOR LIGHTS ILLUMINATION PROFILE (KC-135)

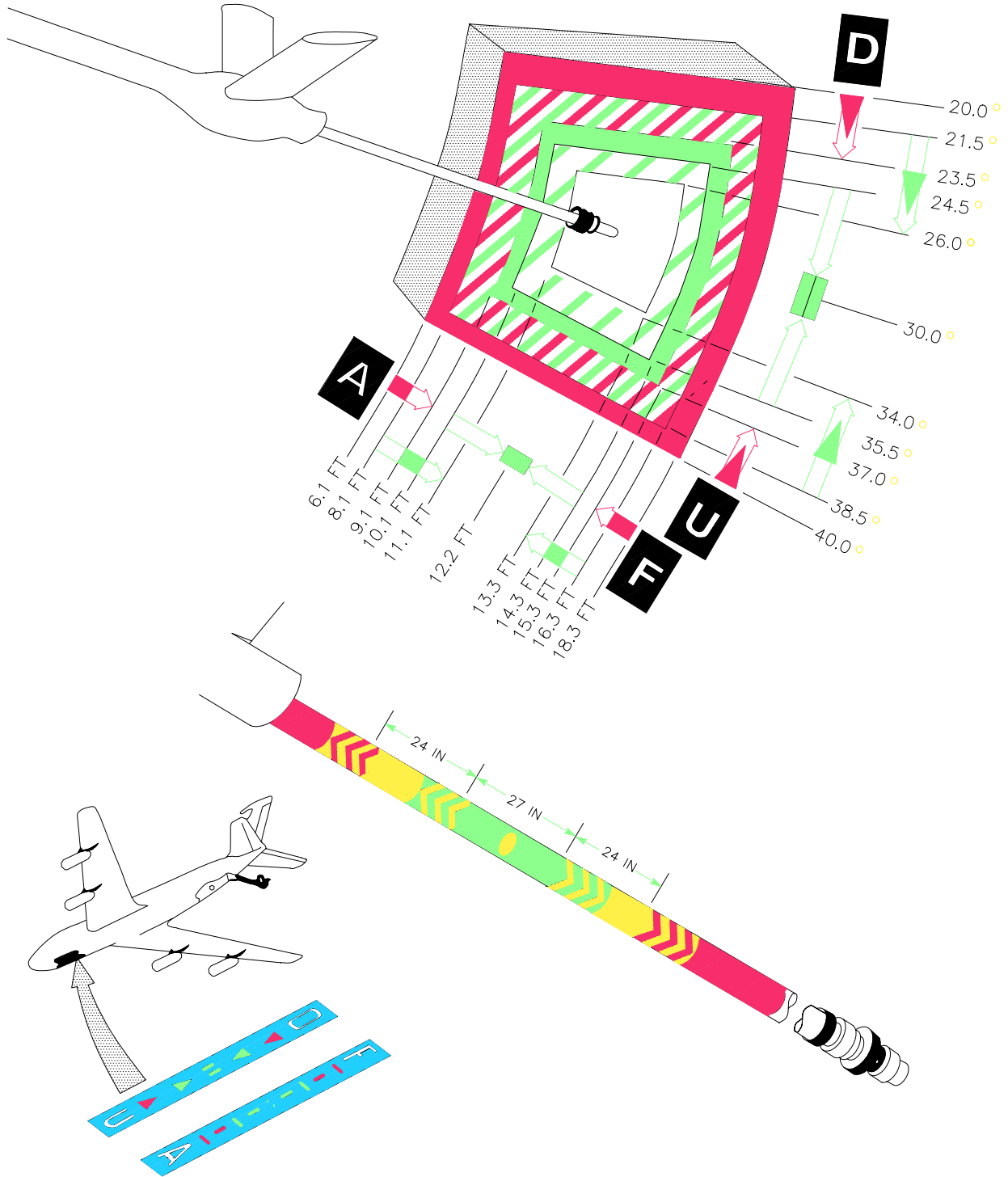

XX1F-16A-1-0162X®

Figure 8-5. (Sheet 1)

# RECEIVER DIRECTOR LIGHTS (KC-10/KDC-10)

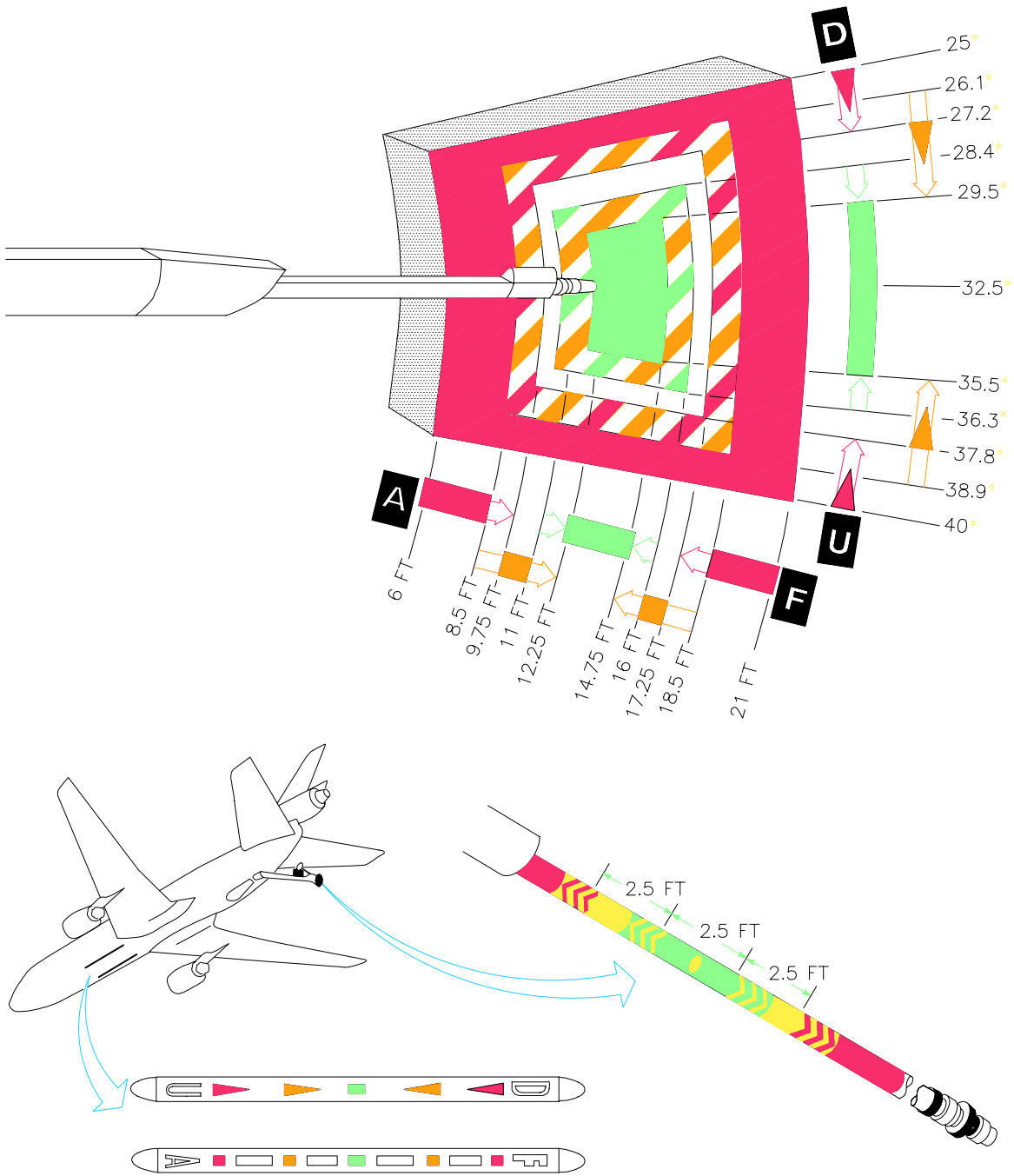

XX1F-16A-1-0163X®

Figure 8-5. (Sheet 2)

# Boom Envelope Limits (KC-135)

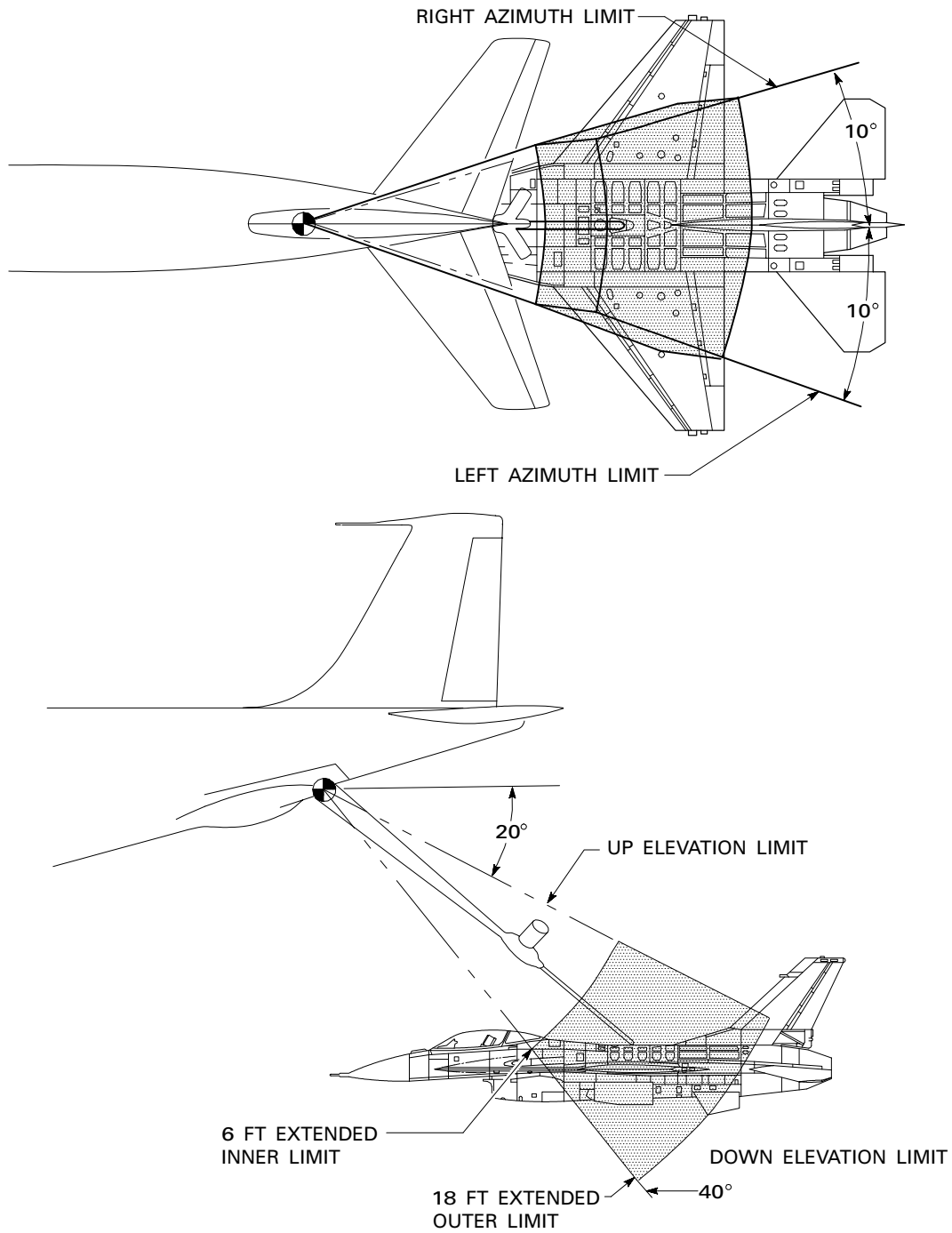

1F-16X-1-8002X ©

Figure 8-6. (Sheet 1)

# Boom Envelope Limits (KC-10/KDC-10)

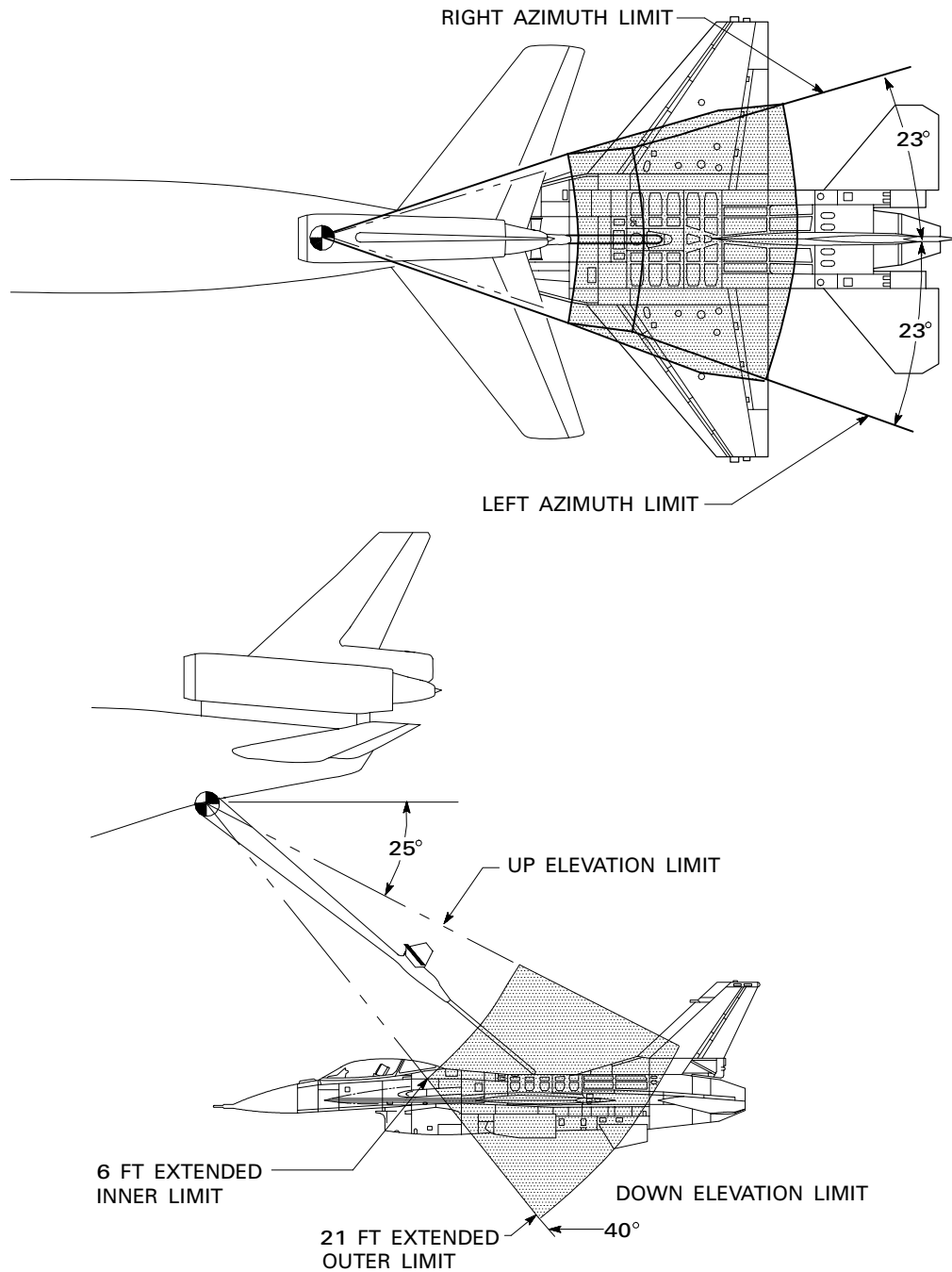

1F-16X-1-8001X®

Figure 8-6. (Sheet 2)

# AIR REFUELING PROCEDURES

## NOTE

### DEPARTURE/ENROUTE PROCEDURES

#### Cell Leader Responsibility

The tanker cell leader or specified commander is responsible for the command and control of the formation and the air refueling operation. The cell leader or specified commander will coordinate with the receiver force commander to insure successful mission completion. Formation integrity and discipline begin with the formation briefing. The cell leader must insure that all aspects of the mission are clarified and understood.

Normally, lead responsibilities pass from number one to number two to number three; however, all pilots must be prepared to assume full responsibility for the formation at any time. When it is necessary to transfer lead responsibilities, all airplanes in the affected formation will be notified when the new leader assumes responsibility for the formation.

The tanker cell leader/specified commander must take every feasible action to enhance the possibility of completing air refueling.

#### Buddy Departure

A buddy departure is effected when the tanker(s) and receiver(s) take off from the same base and visual contact is maintained.

#### TAXI

After engine start, receivers will check in with the tanker on the predetermined frequency. When ready to taxi, each tanker will call, "(Tanker Call Sign), Taxiing." A distance of 300 feet will be maintained between tankers and receivers. Tankers not scheduled to be used during the first air refueling will taxi and takeoff first, followed by refueling elements consisting of a tanker and his mated receivers for the first refueling. Spare tankers will taxi and takeoff last.

#### LINE-UP

On runways at least 300 feet wide, the KC-135 will line up on the downwind side of the runway. The receivers will be positioned on the upwind side of the runway, maintaining wing tip clearance.

On runways less than 300 feet wide, the receiver will remain in the number 1 position until the tanker rolls.

### TAKEOFF

#### WARNING

Wake turbulence generated by a preceding aircraft may create a hazard during buddy takeoffs and join-ups.

The tanker will roll first, followed in 45 seconds by the first receiver in his element. Each element will be individually cleared for takeoff by the tower after the last aircraft in the preceding element has passed the end of the runway. Takeoff interval may be varied when weather, terrain, airfield conditions, or other local considerations dictate.

### ABORTS DURING TAKEOFF

An aborting aircraft will make an abort call on the prebriefed common frequency as soon as possible. Frequency changes will not be made by tanker/receivers until all airplanes in the same element are airborne.

### ELEMENT JOIN-UP AND CLIMB

The climb speed schedule will be based on the first tanker/receiver element climbing at 300 KCAS. Individual tankers launching first will reduce climb airspeed so that a 10 KCAS differential exists between individual tankers and between the last individual tanker and the first refueling element. Example:

Tanker One .....	280 KCAS
Tanker Two .....	290 KCAS
Lead Element .....	300 KCAS
Second Element .....	310 KCAS
Third Element .....	320 KCAS
Fourth Element .....	330 KCAS

**NOTE**

For two and three element cells, tankers without receivers are considered elements. The lead element will climb at 300 KCAS and the following speed schedule will be utilized to expedite closure: In a two element cell, the second element will climb at 330 KCAS. In a three element cell, the second and third elements will climb at 320 KCAS and 330 KCAS, respectively.

If a ceiling is to be encountered prior to the completion of the join-up, the tanker will level-off with a minimum of 500 feet clearance below the cloud layer and maintain assigned climb airspeed to provide visual flight conditions during the element join-up.

The air refueling element (tankers and receivers) join-up will be accomplished on the outside of the turn or on the tanker's left wing during a straight ahead join-up. All turns by the tanker will normally be 20 degrees of bank (Exception: See Lost Wingman Procedures). After the receiver flight has stabilized in its proper formation position, the element leader will inform the tanker pilot.

**Element Cruise Formation**

Receivers will fly route formation position on the tanker. (For extended VMC cell cruise formation, receivers may fly a spread formation.) Route and spread formations will be as specified in the operational procedures manuals. Spacing may be reduced during IMC or night operations. When air refueling is required, the other receiver(s) will assume the observation position.

At night or in IMC, a maximum of 12 aircraft will be assigned to one tanker - a maximum of three aircraft will fly on each wing of the tanker, and additional aircraft/elements will fly in a 1-3 NM trail position, a minimum of 1000 feet below their tanker's altitude. During tanker cell operations, only the last tanker should have receivers in trail. With nine or less receivers, only one element need be in trail (one element refueling while the other two elements are switching positions). With 10 to 12 receivers, two elements will be in trail (one element maintaining trail, and the other two elements switching positions - and with four elements, one element refueling). In this case, offset trail and additional

altitude separation will be used for deconfliction. The following procedures will be used to change positions of flights in trail:

1. The tanker should be in straight and level flight.
2. The flight/element departing the tanker reforms and moves back from the right wing with offset and establishes contact (Radar, Tacan, etc.) with the tanker. Maintain altitude deconfliction from any joining receivers.
3. The next flight/element may then begin to move forward maintaining altitude.
4. Once the flight/elements have horizontal separation (established by Radar, Tacan, etc.), the next receivers can climb and the departing receivers can descend to briefed altitudes.
5. If a flight/element is to rejoin from the trail position and the preceding flight/element elects to stay in formation with the tanker, the flight/element in trail will close on the tanker until they are established in a visual position and then switch positions with the preceding flight.

**Force Extension Procedures**

Force extension procedures are used when force extension tankers air refuel tankers (KC-10/KDC-10/KC-135) escorting fighters during deployment operations. Force Extension missions are often complex and demanding to all aircrews, especially in IMC. All facets of the mission, to include the rendezvous, formation, air refueling, VMC/IMC rejoin procedures, and cell break-up will be briefed and clearly understood by all participants during mission planning. Basic Point Parallel or Enroute Rendezvous procedures apply, except as indicated. Multi-ship tanker cells will fly 60 degree echelon, 2 NM spacing unless otherwise directed. Missions that encounter IMC conditions during air refueling may increase air refueling echelon formation spacing from 2 miles to 3 miles. If a mid-mission rendezvous is planned, the escorting tanker will attempt to contact the force extension tanker and pass the ETA to the ARCP and updated weather information which may effect air refueling. Inflight visibility will be the determining factor in utilizing VMC versus IMC procedures to conduct air refueling. For the purpose of these procedures, VMC is defined as visibility equal to or greater than 2 NM. IMC is defined as visibility less than 2 NM.

## VMC PROCEDURES

Fighters will join on the force extension tanker when cleared by the escorting tanker pilot. After all fighters have joined on the force extension tanker, the escorting tanker will be cleared for refueling. Fighters should fly a loose wing formation and remain with their force extension tankers in the event a breakaway occurs.

## IMC OR NIGHT PROCEDURES

Air-to-air radar equipped fighters, when cleared by the escorting tanker pilot, will fly 1 1/2 to 2 NM trail (6 o'clock) position, 2000 feet below their assigned force extension tanker. Non-air-to-air radar equipped fighters will comply with the VMC procedures.

## POST REFUELING PROCEDURES

Once all air refuelings are complete, the escorting tanker(s) will descend 1000 feet, offset slightly to the right and then move to a position 1 NM in front of the force extension tanker(s). Once the escorting tanker(s) are stabilized 1000 feet below and forward of the force extension tanker, the escorting tanker will assume lead for the formation after a positive verbal lead change. The escorting tanker will then clear the fighters forward to rejoin.

Non-air-to-air radar equipped fighters will rejoin visually with their respective escorting tanker. Air-to-air radar equipped fighters will rejoin using radar guidance if required. If IMC prevails and poor visibility precludes visual rejoins, force extension tanker(s) may momentarily reduce separation to 1/2 NM and 500 feet vertical separation to facilitate the rejoin.

Once all fighters have rejoined on their respective escorting tanker, the force extension tanker(s) will depart the stream from the rear of the formation.

If the formation reaches the End A/R point and visual rejoins are not possible, force extension tankers will continue along the receivers' route of flight until visual rejoins are possible, fuel permitting. If the force extension tanker(s) reach BINGO FUEL at, or after, the End A/R point and the fighters have not rejoined with the escorting tanker(s), the entire formation will abort to a suitable alternate airfield.

The tanker radar should be used for position monitoring throughout the maneuver. It is the force extension tanker leader's responsibility to inform the entire formation of current heading and airspeed until relieved of that responsibility by a lead change. The force extension tanker/cell will reform at the top of the air refueling block. Once the fighters have

rejoined on their respective escorting tankers, the escorting tanker/cell will reform at the bottom of the block. Cell separation will be accomplished by the force extension or escorting tanker cell increasing/decreasing airspeed as determined by mission requirements and/or the pre-mission brief. Force extension or escorting tankers will not make any climbing or descending turns to depart the stream until the tanker cells are identified visually or by radar, are well clear, and verbal coordination is made between tanker cell leaders. All aircrews must clear aggressively and be cognizant of potential converging headings or conflicts.

When simultaneous refueling of fighters and escorting tankers is required, 310 KCAS (KC-10/KDC-10) or 295 KIAS (KC-135) normally will be used as refueling airspeed for the formation. The lead force extension tanker will determine air refueling airspeed based on aircraft type, altitude, weight, weapons load, etc.

The above procedures are the standard for force extension tankers refueling escort tankers. Any deviations to these procedures are not authorized unless coordinated between all tankers (escorting and force extension), receivers, and mission commander. If a pre-departure briefing is not conducted due to geographically separated departure locations, the escorting tanker will coordinate changes inflight to the force extension tanker upon initial contact, prior to the air refueling rendezvous.

## Lost Wingman Procedures

In the event a receiver aircraft becomes lost during refueling operations or during buddy cruise, the following procedures will apply:

1. If a tanker or receiver detects weather (by radar, reduced visibility, etc.) which may require a receiver to go lost wingman, the tanker should make any required navigational corrections, then fly straight and level. Any subsequent turns required should be made with ten degrees of bank maximum and called over the radio (i.e., "Tanker 21 is rolling into a ten degrees right turn.").
2. The receiver flying on the tanker's wing will simultaneously inform the leader and turn away using 15 degrees of bank for 15 seconds, then resume heading.
3. The receiver flying on the wing of the above receiver (second in the echelon) will simultaneously inform the leader and turn away using 30 degrees of bank for 30 seconds, then resume heading.



## T.O. GR1F-16CJ-1

4. The receiver flying on the wing of the above receiver (third in the echelon) will simultaneously inform the leader and turn away using 45 degrees of bank for 30 seconds, then resume heading.
5. The receiver who is flying in the precontact or contact position will simultaneously reduce airspeed 10 knots and descend 500 feet below refueling altitude. Hold refueling heading and after 30 seconds resume normal airspeed.
6. If the above procedures are started while tanker(s) are in a turn, request tanker(s) roll wings-level and call roll-out heading.
7. Notify flight leader or tanker commander of the situation.
8. Attempt rejoin only after receiving clearance from the tanker and when within radar or VMC capability.

### Abort Procedures

If a receiver aborts during an air refueling mission, the receiver leader will determine the course of action to be taken.

## RENDEZVOUS PROCEDURES

### NOTE

Initial visual contact between the receiver and tanker may be enhanced, inflight weather conditions permitting, if the tanker jettisons fuel to increase its visual signature. This procedure may be initiated/requested by the tanker, receiver, or the ground agency controlling the rendezvous. It should only be used if a receiver low fuel state or other similar circumstances require the rendezvous be expedited.

The type of rendezvous will be dictated by mission requirements, weather conditions, etc. If weather conditions for join-up at cruise altitude are VMC, an enroute rendezvous may be used. When tanker and receivers operate as separate flights, the Point Parallel rendezvous will be primary.

After radio contact has been established, both tankers and receivers should be tuned to the same NAVAIID, if possible, to improve rendezvous capability.

### NOTE

- For receiver's directed rendezvous, the receiver's airborne radar equipment (if available) will be the primary means to accomplish a rendezvous. A/A Tacan will be used as a backup.
- Ground radar assistance should be utilized to the maximum for all rendezvous. The tanker commander will monitor ground control radio frequency and confirm receiver range/bearing information to insure positive identification during the rendezvous. Ground radar assistance will be terminated when the receiver reports visual contact with the tanker.

### Altimeter Settings

Unless otherwise directed, an altimeter setting of 29.92 inches Hg will be used for air refueling operations at or above transition altitude or when over water and operating in accordance with ICAO procedures. For all other air refueling operations, the briefed altimeter setting will be used.

### Rendezvous Altitude Block

Four consecutive altitudes shall be requested by the tanker for rendezvous and refueling. When four altitudes are available, the rendezvous will be effected with the tanker at the second altitude and the fighter(s) at the third. For example, when the refueling altitudes are FL290, 300, 310, and 320, the tanker will be at FL310 and the fighter(s) at FL300 for rendezvous, thus providing 1000 feet above the tanker and 1000 feet below the fighter(s). When tankers are in cell, they will stack up from the second altitude from the top of the block, FL310 in this example.

When only three altitudes are available, the tanker shall be at the top altitude with the fighter(s) at the middle altitude, providing 1000 feet below the fighter(s).

When only three altitudes are available and the refueling involves tanker cell formation, the highest tanker within the cell should be at the top of the block. To accomplish this, the tanker leader shall place himself at an altitude that will permit the highest tanker in his cell to be at the top of the block. For example, when there are two tankers and the available block is FL270-290, the tanker leader would be at FL285 with number two tanker at FL290. The fighters would rendezvous at FL275 (1000 feet below the lowest tanker).

The above procedures do not apply when aircraft are operating on an Altitude Reservation (ALTRV) or when clearance has been granted for aircraft to operate as an enroute cell. In these cases, the altitude block will provide airspace necessary to accommodate the type of formations being used (standard or nonstandard), with at least 1000 feet between the highest receiver and lowest tanker during rendezvous, and at least 1000 feet below the air refueling formation once the rendezvous is complete.

### Track

Receivers shall pass over the ARIP, if applicable, and make good the planned inbound track to the ARCP. If a deviation is required because of weather, etc., receivers will not attempt rendezvous or proceed to the ARCP until the deviation has been approved by air traffic control and coordinated with the tanker. If radio contact between the tankers and receivers is not established prior to the ARCT, the tankers will be over the ARCP at the ARCT.

### Tanker Rendezvous Equipment

Tanker rendezvous equipment consists of the following:

- KC-135
  - A/A TACAN - DME only
  - Radar beacon AN/APN-69 (all aircraft) and AN/APN-134 (some aircraft)
  - Automatic Direction Finder - AN/ARA-25
- KC-10/KDC-10
  - A/A TACAN - Range and Bearing
  - Radar beacon APX-78 (Two Pulse, Variable Width)
  - UHF/DF
  - INS

#### NOTE

Radar beacon contact will be short range due to radar polarization incompatibility.

### Receiver Formation During Rendezvous

Formation procedures after level-off or from the ARIP until join-up with the tankers will be as follows:

#### NOTE

Formation lead changes and join-ups will normally be completed prior to departure from the ARIP. Should such maneuvers be required subsequent to departure and prior to join-up on the tanker(s), the rendezvous will not be continued unless the flight leader is positive of his position in relation to the tanker(s) and the published A/R track.

- Day VMC (Visibility five miles or greater). Flights will be in trail, offset to the right of the preceding flight. When all aircraft are in visual contact with the tanker(s), each aircraft/flight will join with his respective tanker as briefed.
- IMC or Night. The receiver formation will be formed into flight(s) of four aircraft in close or route formation. Succeeding flights will be in a like formation, positioned 1500 feet to the rear of the first flight or 2-3 NM radar trail, depending on weather conditions. When the tankers are established on the on-course track, the receiver leader will position his flight 3 NM to the rear of the last tanker. When all tankers in the cell are in positive radar contact, receivers will climb to 1000 feet below base altitude. If visual contact has been established, the flight/element leader will initiate join-up on the last tanker. When the appropriate wingmen have visual contact and are within 1 NM of their tanker, the leader will drop them off and proceed to the next tanker. The receiver leader will continue as above until all wingmen are on their appropriate tanker, then join the lead tanker. If not in visual contact at 3 NM, the receiver flight/element leader will clear the last receiver flight to join on the last tanker. The last receiver flight will then turn to the right and join on the last tanker while climbing to 500 feet below base altitude, then maintain this altitude until visual contact with the tanker is established. The first receiver flight will join on the number 2 tanker, maintaining 1000 feet below base altitude until visual contact is established. Each receiver leader will offset his tanker target 15 degrees to the left and close at approximately 50 knots above the tanker KCAS. Aircraft with operable airborne radar equipment will close no closer than 1500 feet. Receivers losing radar lock between 1 NM and minimum range will ensure 1000 feet altitude separation is maintained and discontinue rendezvous attempts until adequate range separation (1 NM) is achieved or radar lock-on is regained. Range

closure limitation for non-radar equipped receiver(s) or receiver(s) without radar lock-on is 1 NM. When visual contact with the tanker has been established, the receiver element will form in the precontact position, and the receiver flight leader will turn left, then right back to track heading and join on the lead tanker in the cell using the same procedures. The flight leader's wingmen, after flight separation, will echelon to the right. If visual contact with the tankers is not established, receivers will maintain 15 degrees offset, applicable altitude, and minimum slant range until cell termination procedures are accomplished.

### Early Arrival

Once a join-up is initiated, and it is necessary for the joining receivers to hold while waiting for a preceding flight to complete their operations, the joining flight will join in a position 600-800 feet out (laterally) from the receivers in the observation position if in VMC; or fly offset laterally 1-3 NM in trail if in IMC, and maintain 1000 feet below tanker base altitude. The decision on which side to join will be based on the direction of orbit of the tanker, departure intentions of the receiver flight refueling, and the presence of additional holding receiver flights.

### WARNING

Joining flights of receivers should not close astern of a tanker that is conducting refueling operations with other receivers. The wake turbulence generated by these aircraft during departure/changing of positions, if encountered, can result in loss of aircraft control.

In the event the receiver(s) arrives ahead of the tanker at the ARIP or ARCP point, the receiver will orbit at an altitude that ensures at least 1000 feet separation between tanker and receiver or any elements of tanker and receiver cells. If receivers hold at the ARCP, they will normally enter a left hand holding pattern using 2 minute legs at 1000 feet below air refueling altitude.

### Tanker Identification

Tanker identification is critical in congested refueling airspace. Available aids used in any combination should be used to confirm tanker location/identification prior to and during the rendezvous. These aids include ground radar, tanker/receiver radar, INS, A/A TACAN, UHF/DF steers, common ground TACAN stations, and radar beacons/IFF/SIF interrogation systems for receivers so equipped.

### NOTE

If the radar beacon is to be used to positively identify the tanker, the receiver should attempt to identify the tanker rendezvous beacon as soon as possible so that an alternate method of identification may be used if unable to receive the beacon. Only the tanker cell leader or his designated alternate, if applicable, will operate the rendezvous beacon.

### Point Parallel Rendezvous

The point parallel rendezvous is used to effect a rapid join-up between the tanker and receiver with minimum receiver maneuvering. The tanker and receiver approach on reciprocal headings offset, left or right, a distance equal to the tanker turn diameter. At a predetermined turn range, the tanker executes a turn to the receiver heading to roll out approximately 1-3 NM ahead of the receiver.

Normally, the tanker aircrew has responsibility for the overall refueling operation and rendezvous and establishes the offset and turn point. When tanker systems are degraded, the situation dictates, or for training, the Tactical Air Controller or receiver may be responsible for the execution of the rendezvous. Specific rendezvous responsibilities will be in accordance with command guidance. Receivers will monitor the air refueling frequency and attempt to establish contact as soon as possible. If both tankers and receivers are on a common radio frequency to obtain ground radar rendezvous assistance, the change to air refueling frequency may be delayed until positive radar/visual contact is established. If under radar control, obtain bearing and distance to the tanker prior to changing to air refueling frequency.

A successful point parallel rendezvous requires the tanker to maintain the proper offset and the receiver to fly the specified rendezvous track from the ARIP to the ARCP. Emission Option 2 will be the normal rendezvous and air refueling procedure. The receiver will call 15 minutes prior to the ARCT and relay call sign, ETA (minutes early or late), and altitude. The tanker will then confirm his call sign, air refueling altitude and timing (minutes early or late) if it will affect the rendezvous. If either the tanker or the receiver is not on appropriate rendezvous altitude, another radio call will be made when the proper rendezvous altitudes are established. Receivers departing the ARIP will maintain cruise speed at 1000 feet below tanker base altitude until positive radar or visual contact is made from in trail with the appropriate tanker(s). The receivers will proceed

from the ARIP to the ARCP using all navigational aids available to maintain the centerline. When it is determined the receiver is at or inside the ARIP, the tanker will turn to, or continue on, the reciprocal of the receiver's inbound track and will establish and maintain the proper offset until reaching the planned turn range. However, receivers will not deviate from the ARIP/ARCP centerline unless directed to do so by the tanker.

The tanker will adjust to appropriate air refueling speed when rolled out toward the ARCP. The tanker INS/DNS will be the primary means of maintaining the offset and the A/A TACAN will be primary for range information. To provide A/A TACAN ranging, the tanker and the receiver (1 airplane per cell) will tune the assigned A/A TACAN channels 15 minutes prior to the ARCT. The receiver will set the numerically lower A/A TACAN Y-channel and the tanker will set the higher V-channel. A/A TACAN should be left in A/A until the receiver reaches precontact.

**NOTE**

Radio silence will be broken if the tanker or receiver determines that either the tanker or receiver will exceed ATC protected airspace while maneuvering to attain the offset.

The tanker will note the receiver's distance when halfway through the turn back to the ARCP. This is the best time to determine if an overrun condition exists and the best time for visual sighting. If an overrun condition exists, appropriate action should be taken. Tactical Air Controllers or receivers who have established radar contact and positively identified the tanker will offset the tanker in order to establish a 26 degree relative bearing at 21 NM range. The receiver/weapons controller will offset the tanker as follows:

APPROXIMATE SLANT RANGE (NM)	BEARING (DEGREES)
100	5
80	6
60	8
50	10
40	13
30	18
25	21
21	26
20	27
13	45

**NOTE**

- The above slant range/bearing chart applies only to the KC-135 at approximately 28,000 feet. It is based on 9.5 NM lateral offset with the tanker using 30 degrees of bank during the turn to refueling heading. The KC-10/KDC-10 normally uses 25 degrees of bank or less during the turn to refueling heading and approximately an 11.5 NM offset. Normally, the turn range with the KC-10/KDC-10 will be 2-6 NM greater than the turn range with the KC-135.
- When more than one tanker is involved, it may be necessary to add 1 NM to the turn range for each additional tanker in the formation to ensure receiver leader is 3 NM in trail of the appropriate tanker at roll-out.

At the turn range, the tankers will turn to the refueling track and adjust to refueling formation. The receiver will assume responsibility for closing on the tanker at the turn range. The last tanker in a cell will turn the radar beacon to operate, single code, on roll-out to refueling heading at the completion of the turn. The receivers will normally be 3 NM in trail of the tanker(s). When rolled out toward the ARCP, the tanker will adjust to the appropriate air refueling speed.

**Point Parallel Rendezvous With Tanker Escort**

Refer to figure 8-7. The receivers will join on the escorting tanker in the briefed sequence. The orbiting and escorting tankers are responsible for effecting the rendezvous.

An air refueling anchor is a left-hand racetrack pattern with legs separated by 20 NM and normally a minimum leg length of 50 NM. Tankers will adjust from enroute cell formation to the air refueling formation of 20 degrees right echelon, 1 NM nose-to-nose separation, stacked up at 500 foot intervals during the final turn to the air refueling track.

When the receivers are inbound, the rendezvous will be directed by the Tactical Air Controller or the receiver leader. The Tactical Air Controller or the receiver leader (as appropriate) will determine the type rendezvous to be made. The tanker will adjust to

refueling airspeed when directed by receiver leader. Receivers will rendezvous 1000 feet below refueling base altitude until visual contact is established. In the event Tactical Air Control radar is not available to control anchor refueling operations, the following alternate procedure will be used:

The tanker will establish a normal point parallel rendezvous at the anchor point. Receiver flights will proceed to an anchor ARIP a minimum of 70 NM upstream from the anchor point. Receivers will rendezvous 1000 feet below the refueling base altitude until visual contact is established. Normal point parallel rendezvous orbit (fighter) procedures will be used for the rendezvous.

#### **NOTE**

Unless directed otherwise by the tanker, the receiver flight will accomplish a 360 degree left turn at the upstream end of the anchor pattern to enable the tanker to turn toward the receiver flight for rendezvous.

After the receiver flight is joined up, the anchor pattern will be used for refueling. If cleared by the tanker commander, subsequent receiver flights may depart the ARIP prior to the previous receiver flights departing the anchor area when the receivers have the capability to assure safe aircraft separation and to join on the tanker using receiver turn-on rendezvous procedures.

Ensure at least 1000 feet separation is provided between each joining flight, and between the highest flight and the lowest refueling element until visual contact is established. Use of secondary frequency is recommended. To preclude conflict with receivers clearing the tanker or during a breakaway, ensure fighters maintain adequate in-trail spacing from the refueling formation.

#### **NOTE**

If subsequent flights are cleared to depart the ARIP and air refueling is not complete prior to join-up, a fighter turn on rendezvous should be made. If this is not possible, these fighters should hold at the ARIP until air refueling is complete.

### **Receiver Turn-On Rendezvous**

Receiver turn-on rendezvous will be conducted in accordance with the procedures established in command guidance. Receivers will maintain required vertical separation until visual contact is made with the tanker(s).

### **Rendezvous Overrun**

In the event of an overrun by fighters, the receiver(s) will pass 1000 feet below the tanker to insure positive vertical separation. The receiver will decelerate to 290 KCAS and maintain air refueling heading. The tanker will accelerate to 355 KIAS (350 KCAS) or Mach 0.90, whichever is lower, and maintain air refueling heading. When the tanker is in positive visual contact ahead of the receiver, the tanker will decelerate to air refueling airspeed and normal closure procedures will be employed to establish contact.

### **Enroute Rendezvous**

#### **DEPARTURE AND CLIMB**

The receiver departure time will be adjusted to place him at altitude in trail of the tanker.

The tanker will level off, on course, at the programmed cruise altitude and establish 260 KCAS to permit receiver overtake. The receiver will level off, on course, 1000 feet below the tanker's base altitude and establish a closing airspeed. All available rendezvous aids will be used to effect tanker/receiver closure until visual contact is made. Receivers will call "visual" when visual contact is established with the tanker. Tankers will accelerate to enroute or refueling airspeed at the direction of the receiver.

#### **ENROUTE RENDEZVOUS PROCEDURES**

An enroute rendezvous may be used when the tanker(s) and receiver(s) fly individual flight plans to a common rendezvous point (RZ), where join-up is accomplished, and continue enroute cell formation to the ARCP.

These procedures may provide an orbit delay or timing triangle enroute to the ARCP. It is not appropriate to accomplish a point parallel rendezvous at the RZ because the length of the orbit legs cannot be extended. Tankers will depart the RZ to make good the ARCT or the receiver's ETA to the ARCP.

Either tanker(s) or receiver(s) may be scheduled to arrive at the RZ first, orbit if necessary, and then depart at a preplanned time.

# Racetrack Patterns (Typical)

## Anchor Pattern

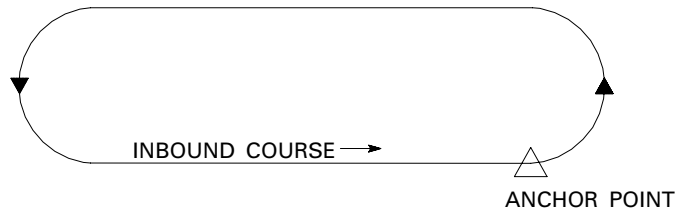

## Anchor Pattern (Alternate Procedure)

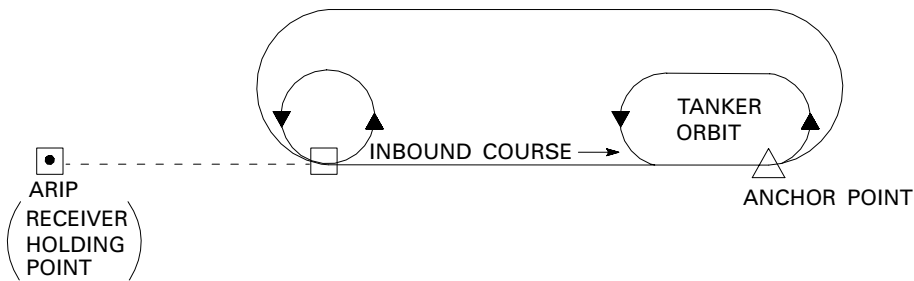

## Enroute Rendezvous (Typical)

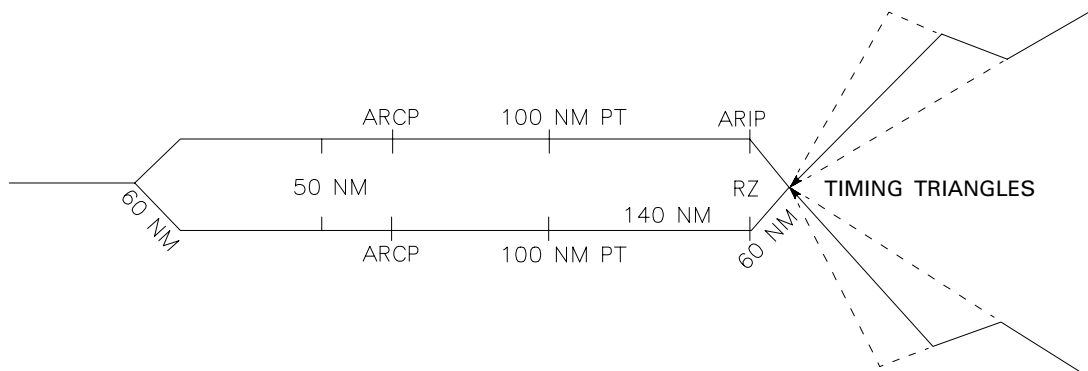

1F-16X-1-8006X®

Figure 8-7.

**WARNING**

When close interval stream operations are being conducted, do not use orbit delays to control timing.

The RZ will be located a minimum of 50 NM prior to the ARIP/SD. Tracks from the ARIP/SD may be established from any direction and need not necessarily be an extension of the air refueling track.

If orbit delays are required, they will be accomplished by orbiting at the RZ point along an extension of the track from the RZ to the ARIP/SD. Orbit in a racetrack pattern using 30 degree banked turns and a maximum of 15 NM straight legs (unless operational directives specify longer straight legs).

Tanker(s) and receiver(s) will join-up at the RZ by controlling timing so they arrive at the RZ at the same time. Timing to the RZ may be adjusted using differential airspeeds, orbit delays or timing triangles. If a planned orbit delay is used, receiver(s) and tanker(s) may accomplish join-up in the orbit.

Assigned altitudes at the RZ will provide at least 1000 feet separation between affected airplanes (highest tanker and lowest receiver), with the receivers normally at the highest altitude. If the receiver(s) planned level off altitude is within 30 minutes flying time from the ARIP, the receiver(s) may level off below the tanker and maintain an altitude which provides a minimum of 1000 feet vertical separation between the highest receiver(s) and the lowest tanker(s).

Communications will be in accordance with specified emission option. If radio contact between the airplanes has not been established prior to the rendezvous control time, or the adjusted rendezvous control time, airplanes will maintain altitude and depart the RZ to cross the ARCP at the ARCT. Delays at the ARCP will use normal orbit procedures unless otherwise directed. If there is minimal separation between following aircraft or cells using the same track, orbits at the ARCP will require close coordination and a thorough crew briefing to ensure altitude separation.

When the aircraft or cells pass the ARIP/SD, the tanker(s) and receiver(s) will echelon and the receiver(s) will begin descent to the base air refueling altitude. Receiver(s) will descend to be at the base altitude 80 NM prior to the ARCP. Tanker(s) will maintain published buddy cruise KCAS and adjust to air refueling airspeed crossing the ARCP.

**NOTE**

For peacetime training missions, the ARIP or the ARCP may be designated as the RZ. In these cases, cells will echelon and start descent at the base refueling altitude as soon as practical after rendezvous completion.

If prebriefed, tanker(s) and receiver(s) may adjust to air refueling airspeed and begin air refueling after passing the RZ. Once departing the RZ/ARIP, the tanker(s) should fly centerline. The receiver is the maneuvering aircraft. If the tanker is behind the receiver, the tanker should accelerate and pass slightly off the left wing of the receiver.

**Alternate Rendezvous Procedures**

Tanker and receiver crews must be prepared at all times to accomplish the rendezvous using whatever resources are available. When rendezvous equipment is degraded, tankers and receivers will fly the same profiles as described in previous paragraphs. The following are some suggested alternate rendezvous procedures which should be used in any combination to ensure a successful rendezvous:

**NOTE**

Initial visual contact between the receiver and tanker may be enhanced, inflight weather conditions permitting, if the tanker jettisons fuel to increase its visual signature. This procedure may be initiated/requested by the tanker, receiver, or the ground agency controlling the rendezvous. It should only be used if a receiver low fuel state or other similar circumstances require the rendezvous be expedited. If required, the tanker will dump fuel in 500 - 1000 pound increments until positive visual contact can be maintained.

- **Radar/Rendezvous Beacons.** The receiver/tanker beacons may be used for range and offset information with suitably equipped airplanes. Depending on equipment capability, one airplane should maintain the planned outbound or inbound track while the other airplane maneuvers to establish the planned offset. The tanker will clearly establish which airplane will be maneuvering.

- Common Ground Station. If A/A TACAN is not available, switching to a common ground TACAN/VORTAC station for range information may be necessary. The final turn to refueling track is made when the DME difference equals proper turn range.
- UHF/DF. For DF steers, receivers will be requested to use the MIC switch without talking. The receiver will transmit on the air refueling frequency approximately 10 seconds out of every 20 second period, ending each transmission with the receiver's call sign. When the receiver position shows proper turn range bearing (No Wind) from the tanker heading, the tanker will turn to the refueling track. Notify the receiver when the turn is started. At the receiver's request, the tanker will transmit a homing signal.
- ETA. When adequate navigational check points are available, the tanker may adjust final orbit pattern to arrive over the ARCP on the air refueling heading at the receiver(s) ETA to the ARCP.
- Ground Radar Assistance. Ground radar facilities may be used for vector and separation advisories. Ground radar assistance will be used to the maximum when conducting rendezvous with significantly degraded equipment to ensure a successful rendezvous.

### Emission Option 3

The elimination of the 15 minute prior calls increase the element of risk, and the following guidelines should enhance safety considerations:

- Normally accomplish when clear of clouds.
- If unable to remain clear of clouds, tanker(s) and receiver(s) will immediately confirm altitudes.
- The receiver and tanker inbound courses to the RZ/ARIP must be separated by a minimum of 30 degrees.
- The receiver and tanker inbound legs to the RZ/ARIP must be a minimum of 40 NM in length.

This type rendezvous should be an enroute rendezvous at the ARIP with both aircraft using the same RZ time. The receiver should rendezvous 1000 feet below the tanker. An ETE from the ARIP to the ARCP should be planned which permits an airspeed which falls in the middle of the aircraft speed performance envelope. It is essential that crews/planners coordinate certain items during mission planning/development. Minimum items include:

- Rendezvous altitudes
- RZ time and ARCT

- Inbound courses to the RZ/ARIP
- Radio silent termination time in the event of a missed rendezvous

### Missed Rendezvous Procedures

If contact is not established at the RZ/ARIP, the tanker will arrive at the ARCP at the ARCT. This procedure begins when either aircraft arrives at the ARCP and does not have visual contact with the other. In this case, a left hand orbit should be entered and orbit controlled so as to be over the ARCP at intervals of every eight minutes (ARCT plus 8, plus 16, etc.). While in the orbit, every attempt should be made to establish visual contact with the other aircraft. The length of the delay and decision as to how long to continue radio silence should be determined during mission planning/development prior to flight.

### SPECIAL AIR REFUELING PROCEDURES

The tanker boom is controlled by the boom operator while the fuel transfer (pressure, flow, quantity, etc.) is normally controlled by the tanker crew from the pilots' compartment. In IMC, when visibility is such that Lost Wingman Procedures may be necessary, receiver formations and the refueling sequence will be structured so that no more than three aircraft are on each wing of the tanker.

### Refueling Sequence

#### FINGERTIP FORMATION

Normally, the leader will proceed to the precontact position. Number 2 will proceed to the lead element's observation position. The second element will proceed to an observation position on the tanker's opposite wing. Each subsequent receiver will visually clear and move from the observation position to the precontact position. The refueling sequence will be designated by the receiver leader. Each receiver, after refueling is completed, will rejoin to an outside wing position of his original element. When all receivers have completed refueling, the receiver force will rejoin to the left or right, as briefed, and slightly below the tanker.

#### ECHELON FORMATION (VMC ONLY)

Normally, the leader will proceed to the precontact position. Number 2 will proceed to the observation position with the remainder of the flight. Refueling sequence will be as directed by the receiver leader. Each receiver will visually clear and move from the observation position to the precontact position. The receivers, after refueling is completed, will rejoin in echelon formation on the tanker's opposite wing.



## Fuel Management

The ENG FEED switch should be in the NORM or proper position, and the fuel distribution will be checked within flight manual tolerances on the fuel quantity indicator prior to contact with the tanker. The fuel system operation is automatic (fuel being distributed to internal and external tanks simultaneously).

### NOTE

- If a partial fuel load is unloaded, a fuel spread in excess of flight manual limits should be anticipated.
- **B** Disconnect from the boom may occur before all tanks are full if the external fuel tank configuration consists of only a centerline fuel tank. Such a disconnect typically occurs when refueling with an initial internal fuel load of 4000 pounds or more and the centerline tank empty. At disconnect, the aircraft total fuel may be up to 1600 pounds less than full, with many occurrences resulting in approximately 1000 pounds less than full.

## Precontact

All precontact air refueling checks will be completed in the observation position or prior to reaching 1 NM in trail, except for final exterior light adjustment. After the receiver has stabilized in the precontact position, the receiver will move to the contact position.

### WARNING

- The receiver will stabilize in the precontact position and attain a zero rate of closure. If the receiver fails to attain a stabilized position, or it becomes apparent that a closure overrun will occur, a breakaway will be initiated. Failure to initiate a breakaway under closure overrun conditions can result in a midair collision.

- Upwash and downwash effects may occur, drawing the aircraft together. Low pressure areas created by an overrunning receiver flying under the tanker will affect static ports, causing possible erroneous airspeed and altitude indications to both aircraft. The tanker autopilot altitude hold function may sense the low pressure as a climbing indication and initiate a descent into the lower aircraft.

## Boom and Receptacle Procedures

### NOTE

For night operations, prior to closing for contact with the tanker, coordinate with the boom operator on exterior lighting to avoid impairing night vision.

When cleared, move forward to the contact position and the boom operator will make contact. The receiver may request assistance from the boom operator in obtaining and maintaining position.

From the precontact position, the receiver moves slowly with a 2-3 knot closure until reaching the contact position. When closing on the boom, constant cross reference between the boom and the tanker fuselage will alleviate any tendency to “chase” variations of boom trail position due to turbulence.

When stabilized in the contact position, maintain this position. The boom operator will then make the contact.



- If the receiver director lights fail to illuminate when contact is established, the receiver pilot will inform the boom operator if he wishes to continue refueling operations. If refueling is continued, verbal corrections from the boom operator may be requested.
- Attempts to affect a contact during loss of any air refueling lighting that results in less than desired illumination will be at the discretion of the boom operator.

To maintain proper contact elevation and boom extension, refer to the director lights located on the bottom of the fuselage of the tanker (See figure 8-5). While in contact position, there is freedom in all three axes as depicted in figure 8-6.

If, for any reason, fuel is not transferring or is transferring at less than normal rate, the receiver pilot will disconnect and monitor the aerial refueling status indicator. The bottom lamp (DISC) lights amber when a disconnect has been accomplished. The system will automatically reset to ready and the top lamp (RDY) relights blue after a 3-second delay. A second contact may then be accomplished. If this does not resolve the problem, the pilot may then disconnect, confirm disconnect with the boom operator, and recycle the system by closing and opening the slipway door using the AIR REFUEL switch.

### DISCONNECT KC-135

In the event of failure to obtain a contact and after each disconnect, the receiver will move aft and stabilize in a position in trail of the boom or in precontact position and await clearance from the boom operator to return to the contact position.



- Remain stabilized in the contact position until visually confirming a disconnect has been made. This will prevent damage to the boom and/or receptacle through a brute force disconnect.
- Brute force disconnects can occur unintentionally as the result of rapidly exceeding boom limits or failure of the receptacle toggles to release when a disconnect is initiated.

### DISCONNECT KC-10/KDC-10

The KC-10/KDC-10 aerial refueling boom is controlled by a digital fly-by-wire system. Certain failure conditions of this system may cause one or more axes of the boom control system to become inoperative. Should this occur, the boom operator may not be able to maneuver the boom to avoid striking the receiver airplane. In this situation, the boom operator will issue instruction to direct the receiver to a position where a safe disconnect can be effected.

### WARNING

- When notified that a KC-10/KDC-10 boom flight control system failure has occurred, do not initiate a disconnect unless directed by the boom operator.

- Follow the boom operator's instruction explicitly. To reduce the probability of boom strike after disconnect, it may be necessary to remain in a stabilized position to allow for aerodynamic fairing of the boom control surfaces.

Another feature of the KC-10/KDC-10 is the Independent Disconnect System. This system allows the boom operator to obtain a disconnect even when the receiver's toggles remain in the latched position. This system should be used in lieu of a Brute Force disconnect.

### Quick Flow Air Refueling Procedures

Refer to figure 8-8. Fighter type receivers may use Quick Flow procedures to expedite air refueling operations. Quick Flow allows receivers to minimize refueling time with maximum fuel transfer. Quick Flow may be used during day or night operations, in VMC conditions only. If it appears that the flight may encounter adverse weather conditions, standard IMC procedures will be used. Coordination between tanker(s) and receivers prior to initiation of Quick Flow procedures is required. Air tasking guidance, direct communication with the tanker unit, or adding the term "Quick Flow" to the initial radio call will satisfy coordination requirements. Tanker lead is the final authority for Quick Flow operations. Right echelon formation is normally used for Quick Flow; however, variations are authorized with flight lead coordination and tanker lead approval.

Normally, the receiver flight will join on the tanker with the flight lead moving to the precontact position. Remaining aircraft will proceed to the right observation position. Once the flight lead commences refueling, the second aircraft in the air refueling sequence will move to the On-Deck position. The On-Deck position is normally flown as a route formation with approximately 10' spacing. When the flight lead completes refueling, that aircraft moves to an observation position on the tanker's left wing. The second receiver moves from the On-Deck position to the precontact and contact position. With three or more receivers, the third receiver moves to the On-Deck position. The right to left flow continues until all fighters have refueled. When the air refueling operation is complete, the flight may depart the tanker or, if additional refueling is required, remain in echelon formation on the tanker's left wing and reverse the Quick Flow procedures, with a left to right flow. The second receiver will assume a left On-Deck position and Quick Flow will continue in order. Additional receivers arriving prior to the first flight completing refueling operations will remain in trail position until they are cleared by the tanker to the observation and/or precontact position.

# Quick Flow Air Refueling

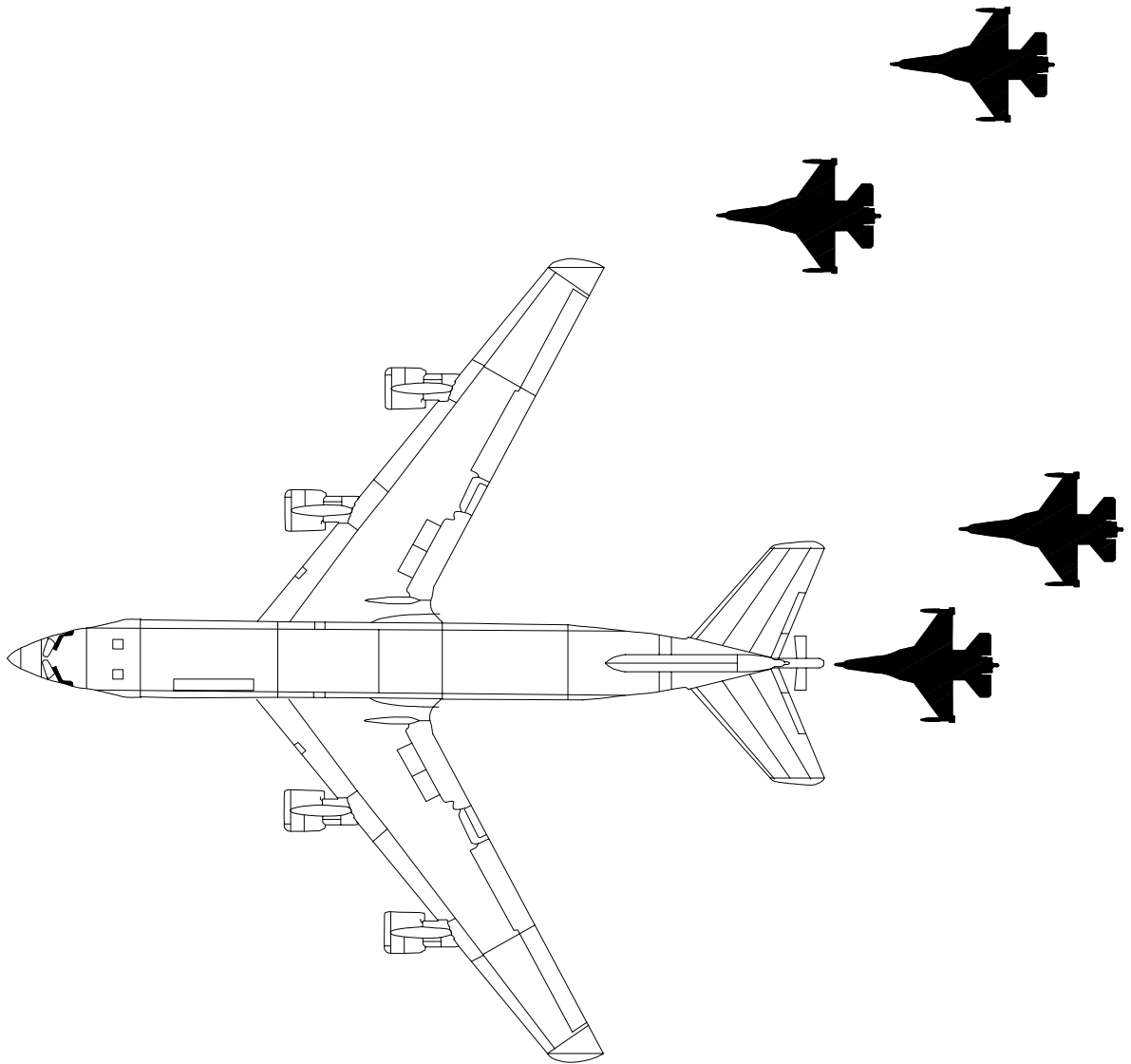

1F-16X-1-8007X ©

Figure 8-8.

In the event of a breakaway, the On-Deck receiver follows the receiver that was on the boom. Any receivers on the wing will remain with the tanker. In the event a breakaway is initiated while a receiver is transitioning from the observation position to the On-Deck position, that receiver will follow the receiver that was on the boom.

### **Toboggan**

When altitude and atmospheric conditions result in thrust requirements that exceed the receiver's available thrust, a toboggan will be necessary. The toboggan technique is a coordinated effort between the tanker pilot and the receiver pilot in which refueling is accomplished in a slight descent, allowing the receiver to perform the refueling with available thrust.

The receiver pilot must signal or call on boom interphone that a toboggan maneuver will be required before reaching full military power.

The tanker pilot will very gently reduce power and initiate a rate of descent of approximately 300 FPM while maintaining the air refueling airspeed throughout the toboggan maneuver.

### **Weather Abort Procedures**

Receivers must take every feasible action to enhance the possibility of completing air refueling. Such actions include altitude and course deviations necessary to avoid severe weather. Deviations, when required, must be made judiciously. When the receiver leader determines that weather conditions are such as to make formation refueling hazardous, he may abort the cell. When the cell is to be aborted, the receiver leader will instruct the tanker leader to clear refueling track. Normal end refueling procedures will apply.

### **Afterburner Air Refueling**

Afterburner Air Refueling is not recommended.

### **Separation/Termination Procedures**

Following completion of air refueling, the receiver(s) will maneuver to the prescribed formation position, obtain tanker post air refueling report, and return to the primary refueling frequency (if applicable). After the receivers have reformed, the tanker leader will provide the receiver leader with present position in relation to the planned completion point. Additional information will be provided if requested; i.e., weather information, nearest abort bases, etc. The receiver leader will request the no wind heading and distance to the next checkpoint unless he has a positive fix from which to navigate.

### **SEPARATION FROM A SINGLE TANKER**

The tanker and receiver leader will coordinate on the method of separation. Normally, after the receiver flight has reformed, they will clear the tanker by descending or as directed by the controlling agency. The tanker will advise and receive clearance from the receiver leader before changing altitude or heading. Receivers will maintain a safe clearance from the tanker as they proceed on their assigned mission.

### **CRUISE CELL TERMINATION (VMC)**

When cleared by the receiver leader, elements will join on their respective flight leaders. The receiver force will then reform to the left and slightly below the lead tanker. After receiving clearance from the tanker leader and the appropriate controlling agency, the receivers will proceed on their assigned missions, maintaining safe clearance from the tanker formation.

### **CRUISE CELL TERMINATION (IMC)**

Refer to figure 8-9. Ten minutes prior to reaching the cell termination point (if the point is other than destination approach fix), the receivers will reform in left echelon on the left wing of the tanker(s). Upon reaching the cell termination point, the tanker(s) will climb straight ahead 3000 feet and then turn to the desired track, maintaining cell formation. Receivers will maintain heading, altitude, and airspeed for 3 minutes. At this time, if flight formation rejoin is impractical, number 1 receiver element will descend 1000 feet below base altitude, number 2 receiver element will descend 500 feet to the base altitude, number 3 receiver element will maintain altitude (which will be 1000 feet above the base altitude), and number 4 receiver element will climb 500 feet to an altitude which is 2000 feet above base altitude. Receiver elements will then proceed with their mission independently.

### **CELL TERMINATION AT TERMINAL APPROACH FIX**

Due to the many possible combinations of tanker/receiver formations, terminal destination weather, and terminal airfield penetration facilities, it is impractical to designate one optimum method for penetration at the destination. The following methods should be applied as applicable:

1. From the final air refueling point, tankers and receivers can be scheduled at their individual optimum airspeeds to provide spacing for the penetration.

## T.O. GR1F-16CJ-1

2. After the receivers have a positive TACAN lock-on, they will normally depart the tankers and proceed to destination as directed by the appropriate controlling agency.
3. When available, approach control should be used with enroute descents to obtain aircraft separation.
4. The element (one tanker/two receivers) may penetrate as a unit. Weather minimums for this type approach are 2500 feet and 3 NM.

### **NOTE**

A low fuel altitude will be designated 2000 feet below base altitude for immediate descent of receivers with low fuel or an emergency condition. Receiver altitude changes will be coordinated by the receiver cell leader with the ATC agency. All aircraft of the cell will note individual altimeter errors at the cruise altitude with 29.92 inches Hg set on the altimeter and fly their assigned altitudes after cell separation with these errors applied.

## ELEMENT PENETRATION

If conditions exist which necessitate a more expeditious recovery (fuel shortage, emergency, etc.), a basic cell penetration may be made. Penetration airspeed and descent rate will be coordinated between the tanker and receiver leader. When VFR, the receivers will break off and enter initial for a VFR landing.

## RECEIVER RADAR REJOIN PROCEDURES (IMC)

If receiver radar rejoin is desired at the completion of the cell termination, the following procedure will be initiated:

1. Each receiver will maintain his respective altitude.
2. The receiver formation leader will maintain heading and each of the following receiver elements will simultaneously turn left 15 degrees on the formation leader's command.
3. Numbers 2, 3, and 4 elements will maintain this heading for 1, 2, and 3 minutes respectively, and then resume the original heading.
4. The flight will then rejoin on radar using the procedures for radar join-up with tankers.

# Cell Termination Procedure

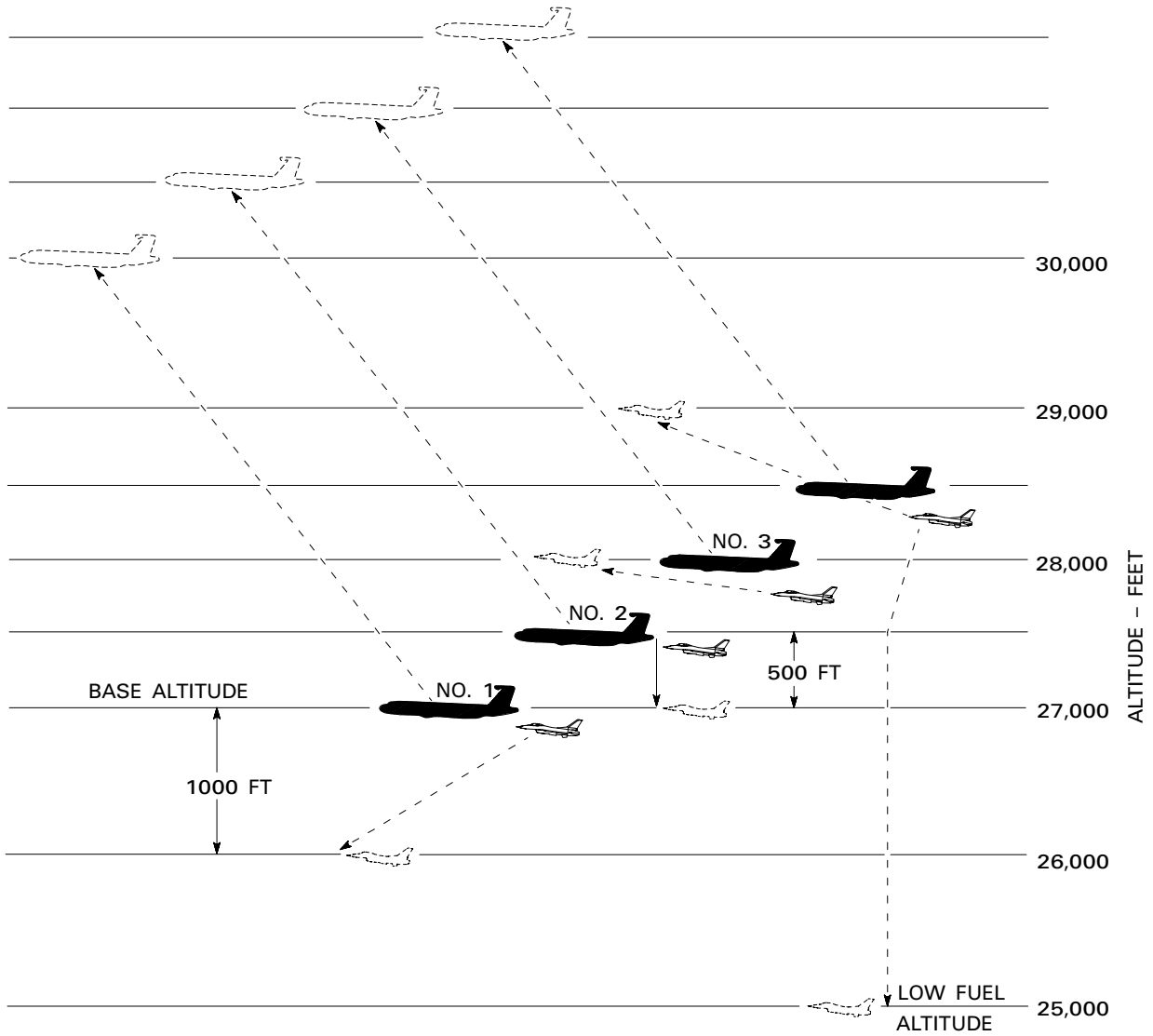

ALTITUDES LISTED ARE FOR SAMPLE ONLY USING 27,000 FT AS A BASE ALTITUDE.

Figure 8-9.

## NORMAL AIR REFUELING PROCEDURES

### Armament Safety Check

Prior to closing within lethal range of the tankers, complete the following checks:

1. MASTER ARM switch - OFF or SIMULATE.
2. LASER ARM switch - OFF.
3. SMS - Confirm ordnance safe.
4. CMDS switches (9) - As required.

### Precontact

Prior to air refueling, the following checks will be completed:

1. TACAN - As required.
2. Emitters (ECM/FCR/RDR ALT) - As required (Quiet/Silent/STBY/OFF).
3. HOT MIC CIPHER switch - HOT MIC.
4. Exterior lights (Night) - DIM, STEADY.
5. ANTI COLLISION light switch (Night) - OFF.
6. AIR REFUEL switch - OPEN.
7. AR status indicator light - RDY.

### Contact

1. AR status indicator light - AR/NWS.

#### NOTE

Once contact is made, boom interphone communications can be established with the boom operator if HOT MIC is selected. Volume is controlled by the intercom volume control. The boom interphone capability is provided on all KC-10/KDC-10 and KC-135 tankers.

2. Fuel transfer - Monitor.

### Disconnect

1. A/R DISC button - Depress momentarily, then release.



If making an outer limit disconnect, high separation rates should be avoided to prevent damage to the boom or receptacle.

2. AR status indicator light - DISC.



Remain stabilized in the contact position until positive visual confirmation of boom separation is confirmed by the boom operator.

### Post Air Refueling

1. AIR REFUEL switch - CLOSE.



Failure to close the air refueling switch will result in the FLCS remaining in takeoff and landing gains, the roll rate restricted to a fixed value, and the failure of external fuel to transfer.

2. AR status indicator lights (3) - Off.
3. Fuel Quantity - Check.
4. MASTER ARM switch - As required.
5. SMS - As required.
6. CMDS switches (9) - As required.
7. TACAN - As required.
8. FCR - As required.
9. RDR ALT - As required.
10. LASER ARM switch - As required.
11. Exterior lights - As required.

## EMERGENCY AIR REFUELING PROCEDURES

### Breakaway Procedures

Relative position of both airplanes must be closely monitored by all crew members during all phases of air refueling. When either a tanker or receiver crewmember determines that an abnormal condition exists which requires an immediate separation of the airplanes, that crewmember will transmit the breakaway call on air refueling frequency. Abnormal conditions include excessive rate of closure, closure overrun, and engine failure. The receiver does not have to be in the contact position to call a breakaway.

For all breakaways, transmit the tanker's call sign and the word "breakaway" three times (Example: "Chevy 2, breakaway, breakaway, breakaway") and simultaneously take the following actions:

- Actuate disconnect switches as applicable.
- Retard throttle and establish a definite rate of descent, using speed break if necessary.
- If possible, drop aft of tanker until entire tanker is in sight and monitor flight instruments.

The tanker pilot will increase power to obtain forward separation. Unless lateral separation cannot be assured, the tanker will accelerate in level flight and will not climb. The lower rotating beacon will be turned on, the pilot director lights will be flashed, and the Radar/Rendezvous Beacon will be turned to operate, if appropriate. When the receiver is well clear, the breakaway may be terminated. The receiver pilot will be notified of and will acknowledge any reduction in power by the tanker to resume air refueling speed. If a climb is required, the tanker pilot will disengage the autopilot and climb straight ahead. If in a turn, the tanker will maintain the established bank angle until the receiver is well clear.

#### NOTE

- If a breakaway is called prior to any receiver reaching the observation position, the entire receiver flight will execute the breakaway procedure. If a breakaway is called after receiver(s) have reached the observation position, only the receiver in the contact or precontact position will execute the breakaway procedure. The receiver(s) in the observation position will maintain formation on the tanker.

- With certain gross weights and aircraft configurations, the tanker rate of acceleration on a breakaway may exceed the rate of acceleration for the receiver aircraft in the observation position.

### System Malfunctions

When any system malfunction or condition exists which could jeopardize safety, air refueling will not be accomplished except during fuel emergencies or when continuance of fueling is dictated by operational necessity. At any time fuel siphoning is noticed, fuel transfer will be stopped and the receiver notified. The requirement to continue fuel transfer will be at the discretion of the receiver pilot.

#### NOTE

A small amount of fuel spray from the nozzle and receptacle during fuel transfer does not require fuel transfer to be terminated. The receiver pilot should be notified if this condition exists and the air refueling operations will be continued or discontinued at his discretion.

### SLIPWAY DOOR WILL NOT OPEN

No back-up system is provided to open or close the slipway door if hydraulic system B fails.

### SLIPWAY DOOR WILL NOT CLOSE

If the slipway door will not close, perform the following:

1. AR switch - CLOSE.  
Normal FLCS gains and tank pressures will be regained.

#### NOTE

The RDY, AR/NWS, and DISC lights will not indicate normally. The NWS light will not illuminate when nose-wheel steering is engaged.



**INOPERATIVE BOOM/RECEPTACLE LATCHING**

When all other recognized means of fuel transfer have failed, and an actual fuel shortage emergency aboard the receiver airplane exists, fuel can be transferred by maintaining boom/receptacle contact using a slight extend pressure on the boom telescope lever. Unusual and varying trim changes may be required of both tanker and receiver airplanes.

If a fuel shortage emergency requires:

1. Boom operator - Inform of the need to accomplish manual boom/receptacle pressure refueling.

**WARNING**

The receiver pilot must inform the tanker he is ready to receive fuel and coordinate the disconnect cycle for the conclusion of refueling.

**CAUTION**

Prior to attempting this method of transferring fuel, the boom operator will brief the receiver pilot and thoroughly coordinate the procedures to be used. Both tanker and receiver crews will monitor the refueling with extreme caution.

**KC-10/KDC-10 Boom FLCS Failure**

Do not disconnect until cleared by boom operator.

**WARNING**

- When notified that a KC-10/KDC-10 boom flight control system failure has occurred, do not initiate a disconnect unless directed by the boom operator.
- Follow the boom operator's instruction explicitly. To reduce the probability of boom strike after disconnect, it may be necessary to remain in a stabilized position to allow for aerodynamic fairing of the boom control surfaces.

**Brute Force Disconnect**

There are two types of brute force disconnects: Inadvertent and Controlled Tension.

**NOTE**

Enter any brute force disconnect as a discrepancy in the AFTO Form 781. The entry will specify which type of brute force disconnect occurred.

**INADVERTENT DISCONNECT**

An inadvertent brute force disconnect is defined as any unplanned disconnect which is the result of one of the following:

- The receiver aircraft moving rapidly to the aft limit, causing mechanical tanker/receiver separation.
- Boom pullout occurs at 38 degrees elevation or below.

**CAUTION**

Following an inadvertent brute force disconnect, air refueling will be terminated except during fuel emergencies or when continuation of air refueling is dictated by operational necessity.

**CONTROLLED TENSION DISCONNECT**

A controlled tension brute force disconnect is defined as an intentional, coordinated disconnect occurring above 38 degrees elevation, accomplished by gradual movement of the receiver aircraft to the aft limit, and ending with a smooth tension boom pullout. Coordination between the receiver pilot and the boom operator is required to ensure as smooth a disconnect as possible.

1. Slide out boom with gradual power reduction.
2. When at full boom extension, tension disconnect will occur with slight power reduction.

**CAUTION**

A controlled tension brute force disconnect will be accomplished only as a last resort, after all other normal and emergency methods of disconnect have failed.

**CAUTION**

- The receiver pilot must not jerk the boom out with rapid thrust change toward idle or by using speed brakes; to do so may cause serious structural damage. Gradual power reduction will suffice to effect a disconnect.

- Fly stabilized at contact altitude until certain the nozzle is clear of the receptacle and slipway.
- Air refueling for the receiver which required controlled tension disconnect will be terminated except during fuel emergencies or when continuation of air refueling is dictated by operational necessity.

## GLOSSARY

### STANDARD AND NONSTANDARD ABBREVIATIONS

A		BATT	Battery
AA	Advance Attack	BDU	Bomb Dummy Unit
A/A, A-A	Air to Air	BIT	Built-In Test or Binary Digit
AAM	Air-to-Air Missile	BL	Buttock Line
AB	Afterburner	BLU	Bomb Live Unit
ac, AC	Alternating Current	BOS	Backup Oxygen Supply
A/C GW	Aircraft Gross Weight	BSU	Bomb Stabilizing Unit
ACM	Air Combat Maneuvering	C	
ACMI	Air Combat Maneuvering Instrumentation	CADC	Central Air Data Computer
ADG	Accessory Drive Gearbox	CARA	Combined Altitude Radar Altimeter
ADI	Attitude Director Indicator	CBU	Cluster Bomb unit
AFC	Afterburner Fuel Control	CCIP	Continuously Computed Impact Point
AGL	Above Ground Level	CCM	Coil Current Monitor
AGM	Air-to-Ground Missile	CCRP	Continuously Computed Release Point
AIFF	Advanced Identification Friend or Foe	CCW	Counterclockwise
AIM	Air Intercept Missile	CDI	Course Deviation Indicator
AIS	Aircraft Instrumentation System	CENC	Convergent Exhaust Nozzle Control
AJ	Antijamming	CFT	Conformal Fuel Tank
AL	Aft/Left	CG	Center of Gravity
ALOW	Automatic Low Altitude Warning	CHAN	Channel
ALT	Altitude or Altimeter or Alternate	CIU	Central Interface Unit
AM	Amplitude Modulation	CIVV's	Compressor Inlet Variable Vanes
AMMO	Ammunition	CNI	Communications, Navigation, and IFF
AMRAAM	Advanced Medium Range Air-to- Air Missile	C & I	Communications and IFF
ANT	Antenna	CONFIG	Configuration
AOA	Angle of Attack	CONT	Control
AOS	Angle of Sideslip	CO2	Carbon Dioxide
AP	Autopilot	CRS	Course
AR, A/R	Air Refueling	CRV	Canadian Rocket Vehicle
ARCP	Air Refueling Control Point	CSD	Constant-Speed Drive
ARCT	Air Refueling Control Time	CSFDR	Crash Survivable Flight Data Recorder
ARI	Aileron-Rudder Interconnect	CTVS	Cockpit Television Sensor
ARIP	Air Refueling Initial Point	CW	Clockwise
ARMT	Armament	D	
ASE	Aeroservoelastic	dBA	Adjusted (Human Ear Response) Decibels
ASHM	Aft Seat HUD Monitor	DBU	Digital Backup
ASIU	Aft Station Interface Unit	dc, DC	Direct Current
ASPIS	Airborne Self Protection Integrated System	DEEC	Digital Electronic Engine Control
ATT, ATTD	Attitude	DED	Data Entry Display
AUX	Auxiliary	DEEU	Data Entry Electronic Unit
AVTR	Airborne Videotape Recorder	DEGR	Degraded
B		DI	Drag Index
BAK-	Arresting Cable Prefix (e.g., BAK-9)		
BARO	Barometric		

T.O. GR1F-16CJ-1

DIA Diameter  
 DIFF Differential  
 DIS Disable  
 DISC Disconnect  
 DME Distance Measuring Equipment  
 DN Down  
 DOI Display of Interest  
 DSG RS Designate/Return to Search  
 DTC Data Transfer Cartridge  
 DTOS Dive Toss  
 DTU Data Transfer Unit  
 DTS Digital Terrain System  
 DVAL D-Value  
 DWAT Descent Warning After Takeoff

E

EAS Equivalent Airspeed  
 ECM Electronic Countermeasures  
 ECP Engineering Change Proposal  
 ECS Environmental Control System  
 EDU Engine Diagnostic Unit  
 EED Electroexplosive Device  
 EGI Embedded GPS/INS  
 EGT Exhaust Gas Temperature  
 ELECT Electronic (primary altimeter operating mode)  
 ELEV Elevation  
 EMCON Emission Control Option  
 EMER Emergency  
 EMS Engine Monitoring System  
 EMSC Engine Monitoring System Computer  
 ENDUR Endurance  
 ENG Engine  
 EOS Emergency Oxygen Supply  
 EPU Emergency Power Unit  
 EQUIP Equipment  
 EST Estimate  
 ETA Estimated Time of Arrival  
 ETE Estimated Time Enroute  
 EXT External

F

F-ACK Fault Acknowledge  
 FAULT ACK Fault Acknowledge  
 FC Flight Control  
 FCC Fire Control Computer  
 FCR Fire Control Radar  
 FFAR Folding Fin Aircraft Rocket  
 FFP Fuel Flow Proportioner  
 FLCC Flight Control Computer  
 FLCP Flight Control Panel  
 FLCS Flight Control System  
 FLIR Forward Looking Infrared Radar  
 FM Frequency Modulation  
 FO Foldout  
 FOD Foreign Object Damage

FORM Formation  
 FOV Field of View  
 fpm, FPM Feet per Minute/Flightpath Marker  
 FR Forward/Right  
 FT, ft Feet  
 FTIT Fan Turbine Inlet Temperature  
 FWD Forward

G

g, G Force of Gravity  
 GAAF Ground Avoidance Advisory Function  
 gal, GAL Gallon  
 GBU Guided Bomb Unit  
 GCA Ground Controlled Approach  
 GCAS Ground Collision Avoidance System  
 GCU Generator Control Unit  
 GD Guard  
 GEN Generator  
 GM Ground Map  
 GND Ground  
 GP Group  
 GPS Global Positioning System  
 GRDCUS Gulf Range Drone Control Upgrade System  
 GS Glide Slope  
 GW Gross Weight

H

HDG Heading  
 HDG SEL Heading Select  
 HF High Frequency  
 HMCS Helmet Mounted Cueing System  
 HQ HAVE QUICK  
 HSI Horizontal Situation Indicator  
 HUD Head-Up Display  
 HYB VSV Hybrid Variable Stator Vanes  
 HYB Hybrid  
 HYDRAZN Hydrazine  
 Hz Hertz

I

IAS Indicated Airspeed  
 IAW In Accordance With  
 ICP Integrated Control Panel  
 ID Identification  
 IFF Identification, Friend or Foe  
 IGV Inlet Guide Vanes  
 IKP Integrated Keyboard Panel  
 ILS Instrument Landing System  
 IMC Instrument Meteorological Conditions  
 IMSP Instrument Mode Select Panel  
 In., IN. Inches  
 INC Increase  
 IND Indicator  
 INOP Inoperative

INS Inertial Navigation Set (or System)  
 INT Intensity or Internal or Interval  
 INST, INSTR Instrument  
 INU Inertial Navigation Unit  
 I/P Identification of Position  
 ISA Integrated Servoactuator

## J

JETT, JTSN Jettison  
 JFS Jet Fuel Starter  
 JHMCS Joint Helmet Mounted Cueing System  
 JOAP Joint Oil Analysis Program

## K

K Thousand (e.g., 40K = 40,000)  
 KCAS Knots Calibrated Airspeed  
 KEAS Knots Equivalent Airspeed  
 KIAS Knots Indicated Airspeed  
 KT(S) Knot(s)  
 KTAS Knots True Airspeed  
 KVA Kilovolt Ampere

## L

L Left  
 LADD Low Angle Drogue Delivery  
 LAU Launcher Armament Unit  
 lb, LB Pound(s)  
 LB/HR Pounds per Hour  
 LB/MIN Pounds per Minute  
 LCO Limit Cycle Oscillation  
 LCOS Lead Computing Optical Sight  
 LD Load or Low Drag  
 LE Leading Edge  
 LEF's Leading Edge Flaps  
 LG Landing Gear  
 LMLG Left Main Landing Gear  
 LOD Light-Off Detector  
 LOX Liquid Oxygen  
 LPU Life Preserver Unit  
 LRU Line Replaceable Unit  
 LTS Lights  
 LWD Left Wing Down

## M

M Mach  
 MAAS Mobile Aircraft Arrestment System  
 MAC Mean Aerodynamic Chord  
 MAL Malfunction  
 MAL & IND Malfunction and Indicator  
 MAN. Manual  
 MAU Miscellaneous Armament Unit  
 MAX Maximum  
 MAX AB Maximum Afterburner  
 mb Millibar  
 MDTC Mega Data Transfer Cartridge

MEC Main Engine Control  
 MECH Mechanical  
 MEM Memory  
 MFC Main Fuel Control  
 MFD Multifunction Display  
 MFDS Multifunction Display Set  
 MFL Maintenance Fault List  
 MFP Main Fuel Pump  
 MHz Megahertz  
 MIC Microphone  
 MIL Military  
 MIN Minute or Minimum  
 MK Mark (equivalent of model)  
 MLG Main Landing Gear  
 mm Millimeter  
 MMC Modular Mission Computer  
 MPO Manual Pitch Override  
 MRK BCN Marker Beacon  
 ms Milliseconds  
 MSL Missile or Mean Sea Level  
 MUX BUS Multiplex Bus

## N

NA Not Applicable  
 NAM Nautical Air Miles  
 NFOV Narrow Field of View  
 NLG Nose Landing Gear  
 nm, NM Nautical Miles  
 No., NO. Number  
 NORM Normal  
 NOZ POS Nozzle Position  
 NVG Night Vision Goggles  
 NVIS Night Vision Imaging System  
 NWS Nosewheel Steering

## O

OAT Outside Air Temperature  
 OBOGS Onboard Oxygen Generating System  
 OCSC Overcurrent Sensing Contactor  
 OHEAT Overheat  
 OP Operational or Optimum  
 OPT Optional  
 OSB Option Select Button  
 OVRD Override  
 OXY Oxygen  
 O<sub>2</sub> Oxygen

## P

PBG Pressure Breathing for g  
 PDG Programmable Display Generator  
 PFL Pilot Fault List  
 PFLD Pilot Fault List Display  
 PMG Permanent Magnet Generator  
 PNEU Pneumatic (secondary altimeter operating mode)  
 PNL Panel

T.O. GR1F-16CJ-1

pph, PPH	Pounds per Hour	SUU	Suspension Utility Unit
PRE	Preset	SW	Switch
PRESS.	Pressure, Pressurization	SYM	Symmetrical
PRI	Primary	SYS	System
PSA	Pneumatic Sensor Assembly		
psi, PSI	Pounds per Square Inch		T
PTO	Power Takeoff (shaft from engine gearbox to ADG)	TACAN	Tactical Air Navigation
PWR	Power	TAS	True Airspeed
		TBRF	Tunable Band Reject Filter
	Q	TCN	TACAN
		TCTO	Time Compliance Technical Order
QTY	Quantity	TEF's	Trailing Edge Flaps
		TEMP	Temperature
	R	TER	Triple Ejector Rack
RAD	Radio (e.g., RAD 1 or RAD 2)	TEU	Trailing Edge Up
RCR	Runway Condition Reading	TGM	Training Guided Missile
RCVV	Rear Compressor Variable Vanes	TGT	Target
RDR	Radar	THEO	Theory
RDY	Ready	T.O.	Takeoff
REL	Release	TOD	Time of Day
RER	Radial Error Rate	TR, T/R	Transmit/Receive
RIU	Remote Interface Unit	TRV	Travel
RMLG	Right Main Landing Gear	TT	Total Temperature
RNDS	Rounds (Gun)	TV	Television
RNG	Ranging	TVS	Television Sensor
rpm, RPM	Revolutions per Minute	TWS	Threat Warning System
RS	Return to Search		U
RSE	Reduced Speed Excursion	UFC	Upfront Control
RSVR	Reservoir	UHF	Ultra High Frequency
RSVRS	Reservoirs	UNK	Unknown
RT	Retarded		V
RV	Receive Variable		
RWD	Right Wing Down	VAC	Volts ac
RWR	Radar Warning Receiver	VDC	Volts dc
RZIP	Rendezvous Initial Point	VHF	Very High Frequency
		VIP	Visual Initial Point
	S	VMC	Visual Meteorological Conditions
SAI	Standby Attitude Indicator	VMS	Voice Message System
SD	Start Descent Point	VOL	Volume
SEC	Secondary Engine Control	VSV	Variable Stator Vanes
SEL	Select	VVI	Vertical Velocity Indicator
SEAWARS	Seawater Activated Release System		W
SFO	Simulated Flameout Landing		
SIF	Selective Identification Feature	W/	With
SL	Sea Level	WB	Wideband
SMS	Stores Management System	W/O	Without
SNSR	Sensor	WOD	Word of Day
SPD BRK	Speedbrake	WOW	Weight on Wheels
SPL	Sound Pressure Level	WPN	Weapon
SQ	Square	WPN REL	Weapon(s) Release
SQL	Squelch	wt, WT	Weight
STA	Station		Y
STAPAC	Stabilization Package		
STBY	Standby		
STD	Standard		
ST STA	Stores Station	Y	Yaw

**TERMS/SYMBOLS**

$a_n$	Normal Acceleration (G's)	$\sigma$	Density Ratio
$a_0$	Speed of Sound at Sea Level, Standard Day	$\beta$	Angle of Sideslip
&	And	$F_e$	Elevator Stick Force (lb)
$\phi$	Roll Rate (Deg/Sec)	$F_a$	Aileron Stick Force (lb)
$\dot{\psi}$	Yaw Rate (Deg/Sec)	$F_p$	Rudder Pedal Force (lb)
$A_y$	Lateral Acceleration (Ft/Sec <sup>2</sup> )	N2	Engine Compressor RPM or Nitrogen
$\dot{\theta}$	Pitch Rate (Deg/Sec)	P	Pressure
$\alpha$	Angle of Attack (Deg)	T	Absolute Air Temperature
$P_0$	Pressure at Sea Level, Standard Day	W	Specific Weight (Lb/Ft <sup>3</sup> )
$P_t$	Total Pressure	$V_c$	Calibrated Airspeed
$P_s$	Static Pressure or Specific Energy Rate	$V_t$	True Airspeed
$q_c$	Impact Pressure ( $P_t - P_s$ )	$\Delta H$	Delta Change Altitude (Ft)
$\rho_0$	Density at Sea Level, Standard Day	$\dot{H}$	Altitude Rate (FPS)