

EC STUDIO

Designing and producing displays for accessories

Wallet

Strap

Backpack

Shoe

Belt, Hat

Belt bag

Eyewear

Bag

Key, Box

Sign

Jewelry

displays

Index

- 7 About us
- 11 Products
 - 12 Handbag display
 - 22 Shoulder strap display
 - 26 Backpack display
 - 30 Shoe display
 - 40 Belt display
 - 46 Belt bag display
 - 50 Eyewear display
 - 54 Hat display
 - 58 Wallet display
 - 62 Key display
 - 66 Box
 - 70 Sign holder
 - 76 Jewelry display
- 81 Creative collection
- 91 Finishes



EC Studio è un'azienda italiana che opera nel settore del visual merchandising, specializzata nella progettazione e produzione di display per accessori. La sua storia ha inizio nel 1994, quando Enrico Caruso, in seguito alla sua pluriennale esperienza nel settore, decide di dar vita ad una linea personale di espositori. Pianificazione attenta, ricercatezza dei materiali, conoscenze specifiche e un alto grado di professionalità ci consentono di creare una vasta tipologia di articoli che evidenziano le caratteristiche del prodotto esposto con la cura e la maestria tipica del made in Italy.

Design

Le linee guida che contraddistinguono il nostro design sono essenzialità, purezza e minimalismo. Eliminare il superfluo allo scopo di valorizzare ciò che resta, lasciando che sia il prodotto ad emergere – questo è la filosofia che orienta ogni nuovo progetto.

Il lavoro progettuale all'interno dell'azienda segue un iter che parte dall'ideazione e dalla progettazione del prodotto, passa attraverso la trasformazione delle materie prime (metallo, legno, plexiglass ecc.), prosegue con la loro finitura e si conclude con l'imballaggio e la spedizione. La progettazione si suddivide tra articoli standard, creati all'interno del nostro ufficio stile, e articoli su misura, frutto di un rapporto diretto con le aziende e con gli studi di architettura.

Distribuzione

Nel corso degli anni abbiamo vissuto un costante processo di crescita e una intraprendente trasformazione, anche grazie all'acquisizione di importanti rivenditori in tutto il mondo. Nell'ottobre 2015 abbiamo consolidato la presenza ultravennale nel mercato americano con l'apertura di una sede a New York.

EC Studio is an Italian visual merchandising supplier specialized in the design and production of accessory displays. Our story began in 1994 when industry expert Enrico Caruso decided to give life to a line of customizable displays. Attentive planning, expert knowledge, refined materials, and a high degree of professionalism have allowed us to create a vast array of pieces that not only highlight the characteristics of the respective product on display but also exhibit the care and craftsmanship of all products that carry the Made in Italy signature.

Design

Our products are inspired by the principles of minimalism and purity. Our streamlined designs ensure that the respective products stand out. This is the philosophy that drives each of our new projects.

Production

Design is at the heart of the company and influences a multi-step process, beginning with project conception and planning. Raw materials (metal, wood, plexiglass, etc.) are then fabricated into a finished product before packaging and shipment. Designs can be done either with prefabricated pieces created within our styling department or with custom-made pieces, the result of a direct relationship with related businesses and architecture firms.

Distribution

Over the years, we've experienced both constant growth and a dynamic transformation. This is thanks, in part, to the acquisition of important retailers around the world. In October 2015, after over twenty years in the American market, we consolidated our presence and opened our headquarters in New York.

EC Studio est une entreprise italienne œuvrant dans le secteur du visual merchandising et spécialisée dans la conception et la production de présentoirs pour accessoires. Tout commence en 1994 lorsqu'Enrico Caruso décide de créer sa propre ligne de présentoirs. Un design soigné, des matériaux raffinés, une expertise et un grand professionnalisme permettent à l'entreprise de créer une vaste gamme d'articles. Ils mettent non seulement en valeur le produit exposé mais reflètent également les valeurs chères au Made in Italy: sens du détail et savoir-faire d'exception.

Design

L'essentialité, la pureté, le minimalisme sont les lignes directrices qui distinguent nos collections. Éliminer le superflu de manière à magnifier le produit, telle est la philosophie qui guide chacun de nos projets.

Production

Le design est au cœur de tout ce que nous entreprenons, il influence ainsi tout le parcours de production de nos articles, de la conception et l'étude du projet, en passant par la transformation des matières premières (métal, bois, plexiglas...), se poursuivant par le travail de finition et se concluant par l'emballage et l'expédition. Les projets créatifs se divisent en deux typologies, les articles standards créés au sein de notre bureau de style et les articles sur mesure, fruit d'un travail collaboratif avec nos clients.

Distribution

Au fil des années, nous avons vécu une croissance constante et une transformation dynamique, dues en partie à la contribution d'importants distributeurs dans le monde. En octobre 2015, nous avons consolidé, grâce à l'ouverture d'un siège à New York, notre présence sur le marché américain, active depuis plus de 20 ans.

EC Studio ist ein italienischer Visual Merchandising-Anbieter, der auf Design und Produktion von Zubehör Displays spezialisiert ist. Unsere Geschichte begann 1994, als der Branchenexperte Enrico Caruso beschloss, eine Serie von anpassbaren Displays ins Leben zu rufen. Sorgfältige Planung, Fachkenntnis, raffinierte Materialien und ein hohes Maß an Professionalität haben es uns ermöglicht, eine große Auswahl an Displays zu erschaffen, die nicht nur die Eigenschaften des jeweiligen ausgestellten Produkts hervorheben, sondern auch die Sorgfalt und die Handwerkskunst aller Produkte zeigen, die die Marke Made in Italy tragen.

Design

Unsere Produkte sind von den Prinzipien des Minimalismus und der Feinheit inspiriert. Unsere optimierten Designs sorgen dafür, dass die jeweiligen Produkte hervortreten. Dies ist die Philosophie, die jedes unserer neuen Projekte antreibt.

Produktion

Design ist das Herzstück des Unternehmens und beeinflusst einen mehrstufigen Prozess, beginnend mit der Projektkonzeption und -planung. Rohstoffe (Metall, Holz, Plexiglas usw.) werden zu einem fertigen Produkt verarbeitet bevor sie verpackt und versandt werden. Entwürfe können entweder mit vorgefertigten Teilen, die in unserer Styling-Abteilung hergestellt wurden, oder mit maßgeschneiderten Teilen ausgeführt werden, resultierend aus einer direkten Beziehung zu entsprechenden Unternehmen und Architekturbüros.

Vertrieb

Im Laufe der Jahre haben wir sowohl ein konstantes Wachstum als auch einen dynamischen Wandel erlebt. Dies ist zum Teil der Akquisition wichtiger Vertriebspartner auf der ganzen Welt zu verdanken. Nach über zwanzig Jahren auf dem amerikanischen Markt haben wir im Oktober 2015 unsere Präsenz verstärkt und unser Hauptquartier in New York eröffnet.

Products



V13

V21

UB

U²B

Handbag display

Portaborse

Porte sac

Taschenhalter

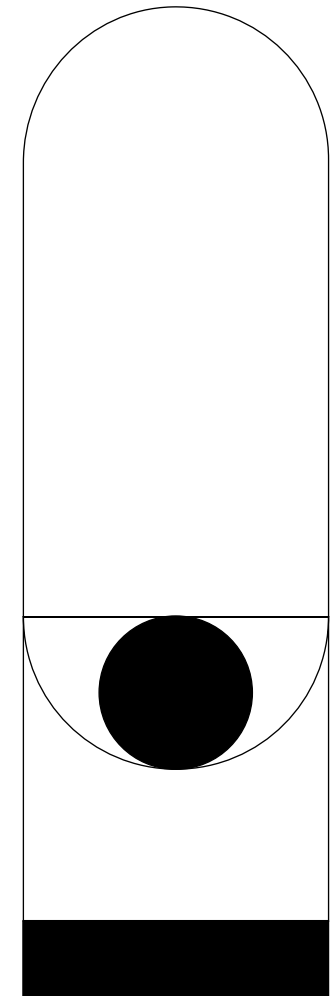
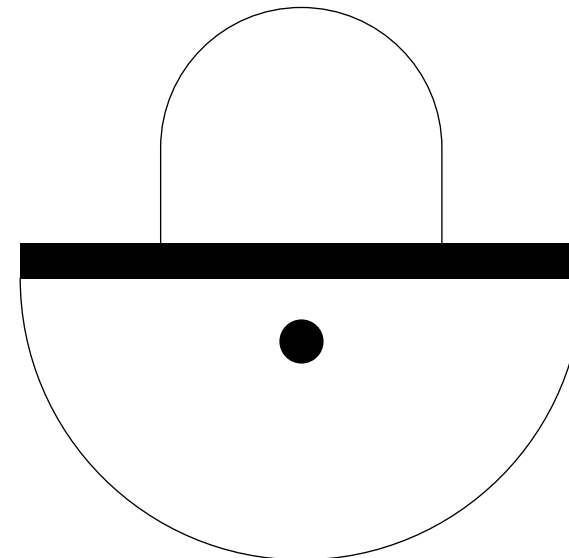
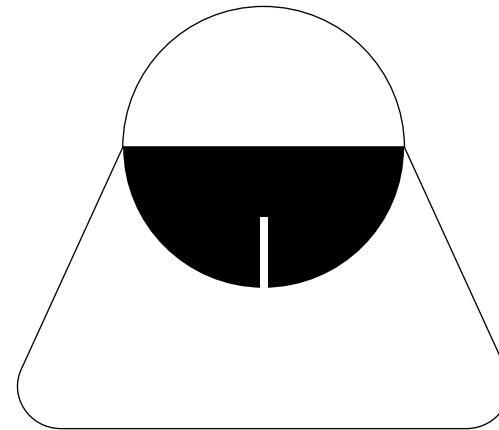

Handbag display **V13A, V13B**

Description Porta borsa regolabile in altezza h 30/60 cm (V13A) e h 40/80 cm (V13B) Adjustable handbag display h 30/60 cm (V13A) and h 40/80 cm (V13B) Porte sac ajustable h 30/60 cm (V13A) et h 40/80 cm (V13B) Taschenhalter H. 30/60 cm (V13A) und H. 40/80 cm (V13B)

Finishes 1.  Dark Metal (M) 2.  Satinity Steel (S) 3.  Glossy Steel (L) 4.  Bronze Brass (B) 5.  Satinity Brass (DS) 6.  Gold (D)

Dimensions V13A LxPxH 14x9x30/60 cm WxDxH 5.5x3.5x11.8/23.6 in V13B LxPxH 18x12x40/80 cm WxDxH 7.1x4.7x15.7/31.5 in

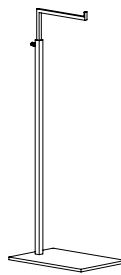
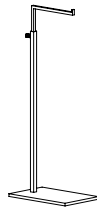

Handbag display **V21A, V21B**

Description Portaborsa lunetta piccola regolabile in h 30/60 cm (V21A) e h 40/80 cm (V21B) Small adjustable half-moon handbag display h 30/60 cm (V21A) and h 40/80/80 cm (V21B) Porte sac demi-lune ajustable h 30 /60 cm (V21A) et h 40/80 cm (V21B) Kleiner Halbmond Taschenhalter H. 30/60 cm (V21A), H. 40/80 cm (V21B)

Finishes 1. Dark Metal (M) 2. Satinity Steel (S) 3. Glossy Steel (L) 4. Bronze Brass (B) 5. Satinity Brass (DS) 6. Gold (D)

Dimensions V21A 12x20x30/60 cm 4.7x7.9x11.8/23.6 in V21B 14x24x40/80 cm 5.5x9.4x15.7/31.5 in

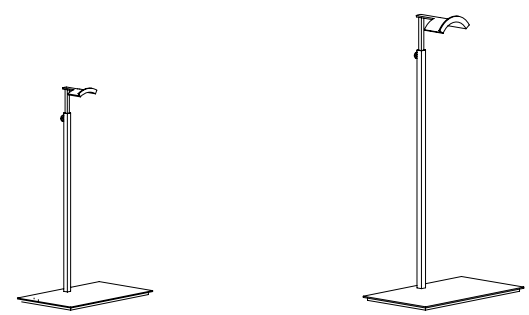



UB30, UB40

Description

UNICO portaborsa regolabile h 30/50 cm (UB30) e h 40/70 cm (UB40)	UNICO adjustable handbag display h 30/50 cm (UB30) and h 40/70 cm (UB40)	UNICO portesac ajustable h 30/50 cm (UB30) et h 40/70 cm (UB40)	UNICO Taschenhalter H. 30/50 cm (UB30) und H. 40/70 cm (UB40)
---	--	---	---

Finishes

4.  Bronze Brass (B)	5.  Satinity Brass (DS)	6.  Gold (D)
---	--	---



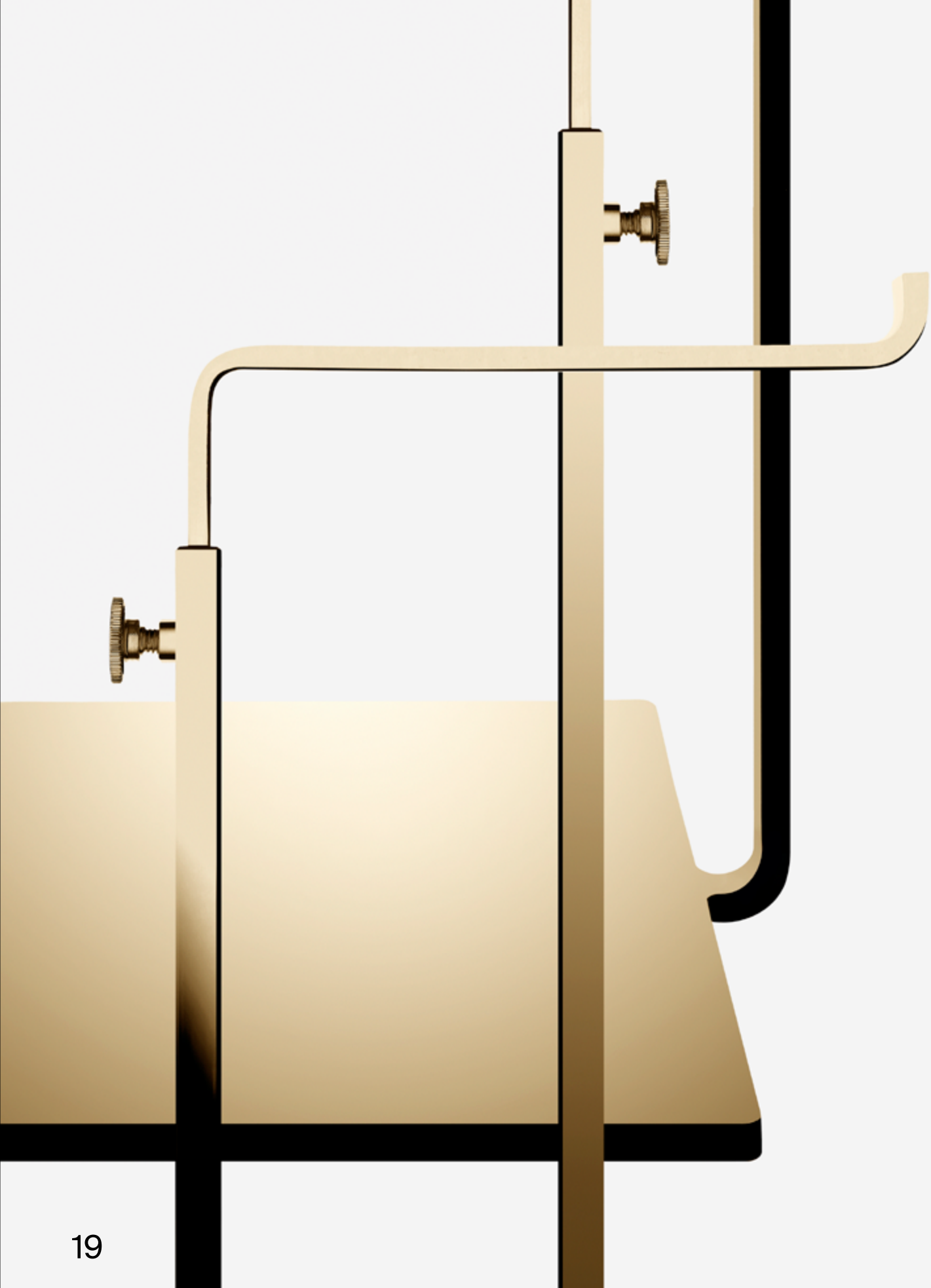
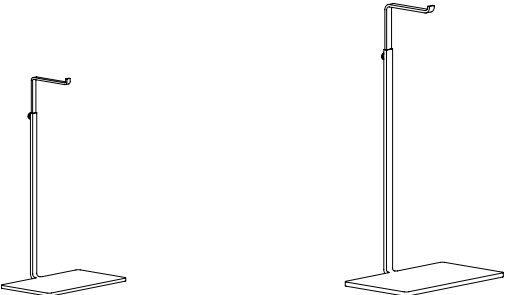

Dimensions

UB30 LxPxH 12.5x19x30/50 cm WxDxH 4.9x7.5x11.8/19.7 in	UB40 LxPxH 15.5x24x40/70 cm WxDxH 6.1x9.4x15.7/27.6 in
---	---



Handbag display **U²B40, U²B50, U²B60**

Description	UNICO ² porta borsa h 40, h 50 e h 60 cm	UNICO ² handbag display h 40, h 50 and h 60 cm	UNICO ² porte sac h 40, h 50 et h 60 cm	UNICO ² Taschenhalter H. 40, H. 50 und H. 60 cm
-------------	--	--	---	---

Finishes	3.  Glossy Steel (L)	7.  Delabré Steel (DLS)	8.  Delabré Dark (DLM)	9.  Delabré Brass (DLD)
----------	---	--	---	--

Dimensions	U2B40 14x14x40 cm 5.5x5.5x15.7 in	U2B50 14x14x50 cm 5.5x5.5x19.7 in	U2B60 14x14x60 cm 5.5x5.5x23.6 in
------------	--	--	--

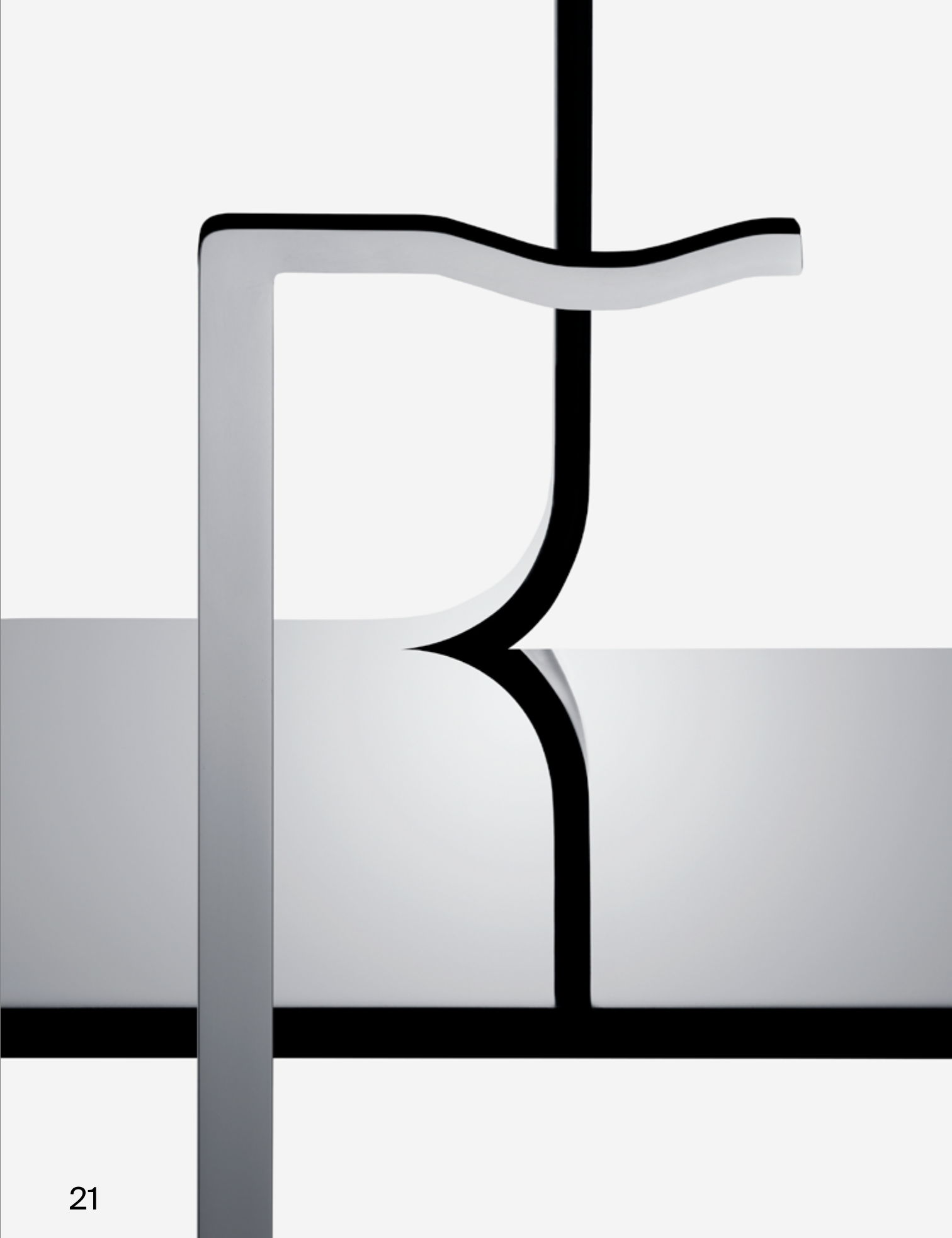

SSTR

Shoulder strap display

Tendi tracolla

Présentoir pour bandoulière

Schultergurthalter

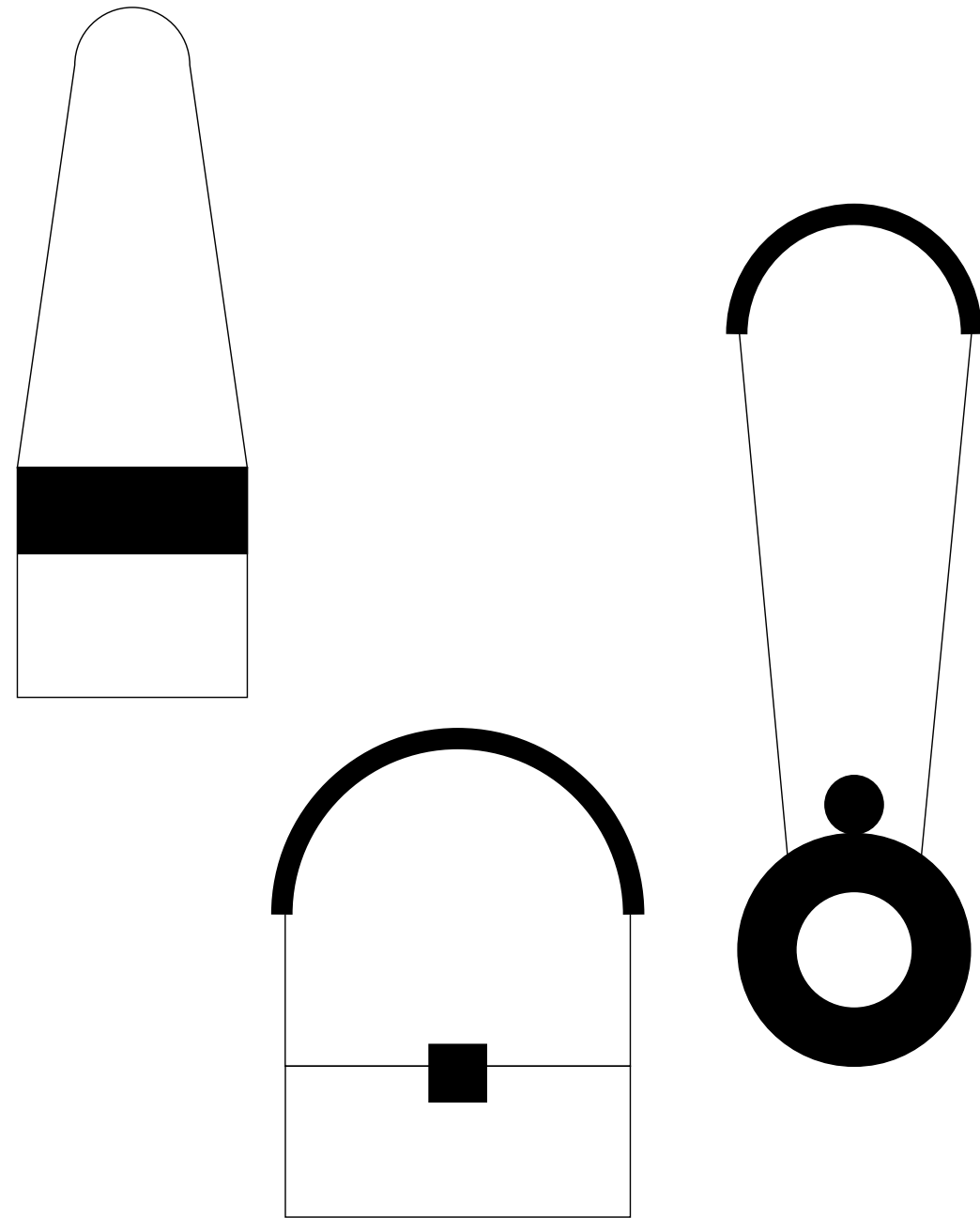

SSTR1, SSTR2, SSTR3

Description
Espositore tendi tracolla regolabile h 40/65 cm
Adjustable shoulder strap display h 40/65 cm
Présentoir ajustable pour bandoulière, de 40 à 65 cm de haut
Schultergurthalter, H. 40 bis 65 cm

Finishes
1.  Dark Metal (M) 2.  Satinity Steel (S) 3.  Glossy Steel (L) 4.  Bronze Brass (B) 5.  Satinity Brass (DS) 6.  Gold (D)

Dimensions
LxPxH
WxDxH
SSTR1
8x12x40/65 cm
3.1x4.7x15.7/25.6 in
SSTR2
14x22x40/65 cm
5.5x8.6x15.7/25.6 in
SSTR3
14x34x40/65 cm
5.5x13.4x15.7/25.6 in

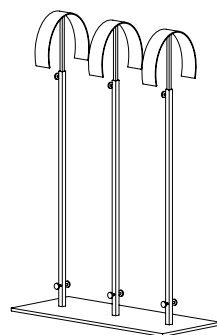
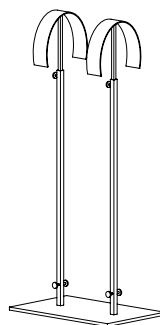
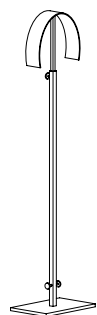

PZ

Backpack display

Porta zaino

Présentoir pour
sac à dos

Rucksackhalter

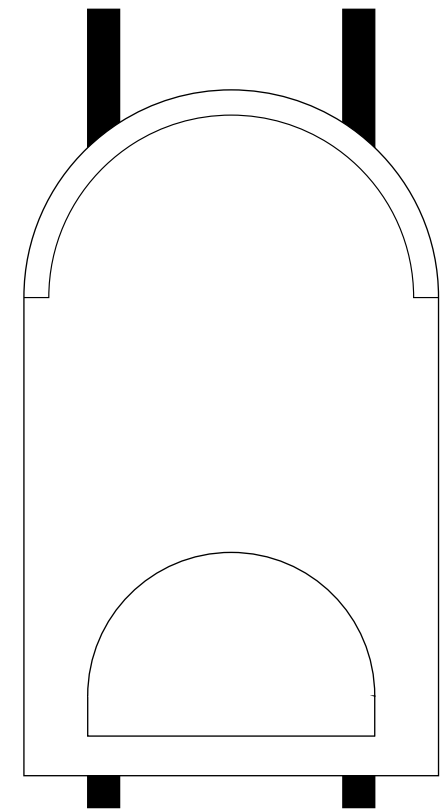
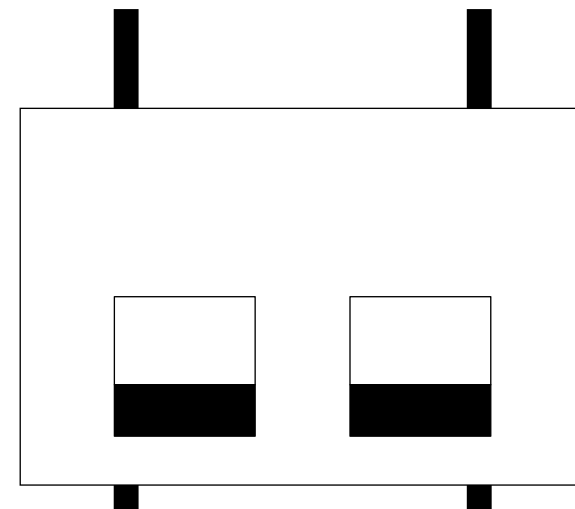
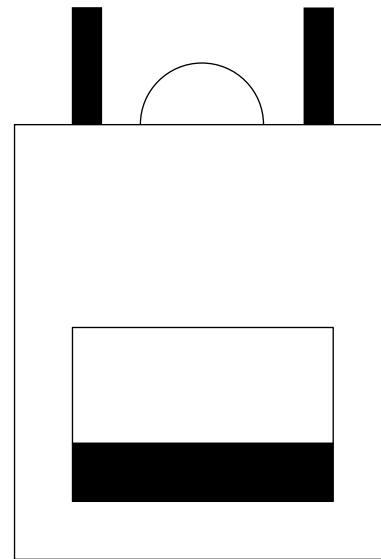

Backpack display **PZ**

Description Porta zaino regolabile in altezza Backpack display adjustable in height Présentoir ajustable pour sac à dos Höhenverstellbar Rucksackhalter

Finishes 1. Dark Metal (M) 2. Satinity Steel (S) 3. Glossy Steel (L) 4. Bronze Brass (B) 5. Satinity Brass (DS) 6. Gold (D)

Dimension PZ
LxPxH 22x30x50/70 cm
WxDxH 8.6x11.8x19.7/27.6 in

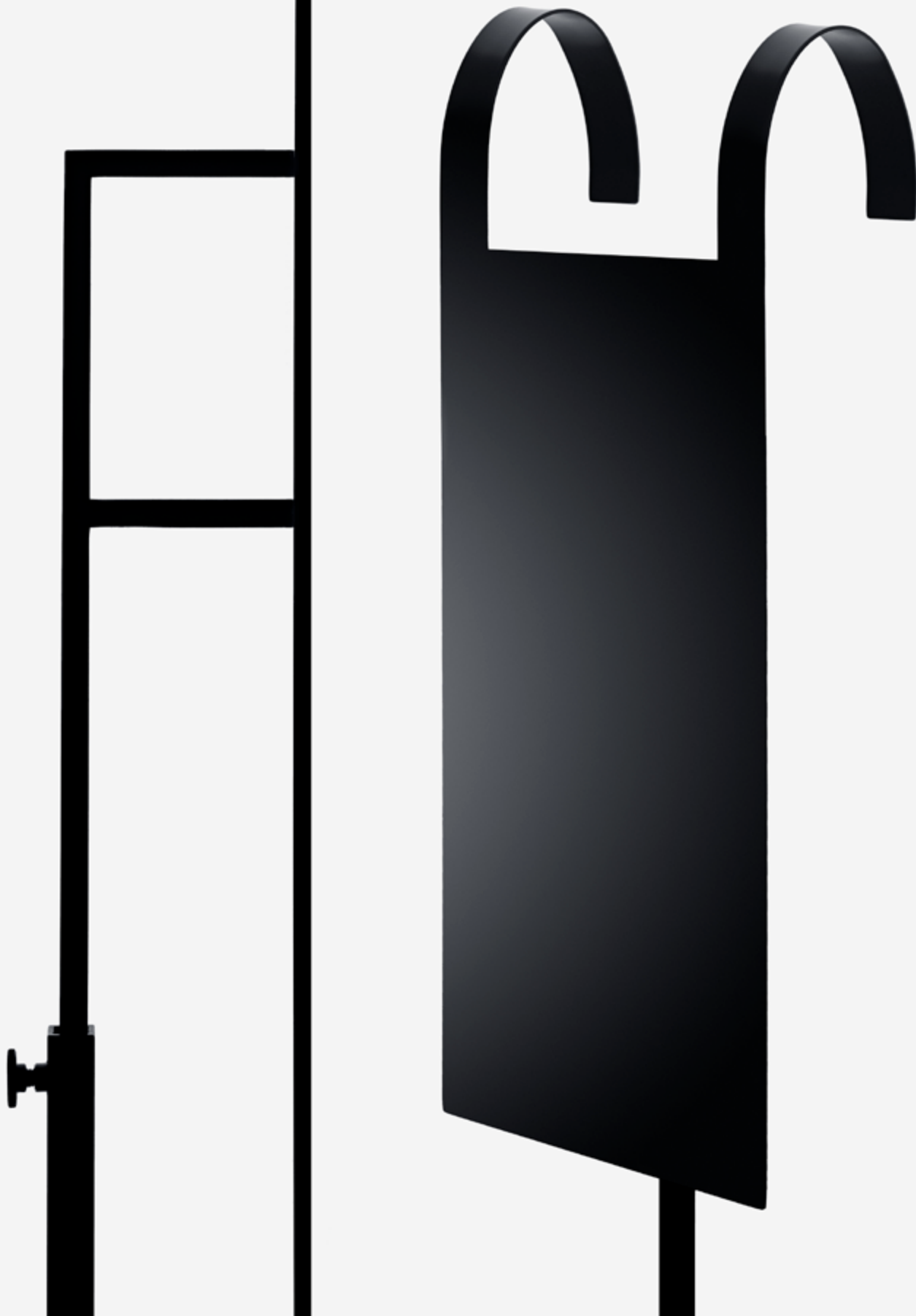
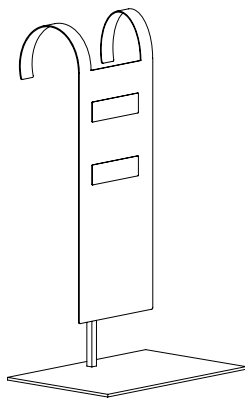

U²

V14

V22

U

Shoe display

Portascarpa Porte chaussure Schuhhalter

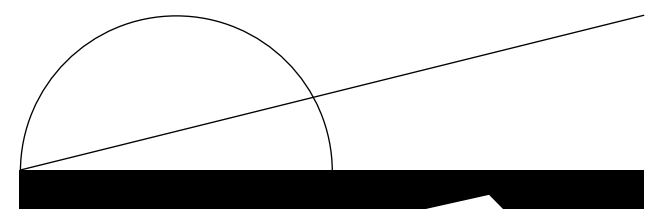
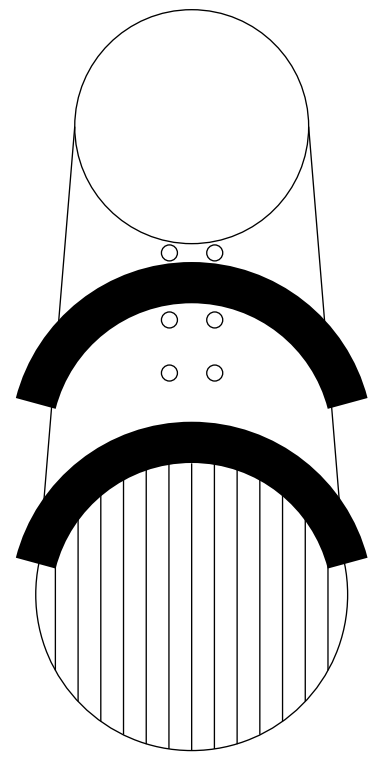
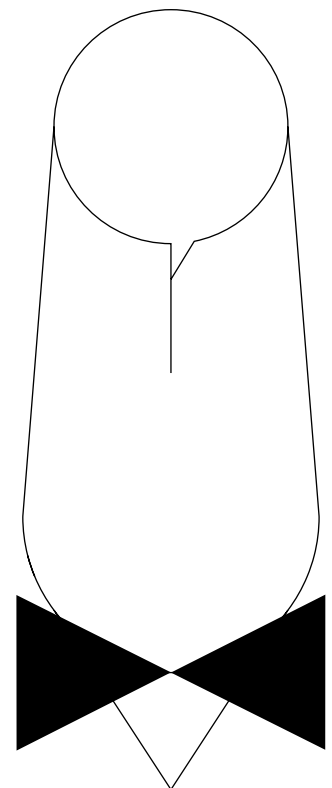





Description UNICO² porta scarpa inclinato e piatto, destro e sinistro h 15, h 25

Inclined and flat, right and left, UNICO² shoe display h 15, h 25

Présentoir incliné, plat UNICO² pour chaussure droite et gauche, h 15, h 25 cm

UNICO² geneigter und gerader, rechts und links Schuhhalter H. 15, H. 25

Finishes 3.  Glossy Steel (L) 7.  Delabré Steel (DLS) 8.  Delabré Dark (DLM) 9.  Delabré Brass (DLD)

Inclined display

Dimensions U2DX15 / U2SX15
LxPxH 17x10x15 cm
WxDxH 6.7x3.9x5.9 in

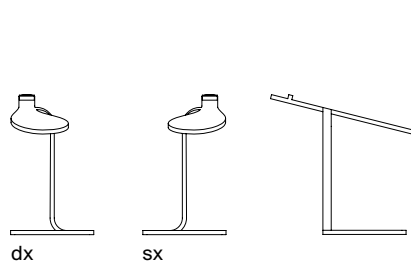

U2DX25 / U2SX25
17x10x25 cm
6.7x3.9x9.8 in

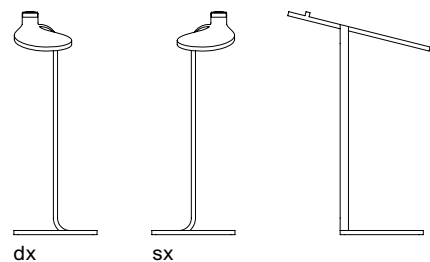

Flat display

Dimensions U2PDX15 / U2PSX15
LxPxH 17x10x15 cm
WxDxH 6.7x3.9x5.9 in

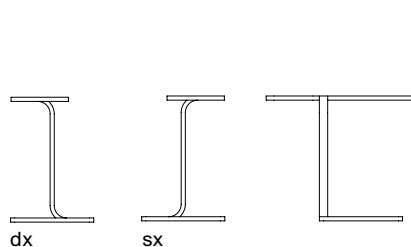

U2PDX25 / U2PSX25
17x10x25 cm
6.7x3.9x9.8 in

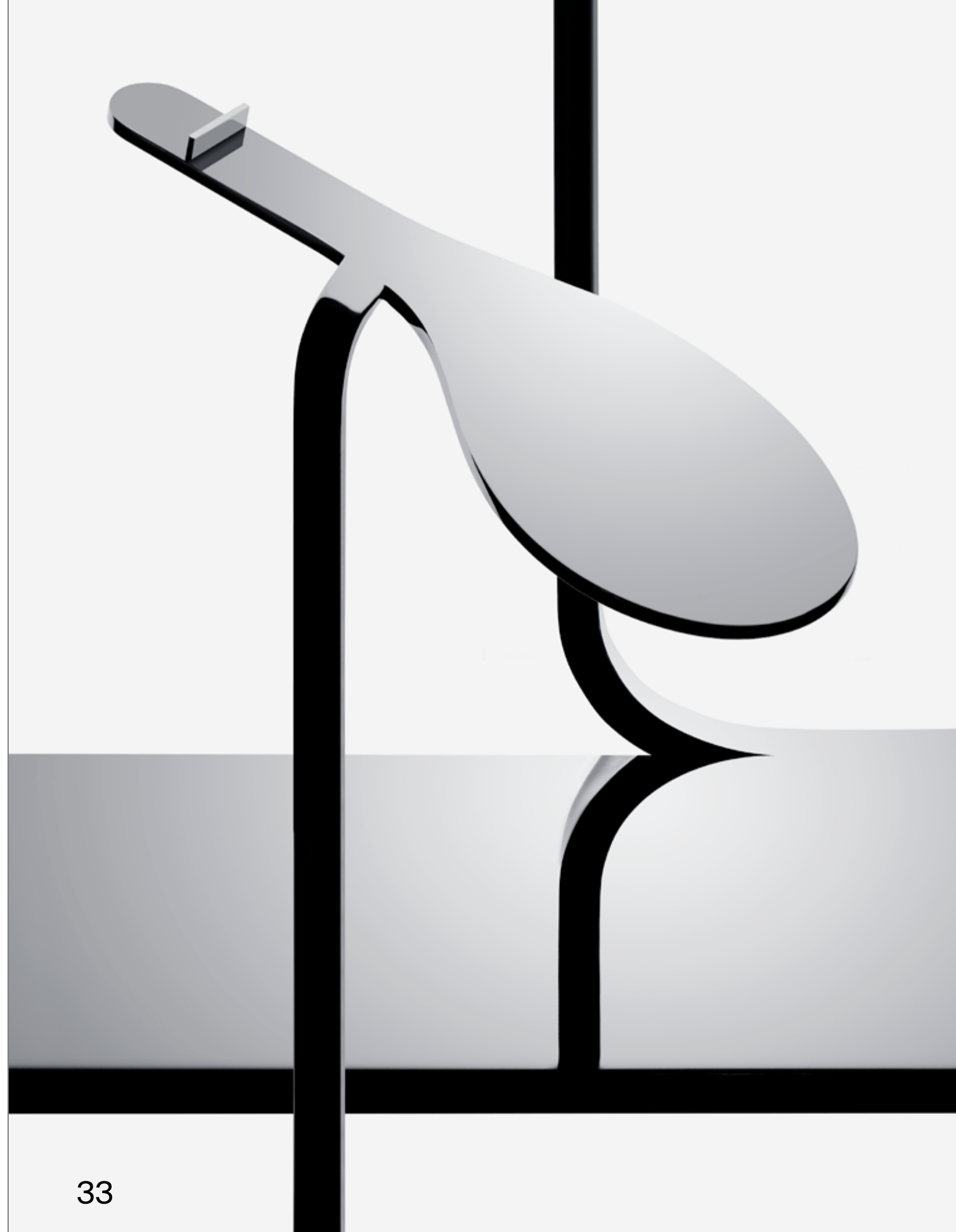
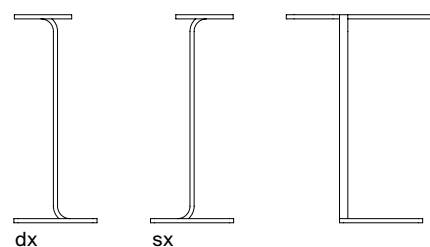

V14, DV14

Description Porta scarpe singolo, doppio e regolabile in altezza (V14, DV14) Double, single and adjustable high shoes display (V14, DV14) Porte chaussure simple et double et ajustable (V14, DV14) Einzel- und Doppel-schuhhalter und Halbmond (V14, DV14)

Finishes 1.  Dark Metal (M) 2.  Satinity Steel (S) 3.  Glossy Steel (L) 4.  Bronze Brass (B) 5.  Satinity Brass (DS) 6.  Gold (D)

Single shoe display

Dimensions	V14A	V14B	V14C	V14
LxPxH	17x8x15 cm	17x8x25 cm	17x8x35 cm	17x8x15/35 cm
WxDxH	6.7x3.1x5.9 in	6.7x3.1x9.8 in	6.7x3.1x13.8 in	6.7x3.1x5.9/13.8 in → adjustable

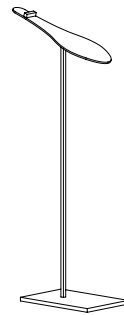
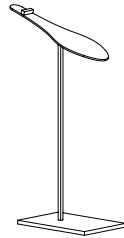

Double shoes display

Dimensions	DV14A	DV14B	DV14C	DV14
LxPxH	17x18x15 cm	17x18x25 cm	17x18x35 cm	17x18x15/35 cm
WxDxH	6.7x7.1x5.9 in	6.7x7.1x9.8 in	6.7x7.1x13.8 in	6.7x7.1x5.9/13.8 in → adjustable

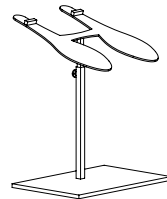
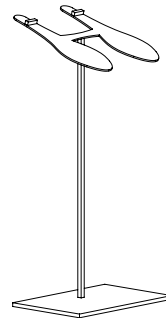
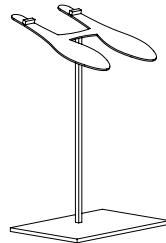
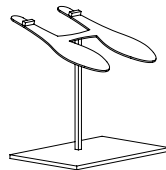

V22, DV22

Description Porta scarpe singolo e doppio h 15, 25, 35. Regolabile in altezza (V22, DV22) Double and single shoes display h 15, 25, 35. Adjustable high (V22, DV22) Porte chaussure simple et double h 15, 25, 35. Ajustable (V22, DV22) Einzel- und Doppelschuhhalter H. 15, 25, 35. Halbmond (V22, DV22)

Finishes 1.  Dark Metal (M) 2.  Satinity Steel (S) 3.  Glossy Steel (L) 4.  Bronze Brass (B) 5.  Satinity Brass (DS) 6.  Gold (D)

Single shoe display

Dimensions V22A 15.5x12x15 cm LxPxH 6.1x4.7x5.9 in V22B 15.5x12x25 cm LxPxH 6.1x4.7x9.8 in V22C 15.5x12x35 cm LxPxH 6.1x4.7x13.8 in V22 15.5x12x15/35 cm LxPxH 6.7x4.7x5.9/13.8 in → adjustable

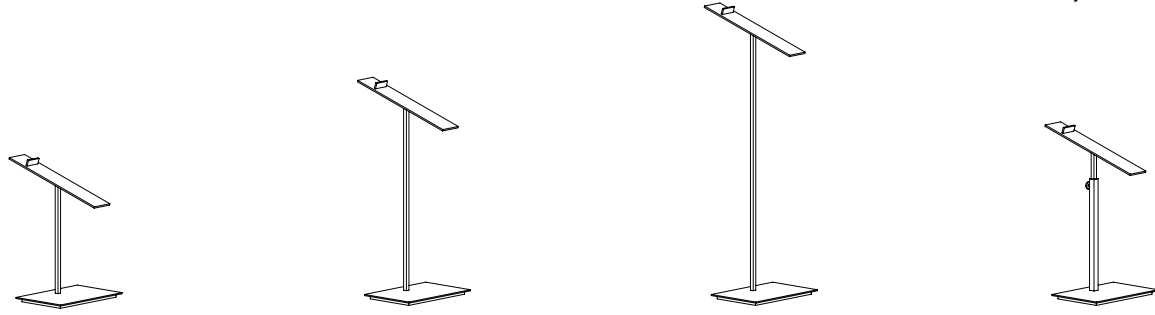

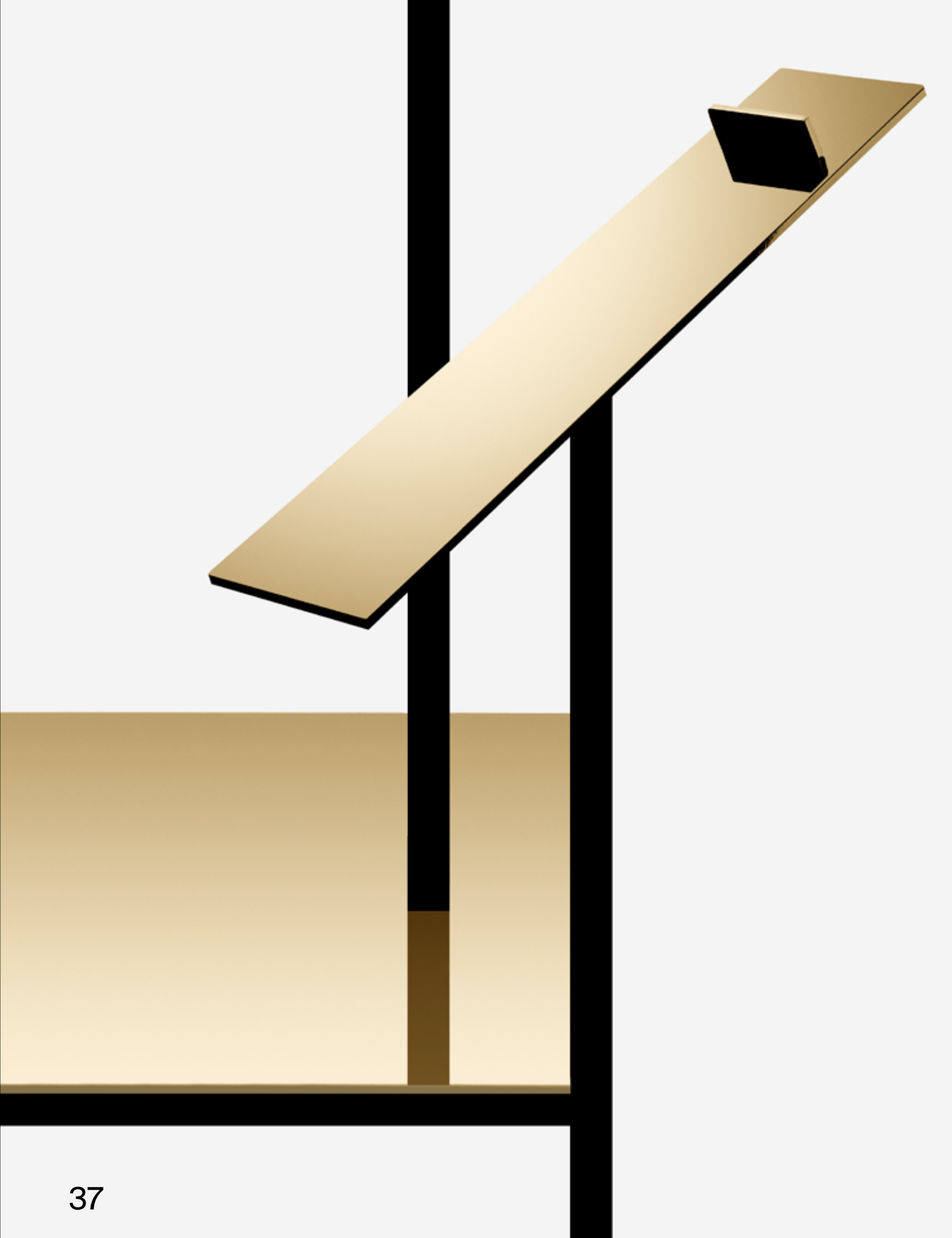
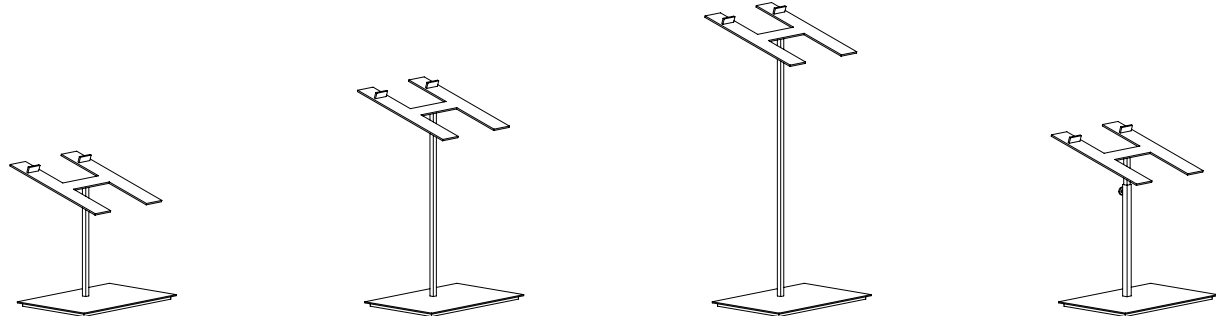

Double shoes display

Dimensions DV22A 15.5x18x15 cm LxPxH 6.1x7.1x5.9 in DV22B 15.5x18x25 cm LxPxH 6.7x7.1x9.8 in DV22C 15.5x18x35 cm LxPxH 6.7x7.1x13.8 in DV22 15.5x18x15/35 cm LxPxH 6.7x7.1x5.9/13.8 in → adjustable



U18, U28

Description	UNICO porta scarpa h 18, h 28 cm	UNICO shoe display h 18, h 28 cm	UNICO porte chaussure h 18, h 28 cm	UNICO Schuhhalter h 18, h 28 cm
-------------	--	--	---	---------------------------------------

Finishes	4.  Bronze Brass (B)	5.  Satinity Brass (DS)	6.  Gold (D)
----------	--	---	--

Dimensions LxPxH WxDxH	U18 16.5x8x18 cm 6.5x3.1x7.1 in	U28 16.5x8x28 cm 6.5x3.1x11 in
------------------------------	---------------------------------------	--------------------------------------

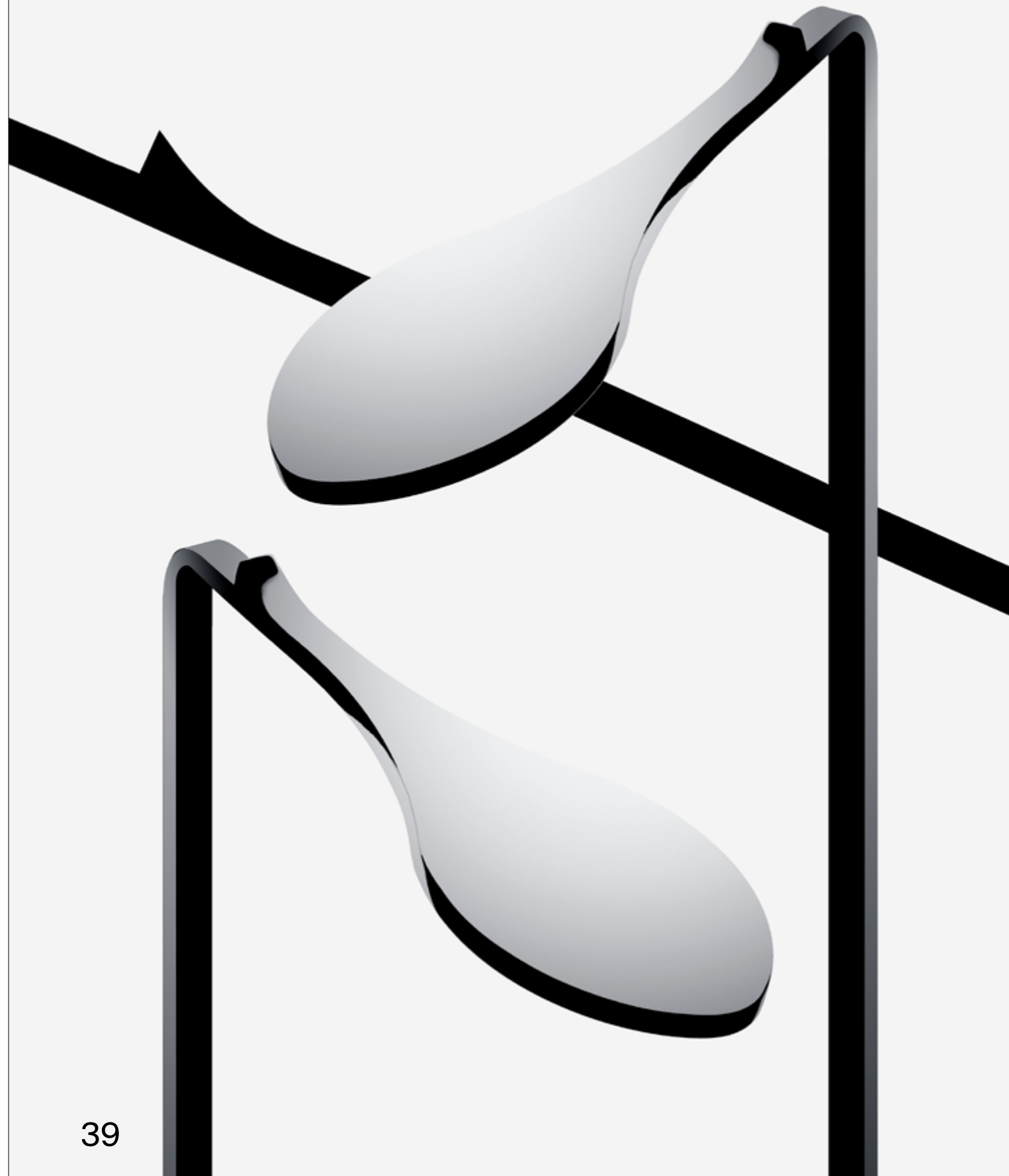
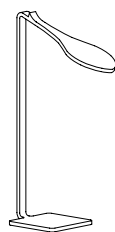
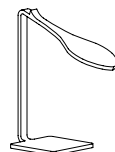

PCO
V161
V31

Porta cintura Présentoir
pour ceinture Gürtelhalte

Belt display

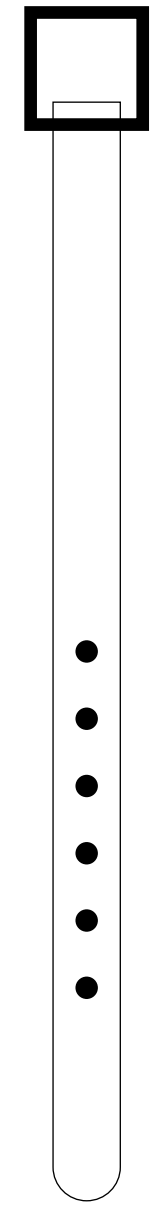
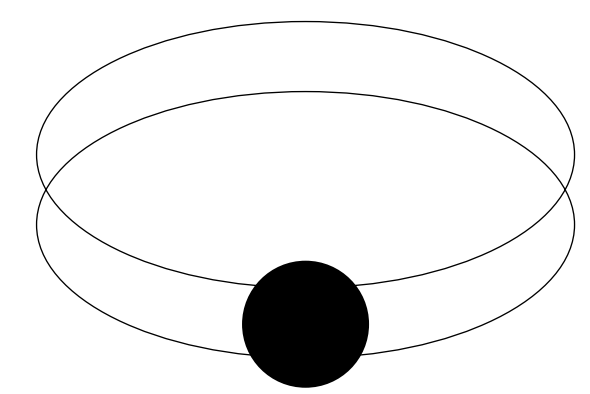
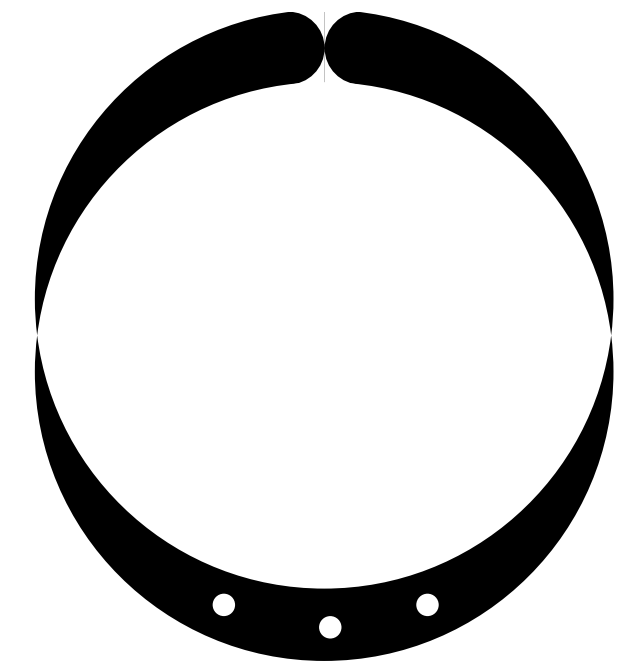

PCO, PCOS

Description

Porta cintura orizzontale singolo, doppio e triplo. Misura standard e small

Horizontal belt display, single, double and triple. Standard e small dimension

Présentoir single, double, triple, horizontal pour ceinture, taille standard

Horizontaler einfach, doppelter, dreifacher, Gürtelhalter, schmal

Finishes

- 1. Dark Metal (M)
- 2. Satinity Steel (S)
- 3. Glossy Steel (L)
- 4. Bronze Brass (B)
- 5. Satinity Brass (DS)
- 6. Gold (D)

Standard

Dimensions
LxPxH
WxDxH

PCO1
20x38x14.5 cm
7.8x15x5.7 in

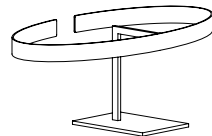

PCO2
20x38x24 cm
7.8x15x9.4 in

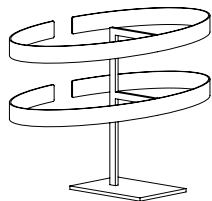

PCO3
20x38x33.5 cm
7.8x15x13.2 in

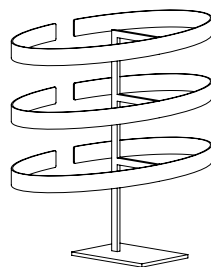

Small

Dimensions
LxPxH
WxDxH

PCOS1
18x32x12.5 cm
7x12.6x4.9 in

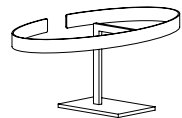

PCOS2
18x32x20.5 cm
7x12.6x8 in

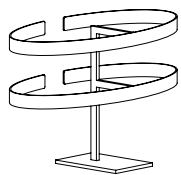

PCOS3
18x32x28.5 cm
7.1x12.6x11.2 in

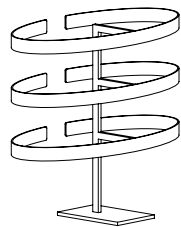

V161, V31

Description

Porta cintura orizzontale singolo, doppio e triplo. Misura standard e small

Horizontal belt display, single, double and triple. Standard e small dimension

Présentoir vertical pour ceinture, 48 cm de haut, taille, petite et standard

Vertikaler Gürtelhalter H. 48 cm, Standard, und schmal Breite

Finishes

- 1. Dark Metal (M)
- 2. Satinity Steel (S)
- 3. Glossy Steel (L)
- 4. Bronze Brass (B)
- 5. Satinity Brass (DS)
- 6. Gold (D)

Dimensions
LxPxH
WxDxH

Small

V161W
8x17x38 cm
3.1x6.7x15.1 in

Standard

V161
8x19x48.5 cm
3.1x7.5x19.1 in

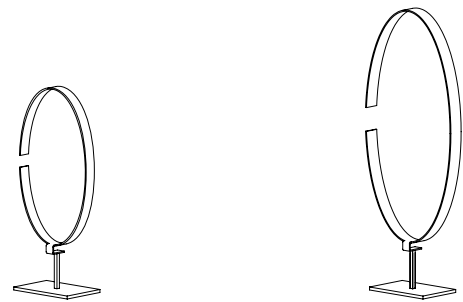

Dimensions
LxPxH
WxDxH

V312
16x29x45 cm
6.3x11.4x17.7 in

V313
16x39x45 cm
6.3x15.3x17.7 in

V314
16x49x45 cm
6.3x19.3x17.7 in

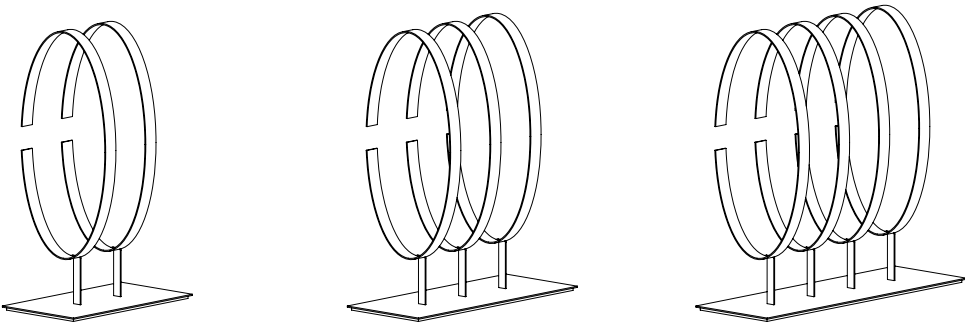

MPD

Belt bag display

Porta marsupio Présentoir
pour bananes
et pochettes Gürteltas-
chenhalter

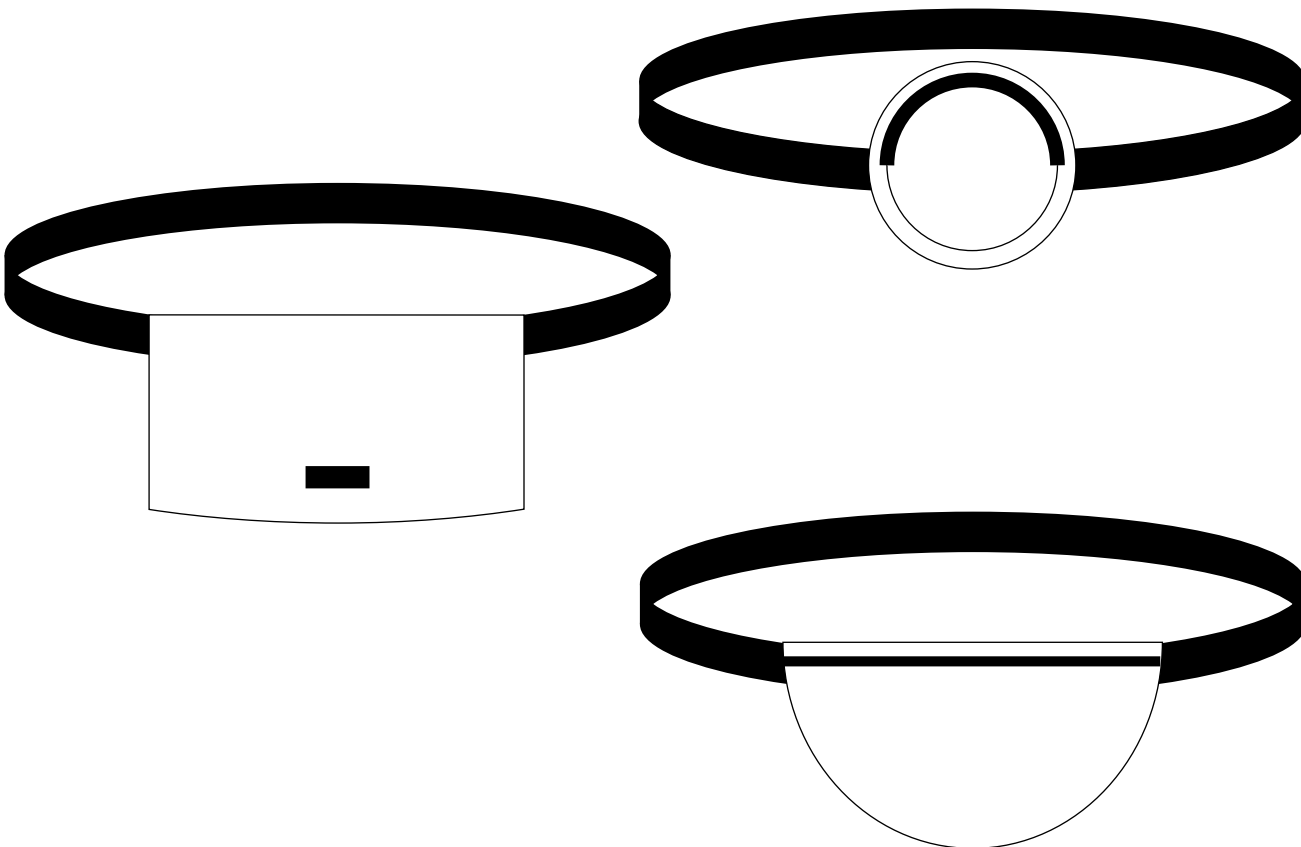

Belt bag display **MPD**

Description Porta marsupio Belt bag display
Présentoir pour bananes et pochettes Gürteltaschenhalter

Finishes 1.  Dark Metal (M) 2.  Satinity Steel (S) 3.  Glossy Steel (L) 4.  Bronze Brass (B) 5.  Satinity Brass (DS) 6.  Gold (D)

Dimensions MPD
LxPxH 19.5x38x24.5 cm
WxDxH 7.7x15x9.6 in

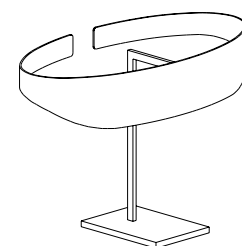

PO

Eyewear display

Portaocchiale Porte-lunettes Brillenhalter

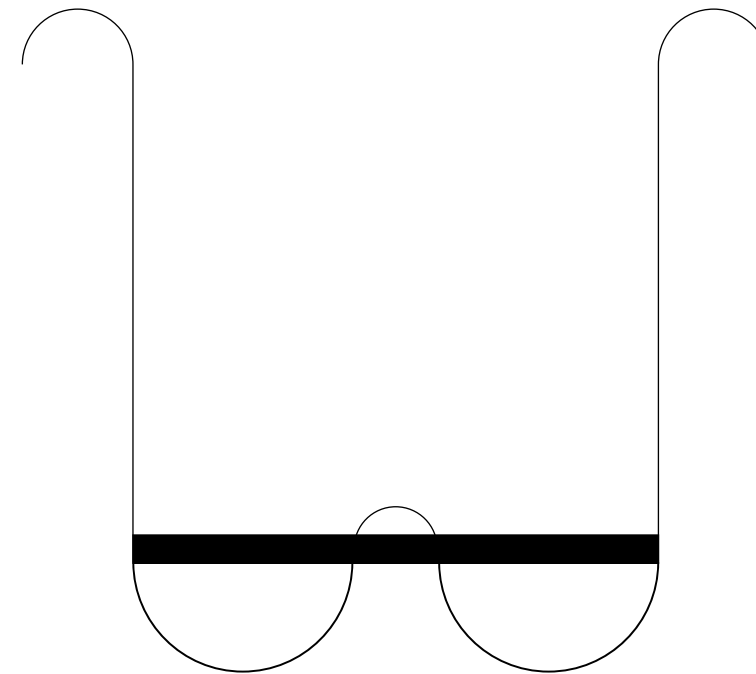
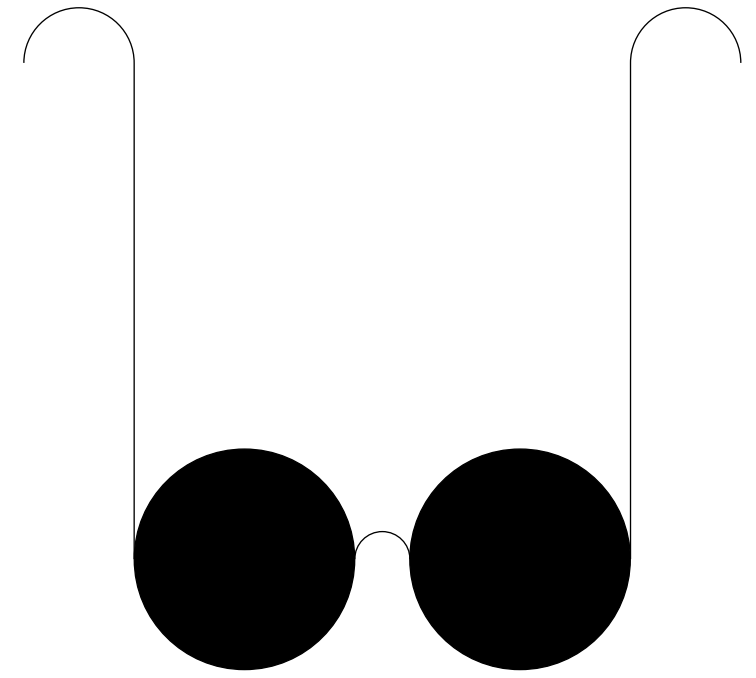

Eyewear display **PO**

Description Portaocchiale Adjustable Double Drehbarer
 singolo double eye- porte-lunettes doppelter
 orientabile wears display ajustable Brillenhalter
 h 10, 19, 28 cm h 10, 19, 28 cm h 10, 19, 28 cm H. 10, 19, 28 cm

Finishes 1.  Dark Metal (M) 2.  Satinity Steel (S) 3.  Glossy Steel (L) 4.  Bronze Brass (B) 5.  Satinity Brass (DS) 6.  Gold (D)

Dimensions PO1 PO2 PO3
 LxPxH 12x16x9.5 cm 12x16x18.5 cm 12x16x27.5 cm
 WxDxH 4.7x6.3x3.7 in 4.7x6.3x7.3 in 4.7x6.3x10.8 in

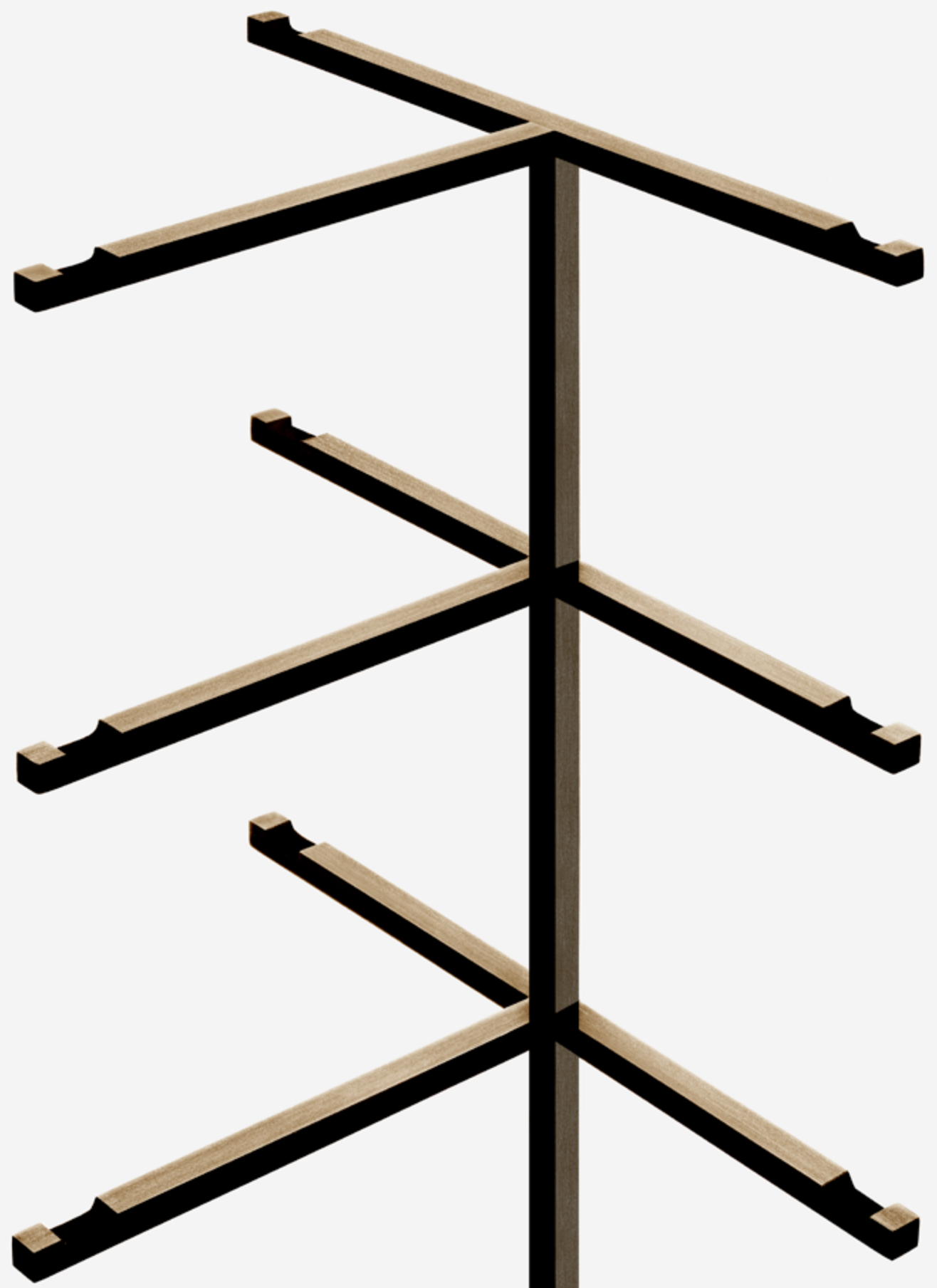
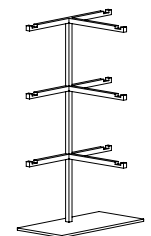
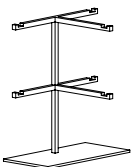
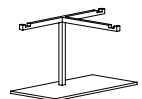

V24

V25

Hat display

Portacappello

Porte chapeau

Huthalter

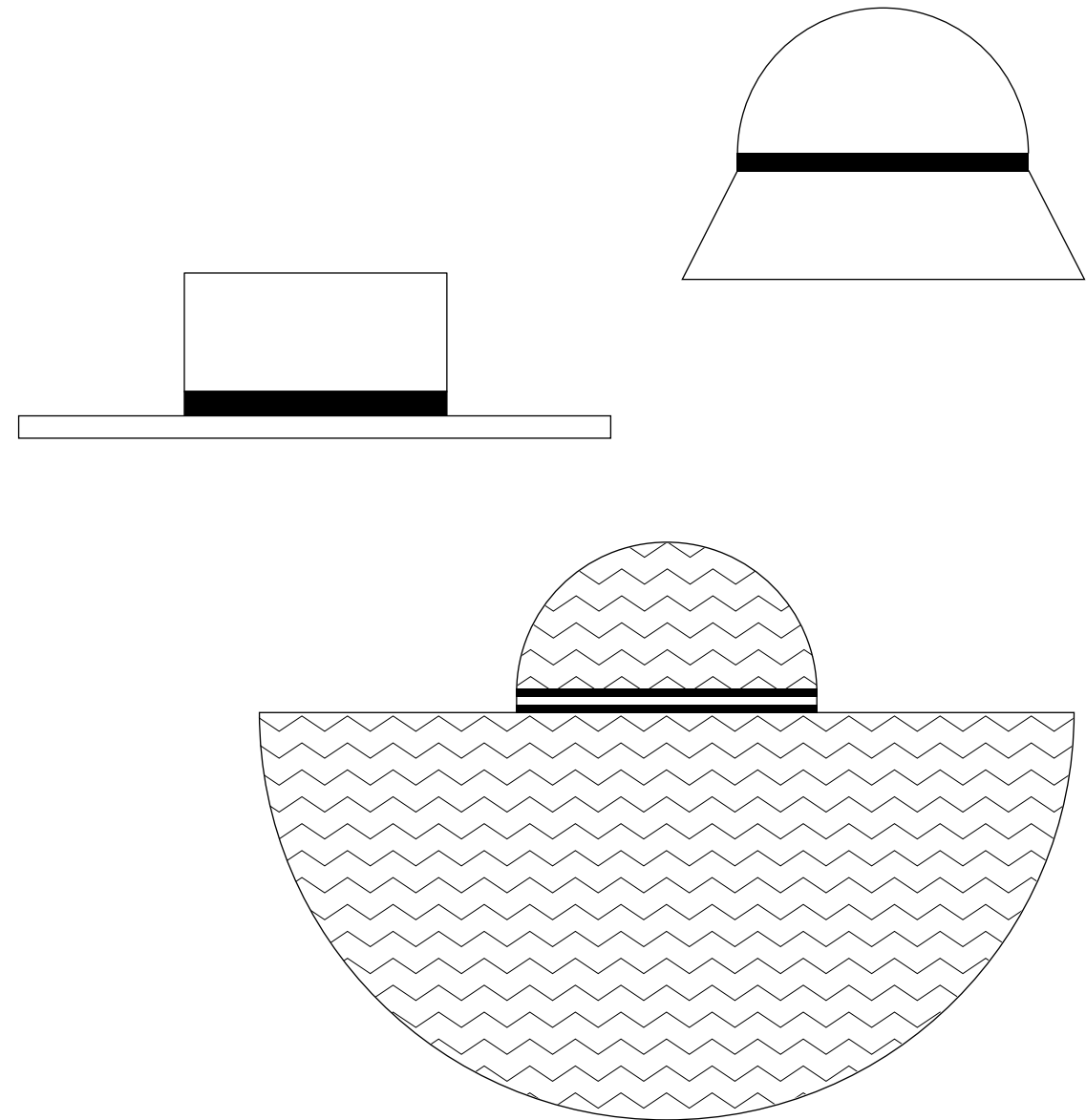

Hat display

V24, V25

Description Porta cappello h 25, 35 cm o regolabile in altezza Hat display h 25, 35 cm or adjustable in high Porte chapeau h 25, 35 cm o ajustable. Huthalter h 25, 35 cm oder regulierbar

Finishes 1.  Dark Metal (M) 2.  Satinity Steel (S) 3.  Glossy Steel (L) 4.  Bronze Brass (B) 5.  Satinity Brass (DS) 6.  Gold (D)

Dimensions LxPxH V24A 11x12x25 cm WxDxH 4.3x4.7x9.8 in

V24B 11x12x35 cm 4.3x4.7x13.8 in

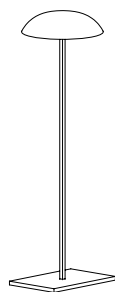
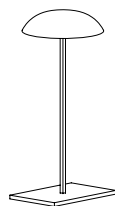

Dimensions LxPxH V25 11x12x30/60 cm WxDxH 4.3x4.7x11.8/23.6 in → adjustable

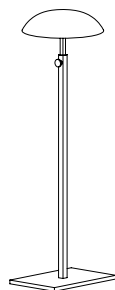

PF

Wallet display

Porta
portafoglio

Présentoir pour
portefeuille

Portemonnaie-
halter

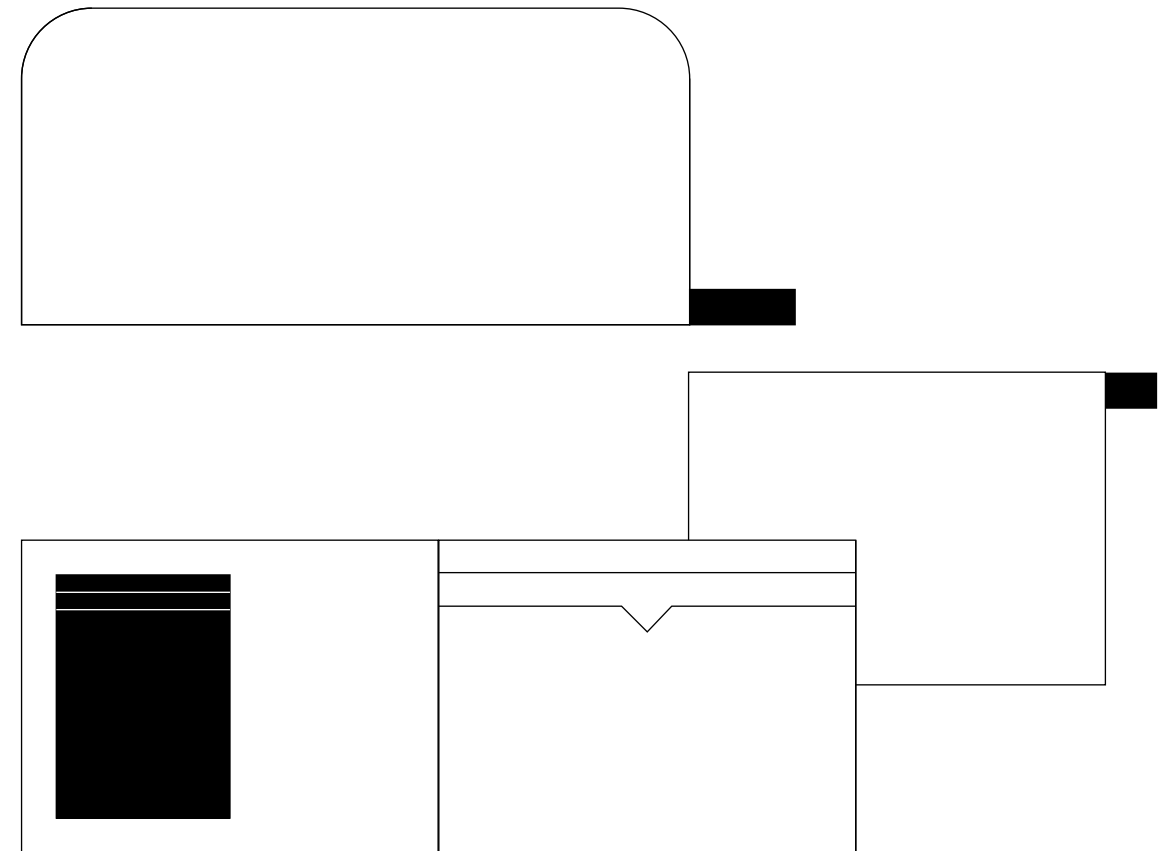

PF16, PF26, PF26T

Description







Espositore portafogli singolo h 14, h 26 cm e doppio h 26 cm

Wallet single display h 14, h 26 cm, and double display h 26 cm

Présentoir singolo pour portefeuille h. 14, 26 cm, o double h 26 cm

Portemonnaie-halter H. 14, 16 cm, oder doppelter H. 26 cm

Finishes

- 1.  Dark Metal (M)
- 2.  Satinity Steel (S)
- 3.  Glossy Steel (L)
- 4.  Bronze Brass (B)
- 5.  Satinity Brass (DS)
- 6.  Gold (D)

Dimensions
LxPxH
WxDxH

PF16
9x6x14 cm
3.5x2.4x5.5 in

PF26
9x6x26 cm
3.5x2.4x10.2 in

PF26T
9x6x26 cm
3.5x2.4x10.2 in

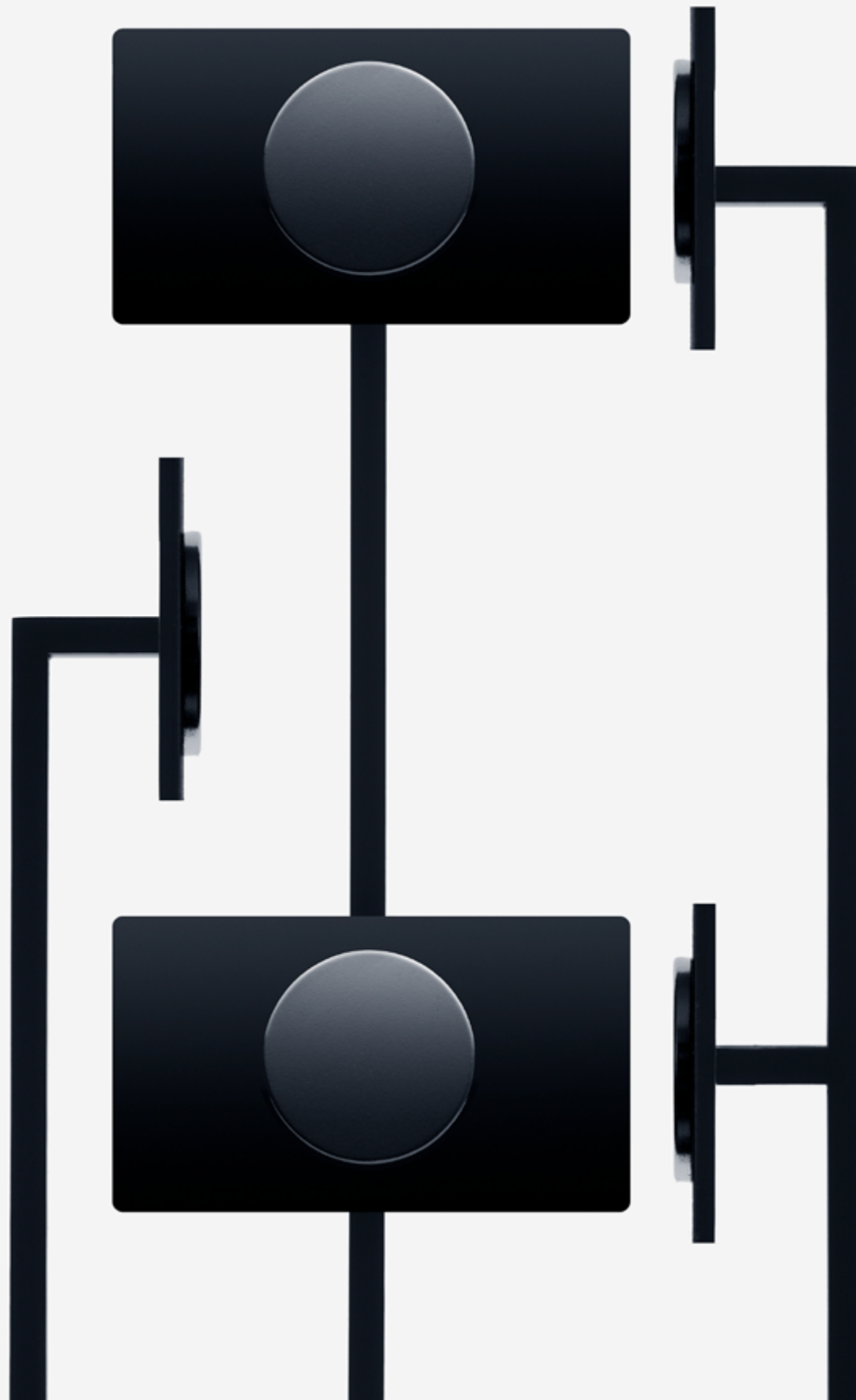
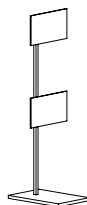
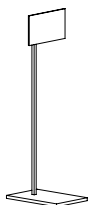

U²K

Keychain display

Porta
portachiavi

Présentoir pour
porte clef

Schlüsselan-
hänger Halter

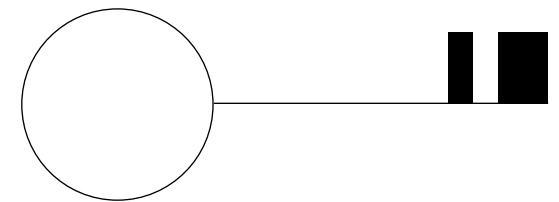
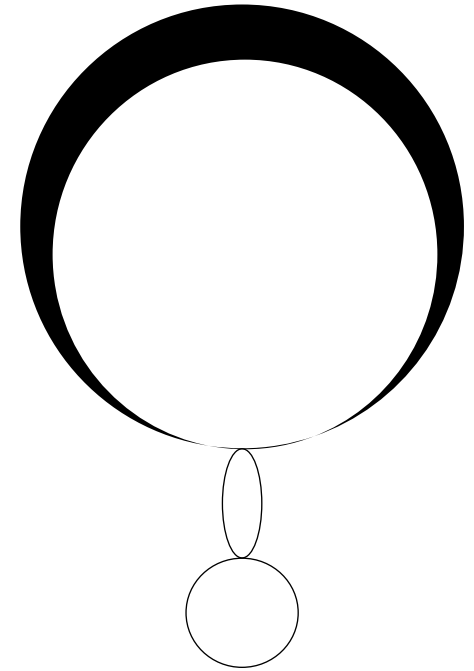
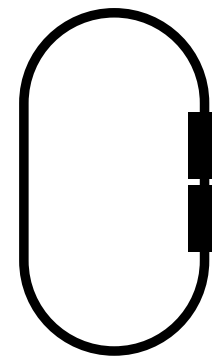
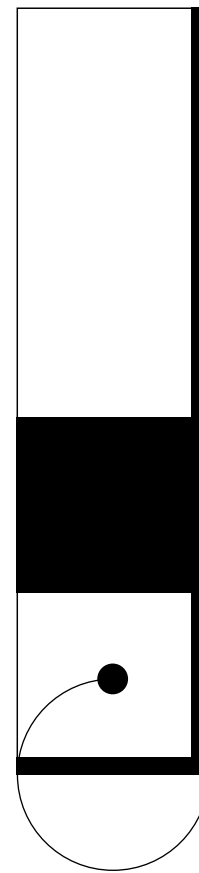





U²K15, U²K20, U²K25

Description

Espositore portachiavi UNICO ² h 15, 20, 25 cm	Keychain display UNICO ² h 15, 20, 25 cm	Présentoir UNICO ² pour porte clef, 15, 20, 25 cm de haut	UNICO ² Schlüsselanhänger Halter H. 15, 20, 25 cm
---	---	--	--

Finishes

3.  Glossy Steel (L)	7.  Delabré Steel (DLS)	8.  Delabré Dark (DLM)	9.  Delabré Brass (DLD)
---	--	---	--

Dimensions

U2K15 LxPxH 6x6x15 cm WxDxH 2.4x2.4x5.9 in	U2K20 LxPxH 6x6x20 cm WxDxH 2.4x2.4x7.9 in	U2K25 LxPxH 6x6x25 cm WxDxH 2.4x2.4x9.8 in
---	---	---

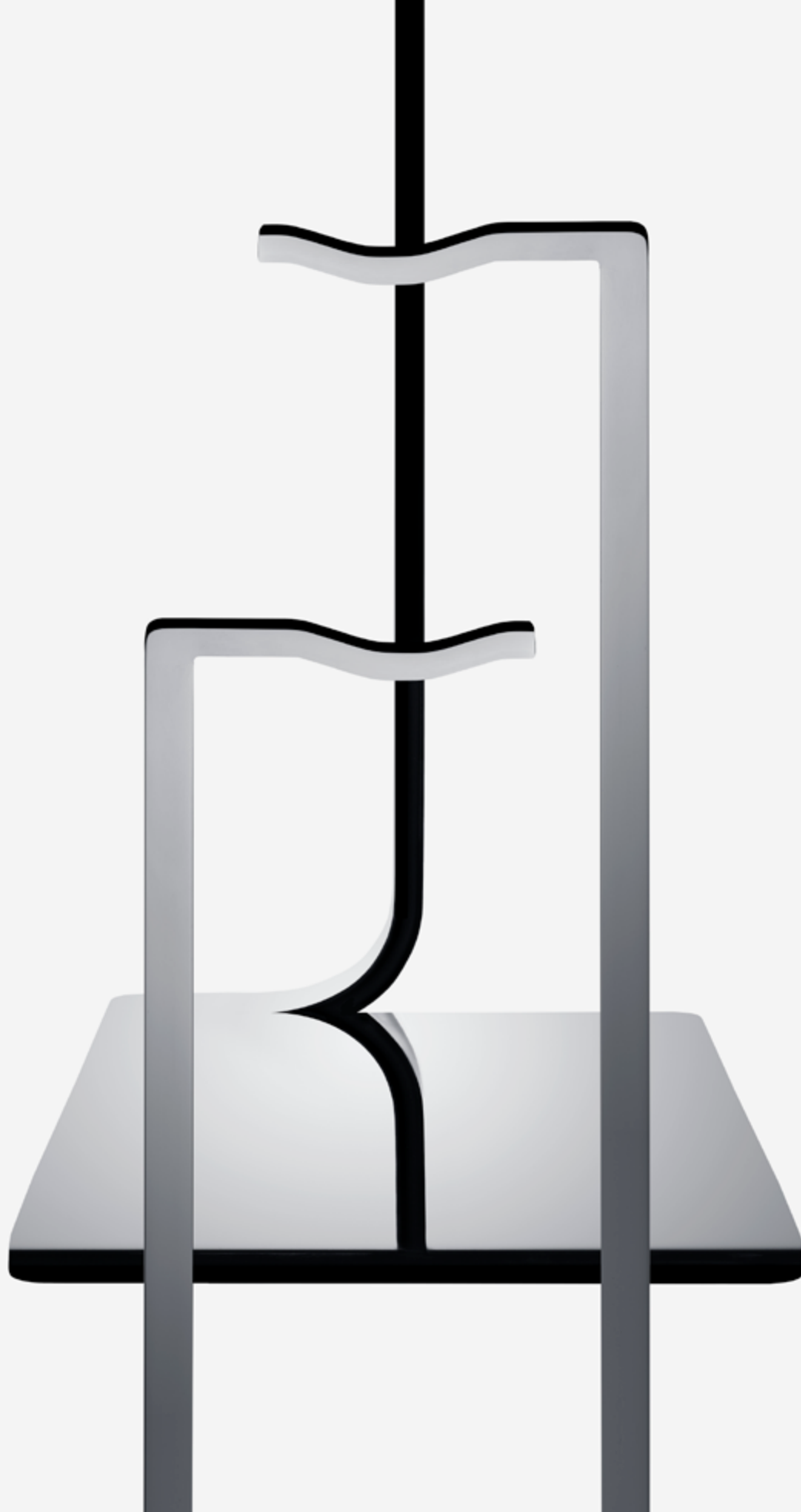

BO

Box display

Box

Boite

Box

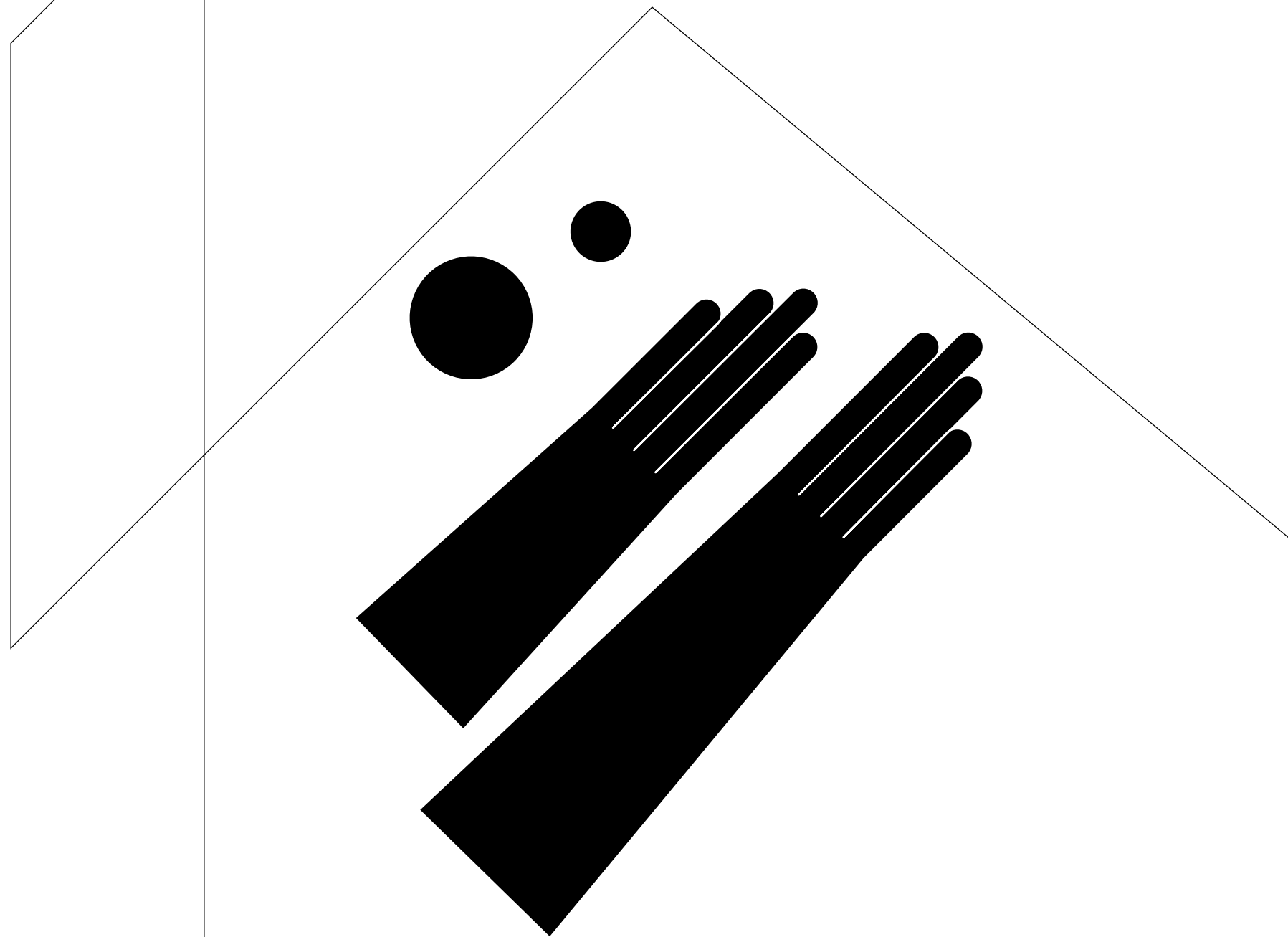







BOQ10, BOQ20, BOR10, BOR20

Description

Box in plexi- trasparente con vassoio metallico	Clear plexi- glass box with metal tray	Boite en plexiglass avec base en métal	Klare Plexi- glas-Box mit Metallschale
--	--	--	--

Finishes

- | | | | | | |
|--|--|--|--|---|--|
| 1.  Dark
Metal (M) | 2.  Satinity
Steel (S) | 3.  Glossy
Steel (L) | 4.  Bronze
Brass (B) | 5.  Satinity
Brass (DS) | 6.  Gold
(D) |
|--|--|--|--|---|--|

Square box

Dimensions
LxPxH
WxDxH

BOQ10
38x38x10 cm
15x15x3.9 in
→ metal tray 1 cm

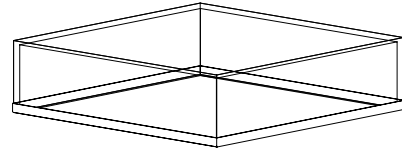

BOQ20
38x38x20 cm
15x15x7.9 in
→ metal tray 1 cm

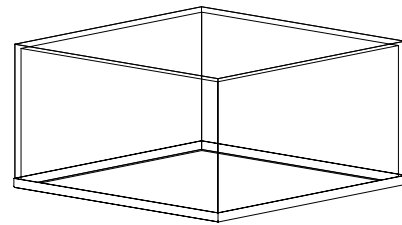

Rectangular box

Dimensions
LxPxH
WxDxH

BOR10
28x38x10 cm
11x15x3.9 in
→ metal tray 1 cm

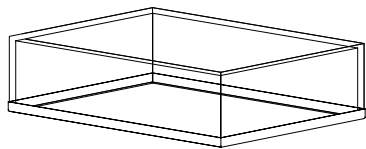

BOR20
28x38x20 cm
11x15x7.9 in
→ metal tray 1 cm

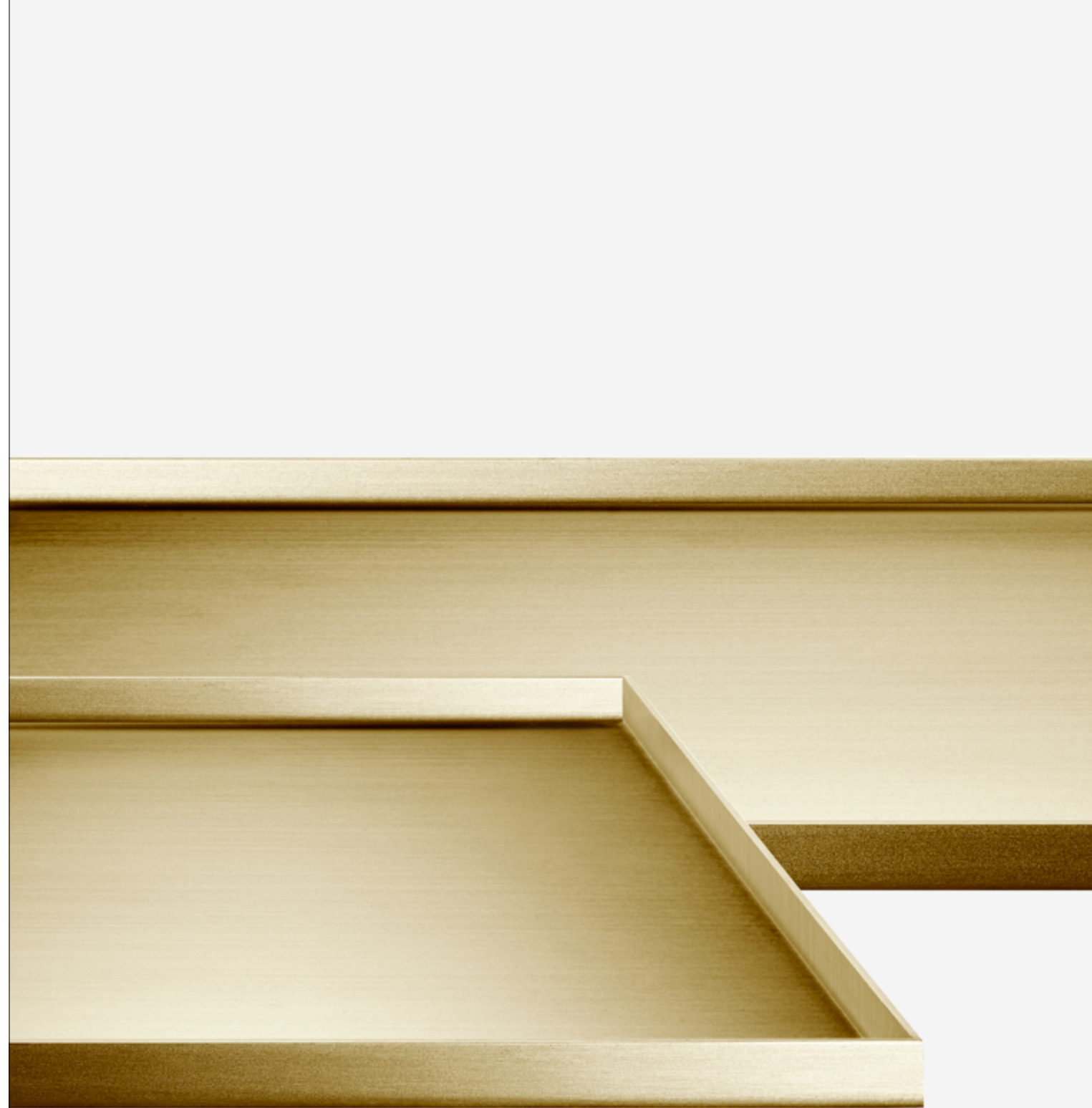
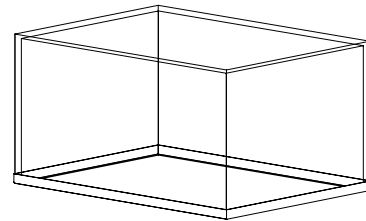

ST
SM
SP
S6/S7
SN
SR

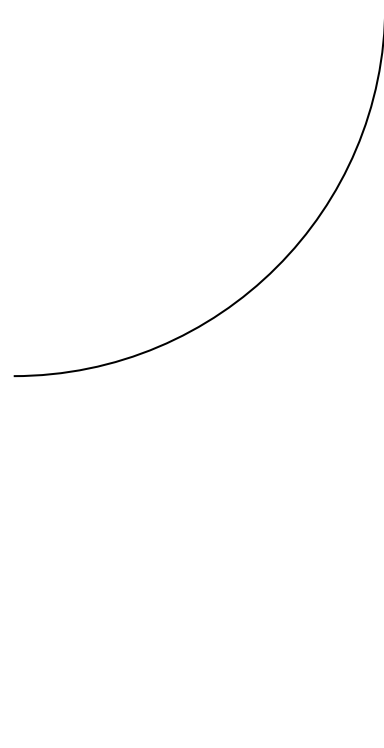

Sign holders

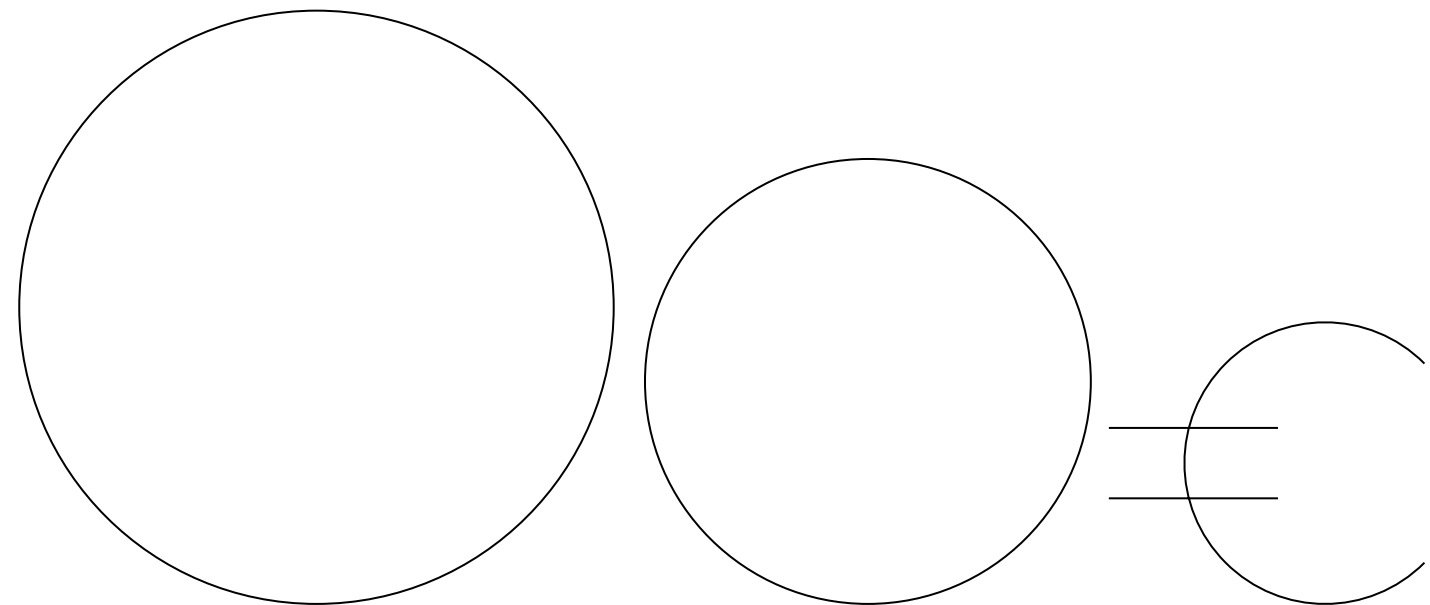
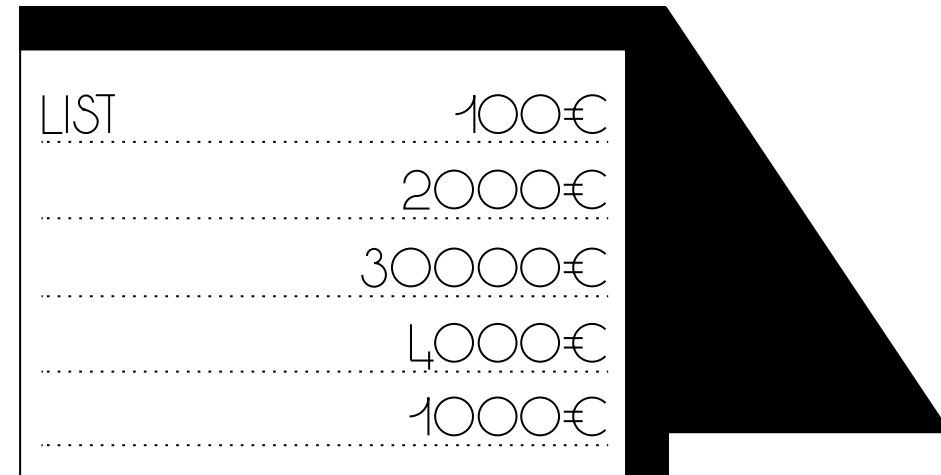

ST, SM, SP

Description







Segnaprezzi di diversi modelli e misure

Different size and models of sign holders

Support signalétique en différents modèles et mesure

Preisschildhalter in verschiedenen Größen und Preisen

Finishes

- 1.  Dark Metal (M)
- 2.  Satinity Steel (S)
- 3.  Glossy Steel (L)
- 4.  Bronze Brass (B)
- 5.  Satinity Brass (DS)
- 6.  Gold (D)

Models

LxPxH
WxDxH

ST
3.5x11x14.5 cm
1.4x4.3x5.7 in

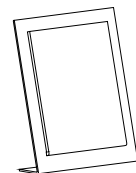

SM10 / SM15
2.8x10.5x10 / 3.5x15x12.5 cm
1.1x4.1x3.9 / 1.4x5.9x4.9 in

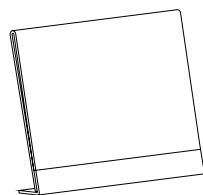
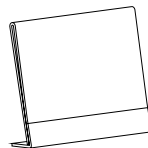

SP
14.8x21x2 cm
5.8x8.3x0.8 in



S6/S7, SN, SR

Description Segnaprezzi di diversi modelli e misure / Different size and models of sign holders / Support signalétique en différents modèles et mesure / Preisschildhalter in verschiedenen Größen und Preisen

Finishes 1. Dark Metal (M) 2. Satinity Steel (S) 3. Glossy Steel (L) 4. Bronze Brass (B) 5. Satinity Brass (DS) 6. Gold (D)

Models S7S / S6S
 LxPxH A7: 3x10.7 x 7.5 / A6: 3.8x15x10.5 cm
 WxDxH A7: 1.2x4.2x3 / A6: 1.5x5.9x4.1 in

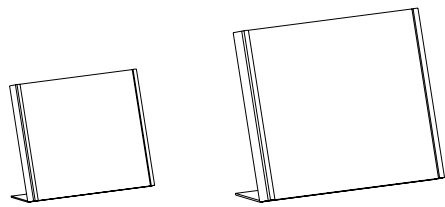

S7 / S6
 A7: 7.4x10.7x1 / A6: 10.5x15x1 cm
 A7: 2.9x4.2x0.4 / A6: 4.1x5.9x0.4 in

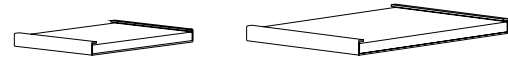

SN7 / SN6 / SN5
 A7: 3x10.5x7.3 / A6: 4x14.8x10.3 / A5: 5.5x21x14.3 cm
 A7: 1.2x4.1x2.9 / A6: 1.6x5.8x4 / A5: 2.2x8.3x5.6 in

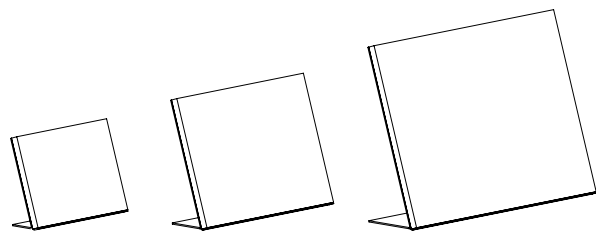

SR7 / SR6
 A7: 9.5x13.4x0.8 / A6: 13x17.8x0.8 cm
 A7: 3.7x5.3x0.31 / A6: 5.1x7x0.31 in



SR7 ↗ Glossy Steel finish SN5 ↗ Satinity Steel finish S7S ↗ Gold finish

JB
JC
JA
JB
JK

Jewelry display

Porta gioielli

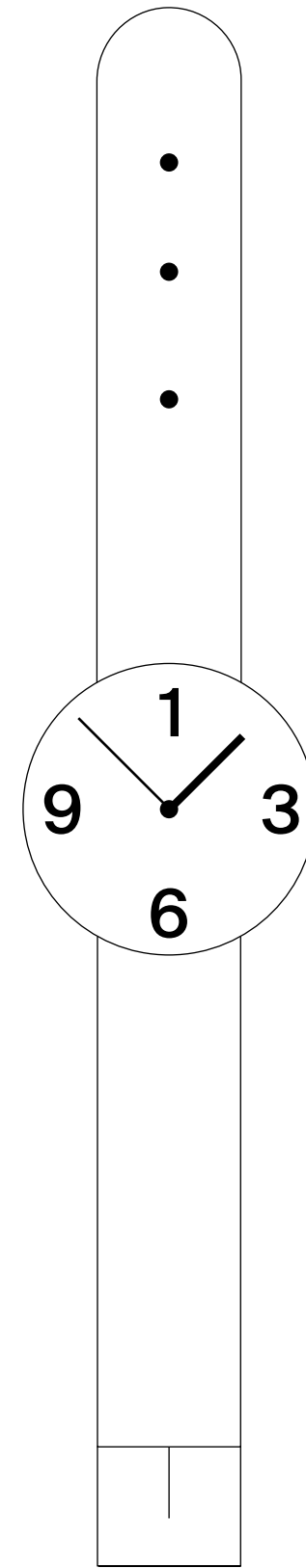
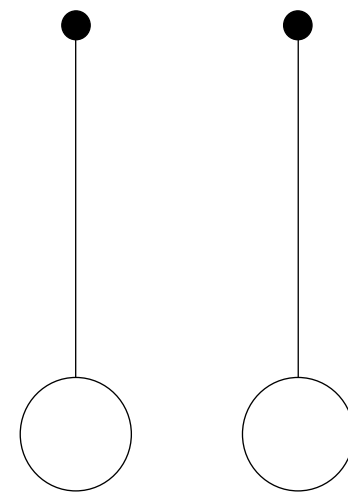
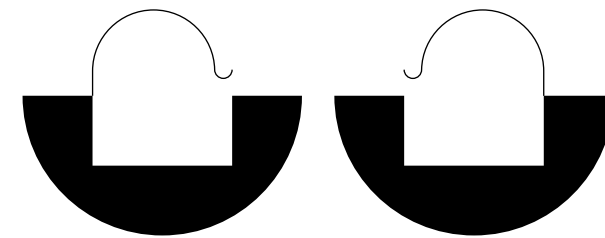

Présentoir de bijoux

Schmuck Display



JB, JC, JA, JB, JK

Description Base, portao-
recchini, porta
anello, porta
orologio, porta
portachiavi Base, earrings
display, ring
display, watch
display, key-
chain display Base, porte
boucles
d'oreilles,
porte-bague,
porte-montre,
porte-clef Base, Ohrrin-
ghalter, Ringhal-
ter, Uhrenhalter,
Schlüsselanhän-
ger Halter

Finishes 1.  Dark
Metal (M) 4.  Bronze
Brass (B) 5.  Satinity
Brass (DS)

Dimensions
LxPxH
WxDxH
JB
15x35x0.65 cm
5.9x13.8x0.2 in



JC8-12-16
2x6x8.6-12.6-18.6 cm
0.8x2.4x3.4-5-7.3 in

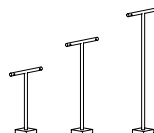

JA8-12-16
2.2x2.2x10.5-14.5-18.5 cm
0.9x0.9x4.1-5.7-7.3 in

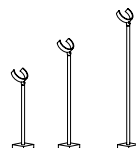

Dimensions
LxPxH
WxDxH
JB8-12-16
5.5x2x16.8-20.8-24.8 cm
2.2x0.8x6.6-8.2-9.8 in

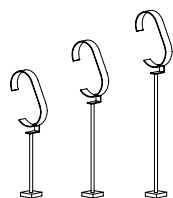

JK12-16-20
4.8x2x12.6-16.6-20.6 cm
1.9x0.8x5-6.5-8.1 in

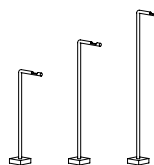

Creative collection



“Espositori custom: eco di un progetto architettonico.”

“Custom displays: echo
of an architectural project.”

“Présentoirs personnalisés:
écho d'un projet architectural.”

“Individuelle Displays:
Echo eines Architekturprojekts.”

Intervista

Che cosa si intende per Creative Collection?

Creative Collection è un programma di personalizzazione. È un modo pratico e intuitivo attraverso il quale il cliente può creare espositori unici e adatti alle proprie esigenze. È il riassunto di tanti anni di lavoro e d'intermediazione con le aziende e gli studi d'architettura con cui siamo in costante contatto. Creative collection è unica per la sua capacità di adattarsi alle esigenze dei clienti, grazie all'ampia gamma di rivestimenti e finiture di cui disponiamo che permettono molteplici combinazioni materiche, cromatiche e tattili.

Cosa significa per voi il "su misura" o "custom"?

Viviamo in un mondo fatto di personalizzazioni. Tutto, dal mobile alla tecnologia, è ormai personalizzabile. I nostri clienti ricercano sempre di più un prodotto specificamente modellato sulle loro esigenze. Sono consumatori evoluti che sanno quello che vogliono e noi cerchiamo di soddisfare le loro richieste.

Come funziona il processo creativo?

Gli articoli "custom", come detto, sono il risultato di una diretta relazione con le aziende e di una produzione dedicata esclusivamente a loro. Cerchiamo di coinvolgerli nel processo creativo instaurando così un rapporto di scambio e arricchimento reciproco che porti a soluzioni appropriate ma anche nuove, audaci e innovative. Segue poi lo sviluppo e la realizzazione di una prototipia degli espositori richiesti che a loro volta vengono 'testati' nel contesto o spazio progettato.

Interview

What does Creative Collection mean?

EC Studio's Creative Collection focuses on providing customizable display solutions. It is a practical way for clients to create one-of-a-kind displays that suit their individual needs. Long standing partnerships with architectural design and fabrication firms give our clients a myriad of materials and finishes for virtually unlimited possibilities.

What does "custom-made" mean to you?

We live in a world of customization. Today's day in age, everything from furniture to technology is customizable. Now more than ever, our clients are looking for products tailored specifically to their needs. They are mature consumers who know what they want. We look to satisfy their requests.

How does the creative process work?

Custom pieces are the result of a close collaboration with our clients and a design process that is vigilant of their needs. We involve our clients in the creative process, establishing a working relationship that fosters the free exchange of ideas, producing bold and innovative solutions. All products are prototyped and tested before final manufacturing and delivery.

How do the pieces fit with the companies that order them?

Our clients are creative individuals (visual merchandisers, architects, designers, etc.) who value collaborative exchange. Their unique style is represented throughout our displays, complementing their respective exhibition spaces.

Interview

Qu'entend- on par Creative Collection?

Creative Collection est un programme de personnalisation qui met le client en condition de créer d' une façon pratique et intuitive des présentoirs uniques adaptés à ses exigences. C'est le résultat de nombreuses années de travail et d'échanges avec les entreprises et les cabinets d'architecture avec lesquels nous sommes en contact constant. Creative collection est unique pour sa capacité de s'adapter aux besoins du client grâce à une vaste gamme de revêtements et de finitions dont nous disposons et qui permettent un grand nombre de combinaisons tactiles ainsi que des matières et des couleurs.

Que signifie pour vous "sur mesure" ou "custom"?

Nous vivons dans un monde fait de personnalisations. Tout, du téléphone portable aux nouvelles technologies, est désormais personnalisable. Nos clients recherchent de plus en plus un produit modelé sur leurs exigences. Ce sont des consommateurs évolués, ils savent ce qu'ils veulent et de notre côté nous tentons de satisfaire leurs demandes.

Comment fonctionne ce processus créatif?

Les articles "custom", comme nous venons de le dire, sont le fruit de relations directes avec l'entreprise et d'une production qui lui est exclusivement consacrée. Nous essayons de l'impliquer dans le processus créatif instaurant ainsi un échange d'idées, enrichissement réciproque qui mène à des solutions appropriées, mais aussi nouvelles, audacieuses et innovantes. Après quoi, nous

Interview

Was bedeutet Creative Collection?

Die Creative Collection von EC Studio konzentriert sich auf die Bereitstellung individualisierbarer Display-Lösungen. Kunden können auf praktische Weise einzigartige Displays erstellen, die ihren individuellen Bedürfnissen entsprechen. Langjährige Partnerschaften mit Architektur- und Fertigungsunternehmen bieten unseren Kunden eine Vielzahl von Materialien und Oberflächen mit nahezu unbegrenzten Möglichkeiten.

Was bedeutet für Sie „Sonderanfertigung“?

Wir leben in einer Welt der Individualisierung. Im heutigen Zeitalter ist alles, von Möbeln bis hin zu Technologie, individualisierbar. Unsere Kunden suchen mehr denn je nach Produkten, die speziell auf ihre Bedürfnisse zugeschnitten sind. Sie sind erfahrene Verbraucher, die wissen, was sie wollen. Wir bemühen uns, ihre Wünsche zu erfüllen.

Wie funktioniert der kreative Prozess?

Sonderanfertigungen sind das Ergebnis einer engen Zusammenarbeit mit unseren Kunden und eines Designprozesses, der deren Bedürfnisse berücksichtigt. Wir beziehen unsere Kunden in den kreativen Prozess ein und bauen eine Arbeitsbeziehung auf, die den freien Austausch von Ideen fördert und mutige und innovative Lösungen hervorbringt. Alle Produkte werden vor der endgültigen Herstellung und Lieferung als Prototyp erstellt und getestet.

Wie passen die Stücke zu den Firmen, die sie bestellen?

Unsere Kunden sind kreative



In che modo avviene il confronto con le aziende?

Lo sviluppo di una serie di espositori “custom” fa sempre eco ad un progetto architettonico, dove i display diventano il completamento dello spazio espositivo. Solitamente i nostri interlocutori sono persone creative quali visual merchandiser, architetti e designer con i quali discutiamo delle nostre e delle loro idee.

Come soddisfatte le esigenze delle aziende?

Il nostro lavoro consiste nel consigliare e guidare i nostri clienti nella scelta delle finitura e dei rivestimenti che meglio dialogano con l'ambiente. Noi subentriamo in una fase progettuale matura, nella quale sono già state definite delle linee guida.

I progetti su misura, riguardano sono articoli standard?

No, benché la Creative Collection nasca come un servizio di arricchimento e personalizzazione dei nostri articoli standard, i progetti su misura comprendono creazioni ad hoc e variazioni al nostro design.

Per concludere?

Crediamo che solo dal confronto nascano risultati di cui essere vicendevolmente orgogliosi e soddisfatti. Ogni progetto diventa unico e irripetibile.

How do you meet the needs of your clients?

From design to production, we work hand-in-hand with our clients to execute their vision; guiding them through every step of the design process including the selection of materials and finishes that complement their retail space. Our manufacturing process follows time-tested processes that have been perfected throughout our years of experience.

Does the Creative Collection include standard products?

Although the Creative Collection was conceived to utilize components from our existing product lines, we offer our clients the opportunity to create bespoke displays based upon their specific needs.

In conclusion?

Every EC Studio project is unique and exceptional. We believe that collaboration is essential to creating products that foster a shared sense of pride between our clients and our team.

développons les prototypes des présentoirs demandés, puis nous les testons en contexte ou dans l'espace projeté.

De quelle manière les rapports ont ils lieu avec les entreprises?

Le développement d'une série de présentoirs sur mesure est toujours l'écho d'un projet architectural où les displays deviennent le complément de l'espace d'exposition. Habituellement nos interlocuteurs sont des personnes créatives telles que les marchandiseurs, les architectes et les designers avec lesquels nous discutons de nos idées et des leurs.

Comment satisfaites-vous les exigences des entreprises?

Notre travail consiste à conseiller et guider nos clients dans le choix des finitions et des revêtements qui dialogueraient le mieux avec l'espace à aménager. Nous intervenons dans une phase avancée du projet alors que des lignes directrices ont déjà été définies.

Les projets sur mesure concernent-ils les articles standards?

Non, bien que notre Creative Collection naisse comme un service de personnalisation et d'enrichissement de nos articles standards, les projets sur mesure comprennent des créations ad hoc et des variantes de notre design.

En conclusion?

Nous croyons que seulement de l'échange d'idées naissent des résultats dont on peut être réciproquement orgueilleux et satisfaits. Chaque projet se fait ainsi unique et irremplaçable.

Persönlichkeiten (Visual Merchandiser, Architekten, Designer usw.), die Wert auf gemeinschaftlichen Austausch legen. Ihr einzigartiger Stil wird auf unseren Displays dargestellt und ergänzt ihre jeweiligen Ausstellungenräume.

Wie gehen Sie auf die Bedürfnisse Ihrer Kunden ein?

Vom Design bis zur Produktion arbeiten wir Hand in Hand mit unseren Kunden, um ihre Vision umzusetzen. Sie werden durch jeden Schritt des Designprozesses geführt, einschließlich der Auswahl der Materialien und Oberflächen, die ihre Verkaufsfläche ergänzen. Unser Herstellungsprozess folgt bewährten Prozessen, die im Laufe unserer jahrelangen Erfahrung perfektioniert wurden.

Enthält die Creative Collection Standardprodukte?

Obwohl die Creative Collection so konzipiert wurde, dass Komponenten aus unseren bestehenden Produktlinien verwendet werden, bieten wir unseren Kunden die Möglichkeit, maßgeschneiderte Displays zu erstellen, die auf ihre spezifischen Bedürfnisse zugeschnitten sind.

Abschließend?

Jedes EC Studio Projekt ist einzigartig und außergewöhnlich. Wir sind davon überzeugt, dass die Zusammenarbeit von entscheidender Bedeutung ist, um Produkte zu entwickeln, die ein gemeinsames Gefühl des Stolzes zwischen unseren Kunden und unserem Team fördern.

Finishes

1.



Dark metal
(M)

2.



Satinity steel
(S)

4.



Bronze brass
(B)

5.



Satinity brass
(DS)

3.



Glossy steel
(L)

6.



Gold
(D)

Contacts

Ec Studio Headquarters

Via Alice Castello 1

13048 Santhià (VC), Italy

+39 0161 94 12 6

info@ecstudio.com

Ec Studio USA

379W Broadway

New York 10012

+1 (929) 321 424 3

info.nyc@ecstudio.com

Credits

Art direction

Studio CCRZ

Photography

Simone Cavadini

Drawings

Sabrina Cerea

Paper

Colorplan Sandgrain, Ice White

Munken Print white 1,5

Font

Suisse BP Int'l

Printed by

Linea Optima, Milano

Printed and bound in Italy

December 2019

©All rights reserved

