

★  
T.O. 1F-106A-2-4

TECHNICAL MANUAL  
MAINTENANCE

POWER PLANT

USAF SERIES

**F-106A AND F-106B**

AIRCRAFT

(GENERAL DYNAMICS/CONVAIR)

AF 336000-36546  
AF 436000-15287

THIS PUBLICATION REPLACES T.O. 1F-106A-2-4, DATED 1 DECEMBER 1960.  
THIS PUBLICATION INCLUDES SUPPLEMENT T.O. 1F-106A-2-4N, DATED 5  
NOVEMBER 1962, AND ALL SUPPLEMENTS OF PRIOR DATES.

PUBLISHED UNDER AUTHORITY OF THE SECRETARY OF THE AIR FORCE

Reproduction for nonmilitary use of the information or illustrations contained in this publication is not permitted without specific approval of the issuing service. The policy for use of Classified Publications is established for the Air Force in AFR 205-1.

INSERT LATEST CHANGED PAGES. DESTROY SUPERSEDED PAGES.

**LIST OF EFFECTIVE PAGES**

NOTE: The portion of the text affected by the changes is indicated by a vertical line in the outer margins of the page.

TOTAL NUMBER OF PAGES IN THIS PUBLICATION IS 297 CONSISTING OF THE FOLLOWING:

<i>Page No.</i>	<i>Issue</i>
Title .....	Original
A .....	Original
i thru iv .....	Original
1-1 thru 1-20 .....	Original
1-20A .....	Original
1-20B Blank .....	Original
1-21 thru 1-96 .....	Original
2-1 thru 2-24 .....	Original
3-1 thru 3-15 .....	Original
3-16 Blank .....	Original
4-1 thru 4-62 .....	Original
5-1 thru 5-16 .....	Original
6-1 thru 6-17 .....	Original
6-18 Blank .....	Original
7-1 thru 7-5 .....	Original
7-6 Blank .....	Original
8-1 thru 8-6 .....	Original
9-1 thru 9-20 .....	Original
9-20A .....	Original
9-20B Blank .....	Original
9-21 thru 9-39 .....	Original
9-40 Blank .....	Original
10-1 thru 10-4 .....	Original
1 thru 5 .....	Original
6 Blank .....	Original

\*The asterisk indicates pages changed, added, or deleted by the current change.

ADDITIONAL COPIES OF THIS PUBLICATION MAY BE OBTAINED AS FOLLOWS:  
 USAF ACTIVITIES.—In accordance with T.O. 00-5-2.

USAF

**TABLE OF CONTENTS**

	<i>Page</i>
Introduction .....	ii
List of F-106A and F-106B Systems Maintenance Manuals.....	iv
<b>SECTION I</b>	
Power Plant General .....	1-1
<b>SECTION II</b>	
Main Fuel System .....	2-1
<b>SECTION III</b>	
Afterburner Systems .....	3-1
<b>SECTION IV</b>	
Air Induction Systems .....	4-1
<b>SECTION V</b>	
Starting and Ignition Systems .....	5-1
<b>SECTION VI</b>	
Lubrication System .....	6-1
<b>SECTION VII</b>	
Anti-Surge Bleed System .....	7-1
<b>SECTION VIII</b>	
Engine Anti-Icing System .....	8-1
<b>SECTION IX</b>	
Constant Speed Generator Drive System .....	9-1
<b>SECTION X</b>	
Drainage Provisions .....	10-1
ALPHABETICAL INDEX .....	1

# INTRODUCTION

## POWER PLANT MANUAL

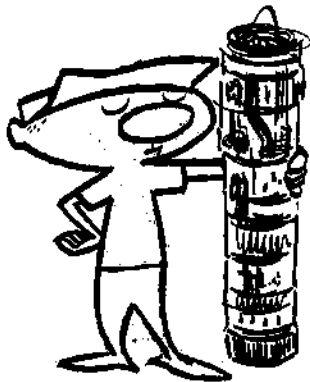

### EFFECTIVITY

The information contained in this manual is *applicable to F-106A airplanes 56-453, -454, 56-456 and subsequent, and F-106B airplanes 57-2508 and subsequent.* When the information on a particular system, component, or procedure is peculiar to a certain model or series, applicability to that model and the airplanes affected is specified.

### DESCRIPTION

This subsection contains the step-by-step checkout of the system and components to assure that minimum requirements for the proper operation of the system are met.

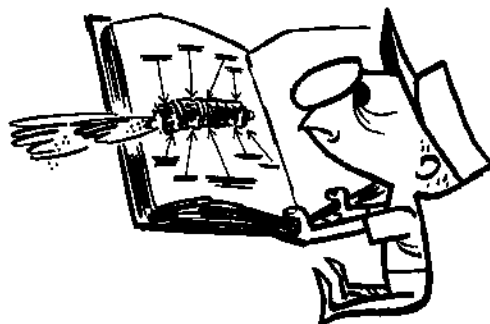

### OPERATIONAL CHECKOUT

This subsection contains the step-by-step checkout of the system and components to assure that minimum requirements for the proper operation of the system are met.

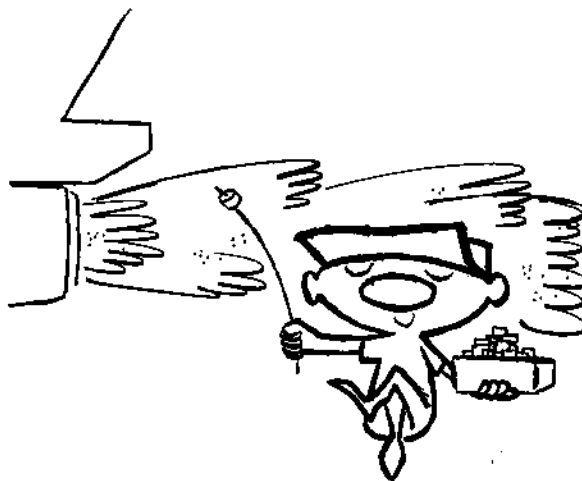

## SYSTEM ANALYSIS

Contained under this heading is a list of troubles which could develop within the system or in one of its components. The trouble shooting chart lists the possible cause of the malfunction, indicates the isolation procedure to direct the mechanic as easily as possible to the trouble area, and prescribes the remedial maintenance action.



## REPLACEMENT

This subsection contains detailed step-by-step procedures for removal and installation of system components.

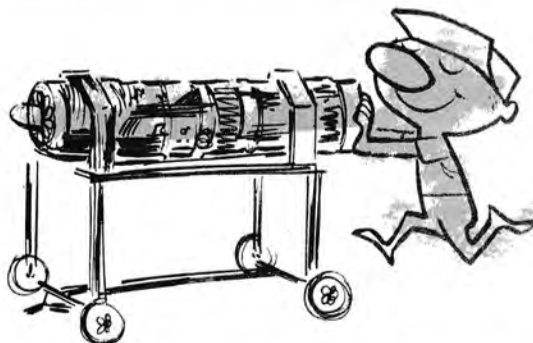

## ADJUSTMENT

This subsection includes detailed step-by-step procedures for the adjustment of the complete system and the system components.

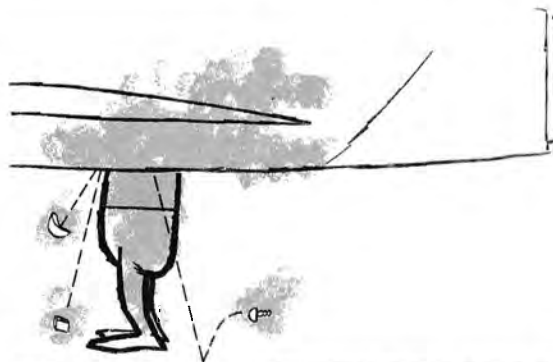

## SERVICING

This subsection includes instructions for cleaning, draining, replenishing, and lubricating the system and components.

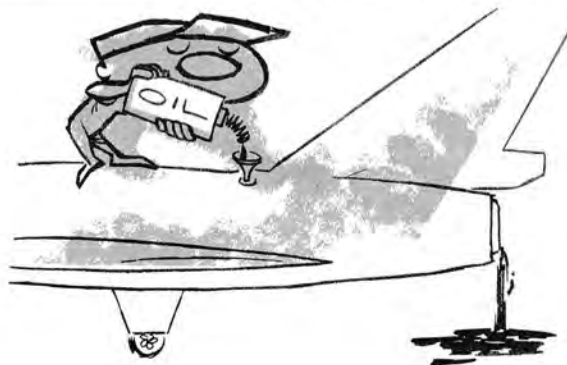

**LIST OF F-106A AND F-106B SYSTEMS MAINTENANCE MANUALS**

- |                   |  |                   |  |
|-------------------|--|-------------------|--|
| T.O. 1F-106A-2-1  | General Airplane   | T.O. 1F-106A-2-15 | Aircraft and Weapon Control Interceptor Systems, Type MA-1 and Type AN/ASQ-25, Dock Instructions   |
| T.O. 1F-106A-2-2  | Ground Handling, Servicing, And Airframe Group Maintenance | T.O. 1F-106A-2-24 | Aircraft and Weapon Control Interceptor System, Type MA-1, Wiring Data (F-106A); Serial Nos. 57-246, 57-2453 thru 57-2464, 57-2466 thru 57-2506.   |
| T.O. 1F-106A-2-3  | Hydraulic and Pneumatic Power Systems                      | T.O. 1F-106B-2-24 | Aircraft and Weapon Control Interceptor System, Type AN/ASQ-25, Wiring Data (F-106B); Serial Nos. 57-2516 thru 57-2522, 57-2524 thru 57-2531.  |
| T.O. 1F-106A-2-4  | Power Plant  | T.O. 1F-106A-2-25 | Aircraft and Weapon Control Interceptor System, Type MA-1, Wiring Data (F-106A); Serial Nos. 56-453, 56-454, 56-456 thru 56-467, 57-230 thru 57-238, 57-240 thru 57-245, 57-2465, 58-759 and subsequent. |
| T.O. 1F-106A-2-5  | Fuel Supply System   | T.O. 1F-106B-2-25 | Aircraft and Weapon Control Interceptor System, Type AN/ASQ-25, Wiring Data (F-106B); Serial Nos. 57-2508 thru 57-2515, 57-2523, 57-2532 and subsequent.   |
| T.O. 1F-106A-2-6  | Air Conditioning, Anti-Icing, And Oxygen Systems           | T.O. 1F-106A-2-27 | MA-1 AWCIS Pocketbook  |
| T.O. 1F-106A-2-7  | Flight Control Systems                                     | Vol. I            | Flight Line Instructions   |
| T.O. 1F-106A-2-8  | Landing Gear   | Vol. II           | Dock Instructions for Power, Radar and AAI Subsystems  |
| T.O. 1F-106A-2-9  | Instrument Systems   | Vol. III          | Dock Instructions for FC&M, Computer, CN&L Subsystems  |
| T.O. 1F-106A-2-10 | Electrical Systems   |                   |  |
| T.O. 1F-106A-2-12 | Armament Systems   |                   |  |
| T.O. 1F-106A-2-13 | Wiring Diagrams, Airframe (F-106A)                         |                   |  |
| T.O. 1F-106B-2-13 | Wiring Diagrams, Airframe (F-106B)                         |                   |  |

**SUPPLEMENTARY DATA**

- |                     |  |                        |  |
|---------------------|--|------------------------|--|
| T.O. 1F-106A-01     | List of Applicable Publications                            | T.O. 1F-106A-10        | Power Package Buildup Instructions           |
| T.O. 1F-106A-1      | Flight Manual  | T.O. 1F-106A-16-1      | Weapon Loading Procedures                    |
| T.O. 1F-106B-1      | Flight Manual  | T.O. 1F-106A-16-2      | Job-Oriented Weapon Loading Procedures       |
| T.O. 1F-106A-CL-1-1 | Pilot's Checklist  | T.O. 1F-106A-CL-16-1-1 | Supervisory Control Sheet                    |
| T.O. 1F-106B-CL-1-1 | Pilots' Checklist  | T.O. 1F-106A-CL-16-1-2 | Loading Crew Chief's Abbreviated Checklist   |
| T.O. 1F-106A-3      | Structural Repair Manual                                   | T.O. 1F-106A-17        | Storage of Aircraft                          |
| T.O. 1F-106A-4      | Illustrated Parts Breakdown                                | T.O. 1F-106A-18        | Field Maintenance of Airborne Material       |
| T.O. 1F-106B-4      | Illustrated Parts Breakdown                                | T.O. 1F-106A-20        | Product Improvement Digest                   |
| T.O. 1F-106A-5      | Basic Weight Checklist and Loading Data                    | T.O. 1F-106A-21        | Master Guide Aircraft Inventory Record       |
| T.O. 1F-106B-5      | Basic Weight Checklist and Loading Data                    | T.O. 1F-106A-29        | Aircrew Weapon Delivery                      |
| T.O. 1F-106A-6      | Aircraft Scheduled Inspection and Maintenance Requirements | T.O. 1F-106A-CL-29-1   | Aircrew Weapon Delivery Procedures Checklist |

## Section I

### POWER PLANT GENERAL

<i>Contents</i>	<i>Page</i>
Description .....	1-1
Operational Checkout .....	1-11
System Analysis .....	1-27
Replacement .....	1-33
Adjustment .....	1-66
Servicing .....	1-87
Extreme Weather Conditions .....	1-96

#### DESCRIPTION

#### 1-1. GENERAL

F-106A and F-106B airplanes are powered by Pratt and Whitney J75 continuous flow gas turbine engines. See figures 1-1 and 1-2 for illustrations of the engine installation in relation to the airplane fuselage. The engine consists of the following major sections: the compressor section, the combustion section, the turbine section, the afterburner section, and the accessory section. See figure 1-3 for an illustration of the engine sections. The engine incorporates an axial flow compressor, an eight-unit combustion chamber, a split three-stage turbine, and an afterburner equipped with a two-position iris type exhaust nozzle. The axial flow compressor consists of two sections of eight and seven stages each. The eight-stage or N1 compressor is a low-pressure unit, connected by a through shaft to the second and third stage turbine wheels. The seven-stage or N2 compressor section is a high-pressure unit, connected to the first stage turbine wheel by a hollow shaft that encircles the N1 compressor shaft.

#### NOTE

Air inlet section and tailcone covers must be used at all times during nonmaintenance periods. Engine must be covered during an inlet section inspection after transit operations. After each maintenance operation personnel must inventory tools and parts used. Inlet guide section of engine must not be used as resting place for tools, parts, nuts, bolts, etc. during maintenance operation.

#### 1-2. DIRECTIONAL REFERENCES.

Right and left, clockwise and counterclockwise, upper and lower, and similar directional references apply to the engine as viewed from the rear or afterburner end. The engine is in the normal horizontal position with the N2 accessory section at the bottom. Direction of rotation of the compressor and turbine assemblies is clockwise. The combustion chambers are numbered from one through eight in a clockwise direction, with the number one burner being located to the right of the top centerline of the engine.

#### 1-3. ENGINE MOUNTED ACCESSORIES AND SYSTEMS.

Description and operation of engine systems will be found in the applicable sections of this manual. Installation and removal procedures for accessories are incorporated with the system illustration. See figure 1-4 for an illustration of the engine assembly.

#### 1-4. COMPRESSOR SECTION.

The compressor section is made up of the inlet guide vane and shroud, front accessory drive support, compressor front bearing support, N1 low-pressure compressor assembly, N1 accessory section, compressor intermediate case, N2 high-pressure compressor assembly, and the diffuser case. In operation, the compressor section supplies the combustion section of the engine with a high-velocity flow of compressed air. The compressor is divided into two sections. The first is the low-pressure or N1 compressor, which consists of eight compression stages. The second section is the high-pressure or N2 compressor section, which is made up of seven compression stages. The N1 compressor is connected by a shaft to the second and third

**NOTE**

IN ESTABLISHING LOCATION OF EQUIPMENT IN THE AIRPLANE, REFERENCES ARE SOME TIMES MADE TO STA. (STATION) 'BL' (BUTTOCK LINE) AND WL (WATERLINE). THESE TERMS ARE EXPLAINED AS FOLLOWS: STATIONS ARE MEASURED IN INCHES, EITHER FORE OR AFT FROM STATION 0.00. FOR EXAMPLE, STATION -44.90 IS A POINT 44.90 INCHES FORWARD OF STATION 0.00 WHILE STATION 40.89 IS A POINT 40.89 INCHES AFT OF STATION 0.00.

BL 0.00 REFERS TO THE VERTICAL CENTERLINE OF THE AIRPLANE. ALL DIMENSIONS OUTBOARD ARE MEASURED IN INCHES FROM THIS POINT. WL 0.00 IS AN ARBITRARILY ESTABLISHED HORIZONTAL PLANE FROM WHICH VERTICAL DIMENSIONS ARE MEASURED IN INCHES. DIMENSIONS BELOW THIS PLANE ARE TERMED MINUS; DIMENSIONS ABOVE ARE TERMED PLUS. FOR EXAMPLE, WL -17.00 IS A POINT 17.00 INCHES BELOW WL 0.00.

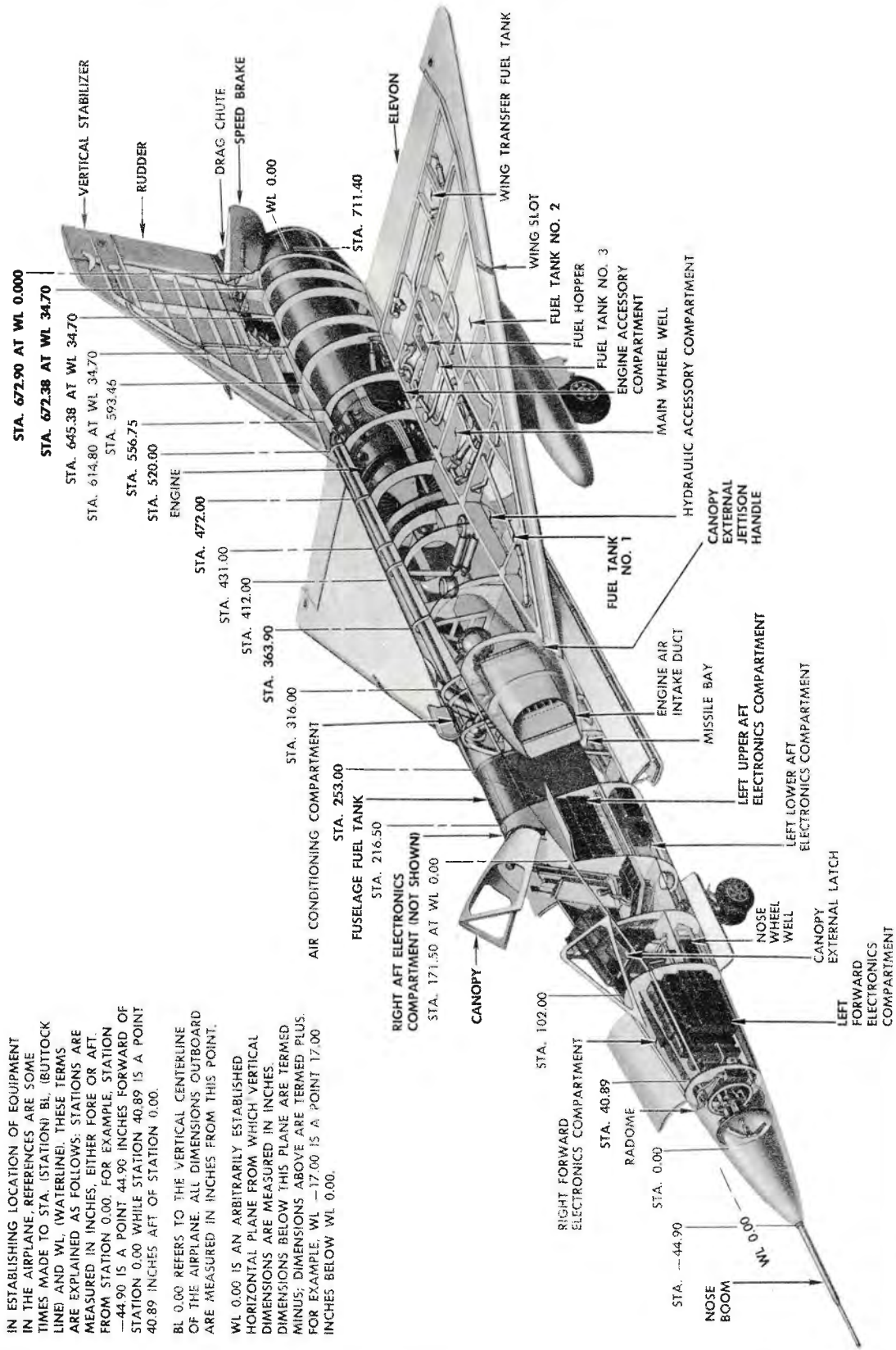
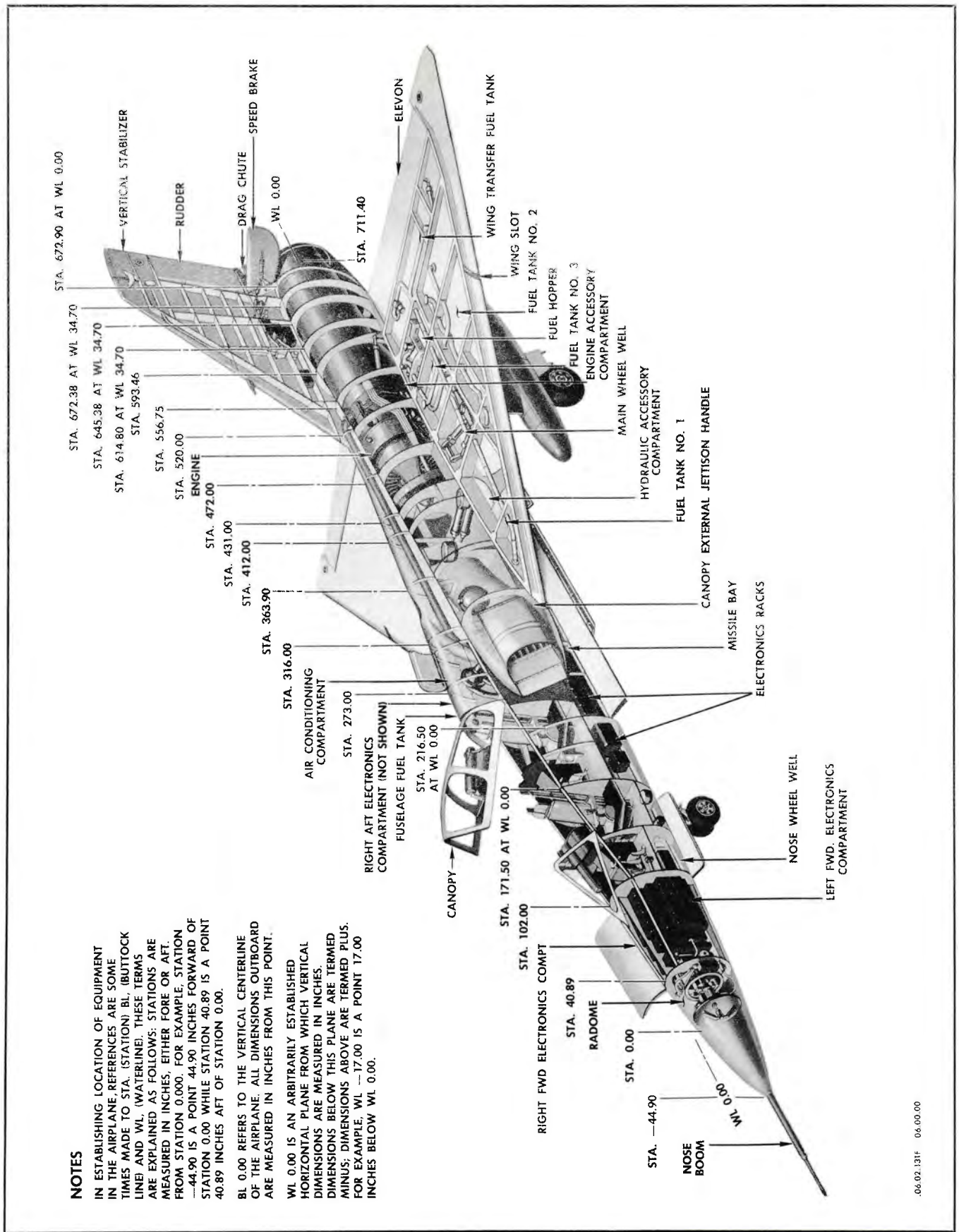

Figure 1-1. Airplane Stations and Compartments, F-106A





06.02.131F 06.00.00

Figure 1-2. Airplane Stations and Compartments, F-106B

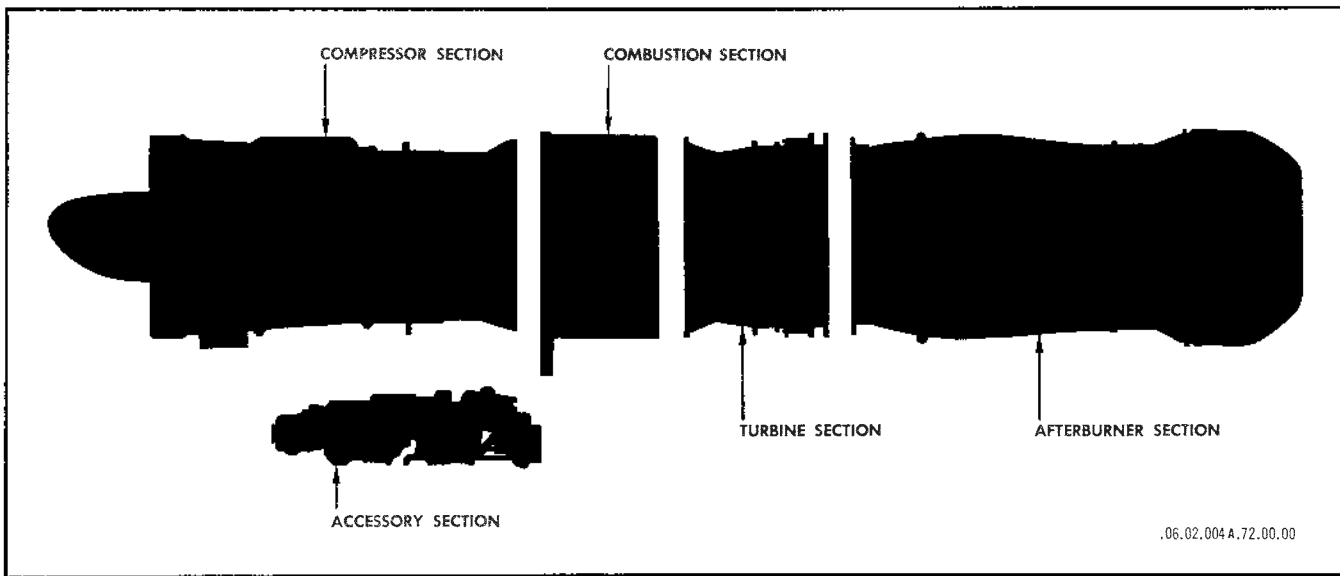

Figure 1-3. Engine Sections

stage turbine wheels. The  $N_2$  compressor is connected to the first stage turbine wheel by a hollow shaft that encircles the inner shaft. Each rotor assembly is free to rotate at its optimum speed. The engine starter is connected only to the  $N_2$  compressor rotor, thereby reducing the required size of the starter system. The forward accessory drive section is mounted on the forward face of the compressor inlet guide vane and shroud center support. This accessory section is not used on F-106 type airplanes. Lubrication lines for the compressor front bearing are routed through the inlet guide vanes.

#### 1-5. COMBUSTION SECTION.

The combustion section is of the can-annular configuration with eight cylindrical combustion chambers (cans). The separate combustion chambers are supported by the nozzle clusters of the fuel manifold at the front and by the exit duct at the rear. Cross-over tubes located on each side of the combustion chambers serve as flame connectors. Ignition sparkigniters are inserted into the forward end of the No. 4 and 5 combustion chambers. A one-piece cylindrical combustion chamber outer case completely encloses this section.

#### 1-6. TURBINE SECTION.

The turbine section consists of the turbine front bearing support, turbine nozzle case, compressor drive turbine assembly, and the turbine exhaust case. The compressor drive turbine assembly consists of three stages. The first stage drives the  $N_2$  compressor; the second and third stages drive the  $N_1$  compressor. In each stage of the turbine, a nozzle ring precedes the turbine wheel. The force of the combustion gases being routed against the turbine rotors causes the rotors to turn and drive the compressors. The gases continue traveling aft into the afterburner diffuser section of the engine.

#### 1-7. AFTERBURNER SECTION.

The afterburner section consists of the afterburner diffuser, afterburner duct, and the variable area two-position exhaust nozzle assembly. The afterburner diffuser section of the engine contains 24 equally spaced spray nozzles located radially around the inner diameter of the diffuser section and three concentric flameholders. Metered fuel from the afterburner fuel control is routed to the spray nozzles during afterburning. Due to temperature limitations, only a relatively small amount of the air entering the engine can be used for combustion ahead of the turbine. There remains a large amount of unused oxygen in the air aft of the turbine section. The injection of metered fuel from the afterburner spray nozzles and the subsequent ignition produces additional thrust. The exhaust nozzle assembly is composed of iris type shutters, which are operated by pneumatic actuating cylinders. The pneumatic cylinders are mounted around the outer diameter of the afterburner duct, and are actuated by compressor bleed air from the exhaust nozzle control valve. During normal engine operation, the cylinders hold the nozzle iris in the closed position. When afterburning occurs, the cylinders open the nozzle to permit the less restricted passage of engine and afterburning gases.

#### 1-8. ACCESSORY SECTION.

The accessory section is located at the bottom of the engine at the "wasp waist" or smallest engine diameter. Components mounted in the  $N_2$  accessory section area are the oil pump and accessory drive housing, fuel pressurizing and dump valve, fuel pump, main fuel control unit, afterburner fuel control unit, and the exhaust nozzle control. The two hydraulic pumps, engine starter, and constant-speed drive system engine mounted gearbox are installed on the forward face of the oil pump and

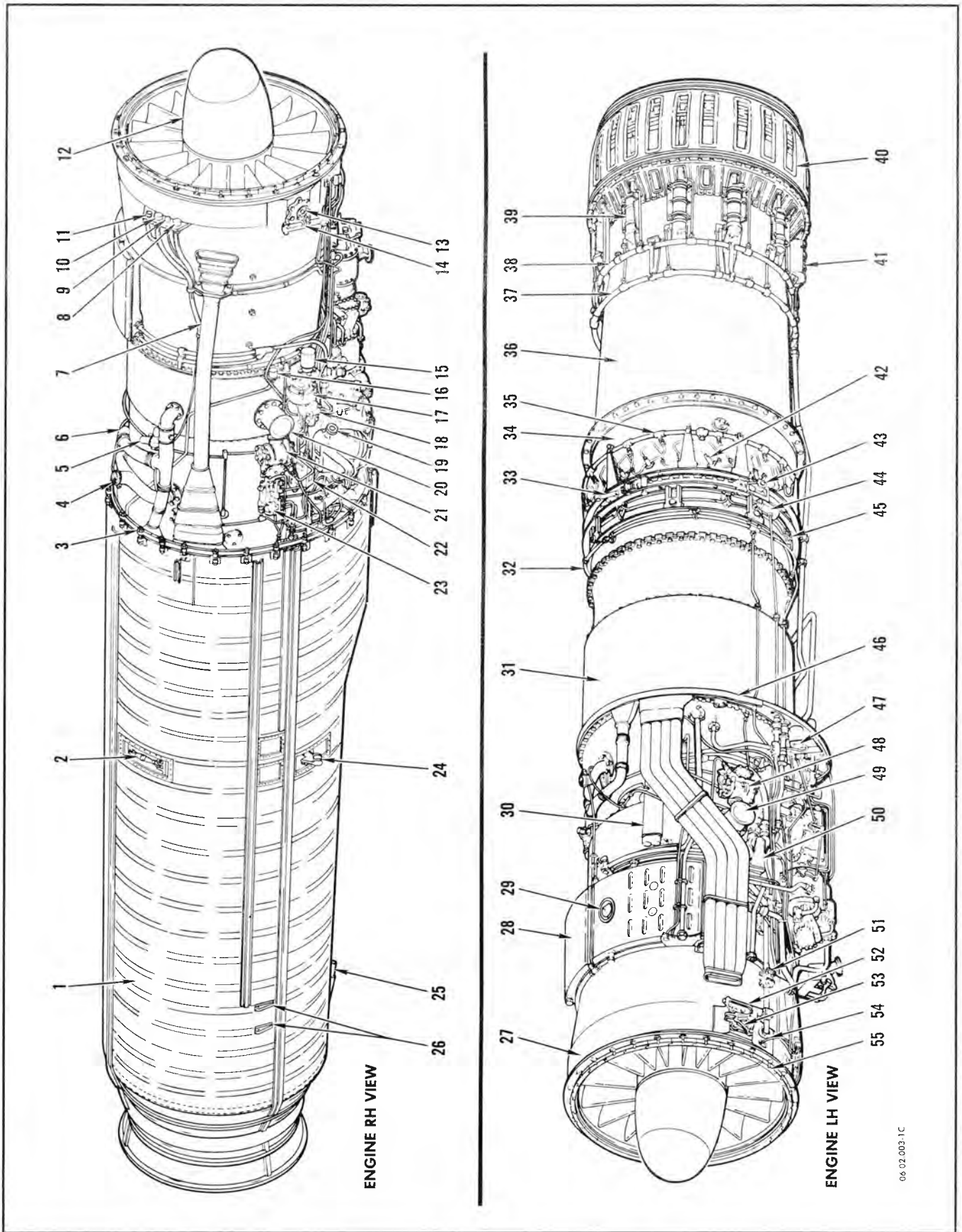
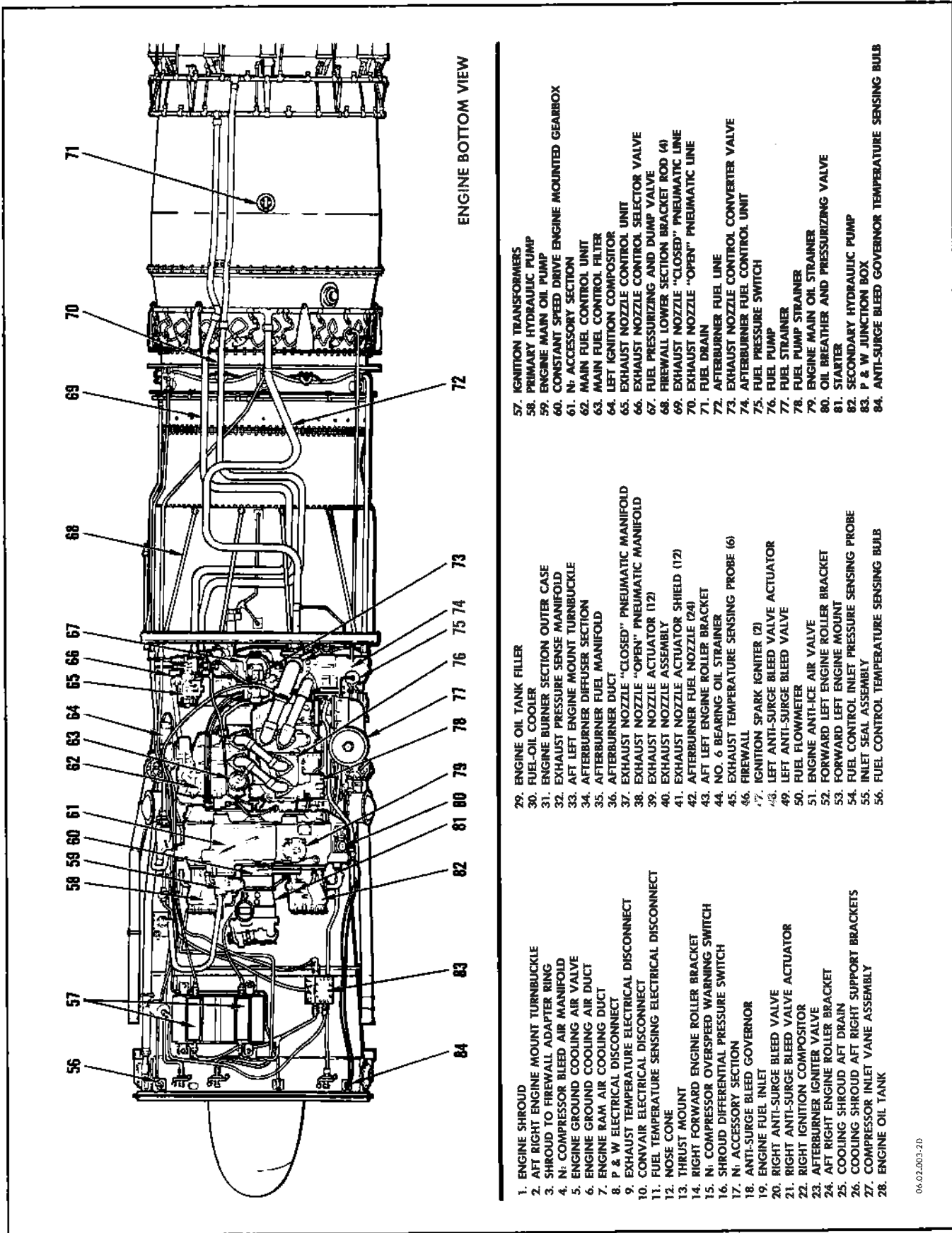

Figure 1-4. Engine Assembly (Sheet 1 of 2)



ENGINE BOTTOM VIEW

- 1. ENGINE SHROUD
- 2. AFT RIGHT ENGINE MOUNT TURNBUCKLE
- 3. SHROUD TO FIREWALL ADAPTER RING
- 4. N: COMPRESSOR BLEED AIR MANIFOLD
- 5. ENGINE GROUND COOLING AIR VALVE
- 6. ENGINE GROUND COOLING AIR DUCT
- 7. ENGINE RAM AIR COOLING DUCT
- 8. P & W ELECTRICAL DISCONNECT
- 9. EXHAUST TEMPERATURE ELECTRICAL DISCONNECT
- 10. CONVAIR ELECTRICAL DISCONNECT
- 11. FUEL TEMPERATURE SENSING ELECTRICAL DISCONNECT
- 12. NOSE CONE
- 13. THRUST MOUNT
- 14. RIGHT FORWARD ENGINE ROLLER BRACKET
- 15. N: COMPRESSOR OVERSPEED WARNING SWITCH
- 16. SHROUD DIFFERENTIAL PRESSURE SWITCH
- 17. N: ACCESSORY SECTION
- 18. ANTI-SURGE BLEED GOVERNOR
- 19. ENGINE FUEL INLET
- 20. RIGHT ANTI-SURGE BLEED VALVE
- 21. RIGHT ANTI-SURGE BLEED VALVE ACTUATOR
- 22. RIGHT IGNITION COMPOSITOR
- 23. AFTERBURNER IGNITER VALVE
- 24. AFT RIGHT ENGINE ROLLER BRACKET
- 25. COOLING SHROUD AFT DRAIN
- 26. COOLING SHROUD AFT RIGHT SUPPORT BRACKETS
- 27. COMPRESSOR INLET VANE ASSEMBLY
- 28. ENGINE OIL TANK
- 29. ENGINE OIL TANK FILLER
- 30. FUEL-OIL COOLER
- 31. ENGINE BURNER SECTION OUTER CASE
- 32. EXHAUST PRESSURE SENSE MANIFOLD
- 33. AFT LEFT ENGINE MOUNT TURNBUCKLE
- 34. AFTERBURNER DIFFUSER SECTION
- 35. AFTERBURNER FUEL MANIFOLD
- 36. AFTERBURNER DUCT
- 37. EXHAUST NOZZLE "CLOSED" PNEUMATIC MANIFOLD
- 38. EXHAUST NOZZLE "OPEN" PNEUMATIC MANIFOLD
- 39. EXHAUST NOZZLE ACTUATOR (12)
- 40. EXHAUST NOZZLE ASSEMBLY
- 41. EXHAUST NOZZLE ACTUATOR SHIELD (12)
- 42. AFTERBURNER FUEL NOZZLE (24)
- 43. AFT LEFT ENGINE ROLLER BRACKET
- 44. NO. 6 BEARING OIL STRAINER
- 45. EXHAUST TEMPERATURE SENSING PROBE (6)
- 46. FIREWALL
- 47. IGNITION SPARK IGNITER (2)
- 48. LEFT ANTI-SURGE BLEED VALVE ACTUATOR
- 49. LEFT ANTI-SURGE BLEED VALVE
- 50. FUEL FLOWMETER
- 51. ENGINE ANTI-ICE AIR VALVE
- 52. FORWARD LEFT ENGINE ROLLER BRACKET
- 53. FORWARD LEFT ENGINE MOUNT
- 54. FUEL CONTROL INLET PRESSURE SENSING PROBE
- 55. INLET SEAL ASSEMBLY
- 56. FUEL CONTROL TEMPERATURE SENSING BULB
- 57. IGNITION TRANSFORMERS
- 58. PRIMARY HYDRAULIC PUMP
- 59. ENGINE MAIN OIL PUMP
- 60. CONSTANT SPEED DRIVE ENGINE MOUNTED GEARBOX
- 61. N: ACCESSORY SECTION
- 62. MAIN FUEL CONTROL UNIT
- 63. MAIN FUEL CONTROL FILTER
- 64. LEFT IGNITION COMPOSITOR
- 65. EXHAUST NOZZLE CONTROL UNIT
- 66. EXHAUST NOZZLE CONTROL SELECTOR VALVE
- 67. FUEL PRESSURIZING AND DUMP VALVE
- 68. FIREWALL LOWER SECTION BRACKET ROD (4)
- 69. EXHAUST NOZZLE "CLOSED" PNEUMATIC LINE
- 70. EXHAUST NOZZLE "OPEN" PNEUMATIC LINE
- 71. FUEL DRAIN
- 72. AFTERBURNER FUEL LINE
- 73. EXHAUST NOZZLE CONTROL CONVERTER VALVE
- 74. AFTERBURNER FUEL CONTROL UNIT
- 75. FUEL PRESSURE SWITCH
- 76. FUEL PUMP
- 77. FUEL STRAINER
- 78. FUEL PUMP STRAINER
- 79. ENGINE MAIN OIL STRAINER
- 80. OIL BREATHER AND PRESSURIZING VALVE
- 81. STARTER
- 82. SECONDARY HYDRAULIC PUMP
- 83. P & W JUNCTION BOX
- 84. ANTI-SURGE BLEED GOVERNOR TEMPERATURE SENSING BULB

06.02.003.2D

Figure 1-4. Engine Assembly (Sheet 2 of 2)

accessory drive housing. The engine starter is geared through the oil pump and accessory drive housing to the  $N_2$  compressor rotor by interconnecting shafts. These interconnecting shafts, in turn, transmit power from the  $N_2$  rotor to the oil pump and accessory drive housing for driving the engine accessories during engine operation.

The  $N_2$  accessory drive adapter is bolted to the lower right side of the compressor intermediate case. The  $N_1$  accessory section is installed on the lower right-hand side of the engine adjacent to the  $N_2$  accessory section. The compressor bleed valve governor is mounted on this accessory section. Power for driving the  $N_1$  accessory section is taken from the aft end of the  $N_1$  compressor rotor.

### 1-9. ENGINE INSTRUMENT SYSTEMS AND RELATED EQUIPMENT.

For a description of engine indicating units not found in the following list, refer to system descriptions in the various sections of this manual. Refer to T. O. 1F-106A-2-9 for instrument and indicating systems maintenance information.

ITEM	LOCATION	FUNCTION
Tachometer Indicator.	Pilot's panel.	To provide pilot with an indication of $N_2$ compressor rpm.
Pressure Ratio Indicator.	Pilot's panel.	To provide pilot with an indication of engine thrust output.
Exhaust Temperature Indicator.	Pilot's panel.	To provide pilot with an indication of engine exhaust gas temperature.
Fuel Flow Indicator.	Pilot's panel.	To provide pilot with an indication of the fuel consumption of the engine.
$N_1$ Compressor Overspeed Warning Light.	Master warning panel.	To provide pilot with an indication of $N_1$ compressor overspeed.
Engine Oil Pressure Indicator.	Pilot's panel.	To provide pilot with an indication of engine oil pressure.
Engine Oil Low-Pressure Warning Light.	Master warning panel.	To provide pilot with a warning indication of low engine oil pressure.
Variable Ramp Not Retracted Warning Light.	Pilot's panel.	To provide pilot with an indication that the ramps are not fully retracted.
Fire and Overheat Detection Warning Light and Test Switch.	Pilot's Panel.	To provide pilot with a warning indication of fire or overheat conditions around the engine.

### 1-10. ENGINE EXHAUST TEMPERATURE INDICATING SYSTEM.

The engine exhaust temperature indicating system consists of six alumel-chromel thermocouples installed in the engine exhaust duct, an indicator on the pilot's main instrument panel on F-106A airplanes, a calibrating resistor, and a connecting electrical circuit. On F-106B airplanes two indicators are incorporated, one on the forward instrument panel, and one on the aft instrument panel. The thermocouples sense exhaust temperature and send electrical signals to the indicator which registers the exhaust temperature in degrees centigrade. A calibrating resistor is used to calibrate the circuit whenever any component is replaced. The resistor is

mounted on the structural member forward of the instrument panel, on the right side of the fuselage at sta. 118.0. Whenever an engine is replaced, the circuit must be recalibrated since resistance of the thermocouple loop circuit incorporated in the replacement engine may differ. For the system calibration procedure and additional system information, refer to T.O. 1F-106A-2-9.

### 1-11. FUEL FLOW INDICATING SYSTEM.

The fuel flow indicating system indicates the rate of fuel flow to the engine in pounds per hour. The system consists of a fuel flow indicator, a fuel flow meter (transmitter), and connecting electrical leads. The indicator is located on the pilot's main instrument panel on

F-106A airplanes, and on the forward and aft main instrument panels on F-106B airplanes. The flowmeter is mounted on the outlet side of the fuel control unit on the engine. All fuel entering the engine except afterburning fuel, passes through the flow meter. The flowmeter incorporates a vane and hub assembly, an ac synchro transmitter, and a magnetic coupling device. The rate of fuel flow is transmitted from the vane and hub assembly to the synchro transmitter by the magnetic coupling. For additional information on this system, refer to T.O. 1F-106A-2-9.

#### 1-12. TACHOMETER SYSTEM.

The tachometer system is provided to indicate the speed of the airplane engine high-pressure (N<sub>2</sub>) compressor in percent of rated rpm. The system consists of a tachometer and a tachometer generator. On F-106A airplanes, the tachometer indicator is located on the pilot's main instrument panel. F-106B airplanes incorporate two indicators, one on the forward main instrument panel, and one on the aft main instrument panel. The indicator is remotely positioned by the tachometer generator mounted on the aft left side of the N<sub>2</sub> accessory drive gear train. The output of the generator is directly proportional to the speed of the engine N<sub>2</sub> compressor. The tachometer indicates engine speed from 0 to 110%. The rated rpm varies with each engine and is stamped on the engine data plate. For additional information on this system, refer to T.O. 1F-106A-2-9.

#### 1-13. ENGINE PRESSURE RATIO INDICATING SYSTEM.

The engine pressure ratio indicating system indicates the ratio of exhaust pressure to pitot (ram air) pressure. The pressure ratio indicating system consists of an engine pressure probe, a pressure ratio transmitter in the nose wheel well, a pressure ratio indicator in the cockpit, and connecting tubing. The pressure ratio indicator is mounted on the pilot's main instrument panel on F-106A airplanes, and on the forward and aft main instrument panels on F-106B airplanes. Exhaust pressure is conducted from the engine pressure probe, through tubing, to the transmitter. Pitot pressure from the pitot-static system is also conducted to the transmitter where turbine discharge (engine exhaust) pressure is compared to pitot pressure. The indicator presents the ratio of exhaust-to-pitot pressure (thrust) on the face of the dial. Drains are provided in the system tubing on the aft bulkhead of the nose wheel well compartment. Frequent draining of the system at the drain points is mandatory, especially during cold weather operation. For draining procedures and additional information on this system, refer to T.O. 1F-106A-2-9.

#### 1-14. ENGINE OIL PRESSURE INDICATING SYSTEM.

The engine oil pressure indicating system consists of a single indicator on the main instrument panel of the F-106A

airplanes. On F-106B airplanes, separate indicators are installed on the forward and aft instrument panels. The system consists of the indicator in the cockpit, a pressure transmitter installed on the N<sub>2</sub> accessory section oil pressure port, and the connecting circuit. Electrical power is taken from the 26-volt instrument transformer located in the nose wheel well. Oil pressure is indicated by a single pointer on the instrument face, marked in 5 pound increments from 0 psi to 100 psi. For additional information on this system, refer to T.O. 1F-106A-2-9.

#### 1-15. OIL LOW-PRESSURE WARNING SYSTEM.

The oil low-pressure warning system is provided to give the pilot an indication of low engine oil pressure. The system consists of an oil pressure warning light on the warning indication panel and a pressure switch in the engine accessory gear case oil pressure port. On F-106A airplanes, the indicator is installed on the warning indication panel on the right side of the cockpit. F-106B airplanes have two warning indication panels; one below the forward main instrument panel, and one below the aft main instrument panel. The oil low-pressure warning switch is set to extinguish the warning light on an increasing pressure of 40 psi maximum, and to illuminate the light on a decreasing pressure of 37(±2) psi.

#### 1-16. VARIABLE RAMP NOT RETRACTED WARNING SYSTEM.

*Applicable to F-106A airplanes 57-246 thru 59-058. Applicable to F-106B airplanes 57-2516 thru 58-904.* An amber warning light, placarded "VARIABLE RAMP NOT RETRACTED," is located on the pilot's main instrument panel on F-106A airplanes, and on the forward instrument panel only on F-106B airplanes. On F-106A airplanes 56-453, -454, 56-456 thru 57-245, 59-059 and subsequent, and on F-106B airplanes 57-2508 thru 57-2515, 59-149 and subsequent, the ramp position warning light is located on the Master Warn Panel. The light illuminates to indicate that the variable ramps have not retracted. Retraction normally occurs when the airplane decelerates to below Mach 1.20. During emergency operation, the light will remain illuminated until the ramps have fully retracted. The warning light receives 28-volt dc power from the essential bus through a 5-ampere circuit fuse in the cockpit left fuse panel. Power is directed to the warning light when the variable ramp control unit deenergizes a ramp position warning light relay. With the ramp position relay deenergized, electrical power is free to pass through the variable ramp retract limit switch to the warning light if the switch is still in the extended position. The ramp position warning light relay is installed on the right side of the nose wheel well compartment. The variable ramp not retracted warning light is a push-to-test type light. The variable ramp not

retracted warning system is an integrated part of the variable ramp control circuit. Refer to T.O. 1F-106A-2-9 for additional information on this system.

### 1-17. FIRE AND OVERHEAT DETECTION SYSTEM.

The fire and overheat detection system warns the pilot of fire or overheat conditions around the engine. The pilot receives visual indication of this condition when the "FIRE" warning light illuminates. The light is on the pilot's instrument panel *on F-106A airplanes*, and on the forward and aft instrument panels *on F-106B airplanes*. The system operates on electrical power from the 28-volt dc essential bus through the 5-ampere "FIRE & OVERHEAT WARN" fuse in the main wheel well fuse panel. Power for testing the system originates from the 28-volt dc essential bus through the "FIRE & OVERHEAT TEST" fuse in the cockpit right fuse panel *on F-106A airplanes*, and in the cockpit right forward fuse panel *on F-106B airplanes*.

1-18. *Applicable to F-106A airplanes 57-246 thru 57-2465, and F-106B airplanes 57-2516 thru 57-2522.* The fire detection system consists of an overheat detect loop, a fire detect loop, an overheat detector, a fire detector, an overheat detector flasher, an overheat detect relay, a fire detect relay, a test switch, and the "FIRE" warning light. The "FIRE" warning light is connected to the master warning dimming relay for dimming purposes. The fire detect loop is installed around the inner perimeter of the fuselage in the engine section. The overheat loop is installed around the inner perimeter of the fuselage in the afterburner section. When an overheat condition exists, the overheat detect loop completes a circuit through the overheat detector to the overheat detector flasher. The overheat detector flasher, in the right missile bay, intermittently illuminates the "FIRE" warning light. A fire condition is detected in a similar manner. When a fire condition exists the fire detect loop completes a circuit through the fire detector directly to the "FIRE" warning light. Under fire conditions the warning light illumination is steady. The fire and overheat detection

system test switch is on the pilot's instrument panel *on F-106A airplanes*, and on the forward instrument panel *on F-106B airplanes*. The test switch is normally positioned in the "OFF" position. When the test switch is placed in the "OVERHEAT" position, the overheat detect relay is energized and the "FIRE" warning light flashes on and off. When the test switch is placed in the "FIRE" position, the fire detect relay is energized and "FIRE" warning light is steadily illuminated.

1-19. *Applicable to F-106A airplanes 56-453, -454, 56-456 thru 57-245, 57-2466 and subsequent, and F-106B airplanes 57-2508 thru 57-2515, 57-2523 and subsequent.* Fire and overheat detection is accomplished by a system incorporating two parallel detector loops (loop 1 and loop 2) installed around the inner perimeter of the fuselage. The detector loops surround the entire length of the engine. Included in the fire and overheat detection system with loop 1 and loop 2 is a detector control box for each loop, a test relay for each loop, and an induction relay for each loop. The system also consists of an overheat flasher, a fire warning relay, a test switch, and the "FIRE" warning light with a dimming switch. The "FIRE" warning light is the push-to-dim type. When an overheat condition exists in any area around the engine, but only severe enough to affect one loop, the "FIRE" warning light in the cockpit flashes on and off. In this condition, the detector loop affected completes a circuit through its detector control box and induction relay to the overheat flasher. The overheat flasher in the right missile bay then supplies intermittent electrical power to the warning light. If the overheat condition is severe enough to affect both loops, the flasher unit is bypassed and the "FIRE" warning light is steadily illuminated. The fire and overheat detection system test switch is on the pilot's instrument panel *on F-106A airplanes*, and on the forward instrument panel *on F-106B airplanes*. When the test switch is placed in either the "LOOP 1" or "LOOP 2" position, test relays are energized and the "FIRE" warning light will flash on and off. Refer to T.O. 1F-106A-2-10 for complete information on the fire and overheat detection system.

### 1-20. Engine Tools.

The following listed tools are manufactured by Pratt & Whitney Aircraft, East Hartford 8, Conn., and may be used for maintenance on J75 type engines.

NAME	TYPE AND STOCK NUMBER	USE AND APPLICATION
Guide	PWA-3095 (4920-169-8126)	Fuel pump drive shaft gear oil seal guide (large shaft).
Wrench	PWA-3626 (5120-095-3000)	Main oil screen check valve removal.
Sling	PWA-6580 (1730-696-6592)	Compressor rotor chamber outer case lifting.
Drift	PWA-6676 (5120-398-2911)	Starter drive and hydraulic pump drive face oil seal replacement.
Wrench	PWA-7025-2 (5120-303-0904)	Exhaust nozzle actuating cylinder rod end nut adjusting.

## 1-20. Engine Tools (Cont).

NAME	TYPE AND STOCK NUMBER	USE AND APPLICATION
Puller	PWA-7146 (5120-212-2474)	N <sub>1</sub> gear box oil seal housing, removal.
Truck	PWA-7355 (3920-037-5139)	Afterburner duct and nozzle support stand.
Adapter	HS-7355 (4920-653-8936)	Power assembly remote control adapter.
Sling	PWA-7356 (1730-294-3370)	Afterburner duct and nozzle assembly maintenance.
Burette Valve	PWA-7441 (4920-300-3856)	Fuel manifold pressure check tool.
Test Stand	PWA-8000 (4920-305-0197)	Main Fuel nozzle and afterburner manifold leak test stand.
Bracket — A/B Nozzle Lifting	PWA-8052 (4920-324-9583)	Afterburner nozzle replacement.
Indicator	PWA-8076 (4920-563-1347)	Turbine exhaust temperature test indicator.
Cover	PWA-9045 (4920-510-1234)	Main fuel nozzle cluster cover.
Puller	PWA-10008 (5120-511-1478)	Accessory drive oil seal housing replacement.
Bracket	PWA-10011 (1730-294-3143)	Afterburner duct and nozzle lifting brackets.
Guide	PWA-10012 (4920-693-8153)	Fuel control oil seal (small shaft) replacement.
Puller	PWA-10013 (5120-693-8154)	Afterburner flame holder tie rod replacement.
Wrench	PWA-10014 (5120-596-1196)	Main oil screen and spacer retaining nut replacement.
Wrench	PWA-10015 (5120-693-8155)	Oil pressure relief valve replacement.
Guide	PWA-10016 (4920-693-8156)	N <sub>1</sub> and N <sub>2</sub> tachometer shaft oil seal replacement.
Drift	PWA-10017 (5120-693-8157)	Fuel pump and fuel control oil seal replacement.
Base	PWA-10018 (4920-326-2011)	Fuel pump and fuel control oil seal replacement.
Wrench	PWA-10030 (5120-693-8158)	Fuel nozzle replacement.
Crimper	PWA-10031 (5120-693-8159)	Fuel nozzle tab lock installation.
Base	PWA-10034 (4920-506-3777)	N <sub>2</sub> tachometer drive oil seal replacement.
Drift	PWA-10035 (5120-511-1481)	N <sub>2</sub> tachometer drive oil seal replacement.
Clamp	PWA-10067 (4920-570-9005)	Fuel nozzle sealing replacement.
Seal	PWA-10067-D12 (4920-623-2829)	Neoprene seal for use with PWA No. 10067 (Excello fuel nozzle).
Seal	PWA-10067-D13 (4920-623-2830)	Neoprene seal for use with PWA No. 10067 (Delevan fuel nozzle).
Adapter	PWA-10068 (4920-570-9006)	Fuel manifold pressure check at engine.
Stand	PWA-10069 (4920-570-7384)	Afterburner nozzle actuation test stand.
Spreader	PWA-10077 (5120-570-7416)	Combustion chamber outlet duct clamp removal.
Collar	PWA-10080 (1730-555-4588)	Combustion chamber outer case lifting collar.
Drift	PWA-10226 (5120-534-0724)	Starter oil seal drift.
Drift	PWA-10228 (5120-534-0722)	Starter and hydraulic pump oil seal drift.
Wrench	PWA-10237 (5120-534-0719)	Anti-icing air tube retaining nut wrench.



## 1-20. Engine Tools (Cont).

NAME	TYPE AND STOCK NUMBER	USE AND APPLICATION
Puller	PWA-10290 (5120-592-6325)	Combustion chamber positioning pin puller.
Wrench	PWA-10318 (5120-541-6836)	Fuel manifold inlet adapter retaining nut wrench.
Support	PWA-10319 (5120-593-3564)	Fuel manifold inlet adapter retaining nut support.
Puller	PWA-10332 (5120-592-9079)	Main oil pump puller.
Fixture	PWA-10347 (4920-593-4099)	Main oil screen assembly fixture.
Puller	PWA-10392 (5120-593-9211)	Afterburner bypass fuel screen weldment puller.
Wrench	PWA-10480 (5120-610-6867)	Tube connecting nut spanner wrench.
Adapter	PWA-10518 (4920-611-2208)	Fuel manifold pressure test in diffuser case.
Adapter	PWA-10572 (4920-650-6272)	Fuel manifold pressure test in diffuser case.
Stand	PWA-10602 (4920-625-6851)	Fuel manifold pressure test in diffuser case.
Cap	PWA-10628 (4920-650-6311)	Fuel manifold pressure test in diffuser case.
Gage	PWA-10809 (5220 NSL)	First stage turbine blade stretch.
Spreader	PWA-10874 (5120-717-4818)	Combustion chamber outlet duct clamp removal.
Power Assembly	PWA-15180 (4920-589-9624)	Fuel control remote trimmer power assembly.
Adapter	PWA-15198 (4920-654-8433)	Power source cart adapter.

### OPERATIONAL CHECKOUT

## 1-21. ENGINE STARTING DESCRIPTION.

#### WARNING

The areas around engine air intake ducts can be dangerous to ground personnel during engine runup due to suction of inrushing air. The area aft of the engine tailpipe is dangerous because of the high temperature and velocity of exhaust gases. These danger areas are illustrated in figure 1-5. The tailpipe area remains dangerous for at least 15 minutes after engine shutdown, and particularly when smoke or vapors are apparent.

During the engine starting procedure, care must be exercised to correctly operate the starter, ignition, and throttle controls to successfully complete the engine start. Actuation of the combustion starter is initiated by first depressing the ignition button and holding. The throttle lever is then moved to the "START" position. This action opens the starter air solenoid valve permitting air

rotation of the starter to begin. Engine and starter ignition is also armed at this time. With the ignition button still depressed, the throttle is moved to the "OFF" position, then to "IDLE." The throttle movement during engine start is to be one continuous motion with no hesitation at the "OFF" position. Movement of the throttle from "START" to "IDLE" actuates the starter and engine ignition systems and permits fuel to be injected into the engine combustion chambers. Operation of the starter will continue as long as the ignition button is depressed, or until the starter fuel accumulator fuel supply is depleted, or upon actuation of the starter over-speed switch.

#### CAUTION

Adequate starter cooling periods must be observed at all times. Refer to paragraph 1-26 for combustion starter duty cycle limitations.

In the event the ignition button is momentarily released, when the throttle is between "OFF" and "IDLE," and an engine lightoff has not been attained, return the throttle

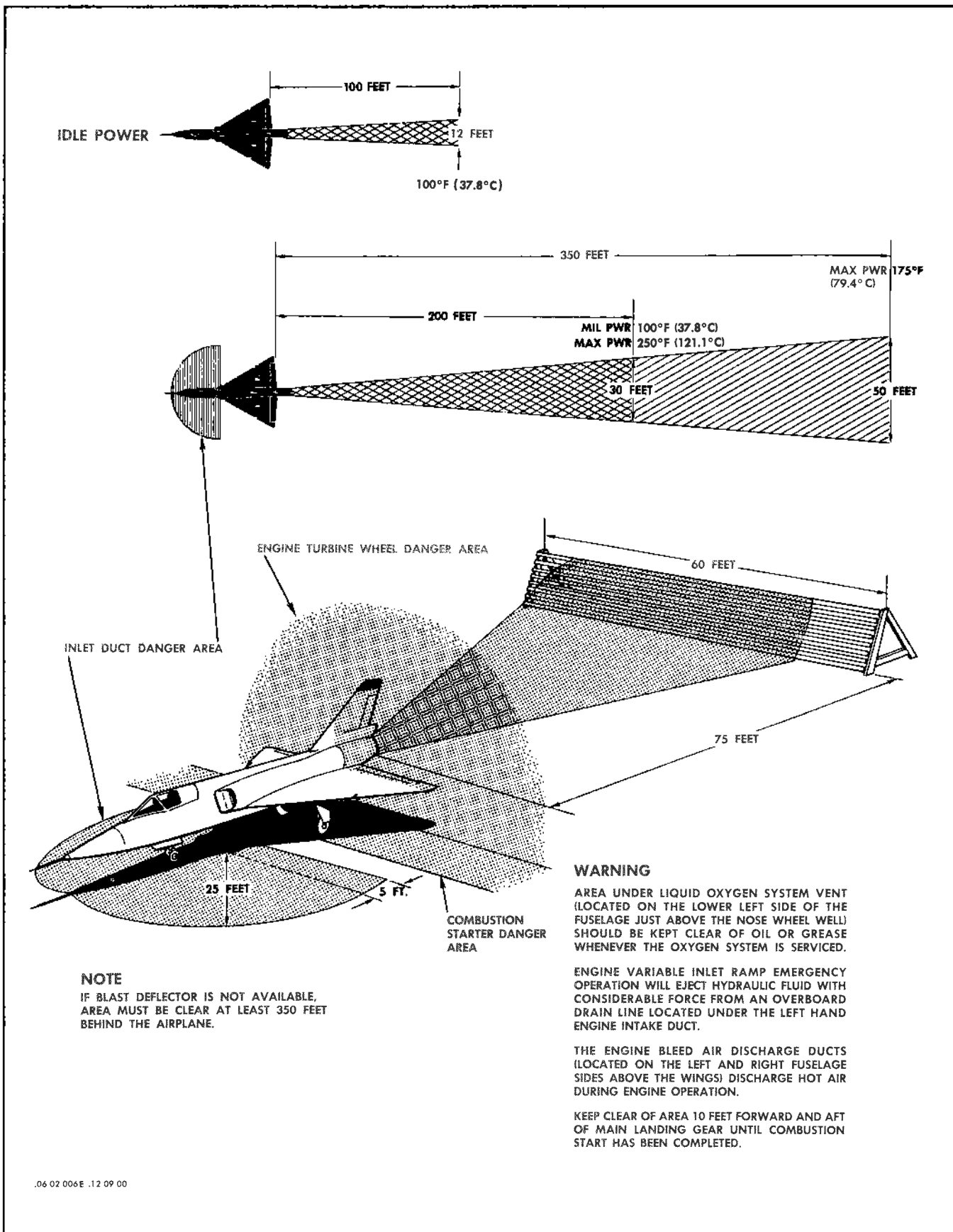

Figure 1-5. Danger Areas

lever to the "OFF" position. This action will prevent additional fuel from being injected into the engine combustion section. Ignition cannot be reinitiated without performing the complete starting procedure from the beginning. After returning the throttle to the "OFF" position, do not attempt another start until fuel drainage from the engine combustion chamber drain has ceased. If there is no fuel drainage from the engine at this time, check and correct cause of this malfunction.

### 1-22. J-75 ENGINE GROUND RUN COMPRESSOR STALLS.

Compressor stalls during ground run operation, commonly referred to as "off idle stalls," sometimes occur within the idle to military power range of operation. Rapid movement of the throttle within this operating range should not induce a stall due to the action of an acceleration cam in the fuel control. However, it is possi-

ble to induce compressor stall by inadvertent switching of the engine fuel control system from "EMER" to "NORMAL" during engine high rpm operation.

#### CAUTION

After operational check of the engine emergency fuel system, reduce engine rpm to idle before switching fuel system to "NORMAL."

In the event that a compressor stall is encountered, the engine will usually accelerate through and out of the stall with minor temperature fluctuations. Should engine operation temperature limits be exceeded, it will be necessary to visually check the engine as outlined in paragraph 1-33. Should an over-temperature condition continue to be encountered during stalls, it is recommended that the fuel control be replaced.

### 1-23. ENGINE OPERATIONAL CHECKOUT AND TESTING.

It will be necessary to conduct an operational check of the engine after completion of engine component replacement and maintenance. The type of operational checkout required for components that have been replaced is shown in the following chart.

ENGINE COMPONENTS REPAIRED OR REPLACED	OPERATIONAL TEST REQUIRED
Exhaust nozzle actuating cylinders. Exhaust nozzle linkage adjustment.	Conduct afterburner operational check. Conduct engine trim check using external gage.
Exhaust nozzle control valve. Exhaust nozzle control selector valve. Exhaust nozzle control converter valve. Afterburner igniter control unit. Afterburner fuel control unit.	Conduct afterburner operational check.
Afterburner or complete engine replacement.	Conduct complete engine ground run check and trim procedures. Use external gage for trim check.
Afterburner fuel spray nozzle. combustion chamber liners. Main fuel system manifold. Main fuel nozzles. Turbine nozzle guide vanes (first stage).	Conduct complete engine ground run check procedure.
Electrical junction boxes. Electrical harnesses.	Conduct afterburner operational check. Check anti-icing controls. Conduct emergency fuel system operation check.
Fuel flowmeter.	Conduct complete engine ground run check procedure.
Main fuel control unit. Fuel pump. Fuel pressurizing and dump valve.	Conduct engine trim procedure using external gage. Conduct emergency fuel system operational check. Conduct afterburner operational check.
Ignition transformers. Indicating systems (harness, transmitters, or probes). Oil strainer.	Conduct engine ground run check procedure.
Oil coolers.	Run engine. Check for leaks.
Engine starter.	Conduct engine start.

## 1-24. Equipment Requirements.

FIGURE	NAME	TYPE	ALTERNATE	USE AND APPLICATION
1-6.	Airplane Restraining Bridle.	SE 0583-801 (1730-651-0315)		To secure airplane for engine ground run.
	Wheel Chocks.	P/N 42D6594-2 (1730-294-3695)		To chock main landing gear wheels.
	Wheel Chocks.	P/N 50D6602 (1730-268-9822)		To chock main landing gear wheels during ice and snow conditions.
1-6	Engine Inlet Duct Screens.	8-96176-1-2 -1(1730-650-1413) -2(1730-646-8903)		To prevent foreign material from entering ducts during engine ground run.
Refer to T.O. 1F- 106A-2-3	High-Pressure Air Compressor.	MC-11 (4310-541-7060)	SE 0704-801 (4310-697-0858)	To provide air for combustion starter operation.
Refer to T.O. 1F- 106A-2-10	Generator Set (Gas).	8-96026-801 AF/M32A-13 (6115-583-9365)	8-96026 AF/M32M-2 (6115-617-1417)	To energize electrical systems on aircraft equipped with special quick disconnect receptacle.
	Generator Set (Elec).	8-96025-803 (6125-583-3225)	8-96025-805 A/M24M-2 (6125-623-3566)	
			8-96025 AF/M24M-1 (6125-620-6468)	
	Generator Set.		MC-1 (6125-500-1190) MD-3 (6115-635-5595)	To energize electrical systems (except AWCIS) on aircraft equipped with standard AN receptacle and on others by using adapter cable 8-96052.
	Adapter Cable.	8-96052 (6115-557-8548)		To connect MC-1 and MD-3 units to aircraft equipped with special quick disconnect receptacle.
	Fire-fighting Equipment.			Fire extinguishing agent in case of fire.
	Intercommunication Equipment.			For contact from cockpit to ground observers.

### 1-25. Preparing and Securing Airplane for Ground Run.

The following procedure is recommended for preparing and securing the airplane for ground run:

a. Park airplane on hard surfaced area with nose of airplane into the wind; airplane must be located so that other parked airplanes are not blasted during run-up; check that area around airplane is free of foreign objects.

#### WARNING

Danger areas around the engine intake and discharge ducts must be kept clear of all personnel, vehicles, loose gear, stones, hardware, stands, etc. Refer to figure 1-5 of this manual for an illustration of danger areas.

b. Secure airplane to an approved engine runup anchor, using the airplane restraining bridle, SE 0583-801 secured to the attachment rings on the main landing gear. See figure 1-6 for an illustration of engine ground run preparation procedure.

#### CAUTION

Prior to starting engine, assure that all slack has been removed from restraining bridle and that main landing gear wheel chocks are in place, fore and aft. Engine power must not, under any circumstances, be used to remove the slack from the restraining bridle.

c. Check all logs and records to see that work on previous flight discrepancies has been completed.

d. Check the following ballistic ejection systems for installation of safety pins or deactivation of systems:

1. Cockpit canopy. (Refer to T.O. 1F-106A-2-2)
2. Pilot's seat ejection. (Refer to T.O. 1F-106A-2-2)
3. Armament system. (Refer to T.O. 1F-106A-2-12)
4. External fuel tanks. (Refer to T.O. 1F-106A-2-5)

e. Check that landing gear safety pins are installed.

f. Check that landing gear control handle is in the "DOWN" position.

g. Check that tail hook safety pin is installed.

h. Check that fire-fighting personnel and equipment are on hand and ready for engine start.

i. Remove all plugs and covers from engine air inlet and discharge ducts.

j. Check skin fasteners, etc., in vicinity of engine inlet for security; check that all ducts are free of foreign objects, dirt, oil, etc., and that ducts are not cracked or damaged; check ramps for security and fully retracted position. Perform foreign object damage (FOD) check as follows:

#### NOTE

A thorough check of engine air inlet ducts for foreign objects is required prior to engine start to minimize the probability of engine sustaining foreign object damage.

1. Upon entering either left or right air inlet duct, first check the forward opening of the vari-ramp panel. This complete area may be visually checked with a flashlight and mirror. Pay special note to the two attached hinge points on the inboard side of the area. The hinge points, upper and lower, form a pocket where hardware may lie undetected. Adjacent to the hinge points several gussets are installed, one above the other, where hardware may accumulate.

2. As you move into the inlet duct, stop at the aft slot in the vari-ramp panel. This is a critical area. At this point, it is almost impossible to visually check forward and aft while entering the duct. Continue down the duct and visually check the horizontal stiffeners.

3. Proceed down the duct to the engine, reverse your position and come out the same duct and visually check aft along the inside of the panel. In this position most areas can be observed.

4. Go back to the scroll duct and visually inspect the area. There are corners of the shelf areas in the scroll duct structure which cannot be seen and must be inspected through the scroll access doors.

5. Using a rawhide or rubber mallet, tap the scroll area directly overhead where the left and right scrolls join together to dislodge any hardware from the flat area. This will cause objects to roll down the scroll where they can be picked up and removed.

6. Tap along the angles, down from the center line of the scrolls. Hardware will lodge along structural rivets and hang until dislodged by some disturbance. This is very critical due to the closeness of the engine. Any piece of hardware dislodged must be located, making sure it did not come through the scroll pores and roll into the engine. Proceed out the opposite intake duct and inspect areas outlined in steps (1) and (2).

k. *Applicable to F-106A airplanes*, close left and right upper aft electronic compartment doors; secure all stressed panel fasteners.

l. Install engine air inlet duct screens. See figure 1-6 for this procedure.

#### WARNING

Inlet screens must be installed for engine run. Do not install or remove screens with engine running.

m. Check airplane for proper fuel servicing. Refer to T.O. 1F-106A-2-5 for this procedure.

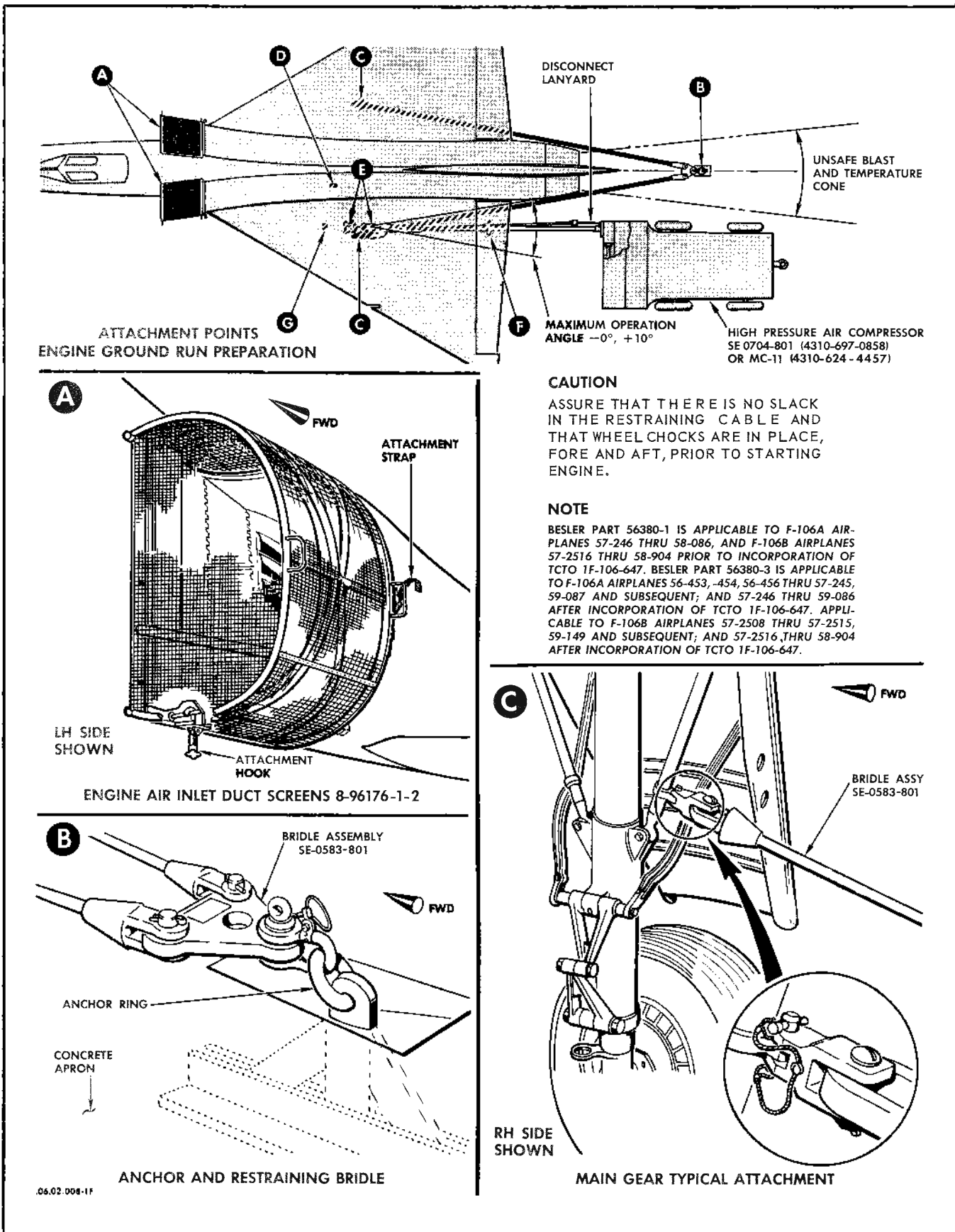

Figure 1-6. Engine Ground Run Preparation (Sheet 1 of 2)

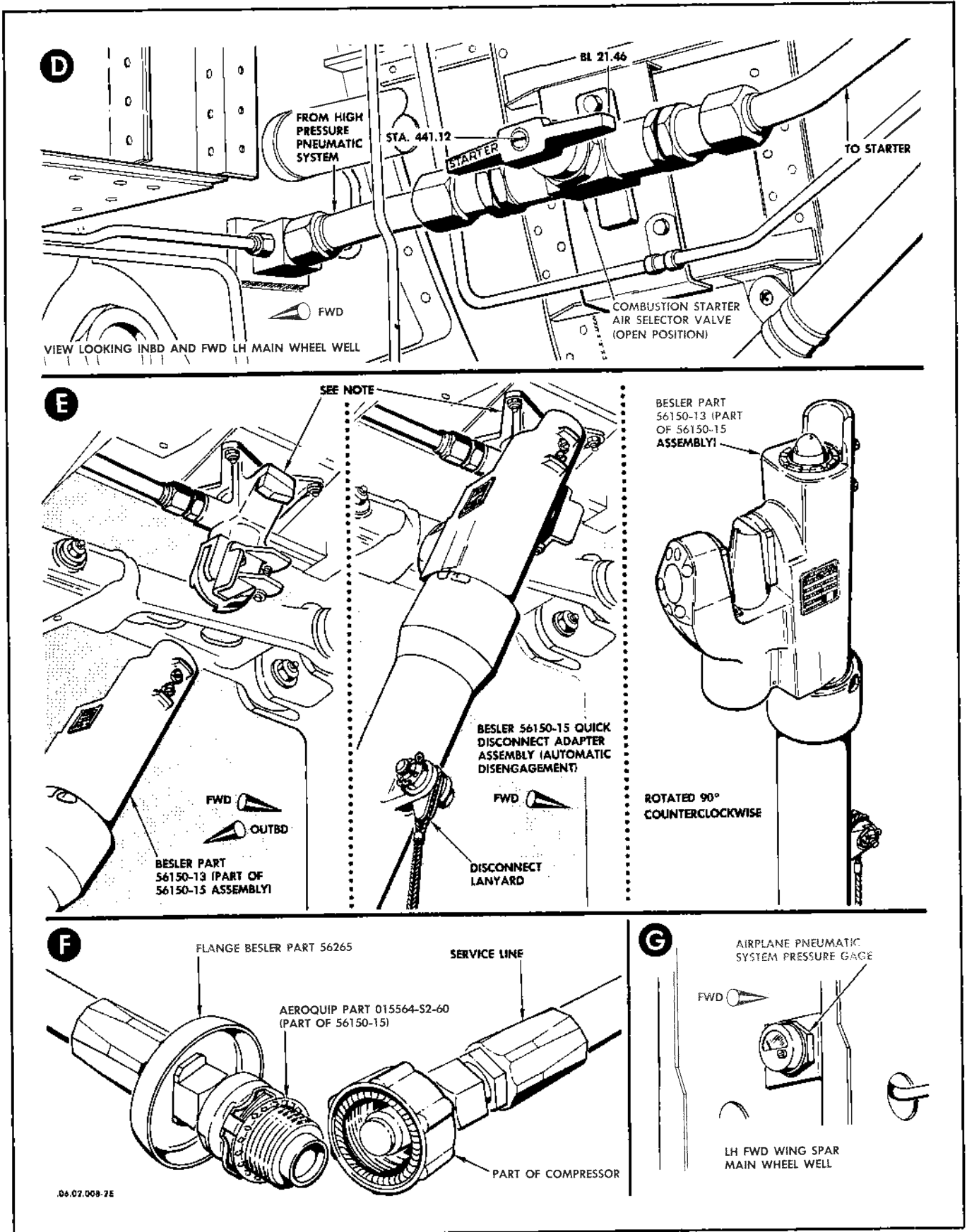

Figure 1-6. Engine Ground Run Preparation (Sheet 2 of 2)

**NOTE**

It is permissible to use the lowest available grade of aviation gasoline, Military Specification MIL-G-5572 (no oil mix required), JP-5, Military Specification MIL-J-5624, or JP-6, Military Specification MIL-F-25656, as emergency fuels for one-time ferry missions. Where the tactical situation requires the use of these fuels, the engine military trim must be readjusted to meet the pressure ratios shown in figures 1-28 and 1-29 before the airplane can be flown. Since JP-5 freezes at  $-48.3^{\circ}\text{C}$  ( $-55^{\circ}\text{F}$ ) and JP-6 at  $-40^{\circ}\text{C}$  ( $-40^{\circ}\text{F}$ ), missions in which these fuels are used shall be restricted to altitudes where temperatures below these limits are not encountered. When using aviation gasoline, particular attention shall be given to engine tailpipe temperature during starting and throughout the flight.

n. Service engine oil tank. Refer to Section VI for servicing instructions.

**NOTE**

Refer to servicing portion of this manual for depreserving the engine fuel system, engine lubrication system, and the constant-speed drive system.

o. Check that the hydraulic reservoirs are pressurized and that the reservoirs are serviced to the "FULL" mark. Refer to T.O. 1F-106A-2-3 for these procedures.

**CAUTION**

*Applicable to F-106A airplanes 56-463, -466, 56-467, 57-233 thru -235, -237 and 57-241, and F-106B airplanes 57-2508, -2510, -2512, -2514 and 57-2517; and all other airplanes after incorporation of TCTO 1F-106-631.* A reservoir servicing panel is installed directly below the primary hydraulic reservoir. The reservoir pressure shutoff valve, located on the panel, must be locked in the "OPEN" position prior to engine start. Hydraulic reservoir pressure gages located on the servicing panel shall indicate 50 ( $\pm 5$ ) psi. This precharge pressure is necessary to prevent hydraulic pump cavitation.

**NOTE**

Prime and bleed the hydraulic system prior to engine run upon completion of hydraulic system maintenance, when the system has been opened, or upon completion of an engine or a hydraulic pump replacement. Refer to T.O. 1F-106A-2-3 for this information.

p. Check air preload of hydraulic accumulators. Refer to T.O. 1F-106A-2-3 for this procedure.

q. Check high-pressure pneumatic system for charge to 3000 psi. Refer to T.O. 1F-106A-2-3 for this procedure. Connect external high-pressure air source to fitting in left main wheel well; starter air selector valve in left wheel to be in the "CLOSED" position. If start is to be made from airplane high-pressure pneumatic system, position starter air selector valve to the "OPEN" position.

r. Check engine starter and constant-speed drive systems for proper oil servicing. Refer to Sections V and IX for these procedures.

**NOTE**

Prime the oil system upon completion of constant-speed drive system maintenance when the constant-speed oil supply system has been disturbed, or upon completion of a remote or engine mounted gearbox replacement. Refer to Section IX for this information.

s. *Applicable to F-106A airplanes 57-246 thru 57-2465, and F-106B airplanes 57-2516 thru 57-2522.* Check that constant-speed system generator air pressurization (purge air) line is disconnected at T fitting below right hydraulic pump and that warning streamer is attached. The line is to remain disconnected until after engine start to purge possible fuel fumes.

t. Check that external electrical power source is turned off. Connect external ac and dc power source to the airplane external power receptacle.

u. Check that the engine ignition disarming switch in main right wheel well is in "ARMED" position.

v. *Applicable to all F-106A and B airplanes after incorporation of TCTO 1F-106-675.* Check that starter ignition disarm switch is in the "ON" position.

**CAUTION**

The starter ignition switch is to be used only for an air motor start subsequent to an unsuccessful attempt at starting engine utilizing the combustion capabilities of the starter. During the air motor start procedure, the starter ignition disarm switch must be in the "OFF" position. Refer to paragraph 5-9 for description of starter ignition disarm switch.

w. Check that fuses are installed in the following panels:

1. Nose wheel well fuse panel.
2. Main wheel well fuse panel.
3. Cockpit RH fuse panel.
4. Cockpit LH fuse panel.



1. VARIABLE RAMP NOT RETRACTED WARNING LIGHT.  
(APPLICABLE TO 57-246 THRU 59-059).
2. ENGINE PRESSURE RATIO INDICATOR.
3. FIRE WARNING LIGHT.
4. ENGINE EXHAUST TEMPERATURE INDICATOR.
5. FIRE AND OVERHEAT TEST SWITCH.
6. TACHOMETER.
7. FUEL QUANTITY TEST SWITCH.
8. FUEL FLOW INDICATOR.
9. FUEL QUANTITY INDICATOR.

10. FUEL QUANTITY SELECTOR SWITCH.
11. HYDRAULIC FAILURE WARNING LIGHT.
12. MASTER WARNING LIGHT.
13. WARNING INDICATION PANEL.
14. ENGINE OIL PRESSURE INDICATOR.
15. HYDRAULIC PRESSURE INDICATOR (SECONDARY SYSTEM).
16. HYDRAULIC PRESSURE INDICATOR (PRIMARY SYSTEM).
17. WARNING LIGHTS TEST SWITCH.
18. IDLE THRUST CONTROL (APPLICABLE TO 56-453, -454, 56-456 THRU 57-245, 58-759 AND SUBSEQUENT; AND 57-246, 57-2453 THRU 57-2506 AFTER INCORPORATION OF TCTO 1F-106-557).

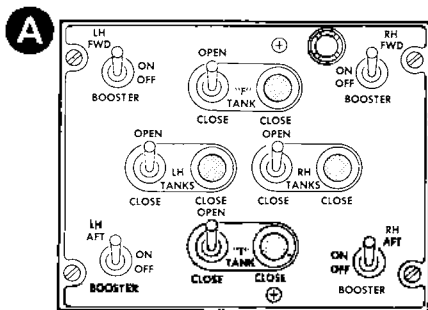
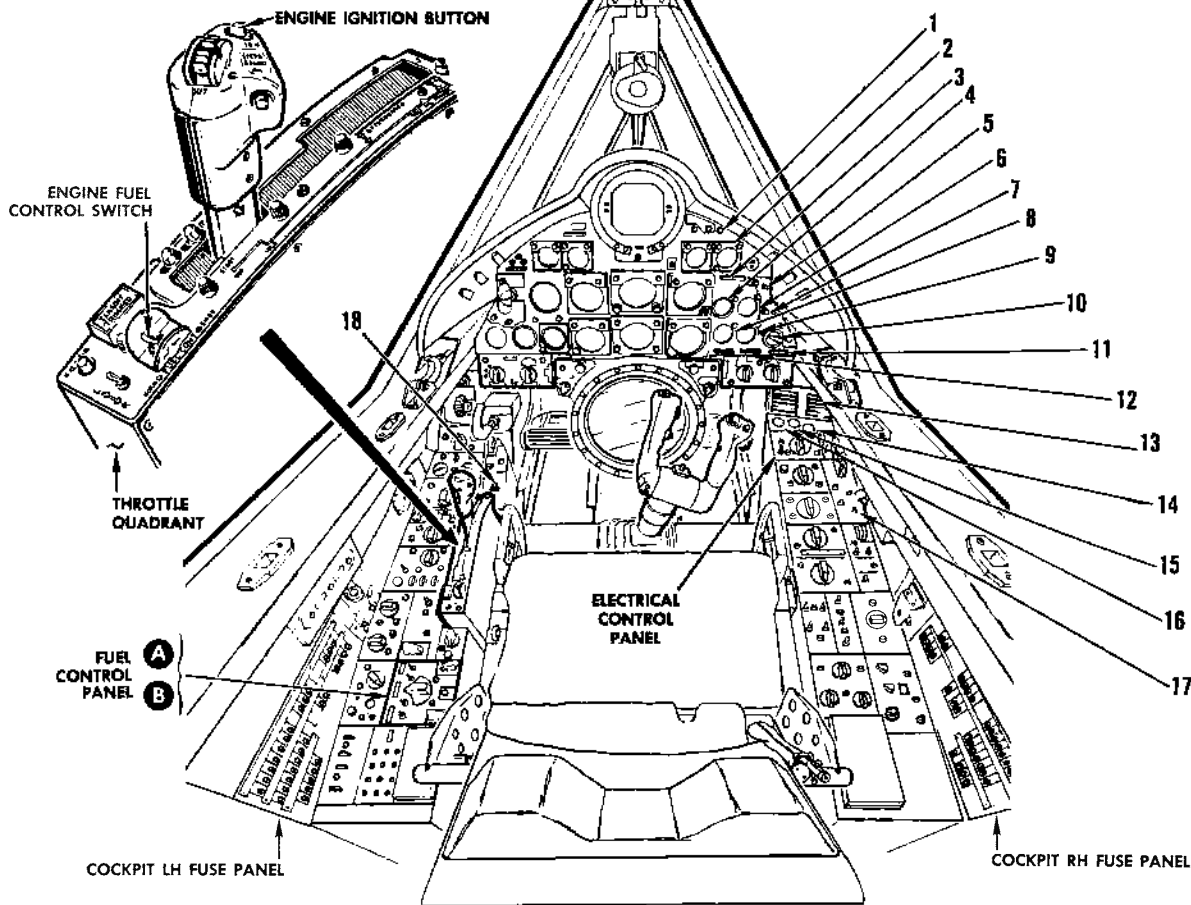

APPLICABLE TO 56-453, -454, 56-456 THRU 57-245, -2453, 57-2456 AND SUBSEQUENT; AND 57-246, -2454 AND 57-2455 AFTER INCORPORATION OF TCTO 1F-106-522.

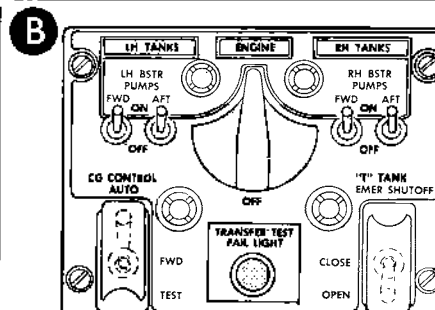

APPLICABLE TO 57-246, -2454 AND 57-2455 AFTER INCORPORATION OF TCTO 1F-106-522.

06.02 761 E

Figure 1-7. Engine Controls and Indicators, F-106A

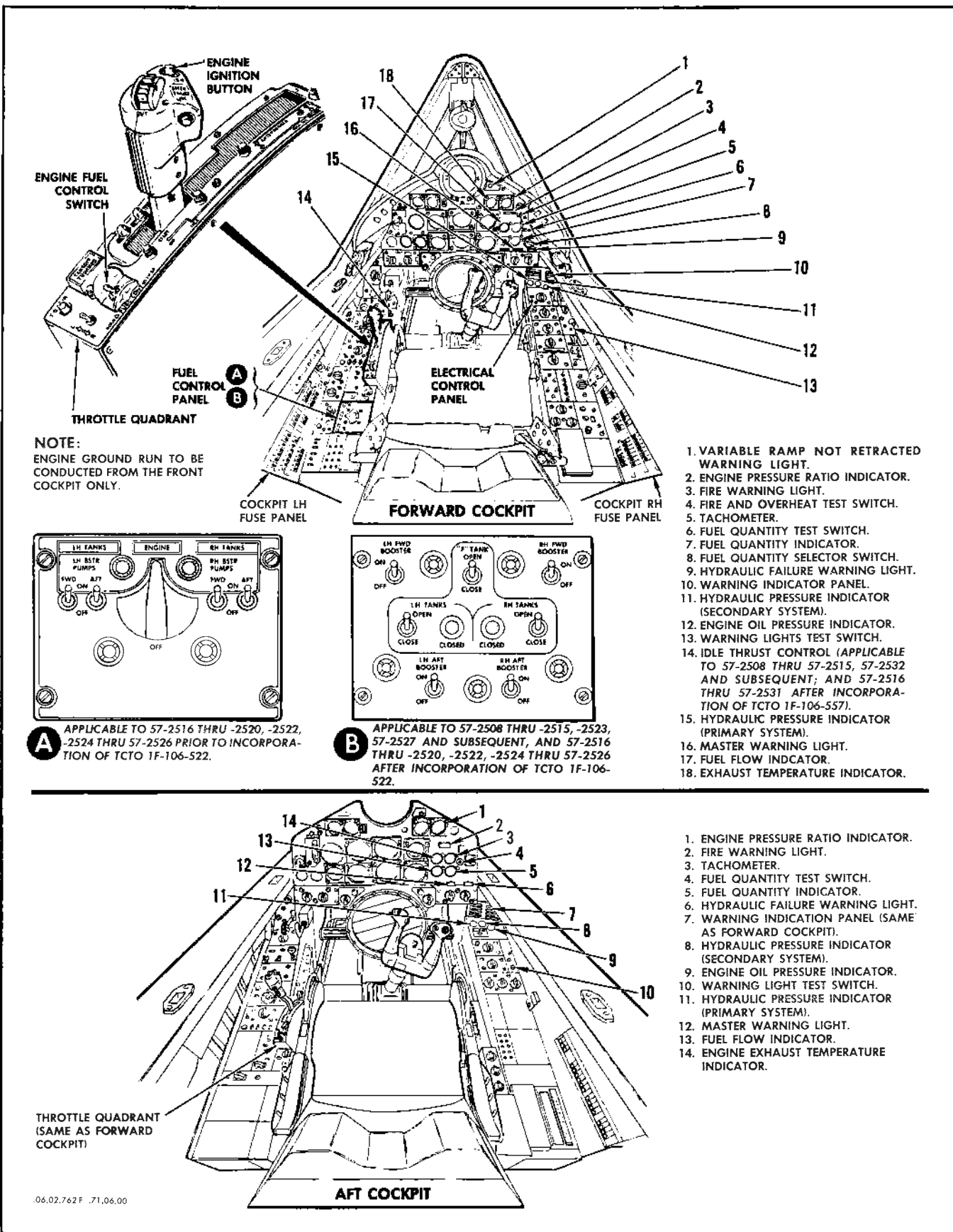

Figure 1-8. Engine Controls and Indicators, F-106B

PROCEDURE

- A. PLACE THERMOMETER IN THE SHADE OF THE AIRPLANE PRIOR TO ENGINE RUN. AFTER THERMOMETER HAS STABILIZED, RECORD AMBIENT AIR TEMPERATURE.
- B. OBTAIN ACTUAL FIELD BAROMETRIC PRESSURE FROM CONTROL TOWER (NOT BAROMETRIC PRESSURE CORRECTED TO SEA LEVEL) WITHIN 15 MINUTES PRIOR TO ENGINE RUN.
- C. ENTER TRIM CHART AT THE  $P_{amb}$  - INCHES Hg (FIELD BAROMETRIC PRESSURE) AND PROCEED VERTICALLY TO DIAGONAL MINIMUM LIMIT TEMPERATURE LINE. PROCEED HORIZONTALLY TO THE LEFT TO OBTAIN MINIMUM ACCEPTABLE EPR.
- D. ENTER TRIM CHART AT THE  $P_{amb}$  - INCHES Hg AND PROCEED VERTICALLY TO DIAGONAL MAXIMUM LIMIT TEMPERATURE LINE, PROCEED HORIZONTALLY TO THE LEFT TO OBTAIN MAXIMUM ACCEPTABLE EPR.

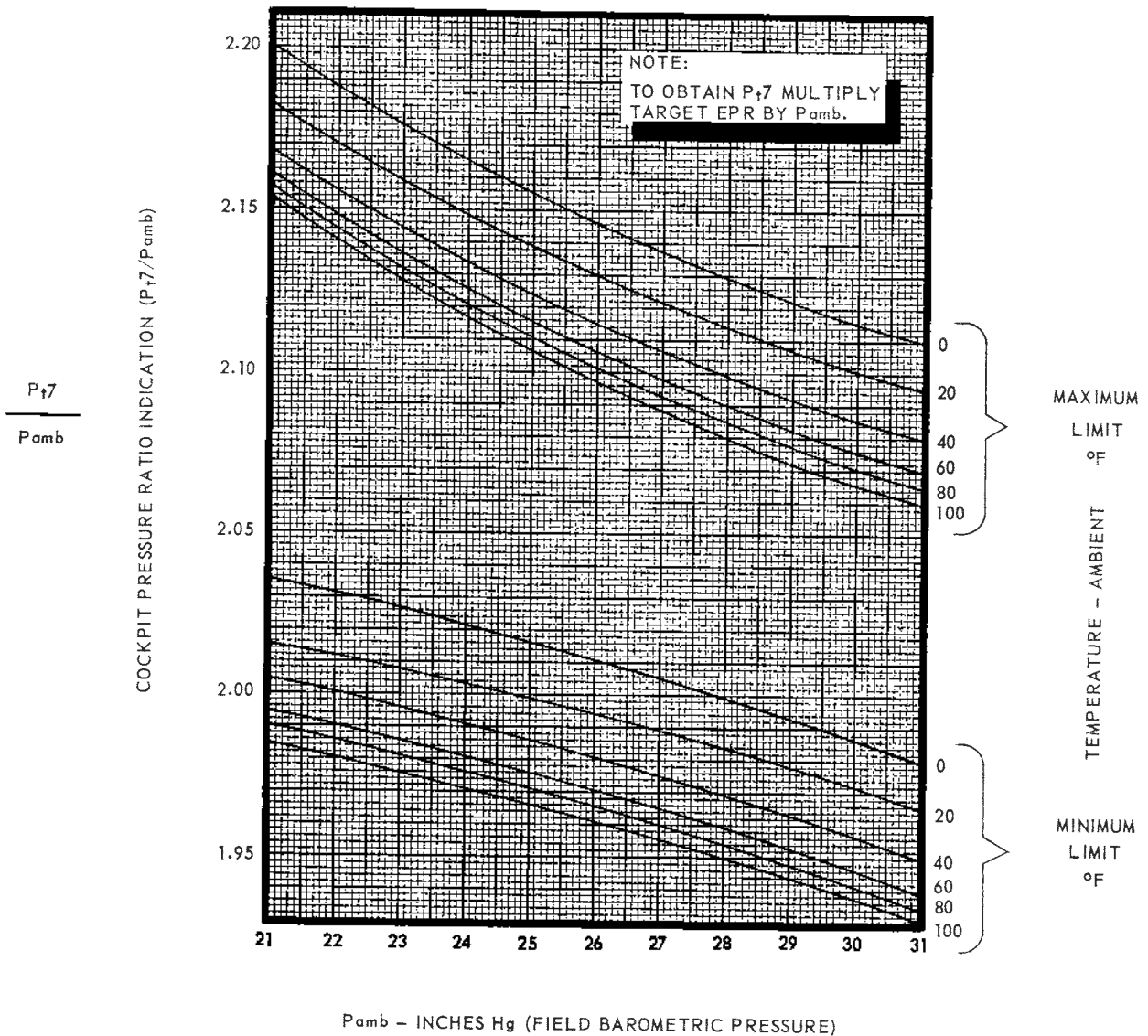

Figure 1-8A. Emergency Fuel Control Limits Chart



x. Check that the constant-speed drive shaft and shaft cover are properly installed. Refer to Section IX for this procedure.

**CAUTION**

Refer to paragraph 9-4 for engine mounted gearbox conditioning and operational limitations which must be followed if the engine is to be operated with the constant-speed drive shaft removed.

y. Check that there are no fuel puddles in engine tail-pipe or in the fuselage areas near drain lines.

**NOTE**

It will be necessary to trim check the engine using calibrated external instruments, according to paragraphs 1-58 thru 1-68 if any of the following conditions exist:

- Engine has been replaced.
- Fuel control has been replaced.
- Afterburner has been replaced.
- Maintenance or adjustment has been performed on the afterburner exhaust nozzle.
- Performance decay has been reported from previous flight operation.
- Pressure ratio indication out of limits from previous run.
- Fuel control "IDLE" or "TRIM" screw paint seal has been broken.
- Fuel control "IDLE" adjustment has been made.
- Throttle quadrant or throttle teleflex cable has been replaced.

**1-26. Engine Start Procedure.**

The following procedure is recommended for starting the engine. See figures 1-7 and 1-8 for illustrations of the cockpit equipment used for engine run.

**NOTE**

On F-106B airplanes, ground starting is accomplished from the front cockpit only.

a. Place the following switches in the indicated positions:

- |  |                               |
|--|-------------------------------|
| 1. Master electrical power switch<br>(F-106B, aft cockpit "ON,"<br>forward cockpit "OFF")  | "OFF"                         |
| 2. DC generator switch   | "OFF"                         |
| 3. AC generator switch   | "OFF"                         |
| 4. Fuel control<br>( "EMER FUEL ON" light)   | "NORMAL"<br>"OFF"             |
| 5. Fuel valve selector switches<br>(Applicable to F-106A airplanes<br>57-246 thru 57-2464) | "ENGINE" and<br>safety wired. |

(Applicable to F-106A airplanes  
56-453, -454, 56-456 thru 57-245,  
57-2466 thru 57-2477)

"OPEN" and  
safety wired.

(Applicable to F-106B airplanes  
57-2516 thru 57-2522, 57-2524  
thru 57-2526)

(Fwd. cockpit)

"ENGINE" and  
safety wired.

(Aft cockpit)

"NORMAL" and  
safety wired.

**NOTE**

If the safety on the fuel selector switches listed in step "a.5," has been broken, it will be necessary to perform a visual inspection of the fuel shutoff valves to ascertain that they are in the open position prior to engine run. Refer to fuel shutoff valve operational checkout in T.O. 1F-106A-2-5. Applicable after incorporation of TCTO 1F-106-556, safety wiring of switches is not required.

(Applicable to F-106A airplanes  
56-453, -454, 56-456 thru 57-245,  
57-2465, 57-2478 and subsequent)

"OPEN"

(Applicable to F-106B airplanes  
57-2508 thru 57-2515, 57-2523,  
57-2527 and subsequent)

(Fwd. cockpit)

"OPEN"

(Aft cockpit)

"NORMAL"

- |  |          |
|--|----------|
| 6. Throttle lever  | "OFF"    |
| 7. Fuel boost pumps  | "OFF"    |
| 8. Idle thrust control   | "OFF"    |
| 9. C. G. Control   | "AUTO"   |
| 10. Variable inlet override switch   | "NORMAL" |
| 11. All electronic equipment including MA-1 or AN/ASQ-25 system and communications equipment | "OFF"    |
| 12. Refrigeration switch   | "OFF"    |
| 13. Cabin air switch   | "OFF"    |
| 14. Cockpit Canopy   | "OPEN"   |
| 15. Rain clearing  | "OFF"    |
| 16. All other switches in the nonoperating position.   |          |

**WARNING**

Items 1, and 11 through 13 must be maintained in the condition indicated after engine start to prevent entry of fuel fumes into the cockpit and electronic compartments via the air conditioning system.

b. Turn external ac and dc power on. Power failure warning lights shall illuminate.

c. *Applicable to F-106A airplanes 57-246 thru 57-2465 and F-106B airplanes 57-2516 thru 57-2522.* Check fire detection system by holding fire test switch in "OVERHEAT;" light shall flash on and off. Position switch to "FIRE;" light shall illuminate steadily. *Applicable to F-106A airplanes 56-453, -454, 56-456 thru 57-245, 57-2466 and subsequent, and F-106B airplanes 57-2508 thru 57-2515, 57-2523 and subsequent.* Check fire detection system by placing test switch in "LOOP 1;" then place switch in "LOOP 2." The "FIRE" warning light shall flash on and off when placed in either loop position.

d. Check master warning system by depressing warning lights test switch on right console panel; all warning lights shall illuminate.

e. Set pressure ratio indicator "TAKEOFF" reading for the correct ambient air temperature. This value is determined by computing the ambient temperature at a point half way between the minimum and maximum lines of the takeoff trim check band on the trim charts.

f. Check that all boost pump switches are in "OFF" position and that both "FUEL BOOST PRESS" lights are illuminated. Check operation of fuel boost pumps as follows:

1. Place both forward boost pump switches in "ON" position; both "FUEL BOOST PRESS" lights shall extinguish.
2. Place both forward boost pump switches in "OFF" position; both "FUEL BOOST PRESS" lights shall illuminate.
3. Place both aft boost pump switches in "ON" position; both "FUEL BOOST PRESS" lights shall extinguish.
4. Place both forward boost pump switches in "ON" position; leave aft boost pump switches in "ON" position.

g. *Applicable after incorporation of TCTO 1F-106-688,* bleed the air from the starter fuel accumulator as follows:

1. Place suitable container under push-to-bleed valve on bottom of fuselage at Sta. 507. Ground container to airplane structure.
2. Actuate push-to-bleed valve and bleed at least one gallon of fuel from the accumulator. Continue bleeding until a solid stream of fuel is obtained; release valve.
3. Disconnect drainage container ground from airplane structure and remove container.

h. Initiate engine start as follows:

1. Depress the ignition button and hold; move the throttle outboard to "START" position. Check tachometer for positive rpm indication, then move the throttle inboard to "OFF", then forward to "IDLE". This procedure is accomplished by a continuous movement of the throttle.

## WARNING

Release ignition button immediately if no "RPM" reading is evident on the tachometer. Do not move the throttle inboard to the "OFF" position with the ignition button depressed if there is no "RPM" indication. This could result in disintegration of the combustion starter. No "RPM" reading indicates the starter failed to engage the engine. A maximum of two attempts should be made, but if still unsuccessful, the operation should be discontinued until the cause has been established and corrected.

2. Hold ignition button down until the engine instruments indicate a positive, self-sustaining lightoff, or until 30% rpm is reached; release ignition button. During the start procedure, do not jockey the throttle lever.

## CAUTION

Do not jockey the throttle as the starting fuel schedule is automatically controlled by the fuel control unit. Jockeying the throttle will interrupt this schedule.

Combustion starter duty cycle, at ambient temperatures up to 32.2°C (90°F), must be limited to two consecutive combustion runs in rapid succession followed by a cooling time of 30 minutes minimum. Succeeding runs must then be spaced a minimum of 25 minutes apart. If combustion starter duty cycle limitations are exceeded, remove the starter for overhaul.

Combustion starter duty cycle, at ambient temperatures above 32.2°C (90°F), must be limited to two consecutive combustion runs in rapid succession followed by a cooling time of 45 minutes minimum. Succeeding runs must then be spaced a minimum of 40 minutes apart. If combustion starter duty cycle limitations are exceeded, remove the starter for overhaul.

i. Engine indicators shall read as follows:

1. The exhaust temperature shall not exceed 400°C during acceleration to idle.
2. Idle rpm shall be 57 to 59%. *Applicable to airplanes equipped with idle thrust control provisions,* idle rpm with exhaust nozzle closed shall be 59 to 61%. Indication shall stabilize in total elapsed time of 35 to 50 seconds.

3. Exhaust temperature shall stabilize at 340°C or below.
4. Fuel flow shall be 1200 to 1500 pounds per hour.
5. Oil low-pressure warning light shall be extinguished; gage shall indicate 45(±5) psi.

#### NOTE

A 40 to 50 psi oil pressure on the cockpit oil pressure gage is acceptable for continuous engine operation.

j. Momentarily actuate rain clearing switch to "ON" then "OFF" to remove any moisture from system.

k. Actuate "MASTER ELEC POWER" switch to "ON" position.

l. Actuate "AC GEN CONT" and "DC GEN CONT" switches to "ON" position.

m. Turn off external ac and dc power and disconnect the external power plug(s); ac and dc power failure warning lights shall extinguish. If lights fail to extinguish, shutdown engine and investigate cause of malfunction.

n. Reposition starter air selector valve in the left main wheel well to the "CLOSED" position if airplane high pressure air system was used to operate the combustion starter.

o. *Applicable to F-106A airplanes 57-246 thru 57-2465, and F-106B airplanes 57-2516 thru 57-2522.* Connect constant speed system generator air pressurization (purge air) flex line to T fitting located below the right hydraulic pump. Remove warning streamer.

#### 1-27. Unsatisfactory Start.

An unsatisfactory start has occurred if one or more of the following conditions occur:

a. Hot Start. The turbine discharge temperature exceeds the starting temperature limit of 400°C. If a greater than normal fuel flow is observed when the power lever is first placed in the idle position, a "hot start" may be anticipated and the operator should be prepared to abort the start before the turbine discharge temperature is exceeded. A hot start may also be caused by a "false or hung start." Refer to paragraph 1-33 for engine over-temperature limitation data.

b. False Start or Hung Start. After lightoff has occurred, the rpm does not increase to idle but remains at some lower rpm. The turbine discharge temperature may continue to rise and the operator should be prepared to abort the start before temperature limits are exceeded.

c. No Start. Combustion starter does not lightoff during full starter operating cycle. If the turbine discharge temperature gage does not indicate a temperature rise, or is there is no increase in rpm, a lightoff has not been obtained.

d. The following procedure should be used in the event any of the requirements of a satisfactory start are not met or if any of the preceding conditions occur:

- |   |               |
|---|---------------|
| 1. Ignition button  | Not Depressed |
| 2. Throttle   | "OFF"         |
| 3. Fuel boost pump switches   | "OFF"         |
| 4. Refer to the troubleshooting chart and investigate the reason for the difficulty.    |               |
| 5. Allow a fuel drainage period of at least 30 seconds before attempting another start. |               |

#### 1-28. Procedure, Engine Clearing.

To clear the engine of trapped fuel or vapors, use the same procedure used for excessive EGT or fire in engine tail pipe during ground operation. Refer to paragraph 1-31 for this procedure.

#### 1-29. Engine Ground Run Check Procedure.

The following procedure is recommended for checking engine operation after a normal start has been completed.

a. Run engine at idle until instrument readings have stabilized (approximately 3 minutes). After a new engine installation, or if fuel system has been opened since last engine run, run engine at idle for 5 minutes before advancing throttle.

b. *Applicable to F-106A airplanes 56-453, -454, 56-456 thru 57-245, 58-759 and subsequent; 57-246, 57-2453 thru 57-2506 after incorporation of TCTO 1F-106-557. Applicable to F-106B airplanes 57-2508 thru 57-2515, 57-2532 and subsequent; and 57-2516 thru 57-2531 after incorporation of TCTO 1F-106-557.* Actuate "IDLE THRUST CONT" switch to "ON" then to "OFF." Have ground observer check for opening and closing of the exhaust nozzle.

c. Advance throttle lever to "MIL POWER" and allow instrument reading to stabilize. Engine exhaust temperature shall not exceed 650°C during acceleration. Engine rpm shall not exceed 105.5 per cent. Temperature shall not exceed 635°C after 2 minutes stabilization at military power. Oil pressure shall be 45(±5) psi (oil pressure warning light extinguished). Pressure ratio indicator shall be within the minimum and maximum points on the indicator bug.

#### CAUTION

Engine operation at "MIL POWER" setting not to exceed 15 minutes. Engine operation at maximum power (throttle full forward and in afterburning) not to exceed 5 minutes.

d. Record engine instrument readings.

e. Advance throttle to the full forward position, then outboard to "AFTERBURNING."

#### CAUTION

The exhaust nozzle has failed to open if there is a rapid increase of tailpipe temperature and an rpm reduction. Terminate afterburning immediately; investigate malfunction.

Allow engine to stabilize. Record engine instrument readings. Readings shall be within limits outlined in step "c."

f. Simulate afterburner electrical failure by removing "AB PWR" fuse from main wheel well fuse panel. Move throttle lever to nonafterburning, but do not retard; afterburning shall continue.

g. Check operation of afterburner mechanical shutoff valve as follows:

1. Retard throttle lever until afterburning terminates.
2. Advance throttle lever to a position above minimum afterburning range; afterburning shall not occur.
3. Install "AB PWR" fuse. Advance throttle lever to "MIL POWER," then outboard to "AFTERBURNING." Afterburning shall occur.

h. Turn off all boost pumps momentarily; boost pump failure warning and master warning lights shall illuminate. Turn on "FWD L" and "FWD R" boost pumps. Actuate master warning light switch to "RESET" to extinguish light.

i. Retard throttle slowly to minimum afterburning. There shall be no indication of engine roughness as throttle is being retarded. Terminate afterburning immediately if roughness is encountered.

j. Retard throttle to "IDLE." Allow afterburner drainage period of 3 minutes maximum.

k. Check engine emergency fuel system operation by setting throttle at "IDLE". Place fuel control switch to "EMER" position; "EMER FUEL" light shall illuminate.

**CAUTION**

To prevent possible engine overspeed, do not position fuel control switch to "EMER" when engine is operating at full power. To prevent possible compressor stalls, reduce engine speed to idle before switching from "EMER" to "NORMAL." During operation of the emergency fuel system, the automatic control features of the fuel control are bypassed. Extreme care must be exercised when operating the throttle lever. Carefully check the exhaust temperature and tachometer to prevent engine over-temperature or overspeed. Damage to the turbine section will occur and lead to engine failure if these procedures are not carefully followed.

1. Advance throttle slowly to "MIL POWER" and stabilize for 1 minute. Record rpm, pressure ratio, and exhaust gas temperature.

**CAUTION**

An adjusted fuel flow of as much as 800 pph less than the above established minimums is acceptable; however, when this condition exists, the afterburner must be checked for proper operation prior to releasing the airplane for flight.

**NOTE**

The above fuel flow figures have been adjusted for duct loss with inlet screens installed. If inlet screens are removed, add 130 pph to the above values.

For each 1000 feet of field elevation above sea level, subtract 210 pph fuel flow from the above values. The effect of temperature on fuel flow need not be considered in fuel flow calculations.

**NOTE**

For each degree F (0.55°C) ambient temperature reading above standard day, only 1 pph would be added to the fuel flow limits. For each degree F (0.55°C) ambient temperature reading below standard day, only 1 pph would be subtracted from the fuel flow limits.

m. Pressure ratio curves, Figure 1-8A, will be utilized in lieu of observed fuel flow to determine proper operation of the emergency fuel control system.

**NOTE**

Fuel flow indicator needle fluctuations shall not exceed distances between any two graduations (400 pph) either in normal or emergency system. Fluctuations resulting in blurring of the needle are not acceptable and shall be cause for investigation. When fluctuations are accompanied by erratic engine RPM or Pressure Ratio, engine malfunction will be suspected and investigated.

n. Move throttle momentarily to "AFTERBURNER" to check afterburner action; afterburner shall light. Return throttle to normal; afterburner shall cease. Retard throttle to "IDLE." Place fuel control switch in "NORMAL" position; "EMER FUEL" light shall extinguish.

**1-30. Engine Shutdown Procedure.**

a. Idle engine for 5 minutes after power run before shutting down, to prevent possible seizure of the engine rotors.

**NOTE**

In an emergency, the engine may be shutdown at once. Refer to paragraphs 1-31 and 1-32 for emergency fire procedures.



b. Connect external ac and dc power sources to the external receptacle. Airplane ac and dc generator switches "OFF"; master power switch "OFF."

c. Fuel boost pump switches "OFF."

d. Transfer tank shutoff switch "CLOSED."

e. Connect external high-pressure air source to adapter in left wheel well. Starter air shutoff valve positioned to the "CLOSED" position.

f. Retard throttle lever to "OFF" position.

g. Check primary and secondary hydraulic system warning lights by slight movement of flight controls as engine coasts down. Flashing light indicates one system decreasing below 1000 to 800 psi pressure. Steady light indicates both systems are below 1000 to 800 psi pressure.

h. Return all switches to the nonoperating position, except safety wired fuel selector switches as noted in paragraph 1-26, step "a.5."

i. Check engine and constant-speed drive oil levels.

j. *Applicable to F-106A airplanes 57-246 thru 57-2465, and F-106B airplanes 57-2516 thru 57-2522.* Disconnect constant-speed system generator air pressurization (purge air) flex line at T fitting located below the right hydraulic pump. Install warning streamer at this point.

#### NOTE

This procedure is necessary to prevent possible entry of engine fuel into the generator pressurization system. The flex line will remain disconnected until the next engine operation. Refer to paragraph 1-25 for the proper method of connecting the flex line.

#### 1-31. EXCESSIVE EGT OR FIRE IN ENGINE TAILPIPE DURING GROUND OPERATION.

In the event of excessive exhaust gas temperature, or if ground observers report fire in the engine tailpipe during ground operation, perform the following:

a. Throttle "OFF."

b. External high-pressure air connected to airplane.

#### NOTE

If external high-pressure air is not available, open the starter air shutoff valve located in left main wheel well.

c. If external electrical power is connected to the airplane, position the master power switch to "OFF." If external electrical power is not available, the master power switch must be placed in "ON" position.

d. Engine ignition disarming switch in right main wheel well "DISARMED."

#### CAUTION

*Applicable prior to incorporation of TCTO 1F-106-556.* When repositioning fuel shutoff valve switches to "ENGINE" or "OPEN" position in preparation for engine operation, it will be necessary to visually check the left and right fuel shutoff valve position indicators to determine that the valves are in the open position. This procedure requires removal of the fire seal doors inboard of the valves. Refer to T.O. 1F-106A-2-5 for an illustration of the fuel shutoff valves. Safety-wire switches in the "ENGINE" or "OFF" position.

e. All fuel shutoff switches—"CLOSED" or "OFF."

f. Boost pump switches—"OFF."

g. Engine ignition button—Depress and hold.

h. Move throttle to "START"; check for positive rpm, then move throttle to "OFF." Permit starter to run full cycle, then release ignition button.

#### NOTE

Do not advance throttle from the "OFF" position. Advancing the throttle from "OFF" to "IDLE" opens fuel valves in the fuel control unit, allowing fuel to flow into the engine. Under this condition the fuel control unit would require repriming.

#### 1-32. FIRE WITHIN ENGINE COMPARTMENT.

Fire within the engine accessory compartment or in the engine compartment is indicated when the fire detector warning light is illuminated. To extinguish fire proceed as follows:

a. Shutdown engine.

b. All fuel shutoff switches—"CLOSED" or "OFF."

c. Open fire access door with fire extinguisher nozzle and discharge fire extinguisher.

#### CAUTION

*Applicable prior to incorporation of TCTO 1F-106-556.* When repositioning fuel shutoff valve switches to "ENGINE" or "OPEN" positions in preparation for engine operation, it will be necessary to visually check the left and right fuel shutoff valve position indicators to determine that the valves are in the open position. This procedure requires removal of the fire seal doors inboard of the valves. Refer to T.O. 1F-106A-2-5 for an illustration of the fuel shutoff valve installation. Safety-wire switches in the "ENGINE" or "OPEN" position.

**1-33. INSPECTION OF ENGINES SUBJECTED TO OVER-TEMPERATURE CONDITIONS.**

The following table indicates the inspection required for engines subjected to over-temperature operation:

CONDITION	INSPECTION REQUIRED
If $T_{t7}$ exceeds the maximum allowable limit of 650°C for not more than 1 minute, and does not exceed 700°C.	Continue engine in service. No inspection required.
If $T_{t7}$ exceeds the maximum allowable limit of 650°C for more than 1 minute but less than 2 minutes, or exceeds 700°C for less than 5 seconds. If $T_{t7}$ exceeds the allowable of 635°C for more than 3 minutes but less than 4 minutes. HOT START – If the engine experiences 5 starts at temperatures exceeding the maximum allowable exhaust gas temperature of 400°C for starting.	Perform visual inspection as follows: (a) Inspect the exhaust duct for foreign particles and inspect the rear of the turbine for apparent damage. (b) Slide back the combustion chamber outer case. Remove the combustion chambers and inspect the burner section, the turbine nozzle guide vanes, and the front of the turbine section for excessive distortion or damage. (c) Measure first stage turbine blades for stretch. Refer to T.O. 2J-J75-6.
Five instances of over-temperature requiring visual inspection of hot section.	Perform hot section teardown inspection as described in T.O. 2J-J75-6.
If $T_{t7}$ exceeds the maximum allowable limit of 650°C for more than 2 minutes or exceeds 700°C for more than 5 seconds.	
If $T_{t7}$ exceeds the allowable limit of 635°C for more than 4 minutes.	
If $T_{t7}$ exceeds 725°C.	
After 25 instances of starts in excess of 400°C.	

**1-34. INSPECTION OF ENGINES SUBJECTED TO OVERSPEED CONDITIONS.**

The following table indicates the inspection required for engines subjected to overspeed conditions:

CONDITION	INSPECTION REQUIRED
If the observed N <sub>2</sub> rotor speed exceeds 106.5% rpm but does not exceed 108.0% rpm.	(a) Check engine as specified in T.O. 1F-106A-6 prior to continued operation. (b) If any abnormal condition is evident, perform teardown inspection as described in T.O. 2J-J75-6.
If the observed N <sub>2</sub> rotor speed exceeds 108.0% rpm.	Shutdown the engine as soon as practicable and send the engine to overhaul for complete inspection.

**1-35. OPERATIONAL CHECKOUT, CONSTANT-SPEED GENERATOR DRIVE SYSTEM.**

For operational checkout and testing of the constant-speed generator drive system, refer to T.O. 1F-106A-2-10.

**1-36. OPERATIONAL CHECKOUT, TACHOMETER INDICATOR SYSTEM.**

For information in regard to the tachometer indicator system check, refer to T.O. 1F-106A-2-9.

**1-37. OPERATIONAL CHECKOUT, ENGINE PRESSURE RATIO INDICATING SYSTEM.**

For information in regard to the engine pressure ratio indicating system check, refer to T.O. 1F-106A-2-9.

**1-38. OPERATIONAL CHECKOUT AND CALIBRATION, ENGINE EXHAUST TEMPERATURE SYSTEM.**

For information in regard to the engine exhaust temperature system check and calibration, refer to T.O. 1F-106A-2-9.

**1-39. OPERATIONAL CHECKOUT, FUEL FLOW INDICATING SYSTEM.**

For information in regard to the fuel flow system check, refer to T.O. 1F-106A-2-9.

**1-40. OPERATIONAL CHECKOUT, OIL LOW PRESSURE WARNING AND INDICATING SYSTEMS.**

For information in regard to the oil low-pressure warning system check, refer to paragraph 6-14.

**SYSTEM ANALYSIS**

**1-41. SYSTEM ANALYSIS, GENERAL.**

PROBABLE CAUSE	ISOLATION PROCEDURE	REMEDY
----------------	---------------------	--------

**STARTER DOES NOT ROTATE ENGINE.**

Refer to Section V for starter system analysis.		
---	--	--

**THROTTLE STICKING OR BINDING (ON GROUND WITH TEMPERATURE BELOW FREEZING, OR IN FLIGHT)**

Ice formation in the teleflex cable throttle control.	Disconnect cable from linkage at fuel control unit and remove cable from conduit.	Blow moisture out of conduit with nitrogen; clean and degrease teleflex cable; soak teleflex cable in oil, Military Specification MIL-L-7808 and reinstall.
Malfunctioning throttle quadrant.	Disconnect telescopic unit from quadrant bell crank; try to move throttle.	Replace defective component.

**ENGINE FAILS TO START.**

Insufficient starter speed.	Check external air source and engine starter. Refer to Section V for starter system analysis.	Replace defective components.
Ignition system inoperative.	Energize the ignition system momentarily with the fuel supply off. Listen for audible sparking with the ear as close as possible to the spark igniters. <div style="text-align: center; margin: 10px 0;"> <div style="border: 1px dashed black; padding: 2px; display: inline-block;"><b>CAUTION</b></div> </div> Clear engine of fuel before attempting this procedure.	Check for improper or loose connection.  Remove spark igniters and inspect condition. Clean or replace if necessary.

## 1-41. SYSTEM ANALYSIS, GENERAL (CONT).

PROBABLE CAUSE	ISOLATION PROCEDURE	REMEDY
<b>ENGINE FAILS TO START (CONT).</b>		
	<p>Refer to Section V of this manual for additional ignition and starting system troubleshooting.</p> <div style="border: 2px solid black; padding: 5px; text-align: center; margin: 10px 0;"><b>WARNING</b></div> <p>The electrical energy produced by the engine ignition system is sufficient to produce a shock that can be fatal. Be sure that electrical power has been removed from the ignition system before performing system maintenance.</p>	
Lack of fuel to engine.	Check fuel supply in tanks.	
	Fuel pressurizing-and-dump valve draining fuel overboard during engine starting attempt.	Replace valve.
	Check fuel tank boost pump operation.	Repair or replace defective pump.
	Check for obstructed fuel pump inlet line and fuel filter.	Clean lines and the filter.
	Fuel control unit cutoff not opening because of rigging error.	Adjust linkage.
<b>HOT START.</b>		
Insufficient starter speed.	Check external air source and starter. Refer to Section V for starter system analysis.	Repair or replace defective component.
Accumulation of fuel in the engine or afterburner.		Remove excess fuel from afterburner and perform engine clearing procedure.
Starting fuel flow too high.	Observe fuel flow indicator during starting attempt. Confirm accuracy of flowmeter.	Replace the fuel control.

**1-41. SYSTEM ANALYSIS, GENERAL (CONT).**

PROBABLE CAUSE	ISOLATION PROCEDURE	REMEDY
<b>HUNG START (ENGINE LIGHTS OFF BUT DOES NOT ACCELERATE TO IDLE).</b>		
Starter cutout speed too low.	Check gas turbine compressor and starter. Refer to Section V for starter system analysis.	Repair or replace gas turbine compressor and starter.
Loose or broken burner pressure sensing line.	Check sense line for security or damage.	Tighten or replace burner pressure sense line.
Burner pressure limiter stuck open.	Remove fuel control unit.	Install replacement item. Trim engine.
Fuel control unit acceleration schedule out of limits.		
<b>FLAMEOUT.</b>		
Lack of fuel to engine.	Check fuel supply.	
Broken or obstructed fuel line, valve, or pump.	Check fuel lines, valves, and pumps.	Replace broken line or remove obstruction.
Inadvertent placing of power lever in off position.		
Power lever retarded or advanced too rapidly while operating on emergency fuel system.		Check emergency operation procedure.
Too rich fuel control unit acceleration schedule when in normal operation at high altitude.	Remove fuel control unit.	Install replacement item.
Too lean fuel control unit deceleration schedule when in normal operation.		
<b>FAILURE OF ENGINE TO DECELERATE PROPERLY.</b>		
Fuel control unit rigging error.	Inspect linkage.	Adjust linkage.
Malfunctioning fuel control unit.	Remove fuel control unit.	Install replacement item and trim engine.
<b>FLUCTUATING RPM.</b>		
Water in fuel.	Check for water or other foreign material in fuel.	Check tank drains.
Compressor bleed valve malfunctioning.	Refer to System Analysis, Anti-Surge System in Section VII.	
Air in engine fuel system.		Purge air from system by operating engine.
Clogged fuel filters.	Check filters.	Clean or replace filters.

## 1-41. SYSTEM ANALYSIS, GENERAL (CONT).

PROBABLE CAUSE	ISOLATION PROCEDURE	REMEDY
<b>ENGINE DOES NOT MAINTAIN MAXIMUM FUEL FLOW.</b>		
Incorrect trim.	Check trim.	Replace fuel control unit if trim cannot be obtained.
Incorrect travel of throttle linkage.	Check linkage for proper travel between the throttle and fuel control unit.	Readjust or replace linkage.
Loose connection in the combustion chamber pressure to fuel control unit (Pt <sub>4</sub> ) line.	Check line for security of connection.	
Malfunctioning fuel control unit.	Check fuel flow through flowmeter.	Replace the fuel control and trim engine.
Clogged fuel filters.	Remove and inspect the fuel filters.	Replace filters.
<b>HIGH OR LOW OIL PRESSURE INDICATION.</b>		
Oil pressure gage not functioning properly.	Remove gage.	Install replacement item.
Oil pressure transmitter not functioning properly.	Remove transmitter.	Install replacement item.
Oil pressure switch not functioning properly.	Remove switch.	Install replacement item.
Oil pressure relief valve sticking.	Remove oil pressure relief valve and examine for dirt or foreign matter.	Clean thoroughly and, if necessary, clean up the valve with crocus cloth and lap the valve seat.
<b>FLUCTUATING OIL PRESSURE.</b>		
Fuel-oil cooler pressure relief bypass valve malfunctioning.	Remove fuel-oil cooler.	Install replacement item.
<b>HIGH OIL TEMPERATURE.</b>		
Insufficient oil in tank.	Check oil level.	Replenish as necessary.
Clogged oil strainer.	Remove and inspect oil strainer.	Clean and install strainer.
Oil temperature gage not functioning properly.	Check gage and sensing unit for accuracy.	Replace as necessary.
Thermostatic valve in the fuel coolant oil cooler not functioning.	Remove cooler for bench check.	Install replacement item.
Defective oil pump.	Check pump operation with master gage.	Replace pump.
Bearing failure.	Check oil and strainers for metal particles.	Remove engine for overhaul.

**1-41. SYSTEM ANALYSIS, GENERAL (CONT).**

PROBABLE CAUSE	ISOLATION PROCEDURE	REMEDY
<b>EXCESSIVE OIL CONSUMPTION.</b>		
Oil leakage.	Visually inspect all external tubing and case parting flanges for evidence of oil leaks.	Tighten connectors. Replace seals or gaskets as necessary.
Loose oil tank cap.	Check oil tank cap.	Tighten cap.
Breather pressurization valve not functioning properly.	Remove and check the valve for proper operation.	Replace the breather pressurizing valve.
Main bearing oil seal leakage.	Check for engine smoking, oil in the exhaust duct; oil in the fuel drain collector; oil on the anti-icing air outlet screen.	Replace the engine if required.
<b>HIGH EXHAUST TEMPERATURE.</b>		
Engine over-trimmed.	Check engine trim.	Retrim engine.
Insufficient air.	Check the air intake for obstructions.	Remove obstructions.
Defective thermocouple leads, or temperature gage.	Check thermocouple leads and instruments.	Repair or replace thermocouple leads and instruments. Calibrate system.
Damaged compressor blades. Damaged turbine blades or nozzle guide vanes.	Visually inspect compressor blades, turbine blades, and nozzle guide vanes for damage.	If excessive damage is found, replace engine.
<b>LOW EXHAUST TEMPERATURE.</b>		
Defective thermocouple leads or instruments.	Check thermocouple leads and instruments.	Repair or replace defective leads or instruments. Calibrate system.
Malfunctioning fuel control.	Check for proper trim.	Trim engine. Replace the fuel control unit if proper trim cannot be attained.
<b>ENGINE ROUGHNESS.</b>		
Interference between turbine rotor inner air seals and the inner seal rings.	Check for scraping noise as engine coasts down, after closing of fuel pressurizing-and-dump valve.	Replace the engine if required.
Main bearing failure.	Check the oil strainer for metal particles.	Replace the engine if required.
Malfunctioning accessory.	Check for unusual noises from accessories.	Replace faulty unit.
Erratic fuel flow.	Remove fuel control unit.	Install replacement item. Trim engine.

## 1-41. SYSTEM ANALYSIS GENERAL (CONT).

PROBABLE CAUSE	ISOLATION PROCEDURE	REMEDY
<b>ENGINE PULSATION.</b>		
Erratic fuel flow to engine.	Remove fuel control unit.	Install replacement item. Trim engine.
Compressor bleed valve not functioning properly.	Visually check valve positioning during engine operation.	Clean lines to bleed valve governor and check bleed valve for freedom of movement.
		Replace bleed valve governor.
<b>FAILURE TO SHIFT TO EMERGENCY FUEL SYSTEM.</b>		
Emergency solenoid not energized.	Check for 28-volt dc at the fuel control connection.	Repair or replace defective electrical equipment.
Malfunctioning of fuel control emergency system.	Remove fuel control unit.	Install replacement item. Trim engine.
<b>FLUCTUATING TAIL PIPE TEMPERATURES.</b>		
Faulty temperature indicating system.  <b>NOTE</b> Trouble is not in the fuel control unit if tailpipe temperature fluctuates at a constant rpm, fuel flow, airspeed, altitude, and throttle position.	Check thermocouples, leads and instruments.	Repair or replace parts as necessary. Calibrate system.
<b>ENGINE SPEED AND/OR ENGINE TEMPERATURE BECOMES ABNORMAL AS ALTITUDE INCREASES.</b>		
Fuel control unit altitude compensating system malfunctioning.	Remove fuel control unit.	Install replacement item. Trim engine.
<b>INSUFFICIENT THRUST FOR HIGH FLIGHT SPEEDS.</b>		
Variable ramp system malfunctioning.	Refer to variable ramp system analysis procedures in Section IV.	
<b>ENGINE CONTINUES TO RUN WITH THROTTLE IN OFF POSITION.</b>		
Throttle rigging error.	Check linkage for proper rigging.	
Cutoff valve in fuel control unit not functioning properly.	Remove fuel control unit.	Install replacement item. Trim engine.
<b>EXHAUST NOZZLE FAILS TO OPEN OR CLOSE PROPERLY WHEN AFTERBURNING IS INITIATED OR TERMINATED.</b>		
Sticking nozzle segments.	Check the tracks, roller and linkage for freedom of movement.	Lubricate. Refer to afterburner servicing for this procedure.
Loose exhaust nozzle control lines.	Check the security of all the lines.	Tighten the lines.
Exhaust nozzle control unit not functioning properly.	Remove exhaust nozzle control unit.	Install replacement item.



**1-41. SYSTEM ANALYSIS, GENERAL (CONT).**

PROBABLE CAUSE	ISOLATION PROCEDURE	REMEDY
<b>EXHAUST NOZZLE FAILS TO REMAIN OPEN DURING AFTERBURNING.</b>		
Loose exhaust nozzle control lines.	Check the security of all lines.	Tighten the lines.
Exhaust nozzle control unit not functioning properly.	Remove exhaust nozzle control unit.	Install replacement item.
<b>EXHAUST NOZZLE OPENS DURING NONAFTERBURNING OPERATION.</b>		
Loose exhaust nozzle control lines.	Check the security of all lines.	Tighten the lines.
Internal leaking of exhaust nozzle control unit.	Remove exhaust nozzle control unit.	Install replacement item.
Exhaust nozzle control unit not functioning properly.	Remove exhaust nozzle control unit.	Install replacement item.
<b>EXHAUST NOZZLE OPENS AND FUEL FLOWS BUT AFTERBURNER DOES NOT LIGHT.</b>		
Error in connections to afterburner igniter valve.	Check connections.	Make necessary corrections.
Malfunctioning afterburner fuel igniter valve.	Remove afterburner igniter valve.	Install replacement item.
<b>FULL AFTERBURNER POWER NOT AVAILABLE.</b>		
Afterburner fuel control unit pressure sensing line or fuel screen clogged.	Inspect sensing line and screen for obstruction.	Clean and replace line and/or screen.
Defective fuel pump.	Remove fuel pump.	Install replacement item.
Faulty afterburner fuel control unit.	<b>Remove afterburner fuel control unit.</b>	Install replacement item.
<b>FAILURE TO GET AFTERBURNER FUEL FLOW THROUGH THE AFTERBURNER FUEL CONTROL UNIT.</b> (Afterburner does not light and no evidence of afterburner fuel flow).		
Fuel pump failure.	Remove fuel pump.	Install replacement item.
No electrical signal to afterburner fuel control unit.	Check for 28-volts dc at control connection.	Repair or replace defective electrical equipment.
Actuator section of afterburner fuel control unit failure.	<b>Remove afterburner fuel control unit.</b>	Install replacement item.

**REPLACEMENT****1-42. REPLACEMENT, ENGINE.**

Refer to paragraph 1-76 for engine preservation information prior to removal of the engine from the airplane. To remove the engine from the airplane, it will first be necessary to remove the fuselage tail cone from the airplane and to install the engine removal rails and brackets.

**NOTE**

When conducting the airplane leveling procedure for engine removal, the engine removal rails in the fuselage will be leveled longitudinally. The airplane will be leveled laterally.

See figure 1-9 for an illustration of the engine disconnect point access. For lubrication of the engine support attachments to the fuselage, refer to T.O. 1F-106A-2-2. Upon

completion of the engine replacement it will be necessary to conduct an operational test of the engine. Refer to paragraph 1-23 for this procedure.

### 1-43. Equipment Requirements.

FIGURE	NAME	TYPE	ALTERNATE	USE AND APPLICATION
1-13 thru 1-17	Engine Stand.	USAF ETU-8/E (1740-294-3397) with Adapter Kits 8-96398-1 (1730-676-6848) or 8-96165 (1730-632-0059) installed	SE 1012-803 (1740-568- 1339)	To aid in removal and installation of engine. To support engine when removed from airplane.
1-11 1-12	Engine Removal Rail and Bracket Set.	8-96017 Basic (1730-570-1387) -801 (1730- 632-8435) -803 (1730- 654-8392) -805 (1730- 676-6856)		To aid in engine removal or installation.
1-19	Engine Forward Roller Assemblies.	8-96041-1 (1730-565-5321) 8-96041-2 (1730-565-5322) 8-96041-803 (1730-710-7308) 8-96041-804 (1730-710-7309)		Removal roller for forward end of engine.
1-10	Tail Cone Adapter Stand.	8-96010 (1730-571- 9010)		To support tail cone. <i>Applicable to airplanes prior to incorporation of the tail hook.</i>
		8-96010-801 (1730-710-7306)		To support tail cone. <i>Applicable to airplanes after incorporation of the tail hook.</i>
1-10	Retractable Truck.	(8220-780800)		To aid in installation and removal of tail cone.
Refer to T.O. 1F- 106A-2-2	Jack Pad (3).	SE 0580-7 (1730-640- 7155)		Provides bearing surface on wings and fuselage for airplane jacks.
Refer to T.O. 1F-106A-2-2	Airplane Jack (3).	USAF B-6 (5120-246-9178)		To raise and support airplane.
1-19	Shroud Positioning Wedge.	8-96174 (4920-611-9695)		To support and position aft end of shroud. To be used with shroud part No. 8-22654 basic, -3 or -5.

**1-43. Equipment Requirements (Cont).**

FIGURE	NAME	TYPE	ALTERNATE	USE AND APPLICATION
1-19	Shroud Positioning Wedge.	8-96200 (1560-679-4482)		To support and position aft end of shroud. To be used with shroud part No. 8-22654-801, -803, -805 or -811.
	Shroud Ejector Insert Alignment Tool.	8-96491 (4920-691-4274)		For use with shroud part No. 8-22654-809.
	Sling.	SE 0945-803 (1730-660-0992)		Engine suspension from hoist attachment.
	Engine Compartment Mobile Work Stand.	SE 0867-803 (4920-656-4944)		To support maintenance personnel working inside fuselage after engine removal.
1-19	Engine to Fuselage Locating Gage.	8-96201 (4920-649-5313)		To adjust position of engine in relation to the fuselage prior to installation of the tail cone. This gage is used in conjunction with Shroud Positioning Wedge 8-96200 or ejector alignment tool 8-96491.
	Flight Controls Mixer Assembly Protection Cover.	8-96186 (1730-632-8436)		To cover flight controls mixer assembly when engine is removed from the airplane.

**1-44. Procedure, Tail Cone Removal.**

See figure 1-10 for the fuselage tail cone removal procedure.

**1-45. Procedure, Engine Replacement Rail and Bracket Installation.**

See figures 1-11 and 1-12 for engine replacement rail and bracket installation.

**1-46. Engine Stand Preparation.**

Prior to using engine stand USAF type ETU-8/E for F-106 maintenance, it will be first necessary to install 8-96398 or 8-96165 adapter kit on the stand. See figure 1-13 or 1-14 for this procedure.

**1-47. Procedure, Engine Replacement.**

See figures 1-15 thru 1-19 for engine removal and installation procedures. If the engine is to be removed from the engine stand following removal from the airplane, use sling SE 0945-803 with the hoisting attachment. Use mobile work stand SE 0867-803 while performing work inside the fuselage following engine removal.

**NOTE**

When an engine equipped with a constant rise oil pressure system is installed in the airplane, an engine oil pressure reduction orifice plate, part No. 8-27544-27, must be installed at the oil "OUT" line elbow connection of the engine air-oil cooler. J75-P17 engines, S/N 610494 and subsequent (with main oil pump P&WA part No. 384830), have the constant rise oil pressure system. If a J75-P17 engine S/N 610493 and prior is installed in the airplane, the oil pressure reduction orifice plate must be removed from the oil "OUT" elbow connection of the engine air-oil cooler. Refer to Section VI, for orifice plate removal and installation procedures.

Some hose and tube attachment nuts are drilled for safetying. These attachment nuts must be safetied when completing an engine installation.

During engine removal, all engine and airplane tubing that has been disconnected must be capped with suitable plugs and coverings to prevent the entry of dirt, dust, and other foreign material. Before installation, make certain that all plugs and coverings have been removed.

**1-48. REPLACEMENT, COMBUSTION CHAMBERS.****1-49. Equipment Requirements.**

FIGURE	NAME	TYPE	ALTERNATE	USE AND APPLICATION
1-20 thru 1-22	Engine Stand.	USAF ETU-8/E (1740-294-3397) with Adapter Kits 8-96398-1 (1730-676-6848) and 8-96398-3 (1730-676-6849) or 8-96165 (1630-632-0059) installed.	SE 1012-803 (1740-568- 1339)	To support engine when re- moved from airplane.
1-22	Engine Hoisting Adapter.		8-96068 (1730-540- 5034) (for use with engine stand SE 1012-803)	To support engine center sec- tion during combustion cham- ber removal.

**1-50. Procedure.**

See figures 1-20 through 1-23 for combustion chamber replacement procedure.

**1-51. LIMITS OF ACCEPTABILITY FOR COMBUSTION CHAMBERS.**

For the limits of acceptability for combustion chambers, refer to T.O. 2J-J75-6.

**1-52. REPLACEMENT, CONSTANT-SPEED DRIVE ENGINE MOUNTED GEARBOX.**

Removal and installation procedures for the constant-speed drive engine mounted gearbox are shown in figure 9-4.

**1-53. REPLACEMENT, HYDRAULIC PUMPS.**

For information regarding the replacement of the engine mounted hydraulic pumps, refer to T.O. 1F-106A-2-3.

**1-54. ENGINE EXTERNAL TUBE SEALING REQUIREMENTS.**

Figure 1-24 illustrates the sealing configurations for external tubes on J-75 engines. When fitting tubes to the engine, visual comparison of the tube with the examples shown will indicate the number and location of seals required. Examples 1 and 2 are two types of external tube connections which require no seals. They are called metal-to-metal type sealing connections and are readily identified by the conical mating seat on the ferrule. Examples 3 and 4 are typical tube connections which pass through the engine fireseal. The packing or seal is placed in the groove as shown and then the tube is inserted through the correct hole location in the fireseal. Examples 5, 6, 7, 8,

and 9 are primarily related to oil pressure, scavenge, and breather tube connections. The number of grooves in the tube ferrule dictates the required number of seals. Example 10 shows a tube having no attaching connectors, or fittings, but is slipped into two elbows, then mounted on outlet and inlet ports of engine components. A seal rests against the flat face of each tube ferrule. Examples 11 and 12 show two tubes having different types of fixed flanges which are bolted to the engine cases. Install seal or gasket as indicated. Example 13 shows a tube end adapter that is secured to the engine case with a single bolt. Install a gasket at each end. Examples 14 and 15 show the sealastic type tube connections. Example 14 has a fixed ferrule while example 15 has a loose ferrule. A ferrule (loose or fixed) such as shown in these examples will always indicate a seal requirement. Example 16 shows the sealastic type tube connection at the engine fireseal. This arrangement is used only at the fireseal on oil pressure, scavenge, and breather tubes.

**1-55. QUICK DISCONNECT COUPLINGS.**

The quick disconnect couplings used on hydraulic, pneumatic, and oil lines are of the self-sealing type and are used when frequent uncoupling of lines is required. The coupling consists of two self-sealing halves, which may be disconnected without draining the system. Figure 1-25 illustrates the types of couplings in both the coupled and uncoupled configurations.

**NOTE**

Quick disconnect couplings require hand tightening only. Couplings should always be covered when disconnected to prevent entry of foreign material.

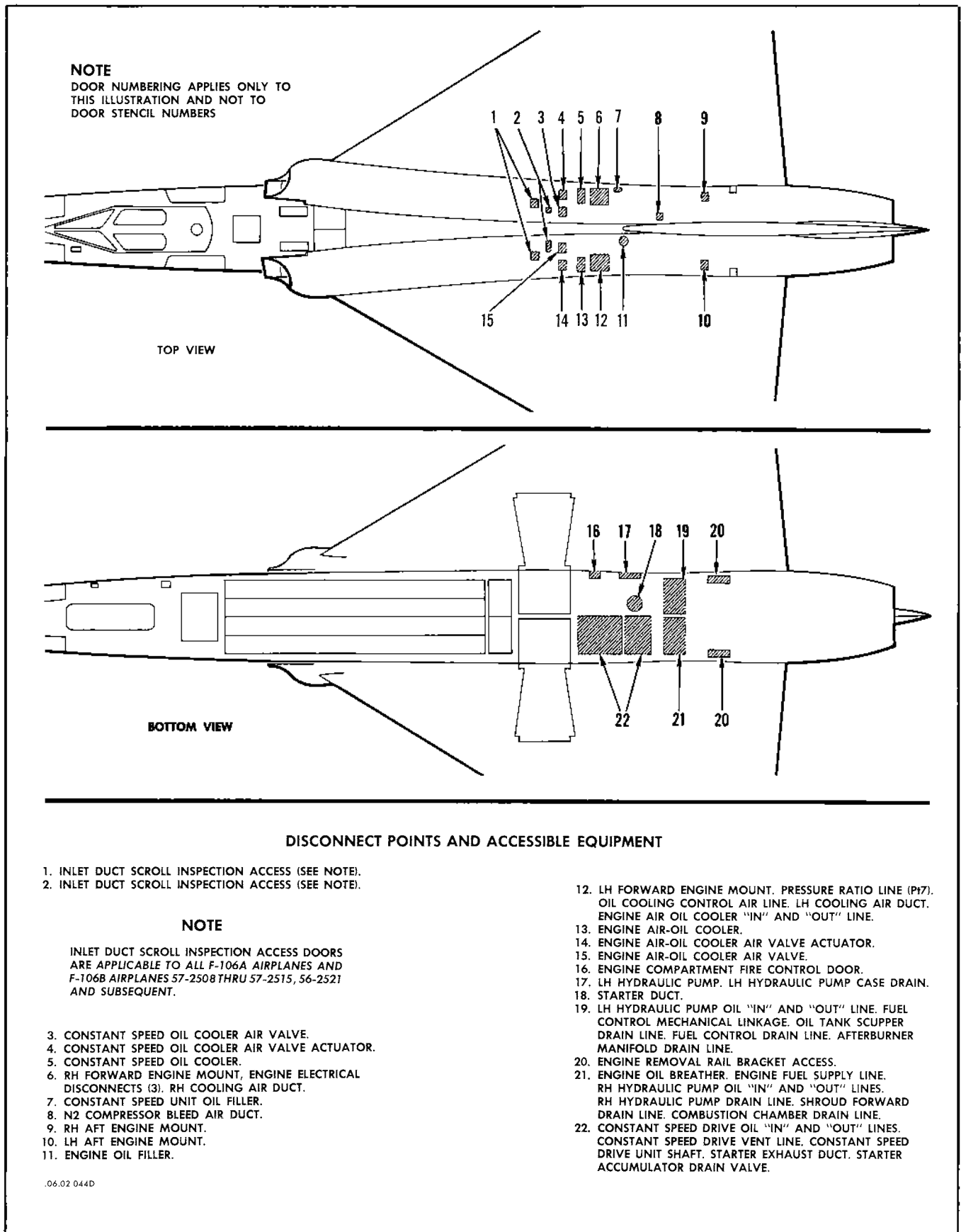
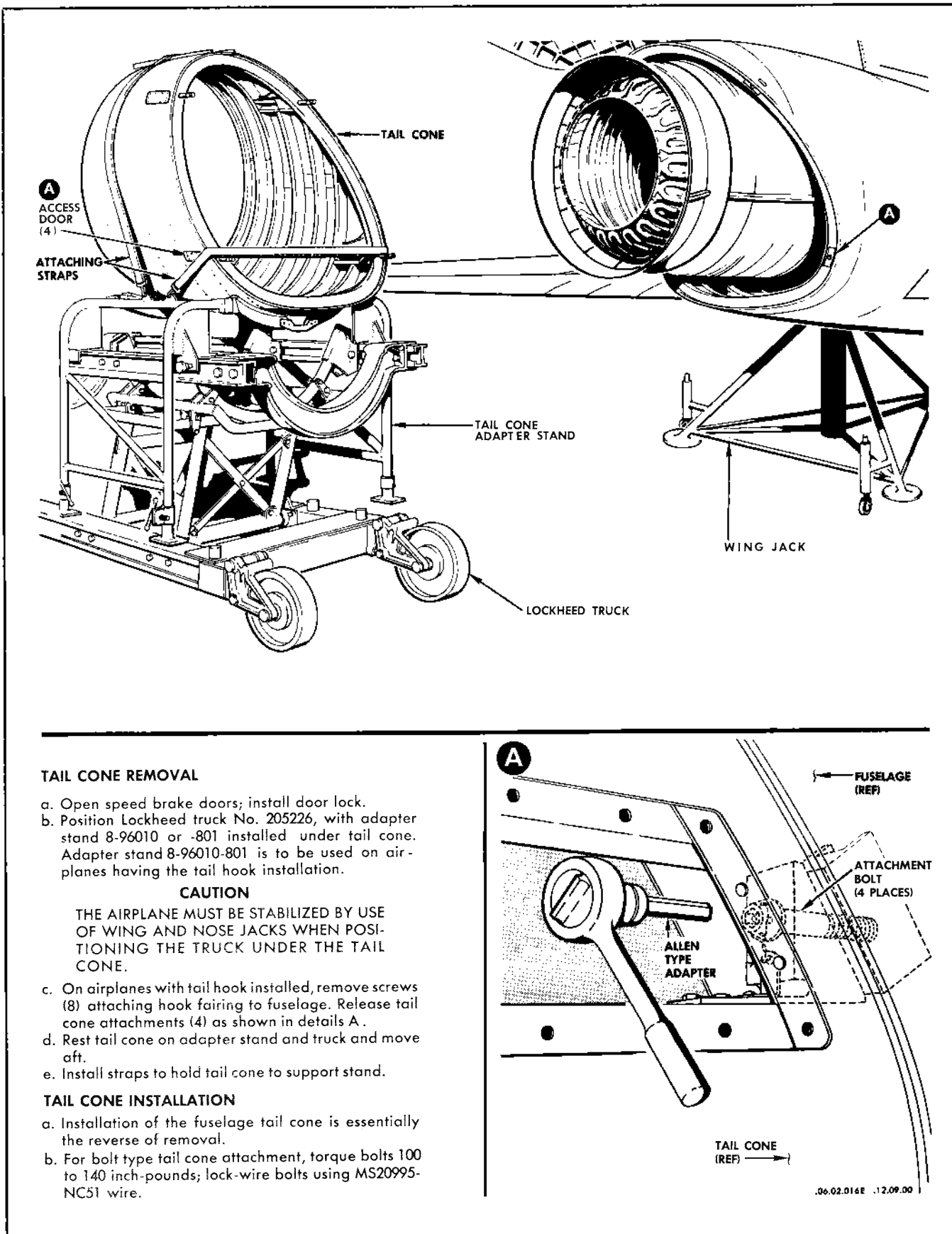

Figure 1-9. Engine Disconnect Point Access



**TAIL CONE REMOVAL**

- a. Open speed brake doors; install door lock.
- b. Position Lockheed truck No. 205226, with adapter stand 8-96010 or -801 installed under tail cone. Adapter stand 8-96010-801 is to be used on airplanes having the tail hook installation.

**CAUTION**

THE AIRPLANE MUST BE STABILIZED BY USE OF WING AND NOSE JACKS WHEN POSITIONING THE TRUCK UNDER THE TAIL CONE.

- c. On airplanes with tail hook installed, remove screws (8) attaching hook fairing to fuselage. Release tail cone attachments (4) as shown in details A.
- d. Rest tail cone on adapter stand and truck and move aft.
- e. Install straps to hold tail cone to support stand.

**TAIL CONE INSTALLATION**

- a. Installation of the fuselage tail cone is essentially the reverse of removal.
- b. For bolt type tail cone attachment, torque bolts 100 to 140 inch-pounds; lock-wire bolts using MS20995-NC51 wire.

Figure 1-10. Replacement, Tailcone

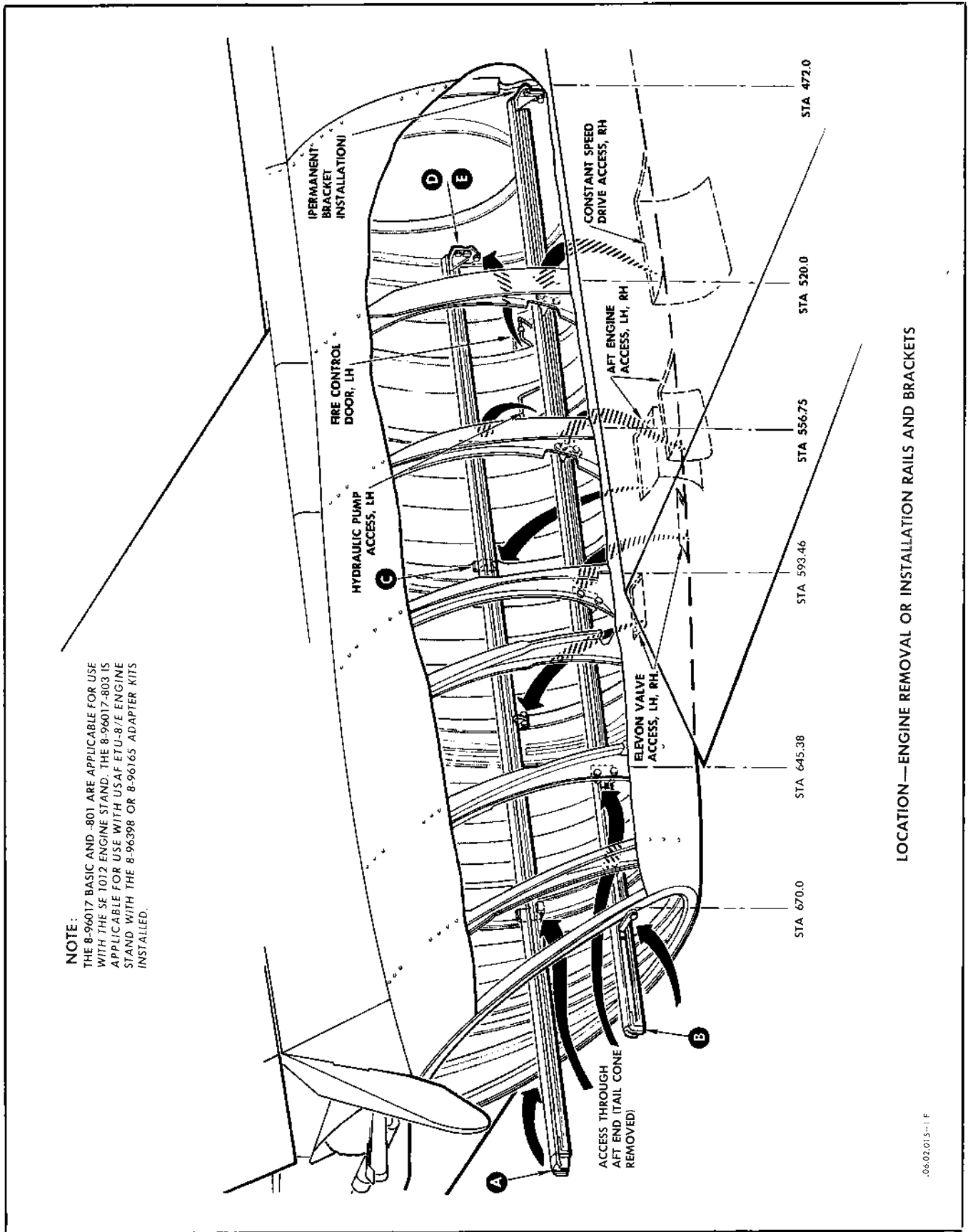

Figure 1-11. Engine Replacement, Rail and Bracket Installation, 8-96017 Basic, -801, -803 (Sheet 1 of 2)  
 Applicable to F-106A airplanes 57-246 thru 58-798, and F-106B airplanes 57-2516 thru 57-2541

**INSTALLATION,  
ENGINE REMOVAL RAILS AND BRACKETS**

- a. Open engine compartment access doors.
- b. Remove fuselage tail cone.
- c. Install rail brackets and rails as follows:

QTY	PART NUMBER	STATION LOCATION	POSITION
1	8-96017-21 BRACKET	472.0	LEFT
2	-9 BRACKET	520.0	LEFT AND RIGHT
2	-11 BRACKET	556.75	LEFT AND RIGHT
2	-13 BRACKET	593.46	LEFT AND RIGHT
2	-15 BRACKET	645.38	LEFT AND RIGHT
1	-17 BRACKET	670.0	LEFT
1	-18 BRACKET	670.0	RIGHT
1	-27, -59 OR -67 RAIL	FUSELAGE	LEFT
1	-28, -63 OR -69 RAIL	FUSELAGE	RIGHT

**NOTE**

CHECK THAT THE ABOVE LISTED BRACKETS HAVE BEEN REMOVED UPON COMPLETION OF ENGINE REPLACEMENT.

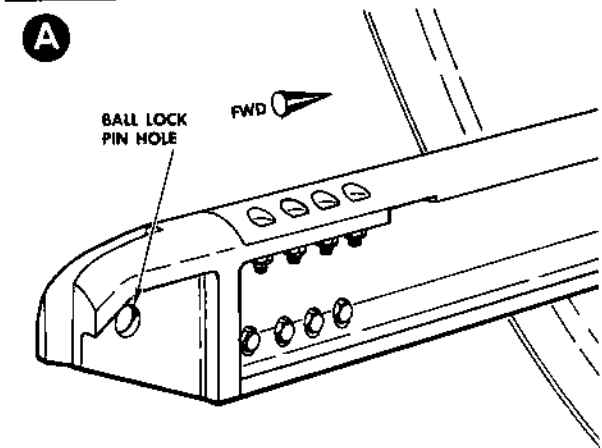
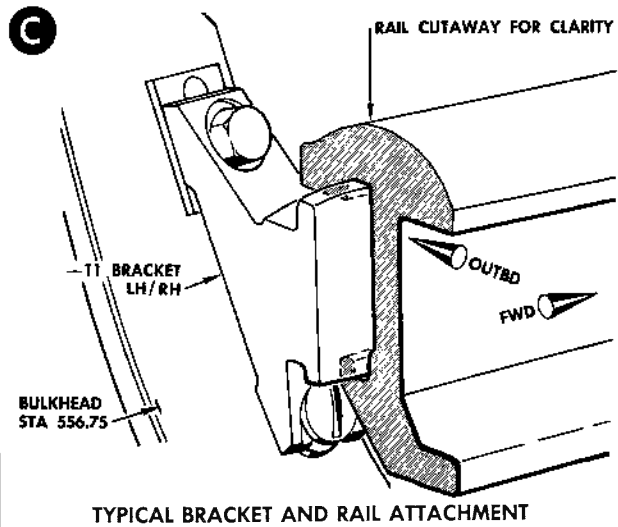

AFT END OF LEFT RAIL FOR -803

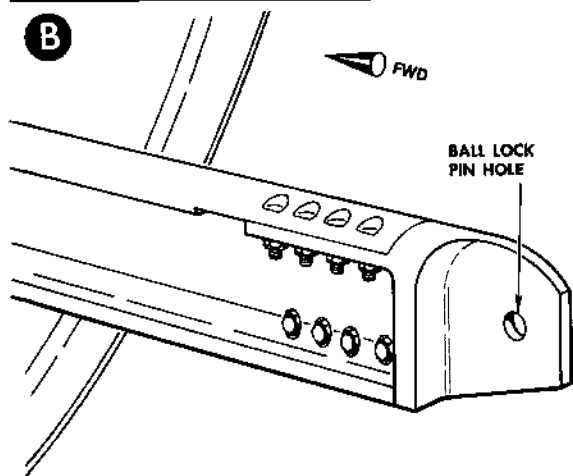

AFT END OF RIGHT RAIL FOR -803

06.02.013-7

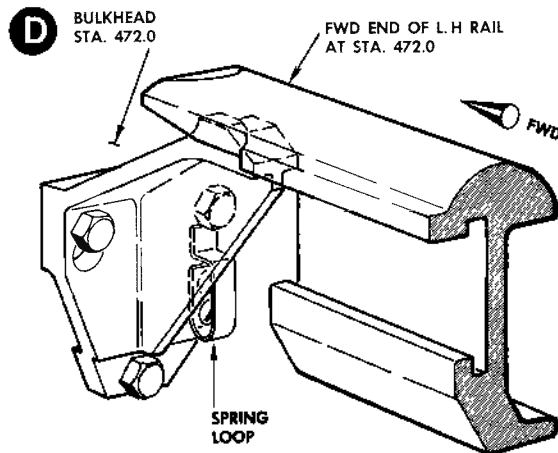

FORWARD MOUNT BRACKET FOR BASIC

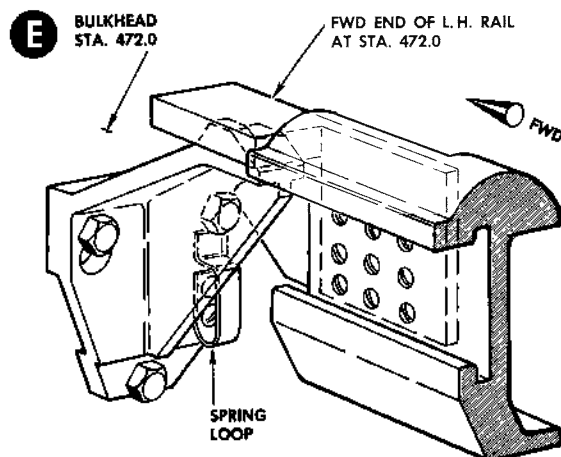

FORWARD MOUNT BRACKET FOR -801 AND -803

Figure 1-11. Engine Replacement, Rail and Bracket Installation, 8-96017 Basic, -801, -803 (Sheet 2 of 2)  
Applicable to F-106A airplanes 57-246 thru 58-798, and F-106B airplanes 57-2516 thru 57-2541



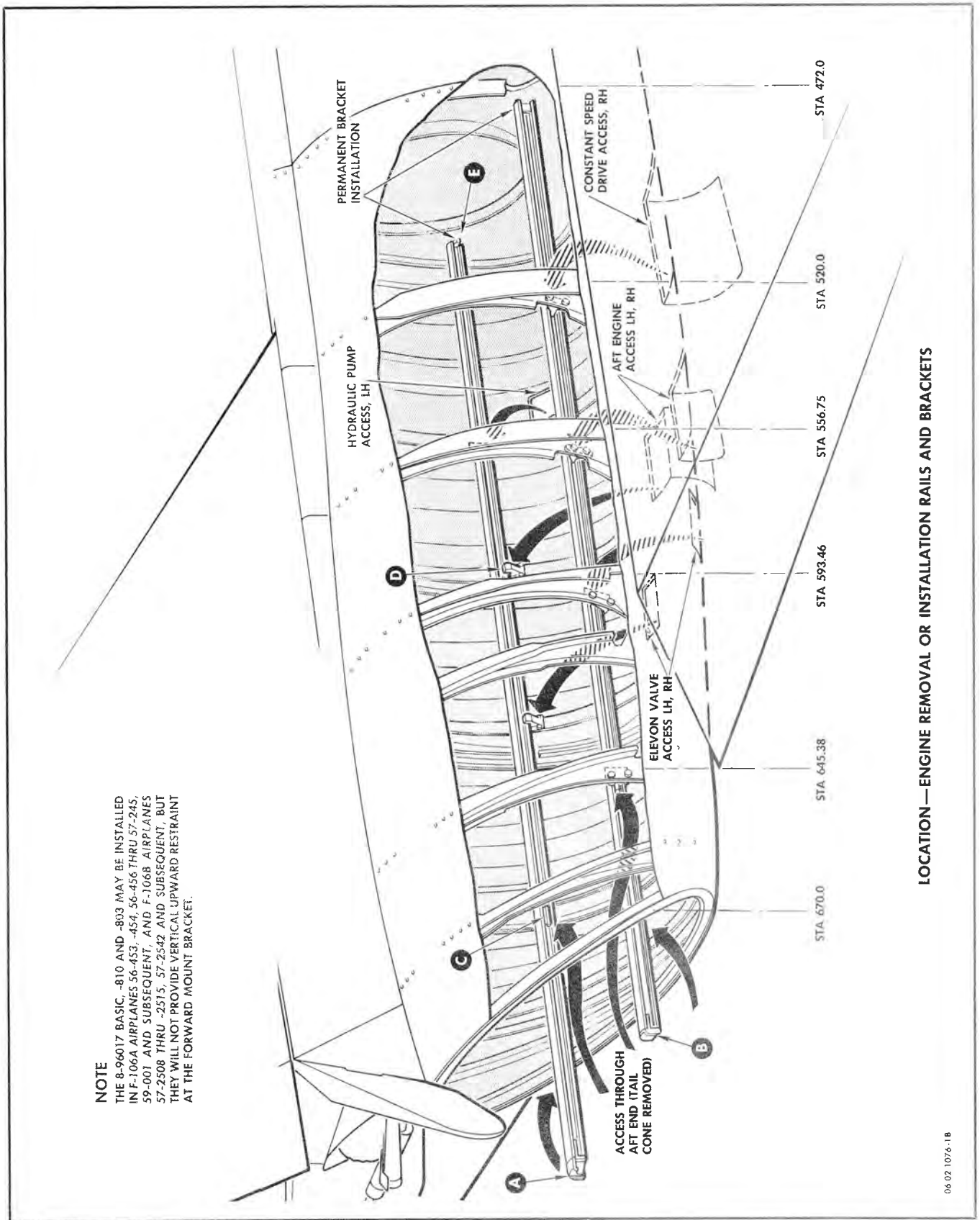

**NOTE**  
 THE 8-96017 BASIC -810 AND -803 MAY BE INSTALLED IN F-106A AIRPLANES 56-453, -454, 56-456 THRU 57-245, 59-001 AND SUBSEQUENT, AND F-106B AIRPLANES 57-2508 THRU -2515, 57-2542 AND SUBSEQUENT, BUT THEY WILL NOT PROVIDE VERTICAL UPWARD RESTRAINT AT THE FORWARD MOUNT BRACKET.

LOCATION—ENGINE REMOVAL OR INSTALLATION RAILS AND BRACKETS

06 02 1076-1B

**Figure 1-12. Engine Replacement, Rail and Bracket Installations, 8-96017-805 (Sheet 1 of 2)**  
 Applicable to F-106A airplanes 56-453, 56-454, 56-456 thru 57-245, 59-001 and subsequent, and F-106B airplanes 57-2508 thru 57-2515, 57-2542 and subsequent

**INSTALLATION, ENGINE REMOVAL RAILS AND BRACKETS**

- a. Open engine compartment access doors.
- b. Remove fuselage tail cone.
- c. Install rail brackets and rails as follows:

QTY	PART NUMBER	STATION LOCATION	POSITION
2	8-96017-91 BRACKET	520.0	LEFT AND RIGHT
2	8-96017-93 BRACKET	556.75	LEFT AND RIGHT
2	8-96017-95 BRACKET	593.46	LEFT AND RIGHT
2	8-96017-97 BRACKET	645.38	LEFT AND RIGHT
1	8-96017-85 RAIL	FUSELAGE	LEFT
1	8-96017-87 RAIL	FUSELAGE	RIGHT

**NOTE**

CHECK THAT THE ABOVE LISTED BRACKETS HAVE BEEN REMOVED UPON COMPLETION OF ENGINE REPLACEMENT.

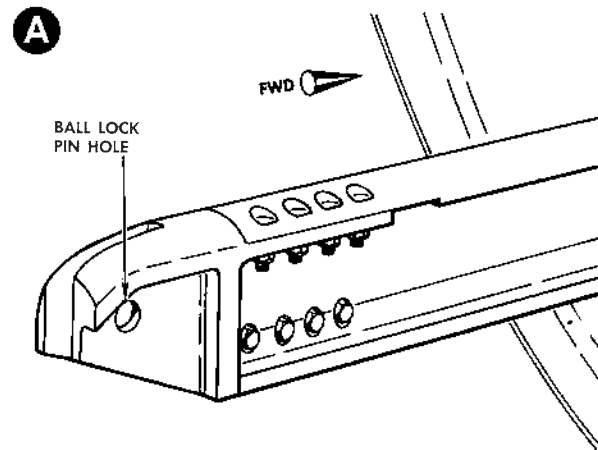

AFT END OF LEFT RAIL

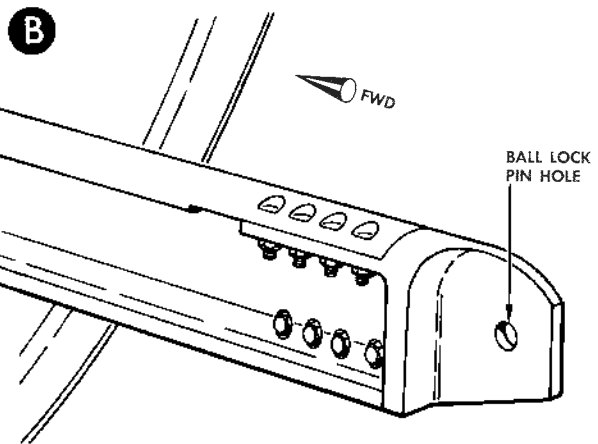

AFT END OF RIGHT RAIL

.06.02.1076 -2

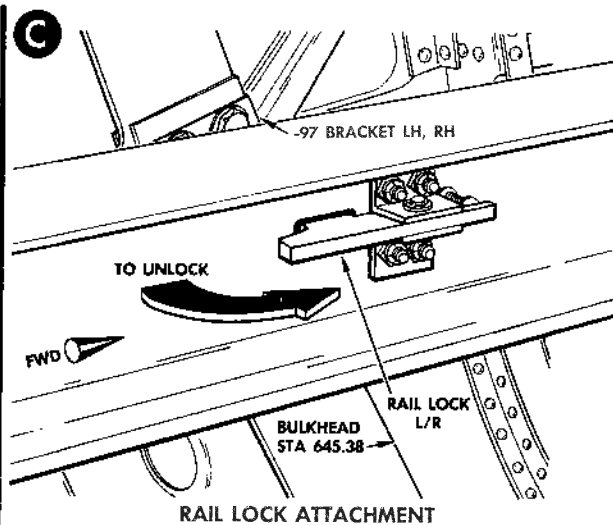

RAIL LOCK ATTACHMENT

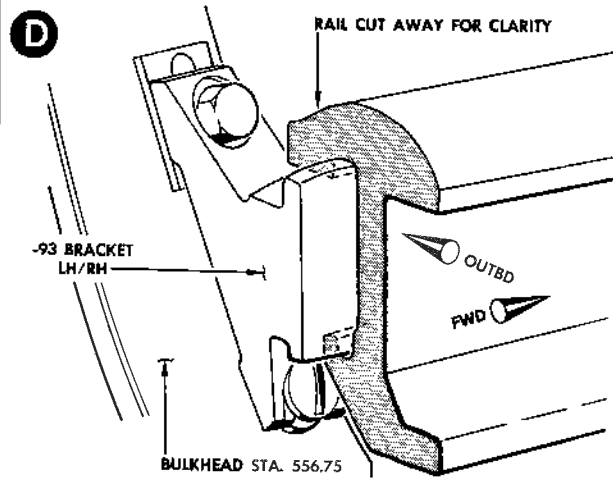

TYPICAL BRACKET AND RAIL ATTACHMENT

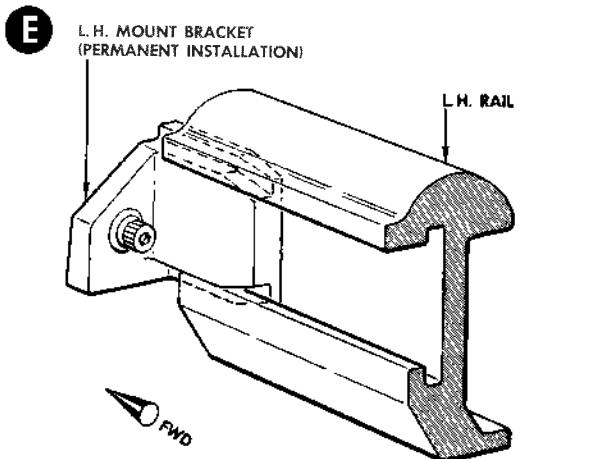

FORWARD MOUNT BRACKET

**Figure 1-12. Engine Replacement, Rail and Bracket Installations, 8-96017-805 (Sheet 2 of 2)**  
 Applicable to F-106A airplanes 56-453, 56-454, 56-456 thru 57-245, 59-001 and subsequent,  
 and F-106B airplanes 57-2508 thru 57-2515, 57-2542 and subsequent

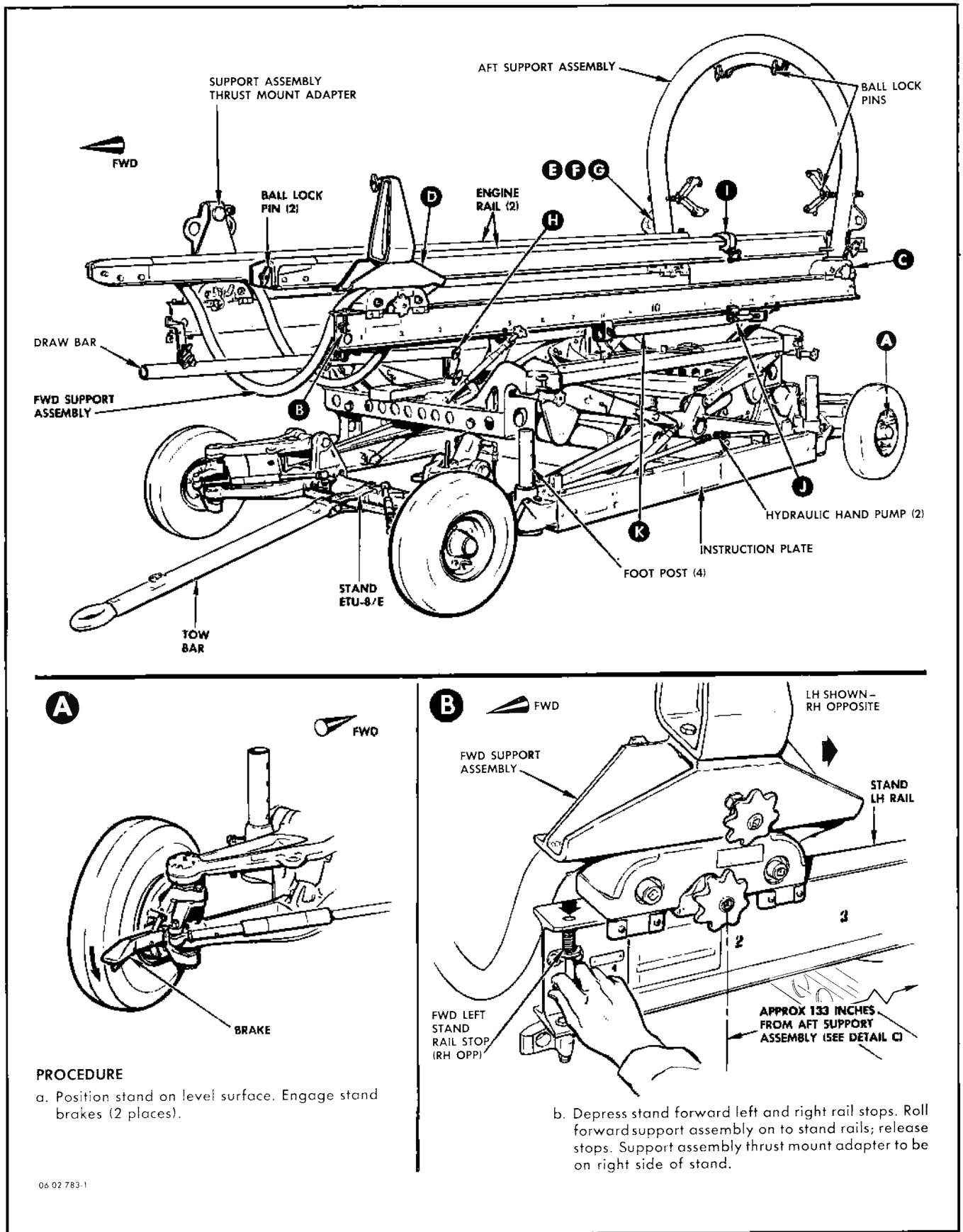

Figure 1-13. Engine Stand Preparation, Type USAF ETU-8/E Using Adapter Kit 8-96398 (Sheet 1 of 3)

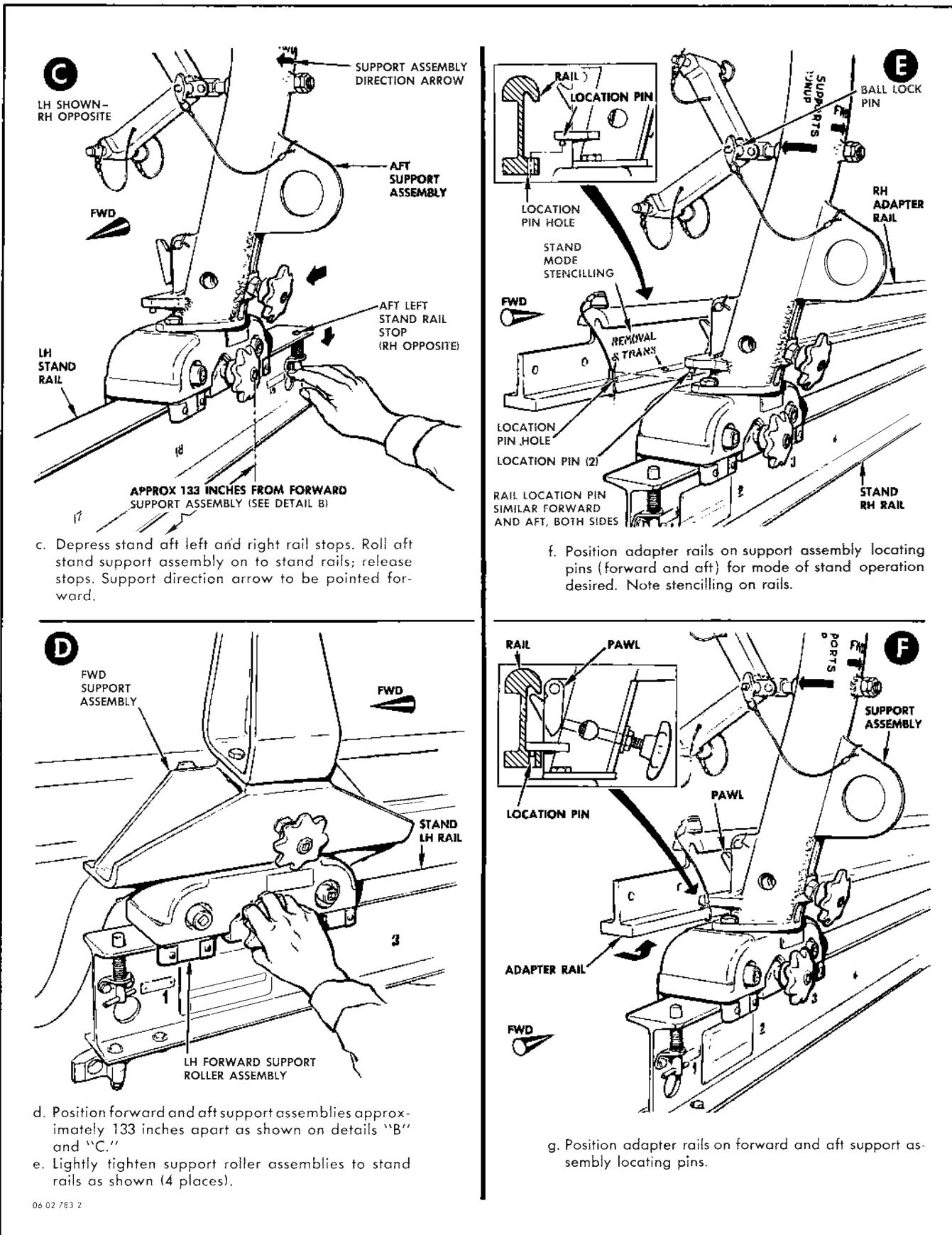

Figure 1-13. Engine Stand Preparation, Type USAF ETU-8/E Using Adapter Kit 8-96398 (Sheet 2 of 3)

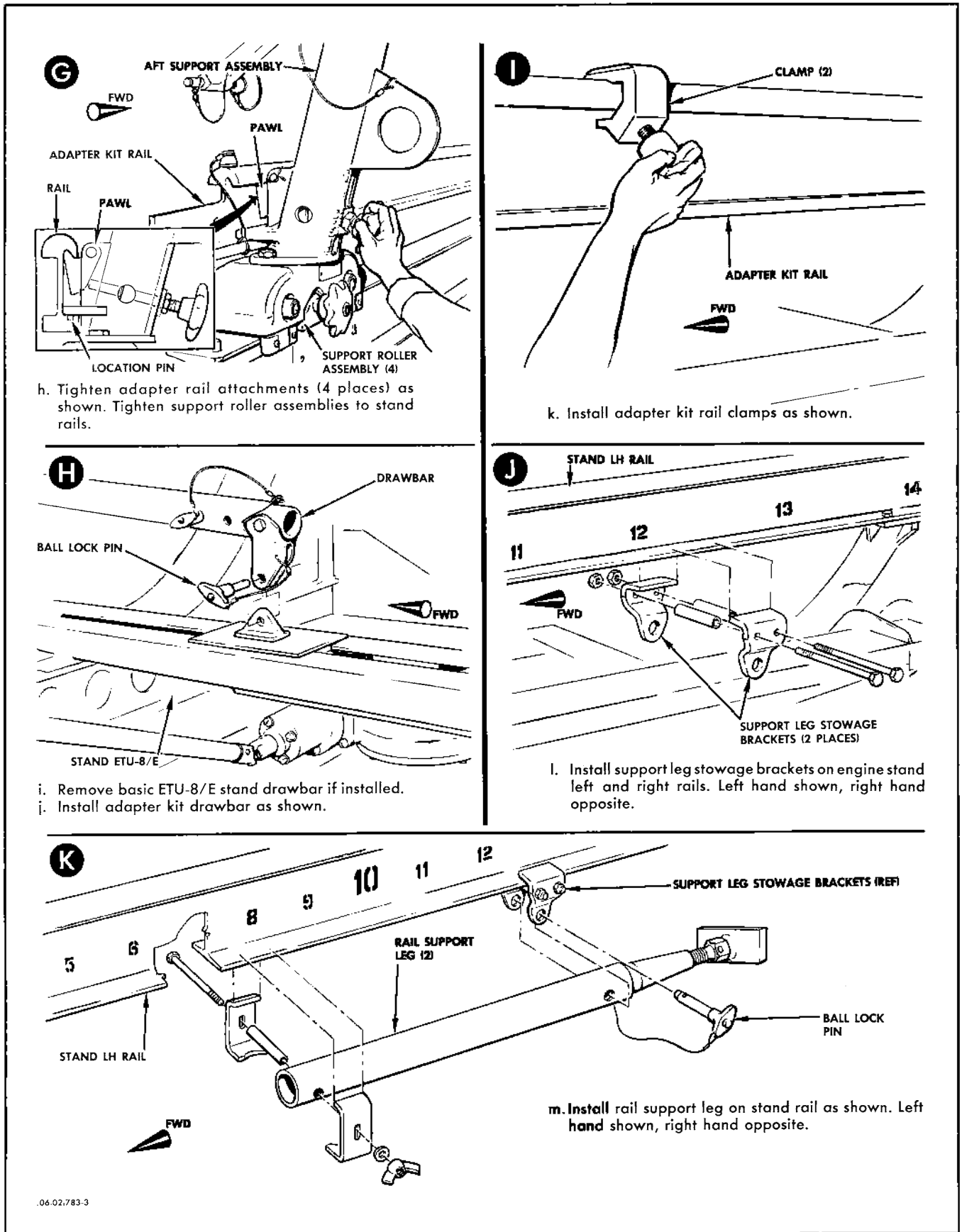

Figure 1-13. Engine Stand Preparation, Type USAF ETU-8/E Using Adapter Kit 8-96398 (Sheet 3 of 3)

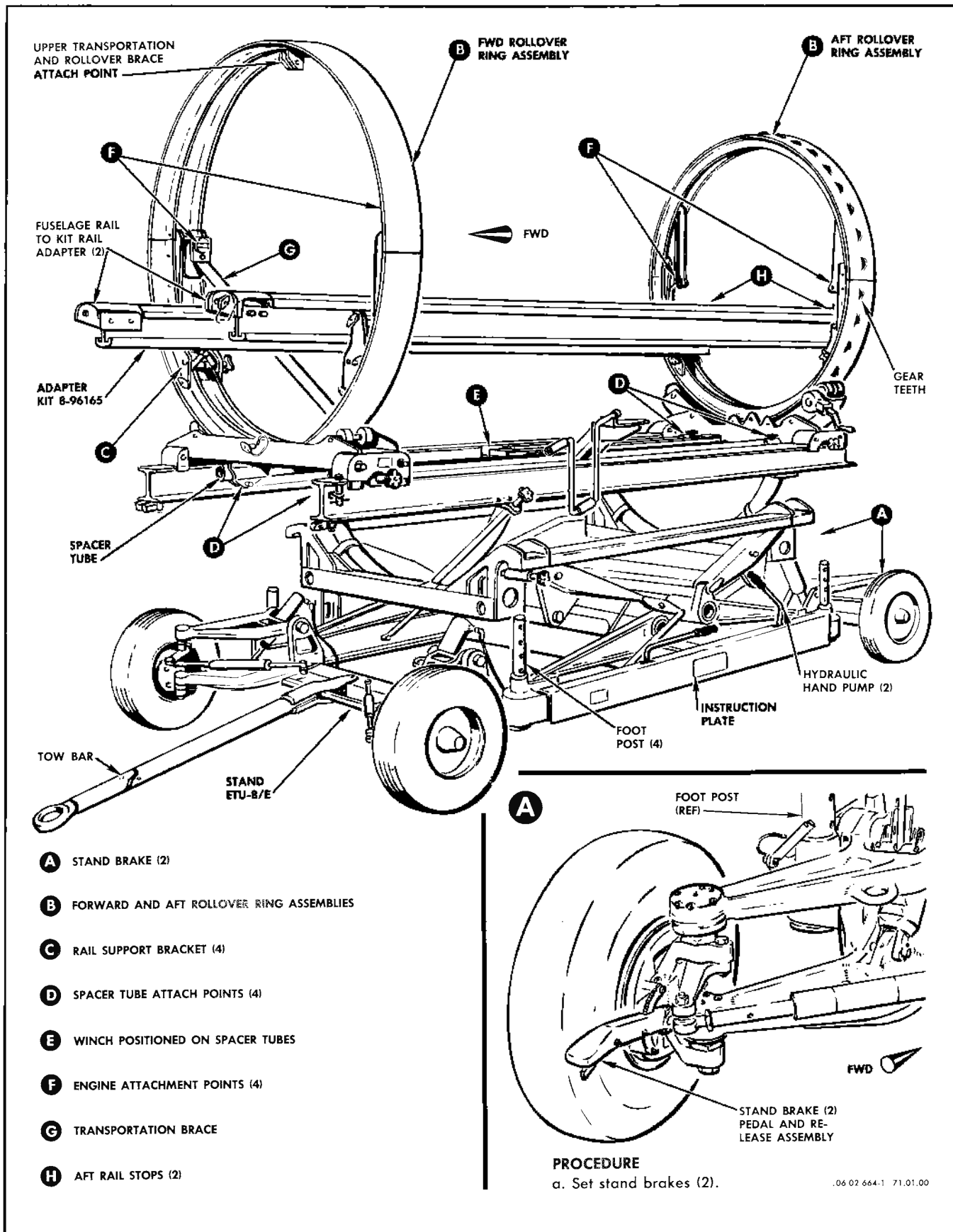

Figure 1-14. Engine Stand Preparation, Type USAF ETU-8/E Using Adapter Kit 8-96165 (Sheet 1 of 3)

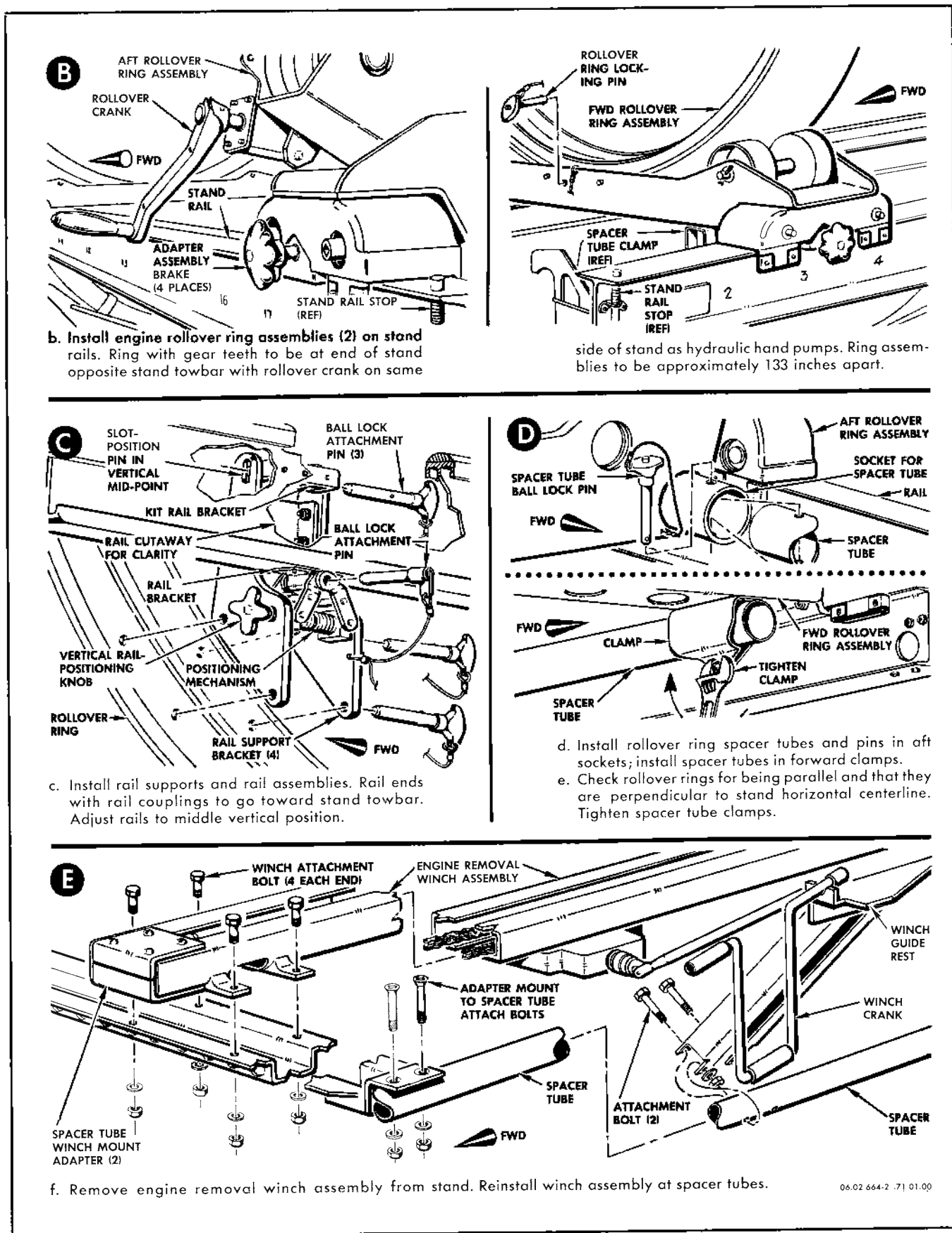

Figure 1-14. Engine Stand Preparation, Type USAF ETU-8/E Using Adapter Kit 8-96165 (Sheet 2 of 3)

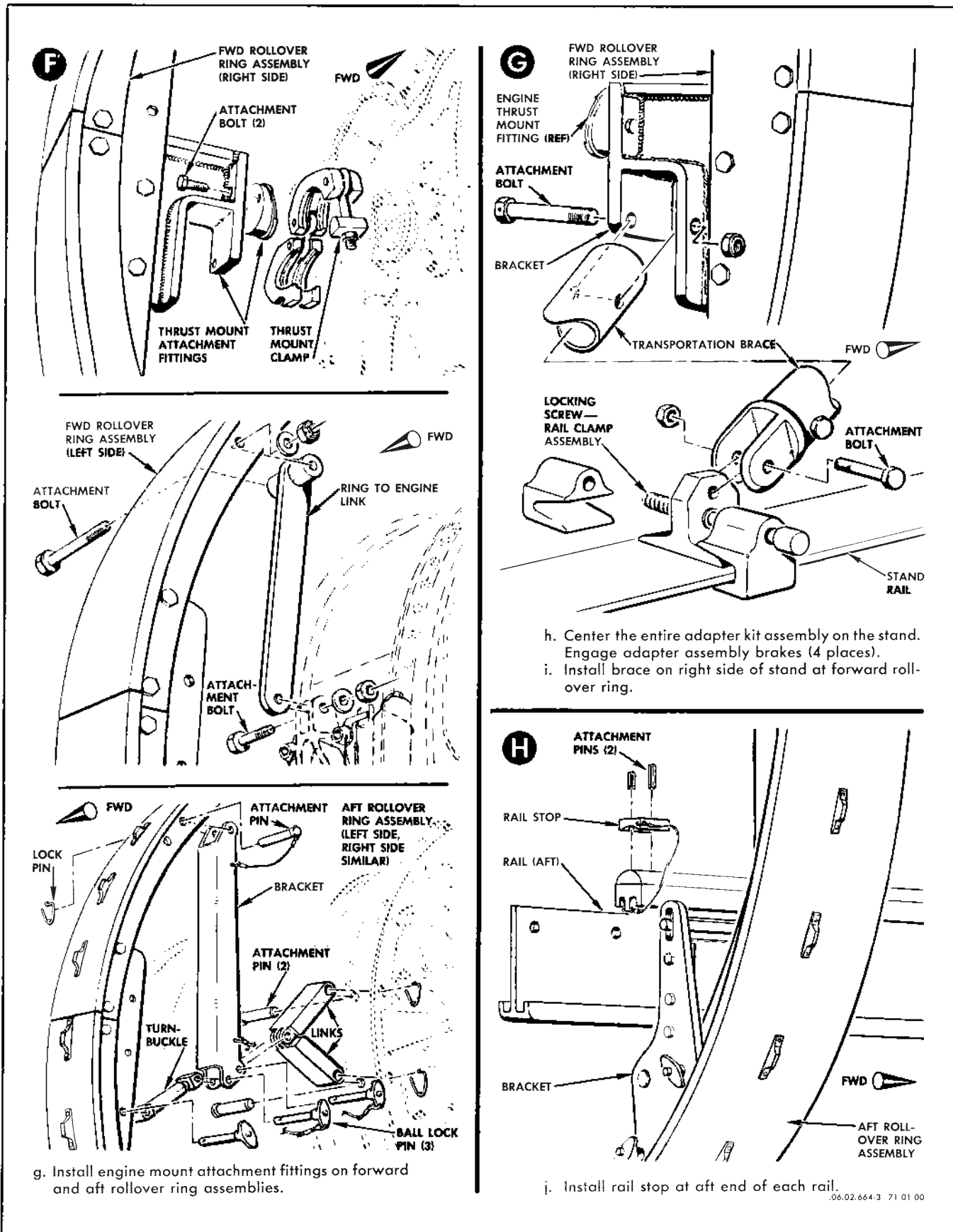
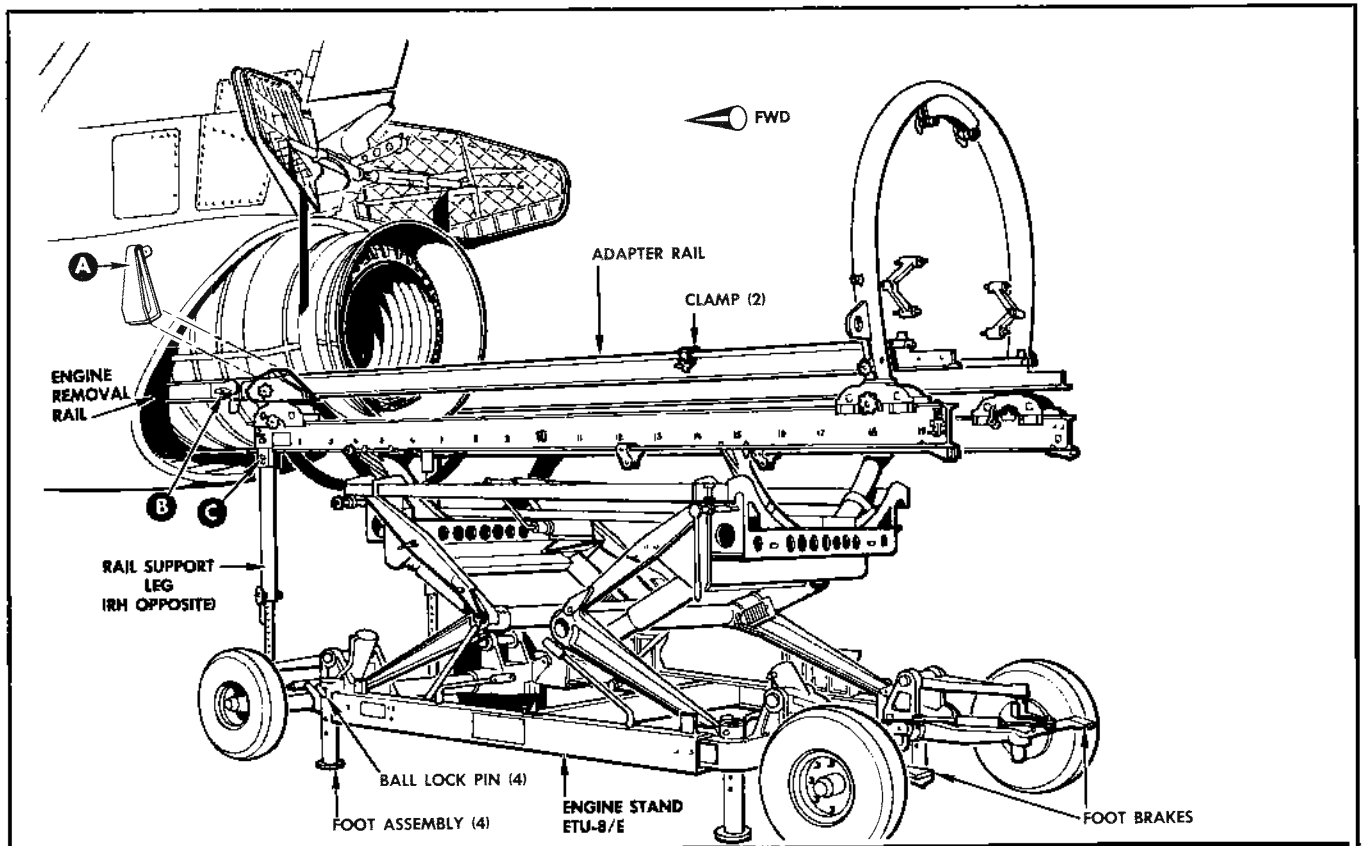

Figure 1-14. Engine Stand Preparation, Type USAF ETU-8/E Using Adapter Kit 8-96165 (Sheet 3 of 3)





**PROCEDURE**

- a. Remove tail cone from airplane.
- b. Open engine access doors in fuselage.
- c. Install engine removal rails and brackets in fuselage.

**CAUTION**

WHEN INSTALLING THE ENGINE RAILS, DO NOT ALLOW ANY WEIGHT TO BE PLACED ON THE ELEVON FEEDBACK POTENTIOMETER SHAFT. ANY WEIGHT THAT MIGHT BE EXERTED TENDS TO BEND THE FLEXIBLE CABLE SECTION OF THE SHAFT OUT OF ALIGNMENT.

- d. Stabilize airplane in level position by jacking aircraft. Refer to T.O. 1F-106A-2-2 for jacking procedure. For engine replacement procedure, lateral level will be checked at the airplane leveling lugs. Longitudinal level will be checked at the engine removal rails in the fuselage with the removal rails level, the airplane will have a slight nose up attitude.
- e. Remove left forward adapter assembly as shown in detail A.
- f. Position engine stand aft of airplane. Adjust height of engine stand until stand and fuselage rails are in alignment. Install ball lock pins as shown in detail B.

**CAUTION**

ALIGNMENT OF FUSELAGE AND STAND RAILS IS NECESSARY TO PREVENT INTERFERENCE OF ENGINE COMPONENTS AND FUSELAGE STRUCTURE DURING ENGINE REPLACEMENT.

- g. Engage stand brakes (2) and foot assemblies (4).
- h. Install rail support legs (2) at forward end of stand as shown in detail C.

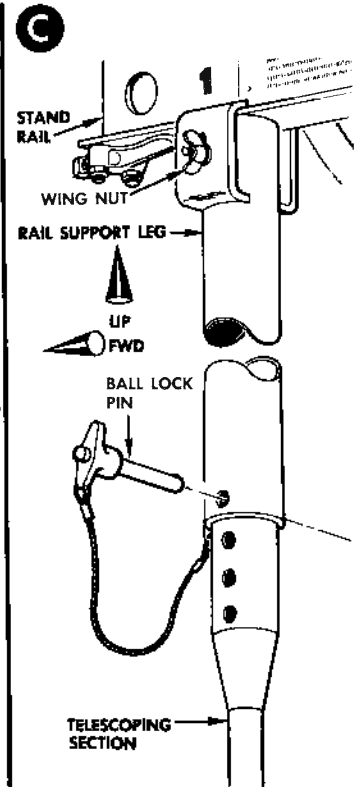
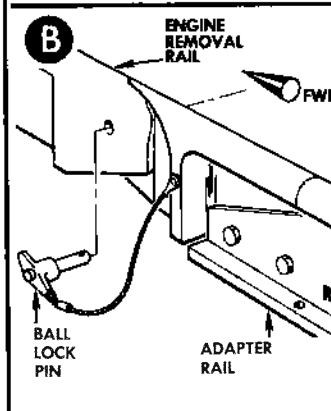
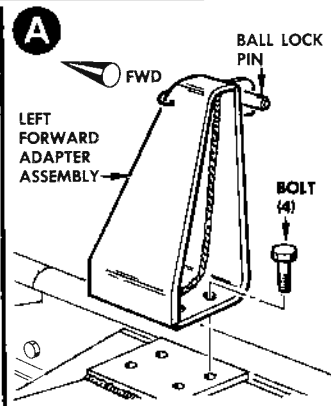

06.02.784B .71.01.00

Figure 1-15. Engine Replacement Preparation Using Stand Type USAF ETU-8/E and Adapter Kit 8-96398

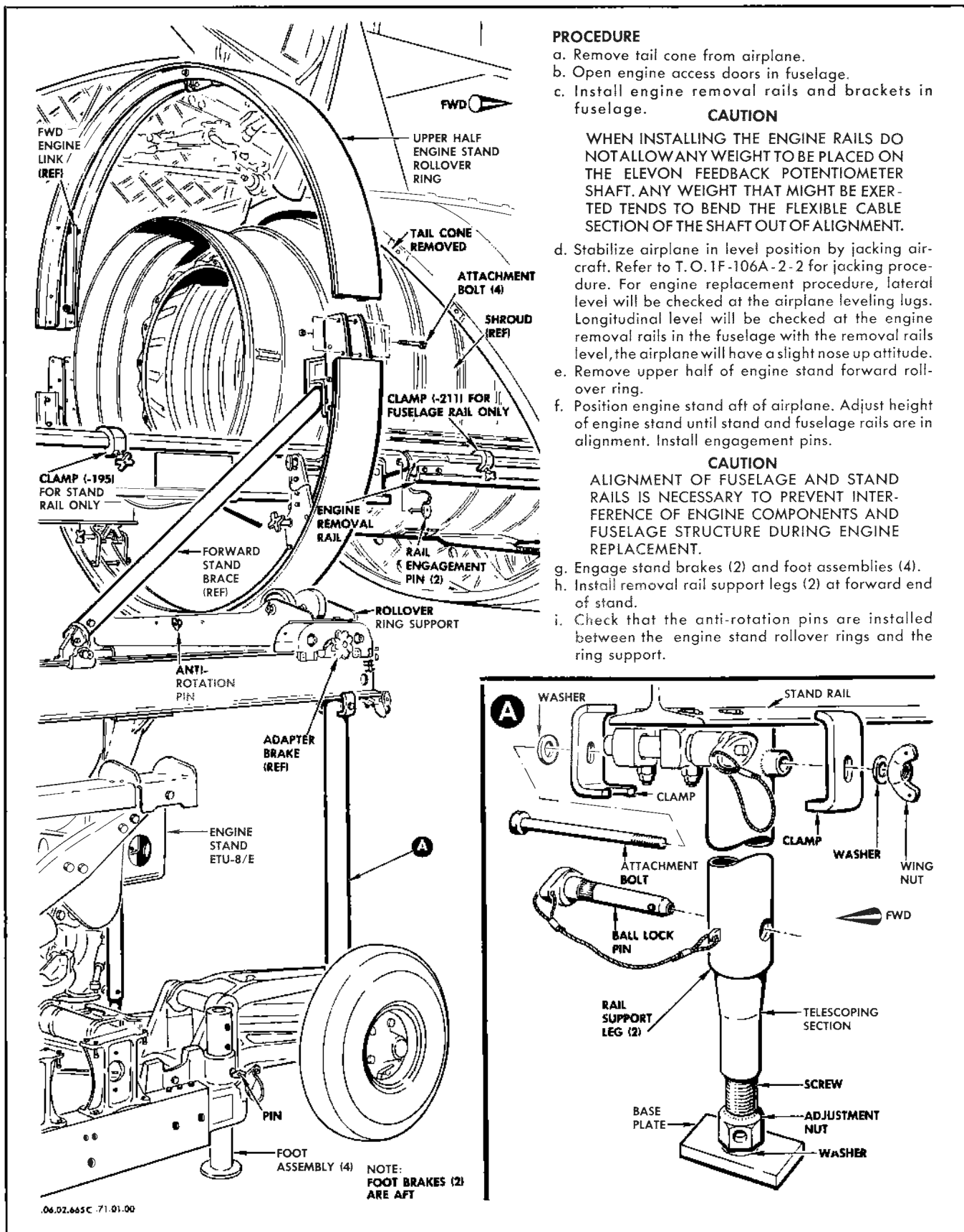

**PROCEDURE**

- a. Remove tail cone from airplane.
- b. Open engine access doors in fuselage.
- c. Install engine removal rails and brackets in fuselage.

**CAUTION**

WHEN INSTALLING THE ENGINE RAILS DO NOT ALLOW ANY WEIGHT TO BE PLACED ON THE ELEVON FEEDBACK POTENTIOMETER SHAFT. ANY WEIGHT THAT MIGHT BE EXERTED TENDS TO BEND THE FLEXIBLE CABLE SECTION OF THE SHAFT OUT OF ALIGNMENT.

- d. Stabilize airplane in level position by jacking aircraft. Refer to T.O. 1F-106A-2-2 for jacking procedure. For engine replacement procedure, lateral level will be checked at the airplane leveling lugs. Longitudinal level will be checked at the engine removal rails in the fuselage with the removal rails level, the airplane will have a slight nose up attitude.
- e. Remove upper half of engine stand forward rollover ring.
- f. Position engine stand aft of airplane. Adjust height of engine stand until stand and fuselage rails are in alignment. Install engagement pins.

**CAUTION**

ALIGNMENT OF FUSELAGE AND STAND RAILS IS NECESSARY TO PREVENT INTERFERENCE OF ENGINE COMPONENTS AND FUSELAGE STRUCTURE DURING ENGINE REPLACEMENT.

- g. Engage stand brakes (2) and foot assemblies (4).
- h. Install removal rail support legs (2) at forward end of stand.
- i. Check that the anti-rotation pins are installed between the engine stand rollover rings and the ring support.

Figure 1-16. Engine Replacement Preparation Using Stand Type USAF ETU-8/E and Adapter Kit 8-96165

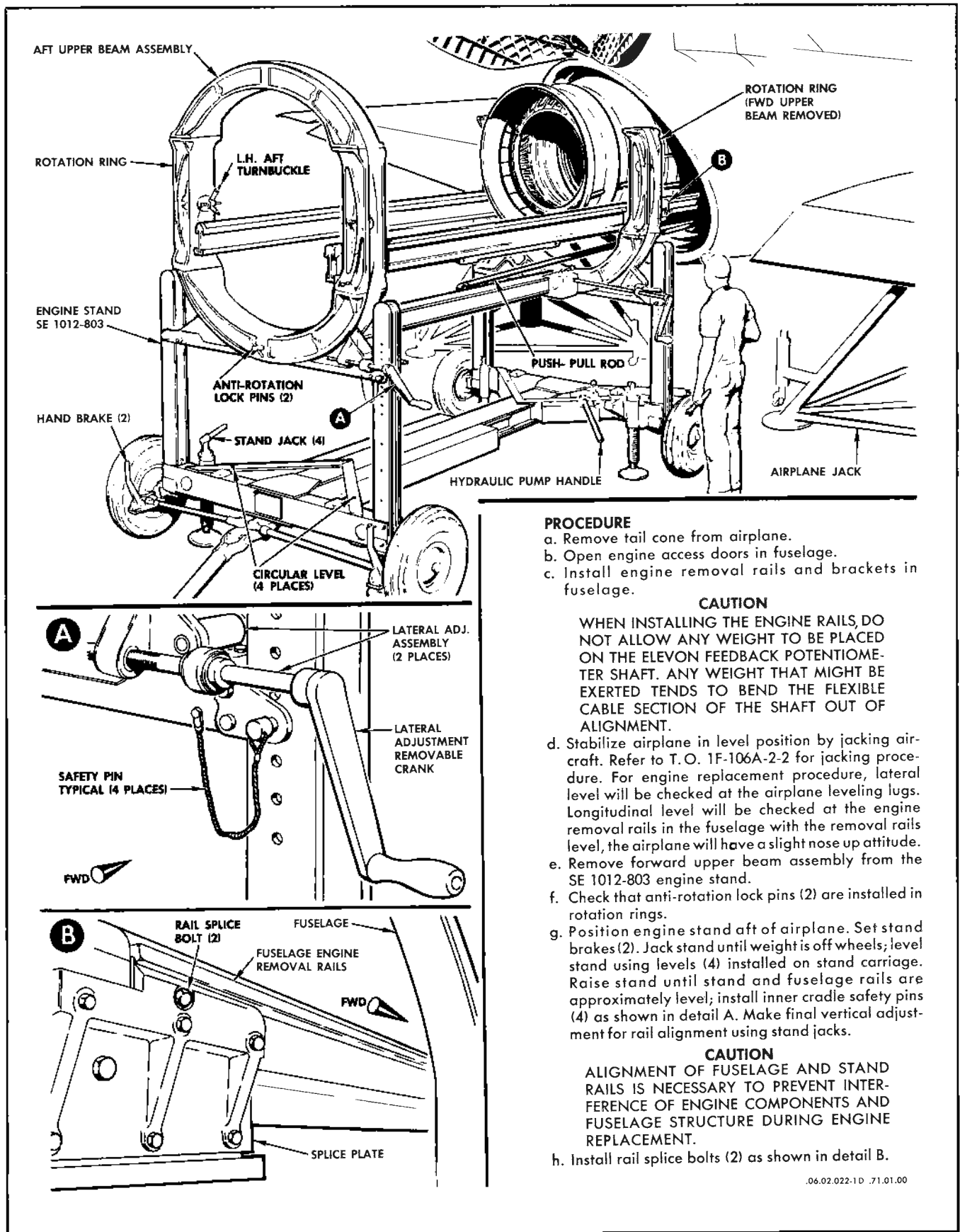

**PROCEDURE**

- a. Remove tail cone from airplane.
- b. Open engine access doors in fuselage.
- c. Install engine removal rails and brackets in fuselage.

**CAUTION**

WHEN INSTALLING THE ENGINE RAILS, DO NOT ALLOW ANY WEIGHT TO BE PLACED ON THE ELEVON FEEDBACK POTENTIOMETER SHAFT. ANY WEIGHT THAT MIGHT BE EXERTED TENDS TO BEND THE FLEXIBLE CABLE SECTION OF THE SHAFT OUT OF ALIGNMENT.

- d. Stabilize airplane in level position by jacking aircraft. Refer to T.O. 1F-106A-2-2 for jacking procedure. For engine replacement procedure, lateral level will be checked at the airplane leveling lugs. Longitudinal level will be checked at the engine removal rails in the fuselage with the removal rails level, the airplane will have a slight nose up attitude.
- e. Remove forward upper beam assembly from the SE 1012-803 engine stand.
- f. Check that anti-rotation lock pins (2) are installed in rotation rings.
- g. Position engine stand aft of airplane. Set stand brakes (2). Jack stand until weight is off wheels; level stand using levels (4) installed on stand carriage. Raise stand until stand and fuselage rails are approximately level; install inner cradle safety pins (4) as shown in detail A. Make final vertical adjustment for rail alignment using stand jacks.

**CAUTION**

ALIGNMENT OF FUSELAGE AND STAND RAILS IS NECESSARY TO PREVENT INTERFERENCE OF ENGINE COMPONENTS AND FUSELAGE STRUCTURE DURING ENGINE REPLACEMENT.

- h. Install rail splice bolts (2) as shown in detail B.

.06.02.022-1D .71.01.00

Figure 1-17. Engine Replacement Preparation Using Stand Type SE 1012-803

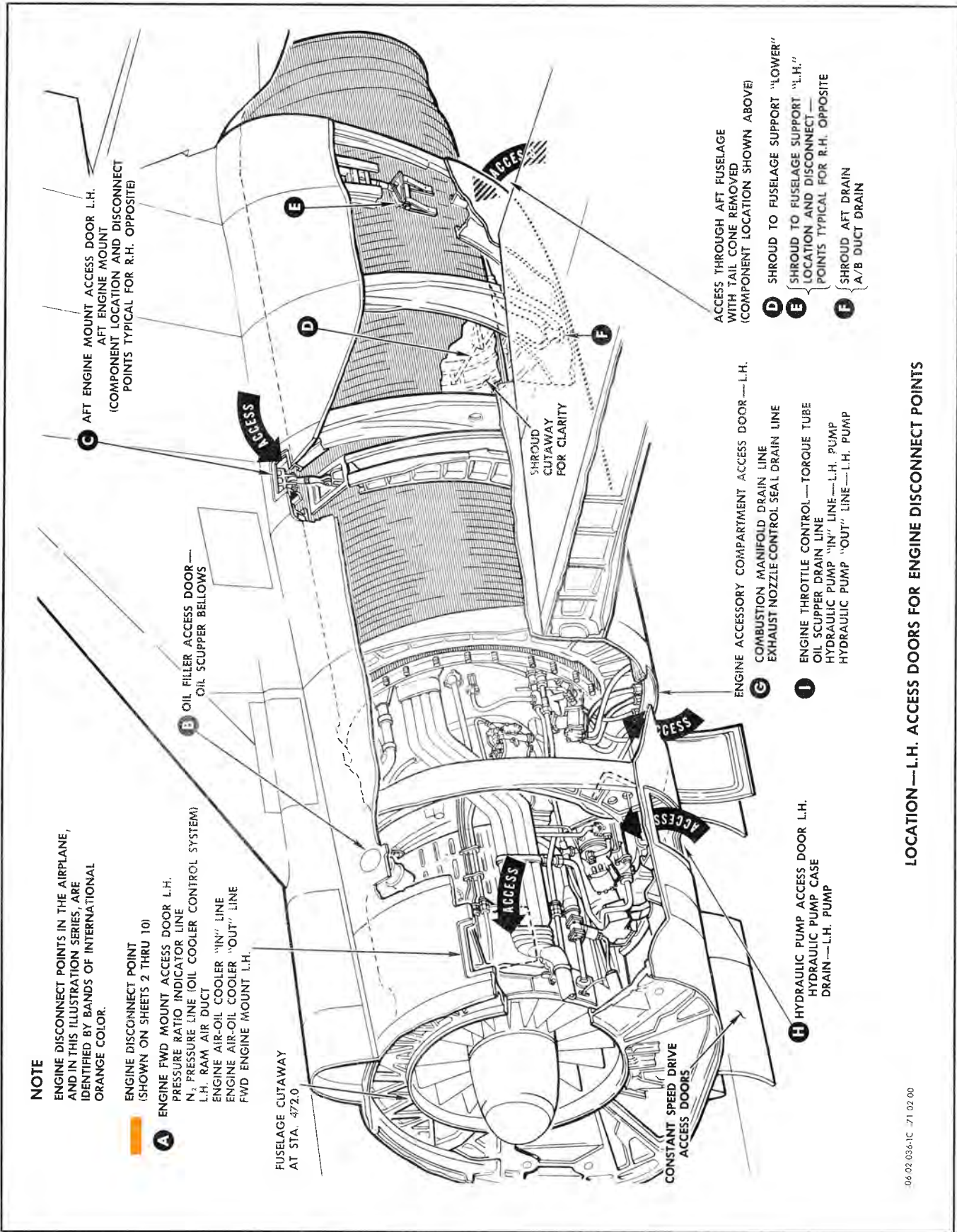

**NOTE**

ENGINE DISCONNECT POINTS IN THE AIRPLANE, AND IN THIS ILLUSTRATION SERIES, ARE IDENTIFIED BY BANDS OF INTERNATIONAL ORANGE COLOR.

- ENGINE DISCONNECT POINT (SHOWN ON SHEETS 2 THRU 10)
- A** ENGINE FWD MOUNT ACCESS DOOR L.H.
- PRESSURE RATIO INDICATOR LINE
- N<sub>2</sub> PRESSURE LINE (OIL COOLER CONTROL SYSTEM)
- L.H. RAW AIR DUCT
- ENGINE AIR-OIL COOLER "IN" LINE
- ENGINE AIR-OIL COOLER "OUT" LINE
- FWD ENGINE MOUNT L.H.

FUSELAGE CUTAWAY AT STA. 472.0

CONSTANT SPEED DRIVE ACCESS DOORS

- C** AFT ENGINE MOUNT ACCESS DOOR L.H. (COMPONENT LOCATION AND DISCONNECT POINTS TYPICAL FOR R.H. OPPOSITE)
- D** SHROUD TO FUSELAGE SUPPORT "LOWER"
- E** SHROUD TO FUSELAGE SUPPORT "L.H." (COMPONENT LOCATION SHOWN ABOVE)
- F** SHROUD AFT DRAIN A/B DUCT DRAIN

- G** ENGINE ACCESSORY COMPARTMENT ACCESS DOOR — L.H.
- COMBUSTION MANIFOLD DRAIN LINE
- EXHAUST NOZZLE CONTROL SEAL DRAIN LINE
- I** ENGINE THROTTLE CONTROL — TORQUE TUBE
- OIL SCUPPER DRAIN LINE
- HYDRAULIC PUMP "IN" LINE — L.H. PUMP
- HYDRAULIC PUMP "OUT" LINE — L.H. PUMP

- H** HYDRAULIC PUMP ACCESS DOOR L.H.
- HYDRAULIC PUMP CASE DRAIN — L.H. PUMP

LOCATION — L.H. ACCESS DOORS FOR ENGINE DISCONNECT POINTS

06-02 036-1C 71 02 00

Figure 1-18. Engine Replacement, Disconnect Points (Sheet 1 of 10)

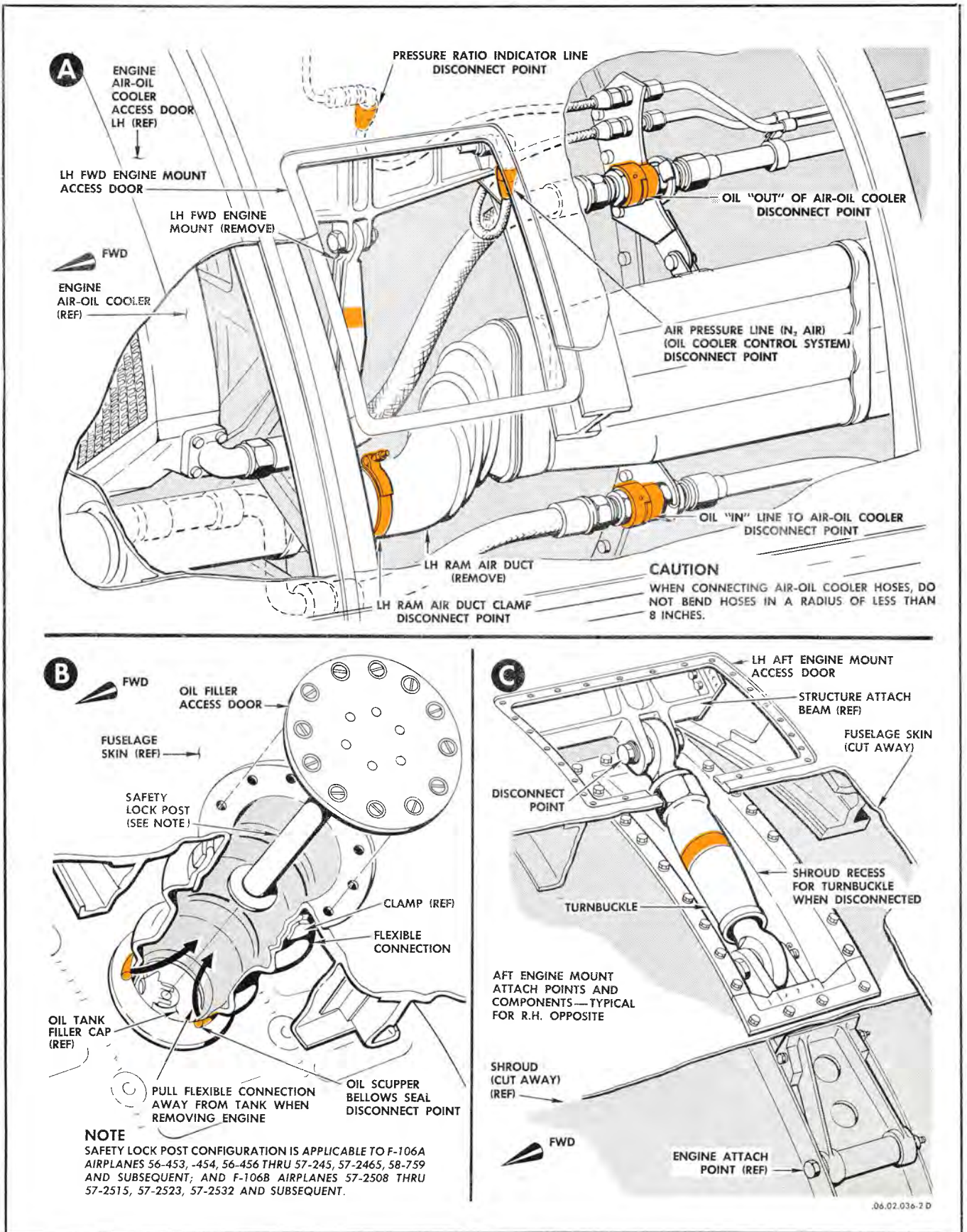

Figure 1-18. Engine Replacement, Disconnect Points (Sheet 2 of 10)

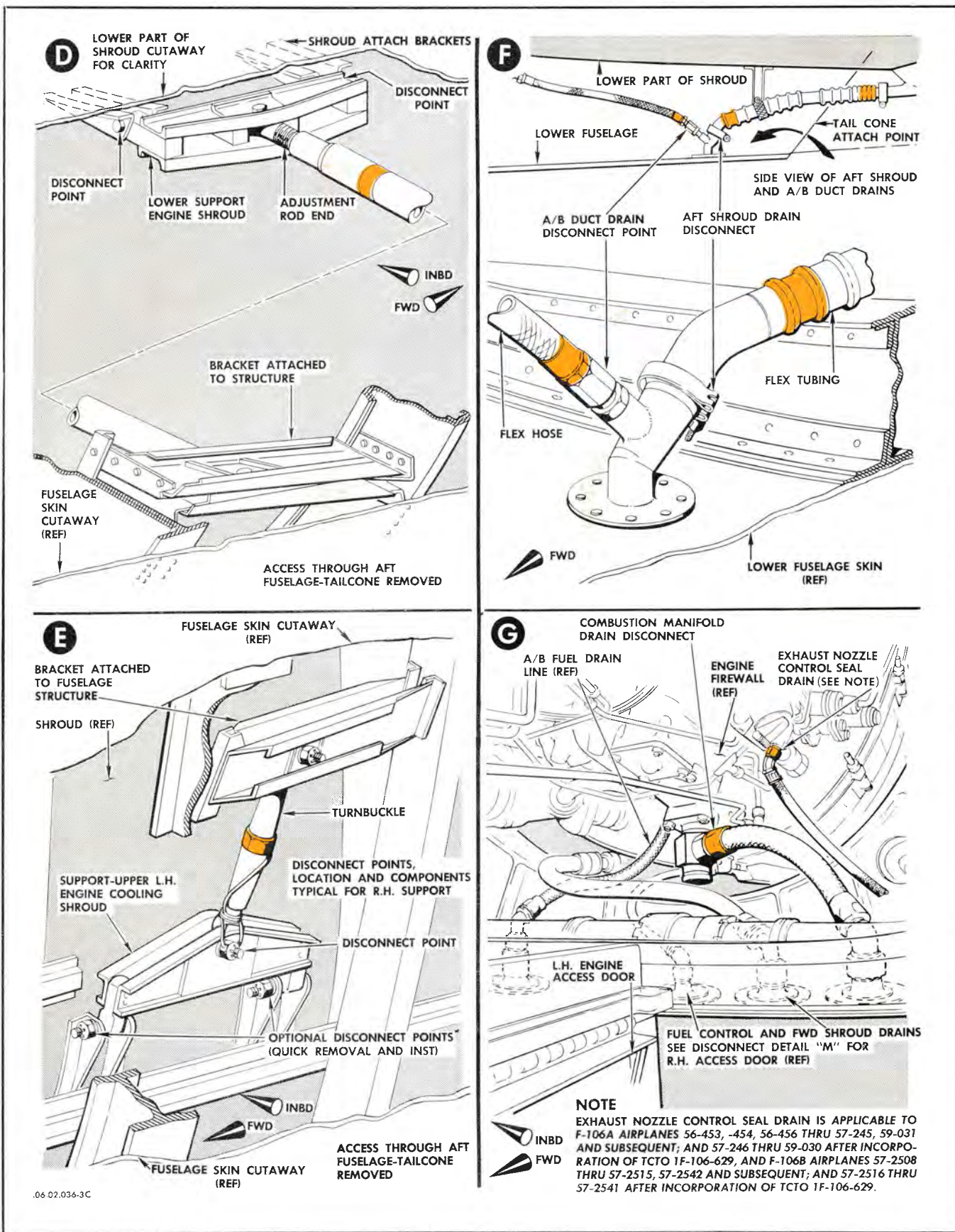

Figure 1-18. Engine Replacement, Disconnect Points (Sheet 3 of 10)

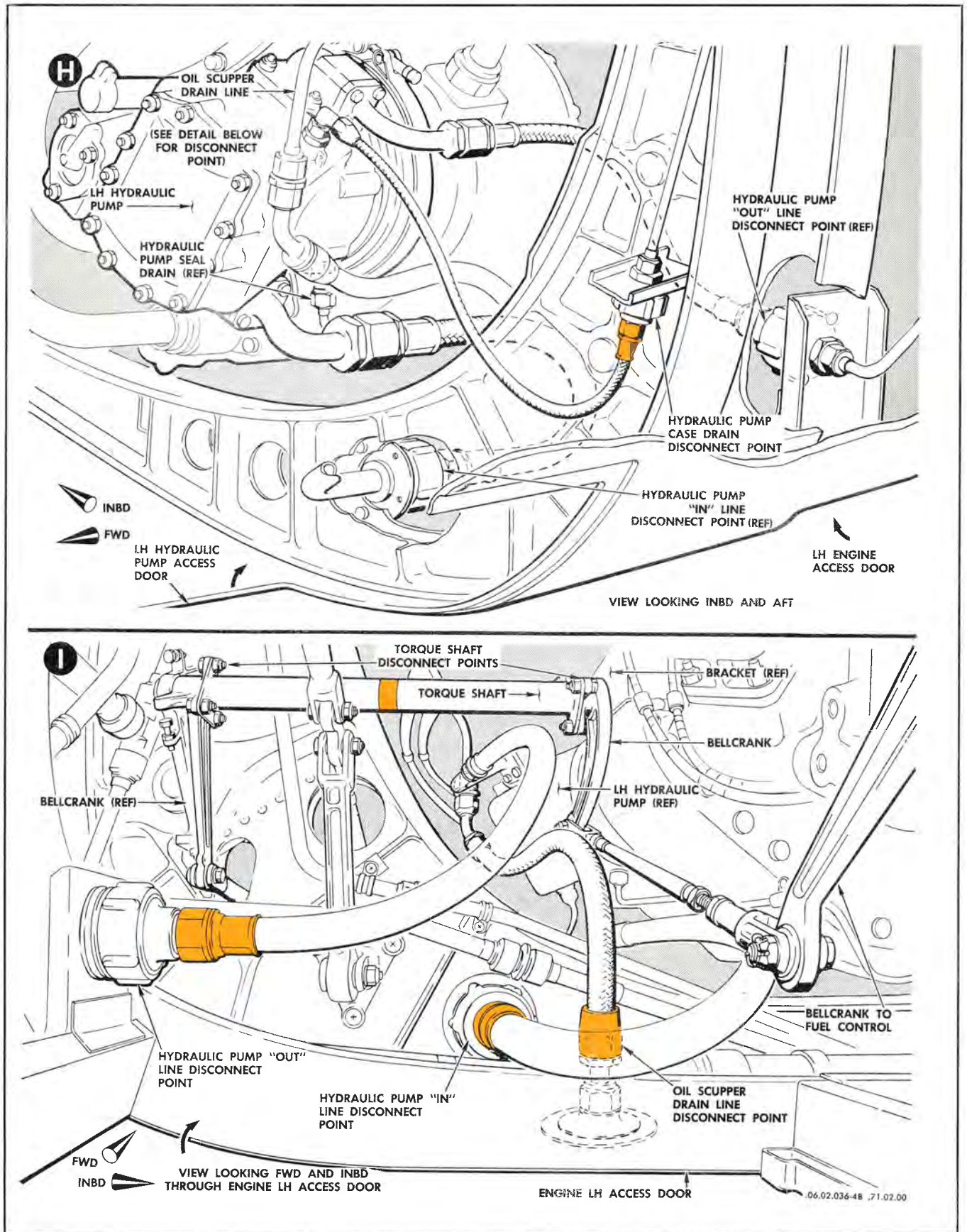

Figure 1-18. Engine Replacement, Disconnect Points (Sheet 4 of 10)

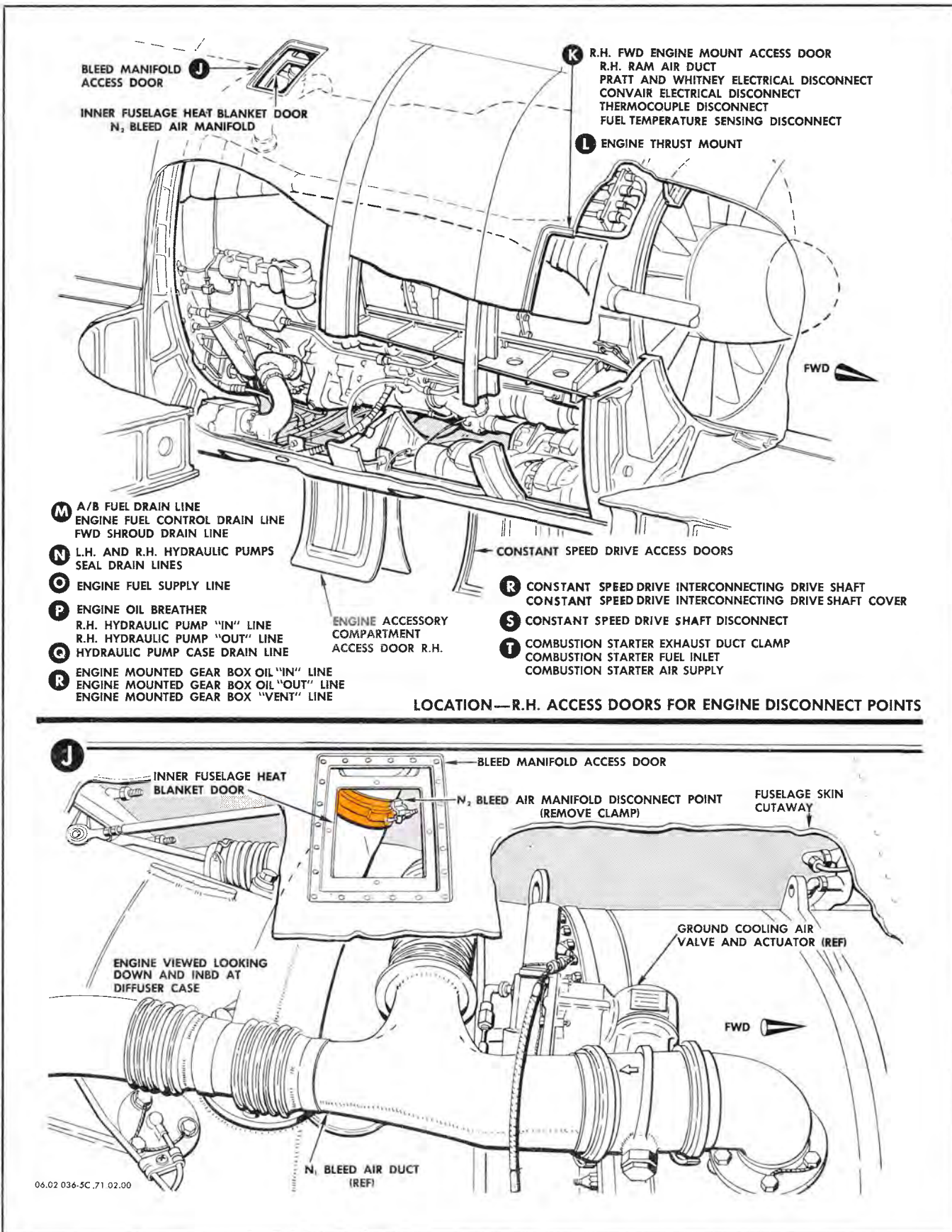

Figure 1-18. Engine Replacement, Disconnect Points (Sheet 5 of 10)



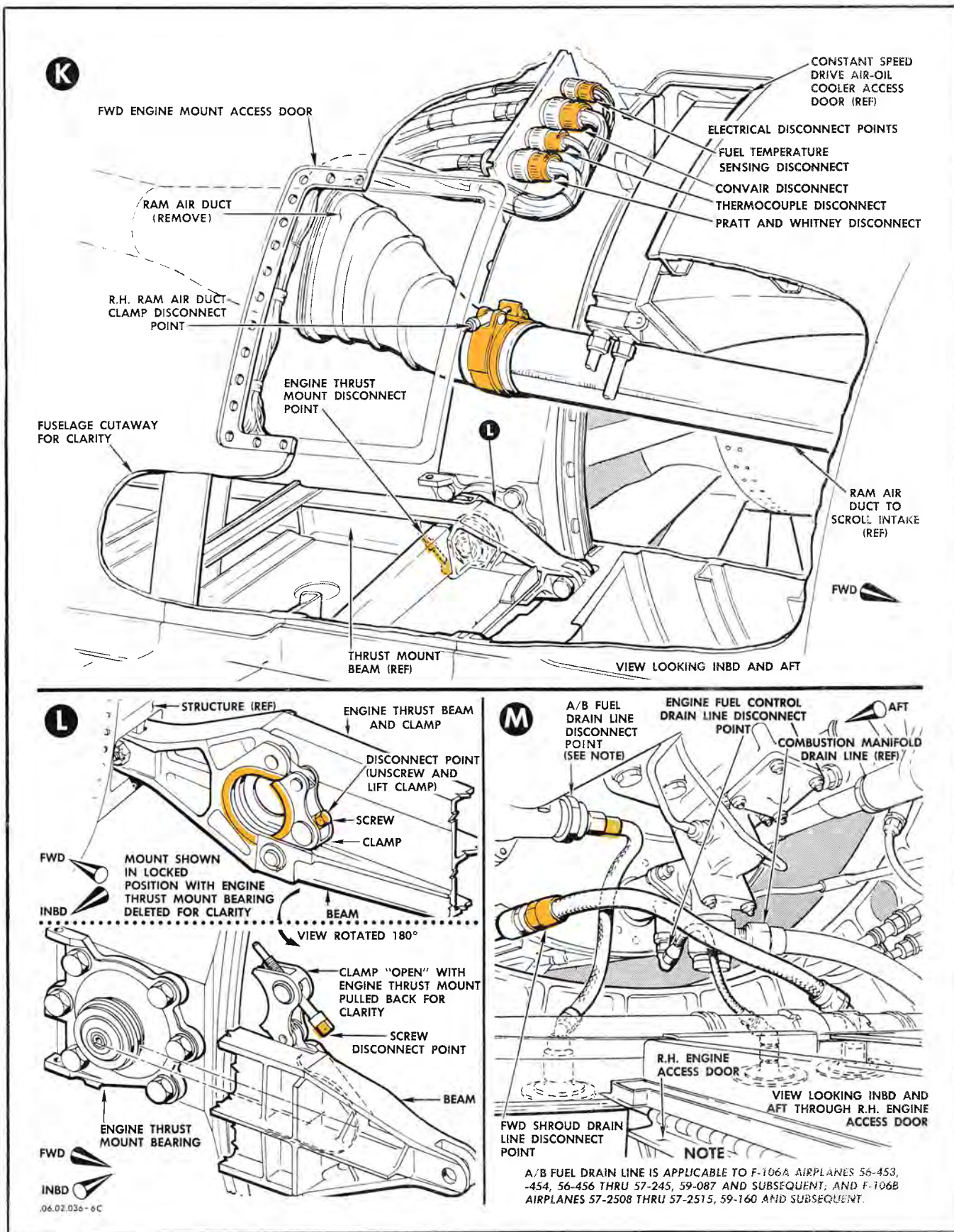

Figure 1-18. Engine Replacement, Disconnect Points (Sheet 6 of 10)

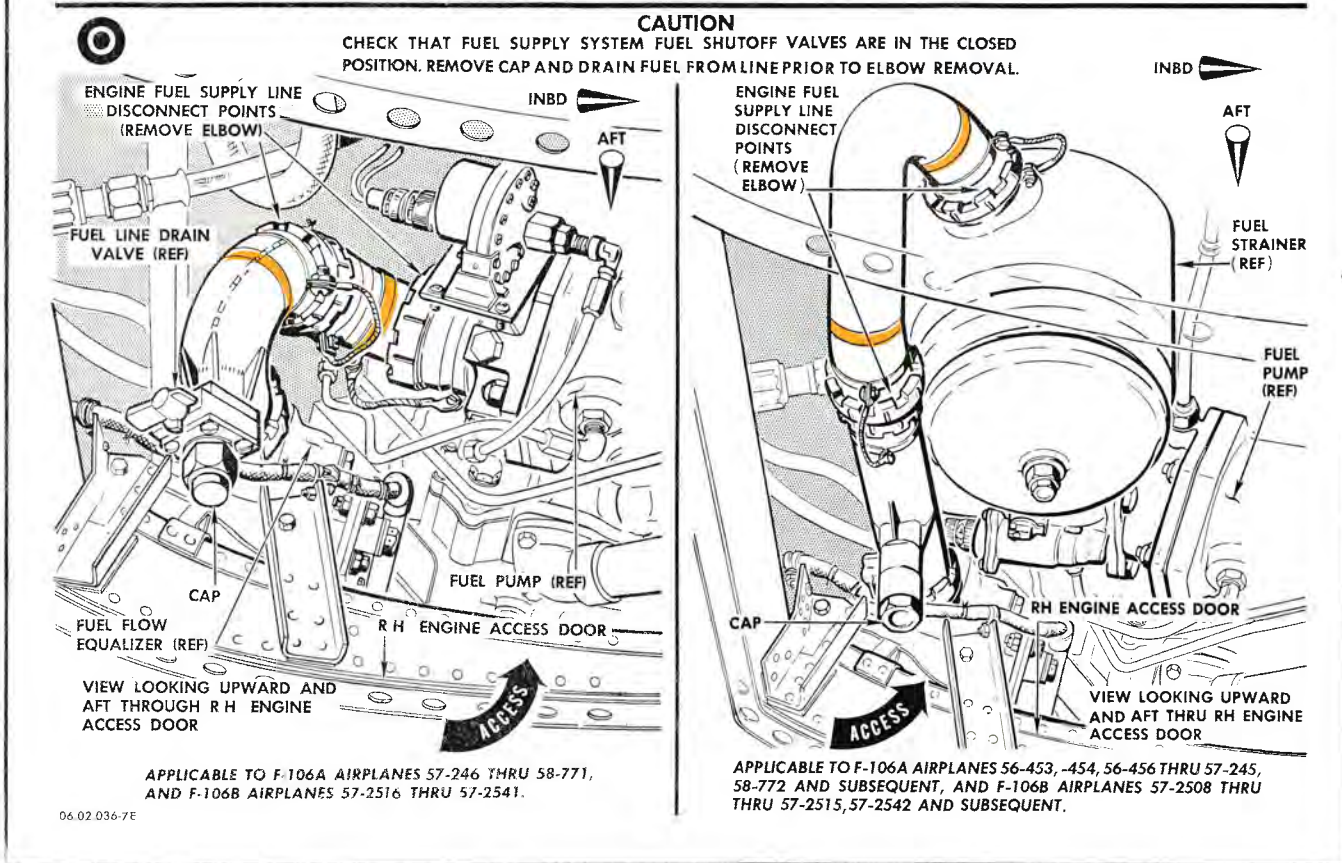
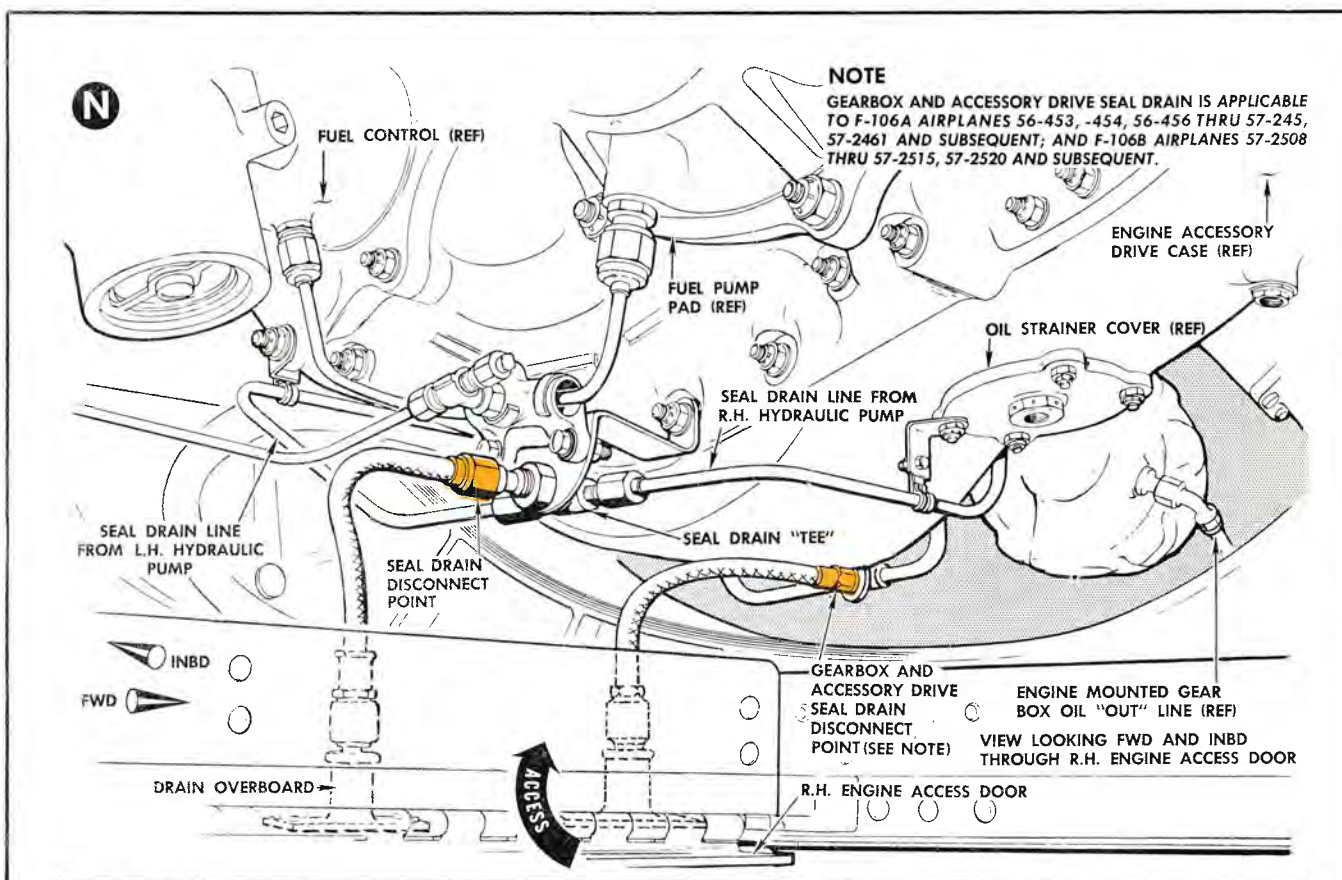

Figure 1-18. Engine Replacement, Disconnect Points (Sheet 7 of 10)

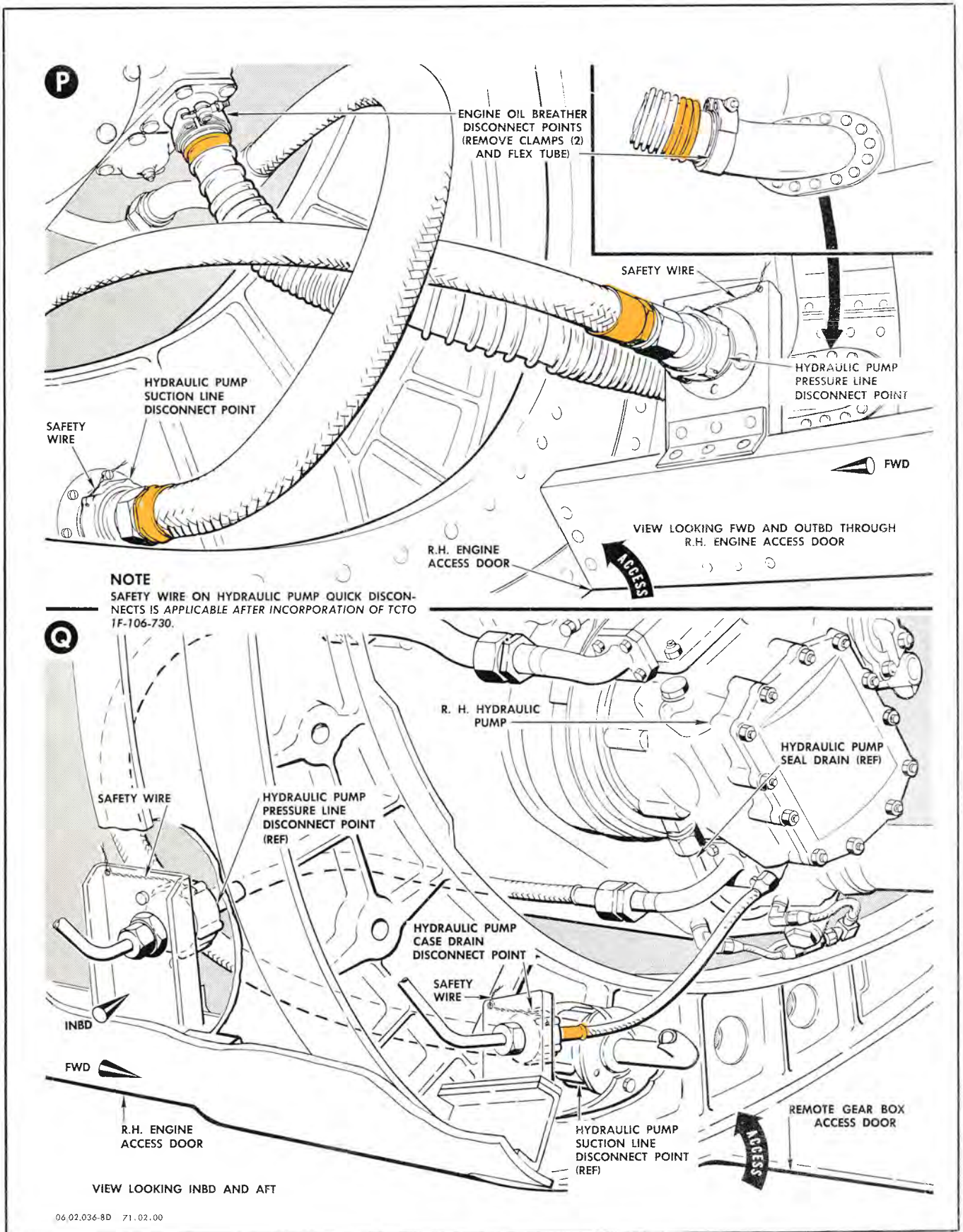

Figure 1-18. Engine Replacement, Disconnect Points (Sheet 8 of 10)

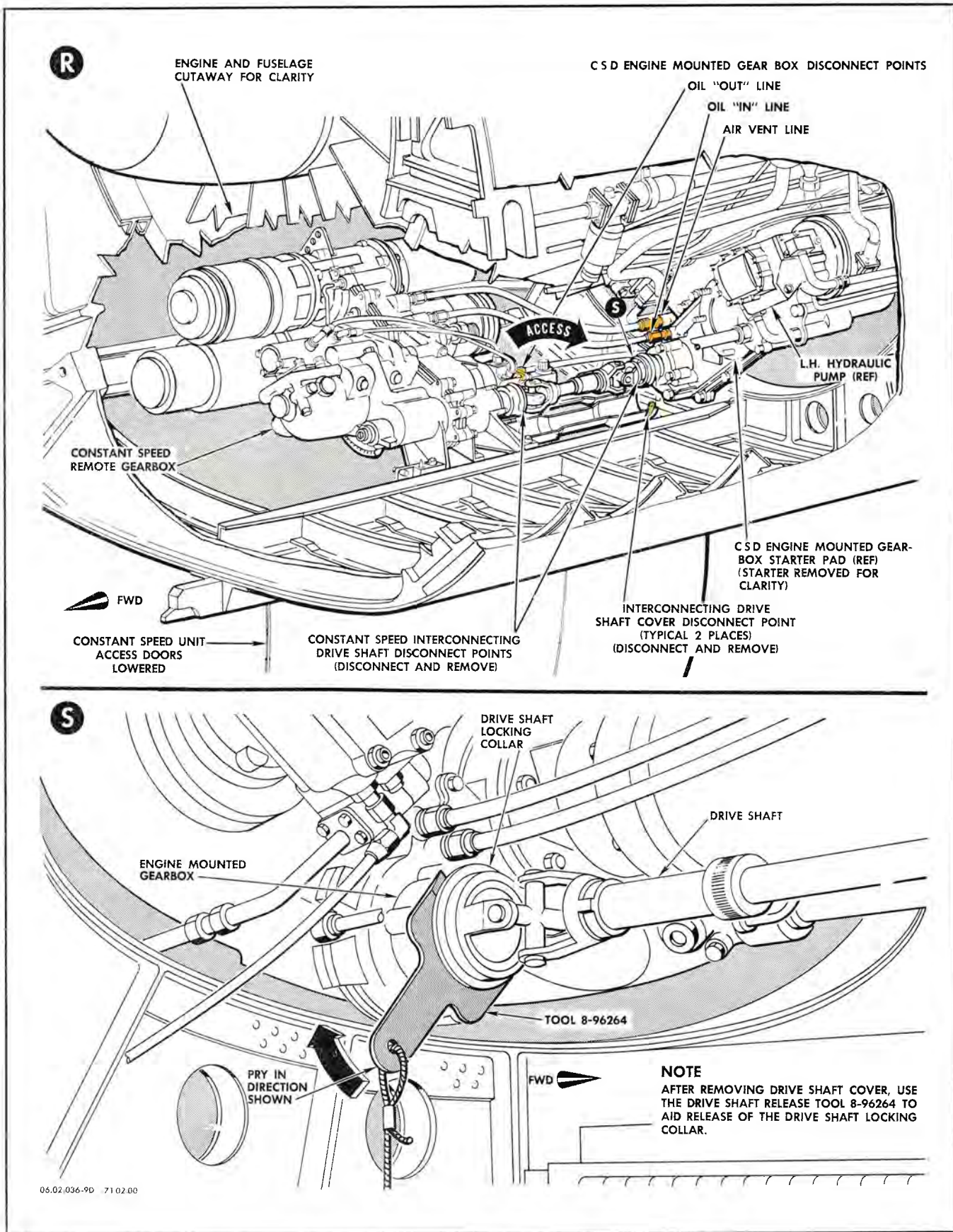

Figure 1-18. Engine Replacement, Disconnect Points (Sheet 9 of 10)

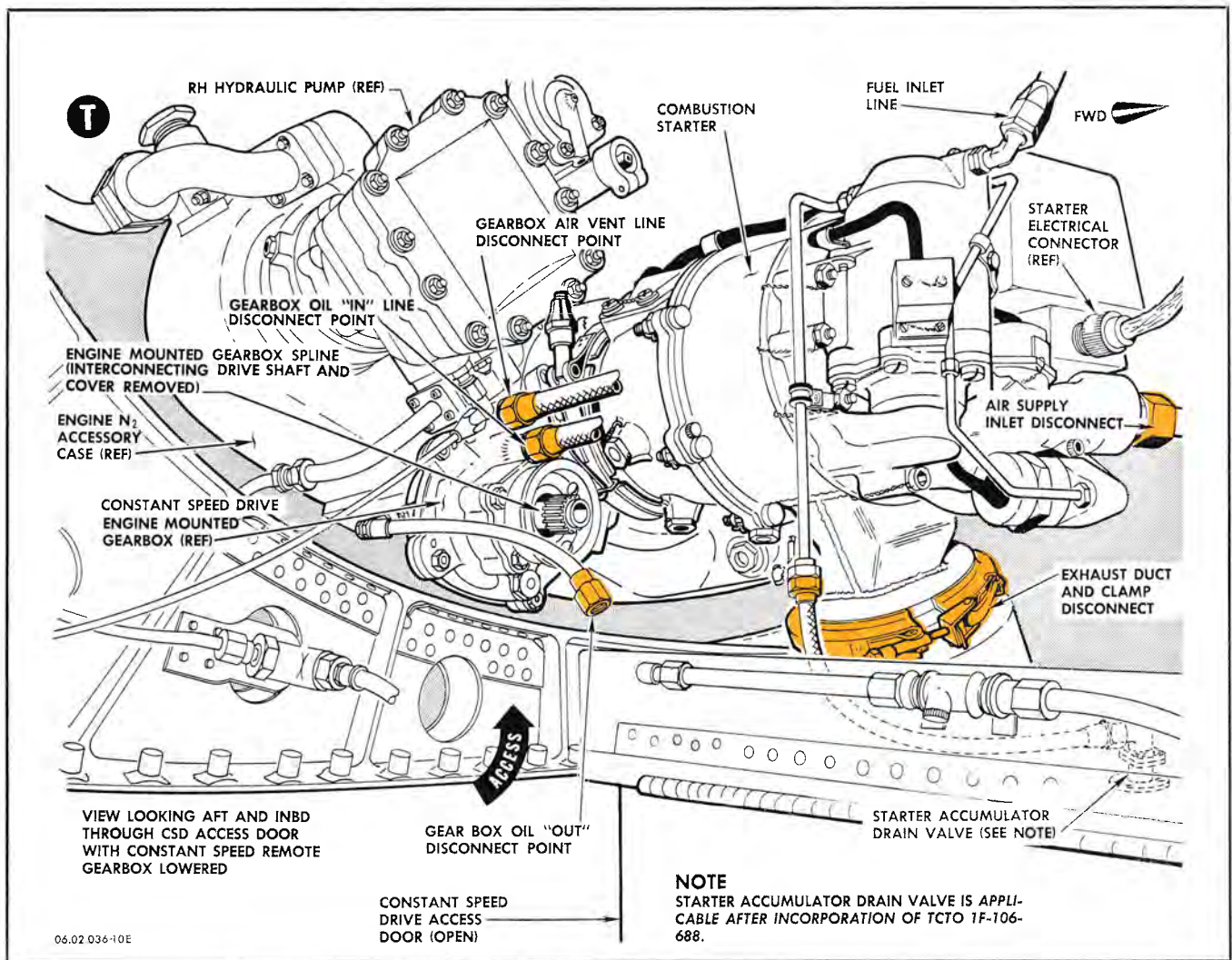

Figure 1-18. Engine Replacement, Disconnect Points (Sheet 10 of 10)

### 1-56. ENGINE JAM NUT TYPE FITTINGS.

Jam nut type fittings used on engine components are comprised of an assembly consisting of a fitting, jam nut, seal ring, and an O-ring seal. When installing this type of fitting, the following procedure is to be used.

- Thread the jam nut on the fitting until the counter-bored face of the nut is beyond the seal groove in the fitting.
- Install the seal ring on the fitting. It will be necessary to work, or roll, the ring over the lead thread and then to thread it to the seal groove in the fitting. Inspect the ring after completing this operation and if it has been damaged, replace the ring.
- Lubricate a new O-ring seal with engine oil and install it in the groove on the fitting.
- Work the seal ring and the O-ring seal toward the inner end of the seal groove.
- Thread the fitting into the related part until the seal contacts the mating face. This contact can be determined by the pronounced increase in resistance to the

tightening torque. Thread the fitting in an additional half turn. Any further adjustment to align the fitting should be accomplished by threading in further, up to a maximum of one additional turn.

- When the fitting has been properly aligned, hold the fitting in the proper position with a wrench and tighten the jam nut until it bottoms firmly against the face of the related part.

#### NOTE

A slight extrusion of the O-ring seal between the mating face and the nut is acceptable if it does not prevent a metal-to-metal bottoming of the nut by more than a few thousandths of an inch. If the ring extrudes badly from under the edge of the nut, begin again with new sealing parts.

### 1-57. TUBING AND BOLT TORQUE VALUES.

See figures 1-26 and 1-27 for illustrations showing tubing and bolt standard torque values.

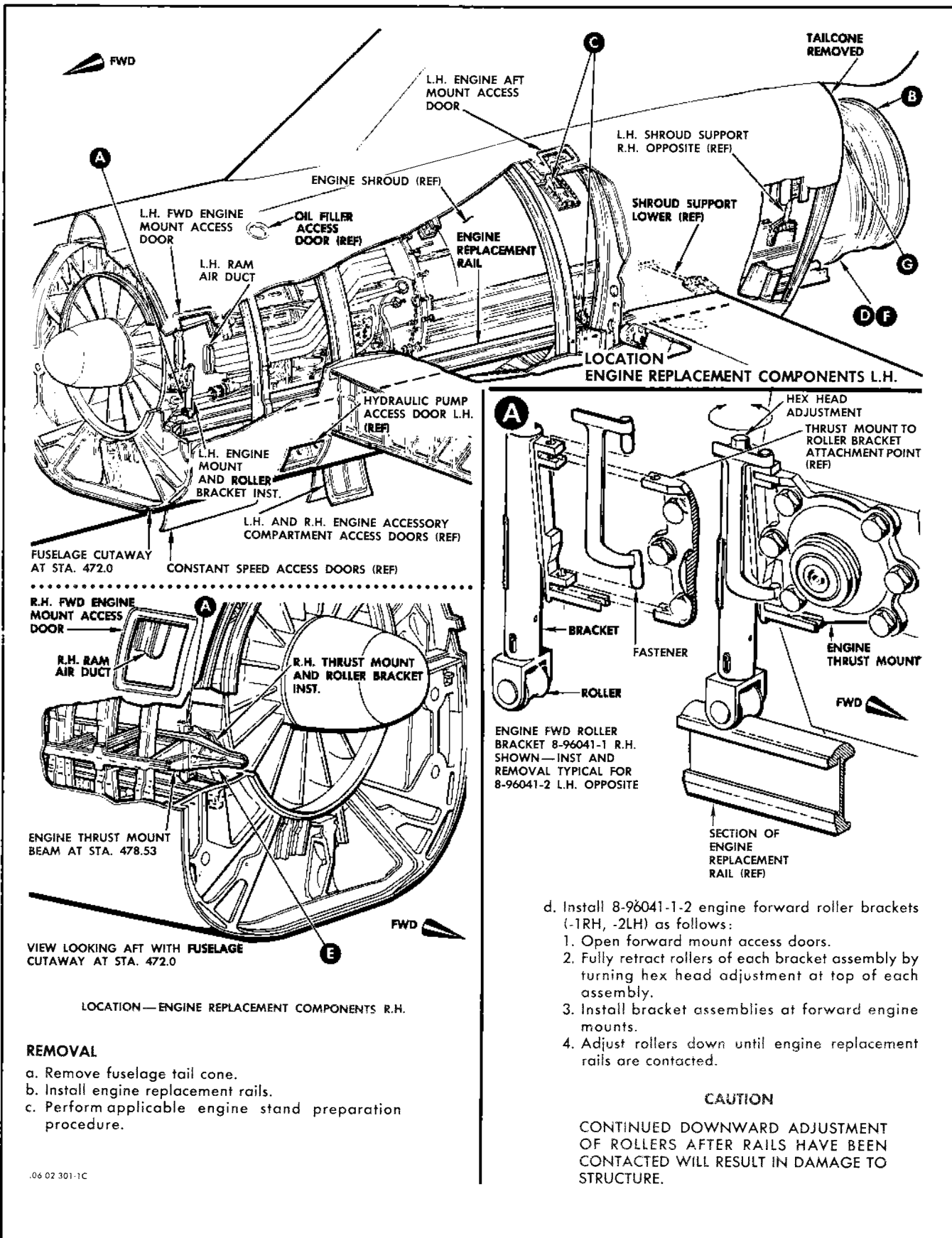
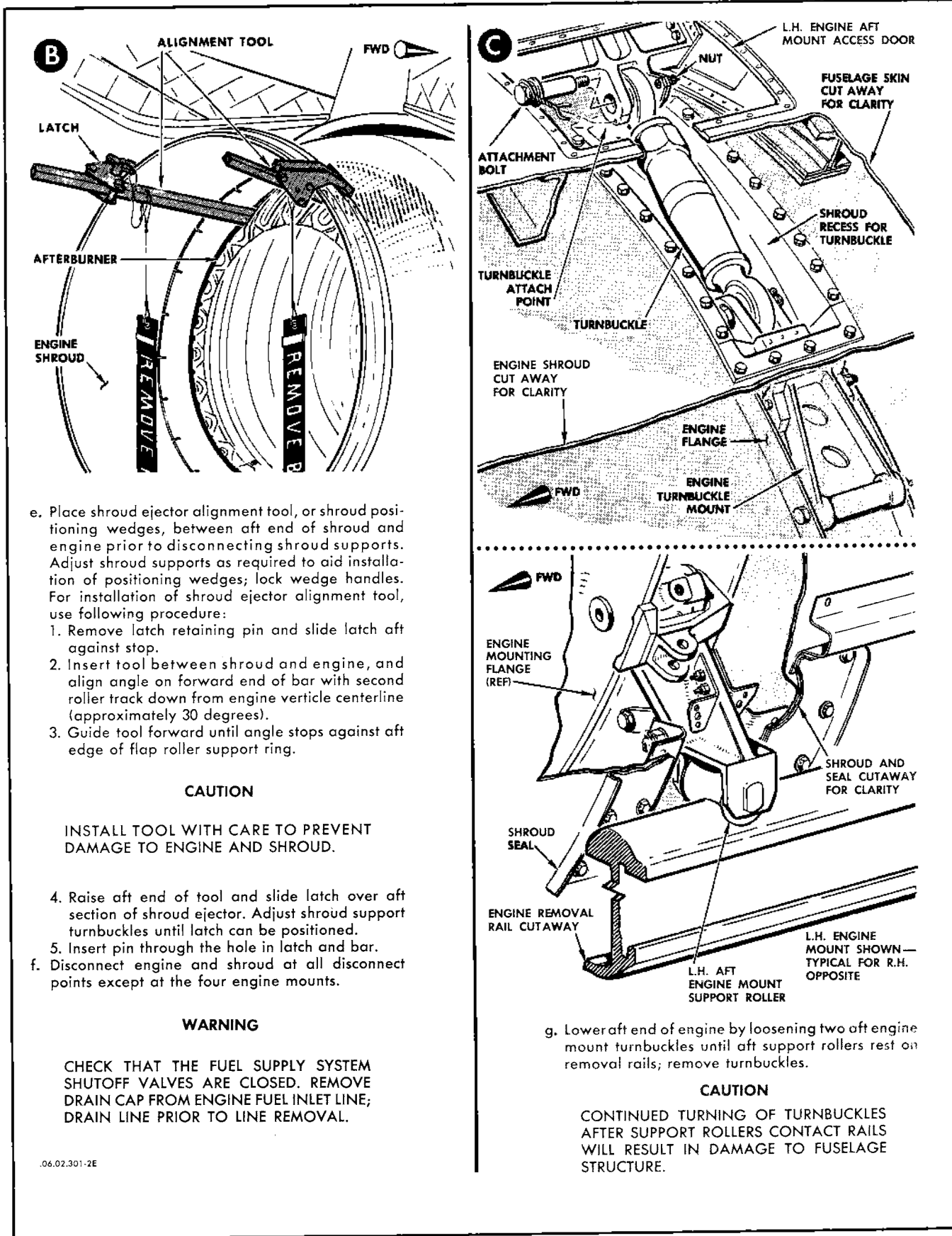

Figure 1-19. Engine Replacement (Sheet 1 of 4)



.06.02.301-2E

Figure 1-19. Engine Replacement (Sheet 2 of 4)

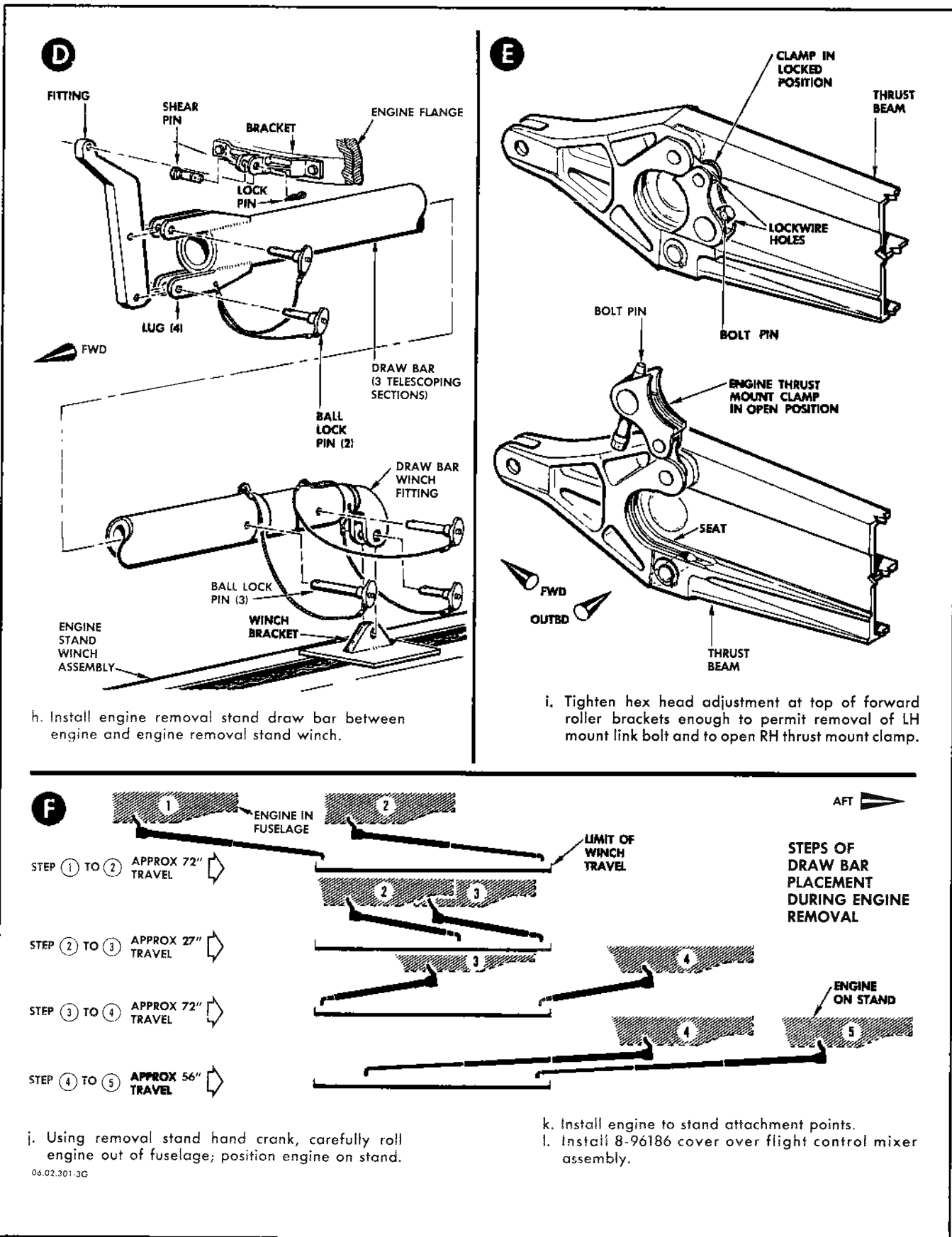

Figure 1-19. Engine Replacement (Sheet 3 of 4)



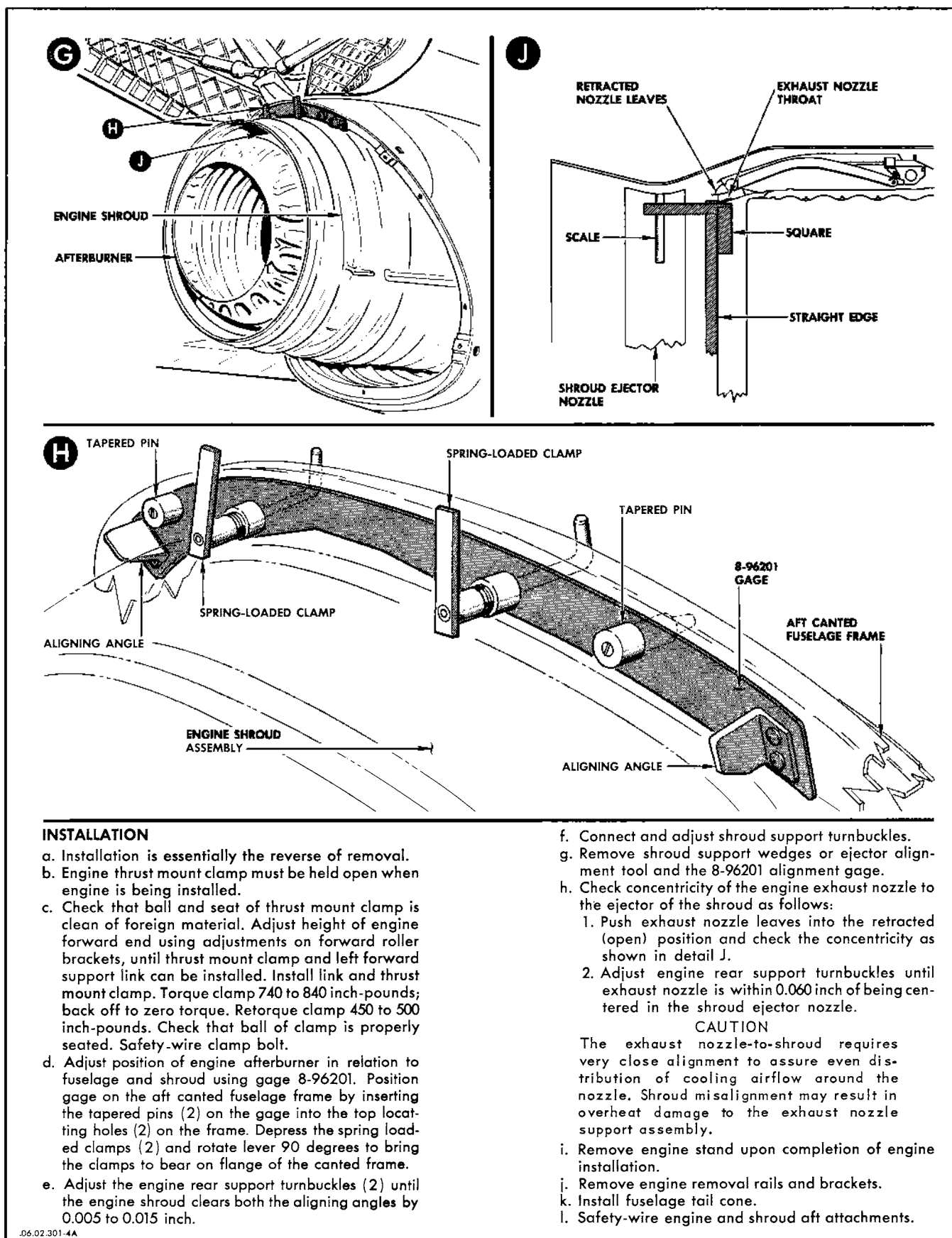

Figure 1-19. Engine Replacement (Sheet 4 of 4)

**ADJUSTMENT****1-58. ENGINE TRIMMING.**

As service time is accumulated on an engine, it will be noted that the engine pressure ratio will tend to diminish. This is due primarily to contamination of the engine air passage. It is permissible to increase (trim) the  $N_2$  compressor speed up to 1.7% rpm (150 rpm) above the engine adjusted data plate speed. When it becomes necessary to increase the engine speed more than the specified values, the engine air passages should be cleaned prior to continued engine operation. Refer to paragraph 1-69 for procedure. See figures 1-28 and 1-29 for the engine trim check charts.

**NOTE**

It is permissible to use the lowest available grade of aviation gasoline, Military Specification MIL-G-5572 (no oil mix required); JP-5, Military Specification MIL-J-5624; or JP-6, Military Specification MIL-F-25656, as emergency fuels for one-time ferry missions. Where the tactical situation requires the use of these fuels, the engine military trim must be readjusted to meet the pressure ratios shown in figure 1-28 before the airplane can be flown. Since JP-5 freezes at  $-48.3^{\circ}\text{C}$  ( $-55^{\circ}\text{F}$ ) and JP-6 at  $-40^{\circ}\text{C}$  ( $-40^{\circ}\text{F}$ ), missions in which these fuels are used shall be restricted to altitudes where temperatures below these limits are not encountered. When using aviation gasoline, particular attention shall be given to engine tailpipe temperature during starting and throughout the flight.

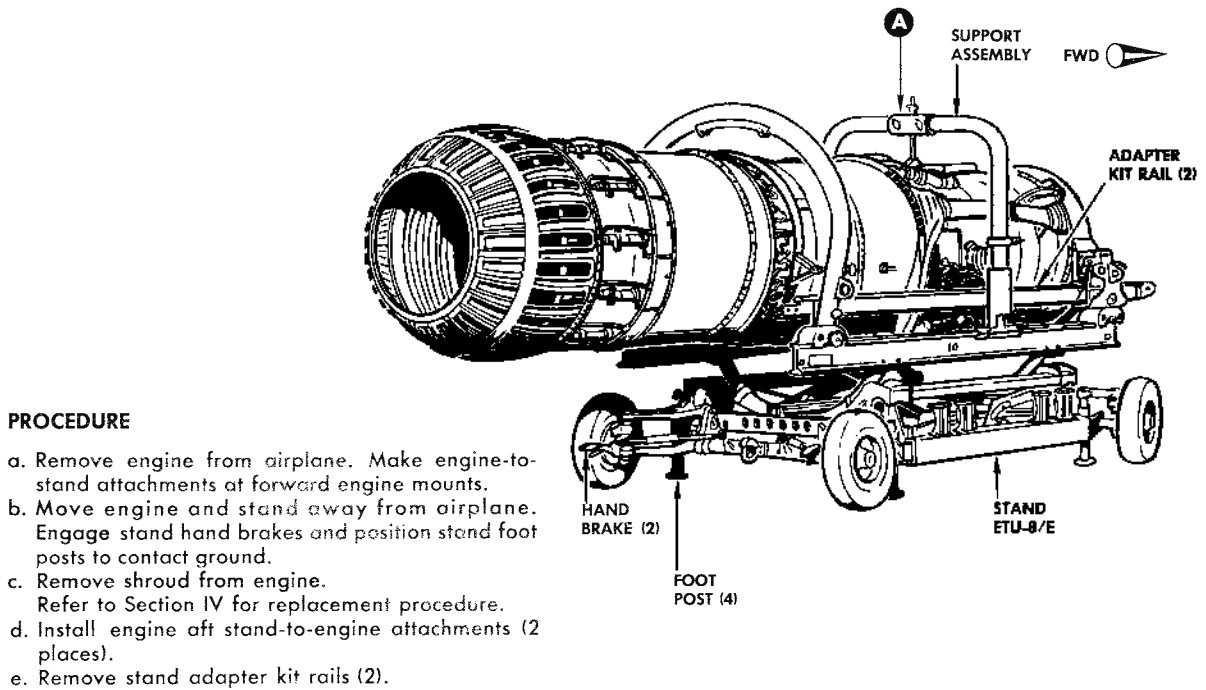
**PROCEDURE**

- Remove engine from airplane. Make engine-to-stand attachments at forward engine mounts.
- Move engine and stand away from airplane. Engage stand hand brakes and position stand foot posts to contact ground.
- Remove shroud from engine. Refer to Section IV for replacement procedure.
- Install engine aft stand-to-engine attachments (2 places).
- Remove stand adapter kit rails (2).

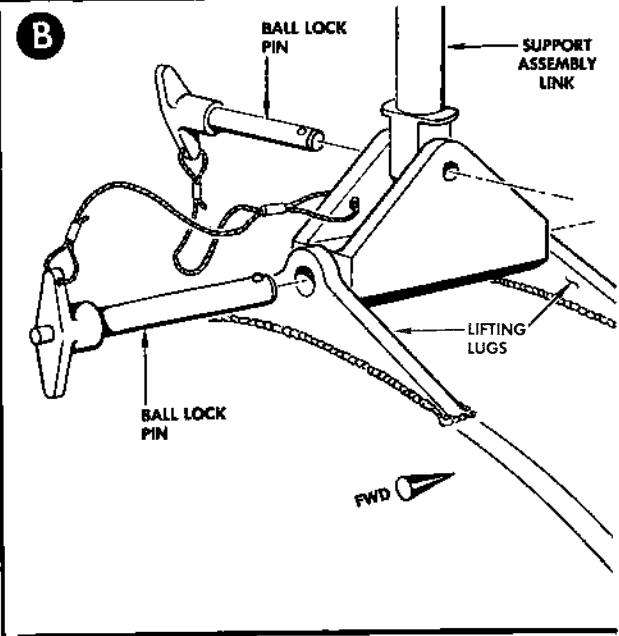
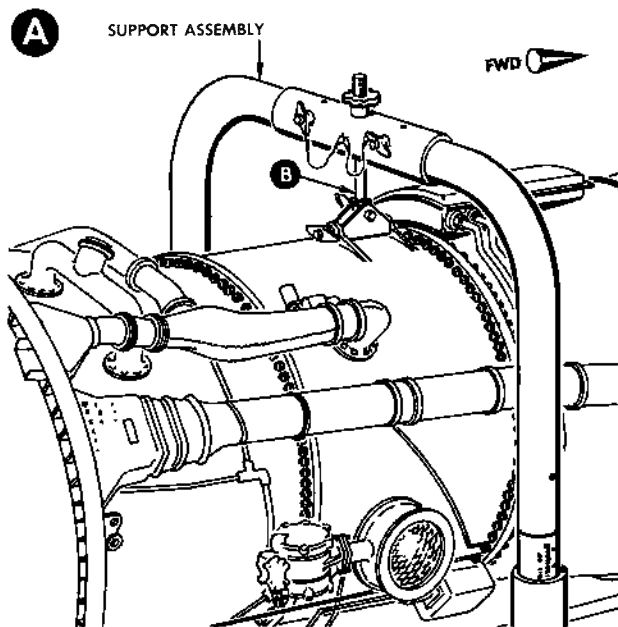

- Position engine support assembly over engine forward lifting lug; secure support assembly to stand rails.
- Connect support assembly link to engine lifting lug.
- Tighten support link nut until nut is finger tight.

**CAUTION**

DO NOT LIFT ENGINE WITH SUPPORT ADAPTER ASSEMBLY. CONTINUED TIGHTENING OF ADJUSTMENTS WILL RESULT IN DAMAGE TO ENGINE.

06.02.1008A .72 05 00

**Figure 1-20. Combustion Chamber Replacement Preparation Using Stand ETU-8/E and Adapter Kit 8-96398**

**PROCEDURE**

- a. Remove engine from airplane.
- b. Move engine and stand away from airplane. Install stand forward rollover ring upper half.
- c. Remove engine shroud. Refer to Section IV for replacement procedure.

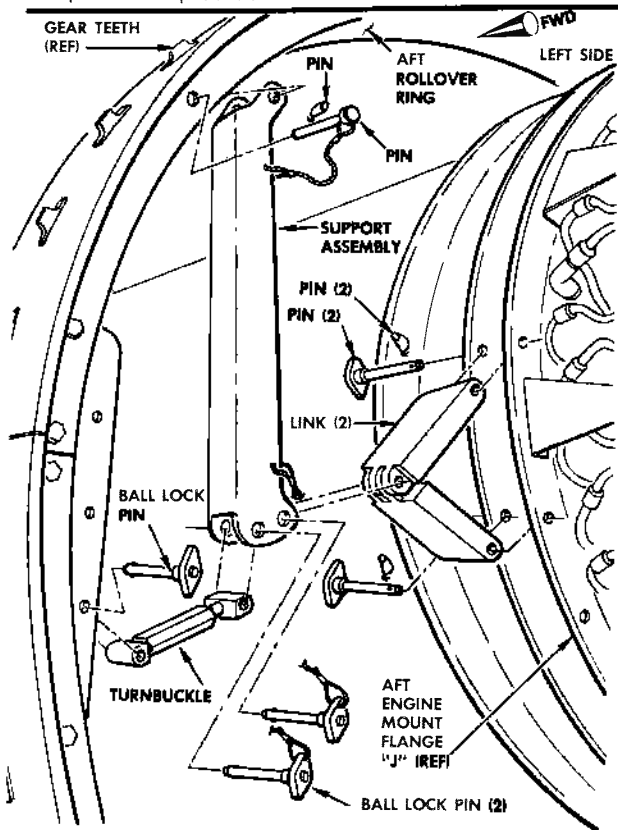

- d. After shroud removal, lower engine at engine intermediate support until engine-to-aft-rollover ring attachments can be made. Install attachments.
- e. Disconnect engine intermediate support at engine support brackets and move support assembly forward.

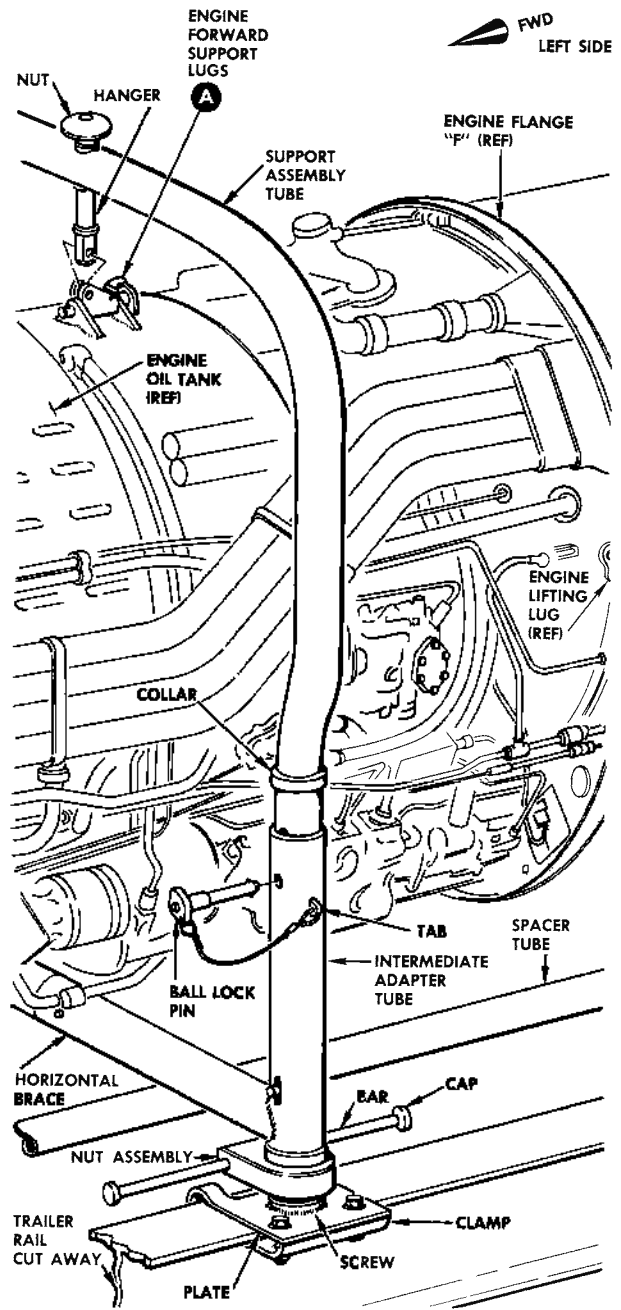
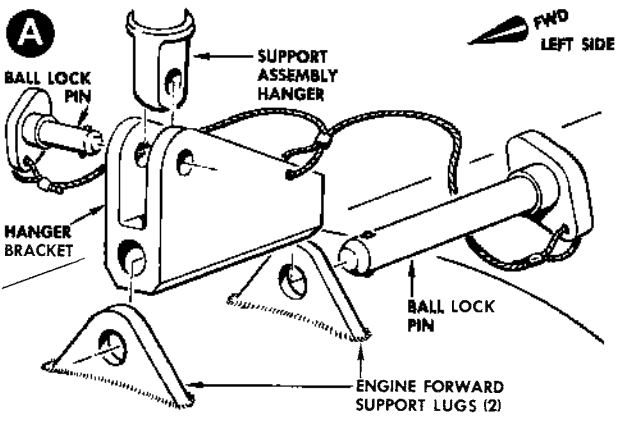

- f. Make overhead attachment at engine forward support lugs using support assembly. Support assembly legs to be perpendicular to engine stand rails.
- g. Tighten support assembly adjustment screws by hand until light tension is noticed.

**CAUTION**  
DO NOT LIFT ENGINE WITH SUPPORT ADAPTER ASSEMBLY. CONTINUED TIGHTENING OF ADJUSTMENTS WILL RESULT IN DAMAGE TO ENGINE.

04 02 6678, 72.05.00

**Figure 1-21. Combustion Chamber Replacement Preparation Using Stand ETU-8/E and Adapter Kit 8-96165**

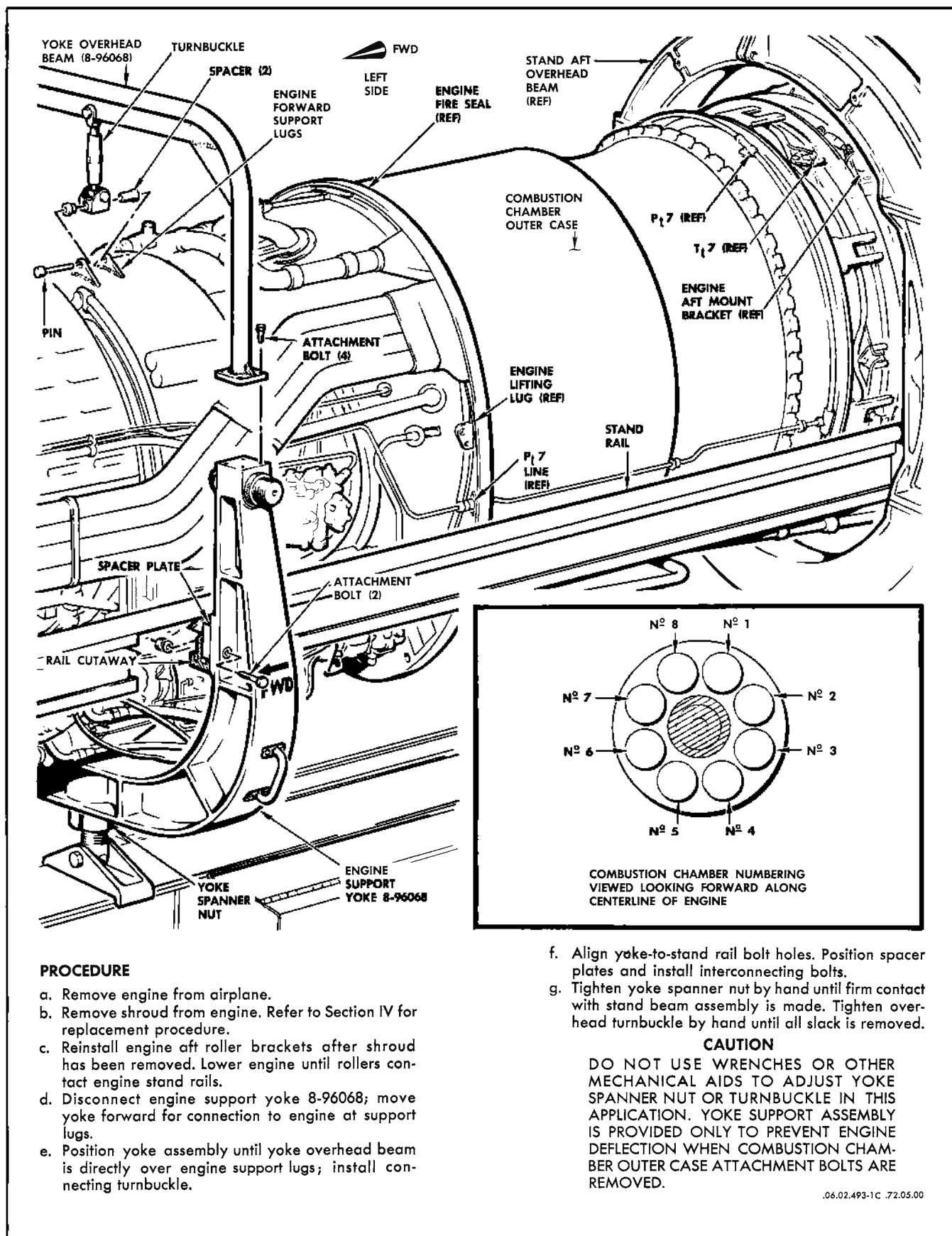
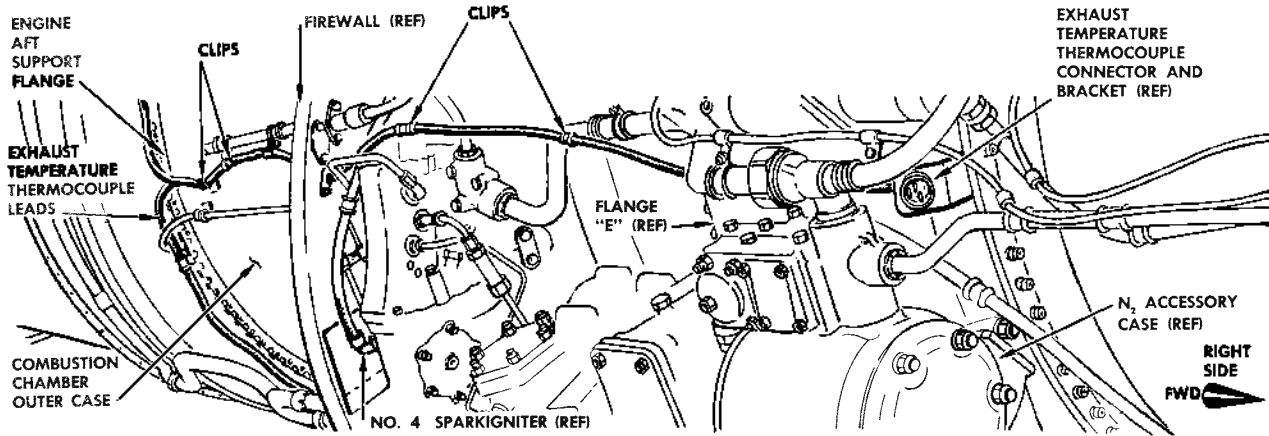
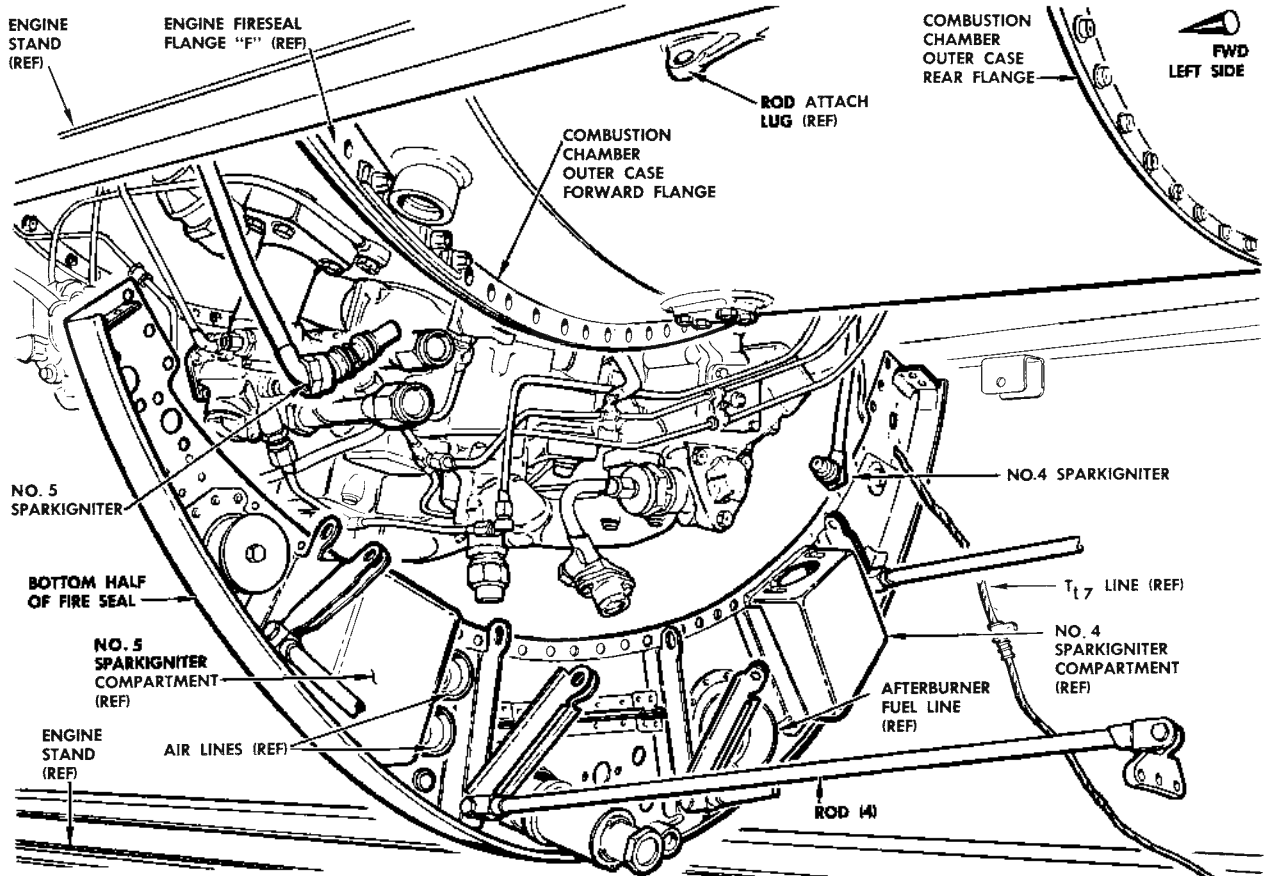

Figure 1-22. Combustion Chamber Replacement Preparation Using Stand SE 1012-803



**PROCEDURE**

- a. Disconnect exhaust temperature thermocouple ( $T_{17}$ ) at forward flange of the combustion chamber outer case; remove thermocouple clipping aft to engine aft support flange.



- b. Remove all tubing and brackets from the area between the fire wall and the engine aft support ring. Cap all tube and port openings.
- c. Disconnect and remove sparkigniters from Nos. 4 and 5 combustion chambers.
- d. Disconnect tubing attached to bottom half of firewall. Remove firewall attachment to flange "F"; lower bottom half of firewall to permit passage of combustion chamber outer case forward flange.

**NOTE**

BEFORE REMOVING BRACKETS FROM ENGINE ATTACHMENT, NOTE BRACKET LOCATION FOR REINSTALLATION.

06.02 493-2A 72.05.00

Figure 1-23. Replacement, Combustion Chambers (Sheet 1 of 3)

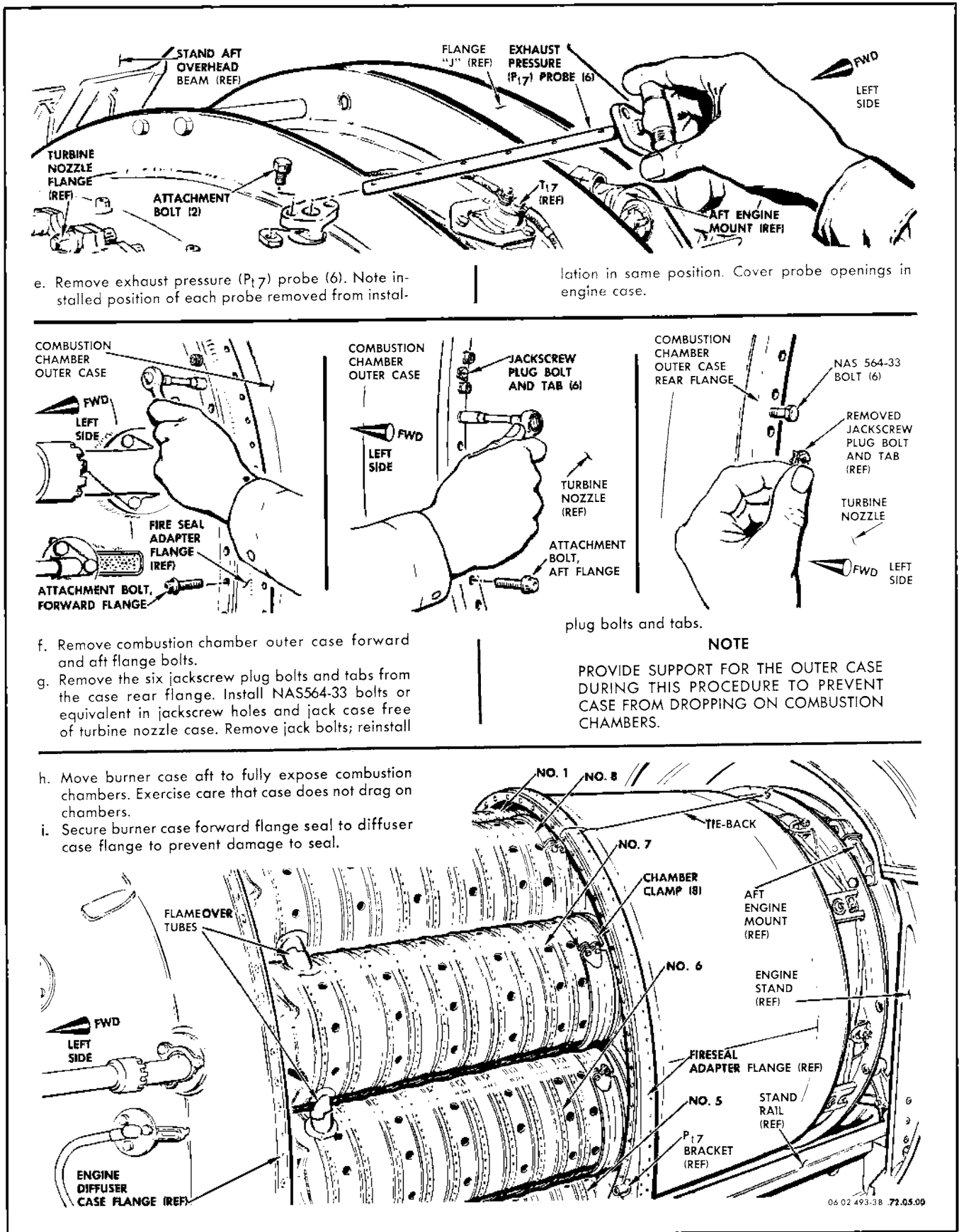

e. Remove exhaust pressure (P<sub>17</sub>) probe (6). Note installed position of each probe removed from instal-

lation in same position. Cover probe openings in engine case.

f. Remove combustion chamber outer case forward and aft flange bolts.  
 g. Remove the six jackscrew plug bolts and tabs from the case rear flange. Install NAS564-33 bolts or equivalent in jackscrew holes and jack case free of turbine nozzle case. Remove jack bolts; reinstall

plug bolts and tabs.  
**NOTE**  
 PROVIDE SUPPORT FOR THE OUTER CASE DURING THIS PROCEDURE TO PREVENT CASE FROM DROPPING ON COMBUSTION CHAMBERS.

h. Move burner case aft to fully expose combustion chambers. Exercise care that case does not drag on chambers.  
 i. Secure burner case forward flange seal to diffuser case flange to prevent damage to seal.

Figure 1-23. Replacement, Combustion Chambers (Sheet 2 of 3)

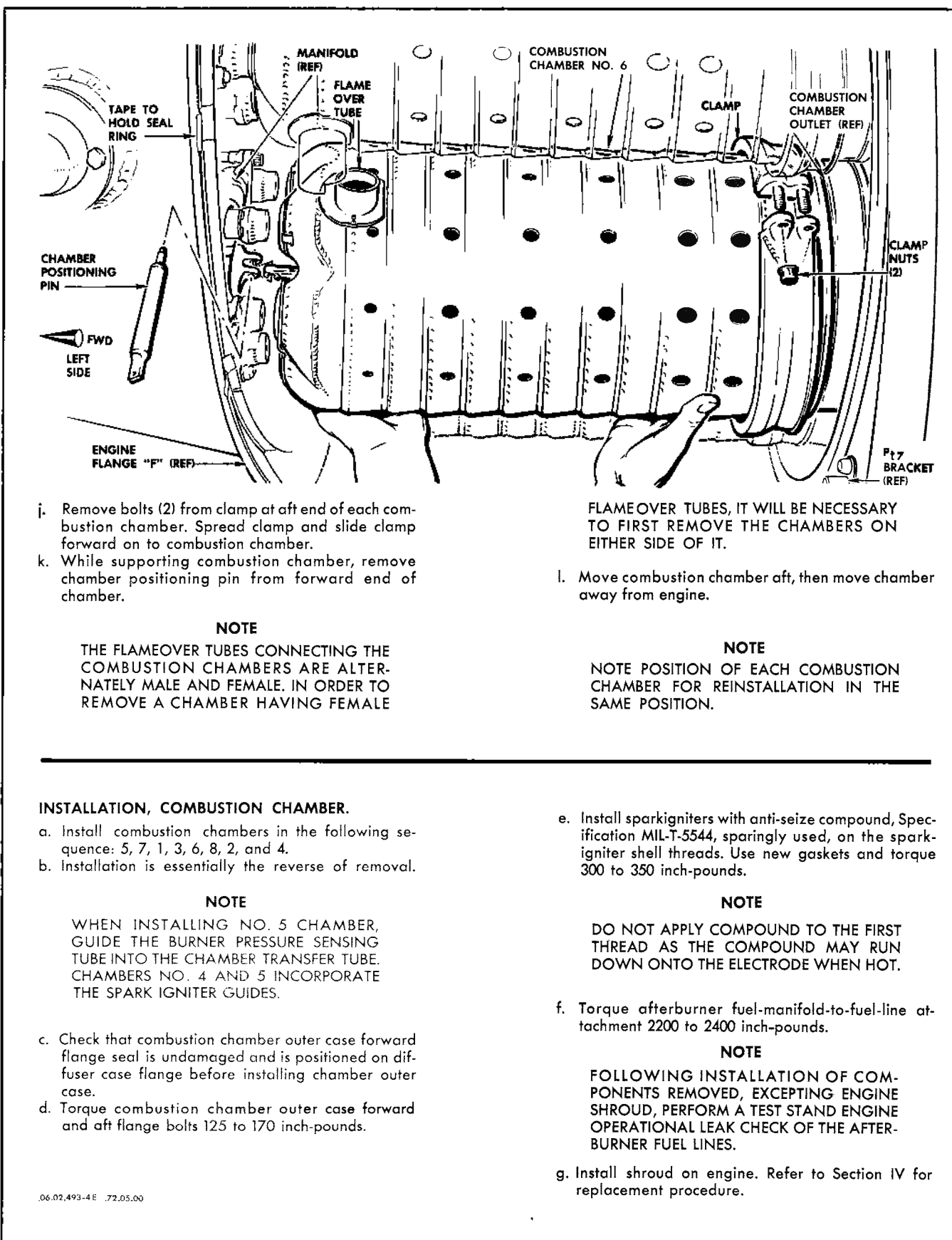

Figure 1-23. Replacement, Combustion Chambers (Sheet 3 of 3)



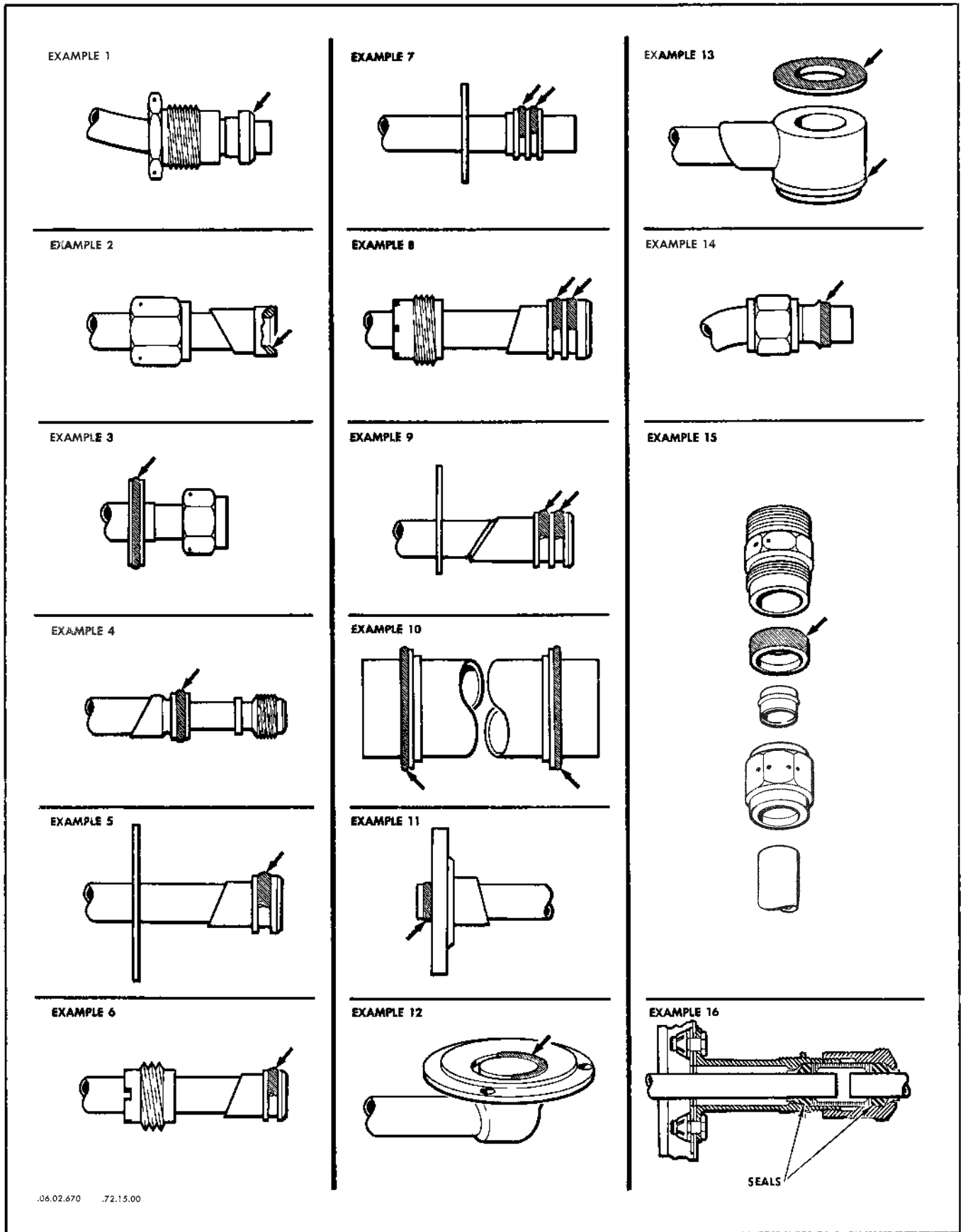
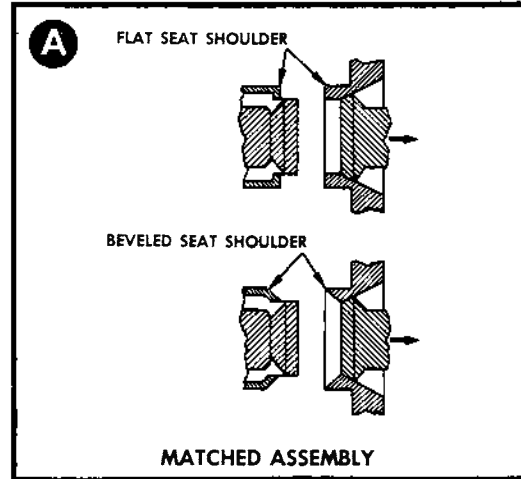
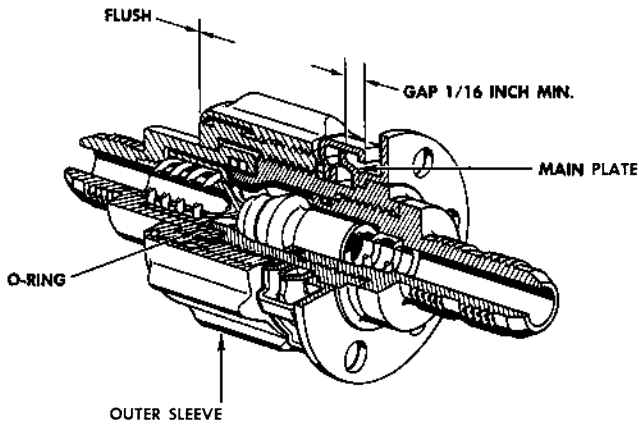
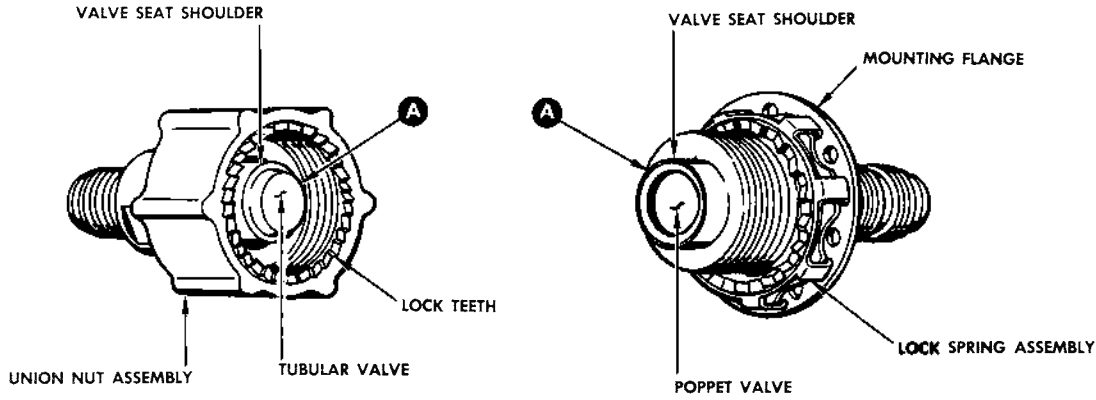

Figure 1-24. Engine External Tube Seals



**AEROQUIP COUPLING PROPERLY TIGHTENED**

**CONNECTING COUPLING HALVES**

Connect the coupling halves by rotating the union nut clockwise. The union may be hand tightened. When coupling location prevents hand tightening a crowfoot wrench similar to AN8508 is recommended. Do not use a striking block, pipe wrench, or pliers. Tighten until teeth of union nut fully engage teeth of the lock spring; listen for audible click. Proper tightening extends the lock spring leg ends beyond the mainplate forming a gap.

**CAUTION**

THE COUPLING LOCK SPRING IS PROVIDED FOR SAFETY. IN NO CASE SHALL THE COUPLING BE CONNECTED WITHOUT THE LOCK SPRING BEING INSTALLED.

The inner ring and outer sleeve are flush as shown; the outer sleeve remains loose. The outer sleeve is provided to release the teeth of the union nut from the lock spring when disconnecting the coupling.

COUPLING SIZE	TORQUE VALUE
4 & 5	10 foot-pounds
6 & 8	15 foot-pounds
10 & 12	20 foot-pounds
16, 20, 24	30 foot-pounds

**CAUTION**

EXCESSIVE TORQUING OF COUPLINGS WILL RESULT IN DAMAGE TO THE UNION NUT AND CAUSE MALFUNCTIONING OF THE LOCK SPRING RELEASING MECHANISM.

.06.02.729A .12.09.00

Figure 1-25. Quick Disconnect Couplings (Sheet 1 of 2)

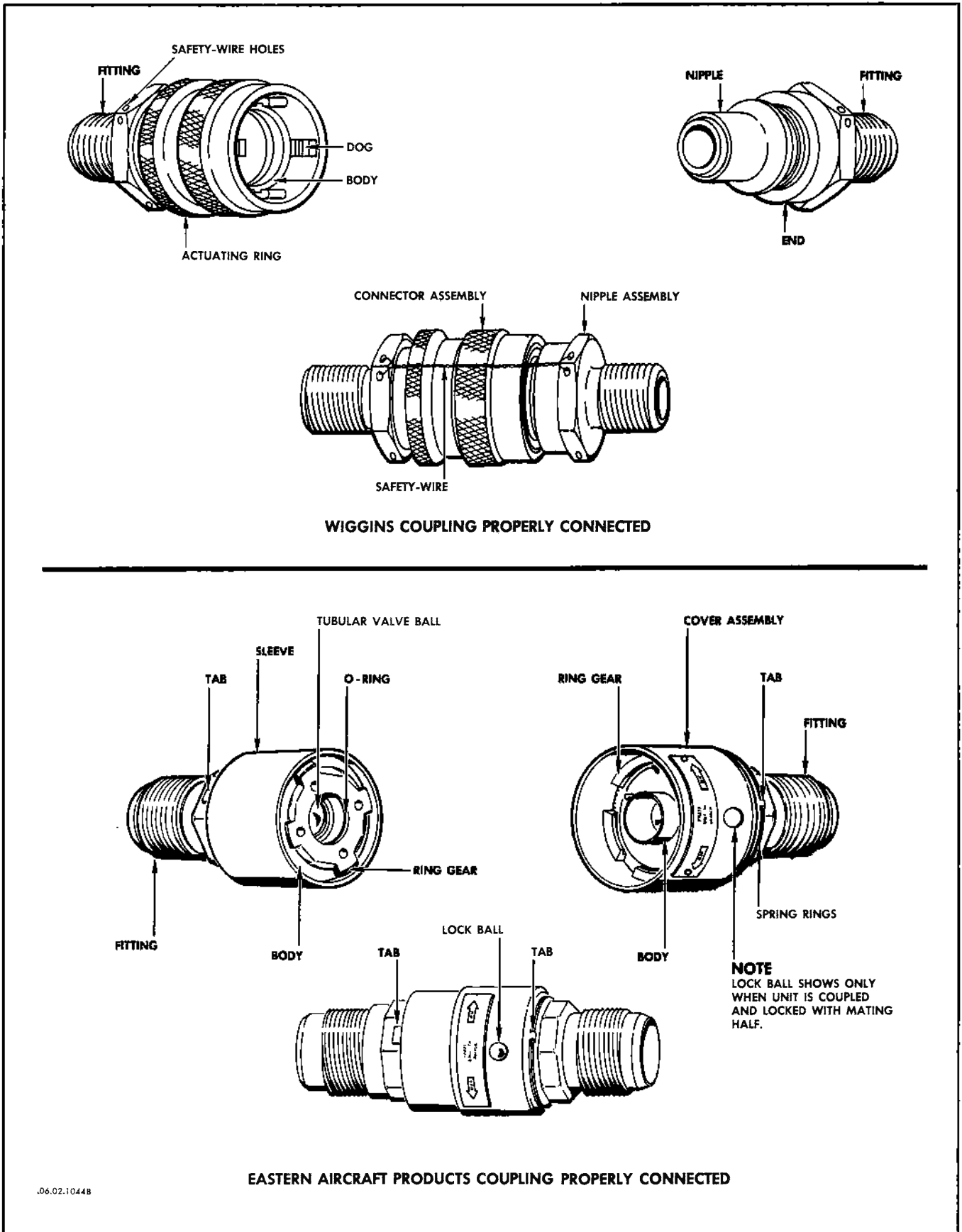
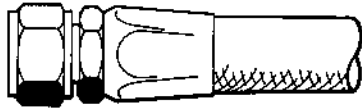
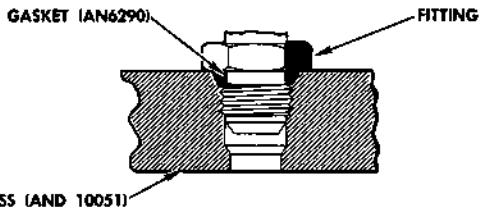

Figure 1-25. Quick Disconnect Couplings (Sheet 2 of 2)



**INSTALLATION OF HOSE ASSEMBLIES**

- a. Lubricate threads on hydraulic hose fittings with the system hydraulic fluid.
- b. Lubricate threads on pneumatic hose fittings with grease, Specification MIL-L-4343.
- c. Lubricate threads on oxygen hose fittings with MIL-T-5542; see warning.
- d. Torque hose assembly fittings to values shown in right-hand column of table below.



**INSTALLATION OF FLARED NON-POSITIONING TYPE FITTINGS**

- a. Lubricate gasket with applicable lubricant; see sheet 2 and warning.
- b. Install gasket in groove on fitting.
- c. Screw fitting assembly into boss until it bottoms tightly against boss.

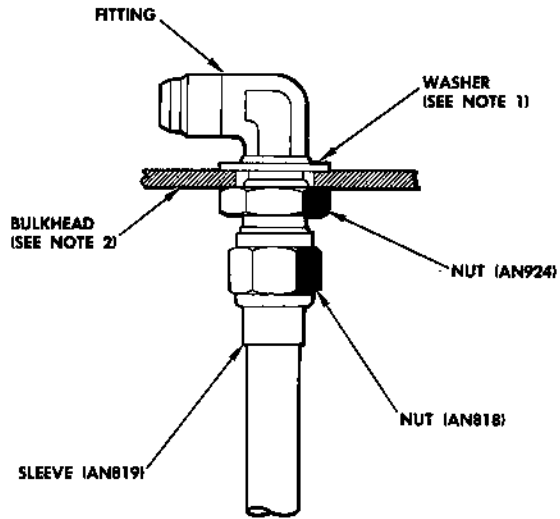

**INSTALLATION OF FLARED-TUBE, STRAIGHT-THREADED CONNECTORS**

**NOTES**

- 1. USE AN AN690 WASHER, 1/16 INCH THICK FOR FITTINGS SIZE -6 OR SMALLER, AND A WASHER 3/32 INCH THICK FOR FITTINGS LARGER THAN SIZE -6. A WASHER IS NOT REQUIRED WHERE FITTING END HAS HEX INSTEAD OF FLANGE SHOWN.
- 2. FITTING WITH BULKHEAD END CONFORMING TO AND 10057 IN SIZE -6 AND SMALLER MAY BE USED THROUGH BULKHEADS UP TO 3/16 INCH MAXIMUM THICKNESS. FITTING WITH BULKHEAD END CONFORMING IN SIZE -8 AND LARGER, AND ALL SIZES OF AN832 FITTINGS MAY BE USED THROUGH BULKHEADS UP TO 3/8 INCH MAXIMUM THICKNESS.

**WRENCH TORQUE VALUES FOR FLARED TUBING NUTS (INCH-POUNDS)**

TUBING OD INCHES (HOSES ID)	5052-0 ALUMINUM ALLOY TUBING FLARE AND 10061 OR AND 10078		6061-T6 ALUMINUM ALLOY TUBING FLARE AND 10061 OR AND 10078		STEEL AND TITANIUM TUBING FLARE AND 10061		HOSE ASSEMBLY FITTINGS MS28740 AN6292 AN6270	
	MIN	MAX	MIN	MAX	MIN	MAX	MIN	MAX
3/16	35	60	35	70	90	100	70	100
1/4	40	65	70	120	135	150	70	120
*5/16	60	80	80	130	180	200	85	180
*3/8	75	125	130	180	270	300	100	250
*1/2	150	250	300	400	450	500	210	420
5/8	200	350	430	550	650	700	300	480
3/4	300	500	650	800	900	1000	500	850
1	500	700	900	1100	1200	1400	700	1150
1-1/4	600	900	—	—	—	—	—	—
1-1/2	600	900	—	—	—	—	—	—

\* SEE NOTE 3

**NOTES**

- 1. WHERE ALUMINUM ALLOY TUBING IS USED IN STEEL FITTINGS, TORQUE VALUES FOR ALUMINUM ALLOY TUBING WILL APPLY.
- 2. WHERE ALUMINUM ALLOY THREADED PARTS ARE MATED WITH STEEL THREADED PARTS, TORQUE VALUES FOR ALUMINUM ALLOY TUBING WILL APPLY.
- 3. APPLICABLE TO 5052-0 ALUMINUM ALLOY TUBING USED IN LIQUID OXYGEN SYSTEM ONLY, SUBSTITUTE THE FOLLOWING VALUES:  
 5/16 — 100 MIN, 125 MAX  
 3/8 — 200 MIN, 250 MAX  
 1/2 — 300 MIN, 400 MAX

**WARNING**

DO NOT USE PETROLEUM LUBRICANTS WITH OXYGEN FITTINGS.

.06,02,025-1C .03.24.00

Figure 1-26. Tubing Torque Values (Sheet 1 of 2)

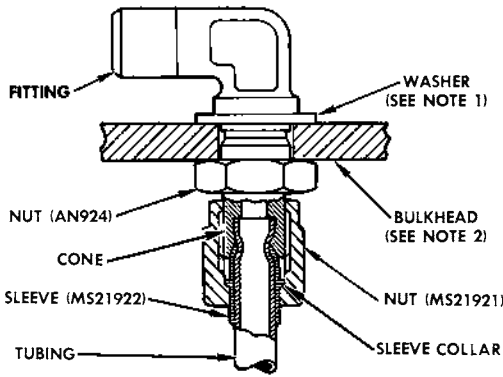

**NOTES:**

1. USE WASHER AN960, 0.062 THICK FOR FITTINGS SIZE -6 OR SMALLER, AND 0.031 THICK FOR FITTINGS SIZE -8 OR LARGER WHEN BULKHEAD IS 0.187 THICK OR LESS. WHEN BULKHEAD IS THICKER THAN 0.187, WASHER IS NOT REQUIRED PROVIDED HOLE IN BULKHEAD IS EQUAL TO THE HOLE IN APPLICABLE AN960 WASHER. SIZES -8 AND LARGER MAY BE USED THROUGH BULKHEADS UP TO 0.281 MAXIMUM THICKNESS. ENDS IN ACCORDANCE WITH MS33515, STYLE E, MAY BE USED THROUGH BULKHEADS UP TO 0.187 MAXIMUM. WASHER IS NOT REQUIRED WHERE FITTING END HAS HEX INSTEAD OF FLANGE SHOWN, PROVIDED HOLE IN BULKHEAD IS EQUAL TO HOLE SIZE IN APPLICABLE AN960 WASHER.
2. FITTING WITH BULKHEAD END CONFORMING TO MS33515, STYLE S, IN SIZES -6 AND SMALLER MAY BE USED THROUGH BULKHEADS UP TO 0.250 MAXIMUM THICKNESS. SIZES -8 AND LARGER AND ALL SIZES OF MS21903 MAY BE USED THROUGH BULKHEADS UP TO 0.375 MAXIMUM THICKNESS.

**INSTALLATION AND TORQUE PROCEDURES FOR FLARELESS TUBE FITTINGS**

- a. Check that all parts are free from dirt, burrs and foreign particles.
- b. Lubricate fittings and tube sleeve. See gasket selection table.
- c. Install tube in fitting. Check that sleeve is in full contact with cone seat and that nut makes full contact with sleeve collar.
- d. Tighten tube nut with wrench until sleeve is in full contact with tube. This will be indicated by a sharp rise in torque. Nut must tighten smoothly until this contact is made.

**CAUTION**

- NEVER OVERTIGHTEN A LEAKING MS FITTING. THIS WILL DEFORM THE SLEEVE OR TUBE AND CAUSE ADDITIONAL LEAKS.
- e. Tighten nut an additional 1/3 turn more (two hex flats of nut), no more or less. Fittings must be firmly held during this procedure to prevent rotation.
  - f. If leak occurs after installation, disconnect fitting and check for foreign material that may prevent tight seal. Check inside diameter of the affected tube at the sleeve area using ball gage test. If tube collapse is too great, replace tube. If tube passes test, reinstall and repeat tightening procedures.

**TUBE BALL GAGE TEST CHART**

TUBE O.D.	WALL THICKNESS					
	0.022	0.028	0.035	0.042	0.049	0.058
	BALL SIZE					
3/16	1/8	7/64	3/32	5/64	1/16	-
1/4	3/16	11/64	5/32	9/64	1/8	7/64
3/8	5/16	19/64	9/32	17/64	1/4	15/64
1/2	7/16	27/64	13/32	25/64	3/8	23/64
5/8	9/16	35/64	17/32	33/64	1/2	31/64
3/4	11/16	43/64	21/32	41/64	5/8	39/64
1	15/16	59/64	29/32	57/64	7/8	55/64
1-1/4	1-3/16	1-11/64	1-5/32	1-9/64	1-1/8	1-7/64
1-1/2	1-7/16	1-27/64	1-13/32	1-25/64	1-3/8	1-23/64

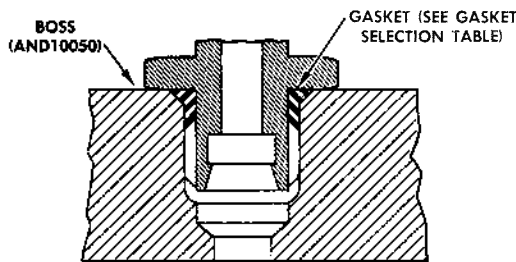

**INSTALLATION OF FLARELESS NON-POSITIONING TYPE FITTINGS**

- a. Lubricate the gasket in appropriate liquid (see table).
- b. Install gasket on the fitting as shown in detail.
- c. Screw the fitting assembly into the boss until it bottoms tightly on the boss as shown.

**GASKET SELECTION TABLE**

APPLICATION	GASKET AN OR MS NO.	APPROPRIATE LUBRICANT FOR GASKETS AND TUBE FITTINGS
HYDRAULIC	AN6290	MIL-H-5606
PNEUMATIC	AN6290	MIL-L-4343
ENGINE OIL	AN6290	MIL-L-7808
FUEL	MS29512	MIL-H-5606
OXYGEN	AN6290	MIL-T-5542
OTHER USES	AN6290	FLUID USED IN SYSTEM

**WARNING**

DO NOT USE PETROLEUM LUBRICANTS WITH OXYGEN FITTINGS.

.06.02.025-2F .03.24.00

Figure 1-26. Tubing Torque Values (Sheet 2 of 2)

BOLT SIZE	STEEL BOLTS				ALUMINUM ALLOY BOLTS (AN365D NUTS)		
	NUT TYPES AN365 AND AN310		NUT TYPES AN364 AND AN320		BOLT SIZE	INCH LBS	FOOT LBS
	INCH LBS	FOOT LBS	INCH LBS	FOOT LBS			
10-32	20-25	—	12-15	—	3/16	10-14	—
1/4-28	50-70	—	30-40	—	1/4	20-35	—
5/16-24	100-140	9-12	60-85	5-7	5/16	50-75	4-6
3/8-24	160-190	13-16	95-110	8-9	3/8	80-110	7-9
7/16-20	450-500	38-42	270-300	23-25	7/16	100-140	8-12
1/2-20	480-690	40-57	290-410	24-34	1/2	170-220	14-18
9/16-18	800-1000	67-83	480-600	40-50	5/8	400-460	34-38
5/8-18	1100-1300	92-108	660-780	55-65			
3/4-16	2300-2500	192-208	1300-1500	109-125			
7/8-14	2500-3000	209-250	1500-1800	125-150			
1-14	3700-5500	308-458	2200-3300	184-275			
1-1/8-12	5000-7000	417-583	3000-4200	250-350			
1-1/4-12	9000-11000	750-916	5400-6600	450-550			

When using torque wrench adapters, if the desired torque is known, the torque wrench dial reading may be found as follows:

- $T_w$  = Wrench dial reading.
- $T_a$  = Desired torque at end of adapter.
- $L$  = Lever length of torque wrench.
- $A$  = Length of adapter (center distance).

FORMULA  $T_w = \frac{T_a \times L}{L + A}$

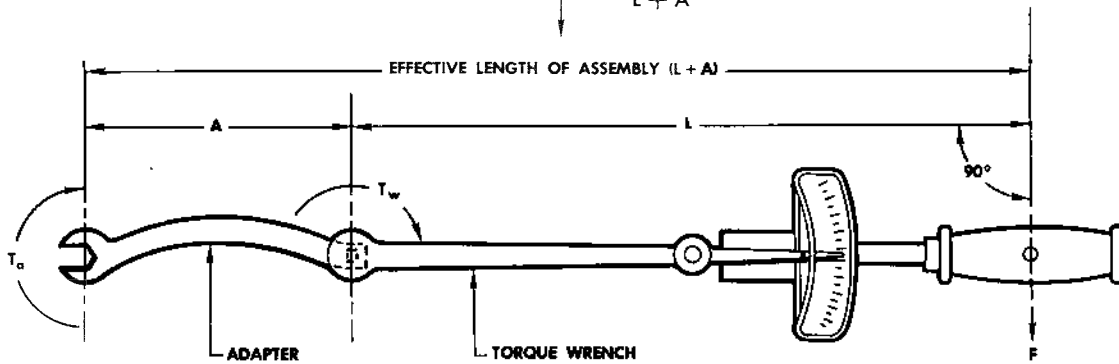

.06.02.026A .12.09.00

Figure 1-27. Bolt Torque Values

**1-59. TEMPERATURE CONVERSION TABLE.**

The following table is provided for use during engine trim check and adjustment.

READING IN °F ← °C OR °F → °C TO BE CONVERTED	READING IN °F ← °C OR °F → °C TO BE CONVERTED	READING IN °F ← °C OR °F → °C TO BE CONVERTED	READING IN °F ← °C OR °F → °C TO BE CONVERTED
- 18.4 - 28 -33.33	+ 66.2 + 19 - 7.22	+132.8 + 56 +13.33	+199.4 + 93 +33.89
- 14.8 - 26 -32.22	+ 68.0 + 20 - 6.67	+134.6 + 57 +13.89	+201.2 + 94 +34.44
- 11.2 - 24 -31.11	+ 69.8 + 21 - 6.11	+136.4 + 58 +14.44	+203.0 + 95 +35.00
- 7.6 - 22 -30.00	+ 71.6 + 22 - 5.56	+138.2 + 59 +15.00	+204.8 + 96 +35.56
- 4.0 - 20 -28.89	+ 73.4 + 23 - 5.00	+140.0 + 60 +15.56	+206.6 + 97 +36.11
- 0.4 - 18 -27.78	+ 75.2 + 24 - 4.44	+141.8 + 61 +16.11	+208.4 + 98 +36.67
+ 3.2 - 16 -26.67	+ 77.0 + 25 - 3.89	+143.6 + 62 +16.67	+210.2 + 99 +37.22
+ 6.8 - 14 -25.56	+ 78.8 + 26 - 3.33	+145.4 + 63 +17.22	+212.0 +100 +37.78
+ 10.4 - 12 -24.44	+ 80.6 + 27 - 2.78	+147.2 + 64 +17.78	+213.8 +101 +38.33
+ 14.0 - 10 -23.33	+ 82.4 + 28 - 2.22	+149.0 + 65 +18.33	+215.6 +102 +38.89
+ 17.6 - 8 -22.22	+ 84.2 + 29 - 1.67	+150.8 + 66 +18.89	+217.4 +103 +39.44
+ 19.4 - 7 -21.67	+ 86.0 + 30 - 1.11	+152.6 + 67 +19.44	+219.2 +104 +40.00
+ 21.2 - 6 -21.11	+ 87.8 + 31 - 0.56	+154.4 + 68 +20.00	+221.0 +105 +40.56
+ 23.0 - 5 -20.56	+ 89.6 + 32 ± 0.00	+156.2 + 69 +20.56	+222.8 +106 +41.11
+ 24.8 - 4 -20.00	+ 91.4 + 33 + 0.56	+158.0 + 70 +21.11	+224.6 +107 +41.67
+ 26.6 - 3 -19.44	+ 93.2 + 34 + 1.11	+159.8 + 71 +21.67	+226.4 +108 +42.22
+ 28.4 - 2 -18.89	+ 95.0 + 35 + 1.67	+161.6 + 72 +22.22	+228.2 +109 +42.78
+ 30.2 - 1 -18.33	+ 96.8 + 36 + 2.22	+163.4 + 73 +22.78	+230.0 +110 +43.33
+ 32.0 ± 0 -17.78	+ 98.6 + 37 + 2.78	+165.2 + 74 +23.33	+231.8 +111 +43.89
+ 33.8 + 1 -17.22	+100.4 + 38 + 3.33	+167.0 + 75 +23.89	+233.6 +112 +44.44
+ 35.6 + 2 -16.67	+102.2 + 39 + 3.89	+168.8 + 76 +24.44	+235.4 +113 +45.00
+ 37.4 + 3 -16.11	+104.0 + 40 + 4.44	+170.6 + 77 +25.00	+237.2 +114 +45.56
+ 39.2 + 4 -15.56	+105.8 + 41 + 5.00	+172.4 + 78 +25.56	+239.0 +115 +46.11
+ 41.0 + 5 -15.00	+107.6 + 42 + 5.56	+174.2 + 79 +26.11	+240.8 +116 +46.67
+ 42.8 + 6 -14.44	+109.4 + 43 + 6.11	+176.0 + 80 +26.67	+242.6 +117 +47.22
+ 44.6 + 7 -13.89	+111.2 + 44 + 6.67	+177.8 + 81 +27.22	+244.4 +118 +47.78
+ 46.4 + 8 -13.33	+113.0 + 45 + 7.22	+179.6 + 82 +27.78	+246.2 +119 +48.33
+ 48.2 + 9 -12.78	+114.8 + 46 + 7.78	+181.4 + 83 +28.33	+248.0 +120 +48.89
+ 50.0 + 10 -12.22	+116.6 + 47 + 8.33	+183.2 + 84 +28.89	+249.8 +121 +49.44
+ 51.8 + 11 -11.67	+118.4 + 48 + 8.89	+185.0 + 85 +29.44	+251.6 +122 +50.00
+ 53.6 + 12 -11.11	+120.2 + 49 + 9.44	+186.8 + 86 +30.00	+253.4 +123 +50.56
+ 55.4 + 13 -10.56	+122.0 + 50 +10.00	+188.6 + 87 +30.56	+255.2 +124 +51.11
+ 57.2 + 14 -10.00	+123.8 + 51 +10.56	+190.4 + 88 +31.11	+257.0 +125 +51.67
+ 59.0 + 15 - 9.44	+125.6 + 52 +11.11	+192.2 + 89 +31.67	+258.8 +126 +52.22
+ 60.8 + 16 - 8.89	+127.4 + 53 +11.67	+194.0 + 90 +32.22	
+ 62.6 + 17 - 8.33	+129.2 + 54 +12.22	+195.8 + 91 +32.78	
+ 64.4 + 18 - 7.78	+131.0 + 55 +12.78	+197.6 + 92 +33.33	

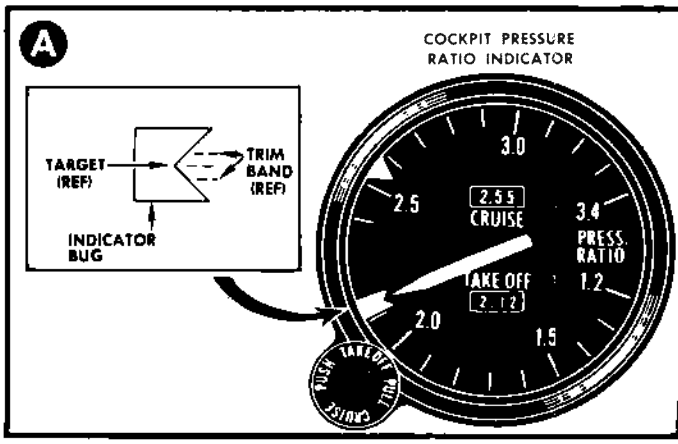

COCKPIT PRESSURE RATIO INDICATION ( $P_{17}/P_{amb}$ )

2.80  
2.70  
2.60  
2.50  
2.40  
2.30  
2.20  
2.10  
2.00  
1.90  
1.80

-60°C -50°C -40°C -30°C -20°C -10°C 0°C 10°C  
-76°F -58°F -40°F -22°F -4°F 14°F 32°F 50°F

TEMPERATURE — AMBIENT



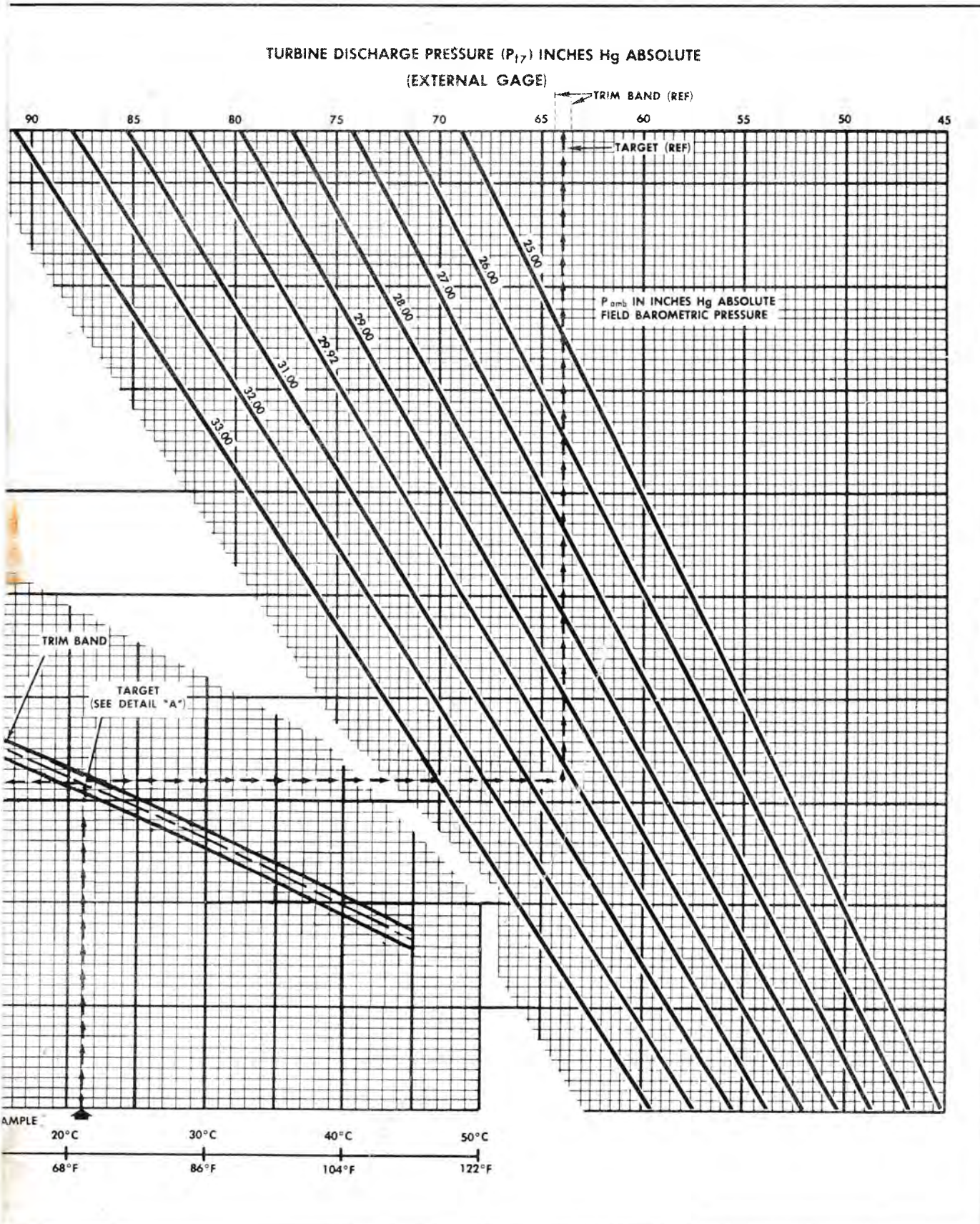

Figure 1-28. Engine Trim Chart, J75-P-17 Engine with Ham. Std. Fuel Control  
546850, 547300, 552555, 553080, 557200, 557557, 568222, 576408, 576410, 576411, or 576412

### 1-60. ADJUSTED DATA PLATE SPEED DETERMINATION.

The speed at which a new engine originally produced military rated thrust is stamped on the engine data plate. This speed is for "standard day," 15°C (59°F) at 29.92 inches Hg. The engine fuel control unit is designed to automatically vary the engine speed with changes in compressor inlet temperature ( $T_{t2}$ ) as shown in figures 1-29 and 1-30. To determine adjusted data plate speed for the ambient field conditions, proceed as follows:

a. Obtain the ambient air temperature using an accurate mercury thermometer in the shade of the airplane.

Do not use cockpit ambient or Control Tower temperatures. Position thermometer so engine temperature will not affect reading.

b. Enter the temperature-rpm chart (figures 1-29 and 1-30) at the temperature obtained in step "a." Proceed vertically to the military rated thrust line. Move horizontally to the left from this point to the percentage of data plate speed to be expected at this temperature. This is known as speed bias.

c. Multiply data plate speed by the percentage value (speed bias) determined in step "b." This is known as adjusted data plate speed.

### 1-61. ENGINE TRIM AND IDLE SPEED ADJUSTMENT.

#### 1-62. Equipment Requirements.

FIGURE	NAME	TYPE	ALTERNATE	USE AND APPLICATION
Refer to T.O. 1F-106A-2-9.	Pitot Static System Field Tester.	MB-1 (6635-334-7433)	Engine Trim Kit U.S. Accessory Prod. P/N 817D-1200 (1560-690-8092)	To measure turbine discharge pressure ( $P_{t7}$ ).
	Mercury Thermometer. (10 inches minimum length.)	Local Procurement	Equivalent	To determine ambient temperature.
	T Fitting.	AN829-4D (4730-278-8167)	Equivalent	To provide attachment point to measure turbine discharge pressure.
	Flex Hose.	MS28741-4-0200 (4720-595-2770)	Equivalent	To aid connecting T fitting to engine fire-wall fitting.

#### 1-63. Preparation of Airplane and Engine for Trim and Idle Speed Adjustment.

a. Check throttle control linkage for correct adjustment and security. See figure 2-7 for this procedure.

b. Prepare airplane for engine ground run. Refer to paragraph 1-25 for this procedure.

c. Park airplane in a thoroughly cleaned area and pointed into the wind. It is permissible to vary airplane heading as much as  $\pm 15$  degrees of indicated wind direction. The wind velocity shall not exceed 8 knots. Cross winds or tail winds will affect engine trim.

#### NOTE

The engine may be trimmed in wind velocities up to 15 knots. The airplane is acceptable for flight following this trim if pilot's takeoff trim check parameters are met. If it is necessary to trim the engine at velocities exceeding 8 knots, the trim must be rechecked as soon as 8 knot conditions prevail.

d. Check that the exhaust nozzle is in the closed position.

e. Inlet duct screens removed.

f. Inlet duct variable ramps retracted.

g. Ground cooling air on (engine ground cooling valve open).

h. Cabin air ( $N_2$  bleed) on.

i. Constant-speed generating system electrical load on or off.

j. Anti-icing air off (valve closed).

#### NOTE

Position anti-icing switch to cockpit to "MAN ON" for 5 seconds, then to "OFF." Visually check valve position indicator on body of valve for valve being closed.

k. Check that the constant-speed drive air-oil cooler air valve is open and that the engine air-oil cooler valve is closed.

l. Check that all upper fuselage access doors are installed.

#### CAUTION

Engine trimming should be avoided, if possible, under either of the following conditions:

1. When temperature is between  $-10^\circ\text{C}$  ( $14^\circ\text{F}$ ) and  $5^\circ\text{C}$  ( $41^\circ\text{F}$ ) and fog is present.
2. When the dew point is within  $4^\circ\text{C}$  ( $7^\circ\text{F}$ ) of ambient temperature.

#### NOTE

When operational necessity makes it mandatory to trim engine under conditions cited in above CAUTION, Anti-ice will be turned on manually for duration of high power setting run and engine will be trimmed  $\frac{1}{2}$  inch Hg. below  $P_{t7}$  target. Engine is acceptable for flight following such trim if pilots take-off trim parameter is met. Trim should be rechecked at earliest opportunity when temperature and dew point are within acceptable range.

Figure 1-29. Deleted.

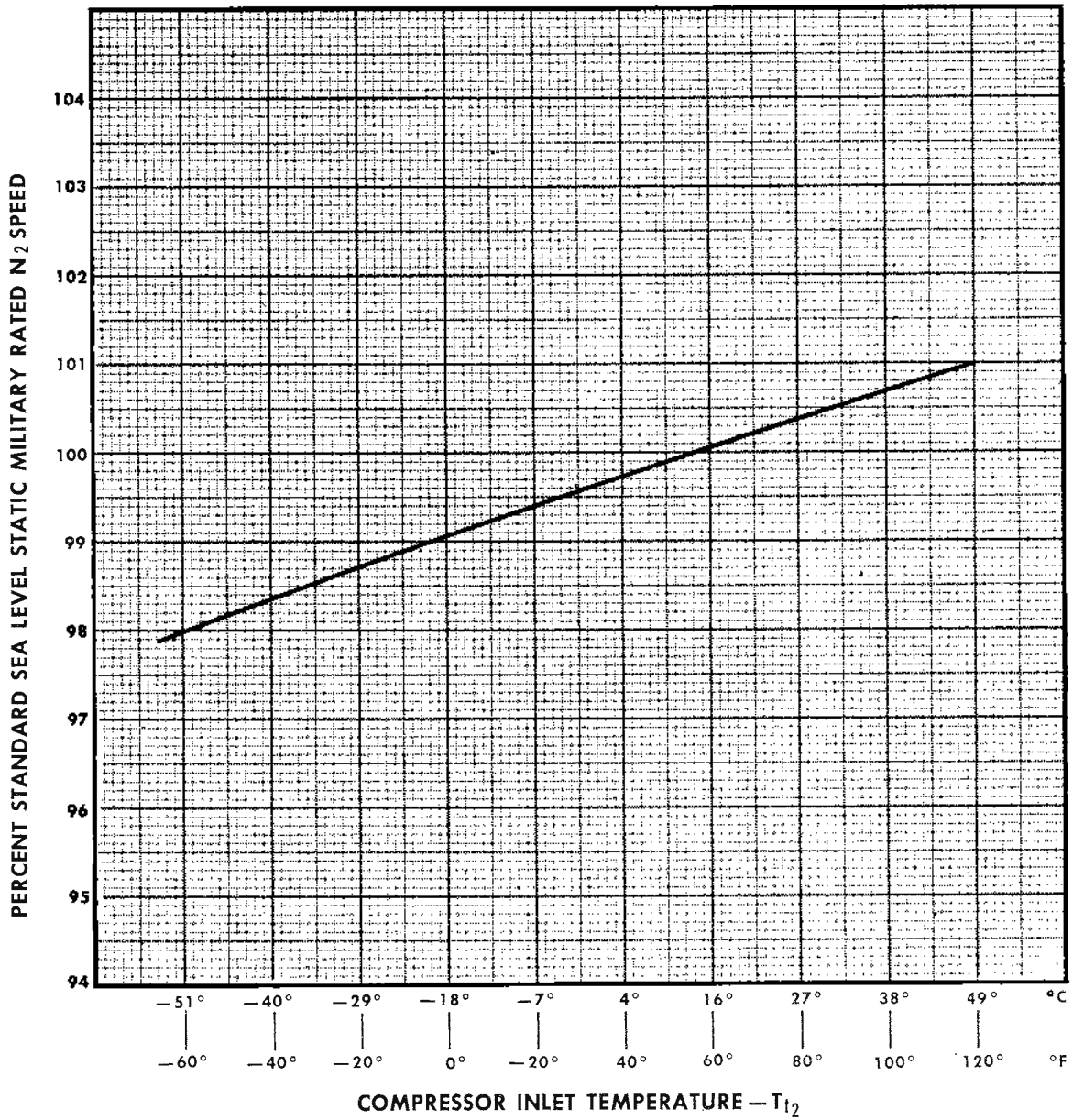

.06.02.1157

Figure 1-30. Temperature-RPM Curve, for Hamilton Standard Fuel Controls 544750, 546850, 546920, 547300, 552555, 553080, 557200, 557557, 568222, 576408, 576410, 576411, and 576412

m. Gain access to trimming and idle speed adjustment points on bottom side of fuel control unit through the engine accessory compartment left access door.

n. Connect pressure gage portion of MB-1 Tester to pressure ratio line tee fitting located just forward of engine firewall on left side of engine.

o. On engines not equipped with the tee fitting, disconnect the pressure ratio line from fitting at forward left side of the engine firewall. Install T fitting on line disconnected. Install flex hose between T fitting and firewall fitting. Connect pressure gage portion of MB-1 Tester to T fitting.

#### 1-64. Procedure.

##### NOTE

Engine trim data will be recorded on AFTO Form 111 each time the engine is trimmed. This form will be filed and maintained with the engine historical records.

a. Place thermometer in the shade of the airplane. Thermometer to be accurate within  $0.3^{\circ}\text{C}$  ( $0.5^{\circ}\text{F}$ ) with sufficient range to measure the highest ambient air temperature. After thermometer has stabilized, record ambient air temperature.

b. Obtain actual field barometric pressure from Control Tower (not barometric pressure corrected to sea level) within 15 minutes prior to engine trim run operation.

c. Enter trim chart (figure 1-28) at the ambient air temperature and proceed vertically to the trim band target line half way between the minimum and maximum limits of the trim band.

d. Proceed horizontally to the left to obtain pressure ratio indicator "TAKEOFF" setting; set indicator at this value.

e. Enter trim chart at the ambient air temperature and proceed vertically to the target line. Proceed horizontally to the right from this point to the field barometric pressure obtained in step "b." Proceed vertically from this point of intersection to determine the turbine discharge pressure ( $P_{t7}$ ) test gage target value.

##### NOTE

$P_{t7}$  tolerance is found by projecting the trim band minimum and maximum lines to the  $P_{t7}$  line.

f. Start and run engine at military power for 5 minutes to stabilize operation and temperatures. Refer to paragraph 1-26 for this procedure.

##### CAUTION

Engine over-temperature and overspeed limits must be closely watched during this operation to prevent exceeding the specified limits.

g. Record the following readings at the end of 5 minutes of military power operation.

1. Turbine discharge pressure from test manifold pressure gage.
2. Tachometer percentage rpm.
3. Pressure ratio.

h. Reduce power to idle.

i. Determine that the cockpit pressure ratio gage pointer has not exceeded the minimum or maximum limits of the trim band, and that the turbine discharge pressure external gage has not exceeded the limits determined in step "e."

j. If jet engine trim band has been exceeded, adjust the engine fuel control military trim adjustment screw and repeat steps "f" through "i." Turning the trim screw clockwise will increase engine power. Turning the trim screw counterclockwise will decrease engine power.

##### NOTE

Before making trim adjustment, loosen the set screw on the side of the fuel control in line with the trim screw. After trim adjustment, tighten the set screw to prevent change in trim adjustment.

k. Check idle rpm; indication shall be 57 to 59%. On airplanes equipped with idle thrust control provisions, idle rpm with exhaust nozzle closed shall indicate 59 to 61%. Idle adjustment screw is located adjacent to military trim adjustment screw. Idle adjustment shall be made with the exhaust nozzle closed.

##### NOTE

If idle adjustment is made, it is mandatory that the military trim adjustment be rechecked.

l. Check that engine maximum allowable speed increase or adjusted data plate speed has not been exceeded. Refer to paragraphs 1-58 and 1-60 for these limits.

m. Shutdown engine. Refer to paragraph 1-30 for this procedure.

n. Paint "IDLE" and "TRIM" adjustment screws with a narrow band of brightly colored lacquer to "seal" the adjustment.

o. Remove test equipment.

#### 1-65. ENGINE TRIM AND IDLE SPEED ADJUSTMENT USING SE 1122 ENGINE TRIM KIT.

##### NOTE

The following trim procedure is applicable to airplanes having Pratt and Whitney engine equipped with a dual thermocouple type harness. The individual thermocouple temperature lead connector, located on lower left side of fireseal, denotes engine having this type of harness (see figure 1-31).

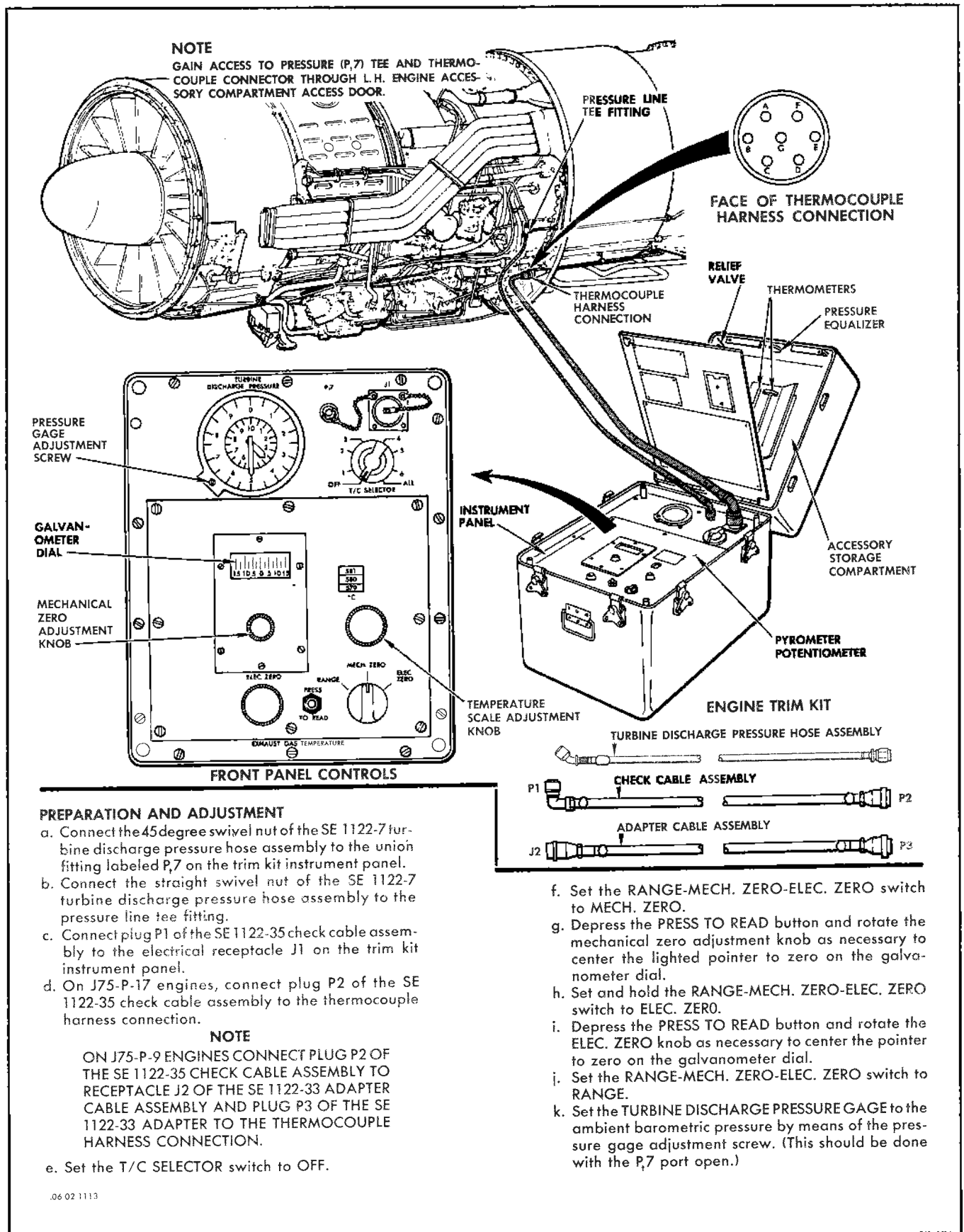

**PREPARATION AND ADJUSTMENT**

- Connect the 45 degree swivel nut of the SE 1122-7 turbine discharge pressure hose assembly to the union fitting labeled P,7 on the trim kit instrument panel.
- Connect the straight swivel nut of the SE 1122-7 turbine discharge pressure hose assembly to the pressure line tee fitting.
- Connect plug P1 of the SE 1122-35 check cable assembly to the electrical receptacle J1 on the trim kit instrument panel.
- On J75-P-17 engines, connect plug P2 of the SE 1122-35 check cable assembly to the thermocouple harness connection.

**NOTE**

ON J75-P-9 ENGINES CONNECT PLUG P2 OF THE SE 1122-35 CHECK CABLE ASSEMBLY TO RECEPTACLE J2 OF THE SE 1122-33 ADAPTER CABLE ASSEMBLY AND PLUG P3 OF THE SE 1122-33 ADAPTER TO THE THERMOCOUPLE HARNESS CONNECTION.

- Set the T/C SELECTOR switch to OFF.

- Set the RANGE-MECH. ZERO-ELEC. ZERO switch to MECH. ZERO.
- Depress the PRESS TO READ button and rotate the mechanical zero adjustment knob as necessary to center the lighted pointer to zero on the galvanometer dial.
- Set and hold the RANGE-MECH. ZERO-ELEC. ZERO switch to ELEC. ZERO.
- Depress the PRESS TO READ button and rotate the ELEC. ZERO knob as necessary to center the pointer to zero on the galvanometer dial.
- Set the RANGE-MECH. ZERO-ELEC. ZERO switch to RANGE.
- Set the TURBINE DISCHARGE PRESSURE GAGE to the ambient barometric pressure by means of the pressure gage adjustment screw. (This should be done with the P,7 port open.)

.06 02 1113

Figure 1-31. Connecting SE 1122 Engine Trim Kit

**1-66. Equipment Requirements.**

FIGURE	NAME	TYPE	ALTERNATE	USE AND APPLICATION
1-31	Engine Trim Kit	817D1200 (4920-601-8092)	SE1122 (4920- 626-6385)	To trim engine

**1-67. Preparation.**

- a. Check throttle control linkage for correct adjustment and security. See figure 2-7 for this procedure.
- b. Prepare airplane for engine ground run. Refer to paragraph 1-25 for this procedure.
- c. Park airplane in a thoroughly cleaned area and pointed into the wind. It is permissible to vary airplane heading as much as  $\pm 15$  degrees of indicated wind direction. The wind velocity shall not exceed 8 knots. Cross winds or tail winds will affect engine trim.

**NOTE**

The engine may be trimmed in wind velocities up to 15 knots. The airplane is acceptable for flight following trimming in 15 knot wind velocity if pilot's takeoff trim check parameters are met. If it is necessary to trim the engine at velocities exceeding 8 knots, the trim must be rechecked as soon as 8 knot conditions prevail.

- d. Check that the exhaust nozzle is in the closed position.
- e. Inlet duct screens removed.
- f. Inlet duct variable ramps retracted.
- g. Ground cooling air on (engine ground cooling valve open).
- h. Cabin air ( $N_2$  bleed) on.
- i. Constant-speed generating system electrical load on or off.
- j. Anti-icing air off (valve closed).

**NOTE**

Position anti-icing switch in cockpit to "MAN ON" for 5 seconds, then to "OFF." Visually check valve position indicator on body of valve for valve being closed.

- k. Check that the constant-speed drive air-oil cooler air valve is open and that the engine air-oil cooler valve is closed.

- l. Check that all fuselage upper access doors are installed.

- m. Connect and adjust the engine trim kit as shown in figure 1-31.

**1-68. Procedure.****Note**

Engine trim data will be recorded on AFTO Form 111 each time the engine is trimmed. This form will be filed and maintained with the engine historical records.

- a. Place trim kit thermometer in the shade of the airplane. After thermometer has stabilized, record ambient air temperature.
- b. Obtain actual field barometric pressure from Control Tower (not barometric pressure corrected to sea level) within 15 minutes prior to engine trim run operation.
- c. Enter trim chart (figure 1-28) at the ambient air temperature and proceed vertically to the trim band target line half way between the minimum and maximum limits of the trim band.
- d. Proceed horizontally to the left to obtain pressure ratio indicator "TAKEOFF" setting; set cockpit indicator at this value.
- e. Enter trim chart at the ambient air temperature and proceed vertically to the target line. Proceed horizontally to the right from this to the field barometric pressure obtained in step "b." Proceed vertically from this point of intersection to determine the turbine discharge pressure ( $P_{t7}$ ) test gage target value.

**NOTE**

$P_{t7}$  tolerance is found by projecting the trim band minimum and maximum lines to the  $P_{t7}$  line.

- f. Start and run engine at military power for 5 minutes to stabilize operation and temperatures. Refer to paragraph 1-26 for this procedure.

**CAUTION**

Engine over-temperature and overspeed limits must be closely watched during this operation to prevent exceeding the specified limits.

- g. Record the following readings at end of 5 minutes of military power operation.

1. Turbine discharge pressure directly from the "TURBINE DISCHARGE PRESSURE" test gage.

2. Tachometer percentage rpm.
3. Pressure ratio from cockpit indicator.
4. Measure individual thermocouple and average engine exhaust gas temperature (EGT) by setting the "T/C SELECTOR" switch to the desired position, depressing the "PRESS TO READ" button, and rotating the temperature scale adjustment knob as necessary to center the lighted pointer to zero on the galvanometer dial. The measured EGT will appear between the hair-lines in the "°C" window.

**CAUTION**

If the temperature of any one thermocouple exceeds 649°C, or if a temperature spread between any of the thermocouples exceeds 139°C, a condition of fuel nozzle flow restriction should be suspected. Shutdown the engine.

- h. Reduce power to idle.
- i. Determine that the cockpit pressure ratio gage pointer has not exceeded the minimum or maximum limits of the trim band, and that the "TURBINE DISCHARGE PRESSURE" test gage reading is within the maximum and minimum limits determined in step "e."
- j. If engine trim band has been exceeded, adjust the engine fuel control military trim adjustment screw and repeat steps "f" through "i." Turning the trim screw clockwise will increase engine power. Turning the trim screw counterclockwise will decrease engine power.

**Note**

Before making trim adjustment, loosen the set screw on the side of the fuel control in line with the trim screw. After trim adjustment, tighten the set screw to prevent change in trim adjustment.

- k. Check idle rpm; indication shall be 57 to 59%. On airplanes equipped with idle thrust control provisions, idle rpm with exhaust nozzle closed shall indicate 59 to 61%. Idle adjustment screw is located adjacent to military trim adjustment screw. Idle adjustment shall be made with the exhaust nozzle closed.

**NOTE**

If idle adjustment is made, it is mandatory that the military trim adjustment be rechecked.

- l. Check that engine maximum allowable speed increase or adjusted data plate speed has not been exceeded. Refer to paragraphs 1-58 and 1-60 for these limits.

- m. Shutdown engine. Refer to paragraph 1-30 for this procedure.

- n. Paint "IDLE" and "TRIM" adjustment screws with a narrow band of brightly colored lacquer to "seal" the adjustment.

- o. Remove test equipment.

**SERVICING**

**1-69. CLEANING, ENGINE AIR PASSAGES.**

Cleaning of the air passages is intended for use on engines displaying definite evidence of performance deterioration due to accumulation of foreign material on compressor blades and in air passages. Deterioration due to this cause may be detected by repeated necessity to increase military trim high-pressure rotor speed ( $N_2$ ) to maintain constant corrected engine thrust. It is recommended that the engine passages be cleaned if the rpm required to obtain military rated thrust exceeds 1.7% rpm above the engine adjusted data plate speed, or 102.75%  $N_2$  rpm (J75-P-17 engines). Refer to paragraph 1-60 to determine adjusted data plate speed. The cleaning procedure should not be used except in cases where thrust loss is definitely indicated. It will be necessary to remove the engine from the airplane and install the engine in

a ground run test stand. Refer to T.O. 1F-106A-10 for engine running in a test stand.

**CAUTION**

If the test stand concept differs from T.O. 1F-106A-10 equipment, it will be necessary to remove the hydraulic pumps and the CSD engine mounted gearbox. The service life of these components can be shortened due to possibility of incorrect inlet and case pressures, insufficient fluid in the cases, high fluid temperature, or contaminated fluid. For hydraulic pump removal information, refer to T.O. 1F-106A-2-3.



For engine removal information, refer to paragraph 1-42. For constant-speed drive engine mounted gearbox removal information, refer to paragraph 9-10. For starter removal information, refer to paragraph 5-21. For the cleaning of engine air passages procedure, refer to T.O. 2J-J75-6.

### 1-70. IDENTIFICATION OF METAL PARTICLES.

When particles of metal are found in the fuel filter, fuel screens, or oil screens, they may be either steel, tin, aluminum, magnesium, silver, bronze, or cadmium. When par-

ticles cannot be positively identified by visual inspection, use the following chart to determine the kind of metal present:

## WARNING

Exercise extreme care when working with acids. Wear protective clothing and work in a well ventilated area. If acid should come in contact with the skin, wash immediately with water and obtain medical attention at once.

METAL TO BE IDENTIFIED	EQUIPMENT AND CHEMICALS REQUIRED	IDENTIFYING REACTION
Steel	Permanent magnet.	Steel or iron will be attracted by the magnet.
Cadmium	Solution of ammonium nitrate (NH <sub>4</sub> NO <sub>3</sub> ), Military Specification JAN-A-175. Solution to consist of two ounces aqueous (water) containing 10% ammonium nitrate.	Place particles in ammonium nitrate solution. If all or any of the particles dissolve in the solution, they are cadmium. Rinse and dry any remaining particles before continuing with next test.
Tin	Clean soldering iron, heated to 260°C (500°F) and tinned with 50-50 solder (50% tin, 50% lead).	Drop particles on heated soldering iron. If particles melt and fuse with the solder they are tin.
Aluminum	Two ounces each of 50% by volume hydrochloric acid (HCL), Federal Specification O-A-86.	When a particle of aluminum is placed in hydrochloric acid, it will fizz with a rapid emission of gas bubbles and gradually disintegrate and form a black residue (aluminum chloride ALCL <sub>3</sub> ).  <b>NOTE</b> Silver and bronze are not noticeably attacked by hydrochloric acid (HCL).
Silver	Concentrated nitric acid (HNO <sub>3</sub> ), Federal Specification O-A-88.	When a silver particle is placed in nitric acid (HNO <sub>3</sub> ) it reacts rather slowly, producing a whitish fog in the acid.
Bronze or Copper	Concentrated nitric acid (HNO <sub>3</sub> ), Federal Specification O-A-88.	When a bronze or copper particle is placed in nitric acid (HNO <sub>3</sub> ) a bright green cloud is produced.
Magnesium	A source of open flame.	When exposed to an open flame magnesium will burn with a bright white flash.  <b style="border: 2px solid black; padding: 5px; display: inline-block;">WARNING</b>  Never attempt to burn more than a few particles of metal suspected to be magnesium. Magnesium powder or dust is explosive.

**1-70. IDENTIFICATION OF METAL PARTICLES (CONT).**

METAL TO BE IDENTIFIED	EQUIPMENT AND CHEMICALS REQUIRED	IDENTIFYING REACTION
Aluminum Silicone Paint  <b>NOTE</b> Aluminum silicone paint may be found on the main oil screen in the form of silver colored flakes. These flakes are magnetic and may be mistaken for aluminum or silver. Use this test to identify silver colored flakes on the main oil screen.	A solution of sodium hydroxide consisting of one pellet sodium hydroxide to three cc's of water. Add the solution to a watch glass.	When aluminum silicone paint is placed in sodium hydroxide there will be a mild reaction in the form of gas bubbles and some visible gas as the particles change to sodium aluminate. When aluminum chips are placed in sodium hydroxide the reaction will be much more active with more gas bubbles forming and more gas visible. When silver particles are placed in sodium hydroxide there will be no reaction.

**1-71. SERVICING ENGINE LUBRICATION SYSTEMS.**

For engine lubrication system servicing instructions, refer to Section VI.

**1-72. SERVICING CONSTANT-SPEED DRIVE LUBRICATION SYSTEM.**

For the constant-speed drive lubrication system information and servicing, refer to Section IX.

**1-73. LUBRICATION, ENGINE COMPONENTS.**

For engine component service lubrication, refer to T.O. 1F-106A-2-2.

**1-74. BLEEDING, HYDRAULIC SYSTEM.**

Bleed the airplane hydraulic system following the installation of the engine in the airplane. Refer to T.O. 1F-106A-2-3 for this procedure.

**1-75. REPLACEMENT, HYDRAULIC SYSTEM LOW PRESSURE FILTER ELEMENT.**

Clean or replace the hydraulic system low-pressure filter element after first engine ground run following installation of the engine in the airplane. Refer to T.O. 1F-106A-2-3 for this procedure.

**1-76. PRESERVATION, GENERAL.**

For extended periods of airplane inactivity, it is necessary that the engine fuel and oil systems, and the constant-speed drive oil system be preserved. The period of inactivity can fall in one of three categories as determined by maintenance control personnel prior to beginning of the inactivity period. These periods of airplane inactivity can be 1 to 28 days, 28 to 119 days, or beyond 119 days. For the inactivity period of 1 to 28 days, no preservation is required. However all inlet, exhaust, vent, drain and service openings should be covered to prevent entry of moisture and foreign materials. For the inactivity period of 28 to 119 days, preservation of the systems will be required as outlined in following paragraphs. For pres-

ervation beyond 119 days, the procedure for the 28 to 119 days period will be conducted, then the engine will be removed from the airplane.

**NOTE**

During preserving procedures, it is necessary to air motor the engine. Refer to paragraph 5-13 for the air motoring procedure.

The engine will be prepared for storage and installed in a shipping container in accordance with T.O. 2J-1-18.

**1-77. PRESERVATION, ENGINE OIL SYSTEM (28 TO 119 DAYS).**

a. Prepare engine for ground run operation. Refer to paragraph 1-25 for this procedure. Remove constant-speed system drive shaft to prevent generator oil flooding. Refer to paragraph 9-4 for engine mounted gearbox conditioning and operational limitations which must be followed during this operation. Check engine starter oil level; service as required.

b. Place drainage receptacles under engine oil tank drain, N<sub>2</sub> accessory section case drain, and the engine air-oil cooler and engine fuel-oil cooler drains.

c. Motor engine with starter until oil pressure and engine rpm is indicated; disengage starter. Open drains and allow oil to drain to a slow drip.

d. Open drains. Motor engine with starter, permitting scavenge pumps to clear engine. Disengage starter when steady flow from drains ceases.

**CAUTION**

Do not exceed starter operation limitation of 90 seconds in a 20 minute period.

e. Clean and reinstall main oil strainer. Refer to paragraph 6-41 for this procedure.

f. Close and secure all oil drain points.

**CAUTION**

When installing the engine oil drain plug in the N<sub>2</sub> accessory case drain, a maximum of 75 to 100 inch-pounds torque shall be used. Do not over torque and strip accessory case threads.

g. Fill engine oil tank to "FULL" mark on dip stick with oil, Military Specification MIL-L-7808.

h. Motor engine with starter until oil pressure is indicated; disengage starter. Reinstall constant-speed system drive shaft. Disconnect coupled engine mounted gear

box oil "in" and "out" lines at quick disconnect fittings. Reconnect lines to the constant-speed remote gear box.

**NOTE**

Preservation of the constant-speed drive system should be conducted at this time. Refer to paragraph 1-81 for this procedure.

i. Start engine and operate at idle. Refer to paragraph 1-26 for this procedure.

j. With engine pressures and temperatures stabilized, advance throttle to 75% rpm. Operate at this setting for 5 minutes; shutdown engine. Refer to paragraph 1-30 for engine shutdown procedure.

**1-78. PRESERVATION, ENGINE FUEL SYSTEM (28 to 119 days).****1-79. Equipment Requirements.**

FIGURE	NAME	TYPE	ALTERNATE	USE AND APPLICATION
1-6	External High-Pressure Air Compressor.	SE 0704-801 (4310-697-0858)	Equivalent.	To provide sufficient air supply for combustion starter air motoring operation.
Refer to T.O. 1F-106A-2-3	High-Pressure Air Compressor.	MC-11 (4310-541-7060)	SE 0704-801 (4310-697-0858)	To provide air supply for combustion starter air motoring operation.
Refer to T.O. 1F-106A-2-10	Generator Set (Gas).	8-96026-801 AF/M32A-13 (6115-583-9365)	8-96026 AF/M32M-2 (6115-617-1417)	To energize electrical systems on aircraft equipped with special quick disconnect receptacle.
	Generator Set (Elec).	8-96025-803 AF/ECU-10/M (6125-583-3225)	8-96025-805 A/M24M-2 (6125-628-3566)	
			8-96025 AF/M24M-1 (6125-620-6468)	
	Generator Set.		MC-1 (6125-500-1190)	
MD-3 (6115-635-5595)				
Adapter Cable.		8-96052 (6115-557-8548)		To connect MC-1 and MD-3 units to aircraft equipped with special quick disconnect receptacle.

## 1-79. Equipment Requirements (Cont).

FIGURE	NAME	TYPE	ALTERNATE	USE AND APPLICATION
	Engine Inlet Duct Screens.	8-96176-1-2 -1(1730-650-1413) -2(1730-646-8903)		To prevent foreign material from entering ducts during engine ground run.
	Wheel Chocks.	P/N42D-65942 (1730-294-3695) Class 19A or equivalent.		To chock landing gear wheels.
		P/N50D-6602 (1730-268-9822) Class 10A		To chock landing gear wheels during ice and snow conditions.
	Variable controlled pressure flushing oil source of 5 to 25 psi (Flushing oil Military Specification MIL-O-6081, grade 1010).			To flush and preserve engine fuel system.
	Variable controlled dry air pressure source of 0 to 60 psi (2).			To aid in preservation of afterburner igniter valve.
	Variable controlled preserving source of 0 to 10 psi (2) (Preserving oil Military Specification MIL-C-6529A).			To preserve afterburner igniter valve.
	Dehydrating Agent. (52, one pound bags.)	Military Specification MIL-D-3464, type 5, grade A	Equivalent	To preserve engine area.
	Humidity Indicators.	AN7511-1	Equivalent	To provide visual indication of fuselage area preservation condition.
	Stop Watch.	A-8 (6645-557-0322)	Equivalent	To time depreserving operation.
	Drain Receptacles.			To catch drainage fluids during preserving procedure.
	Intercommunication Equipment.			For contact from cockpit to ground observers.
	Fire-fighting Equipment.			To extinguish flames in case of fire.

## 1-80. Procedure.

a. Place 5 gallon drain receptacle under fuel pressurizing and dump valve overboard drain.

b. Disconnect signal line from main fuel control unit where it attaches to pressurizing and dump valve; leave dump valve connection open to atmosphere. Cap signal line from main fuel control unit.

c. Remove upper aft plug from right side of afterburner fuel control; install drain hose. Place 5 gallon drain receptacle under drain hose.

**NOTE**

Some fuel will spray out tailpipe during engine air motoring.

d. Disconnect and cover engine fuel inlet line at engine fuel pump inlet port. Remove constant-speed system drive shaft.

**NOTE**

Refer to paragraph 9-4 for engine mounted gearbox conditioning and operational limitations which must be followed during this operation.

e. Connect 5 to 25 psi pressure source of flushing oil, Military Specification MIL-O-6081, grade 1010, to the engine fuel pump inlet port.

f. Remove engine ignition power fuse from main wheel well fuse panel.

g. Check that fuel control and afterburner control fuses on nose wheel well fuse panel are installed.

h. Place controls in following position:

- |                             |          |
|-----------------------------|----------|
| 1. Fuel valve selector      | "OFF"    |
| 2. Fuel boost pump switches | "OFF"    |
| 3. Fuel control switch      | "NORMAL" |
| 4. Throttle                 | "OFF"    |

i. With engine starter applicable air source connected to the airplane, depress ignition button and move throttle to "START" position; start stop watch. Starter shall motor engine. Ignition button to be depressed during entire procedure.

j. Move throttle to "OFF;" ignition shall not occur. Advance throttle to "MIL POWER."

1. After 15 seconds move throttle to afterburning.
2. After 25 seconds move throttle to "MIL POWER."
3. After 30 seconds place fuel control switch in emergency.
4. After 40 seconds place fuel control switch in normal.
5. Move throttle to "OFF;" then to full forward position at a slow steady rate; 5 seconds for full quadrant travel.
6. When stop watch reads 60 seconds, move throttle to "OFF" and release ignition button. Starter operation shall cease. Shut off gas turbine compressor; remove electrical power from airplane.

**NOTE**

During this procedure a minimum of 3 gallons of fluid should drain from the dump valve and 2 gallons from the afterburner manifold.

k. Remove flushing equipment from engine, reconnect lines.

l. Drain engine oil tank and engine N<sub>2</sub> accessory section of oil; close tank drain and reinstall accessory section drain plug.

**CAUTION**

When installing the N<sub>2</sub> accessory section drain plug, use only a maximum of 75 to 100 inch-pounds torque to prevent stripping of accessory case threads.

m. Remove and clean fuel system filters and screens. Refer to Sections II and III for these procedures.

n. Remove the following lines from the afterburner igniter valve:

1. Fuel supply line.
2. Tailpipe drain line.
3. Fuel discharge line.
4. Air supply line from diffuser case.
5. Air line from exhaust nozzle control open line.

**NOTE**

Refer to T.O. 2J-J75-6 for line identification.

o. Connect controlled variable air pressure source of 0 to 60 psi where air supply line from diffuser case normally attaches to igniter valve. Apply 60 psi air pressure.

p. Using a 0 to 10 psi controlled pressure source of preserving oil, Military Specification MIL-C-6529A, type III, connect preserving oil source to fuel inlet port of igniter valve. Apply 8 to 10 psi oil pressure. When oil flows freely from igniter valve drain fitting, reduce air pressure to 5 to 10 psi.

q. Oil flow will decrease from drain fitting and oil will start to drip from igniter valve fuel discharge port.

When oil flow decreases at fuel discharge port, repeat steps "o" and "p."

r. Adjust air and oil pressure to 10 psi.

s. Connect second 0 to 10 psi controlled pressure source of preserving oil, Military Specification MIL-C-6529A, type III, to exhaust nozzle air line port on igniter valve. Raise oil pressure to 8 to 10 psi; reduce oil pressure to zero.

t. Repeat step "s." Remove oil source connected in step "s." Allow oil to drain from igniter valve. Reduce first oil source pressure and air pressure to zero; remove air and oil line. Allow oil to drain from igniter valve into a receptacle. Reconnect engine lines to igniter valve.

u. If engine is to remain in the airplane, perform the following:

1. Install dehydrating agent, Military Specification MIL-D-3464, Type 5, Grade A in one pound bags in engine and duct areas. Distribute 26 pounds throughout engine compartment. Distribute 13 pounds in engine air inlet ducts, and 13 pounds in engine exhaust duct. Record amount of dehydrating agent placed in each area.
2. Seal engine intake, exhaust, vent, and drain openings, and boundary layer bleeds. Humidity indicators and inspection windows to be provided at intake and exhaust ducts.
3. Checking of preserved unit to be made at 2 week intervals if airplane is stored outside, or every 30 days if stored inside.

### 1-81. PRESERVATION, CONSTANT-SPEED DRIVE OIL SYSTEM (28 TO 119 DAYS).

At the time of engine preservation, it will be necessary to also preserve the constant-speed oil system. Just prior to the engine preserving run, perform the the following procedure:

- a. Drain the constant-speed system oil tank only. Refer to Section IX for this procedure.
- b. Fill the constant-speed system oil tank with oil, Military Specification MIL-L-7808.

### 1-82. DEPRESERVATION, GENERAL.

For an airplane inactivity period of 1 to 28 days, depreservation of the engine fuel and oil systems, and the constant speed drive system is not required. However all covers should be removed from the inlet, exhaust, vent, drain and service openings and the areas checked for normal operating condition. For an inactivity period of 28 to 119 days, the previously listed systems are preserved and will require depreserving action. The following paragraphs outline the steps necessary to depreserve these

systems. These procedures also apply to a new engine, engine preserved for a period beyond 119 days, a new fuel control, or a new constant-speed drive unit after being installed in the airplane.

### 1-83. DEPRESERVATION, ENGINE OIL SYSTEM.

- a. Place drain receptacles under the oil tank drain, N<sub>2</sub> accessory section oil drain, fuel-oil cooler oil drain, and air-oil cooler drain.
- b. With drains open, allow preserving oil to drain to slow drip.
- c. Remove engine oil strainer and clean. Refer to paragraph 6-41 for this procedure.
- d. Reinstall oil strainer and all plugs removed for the draining procedure.

#### CAUTION

When installing oil drain plug in the N<sub>2</sub> accessory case, torque plug to maximum of not more than 75 to 100 inch-pounds to prevent stripping of accessory case threads.

- e. Service engine oil tank.

### 1-84. DEPRESERVATION, ENGINE FUEL SYSTEM.

When depreserving an installed engine, or when installing a new control unit, or installing a preserved engine in the airplane, it is necessary that the preservative oil be flushed from the engine fuel system with engine fuel, prior to engine operation. An 8 hour soaking period after the flushing process is not required; however, if malfunction, erratic operation, or leakage by the shaft seals is encountered during initial operation, assure that the system is filled with fuel and allow the system to soak for 8 hours, and then recheck the operation prior to rejecting a component of the system.

### 1-85. Equipment Requirements.

FIGURE	NAME	TYPE	ALTERNATE	USE AND APPLICATION
Refer to T.O. 1F-106A-2-3	High-Pressure Air Compressor.	MC-11 (4310-541-7060)	SE 0704-801 (4310-697-0858)	To provide air supply for combustion starter air motoring operation.
Refer to T.O. 1F-106A-2-10	Generator Set (Gas).	8-96026-801 AF/M32A-13 (6115-583-9365)	8-96026 AF/M32M-2 (6115-617-1417)	To energize electrical systems on aircraft equipped with special quick disconnect receptacle.

## 1-85. Equipment Requirements (Cont).

FIGURE	NAME	TYPE	ALTERNATE	USE AND APPLICATION
	Generator Set (Elec).	8-96025-803 AF/ECU- 10/M (6125-583- 3225)	8-96025-805 A/M24M-2 (6125-628- 3566)	
			8-96025 AF/M24M-1 (6125-620- 6468)	
	Generator Set.		MC-1 (6125-500- 1190)	To energize electrical systems (except AWCIS) on aircraft equipped with standard AN receptacles and on others by using adapter cable 8-96052.
			MD-3 (6115-635- 5595)	
	Adapter Cable.	8-96052 (6115- 557-8548)		To connect MC-1 and MD-3 units to aircraft equipped with special quick disconnect receptacle.
	Engine Inlet Duct Screens.	8-96176-1-2 -1(1730-650- 1413) -2(1730-646- 8903)		To prevent foreign material from entering ducts during engine ground run.
	Wheel Chocks.	P/N42D- 65942 (1730-294- 3695) Class 19A or equivalent		To chock landing gear wheels.
		P/N 50D6602 (1730-268- 9822) Class 10A		To chock landing gear wheels during ice and snow conditions.
	Stop Watch.	A-8 (6645-557- 0322)	Equivalent	To time depressurizing operation.
	Drain Receptacles.			To catch drainage fluids during depressurizing procedure.
	Intercommunication Equipment.			For contact from cockpit to ground observers.
	Fire-fighting Equipment.			To extinguish flames in case of fire.

**1-86. Procedure**

The following procedure is used to depreserve the engine fuel system while the engine is installed in the airplane:

- a. Disconnect fuel pressurizing and dump valve sensing line at the fuel control. Cap fitting on fuel control and leave sensing line open to atmosphere.
- b. Place drain receptacle under fuel pressurizing and dump valve drain, and the afterburner duct drain.
- c. Connect external ac and dc power to airplane receptacles. Refer to T.O. 1F-106A-2-10 for this procedure.
- d. Prepare combustion starter for air motoring. Refer to paragraph 5-13 for this procedure. Check starter oil level; service as required.
- e. Remove constant-speed system drive shaft to prevent generator oil flooding. Refer to paragraph 9-4 for engine mounted gearbox conditioning and operational limitations which must be followed during this operation.

**NOTE**

Check that requirements for engine oil system depreserving have been accomplished.

- f. Check that the following fuses are installed:
  1. "EXT PWR" Main wheel well fuse panel.
  2. "FUEL CONT" Nose wheel well fuse panel.
  3. "AB CONT" Nose wheel well fuse panel.
  4. "LH FUEL VALVE SHUTOFF" Cockpit LH fuse panel.
  5. "RH FUEL VALVE SHUTOFF" Cockpit LH fuse panel.
  6. "FWD FUEL VALVE SHUTOFF" Cockpit LH fuse panel.

**CAUTION**

Check that engine ignition fuse has been removed.

- g. Place the following switches in the position indicated:

- |  |          |
|--|----------|
| 1. Fuel Control                                | "NORMAL" |
| 2. Fuel selector valve                         | "ENGINE" |
| 3. Fuel Boost pumps (2)<br>one left, one right | "ON"     |

- h. Move throttle lever to "START." Depress ignition button and hold in the depressed position during the period of starter operation.

- i. With ignition button depressed, move throttle to "OFF" then to "MIL POWER" position. Use stop watch to check operation.

**CAUTION**

If engine oil low pressure warning light does not extinguish, release ignition button and move throttle lever to "OFF" position. Investigate and correct cause of malfunction.

- j. After cranking engine with throttle at "MIL POWER" for approximately 30 seconds, place fuel control switch in "EMERGENCY" position.

- k. After total elapsed time of 40 seconds, move fuel control switch back to "NORMAL" position.

- l. Move throttle to "OFF" position then to full power position (take 5 seconds for full quadrant travel). At 60 seconds, release "IGNITION" button and return throttle to "OFF."

**NOTE**

During the depreservation operation, a minimum of 3 gallons of oil-fuel mixture should drain from the dump valve. If minimum amount of liquid does not drain, repeat depreserving procedure.

- m. Remove drain hoses, reconnect fuel lines, and shut down gas turbine compressor.

- n. Install engine ignition fuse in main wheel well fuse panel.

- o. Allow fuel to remain in fuel control unit a minimum of 8 hours.

- p. Remove and clean the following engine filters.

1. Fuel pump strainer. See figure 2-7.
2. Fuel control filter. See figure 2-7.
3. Fuel pressurizing and dump valve screen. See figure 2-8.

- q. Reinstall constant-speed system drive shaft. Refer to Section IX for this procedure. Disconnect coupled engine mounted gearbox oil "in" and "out" at quick disconnect fittings. Reconnect lines to the constant-speed remote gearbox.

- r. Perform engine run and operational check. Refer to paragraph 1-25 for this procedure.

**NOTE**

Check that requirements for depreserving of the engine oil system and the constant-speed drive system have been accomplished before running the engine.

**1-87. DEPRESERVATION, CONSTANT-SPEED DRIVE SYSTEM.**

- a. Drain and prime the constant-speed oil system. Refer to Section IX for this procedure.



b. After the first engine run, check the constant-speed oil tank for oil level to the "FULL" mark on the dip stick. Refer to Section IX for this procedure.

## EXTREME WEATHER CONDITIONS

### 1-88. GENERAL.

Airplanes stationed in arctic or desert regions are subject to extreme temperature and weather conditions and will require special precautionary measures during maintenance.

### 1-89. HOT WEATHER OPERATION.

During hot weather operations, normal starting procedures will be used. Temperatures will possibly be on the high side of operating ranges. This will require that engine ground run operations be accomplished as rapidly as possible.

### 1-90. COLD WEATHER OPERATION.

#### 1-91. Engine Fuel System.

As atmospheric temperatures are reduced, the solubility of water in fuel is also reduced. This results in water separating from fuel and settling in low points of fuel system accessories and equipment. With the occurrence of freezing temperatures, this water will freeze, causing malfunction of the fuel system. Water in fuel will also freeze, forming needle-shaped crystals that may be found in fuel strainer. This will restrict fuel flow and in severe cases will completely clog the strainer. To remedy this condition, heated air must be applied to the engine and fuel system components. Use ground heating unit 8-96106 or 8-96107.

### CAUTION

Continue heat application for sufficient time to insure positive removal of all ice. Fuel flow at engine start may cause any remaining lumps of ice to slip and block fuel passages. All fuel filters, screens, and fuel supply system low points must be inspected and drained after application of heat.

#### 1-92. Engine Oil System.

Icing conditions may exist in the oil system at the same time as in the fuel system. During cold weather, an airplane left outside after engine run will have greater possibility of water in the fuel and oil systems due to condensation. In the event that ice conditions are suspected, the airplane should be placed in a heated area for a period of time sufficient to warm the affected areas.

#### 1-93. Engine Cold Weather Operating Procedures.

Starting of the engine during cold weather will be conducted in the normal manner. Operate the engine at idle for 2 minutes before advancing the throttle. Upon completion of operations, the engine will be shutdown in the normal manner.

### NOTE

Because of low ambient temperatures, thrust developed by the engine will be noticeably greater than normal. Refer to engine trim procedure to compute thrust limits for the ambient temperature.

## Section II

### MAIN FUEL SYSTEM

<i>Contents</i>	<i>Page</i>
Description .....	2-1
Operational Checkout .....	2-5
Replacement .....	2-6
Adjustment .....	2-10
Servicing .....	2-10

#### DESCRIPTION

#### 2-1. GENERAL.

The main fuel system is controlled and operated by the pilot through a Teleflex cable system from the cockpit. In the F-106B airplane, dual throttle quadrants are installed to provide the forward and aft pilot positions with individual throttles. The throttles are interconnected and attached to the Teleflex system to complete the hookup. The fuel system regulates the flow of fuel received from the supply system, and injects the proper amount into the engine. The main fuel system is made up of the following principal accessories with their connecting tubing and electrical wiring: fuel control, engine and afterburner fuel pump, fuel transfer valve, fuel flowmeter, fuel-oil cooler, fuel pressurizing and dump valve, and the engine fuel manifolds and nozzles. See figure 2-1 for a schematic illustration of the main engine fuel system. JP-4 fuel, Military Specification MIL-J-5624 is used in this airplane.

#### NOTE

It is permissible to use the lowest available grade of aviation gasoline, Military Specification MIL-G-5572 (no oil mix required); JP-5, Military Specification MIL-J-5624; or JP-6, Military Specification MIL-F-25656, as emergency fuels for one-time ferry missions. Where the tactical situation requires the use of these fuels, the engine military trim must be readjusted to meet the pressure ratios shown in figure 1-28 before the airplane can be flown. Since JP-5 freezes at  $-48.3^{\circ}\text{C}$  ( $-55^{\circ}\text{F}$ ) and JP-6 at  $-40^{\circ}\text{C}$  ( $-40^{\circ}\text{F}$ ), missions in which these fuels are used shall be restricted to altitudes where temperatures below these limits are not encountered. When using aviation gasoline, particular attention shall be given to engine tailpipe temperature during starting and throughout the flight.

#### 2-2. NORMAL FUEL REGULATION.

Normal fuel regulation is accomplished by the fuel control unit and other components of the system, which automatically meter fuel according to engine requirements. Fuel requirements are determined by the position of the pilot's throttle, and engine operating conditions. These operating conditions, which affect fuel flow, are air inlet temperature, pressure altitude, compressor discharge pressure, and compressor rpm (as related to acceleration and deceleration). Subject to these conditions, the control is capable of accurately maintaining engine rpm during steady state operation by use of a permanent droop system in conjunction with a speed sensing governor. During starting and acceleration, the control senses compressor discharge pressure, engine inlet temperature, and engine rpm, and as a result, schedules fuel flow to permit the maximum rate of acceleration allowable within the engine temperature limits. During deceleration, the control schedules fuel flow as a function of burner pressure to insure sufficient flow to support combustion.

#### 2-3. EMERGENCY FUEL REGULATION.

Emergency fuel regulation is provided for within the same control unit that controls normal fuel flow. Emergency fuel control is initiated by operation of a 28-volt dc solenoid, controlled by a switch on the pilot's throttle quadrant. The solenoid operates a flapper type valve in the fuel control. Closing of the flapper valve causes engine fuel pump discharge pressure to build up in the servo area of an emergency shuttle valve. This servo pressure repositions the shuttle valve that directs pump discharge pressure to an emergency transfer valve. The transfer valve repositions, closing off the fuel control normal operating system, and directs high-pressure fuel to the emergency system. A warning light is provided on the

pilot's instrument panel to indicate that the fuel control system is in the emergency operating condition.

**CAUTION**

Always retard throttle to idle when switching back from "EMER" to "NORMAL." This precaution will prevent compressor stall.

#### 2-4. THROTTLE QUADRANT AND LINKAGE.

The throttle quadrant, shown in figure 2-2, provides a manual means of controlling the engine power output, through a system of Teleflex cable and linkage to the main fuel control unit. The throttle lever provides convenient mounting for switches controlling ignition, microphone, and speed brakes. Engine and afterburner operating ranges are identified on the quadrant, and detented slots guide the throttle movement.

**NOTE**

*Applicable to F-106A airplanes 56-453, -454, 56-456 thru 57-245, 59-001 and subsequent, and F-106B airplanes 57-2508 thru 57-2515, 57-2542 and subsequent.* The throttle lever is spring-loaded, inboard at the "IDLE" position, at a tension of 12 to 19.5 pounds.

Actuation of the engine starter system is provided by moving the throttle outboard from the "OFF" position. This movement actuates a switch which initiates the engine starting sequence. Afterburning system activation is provided by moving the throttle outboard from the military power operating range. The throttle must be retarded approximately 2½ degrees from the full forward position before it can be brought out of the afterburner range. Movement of the throttle into the afterburner range actuates a switch to initiate afterburning. A spring detent is provided to hold the throttle in the afterburning range. A switch is provided in the quadrant to actuate the landing gear warning system, when the throttle is retarded past a safe power range with the landing gear retracted at low altitude and airspeed. A spring assembly is provided in the linkage to prevent throttle creep in fore and aft directions.

#### 2-5. THROTTLE LINKAGE, AFT (ENGINE) QUADRANT.

The aft throttle quadrant is located in the fuselage at sta. 526.25, left side, adjacent to the engine compressor. The quadrant is the aft terminus of the Teleflex cable

from the pilot's throttle quadrant, and provides the connecting linkage to the main fuel control unit. Stops are provided at the aft quadrant for the off and full power positions of the throttle system.

#### 2-6. ENGINE MAIN FUEL CONTROL UNIT.

The main fuel control unit is a high-flow capacity metering unit incorporating both normal and emergency fuel control systems. The normal system consists of a shutoff and minimum pressure valve, compressor discharge pressure limiting valve, speed limiting rotor assembly, pressure regulating valve, speed sensing governor, temperature sensing bellows and servo, and the throttle valve. This system provides scheduled fuel flow for starting, acceleration and deceleration, together with all speed governing. The fuel flow schedule is altitude-compensated, and biased by changes in compressor inlet temperature. The normal system is controlled by mechanical linkage to the pilot's control quadrant. The emergency system is activated by an electrical solenoid, controlled by a switch on the pilot's throttle quadrant. The emergency system provides a means of bypassing the main system, in the event of failure of any part of the main system. Indicator lights are provided on the pilot's master warning light panel to indicate that the fuel control is operating on the emergency system. The electrical system is protected by a 5-amp fuse located on the nose wheel well fuse panel. Adjustment points for minor field adjustments are provided on the fuel control unit.

#### 2-7. FUEL-OIL COOLER.

The fuel-oil cooler is a heat exchanger employing fuel flow as a coolant for engine oil. The cooler is installed on the left side of the engine and works in conjunction with the air-oil cooler in cooling engine oil. Oil flow through the cooler is regulated by a thermostatic valve located on the cooler inlet connection. The cooler is installed in the fuel system between the fuel control and the fuel pressurization and dump valve. All fuel for normal engine (nonafterburning) operation is routed through the cooler.

#### 2-8. ENGINE AND AFTERBURNER FUEL PUMP.

The engine and afterburner fuel pump assembly consists of a centrifugal boost stage supplying three gear-type pumps. During normal operation, fuel from one of the pumps supplies the main fuel system requirements. The two remaining pumps supply the afterburner fuel system requirements. During periods of nonafterburner operation, fuel from the afterburner pumps is returned to the inlet of the gear type pumps. A transfer valve is provided to divert the output from one of the afterburner pumps to the main fuel system in case of main fuel system pump failure. Under this condition the remaining afterburner pump will supply fuel for limited afterburner operation.

- █ PUMP INLET (BOOST) FUEL PRESSURE
- █ FUEL BY-PASS (INTERSTAGE) PRESSURE
- █ CONTROL SYSTEM INLET FUEL PRESSURE
- █ METERED FUEL PRESSURE
- █ PRIMARY MANIFOLD FUEL PRESSURE
- █ SECONDARY MANIFOLD FUEL PRESSURE
- █ SERVO FUEL PRESSURE
- █ REGULATOR FUEL PRESSURE
- █ ATMOSPHERIC PRESSURE
- █ COMPRESSOR INLET AIR PRESSURE
- █ BURNER PRESSURE
- █ COMPRESSOR INLET TEMPERATURE
- INACTIVE. USED DURING EMER. OPERATION
- ELECTRICAL CIRCUIT
- ENERGIZED ELECTRICAL CIRCUIT
- ENERGIZED SIGNAL CIRCUIT

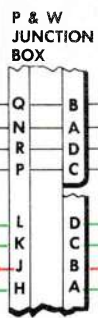
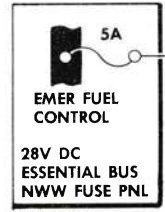
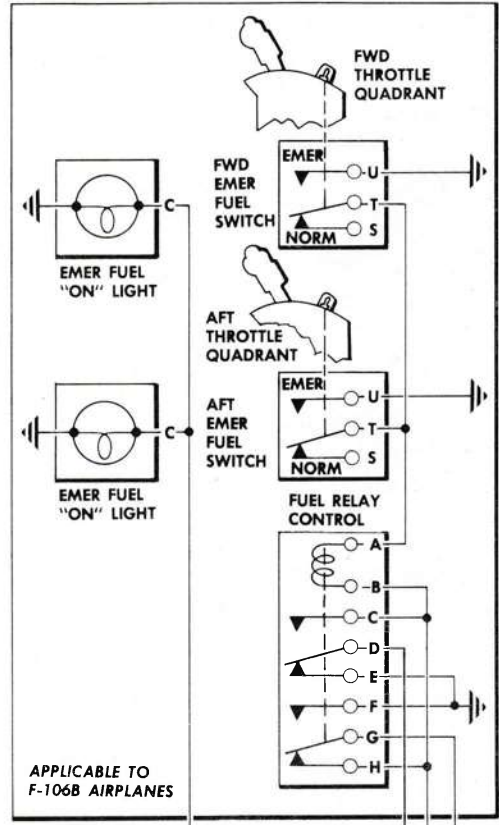
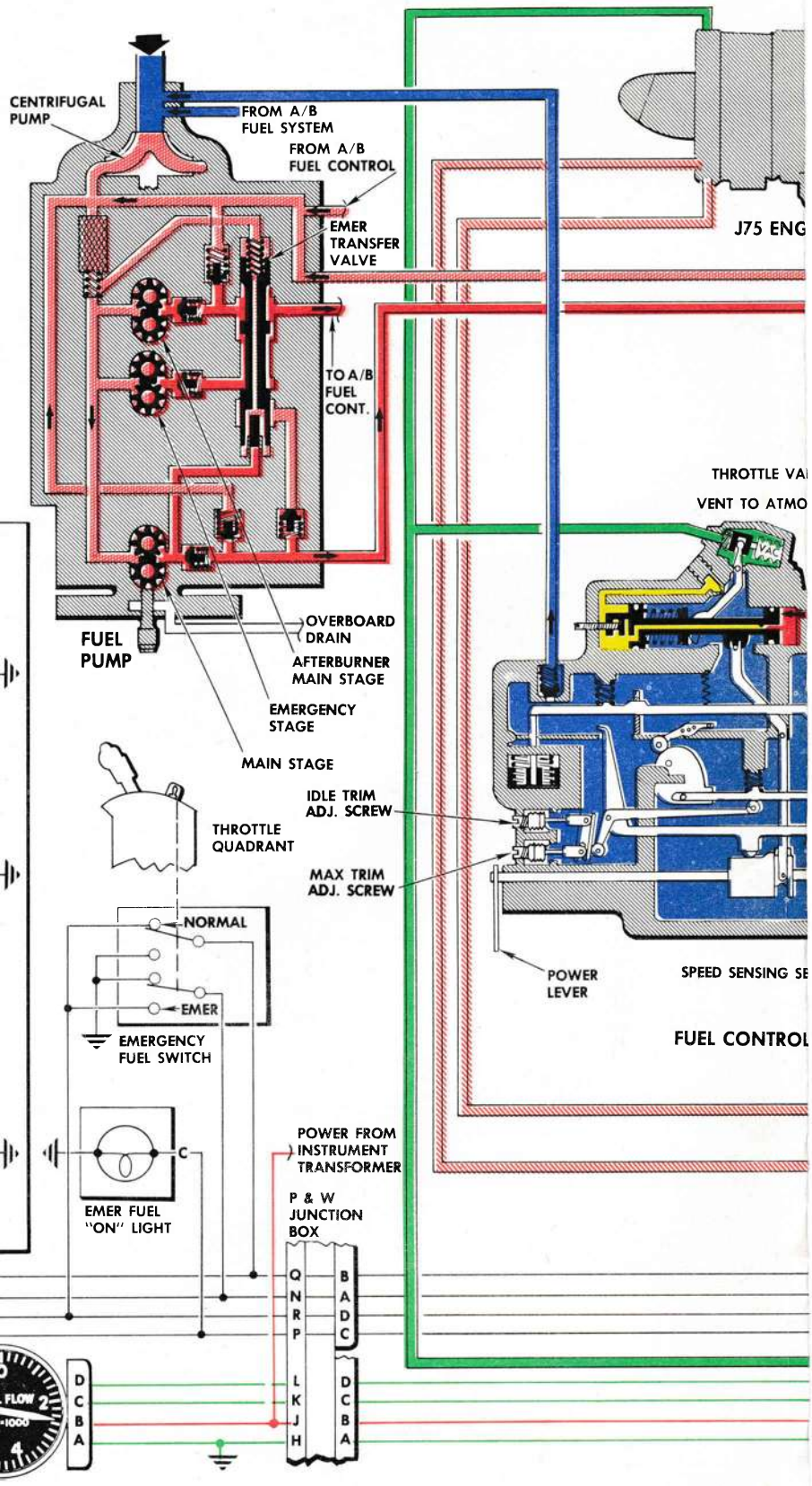

.06.02.1109 A

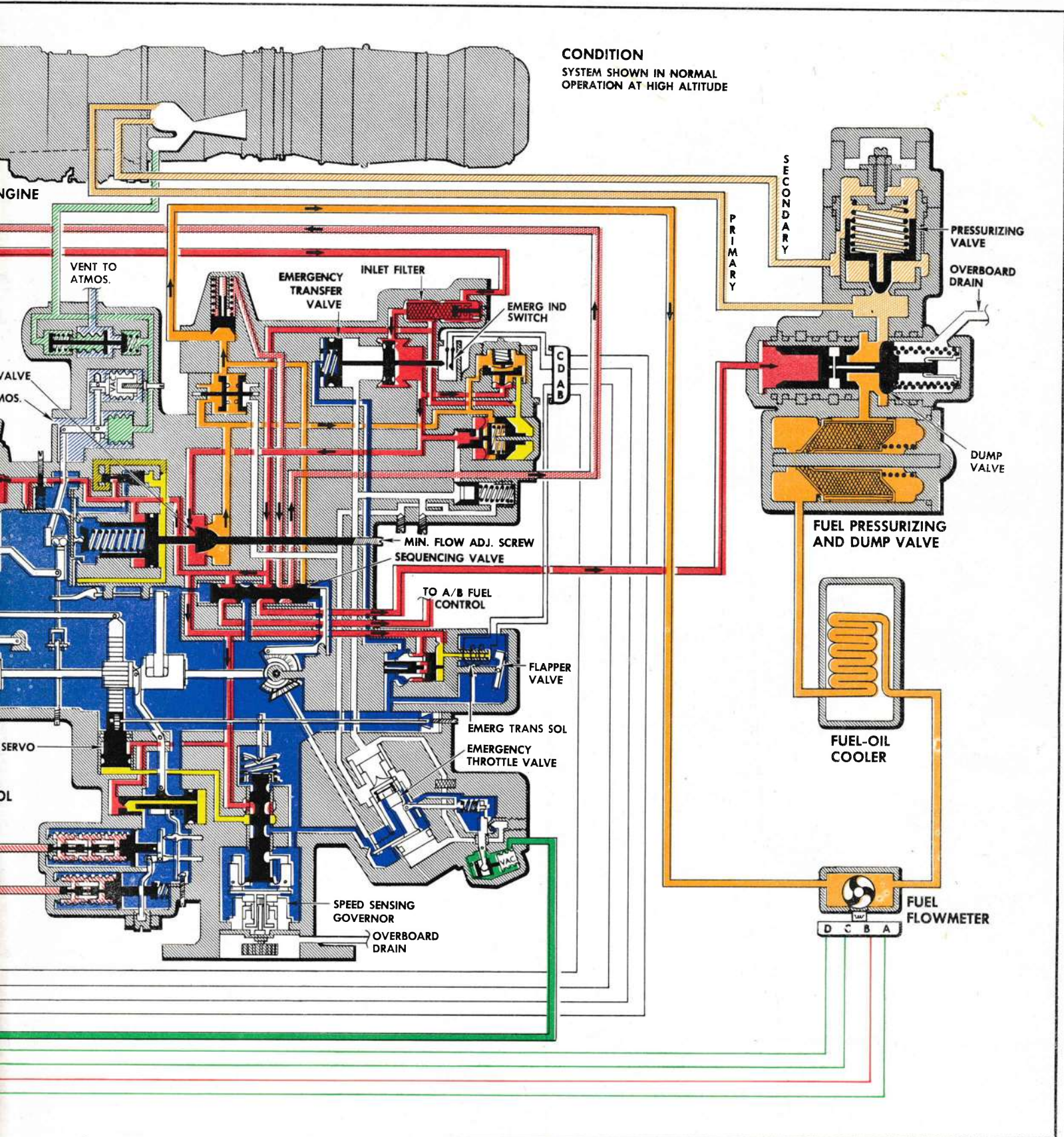

Figure 2-1. Engine Main Fuel System Schematic

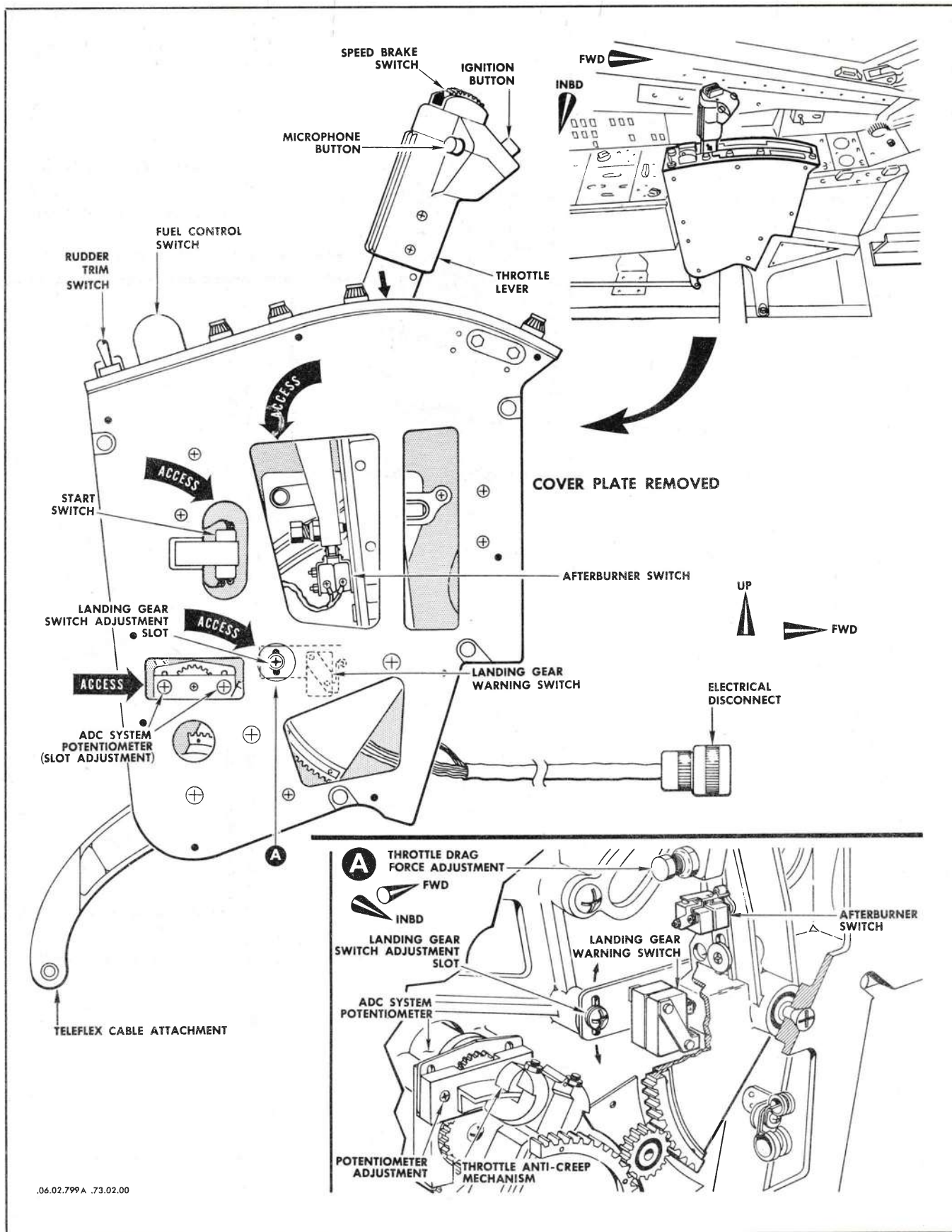

Figure 2-2. Throttle Quadrant

**2-9. FUEL FLOWMETER.**

The fuel flowmeter is installed on the lower left side of the engine, adjacent to the engine oil tank. The flowmeter, located in the fuel system between the main fuel control unit and the fuel-oil cooler, measures the rate of fuel flow to the engine. The flowmeter transmits an auto-syn signal to the fuel flow indicator on the pilot's instrument panel. The indicator registers fuel flow in pounds per hour.

**2-10. FUEL PRESSURIZING AND DUMP VALVE.**

The fuel pressurizing and dump valve is installed on the bottom center line of the engine, just aft of the fuel control unit. The fuel pressurizing-and-dump valve is installed in the fuel system between the fuel-oil cooler and the engine fuel discharge manifold. This valve controls fuel flow to the pilot and main orifices of the fuel nozzles in the engine combustion chambers. Fuel flow to

the main orifice of the nozzles is restricted until fuel pressure has increased sufficiently to overcome combustion chamber pressure and spring tension of the pressurizing valve. During engine operation, the integral dump valve is held in the closed position by fuel pressure from the fuel control unit. The dump valve is spring-loaded to open the engine fuel manifold drain, and to close the inlet port to the pressurizing valve, when control fuel pressure decreases as the throttle is moved to the "OFF" position.

**2-11. ENGINE FUEL SUPPLY STRAINER.**

The engine fuel supply strainer, which is attached to the inlet port of the engine fuel pump, is an integral part of the airplane main engine fuel supply system. Refer to T.O. 1F-106A-2-5 for information on this component.

<b>OPERATIONAL CHECKOUT</b>
-----------------------------

**2-12. MAIN FUEL SYSTEM TESTS.****2-13. Equipment Requirements, Main Fuel System Tests.**

FIGURE	NAME	TYPE	ALTERNATE	USE AND APPLICATION
Refer to T. O. 1F-106A-2-10	Test Light, 28-volt dc (2).			To test circuit continuity.
	Jumper Wire.			To connect electrical plug pins.

**NOTE**

Equipment called for in the engine ground run test procedure will also be required for the main fuel system leak test.

**2-14. Procedure, Leak Test.**

- a. Prepare airplane for ground run; refer to paragraph 1-25.
- b. Position engine ignition disarming switch in the main wheel well to the disarmed position.
- c. Fuel valve selector "ENGINE."
- d. Pilot's throttle "OFF."
- e. Fuel control switch "NORMAL."
- f. Fuel boost pumps,  
forward left and forward right "ON."
- g. Check fuel lines from wing connections to engine and in fuel control area for leaks.

h. Connect external high pressure air source to fitting in left main-wheel well. Starter air selector valve in left wheel well to be in the "CLOSED" position.

i. Energize starter; advance throttle to approximately "IDLE" position while still engaging starter.

j. Have observer make a quick check of all engine fuel components and tubing for fuel leaks.

k. Disengage starter, and return throttle to "OFF" position. Allow 5 minutes for fuel drainage before attempting start.

l. Install ignition fuse.

m. Make normal engine start (refer to paragraph 1-26 for this procedure); set throttle at "IDLE."

n. Make check of fuel system components and tubing for fuel leaks.

o. Make normal shutdown of engine.

**2-15. Procedure, Fuel Control Circuit Test.**

- a. Remove the following fuses:
  1. "FUEL CONT," nose wheel well fuse panel.
  2. "MASTER WARN," cockpit RH fuse panel.
- b. Disconnect P&W engine disconnect plug from engine junction box.
- c. Connect 28-volt dc test light between pins C and Q of plug. Connect 28-volt dc test light between pins C and N of plug.
- d. Install jumper wire between pins P and N of plug.
- e. Install fuses removed in step "a."
- f. With external 28-volt dc power connected to airplane and the fuel control switch in "NORMAL,"

test light between pins C and Q shall illuminate. Test light between pins C and N, "MASTER WARN" light, and the "EMERGENCY FUEL" light shall remain extinguished.

- g. Actuate fuel control switch to "EMERGENCY." Test light between pins C and Q shall extinguish. Test light between pins C and N, "MASTER WARN" light, and "EMERGENCY FUEL" light shall illuminate.

- h. Momentarily actuate "MASTER WARN" light to reset; "MASTER WARN" light shall extinguish.

- i. Remove test lights and jumper wire; reconnect electrical plug to engine junction box.

**REPLACEMENT****2-16. MAIN FUEL SYSTEM SAFETY PRECAUTIONS.**

During replacement of the main fuel system components, it will be necessary to disconnect fuel lines. The following precautions must be taken at all times:

- a. Provide fuel drainage receptacles and suitable fire extinguishers.
- b. Check that the airplane is properly grounded and parked in an area providing adequate ventilation.
- c. Remove all equipment, which might cause sparks, from the work area.
- d. Remove electrical power from the airplane before disconnecting fuel lines.

- a. Gain access to the main fuel control through the engine accessory compartment access doors, left hydraulic pump access door, and the constant-speed remote gearbox access doors.

- b. Lower the constant-speed remote gearbox to the hanging position. Refer to Section IX for this procedure.

- c. Disconnect and remove throttle bell crank from fuel control.

- d. Check that the fuel tank shutoff valves are in the closed position.

- e. Provide fuel drainage receptacles.

- f. Remove lines attached to the fuel control. Cover lines and openings with plugs or polyethylene sheet.

**WARNING**

Wear suitable plastic gloves and coveralls, and avoid prolonged skin contact with JP-4 fuel, Military Specification MIL-J-5624. Do not breathe an excess amount of fuel fumes.

After completion of fuel system component replacement, it will be necessary to conduct an operational checkout of the engine. Refer to Section I for engine operating procedure.

**2-17. REMOVAL, MAIN FUEL CONTROL UNIT.**

Observe the safety precautions outlined in paragraph 2-16 during removal of the main fuel control unit.

**NOTE**

Note the location of attachment clips and brackets so that they may be reinstalled in their proper locations.

- g. Disconnect electrical connector from fuel control.

- h. Remove bolts (4) attaching the inlet temperature sensing bulb to the lower left side of the compressor inlet guide vane and shroud.

**NOTE**

The inlet temperature bulb is an integral part of the fuel control, and shall not be detached from the control. Carefully coil the lead to avoid kinking. Wrap the temperature bulb in protective paper.



i. Provide support for fuel control; remove attachment nuts (6) holding fuel control to the N<sub>2</sub> accessory case. Move fuel control aft and remove. Discard mating flange seal.

### 2-18. INSTALLATION, MAIN FUEL CONTROL UNIT.

a. Install the main fuel control unit in essentially the reverse of the removal procedure. Use a new mating flange seal. Coat the main fuel control unit shaft and mating splines with grease, Military Specification MIL-G-3545, prior to installation.

b. Install fuel control on N<sub>2</sub> accessory case adapter. Ascertain that positive drive shaft spline engagement is being made during installation.

#### NOTE

The seal drain tubes (2) are to be torqued 90 to 100 inch-pounds. Do not over-torque.

c. Conduct fuel control flushing and soaking procedure. Refer to paragraph 1-84 for this procedure.

d. Conduct throttle control system rigging check. See figure 2-6 for this procedure.

e. Conduct engine operational checkout. Refer to paragraph 1-23 for procedure.

### 2-19. REMOVAL, ENGINE FUEL PUMP.

a. Gain access to the engine fuel pump through the accessory compartment left and right access doors.

b. Observe safety precautions as outlined in paragraph 2-16 during removal of the engine fuel pump.

c. Check that the fuel tank shutoff valves are in the closed position.

d. Remove cap and drain fuel inlet line or fuel strainer.

e. Remove fuel inlet line or strainer assembly which ever is installed.

f. Remove lines attached to fuel pump. Cover lines and openings with plugs or polyethylene sheet.

#### NOTE

Note location of attachment clips and brackets so that they may be reinstalled in their proper locations.

g. Provide support for fuel pump; remove attachment nuts holding fuel pump to the N<sub>2</sub> accessory case. Move fuel pump aft and remove. Discard mating flange seal.

#### NOTE

When removing the fuel pump, make sure that the fuel pump mounting bracket, which is supporting the pump at the diffuser case front flange, is not binding in the bracket supports.

#### CAUTION

Care must be taken when removing fuel pump so as not to allow pump to hang on spline drive gear. If this precaution is not observed, damage to the drive gear may occur.

### 2-20. INSTALLATION, ENGINE FUEL PUMP.

a. Prior to installation, thoroughly clean the shaft gear spline in the engine accessory case. When old lubricant and residue have hardened, it may be necessary to use a solvent spray gun and a sharpened soft wood stick to loosen and wash out this contamination.

b. Lubricate engine spline with plastilube Moly No. 3.

#### NOTE

Excessive amounts of lubricant are not necessary. An even coat can be applied to the spline surface with a small clean paste brush.

c. Install the engine fuel pump in essentially the reverse of the pump removal procedure. Use a new mating flange seal. Coat the pump shaft and mating splines with grease, Military Specification MIL-G-3545, prior to installation.

d. Ascertain that positive drive shaft spline engagement is made during pump installation. Check that the pump mounting brackets position properly into the support attachments to the front flange of the diffuser case.

#### CAUTION

Care must be taken when installing fuel pump so as not to allow pump to hang on spline drive gear.

e. Conduct engine operational checkout. Refer to paragraph 1-23 for procedure.

### 2-21. REMOVAL, FUEL PRESSURIZING AND DUMP VALVE

a. Gain access to the fuel pressurizing and dump valve through the engine accessory compartment access doors.

b. Observe safety precautions as outlined in paragraph 2-16 during removal of the fuel pressurizing and dump valve.

c. Remove lines attached to valve assembly. Cover lines and openings with plugs or polyethylene sheet.

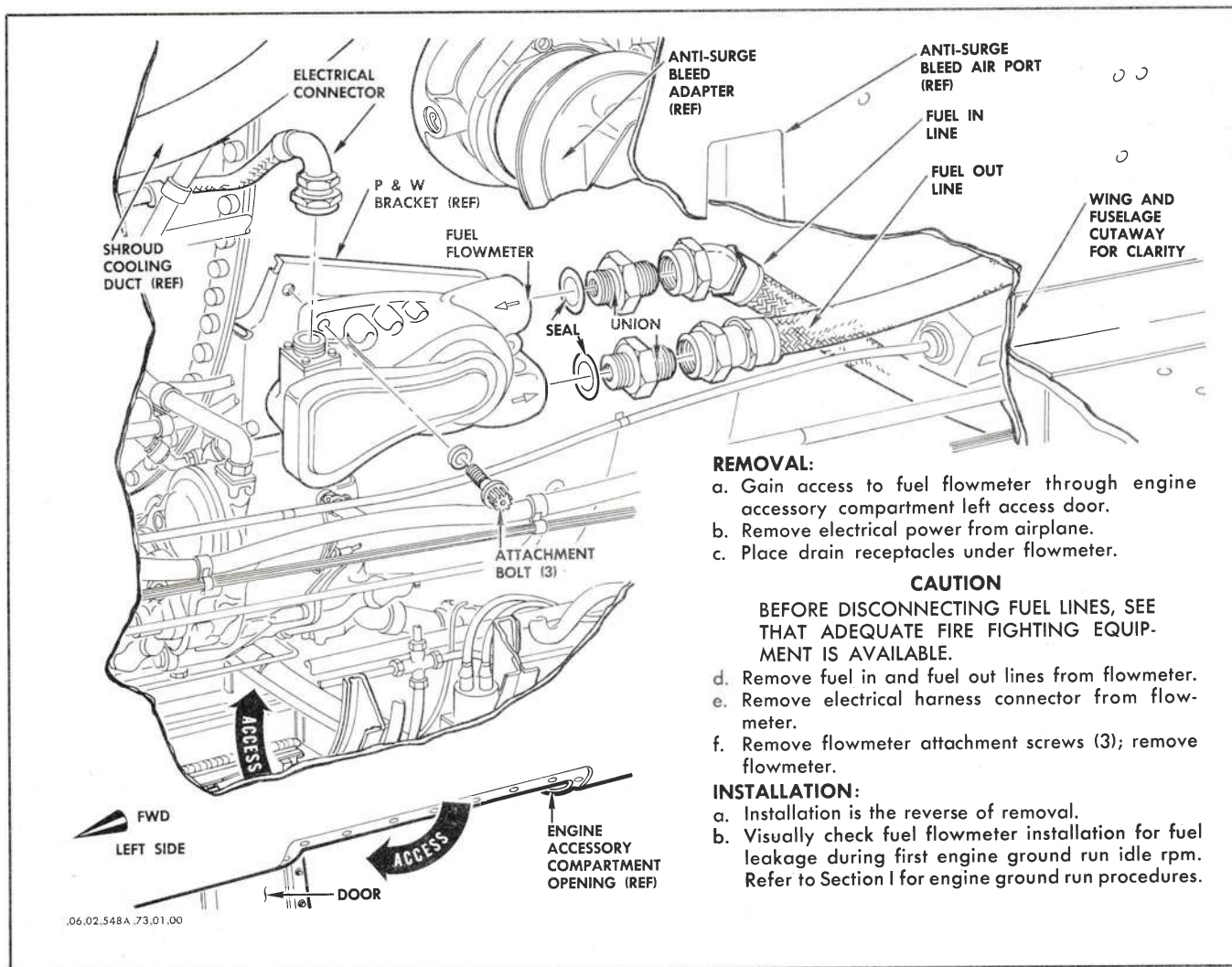

**REMOVAL:**

- a. Gain access to fuel flowmeter through engine accessory compartment left access door.
- b. Remove electrical power from airplane.
- c. Place drain receptacles under flowmeter.

**CAUTION**

BEFORE DISCONNECTING FUEL LINES, SEE THAT ADEQUATE FIRE FIGHTING EQUIPMENT IS AVAILABLE.

- d. Remove fuel in and fuel out lines from flowmeter.
- e. Remove electrical harness connector from flowmeter.
- f. Remove flowmeter attachment screws (3); remove flowmeter.

**INSTALLATION:**

- a. Installation is the reverse of removal.
- b. Visually check fuel flowmeter installation for fuel leakage during first engine ground run idle rpm. Refer to Section I for engine ground run procedures.

**Figure 2-3. Replacement, Fuel Flowmeter**

d. Remove the bolts (2) securing the dump valve overboard drain cover to the combustion chamber overboard fuel drain adapter.

e. Remove the valve attachment bolts (2); remove valve. Discard all gaskets.

**2-22. INSTALLATION, FUEL PRESSURIZING AND DUMP VALVE.**

a. Installation of the fuel pressurizing and dump valve is essentially the reverse of the removal procedure.

b. Use new gaskets on the fuel manifold inlet adapter ferrules. Place new gasket between the valve overboard drain cover and combustion chamber overboard full drain adapter.

c. Safety-wire all bolts and tube nuts.

d. Conduct engine operational checkout. Refer to paragraph 1-23 for this procedure.

**2-23. REMOVAL, FUEL-OIL COOLER.**

a. Remove engine from airplane. Refer to paragraph 1-42 for this procedure.

b. Provide drainage receptacles.

c. Remove lines attached to cooler. Cover lines and openings with plugs or polyethylene sheet.

d. Remove cooler attachment bolts; remove cooler.

**2-24. INSTALLATION, FUEL-OIL COOLER.**

a. Install the fuel oil-cooler in essentially the reverse of the removal procedure.

b. Conduct leak check of installation at first engine run.

**2-25. REPLACEMENT, FUEL FLOWMETER.**

For replacement of the fuel flowmeter, see figure 2-3.

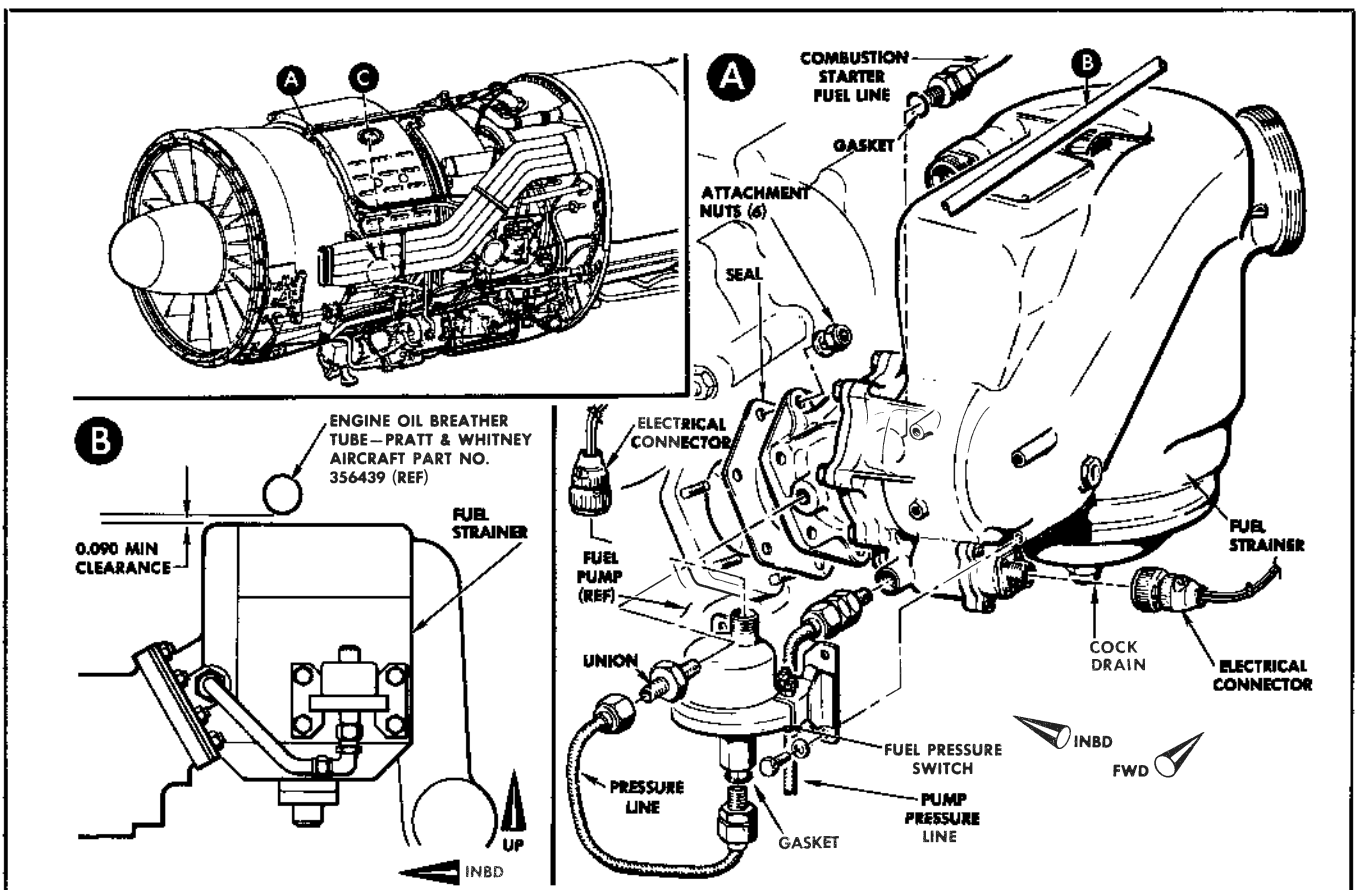
**REMOVAL****CAUTION**

OBSERVE ALL FUEL SYSTEM SAFETY PRECAUTIONS OUTLINED IN SECTION 1 OF T.O. 1F-106A-2-5.

- Close fuel system shutoff valves. Placard cockpit switches stating maintenance is being performed on the system.
- Drain fuel from lines adjacent to strainer at push-to-drain valves (2) in lines to fuel flow equalizer. Drain fuel from strainer drain cock.
- Disconnect main fuel line from strainer inlet.
- Disconnect combustion starter fuel line, pump pressure line, and electrical connectors from strainer assembly.

**NOTE**

APPROPRIATELY IDENTIFY CONNECTORS FOR STRAINER BYPASS SOLENOID AND FUEL PRESSURE SWITCH LEADS BY PAINTING OR TAGGING TO PRECLUDE REVERSING CONNECTORS WHEN REINSTALLING.

- Remove attachment nuts (6) securing strainer to fuel pump; remove strainer and pressure switch assembly.
- Remove fuel pressure switch and pressure line from strainer housing.
- Cover fuel pump opening.

**INSTALLATION**

- Installation of fuel strainer and pressure switch is essentially the reverse of the removal procedure.

**CAUTION**

CHECK ALL LINES FOR CHAFING AND THAT CLAMPS INSTALLED TO PREVENT CHAFING DO NOT CAUSE FLEX LINES TO BECOME RIGID.

**NOTE**

IF STRAINER INTERFERES WITH ENGINE OIL BREATHER TUBE AFTER INSTALLATION, OR, IF CLEARANCE BETWEEN TUBE AND STRAINER BODY IS LESS THAN 0.090 INCH (SEE DETAIL B), RELOCATE THE BREATHER TUBE BY ROTATING THE TUBE AS FOLLOWS:

- LOOSEN TUBE COUPLING NUT AT ELBOW CONNECTOR ON DIFFUSER CASE.
  - LOOSEN BOLTS (3) SECURING ELBOW CONNECTOR TO DIFFUSER CASE. LEAVE BOLTS FINGER TIGHT, DO NOT REMOVE.
  - ROTATE BREATHER TUBE UP AND OUTWARD UNTIL 0.090 INCH MINIMUM CLEARANCE IS OBTAINED.
  - FINGER TIGHTEN TUBE COUPLING NUT WHILE MAINTAINING 0.090 INCH MINIMUM CLEARANCE AND ALLOW ELBOW TO ROTATE WITHIN BOLT HOLE CLEARANCE AGAINST BOLTS.
  - RETORQUE BOLTS (3) SECURING ELBOW CONNECTOR TO DIFFUSER CASE 125 TO 170 INCH-POUNDS. RETORQUE COUPLING NUT 300 TO 500 INCH-POUNDS. SAFETY-WIRE BOLTS AND COUPLING NUT.
  - VISUALLY CHECK FITTINGS FOR OIL LEAKAGE DURING FIRST ENGINE GROUND RUN IDLE RPM.
- Safety-wire following: Pressure switch attachment bolts (4), fittings on pressure switch line, starter fuel line, strainer pump pressure line, and electrical connectors.
  - Leak check all components removed in accordance with procedures outlined in T.O. 1F-106A-2-5.
  - Conduct engine operational checkout.

.06,02,293-17G

Figure 2-4. Replacement, Engine Fuel Supply Strainer and Fuel Pressure Switch

**2-26. REPLACEMENT, ENGINE FUEL SUPPLY STRAINER, FUEL PRESSURE SWITCH, AND FUEL INLET ADAPTER.**

For replacement of the engine fuel supply strainer, fuel pressure switch, and fuel inlet adapter, see figure 2-4.

**2-27. REPLACEMENT, THROTTLE TELEFLEX CABLE.**

For replacement of the throttle teleflex cable, see figure 2-5.

**ADJUSTMENT**

**2-28. THROTTLE SYSTEM RIGGING.**

**2-29. Equipment Requirements.**

FIGURE	NAME	TYPE	ALTERNATE	USE AND APPLICATION
2-6	Rigging Pin.	8-96076-11		To hold aft bellcrank at sta. 526.25 in rigged position.
2-6	Rigging Gage.	8-96095 (5220-591-8562)		To measure aft bellcrank travel.
	Spring Tension Scale.	0 to 20 pounds		To check throttle lever action.
	Spring Compression Scale.	0 to 20 pounds		To check throttle lever action.

**2-30. Preparation, Throttle System Rigging.**

For throttle system rigging preparation procedures, see figure 2-6.

**2-31. Procedure, Throttle System Rigging.**

For the throttle system rigging procedure, see figure 2-6.

**2-32. MAIN FUEL CONTROL FIELD ADJUSTMENT.**

For the main fuel control adjustment and the engine trim procedure, refer to Section I.

**SERVICING**

**2-33. PRESERVATION, ENGINE FUEL CONTROL UNIT AND ENGINE FUEL SYSTEM.**

For preservation information for the engine fuel control unit and the engine fuel system, refer to Servicing in Section I.

**2-34. DEPRESERVATION, ENGINE FUEL CONTROL UNIT AND ENGINE FUEL SYSTEM.**

For depreservation information for the engine fuel control unit and the engine fuel system, refer to Servicing in Section I.

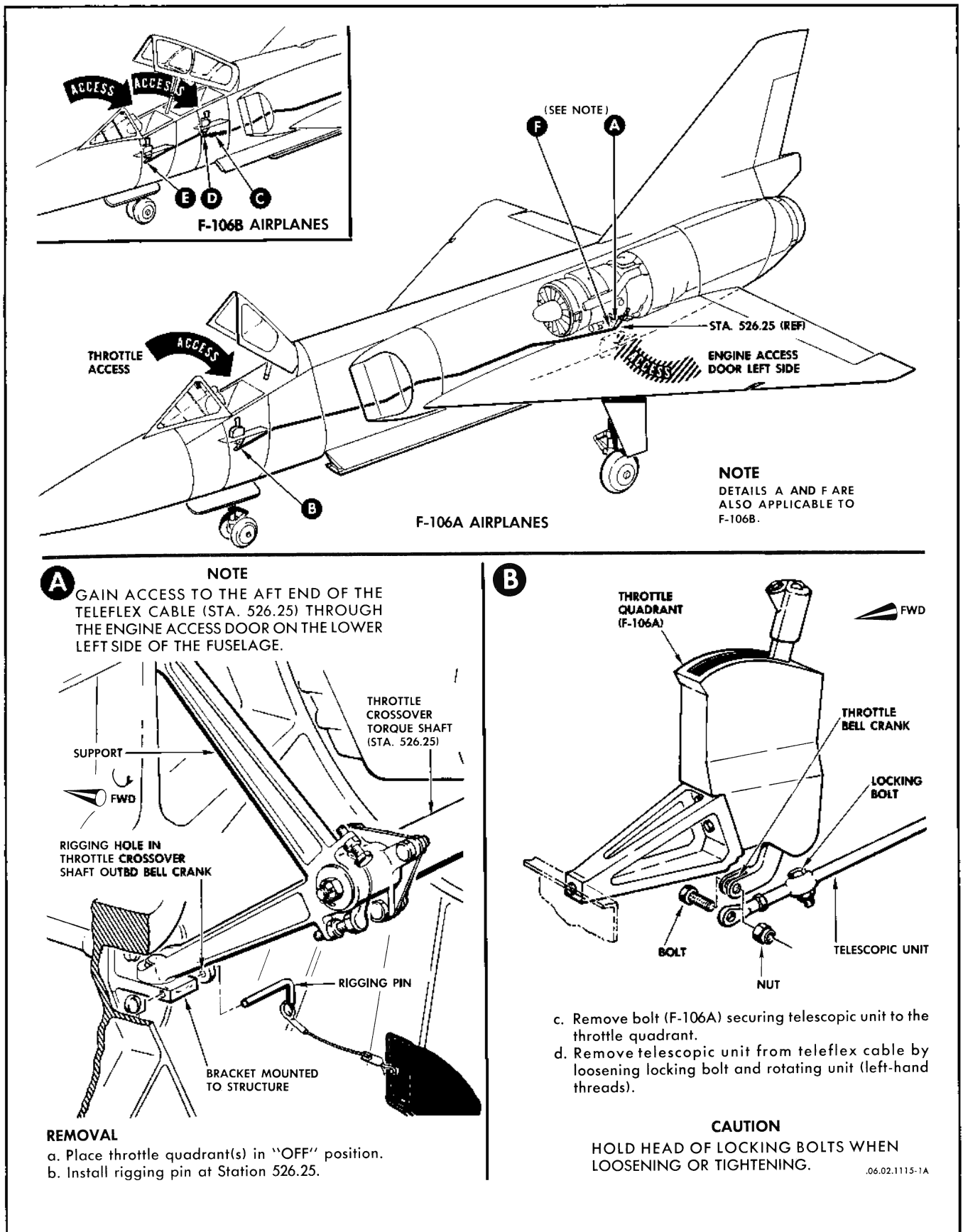
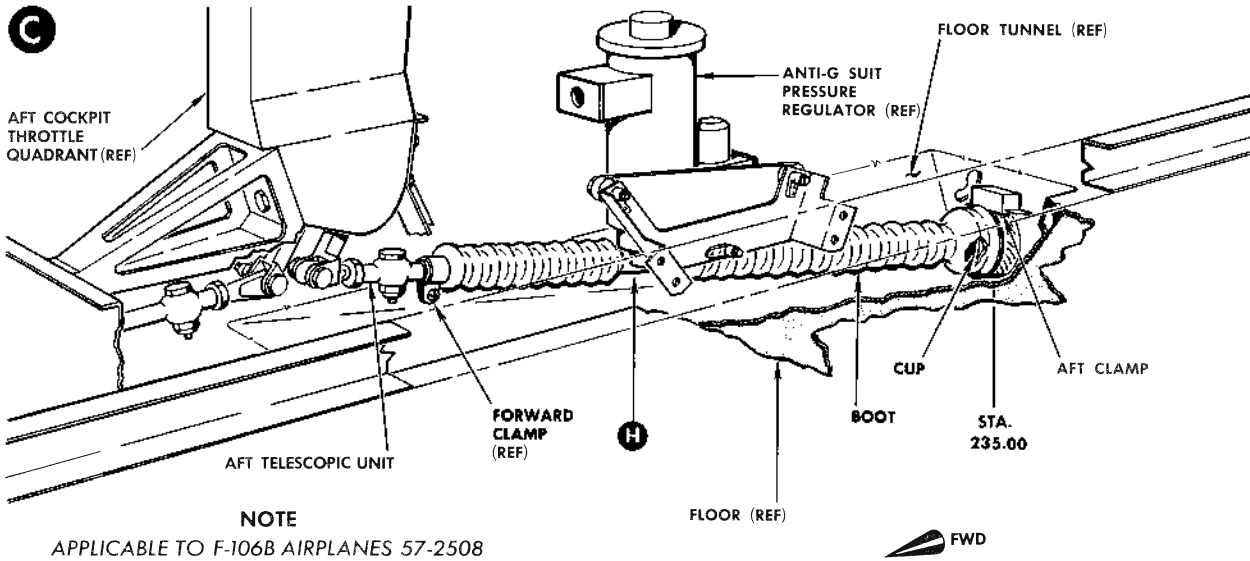

Figure 2-5. Replacement, Throttle Teleflex Cable (Sheet 1 of 3)



**NOTE**

APPLICABLE TO F-106B AIRPLANES 57-2508 THRU 57-2515; 57-2516 THRU 57-2522, 57-2524 AND SUBSEQUENT AFTER INCORPORATION OF TCTO 1F-106B-528.

- e. Loosen aft clamp securing boot to cup; pull boot free of cup.

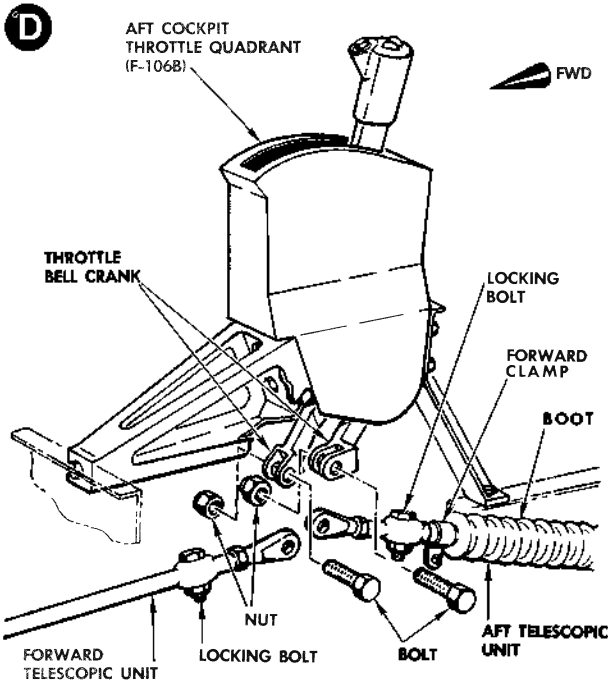

- f. Remove bolts (F-106B) securing telescopic units to the two bell cranks of aft throttle quadrant.
- g. Remove telescopic units from ends of forward and aft teleflex cables by loosening locking bolts and rotating units (left-hand threads).
- h. *Applicable to F-106B airplanes 57-2508 thru 57-2515; and 57-2516 thru 57-2522, 57-2524 and subsequent after incorporation of TCTO 1F-106B-528.*

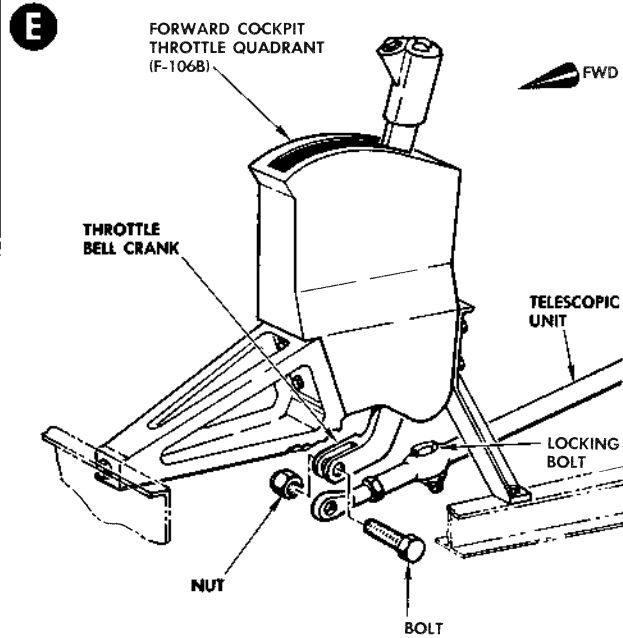

- i. Remove bolt (F-106B) securing telescopic unit to forward throttle quadrant.
- j. Remove teleflex cable (F-106B) from the conduit between the forward and aft throttle quadrants by slowly pulling forward.
- k. Remove telescopic unit from forward end of teleflex cable by loosening locking bolt and rotating unit (left-hand threads).

.06.02.1115-2C

Figure 2-5. Replacement, Throttle Teleflex Cable (Sheet 2 of 3)

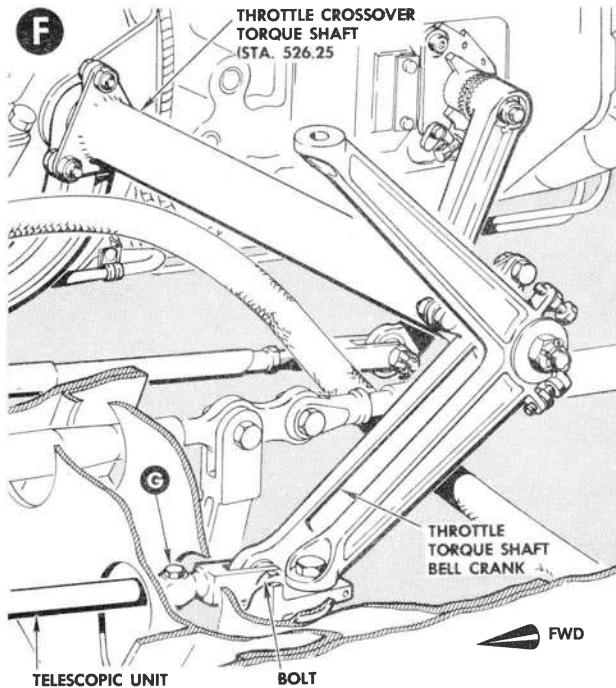

- l. Remove bolt securing telescopic unit to throttle torque shaft bell crank.
- m. Remove teleflex cable from conduit by slowly pulling to rear.
- n. Remove telescopic unit from aft end of teleflex cable by loosening locking bolt and rotating unit (left-hand threads).

**INSTALLATION**

- a. Before installation of teleflex cable assemblies, the cable conduit and the cable must be cleaned and lubricated as follows:
  - 1. After radius has been filed on both ends of the cable, wash thoroughly with cleaning solvent, Federal Specification P-S-661, or clean by vapor degreasing to remove all dirt or protective coating of corrosion preventive compound. Apply a light coat of grease, Specification MIL-G-3278, to cable.

**NOTE**

USE EVERY PRECAUTION TO PREVENT THE CLEANED CABLE FROM COMING IN CONTACT WITH DIRT AND GRIT PRECEDING AND DURING INSTALLATION IN THE CONDUIT.

- 2. Blow compressed air through the conduit to remove chips and dirt then draw cable completely through conduit.
- 3. Clean cable per step 1; do not lubricate cable with grease.
- 4. Place cable in a container, cover cable with oil, Specification MIL-L-7808, and allow to soak for a minimum of 10 minutes. No further lubrication is required.
- b. Installation of the teleflex cable is essentially the reverse of the removal procedure.

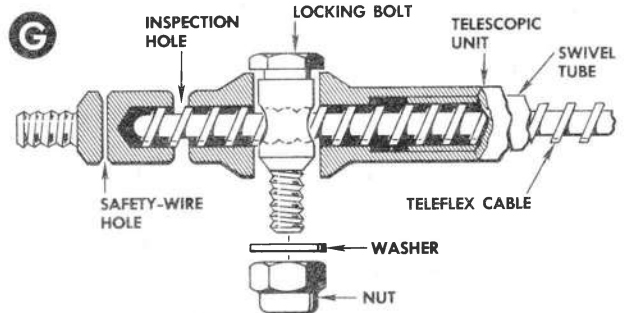

- c. When installing telescopic units on cable, continue rotating unit until the cable has passed the inspection hole located one-half inch from the center of the locking bolt. An additional one-half inch of space is provided for the cable end for adjustment purposes.
- d. On F-106A airplanes, install the cable attachment bolt at the throttle quadrant bell crank with the head inboard. See detail B.
- e. Torque the nuts on the locking bolts to 20 to 25 inch-pounds.

**CAUTION**

THE CABLE LOCKING BOLTS MUST BE HELD WITH A WRENCH WHILE TORQUING THE NUTS. DO NOT OVERTORQUE NUTS.

- f. Install cotter pin at aft telescopic unit attachment bolt and seal inspection holes in telescopic units by wrapping units with 2 turns of YBB-22 vinyl tape, manufactured by 3M Co., St. Paul 6, Minn.

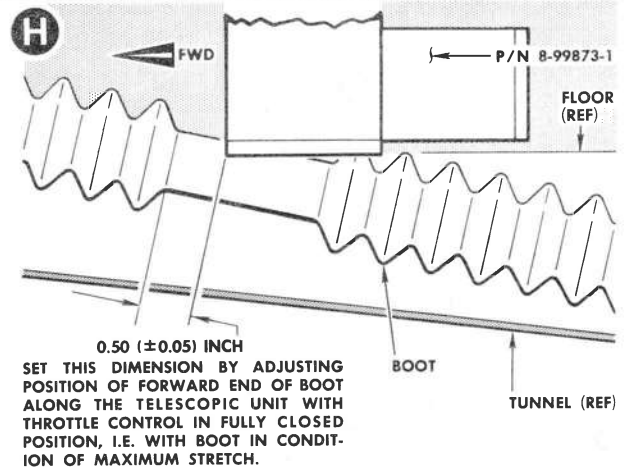

**NOTE**

APPLICABLE TO F-106B AIRPLANES 57-2508 THRU 57-2515; 57-2516 THRU 57-2522, 57-2524 AND SUBSEQUENT AFTER INCORPORATION OF TCTO 1F-106B-528.

- g. Applicable to F-106B airplanes 57-2508 thru 57-2515; and 57-2516 thru 57-2522, 57-2524 and subsequent after incorporation of TCTO 1F-106B-528, attach boot to cup at station 235.00 with aft clamp.
- h. Position boot on telescopic unit within 0.50 (±0.05) inch of P/N 8-99873-1; then tighten forward clamp.
- i. Remove rigging pins at station 526.25.
- j. Conduct throttle rigging check procedure.

.06.02.1115.3C

Figure 2-5. Replacement, Throttle Teleflex Cable (Sheet 3 of 3)

**2-35. CLEANING, MAIN FUEL CONTROL UNIT FILTER AND PUMP STRAINER.**

For the main fuel control filter and the fuel pump strainer cleaning procedures, see figure 2-7.

**2-36. CLEANING, FUEL PRESSURIZING AND DUMP VALVE FUEL SCREEN.**

For the fuel pressurizing and dump valve fuel screen cleaning procedures, see figure 2-8.

**2-37. CLEANING, ENGINE FUEL SUPPLY STRAINER.**

For cleaning information for the engine fuel supply strainer, refer to T.O. 1F-106A-2-5.



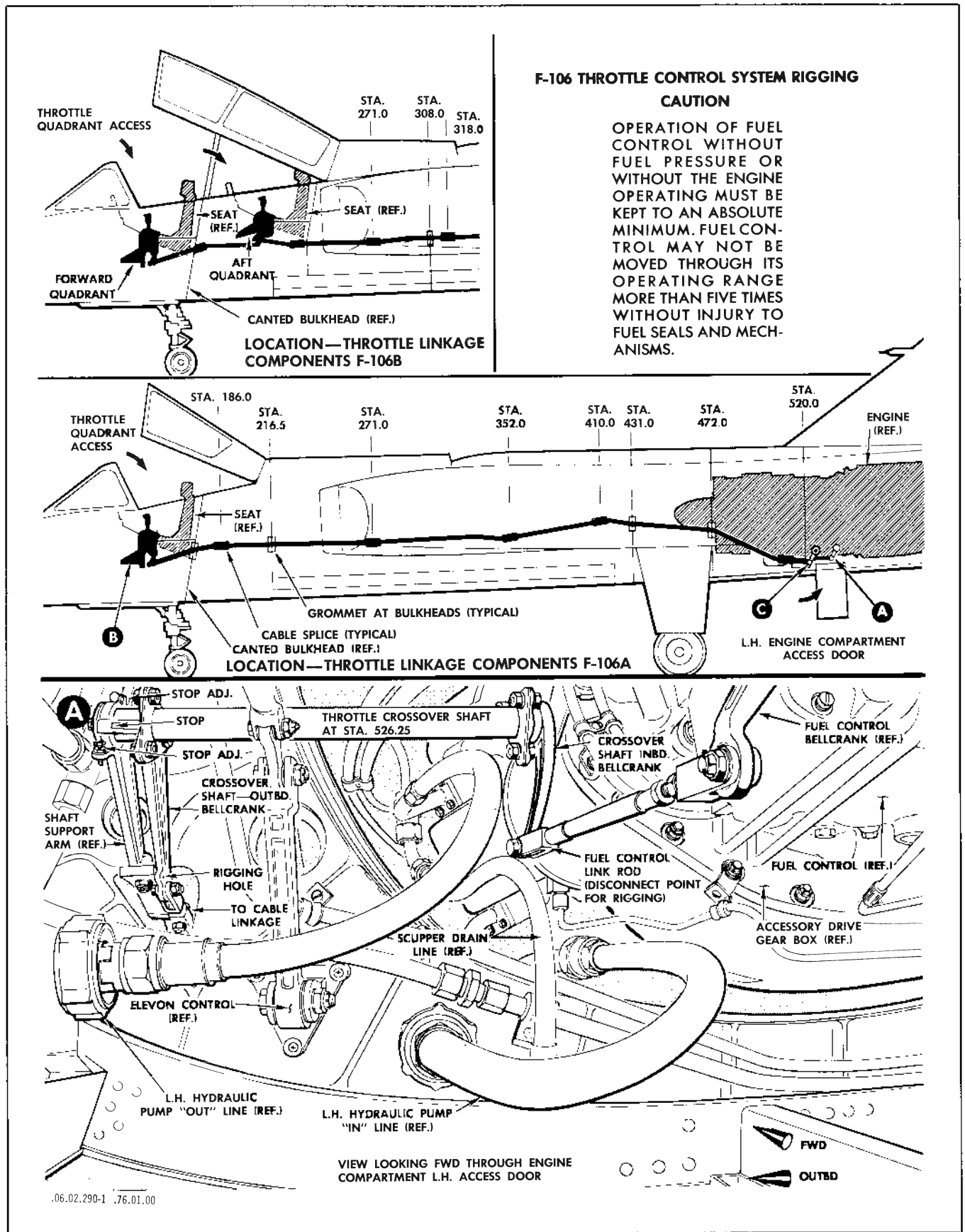

Figure 2-6. Throttle Control System Rigging (Sheet 1 of 8)

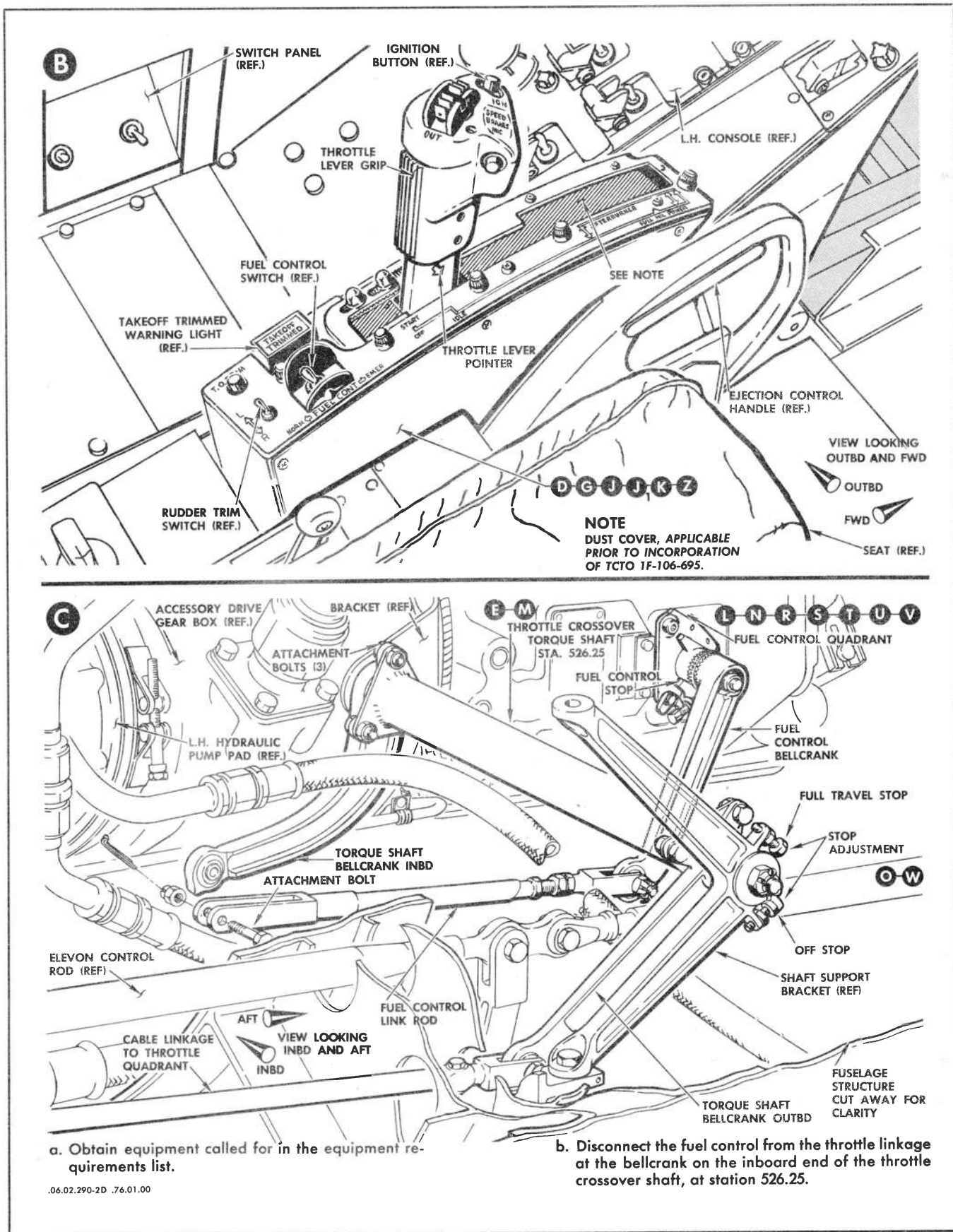

Figure 2-6. Throttle Control System Rigging (Sheet 2 of 8)

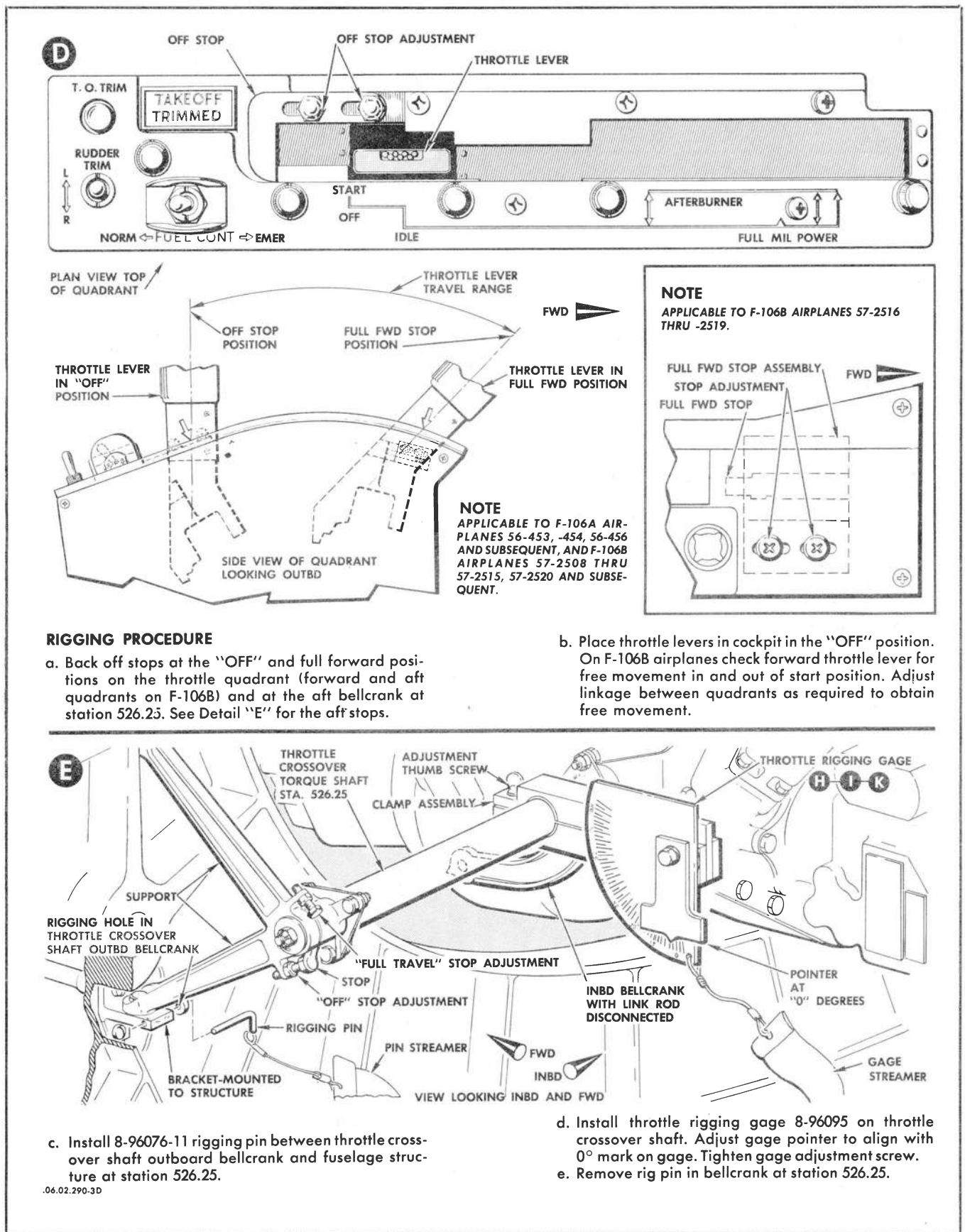
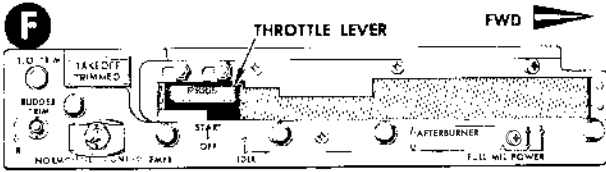
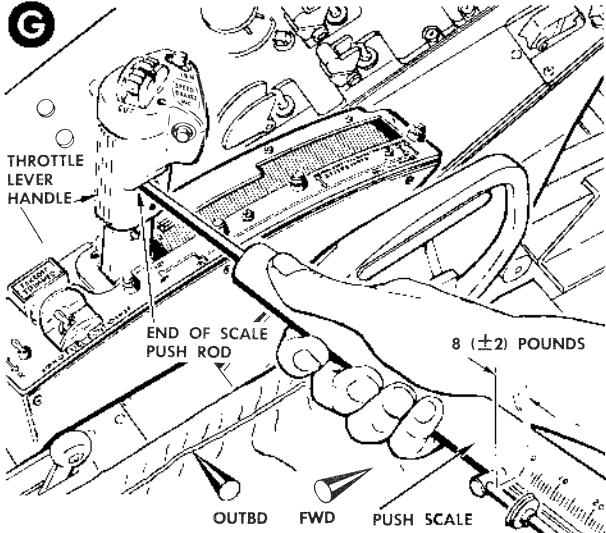

Figure 2-6. Throttle Control System Rigging (Sheet 3 of 8)



f. Move throttle lever outboard from "OFF" to "START" position. Listen for positive actuation of starter switch in the forward quadrant. Lever will return to "OFF" position when released. On F-106B airplanes, switch is located in forward quadrant only.



g. Measure force required to move throttle from "OFF" to "START," using spring compression type scales. Force required shall be 8 (±2) pounds measured at base of throttle lever grip.

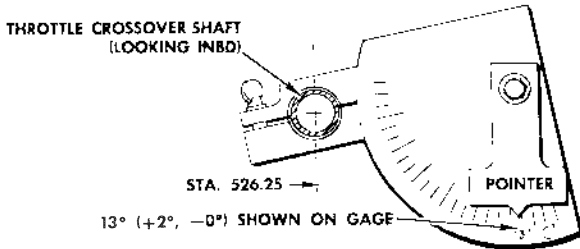
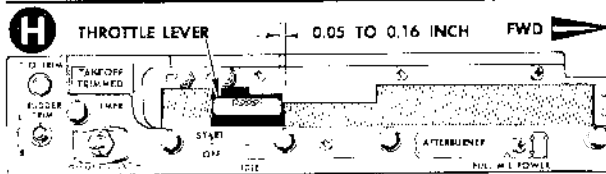

h. Move throttle lever or levers from "OFF" position until lever is within 0.05 to 0.16-inch from quadrant "IDLE" stop; gage reading shall be 13°(+2°, -0°).

.06 02-290-4D

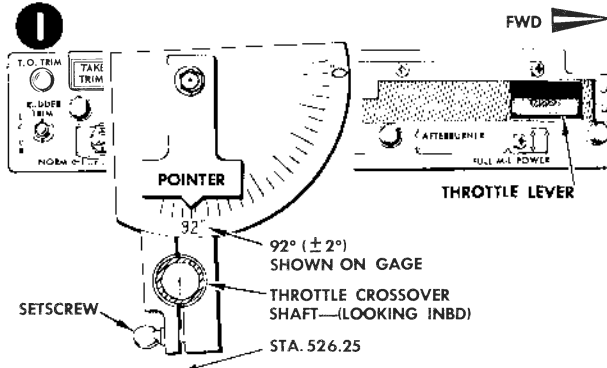

i. Move throttle forward to "FULL MILPWR." Check rigging gage at station 526.25 for 92° (± 2°) travel from the "OFF" position. Listen for deactuation of landing gear warning switch in throttle quadrant when "FULL MILPWR" is reached. On F-106B airplanes, switch is in forward quadrant only.  
 j. Move throttle lever or levers forward enough to see that 97° to 100° travel, as indicated on rigging gage at station 526.25, is obtainable without teleflex cable bottoming out.

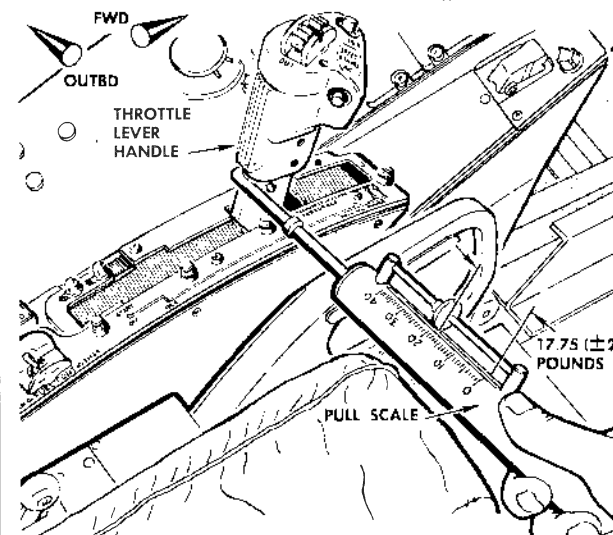
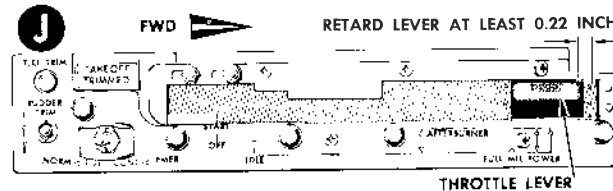

k. Move throttle lever or levers individually outboard to "AFTERBURNER;" listen for "AFTERBURNER" switch actuation. Move lever forward as far as possible. It shall not be possible to move throttle out of "AFTERBURNER" sector until throttle has been retarded at least 0.22 inch. Force required to move throttle in or out of "AFTERBURNER" sector, using springscales, shall be 17.75 (± 2) pounds. Scales to be applied at the base of throttle lever grip.

Figure 2-6. Throttle Control System Rigging (Sheet 4 of 8)

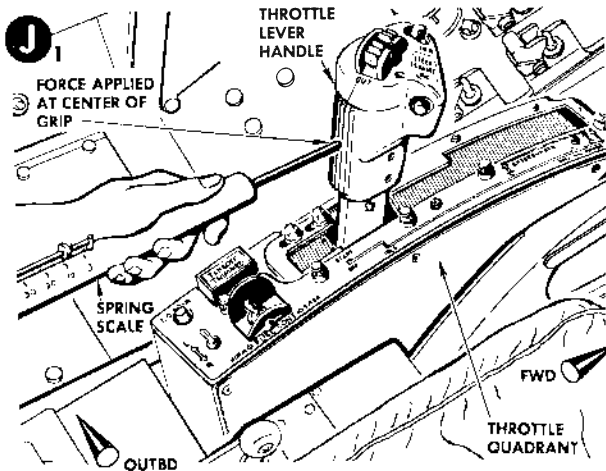

k1. Using a spring scale, check throttle for the following maximum operating forces: Applicable to F-106A airplanes, "OFF" to "IDLE", 6.0 pounds; "IDLE" to forward stop, 4.0 pounds. Applicable to F-106B airplanes, "OFF" to "IDLE", 6.5 pounds; "IDLE" to forward stop, 4.5 pounds.

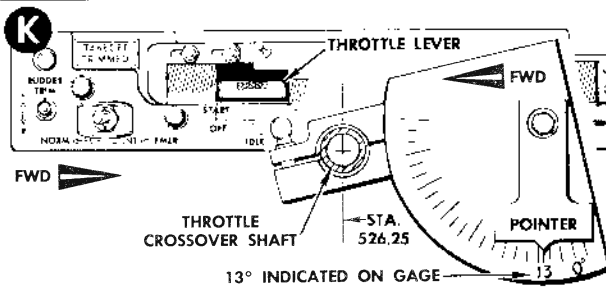

l. Position throttle in cockpit at "IDLE;" 13° indicated on rigging gage.

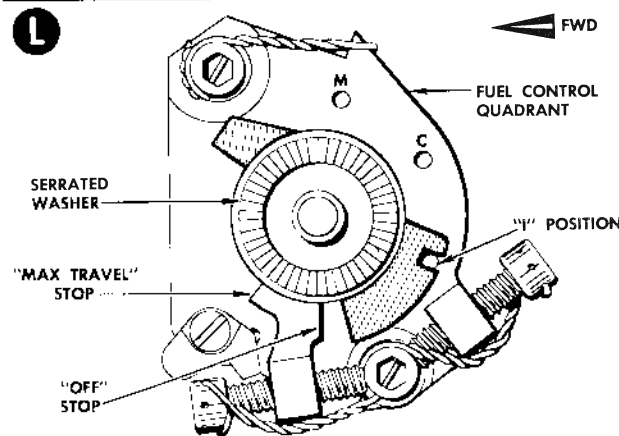

m. Set fuel control quadrant indicator at "I" position on fuel control quadrant. Fuel control linkage shall be in noticeable "IDLE" detent.

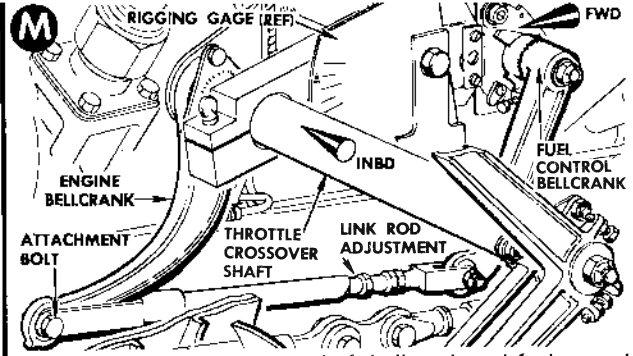

n. Throttle crossover shaft bellcrank and fuel control linkage rod holes shall align. Adjust linkage rod as required to obtain hole alignment; install attachment bolt.

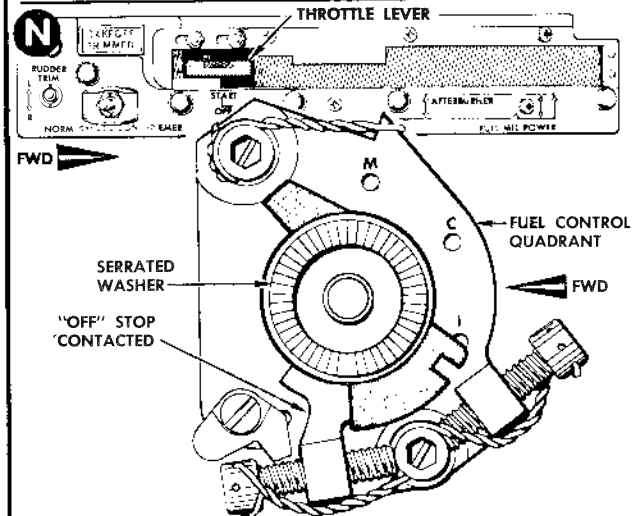

o. Move throttle lever to "OFF." Fuel control quadrant shall be in the "OFF" position with stop on fuel control contacted.

**NOTE**

IN F-106B AIRPLANES, WHEN MOVING THE THROTTLE FROM "IDLE" TO "OFF" FROM THE REAR COCKPIT, IT WILL BE NECESSARY TO MANUALLY POSITION THE FORWARD THROTTLE OUTBOARD BEYOND THE IDLE STOP.

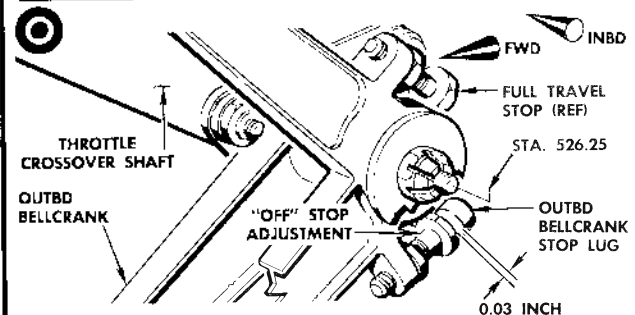

p. Adjust "OFF" stop at outboard end of throttle crossover shaft at station 526.25 for a clearance of 0.03 inch; lock stop with jam nut.

06.02.290-58 .76.01.00

Figure 2-6. Throttle Control System Rigging (Sheet 5 of 8)

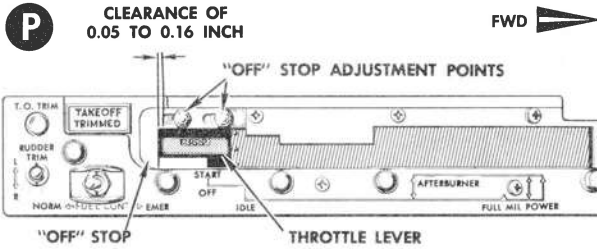

q. Adjust "OFF" stop at throttle quadrant or quadrants for a clearance of 0.05 to 0.16 inch; tighten stop bolts.

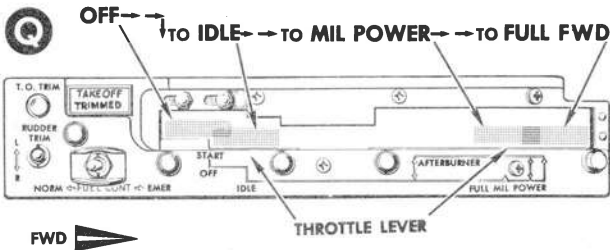

r. Move throttle lever from "OFF" to "IDLE," to "MIL PWR," to full forward position and record fuel control quadrant readings. Reading shall be as follows:

- "OFF" Off stop on fuel control contacted.
- "IDLE" "I" position on fuel control aligned with arm.
- "MIL PWR" "M" position on fuel control aligned with arm.
- Full Forward position Forward stop on fuel control contacted.

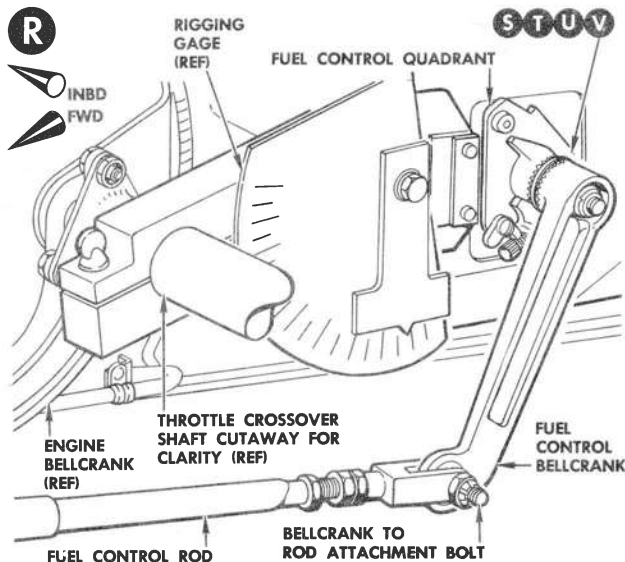

s. If the adjustment of the fuel control rod assembly is not adequate to obtain these values, adjust the location of the fuel control bellcrank. The serrated

06.02.290-6B 74.01.00

washer between the fuel control bellcrank has 25 teeth that mesh with the fuel control shaft, and 24 teeth that mesh with the bellcrank. By following the procedure given below, a net adjustment of approximately  $\frac{1}{2}$  or multiples of  $\frac{1}{2}$  is obtainable.

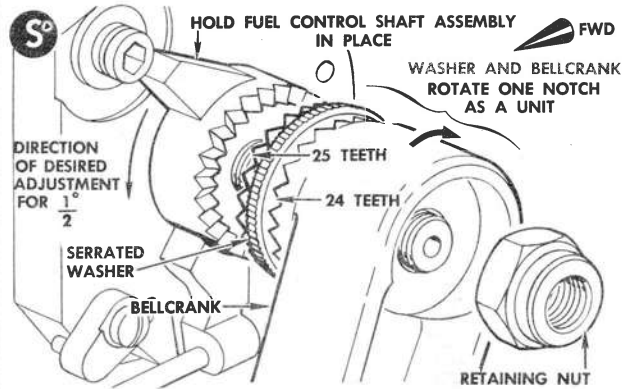

t. Loosen fuel control bellcrank retaining nut. Consider washer and bellcrank as an assembly. While holding the fuel control shaft stationary, rotate one notch in the opposite direction of the desired adjustment.

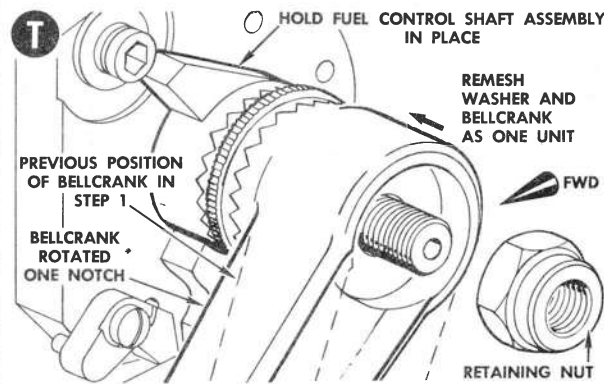

u. Remesh assembly with fuel control shaft.

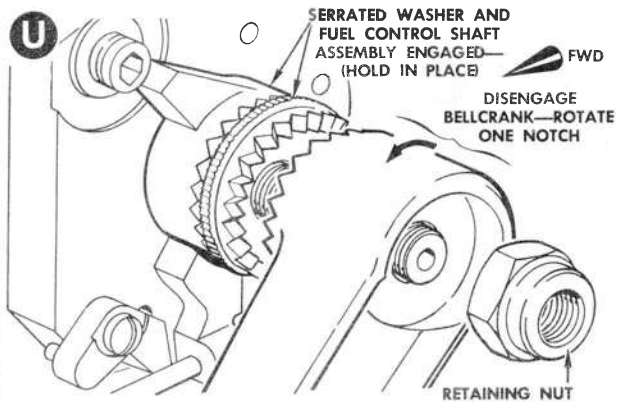

v. Pull bellcrank out of mesh with washer and rotate bellcrank one notch in opposite direction from that performed in step "t."

Figure 2-6. Throttle Control System Rigging (Sheet 6 of 8)

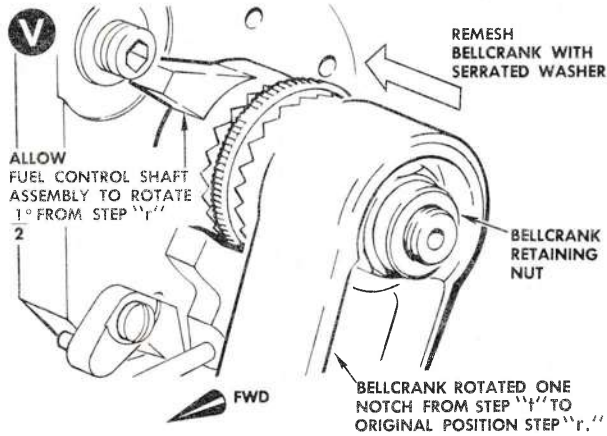

w. Remesh and tighten bellcrank retaining nut. Net rotation will be approximately  $\frac{1}{2}^\circ$  in direction of bellcrank rotation in step "u." Net rotation may be increased by increasing number of notches rotated. For example, rotate assembly 4 notches in one direction as stated in step "t" and 4 notches in opposite direction as stated in step "v" to obtain a net change of approximately  $2^\circ$ . Net rotation will always be in direction bellcrank was rotated.

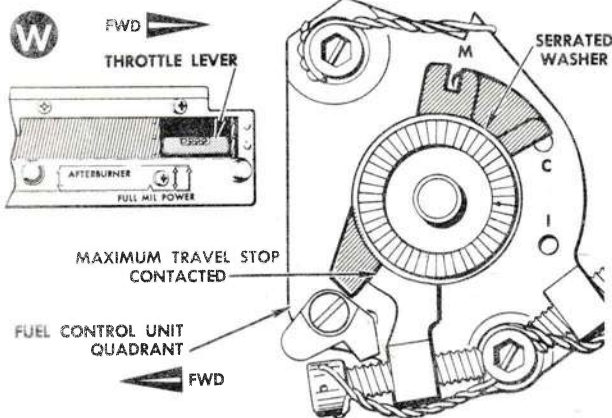

x. With throttle lever in full forward position, the fuel control maximum travel stop shall be contacted.

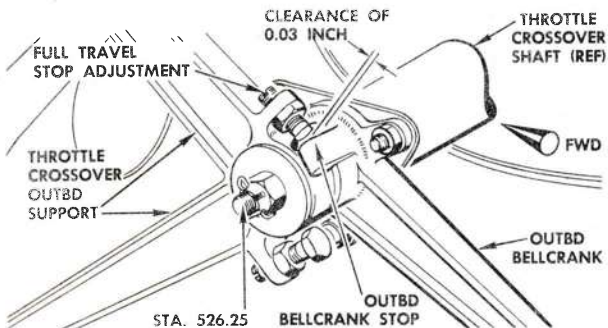

Adjust full travel stop at outboard end of throttle crossover shaft at station 526.25 for a clearance of 0.03 inch; lock stop with jam nut.

.06.02 290-7D

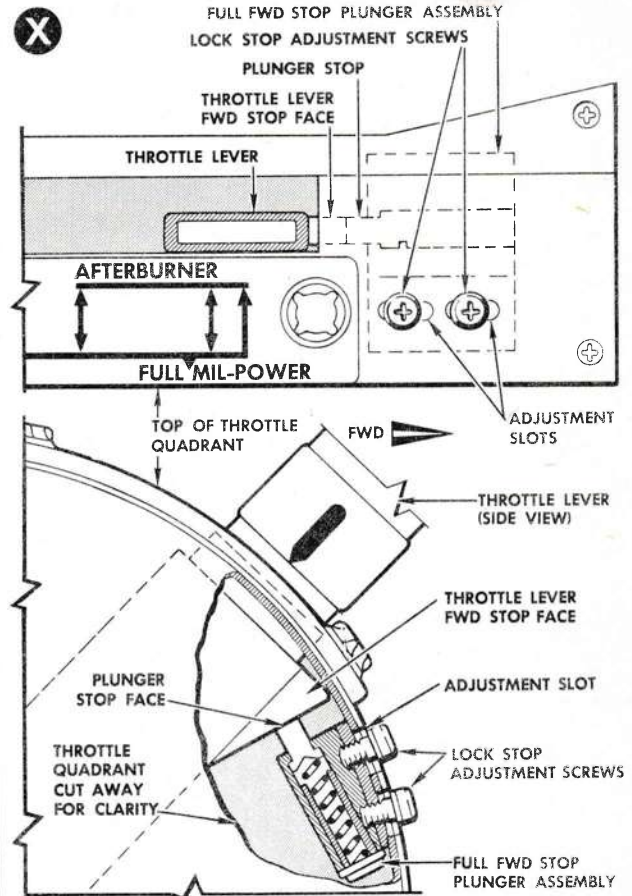

NOTE  
APPLICABLE TO F-106B AIRPLANES 57-2516 THRU -2519.

y. Move throttle quadrant full forward stop until contact is made with throttle lever; secure stop.

NOTE  
APPLICABLE TO F-106A AIRPLANES 56-453, -454, 56-456 AND SUBSEQUENT, AND F-106B AIRPLANES 57-2508 THRU 57-2515, 57-2520 AND SUBSEQUENT.

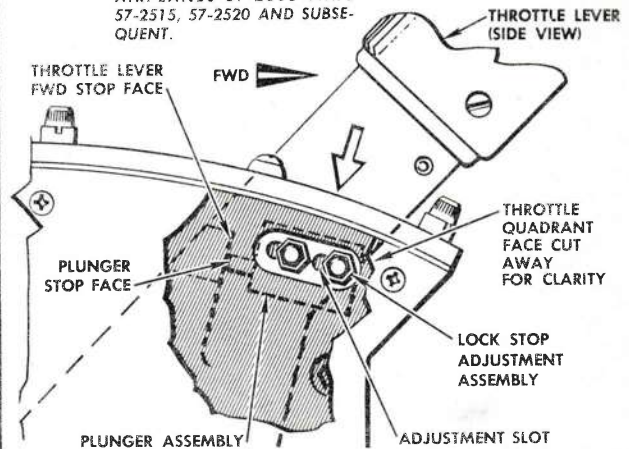

Figure 2-6. Throttle Control System Rigging (Sheet 7 of 8)

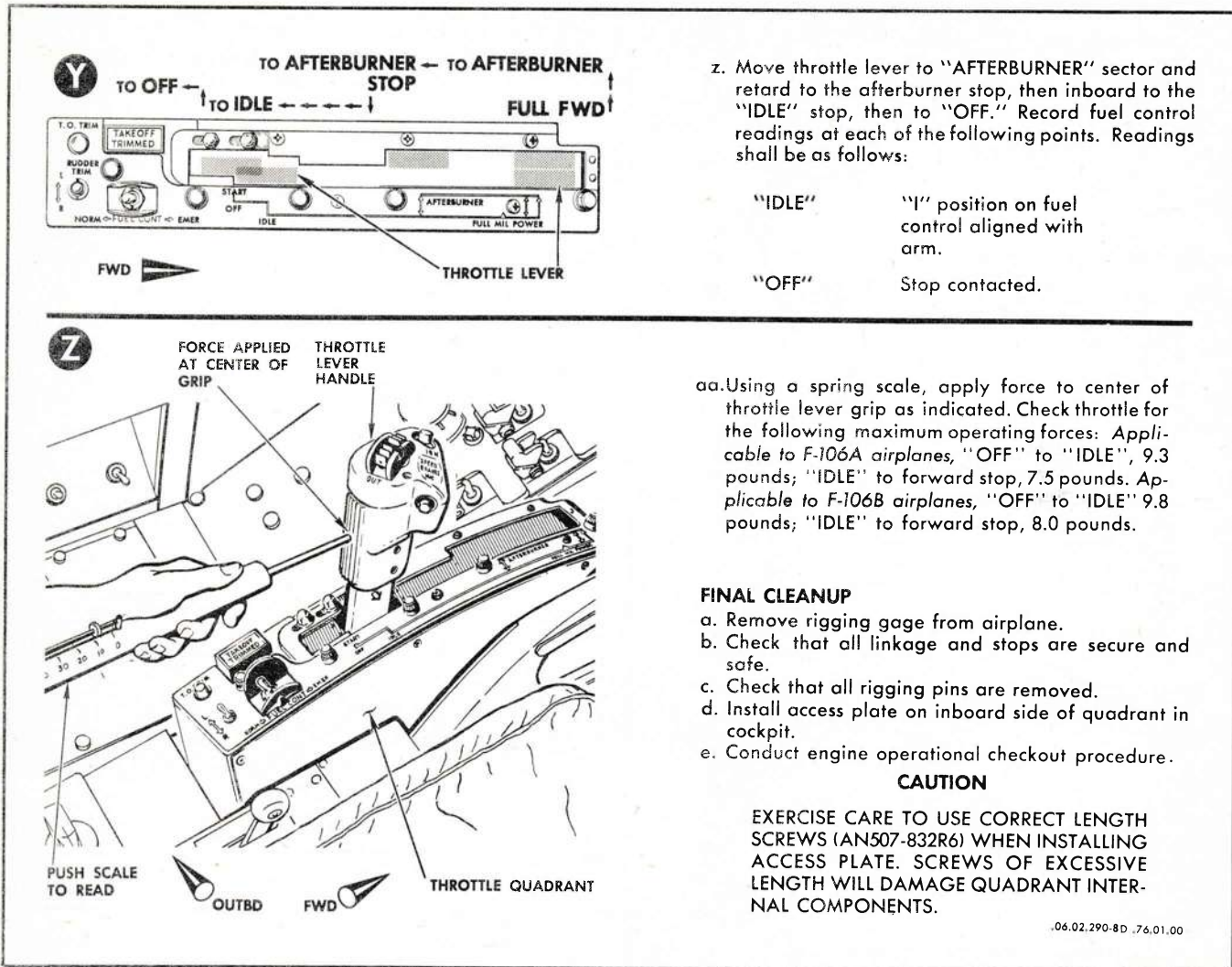

Figure 2-6. Throttle Control System Rigging (Sheet 8 of 8)



**CLEANING, MAIN FUEL CONTROL FILTER**

- Gain access to main fuel control unit through the engine accessory compartment left-hand access door.
- Cut safety wire and remove filter retaining bolt.

**NOTE**

FILTER IS LOCATED ON LOWER SIDE OF FUEL CONTROL UNIT, JUST FORWARD OF THE FUEL INLET.

- Remove filter retaining cap, filter, and O-rings.
- Check filter screen for contamination. Replace filter screen if it is clogged, bent, or otherwise damaged.
- Clean filter screen using cleaning solvent, Federal Specification P-S-661; blow dry with compressed air.
- Install filter screen using new O-ring seal.
- Install filter retaining cap, new O-ring, and bolt; safety bolt.
- Visually check fuel control filter installation for fuel leakage during first engine ground run idle rpm. Refer to Section I for engine ground run procedures.

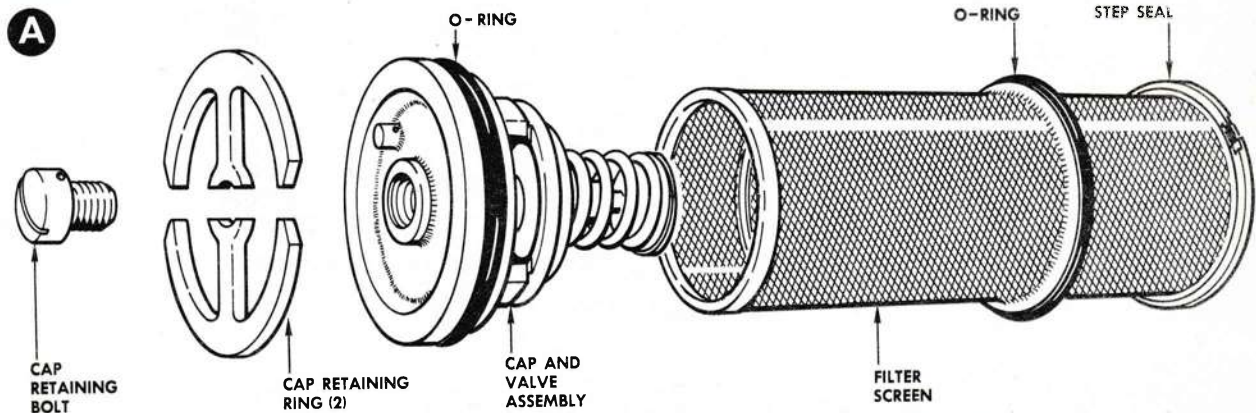
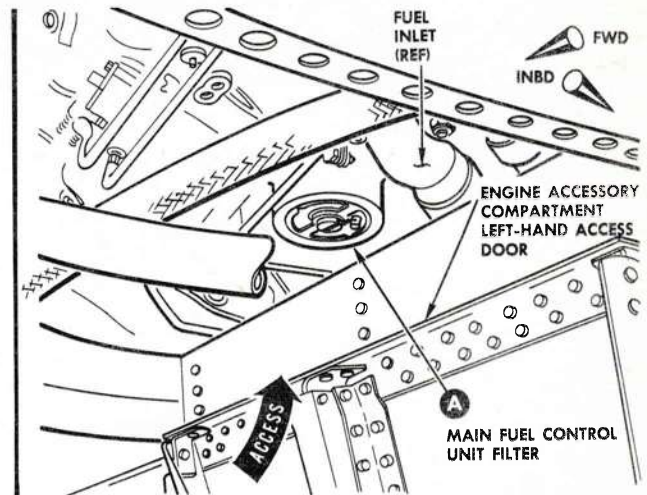
**CLEANING, MAIN FUEL PUMP STRAINER**

- Gain access to engine fuel pump through the engine accessory compartment right-hand access door.
- Remove attachment bolts (4) and remove strainer cover; remove strainer.

**NOTE**

STRAINER IS LOCATED ON THE LOWER RIGHT-HAND SIDE OF THE FUEL PUMP.

- Check strainer for contamination. Replace strainer if it is clogged, bent or otherwise damaged.
- Clean strainer using solvent, Federal Specification P-S-661; blow dry with compressed air.
- Install strainer in fuel pump using new seal; install cover. Safety bolts in pairs.
- Visually check fuel pump strainer installation for fuel leakage during first engine ground run idle rpm. Refer to Section I for engine ground run procedures.

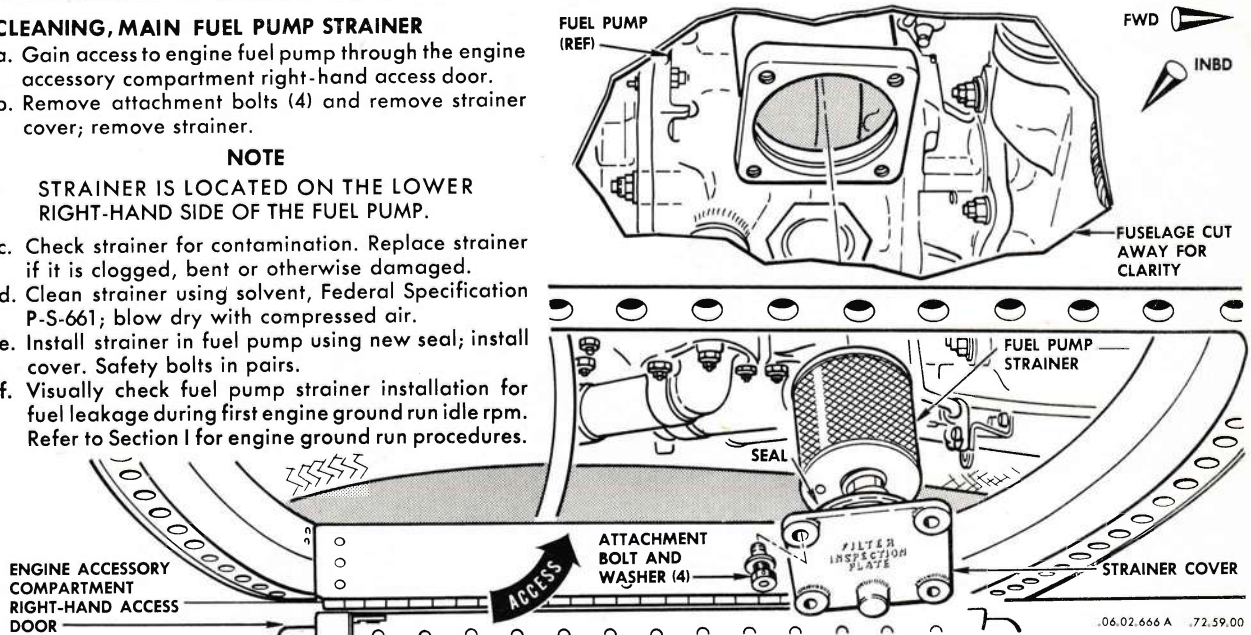

Figure 2-7. Cleaning, Main Fuel Filter and Fuel Pump Strainer

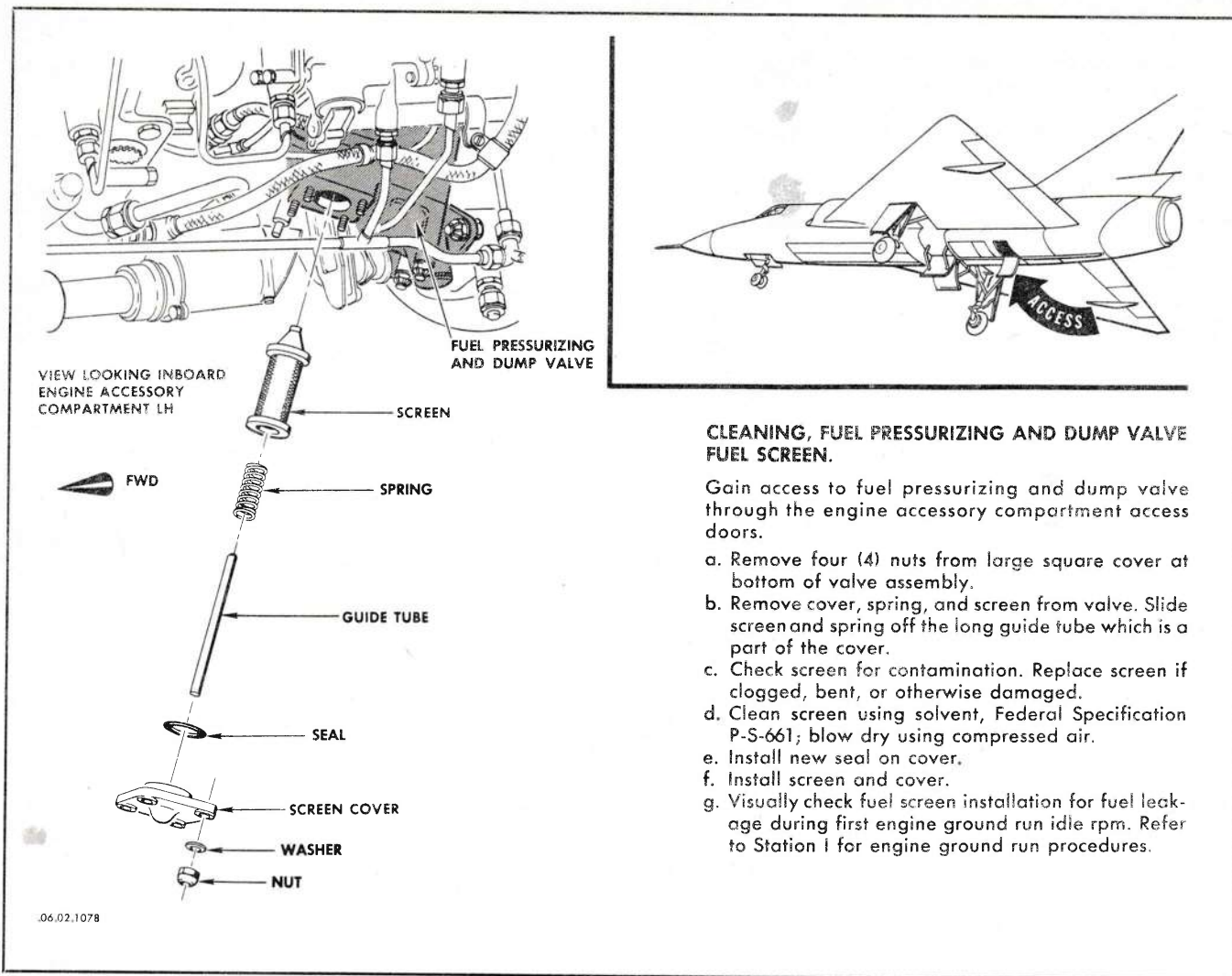

Figure 2-8. Cleaning, Fuel Pressurizing and Dump Valve Screen

## Section III

## AFTERBURNER SYSTEMS

<i>Contents</i>	<i>Page</i>
<b>AFTERBURNER</b>	
Description .....	3-1
Operational Checkout .....	3-2
System Analysis .....	3-2
Replacement .....	3-3
Adjustment .....	3-6
Servicing .....	3-7
<b>AFTERBURNER FUEL SYSTEM</b>	
Description .....	3-7
Operational Checkout .....	3-8
System Analysis .....	3-11
Replacement .....	3-12
Servicing .....	3-13

---

**AFTERBURNER**

---

**DESCRIPTION**

**3-1. AFTERBURNER.**

The engine afterburner system is provided as a means of producing additional engine thrust during takeoff, climb, and maximum performance flight. Additional thrust is provided by the injection and ignition of fuel in the engine exhaust section. A variable, two position exhaust nozzle is provided at the aft end of the exhaust duct to increase the duct opening during afterburning operation. The afterburner assembly consists of the afterburner duct and the variable area, two position exhaust nozzle. The exhaust nozzle assembly is composed of iris shutters, operated by pneumatic actuating cylinders. The cylinders, which are mounted around the aft outer circumference of

the afterburner duct, are actuated by N<sub>2</sub> compressor bleed air metered by the exhaust nozzle control valve. The nozzle control valve is actuated by high-pressure fuel from the afterburner fuel control. During normal engine operation, the cylinders hold the nozzle iris in the closed position. During afterburning operation, the cylinders automatically open the nozzle to permit the less restricted passage of afterburning gases.

**3-2. EXHAUST NOZZLE ACTUATORS.**

Twelve double acting exhaust nozzle actuating cylinders are installed around the engine afterburner duct to actuate the exhaust nozzle shutters. The shutters are installed on the aft end of the afterburner duct to increase or

decrease the exhaust nozzle aperture. The nozzle must be closed during nonafterburning to prevent loss of engine thrust. The nozzle must be open during afterburning to

prevent excessive engine temperature and pressure. The actuating cylinders are air-actuated by  $N_2$  compressor bleed air directed by the exhaust nozzle control valve.

## OPERATIONAL CHECKOUT

### 3-3. OPERATIONAL CHECKOUT, AFTERBURNER SYSTEM.

Information in regard to checkout of the afterburner system is a part of the engine ground run procedure. Refer to Section I for this information.

### 3-4. OPERATIONAL CHECKOUT, EXHAUST NOZZLE.

### 3-5. Equipment Requirements.

FIGURE	NAME	TYPE	ALTERNATE	USE AND APPLICATION
	Pressure Gage, 0-100 psi.	(6685-526-8474)		To read specified air pressure values.
	Controlled Air Pressure Source, 0 to 100 psi.			Pressure to actuate exhaust nozzle.

### 3-6. Procedure.

a. Gain access to the exhaust nozzle control valve through the engine accessory compartment left access door.

b. Remove the exhaust nozzle control valve. Refer to paragraph 3-35 for this procedure.

c. Connect controlled air pressure to the nozzle open line (upper line) and apply air pressure of 8 psi maximum. Exhaust nozzle shall open freely to the fully open position. Reduce air pressure to zero and disconnect air line.

d. Connect controlled air pressure to the nozzle closed line (lower line) and apply air pressure of 12 psi maximum. Exhaust nozzle shall close freely to the fully closed position.

e. Increase controlled air pressure on nozzle closed line to 20 psi maximum. The closed inside diameter of the exhaust nozzle shall be 25.58 inches to 25.62 inches.

#### NOTE

If adjustment is needed, refer to paragraph 3-11.

f. Connect increased controlled air pressure source of 90 to 100 psi maximum alternately to the open and closed lines. Open and closing action shall occur rapidly (less than one second). Reduce air pressure to zero.

g. Remove air pressure source and reinstall exhaust nozzle control. Conduct operation checkout of the engine afterburning system. Refer to paragraph 1-23 for this procedure.

## SYSTEM ANALYSIS

### 3-7. SYSTEM ANALYSIS, AFTERBURNER.

PROBABLE CAUSE	ISOLATION PROCEDURE	REMEDY
<b>EXHAUST NOZZLE OPENS BUT AFTERBURNER DOES NOT IGNITE.</b>		
Binding servo valve in igniter valve.	Remove igniter valve for bench check.	Install replacement item.

**3-7. SYSTEM ANALYSIS, AFTERBURNER (CONT).**

PROBABLE CAUSE	ISOLATION PROCEDURE	REMEDY
<b>EXHAUST NOZZLE OPENS BUT AFTERBURNER DOES NOT IGNITE (CONT).</b>		
Igniter fuel discharge nozzle restricted.	Remove discharge nozzle.	Install replacement item.
Loose connections at igniter valve.		Check all tubing attachments at valve.

**NOZZLE FAILS TO OPEN AFTER AFTERBURNER IGNITION.**

Exhaust nozzle control relay valve binding.	Remove valve for bench check.	Install replacement item.
Air supply line to nozzle control valve loose.		Tighten all nozzle control air lines.
Excessive drag in nozzle actuators and linkage.	Operate nozzle by manually opening and closing.	Check components for proper adjustment and cleanliness.

**EXHAUST NOZZLE OPENS DURING NON-AFTERBURNING.**

Signal pressure leakage in nozzle control valve.	Remove control valve for bench check.	Install replacement item.
Failure of main stage of fuel pump.	Remove fuel pump for bench test.	Install replacement item.
Low burner pressure signal.	Check burner pressure line for damage and loose connections.	

**REPLACEMENT**

**3-8. REPLACEMENT, AFTERBURNER.**

For afterburner replacement procedure, see figure 3-1.

**3-9. REMOVAL, EXHAUST NOZZLE ACTUATING CYLINDERS.**

a. Remove engine from airplane. Refer to Section I for this procedure.

b. Remove shroud from engine. Refer to Section IV for this procedure.

c. Disconnect lines attached to the cylinders being removed. Cover lines and openings with plugs or polyethylene sheet.

d. Remove attachment bolts; remove cylinders.

e. Remove the following parts and retain for installation on new cylinders.

1. Remove the air supply tube from the cylinder.
2. Remove the cylinder air transfer bolt and the front mounting bracket from the cylinder.
3. Unfasten the two clamps and remove the heat-shield from the cylinder.

**REMOVAL**

- a. Remove engine from airplane. Refer to Section I for engine replacement procedure.
- b. Move engine away from airplane. Engage stand brakes and position stand foot posts to contact ground.
- c. Remove shroud from engine. Refer to Section IV for shroud replacement procedure.

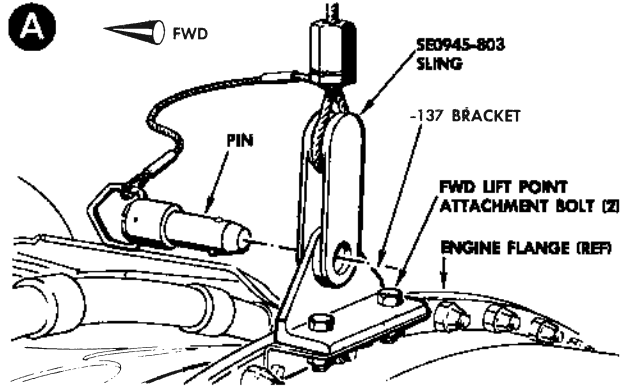
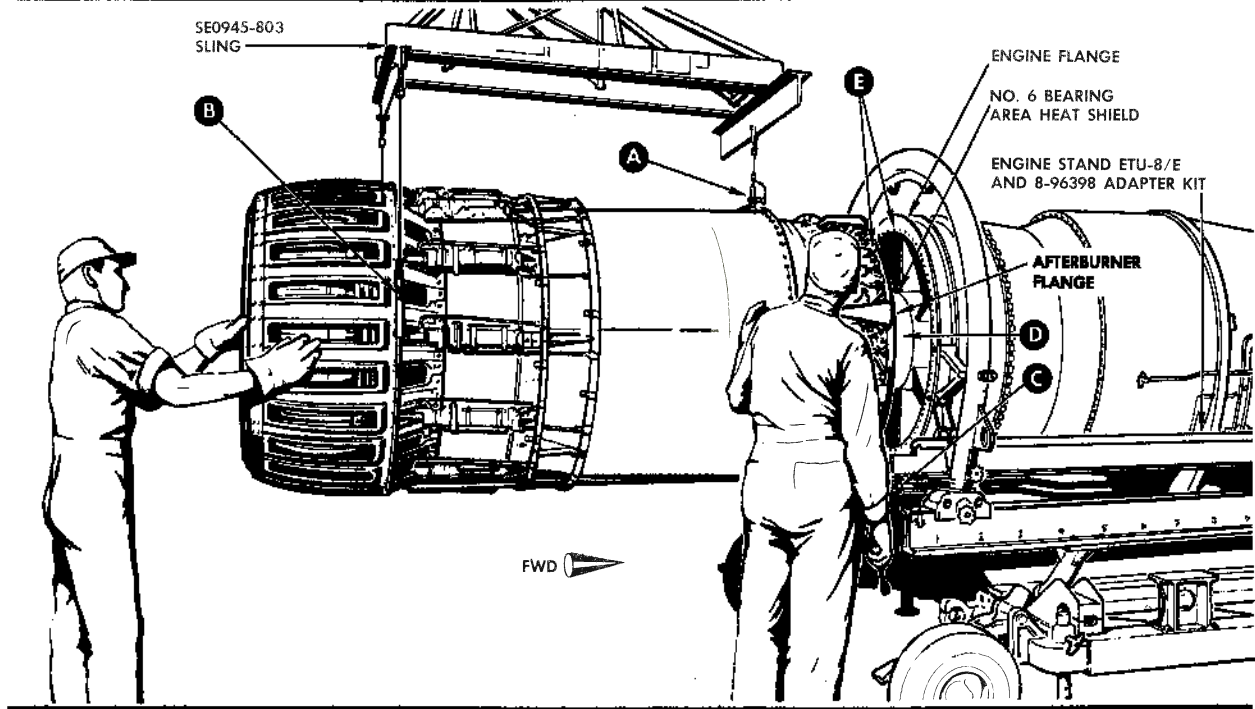
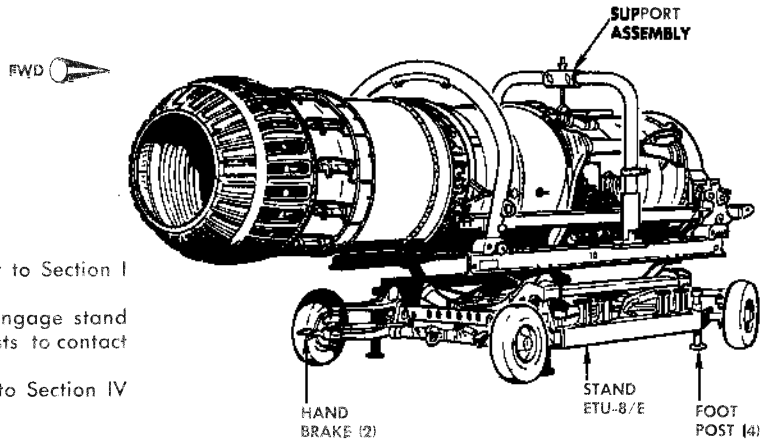

d. Using SE 0945-803 Sling, suspended from hoist, attach to afterburner forward lift point.

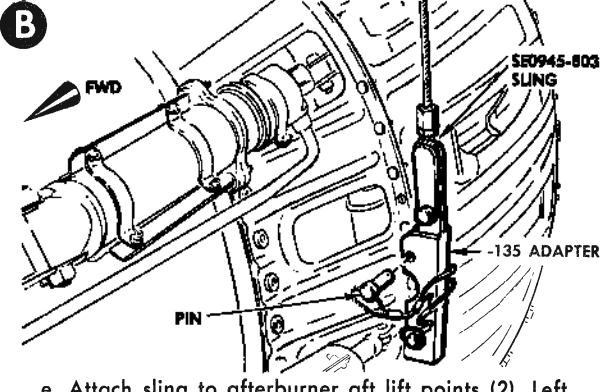

e. Attach sling to afterburner aft lift points (2). Left attachment shown; right attachment opposite. Remove slack from hoist cables.

.06.02.1164-1

Figure 3-1. Replacement, Afterburner (Sheet 1 of 2)

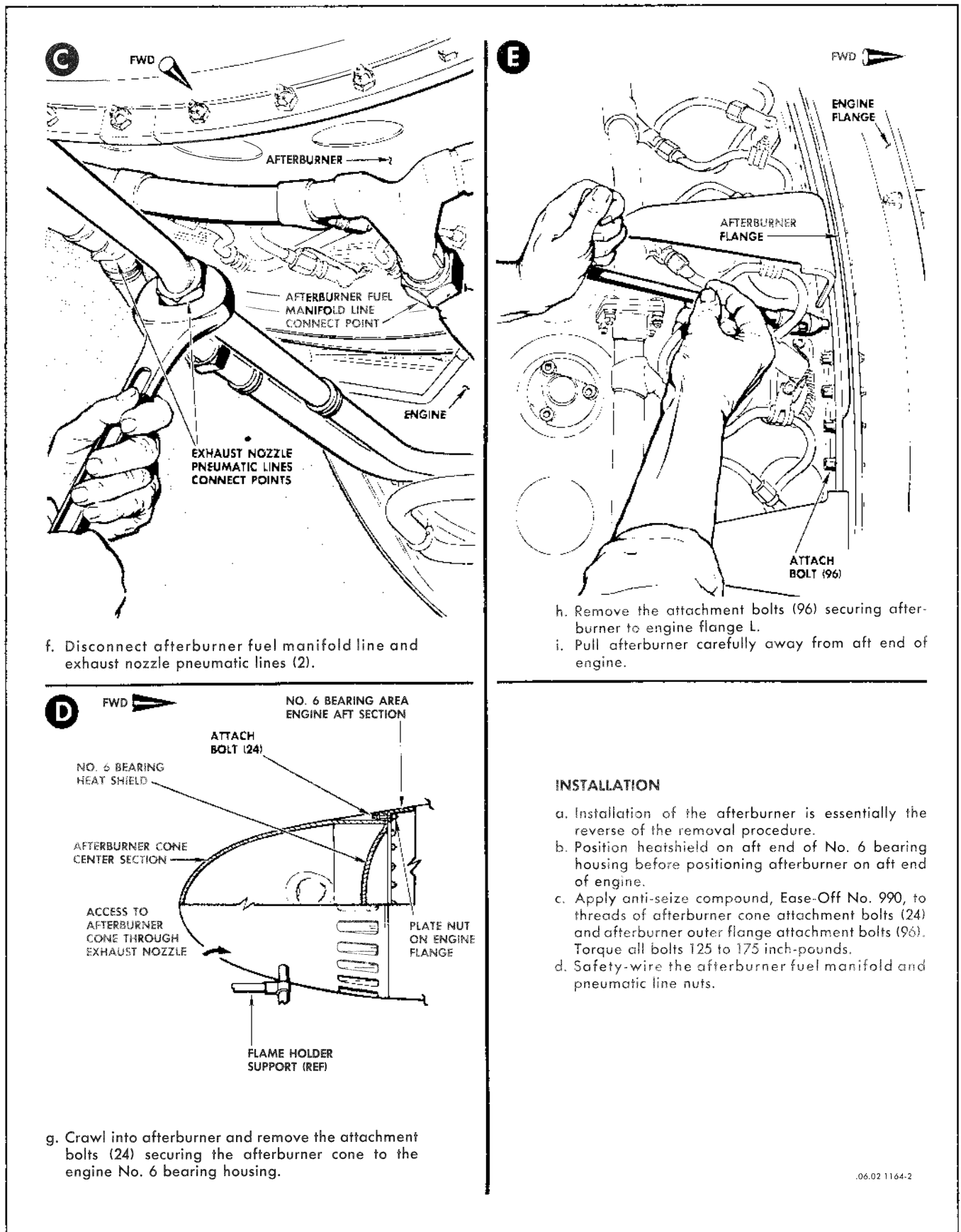

Figure 3-1. Replacement, Afterburner (Sheet 2 of 2)

4. Remove the cotterpin, spherical ball rod end, and ball rod end spacer from the rear end of the actuating rod.

### 3-10. INSTALLATION, EXHAUST NOZZLE ACTUATING CYLINDERS.

- a. Position the adjusting spacer over the bushing projecting from the cylinder actuating rod. The tang on the bushing will fit into the slot in the spacer.
- b. Insert the spherical ball rod through the spacer and thread into the actuating rod bushing.
- c. Rotate the spherical ball rod to set the tang on the bushing to the dimension shown in figure 3-2.
- d. Install the actuating cylinder heatshield with the thin tapered end toward the forward end of the cylinder. Secure the heatshield with two clamps, four bolts and locknuts.
- e. Position the front mounting bracket on the cylinder and install the air transfer bolt through the mounting bracket and cylinder.
- f. Install the air supply tube on the cylinder.
- g. Position the actuating cylinder on the rear duct and finger tighten the air supply tube connectors and the front bracket securing bolts.
- h. Position the nozzle assembly in the closed position, then secure the piston rod end to the nozzle actuating support with the nut, bolt and two tab washers. Bend tab washers over hex flats.

#### NOTE

The cylinder and the air supply tubes shall align with their mating connections with no evidence of cocking of the cylinder or air tube. If mis-alignment is evident, all of the cylinder

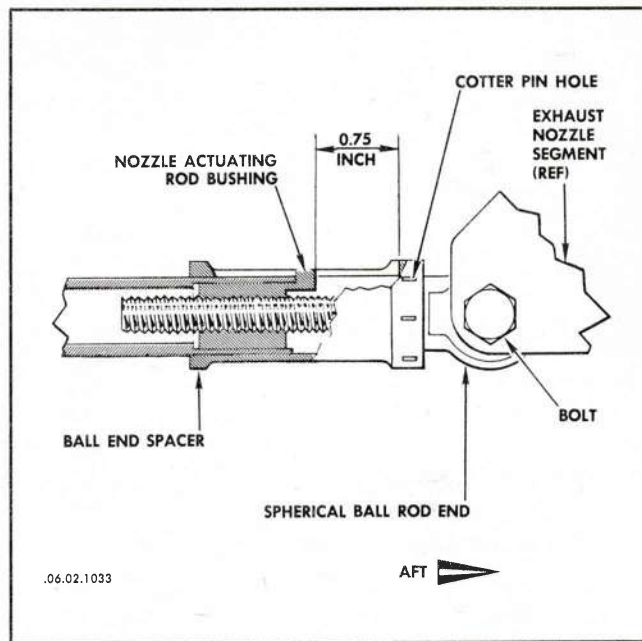

Figure 3-2. Afterburner Nozzle Adjustment

mounting brackets, the air manifold brackets, and the support clips must be loosened. This will permit a limited repositioning of the air supply manifold.

- i. When alignment has been accomplished, tighten and lockwire the air supply tube connectors and front bracket securing bolts. Tighten all other bracket bolts and clips previously loosened.
- j. Conduct exhaust nozzle operational checkout. Refer to paragraph 3-4 for procedure.
- k. Conduct operational checkout of the afterburner system. Refer to paragraph 3-3 for procedure.

## ADJUSTMENT

### 3-11. ADJUSTMENT, EXHAUST NOZZLE LINKAGE.

- a. Remove engine from airplane. Refer to Section I for this procedure.
- b. Remove shroud from engine. Refer to Section IV for this procedure.
- c. Remove cotter pins from each actuator piston rod end.
- d. Turn each piston rod end bushing forward or backward an equal number of turns as required to obtain

correct nozzle diameter. Refer to paragraph 3-6 for nozzle diameter requirements.

- e. Install rod end cotter pins.

#### NOTE

The slot in each rod end bushing must be facing outward after completion of adjustment.

- f. Install engine shroud. Install engine in fuselage.
- g. Perform an afterburner system operational checkout. Refer to Section I for these procedures.



## SERVICING

### 3-12. SERVICING, AFTERBURNER.

No servicing of the afterburner is required other than checking to see that all parts of the exhaust nozzle are free of lubricants and accumulations of foreign materials.

### 3-13. AFTERBURNER INNER DIAMETER CHECK.

At specified intervals, it will be necessary to check the inner diameter of the afterburner from the afterburner fuel nozzles aft for possible deformation. This is necessary to prevent possible malfunction and failure of the afterburner. Check the afterburner inner area as follows:

- a. Smooth section of afterburner liner.
  1. Out-of-roundness shall not exceed 0.375 inch with no flat spots exceeding 0.375 inch penetration into gas path.

#### NOTE

Measurement for depth of protrusion may be made by using a steel tape. Measure the liner inner diameter at a protrusion free area adjacent to the protrusion being checked; measure diameter at the point of greatest protrusion. Subtract the second measurement from the first to get the protrusion depth.

2. Cracks occurring in this area may be repaired by Heliarc welding providing the cracks do not exceed 7 inches in length and are at least 2 inches apart. No stress relief required.

- b. Corrugated section of afterburner liner.
  1. One flat spot with 10 inches maximum circumferential and/or 14 inches maximum axial lengths, with the center of the flat spot not to extend into the gas path more than 0.300 inch from the normal position. If two flat spots are present, each must not exceed two thirds of the above limits.
  2. Cracks occurring in this area may be repaired by Heliarc welding providing the cracks do not exceed 7 inches in length and are at least 2 inches apart.
  3. Cracks in the flange progressing from the bolt holes outward are acceptable and need not be welded.

- c. Any condition found that exceeds the limits given in steps "a" and "b," will require replacement of the afterburner.

---

## AFTERBURNER FUEL SYSTEM

---

## DESCRIPTION

### 3-14. AFTERBURNER FUEL CONTROL SYSTEM.

Afterburner fuel supply, provided by the engine fuel pump, is normally controlled by a switch installed in the cockpit throttle quadrant. The switch is actuated by moving the throttle lever outboard to the "AFTERBURNING" section of the throttle quadrant. This action electrically opens valves in the afterburner fuel control which permits fuel to flow into the afterburner fuel control. Signal fuel pressures issue from the fuel control causing the exhaust nozzle control and the afterburner igniter valve to function. At the same time metered fuel is being routed from the afterburner fuel control to the afterburner duct fuel discharge nozzles to complete the afterburning start cycle. Normal termination of afterburning is accomplished by moving the throttle lever out of the "AFTERBURNING" section of the throttle quadrant. The afterburner fuel control valves then close and

terminate fuel flow into the afterburning system. Field adjustment of the afterburner fuel system components shall not be attempted. The units must be set with use of proper flow bench facilities. For a schematic illustration of the afterburner fuel system, see figure 3-3.

### 3-15. AFTERBURNER EMERGENCY CONTROL.

No provisions are made for emergency starting of the afterburner operation; however, emergency provisions are made for cutting off afterburning in case of electrical system failure. In case of normal electrical control system malfunction, retarding the throttle lever below military power position will terminate afterburning. After termination of afterburning in this manner, forward movement of the throttle lever will not reinstate afterburning. The cause of afterburner control system electrical malfunction must be corrected before the afterburner system

can again be used. During normal afterburner operation, a sudden noticeable decrease in afterburner thrust indicates that the main stage of the engine fuel pump has become inoperative. During this condition the two afterburner stages of the pump are supplying both the main and afterburner fuel systems. Engine operation should be terminated and the malfunction corrected.

### 3-16. ENGINE IDLE THRUST CONTROL SYSTEM.

*Applicable to F-106A airplanes 56-453, -454, 56-456 thru 57-245, 58-759 and subsequent; and 57-246, 57-2453 thru 57-2506 after incorporation of TCTO 1F-106-557. Applicable to F-106B airplanes 57-2508 thru 57-2515, 57-2532 and subsequent; and 57-2516 thru 57-2531 after incorporation of TCTO 1F-106-557.* The engine idle thrust control system is provided to reduce engine thrust during airplane taxiing operations. The system is electrically controlled and pneumatically actuated. Actuation of the switch on the cockpit left console panel to the "ON" position opens the exhaust nozzle and results in approximately 40% reduction in engine idle thrust. This reduced thrust permits reduced taxi speed and landing gear brake wear. The idle thrust control circuit is routed through the left main landing gear safety switch to provide thrust reduction on the ground only. The pneumatic portion of the system consists of a selector valve and a converter valve installed on the engine. These valves route  $N_2$  compressor bleed air, as an actuating signal, to the exhaust nozzle control valve, which ports air pressure to the exhaust nozzle actuating cylinders. See figure 3-2 for a schematic illustration of this system.

### 3-17. EXHAUST NOZZLE CONTROL VALVE.

The exhaust nozzle control installed on the lower left side of the engine, is a two position pneumatic valve that is actuated by fuel pressure. At the time of afterburner actuation, high-pressure fuel from the afterburner fuel control positions the nozzle control valve to the "open" position which in turn routes  $N_2$  compressor air to the exhaust nozzle actuators. Termination of afterburning removes the fuel pressure and permits the nozzle control valve to reposition.  $N_2$  compressor bleed air is then routed to "closed" side of the exhaust nozzle actuators. The exhaust nozzle then returns to the closed position.

### 3-18. AFTERBURNER FUEL CONTROL UNIT.

The afterburner fuel control unit is an electrically actuated hydromechanical unit installed on the right side of the engine accessory section. The control unit meters afterburner fuel during afterburner operation. Operation of the control unit is initiated by an electrical actuator that moves a pilot valve. This action permits a high-pressure fuel signal to hydraulically position a second valve that permits high pressure fuel to close the control unit unloading valve. Metered fuel is then routed into the afterburner fuel manifold system. Actuation of the fuel control also provides fuel pressure to the afterburner igniter valve for actuation of afterburner ignition. Mechanical control provisions are incorporated within the control unit to allow termination of afterburning in the event of electrical actuator control malfunction. The mechanical control is linked to the pilot's throttle. Retarding the throttle lever will terminate afterburning. Afterburning cannot be reinitiated until the electrical malfunction has been corrected.

### 3-19. AFTERBURNER IGNITER VALVE.

The afterburner igniter valve, installed on the right side of the engine, is a hot streak igniter which injects a predetermined quantity of fuel into number three combustion chamber. This provides a momentary stream of burning fuel through the engine turbine section to ignite afterburner fuel. Fuel pressure from the afterburner fuel manifold initiates the igniter operating cycle, while engine compressor pressure motivates the igniter control piston. The resulting piston action supplies the spurt of fuel under pressure to the number three combustion chamber.

### 3-20. AFTERBURNER FUEL NOZZLES.

The afterburner front duct is equipped with 24 equally spaced fuel nozzles. Each nozzle is bolted to the duct outer surface with the tube portion of the nozzle projecting into the duct to the number six turbine bearing fairing. The nozzles are connected to a common manifold that encircles the front duct. Fuel is routed from the afterburner fuel control, through the manifold to the nozzles. Fuel is discharged into the afterburner duct through small holes drilled in each nozzle tube.

## OPERATIONAL CHECKOUT

### 3-21. OPERATIONAL CHECKOUT, AFTERBURNER.

For afterburner operational check and engine run procedure, refer to Section I.

### 3-22. OPERATIONAL CHECKOUT, IDLE THRUST CONTROL.

For operational checkout of the idle thrust control system, refer to the engine ground run procedure in Section I.

- ELECTRICAL CIRCUIT
- ENERGIZED ELECTRICAL CIRCUIT
- PUMP INLET (BOOST) FUEL PRESSURE
- FUEL BY-PASS (INTERSTAGE) PRESSURE
- CONTROL SYSTEM INLET FUEL PRESSURE
- METERED FUEL PRESSURE
- AFTERBURNER MANIFOLD FUEL PRESSURE
- AFTERBURNER "ON" SIGNAL FUEL PRESSURE
- CONTROL BODY PRESSURE
- N<sub>1</sub> COMPRESSOR DISCHARGE AIR PRESSURE
- N<sub>2</sub> COMPRESSOR DISCHARGE AIR PRESSURE
- ATMOSPHERIC PRESSURE
- TURBINE DISCHARGE AIR PRESSURE
- AFTERBURNER IGNITION SQUIRT. BY-PASS (INTERSTAGE) FUEL FLOWS THROUGH THIS LINE WHEN THROTTLE LEVER IS POSITIONED TO "AFTERBURNING."
- INACTIVE. USED WHEN IDLE THRUST SYSTEM IS IN OPERATION DURING GROUND RUN.

**NOTES**

1. ENGINE IDLE THRUST CONTROL SYSTEM IS APPLICABLE TO F-106A AIRPLANES 56-453, 56-454, 56-456 THRU 57-245, 58-759 AND SUBSEQUENT; AND 57-246, 57-2453 THRU 57-2506 AFTER INCORPORATION OF TCTO 1F-106-557. APPLICABLE TO F-106B AIRPLANES 57-2508 THRU 57-2515, 57-2532 AND SUBSEQUENT; AND 57-2516 THRU 57-2531 AFTER INCORPORATION OF TCTO 1F-106-557.
2. APPLICABLE TO F-106A AIRPLANES 56-453, 56-454, 56-456 THRU 57-245, 57-2454, 59-060 AND SUBSEQUENT; AND 57-246, 57-2453, 57-2455 THRU 59-059 AFTER INCORPORATION OF TCTO 1F-106-628. APPLICABLE TO F-106B AIRPLANES 57-2508 THRU 57-2515, 57-2517, 59-149 AND SUBSEQUENT; AND 57-2516, 57-2518 THRU 58-904 AFTER INCORPORATION OF TCTO 1F-106-628.

**CONDITION**

SYSTEM SHOWN IN AFTERBURNING OPERATION AT HIGH ALTITUDE.

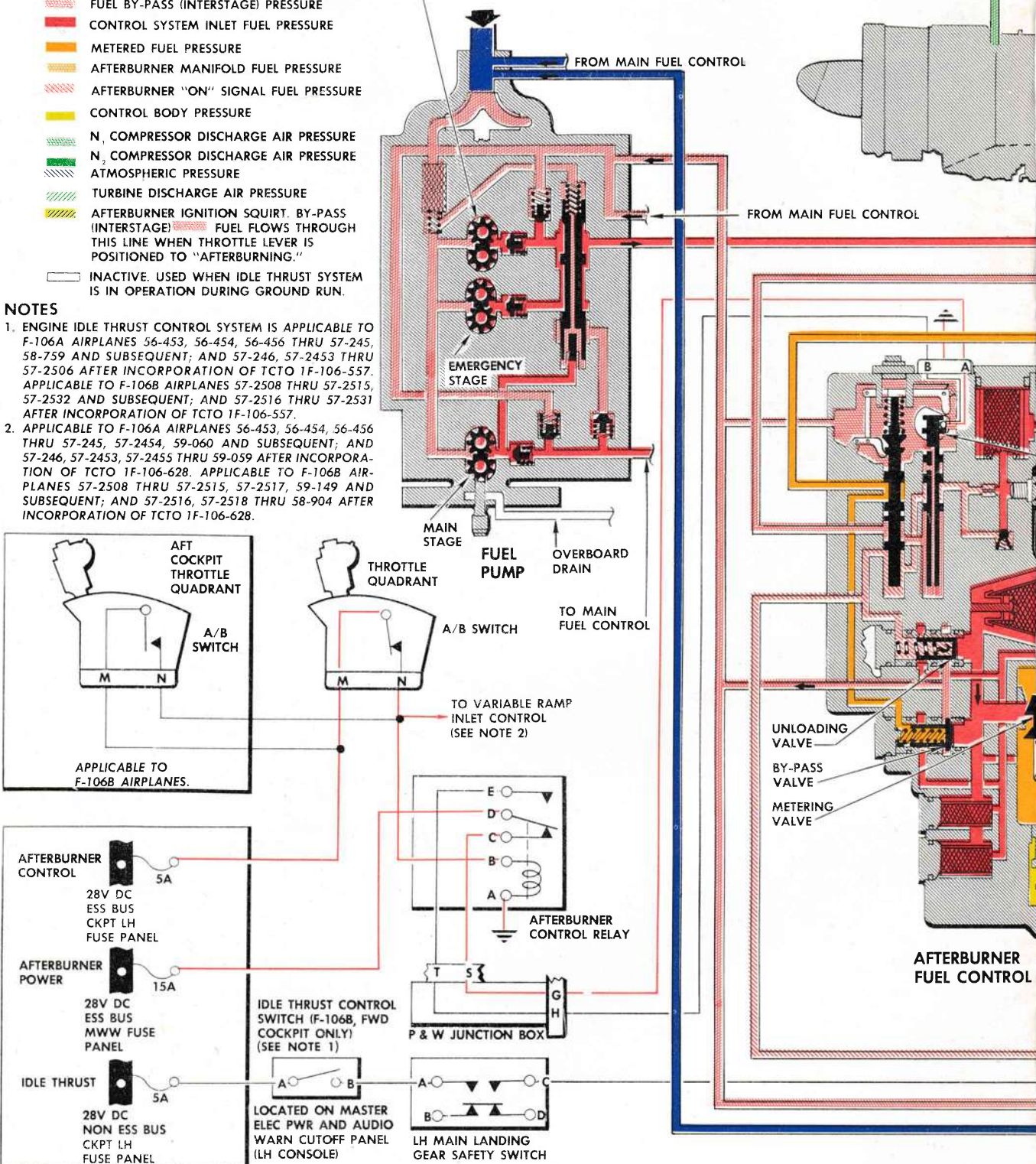

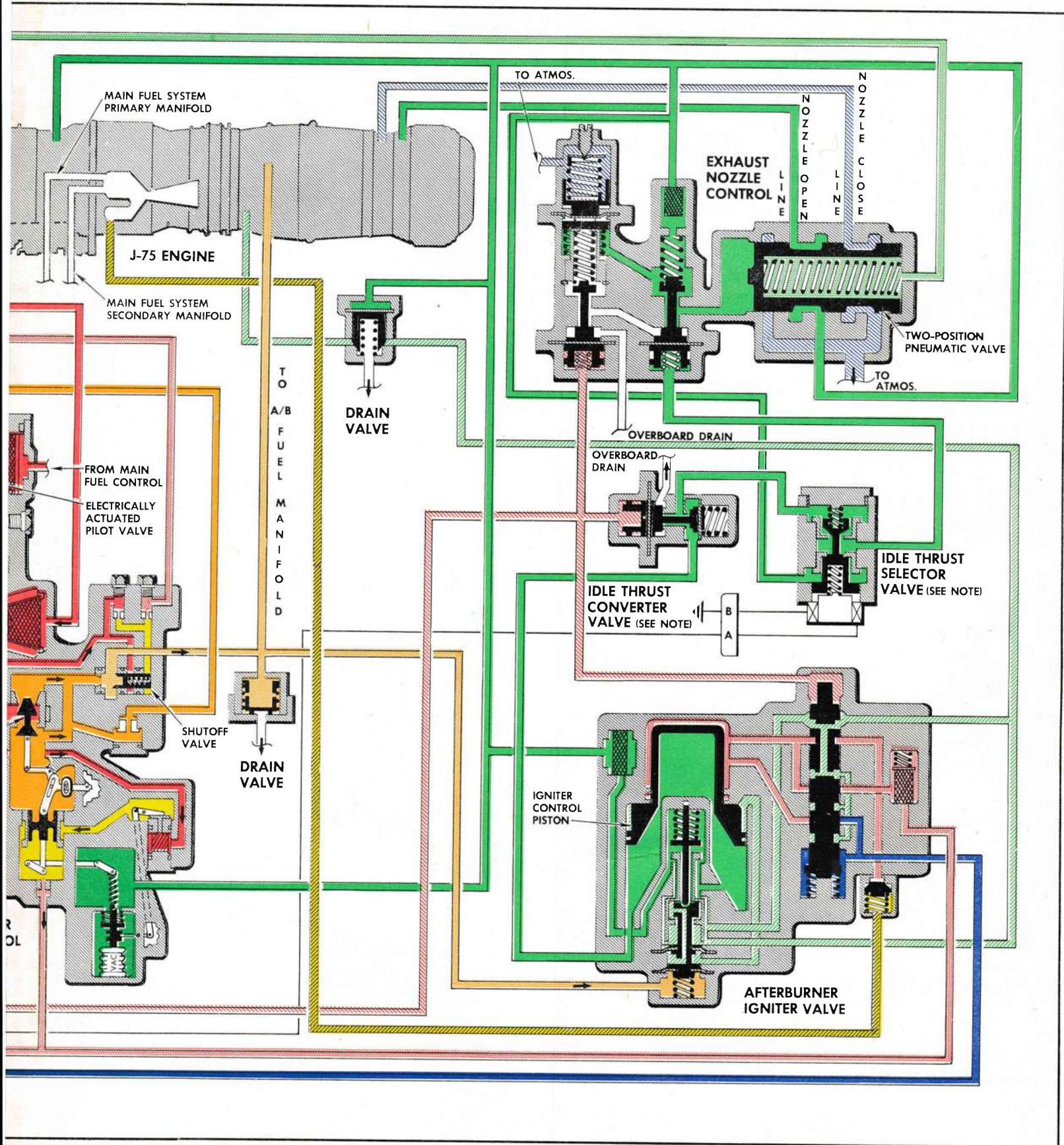

Figure 3-3. Engine Afterburner Fuel System Schematic

**3-23. CIRCUIT TEST PROCEDURE, AFTERBURNER CONTROL.****3-24. Equipment Requirements.**

FIGURE	NAME	TYPE	ALTERNATE	USE AND APPLICATION
Refer to T. O. 1F- 106A-2-10.	Test Light, 28-volt dc (2).			To test circuit continuity.
	Generator Set (Gas).	8-96026-801 AF/M32A-13 (6115- 583-9365)	8-96026 AF/M32M-2 (6115-617- 1417)	To energize electrical systems on aircraft equipped with special quick disconnect receptacle.
	Generator Set (Elec).	8-96025-803 AF-ECU- 10/M  (6125-583- 3225)	8-96025-805 A/M24M-2 (6125-628- 3566)	
			8-96025 AF/M24M-1 (6125-620- 6468)	
	Generator Set.		MC-1 (6125-500- 1190)	To energize electrical systems (except AWCIS) on aircraft equipped with standard AN receptacle and on others by using adapter cable 8-96052.
			MD-3 (6115-635- 5595)	
Adapter Cable.	8-96052 (6115- 557-8548)		To connect MC-1 and MD-3 units to aircraft equipped with special quick disconnect receptacle.	

**3-25. Procedure.**

a. Disconnect electrical plug from P&W engine junction box. Place throttle lever in off position.

b. Connect 28-volt dc test lights between plug pins as follows:

1. Pin T and structure.
2. Pin S and structure.

c. Check that afterburner fuses are installed as follows:

Afterburner Control Fuse <i>All F-106B airplanes.</i>	Nose wheel well fuse panel.
Afterburner Control Fuse <i>All F-106A airplanes.</i>	Cockpit left fuse panel.
Afterburner Power Fuse	Main wheel well fuse panel.

d. Connect 28-volt dc power to airplane external power receptacle.

e. Move throttle to full forward position. Test lights shall be as follows:

1. Light at pin T— Illuminated.
2. Light at pin S— Extinguished.

f. Move throttle lever to "AFTERBURNING." Test lights shall be as follows:

1. Light at pin T— Extinguished.
2. Light at pin S— Illuminated.

Lights shall remain in this condition throughout full "AFTERBURNER" range.

g. Move throttle lever to "OFF." Test lights shall be as follows:

1. Light at pin T— Illuminated.
2. Light at pin S— Extinguished.

h. For F-106B airplanes, repeat step "e" through "g" using aft cockpit throttle.

i. Remove electrical power and test lights. Install electrical plug to engine junction box.

**3-26. CIRCUIT TEST PROCEDURE, ENGINE IDLE THRUST CONTROL.****3-27. Equipment Requirements.**

FIGURE	NAME	TYPE	ALTERNATE	USE AND APPLICATION
Refer to T.O. 1F- 106A-2-10	Generator Set (Gas).	8-96026-801 AF/M32A-13 (6115- 583-9365)	8-96026 AF/M32M-2 (6115-617- 1417)	To energize electrical systems on aircraft equipped with special quick disconnect receptacle.
	Generator Set (Elec).	8-96025-803 AF/ECU- 10/M (6125-583- 3225)	8-96025-805 A/M24M-2 (6125-628- 3566)	
			8-96025 AF/M24M-1 (6125-620- 6468)	
	Generator Set.		MC-1 (6125-500- 1190)	To energize electrical systems (except AWCIS) on aircraft equipped with standard AN receptacle and on others by using adapter cable 8-96052.
			MD-3 (6115-635- 5595)	
Adapter Cable.	8-96052 (6115- 557-8548)		To connect MC-1 and MD-3 units to aircraft equipped with special quick disconnect receptacle.	
Multimeter.	AN/PSM-6 (6625-643- 1686)	Equivalent	To measure voltage and resistance.	

**3-28. Procedure.**

- a. Gain access to engine electrical disconnects at upper right side of engine.
- b. Connect external power to airplane.
- c. Disconnect Convair engine electrical disconnect plug.
- d. Install engine idle thrust fuse in cockpit left fuse panel.

- e. Actuate cockpit "IDLE THRUST CONT" switch to "ON."
- f. Check for 28-volts dc between plug pins H and L.
- g. Check for 13 to 15 ohms resistance between pins H and L of plug.
- h. Position cockpit switch to "OFF."
- i. Reconnect electrical plug; remove electrical power from airplane.

**SYSTEM ANALYSIS****3-29. SYSTEM ANALYSIS, AFTERBURNER FUEL SYSTEM.**

For information in regard to troubleshooting of the afterburner fuel system, refer to paragraph 3-7.

**REPLACEMENT**

**3-30. AFTERBURNER FUEL SYSTEM SAFETY PRECAUTIONS.**

During replacement of the afterburner fuel system components, it will be necessary to disconnect fuel lines. The following precautions must be taken at all times:

- a. Provide fuel drainage receptacles and suitable fire extinguishers.
- b. Check that the airplane is properly grounded and parked in an area to provide adequate ventilation.
- c. Remove all equipment from the work area vicinity that might cause sparks.
- d. Remove electrical power from the airplane before disconnecting fuel lines.

**WARNING**

Wear suitable plastic gloves and coveralls and avoid prolonged skin contact with JP-4 fuel, Military Specification MIL-J-5624. Do not breathe an excess amount of fuel fumes.

After completion of afterburner fuel system component replacement, it will be necessary to conduct an operational checkout of the engine. Refer to Operational Checkout in Section I.

**3-31. REMOVAL, AFTERBURNER FUEL CONTROL UNIT.**

- a. Observe safety precautions outlined in paragraph 3-30 during removal of the afterburner fuel control.
- b. Gain access to the afterburner fuel control through the engine accessory compartment access doors.
- c. Provide drainage receptacles before disconnecting lines.
- d. Remove lines and electrical connector attached to the fuel control. Cover openings with plugs or polyethylene sheet. Note location of clips and brackets to aid reinstallation.

**NOTE**

When removing the fuel pump-to-afterburner fuel control (discharge) tube, remove the 3 nuts from the elbow mounted on the fuel pump and the 4 allen screws from the elbow mounted on the fuel control and lift off the tube and elbows.

When removing the fuel pump-to-afterburner fuel control (by-pass) tube remove the screws securing the tube elbow to the afterburner fuel control; then pull tube from the elbow mounted on the fuel pump.

- e. Remove nuts (2) at the slotted bracket on the bottom of the fuel control; remove control. Discard old seals.

**3-32. INSTALLATION, AFTERBURNER FUEL CONTROL.**

- a. Install the afterburner fuel control in essentially the reverse of the removal procedure.
- b. Use new seals.
- c. Conduct afterburner system operational checkout. Refer to engine run operation in Section I.

**3-33. REMOVAL, AFTERBURNER IGNITER VALVE.**

- a. Gain access to the afterburner igniter valve through the engine accessory compartment access doors.
- b. Observe safety precautions listed in paragraph 3-30.
- c. Provide receptacle for fuel drainage and remove engine fuel inlet filter if installed.
- d. Remove lines attached to igniter. Cover lines and openings using plugs or polyethylene sheet. Note location of clips for reinstallation.
- e. Remove igniter valve.

**3-34. INSTALLATION, AFTERBURNER IGNITER VALVE.**

- a. Install the afterburner igniter valve in essentially the reverse of the removal procedure.

**NOTE**

Five different types of igniter valves are used on J75 engines. These igniter valves are listed below and are to be used for replacement only within the groups designated.

IGNITER PART NO.	GROUP	REMARKS
306100	1	Igniter valves may be interchanged within Group 1 only.
371178		
353178	2	Igniter valves may be interchanged within Group 2 only.
377597		
388610	3	May be used to replace Group 2 igniter valves.

- b. Conduct afterburner system operational checkout. Refer to engine run operation in Section I.

**3-35. REMOVAL, EXHAUST NOZZLE CONTROL VALVE.**

- a. Observe safety precautions outlined in paragraph 3-30 during removal of the exhaust nozzle control valve.
- b. Gain access to the exhaust nozzle control valve through the engine accessory compartment access doors.
- c. Provide a drainage receptacle prior to disconnecting lines.
- d. Disconnect lines attached to control valve. Cover openings with plugs or polyethylene sheet.
- e. Remove control attachment bolts (4); remove control. Discard old seals.

**3-36. INSTALLATION, EXHAUST NOZZLE CONTROL VALVE.**

- a. Install the exhaust nozzle control valve in essentially the reverse of the removal procedure.
- b. Use new seals.
- c. Conduct afterburner system operational checkout. Refer to engine run procedure in Section I.

**3-37. REMOVAL, EXHAUST NOZZLE CONTROL SELECTOR VALVE.**

- a. Gain access to exhaust nozzle control selector valve through the engine accessory compartment access doors.
- b. Accomplish requirements of paragraph 3-30.
- c. Disconnect tubes and electrical connection attached to selector valve.
- d. Remove the valve attachments bolts (2); remove valve.

**3-38. INSTALLATION, EXHAUST NOZZLE CONTROL SELECTOR VALVE.**

- a. Installation of exhaust nozzle control selector valve is essentially the reverse of the removal procedure.
- b. Conduct idle thrust control operational checkout. Refer to engine run procedure in Section I.

**3-39. REMOVAL, EXHAUST NOZZLE CONTROL CONVERTER VALVE.**

- a. Gain access to exhaust nozzle control converter valve through the engine accessory compartment access doors.
- b. Accomplish requirements of paragraph 3-30.
- c. Disconnect tubes attached to converter valve.
- d. Remove the valve attachment nuts (2); remove valve.

**3-40. INSTALLATION, EXHAUST NOZZLE CONTROL CONVERTER VALVE.**

- a. Installation of the exhaust nozzle control converter valve is essentially the reverse of the removal procedure.
- b. Conduct idle thrust control operational checkout. Refer to engine run procedure in Section I.

**3-41. REPLACEMENT, EXHAUST NOZZLE ACTUATING CYLINDERS.**

For replacement of the exhaust nozzle actuating cylinders refer to paragraph 3-9.

**SERVICING****3-42. SERVICING, AFTERBURNER FUEL SYSTEM.**

The afterburner fuel system will not require special servicing other than cleaning of the fuel filters at specified intervals.

**3-43. CLEANING, AFTERBURNER FUEL CONTROL INLET SCREEN.**

For the afterburner fuel control inlet screen cleaning procedures, see figure 3-4.

**3-44. CLEANING, AFTERBURNER FUEL BYPASS SCREEN.**

For the afterburner fuel control fuel bypass screen cleaning procedures, see figure 3-4.

**3-45. CLEANING, AFTERBURNER IGNITER VALVE FUEL SCREEN.**

For the afterburner igniter valve fuel screen cleaning procedures, see figure 3-5.

**3-46. CLEANING, AFTERBURNER IGNITER VALVE AIR SCREEN.**

For the afterburner igniter valve air screen cleaning procedures, see figure 3-5.



**NOTE**

GAIN ACCESS TO THE AFTERBURNER FUEL CONTROL THROUGH THE ENGINE ACCESSORY COMPARTMENT RIGHT ACCESS DOOR.

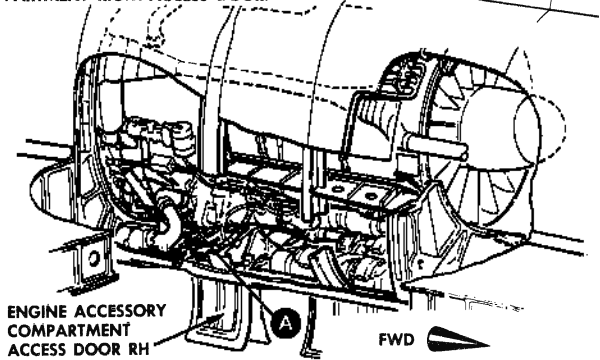

ENGINE ACCESSORY COMPARTMENT ACCESS DOOR RH

FWD

**CLEANING, AFTERBURNER FUEL CONTROL SCREENS**

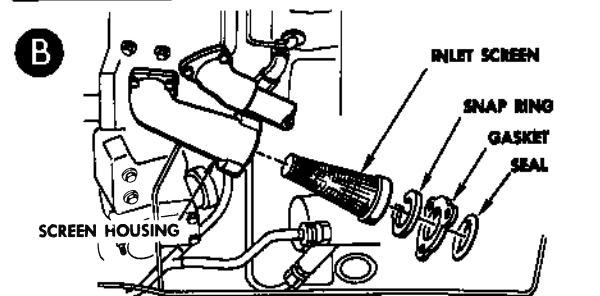
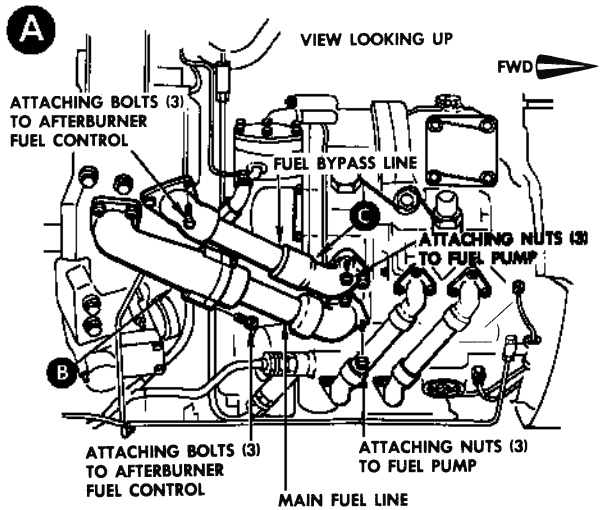

**CLEANING, AFTERBURNER FUEL CONTROL INLET SCREEN.**

- a. Remove attachment nuts and bolts holding the main fuel line (inboard line, see Detail A) to the fuel pump and the afterburner fuel control; remove fuel line.
- b. Remove snap ring from the screen housing; remove screen.

06.02.1079A

**NOTE**

SOME SCREENS WILL BE INSTALLED USING SHIMS FOR PROPER POSITIONING OF THE SCREENS. THESE SHIMS MUST BE REPLACED AS REMOVED TO PRESERVE THE PROPER FUNCTION OF THE SCREEN.

- c. Check screen for contamination. Replace screen if it is cracked, bent, or otherwise damaged.
- d. Clean screen using solvent, Federal Specification P-S-661; blow dry using compressed air.
- e. Use new seals when installing screen and fuel line.
- f. Install screen and fuel line. Safety-wire bolts.
- g. Visually check fuel control inlet screen installation for fuel leakage during first engine ground run idle rpm. Refer to Section I for engine ground run procedures.

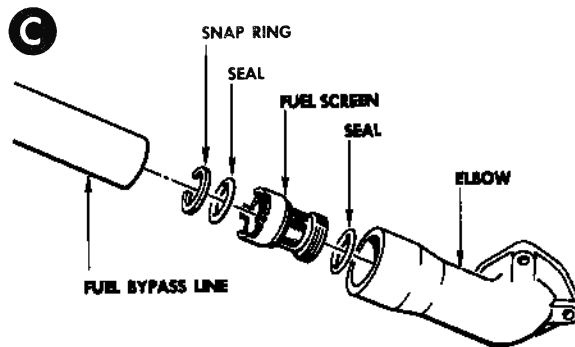

**CLEANING, AFTERBURNER FUEL BYPASS SCREEN.**

- a. Remove attachment nuts and bolts holding fuel bypass line (outboard line, see Detail A) to the fuel pump and the afterburner fuel control; remove fuel line.
- b. Separate the tube elbow from the tube.
- c. Remove snap ring holding fuel screen inside the tube elbow; remove screen and two (2) seals.
- d. Check screen for contamination. Replace screen if it is cracked, bent, or otherwise damaged.
- e. Clean screen using solvent, Federal Specification P-S-661; blow dry using compressed air.
- f. Install new seals (2) in the grooves of the screen housing. Install screen assembly in the tube elbow and secure with snap ring.
- g. Install elbow on tube; install tube assembly on fuel pump and afterburner fuel control. Safety-wire bolts.
- h. Visually check fuel bypass screen installation for fuel leakage during first engine ground run idle rpm. Refer to Section I for engine ground run procedures.

Figure 3-4. Cleaning, Afterburner Fuel Control Screens

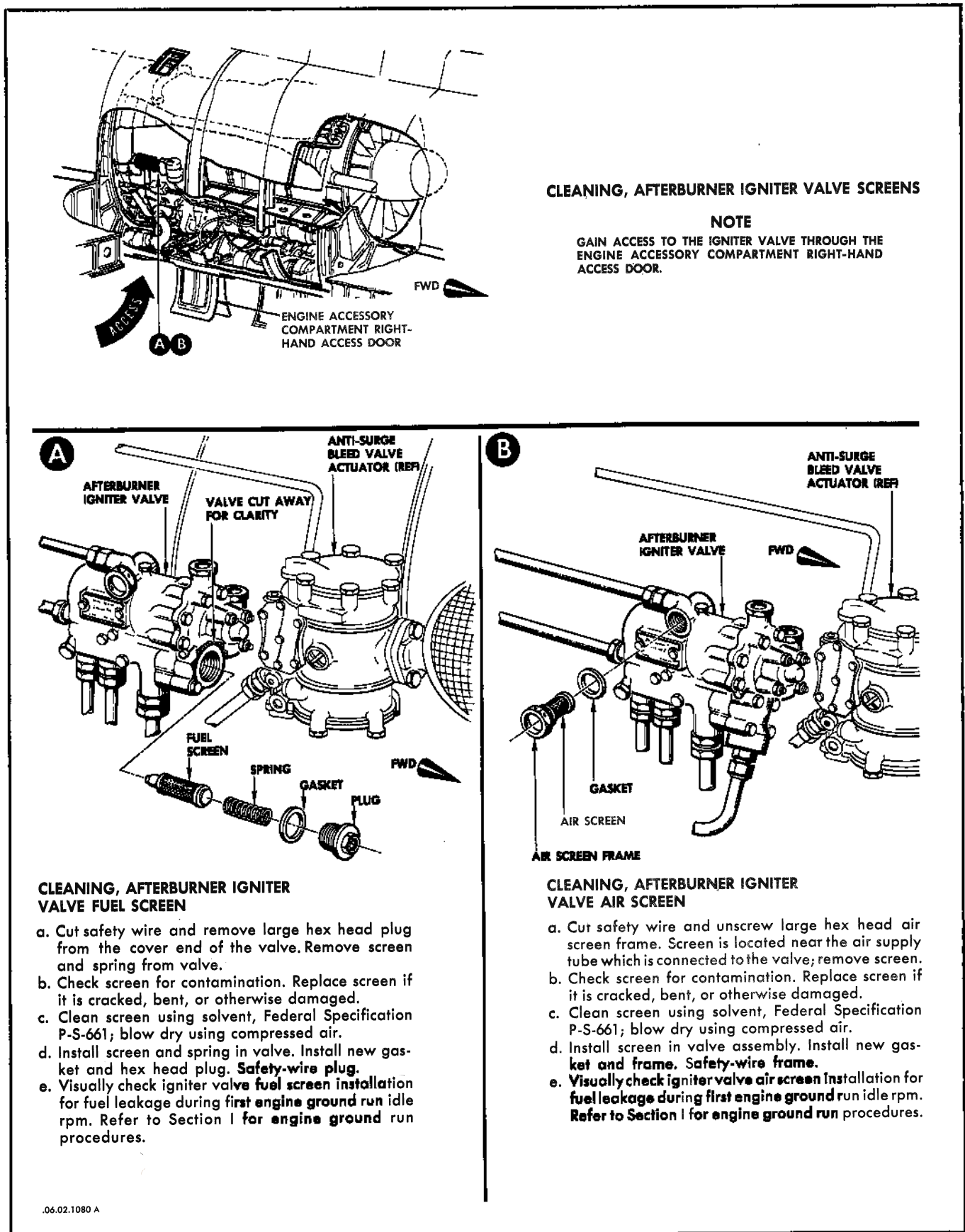

Figure 3-5. Cleaning, Afterburner Igniter Valve Screens



## Section IV

## AIR INDUCTION SYSTEMS

<i>Contents</i>	<i>Page</i>
<b>VARIABLE RAMP SYSTEM</b>	
Description .....	4-1
Operational Checkout .....	4-12
System Analysis .....	4-20
Replacement .....	4-25
Adjustment .....	4-36
Servicing .....	4-36
<b>COOLING AIRFLOW SYSTEM</b>	
Description .....	4-36
Operational Checkout .....	4-45
System Analysis .....	4-47
Replacement .....	4-48
Adjustment .....	4-61

---

**VARIABLE RAMP SYSTEM**

---

**DESCRIPTION**

**4-1. GENERAL.**

The variable ramp system is provided to control the position of shock waves at the inlet duct lip during supersonic flight. Control of the shock waves at supersonic flight speeds is necessary in order to provide the engine with a stable, constant flow of air regardless of airplane speed, and to prevent air spillage at the intake duct lip with resultant aerodynamic drag. The variable ramp assembly in each duct is composed of three hinged, interlocked sections. These sections are automatically positioned to reduce the size of the duct passage and to control the shock wave pattern, providing subsonic airflow to the engine for optimum engine operation. The variable ramp system is controlled by a two position

switch located on the cockpit left-hand switch panel. Switch positions are provided for automatic and emergency operation. The forward edge of the forward ramp section is hinged to the inlet duct, the angle of which may be varied with respect to the airplane centerline. The center ramp section is hinged to the aft side of the forward ramp section and provides a slightly diverging passage through the inlet duct throat. The third section (diverging flow ramp) incorporates a slip joint connection to the aft side of the center section and provides a smooth contour to fair the ramp to the duct wall regardless of the ramp position. The aft side of the aft ramp section is hinged to the inlet duct. The ramp sections are sealed to the top and bottom of the intake

ducts by inflatable seals. These seals are inflated automatically at all times during engine operation, by the airplane low-pressure pneumatic system. A pitot-static probe is installed in the throat of each inlet duct to sense air velocity and pressure through the duct. A normal air flow rate through the ducts is maintained by automatic hydraulic-mechanical positioning of the ramps, resulting in peak engine performance at full power. The ramp total pressure ( $P_t$ ) and static pressure ( $P_s$ ) shuttle valves and the afterburner time delay circuit are incorporated in the system to minimize the effects of ramp inlet duct instability which arise from air flow transients and flight attitudes. Openings are provided in each ramp assembly to bleed low energy boundary layer air out of the intake ducts. This air is routed to the lower side of the fuselage where it is vented overboard. Each variable ramp is extended and retracted by four screw jacks that are driven by flexible shafts from a single hydraulic motor. Hydraulic power for motor operation is derived from the airplane secondary hydraulic system. In the event of hydraulic pressure failure, an emergency source of high-pressure air, stored in a 100 cubic inch flask, can be selected to drive the ramps to the fully retracted position (ducts open). For a data flow diagram of the air induction system, see figure 4-1.

#### 4-2. VARIABLE RAMP CONTROL SYSTEM.

The variable ramp control system consists of an inlet amplifier control unit, hydraulic and pneumatic valves, hydraulic servo motor, and a control switch located in the cockpit. The electrical control system is powered from the 28-volt dc nonessential bus and the 115-volt ac nonessential bus. In the normal or automatic mode of operation, the ramp control circuit is activated by a signal from the air data converter at a specified mach number. The control system is protected by the following fuses:

FUSE	LOCATION
"INLET CONT" 5 amp. (115-volt ac)	Nose wheel well fuse panel.
"INLET CONT" 5 amp. (28-volt dc)	Nose wheel well fuse panel.
"VAR INLET OVERRIDE" 5 amp. (28-volt dc)	Cockpit LH fuse panel.

For schematic illustrations of the variable ramp system, see figures 4-2 through 4-3. The control system operates in two modes: normal and emergency. Either mode can be selected by the pilot. In the normal mode, the system is automatically placed in operation when the airspeed reaches the supersonic range of operation. From this speed on, sensing equipment determines the correct positioning of the ramps for optimum engine operation. System operation is then completely automatic. When the airplane speed decreases to lower supersonic speeds, the system automatically returns the ramps to the retracted position, and actuates the variable ramp retract limit switch, which closes the system hydraulic shutoff valve. If the limit switch fails to operate, the ramp control sys-

tem will be shut off after a delay of 7 to 13 seconds. The normal mode is also equipped with a time delay device that prevents ramp retraction for a period of 1.8 to 2.5 seconds when the engine afterburner exhaust nozzle is either opening or closing. In the emergency mode, all electrical power is removed from the normal control system. The hydraulic dump valve actuates, opening the hydraulic return line from the ramp servo motor and routing the system hydraulic oil to an overboard drain. At the same time a pneumatic selector valve is actuated which routes high-pressure air to the shuttle valve, through the looped retract line to the hydraulic motor. The looped configuration of the retract line serves as a reservoir for hydraulic fluid that is forced through the hydraulic motor by the high-pressure air. This head of fluid provides optimum initial torque and lubrication for motor operation. The motor then drives the ramps to the fully retracted position. *Applicable to F-106A airplanes 57-2453 and F-106B airplanes 57-2517; and all other airplanes after incorporation of TCTO 1F-106-681,* ramp emergency retract time is increased from 2.0 seconds to 5.5 seconds by a restrictor installed in the pneumatic inlet port of the shuttle valve. This extended travel time prevents abrupt cessation of movement when the ramps contact the mechanical stops, thus eliminating possible shearing of the gear teeth or the gear box shaft. As air from the pneumatic system fills the supply line to the hydraulic motor, a pressure switch opens the circuit to a hydraulic shutoff valve. This prevents hydraulic drive power from being restored to the ramp system as long as air pressure is present. For a schematic illustration of the ramp emergency operation, see figure 4-3. When the normal mode of operation is restored, the high-pressure air is then vented by closing of the pneumatic valve; and the hydraulic dump valve then returns to normal operating condition. When the pneumatic pressure in the hydraulic motor supply line drops to 50 psi, the line pressure switch closes, restoring electrical power to the hydraulic shutoff valve. See figures 4-4 and 4-5 for illustrations of the variable ramps and for locations of the ramp system components.

#### 4-3. VARIABLE RAMP SEAL SYSTEM.

The variable ramp seal system is provided to prevent entry of ram air into the area between the fuselage and the inboard side of the variable ramp sections. Each ramp section is equipped with an inflatable rubber boot installed in the outer edge of each ramp section. The boots are automatically inflated during engine operation by compressed air from the airplane low-pressure pneumatic system. Inflation of the boots at the upper and lower surfaces of each ramp section presses silicone rubber seal strips against the inner surface of the inlet ducts to seal the areas. In the areas of the ramp section hinges, the boots inflate and fill the hinged area. The seal pressurization system is protected by a relief valve and a safety valve. The relief valve is set to actuate at 16 ( $\pm 1.5$ ) psi pressure. The safety valve is set to actuate at 30 ( $\pm 1.5$ ) psi pressure. For a schematic illustration of the ramp seal system, see figure 4-6.

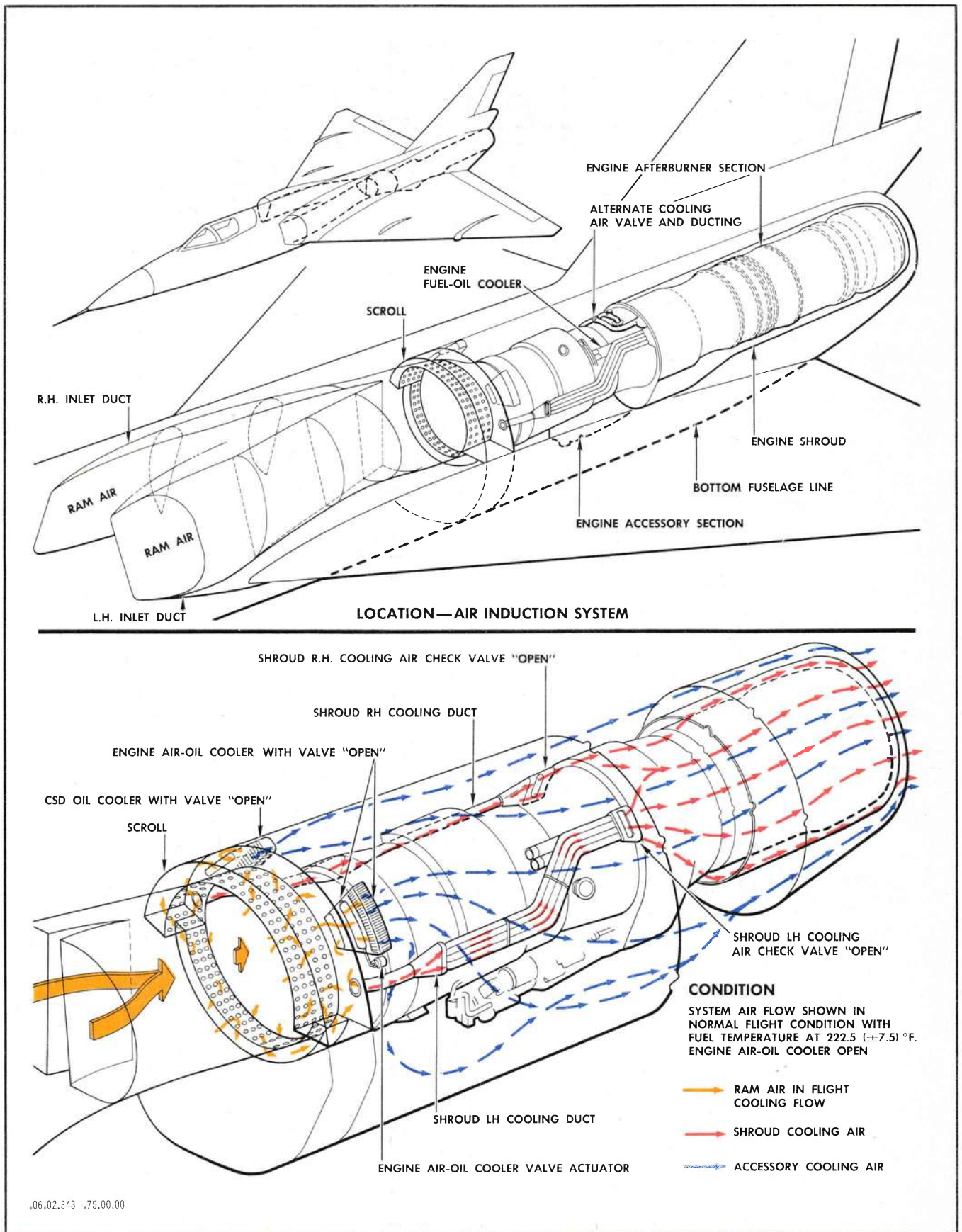
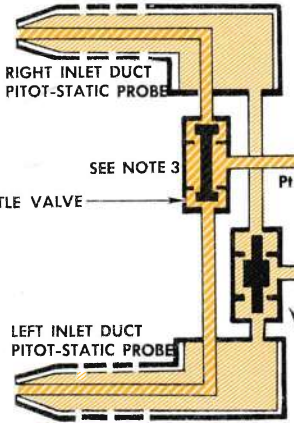

Figure 4-1. Air Induction System Flow Diagram

ENGAGE AND SIGNAL COMPONENTS



CONDITION SYSTEM SHOWN IN NORMAL OPERATION; RAMPS BALANCED

VARIABLE INLET CONTROL UNIT

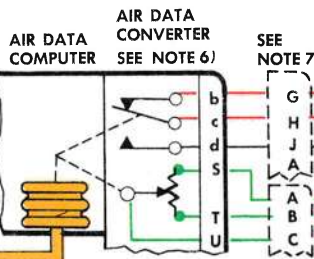
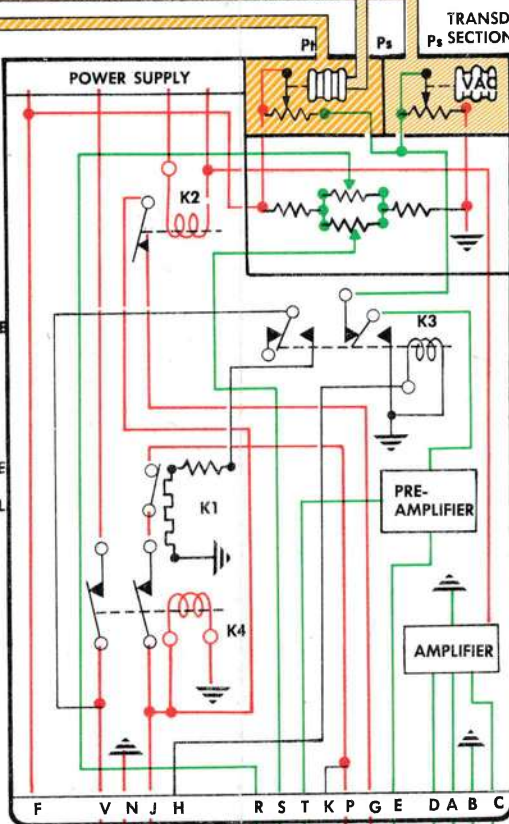

FROM NOSE BOOM

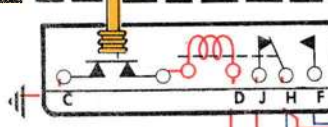

WARNING COMPONENTS

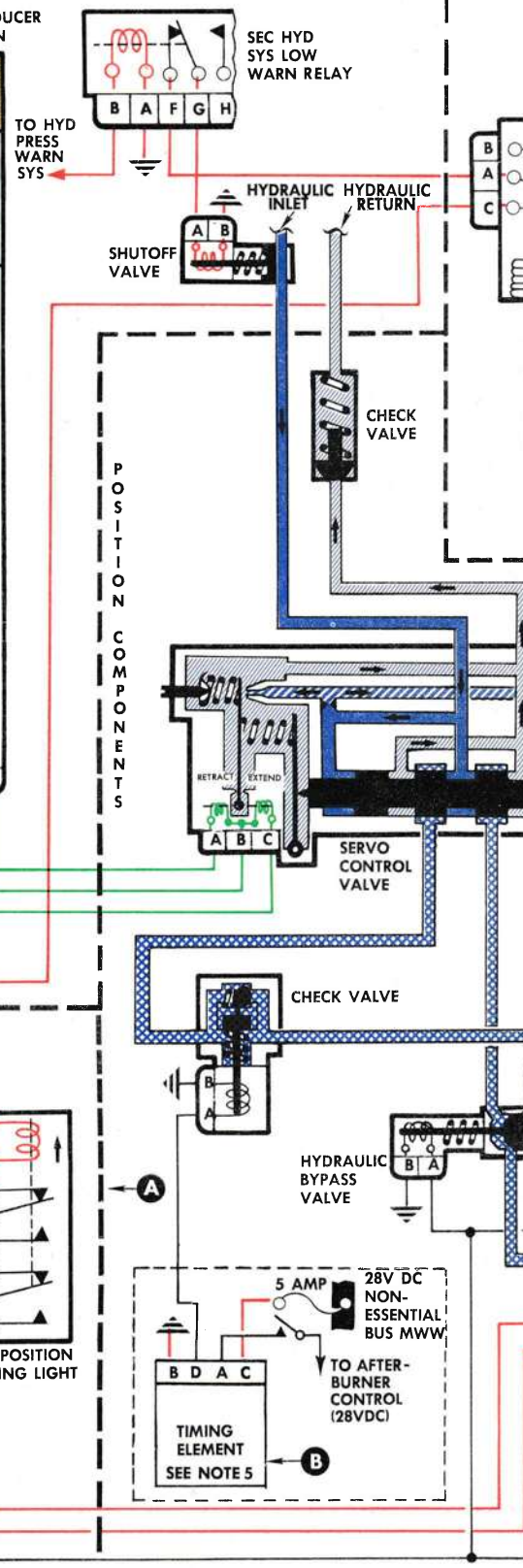
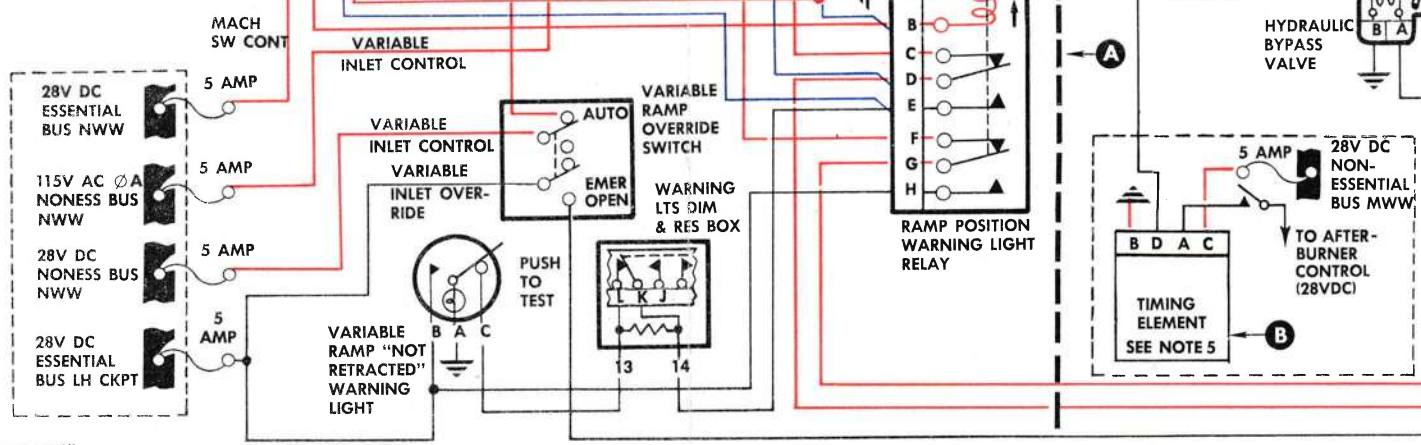

POSITION COMPONENTS

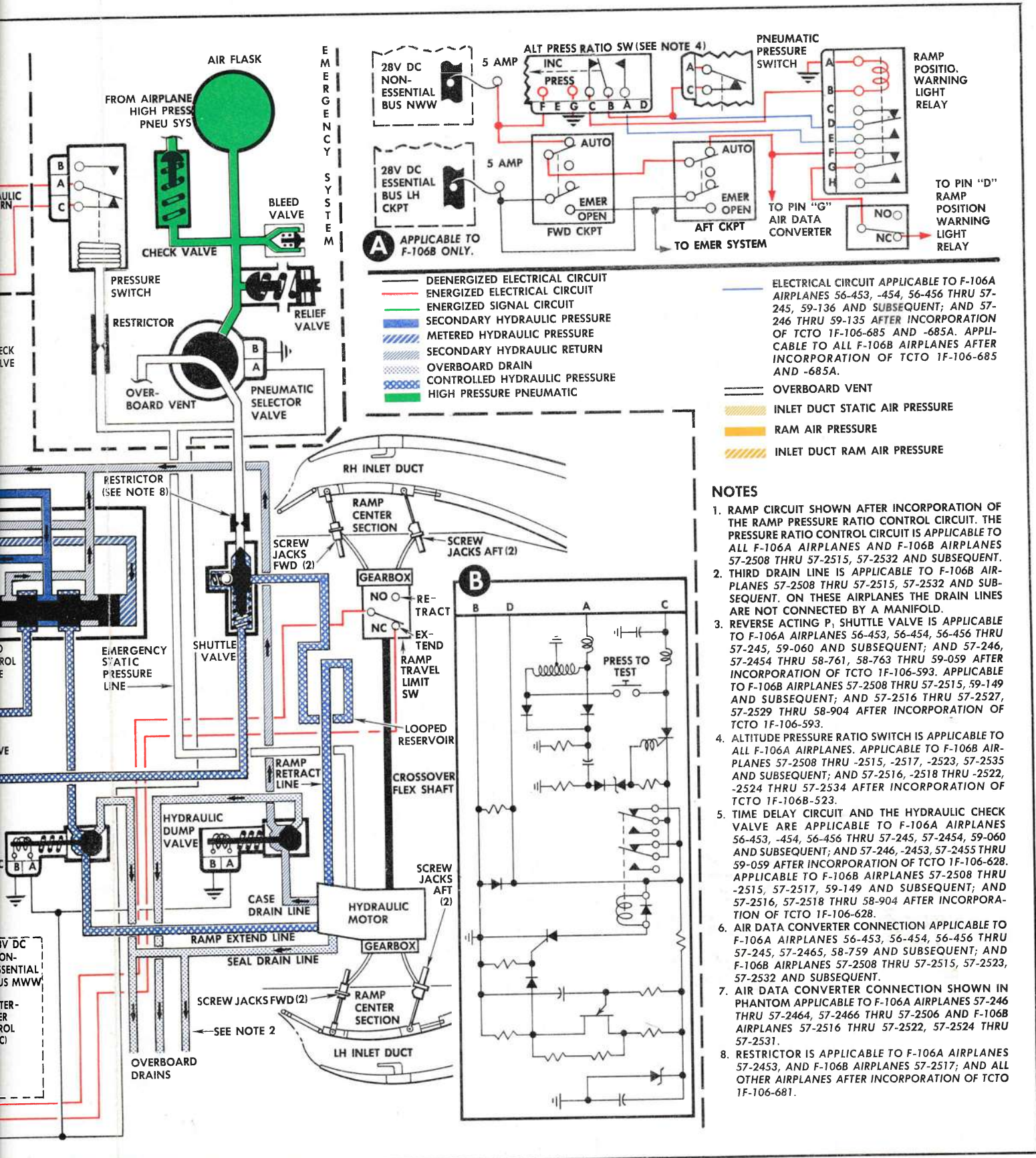

Figure 4-2. Variable Ramp System With Inlet Control Unit 8-06474-1, -3, -5, or -7





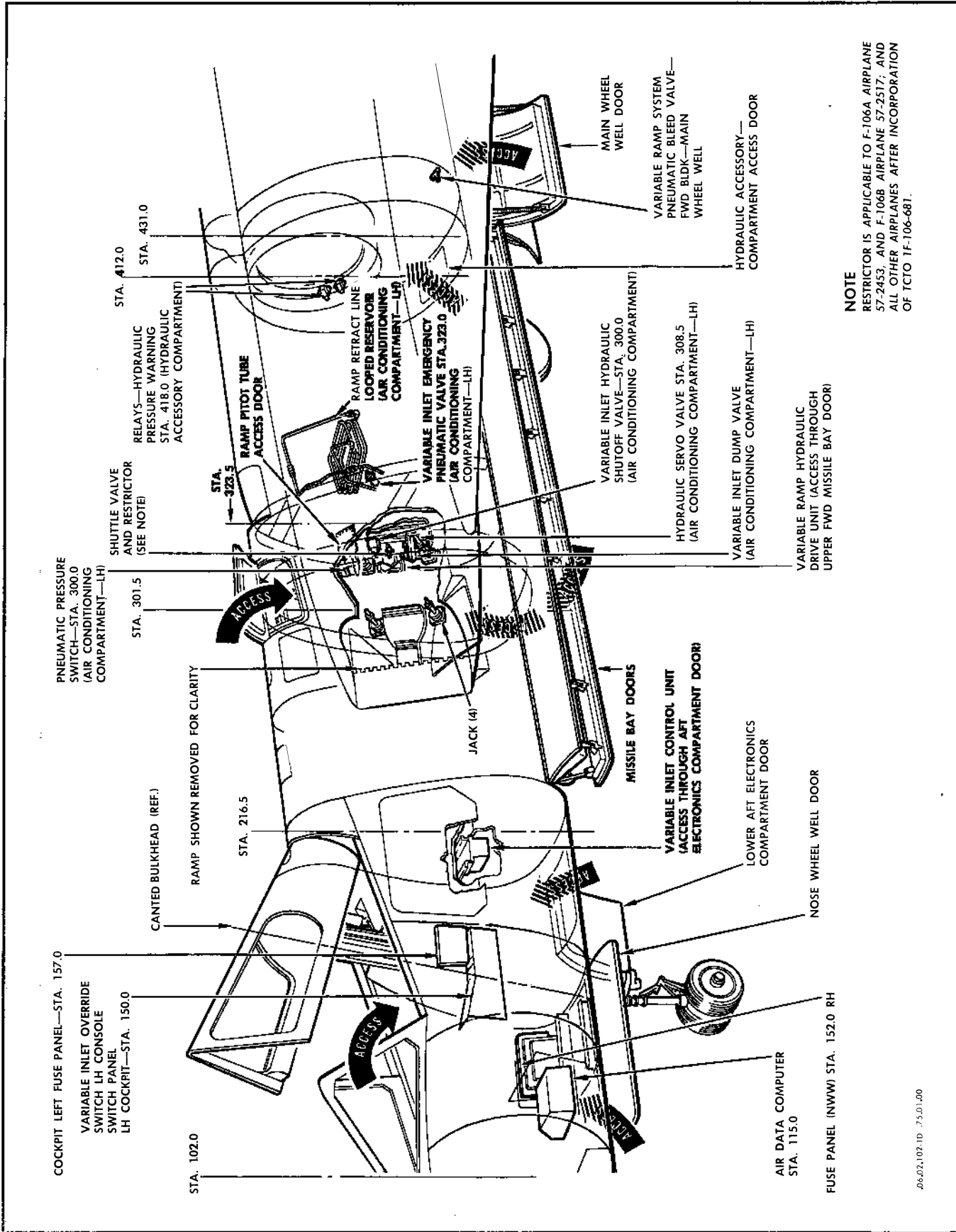

Figure 4-4. Variable Ramp System, Component Location

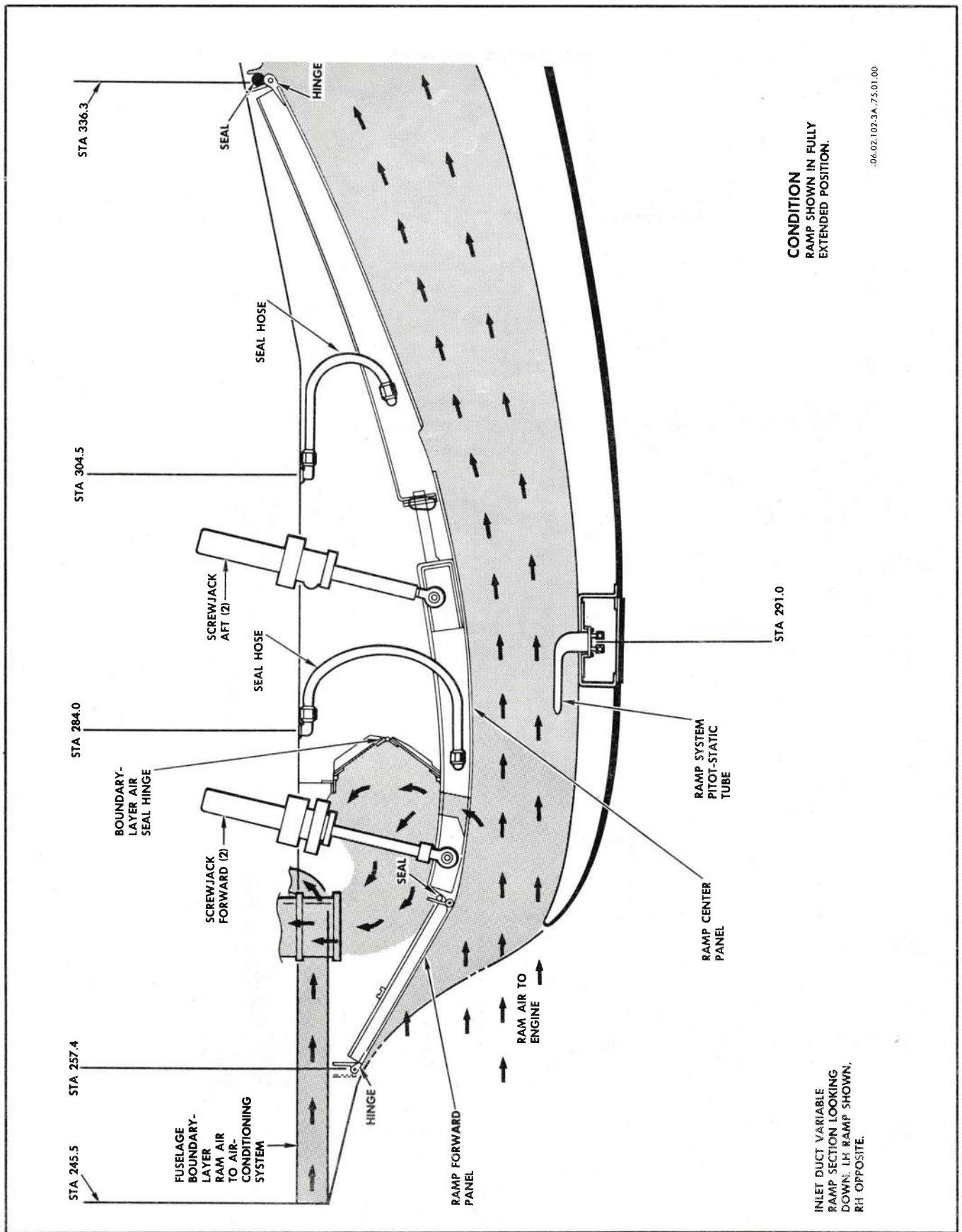

Figure 4-5. Variable Ramp

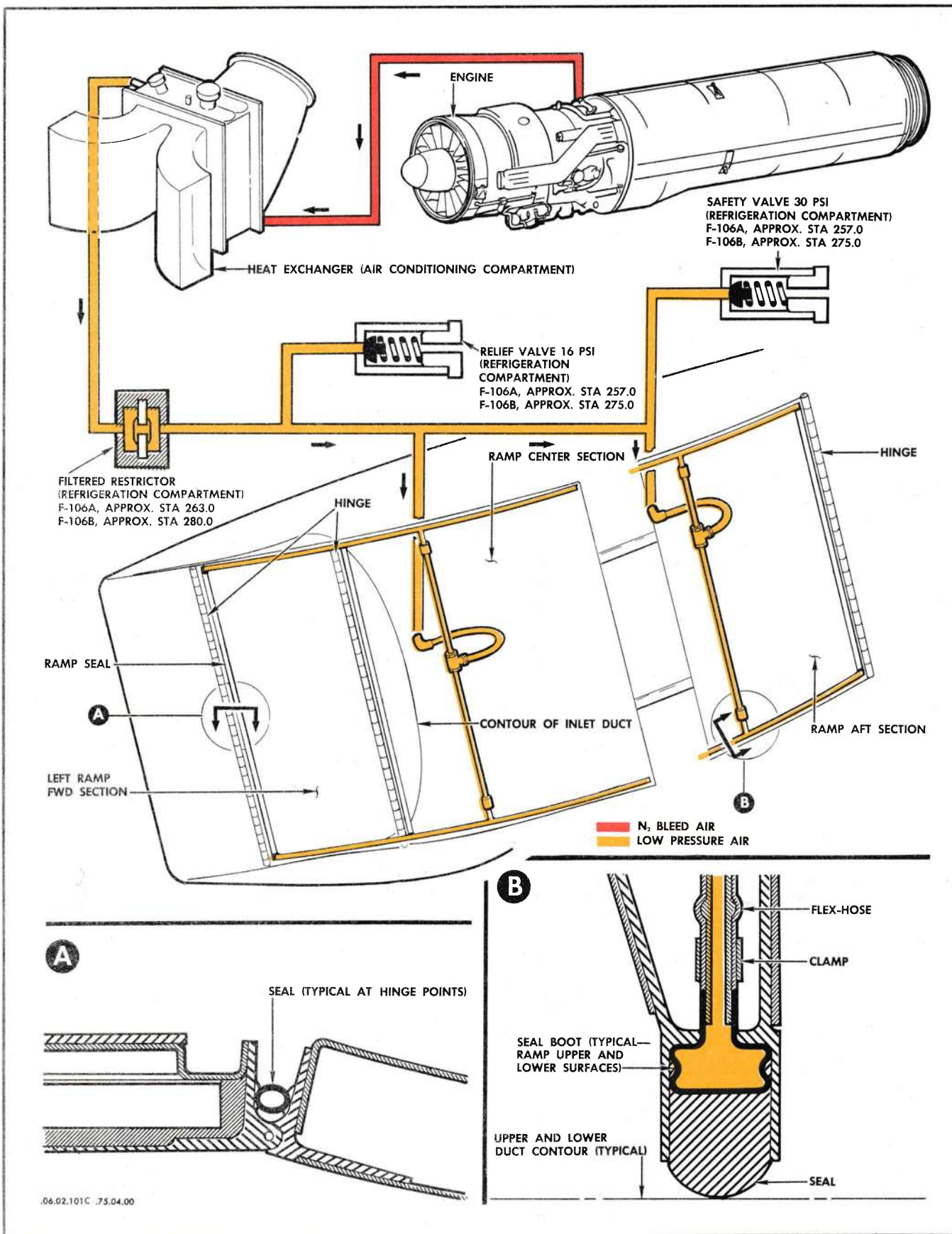

Figure 4-6. Variable Ramp Seal System, Schematic

#### 4-4. VARIABLE RAMP EMERGENCY PNEUMATIC SYSTEM.

Air for emergency operation of the variable ramps is obtained from an isolated flask in the airplane high-pressure pneumatic system. The flask is isolated from the aircraft pneumatic system by a check valve, to provide sufficient air to drive the ramps from the fully extended to the fully retracted positions. A pressure relief valve is installed in the system adjacent to the flask to relieve pneumatic pressure in excess of 3200 psi. The flask is installed in the right side of the air conditioning compartment at sta. 316.0. A screw type air bleed valve is installed in the forward side of the left main wheel well to bleed air pressure from the flask and system. Filling of the ramps pneumatic system is accomplished by normal filling of the airplane high-pressure pneumatic system. Refer to T.O. 1F-106A-2-3 for the pneumatic system filling procedure.

#### NOTE

It will be necessary to purge the ramp hydraulic system of air after each emergency operation. Refer to paragraph 4-71 for this procedure.

#### 4-5. VARIABLE RAMP CONTROL UNIT.

The variable ramp control unit, installed on the left side of the aft lower electronics compartment, is the major control component of the variable ramp system. The control unit consists of a pressure ratio sensor, a ramp retract relay, a servo amplifier, and a time delay circuit. The control unit, which is of the variable set point type, is shown in figure 4-2. The desired signal voltage to the pre-amplifier is varied as a function of airplane mach by the air data converter.

#### NOTE

Pressure ratio in the variable ramp system application is not to be construed as the pressure ratio indicating engine operational thrust.

The error signal from the pre-amplifier is amplified and is then routed to the hydraulic servo valve that controls the hydraulic motor operation.

#### 4-6. VARIABLE RAMP SERVO CONTROL VALVE.

The variable ramp servo control valve is an electrically controlled, hydraulically operated valve installed in the left side of the air conditioning compartment at sta. 308.0. The electrical control consists of two solenoids that position a flapper-type pilot valve across the face of the valve hydraulic orifice. The solenoids receive signals that reflect duct over-pressure or under-pressure from the ramp system control unit. These pressure ratio error signals acting on the solenoids result in pilot valve positioning which determines the direction the hydraulic motor will position the ramps. With full displacement of the pilot valve, the hydraulic motor can drive the ramps through their full travel in approximately 6 seconds. Dur-

ing system operation, as the servo motor drives the ramps toward the desired position, the duct air pressure ratio also changes toward the desired condition. The system control unit senses the change and the correction signal to the servo control valve decreases. When the correct ramp position has been reached, the correction signal from the control unit cancels out and the ramp movement stops.

#### 4-7. AIR DATA CONVERTER.

The air data converter, installed on the left side of the nose wheel well compartment, supplies the factor of airplane mach to the variable ramp control system. When the variable ramp selector switch is in the automatic mode, the mach data is used to turn the ramp system on or off electrically, and provide for variation of the ramp set point. For additional information on the function of the air data converter, refer to T. O. 1F-106A-2-14 and -2-15.

#### 4-8. VARIABLE RAMP HYDRAULIC MOTOR.

The variable ramps are powered by a reversible hydraulic motor installed adjacent to the left ramp assembly, between the two aft jacks. The motor assembly consists of a piston type hydraulic motor, a reduction gear assembly, and a torque sensitive brake. The hydraulic motor is connected to the ramp jack assemblies through a system of flexible shafts and adapters. When ramp movement is desired, hydraulic pressure is directed to the motor, causing the torque sensitive brake to release. This action permits the motor to move the ramps to the desired setting. Upon completion of the desired ramp movement, hydraulic pressure to the motor is terminated, causing the torque sensitive brake to engage. Ramp movement, due to imposed flight air loads, is prevented by the engagement of the brake.

#### 4-9. VARIABLE RAMP CONTROL SWITCH.

The "VAR INLET" ramp control switch is a two position switch located in the cockpit above the left-hand console on the left-hand switch panel. The switch is placarded for "AUTO" and "EMER OPEN" positions. The switch provides the pilot with a means of opening the ramps in case of any automatic system malfunction.

#### 4-10. VARIABLE RAMP RETRACT LIMIT SWITCH.

The variable ramp retract limit switch is a cam actuated micro switch assembly installed adjacent to the right-hand ramp flex drive gear box. As the ramps near the full retract position, the cam lobe contacts the micro switch causing the switch to deactuate. This action removes electrical power from the ramp system solenoid hydraulic shutoff valve, causing the valve to close. This prevents further retraction of the ramps. An adjustment feature is incorporated in the cam assembly that permits adjustment without removing the cam from the switch assembly. Access to the cam and switch assembly is through an access plate on the switch assembly housing.

**4-11. ALTITUDE PRESSURE RATIO SWITCH.**

*Applicable to all F-106A airplanes and F-106B airplanes 57-2508 thru 57-2515, 57-2523 and 57-2532 and subsequent.* An altitude pressure ratio switch is incorporated in the variable ramp control system to provide an alternate indication that the airplane mach has decreased below the ramp system cutoff point. This equipment is provided so that air data computer failure in the ramp system operational range will not deactivate the ramp warning light circuit. The switch assembly is a bellows actuated unit that is energized by pitot pressure from the instrument pitot-static system. Electrical power for the circuit is derived from the 28-volt dc essential bus through a 5-amp fuse located on the nose wheel well fuse panel. The switch assembly also incorporates functions for the F-106A airplane CG fuel transfer system. Refer to T. O. 1F-106A-2-5 for switch replacement information.

**4-12. VARIABLE RAMP TIME DELAY.**

*Applicable to F-106A airplanes 56-453, -454, 56-456 thru 57-245, 57-2454, 59-060 and subsequent; and 57-246, -2453, 57-2455 thru 59-059 after incorporation of TCTO 1F-106-628. Applicable to F-106B airplanes 57-2508 thru -2515, 57-2517, 59-149 and subsequent; and 57-2516, 57-2518 thru 58-904 after incorporation of TCTO 1F-106-628.* The variable ramp time delay is a relay circuit located in the lower aft electronics compartment. The delay unit is equipped with a test switch. Whenever the afterburner switch in the throttle quadrant is actuated (A/B "OFF" or A/B "ON") the delay circuit is energized which acts through a solenoid actuated hydraulic check valve to prevent ramp retraction for 1.8 to 2.5 seconds. The ramps will respond normally to the auto mode extend signals during the time delay period.

**CAUTION**

Do not depress the variable ramp time delay test switch while the engine is operating. Depressing the test switch during engine operation will energize the afterburner control circuit.

**4-13. HYDRAULIC SOLENOID SHUTOFF VALVE.**

The hydraulic solenoid shutoff valve is a two position valve installed in the variable ramp hydraulic system up stream of the ramp servo control valve. The valve is energized to the open position, and closes when the ramps are in the fully retracted position or when ramp emergency operation occurs. Closing of the valve prevents further entry of hydraulic power to the ramp drive system. The valve is energized through the secondary hydraulic system low-pressure warning relay. Deactuation of the relay prevents hydraulic operation of the ramps when the secondary hydraulic system pressure is below 900 psi. At this time, emergency actuation must be selected for ramp retraction. The valve is installed on the left side of the air conditioning compartment at sta. 300.0.

**4-14. HYDRAULIC DUMP VALVE.**

The hydraulic dump valve, installed on the left side of the air conditioning and refrigeration compartment, is incorporated in the ramp system to route hydraulic fluid, in the ramp system plumbing, overboard at the time of ramp emergency operation. The valve is normally closed and actuates upon selection of the ramp control system to the emergency open position. This action permits fast evacuation of hydraulic fluid and enables the ramps to retract in a minimum amount of time.

**4-15. HYDRAULIC CHECK VALVE (RAMP RETRACT LINE).**

*Applicable to F-106A airplanes 56-453, -454, 56-456 thru 57-245, 57-2454, 59-060 and subsequent; and 57-246, -2453, 57-2455 thru 59-059 after incorporation of TCTO 1F-106-628. Applicable to F-106B airplanes 57-2508 thru -2515, 57-2517, 59-149 and subsequent; and 57-2516, 57-2518 thru 58-904 after incorporation of TCTO 1F-106-628.* This hydraulic check valve is solenoid actuated by the variable ramp time delay circuit. During the 1.8 to 2.5 second delay period that the circuit is energized, the check valve prevents hydraulic retract pressure from being applied to the drive motor. This prevents retraction of the ramps when going in or coming out of afterburner. Refer to paragraph 4-12 for a description of the variable ramp time delay system.

**4-16. SHUTTLE VALVE (HYDRAULIC-AIR).**

The ramp system shuttle valve is a spring loaded two position valve installed in the ramp retract line between the servo control valve and the hydraulic motor. During the system automatic operation, the shuttle valve is spring positioned to permit flow of hydraulic oil from the hydraulic motor back to the servo control valve. Upon selection of the emergency open position, high-pressure air moves the shuttle valve to the second position. This action within the shuttle valve blocks off the hydraulic oil flow from the servo valve and routes the high-pressure air to the ramp motor retract port. The motor then operates until the ramps are in the fully retracted position. The valve remains in the second position until the system selector is returned to the automatic position. The shuttle then returns to the first position.

**4-17. SHUTTLE VALVE (RAMP STATIC PRESSURE SENSE).**

The ramp system static pressure sense line shuttle valve is a two position valve installed at the juncture of the static lines from the left and right engine air inlet duct pitot-static probes. During airplane operation, flight conditions can occur that will produce an unbalanced static pressure condition between the two engine air inlet ducts. This condition will automatically cause the shuttle valve to close off the low-pressure side, and will route the high-pressure to the ramp inlet control unit. The valve will always sense and position to the duct having the highest static pressure.

#### 4-18. SHUTTLE VALVE (RAMP TOTAL PRESSURE SENSE).

Applicable to F-106A airplanes 56-453, -454, 56-456 thru 57-245, 59-060 and subsequent; and 57-246, 57-2454 thru 58-761, 58-763 thru 59-059 after incorporation of TCTO 1F-106-593. Applicable to F-106B airplanes 58-2508 thru 57-2515, 59-149 and subsequent; and 57-2516 thru 57-2527, 57-2529 thru 58-904 after incorporation of TCTO 1F-106-593. The function of the reverse-acting ramp total pressure ( $P_t$ ) shuttle valve is to permit the lower of the two duct total pressures to be sensed by the variable ramp control unit. When decreasing pressure is applied to one duct sensing probe, the shuttle valve seals off the other duct sensing probe, allowing flow from the low pressure duct to the control unit.

#### 4-19. PNEUMATIC PRESSURE SWITCH

The pneumatic pressure switch is installed on the left side of the air conditioning compartment. This switch is incorporated in the variable ramp system to prevent introduction of hydraulic pressure into the ramp system during emergency operation, regardless of the position of the variable ramp control switch, until the pneumatic pressure drops to approximately 50 psi. At this pressure the switch closes allowing restoration of electrical power to the hydraulic shutoff valve.

#### 4-20. PNEUMATIC SOLENOID VALVE.

The pneumatic solenoid valve is a three way, two position valve installed on the left side of the air conditioning compartment. The valve is incorporated in the ramp system to control high-pressure air flow for ramp emergency operation. At the time of emergency operation, the valve actuates, permitting high-pressure air to enter the system to drive the ramps to the fully retracted position. Upon selection of the ramps to the automatic system, the valve repositions, shuts off the air pressure source, and vents air pressure from the ramp system plumbing.

#### 4-21. EMERGENCY AIR STORAGE FLASK.

The emergency air storage flask is a fiberglass sphere located just forward and to the right of the main air flask between sta. 316.0 and 323.5. The flask is a part of the high-pressure pneumatic system, and is isolated for use by the variable ramp system by a check valve. Sufficient air is contained in the flask, when fully charged to 3000 psi pressure, for one operation of the ramps from the fully extended to the retracted position. Filling of the flask is accomplished during normal filling of the high-pressure pneumatic system. For servicing of the high-pressure pneumatic system, refer to T.O. 1F-106A-2-3.

#### 4-22. EMERGENCY PNEUMATIC SYSTEM CHECK VALVE.

The emergency pneumatic system check valve is a poppet type valve installed between the airplane high-pressure pneumatic system and the variable ramp emergency pneumatic system. The valve is located on the left side of the

hydraulic accessory compartment, just forward of sta. 431.0. As the main pneumatic system air pressure drops from use, the check valve closes and prevents the ramp supply system air from flowing back into the main system. This isolates sufficient air for one operation of the ramps from the fully extended position to the fully retracted position.

#### 4-23. RAMP SYSTEM PNEUMATIC BLEED VALVE.

The variable ramp emergency pneumatic system is equipped with a screw type bleed valve installed on the forward left side of the main wheel well. The valve is installed adjacent to the main high-pressure pneumatic system bleed valve. Refer to T.O. 1F-106A-2-3 for the ramp pneumatic system bleeding procedure.

#### 4-24. VARIABLE RAMP NOT RETRACTED WARNING SYSTEM.

An amber variable inlet warning light, placarded "VARIABLE RAMP NOT RETRACTED," is located on the pilot's main instrument panel on F-106A airplanes, and on the forward and aft main instrument panels on F-106B airplanes. The light illuminates to indicate that the variable ramps have not retracted. Retraction normally occurs when the airplane decelerates to below mach 1.20. During emergency operation, the light will remain illuminated until the ramps have fully retracted. The warning light receives 28-volt dc power from the essential bus through a 5-ampere circuit fuse in cockpit left-hand fuse panel. Power is directed to the warning light when the variable ramp control unit deenergizes a ramp position warning light relay. With the ramp position relay deenergized, electrical power is free to pass through the variable ramp retract limit switch to the warning light if the switch is still in the extended position. The position warning light relay is installed on the right side of the nose wheel well compartment. The variable ramp not retracted warning light is a push-to-test type light. The variable ramp not retracted warning system is an integrated part of the variable ramp control circuit. Refer to T.O. 1F-106A-2-9 for additional information on this system.

#### 4-25. SAFETY PRECAUTIONS, MAINTENANCE OF PNEUMATICALLY OPERATED SYSTEMS.

Observe the following precautions to prevent injuries due to air blast, and to prevent inadvertent operation of the system in work, or other pneumatically operated systems not in work:

a. Prior to disconnection of pneumatic lines or removal of components on any system powered by high-pressure air, ascertain that the pressure in the entire system is relieved. To relieve pneumatic system pressure, refer to T.O. 1F-106A-2-3.

b. Before reapplying the high-pressure air, check that all components or systems powered by high-pressure air are properly connected. Check that control valves and switches for all pneumatically operated systems are properly positioned to prevent inadvertent operation and injury to personnel.

<b>OPERATIONAL CHECKOUT</b>
-----------------------------

**4-26. OPERATIONAL CHECKOUT AND TEST, VARIABLE RAMP SYSTEM.****4-27. Equipment Requirements.**

FIGURE	NAME	TYPE	ALTERNATE	USE AND APPLICATION
Refer to T. O. 1F- 106A-2-10	Generator Set (Gas).	8-96026-801 AF/M32A-13 (6115- 583-9365)	8-96026 AF/M32M-2 (6115-617- 1417)	To energize electrical systems on aircraft equipped with special quick disconnect receptacle.
	Generator Set (Elec).	8-96025-803 AF/ECU- 10/M (6125-583- 3225)	8-96025-805 A/M24M-2 (6125-628- 3566)	
			8-96025 AF/M24M-1 (6125-620- 6468)	
	Generator Set.		MC-1 (6125-500- 1190)	
MD-3 (6115-653- 5595)				
Adapter Cable.	8-96052 (6115-557- 8548)		To connect MC-1 and MD-3 units to aircraft equipped with special quick disconnect receptacle.	
Refer to T. O. 1F- 106A-2-3.	Portable Hydraulic Test Stand (Gas).	SE 1061-801 (4920-670- 9415)	SE 1061 (4920-517- 1028)	To supply pressure to hydraulic systems for ground test.
			SE 0567-801 (4920-204- 2462)	
	Portable Hydraulic Test Stand (Elec).	SE 0976-801 (4920-675- 4258)	SE 0976 (4920-204- 3115)	



**4-27. Equipment Requirements (Cont).**

FIGURE	NAME	TYPE	ALTERNATE	USE AND APPLICATION
Refer to T.O. 1F- 106A-2-3 (cont).	Hydraulic hose support.	8-96193 (4920-621- 3011)		To support hydraulic test stand return hose.
	Adapter (2 each).	8-96080 (4620- 566-8882)		Used with SE0567 or SE0567-801 to connect test stand hoses to quick disconnect fittings.
	Adapter Kit.	SE 1093		Used with SE1061; MJ-2 or MK-3 to connect test stand hoses to quick disconnect fittings.
4-7 4-8	Tester, Variable Ramp Control.	8-96051-803 (1730-710- 7310)	8-96051-801 (4920-623- 2177)	To check operation of the variable ramp system.
Refer to T.O. 1F- 106A-2-9.	Pitot-Static System Field Tester.	MB-1 (6635-334- 7433)	Equivalent	To supply air pressures for testing ramp retract warning light.
	Multimeter.	USAF TS-505B/U (6625- 620-6366)		To measure variable ramp system electrical values.
	Steel Scale.	6 inches in length		To measure ramp travel.

**4-28. Preparation.**

a. Connect external electrical power source to the airplane electrical power receptacle. Refer to T.O. 1F-106A-2-10 for this procedure.

b. Connect external hydraulic test stand to the airplane hydraulic system. Refer to T.O. 1F-106A-2-3 for this procedure.

c. Apply external electrical power to airplane.

d. Connect ramp control tester pneumatic lines to ramp pitot tubes in inlet duct as shown on figure 4-7 or 4-8.

**NOTE**

The variable ramp system can be functionally checked using only the pneumatic portion of the variable ramp tester. Use the electrical connections for detailed tests and troubleshooting.

e. Attach pneumatic lines to tester  $P_s$  (static) and  $P_t$  (pitot) fittings; pressure and vacuum supply valves, and  $P_s$  and  $P_t$  valves on tester are to be closed.

f. Start hydraulic test stand and set secondary pressure system at 1500 psi.

g. Check that following fuses are installed:

1. "VAR INLET OVERRIDE" Cockpit left fuse panel.

2. "INLET CONTROL" 28-volt dc Nose wheel well fuse panel.

3. "INLET CONTROL" 115-volt ac Nose wheel well fuse panel.

4. "HYDRAULIC PRESS WARN" Cockpit right fuse panel.

5. "AIR DATA COMPUTER" Nose wheel well fuse panel.

6. "MACH SW CONT" Nose wheel well fuse panel.

h. Check that the ramp cockpit control switch is in the "AUTO" position.

i. Connect the MB-1 pitot-static system tester to the airplane nose boom pitot-static probe. Refer to T.O. 1F-106A-2-9 for this procedure.

**4-29. Procedure, Automatic Operation Check.****CAUTION**

To prevent serious damage to the air data computer and variable ramp control unit during the Automatic Operation Check Procedure, static pressure ( $P_s$ ) must not be allowed to exceed pitot pressure ( $P_t$ ).

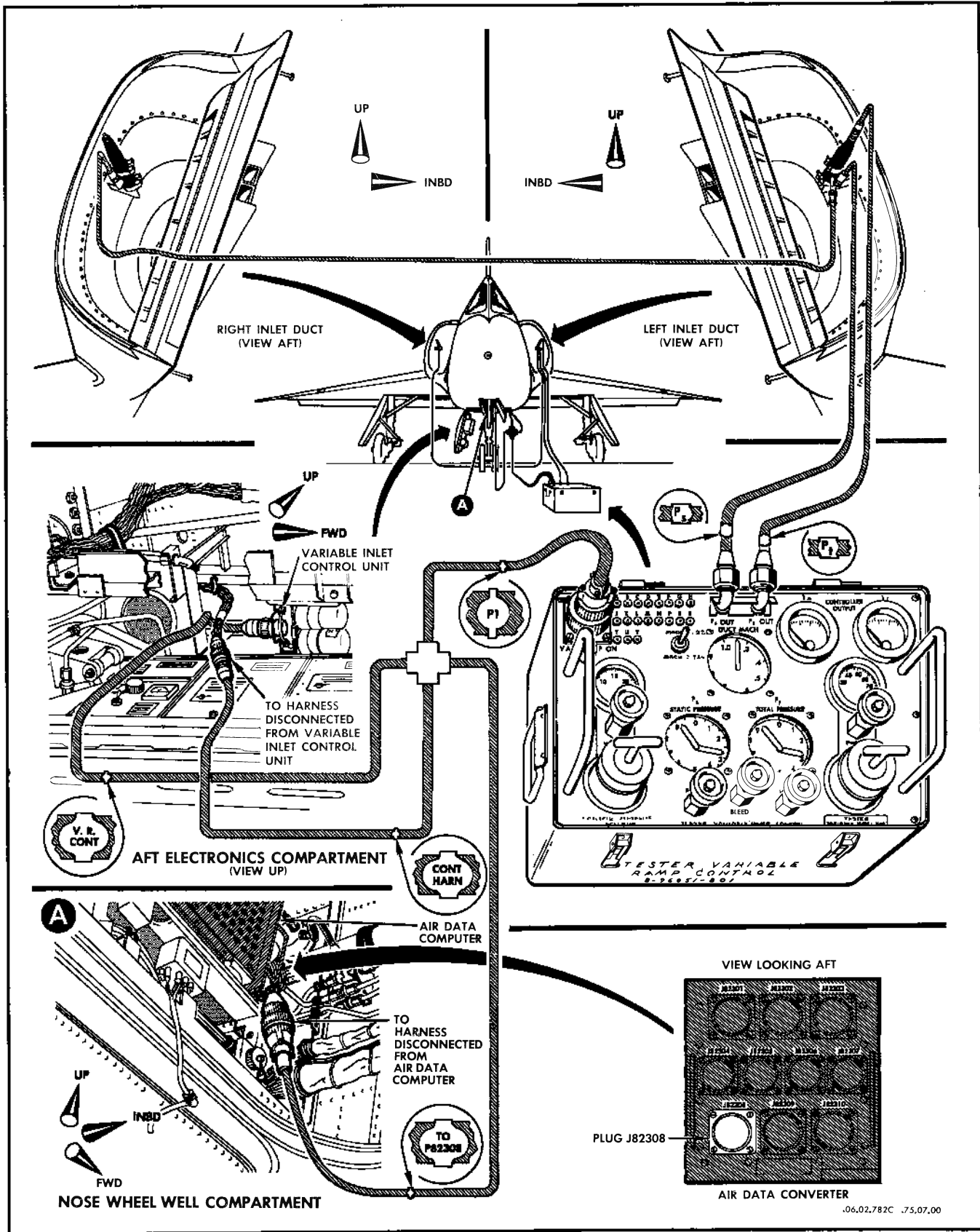

.06.02.782C .75.07.00

**Figure 4-7. Connecting Variable Ramp Tester, 8-96051-801**  
 Applicable to F-106A airplanes 57-246 thru 57-2464, 57-2466 thru 57-2506,  
 and F-106B airplanes 57-2515 thru 57-2522, 57-2524 thru 57-2531

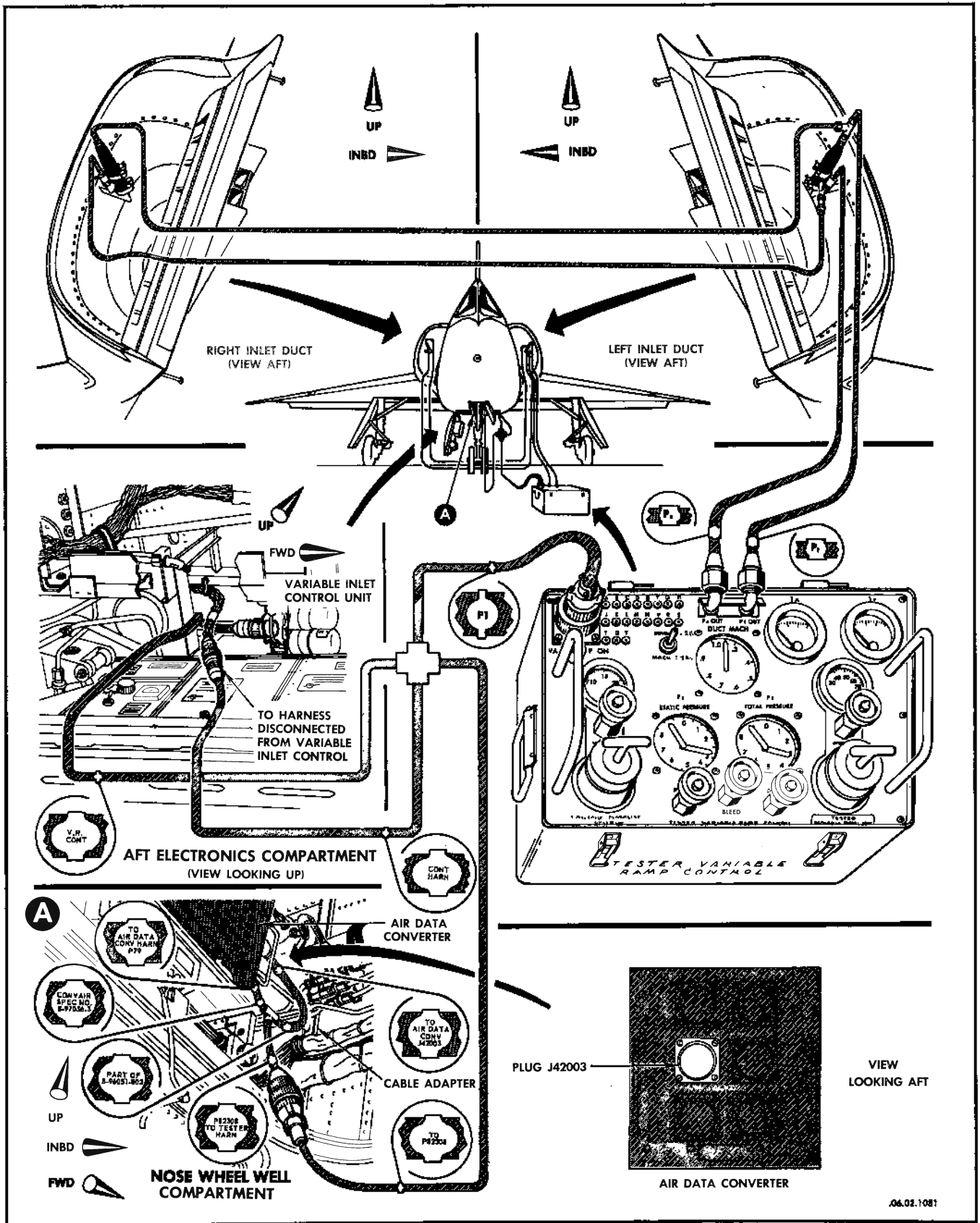

Figure 4-8. Connecting Variable Ramp Tester, 8-96051-803  
 Applicable to F-106A airplanes 56-453 thru 57-245, 57-2465, 58-759 and subsequent;  
 and F-106B airplanes 57-2507 thru 57-2514, 57-2523, 57-2532 and subsequent

a. Pump up pressure on MB-1 tester to establish cockpit mach indicator reading of 1.8. Ramps shall move to the fully extended position.

b. Prior to incorporation of ARDC instrument system, position the cockpit radar switch to "STAND BY."

c. Pump ramp tester pressure supply to 40 inches Hg. Increase secondary hydraulic system pressure to 3000 psi.

**CAUTION**

During the operational checkout period, while the secondary hydraulic system is set at 3000 psi pressure, care must be taken to avoid application of rapid changes in air pressure or vacuum to the ramp system. This care is necessary to prevent fast ramp movement to the limits of travel and resultant damage to ramp mechanisms. This fast ramp movement can occur only during ground operation, since air loads in flight dampen ramp action.

d. Open pressure supply valve. Slowly open  $P_t$  valve, to increase system  $P_t$ , until ramps start to retract.

**NOTE**

Proper checkout requires that ramp movement be detected as soon as possible. Place finger firmly at the juncture of the ramp center section and the inlet duct wall just aft of the center forward hinge.

Hold  $P_t$  constant at this point. Ramp retract movement to the fully retracted position indicates proper  $P_t$  operation. Note tester duct mach indicator reading. Reading shall be as shown in column B of the following table; these values indicate correct control unit set point function. Note readings.

RAMP INLET CONTROL UNIT PART NUMBER	RAMP TESTER MACH READING	
	A	B
8-06474-1	0.74 to 0.78	0.79 to 0.83
8-06474-3	0.63 to 0.67	0.74 to 0.78
8-06474-5		
8-06474-7		

e. Close tester pressure supply valve, and slowly open tester bleed valve enough to decrease  $P_t$  pressure until ramps start to extend. Hold  $P_t$  reading at this point. Ramps shall move to the fully extended position.

f. Note tester duct mach reading. Reading shall be within 0.01 of reading taken in step "d."

g. Close  $P_t$  valve on tester and wait 3 minutes. Tester duct mach reading shall not vary more than 0.03 from the mach indicator reading noted in step "d."

h. Open tester  $P_t$  and bleed valves; permit  $P_t$  indication to return to ambient.

i. Pump tester vacuum supply to 20 inches Hg.

j. Close tester  $P_t$  and bleed valves; open tester vacuum supply valve. Slowly open  $P_s$  valve to decrease  $P_s$  until ramps start to retract. Hold  $P_s$  indication at this point. Observe the following:

1. Ramps shall move to full retract position.
2. Tester duct mach indicator reading shall be as shown in Column B of table in step "d"; note readings.

k. Close tester  $P_s$  valve and wait 3 minutes. Tester duct mach indicator reading shall not vary more than 0.02 from reading taken in step "j-2."

l. Reduce pressure on MB-1 pitot-static system tester until a cockpit mach indicator reading of 1.3 is obtained. Hold nose boom pressure at this point to maintain reading.

m. Close ramp tester vacuum supply valve, and slowly open tester bleed and  $P_s$  valves until ramps start to extend. Hold  $P_s$  pressure at this value. Ramps shall move to the fully extended position. Tester duct mach indicator reading shall be as shown in column A of test table in step "d." Note position of ramp center section forward hinge (light pencil mark).

n. Open  $P_s$  and bleed valves to return pressure to ambient. Close ramp tester  $P_s$  and bleed valves; open pressure supply valve. Slowly open  $P_t$  valve until ramps start to retract. Hold pressure at this point.

**NOTE**

*F-106A airplanes 56-453, -454, 56-456 thru 57-245, 59-060 and subsequent; and 57-246, -2453, 57-2455 thru 59-059 after incorporation of TCTO 1F-106-628. Applicable to F-106B airplanes 57-2508 thru -2515, 57-2517, 59-149 and subsequent; and 57-2516, 57-2518 thru 58-904 after incorporation of TCTO 1F-106-628. These airplanes are equipped with a variable ramp time delay circuit.*

1. If the airplane is equipped with a time delay circuit, depress and hold the time delay test switch (located in the lower aft electronics compartment) when the ramps start to retract. Ramp retract motion shall be delayed for 1.8 to 2.5 seconds. After delay period, ramps will continue to retract; release the test switch. Ramp retract motion shall be delayed for 1.8 to 2.5 seconds, then move to the fully retracted position. If the airplane is not equipped with a delay circuit, ramps shall move to the fully retracted position without interruption.
2. Tester duct mach indicator reading shall be as shown in column A of test table in step "d."

o. Note position of ramp center section forward hinge using 6 inch scale. Distance between position noted in step "m" and ramp center section forward hinge shall be 5.35 ( $\pm 0.05$ ) inches.

p. Close ramp tester pressure supply valve. Slowly open  $P_t$  and bleed valves until ramps start to extend. Hold pressure at this point.

1. Ramps shall go to the fully extended position.
2. *On airplanes equipped with variable ramp time delay circuitry*, depress the time delay test switch when ramps start to extend. Ramps shall continue to extend.

q. Decrease secondary hydraulic system pressure to 1500 psi.

r. *On airplanes equipped with ramp "not retracted" warning light*, remove "INLET CONTROL" 28-volt dc fuse from nose wheel well fuse panel. Warning light in cockpit shall illuminate. Re-install fuse; light shall extinguish.

s. *On airplanes equipped with ramp altitude pressure ratio switch*, check ramp warning light function as follows:

1. With ramps fully extended, light shall extinguish.
2. Remove "MACH SW CONT" fuse from nose wheel well fuse panel; light shall illuminate.
3. Install fuse; light shall extinguish.

t. Slowly return air data converter to ambient condition by returning MB-1 tester pressure to ambient. Ramps shall move to fully retracted position.

u. Note position of ramp center section forward hinge using 6 inch scale. Ramps shall have retracted 0.08 to 0.12 inches less than position noted in step "o" if ramp retract limit switch is properly rigged.

#### 4-30. Procedure, Variable Ramp Emergency Operation Check.

##### NOTE

During the variable ramp emergency operation check, the ramp system may be turned on and off as required using MB-1 pressure applied to the nose boom instead of using the ramp tester mach switch. The variable ramp tester must be electrically connected to the air data converter to utilize the tester mach switch.

- a. Position ramp tester mach switch to the 1.25 position; ramp shall move to the fully extended position.
- b. Bleed ramp pneumatic system to 1500 psi pressure as follows:
  1. Check that the airplane high-pressure pneumatic system gage in the left main wheel well indicates pressure in excess of 1500 psi. This is important in determining ramp pneumatic pressure.

2. Open starter air selector valve in left main wheel well (figure 1-6).
3. Remove ramp system pneumatic system bleed valve plug screw. Bleed valve is located on forward side of the left main wheel well (see figure 1-6).
4. Loosen bleed valve slowly while observing airplane pneumatic system pressure gage. When gage pressure reaches 1500 psi, close valve and install plug screw.
5. Close starter air selector valve and lockwire valve in closed position. Ramp pneumatic system is now charged to 1500 psi pressure.

c. *On F-106B airplanes*, momentarily position aft cockpit ramp control switch to the emergency position. Have observer signal the instant ramps start to move. Immediately position switch back to the "AUTO" position to preserve air supply. This operation checks the aft cockpit emergency selection.

d. Position ramp cockpit control switch (F-106B, forward cockpit) to emergency position. Ramps shall move to the retracted position in 8 seconds maximum.

## WARNING

Stand clear of variable ramp vent port on lower side of fuselage during emergency ramp operation. Hydraulic oil and air will be expelled from this port at high velocity during this procedure.

e. Position ramp cockpit control switch to the "AUTO" position. Ramps shall move to the fully extended position.

f. Purge air from the variable ramp hydraulic system as indicated in the following paragraph.

#### 4-31. Procedure, Bleeding Ramp Hydraulic System.

a. Bleed ramp hydraulic system using bleeding procedure in T.O. 1F-106A-2-3, cycle only the variable ramps, as follows:

##### NOTE

During the ramp hydraulic system bleeding procedure, the ramp system may be turned on and off as required using MB-1 pressure applied to the nose boom instead of using the ramp tester mach switch. The variable ramp tester must be electrically connected to the air data converter to utilize the tester mach switch.

1. Position ramp tester mach switch to the 1.20 position. Ramps shall retract in 8 seconds maximum.

2. Position ramp tester mach switch to the 1.25 position. Ramps shall extend in 8 seconds maximum.
3. Repeat steps 1 and 2 ten times.

**NOTE**

After several operations of the ramp using the tester mach switch, the ramps may not fully retract. This is due to overheating of the ramp time delay shutoff feature. Allow several minutes for time delay to cool; operation should then be normal.

b. At first engine run, perform complete bleeding procedure given in T.O. 1F-106A-2-3.

**4-32. Final Cleanup.**

- a. With ramp tester mach switch in the 1.20 position, check ramps for full retract position as noted in paragraph 4-29, step "o."
- b. Reduce pressure on MB-1 pitot-static tester to ambient; remove tester.
- c. Remove external hydraulic and electrical power from the airplane.
- d. Disconnect ramp tester from airplane. Reconnect harnesses to air data converter and ramp inlet control unit.
- e. Recharge airplane high-pressure pneumatic system to normal full charge. Refer to T.O. 1F-106A-2-3 for this procedure.

**4-33. OPERATIONAL CHECKOUT AND LEAK TEST, VARIABLE RAMP SEAL SYSTEM.**

**4-34. Equipment Requirements.**

FIGURE	NAME	TYPE	ALTERNATE	USE AND APPLICATION
	Compressed dry air source at 35 psi.			To actuate the seal system.
	Air Pressure Gage, 0 to 30 psi.	(6685-526-6881)		To check operation of system relief valve.

**4-35. Preparation.**

- a. Gain access to seal system pressurization line through the air conditioning compartment access door.
- b. Disconnect ramp seal pressurization line at the system inlet filtered restrictor. Restrictor is located approximately at sta. 263.0 under false floor at manifold assembly on *F-106A airplanes*, and approximately at sta. 280.0 on *F-106B airplanes*.
- c. Connect external air source and air pressure gage to seal system inlet at orifice.

**4-36. Procedure, Variable Ramp Seal System Checkout and Leak Test.**

- a. Pressurize system to 30 psi as read on line pressure gage; shut off air source.
- b. Pressure will drop rapidly to 16 ( $\pm 1.5$ ) psi on gage indicating relief valve is operating properly.
- c. System pressure must not decrease more than 2 psi in 1 minute following stabilization.
- d. If system pressure drops more than 2 psi per minute, check all connections for leaks. Replace any component found to be leaking.
- e. Reduce air pressure to zero; remove test equipment. Reconnect system air line.

**4-37. PURGING AND LEAK CHECKING, VARIABLE RAMP PITOT-STATIC SYSTEM.**

**4-38. Equipment Requirements.**

FIGURE	NAME	TYPE	ALTERNATE	USE AND APPLICATION
4-7 4-8	Tester, Variable Ramp Control.	8-96051-803 (1730-710-7310)	8-96051-801 (4920-623-2177)	To provide regulated pressures to pitot-static pressure lines.
	Compressed dry air source of 35 psi pressure.			To purge ramp system pitot-static lines.
	Bubble Fluid.	Military Specification MIL-L-25567		To check pitot-static system for leaks.

**4-39. Preparation.**

a. Gain access to the variable ramp control unit through the lower aft electronics compartment access door.

b. Disconnect  $P_s$  and  $P_t$  lines from the ramp control unit.

c. Using ramp tester, apply a maximum pressure of 32 psi to the pitot-static sensing probe in the engine right air inlet duct. Air shall flow from the  $P_s$  line at the ramp control unit connection. Repeat this procedure for the sensing probe in the left inlet duct.

1. Connect pressure source of 32 psi maximum to the  $P_t$  line at the ramp control unit end and allow air to flow through the line. Air shall flow from the sensing probes in each inlet duct.

d. Reconnect lines to ramp control unit.

e. Seal pitot, static, and drain ports on pitot tube in left intake duct using plastic or vinyl tape.

f. Seal drain ports in pitot tube in right intake duct.

g. Connect ramp tester pressure line to pitot port on pitot tube in right intake duct.

**CAUTION**

Observe the following limitations when applying pressure to the variable ramp pitot-static system.

Static pressure ( $P_s$ ) shall never exceed pitot pressure ( $P_t$ ).

Pitot pressure shall never exceed static pressure by more than 40.72 inches Hg.

Static pressure shall never exceed 67.2 inches Hg.

If these limitations are not observed, the ramp control unit may be damaged.

**4-40. Procedure.**

a. Using ramp tester, slowly pump up pressure until gage on tester indicates 21.5 inches Hg above ambient. Close off pressure and allow system to remain pressurized 3 minutes.

b. Pressure drop shall not exceed 1.6 inches Hg during the 3 minute period.

c. Release pressure to pitot port.

d. Connect ramp tester vacuum source to static port of pitot tube in right intake duct.

e. Slowly draw vacuum on system until tester gage reads 13.8 inches Hg below ambient.

f. Close off vacuum source and hold vacuum for 2 minutes.

g. Vacuum gage reading shall not increase more than 0.5 inches Hg during the 2 minute period.

h. Repeat steps "a" through "g" applying the test values to the left inlet duct pitot-static probe.

i. Release vacuum pressure and remove test equipment. Remove seal tape from pitot and static ports of pitot tube in intake ducts.

**4-41. SHUTTLE VALVE CHECK, VARIABLE RAMP PITOT-STATIC SYSTEM.****4-42. Equipment Requirements.**

FIGURE	NAME	TYPE	ALTERNATE	USE AND APPLICATION
4-7 4-8	Tester, Variable Ramp Control	8-96051-803 (1730-710-7310)	8-96051-801 (4920-623-2177)	To provide regulated vacuum.
	Test Unit, Feel System.	SE 0985 (4920-565-0192)		To provide pneumatic pressure.

**4-43. Preparation.**

a. Connect source of dry filtered air (approximately 30 psig) to SE 0985 test unit. Refer to T. O. 1F-106A-2-7 for operating and hook-up instructions.

b. Connect manometer No. 2 of SE 0985 to total pressure ( $P_t$ ) line of duct pitot-static probe fitting (part of 8-96051-801 or -803 variable ramp tester) using adapters as required. Connect hose from "tee" fitting ( $P_t$ ) to No. 5 fitting on the hose connection panel of the SE 0985 Test Unit.

c. Connect manometer No. 3 of SE 0985 to static pressure ( $P_s$ ) line of duct pitot-static probe fitting using adapter as required. Connect hose from "tee" fitting ( $P_s$ ) to No. 3 fitting on the hose connection panel of SE 0985 Test Unit.

d. Disconnect  $P_s$  and  $P_t$  lines from variable inlet control unit.

e. Install duct pitot-static probe fitting of the variable ramp tester on left duct pitot-static probe. Leave right duct pitot-static probe open to atmosphere.

**NOTE**

Only one fitting of the variable ramp tester is required for shuttle valve checks. The unused fitting must be plugged, or the lines capped, to prevent leakage.

**4-44. Procedure.**

a. Apply pressure to  $P_t$  line using manometer No. 2 control valve until  $P_t$  shuttle valve shuttles and holds pressure. Shuttling will be indicated by a rapid rise in pressure as indicated on manometer No. 2.

b. Check flow from right duct pitot-static probe  $P_t$  port and from  $P_t$  line disconnected from ramp control unit. Flow shall be negligible and represents leakage.

c. Apply pressure to  $P_s$  line using manometer No. 3 control valve.

d. If valve has shuttled, flow shall be noted at  $P_s$  line disconnected from ramp control unit, but not at the right duct pitot-static probe ports.

e. Reduce  $P_t$  and  $P_s$  pressures to ambient and remove fitting from left duct pitot-static probe.

f. Install fitting on right duct pitot-static probe and repeat steps "a" through "e", substituting left for right, and right for left.

g. Remove test equipment and reconnect  $P_t$  and  $P_s$  lines to controller.

**4-45. VARIABLE RAMP PNEUMATIC SYSTEM LEAK CHECK.**

For the variable ramp pneumatic system leak check procedure, refer to T. O. 1F-106A-2-3.

**4-46. OVERBOARD DRAIN HYDRAULIC OIL LEAK CHECK — RAMPS OPERATING.**

a. Leakage from the variable ramp overboard drains (under leading edge of left wing) shall not exceed the following when the ramps are operating in the normal (automatic) mode:

Forward Drain — 5 drops per minute

Aft Drain — 6 drops per minute

b. If excessive leakage is noted from the forward drain, check leakage rate from drive and dump valve. Replace the defective component and repeat emergency operation check.

c. If excessive leakage is noted from the aft drain, crack drain lines on bypass valve and shuttle valve and check individual component leakage rate. Bypass valve allowable leakage is 5 drops per minute. Shuttle valve allowable leakage is 1 drop per minute. Replace the defective component and repeat emergency operation check.

**4-47. OVERBOARD DRAIN HYDRAULIC OIL LEAK CHECK — RAMPS STATIC.**

a. Leakage from the variable ramp overboard drains (under leading edge of left wing) shall not exceed the following when the ramps are operating in the normal (automatic) mode, system energized, and ramps not moving:

Forward Drain — 1 drop per minute

Aft Drain — 3 drops per minute

b. If excessive leakage is noted from the forward drain, crack the seal drains at hydraulic drive unit from dump valve. Drive unit seal drain leakage shall not exceed 15 drops per hour, dump valve leakage shall not exceed 45 drops per hour. Replace the defective component and repeat emergency operation check.

c. If excessive leakage is noted from the aft drain, crack the drain lines on shuttle valve and bypass valve and check individual component leakage rates. Bypass valve allowable leakage is 3 drops per minute, shuttle valve allowable leakage is 15 drops per hour. Replace defective component and repeat emergency operation check.

**SYSTEM ANALYSIS**

**4-48. TROUBLESHOOTING, VARIABLE RAMP SYSTEM.**

Trouble shooting the variable ramp system will require hookup of the ramp operational checkout equipment to the airplane. Refer to paragraph 4-26 for this pro-

cedure. Complete ramp tester hookup (pneumatic and electrical) is shown in figures 4-7 and 4-8. In addition to the equipment specified, it will be necessary to obtain a vacuum tube multimeter, USAF TS-505 B/U, (FSN 6625-620-6366).



**4-49. Variable Ramp System Test Values.**

The following listed values are provided as an aid in isolating malfunctions within the ramp control system. These values are variable ramp tester (8-96051-801 and

-803) jack readings representing normal component function, and are applicable to airplanes equipped with ramp controller part No. 8-06474-1, -3, or -5.

TEST JACK	VALUE	FUNCTION
N	No voltage	Ac and dc ground.
A	*	Servo valve ramp extend coil.
B	No voltage	Servo valve ground return.
C	*	Servo valve ramp retract coil.
D	Less than 26-volt ac	Controller bridge circuit error signal to amplifier stage.
E		Controller bridge circuit error signal from bridge circuit.
G	28-volt dc	Energizes ramp position warning relay and hydraulic shutoff valves.
H	28-volt dc (ADC below mach 1.20)	Energizes controller K-3 relay. K-3 relay provides automatic retract signal and starts 7 to 13 seconds time delay. K-1 relay shuts off system after the 7 to 13 seconds delay.
J	28-volt dc (ADC below mach 1.25)	Center pole of ADC mach switch (after ramp system actuation).
P	28-volt dc	Power input interlock.
R	**	High end of ADC mach pot (mach pot pin "A").
S		Low end of ADC mach pot (mach pot pin "B").
T		ADC mach pot wiper.
V	115-volt ac	System power input.
F, K, L, M, U		These test jacks are not used.

\*Normal current through each coil of the servo control valve, with the ramps motionless (no ramp movement signals), will range from 0 ma dc to 7 ma dc. A current differential of 8.0 ma or greater between the coils represents maximum movement signal.

\*\*ADC mach potentiometer resistance is 10K ohms. The ac signal across the potentiometer should not exceed 5.0 volts. To prevent loading the ramp controller ac bridge when making this measurement, the vacuum tube voltmeter being used must have an impedance ratio of at least 5K ohms per volt.

**4-50. Procedure.**

PROBABLE CAUSE	ISOLATION PROCEDURE	REMEDY
Ramp hydraulic shutoff valve closed.	Position tester mach switch alternately between 1.20 and 1.25 positions. Listen for valve actuation.	<ol style="list-style-type: none"> <li>If valve action is heard, valve is not at fault. Go to servo control valve malfunctioning under this heading.</li> <li>If no valve action is heard, go to next isolation procedure.</li> </ol>
	Check for 28-volt dc at valve pin A.	<ol style="list-style-type: none"> <li>If voltage exists, but valve inoperative, replace valve.</li> <li>If no voltage exists, go to next probable cause.</li> </ol>

## 4-50. Procedure (Cont).

PROBABLE CAUSE	ISOLATION PROCEDURE	REMEDY
Secondary hydraulic system low warning relay malfunctioning.	Check relay for continuity from pins F to G.	<p>a. If continuity exists, relay is not at fault. Go to next probable cause.</p> <p>b. If no continuity exists, go to next isolation procedure.</p>
	Check for 28-volt dc at relay pin B.	<p>a. If voltage exists, but no continuity from F to G, replace relay.</p> <p>b. If no voltage exists, refer to hydraulic low-pressure warning system trouble shooting in T.O. 1F-106A-2-9.</p>
Ramp emergency pneumatic pressure switch malfunctioning.	Check for 28-volt dc at switch pin A.	<p>a. If voltage exists, switch is not at fault.</p> <p>b. If voltage does not exist, go to next isolation procedure.</p>
	Check for 28-volt dc at switch pin C.	<p>a. If voltage exists at C but not at A, change switch.</p> <p>b. If voltage does not exist, go to next probable cause.</p>
Inlet control unit malfunctioning.	Check for 28-volt dc at control unit pin G.	<p>a. If voltage exists, controller is not at fault.</p> <p>b. If no voltage exists, go to next isolation procedure.</p>
	Check for 28-volt dc at controller pin J.	<p>a. If voltage exists at J but not at G, replace control unit.</p> <p>b. If no voltage exists, go to next probable cause.</p>
Switch in ADC malfunctioning.	Refer to T.O. 1F-106A-2-15 for ADC system checkout and trouble shooting.	
Servo control valve malfunctioning.	Check for continuity between valve pins A and B, and between pins B and C.	<p>a. If continuity exists, go to next isolation procedure.</p> <p>b. If continuity does not exist, replace valve.</p>
	Check for current flow differential between valve pins A and B vs B and C. Refer to paragraph 4-49 for specified value limits.	<p>a. If current differential exists as specified, valve is not at fault. Go to next probable cause.</p> <p>b. If current differential does not exist, go to next isolation procedure.</p>
	Pump static pressure ( $P_s$ ) to 26.0 inches Hg and hold. Vary pitot pressure ( $P_t$ ) from 30 inches Hg to 40 inches Hg. Check ramp tester pins A and C for voltage variance as $P_t$ pressure is varied.	<p>a. If voltage variance does not occur, replace inlet control unit.</p> <p>b. If voltage variance does occur, go to next probable cause.</p>

**4-50. Procedure (Cont).**

PROBABLE CAUSE	ISOLATION PROCEDURE	REMEDY
<b>RAMPS DO NOT EXTEND WITH AMBIENT PRESSURE AT PITOT-STATIC PORTS (Refer to paragraph 4-29, step "a") (Cont).</b>		
Hydraulic motor malfunctioning.	Disconnect drive shafts from motor; check motor for freedom of rotation.	a. If motor binding is found, replace motor. b. If motor rotation is free, go to next probable cause.
Excessive ramp friction.	Check components of system for correct installation and freedom of actuation.	Adjust as required. Install replacement items as required.
<b>RAMPS DO NOT RETRACT WITH PRESSURE APPLIED TO PITOT PORT (Refer to paragraph 4-29, step "d").</b>		
Refer to probable causes in previous trouble item.		
<b>RAMPS DO NOT MEET SPECIFIED TRAVEL REQUIREMENTS (Refer to paragraph 4-29, step "o").</b>		
Interference from structure or other systems components.	Check for interference at screw-jacks.	Make correction as required.
	Foreign material between ramp panels and fuselage structure.	
Ramps improperly rigged.	Conduct rigging procedure.	
<b>TESTER DUCT MACH READING DOES NOT HOLD SPECIFIED VALUE IN STATIC CONDITION (Refer to paragraph 4-29, step "e").</b>		
Pressure leakage in P <sub>t</sub> line.	Conduct line leak test.	a. Repair lines as required. b. If no line leaks are found, go to next probable cause.
Internal leakage in ramp control unit.	Remove control unit.	Install replacement item.
<b>RAMP NOT RETRACTED WARNING LIGHT DOES NOT ILLUMINATE WHEN INLET CONTROL FUSE IS REMOVED (Refer to paragraph 4-29, step "t").</b>		
Ramp travel limit switch malfunctioning.	Check for continuity thru switch,	a. If continuity exists, go to next probable cause. b. If no continuity exists, replace switch.
Position warning light relay malfunctioning.	Check for continuity from pins E thru H of relay.	a. If continuity exists, go to next isolation procedure. b. If no continuity exists, replace relay.
	Check condition of "INLET CONTROL" 28-volt dc fuse.	Install replacement fuse as required.
<b>RAMPS DO NOT RETRACT WHEN SYSTEM IS SELECTED TO EMERGENCY.</b>		
Ramp pneumatic solenoid valve not opening. Ramp hydraulic bypass valve not positioned to emergency position.	Check for continuity from pin A thru B of valve. Check for 28-volt dc at valve pin A.	a. If no continuity exists, replace valve. b. If no voltage exists, replace variable inlet override fuse.

**4-50. Procedure (Cont).**

PROBABLE CAUSE	ISOLATION PROCEDURE	REMEDY
<b>RAMP EMERGENCY TOTAL TRAVEL TIME EXCEEDS 8 SECONDS MAXIMUM TIME LIMIT (Refer to paragraph 4-30, step "d").</b>		
Excessive ramp friction.	Check components of system for correct installation and freedom of operation.	Adjust as required. Install replacement items as required.

**DUCT BUZZ REPORTED DURING FLIGHT.**

Ramp scheduling (and/or engine trim) is incorrect.	If engine trim correct, perform operational checkout of system.	Replace the unit as required.
Switching afterburner "ON" or "OFF" at high mach speeds.	Afterburner nozzle positioning causes rapid increase or decrease of engine air demands thus making ramp schedule momentarily incorrect.	
Extreme yawing or rapid deceleration at high mach speeds.	Engine air demands momentarily not compatible with ramp scheduling.	

**RAMPS MALFUNCTIONING IN FLIGHT.**

Sheared flex drive shaft to one ramp.	Check that both right and left ramp are in retracted position.	Replace defective part in ramp that is not retracted.
Ramp pitot and static lines crossed (F-106B).	Check pitot and static flex lines in missile bay for proper connection.	Connect lines properly and perform system operational checkout.
Servo valve differential torque current too low.	Check that differential torque current (pins A to B, and pins B to C) is at least 8.0 ma during ramp movement.	If current is below specified limit, replace inlet control unit.

**PILOT REPORTS SLOW RECOVERY FROM STALL-BUZZ.**

Defective shuttle valve.	Perform shuttle valves check. Refer to paragraph 4-41.	Replace defective valve.
--------------------------	--	--------------------------

**RAMPS DO NOT RETRACT WHEN COCKPIT MACH INDICATION IS BELOW 1.25.**

Leak in static side of the pitot-static system.	Check all static lines and connections.	Tighten and/or replace as required.
---	---	-------------------------------------

**RAMPS EXTEND WHEN HYDRAULIC PRESSURE IS APPLIED TO AIRPLANE.**

AWCIS "Short System Ground Check" performed without removing HYDRAULIC PRESS WARN fuse.		Check that "HYDRAULIC PRESS WARN" fuse is installed when external hydraulic pressure is applied to airplane. Connect MB-1 tester to nose boom and apply pitot-static pressure until ramps retract.
---	--	--

<b>REPLACEMENT</b>
--------------------

**4-51. REPLACEMENT, ELECTRICAL COMPONENTS GENERAL.**

When removing components equipped with pigtail electrical leads, always cut leads at an existing splice. This is necessary to preserve the component lead identity and to provide sufficient length for reinstallation.

**4-52. REPLACEMENT, VARIABLE RAMP SECTIONS.****4-53. Equipment Requirements.**

FIGURE	NAME	TYPE	ALTERNATE	USE AND APPLICATION
4-9	Ramp Spring Depressing Tool.	8-96049 (5120-587-5894)		To depress spring on inlet ramp center section.
	Ramp Rigging Tool.	8-96184-801 8-96184-803 (5120-675-9229)		To position ramp center section at fully extended position (for use in thin lip inlet ducts).
		8-78501-300, -301, -400, -401, (Tools called for in TCTO 1F-106J-509)		To position ramp center section at fully extended position (for use in thick lip inlet ducts).
	Ramp Stop Rigging Tool.	8-96198 (1730-632-8434)		To establish position for stop adjustment.
4-7 4-8	Tester, Variable Ramp Control.	8-96051-803 (1730-710-7310)	8-96051-801 (4920-623-2177)	To actuate the ramp control system.
4-9	Ramp Dummy Door (2).	8-96183 (1730-625-5344)		To aid positioning of ramp center section.
	Ramp Section Hinge Pin Puller.	8-96043 (5120-525-7017)		To remove ramp forward and aft hinge pins.
	Forward Ramp Hold-open Tool.	8-96187 (1730-613-6610)		To hold forward ramp open during ramp maintenance.
	Ramp Actuator Rod Holding Tool.	8-96212 (1730-632-8432)		Prevent rod rotation during rigging.

## 4-53. Equipment Requirements (Cont).

FIGURE	NAME	TYPE	ALTERNATE	USE AND APPLICATION		
Refer to T.O. 1F- 106A-2-3	Portable Hydraulic Test Stand (Gas).	SE 1061-801 (4920-670- 9415)	SE 1061 (4920-517- 1028)	To supply pressure to hydraulic systems for ground test.		
			SE 0567-801 (4920-204- 2462)			
	Portable Hydraulic Test Stand (Elec).	SE0976-801 (4920-675- 4258)	SE 0976 (4920-204- 3115)			
	Hydraulic hose support.	8-96193 (4920-621- 3011)			To support hydraulic test stand return hose.	
	Adapter (2 each).	8-96080 (4920- 566-8882)			Used with SE 0567 or SE 0567-801 to connect test stand hoses to quick disconnect fittings.	
Adapter (2 each).	SE 1093		Used with SE 1061, MJ-2 or MK-3 to connect test stand hoses to quick disconnect fittings.			
Refer to T.O. 1F- 106A-2-10	Generator Set (Gas).	8-96026-801 AF/M32A-13 (6115-583- 9365)	8-96026 AF/M32M-2 (6115-617- 1417)	To energize electrical systems on aircraft equipped with special quick disconnect receptacle.		
			Generator Set (Elec).		8-96025-803 AF/ECU-10/M (6125-583- 3225)	8-96025-805 A/M24M-2 (6125-628- 3566)
						8-96025 AF/M24M-1 (6125-620- 6466)
	Generator Set.		MC-1 (6125-500- 1190) MD-3 (6115-635- 5595)		To energize electrical systems (except AWCIS) on aircraft equipped with standard AN receptacle and on others by using adapter cable 8-96052.	
	Adapter Cable.	8-96052 (6115-557- 8548)			To connect MC-1 and MD-3 units to aircraft equipped with special quick disconnect receptacle.	

**4-54. Procedure.**

For replacement and rigging of the variable ramp sections, see figure 4-9.

**NOTE**

After replacing and/or rigging any portion of the variable ramp system, perform an operational check of the system; refer to paragraph 4-29 for procedure.

**4-55. REPLACEMENT, VARIABLE RAMP CONTROL SYSTEM COMPONENTS.****4-56. Procedure.**

For replacement procedures for the variable ramp screw jacks, hydraulic drive unit, servo control valve, or the inlet pitot-static tubes, see figure 4-10.

**4-57. REPLACEMENT, VARIABLE RAMP AIR STORAGE FLASK.**

a. Bleed air from high-pressure pneumatic system. Refer to T.O. 1F-106A-2-3 for this procedure.

b. *On F-106A airplanes*, gain access to the air storage flask through the access door along centerline of missile bay roof at approximately sta. 253.0. *On F-106B airplanes*, remove the refrigeration unit. Refer to T.O. 1F-106A-2-6 for this procedure.

c. Disconnect pneumatic line from ramp pneumatic flask, located at right side of fuselage at sta. 323.5.

d. Disconnect flask strap; remove flask. Installation procedure for the ramp pneumatic system flask is essentially the reverse of the removal procedure. Torque flask attachment strap 5 to 10 inch-pounds maximum.

e. Perform variable ramp pneumatic system leak check. Refer to T.O. 1F-106A-2-3 for this procedure.

f. Recharge the variable ramp high-pressure pneumatic system when test has been completed. Refer to T.O. 1F-106A-2-3 for the charging instructions.

**4-58. REPLACEMENT, VARIABLE RAMP STATIC PRESSURE SENSE SHUTTLE VALVE.**

a. Gain access to the upper forward surface of the forward missile bay. Refer to T.O. 1F-106A-2-12.

b. Remove forward center and forward right access doors in upper surface of missile bay to gain access to refrigeration compartment forward right side. Shuttle valve is located just aft of refrigeration compartment forward bulkhead on the right side.

c. Remove lines (3) attached to valve.

d. Remove valve attachment bolts (2); remove valve. Installation of the variable ramp pressure sense shuttle valve is essentially the reverse of the removal procedure. Replace access doors and close missile bay. Refer to T.O. 1F-106A-2-12 for missile bay door closing procedure.

e. Perform pitot-static leak check. Refer to paragraph 4-37.

f. Conduct pitot-static system shuttle valve operational check; refer to paragraph 4-41 for procedure.

**4-59. REPLACEMENT, VARIABLE RAMP TOTAL PRESSURE (P<sub>t</sub>) SHUTTLE VALVE**

a. Gain access to the upper forward surface of the forward missile bay. Refer to T.O. 1F-106A-2-12.

b. Remove forward center and forward right access doors in upper surface of missile bay to gain access to refrigeration compartment forward right side. The reverse-acting P<sub>t</sub> shuttle valve is located just aft of refrigeration compartment forward bulkhead on the right side.

c. Remove lines (3) attached to the valve.

d. Remove valve attachment bolts (2); remove valve.

e. Installation of the variable ramp pitot-static system total pressure (P<sub>t</sub>) shuttle valve is essentially the reverse of the removal procedure. Replace access doors and close missile bay. Refer to T.O. 1F-106A-2-12 for missile bay door closing procedure.

f. Perform pitot-static leak check. Refer to paragraph 4-37.

g. Conduct pitot-static system shuttle valve operational check; refer to paragraph 4-41 for procedure.

**4-60. REPLACEMENT, VARIABLE RAMP SYSTEM HYDRAULIC CHECK VALVE.**

a. Relieve hydraulic system pressure by operating elevons. Refer to T.O. 1F-106A-2-3 for this procedure. Relieve the secondary hydraulic reservoir pneumatic pressure by pressing relief valve on top of the manual filler cap of the reservoir.

b. Gain access to the hydraulic check valve through the refrigeration compartment access door. Valve is located on LH side of refrigeration compartment.

c. Remove bolts (2) attaching valve to structure; remove valve.

d. Installation of the variable ramp system hydraulic check valve is essentially the reverse of the removal procedure.

e. Bleed ramp hydraulic system. Refer to T.O. 1F-106A-2-3 for this procedure.

f. Conduct an operational checkout of the variable ramp system.

**4-61. REPLACEMENT, AIR DATA CONVERTER.**

For the air data converter replacement procedures, refer to T.O. 1F-106A-2-15.

**4-62. REPLACEMENT, ALTITUDE PRESSURE RATIO SWITCH.**

For the altitude pressure ratio switch replacement procedures, refer to T.O. 1F-106A-2-5.

**4-63. REPLACEMENT, PNEUMATIC SELECTOR VALVE.**

a. Relieve high pneumatic system pressure. Refer to T.O. 1F-106A-2-3 for this procedure.

b. Gain access to the selector valve through the refrigeration compartment access door. Valve is located on the left side of the refrigeration compartment.

c. Remove electrical leads from valve.

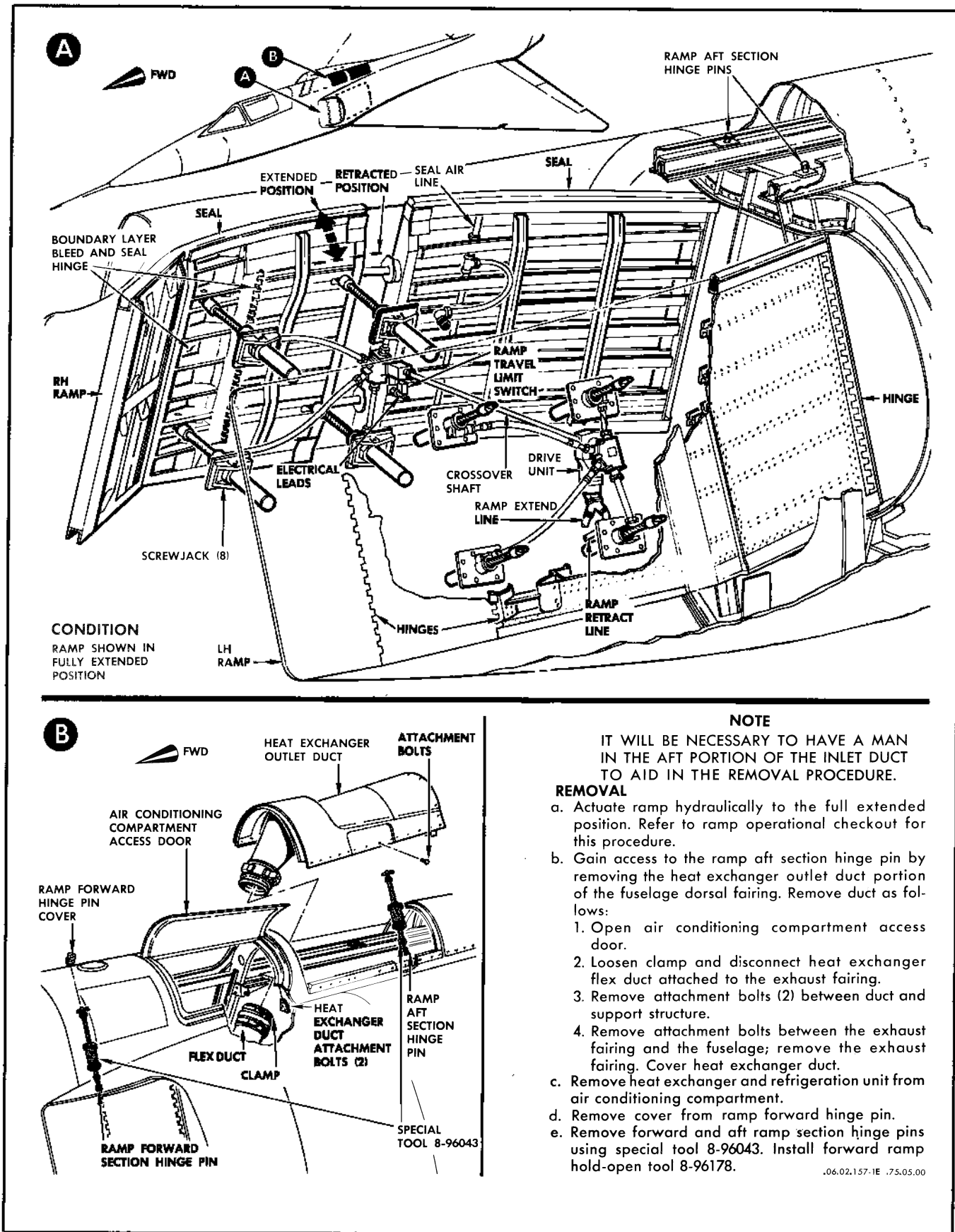

Figure 4-9. Replacement and Rigging, Variable Ramp (Sheet 1 of 4)



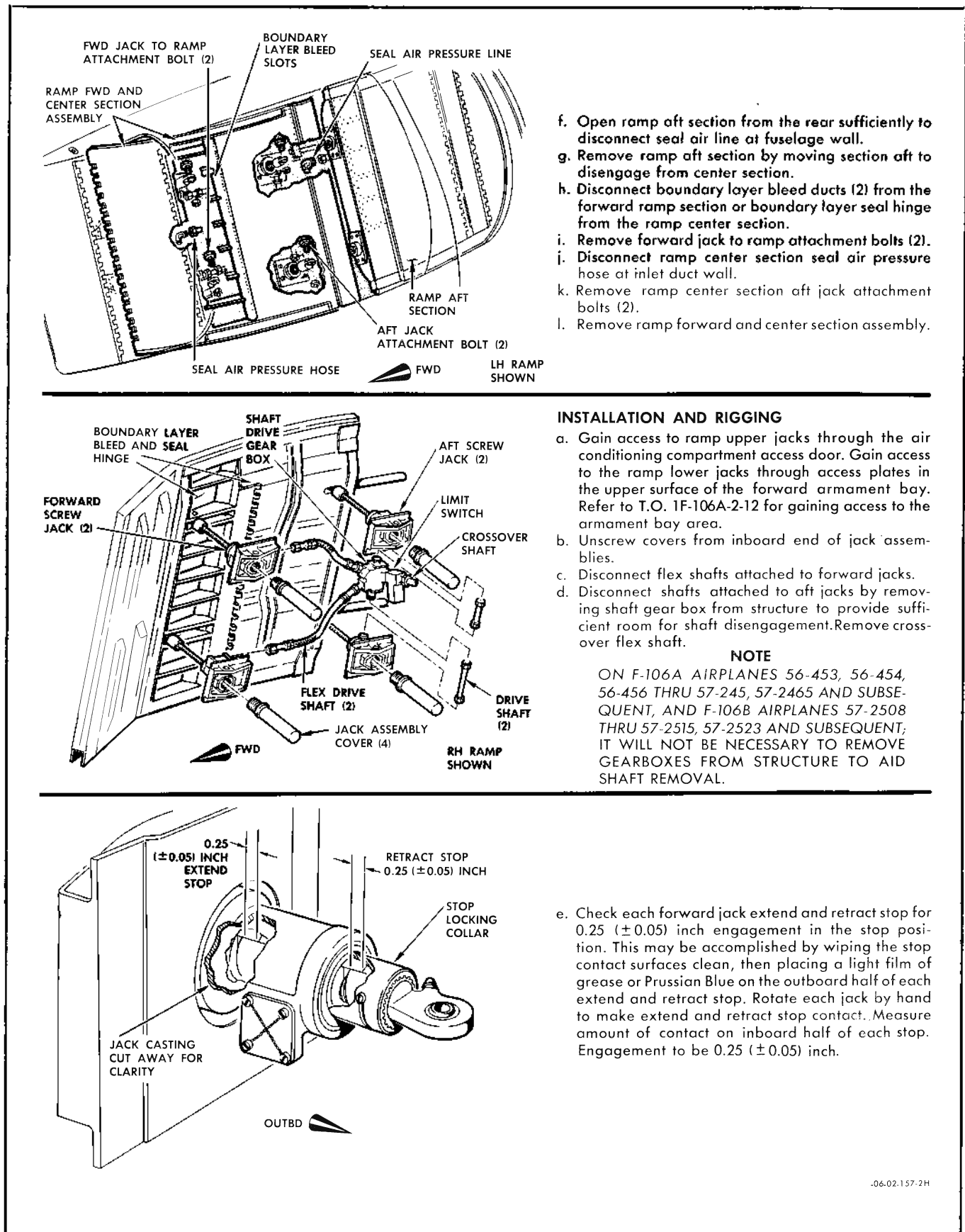
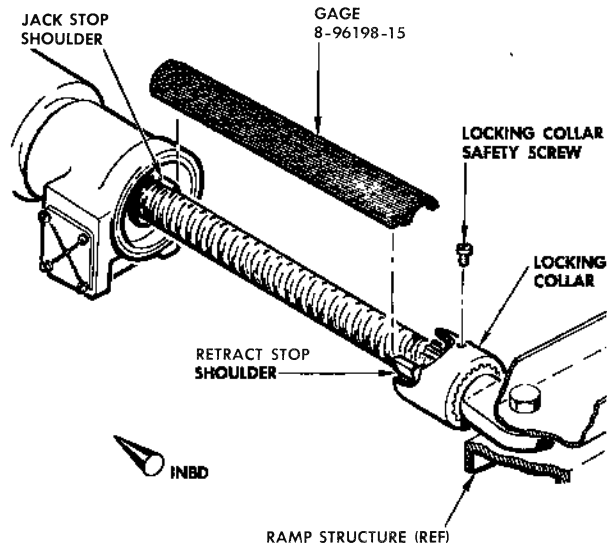
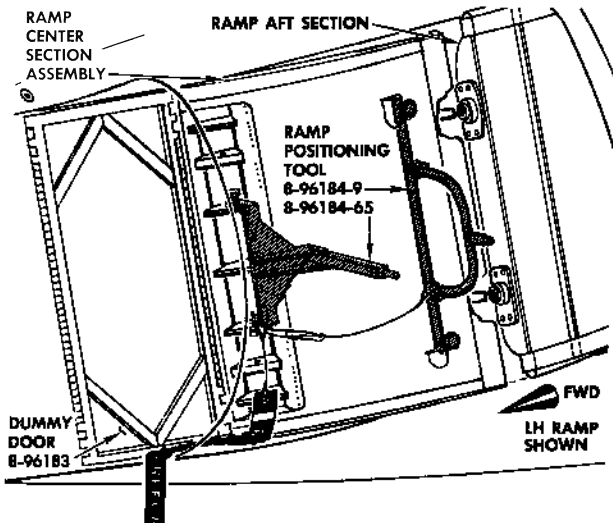
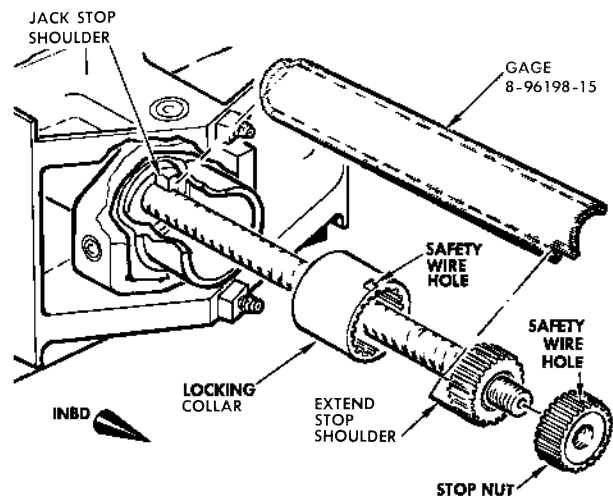

Figure 4-9. Replacement and Rigging, Variable Ramp (Sheet 2 of 4)



- f. Place ramp aft section in inlet aft section but do not connect to duct or ramp center section at this time.
- g. Establish ramp center section full extend point as follows:
  1. Remove ramp forward-to-center section hinge pin; remove forward section.
  2. Attach ramp forward section dummy door 8-96183 to center section using hinge pin removed in previous step.
  3. Position ramp dummy door and center section assembly in the inlet duct in the full extend position using special tool 8-96184-9-65.
  4. Position dummy door forward hinge to duct hinge; install hinge pin.
  5. Attach one forward jack to center section panel and extend ramp until spring-loaded points of rigging tools contact duct outer wall. This is the fully extended position.
  6. Extend three other jacks out to panel and attach.

- h. Deleted.
- i. Install ramp flex and universal drive shafts, and shaft gearboxes. Installation is the reverse of removal. Do not install crossover flex shaft.
- j. Adjust the forward jacks retract stops as follows:
  1. Use gage 8-96198-15 as shown. Gage positions under locking collar.
  2. After adjusting stop to gage, make engagement of locking collar between stop and stop nut. Install safety screw and torque to 5 inch-pounds maximum. Safety-wire and remove gage.
- k. Retract left ramp hydraulically and right ramp by hand until stops are contacted.



- l. Adjust ramp extend stops on inboard end of forward jacks as follows:
  1. Use gage 8-96198-15 as shown in application diagram. Gage positions under locking collar.
  2. Hold extend stop at this point. Install stop nut on shaft and turn until contact is made with stop; align splines. If stop does not fit in notch of gage, start stop nut rotation on another thread of screw.
  3. Engage stop and stop nut by sliding locking collar over stop and stop nut. Align safety-wire holes and install safety wire; remove gage.

**NOTE**

RECESSED FACE OF STOP NUT MUST NOT EXTEND BEYOND END OF JACK SCREW.

- m. Extend left ramp enough to permit insertion of a 0.090 inch temporary shim on the retract stop face of both left forward screw jacks. Retract left ramp until stops engage - (right ramp retract stops engaged).

06.02.157.3

Figure 4-9. Replacement and Rigging, Variable Ramp (Sheet 3 of 4)

n. On airplanes equipped with ramp retract travel limit switch, adjust ramp retract travel limit switch to actuate as follows:

1. Extend right ramp by hand 0.10 inch from the retract position; adjust switch to actuate at this point. Coarse adjustment is accomplished by removing cover plate from switch assembly. Depress and rotate switch drive cam in direction necessary to cause cam to actuate switch; re-engage cam. Fine or vernier adjustment is accomplished by turning adjustment screw on side of switch assembly. Install switch cover plate.
2. Retract right ramp by hand to the full retract position.

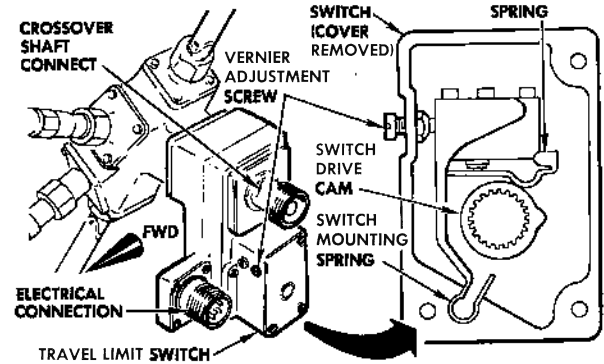

- o. Install crossover flex shaft between left and right ramp gearboxes. Remove rigging tools.
- p. With a man in the aft portion of inlet duct, extend the ramps hydraulically to the full extended position. Remove temporary shims installed in step "m." Re-check extend position. Install covers over inboard end of jacks and lockwire cover screws.
- q. Remove jack to ramp attachment bolts; remove ramp center section and dummy door assembly from inlet duct. Install jack rod holding tool 8-96212 (2) in rod ends to prevent rod rotation.

#### CAUTION

EXERCISE EXTREME CARE NOT TO ROTATE JACK ROD ENDS AT THIS TIME. ROTATED ROD ENDS WILL REQUIRE RE-RIGGING OF SYSTEM.

- r. Prepare and install ramps as follows:
  1. Remove dummy door from ramp center section.
  2. Position ramp forward section to center section; install hinge pin.
  3. Place ramp forward and center section assembly in inlet duct.
  4. Remove jack rod end holding tool 8-96212(2).
  5. Install jack to ramp attachment bolts.
  6. Connect ramp center section seal hinge to ramp if applicable.
  7. Connect ramp forward and center section seal air line to fuselage fitting.
  8. Connect ramp forward section bleed air flex ducts to ramp if applicable.

06,02,157-4 F

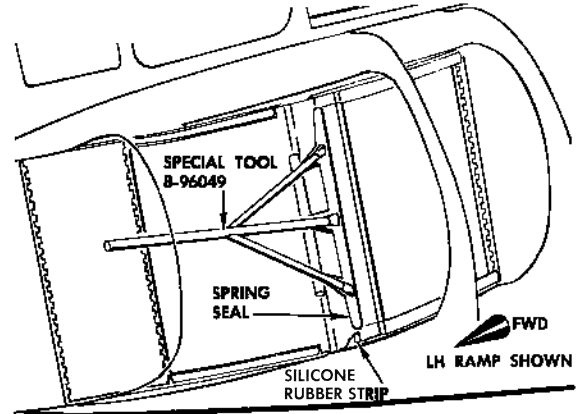

- s. Make engagement of ramp aft section to center section. If ramp seal spring is installed on aft edge of center section, use special tool 8-96049 to depress spring when making ramp section engagement.
- t. Install aft ramp section seal air hose and hinge pin, forward ramp hinge pin and access cover, and dorsal fairing section. Installation of these components is essentially the reverse of removal.
- u. Install jack access doors in armament bay area.
- v. Perform operational checkout of the ramp system.
- w. Actuate ramp to fully retracted position; remove actuation equipment.
- x. Reinstall refrigeration unit and heat exchanger.

Figure 4-9. Replacement and Rigging, Variable Ramp (Sheet 4 of 4)

- d. Remove lines (3) attached to valve.
- e. Remove bolts (2) and screw attaching valve to structure; remove valve.
- f. Installation of the pneumatic selector valve is essentially the reverse of removal.
- g. Charge and leak test variable ramp high-pressure pneumatic system. Refer to T.O. 1F-106A-2-3 for this procedure.
- h. Conduct operational checkout of variable ramp system.

#### 4-64. REPLACEMENT, VARIABLE RAMP SYSTEM HYDRAULIC SHUTOFF VALVE.

- a. Remove the "VAR INLET OVERRIDE" fuse from the cockpit left fuse panel to prevent accidental high pressure pneumatic operation.
- b. Relieve hydraulic system pressure by operating elevons. Refer to T.O. 1F-106A-2-3 for this procedure.
- c. On F-106A airplanes, gain access to the hydraulic shutoff valve through the access door along centerline of missile bay roof. On F-106B airplanes, gain access through the refrigeration compartment access door. The valve is located on left side of refrigeration compartment.

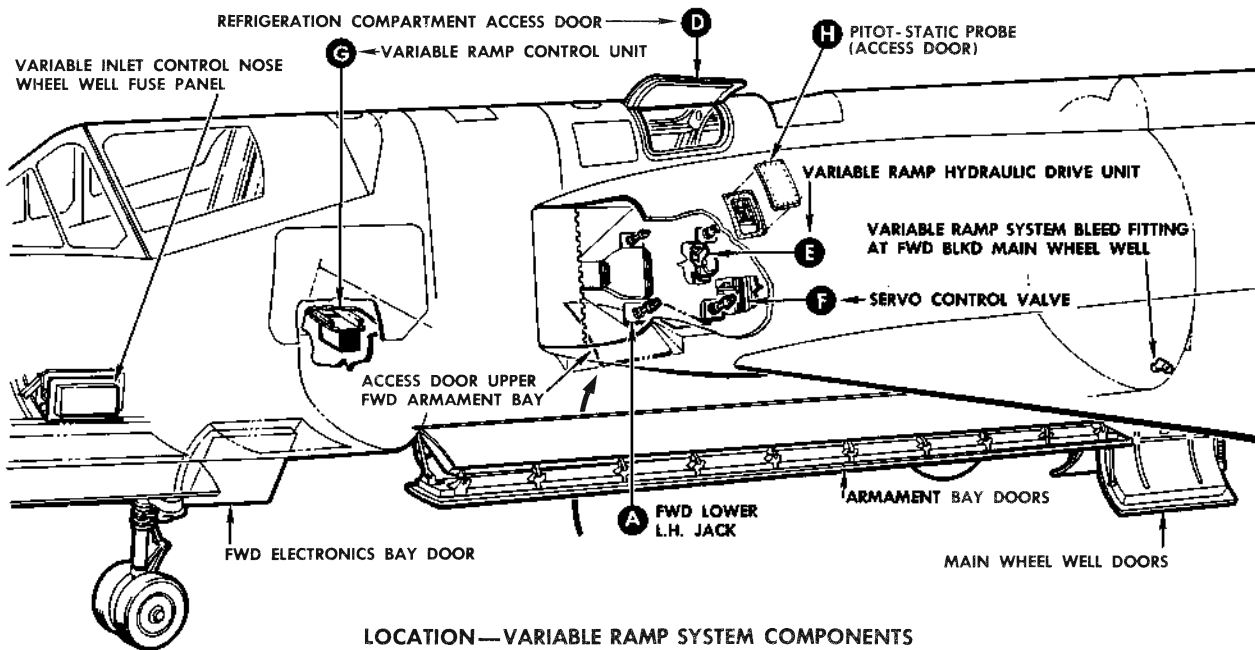

LOCATION—VARIABLE RAMP SYSTEM COMPONENTS

**PREPARATION**

- Operate ramps to the fully extended position. Refer to ramp system hydraulic purging procedure in this handbook section for this procedure.
- Open armament bay doors as required to facilitate component removal. Refer to T.O. 1F-106A-2-12 for opening procedure.
- Relieve hydraulic system pressure by operating elevons. Refer to T.O. 1F-106A-2-7 for procedure.
- Relieve high pressure pneumatic system pressure at variable ramp system bleed fitting and at main pneumatic system bleed fitting. Fittings are located on the forward bulkhead of the main wheel well. Refer to T.O. 1F-106A-2-3 for this procedure.
- Remove the following system fuses and placard fuse receptacles to prevent inadvertent operation of system:
  - "INLET CONT"—nose wheel well fuse panel, 115-volt nonessential bus.
  - "INLET CONT"—nose wheel well fuse panel, 28-volt nonessential bus.
  - "VAR INLET OVERRIDE"—cockpit lefthand fuse panel, 28-volt nonessential bus.
- Remove air conditioning system heat exchanger and refrigeration unit. Refer to T.O. 106A-2-6 for this procedure.

**VARIABLE RAMP JACK, REMOVAL**

- Gain access to ramp upper jacks through the refrigeration compartment access door. Gain access to ramp lower jacks through access plates in the upper surface of the forward armament bay.

.06.02.287-18 .75.06.00

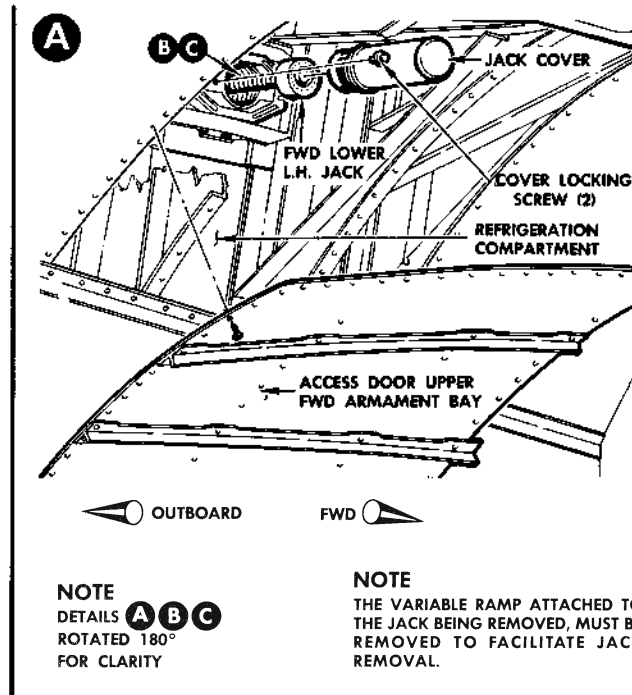

**NOTE**  
DETAILS **A B C**  
FOR CLARITY  
ROTATED 180°

**NOTE**  
THE VARIABLE RAMP ATTACHED TO THE JACK BEING REMOVED, MUST BE REMOVED TO FACILITATE JACK REMOVAL.

**NOTE**

FORWARD, LOWER, LEFT-HAND JACK REMOVAL SHOWN. REMOVAL OF OTHER JACKS SIMILAR.

- Perform all steps of preparation procedure; remove access plate in upper surface of left-hand armament bay.
- Remove cover from inboard end of jack.

Figure 4-10. Replacement, Variable Ramp System Components (Sheet 1 of 3)

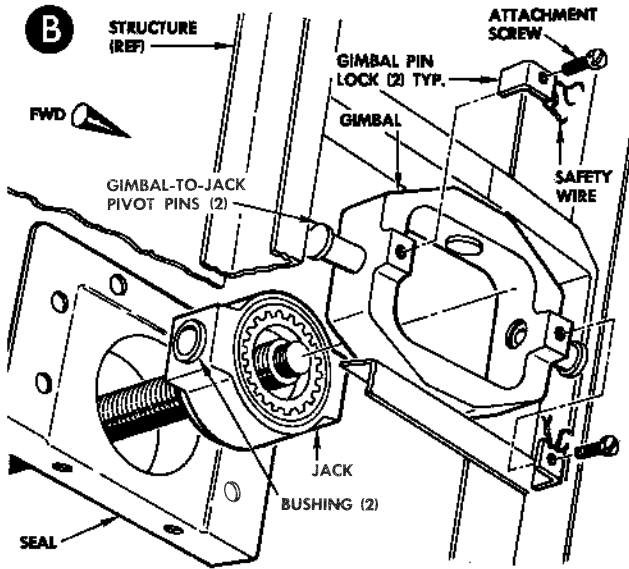

- d. Remove screwjack seal.
- e. Cut safety wire and remove gimbal pin locks (2).
- f. Move gimbal-to-jack pivot pins away from jack; remove jack from gimbal.

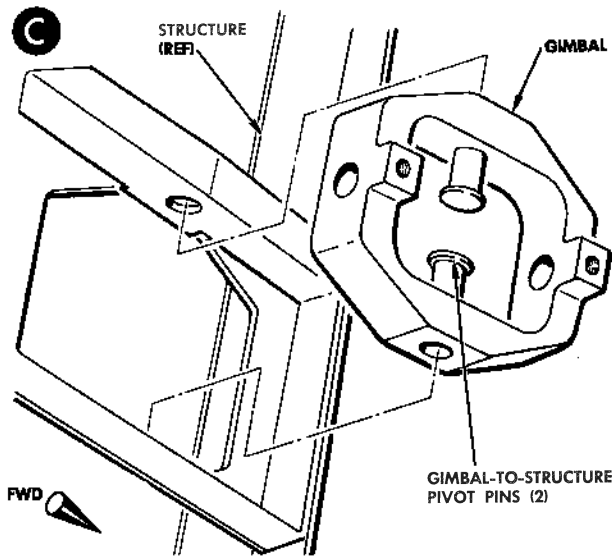

- g. Move gimbal-to-structure pivot pins (2) in toward center of gimbal; remove gimbal.

**INSTALLATION**

- a. Installation is essentially the reverse of removal. Safety-wire all nuts, bolts, and gimbal lock pins.
- b. Use sealant EC1293 (FSN 8030-576-8360) between screwjack seal and fuselage.
- c. Perform ramp rigging procedure.
- d. Perform all steps of the final cleanup procedure (sheet 3).

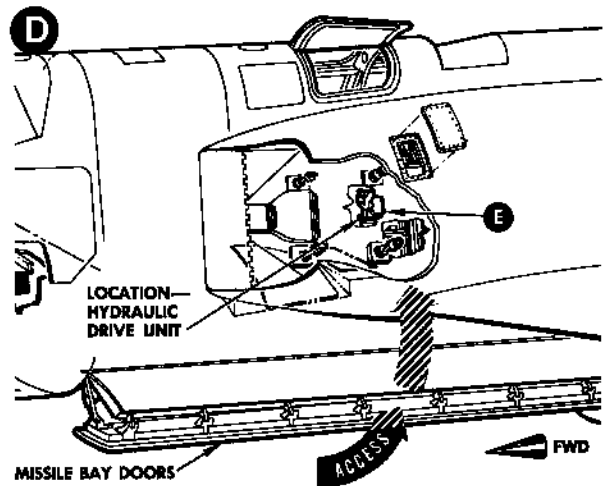

**VARIABLE RAMP HYDRAULIC DRIVE UNIT, REMOVAL**

- a. Perform steps "a" through "e" of preparation procedure (Sheet 1).
- b. Gain access to drive unit through the access door along centerline of missile bay roof at approximately sta. 253.

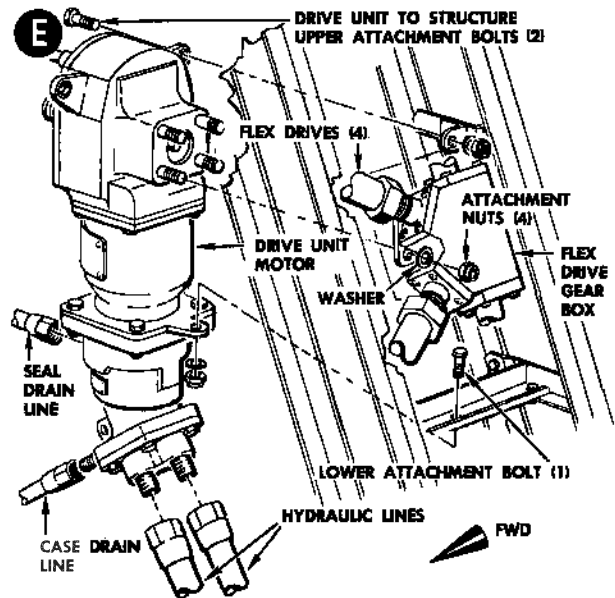

- c. Remove lines attached to drive unit. Provide receptacle for drainage.
- d. Remove attachment nuts holding flex drive gear box to drive unit.
- e. Remove attachment bolts holding drive unit to structure; remove drive unit.

**INSTALLATION**

- a. Installation is essentially the reverse of removal. Safety-wire all nuts and bolts in groups of 2 or 3.
- b. Perform ramp rigging procedure.
- c. Perform all steps of the final cleanup procedure (sheet 3).

.06.02.287-2D .75.06.00

Figure 4-10. Replacement, Variable Ramp System Components (Sheet 2 of 3)

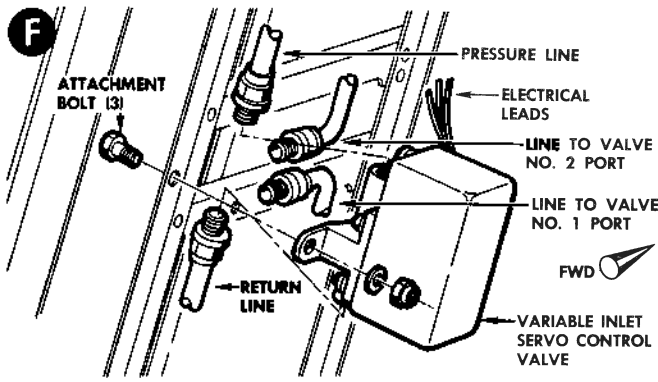

**VARIABLE INLET SERVO CONTROL VALVE, REMOVAL.**

- a. Perform step "b," of preparation procedure.
- b. Gain access to the valve through the access door along the top centerline of missile bay.
- c. Remove electrical leads from valve.
- d. Remove lines attached to valve. Provide receptacle for drainage.
- e. Remove bolts attaching valve to structure; remove valve.

**INSTALLATION**

- a. Installation is essentially the reverse of removal.
- b. Perform all steps of the final cleanup procedure. See detail "G".

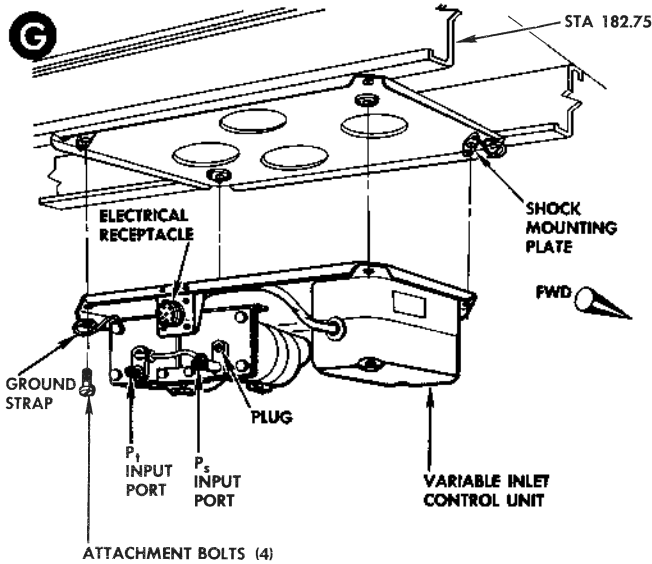

**VARIABLE INLET CONTROL UNIT, REMOVAL.**

- a. Gain access to the control unit through the aft lower electronics compartment.
- b. Remove electrical leads from control unit.
- c. Remove lines attached to control unit.
- d. Remove attachment bolts holding control unit to structure; remove control unit.

**INSTALLATION**

- a. Installation is essentially the reverse of removal.

**NOTE**

IF RAMP PITOT OR STATIC TUBE IS REPLACED, THE NEW TUBE MUST NOT BE INCREASED IN LENGTH. THE LENGTH OF THE TUBE DETERMINES PROPER SYSTEM FUCTION.

- b. Conduct ramp pitot static system leak check.
- c. Perform all steps of the final cleanup procedure.

**FINAL CLEANUP**

- a. Replace fuses removed in step "d" of preparation procedure (sheet 1).
- b. Conduct operational checkout of variable ramp system.

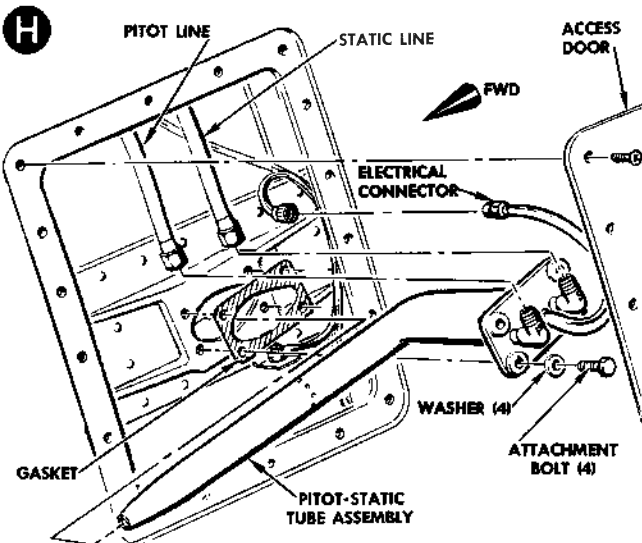

**VARIABLE INLET PITOT-STATIC TUBE, REMOVAL.**

- a. Check that pitot-static heat switch in cockpit is in the "OFF" position.
- b. Remove access door from outboard side of engine air inlet duct.
- c. Disconnect electrical connector from pitot tube assembly.
- d. Disconnect pitot and static lines from pitot tube assembly.
- e. Remove attachment bolts (4); remove pitot tube.

**INSTALLATION:**

- a. Installation is essentially the reverse of removal.
- b. Use new gasket on installation. Fill the void between pitot-static probe head and duct skin with sealant, EC1293 (FSN 8030-576-8360).
- c. Safety-wire probe attachment bolts in pairs.
- d. Conduct ramp pitot-static system leak check upon completion of replacement.

.06.02.287-3 E .75.06.00

Figure 4-10. Replacement, Variable Ramp System Components (Sheet 3 of 3)

- d. Remove electrical leads from valve.
- e. Remove lines (2) attached to valve. Provide receptacle for drainage.
- f. Remove bolts (2) attaching valve to structure; remove valve.
- g. Installation of the variable ramp system hydraulic shutoff valve is essentially the reverse of the removal procedure.
- h. Bleed ramp hydraulic system. Refer to T.O. 1F-106A-2-3 for this procedure.
- i. Conduct an operational checkout of the variable ramp system.

#### **4-65. REPLACEMENT, VARIABLE RAMP SYSTEM HYDRAULIC SHUTTLE VALVE.**

- a. Remove the "VAR INLET OVERRIDE" fuse from the cockpit left fuse panel to prevent accidental high pressure pneumatic operation.
- b. Relieve hydraulic system pressure by operating elevons.
- c. *On F-106A airplanes*, gain access to the hydraulic shuttle valve through the access door along centerline of missile bay roof. *On F-106B airplanes*, gain access through the refrigeration compartment access door. The valve is located on left side of refrigeration compartment at approximately sta. 290.0.
- d. Remove lines (3) attached to valve. Provide receptacle for drainage. *Applicable to F-106A airplanes 57-2453, and F-106B airplanes 57-2517; and all other airplanes after incorporation of TCTO 1F-106-681*, remove restrictor from pneumatic inlet port of valve.
- e. Remove bolts (2) attaching valve to structure; remove valve.
- f. Installation of the variable ramp system hydraulic shuttle valve is essentially the reverse of the removal procedure.

#### **NOTE**

*On applicable airplanes*, when installing restrictor ascertain that restricted flow is toward shuttle valve.

- g. Bleed ramp hydraulic system. Refer to T.O. 1F-106A-2-3 for this procedure.
- h. Conduct an operational checkout of the variable ramp system.

#### **4-66. REPLACEMENT, VARIABLE RAMP SYSTEM HYDRAULIC BYPASS VALVE.**

- a. Remove the "VAR INLET OVERRIDE" fuse from the cockpit left fuse panel to prevent accidental high pressure pneumatic operation.

- b. Relieve hydraulic system pressure by operating elevons.

c. *On F-106A airplanes*, gain access to the hydraulic bypass valve through the access door along centerline of missile bay roof. *On F-106B airplanes*, gain access through the refrigeration compartment access door. The valve is located on left side of refrigeration compartment at approximately sta. 290.0.

- d. Remove electrical leads from valve.
- e. Remove lines (3) attached to valve. Provide receptacle for drainage.
- f. Remove bolts (3) attaching valve to structure; remove valve.
- g. Installation of the variable ramp system hydraulic bypass valve is essentially the reverse of the removal procedure.
- h. Bleed ramp hydraulic system. Refer to T.O. 1F-106A-2-3 for this procedure.
- i. Conduct an operational checkout of the variable ramp system.

#### **4-67. REPLACEMENT, VARIABLE RAMP SYSTEM HYDRAULIC DUMP VALVE.**

- a. Remove the "VAR INLET OVERRIDE" fuse from the cockpit left fuse panel to prevent accidental high pressure pneumatic operation.
- b. Relieve hydraulic system pressure by operating elevons.
- c. *On F-106A airplanes*, gain access to the hydraulic dump valve through the access door along the centerline of missile bay roof. *On F-106B airplanes*, gain access through the refrigeration compartment. The valve is located on left side of refrigeration compartment at approximately sta. 290.0.

- d. Remove electrical leads from valve.
- e. Remove lines (3) attached to valve. Provide receptacle for drainage.
- f. Remove bolts (3) attaching valve to structure; remove valve.
- g. Installation of the variable ramp system hydraulic dump valve is essentially the reverse of the removal procedure.
- h. Bleed ramp hydraulic system. Refer to T.O. 1F-106A-2-3 for this procedure.
- i. Conduct an operational checkout of the variable ramp system.

## ADJUSTMENT

**4-68. VARIABLE RAMP SYSTEM RIGGING.****4-69. Equipment Requirements.**

For the variable ramp system rigging equipment requirements, refer to paragraph 4-52.

**4-70. Procedure.**

For the variable ramp system rigging procedure see figure 4-9.

## SERVICING

**4-71. BLEEDING, VARIABLE RAMP HYDRAULIC SYSTEM.**

After each emergency actuation of the variable ramp system, or after replacement of any ramp hydraulic system component, it is necessary that the hydraulic system be bled of air. Refer to paragraph 4-31 for this procedure.

**4-72. DRAINING, RAMP PITOT-STATIC SYSTEM DRAIN TRAPS.**

*Applicable to F-106A airplanes*, the drain traps (2) are located on the forward bulkhead of the armament bays. *Applicable to F-106B airplanes*, the drain traps (2) are located on the aft bulkhead of the lower aft electronics compartment in the missile bay.

a. Open armament bays. Refer to T.O. 1F-106A-2-12 for this procedure.

b. Remove caps from pitot and static lines, drain traps. Allow moisture to drain from lines.

c. Dry inside of drain trap caps and reinstall.

**4-73. BLEEDING AIR PRESSURE, VARIABLE RAMP EMERGENCY PNEUMATIC SYSTEM.**

a. Gain access to pneumatic bleed valve through the left main wheel well. Plug is installed on forward bulk-

head, above the main high-pressure pneumatic system bleed valve.

**NOTE**

Refer to T.O. 1F-106A-2-3 for bleeding procedures for the entire high-pressure pneumatic system.

b. Remove screw from bleed valve and loosen valve 1½ turns. Allow all pressure to escape.

## WARNING

Plug will be expelled with explosive force if loosened excessively before pressure has bled off.

**4-74. CHARGING, VARIABLE RAMP EMERGENCY HIGH PRESSURE PNEUMATIC SYSTEM.**

Charging of the variable ramp emergency high-pressure pneumatic system is accomplished as a part of the charging procedure for the airplane's main high-pressure pneumatic system. Refer to T.O. 1F-106A-2-3 for this procedure.

## COOLING AIRFLOW SYSTEM

## DESCRIPTION

**4-75. GENERAL.**

The engine compartment cooling air flow is divided into two flow systems that are provided to cool two separated engine area compartments. The first compartment con-

sists of the engine accessory area that receives cooling air through the constant-speed drive unit air-oil cooler and the engine air-oil cooler. The second compartment consists of the combustion chamber and turbine area. This



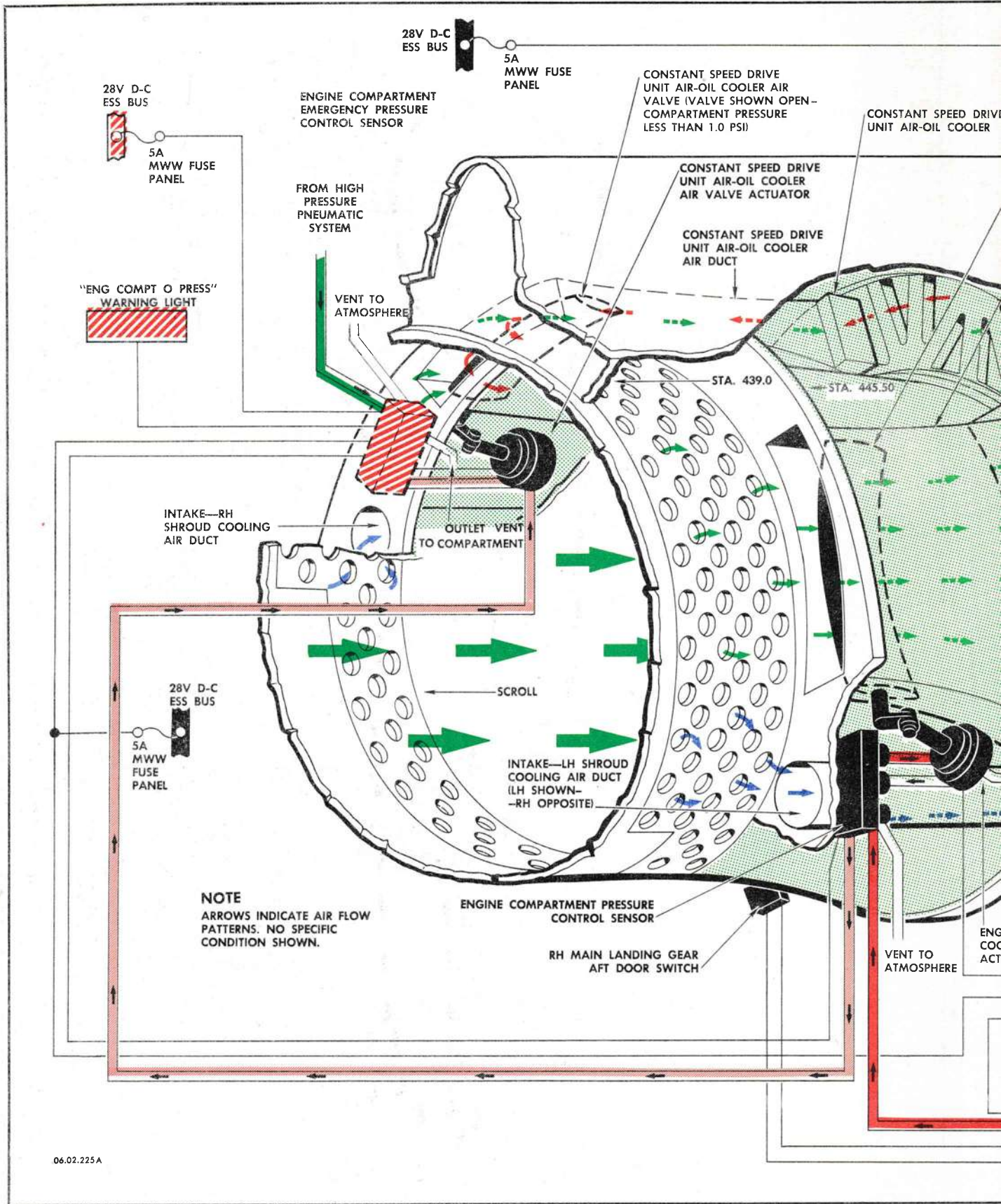



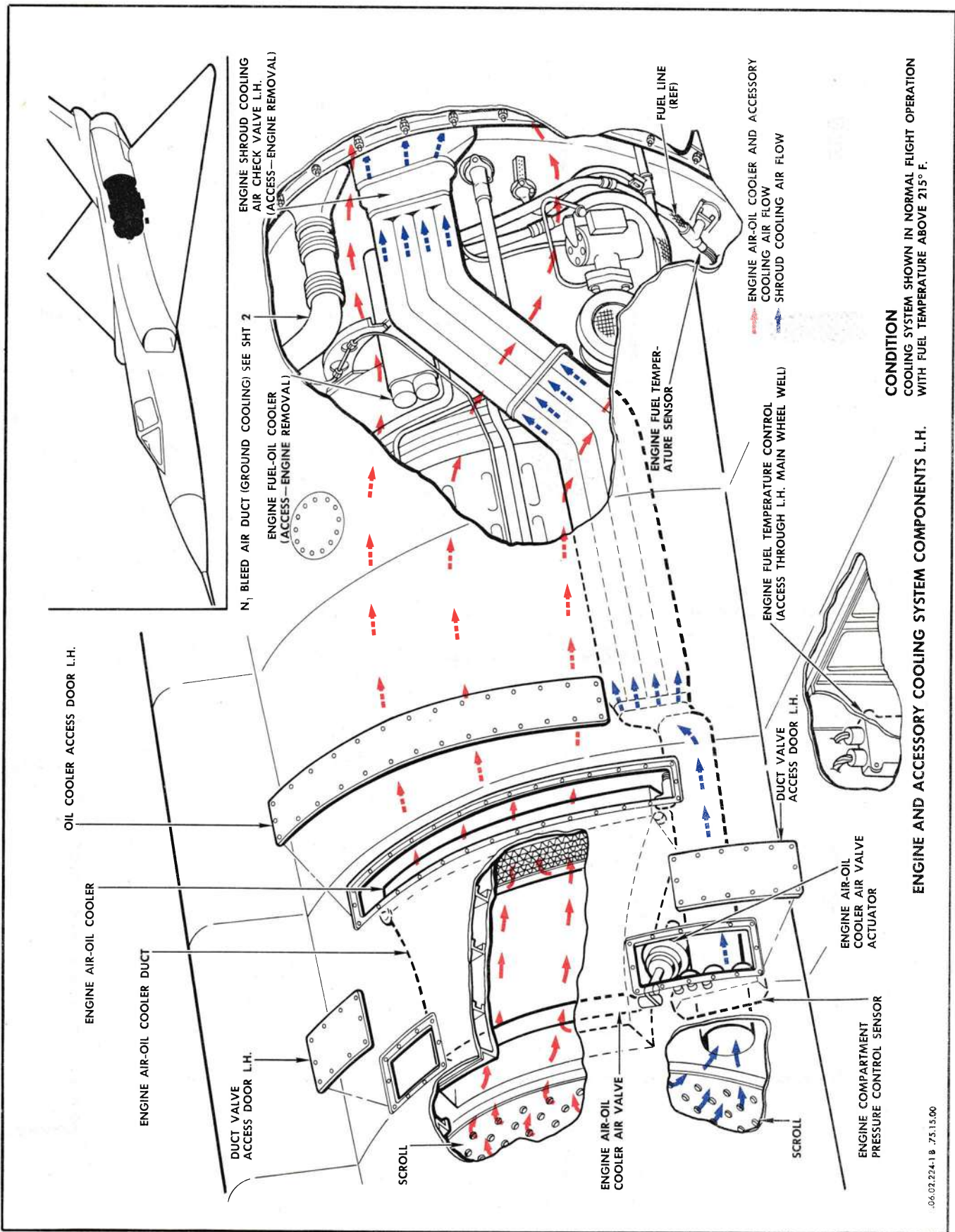

Figure 4-12. Engine and Accessory Cooling System (Sheet 1 of 2)

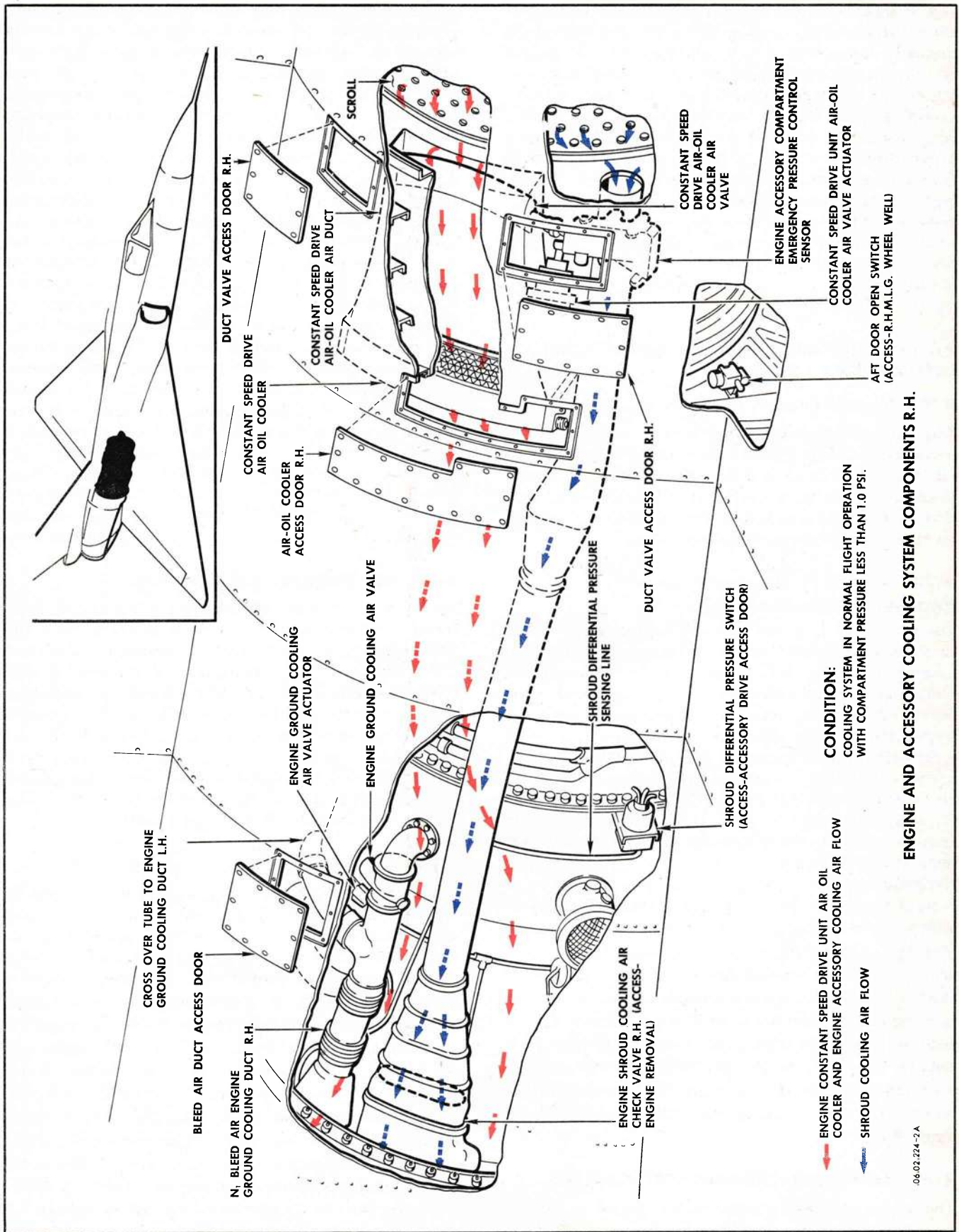

Figure 4-12. Engine and Accessory Cooling System (Sheet 2 of 2)

06.02.224-7A

area is separated from the accessory area by a titanium shroud and firewall. Cooling air for the shrouded area is normally ducted from a scroll which encircles the engine air inlet duct. During engine ground run operations, cooling air for this area is ducted from the engine  $N_1$  compressor section. The combustion chamber and turbine compartment cooling air is vented overboard between the afterburner nozzle and the engine shroud. Cooling air from the accessory compartment passes between the fuselage and the turbine area shroud and is vented overboard between the fuselage tail cone and the shroud. Operation of the cooling air flow system is automatic with operation of the engine and airplane. For schematic and component location illustrations of the cooling system, see figures 4-11 and 4-12.

#### **4-76. COMBUSTION CHAMBER AND TURBINE COMPARTMENT COOLING.**

##### **4-77. Normal Cooling in Flight.**

The combustion chamber and turbine compartment is normally cooled in flight by air ducted from the engine air inlet duct. The air is routed aft to the engine shroud through two ducts. A check valve is installed in each duct, immediately ahead of the shroud, to prevent cooling air reverse flow during ground operation.

##### **4-78. Ground Cooling and Pressure Augmentation During Flight.**

For ground cooling and pressure augmentation of the shrouded combustion chamber and turbine compartment, a supply of cooling air is ducted from the  $N_1$  compressor. During certain flight maneuvers, such a climb with afterburner on, pumping action of the engine exhaust tends to pull the air from within the shroud area. This causes a negative pressure that could collapse the shroud if permitted to build up. To prevent this condition, a solenoid air valve is provided to control air flow from the engine  $N_1$  compressor bleed air port. This valve receives power from two switches wired in series; the main landing gear door open switch and a pressure switch in the engine compartment. The door open switch prevents the valve from closing when the landing gear is extended, thus providing  $N_1$  compressor air for cooling during ground operation. During flight operation, the pressure switch actuates when the pressure differential within the shroud reaches 2.5 psi. This operates the solenoid valve which in turn permits  $N_1$  compressor air to enter the shroud. This reduces the pressure differential. When the differential is reduced to 1.3 psi, the pressure switch actuates the solenoid and causes the valve to close. For a schematic illustration of system in the ground cooling condition, see figure 4-13.

##### **4-79. ACCESSORY COMPARTMENT COOLING.**

The engine accessory compartment is cooled by exit air from the engine air-oil cooler and the constant-speed air-oil cooler. The air flows through the engine accessory

compartment, passes over the burner and turbine compartment shroud and exhausts at the rear of the airplane between the tail cone and the shroud. Some flight conditions increase pressure at the tail cone area and tend to increase the accessory compartment pressure. In order to protect the fuselage from high pressures resulting from this condition, pressure control is provided by the modulating air valves in the engine and constant-speed drive oil cooling systems. The constant-speed drive air-oil cooler air valve is open as long as the differential between engine accessory compartment pressure and ambient is below 1.0 psi. The valve is modulated closed as the engine accessory compartment pressure differential increases to 1.5 psi. The engine air-oil cooler is regulated by the fuel temperature sensing phase of the system. It remains under this control as long as the engine accessory compartment pressure is less than 2.0 psi. At 2.0 psi the fuel temperature control is overridden by the pressure control and the engine air-oil cooler air valve is also closed. At this point the compartment ventilation is completely shut off, with the exception of a fixed amount of air allowed to leak past the closed constant-speed drive unit oil cooler air valve. At 1.50 psi the fuel temperature control again becomes operative and the engine air-oil cooler air valve opens. The source of power for valve operation is engine bleed air controlled by solenoid valves.

##### **4-80. OIL COOLING AIR CONTROL.**

During flight, cooling air is provided to the engine air-oil cooler and the constant-speed drive oil cooler from the engine air inlet duct by means of a common annular bleed scroll. Separate ducts route the air from the scroll to each cooler. Constant-speed drive oil cooling for ground operation is accomplished by reversing the air flow through the constant-speed drive oil cooler, using engine air inlet duct negative pressure as the motive force. There is no air flow through the engine air-oil cooler during ground operation, since the fuel-oil cooler is capable of cooling the engine oil sufficiently for ground operation.

##### **4-81. Engine Air-Oil Cooler Control.**

Engine air-oil cooler air flow is regulated by a butterfly type throttling valve located in the air supply duct upstream from the cooler. The valve is electrically controlled, pneumatically actuated, and modulated according to the engine fuel temperature. A pressure override feature is actuated by engine accessory compartment internal pressure. Fuel temperature is used to dictate the need for air-oil cooler operation. The air-oil cooler and the fuel-oil cooler are mounted in series in the oil out line, the oil passing first through the air-oil cooler. In order to minimize internal air drag, the air-oil cooler is initially closed, and the fuel-oil cooler provides the necessary cooling requirements for the engine oil. The maximum allowable temperature of the fuel is 110°C (230°F). The valve remains closed preventing airflow through the air-oil cooler when fuel temperature is less than 101.7°C (215°F), and modulates to maintain fuel temperature at



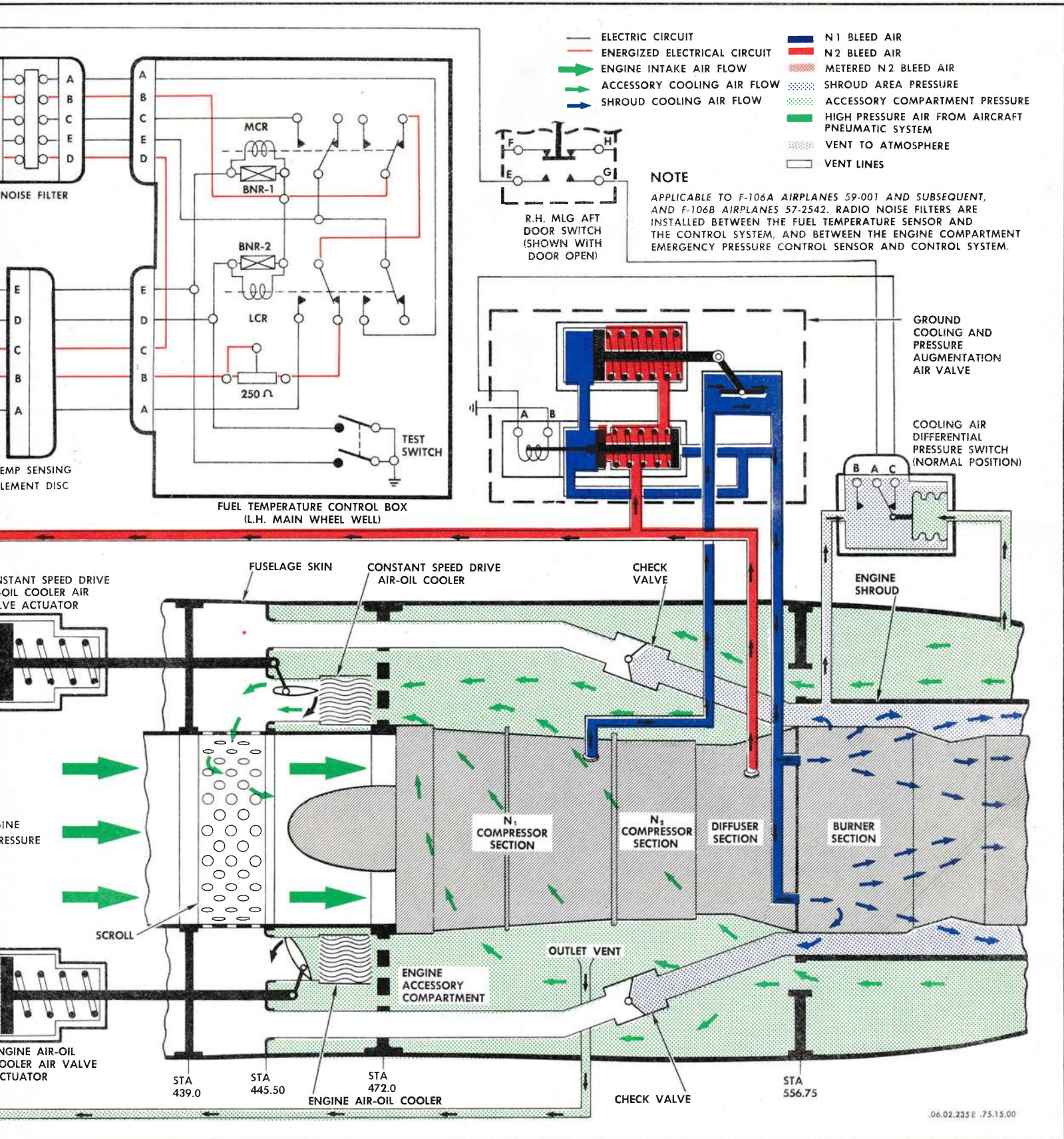

Figure 4-13. Engine and Accessory Cooling System, Ground Cooling Operation

105.8° ±4.2°C (222.5° ±7.5°F). The temperature control becomes inoperative when the engine compartment pressure rises to 2.0 psi and does not regain control until the pressure is reduced to 1.5 psi.

#### 4-82. Constant-Speed Drive Oil Cooler Control.

The constant-speed drive oil cooler air flow is regulated by a butterfly type throttling valve located in the cooling air supply duct upstream from the cooler. This valve is controlled and actuated pneumatically, and is modulated according to the pressure requirements in the engine accessory compartment. In the closed position, sufficient air is permitted to pass through the valve for minimum oil and accessory compartment cooling requirements.

#### 4-83. Emergency Operation, Accessory Compartment Cooling Air Control.

In the event of failure of the high-pressure bleed air system, or other failure causing the engine accessory compartment pressure to rise to 3.0 psi, the accessory compartment emergency air control system is automatically activated. The emergency system uses high-pressure air and electrical power, and when energized closes both the engine air-oil cooler air valve and the constant-speed drive oil cooler air valve. The constant-speed oil cooler air valve is closed by high-pressure pneumatic system air routed through the compartment emergency pressure sensor. The engine air-oil cooler air valve is closed by the actuator spring action. The electrical signal actuates solenoids to close the air inlet control valve and open the air outlet valve. Simultaneously, a warning light is energized on the pilot's emergency warning panel. The warning light will remain on for the duration of the flight, since the system can only be reset on the ground.

#### NOTE

To reset the emergency control system and to extinguish the warning light, momentarily remove electrical power from the airplane, or remove and reinstall the "COMP PRESS WARN" fuse from the main wheel well fuse panel. This procedure deenergizes a feedback circuit that holds the sensor electrical relays in the emergency position.

When the warning light goes on, the pilot must reduce the speed of the airplane to mach 1 or less within 2½ minutes of the initial warning. This is necessary in order to conserve the high-pressure pneumatic supply. When the engine accessory compartment pressure is reduced to 0.75 psi, the engine air-oil cooler control valve remains closed. At the same time, the constant-speed oil cooler air control valve is returned to control of the normal system. Emergency control will be resumed if the compartment pressure again builds up to 3.0 psi. A time delay is designed into the emergency pressure control system to limit the reopening cycle to a minimum of 30 seconds.

#### 4-84. ENGINE COMPARTMENT PRESSURE CONTROL SENSOR.

The engine accessory compartment pressure control sensor component is composed of five units. These units are: a controlling orifice for bleed air pressure regulator, the constant-speed drive unit oil cooler air valve actuating air, the constant-speed drive unit oil cooler air valve pressure modulator, the emergency timing solenoid valve, and the engine oil temperature control pressure override.

#### 4-85. Engine Accessory Compartment Bleed Air Pressure Regulator.

The engine accessory compartment bleed air pressure regulator is provided to regulate N<sub>2</sub> compressor bleed air to 60 psi pressure. Air flow from the regulator is routed through two ports. One port is connected to the inlet side of the engine air-oil cooler valve actuator. The second port routes air through a controlling orifice and an emergency timing solenoid to the constant-speed oil cooler valve actuator. A line tees off of the constant-speed line to the pressure modulator.

#### 4-86. Constant-Speed Oil Cooler Air Valve Pressure Modulator.

The constant-speed oil cooler air valve pressure modulator is provided to vary the air pressure to the constant-speed oil cooler air control actuator according to engine accessory compartment pressure. This modulates the valve to maintain proper compartment pressure by bleeding off varying amounts of the air ported to the cooler air control actuator from the engine bleed air pressure regulator. The pressure modulator operates on pressure differential existing between ambient and engine accessory compartment pressure. The bleed nozzle of the pressure modulator remains open, bleeding off most of the air pressure until the engine accessory compartment pressure is 1.0 psi. higher than ambient. From this point the bleed is gradually reduced until at 1.5 psi the bleed is cut off. This results in gradually increasing pressure in the line to the actuator. This pressure acts upon the cooler air control actuator to modulate the valve toward the closed position.

#### 4-87. Emergency Timing Solenoid Valve.

The emergency timing solenoid valve, in the air line to the constant-speed drive unit oil cooler valve actuator, provides a means of limiting the amount of emergency pneumatic system air used for emergency valve operation. This is accomplished by timing solenoid action in delaying the reopening cycle of the cooler valve actuator to a minimum of 30 seconds for each cycle when operating on the emergency system. When the emergency system is actuated, the cooler valve actuator solenoid valves are deenergized and closed. Simultaneously the emergency air pressure operates the cooler valve actuator to the closed



position. Closing the oil cooler air valve relieves the pressure condition and the emergency system is deenergized, thus shutting off emergency air and opening the actuator solenoid valves. However, the holding coil of the warning relay continues to hold the emergency timing valve deenergized (closed). The air in the actuator, instead of escaping rapidly, bleeds off slowly through a small drilled passage in the timing valve plunger. This limits the emergency operation of the cooler valve actuator to a minimum of 30 seconds for each cycle. The timing valve will remain deenergized for the remainder of the flight.

#### **4-88. Engine Oil Temperature Control Pressure Override.**

The engine oil temperature control pressure override provides a means whereby excessive engine accessory compartment pressure overrides temperature control and closes the engine oil cooler air valve. To accomplish this, the pressure override responds to the pressure differential between the engine accessory compartment pressure and ambient. The pressure override valve is normally closed as long as the pressure differential remains below 2.0 psi. When the differential reaches 2.1 psi the valve opens, air exhausts from the actuator, and causes the cooler air valve to close. When the pressure differential is reduced to 1.65 psi the valve closes, allowing the actuator to again respond to temperature control.

#### **4-89. ENGINE FUEL TEMPERATURE CONTROL AND SENSOR.**

The fuel temperature control receives signals from the fuel temperature sensor which is located in the main fuel line near the inlet port of the fuel pressurizing and dump valve. The signals are relayed as "open" or "close" signals to the engine air-oil cooler air valve actuator. The control unit has an external push to test button that may be used to simulate a signal for "more cooling" during ground operational check. The fuel temperature sensor is a thermostatic device provided to sense the temperature of fuel that has passed through the fuel-oil cooler. The sensor contains a mercury thermometer tube with a grounded mercury column and contact points in the tube at 110°C (230°F) and 111.5°C (240°F). The sensor also contains a heater element with electrical connections to provide high range and low range rates of heating. When the fuel is cold, neither of the relays in the temperature control box will be energized. The air control valve will remain in its normal position with the inlet solenoid valve closed and the outlet solenoid valve open. At this time power is being supplied through the temperature control unit to the high heat range of the heating element in the temperature sensor. While most of this heat from the heating element is dissipated into the fuel, the temperature of the mercury column is increased several degrees above that of the fuel in the temperature bulb well. As this increase in temperature causes the mercury column to reach the 110°C (230°F) electrode, the "less cooling" relay in the control unit is energized. The "less cooling" relay switches the temperature sensor heating element to the low heat range and

signals the actuator outlet solenoid of the engine air-oil cooler air valve to close. With less heat supplied to the mercury column, due to the heating element being on low range, the column will cool and break contact. This deenergizes the "less cooling" relay. With the relay deenergized, the actuator outlet solenoid is open. The heating element is again switched to the high range, and starts a new cycle. If the temperature of the fuel becomes excessive, the mercury will pass the 110°C (230°F) contact and will contact the 111.5°C (240°F) electrode. This energizes the "more cooling" relay in the control unit, which switches power to the inlet solenoid of the cooler actuator to open the air valve. At this time, power to the temperature sensor heating element is off. The energized solenoid permits air to flow into the actuator, moving the air-oil cooler air valve toward the open position to increase the cooling capacity. The sensor mercury column will cool and drop below the 111.5°C (240°F) electrode in a few seconds, switching the heater on the inlet solenoid off. When the fuel temperature is low, the actuator and valve remain in the closed position.

#### **4-90. ENGINE ACCESSORY COMPARTMENT EMERGENCY PRESSURE CONTROL SENSOR.**

The engine accessory compartment emergency sensor unit is designed to initiate closing of the engine oil cooler air valve and the constant-speed oil cooler air valve. The closing signal will occur when the pressure differential between the engine accessory compartment and ambient reach 3.0 psi. At this time the sensor will also energize a warning light on the pilot's panel. The sensor consists of an emergency sensing unit, emergency relay, emergency shutoff solenoid, emergency pressure regulator and relief valve, and a warning relay as described in the following paragraphs, 4-91 through 4-95.

#### **4-91. Emergency Sensing Unit.**

In operation, engine accessory compartment pressure is ported to the upper surface of the emergency sensing unit piston. Ambient pressure is applied to the lower surface of the piston. When the accessory compartment pressure exceeds ambient pressure by 3.0 psi, the piston moves and actuates an internal switch. This switch energizes the emergency relay. The emergency sensing unit resets when pressure differential drops to 0.75 psi; the emergency relay then returns to the normal position.

#### **4-92. Emergency Relay.**

The emergency relay controls five circuits, and performs the following functions:

- a. Energizes the emergency shutoff solenoid. This admits high-pressure pneumatic air to the emergency pressure regulator for actuating the constant-speed oil cooler valve.
- b. Operates and sets the warning relay.
- c. Deenergizes the inlet and outlet solenoids of the engine air-oil cooler air valve actuator causing the valve to close.

d. Deenergizes the two solenoids at the constant-speed oil cooler air valve actuator, permitting the solenoids to close.

#### 4-93. Emergency Shutoff Solenoid.

The emergency shutoff solenoid is provided to control flow of emergency high-pressure air. Operation of the solenoid admits high-pressure air to the emergency pressure regulator for constant-speed oil cooler valve operation.

#### 4-94. Emergency Pressure Regulator.

The emergency pressure regulator is provided to reduce pressure of the emergency high pressure air to 75 psi. Engine accessory compartment pressure in the upper chamber of the regulator works in conjunction with a spring loaded piston to reduce the pressure. A relief valve, which is incorporated in the diaphragm of the regulator, protects the regulator and actuator from high pressures resulting from leakage of the regulator valve. The relief valve is designed to relieve pressures in excess of approximately 80 psi.

#### 4-95. Emergency Warning Relay.

The emergency warning relay, when actuated, illuminates the warning light in the cockpit. At the same time the relay breaks the circuit to the emergency timing solenoid in the engine accessory compartment pressure control sensor. When initially energized, the warning relay receives power from emergency relay and remains energized after the emergency sensing unit has broken the circuit to the emergency relay. This is accomplished in the warning relay when holding coil power is transferred from the emergency relay to an emergency power contact in the warning relay. The warning relay will remain energized, retaining the warning light and the emergency timing valve in the emergency condition, until aircraft electrical power is shut off.

#### 4-96. ENGINE AIR-OIL COOLER AIR CONTROL VALVE.

The engine air-oil cooler air control valve is installed in the cooler air inlet duct on self-aligning bearings. The valve, equipped with silicone rubber leading and trailing edge seal strips, is contoured to fit the duct wall when in the closed position. The valve is streamlined in cross section and completely closes off the duct when in the closed position. The valve is actuated by a pneumatically powered actuator through an arm splined to the valve shaft. In normal flight cooling operation, the valve remains closed. The valve will open with the need of additional oil cooling.

#### 4-97. ENGINE AIR-OIL COOLER AIR CONTROL VALVE ACTUATOR.

The engine air-oil cooler air valve actuator is an electrically controlled, pneumatically actuated unit that operates the engine air-oil cooler air valve. The actuator is equipped with three ports; a solenoid controlled air

inlet port, a solenoid controlled air outlet port that vents to the engine accessory compartment, and a second air outlet port that is pneumatically controlled by pressure override in the engine compartment pressure sensor. When electrical power to the actuator is off, the inlet solenoid valve is closed and the outlet solenoid valve is open. At this time the actuator is in the retracted position and the air-oil cooler air valve is closed. The actuator is equipped with a diaphragm that extends the piston rod when the actuator is pressurized. A spring retracts the actuator as air pressure is relieved. The inlet and outlet solenoids are controlled by fuel temperature signals from the temperature control box. The inlet solenoid is normally closed and the outlet solenoid is normally open. As temperature signals call for more cooling air, the inlet solenoid opens and the outlet solenoid closes, permitting  $N_2$  bleed air pressure to position the actuator. A temperature signal calling for less cooling air will deenergize the outlet solenoid and permit spring pressure to retract the piston and close the valve. If the engine accessory compartment pressure becomes excessive, the pressure override will open the second outlet port regardless of temperature signals and permit actuator pressure to bleed off closing the valve.

#### 4-98. CONSTANT-SPEED SYSTEM OIL COOLER AIR CONTROL VALVE.

The constant-speed oil cooler air control valve is a self-aligning-bearing supported valve installed in the cooler air inlet duct. The valve is shaped to the duct contour when in the closed position. In the closed position the valve permits a given quantity of air to continue flowing through the cooler. The valve is streamlined in contour and is actuated through an arm splined to the valve pivot shaft.

#### 4-99. CONSTANT-SPEED SYSTEM OIL COOLER AIR CONTROL VALVE ACTUATOR.

The constant-speed oil cooler air control valve actuator is an electrically controlled pneumatically actuated unit that operates the constant-speed oil cooler air valve. The actuator is equipped with three ports: two solenoid controlled air inlet ports and an emergency air control system inlet port. In normal operation, the actuator is extended by pneumatic pressure, and retracted to the cooler valve open position by spring pressure. When energized, the air inlet solenoids permit engine  $N_2$  compressor bleed air to position the cooler valve to the desired valve opening. Normal operation of the valve is controlled by a pressure modulator valve located in the engine compartment pressure control unit. Emergency operation (closing) of the cooler valve and actuator occurs when the engine compartment pressure rises to 3 psi. High-pressure pneumatic air is used for this operation.

#### 4-100. GROUND COOLING AND PRESSURE AUGMENTATION AIR VALVE.

The ground cooling and pressure augmentation air valve is provided to control flow of  $N_1$  compressor bleed air

to the area within the engine shroud.  $N_1$  compressor air is used within the shroud area for cooling during engine ground run operation and to relieve negative pressure buildup during flight operation. The valve assembly consists of a butterfly type valve, a spring loaded piston and cylinder and a solenoid operated pilot valve. The pilot valve is provided to route  $N_2$  compressor bleed air to either side of the spring loaded piston assembly for control of the  $N_1$  bleed air butterfly valve. The butterfly valve is open during engine ground operation to provide  $N_1$  bleed air for engine cooling. During normal flight operation, the solenoid pilot valve is energized, causing  $N_2$  bleed air to reposition the spring loaded piston assembly. This causes the butterfly valve to close. During flight operation, a shroud differential pressure switch senses inner shroud negative pressure buildup, which provides a signal to deenergize the solenoid pilot valve,  $N_2$  bleed air is then routed to the spring loaded side of the piston assembly, causing the  $N_1$  bleed air butterfly valve to open, relieving the shroud negative pressure.

#### 4-101. SHROUD DIFFERENTIAL PRESSURE SWITCH.

The shroud differential pressure switch is provided to actuate the ground cooling and pressure augmentation air valve during flight operation. The switch is actuated

by pressure differential between the engine accessory compartment and the area within the engine shroud. When actuated, the switch operates the solenoid actuated pilot valve causing the  $N_1$  bleed air butterfly valve to open. Opening of the bleed air valve relieves pressure differential that tends to collapse the engine shroud. The switch is normally closed and opens when the accessory compartment pressure exceeds inner shroud pressure by 2.5 psi. The switch closes when differential pressure decreases to 1.3 psi. The switch incorporates two ports that are identified by the letters "P" and "V." Port "P" is connected to the inner shroud area. Port "V" is vented to the engine accessory compartment.

#### 4-102. SHROUD RAM AIR COOLING CHECK VALVES.

Each of the shroud ram air inlet ducts are equipped with a spring loaded air flow check valve. These valves, installed on the forward side of the engine firewall, open during flight operation due to the flow of ram air to the inner shroud area. During engine ground run operation, a low pressure area exists within the engine air inlet duct which tends to draw hot exhaust gases in through the shrouded area thereby creating an over temperature condition. The check valves prevent this reverse flow condition and at this time  $N_1$  compressor bleed air is ducted to the inner shroud area for the cooling.

## OPERATIONAL CHECKOUT

#### 4-103. OPERATIONAL CHECKOUT, COOLING AIR FLOW SYSTEM.

#### 4-104. Equipment Requirements.

FIGURE	NAME	TYPE	ALTERNATE	USE AND APPLICATION
	Compressed dry air source of 100 psi.			To actuate oil cooler air valve actuators.
Refer to T. O. 1F- 106A-2-10	Generator Set (Gas).	8-96026-801 AF/M32A-13 (6115-583- 9365)	8-96026 AF/M32M-2 (6115-617- 1417)	To energize electrical systems on aircraft equipped with special quick disconnect receptacle.
	Generator Set (Elec).	8-96025-803 AF/ECU- 10/M (6125-583- 3225)	8-96025-805 A/M24M-2 (6125-628- 3566)	
			8-96025 AF/M24M-1 (6125-620- 6468)	

**4-104. Equipment Requirements (Cont).**

FIGURE	NAME	TYPE	ALTERNATE	USE AND APPLICATION
Refer to T.O. 1F- 106A-2-10 (cont).	Generator Set.		MC-1 (6125-500- 1190)	To energize electrical systems (except AWCIS) on aircraft equipped with standard AN receptacle and on others by using adapter cable 8-96052.
			MD-3 (6115-635- 5595)	
	Adapter Cable.	8-96052 (6115-557- 8548)		To connect MC-1 and MD-3 units to aircraft equipped with special quick disconnect receptacle.
Refer to T.O. 1F- 106A-2-9	Pitot Static System Field Tester.	MB-1 (6635- 334-7433)	Equivalent	To supply vacuum pressure.

**4-105. Preparation.**

a. Connect external dc electrical power source to airplane.

b. Connect external source of 100 psi air pressure to the engine accessory compartment pressure control sensor by removing the engine air hose and attaching the air supply to the tube fitting. The engine air hose is attached to a fitting in the upper right-hand corner of the left-hand forward engine mount access door.

c. Connect the field tested vacuum source to the ambient pressure port in the left side of the fuselage over the wing at sta. 500.0. Use sealer or vacuum cup to hold hose to port.

d. Install the following fuses:

1. "ENG GND COOL"  
Main wheel well fuse panel.
2. "OIL COOL CONT"  
Main wheel well fuse panel.
3. "COMPT PRESS WARN"  
Main wheel well fuse panel.

**4-106. Procedure.**

a. With external air pressure and electrical power applied to the airplane, check position of the engine air-oil cooler and the constant-speed oil cooler air valve actuators. Both shall be retracted (constant-speed oil cooler open, engine air-oil cooler closed).

**NOTE**

Valve position may be checked by looking through the ports located in the air control valve access door at fuselage sta. 450.0 on both sides of the fuselage above the wing. Check that the movement of the valve actuator is smooth. If the movement is erratic, check the linkage for misalignment or binding.

b. Press the "PUSH TO TEST" button on the engine fuel temperature control box mounted on the aft side of the left wheel well near sta. 472.0. This simulates excessive fuel temperature. The engine air-oil cooler actuator will extend, opening the air-oil cooler and valve; release test button.

c. Apply vacuum pressure to fuselage ambient pressure port. When pressure is reduced to approximately  $-2.04$  inches Hg, the constant-speed drive oil cooler air valve will begin to close and will be fully closed before a pressure of  $-3.05$  inches Hg is reached.

d. Hold the "PUSH TO TEST" button in on the engine fuel temperature control box. This will cause the engine air-oil cooler valve to open. Increase vacuum pressure on the left-hand ambient port. At a pressure of  $-4.25 (\pm 0.41)$  inches Hg the engine air-oil cooler valve will close.

e. Reduce vacuum pressure to  $-3.35 (\pm 0.30)$  inches Hg holding in "PUSH TO TEST" button. Actuator will extend, opening the engine air-oil cooler valve.

f. Reduce vacuum pressure to  $-2.04$  inches Hg. The constant-speed oil cooler air valve actuator shall retract, opening the air valve; remove vacuum source from port on LH side of fuselage.

g. Connect vacuum source to port on right side of fuselage above wing at sta. 500.0. Check that the airplane high-pressure pneumatic system is fully charged.

h. With fuel temperature control box test button depressed, increase vacuum to the ambient pressure port to  $-6.11 (+0 -0.82)$  inches Hg. Constant speed and fuel-oil cooler valves shall close. Engine compartment pressure warning lights in the cockpit shall illuminate and remain illuminated.

i. With test button still depressed, reduce vacuum pressure to  $-1.73 (\pm 0.31)$  inches Hg. The engine air-oil

cooler air valve shall remain closed, and the constant-speed cooler air valve shall reach full open in a minimum of 30 seconds. On both groups of airplanes, the master warning and compartment pressure warning lights shall remain illuminated. Reduce vacuum to zero.

j. Remove "COMPT PRESS WARN" fuse from main wheel well fuse panel; warning lights shall extinguish.

k. Install fuse; warning lights shall remain extinguished.

l. Shut off electrical power and remove test equipment.

m. Recharge high-pressure pneumatic system.

n. Gain access to the ground cooling and pressure augmentation air valve through the engine bleed air duct access door located on the upper right side of the fuselage.

o. Gain access to the shroud pressure differential switch through the engine accessory compartment right access door.

p. Remove vent plug from port "V" of shroud pressure differential switch; connect static system tester pressure source to port "V."

q. Prepare airplane and engine for engine ground run. Start engine and run at idle. Refer to paragraph 1-25 for these procedures.

r. Station observer with a mirror and flashlight on right wing at the ground cooling valve access door. With observer watching the cooling valve slotted position indi-

cator, located on the upper inboard side of the valve, position the right landing gear door closed switch to the door closed position (switch actuated); valve shall close. Increase pressure on static test unit until test unit gage reads +7.1 inches Hg maximum. Cooling air valve shall open as pressure reaches +5.08 ( $\pm 0.40$ ) inches Hg.

s. Actuate right landing gear door switch to the open position (switch deactuated); cooling valve shall remain open. Actuate switch to the closed position.

t. Reduce pressure until gage reads +2.24 ( $\pm 0.40$ ) inches Hg; valve shall close.

### CAUTION

Perform this check procedure as quickly as possible to prevent an over temperature condition. Cooling air flow into the inner shroud area is stopped when the cooling valve is closed.

u. Actuate landing gear door switch to the open (deactuated) position; cooling valve shall open.

v. Reduce pressure to 0; cooling valve shall remain open. Shutdown engine. Remove test equipment; reinstall vent plug in port "V" of shroud pressure differential switch. Close access doors.

## SYSTEM ANALYSIS

### 4-107. SYSTEM ANALYSIS, COOLING AIR FLOW SYSTEM.

PROBABLE CAUSE	ISOLATION PROCEDURE	REMEDY
<b>ENGINE AIR-OIL COOLER VALVE DOES NOT CLOSE ON "PUSH-TO-TEST" WITH NORMAL AIR SUPPLIED TO ENGINE COMPARTMENT PRESSURE SENSOR.</b>		
Actuator inlet or outlet solenoid inoperative.	Remove solenoids for bench test.	Replace if found defective.
Engine compartment pressure sensor air pressure regulator inoperative.	Remove sensor for bench test.	Install replacement item.
<b>DURING OPERATIONAL CHECKOUT, CONSTANT-SPEED OIL COOLER ACTUATOR DOES NOT OPERATE. (Refer to paragraph 4-106, step "c.")</b>		
Solenoid valves inoperative.	Open valve access door in RH side of fuselage; observe solenoid operation. Remove defective solenoid.	Install replacement item.

**4-107. SYSTEM ANALYSIS, COOLING AIR FLOW SYSTEM (CONT).**

PROBABLE CAUSE	ISOLATION PROCEDURE	REMEDY
----------------	---------------------	--------

**DURING OPERATIONAL CHECKOUT, CONSTANT-SPEED OIL COOLER ACTUATOR DOES NOT OPERATE (Refer to paragraph 4-106, step "c") (CONT).**

Engine compartment pressure sensor air pressure regulator inoperative.	Remove sensor for bench test.	
--	-------------------------------	--

**ENGINE COMPARTMENT PRESSURE WARNING LIGHT ILLUMINATES DURING FLIGHT**

Failure of normal system.	Perform operational checkout.	Replace defective unit.
Incorrect installation of CSD or engine air-oil cooler air valves.	Inspect from scroll access door.	Install valves correctly. Refer to paragraph 4-109.
Leakage into engine compartment.	Visually inspect for leaks at following locations: 1. Engine inlet seal. 2. Engine firewall seal. 3. Ram air duct leakage.	Repair or replace.
Leaking sense lines.	Pressure check with 10 percent castile soap solution at all fittings.	Repair or replace.

<b>REPLACEMENT</b>
--------------------

**4-108. REPLACEMENT, ELECTRICAL COMPONENTS GENERAL.**

When removing components equipped with pigtail electrical leads, always cut leads at an existing splice. This is necessary to preserve the component lead identity and provide sufficient length for reinstallation.

**4-109. REPLACEMENT, COOLING AIR FLOW SYSTEM COMPONENTS.**

For removal and installation procedure for the cooling air flow system components, see figure 4-14.

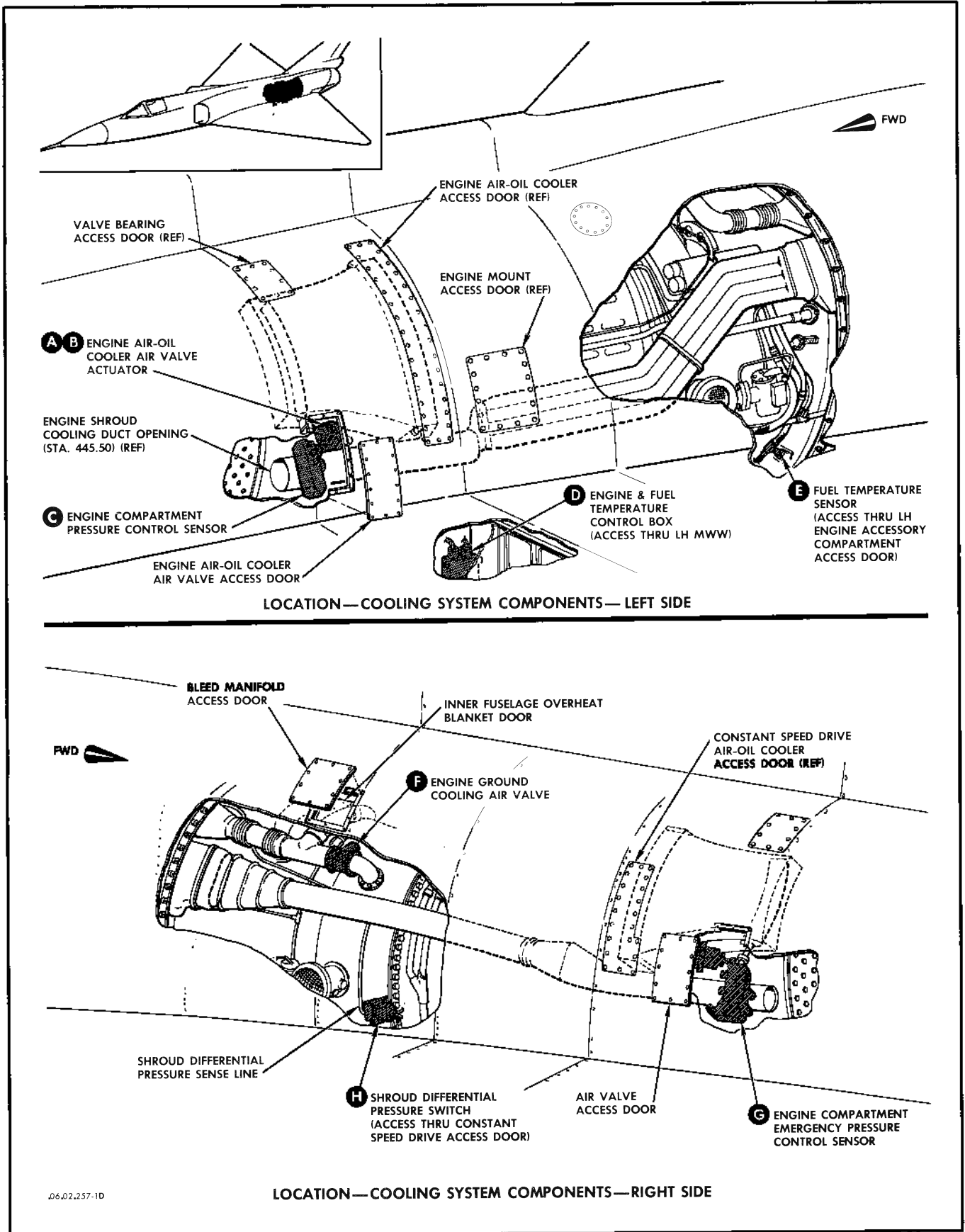

.06.02.257-1D

Figure 4-14. Replacement, Cooling System Components (Sheet 1 of 4)

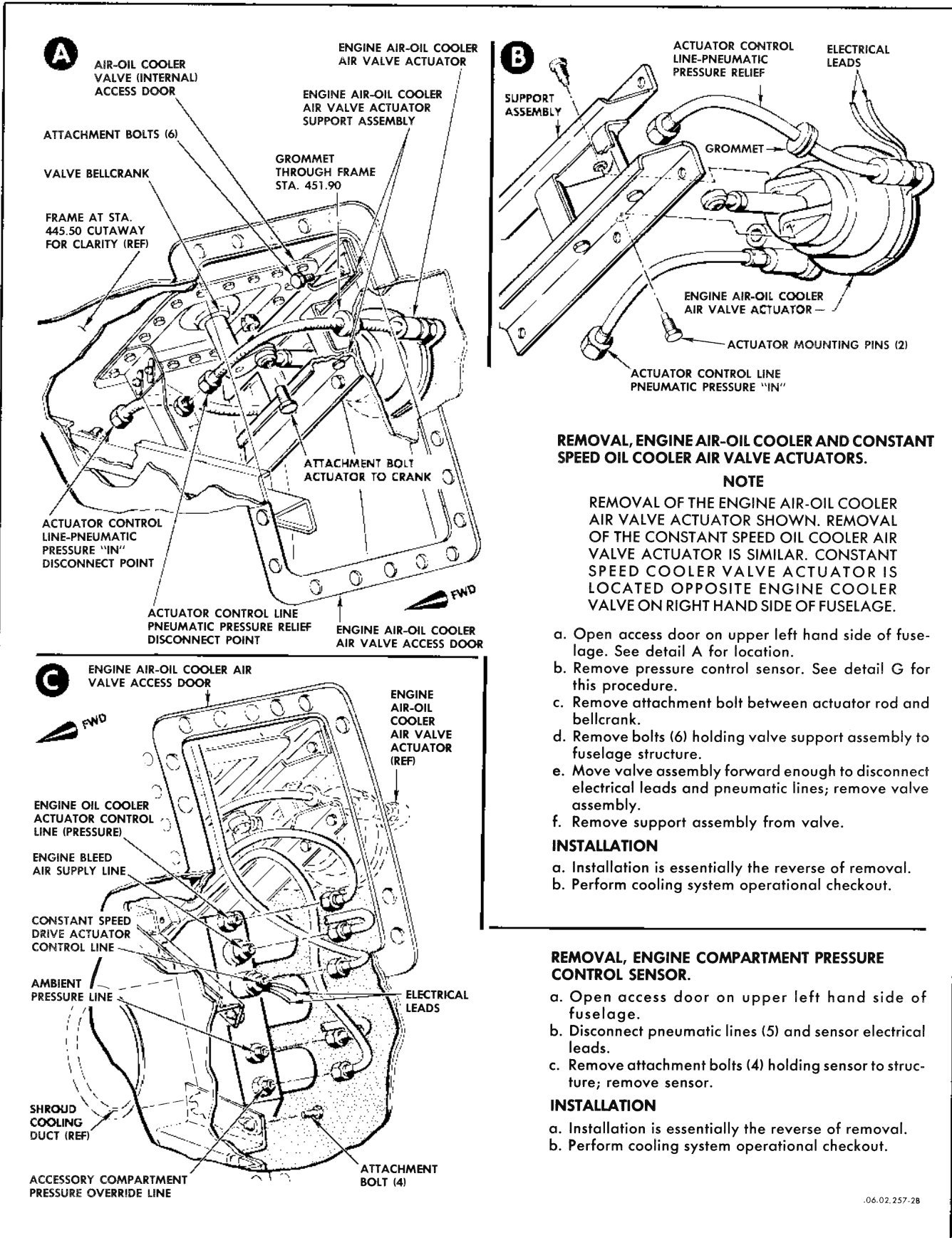

**REMOVAL, ENGINE AIR-OIL COOLER AND CONSTANT SPEED OIL COOLER AIR VALVE ACTUATORS.**

**NOTE**

REMOVAL OF THE ENGINE AIR-OIL COOLER AIR VALVE ACTUATOR SHOWN. REMOVAL OF THE CONSTANT SPEED OIL COOLER AIR VALVE ACTUATOR IS SIMILAR. CONSTANT SPEED COOLER VALVE ACTUATOR IS LOCATED OPPOSITE ENGINE COOLER VALVE ON RIGHT HAND SIDE OF FUSELAGE.

- Open access door on upper left hand side of fuselage. See detail A for location.
- Remove pressure control sensor. See detail G for this procedure.
- Remove attachment bolt between actuator rod and bellcrank.
- Remove bolts (6) holding valve support assembly to fuselage structure.
- Move valve assembly forward enough to disconnect electrical leads and pneumatic lines; remove valve assembly.
- Remove support assembly from valve.

**INSTALLATION**

- Installation is essentially the reverse of removal.
- Perform cooling system operational checkout.

**REMOVAL, ENGINE COMPARTMENT PRESSURE CONTROL SENSOR.**

- Open access door on upper left hand side of fuselage.
- Disconnect pneumatic lines (5) and sensor electrical leads.
- Remove attachment bolts (4) holding sensor to structure; remove sensor.

**INSTALLATION**

- Installation is essentially the reverse of removal.
- Perform cooling system operational checkout.

.06.02.257-28

Figure 4-14. Replacement, Cooling System Components (Sheet 2 of 4)



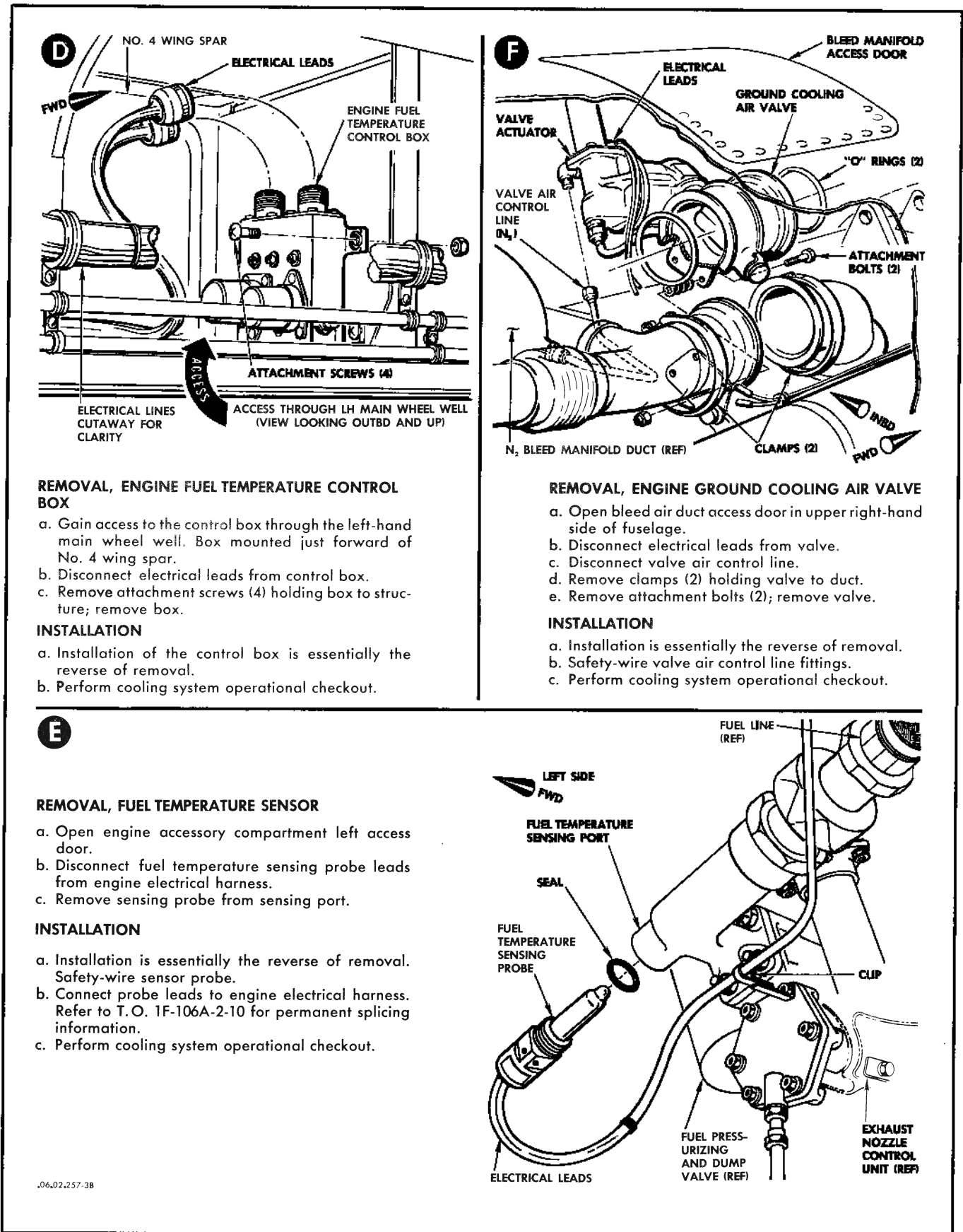

.06.02.257-38

Figure 4-14. Replacement, Cooling System Components (Sheet 3 of 4)

G

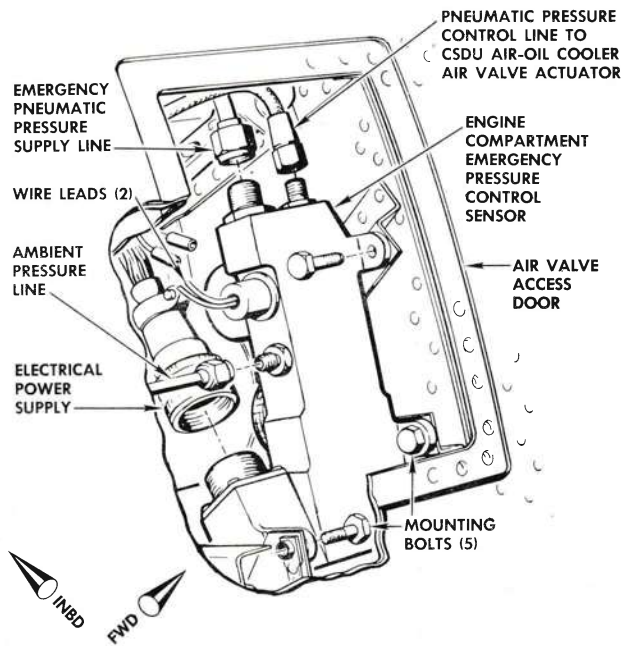

**REMOVAL, ENGINE COMPARTMENT EMERGENCY PRESSURE CONTROL SENSOR.**

- a. Open access door on upper right-hand side of fuselage.
- b. Disconnect electrical leads and pneumatic lines (3) from sensor.
- c. Remove attachment bolts (5); remove sensor. Cover line openings.

**INSTALLATION**

- a. Installation is essentially the reverse of removal.
- b. Perform cooling system operational checkout.

H

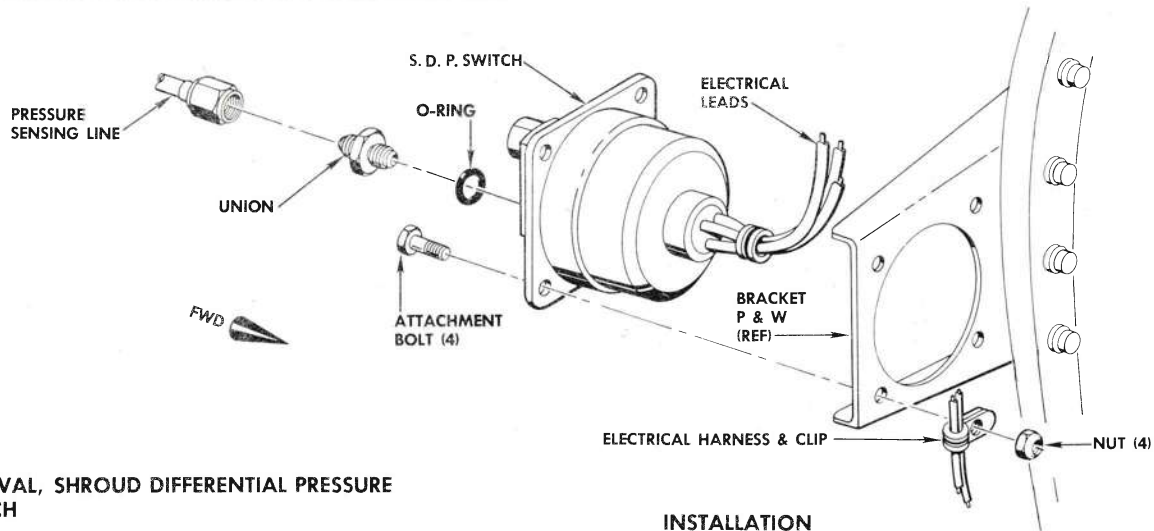

**REMOVAL, SHROUD DIFFERENTIAL PRESSURE SWITCH**

- a. Open constant speed drive access door.
- b. Disconnect shroud differential pressure switch leads from engine electrical harness.
- c. Disconnect pressure sensing line from switch.
- d. Remove attachment bolts (4) securing switch to bracket; remove switch.

**INSTALLATION**

- a. Installation is essentially the reverse of removal.
- b. Connect switch leads to engine electrical harness. Refer to T. O. 1F-106A-2-10 for permanent splicing information.
- c. Perform cooling system operational checkout.

.06.02.257-4

**Figure 4-14. Replacement, Cooling System Components (Sheet 4 of 4)**

**4-110. REPLACEMENT, ENGINE SHROUD.****4-111. Equipment Requirements.**

FIGURE	NAME	TYPE	ALTERNATE	USE AND APPLICATION
4-15 4-16	Shroud Handling Adapter Stand.	USAF MMU-3/E (1730-529-8452) with Adapter Kit 8-96167 (1730-632-0058) installed. For use with engine stand ETU- 8/E with Adapter Kits 8-96398-1 (1730-676-6848) 8-96398-3 (1730-676-6849) or 8-96165 (1730-632-0059) installed	8-96046 (4920-565-0191) (for use with engine stand SE 1012-803) (1740-568-1339)	To aid removal of shroud; to support shroud when removed from engine.
	Engine Hoisting Adapter.		8-96068 (1730-540-5034) (for use with SE 1012-803 engine stand)	To support aft end of engine during shroud removal.
4-15 4-16	Shroud Roller Bracket Set.	8-96047-803 (4920-632-8591)		To support and roll shroud from engine.
	Shroud Positioning Wedge.	8-96174 (4920-611-9695)		To support and position aft end of shroud. To be used with shroud part No. 8-22654 basic, -3, or -5.
		8-96200 (1560-679-4482)		To support and position aft end of shroud. To be used with shroud part No. 8-22654-801, -803, -805, or -811.
	Shroud Ejector Insert Alignment Tool.	8-96491 (4920-691-4274)		For use with shroud part No. 8-22654-809.

**4-112. Procedure.**

For engine shroud replacement procedures, see figures 4-15 and 4-16.

**NOTE**

Refer to T.O. 1F-106A-3 for shroud damage limits and repair information.

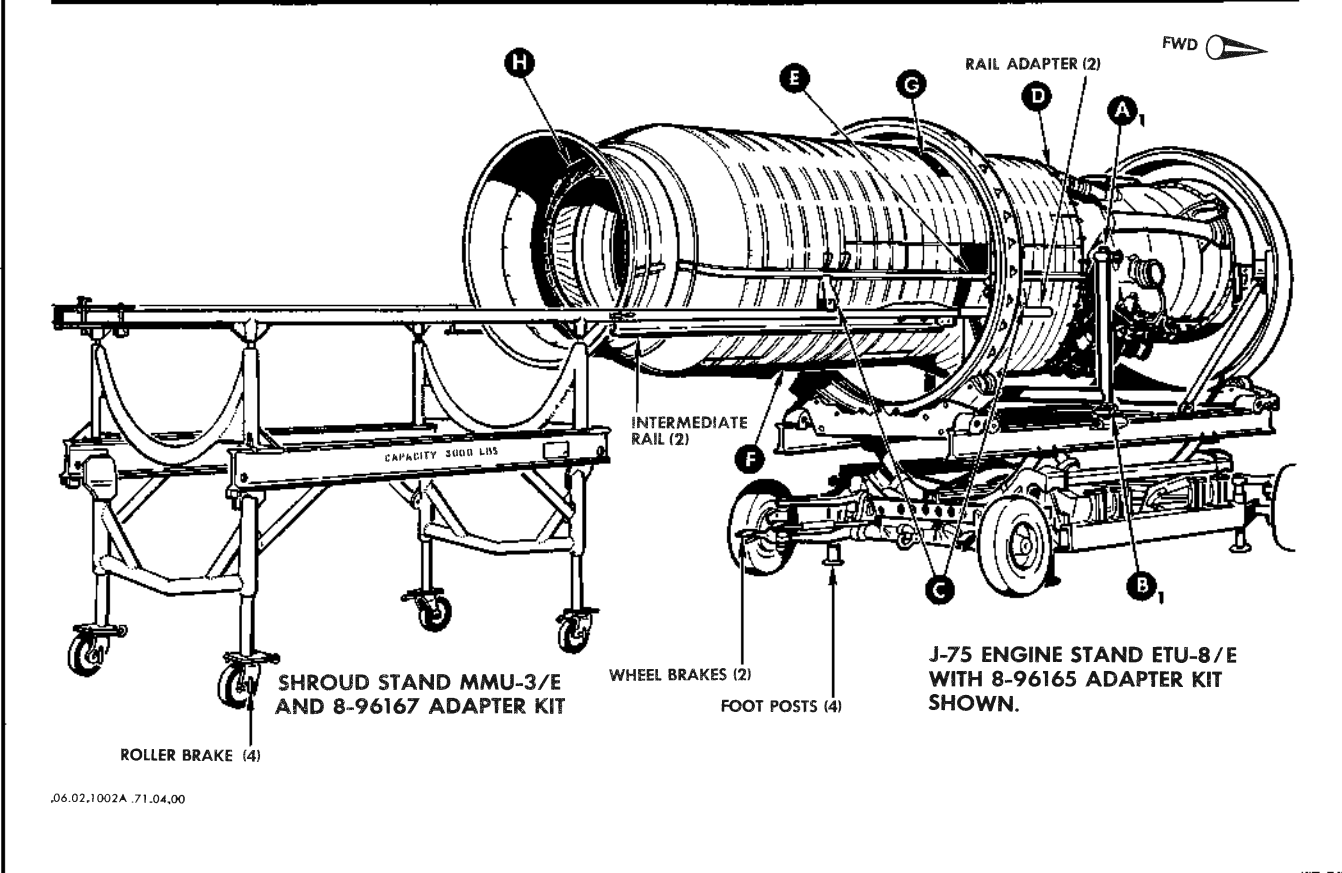
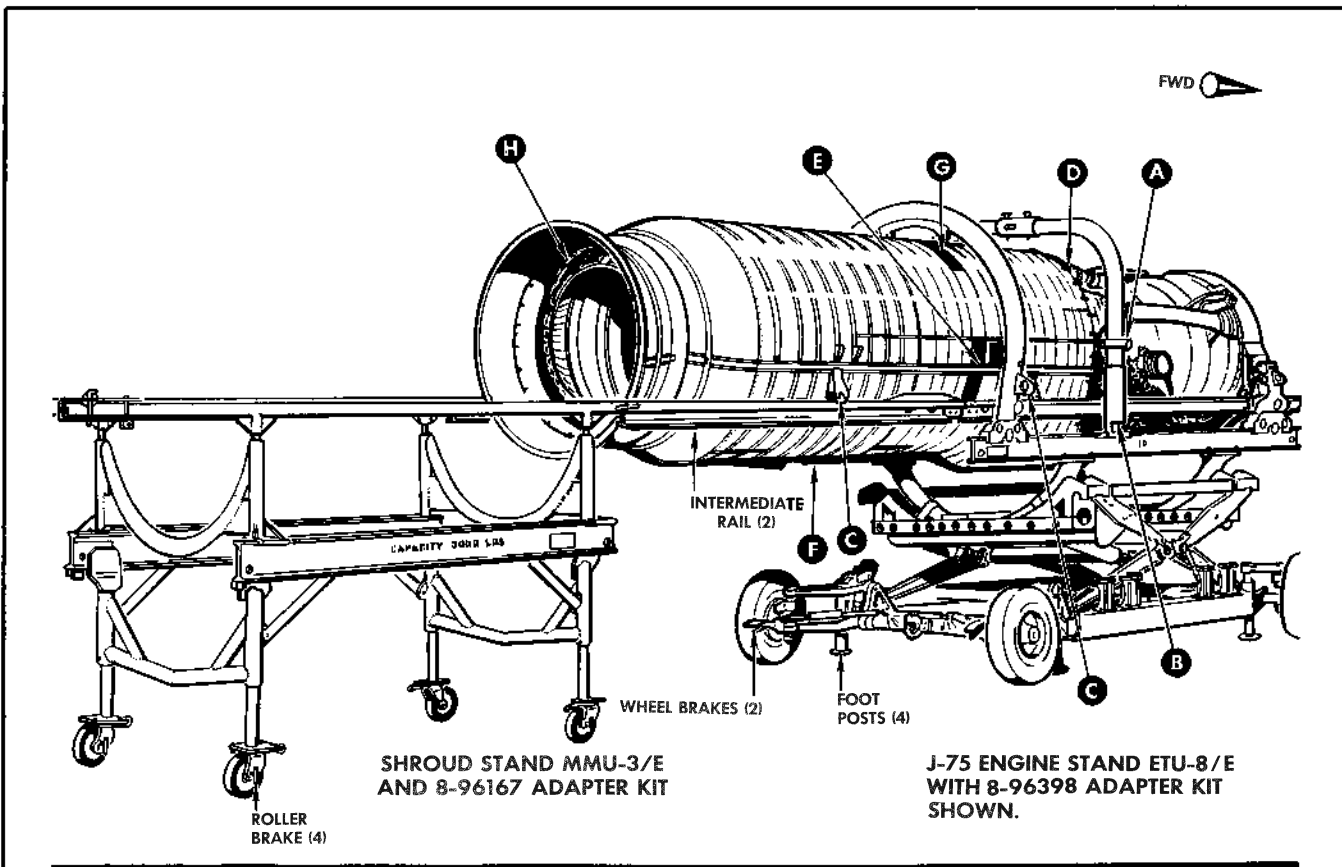

Figure 4-15. Replacement, Engine Shroud Using Stand USAF ETU-8/E (Sheet 1 of 4)

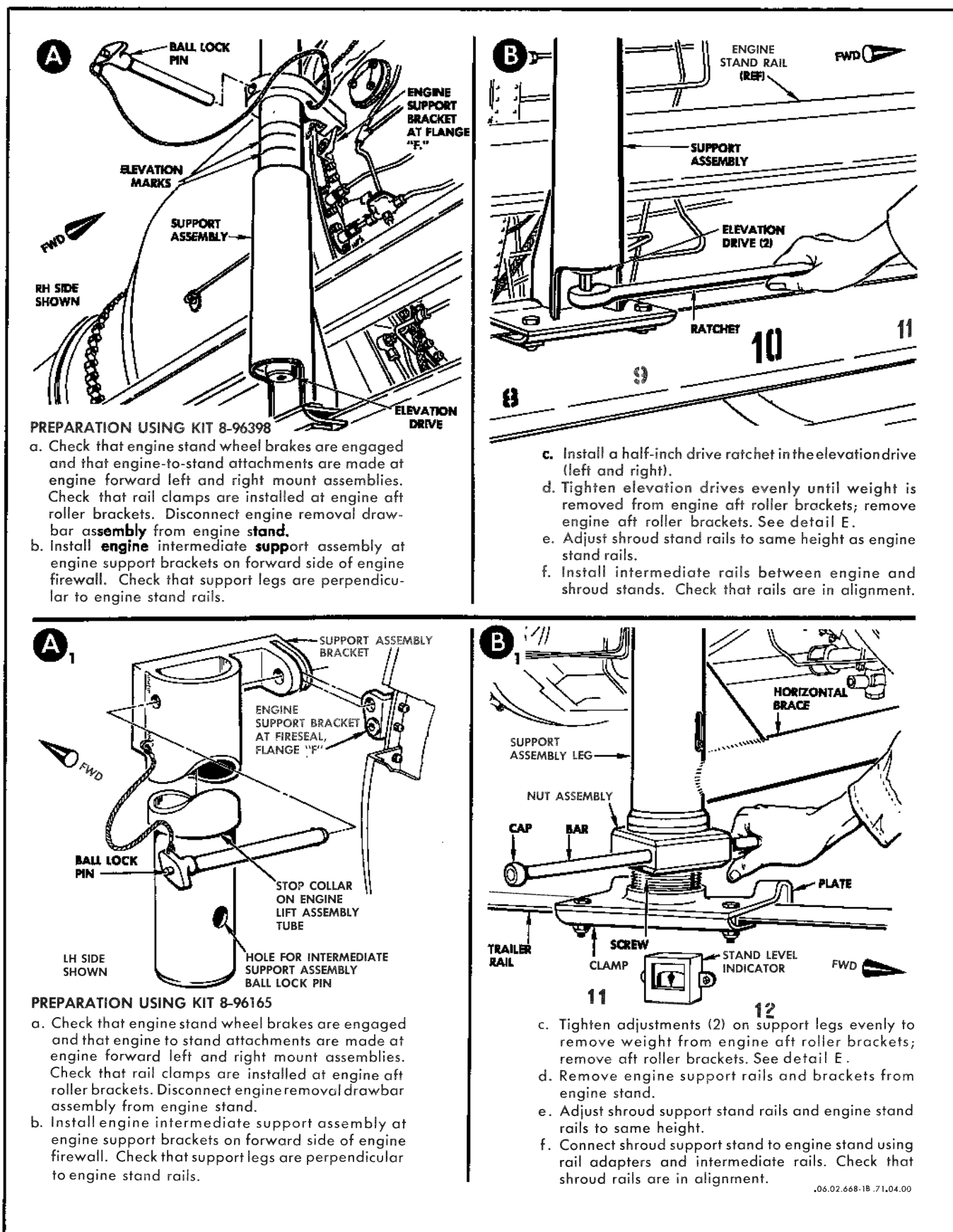

Figure 4-15. Replacement, Engine Shroud Using Stand USAF ETU-8/E (Sheet 2 of 4)

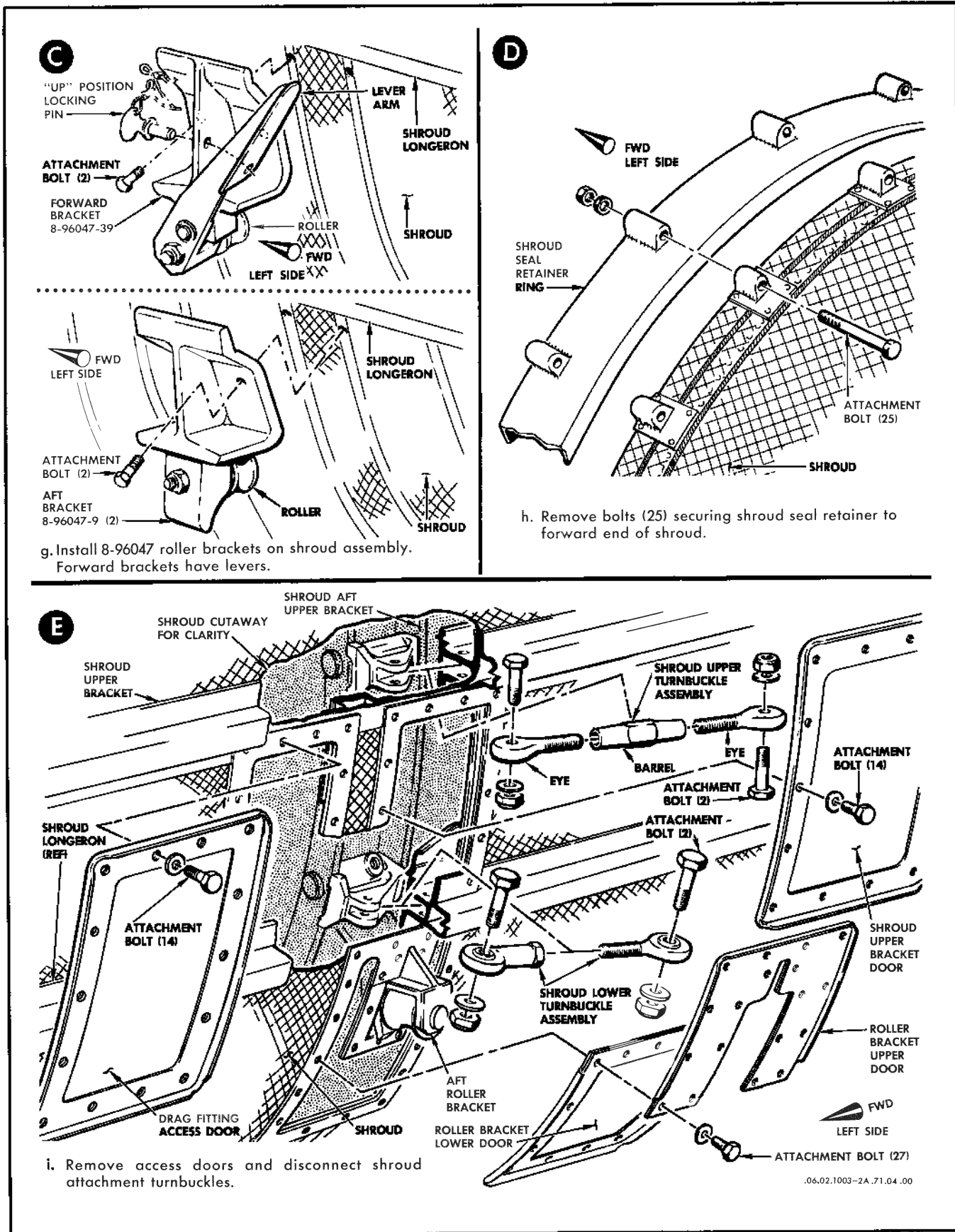

Figure 4-15. Replacement, Engine Shroud Using Stand USAF ETU-8/E (Sheet 3 of 4)

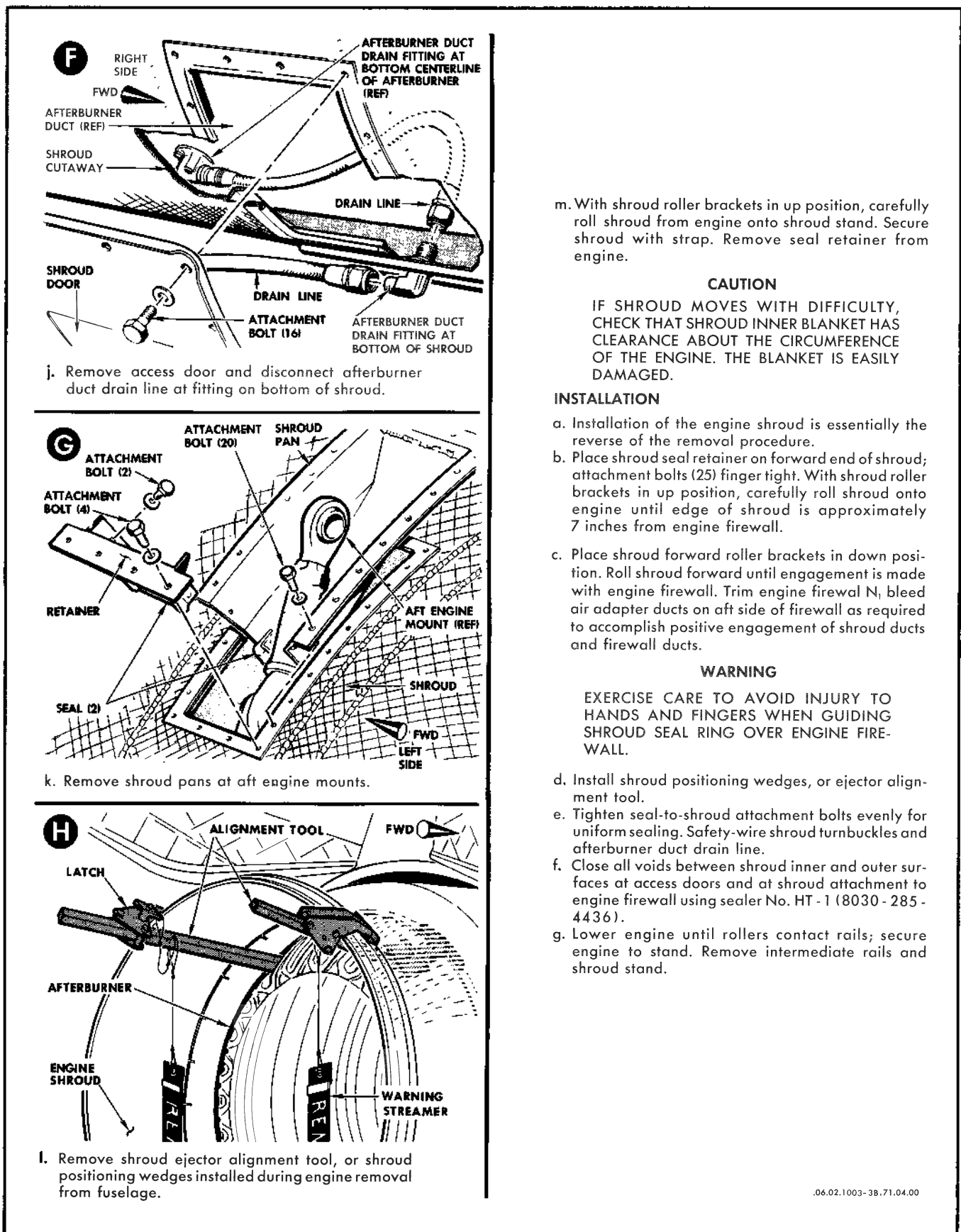

Figure 4-15. Replacement, Engine Shroud Using Stand USAF ETU-8/E (Sheet 4 of 4)

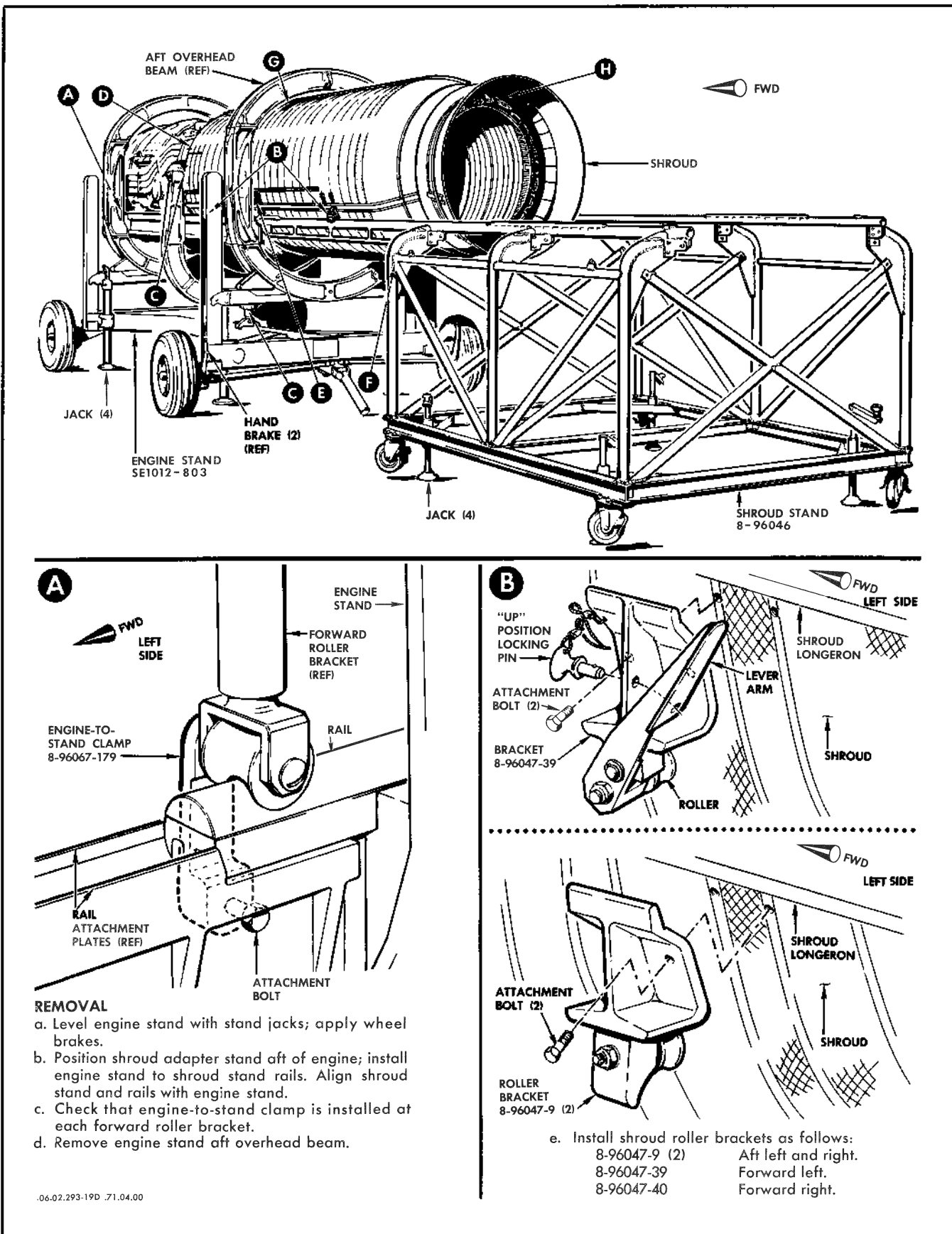

Figure 4-16. Replacement, Engine Shroud Using Stand SE 1012-803 (Sheet 1 of 3)



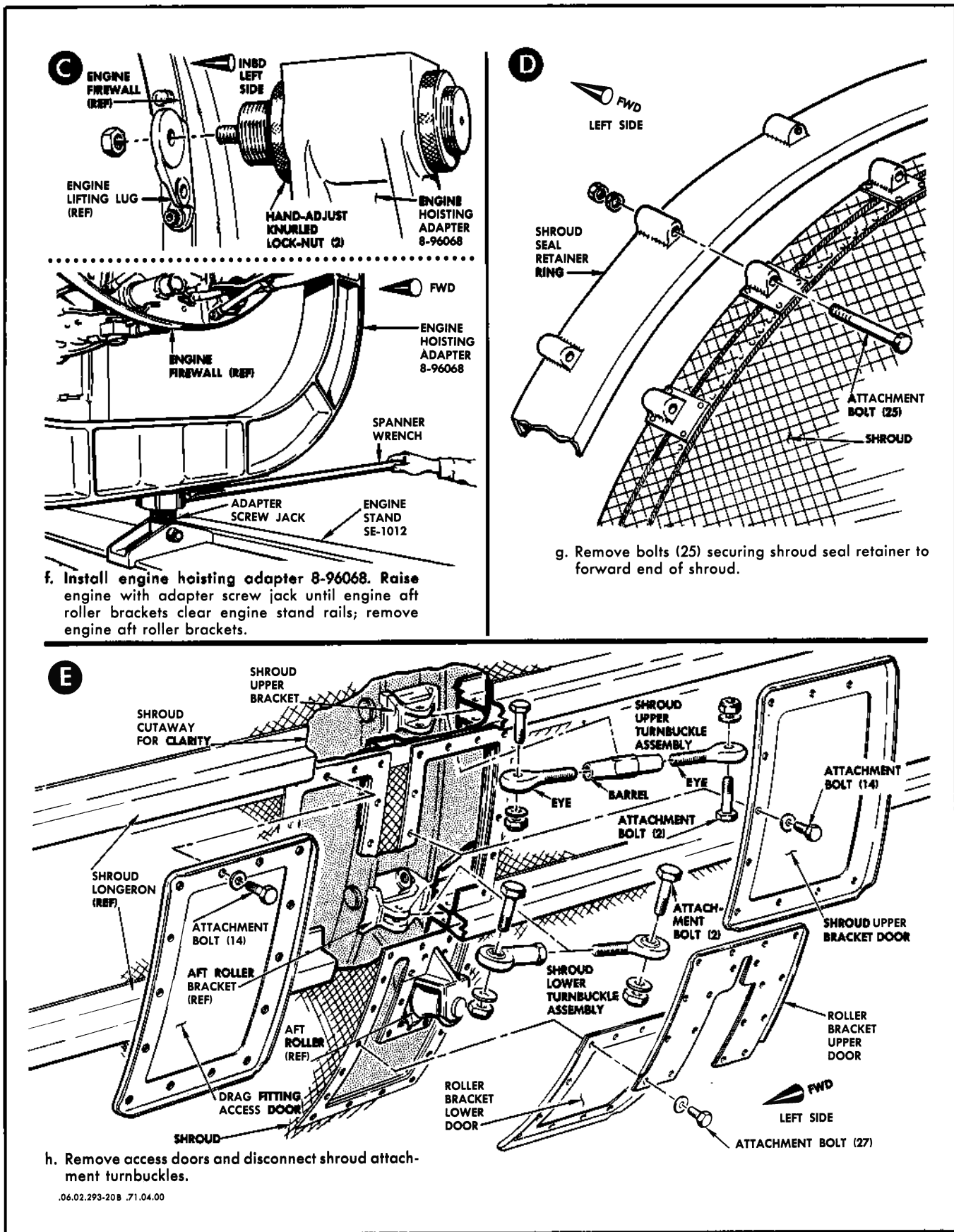
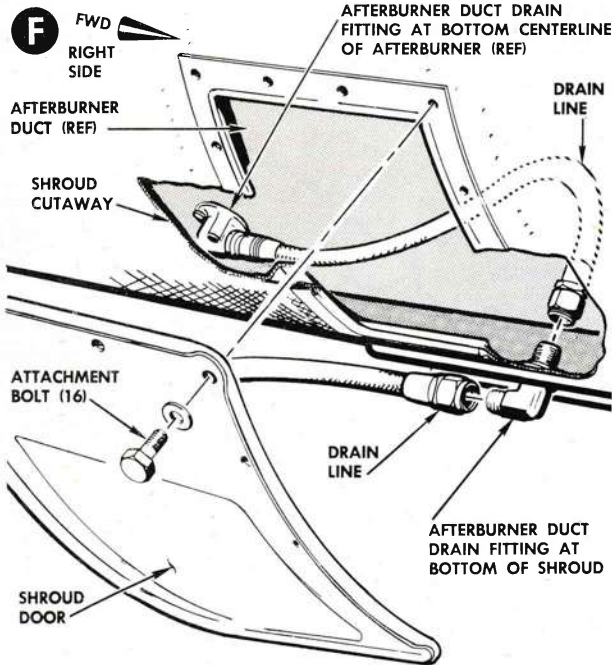
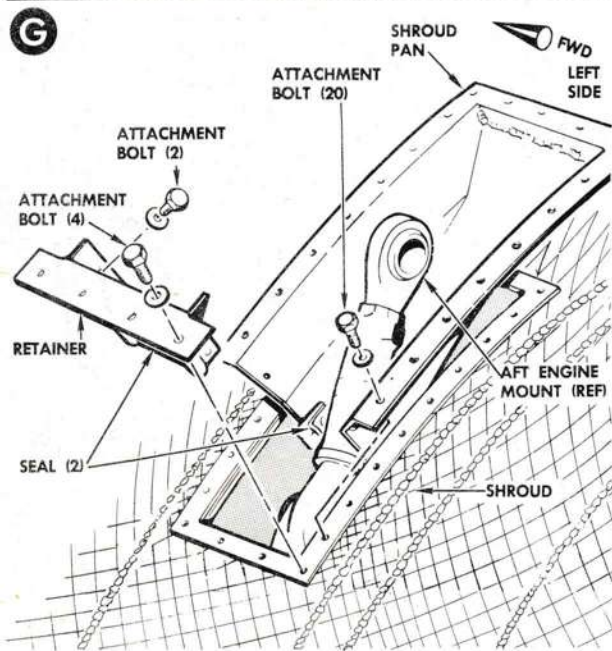

Figure 4-16. Replacement, Engine Shroud Using Stand SE 1012-803 (Sheet 2 of 3)



- i. Remove access door and disconnect afterburner duct drain line at fitting on bottom of shroud.



- j. Remove shroud pans at aft engine mounts.

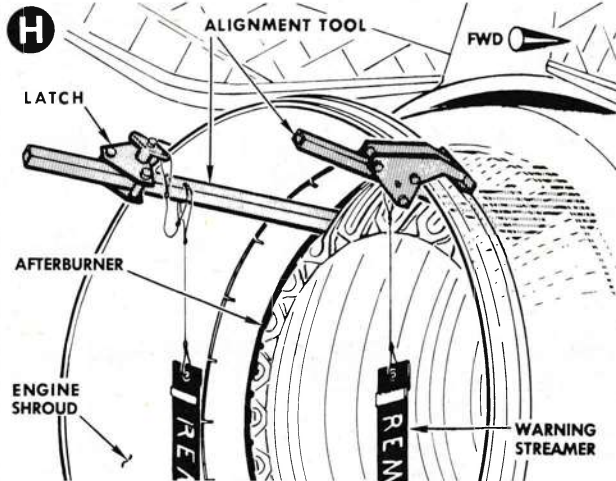

- k. Remove shroud ejector alignment tool, or shroud positioning wedges installed during engine removal from fuselage.
- l. With shroud roller brackets in up position, carefully roll shroud from engine onto shroud stand. Remove seal retainer from engine.

**CAUTION**

IF SHROUD MOVES WITH DIFFICULTY CHECK THAT SHROUD INNER BLANKET HAS CLEARANCE ABOUT THE CIRCUMFERENCE OF THE ENGINE. THE BLANKET IS EASILY DAMAGED.

**INSTALLATION**

- a. Installation of the engine shroud is essentially the reverse of the removal procedure.
- b. Place shroud seal retainer on forward end of shroud; attachment bolts (25) finger tight with shroud roller brackets in up position, carefully roll shroud onto engine until edge of shroud is approximately 7 inches from engine firewall.
- c. Place shroud forward roller brackets in down position. Roll shroud forward until engagement is made with engine firewall. Trim engine firewall N<sub>1</sub> bleed air adapter ducts on aft side of firewall as required to accomplish positive engagement of shroud ducts and firewall ducts.

**WARNING**

EXERCISE CARE TO AVOID INJURY TO HANDS AND FINGERS WHEN GUIDING SHROUD SEAL RING OVER ENGINE FIREWALL.

- d. Install shroud positioning wedges, or ejector alignment tool.
- e. Tighten seal-to-shroud attachment bolts evenly for uniform sealing. Safety-wire shroud turnbuckles and afterburner duct drain line.
- f. Close all voids between shroud inner and outer surfaces at access doors and at shroud attachment to engine firewall using sealer No. HT-1 (8030 - 285 - 4436).

.06.02.293-21D .71.04.00

Figure 4-16. Replacement, Engine Shroud Using Stand SE 1012-803 (Sheet 3 of 3)

<b>ADJUSTMENT</b>
-------------------

**4-113. ADJUSTMENT, OIL COOLER VALVES AND ACTUATORS.****4-114. Equipment Requirements.**

FIGURE	NAME	TYPE	ALTERNATE	USE AND APPLICATION
Refer to T.O. 1F- 106A-2-10	Generator Set (Gas).	8-96026-801 AF/M32A-13 (6115-583- 9365)	8-96026 AF/M32M-2 (6115-617- 1417)	To energize electrical systems on aircraft equipped with special quick disconnect receptacle.
	Generator Set (Elec).	8-96025-803 AF/ECU-10/M (6125-583- 3225)	8-96025-805 A/M24M-2 (6125-628- 3566)	
			8-96025 AF/M24M-1 (6125-620- 6468)	
	Generator Set.		MC-1 (6125-500- 1190)	To energize electrical systems (except AWCIS) on aircraft equipped with standard AN receptacle and on others by using adapter cable 8-96052.
MD-3 (6115-635- 5595)				
	Adapter Cable.	8-96052 (6115-557- 8548)		To connect MC-1 and MD-3 units to aircraft equipped with special quick disconnect receptacle.
	Compressed dry air source of 70 psi.			To actuate oil cooler air valve actuators.

**4-115. Preparation for Adjustment of Engine Air-Oil Cooler Air Valve and Actuator.**

a. Remove engine air-oil cooler to permit checking adjustment of engine air-oil cooler air valve and actuator. See figure 6-2 for this procedure.

b. Connect external dc power source to the airplane receptacle.

c. Connect external 70 psi air pressure source to the engine accessory compartment pressure control sensor; remove engine bleed air hose and connect external source to tube fitting. The engine air hose is attached to a fitting near the upper right corner of the left forward engine mount access door.

d. Install the following fuses:

1. "OIL COOL CONT"      Main wheel well panel
2. "COMPT PRESS WARN" Main wheel well fuse panel

**4-116. Procedure, Adjustment of Engine Air-Oil Cooler Air Valve and Actuator.**

a. Perform steps of preparation procedure.

b. Check alignment of actuator rod bearing with face of the valve shaft arm. Arm may be shifted on shaft to bring the parts into alignment by loosening clamp on hub of arm. End play may be taken up by tightening spring washer on the upper end of valve shaft.

- c. Adjust length of actuator rod to hold valve closed.
- d. Shorten rod one additional turn at bearing attachment.
- e. Extend actuator by depressing test switch on fuel temperature control box to check operation of the valve. With the air valve closed, the silicone and rubber leading and trailing edges shall follow the contour of the duct walls. The convex leading edge of the valve shall close outward. It is important that the valve and actuator swing freely with no binding at any point.
- f. Reinstall oil cooler. See figure 6-2 for this procedure.

#### 4-117. Preparation for Adjustment of Constant-Speed Oil Cooler Air Valve and Actuator.

- a. *Applicable to F-106A airplanes 57-246 thru 57-2455 and F-106B airplanes 57-2516 thru 57-2531.* Remove constant-speed drive oil cooler to permit checking adjustment of drive unit oil cooler air valve and actuator. See figure 9-6 for this procedure.
- b. Connect external dc electrical power source to the airplane receptacle.
- c. Gain access to constant-speed drive (CSD) air-oil cooler valve.

#### 4-118. Procedure, Adjustment of Constant-Speed Oil Cooler Air Valve and Actuator.

- a. Perform steps of preparation procedure.
- b. *Applicable to F-106A airplanes 56-453, -454, -456 through 57-245, 57-2456 and subsequent; F-106B airplanes 57-2508 through -2515, 57-2532, and subsequent.* Adjustment procedure with valve flapper stop incorporated.
- c. Disconnect the actuator rod-end from the valve arm.
- d. Check that valve and actuator pivot freely and that all end play is taken up by spring washer on upper end of valve shaft.
- e. Manually rotate the valve arm counterclockwise until the flapper valve contacts the stops.
- f. Using a 6 inch steel scale, graduated in tenths-of-an-inch, measure the distance between 3.40 inches, minimum, and 3.60 inches, maximum, from apex of the lower mounting flange of CSD actuator valve to the aft edge of bolt hole in the valve arm. Loosen clamp at flapper valve shaft and adjust the valve arm on the splined shaft, as required, to obtain the specified dimensions.

#### NOTE

Valve must be maintained against stops while measurements are taken.

- g. Tighten the clamp at the flapper valve shaft and recheck measurements. Readjust valve arm, if required.
- h. Disconnect the actuator emergency air line at the emergency pressure regulator and relief valve.
- i. Extend the actuator by applying 70 psi to the emergency air line.
- j. While maintaining the flapper valve against the stops, adjust the actuator rod-end to match the hole in valve arm.
- k. Shorten the actuator push rod by  $\frac{1}{2}$  turn of the rod-end, and attach the rod-end to valve arm.
- l. Remove test equipment; reconnect air line. Reinstall oil cooler, if removed (see figure 9-6 for this procedure).
- m. Conduct priming procedure for constant-speed drive system, if oil cooler was removed (refer to Section IX for this procedure).
- n. Operate the engine at full military power and ascertain that the constant-speed drive air-oil cooler valve remains open (indicated by actuator remaining retracted).

*o. Applicable to F-106A airplanes 57-246 through -2455 and F-106B airplanes 57-2507, 57-2516 through -2531.* Adjustment procedure without valve flapper stop incorporated.

p. Accomplish the foregoing procedure, with the following exceptions:

1. Step "e." – Flapper valve must be in full closed position.
2. Step "f." – Adjust valve arm on splined shaft to obtain a dimension between 3.65 inches, minimum, and 3.85 inches, maximum.
3. Step "j." – With the flapper in full closed position, adjust the actuator rod-end to match the hole in the valve arm.
4. Step "k." – Shorten the actuator push rod by  $2\frac{1}{2}$  turns and attach the rod-end to the valve arm.

#### NOTE

Flapper valve should have 0.370 inch clearance between flapper valve and duct walls when in closed position after rigging.

## Section V

### STARTING AND IGNITION SYSTEMS

<i>Contents</i>	<i>Page</i>
Description .....	5-1
Operational Checkout .....	5-7
System Analysis .....	5-9
Replacement .....	5-11
Servicing .....	5-12

#### DESCRIPTION

##### 5-1. GENERAL.

The engine starting and ignition systems are interrelated in that the operation of one system is dependent upon the other for completion of electrical circuits and starting of the engine. Switches for actuation of the starter and the ignition components are incorporated as a part of the pilot's throttle quadrant assembly. *On F-106B airplanes*, airplane starter actuation is accomplished from the front cockpit only. Ignition is used only during starts and functions only while the pilot depresses the ignition button, located on top of the throttle lever. The combustion starter is supplied with fuel from the airplane fuel system, and high-pressure compressed air from the airplane high-pressure pneumatic system or from an external compressed air source. A manual air selector valve, used for selection of either source of compressed air, and an adapter for attachment of an external air source are located in the left main wheel well. The fuel and air mixture is ignited by the starter ignition system. Either starter is actuated by holding the ignition button on the throttle lever depressed and moving the throttle lever to the "START" position. Engine ignition is supplied to spark-ignitors, located in number four and number five combustion chambers, by transformers located on the under side of the engine. Power for transformer operation is supplied from the airplane 28-volt, dc power system. The starting and ignition circuits are protected by the following fuses:

- |                     |                            |
|---------------------|----------------------------|
| 1. "ENG IGN," 15A   | Main wheel well fuse panel |
| 2. "START PWR," 10A | Main wheel well fuse panel |
| 3. "START CONT," 5A | Main wheel well fuse panel |

For illustration of the starting and ignition system, see figures 5-1 and 5-2.

##### 5-2. COMBUSTION STARTER.

The combustion starter incorporates three systems, air, fuel, and ignition, and utilizes the combined pressure-energy of burning fuel to accelerate the starter turbine. The turbine is geared through a clutch to an output shaft which, in turn, engages the engine through the constant speed drive engine mounted gearbox. For a schematic illustration of the combustion starter, see figure 5-3.

##### 5-3. Air System.

Compressed air at pressures between 1200 psi and 3500 psi must be provided either by an independently supplied ground source or by the airplane high-pressure pneumatic system, to support fuel combustion and to provide fuel pressure. The starter contains a dc powered shutoff valve to control this air pressure and a pressure regulating

valve to regulate it at 285 to 295 psi during the start. The 1200 psi to 3500 psi supply pressure is required to provide sufficient air volume for a complete starting cycle.

#### 5-4. Fuel System.

Fuel for the starter is drawn from the airplane fuel system and is contained within an 18 to 20 cubic inch cylindrical accumulator on the starter. A piston in the accumulator separates fuel and air and is acted upon by regulated air pressure whenever the air solenoid is energized. A fuel solenoid in the outlet line of the accumulator prevents fuel entry into the combustion chamber until starter ignition is selected by throttle movement. When the fuel and air solenoids are energized, fuel is forced out of the accumulator by the air pressure acting on the accumulator piston and is sprayed through a nozzle into the combustion chamber. A check valve in the fuel inlet line to the accumulator prevents flowback into the airplane fuel system, yet provides for low flow pressure relief to prevent fuel thermal expansion pressure buildup in the accumulator. After the starting cycle is completed, both the fuel solenoid and air solenoid are deenergized. A spring on the fuel side of the accumulator piston then returns the piston to the full stroke position, drawing fuel in through the check valve to replenish the accumulator. A time delay switch is installed on the fuel accumulator which terminates starter ignition after a 1 to 3 second period. The switch, mounted on the side of the accumulator, is actuated by a pin which is pushed out by the accumulator piston movement after a predetermined quantity of fuel is displaced. *Applicable after incorporation of TCTO 1F-106-688*, a push-to-drain valve, located on bottom of fuselage at sta. 507.0, is provided to bleed the accumulator of entrapped air.

#### 5-5. Ignition System.

The ignition system, consisting of an ignition box and sparkigniter, is similar to that used on the engine. The ignition box consists of a dc vibrator and step-up transformer. The secondary winding of the transformer is used to charge a storage capacitor. The storage capacitor is then discharged through the sparkigniter gap. Ignition is initiated by movement of the throttle inboard and, is terminated 1 to 3 seconds later by a signal from the time delay switch which is activated by displacement of the fuel accumulator piston.

#### 5-6. Starter Components.

The basic starter consists of a combustion chamber; igniter; fuel nozzle; a turbine inlet nozzle assembly, to convert the combustion chamber high-pressure gas discharge into velocity energy; a turbine assembly, to convert this energy into starter output shaft torque; a planetary gear system of 17.17 to 1 gear ratio; a slip clutch assembly, to absorb the impact torque of the combustion start; and a one-way full phasing sprag clutch to transmit the energy from the starter gear train to the engine. The sprag clutch prevents the engine from driving the starter turbine at any time.

#### 5-7. Starter Protective Devices.

A gear train centrifugal cutout switch is set at 2550 ( $\pm 100$ ) starter rpm (35% engine  $N_2$  rpm) and is geared to the engine side of the starter output shaft. The purpose of the switch is to terminate starter operation after the starter has brought the engine up to the switch cutout rpm. The switch also acts to prevent accidental firing of the starter while the engine is operating above the cutout rpm setting of the switch. A turbine centrifugal cutout switch is set at 2850 ( $\pm 100$ ) starter rpm and is provided to terminate starter operation in the event the starter gear train centrifugal cutout switch failed to actuate. Actuation of this switch will require replacement of the starter. The actuator for this switch is located in the center of the starter turbine. The burner pressure switch is a two function switch located on the starter control box. After a time delay of 1 to 3 seconds, if the combustion chamber pressure has not reached 185 to 205 psi as a result of combustion, circuitry through the low-pressure contacts of the burner pressure switch will terminate starter operation. This is done to conserve the high-pressure air supply. Circuitry through the high-pressure contacts of the burner pressure switch will also terminate a start cycle whenever the combustion chamber pressure exceeds 325 to 345 psi. This feature is to protect the starter in the event that a malfunction has created excessive combustion chamber pressures. The high-pressure relief valve, located in the starter nozzle block shroud, vents regulated air through the starter exhaust if pressure exceeds 600 to 700 psi. The starter turbine is designed to minimize damage if a starter malfunction causes the turbine wheel to overspeed. In the event of an overspeed condition, the turbine buckets are designed to separate from the turbine wheel leaving the wheel intact. A shroud is provided around the outboard section of the turbine wheel to minimize external damage in the event of turbine wheel bucket separation. A friction clutch, located in the starter drive assembly between the sprag clutch and the starter output shaft, is provided to act in the initial stages of ignition to reduce the starting impact torque imposed on the engine. A shear coupling engages the engine starter drive and prevents damage to the engine drive should a starter gearbox drive malfunction occur.

#### 5-8. Normal Starter Operation.

During normal operation (paragraph 5-10) with the throttle in "START" position, dc power is supplied to the starter air solenoid. Air at 285 to 295 psi pressure is then supplied to the air side of the fuel accumulator piston and to the combustion chamber from where it passes to the starter turbine, setting the turbine in motion. The output of the turbine is then transmitted through the starter gear train and through the engaged clutches of the starter to the engine. At this time an indication of engine  $N_2$  rpm shall be observed on the tachometer to indicate that the starter has engaged with the engine starter drive. After obtaining an  $N_2$  rpm indication, and while still holding the engine ignition button down, move the throttle

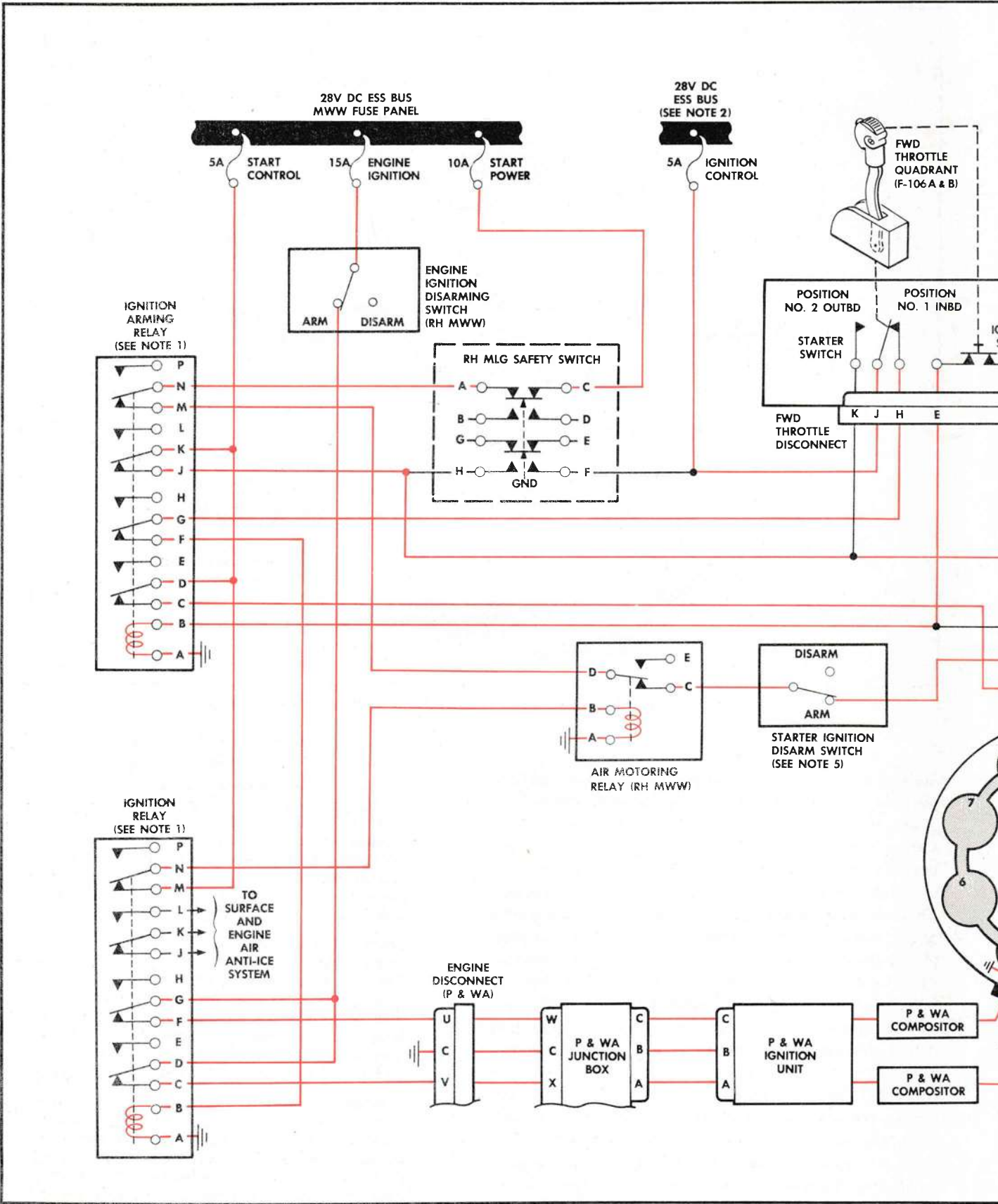

**CONDITION**

FWD IGNITION SWITCH ACTUATED, STARTER AND ENGINE IGNITION SYSTEMS ENERGIZED AT BEGINNING OF STARTER OPERATION CYCLE.

**NOTES**

1. APPLICABLE TO F-106A AIRPLANES, THE IGNITION RELAY AND IGNITION ARMING RELAY ARE LOCATED IN THE RH MISSILE BAY AT STATION 431.0. APPLICABLE TO F-106B AIRPLANES, THE IGNITION RELAY AND IGNITION ARMING RELAY ARE LOCATED IN THE RH MAIN WHEEL WELL AT STATION 380.0.
2. APPLICABLE TO F-106A AIRPLANES, IGNITION CONTROL FUSE IS LOCATED ON THE COCKPIT LEFT FUSE PANEL. APPLICABLE TO F-106B AIRPLANES, IGNITION CONTROL FUSE IS LOCATED ON THE NWW FUSE PANEL.
3. MALFUNCTION IN TURBINE CUT-OUT SWITCH REQUIRES STARTER REPLACEMENT AND BENCH RESET OF SWITCH.
4. NORMALLY OPEN "LOW" SWITCH CLOSURES AT INTERMEDIATE AND HIGH PRESSURE. NORMALLY CLOSED "HI" SWITCH OPENS AT HIGH PRESSURE AND CLOSURES AT INTERMEDIATE PRESSURE.
5. STARTER IGNITION DISARM SWITCH IS APPLICABLE AFTER INCORPORATION OF TCTO 1F-106-675.

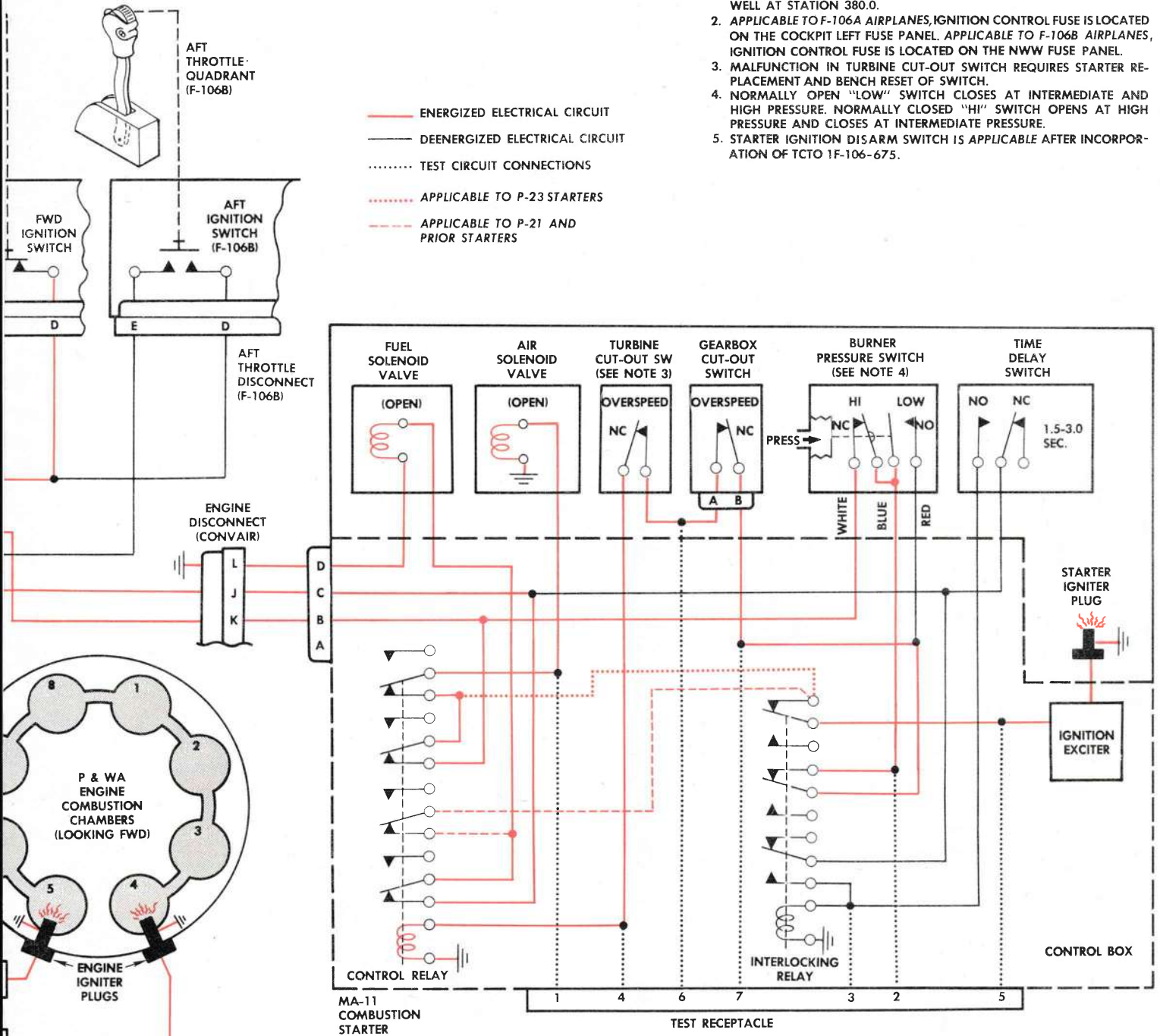

.06.02.614 E

Figure 5-1. Starting and Ignition System Electrical Schematic



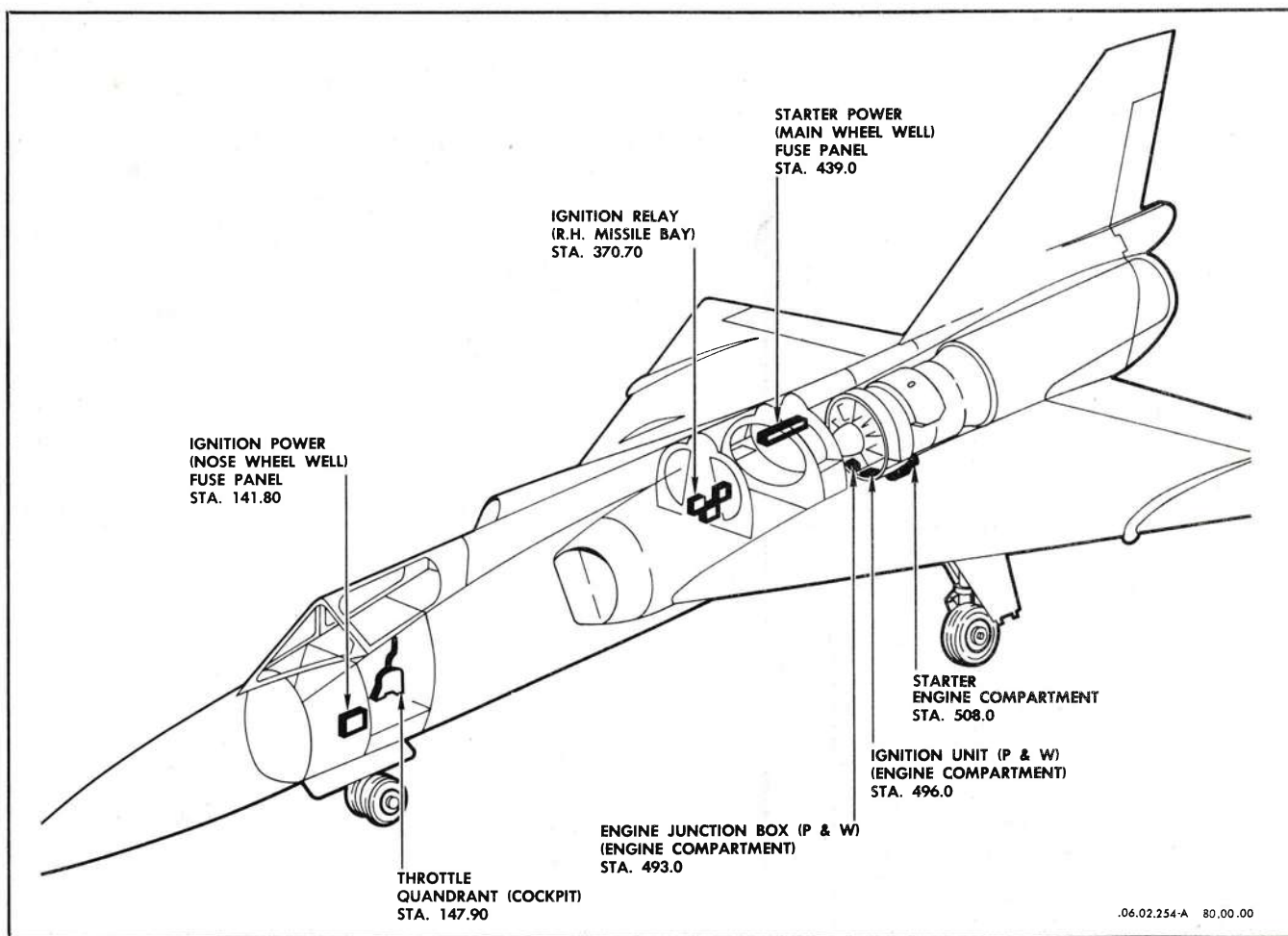

Figure 5-2. Starting and Ignition System, Component Locations

### CAUTION

During the starting cycle, temperatures as high as 954°C (1750°F) can be reached in the combustion chamber. For this reason it is necessary that proper cooling periods for the starter be observed in order to insure that parts are not damaged as a result of excessive heat.

Combustion starter duty cycle, at ambient temperatures up to 32°C (90°F), must be limited to two consecutive combustion runs in rapid succession followed by a cooling time of 30 minutes minimum. Succeeding runs must then be spaced a minimum of 25 minutes apart. If combustion starter duty cycle limitations are exceeded, replace the starter.

Combustion starter duty cycle, at ambient temperature above 32°C (90°F), must be limited to two consecutive combustion runs in rapid succession followed by a cooling time of 45 minutes minimum. Succeeding runs must then be spaced a minimum of 40 minutes apart. If combustion starter duty cycle limitations are exceeded, replace the starter.

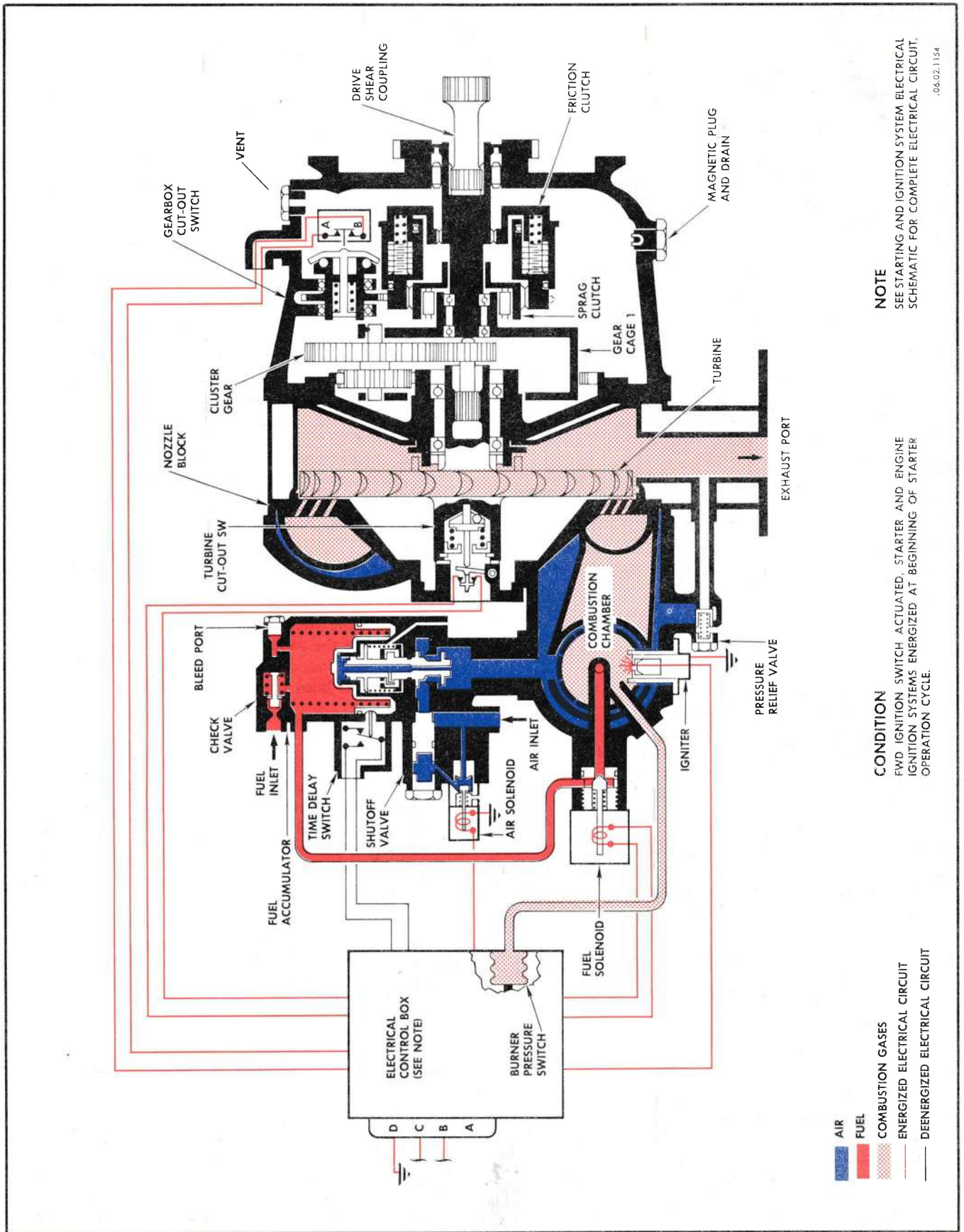

Figure 5-3. Combustion Starter Schematic

**5-9. STARTER IGNITION DISARM SWITCH.**

Applicable to all airplanes after incorporation of TCTO 1F-106-675. The starter ignition disarm switch is located in the right main wheel well. The switch has two positions, "ON" and "OFF," and is used to interrupt power to the starter ignition system. The "OFF" position is used during the air motor start procedure to prevent firing of the combustion portion of the starter system. The switch receives power from the dc essential bus.

**5-10. COMBUSTION STARTER OPERATION.**

Operation of the combustion starter will be conducted as follows:

- a. Prepare airplane and engine for ground run. Refer to Section I of this manual for this information.
- b. Provide source of high-pressure compressed air for starter operation. If external air source is used, starter manual air selector valve, in left main wheel well, must be in the "CLOSED" position. If airplane pneumatic system is to be used, manual air valve must be in the "OPEN" position.
- c. Turn on airplane fuel supply system boost pumps. This provides fuel to the starter fuel accumulator.
- d. Applicable to all airplanes after incorporation of TCTO 1F-106-675. Check that starter ignition disarm switch is in the "ON" position.

**CAUTION**

The starter ignition switch is to be used only for an air motor start subsequent to an unsuccessful attempt at starting engine utilizing the combustion capabilities of the starter. During the air motor start procedure the starter ignition switch must be in the "OFF" position.

- e. Depress the ignition button and hold; move the throttle outboard to "START" position. Check tachometer for positive rpm indication, then move the throttle inboard to "OFF," then forward to "IDLE."

**WARNING**

Release ignition button immediately if no "RPM" reading is evident on the tachometer. Do not move the throttle inboard to the "OFF" position with the ignition button depressed if there is no "RPM" indication. This could result in disintegration of the combustion starter. No "RPM" reading indicates the starter failed to engage the engine. A maximum of two attempts should be made, but if still unsuccessful, the operation should be discontinued until the cause of malfunction has been established and correction made.

This procedure is accomplished by a continuous movement of the throttle. Do not hesitate at any point.

**CAUTION**

Do not jockey the throttle. The starting fuel schedule is automatically controlled by the fuel control unit. Jockeying the throttle will interrupt this schedule.

- f. Continue holding ignition button depressed until engine rpm reaches 30% and the engine instruments indicate a positive light-off; release ignition button. Refer to paragraph 1-26 for the complete engine starting procedure.

**CAUTION**

Adequate combustion starter cooling periods must be observed between starts to prevent damage from overheating. Refer to Section I for starter duty cycle limitations.

**5-11. PNEUMATIC START OPERATION.**

Applicable to all airplanes after incorporation of TCTO 1F-106-675. The procedures for accomplishing a pneumatic start are the same as for a combustion start after the starter ignition disarm switch, located in the right wheel well, has been placed in the "OFF" position.

**NOTE**

Pneumatic starts will be used only after failure to obtain a combustion start. An external compressed air source must be used for all pneumatic starts. The maximum EGT observed during a pneumatic start will be recorded on AFTO Form 781.

After the engine ignition button is released and exhaust gas temperature has stabilized, return the starter ignition disarm switch to the "ON" position before external compressed air and electrical power are disconnected.

**5-12. ENGINE IGNITION SPARKIGNITERS.**

Two ceramic type ignition sparkigniters are used for engine starting ignition. One sparkigniter is installed in No. 4 combustion chamber, the other is installed in No. 5 combustion chamber. Other than checking of the condition of the sparkigniters at specified periods, no maintenance is required. If the sparkigniters are found to have a brown stain on the ceramic surrounding the center electrode, insulation breakdown is indicated and the sparkigniters should be replaced. The sparkigniters must also be replaced when the electrodes are burned

more than 0.225 inch below the surface of the ceramic insulation.

### WARNING

When performing maintenance on sparkigniters or other components of the ignition system, be sure that electrical power has been removed from the ignition system.

#### 5-13. AIR MOTORING OF ENGINE WITH COMBUSTION STARTER (AIR ONLY).

During engine maintenance procedures, it may be necessary to rotate the engine using the combustion starter. This procedure will be conducted as follows:

a. Position engine ignition disarming switch in main wheel well to the disarmed position.

### CAUTION

Refer to system test procedure requiring engine air motoring before performing the motoring procedure.

b. Remove starter "START PWR" fuse from main wheel well fuse panel.

c. *Applicable to all airplanes after incorporation of TCTO 1F-106-675.* Position starter ignition disarm switch to the "OFF" position.

### CAUTION

The starter ignition disarm switch is to be used only for an air motor start subsequent to an unsuccessful attempt at starting engine utilizing the combustion capabilities of the starter. During the air motor start procedure the starter ignition switch must be in the "OFF" position.

d. Connect external high-pressure air source to filler fitting in left main wheel well; starter air selector valve in left wheel well in "CLOSED" position.

e. Depress throttle ignition button and move throttle to "START" position. Allow starter to accelerate engine to a minimum of 14% N<sub>2</sub> rpm. The starter will continue to air motor the engine until the ignition button is released, or until the air supply is shut off or depleted.

### OPERATIONAL CHECKOUT

#### 5-14. TEST, ENGINE STARTER AND IGNITION CIRCUIT.

#### 5-15. Equipment Requirements.

FIGURE	NAME	TYPE	ALTERNATE	USE AND APPLICATION
Refer to T. O. 1F-106A-2-10.	Test Light, 28-volt dc (3).			To test circuit continuity.
	Generator Set (Gas).	8-9026-801 AF/M32A-13 (6115-583- 9365)	8-96026 AF/M32M-2 (6115-617- 1417)	To energize electrical systems on aircraft equipped with special quick disconnect receptacle.
	Generator Set (Elec).	8-96025-803 AF/ECU- 10/M (6125-583- 3225)	8-96025-805 A/M24M-2 (6125-628- 3566)	
			8-96025 AF/M24M-1 (6125-620- 6468)	

## 5-15. Equipment Requirements (Cont).

FIGURE	NAME	TYPE	ALTERNATE	USE AND APPLICATION
	Generator Set.		MC-1 (6125-500-1190)	To energize electrical systems (except AWCIS) on aircraft equipped with standard AN receptacle and on others by using adapter cable 8-96052.
			MD-3 (6115-635-5595)	
	Adapter Cable.	8-96052 (6115-557-8548)		To connect MC-1 and MD-3 units to aircraft equipped with special quick disconnect receptacle.

## 5-16. Procedure.

- a. With electrical power removed from airplane, disconnect plug from P & W engine junction box.
- b. Disconnect electrical plug from starter.
- c. Install 28-volt dc test lights as follows:
  1. Between pin W of P & W plug and ground.
  2. Between pin X of P & W plug and ground.
  3. Between pin B of starter plug and ground.
  4. Between pin C of starter plug and ground.
- d. The following fuses are to be installed:
  1. "ENG IGN" Main wheel well fuse panel
  2. "START CONT" Main wheel well fuse panel
  3. "START PWR" Main wheel well fuse panel
  4. "IGN CONT" Nose wheel well fuse panel
- e. Connect 28-volt dc power to external power receptacle.

**NOTE**

*Applicable to all airplanes after incorporation of TCTO 1F-106-675. Check that starter ignition disarm switch is in "ON" position.*

- f. Move throttle lever to "START" and depress ignition button. Test light at pin B of the starter plug shall illuminate.
- g. With ignition button still depressed, move throttle to the "OFF" position. Lights at the P & W plug and pins B and C at starter plug shall illuminate.
- h. Release ignition button; lights shall extinguish.
- i. Actuate right main landing gear safety switch to the up (actuated) position.
- j. With throttle lever in "OFF" position, depress ignition button. Light at pin C of starter plug shall not illuminate. Light at pin B of starter plug and both lights at P & W plug shall illuminate.

k. Position engine ignition disarming switch in main wheel well to the "DISARMED" position. Light at P & W plug shall extinguish.

l. Reposition right landing gear up-position switch to the gear-down position. Remove electrical power from airplane. Remove test lights and reconnect electrical plugs. Reposition engine ignition disarming switch to the "ARMED" position.

**5-17. LEAK CHECK, ENGINE STARTER ACCUMULATOR CHECK VALVE AND FUEL SOLENOID.**

The following procedure is to be used to detect a leaking check valve or fuel solenoid while the starter is installed in the airplane:

**5-18. Procedure.**

- a. Bleed all air from the starter fuel system; refer to paragraph 5-29 for this procedure.
- b. Disconnect fuel supply line at starter fuel accumulator inlet fitting.
- c. Connect external source of dry compressed air (0-350 psig) to bleed port of fuel accumulator.
- d. Turn on 300 ( $\pm 10$ ) psig air pressure.

**NOTE**

The 300 ( $\pm 10$ ) psig pressure may be applied directly to the accumulator bleed port or to any adapter hose used for remote bleeding of the accumulator.

e. Check for leakage from the accumulator fuel inlet port. There shall be no evidence of leakage from the inlet port, except during the instant of pressure application. At this time a small amount of fuel may be forced out during seating operation of check valve. This leakage shall cease immediately.

- f. Check the fuel solenoid for external leakage while the accumulator is charged.
- g. Replace the starter if leakage is detected during test.
- h. Connect fuel supply line to starter; disconnect external air pressure.
- i. Bleed the starter fuel system; refer to paragraph 5-29 for procedure.
- j. visually check the starter fuel solenoid for leakage under the following conditions:
  - 1. During pressure checking of the fuel accumulator as outlined in the preceding steps, there shall be no external leakage around the fuel solenoid.
  - 2. There shall be no indication of leakage from the starter exhaust after the starter has been idle for any period of time following a combustion start.
  - 3. During the air motoring portion of the starting cycle, the discharge from the starter exhaust shall be clear. A white vapor is an indication of a leaking solenoid.

- b. Position switches and controls as follows:
  - 1. Master power switch "OFF"
  - 2. AC and dc generator control switches "OFF"
  - 3. Engine ignition arming switch (right MWW) "DISARMED"
  - 4. Throttle lever "OFF"
  - 5. All other switches and controls in the nonoperating position.

- c. Check that the following fuses are installed:
  - 1. "START CONTROL" Main wheel well fuse panel
  - 2. "START POWER" Main wheel well fuse panel

d. Connect external ac and dc power to the airplane external power receptacle.

e. Depress and hold ignition button on throttle lever. Move throttle lever to "START," then to "OFF" position. Place ear near the starter ignition transformer and listen for audible operation. Release ignition button; transformer operation shall cease.

f. Reposition engine ignition arming switch to the "ARMED" position.

g. Disconnect external electrical power.

**5-19. AUDIBLE OPERATION CHECK, STARTER IGNITION.**

- a. Check that the starter air supply source is in the "OFF" position.

**SYSTEM ANALYSIS**

**5-20. SYSTEM ANALYSIS, STARTER AND IGNITION SYSTEM.**

PROBABLE CAUSE	ISOLATION PROCEDURE	REMEDY
<b>STARTER OPERATING BUT NOT ENGAGING.</b>		
Faulty starter engagement jaw assembly.	Remove starter for bench test.	Install replacement item.
Starter clutch malfunctioning.		
<b>WITH IGNITION BUTTON DEPRESSED, STARTER DOES NOT REMAIN ENERGIZED WHEN THROTTLE IS MOVED TO "OFF" POSITION.</b>		
Ignition switch on throttle not actuating.	Check for electrical continuity through switch.	Replace switch if found to be faulty.

## 5-20. SYSTEM ANALYSIS, STARTER AND IGNITION SYSTEM (CONT).

PROBABLE CAUSE	ISOLATION PROCEDURE	REMEDY
<b>STARTER INOPERATIVE.</b>		
Loose or faulty electrical connections.	Check physical condition of electrical system.	Repair as required.
Starter turbine cutout switch tripped.	Check for electrical continuity between pins 4 and 6 of starter test receptacle.	Remove starter for overhaul of cutout switch if continuity cannot be obtained. Install replacement starter.
Starter air solenoid valve not opening.	Apply 28-volt dc power through a test switch to pin 1 of the starter test receptacle. Listen for valve operation as power is applied.	Replace starter if valve action is not obtained.
Starter igniter plug inoperative.	Remove plug for bench check.	Install replacement item.
	"Buzz" the starter sparkigniter using the procedure given in paragraph 5-19.	If engine still will not start, replace the sparkigniter.
Starter fuel accumulator malfunctioning.	Remove starter for bench test.	
Air lock in starter fuel system.		Bleed starter fuel system. Refer to paragraph 5-29 for this procedure.
Starter ignition disarm switch in "OFF" position.		Position switch to "ON."
<b>STARTER DOES NOT TURN ENGINE FAST ENOUGH FOR START.</b>		
Starter fuel accumulator malfunctioning.	Remove starter for bench test.	Install replacement item.
Insufficient air supply.	Check air source for volume and unrestricted flow.	Repair as required.
<b>STARTER OPERATION CYCLE OF SHORT DURATION; OR BACKFIRING OCCURS.</b>		
Air in starter fuel system.		Bleed starter fuel system. Refer to paragraph 5-29 for this procedure. If system bleeding does not eliminate malfunction, go to next probable cause.
Starter fuel accumulator piston binding.	Remove starter for bench test.	Install replacement item. Bleed fuel system.
<b>STARTER MISFIRES OR BACKFIRES.</b>		
Preservative oil in starter combustion chamber.	Make a minimum of six engine starts, or attempted starts, to clear up condition.	If condition persists, replace starter.

5-20. SYSTEM ANALYSIS, STARTER AND IGNITION SYSTEM (CONT).

PROBABLE CAUSE	ISOLATION PROCEDURE	REMEDY
<b>SLOW LIGHT-OFF OF ENGINE.</b>		
Half of engine ignition system inoperative.	Remove sparkigniters. Check for condition.	Replace defective unit.
	Operate ignition system without energizing starter. Listen for operation of ignition exciters and sparkigniters.	
	<div style="border: 2px solid black; padding: 5px; text-align: center; margin-bottom: 10px;"><b>WARNING</b></div> <p>The electrical energy produced by the engine ignition system is sufficient to produce a shock that can be fatal to personnel. Be sure that electrical power has been removed from the ignition system before performing system maintenance.</p>	

**REPLACEMENT**

**5-21. REPLACEMENT, ENGINE STARTER.**

See figure 5-4 for the removal and installation procedures for the combustion starter.

**5-22. REPLACEMENT, STARTER EXHAUST DUCT.**

See figure 5-5 for the combustion starter exhaust duct replacement procedure.

**5-23. REMOVAL, ENGINE IGNITION EXCITER UNIT.**

Replacement of the engine ignition exciter unit may be accomplished with the engine installed in the airplane. Access is gained through the constant-speed drive unit access doors.

**CAUTION**

Do not allow hardware or foreign material to fall into the flight control mixer assembly when replacing ignition assemblies.

- a. Disconnect and lower constant-speed remote gearbox to the hanging position. See figure 9-3 for this procedure.

- b. Remove fiberglass cover from flight control mixer assembly.

**WARNING**

Be sure that electrical power has been removed from the ignition circuit before performing maintenance on the system. Ignition must be inoperative for 2 minutes before disconnecting leads.

- c. Disconnect leads from the exciter assemblies. Cover leads and openings with polyethylene sheet.
- d. Remove bolts (4 each); remove exciter assemblies.

**5-24. INSTALLATION, ENGINE IGNITION EXCITER UNIT.**

- a. Install the engine ignition exciter assembly in essentially the reverse of the removal procedure.
- b. Conduct engine start. Refer to Section I for this procedure.



**5-25. REMOVAL, ENGINE IGNITION COMPOSITORS.**

Removal of the engine ignition compositors may be accomplished with the engine installed in the airplane. Access is gained to the necessary work areas through the engine accessory compartment access doors. Compositors are located on the left and right sides of the engine accessory section.

**WARNING**

Be sure that electrical power has been removed from the ignition circuit before performing maintenance on the system. Ignition must be inoperative for 2 minutes before disconnecting electrical leads.

- a. Disconnect leads from compositors. Cover lead and openings with polyethylene sheet.

**NOTE**

On airplanes equipped with the engine fuel supply inlet strainer, removal of the strainer will be required before removal of the right compositors can be accomplished. Refer to Section II for removal procedures.

- b. Remove bolts (4); remove compositor.

**5-26. INSTALLATION, ENGINE IGNITION COMPOSITORS.**

- a. Install the engine ignition compositors in essentially the reverse of the removal procedure.

- b. Apply Molykote powder type "Z," Military Specification MIL-M-7866, to sparkigniter lead coupling nuts on installation.

- c. Conduct engine start. Refer to Section I for this procedure.

**5-27. REPLACEMENT, ENGINE IGNITION SPARKIGNITERS.**

- a. Remove ignition sparkigniters as follows:
  1. Remove engine ignition fuse located on the main wheel well fuse panel.
  2. Open engine accessory compartment access door.

**WARNING**

Be sure electrical power has been removed from the ignition circuit before performing maintenance on the system.

3. Remove ignition leads from sparkigniters. Cover leads with polyethylene sheet.
4. Remove sparkigniters.
- b. Install ignition sparkigniters as follows:
  1. Installation is essentially the reverse of removal.
  2. Use new gasket when installing sparkigniters. Apply anti-seize compound, Military Specification MIL-T-5544, sparingly on the sparkigniter shell threads.

**NOTE**

Do not apply compound to the first thread as the material may run down and ground the electrode.

3. Torque sparkigniters 300 to 360 inch-pounds.
4. Apply Molykote powder type "Z," Military Specification MIL-M-7866, to the sparkigniter lead coupling nut threads. Connect the sparkigniter leads to the sparkigniters.

**NOTE**

Make certain lead is properly positioned as coupling nut is tightened. Safety-wire coupling nuts.

**SERVICING****5-28. SERVICING COMBUSTION STARTER.**

Servicing the combustion starter consists of checking the oil level and changing the oil at specified periods. Check oil level by removing filler plug on left-hand side of starter; oil should be level with the bottom of the oil filler hole. Oil drainage is accomplished by removing drain plug from bottom centerline of the starter.

Service starter with oil, Military Specification MIL-L-7808, to bottom of oil filler hole. See figure 5-6 for illustration of combustion starter oil servicing points.

**5-29. COMBUSTION STARTER, FUEL SYSTEM BLEEDING.**

Upon completion of a combustion starter replacement, or completion of maintenance on the starter where the fuel system has been opened, the following bleeding procedure will be accomplished.

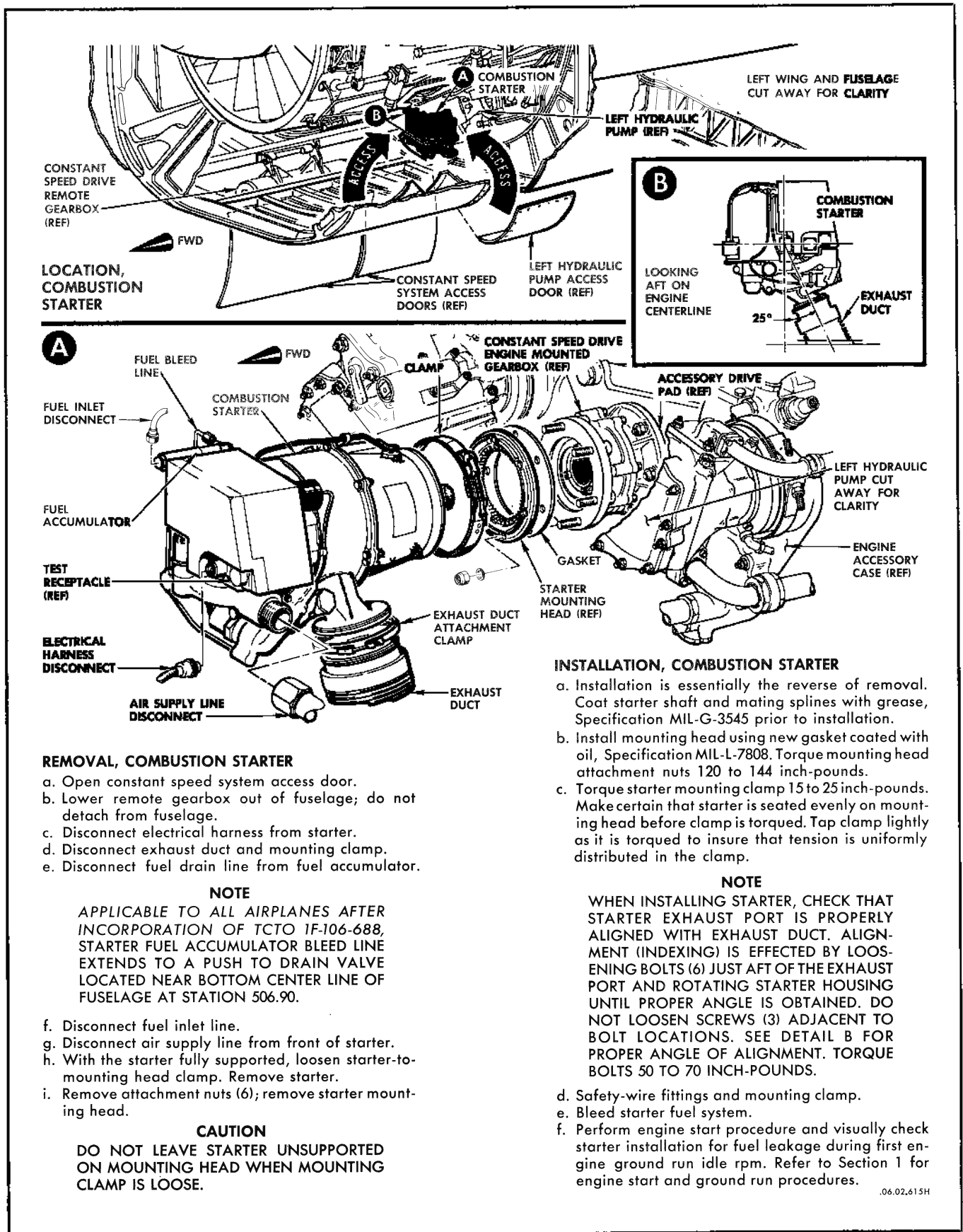

**LOCATION, COMBUSTION STARTER**

**A**

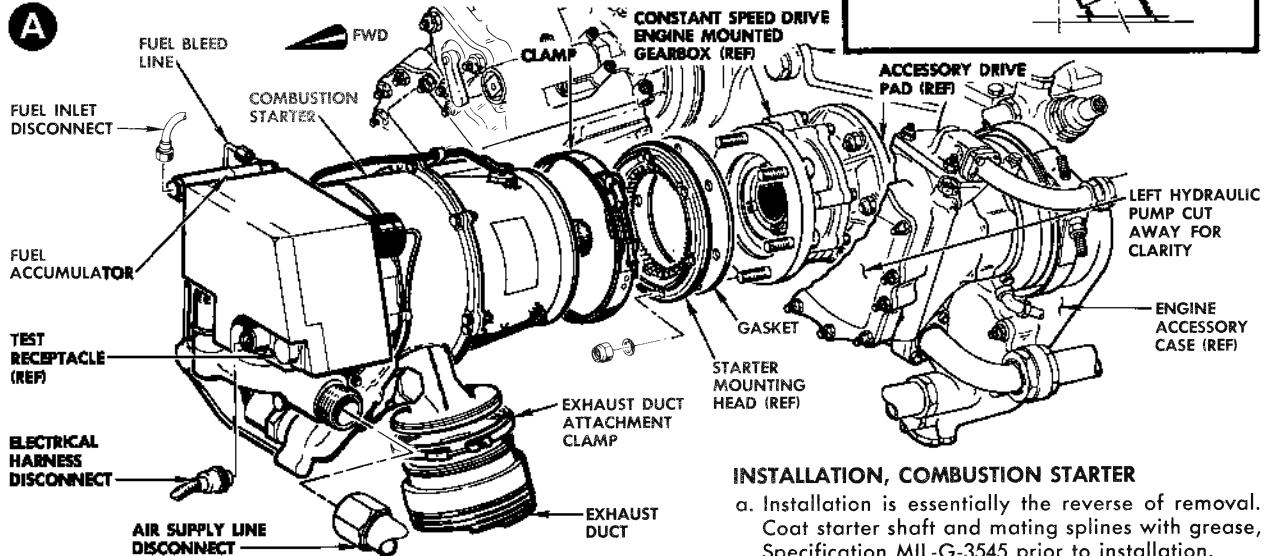

**REMOVAL, COMBUSTION STARTER**

- a. Open constant speed system access door.
- b. Lower remote gearbox out of fuselage; do not detach from fuselage.
- c. Disconnect electrical harness from starter.
- d. Disconnect exhaust duct and mounting clamp.
- e. Disconnect fuel drain line from fuel accumulator.

**NOTE**

APPLICABLE TO ALL AIRPLANES AFTER INCORPORATION OF TCTO 1F-106-688, STARTER FUEL ACCUMULATOR BLEED LINE EXTENDS TO A PUSH TO DRAIN VALVE LOCATED NEAR BOTTOM CENTER LINE OF FUSELAGE AT STATION 506.90.

- f. Disconnect fuel inlet line.
- g. Disconnect air supply line from front of starter.
- h. With the starter fully supported, loosen starter-to-mounting head clamp. Remove starter.
- i. Remove attachment nuts (6); remove starter mounting head.

**CAUTION**

DO NOT LEAVE STARTER UNSUPPORTED ON MOUNTING HEAD WHEN MOUNTING CLAMP IS LOOSE.

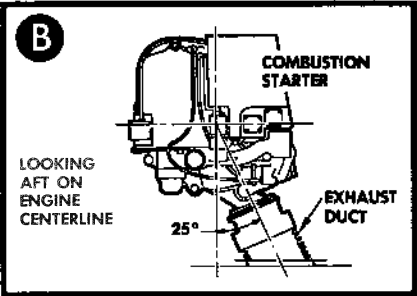

**INSTALLATION, COMBUSTION STARTER**

- a. Installation is essentially the reverse of removal. Coat starter shaft and mating splines with grease, Specification MIL-G-3545 prior to installation.
- b. Install mounting head using new gasket coated with oil, Specification MIL-L-7808. Torque mounting head attachment nuts 120 to 144 inch-pounds.
- c. Torque starter mounting clamp 15 to 25 inch-pounds. Make certain that starter is seated evenly on mounting head before clamp is torqued. Tap clamp lightly as it is torqued to insure that tension is uniformly distributed in the clamp.

**NOTE**

WHEN INSTALLING STARTER, CHECK THAT STARTER EXHAUST PORT IS PROPERLY ALIGNED WITH EXHAUST DUCT. ALIGNMENT (INDEXING) IS EFFECTED BY LOOSENING BOLTS (6) JUST AFT OF THE EXHAUST PORT AND ROTATING STARTER HOUSING UNTIL PROPER ANGLE IS OBTAINED. DO NOT LOOSEN SCREWS (3) ADJACENT TO BOLT LOCATIONS. SEE DETAIL B FOR PROPER ANGLE OF ALIGNMENT. TORQUE BOLTS 50 TO 70 INCH-POUNDS.

- d. Safety-wire fittings and mounting clamp.
- e. Bleed starter fuel system.
- f. Perform engine start procedure and visually check starter installation for fuel leakage during first engine ground run idle rpm. Refer to Section 1 for engine start and ground run procedures.

.06.02.615H

Figure 5-4. Replacement, Combustion Starter

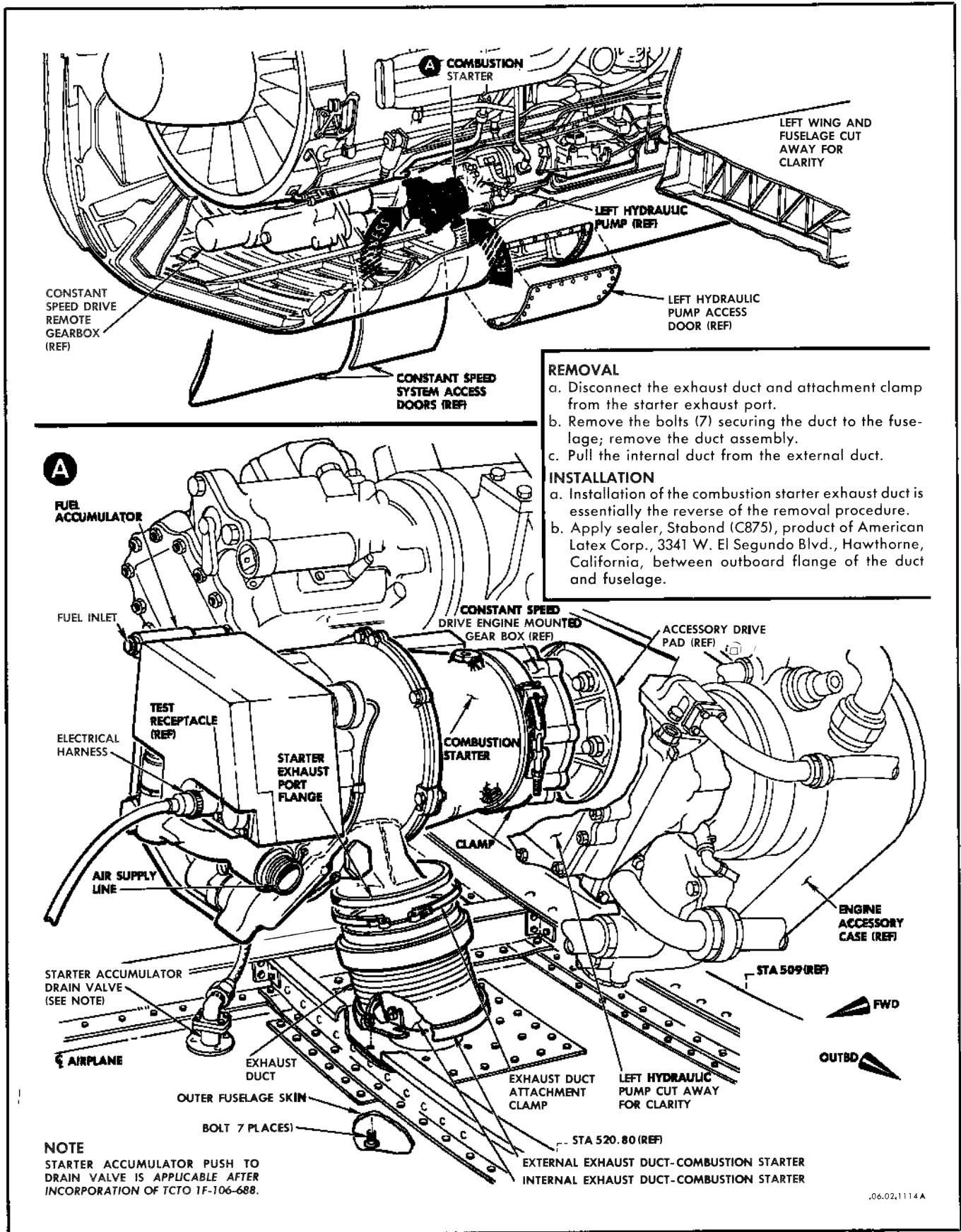

Figure 5-5. Replacement, Combustion Starter Exhaust Duct

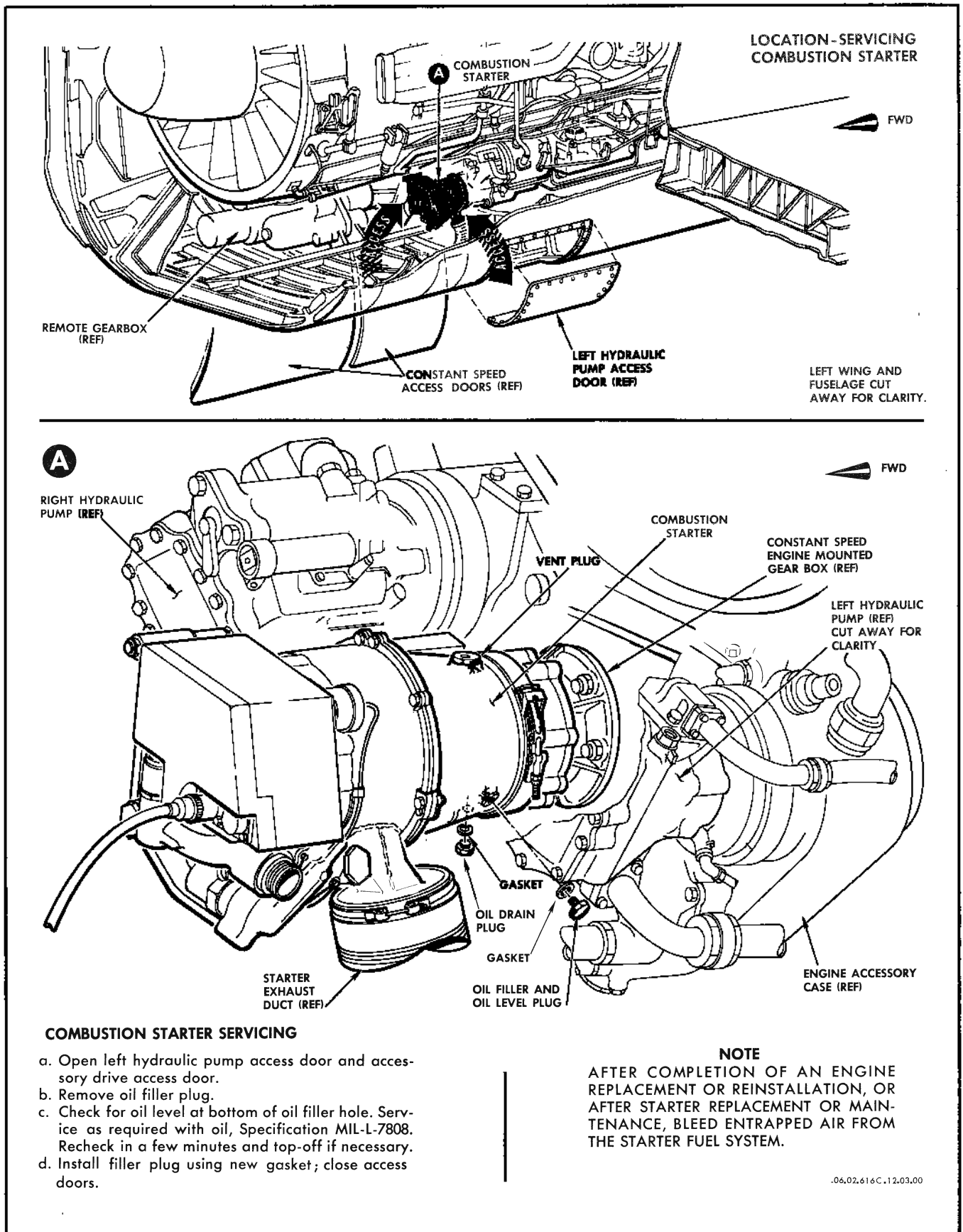

Figure 5-6. Servicing, Combustion Starter

- a. Open constant-speed drive unit access door.

**NOTE**

Check that fire extinguishers are provided before starting the procedure.

- b. Pressurize airplane fuel supply system by actuating one fuel boost pump.
- c. Open fuel bleed line at plugged tube at right side of starter.
- d. Allow fuel to flow out tube into a container until a solid stream of fuel issues from the tube; cap tube.
- e. Turn off boost pump and close access door.

f. *Applicable to all airplanes after incorporation of TCTO 1F-106-688.* Upon completion of combustion starter replacement, completion of maintenance on the starter where the fuel system has been opened, or when difficulty has been experienced in obtaining a combustion start on the preceding attempt, the following bleeding procedure shall be accomplished:

**NOTE**

Make sure that fire extinguishers are provided before starting this procedure.

1. Pressurize airplane fuel supply system by actuating one fuel boost pump.
2. Actuate the push-to-bleed valve located on the lower side of fuselage, forward of starter exhaust duct outlet.

3. Allow fuel to flow out of the push-to-bleed valve into a container until air is bled from the starter accumulator.
4. Turn off boost pump.

**5-30. CLEANING AND TESTING, IGNITION SPARKIGNITERS.**

- a. Degrease the sparkigniter, using hot trichlorethylene solvent, Military Specification MIL-T-7003.
- b. Clean the outer shell of the sparkigniter using a wire brush.
- c. Using hot trichlorethylene solvent and a nonmetallic brush, remove deposits from the external surface of the firing end of the sparkigniter. Do not use abrasive cleaner.

**NOTE**

Cleaning of the recessed center electrode cavity is not recommended.

- d. Clean the ceramic barrel of the sparkigniter with a soft cloth dampened in a cleaning naphtha, Federal Specification P-S-661.
- e. Blow sparkigniter dry using air blast.
- f. If necessary to aid cleaning, chase sparkigniter threads using a 1.000 inch -20 NS die for the barrel threads, and a 15/16 inch -16 NS die for the shell threads.
- g. Check the exposed ceramic section of the sparkigniter. Any cracks are cause for rejection. Inspect the sparkigniter for erosion. Erosion of the center electrode is not to exceed 0.225 inch below the ceramic surface.

**Section VI**

**LUBRICATION SYSTEM**

<i>Contents</i>	<i>Page</i>
Description .....	6-1
Operational Checkout .....	6-4
System Analysis .....	6-5
Replacement .....	6-6
Adjustment .....	6-10
Servicing .....	6-10

**DESCRIPTION**

**6-1. LUBRICATION SYSTEM.**

The engine lubrication is provided by a hot tank type oil pressure system. The hot tank system increases altitude performance by providing better de-aeration of the oil, since air escapes more readily from hot oil. This is accomplished by routing oil, Military Specification MIL-L-7808, from the engine scavenge pumps, directly to the oil tank where de-aeration occurs. From the tank, the oil is gravity fed to an engine driven boost pump which forces the oil through the air-oil cooler, and in to the main oil pressure pump. This system provides a positive inlet pressure for the main pump under all operating conditions. The oil passes through the pump and is routed through the bypass equipped main oil strainer to the pressure distribution system. The oil is then routed through the engine bearings and accessory drive section where it is picked up by the scavenge pumps and returned to the oil tank. An integral breather pressurizing system regulates air pressure in the system to maintain proper oil flow at all altitudes. An engine oil low-pressure warning system is provided to warn the pilot of engine low oil pressure. For a schematic illustration of the engine lubrication system, see figure 6-1.

**WARNING**

Engine oil, Military Specification MIL-L-7808, is detrimental to paint and rubber materials. Spilled oil should be immediately wiped up. This oil has an irritating effect on human skin and prolonged contact should be avoided.

**6-2. OIL BREATHER PRESSURIZING SYSTEM.**

The oil breather pressurizing system is provided to insure proper oil flow, at altitude, from the main bearing oil jets. Pressurizing air is provided by air leakage through the compressor seal and into the inner case of the engine. The breather system connects all of the bearing compartments and oil tank by means of internal passages and external tubing on the right side of the engine. From the tubing, air enters the oil pump and accessory drive housing. In the accessory drive housing, the air is routed to the breather pressurizing valve. Pressurization is provided by action of the valve in retarding the free venting of the air in the system. At sea level pressure, the valve is open. The valve gradually closes with increasing altitude, and maintains a pressure sufficient to insure oil flow at the main bearing jets similar to that provided

at sea level. A spring-loaded blowoff valve acts as a pressure relief for the breather system, and will open to relieve excessive pressure in the event of pressurizing valve malfunctions.

### 6-3. ENGINE OIL TANK.

The engine oil tank is installed on the forward left-hand side of the engine compressor section. The tank, of 4½ gallons minimum usable capacity, is equipped with an internal oil de-aerator. The de-aerator removes entrained air from the oil as it is returned to the tank. The tank is equipped with a filler cap and attached dipstick which is accessible through a door in the upper left side of the fuselage. This door is secured by 12 quick-opening type fasteners. The oil tank scupper is equipped with an adapter to which an overboard drain line is attached.

### 6-4. OIL BOOST PUMP.

The oil boost pump is an engine driven gear-type pump installed in the lower section of the main oil pump housing. Oil is gravity fed from the oil tank to the boost pump. The pump is provided to force oil through the air-oil and fuel-oil coolers, and provides the main oil pump with a constant oil inlet pressure.

### 6-5. PRESSURE OIL PUMP.

The single-section gear-type pressure oil pump is located in the upper left-hand section of the oil pump and accessory drive housing. Oil enters the pump inlet by pressure flow from the oil boost pump. Pump discharge pressure is regulated by a pressure relief valve provided downstream of the pump and strainer. The pressure relief valve is set to maintain a normal operating pressure of 45 psi.

### 6-6. FUEL-OIL COOLER.

The fuel-oil cooler is a heat exchanger employing fuel as coolant for engine oil. The cooler is installed on the upper left side of the engine compressor case and operates in conjunction with the air-oil cooler in cooling engine oil. The cooler is equipped with a thermal relief-bypass valve, and two pressure-relief bypass valves. The pressure relief-bypass valve, on the oil side of the cooler, is set for a differential pressure of 40 psi. A similar valve on the fuel side of the cooler is set for 30 psi.

### 6-7. PRESSURE OIL STRAINER.

An oil strainer assembly, equipped with a bypass valve, is located on the lower right side of the oil pump and accessory drive housing. The strainer is provided to supply the engine lubricating system with a clean supply of oil. The valve permits the oil to bypass the strainer in the event the strainer becomes clogged. The strainer assembly consists of a series of screens in disc form, separated alternately by inlet and outlet spacers, assembled around a perforated tube.

### 6-8. OIL BREATHER PRESSURIZING VALVE.

The oil breather pressurizing valve is installed on the upper right side of engine accessory section. This assembly employs an aneroid valve and a pressure relief valve to regulate pressure in the engine bearing compartments. The aneroid valve is open at sea level and is fully closed at 6 to 9 inches Hg. The pressure relief valve is set to relieve system pressurization in excess of 5 psi.

### 6-9. ENGINE AIR-OIL COOLER.

The engine air-oil cooler is a fuselage mounted, aluminum fin-plate type cooler, using ram air from the engine air inlet duct as its cooling agent. The cooler is installed on the upper left side of the fuselage adjacent to the engine inlet guide vane assembly. The cooler is provided with a spring-loaded push-to-drain assembly. Access to the drain is gained through the left main wheel well. Cooling air, which has passed through the cooler, is discharged into the engine accessory compartment as a cooling aid for that area. Refer to Section IV of this manual for complete information regarding air flow control. Cooling air for the cooler is controlled by the air-oil cooler air inlet valve. A fuel temperature sensing probe, located in the main fuel line at the inlet of the fuel pressurizing and dump valve, transmits fuel temperatures to the fuel temperature control box in the left main wheel well. The fuel temperature control box provides the engine air-oil cooler air valve with an opening signal at 107.2°C (225°F) and a closing signal at 101.7°C (215°F). The fuel temperature sensing system thereby restricts engine air-oil cooler action until the engine fuel-oil cooler function becomes insufficient. On airplanes with J75-P17 engine (S/N 610494 and subsequent) installed, an engine oil pressure reduction orifice plate must be installed at the oil "OUT" elbow connection on the engine air-oil cooler. Engine air-oil coolers on airplanes with J75-P17 engines (S/N 610493 and prior), do not require installation of the oil pressure reduction orifice plate. Refer to Replacement, Oil Pressure Reduction Orifice Plate in this section for pertinent installation instructions.

### 6-10. OIL LOW-PRESSURE WARNING SYSTEM.

The oil low-pressure warning system is provided to give the pilot an indication of low engine oil pressure. The system consists of a warning light located on the cockpit master warning panel, and a pressure switch located on the engine accessory section oil pressure port. The oil low-pressure warning switch is set to extinguish the warning light on an increasing pressure of 40 psi maximum and to illuminate the light on a decreasing pressure of 37 (±2) psi. This provides a warning of undesirable oil pressure. The switch is vented to the accessory case cavity by a tube to permit sensing of differential pressure between oil and engine internal pressure. The system is protected electrically by a 5 amp fuse located on the main wheel well fuse panel.

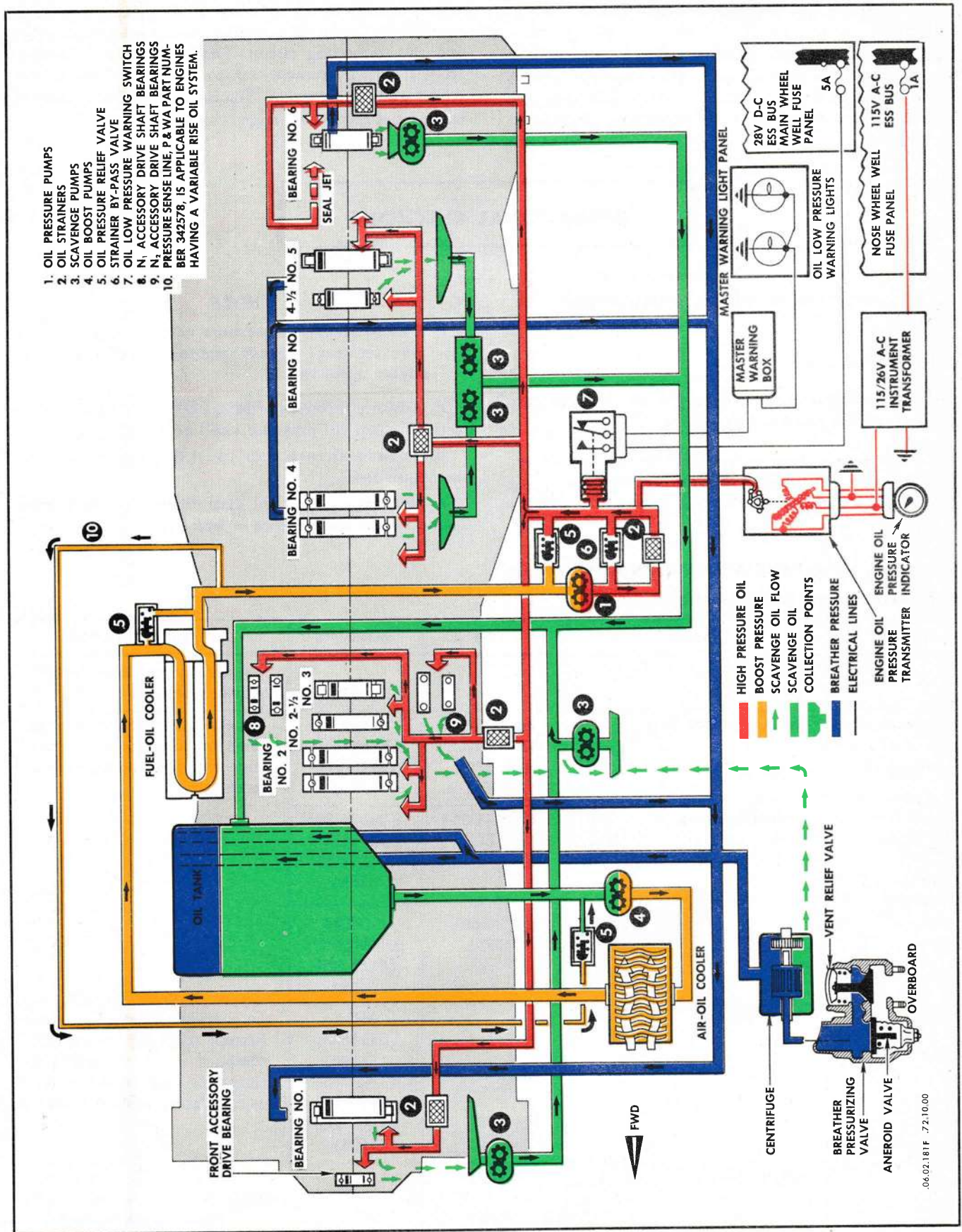

Figure 6-1. Engine Lubrication System, Schematic



**6-11. ENGINE OIL PRESSURE INDICATING SYSTEM.**

The engine oil pressure indicating system consists of a single indicator on the main instrument panel for *F-106A* airplanes. On *F-106B* airplanes, separate indicators are installed on the forward and aft instrument panels. The

system consists of the indicator in the cockpit, a pressure transmitter on the N<sub>2</sub> accessory section oil pressure port and the connecting circuit. Electrical power is derived from 26-volt instrument transformer located in the nose wheel well compartment. The instrument face is marked in 5 pound increments from 0 to 100 psi.

**OPERATIONAL CHECKOUT****6-12. OPERATIONAL CHECK, LUBRICATION SYSTEM.****6-13. Procedure.**

a. Prepare airplane for engine ground run; refer to Section I for this procedure.

b. Start engine; refer to Section I for this procedure. With throttle at "IDLE," oil low-pressure warning light shall be extinguished. Oil pressure will be 45 (±5) psi.

**6-14. OIL LOW-PRESSURE WARNING SYSTEM TEST.****6-15. Equipment Requirements.****NOTE**

A 40 to 50 psi oil pressure on the cockpit oil pressure gage is acceptable for continuous engine operation.

c. Advance throttle to "MIL POWER"; light shall be extinguished. Oil pressure shall be 45 (±5) psi.

d. Return throttle to "IDLE"; light shall be extinguished.

e. Shut off engine; light shall illuminate. Check lubrication system for evidence of leakage.

FIGURE	NAME	TYPE	ALTERNATE	USE AND APPLICATION
	Two Position Test Switch.			To simulate oil low-pressure switch action.
Refer to T. O. 1F- 106A-2-10	Generator Set (Gas).	8-96026-801 AF/M32A-13 (6115-583- 9365)	8-96026 AF/M32M-2 (6115-617- 1417)	To energize electrical systems on aircraft equipped with special quick disconnect receptacle.
	Generator Set (Elec).	8-96025-803 AF-ECU-  10/M (6125-583- 3225)	8-96025-805 A/M24M-2 (6125-628- 3566)	
			8-96025 AF/M24M-1 (6125-628- 6468)	
	Generator Set.		MC-1 (6125-500- 1190)	To energize electrical systems (except AWCIS) on aircraft equipped with standard AN receptacle and on others by using adapter cable 8-96052.
MD-3 (6115-635- 5595)				
Adapter Cable.		8-96052 (6115-557- 8548)		To connect MC-1 and MD-3 units to aircraft equipped with special quick disconnect receptacle.

**6-16. Procedure.**

a. Remove oil low-pressure warning fuse from main wheel well fuse panel.

b. Gain access to oil low-pressure warning switch through the engine accessory compartment access door.

c. Slide outer sleeve from oil low-pressure warning switch permanent splice connectors and connect test switch to the two splice connectors.

d. Install oil low-pressure warning fuse in main wheel well fuse panel. Install master warning control fuse in cockpit right fuse panel. Connect external 28-volt dc electrical power to airplane receptacle.

e. Actuate test switch to "ON"; master warning light and oil low-pressure warning light shall illuminate.

f. Momentarily actuate "WARN LIGHT TEST" switch to "RESET"; master warning light shall extinguish. Oil low-pressure warning light shall remain illuminated.

g. Actuate test switch to "OFF"; oil low-pressure warning light shall extinguish.

h. Remove test switch from splice connectors. Position and secure outer sleeve over permanent splice connectors.

**6-17. ENGINE OIL PRESSURE INDICATING SYSTEM TEST.**

For testing of the engine oil pressure indicating system, refer to paragraph 1-23. The indicating system is checked during engine operation.

<b>SYSTEM ANALYSIS</b>
------------------------

**6-18. SYSTEM ANALYSIS. LUBRICATION SYSTEM.**

PROBABLE CAUSE	ISOLATION PROCEDURE	REMEDY
<b>EXCESSIVE OIL IN TANK.</b>		
Internal leak in fuel-oil cooler. Fuel entering oil system.	Remove cooler for test.	Install replacement item.
<b>OIL FOUND BLACK IN COLOR OR CONTAINING CARBON PARTICLES.</b>		
Carbon seals in engine deteriorating.	Check oil filters for evidence of carbon particles.	Replace component having suspected carbon seal deterioration.
<b>LOW OIL PRESSURE INDICATION.</b>		
Oil tank empty.	Check oil level.	
Oil breather pressurizing valve not closing at altitude.	Remove valve for bench test.	Install replacement item.
Oil low-pressure warning light malfunctioning.	Remove switch for bench test.	
<b>OIL LOW-PRESSURE WARNING LIGHT FLUCTUATING OFF AND ON.</b>		
Loose connection in electrical circuit.	Check circuit for condition and security of attachment of components.	
Low-pressure warning light switch malfunctioning.	Remove switch for bench test.	Install replacement item.
Oil pressure fluctuating.	Check oil level in tank.	

**6-18. SYSTEM ANALYSIS, LUBRICATION SYSTEM (CONT).**

PROBABLE CAUSE	ISOLATION PROCEDURE	REMEDY
<b>OIL LOW-PRESSURE WARNING LIGHT FLUCTUATING OFF AND ON (CONT).</b>		
Oil pressure fluctuating (cont).	Check engine oil strainer for metal particles indicating engine failure.  <b>NOTE</b> If fluctuation occurs only at altitude, check oil breather pressurizing valve.	
	Remove oil pressure indicator and transmitter for bench test.	Install replacement item.

**REPLACEMENT**

**6-19. REPLACEMENT, ELECTRICAL COMPONENTS GENERAL.**

When removing components equipped with pigtail electrical leads, always cut leads at existing splices. This is necessary to preserve the component lead identity and to provide sufficient length for reinstallation.

**6-20. REMOVAL, ENGINE OIL TANK.**

- a. Remove engine from airplane. Refer to Section I for this procedure.
- b. Drain oil tank by opening tank drain valve. Drainage may be facilitated by removing oil tank filler cap (see figure 6-4).
- c. Disconnect lines from tank.
- d. Disconnect tank attachment straps; remove tank.
- e. Cover all lines and openings with plugs or polyethylene sheet.

**6-21. INSTALLATION, ENGINE OIL TANK.**

- a. Install the engine oil tank in essentially the reverse of the removal procedure.
- b. Check that tank support bracket cushions maintain proper positioning during installation.
- c. Fill oil tank, see figure 6-4 for procedure. Conduct lubrication system leak check at first engine run.

**6-22. REPLACEMENT, FUEL-OIL COOLER.**

For the fuel-oil cooler replacement procedure, refer to paragraph 2-23.

**6-23. REPLACEMENT, ENGINE AIR-OIL COOLER.**

For removal and installation of the air-oil cooler, see figure 6-2.

**6-24. REMOVAL, ENGINE BREATHER PRESSURIZING VALVE.**

- a. Gain access to the engine oil breather pressurizing valve through the engine accessory compartment access door.
- b. Remove lines attached to pressurizing valve.
- c. Remove bolts (4); remove pressurizing valve.
- d. Remove pressurizing valve ferrule from the engine accessory case port, and retain for new installation. Cover openings with plugs or polyethylene sheet.

**6-25. INSTALLATION, ENGINE BREATHER PRESSURIZING VALVE.**

- a. Install the engine breather pressurizing valve in essentially the reverse of the valve removal procedure. Use new seals.
- b. Conduct lubrication system leak check at first engine run.

**6-26. REPLACEMENT, ENGINE OIL LOW-PRESSURE WARNING SWITCH AND TRANSMITTER.**

For removal and installation of the oil low-pressure warning switch and transmitter, see figure 6-2.

**6-27. REPLACEMENT, MAIN FUEL CONTROL DRIVE SHAFT GEAR OIL SEAL.**

- a. Drain oil from engine N<sub>2</sub> accessory case. Refer to paragraph 6-39 for this procedure.
- b. Remove main fuel control unit. Refer to paragraph 2-17 for this procedure.
- c. Remove fuel control shaft seal housing using puller, P & W A tool No. 10008.

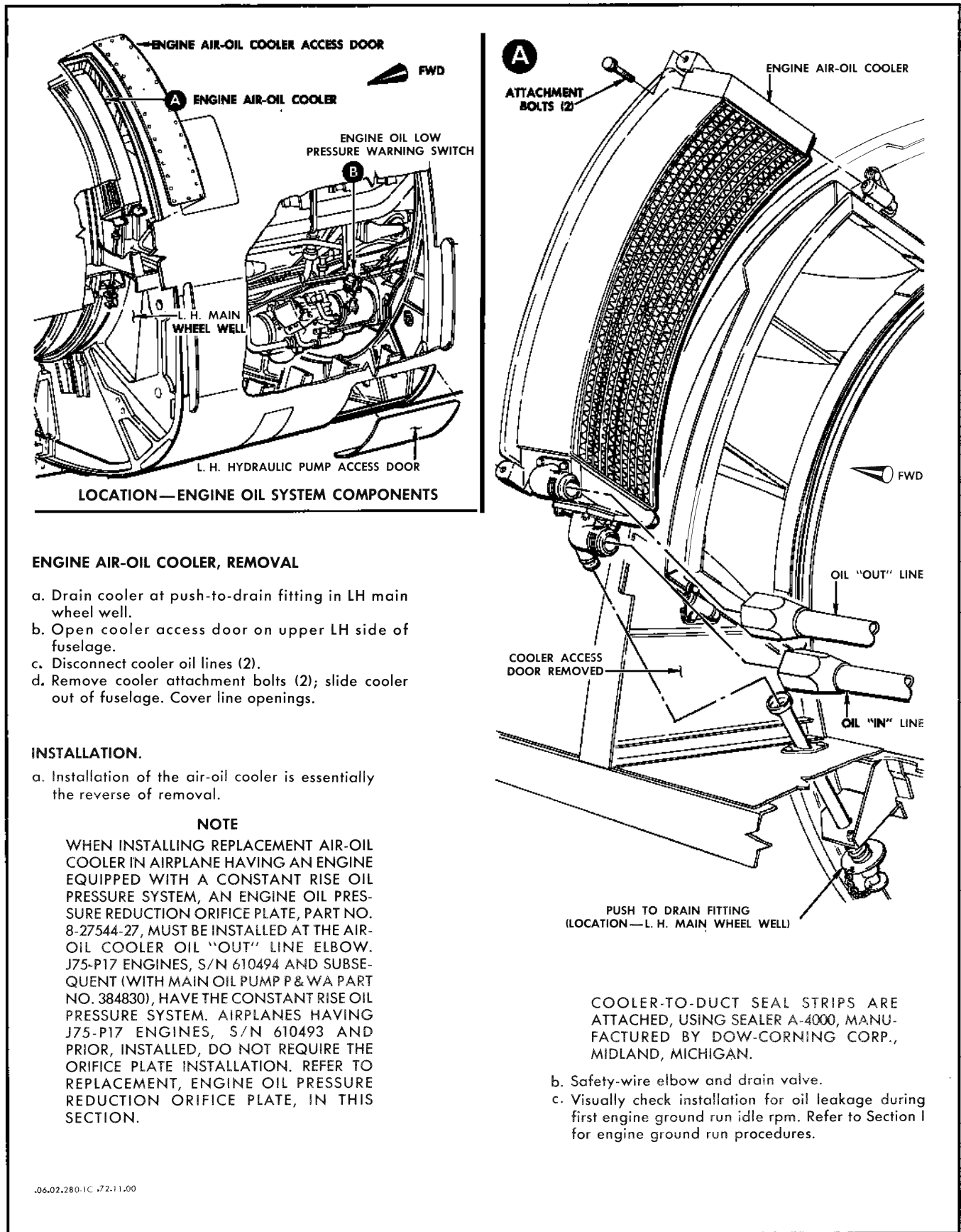

.06.02.280-1C 72-11.00

Figure 6-2. Replacement, Engine Lubrication System Components (Sheet 1 of 2)

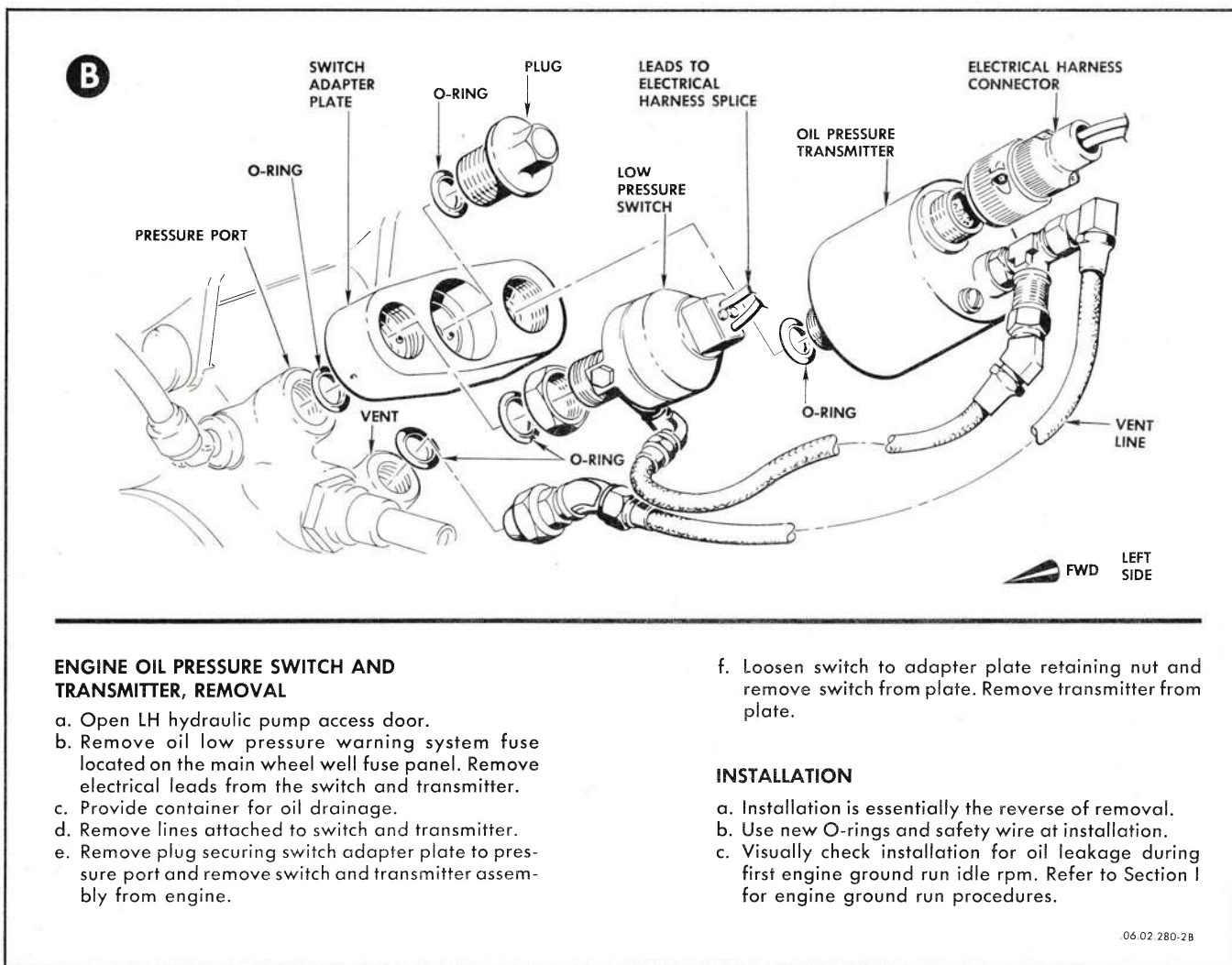

Figure 6-2. Replacement, Engine Lubrication System Components (Sheet 2 of 2)

d. Remove oil seal from housing using drift, P & W A tool No. 10017.

e. Place seal housing on base, P & W A tool No. 10018.

f. Drift new seal into seal housing.

g. Insert guide in splined end of shaftgear.

h. Install seal housing and new O-ring seal over end of guide.

i. Secure with 4 screws and safety-wire.

j. Reinstall fuel control unit.

k. Service engine oil tank. Refer to paragraph 6-39 for this procedure.

l. Visually check fuel control installation for fuel leakage during first engine ground run idle rpm. Refer to Section I for engine ground run procedures.

#### 6-28. REPLACEMENT, ENGINE FUEL PUMP DRIVE SHAFTGEAR OIL SEAL.

a. Drain oil from engine N<sub>2</sub> accessory case. Refer to paragraph 6-39 for this procedure.

b. Remove engine fuel pump.

c. Remove fuel pump shaft seal housing using P & W A tool No. 10008.

d. Remove oil seal from housing using drift, P & W A tool No. 10017.

e. Place seal housing on base, P & W A tool No. 10018.

f. Drift new seal into housing.

g. Place guide in splined end of shaftgear.

h. Install seal housing and new O-ring seal over end of guide.

i. Secure with 4 screws and safety-wire.

j. Reinstall fuel pump.

k. Service engine oil tank. Refer to paragraph 6-39 for this procedure.

l. Visually check fuel pump installation for fuel leakage during first engine ground run idle rpm. Refer to Section I for engine ground run procedures.

**6-29. REPLACEMENT, ENGINE STARTER DRIVE SHAFTGEAR OIL SEAL.**

- a. Drain oil from engine N<sub>2</sub> accessory case. Refer to paragraph 6-39 for this procedure.
- b. Remove starter and constant-speed drive engine mounted gearbox.
- c. Remove snapping securing shaftgear oil seal housing in accessory section.
- d. Remove starter shaftgear seal housing from accessory section using puller, P & W A tool No. 10008.
- e. Remove oil seal from seal housing using drift, P & W A tool No. 10228.
- f. Install new seal in seal housing using drift, P & W A tool No. 10226.
- g. Install seal housing and new O-ring seal over end of shaftgear. Secure seal housing with snapping.
- h. Service engine oil tank. Refer to paragraph 6-39 for this procedure.
- i. Perform engine start procedure and visually check combustion starter installation for fuel leakage during first engine ground run idle rpm. Refer to Section I for engine start and ground run procedures.

**6-30. REPLACEMENT, HYDRAULIC PUMP DRIVE SHAFTGEAR OIL SEAL.**

- a. Drain oil from engine N<sub>2</sub> accessory section.
- b. Remove hydraulic pump from N<sub>2</sub> accessory section. Refer to T.O. 1F-106A-2-3 for this procedure.
- c. Remove hydraulic pump shaftgear oil seal housing using puller, P & W A tool No. 10008.
- d. Remove seal from housing using drift, P & W A tool No. 10228.
- e. Install new seal in housing using drift, P & W A tool No. 6676.
- f. Install seal housing and new O-ring seal over end of shaftgear. Secure with 4 screws and safety-wire.
- g. Install hydraulic pump. Refer to T.O. 1F-106A-2-3 for this procedure.
- h. Service engine oil tank. Refer to paragraph 6-39 for this procedure.
- i. Bleed hydraulic system. Refer to T.O. 1F-106A-2-3 for this procedure.
- j. Visually check installation for oil leakage during first engine ground run idle rpm. Refer to Section I for engine ground run procedures.

**6-31. REPLACEMENT, ENGINE COMPRESSOR BLEED VALVE GOVERNOR DRIVE SHAFTGEAR OIL SEAL (N<sub>1</sub> ACCESSORY SECTION).**

- a. Remove bleed governor from N<sub>1</sub> accessory section.
- b. Remove governor shaftgear oil seal housing from accessory section using puller, P & W A tool No. 7146.

c. Remove oil seal from housing using drift, P & W A tool No. 10375.

d. Position seal housing on base, P & W A tool No. 10376 and install new seal in housing using drift.

**CAUTION**

When the oil seal is positioned on the drift, be sure the exposed spring side of the seal enters the seal housing first.

e. Insert guide, P & W A tool No. 10016, in end of shaftgear. Install seal housing and new O-ring seal over end of shaftgear.

f. Install bleed governor.

g. Perform system operational checkout if system is activated. It will be necessary to check the engine historical record for each engine to determine the operational status of the system.

**6-32. Replacement, N<sub>2</sub> Tachometer Drive Shaft Oil Seal.**

- a. Remove electrical lead from tachometer generator.
- b. Remove generator from N<sub>2</sub> accessory section.
- c. Remove seal housing from N<sub>2</sub> accessory section.
- d. Remove old seal from housing using drift, P&WA tool No. 10035.
- e. Position new seal on pilot of drift so that exposed spring side of seal will enter seal housing first.
- f. Place seal housing on base, P&WA tool No. 10034 and press new seal into housing.
- g. Insert guide, P&WA tool No. 10016 in end of shaftgear.
- h. Install seal housing and new gasket over end of shaftgear.
- i. Install tachometer generator or accessory case.
- j. Install electrical lead on generator.
- k. Perform system operational checkout and visually check tachometer installation for oil leakage during first engine ground run idle rpm. Refer to Section I for engine ground run procedures.

**6-33. REMOVAL, ENGINE OIL PUMP.**

- a. Drain oil from engine oil tank.
- b. Gain access to the engine oil pump through the engine accessory compartment left access door.

**NOTE**

A suitable container shall be placed under main oil pump to catch residual oil when disconnecting tubes from pump and removing pump from gearbox.

- c. Disconnect tubes attached to the main oil pump.

**NOTE**

The presence of a pressure sense tube, P&WA part No. 342578, identifies engines that have a variable rise oil system. The main oil pump for this system will have one of the following P&WA part No. 331946, 334716 or 339642. Engines that do not have the sense tube have a constant rise oil system. The main oil pump for this system is P&WA part No. 384830. It is preferable that a pump be replaced by one of the same configuration. If it is necessary to use part No. 384830 for any of the variable rise system pumps the sense tube must be capped. If it is necessary to use a variable rise pump in place of part No. 384830, the sense tube port on the pump must be uncapped and a sense line installed.

- d. Remove oil pump retaining nuts and position the puller, P&WA tool No. 10322, so that the fixed jaws engage the lugs on the pump body. Engage and

secure the adjustable jaw to the pump body. Use the knocker action to remove the pump.

- e. Remove and discard all seals. Cover openings with plugs or polyethylene sheet.

**6-34. INSTALLATION, ENGINE OIL PUMP.**

a. Place two new seals in the grooves in the pump housing bore and a new seal in the groove of the pump mounting pad. Coat the pump shaft and mating spline with grease, Military Specification MIL-G-3545, prior to installation.

b. Install the pump into the gearbox and secure with the washers and locknuts.

c. Using new seals, connect the tubes to the main oil pump.

d. Service the engine oil tank.

e. Conduct engine ground run check procedure. Check lubrication system for leaks.

**6-35. REPLACEMENT, ENGINE OIL PRESSURE REDUCTION ORIFICE PLATE.**

For removal and installation of the engine oil pressure reduction orifice plate, see figure 6-3.

**ADJUSTMENT**

**6-36. ADJUSTMENT, ENGINE OIL PRESSURE.**

Access to the engine oil pressure adjustment (oil pressure relief valve) is gained through the engine accessory compartment left access door. The valve is located on the left side of the engine N<sub>2</sub> accessory drive housing, aft of the left hydraulic pump. Adjust engine oil pressure as follows:

- a. Remove cap from adjustment screw.
- b. Using slot type screw driver, hold adjustment screw and loosen locknut.

c. Turn adjustment screw clockwise to increase oil pressure or counterclockwise to decrease oil pressure. Adjust oil pressure to 45 (+5, -0) psi with the engine operating at idle. Tighten locknut holding adjustment screw with slot type screw driver.

d. Check oil pressure with engine operating at military power. Pressure shall be 45 (+5, -0) psi.

e. Install cap on adjustment screw.

**SERVICING**

**6-37. PRESERVATION, ENGINE OIL SYSTEM.**

For preservation information for the engine oil system, refer to Servicing in Section I.

**6-38. DEPRESERVATION, ENGINE OIL SYSTEM.**

For depreservation information for the engine oil system, refer to Servicing in Section I.

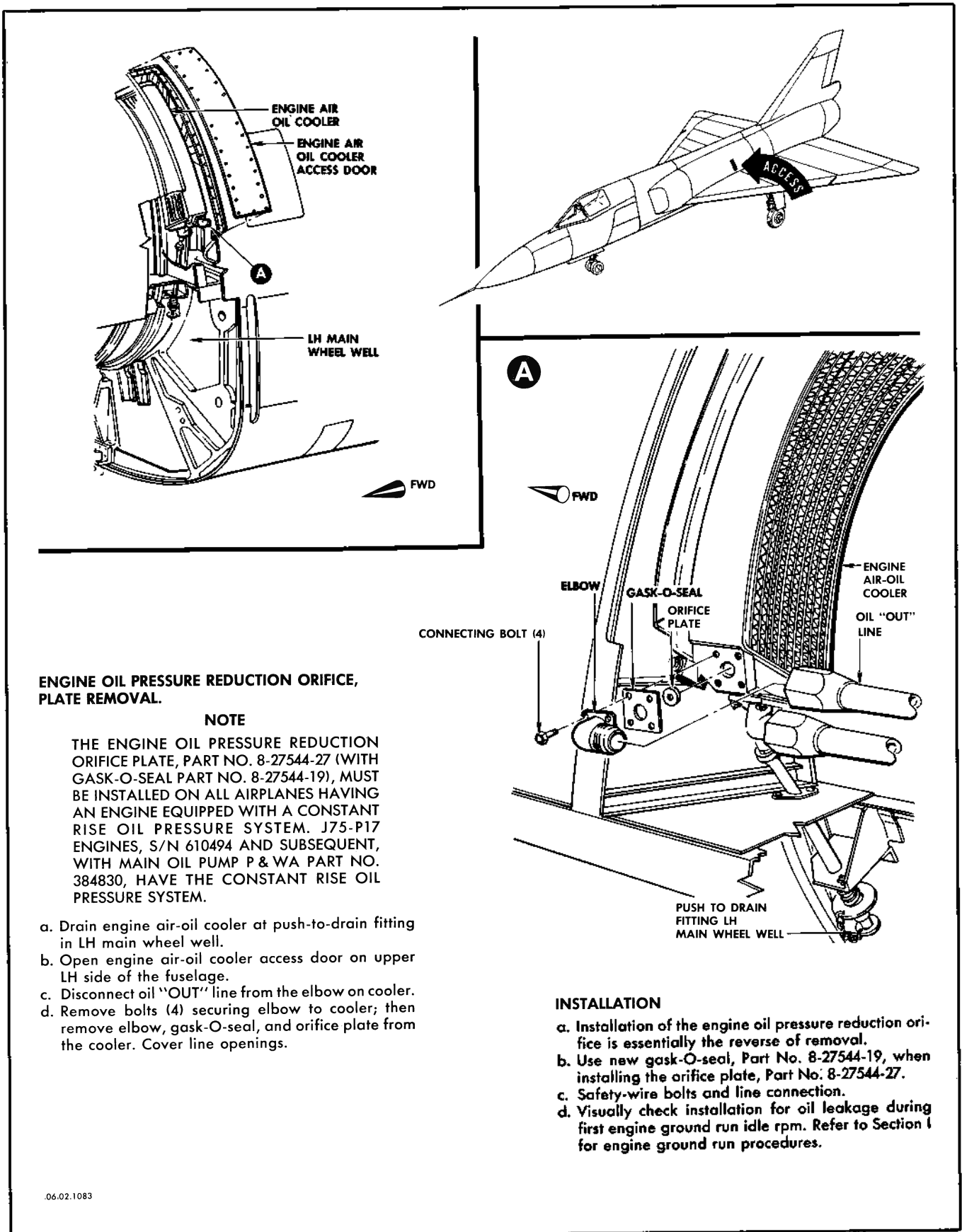

### ENGINE OIL PRESSURE REDUCTION ORIFICE, PLATE REMOVAL.

#### NOTE

THE ENGINE OIL PRESSURE REDUCTION ORIFICE PLATE, PART NO. 8-27544-27 (WITH GASK-O-SEAL PART NO. 8-27544-19), MUST BE INSTALLED ON ALL AIRPLANES HAVING AN ENGINE EQUIPPED WITH A CONSTANT RISE OIL PRESSURE SYSTEM. J75-P17 ENGINES, S/N 610494 AND SUBSEQUENT, WITH MAIN OIL PUMP P & WA PART NO. 384830, HAVE THE CONSTANT RISE OIL PRESSURE SYSTEM.

- Drain engine air-oil cooler at push-to-drain fitting in LH main wheel well.
- Open engine air-oil cooler access door on upper LH side of the fuselage.
- Disconnect oil "OUT" line from the elbow on cooler.
- Remove bolts (4) securing elbow to cooler; then remove elbow, gask-O-seal, and orifice plate from the cooler. Cover line openings.

#### INSTALLATION

- Installation of the engine oil pressure reduction orifice is essentially the reverse of removal.
- Use new gask-O-seal, Part No. 8-27544-19, when installing the orifice plate, Part No. 8-27544-27.
- Safety-wire bolts and line connection.
- Visually check installation for oil leakage during first engine ground run idle rpm. Refer to Section I for engine ground run procedures.

06.02.1083

Figure 6-3. Replacement, Engine Oil Pressure Reduction Orifice Plate



**6-39. DRAINING AND SERVICING.**

The engine lubrication system shall be drained and serviced at specified periods. See figure 6-4 for an illustration of the lubrication system servicing. The following procedure is recommended:

- a. Drain oil tank through drain valve at bottom of tank.
- b. Drain air-oil cooler at push-to-drain fitting in left main wheel well by removing fitting cap, then depressing fitting.
- c. Remove N<sub>2</sub> accessory section drain plugs. Drain oil from fuel-oil cooler.

**NOTE**

Engine oil found black in color or containing particles of carbon does not indicate high temperature breakdown of the oil. When this condition is found, look for other sources of contamination. Engine oil, Military Specification MIL-L-7808 is not a hydro-carbon but a synthetic oil usually having a silicone base.

- d. Replace all plugs, and safety-wire; close oil tank drain valve.

**CAUTION**

When installing engine oil drain plug in the N<sub>2</sub> accessory drive gear box, torque plug to maximum of 75 to 100 inch-pounds to prevent stripping of gear box threads.

- e. Service oil tank to full mark on dip stick with oil, Military Specification MIL-L-7808.

**NOTE**

Oil tank filler cap must be properly installed before oil filler door in fuselage can be installed and secured.

- f. Prepare engine and airplane for engine run.

- g. Start engine, and run until oil temperature is high enough to circulate oil through fuel-oil cooler.

**CAUTION**

Watch closely for oil low warning indication, and for leaks at strainer and drain points.

- h. Stop engine, and service tank to full mark on dip stick. Check system for oil leaks.

**6-40. CHECKING OF ENGINE OIL LEVEL.**

When the engine oil level is to be checked, it should be done immediately after engine shutdown after a flight, or engine ground run. If the oil level is to be checked after an extended shutdown period, the engine shall be run at least 2 minutes prior to checking the oil level. These precautions must be taken since the oil will drain into the engine bearings and sump when the engine is not running. This accumulation of oil, in the low points of the system, will overfill the tank if oil is added and the engine is then started. This will result in the excess oil being discharged overboard through the oil breather-pressurizing valve vent. See figure 6-4 for the oil tank servicing procedure.

**6-41. CLEANING, ENGINE OIL STRAINER.**

For removal and cleaning of the engine oil strainer, see figure 6-5.

**6-42. CLEANING, ENGINE NO. 6 BEARING OIL STRAINERS.**

For removal and cleaning of the engine No. 6 bearing oil strainers, see figure 6-6.

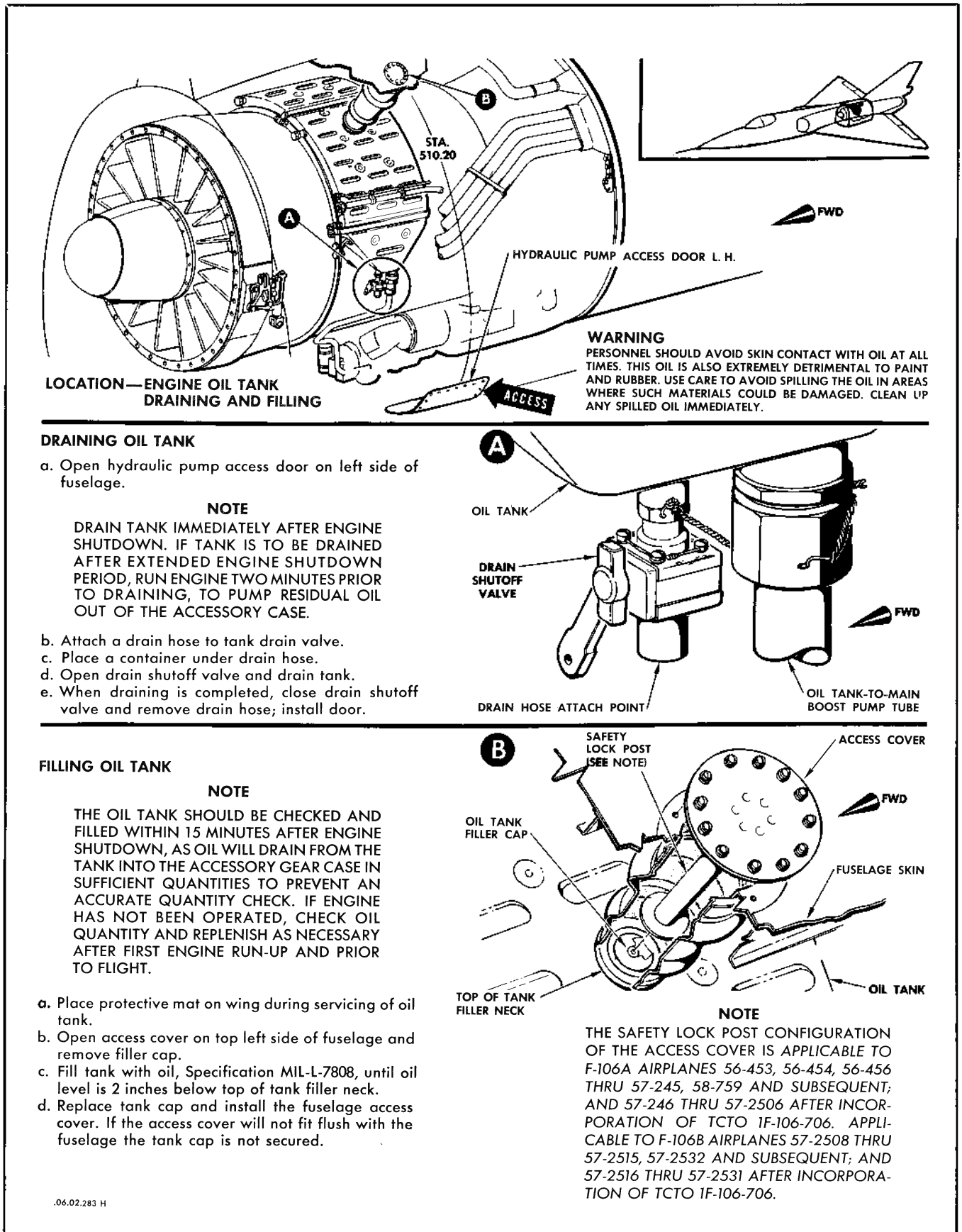
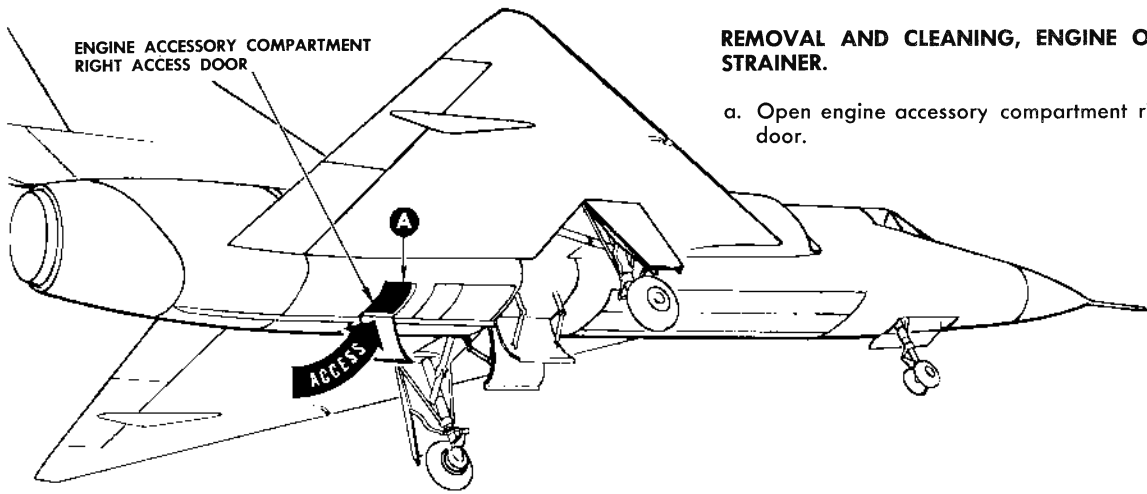
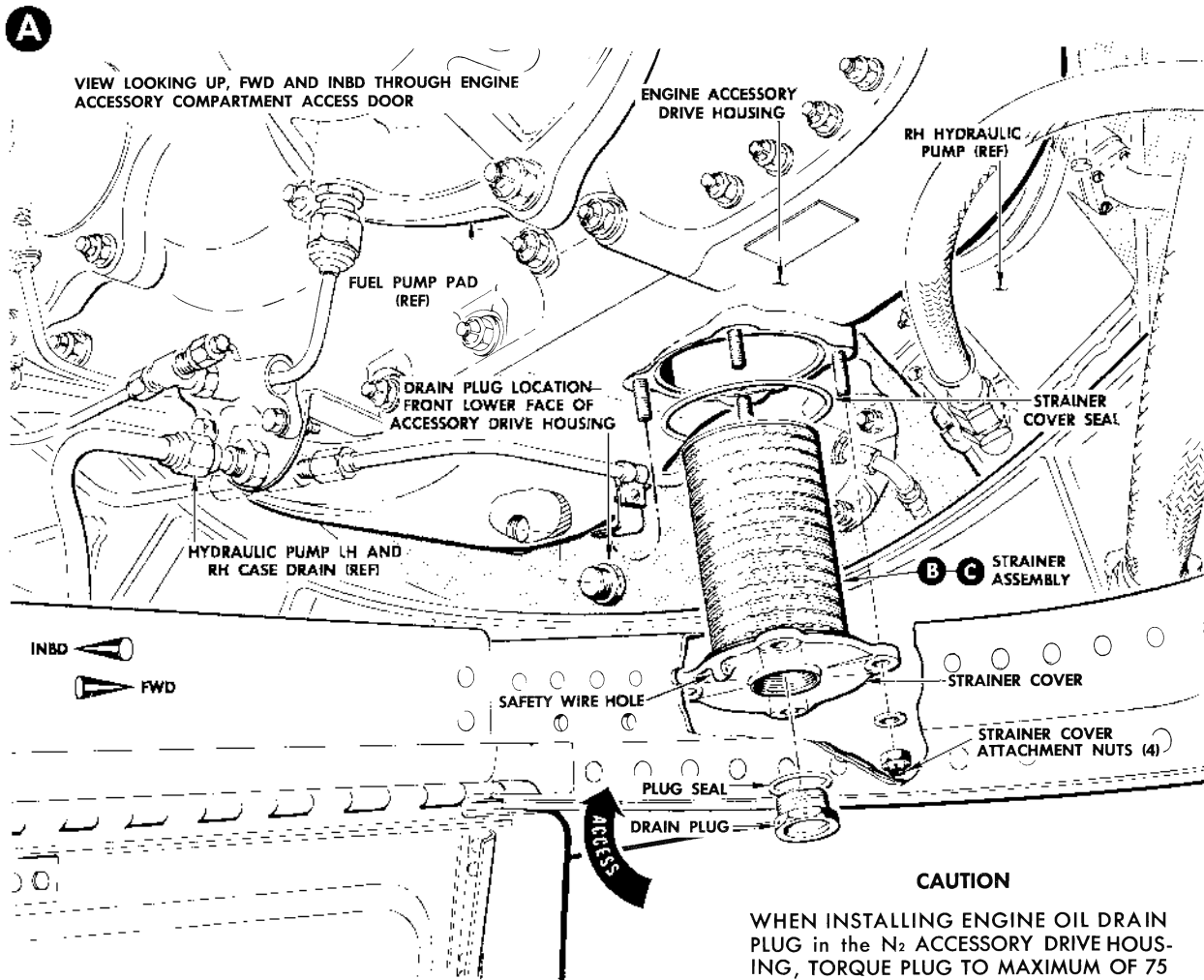

Figure 6-4. Draining and Servicing, Engine Lubrication System



**REMOVAL AND CLEANING, ENGINE OIL STRAINER.**

- a. Open engine accessory compartment right access door.



- b. Place drain receptacle under oil pump and accessory drive housing. Remove drain plug from front face of housing and from oil strainer cover; drain oil. Install drain plug in accessory housing and safety-wire.

.06.02.463-1B .72.13.00

**CAUTION**

WHEN INSTALLING ENGINE OIL DRAIN PLUG in the N<sub>2</sub> ACCESSORY DRIVE HOUSING, TORQUE PLUG TO MAXIMUM OF 75 TO 100 INCH-POUNDS TO PREVENT STRIPPING OF HOUSING THREADS.

- c. Remove strainer attachment nuts (4); remove strainer assembly. Discard strainer cover seal.

Figure 6-5. Cleaning, Engine Oil Strainer (Sheet 1 of 2)

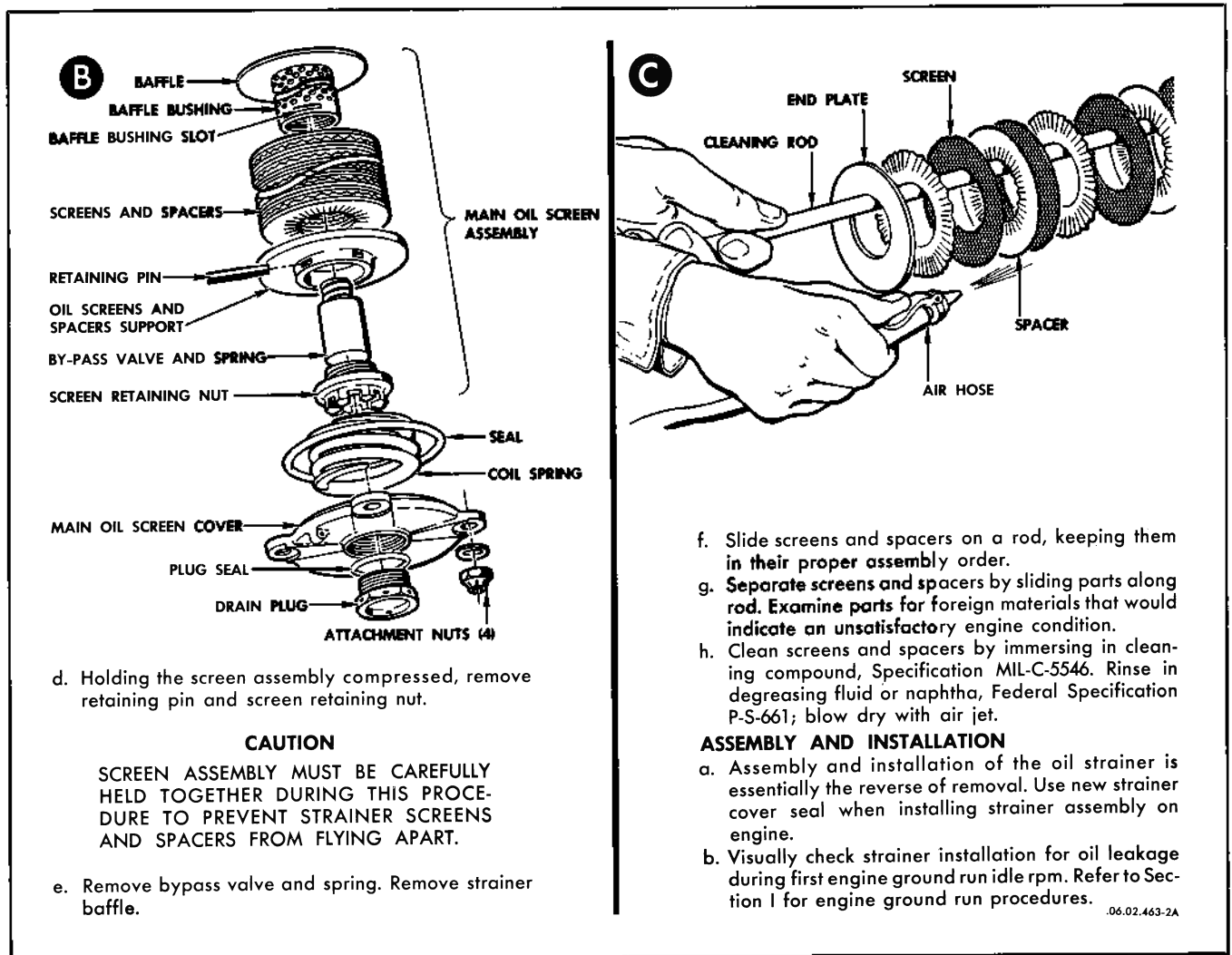
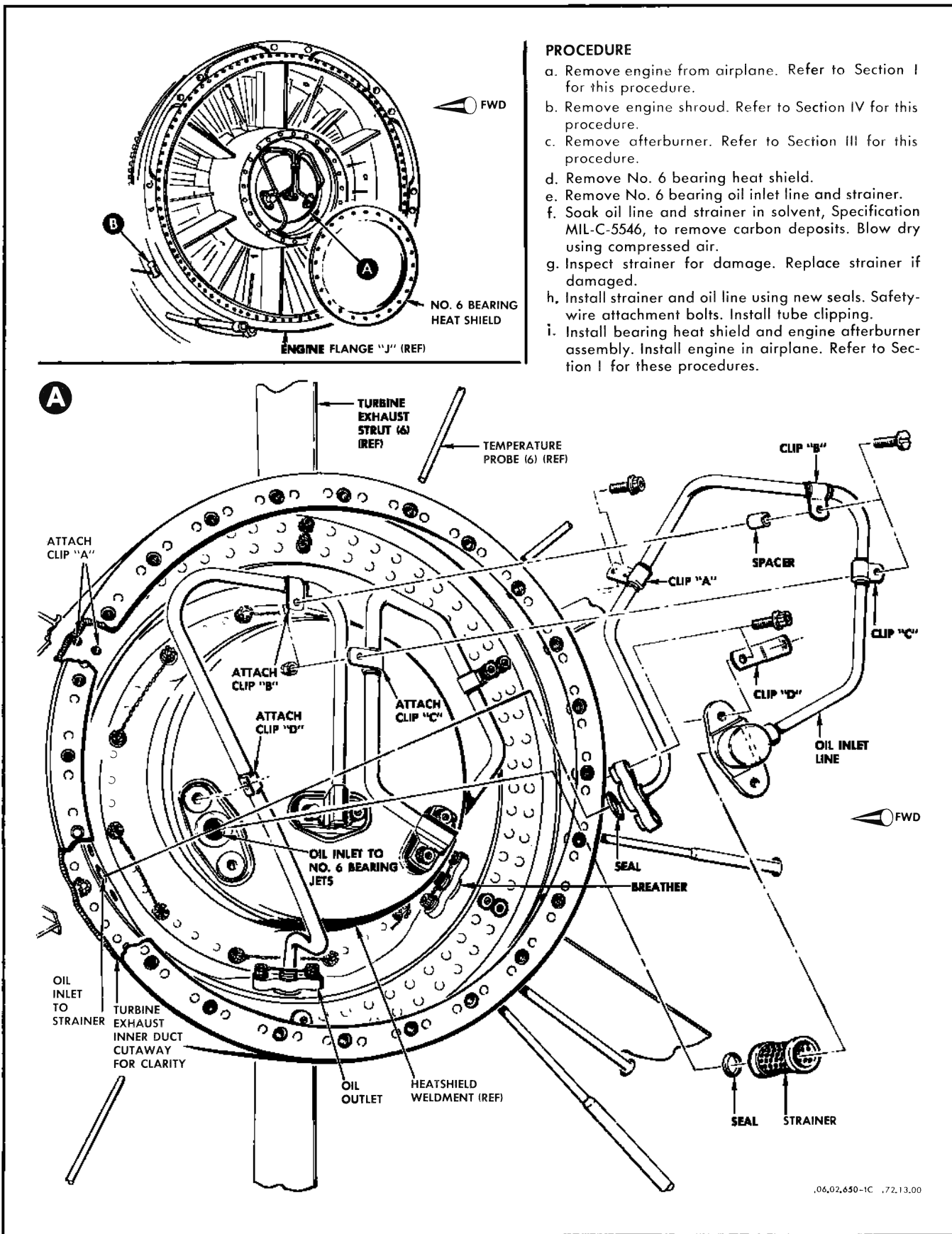

Figure 6-5. Cleaning, Engine Oil Strainer (Sheet 2 of 2)



.06,02,650-1C .72.13.00

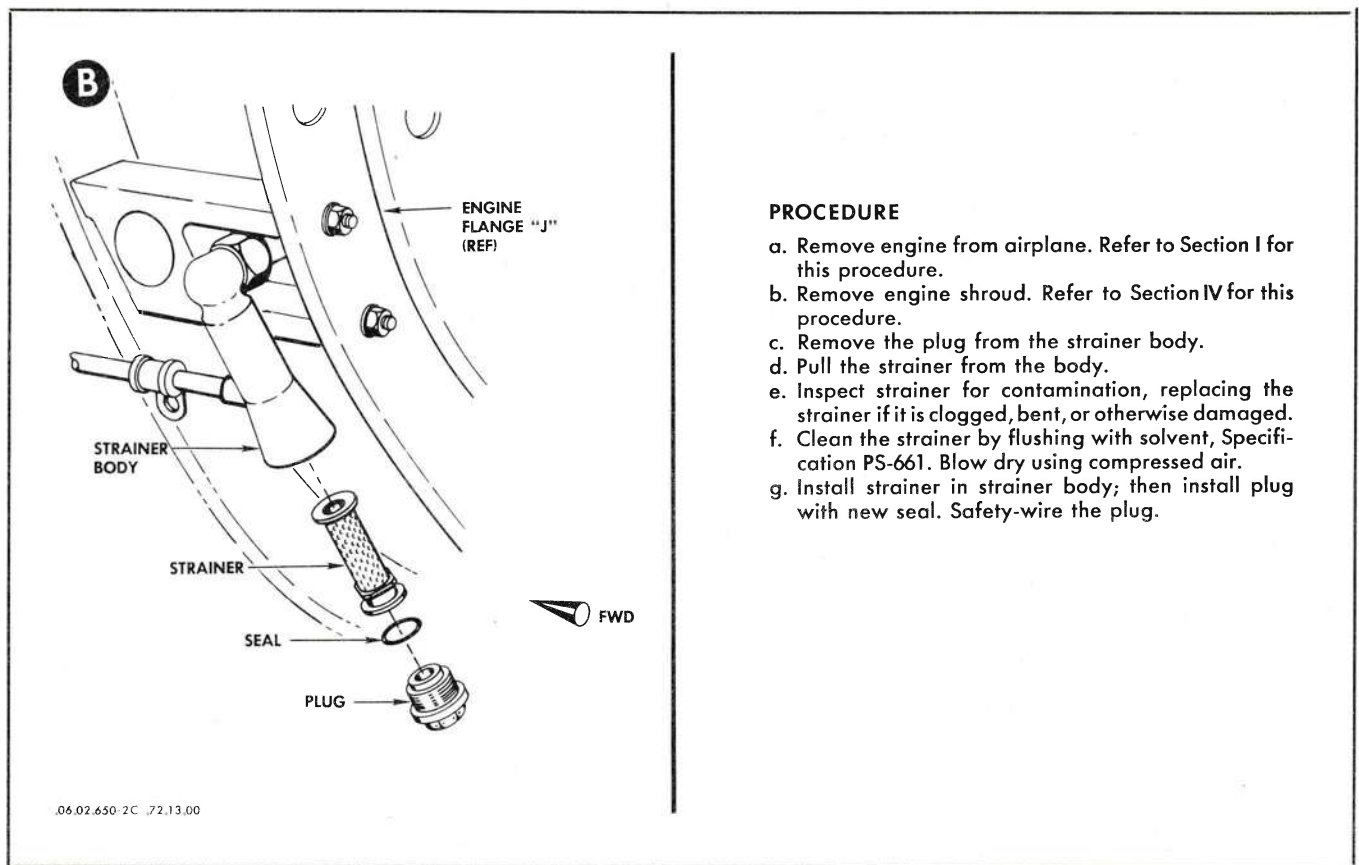

Figure 6-6. Cleaning, Engine No. 6 Bearing Oil Strainers (Sheet 2 of 2)



## Section VII

### ANTI-SURGE BLEED SYSTEM

<i>Contents</i>	<i>Page</i>
Description .....	7-1
Operational Checkout .....	7-2
System Analysis .....	7-2
Replacement .....	7-4

#### DESCRIPTION

##### 7-1. DESCRIPTION.

The engine anti-surge system is provided to prevent surging, pulsating, and possible compressor stalling during engine operation. During acceleration or rapid engine speed changes, the forward or  $N_1$  compressor supplies a greater volume of air than can be readily used by the aft or  $N_2$  compressor. The anti-surge system operates at such times, bleeding off excess air until the compressors are balanced. The system consists essentially of a bleed governor, two bleed valves and actuators, screen assemblies, and ducting. In operation, the compressor bleed governor, driven by the  $N_1$  compressor, senses changes in rpm, air pressure, and temperature in the engine compressor inlet. This intelligence is transmitted to the bleed valve actuators in the form of a pneumatic pressure signal. The pressure signal in turn, actuates the valves to the desired open or closed position. Openings in the fuselage skin vent the bleed air to atmosphere. The bleed governor temperature bulb is located in the right-hand side of the engine air inlet guide vane assembly, and is an integral part of the bleed governor assembly. For an illustration of the anti-surge system, see figure 7-1.

##### 7-2. OPERATION OF ANTI-SURGE BLEED SYSTEM.

The operation of the anti-surge bleed system is automatic with the operation of the engine, and is controlled

by the bleed system governor. Power to operate the bleed system valve is provided by  $N_2$  compressor discharge air. On low engine power settings, both bleed valves are open, to permit a portion of the  $N_1$  compressor output to be vented to atmosphere. As the engine is accelerated, the valves close. As the engine decelerates, the valves open and again vent excess  $N_1$  compressor air to atmosphere. The bleed governor senses  $N_1$  compressor speed, inlet air temperature, and inlet air pressure. These factors are interpreted by the governor, which signals for proper positioning of the bleed valves.

##### 7-3. ANTI-SURGE BLEED GOVERNOR.

The compressor bleed governor is a bench-calibrated unit that controls the function of the bleed valves. The governor is installed on the forward side of the engine  $N_1$  compressor accessory drive adaptor and is driven at  $N_1$  compressor speed. The governor is equipped to sense compressor speed, inlet air pressure, and inlet air temperature. These signals are used to establish the time for action of the bleed valves. A temperature sensing probe, installed in the engine air inlet, is connected to the bleed governor by a capillary tube. The temperature probe and tube are calibrated to, and cannot be removed from the governor.



**7-4. ANTI-SURGE BLEED VALVE AND ACTUATOR.**

Two butterfly-type bleed valve-and-actuator assemblies are installed, one on each side of the engine compressor section. These assemblies bleed air from the area between the N<sub>1</sub> and N<sub>2</sub> compressors. The actuator is a cylinder and piston assembly actuated by N<sub>2</sub> compressor discharge air controlled by the bleed governor. The action of the piston opens and closes the bleed valve. Action of the

bleed valves is very rapid; less than one-half second is required. The valves are equipped with wire mesh screens, to prevent entry of foreign materials into the valves and engine. Each valve assembly is equipped with a bellows-type collar that forms a flex coupling between the engine and the bleed air vent attached to the fuselage. During engine installation or removal, the seals slide free from or to the fuselage duct flange, and automatically connect the valve assemblies and ducting.

**OPERATIONAL CHECKOUT**

**7-5. OPERATIONAL CHECKOUT, ANTI-SURGE SYSTEM.**

- a. Prepare airplane and engine for ground run. Refer to Section I for this procedure and the equipment required.
- b. Start engine and position throttle at idle. Refer to Section I for the engine start and run procedure.
- c. Station a man on each wing to check for opening and closing of bleed valves.

**WARNING**

Keep face and hands away from direct blast of anti-surge bleed air to prevent possible injury.

- d. Advance throttle and check for valve closing at 88% to 90% engine rpm.
- e. Retard throttle to idle; check for valve opening at 90% to 88% rpm.
- f. Shutdown engine.

**SYSTEM ANALYSIS**

**7-6. SYSTEM ANALYSIS, ANTI-SURGE SYSTEM.**

PROBABLE CAUSE	ISOLATION PROCEDURE	REMEDY
<b>ONE BLEED VALVE FAILS TO CLOSE.</b>		
Bleed governor malfunctioning.	Remove governor for bench test.	Install replacement governor.
Defective valve actuator.	Remove actuator for bench test.	Install replacement item.
Excessive friction in valve action.	Remove valve for bench test.	
<b>BOTH BLEED VALVES FAIL TO CLOSE DURING THROTTLE ADVANCE.</b>		
Loose connection in N <sub>2</sub> compressor discharge line to bleed governor.	Check line and fittings for condition and security of attachment.	Repair or replace components as necessary.
Bleed governor malfunctioning.	Remove governor for bench test.	Install replacement item.

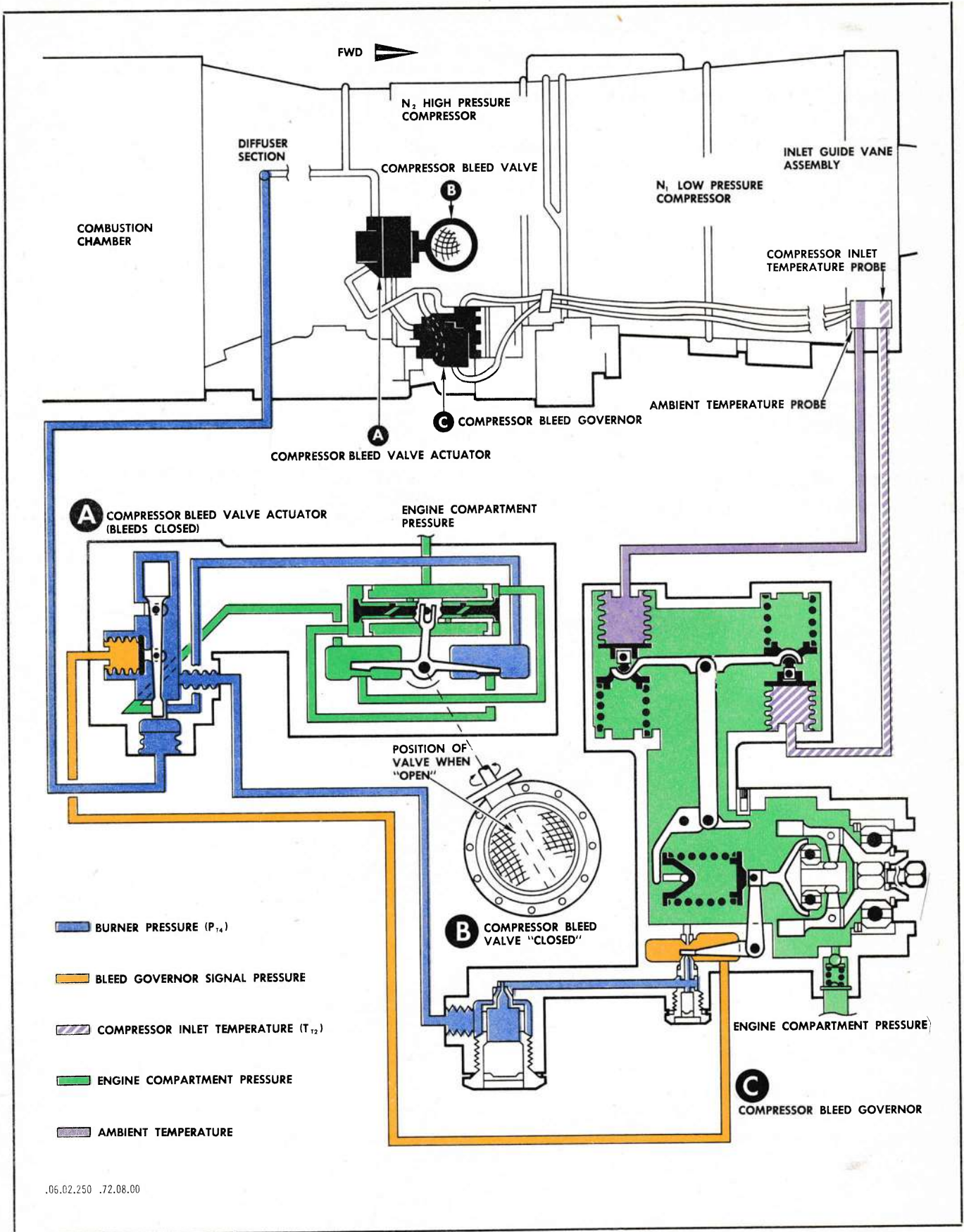

Figure 7-1. Anti-Surge Bleed System, Schematic

**7-6. SYSTEM ANALYSIS, ANTI-SURGE SYSTEM (CONT).**

PROBABLE CAUSE	ISOLATION PROCEDURE	REMEDY
<b>BLEED VALVES OPERATE INTERMITTENTLY THROUGHOUT POWER RANGE.</b>		
Bleed governor malfunctioning.	Remove governor for bench test.	Install replacement item.

**REPLACEMENT**

**7-7. GENERAL.**

Other than periodic inspection and operational checks, maintenance of the anti-surge system will consist mainly of replacement of damaged or malfunctioning components. Component repair or adjustment should not be attempted without special bench testing facilities.

**7-8. REMOVAL, ANTI-SURGE BLEED GOVERNOR.**

For removal and installation of the bleed governor, see figure 7-2.

**7-9. REMOVAL, ANTI-SURGE BLEED VALVE ACTUATOR.**

For removal and installation of the bleed valve actuator, see figure 7-2.

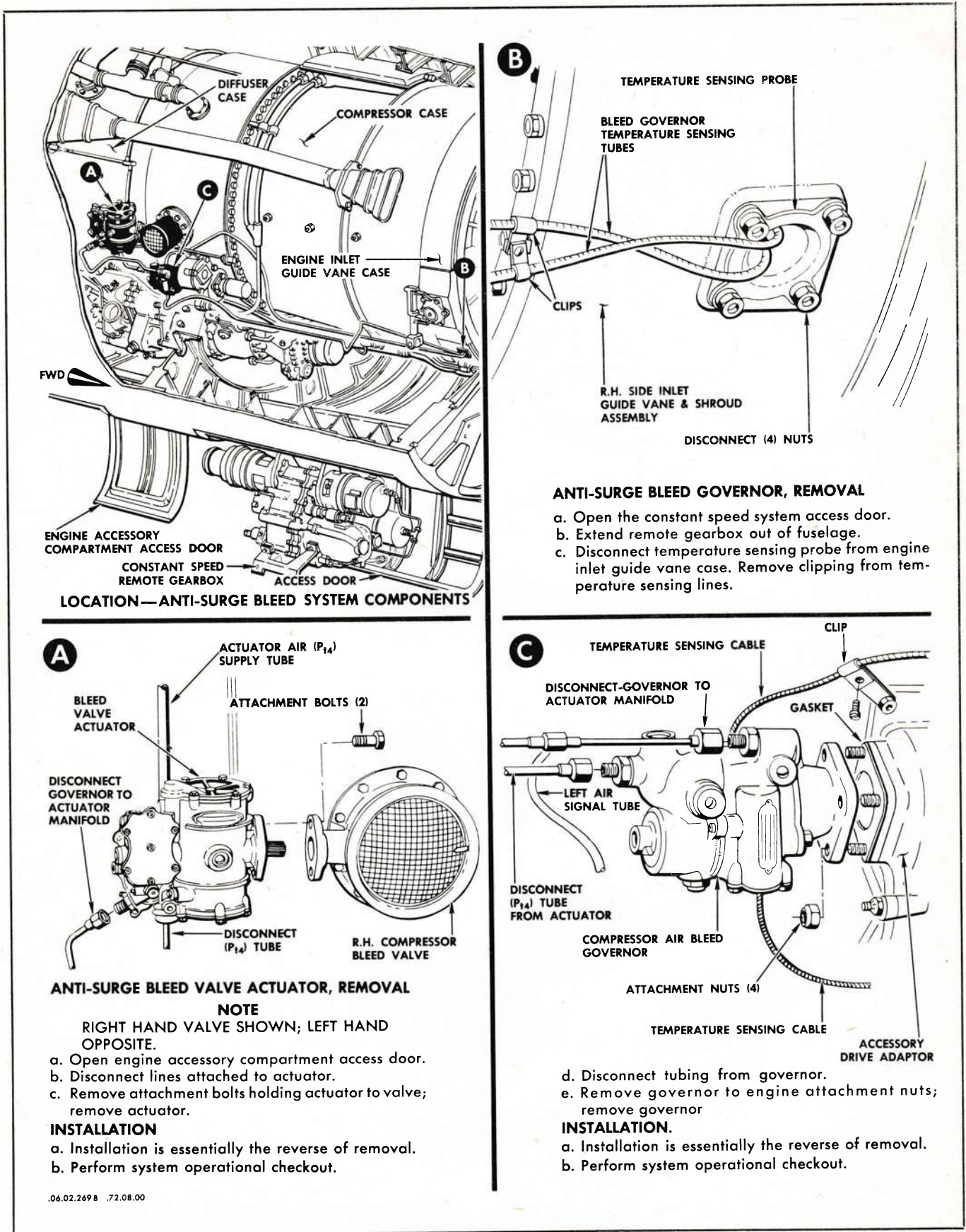

Figure 7-2. Replacement, Anti-Surge Bleed System Components



## Section VIII

### ENGINE ANTI-ICING SYSTEM

<i>Contents</i>	<i>Page</i>
Description .....	8-1
Operational Checkout .....	8-2
System Analysis .....	8-2
Replacement .....	8-2

#### DESCRIPTION

##### 8-1. ENGINE ANTI-ICING SYSTEM.

The engine anti-icing system consists of a bleed air transfer line on the left side of the engine, and an electrically actuated valve. For an illustration of the system, see figures 8-1, 8-2, and 8-3. The air line routes N<sub>2</sub> compressor bleed air, heated by compression, from the engine diffuser section, forward to the engine inlet guide vanes. Control of the air flow is accomplished by an electrically actuated valve installed in this line. The valve operates in conjunction with the airplane anti-icing system. When the valve is open, the heated air flows into the engine inlet guide vane manifold at approximately the nine o'clock position on the inlet case. The air passes inward through the guide vanes and is routed forward into the engine nose cone. The cone then vents the air into the engine intake air stream.

##### 8-2. ENGINE INLET DUCT LIP ANTI-ICE SYSTEM.

The engine inlet duct lip anti-ice system is provided to prevent formation of ice on the leading edges of the engine air inlet ducts. Hot engine bleed air is routed from the bleed air duct at the cockpit air conditioning system heat exchanger. Flow of the air to the duct leading edges is controlled by a solenoid-controlled, pneumatically-actuated pressure regulator and shutoff valve. From the valve the heated air is routed through tubing to the duct

leading edges. The system is controlled by the anti-ice switch located above the cockpit left-hand console panel. For further information and illustrations on this system, refer to T.O. 1F-106A-2-6.

##### 8-3. CONTROL SYSTEM.

The anti-icing system is controlled electrically by the three-position anti-ice switch located above the pilot's right console panel. When the switch is in the "MANUAL" position, the valves are open to allow flow of hot air without the monitoring action of the ice detection system. When the switch is in the "AUTO" position, the system operates only when icing conditions exist. An ice detector is installed in the engine air inlet stub duct, to sense icing condition. This intelligence is relayed to the ice detector interpreter, which is a part of the airplane surface and anti-ice system. Refer to T.O. 1F-106A-2-6 for information in regard to this system.

##### 8-4. ANTI-ICE AIR VALVE.

The anti-ice air valve is an electrically-actuated butterfly-type valve installed on the leftside of the engine. The valve actuates to either the full open or full closed position, as dictated by the anti-icing control system. The actuator is a sealed unit. Any malfunction or misadjustment is cause for replacement of the assembly.

**OPERATIONAL CHECKOUT****8-5. OPERATIONAL CHECKOUT, ENGINE ANTI-ICING SYSTEM.**

Operational checking of the engine anti-icing system consists of actuating the anti-ice switch in the cockpit to the "MANUAL ON" position and listening for the operation of the valve motor.

a. Install anti-ice control and anti-ice power fuses in the cockpit left fuse panel.

b. Connect outside source of 28-volt dc power to the external dc power receptacle.

c. Actuate anti-ice control switch to "MANUAL ON" position.

d. Listen for actuation of the anti-ice valve to the open position.

e. Actuate switch to the "OFF" position; listen for valve to actuate to the closed position.

f. Remove electrical power.

**SYSTEM ANALYSIS****8-6. SYSTEM ANALYSIS, ENGINE ANTI-ICING SYSTEM.**

The engine anti-icing system is a portion of the complete airplane anti-icing system. System analysis of the anti-icing system will be found in T.O. 1F-106A-2-6.

**REPLACEMENT****8-7. REPLACEMENT, ANTI-ICE AIR VALVE.**

For removal and installation of the anti-ice air valve, see figure 8-4.

**8-8. REPLACEMENT, ENGINE NOSE CONE.**

a. Remove engine from airplane. Refer to Section I for engine replacement procedures.

b. Cover compressor inlet to prevent entry of foreign materials into the engine.

c. Remove attachment bolts (10) securing nose cone to cone adapter ring; remove cone.

d. Position nose cone on cone adapter ring with cone short seam splice at top centerline of adapter ring.

e. Install attachment bolts (10); safety-wire bolts to nose cone.

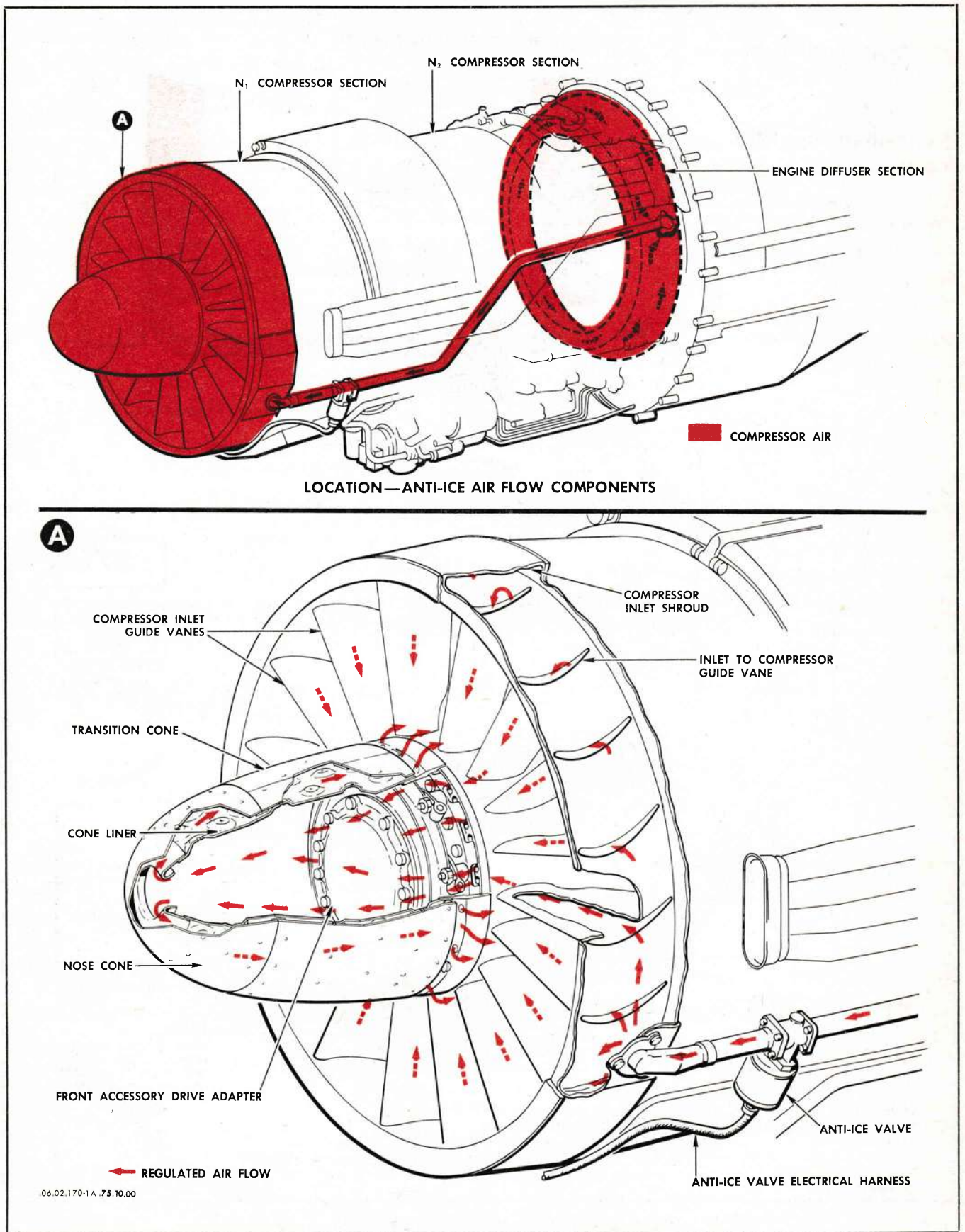
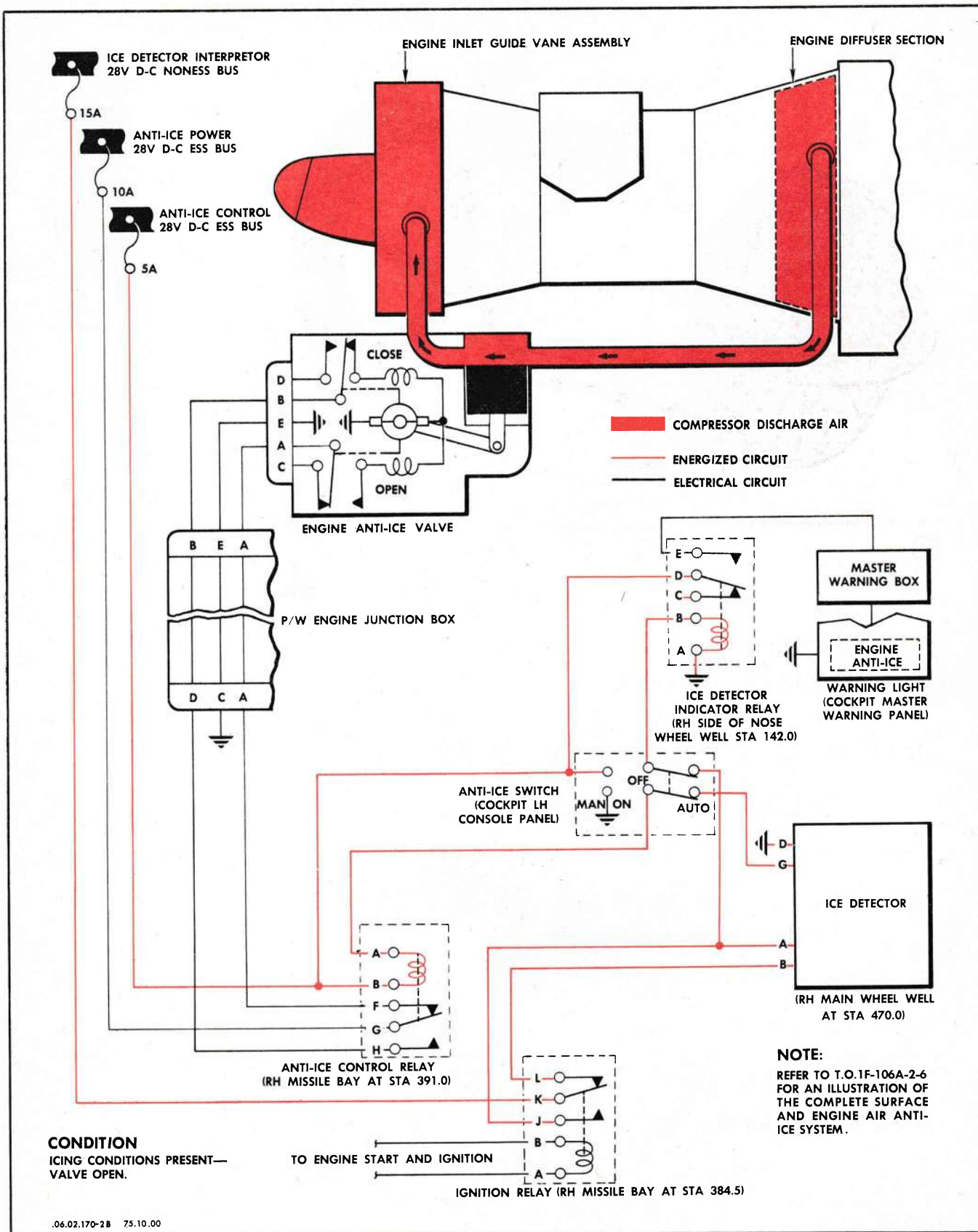
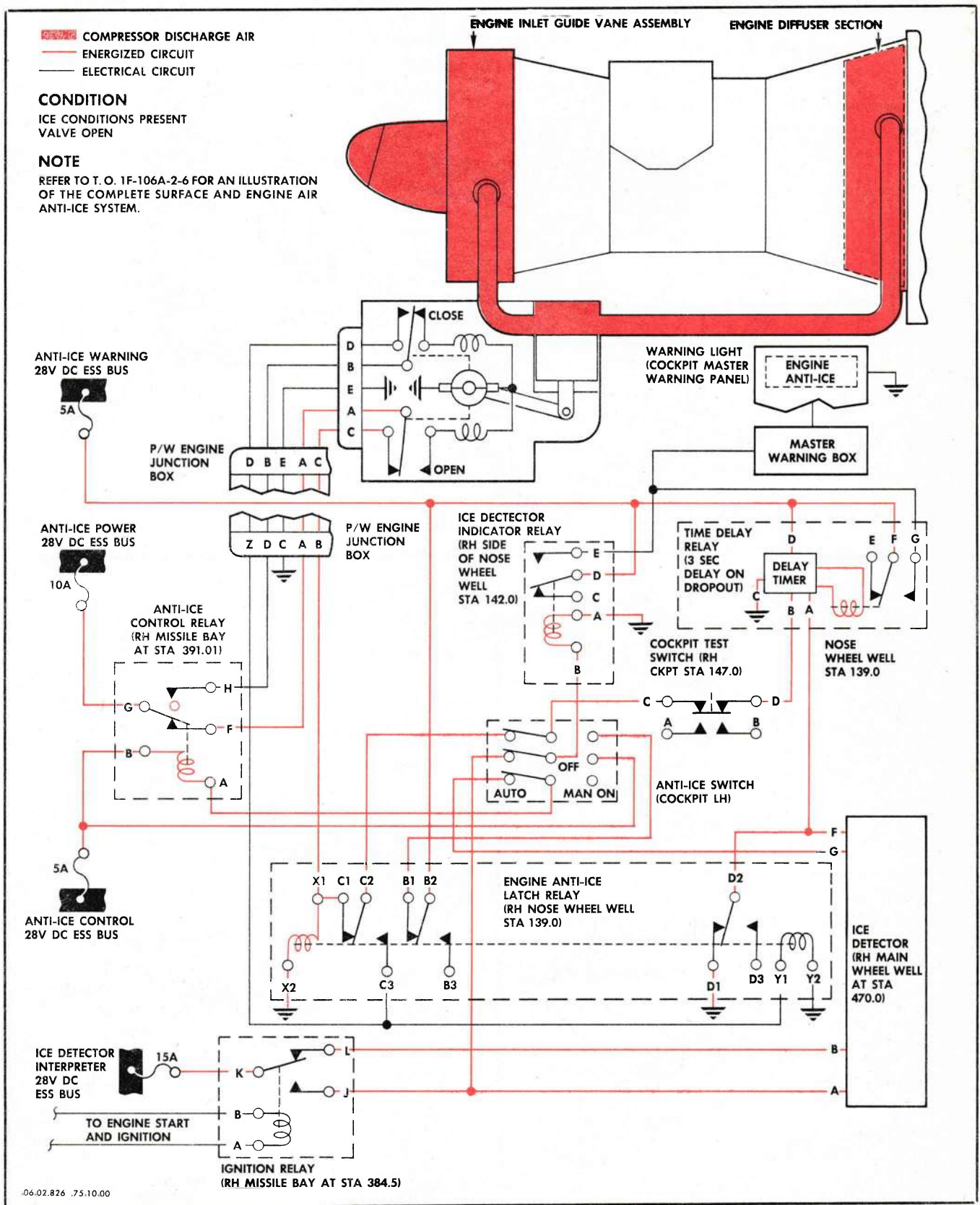

Figure 8-1. Engine Anti-Icing System Air Flow Diagram





**Figure 8-2. Engine Anti-Icing System Schematic**  
Applicable to F-106A airplanes 57-246 thru 57-2506 and F-106B airplanes 57-2516 thru 57-2541 prior to incorporation of TCTO 1F-106-537



06-02.826 75-10.00

Figure 8-3. Engine Anti-Icing System Schematic

Applicable to F-106A airplanes 56-453, -454, 56-456 thru 57-245, 58-759 and subsequent; and 57-246 thru 57-2506 after incorporation of TCTO 1F-106-537. Applicable to F-106B airplanes 57-2508 thru 57-2515, 57-2542 and subsequent; and 57-2516 thru 57-2541 after incorporation of TCTO 1F-106-537

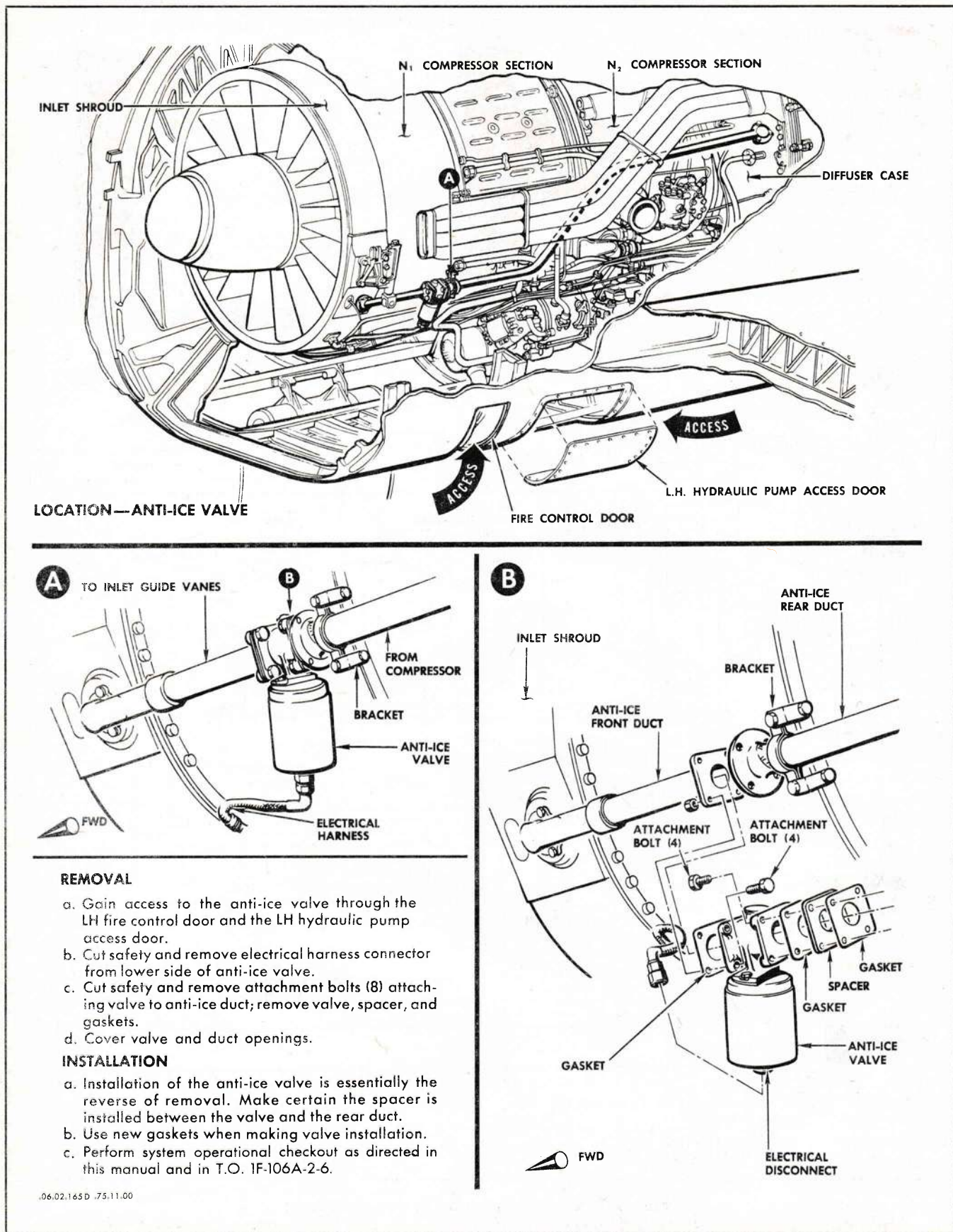

**REMOVAL**

- a. Gain access to the anti-ice valve through the LH fire control door and the LH hydraulic pump access door.
- b. Cut safety and remove electrical harness connector from lower side of anti-ice valve.
- c. Cut safety and remove attachment bolts (8) attaching valve to anti-ice duct; remove valve, spacer, and gaskets.
- d. Cover valve and duct openings.

**INSTALLATION**

- a. Installation of the anti-ice valve is essentially the reverse of removal. Make certain the spacer is installed between the valve and the rear duct.
- b. Use new gaskets when making valve installation.
- c. Perform system operational checkout as directed in this manual and in T.O. 1F-106A-2-6.

.06.02.165D .75.11.00

Figure 8-4. Replacement, Anti-Icing Air Valve

## Section IX

## CONSTANT-SPEED GENERATOR DRIVE SYSTEM

<i>Contents</i>	<i>Page</i>
Description .....	9-1
Operational Checkout .....	9-5
System Analysis .....	9-5
Replacement .....	9-11
Adjustment .....	9-13
Servicing .....	9-13

## DESCRIPTION

**9.1. GENERAL.**

The constant-speed generator drive system is provided to transmit mechanical power from the engine to drive the aircraft generators. The system consists of an engine mounted gearbox or power takeoff assembly, a fuselage mounted transmission and remote gearbox assembly, an interconnecting drive shaft between the gearboxes, and a self contained oil system. The remote gearbox is equipped to mount four generators. A three or a four generator combination may be used. The number of generators to be used on the airplane will depend upon whether the AWCIS (Aircraft and Weapons Control Interceptor System) is installed. This system requires the four-generator installation. For schematic illustrations of the constant-speed drive system, see figures 9-1 and 9-2.

**9.2. ENGINE MOUNTED GEARBOX.**

The engine mounted gearbox is a power takeoff unit installed on the engine between the forward side of the N<sub>2</sub> accessory section and the engine starter. The gear box is equipped with a gear train that provides an offset to permit the drive shaft to extend forward from the gear box without interference with the engine starter. Lubrication is provided as a part of the constant-speed drive lubrication system. The gearbox is equipped with a low point magnetic drain plug.

**9.3. CONSTANT-SPEED REMOTE GEARBOX.**

The constant-speed remote gearbox is a fuselage mounted component located on the lower right side of the fuselage at sta. 495.0. This unit incorporates a mechanical-hydraulic variable speed transmission to provide constant output speed with varying input speed. The constant output speeds are as follows:

- |   |             |
|---|-------------|
| a. Generator mounting pad "A"               | 8000 rpm.   |
| b. Generator mounting pads<br>"B," "C," "D" | 12,000 rpm. |

These output speeds will remain constant at engine power settings between idle and full power. The mounting pads are each designed to receive a specific generator with the exception that the generator normally installed on pad "B" will fit on pad "D;" however, pad "D" generator cannot be installed on pad "B." An indexing pin on each pad mates with a dowel hole on the generator to insure correct generator positioning. The remote gearbox may be removed or installed without removing the engine. The same condition also applies for engine removal or installation. For generator replacement and electrical hookup procedures, refer to T.O. 1F-106A-2-10. The engine mounted and remote gearboxes are equipped with low point chip detector magnetic drain plugs.

#### 9.4. CONSTANT-SPEED SYSTEM DRIVE SHAFT.

The constant-speed system drive shaft transmits power from the engine mounted gearbox to the remote gearbox. The shaft is equipped with flexible couplings to compensate for misalignment of the two interconnected components. Quick detachment provisions are incorporated in the shaft to facilitate constant-speed drive system maintenance and component replacement. A protective cover provided for the shaft is supported by flanged rings on each gearbox. It is permissible to operate the engine with the shaft removed provided the following procedures and conditions are closely observed.

- a. Disconnect constant-speed engine mounted gearbox oil "in" and "out" lines at quick disconnect fittings. Connect oil "in" line, attached to engine mounted gearbox, to "out" line attached to engine mounted gearbox.
- b. Drain oil from engine mounted gearbox. See figure 9-12 for this procedure.
- c. Service engine mounted gearbox with 0.5 pint of oil, Military Specification MIL-L-7808. See figure 9-12 for this procedure.
- d. Engine may be run a maximum of 15 minutes.

**CAUTION**

After a 15 minute run, the engine mounted gearbox must be permitted to cool to ambient temperature. Another run of 15 minutes maximum is then permissible.

#### 9.5. CONSTANT-SPEED DRIVE OIL SYSTEM.

The constant-speed drive oil system is a self contained system provided to supply oil for operation and lubrication of the two gearboxes. The system also provides cooling oil for the generators and lube oil mist for the generator drive end bearings. The system has a capacity of approximately 15.5 quarts of oil, Military Specification MIL-L-7808; 9.5 quarts are contained in the oil reservoir. The 6 remaining quarts are contained within the gear boxes, oil cooler, and attaching lines. For a schematic illustration of the constant-speed oil system, see figures 9-1 and 9-2.









#### 9.6. CONSTANT-SPEED DRIVE OIL SYSTEM PRESSURIZATION.

Oil system pressurization is provided for optimum high altitude operation of the lubrication system. This air pressure maintains a minimum oil pressure of 5 psi at the pump inlets in the remote gearbox at altitudes above 22,000 feet. Pressure is supplied by engine bleed air that is ducted from the main fuel supply system tank pressuri-

zation line. Air from this source is constantly available to the gearboxes and generators through an air pressure regulator which regulates the pressure between 7 and 9 psi. At altitudes below 22,000 feet, the overboard vent valve in the air supply system allows this air to be ducted overboard. Above 22,000 feet, the overboard vent valve closes to maintain the required 5 psi. The vent valve incorporates a pressure relief valve and a vacuum relief to prevent excessive positive or negative pressure buildup within the system. Pressurization air is also supplied to the generators to prevent oil leaking past the generator seals and to vent oil vapor overboard.

#### 9.7. CONSTANT-SPEED DRIVE GENERATOR PRESSURIZATION.

Air and oil in remote gearbox forms an oil mist during gearbox operation. This oil mist lubricates the drive gears and drive-end bearings of all generators. Anti-drive end bearings of all generators are sealed. To keep the oil mist from entering and contaminating AWCIS generators, air pressure (purge air) at slightly above the remote gearbox air pressure is applied to the anti-drive end of both AWCIS generators. The purge air and oil vapors exhaust at the drive end of the generators. The fuel pressurization system air manifold is the air source for the generator pressurization (purge air) system. Before the manifold air enters the generator pressurization system, the pressure is regulated to a pressure of 7 to 9 psi by the air pressure regulator. *Applicable to F-106A airplanes 57-246 thru 57-2503, and F-106B airplanes 57-2516 thru 57-2522, 57-2524 thru 57-2530 prior to incorporation of TCTO 1F-106-597.* Purge air is applied to all generators on the remote gearbox, and in turn exhausts through a vent tube just aft of the remote gearbox access door. *Applicable to F-106A airplanes 56-453, -454, -463 thru 56-466, 57-230 thru 57-245, 57-246, 57-2504 and subsequent; and 57-246 thru 57-2503 after incorporation of TCTO 1F-106-597. Applicable to F-106B airplanes 57-2508 thru -2515, -2523, 57-2531 and subsequent; and all other F-106B airplanes after incorporation of TCTO 1F-106-597.* Purge air is not applied to primary generators. Oil or vapors that may leak past the generator drive end seal are vented and drained through a tube at the bottom of the drive end of the generator. AWCIS generators have purge air applied. Purge air from AWCIS generators and oil from primary generators exhaust from a generator purge air and oil drain manifold on the bottom of the remote gearbox. Tubes from the generators carry purge air and oil to the drain manifold. The drain manifold mates with a generator purge air and oil drain manifold adapter when the remote gearbox access door is closed. Loosening the studs of the pad B generator may cause the oil drain manifold to move slightly. Realignment of the drain manifold and drain manifold adapter is accomplished by manual positioning of the adapter.

-  CHARGE PRESSURE
-  ENGINE BLEED AIR
-  PUMP WOBBLER ANGLE INCREASE
-  PUMP WOBBLER ANGLE DECREASE
-  LUBE PRESSURE
-  GENERATOR COOLING PRESSURE
-  RESERVOIR PRESSURE
-  SCAVENGE OIL
-  VENT LINE

**NOTES**

1. APPLICABLE TO F-106A AIRPLANES 56-453, 56-454, 56-456 THRU 57-2465, AND F-106B AIRPLANES 57-2516 THRU 57-2523.
2. APPLICABLE TO F-106A AIRPLANES 56-453, 56-454, 56-456 THRU 57-245, 57-2466 AND SUBSEQUENT; AND F-106B AIRPLANES 57-2508 THRU 57-2515, 57-2524 AND SUBSEQUENT.
3. APPLICABLE AFTER INCORPORATION OF TCTO 1F-106-533.
4. APPLICABLE AFTER INCORPORATION OF TCTO 1F-106-725.

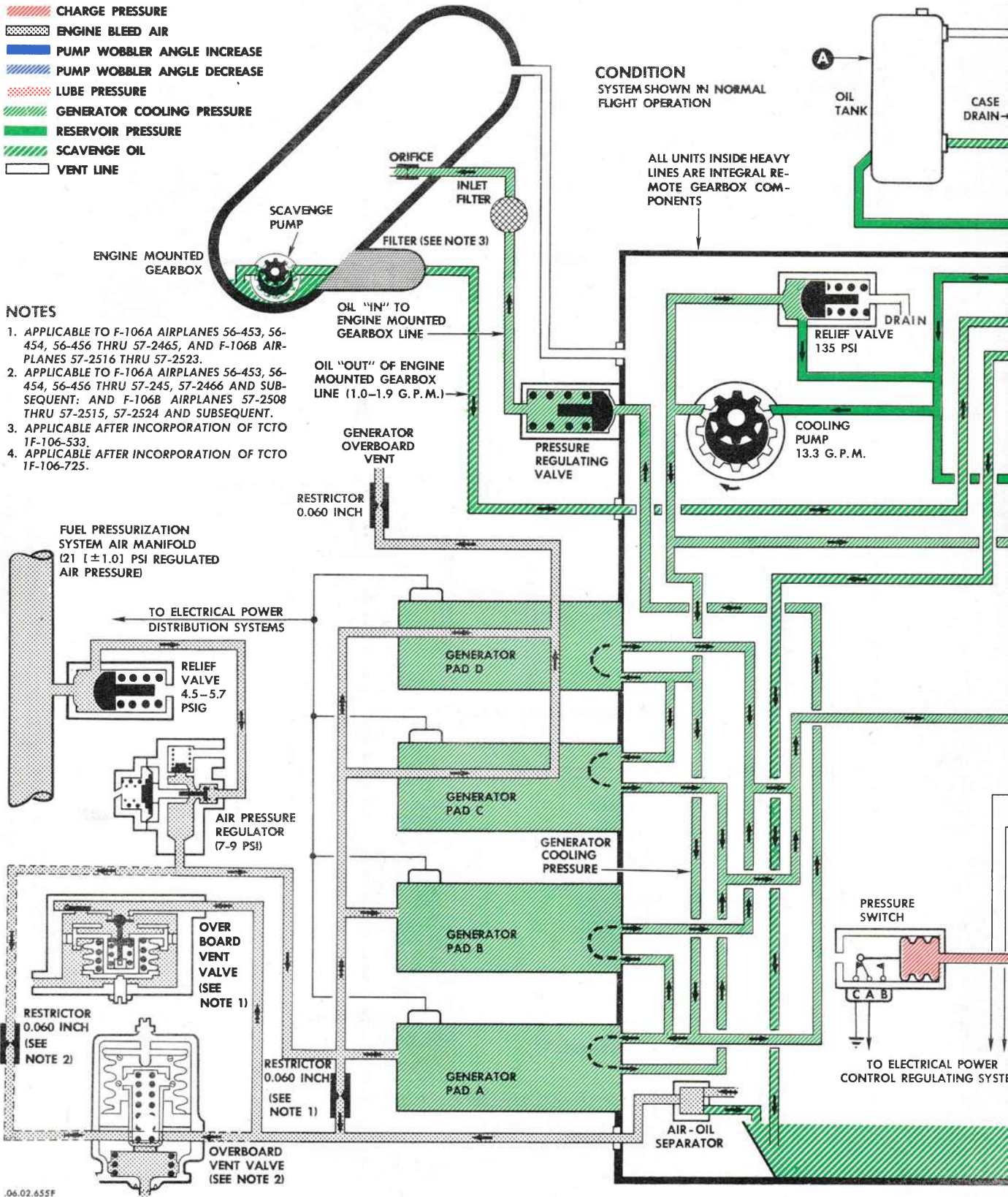

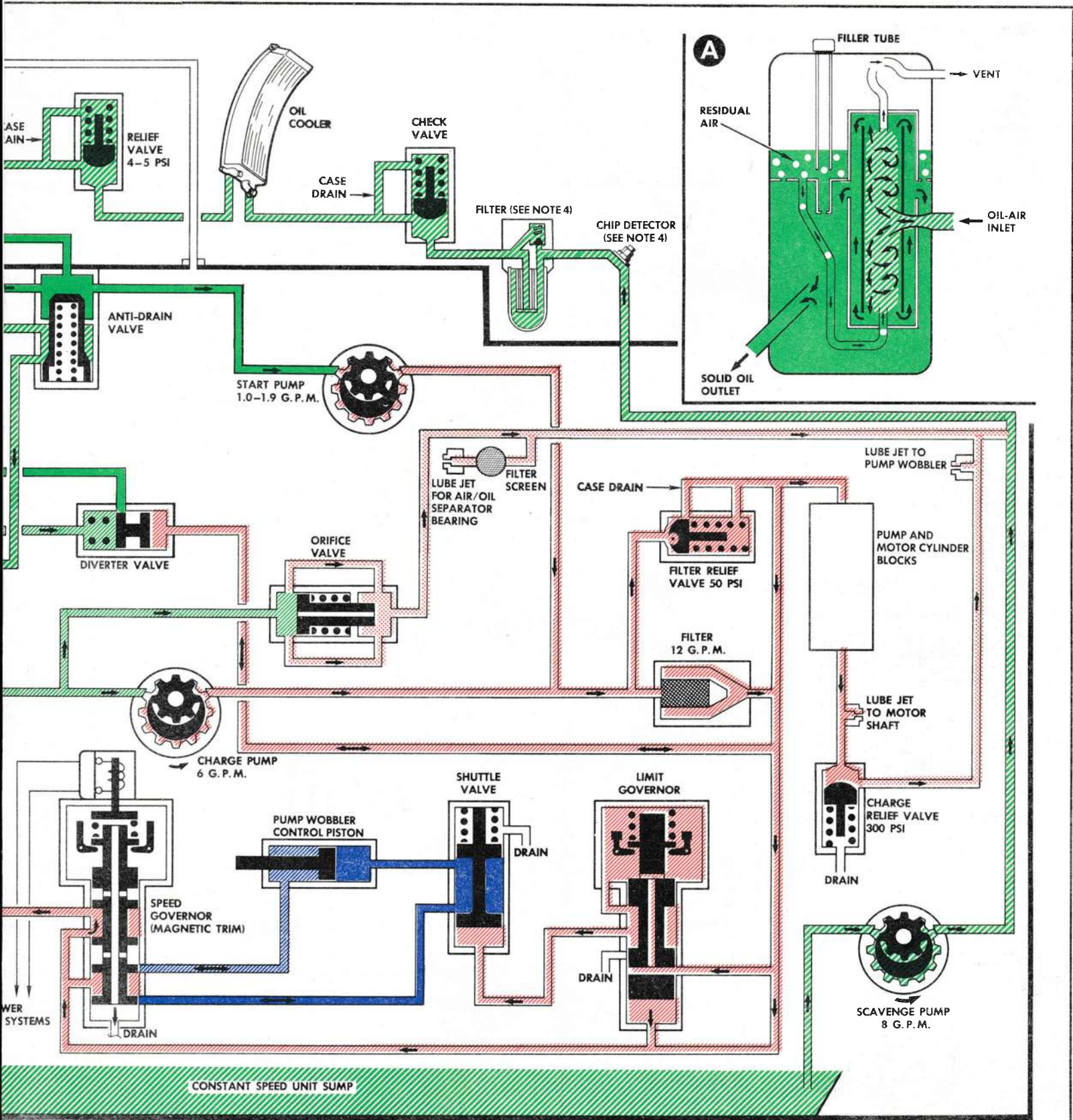











Figure 9-1. Constant-Speed Drive System Schematic  
Applicable to F-106A airplanes 57-246 thru 57-2503, and F-106B airplanes 57-2516  
thru -2522, -2524 thru 57-2531 prior to incorporation of TCTO 1F-106-597

-  CHARGE PRESSURE
-  ENGINE BLEED AIR
-  PUMP WOBBLER ANGLE INCREASE
-  PUMP WOBBLER ANGLE DECREASE
-  LUBE PRESSURE
-  GENERATOR COOLING PRESSURE
-  RESERVOIR PRESSURE
-  SCAVENGE OIL
-  VENT LINE

**CONDITION**  
SYSTEM SHOWN IN NORMAL  
FLIGHT OPERATION

**NOTES**

1. APPLICABLE AFTER INCORPORATION OF TCTO 1F-106-533.
2. APPLICABLE AFTER INCORPORATION OF TCTO 1F-106-725.

**FUEL PRESSURIZATION  
SYSTEM AIR MANIFOLD**  
(21  $\pm$  1.01 PSI REGULATED  
AIR PRESSURE)

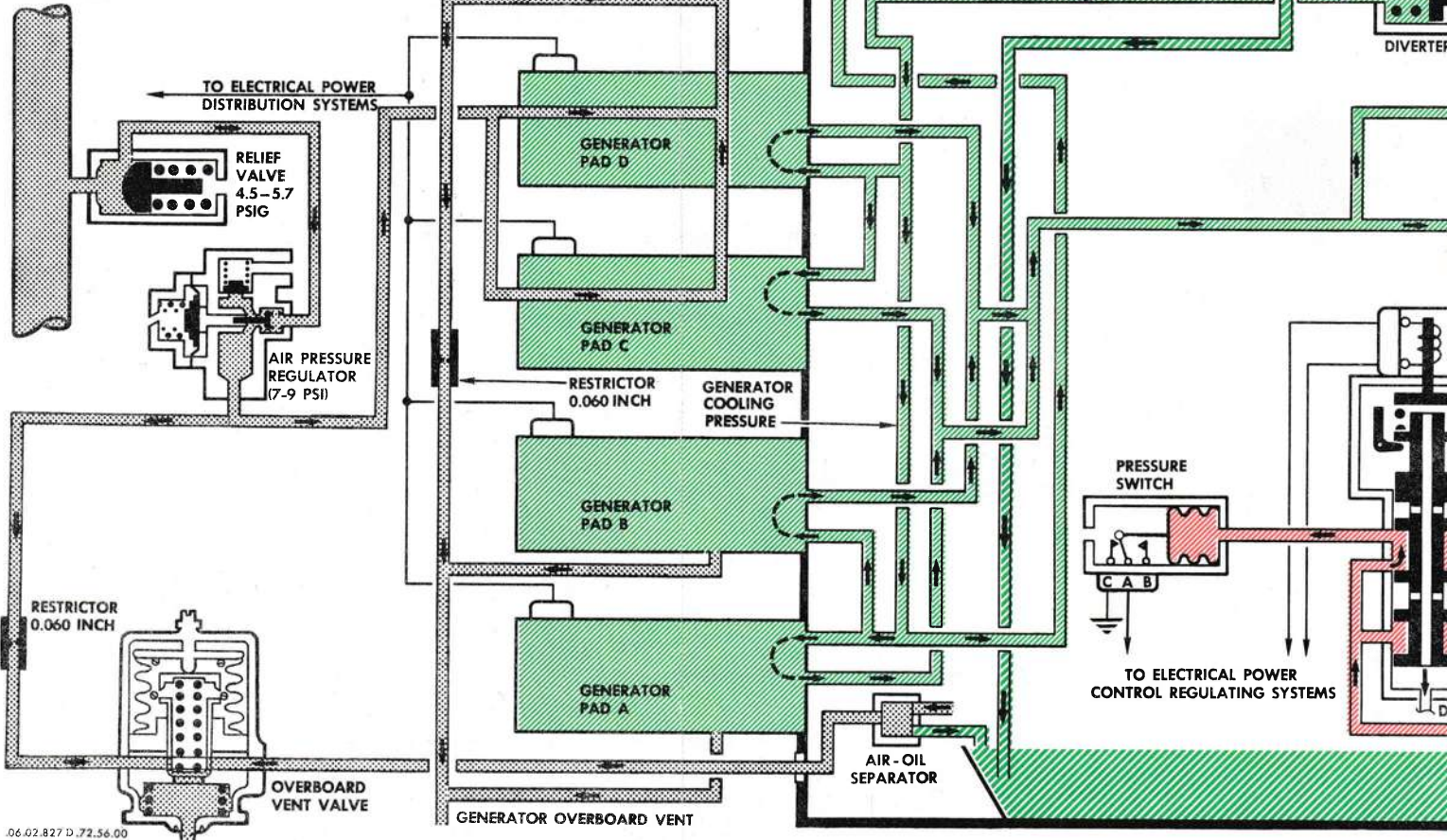



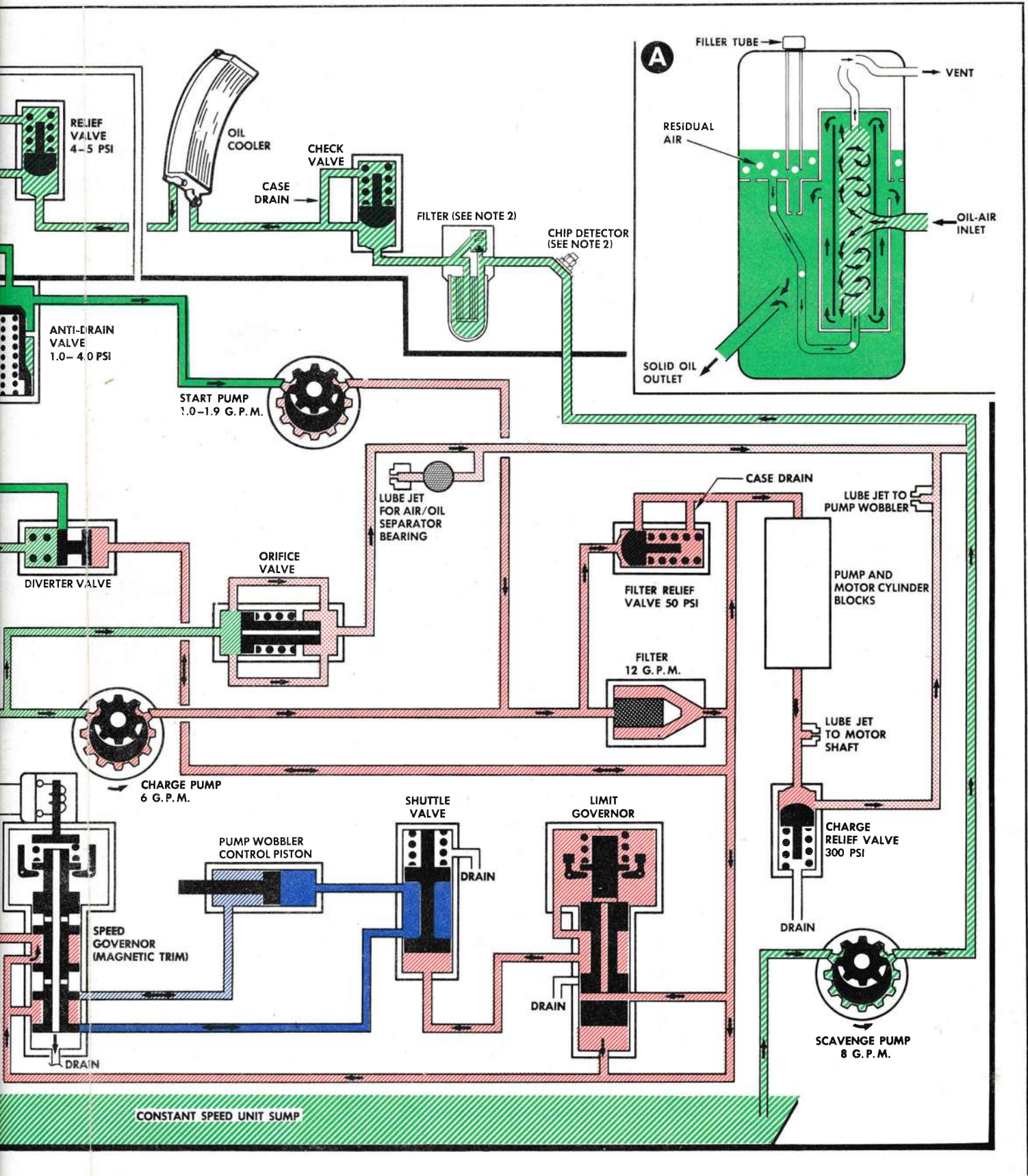

Figure 9-2. Constant-Speed Drive System Schematic

Applicable to F-106A airplanes 56-453, -454, -463 thru 56-466, 57-230 thru 57-245, 57-2465, 57-2504 and subsequent; and 57-246 thru 57-2503 after incorporation of TCTO 1F-106-597. Applicable to F-106B airplanes 57-2508 thru -2515, -2523, 57-2531 and subsequent; and all other F-106B airplanes after incorporation of TCTO 1F-106-597

**OPERATIONAL CHECKOUT****9-8. OPERATIONAL CHECKOUT, CONSTANT-SPEED GENERATOR DRIVE SYSTEM.**

Operational checkout of the constant-speed generator drive system is performed during engine ground run. Refer to Section I for ground run procedures. Refer to T.O. 1F-106A-2-10 for electrical system checks to be performed during operation.

**CAUTION**

A positive flow of oil must be maintained through the constant-speed drive system at all times. Refer to paragraph 9-27 for lubrication and servicing information.

**SYSTEM ANALYSIS****9-9. SYSTEM ANALYSIS, CONSTANT-SPEED GENERATOR DRIVE SYSTEM.****NOTE**

Refer to T.O. 1F-106A-2-10 for electrical component system analysis. Refer to paragraph 9-10 in this manual for MC2 test stand criteria.

PROBABLE CAUSE	ISOLATION PROCEDURE	REMEDY
<b>ONE ELECTRICAL POWER WARNING LIGHT EXTINGUISHED; ONE ILLUMINATED.</b>		
Electrical malfunction.	Manually reset generating system at cockpit control panel.	If trouble persists, refer to T.O. 1F-106A-2-10 for electrical system troubleshooting.

**BOTH ELECTRICAL POWER WARNING LIGHTS ILLUMINATED AFTER SYSTEMS ARE RESET.****NOTE**

If malfunction is accompanied by severe remote gearbox vibration and noise at idle rpm, replace remote gearbox. Do not replace the remote gearbox until any trouble source external to the remote gearbox has been corrected.

Sheared or frozen remote gearbox charge and scavenge pump drive shaft.	Malfunction will be evidenced by oil flow out of remote gearbox overboard vent port during operation.	Remove TRGB and comply with MC2 test stand criteria.
Low constant-speed system oil level.	Check tank oil level.	Service as required.
Interconnecting drive shaft not connected.	Check for shaft installation.	
Defective or kinked oil lines.	Check line condition and installation.	Adjust or replace as required.
Electrical malfunction.	Refer to T.O. 1F-106A-2-10 for isolation procedures.	
Air entering the 1 inch remote gearbox oil line.	Check line connections.	Tighten or replace as required.

9.9. SYSTEM ANALYSIS, CONSTANT-SPEED GENERATOR DRIVE SYSTEM (CONT).

PROBABLE CAUSE	ISOLATION PROCEDURE	REMEDY
<b>BOTH ELECTRICAL POWER WARNING LIGHTS ILLUMINATED AFTER SYSTEMS ARE RESET (CONT).</b>		
Malfunctioning remote gearbox anti-drain valve.	Remove 1 inch oil inlet line. Depress plunger inlet port. Plunger should offer only slight resistance to movement and should return to closed position when released.	Replace or clean valve if action is defective.
Sheared engine mounted gearbox shaft or engine mounted gearbox scavenge pump malfunctioning.	Remove drive shaft and disconnect 0.25 inch oil "OUT" line at engine mounted gearbox. Drain oil from engine mounted gearbox; reprime with 1/2 pint of oil, Military Specification MIL-L-7808. Air motor engine. If oil issues from gearbox oil port, scavenge pump is satisfactory. If gearbox splined stub shaft rotates, shear sections are intact.	Replace engine mounted gearbox if oil does not flow from oil "OUT" port. If EMGB output shaft is sheared, replace EMGB. If input shaft is sheared, remove EMGB and comply with MC2 test stand criteria.
Defective remote gearbox cooling pump.	Disconnect engine mounted gearbox oil in line at quick disconnect fitting. Drain EMGB and prime with 1/2 pint of oil, Military Specification MIL-L-7808. Start airplane engine; advance throttle to idle and shut down immediately, at same time depress fitting on end of oil in hose.	If oil does not flow from fitting, replace remote gearbox and comply with MC2 test stand criteria.
Malfunctioning remote gearbox charge relief valve.	Remove and inspect valve components.	Replace or clean valve if action is defective.
Internal malfunction.	This may be assumed when the above items do not locate trouble.	Replace remote gearbox and comply with MC2 test stand criteria.

**OIL LEAKAGE DURING OPERATION.**

Defective seal or sheared preformed packing.	Motor engine and locate leak.  <p style="text-align: center;"><b>NOTE</b></p> Remote gearboxes with No. Aerno 48-0558 may normally leak some oil overboard after engine shutdown.	Replace seals or preformed packing, if accessible. If not, remove gearbox and comply with MC2 test stand criteria.
--	---	--

**OIL LEAKAGE AT GENERATOR OVERBOARD VENT DURING OPERATION.**

Oil passing generator drive end (air-oil mist) seal (no oil passing through system aneroid vent).	Leakage past drive end (air-oil mist) seal can be caused by: 1. Overfilling of CSD oil system (refer to paragraph 9-28) plus an obstruction in vent system. If oil system has been properly serviced and vent system is clear of obstructions, disconnect vent lines at generators while engine is running. If generator(s) is still leaking, see items 2 and 3.	
---	---	--

## 9-9. SYSTEM ANALYSIS, CONSTANT-SPEED GENERATOR DRIVE SYSTEM (CONT).

PROBABLE CAUSE	ISOLATION PROCEDURE	REMEDY
----------------	---------------------	--------

## OIL LEAKAGE AT GENERATOR OVERBOARD VENT DURING OPERATION (CONT).

	2. Defective drive end (air-oil mist) seal.	Replace generator.
	3. Failure of cooling oil seal or internal remote gearbox drive malfunction plus obstruction in vent system. Check for obstruction in vent system.	Replace generator and/or gearbox.
Rupture of generator oil passage (no oil passing through system aneroid vent).	Disconnect vent lines at generators while engine is operating to isolate the leaking generator.	Replace defective generator.

## OIL LEAKAGE AT OVERBOARD VENT DURING SHUTDOWN.

System oil tank overfilled.	Check oil level on constant-speed drive oil tank filler dipstick. Tank should never be overfilled.	Drain remote gearbox sump. Insure system oil tank is not overfilled.
System oil tank filled too rapidly allowing oil to collect in top compartment of tank and flow into remote gearbox through the vent line.	This condition is evidenced when an empty tank requires more than 9½ quarts to fill it.	Fill system oil tank slowly in future (approximately 1 quart every 30 seconds). Drain remote gearbox.
Malfunctioning remote gearbox anti-drain valve.	Disconnect oil in from tank quick disconnect. If dripping stops, anti-drain valve was leaking.	Remove quick disconnect from tank boss. Remove anti-icing valve assembly from gearbox and inspect for foreign particles or defective O-ring seal on plunger. Check to insure that color code on O-ring seal does not face outside but faces into O-ring seal groove. Replace O-ring seal with <i>correct</i> O-ring seal as required. Clean and reinstall anti-drain valve. Drain remote gearbox sump.
Malfunctioning check valve.	Disconnect oil out to cooler quick disconnect. If dripping stops drain oil cooler and oil out lines. Remove check valve from airplane. Examine for contamination. Stand valve on male end and fill female cavity with oil. Valve should not leak.	If check valve leaks, replace it. Contaminated valves may be cleaned (but not disassembled) and reused. Drain remote gearbox sump.

## UNUSUAL NOISE IN DRIVE SYSTEM.

Internal malfunction of a gearbox.	Remove drive shaft and motor engine to determine if noise is caused by engine mounted gearbox.	Replace affected gearbox.
------------------------------------	--	---------------------------

## IMPROPER AC GENERATOR FREQUENCY.

Electrical malfunction.	Refer to T.O. 1F-106A-2-10 for isolation procedures.	
-------------------------	--	--

9-9. SYSTEM ANALYSIS, CONSTANT-SPEED GENERATOR DRIVE SYSTEM (CONT).

PROBABLE CAUSE	ISOLATION PROCEDURE	REMEDY
<b>IMPROPER AC GENERATOR FREQUENCY (CONT).</b>		
Oil supply low.	Check lubricating system oil supply.	
Oil filters clogged restricting oil flow.	Remove filters.	Clean filters.
Defective or kinked oil lines.	Check line condition and installation.	Adjust or replace as required.
Air entering the 1 inch remote gearbox oil line.	Check line connections.	Tighten or replace, as required.
Malfunctioning remote gearbox anti-drain valve.	Remove 1 inch oil inlet line. Depress plunger inlet port. Plunger should offer only slight resistance to movement and should return to closed position when released.	Replace or clean valve if action is defective.
Defective remote gearbox cooling pump.	Disconnect engine mounted gearbox oil in line at quick disconnect fitting. Drain engine mounted gearbox and reprime with ½ pint of oil, Military Specification MIL-L-7808. Motor engine and at same time depress fitting on end of oil in-hose.	If oil does not flow from fitting, replace remote gearbox and comply with MC2 test stand criteria on removed gearbox.
Malfunctioning remote gearbox charge relief valve.	Remove and inspect valve components.	Replace or clean valve if action defective.
Internal malfunction.	This may be assumed when the above items do not locate trouble.	Replace remote gearbox.

**OIL CONSUMPTION RATE EXCEEDS 1 PINT PER HOUR.**

Remote gearbox sump has been drained since last engine run; dipstick reading after subsequent shut-down shows ½ to 1½ quarts low.	Check oil level.	Add oil to "FULL" mark.
Oil tank not filled after last flight or prolonged engine run.	Check oil level.	Fill oil tank to "FULL" mark.
Oil added to system at rate exceeding 1 quart every 30 seconds.	Check oil level.	Refer to paragraph 9-28 for servicing information.
Leak in oil system lines.	Check for leaks at all B-nuts and quick disconnect couplings.	Tighten and/or replace as required.
Check valve in oil OUT line in main wheel well or the anti-drain valve in remote gearbox is leaking.	Check valves as follows: Drain remote gearbox sump. Check magnetic drain plug for chips. Normal sump oil quantity varies between ½ to 1½ quarts. Disconnect remote gearbox 1 inch oil IN and OUT lines at the quick disconnect fittings. After oil stops dripping from sump drain port, connect oil IN line. If sump drain port starts dripping oil within 5 minutes, remove anti-drain valve.	Install replacement item.

## 9-9. SYSTEM ANALYSIS, CONSTANT-SPEED GENERATOR DRIVE SYSTEM (CONT).

PROBABLE CAUSE	ISOLATION PROCEDURE	REMEDY
<b>OIL CONSUMPTION RATE EXCEEDS 1 PINT PER HOUR (CONT).</b>		
	If no oil appears within 5 minutes disconnect oil IN line and connect oil OUT line. If sump drain port starts dripping oil within 5 minutes, remove check valve.	Install replacement item.
Remote gearbox scavenge sump shaft sheared.	If oil flows from the remote gearbox overboard vent during operation.	Remove TRGB and comply with MC2 test stand requirements.
Generator drive gear face seal is leaking.	If oil drips from remote gearbox overboard vent valve port during engine run or after shutdown, drain remote gearbox. Inspect generator gear seal face for nicks, or the bronze seals in gearbox for scoring or damage. If seals are scored or damaged, remove gearbox. If gear face is nicked or damaged, remove generator.	Install replacement item.
Defective seal at EMGB mating surfaces, input seal or starter mounting pad.	Check for oil in lower fuselage.	Remove EMGB. If leak is at mating surfaces, return to depot. If leak is at EMGB input seal or starter pad, comply with MC2 test stand criteria.
Defective or missing O-ring seals at generator mounting face.	Check for evidence of oil around generator mount pad.	Remove generator and install new seals. Refer to T.O. 1F-106A-2-10 for replacement procedure.
Generator leaking.	Check for evidence of leaking on generator surface, terminal strip, or excessive oil streaks on outside of fuselage behind to generator overboard vent. If leakage is found, drain remote gearbox and proceed as follows: If sump oil quantity is normal ( $\frac{1}{2}$ to $1\frac{1}{2}$ quarts), remove generator and check mounting face seals. If seals are satisfactory, the leak is inside the generator.	Replace generator.
	If sump oil quantity is more than $1\frac{1}{2}$ quarts, check preceding probable causes. In addition, disconnect air supply line to overboard vent and plug the vent valves air supply line port. Disconnect the remote gearbox overboard vent line at gearbox. Cup hand around flex line and blow by mouth. If no air comes from overboard vent valve port, remove valve.	Install replacement item.
	Install all disconnected lines. Wipe off generator case. Refill CSD oil tank. Start engine. If generator continues to leak, remove generator.	Install replacement item.

9-9. SYSTEM ANALYSIS, CONSTANT-SPEED GENERATOR DRIVE SYSTEM (CONT).

PROBABLE CAUSE	ISOLATION PROCEDURE	REMEDY
----------------	---------------------	--------

**OIL CONSUMPTION RATE EXCEEDS 1 PINT PER HOUR (CONT).**

CSD generator pressurization system malfunction.	See next probable cause.	
--	--------------------------	--

**CSD GENERATOR PRESSURIZATION SYSTEM MALFUNCTION.**

Faulty connection or leaking line.	Check all connections and lines.	Tighten or replace as necessary.
Air pressure regulator malfunction (outlet pressure below 7 psi).	Check pressure at inlet of regulator. If inlet pressure is above 10 psi, remove regulator.	Install replacement item.
Relief valve malfunction.	Check air pressure at valve outlet. Pressure shall be above 4.5 to 5.7 psi (normal pressure $21 \pm 1$ psi from fuel pressurization manifold). If pressure is below 4.5 psi, remove valve.	Install replacement item.
	If pressure is below $21 \pm 1$ psi, fuel pressurization system is not functioning properly. See next item.	
Fuel pressurization system malfunction.	Check fuel pressurization system. Refer to T.O. 1F-106A-2-5.	Correct as required.

**AC AND DC POWER FAILURE WARNING LIGHTS ILLUMINATE AT ALTITUDE AND EXTINGUISH UPON DESCENT.**

Overboard vent valve malfunction.	Bench test valve.	Replace as necessary.
Air pressure regulator malfunction (outlet pressure below 7 psi).	Check pressure at regulator inlet. If above 10 psi, remove regulator.	Install replacement item.
Defective seal on constant-speed oil tank filler cap.	Check seal.	Replace seal if found defective.

**9-10. CRITERIA FOR USE OF MC-2 TEST STAND FOR CHECKING TRANSMISSION REMOTE GEAR BOX (TRGB) AND ENGINE MOUNTED GEAR BOX (EMGB).**

a. All tests will be made in accordance with T.O. 9H6-3-14-2.

**NOTE**

The following must be accomplished prior to each test:

1. Inspect and clean TRGB and EMGB filters and chip detector plugs.
2. Inspect TRGB three generator mounting pad holes. Contamination in this area is cause for rejection.
3. Check rotation of gear trains on TRGB and EMGB to assure free and even rotation.
4. Inspect TRGB and EMGB filters and chip detector plugs after completion of test. If unacceptable contamination is present, return units to depot; otherwise, return to service if units have passed all phases of test.

b. Test parameters are listed by paragraph with their respective conditions.

1. When the TRGB and/or EMGB are removed for contamination, test in accordance with paragraphs 4-10 through 4-45, T.O. 9H6-3-14-2.
2. When an ac-dc power loss occurs and failure of TRGB and EMGB is not evident, test TRGB in accordance with paragraphs 4-10 through 4-45 and EMGB in accordance with paragraphs 4-10 through 4-14.
3. When a cooling pump or charge and scavenge pump failure occurs, inspect for contamination as indicated preceding NOTE. Replace defective pump and perform test in accordance with paragraphs 4-10 through 4-20.
4. Test TRGB when low or no output rpm is encountered, provided generators are operating properly and CSD system prime was assured. Test in accordance with paragraphs 4-10 through 4-45.

5. Test TRGB when input seal or external "O" ring packings have been replaced. This applies to those cases where leakage cannot be corrected on aircraft. Test in accordance with paragraphs 4-10 through 4-14.
6. Test TRGB when EMBG output shaft shears, provided TRGB gear train rotates freely and evenly. Test in accordance with paragraphs 4-10 through 4-45.
7. Check and reset limit governor in event of nuisance trips. Test in accordance with paragraph 4-54.
8. Check and reset magnetic trim (basic) governor when TRGB will not govern any output from one or more generators. Test in accordance with paragraphs 4-46 through 4-53.
9. Test pressure switch when frequency and voltage are temporarily lost when loads are applied. Test in accordance with paragraphs 4-28 through 4-40.
10. Test EMBG when input shaft shears and gear train rotates freely. Replace input shaft and test in accordance with paragraphs 4-4, 4-10 through 4-14.
11. When EMGB is removed for contamination and failure of EMGB is not evident, test in accordance with paragraphs 4-10 through 4-14.
12. When leak occurs at EMGB input or starter pad seals, replace seals and test in accordance with paragraphs 4-10 through 4-14.

<b>REPLACEMENT</b>
--------------------

**9-11. REPLACEMENT, CONSTANT-SPEED DRIVE SYSTEM COMPONENTS.****9-12. Equipment Requirements.**

FIGURE	NAME	TYPE	ALTERNATE	USE AND APPLICATION
9-3	Retractable Stand.	AF Type ETU-8/E (1740-294- 3397)	8220-780800	To support remote gearbox during removal procedure.
	Adapter Kit.	8-96253 (for use with ETU-8/E) (1740-657- 1185)	8-96024 (for use with 8220-780800)	To adapt remote gearbox to retractable stand.
	Constant Speed Remote Gearbox Hoist.	8-96044-1 (1730-788- 4690)	8-96044 (1730-589- 9469)	For lowering gearbox from the installed to the hanging position.
	Constant-Speed Shaft Release Tool.	8-96264 (4920-705- 0190)		To aid removal of constant speed drive shaft.
	Sling.	8-96116 (1730-619- 6576)		To be used to remove/install remote gearbox from/in retractable transport stand.



**9-13. Procedure.**

a. See figures 9-3 thru 9-9 for removal and installation of constant-speed drive system components. If the constant-speed remote gearbox is to be removed from the retractable stand following removal from the airplane, use the sling 8-96116.

**NOTE**

*Applicable to F-106A airplanes 56-453, -454, 56-456 thru 57-245, 59-001 and subsequent, and F-106B airplanes 57-2508 thru 57-2515, 57-2542 and subsequent, the remote gearbox generator purge air line, vent to tank line, and overboard vent line are equipped with in-line swivel fittings. This eliminates the need for disconnecting these lines when swinging the remote gearbox to the hanging position.*

**CAUTION**

Check that the generator electrical conduits do not chafe fuselage structure or the right elevon push-pull tube when raising or lowering the remote gearbox.

b. Conduct an operational checkout of the constant-speed system after completion of component replacement.

**CAUTION**

Remove remote gearbox hoist 8-96044-1 prior to operation of the flight control system.

**9-14. REPLACEMENT, CONSTANT-SPEED REMOTE GEARBOX CHARGE RELIEF VALVE.**

See figure 9-9 for replacement procedure.

**9-15. REPLACEMENT, CONSTANT-SPEED REMOTE GEARBOX ANTI-DRAIN VALVE.**

See figure 9-9 for replacement procedure.

**9-16. REPLACEMENT, CONSTANT-SPEED REMOTE GEARBOX PRESSURE SWITCH.**

See figure 9-9 for replacement procedure.

**9-17. REPLACEMENT, CONSTANT-SPEED DRIVE SYSTEM GENERATORS.**

Refer to T.O. 1F-106A-2-10 for replacement procedures.

**NOTE**

Exercise extreme care when installing the dc generator on pad "A" of the remote gearbox. Make sure the generator drive gear is in alignment with the idler gear of the remote gearbox and the generator mounting flange is flush against the remote gearbox mounting pad prior to installing the generator mounting nuts. Do not jam the generator against the remote gearbox mounting pad as damage to the remote gearbox idler gear and idler gear bearing will result.

**CAUTION**

Prevent contamination of the inside of the remote mounted gearbox while generators are removed by covering the mounting pads with noncorrosive paper. Absolute cleanliness must be maintained, as serious damage to the units can be caused by very small amounts of foreign matter. Generator pad covers should be installed if generators are removed for extended maintenance periods.

**9-18. REPLACEMENT, CONSTANT-SPEED DRIVE GENERATOR PRESSURIZATION SYSTEM AIR PRESSURE REGULATOR.**

See figure 9-7 for replacement procedure.

**9-19. REPLACEMENT, CONSTANT-SPEED DRIVE OVERBOARD VENT VALVE.**

See figure 9-8 for replacement procedure.

**9-20. REPLACEMENT, CONSTANT-SPEED REMOTE GEARBOX LIMIT GOVERNOR.**

See figure 9-10 for replacement procedure.

**9-21. REPLACEMENT, CONSTANT-SPEED REMOTE GEARBOX MAGNETIC TRIM (BASIC) GOVERNOR.**

See figure 9-10 for replacement procedure.

**9-22. REPLACEMENT, ENGINE MOUNTED GEARBOX OIL OUT PORT FILTER.**

See figure 9-16 for replacement procedure.

## ADJUSTMENT

### 9-23. ALIGNMENT CHECK, CONSTANT-SPEED REMOTE GEARBOX.

Alignment checking of the constant-speed remote gearbox is required only after suspected structural damage, or after completion of structural modification.

### 9-24 Equipment Requirements.

FIGURE	NAME	TYPE	ALTERNATE	USE AND APPLICATION
9-11	Alignment Gage, Constant-Speed Drive Shaft.	8-96090 (5220-601-9973)		To check alignment between constant-speed drive unit and engine mounted gear box.

### 9-25. Preparation.

a. Check alignment gage 8-96090 for damage or distortion, and for recent calibration.

#### CAUTION

The constant-speed drive unit alignment gage is a precision optical instrument and must be handled with extreme care.

b. Open constant-speed unit access doors. Check constant-speed unit for proper installation and security; hinge and support fittings for wear.

c. Check engine mount fittings for condition and installation; engine centered in tail cone.

d. Check that the airplane is in a normal groundborne attitude.

### 9-26. Procedure.

See figure 9-11 for the alignment procedure for the constant-speed drive remote gearbox.

## SERVICING

### 9-27. DRAINING AND PRIMING CONSTANT-SPEED OIL SYSTEM.

See figure 9-12 for the oil system draining and priming procedure. As an alternate priming procedure, if priming equipment is not available, perform the following:

a. Insure that constant-speed drive shaft and cover are properly installed and safetied.

b. Fill oil tank to "FULL" mark with oil, Military Specification MIL-L-7808. Refer to paragraph 9-28 for servicing procedure.

c. Check that oil is available at the remote gearbox inlet by disconnecting the quick disconnect coupling and lowering the oil line to allow any air trapped in the line to escape to the tank.

d. Connect the oil "IN" line quick disconnect.

#### CAUTION

Improperly installed quick disconnect couplings can result in oil starvation and subsequent malfunction of the remote gearbox.

e. Disconnect the line at engine mounted gearbox vent port and pour ½ pint of oil, Military Specification MIL-L-7808, into gearbox. Connect vent line.

f. Attach ac voltmeter across terminals P<sub>1</sub> and P<sub>2</sub> on the ac generator mounted on pad B of the remote gearbox.

g. Start engine and accelerate to IDLE rpm, then shutdown engine immediately.

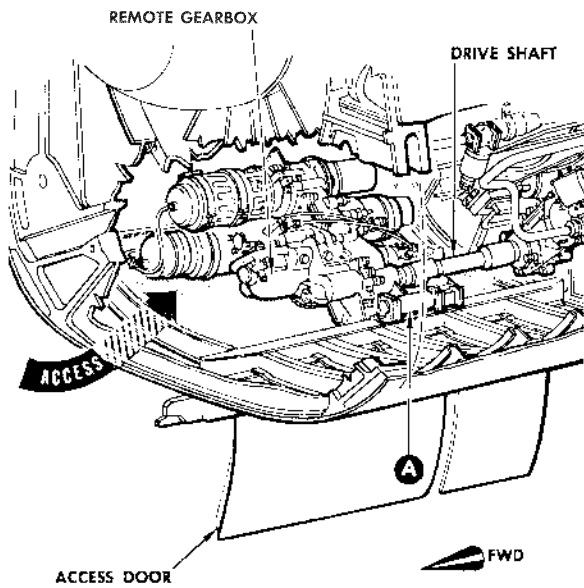

**REMOVAL PREPARATION**

- Open constant speed access door on lower RH side of fuselage.
- Remove drive shaft. See replacement, constant speed drive shaft for proper removal procedure.

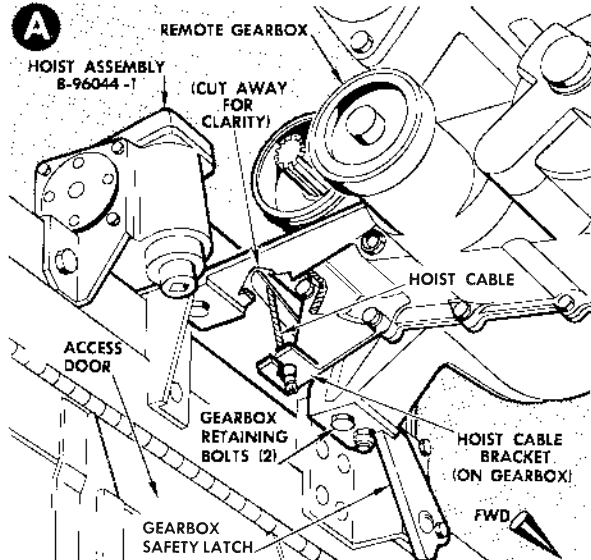

- Install hoist assembly 8-96044-1 at attachment point on inboard side of the access door frame.

**WARNING**

USE HOIST ASSEMBLY 8-96044-1 TO MOVE THE REMOTE GEARBOX IN OR OUT OF THE FUSELAGE. REMOTE GEARBOX WITH FOUR GENERATORS INSTALLED WEIGHS 300 POUNDS.

- Install hoist cable in drive unit cable attachment bracket.

**NOTE**

APPLICABLE TO F-106A AIRPLANES 56-453, -454, -463 THRU 56-466, 57-230 THRU 57-245, 57-2465, 57-2504 AND SUBSEQUENT; AND 57-246 THRU 57-2503 AFTER INCORPORATION OF TCTO 1F-106-597. APPLICABLE TO F-106B AIRPLANES 57-250B THRU 57-2515, 57-2523, 57-2531 AND SUBSEQUENT; AND ALL OTHER F-106B AIRPLANES AFTER INCORPORATION OF TCTO 1F-106-597. ALL PURGE AIR LINES TO THE GENERATORS ARE REMOVED AND AN OVERBOARD DRAIN LINE IS INSTALLED FOR EACH GENERATOR. THE DRAIN LINES MANIFOLD AND DRAIN THROUGH A FITTING IN THE CSD ACCESS DOOR, STATION 493.00.

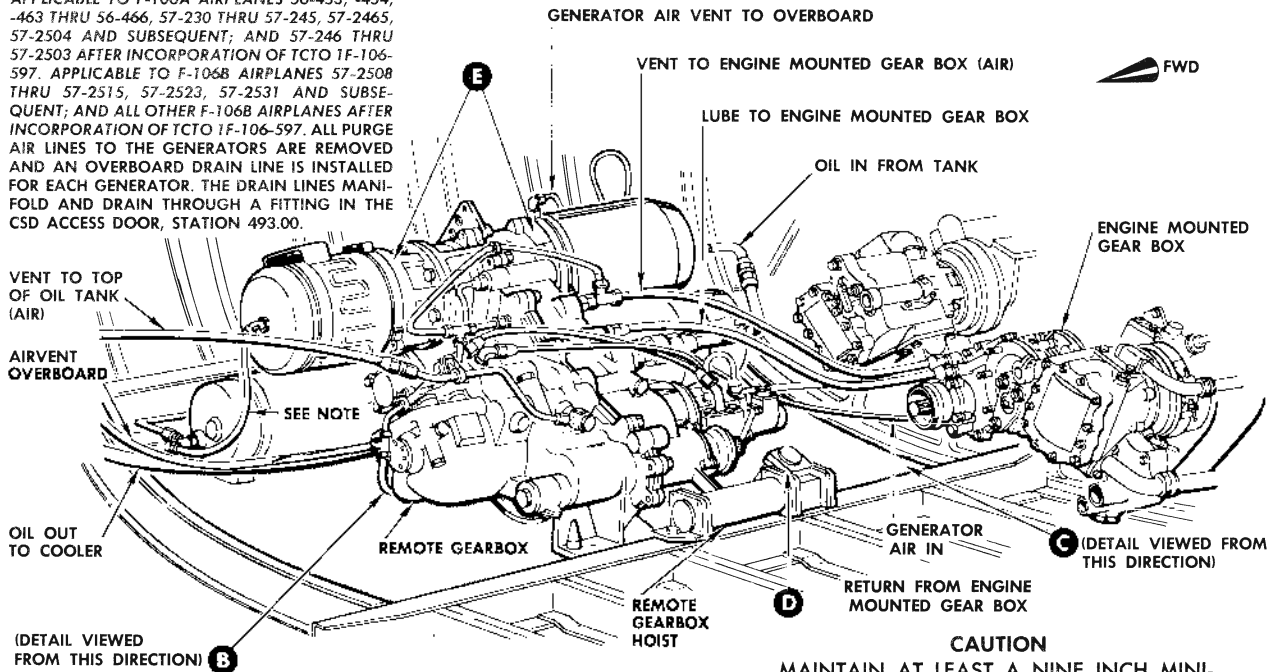

- Disconnect oil and pressurization lines. See details "B" and "C."

**CAUTION**

MAINTAIN AT LEAST A NINE INCH MINIMUM BEND RADIUS FOR OIL INLET AND OUTLET FLEX LINES TO PREVENT DAMAGE TO LINES.

.06.02.162-1E .72.56.00

Figure 9-3. Replacement, Constant-Speed Remote Gearbox (Sheet 1 of 4)

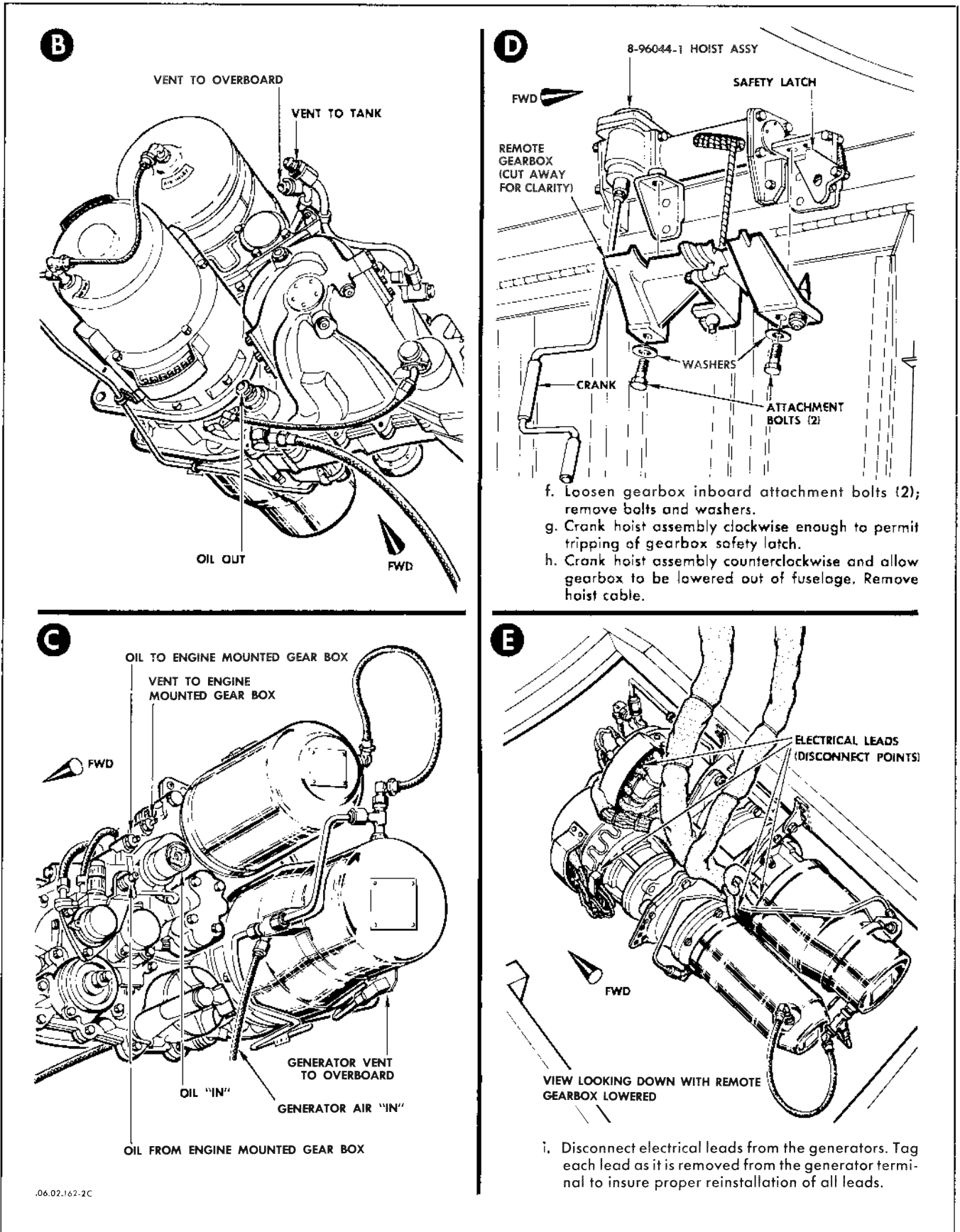
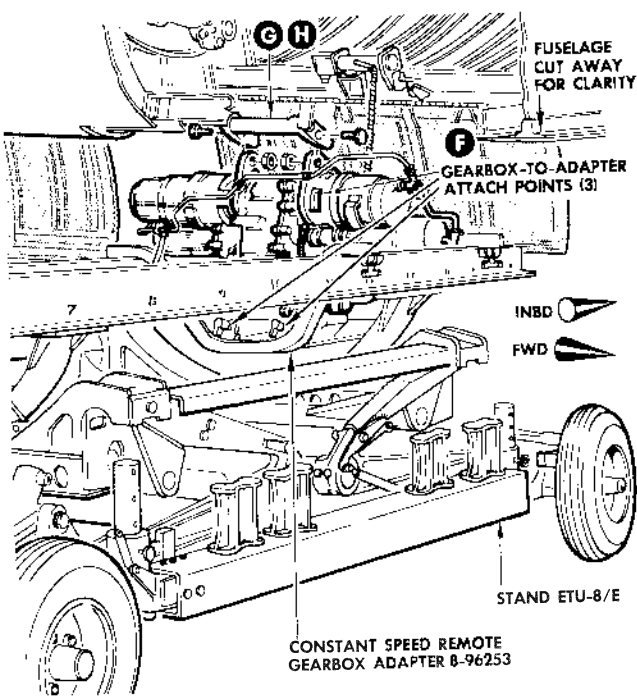
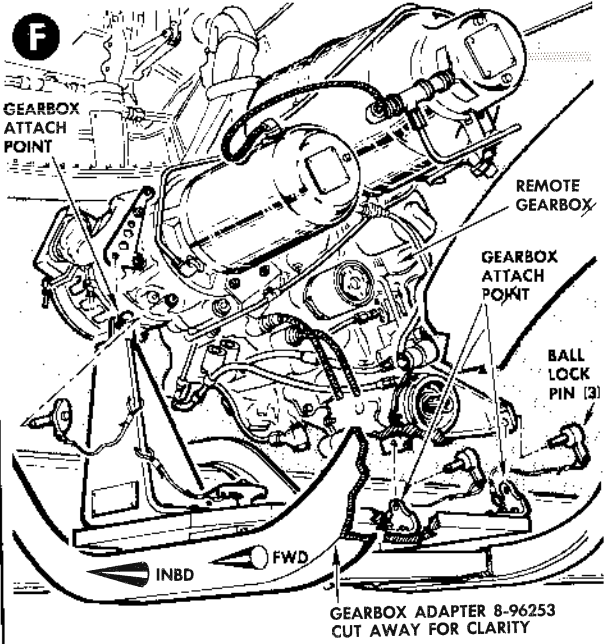

Figure 9-3. Replacement, Constant-Speed Remote Gearbox (Sheet 2 of 4)



**REMOVAL PROCEDURE USING STAND USAF ETU-8/E**

a. Using stand ETU-8/E with remote gearbox adapter 8-96253 installed, position stand and adapter assembly under remote gearbox; engage stand brakes.



b. Install gearbox to stand attachment pins (3 places).  
c. Remove gearbox to fuselage attachment bolts (2). Lower and move stand away from airplane. Refer to detail G.

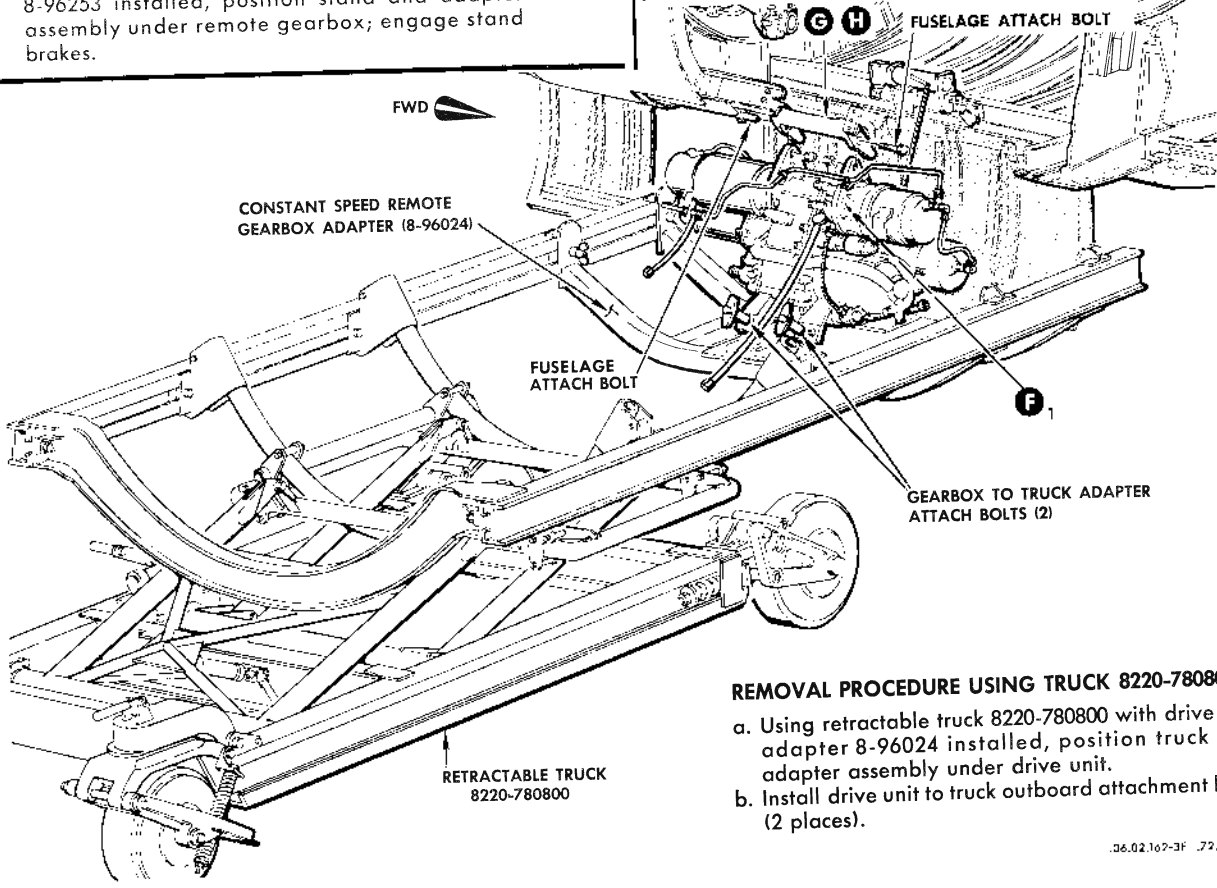

**REMOVAL PROCEDURE USING TRUCK 8220-780800**

a. Using retractable truck 8220-780800 with drive unit adapter 8-96024 installed, position truck and adapter assembly under drive unit.  
b. Install drive unit to truck outboard attachment bolts (2 places).

36.02.107-3F 72.56.3C

Figure 9-3. Replacement, Constant-Speed Remote Gearbox (Sheet 3 of 4)

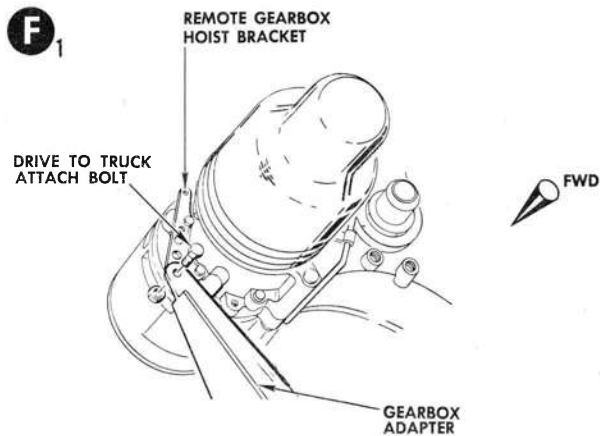

- c. Install drive unit to truck inboard attachment bolt (1 place).

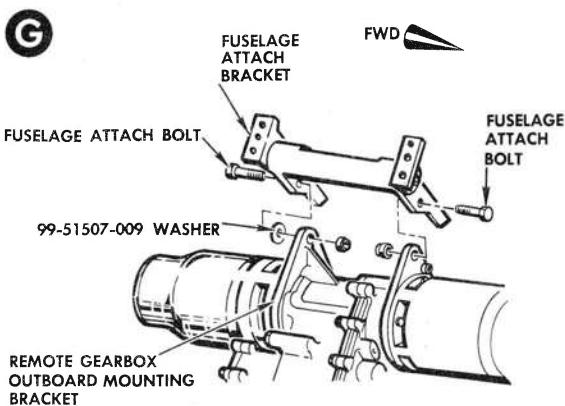

- d. Remove gearbox to fuselage attachment bolts; remove gearbox.

#### INSTALLATION

- Install gearbox using essentially the reverse of removal procedure. See the engine mounted gearbox replacement procedure for correct interconnecting line and fitting installations.
- Install washers No. 99-51507-009 between gearbox aft outboard mounting bracket and fuselage attaching bracket to maintain a maximum end play clearance of 0.015 inch.
- Install constant speed interconnecting drive shaft. See Replacement, Constant Speed Drive Shaft for proper installation procedure.
- After completion of gearbox installation, adjust stop bolts as shown in Detail J. Torque bolts 80 to 100 inch-pounds.

.06.02.162-4H .72.56.00

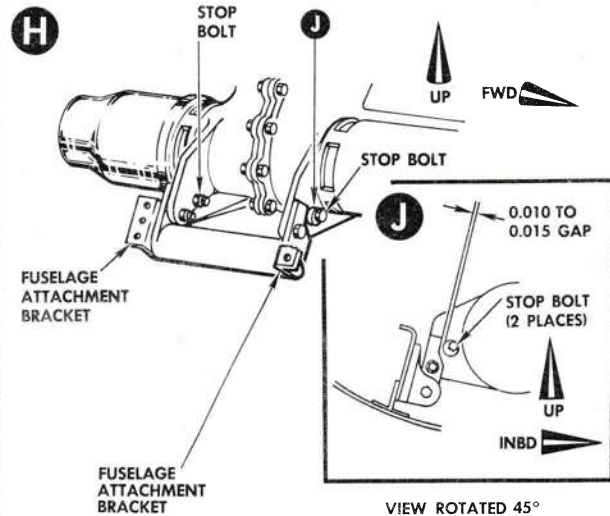

#### CAUTION

CHECK THAT QUICK DISCONNECT COUPLINGS ARE PROPERLY COUPLED. REFER TO SECTION I FOR QUICK DISCONNECT COUPLING INFORMATION.

MAINTAIN AT LEAST A NINE-INCH MINIMUM BEND RADIUS FOR REMOTE GEARBOX OIL IN AND OUT FLEX LINES TO PREVENT DAMAGE TO LINES. DO NOT TWIST OIL IN FLEX LINE WHEN CONNECTING QUICK DISCONNECT COUPLING. EXERCISE EXTREME CARE TO PREVENT GENERATOR HARNESS BUNDLE AND CONDUIT FROM CHAFING OR BINDING AGAINST FLIGHT CONTROL COMPONENTS OR AIRPLANE STRUCTURE.

- Conduct filling and priming procedure as specified in this section of the manual.
- Conduct engine ground run; perform drive unit operational checkout and check for possible oil filter leakage. Refer to Section I of this manual for the engine ground run procedure.
- Start engine and operate at "IDLE" rpm. Within 10 seconds after reaching "IDLE" rpm and with external electrical power removed from airplane, energize the airplane electrical generating system, and check that the ac and dc power failure warning lights are extinguished. If lights are illuminated, terminate engine operation immediately and correct cause of malfunction. Refer to T. O. 1F-106A-2-10 for complete checkout procedure of the electrical generating system.

Figure 9-3. Replacement, Constant-Speed Remote Gearbox (Sheet 4 of 4)

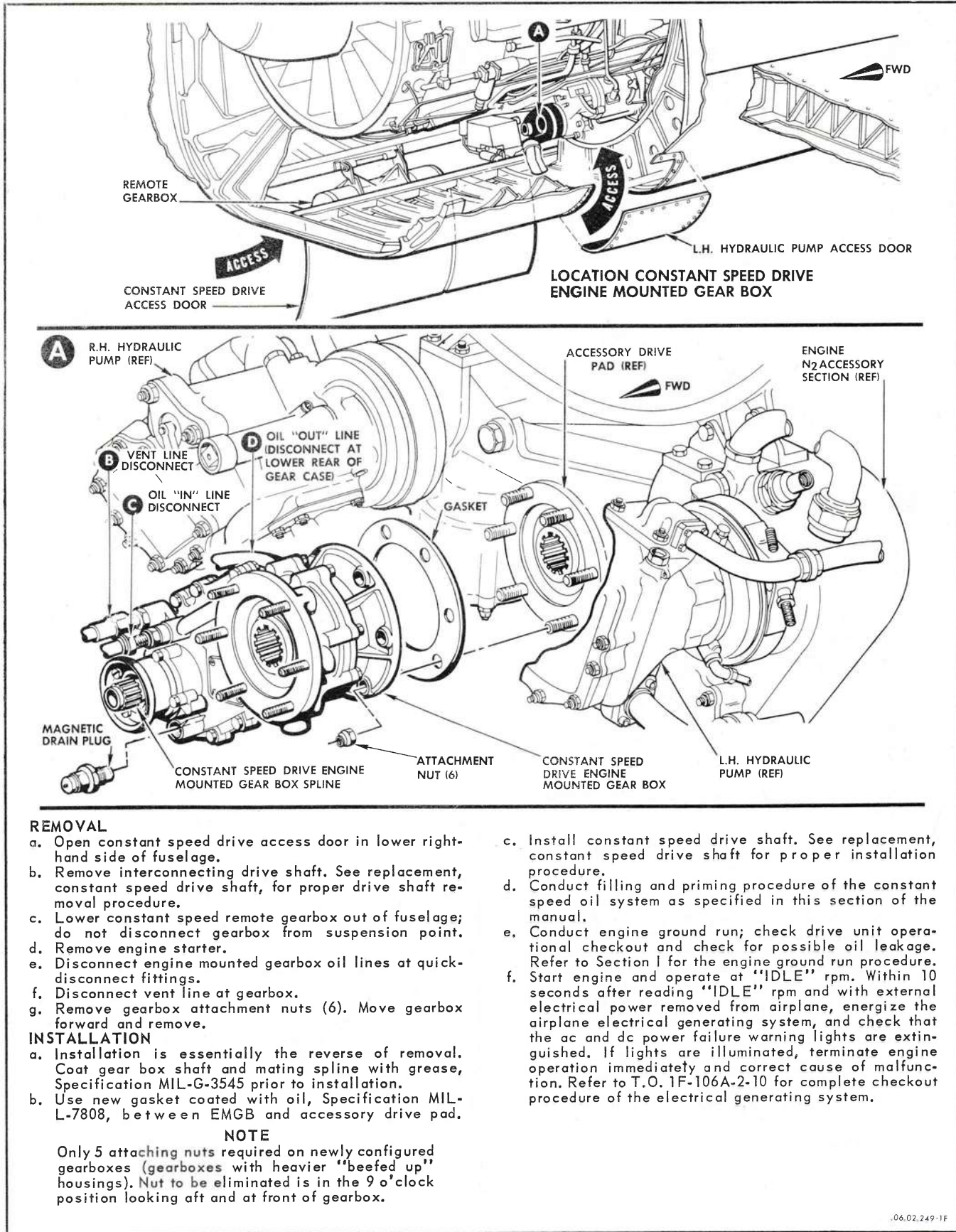

**REMOVAL**

- a. Open constant speed drive access door in lower right-hand side of fuselage.
- b. Remove interconnecting drive shaft. See replacement, constant speed drive shaft, for proper drive shaft removal procedure.
- c. Lower constant speed remote gearbox out of fuselage; do not disconnect gearbox from suspension point.
- d. Remove engine starter.
- e. Disconnect engine mounted gearbox oil lines at quick-disconnect fittings.
- f. Disconnect vent line at gearbox.
- g. Remove gearbox attachment nuts (6). Move gearbox forward and remove.

**INSTALLATION**

- a. Installation is essentially the reverse of removal. Coat gear box shaft and mating spline with grease, Specification MIL-G-3545 prior to installation.
- b. Use new gasket coated with oil, Specification MIL-L-7808, between EMGB and accessory drive pad.

**NOTE**

Only 5 attaching nuts required on newly configured gearboxes (gearboxes with heavier "beefed up" housings). Nut to be eliminated is in the 9 o'clock position looking aft and at front of gearbox.

- c. Install constant speed drive shaft. See replacement, constant speed drive shaft for proper installation procedure.
- d. Conduct filling and priming procedure of the constant speed oil system as specified in this section of the manual.
- e. Conduct engine ground run; check drive unit operational checkout and check for possible oil leakage. Refer to Section I for the engine ground run procedure.
- f. Start engine and operate at "IDLE" rpm. Within 10 seconds after reading "IDLE" rpm and with external electrical power removed from airplane, energize the airplane electrical generating system, and check that the ac and dc power failure warning lights are extinguished. If lights are illuminated, terminate engine operation immediately and correct cause of malfunction. Refer to T.O. 1F-106A-2-10 for complete checkout procedure of the electrical generating system.

.06.02.249-1F

Figure 9-4. Replacement, Constant-Speed Engine Mounted Gearbox (Sheet 1 of 2)

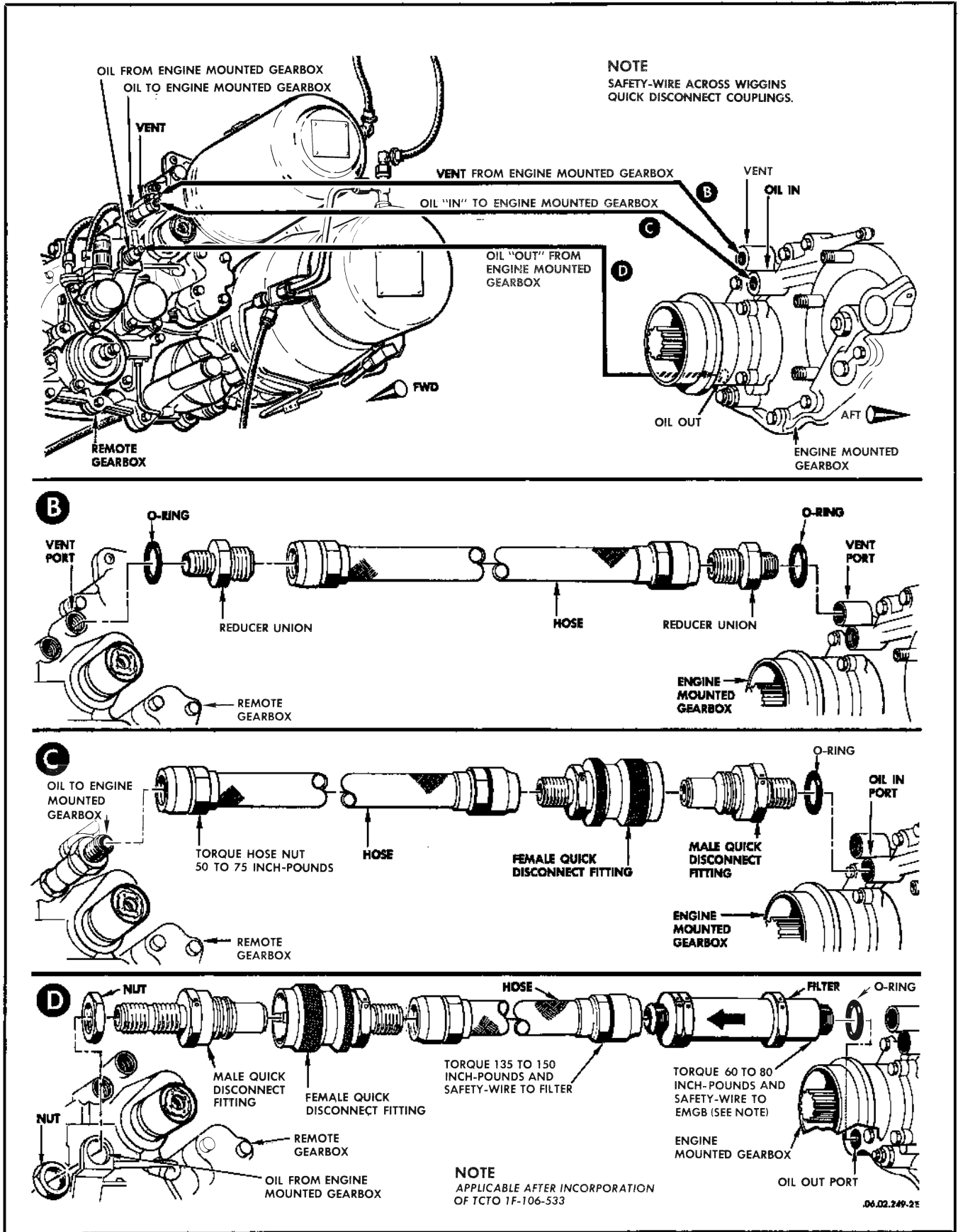
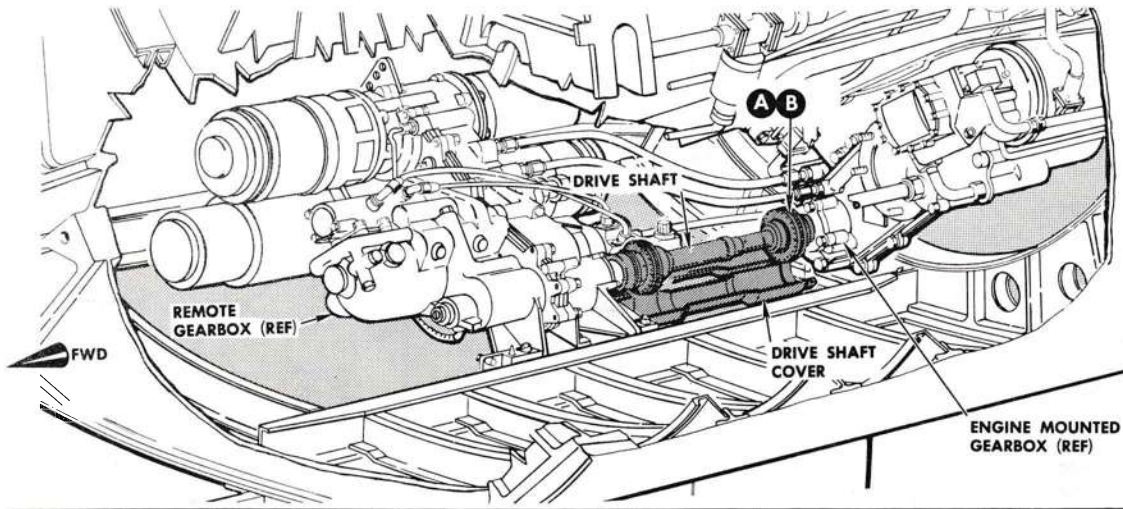

Figure 9-4. Replacement, Constant-Speed Engine Mounted Gearbox (Sheet 2 of 2)





**A** REMOVAL

- a. Open constant speed drive access door on lower right side of fuselage.
- b. Remove drive shaft cover.
- c. Remove interconnecting shaft and adapter assemblies as follows:
  1. Remove safety wire.
  2. Using spanner wrench U3501 loosen ring nuts.
  3. Compress shaft and remove.
  4. Loosen adapter attaching screws.
  5. Remove retaining ring and remove adapters as assemblies.

**CAUTION**

DO NOT PRY, HAMMER, OR USE TOOLS THAT WILL IN ANY WAY CAUSE DAMAGE TO THE SHAFT.

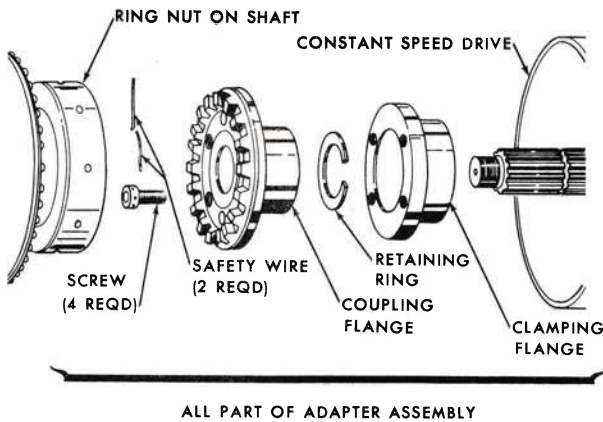

.06.02.1158

**B** INSTALLATION

- a. Prior to drive shaft installation, check transmission remote gear box (TRGB) and engine mounted gear box (EMGB) drive splines for wear and play in support bearings (reference Figure 9-11, Details B and C for side play allowances).
- b. Inspect and install the drive shaft assembly using the following procedure to ensure that the drive shaft is properly installed and secured at both the TRGB and EMGB.
  1. Using spanner wrench U3501 to engage the ring nuts on both ends of flexible power transmission shaft; unscrew adapter assemblies.
  2. Apply a light coating of molybdenum disulfide grease (Military Specification MIL-G-21164) to the splines and the retaining ring groove.
  3. Do not disassemble adapters, but install adapter as an assembly with adapter screws no more than finger tight insuring that retaining ring is positioned in the slot. This can readily be noticeable as retaining ring will snap lightly into place.

**NOTE**

THE ADAPTER ASSEMBLY IS AXIALLY LOOSE ON THE SPLINES AT THIS POINT. FURTHER TIGHTENING OF THE SCREWS WILL COLLAPSE THE RETAINING RING INTO THE RETAINING RING GROOVE OF THE CONSTANT SPEED DRIVE SPLINES. THUS, IT IS ESSENTIAL THAT THE RETAINING RING IS PROPERLY INSTALLED.

Figure 9-5. Replacement, Constant-Speed Drive Shaft (Sheet 1 of 2)

4. Tighten the screws progressively in clockwise sequence, taking up the slack and tightening no more than 1/4 additional turn each time. If this procedure is not carefully followed, the parts may jam and become damaged. Check the progress of positioning of the retaining ring by sliding the adapter assembly on the spline at frequent intervals.
5. Tighten the screws to a torque of 25 inch-pounds, and safety wire screws in pairs using 0.020 inch diameter stainless steel wire.
6. When the adapter assembly is properly positioned on the spline, a gap of approximately 0.091 inch exists between the clamping flange and coupling flange.
7. Follow steps 1 thru 5 for installing adapter assembly on opposite end.

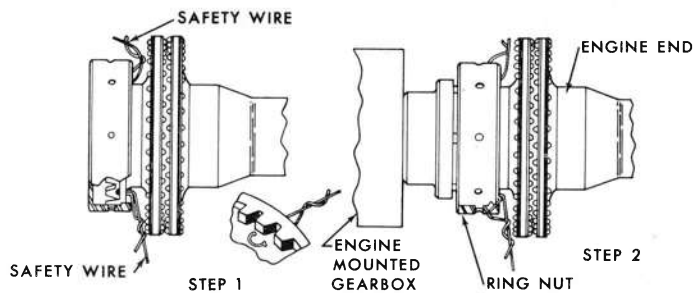

8. Insert two pieces 0.032 inch diameter stainless steel wire (approximately 10 inches long (180 degrees apart, through the shaft coupling on each end of the shaft in the positions shown above.
9. Apply a light coating of molybdenum disulfide grease (Military Specification MIL-G-21164) to the curvic teeth on both shaft couplings of the flexible power transmission shaft.
10. Compress the flexible power transmission shaft and install between the adapter assemblies with the end marked "engine end" mounted on the engine mounted gear box.
11. Hand-start the ring nuts on the shaft, then, using spanner wrench Part No. U3501, tighten the ring nuts as tight as possible.
12. Complete the safety wiring installation by running one end of the safety wire through the approaching hole in the ring nut. Tie the safety wire together on top of the ring nuts. Repeat operation for second safety wire. Use same procedure for safety wiring opposite end.
13. Install cover assembly Part No. 647861-1A over the flexible power transmission shaft so that the clamp nuts are accessible from the bottom. Close cover, engage T-bolts and secure in place.

Figure 9-5. Replacement Constant-speed Drive Shaft (Sheet 2 of 2)



**REMOVAL, CONSTANT SPEED SYSTEM OIL TANK**

- a. Open constant speed system access doors.
- b. Remove interconnecting drive shaft. See replacement, constant speed drive shaft, for proper removal procedure.
- c. Lower remote gearbox out of fuselage; do not detach from fuselage.

**CAUTION**  
DO NOT ACTUATE THE AIRPLANE FLIGHT CONTROL SYSTEM WITH THE REMOTE GEARBOX HOIST INSTALLED.

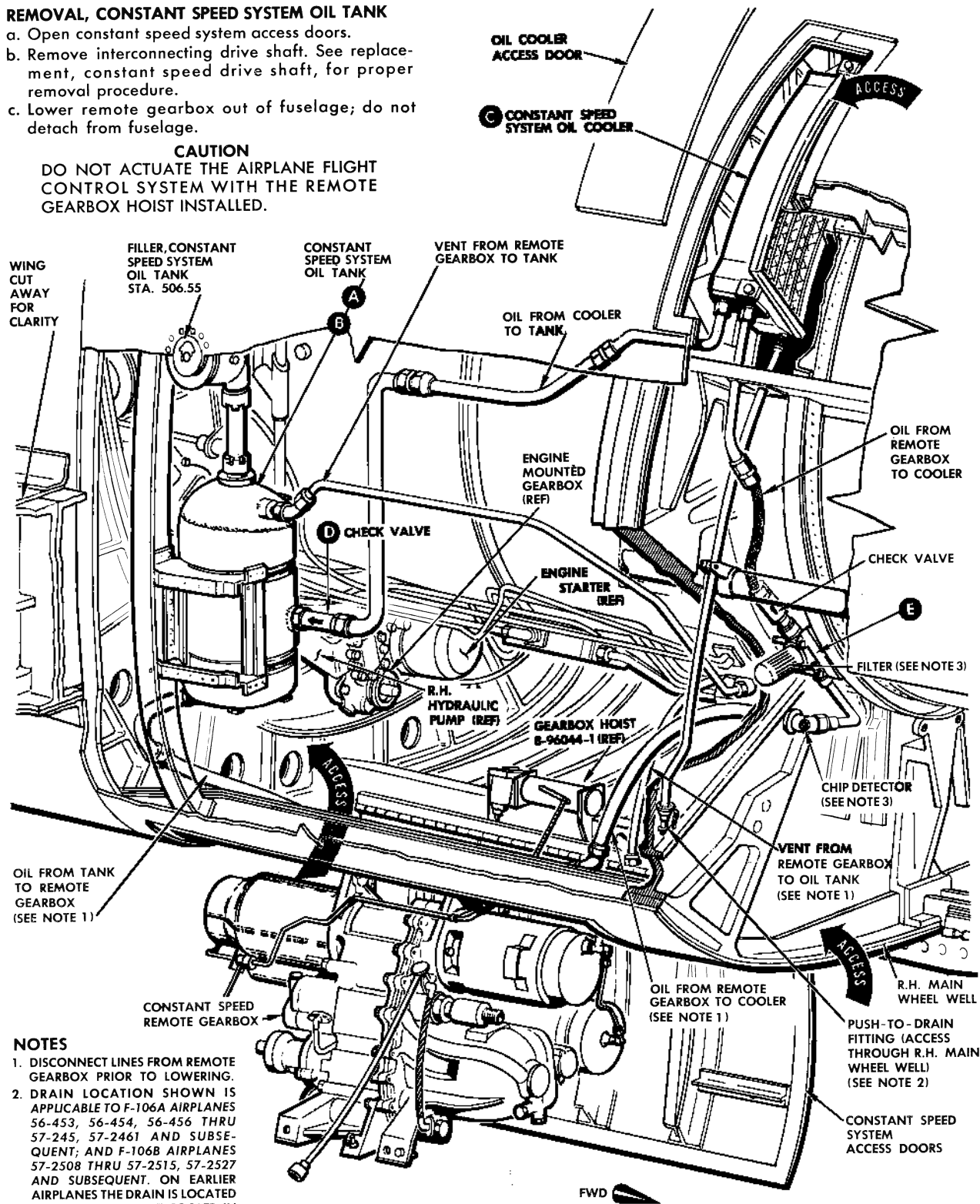

**NOTES**

1. DISCONNECT LINES FROM REMOTE GEARBOX PRIOR TO LOWERING.
2. DRAIN LOCATION SHOWN IS APPLICABLE TO F-106A AIRPLANES 56-453, 56-454, 56-456 THRU 57-245, 57-2461 AND SUBSEQUENT; AND F-106B AIRPLANES 57-2508 THRU 57-2515, 57-2527 AND SUBSEQUENT. ON EARLIER AIRPLANES THE DRAIN IS LOCATED DIRECTLY UNDER THE COOLER IN THE MAIN WHEEL WELL.
3. APPLICABLE AFTER INCORPORATION OF TCTO 1F-106-725.

.06.02.248-1E

Figure 9-6. Replacement, Constant-Speed Oil System Components (Sheet 1 of 3)

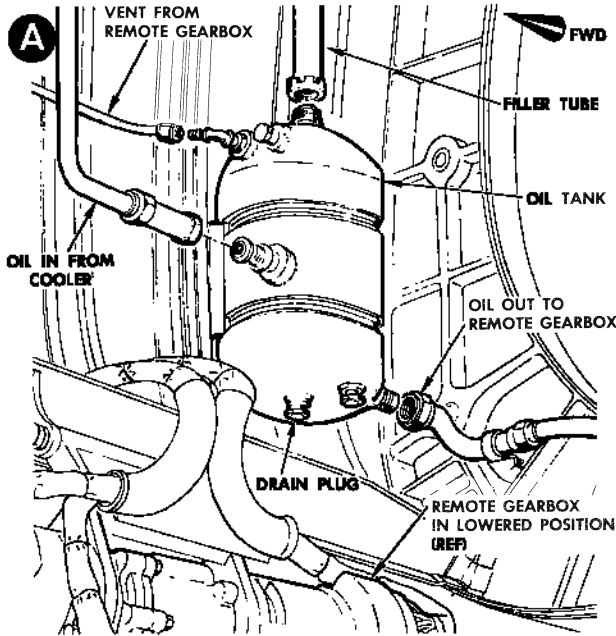

- d. Provide receptacle and remove drive system oil tank drain in bottom of tank; drain oil.
- e. Disconnect lines attached to tank.

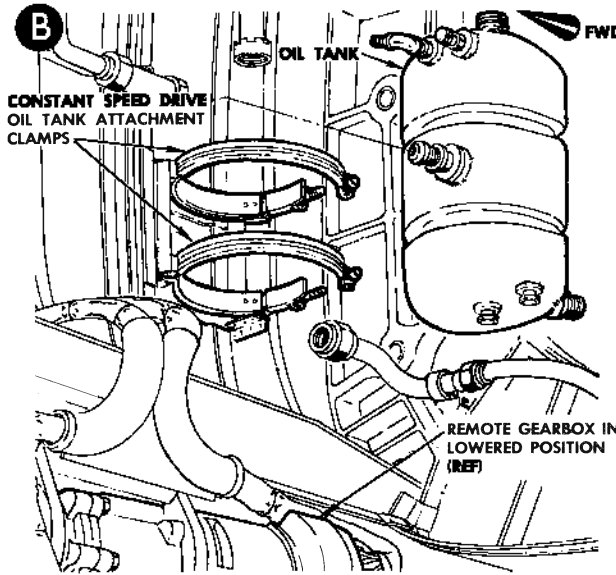

- f. Loosen straps (2) holding tank to structure; remove tank. Cap all lines.

**INSTALLATION, CONSTANT SPEED DRIVE SYSTEM OIL TANK**

- a. Installation is essentially the reverse of removal.
- b. Install remote gearbox and drive shaft.
- c. Conduct filling and priming procedure as specified in this section of the manual.
- d. Conduct engine ground run; check drive unit operational checkout and check for possible oil leakage. Refer to Section I for the engine ground run procedure.

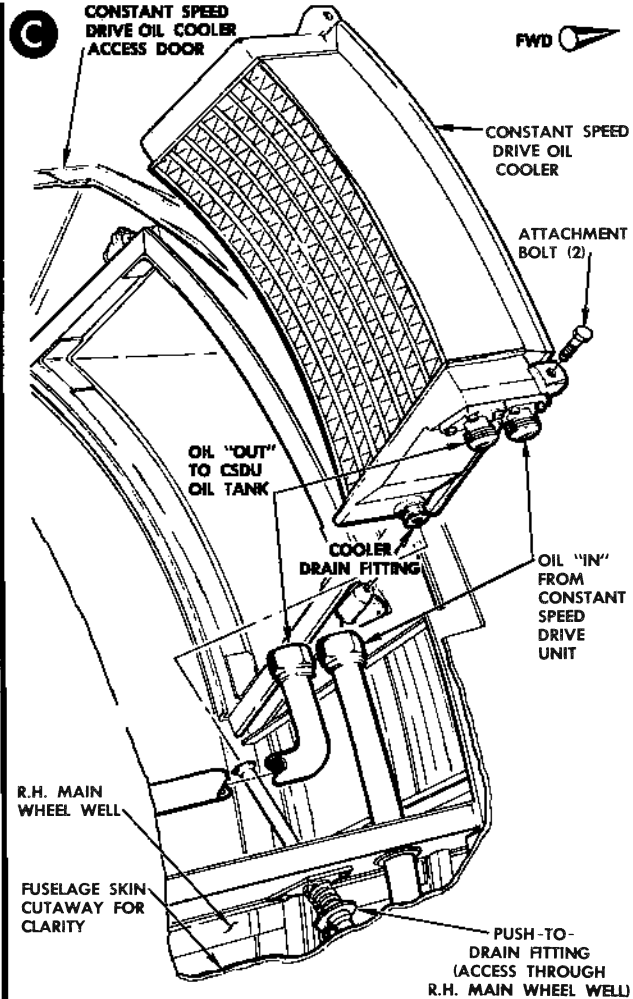

**REMOVAL, CONSTANT SPEED DRIVE SYSTEM OIL COOLER**

- a. Drain cooler at push-to-drain fitting in right-hand main wheel well.
- b. Open cooler access door on upper right-hand surface of fuselage.
- c. Disconnect cooler oil lines (2).
- d. Remove cooler attachment bolts (2); slide cooler out of fuselage. Cover line openings.

**INSTALLATION, CONSTANT SPEED DRIVE SYSTEM OIL COOLER**

- a. Installation is essentially the reverse of removal.
- b. Conduct filling and priming procedure as specified in this section of the manual.
- c. Conduct engine ground run; check drive unit operational checkout and check for possible oil leakage. Refer to Section I for the engine ground run procedure.

**NOTE**

OIL COOLER-TO-DUCT SEAL STRIPS ARE ATTACHED TO DUCTS USING SEALER A-4000 (8040-200-6414).

06.02.248-2C. 72.57.00

Figure 9-6. Replacement, Constant-Speed Oil System Components (Sheet 2 of 3)

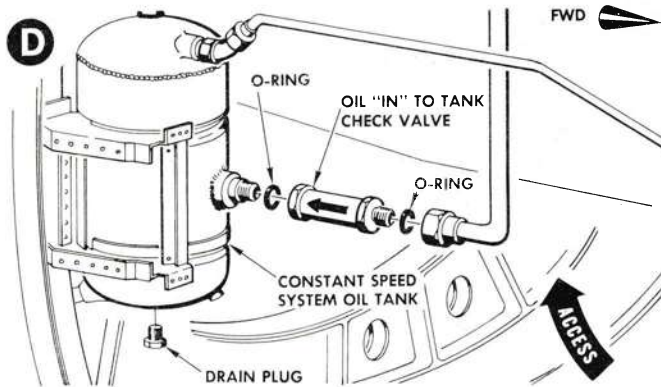
**REMOVAL, OIL "IN" TO TANK RELIEF VALVE**

- Open constant speed drive system access doors.
- Remove interconnecting drive shaft. See replacement, constant speed drive shaft, for proper removal procedure.
- Lower remote gear box out of fuselage; do not detach.

- Provide receptacle and remove drain plug from bottom of oil tank; allow all oil to drain from tank.
- Disconnect oil in from cooler line from relief valve; remove relief valve from fitting on oil tank.

**INSTALLATION, OIL "IN" TO TANK RELIEF VALVE**

- Installation is essentially the reverse of the removal procedure except new O-rings must be used and all fittings must be torqued as specified in Section I of manual.

**CAUTION**

MAKE CERTAIN THAT FREE FLOW (INDICATED BY ARROW STAMPED ON VALVE) IS IN THE DIRECTION OF THE OIL TANK.

- Install remote gear box and drive shaft.
- Conduct filling and priming procedure as specified in this section of manual.
- Conduct engine ground run; perform drive unit operational checkout and check for leakage. Refer to Section I for engine ground run procedure.

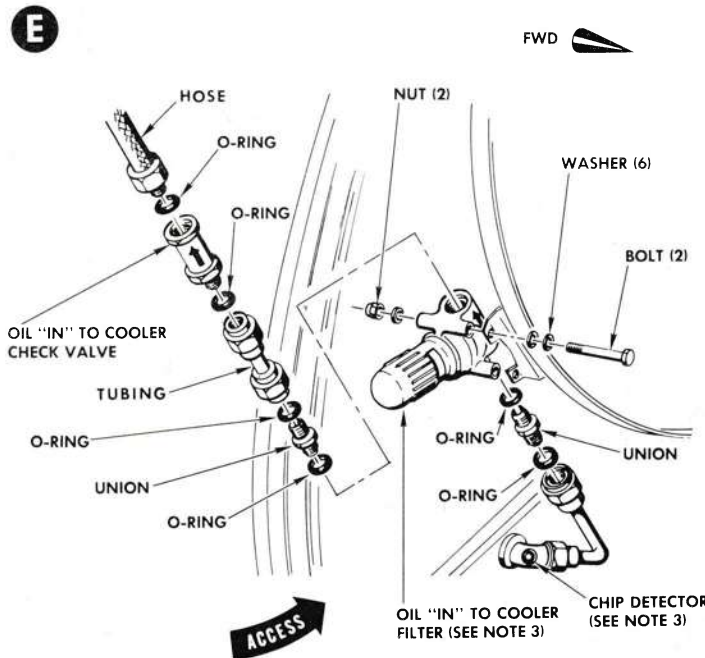
**REMOVAL, OIL "IN" TO COOLER FILTER**

- Disconnect tubing from inlet and outlet ports on filter head.
- Remove unions from filter head and retain for reinstallation.
- Remove nuts, washers, and bolts securing filter to support bracket.

**INSTALLATION, OIL "IN" TO COOLER FILTER**

- Installation is essentially the reverse of the removal procedure except new O-rings must be used and fittings, unions, and bolts must be torqued as specified in Section I of manual.

**CAUTION**

MAKE CERTAIN THAT DIRECTION OF FLOW (INDICATED BY ARROW STAMPED ON FILTER HEAD) IS IN THE DIRECTION OF OIL COOLER.

- Disconnect and rotate the main landing gear door mechanism arm P/N 8-44565, to determine that a minimum clearance of 0.75 inch is maintained between arm and filter. If necessary, omit washers between filter and mounting bracket to gain correct clearance.
- Conduct filling and priming procedure as specified in this section of manual.
- Conduct engine run; perform drive unit operational checkout and check for leakage. Refer to Section I for engine ground run procedure.

**REMOVAL, OIL "IN" TO COOLER CHECK VALVE**

- Drain cooler at push-to-drain fitting in right-hand main wheel well.
- Disconnect tubing from inlet port of check valve; and remove check valve from cooler inlet hose.

**INSTALLATION, OIL "IN" TO COOLER CHECK VALVE**

- Installation is essentially the reverse of removal, except new O-rings must be used and all fittings must be torqued as specified in Section I of manual.

**CAUTION**

MAKE CERTAIN THAT FREE FLOW (INDICATE BY ARROW STAMPED ON VALVE) IS IN THE DIRECTION OF THE OIL COOLER.

- Conduct filling and priming procedure as specified in this section of manual.
- Conduct engine run; perform drive unit operational checkout and check for leakage. Refer to Section I for engine ground run procedure.

06.02.1447

Figure 9-6. Replacement, Constant-Speed Oil System Components (Sheet 3 of 3)

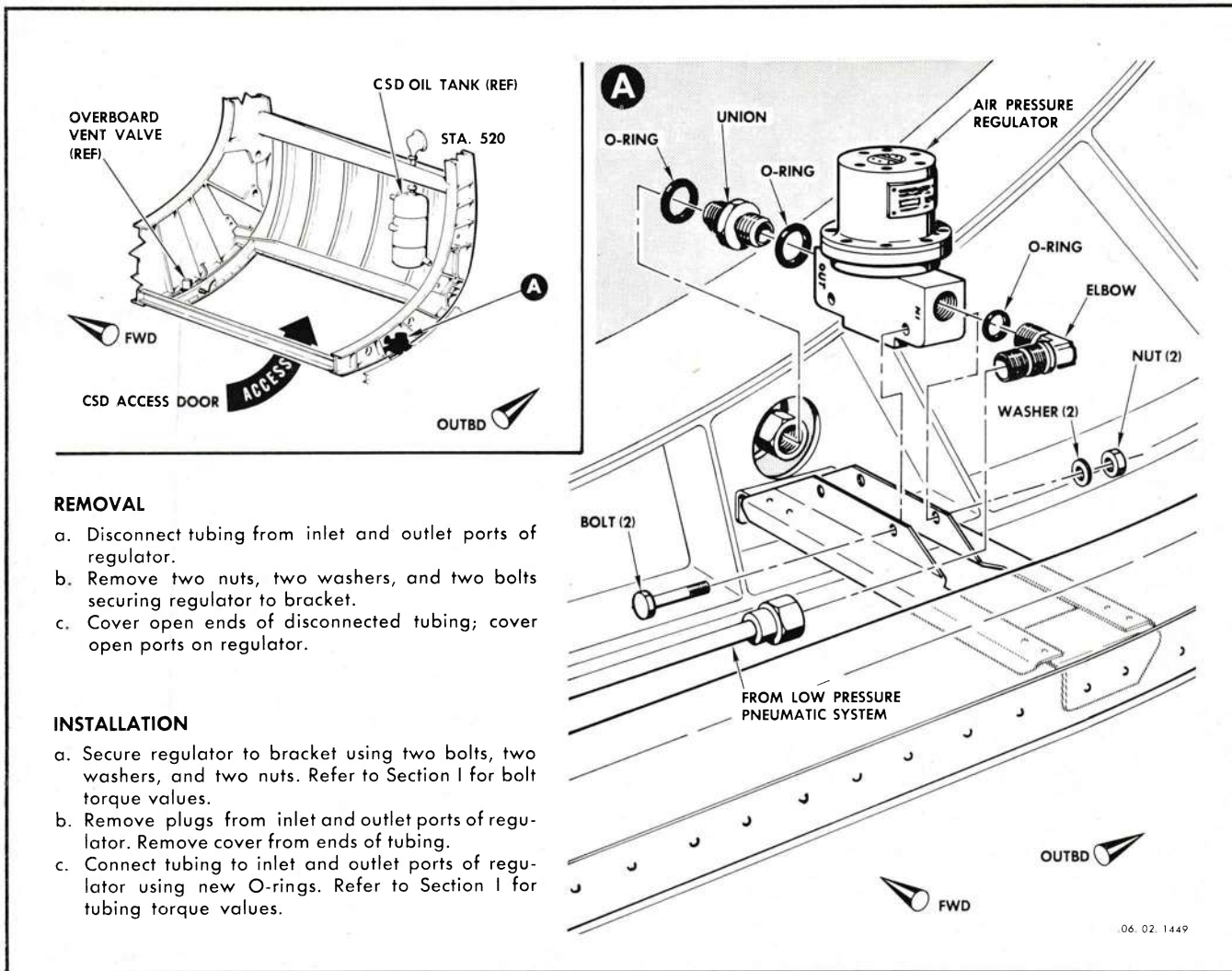

**REMOVAL**

- Disconnect tubing from inlet and outlet ports of regulator.
- Remove two nuts, two washers, and two bolts securing regulator to bracket.
- Cover open ends of disconnected tubing; cover open ports on regulator.

**INSTALLATION**

- Secure regulator to bracket using two bolts, two washers, and two nuts. Refer to Section I for bolt torque values.
- Remove plugs from inlet and outlet ports of regulator. Remove cover from ends of tubing.
- Connect tubing to inlet and outlet ports of regulator using new O-rings. Refer to Section I for tubing torque values.

Figure 9-7. Replacement, Constant-Speed Drive Generator Pressurization System Air Pressure Regulator

**CAUTION**

If monitor voltmeter voltage does not increase steadily on starting to a maximum steady value at IDLE, determine the cause of malfunction before proceeding.

h. Check oil supply system for signs of leakage. Repair as required.

i. Reservice oil tank to the FULL mark.

**NOTE**

If quantity of oil required to refill tank is greater than 4 quarts, repeat steps "c" through "i."

j. Start engine and accelerate to idle rpm.

k. Within 10 seconds after reaching idle rpm and with external electrical power removed from the airplane, energize airplane electrical generating system and check that the ac and dc power failure warning lights are extinguished. If lights are illuminated, terminate engine operation immediately and correct cause of malfunction.

l. Refer to T.O. 1F-106A-2-10 for complete checkout of the electrical generating system.

**9-28. SERVICING CONSTANT-SPEED OIL SYSTEM**

The constant speed oil system shall be checked and serviced to the "FULL" mark immediately after engine shut-down. See figure 9-13 for constant-speed oil system servicing instructions. Refer to T.O. 1F-106A-2-2 for servicing lubrication of the constant-speed drive shaft. If the airplane has been idle for a period exceeding

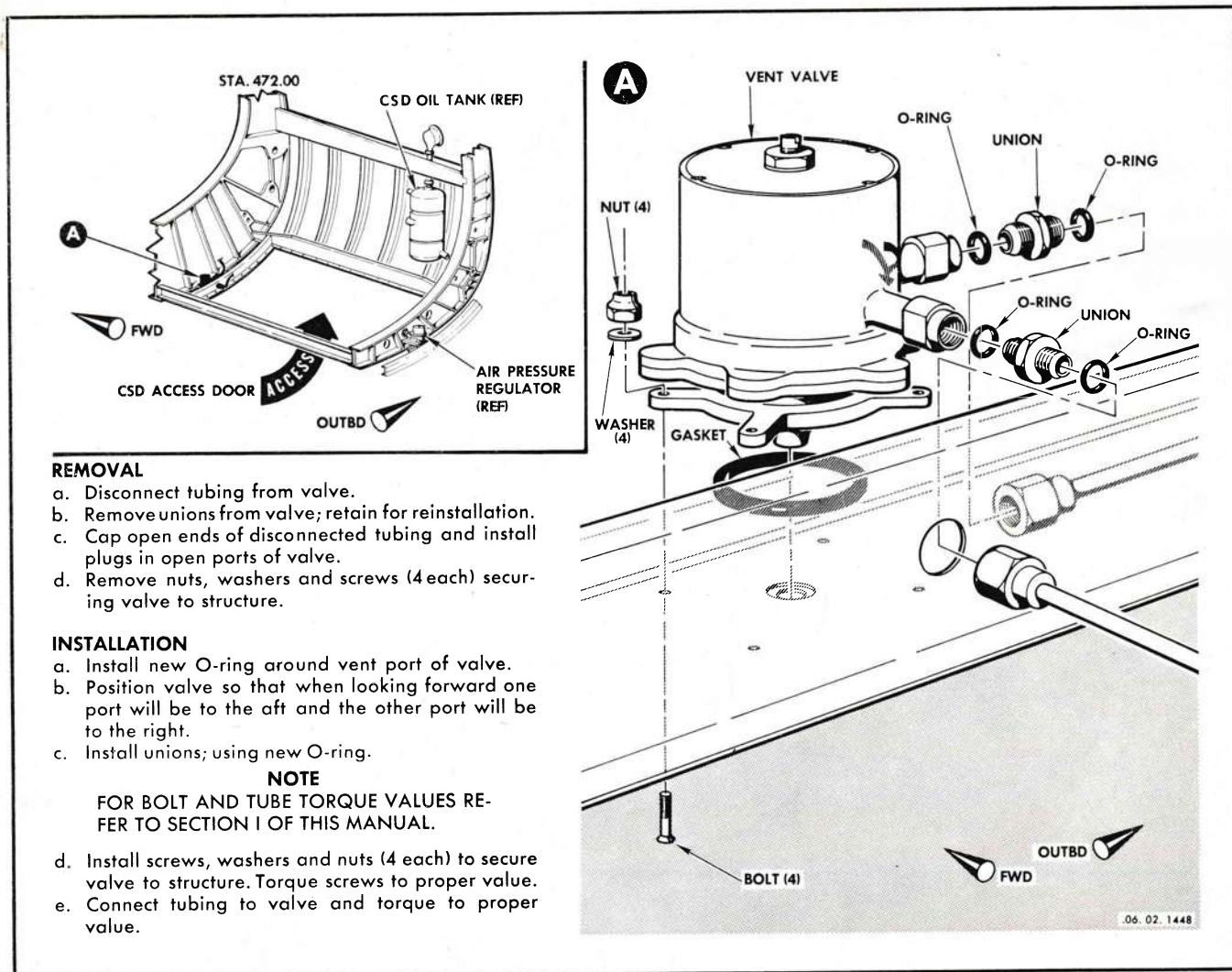

Figure 9-8. Replacement, Constant-Speed Drive Overboard Vent Valve

12 hours, check the constant-speed tank oil level prior to starting the engine. The oil level shall not have changed appreciably from the "FULL" mark regardless of the length of time that the airplane has been idle.

#### NOTE

Normal oil consumption for the constant speed drive system is 1 pint for each hour of operation. Oil consumption exceeding 1 pint per hour will require checking system for external leaks and for excessive oil drainage at the overboard vent. Refer to System Analysis, paragraph 9-9.

Applicable to F-106A airplanes 56-453, -454, 56-456 thru 57-245, 59-001 and subsequent, and F-106B airplanes 57-2508 thru 57-2515, 57-2542 and subsequent. A trap is formed in the vent-to-tank line which under normal condition does not affect the performance of the system.

However, if the tank is filled at a rate exceeding 1 quart every 30 seconds, or if the tank is overfilled, the trap in the vent-to-tank line fills with oil, causing an airlock. The airlock, in turn, causes a false oil level indication on the tank dipstick when servicing the tank past the 8.5 quarts to the 9.5 quarts "FULL" level because of the premature filling of the dipstick well. Rapid filling of the dipstick well past the 8.5 quarts oil level is the only indication personnel have that the vent-to-tank line contains oil. Subsequent engine operation will blow the oil out of the vent-to-tank line and empty the dipstick well to the 8.5 quarts level. A check of the oil level following such an occurrence would indicate the system was approximately 1 quart below capacity. To insure that the oil tank is filled to the 9.5 quarts "FULL" level, the amount of oil added shall be checked against the change in oil level indicated on the dipstick. If the amount added is less than the amount indicated on the dipstick, the vent-



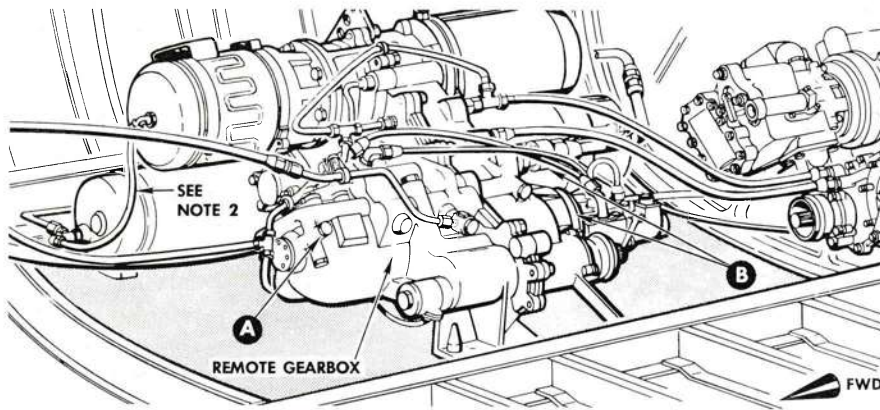

**NOTES**

1. FOR THE REMOVAL AND INSTALLATION OF THE CONSTANT SPEED DRIVE COMPONENTS, IT WILL BE NECESSARY TO GAIN ACCESS TO THE REMOTE GEARBOX THROUGH THE ACCESS DOORS ON THE LOWER SIDE OF THE FUSELAGE.
2. APPLICABLE TO F-106A AIRPLANES 56-453, -454, -463 THRU 56-466, 57-230 THRU 57-245, 57-2465, 57-2504 AND SUBSEQUENT; AND 57-246 THRU 57-2503 AFTER INCORPORATION OF TCTO 1F-106-597. APPLICABLE TO F-106B AIRPLANES 57-2508 THRU 57-2515, 57-2523, 57-2531 AND SUBSEQUENT; AND ALL OTHER F-106B AIRPLANES AFTER INCORPORATION OF TCTO 1F-106-597. ALL PURGE AIR LINES TO THE GENERATORS ARE REMOVED AND AN OVERBOARD DRAIN LINE IS INSTALLED FOR EACH GENERATOR. THE DRAIN LINES MANIFOLD AND DRAIN THROUGH A FITTING IN THE CSD ACCESS DOOR, STATION 493.00.

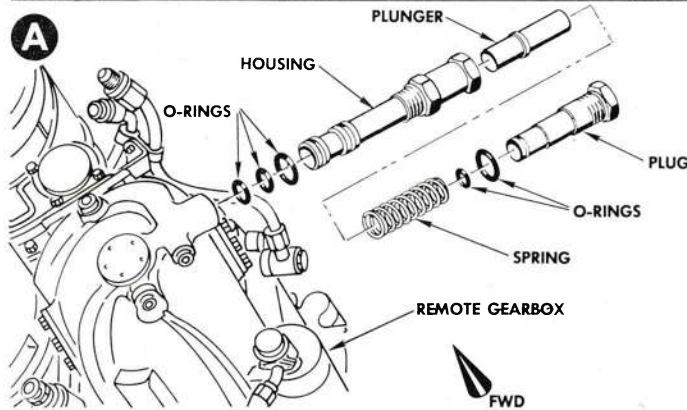

**CHARGE RELIEF VALVE, REMOVAL**

- a. Remove plug.
- b. Remove valve spring, plunger, and housing.
- c. Remove and discard all seals.

**INSTALLATION**

- a. Installation of the charge relief valve is essentially the reverse of the removal procedure.
- b. Use new seals on installation.
- c. Torque plug 100 to 150 inch-pounds, and safety-wire.

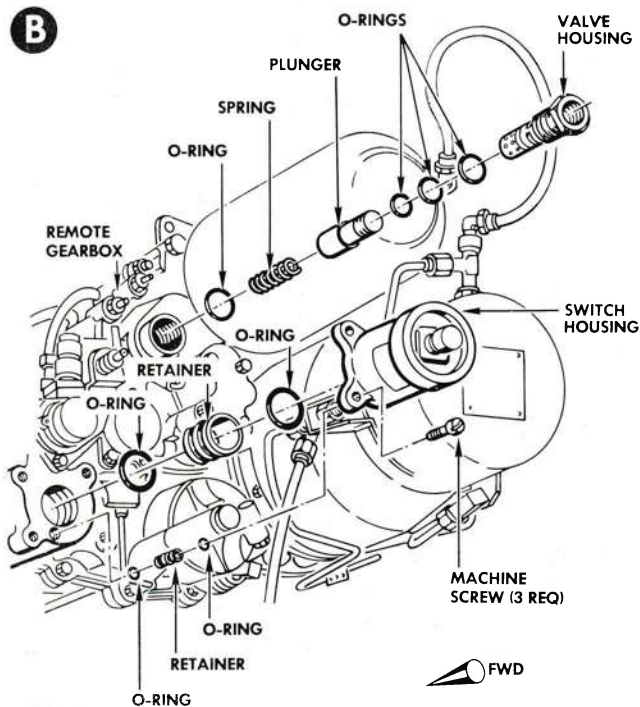

**ANTI-DRAIN VALVE, REMOVAL**

- a. Remove valve housing from gearbox.
- b. Remove plunger from valve housing. If plunger is hard to remove, reach through hole in housing and remove seal from plunger.
- c. Remove spring and seal from gearbox.
- d. Remove and discard all seals.

**INSTALLATION**

- a. Installation of the anti-drain valve is essentially the reverse of the removal procedure.
- b. Use new seals on installation.
- c. Torque valve housing 180 to 220 inch-pounds and safety-wire.

**PRESSURE SWITCH, REMOVAL**

- a. Disconnect the electrical lead.
- b. Remove the three screws securing the switch assembly to the gearbox.
- c. Pull the switch assembly from the gearbox. Remove the seal retainers from the switch body.
- d. Remove and discard all seals.

**INSTALLATION**

- a. Installation of the pressure switch is essentially the reverse of the removal procedure.
- b. Use new seals on installation.
- c. Safety-wire screws and electrical lead.

Figure 9-9. Replacement, Constant-Speed Drive Pressure Switch, Charge Relief Valve, and Anti-Drain Valve

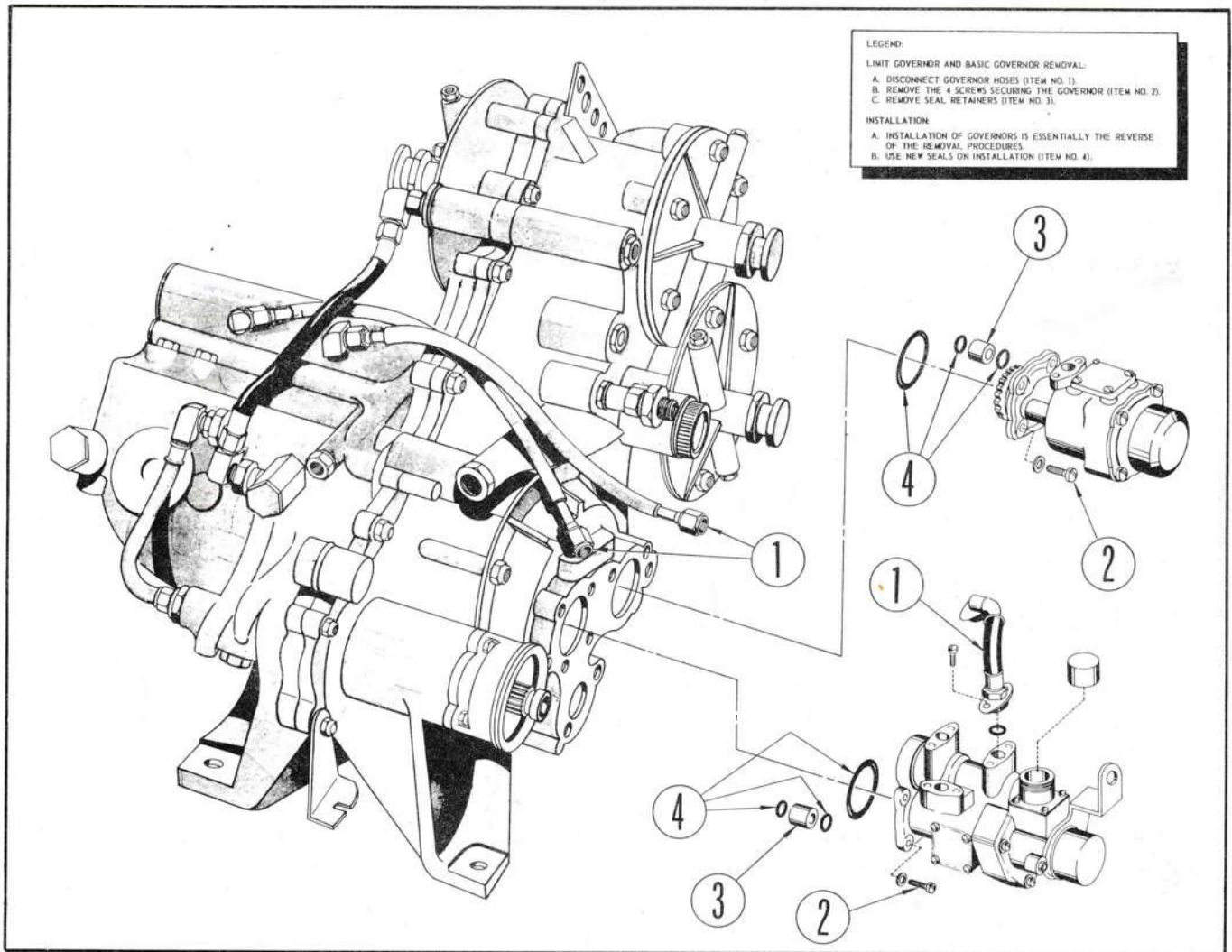

Figure 9-10. Replacement, Constant-Speed Drive Limit and Magnetic Trim Governor.

to-tank line contains oil. To eliminate the airlock, disconnect the vent-to-tank line at the swivel fitting and drain the line. Gain access to the swivel fitting through the small aft constant-speed drive access door on the lower right side of the fuselage.

#### 9-29. CONTAMINATION CHECK, CONSTANT-SPEED OIL SYSTEM.

a. See figure 9-14 for the contamination check procedure of the constant-speed drive oil system. This procedure shall be accomplished at the frequency outlined in T.O. 1F-106A-6 and each time engine mounted gearbox, remote mounted gearbox, or generator internal mechanical failure occurs. Refer to paragraph 9-30 for contamination check of generators.

#### NOTE

In most instances when failure of the airplane ac generator drive end bearing occurs, copper shunt bars are thrown from the permanent magnet generators (PMG) rotor into the remote gearbox sump and gear train. These bars are usually ground into smaller particles by the gear train, picked up by the scavenge pump and forced upstream to the oil cooler and oil tank. This type of metal particle (nonferrous) contamination will not be revealed by the chip detector plugs (reference figure 9-14) and will not in all instances be revealed by the remote gearbox charge filter.

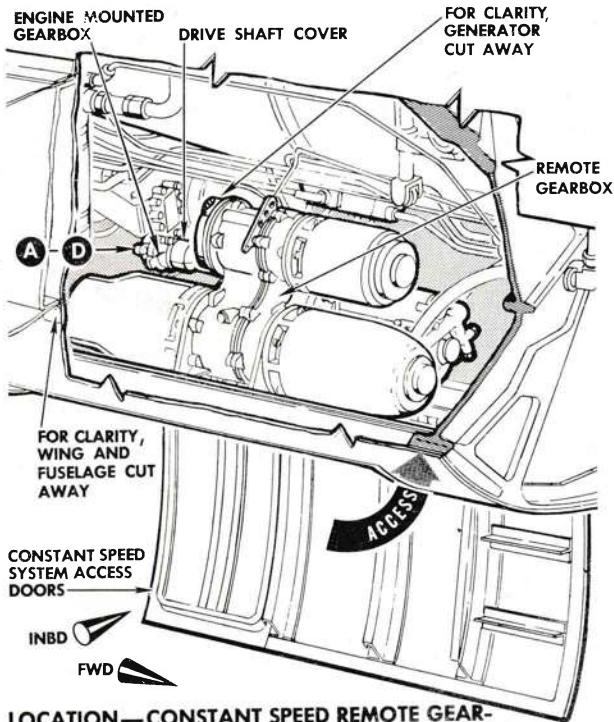

LOCATION—CONSTANT SPEED REMOTE GEARBOX, ENGINE MOUNTED GEARBOX, AND CONNECTING DRIVE SHAFT.

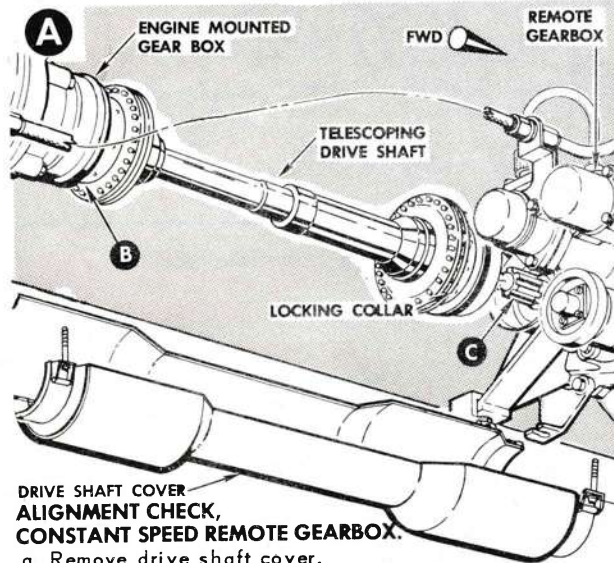

**DRIVE SHAFT COVER ALIGNMENT CHECK, CONSTANT SPEED REMOTE GEARBOX.**

- a. Remove drive shaft cover.
- b. Remove interconnecting shaft and adapter assemblies as follows:
  1. Remove safety wire.
  2. Using spanner wrench U3501, loosen ring nuts.
  3. Compress shaft and remove.
  4. Loosen adapter attaching screws.
  5. Remove retaining ring and remove adapters as assemblies.

**CAUTION**

DO NOT PRY, HAMMER, OR USE TOOLS THAT WILL IN ANY WAY CAUSE DAMAGE TO THE SHAFT.

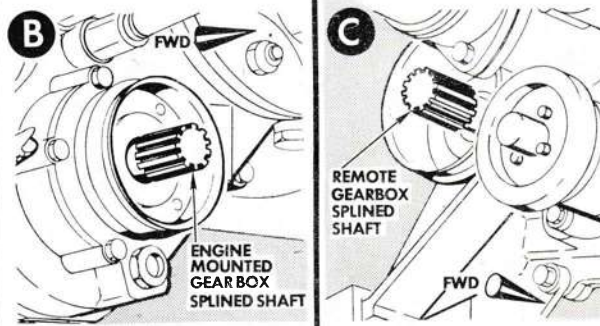

- c. Check remote gearbox and engine mounted gearbox splined drive shafts for indication of wear and play in support bearing. Remote gearbox shaft maximum sideplay, 0.007 inch. Engine mounted gearbox shaft maximum sideplay, 0.028 inch.

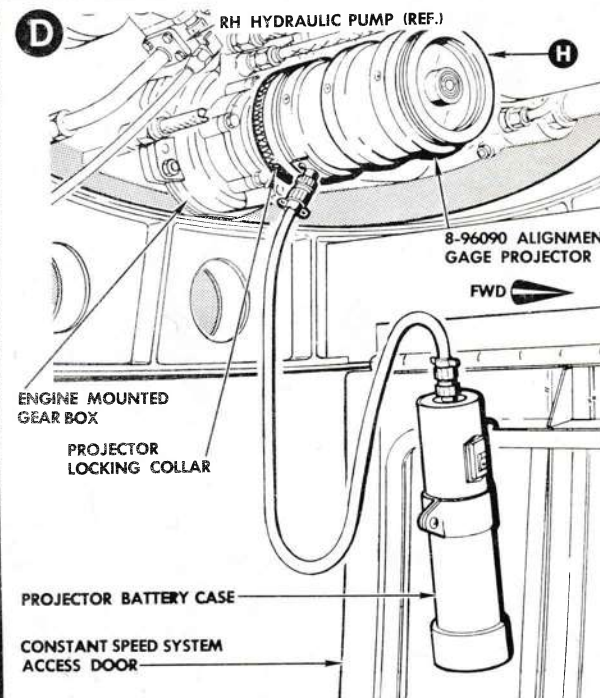

- d. Using a recently calibrated alignment gage 8-96090, install projector portion of gage on engine mounted gear box splined shaft as follows:

**CAUTION**

THE CONSTANT SPEED GEARBOX ALIGNMENT GAGE IS A PRECISION OPTICAL INSTRUMENT AND MUST BE HANDLED WITH EXTREME CARE.

1. Remove projector portion of gage from carrying case and hang battery case from drive unit access door frame.
2. Loosen projector locking collar (turn counterclockwise) and install projector on gearbox splined shaft.
3. Tighten locking collar by hand until it is snug. Do not overtighten collar.

.06.02.485-1B .72.58.00

Figure 9-11. Alignment Check, Constant-Speed Remote Gearbox (Sheet 1 of 3)

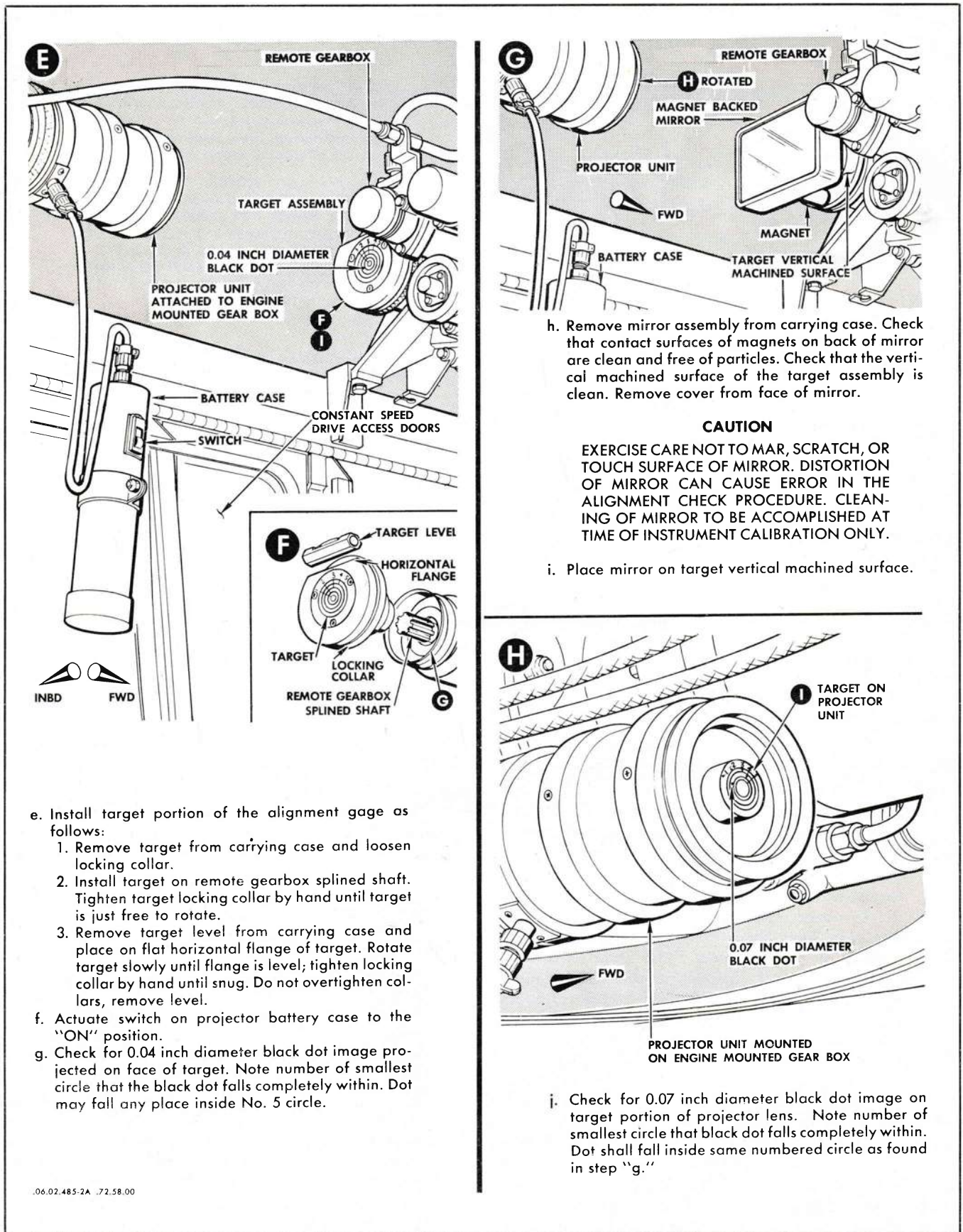
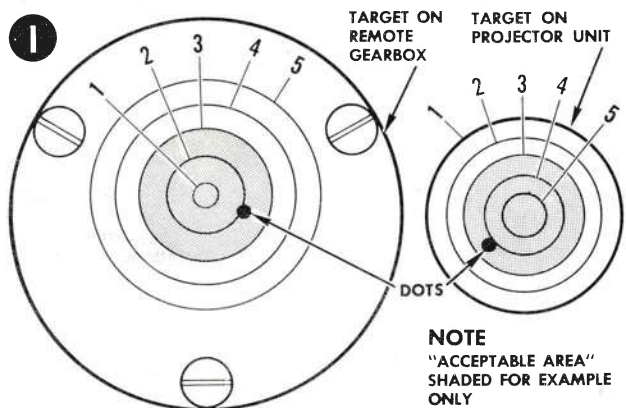

Figure 9-11. Alignment Check, Constant-Speed Remote Gearbox (Sheet 2 of 3)



**EXAMPLE:**

IF DOT FALLS WITHIN AREA BETWEEN CENTER AND CIRCLE NO. 3 OF REMOTE GEARBOX TARGET, THEN DOT SHOULD APPEAR WITHIN AREA BETWEEN CENTER AND CIRCLE NO. 3 ON PROJECTOR TARGET.

- k. If black dots fall inside same numbered circle on both targets, the remote gearbox is in alignment.
- l. If the dots do not fall within the same circles, perform the following:
  1. Check alignment gage target and projector for

TARGET ON  
REMOTE  
GEARBOX

TARGET ON  
PROJECTOR UNIT

DOTS

**NOTE**  
"ACCEPTABLE AREA"  
SHADED FOR EXAMPLE  
ONLY

- security of attachment; mirror magnets, target vertical and horizontal machined surfaces clean.
- 2. Check that contact surface of target level is clean and undistorted; check leveling of target.
- 3. Recheck all steps of preparation procedure.

**NOTE**

IF MISALIGNMENT IS INDICATED AFTER A RECHECK, CHECK FOR STRUCTURAL DAMAGE OR MISALIGNMENT OF FUSELAGE IN ENGINE OR REMOTE GEARBOX MOUNT FITTING AREAS. DO NOT ATTEMPT TO ALIGN REMOTE GEARBOX USING STOPS (2) AT GEARBOX OUTBOARD HINGE.

**CLEANUP :**

- a. Remove alignment gage.
- b. Install constant speed drive shaft and shaft cover. See replacement, constant speed drive shaft for proper installation procedure.

**CAUTION**

PULL ON EACH END OF DRIVE SHAFT TO CHECK FOR SECURE SHAFT INSTALLATION. CHECK THAT THE SHAFT LOCKING COLLAR AT EACH END OF SHAFT IS IN THE LOCKED POSITION.

- c. Close access doors.

.06.02.485-3D .72.56.00

Figure 9-11. Alignment Check, Constant-Speed Remote Gearbox (Sheet 3 of 3)

b. In the event of an airplane ac generator failure, the following procedure will be accomplished in addition to the procedures outlined in figure 9-14:

1. Remove the ac generator from pad "B." Refer to T.O. 1F-106A-2-10 for generator removal instructions. Check the generator drive end area for evidence of mechanical failure. Particular emphasis should be placed on the condition of the 16 copper shunt bars on the PMG rotor of the generator. Visually examine the exposed portion of the generator PMG rotor area for evidence of metal particles. If the PMG shunt bars are all intact, no further examination is required. Replace the generator in accordance with instructions in T.O. 1F-106A-2-10.
2. If copper shunt bars are found missing, examine the interior of the remote gearbox pad "B" area for evidence of copper particles. Remove the constant-speed drive oil cooler. Visually examine the oil-in and oil-out ports of the cooler for evidence of copper particles. If copper particles are found, replace components and perform maintenance as outlined in paragraph 9-31.

**9-30. CONTAMINATION CHECK, CONSTANT-SPEED SYSTEM GENERATORS.**

See figure 9-15 for the contamination check procedure for the constant-speed system generators. This procedure is to be followed in the event of a remote gearbox or generator malfunction of a nature which would contaminate the constant-speed oil system with metal chips.

**NOTE**

If remote gearbox malfunction occurs, resulting in contamination, replace the gearbox and check all generators and filters for contamination. If a generator mechanical failure of a nature to contaminate the remote gearbox occurs, replace the generator and the remote gearbox. Clean the constant-speed oil system filters, since the remote gearbox cannot be cleaned; check the remaining generators for contamination. See figure 9-25 for procedures on cleaning the constant-speed oil system filters. Refer to paragraph 1-25 for contamination check procedure of the constant-speed drive oil system.

LOCATION—OIL SYSTEM REPLACEMENT COMPONENTS

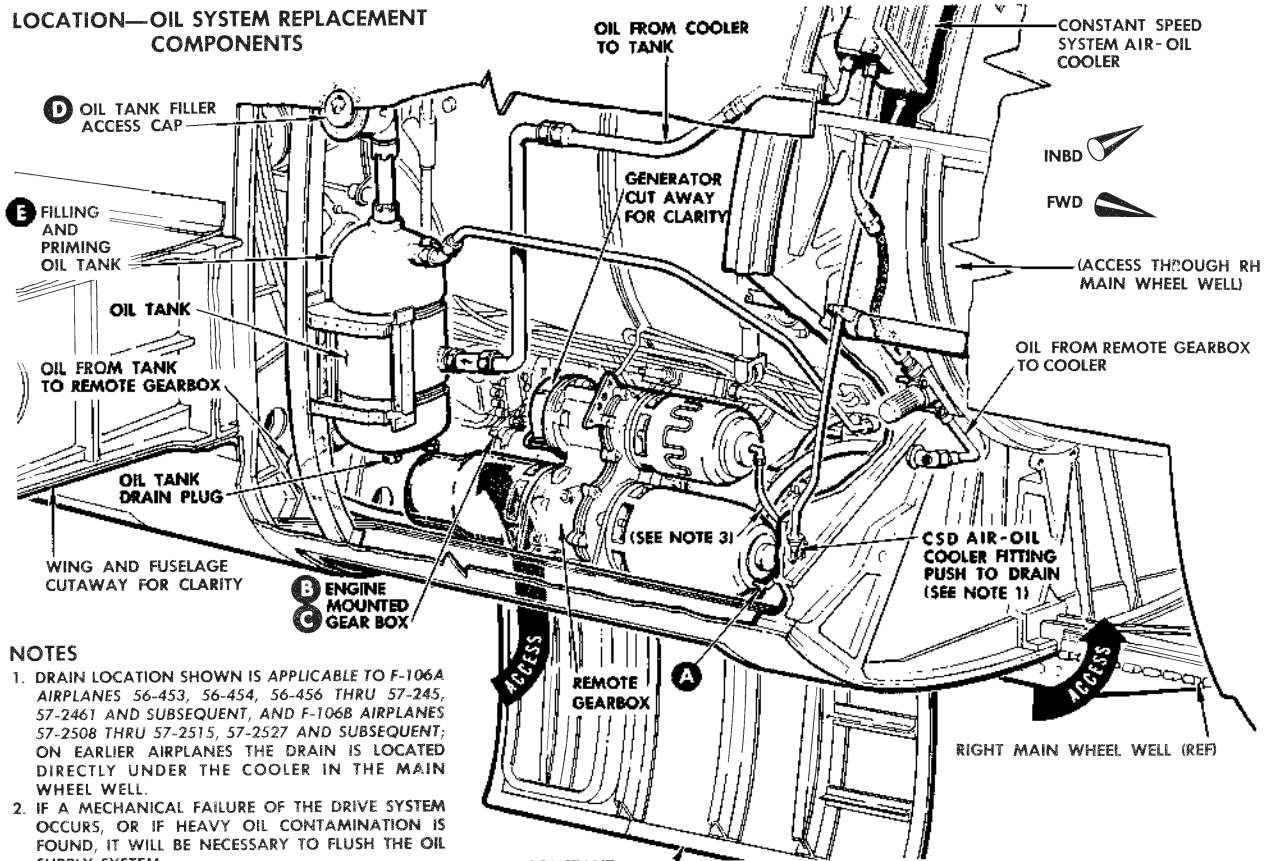

NOTES

1. DRAIN LOCATION SHOWN IS APPLICABLE TO F-106A AIRPLANES 56-453, 56-454, 56-456 THRU 57-245, 57-2461 AND SUBSEQUENT, AND F-106B AIRPLANES 57-2508 THRU 57-2515, 57-2527 AND SUBSEQUENT; ON EARLIER AIRPLANES THE DRAIN IS LOCATED DIRECTLY UNDER THE COOLER IN THE MAIN WHEEL WELL.
2. IF A MECHANICAL FAILURE OF THE DRIVE SYSTEM OCCURS, OR IF HEAVY OIL CONTAMINATION IS FOUND, IT WILL BE NECESSARY TO FLUSH THE OIL SUPPLY SYSTEM.
3. APPLICABLE TO F-106A AIRPLANES 56-453, -454, -463 THRU 56-466, 57-230 THRU 57-245, 57-2465, 57-2504 AND SUBSEQUENT; AND 57-246 THRU 57-2503 AFTER INCORPORATION OF TCTO 1F-106-597. APPLICABLE TO F-106B AIRPLANES 57-2508 THRU 57-2515, 57-2523, 57-2531 AND SUBSEQUENT; AND ALL OTHER F-106B AIRPLANES AFTER INCORPORATION OF TCTO 1F-106-597. ALL PURGE AIR LINES TO THE GENERATORS ARE REMOVED AND AN OVERBOARD DRAIN LINE IS INSTALLED FOR EACH GENERATOR. THE DRAIN LINES MANIFOLD AND DRAIN THROUGH A FITTING IN THE CSD ACCESS DOOR, STATION 493.00.

CONSTANT SPEED SYSTEM OIL DRAINING

- a. Open constant speed system access door.
- b. Provide drain receptacle; remove plug from bottom of oil tank and drain oil from tank. Replace plug using new gasket; safety wire.
- c. Gain access to oil cooler drain through right aft side of main wheel well. Provide drain receptacle. Remove cap and push cooler drain; drain oil from cooler. Release drain.

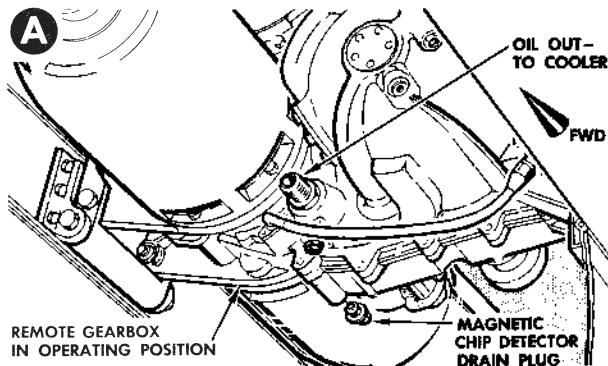

- d. Gain access to remote gearbox at door on lower right side of fuselage. Remove magnetic drain plug from lower surface of drive unit. Drain oil; replace plug. Torque plug to 20 inch-pounds maximum; safety-wire.

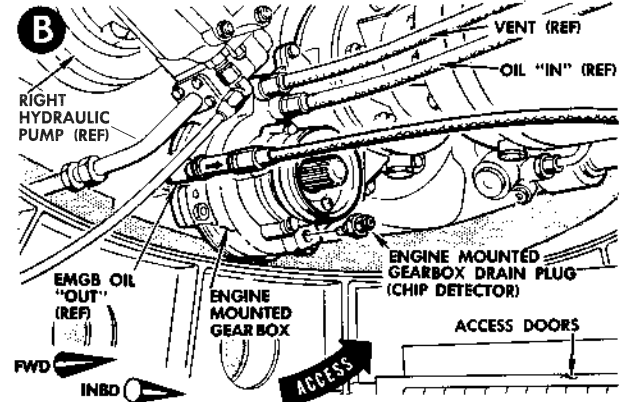

- e. Remove drain plug from lower surface of engine mounted gear box. Drain oil; replace plug. Torque plug to 20 inch-pounds maximum; safety-wire.

.06.02.342-1 G

Figure 9-12. Draining and Priming, Constant-Speed Oil Supply System (Sheet 1 of 2)

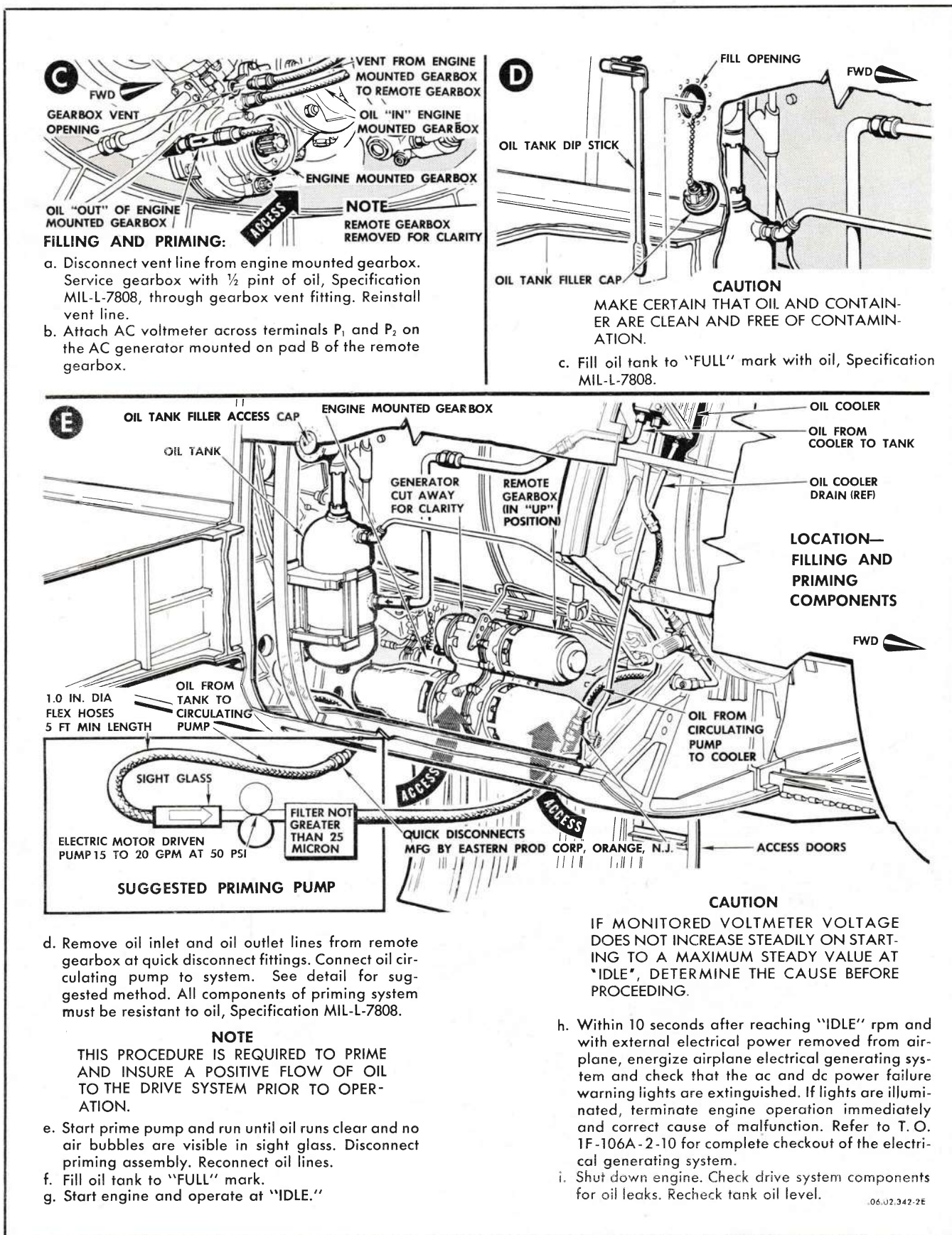

- FILLING AND PRIMING:**
- Disconnect vent line from engine mounted gearbox. Service gearbox with ½ pint of oil, Specification MIL-L-7808, through gearbox vent fitting. Reinstall vent line.
  - Attach AC voltmeter across terminals P<sub>1</sub> and P<sub>2</sub> on the AC generator mounted on pad B of the remote gearbox.

- Fill oil tank to "FULL" mark with oil, Specification MIL-L-7808.

- Remove oil inlet and oil outlet lines from remote gearbox at quick disconnect fittings. Connect oil circulating pump to system. See detail for suggested method. All components of priming system must be resistant to oil, Specification MIL-L-7808.

- NOTE**  
THIS PROCEDURE IS REQUIRED TO PRIME AND INSURE A POSITIVE FLOW OF OIL TO THE DRIVE SYSTEM PRIOR TO OPERATION.
- Start prime pump and run until oil runs clear and no air bubbles are visible in sight glass. Disconnect priming assembly. Reconnect oil lines.
  - Fill oil tank to "FULL" mark.
  - Start engine and operate at "IDLE."

- Within 10 seconds after reaching "IDLE" rpm and with external electrical power removed from airplane, energize airplane electrical generating system and check that the ac and dc power failure warning lights are extinguished. If lights are illuminated, terminate engine operation immediately and correct cause of malfunction. Refer to T.O. 1F-106A-2-10 for complete checkout of the electrical generating system.
- Shut down engine. Check drive system components for oil leaks. Recheck tank oil level.

Figure 9-12. Draining and Priming, Constant-Speed Oil Supply System (Sheet 2 of 2)

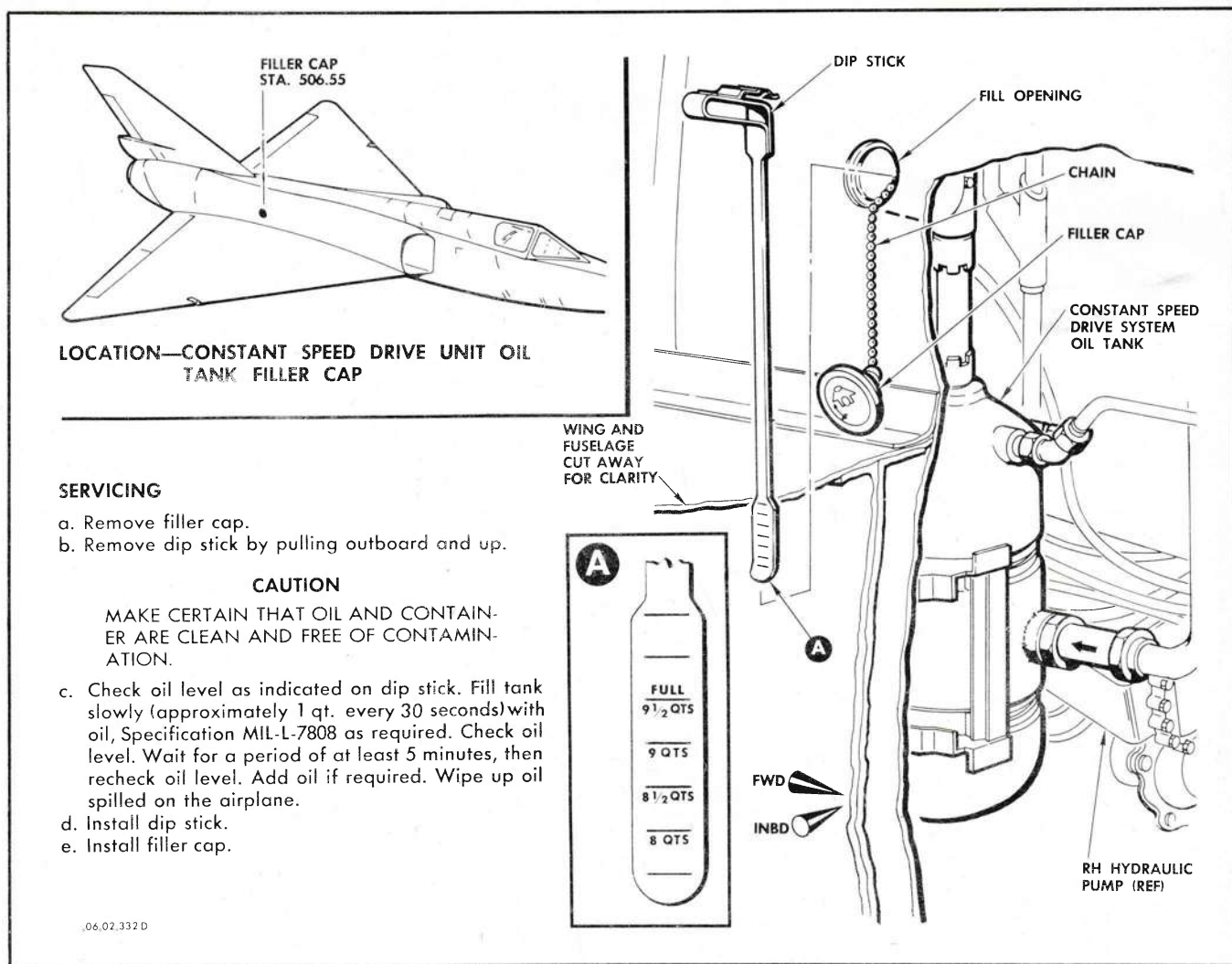

Figure 9-13. Servicing Constant-Speed Oil System

9-31. CONSTANT-SPEED OIL SYSTEM FLUSHING AND COMPONENT REPLACEMENT.

In the event of remote mounted gearbox, engine mounted gearbox, or generator mechanical failure resulting in contamination, or if contamination check (figure 9-14) reveals an unacceptable condition in either gearbox, perform the maintenance outlined in the following table:

**CAUTION**

Exercise care during maintenance to assure that cleanliness of all components is maintained. Serious damage to the units can be caused by very small amounts of foreign material.

COMPONENT	MAINTENANCE REQUIRED
Transmission and Remote Gearbox (TRGB)	If TRBG failure or chip detector reveals unacceptable contamination, proceed as follows:

COMPONENT	MAINTENANCE REQUIRED
	<p>a. Inspect scavenge return line (wheel well) filter and chip detector plugs. If contamination is found, remove filter and check Delta "P." If check shows filter has bypassed, make contamination check of generators, replace EMGB, cooler, and oil tank and flush lines.</p> <p>b. If filter has not bypassed, remove TRGB only and make contamination check of generators.</p> <p>c. If TRGB failed, remove and return to depot for overhaul. If TRGB has not failed but shows unacceptable contamination, remove and bench check. See figure 9-3 for replacement procedure.</p>



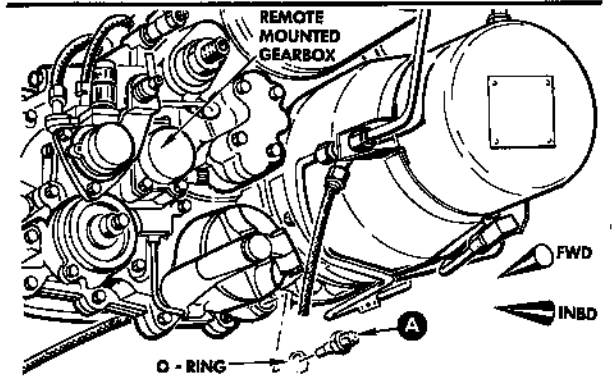
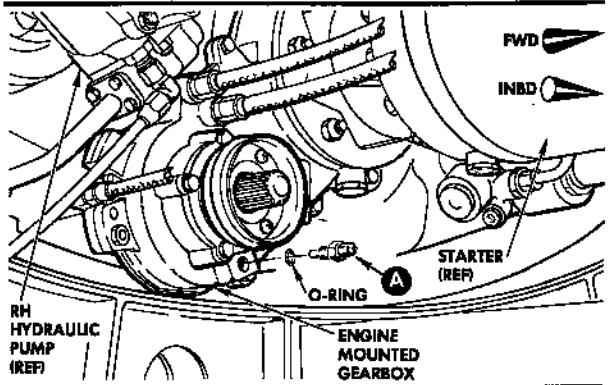
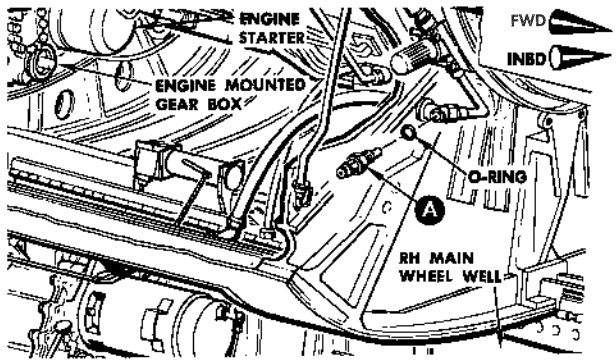

**PROCEDURE**

- Gain access to the constant speed drive remote and engine mounted gearboxes through the constant speed drive aft access door on the lower side of the fuselage.
- Using a standard ohmmeter, check resistance between center pin and shoulder of chip detector magnetic drain plugs. If resistance readings are more than 5000 ohms, no further check need be made.
- If reading at either plug is less than 5000 ohms, remove affected plug. If examination of plug reveals metal chip contamination not exceeding that shown in detail C, clean plug and filter of affected gearbox. Reinstall using new O-rings. Torque magnetic plug 35 to 50 inch-pounds and lock-wire; recheck resistance. If engine mounted gearbox plug has been removed, reprime gearbox per draining and priming instructions.
- If examination reveals metal chip contamination similar or worse than that shown in detail "D," replace plug without cleaning. Replace affected gearbox and drain oil supply system. Refer to constant speed oil system flushing and component replacement procedures.
- Prime constant speed oil system.

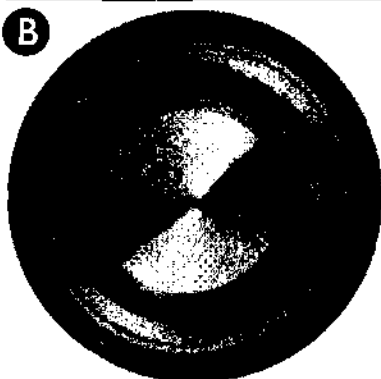
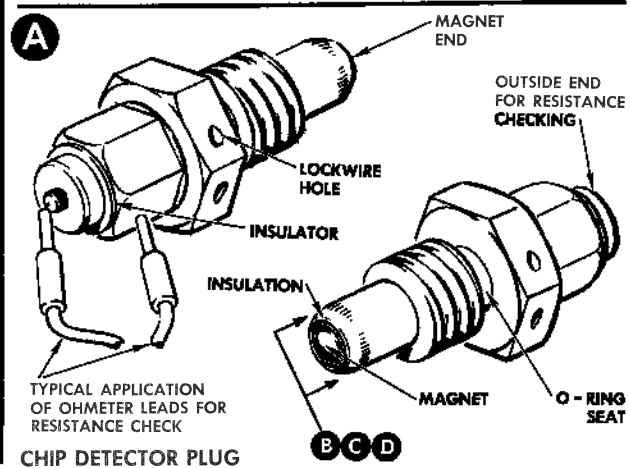

CLEAN PLUG

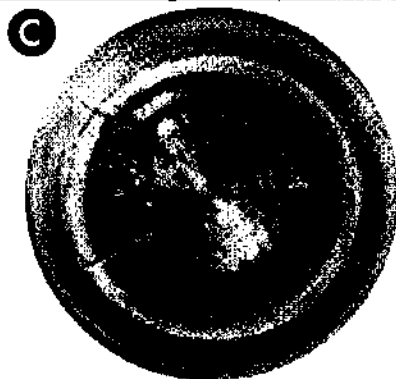

ACCEPTABLE CONDITION  
PARTICLES LESS THAN 3/32 INCH IN LENGTH, OR LESS THAN 1/32 INCH IN DIAMETER.



UNACCEPTABLE CONDITION  
PARTICLES 3/32 INCH IN LENGTH OR LONGER, OR 1/32 INCH IN DIAMETER OR LARGER.

.06.02.672D

Figure 9-14. Contamination Check, Constant-Speed Oil System

**PROCEDURE**

- a. Gain access to the constant speed remote gearbox through the constant speed access doors on the lower right side of the fuselage. Lower the constant speed remote gearbox out of fuselage; do not detach from fuselage.
- b. Refer to T. O. 1F-106A-2-10 for the removal and installation procedure for the constant speed system generators.
- c. Check each generator by placing it on end, with drive gear up. Pour clean oil, Specification MIL-L-7808, into a stator oil port until the oil level reaches the port; then apply low pressure shop air into the port. Direct the air and oil issuing from the opposite stator oil port into a clean, lint free cloth. Cut off shop air when the air flowing from the opposite port is free of oil mist. Inspect the cloth. If metal chips are found, replace the generator; if not, repeat this procedure for both the remaining stator oil port and the center rotor oil tube. If either of these procedures discloses metal chips, replace the generator.

.06.02.1042

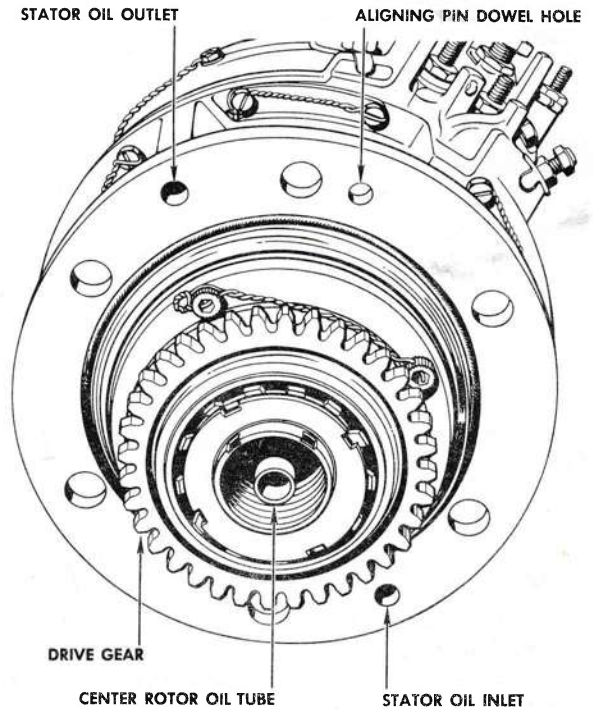

Figure 9-15. Contamination Check, Constant-Speed System Generators

COMPONENT	MAINTENANCE REQUIRED
Engine Mounted Gearbox (EMGB)	<p>If EMGB fails or chip detector plug reveals unacceptable contamination, proceed as follows:</p> <ol style="list-style-type: none"> <li>a. Check EMGB oil out port filter. If contamination is found remove filter and check Delta "P." If check shows filter has bypassed then check TRGB filter and chip detector plug. If contamination is found at these two points remove TRGB for bench check and perform contamination check of generators.</li> <li>b. Inspect scavenge return line chip detector plug and filter (wheel well) and if contamination is found remove filter and check Delta "P." If filter has bypassed remove cooler and tank and flush lines.</li> <li>c. If EMGB has failed remove and return to depot for overhaul. If EMGB has not failed but shows unacceptable contamination, remove and bench check. See figure 9-4 for replacement procedures.</li> </ol>

COMPONENT	MAINTENANCE REQUIRED
CSD Oil Tank	Replace tank if scavenge return line (wheel well) filter Delta "P" check shows filter has bypassed. See figure 9-6 for replacement procedures. Flush in accordance with T.O. 7J10-6-3.
CSD Oil Cooler	Replace cooler if scavenge return line (wheel well) filter Delta "P" check shows filter has bypassed. See figure 9-6 for replacement procedures. Return replaced item to depot for flushing.
CSD Generators	Perform contamination check of generators if contamination is found in TRGB and/or if contamination is found in EMGB and EMGB oil out port filter Delta "P" check reveals filter has bypassed. See figure 9-15.
CSD Oil System Lines	Remove all lines and flush with solvent, Federal Specification P-S-661 if scavenge return line (wheel well) filter Delta "P" check shows filter has bypassed.

COMPONENT	MAINTENANCE REQUIRED
	If cleaning not accomplished by flushing, replace lines.
Oil "IN" to Cooler Check Valve and Oil "IN" to Tank Relief Valve	Remove valves from lines if scavenge return line (wheel well) filter Delta "P" check shows filter has bypassed. Flush valves, in direction of free flow, with solvent, Federal Specification P-S-661. Pump solvent at 15 to 20 GPM. Valves cannot be disassembled. See figure 9-6 for procedure on replacement of oil system check valves.
Generator Pressure and Vent Lines	Remove lines and flush with solvent, Federal Specification P-S-661 when unacceptable contamination is found in TRGB. If cleaning not accomplished by flushing, replace lines.
Oil "OUT" of EMGB and Oil "IN" to Cooler Filter	Check filters for contamination and clean if necessary. See figure 9-16 for procedure on cleaning oil system filters.

**NOTE**

- a. Scavenge return line (wheel well) filter: Filter has bypassed if Delta "P" exceeds 12 psi when applying 50 psi pressure at 12 gpm flow.
- b. EMGB oil out port filter: Filter has bypassed if Delta "P" exceeds 15 psi when applying pressure required to flow 400-500 cc/minute.

**9-32. PRESERVATION CONSTANT-SPEED DRIVE SYSTEM.**

Refer to paragraph 1-81 for preservation information for the constant-speed drive system.

**9-33. DEPRESERVATION, CONSTANT-SPEED DRIVE SYSTEM.**

Refer to paragraph 1-82 for depreservation information for the constant-speed drive system.

**9-34. CLEANING, CONSTANT-SPEED OIL SYSTEM FILTERS.**

See figure 9-16 for cleaning procedures for the constant-speed remote and engine mounted gearbox oil filters.

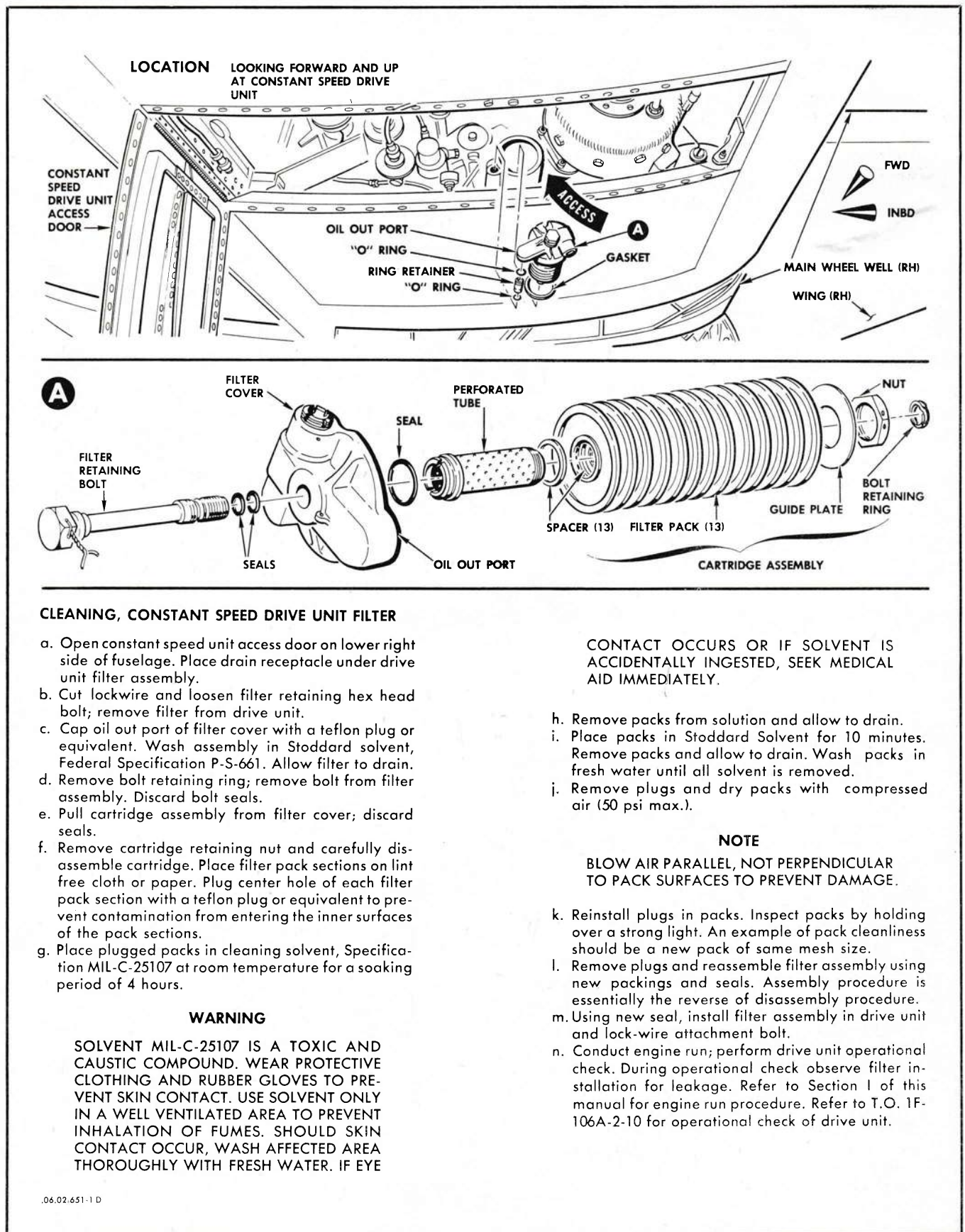
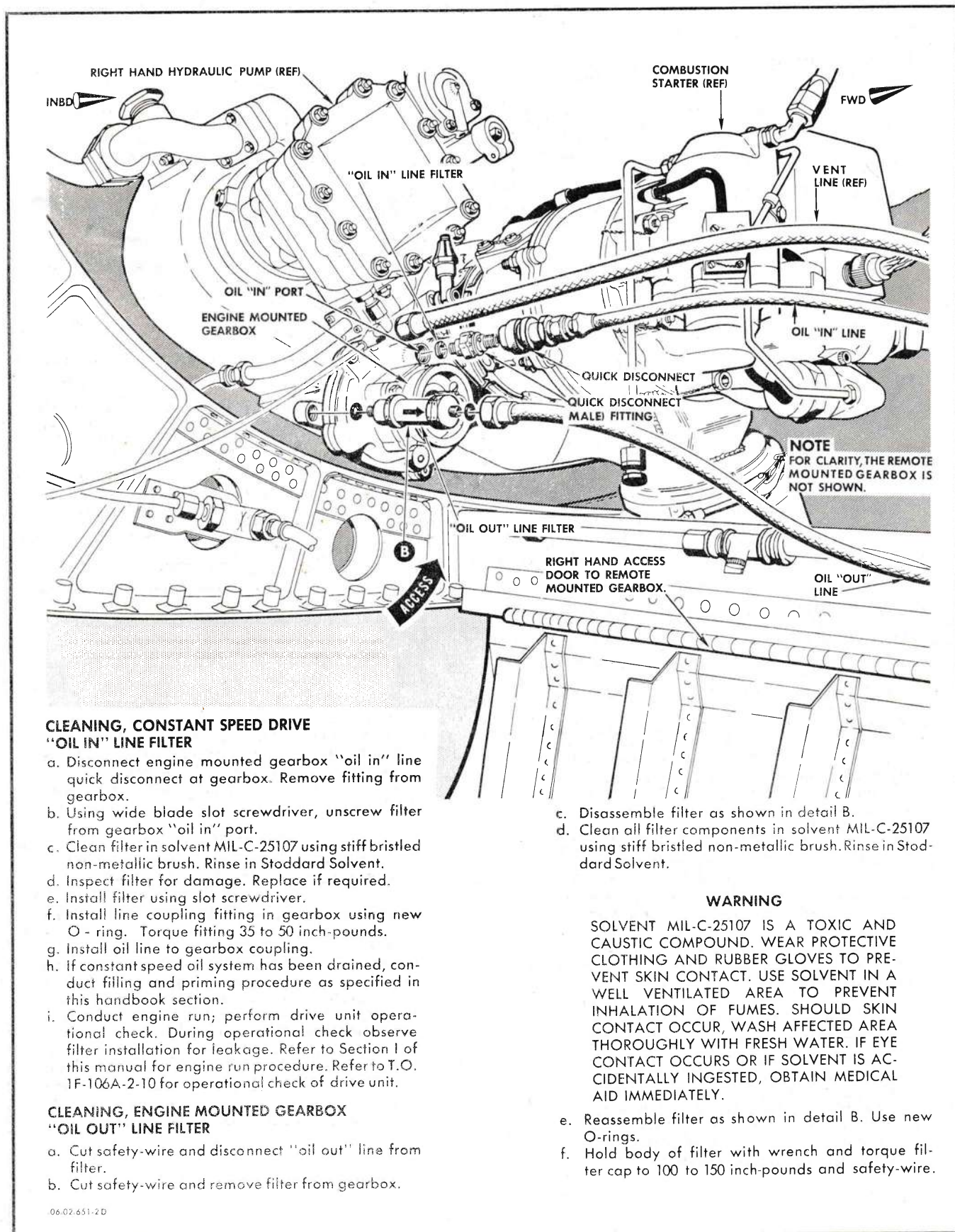

Figure 9-16. Cleaning, Constant-Speed Oil System Filters (Sheet 1 of 3)



**CLEANING, CONSTANT SPEED DRIVE  
"OIL IN" LINE FILTER**

- Disconnect engine mounted gearbox "oil in" line quick disconnect at gearbox. Remove fitting from gearbox.
- Using wide blade slot screwdriver, unscrew filter from gearbox "oil in" port.
- Clean filter in solvent MIL-C-25107 using stiff bristled non-metallic brush. Rinse in Stoddard Solvent.
- Inspect filter for damage. Replace if required.
- Install filter using slot screwdriver.
- Install line coupling fitting in gearbox using new O-ring. Torque fitting 35 to 50 inch-pounds.
- Install oil line to gearbox coupling.
- If constant speed oil system has been drained, conduct filling and priming procedure as specified in this handbook section.
- Conduct engine run; perform drive unit operational check. During operational check observe filter installation for leakage. Refer to Section I of this manual for engine run procedure. Refer to T.O. 1F-106A-2-10 for operational check of drive unit.

**CLEANING, ENGINE MOUNTED GEARBOX  
"OIL OUT" LINE FILTER**

- Cut safety-wire and disconnect "oil out" line from filter.
- Cut safety-wire and remove filter from gearbox.

- Disassemble filter as shown in detail B.
- Clean all filter components in solvent MIL-C-25107 using stiff bristled non-metallic brush. Rinse in Stoddard Solvent.

**WARNING**

SOLVENT MIL-C-25107 IS A TOXIC AND CAUSTIC COMPOUND. WEAR PROTECTIVE CLOTHING AND RUBBER GLOVES TO PREVENT SKIN CONTACT. USE SOLVENT IN A WELL VENTILATED AREA TO PREVENT INHALATION OF FUMES. SHOULD SKIN CONTACT OCCUR, WASH AFFECTED AREA THOROUGHLY WITH FRESH WATER. IF EYE CONTACT OCCURS OR IF SOLVENT IS ACCIDENTALLY INGESTED, OBTAIN MEDICAL AID IMMEDIATELY.

- Reassemble filter as shown in detail B. Use new O-rings.
- Hold body of filter with wrench and torque filter cap to 100 to 150 inch-pounds and safety-wire.

06.02.651-2D

Figure 9-16. Cleaning, Constant-Speed Oil System Filters (Sheet 2 of 3)

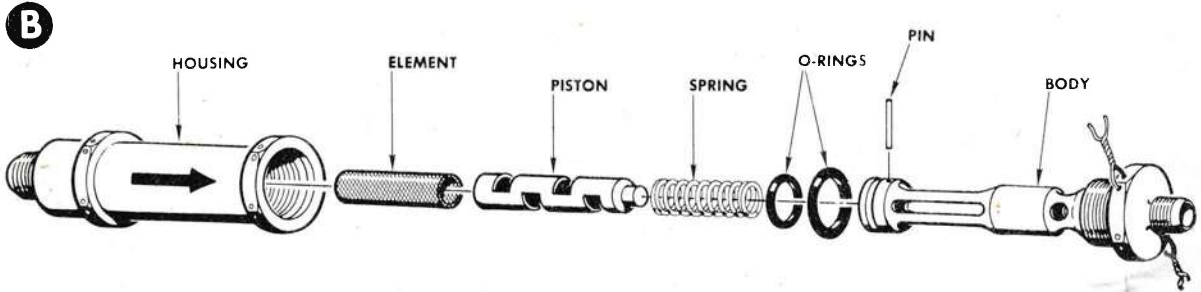

- g. Install O-ring in inlet port of filter. Install filter in engine mounted gearbox "oil out" port and torque to 60-80 inch-pounds. Safety-wire filter to gearbox.

**CAUTION**

MAKE CERTAIN THAT ARROW STAMPED ON FILTER IS POINTING AWAY FROM ENGINE MOUNTED GEARBOX.

- h. Connect "oil out" hose to filter; hold filter with wrench and torque hose fitting to 135 to 180 inch-pounds. Safety-wire hose fitting to filter.
- i. Conduct engine run; perform drive unit operational check. During operational check observe filter installation for leakage. Refer to Section I of this manual for engine run procedure. Refer to T.O. 1F-106A-2-10 for operational check of drive unit.

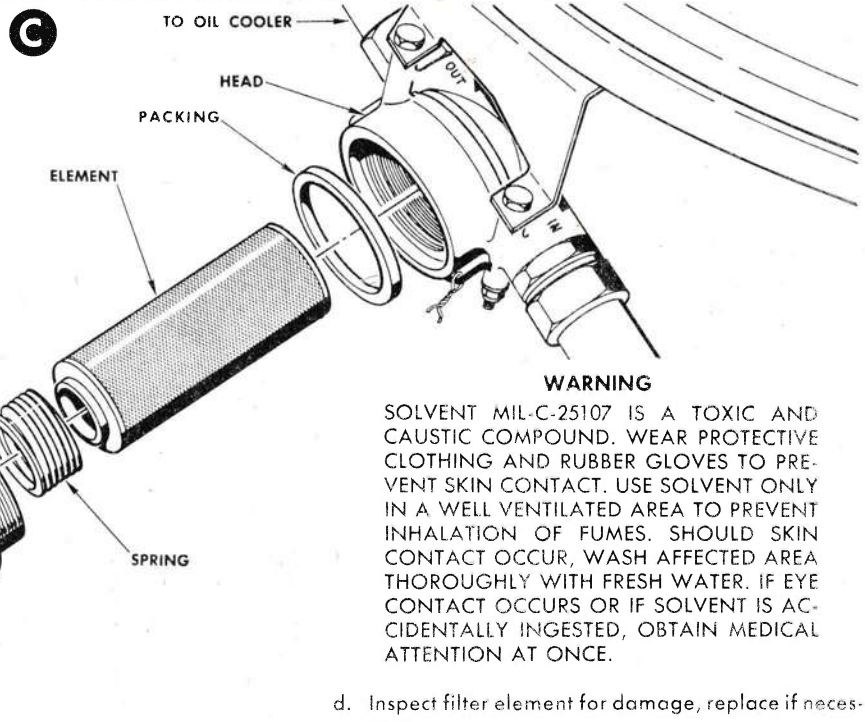
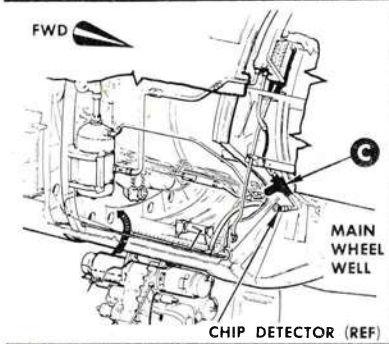

**WARNING**

SOLVENT MIL-C-25107 IS A TOXIC AND CAUSTIC COMPOUND. WEAR PROTECTIVE CLOTHING AND RUBBER GLOVES TO PREVENT SKIN CONTACT. USE SOLVENT ONLY IN A WELL VENTILATED AREA TO PREVENT INHALATION OF FUMES. SHOULD SKIN CONTACT OCCUR, WASH AFFECTED AREA THOROUGHLY WITH FRESH WATER. IF EYE CONTACT OCCURS OR IF SOLVENT IS ACCIDENTALLY INGESTED, OBTAIN MEDICAL ATTENTION AT ONCE.

**CLEANING, "OIL IN" TO COOLER FILTER**

- Cut safety wire and unscrew filter element housing from filter head. Do not use wrench; loosen by hand.
- Remove filter element and spring.
- Clean element, spring and housing in solvent MIL-C-25107 using stiff bristled non-metallic brush. Rinse in Stoddard Solvent.

- Inspect filter element for damage, replace if necessary.
- Reassemble filter using new packing. Hand tighten filter element housing on filter head; do not use wrench.
- Safety-wire filter element housing to filter head.
- Conduct engine run; perform drive system operational check. During operational check, observe filter installation for leakage. Refer to Section I of this manual for engine run procedure. Refer to T.O. 1F-106A-2-10 for operational check of drive system.

.06.02.1430

Figure 9-16. Cleaning, Constant-Speed Oil System Filters (Sheet 3 of 3)



## Section X

## DRAINAGE PROVISIONS

<i>Contents</i>	<i>Page</i>
Description .....	10-1
Operational Checkout .....	10-3
System Analysis .....	10-4
Extreme Weather Conditions .....	10-4

**DESCRIPTION**

**10-1. DESCRIPTION.**

Liquid leakage from engine-mounted components, and associated systems is manifolded and drained overboard through drain ports along the lower side of the fuselage, adjacent to the engine. Each of the drain lines is equipped with disconnect points to facilitate removal of the engine. The function and operation of drainage from the various components is governed by the type of system involved. Some areas drain only when the engine is not

operating. These eliminate the accumulation of liquids that are normally used during engine operation. The drains may be classified as two types: the first as weep drains which permit elimination of liquids at any time, independent of engine operation; the second as those permitting drainage only during certain engine operating configurations. An abnormal amount of drainage at any of the drain points indicates engine component malfunction or possible impending failure. For an illustration of the engine drainage provisions, see figure 10-1.

**10-2. ENGINE DRAINS.**

DRAIN	LOCATION	TYPE OF DRAIN
Constant-speed remote gearbox vent.	Fuselage sta. 476.25, right side of fuselage centerline.	Weep drain.
Constant-speed remote governor drain.	Fuselage sta. 514.41, right side of fuselage centerline.	Weep drain.
Engine mounted gearbox and accessory seal drain. <i>Applicable to F-106A airplanes 56-453, -454, 56-456 thru 57-245, 57-2461 and subsequent, and F-106B airplanes 57-2508 thru 57-2515, 57-2520 and subsequent.</i>	Fuselage sta. 524.60, left side of fuselage centerline.	Weep drain.
Oil tank scupper drain.	Fuselage sta. 525.0, left side of fuselage centerline.	Weep drain.
Afterburner manifold drain.	Fuselage sta. 551.75, right side of fuselage centerline.	Drains when afterburner is not in use.





**10-2. ENGINE DRAINS (CONT).**

DRAIN	LOCATION	TYPE OF DRAIN
Afterburner fuel drain. <i>Applicable to all F-106A airplanes except 56-455 and all F-106B airplanes except 57-2507 after incorporation of TCTO 1F-106-667.</i>	Fuselage sta. 551.75, right side of fuselage centerline.	Drains when afterburner is not in use.
Fuel control drain.	Fuselage sta. 551.75, left side of fuselage centerline.	Drains at engine shutdown.
Combustion manifold drain.	Fuselage sta. 551.75, left side of fuselage centerline.	Drains at engine shutdown.
Forward shroud drain.	Fuselage sta. 551.75, left side of fuselage centerline.	Weep drain.
Aft shroud drain.	Fuselage sta. 646.50, left side of fuselage centerline.	Weep drain.
Afterburner duct drain.	Fuselage sta. 646.50, left side of fuselage centerline.	Drains at engine shutdown.
Variable ramp hydraulic motor seal drain.	Sta. 345.5, under side of left wing adjacent to fuselage.	Weep drain.
Variable ramp emergency operation vent.	Sta. 354.3, under side of left wing adjacent to fuselage.	Vents during ramp emergency operation.
Exhaust nozzle control seal drain. <i>Applicable to F-106A airplanes 56-453, -454, 56-456 thru 57-245, 59-031 and subsequent; and 57-246 thru 59-030 after incorporation of TCTO 1F-106-629. Applicable to F-106B airplanes 57-2508 thru 57-2515, 57-2542 and subsequent; and 57-2516 thru 57-2541 after incorporation of TCTO 1F-106-629.</i>	Fuselage sta. 551.75, left side of fuselage centerline.	Weep drain.

**OPERATIONAL CHECKOUT****10-3. OPERATIONAL CHECKOUT, DRAINAGE SYSTEM.**

Operation of the drainage systems is a function of the engine operation. Refer to Section I for the engine ground run check procedure.

**SYSTEM ANALYSIS****10-4. SYSTEM ANALYSIS, ENGINE DRAINAGE PROVISIONS.**

Continuous draining from weep type drains, as identified in paragraph 10-2, is an indication of component malfunction. Failure of drains normally functioning at time of engine shutdown, as identified in paragraph 10-2, is an indication of component malfunction. These malfunctions must be corrected prior to continued engine operation.

**EXTREME WEATHER CONDITIONS****10-5. COLD WEATHER OPERATION.**

During ground run operation of the engine under normal conditions, drainage will occur during and after engine shutdown as specified. Care must be exercised to see that the drains function properly as indicated by the specified operating procedures. During cold weather conditions,

some drains can become blocked by moisture condensation frozen in the lines. At this time it will be necessary to make heat application to the affected areas until positive drainage occurs prior to continued operation. Heat may be applied using Ground Heating Unit 8-96106 (gas) (4520-555-1293), or 8-96107 (electric).

## ALPHABETICAL INDEX

<i>Title</i>	<i>Paragraph</i>	<i>Title</i>	<i>Paragraph</i>	<i>Title</i>	<i>Paragraph</i>
<b>A</b>					
Accessories, Engine Mounted.....	1-3	-Data Converter, Replacement ....	4-61	-And Testing, Engine Spark-igniters.....	5-30
Accessory Compartment Cooling ....	4-79	-Induction Systems, Variable Ramp System .....	4-1	-Constant-Speed Oil System Filters .....	9-34
Accessory Section.....	1-8	-Motoring of Engine With Combustion Starter (Air Only)..	5-13	-Engine Air Passages .....	1-69
Actuators, Exhaust Nozzle .....	3-2	-Valve, Ground Cooling and Pressure Augmentation .....	4-100	-Engine Fuel Supply Strainer .....	2-37
Adjustment		Alignment Check, Constant Speed Remote Gearbox .....	9-23	-Engine No. 6 Bearing Oil Strainers.....	6-42
-Afterburner .....	3-11	Altitude Pressure Ratio Switch .....	4-11	-Engine Oil Strainer .....	6-41
-Constant-Speed Generator Drive System .....	9-23	Altitude Pressure Ratio Switch, Replacement .....	4-62	-Fuel Pressurizing and Dump Valve Fuel Screen .....	2-36
-Cooling Airflow System .....	4-113	Anti-Ice		-Main Fuel Control Unit Filter and Pump Strainer .....	2-35
-Engine Oil Pressure .....	6-36	-Air Valve .....	8-4	Cold Weather Operation I-90, 10-5	
-Exhaust Nozzle Linkage .....	3-11	-Air Valve, Replacement .....	8-7	Combustion	
-Lubrication System .....	6-36	-Storage Flask, Emergency .....	4-21	-Chamber and Turbine Compartment Cooling .....	4-76
-Main Fuel System .....	2-28	-System, Engine Inlet Duct Lip ...	8-2	-Chambers, Replacement .....	1-48
-Oil Cooler Valves and Actuators .....	4-113	Anti-Surge Bleed		-Section .....	1-5
-Power Plant General.....	1-58	-Governor .....	7-3	Combustion Starter .....	5-2
-Variable Ramp System .....	4-68	-Governor, Removal .....	7-8	-Chambers, Limits of Acceptability.....	1-51
Aft (Engine) Quadrant, Throttle Linkage .....	2-5	-Valve, Actuator .....	7-4	-Fuel System Bleeding.....	5-29
Afterburner		-Valve Actuator, Removal .....	7-9	-Operation .....	5-10
-Adjustment .....	3-11	Anti-Surge Bleed System		-Servicing.....	5-28
-Control, Circuit Test Procedure.....	3-23	-Description.....	7-1	Compressor Section .....	1-4
-Description.....	3-1	-Operation .....	7-2	Compressor Stalls.....	1-22
-Emergency Control .....	3-15	-Operational Checkout.....	7-5	Constant-Speed Drive	
-Fuel Bypass Screen, Cleaning ..	3-44	-Replacement.....	7-7	-Engine Mounted Gearbox, Replacement .....	1-52
-Fuel Control Inlet Screen, Cleaning.....	3-43	-System Analysis .....	7-6	-Generator Pressurization .....	9-7
-Fuel Nozzles .....	3-20	Audible Operation Check, Starter Ignition .....	5-19	-Generator Pressurization System Air Pressure Regulator, Replacement .....	9-18
-Igniter Valve Air Screen, Cleaning.....	3-46	<b>B</b>			
-Igniter Valve Fuel Screen, Cleaning.....	3-45	Bleed Valve, Ramp System .....	4-23	-Lubrication System, Servicing....	1-72
-Inner Diameter Check .....	3-13	Bleeding		-Overboard Vent Valve, Replacement .....	9-19
-Operational Checkout .....	3-3	-Air Pressure, Variable Ramp Emergency Pneumatic System..	4-73	-System Components, Replacement .....	9-11
-Replacement.....	3-3	-Hydraulic System .....	1-74	Constant-Speed Drive System	
-Section .....	1-7	-Variable Ramp Hydraulic System .....	4-71	-Depreservation .....	1-87, 9-33
-Servicing.....	3-12	Bolt Torque Values .....	1-57	-Generators, Replacement .....	9-17
-System Analysis .....	3-7	Boost Pump, Oil .....	6-4	-Preservation.....	9-32
Afterburner Fuel Control		<b>C</b>			
-Installation.....	3-32	Charging, Variable Ramp Emergency High-Pressure Pneumatic System .....	4-74	Constant-Speed Drive Oil System.....	9-5
-System.....	3-14	Checking of Engine Oil Level .....	6-40	-Preservation.....	1-81
-Unit .....	3-18	Circuit Test Procedure, Afterburner Control.....	3-23	-Pressurization .....	9-6
-Unit, Removal .....	3-31	Circuit Test Procedure, Engine Idle Thrust Control .....	3-26	Constant-Speed Generator Drive System..	
Afterburner Fuel System		Cleaning		-Adjustment .....	9-23
-Description.....	3-14	-Afterburner Fuel Bypass Screen .....	3-44	-Description.....	9-1
-Operational Checkout .....	3-21	-Afterburner Fuel Control Inlet Screen .....	3-43	-Operational Checkout .....	1-35, 9-8
-Replacement.....	3-30	-Afterburner Igniter Valve Air Screen .....	3-46	-Replacement .....	9-11
-Safety Precautions .....	3-30	-Afterburner Igniter Valve Air Screen .....	3-46	-Servicing.....	9-27
-Servicing.....	3-42	-Afterburner Igniter Valve Fuel Screen .....	3-45	-System Analysis .....	9-9
-System Analysis .....	3-29			Constant-Speed Oil System	
Afterburner Igniter Control Valve....	3-19			-Contamination Check .....	9-29
-Installation .....	3-34			-Filters, Cleaning.....	9-34
-Removal .....	3-33			-Flushing and Component Replacement .....	9-31
Air				-Servicing.....	9-28
-Control Valve, Engine Air-Oil Cooler .....	4-95				
-Data Converter.....	4-7				

ALPHABETICAL INDEX (CONT)

Title	Paragraph	Title	Paragraph	Title	Paragraph
<b>C</b>					
Constant-Speed Remote Gearbox .....	9-3	Detection System, Fire and Overheat .....	1-17	-Mounted Gearbox .....	9-2, 9-10
-Alignment Check .....	9-23	Directional References .....	1-2	-No. 6 Bearing Oil Strainers, Cleaning .....	6-42
-Anti-Drain Valve, Replacement ..	9-15	Drainage Provisions .....	10-1	-Nose Cone, Replacement .....	8-8
-Pressure Switch, Replacement ..	9-16	-Description .....	10-1	-Oil Level, Checking .....	6-40
-Relief Valve, Replacement .....	9-14	-Extreme Weather Conditions .....	10-5	-Oil Low-Pressure Warning Switch and Transmitter, Replacement ..	6-26
Constant-Speed System .....		-Operational Checkout .....	10-3	-Oil Pump, Installation .....	6-34
-Drive Shaft .....	9-4	-System Analysis .....	10-4	-Oil Pump, Removal .....	6-33
-Generators, Contamination Check .....	9-30	Draining and Priming Constant- Speed Oil System .....	9-27	-Oil Strainer, Cleaning .....	6-41
-Oil Cooler Air Control Valve .....	4-98	Draining, Ramp Pitot-Static System Drain Traps .....	4-72	-Oil System, Depreservation .....	1-83, 6-38
-Oil Cooler Air Control Valve Actuator .....	4-99	Drains, Engine .....	10-2	-Oil System, Preservation .....	1-77, 6-37
Contamination Check, Constant- Speed Oil System .....	9-29	Drive Shaft, Constant-Speed System .....	9-4	-Operational Checkout and Testing .....	1-23
Contamination Check, Constant- Speed System Generators .....	9-30	Dump Valve and Fuel Pressurizing ..	2-10	-Overspeed and Over-temperature Conditions .....	1-33
Control .....		<b>E</b>			
-Switch, Variable Ramp .....	4-9	EGT Excessive or Fire in Engine Tailpipe During Ground Operation .....	1-31	-Pressure Ratio Indicating System .....	1-13
-System .....	8-3	Electrical Components General, Replacement .....	4-51, 4-108, 6-19	-Pressure Ratio Indicating System, Operational Checkout .....	1-37
-System, Variable System .....	4-2	Emergency .....		-Replacement .....	1-42
-Unit, Variable Ramp .....	4-5	-Air Storage Flask .....	4-21	-Shroud, Replacement .....	4-110
-Valve, Exhaust Nozzle .....	3-17	-Control, Afterburner .....	3-15	-Starter Accumulator Check Valve and Fuel Solenoid, Leak Check .....	5-17
Conversion Table, Temperature .....	1-59	-Fuel Regulation .....	2-3	-Starter and Ignition Circuit, Test .....	5-14
Cooler .....		-Pneumatic System Check Valve .....	4-22	-Starter Drive Shaftgear Oil Seal .....	6-29
-Engine Air-Oil .....	6-9	-Pneumatic System, Variable Ramp .....	4-4	-Starting Description, Engine .....	1-20
-Fuel-Oil .....	2-7, 6-6	-Pressure Control Sensor, Engine Accessory Compartment .....	4-90	-Trim and Idle Speed Adjustment .....	1-61
-Valves and Actuators (Oil) .....	4-118	Engine .....		-Trim and Idle Speed Adjustment Using SE 1122 Engine Trim Kit .....	1-65
Cooling .....		-Accessory Compartment Emergency Pressure Control Sensor .....	4-90	-Trimming .....	1-58
-Accessory Compartment .....	4-79	-Air Passages, Cleaning .....	1-69	Engine Air-Oil Cooler .....	6-9
-Air Control .....	4-80	-And Afterburner Fuel Pump .....	2-8	-Air Control Valve .....	4-96
-Combustion Chamber and Turbine Compartment .....	4-75	-Breather Pressurizing Valve, Installation .....	6-25	-Air Control Valve Actuator .....	4-97
Cooling Airflow System .....		-Breather Pressurizing Valve, Removal .....	6-24	-Replacement .....	6-23
-Adjustment .....	4-113	-Compartment, Fire .....	1-32	Engine Anti-Icing System .....	
-Components, Replacement .....	4-109	-Compartment Pressure Control Sensor .....	4-84	-Description .....	8-1
-Description .....	4-75	-Components, Lubrication .....	1-73	-Operational Checkout .....	8-5
-Operational Checkout .....	4-103	-Compressor Bleed Valve, Replacement .....	6-31	-Replacement .....	8-7
-Replacement .....	4-108	-Drains .....	10-2	-System Analysis .....	8-6
-System Analysis .....	4-107	-Exhaust Temperature Indicating System .....	1-10	Engine Fuel .....	
Couplings, Quick Disconnect .....	1-55	-Fuel Supply Strainer, Cleaning ..	2-37	-Control Unit and Engine Fuel System, Depreservation .....	2-34
<b>D</b>					
Data Plate Speed Determination, Adjusted .....	1-60	-Exhaust Temperature System, Calibration .....	1-38	-Control Unit and Engine Fuel System, Preservation .....	2-33
Depreservation .....		-External Tube Sealing Requirements .....	1-54	-Pump, Installation .....	2-20
-Constant-Speed Drive System .....	1-87, 9-33	-Ground Run Compressor Stalls ..	1-22	-Pump, Removal .....	2-19
-Engine Fuel Control Unit and Engine Fuel System .....	2-34	-Idle Thrust Control, Circuit Test Procedure .....	3-26	-Supply Strainer .....	2-11
-Engine Fuel System .....	1-84	-Idle Thrust Control System .....	3-16	-Supply Strainer, Fuel Pressure Switch, and Fuel Inlet Adapter, Replacement .....	2-26
-Engine Oil System .....	1-83, 6-38	-Inlet Duct Lip Anti-Ice System ...	8-2	-System, Depreservation .....	1-84
-General .....	1-82	-Instrument Systems and Related Equipment .....	1-9	-System, Preservation .....	1-78
Description .....		-Jam Nut Type Fittings .....	1-56	-Temperature Control and Sensor .....	4-89
-Afterburner .....	3-1	-Lubrication Systems, Servicing ..	1-71	Engine Ignition .....	
-Afterburner Fuel System .....	3-14	-Main Fuel Control Unit .....	2-6	-Compositors, Installation .....	5-26
-Anti-Surge Bleed System .....	7-1	-Mounted Accessories and Systems .....	1-3	-Compositors, Removal .....	5-25
-Constant-Speed Generator Drive System .....	9-1			-Exciter Unit, Installation .....	5-24
-Cooling Airflow System .....	4-75			-Exciter Unit, Removal .....	5-23
-Drainage Provisions .....	10-1				
-Engine Anti-Icing System .....	8-1				
-Lubrication System .....	6-1				
-Main Fuel System .....	2-1				
-Power Plant General .....	1-1				
-Starting and Ignition Systems .....	5-1				
-Variable Ramp System .....	4-1				

ALPHABETICAL INDEX (CONT)

Title	Paragraph	Title	Paragraph	Title	Paragraph
<b>E</b>					
Engine Ignition (Cont.)		-Removal .....	2-23	-Exhaust Nozzle	
-Sparkigniters .....	5-12	Fuel Pressurizing and Dump		Control Selector Valve.....	3-38
-Sparkigniters, Replacement .....	5-27	Valve .....	2-10	-Exhaust Nozzle Control	
Engine Oil Pressure		-Fuel Screen, Cleaning .....	2-36	Valve .....	3-36
-Adjustment .....	6-36	-Installation .....	2-22	-Fuel-Oil Cooler .....	2-24
-Indicating System .....	1-14, 6-11	-Removal .....	2-21	-Fuel Pressurizing and Dump	
-Indicating System Test.....	6-17	<b>G</b>			
Engine Oil Tank .....	6-3	Gearbox, Constant-Speed Remote.....	9-3	-Main Fuel Control $U_2$ it .....	2-18
-Installation.....	6-21	Gearbox, Engine Mounted .....	9-2	Instrument Systems, Engine .....	1-9
-Removal .....	6-20	Generator Pressurization, Constant-		<b>J</b>	
Engines Subjected to Overspeed		Speed Drive .....	9-7	J-75 Engine Ground Run Compressor	
Conditions, Inspection of .....	1-34	Ground Cooling and Pressure		Stalls .....	1-22
Engines Subjected to Over-temperature		Augmentation Air Valve .....	4-100	<b>K</b>	
Conditions, Inspection of .....	1-33	<b>H</b>			
Exhaust Duct, Starter,		Hot Weather Operation .....	1-89	<b>L</b>	
Replacement .....	5-22	Hydraulic		Leak Check, Engine Starter	
Exhaust Nozzle		-Check Valve (Ramp Retract		Accumulator Check Valve and	
-Actuating Cylinders,		Line).....	4-15	Fuel Solenoid .....	5-17
Installation .....	3-10	-Dump Valve .....	4-14	Leak Check, Variable Ramp	
-Actuating Cylinders, Removal.....	3-9	-Motor, Variable Ramp .....	4-8	Pneumatic System .....	4-45
-Actuating Cylinders,		-Oil Leak Check, Overboard		Limits of Acceptability for	
Replacement .....	3-41	Drain.....	4-46	Combustion Chambers .....	1-51
-Actuators .....	3-2	-Pump Drive Shaftgear Oil Seal,		Linkage and Throttle Control .....	2-4
-Control Converter Valve,		Replacement .....	6-30	Lubrication, Engine Components ...	1-73
Installation .....	3-40	-Pumps, Replacement.....	1-53	Lubrication System	
-Control Converter Valve,		-Solenoid Shutoff Valve .....	4-13	-Adjustment .....	6-36
Removal.....	3-39	-System, Bleeding.....	1-74	-Description.....	6-1
-Control Valve .....	3-17	-System Low-Pressure Filter		-Draining and Servicing .....	6-39
-Control Valve, Installation .....	3-36	Element, Replacement .....	1-75	-Operational Checkout .....	6-12
-Control Valve, Removal .....	3-35	<b>I</b>			
-Linkage, Adjustment.....	3-11	Identification of Metal Particles ...	1-70	-Replacement.....	6-19
-Operational Checkout .....	3-4	Idle		-Servicing.....	6-37
-Selector Valve, Installation.....	3-38	-Speed Adjustment .....	1-61	<b>M</b>	
-Selector Valve, Removal .....	3-37	-Speed and Engine Trim		Main Fuel Control	
Extreme Weather Conditions		Adjustment Using SE 1122		-Field Adjustment.....	2-32
-Drainage Provisions .....	10-5	Engine Trim Kit .....	1-65	-Unit Filter and Pump Strainer,	
-Power Plant General.....	1-88	-Thrust Control, Operational		Cleaning.....	2-35
<b>F</b>					
Fire and Overheat Detection		Checkout .....	3-22	-Unit, Removal .....	2-17
System .....	1-17	-Thrust Control System, Engine ..	3-16	Main Fuel System	
Fire in Engine Tailpipe During		Igniter Control Valve, Afterburner ..	3-19	-Adjustment .....	2-28
Ground Operation .....	1-31	Ignition Disarm Switch, Starter.....	5-9	-Description.....	2-1
Fire Within Engine Compartment ...	1-32	Ignition Sparkigniters, Cleaning		-Operational Checkout .....	2-12
Fittings, Engine Jam Nut Type .....	1-56	and Testing .....	5-30	-Replacement.....	2-16
Fuel		Indicating System		-Safety Precautions .....	2-16
-Control Drive Shaftgear Oil Seal,		-Engine Oil Pressure .....	1-14, 6-11	-Servicing.....	2-10
Replacement .....	6-27	-Engine Pressure Ratio .....	1-13	-Tests.....	2-12
-Control Field Adjustment .....	2-32	-Fuel Flow.....	1-11	Metal Particles, Identification of....	1-70
-Control System, Afterburner.....	3-14	-Test, Engine Oil Pressure.....	6-17	<b>N</b>	
-Flow Indicating System .....	1-11	Inspection of Engines Subjected to		Normal Fuel Regulation .....	2-2
-Flow Indicating System,		Overspeed Conditions .....	1-34	<b>O</b>	
Operational Checkout .....	1-39	Inspection of Engines Subjected to		Oil	
-Flowmeter .....	2-9	Over-temperature Conditions....	1-33	-Boost Pump .....	6-4
-Flowmeter, Replacement .....	2-25	Installation		-Breather Pressurizing System .....	6-2
-Nozzles, Afterburner .....	3-20	-Afterburner Fuel Control .....	3-32	-Breather Pressurizing Valve .....	6-8
-Pump, Engine and Afterburner .....	2-8	-Afterburner Igniter Control		-Cooling Air Control .....	4-80
-Regulation, Emergency.....	2-3	Valve .....	3-34	-System, Constant-Speed Drive.....	9-5
-Regulation, Normal .....	2-2	-Engine Breather Pressurizing		-System Pressurization, Constant-	
-System Bleeding, Combustion		Valve .....	6-25	Speed Drive .....	9-6
Starter .....	5-26	-Engine Fuel Pump.....	2-20	Oil Low-Pressure Warning	
-System Tests, Main .....	2-12	-Engine Ignition Compositors .....	5-26	-And Indicating Systems,	
Fuel Control Unit		-Engine Ignition Exciter Unit .....	5-24	Operational Checkout.....	1-40
-Afterburner .....	3-18	-Engine Oil Pump .....	6-34	-System.....	1-15, 6-10
-Engine.....	2-6	-Engine Oil Tank .....	6-21	-System Test .....	6-14
-Installation.....	2-18	-Exhaust Nozzle Actuating		Operational Checkout	
Fuel-Oil Cooler .....	2-7, 6-6	Cylinders .....	3-10	-Afterburner .....	3-3
-Installation .....	2-24	-Exhaust Nozzle		-Afterburner Fuel System.....	3-21
		Control Converter Valve .....	3-40		

ALPHABETICAL INDEX (CONT)

<i>Title</i>	<i>Paragraph</i>	<i>Title</i>	<i>Paragraph</i>	<i>Title</i>	<i>Paragraph</i>
<b>O</b>					
Operational Checkout (Cont.)					
-Anti-Surge Bleed System	7-5	Quick Disconnect Couplings	1-55	-Hydraulic Pump Drive Shaftgear Oil Seal	6-30
-Calibration, Engine Exhaust Temperature System	1-38	<b>R</b>			
-Constant-Speed Generator Drive System	1-35, 9-8	Ramp Pitot-Static System Drain Traps, Draining	4-72	-Hydraulic Pumps	1-53
-Cooling Airflow System	4-103	Ramp System Pneumatic Bleed Valve	4-23	-Hydraulic System Low-Pressure Filter Element	1-75
-Drainage Provisions	10-3	References, Directional	1-2	-Lubrication System	6-19
-Engine	1-23	Removal		-Main Fuel Control Drive Shaftgear Oil Seal	6-27
-Engine Anti-Icing System	8-5	-Afterburner Fuel Control Unit	3-31	-Main Fuel System	2-16
-Engine Pressure Ratio Indicating System	1-37	-Afterburner Igniter Control Valve	3-33	-Pneumatic Selector Valve	4-63
-Exhaust Nozzle	3-4	-Anti-Surge Bleed Governor	7-8	-Power Plant General	1-42
-Fuel Flow Indicating System	1-39	-Anti-Surge Bleed Valve Actuator	7-9	-Starter Exhaust Duct	5-22
-Idle Thrust Control	3-22	-Engine Breather Pressurizing Valve	6-24	-Starting and Ignition Systems	5-21
-Lubrication System	6-12	-Engine Fuel Pump	2-19	-Throttle Teleflex Cable	2-27
-Main Fuel System	2-12	-Engine Ignition Compositors	5-25	-Variable Ramp Sections	4-52
-Oil Low-Pressure Warning and Indicating Systems	1-40	-Engine Ignition Exciter Unit	5-23	Replacement, Constant-Speed Remote Gearbox	
-Power Plant General	1-21	-Engine Oil Pump	6-33	-Anti-Drain Valve	9-15
-Starting and Ignition Systems	5-14	-Engine Oil Tank	6-20	-Charge Relief Valve	9-14
-Tachometer Indicator System	1-36	-Exhaust Nozzle Actuating Cylinders	3-9	-Pressure Switch	9-16
-Variable Ramp Seal System	4-33	-Exhaust Nozzle Control Converter Valve	3-39	Replacement, Engine	1-42
-Variable Ramp System	4-26	-Exhaust Nozzle Control Selector Valve	3-37	-Air-Oil Cooler	6-22
Overboard Drain Hydraulic Oil Leak Check-Ramps Operating	4-46	-Exhaust Nozzle Control Valve	3-35	-Anti-Icing System	8-7
Overboard Drain Hydraulic Oil Leak Check-Ramps Static	4-47	-Fuel-Oil Cooler	2-23	-Compressor Bleed Valve Governor Drive Shaftgear Oil Seal (N1 Accessory Section)	6-31
Overspeed and Over-temperature Limits, Engine	1-33	-Fuel Pressurizing and Dump Valve	2-21	-Fuel Pump Drive Shaftgear Oil Seal	6-28
<b>P</b>					
Pneumatic		-Main Fuel Control Unit	2-17	-Fuel Supply Strainer, Fuel Pressure Switch and Fuel Inlet Adapter	2-26
-Pressure Switch	4-19	Replacement		-Ignition Sparkigniters	5-27
-Selector Valve, Replacement	4-63	-Afterburner	3-8	-Nose Cone	8-8
-Solenoid Valve	4-20	-Afterburner Fuel System	3-30	-Oil Low-Pressure Warning Switch and Transmitter	6-26
-Start Operation	5-11	-Air Data Converter	4-61	-Shroud	4-110
-System Check Valve, Emergency	4-22	-Altitude Pressure Ratio Switch	4-62	-Starter	5-21
Pneumatically Operated Systems, Safety Precautions	4-25	-Anti-Ice Air Valve	8-7	-Starter Drive Shaftgear Oil Seal	6-29
Power Plant General		-Anti-Surge Bleed System	7-7	Replacement, Variable Ramp	
-Adjustment	1-58	-Constant-Speed Drive Overboard Vent Valve	9-19	-Air Storage Flask	4-57
-Description	1-1	-Constant-Speed Drive Generator Pressurization System Air Pressure Regulator	9-18	-Control System Components	4-55
-Extreme Weather Conditions	1-88	-Constant-Speed Drive System Generators	9-17	-Static Pressure Sense Shuttle Valve	4-58
-Operational Checkout	1-21	-Combustion Chambers	1-48	-System	4-51
-Replacement	1-42	-Constant-Speed Drive Engine Mounted Gearbox	1-52	-Total Pressure (P1) Shuttle Valve	4-59
-Servicing	1-69	-Constant-Speed Drive System Components	9-11	Replacement, Variable Ramp System	
-System Analysis	1-41	-Constant-Speed Remote Gearbox Limit Governor	9-20	-Hydraulic Bypass Valve	4-66
Preservation		-Constant-Speed Remote Gearbox Magnetic Trim	9-21	-Hydraulic Check Valve	4-60
-Constant-Speed Drive Oil System	1-81	-Cooling Airflow System	4-108	-Hydraulic Dump Valve	4-67
-Constant-Speed Drive System	9-32	-Cooling Airflow System Components	4-109	-Hydraulic Shuttle Valve	4-65
-Engine Fuel Control Unit and Engine Fuel System	2-33	-Electrical Components General	4-51, 4-108, 6-19	-Hydraulic Shutoff Valve	4-64
-Engine Fuel System	1-78	-Engine Mounted Gearbox Oil Out Port Filter	9-22	Retract Limit Switch, Variable Ramp	4-10
-Engine Oil System	1-77, 6-37	-Exhaust Nozzle Actuating Cylinders	3-41	Rigging, Variable Ramp System	4-68
-General	1-76	-Fuel Flowmeter	2-25	<b>S</b>	
Pressure				Safety Precautions	
-Oil Pump	6-5			-Afterburner Fuel System	3-30
-Oil Strainer	6-7			-Main Fuel System	2-16
-Switch, Shroud Differential	4-101			-Maintenance of Pneumatically Operated Systems	4-25
Pressurizing System, Oil Breather	6-2			Seal System, Variable Ramp	4-3
Pressurizing Valve, Oil Breather	6-8			Sealing Requirements, Engine External Tube	1-54
Pump, Pressure Oil	6-5				
Purging and Leak Checking, Variable Ramp Pitot-Static System	4-37				

## ALPHABETICAL INDEX (CONT)

<i>Title</i>	<i>Paragraph</i>	<i>Title</i>	<i>Paragraph</i>	<i>Title</i>	<i>Paragraph</i>
<b>S</b>					
Sensor, Engine Compartment Pressure Control.....	4-84	-Pneumatic Pressure .....	4-19	-Control Unit .....	4-5
Servicing		-Variable Ramp Retract Limit.....	4-10	-Emergency Pneumatic System.....	4-4
-Afterburner .....	3-12	System Analysis		-Emergency Pneumatic System, Bleeding Air Pressure .....	4-73
-Afterburner Fuel System.....	3-42	-Afterburner .....	3-7	-Hydraulic Motor .....	4-8
-Constant-Speed Drive Lubrication System .....	1-72	-Afterburner Fuel System.....	3-29	-Hydraulic System, Bleeding.....	4-71
-Constant-Speed Generator Drive System .....	9-27	-Anti-Surge Bleed System .....	7-6	-Not Retracted Warning System .....	1-16, 4-24
-Constant-Speed Oil System .....	9-28	-Constant-Speed Generator Drive System .....	9-9	-Pitot-Static System, Purging and Leak Checking.....	4-37
-Engine Lubrication Systems .....	1-71	-Cooling Airflow System .....	4-107	-Pitot-Static System, Shuttle Valve Check .....	4-41
-Lubrication System .....	6-37	-Drainage Provisions .....	10-4	-Pneumatic System Leak Check ..	4-45
-Main Fuel System .....	2-33	-Engine Anti-Icing System .....	8-6	-Retract Limit Switch.....	4-10
-Power Plant General.....	1-69	-Lubrication System .....	6-18	-Seal System .....	4-3
-Starter, Combustion .....	5-28	-Power Plant General.....	1-41	-Seal System, Operational Check- out and Leak Test .....	4-33
-Starting and Ignition Systems .....	5-28	-Starting and Ignition Systems ....	5-20	-Sections, Replacement.....	4-52
-Variable Ramp System .....	4-71	-Variable Ramp System .....	4-48	-Servo Control Valve .....	4-6
Servo Control Valve, Variable Ramp.....	4-6	<b>T</b>			
Shroud Differential Pressure Switch .....	4-101	Tachometer Indicator System, Operational Checkout.....	1-36	-Static Pressure Sense Shuttle Valve, Replacement .....	4-58
Shroud Ram Air Cooling Check Valves .....	4-102	Tachometer System.....	1-12	-Time Delay.....	4-12
Shuttle Valve		Temperature		-Total Pressure (P1) Shuttle Valve, Replacement .....	4-59
-Check, Variable Ramp Pitot-Static System.....	4-41	-Control, Engine Fuel and Sensor .....	4-89	Variable Ramp System	
-Hydraulic Air .....	4-16	-Conversion Table .....	1-59	-Adjustment .....	4-69
-Ramp Static Pressure Sense .....	4-17	-Indicating System, Engine Exhaust .....	1-10	-Description.....	4-1
-Ramp Total Pressure Sense.....	4-18	Test, Engine Starter and Ignition Circuit .....	5-14	-Hydraulic Bypass Valve, Replacement .....	4-66
Sparkigniters, Engine Ignition .....	5-12	Throttle		-Hydraulic Check Valve, Replacement .....	4-60
Speed Determination, Adjusted Data Plate .....	1-60	-Linkage, Aft (Engine) Quadrant.....	2-5	-Hydraulic Dump Valve, Replacement .....	4-68
Starter		-Quadrant and Linkage.....	2-4	-Hydraulic Shutoff Valve, Replacement .....	4-64
-Combustion.....	5-2	-System Rigging .....	2-28	-Hydraulic Shuttle Valve, Replacement .....	4-65
-Engine.....	5-21	-Teleflex Cable, Replacement ....	2-27	-Operational Checkout .....	4-26
-Ignition, Audible Operation Check .....	5-19	-Transmission, Remote Gearbox..	9-10	-Replacement.....	4-51
-Ignition Disarm Switch .....	5-9	Trimming, Engine .....	1-58	-Rigging .....	4-68
-Operation, Combustion .....	5-10	Troubleshooting, Variable Ramp System .....	4-48	-Servicing.....	4-71
-Servicing.....	5-28	Tubing and Bolt Torque Values .....	1-57	-System Analysis .....	4-48
Starting Description		Turbine Section.....	1-6	-Troubleshooting.....	4-48
-Engine.....	1-21	<b>U</b>			
Starting and Ignition Systems		<b>V</b>			
-Description.....	5-1	Valve, Pneumatic Solenoid.....	4-20	<b>W</b>	
-Operational Checkout .....	5-14	Variable Ramp		Warning System	
-Replacement.....	5-21	-Air Storage Flask, Replacement .....	4-57	-Oil Low-Pressure .....	1-15, 6-10
-Servicing.....	5-28	-Control Switch .....	4-9	-Test, Oil Low-Pressure .....	6-14
-System Analysis .....	5-20	-Control System.....	4-2	-Variable Ramp Not Retracted .....	1-16, 4-24
Strainer, Engine Fuel Supply .....	2-11	-Control System Components, Replacement .....	4-55	<b>X—Y—Z</b>	
Strainer, Pressure Oil .....	6-7				
Switch					
-Altitude Pressure Ratio .....	4-11				



320 PAGES

★  
T.O. 1F-106A-2-4

TECHNICAL MANUAL  
MAINTENANCE

POWER PLANT

USAF SERIES

**F-106A AND F-106B**

AIRCRAFT

(GENERAL DYNAMICS/CONVAIR)

AF 336000-36546  
AF 436000-15287

THIS PUBLICATION REPLACES T.O. 1F-106A-2-4, DATED 1 DECEMBER 1960.  
THIS PUBLICATION INCLUDES SUPPLEMENT T.O. 1F-106A-2-4N, DATED 5  
NOVEMBER 1962, AND ALL SUPPLEMENTS OF PRIOR DATES.

PUBLISHED UNDER AUTHORITY OF THE SECRETARY OF THE AIR FORCE