

AH-TW

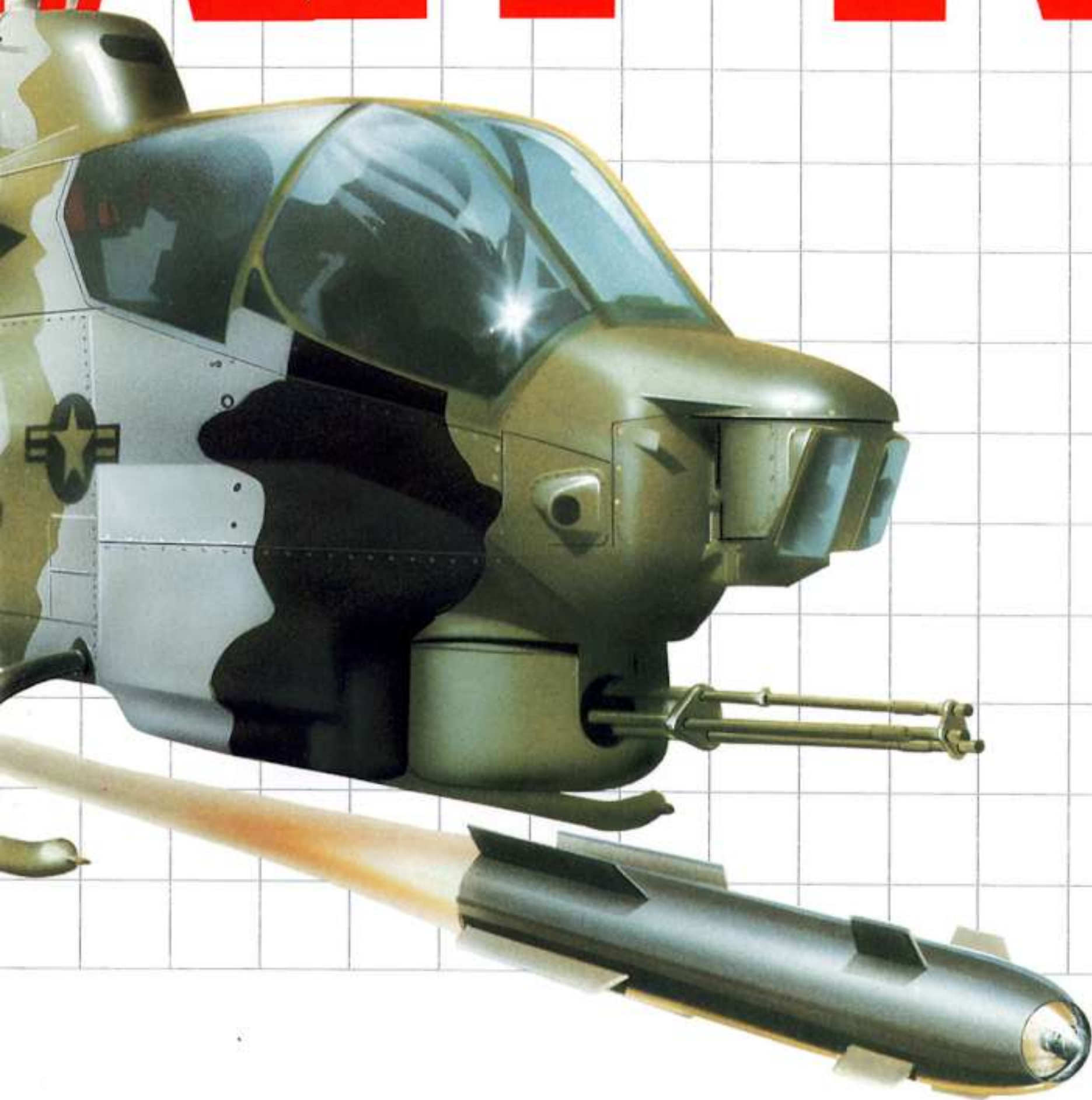

AH-TW SuperCobra

AH-1(4B)W

Bell Helicopter **TEXTRON**
A Subsidiary of Textron Inc.

Specifications

Engines: (Two)

TYPE	T700-GE-401
MANUFACTURER	GENERAL ELECTRIC
HORSEPOWER	3380 SHP

Transmission Ratings:

CONTINUOUS HORSEPOWER	2625
-----------------------	------

Main Rotor:

TYPE	FOUR-BLADED, HINGELESS, BEARINGLESS, ROTOR 48 FT
CONSTRUCTION	COMPOSITE
ROTOR SPEED	NORMAL POWER ON 287 RPM

Tail Rotor:

TYPE	FOUR-BLADED, HINGELESS, BEARINGLESS
CONSTRUCTION	COMPOSITE
ROTOR SPEED	1454 RPM

Aircraft:

EMPTY WEIGHT	10,700 LBS
MAX GROSS WT	16,800 LBS
USEFUL LOAD	6,100 LBS

Max Internal GW Sea Level

MAX ATTAINABLE SPEED	210 KN
MAX CRUISE SPEED	160 KN
MAX RANGE	327 NM
RATE OF CLIMB	2000 FT/MIN
SERVICE CEILING	18000 FT
HOVER CEILING, IGE	13600 FT
HOVER CEILING, OGE	4200 FT
MAX ENDURANCE	3.4 HOURS

Fuel System:

TYPE	NON-SUCTION, CRASH WORTHY
FUEL CELLS CAPACITY	TWO SELF-SEALING INTERNAL 307 GAL. AUX 2-77 GAL. TANKS 2-100 GAL. TANKS

Electrical System:

TYPE	28V SINGLE CONDUCTOR
GENERATORS	TWO 28V, 400 AMP
BATTERIES	TWO 40 AMP HOUR 24V NI-CAD
INVERTERS	1000 VA MAIN 750 VA 3 PHASE 365 VA (AIM-9)

Hydraulic System:

TYPE	DUAL, VARIABLE DELIVERY
RATING	3000 PSI

MULTI-MISSION ARMAMENT AND STORES

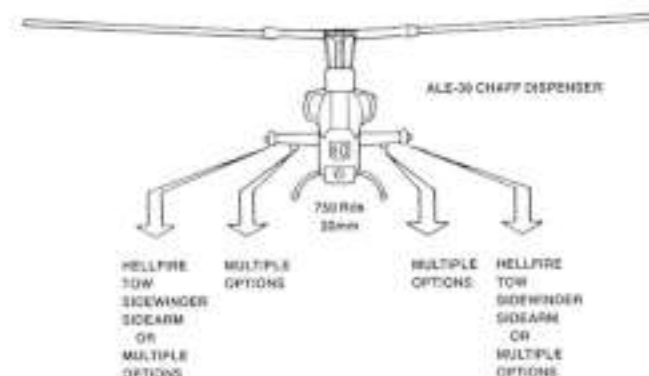

MULTIPLE OPTIONS:

- 2.75 INCH ROCKETS
- 8-INCH ZUNI ROCKETS
- GPU-2A 30mm GUN PODS
- CBU-55B FUEL AIR EXPLOSIVE BOMBS
- 250 LB. FRAGMENTATION BOMBS
- 100 GAL. NAPALM BOMBS
- SUU-44 FLARE DISPENSER
- M-116 SMOKE GRENADE DISPENSER
- 77 GAL. AND 100 GAL. AUX FUEL TANKS

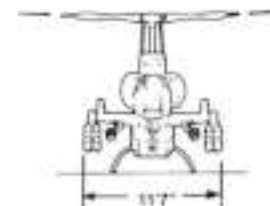
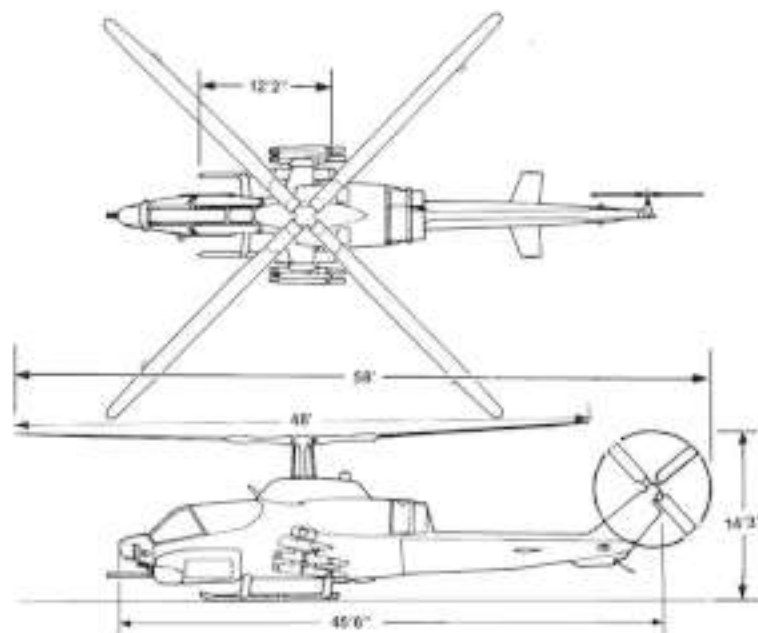





MARINES

Versatile, venomous and very much a marine — the AH-1W SuperCobra!

A few good men demanded one exceptional helicopter — a gunship with *muscle* ... an attack ship with a bite so sharp, so powerful, an enemy has barely an instant to blink, awe-struck at what high technology can do.

SuperCobra! Quickly, it slips over the trees, moving effortlessly to to the tune of 3,250 SHP. It streaks forward, hits low ... fast. And then it's gone, leaving behind the havoc that can only come from the world's most versatile attack helicopter.



The power of persuasion

When talking about SuperCobras, start with an important word ...

Power. Lots of it. Twin General Electric T700-GE-401 engines will startle seasoned pilots of the SuperCobra's predecessor — the AH-1T. Improvements in hover capability, vertical rate of climb and sheer performance are dramatic.

In fact, the AH-1W strikes with the *highest* power-to-weight ratio of any attack helicopter.

Hot day? No matter. A SuperCobra hovers OGE at 3,000 feet with four TOW and four Hellfire missiles, full turret ammunition and rockets ... with power to spare!

Another way of looking at it: In standard conditions, the SuperCobra can take off on a *single engine* and *climb* at more than 800 ft./min.! Again, that's better than any attack helicopter anywhere.

No wonder pilots return from a first flight with a big grin. Indeed, this is a combat pilot's best friend.





20 years of Marine Corps experience

Every time a SuperCobra lifts off, Bell's 20 years of experience in meeting Marine Corps demands goes with it.

Its predecessor — the U.S. Marines' multimission SeaCobra — reflected Bell's heritage for reliability by displaying the second-highest operational readiness of all aircraft in the USMC inventory, fixed-wing *or* helicopter.

And the AH-1W will continue that tradition.

Now add more firepower, the improved performance and even greater multimission capability ... and you'll see why Bell unhesitatingly calls the AH-1W the world's most versatile attack helicopter.

Its vulnerability's been reduced to the lowest level ever.

Its maneuverability is greater than ever.

It's a smoother machine.

It goes to work with increased engagement ranges.

And it shows a healthy respect for procurement dollars and time schedules, taking off less than 6 months from receipt of a firm, fixed-price development and qualification contract.

From Bell Helicopter — the world's most experienced helicopter manufacturer.



Sidewinder air-to-air missile



TOW missile



Armed and ready

If you stood in front of a loaded SuperCobra, you'd understand the experience of feeling a little humble.

An adversary, on the other hand, would express something entirely different ...

He would face the most versatile weapons capability available in a modern attack helicopter. He would face the cutting edge of a turreted 20mm weapons system that can be loaded with 750 rounds of

ammunition. In addition, four lower wing stores are designed to accommodate 680 pounds *each*. And that load can include a lethal variety of sophisticated weapons.

Dual anti-armor capability

For anti-armor roles, equip the SuperCobra with up to eight TOW or Hellfire missiles. No other attack helicopter offers this dual armor capability.

Use TOW to attack light armor, personnel carriers and light bunkers. (TOW electronics have been relocated on the SuperCobra to just below the cockpit for improved reliability and weight savings.)

Hellfire can be carried for attack against heavy armor and heavy fortifications. With Hellfire, a

SuperCobra crew has launch-and-leave capability — it can be fired in the cooperative mode with targets illuminated by an infantryman using a laser, which allows the SuperCobra to begin an evasive maneuver without waiting for target strike.

Air-to-air

SuperCobras will take on one of the Marines' most demanding assignments: escort for troop-carrying helicopters, which requires fast, accurate air-to-air capability in defense of the troop carriers.

SuperCobras are therefore qualified to carry two of the venerable, long-range Sidewinder missiles. Also the new, light STINGER, for airborne use, can easily be accommodated by the AH-1W.



5" ZUNI rocket



Hellfire missile

Turreted terror

Call 'em the fangs of the SuperCobra — the combat-proven, three-barreled 20mm turret.

It gives the pilot and copilot/gunner an awesomely rapid target-acquisition and fire-suppression capability. Either crewmember can fire the system. With guns in the fixed-forward position, the pilot can aim by simply maneuvering the AH-1W. Or he can slave the turret to the helmet-mounted sight, allowing him to aim at a target just by *looking* at it.

The copilot/gunner can aim like this too, or he can track the target through the Telescopic Sight Unit (TSU).

Of course, standard M-57 rounds can be loaded into this sys-

tem, but the gun can also fire the Navy's Phalanx round that features a depleted uranium/tungsten steel penetrator encased in a discarding sabot sheath. It provides three times the armor penetration and twice the velocity of the M-57.

Landing-zone suppression and close-in support

SuperCobras offer a compelling set of numbers for other types of missions.

Example: 76 2.75-inch folding-fin aerial rockets ...
16 5-inch ZUNI rockets ...
2 GPU-2A self-contained 20mm gun pods ...
All are part of the SuperCobra's arsenal.

For other special missions, the AH-1W carries flare dispensers for night illumination and the M-118 smoke grenade dispenser for marking targets.

The SuperCobra can survive

The SuperCobra even *looks* lethal. But that lean, low silhouette also enhances its survivability by narrowing its visibility.

Armor protection around the crew provides another measure of assurance. And the fuel system is designed to survive 23mm shell hits.

SuperCobras also provide dual radar warning ... infrared jammers ... and dual chaff-dispensing systems ...

And the helicopter is painted with low infrared reflective paint.



Bell Helicopter — a tradition for high technology

As amazing as the SuperCobra is, it's only one example of the kind of technology you'll find at Bell Helicopter.

Here are two other directions technology is moving at Bell.

680 rotor

Mechanically, it's remarkably simple — a totally *bearingless* four-blade rotor system that turns with a minimum of moving parts. A single-piece fiberglass yoke replaces the dozens of bearings, pins, straps, grips and hinges used in ordinary rotors.

And hundreds of hours of

flight-test and user evaluation have confirmed a near vibration-free ride. Pilots returning from a flight in our 680-equipped Model 222 helicopter consistently express amazement at "jet-like smoothness," and "exceptional handling qualities," with "low gust sensitivity!"

The 680 rotor is bringing together the best of several worlds...

- Mechanical simplicity
- Low vibration levels
- Excellent maneuverability
- Low gust sensitivity
- On-condition maintenance
- Unlimited life

The XV-15 TiltRotor

Imagine the possibilities — an airplane that can take off, maneuver and land vertically like a helicopter ...

yet can streak forward at speeds of over 300 knots!

It's not just an idea — the NASA-Army-Bell XV-15 has already accumulated hundreds of hours of flight-test evaluation. And after extensive pre-design work, a Department of the Navy program is bringing this concept into Full Scale Development as the joint-service V-22 Osprey.

The team of Bell Helicopter Textron Inc. and Boeing Helicopter Company will lead this new era of combat aviation. And the V-22 will totally rewrite many mission profiles for the U.S. Navy and the U.S. Marine Corps.

Rapid response... long-range capability... airplane *and* helicopter capabilities — again, the best of several worlds is already flying at Bell Helicopter.

AH-1W — worldwide support that's the best in the world

One of the best features of the AH-1W — it's a Bell. And no manufacturer can match the service and support provided by Bell Helicopter.

This service/support structure is literally the world's *largest* and *best*. Bell independent representatives and technicians are strategically located around the world and are backed by a worldwide network of supply centers, each carrying large inventories of spare parts for quick delivery.

Over 260,000 square feet of capability dedicated to customer support makes up the centerpiece of this effort. Bell maintains a multimillion-

dollar spare parts inventory that is all computer-controlled. A full-time staff handles requests for parts by a telephone hot line.

Result: If an aircraft is ever grounded for need of a part, one will be on the way within hours.

Bells are specifically designed for reliability. But when service is needed, Bell helps get it back in the air fast.

That's just what you'd expect of the world's most experienced helicopter manufacturer.





AH-1 (4B)W

Bell Helicopter **TEXTRON**
A Division of Textron

Specifications

Engines: (Two)

TYPE	T700-GE-401
MANUFACTURER	GENERAL ELECTRIC
HORSEPOWER	3380 SHP

Transmission Ratings:

CONTINUOUS HORSEPOWER	3625
-----------------------	------

Main Rotor:

TYPE	FOUR-BLADED, HINGELESS, BEARINGLESS, ROTOR 48 FT
CONSTRUCTION	COMPOSITE
ROTOR SPEED	NORMAL POWER ON 287 RPM

Tail Rotor:

TYPE	FOUR-BLADED, HINGELESS, BEARINGLESS
CONSTRUCTION	COMPOSITE
ROTOR SPEED	1454 RPM

Aircraft:

EMPTY WEIGHT	10,700 LBS
MAX GROSS WT	16,800 LBS
USEFUL LOAD	6,100 LBS

Max Internal GW Sea Level

MAX ATTAINABLE SPEED	210 KN
MAX CRUISE SPEED	180 KN
MAX RANGE	327 NM
RATE OF CLIMB	3000 FT/MIN
SERVICE CEILING	18000 FT
HOVER CEILING, IGE	13600 FT
HOVER CEILING, OGE	4200 FT
MAX ENDURANCE	3.4 HOURS

Fuel System:

TYPE	NON-SUCTION, CRASH WORTHY
FUEL CELLS	TWO SELF-SEALING
CAPACITY	INTERNAL 307 GAL. AUX 2-77 GAL. TANKS 2-100 GAL. TANKS

Electrical System:

TYPE	28V SINGLE CONDUCTOR
GENERATORS	TWO 28V, 400 AMP
BATTERIES	TWO 40 AMP HOUR 24V Ni-CAD
INVERTERS	1000 VA MAIN 750 VA 3 PHASE 365 VA (A/M-B)

Hydraulic System:

TYPE	DUAL, VARIABLE DELIVERY
RATING	3000 PSI

MULTI-MISSION ARMAMENT AND STORES

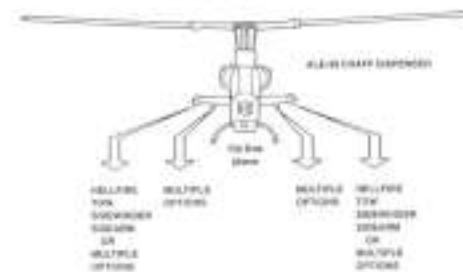

MULTIPLE OPTIONS:

- 1.75 INCH ROCKETS
- 5-INCH ZUM ROCKETS
- OFU 34 20mm GUN PODS
- CSU-533 FUEL AIR EXPLOSIVE BOMBS
- 200 LB. FRAGMENTATION BOMBS
- 100 GAL. NAPALM BOMBS
- M118 FLARE DISPENSER
- M-118 SMOKE GRENADE DISPENSER
- 77 GAL. AND 100 GAL. AUX FUEL TANKS

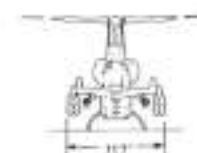
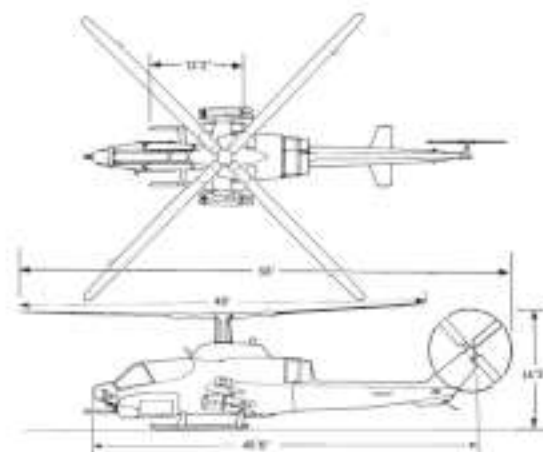

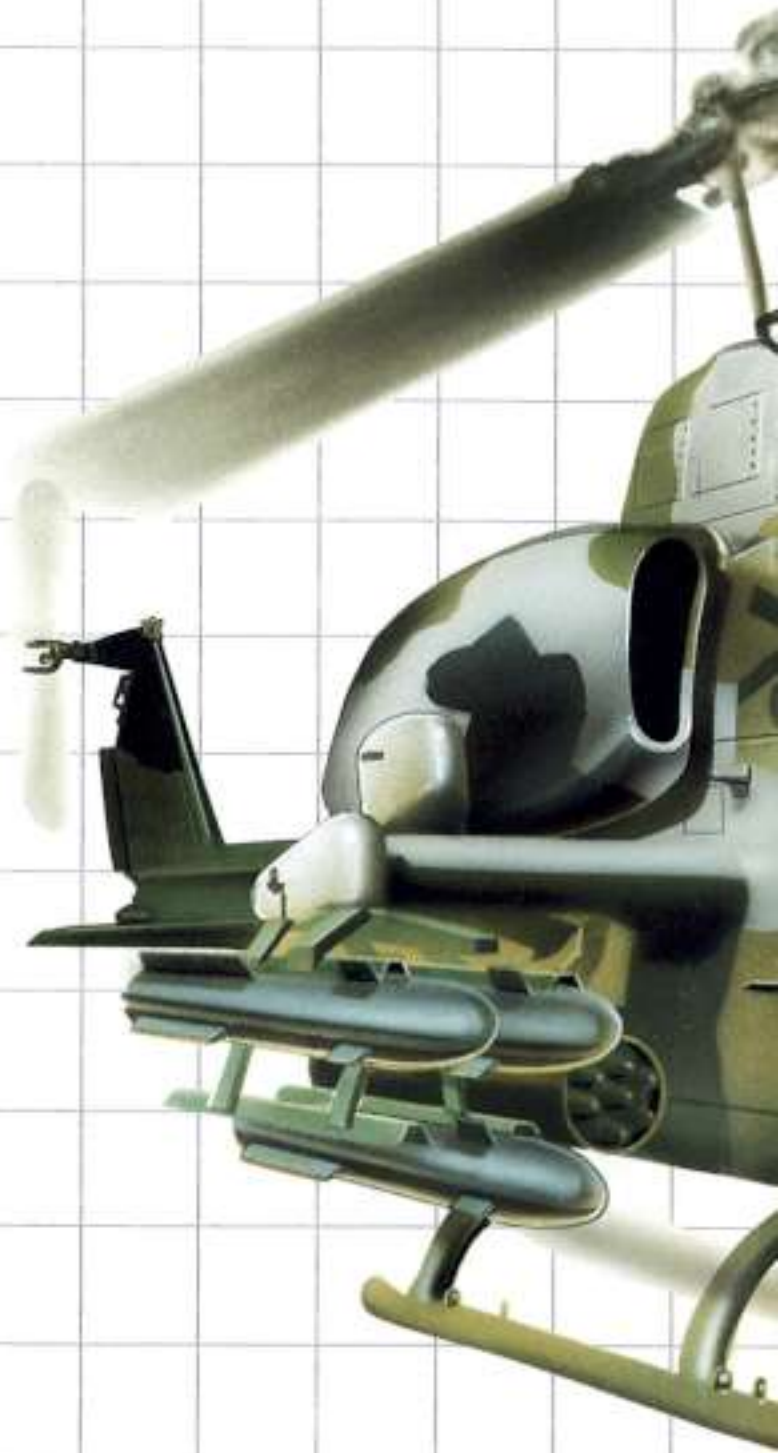

*For more information, call or write
International Marketing, Bell Helicopter
Textron Inc., Box 482, Ft. Worth, Texas
76101, U.S.A., (817) 280-3182. Telex:
75-8229. Cable: Bell Craft.*

The future is ours by design.

Bell Helicopter **TEXTRON**

A Subsidiary of Textron Inc.

The data set forth in this brochure are general in nature and may vary with conditions. For performance data and operating limitations for any specific flight mission, reference must be made to the approved flight manual.

© 1988 Bell Helicopter Textron Inc.
Printed in U.S.A.
4.5M/1-88/WMSN