

B-2: The Spirit of Innovation

B-2: The Spirit of Innovation

Rebecca Grant

Rebecca Grant

B-2: 
The Spirit of
Innovation

Rebecca Grant

B-2: The Spirit of Innovation

Table of Contents



Foreword	<i>pg. v</i>
Chapter One: Cones, Drones, and Low Observables ...	<i>pg. 1</i>
Chapter Two: Two Horses in the Race	<i>pg. 7</i>
Chapter Three: Cruise Missiles and Tacit Blue	<i>pg. 15</i>
Chapter Four: A Bomber?	<i>pg. 23</i>
Chapter Five: Another Horse Race	<i>pg. 33</i>
Chapter Six: Risk Closure	<i>pg. 43</i>
Chapter Seven: "My Airplane Blew Up On Me"	<i>pg. 55</i>
Chapter Eight: A Miracle a Day	<i>pg. 63</i>
Chapter Nine: Slip and Recovery	<i>pg. 73</i>
Chapter Ten: Success	<i>pg. 83</i>
Endnotes	<i>pg. 93</i>



Look skyward, and wonder. Wilbur and Orville Wright wondered if they could fathom the secrets of birds in flight. Every aerospace pioneer since – and every individual who has helped them – channels that very human curiosity and wonder into a desire to innovate. The lucky ones get to do it with brilliant iconoclasts, tough managers, and skilled teams, and the very most fortunate see their flashes of insight take flight.

For ten years, from 1979 to 1989, the development of the B-2 was kept secret. Inside that black world, thousands of people worked their wonder creating a stealth bomber unlike anything the aerospace world had ever seen.

“The B-2 evolved from that very first question,” said one engineer. “What can you do in the design of an airplane when the only priority was to carry a man and be as small as possible in all the characteristic observables?”¹

Observables . . . through radar, infrared, and the naked eye, tracking bombers had gotten easier and easier since the first integrated use of radar in World War II. Surface-to-air missiles and ground-controlled Soviet fighters were close to locking up the borders of the Soviet Union. If a bomber could not penetrate, deterrence weakened. Engineers wondered: if an understanding of the phenomenology of radar could help improve tracking, was there a way to turn the tables?



Left and below: Wilbur and Orville Wright perform early test flights with two of their flying machines at Kitty Hawk circa 1910.



Opposite: The B-2 Spirit Stealth Bomber soars into the blue.

Could the return of radar from a combat aircraft be measured and controlled to let an aircraft steal through the world's most formidable networks?



Chapter One: Cones, Drones, and Low Observables

Engineers had been thinking about how to counter airborne tracking radar practically since its invention. During World War II, British engineers theorized about creating a plasma field around an aircraft to obscure its radar return. If they could find a material with the right electrical properties, it could disrupt normal radar return at certain frequencies.

With the war against Germany raging, the British settled for a much quicker fix called “Window,” strips of foil dropped from bombers to create a cloud of chaff and white out German radar. Window was such a secret technology that the RAF kept it under wraps for more than a year, until the summer of 1943, even as their bomber crews suffered tremendous losses. Commanders feared that just one use of Window would lead the Germans to exploit and counter it. When the RAF finally took it into combat, chaff worked wonders.

Nothing came of the first inklings of designing an aircraft to minimize its radar return. But the idea lingered. In 1953, Air Force specifications for a potential new reconnaissance aircraft included the stipulation that “consideration will be given in the design of the vehicle to minimizing the detectability to enemy radar.”²

That same year, NATO intelligence picked up reports of Soviet deployment of the SA-2. Its radar-guided missile moved at Mach 3.5 to heights of 60,000 feet and distances out to about 20 miles. Tracking came from gathering information about the timing and angle of reflected radar waves.



Opposite: Remnants of a World War II era radar station.

Below (top): British bombers drop clouds of foil chaff to white-out German radar; (bottom): Soviet SA-2 radar-guided missile.





Right and background: Pyotr Ufimtsev holding his book that truly unleashed the stealth revolution.

Below: The inherently stealthy and survivable SR-71.



How would future aircraft survive? Although it was a sideline, research in the 1950s and 1960s probed at low observables for shaping Minuteman missile warheads and cruise missiles like Snark and Hound Dog.

As far as anyone knew, there was still no way to apply the low observable benefits of a sphere to a combat aircraft.

Under Kelly Johnson's leadership, the Mach 3 SR-71 program tried out a few of the principles of stealth. Because the SR-71 development was so highly classified, few knew how far Lockheed had gone in exploring the potential of stealth.

The engineering of the day lacked principles for how to measure and control the total sum of an aircraft's radar reflectivity. The best they could do with radar return was to soak some of it up with absorbent material. What they couldn't do, yet, was

to control the waves.

Part of the answer was lying in stacks of foreign technical literature, waiting to be translated by the Air Force Institute of Technology. The document in question was a report titled *Method of Edge Waves in the Physical Theory of Diffraction*. The author was Russian physicist Pyotr Ufimtsev. He'd first published

the research in 1962. His discussion of James Clerk Maxwell's equations as a basis for predicting how a geometric shape would reflect electromagnetic waves was the path to a breakthrough for stealth aircraft.

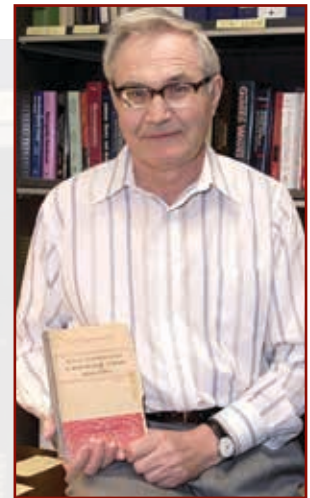

What Ufimtsev realized was that radar waves, a notch farther down the electromagnetic spectrum, would behave the same way as optical light. Ufimtsev's insight was to apply the principle to calculate the sum of the radar cross sections of different geometric shapes. Fortunately, it was a snooze for the Soviet Union's censors. After all, Maxwell had died in 1879.

The Soviet Union saw no national security value in the paper and it was cleared for publication.

DRONES

What first convinced the U.S. government to push stealth forward was not research by the Russians but a strange test result with a miniature drone on a range in Florida.

The Defense Advanced Research Projects Agency (DARPA) ran several experiments with miniature

remotely-piloted vehicles or RPVs – today’s equivalent of small, tactical unmanned aerial vehicles. One mini-RPV, made by McDonnell Douglas, surprised operators with its small radar cross section in tests at the company’s Grey Butte Microwave Measurement Facility range in the Mojave Desert in California.

The RPV data suggested that flying objects with smaller radar cross sections could work around the Soviet defensive systems. In 1973, the Defense Advanced Research Projects Agency, the Pentagon’s idea factory, was impressed enough to take the mini-RPV to Eglin AFB for a bigger test against the ZSU-23. First fielded in 1965, this formidable self-propelled air defense gun quickly became the scourge of pilots because it could take on aircraft at low altitudes. Pilots could not fly low enough to get under the detection radar for SAMs if



ZSU-23s were with the front-line forces. They were so popular that the Soviet Union eventually exported 2,500 of them.

One ZSU-23 in particular found its way to the Eglin test range in

Florida where operators set up a test against the miniature drones.

The big gun spat shells at the mini-RPV as it flew down the range, trying to track and engage the little drone by radar. Due to its size and shape, the drone was just too small to reflect back enough radar energy for the ZSU-23 to guide its guns. “The radar could not guide the gun accurately and the gun never hit the airplane,” recalled John Cashen, who would soon find himself designing the B-2. Finally, the test crew manning the gun had to resort to optical tracking.

It was a revelation. Cashen, who learned of the tests later, described the impact. “This was the first evidence, at least to DARPA, that you could beat a Soviet anti-aircraft system with a reduced radar cross section,” Cashen said. “Everybody understood based on the ZSU-23 test that if you could reduce the range of first radar detection, then air defense radars searching for incoming objects would not detect and track a low observable aircraft until much later than the radar designers intended.

“On top of that, it would also affect the in-close tracking, even if it was not by radar,” Cashen added. Skewing close-in tracking would interfere with higher-frequency fire control radar. Put those elements together, and an object with a small RCS could, in theory, get close enough to render Soviet air defense systems ineffective.



Left: ZSU-23/4 tracked vehicle.

Above: An RPV similar to that used in tests against the ZSU-23.



Above: Soviet SA-5 missile.

Right: Kent Kresa

Below (left to right): F-5, F/A-18, A-10 aircraft.

Low observables were worth a try to confound the ever-increasing Soviet air defenses.

By the early 1970s, the situation was bleak. Even the SR-71 was no longer entirely safe.

The SA-5 debuted

in 1967 with a range of about 37 miles and a ceiling up to 105,000 feet. In Vietnam, a new array of Soviet-made SAMs bagged U.S. fixed-wing aircraft and helicopters by the hundreds. The 1973 Yom Kippur war showed how effective a mix of integrated, surface-to-air missile systems could be. Soviet-built systems claimed up to 100 Israeli aircraft in about two weeks of war. The Egyptian and Arab coalition losses were four times higher, but the war was another demonstration of how much trouble Soviet-made air defenses could cause for tactical aircraft.

Many in the Pentagon were eager for more innovative research on future aircraft survivability. Cones

and drones were achieving low observables – could a stealth combat aircraft be the answer?

At DARPA, Ken Perko had already set out to ask that question in December 1974. Perko had been recruited by Kent Kresa, who was head of the Tactical Technology Office, to help build up research on tactical aircraft for the

government’s innovative bureau. The mini-RPV and other unmanned vehicle tests

indicated to Perko that there might be some promising technology at hand. The only way to find out was to ask.

“We got a Telex from DARPA asking what Northrop would propose for a design driven by low observables,” recalled Cashen.

The request from Perko asked two questions. What were the signature thresholds that an air vehicle would have to achieve to be essentially



undetected at an operationally useful range? And what were the capabilities of each company to design and build an aircraft with the necessary signatures?

“Industry didn’t propose any of this. It was truly a government-instigated question to industry: could you do it?” said Cashen.

Northrop made the list because it was manufacturing the F-5, a popular export fighter. The company had lost out on competitions for what became the A-10, and the Navy’s F/A-18 Hornet. It was craving future work to complement the steady flow generated by the F-5 international sales.

DARPA sent Perko’s request to all the companies they could think of which made fighters. For some reason, they skipped Lockheed.

It was a huge oversight. Someone had finally read Ufimtsev’s paper as translated by the Air Force, and it was a thirty-something engineer keenly interested in low observables. He realized that by treating an aircraft as a group of geometric shapes, each with its own radar-reflecting properties, it might be possible to tally up the radar cross section of the aircraft as a whole. In fact, the young engineer believed he could write a computer program for designing a stealth aircraft. It was Lockheed’s Denys Overholser.

The advanced design team at Northrop knew nothing of this. Their approach to stealth came from a different lineage of low observable research.

Since the mid-1960s, the Air Force and Army had paid a handful of Northrop engineers to evaluate the radar cross section of ordinary types of aircraft as part of a larger interest in improving defenses. Among the group’s long-time members were S. Stanley Locus, Fred K. Oshiro, Hugh C. Heath, Moe Star, J. Randall Coleman, and Kenneth M. Mitzner. John Cashen then joined as a radar expert from Hughes. Their task was not exotic. But it developed over time a deep reservoir of expertise in the techniques for measuring and calculating RCS. From this group would come many of the key insights on how to design a stealth aircraft.

“We knew that it was the laws of physics that caused radar to be invented in the first place,” said Tom Jones, the dynamic CEO of Northrop. By the same token, understanding those phenomena could lead to the defeat of radar tracking and enhance the survival rates of aircraft.

Preliminary studies by Grumman, McDonnell-Douglas and Northrop were followed by full concept white papers commissioned from McDonnell-Douglas, Northrop and Hughes, which was selected for its radar expertise.³

DARPA accepted the proposals from both McDonnell Douglas and Northrop. In the end, Lockheed’s Ben Rich got into the program, too, by gaining permission to tell DARPA more about the SR-71 techniques. The race for stealth was on.



Above (top to bottom): Denys Overholser, John Cashen, Tom Jones.



Chapter Two: Two Horses in the Race

Lockheed and Northrop were both selected to work on demonstrators in the fall of 1975. The program was judiciously named the Experimental Survivable Testbed (XST). Wedding survivability with aerodynamics was the first test. No one really knew whether it would be a fighter, bomber or reconnaissance vehicle.

Over the next five years, the advanced design teams at Lockheed and Northrop would transform stealth from a slap-on, modification technology to a revolutionary approach to combat aircraft design.

While there were two horses in the race, Lockheed had a more mature technical stable. Their genius lay in being able to design an aircraft whose outer surface was a series of strict geometric shapes. Flat planes, triangles and parallelograms defined what would become known as Have Blue. By designing an air-

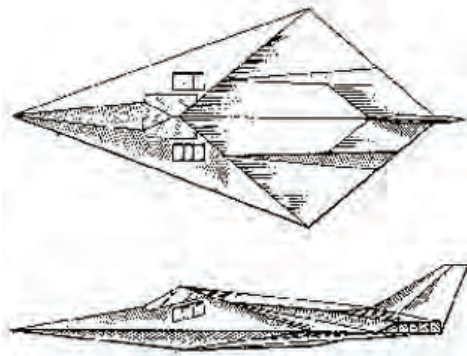

craft with a surface consisting of flat plates, the Lockheed team could precisely estimate the radar cross section of its demonstrator.

The Northrop approach was different from the outset. Its core was built around the deep experience and insights of a handful of radar cross section experts that for years had honed techniques for predicting RCS of ordinary aircraft. However, as 1974 ended, most of those contracts had lapsed. Northrop had all but decided not to invest any more money in it. The RCS experts were dispersing to other jobs in the company. John Cashen had been hired into the group as it was getting ready to pack up. He was told to forget his electromagnetics background and concentrate on avionics integration.

Perko's telex rattled in to this sleepy environment.



Opposite (top): Northrop Grumman B-2 Spirit on the tarmac at Andersen Air Force Base, Guam; (bottom): Lockheed Martin F-117 Stealth Fighter.

Below, left: Early Lockheed XST conceptual sketches showing design based on strict geometric shapes.



Below: The Northrop XST faceted design with flat bottom.

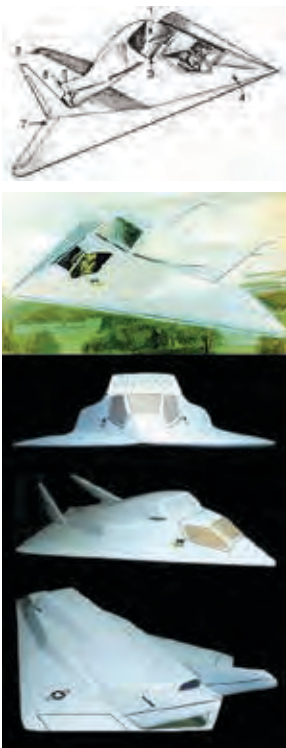

Northrop saw an opportunity and leapt at it. George Urquhart became the first manager while Mo Hesse oversaw the XST proposal work. Most of the team were part-timers with Cashen working IR, visual and acoustic and the brilliant Stan Locus, a Manhattan project alumnus, handling the radar cross section.

All the ingredients would not add up to a win on the XST. But in the process, the Northrop advanced design team would be building a foundation for the B-2.

Early Northrop designs for XST were “100% faceted, and flat-bottomed,” noted Cashen. However, the group soon began discussing another way to achieve low observables through curvature. Cashen believed that “you could make an airplane look like a re-entry vehicle.” Radar cross section was not size-driven. To be sure, there was a size factor, but it was small.

Stealth design in those days was a process of drawings, clay models and shop work on wooden models. Promising designs were driven out for night-time testing at Grey Butte, the only range with the sensitivity to assess the very low signature levels sought in the competition. None of it was highly classified as yet.

“It was the most creative period,” recalled Cashen. “We were drawing an airplane and before you know it, curvature started to come in.”

The Northrop team was branching off significantly from the sophisti-

cated, controlled approach marching ahead at Lockheed. The Lockheed team stayed away from any design features that could not be predicted in the Overholser computer. Northrop did not have Lockheed’s computer model, and it both penalized and liberated them.

“Computers in those days could not do anything more than put facets together. We knew that,” explained Cashen. “We knew more about predicting radar cross section of three-dimensional shapes than anybody in the world because of the Air Force contracts experience.”

The Northrop RCS experts knew the limitation of RCS prediction with the computers of the day. Mercurial and aggressive, Locus and Cashen simply pushed beyond it. Since they did not have confidence in summing the predictions mathematically, the Northrop method on XST was to rely on modeling and testing to validate their highly-refined instincts.

Cashen and Locus soon came to believe that curvature would not degrade the radar cross section. In fact, it might produce even better range results. “I could see the waves,” said Cashen. Locus saw it that way too, and the whole group concurred. “We didn’t need a computer program to tell us what the RCS could be. That was the difference between Northrop and Lockheed,” as Cashen put it.

Curvature also made good aerodynamic sense. “For one thing, we were trying to make an airplane that could fly,” acknowledged Cashen. The Northrop team elected not to depend on a fly-by-wire system because they felt it would cost too much. Therefore, the design had to be stealthy and aerodynamic. Drag and stability problems drove the small team to try to add curvature.

Measuring RCS was one thing, but the key to designing a stealth aircraft was *reducing* RCS. The fundamental insight was that the aircraft could be less than the sum of its parts. “If you deal with each local phenomenon, you can make a very large object very small on radar,” Cashen said.⁴

“These guys were brilliant,” said Cashen, and Locus the most brilliant of all. They talked through curvature consequences and backscatter. “Stan would put it all together on the model, take it to the range, and by God, it worked.”

By early May, Northrop had its first results when Stan Locus returned from testing models on the Grey Butte range. The radar cross section engineers gathered around the light table to examine the data. “We were amazed,” said Cashen.

Spurred by the possibilities, the XST design team shifted into high gear, working after hours all through the summer of 1975.

Engaging in almost daily peer review of data kept up the momen-

tum and pace of the work. With so many part-timers due to the minimal budget, the data review accelerated the pace and gave the best results.

“That’s how Northrop’s airplanes were created. Not with some computer code,” said Cashen.

THE STALKING HORSE

In August 1975, Perko issued a formal request for proposal. Perko’s criteria insisted the airplane be flyable as judged by wind tunnel testing. But he also made clear that victory would go to the team with the lowest radar cross section reduction, based on evaluation criteria set by DARPA.

Northrop plunged in with a new contract and the guidance of Welko Gasich, who had run the F-5 program. Thrilled as the Northrop team was with their exciting progress, it was Lockheed that held the high cards. Their work on the SR-71 and their modeling put them so far ahead as to make Northrop “almost a stalking horse,” as Cashen termed it.

The two rivals kept their work completely separated by alternating time on the range. They got a chance to size up each other’s different approaches when they had to agree on the design of a pole for range testing – and split the costs, since the government declined to pay for it. Northrop wanted to build a pole with curves; Lockheed preferred facets covered with radar absorbent material (RAM).



Above: The Northrop XST going on the pole for RCS testing.

Below: Welko Gasich



The role of RAM was another big distinction. The Northrop design philosophy for this very first low observable aircraft competition was to use RAM only where needed. That was just as well, for Northrop was literally buying RAM commercially from a catalogue. “What we found with the commercial-grade stuff was the RAM itself created radar cross section,” said Cashen.

In contrast, Lockheed fabricated their own, benefitting again from the experience of their SR-71 work.

However, the most significant difference between Lockheed and Northrop centered on the radar cross section design trades chosen by each contender. Perko’s criteria for the XST competition called for measuring the radar cross section reduction by quadrants.

Northrop put top priority on reducing the nose-on RCS, and second priority on reducing the tail. This design, like others to come, sought to achieve what the Northrop team called the “basic minimum,” a reduction of radar return all around the aircraft. The basic minimum used design to pull the wildly reflecting radar energy of an ordinary aircraft into a smaller signature. It shrank return, then herded the radar return into very thin, controlled spikes of energy that would be reflected at the side of the aircraft, where they were less significant to enemy radar.

That was the theory – the proof came on the range at Grey Butte.

Radar waves were not vaporized, but organized. Sometimes they popped off the aircraft in unexpected ways. RCS testing on the range quickly revealed that they would have to work harder to deal with phenomena such as traveling waves. According to Cashen, the phenomena of travelling waves had been seen on the SRAM missile, but SRAM was symmetric. With their XST design, they found “that in flush, edge-dominated designs, the same phenomenon occurred on the edges.”

Edge waves occurred when the radar wave encountered an edge and began a loosely-coupled traveling along the edge. As the wave went down the edge, controlling RCS depended on catching and directing its energy.

“Two things will happen,” said Cashen. “It’s going to reflect back, or it’s going to radiate off. When you have a sharp edge, most of it’s going to reflect.”

XST had a sharp nose. The solution was to put RAM on the



Below: Various forms of RAM.

Lower right: A version of the symmetric SRAM missile in flight.

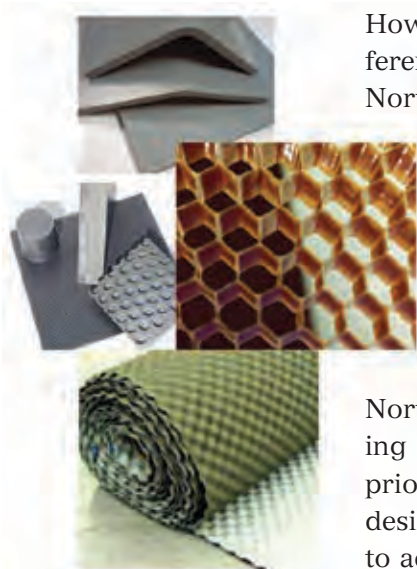

reflecting point, then catch the wave coming the other way. “We shed it at the other end and we killed the edge wave beautifully that way,” Cashen explained. “It was invention. Simple as that.”

The happy result was an XST design with decent ability to control RCS at low frequencies. On this criterion at least, Cashen thought they might have done a better job than the Lockheed demonstrator. “We beat them at low frequency by tens of dBs because they didn’t pay any attention to it,” he later judged.

However, signature reduction at low frequency was not a dominant criterion at the time, and the Lockheed team had done a better job at fulfilling the criteria set by DARPA and the Air Force.

Top members from both teams flew back to Washington, D.C. to debrief their results. Cashen remembered the briefing well. Northrop’s delegation included aircraft design engineer Irv Waaland, along with Cashen and their boss Mo Hesse. Theirs was the second appointment, and the body language didn’t look good.

“Waaland, myself and Mo Hesse were walking in to the conference room as Kelly Johnson, Overholser and the Lockheed side were walking out,” he said. The Lockheed demonstrator model was in a closed box Kelly Johnson carried under his arm.



Above: Irv Waaland ID photo, and at the B-2 rollout ceremony.

That night, after the formal presentations, both teams met for a small party at Ken Perko’s home. It was a tense gathering. The next day, DARPA announced that Lockheed had won and would go on to build the F-117.

The Northrop signature reduction was not what DARPA wanted. While nose-on reduction was achieved, the rear aspect low observability just wasn’t low enough. The butterfly shape of the controlled return carried too big a penalty under the quadrant criteria used to compare the signatures of the two demonstrators. The Lockheed shape had reduced signature across a 90 degree sweep on the rear quadrant. Northrop’s signature reduction began to bulge after 70 degrees. To top it off, “that last 10 degrees held a big spike,” admitted Cashen. “The term was “big-ass.”



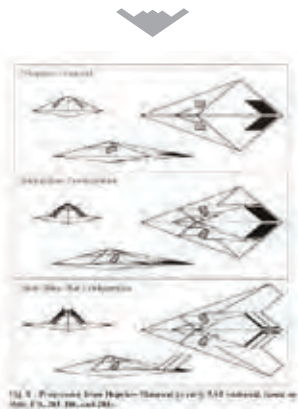

Above (left): The evolution of Lockheed's design from the "hopeless diamond" to Have Blue; (center): the details of the pure diamond shape; (right): The Have Blue design being tested. Note the vertical tails canted inward, compared to the F-117 outward canted design.

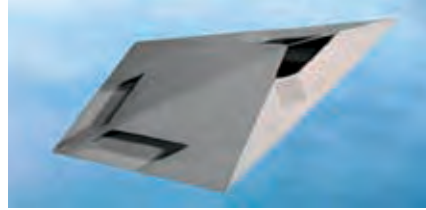

In the simplest terms, the aerodynamic design features of the XST constrained signature reduction. A major limitation for Northrop was their decision not to rely on fly-by-wire flight controls. Confident that nose-on signature mattered most, the designers achieved a good radar cross section reduction across the front from a swept leading edge. The Northrop XST aerodynamic design clashed with radar cross section reduction requirements at the trailing edge.

With fly-by-wire Lockheed could control the swept, diamond shape of its demonstrator. As a result, "they had a great deal more flexibility in what they did," said Cashen. It paid off in better signature reduction. By the time the Northrop team realized their design was running a risk given the DARPA preference, it was too late. Northrop would have had to scrap the XST model and retrace their steps to include fly-by-wire in order to bring down the rear-aspect RCS. However, their design was already being built to go on the pole. There was no time to start over.

The total signature for the Lockheed demonstrator was lower, pure and simple. "When they added all the numbers up, Lockheed got an A+," Cashen said later.

But losing the XST did not take Northrop out of the stealth game.



The head-to-head competition between teams from Northrop and Lockheed to develop an Experimental Survivable Testbed (XST) led both to significant technological breakthroughs that would later make the B-2 Stealth Bomber and F-117 Fighter a reality.

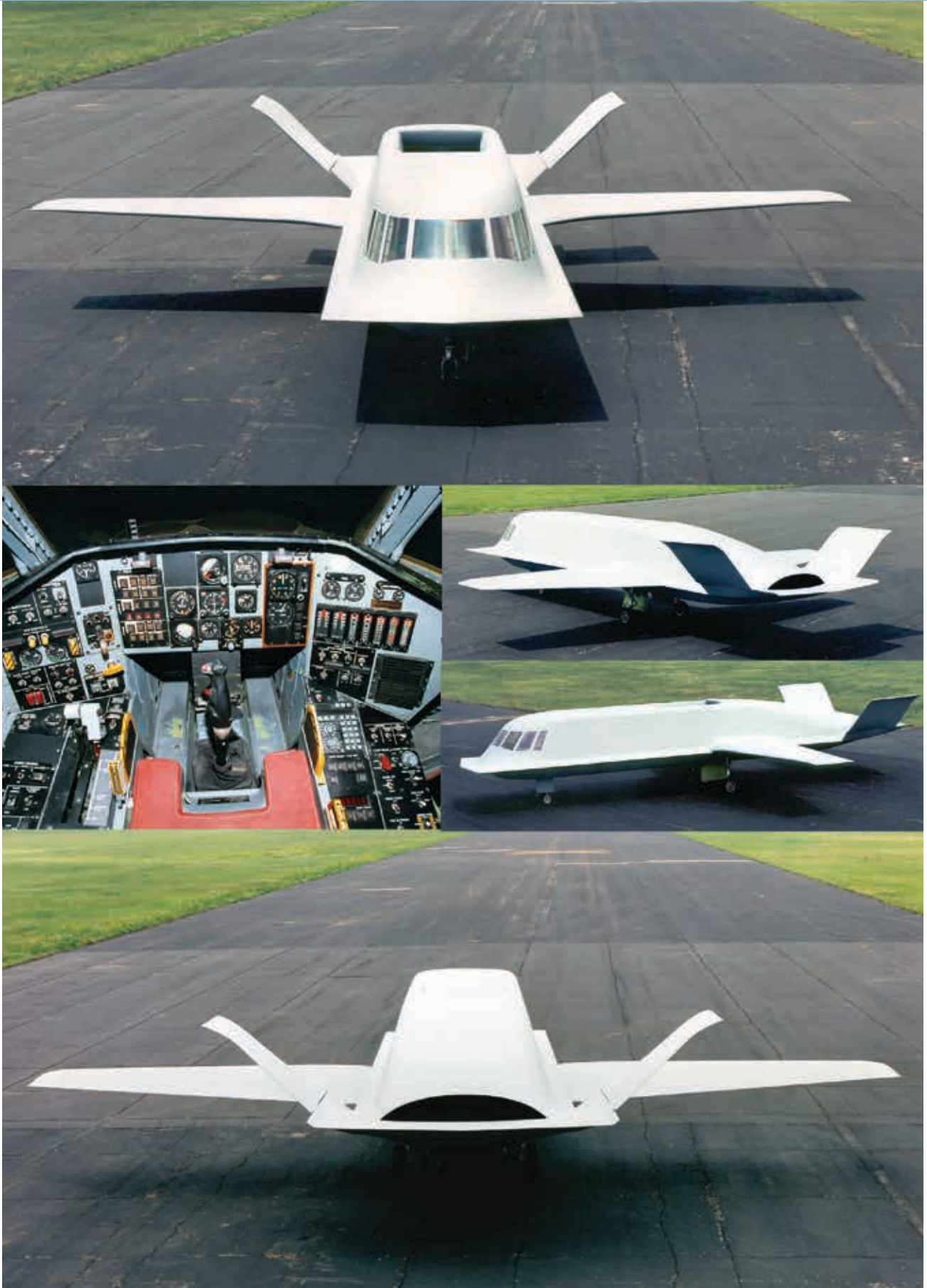

Chapter Three: Cruise Missiles and Tacit Blue

Tom Jones got a mysterious telephone call not long after Northrop's advanced design team lost the XST duel. Dr. William Perry was serving as Director, Defense Research and Engineering, at the Pentagon. Perry called Jones to encourage the Northrop chief to bid on whatever low observables projects came Northrop's way. For years, Jones told no one of the call. But the RCS coterie on the advanced design team would soon find they had a steadfast, if not cagey, ally in Jones.

Back at DARPA, the Northrop proposal for XST had excited a lot of interest. The stalking horse had shown itself to be a real contender with an innovative approach. However, the stealth fighter down-select left Northrop without a program to keep its team engaged.

The first new work came in the form of a program for a stealthy, intercontinental cruise missile, which later flowed into the Air Force's development of the advanced cruise missile (AGM-129). In 1976, it was a study project. DARPA experience in low observables was incorporated into the design of the low-signature engine inlet and nozzle.

Because the missile was an unmanned system, Northrop's Ventura division took the lead and borrowed several stealth experts loaned from the aircraft division in Hawthorne.

This development was special. Coming after the XST experience, this gave the advanced design team a chance for in-depth research that led to conceptual breakthroughs in the understanding of edge waves, for example. Cashen felt that it was during this program that Stan Locus, in particular, codified principles of design for stealth that would see the light of day for Tacit Blue and for the B-2. In a series of memos, Locus worked out the understanding of how to treat edges in a low observable design. "He evaluated – without the computer – the basics of scattering from edges," said Cashen.



Opposite: Northrop's Tacit Blue experimental airborne command platform.

Below: Advanced design work flowed into the Air Force's development of the AGM-129A Advanced cruise missile.



Analysis and a simplified understanding of the physics led them to a startling conclusion. “If an ice cream cone was the perfect re-entry vehicle, then the thin flat plate was the perfect airplane,” summed up Cashen.

It would be a few years before they realized how valuable that insight was.

Meanwhile, the customer changed course. With Lockheed busy turning the XST into Have Blue and the F-117, the best place to continue

consolidate airborne management of battlespace data. Like other stealth projects, Tacit Blue began life under a different moniker. It was first called BSAX, for Battlefield Surveillance Aircraft – Experimental. The specific role for BSAX was to collect precise threat and targeting data and relay it to bombers and fighters. The aircraft itself would be unarmed.

By any name it was “a whole different push on stealth,” as Kresa described it.

“We went under contract in April 1978 to build an LO bird with a radar,” Waaland said. “Unlike XST, it was going to be all aspect stealth,” Waaland added.

The reason why the radar and the all-aspect signature were so important became evident when the Northrop team was briefed on the concept of operations.

BSAX was to fit in with a larger operational concept known as Assault Breaker. This DARPA-led concept envisioned launching missiles to kill clusters of tanks in Soviet echelons without resorting to nuclear weapons. Cashen described it as “a way for



Right: Lockheed’s Have Blue experimental stealth aircraft was the next evolutionary step from their XST Program.



Below (left): T-16 Assault Breaker missile releasing multiple explosive charges designed to kill clusters of tanks; (right) T-22 Assault Breaker.

stealth development along different lines was at Northrop.

“Perry said get them into the game,” Kent Kresa recalled. A Northrop team travelled back to Washington to hear specifics on a new Pentagon idea for a stealthy, battlefield control aircraft later known to all as Tacit Blue, or the Whale.

If there was ever an aircraft driven by an operational concept, it was Tacit Blue. Pictures released publicly in 1996 showed a butter dish with stubby wings and cockpit reminiscent of the front of a VW bus. It looked like it probably couldn’t fly – but it did – 132 flights in fact.

The idea for Tacit Blue sprang from a growing desire in the 1970s to



U.S. technology to defeat the overwhelming superiority of Warsaw Pact armor by using precision-guided weapons.” Missiles launched from the air or ground would be controlled by command guidance from the radar aircraft in the mid-course of their flight, then switch to terminal guidance to strike individual vehicles (the radar concept was developed under the Pave Mover program and eventually became J-STARS).



What Tacit Blue became, however, was the crucial conceptual bridge from rolling the dice on XST to preparing the concepts for the B-2 bomber.

The unique requirements ensured that Tacit Blue would start making key contributions to the B-2 well before the Whale itself ever flew. Four stood out – radar, spikes, curves, and low frequency.

Radar was a major threshold. Incorporating a powerful radar and its antennae into a stealth aircraft was a new frontier. Tacit Blue would be the first stealth aircraft to carry a massive low-probability of intercept radar, which was the core of its mission system.

Northrop paired up with Hughes. “We convinced ourselves, and therefore DARPA, that a low probability

BSAX – Tacit Blue – was supposed to be that airborne command platform. As a command ship, it had to be as close to the forward edge of the battle as possible without getting shot down. That, of course, put it smack in range for everything from the SA-6 to the ZSU-23.

Stealth was the only way to make the concept work. This time, there would be no butterfly shapes as with XST. The platform had to be low observable from all aspects – 360 degrees around.

At first, the new program really meant a chance for Cashen and other XST alumni to keep building their skills on the advanced design team. The Pentagon was placing another bet on nurturing the stealth design base. “It was pioneering work. Every day was a discovery,” said Cashen.⁵

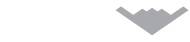

Left: The Tacit Blue performed beyond many people’s expectations and flew 132 test flights.

Below: Drawing a crowd outside it’s hangar at the Air Force Museum, Wright-Patterson AFB.



Right: The Tacit Blue's gracefully tilted vertical stabilizers give it the distinctive "whale tail." The aft deck design directly contributed to that on the future B-2.



of intercept radar would make this airplane non-targetable," said Cashen. The issue was not making it non-detectable, but controlling radar returns to give the platform a good chance of surviving near the battle's edge.

Basically, the designers were taking a low probability of intercept radar and wrapping a stealth airplane around it. The team "needed a box with enough dimension to house the mechanically-scanned fixed phase array antenna" and to be covered with a band-pass radome to shield it. At 35,000 feet there wouldn't be much threat from above. Unlike XST, the front and rear aspects were not top priorities. This aircraft would be far more vulnerable in exposing its sides all the time while orbiting around the battlespace and guiding all those missiles.

Thinking through the tactics helped them settle on the concept of spikes – the second big innovation. Instead of radiating in all directions, the Tacit Blue aircraft would reduce reflectivity to the basic minimum, then gather and control the remainder in narrow spikes to

confound the detection lobes of enemy radars. No matter where it flew on its commandship orbit it could ensure that only brief spikes of signature appeared, enough to whet the appetites of enemy ground controllers but not enough for them to build a good track.

The third, and most famous, of Tacit Blue's innovations: the perfection of the rounded shapes. Tacit Blue was the program where all the curves began.

Facets were not working. "We knew we had to incline the walls," Cashen said. At one point the DARPA managers grew so concerned about the obstacles Northrop was encountering that they asked Lockheed to take a look at some different shapes for the battlefield plane. They also cracked down on Northrop, forcing them to evaluate an alternate design if they wanted to keep going on the contract. "They let it be known we should look at a flying wing," said Cashen.

The XST team had started to understand the value of curvature both for stealth and aero-

dynamic benefits and work on the advanced cruise missile carried it forward. The challenge of embedding a big antenna in Tacit Blue made the issue critical.

Then the problem was solved one night at Disneyland.

Brainstorming for aircraft designers in those days involved a lot of modeling clay. In these last years before computer-aided design, clay was the quickest way to transfer 3-D shapes out of the designer's mind's eye and into something that could be modeled and tested.

The Tacit Blue team was a little obsessed. One of the designers, Fred Oshiro, was struggling to finish the front shape. He carried modeling clay with him when he took his children to Northrop night at Disneyland. Sitting on a bench, he pressed the clay into an unusual form, a steep sloping front section, flaring into a flat, sharp leading edge.

"He came up with this shape with a wide angle radius, just like the front of a Winnebago," quipped Cashen.

Oshiro came into work the next morning, put the clay on the bench and told the shop foreman to build the model. "That was Fred and his genius," said Cashen. He just came up with it."

The body of Tacit Blue produced the needed RCS. Head on it was like a prototype for the B-2 center body.

Tacit Blue eventually added stubby wings and gracefully tilted vertical stabilizers. From the back and sides, Tacit Blue foreshadowed some of the shapes and angles of stealth aircraft yet to come like the F-22 and F-35 fighters. "If you've got to have tails, butterfly is the best thing," Cashen shrugged.

The fourth memorable breakthrough concerned low frequency. Previous programs concentrated low observables work on the shorter wavelengths employed by fire control radars. During the Tacit Blue program, designing for low frequency became a priority for the first time. "Tacit Blue did not start with any low frequency. That was the thing that General Allen threw in," explained Waaland, who was



Above: Fred Oshiro.



Left: The B-2 center body (below) was a direct descendant of the Tacit Blue's ingeniously-shaped front end.





Above: Tejon desert test site.

Below: The cockpit of the Tacit Blue has been compared to the cab of a Volkswagen microbus.

referring to Air Force Chief of Staff General Lew Allen.

Cruise missiles played a role again. “They were doing tests of cruise missiles out in the desert. All of a sudden they noticed you could follow the thing straight in if you used a low frequency radar.” The wingspan of the cruise missile matched the wavelength of the low frequency radar and “it just lit up,” said Waaland.

Making Tacit Blue work at low frequencies would turn out to be an enormous breakthrough for the B-2. Tacit Blue went on to successful flight tests – although it was one of the least stable aircraft ever flown. Northrop had of course come around to the necessity of fly-by-wire for the exotic missile control platform.

In the end it achieved a tremendously low signature. Tacit Blue’s

flight tests ended in 1985, and the demonstrator then spent a decade hidden in a guarded hangar. What worried those involved was the fact that the aircraft could be picked up visually. The Air Force finally decided to retire it. They declassified just enough about the innovative airship to allow it to find a home in a museum and in the annals of stealth.

All that was in the future. At Northrop, the work on Tacit Blue drew together a number of innovations that paved the way for the B-2. Tacit Blue had a flush topside inlet, the first in the business. Its broad curvature dominated Tacit Blue’s one of a kind design. Stare at the front cockpit and Tacit Blue’s shape is pure B-2.

“You can’t talk about the B-2 without talking about Tacit Blue,” summed up Cashen.





The Tacit Blue's flush topside inlet, the first in the business, was just one of many innovations that would be incorporated into the design of the B-2 Spirit.





Chapter Four: A Bomber?

Byond the exotic Tacit Blue, could there be other applications for stealth? Northrop quietly started investing some its own money into research on a stealthy fighter in 1978. The Air Force had other ideas. On a visit to Hawthorne in the spring of 1979, government officials led the team into Waaland's office and asked what ideas they might have for future applications of stealth.

Did you ever think about a strategic bomber?, asked one of the Air Force officers, Major Dave Englund.

Waaland and Cashen immediately thought the same thing. According to the grapevine, Lockheed was working on a low-observable bomber. Surely the nonchalant question from the government's team proved it. Were they once again looking for a stalking horse? And did Northrop want to play that role?

Their boss John Patierno puffed on his pipe. "I've got to tell you Dave, Northrop doesn't do big bombers. That's not our business."

The Air Force did not rest easy with that answer. Jack Twigg reminded the design team that they were in business in no small part because



the Air Force had fed them Tacit Blue, and wanted them to keep working.

Then there was Tom Jones's commitment. True to his promise to work on stealth projects, no matter if they came out of the blue, Jones backed the concept of a bomber from the beginning.

"I'd been asked by Perry would you please, you, Northrop, respond. Well, I had to say yes. I knew we knew enough to configure that bomber," Jones said.

The formal request came from Air Force General Tom Stafford. By spring 1979, the team was looking at the problem. Step one was to review the threat models and synthesize the problem.

Jones told them to give it six weeks. "Tell them that on that date we will be in the Pentagon to brief on our studies of a manned, penetrating bomber," he said to



Opposite: The YB-49 Bomber, forerunner to the modern B-2 Spirit.

Left: John Patierno.

Below: U.S. Air Force Lt. General Tom Stafford, NASA astronaut and veteran of four missions – Gemini 6 and 9, Apollo 10, and the Apollo-Soyuz Test Project.





Top right: The B-1 Bomber had the supersonic capabilities but lacked the desired stealth.

Below: Jim Kinnu.

Welko Gasich. Jones wanted the first B-2 concept briefing to communicate the possibilities to the top leadership of the Air Force, just to show them it was theoretically possible to make a stealth bomber out of a flying wing and that Northrop believed in it.

“I picked the date because I knew that our guys – Waaland and Cashen and Patierno – they briefed me all the time” and they could deliver, Jones recalled.

“The possibility was there. We didn’t know how to do it in detail. A lot of things had to be discovered to be able to do it. We saw that there was an opportunity here. Maybe we can make it work. It was like a prize,” summed up Jones.

Bringing home the prize fell in large part to Jim Kinnu, a veteran who’d joined Northrop in time to help straighten out Tacit Blue. This taciturn engineer with extensive experience outside Northrop soon became the long-time program manager for the B-2, leading the program from 1980 to 1987.

Yet it was with Tacit Blue that he learned one big management lesson. “The first step was to get Waaland and Cashen to work together,” he recalled. Like prodigies, they were brilliant separately, but they worked together “about like oil and water,” said Kinnu.

It had taken Kinnu three intense weeks of meetings in the big conference room in Building 3-60 to



extract from Waaland, Cashen and others on the advanced design team a way forward for Tacit Blue. By the end of it, Kinnu had a risk closure plan for how to narrow the technical gaps. It taught him all over again that it was critical to lay out a risk closure plan before cementing a program schedule.

Now, in the early summer of 1979, Kinnu joined a meeting where the advanced design leaders considered how to apply Northrop’s approach to a bomber.

On a blackboard he drew four quadrants for combinations of high and low altitude and subsonic or supersonic speed. The B-1 already had low supersonic.

All agreed the technology was not there yet for supersonic stealth. “We were already starting to work on a fighter application for stealth technology,” said Kinnu. It was a supersonic problem, of course, and those familiar with the project realized there was a long way to go to match low observables with speeds beyond Mach 1.



To Kinnu, the sweet spot for a bomber was high and subsonic. “You gain a lot more range, and there are less things coming at you, and if you are stealthy, they aren’t going to see you,” he later explained.

“Waaland and Cashen got the assignment to work on a bomber application of our technology,” continued Kinnu. Northrop still had substantial advanced design work in the white world. Kinnu kept feeding designers, configuration experts, and others to the black world design. Whenever subsystems could be designed in the white world, Kinnu kept them there. Already, the momentum for the bomber and the pull on manpower made it prudent to slim down the shotgun-style approach to other advanced design and leave only a few projects in the white world, plus the black world bomber.

Disciplined as they were they began with the fundamentals. This airplane demanded all-aspect signature reduction. A strategic bomber was not going to melt away in a plasma fuzz anymore than the F-117 or Tacit Blue demonstrators. The designers would have to capture and manage RCS to create a minimum signature instead of a radiating blob like the B-52 and all other bombers. Flying an ideal profile, the bomber crew would have to maneuver away from the worst radar threats. Northrop survivability analysts worked for advanced design and

the picture they painted was of a dense Soviet air threat where survivability would have to be 360 degrees around the airplane, “I looked at the results,” Cashen recalled, “and to me it said *flying wing*.”

XST was a wedge, Tacit Blue a clever radar box, but the bomber would be something different altogether.

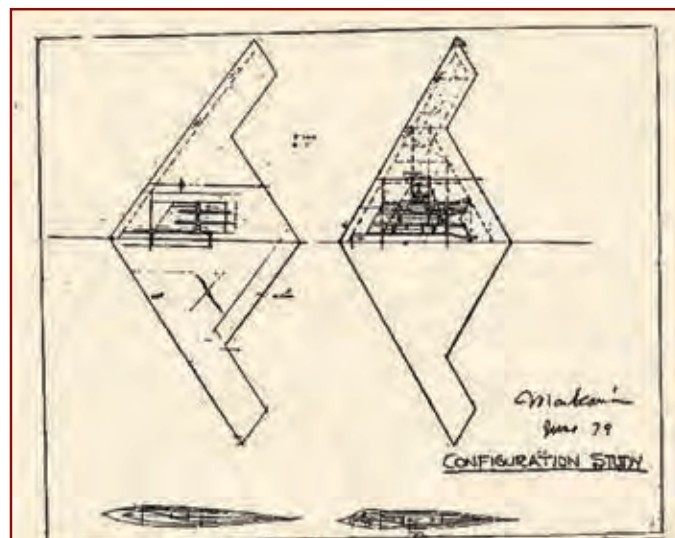

Above: Early flying wing sketch.

Both remembered their experience with reviewing a flying wing during the tough times on Tacit Blue. “Waaland had looked at the results too and he thought the same thing,” said Cashen.

“We took one look at the flying wing and said that’s the shape that gives you more efficient structures and more efficient aerodynamics – lift to drag ratio,” added Jones.

FROM FLAT PLATE TO FLYING WING

The reason the flying wing was perfect was that it most closely resembled that infinite flat plate –

the perfect stealth shape. Consider the theory. A thin plate would have no angles to reflect back. Radar return would flow over and race beyond the aircraft. Reaching to infinity, there would be no edges to grab and scatter radar waves.



Below: What was once old is new again. Waaland and Cashen soon realized that the wing was the perfect stealth shape.



Obviously no bomber containing fuel, a weapons bay, and a cockpit could be a true flat plate. Any incline or slope to accommodate the cockpit, for example, violated the basic principle. Still, the RCS specialists and the aerodynamicists all had to strive for that low observable effect, making design trades based on staying as close as possible to the ideal.

“Anything you do in stealth design is to endeavor to create this infinitely thin, flat plate,” said Cashen of this period.

Coming together now was a revolutionary body of knowledge which had begun to emerge from XST, and been articulated with the advanced cruise missile. The control of the RCS, and the management of edge waves all had to function within one design. Plus it had to fly.

Step one was curvature. What could not be kept flat and thin would

be curved. “The answer was the introduction in every possible way of general curvature,” summarized Cashen.

Step two was dealing with edge waves. Here the designers faced a choice, but work on XST, advanced cruise missile and Tacit Blue showed them the way.

“The law that Stan came up with says you are going to get spikes from the straight edges,” explained Cashen. “The corollary says if you curve, you eliminate spikes, but the RCS grows where you curve. You can’t get rid of RCS, all you can do is push and pull it around, like a balloon.”

The choice lay in where to crowd together the RCS return. Years of models and range results had piled up data on how to manipulate radar return – the very essence of stealth. Shaping and other techniques enabled the designers to select where they wanted the RCS to reflect, how intense that reflection would be, and whether it would scatter or be contained in spikes.

Of course, there was a dilemma. “If you put all the RCS in the spikes to achieve low basic minimum, then you have to deal with the spikes,” said Cashen. “If you choose to get rid of the spikes by curving everything you have to deal with the basic minimum.”

Choices like these would weigh heavily on the designers. Fortunately, experience counted. “It turns

out its easier to deal with the spikes than the basic minimum. The reason is because basic minimum dwells as it flies by radars. Spikes, if they are narrow, appear as glimpses," Cashen said.

That was the whole idea of stealth. It was inherently tactical, and it was always about tilting the odds. With all-aspect reduction, the odds soared in favor of the attacker.

ENTER THE B-2

Although the advanced bomber would not get its official designation until 1984, the B-2 emerged clearly from Waaland's secret, hand-drawn briefing charts in the summer of 1979.

Following the guidance from CEO Jones, the team put together designs to present to the Air Force quickly, sticking to what they knew. Settling on a radar cross section reduction concept was one thing but it also took a number of aerodynamic decisions to create a flyable design. The flying wing design was neutrally stable. It would be up to the aerodynamicists to introduce control systems to make it trim and stable. Radar cross section constraints necessarily "threw away a lot of the aerodynamic solutions" noted Bill Haub, a young aerodynamicist who joined the team as they labored over the proposal.

Other Northrop designs like the F-5 took advantage of standard techniques such as tilting the engines

half a degree to assist trim. "In the B-2, you couldn't just cant the engines, because the engines were buried," said Haub. Inlets, exhaust, engines: all were affected. "The normal rules changed quite a bit," noted Haub.

Control was another issue. For a time, for yaw control, they had thrusters. Waaland's first concept briefs depicted a B-2 shape with two small, canted tails.

No one was satisfied. Cashen and the RCS mafia did not like things that popped up. "I wanted everything to be installed and flush and stealthy," he said. "It was just more elegant that way."

"Finally, somebody got the bright idea that Jack Northrop had controlled that thing with split

Below: Understanding the RCS allowed planners to find survivable routes through sophisticated enemy defenses.

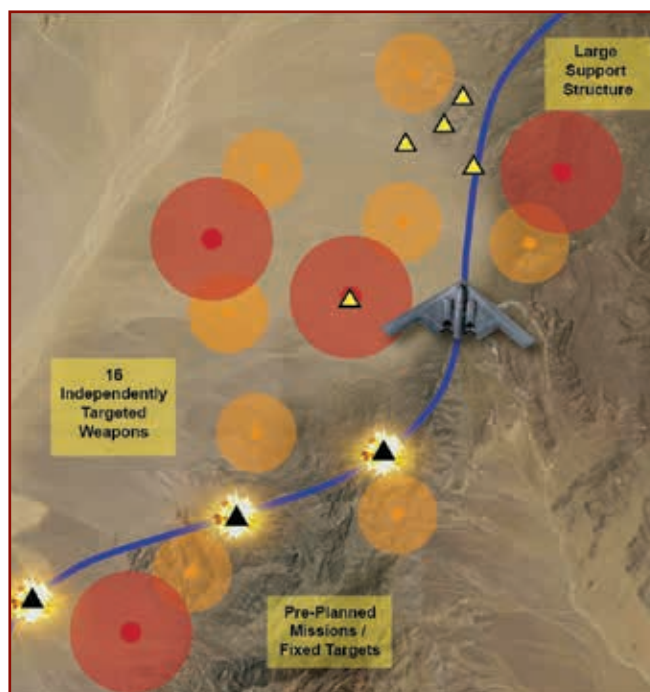

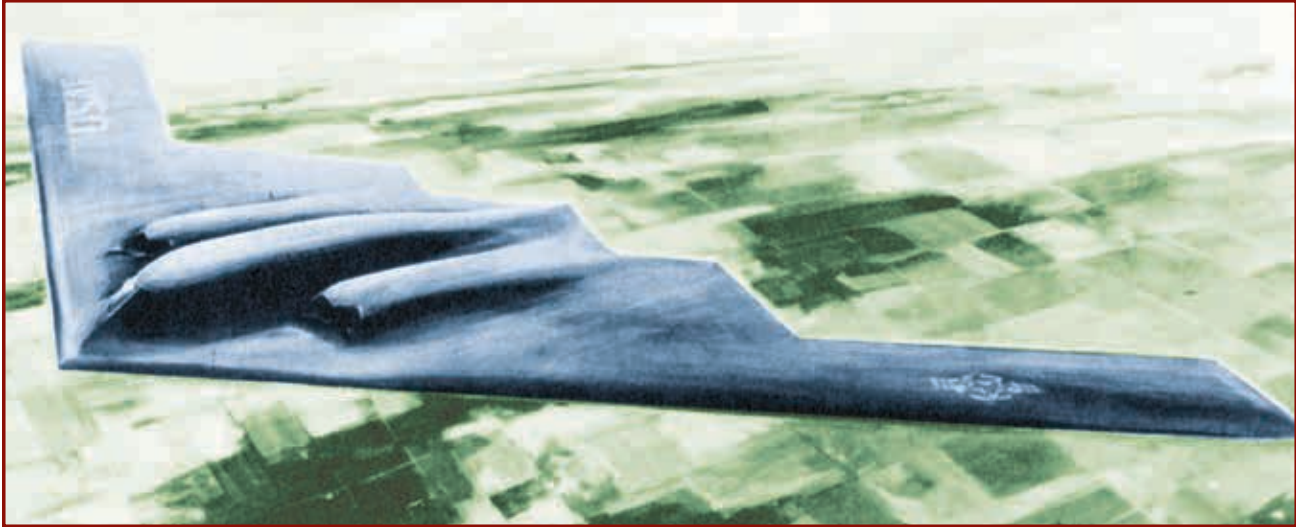

Above: Copy of the original artist concept rendering of the advanced bomber.



rudders,” recalled Cashen. Split rudders became the one major inheritance passed from the YB-49 to the B-2.

On August 7, 1979, Waaland briefed General Stafford on the Low Observables Bomber Study. The time elapsed was not much more than the “six weeks” mandated by Jones. True to their word, the briefing concentrated on range, payload, and the concept of low observables. Waaland and the team decided the range would need to be at least 6,000 nm. Their primary threat concern was the SA-2, “the one that shot down Gary Francis Powers,” in the U-2. One chart featured a low altitude concept, but the real beauty was the sketched B-2 presented as the high altitude penetrator. “In the first configuration, we had fins on it,” recalled Waaland. Wingtip spoilers, elevons, split flaps and differential engine thrust were also needed for control.

Waaland and team believed they could bring the baseline RCS of the bomber well below Tacit Blue’s signature. “At the lower frequencies, we could do better” than Tacit Blue, Waaland said. The Northrop team was excited about the prospects, especially given the need for the bomber to elude low frequency early warning radars and penetrate deep into the Soviet Union.

At high altitude, the bomber would survive by defeating both detection systems and kill systems. Discrete, narrow side spikes with a specified (and still classified) RCS as measured in decibels per square meter would help it get past the Tall King radars and foil the Soviet-style AWACS. Shielding the exhaust and minimizing skin temperature would dampen the infrared signature and help prevent Soviet satellites from picking it up. Full RCS reduction and a high subsonic speed were critical

for eluding radar SAMs. If airborne interceptors showed up, all of the above would work in combination to elude or outrun them.

For bomber pilots, it was irresistible. “Perry and the government wanted a stealthy bomber. They saw it as the only way to counter the Soviet Union,” said Waaland. The F-117 was thriving. “They were still nervous about whether you could do it at high altitude,” said Waaland.

Lieutenant General Tom Stafford had seen a lot by the time the Northrop team arrived with Waaland’s charts. He was a fighter pilot and astronaut who flew Apollo X. Now, as three-star head of the Air Force Research, Development and Acquisition on the Air Staff, he was nearing retirement. But he knew a good thing when he saw it.



Above: Bill Haub

Below (left): Early B-2 models with small vertical tails or small wingtip stabilizers – direct descendants of the YB-49; (right): Photo clearly shows the left hand split rudder.

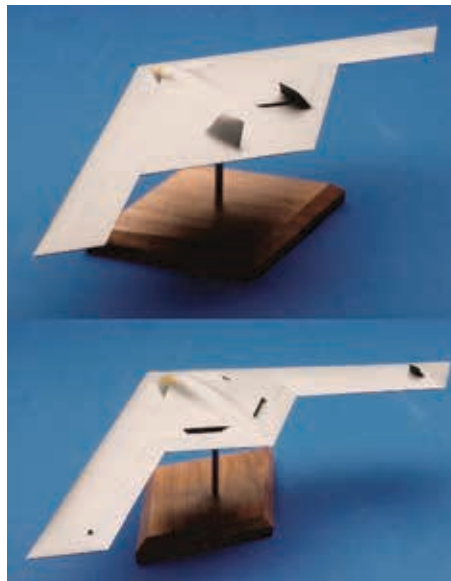



Above: The Soviet TU-114
AWACS aircraft.

Right: A Soviet Oborona Tall-King
radar tower.





Above (left to right): B-2 Spirit, B-1B, and B-52. The nation's bomber force that is still active today, although, only the B-2 has the survivability to penetrate and survive enemy defenses.





Chapter Five: Another Horse Race

By January 1980, then program manager Waaland had a formal study contract to turn the ideas they'd briefed to General Stafford into a full proposal. "It was going to be the bomber," Waaland recalled. The B-1 was history – cancelled, back in 1977 – and the new bomber was going to take over a conventional and a nuclear role for Strategic Air Command. It was the prize, just as Jones had foreseen.

But Lockheed was working on a bomber, too. "We were in a horse race," said Kinnu. Cashen, Waaland, Kinnu and the rest of the team were right in their instinct. The Air Force already had Lockheed under contract to study a penetrating bomber based on their faceted approach.⁶

The enthusiasm of the designers was tempered by the sense that Northrop might once again be in the race only to spur on Lockheed.

"We were advised at the highest levels that we were an insurance policy," Waaland said.⁷

For XST, Northrop had been the stalking horse. Now, while Lockheed was engaged on the approaching first flight of the F-117, Northrop had moved forward with the design breakthroughs of Tacit Blue.

Could Lockheed make the jump for an all-aspect bomber? Certainly they would try. "I think we have

pretty strong evidence that they originally started the bomber design with a prismatic approach, but then converted it over at some point in time to an approach using second-generation technology," recalled Kinnu.

In August 1980 came the announcement that there would be a formal competition between Lockheed and Northrop for the advanced technology bomber. A formal competition called for proposals, manufacturing plans, and of course, price estimates. The program would be huge. For Northrop, it also meant finding team members. Lockheed had already joined forces with Rockwell, maker of the B-1.

Patierno and Kinnu talked one evening that summer of 1980 about who to team with. Boeing was their first pick. "They'd never been a subcontractor, but they were the right guys to get," said Kinnu. At



Opposite: The B-2's unique combination of flat planar shapes and precise curves make it the ideal low observable bomber.



Below (top): Albert Myers;
(bottom): T. Wilson

Bottom: Chart representing the vast supplier team that ultimately came together on the B-2.



the time Northrop had no one with bomber experience. Boeing was the maker of the B-17, the B-29, the B-47 and the B-52, literally tens of thousands of bombers. Drawing from their expertise was critical. LTV was another rapid choice, a good producer with a strong technical staff. For radar, they would let superstars Westinghouse and Hughes compete.

Flight controls presented even more challenges, so the approach was to hire a smart specialist to help. The first name that came to mind was Albert F. Myers at NASA Dryden. They hired him in 1981 to manage flight control engineering, and it was a prescient move.

Jones handled the Boeing negotiation himself. On the other side of the table was T. Wilson, CEO of Boeing. It was a turnabout for giant Boeing, to be taking a briefing from “little Northrop.” Boeing had built literally tens of thousands of bombers. Northrop had to its credit only a handful of B-35 and B-49

flying wings, which had been cut up for scrap when the Air Force gave up on the program 30 years earlier.

But Northrop had stealth. Boeing agreed to join the team.

While Northrop held its cards with confidence, behind the scenes concerns were growing. Work on Tacit Blue was still proceeding at full speed. There simply were not enough RCS specialists to fuel two programs. Cashen, Locus and others were helping out on B-2 but still trying to meet requirements for the Whale.

The design wasn’t moving fast enough for the competition schedule.

“We’ve got a date to be on a pole with a 6,000-lb. 4/10ths scale model of this bomber,” Cashen said at one tense meeting that summer of 1980, “and if we don’t close the design within the next two months, we are not going to make the date.”

Cashen dropped everything and worked on the problem, with Don Heinz, Hal Markarian, Dick Scherrer, who had been instrumental on Have Blue at Lockheed, and others.

Scherrer produced the hawk bill shape of the leading edge. It gave them the needed aero performance for the high subsonic airframe.

On every stealth aircraft they’d done, propulsion integration was the obstacle and the inlet the last element to close. “The key to the closure of the design was to





Left: Details of the complex inlet structures for the engines – a compromise between air flow and RCS.

Below: Nuclear bomb testing.

We're just not making it, Patierno told him. It's just not happening. We'd like you to take it over, become the proposal manager and then the program manager, Patierno told Kinnu.

Kinnu's immediate response was: "I can't make that kind of decision now. I have to go home and talk to my wife."

"You can't talk to your wife about this!" Patierno exclaimed.

NATIONAL TREASURE

Stealth was no longer a loose collection of open-source papers or a research project tended by a fenced-off coterie of technologists. It was becoming a national treasure, an advantage so powerful it could turn the Soviet Union's air defense advantages on their head. The new black world/white world lines within Northrop's advanced design division were just a sign of the massive security measures to come.

Stealth technology as it evolved was guarded carefully because of its military and geopolitical impact.

All through the Cold War the United States and the West strove to maintain capabilities for a credible attack on the Soviet Union in order to deter a Soviet attack on the U.S. or its allies. But the Soviets had a way with surprises. The first was the detonation of an atomic bomb in 1949. Next came their hydrogen bomb, again earlier than expected,

separate the propulsion integration from the rest of the airplane as much as possible," Cashen recalled. To house the engines in a top-side "nacelle," their solution was to install a gutter, a curve between the body and the wing, to assist in the separation.

A management change was also essential. In the fall of 1980 the Air Force issued a Request for Proposal for an Advanced Technology Bomber. The Air Force gave them 90 days for the initial proposal. "About three weeks into it, at 6 PM, Patierno came over to my office and shut the door," said Kinnu.





Below: Sputnik.

Bottom, right: The government's program manager, a young one-star Dick Scofield evaluating early cockpit designs.



and in 1957, the Soviet Union orbited Sputnik, the first man-made earth satellite. Nuclear arsenals numbered thousands of warheads by the 1970s. Treaties had outlawed most ballistic missile protection systems, but the bombers still had to contend with Soviet air defenses.

After détente in the mid-1970s, America and the Soviet Union were entering a second Cold War. The Soviet Union invaded Afghanistan in 1979. The U.S. and western allies boycotted the 1980 Moscow Summer Olympics in protest. Iran's government fell and U.S. diplomats spent 444 days as hostages in Tehran.

"The technology coming along in the late 1970s provided the leadership with a new way to approach the task of dealing with the Soviets and the sophisticated defenses they had at that time," summed up Air Force Lieutenant General Dick Scofield, who at the time was a young officer working for the Air Force's Systems Command.

Perry, in the Carter administration, had called it the Offset Strategy. "Its central idea was that synergistic application of improved technologies – command and control, stealth, embedded computers, and precision guidance – would allow the U.S. to overcome Soviet defenses and destroy Soviet tanks," noted a history of the period.⁸ The Offset Strategy was to be the intellectual cradle for high-level government support for stealth. Analysts saw a window of vulner-

ability opening when the U.S. bomber force could not get through.

"We had shortfalls in our ability to match the Soviets and we were losing our ability to deter them, or at least the perception was we were losing our ability to provide proper deterrence. The Soviet IADS had become sophisticated enough that it would be very difficult to call it a viable deterrent force without something like the B-2," said Scofield.

A stealth technology bomber was the revolutionary solution that could close the window of vulnerability and keep deterrence alive.

With this as background, Northrop's team did not lack for motivation. They took over a red brick building on Chadron Street in Hawthorne and made it into a classified facility. Eighty and 90 hour weeks were common. Engineers in those days wore white shirts and neckties, except for Kinnu, and except on



Saturdays, when they might skip the tie. Kinnu instigated another crash effort to sort out the major development risks and tasks and align them



Left: Jack Northrop in front of his flying wing in his favorite pith helmet.

Below: Irv Waaland and Jack Northrop



into a work breakdown structure. The structure helped them carve out major hunks of the program to delegate to subcontractors.

One bright spot came when the advanced design team was allowed to show a small model of the bomber to Jack Northrop himself. By coincidence, the B-2 would have a wingspan just six inches shorter than that of his YB-49 flying wing. The man who had founded the company was 85 years old and suffering from Parkinson's disease, which would claim his life just a few months later in February 1981.

Mr. Northrop's delight in the B-2 model was plain to see. "Now I know why God has kept me alive all these years," they heard him say.

POLE OFF

The proof of stealth is always on the range. For Northrop and Lockheed, the data from pole tests of their

scale models for the bomber would again be the deciding factor in the competition.

"We had reached a point through XST and so on where this head-to-head, winner take all on the pole was the norm. Which was kind of neat," said Cashen. "Technical solutions determined the contractor."

Winning on the pole was tantamount to winning the program and by all indications Lockheed appeared to be ahead. For one thing, Ben Rich's team had started work on the range earlier as Northrop struggled to finalize their model.

With supreme effort, Northrop got its flying wing model ready for range work in October 1980. The tests didn't go well.

"We came home with results that we were less than happy with. Frankly, we were wondering if we had a shot at this thing," said Cashen.

CHAPTER FIVE

*The redesigned B-2 on the pole
for RCS verification tests.*

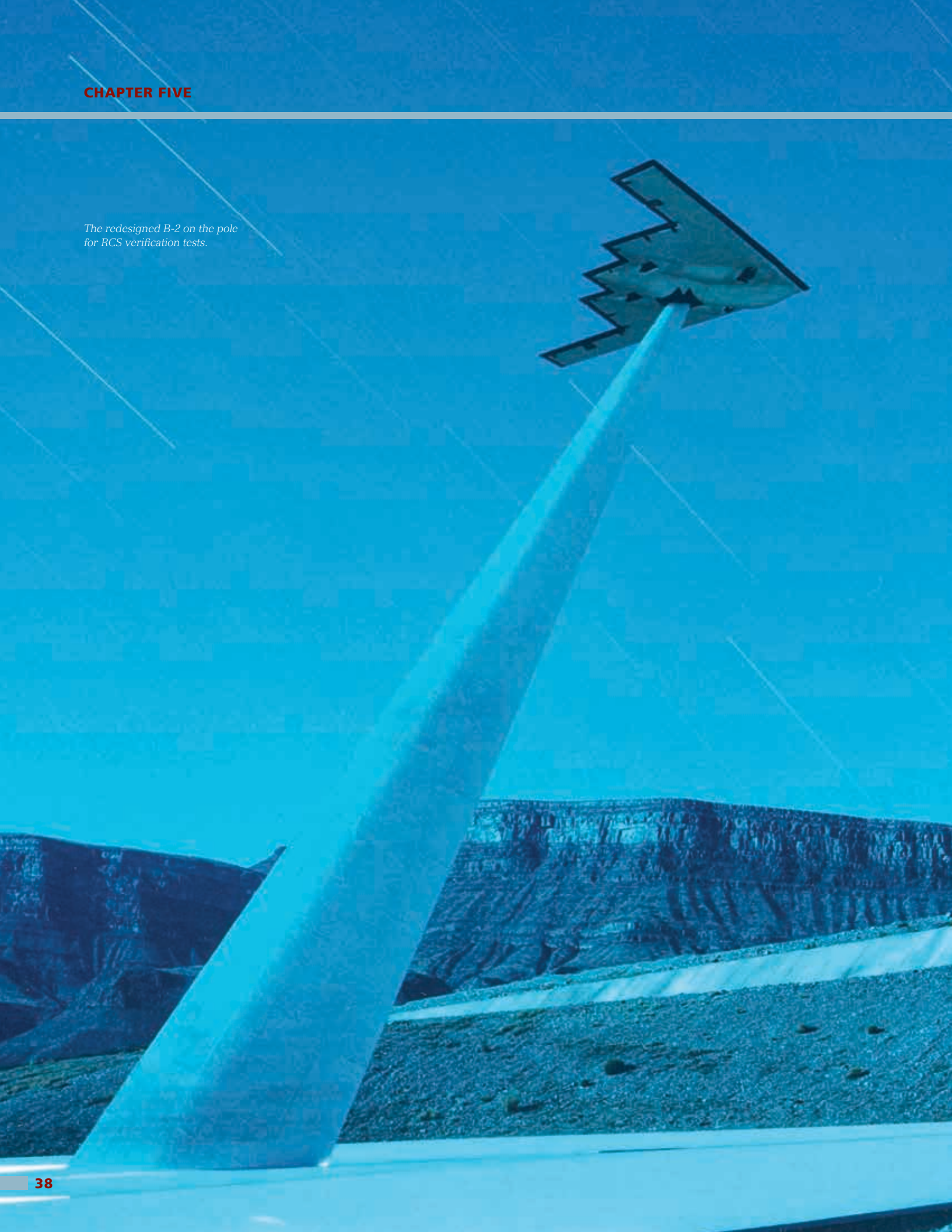

Northrop was convinced they had the right airplane. At full size, their B-2 would have range and payload near that of the B-52. They believed Lockheed was offering something considerably smaller and shorter-legged, more in the category of the F-111 fighter bomber.

But without good scores for the all-aspect signature reduction results, Northrop's design would not stand a chance.

The team plunged in to figure out what was wrong. The model of the bomber used in range testing was constructed of wood and painted silver to simulate metal. On the range, the model was elevated 50 feet in the air. It baked in the desert heat by day and contracted in the cooler air when pole and model were elevated for night-time radar cross section testing. The model was hauled on and off the pole. Mechanics and engineers leaned out of a cherry-picker to work on it. The wear and tear was too much.

The design itself was fine. "In the second test of the contract we had micro-cracking of the paint," explained Kinnu. Subtle dings and dents in the model were generating radar cross section return and skewing the results.

"We discovered that the finish on the model at almost the microscopic level was cracked. We had painted over wood, and the wood was expanding, contracting, and cracking the silver paint," said Cashen.

"The model would flex and the paint would crack. So we had to stiffen the model," as Kinnu put it.

"When you had micro-cracking you'd get a radar return off that. You didn't want that to happen. It was significant," said Kinnu.

On the night of November 30, 1980, typists, secretaries and engineers worked through the night, then set up the 15-volume proposal on tables for every member of the Air Force evaluation team.

"It was one of the best proposal efforts I'd been on, and we ended up feeling pretty buoyant," Waaland later said.

The team arrived on December 1. They stayed several days, issuing requests for information, then left to do the same thing at Lockheed.

The crisis came when the Air Force alerted them to a protest from none other than Ben Rich. Lockheed claimed that the Northrop model



did not have all the required details specified for the competition.

Although the 15-volume proposal was in, the Air Force was still looking over the work of the two teams, and awaiting final cost proposals



Below: Workers doing final checks before nighttime RCS testing.



Below: Ronald Reagan, 40th president of the United States.



from both. The only way to clear the air was to send Northrop back to the range facility in the middle of winter to test additional details on the model.

The protest gave Northrop another chance to run the RCS tests with a clean model, this time coated in fiberglass.

“At the end of January, we went on the range again, on our own bid and proposal money,” said Kinnu.

It was a good investment. The results were better. “Substantially better,” added Kinnu. The new data on the clean model was submitted with final cost proposals in the winter of 1981.

Aircraft division head Welko Gasich took the radar engineers to dinner to celebrate their outstanding results at a Cloudcroft, New Mexico restaurant near the range. Sean Connery was dining there too, with a group from his nearby film set. Meeting 007 seemed like a good omen indeed.

Although they were not sure of it at the time, the big, flying wing design was going to make the difference for them. Ben Rich later revealed why. The Lockheed strategy was to build a medium-sized aircraft in hopes the customer would be forced to a smaller, cheaper option. “Because our airplane was designed to be smaller, the control surfaces on the wing were smaller, too, which meant we needed a small tail for added aerodynamic stability. Northrop had

larger control surfaces and needed no tail at all,” Rich said.⁹

The real celebration came back in Hawthorne later at a routine lunch-hour data review.

“Welko set a heavy book bag down on the light table,” Cashen recalled. He opened it and started pulling out wineglasses and champagne. Six months remained until the announcement. “But we all knew, just from the RCS standpoint,” said Cashen. Northrop was going to win this horse race. If there was going to be a program, we would be the winner, Kinnu felt. The doubt hinged on whether funding of the B-1 would pre-empt the B-2.

Of equal significance were developments in Washington, the Air Force and the world that would greatly add to challenges for the bomber.

President Ronald Reagan took office on January 20, 1981, just as the Northrop team was finishing its successful range work on the clean model. Reagan had campaigned hard on renewing American military power. He wanted superiority – and among other things, that meant stealth.

“There was the window of vulnerability, which the administration at that time felt very strongly about being able to close,” said Scofield.

His new Defense Secretary, Caspar Weinberger would turn out to be perhaps the B-2’s staunchest ally. Derided by the right as a



“liberal” Republican, Weinberger was a Harvard-trained lawyer who had enlisted in the Army and ended up serving on MacArthur’s staff in World War II. Two years as Director of Office of the Management of the Budget in the Nixon administration earned Weinberger his nick-name “Cap the Knife.”

Soon after he was sworn in as Secretary of Defense, reporters asked what surprised him most about the Pentagon.

“The principal shock was to find out, through daily briefings, the extent and the size of the Soviet build-up and the rapidity with which it had take place – in all areas, land, sea and air,” Weinberger replied.

“He believes in this Cold War stuff and now he’s in a position to do something about it,” carped one detractor.¹⁰

It didn’t take long for Weinberger to make his decision. The B-1 line would be reopened and 100 B-1 bombers would be built as a stopgap measure. This would be followed by a new program for 132 advanced tactical bombers – the

stealthy B-2 – with Northrop being selected as the Prime contractor and winner of the Advanced Technology Bomber competition against Lockheed. Of course, only part of the package was revealed to the public. Jones insisted on a terse public announcement to comply with the law, and the Air Force approved a 12-line public statement about a “study contract.” While Jones was working on the press release, the Pentagon made a big formal announcement of the decision to resume B-1 production on October 2, 1981.

Colonel Keith Glenn made it official with a phone call to Patierno, who then called Kinnu down to his office. “We were dancing!” said Kinnu. “It’s a moment I’ll never forget.”

Above (left): T.V. Jones at the B-2 contract award announcement ceremony; (center): Irv Waaland; (right): Jim Kinnu.





Chapter Six: Risk Closure

The story of the B-2 engineering development is rich with the trials and tribulations of a very complex aeronautical system.” So wrote Kinnu and John Griffin, a senior Air Force engineer, in a study two decades later. Technology risk was an essential part of the B-2 program. Nothing like it had ever been done before. As designed, the wing surface would add up to over 10,000 square feet, and all of it had to conform to the strictest low observable requirements.

The engineers were happy to take risks – as long as they had a firm plan for how to zero them out. Their term was risk closure. The Northrop team knew plenty about the trials of stealth by the time they won the B-2. All agreed on the guiding philosophy. “The key to Tacit Blue and the B-2 was risk identification, selection, and management,” said Cashen. “If you take on too much risk and you can’t close it in time, people lose confidence and you lose the program.”

The contract award specified several areas where the B-2 engineers would first work to gain confidence in the design, long before moving on to assembly of the first aircraft. The key areas of uncertainty were identified as “risks” and closing them out became the top analytic priority. Until the risks closed on paper and on the designer’s CAD

screens, the final configuration or design of the B-2 could not be established.

Risk closure became the essential task in the years following the contract award.

Task one was setting the schedule. How soon could Northrop build and fly the bomber?



The international climate injected urgency into the bomber program. Responding to it, Kinnu and his team laid out in the original



Opposite: Every square inch of the B-2 wing surface – about a million and a half – must conform to the strictest low observable requirements to achieve optimum stealth.

Bottom: Early government/contractor ‘team meeting.’ Note the “tools” on the wall for managing the program.

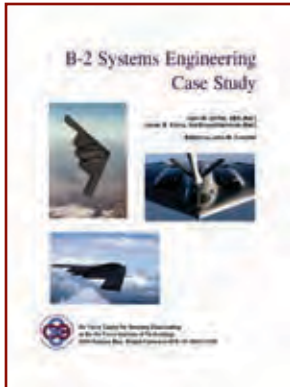

Above: B-2 Case Study by John Griffin and Jim Kinnu documented the B-2 development and is a must-read on any new program.

Bottom, right: Original SAC patch.

proposal a fast schedule to develop the bomber and fly it in December 1986. “They needed a bomber right away, there wasn’t going to be a B-1B, it was balls to the walls,” said Kinnu.

The Air Force “thought that was too gutsy” as Kinnu put it and instructed Northrop to add a year for risk closure up front in the program. Now the bomber would aim for a configuration freeze in the summer of 1983, and follow a schedule leading to first flight in December 1987. Northrop planned to increase production to a rate of 30 bombers per year and provide enough for the Air Force’s initial operational capability by the end of 1990.

Naturally, the Air Force was determined that its new advanced technology bomber would stay abreast of the latest threat developments. Beginning in the spring of 1981, Waaland and others made contact with action officers from Strategic Air Command, who would lay out more of their requirements.

Waaland “got SAC in and they kept feeding us performance requirements,” said Kinnu. Items like navigation without land references and other bomber basics were emphasized by SAC. “That’s why we have the astral inertial tracker that came off the SR-71, plus an inertial navigation system, so that one could update the other,” he said.

Goals for low observables were another matter. They listed what

they desired, but Northrop warned them that they were asking for a level of technology which no one could guarantee. Although the range work showed “all the promise in the world” Kinnu was well aware that there was no hardware yet. Northrop and the Air Force ended up agreeing on a performance specification that set a series of goals for low observables. One metric was the current status, another was the desired result. In the end, they would negotiate as to what could be done.

“They left it up to us how to achieve that,” Kinnu said. Meanwhile, Air Force analysts – including a counter-stealth red team – would continue to evaluate threat scenarios and feed the information into the B-2 program requirements.

Soon enough, Northrop would close risk and begin the manufacturing process. Kinnu implemented a manufacturing technology plan alongside the final bomber proposal.



Composites were one of the first major risk areas identified. The B-2 was going to be enormous. As a flying wing with a 172-foot wingspan, the surface area was immense. Conventional metals like steel, titanium and aluminum would weigh down the big bomber too much to be of any practical use. Composites were not new in the aerospace industry but no one had used them on the scale contemplated for the B-2. According to Kinnu and Griffin, composites were “considered a major risk.”

Kinnu’s plan called for the composite structures risk to close by late 1983. It illustrated just one of the many processes by which Northrop brought the B-2 from theory to reality.

First, Northrop worked with the Air Force to fund research on MANTECH – short for manufacturing technology. LTV got a contract to learn how to insert fasteners in composites and improve techniques such as composite water jet cutting. Boeing set to work on pultrusion, autoclave improvements and methods for using ultrasound to inspect the composite structures. Central to the strategy was fabricating several large, composite parts, including major sections of the wing. Once



the parts were made they were torn down again for full analysis of their ability to carry the design structural loads. For a time, the Air Force insisted that Northrop keep subcontractor Boeing at work on an alternate aluminum wing, just in case. However, the Northrop team was able to prove they could design, manufacture and quality-test composites for the 172-foot wingspan bomber.

In those days the size and capacity for composite facilities was a source of bragging rights. Later, as the program grew, Northrop’s autoclave capacity went beyond anything seen in the aerospace industry. It caused one visitor to the Pico plant to exclaim: “you could do the composite work of the free world in there!”

In this area, the learning curve for the B-2 drove the learning curve for America’s entire aerospace industry. Composite work on the B-2 eventually paved the way for composites and integrated digital design on programs like Boeing’s 777 and 787.

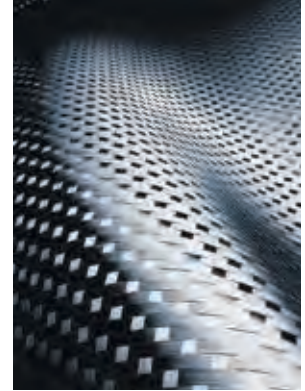

Above: Close-up of composite material.

Below, left: Learning to precisely insert thousands of fasteners in composites.

Bottom: One of the huge autoclaves required for composite curing.



Below: The stealthy force – F-117s with the B-2.

Two new areas were added into the requirements, and both reopened risk. One was to study a defensive electronics system for a stealth aircraft. The second was a major trade study on a three-man crew, versus the original plan for a two-man crew.

All the brilliant innovations from XST on would not matter if the company could not finalize the technical design and manufacturing plan to build the first B-2s, and scale up again into an efficient production line. Although the schedule now contained an extra year, the task ahead was daunting.

ORDER OF MAGNITUDE

Risk closure was vital, because the B-2 was without question the most complex, ambitious stealth program yet conceived.

The bomber was “a much more complex airplane than the F-117. The degree of complexity from F-117 to B-2 was 5 or 6 times great-

er or more,” said Scofield. He knew, because he was the Air Force’s F-117 program manager when he got a call to take over the B-2 program from Colonel Keith Glenn. Sorry as he was to leave the F-117 just as production was ramping up, the B-2 was irresistible. Little did Scofield know that new job would turn into an unheard of eight-year assignment. Scofield would stay in place as the Air Force B-2 program manager from 1983 until 1991, rising from colonel to two-star general in the process.

With the F-117, the Air Force controlled its first big bet on stealth by limiting the mission to specific tasks and planning to buy only a squadron’s worth of aircraft. The B-2 was different. Everything about it was bigger and more ambitious. The mission systems from radar to defensive electronics to nuclear hardening were complete departures from the F-117 experience. Over time, the bomber would become part of the force structure, conducting routine operations from nuclear alert to conventional missions.

That was never in the cards for the F-117. “Their mission was to carry two laser-guided bombs to strike missile sites in Eastern Europe and leave. That was it,” said Scofield. Later it grew beyond the silver bullet role, but in the 1980s, it was a much simpler mission with a much more focused capability. The F-117



had also lifted many of its subsystems directly from other aircraft.

Then again, the B-2 was big. Dave Mazur had come from the Air Force F-117 program where he'd been an engineer. The B-2 had "so many more square feet, so many more fasteners," to deal with, said Mazur.

Unlike the F-117, Strategic Air Command wanted its B-2 to have a full suite of defensive system avionics. The imaging radar was part of it. So was a concept for a system to detect enemy threat emissions.

All this required integrated cockpit displays. These mission avionics were over and above the on-board computer systems required for the quadruple-redundant flight controls.

As Mazur pointed out, the B-2 had sensors requiring many small, low-observable antennae, another huge contrast with the F-117. High-gain antennae in particular could be "a big scatterer," creating yet another challenge to solve.

"People wonder why we designed the avionics architecture to the complexity that we did in the B-2. If you think back to the early 1980s, a fast processor was 512 kilobytes," Scofield said. Processing at 512 kilobytes was not a problem, as long as there were plenty of processors. "We had many more processors to handle parallel processing of the data on the airplane than we would have today," he said.

To top it off, the "B-2 program planned full capabilities on the first airplane," said Scofield. There would be no prototype. The first air vehicle had to incorporate all the low observable requirements right from the beginning.

As design risk closed, the next major hurdle would be the transition to manufacturing. Northrop as a corporation had to spin up an immense production facility, all to be conducted under the strictest possible security. In a few short years the bomber team would balloon from a few dozen engineers in one building to several thousand



Top: Dave Mazur.

Above: Wiring electronic components.

Below: Early cockpit design "cut and paste." Note, the side stick was eventually replaced by the more traditional center stick.



employees and subcontractors at multiple sites, all with a common goal.

Taking an aircraft from paper to flight was a process the senior Northrop team knew well. Step one was to reach the point called configuration freeze. At configuration freeze, design engineers ceased their endless tweaks and modifications so other engineers could lay out the incredibly intricate stages of building the aircraft and scaling it up for production. A few unavoidable changes might creep in later, but always with a penalty. Subsequent changes could impact other systems and components already set in their final configuration, causing changes to roar through the design like spring river floods. Consequently, the goal was to make all those critical trade-offs before the freeze.

The complex bomber was already being divided into numerous segments so that managers could add manpower and complete literally thousands of designs for everything from running lights to advanced electronics.

Northrop put in place “zone management” by dividing the aircraft in to zones for structures, flight controls, propulsion, environmental control system, and so on. One single design engineer managed each zone and “he was responsible for everything that went into that part of the aircraft – all installations, all the wiring, piping,

where structure penetrations were located – everything,” said Myers.¹¹

To guide the work of the teams the senior managers worked in lock-step towards design reviews where all elements of the airplane would be reviewed together. Preliminary design review brought all the elements together formally for the first time. Critical design review would give top managers a look at the final plan for the real airplane.

Much of the risk closure plan focused on design changes. However, preparing for production was equally important and included a lot of firsts. The risk closure plan also sent Northrop and its top subcontractors to the factory floor to try out manufacturing techniques that had to work for the stealthy B-2 to be built. Boeing would build and certify the biggest autoclave in the world to make the composite wings. The Seattle giant would also build the world’s largest ultrasound facility to inspect the composite parts. In Texas, LTV was figuring out how to mold the sawtooth engine inlet duct for stealth. Northrop built several small autoclaves for forming edge structures. And the list went on.

WORKFORCE

Patierno and Kinnu knew the win was a game-changing program. Northrop was committed to invest nearly two billion dollars just at the beginning of the program. Ultimately it would change the

Background: The original B-2 planform.





Left: Learning to work with composites.

Below: On the line.

face of Northrop and its facilities, although that all seemed hazy to the leaders trying to close risk and look ahead to production.

Surrounding the technical issues was the challenge of expanding the number of people working on the B-2 program and acquiring the facilities to house them.

Kinnu saw it as a shock to the system of the brilliant, but small, advanced design team in the Chadron building that had taken them so

far. The Lockheed Skunk Works had its own way of doing business and a deeper company bench to draw on thanks to Lockheed's work on other programs. Northrop had the brains but lacked the organizational sophistication.

The euphoria at beating "Ben Rich and that team from over the hill" at the Lockheed Skunk Works in Burbank carried them only so far. Ahead lay the mammoth task of building up a huge bomber program





Below (top to bottom): Doug Wood, Valerie Lewis-Corder, Mark Tucker.



and racing to field the technology to close the window of vulnerability.

“One of the biggest struggles was manning up, and getting the right people,” said Kinnu. Top talent came from programs like the space shuttle and from around the pool of southern California’s aerospace industry. However, they’d all have a lot to learn about working on stealth. Before that, they had to be cleared for the most top secret, special access data.

Those who came over were often amazed at what they found after endless waits for security clearance. First glimpses of the plans for the B-2 made for memorable moments.

“I was shocked it wasn’t a fighter,” commented Doug Wood, an engineer who joined the team in July 1980.

Valerie Lewis-Corder was a New York attorney with other experience in the aerospace field when she joined Northrop’s four-person contract shop in 1982. Her shock was in seeing the dollar figures already committed to the contract. One document listed a figure of \$9 billion. “Is that really nine billion?” she recalled asking in amazement.

Mark Tucker joined the program in 1983, specializing first in manufacturing. When he saw the B-2 mock-up, “that was eye-watering,” he said. He was surprised at the aerodynamic design and stealthiness – and immediately aware of how stringent the requirements would

be where the structure crossed into the radar absorbing materials.

Then there was the high pressure culture of the advanced design team. Cashen, Waaland, Kinnu and Patierno stood out as larger-than-life figures to the young engineers joining the team.

“Kinnu was in charge, Waaland did technical matters, Cashen worked the spooky stuff,” recalled one. Together they were known as “John Patierno’s junkyard dogs.” The younger staff had to admire their absolute dedication. “By today’s standards, they were firmer and harder as managers than would be allowed now,” Haub said. “But nothing was personal.”

The junkyard dogs drove their teams hard. “It was not an exaggeration to say we were working 80-90 hours per week,” said Haub. As the team expanded it was not unusual to come in and find another person sharing the desk you thought was yours.

When they did attract people willing to make the commitment, they got stand-outs. Lewis-Corder’s office started staffing up in 1983. Before long, there were over 100 people working on contracts alone. Lewis-Corder stayed with the B-2 and Northrop for the next 25 years. “That’s the kind of company Northrop was,” she said.

Back in Ohio, Dick Scofield faced a similar problem ramping up the B-2 program office. The Air Force



encouraged him to hand-pick the team, but even then it was not easy. “Not all the best people can work in that environment where you can’t tell anyone what you are doing,” Scofield realized. “You have to take on the decision-making responsibility yourself because you can’t go ask your boss for help.” Scofield’s solution? “We had to go hire intelligent people who were also very smart,” he commented.

Scofield also learned there were some top picks in the Air Force who refused to dedicate themselves to a top priority, black world program. For the dedicated ones, Dayton’s black world management arena was a breeding ground for general officers.

Kinnu had the same problems and successes at Northrop. He had his core people like Cashen, Waaland and others but some of the other senior people he wanted “got to say no because they just didn’t want to come over to a black world program.”

One key engineer who joined in 1985 was Ed Smith. Ed had just come off the Orbiter program and saw the B-2 as a very similar challenge – one of a kind system, fly-by-wire, no tails and stealthy. As Vice President of Engineering, Ed was the program’s Chief Engineer and saw they needed to distribute work across a thousand suppliers while moving to a new facility, lock the



Top: Inside the cockpit as it takes shape.

Above: Ed Smith





Right: Scott Seymour confers with BG Tom Goslin, 509 Bomb Wing Commander

Below: The Century Boulevard corporate office tower.

doors and pull the team together under their rigorous security umbrella. His key observation was that most of the team had not worked together before, and building the team became one of his most important activities. This was evident with one of his first challenges – the airplane had a weight problem, very similar to Orbiter. He attacked it with an iterative design and fed work out to suppliers, put in sub-systems, and modified the structure to account for the new low altitude requirement. The solution was a team solution, and in solving it he significantly improved overall team effectiveness.

Many of the young engineers joining the B-2 program at Northrop later rose to lead manufacturing divisions, advanced design work,



and major programs. Names like Scott Seymour and of course Kent Kresa went on to take the top jobs in company management. B-2 was a school for talent. Couples met and married, sons joined fathers on the work force, and the B-2 team, as big as it was, kept a family feeling that went well beyond the average assembly line esprit de corps.

But that bright cultivation of talent was just beginning as Kinnu in California and Scofield in Dayton wrestled with the reality of the aggressive schedule they'd adopted. Where would they put everyone?

Kinnu's team quickly outgrew the Chadron building. They moved into a leased glass office tower on Century Boulevard in West Los Angeles and soon had nearly 1,000 people employed on the bomber.

Finally they had to go big. "We got the Ford plant at Pico Rivera in California. We acquired it, stripped it totally bare," Kinnu said. "We built the facilities we needed." In place of the automobile assembly lines grew a secure facility equipped for all but final assembly of the B-2.

But there was a major shock ahead.



Right: The Ford plant in Pico Rivera.

Below: The restructured and fully operational B-2 facility. Note the design partially evident in the park area at the lower right corner.





Chapter Seven: “My Airplane Blew Up On Me”

People and dollars were pouring in, the composite analysis was going strong, but at this point, the B-2 was still a series of drawings on computer screens, with engineers toiling to bring all the pieces together for a preliminary design review. One lurking risk closure issue was about to hit with gale force. Back in April 1981, before contract award, the Air Force had inquired about a mission modification. Could the bomber fly low, too?

The B-2 was designed as a high-altitude penetrator. The Air Force had picked it almost two years earlier from Waaland’s conceptual briefing to General Stafford. As it turned out, the high altitude bomber had what Kinnu termed a fallback capability. Waaland had designed it to cruise at low level using a terrain-avoidance system.

Still, Northrop felt the first thing they had to do was reassess the whole concept. It wasn’t just a matter of finding a fix. Was this really the right aircraft design for both the high and low altitude missions?

“They asked us to do a clean sheet of paper analysis. Would we have the same airplane?” recalled Waaland.

“Irv, John and I agreed that the thing to do was to go back to our starting point and re-examine everything we had done,” Kinnu said. The team launched a study

that looked afresh at the flying wing plus a range of other designs, such as the delta-shape low altitude penetrator briefed to the Air Force in August 1979. All the pole work and their success of three months earlier did not matter if the basic shape of the airplane was wrong for the Air Force’s mission.

The studies showed that the flying wing concept was still the right shape. “There’s no contest, it’s the right way to go,” Waaland concluded. However these new Air Force requirements would require design changes to the flying wing.

Northrop put the low altitude modifications high on the risk closure task list. The plan was to stiffen the wings, and add fuel. “Fortunately, we were a flying wing,” said Kinnu, and there was already plenty of room to add more fuel without having to build on more structure.



Opposite: Banking over the Pacific Ocean the B-2, originally designed as a high-altitude penetrator, had to perform at low altitudes as well.



Right: Two views of a model depicting the original B-2 design.



“It was still an extremely good high flier, and now it was a good flier on the deck,” said Kinnu. Up went the gross weight, and both design missions went in. The Air Force officially issued a change request to Northrop to include low altitude. Jones, at headquarters, backed the plan to treat it as the kind of change where Northrop would absorb the cost instead of submitting a new bid. They’d wait for the results of further studies on increased loads due to the low altitude mission

Then two things happened. First, the Air Force analysts revealed their projections for a new, more ominous Soviet radar threat. A team at Lincoln Labs fed in a steady stream of new potential threats, and Northrop engineers responded as to how the planned signature of the bomber would cope with them. “It was good of the Air Force to do it and good for the program as a whole,” Kinnu concluded.

However, this was no mere update. Stealth had always relied in part on canny estimation of Soviet tactics – how they would link their

ground control centers, airborne interceptor fighters, and surface-to-air missiles sites. Now the threat appeared to be changing to the point where the Air Force felt compelled to add a second major combat mission profile to the bomber requirements. Not only had the Air Force run their survivability models against the threat, as they routinely did; this time they had raised the threat and increased its capability with little explanation. “Suffice it to say, instead of being three feet tall, it was ten feet tall,” said Kinnu.

If the threat emerged as the Air Force believed it would, the Soviets could potentially send fighters to chase after the B-2. Given enough warning, the fighters might light their afterburners and catch the bomber at high altitude.

“You would have to penetrate low rather than high,” said Kinnu. Low altitude became a way to run the fighters out of fuel and chase time. As Kinnu explained, if the fighters launched, the Air Force thought the bomber would dive low. “Now they lose you, so they don’t know

where you are, and with stealth and the clutter of earth, they'd have a heck of a hard time finding you. They light their afterburner to go up there and catch you then they have to come down and search for you and still keep their speed up and they are going to hit bingo fuel quickly and they'll have to break off contact, even if they have a contact." Of course, the whole stealth plan was to elude contact in the first place. Low altitude was just another complication to throw at the defenders.

"This changed the flight envelope," recognized Al Myers, the flight



controls specialist. "In the most dense threat environment, you might need a low altitude route," he said.

The second problem was speed. SAC wanted the B-2 to fly near Mach 1 – on the deck. Introducing the low altitude requirement was logical "if you agreed with this projected capability" noted Kinnu. Since the B-2 was all about offsetting Soviet advantages down the road, it had to be able to cope with

the most pessimistic projections.

The Northrop team understood the magnitude of the problem and the pain it would cause to the B-2 design and schedule. They set out to complete risk closure analysis.

Then came the bad news. In early 1983, the data was in. The B-2 was going to need a major redesign.

"Everything was going along fine until we got to the aeroelastic analysis," Kinnu said. The idea behind aeroelastic analysis was to test loads and structures in wind tunnel models, derive the results, and use the data to design actuators swift enough for the hydraulic controls. When the data was in, it showed that the controls worked fine in the smooth air at high altitude. But at low altitude, the controls would become saturated in a strong gust environment. "It turned out to be a much tougher environment than they thought," said Scofield. The B-2 had been optimized for high altitude but now it would be subject to stresses similar to that of a supersonic fighter. "Now we were going to go at a high Q on the deck," explained Kinnu.

Both pitch and roll were handled by trailing edge controls so the problem was severe. To fix the problem, the control surfaces had to come inboard of the wing's first bending node line, all the way in to the trailing edge notch.

"My airplane blew up on me," Kinnu told Patierno.

Left: Soviet fighters, such as the MiG-25, posed a serious threat to the B-2 unless low altitude flight could be perfected.



Air Force requirements changed along with the rapid technological advances during the Cold War.



THE GUST LOAD GENIUS

What Kinnu’s team eventually concluded was that the flight controls – for pitch in particular – were malpositioned on the wings. They could not respond strongly or swiftly enough to gusts and buffeting at low altitudes. Pressure loads and bending would hit at the wrong places, and all sorts of things were bound to go wrong. The pilots would not have enough power to counteract severe gusts. Load transfers from the outboard wing to the inboard wing were poor. Around the engine inlet ducts, there were several places for single point failure and excessive fatigue on the structure. Added to that, the bomber would get into trouble at high angles of attack because there wouldn’t be enough airflow to make the ailerons effective.

To meet the new Air Force requirements, the B-2 would have to be redesigned, moving control surfaces and compensating for the stresses of high-speed, low altitude flight.

Jones reviewed the data with them.

It was no small matter. “The redesign would be the largest single internal event that occurred during development” of the B-2, Kinnu and Griffin concluded later.¹²

Fortunately, the man to tackle the problem was already on the B-2 team. Al Myers led the effort to build the model for the redesign of the B-2 for its demanding low altitude mission.

Just building the models to use for the redesign was beyond the current state of the art. “The analysis tools and techniques simply didn’t exist,” said Myers. “Immediately that became one of our priority activities – to pull together the right collection of people capable of developing such a model. This was a joint effort between the flight controls organization and the structural dynamics organization.”

Myers later described the magnitude of the computer modeling task they faced. In the early 1980s the complexity of flight control models was described in terms of the number of states in the model. “Flight control design was normally done on models that had on the order of 10th and some really ambitious models had 12th order systems,” Myers said. Not so the B-2. “Once we had the models put together, it took a lot of work to residualize them down to the size where they were 110th order systems,” Myers explained.

To work the problem, “I brought in everybody I knew in the country that I felt could contribute to [solving] the problem,” said Myers.

The team Myers pulled together to work the modeling and analysis capability included outside experts from Honeywell and NASA Langley assisting the in-house Northrop experts.

The specific problem of low altitude ride was solved by invention of

a gust load alleviation system. Al Myers tackled it. The gust loads had been a factor early on, during the late proposal phases. But with the new mission, the original gust load alleviation was “almost worthless,” Myers said.

With SAC now insisting that the B-2 go at high subsonic speeds on the deck as well as at higher altitudes, the airspeed increased the proportional response from the gust loads.

“We were not certain what we were doing would comply with the laws of physics,” Myers said as the process began.

Myers came up with a gust load alleviation system to quell it. Quick response by the flight controls would steer the B-2 to compensate for the gusts.

By the time they finished, the B-2 had relatively larger control surfaces than a typical fighter. They moved faster, too. The F-16 surfaces clocked 80 degrees of motion per second, while the B-2’s inboard elevons hit 100 degrees per second.

Just how good was it? A typical standard was to decrease 10% to 12% of the gust load. On the B-2, the fast-responding flight control system decreased a whopping 40% of the gust load.

Together the changes created a significantly different design. Gone was the basic diamond-shape body. In its place was a stronger

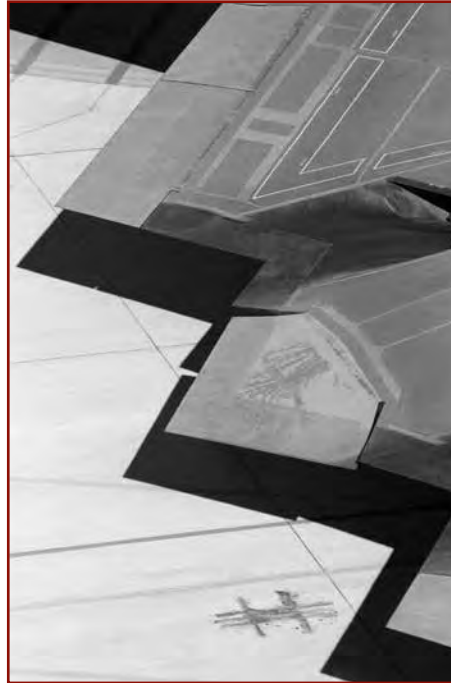

Left and below: Views of the redesigned aft end and the larger flight control surfaces needed for low altitude flight.



center body and the distinctive shape of the trailing edge of the B-2 so widely recognized today

The Air Force watched the changes unfold. By the spring of 1983, when Scofield joined the program, “they’d pretty much decided that



Right: Comparison of the original B-2 planform with the final design.

Below: General Charles Gabriel.

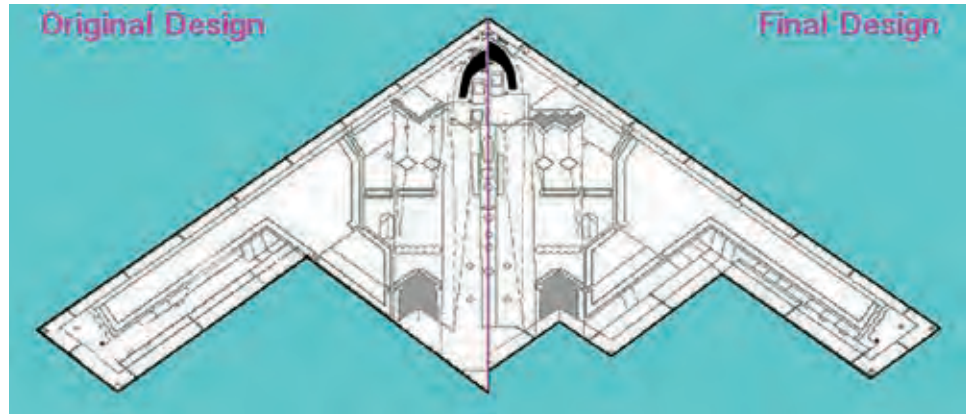

they had to redesign the planform to add the additional flight control surfaces and beef up the structure,” he recalled. Northrop was also working with members of the Defense Science Board, who continually reviewed the change process.

It fell to Scofield himself to take the news to Chief of Staff General Charles Gabriel.

“The first briefing I had to give on the program was to General Gabriel to say we’re going to change the airplane,” he said.

“If that’s what we have to do to have a good airplane, that’s what we’ll do,” Gabriel told the tall, young colonel.

Northrop’s technical fix was extensive but elegant. It was also expensive, with estimates for the redesign running close to \$2 billion.

“Jim, being a structures engineer, knew we had an inefficient primary structure,” said Cashen. Although the flight control inadequacy was what pushed them over the edge,

the redesign allowed engineers to make other beneficial changes such as improving the shape of the center body. The team added a sawtooth trailing edge to place flight control surfaces well aft of the center of pressure. Other changes included a symmetric W inlet and symmetric exhaust. The cockpit also moved forward.

The silver lining was a very efficient new structure at the front of the airplane.

Undoubtedly, the reconfiguration resulted in a better bomber. “Jim had a big smile on his face,” Cashen said of Kinnu when it was over.

THE INFAMOUS CEO MEETING

Now, the question was whether to extend the schedule to cope with the redesign. Kinnu and his fellow program managers from the major subcontractors voted unanimously for moving first flight out by nine months, to late 1988.

This was a decision for the top dogs. In September 1983, Tom Jones met with Lieutenant General Tom





Below: Details of the redesigned platform.

McMullin, who was commander of the massive Aeronautical Systems Center at Dayton, and Scofield's boss.

The CEOs said no. If they relaxed the schedule, the momentum of the program might slack off. Losing momentum might lead to an even bigger slip to the schedule than was already projected. Would that open a window to simply scrap the B-2 and extend B-1 production?

In the end, as Scofield put it, national security priorities won the day. "We really needed to continue because of the priority of the program within the department, and the desire to field

the capability that the technology could give us as quickly as we can," he said. First flight stayed on the schedule for 1987. Kinnu hoped there would be some "understanding" from the Air Force when milestones like first flight approached.

Slowing down work on the structures and the major subsystems was the price to be paid. But as General Gabriel had said, if it made for a better airplane, it had to be done.

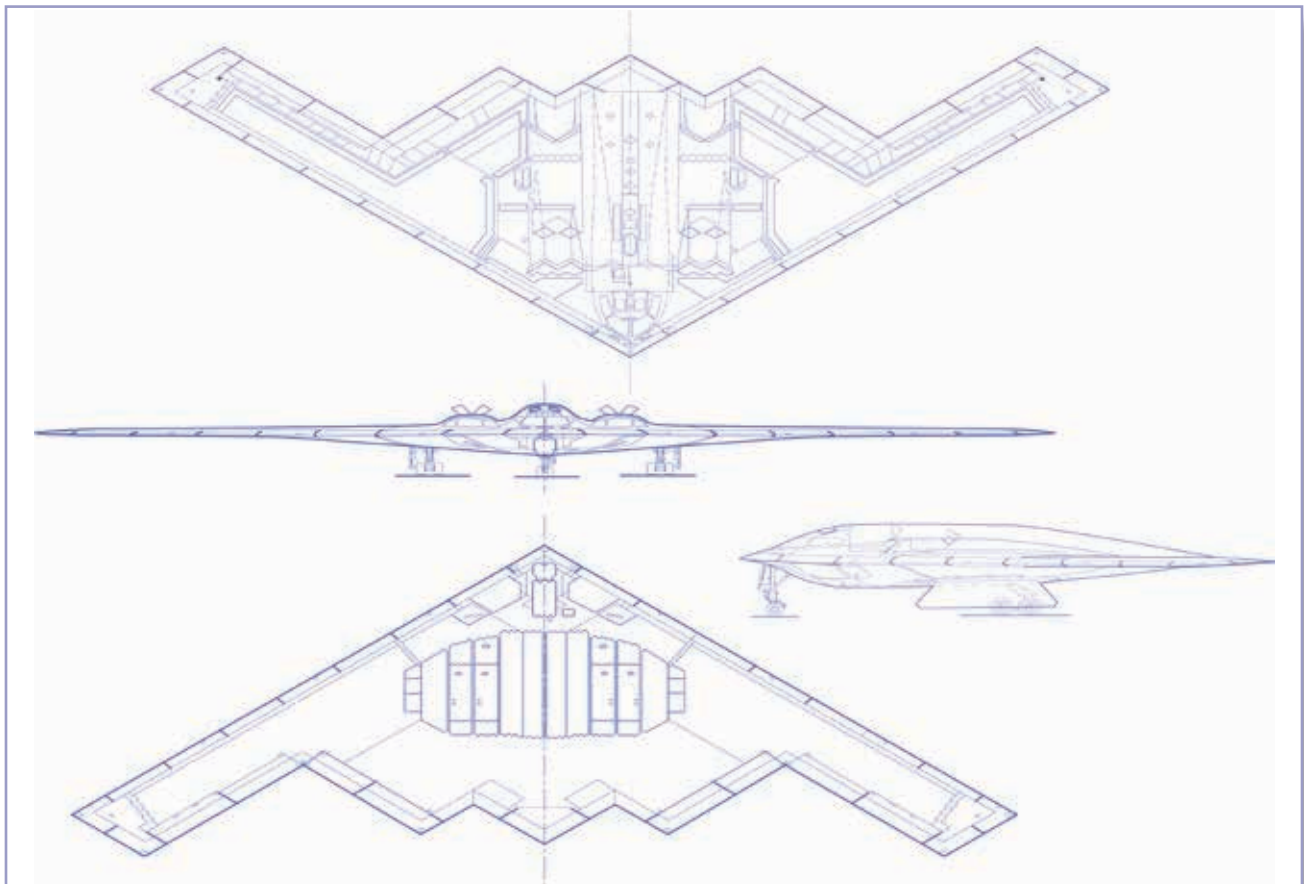

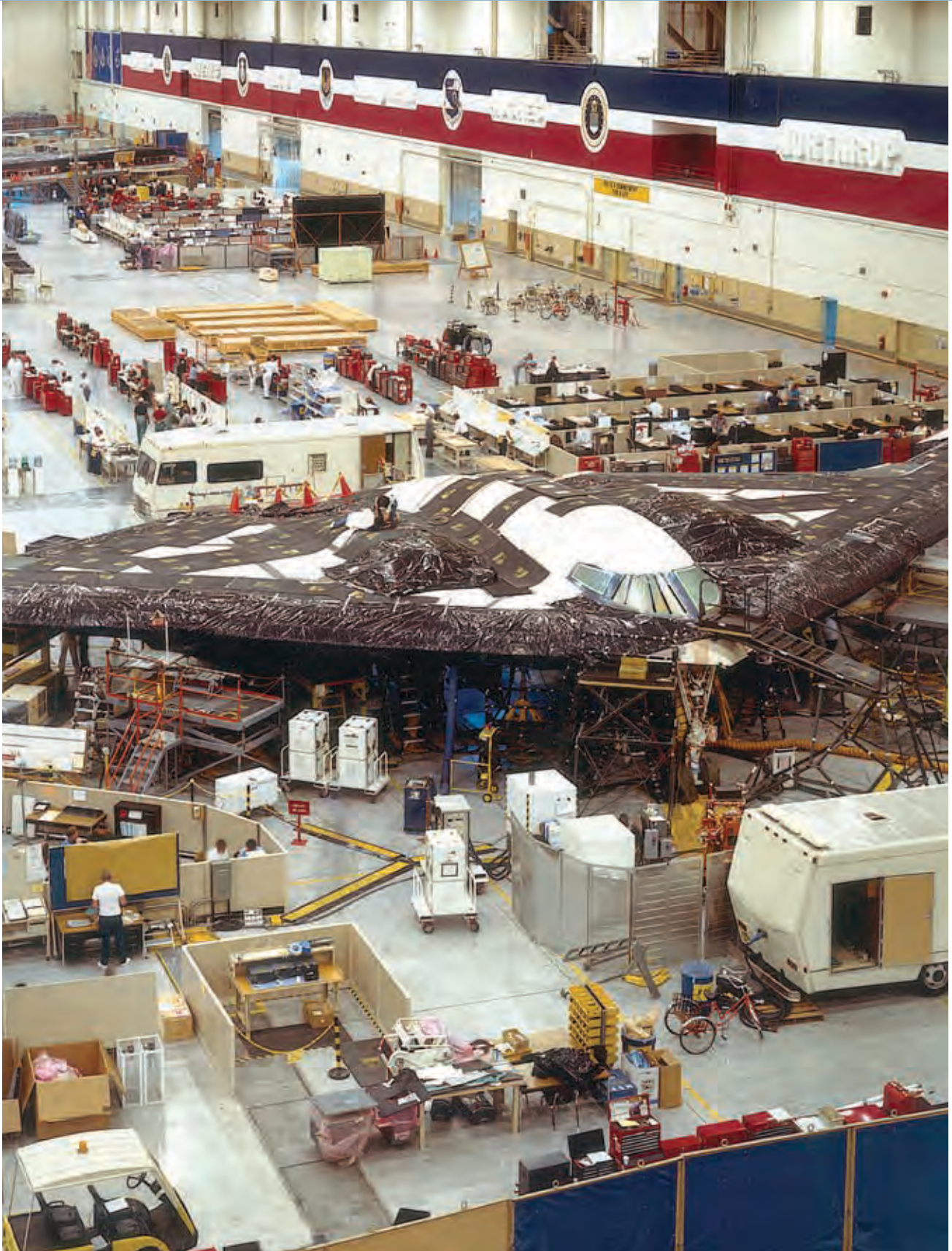

Chapter Eight: A Miracle a Day

From 1984 through 1989, the B-2 program entered into a period of invention, discovery, and innovation on a scale rarely seen in the American aerospace industry. It would change Northrop forever, and help vault America's air dominance far ahead of what potential adversaries could offer. Not that it was all smooth sailing. At times, the technical challenges threatened to overwhelm even the savviest engineers. "We thought for a while they were just letting us go to see how far we could," Scofield felt at times as the technical challenges deepened.

Complex and ambitious as the aircraft was, there was simply a lot to invent. "A miracle a day," was the phrase they lived by.

All new aircraft aim toward a goal known as Critical Design Review (CDR) – the moment when the program manager, with the advice of numerous other lead engineers and teams, will certify that every detail and subsystem of the design is complete. The schedule for the B-2 still called for the process to culminate with a Critical Design Review in December 1985.

Preliminary reviews would target subsystems, but the idea behind CDR was that the airplane should be close to completion, ready for a final scrub of plans before lay-up for the first air vehicle began in earnest.

To complete CDR, the plan called for a team numbering literally thousands of engineers and production specialists to draw the plans for every piece of the bomber. Good systems engineering practice grouped subsystems into major categories such as propulsion and worked to refine the details for each, always keeping track of how the elements of one subsystem impacted another. Done right, the interfaces would all be diagrammed well before building of the first B-2 bomber began. Many major elements – such as the composites for the wings – would have been tested in prototype or mock-up. Of course, to trim schedule time, there would be no full system prototype, which made the critical design review process that much more critical.



Opposite: B-2 production in the purpose-built facility in Palmdale – an incredible government investment that will pay dividends well into the future.



Background: Rendering showing color-coded groupings of B-2 subsystems.

Meeting the CDR by the end of 1985 was essential to achieve B-2 first flight in late 1987.

Given the risk closure objectives, and the stance of the CEOs, the push toward CDR for the B-2 would be more dramatic than most. For example, the B-2 was still in the midst of design trade-offs that would affect major items like radar, navigation, and even the number of crew-members after Strategic Air Command asked them to look at adding a third crew station in the cockpit.

Although the advanced design team had a good grip on the low observables and aerodynamic requirements, major questions for the stealth bomber lurked in all the unknowns likely to appear during the final design and manufacturing process.

The unknowns popped up almost from the start. One sent Cashen and the advanced design team back to rework the leading edge of the wing. They called it the toothpick.

TOOTHPICK EDGE

The B-2's leading edge was already a marvel of fabrication and design, and its shape was the jealous domain of the RCS engineers.

Wartime conditions and aerodynamics now demanded a change in that edge. The B-2 might be compelled to land at some unusual airfield during wartime. SAC wanted their new bomber to be

able to operate out of different bases during wartime – in fact, they wanted the B-2 to be able to land and take-off from any airfield that could accommodate a 737. The original, low observable design called for a sharp leading edge – all part of creating an airplane as close as possible to an infinite flat plate. Now the issue was getting enough airflow over the wing for a safe take-off at high angle of attack on some hot day at an unusual wartime airfield.

“With a sharp edge, as you start to pull angle of attack at a low speed, the airflow starts to go span-wise,” said Cashen. Without enough air rushing back, the trailing edge control surfaces lose power. The numbers were conclusive. “With a full bomb load on a hot day, we could stall the airplane,” said Cashen.

Solutions acceptable for normal airplanes just wouldn't work for stealth. One afternoon Sam Craig, one of the aerodynamics experts working the problem, called Cashen into his office.

“Give it to me in the simplest terms,” Cashen asked.

I need radius here, Craig indicated, pointing to a section of the wing's leading edge.

Ultimately, the solution was to put radius only where it had to be to generate the airflow. The leading edge originally had a constant thickness. With the change, the design



Left: The non-linear dimensions of the B-2 wing are evident.



tapered the edge radius to increase airflow to crucial wing sections. The leading edge section was now rounder in the middle and thinner at the ends – like a toothpick.

Ken Mitzner, their great theorist, had done experiments which reminded Cashen that only the main lobe of radar return would be affected by plumping up the radius. Kinnu let them send Locus to the range with a model of the toothpick. The first time, it didn't work. Kinnu let them try again, and this time they got the taper right, and brought home the range results that proved it.

Caspar Weinberger reportedly called it “the last great invention of the B-2.”

Of course, it wasn't. There were many more to come.

MANUFACTURING

Most of them were in the manufacturing process. Kent Kresa had come back to the aircraft division just as the B-2 was building up as a program. “Kinnu's vision was innovative but also risky and crazy,” Kresa said of this period. “On production, we had never done anything like this,” he said.

As a stealth aircraft the B-2's skin had to be absolutely pristine to play



Above: Working skin composites was a laborious process.



Right: Complex parts like this inlet duct proved challenging, to say the least.

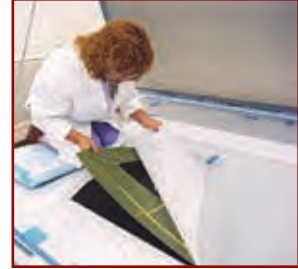

its part in electrical conductivity to manage the radar cross section. Previously, airplanes were tooled from the inside out. When tolerances built up, the outside surface could vary. Nearly all fighters and bombers were built with some degree of shims to nudge it all into place. Most aircraft could tolerate a fractional bulge here or there to help make the guts of the aircraft fit.

With stealth that wouldn't work.

The tolerances had to be exact or the low observables would suffer. That led to a complete reversal of the usual aircraft manufacturing philosophy.

"On the B-2, everything had to be solved without penetrating the outer mold line," recalled Scott Seymour, who was then an engineer new to the program.

The process of actually building the B-2 brought to mind Jones' caution from earlier years about laying in "a program to discover the knowledge we don't have."

Work on everything from composites to electronics had considerably added to the body of knowledge.

Still, nearly every major manufacturing step on the B-2 was a matter of breaking new ground.

Take, for example, the engine inlet duct. Cashen was confident a flush-mounted duct would work for the B-2 as it had for Tacit Blue. Actually manufacturing the duct was another matter. "This was almost a flush inlet, which we had a lot of trouble making work," Waaland said later. The technology was beyond difficult. LTV had to build a mold, form it and pull the tool out of it. Learning how to do that to exact specifications took time.



A blessing came in the form of information technology beginning to blossom in the early 1980s, such as computer aided design. However, the process wasn't easy.

The decision to shift all design and engineering work to computer-aided design was revolutionary at the time. Kinnu invested Northrop money in a process called NCAD – Northrop Computer Aided Design.

Northrop personnel wrote the program for this proprietary design. This was Northrop's approach to taking an older 2-D computer aided design and a 3-D system called Nor-Loft and making it into a new 3-D design system.

Of course, Kinnu had to justify spending dollars on infrastructure. "You've got to design these stealthy airplanes and the way it's going with Cashen and Waaland in terms of designing and controlling a

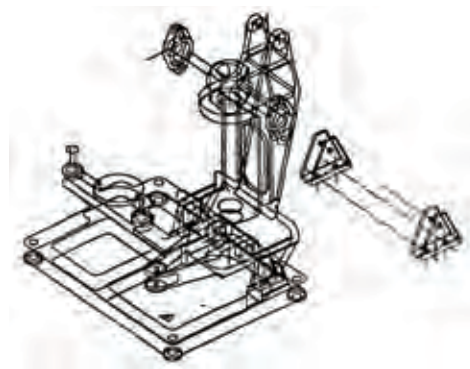

smooth surface, you are going to need computer-aided design to build the airplane from the outside in," he reasoned to his bosses.

"Northrop had to grow into it," said Seymour later.

Like the composite work, CAD was a good investment for the B-2 and for the nation. Ultimately, it was sharing the computer-aided design with the team and major subcontractors that kept the B-2 design and manufacturing preparation moving forward.

Kinnu then linked the CAD systems to major suppliers. "It was brilliant

to get them all on a common CAD, classified system," Kresa remarked later.

Eventually, it resulted in a first – total design integration within one computer database, accessible to the prime contractor and subcontractors alike.

Al Myers later found that in a poll taken among aerospace engineers in the 1990s, two-thirds said they had first trained on computer-aided design with NCAD. "We trained the country to do digital design," Myers said.

Northrop also invested in robotic systems to carry tools and parts from supply to autoclave and back, for example. The investment made Pico Rivera practically a "factory of the future."



Left: An early NCAD rendering of the cockpit stick lower assembly.

Below: Screen-shot of a CAD system, and several versions of the system being used.

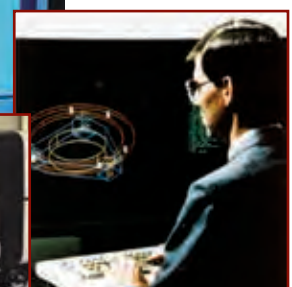
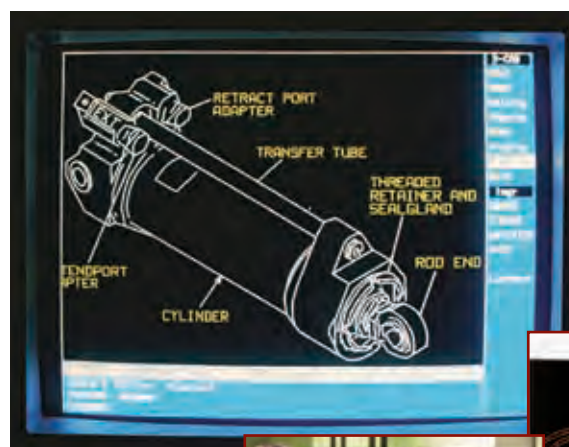

“We were investing a little over \$1.5 billion, Boeing was investing a little over a billion, and Vought put in \$800 million,” just to set up the line, Kinnu recalled.

BLACK BOMBER IN A GREEN WORLD

The enormous, secretive Pico Rivera plant could not help but attract the attention of one of California’s most powerful entities: the South Coast Air Quality Management District. Known and feared throughout the southland, the AQMD wanted to know what was going on in there, and what environmentally suspect materials were in use, and they would not be denied.

The fact that Pico Rivera housed a black program only made the prospect of hunting for exotic fumes and chemicals more enticing. AQMD had already scored a victory with a \$200,000 fine levied on Lockheed. One inspector with a gleam in his eye made a visit to the Pico Rivera plant, and compiled a list of hundreds of violations, most relating to incomplete records or other clerical matters.

Then AQMD decided to sue. Top Northrop executives were actually named in the suit. After a year of wrangling by lawyers, the AQMD made known it would be content with a sum of one million dollars.

What Northrop did instead was to make B-2 production at Pico Rivera a model of green compliance. They instituted a joint inspection manu-

facturing system to inject quality and environmental criteria from the composite shop to the factory floor.

In the end the environmental policies were such a success that Northrop was awarded the inaugural Tom Bradley environmental award by the AQMD. Of course, there were a few special materials that got environmental waivers. But the changes at Pico Rivera and later at Palmdale added up to a culture shift. From carpooling rates to operating some of the first natural gas cars, Northrop made itself, in the words of Denny Beroiz, “a good green company making black airplanes.”

NUCLEAR MISSION

Had they known about it, another “environmental” challenge was being faced by the B-2. It would have caused an AQMD inspector to faint. This was the nuclear environment. The B-2 was hardened and shielded from nuclear effects to a degree matched by no other aircraft – before or since.

Waaland’s 1979 brief to the Air Force had discussed “atomic cloud avoidance.” What SAC really wanted was for the B-2 to fly through a radioactive environment if necessary and still do its mission.

While it always had a conventional role – that’s what the Offset Strategy was all about – SAC also expected the B-2 to be its mainstay bomber. It would carry all nuclear weapons in the inventory from hard-target



Below (top): The emblem of the South Coast AQMD; (bottom): Denny Beroiz



penetrators to the multiple-megaton B53. Beyond this, it might have to “go low” on the deck through radiated atmosphere or cope with the shock waves from its own nuclear bombs on egress from the target. Just as the B-2 relied on low observable technology to get into the target area, it depended on surviving nuclear blast from its own weapons or from nuclear-tipped Soviet air defense missiles.

Of course, all this had to be done with respect for the unique composites and radar absorbent material that kept the B-2 stealthy. No small number of those daily miracles concerned finding materials that would also hold up against the effects of nuclear weapons.

This was uncharted territory. “None of the materials we used on Tacit Blue made it to the B-2,” said Waaland. “They hadn’t been developed for the nuclear environment.” Strategic Air Command tightened the nuclear requirement in 1984, well into the second phase of preliminary design. Among other things they wanted 100% hardening of all avionics boxes against nuclear effects.

John Mall¹⁷ was hired at Northrop in 1978 to work on the F-18, but by 1984, he found himself absorbed in all things nuclear for the B-2.

Nuclear hardening actually involved several different, nasty scenarios. First there was pre-detonation dust, “very bad on paint,” said



Left and background: Special coatings had to be formulated that would do their stealth “jobs” and still survive nuclear blast effects.

Below (top): John Mall;
(bottom): A Mark-53
Thermonuclear Bomb.



Mall. The detonation itself gave off gamma-neutron radiation. Next, a massive thermal wave of great intensity could sweep over the aircraft and scorch everything inside it. Then came electromagnetic pulse or EMP – the result of exo-atmospheric gamma rays interacting on the magnetic field.

“We had to make sure coatings, crew, and systems survived,” said Mall. The principal challenge was testing the stealth coatings to find the ones that could do their stealth “jobs” and still survive the spate of nuclear blast effects. This took a lot of time.

Sometimes, materials that passed the test still had to be discarded because they were too venomous to use in large scale production.

“Environmental compliance drove us nuts,” recalled Mall. The AQMD would have been pleased to hear it.

Ultimately, the Northrop team found the right materials for durable survivability. Best protected of all was the cockpit. It had a passive thermal protection system, and a



windscreen with “a quick-reacting photochromic that reflected thermal waves back,” said Mall. The process had been developed especially for the B-2 by one of the suppliers.

The B-2 also had to be able to detect nuclear flash and instantly shut down then reboot many of its electronic systems. Shutting down was the only way to avoid a pulse that would fry the components.

“About the only thing that was not rad-hardened was the anti-skid system,” Waaland jested.¹³

There was just one more thing – lightning. An F-16 had recently suffered a catastrophic lightning strike and SAC insisted the B-2 not fall victim to a lightning bolt.

“Lightning was actually harder than EMP,” recalled Mall. Since lightning was basically overamperage, by nature lightning striking an aircraft wanted to find and fry the

wiring. To counter it, individual electrical components were guarded against the over-amperage.

“The B-2 is a very robust airplane,” Mall said. “That airplane will be good for a very long time.”

CAP THE KNIFE

As the complex trial and error process went forward, it fell to Scofield to take progress reports both good and bad back to Washington. There, the spirit sur-



rounding the B-2 evolved into an extraordinary, durable partnership between the Pentagon leadership, the Air Force, and Northrop.

Jones later said it was Brown and Perry who had devised “such a simple set of relationships” with the government. To him, it was unique in his experience in the aerospace industry. From the first proposal evaluations, close contact with the Air Force team cemented strong working relationships.

Brown’s and Perry’s support was founded on technical insight in the Carter administration carried over seamlessly to the Reagan adminis-



Below and right: The complexity of stealth needed to be retained through the structural curves and dissimilar materials of composite, metal and glass – as well as under the stress of a nuclear environment.



tration and especially to Secretary Weinberger.

“Caspar Weinberger was a very strong supporter. We had a lot of help,” said Scofield. As the Air Force program manager, Scofield briefed Weinberger every three months. After completing briefings to the select few on the Air Staff he briefed the Chief of Staff. “Then I’d go straight to Weinberger,” said Scofield. “He’d have five or six of his direct reports. He always took the meetings. We always had good dialogue, good interchange. I didn’t always have the best of news, but he was always appreciative of the fact he was getting straight information,” said Scofield.

Through his steady personal supervision, Weinberger gave the B-2 the support needed on a complex, vital program. To Weinberger, it was important for the Air Force to succeed with its ambitious and vital B-2 program. “He was always willing to give us whatever resources we needed to solve the problems we had to deal with. It was important to him,” Scofield concluded.

Not that he took it all on faith. In late 1987, Weinberger heard a highly classified briefing from analysts at the RAND Corporation. This southern California think-tank had been set up by the Air Force after World War II, and earned its reputation in part as an expert watchdog of aerospace programs. Now operating independently, one of the vice

presidents briefed Weinberger on RAND’s independent study of the B-2. This vice president had literally grown up around stealth and its pioneers. He gave the program high marks for its early risk closure steps, but flagged the pending first flight delay and its slow-down of the flight test program as potential problems. The senior RAND executive who took the briefing to Weinberger, and later to Congress, was Michael Rich – Ben Rich’s son.¹⁴



Above: Caspar Weinberger, U.S. Secretary of Defense under President Ronald Reagan.





Chapter Nine: Slip and Recovery

The B-2 program had its share of disappointments and one of the biggest was the failure, after much effort, to prevent a slip in the schedule for first flight. In the end it took place a year and a half later than first agreed. Had the CEOs been right to insist that the B-2 hold to the schedule even after the major redesign?

At first, keeping a fast pace seemed to be working. Critical design review for the B-2 occurred on time from October to December of 1985. The program was still on schedule, but it was a mixed blessing. “With that closeout,” recalled Scofield, we had a number of action plans that the 3 major companies would have to execute in a timely fashion” to make first flight.

Structural design drawings were 90% complete. But only about 20% of the vehicle subsystems were closed with final drawings released. This was a huge problem. A better number would have been 90%. Any incomplete drawings injected risk of changes elsewhere in the systems. Areas such as electrical wiring and full testing of the exhaust effects on the aft decks would later turn into problems. The B-2 would have to play catch-up all the way to first flight.

There was a cost, too. First, the program had to make up time. In

holding on to the CDR schedule the team dropped off items such as additional testing of the effect of engine exhaust heat moving across the aft deck. It would turn out to be a momentous decision, as the surprisingly hot temperatures on the aft deck recorded a few years later in flight test led to years of problems.

Second, delay added up to more cost. The B-2 program had famously proceeded without the need for cost-cutting. The leadership of Northrop, the Air Force and the Pentagon did their best to insulate it from cost-driven problems – and it was, after all, the era of the Reagan defense build-up. But the schedule slip inevitably brought cost to the forefront.

Third, the delay in first flight also meant a delay in flight test. The Air Force, and the select few in Congress who knew about the program, would not have nearly the amount of flight test data they



Left: The shared workspace of the B-2 cockpit – pilot, left; mission commander, right.



Below: Iron Bird for component and system test.



expected as the B-2 moved toward full production. A crisis in confidence was brewing.

From CDR onwards, it was all about timing to complete manufacturing and test. “They had to complete not only the technical aspect of design, but the manufacturing design which would allow the airplane to be actually manufactured,” explained Scofield.

As the prime contractor, Northrop was responsible for manufacturing critical pieces of the B-2 such as wing leading edges, but the company was also responsible for integrating the work of its suppliers – including big ones, like Boeing. In many cases, Northrop engineers had to lead an

education process to get the suppliers accustomed to the demands of stealth manufacturing.

Antennae were a case in point. The B-2 needed antennae that did not radiate in a way that added to the radar cross section. Putting two dozen big radiating antennae even on an infinite flat plate would give it the radar cross section of Jupiter. But when Al Myers asked suppliers about manufacturing non-radiating antennae, they would “give us a blank stare, as if to say, ‘Isn’t that an oxymoron?’” Myers recounted. “Because there was no alternative, we had to develop an in-house group

of engineers and physicists to figure out how to design antennae that worked in an LO system,” Myers added. Northrop was not about to get into the antenna business – so “we taught manufacturers how to design and build [LO] antennae,” said Myers.¹⁵

Change began to pop up everywhere. These were not, for the most part, new requirements. Rather, they were identifications of problems that had to be solved in order to proceed with assembly of the very first B-2.

More changes caused more churn. “Each time there would be a change it would ripple the whole system,” observed Scofield.

“The effort from CDR to first flight is centered on manufacturing the parts, assembling the aircraft, qualifying the components, and checking out the assembled system. This is simply hard work,” Kinnu and Griffin noted.

At the working level, there was constant pressure to make changes as assembly took shape. But too many changes could unravel the work plan for good. Kinnu and his engineering leadership team realized “there was always a ‘better’ way to implement design features” or make enhancements. They kept change orders on a tight leash, with Scofield’s help.¹⁶

Pressure continued as projected dates for roll-out and first flight

approached. Soon all realized that the December 1987 first flight wasn't going to happen. Major contributors to delay ranged from electrical system installation and check-out to new criteria for Air Vehicle 1 (AV-1's) pre-flight test requirements. "There was no basis for estimating this kind of product," said Doug Wood.

Still, the excitement of the program and the sense of teamwork kept them at it with a passion.

New hires joined in the spirit, too. They came from all over California and indeed, the nation. As AV-1 took shape Northrop began to prepare for a future production ramp-up. After all, Northrop was gearing up to build 132 B-2 bombers.

The core of the expanding work force came from other Northrop programs like the T-38, F-5, and their subcontract work on F/A-18 and the 747. A number had worked previously at Rockwell. Of course, all had to wait out the detailed security clearance process before they could begin their jobs, and they all had to learn how to work within a black program where major components were designed, built and assembled in different locations.

Chris Hernandez joined the electrical wiring group as a young engineer in 1987. He would later become the B-2's chief engineer. But in 1987, he was amazed at the problems. The B-2 had 22,000 circuits, and it seemed like half of them did not go where they should.

Below: Chris Hernandez.

Bottom: The first B-2 taking shape in Palmdale Hangar 401.





Above: Dave Moore.

Below: Just some of the circuits Chris Hernandez had to deal with before they could be installed in the aircraft.

The design tools for wiring were “almost non-existent,” Hernandez recalled. It took a methodical approach to sort that out.

The B-2 incorporated the most advanced mission systems ever attempted for a stealth aircraft, and probably any aircraft up to that time. Dave Moore joined the program in 1983 to work on the defensive systems, then spent time on mission planning – the onboard systems calculating “targets to go

to, and known radars to avoid, weather, and so on,” as Moore described it.

It was all a big software exercise, and too often there was tension between the avionics and the software. Problems were booted up to managers and integration was done on the 3rd shift, until the 8 AM turnover meeting.

John Mall was still working with the team on nuclear hardening. He, like others, found the environment intense but productive. “This was not a politically correct environment,” he said later. “You could yell at people.” In his opinion, that was part of what made the B-2 work.

Due to its complexity, the B-2 required innovative thinking on nearly everything. As expected, validating the composites held its challenges. While not a pacing item, the composite work generated its share of unknowns. Ultrasound tests sometimes revealed voids in the composite molding or disbonding. That meant cutting the skin, patching, and repairing – and then of course, reestablishing the low observables.

Here again the investment in CAD paid off. The manufacturing approach for the B-2 was able to eliminate most prototyping. The plan to go from design to production was based on the use of 3-D modeling as made possible by computer-aided design. With CAD, the team could skip prototype

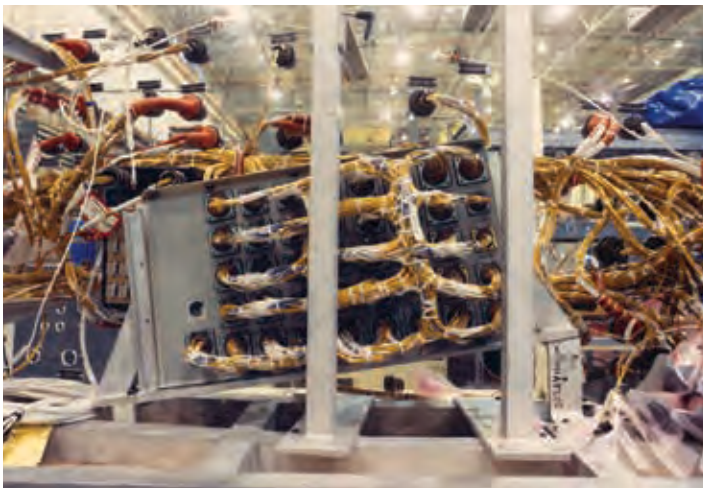
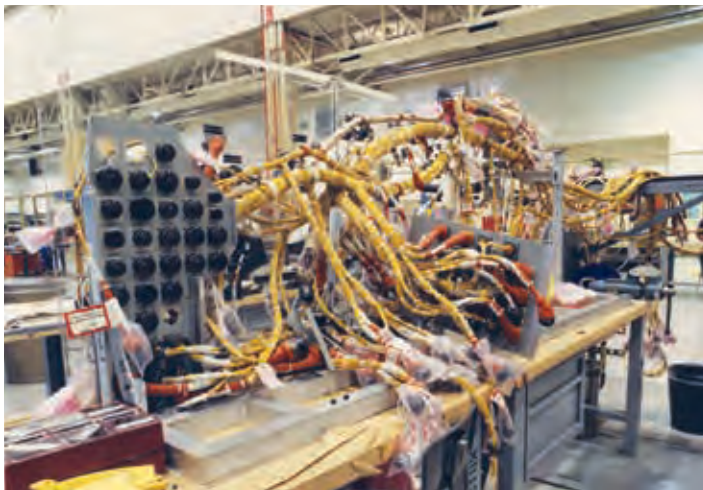



tooling and prototype manufacturing of aircraft. The first B-2 built would also be the first to fly. This cut significant time off the engineering and manufacturing development schedules.

The flip side of streamlining was that the B-2 was a highly concurrent program. The idea behind concurrency was precisely to cut engineering and manufacturing development time by doing the final aspects of design, build, and test all at the same time. Overlap could be highly efficient but it also called for superstar performance from all involved. However, if a change had to be made, it could slow down other parts of AV-1 and the next low-rate production bombers.

The only relief was that each of the first six B-2s had a special role to play in the flight test program. AV-1 would test the low observables, while AV-2 would go through spe-



cialized structural test. AV-3 was the avionics integration bird while AV-4 would test weapons and AV-5 would validate further integration. Segmentation allowed for test to move forward, and the early air vehicles would simply be retrofitted after they finished up flight test.

Still, the “concurrency of engineering development and production was creating havoc,” Chris Hernandez said of the frenetic period before first flight. In other words, it was crunch time.

Scott Seymour had been working at the Navy test facility at Patuxent River in Maryland prior to joining the B-2 program. He worked first on flight test plans and landing gear, then moved into management. He became head of test site operations in 1988.

By then, the first B-2, AV-1, was coming together in completed form. But everything demanded a “huge

Left: Building up electrical panels.

Right: Wiring complexity in the weapons bay. Note the air defectors, and the round attach point for the rotary launcher.





Right: Team focus is evident as everyone signs up for Total Quality products for the warfighter.

learning curve,” as Seymour put it. Dealing with a low observable aircraft whose surface had to be taken into consideration at all times posed a special challenge. Engineers might just want to change out a box – one of the line replaceable units of avionics, for example. Yet if they went in to get the box it meant restoring the low observable coatings. AV-1 “had to be 100% green for low observables,” recalled Seymour.

Seymour saw that solving all the problems without penetrating the outer mold line was “quite a cultural difference.”

The key, he believed, was the culture of trust between Northrop and its main subcontractors, and Northrop and the government personnel now closely integrated with the program.

It took long hours to put “a miracle a day” into practice. At one point, they finally had pieces to assemble a mid-elevon. Mark Tucker came in on a Saturday planning to work from about 6 AM until noon. Absorbed in the work, his team stayed until after midnight. “That was pretty rampant through the program,” Tucker commented.

“We were blessed on this program with such incredible people,” said Seymour.

One feature of the B-2 gave everyone exceptional pride. “The B-2 was probably the only big airplane that never leaked fuel,” said Jorge Diaz, who was about to take over as Chief Engineer.



PREPARING FOR FIRST FLIGHT

In November 1988, the hangar doors at Palmdale opened. Out rolled AV-1. The plane was not ready to fly and only a select few viewed it. Sanctioned pictures showed only the front of the aircraft, but a trade photographer got an aerial shot of the unique engine inlets and ducts.

For the B-2 team, roll-out began a period of redoubled efforts. The criteria for AV-1 demanded not only preparation for first flight,

but significant low observable features, too. Both groups were scrambling to complete their tasks, and changes from one group often impeded progress by the other.

“One of the biggest challenges leading up to first flight was the series of compromises that had to be made between the aero guys and the LO guys,” said Mazur.

Once again, it was a matter of finding the right people to infuse technical leadership into a complex program.



Diaz arrived to take over as Chief Engineer for the B-2 on January 16, 1989. Soft-spoken, with old world charm, Diaz had graduated

from Universidad Nacional Autonoma de Mexico as a metallurgist and come to work for Rockwell in 1959.

Diaz had actually retired with the usual plans to spend more time with his wife and family. Instead, he moved to Palmdale as a temporary bachelor to chart a path through the fragmentation that had crept into the program. His work on Apollo, Saturn, and the Space Shuttle Discovery made him no stranger to complex program management and split-second decisions.

“The pioneers – Irv, John, Jim, they did a fantastic job,” Diaz recalled. The B-2 was sound – it just needed firm nudges in the right direction.

The bar was set especially high for the first B-2, for two reasons. First, AV-1 was not a simplified demonstrator but a bomber with full low observable functionality. As test articles went, the B-2 was setting very high expectations.

Second, the low rate production was still highly concurrent. Concurrency made it very hard for the manufacturing section to plan their work. Changes might come along and upset one plan and delay another. That meant that any changes in any segment “really rocked the boat,” said Diaz.

As 1989 began, the entire B-2 team was working flat out. Technical talent abounded. Engineers and production personnel were putting in endless hours. Many slept at the plant. They jokingly formed the “Century Club” for those who’d worked 100 days straight – or more. The main task was to cull what absolutely had to be done and organize the work flow to accomplish it.

As Diaz knew well, engineers tended to be entrepreneurs. With first flight approaching, everyone thought they owned the B-2 – engineering, manufacturing, pilots. Just as Kinu had found, the major problem was working through changes on what was essentially

Left: Jorge Diaz, Chief Engineer



Background: The B-2 Spirit takes off from the desert floor for its inaugural flight.

a hand-built aircraft. Diaz's fix was to reorganize the engineering progression so that those working on the airplane got a chance to proceed. "Everything that couldn't be fixed ended in my office," Diaz said.

JULY 1989

The main driver was the series of flight justification tests. They'd been coded "red for four years," said Wood, but in the late spring of 1989 it all came together.

High speed taxi tests gave them a jolt of excitement. The test was done at night. "I could hear the throttles come up," recalled Wood. The feeling was "pretty indescribable," he said.

Saturday, July 15, 1989 was the date officially planned for the first flight of the B-2. Workers drove up from Pico Rivera to witness it. Cashen, Waaland, and Kinnu had all been

promoted to other jobs but they gathered, too. Family members flocked to Palmdale for the event.

Diaz watched the control panels closely. Suddenly, "I saw that the fuel was getting hot and the pressure dropping," Diaz said. He was worried. Someone told him, *you have ten seconds to decide. I don't need ten seconds*, Diaz thought.

"We're not flying today. We're aborting the flight," he said.

It turned out to be a decision that saved the aircraft. The hangar at Palmdale had an air filtration system to keep the environment as clean as possible. Workers used cheesecloth rags to clean the fuel cells. Over time, miniscule particles of lint wore off, circulated through the air, and into the fuel filters. Fueling the



B-2 loosened the lint and created a block in all four AMADS. It was just like having four clogged fuel filters. “What was the chance of that – all four?” Seymour wondered. On take-off the fuel flow could have stopped and the B-2 might well have crashed.

“I felt really bad cancelling the B-2 first flight, but I was doing my job,” said Diaz. Actually, this was familiar territory to Diaz. “I’d already cancelled three space shuttle flights,” he demurred.

The disappointed crowds dispersed and over the weekend the Northrop

team diagnosed and fixed the problem. The press to get the B-2 into the air was feverish. “Even today it’s a blur to me,” said Chris Hernandez of that final weekend.

A much smaller, more somber group gathered two days later when the B-2 tried again.

On Monday, July 17, 1989, the B-2 took flight. “I cried,” said Kinnu.



Below: The initial flight test crew of Bruce Hinds, Northrop Grumman Chief Test Pilot, and Colonel Richard Crouch, Commander of the B-2 Combined Test Force at Edwards AFB being congratulated (top) and at the post-flight interview (left).





Chapter Ten: Success

When the triumph of first flight receded, there was still much work left to be done on the B-2. For starters, when the first B-2 flew across the range, it bobbed its low observable signature tests. As usual, the problems lay in the process, not in the design. Engineers went back to the basics to diagnose each small piece of the surface area to determine where there were low observable problems. Small fixes added up to a big improvement.

It would take more than three years for Northrop to deliver the first B-2 to the Air Force. “How will we know the B-2 is a success?” those working on the plane often wondered.

It wasn’t just about the range results or the maintenance or the avionics integration or even the remarkable, unprecedented, and total absence of fuel leaks. To Hernandez, there was a simple answer: “when the pilots come back from war.”

Almost ten years would pass from that July day when the B-2 flew until the bomber made its debut in combat in the dark skies over Yugoslavia in the spring of 1999.

THE SLEDGEHAMMER

In December 1989, Northrop added fire to the mix in the person of Ollie Boileau. A long-time aerospace executive, Boileau had briefly retired from General Dynamics in St. Louis when he took over as

general manager for the B-2 program.

“Ollie came in with a sledgehammer,” recalled Kresa. Diaz, his Chief Engineer through 1992, saw the impact right away. “He really made a cohesive team,” Diaz said. “B-2 owes him a lot.”

After first flight the goals were to get production underway and to prepare for the Air Force test pilots to give the B-2 a workout.

Major Tony Imondi was the first Strategic Air Command pilot to fly the B-2. He’d come to Edwards with a group of six hand-picked pilots, and spent time learning the B-2 systems and flying T-38s until the B-2 itself was ready. “It handled like an F-111 with four fuel tanks,” he said. The engineers drew on the pilots’ assessments of the simulators and test-bird avionics to make several changes.



Opposite: B-2 production in full swing at Palmdale.

Below: Ollie Boileau brought the right approach at the right time – he remains a management legend at Northrop Grumman.

Bottom: Tony Imondi was instrumental in getting the B-2 operational.





Above: Taking ownership of the operational aircraft.

Below: The B-2 flying above Whiteman AFB.

Bottom: Margaret Calomino



Waiting was not easy. Resolving the inevitably complex problems that arose with the massive stealth aircraft strained the patience of government and manufacturer alike. Over time, manufacturing smoothed, and Northrop had the right aircraft, AV-6, to deliver to the Air Force as its first operational stealth bomber.

At last, on December 17, 1993, the first B-2 touched down at Whiteman AFB, Missouri. “Everything changed when we delivered an airplane,” Imondi said. “When we got a flyable, combat airplane, everything changed.”

By the mid-1990s, there were several B-2s at Whiteman. The fleet was now grouped as Block 10, Block 20, or Block 30 aircraft, according to the sophistication of the avionics. The newest B-2s were coming off the production line as Block 30 aircraft – ready for war – and sailing through customer acceptance.

Unfortunately, the B-2 would never achieve full production. A 1992 decision capped the fleet at a mere

20 aircraft, although money to retrofit AV-1 into a 21st plane was added at the end of the decade.

Nevertheless, the B-2 was destined to make a big impact as a combat bomber.

Officially, the B-2 achieved “initial operational capability” in April 1997. The B-2 owed its speedy IOC in part to a specially-designed Northrop precision weapon called GATS/GAM.

GATS/GAM was an acronym on an acronym. It stood for GPS-aided Targeting System/GPS-aided munition, with GPS, of course, being the Global Positioning System satellite constellation developed by the Air Force.

One person involved was Margaret Calomino, who joined the Armament Division in 1984, integrating all weapons onto the airplane. She remembers being briefed on a program to combine accurate positioning with a synthetic-aperture radar picture on board the B-2. Starting many miles out, the synthetic aperture radar could

paint a picture of a target such as a surface-to-air missile battery. The combination of radar image and GPS gave the weapon coordinates for a precise hit.

Dave Moore had a hand in this program that designed the special, state-of-the-art precision munition for the B-2. “It was supposed to be a quick and dirty program,” recalled Moore. Those working on it were isolated from other contracts, but we understood that it was important to get the B-2 into combat and show its versatility. Kent Kresa wrote the government to say that Northrop would not compete for the upcoming JDAM competition if we could upgrade all the B-2s. “We had to sign a non-compete agreement with the Air Force,” Moore and Calomino said. Calomino notes that while there were those in government initially against the investment, ultimately, it was the GATS/GAM that allowed the B-2 to take its place as a conventional bomber in the years before JDAM was fully tested, ultimately demonstrating its capability in the skies over Serbia.

Thanks in part to Imondi, the B-2 was at the front of the line for Joint Direct Attack Mission (JDAM) integration.

One day in 1995 he had the honor of flying Secretary of Defense William Perry in the B-2. In deference to his instrumental work on his first tour in the Pentagon in the 1970s Perry was often called “the father of stealth.” Imondi took the opportunity with



Above: Preparing JDAMs to go to war.

Perry in the cockpit to bend the Secretary of Defense’s ear about the B-2 and JDAM. The B-2 became the first Air Force jet to be certified to employ JDAM, and the wing liked the new weapons with its all-weather precision.

Most of all, the pilots at Whiteman grew to love the B-2 as they moved together from training to combat rehearsal. In October 1996, a B-2 destroyed 16 separate targets using GATS/GAM. That “opened a lot of eyes,” said one pilot.

THE QUIET WARBIRD

The B-2 made its combat debut on the first night of Operation Allied Force on March 24, 1999. The B-2’s primary weapon was the 2000-lb. JDAM, also making its combat debut. Stealth, precision, range and mass united for the first time.

Of all the remarkable achievements of the B-2 at war, four stood out: opening the air campaign, flying alone, destroying an SA-3, and taking down the Novi Sad bridge.



Above: A Soviet MiG-29.

Below: Night refueling enroute to the combat zone on an extended mission from CONUS.

Imondi was the Operations Group Commander, the man in charge of the B-2 squadrons going to war.

Whiteman launched two B-2s on night one. There had been false starts to this air war, so those gathered in the command post half expected the bombers to be recalled.

They're not coming back, Imondi told them. Not tonight.

Leading the mission was Lieutenant Colonel Eric Single. Ahead lay Serbian integrated air defenses and fighters, including the formidable MiG-29.

As they entered Serbian airspace NATO and Serbian fighters were mixing it up below them. The other B-2 saw the white trail of an air-to-air missile.

Single saw no dog-fights below his B-2 but he did see flashes from the TLAMs and CALCMs going off “about the time we started ingressing in country.” Other than that, the sky was quiet. “Do they know I’m here, do they not know I’m here?,” he wondered.

He didn’t have much time to think about it. “Once you get into the target areas,

the target runs, you are doing a lot of aiming, a lot of radar scope interpretation, so you are very busy. You don’t have time to think about anything but getting the weapons out,” he said. The weapons releases were good. Time to turn for the border. “Then it seemed like it took about three days to get out of country,” as Single remembered it.¹⁷

The B-2 soon proved it could do what no other asset could do: fly alone and arrive in a hostile environment. Fighters and jamming aircraft were routinely in the air, but on this night, the weather was too bad to launch all the tankers and other assets needed. The air war stood down – but not the B-2.

Two B-2s entered hostile airspace by themselves. “It was eerily quiet,” said Major Tom Bussiere of the target run. One B-2 kept pre-planned targets, but Bussiere’s retargeted all 16 weapons in flight for new coordinates.

No other aircraft flew in-country that night. For their solo effort, the B-2 pilots were awarded the Distinguished Flying Cross.

Another deeply satisfying mission was rapid re-targeting to destroy an SA-3. The B-2 had been designed to elude air defenses. Now, with precision, it could destroy them, too. A B-2 crew was refueling before crossing the Yugoslav border when they got a SATCOM message to plug in a new target. They released JDAMs on the new





Right: The Novi Sad Bridge before and after bombing.

Below: A GBU-31 2,000 lb. JDAM being loaded.



target, and a few days later, an intelligence officer said to them, *hey, you guys blew up an SA-3.*¹⁸

Perhaps the most famous target destroyed by the B-2 was the Novi Sad Bridge. By May 1999, that bridge had been attacked by conventional fighters and by F-117s but it was still standing. Mission planners at Whiteman decided to take no chances and employ a full round of 8 weapons on the Novi Sad bridge. In one quick pass, a single B-2 targeted six JDAMs on the center span with another 2 JDAMs at one end. The bridge collapsed into the water.

Over the 78-day campaign the B-2 pilots flew 51 sorties, all from Missouri to the European theater and back. Their epic intercontinental flights proved a level of reliability for the B-2 which no other combat aircraft ever attempted.

Imondi flew a mission near the end of the campaign, after all his young crews had their turns. Twelve years had passed since he first laid eyes on the B-2 tucked away in its not-quite-lint-free hangar in Palmdale. On that May night the target area was dark, cloudy, and quiet. “I was almost overcome with emotion,” Imondi recalled. The target run was over almost as fast as it started and the B-2 slipped away unscathed yet again

FUTURE IMPACT

From 1999 to 2003, the B-2 flew combat missions in three very different campaigns in distinct regions of the world with varied air threats.

For Afghanistan, the B-2 opened the campaign soon dubbed Operation Enduring Freedom. It flew several missions, then pulled back to let other bombers and fight-

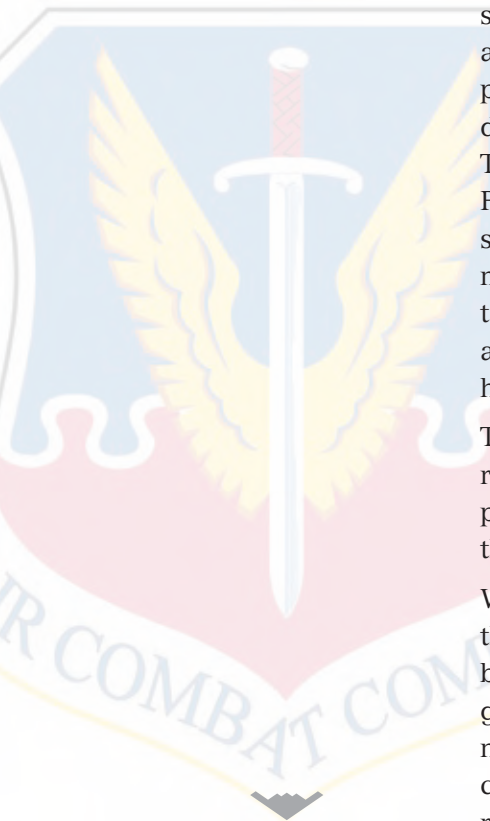

Above and background: The Shield of the Air Combat Command

Right: Details of the original surface material "stack", and the simplified version with updated fasteners that greatly enhanced LO reliability and maintainability.

ers continue the work, since the airspace held no threats.

At the beginning of Operation Iraqi Freedom in 2003, the B-2 again took on the most dangerous targets in areas where the remnants of Iraq's air defenses were most active. The B-2s logged 22 sorties from a forward base and 27 from Whiteman AFB, primarily during the first 10 days of Operation Iraqi Freedom. The B-2 targeted equipment in Republican Guard strongholds and struck fixed targets. These precision missions with up to the minute target updates were well beyond anything the first SAC planners had dreamed of in 1979.

The combination of precision, retargeting flexibility, stealth, and payload made the B-2 perfect for the job.

With a fleet of only 20 aircraft, the B-2 remains the nation's only bomber for heavily defended targets. Where the B-2 will fly combat next is impossible to predict. What's certain is that even today there are regions of the world with dense air defenses where only the B-2 has the ability to survive and complete the mission. The Air Force intends to

develop and build a new bomber as early as mid-2020, but there are no plans to retire the B-2 from its conventional or nuclear deterrence missions.

The B-2 is very much a front line asset. Innovation on the B-2 has not stopped, and its lineage within Northrop Grumman and the aerospace industry is still producing payoffs.

Fifteen years of operational history in the Air Force did not cut the ties between Northrop's B-2 team and the bomber they created. "No matter what, I'm still in awe to see it fly," said Mall.

The B-2 itself is a different creature in many ways after a decade and a half in the fleet. Through constant innovation, the Northrop and Air Force team have improved on many of the most vexing compromises made for the sake of the breakthrough design.

For example, the tape is gone. "We eliminated 2800 feet of tape off the airplane," explained Mazur, who was promoted to B-2 program manager.

Tape once covered the seams around access panels and other gap

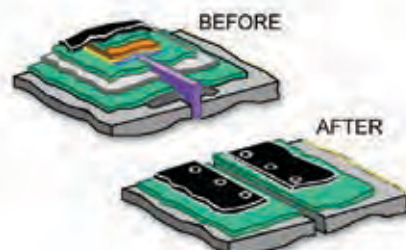

points. When it came off for panels to open it had to be resealed and cured to reestablish the smooth conducting surface for stealth.

A new crew at Northrop Grumman proposed a radical fix with new, simpler materials and fasteners.



Now the panel comes off and goes back on in 15 minutes," finished Mazur.

The B-2 has continued to infuse a spirit of innovation and competition throughout Northrop Grumman. Take, for example, the project that became the X-47A. While it looks somewhat like the B-2, the real

blood ties came from the people. "The people who are here come from that B-2 culture," said Chris Hernandez, who had risen to the head of advanced design.

The short story of how Pegasus evolved echoed the Northrop spirit of discovery. "We lost the Air Force UCAV competition to Boeing in 1999 and took it back from Boeing by winning UCAS-D in 2007," said Hernandez. How did they do it? In a way very reminiscent of Cashen, Waaland, Kinnu and the pioneering advanced designers who invented the B-2.

After their first loss, "Bill Haub and I scratched our heads and said we could come back and win this program in SDD, because this is just an ACTD, but we've got to fly something. We cobbled together

Left: Top view of the original "tape and butter" materials over gaps. Bottom view of updated technique that eliminated hundreds of feet of tape.

Bottom: X-47A on the ramp – a complex LO tailless air vehicle.





Right: X-47A in flight.

Below: Scott Seymour, visionary, strategist, and supporter.



this thing based on work we'd done over the years on different airplanes and ideas and thought, this could probably work." They focused on the Navy as their customer.

"From an aeroelastic standpoint there's a lot of learning that we take from B-2 to UCAS," Hernandez added.

Scott Seymour had moved from the B-2 program to leadership of the entire Integrated Systems sector. Just like Jones had done, he told his enterprising advanced design team "that's a great idea, go do it." It was a significant amount of money to invest, and an uncertain outcome, but they all saw the technical possibilities and

the benefit for the joint force. That advanced design team remains in place and continues to work on developing future capabilities for the warfighter, leveraging the successes and lessons learned of the past with maturing and proven technologies. The B-2 was and is unique – a success born out of necessity and facilitated by a dedicated, capable government-contractor team – a stepping stone to a next generation of air dominance.

And of course, Northrop Grumman is always up for a race on stealth.



Endnotes

By Chapter

Foreword

1. Rebecca Grant Interview with John Cashen, May 2008. pg. v

Chapter One: Cones, Drones, and Low Observables

2. Richardson, p. 96. pg. 1
3. Richard Van Atta and Michael Lippitz: *Transformation and Transition, DARPA's Role in Fostering and Emerging Revolution in Military Affairs, IDA Paper 3698, April 2003, p. 12.* pg. 5

Chapter Two: Two Horses in the Race

4. Cashen, *ibid.* pg. 9

Chapter Three: Cruise Missiles and Tacit Blue

5. Cashen, *ibid.* pg. 17

Chapter Four: A Bomber?

Chapter Five: Another Horse Race

6. B-2 Systems Engineering Case Study, John Griffin and Jim Kinnu, p. 16. pg. 33
7. Rebecca Grant Interview with Irv Waaland, May 2008. pg. 33
8. Van Atta, *ibid.* pg. 36
9. *Skunk Works: A Personal Memoir of My Years at Lockheed*, Ben Rich and Leo Janos, 1994, p.310. pg.40
10. *Reagan's Ruling Class: Portraits of the President's Top 100 Officials*, 1982, Ronald Brownstein, p. 434. pg. 41

Chapter Six: Risk Closure

11. William B. Scott, "Stealthy Genesis," *Aviation Week and Space Technology*, March 26, 2006. pg. 48

Chapter Seven: "My Airplane Blew Up On Me"

12. Griffin and Kinnu, *ibid.*, p. 37. pg. 58

Chapter Eight: A Miracle a Day

13. Waaland, *ibid.* pg. 70
14. Reference to Michael Rich briefing in NATIONAL DEFENSE AUTHORIZATION ACT FOR FISCAL YEARS 1992 AND 1993 (Senate - August 02, 1991), AMENDMENT NO. 1056, (PURPOSE: TO ADD AN ITEM TO THE CERTIFICATE REQUIREMENT RELATING TO THE B-2 BOMBER AIRCRAFT PROGRAM), April 2003. pg. 71

Endnotes

By Chapter

Chapter Nine: Slip and Recovery

- 15. William B. Scott, "Stealthy Genesis," *Aviation Week and Space Technology*, March 26, 2006. pg. 74
- 16. Griffin and Kinnu, *ibid*, p. 48. pg. 74

Chapter Ten: Success

- 17. Rebecca Grant interview with Lt. Col. Eric Single, October 19, 2000. pg. 86
- 18. Rebecca Grant interview with Major Scott Young, August 30, 2000. pg. 87



Dr. Rebecca Grant is President of IRIS Independent Research, a defense and aerospace research organization she founded in 1995. She earned her PhD in International Relations from the London School of Economics, then worked for RAND and the offices of the Secretary of the Air Force and Chief of Staff of the Air Force. She has written regularly for Air Force Magazine and has appeared on television and radio as a commentator on airpower. Dr. Grant also serves as director of the Washington Security Forum.