

TECHNICAL MANUAL
ILLUSTRATED PARTS BREAKDOWN

USAF SERIES
F-106A
AIRCRAFT

(GENERAL DYNAMICS/CONVAIR®)

AF 33(600)-16544
#41606-B7-D-A288

PUBLISHED UNDER AUTHORITY OF THE SECRETARY OF THE AIR FORCE

1 NOVEMBER 1981

CHANGE 23 1 JANUARY 1988

INSERT LATEST CHANGED PAGES. DESTROY SUPERSEDED PAGES.

LIST OF EFFECTIVE PAGES

NOTE: The portion of the text affected by the changes is indicated by a vertical line in the outer margins of the page. Changes to illustrations are indicated by miniature pointing hands. Changes to wiring diagrams are indicated by shaded areas.

Dates of issue for original and changed pages are:

Original...0...1 Nov 81	Change...10...30 Jun 84	Change...20...15 Apr 86
Change...1...30 Apr 82	Change...11...31 Aug 84	Change...21...1 Jun 86
Change...2...15 Jul 82	Change...12...31 Oct 84	Change...22...1 Mar 87
Change...3...31 Dec 82	Change...13...1 Dec 84	Change...23...1 Jan 88
Change...4...1 Mar 83	Change...14...15 Feb 85	
Change...5...15 Apr 83	Change...15...1 May 85	
Change...6...1 Sep 83	Change...16...31 Aug 85	
Change...7...15 Dec 83	Change...17...1 Jan 86	
Change...8...15 Mar 84	Change...18...1 Feb 86	
Change...9...31 May 84	Change...19...1 Mar 86	

TOTAL NUMBER OF PAGES IN THIS PUBLICATION IS 2634 CONSISTING OF THE FOLLOWING:

Page No.	*Change No.	Page No.	*Change No.	Page No.	*Change No.
Title.....	23	2.4-4 - 2.4-5.....	1	2.6-136 - 2.6-174.0	
A - D.....	23	2.4-6 - 2.4-8.....	0	2.6-175.....	1
E Blank.....	23	2.4-9.....	21	2.6-176 - 2.6-197.0	
i - xi.....	0	2.4-10 Blank.....	21	2.6-198 Blank.....	0
xii Blank.....	0	2.4-11 - 2.4-39...0		2.7-1 - 2.7-33.....0	
1-1 - 1-17.....0		2.4-40 - 2.4-41...2		2.7-34 Blank.....0	
1-18 Blank.....0		2.4-42 - 2.4-43...0		2.7-35.....0	
1-19 - 1-32.....0		2.4-44 Blank.....0		2.7-36 Blank.....0	
1-33.....8		2.4-45 - 2.4-49...0		2.8-1 - 2.8-4.....0	
1-34 - 1-37.....0		2.4-50 - 2.4-51...2		2.8-5.....3	
1-38 Blank.....0		2.4-52 - 2.4-63...0		2.8-6.....0	
2.1-1 - 2.1-13.....0		2.4-64 Blank.....0		2.8-7.....9	
2.1-14 Blank.....0		2.5-1 - 2.5-2.....0		2.8-8 - 2.8-12.....0	
2.2-1 - 2.2-17.....0		2.5-3.....4		2.8-13.....3	
2.2-18 Blank.....0		2.5-4 - 2.5-5.....0		2.8-14.....0	
2.2-19 - 2.2-33...0		2.5-6.....2		2.8-15.....15	
2.2-34 Blank.....0		2.5-7.....8		2.8-16 - 2.8-19...0	
2.2-35 - 2.2-75...0		2.5-8 - 2.5-23...0		2.8-20.....6	
2.2-76 - 2.2-77...13		2.5-24 Blank.....0		2.8-21 - 2.8-47...0	
2.2-78 - 2.2-79...0		2.5-25 - 2.5-27...0		2.8-48 Blank.....0	
2.2-80 Blank.....0		2.5-28 Blank.....0		2.8-49 - 2.8-60...0	
2.2-81 - 2.2-107..0		2.5-29 - 2.5-35...0		2.8-63.....5	
2.2-108 Blank.....0		2.5-36 - 2.5-37...1		2.8-64 - 2.8-69...0	
2.3-1 - 2.3-43.....0		2.5-38 - 2.5-39...0		2.8-70 Blank.....0	
2.3-44 Blank.....0		2.5-40 Blank.....0		2.8-71 - 2.8-73...0	
2.3-45 - 2.3-86...0		2.6-1 - 2.6-133...0		2.8-74.....2	
2.3-87.....3		2.6-134.....1		2.8-75.....3	
2.3-88 - 2.3-105..0		2.6-134A.....1		2.8-76.....2	
2.3-106 Blank.....0		2.6-134B Blank...1		2.8-77.....0	
2.4-1 - 2.4-3.....0		2.6-135.....1		2.8-78.....2	

* Zero in this column indicates an original page.

LIST OF EFFECTIVE PAGES

Page No.	*Change No.	Page No.	*Change No.	Page No.	*Change No.
2.8-79.....	0	2.12-1.....	0	2.13-109.....	1
2.8-80.....	2	2.12-2 Blank.....	0	2.13-110.....	3
2.8-81 - 2.8-113..	0	2.12-3 - 2.12-5...0	0	2.13-111.....	0
2.8-114 Blank.....	0	2.12-6 - 2.12-7...6	6	2.13-112.....	3
2.8-115.....	0	2.12-8 - 2.12-28..0	0	2.13-113.....	0
2.8-116 - 2.8-117.9	0	2.12-29.....	15	2.13-114.....	3
2.8-118 - 2.8-119.4	0	2.12-30 - 2.12-35.0	0	2.13-115.....	0
2.8-120 - 2.8-135.0	0	2.12-36.....	2	2.13-116 -	
2.8-136 Blank.....	0	2.12-37.....	3	2.13-118.....	3
2.9-1 - 2.9-3.....	0	2.12-38 - 2.12-39.7	7	2.13-119.....	0
2.9-4.....	2	2.12-40 - 2.12-42.0	0	2.13-120.....	3
2.9-5.....	19	2.12-43.....	23	2.13-121 -	
2.9-6 - 2.9-10....	0	2.12-44.....	0	2.13-124.....	0
2.9-11.....	2	2.12-45.....	3	2.13-125.....	4
2.9-12 - 2.9-52...0	0	2.12-46 -		2.13-126 -	
2.9-53.....	1	2.12-162.....	0	2.13-131.....	0
2.9-54 - 2.9-82...0	0	2.12-163.....	3	2.13-132 Blank....	0
2.9-83.....	2	2.12-164 -		2.14-1 - 2.14-26..0	0
2.9-84 - 2.9-96...0	0	2.12-194.....	0	2.14-27.....	4
2.9-97 - 2.9-99...5	5	2.12-195.....	3	2.14-28 - 2.14-48.0	0
2.9-100 - 2.9-116.0	0	2.12-196 -		2.14-49.....	4
2.9-117.....	8	2.12-340.....	0	2.14-50.....	0
2.9-118 - 2.9-119.0	0	2.12-341.....	3	2.14-51.....	5
2.9-120.....	6	2.12-342 -		2.14-52 - 2.14-73.0	0
2.9-121 - 2.9-130.0	0	2.12-348.....	0	2.14-74.....	11
2.9-131.....	6	2.12-349.....	8	2.14-75 - 2.14-94.0	0
2.9-132 - 2.9-133.4	4	2.12-350.....	0	2.14-95.....	15
2.9-134 - 2.9-139.0	0	2.12-351.....	8	2.14-96 -	
2.9-140 Blank.....	0	2.12-352 -		2.14-130.....	0
2.10-1 - 2.10-2...0	0	2.12-379.....	0	2.14-131.....	3
2.10-3.....	4	2.12-380 Blank....	0	2.14-132 -	
2.10-4 - 2.10-10..0	0	2.12-381 -		2.14-141.....	0
2.10-11.....	4	2.12-391.....	0	2.14-142 Blank....	0
2.10-12 - 2.10-22.0	0	2.12-392 Blank....	0	2.14-143 -	
2.10-23.....	8	2.13-1 - 2.13-8...0	0	2.14-156.....	0
2.10-24 - 2.10-27.0	0	2.13-9.....	3	2.14-157.....	6
2.10-28 - 2.10-29.2	2	2.13-10 - 2.13-26.0	0	2.14-158 -	
2.10-30 - 2.10-31.4	4	2.13-27.....	3	2.14-165.....	0
2.10-32.....	9	2.13-28 - 2.13-36.0	0	2.14-166 Blank....	0
2.10-33.....	10	2.13-37.....	6	2.15-1 - 2.15-10..0	0
2.10-34 - 2.10-91.0	0	2.13-38 - 2.13-63.0	0	2.15-11.....	16
2.10-92.....	5	2.13-64.....	4	2.15-12.....	0
2.10-93 -		2.13-65 - 2.13-95.0	0	2.15-13.....	16
2.10-123.....	0	2.13-96 - 2.13-97.4	4	2.15-14.....	0
2.10-124 Blank....	0	2.13-98 -		2.15-15.....	14
2.11-1 - 2.11-24..0	0	2.13-102.....	0	2.15-16 - 2.15-50.0	0
2.11-25.....	16	2.13-103.....	5	2.15-51.....	1
2.11-26 - 2.11-39.0	0	2.13-104 -		2.15-52 - 2.15-53.9	9
2.11-40 Blank.....	0	2.13-108.....	0	2.15-54 - 2.15-67.0	0

*Zero in this column indicates an original page.

LIST OF EFFECTIVE PAGES

Page No.	*Change No.	Page No.	*Change No.	Page No.	*Change No.
2.15-68 - 2.15-69.9		2.17-98 - 2.17-99.5		2.18-46.....12	
2.15-70 - 2.15-78.0		2.17-100 -		2.18-47.....15	
2.15-79.....9		2.17-101.....0		2.18-48 - 2.18-51.0	
2.15-80 - 2.15-92.0		2.17-102 -		2.18-52.....3	
2.15-93.....6		2.17-103.....5		2.18-53.....0	
2.15-94 -		2.17-104 -		2.18-54 - 2.18-55.7	
2.15-105.....0		2.17-105.....0		2.18-56 - 2.18-64.0	
2.15-106 -		2.17-106 -		2.18-65.....3	
2.15-107.....22		2.17-107.....5		2.18-66 - 2.18-70.0	
2.15-108 -		2.17-108 -		2.18-71.....2	
2.15-109.....0		2.17-111.....0		2.18-72 - 2.18-81.0	
2.15-110 -		2.17-112 -		2.18-82 - 2.18-83	
2.15-111.....22		2.17-115.....5		Deleted.....2	
2.15-112 -		2.17-116 -		2.18-84 - 2.18-85.0	
2.15-126.....0		2.17-119.....0		2.18-86 - 2.18-87.2	
2.15-127.....3		2.17-120 -		2.18-88 - 2.18-91.0	
2.15-128 -		2.17-121.....5		2.18-92 - 2.18-93.3	
2.15-131.....0		2.17-122 -		2.18-94 - 2.18-97.0	
2.15-132 Blank....0		2.17-123.....0		2.18-98 Blank....0	
2.16-1 - 2.16-20.0		2.17-124 Blank....0		2.19-1 - 2.19-8...0	
2.16-21.....2		2.17-125 -		2.19-9.....3	
2.16-22 - 2.16-46.0		2.17-127.....0		2.19-10 - 2.19-17.0	
2.16-47.....6		2.17-128 -		2.19-18 Blank....0	
2.16-48 - 2.16-50.0		2.17-129.....5		2.20-1.....8	
2.16-51.....1		2.17-130 -		2.20-2 - 2.20-5...0	
2.16-52 - 2.16-58.0		2.17-131.....0		2.20-6.....9	
2.16-59.....9		2.17-132 Blank....0		2.20-7.....15	
2.16-60.....0		2.17-133 -		2.20-8 Blank....15	
2.16-61.....9		2.17-142.....0		2.20-9.....0	
2.16-62 - 2.16-72.0		2.17-143.....2		2.20-10 - 2.20-13.5	
2.16-73.....7		2.17-144 -		2.20-14.....0	
2.16-74 - 2.16-91.0		2.17-149.....0		2.20-15.....8	
2.16-92 Blank....0		2.17-150 Blank....0		2.20-16.....0	
2.17-1.....0		2.18-1.....2		2.20-17.....16	
2.17-2 - 2.17-5...13		2.18-2 - 2.18-9...0		2.20-18.....0	
2.17-6 - 2.17-19...0		2.18-10 - 2.18-11		2.20-19.....16	
2.17-20.....2		Deleted.....2		2.20-20.....0	
2.17-20A -		2.18-12 - 2.18-13.0		2.20-21.....16	
2.17-20B.....2		2.18-14.....12		2.20-22 - 2.20-24.0	
2.17-21.....2		2.18-15.....0		2.20-25.....13	
2.17-22 - 2.17-50.0		2.18-16 -		2.20-26 - 2.20-45.0	
2.17-51.....2		2.18-17.....12		2.20-46.....5	
2.17-52 - 2.17-75.0		2.18-18 - 2.18-38.0		2.20-47.....3	
2.17-76 - 2.17-77.5		2.18-39.....4		2.20-48 - 2.20-75.0	
2.17-78 - 2.17-83.0		2.18-40 -		2.20-76.....12	
2.17-84 - 2.17-85.5		2.18-42.....12		2.20-77.....15	
2.17-86 - 2.17-93.0		2.18-43.....15		2.20-78.....12	
2.17-94 - 2.17-95.5		2.18-44 Blank....15		2.20-79 - 2.20-81.0	
2.17-96 - 2.17-97.0		2.18-45.....0		2.20-82.....8	

*Zero in this column indicates an original page.

LIST OF EFFECTIVE PAGES

Page No.	*Change No.	Page No.	*Change No.	Page No.	*Change No.
2.20-82A -		3-26.....	23	3-148 - 3-161.....	0
2.20-82B.....	8	3-27.....	13	3-162.....	13
2.20-83 -		3-28.....	17	3-163 - 3-167.....	0
2.20-102.....	0	3-29.....	3	3-168.....	4
2.20-103.....	16	3-30.....	2	3-169 - 3-170.....	0
2.20-104 -		3-31.....	8	3-171.....	15
2.20-119.....	0	3-32 - 3-33.....	3	3-172 - 3-173.....	2
2.20-120.....	3	3-34.....	8	3-174 - 3-175.....	4
2.20-121.....	6	3-35.....	6	3-176 Blank.....	4
2.20-122 -		3-36.....	3		
2.20-123.....	3	3-37.....	15		
2.20-124.....	1	3-38 - 3-40.....	3		
2.20-125 -		3-41.....	13		
2.20-134.....	0	3-42.....	6		
2.20-135.....	17	3-43.....	3		
2.20-136 -		3-44.....	19		
2.20-138.....	0	3-45.....	3		
2.20-139.....	2	3-46.....	13		
2.20-140 -		3-47 - 3-49.....	12		
2.20-144.....	0	3-50.....	19		
2.20-145.....	16	3-51.....	12		
2.20-146 -		3-52 - 3-57.....	3		
2.20-164.....	0	3-58.....	21		
2.20-165.....	20	3-59.....	8		
2.20-166 Blank.....	20	3-60 - 3-61.....	3		
2.21-1 - 2.21-41.....	0	3-62.....	4		
2.21-42 Blank.....	0	3-63.....	3		
3-1 - 3-3.....	0	3-64.....	9		
3-4.....	9	3-65.....	15		
3-5.....	13	3-66.....	3		
3-6.....	9	3-67 - 3-95.....	4		
3-7.....	5	3-96.....	6		
3-8.....	23	3-97.....	4		
3-9.....	4	3-98.....	6		
3-10.....	12	3-99 - 3-113.....	4		
3-11.....	4	3-114 - 3-115.....	12		
3-12.....	6	3-116.....	4		
3-13.....	0	3-117 - 3-119.....	6		
3-14.....	6	3-120.....	12		
3-15.....	9	3-121 - 3-125.....	6		
3-16.....	7	3-126.....	8		
3-17.....	3	3-127.....	12		
3-18.....	16	3-128.....	8		
3-19.....	22	3-129.....	6		
3-20.....	20	3-130.....	5		
3-21.....	19	3-131 - 3-139.....	0		
3-22.....	12	3-140.....	3		
3-23.....	4	3-141 - 3-146.....	0		
3-24 - 3-25.....	8	3-147.....	2		

*Zero in this column indicates an original page.

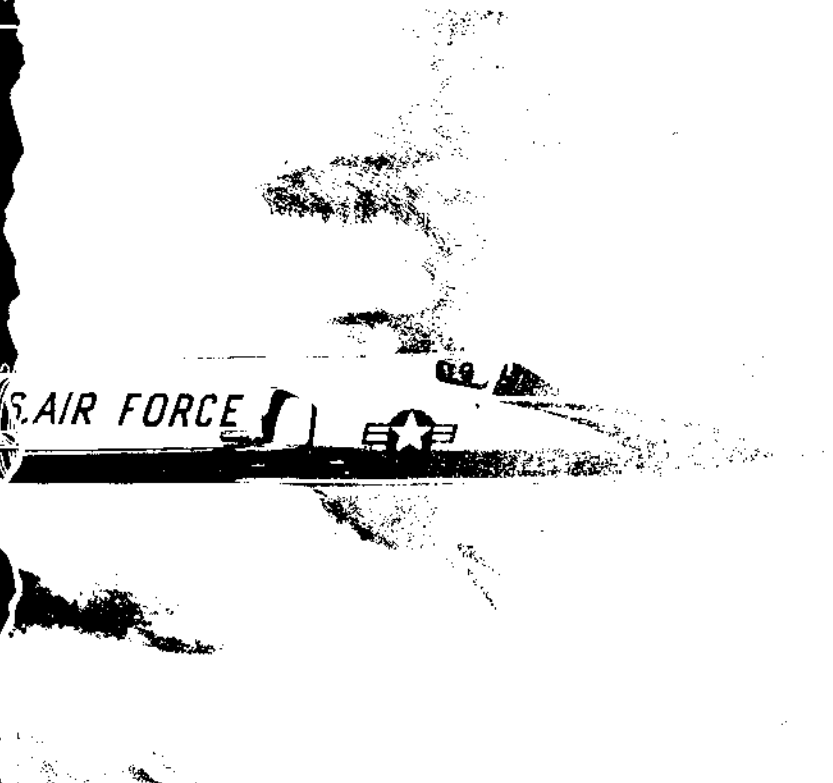
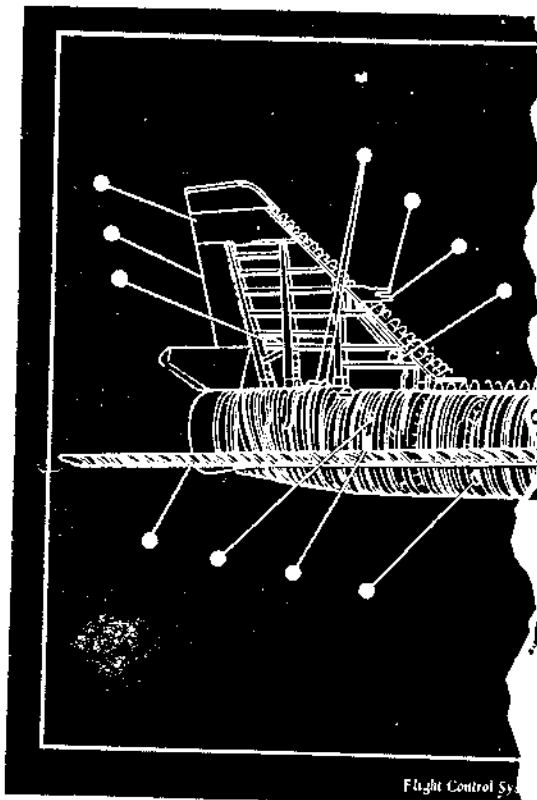

DON'T JUST LEAF THROUGH THIS TECHNICAL MANUAL, HOPING TO COME ACROSS THE PART YOU ARE LOOKING FOR.

DO READ THE INTRODUCTION - SECTION I FIRST, TO FIND OUT HOW TO USE THIS TECHNICAL MANUAL QUICKLY AND EASILY!

TABLE OF CONTENTS

SECTION TITLE	PAGE	SECTION TITLE	PAGE
ALPHABETICAL INDEX	ii	II GROUP ASSEMBLY PARTS LIST (CONT.)	
I INTRODUCTION	1-1	FUNCTIONAL GROUP (SUBSECTION)	
MANUFACTURERS' CODE	1-19	HYDRAULIC	2-13
TIME COMPLIANCE TECHNICAL ORDERS		PNEUMATIC	2-17
INCORPORATED INTO THIS MANUAL	1-30	POWER PLANT	2-18
MASTER USABLE ON CODE	1-31	VARIABLE AIR RAMP	2-19
EXPLODED VIEW OF COMPLETE		FUEL	2-20
AIRPLANE	1-34	AIR CONDITIONING, PRESSURE	2-21
II GROUP ASSEMBLY PARTS LIST	2.0-1	ICE & RAIN PROTECTION	2-22
FUNCTIONAL GROUP (SUBSECTION)		FLIGHT CONTROLS	2-23
GENERAL AIRPLANE	2.1-1	LANDING GEAR	2-24
ACCESS DOORS	2.2-1	INSTRUMENTS	2-25
FUSELAGE	2.3-1	ELECTRICAL	2-27
WINDSHIELD CANOPY & SEAT	2.4-1	ELECTRONIC	2-28
FURNISHINGS	2.5-1	OXYGEN	2-29
WING	2.6-1	ARMAMENT	2-30
VERTICAL STABILIZER SPEED BRAKE &		EXTERNAL MARKINGS	2.21-1
DRAG CHUTE	2.7-1	III NUMERICAL INDEX	3-1

NOTE

A Table of Contents pages listings Illustration Titles, Figures and Page Numbers, precedes all Functional Group Subsections within the group Assembly Parts list.

ALPHABETICAL INDEX

<i>Title</i>	<i>Page</i>	<i>Title</i>	<i>Page</i>	<i>Title</i>	<i>Page</i>
A					
Accelerometer, Normal	2.14-27	-Variable Air Ramp Slip Joint	2.11-19	Armament	
Accelerometer, Pitch G Limiter	2.14-27	AIS Pod Installation	2.20-165	-Aft Displacement Gear Support	2.20-101
Accumulator, Primary Hydraulic	2.8-13	Alternator, Emergency Hydraulic	2.17-25	-Aft Displacement Up-Latch	2.20-115
Accumulator, Secondary Hydraulic	2.8-13	Altimeter, Standby	2.16-25	-Aft Down Switch	2.20-103
Actuator		Altitude Warning System Installation	2.18-95	-Aft Igniter Harness	2.20-103
-Accessory Oil Cooler Air Valve	2.10-83	Amplifier		-Aft Launcher Disconnect Harness	2.20-118
-Aileron Fecl	2.14-113	-ADF Audio Electronic Control	2.18-55	-Aft Launcher Harness	2.20-101
-Armament Bay Door	2.20-33, 2.20-37	-Antenna Control Computer	2.18-43	-Bay Door Center Pneumatic Selector Valve	2.20-31
-Armament Displacement	2.20-81	-Antenna Servo Electrical Control	2.18-43	-Bay Door Manual Valve	2.20-5
-Barrier Hook Indicator Light	2.15-131	-Anti-Video Synchronizer	2.18-43	-Bay Door Master Pneumatic Selector Valve	2.20-29
-Control Rudder, Servo Valve	2.14-161	-Attack Display	2.18-43	-Bay Door Support	2.20-33
-Displacement Gear Uplatch	2.20-117	-Electronic Control Roll and Pitch	2.18-43	-Bay Door Valve	2.20-3
-Drag Chute Release	2.7-11	-Horizontal Situation Display	2.18-47	-Crossbridge Support	2.20-151
-Elevator Trim	2.14-107	-Indicated Air Speed Mach No.	2.18-47	-Door Hinge	2.20-45, 2.20-63
-Elevon	2.14-57	-Intermediate Frequency	2.18-43	-Door Idler	2.20-33
-Engine Oil Cooler Air Valve	2.10-87	-Pitch and Yaw Damper	2.14-29	-Door Link	2.20-35
-Main Landing Gear Door	2.15-69	-Preamplifier Video Tracking	2.18-43	-Door Open Switch	2.20-19
-NLG Door	2.15-41	-Rate Gyro Torque Generator	2.18-43	-Door Position and Auxiliary Aft Misfire Relay	2.20-7
-Rudder Trim	2.14-157	-Steering Signal Filter	2.18-43	-Door Rod	2.20-35, 2.20-71
-Speed Brake	2.7-3	-Transmitter Tuning Electronic Control	2.18-43	-Drag Arm Support	2.20-93
Adapter		-Vertical Situation	2.18-47	-Extension Actuator Support	2.20-5
-Afterburner Fuel Manifold Drain	2.10-69	-Video and Azimuth Sweep Generator Indicator	2.18-43	-Forward Aft and Special Weapon Misfire Relay	2.20-7
-Air Intake Duct	2.11-15	Annunciator, Computer Mode	2.16-7, 2.16-21	-Forward Displacement Gear Actuator Shroud	2.20-81
-Armament Bay Door Aft Actuator Support	2.20-43	Antenna		-Forward Igniter Harness	2.20-77
-Combustion Manifold	2.10-69	-ADF	2.18-25	-Forward Launcher Attachment Adjustment Plate	2.20-77
-Compressor Bleed	2.10-27	-Data Link	2.18-87	-Forward Launcher Harness	2.20-77
-Constant Speed Drive Gearbox Vent	2.10-69	-IFF Lower	2.18-19	-Forward Umbilical Plug Retainer	2.20-125
-Constant Speed Drive Generator Vent	2.01-69	-IFF Upper	2.18-19	-Intervalometer	2.20-7
-Crossbridge	2.20-151	-ILAS Glide Slope	2.18-15	-Launcher Adjustment Plate	2.20-101
-Engine Fire Seal	2.10-47	-ILAS Localizer	2.18-21	-Launcher Aft	2.20-101
-Engine Fuel Control Drain	2.10-69	-Marker Beacon	2.18-19	-Launcher Attachment Adjustment Plate	2.20-153
-Engine Fuel Tube Drain	2.10-69	-TACAN	2.18-19	-Launcher Forward	2.20-77
-External Fuel Tank Filler	2.12-53	-UHF	2.18-19	-Manual Control Panel	2.20-11
-Exhaust Nozzle Control Seal Drain	2.10-69	Arm		-Manual Gear Lock Valve	2.20-3
-Forward Shroud Drain	2.10-69	-Aft Displacement Gear Drag	2.20-101	-MB-1 Ejector Support	2.20-123
-Fuel System Checkout	2.12-241	-Aft Displacement Gear Lower Drag	2.20-113	-Power Supply Control	2.18-59
-Main Landing Gear Actuating Cylinder	2.15-7	-Displacement Uplatch Switch	2.20-117	-Selection Relay	2.18-59
-MLG Door Actuator Cylinder	2.15-7	-Fwd Displacement Gear Upper Drag	2.20-87	-Selector Valve	2.20-3
-Missile Bay Door Inlet Duct	2.20-61	-Main Landing Gear Actuator Limit Switch	2.15-15	-Test Relay	2.18-59
-NLG Door Actuator	2.15-45	-Main Landing Gear Door	2.15-81	-Up-Latch Support	2.20-117
-Oil Scupper Drain	2.10-69	-Main Landing Gear Door Actuator Limit Switch	2.15-83	-Up-Latch Switch Lever	2.20-117
-Ramp Border	2.11-19	-Nose Wheel Steering Limit Switch	2.15-49	Attachment, Armament Bay Door	2.20-45
-Shroud Drain	2.3-57, 2.7-23			Attachment, Wing to Fuselage	2.6-73
-Starter Seal Drain	2.10-69				
-T Tank Air Pressure Regulator Bleed Drain	2.10-69				
-T Tank Regulator Crossover Tube Drain	2.10-69				

ALPHABETICAL INDEX (CONT)

<i>Title</i>	<i>Page</i>	<i>Title</i>	<i>Page</i>	<i>Title</i>	<i>Page</i>
B					
Baffle, Missile Bay	2.3-63	Brace, Fwd Sway MB-1		Compensator, Fuel Quantity	
Baffle, Windshield Reflection	2.5-9	-Ejection System	2.20-105	-Probe	2.12-11
Baffle, Wing Tank #3	2.6-191	Brace, MB-1 Aft Sway	2.20-117	Compressor, Air	2.18-35
Barrier, Fuselage Fuel		Bracket		Computer	
-Tank Fume	2.12-369	-Engine Oil Cooler Drain	2.10-95	-Air Data	2.18-71
Base		-Marker Beacon		-IFF Flight Director	2.18-5
-Canopy Unlock		-Transformer	2.18-79	-Steering Signal	2.18-43
-Indicator	2.16-9	-Missile Bay Launcher		Conduit, Pitot and Static Tube	2.11-13
-Fire Warning		-Up-Latch Roller	2.20-111	Conduit, Teleflex Power	
-Indicator	2.16-9, 2.16-19	-Oil Cooler Drain		-Control	2.10-11
-Gear Unsafe		-Accessory Drive	2.10-5	Connector, High Pressure	
-Indicator	2.16-3, 2.16-19	-Pitch G Limiter Mounting	2.14-31	-Pneumatic Ground Filler	2.9-5
-Hydraulic Failure		-Pneumatic Flask	2.9-13	Connector, Receptacle	
-Indicator	2.16-11	-Torque Shaft Support	2.10-13	-Electrical Fwd Umbilical	2.20-119
-Master Warning		C			
-Indicator	2.16-11	Cable		Connector, Static Air	2.14-4
-Maximum Maneuver Limit		-Drag Chute	2.7-7	Constant Speed Drive	
-Indicator	2.16-5, 2.16-19	-Elevator Feel Cylinder	2.14-116	-Accessory Drive Gearbox	2.10-93
Battery, Emergency DC		-Emergency Canopy Jettison	2.4-39	-Accessory Oil Cooler Air	
-Power Supply	2.17-35	-Localizer Antenna Lead In	2.18-15	-Valve	2.10-83
Beam, Engine Mount	2.10-123	-MLG Door Cylinder		-Gearbox Vent Adapter	2.10-69
Beam, Engine Thrust	2.10-115	-Restrainer	2.15-9	-Generator Vent Adapter	2.10-69
Bearing, Pilots Canopy		-Power Control	2.10-11	-Oil Cooler	2.10-99
-Fairing	2.4-47	-Rudder Control	2.14-131	-Oil Cooler Access Door	2.2-39
Bell Crank		Canopy, Electrical		-Oil Cooler Air Valve	2.10-83
-Aileron	2.14-79	-Equipment	2.4-17	-Oil Cooler Mount	2.10-97
-Aileron Control	2.14-103	Canopy, Spares	2.4-41	-Oil Inlet Hose	2.10-99
-Control Stick Shaft	2.14-45	Cap		-Oil Scupper Drain Adapter	2.10-67
-Dumper Control Stick	2.14-41	-Canopy Unlock		-Shaft Cover	2.10-109
-Displacement Upatch	2.20-115	-Indicator	2.16-9	-Unit Access Door	2.2-43
-Elevator	2.14-88	-Fire Warning		Container, Global Survival	
-Elevator and Aileron	2.14-83	-Indicator	2.16-7, 2.16-19	-Kit	2.4-51
-Elevator Feel	2.14-109	-Gear Unsafe		Container, Luggage	2.5-18
-Elevon Control Mixer	2.10-103	-Indicator	2.16-3, 2.16-19	Container, MLG Down Lock	
-Fuel Control	2.10-15	-Glycol Tank Radome	2.13-45	-Pin	2.15-9
-Power Control	2.10-15	-Hydraulic Failure		Control	
-Rudder Control	2.14-137	-Indicator	2.16-11	-Aerial Refuel, LH Console	2.16-69
-Torque Shaft	2.10-13	-Master Warning		-Aircraft and Radar Manual	2.14-49
Bellows, Engine Oil Tank		-Indicator	2.16-11	-Analog Signal Barometer	
Scupper	2.10-3	-Maximum Maneuver Indicator	2.16-5	-Setting	2.16-7
Blanket		-Maximum Maneuver		-Auto Navigation	2.16-49
-Engine Shroud	2.10-65	-Limit Indicator	2.16-19	-Canopy Anti-Fog	2.13-9
-Engine Shroud Insulation	2.10-53	-Speed Brake Door	2.7-35	-Canopy External Jettison	2.2-7
-Fuselage Overheat		Capacitor, Pitch G Limiter	2.14-37	-Canopy Latch	2.4-19
-Insulation	2.10-67	Card, Compass Correction	2.5-3	-Canopy Latch Teleflex	2.4-57
-Thermal Cockpit	2.5-31	Case, Map and Flight Report	2.5-17	-Canopy Valve	2.4-55
Board, Accelerometer Terminal	2.17-145	Catapult, Ejection Seat		-Cockpit Air Pressure	
Boom, Nose	2.3-3	-Type MK-1	2.4-53	-Regulator	2.13-25
Boot		Chamber, Brake Hydraulic		-Cockpit Temperature	2.16-51
-Harness Feed Thru	2.17-53	-Expansion	2.8-3	-Coder-Decoder LH Console	2.16-47
-Screw Jack Curtain Seal	2.3-79	Chassis, Pitch G Limiter		-Converter Bearing Selector	2.16-27
-Variable Air Ramp Screw		-Electrical	2.14-33	-Drag Chute Release	2.16-7
Jack	2.11-31	Check List, Pilot	2.5-11	-Drag Chute Release Switch	2.16-19
Box		Chock, Fwd Sway Brace	2.20-105	-Electrically Heated	
-Canopy Latch Control	2.4-21	Clamp, Engine Thrust Mount	2.10-115	-Windshield	2.13-5
-Electrical Connector		Clamp, External Fuel Tank		-Elevator Trim Switch	2.14-107
-Mounting	2.18-85	-Ejection Resistor	2.6-15	-Elevon	2.14-99
-Fuse Panel	2.20-11	Clamp, Fwd Armament Harness	2.20-23	-Emergency Hydraulic Power	2.9-3
-Main Wheel Well Circuit Breaker		Clock	2.16-25	-Frequency Selector	2.16-47
-Panel	2.17-119	Cooler, Accessory Drive Oil	2.10-99	-Flight Mode AFCS	2.16-25
-Nose Wheel Well Circuit Breaker	2.17-75	Cooler, Engine Oil	2.10-81	-IG Emergency Release	2.15-21
-Warning Light Dimming	2.17-57	Compass, Magnetic Pilot		-Mask De-Fog Switch	2.16-65
		-Standby	2.16-85	-Power System LH Console	2.16-47
				-Radar Set	2.16-15, 2.16-27
				-Radar Set-Azimuth Scan and	
				-Horizon Adjust	2.16-47

ALPHABETICAL INDEX (CONT)

<i>Title</i>	<i>Page</i>	<i>Title</i>	<i>Page</i>	<i>Title</i>	<i>Page</i>
C		D			
-Radar Set Identification	2.16-17	Damper, Control Stick	2.14-41	-Fuel Shutoff Valve Access	2.2-79
-Ram Air Turbine Power	2.9-3	Damper, Nose Landing Gear Steering	2.15-55	-Fuselage Top Deck	2.2-39
-Rudder	2.14-135	Decal Installation	2.20-164	-Hydraulic Access	2.2-31
-Rudder Trim and Feel	2.14-157	Deflector, MB-1 Nose	2.20-65	-Heat Exchanger Access	2.2-25
-Selector Navigation	2.16-17	Dehydrator	2.18-35	-Hydraulic Fluid Tube Heat Exchanger	2.2-49
-Telescopic Power	2.10-11	Detector, Fire and Overheat	2.10-111	-Infrared Seeker	2.2-5
-Telescopic Unit	2.4-19	Detector, Fire and Overheat Control	2.17-59	-Liquid Oxygen Access	2.2-6
-Variable Air	2.11-7	Detector, Ice	2.13-19	-Lower Duct Valve	2.2-37
Control Box, Landing Gear	2.15-59	Disconnect, Survival Kit Container to Airplane	2.4-51	-Main Landing Gear	2.15-99
Control Box, MLG Steering and Damping	2.17-37	Door -Access Air Driven Emerg AC Generator	2.2-82	-Midbay Electronic Compartment Access	2.2-67
Controller, Elevon Trim and Feel Servo	2.14-25	-Access Waveguide Fin Tip	2.18-9	-Nose Landing Gear	2.15-43
Controller, Frequency and Load	2.17-27	-Accessory Drive Unit	2.2-42	-Oil Filler Cap Access	2.2-49
Control Unit, Canopy DC Power Supply	2.4-17	-Accessory Oil Cooler	2.2-39	-Pneumatic Starter	2.2-49
Converter -AGC and Angle of Attack Wave Form	2.18-43	-Aft Engine Mount Access	2.2-51	-Pylon Access	2.12-39
-Attack Display Signal Data	2.18-43	-Air Control Oil Cooler Valve	2.10-83	-Radar Compartment	2.2-3
-Flight Director Signal Data	2.18-3	-Armament Bay	2.20-47	-Ram Air Turbine	2.8-21
-Liquid to Gaseous Oxygen	2.19-3	-Armament Bay Access	2.2-23	-Refrigeration Access	2.2-70
-Signal Data Time Sharing	2.18-43	-Armament Bay Ground Air-Conditioning Duct Access	2.13-89	-Refueling	2.2-27
Counterbalance, Control Stick	2.14-165	-Armament Bay Roof	2.2-25	-Roller Bracket Access	2.10-57
Coupling, Heat Exchanger Exhaust Exit Duct	2.13-111	-Armament Bay Side	2.2-72	-Rudder Hinge Access	2.2-85
Coupling, Hydraulic Pressure and Suction	2.8-9	-Bleed Air Duct Access	2.2-49	-Scroll Area Inspection	2.2-37
Cover -ADF AN/ARA-25 Antenna	2.18-25	-Cockpit Air Pressure Regulator Access	2.2-3	-Speed Brake	2.2-47
-Armament Manual Control Panel	2.20-11	-Dorsal Access	2.2-27	-Speed Brake Support	2.2-87
-Center Stick Control	2.5-27	-Drag Fitting Shroud Access	2.10-53	-Tail Cone Latch	2.3-99
-Constant Speed Drive Shaft	2.10-109	-Electrical Harness Access	2.2-27	-Torque Tube Access	2.2-6
-Emergency Hydraulic Power	2.9-3	-Electronic Access	2.2-17	-Upper Duct Valve	2.2-39
-Main Wheel Well Circuit Breaker Panel	2.17-119, 2.17-127	-Electronic Compartment Ground Connection Access	2.2-40, 2.13-17	-Variable Air Ramp Pitot Tube Access	2.2-23
-Nose Wheel Well AIG-10 Receptacle	2.18-85	-Electronic Equipment Fin	2.2-85	-Waveguide Access	2.2-85
-Nose Wheel Well Fuse Panel	2.17-41	-Elevon	2.2-51	-Wing Access Tank #1	2.2-89
-Nose Wheel Well Splash	2.5-33	-Elevon Cylinder Access	2.2-51	-Wing Access Tank #2	2.2-91
-Pitch G Limiter	2.14-31	-Elevon Control Valve Access	2.2-51	-Wing Access Tank #3	2.2-93
-Transformer, 26 Volt Instrument	2.17-21	-Elevon Hinge Access	2.2-102	-Wing Access Trailing Edge	2.2-97
Cradle, Pneumatic Flask	2.9-13	-Elevon Link Access	2.6-25	-Wing Access Transfer Tank	2.2-97
Crank, Elevon Followup	2.14-119	-Emergency Canopy Jettison	2.4-39	-Wing Outboard Intermediate Box	2.2-104
Cup, Emergency Canopy Jettison	2.4-39	-Emergency Canopy Release	2.2-7	-Wing Outboard Intermediate Box Access	2.2-91
Cylinder -Drag Chute Release	2.7-13	-Engine Access	2.2-77, 2.10-53	Door and Cable, Canopy Jettison Control	2.4-35
-Elevator Feel	2.14-117, 2.14-141	-Engine Air Intake Duct	2.11-11	Door and Panel, Fwd Radar Compartment	2.3-47
-Infrared Seeker	2.20-159	-Engine Mount Access	2.2-47	Dorsal, Heat Exchanger Exhaust	2.13-19
-Main Landing Gear Door	2.15-75	-Engine Oil Cooler	2.2-39	Dorsal, Removable	2.2-33
-Master Brake	2.14-121	-External Power Access	2.2-64	Drag Angle, Wing to Fuselage	2.6-55
		-Fin Access	2.2-85	Drag Chute	2.7-55
		-Fin Bay #1 Bleed Air Access	2.2-85	Drain -Accessory Drive Oil Cooler	2.10-5
		-Fin Equipment Panel	2.2-85	-Aft Shroud and Afterburner Duct	2.10-69
		-Fin Rudder Control	2.2-87	-Canopy Actuator Well	2.4-7
		-Fire Access	2.2-47	-Engine Oil Cooler	2.10-95
		-Forward Radar Compartment	2.2-52	-Landing Gear Emergency	2.3-55
				-MLG Wheel Well Fuel Tubing	2.12-13
				Drive, Emergency Hyd Alternator	2.17-25
				Drive, Variable Air Ramp Intake Duct	2.11-3

ALPHABETICAL INDEX (CONT)

<i>Title</i>	<i>Page</i>	<i>Title</i>	<i>Page</i>	<i>Title</i>	<i>Page</i>
D					
Duct		Exhaust Gas Temperature Equipment Installation	2.16-89	-Potentiometer Nose Wheel	2.15-25
-Armament Bay Ground Air-Conditioning Connector	2.13-89	Exhaust Gas Temperature Recorder Installation	2.16-87	-Variable Air Ramp Screw Jack	2.11-31
-Armament Bay Heating	2.13-89	Extractor, Instrument Panel	2.16-37	-Tachometer	2.10-27
-Boundary Bleed	2.13-13	F			
-Cockpit Air	2.13-67	Fairing		Glass, Windshield	2.4-9
-Cockpit Air-Conditioning	2.13-53	-Elevon Actuator	2.6-37	Guard, Aileron Control Tube	2.14-43
-Cockpit Hot Air Bypass	2.13-95	-Elevon Actuator Wing	2.6-17	Guard, Cockpit Control	2.5-27
-Combustion Starter Exhaust	2.10-21	-Elevon Hinge	2.6-174	Guide, Drain Oil Cooler Accessory Drive	2.10-5
-Compression Inlet	2.13-117	-Engine Air Intake	2.10-23	Gyroscope Displacement	2.18-75
-Electronic Compartment	2.13-17	-Main Landing Gear Wing	2.15-61	-J-4 Rate	2.18-73
-Electronic Cooling	2.13-37	Fair-Lead, Engine Oil Cooler Drain	2.10-5	H	
-Emergency Electronic Ram Air	2.13-9	Fair-Lead, Rudder Cable	2.14-137	Handle, Canopy Emergency Release	2.4-57
-Engine Air Cooling	2.10-17	Feed Thru, Fwd Launcher Harness	2.20-93	Handle, Canopy Latch Control	2.4-19
-Engine Air Intake	2.11-9	Filter		Harness	
-Engine Bleed Air	2.13-96	-Cathode Ray Tube	2.18-29	-Aft Igniter	2.20-103
-Engine Bleed Air manifold	2.10-29	-Fuel Tank Pressurization Air	2.12-361	-Aft Launcher	2.20-101
-Engine Cooling Air Supply	2.10-41	-Hydraulic High Pressure	2.8-7	-Aft Launcher Disconnect	2.20-121
-Engine Oil Breather	2.10-7, 2.10-25	-Radio Noise	2.10-83	-Center Stick	2.14-49
-Fwd Radar Compartment Cooling Outlet	2.13-27	-Radome Anti-Icing	2.13-3	-Fwd Igniter	2.20-76
-Generator Drive Oil Cooler	2.3-77	Fitting		-Fwd Launcher	2.20-76
-Ground Air Delivery	2.13-93	-Cockpit Pressure Ground Test	2.13-21	-Pilot Power Control Quadrant	2.10-9
-Ground Air Distribution	2.13-93	-Fuel, Oil Vent, and Drain	2.10-69	-Pilot Heater Disconnect	2.3-7
-Ground Connector Electronic Compartment	2.13-17	-Fuselage Wing Attach	2.3-57	-Switch Heading Selector	2.16-25
-Heat Exchanger Bypass	2.13-111	-Gas Tight Corner Injection	2.6-165	Header, Heat Exchanger Inlet	2.13-111
-Heat Exchanger Exhaust	2.13-119	-Hydraulic Heat Exchanger Wing	2.8-9	Heat Exchanger, Refrigeration Unit	2.13-121
-Heat Exchanger to Boundary Bleed	2.13-115	-Hydraulic Pump Seal Drain	2.8-9	Hinge	
-IFF Cooling	2.13-55	-N/G Drag Strut	2.15-123	-Elevon Actuator	2.6-47
-Pressure Suit Ventilation	2.13-75	-Ram Air Turbine	2.8-21	-Engine Air Intake Duct	2.11-11
-Rain Removal	2.13-77	-Ramp Edge Intermediate Slip Joint	2.11-19	-Half Duct Ramp Fuselage	2.3-73
-Refrigeration Turbine Outlet	2.13-117	-Rudder Support	2.7-25	-Inboard Elevon	2.6-45
-Shroud Cooling	2.10-3	-Tail Hook	2.15-125	-Main Landing Gear Door	2.15-115
-Shroud Ground Cooling	2.10-53	-Variable Air Ramp Intermediate	2.11-19	-Outboard Elevon	2.6-63
-Transition Ground Connector	2.13-17	Flasher, Fire Detector, Overheat and Hydraulic Pressure Warning	2.17-63	-Upper Missile Door Fuselage	2.20-69
-Windshield Rain Removal	2.13-87	Flask, Air Storage Variable Air Ramp	2.11-5	Hook, Emergency Arresting	2.15-127
E					
Ejector, Engine Shroud	2.10-61	Flask, Pneumatic	2.9-13	Horn, Outboard Elevon Actuator	2.6-35
Elevon, Inboard	2.6-43	Flight Loads Recorder System	2.18-97	Horn, Rudder Actuator	2.7-19
Elevon, Inboard Spares	2.6-51	G			
Elevon, Outboard	2.6-35	Gauge		Hose	
Engine, J75P17 Turbojet	2.10-25	-Direct Indicating Primary Pressure	2.8-13	-Accessory Drive Oil Cooler Inlet	2.10-99
Enclosure, Drag Chute	2.7-31	-Direct Indicating Secondary Pressure	2.8-13	-Afterburner Drain	2.10-73
Equalizer, Fuel Flow	2.12-363	Gear, Main Landing	2.15-87	-Anti-G Suit	2.9-5
Installation, Standby Attitude Indicator	2.18-11	Gear, Nose Landing	2.15-49	-Canopy Jettison External	2.4-35
-Liquid Oxygen	2.19-3	Gear, Synchro Drive Sector Nose Wheel Steering	2.15-27	-Canopy Jettison Quick Disconnect to Check Valve	2.4-29
-Pilot Instrument Panel	2.16-3	Gearbox		-Combustion Manifold Drain	2.10-73
-Pitch G Limiter Electrical	2.14-33	-Engine Mounted	2.10-29	-Drag Brace Servicing, Fwd and Aft	2.9-77
-Radome Anti-Icing	2.13-3	-Inlet Duct	2.11-31	-Elevator and Rudder Airfoil Intake	2.14-151
-Vertical Stabilizer	2.7-21				
-Wing	2.6-125				

ALPHABETICAL INDEX (CONT)

<i>Title</i>	<i>Page</i>	<i>Title</i>	<i>Page</i>	<i>Title</i>	<i>Page</i>	
H						
-Engine Oil Inlet and Outlet	2.10-75	Initiator, Canopy Jettison Control	2.4-35	Landing Gear Nose		
-Fwd Shroud Drain	2.10-74	Initiator, Cartridge Actuated	2.4-23	-Adapter, Door Actuator	2.15-45	
-Heat Exchanger Outlet	2.9-11	Inlet, Static Air Regulator		-Box, Steering and Damping Control	2.17-25	
-Manifold Fuel Drain	2.10-73	Airfeel	2.14-143	Landing Gear Nose		
-Oil Cooler Inlet	2.10-99	Insert, Rudder Support		-Adapter, Door Actuator	2.15-45	
-Oil Cooler Outlet	2.10-105	Bearing	2.7-25	-Box, Steering and Damping Control	2.17-25	
-Oil Scupper Drain	2.10-73	Insulator, External Fuel Tank		-Cover, Wheel Well Splash	2.5-33	
-Pilot Suit Ventilating	2.13-7	Ejection Resistor	2.6-15	-Damper, Steering	2.15-55	
-Seat Jettison Quick Disconnect to MK-1 Catapult	2.1-23	Intake, Elevator and Rudder		-Door	2.15-43	
-Secondary Hydraulic Reservoir Suction	2.8-33	Airfeel	2.14-151	-Fitting, Drag Strut	2.15-123	
-Variable Air Ramp Seal	2.11-23	Intervalometer, Armament	2.20-7	-Stop, Door	2.3-57	
-Vent and Drain	2.10-73	J			-Switch, Door Close	2.15-13
I						
Idler		Jack, Ground Fuel Loading		-Switch, Up and Down	2.15-11	
-Armament Bay Door	2.20-33	Nozzle	2.12-233	-Switch, Wheel Steering Limit	2.15-49	
-Elevator	2.14-85	K			-Transmitter, Wheel Steering	2.15-29
-Elevator and Aileron Control	2.14-63, 2.14-145	Kit, Engine Buildup	2.10-23	-Transmitter, Wheel Steering Followup Control Synchro	2.15-53	
-Elevon Control	2.14-103, 2.14-155	L			-Valve, Hydraulic Control	2.15-3
-Infrared Seeker	2.20-161	Lamp		-Valve, Wheel Steering	2.15-55	
-Main Landing Gear Door	2.15-79	-Airplane Lighting	2.16-19, 2.16-51	-Valve, Wheel Steering Hydraulic Control	2.15-3	
Indicator		-Emergency Hydraulic Power	2.9-3	Latch, Canopy Electrical		
-Airspeed	2.16-9	-Emergency I.G. Control	2.15-23	Actuator	2.4-55	
-Airspeed Standby	2.16-23	-RII Console Panel and Control Box Master Warning Panel	2.16-72	Latch, Emergency Canopy Release	2.2-6	
-Altitude Vertical Speed	2.16-23	-Wing Tip Lights	2.17-5	Latch, External Power		
-Armament	2.16-59	Landing Gear		Access Door	2.2-21	
-Cabin Air Pressure	2.16-5, 2.16-49	-Bumper Stop	2.15-103	Latch, Tail Cone	2.3-95	
-Command Target Altitude	2.16-11	-Control Box	2.15-59	Latch, Windshield Reflection Baffle	2.4-13, 2.5-9	
-Course	2.16-9	-Emergency Control Lamp	2.15-23	Launcher, Aft	2.20-101	
-Electrical		-Emergency Release Control	2.15-23	Launcher, Fwd	2.20-77	
Tachometer	2.16-13	-Landing Light	2.15-17	Leading Edge, Wing		
-Engine Exhaust		-Taxi Light	2.15-21	Cambered Stub	2.6-97	
Temperature	2.16-13	-Taxi Light Relay	2.15-33	Leading Edge, Fin	2.7-17	
-Flight Command		Landing Gear, Main		Leading Edge, Wing	2.6-85, 2.6-101	
Search and Attack	2.18-29	-Actuator Limit Switch	2.15-83	Lever, Up-Latch Switch	2.20-117	
-Frequency Channel	2.16-11, 2.16-25	-Adapter, Actuating Cylinder	2.15-7	Light		
-Fuel Flow	2.16-13	-Adapter, Door Actuating	2.15-7	-Aircraft Landing	2.15-17	
-Fuel Flow Rate	2.16-13, 2.16-25	-Arm, Actuator Limit Switch	2.15-15	-Beacon and Fuselage	2.17-5	
-Fuel Quantity	2.16-25	-Arm, Landing Gear Door	2.15-79	-Cockpit Flood and Thunderstorm	2.17-13	
-Fuel Quantity Selector	2.16-15	-Cable, Door Cylinder Restrainer	2.15-9	-Indicator	2.16-9, 2.16-18	
-Horizontal Situation	2.16-25	-Container, Down Lock Pin	2.15-9	-Indicator Marker Beacon	2.16-21	
-Hydraulic Pressure	2.16-75	-Cylinder, Gear Door	2.15-79	-Indicator Post	2.16-21	
-Indicated Airspeed	2.16-23	-Door	2.15-99	-Indicator Press to Test	2.16-33, 2.16-67	
-Liquid Oxygen		-Fairing, Gear	2.15-67	-Instrument Panel	2.17-11	
Quantity	2.16-17	-Hinge and Longeron, Door	2.15-109	-Landing	2.17-5	
-Mach Number	2.16-9	-Hinge, Door	2.15-115	-Map Reading	2.5-5	
-Pressure Ratio	2.16-5	-Idler, Door	2.15-79	-Navigation Beacon and Fuselage	2.17-3	
-Rate of Climb	2.16-13	-Link, Wing Fairing	2.15-65	-Plastic Plate Panel	2.16-51	
-Rate of Fuel Flow	2.16-13	-Stop, Door	2.15-83	-Position Vertical Fin	2.17-5	
-Remote Attitude	2.16-9	-Switch, Door Open	2.15-113	-Press to Test		
-Tactical Situation Display	2.18-31	-Up-Switch	2.15-15	-Indicator	2.16-3	
-Thrust	2.16-23	-Valve, Selector	2.15-7	-Taxi	2.15-21	
-Turn and Slip	2.16-5			-Variable Ramp Not Retracted	2.16-21	
-Turn and Slip 4 Minute Turn	2.16-5			-Wing Tip Position	2.6-11	

ALPHABETICAL INDEX (CONT)

<i>Title</i>	<i>Page</i>	<i>Title</i>	<i>Page</i>	<i>Title</i>	<i>Page</i>
L					
Limiters, Pitch G.	2.14-29	-Electronic Equipment Fin.	2.2-87	-Fuel Quantity Transfer Tank	2.12-33
Link		-Electronic Fuse	2.18-13	-Fuel Tank #1 and 2	2.12-31
-Armament Bay Door	2.20-35	-Fuel Control LH Console	2.16-71	-Fuselage Fuel Tank	2.12-337
-Drag Chute	2.7-15	-Fuel System Checkout	2.12-237	-Total Temperature	2.11-25
-Elevon Connecting	2.6-33, 2.6-41	-Hydraulic Indicator Generator Refrigeration and Cockpit Air Switch	2.16-75	Pulley, Drag Chute	2.7-13
-Elevon Control	2.14-69	-Lighting Control Powerstat	2.16-51	Pulley, Rudder Cable	2.14-139
-Elevon Mixer	2.14-103	-Lighting Control RH Console	2.16-83	Pulley, Rudder Control	2.14-131
-Main Landing Gear Fairing Wing	2.15-65	-Liquid Oxygen Control	2.16-47	Pump, Fuel Boost	2.12-11, 2.12-341
Liquid Oxygen		-Main Wheel Well Fuse	2.17-121, 2.17-129	Pump, Hydraulic	2.10-35
-Access Door	2.2-7	-Master Electrical Power and Audio Warning Cutoff LH Console	2.16-53	Q	
-Liquid To Gaseous Converter	2.19-3	-Master Warning Control	2.16-47	Quadrant, Elevator Feel	2.14-111
-Panel	2.16-89	-Matts Switch	2.16-51	Quadrant, Pilot Power Control	2.10-9
-Quantity Indicator	2.16-47, 2.16-89	-MA-1 Anti-Ice De-Fog and Rain Removal Switch RH Console	2.16-77	R	
-Shutoff Valve	2.16-89	-Miscellaneous Switch RH Console	2.16-57	Rack	
-Tubing Shroud	2.19-3	-Mounting Lighting Control	2.16-81	-AFCS Electronic Equipment	2.18-57
M					
Magnetic Drum, Data Storage	2.18-47	-Mounting Master Electrical	2.16-53	-Antenna Transmitter-Receiver Group	2.18-17
Manifold, Instrument Panel Static Line	2.14-3	-Mounting MA-1 Anti-Ice De-Fog and Rain Removal Switch	2.16-71	-Cockpit Display	2.18-51
Mechanism, Drag Chute	2.7-9	-Pilot Instrument	2.16-29, 2.16-39	-Dehydrator	2.18-35
Mount		-Receive ILAS	2.16-47	-Electrical Equipment	2.18-29
-Accessory Drive Oil Cooler	2.10-99	-Speed Brake Support Switch LH Console	2.16-63	-Electrical Equipment Compensator Air Data	2.18-71
-Actuator Air Valve Oil Cooler	2.10-85	-Tacan Power Source Switch	2.17-33	-Electrical Equipment Computer Air Data	2.18-71
-Engine	2.10-37	-Variable Air Ramp Intermediate	2.11-19	-Electrical Equipment Converter Air Data	2.18-71
-Engine Oil Cooler	2.10-81	-Variable Air Ramp Seal	2.11-17	-Electrical Equipment Tactical Situation Indicator	2.18-33
-Glide Slope Antenna	2.18-15	Pedal, Rudder and Brake	2.14-121	-Electrical Equipment LH Forward Compartment	2.18-43
-Oil Cooler Air Valve	2.10-89	Pedestal, Power Control	2.10-9	-Electronic Equipment	2.18-43, 2.18-55
-Pitch G Limiter Shock	2.14-37	Piccolo, Cockpit Air Plate	2.13-63	-Flight Director Electronic Equipment	2.18-3
-Pitot Static Tube	2.11-7	-Adjustment Launcher Attachment	2.20-153	-Tactical Situation Indicator Electrical Equipment	2.18-31
N					
Nozzle, Rain Removal	2.13-77	-Drag Chute Instruction Eccentric Index	2.20-101	-IFF Receiver-Transmitter	2.18-47
O					
Outlet, Fuel Tank Vent	2.12-9	-Emergency Hydraulic Power Designation	2.9-3	-Pilot Instrument Panel	2.16-35, 2.16-37
P					
Panel		-Engine Air Intake Duct	2.11-11	Radome and Boom, Plastic	2.3-3
-AC Emergency Generator	2.17-21	-Fwd Launcher Attachment Adjustment	2.20-77	Radome and Boom, Spares	2.3-3
-AC Generator Control	2.17-27	-Launcher Adjustment	2.20-101	Ramp, Engine Air Intake Duct	2.11-11
-Air Shutoff Valve	2.12-37	-Rudder, Streamline Position	2.7-5	Ramp, Midbay Electronic Door Seal	2.3-57
-Anti-G Suit and Mask De-Fog	2.16-65	Port, Pneumatic Sensing Static	2.9-3	Ramp, Variable Air	2.11-21
-Armament Electrical Test	2.18-27	Potentiometer, Aileron Position	2.14-7	Ramp, Variable Air Intake Duct	2.11-17
-Armament Manual Control	2.20-11	Potentiometer, Elevon Position	2.14-57	Receiver	
-Cockpit Floor	2.5-27	Powerstat, Lighting Control	2.16-51	-Data Link	2.18-55
-Cockpit Fuse	2.17-95, 2.17-107	Power Plant	2.10-17	-Data Link RH Console	2.16-49
-Control Gyro Compass RH Console	2.16-51	Power Supply -GAR Gyro	2.18-59	-ILAS Guide Slope and Marker Beacon Radio	2.18-55
Q					
R					
Probe					
		-Fuel Quantity Tank #3	2.12-33	-ILAS Localizer Radio	2.18-55
				-Transmitter, IFF Radio	2.18-47

ALPHABETICAL INDEX (CONT)

<i>Title</i>	<i>Page</i>	<i>Title</i>	<i>Page</i>	<i>Title</i>	<i>Page</i>
R				S	
-Transmitter, Radar	2.18-27	-Fuel Scavenge	2.17-69	Screen, Static Air Connector	2.14-5
-UHF Radio Communication	2.18-55	-Fuel Transfer Test	2.12-33	Screw Jack, Variable Air	2.11-29
Receptacle, External Power	2.17-49	-Fwd Aft and Special Weapon Misfire	2.20-7	Screw Jack, Variable Air Ramp	2.11-27
Receptacle, Wing Fuel Tank	2.12-29	-G Accelerometer Limiter	2.14-25	Seal	
Recorder System, Flight Loads	2.18-97	-Gear Unsafe	2.17-83	-Aileron Rod	2.15-5
Refrigeration Unit	2.13-117	-Hydraulic Low Pressure Warning	2.17-45	-CG Transfer Pressure Fitting	2.12-197
-Air Pressure	2.9-7	-Ice Detector	2.17-37	-Cockpit Pressure Test Fitting	2.13-21
-Air Pressure CG Control	2.9-11	-Ignition Arming Anti-Ice Control and Ignition	2.17-63	-Command Synchro Transmitter	2.15-35
-Air Pressure Transfer Tank	2.12-229	-Instrument Flag Interlock	2.18-53	-Door Fwd Radar Compartment	2.3-47
-BTU Sensor Voltage	2.17-23	-J-4 Interlock	2.18-73	-Electronic Access Door	2.2-17
-Cockpit Air Pressure	2.13-25	-Lower Beacon Light	2.17-45	-Electronic Access Door Ramp	2.2-11
-Diluter Demand Oxygen	2.16-47	-Main Wheel Well Door Close and Hydraulic Flasher Reset	2.17-63	-Elevator and Aileron Control Tube	2.14-81
-Duct Lip Anti-Icing Air Pressure Shutoff	2.13-121	-Mode Selection	2.18-59	-Elevator Rod	2.15-5
-Elevator Control Feel System	2.14-97	-Nose Wheel Steering Control	2.17-39	-Engine Air Intake	2.10-27
-Hydraulic Reservoir	2.8-3	-Parameter Setting	2.18-59	-Engine Cooling Shroud	2.10-57
-Hydraulic Sensitive Pressure	2.8-35	-Pitot Heat	2.13-5	-Engine Fire	2.10-47
-Pneumatic Pressure	2.9-5	-Rudder Interlock	2.14-29	-Engine Mount	2.10-59
-Rudder Cable Tension	2.14-157	-Speed Brake and Emergency Retract	2.17-39	-Flexible Wing to Fuselage Tube	2.3-85
-Variable Air Pressure	2.14-5	-Taxi Light	2.15-33	-Inboard Elevon Horn	2.5-49
-Wing Fuel Tank Pressure	2.12-15	-Trim and Servo Emergency Disconnect	2.14-25	-Oil Cooler Duct Flange	2.10-81
Relay		-Variable Air Ramp Position	2.17-39	-Ramp Edge	2.11-23
-AC Emergency Power Disconnect	2.17-27	-Warning Light Dimming	2.17-37, 2.17-83	-Ramp Hinge	2.11-23
-AC Power Disconnect	2.17-27	-Warning Light Test Relay #2	2.17-39	-Speed Brakes Door	2.7-32
-Armament Door Remote Control	2.20-12	-Windshield Anti-Icing Shut-Down	2.13-7	-Variable Air Ramp	2.11-17, 2.11-23
-Armament Selection	2.18-59	Release, Drag Chute	2.7-11	-Windshield	2.4-11
-Armament Test	2.18-59	Remover, Electrical Canopy	2.4-61	Seeker, Infrared	2.20-155
-Auxiliary Dimming Overheat	2.17-39	Reservoir, Primary Hydraulic	2.8-15	Sensor, Engine Compartment Emergency Pressure Control	2.10-43
-Barrier Hook Indicator Light Dimming	2.17-135	Reservoir, Secondary Hydraulic	2.8-17	Sensor, Engine Compartment Pressure Control Envelope	2.10-87
-Barrier Hook Indicator Light Test	2.17-135	Resistor		Sensor, Engine Fuel Temperature Envelope	2.10-29
-Canopy Clutch Disengage	2.4-17	-Engine Exhaust Temperature Calibrating	2.17-21	Shaft	
-Canopy Down Actuator Motor	2.4-17	-External Fuel Tank Ejection	2.12-27	-Constant Speed Drive Connecting	2.10-109
-Canopy Unlocked Fire and Gear Unsafe	2.17-83	-Marker Beacon	2.18-79	-Control Canopy Latch 100 Tooth	2.4-21
-Canopy Up Actuator Motor	2.4-17	-Mask De-Fog	2.13-7	-Eccentric	2.20-101
-DC Bus Tie Nonessential	2.17-21	-Pitch G Limiter	2.14-39	-Screw Jack	2.11-27
-Door Position	2.20-7	-Warning Light Dimming	2.17-83	-Torque Power Control	2.10-13
-Door Position and Auxiliary Aft Misfire	2.20-7	Resistor Board, Steering Computer	2.18-77	Shield, Reflection	2.5-3
-Elevon Interlock	2.17-45	Restrictor, Hydraulic Dual Rate	2.15-53	Shroud	
-Emergency Extend and Control	2.17-39	Retainer, Canopy Seal	2.4-19	-Engine Air Cooling	2.10-53
-Engine Anti-Ice Latch	2.17-45	Retainer, Fwd Umbilical Plug	2.20-125	-Engine Cooling	2.10-61
-Engine Anti-Ice Time Delay	2.17-45	Ring, Antenna Support	2.3-57	-Fwd Displacement Gear Actuator	2.20-81
-External Fuel Valve Control	2.17-49	Rod, Armament Bay Door	2.20-35, 2.20-71	-Liquid Oxygen Tubing	2.19-3
-Fire Detector Indicator Loop	2.17-39	Rod, Canopy Emergency Release	2.4-55	-Ram Air Check Valve	2.10-49
-Flood Light Transfer	2.17-3	Rod, MB-1 Ejector	2.20-123	Splice, AC Distribution	2.17-7
-Fuel Boost Pump	2.17-69	Rod, Ram Air Turbine	2.8-21	Splice, DC Generator	2.18-83
-Fuel Boost Pump and Miscellaneous	2.17-69	Roller, Engine	2.10-121	Splice, Generator	2.18-83

ALPHABETICAL INDEX (CONT)

<i>Title</i>	<i>Page</i>	<i>Title</i>	<i>Page</i>	<i>Title</i>	<i>Page</i>
S		Switch		T	
Splice, Ground Power	2.18-83	-Aft Armament Down	2.20-103	Tank, Glycol Radome	
Spring, Slip Joint Seal	2.11-19	-Altitude Pressure Ratio		Anti-Icing	2.13-15
Starter, Combustion	2.10-29	CG Transfer Unit	2.12-39	Tank and Pylon, External	
Steer-Damp Unit	2.15-55	-Armament Door and		Fuel	2.12-35
Stick, Flight Control	2.14-41	Launcher	2.20-11	Teleflex, Power Control	2.10-11
Stop, Main Landing Gear		-Armament Launcher	2.20-17	Test Set, Computer Digital	2.18-47
Bump	2.15-103	-Barrier Hook Indicator		Thermostat, Electronic	
Stop, Main Landing Gear		Light	2.15-131	Cooling Bypass	2.13-47
Door	2.15-83	-Boost Pump Pressure	2.12-11	Thermostat, Turbine	
Strainer, Engine Fuel		-Canopy Limit	2.4-61	Discharge	2.13-111
Supply	2.12-375	-Cockpit Low Pressure		Thruster, Canopy	
Streamer, Ejection Seat		Warning	2.13-3	Jettison	2.4-27
Safety Pin Stowage	2.5-13	-Differential Pressure		Timer, Cabin Air Control	
Structure		Cooling Air	2.10-39	Missile Launching	2.20-7
-Canopy	2.4-47	-Drag Chute Jettison	2.7-9	Tip, Drag Chute	
-Vertical Stabilizer	2.7-25	-Elevator Trim Followup	2.14-107	Enclosure Support	2.7-5
-Wing	2.6-151	-Engine Ignition Disarming	2.17-43	Tip, Fin	2.18-9
-Wing Aft Tank	2.6-167	-External Fuel Tank High		Tip, Wing	2.6-77
-Wing Equipment	2.6-77	Pressure	2.12-223	Trailing Edge, Inboard Elevon	2.6-43
-Wing Fwd Tank	2.6-157	-Fire Detection Test	2.16-21	Trailing Edge, Outboard	
-Wing Transfer Tank	2.6-175	-Fuel Flow Level Warning	2.12-11	Elevon	2.6-33
Strut, Door Mechanism		-Fuel Quantity		Transformer	
Support	2.20-41	Selector	2.16-15	-Canopy Heating	2.13-9
Strut, Heat Exchanger		-Fuselage Tank Low		-Console Lighting	2.17-7
Stabilizer	2.13-113	Pressure and Emergency		-Flight Power Sensing	2.18-73
Support		Pressure	2.12-235	-Lighting Instrument Panel	2.17-7
-Aft Displacement Gear	2.20-109	-Heading Selector	2.16-25	-Marker Beacon	2.18-79
-Armament Day Door	2.20-33	-Hydraulic Thermal	2.8-5	-Pitch G Limiter	2.14-33
-Armament Crossbridge	2.20-151	-Intervalometer Reset	2.20-7	-Position Light	2.17-39
-Armament Extension		-Main Landing Gear		-Windshield Anti-Ice	2.17-25
Actuator	2.20-5	Door Open	2.15-13	Transmitter	
-Armament Upper and		-Main Landing Gear Up	2.15-15	-Accelerometer, Linear	2.14-27
Lower Drag Arm	2.20-93	-Mask De-Fog	2.16-65	-Angle of Attack	2.18-81
-Cockpit and Electronic		-Nose Landing Gear Door		-Engine Pressure Ratio	2.17-27
Cooling Duct	2.13-13	Close	2.15-13	-Fuel Flow Rate	2.10-35
-Drag Chute Enclosure	2.7-5	-Nose Landing Gear		-Nose Landing Gear	2.15-25
-Elevator Torque Tube	2.14-47	Up and Down	2.15-11	-Primary Hydraulic Pressure	2.8-13
-Elevon Actuator	2.6-177	-Nose Wheel Steering		-Pressure Ratio	2.17-37
-Engine Cooling Shroud	2.10-19	Limit	2.15-49	-Rate Gyro	2.18-53
-Engine Removal Rail	2.10-117	-Pressure Indicated Airspeed	2.14-5	-Secondary Hydraulic Pressure	2.8-13
-Engine Thrust Bearing	2.10-115	-Radar Self Test Relay	2.18-43	-Turn Rate	2.14-29
-Glide Slope Antenna	2.18-17	-Refrigeration	2.16-75	Trap, Airspeed Tubing Water	2.14-23
-Instrument Panel Lower	2.16-45	-Rotary, Altitude Band Selector	2.16-71	Trap, Ratio Tubing Water	2.10-77
-Instrument Panel Rack	2.16-33	-Shroud Pressure	2.10-39	Trim, Cockpit	2.5-20
-Instrument Panel Upper	2.16-43	-Starter Ignition Disarming	2.17-43	Tubing	
-Localizer Antenna	2.18-17	-Barrier Hook Warning		-Afterburner Igniter Drain	2.10-39
-NLG Door	2.15-5	Light	2.16-7, 2.16-21	-Airspeed	2.3-3, 2.14-9
-Pneumatic Flask	2.9-13	-Tank and Boost Pump Low		-Anti-Icing Air Intake Duct	2.13-109
-Radar Antenna Station 41	2.18-23	Pressure Warning	2.12-11	-Anti-Icing Leading	
-Radarscope Fwd and Aft	2.18-29	-Taxi and Landing Light		Edge Duct	2.13-105
-Ram Air Turbine	2.8-5	G Suit and No Fog	2.15-39	-CG Fuel Transfer	2.12-19
-Remote Gearbox,		-Test Fire Overheat	2.16-15	-Duct Leading Edge	2.11-9
Accessory Drive	2.10-103	-Transfer Tank Fuel Low		-Elevator and Rudder	
-Speed Brake Door	2.7-31	Level	2.12-17	Airfeel	2.14-141
-Tactical Situation		-Trim Servo	2.16-7	-Elevon Control	2.14-91
Indicator	2.18-31	Switch and Transmitter,		-Engine Bleed Air	
-Up Latch	2.20-117	Engine Oil Pressure	2.10-35	Control Oil Cooler	2.10-27
-Variable Air Ramp		Synchronizer, Master		-Engine Fuel Pressure	2.12-367
Screw Jack	2.11-33	Timer Electrical	2.18-43	-Engine Fuel Supply	
-Variable Air Ramp Flask	2.11-5	Synchronizer, Range		and Strainer	2.12-373
-Wing	2.6-157	Tracking Electrical	2.18-43		
		Synchro Transmitter, Nose			
		Wheel Steering Follow-			
		up Control	2.15-57		

ALPHABETICAL INDEX (CONT)

<i>Title</i>	<i>Page</i>	<i>Title</i>	<i>Page</i>	<i>Title</i>	<i>Page</i>		
T							
-Engine Fuel Supply Wing	2.12-365	-Cockpit Pressurization, Emergency	2.9-45	-Cockpit Air Diverter	2.13-65		
-Engine Oil	2.10-91	-Control, Cockpit Pressure	2.9-25	-Cockpit Air Diverter and Shutoff	2.13-95		
-Engine Oil Cooler	2.10-75	-Drive Unit, Variable Air Ramp	2.9-85	-Cockpit Air Safety	2.13-85		
-Fuel Flow Wing	2.12-59	-Engine Starter	2.9-53	-Cockpit Diverter and Shutoff	2.13-13		
-Fuel Tank Pressure	2.12-243	-Fuel Transfer and Armament Supply, High Pressure	2.9-109	-Drag Chute Actuating	2.7-3		
-Fuel Transfer Pressure	2.12-183	-G Suit and Flow Control	2.9-21	-Drain	2.12-371		
-Fuselage Fuel Tank Vent	2.12-321	-Gauge, High Pressure Filler	2.9-97	-Drain Oil Cooler	2.10-81		
-Fuselage Tank to Wing Fuel Transfer	2.12-315	-Gear, Main Landing	2.9-67	-Dual Air Check	2.9-11		
-Liquid Oxygen	2.19-7	-Gear, Nose Landing	2.9-63	-Electronic Compartment Check	2.13-11		
-Main Landing Gear Wheel Well Fuel Control	2.12-201	-Infrared Seeker	2.9-49	-Elevon Control	2.14-59		
-Oil Cooler Engine Bleed Air	2.10-3	-Lock, High Pressure Armament Gear	2.9-133	-Emergency Cockpit Pressurization	2.13-9		
-Pitot Static	2.11-7	-Radome Anti-Icing	2.9-15	-Emergency Fuel Transfer	2.12-191		
-Power Plant to Fuselage Vent and Drain	2.10-73	-Ram Air, High-Pressure	2.9-91	-Emergency Fuselage Tank Pilot	2.12-333		
-Power Plant Vent and Drain	2.10-73	-Refrigeration Unit, Low Pressure Bleed Air Sensing	2.9-31	-Emergency Generator Shutoff Station 468	2.8-5		
-Pressure Ratio Indicator	2.10-77	-Seal, Canopy	2.9-33	-Emergency Hydraulic Power	2.9-3		
-Radar Pressurization	2.18-37	-Seal, Variable Air Ramp	2.9-23	-Emergency Speed Brake	2.7-5		
-Tank #1 Vent Line	2.12-5	-Speed Brake and Drag Chute, High Pressure	2.9-101	-Engine Oil Cooler Air	2.10-87		
-Variable Air Ramp Pitot Static	2.11-7, 2.11-35	-Stabilizer, Dorsal and Vertical High Pressure	2.9-103	-Engine Oil Cooler Air Control	2.10-89		
-Vent Fuselage Tank to Wing	2.12-313	-Suit, Anti-G	2.9-5	-External Fuel Tank Check and Pressure	2.12-9		
-Wing Fuel Tank Air Pressure	2.12-19	-Valve, Armament Door Actuator Shuttle	2.9-111	-External Tank Shutoff	2.12-57		
-Wing Tank #1 Fuel Control	2.12-113	-Valve, Emergency Landing Gear Selector	2.9-87	-Flow Divider	2.13-15		
-Wing Tank #2 Fuel Control	2.12-117	Turbine and Compressor	2.13-117	-Fuel Pressure Shutoff	2.12-347		
-Wing Tank #3 Fuel Control	2.12-123	Turbine, Hydraulic Ram Air	2.8-21	-Fuel Tank #1 Pressure Relief	2.12-5		
-Wing Transfer Tank Fuel Control	2.12-129	U					
Tubing, Hydraulic							
-Actuator, Elevon	2.8-87	Up-Latch, Aft Displacement Gear	2.20-115	-Fuel Tank Air Check	2.12-229		
-Actuator, M/G	2.15-75	V					
-Actuator, Rudder	2.8-105	Valve					
-Brake, Speed	2.8-107	-Accessory Oil Cooler Air	2.10-83	-Fuel Tank Air Pressure Relief	2.12-207		
-Elevon, Wing	2.8-95	-Air Check	2.9-9	-Fuel Tank Pilot Float	2.12-5		
-Main Landing Gear	2.8-79	-Air Control	2.10-85	-Fuel Tank Vent	2.12-7		
-Nose Landing Gear	2.8-69, 2.8-111	-Air Pressure Shutoff	2.12-371	-Fuel Tank Vent Refueling	2.12-171		
-Power Plant	2.10-31	-Air Shutoff	2.12-371	-Fuel Transfer Drain	2.12-227		
-Power Source	2.8-25	-Anti-G Suit	2.9-5	-Fuel Capacity Fuselage Tank Pilot	2.12-331		
-Ramp, Variable Air	2.8-83	-Armament Bay Door Center Pneumatic Selector	2.20-31	-Fuselage Fuel Tank Vent	2.12-345		
-Refrigeration Compartment, Power Source	2.8-25	-Armament Bay Door Manual	2.20-5	-Fuselage Tank Drain	2.12-221		
Tubing, Pneumatic							
-Actuator, Armament Door Aft	2.9-125	-Armament Bay Door Master Pneumatic Selector	2.20-29	-Ground Cooling	2.13-91		
-Actuator, Armament Door Center	2.9-119	-Armament Gear Lock Manual	2.20-3	-High Level Fuselage Tank Pilot	2.12-333		
-Actuator, Armament Door Fwd	2.9-113	-Armament Selector	2.20-3	-High Pressure Priority Pneumatic	2.9-63		
-Actuator, Master Brake to Wheel Brake Relay Valve	2.9-59	-Bleed Control	2.9-95	-Hydraulic Bypass	2.11-25		
-Armament Displacement	2.9-103	-Brake Relay	2.15-7	-Hydraulic Control Nose Wheel Steering	2.15-3		
-Bleed, High Pressure	2.9-95	-Canopy Defog-Pressure Regulator	2.13-123	-Hydraulic Relief Station 530	2.8-7		
-Brake Supply, Main Landing Gear	2.9-77	-Canopy Seal	2.4-61	-Main Line Check	2.9-87		
-Bypass, Electronic Cooling Hot Air	2.9-39	-G Transfer Line Shutoff	2.12-197	-M/G Selector	2.15-7		
		-Cockpit Air Check	2.13-69	-Manifold Check Fuselage Tank	2.12-333		
				-Manual Refuel Selector	2.12-23		
				-Manual Shutoff Selector	2.10-3		
				-N/G Hydraulic Control	2.15-3		
				-Nose Wheel Steering	2.15-55		
				-Outflow, Cockpit Air	2.13-25		
				-Pneumatic Escape System Check	2.4-29		
				-Pressure Operated Pilot	2.12-7		

ALPHABETICAL INDEX (CONT)

<i>Title</i>	<i>Page</i>	<i>Title</i>	<i>Page</i>	<i>Title</i>	<i>Page</i>
V					
-Pressure Regulator and Shutoff	2.13-117	-Shutoff and Check	2.12-115	-Transfer Tank Outboard Shutoff	2.12-173
-Pressure Regulator Refueling	2.12-349	-Shuttle	2.11-25	-Transfer Tank Pressure Relief	2.12-17
-Pressure Regulator Suit Ventilation	2.13-75	-Shuttle, Variable Air Ramp	2.3-63, 2.11-39	-Transfer Tank Refuel Pilot and Vent	2.12-171
-Pressure Suit Ventilation	2.13-75	-Solenoid Air Shutoff	2.12-229	-Transfer Tank Vent	2.12-167
-Primary High Pressure Charging	2.8-13	-Solenoid Operated Hydraulic Check	2.8-5	-Variable Air Ramp Selector	2.11-3
-Purge Air Check	2.13-7	-Solenoid Selector Fwd Launcher	2.20-81	-Variable Air Ramp Servo Control	2.11-25
-Radome Anti-Icing	2.13-3	-Swing Check	2.13-11	-Variable Air Ramp Shuttle	2.3-63
-Ram Air	2.13-9	-Tank #1 Refuel Pilot	2.12-5	Ventilator, Pilot	2.13-53
-Ram Air Duct	2.13-13	-Tank #1 Refuel Shutoff	2.12-165	Vertical Stabilizer, Speed Brake and Drag Chute	2.7-3
-Ram Air Shroud Cooling Check	2.10-49	-Tank #1 Refuel Vent	2.12-7	Vertical Stabilizer Equipment	2.7-21
-Refueling Regulator and Check	2.12-349	-Tank #1 Suction Relief	2.12-163		
-Refueling Shutoff Transfer Tank	2.12-21	-Tank #2 Pilot Float	2.12-15	W	
-Regulator and Shutoff Hot Air Pressure	2.13-95	-Tank #2 Pressure Relief	2.12-15	Web, Shock Crossbridge	2.20-99
-Secondary High Pressure Charging	2.8-13	-Tank #3 Refuel Pilot	2.12-13	Window, Canopy	2.4-3
-Selector	2.20-3	-Tank #3 Refuel Shutoff and Pilot	2.12-113	Windshield	2.4-10
-Selector Speed Brake Control	2.3-87	-Tank #3 Vent Relief	2.12-13	Wing	2.6-3
		-Transfer Tank Emergency Pilot	2.12-193	Wing, Spares	2.6-11
		-Transfer Tank Inboard Pilot	2.12-175		
		-Transfer Tank Inboard Shutoff	2.12-179	X—Y—Z	
		-Transfer Tank Outboard Pilot	2.12-177		

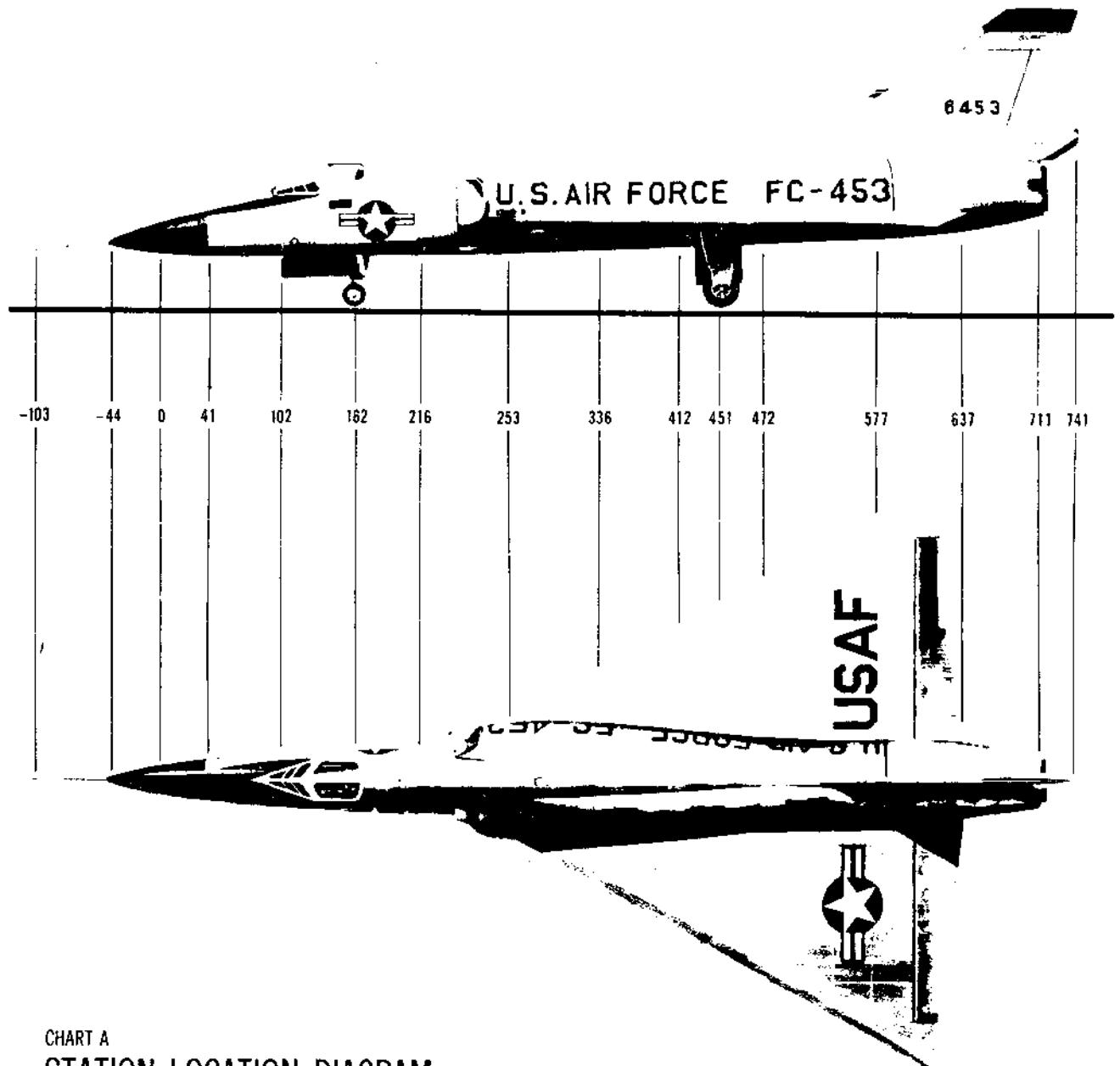

CHART A
STATION LOCATION DIAGRAM

MODEL F-106A TURBO-JET ALL-WEATHER INTERCEPTOR

— manufactured by GENERAL DYNAMICS/CONVAIR,
San Diego, California.

This Technical Manual is intended for use by USAF maintenance and overhaul personnel, for the purposes of identifying, ordering, and stocking replaceable parts.

WHAT TO LOOK FOR

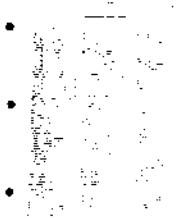

THE ALPHABETICAL INDEX PRECEDES THE INTRODUCTION TEXT. THE SIGNIFICANT COMPONENTS OF THE AIRPLANE ARE LISTED, FOR EXAMPLE:

COOLER, ENGINE OIL.....PAGE 2. XXXX



THE INTRODUCTION CONSISTS OF INSTRUCTIONS ON HOW TO USE THIS TECHNICAL MANUAL. THE FOLLOWING CHART AIDS ARE INCLUDED; CHART A; STATION LOCATION DIAGRAM, CHART B; FUNCTIONAL GROUP DIVISIONS, CHART C; CONVAIR PART NUMBER FORMATION AND CHART D; PARTS-LISTING INDENTION SYSTEM.

general description, contents of

MANUFACTURER'S CODE

These pages contain a complete listing of all manufacturer's codes used in the Group Assembly Parts Lists, with corresponding manufacturer's names and addresses.

general description, contents of

MASTER 'USABLE ON' CODE

These pages contain listings of Convair-assigned Catalog Airplane numbers cross-referenced to USAF Airplane Serial Numbers. The catalog numbers shown in the Group Assembly Parts Lists, Converted to serial numbers by use of these codes, indicates airplane effectivities for specific parts

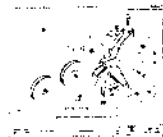

IN THIS SECTION, EACH GROUP ASSEMBLY PARTS LIST, TOGETHER WITH ITS ACCOMPANYING ILLUSTRATION, DEALS WITH A GROUP OF RELATED PARTS WHICH EITHER SERVE A SPECIFIC PURPOSE, OR ARE LOCATED IN A SPECIFIC AREA IN THE AIRPLANE.

FUNCTIONAL GROUP DIVISIONS

— of the group assembly parts lists

To facilitate location of individual parts in this Technical Manual, the Group Assembly Parts List Section is divided into major functional groups under the following headings:

CHART B

FUNCTIONAL GROUP DIVISIONS

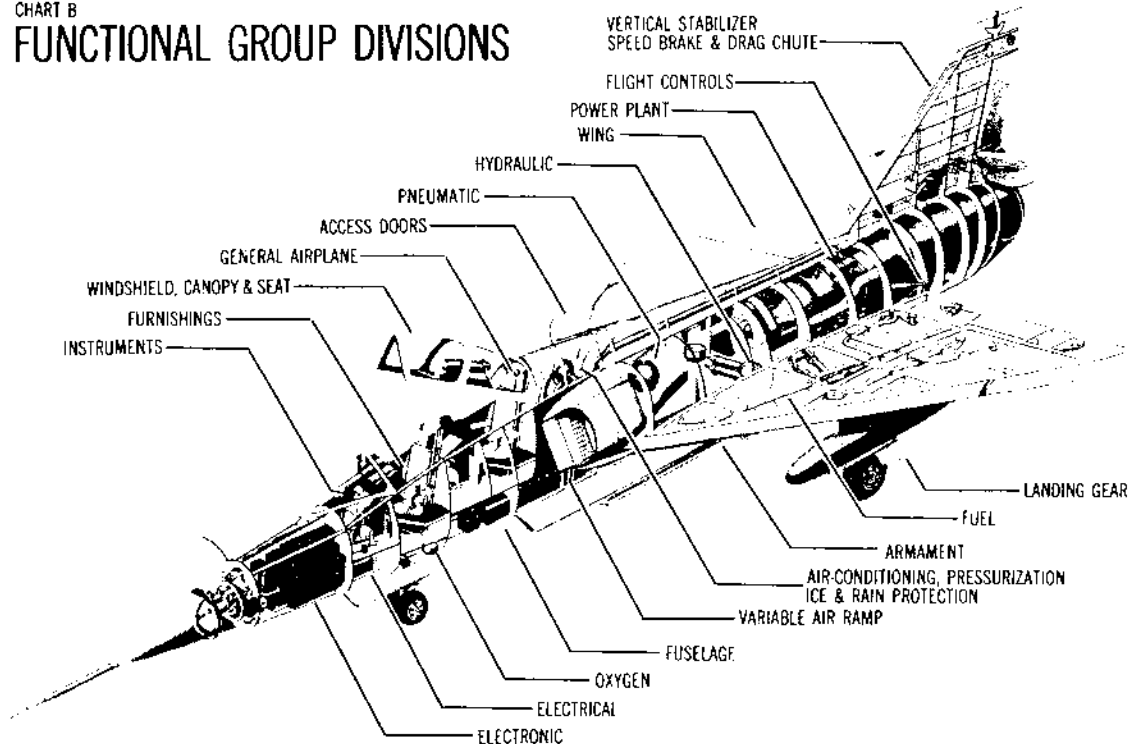

The groups are systematically broken down into installations, assemblies and detail parts, which fall into the following categories: those which have been procured as spares, those considered impractical to fabricate with standard field equipment, and those which are subject to frequent removal and replacement.

general description of the contents of section II (cont.)

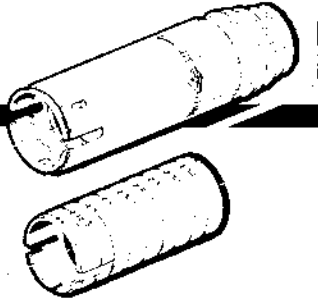

SPARES ASSEMBLIES

– of the group assembly parts lists

Spares assemblies have been created by the contractor when engineering production assemblies are not suitable as spares replacement. These have been illustrated and listed in this Technical Manual and may be found following the listing of the production assemblies.

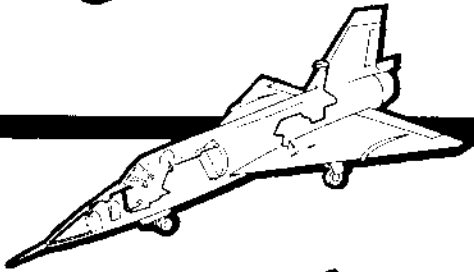

SYSTEM ILLUSTRATIONS

– of the group assembly parts lists

The Detail Table of Contents page for each of the Major Functional Group Divisions is, in most instances, followed by an over-all system illustration which shows the location and inter-relationship of the major components of that system, or functional group. The parts list which accompanies this illustration refers to individual figures where major components and assemblies are broken down.

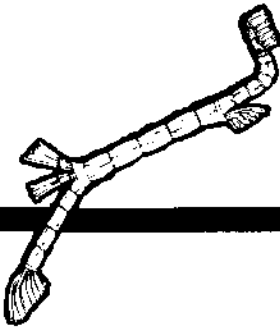

ELECTRICAL HARNESSES

... are not listed in the Group Assembly Parts Lists, unless they include, as integral parts, components considered unusual to a harness assembly, or when specifically ordered as spares.



THE FOLLOWING ARE NOT LISTED:

– in the group assembly parts lists:

PARTS CUT FROM RAW STOCK

... such as stringers or skins, and rolled, brake-formed, or drawn sections, except where such parts are considered likely to need occasional replacement.

DETAILS OF WELDED ASSEMBLIES

... and other detail parts which have lost their identity by being fabricated into permanent assemblies, except where such parts are considered likely to need occasional replacement.

AF-STOCKED STANDARD PARTS

... such as rivets, cotter pins, lockwire, and nuts and bolts which are not used as attaching parts.

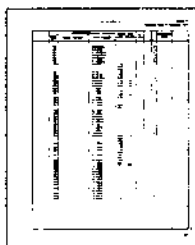

THE NUMERICAL INDEX HAS SEVERAL FUNCTIONS. IT TELLS WHETHER EACH PART IS LISTED AND ILLUSTRATED IN THIS TECHNICAL MANUAL, AND IF SO, WHERE; ALL AVAILABLE STOCK NUMBER INFORMATION: I.E., CLASS CODE AND SERIAL NUMBER FOR EACH PART; AND THE SOURCE FROM WHICH MAINTENANCE PARTS MAY BE OBTAINED, LISTED IN CODED FORM. THE INDEX IS LISTED IN ALPHA/NUMERICAL ORDER CONSISTING OF.

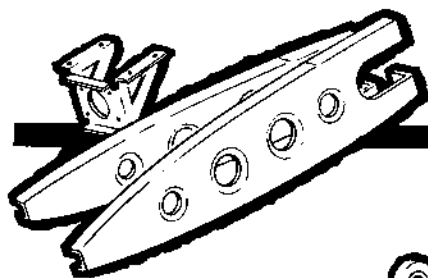

CONTRACTOR PART NUMBERS

—parts listed and illustrated in Section II. The formation of Convair Part Numbers is explained in Chart C. . . .

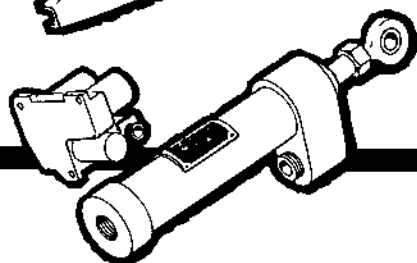

...and

VENDOR AND STANDARD PART NUMBERS

—a numerical listing which includes government standards, contractor standards, and all vendor part numbers.

FOR CONVENIENCE IN USING THIS TECHNICAL MANUAL, DETAILED EXPLANATION OF THE CONTENTS AND USE OF THE NUMERICAL INDEX WILL BE FOUND AT THE BEGINNING OF SECTION 111.

THIS INFORMATION INCLUDES:

- EXPLANATION OF THE ENTRIES FOUND IN EACH COLUMN;
- EXPLANATION OF THE USAF SOURCE CODING SYSTEM;
- EXPLANATION OF THE 'STOCK NUMBER' GROUP OF COLUMNS, AND THEIR INTER-RELATIONSHIP.

CHART C CONVAIR PART-NUMBER FORMATION

There is an engineering drawing for every part which goes into the F-106A aircraft. Except for vendor and standard parts, all drawings are made, and have numbers assigned by Convair Engineering.

PART-NUMBER EXPLANATION

EXAMPLE: 8-51156 — Plate, Mounting, 'MLG UP' Switch*

AIRPLANE MODEL NO. (F-106A) 8 - 5 1 1 5 6
 GROUP FUNCTION NO. (ALIGHTING GEAR & ARMAMENT)
 AREA OR EXPANSION NO. (ALIGHTING GEAR, MAIN)
 SUPPLEMENTAL NO. (DETAILS & MINOR ASSEMBLIES)

Group Function Numbers are broken down into the following categories:

- 0—Basic Airplane (Mockup, Proposal, Study, Layout, Control Drawings, Special Tools, etc.)
- 1—Wing and Empennage
- 2—Power Plant and Air Conditioning
- 3—Electronics and Instruments

- 4—Controls and Mechanisms
- 5—Alighting Gear and Armament
- 6—Electrical
- 7—Body
- 8—Hydraulics, High-Pressure Pneumatics, Heating, and Ventilating
- 9—Furnishings and Handling Gear

Following each Group Function Number is the Area or Expansion Number, which goes one step farther in establishing the location of the installation. The detail part or assembly is pin-pointed by the Supplemental Number

DETAIL BREAKDOWN OF CONVAIR GROUP FUNCTION, AREA OR EXPANSION, AND SUPPLEMENTAL NUMBERS

WING AND EMPENNAGE		
Model	Function And Area	Supplemental Number

8	10-General 16-Wing 17-Wing 18-Wing	000-099 Main Assys & Instl 100-149 Main & Aux Spars 150-199 Skin Panels 200-299 Leading Edge 300-399 Ribs and Bulkheads 400-499 Trailing Edge 500-549 Body-to-Wing Attach Details, Ribs & Bulkheads, LG prov 550-599 Fairing & Gas-Tight Corners 600-699 Removable Panels, Access Doors 700-799 Fittings 800-899 Extrusions, Fittings, Special Parts 900-909 Wing Tip 910-929 Loft Lines Layout 930-999 Miscellaneous
		000-099 Main Assys & Instl 100-199 Spars & Skins 200-299 Leading Edge 300-399 Ribs 400-499 Fairings & Ribs 500-599 Fin Tip 600-699 Removable Panels, Access Doors 700-799 Fittings 800-899 Extrusions & Special Parts 900-929 Loft Lines Layout 930-999 Miscellaneous

8	12-Elevon 13-Elevon 14-Vertical Stabilizer 15-Rudder	000-099 Main Assys & Instl 100-199 Spars & Skins 200-299 Leading Edge 300-399 Ribs 400-499 Fairings & Ribs 500-599 Fin Tip 600-699 Removable Panels, Access Doors 700-799 Fittings 800-899 Extrusions & Special Parts 900-929 Loft Lines Layout 930-999 Miscellaneous
		000-099 Main Assys & Instl 100-199 Spars & Skins 200-299 Leading Edge 300-399 Ribs 400-499 Fairings & Ribs 500-599 Fin Tip 600-699 Removable Panels, Access Doors 700-799 Fittings 800-899 Extrusions & Special Parts 900-929 Loft Lines Layout 930-999 Miscellaneous

POWER PLANT & AIR CONDITIONING		
Model	Function And Area	Supplemental Number

8	20-General 22-P.P./De-mountable 25-Body 26-P.P./De-mountable 27-Body 28-Body Guidance System	000-099 Structure Mount & Removal Prev 100-199 Induction System 200-299 Fuel System 300-399 Shrouding & Firewall 400-499 Cooling & Ventilating Prev 500-599 Starter Including GTCI 600-699 Lines Layout 900-999 Miscellaneous
		000-599 Fuel

8	21-Wing	000-599 Fuel
8	23 Air Conditioning 25-Body	Assigned in sequence 000-649 Air Conditioning 650-999 Power Plant

ELECTRONICS AND INSTRUMENTS		
Model	Function And Area	Supplemental Number

8	30-General Airplane	000-009 Radio Gen'l Arrangement 100-399 Radio Connection Diagrams 500-749 Radio Wiring Diagrams
		000-009 Radio Gen'l Arrangement 100-399 Radio Connection Diagrams 500-749 Radio Wiring Diagrams
8	31-Wing 33-Empennage 34-Body 36-Body 37-Body 38-Instruments 39-Instruments	000-449 Main Assy & Instl 450-800 Details & Minor Assys 801-999 Harnesses
		000-449 Main Assy & Instl 450-800 Details & Minor Assys 801-999 Harnesses

8	35-Body	000-249 Main Assys & Instl 250-449 Harnesses 450-800 Details & Minor Assys 801-999 Harnesses
---	---------	---

CONTROLS AND MECHANISMS		
Model	Function And Area	Supplemental Number

8	40-General 41-Wing 42-Body 43-Empennage 47-Body 49-Body	000-099 Main Assys & Instl 100-199 Gen'l Controls 200-299 Rudder Controls 300-399 Elevon Controls 400-699 Castings & Forgings 700-799 P. P. & Sec Controls 800-849 Automatic Flight Controls 850-899 P. P. & Sec Controls 900-929 Loft Lines Layout 930-999 Castings & Forgings
		000-099 Main Assys & Instl 100-199 Gen'l Controls 200-299 Rudder Controls 300-319 Speed Break Mech 320-499 Drag Chute Mech 500-599 MILG Door Mech 600-699 NIG Door Mech 700-799 Misc Mech 800-899 Armament Door Mech 900-999 Misc Mech

8	44-Mechanisms 45-Mechanisms 46-Mechanisms	000-099 Main Assys & Instl 100-199 Gen'l Controls 200-299 Rudder Controls 300-319 Speed Break Mech 320-499 Drag Chute Mech 500-599 MILG Door Mech 600-699 NIG Door Mech 700-799 Misc Mech 800-899 Armament Door Mech 900-999 Misc Mech
		000-099 Main Assys & Instl 100-199 Gen'l Controls 200-299 Rudder Controls 300-399 Elevon Controls 400-699 Castings & Forgings 700-800 P. P. & Sec Controls 900-999 Castings & Forgings

8	48-Body	000-099 Main Assys & Instl 100-199 Gen'l Controls 200-299 Rudder Controls 300-399 Elevon Controls 400-699 Castings & Forgings 700-800 P. P. & Sec Controls 900-999 Castings & Forgings
---	---------	--

ALIGHTING GEAR AND ARMAMENT		
Model	Function And Area	Supplemental Number

8	50-General 51-Alighting Gear - Main	000-099 Main Assy & Instl 100-299 Details and Minor Assys 900-999 Lines Layout
		000-099 Main Assy & Instl 100-299 Details and Minor Assys 900-999 Lines Layout

8	53-Instr & Flight Test	000-499 Instrumentation 500-999 Eng Flight Test
---	------------------------	--

8	54-Armament 56-Armament 57-Armament	000-199 Missile Instl, Assy & Details 200-399 Rocket Instl, Assy & Details 400-499 Armament Displacement Mech 500-699 Missile Bay Doors Instl, Assy, & Details 700-799 Missile Bay Beams Assy & Details 800-899 Rocket Instl, Assy, & Details 900-999 Armament Trunnions
		000-199 Missile Instl, Assy & Details 200-399 Rocket Instl, Assy & Details 400-499 Armament Displacement Mech 500-699 Missile Bay Doors Instl, Assy, & Details 700-799 Missile Bay Beams Assy & Details 800-899 Rocket Instl, Assy, & Details 900-999 Armament Trunnions

8	58-Instrumentation 59-Instrumentation	Assigned in sequence Assigned in sequence
---	--	--

ELECTRICAL		
Model	Function And Area	Supplemental Number

8	60-General Airplane 69-General Airplane	000-049 Gen'l Arrangement & Major Instl 050-199 Schematic & Load Analyses 200-599 Connection Diagrams 600-899 Circuit Diagrams 900-999 Connection Diag (-60) 900-999 Schematic Diag (-69)
		000-049 Gen'l Arrangement & Major Instl 050-199 Schematic & Load Analyses 200-599 Connection Diagrams 600-899 Circuit Diagrams 900-999 Connection Diag (-60) 900-999 Schematic Diag (-69)

ELECTRICAL (CONT.)		
Model	Function And Area	Supplemental Number

8	61-Wing & Emp 63-Cockpit 64-Cockpit 66-Body 67-Body	000-249 Main Assys & Instl 250-549 Details & Minor Assys 550-999 Harnesses
		000-249 Main Assys & Instl 250-499 Details & Minor Assys 500-999 Harnesses

8	62-Cockpit 68-Body	000-249 Main Assys & Instl 250-499 Details & Minor Assys 500-999 Harnesses
---	-----------------------	--

8	65-Body	000-249 Main Assys & Instl 250-699 Details & Minor Assys 700-899 Harnesses
---	---------	--

BODY		
Model	Function And Area	Supplemental Number

8	70-Structure 71-Structure 72-Structure 73-Structure 75-Structure 76-Structure 77-Structure	000-099 Equip. Panel Assys 100-199 Longerons & Beams 200-399 Frames 400-499 Structure Panel Assys 500-599 Misc & Figs 600-699 Doors (Insp & Access) 700-799 Figs 800-899 Windows & Enclosures 900-999 Misc
		000-099 Equip. Panel Assys 100-199 Longerons & Beams 200-399 Frames & Frame Figs 400-499 Structure Panel Assys 500-599 Misc 600-699 Doors 700-799 Figs 800-899 Canopy, Windshield & Figs 900-999 Misc

8	74-Structure	000-099 Equip. Panel Assys 100-199 Longerons, Beams & Assoc Figs 200-399 Frames & Frame Figs 400-499 Structure Panel Assys 500-599 Misc 600-699 Doors 700-799 Figs 800-899 Canopy, Windshield & Figs 900-999 Misc
---	--------------	---

PNEUMATICS - PRESSURIZATION - HEATING VENTILATING - ANTICIPATION - HYDRAULIC		
Model	Function And Area	Supplemental Number

8	80-General 81-Hyd-Body 82-Hyd-Wing & Emp 83-Hyd-Engine 84-Hyd-Landing Gear 85-Pnev-Body 86-Pnev-LG 87-H & V-Body 88-H & V-Wing & Emp 89-H & V-Body	000-099 Instl & Gen'l Diag 100-199 Assys 200-259 Details 300-359 Instl & Gen'l Diag 400-459 Assys 500-559 Details 600-659 Instl & Gen'l Diag 700-759 Assys 800-949 Details
		000-099 Instl & Gen'l Diag 100-199 Assys 200-259 Details 300-359 Instl & Gen'l Diag 400-459 Assys 500-559 Details 600-659 Instl & Gen'l Diag 700-759 Assys 800-949 Details

FURNISHINGS AND EQUIPMENT		
Model	Function And Area	Supplemental Number

8	90-General 92-Body 94-Cockpit 99-Body & Cockpit	000-099 Main Assys & Instl 100-199 Accommodations (Seats, etc.) 200-299 Interior Trim 300-399 Fire Ext Equip & Cont 400-499 Oxygen Equip 500-699 Instr Panel Prev 700-999 Elec Prev 800-999 Misc
		000-099 Main Assys & Instl 100-199 Accommodations (Seats, etc.) 200-299 Interior Trim 300-399 Fire Ext Equip & Cont 400-499 Oxygen Equip 500-699 Instr Panel Prev 700-999 Elec Prev 800-999 Misc

8	96-Handling Gear 97-Handling Gear	Assigned in Sequence Assigned in Sequence
---	--------------------------------------	--

TO LOOK FOR WHERE TO FIND IT TO USE IT

THIS TECHNICAL MANUAL CONTAINS ALL AVAILABLE INFORMATION REQUIRED FOR IDENTIFYING AND ORDERING REPLACEABLE PARTS. THIS INFORMATION HAS BEEN TABULATED AND LISTED IN CODED OR ABBREVIATED FORM.

BEFORE THE TECHNICAL MANUAL CAN BE USED QUICKLY AND EASILY, IT IS NECESSARY TO UNDERSTAND BOTH HOW THE INFORMATION HAS BEEN TABULATED, CODED AND ABBREVIATED AND WHERE EACH ITEM OF NECESSARY INFORMATION CAN BE FOUND.

group assembly parts lists

group assembly parts lists – FIGURE AND INDEX NUMBER COLUMN

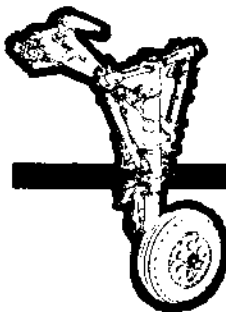

Section II
Group Assembly Parts List

Section II
Group Assembly Parts List

FIGURE AND INDEX NUMBER	PART NUMBER	DESCRIPTION	UNITS PER ASSY	USABLE ON CODE	
				FROM	TO
2-15-00 - 1	8-48804	CONTROL INSTALLATION; EMERGENCY LANDING GEAR RELEASE FOR NHA SEE FIG. 28	RF	1	13
	8-48804-1	CONTROL INSTALLATION; EMERGENCY LANDING GEAR RELEASE FOR NHA SEE FIG. 28	RF	14	
	12417-250	* CONTROL ASSY; EMERGENCY LANDING GEAR FWD TEX SPEC 8-04916-250	1	A	
	12417-260	* CONTROL ASSY; EMERGENCY LANDING GEAR FWD	1	C	

FIGURE AND INDEX NUMBER	PART NUMBER	DESCRIPTION
2-15-00 - 1	8-48804	CONTROL RELFA
	8-48804-1	CONTROL RELEA
	12417-250	* CONTR TEX
	12417-260	* CONTR

The illustration figure number is shown opposite the first item listed on each parts list page. The illustration index number is found immediately to the left of the part number it represents.

group assembly parts lists— PART NUMBER COLUMN

Section II
Group Assembly Parts List

FIGURE AND INDEX NUMBER	PART NUMBER	DESCRIPTION	UNITS PER ASSY	USABLE ON CODE	
				FROM	TO
2-15-00 - 1	8-48804	CONTROL INSTALLATION, EMERGENCY LANDING GEAR RELEASE FOR NHA SEE FIG. 28	RF	1	13
	8-48804-1	CONTROL INSTALLATION, EMERGENCY LANDING GEAR RELEASE FOR NHA SEE FIG. 28	RF	14	
	12417-250	CONTROL ASSY, EMERGENCY LANDING GEAR FWD TEX SPEC 8-04916-250	1	A	
	12417-260	CONTROL ASSY, EMERGENCY LANDING GEAR FWD	1	C	

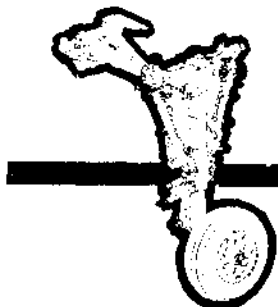

ONLY THREE KINDS OF NUMBERS APPEAR IN THIS COLUMN:

CONTRACTOR'S PART NUMBERS

Each part designed and manufactured by the contractor is identified by the number of its engineering drawing. For the formation of these numbers, refer to Chart C.

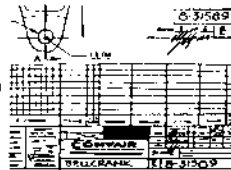

VENDOR'S PART NUMBERS

The vendor assemblies listed in this Technical Manual are listed as assemblies only. Details of vendor parts are not listed or illustrated, when such parts are used without change or modification. Separate Illustrated Parts Breakdowns are being procured for those items which are subject to wear or overhaul. When available, the Technical Order Number of the Illustrated Parts Breakdown covering the specific item will be listed in the description column. Vendor items which have been altered by the contractor have been assigned the contractor's part number. If the part number is too long to be completed in the parts number column, the number is broken at a dash or slash symbol and the balance of the part number is then continued in the description column after the noun.



STANDARD PART NUMBERS

Government standard parts which have been altered by the contractor have been assigned contractor's part numbers. Standard part numbers have an alphabetical prefix. These parts are not designed for any particular model of airplane. Prefix letters and types of parts designated are:

- | | | | |
|---------------------------|-------------------------------------|-----------------------------|------------------------------|
| standards prefixes | NAS | National Aircraft Standards | |
| AF | Air Force Standards | NSC | Spring Coiled Semi-Standards |
| AN | Army-Navy Standards | MS | Military Standards |
| NAF | National Aircraft Factory Standards | Q | Contractor's Standards |

group assembly parts lists— DESCRIPTION COLUMN

Section II
Group Assembly Parts List

FIGURE AND INDEX NUMBER	PART NUMBER	DESCRIPTION	UNITS PER ASSY	USABLE ON CODE	
				FROM	TO
2-15-00 - 1	8-48804	CONTROL INSTALLATION, EMERGENCY LANDING GEAR RELEASE FOR NHA SEE FIG. 28	RF	1	13
	8-48804-1	CONTROL INSTALLATION, EMERGENCY LANDING GEAR RELEASE FOR NHA SEE FIG. 28	RF	14	
	12417-250	CONTROL ASSY, EMERGENCY LANDING GEAR FWD TEX SPEC 8-04916-250	1	A	
	12417-260	CONTROL ASSY, EMERGENCY LANDING GEAR FWD	1	C	

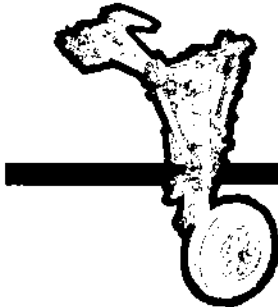

THIS COLUMN CONTAINS A DESCRIPTION OF EACH REPLACEABLE PART. IN ADDITION, EACH PART'S RELATION TO ITS NEXT HIGHER ASSEMBLY IS SHOWN BY ITS INDENTATION.

description column (cont.)

CHART D

PARTS-LISTING INDENTATION SYSTEM

— used in the description column

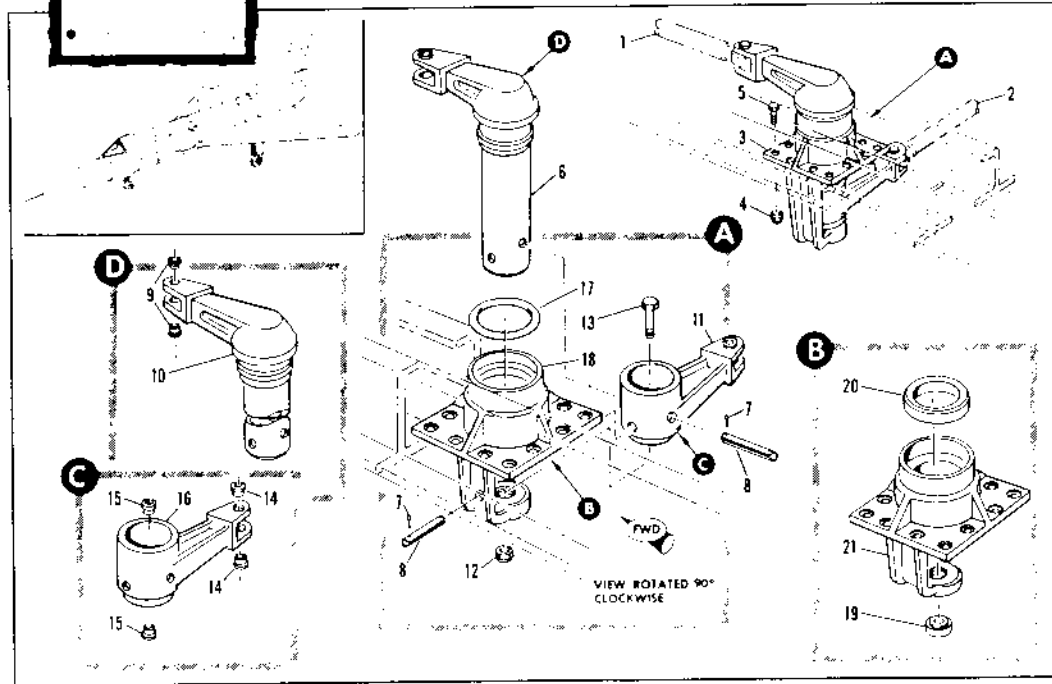

Each Parts List is broken down into installations, assemblies, sub-assemblies, detail parts, and attaching parts. The order in which the items are listed, and the indentation of the description normally indicates the proper sequence of disassembly.

Figure 000. Aileron Torque Tube Bellcrank Installation, Sta 159

FIGURE AND INDEX NUMBER	PART NUMBER	DESCRIPTION						UNITS PER ASSY.
		1	2	3	4	5	6	
2,6-400	B-48503	BELLCRANK INSTALLATION, AILERON TORQUE TUBE STA 159 FOR NHA SEE FIG. 182						RF
- 1	B-40120-715	• ROD ASSY, AIL COMT SEE FIG. 21						1
- 2	B-40120-711	• ROD ASSY, AIL COMT SEE FIG. 21						1
- 3	B-48503-7	• BOX ASSY, AILERON TORQUE TUBE						1
		ATTACHING PARTS						
- 4	AN365-428	• NUT						12
- 5	AN4-6A	• BOLT						12
		-----X-----						
- 6	B-48976	• CRANKSHAFT ASSY, AILERON CONT						1
		ATTACHING PARTS						
- 7	AN381-2-8	• PIN						4
- 8	B-49120-9	• PIN, ALTERED FROM 79-062-312-2550 EN						2
	B-49120-35	• PIN, ALTERED FROM 52-062-312-2250 EN						2
		-----X-----						
- 9	NAS77-4-25	• BUSHING						2
- 10	B-48976-9	• CRANKSHAFT						1
- 11	B-48975	• BELLCRANK ASSY, AILERON CONT						1
		ATTACHING PARTS						
- 12	AN320-6	• NUT						1
- 13	NAS464P6-14	• BOLT						1
		-----X-----						
- 14	NAS77-6-22	• BUSHING						2
- 15	NAS77-4-25	• BUSHING						2
- 16	B-48975-4	• BELLCRANK						1
- 17	AN6226-29	• O RING						1
- 18	B-48985	• HOUSING ASSY, BEARING						1
- 19	AN201KP6A	• BEARING						1
- 20	AN202KP23B	• BEARING						1
- 21	B-48985-9	• HOUSING						1

- 1st-column item (installation or assembly) is made up of all items below it and indented one column to the right.
- 2nd-column items (installations, assemblies or detail parts), together with their attaching parts, make up the 1st-column item.
- Each 2nd-column installation or assembly may, in turn, be broken down into its own sub-installations, sub-assemblies, and detail parts, indented to the 3rd column.
- 3rd-column items (sub-installations, sub-assemblies, or detail parts), together with their attaching parts, make up the 2nd-column item beneath which they are indented.
- Each 3rd-column sub-installation or sub-assembly may be further broken down into its own component items, which are indented to the 4th column. This process is continued until breakdown is complete.

Note — The attaching parts follow immediately after the item which they attach, and precede any components of that item. Attaching parts have the same indentation as the

part they attach, are captioned "ATTACHING PARTS," and are separated from subsequent listing by the symbol "-----X-----".

description column (cont.)

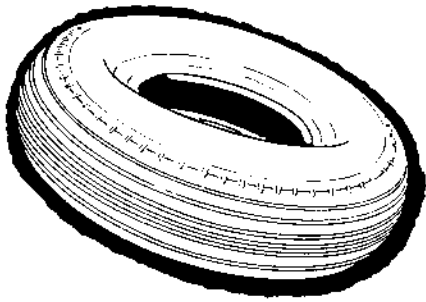

...“GFAE” & “GFAE AF INSTALLED”

Items of Government Furnished Aeronautical Equipment are listed in the Technical Manual as assemblies only and are identified in the description column by the symbol “GFAE.” For more detailed information concerning these items, consult the Technical Order Index and list of applicable publications (T.O. 1F-106A-01) for the Technical Order Number of the Illustrated Parts Breakdown for the specific item of equipment. If the item is contractor-installed, the description is followed by “GFAE”; however, if the item is customer installed, the description is followed by “GFAE AF INSTALLED.”

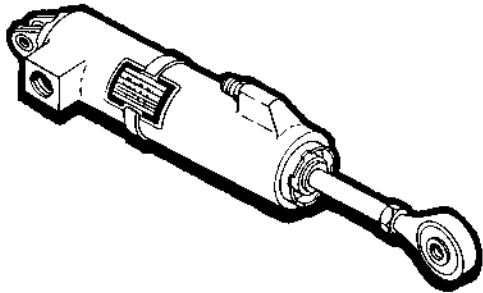

...“SPEC 8-XXXXX”

Items of equipment which have been manufactured by vendors to contractor's specification control drawings, have been treated as vendor parts, and are listed by the vendor part numbers when available. The description of these items is followed by “SPEC 8-XXXXX-X.”

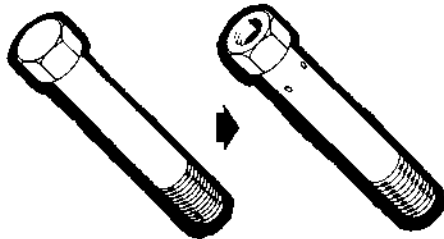

...“ALTERED FROM ...”

When a vendor part is altered by the contractor, a contractor's part number is assigned and the description is followed by “ALTERED FROM ...”

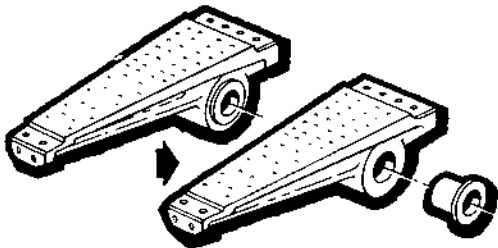

...“FOR BREAKDOWN SEE FIG. ...”

Where an assembly has required a detail breakdown on a separate figure, the description of the assembly is followed by “FOR BREAKDOWN SEE FIG. ...”

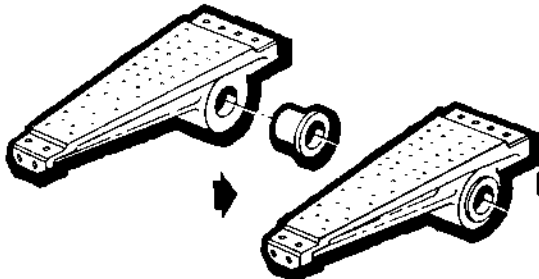

...“FOR NHA SEE FIG. ...”

Where an assembly has been broken down on one figure, and referenced to the next higher assembly on another figure, the description is followed by “FOR NHA. SEE FIG. ...”

description column (cont.)

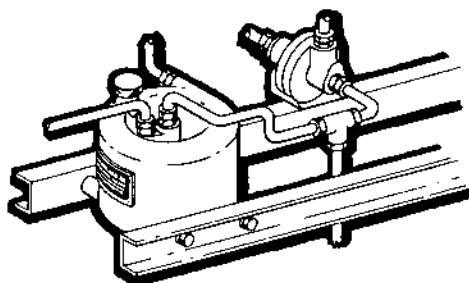

...“SEE FIG. . . .”

Where an assembly or a detail part has been referenced under an improper next assembly to obtain clarity and continuity in the illustration, the description is followed by “SEE FIG. . . .”

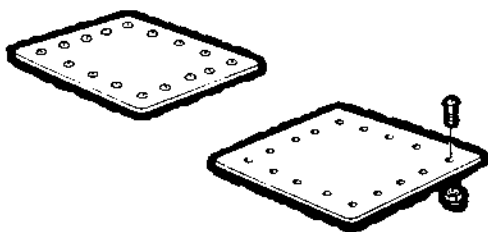

GROUPS OF IDENTICAL PARTS

Where an identical combination of standard parts, such as a nut, washer, or screw, is used more than once for the attachment of a specific item, only one combination is shown in detail on the illustration.

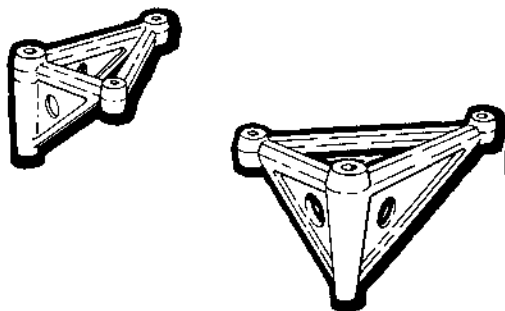

...“LH & RH . . .”

Where left-hand and right-hand assemblies have common parts, the assemblies are broken down together. When items are common to left- and right-hand assemblies, the quantity listed is that required for one next higher assembly only. A detail which is used only on the left-hand or right-hand portion of its next higher assembly carries “LH” or “RH” respectively at the end of the description.

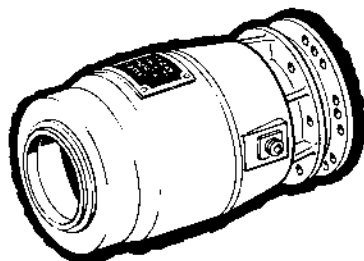

MANUFACTURERS' CODING

Parts procured from a vendor are identified by a manufacturer's code immediately following the description of the part. The manufacturer's codes are used in accordance with “Cataloging Handbook H4-1 and H4-2” (Federal Supply Code for Manufacturers). A complete list of codes used in this manual, together with the corresponding manufacturers' names and addresses, is given at the end of the introduction.

description column (cont.)



“ALT INTCHG WITH...” & “ALTERNATE PART FOR...”

Where alternate and interchangeable parts are listed, the description is followed by “ALT INTCHG WITH;” where alternate parts are listed and the parts are not interchangeable, the description is followed by “ALTERNATE PART FOR.”

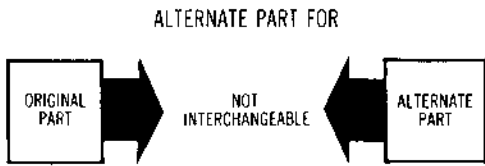

REPLACED BY NOT INTCHG WITH

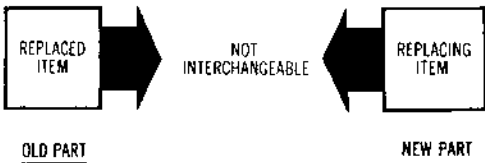

“...REPLACED BY NOT INTCHG WITH...”

Where a replaced item is listed which is not interchangeable with and which bears a different effectivity than the replacing item, the description of the replaced item is followed by the phrase “REPLACED BY NOT INTCHG WITH.” This phrase does not imply that replacement of the old item is mandatory in all applications.

REPLACES NOT INTCHG WITH

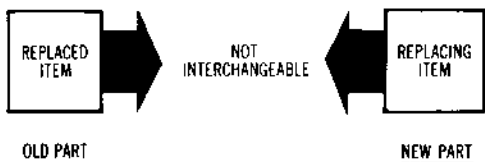

“...REPLACES NOT INTCHG WITH...”

Where a replacing item is neither interchangeable with nor bears the same effectivity as the item being replaced, the description of the replacing item is followed by the phrase “REPLACES NOT INTCHG WITH.”

REPLACED BY SUITABLE SUB



“...REPLACED BY SUITABLE SUB...”

The phrase “REPLACED BY SUITABLE SUB” follows the description of replaced items characterized by “one-way” interchangeability—that is, when the replacing item can be used in all applications specified for the replaced item. This phrase does not imply that replacement of the old item is mandatory in all applications.

description column (cont.)

REPLACES SUITABLE SUB FOR



“...REPLACES SUITABLE SUB FOR...”

The phrase “REPLACES SUITABLE SUB FOR” follows the description of replacing items characterized by “one-way” interchangeability—that is, when the replacing item can be used in all applications specified for the replaced item.

REPLACED BY INTCHG WITH



“...REPLACED BY INTCHG WITH...”

Where full interchangeability between replaced and replacing items exists, the description of the replaced item is followed by the phrase “REPLACED BY INTCHG WITH.” This phrase does not imply that replacement of the old item is mandatory in all applications.

REPLACES INTCHG WITH



“...REPLACES INTCHG WITH...”

The description of a replacing item which is fully interchangeable with the item replaced is followed by the phrase “REPLACES INTCHG WITH.”

NO DIRECT REPLACEMENT



“...NO DIRECT REPLACEMENT.”

The phrase “NO DIRECT REPLACEMENT” follows the description of items bearing a limited effectivity—that is, items whose function is omitted or performed by other equipment in subsequent aircraft.

description column (cont.)

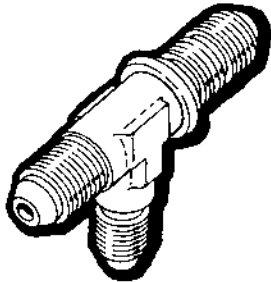
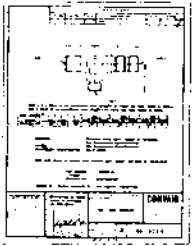

CONVAIR PART CONTROL NUMBERS

Part Control Numbers have been assigned by the Contractor to many of the parts purchased from Vendors, to help in identifying, processing, and handling these parts inside the Contractor's factories. A Part Control Number will appear in the Part Number Column of the Group Assembly Parts Lists only when it identifies a Contractor's Standard Part, such as a nut, or a washer; however, it will appear in the Description Column (if one has been assigned), to further supplement the part description. Each Part Control Number is a ten-digit number, starting with a constant digit, nine (9), which identifies it as a Part Control Number. (Examples: 94-80526-039; 97-36021-467.)

ABBREVIATIONS

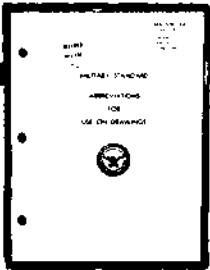

All abbreviations used in the Group Assembly Parts Lists are in accordance with Standard MIL-STD-12B.

**group assembly parts lists –
UNITS PER ASSEMBLY COLUMN**

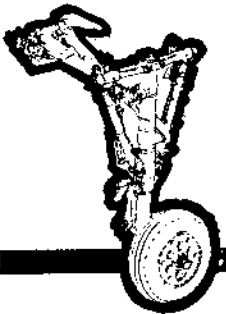
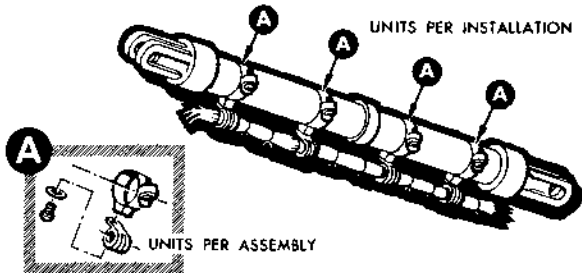

FIGURE AND INDEX NUMBER	PART NUMBER	DESCRIPTION	UNITS PER ASSY.	USABLE ON CODE		FROM TO
				FROM	TO	
2-15-00 - 1	8-48804	CONTROL INSTALLATION, EMERGENCY LANDING GEAR RELEASE FOR NHA SEE FIG. 28	RF	1	13	
	8-48804-1	CONTROL INSTALLATION, EMERGENCY LANDING GEAR RELEASE FOR NHA SEE FIG. 28	RF	14		
	12417-250	CONTROL ASSY, EMERGENCY LANDING GEAR FWD TEX SPEC 8-04916-250	1	A		
	12417-260	CONTROL ASSY, EMERGENCY LANDING GEAR FWD	1	C		



The quantity shown in the units per assembly column for a given part represents the total required per next higher assembly. The letters "RF" (reference) designate those items which are listed for reference purposes only, and the units per assembly as noted on the referenced figure. Where alternate parts are listed, the quantity per assembly is shown as "RF." The letters "AR" (as required) are used for bulk items and standard parts, the quantity of which is to be determined on assembly.

group assembly parts lists - 'USABLE ON' CODE COLUMN

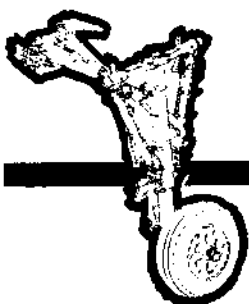

FIGURE AND INDEX NUMBER	PART NUMBER	DESCRIPTION	UNITS PER ASSY	USABLE ON CODE	
				FROM	TO
				1	2
2415-00 - 1	8-48804	CONTROL INSTALLATION, EMERGENCY LANDING GEAR RELEASE FOR NHA SEE FIG. 28	RF	1	13
	8-48804-1	CONTROL INSTALLATION, EMERGENCY LANDING GEAR RELEASE FOR NHA SEE FIG. 28	RF	14	A
	12417-250	CONTROL ASSY, EMERGENCY LANDING GEAR FWD TEX SPEC 8-04916-250	1	A	
	12417-260	CONTROL ASSY, EMERGENCY LANDING GEAR FWD	1	C	

CATALOG AIRPLANE NUMBERS

Parts or Assemblies which are released for use only on a limited number of airplanes within one Model are indicated by listing the applicable Convair Catalog Airplane Numbers in the 'Usable On' Code Column. The Master Usable On Code Listing, located at the end of the Introduction, Section I, cross-references these Catalog Numbers with the corresponding USAF Airplane Serial Numbers.

NUMBERS IN BOTH COLUMNS

Entries in the "FROM" and "TO" columns for a particular part are inclusive.

NUMBERS IN "FROM" COLUMN ONLY

An entry only in the "FROM" column indicates that the part is used on the noted Catalog-Numbered Airplane, and on all subsequent airplanes.

LETTERS IN "FROM" COLUMN ONLY

A letter, instead of a number, in the "FROM" column is used to refer to a footnote at the bottom of each page. The footnote indicates the use of the particular part only on certain Catalog-Numbered Airplanes.

FIGURE AND INDEX NUMBER	PART NUMBER	DESCRIPTION	UNITS PER ASSY	USABLE ON CODE
2415-00 - 1	8-48804	CONTROL INSTALLATION, EMERGENCY LANDING GEAR RELEASE FOR NHA SEE FIG. 28	RF	1 13
	8-48804-1	CONTROL INSTALLATION, EMERGENCY LANDING GEAR RELEASE FOR NHA SEE FIG. 28	RF	14 A
	12417-250	CONTROL ASSY, EMERGENCY LANDING GEAR FWD TEX SPEC 8-04916-250	1	A
	12417-260	CONTROL ASSY, EMERGENCY LANDING GEAR FWD	1	C
	8-48804-2	CONTROL INSTALLATION, EMERGENCY LANDING GEAR RELEASE FOR NHA SEE FIG. 28	RF	15
	8-48804-3	CONTROL INSTALLATION, EMERGENCY LANDING GEAR RELEASE FOR NHA SEE FIG. 28	RF	16
	8-48804-4	CONTROL INSTALLATION, EMERGENCY LANDING GEAR RELEASE FOR NHA SEE FIG. 28	RF	17
	8-48804-5	CONTROL INSTALLATION, EMERGENCY LANDING GEAR RELEASE FOR NHA SEE FIG. 28	RF	18
	8-48804-6	CONTROL INSTALLATION, EMERGENCY LANDING GEAR RELEASE FOR NHA SEE FIG. 28	RF	19
	8-48804-7	CONTROL INSTALLATION, EMERGENCY LANDING GEAR RELEASE FOR NHA SEE FIG. 28	RF	20
	8-48804-8	CONTROL INSTALLATION, EMERGENCY LANDING GEAR RELEASE FOR NHA SEE FIG. 28	RF	21
	8-48804-9	CONTROL INSTALLATION, EMERGENCY LANDING GEAR RELEASE FOR NHA SEE FIG. 28	RF	22

- A Airplanes * 1, 6, 7 and 9
- B Airplanes * 2, 4, 8, 10 and on
- C Airplanes * 3 and 5

The diagram below illustrates the three basic configurations noted on the Parts List Page. The first variation is symbolized by the black nose and is shown on the "A" coded airplanes—1, 6, 7 and 9. The second variation is symbolized by the black tail and is shown on the "B" coded airplanes—2, 4, 8, 10 and on. Those aircraft incorporating both variations as indicated by both the black nose and tail are coded "C"—airplanes 3 and 5.

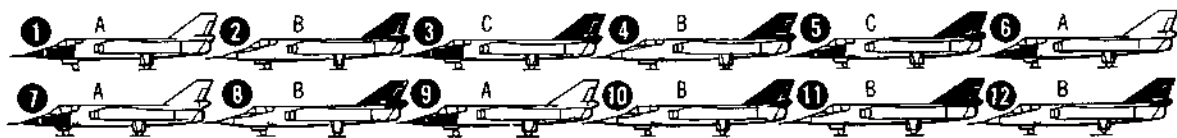

group assembly parts lists - REVISION SYMBOL COLUMN

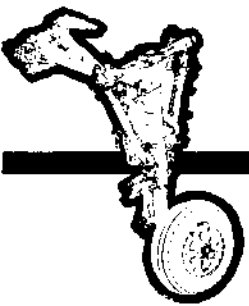

FIGURE AND INDEX NUMBER	PART NUMBER	DESCRIPTION	UNITS PER ASSY	USABLE ON CODE	
				FROM	TO
				1	2
2415-00 - 1	8-48804	CONTROL INSTALLATION, EMERGENCY LANDING GEAR RELEASE FOR NHA SEE FIG. 28	RF	1	13
	8-48804-1	CONTROL INSTALLATION, EMERGENCY LANDING GEAR RELEASE FOR NHA SEE FIG. 28	RF	14	A
	12417-250	CONTROL ASSY, EMERGENCY LANDING GEAR FWD TEX SPEC 8-04916-250	1	A	
	12417-260	CONTROL ASSY, EMERGENCY LANDING GEAR FWD	1	C	

In order to facilitate efficient compilation of the Group Assembly Parts Lists, the latest parts list revisions are now indicated by the insertion of an "x" in the Revision Symbol Column, opposite the revised entry.

to sum up where information is located...

ALL THE DIFFERENT PARTS OF THIS TECHNICAL MANUAL WORK TOGETHER TO GIVE COMPLETE, UP-TO-DATE REPLACEABLE-PARTS INFORMATION.

T.O. 1F-106A-4 Section III Manual Index

Part Number	Trade Number	Figure and Index Number	Part Number	Trade Number	Figure and Index Number
...
B-65255-1	1560-573-8482-BK	2.15-21	7855-1	59	...

T.O. 1F-106A-4 Section I

MASTER USABLE ON CODE

Catalog Airplane Numbers	Model and Basic Designation	Air Force Serial Numbers	Catalog Airplane Numbers	Model and Basic Designation	Air Force Serial Numbers
...	F-106B-45	AF57-2524	49
...	F-106B-46	AF57-2525	50
...	F-106B-47	AF57-2526	51
...	F-106B-48	AF57-2527	52
...	F-106B-49	AF57-2528	53
...	F-106B-50	AF57-2529	54

T.O. 1F-106A-4

FIGURE AND INDEX NUMBER	PART NUMBER	DESCRIPTION	1 2 3 4 5 6						
			2.15-21 - 21	7855-1	ACTUATOR ASSY. MLG <75662> SPEC 8-0848-3				
	7855-3	ACTUATOR ASSY. MLG <75662> SPEC 8-0848-3 REPLA BY SUITABLE SUB FOR 7855-1							
		ACTUATOR ASSY. MLG <75662> SPEC 8-0848-3 REPLA BY SUITABLE SUB FOR 7855-1							

THE MASTER 'USABLE ON' CODE LISTING GIVES A CROSS-REFERENCE BETWEEN CONVAIR CATALOG AIRPLANE NUMBERS, AND USAF AIRPLANE SERIAL NUMBERS.

THE NUMERICAL INDEX TELLS WHERE REPLACEABLE PARTS ARE LISTED AND ILLUSTRATED, AND GIVES NECESSARY PART-ORDERING INFORMATION.

THE MANUFACTURER'S CODE LISTING GIVES THE FULL NAME AND ADDRESS OF THE MANUFACTURER OF ANY VENDOR PART OR ASSEMBLY.

THE ALPHABETICAL INDEX TELLS WHERE EACH SIGNIFICANT COMPONENT AND MAJOR ASSEMBLY IS ILLUSTRATED.

FIGURE AND INDEX NUMBER	PART NUMBER	DESCRIPTION	ATTACHMENT PARTS
- 55	B-65255-1	PLATE, <97198> SPEC 8-06986-7	
- 56	NAS...	SWITCH, <97198> SPEC 8-06986-7	
- 57	...	NUT	
- 58	...	WASHER	
- 59	B-65255-1	BOLT	

T.O. 1F-106A-4 Section I

MANUFACTURERS' CODE LISTING (CONT.)

Code	Manufacturer Name	Address
97947	WYTE ENGINE WORKS OR WELL	SEPPY DIV OF UNITED STATES STEEL CORP., Kansas City, Mo.
97960	DSD MFG CO.	Hawarden, Conn.
97990	CROCKER MFG CO.	Calver City, Calif.
98159	RUBBER TECH, INC.	Golden, Calif.
97198	CONTROL SWITCH DIV, CONTROLS CO. OF AMERICA	Chicago, Ill.
98159	PADWAY AIRCRAFT PRODUCTS, INC.	San Ysidro, Calif.
98441	STRATO FLEX INC.	Fort Worth, Tex.

T.O. 1F-106A-4 Section I

Alphabetical Index

Title	Page	Title	Page
Actuator	2.15-77
-MLG	2.15-77
...

CATALOG

HOW

HOW

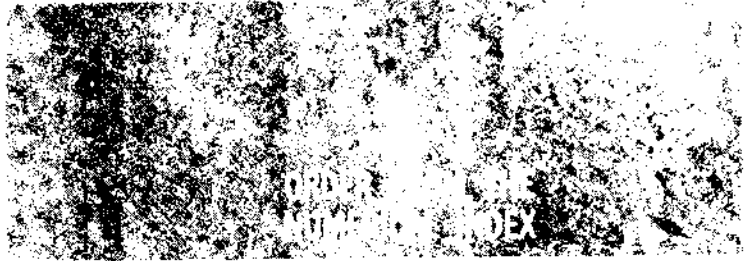

IF PART NUMBER IS KNOWN

START HERE TO LOCATE PART

- 1 TURN TO THE NUMERICAL INDEX NUMBER OF THE DESIRED PART

TURN TO THE FIGURE & ITS INDEX CHECK THE PART DESCRIPTION CHECK THE NEED FOR ASSOCIATED PARTS CHECK THE CATALOG NUMBER OF THE PART

TURN TO THE MASTER INDEX TO OBTAIN THE AF SERIAL NUMBERS OF THE PART

TURN TO THE NUMERICAL INDEX TO OBTAIN THE SOURCE CODE

IF PART NUMBER IS UNKNOWN

START HERE TO DETERMINE PART

- 2 TURN TO THE ALPHABETICAL INDEX OF THE DESIRED PART'S MAJOR GROUP THE NUMBER OF THE PART GROUP AT THE BEGINNING OF THE INSTALLATION IS ILLUSTRATED

TURN TO THE TABLE OF CONTENTS TO OBTAIN THE NUMBER OF THE BEGINNING OF THE PART GROUP

TURN TO THE PROPER FIGURE, FIND THE PART, & ITS INDEX REFER TO THE PARTS LIST INDEX CHECK THE PART DESCRIPTION CHECK THE NEED FOR ASSOCIATED PARTS CHECK THE CATALOG NUMBER OF THE PART

TURN TO THE MASTER INDEX TO OBTAIN THE AF SERIAL NUMBERS OF THE PART

TURN TO THE NUMERICAL INDEX TO OBTAIN THE SOURCE CODE

Y.O. 1F-106A-4

Part Number	Stock Number	Part Description	Source Code	AF Serial Number
1560-573-4622-BK	215-21			

NOTE

1. Maintenance personnel, remember to Record the part number correctly. Order by the Stock Number, if it is given. Procure as directed by the Source Code.
2. Supply personnel, remember to Verify or determine the Stock Number, and procure per instructions.

Y.O. 1F-106A-4

AF SERIAL NUMBER ON CODE

Part Number	AF Serial Number
F 106A	AF 106-011
F 106A	AF 106-012
F 106A	AF 106-013
F 106A	AF 106-014
F 106A	AF 106-015
F 106A	AF 106-016
F 106A	AF 106-017
F 106A	AF 106-018
F 106A	AF 106-019
F 106A	AF 106-020
F 106A	AF 106-021
F 106A	AF 106-022
F 106A	AF 106-023
F 106A	AF 106-024
F 106A	AF 106-025

HOW TO LOOK FOR HOW TO FIND IT HOW TO USE IT

1. HOW TO FIND IT

START HERE TO LOCATE PART NUMBER IN THIS TECHNICAL MANUAL.

- 1 TURN TO THE NUMERICAL INDEX FOR THE FIGURE & INDEX NUMBER OF THE DESIRED PART'S ILLUSTRATION.

TURN TO THE FIGURE & ITS PARTS LIST TO CHECK THE PART DESCRIPTION, CHECK THE NEED FOR ASSOCIATED PARTS, CHECK THE CATALOG NUMBERS OF AIRPLANES USING THE PART.

TURN TO THE MASTER USABLE ON CODE LISTING TO VERIFY THE AF SERIAL NUMBERS OF AIRPLANES USING THE PART.

TURN TO THE NUMERICAL INDEX FOR PART ORDERING INFORMATION - SOURCE CODE, CLASS CODE & SERIAL NUMBER.

2. HOW TO USE IT

START HERE TO DETERMINE PART NUMBER.

- 2 TURN TO THE ALPHABETICAL INDEX, FIND THE LISTING OF THE DESIRED PART'S MAJOR ASSEMBLY OR INSTALLATION, & NOTE THE NUMBER OF THE PAGE WHERE THAT ASSEMBLY OR INSTALLATION IS ILLUSTRATED, OR

TURN TO THE TABLE OF CONTENTS, & LOCATE THE PAGE NUMBER OF THE BEGINNING OF THE DESIRED PART'S FUNCTIONAL GROUP.

TURN TO THE PROPER FIGURE & ITS PARTS LIST, TO FIND THE PART, & ITS INDEX NUMBER, IN THE ILLUSTRATION, REFER TO THE PARTS LIST FOR THE PART NUMBER, CHECK THE PART DESCRIPTION, CHECK THE NEED FOR ASSOCIATED PARTS, CHECK THE CATALOG NUMBERS OF AIRPLANES USING THE PART.

TURN TO THE MASTER USABLE ON CODE LISTING, TO VERIFY THE AF SERIAL NUMBERS OF AIRPLANES USING THE PART.

TURN TO THE NUMERICAL INDEX, FOR PART ORDERING INFORMATION - SOURCE CODE, CLASS CODE, & SERIAL NUMBER.

FIG. 11-10-1

Part Number	Part Name	Part Description	Part Description	Part Description	Part Description	Part Description	Part Description	Part Description	Part Description
65262	1560-573-4672-BK	215-21							

FIG. 11-10-2

ALPHABETICAL INDEX (CONT.)

Page	Page	Page	Page
...
Air Assembly	215
M.G. Safety Switch	215



TABLE OF CONTENTS

Page	Page
...	...
LANDING GEAR	211

NOTE: A Detail Table of Contents precedes each Functional Group of the Ground Assembly Parts List, using the Illustration Title and Figure Number of each Illustration found in that section.

IDENTIFICATION AND PARTS LIST FOR APPLICABLE AIRCRAFT

Section II
Group Assembly Part List
T.O. 1F-106A-4
LANDING GEAR

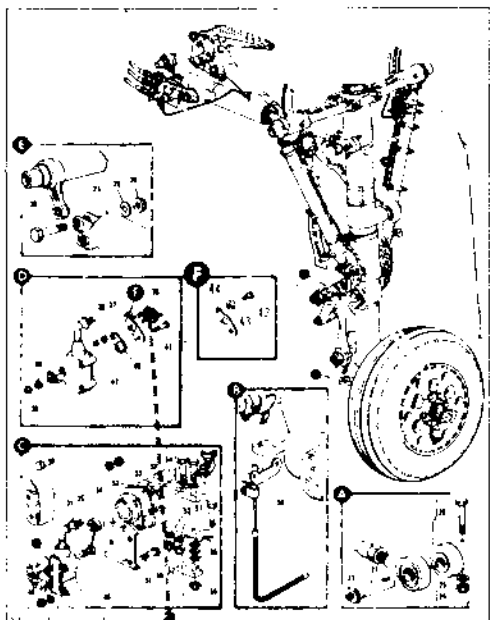

FIGURE 215 T

T.O. 1F-106A-4
Section III
Master Usable On Code

Part Number	Stock Number	Part Name	QTY	Unit	Part Number	Stock Number	Part Name	QTY	Unit
8-65262	1560-573-4622-BK	ARM ASSY, SAFETY SWITCH	1	EA	215-2	91			

Section III
Group Assembly Part List
T.O. 1F-106A-4
Section III
Group Assembly Part List

FIGURE AND INDEX NUMBER	PART NUMBER	DESCRIPTION	UNITS USABLE PER ASSY
215 T	8-65262	ARM ASSY, SAFETY SWITCH	1, 14
49	8-68051-7	STUD	1, 14
50	8-68052-7	ROLLER	1, 14
51	8-65262-7	ARM	1, 14

NOTE

- Maintenance personnel, remember to:
Record the part number correctly.
Order by the Stock Number, if it is given.
Procure as directed by the Source Code
- Supply personnel, remember to:
Verify or determine the Stock Number, and
procure per instructions

T.O. 1F-106A-4
MASTER USABLE ON CODE

Code	Part Number	Stock Number
F 106A	AF16-411	AF16-411
F 106A	AF16-412	AF16-412
F 106A	AF16-413	AF16-413
F 106A	AF16-414	AF16-414
F 106A	AF16-415	AF16-415
F 106A	AF16-416	AF16-416
F 106A	AF16-417	AF16-417
F 106A	AF16-418	AF16-418
F 106A	AF16-419	AF16-419
F 106A	AF16-420	AF16-420
F 106A	AF16-421	AF16-421
F 106A	AF16-422	AF16-422
F 106A	AF16-423	AF16-423
F 106A	AF16-424	AF16-424
F 106A	AF16-425	AF16-425
F 106A	AF16-426	AF16-426
F 106A	AF16-427	AF16-427
F 106A	AF16-428	AF16-428
F 106A	AF16-429	AF16-429
F 106A	AF16-430	AF16-430

MANUFACTURERS' CODE

00000	ORDNANCE CORPS	01515	PEARCES PLASTIC MODELS Glendale, Calif.
00048	ABRAMS INSTRUMENT CORP., Lansing, Mich.	01547	AIRBORNE RESEARCH AND DEVELOPMENT CORP., Sun Valley, Calif.
00141	PIC DESIGN CORP., East Rockaway, N.Y.	01881	ANACONDA AMERICAN BRASS CO., Waterbury, Conn.
00254	FAB AIR, INC., Long Beach, Calif.	01976	AMERICAN CHAIN AND CABLE CO., INC., Bridgeport, Conn.
00303	SHELLY ASSOCIATES El Segundo, Calif.	02005	HAYDONS SWITCH, INC., Waterbury, Conn.
00307	POWER ENGINEERING AND EQUIPMENT CO., Torrance, Calif.	02114	FERROX CUBE CORP. of AMERICA, Saugerties, N.Y.
00500	ADELPHI MFG. CO., Brooklyn, N.Y.	02217	ZEP AERO El Segundo, Calif.
00502	ADEL PRECISION PRODUCTS DIV OF GENERAL METALS CORP., Burbank, Calif.	02297	ACE ELECTRONICS ASSOCIATES, INC., Somerville, Mass.
00524	VAL AERO DIV OF DARCO INDUSTRIES, INC., El Segundo, Calif.	02615	NYLOK CORP., Paramus, N.J.
00543	ROBERTSHAW FULTON CONTROLS CO., AERONAUTICAL DIV., Anaheim, Calif.	02660	AMPHENOL-BURG ELECTRONICS CORP., Broadview (Chicago), Ill.
00624	AEROQUIP CORP., AIRCRAFT DIV, JACKSON PLANT, Jackson, Mich.	02758	U.S. BEARING CORP., Van Nuys, Calif.
00672	ALTAIR, INC., Terryville, Conn.	02828	BREINER AND CO., INC., Indianapolis, Ind.
00779	AMP, INC., Harrisburg, Pa.	02918	MARKITE CORP., New York, N.Y.
00986	JOCLIN MFG. CO., Wallingford, Conn.	02964	AMERICAN STERILIZER CO., Erie, Pa.
01045	ALEMITE CO. OF SOUTH CALIFORNIA, Los Angeles, Calif.	02987	BENDIX CORP., MONTROSE DIV., South Montrose, Pa.
01048	LAMB RUBBER CORP., Glendale, Calif.	03024	AMETEK/STRAZA 790 Greenfield Dr. El Cajon Calif. 92022
01170	BELLOFRAM CORP., Burlington, Mass.	03034	PENN KEYSTONE CORP., Derby, Conn.
01226	VLIER ENGINEERING CORP., Los Angeles, Calif.	03038	LONG-LOK CORP., Santa Monica, Calif.
01278	R.C. ALLEN CO., Boston, Mass.	03040	AMERICAN TIME PRODUCTS, INC., New York, N.Y.
01414	AIRCRAFT POROUS MEDIA, INC., Glen Cove, N.Y.		

MANUFACTURERS' CODE (CONT).

03100	GARLOCK OF CALIFORNIA, INC., AIRCRAFT AND MISSILE DIV OF GARLOCK, INC., Los Angeles, Calif.	05555	MILLRICH ENGINEERING CORP., Burbank, Calif.
03487	ANDREA RADIO CORP., Long Island City, N.Y.	05574	VIKING ELECTRIC CO., Canogo Park, Calif.
03818	PARKER SEAL CO., Los Angeles, Calif.	05683	MEG PRODUCTS DIV OF MANDREL INDUSTRIES, INC., Seattle, Wash.
03972	AUTRONICS CORP., Los Angeles, Calif.	06177	PNEUDRAULICS, INC., Montclair (Ontario), Calif.
03990	ARO EQUIPMENT CORP., Bryan, Ohio	06506	AIR CONDUCTORS LTD., Gardena, Calif.
04072	A.D.C. ELECTRONICS, INC., North Long Beach, Calif.	06840	BENDIX CORP., Detroit, Mich.
04190	PNEU-HYDRO VALVE CORP., East Orange, N.J.	06845	BENDIX RADIO DIV OF BENDIX CORP., Towson, Md.
04211	COASTAL MFG. CO., Venice, Calif.	06851	RESISTOFLEX CORP., Anaheim, Calif.
04223	ALLIS-CHALMERS MFG. CO., Chicago, Ill.	06862	JOSEPH T. RYERSON AND SON, INC., Los Angeles, Calif.
04274	ROSEMOUNT ENGINEERING CO., Minneapolis, Minn.	07056	BESLER CORP., Oakland, Calif.
04329	TALLEY AIRCRAFT SALES CORP., Los Angeles, Calif.	07096	HADBAR DIV. OF PUROLATOR INC. 723 South Fremont Ave. Alhambra, Calif. 91803
04406	MERIDIAN METALCRAFT, INC., Whittier, Calif.	07148	DYNAMIC CONTROLS CORP., Windsh, Conn.
04795	AIR SUPPLY-AERO ENGINEERING CO., Beverly Hills, Calif.	07199	UNITED STATES RADIUM CORP. North Hollywood, Calif.
04811	PRECISION COIL SPRING CO., El Monte, Calif.	07244	ELECTRONIC WIRE AND CABLE CORP., Burbank, Calif.
04849	AERO RESEARCH INSTRUMENT CO., INC., Chicago, Ill.	07268	F.W. STEWART CORP., Los Angeles, Calif.
04958	JOHN RADOVICH AND CO., La Mesa, Calif.	07294	GENISIO TECHNOLOGY CORP., Compton, Calif.
05214	HYDROMATICS, INC., Bloomfield, N.J.	07639	LELAND AIRBORNE PRODUCTS DIV OF AMERICAN MACHINE AND FOUNDRY CO., Vandalia, Ohio
05399	BEMCO, INC., Centerton, Ark.	07811	BOBRICK MFG. CORP., Los Angeles, Calif.
05528	VIBRATROL PNEUMAFIL CORP., Los Angeles, Calif.		

MANUFACTURERS' CODE (CONT).

07940	PNEU-TECH LABORATORIES, INC., Inglewood, Calif.	13445	COLE-HERSEE CO., Boston, Mass.
08524	DEUTSCH FASTENER CORP., Los Angeles, Calif.	13499	COLLINS RADIO CO. Cedar Rapids, Iowa
08588	BRIDGEPORT BRASS CO., Bridgeport, Conn.	13636	BARRY WESTERN OPN DIV. OF BARRY WRIGHT CORP. 2323 Valley St. Burbank, Calif. 91505
08798	GENERAL ELECTRIC CO., APPARATUS SALES DIV OF APPARATUS GROUP Schenectady, N.Y.	14170	GENERAL DYNAMICS/CONVAIR DIV OF GENERAL DYNAMICS CORP., San Diego, Calif.
08994	NATIONAL ROLL-FORM CO., Costa Mesa, Calif.	15605	CUTLER HAMMER, INC., Milwaukee, Wis.
09049	CUSTOM COMPONENT, Chatsworth, Calif.	15653	KAYNAR MFG. CO., INC., Fullerton, Calif.
09409	CALDWELL ENGINE LABORATORIES, Sun Valley, Calif.	17419	THE DEUTSCH CO., Los Angeles, Calif.
09453	MAXIMOFF RESEARCH CO., Van Nuys, Calif.	18355	DOUGLAS AIRCRAFT CO., INC., Santa Monica, Calif.
09455	MICRO-PRECISION DIV OF MICROMATIC HONE CORP., Los Angeles, Calif.	18750	ANSOL CHEMICAL CO. Marinette, Wis.
09790	CONSOLIDATED CONTROLS CORP., Inglewood, Calif.	19315	ECLIPSE-PIONEER DIV OF BENDIX CORP., Teterboro, N.J.
09922	BURNDY CORP., Norwalk, Conn.	19500	THOS. A. EDISON, INDUSTRIES DIV OF McGRAW-EDISON CO., West Orange, N.J.
10009	RAYBESTOS-MANHATTAN, INC. GENERAL ASBESTOS AND RUBBER DIVISION, NORTH Charleston, S.C.	19956	ELECTRIC PRODUCTS CO., Cleveland, Ohio
10219	MECHANICAL COIL SPRING CO., El Monte, Calif.	20955	ESSANNAY ELECTRIC MFG. CO., Chicago, Ill.
10237	CADILLAC GAGE CO., Detroit, Mich.	21335	THE FAFNIR BEARING CO., New Britain, Conn.
10630	ANILLO INDUSTRIES INC., 2090 N. Glassell, Orange, Calif. 92667	21964	ITT FEDERAL DIV OF INTERNATIONAL TELEPHONE AND TELEGRAPH CORP., Clifton, N.J.
11685	CHARLES PRODUCTS CO., New York, N.Y.	24446	GENERAL ELECTRIC CO., Schenectady, N.Y.
11938	SUNBEAM CORP., Chicago, Ill.	24455	GENERAL ELECTRIC CO. LAMP DIV OF CONSUMER PRODUCTS GROUP Nela Park (Cleveland), Ohio
12116	TALLEY INDUSTRIES 4551 E. McKellips Road P.O. Box 920 Mesa, Arizona 85201	24494	GENERAL NUCLEONICS DIV. TYCO LABORATORIES INC. Pomona, Calif.
12439	PROSSER INDUSTRIES, INC., Anaheim, Calif.		

MANUFACTURERS' CODE (CONT).

25140	GLOBE INDUSTRIES, INC., Dayton, Ohio	40931	MINNEAPOLIS-HONEYWELL REGULATOR CO., Minneapolis, Minn.
26032	PETER GRAY CORP., Cambridge, Mass.	41349	MOORE MASTER MFG. CO., Chicago, Ill.
27462	HARRISON RADIATOR DIV OF GENERAL MOTORS CORP., Lockport, N.Y.	42280	THE NASH ENGINEERING CO., South Norwalk, Conn.
27996	THE HEIL CO., Milwaukee, Wis.	43002	NATIONAL UTILITIES CORP., Milwaukee, Wis.
29666	HUCK MFG CO., Detroit, Mich.	44655	OHMITE MFG CO., Skokie, Ill.
30323	ILLINOIS TOOL WORKS Chicago, Ill.	45402	PACIFIC SCIENTIFIC CO., Los Angeles, Calif.
31189	INTERSTATE ENGINEERING CORP., Anaheim, Calif.	45598	PANTEX MFG CO., Pawtucket, R.I.
31435	JACK AND HEINTZ, INC., Maple Heights (Cleveland), Ohio	45681	PARKER-HANNIFIN CORP., Cleveland, Ohio
31574	JACUZZI BROTHERS, INC., Richmond, Calif.	49671	RADIO CORP. OF AMERICA New York, N.Y.
32770	KATO ENGINEERING CO., Mankato, Minn.	50599	RESISTOFLEX CORP., Roseland, N.J.
33525	KIDDE WALTER AND CO., INC., Belleville, N.J.	50625	REVERE CORP. OF AMERICA Wallingford, Conn.
34199	KOHLER CO., Kohler, Wis.	51116	ROBINSON TECHNICAL PRODUCTS, INC., Teterboro, N.J.
35344	LEACH RELAY CO., DIV LEACH CORP., Los Angeles, Calif.	51240	AMERICAN-STANDARD CONTROLS DIV OF AMERICAN RADIATOR AND STANDARD SANITARY CORP., Rochester, N.Y.
35351	INSTRUMENT DIV LEAR SIEGLER, INC., Grand Rapids, Mich.	51588	ROLLER BEARING CO. OF AMERICA Trenton, N.J.
35662	LELAND OHIO ELECTRIC CO., Dayton, Ohio	53655	SCOTT AVIATION CORP., Lancaster, N.Y.
35918	THE LEWIS ENGINEERING CO., Naugatuck, Conn.	53750	SEABOARD ELECTRONIC CORP., New York, N.Y.
36540	LISLE CORP., Clarinda, Iowa	55820	SOLAR AIRCRAFT CO., San Diego, Calif.
37581	MAC WHYTE CO., Kenosha, Wis.	56118	SPARTON CORP., Jackson, Mich.
37942	P.R. MALLORY AND CO., INC., Indianapolis, Ind.	56232	SPERRY GYROSCOPE CO., DIV OF SPERRY RAND CORP., Great Neck, N.Y.
38315	HONEYWELL INC., Manchester, N.H.		
39661	MENASCO MFG CO., Burbank, Calif.		

MANUFACTURERS' CODE (CONT).

56289	SPRAGUE ELECTRIC CO., North Adams, Mass.	65149	BARBER-COLMAN CO., CONTROLS DIV., Rockford, Ill.
56878	STANDARD PRESSED STEEL CO., Jenkintown, Pa.	70127	ABSCOA INDUSTRIES Hartsdale, N.Y.
57448	STEPHENS-ADAMSON MFG CO., Aurora, Ill.	70128	AEROQUIP CORP., AIRCRAFT DIV, WESTERN PLANT Burbank, Calif.
57711	F.W. STEWART CORP., Chicago, Ill.	70133	AERIAL MACHINE AND TOOL CORP., Long Island City, N.Y.
57771	EDWIN B. STIMPSON CO., INC., Brooklyn, N.Y.	70134	AERO INSTRUMENT CO., Cleveland, Ohio
58189	GENERAL DYNAMICS/ELECTRONICS Rochester, N.Y.	70210	AIRESEARCH MFG, DIV OF GARRETT CORP., Los Angeles, Calif.
58417	SUNDSTRAND CORP., Rockford, Ill.	70491	AMERICAN GAS ASSOCIATION New York, N.Y.
58474	THE SUPERIOR ELECTRIC CO. Bristol, Conn.	70628	ARROWHEAD PRODUCTS, DIV OF FEDERAL-MOGUL-BOWER BEARINGS, INC., Long Beach, Calif.
59730	THOMAS AND BETTS CO., Elizabeth, N.J.	70955	BLACKSTONE MFG CO., Chicago, Ill.
59747	THOMAS FLEXIBLE COUPLING CO., Warren, Pa.	71041	BOSTON GEAR WORKS DIV OF MURRAY CO. OF TEXAS, Quincy, Mass.
60380	THE TORRINGTON CO. Torrington, Conn.	71087	BOOTS AIRCRAFT NUT CORP., Norwalk, Conn.
61349	UNITED STATES GAUGE DIV OF AMETEK, INC., Sellersville, Pa.	71207	BRUNSWICK CORP., Chicago, Ill.
61463	UNITED STATES RUBBER CO., New York, N.Y.	71279	CAMBRIDGE THERMIONIC CORP., Cambridge, Mass.
61775	UNION SWITCH AND SIGNAL DIV OF WESTINGHOUSE AIR BRAKE CO., Swissvale, Pa.	71286	CAMLOC FASTENER CORP., Paramus, N.J.
61864	UNITED-CARR FASTENER CORP., Boston, Mass.	71400	BUSSMANN MFG DIV OF McGRAW- EDISON CO., St. Louis, Mo.
62983	VICKERS AOM DIV. SPERRY RAND CORP. P.O. Box 302 Troy, Mich. 48084	71419	CHARLESTON SHIPBUILDING AND DRYDOCK CO., Charleston, S.C.
63135	VIKING TOOL AND MACHINE CORP., Belleville, N.J.	71447	CALIFORNIA SPRING CO., INC., Pico-Rivera, Calif.

MANUFACTURERS' CODE (CONT).

71468	CANNON ELECTRIC CO., Los Angeles, Calif.	73138	HELIPOT DIV OF BECKMAN INSTRUMENTS, INC., Fullerton, Calif.
71503	CLARY CORP., San Gabriel, Calif.	73168	FENWAL, INC., Ashland, Mass.
71636	EARL S. CONDON CO., Los Angeles, Calif.,	73197	HI-SHEAR CORP., Torrance, Calif.
71643	CONNECTICUT HARD RUBBER CO., New Haven, Conn.	73227	P.R. HOFFMAN CO., Carlisle, Pa.
71688	COOK ELECTRONIC CO., Chicago, Ill.	73240	KAISER FLEETWINGS, INC., Bristol, Pa.
72110	ELECTRIC SERVICE CONTROLS, INC., Newark, N.J.	73249	B. F. GOODRICH FOOTWEAR AND FLOORING CO., Watertown, Mass.
72152	ELECTRONIC SPECIALTY CO., Los Angeles, Calif.	73475	FULTON SYLPHON DIV OF ROBERT-SHAW-FULTON CONTROLS CO., Knoxville, Tenn.
72285	EXACTO INDUSTRIES Los Angeles, Calif.	73760	GENERAL CONTROLS CO., Glendale, Calif.
72433	FLEXITALLIC GASKET CO., Camden, N.J.	73808	GENERAL TIRE AND RUBBER CO., Akron, Ohio
72480	FOX PRODUCTS CO., Philadelphia, Pa.	74063	HARTMAN ELECTRICAL MFG. Div A-T-D Inc., Mansfield, Ohio
72596	GARDER PROPELLER CO., Forest Park, Ill.	74144	CAM-STAT INC., Los Angeles, Calif.
72606	GASKET MFG CO., Los Angeles, Calif.	74193	HEINEMANN ELECTRIC CO., Trenton, N.J.
72737	GIANNINI CONTROLS CORP., TRANSDUCER DIV., Pasadena, Calif.	74212	HENRY ENGINEERING CO., Moline, Ill.
72794	DZUS FASTENER CO., INC., West Islip, N.Y.	74687	HUNTINGTON RUBBER MILLS, INC., Portland, Oreg.
72914	GRIMES MFG CO., Urbana, Ohio	74868	FXR DIV OF AMPHENOL-BURG ELECTRONICS CORP., Danbury, Conn.
72928	GUDEMAN CO., Chicago, Ill.	75224	KAISER INDUSTRIES-CORP., Oakland, Calif.
72962	ELASTIC STOP NUT CORP. OF AMERICA Union, N.J.	75237	KAYNAK MFG CO., Pico-Rivera, Calif.
73030	HAMILTON STANDARD DIV OF UNITED AIRCRAFT CORP., Windsor Locks, Conn.	75323	KILFROST MFG CO., LTD., Northumberland, England
73061	HANSEN MFG CO., INC., Princeton, Ind.	75345	KIRKHILL RUBBER CO., Brea, Calif.
73134	THE HEIM CO., Fairfield, Conn.		

MANUFACTURERS' CODE (CONT).

75361	KOEHLER AIRCRAFT PRODUCTS CO., Dayton, Ohio	77447	PRECISION SPRING CORP., Detroit, Mich.
75485	LACKNER CO., INC., Cincinnati, Ohio	77609	RCA SERVICE CO., DIV OF RADIO CORP. OF AMERICA Camden, N.J.
75662	H.W. LOUD MACHINE WORKS Pomona, Calif.	77820	SCINTILLA DIV BENDIX CORP., Sidney, N.Y.
76005	LORD MFG CO., Erie, Pa.	77896	SHAFFER BEARING DIV OF CHAIN BELT CO., Downers Grove, Ill.
76050	M.C. MFG CO., Lake Orion, Mich.	77932	SIMMONDS PRECISION PRODUCTS, INC., Tarrytown, N.Y.
76152	EDWARD D. MALTBY CO., Los Angeles, Calif.	77970	A.O. SMITH CORP., Milwaukee, Wis.
76301	MCDONNELL DOUGLAS CORP. MCDONNELL AIRCRAFT DIVISION P.O. Box 516 Lambert St. Louis Municipal Airport St. Louis, Mo. 63166	78062	SARGENT ENGINEERING CORP., Huntington Park, Calif.
76381	MINNESOTA MINING AND MFG CO., St. Paul, Minn.	78189	SHAKEPROOF DIV OF ILLINOIS TOOL WORKS Elgin, Ill.
76530	MONADNOCK MILLS San Leandro, Calif.	78433	THE TESTING APPARATUS CO., INC., Detroit, Mich.
76665	NATIONAL LOCK WASHER CO., Newark, N.J.	78493	STANDARD-THOMAS CORP., Waltham, Mass.
76689	NATIONAL SCREW AND MFG CO., Cleveland, Ohio	78553	TINNERMAN PRODUCTS, INC., Cleveland, Ohio
76691	NATIONAL TELEPHONE SUPPLY CO., INC., Cleveland, Ohio	78570	TITFLEX, INC., Springfield, Mass.
76760	NEW PROCESS GEAR DIV OF CHRYSLER CORP., Syracuse, N.Y.	78626	GUIDANCE TECHNOLOGY, INC., Santa Monica, Calif.
77045	JOHN OSTER MFG CO., Racine, Wis.	78710	TELEFLEX, INC., North Wales, Pa.
77068	BENDIX PACIFIC DIV OF BENDIX CORP., North Hollywood, Calif.	78712	TELERADIO ENGINEERING CORP., New York, N.Y.
77138	HENRY PAUL, INC., New York, N.Y.	78741	HITCO Gardenia, Calif.
77196	PERMOFLUX DIV OF DX RADIO PRODUCTS CO., INC., Chicago, Ill.	78790	TRANSFORMER ENGINEERS, San Gabriel, Calif.
77326	JOSEPH POLLACK CORP., Boston, Mass.	78947	UCINITG CO., Newtonville, Mass.
77445	PRATT AND WHITNEY AIRCRAFT DIV OF UNITED AIRCRAFT CORP., East Hartford, Conn.	79067	VALVE AND PRIMER CORP., Chicago, Ill.
		79076	VAUGHAN CO., Chicago, Ill.
		79136	WALDES KOHINOOR, INC., Long Island City, N.Y.

MANUFACTURERS' CODE (CONT).

79228	WAUGH EQUIPMENT CO., New York, N.Y.	80935	MUTUAL ENGINEERING CO., San Francisco, Calif.
79294	WESTON HYDRAULICS, LTD., North Hollywood, Calif.	81032	PASTUSHIN AVIATION CORP., Los Angeles, Calif.
79300	WALTHAM PRECISION INSTRUMENT CO., Waltham, Mass.	81039	AIRBOURNE ACCESSORIES CORP., Hillside, N.J.
79318	WHITTAKER CONTROLS AND GUIDANCE DIV OF TELECOMPETING CORP., Los Angeles, Calif.	81095	TRIAD TRANSFORMER CORP., Venice, Calif.
79326	F.B. WIGGINS OIL TOOL CO., Los Angeles, Calif.	81205	THE BOEING CO. Seattle, Wash.
79470	JHF WEATHERHEAD CO., Cleveland, Ohio	81312	WINCHESTER ELECTRONICS CO., INC. Norwalk, Conn.
80048	ELECTRIC PRODUCTS DIV VICKERS, INC., St. Louis, Mo.	81321	PUROLATOR PRODUCTS, INC., Rahway, N.J.
80099	EDISON INSTRUMENT DIV OF McGRAW- EDISON CO., West Orange, N.J.	81376	SOUTHWEST PRODUCTS CO. Monrovia, Calif.
80205	NATIONAL AEROSPACE STANDARDS COMMITTEE AEROSPACE INDUSTRIES ASSOCIATION OF AMERICA, INC. 1725 De Sales N.W. Washington D.C. 20036 Formerly National Aerospace Standards Committee Aeronautical Industries Association of America Washington D.C.	81395	BOSTON DIV MINNEAPOLIS-HONEYWELL REGULATOR CO., Boston, Mass.
80223	UNITED TRANSFORMER CO., New York, N.Y.	81400	HASKEL ENGINEERING AND SUPPLY CO., Glendale, Calif.
80234	VAPOR HEATING CORP., Chicago, Ill.	81413	LORAL ELECTRONICS CORP., New York, N.Y.
80534	CALVAN MACHINE PRODUCTS, INC., Jackson, Mich.	81481	AVICA CORP., Newport, R.I.
80539	NUTT-SHEL DIV OF SPS WESTERN CO., Santa Anna, Calif.	81482	COOPERATIVE INDUSTRIES, INC., Chester, N.J.
80626	ROBERTSHAW FULTON CONTROLS CO., Youngwood, Pa.	81579	MASON ELECTRIC CORP Los Angeles, Calif.
80756	RAMSEY CORP., St. Louis, Mo.	81590	KORRY MFG CO., Seattle, Wash.
80795	INTERNATIONAL TELEPHONE AND TELEGRAPH CORP., New York, N.Y.	81629	HALFCO DIV OF U.S. BEARING CORP., Los Angeles, Calif.
		81640	CONTROL SWITCH DIVISION, CONTROLS CO. OF AMERICA Folcroft, Pa.

MANUFACTURERS' CODE (CONT).

81645	E. HORTON AND SON CO., East Hartford, Conn.	82654	STANDARD PRODUCTS CO., Cleveland, Ohio
81817	HOOVER ELECTRIC CO., Los Angeles, Calif.	82700	THOMPSON RAMO WOOLDRIDGE, INC., WEST COAST DIV OF TAPCO GROUP Bell, Calif.
81818	MELETRON CORP., Los Angeles, Calif.	82768	PHILLIPS CONTROL CO. DIV. OF PHILLIPS-ECKHARDT ELECTRONICS CORP., Joliet Ill.
81825	AERO INSTRUMENT CO., North Hollywood, Calif.	82829	ALLEN AIRCRAFT PRODUCTS, INC., Ravenna, Ohio
81839	CARMA MFG CO., Torrance, Calif.	82830	CALIFORNIA RUBBER PRODUCTS, INC., Torrance, Calif.
81861	BURTON ELECTRICAL ENGINEERING CO., El Segundo, Calif.	82831	DELRON CO., INC., South Gate, Calif.
81873	HYDRAULIC RESEARCH AND MFG CO., Burbank, Calif.	82999	STONER RUBBER CO., Anaheim, Calif.
81896	AIRITE PRODUCTS CO., Los Angeles, Calif.	82833	HANSEN LYNN CO., INC., Burbank, Calif.
81920	BURTON MFG CO., Santa Monica, Calif.	82922	WALTER E. KIDDE CONSTRUCTORS, INC., New York, N.Y.
81982	HYDRO-AIRE, INC., Burbank, Calif.	83008	STANDARD ELECTRICAL PRODUCTS CO., Dayton, Ohio
82106	BERTEA PRODUCTS, INC., Pasadena, Calif.	83014	HARTWELL CORP., Los Angeles, Calif.
82152	TRANSCO PRODUCTS, INC., Los Angeles, Calif.	83046	STANLEY AVIATION CORP., Denver, Colo.
82254	CURTIS AUTOMOTIVE DEVICES, INC., Westfield, Ind.	83144	FLEXIBLE TUBING CORP., Guilford, Conn.
82267	SHULZ TOOL AND MFG CO., San Gabriel, Calif.	83148	ELECTRO CORDS CO., Los Angeles, Calif.
82293	OLYMPIC PLASTICS DIV OF CENTURY INVESTORS CORP., Los Angeles, Calif.	83259	PARKER SEAL CO., Culver City, Calif.
82402	PRECISION PRODUCTS DIV, WESTERN GEAR CORP., Lynwood, Calif.	83298	RED BANK DIV, BENDIX CORP., Red Bank (Eatontown), N.J.
82577	HUGHES AIRCRAFT CO., Culver City, Calif.	83324	ROSAN, INC., Newport Beach, Calif.

MANUFACTURERS' CODE (CONT).

83331	SOUTHWEST PRODUCTS CO., Baltimore, Md.	86849	PACIFIC BEARING CO., Los Angeles, Calif.
83349	ALTAIR MACHINERY CORP., New York, N.Y.	87034	MARCO INDUSTRIES CO., Anaheim, Calif.
83564	WEMAC CO., Inglewood, Calif.	87273	STAINLESS STEEL PRODUCTS Philadelphia, Pa.
83612	KIDDE MFG CO., INC., Bloomfield, N.J.	87567	M. STEINTHAL AND CO., INC., New York, N.Y.
83646	GABB SPECIAL PRODUCTS DIV OF E. HORTON AND SON CO., Windsor Locks, Conn.	88044	AERONAUTICAL STANDARDS GROUP DEPT. OF NAVY AND AIR FORCE
83843	WESTINGHOUSE ELECTRIC CORP., Aerospace Electrical Div., Lima, Ohio	88245	U. S. ENGINEERING CO., Van Nuys, Calif.
84256	AVDEL, INC., Burbank, Calif.	88287	WESTON INSTRUMENTS DIV OF DAYSTROM, INC., New York, N.Y.
84685	HYDRA-POWER CORP., New Rochelle, N.Y.	88422	GENERAL ELECTRIC CO., GENERAL PURPOSE MOTOR DEPT OF COMPONENT PRODUCTS DIV., Fort Wayne, Ind.
84914	LOS ANGELES STANDARD RUBBER CO., Los Angeles, Calif.	88818	KEARFOTT DIV OF GENERAL PRECISION, INC., Little Falls, N.J.
84971	T.A. MFG CORP., Los Angeles, Calif.	89259	SUPERIOR SHIPBUIDING DIV OF KNUDSEN SHIPBUILDING AND DRY DOCK CO., Superior, Wis.
84987	INDUSTRIAL DESIGN LABORATORIES Culver City, Calif.	89660	THOMPSON RAMO WOOLDRIDGE, INC., WEST COAST DIV OF TAPCO GROUP Long Beach, Calif.
85226	DORNE AND MARGOLIN, INC., Westbury, Long Island, N.Y.	89690	GENERAL MOTORS CORP. Trenton, N.J.
86090	J.C. CARTER CO., Costa Mesa, Calif.	89944	KOLLSMAN INSTRUMENT CORP. Elmhurst, N.Y.
86162	CHIPPEWA PAPER PRODUCTS CO., INC., Chicago, Ill.	90056	DU PONT E I DE NEMOURS AND CO., INC., Fairfield, Conn.
86302	CROCKET MFG CO., Culver City, Calif.	90471	VORNADO, INC., Wichita, Kans.
86403	PARTS DIV CHRYSLER CORP., Detroit, Mich.	90615	BALDWIN-LIMA-HAMILTON CORP., INDUSTRIAL EQUIPMENT DIV., Eddystone, Pa.
86535	PLASTECK, INC., Poteau, Okla.		
86579	PRECISION RUBBER PRODUCTS CORP., Dayton, Ohio		
86671	NOURSE EQUIPMENT AND ENGINEERING CO., San Francisco, Calif.		
86831	ROYLYN, INC., Glendale, Calif.		

MANUFACTURERS' CODE (CONT).

90763	UNITED CARR FASTENER CORP., Chicago, Ill.	92482	AMECO AMERICAN ELECTRONICS., INC., New York, N.Y.
91130	VINSON MFG CO., Van Nuys, Calif.	92799	QUAKER RUBBER DIV. AERODUCT WORKS OF H.K. PORTER CO. OF DELAWARE Southgate, Calif.
91198	FLEXICO PRODUCTS, INC., Metuchen, N.J.	92824	WEBER AIRCRAFT CORP., Burbank, Calif.
91207	GAR PRECISION PARTS, INC., Stamford, Conn.	93539	WESTINGHOUSE ELECTRIC CORP., Los Angeles, Calif.
91260	CONNOR SPRING MFG CO., San Francisco, Calif.	92983	VAN NORMAN INDUSTRIES, INC., ELECTRONIC DIV., Manchester, N. H.
91467	AMERICAN ASBESTOS CO., San Francisco, Calif.	94310	TRU OHM PRODUCTS DIV OF MODEL ENGINEERING AND MFG., INC., Chicago, Ill.
91511	AUTO VALVE, INC., Dayton, Ohio	94640	HENRY ENGINEERING CO., INC., Burbank, Calif.
91561	BRUNING CO., Lincoln, Nebr.	94641	RONSON HYDRAULIC UNITS CORP., Pasadena, Calif.
91629	CONTINENTAL RUBBER WORKS Boston, Mass.	94696	MAGNECRAFT ELECTRIC CO., Chicago, Ill.
91763	HAYES INTERNATIONAL CORP., Birmingham, Ala.	94697	MOOG SERVOCONTROLS, INC., East Aurora, N.Y.
91767	HELL-COIL CORP., Denbury, Conn.	94903	REID ENTERPRISES Long Beach, Calif.
91812	JANCO CORP., Burbank, Calif.	94988	CHATHAM ELECTRONIC DIV OF TUNG-SOL ELECTRIC, INC., Livingston, N.J.
91816	JAMES POND CLARK CO., Pasadena, Calif.	95105	COLLINS RADIO CO., INFORMATION SCIENCE CENTER Newport Beach, Calif.
91864	WALLACE O. LEONARD, INC., Pasadena, Calif.	95266	OSBORNE ELECTRONIC CORP., Portland, Oreg.
91929	MINNEAPOLIS-HONEYWELL REGULATOR CO., MICRO SWITCH DIV., Freeport, Ill.	94272	STILLMAN RUBBER CO., Culver City, Calif.
92003	PARKER AIRCRAFT CO., Los Angeles, Calif.	95402	ELECTRO DYNAMIC DIV OF GENERAL DYNAMICS CORP., Bayonne, N.J.
92196	UNIVERSAL INDUSTRIES, INC., City of Industry, Calif.		
92250	WORTH MFG CO., Los Angeles, Calif.		

MANUFACTURERS' CODE (CONT).

95542	NORDEN DIV OF UNITED AIRCRAFT Corp., Norwalk, Conn.	96736	SWEENEY ENGINEERING CORP., Culver City, Calif.
95712	DAGE ELECTRIC CO., INC., Beech Grove, Ind.	96791	BORG EQUIPMENT DIV OF AMPHENOL-BORG ELECTRONICS CORP., Janesville, Wis.
95764	ELECTRONICS COMMUNICATIONS, INC., Chicago, Ill.	96881	THOMSON INDUSTRIES, INC., New Hyde Park, Long Island, N.Y.
95950	WAGNIERE FORREST ENGINEERING CO. Inglewood, Calif.	96906	MILITARY STANDARDS Promulgated by Military Departments by Military Departments under authority of Defense Standardization Manual 4120 3-M. Applies to book form documents that establish engineering and technical limitations and applications for items and which are identified by numbers such as MIL-STD-198 and MIL-STD-242 etc. also sheet form documents that depict design criteria for items and which are identified by numbers such as MS3057 and MS75057 etc.
95987	WECKESSER CO., CHICAGO, Ill.		
96124	ACCESSORY PRODUCTS DIV OF TEXTRON, INC., Whittier, Calif.		
96138	SIERRA SCHROEDER CONTROLS DIV. OF CAL-VAL RESEARCH AND DEVELOPMENT CORP., Glendale, Calif.	97100	ELDON INDUSTRIES, INC., Hawthorne, Calif.
96157	ALL AMERICAN ENGINEERING CO., Wilmington, Del.	97196	THOS. S. EDISON, INDUSTRIES DIV. OF McGRAW-EDISON CO., West Orange N.J.
96193	STRATOS DIV OF FAIRCHILD STRATOS CORP., Bay Shore, N.Y.	97198	CONTROL SWITCH DIV, CONTROLS CO. OF AMERICA Chicago, Ill.
96215	CARL DRESCHER Burbank, Calif.	97393	SHUR-LOK CORP., Anaheim, Calif.
96261	CONTROLS DIV, LEACH CORP., Azusa, Calif.	97395	O AND M MACHINE CO., INC., Los Angeles, Calif.
96452	AMERICAN-STANDARD CONTROLS DIV. OF AMERICAN RADIATOR AND STANDARD SANITARY CORP. Detroit, Mich.	97413	FIREWEL CO., INC., Buffalo, N.Y.
96470	POLY INDUSTRIES, INC., Pacoima, Calif.	97424	GENERAL ELECTRIC CO., INSTRUMENT DEPT OF INDUSTRIAL ELECTRONICS DIV., West Lynn, Mass.
96487	VALCOR ENGINEERING CORP., Denilworth, N. J.	97592	PNEUMAFIL CORP., Charlotte, N.C.
96655	CALIFORNIA PLASTECK, INC., Los Angeles, Calif.	97613	KAHR BEARING CORP. Burbank, Calif.

MANUFACTURERS' CODE (CONT).

97820	U.S. SHAMBAN AND CO., Culver City, Calif.	98708	TALLEY INDUSTRIES ROCKET POWER OPERATIONS FALCON FIELD Mesa, Arizona 85201 Formerly Rocket Power Inc. Mesa, Arizona Rocket Power Division of Gabriel Co. Mesa, Arizona Rocket Power/TALCO Div. of Gabriel Co. Mesa, Arizona
97896	UNITED CONTROL CORP., Seattle, Wash.		
97926	U.S. SCIENCE CORP., Los Angeles, Calif.		
97947	WITTE ENGINE WORKS OIL WELL SUPPLY DIV OF UNITED STATES STEEL CORP., Kansas City, Mo.		
97968	DSD MFG CO., Hamden, Conn.	98817	SANTA ANITA ENGINEERING CO., Pasadena, Calif.
97990	CROCKER MFG CO., Culver City, Calif.	98889	TALLEY CORP., Newbury Park, Calif.
98159	RUBBER TECK, INC., Gardena, Calif.	98894	HASKET-LOUD AIRCRAFT SERVICE CORP., Glendale, Calif.
98284	HUMPHREY, INC., San Diego, Calif.	98978	INTERNATIONAL ELECTRONIC RESEARCH CORP., Burbank, Calif.
98403	ELIZABETH DIV, ELASTIC STOP NUT CORP. OF AMERICA Elizabeth, N.J.	98732	LIECO, INC., Syosset, N.Y.
98439	PADWAY AIRCRAFT PRODUCTS, INC., Sun Valley, Calif.	98750	SAN ANTONIO AIR MATERIAL AREA Kelly AFB, Tex.
98441	STRATO FLEX INC., Fort Worth Tex.	98769	STAINLESS STEEL PRODUCTS CO., Burbank, Calif.
98505	HYDRA ELECTRIC Burbank, Calif.	99034	EASTERN AIRCRAFT PRODUCTS DIV OF WEATHERHEAD CO., Cleveland, Ohio
98524	CALIFORNIA DIV., NATIONAL SCREW AND MFG CO., Los Angeles, Calif.	99135	FLEX CO, INC., Huntington Park, Calif.
98580	ROCKET JET ENGINEERING COPR. Glendale, Calif.	99167	SUNSTRAND AVIATION DIV. OF SUNSTRAND CORP., Rockford, Ill.
98625	MARMAN DIV, AEROQUIP CORP., Los Angeles, Calif.	99217	SOUTHERN ELECTRONICS CORP., Burbank, Calif.

MANUFACTURERS' CODE (CONT).

99224	WESTERN HYDRAULIC AND SERVICE CO., Gardena, Calif.	99540	POWER-BILT CORP., DIV OF POWER- ENGINEERING CORP., Mingo Junction, Ohio
99251	PIONEER-CENTRAL DIV OF BENDIX CORP., Davenport, Iowa	99643	STERER ENGINEERING AND MFG CO., North Hollywood, Calif.
99407	GENERAL ELECTRIC CO., ARMAMENT AND CONTROL SECTION OF LIGHT MILITARY ELECTRONICS DEPT OF DEFENSE ELECTRONICS DIV OF ELEC- TRONIC, ATOMIC AND DEFENSE SYSTEMS GROUP, Schenectady, N.Y.	99699	FILTORS, INC., Port Washington, N.Y.
99447	GRAY AND HULEGUARD, INC., Los Angeles, Calif.	99707	CONTROL SWITCH DIV CONTROLS CO OF AMERICA El Segundo, Calif.
		99817	ORCHARD INDUSTRIES, INC., Hastings, Mich.
		99832	HUBER WARCO CO., Marion, Ohio

TIME COMPLIANCE TECHNICAL ORDERS INCORPORATED INTO THIS MANUAL

T.O. 1F-106-511
 T.O. 1F-106-519
 T.O. 1F-106-533
 T.O. 1F-106-533A
 T.O. 1F-106-537
 T.O. 1F-106-537A
 T.O. 1F-106-556
 T.O. 1F-106-557
 T.O. 1F-106-561
 T.O. 1F-106-563
 T.O. 1F-106-564
 T.O. 1F-106-565
 T.O. 1F-106-567
 T.O. 1F-106-568
 T.O. 1F-106-569
 T.O. 1F-106-570A
 T.O. 1F-106-571
 T.O. 1F-106-571A
 T.O. 1F-106-573
 T.O. 1F-106-579
 T.O. 1F-106-579A
 T.O. 1F-106-579B
 T.O. 1F-106-580
 T.O. 1F-106-589
 T.O. 1F-106-593A
 T.O. 1F-106-596
 T.O. 1F-106-597
 T.O. 1F-106-602
 T.O. 1F-106-602A
 T.O. 1F-106-604
 T.O. 1F-106-607
 T.O. 1F-106-609
 T.O. 1F-106-613
 T.O. 1F-106-626
 T.O. 1F-106-628
 T.O. 1F-106-629
 T.O. 1F-106-630A
 T.O. 1F-106-631
 T.O. 1F-106-632A
 T.O. 1F-106-635A
 T.O. 1F-106-637
 T.O. 1F-106-640
 T.O. 1F-106-641A
 T.O. 1F-106-644
 T.O. 1F-106-644A
 T.O. 1F-106-646
 T.O. 1F-106-649
 T.O. 1F-106-651

T.O. 1F-106-653
 T.O. 1F-106-654A
 T.O. 1F-106-659
 T.O. 1F-106-661
 T.O. 1F-106-666
 T.O. 1F-106-667
 T.O. 1F-106-673
 T.O. 1F-106-675
 T.O. 1F-106-676
 T.O. 1F-106-678
 T.O. 1F-106-678A
 T.O. 1F-106-681
 T.O. 1F-106-684
 T.O. 1F-106-686
 T.O. 1F-106-687
 T.O. 1F-106-688
 T.O. 1F-106-691
 T.O. 1F-106-693
 T.O. 1F-106-697
 T.O. 1F-106-698
 T.O. 1F-106-701
 T.O. 1F-106-706
 T.O. 1F-106-707
 T.O. 1F-106-710
 T.O. 1F-106-712
 T.O. 1F-106-714
 T.O. 1F-106-719
 T.O. 1F-106-719A
 T.O. 1F-106-724
 T.O. 1F-106-724A
 T.O. 1F-106-725
 T.O. 1F-106-726
 T.O. 1F-106-728
 T.O. 1F-106-735
 T.O. 1F-106-736
 T.O. 1F-106-738A
 T.O. 1F-106-740
 T.O. 1F-106-750
 T.O. 1F-106-750A
 T.O. 1F-106-789
 T.O. 1F-106-804
 T.O. 1F-106-811
 T.O. 1F-106-812
 T.O. 1F-106-817
 T.O. 1F-106-818
 T.O. 1F-106-820
 T.O. 1F-106-823

T.O. 1F-106-825
 T.O. 1F-106-826
 T.O. 1F-106-829
 T.O. 1F-106-831
 T.O. 1F-106-840
 T.O. 1F-106-844
 T.O. 1F-106-846
 T.O. 1F-106-854
 T.O. 1F-106-859
 T.O. 1F-106-862
 T.O. 1F-106-877C
 T.O. 1F-106-877D
 T.O. 1F-106-881
 T.O. 1F-106-905
 T.O. 1F-106-906
 T.O. 1F-106-911
 T.O. 1F-106-915
 T.O. 1F-106-922
 T.O. 1F-106-925
 T.O. 1F-106-926
 T.O. 1F-106-927
 T.O. 1F-106-929
 T.O. 1F-106-934
 T.O. 1F-106-936
 T.O. 1F-106-953
 T.O. 1F-106-955
 T.O. 1F-106-958
 T.O. 1F-106-959
 T.O. 1F-106-960
 T.O. 1F-106-965
 T.O. 1F-106-968
 T.O. 1F-106-969
 T.O. 1F-106-982
 T.O. 1F-106-986
 T.O. 1F-106-988
 T.O. 1F-106-989
 T.O. 1F-106-994
 T.O. 1F-106-997
 T.O. 1F-106-1004
 T.O. 1F-106-1005
 T.O. 1F-106-1008
 T.O. 1F-106-1011
 T.O. 1F-106-1012
 T.O. 1F-106-1013
 T.O. 1F-106-1018
 T.O. 1F-106-1020
 T.O. 1F-106-1034
 T.O. 1F-106-1037
 T.O. 1F-106-1042
 T.O. 1F-106-1044

T.O. 1F-106-1047
 T.O. 1F-106-1051
 T.O. 1F-106-1054
 T.O. 1F-106-1055
 T.O. 1F-106-1056
 T.O. 1F-106-1058
 T.O. 1F-106-1062
 T.O. 1F-106-1072
 T.O. 1F-106-1076
 T.O. 1F-106-1078
 T.O. 1F-106-1081
 T.O. 1F-106-1084
 T.O. 1F-106-1085
 T.O. 1F-106-1086
 T.O. 1F-106-1087
 T.O. 1F-106-1090
 T.O. 1F-106-1090
 T.O. 1F-106-1093
 T.O. 1F-106-1096
 T.O. 1F-106-1106
 T.O. 1F-106-1110
 T.O. 1F-106-1113
 T.O. 1F-106-1114
 T.O. 1F-106-1119
 T.O. 1F-106-1119D
 T.O. 1F-106-1121
 T.O. 1F-106-1127
 T.O. 1F-106-1129
 T.O. 1F-106-1130
 T.O. 1F-106-1131
 T.O. 1F-106-1156
 T.O. 1F-106-1158
 T.O. 1F-106-1159
 T.O. 1F-106-1161
 T.O. 1F-106-1163
 T.O. 1F-106-1175
 T.O. 1F-106-1188
 T.O. 1F-106-1208
 T.O. 1F-106-1224
 T.O. 1F-106-1230
 T.O. 1F-106A-515
 T.O. 1F-106A-521
 T.O. 1F-106A-550
 T.O. 1F-106A-555
 T.O. 1F-106A-557
 T.O. 1F-106A-563
 T.O. 1F-106A-566
 T.O. 1F-106A-567
 T.O. 1F-106A-570

MASTER USABLE ON CODE

<i>Catalog Airplane Numbers</i>	<i>Model and Block Designation</i>	<i>Air Force Serial Numbers</i>	<i>Catalog Airplane Numbers</i>	<i>Model and Block Designation</i>	<i>Air Force Serial Numbers</i>
35	F-106A-64	AF57-246	81	DELETED	AF57-2498
36	F-106A-64	AF57-2453	82	F-106A-90	AF57-2499
37	DELETED	AF57-2454	83	DELETED	AF57-2500
38	F-106A-64	AF57-2455	84	F-106A-90	AF57-2501
39	F-106A-70	AF57-2456	85	DELETED	AF57-2502
40	DELETED	AF57-2457	86	F-106A-90	AF57-2503
41	DELETED	AF57-2458	87	F-106A-90	AF57-2504
42	F-106A-70	AF57-2459	88	F-106A-90	AF57-2505
43	DELETED	AF57-2460	89	F-106A-90	AF57-2506
44	F-106A-75	AF57-2461	90	DELETED	AF58-759
45	DELETED	AF57-2462	91	F-106A-95	AF58-760
46	F-106A-75	AF57-2463	92	DELETED	AF58-761
47	F-106A-75	AF57-2464	93	DELETED	AF58-762
48	F-106A-75	AF57-2465	94	DELETED	AF58-763
49	F-106A-80	AF57-2466	95	F-106A-95	AF58-764
50	F-106A-80	AF57-2467	96	DELETED	AF58-765
51	DELETED	AF57-2468	97	F-106A-95	AF58-766
52	DELETED	AF57-2469	98	F-106A-95	AF58-767
53	F-106A-80	AF57-2470	99	DELETED	AF58-768
54	DELETED	AF57-2471	100	DELETED	AF58-769
55	DELETED	AF57-2472	101	DELETED	AF58-770
56	F-106A-80	AF57-2473	102	DELETED	AF58-771
57	DELETED	AF57-2474	103	F-106A-100	AF58-772
58	F-106A-80	AF57-2475	104	F-106A-100	AF58-773
59	F-106A-80	AF57-2476	105	F-106A-100	AF58-774
60	F-106A-80	AF57-2477	106	F-106A-100	AF58-775
61	F-106A-85	AF57-2478	107	DELETED	AF58-776
62	DELETED	AF57-2479	108	DELETED	AF58-777
63	F-106A-85	AF57-2480	109	F-106A-100	AF58-778
64	F-106A-85	AF57-2481	110	F-106A-100	AF58-779
65	F-106A-85	AF57-2482	111	F-106A-100	AF58-780
66	F-106A-85	AF57-2483	112	DELETED	AF58-781
67	DELETED	AF57-2484	113	F-106A-100	AF58-782
68	F-106A-85	AF57-2485	114	F-106A-100	AF58-783
69	DELETED	AF57-2486	115	F-106A-100	AF58-784
70	F-106A-90	AF57-2487	116	DELETED	AF58-785
71	DELETED	AF57-2488	117	F-106A-100	AF58-786
72	DELETED	AF57-2489	118	F-106A-100	AF58-787
73	F-106A-90	AF57-2490	119	F-106A-100	AF58-788
74	DELETED	AF57-2491	120	DELETED	AF58-789
75	F-106A-90	AF57-2492	121	F-106A-100	AF58-790
76	F-106A-90	AF57-2493	122	F-106A-100	AF58-791
77	F-106A-90	AF57-2494	123	F-106A-100	AF58-792
78	F-106A-90	AF57-2495	124	F-106A-100	AF58-793
79	F-106A-90	AF57-2496	125	DELETED	AF58-794
80	F-106A-90	AF57-2497	126	F-106A-100	AF58-795

MASTER USABLE ON CODE (CONT)

<i>Catalog Airplane Numbers</i>	<i>Model and Block Designation</i>	<i>Air Force Serial Numbers</i>	<i>Catalog Airplane Numbers</i>	<i>Model and Block Designation</i>	<i>Air Force Serial Numbers</i>
127	DELETED	AF58-796	173	F-106A-110	AF59-044
128	F-106A-100	AF58-797	174	DELETED	AF59-045
129	DELETED	AF58-798	175	F-106A-110	AF59-046
130	DELETED	AF59-001	176	F-106A-110	AF59-047
131	F-106A-105	AF59-002	177	F-106A-110	AF59-048
132	F-106A-105	AF59-003	178	F-106A-110	AF59-049
133	DELETED	AF59-004	179	DELETED	AF59-050
134	F-106A-105	AF59-005	180	F-106A-110	AF59-051
135	F-106A-105	AF59-006	181	DELETED	AF59-052
136	F-106A-105	AF59-007	182	F-106A-110	AF59-053
137	F-106A-105	AF59-008	183	F-106A-110	AF59-054
138	DELETED	AF59-009	184	DELETED	AF59-055
139	F-106A-105	AF59-010	185	F-106A-110	AF59-056
140	F-106A-105	AF59-011	186	F-106A-110	AF59-057
141	F-106A-105	AF59-012	187	F-106A-110	AF59-058
142	DELETED	AF59-013	188	F-106A-110	AF59-059
143	DELETED	AF59-014	189	F-106A-120	AF59-060
144	F-106A-105	AF59-015	190	F-106A-120	AF59-061
145	F-106A-105	AF59-016	191	F-106A-120	AF59-062
146	DELETED	AF59-017	192	F-106A-120	AF59-063
147	DELETED	AF59-018	193	F-106A-120	AF59-064
148	DELETED	AF59-019	194	F-106A-120	AF59-065
149	F-106A-105	AF59-020	195	F-106A-120	AF59-066
150	DELETED	AF59-021	196	DELETED	AF59-067
151	DELETED	AF59-022	197	DELETED	AF59-068
152	F-106A-105	AF59-023	198	F-106A-120	AF59-069
153	F-106A-105	AF59-024	199	DELETED	AF59-070
154	F-106A-105	AF59-025	200	F-106A-120	AF59-071
155	F-106A-105	AF59-026	201	F-106A-120	AF59-072
156	F-106A-105	AF59-027	202	DELETED	AF59-073
157	DELETED	AF59-028	203	F-106A-120	AF59-074
158	DELETED	AF59-029	204	DELETED	AF59-075
159	DELETED	AF59-030	205	F-106A-120	AF59-076
160	F-106A-110	AF59-031	206	F-106A-120	AF59-077
161	F-106A-110	AF59-032	207	DELETED	AF59-078
162	F-106A-110	AF59-033	208	F-106A-120	AF59-079
163	F-106A-110	AF59-034	209	F-106A-120	AF59-080
164	F-106A-110	AF59-035	210	F-106A-120	AF59-081
165	DELETED	AF59-036	211	F-106A-120	AF59-082
166	F-106A-110	AF59-037	212	F-106A-120	AF59-083
167	F-106A-110	AF59-038	213	DELETED	AF59-084
168	DELETED	AF59-039	214	F-106A-120	AF59-085
169	F-106A-110	AF59-040	215	F-106A-120	AF59-086
170	DELETED	AF59-041	216	DELETED	AF59-087
171	F-106A-110	AF59-042	217	DELETED	AF59-088
172	F-106A-110	AF59-043			

MASTER USABLE ON CODE (CONT)

<i>Catalog Airplane Numbers</i>	<i>Model and Block Designation</i>	<i>Air Force Serial Numbers</i>	<i>Catalog Airplane Numbers</i>	<i>Model and Block Designation</i>	<i>Air Force Serial Numbers</i>
218	DELETED	AF59-089	263	DELETED	AF59-134
219	F-106A-125	AF59-090	264	F-106A-135	AF59-135
220	F-106A-125	AF59-091	265	F-106A-135	AF59-136
221	F-106A-125	AF59-092	266	F-106A-135	AF59-137
222	F-106A-125	AF59-093	267	F-106A-135	AF59-138
223	F-106A-125	AF59-094	268	DELETED	AF59-139
224	F-106A-125	AF59-095	269	F-106A-135	AF59-140
225	F-106A-125	AF59-096	270	F-106A-135	AF59-141
226	F-106A-125	AF59-097	271	DELETED	AF59-142
227	DELETED	AF59-098	272	F-106A-135	AF59-143
228	F-106A-125	AF59-099	273	DELETED	AF59-144
229	F-106A-125	AF59-100	274	F-106A-135	AF59-145
230	DELETED	AF59-101	275	F-106A-135	AF59-146
231	F-106A-125	AF59-102	276	F-106A-135	AF59-147
232	F-106A-125	AF59-103	277	DELETED	AF59-148
233	F-106A-125	AF59-104	278	F-106A-131	AF56-453
234	F-106A-125	AF59-105	279	F-106A-131	AF56-454
235	F-106A-125	AF59-106	280	DELETED	AF56-456
236	DELETED	AF59-107	281	F-106A-131	AF56-457
237	F-106A-125	AF59-108	282	F-106A-131	AF56-458
238	F-106A-125	AF59-109	283	F-106A-131	AF56-459
239	F-106A-125	AF59-110	284	F-106A-131	AF56-460
240	DELETED	AF59-111	285	F-106A-131	AF56-461
241	DELETED	AF59-112	286	DELETED	AF56-462
242	DELETED	AF59-113	287	DELETED	AF56-467
243	DELETED	AF59-114	288	F-106A-131	AF56-463
244	F-106A-130	AF59-115	289	DELETED	AF56-464
245	F-106A-130	AF59-116	290	F-106A-131	AF56-465
246	DELETED	AF59-117	291	F-106A-131	AF56-466
247	DELETED	AF59-118	292	F-106A-131	AF57-230
248	F-106A-130	AF59-119	293	F-106A-131	AF57-231
249	DELETED	AF59-120	294	F-106A-131	AF57-232
250	DELETED	AF59-121	295	DELETED	AF57-233
251	F-106A-130	AF59-122	296	F-106A-131	AF57-234
252	F-106A-130	AF59-123	297	F-106A-131	AF57-235
253	DELETED	AF59-124	298	F-106A-131	AF57-236
254	DELETED	AF59-125	299	DELETED	AF57-237
255	F-106A-130	AF59-126	300	DELETED	AF57-238
256	F-106A-130	AF59-127	301	F-106A-131	AF57-240
257	F-106A-130	AF59-128	302	F-106A-131	AF57-241
258	F-106A-130	AF59-129	303	F-106A-131	AF57-243
259	F-106A-130	AF59-130	304	F-106A-131	AF57-244
260	DELETED	AF59-131	305	F-106A-131	AF57-245
261	F-106A-130	AF59-132			
262	F-106A-130	AF59-133			

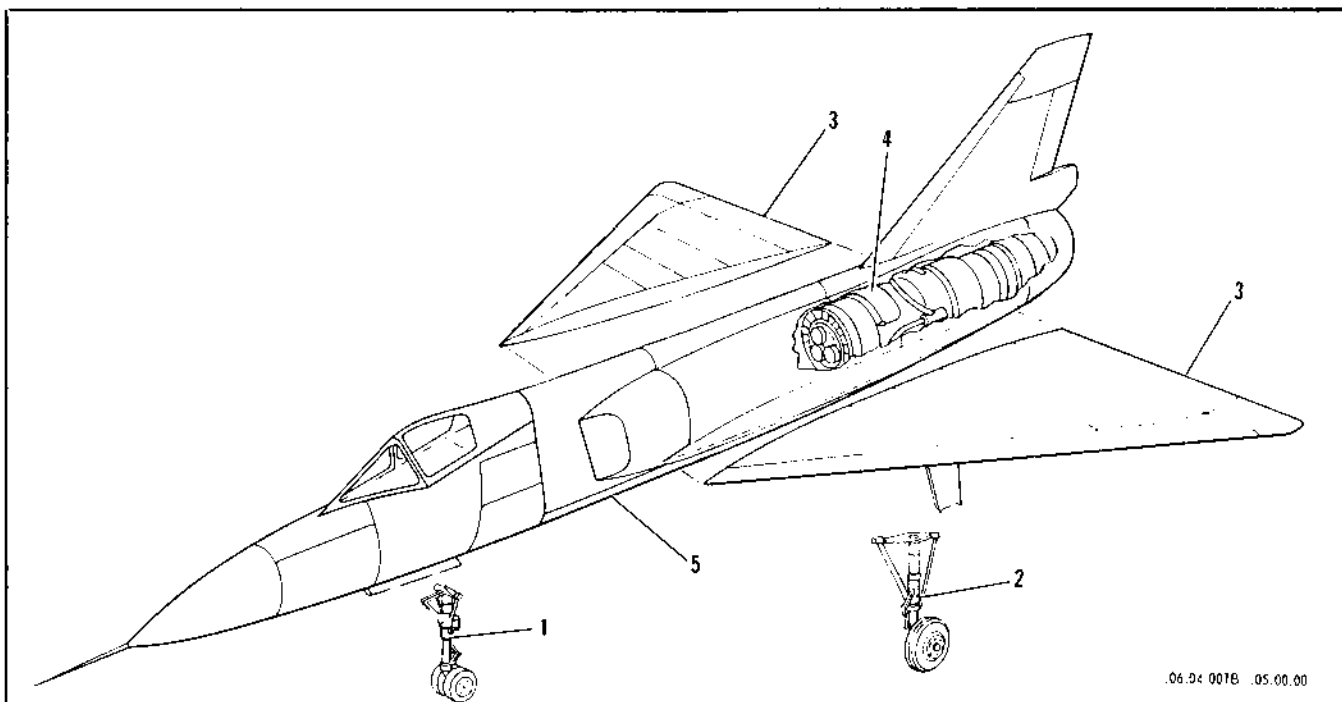

.06.04 0078 .05.00.00

<i>Index Number</i>	<i>Subject</i>	<i>Page</i>
1	NOSE LANDING GEAR	2.15-48
2	MAIN LANDING GEAR	2.15-86
3	WING	
	Access Doors	2.2-88
	Structure	2.6-150
	Hydraulic	2.8-1
	Pneumatic	2.9-1
	Fuel	2.12-2
	Electrical	2.17-1
4	POWER PLANT	2.10-1
5	FUSELAGE	
	Access Doors	2.2-1
	Structure	2.3-16
	Windshield, Canopy & Seat	2.4-1
	Furnishings	2.5-1
	Vertical Stabilizer, Speed Brake & Drag Chute	2.7-1
	Hydraulic	2.8-3
	Pneumatic	2.9-1
	Variable Air Ramp	2.11-1
	Fuel	2.12-220
	Air-Conditioning & Pressurization	2.13-1
	Flight Controls	2.14-1
	Instruments	2.16-1
	Electrical	2.17-1
	Electronic	2.18-1
	Oxygen	2.19-1
	Armament	2.20-1

Figure 1-1. Exploded View of Complete Airplane

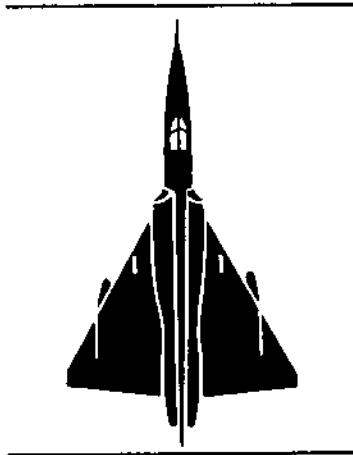

SECTION II

GROUP ASSEMBLY PARTS LISTS

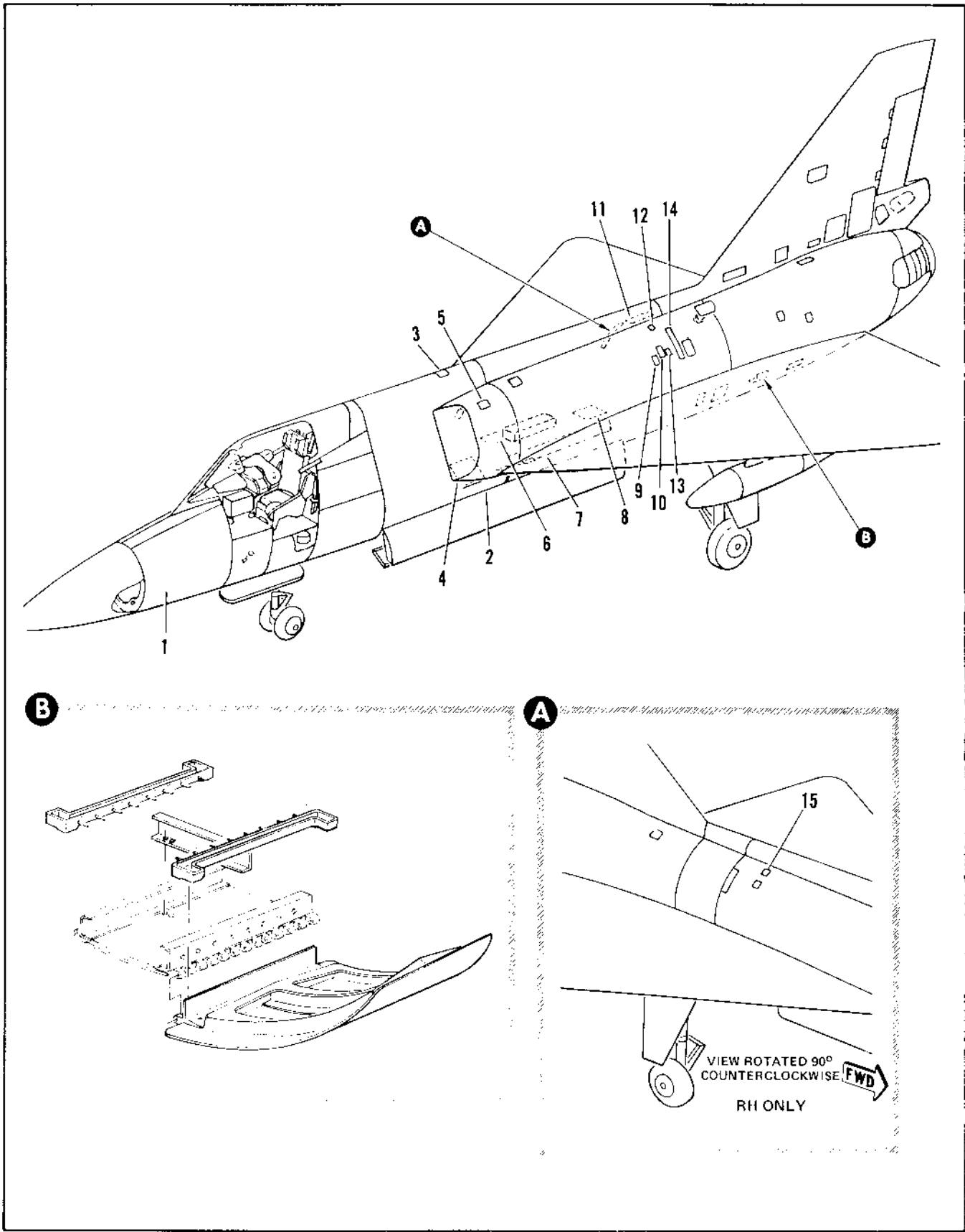
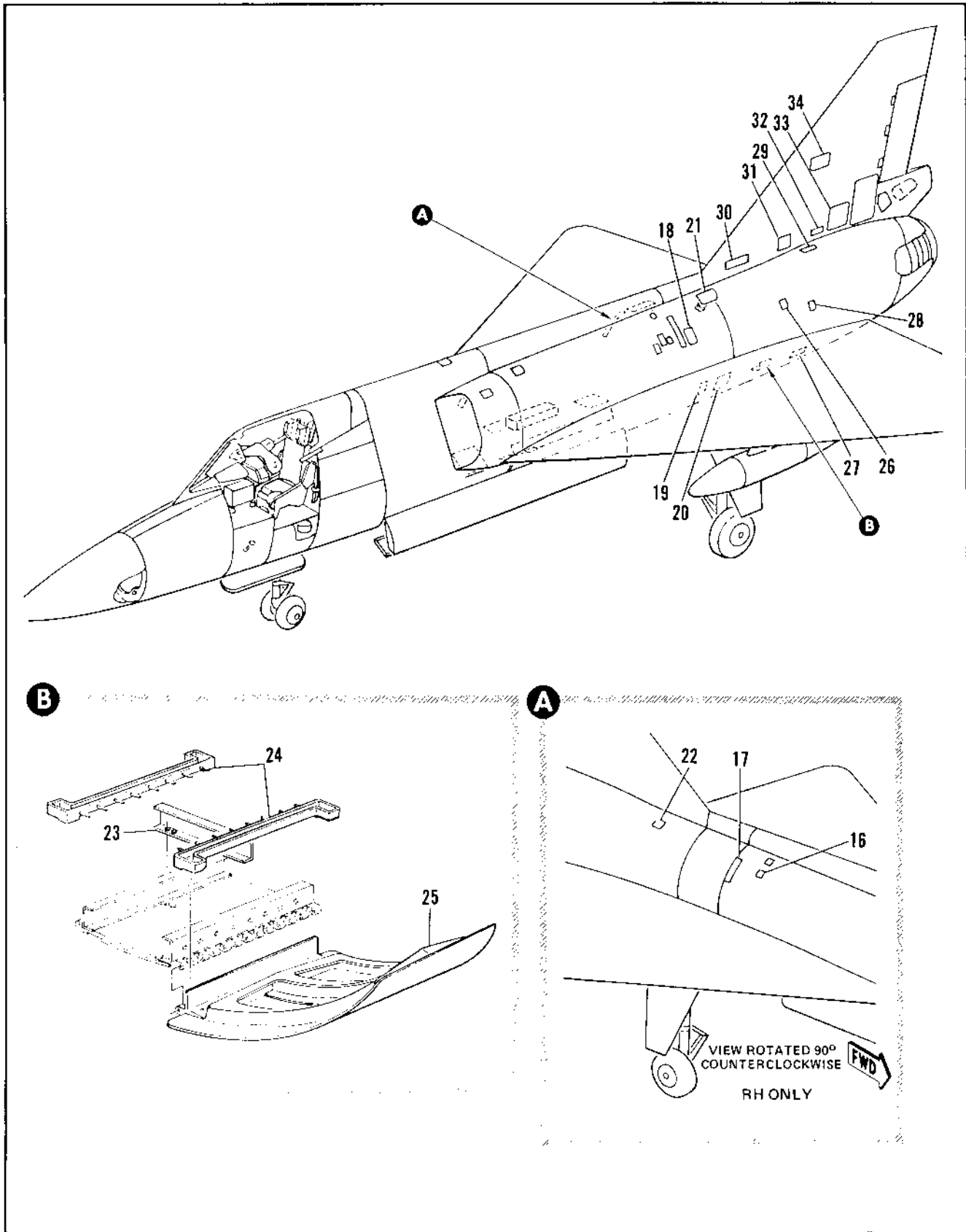
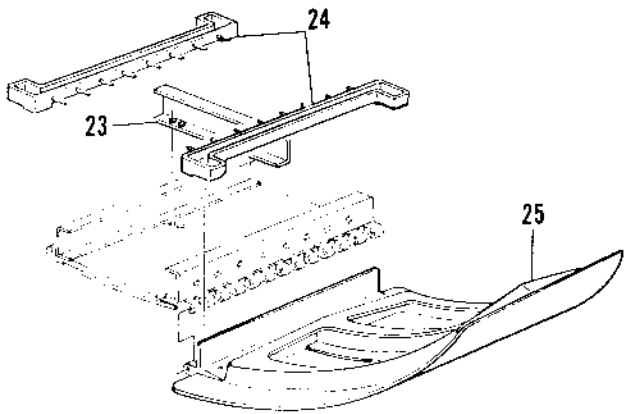

Figure 2.1-1. General Airplane (Sheet 1 of 6)

FIGURE AND INDEX NUMBER	PART NUMBER	DESCRIPTION 1 2 3 4 5 6	UNITS PER ASSY.	USABLE ON CODE		
				FROM	TO	
2.1-1	8-00053-803	GENERAL AIRPLANE FWD OF STA 472 MODIFIED BY 8-31983-803 AND 8-32882-3	1	35	277	
	8-00053-807	GENERAL AIRPLANE FWD OF STA 472	1	278		
	8-00053-803	GENERAL AIRPLANE AFT OF STA 472 MODIFIED BY 8-21908, 8-71153 AND 8-44805	1	A		
	8-00053-1	GENERAL AIRPLANE AFT OF STA 472 MODIFIED BY 8-21908, 8-71153 AND 8-44805	1	278	280	
	8-00053-3	GENERAL AIRPLANE AFT OF STA 472 MODIFIED BY 8-21908, 8-71153 AND 8-44805	1	281	287	
	8-00053-5	GENERAL AIRPLANE AFT OF STA 472 MODIFIED BY 8-21908, 8-71153 AND 8-44805	1	288	293	
	- 1	8-74405-801	• DOOR INSTL, RADAR COMPARTMENT STA 41 TO 102 FOR BREAKDOWN SEE FIG. 2.2-1	1	35	
	- 2	8-74483-3	• DOOR INSTL, ARMAMENT BAY ACCESS STA 246 TO 316 FOR BREAKDOWN SEE FIG. 2.2-7	1	35	
	- 3	8-74497-3	• DOOR INSTL, DORSAL ACCESS STA 269 FOR BREAKDOWN SEE FIG. 2.2-7	1	35	
	- 4	8-74481-801	• ROOF INSTL, ARMAMENT BAY STA 253 TO 316 FOR BREAKDOWN SEE FIG. 2.2-7	1	35	
	- 5	8-77599-3	• DOOR INSTL, VARIABLE AIR RAMP PITOT TUBE ACCESS STA 288 TO 295 FOR BREAKDOWN SEE FIG. 2.2-7	1	35	60
		8-77599-801	• DOOR INSTL, VARIABLE AIR RAMP PITOT TUBE ACCESS STA 288 TO 295 FOR BREAKDOWN SEE FIG. 2.2-7	1	61	
	- 6	8-74489-3	• DOOR INSTL, ARMAMENT BAY ROOF FOR BREAKDOWN SEE FIG. 2.2-7	1	35	
	- 7	8-74484-803	• DOOR INSTL, ARMAMENT BAY SIDE STA 316 TO 412 FOR BREAKDOWN SEE FIG. 2.2-14	1	35	
	- 8	8-74609	• DOOR INSTL, HYDRAULIC ACCESS STA 414 FOR BREAKDOWN SEE FIG. 2.2-7	1	35	
- 9	8-77638-3	• DOOR INSTL, SCROLL AREA INSPECTION STA 435 LH FOR BREAKDOWN SEE FIG. 2.2-7	1	35		
	8-77638-4	• DOOR INSTL, SCROLL AREA INSPECTION STA 435 RH FOR BREAKDOWN SEE FIG. 2.2-7	1	35		
- 10	8-77639-3	• DOOR INSTL, SCROLL AREA INSPECTION STA 441 LH FOR BREAKDOWN SEE FIG. 2.2-7	1	35		
	8-77640-3	• DOOR INSTL, SCROLL AREA INSPECTION STA 441 RH FOR BREAKDOWN SEE FIG. 2.2-7	1	35		
- 11	8-74494-3	• DOOR INSTL, FUSELAGE TOP DECK FOR BREAKDOWN SEE FIG. 2.2-7	1	35		
- 12	8-74603-803	• DOOR INSTL, UPPER DUCT VALVE LH STA 451 TO 455 FOR BREAKDOWN SEE FIG. 2.2-7	1	35		
- 13	8-74661-803	• DOOR INSTL, LOWER DUCT VALVE LH STA 446 TO 452 FOR BREAKDOWN SEE FIG. 2.2-7	1	35		
- 14	8-74602-801	• DOOR INSTL, ENGINE OIL COOLER LH FOR BREAKDOWN SEE FIG. 2.2-7	1	35		
- 15	8-74660-803	• DOOR INSTL, UPPER DUCT VALVE RH STA 445 TO 451	1	35		
A AIRPLANES #35 THRU 277, 294 AND ON						



B



A

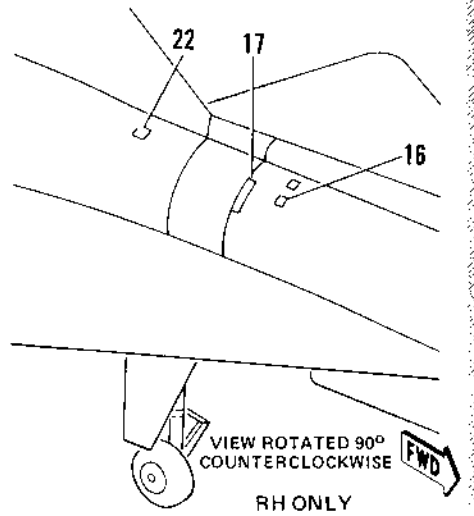

Figure 2.1-1. General Airplane (Sheet 2 of 6)

FIGURE AND INDEX NUMBER	PART NUMBER	DESCRIPTION	UNITS PER ASSY.	USABLE ON CODE	
				FROM	TO
		1 2 3 4 5 6			
2.1-1-16	8-74662-803	• DOOR INSTL, LOWER DUCT VALVE RH STA 446 TO 452 FOR BREAKDOWN SEE FIG. 2.2-7	1	35	
- 17	8-74659-801	• DOOR INSTL, ACCESSORY OIL COOLER RH	1	35	
- 18	8-74614-21	• DOOR INSTL, ENGINE MOUNT ACCESS FWD LH FOR BREAKDOWN SEE FIG. 2.2-9	1	278	300
	8-74614-43	• DOOR INSTL, ENGINE MOUNT ACCESS FWD LH FOR BREAKDOWN SEE FIG. 2.2-9	1	8	
	8-74614-22	• DOOR INSTL, ENGINE MOUNT ACCESS FWD RH FOR BREAKDOWN SEE FIG. 2.2-9	1	278	300
	8-74614-44	• DOOR INSTL, ENGINE MOUNT ACCESS FWD RH FOR BREAKDOWN SEE FIG. 2.2-9	1	8	
- 19	8-74622-3	• DOOR INSTL, FIRE ACCESS STA 488 TO 496 FOR BREAKDOWN SEE FIG. 2.2-9	1	35	
- 20	8-74648-1	*1 • DOOR INSTL, HYDRAULIC PUMP ACCESS STA 502 TO 520 FOR BREAKDOWN SEE FIG. 2.2-9	1	35	
	7839559-90	*2 • DOOR INSTL, HYDRAULIC PUMP AND STARTER STA 502 TO 520 FOR BREAKDOWN SEE FIG 2.2-9	1	48	305
- 21	8-74608-27	• DOOR ASSY, OIL FILLER CAP ACCESS STA 509 FOR BREAKDOWN SEE FIG. 2.2-9	1	35	89
	8-74608-41	• DOOR ASSY, OIL FILLER CAP ACCESS STA 509 FOR BREAKDOWN SEE FIG. 2.2-9	1	90	
- 22	8-74617-3	• DOOR INSTL, BLEED AIR DUCT ACCESS FOR BREAKDOWN SEE FIG. 2.2-9	1	35	
	8-74619-3	• DOOR INSTL, ENGINE ACCESS	1	35	
- 23	8-74619-11	• CHANNEL	1	35	
- 24	8-74961-7	• SEAL, ENGINE ACCESS DOOR	2	35	
- 25	8-74621-1	• DOOR INSTL, ENGINE ACCESS LH FOR BREAKDOWN SEE FIG. 2.2-15	1	35	
	8-74621-2	• DOOR INSTL, ENGINE ACCESS RH FOR BREAKDOWN SEE FIG. 2.2-15	1	35	
- 26	8-74627-3	• DOOR INSTL, ELEVON CYLINDER ACCESS STA 569 TO 577 FOR BREAKDOWN SEE FIG. 2.2-9	1	35	
- 27	8-74628-3	• DOOR INSTL, ELEVON CONTROL VALVE ACCESS FOR BREAKDOWN SEE FIG. 2.2-9	1	35	
- 28	8-74625-3	• DOOR INSTL, ELEVON STA 593 TO 602 FOR BREAKDOWN SEE FIG. 2.2-9	1	35	
- 29	8-74607-3	• DOOR INSTL, AFT ENGINE MOUNT ACCESS STA 602 FOR BREAKDOWN SEE FIG. 2.2-9	1	35	
- 30	8-14639	• DOOR INSTL, FIN BAY #1 BLEED AIR ACCESS STA 541 FOR BREAKDOWN SEE FIG. 2.2-18	1	35	
- 31	8-14640-3	• DOOR INSTL, FIN EQUIPMENT PANEL STA 519 FOR BREAKDOWN SEE FIG. 2.2-18	1	35	
- 32	8-14655	• DOOR INSTL, FIN ACCESS STA 603 TO 610 FOR BREAKDOWN SEE FIG. 2.2-18	1	0	
	8-14618	• DOOR INSTL, BAY #1 LWR AFT ACCESS FOR BREAKDOWN SEE FIG. 2.2-18	1	90	277
- 33	8-14642	• DOOR INSTL, ELECTRONIC EQUIPMENT FIN STA 615 FOR BREAKDOWN SEE FIG. 2.2-18	1	35	
- 34	8-14641-3	• DOOR INSTL, WAVEGUIDE ACCESS STA 615 FOR BREAKDOWN SEE FIG. 2.2-18	1	35	
		B AIRPLANES #35 THRU 277, 301 ON C AIRPLANES #35 THRU 89, 278 AND ON			
		*1 REMOVED BY TCTO 1F-106-1208			
		*2 ADDED BY TCTO 1F-106-1208			

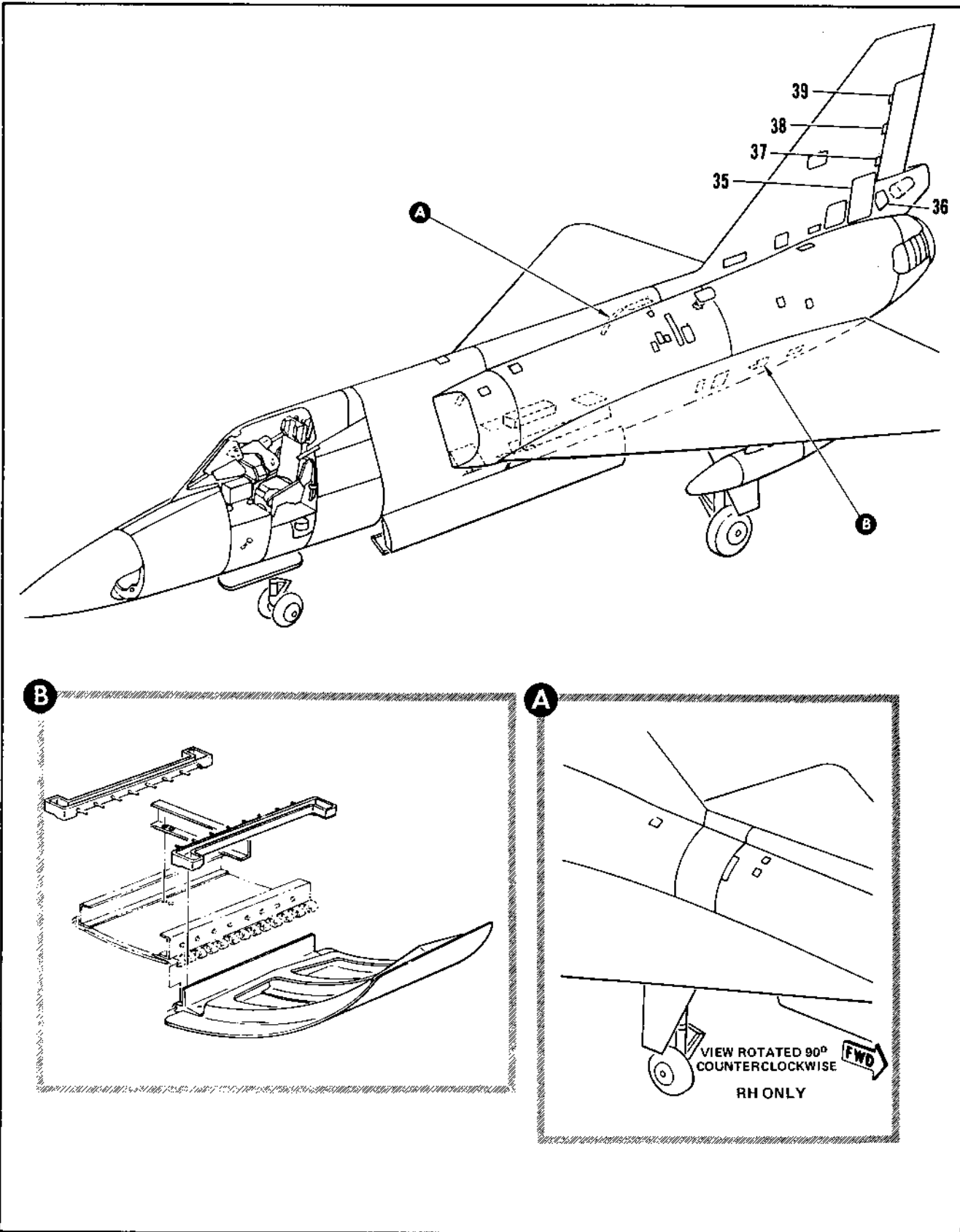

Figure 2.1-1. General Airplane (Sheet 3 of 6)

FIGURE AND INDEX NUMBER	PART NUMBER	DESCRIPTION	UNITS PER ASSY.	USABLE ON CODE	
				FROM	TO
		1 2 3 4 5 6			
2.1-1-35	8-14644	• DOOR INSTL, FIN RUDDER CONTROL ACCESS STA 646 FOR BREAKDOWN SEE FIG. 2.2-18	1	35	
- 36	8-74863-3	• PANEL INSTL, SPEED BRAKE SUPPORT LH STA 672 FOR BREAKDOWN SEE FIG. 2.2-18	1	35	
- 37	8-14650-5	• DOOR INSTL, RUDDER HINGE ACCESS LOWER FOR BREAKDOWN SEE FIG. 2.2-18	1	35	
- 38	8-14650-3	• DOOR INSTL, RUDDER HINGE ACCESS CENTER FOR BREAKDOWN SEE FIG. 2.2-18	1	35	
- 39	8-14650-1	• DOOR INSTL, RUDDER HINGE ACCESS UPPER FOR BREAKDOWN SEE FIG. 2.2-18	1	35	
	8-32855-1	• PANEL ASSY, TACAN POWER SOURCE SWITCH FOR BREAKDOWN SEE FIG. 2.17-9	1		
	8-32855-5	• PANEL ASSY, TACAN POWER SOURCE SWITCH FOR BREAKDOWN SEE FIG. 2.17-9	1	278	
	8-32855-3	• PANEL ASSY, TACAN POWER SOURCE SWITCH FOR BREAKDOWN SEE FIG. 2.17-9	1		
		C AIRPLANES #35 THRU 89, 278 AND ON			

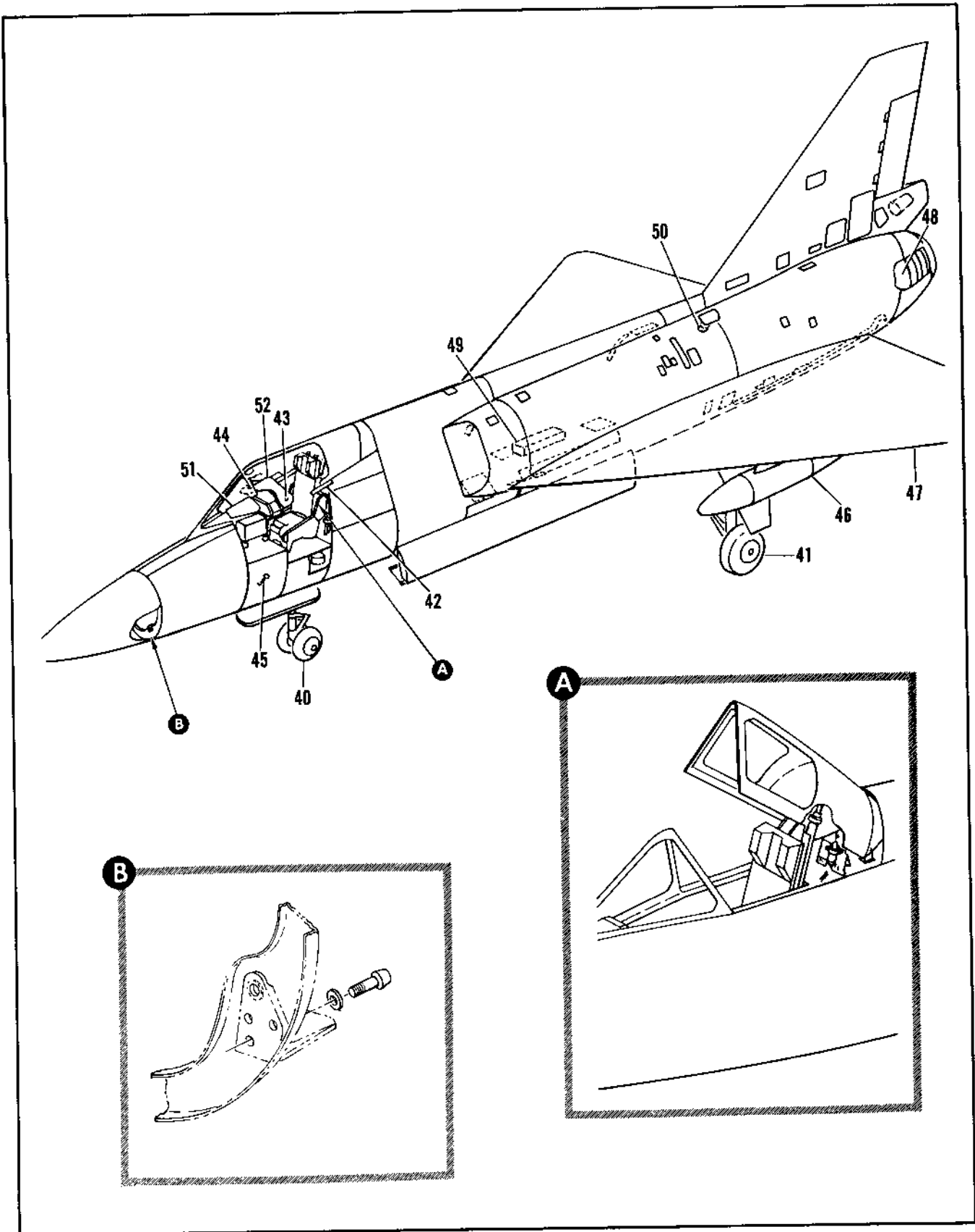

Figure 2.1-1. General Airplane (Sheet 4 of 6)

FIGURE AND INDEX NUMBER	PART NUMBER	DESCRIPTION	UNITS PER ASSY.	USABLE ON CODE	
				FROM	TO
		1 2 3 4 5 6			
2.1-1-40		• GEAR INSTL, NOSE LANDING SEE FIG. 2.15-16	RF		
- 41		• GEAR INSTL, MAIN LANDING LH SEE FIG. 2.15-25	RF		
- 42	8-94976-805	• LIGHT INSTL, COCKPIT FLOOD AND THUNDERSTORM STA 140 FOR BREAKDOWN SEE FIG. 2.17-4	1	35	
- 43	8-95989-1	• LIGHT INSTL, INSTRUMENT PANEL AMBIENT LH FOR BREAKDOWN SEE FIG. 2.17-3	1	A	
- 44	8-95989-2	• LIGHT INSTL, INSTRUMENT PANEL AMBIENT RH FOR BREAKDOWN SEE FIG. 2.17-3	1	A	
- 45	8-38070-1	• PROBE INSTL, TOTAL TEMPERATURE STA 151 FOR BREAKDOWN SEE FIG. 2.14-6	1	35	47
	8-38070-3	• PROBE INSTL, TOTAL TEMPERATURE STA 151 FOR BREAKDOWN SEE FIG. 2.14-6	1	48	
- 46	8-21040	• TANK AND PYLON INSTL, EXTERNAL FUEL	RF	35	
	65J3320-1	• PYLON INSTALLATION, TANK RELEASE-EXTERNAL FUEL WING LH FOR BREAKDOWN SEE FIG. 2.12-9 (98750)	1	278	291
	65J3320-3	• PYLON INSTALLATION, TANK RELEASE-EXTERNAL FUEL WING RH FOR BREAKDOWN SEE FIG. 2.12-9 (98750)	1	278	291
	65J3320-5	• PYLON INSTALLATION, TANK RELEASE-EXTERNAL FUEL WING LH FOR BREAKDOWN SEE FIG. 2.12-9 (98750)	1	B	
	65J3320-7	• PYLON INSTALLATION, TANK RELEASE-EXTERNAL FUEL WING RH FOR BREAKDOWN SEE FIG. 2.12-9 (98750)	1	B	
	65J33310-1	• TANK ASSEMBLY-FUEL, EXTERNAL FOR BREAKDOWN SEE FIG. 2.12-10 (98750)	2	35	
- 47	8-10060-1	• WING INSTL, LH FOR BREAKDOWN SEE FIG. 2.6-1	1	B	
	8-10040-801	• WING INSTL, LH FOR BREAKDOWN SEE FIG. 2.6-2	1	278	280
	8-10040-1	• WING INSTL, LH FOR BREAKDOWN SEE FIG. 2.6-2	1	281	286
	8-10060-805	• WING INSTL, LH FOR BREAKDOWN SEE FIG. 2.6-1	1	287	287
	8-10040-805	• WING INSTL, LH FOR BREAKDOWN SEE FIG. 2.6-2	1	288	291
	8-10060-2	• WING INSTL, RH FOR BREAKDOWN SEE FIG. 2.6-1	1	B	
	8-10040-802	• WING INSTL, RH FOR BREAKDOWN SEE FIG. 2.6-2	1	278	280
	8-10040-2	• WING INSTL, RH FOR BREAKDOWN SEE FIG. 2.6-2	1	281	286
	8-10060-806	• WING INSTL, RH FOR BREAKDOWN SEE FIG. 2.6-1	1	287	287
	8-10040-806	• WING INSTL, RH FOR BREAKDOWN SEE FIG. 2.6-2	1	288	291
- 48	8-22094-807	• POWER PLANT INSTALLATION FOR BREAKDOWN SEE FIG. 2.10-6	1	35	
- 49	8-93805	• CONTAINER INSTL, LUGGAGE FOR BREAKDOWN SEE FIG. 2.5-8	1	130	
- 50	8-27561-3	• BELLOWS INSTL, ENGINE OIL TANK SCUPPER FOR BREAKDOWN SEE FIG. 2.10-1	1	35	
- 51	8-94879	• SHIELD INSTL, REFLECTION STA 88 FOR BREAKDOWN SEE FIG. 2.5-1	1	35	
- 52	8-94571-1	• SHIELD INSTL, INSTRUMENT PANEL GLARE MODIFIED BY 66J40226 (98750)	1	35	47
	8-94571-801	• SHIELD INSTL, INSTRUMENT PANEL GLARE FOR BREAKDOWN SEE FIG. 2.5-2	RF	A	
	8-94571-801	• SHIELD INSTL, INSTRUMENT PANEL GLARE MODIFIED BY 66J40226 FOR BREAKDOWN SEE FIG. 2.5-2 (98750)	1	A	
	8-94571-5	• SHIELD INSTL, INSTRUMENT PANEL GLARE FOR BREAKDOWN SEE FIG. 2.5-2	RF	49	89
	8-94571-5	• SHIELD INSTL, INSTRUMENT PANEL GLARE MODIFIED BY 66J40226 FOR BREAKDOWN SEE FIG. 2.5-2 (98750)	1	49	89

A AIRPLANES #48, 90 AND ON
 B AIRPLANES #35 THRU 277, 292 AND ON

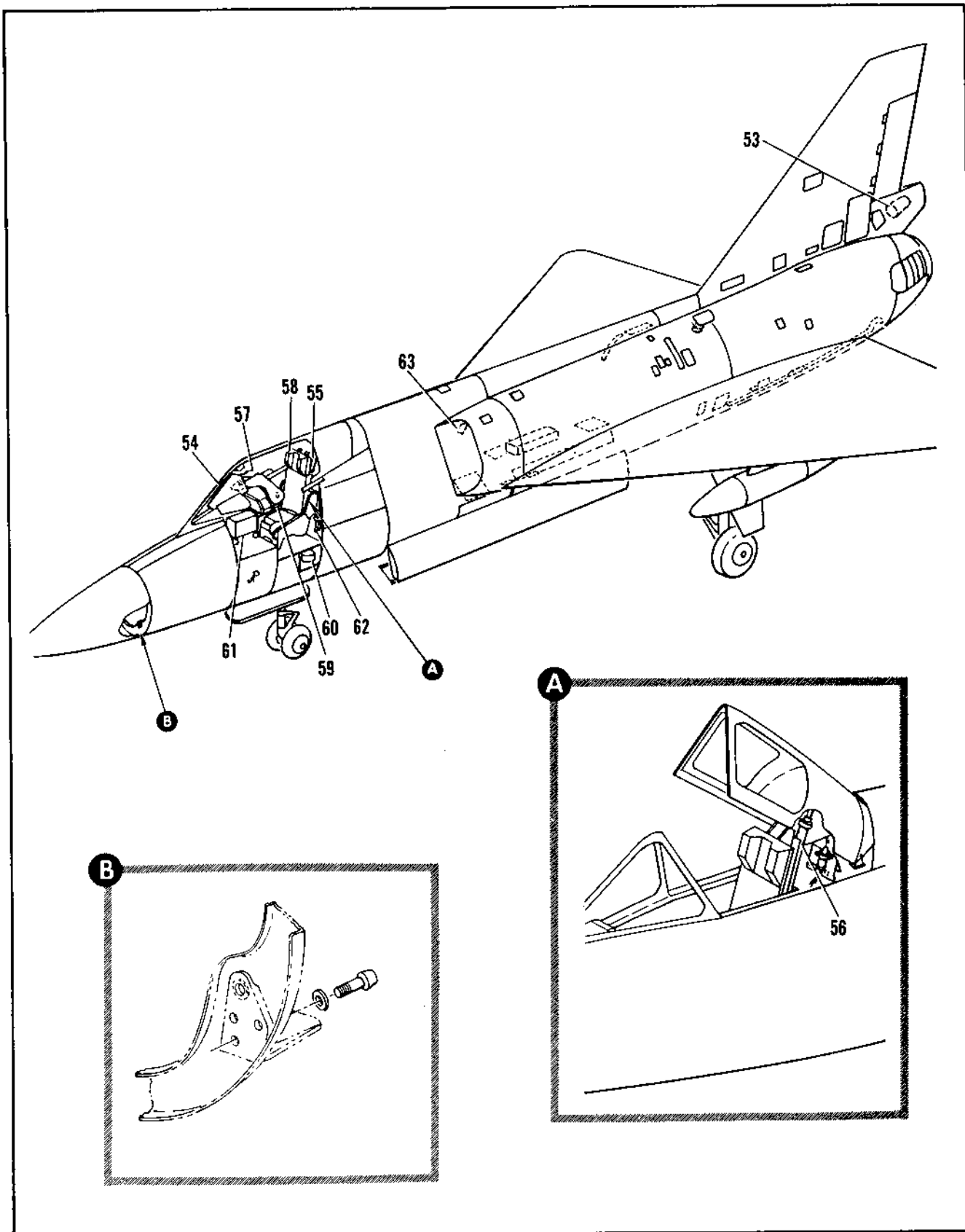

Figure 2.1-1. General Airplane (Sheet 5 of 6)

FIGURE AND INDEX NUMBER	PART NUMBER	DESCRIPTION	UNITS PER ASSY.	USABLE ON CODE	
				FROM	TO
		1 2 3 4 5 6			
2.1-1- 53	8-45011-11	• DRAG CHUTE INSTL. FOR BREAKDOWN SEE FIG. 2.7-2	1	35	
- 54	8-94878-3	• BAFFEL INSTL, WINDSHIELD REFLECTION FOR BREAKDOWN SEE FIG. 2.5-3	1	35	48
	8-94878-5	• BAFFEL INSTL, WINDSHIELD REFLECTION FOR BREAKDOWN SEE FIG. 2.5-3	1	49	
- 55	8-94166-803	• JETTISON INSTL, CARTRIDGE POWERED CANOPY FOR BREAKDOWN SEE FIG. 2.4-7	1	C	
- 56	8-94180-1	• JETTISON INSTL, CARTRIDGE POWERED CANOPY FOR BREAKDOWN SEE FIG. 2.4-7	1	0	
- 57	8-74822-1	• WINDOW INSTL, CANOPY FOR BREAKDOWN SEE FIG. 2.4-1	1	35	
- 58	806598-403	• SEAT INSTL, EJECTION (92824) FOR BREAKDOWN SEE FIG. 2.4-11	1	35	
- 59	8-38056-817	• PANEL INSTL, PILOT INSTRUMENT FOR BREAKDOWN SEE FIG. 2.16-1	1	35	35
	8-38056-815	• PANEL INSTL, PILOT INSTRUMENT FOR BREAKDOWN SEE FIG. 2.16-1	1	36	47
	8-38109-1	• PANEL INSTL, PILOT INSTRUMENT FOR BREAKDOWN SEE FIG. 2.16-2	1	48	48
	8-38056-813	• PANEL INSTL, PILOT INSTRUMENT FOR BREAKDOWN SEE FIG. 2.16-1	1	49	89
	8-38109	• PANEL INSTL, PILOT INSTRUMENT FOR BREAKDOWN SEE FIG. 2.16-2	1	90	
- 60	8-92452-805	• CONVERTER INSTL, LIQUID OXYGEN FOR BREAKDOWN SEE FIG. 2.19-1	RF	35	
	8-92452-805	• CONVERTER INSTL, LIQUID OXYGEN MOD- IFIED BY 65J38401 FOR BREAKDOWN SEE FIG. 2.19-1 (98750)	1	35	
- 61	6-95546-3	• DISPLAY INSTL, TACTICAL SITUATION FOR BREAKDOWN SEE FIG. 2.18-12	1	E	
- 62	8-94872	• HOSE INSTL, PILOT SUIT VENTILATING STA 172 FOR BREAKDOWN SEE FIG. 2.13-1	RF	35	188
	8-94187	• HOSE INSTL, PILOT SUIT VENTILATING STA 172 FOR BREAKDOWN SEE FIG. 2.13-1	RF	189	
	NO NUMBER	• HOSE INSTL, VENT SUIT FOR BREAKDOWN SEE FIG. 2.13-13	1	35	
- 63	8-23130	• COUPLING INSTL, HEAT EXCHANGER EXHAUST EXIT DUCT FOR BREAKDOWN SEE FIG. 2.13-29	1	35	
		C AIRPLANES #35 THRU 242, 244, 245, 247, 249, AND 259			
		D AIRPLANES #243, 246, 248, 250 THRU 258, 260 ON			
		E AIRPLANES #35 THRU 47, AND 49 THRU 89			

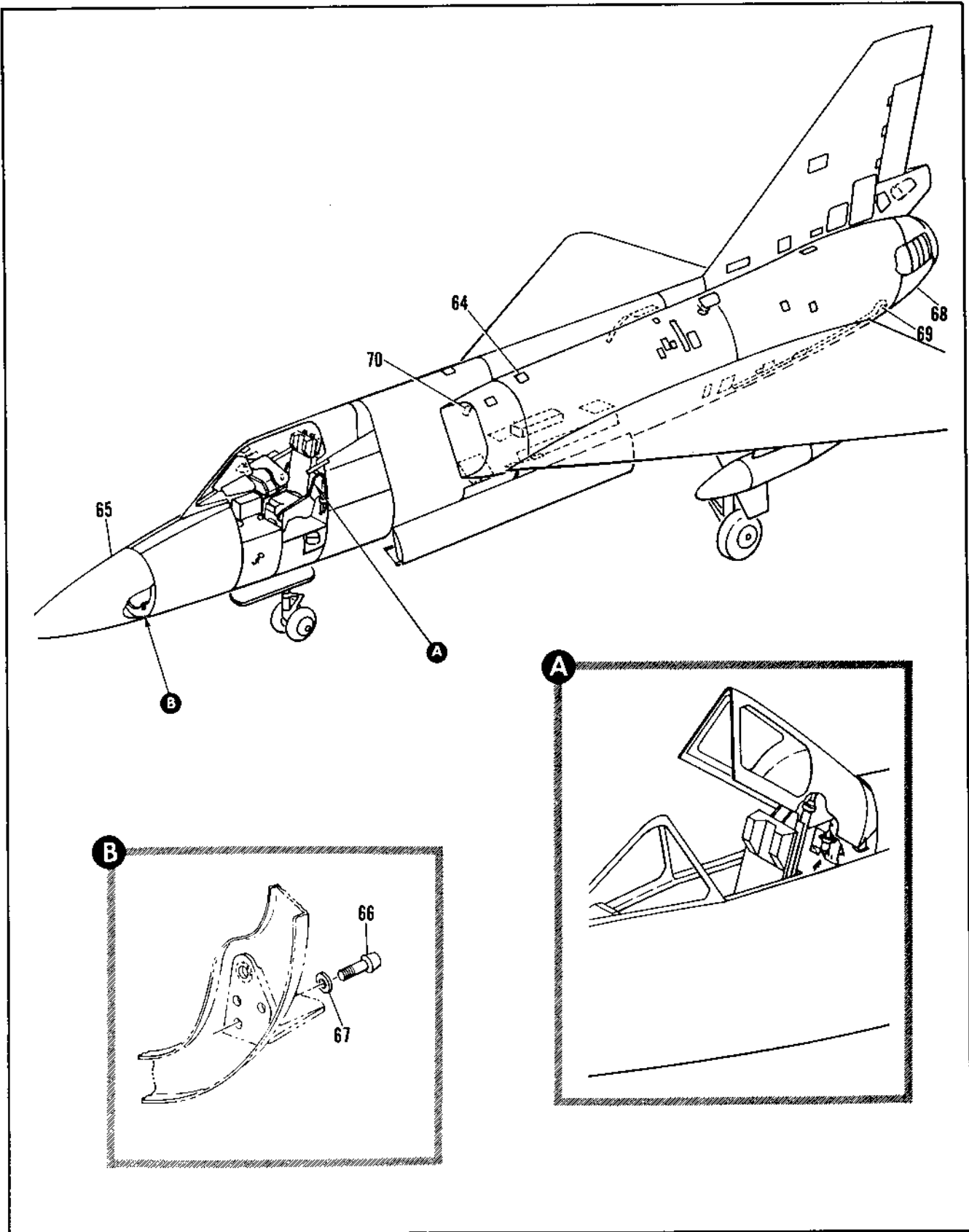

Figure 2.1-1. General Airplane (Sheet 6 of 6)

FIGURE AND INDEX NUMBER	PART NUMBER	DESCRIPTION	UNITS PER ASSY.	USABLE ON CODE	
				FROM	TO
		1 2 3 4 5 6			
2.1-1-64	8-74948-1	• DORSAL INSTL, HEAT EXCHANGER EXHAUST FOR BREAKDOWN SEE FIG. 2.13-1	RF	55	
	8-74011-525	• RADOME AND BOOM ASSY, SPARES ONLY	1	35	
	66J40245-1	• DORSAL INSTL, STA 308 TO STA 370 FOR BREAKDOWN SEE FIG. 2.13-1 (98750)	1	35	
- 65	8-74011-3	• RADOME AND BOOM ASSY, PLASTIC FOR BREAKDOWN SEE FIG. 2.3-1 ATTACHING PARTS	1	35	
	8-74960	• ATTACHMENT INSTL, RADOME	1	35	
- 66	NAS625-26	• • BOLT (80205)	4	35	
- 67	MS20002C5	• • WASHER (96906)	4	35	
		-----X-----			
- 68	8-77386	• TAIL CONE INSTALLATION, FOR BREAKDOWN SEE FIG. 2.3-16	1	G	
	8-77386-1	• TAIL CONE INSTALLATION, FOR BREAKDOWN SEE FIG. 2.3-16	1	H	
	8-71152-3	• TAIL CONE INSTALLATION, FOR BREAKDOWN SEE FIG. 2.3-16	1	J	
	8-74490	• STRUCTURE ASSY, TAIL CONE FOR BREAKDOWN SEE FIG. 2.3-16	1	H	
- 69	8-78736-1	• FAIRING INSTL, TAIL HOOK FOR BREAKDOWN SEE FIG. 2.15-37	1	130	
- 70	8-74000-803	• FUSELAGE ASSY, GENERAL FWD OF STA 472 FOR BREAKDOWN SEE FIG. 2.3-3	1	35	277
	8-74000-809	• FUSELAGE ASSY, GENERAL FWD OF STA 472 FOR BREAKDOWN SEE FIG. 2.3-3	1	278	
	8-74000-803	• FUSELAGE ASSY, GENERAL AFT OF STA 472	1	F	
	8-74000-1	• FUSELAGE ASSY, GENERAL AFT OF STA 472 FOR BREAKDOWN SEE FIG. 2.3-3	1	278	289
	8-74000-3	• FUSELAGE ASSY, GENERAL AFT OF STA 472 FOR BREAKDOWN SEE FIG. 2.3-3	1	281	287
	8-74000-5	• FUSELAGE ASSY, GENERAL AFT OF STA 472 FOR BREAKDOWN SEE FIG. 2.3-3	1	288	293
		F AIRPLANES #35 THRU 277, 294 AND ON G AIRPLANES #35 THRU 129, 301 AND ON H AIRPLANES #284, 288, 292, AND 295 J AIRPLANES #278 THRU 283, 285 THRU 287, 289 THRU 291, 293, 294, AND 296 THRU 300			

ACCESS DOORS SUBSECTION

TABLE OF CONTENTS

Fig. No.	Title	Page	Fig. No.	Title	Page
2.2-1	Fuselage Access Doors Sta 41 to 110	2.2-2	2.2-11	External Power Access Door Assembly Sta 171 to 175	2.2-64
2.2-2	Infrared Seeker Fairing and Door Installation	2.2-4	2.2-12	Midbay Electronic Compartment Access Door Assembly	2.2-66
2.2-3	Fuselage Access Doors Sta 108 to 213	2.2-6	2.2-13	Refrigeration Access Door Installation	2.2-70
2.2-4	Aft Electronic Access Door Frame Installation	2.2-14	2.2-14	Armament Bay Side Door Installation Sta 316 to 412	2.2-72
2.2-5	Upper Aft Electronic Compartment Access Door Installation	2.2-16	2.2-15	Engine Access Door Installation	2.2-76
2.2-6	External Power Access Door Latch Installation	2.2-20	2.2-16	Fuel Shutoff Valve Access Door Installation	2.2-78
2.2-7	Fuselage Access Doors Sta 213 to 488	2.2-22	2.2-17	Air Turbine Driven Emergency AC Generator Access Door Installa- tion	2.2-82
2.2-8	Electronic Compartment Ground Connection Access Door Assembly	2.2-40	2.2-18	Fin Access Doors	2.2-84
2.2-9	Fuselage Access Doors Sta 472 to 602	2.2-42	2.2-19	Lower Wing Access Doors	2.2-88
2.2-10	Fwd Radar Compartment Door Installation	2.2-52	2.2-20	Elevon Hinge Access Door Installation	2.2-102
			2.2-21	Wing Outbd Intermediate Box Access Door Installation	2.2-104

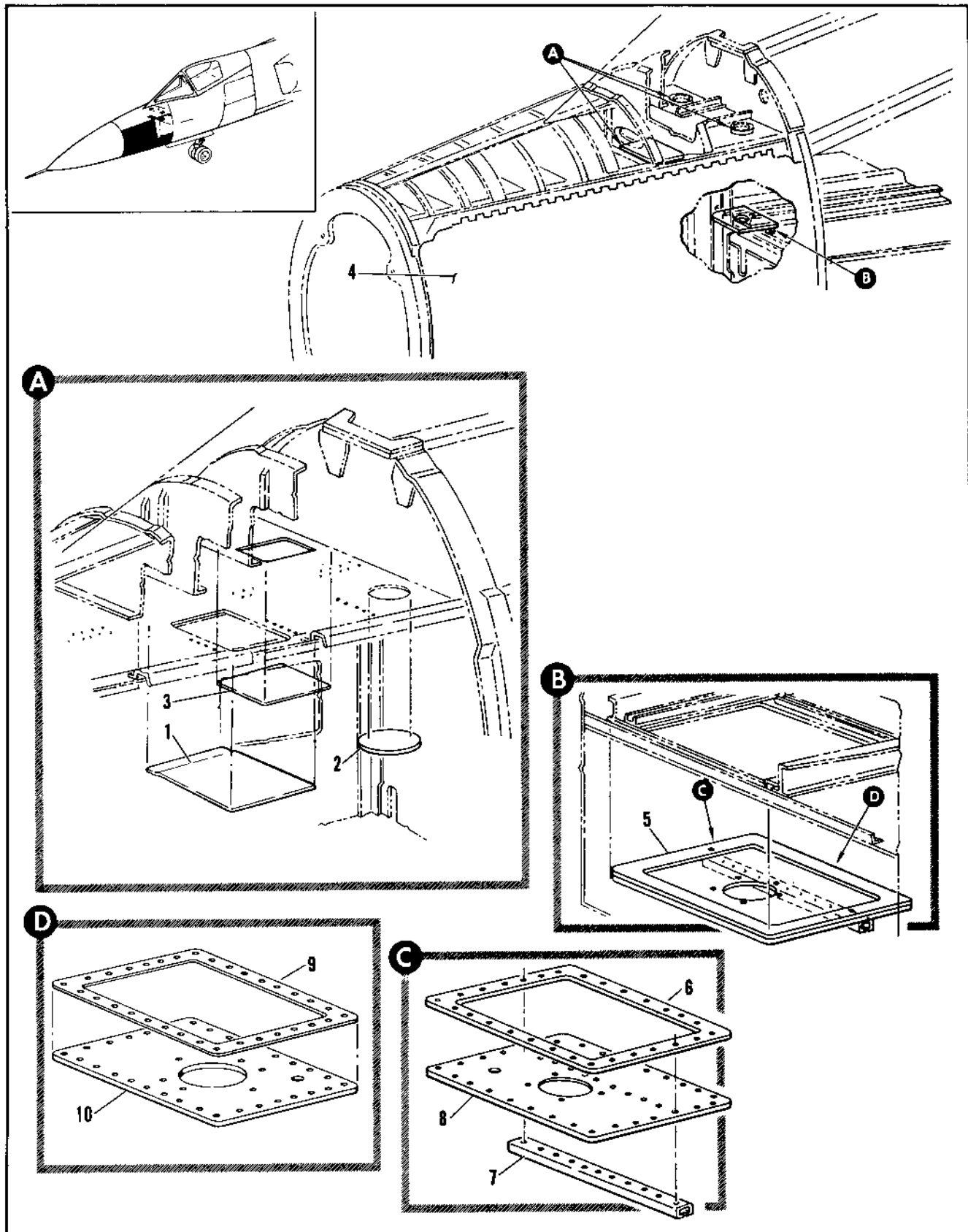

Figure 2.2-1. Fuselage Access Doors Sta 41 to 110

FIGURE AND INDEX NUMBER	PART NUMBER	DESCRIPTION	UNITS PER ASSY.	USABLE ON CODE	
				FROM	TO
		1 2 3 4 5 6			
2.2-1	8-74405-801	FUSELAGE ACCESS DOORS STA 41 TO 110	RF	35	
- 1	8-44894-145 66D40768-1	. DOOR INSTL, RADAR COMPARTMENT STA 41 TO 102 FOR NHA SEE FIG. 2.1-1	1	35	
		. . DOOR, MAKE FROM 8-74405-51	1		
		. . DOOR, RADAR COMPARTMENT (98750) ATTACHING PARTS	39	35	
	NAS221-8	. . SCREW (80205) ----X----			
- 2	8-74405-63	. . COVER, ACCESS ATTACHING PARTS	1	35	
	NAS221-5	. . SCREW (80205) ----X----	12	35	
- 3	66D40883-1	. . DOOR, ACCESS (98750) ATTACHING PARTS	1	35	
	NAS221-9	. . SCREW(80205) ----X----	21	35	
- 4		. DOOR INSTL, FWD RADAR COMPARTMENT LH SEE FIG. 2.2-10 INDEX 3	RF		
	8-74630	. DOOR INSTL, COCKPIT AIR PRESSURE REGULATOR ACCESS STA 102 TO 110 FOR NHA SEE FIG. 2.3-4	RF	A	
- 5	8-74630-17	. . DOOR ASSY, COCKPIT AIR PRESSURE REGULATOR ACCESS REPLACED BY NOT INTCHG WITH 8-78589-15 ATTACHING PARTS	1	A	
	NAS464-3A3	. . BOLT (80205)	24	A	
	NAS464-3A4	. . BOLT (80205)	2	A	
	NAS464-3A9	. . BOLT (80205) ----X----	2	A	
- 6	8-74629	. . . GASKET	1	A	
- 7	8-74630-15	. . . STIFFENER	1	A	
- 8	8-74630-7 8-78589	. . . DOOR	1	A	
		. DOOR INSTL, COCKPIT AIR PRESSURE REGULATOR ACCESS STA 102 TO 110 FOR NHA SEE FIG. 2.3-4	RF	B	
	6-78589-15	. . DOOR ASSY, COCKPIT AIR PRESSURE REGULATOR ACCESS REPLACES NOT INTCHG WITH 8-74630-17 ATTACHING PARTS	1	B	
	NAS1103-6	. . BOLT (80205)	22	B	
	NAS1103-4	. . BOLT (80205)	8	B	
	NAS1103-7	. . BOLT (80205) ----X----	2	B	
- 9	8-78590	. . . GASKET	1	B	
- 10	8-78589-7	. . . DOOR	1	B	
		A AIRPLANES #35 THRU 47 AND 49 THRU 89 B AIRPLANES #48, 90 AND ON			

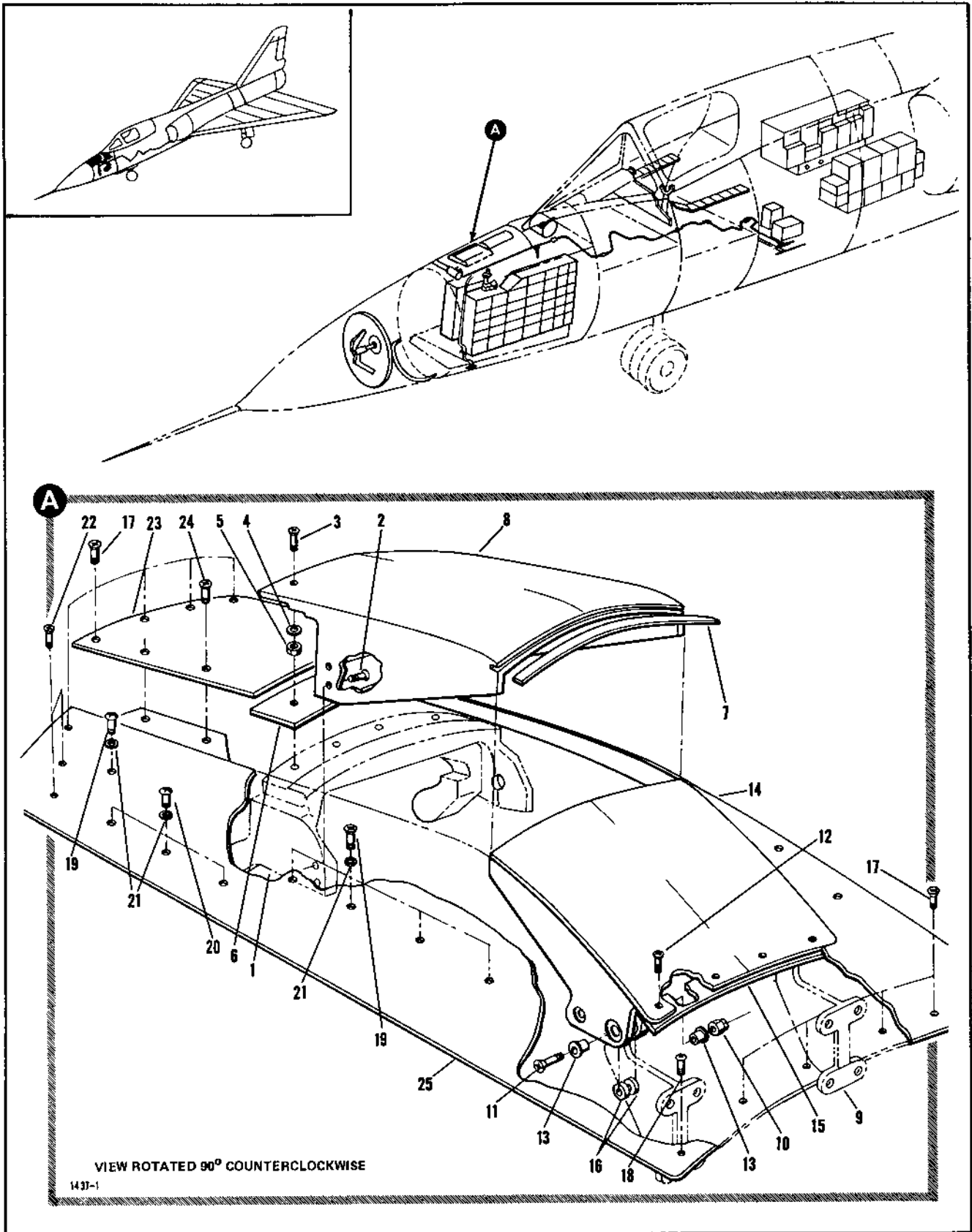

Figure 2.2-2. Infrared Seeker Fairing and Door Installation

FIGURE AND INDEX NUMBER	PART NUMBER	DESCRIPTION 1 2 3 4 5 6	UNITS PER ASSY.	USABLE ON CODE	
				FROM	TO
2.2-2	8-44892-1	FAIRING AND DOOR INSTALLATION, INFRARED SEEKER FOR NHA SEE FIG. 2.20-48	RF	35	
- 1	8-44892-9	• RACK, RECEIVER INFRARED SEEKER • DOOR ASSEMBLY ATTACHING PARTS	RF 1		
- 2	NAS1189C08P7L	• SCREW (80205)	4		
- 3	NAS1189C3P8N	• SCREW (80205)	4		
- 4	AN960-10L	• WASHER (88044)	6		
- 5	AN960-10	• WASHER (88044) -----X-----	4		
- 6	8-44892-21	• SEAL	1		
- 7	8-44892-23	• SEAL	1		
- 8	8-44872-11	• DOOR, AFT INFRARED SEEKER • PIVOT, HINGE FWD DOOR INFRARED SEEKER	1 RF		
- 9	8-44871-1	• DOOR ASS, INFRARED SEEKER ATTACHING PARTS	1		
- 10	NAS1291-3	• NUT (80205)	2		
- 11	NAS333CPA11	• BOLT (80205)	2		
- 12	MS24694-5	• SCREW (96906) -----X-----	4		
- 13	8-44897-7	• BUSHING	4		
- 14	8-44871-9	• DOOR	4		
- 15	8-44892-39	• DOUBLER ASSY, FWD DOOR SEAL CEMENTED AND RIVETED	1		
- 16	NAS77-3-43	• BUSHING (80205)	2		
	8-44892-57	• FAIRING ASSEMBLY ATTACHING PARTS	1		
- 17	NAS333CPA5	• BOLT (80205)	10		
- 18	NAS333CPA4	• BOLT (80205)	2		
- 19	NAS221-15	• SCREW (80205)	10		
- 20	NAS221-13	• SCREW (80205)	6		
- 21	AN960-10	• WASHER (88044)	16		
- 22	NAS333CPA6	• BOLT (80205) -----X-----	4		
- 23	8-44892-25	• DOOR ATTACHING PARTS	1		
- 24	NAS333CPA5	• BOLT (80205) -----X-----	4		
- 25	8-44892-55	• FAIRING	1		

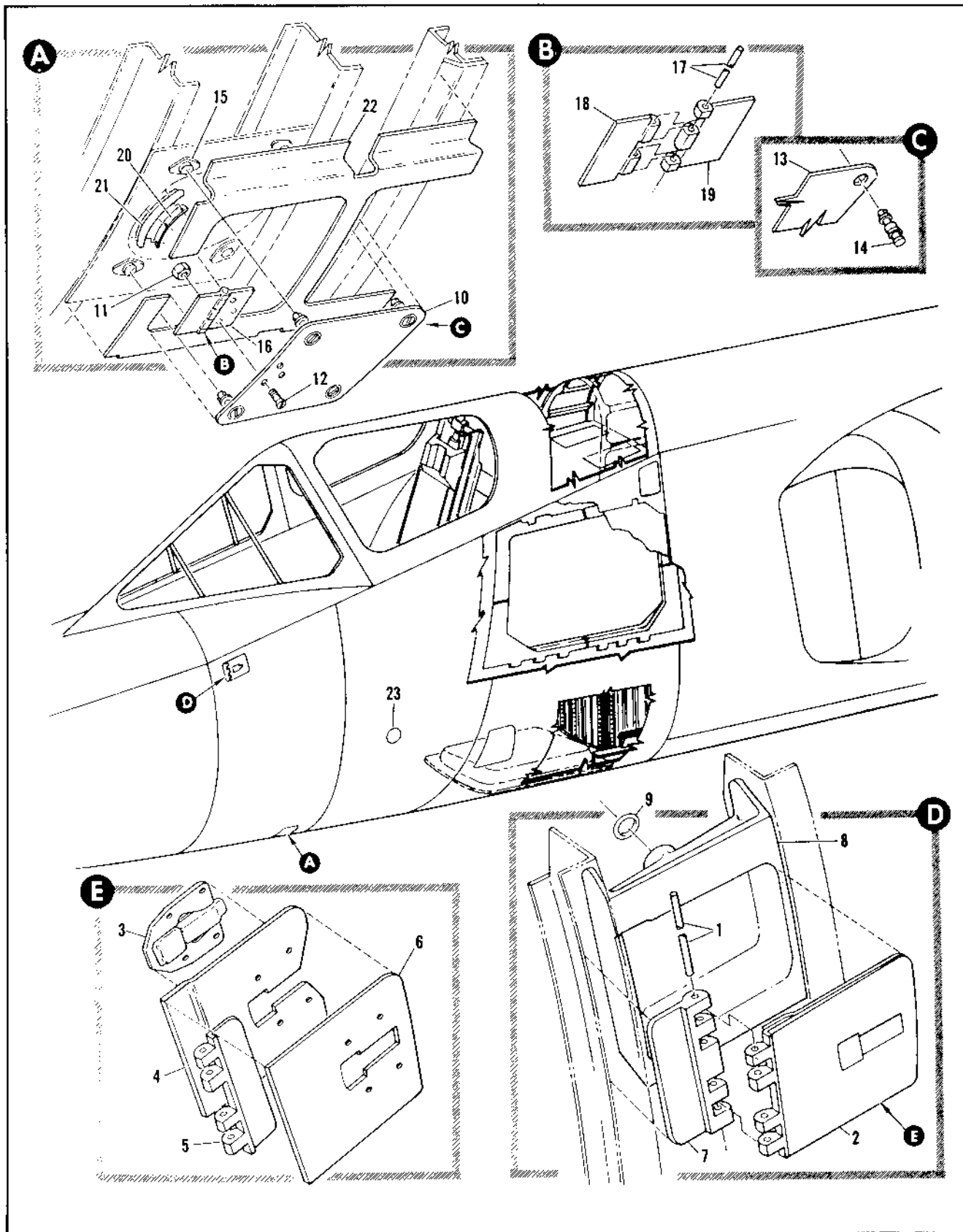

Figure 2.2-3. Fuselage Access Doors Sta 108 to 213 (Sheet 1 of 4)

FIGURE AND INDEX NUMBER	PART NUMBER	DESCRIPTION	UNITS PER ASSY.	USABLE ON CODE	
				FROM	TO
		1 2 3 4 5 6			
2.2-3	8-74652-3	FUSELAGE ACCESS DOORS STA 108 TO 213 • DOOR INSTL, EMERGENCY CANOPY RELEASE ACCESS STA 108 FOR NHA SEE FIG. 2.3-7	RF	35	
- 1	MS20253-2-190	• • PIN, HINGE (96906)	2	35	
- 2	8-74652-15	• • DOOR ASSY, EMERGENCY CANOPY RELEASE	1	35	
- 3	H5000-081-091	• • • LATCH, EMERGENCY CANOPY RELEASE <83014> 95-50500-001	1	35	
- 4	8-74652-19	• • • DOUBLER	1	35	
- 5	8-74634-11	• • • HINGE, HALF	1	35	
- 6	8-74652-17	• • • DOOR	1	35	
- 7	8-74634-13	• • HINGE, HALF	1	35	
- 8	8-77771-1	• • ADAPTER ASSY, RIVETED	1	35	
- 9	AN6227B12 8-77635	• • PACKING (88044) 96-58508-012 • DOOR INSTL, LIQUID OXYGEN ACCESS STA 123 FOR NHA SEE FIG. 2.3-7	RF	35	
- 10	8-77635-23	• • DOOR ASSEMBLY ATTACHING PARTS	1	35	
- 11	NAS679A3	• • NUT, (80205) 96-37545-002	3	35	
- 12	NAS333CPA4	• • SCREW (80205) ----X----	3	35	
- 13	8-77635-7	• • • DOOR	1	35	
- 14	4CS51A070-3A	• • • STUD, FASTENER <71286> 98-58003-007	4	35	
- 15	212-12N 40R12-1	• • RECEPTACLE, FASTENER <71286> 97-31002-002 • • RECEPTACLE, FASTENER <71286> 97-31017-002	4	35	35
- 16	8-77635-21	• • HINGE ASSEMBLY	1	35	
- 17	MS20253-1-155	• • • PIN (96906)	1	35	
- 18	8-77636-13	• • • HINGE, HALF	1	35	
- 19	8-77636-11	• • • HINGE, HALF	1	35	
- 20	8-77635-29	• • RETAINER, SEAL	1	35	
- 21	8-77635-25	• • SEAL	1	35	
- 22	8-77635-9 8-77629	• • DOUBLER • DOOR INSTL, TORQUE TUBE ACCESS STA 145 FOR NHA SEE FIG. 2.3-7	RF	35	
- 23	8-77629-7	• • DOOR ATTACHING PARTS	1	35	
	MS24694-48	• • SCREW (96906) ----X----	6	35	

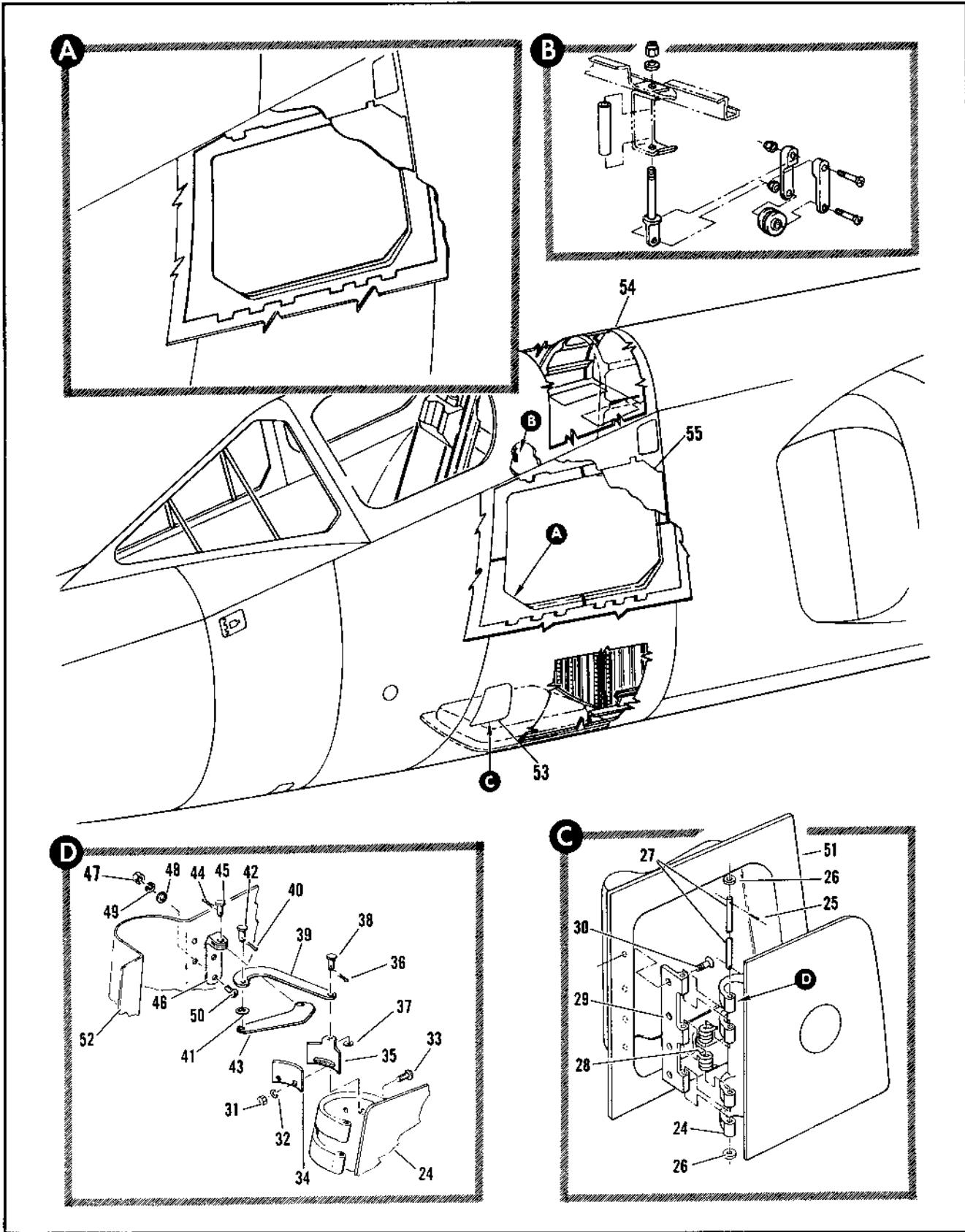

Figure 2.2-3. Fuselage Access Doors Sta 108 to213 (Sheet 2 of 4)

FIGURE AND INDEX NUMBER	PART NUMBER	DESCRIPTION	UNITS PER ASSY.	USABLE ON CODE	
				FROM	TO
2.2-3	8-74641-1	• DOOR INSTL, ELECTRICAL POWER GROUND ACCESS STA 171 TO 175 FOR NHA SEE FIG. 2.3-4	RF	35	
- 24	8-44719	• • DOOR ASSY, EXTERNAL POWER ACCESS STA 171 TO 175 FOR BREAKDOWN SEE FIG. 2.2-11	1	35	129
	8-44719-1	• • DOOR ASSY, EXTERNAL POWER ACCESS STA 171 TO 175 FOR BREAKDOWN SEE FIG. 2.2-11 ATTACHING PARTS	1	130	
- 25	MS24655-132	• • PIN (96906)	2	35	
- 26	99-53001-008	• • WASHER	2	35	
- 27	8-74641-23	• • PIN -----X-----	1	35	
- 28	8-44730	• • SPRING	1	35	
- 29	8-74676	• • HINGE ATTACHING PARTS	1	35	
- 30	MS24694-50	• • SCREW (96906) -----X-----	4	35	
	8-44963	• • HOLD OPEN INSTL, EXTERNAL POWER ACCESS DOOR	RF	130	
- 31	AN315C3R	• • • NUT (88044)	2	130	
- 32	MS35338-43	• • • WASHER (96906)	2	130	
- 33	MS51958-64	• • • SCREW (96906)	2	130	
- 34	8-44963-7	• • • PLATE	1	130	
- 35	8-44961	• • • BRACKET, EXTERNAL POWER ACCESS DOOR	1	130	
- 36	MS24665-132	• • • PIN, COTTER (96906)	1	130	
- 37	NAS620A5	• • • WASHER (80205)	3	130	
- 38	MS20392-1-7	• • • PIN (96906)	1	130	
- 39	8-44960	• • • LINK, EXTERNAL POWER ACCESS DOOR	1	130	
- 40	MS24665-132	• • • PIN, COTTER (96906)	1	130	
- 41	NAS620A5	• • • WASHER (80205)	2	130	
- 42	MS20392-1-7	• • • PIN (96906)	1	130	
- 43	8-44959	• • • ARM, EXTERNAL POWER ACCESS DOOR	1	130	
- 44	MS24665-132	• • • PIN, COTTER (96906)	1	130	
- 45	MS20392-1-7	• • • PIN (96906)	1	130	
- 46	8-44962	• • • BRACKET, EXTERNAL POWER ACCESS DOOR ATTACHING PARTS	1	130	
- 47	AN315C3R	NUT (88044)	2	130	
- 48	AN955-3	• • • WASHER (88044)	2	130	
- 49	MS35338-43	• • • WASHER (96906)	2	130	
- 50	MS51958-62	• • • SCREW (96906) -----X-----	2	130	
	8-74641-3	• PAN INSTL, ELECTRICAL POWER GROUND ACCESS DOOR FOR NHA SEE FIG. 2.3-9	RF	35	
- 51	8-74641-37	• • PAN, REPLACED BY SUITABLE SUB 8-74641-43	1	35	129
- 52	8-74641-43	• • PAN, REPLACES SUITABLE SUB FOR 8-74641-37	1	130	
- 53		• LATCH INSTL, EXTERNAL POWER ACCESS DOOR SEE FIG. 2.2-6	RF		
- 54		• DOOR INSTL, CANOPY ACCESS RH SEE FIG. 2.4-10	RF		
- 55		• DOOR INSTL, UPPER AFT ELECTRONIC COMPARTMENT ACCESS LH SEE FIG. 2.2-5	RF		

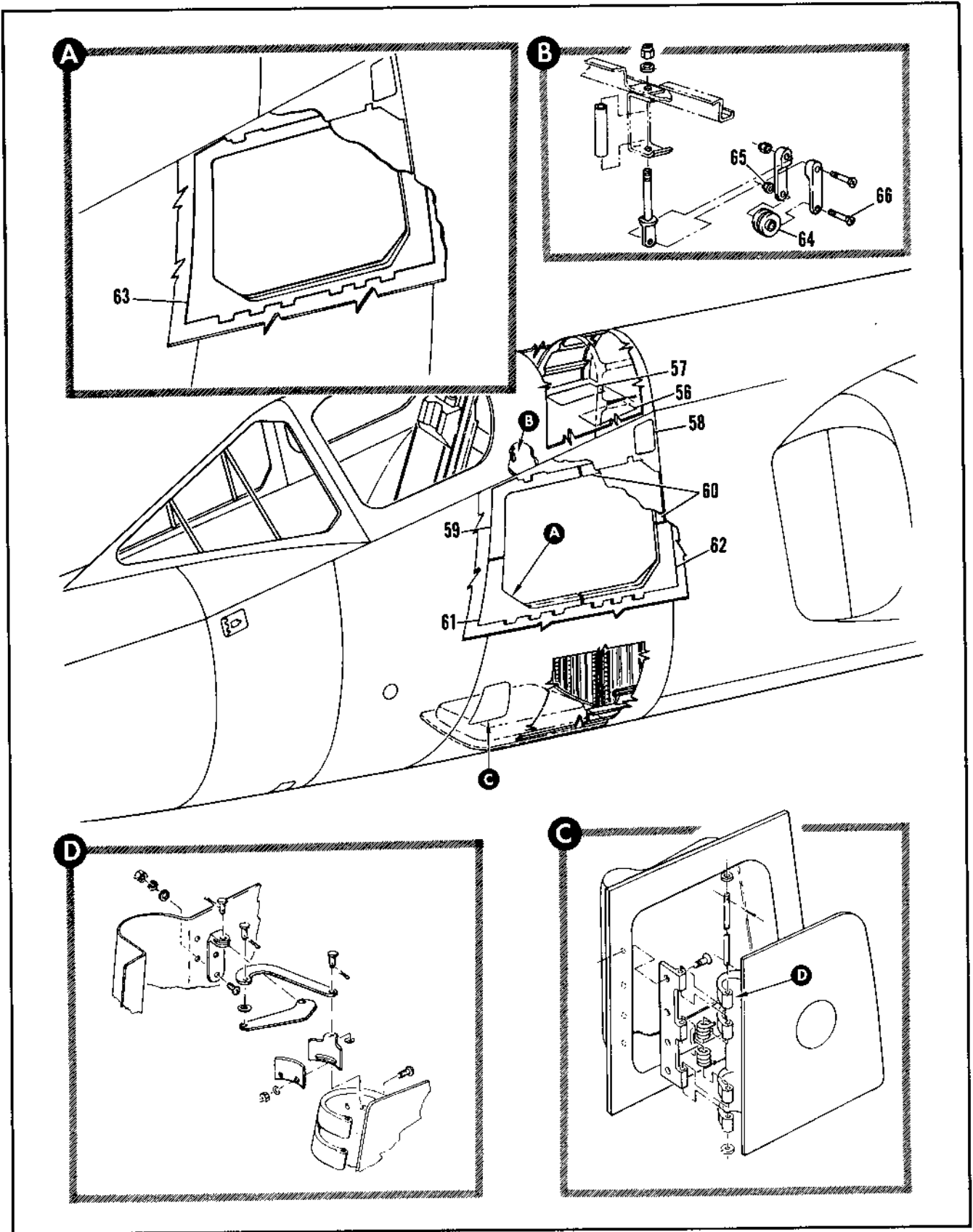

Figure 2.2-3. Fuselage Access Doors Sta 108 to 213 (Sheet 3 of 4)

FIGURE AND INDEX NUMBER	PART NUMBER	DESCRIPTION	UNITS PER ASSY.	USABLE ON CODE	
				FROM	TO
		1 2 3 4 5 6			
2.2-3	8-77409	. PANEL INSTL, CANTED UPPER STA 172 TO 217 FOR NHA SEE FIG. 2.3-4	RF	35	
- 56	8-77409-61	. . DOOR, LH STA 208	1	35	
- 57	8-77409-62	. . DOOR, RH STA 208	1	35	
	AN3-4A	. . BOLT (88044) ----X----	44	35	
	8-77409-3	. . PANEL ASSY, CANTED UPPER STA 172 TO 217 LH	1	35	
	8-77409-4	. . PANEL ASSY, CANTED UPPER STA 172 TO 217 RH	1	35	
- 58	8-77611-7	. . . DOOR, STA 213 LH	1	35	
	8-77611-8	. . . DOOR, STA 213 RH	1	35	
	NAS333PA4	. . . SCREW (80205) ----X----	21	35	
- 59	8-74928-15	. . . SEAL, UPPER ELECTRONIC ACCESS DOOR RAMP LH REPLACED BY NOT INTCHG WITH 8-74928-23	1	35	38
	8-74928-16	. . . SEAL, UPPER ELECTRONIC ACCESS DOOR RAMP RH REPLACED BY NOT INTCHG WITH 8-74928-24	1	35	38
- 60	8-74928-17	. . . SEAL, UPPER ELECTRONIC ACCESS DOOR RAMP LH REPLACED BY NOT INTCHG WITH 8-74928-23	1	35	38
	8-74928-18	. . . SEAL, UPPER ELECTRONIC ACCESS DOOR RAMP RH REPLACED BY NOT INTCHG WITH 8-74928-24	1	35	38
	8-77403	. . SEAL INSTL, UPPER ELECTRONIC COMPARTMENT ACCESS DOOR FOR NHA SEE FIG. 2.3-9	RF	35	
- 61	8-74928-7	. . . SEAL, ELECTRONIC ACCESS DOOR RAMP AFT LH REPLACED BY NOT INTCHG WITH 8-74928-23	1	35	38
	8-74928-8	. . . SEAL, ELECTRONIC ACCESS DOOR RAMP AFT RH REPLACED BY NOT INTCHG WITH 8-74928-24	1	35	38
- 62	8-74928-9	. . . SEAL, ELECTRONIC ACCESS DOOR RAMP FWD LH REPLACED BY NOT INTCHG WITH 8-74928-23	1	35	38
	8-74928-10	. . . SEAL, ELECTRONIC ACCESS DOOR RAMP FWD RH REPLACED BY NOT INTCHG WITH 8-74928-24	1	35	38
- 63	8-74928-23	. . . SEAL, ELECTRONIC ACCESS DOOR RAMP FWD LH REPLACES NOT INTCHG WITH 8-74928-7 8-74928-9 8-74928-15 AND 8-74928-17	1	39	
	8-74928-24	. . . SEAL, ELECTRONIC ACCESS DOOR RAMP FWD RH REPLACES NOT INTCHG WITH 8-74928-8 8-74928-10 8-74928-16 AND 8-74928-18	1	39	
- 64	64Y17	. . . BEARING, (21335) 90-58025-001	1	35	
- 65	NAS679A4	. . . NUT (80205)	1	35	
- 66	NAS222-21	. . . SCREW (80205) ----X----	1	35	

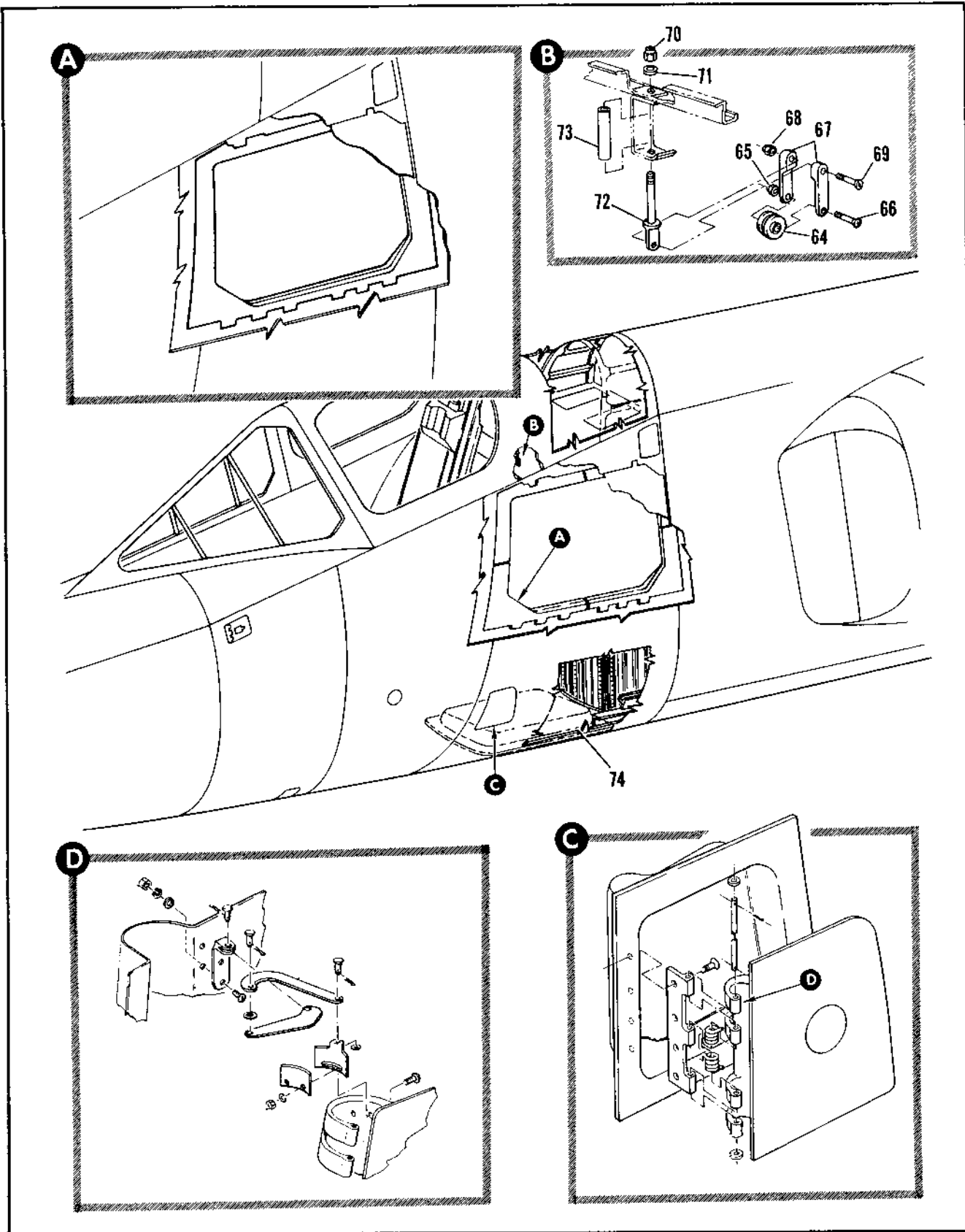

Figure 2.2-3. Fuselage Access Doors Sta 108 to 213 (Sheet 4 of 4)

FIGURE AND INDEX NUMBER	PART NUMBER	DESCRIPTION	UNITS PER ASSY.	USABLE ON CODE	
				FROM	TO
		1 2 3 4 5 6			
2.2-3-67	8-77562	• • • LUG ATTACHING PARTS	1	35	
- 68	NAS679A3	• • • NUT (80205)	1	35	
- 69	NAS221-20	• • • SCREW (80205) -----X-----	1	35	
- 70	NAS679A3	• • • NUT (80205)	1	35	
- 71	AN960D10	• • • WASHER (88044)	1	35	
- 72	AN426-25A	• • • BOLT (88044)	1	35	
- 73	98-29503-018	• • • SPACER	1	35	
- 74		• DOOR ASSY, MIDBAY ELECTRONIC COMPARTMENT ACCESS SEE FIG. 2.2-12	RF		

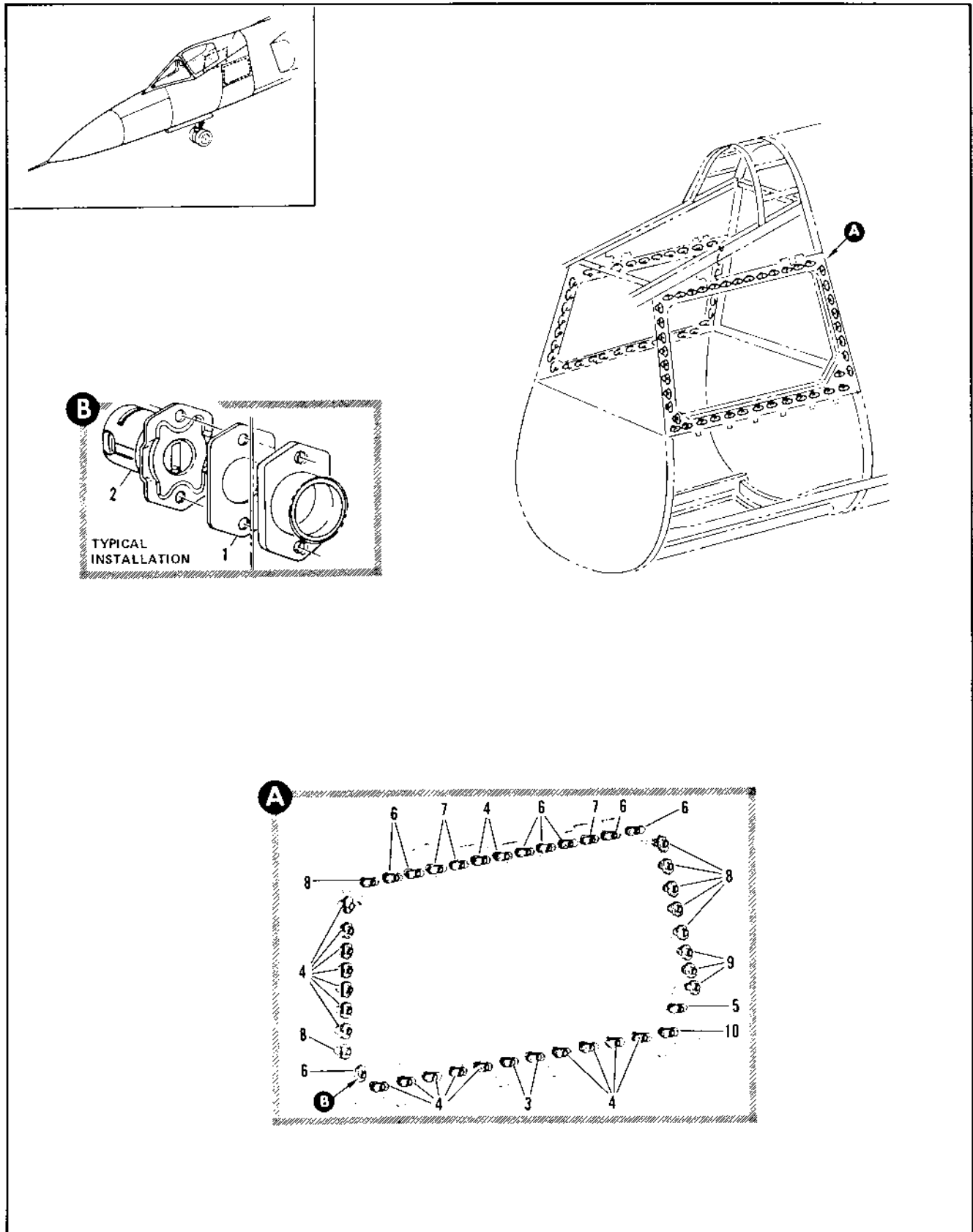

Figure 2.2-4. Aft Electronic Access Door Frame Installation

FIGURE AND INDEX NUMBER	PART NUMBER	DESCRIPTION	UNITS PER ASSY.	USABLE ON CODE	
				FROM	TO
		1 2 3 4 5 6			
2.2-4	8-74636-801	FRAME INSTALLATION ELECTRONIC ACCESS DOOR AFT LH FOR NHA SEE FIG. 2.3-4	RF	35	
	8-74636-802	FRAME INSTALLATION, ELECTRONIC ACCESS DOOR AFT RH FOR NHA SEE FIG. 2.3-4	RF	35	
- 1	4R33-16	• PLATE, BUFFER <72186> 91-15001-001	43	35	
- 2	4R51-1	• RECEPTACLE, <71286> 97-31000-006	43	35	
- 3	KM835-25	• PLATE, SHEAR <71286> 98-01800-008	2	35	
- 4	KM835-15	• PLATE, SHEAR <71286> 98-01800-011	18	35	
- 5	KM835-12	• PLATE, SHEAR <71286> 98-01800-002	1	35	
- 6	KM835-10	• PLATE, SHEAR <71286> 98-01800-020	8	35	
- 7	KM835-18	• PLATE, SHEAR <71286> 98-01800-005	3	35	
- 8	KM835-20	• PLATE, SHEAR <71286> 98-01800-006	7	35	
- 9	8-77796-11	• PLATE, SHEAR TURNLOCK FASTENER	3	35	
- 10	KM835-29	• PLATE, SHEAR <71286> 98-01800-014	1	35	
	8-77796-7	• PLATE, SHEAR TURNLOCK FASTENER	AR	35	
	8-77796-9	• PLATE, SHEAR TURNLOCK FASTENER	AR	35	
	8-77796-13	• PLATE, SHEAR TURNLOCK FASTENER	AR	35	
	8-77796-15	• PLATE, SHEAR TURNLOCK FASTENER	AR	35	

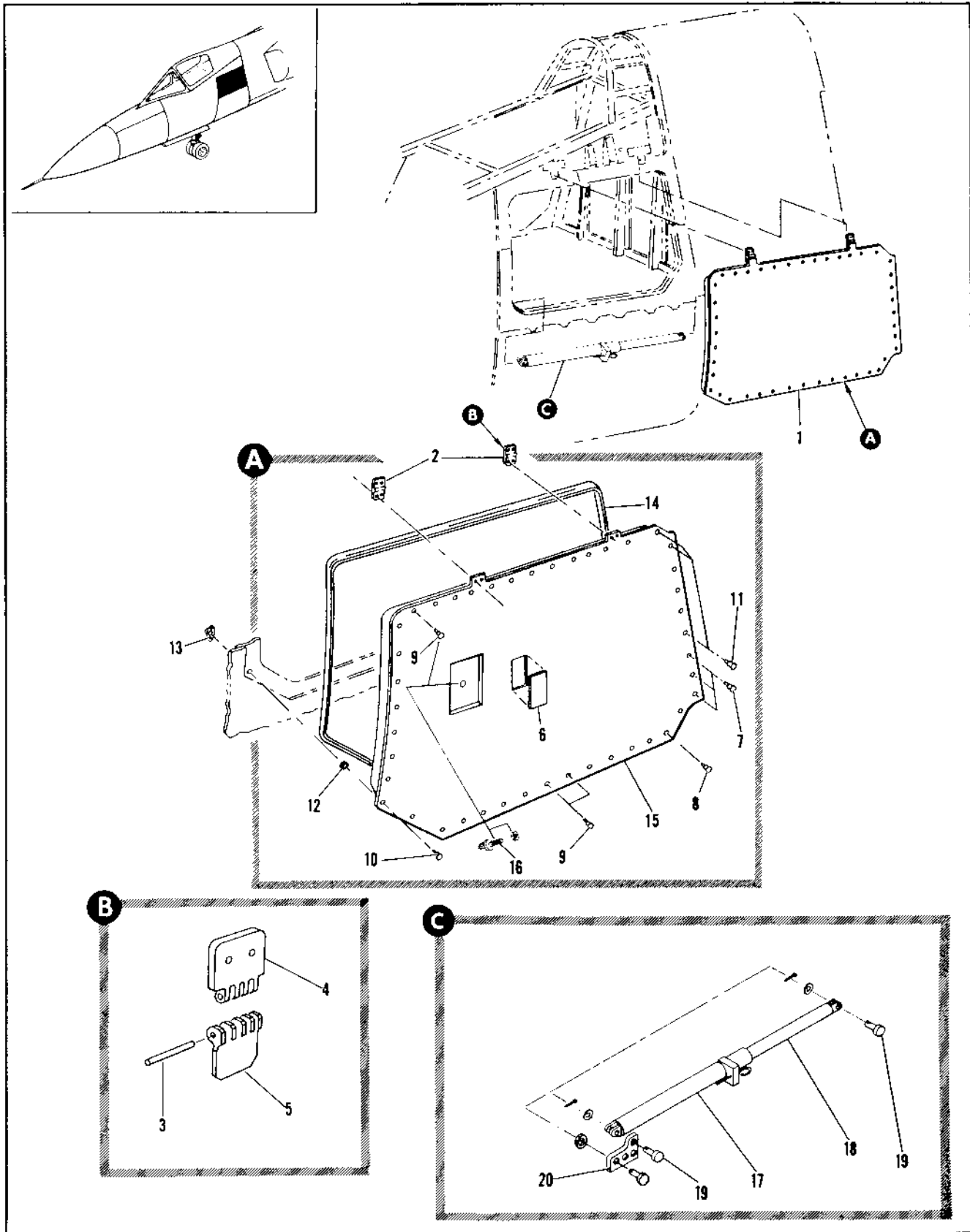

Figure 2.2-5. Upper Aft Electronic Compartment Access Door Installation

FIGURE AND INDEX NUMBER	PART NUMBER	DESCRIPTION	UNITS PER ASSY.	USABLE ON CODE	
				FROM	TO
2.2-5	8-74636-5	DOOR INSTALLATION, UPPER AFT ELECTRONIC COMPARTMENT ACCESS LH FOR NHA SEE FIG. 2.3-4	RF	35	
	8-74636-6	DOOR INSTALLATION, UPPER AFT ELECTRONIC COMPARTMENT ACCESS RH FOR NHA SEE FIG. 2.3-4	RF	35	
- 1	8-74669-3	• DOOR ASSY, ELECTRONIC ACCESS LH REPLACED BY SUITABLE SUB 8-74669-5	1	35	89
	8-74669-5	• DOOR ASSY, ELECTRONIC ACCESS LH REPLACES SUITABLE SUB FOR 8-74669-3	1	90	
	8-74669-4	• DOOR ASSY, ELECTRONIC ACCESS RH REPLACED BY SUITABLE SUB 8-74669-6	1	A	
	8-74669-8C1	• DOOR ASSY, ELECTRONIC ACCESS RH REPLACED BY SUITABLE SUB 8-74669-6	1	B	
	8-74669-6	• DOOR ASSY, ELECTRONIC ACCESS RH REPLACES SUITABLE SUB FOR 8-74669-4 AND 8-74669-801	1	90	
	NAS1067A3	ATTACHING PARTS	35		
	NAS333PA4	• NUTPLATE (80205) • SCREW (80205)	4	35	
		-----X-----			
- 2	8-77989	• • HINGE ASSEMBLY	2	35	
- 3	8-77989-11	• • • PIN, HINGE	1	35	
- 4	8-77989-7	• • • HINGE, HALF	1	35	
- 5	8-77989-9	• • • HINGE, HALF	1	35	
- 6	4F10-2	• • DECAL, FASTENER RH <71286> 92-93500-001	1	35	
- 7	KM837-12	• • STUD, FASTENER <71286> 98-56504-004	3	35	
- 8	KM837-10	• • STUD, FASTENER <71286> 98-56504-003	1	35	
- 9	KM837-8	• • STUD, FASTENER <71286> 98-56504-002	3	35	
- 10	KM837-6	• • STUD, FASTENER <71286> 98-56504-001	36	35	
- 11	KM837-6	• • STUD, FASTENER <71286> 98-56504-001	6	C	
	KM837-8	• • STUD, FASTENER <71286> 98-56504-002	6	B	
- 12	KM836-8	• • RING, FASTENER <71286> 98-02000-001	43	35	
- 13	4R51-1	• • RECEPTACLE, (71286) 97-31000-006	43	35	
- 14	8-74668-7	• • SEAL, ELECTRONIC ACCESS DOOR LH	1	35	
- 15	8-74669-7	• • DOOR, LH	1	35	
	8-74669-8	• • DOOR, RH	1	35	
	8-74668-8	• • SEAL, ELECTRONIC ACCESS DOOR RH	1	35	
- 16	AN428-3	• • BOLT, EYE (88044)	1		
	MS21044N3	• • NUT (96906)	1		
- 17	68F37569-1	• • SLEEVE ASSY, DOOR HOLD OPEN, LH AND RH ELECT COMP, AFT (98750)	2	35	
	58A46236	• • RING (98750)	1		
	68C37566-7	• • HOUSING (98750)	1		
	68C37567-7	• • SPRING (98750)	1		
	68C37568-7	• • LOCK PIN (98750)	1		
	66F38713-11	• • PLATE (98750)	2		
	66F38713-7	• • SLEEVE (98750)	1		
- 18	66038719-1	• • SUPPORT ROD, DOOR HOLD OPEN LH AND RH ELCT COMP, AFT (98750)	1	35	
	66038719-11	• • PLATE (98750)	2		
	66038719-7	• • TUBE (98750)	1		
- 19	MS20392-2C17	• • PIN (96906)	2	35	
	AN960C-10	• • WASHER (88044)	2		
	MS24665-208	• • PIN, COTTER (96906)	2		
- 20	66C38712-7	• • PLATE, MOUNTING (98750)	1	35	

FIGURE AND INDEX NUMBER	PART NUMBER	DESCRIPTION	UNITS PER ASSY.	USABLE ON CODE	
				FROM	TO
2.2-5	AN3-6A MS21044N3	1 2 3 4 5 6 • • BOLT (88044) • • NUT (96906) A AIRPLANES #35 THRU 37, 39 THRU 74, AND 76 THRU 89 B AIRPLANES #38 AND 75 C AIRPLANES #35 THRU 37, 39 THRU 74, 76 AND ON	3 3		

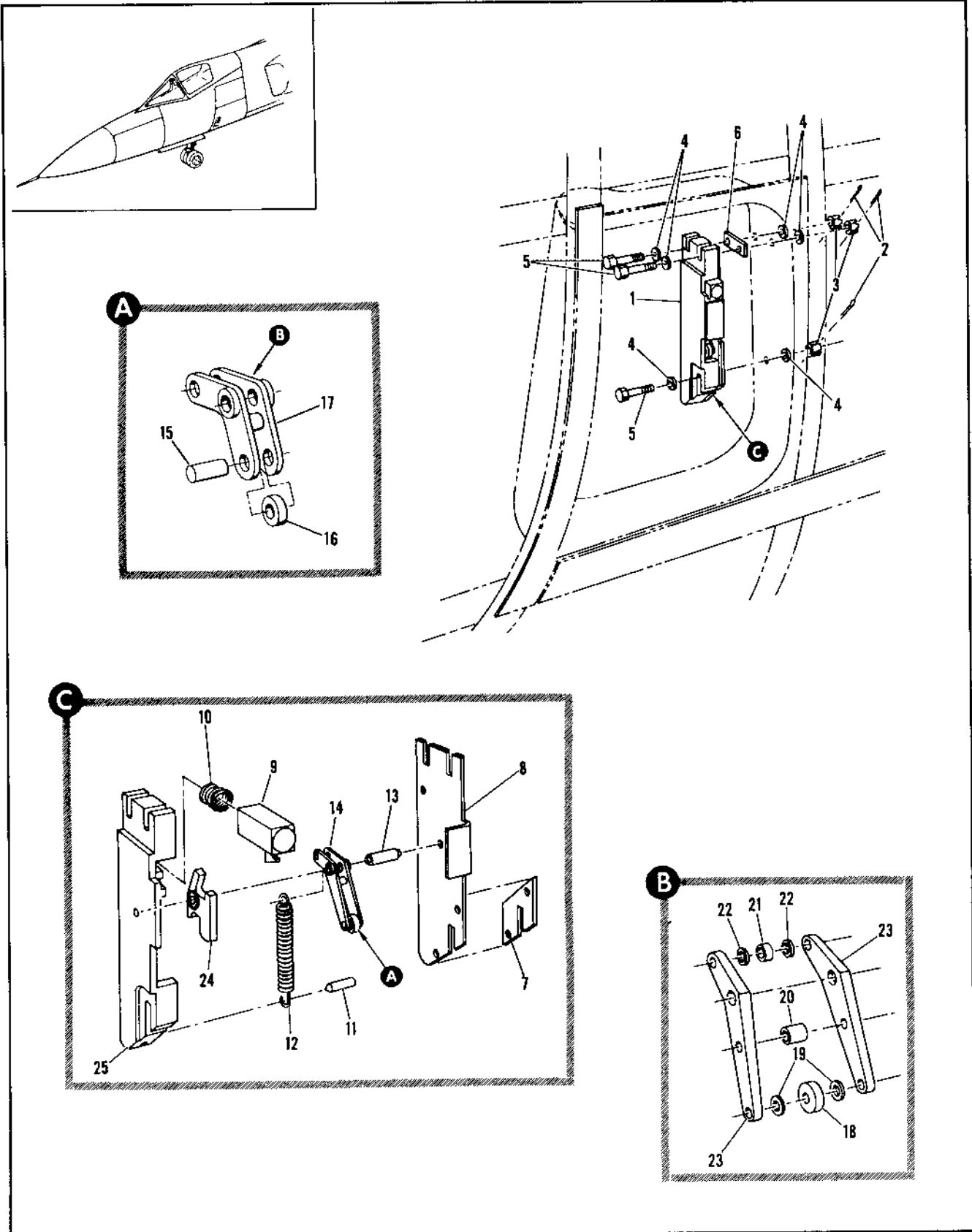

Figure 2.2-6. External Power Access Door Latch Installation

FIGURE AND INDEX NUMBER	PART NUMBER	DESCRIPTION	UNITS PER ASSY.	USABLE ON CODE	
				FROM	TO
		1 2 3 4 5 6			
2.2-6	8-44747	LATCH INSTALLATION, EXTERNAL POWER ACCESS DOOR FOR NHA SEE FIG. 2.3-4	RF	35	
- 1	8-44743-1 8-44743	• LATCH ASSY, EXTERNAL POWER ACCESS DOOR • LATCH ASSY, EXTERNAL POWER ACCESS DOOR ALT INTCHG WITH 8-44743-1	1 RF	35 35	
- 2	MS24665-132	ATTACHING PARTS • PIN, COTTER (96906)	3	35	
- 3	AN310-3	• NUT (88044)	3	35	
- 4	AN960-10L	• WASHER (88044)	6	35	
- 5	AN3-14	• BOLT (88044)	3	35	
- 6	8-44736	• SHIM	1	35	
- 7	8-44735	• • SHIM	1	35	
- 8	8-44721	• • PLATE	1	35	
- 9	8-45022 8-44726	• • LOCK, LATCH MECHANISM • • LOCK, LATCH MECHANISM ALT INTCHG WITH 8-45022	1 RF	35 35	
- 10	8-44728	• • SPRING, HELICAL COMPRESSION LATCH MECHANISM	1	35	
- 11	8-44725	• • SUPPORT, LATCH MECHANISM USE WITH 8-44743	RF	35	
- 12	96-79700-049	• • PIN	1	35	
- 13	8-44729	• • SPRING, HELICAL EXTENSION LATCH MECHANISM	1	35	
- 14	8-44724	• • SHAFT, LATCH MECHANISM	1	35	
- 15	8-45020	• • CAM ASSY, DOOR HOLD OPEN LATCH	1	35	
- 16	96-79700-049	• • • PIN	1	35	
- 17	8-45030	• • • ROLLER	1	35	
- 17	8-45029-7	• • • ARM, HOLD OPEN CAM	1	35	
- 17	8-44723	• • CAM ASSY, DOOR HOLD OPEN LATCH ALT INTCHG WITH 8-45020	RF	35	
- 18	8-44731	• • • ROLLER	1	35	
- 19	AN96004L	• • • WASHER (88044)	2	35	
- 20	NAS42003-9	• • • SPACER (80205)	1	35	
- 21	NAS42003-5	• • • SPACER (80205)	1	35	
- 22	AN96002	• • • WASHER (88044)	2	35	
- 23	8-44732	• • • ARM	2	35	
- 23	99-53000-022	• • WASHER, USE WITH 8-44743	RF	35	
- 23	99-53001-009	• • WASHER, USE WITH 8-44743	RF	35	
- 24	8-45023-7	• • HOOK, LATCH MECHANISM	1	35	
- 24	8-44722	• • HOOK ASSY, LATCH MECHANISM RIVETED ALT INTCHG WITH 8-45023-7	RF	35	
- 25	8-45021-7	• • HOUSING, LATCH MECHANISM	1	35	

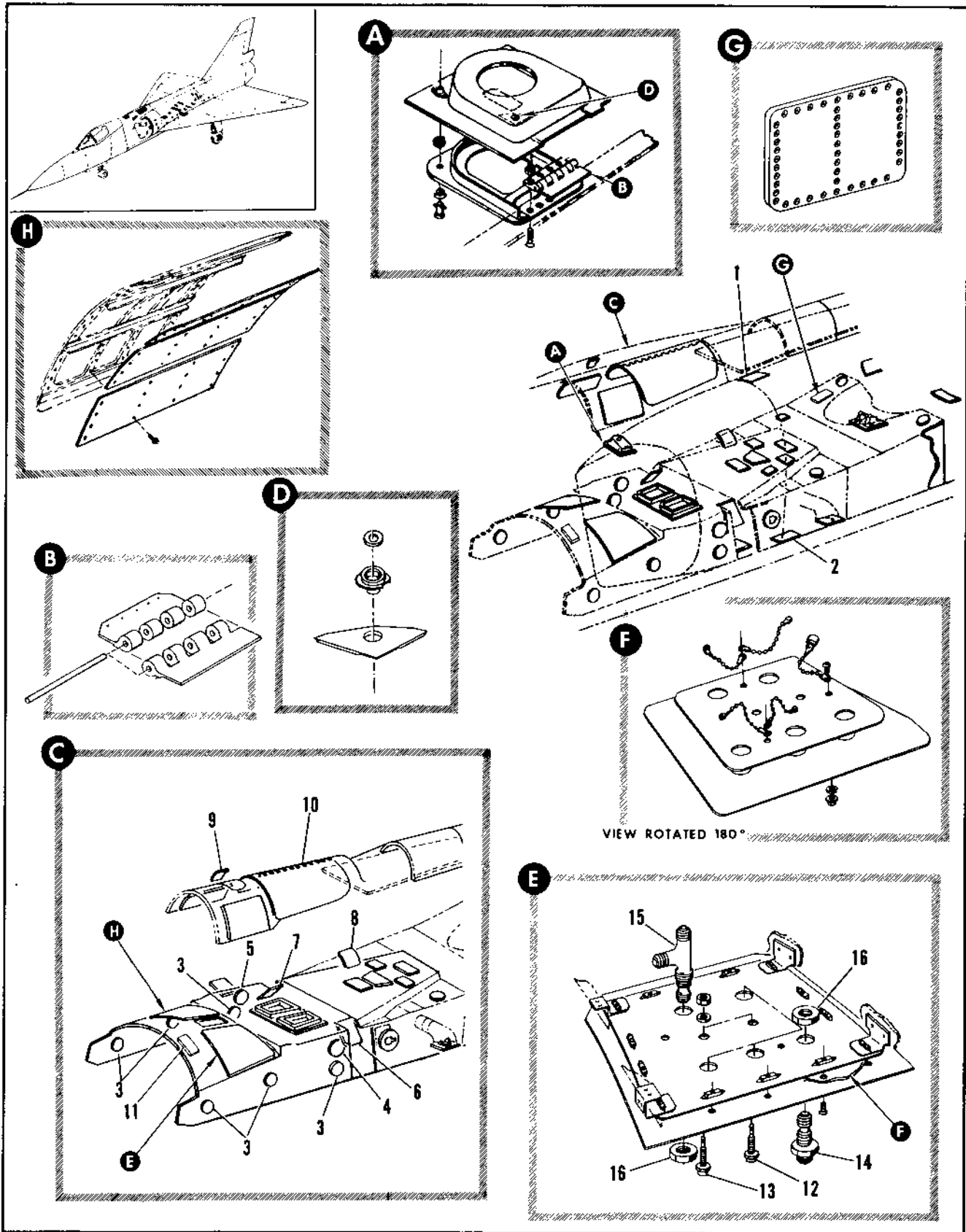

Figure 2.2-7. Fuselage Access Doors Sta 213 to 488 (Sheet 1 of 8)

FIGURE AND INDEX NUMBER	PART NUMBER	DESCRIPTION	UNITS PER ASSY.	USABLE ON CODE	
				FROM	TO
		1 2 3 4 5 6			
2.2-7		FUSELAGE ACCESS DOORS STA 213 TO 488			
- 1		• DOOR, ENGINE AIR INTAKE DUCT UPPER LH SEE FIG. 2.11-3 INDEX 29	RF		
- 2		• DOOR, ENGINE AIR INTAKE DUCT LOWER RH SEE FIG. 2.11-3 INDEX 30	RF		
	8-74483-3	• DOOR INSTL, ARMAMENT BAY ACCESS STA 246 TO 316 FOR NHA SEE FIG. 2.1-1	RF	35	
- 3	8-74483-67	• DOOR, ACCESS STA 256 284 AND 305 ATTACHING PARTS	6	35	
	NAS221-9	• SCREW (86205) -----X-----	48	35	
- 4	8-74483-69	• DOOR, ACCESS STA 305 LH	1	35	
- 5	8-74483-70	• DOOR, ACCESS STA 305 RH ATTACHING PARTS	1	35	
	NAS221-9	• SCREW (80205) -----X-----	10	35	
- 6	8-74483-65	• DOOR, ACCESS STA 312 LH	1	35	
- 7	8-74483-66	• DOOR, ACCESS STA 312 RH ATTACHING PARTS	1	35	
	NAS221-11	• SCREW (80205)	21	35	89
	AN173-5A	• BOLT (A8044) -----X-----	21	90	
	8-77599-3	• DOOR INSTL, VARIABLE AIR RAMP PITOT TUBE ACCESS STA 288 TO 295 FOR NHA SEE FIG. 2.1-1	RF	35	60
	8-77599-801	• DOOR INSTL, VARIABLE AIR RAMP PITOT TUBE ACCESS STA 288 TO 295 FOR NHA SEE FIG. 2.1-1	RF	61	
- 8	8-77599-7	• DOOR, LH REPLACED BY NOT INTCHG WITH 8-77599-17	1	35	60
	8-77599-17	• DOOR, LH REPLACES NOT INTCHG WITH 8-77599-7	1	61	
- 9	8-77599-8	• DOOR, RH REPLACED BY NOT INTCHG WITH 8-77599-18	1	35	60
	8-77599-18	• DOOR, RH REPLACES NOT INTCHG WITH 8-77599-8 ATTACHING PARTS	1	61	
	NAS333CPA6	• SCREW (80205)	18	35	
	NAS333CPA6	• SCREW (86205) -----X-----	1	61	
- 10		• DOOR INSTL, REFRIGERATION ACCESS SEE FIG. 2.2-13	RF		
	8-74481-801	• ROOF INSTL, ARMAMENT BAY STA 253 TO 316 FOR NHA SEE FIG. 2.1-1 MOD BY 7144599 (98750)	RF	35	
- 11	65C33810-7	• COVER, ACCESS DOOR (98750) STA 259.5 TO 266.5 ATTACHING PARTS	1	35	
	MS27039-1-06	• SCREW (96906) -----X-----	16	35	
	64E34184-1	• PANEL INSTL, TEST ENVIRONMENTAL CONTROL SYSTEM (98750)	1	35	
- 12	MS16108-2C	• JACK (96906)	1	35	
- 13	MS16108-3C	• JACK (96906)	1	35	
- 14	MS21924-4	• UNION (96906)	4	35	
- 15	MS21912-4	• TEE (96906)	1	35	
- 16	AN924-4	• NUT (88044)	1	35	

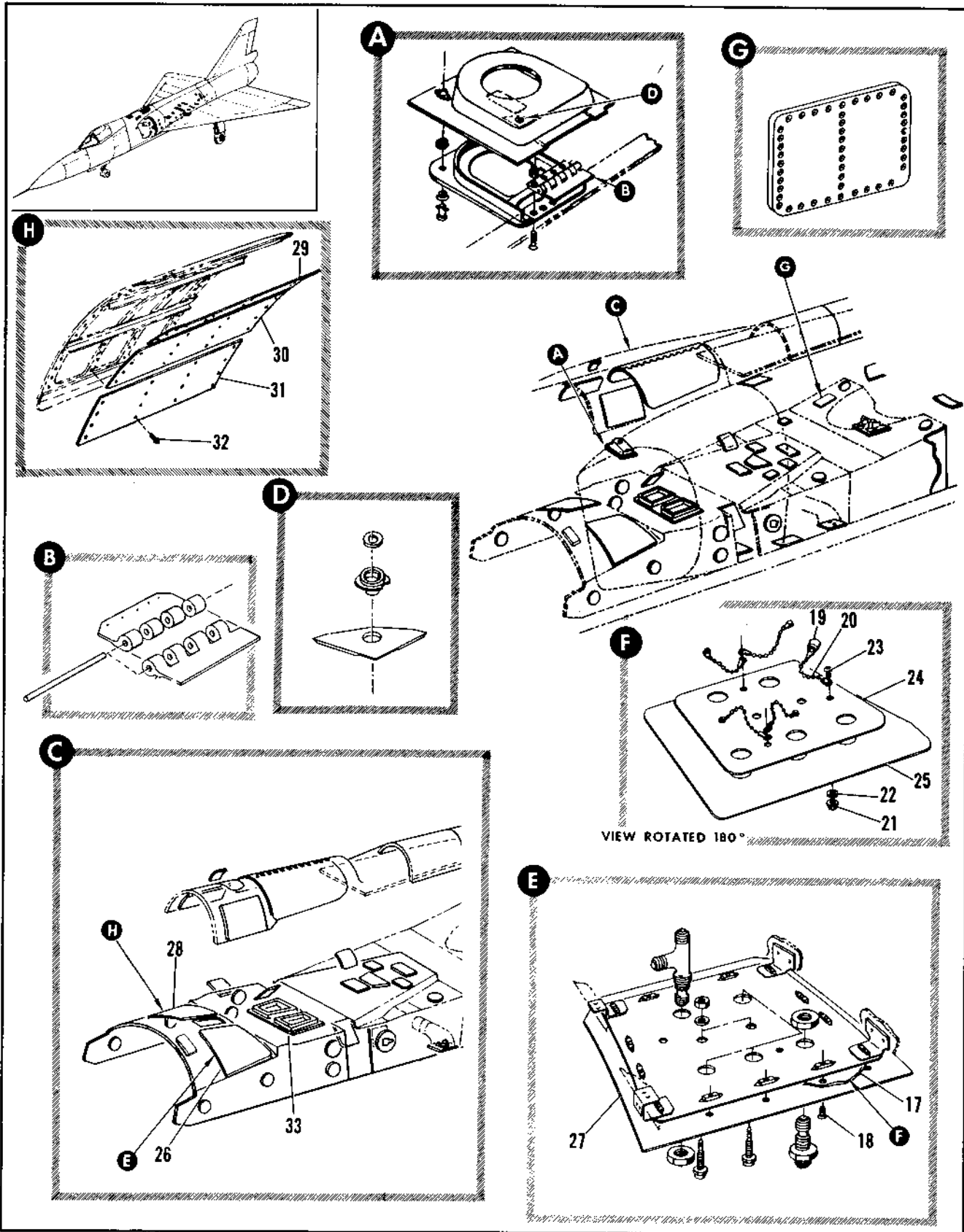

Figure 2.2-7. Fuselage Access Doors Sta 213 to 488 (Sheet 2 of 8)

FIGURE AND INDEX NUMBER	PART NUMBER	DESCRIPTION	UNITS PER ASSY.	USABLE ON CODE	
				FROM	TO
		1 2 3 4 5 6			
2.2-7-17	64F34185-1	. . . PANEL ASSY (98750), TEST ENVIRONMENTAL CONTROL SYSTEM ATTACHING PARTS	1	35	
- 18	MS27039-1-09	. . . SCREW (96906)	14	35	
- 19	MS21914-4	. . . CAP (96906)	5	35	
- 20	NAS12010687A	. . . CHAIN (83265) ATTACHING PARTS	5	35	
- 21	MS21042L06	. . . NUT (96906)	3	35	
- 22	AN96006L	. . . WASHER (88044)	3	35	
- 23	MS35206-228	. . . SCREW (96906)	3	35	
		-----X-----			
- 24	64C34188-1	. . . PLATE, INSTRUCTION DECAL (98750)	1	35	
- 25	64E34185-3	. . . PLATE (98750)	1	35	
- 26	8-77961-5	. . . DOOR ASSY, ARMAMENT BAY ROOF STA 266 TO 287 LH REPLACED BY NOT INTCHG WITH 8-77961-3	RF	35	62
	64E34186-3	. . . PLATE INSTL, ACCESS COVER (98750)	1	35	62
	8-77961-3	. . . DOOR ASSY, ARMAMENT BAY ROOF STA 266 TO 287 LH REPLACES NOT INTCHG WITH 8-77961-5 REPLACED BY SUITABLE SUB 8-77961-801	RF	63	
	64F34186-1	. . . PLATE INSTL, ACCESS COVER (98750)	1	63	80
	8-77961-801	. . . DOOR ASSY, ARMAMENT BAY ROOF STA 266 TO 287 LH REPLACES SUITABLE SUB FOR 8-77961-3	RF	81	
	64E34186-5	. . . PLATE INSTL, ACCESS COVER (98750)	1	81	
- 27	64E34187-1	. . . PLATE (98750)	1	35	
- 28	8-77961-6	. . . DOOR ASSY, ARMAMENT BAY ROOF STA 266 TO 287 RH REPLACED BY NOT INT CHG WITH 8-77961-4	1	C	
	8-77961-6	. . . DOOR ASSY, ARMAMENT BAY ROOF STA 266 TO 287 RH	RF	48	48
	8-77961-4	. . . DOOR ASSY, ARMAMENT BAY ROOF STA 266 TO 287 RH REPLACES NOT INTCHG WITH 8-77961-6 REPLACED BY SUITABLE SUB 8-77961-802	1	63	80
	8-77961-802	. . . DOOR ASSY, ARMAMENT BAY ROOF STA 266 TO 287 RH REPLACES SUITABLE SUB FOR 8-77961-4	1	81	89
	8-77961-802	. . . DOOR ASSY, ARMAMENT BAY ROOF STA 266 TO 287 RH	RF	90	149
	8-77961-805	. . . DOOR ASSY, ARMAMENT BAY ROOF STA 266 TO 287 RH ATTACHING PARTS	1	150	
	NAS221-9	. . . SCREW (80205)	AR	D	
	NAS221-9	. . . SCREW (80205)	RF	E	
	NAS221-10	. . . SCREW (80205)	F	D	
	NAS221-10	. . . SCREW (8025)			
		-----X-----			
- 29	7144599-05	. . . PANEL, ARMAMENT BAY ROOF STA 266 TO 287 RH (98750)	1	E	
- 30	7144599-07	. . . PANEL, ARMAMENT BAY ROOF STA 266 TO 287 RH (98750)	1	E	
- 31	7144599-11	. . . PANEL, ARMAMENT BAY ROOF STA 266 TO 287 RH (98750) (ATTACHING PARTS)	1	E	
- 32	NAS221-11	. . . SCREW (80205)	47	E	
- 33	8-77963	. . . DOOR ASSY, HEAT EXCHANGER ACCESS STA 294 TO 308	1	35	
	AN4-5A	. . . BOLT (88044)	2	35	
		C AIRPLANES 35 THRU 47, 49 THRU 62 D AIRPLANES 35 THRU 47, 49 THRU 89 E AIRPLANES 48, 90 AND ON			

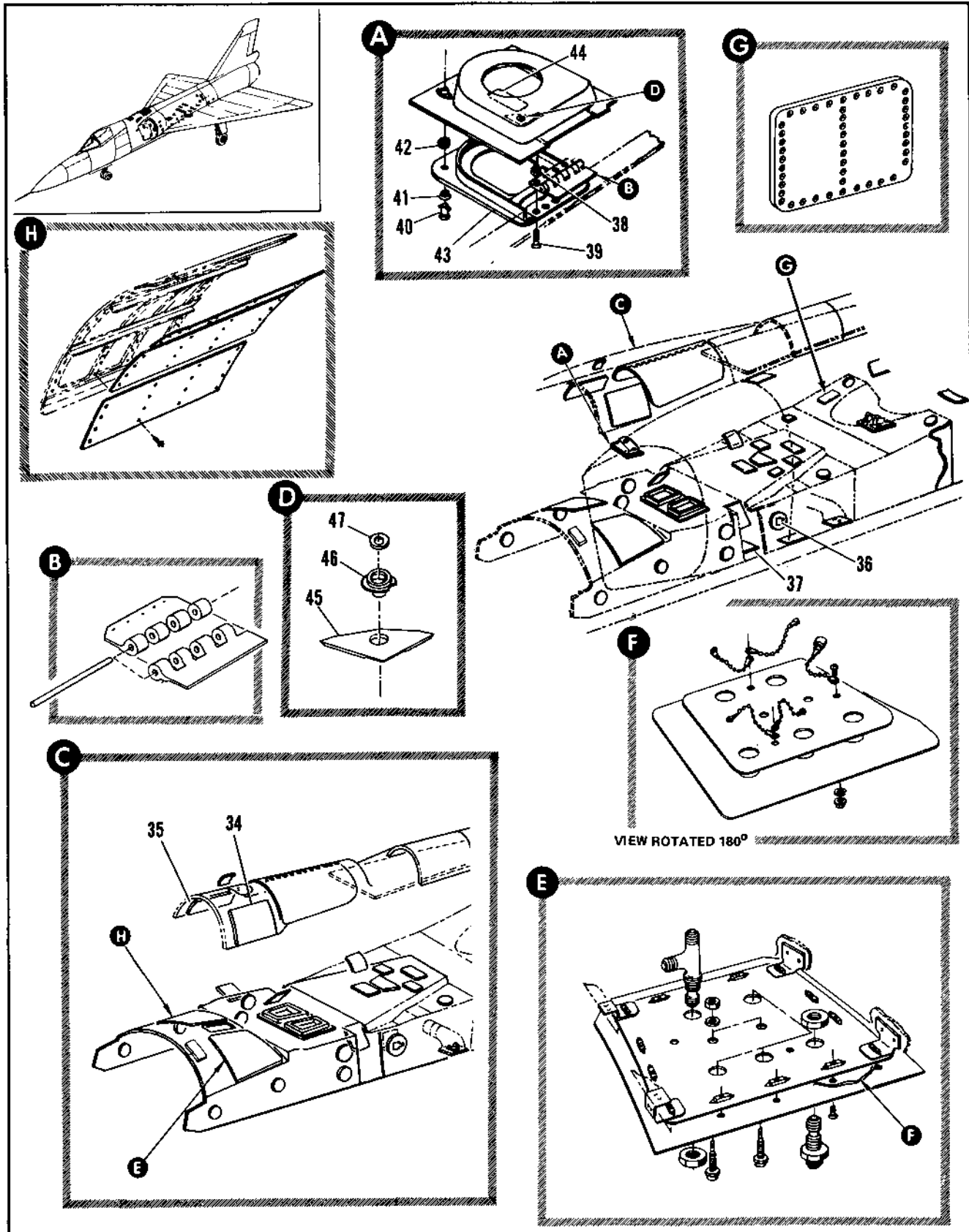

Figure 2.2-7. Fuselage Access Doors Sta 213 to 488 (Sheet 3 of 8)

FIGURE AND INDEX NUMBER	PART NUMBER	DESCRIPTION	UNITS PER ASSY.	USABLE ON CODE	
				FROM	TO
		1 2 3 4 5 6			
2.2-7	NAS221-9	• • SCREW (80205)	43	35	
	NAS221-10	• • SCREW (80205)	5	35	
	NAS221-11	• • SCREW (80205)	2	35	
		----X----			
	8-74481-187	• • DOOR ATTACHING PARTS	1	35	
	NAS221-10	• • SCREW (80205)	18	35	
		----X----			
	8-74481-189	• • DOOR ATTACHING PARTS	1	35	
	NAS221-12	• • SCREW (80205)	26	35	
		----X----			
	8-74497-3	• DOOR INSTL, DORSAL ACCESS STA 269 FOR NHA SEE FIG. 2.1-1	RF	35	
- 34	8-74497-7	• • DOOR ASSY, LH RIVETED	1	35	
- 35	8-74497-8	• • DOOR ASSY, RH RIVETED ATTACHING PARTS	1	35	
	NAS333CPA4	• • BOLT (80205)	66	35	
		----X----			
- 36		• DOOR ASSY, EMERGENCY CANOPY JETTISON SEE FIG. 2.4-8	RF		
- 37		• DOOR ASSY, ELECTRONIC COMPARTMENT GROUND CONNECTION ACCESS SEE FIG. 2.2-8	RF		
	8-77590	• DOOR INSTL, REFUELING STA 312 RH FOR NHA SEE FIG. 2.3-12	RF	35	
	8-77590-23	• • DOOR ASSY, REFUELING REPLACED BY NOT INTCHG WITH 8-77590-37	1	35	38
	8-77590-37	• • DOOR ASSY, REFUELING REPLACES NOT INTCHG WITH 8-77590-23 REPLACED BY SUITABLE SUB 8-77590-39	1	39	89
	8-77590-39	• • DOOR ASSY, REFUELING REPLACES SUITABLE SUB FOR 8-77590-37	1	A	
	8-77590-47	• • DOOR ASSY, REFUELING	1	B	
	8-77590-45	• • DOOR ASSY, REFUELING ATTACHING PARTS	1	216	
- 38	NAS679A3	• • NUT, (80205) 96-37545-002	4	35	
- 39	NAS333CPA4-5	• • SCREW (80205)	4	35	
- 40	4S14-4	• • • STUD, FASTENER <71286> 98-58007-001	4	35	89
	40S5-6	• • • STUD, FASTENER <71286> 98-58008-002	1	90	
	40S5-3	• • • STUD, FASTENER <71286> 98-58008-003	1	90	
	40S5-7	• • • STUD, FASTENER <71286> 98-58008-005	1	90	
- 41	40026	• • • GROMMET, FASTENER <71286> 94-35500-003	4	90	
- 42	4S9-2	• • • RING, FASTENER <71286> 97-61506-004	4	35	89
	R46	• • • RING, FASTENER <71286> 97-61506-003	4	90	
- 43	8-77590-7	• • DOOR	1	35	89
	8-77590-41	• • DOOR	1	90	
- 44	4F10-2	• • • DECAL, INSTRUCTION <71286> 92-93500-001	1	35	89
	8-77590-35	• • FLANGE ASSEMBLY	1	35	215
	8-77590-43	• • FLANGE ASSEMBLY	1	216	
- 45	8-28361	• • • DOUHLER	1	35	
- 46	8-28362	• • • FLANGE	1	35	215
	8-28362-7	• • • FLANGE	1	216	
- 47	8-28364	• • • SEAL	1	35	215
	8-77590-1	• SUPPORT INSTL, REFUELING DOOR STA 312 RH FOR NHA SEE FIG. 2.11-4	RF	35	
		A AIRPLANES 90 THRU 143, 146, 147, 150, 152, 154, 156, 158, AND 185 THRU 215			
		B AIRPLANES 144, 145, 148, 149, 151, 153, 157, AND 159 THRU 184			

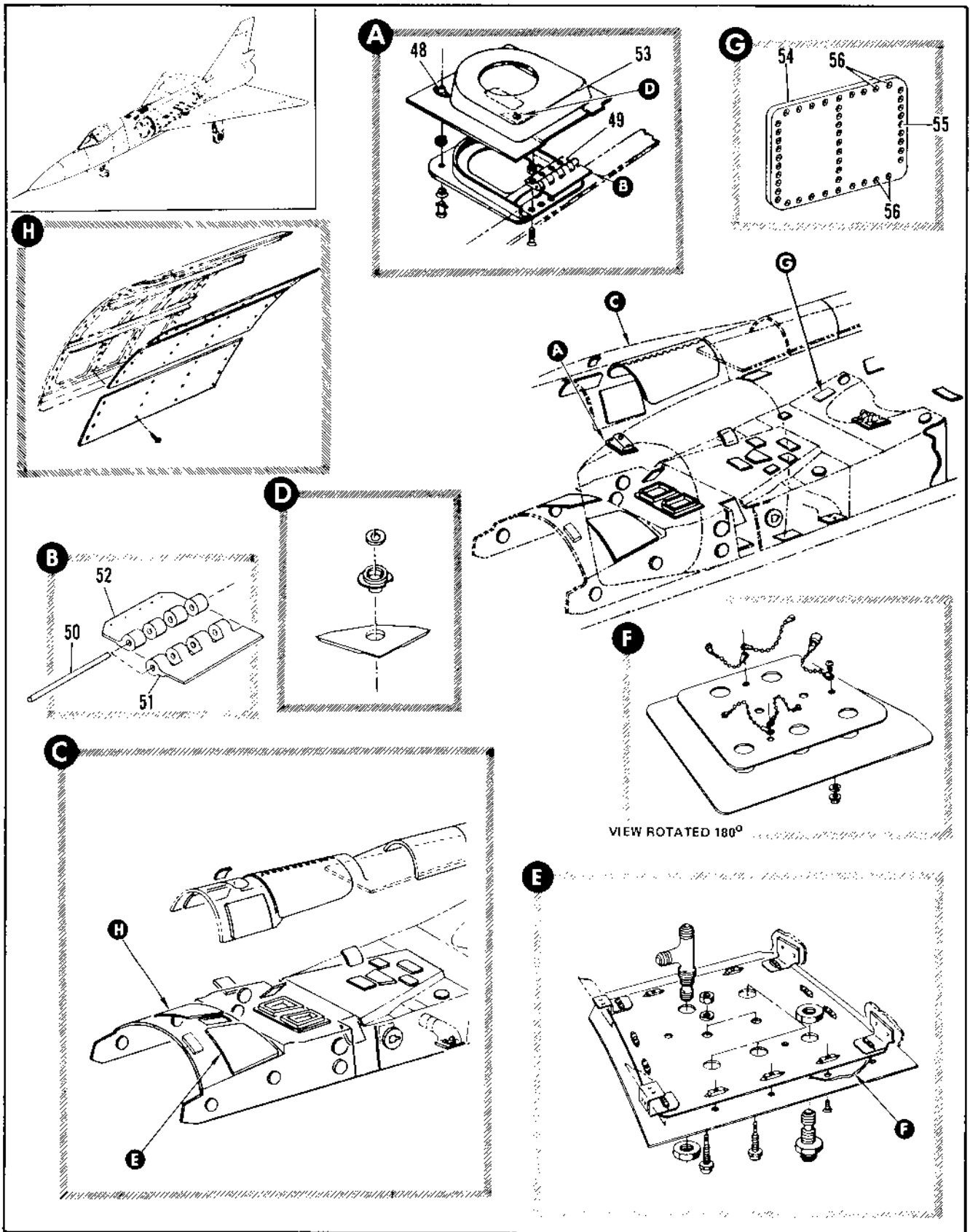

Figure 2.2-7. Fuselage Access Doors Sta 213 to 488 (Sheet 4 of 8)

FIGURE AND INDEX NUMBER	PART NUMBER	DESCRIPTION	UNITS PER ASSY.	USABLE ON CODE	
				FROM	TO
2.2-7-48	4R51-1				
	214-16	• • RECEPTACLE, FASTENER <71286> 97-31000-006	4	35	89
	8-77590-25	• • RECEPTACLE, FASTENER <71286> 97-31004-001	4	90	
- 49	8-77590-25	• • HINGE ASSY, REFUELING DOOR STA 312 RH	1	35	
- 50	MS20253-5-388	• • • PIN, HINGE (96906)	1	35	
- 51	8-77590-15	• • • HINGE, HALF	1	35	
- 52	8-77590-17	• • • HINGE, HALF	1	35	
	8-77590-27	• • PAN ASSEMBLY	1	35	
- 53	8-77590-9	• • • PAN	1	35	
	64E34481-35	• DOOR INSTALLATION, EXHAUST GAS (98750) TEMPERATURE EQUIPMENT STA 343 TO 357 RH	1		
- 54	64E34481-37	• • PANEL (98750) ATTACHING PARTS	1		
- 55	NAS333CPA4	• • SCREW (80205)	43		
- 56	NAS333CPA5	• • SCREW (80205)	4		

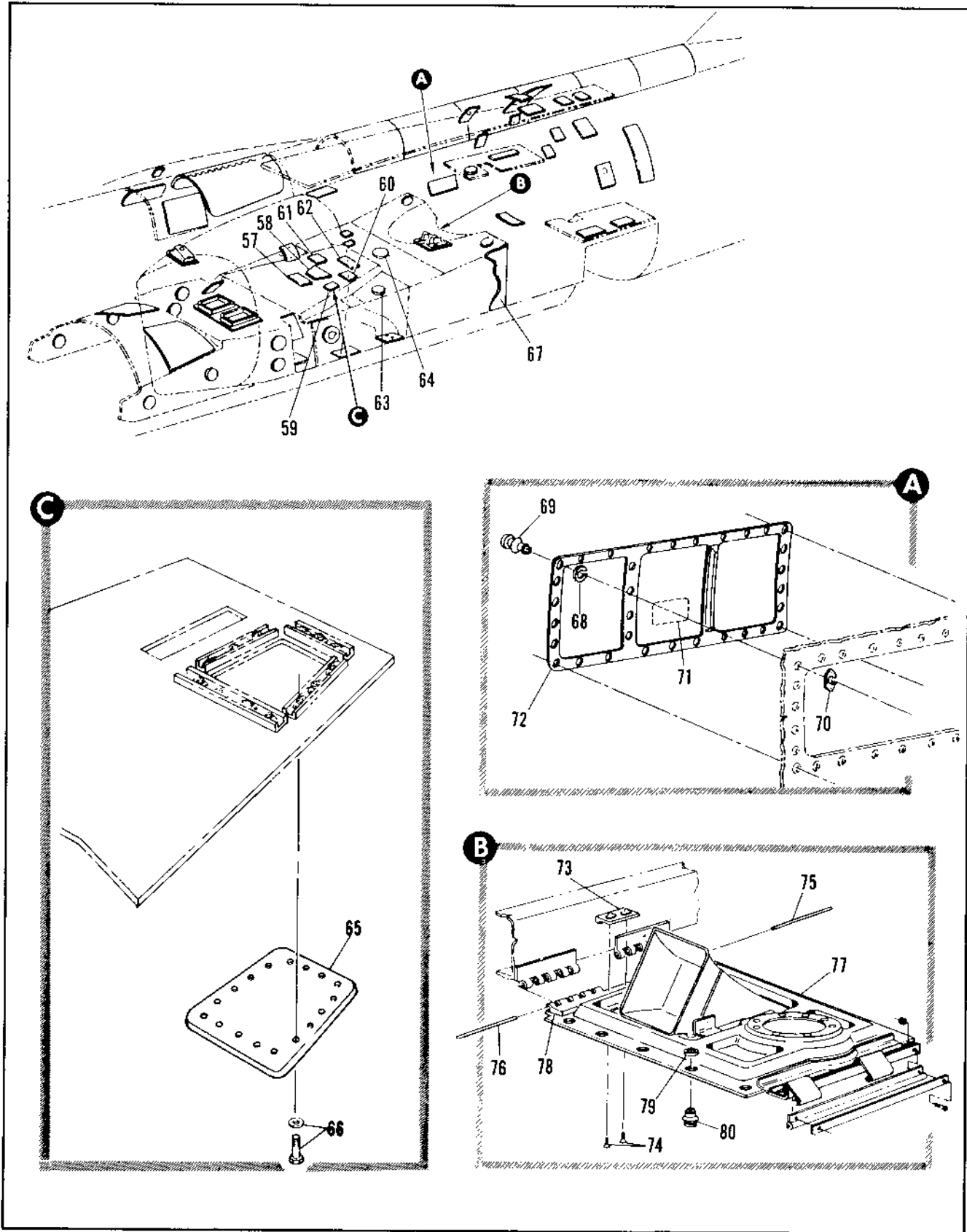

Figure 2.2-7. Fuselage Access Doors Sta 213 to 488 (Sheet 5 of 8)

FIGURE AND INDEX NUMBER	PART NUMBER	DESCRIPTION	UNITS PER ASSY.	USABLE ON CODE	
				FROM	TO
		1 2 3 4 5 6			
2.2-7	8-74489-3	• DOOR INSTL, ARMAMENT BAY ROOF MOD BY 7144596 (98750) FOR NHA SEE FIG. 2.1-1	RF	35	
- 57	8-74489-45	• . DOOR, STA 333	1	35	
	NAS221-8	• . SCREW (80205)	16	35	
- 58	8-74489-47	• . DOOR, RH STA 340	1	D	
- 59	8-74489-203	• . DOOR, LH STA 340	1	D	
	NAS211-8	• . SCREW (80205)	18	35	
	NAS221-8	• . SCREW (80205)	13	35	
	NAS221-9	• . SCREW (80205)	4	35	
- 60	8-74489-49	• . DOOR, LH STA 347	1	35	
- 61	8-74489-50	• . DOOR, RH STA 347	1	35	
	NAS221-8	• . SCREW (80205)	44	35	159
	NAS1103-2	• . BOLT (80205)	44	160	
- 62	8-74489-201	• . DOOR, RH STA 354	1	35	
	NAS221-8	• . SCREW (80205)	24	35	
- 63	8-74489-85	• . DOOR, LH STA 354	1	35	
	NAS211-7	• . SCREW (80205)	13	35	
- 64	8-74482-117	• . DOOR, ELECTRICAL HARNESS ACCESS STA 395	1	35	
	NAS221-4	• . SCREW (80205)	9	35	
	7144595-10	• . COVER ASSY, M61A1 GUN SYSTEM LH (98750)	1	35	
	7144595-20	• . COVER ASSY, M61A1 GUN SYSTEM RH (98750)	1	E	
- 65	7144595-03	• . DOOR (98750)	1	E	
		ATTACHING PARTS			
- 66	NAS221-9	• . . SCREW (80205)	17	E	
	AN960-16L	• . . WASHER (88044) ----X----	17	E	
- 67		• DOOR INSTL, ARMAMENT BAY SIDE STA 316 TO 412 SEE FIG. 2.2-14	RF		
	8-77649-7	• DOOR ASSY, RH STA 384 TO 405 REPLACED BY NOT INTCHG WITH 8-77649-41 FOR NHA SEE FIG. 292-14	RF	35	42
	8-77649-41	• DOOR ASSY, RH STA 384 TO 405 REPLACES NOT INTCHG WITH 8-77649-7 FOR NHA SEE FIG. 2.3-14	RF	43	
- 68	4S9-2	• . RING, FASTENER <71286> 97-61506-004	32	35	
- 69	4S14-4	• . STUD, FASTENER <71286> 98-58007-001	32	35	
- 70	4R41-1	• . RECEPTACLE, FASTENER <71286> 97-31000-005	32	35	
- 71	4F10-2	• . DECAL, <71286> 92-93500-001	1	35	
- 72	8-77648	• . DOOR, RH STA 384 TO 405	1	35	
	8-74609	• DOOR INSTL, HYDRAULIC ACCESS STA 414 FOR NHA SEE FIG. 2.1-1	RF	35	
- 73	8-74609-29	• . STOP ASSY, RIVETED ATTACHING PARTS	1	35	
- 74	MS24694-52	• . SCREW (96906)	2	35	
- 75	8-74609-37	• . PIN, HINGE	1	35	
- 76	8-74609-39	• . PIN, HINGE	1	35	
- 77	8-74609-49	• . DOOR ASSY, REPLACED BY SUITABLE SUB 8-74609-63	1	35	38
	8-74609-63	• . DOOR ASSY, REPLACES SUITABLE SUB FOR 8-74609-49	1	39	
	4F10-2	• . . DECAL, <71286> 92-93500-001	1	35	
- 78	8-74912-13	• . . HINGE, HALF	1	35	
- 79	4S9-2	• . . RING, FASTENER <71286> 97-61506-004	18	35	
- 80	4S14-4	• . . STUD, FASTENER <71286> 98-58002-001	18	35	

D AIRPLANES 35 THRU 47, 49 THRU 89
E AIRPLANES 48, 90 AND ON

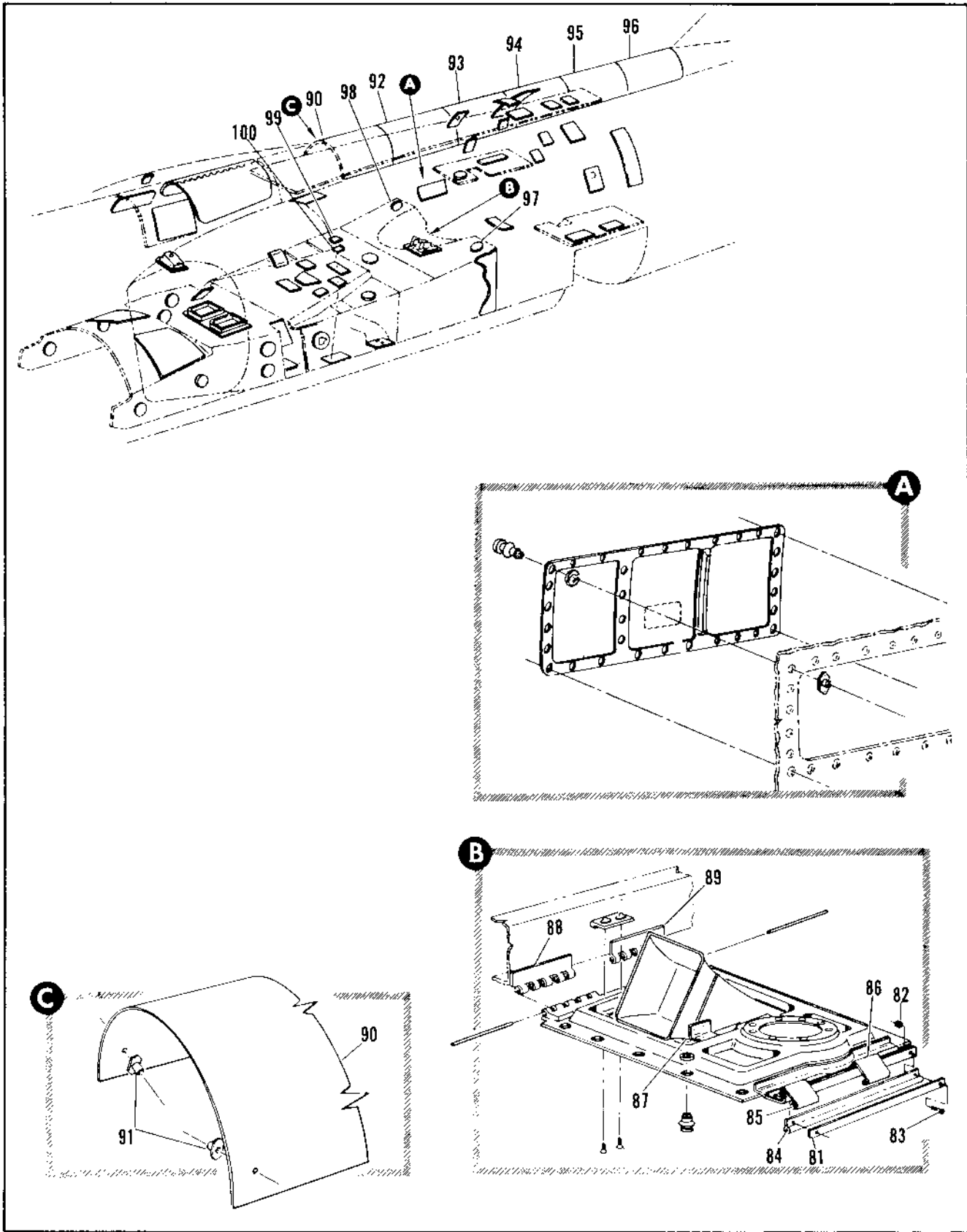

Figure 2.2-7. Fuselage Access Doors Sta 213 to 488 (Sheet 6 of 8)

FIGURE AND INDEX NUMBER	PART NUMBER	DESCRIPTION	UNITS PER ASSY.	USABLE ON CODE	
				FROM	TO
2.2-7	8-77797-3	• • • SEAL INSTL, HYDRAULIC ACCESS DOOR	1	35	
- 81	8-77797-9	• • • RETAINER	1	35	
- 82	NAS679A06	ATTACHING PARTS			
- 83	MS24693-25	• • • NUT (80205), 96-37545-006	12	35	
		• • • SCREW (96906)	12	35	
		-----X-----			
- 84	8-77798-9	• • • SEAL	1	35	
- 85	8-74609-57	• • • SPRING, FWD	1	35	60
- 86	8-74609-59	• • • SPRING, AFT	1	35	60
- 87	8-74991	• • • FAIRING, HYDRAULIC ACCESS DOOR	1	35	
	8-74609-1	• HINGE INSTL, HYDRAULIC ACCESS DOOR	RF	35	
		FOR NHA SEE FIG. 2.3-10			
- 88	8-74912-15	• HINGE, HALF	1	35	
- 89	8-74912-9	• HINGE, HALF	1	35	
	8-74498	• DORSAL INSTL, REVOVABLE STA 343 TO 510	RF	35	
		FOR NHA SEE FIG. 2.3-3			
- 90	8-74498-7	• FAIRING ASSY, WELDED	RF	35	
	66J40245	• DORSAL INSTL (98750), FOR BREAKDOWN SEE	RF	35	
		FIG. 2.13-1			
- 91	2935-640	• RECEPTACLE, QUICK RELEASE PIN SPRING	2	35	
		LOAD (84256) 97-30800-004			
- 92	8-74498-9	• FAIRING ASSY, WELDED	RF	35	
	66J40669-75	• FAIRING ASSY (98750), ALTERED FROM 8-74498-9	1	35	
		FOR BREAKDOWN SEE FIG. 2.12-66			
- 93	8-74498-11	• FAIRING ASSY, WELDED	RF	35	
	66E40029-1	• FAIRING, ASSY, WELDED, ALTERED FROM (98750)	1	35	
		8-74498-11			
- 94	8-74498-13	• FAIRING ASSY, WELDED	RF	35	
	66E40030-1	FAIRING, ASSY, WELDED (98750), ALTERED FROM	1	35	
		8-74498-13			
- 95	8-74498-15	• FAIRING ASSY, WELDED	RF	35	
	67E36617-1	FAIRING ASSY, WELDED (98750), ALTERED FROM	1	35	
		8-74498-15			
- 96	8-74498-17	• FAIRING ASSY, WELDED REPLACED BY NOT	1	35	215
		INTCHG WITH 8-74498-153			
	8-74498-153	• FAIRING ASSY, WELDED REPLACES NOT INTCHG	1	216	
		WITH 8-74498-17			
		ATTACHING PARTS			
	MS24694	• SCREW (96906)	AR	35	
		-----X-----			
	8-74482-1	• DOOR INSTL, STA 408 LH	RF	35	42
		FOR NHA SEE FIG. 2.3-12			
	8-74482-603	• DOOR INSTL, STA 408 LH	RF	43	
		FOR NHA SEE FIG. 2.3-12			
	8-74482-2	• DOOR INSTL, STA 408 RH	RF	35	42
		FOR NHA SEE FIG. 2.3-12			
	8-74482-809	• DOOR INSTL, STA 408 RH	RF	43	
		FOR NHA SEE FIG. 2.3-12			
- 97	8-74482-73	• DOOR LH	1	35	
		ATTACHING PARTS			
	NAS221-5	• BOLT (80205)	8	35	
		-----X-----			
- 98	8-74482-715	• DOOR, RH	1	43	
		ATTACHING PARTS			
	NAS221-5	• BOLT (80205)	8	43	
		-----X-----			

FIGURE AND INDEX NUMBER	PART NUMBER	DESCRIPTION	UNITS PER ASSY.	USABLE ON CODE	
				FROM	TO
		1 2 3 4 5 6			
2.2-7	8-78514	. . DOOR INSTL, ACCESS RH	1	35	
- 99	8-78514-7	. . . DOOR, RH	1	35	
	NAS1103-2	ATTACHING PARTS	1	35	
		. . . BOLT (80205)	20	35	
		----X----			
-100	7445782	. . DOOR INSTL, FUEL PRESSLINE (98750)	1	35	

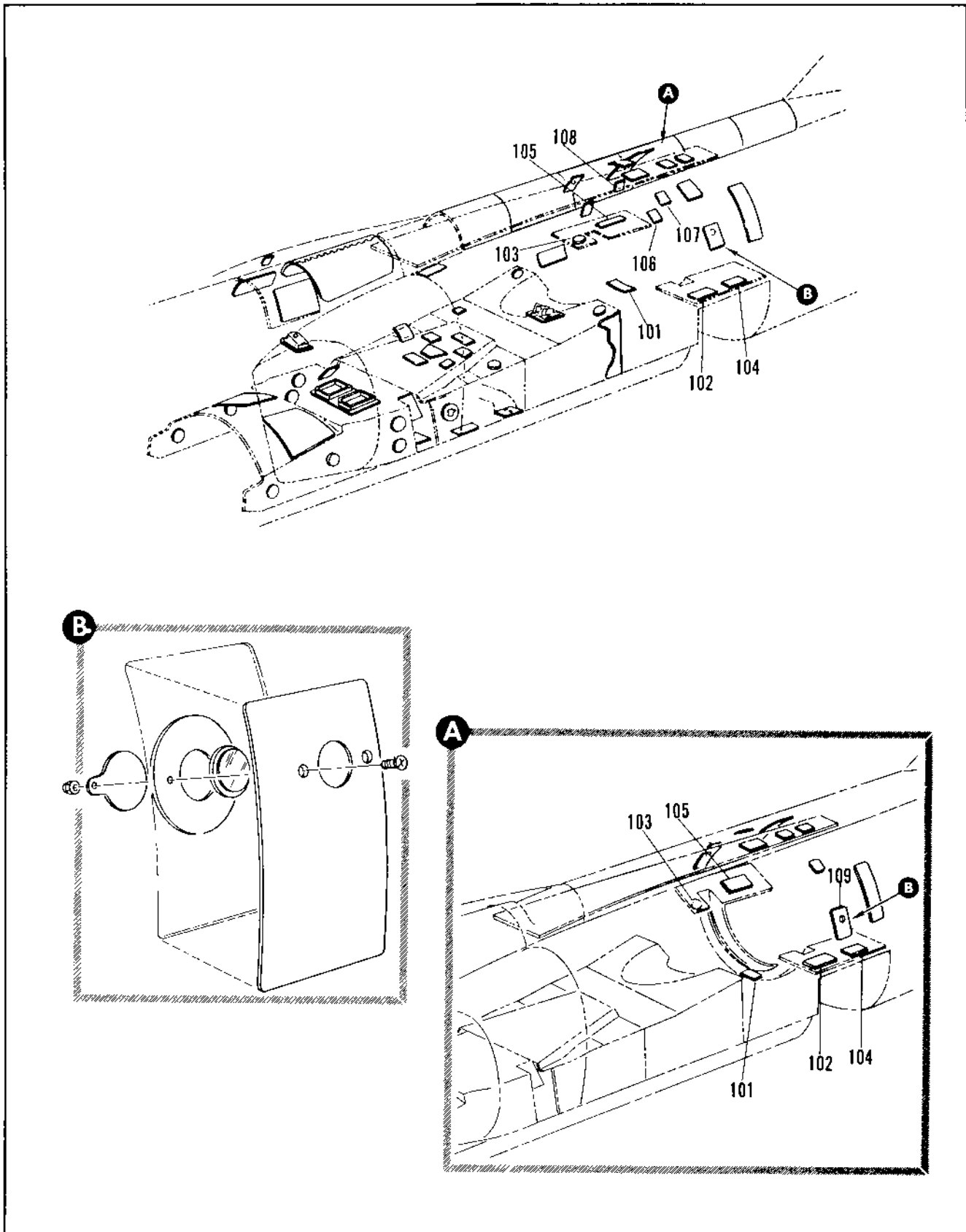

Figure 2.2-7. Fuselage Access Doors Sta 213 to 488 (Sheet 7 of 8)

FIGURE AND INDEX NUMBER	PART NUMBER	DESCRIPTION	UNITS PER ASSY.	USABLE ON CODE	
				FROM	TO
2.2-7	8-74462-3	. DOOR INSTL, STA 439 FOR NHA SEE FIG. 2.3-10	RF	35	
-101	8-74462-9	. . DOOR ASSY, STA 439 ATTACHING PARTS	1	35	
	NAS221-8	. . SCREW (80205) -----X-----	22	35	
	8-74104-3	. DOOR INSTL, LH STA 431 TO 472 FOR NHA SEE FIG. 2.3-3	RF	35	
	8-74164-801	. DOOR INSTL, RH STA 431 TO 472 FOR NHA SEE FIG. 2.3-3	RF	35	
-102	8-74104-35	. . DOOR, LH STA 435	1	35	53
	8-74104-95	. . DOOR, LH STA 435	1	54	
-103	8-74164-99	. . DOOR, RH STA 435 ATTACHING PARTS	1	35	
	NAS221-9	. . SCREW, LH (80205)	42	35	
	NAS221-6	. . SCREW, RH (80205) -----X-----	15	35	
-104	8-74104-67	. . DOOR ASSY, LH STA 456 RIVETED	1	35	
-105	8-74164-69	. . DOOR, RH STA 456 ATTACHING PARTS	1	35	
	NAS221-9	. . SCREW, LH (80205)	41	35	
	AN3-3A	. . BOLT, LH (88044)	1	35	
	NAS221-9	. . SCREW, RH (80205) -----X-----	39	35	
	8-77638-3	. DOOR INSTL, SCROLL AREA INSPECTION STA 435 LH FOR NHA SEE FIG. 2.1-1	RF	35	
	8-77638-4	. DOOR INSTL, SCROLL AREA INSPECTION STA 435 RH FOR NHA SEE FIG. 2.1-1	RF	35	
-106	8-77638-9	. . DOOR, LH	1	35	
	8-77638-10	. . DOOR, RH ATTACHING PARTS	1	35	
	NAS333CPA4	. . SCREW (80205) -----X-----	28	35	
	8-77639-3	. DOOR INSTL, SCROLL AREA INSPECTION STA 441 LH FOR NHA SEE FIG. 2.1-1	RF	35	
	8-77640-3	. DOOR INSTL, SCROLL AREA INSPECTION STA 441 RH FOR NHA SEE FIG. 2.1-1	RF	35	
	68J37309-7	. . DOOR, LH (98750)	1	35	
-107	68J37309-9	. . DOOR, RH (98750)	1	35	
	8-77639-9	. . DOOR, LH	1	35	
-108	8-77640-9	. . DOOR, RH ATTACHING PARTS	1	35	
	NAS333CPA4	. . SCREW, LH (80205)	30	35	
	NAS333CPA4	. . SCREW, RH (80205) -----X-----	22	35	
	8-74661-803	. DOOR INSTL, LOWER DUCT VALVE STA 446 TO 452 LH FOR NHA SEE FIG. 2.1-1	RF	35	
	8-74662-803	. DOOR INSTL, LOWER DUCT VALVE STA 446 TO 452 RH FOR NHA SEE FIG. 2.1-1	RF	35	
-109	8-74661-21	. . DOOR ASSY, LH	1	35	

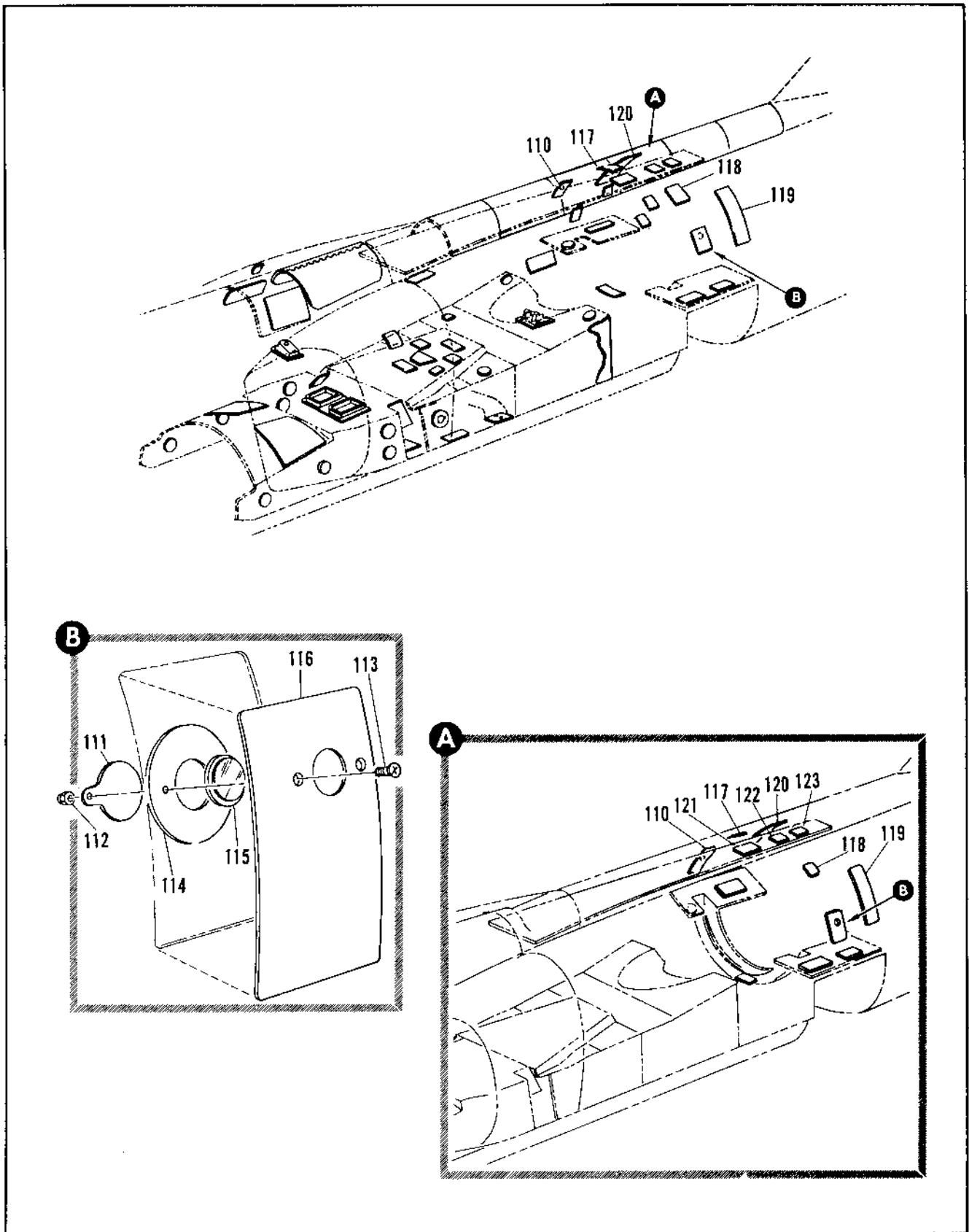

Figure 2.2-7. Fuselage Access Doors Sta 213 to 488 (Sheet 8 of 8)

FIGURE AND INDEX NUMBER	PART NUMBER	DESCRIPTION 1 2 3 4 5 6	UNITS PER ASSY.	USABLE ON CODE	
				FROM	TO
2.2-7-110	8-74662-21	• DOOR ASSY, RH ATTACHING PARTS	1	35	
	NAS333CPA4	• SCREW, LH (80205)	46	35	
	NAS333CPA4	• SCREW, RH (80205) -----X-----	44	35	
-111	8-77523-9	• RETAINER ATTACHING PARTS	1	35	
-112	NAS679A3	• NUT (80205)	2	35	
-113	NAS333CPA4	• SCREW (80205) -----X-----	2	35	
-114	8-77523-7	• DOUBLER	1	35	
-115	8-77524	• WINDOW	1	35	
-116	8-74661-19	• DOOR, LH	1	35	
	8-74662-19	• DOOR, RH	1	35	
	8-74660-803	• DOOR INSTL, UPPER DUCT VALVE STA 445 TO 451 RH FOR NHA SEE FIG. 2.1-1	RF	35	
-117	8-74660-25	• DOOR ATTACHING PARTS	1	35	
	NAS333CPA5	• SCREW (80205) -----X-----	33	35	
-118	8-74603-803	• DOOR INSTL, UPPER DUCT VALVE STA 451 TO 455 LH FOR NHA SEE FIG. 2.1-1	RF	35	
	8-74603-21	• DOOR, UPPER DUCT VALVE LH ATTACHING PARTS	1	35	
-119	NAS333CPA5	• SCREW (80205) -----X-----	34	35	
	8-74602-801	• DOOR INSTL, ENGINE OIL COOLER LH FOR NHA SEE FIG. 2.1-1	RF	35	
	8-74602-23	• DOOR, ENGINE OIL COOLER LH ATTACHING PARTS	1	35	
-120	NAS333CPA5	• SCREW (80205) -----X-----	95	35	
	8-74659-801	• DOOR INSTL, ACCESSORY OIL COOLER RH FOR NHA SEE FIG. 2.1-1	RF	35	
-121	8-74659-13	• DOOR ATTACHING PARTS	1	35	
	NAS333CPA5	• SCREW (80205) -----X-----	73	35	
-122	8-74494-3	• DOOR INSTL, FUSELAGE TOP DECK FOR NHA SEE FIG. 2.1-1	RF	35	
	8-74494-85	• DOOR, STA 439 TO 445 ATTACHING PARTS	1	35	
-123	NAS221-9	• SCREW (80205) -----X-----	16	35	
	8-74494-87	• DOOR, STA 452 TO 458 ATTACHING PARTS	1	35	
-124	NAS221-9	• SCREW (80205) -----X-----	12	35	
	8-74494-79	• DOOR, STA 458 TO 464 ATTACHING PARTS	1	35	
	NAS221-9	• SCREW (80205) -----X-----	12	35	

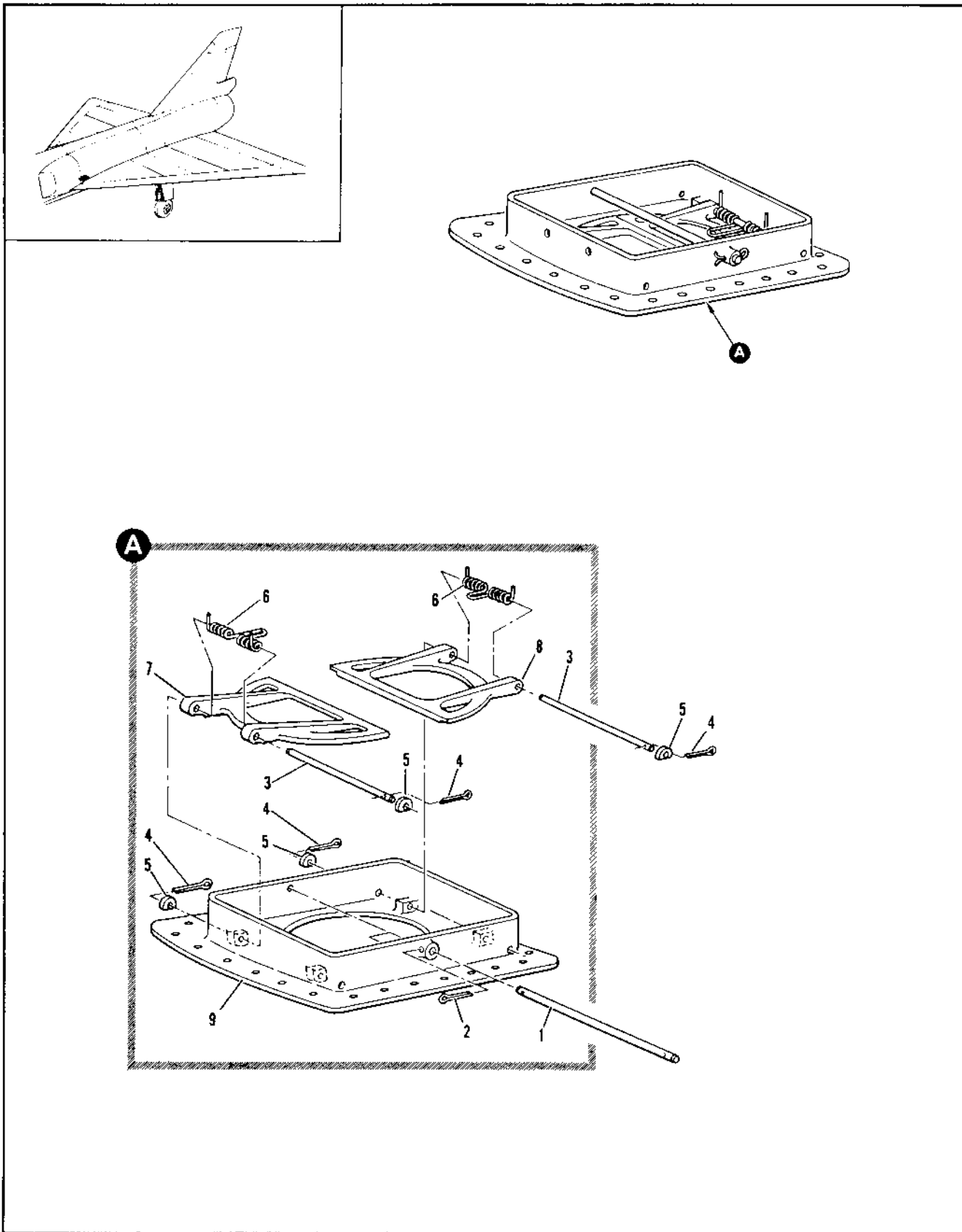

Figure 2.2-8. Electronic Compartment Ground Connection Access Door Assembly

FIGURE AND INDEX NUMBER	PART NUMBER	DESCRIPTION 1 2 3 4 5 6	UNITS PER ASSY.	USABLE ON CODE	
				FROM	TO
2.2-8	8-23527-1	DOOR ASSEMBLY, ELECTRONIC COMPARTMENT GROUND CONNECTION ACCESS FOR NHA SEE FIG. 2.13-1	RF	35	
- 1	8-23548	• SHAFT ATTACHING PARTS	1	35	
- 2	MS24665-134	• PIN, COTTER (96906) -----X-----	2	35	
- 3	8-23528	• PIN ATTACHING PARTS	2	35	
- 4	MS24665-132	• PIN, COTTER (96906)	4	35	
- 5	8-23527-7	• WASHER -----X-----	4	35	
- 6	8-00688-1	• SPRING	2	35	
- 7	8-23547-29	• DOOR	1	35	
- 8	8-23547-27	• DOOR	1	35	
- 9	8-77785-17	• SUPPORT	1	35	

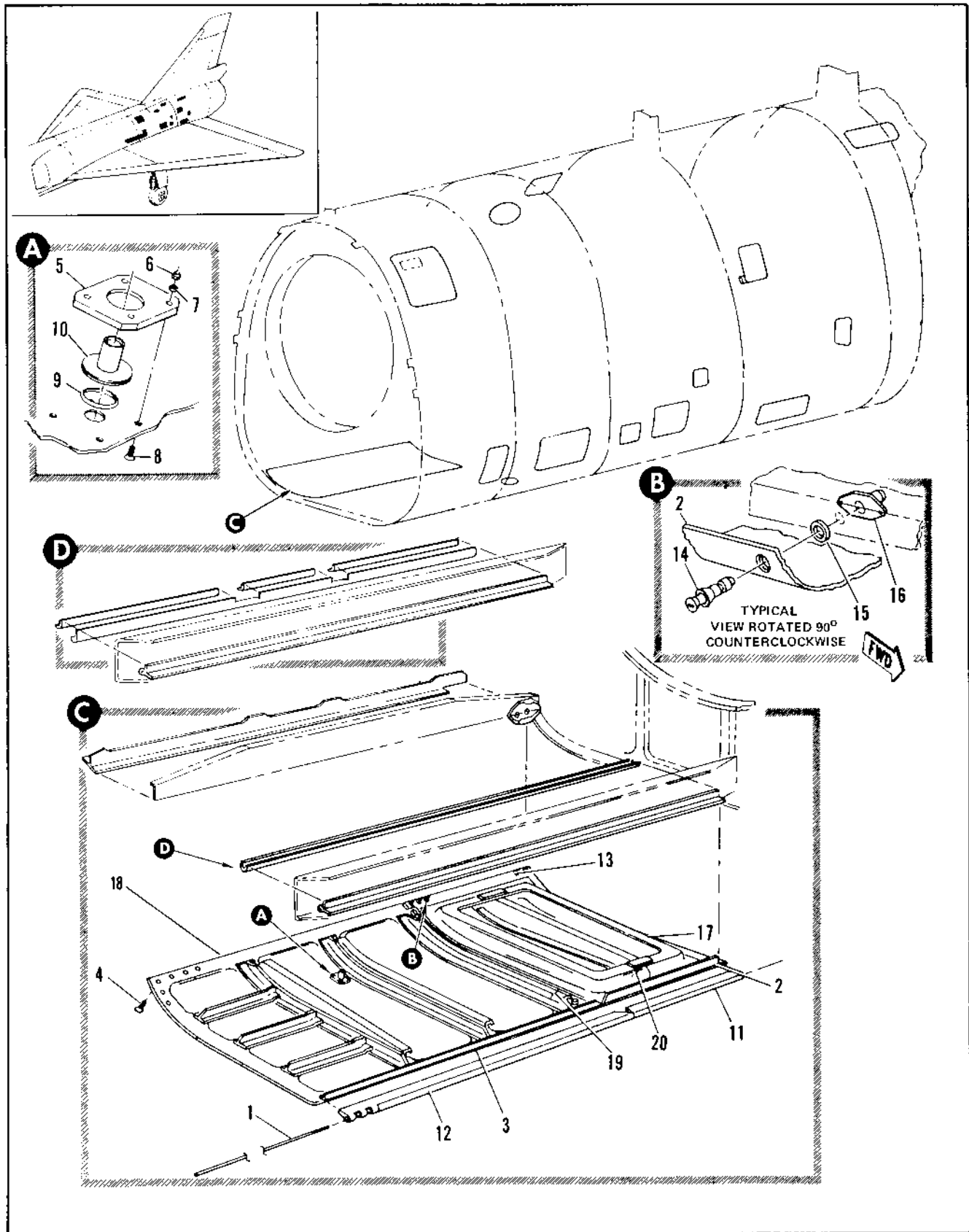

Figure 2.2-9. Fuselage Access Doors Sta 472 to 602 (Sheet 1 of 5)

FIGURE AND INDEX NUMBER	PART NUMBER	DESCRIPTION	UNITS PER ASSY.	USABLE ON CODE	
				FROM	TO
2.2-9	8-74618	FUSELAGE ACCESS DOORS STA 472 TO 602 • DOOR INSTL, ACCESSORY DRIVE UNIT STA 472 TO 520 FOR NHA SEE FIG. 2.3-3	RF	35	
- 1	8-74955	• . PIN, HINGE	1	35	
- 2	8-74618-73	• . DOOR ASSY, DRIVE UNIT AFT REPLACED BY NOT INTCHG WITH 8-74618-105	1	35	48
	8-74618-105	• . DOOR ASSY, DRIVE UNIT AFT REPLACES NOT INTCHG WITH 8-74618-73 REPLACED BY SUITABLE SUB 8-74618-141	1	49	129
	8-74618-141	• . DOOR ASSY, DRIVE UNIT AFT REPLACES SUITABLE SUB FOR 8-74618-105	1	130	
- 3	8-74618-75	• . DOOR ASSY, DRIVE UNIT FWD MODIFIED BY 6-28516 REPLACED BY NOT INTCHG WITH 8-74618-107	1	35	48
	8-74618-107	• . DOOR ASSY, DRIVE UNIT FWD REPLACES NOT INTCHG WITH 8-74618-75 REPLACED BY NOT INTCHG WITH 8-74618-127	1	49	89
	8-74618-127	• . DOOR ASSY, DRIVE UNIT FWD REPLACES NOT INTCHG WITH 8-74618-107 REPLACED BY SUITABLE SUB 8-74618-145	1	90	129
	8-74618-145	• . DOOR ASSY, DRIVE UNIT FWD REPLACES SUITABLE SUB FOR 8-74618-127 ATTACHING PARTS	1	130	
- 4	NAS333CPA5	• . SCREW (80205) ----X----	52	35	
- 5	8-28442-7	• . . RETAINER, GENERATOR DRAIN SEAL ATTACHING PARTS	1	35	
- 6	NAS679A3	• . . NUT (80205)	4	35	
- 7	AN969PD10L	• . . WASHER (88044)	4	35	
- 8	MS24694-55	• . . SCREW (96906) ----X----	4	35	
- 9	NAS617-16	• . . GASKET (80205)	1	35	
- 10	8-28443-7	• . . FLANGE	1	35	
- 11	8-74644-11	• . . HINGE, AFT	1	35	
- 12	8-74644-9	• . . HINGE, FWD	1	35	
- 13	4S14-10	• . . STUD, FASTENER <71286> 98-58007-004	2	35	
- 14	4S14-4	• . . STUD, FASTENER <71286> 98-58002-001	43	35	
- 15	4S9-1	• . . RING, FASTENER <71286> 97-61506-001	45	35	43
	4S9-2	• . . RING, FASTENER <71286> 97-61506-004	45	44	
- 16	4R41-1	• . . RECEPTACLE, FASTENER <71286> 97-31800-005	17	35	
- 17	8-74618-11	• . . SKIN, ACCESSORY DRIVE UNIT DOOR AFT	1	35	
- 18	8-74618-13	• . . SKIN, ACCESSORY DRIVE UNIT DOOR FWD REPLACED BY NOT INTCHG WITH 8-74618-119	1	35	89
	8-74618-119	• . . SKIN, ACCESSORY DRIVE UNIT DOOR FWD REPLACES NOT INTCHG WITH 8-74618-13	1	90	
- 19	8-74618-33	• . . STIFFENER, ACCESSORY DRIVE UNIT FWD REPLACED BY NOT INTCHG WITH 8-74618-95	1	35	48
	8-74618-95	• . . STIFFENER, ACCESSORY DRIVE UNIT FWD REPLACES NOT INTCHG WITH 8-74618-33	1	49	
- 20	8-74618-35	• . . STIFFENER, ACCESSORY DRIVE UNIT AFT REPLACED BY NOT INTCHG WITH 8-74618-101	1	35	48

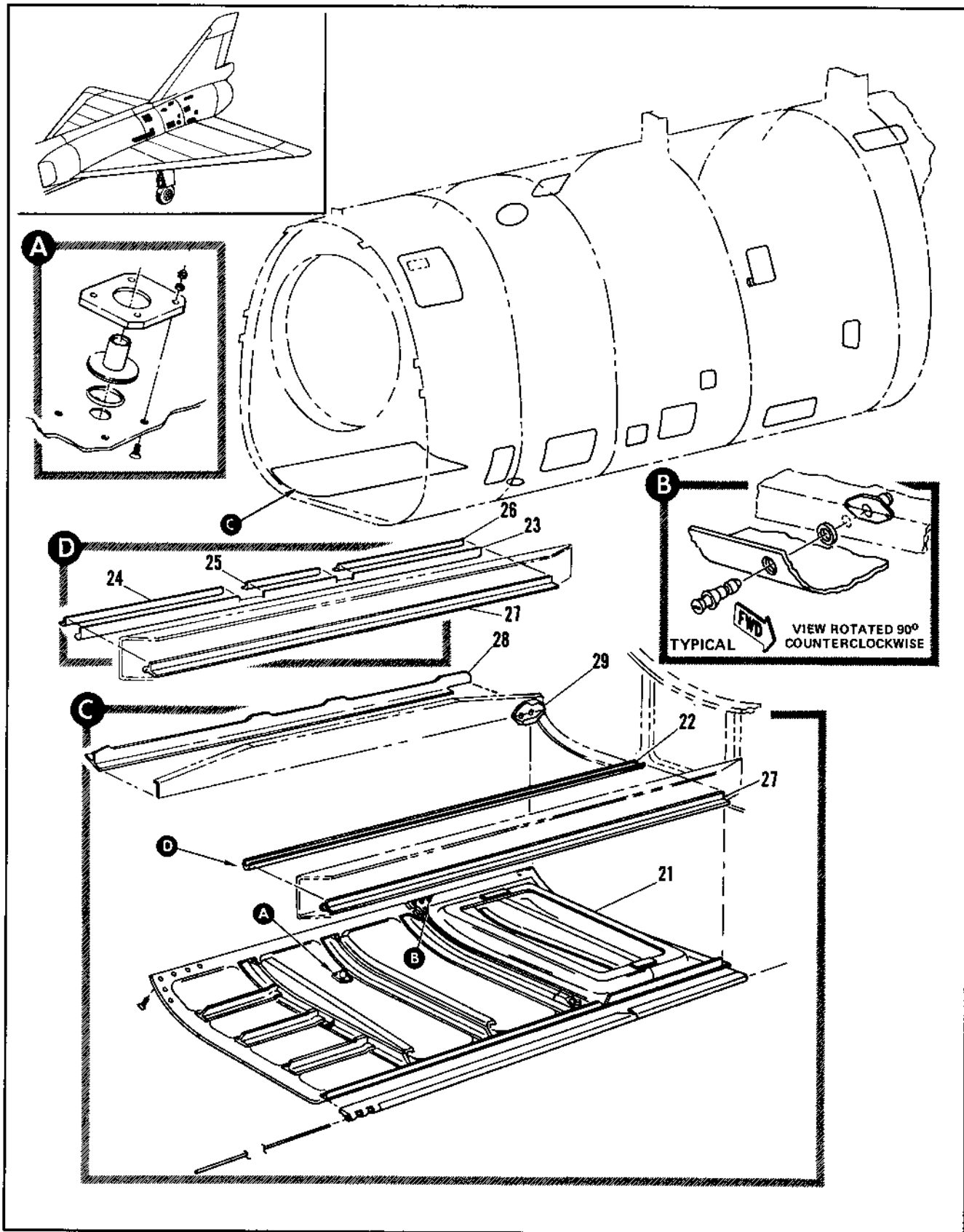

Figure 2.2-9. Fuselage Access Doors Sta 472 to 602 (Sheet 2 of 5)

FIGURE AND INDEX NUMBER	PART NUMBER	DESCRIPTION	UNITS PER ASSY.	USABLE ON CODE	
				FROM	TO
		1 2 3 4 5 6			
2.2-9	8-74618-101	. . . STIFFENER, ACCESSORY DRIVE UNIT AFT REPLACES NOT INTCHG WITH 8-74618-35	1	49	
- 21	8-74618-37	. . . STIFFENER, ACCESSORY DRIVE UNIT AFT REPLACED BY NOT INTCHG WITH 8-74618-79	1	35	48
	8-74618-79	. . . STIFFENER, ACCESSORY DRIVE UNIT AFT REPLACES NOT INTCHG	1	49	
	8-74412-3	. STRUCTURE INSTL, ACCESSORY DRIVE UNIT DOOR FOR NHA SEE FIG. 2-3-3	RF	35	60
	8-74412-803	. STRUCTURE INSTL, ACCESSORY DRIVE UNIT DOOR FOR NHA SEE FIG. 2-3-3	RF	61	
	8-74943	. . PLATE, ACCESSORY DRIVE DOOR FWD	1	35	
	8-74963-7	. . STIFFENER, ACCESSORY DRIVE ACCESS DOOR END BAY	1	35	60
	8-74412-1	. STRUCTURE INSTL, ACCESSORY DRIVE UNIT DOOR FOR NHA SEE FIG. 2-3-14	RF	35	47
	8-74412-801	. STRUCTURE INSTL, ACCESSORY DRIVE UNIT DOOR FOR NHA SEE FIG. 2-3-14	RF	48	
- 22	8-74954-7	. . SEAL, REPLACED BY SUITABLE SUB 8-74954-9	1	35	38
	8-74954-9	. . SEAL, REPLACES SUITABLE SUB FOR 8-74954-7	1	39	47
- 23	8-77798-17	. . SEAL	1	48	
- 24	8-74412-161	. . RETAINER	1	48	
- 25	8-74412-163	. . RETAINER	1	48	
- 26	8-74412-165	. . RETAINER	1	48	
- 27	8-74644-7	. . HINGE, HALF	1	35	
	8-74644-13	. . HINGE, HALF	1	48	60
	8-74644-15	. . HINGE, HALF	1	61	
	8-74412-57	. . BEAM ASSY, ACCESSORY DRIVE UNIT DOOR OUTBD	1	35	47
	8-74412-103	. . BEAM ASSY, ACCESSORY DRIVE UNIT DOOR OUTED	1	48	
- 28	8-74942-7	. . . CAP, ACCESSORY DRIVE DOOR STRUCTURE REPLACED BY NOT INTCHG WITH 8-74942-9	1	35	47
	8-74942-9	. . . CAP, ACCESSORY DRIVE DOOR STRUCTURE REPLACES NOT INTCHG WITH 8-74942-7	1	48	159
	8-74942-11	. . . CAP, ACCESSORY DRIVE DOOR STRUCTURE	1	160	
- 29	8-74944-7	. . . BRACKET, ACCESSORY DRIVE DOOR STRUCTURE AFT	1	35	47

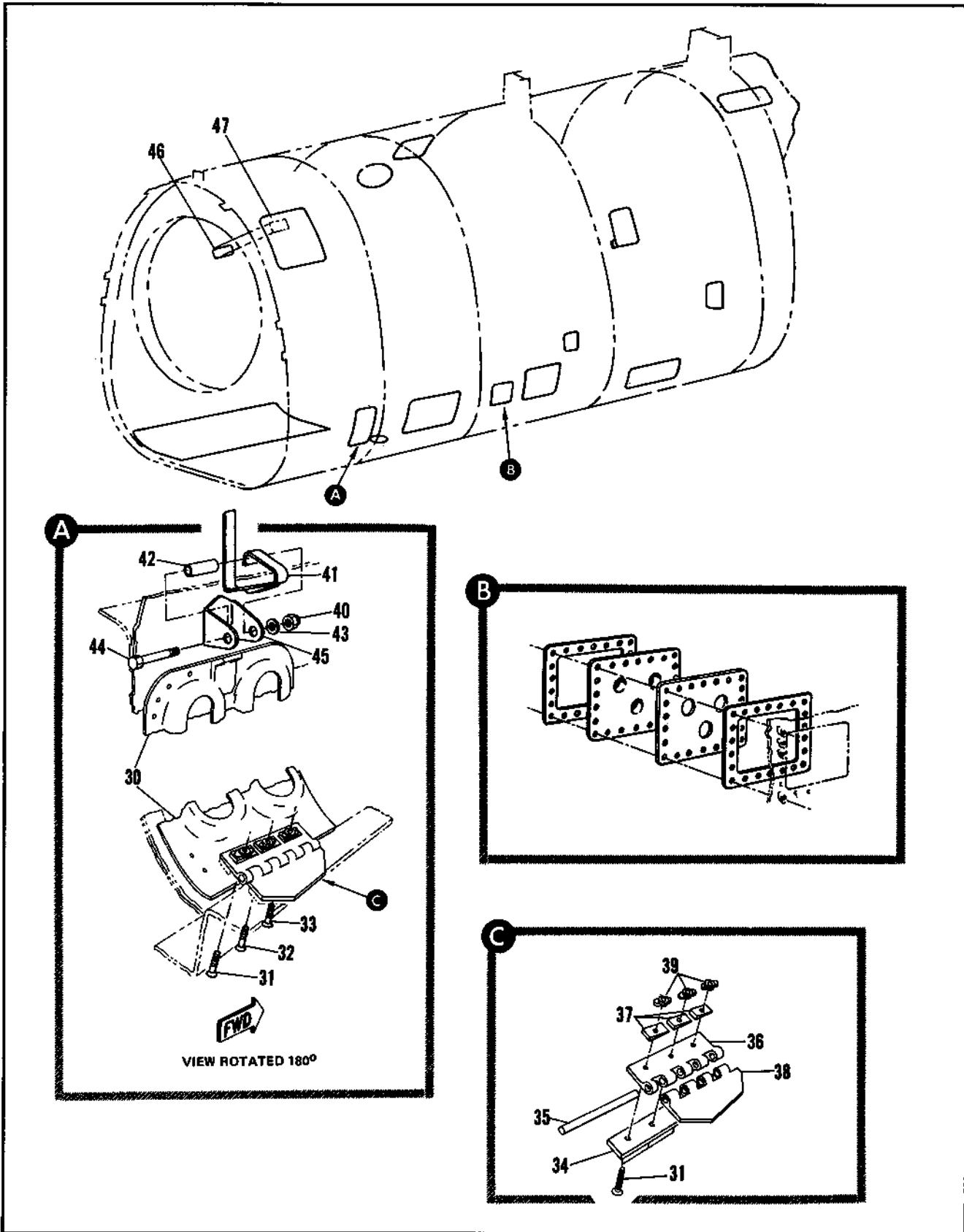

Figure 2.2-9. Fuselage Access Doors Sta 472 to 602 (Sheet 3 of 5)

FIGURE AND INDEX NUMBER	PART NUMBER	DESCRIPTION	UNITS PER ASSY.	USABLE ON CODE	
				FROM	TO
		1 2 3 4 5 6			
2.2-9	8-74622-3	• DOOR INSTL, FIRE ACCESS STA 488 TO 496 FOR NHA SEE FIG. 2.1-1	RF	35	
- 30	8-74622-57	• • DOOR ASSY, FIRE ACCESS ATTACHING PARTS	1	35	
- 31	MS24694-57	• • SCREW (96906)	1	35	
- 32	MS24694-58	• • SCREW (96906)	1	35	
- 33	MS24694-59	• • SCREW (96906) -----X-----	1	35	
- 34	8-74622-51	• • FILLER	1	35	
	4002SW	• • • WASHER, FASTENER <71286> 99-53600-001	1	35	
	4R-20-14-032	• • • SHIM, FASTENER <71286> 98-09501-004	1	35	
	40S8-2-20R	• • • STUD, FASTENER <71286> 98-58004-003	1	35	
	R4G	• • • RING, FASTENER <71286> 97-61506-003	1	35	
	214-16	• • • RECEPTACLE, FASTENER <71286> 97-31004-001	1	35	
	4002G	• • • GROMMET, FASTENER <71286> 94-35500-003	1	35	
	8-74622-1	• HINGE INSTL, FIRE ACCESS DOOR FOR NHA SEE FIG. 2.3-14	RF	35	
- 35	8-74622-45	• • HINGE ASSY, FIRE ACCESS DOOR	1	35	
- 36	MS20253-2-388	• • • PIN (96906)	1	35	
- 37	8-74622-43	• • • HINGE	1	35	
- 38	8-74622-35	• • • FILLER	3	35	
- 39	8-74622-33	• • • HINGE	1	35	
- 39	NAS686A3	• • • NUTPLATE (80205)	3	35	
- 40	MS21044N3	• • NUT (96906)	1	35	
- 41	8-78588-3	• • SPRING ASSY, FIRE ACCESS DOOR	1	35	
- 42	NAS43HT3-88	• • SPACER (80205)	1	35	
- 43	AN960-10	• • WASHER (88044)	2	35	
- 44	AN3-20A	• • BOLT (88044)	1	35	
- 45	8-74622-55	• • BRACKET	1	35	
	8-74614-21	• DOOR INSTL, ENGINE MOUNT ACCESS FWD LH REPLACED BY NOT INTCHG WITH 8-74614-43 FOR NHA SEE FIG. 2.1-1	RF	278	300
	8-74614-43	• DOOR INSTL, ENGINE MOUNT ACCESS FWD LH REPLACES NOT INTCHG WITH 8-74614-21 FOR NHA SEE FIG. 2.1-1	RF	A	
	8-74614-22	• DOOR INSTL, ENGINE MOUNT ACCESS FWD RH REPLACED BY NOT INTCHG WITH 8-74614-44 FOR NHA SEE FIG. 2.1-1	RF	278	300
	8-74614-44	• DOOR INSTL, ENGINE MOUNT ACCESS FWD RH REPLACES NOT INTCHG WITH 8-74614-22 FOR NHA SEE FIG. 2.1-1	RF	A	
- 46	4F10-2	• • DECAL, FASTENER INSTRUCTION <71286> 92-93500-001	1	35	
- 47	8-74614-7	• • DOOR, LH	1	35	
	8-74614-8	• • DOOR, RH	1	35	
	4S14-4	ATTACHING PARTS			
	4S9-1	• • STUD, FASTENER <71286> 98-58002-001	26	35	
	4S9-2	• • RING, FASTENER <71286> 97-61506-001	26	35	43
	4R41-1	• • RING, FASTENER <71286> 97-61506-004	26	44	
		• • RECEPTACLE, FASTENER <71286> 97-31000-005 -----X-----	26	35	
		A AIRPLANES #35 THRU 277, 301 AND ON			

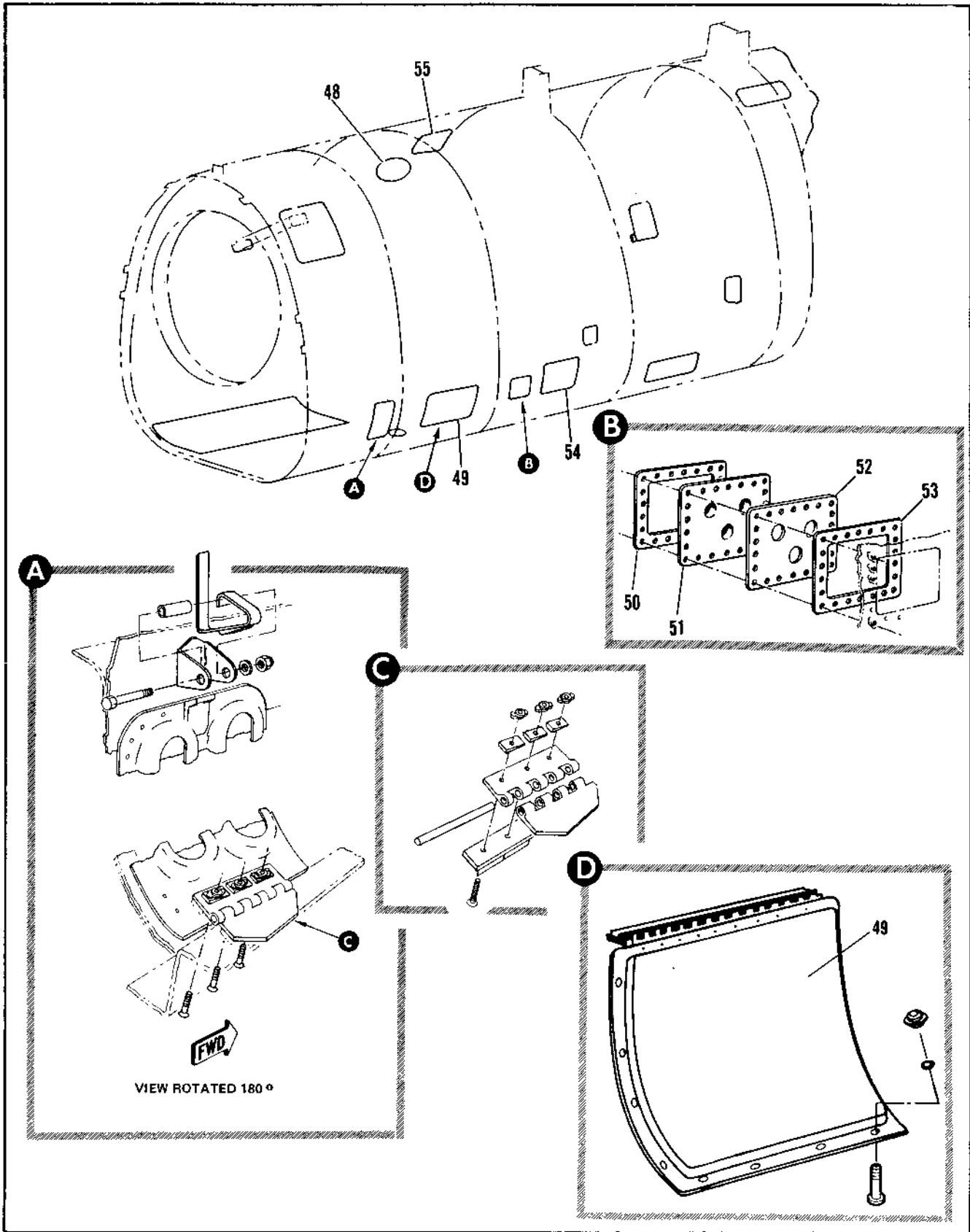

Figure 2.2-9. Fuselage Access Doors Sta 472 to 602 (Sheet 4 of 5)

FIGURE AND INDEX NUMBER	PART NUMBER	DESCRIPTION	UNITS PER ASSY.	USABLE ON CODE	
				FROM	TO
		1 2 3 4 5 6			
2-2-9	8-74608-41	MODIFIED BY 8-21909 REPLACED BY SUITABLE SUB 8-74608-41 FOR NHA SEE FIG. 2.1-1		35	89
	8-74608-41	• DOOR ASSY, OIL FILLER CAP ACCESS STA 509 REPLACES SUITABLE SUB FOR 8-74608-27 FOR NHA SEE FIG. 2.1-1	RF	90	
	4S14-4	• • STUD, FASTENER <71286> 98-58002-001	12	35	
	4S9-2	• • RING, FASTENER <71286> 97-61506-004	12	35	
	4R1-14	• • RECEPTACLE, FASTENER <71286> 97-31000-001	12	35	
	4F10-2	• • DECAL, FASTENER INSTRUCTION <71286> 92-93500-001	1	35	
- 48	8-74608-29	• • DOOR	1	35	
	8-74648-1 *5	• DOOR INSTL, HYDRAULIC PUMP ACCESS STA 502 TO 520 FOR NHA SEE FIG. 2.1-1	RF	35	
- 49	8-74648-7 *5	• • DOOR ASSY, RIVETED REPLACED BY NOT INTCHG WITH 8-74648-27	1	278	295
	8-74648-27 *5	• • DOOR ASSY, RIVETED REPLACES NOT INTCHG WITH 8-74648-7 ATTACHING PARTS	1	0	
	NAS333CPA5-5 *5	• • SCREW (80205)	92	35	
	7839559-90 *6	• DOOR INSTL (98750), HYDRAULIC PUMP AND STARTER STA 502 TO 520 FOR NHA SEE FIG. 2.1-1	1	35	305
	80S01-2-1AA *6	• • STUD (71286)	12	35	305
	4S9-2 *6	• • RETAINING RING (71286)	12	35	305
	80R01-1-1AA *6	• • RECEPTACLE (71286)	12	35	305
	8-77674-1	• DOOR INSTL, HYDRAULIC FLUID TUBE HEAT EXCHANGER LH FOR NHA SEE FIG. 2.3-14	RF	8	
	8-77674-2	• DOOR INSTL, HYDRAULIC FLUID TUBE HEAT EXCHANGER RH FOR NHA SEE FIG. 2.3-14	RF	8	
- 50	8-77674-15	• • RETAINER ATTACHING PARTS	1	8	
	NAS221-12	• • SCREW (80205)	22	8	
	AN960C10L	• • WASHER (88044)	14	8	
- 51	CR697-7	• • SEAL, <82830> SPEC 8-02430-7	1	8	
- 52	8-77674-7	• • DOOR	1	35	69
	8-77674-21	• • DOOR	1	0	
- 53	8-77675	• • SEAL	1	9	
	8-77674-21	• DOOR, HYDRAULIC FLUID TUBE HEAT EXCHANGER ATTACHING PARTS	1	130	
	NAS221-11	• • SCREW (80205)	22	130	
	AN960C10L	• • WASHER (88044)	14	130	
- 54	CR697-7	• • SEAL, <82830> SPEC 8-02430-7 • DOOR INSTL, ENGINE ACCESS LH SEE FIG. 2.2-14	1	130	
	8-74617-5	• DOOR INSTL, BLEED AIR DUCT ACCESS FOR NHA SEE FIG. 2.1-1	RF	35	
- 55	8-74617-9	• • DOOR, REPLACED BY NOT INTCHG WITH 8-74617-21	1	278	294
	8-74617-21	• • DOOR, REPLACES NOT INTCHG WITH 8-74617-9 ATTACHING PARTS	1	0	
	NAS334CPA6	• • SCREW (80205)	24	35	
		B AIRPLANES #35 THRU 129, 278 AND ON C AIRPLANES #70 THRU 129, 278 AND ON D AIRPLANES #35 THRU 277, 296 AND ON E AIRPLANES #35 THRU 277, 295 AND ON			
		*5 REMOVED BY TCTO 1F-106-1208 *6 ADDED BY TCTO 1F-106-1208			

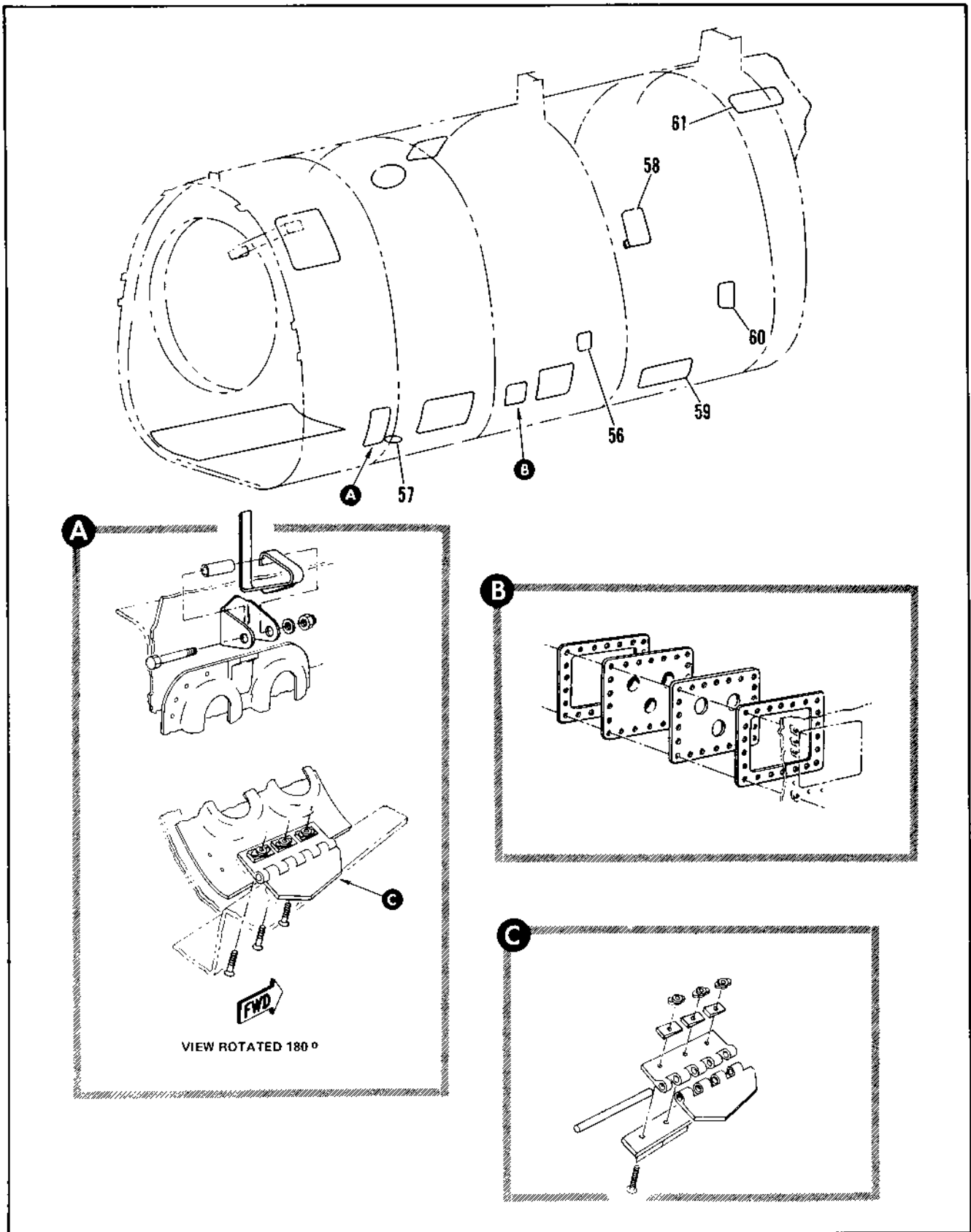

Figure 2.2-9. Fuselage Access Doors Sta 472 to 602 (Sheet 5 of 5)

FIGURE AND INDEX NUMBER	PART NUMBER	DESCRIPTION	UNITS PER ASSY.	USABLE ON CODE	
				FROM	TO
		1 2 3 4 5 6			
2.2-9-56	8-77628	• DOOR INSTL, FUEL SHUTOFF VALVE ACCESSORY LH SEE FIG. 2.2-14	RF		
- 57	8-77628-31 8-74627-3	• DOOR INSTL, PNEUMATIC STARTER FOR NHA SEE FIG. 2.3-14 • DOOR ASSEMBLY • DOOR INSTL, ELEVON CYLINDER ACCESS STA 569 TO 577 FOR NHA SEE FIG. 2.1-1	RF 1 RF	278 278 35	295 295
- 58	69F34535-1 69F34535-2 NAS333CPA5-5 NAS333CPA4-5	• DOOR, LH (98750) • DOOR, RH (98750) ATTACHING PARTS • SCREW (80205) • SCREW (80205) ----X----	1 1 7 41	35 35 35 35	
	8-74628-3	• DOOR INSTL, ELEVON CONTROL VALVE ACCESS FOR NHA SEE FIG. 2.1-1	RF	35	
- 59	8-74628-13 8-74628-25	• DOOR, LH REPLACED BY NOT INTCHG WITH 8-74628-25 • DOOR, LH REPLACES NOT INTCHG WITH 8-74628-13 REPLACED BY SUITABLE SUB 8-74628-27	1 1	278 F	294
	8-74628-27	• DOOR, LH REPLACES SUITABLE SUB FOR 8-74628-25	1	90	277
	8-74628-14 8-74628-26	• DOOR, RH REPLACED BY NOT INTCHG WITH 8-74628-26 • DOOR, RH REPLACES NOT INTCHG WITH 8-74628-14 REPLACED BY SUITABLE SUB 8-74628-28	1 1	278 F	294
	8-74628-28	• DOOR, RH REPLACES SUITABLE SUB FOR 8-74628-26 ATTACHING PARTS	1	90	277
	NAS333CPA4-5 NAS334CP5	• SCREW (80205) • SCREW (80205) ----X----	52 38	35 35	
	8-74625-3	• DOOR INSTL, ELEVON STA 593 TO 602 FOR NHA SEE FIG. 2.1-1	RF	35	
- 60	8-74625-7 8-74625-8 NAS333CPA1	• DOOR, LH • DOOR, RH ATTACHING PARTS • SCREW (80205) ----X----	1 1 52	35 35 35	
	8-74607-3	• DOOR INSTL, AFT ENGINE MOUNT ACCESS STA 602 FOR NHA SEE FIG. 2.1-1	RF	35	
- 61	8-74607-7 8-74607-8 NAS334CPA5	• DOOR, AFT ENGINE MOUNT ACCESS LH • DOOR, AFT ENGINE MOUNT ACCESS RH ATTACHING PARTS • SCREW (80205)	1 1 28	35 35 35	
		F AIRPLANES #35 THRU 89, 295 AND ON			

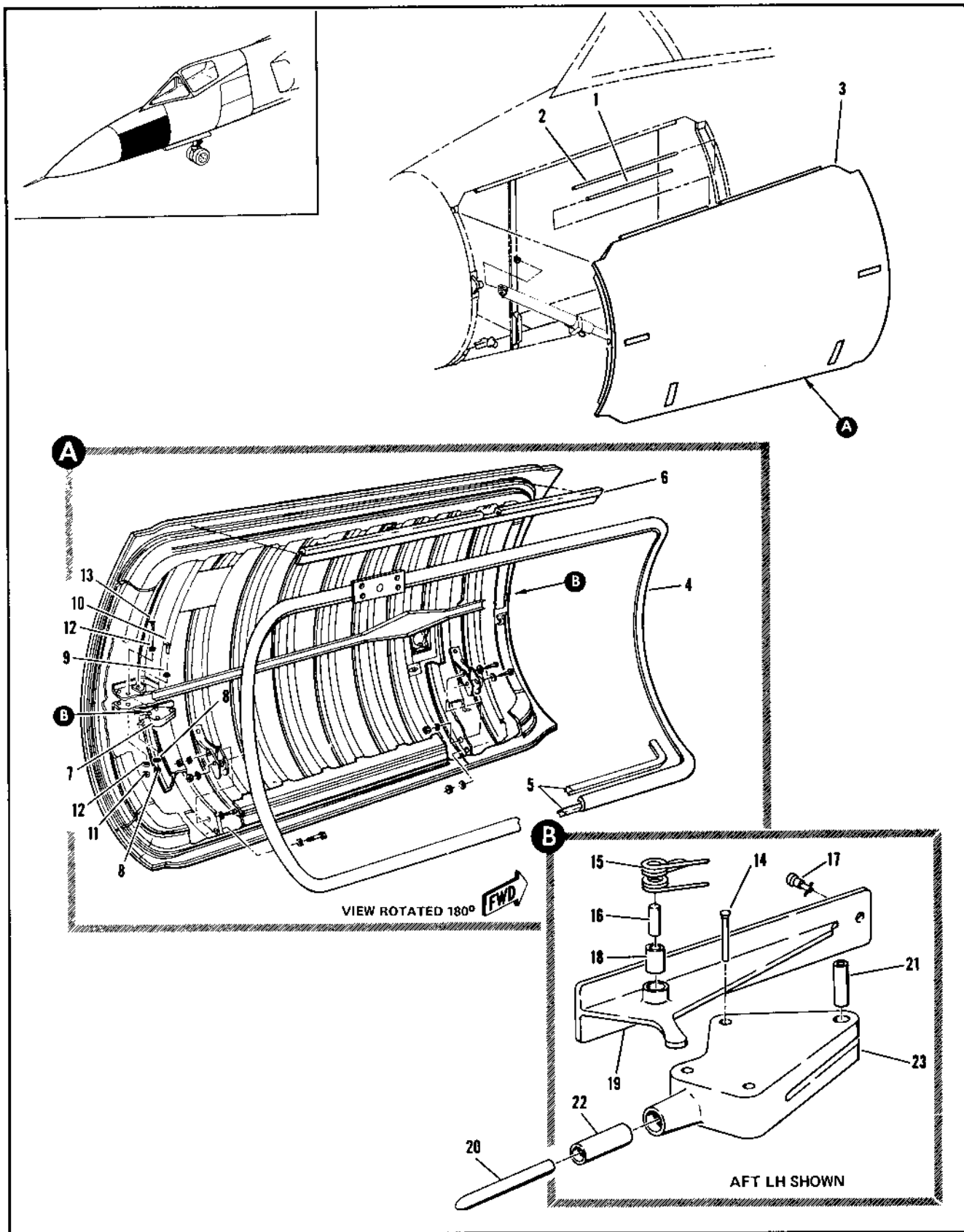

Figure 2.2-10. Fwd Radar Compartment Door Installation (Sheet 1 of 6)

FIGURE AND INDEX NUMBER	PART NUMBER	DESCRIPTION	UNITS PER ASSY.	USABLE ON CODE	
				FROM	TO
		1 2 3 4 5 6			
2.2-10	8-74600-1	DOOR INSTALLATION, FWD RADAR COMPARTMENT LH MODIFIED BY 8-77653 FOR NHA SEE FIG. 2.3-5	RF	35	
	8-74600-2	DOOR INSTALLATION, FWD RADAR COMPARTMENT RH MODIFIED BY 8-77653 FOR NHA SEE FIG. 2.3-5	RF	35	
- 1	8-74600-103	• PIN, HINGE FWD	1	35	
- 2	8-74600-101	• PIN, HINGE AFT	1	35	
- 3	8-74600-263	• DOOR ASSY, FWD RADAR COMPARTMENT LH REPLACED BY SUITABLE SUB 8-74600-295 OR 8-74600-339	1	35	48
	8-74600-295	• DOOR ASSY, FWD RADAR COMPARTMENT LH REPLACES SUITABLE SUB FOR 8-74600-263 REPLACED BY SUITABLE SUB 8-74600-339	1	49	159
	8-74600-339	• DOOR ASSY, FWD RADAR COMPARTMENT LH REPLACES SUITABLE SUB FOR 8-74600-263 OR 8-74600-295	1	160	
	8-74600-220	• DOOR ASSY, FWD RADAR COMPARTMENT RH WITH 0.125 EXCESS MATERIAL ON PERIMETER FOR TRIM ON INSTALLATION REPLACED BY SUITABLE SUB 8-74600-340	1	35	159
	8-74600-340	• DOOR ASSY, FWD RADAR COMPARTMENT RH REPLACES SUITABLE SUB FOR 8-74600-220	1	160	
- 4	8-74937-13	• • SEAL, DOOR DIAPHRAGM REPLACED BY SUITABLE SUB 8-74937-17	1	35	129
	8-74937-17	• • SEAL, DOOR DIAPHRAGM REPLACES SUITABLE SUB FOR 8-74937-13	1	130	
- 5	340-8210303-9	• • INSERT, EXTRUSION	PF	35	
- 6	8-74639-9	• • HINGE HALF LH	1	35	
	8-74639-10	• • HINGE, HALF RH	1	35	
- 7	8-74690	• • LATCH ASSY, RADAR DOOR UPPER ATTACHING PARTS	2	35	
- 8	NAS679A4	• • NUT, <80205> 96-37545-003	2	35	
- 9	AN960-416	• • WASHER (88044)	4	35	
- 10	NAS464P4A20	• • BOLT (80205)	2	35	
- 11	NAS679A3	• • NUT (80205)	4	35	
- 12	AN960-10	• • WASHER (88044)	8	35	
- 13	NAS464P3A20	• • BOLT (80205) -----X-----	4	35	
- 14	MS20426B6	• • • RIVET (96906)	1	35	
- 15	8-74970	• • • SPRING	1	35	
- 16	8-74698-11	• • • BUSHING, LATCH BOSS	1	35	
	8-74682	• • • HANDLE ASSEMBLY	1	35	
	8-74694	• • • HANDLE ASSY, ALT INTCHG WITH 8-74682	RF	35	
- 17	40S51A100-6	• • • STUD ASSY, <71286> 98-58003-003	1	35	
- 18	91-27006-004	• • • BUSHING	1	35	
- 19	8-74682-7	• • • HANDLE	1	35	
	8-74694-7	• • • HANDLE, USE WITH 8-74694	RF	35	
- 20	8-74693	• • • PIN ASSY, BRAZED	1	35	
- 21	8-74969	• • • BUSHING, LATCH HOUSING	1	35	
	8-74692-1	• • • HOUSING ASSY, RADAR DOOR LATCH	1	35	
- 22	8-74698-9	• • • BUSHING, LATCH BOSS	1	35	
- 23	8-74692-7	• • • HOUSING	1	35	

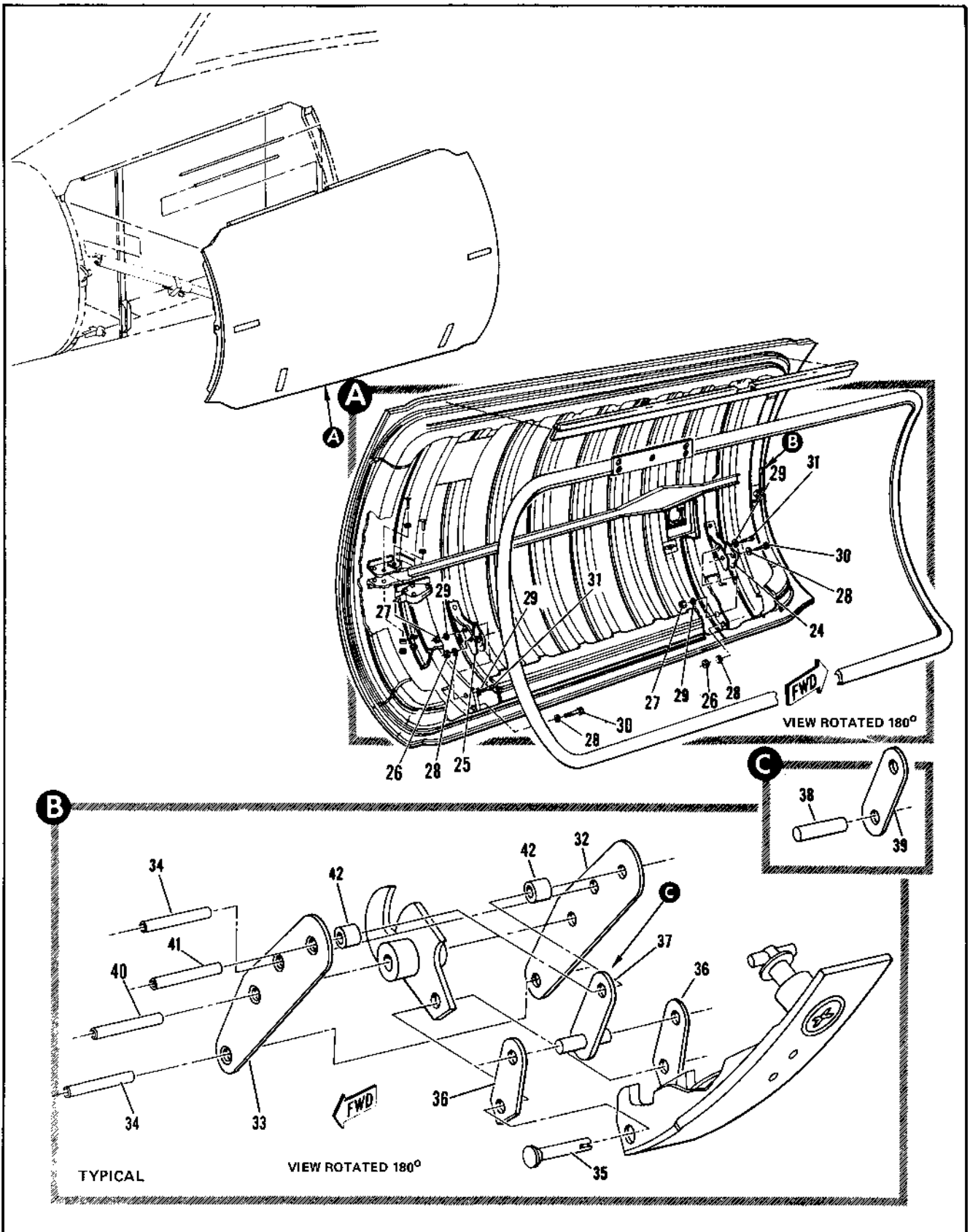

Figure 2.2-10. Fwd Radar Compartment Door Installation (Sheet 2 of 6)

FIGURE AND INDEX NUMBER	PART NUMBER	DESCRIPTION	UNITS PER ASSY.	USABLE ON CODE	
				FROM	TO
		1 2 3 4 5 6			
2.2-10-24	8-74691-1	• • LATCH ASSY, FWD RADAR DOOR LOWER FWD LH REPLACED BY SUITABLE SUB 8-74691-11	1	35	159
	8-74691-11	• • LATCH ASSY, FWD RADAR DOOR LOWER FWD LH REPLACES SUITABLE SUB FOR 8-74691-1	1	160	
- 25	8-74691-3	• • LATCH ASSY, FWD RADAR DOOR LOWER AFT LH REPLACED BY SUITABLE SUB 8-74691-13	1	35	159
	8-74691-13	• • LATCH ASSY, FWD RADAR DOOR LOWER AFT LH REPLACES SUITABLE SUB FOR 8-74691-3	1	160	
	8-74691-2	• • LATCH ASSY, FWD RADAR DOOR LOWER FWD RH REPLACED BY SUITABLE SUB 8-74691-12	1	35	159
	8-74691-12	• • LATCH ASSY, FWD RADAR DOOR LOWER FWD RH REPLACES SUITABLE SUB FOR 8-74691-2	1	160	
	8-74691-4	• • LATCH ASSY, FWD RADAR DOOR LOWER AFT RH REPLACED BY SUITABLE SUB 8-74691-14	1	35	159
	8-74691-14	• • LATCH ASSY, FWD RADAR DOOR LOWER AFT RH REPLACES SUITABLE SUB FOR 8-74691-4 ATTACHING PARTS	1	160	
- 26	NAS679A3	• • NUT (80205)	2	35	
- 27	NAS679A3	• • NUT (80205)	2	35	159
	NAS679A4	• • NUT (80205)	2	160	
- 28	AN960-10	• • WASHER (88044)	4	35	
- 29	AN960-10	• • WASHER (88044)	4	35	159
	AN960-416	• • WASHER (88044)	4	160	
- 30	NAS464P3A20	• • BOLT (80205)	2	35	
- 31	NAS464P3A20	• • BOLT (80205)	2	35	159
	NAS464P4A20	• • BOLT (80205)	2	160	
		-----X-----			
- 32	8-74695-11	• • • LINK, LOWER LATCH RADAR DOOR REPLACED BY NOT INTCHG WITH 8-74695-29	1	35	159
	8-74695-29	• • • LINK, LOWER LATCH RADAR DOOR REPLACES NOT INTCHG WITH 8-74695-11	1	160	
- 33	8-74695-12	• • • LINK, LOWER LATCH RADAR DOOR REPLACED BY NOT INTCHG WITH 8-74695-30	1	35	159
	8-74695-30	• • • LINK, LOWER LATCH RADAR DOOR REPLACES NOT INTCHG WITH 8-74695-12	1	160	
- 34	8-74695-13	• • • SPACER, LOWER LATCH RADAR DOOR	2	35	
- 35	97-67001-004	• • • RIVET	1	35	
- 36	8-74695-7	• • • LINK, LOWER LATCH RADAR DOOR	2	35	
- 37	8-74695-19	• • • LINK ASSY, LOWER LATCH RADAR DOOR REPLACED BY NOT INTCHG WITH 8-74695-33	1	35	159
	8-74695-33	• • • LINK ASSY, LOWER LATCH RADAR DOOR REPLACES NOT INTCHG WITH 8-74695-19	1	160	
- 38	8-74695-21	• • • PIN	1	35	
- 39	8-74695-9	• • • LINK	1	35	159
	8-74695-31	• • • LINK	1	160	
- 40	8-74695-15	• • • SPACER, LINK LOWER LATCH RADAR DOOR REPLACED BY SUITABLE SUB 8-74695-25	1	35	
- 41	8-74695-15	• • • SPACER, LINK LOWER LATCH RADAR DOOR REPLACES NOT INTCHG WITH 8-74695-25	1	35	159
	8-74695-25	• • • SPACER, LINK LOWER LATCH RADAR DOOR REPLACES NOT INTCHG WITH 8-74695-15	1	160	
- 42	8-74695-17	• • • SPACER, LINK LOWER LATCH RADAR DOOR REPLACED BY NOT INTCHG WITH 8-74695-27	2	35	159
	8-74695-27	• • • SPACER, LINK LOWER LATCH RADAR DOOR REPLACES NOT INTCHG WITH 8-74695-17	2	160	

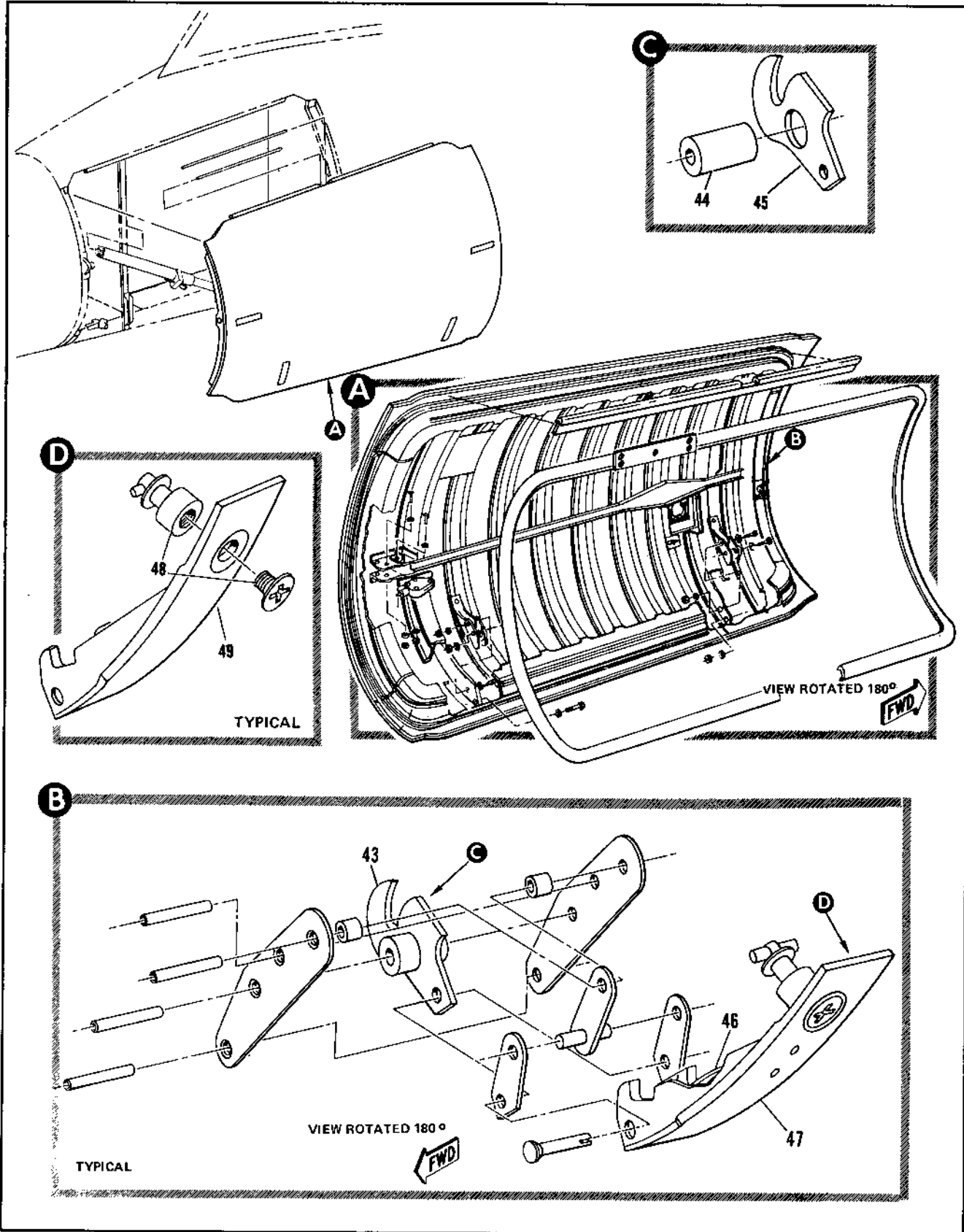

Figure 2.2-10. Fwd Radar Compartment Door Installation (Sheet 3 of 6)

FIGURE AND INDEX NUMBER	PART NUMBER	DESCRIPTION	UNITS PER ASSY.	USABLE ON CODE	
				FROM	TO
		1 2 3 4 5 6			
2.2-10-43	8-74697	. . . HOOK ASSY, LOWER LATCH RADAR DOOR	1	35	
- 44	8-74697-9	. . . HUB	1	35	
- 45	8-74697-7	. . . HOOK	1	35	
	8-74691-7	. . . LATCH ASSY, RADAR DOOR LOWER FWD LH	1	35	
	8-74691-8	. . . LATCH ASSY, RADAR DOOR LOWER FWD RH	1	35	
	8-74691-9	. . . LATCH ASSY, RADAR DOOR LOWER AFT LH	1	35	
	8-74691-10	. . . LATCH ASSY, RADAR DOOR LOWER AFT RH	1	35	
- 46	8-77618	. . . SPRING, RADAR DOOR LATCH LOWER	1	35	
- 47	8-74968-1	. . . HANDLE ASSY, RADAR DOOR LATCH LOWER FWD LH	1	35	
	8-74696-1	. . . HANDLE ASSY, RADAR DOOR LATCH LOWER FWD LH ALT INTCHG WITH 8-74968-1	RF	35	
	8-74968-3	. . . HANDLE ASSY, RADAR DOOR LATCH LOWER AFT LH	1	35	
	8-74696-3	. . . HANDLE ASSY, RADAR DOOR LATCH LOWER AFT LH ALT INTCHG WITH 8-74968-3	RF	35	
	8-74968-2	. . . HANDLE ASSY, RADAR DOOR LATCH LOWER FWD RH	1	35	
	8-74696-2	. . . HANDLE ASSY, RADAR DOOR LATCH LOWER FWD RH ALT INTCHG WITH 8-74968-2	RF	35	
	8-74968-4	. . . HANDLE ASSY, RADAR DOOR LATCH LOWER AFT RH	1	35	
	8-74696-4	. . . HANDLE ASSY, RADAR DOOR LATCH LOWER AFT RH ALT INTCHG WITH 8-74968-4	RF	35	
- 48	40S51A100-5 STUD ASSY, <71286> 98-58003-002	1	35	
- 49	8-74968-7	. . . HANDLE, LOWER FWD LH	1	35	
	8-74968-9	. . . HANDLE, LOWER AFT LH	1	35	
	8-74968-8	. . . HANDLE, LOWER FWD RH	1	35	
	8-74968-10	. . . HANDLE, LOWER AFT RH	1	35	

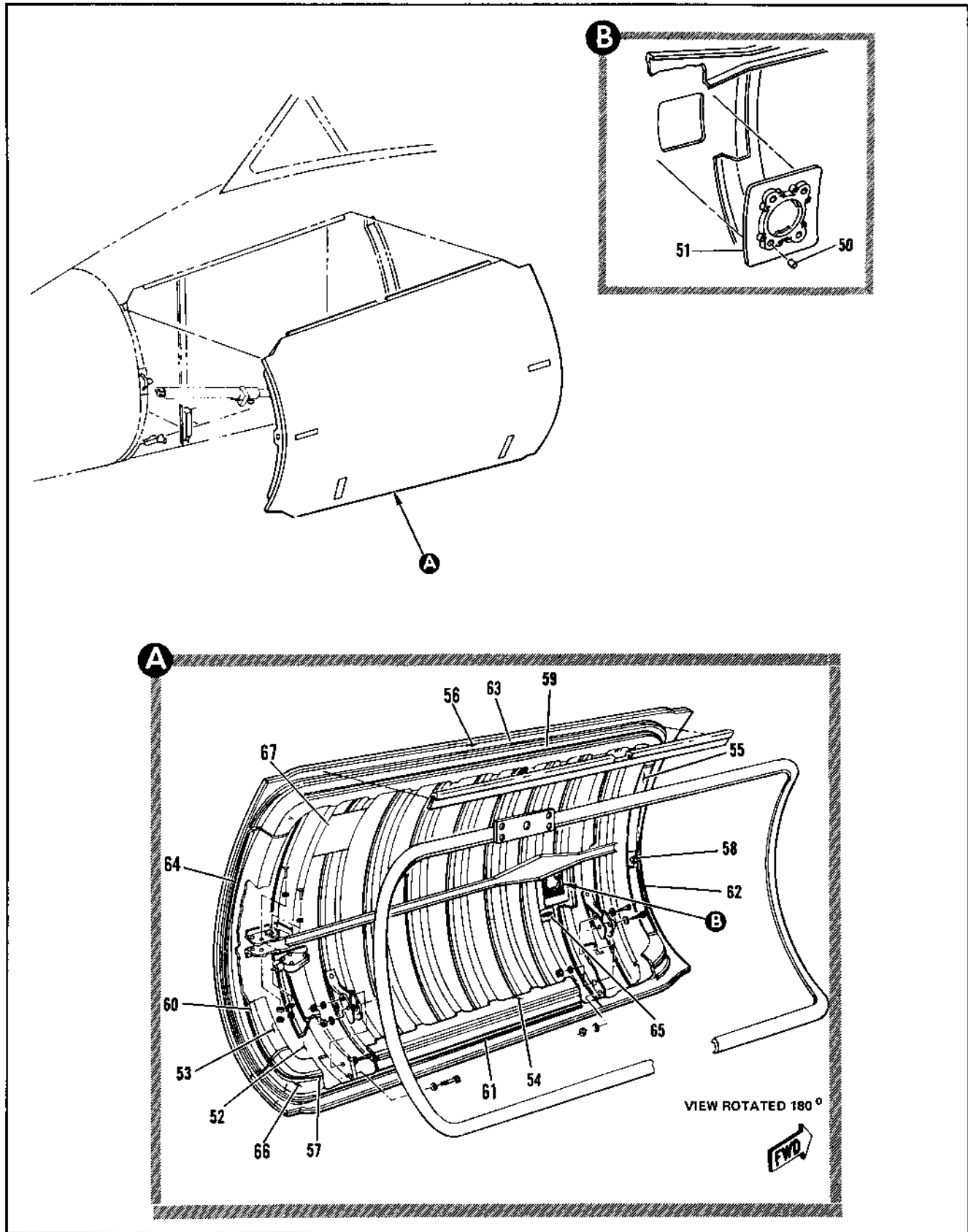

Figure 2.2-10. Fwd Radar Compartment Door Installation (Sheet 4 of 6)

FIGURE AND INDEX NUMBER	PART NUMBER	DESCRIPTION	UNITS PER ASSY.	USABLE ON CODE	
				FROM	TO
		1 2 3 4 5 6			
2.2-10	8-38085-3	. . SUPPORT ASSY, ANGLE OF ATTACK TRANSMITTER LH	1	35	
- 50	3591-4CNX1/2	. . . INSERT, <91767> 95-03003-008	8	35	
	3591-4CNX3/8	. . . INSERT, <91767>95-03003-007	4	35	
- 51	8-38085-11	. . . SUPPORT, ALTERED FROM 8-38085-9	1	35	
	8-38085-9	. . . SUPPORT	RF	35	
- 52	8-74600-241	. . SKIN, LH REPLACED BY SUITABLE SUB 8-74600-285	1	35	48
	8-74600-285	. . SKIN, LH REPLACES SUITABLE SUB FOR 8-74600-241	1	49	
	8-74600-8	. . SKIN, RH	1	35	
- 53	8-74600-9	. . FRAME FWD RADAR COMPARTMENT LH	1	35	
	8-74600-10	. . FRAME, FWD RADAR COMPARTMENT RH	1	35	
- 54	8-74600-11	. . FRAME, FWD RADAR COMPARTMENT LH	1	35	
	8-74600-12	. . FRAME, FWD RADAR COMPARTMENT RH	1	35	
- 55	8-74600-13	. . FRAME, FWD RADAR COMPARTMENT LH	1	35	
	8-74600-14	. . FRAME, FWD RADAR COMPARTMENT RH	1	35	
- 56	8-74600-15	. . FRAME, FWD RADAR COMPARTMENT LH	1	35	
	8-74600-16	. . FRAME, FWD RADAR COMPARTMENT RH	1	35	
- 57	8-74600-181	. . RETAINER, SEAL LH	1	35	
	8-74600-182	. . RETAINER, SEAL RH	1	35	
- 58	8-74600-49	. . RETAINER, SEAL LH	1	35	
	8-74600-50	. . RETAINER, SEAL RH	1	35	
- 59	8-74600-175	. . RETAINER, SEAL LH	1	35	
	8-74600-176	. . RETAINER, SEAL RH	1	35	
- 60	8-74600-53	. . RETAINER, SEAL LH	1	35	
	8-74600-54	. . RETAINER, SEAL RH	1	35	
- 61	8-74600-179	. . RETAINER, SEAL LH	1	35	
	8-74600-180	. . RETAINER, SEAL RH	1	35	
- 62	8-74600-57	. . RETAINER, SEAL LH	1	35	
	8-74600-58	. . RETAINER, SEAL RH	1	35	
- 63	8-74600-177	. . RETAINER, SEAL LH	1	35	
	8-74600-178	. . RETAINER, SEAL RH	1	35	
- 64	8-74600-61	. . RETAINER, SEAL LH	1	35	
	8-74600-62	. . RETAINER, SEAL RH	1	35	
- 65	2035	. . RECEPTACLE QUICK RELEASE PIN SPRING LOADED LH <84256> 97-30800-C03	2	35	
- 66	8-74600-63	. . DOUBLER, LH	1	35	
	8-74600-64	. . DOUBLER RH	1	35	
- 67	459679	. . DECAL, 464096 CHECKOUT LIST U	1	35	

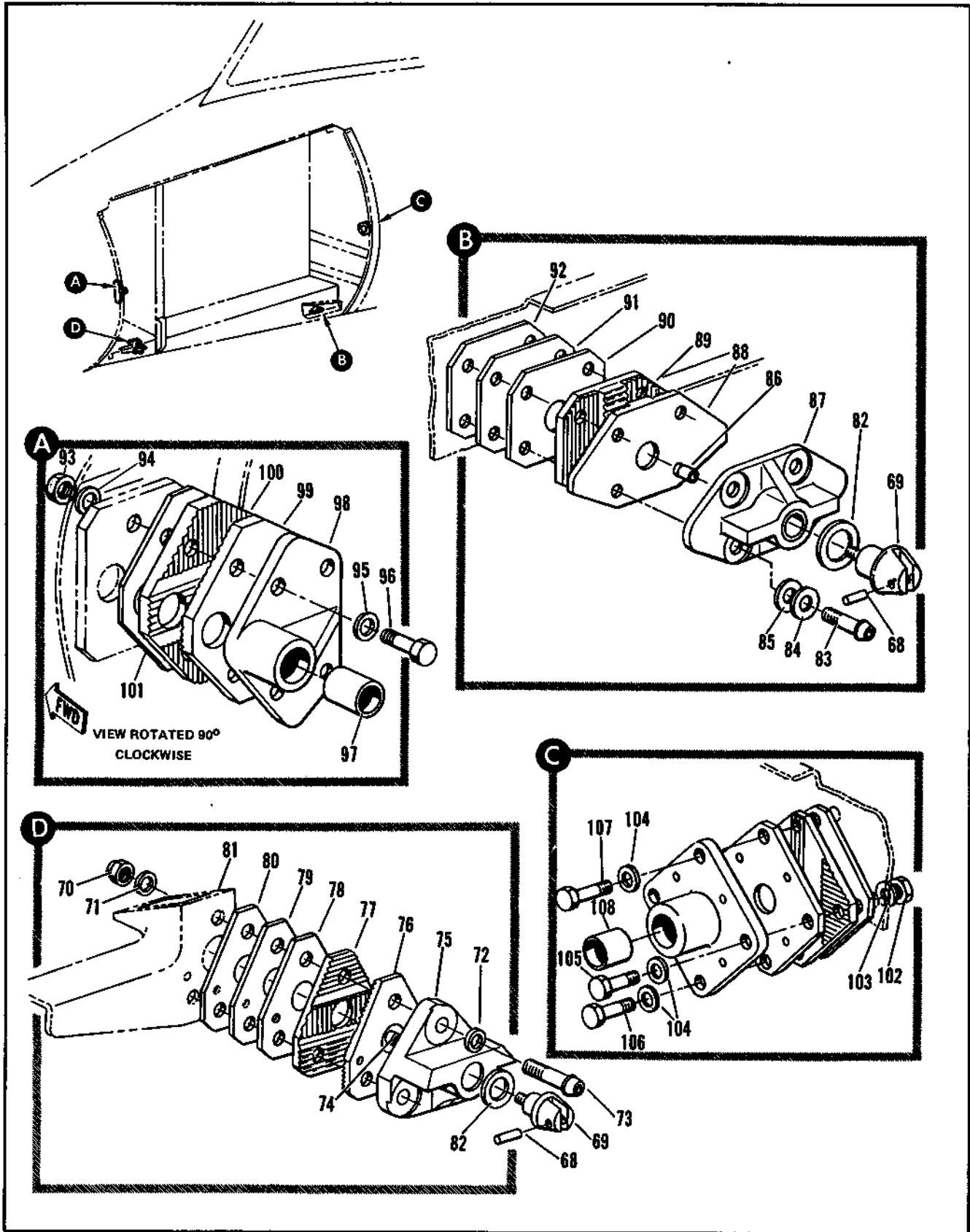

Figure 2.2-10. Fwd Radar Compartment Door Installation (Sheet 5 of 6)

FIGURE AND INDEX NUMBER	PART NUMBER	DESCRIPTION	UNITS PER ASSY.	USABLE ON CODE	
				FROM	TO
		1 2 3 4 5 6			
2.2-10	8-74699-1	• PIN ASSY, RADAR DOOR LOWER LATCH	2	35	
- 68	8-74699-13	• . PIN	1	35	
- 69	8-74699-11	• . PIN	1	35	
	8-74683-3	• BOSS ASSY, RADAR DOOR LOWER LATCH FWD ATTACHING PARTS	1	35	
- 70	42FW428	• NUT, <56878> 96-37510-001	1	35	
- 71	MS20002C4	• WASHER <96906>	3	35	
- 72	MS20002-4	• WASHER (96906)	1	35	
- 73	MS20004-16	• BOLT (96906)	3	35	
		-----X-----			
- 74	3591-4CNX3/8	• . INSERT, <91767> 95-03003-007	1	35	
- 75	8-74683-9	• . BOSS	1	35	
- 76	8-74685-13	• PLATE, ADJUSTMENT FWD RADAR DOOR	1	35	
- 77	8-74685-11	• PLATE, ADJUSTMENT FWD RADAR DOOR	1	35	
- 78	8-74600-117	• SHIM	AR	35	
- 79	8-74600-119	• SHIM	AR	35	
- 80	8-74600-159	• SHIM	AR	35	
- 81	8-74684-11	• ADAPTER, LATCH FWD RADAR DOOR LH	1	35	
	8-74684-12	• ADAPTER, LATCH FWD RADAR DOOR RH	1	35	
- 82	8-74600-213	• SHIM	1	35	
	8-74686-1	• BOSS ASSY, RADAR DOOR LOWER LATCH AFT ATTACHING PARTS	1	35	
- 83	MS20004-14	• BOLT (96906)	4	35	
- 84	MS20002C4	• WASHER (96906)	4	35	
- 85	MS20002-4	• WASHER (96906)	4	35	
		-----X-----			
- 86	3591-4CNX3/8	• . INSERT <91767> 95-03003-007	1	35	
- 87	8-74686-7	• . BOSS	1	35	
- 88	8-74687-9	• PLATE, ADJUSTMENT FWD RADAR DOOR	1	35	
- 89	8-74687-7	• PLATE, ADJUSTMENT FWD RADAR DOOR	1	35	
- 90	8-74600-161	• SHIM	AR	35	
- 91	8-74600-81	• SHIM	AR	35	
- 92	8-74600-83	• SHIM	AR	35	
	8-74681-1	• BOSS ASSY, RADAR DOOR UPPER LATCH FWD ATTACHING PARTS	1	35	
- 93	NAS680A3	• NUT (80205)	4	35	
- 94	AN960-10	• WASHER (88044)	4	35	
- 95	99-51505-015	• WASHER	4	35	
- 96	NAS464P3A10	• BOLT (80205)	4	35	
		-----X-----			
- 97	8-74698-7	• . BUSHING, LATCH BOSS	1	35	
- 98	8-74681-7	• . BOSS	1	35	
- 99	8-74679-9	• PLATE, ADJUSTMENT FWD RADAR DOOR	1	35	
-100	8-74679-7	• PLATE, ADJUSTMENT FWD RADAR DOOR	1	35	
-101	8-74600-223	• SHIM	AR	35	
	8-74688-1	• BOSS ASSY, LATCH AFT RADAR DOOR ATTACHING PARTS	1	35	
-102	NAS680A3	• NUT (80205)	2	35	
-103	AN960-10	• WASHER (88044)	4	35	
-104	99-51505-015	• WASHER	4	35	
-105	NAS464P3A12	• BOLT (80205)	2	35	
-106	NAS464P3A13	• BOLT (80205)	1	35	
-107	NAS464P3A14	• BOLT (80205)	1	35	
		-----X-----			
-108	8-74698-7	• . BUSHING	1	35	

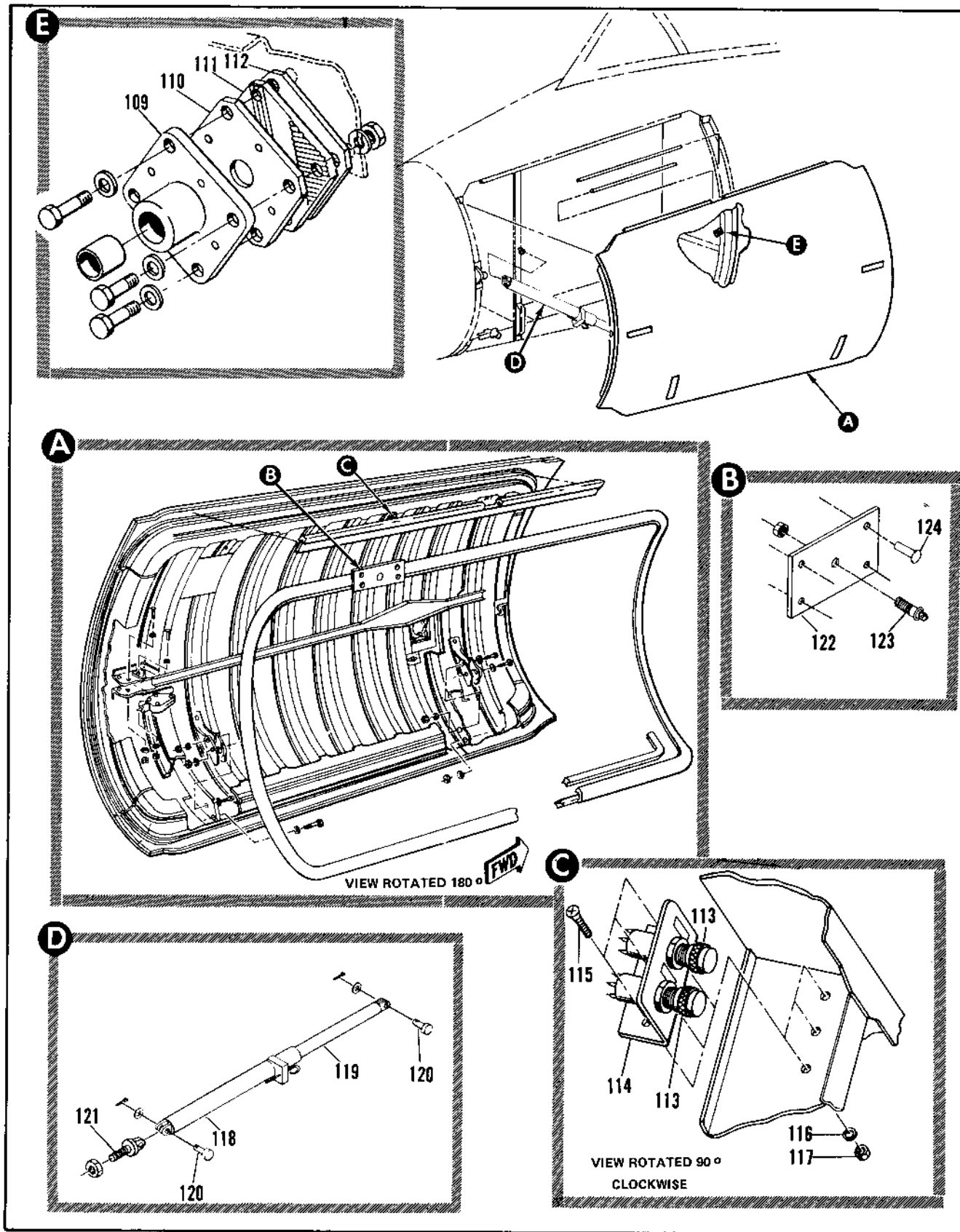

Figure 2.2-10. Fwd Radar Compartment Door Installation (Sheet 6 of 6)

FIGURE AND INDEX NUMBER	PART NUMBER	DESCRIPTION 1 2 3 4 5 6	UNITS PER ASSY.	USABLE ON CODE	
				FROM	TO
2.2-10-109	8-74688-7	• • BOSS	1	35	
-110	8-74689-9	• PLATE, ADJUSTMENT FWD RADAR DOOR	1	35	
-111	8-74689-7	• PLATE, ADJUSTMENT FWD RADAR DOOR	1	35	
-112	8-74680-225	• • SHIM	AR	35	
-113	MS25331-8	• LIGHT ASSY (96906)	2	35	
-114	64C33234-7	• • BRACKET (98750) ATTACHING PARTS	1	35	
-115	MS51958-64	• • SCREW (96906)	3	35	
-116	AN96C-10	• • WASHER (88044)	3	35	
-117	MS21044N3	• • NUT (96906) -----X-----	3	35	
-118	68F37569-3	• • SLEEVE ASSY, DOOR HOLD OPEN, LH AND RH ELCT COMP, FWD (98750)	2	35	
	58A46236	• • RING (98750)	1		
	68C37566-7	• • HOUSING (98750)	1		
	68C37567-7	• • SPRING (98750)	1		
	68C37568-7	• • LOCK PIN (98750)	1		
	66F38713-11	• • PLATE (98750)	2		
	66F38713-7	• • SLEEVE (98750)	1		
-119	66D38719-3	• • SUPPORT ROD, DOOR HOLD OPEN, LH AND RH ELCT COMP FWD (98750)	1	35	
	66D38719-11	• • PLATE (98750)	2		
	66D38719-7	• • TUBE (98750)	1		
-120	MS20392-2C17	• • PIN (96906)	2	35	
	AN960C-10	• • WASHER (88044)	2		
	MS24665-208	• • PIN, COTTER (96906)	2		
-121	AN42B-3	• • BOLT, EYE (88044)	1	35	
	MS21044N3	• • NUT (96906)	1		
-122	66C38716-7	• • CHANNEL (98750), DOOR LH AND RH ELCT COMP, FWD	1	35	
-123	AN42B-3	• • BOLT, EYE (88044)	1	35	
	MS21044N3	• • NUT (96906)	1		
-124	MS20470AD4-5	• • RIVET (96906)	4	35	

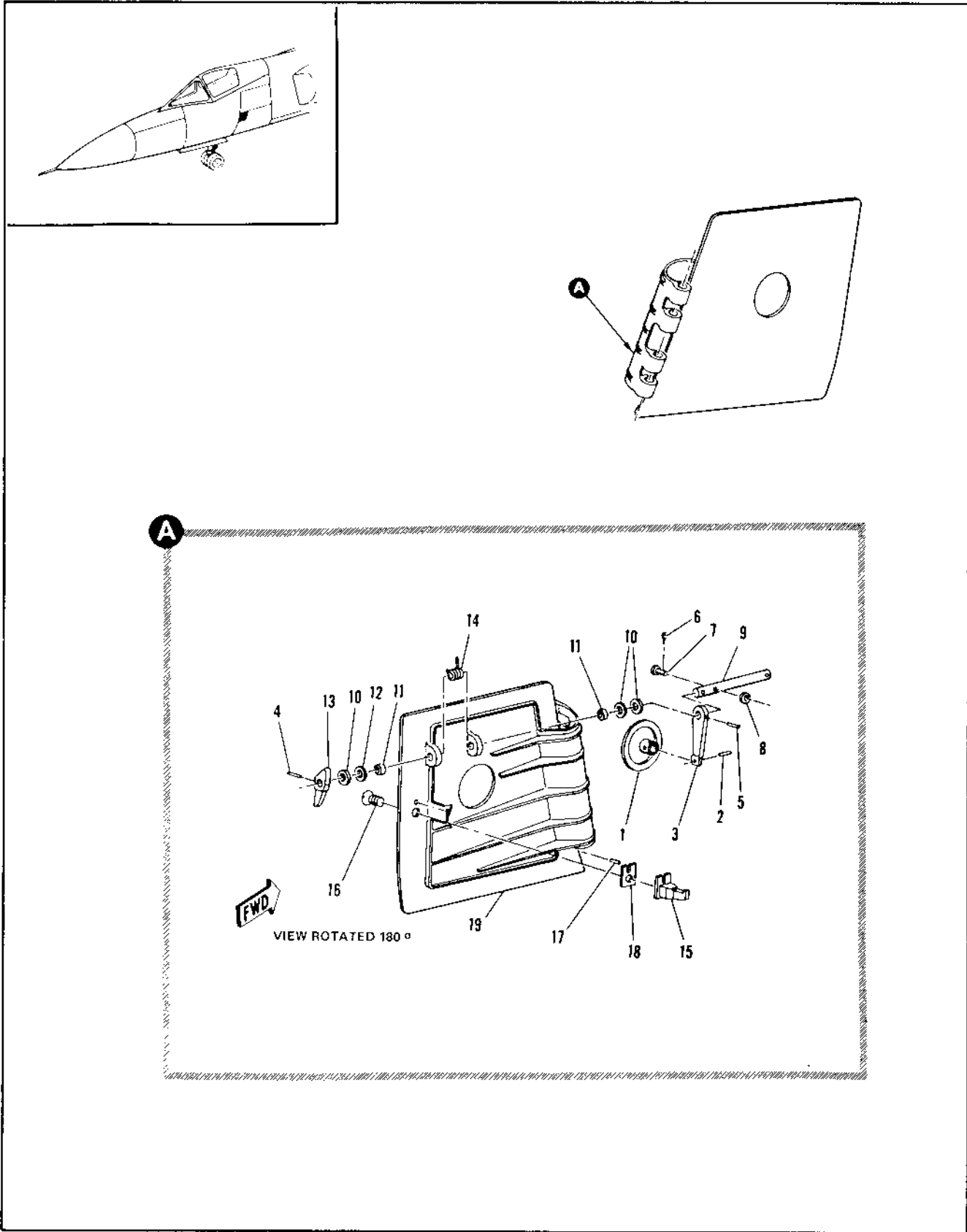

Figure 2.2-11. External Power Access Door Assembly Sta 171 to 175

FIGURE AND INDEX NUMBER	PART NUMBER	DESCRIPTION 1 2 3 4 5 6	UNITS PER ASSY.	USABLE ON CODE	
				FROM	TO
2.2-11	8-44719	DOOR ASSEMBLY, EXTERNAL POWER ACCESS STA 171 TO 175 REPLACED BY SUITABLE SUB 8-44719-9 FOR NHA SEE FIG. 2.2-3	RF	35	129
	8-44719-1	DOOR ASSEMBLY, EXTERNAL POWER ACCESS STA 171 TO 175 REPLACES SUITABLE SUB FOR 8-44719 FOR NHA SEE FIG. 2.2-3	RF	130	
- 1	8-45026-7 8-44741	• BUTTON, LATCH • BUTTON, LATCH WITH 0.128 TO 0.133 DIA HOLES IN LINE ALT INTCHG WITH 8-45026-7 ATTACHING PARTS	1 RF	35 35	
- 2	MS16555-626	• PIN (96906) ----X----	1	35	
- 3	8-45025-7 8-44740	• ARM, BUTTON SUPPORT LATCH DOOR • ARM, BUTTON SUPPORT LATCH DOOR WITH 0.128 TO 0.133 DIA HOLES IN LINE ALT INTCHG WITH 8-45025-7	1 RF	35 35	
- 4	MS16555-620	• PIN (96906)	1	35	
- 5	MS16555-620	• PIN (96906)	1	35	
- 6	MS24665-5	• PIN (96906)	1	35	
- 7	8-44746	• PIN, ATTACHMENT TORSION SPRING	1	35	
- 8	AN960C2	• WASHER (88044)	1	35	
- 9	8-44738	• SHAFT, LATCH DOOR	1	35	
- 10	NAS549-416	• WASHER (80205)	AR	35	
- 11	8-44737	• BUSHING, LATCH DOOR	2	35	
- 12	NAS549-L416	• WASHER (80205)	AR	35	
- 13	8-45024-7 8-44739	• ARM, LATCH RELEASE • ARM, LATCH RELEASE ALT INTCHG WITH 8-45024-7	1 RF	35 35	
- 14	8-44727	• SPRING, HELICAL TORSION PRELOAD EXTERNAL POWER ACCESS DOOR LATCH	1	35	
- 15	8-45027 8-44742	• LINK, LATCH DOOR • LINK, LATCH DOOR ALT INTCHG WITH 8-45027 ATTACHING PARTS	1 RF	35 35	
- 16	MS24694-95	• SCREW (96906) ----X----	1	35	
- 17	8-44748	• PIN, GUIDE LINK EXTERNAL POWER DOOR LATCH	1	35	
- 18	8-44744	• SHIM, LATCH EXTERNAL POWER DOOR	1	35	
- 19	8-74670-7 8-74670-9	• DOOR, EXTERNAL POWER ACCESS • DOOR, EXTERNAL POWER ACCESS	1 1	35 130	129

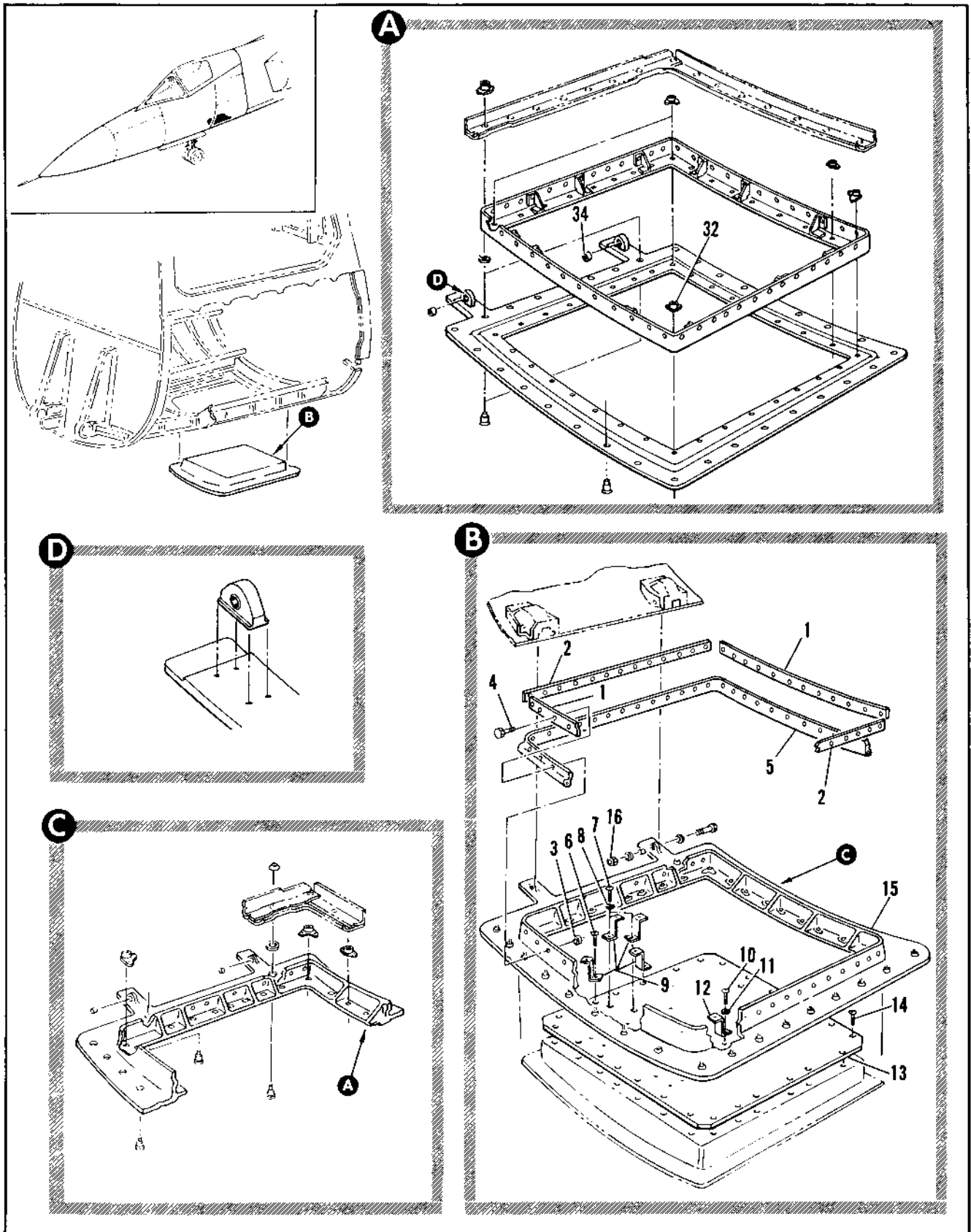

Figure 2.2-12. Midbay Electronic Compartment Access Door Assembly (Sheet 1 of 2)

FIGURE AND INDEX NUMBER	PART NUMBER	DESCRIPTION	UNITS PER ASSY.	USABLE ON CODE	
				FROM	TO
		1 2 3 4 5 6			
2.2-12	8-74611-805	DOOR ASSEMBLY, MIDBAY ELECTRONIC COMPARTMENT ACCESS FOR NHA SEE FIG. 2.3-3	RF	35	47
	8-74611-807	DOOR ASSEMBLY, MIDBAY ELECTRONIC COMPARTMENT ACCESS ALT INTCHG WITH 8-74611-805 FOR NHA SEE FIG. 2.3-3	RF	35	47
	8-61446-5	DOOR ASSEMBLY, MIDBAY ELECTRONIC COMPARTMENT ACCESS	RF	35	47
	8-74611-821	DOOR ASSEMBLY, MIDBAY ELECTRONIC COMPARTMENT ACCESS FOR NHA SEE FIG. 2.3-3	RF	48	48
	8-74611-823	DOOR ASSEMBLY, MIDBAY ELECTRONIC COMPARTMENT ACCESS ALT INTCHG WITH 8-74611-821 FOR NHA SEE FIG. 2.3-3	RF	48	48
	8-74611-809	DOOR ASSEMBLY, MIDBAY ELECTRONIC COMPARTMENT ACCESS FOR NHA SEE FIG. 2.3-3	RF	49	60
	8-74611-827	DOOR ASSEMBLY, MIDBAY ELECTRONIC COMPARTMENT ACCESS ALT INTCHG WITH 8-74611-809 FOR NHA SEE FIG. 2.3-3	RF	49	60
	8-74611-817	DOOR ASSEMBLY, MIDBAY ELECTRONIC COMPARTMENT ACCESS FOR NHA SEE FIG. 2.3-3	RF	61	89
	8-74611-819	DOOR ASSEMBLY, MIDBAY ELECTRONIC COMPARTMENT ACCESS FOR NHA SEE FIG. 2.3-3	RF	90	277
	8-74611-829	DOOR ASSEMBLY, MIDBAY ELECTRONIC COMPARTMENT ACCESS FOR NHA SEE FIG. 2.3-3	RF	278	
	8-74611-527	DOOR ASSY, MID BAY ELECTRONIC COMPARTMENT ACCESS SPARES FOR 8-74611-801, -803, -805, -807, -809, -827, -821, -823, AND -829, REPLACES AND INTERCHG WITH 8-74611-525			
	8-74611-525	DOOR ASSY, MID BAY ELECTRONIC COMPARTMENT ACCESS SPARES FOR 8-74611-817 AND -819 MAKE FROM 8-74611-819. REPLACED BY AND INTERCHG WITH 8-74611-527.			
- 1	8-74611-7	• STRAP	2	35	
- 2	8-74611-23	• STRAP	2	35	
		ATTACHING PARTS			
- 3	NAS679A08	• NUT, (80205) 96-37545-001	50	35	
- 4	MS35206-243	• SCREW (96906)	50	35	
		-----X-----			
- 5	8-74674	• SEAL ASSY, BONDED	1	35	60
	8-77625	• SEAL ASSY, BONDED ALT INTCHG WITH 8-74674	RF	35	60
	8-77625	• SEAL ASSY, BONDED	1	61	
- 6	NAS221-14	• SCREW (80205)	2	35	47
- 7	NAS221-6	• SCREW (80205)	2	35	47
- 8	MS35338-43	• WASHER, LOCK (96906)	2	35	47
- 9	8-36401-29	• CLIP	4	35	47
- 10	NAS221-6	• SCREW (80205)	1	35	47
- 11	MS35338-43	• WASHER, LOCK (96906)	1	35	47
- 12	8-36401-27	• CLIP	1	35	47
- 13	8-61446-9	• PANEL ASSEMBLY ATTACHING PARTS	1	35	47
		• SCREW (80205)	24	35	47
		-----X-----			
- 15	8-74612-1	• FRAME ASSEMBLY ATTACHING PARTS	1	35	60
- 16	AN320-4	• NUT (88044)	2	35	60

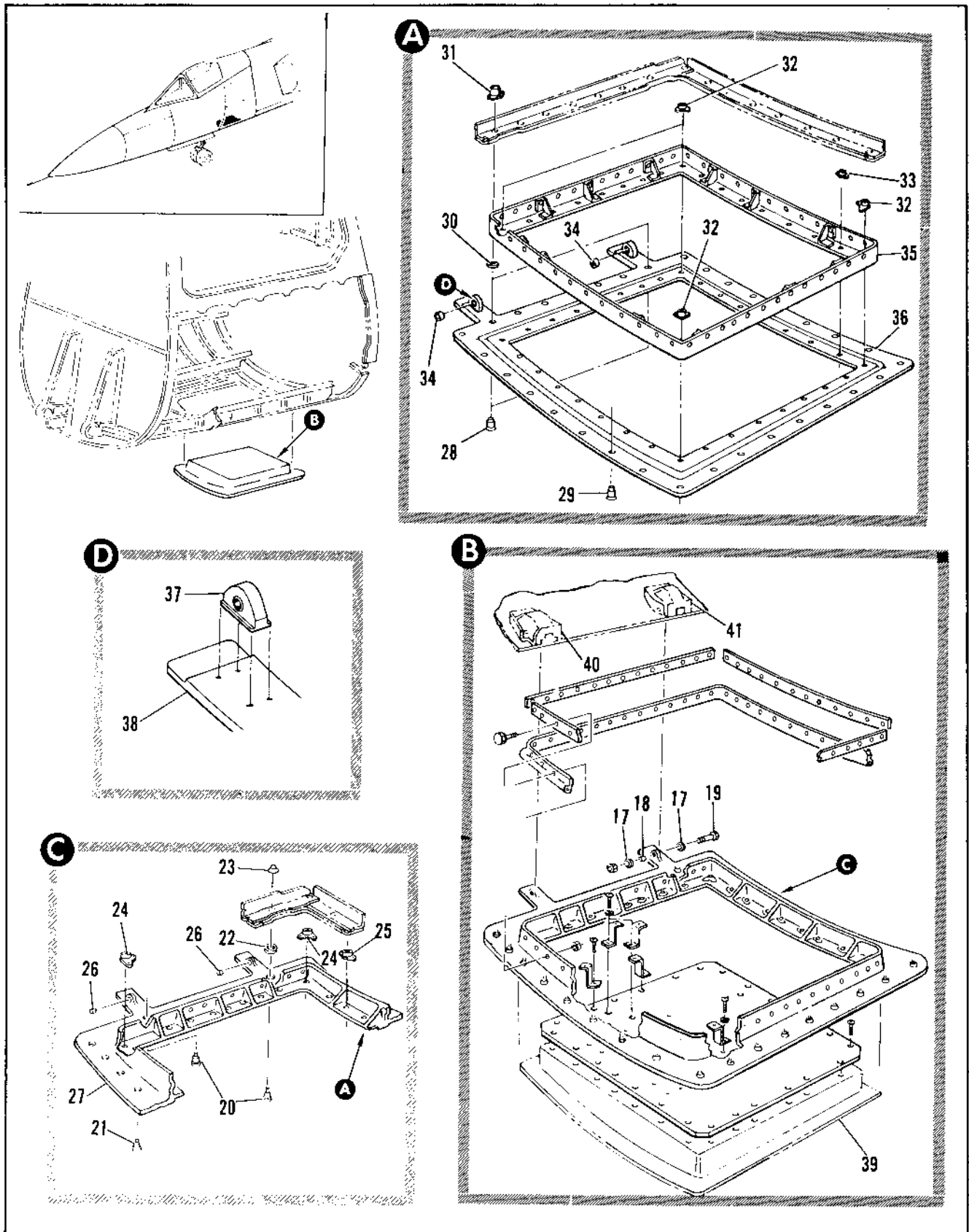

Figure 2.2-12. Midbay Electronic Compartment Access Door Assembly (Sheet 2 of 2)

FIGURE AND INDEX NUMBER	PART NUMBER	DESCRIPTION	UNITS PER ASSY.	USABLE ON CODE	
				FROM	TO
		1 2 3 4 5 6			
2.2-12-17	AN960-416L	• WASHER (88044)	4	35	60
- 18	NAS43004-96	• SPACER (80205)	2	35	60
- 19	AN4H41	• BOLT (88044)	2	35	60
		-----X-----			
- 20	4S14-6	• • STUD ASSY, <71286> 98-58007-002	2	35	60
- 21	4S14-4	• • STUD ASSY, <71286> 98-58007-001	30	35	60
- 22	4S9-1	• • RING, <71286> 97-61506-001	32	35	43
	4S9-2	• • RING, <71286> 97-61506-004	32	44	60
- 23	4R51-1	• • RECEPTACLE, <71286> 97-31000-006	32	35	60
- 24	NAS684A3	• • NUTPLATE, (80205) 96-37560-003	4	35	60
- 25	NAS686A3	• • NUTPLATE (80205) 96-37502-003	28	35	60
- 26	8-74677	• • BUSHING	2	35	60
- 27	8-74612-11	• • FRAME	1	35	60
	8-77624	• FRAME ASSY, ALT INTCHG WITH 8-74612-1	RF	35	60
	8-77624-5	• FRAME ASSEMBLY	1	61	277
	8-77624-801	• FRAME ASSEMBLY	1	278	
- 28	4S15-4	• • STUD ASSY, <71286> 98-58007-002	2	35	
- 29	4S14-4	• • STUD ASSY, .71286> 98-58007-001	30	35	
- 30	4S9-1	• • RING, <71286> 97-61506-001	32	35	89
	4S9-2	• • RING, <71286> 97-61506-004	32	90	
- 31	4R51-1	• • RECEPTACLE, <71286> 97-31000-006	32	35	
- 32	NAS684A3	• • NUTPLATE, (80205) 96-37560-003	4	35	
- 33	NAS686A3	• • NUTPLATE, (80205) 96-37502-003	28	35	
- 34	8-74677	• • BUSHING	2	35	89
	8-74677-7	• • BUSHING	2	90	
- 35	8-77624-31	• • FRAME ASSY, WELDED	1	35	
- 36	8-77624-29	• • DOOR ASSY, WELDED	1	35	
- 37	8-77624-11	• • • HINGE	2	35	
- 38	8-77624-7	• • • FRAME	1	35	
- 39	359	• ANTENNA, UHF COMM SEE FIG. 2.18-6	RF		
- 40	8-74666-7	• HINGE, MIDBAY ELECTRONIC DOOR FWD SEE FIG. 2.3-9	RF		
- 41	8-74658-7	• HINGE, MIDBAY ELECTRONIC DOOR AFT SEE FIG. 2.3-9	RF		

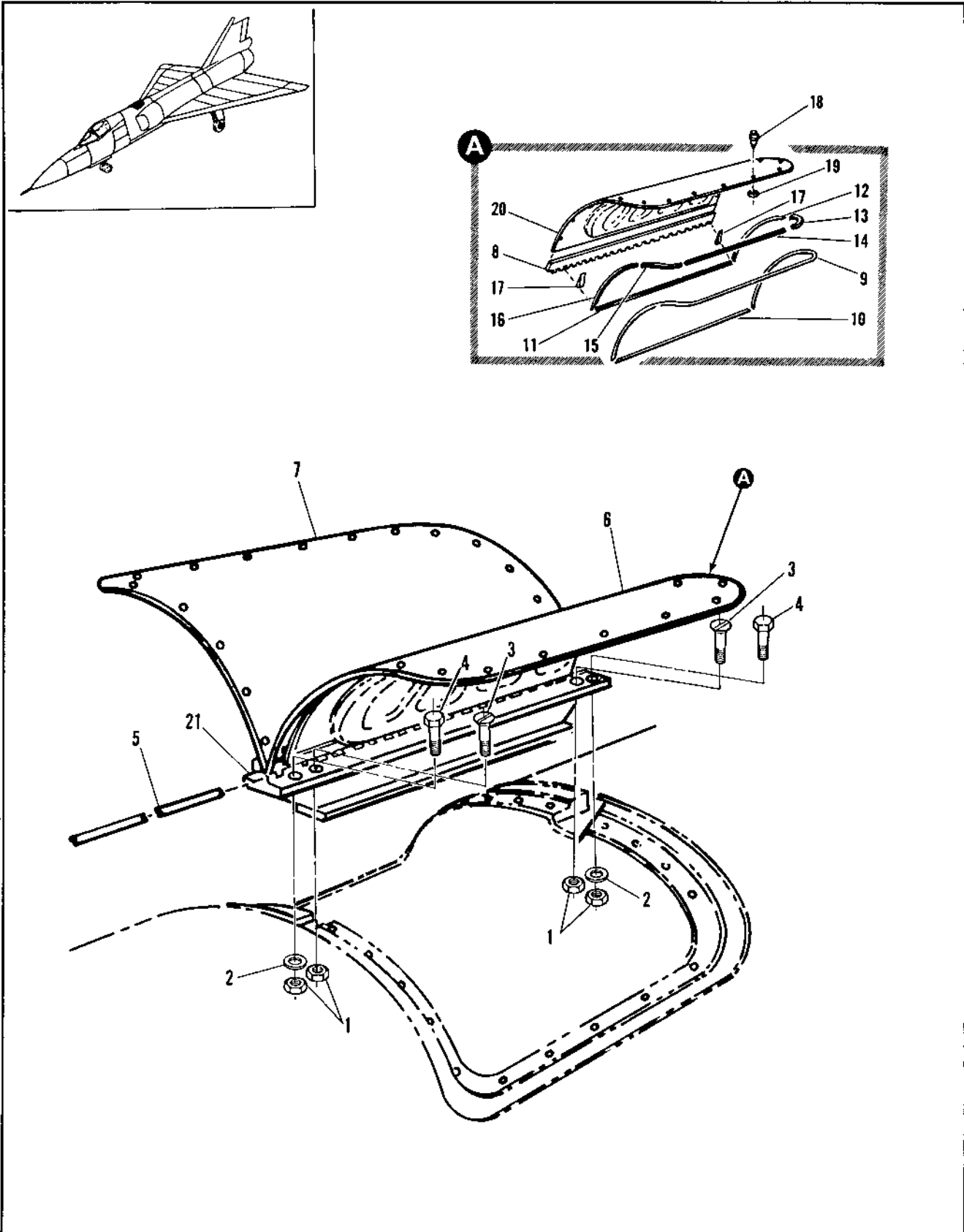

Figure 2.2-13. Refrigeration Access Door Installation

FIGURE AND INDEX NUMBER	PART NUMBER	DESCRIPTION	UNITS PER ASSY.	USABLE ON CODE	
				FROM	TO
		1 2 3 4 5 6			
2.2-13	8-74946	DOOR INSTALLATION, REFRIGERATION ACCESS FOR NHA SEE FIG. 2.3-10	RF	35	
	8-74946-47	• DOOR ASSY, REFRIGERATION ATTACHING PARTS	1	35	
- 1	NAS679A3	• NUT (80205)	8	35	
- 2	AN960-16L	• WASHER (88044)	4	35	
- 3	NAS333PA111	• SCREW (80205)	4	35	
- 4	AN3C11A	• BOLT (88044)	4	35	
		-----X-----			
- 5	8-74946-23	• • PIN	1	35	
- 6	8-74946-41	• • DOOR ASSY, LH	1	35	
- 7	8-74946-42	• • DOOR ASSY, RH	1	35	
- 8	8-77726-7	• • • HINGE	1	35	
- 9	8-74946-15	• • • SEAL	1	35	
- 10	8-74946-17	• • • SEAL	1	35	
- 11	8-74946-29	• • • RETAINER, LH	1	35	
	8-74946-30	• • • RETAINER, RH	1	35	
- 12	8-74946-37	• • • RETAINER, LH	1	35	
	8-74946-38	• • • RETAINER, RH	1	35	
- 13	8-74946-39	• • • RETAINER, LH	1	35	
	8-74946-40	• • • RETAINER, RH	1	35	
- 14	8-74946-35	• • • RETAINER, LH	1	35	
	8-74946-36	• • • RETAINER, RH	1	35	
- 15	8-74946-33	• • • RETAINER, LH	1	35	
	8-74946-34	• • • RETAINER, RH	1	35	
- 16	8-74946-31	• • • RETAINER, LH	1	35	
	8-74946-32	• • • RETAINER, RH	1	35	
- 17	8-74946-27	• • • FILLER	2	35	
- 18	4S14-6	• • • STUD, FASTENER <71286> 98-56007-002	15	35	
- 19	4S9-1	• • • RING, FASTENER <71286> 97-61506-001	15	35	43
	4S9-2	• • • RING, FASTENER <71286> 97-61506-004	15	44	
- 20	8-74946-19	• • • DOOR ASSY, LH WELDED	1	35	
	8-74946-20	• • • DOOR ASSY, RH WELDED	1	35	
- 21	8-77727-7	• • BEAM	1	35	

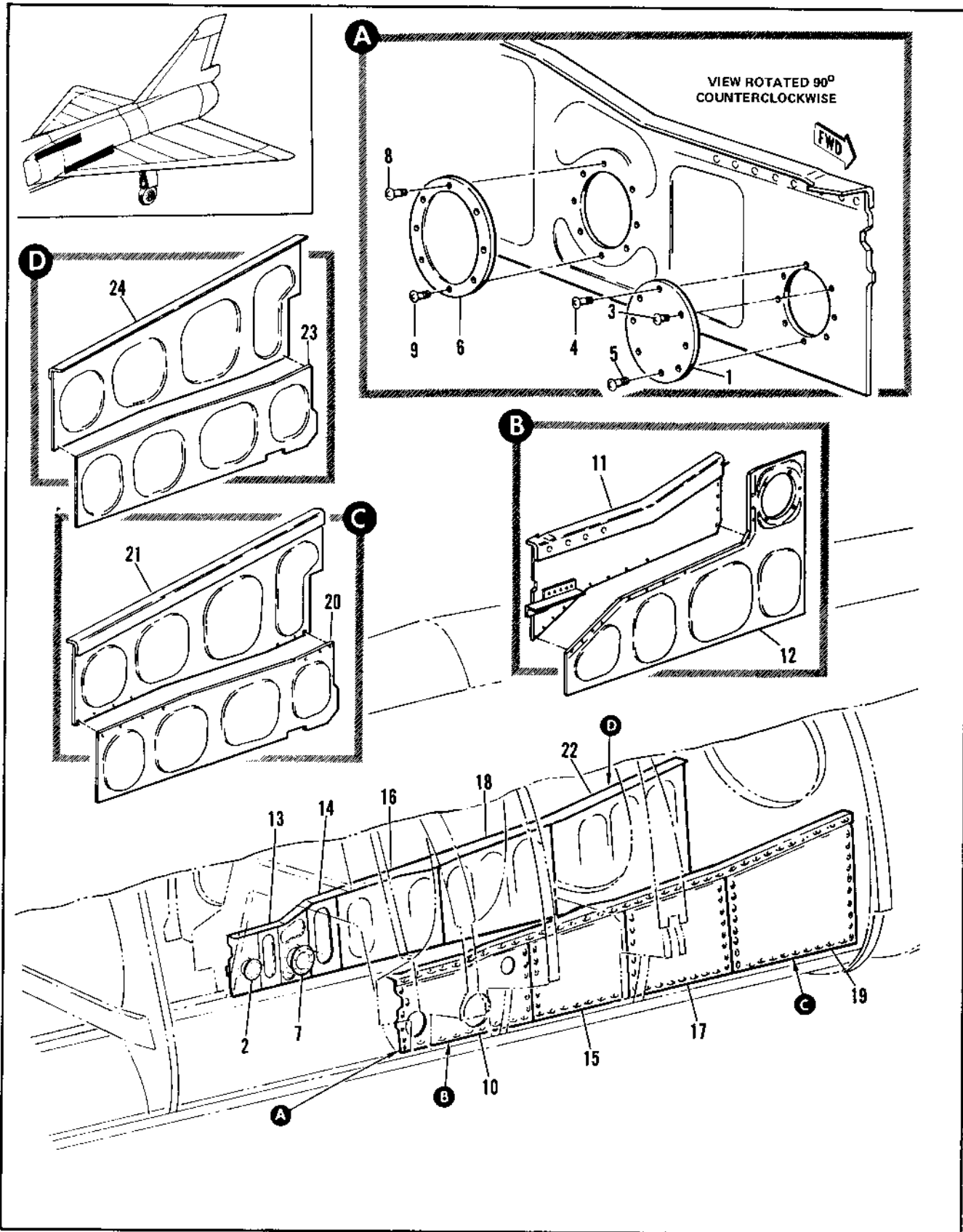

Figure 2.2-14. Armament Bay Side Door Installation Sta 316 to 412 (Sheet 1 of 2)

FIGURE AND INDEX NUMBER	PART NUMBER	DESCRIPTION	UNITS PER ASSY.	USABLE ON CODE	
				FROM	TO
2.2-14	8-74484-803	DOOR INSTALLATION, ARMAMENT BAYSIDE STA 316 TO 412 MOD BY 7144599 (98750) FOR NHA SEE FIG. 2.1-1	RF	35	
- 1	8-74484-37	. DOOR, STA 320 LH	2	35	48
- 2	8-74484-38	. DOOR, STA 320 RH	1	35	
		ATTACHING PARTS			
- 3	NAS333CPA4	. SCREW (80205)	2	35	
- 4	NAS334CPA5	. SCREW (80205)	2	35	
- 5	NAS221-3	. SCREW (80205)	12	35	
		-----X-----			
- 6	8-74484-35	. COVER PLATE, STA 333 LH	1	35	48
- 7	8-74484-35	. COVER PLATE, STA 333 RH	1	35	
		ATTACHING PARTS			
- 8	NAS222-10	. SCREW (80205)	2	35	48
	NAS222-10	. SCREW, RH (80205)	1	49	
- 9	NAS221-9	. SCREW (80205)	16	35	48
	NAS221-9	. SCREW, RH (80205)	1	49	
		-----X-----			
- 10	8-74484-67	. PANEL ASSY, STA 316 TO 343 LH RIVETED	1	35	48
- 11	8-74484-91	. PANEL ASSY, STA 316 TO 336 LH RIVETED	1	49	
- 12	8-74484-89	. PANEL, STA 316 TO 343 LH	1	49	
- 13	8-74484-61	. PANEL ASSY, STA 316 TO 336 RH RIVETED	1	35	
	8-74484-57	. PANEL, STA 336 TO 343 RH MODIFIED BY 66E40276 (98750)			
- 14	8-74484-95	. DOOR, STA 343 TO 364 LH	1		
- 15	8-74484-96	. DOOR, STA 343 TO 364 RH	1		
- 16	8-74484-97	. DOOR, STA 364 TO 385 LH	1		
- 17	8-74484-103	. DOOR, STA 364 TO 385 RH	1		
- 18	8-74484-101	. DOOR, STA 385 TO 412 LH	1		
- 19	8-74484-107	. DOOR ASSY, STA 385 TO 412 LH	1	61	89
- 20	8-74484-109	. DOOR ASSY, STA 385 TO 412 LH	1		
- 21	8-74484-102	. DOOR, STA 385 TO 412 RH	1	F	
- 22	8-74484-108	. DOOR ASSY, STA 385 TO 412 RH	1	61	89
- 23	8-74484-110	. DOOR ASSY, STA 385 TO 412 RH	1		
- 24	64D33120-7	. DOOR, STA 398 TO 405 (98750)	1	F	
		F AIRPLANES 35 THRU 47, 49 THRU 59			

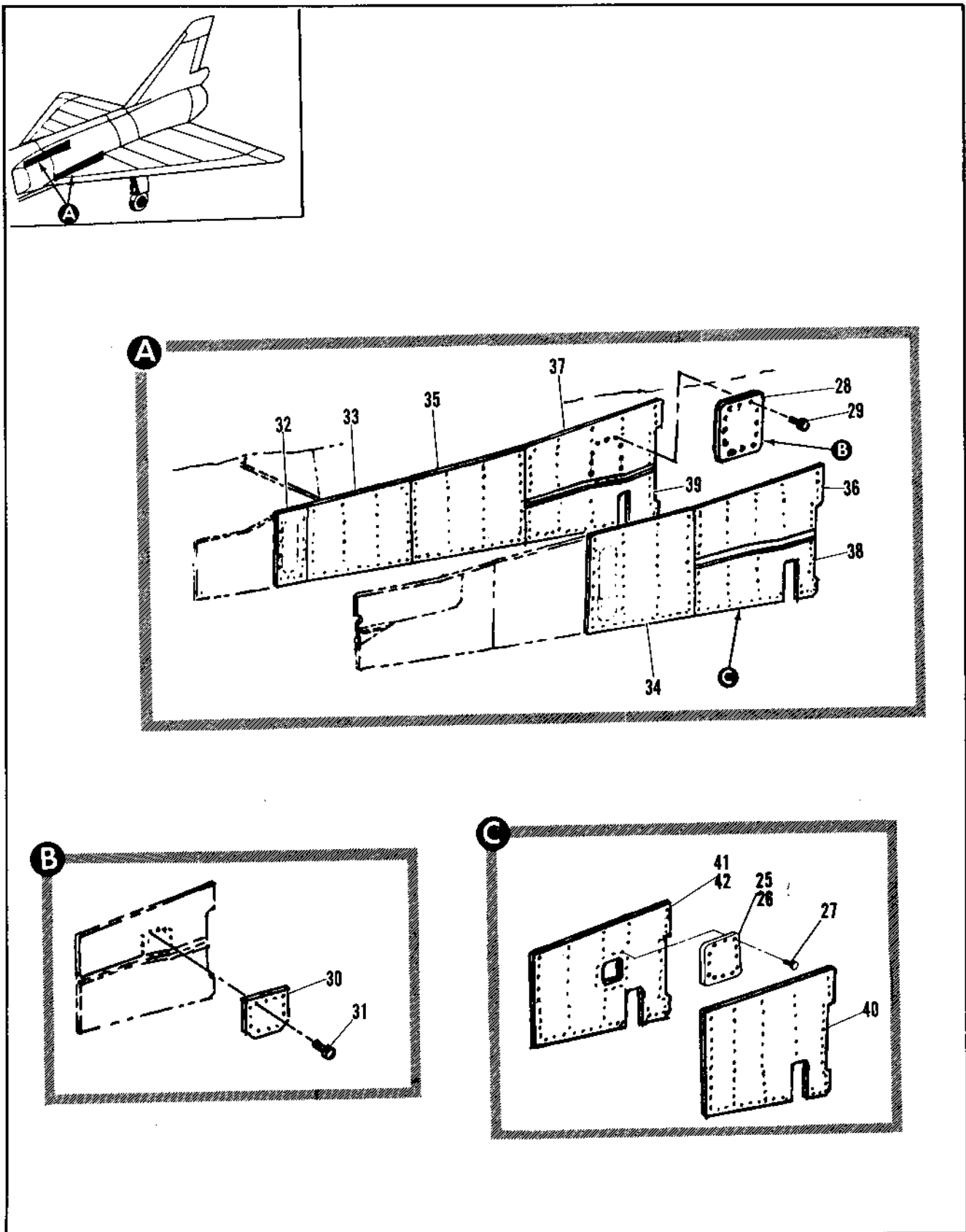

Figure 2.2-14. Armament Bay Side Door Installation Sta 316 to 412 (Sheet 2 of 2)

FIGURE AND INDEX NUMBER	PART NUMBER	DESCRIPTION	UNITS PER ASSY.	USABLE ON CODE	
				FROM	TO
2.2-14- 25 - 26	64033120-11 AN3-5A	• DOOR, STA 398 TO 405 (98750) • BOLT (80205) ATTACHING PARTS	AR	61	89
	NAS221-9 NAS1103-2 NAS221-10 NAS1103-3 NAS221-13 NAS1103-6 NAS221-14 NAS1103-6 NAS222-12	• SCREW (80205) • BOLT (80205) • SCREW (80205) • BOLT (80205) • SCREW (80205) • BOLT (80205) • SCREW (80205) • BOLT (80205) • SCREW (80205) ----X----	AR LR AR 44 AR AR AR AR AR		A A A A A A A A A
- 27	7144599-01	• DOOR, STA 398 TO 405 RH (98750) ATTACHING PARTS	1		
- 28	NAS1103-6	• BOLT (80205) ----X----	12	48	48
- 29	7144599-03	• DOOR, STA 398 TO 405 RH (98750) ATTACHING PARTS	1		B
- 30	NAS1103-6	• BOLT (80205) ----X----	12		B
- 31	7144599-33	• PANEL, STA 336 TO 343 RH (98750)	1		C
- 32	7144599-27	• PANEL, STA 343 TO 364 RH	1		C
- 33	7144599-13	• PANEL, STA 364 TO 385 LH (98750)	1		C
- 34	7144599-15	• PANEL, STA 364 TO 385 RH (98750)	1		C
- 35	7144599-31	• PANEL, STA 385 TO 412 LH (98750)	1		B
- 36	7144599-21	• PANEL, STA 385 TO 412 RH (98750)	1		B
- 37	7144599-17	• PANEL, STA 385 TO 412 LH (98750)	1		B
- 38	7144599-18	• PANEL, STA 385 TO 412 RH (98750)	1		H
- 39	7144599-23	• PANEL, STA 385 TO 412 LH (98750)	1		D
- 40	7144599-24	• PANEL, STA 385 TO 412 RH (98750)	1		E
- 41	7144599-25	• PANEL, STA 385 TO 412 RH (98750) ATTACHING PARTS	1	48	48
	NAS221-10 NAS1103-3 NAS221-11 NAS1103-6 NAS221-14 NAS1103-7 NAS221-15 NAS1103-9	• SCREW (80205) • BOLT (80205) • SCREW (80205) • BOLT (80205) • SCREW (80205) • BOLT (80205) • SCREW (80205) • BOLT (80205) ----X----	AR AR AR AR AR AR AR AR		C C C C C C C C
		A AIRPLANES 35 THRU 47, 49 THRU 89 B AIRPLANES 90 THRU 124, 128, AND 131 THRU 276 C AIRPLANES 48, 90 THRU 124, 128, 131 AND ON D AIRPLANES 48, 90 THRU 278 AND ON E AIRPLANES 278 AND ON			

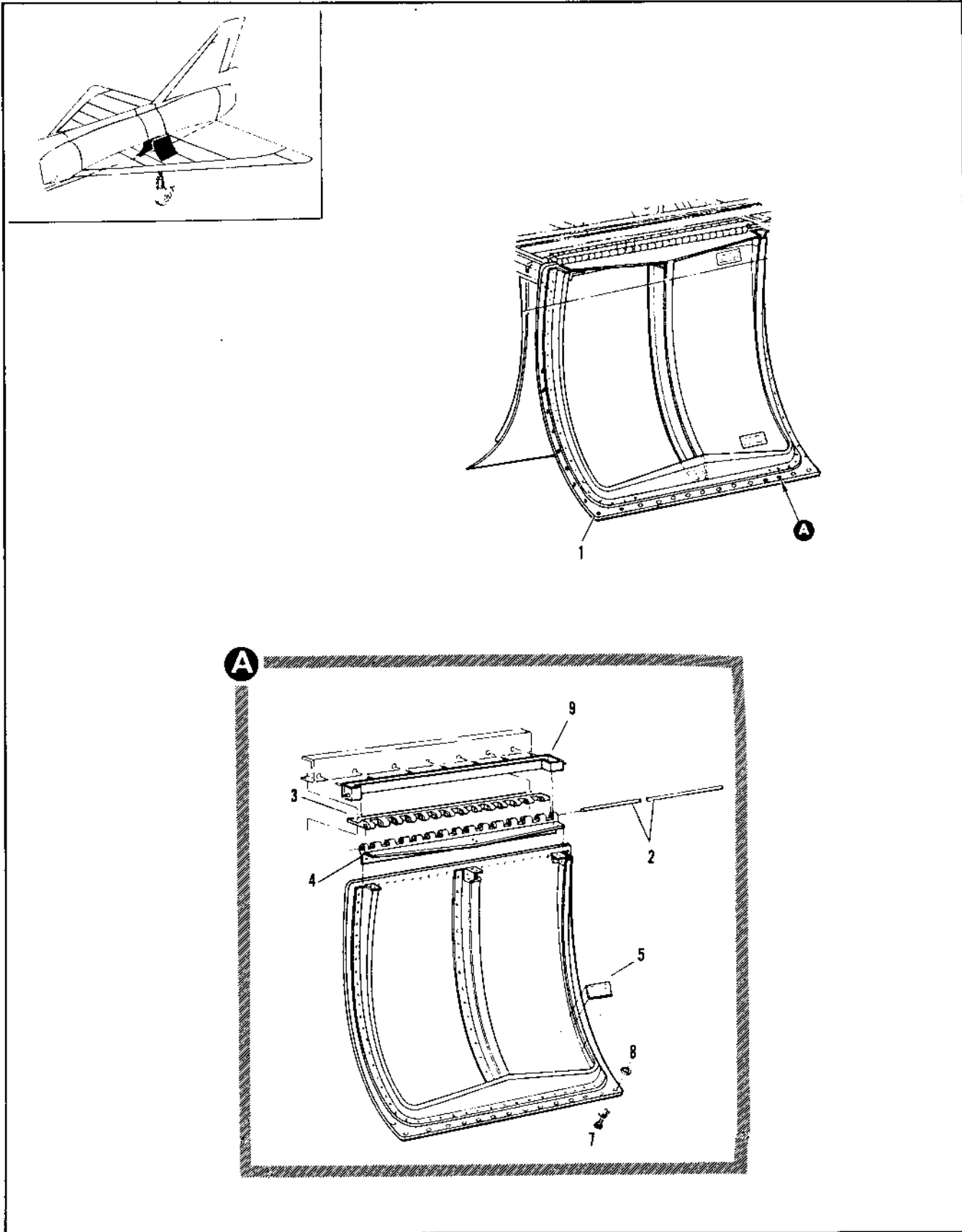

Figure 2.2-15. Engine Access Door Installation

FIGURE AND INDEX NUMBER	PART NUMBER	DESCRIPTION	UNITS PER ASSY.	USABLE ON CODE	
				FROM	TO
		1 2 3 4 5 6			
2.2-15	8-74621-1	DOOR INSTALLATION, ENGINE ACCESS LH FOR NHA SEE FIG. 2.1-1 INDEX 25	RF	35	
	8-74621-2	DOOR INSTALLATION, ENGINE ACCESS RH FOR NHA SEE FIG. 2.1-1	RF	35	
- 1	8-74621-21	• DOOR ASSY, ENGINE ACCESS LH REPLACED BY SUITABLE SUB 8-74621-25	1	35	60
	8-74621-25	• DOOR ASSY, ENGINE ACCESS LH REPLACES SUITABLE SUB FOR 8-74621-21	1	61	
	8-74621-22	• DOOR ASSY, ENGINE ACCESS RH REPLACED BY SUITABLE SUB 8-74621-26	1	35	60
	8-74621-26	• DOOR ASSY, ENGINE ACCESS RH REPLACES SUITABLE SUB FOR 8-74621-22 ATTACHING PARTS	1	61	
	NAS679A3	• NUT, (80205) 96-37545-002	16	35	
	NAS333CPA6	• SCREW, (80205) 97-89004-005 -----X-----	16	35	
- 2	8-74962	• PIN, HINGE	1	35	
- 3	8-74902-7	• HINGE, HALF	1	35	
- 4	8-74902-9	• HINGE, HALF REPLACED BY SUITABLE SUB 8-74902-11	1	35	43
	8-74902-11	• HINGE, HALF REPLACES SUITABLE SUB FOR 8-74902-9	1	44	
- 5	4F10-2	• DECAL, FASTENER OPERATING INSTRUCTION <71286> 92-93500-001	1	35	
- 6	DELETED				
- 7	4S14-4	• STUD ASSY, <71286> 98-58007-001	40	35	60
	4S14-6	• STUD ASSY, <71286> 98-58007-002	40	61	
- 8	4S9-1	• RING, <71286> 97-61506-001	40	35	43
	4S9-2	• RING, <71286> 97-61506-004	40	44	
	4R41-1	• RECEPTACLE <71286> 97-31000-005	40	35	
- 9	8-74961	• SEAL, ENGINE ACCESS DOOR REPLACED BY SUITABLE SUB 8-74961-7	1	35	

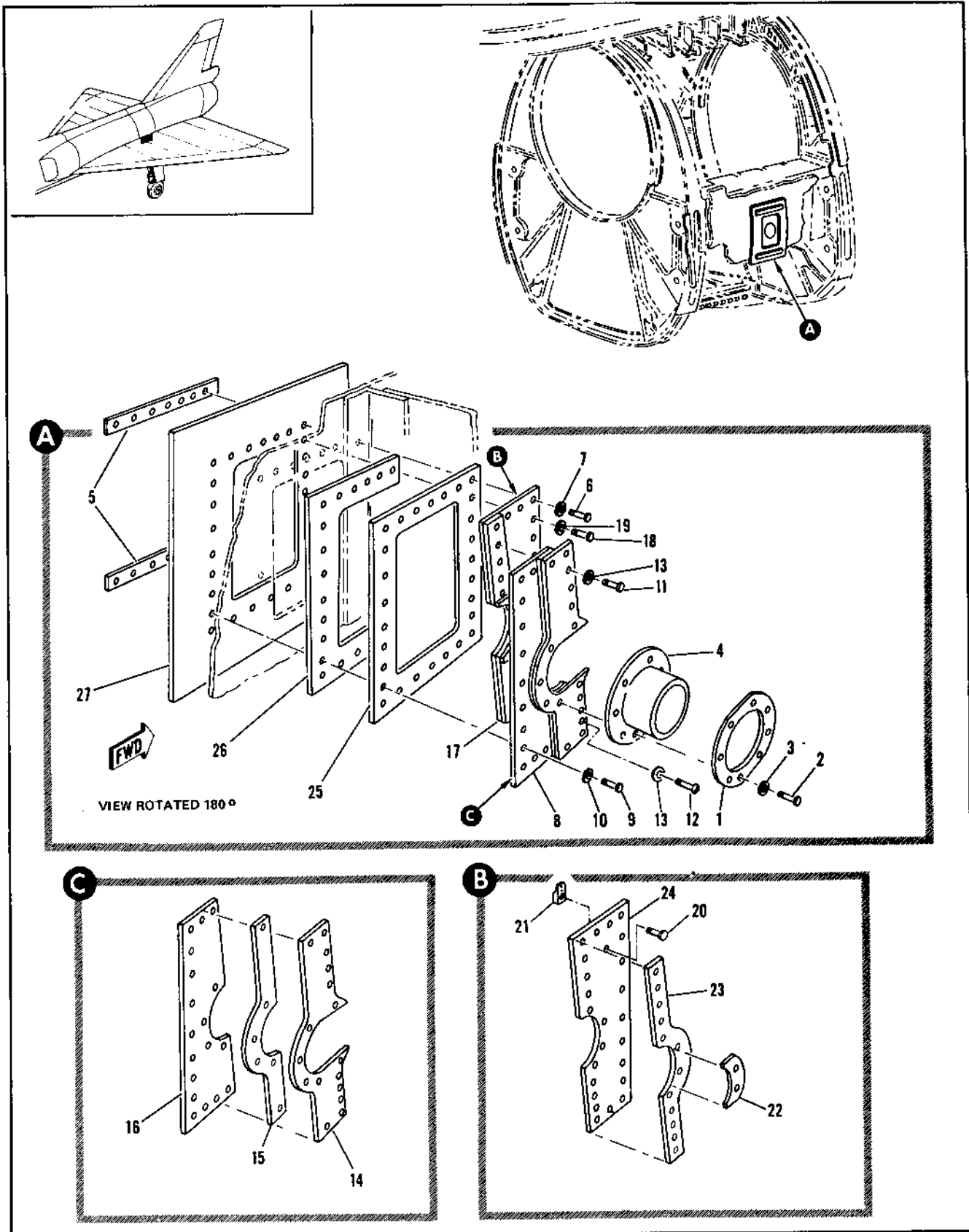

Figure 2.2-16. Fuel Shutoff Valve Access Door Installation

FIGURE AND INDEX NUMBER	PART NUMBER	DESCRIPTION	UNITS PER ASSY.	USABLE ON CODE	
				FROM	TO
		1 2 3 4 5 6			
2.2-16	8-77601-701	DOOR INSTALLATION, FUEL SHUTOFF VALVE ACCESS LH FOR NHA SEE FIG. 2.3-14	RF	35	129
	8-77601-3	DOOR INSTALLATION, FUEL SHUTOFF VALVE ACCESS LH FOR NHA SEE FIG. 2.3-14	RF	130	
	8-77601-702	DOOR INSTALLATION, FUEL SHUTOFF VALVE ACCESS RH FOR NHA SEE FIG. 2.3-14	RF	35	129
	8-77601-4	DOOR INSTALLATION, FUEL SHUTOFF VALVE ACCESS RH FOR NHA SEE FIG. 2.3-14	RF	130	
- 1	8-77601-25	• DOUBLER	1	35	
		ATTACHING PARTS			
- 2	NAS221-9	• SCREW (80205)	8	35	60
	NAS1103-4	• BOLT (80205)	8	61	
- 3	AN960C10L	• WASHER (88044)	8	61	
		-----X-----			
- 4	4679	• SEAL, <91198> SPEC 8-02297-3	1	35	
- 5	8-77601-23	• CHANNEL	2	35	
		ATTACHING PARTS			
- 6	NAS221-9	• SCREW (80205)	14	35	60
	NAS1103-4	• BOLT (80205)	14	61	
- 7	AN960C10L	• WASHER (88044)	14	61	
		-----X-----			
- 8	8-77601-19	• DOOR ASSY, LH AFT	1	35	
	8-77601-20	• DOOR ASSY, RH AFT	1	35	
		ATTACHING PARTS			
- 9	NAS221-9	• SCREW (80205)	7	35	60
	NAS1103-4	• BOLT (80205)	7	61	
- 10	AN960C10L	• WASHER (88044)	7	61	
- 11	NAS221-8	• SCREW (80205)	5	35	60
	NAS1103-3	• BOLT (80205)	5	61	
- 12	NAS221-8	• SCREW (80205)	1	35	60
	NAS1103-3	• BOLT, LH (80205)	1	61	
	NAS1103-3	• BOLT, RH (80205)	1	61	129
	NAS1104-3	• BOLT, RH (80205)	1	130	
- 13	AN960C10L	• WASHER (88044)	6	61	
		-----X-----			
- 14	8-77601-11	• DOUBLER, LH	1	35	
	8-77601-12	• DOUBLER, RH	1	35	
- 15	8-28252-17	• SEAL	1	35	
- 16	8-77601-7	• DOOR, LH	1	35	
	8-77601-8	• DOOR, RH	1	35	
- 17	8-77601-21	• DOOR ASSY, LH FWD	1	35	129
	8-77601-29	• DOOR ASSY, LH FWD	1	130	
	8-77601-22	• DOOR ASSY, RH FWD	1	35	129
	8-77601-30	• DOOR ASSY, RH FWD	1	130	
		ATTACHING PARTS			
- 18	NAS221-9	• SCREW (80205)	7	35	60
	NAS1103-4	• BOLT (80205)	7	61	
- 19	AN960C10L	• WASHER (88044)	7	61	
		-----X-----			
- 20	NAS1104-2	• BOLT (80205)	1	130	
- 21	NAS687A4	• NUTPLATE (80205)	1	130	
- 22	8-77601-13	• FILLER	1	35	
- 23	8-28252-17	• SEAL	1	35	
- 24	8-77601-9	• DOOR, LH	1	35	129

FIGURE AND INDEX NUMBER	PART NUMBER	DESCRIPTION	UNITS PER ASSY.	USABLE ON CODE	
				FROM	TO
		1 2 3 4 5 6			
2.2-16	8-77601-31	• • DOOR, LH	1	130	
	8-77601-10	• • DOOR, RH	1	35	129
	8-77601-33	• • DOOR, RH	1	130	
- 25	8-28252-7	• • SEAL	1	35	
- 26	8-77601-17	• DOUBLER, LH	1	35	
	8-77601-18	• DOUBLER, RH	1	35	
- 27	8-77601-713	• DOUBLER, LH	1	35	40
	8-77601-27	• DOUBLER, LH	1	41	
	8-77601-714	• DOUBLER, RH	1	35	40
	8-77601-28	• DOUBLER, RH	1	41	

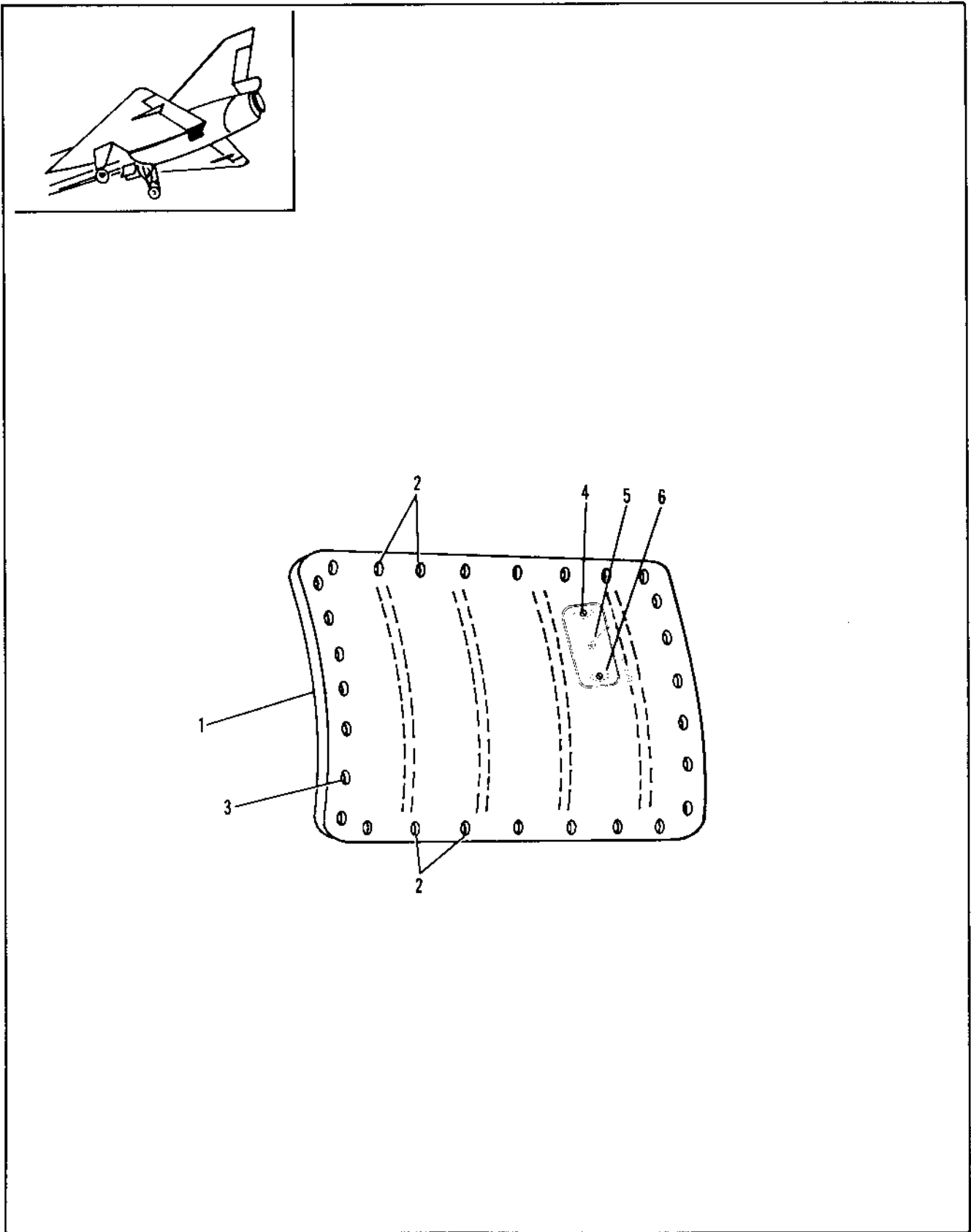

Figure 2.2-17. Air Turbine Driven Emergency AC Generator Access Door Installation

FIGURE AND INDEX NUMBER	PART NUMBER	DESCRIPTION	UNITS PER ASSY.	USABLE ON CODE	
				FROM	TO
2.2-17	8-77140-1	DOOR INSTALLATION, AIR TURBINE DRIVEN EMERGENCY AC GENERATOR ACCESS	1	278	304
	8-77140-3	DOOR INSTALLATION, AIR TURBINE DRIVEN EMERGENCY AC GENERATOR ACCESS	1	A	
- 1	8-77138-1	• DOOR ASSY, AIR TURBINE DRIVEN EMERG AC GEN ACCESS ATTACHING PARTS	1	35	
- 2	NAS333CPA5	• BOLT (80205)	4	35	
- 3	NAS333CPA4	• BOLT (80205)	24	35	
- 4	98-56502-005	• STUD			
- 5	99-52505-001	• WASHER			
- 6	95-49300-001	• LANYARD			
	97-31015-001	• RECEPTACLE -----X-----			
		A AIRPLANES 35 THRU 277 AND 305			

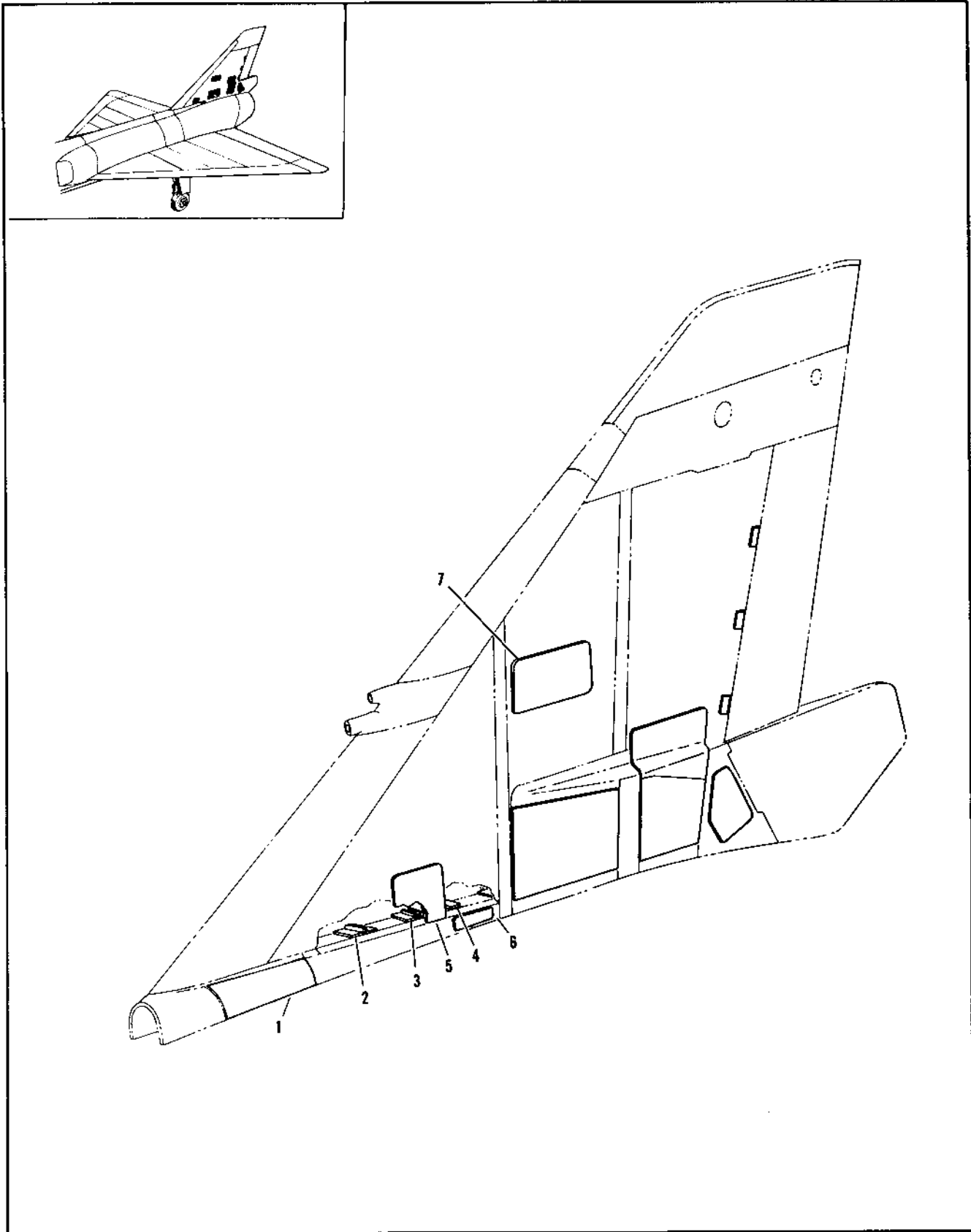

Figure 2.2-18. Fin Access Doors (Sheet 1 of 2)

FIGURE AND INDEX NUMBER	PART NUMBER	DESCRIPTION	UNITS PER ASSY.	USABLE ON CODE	
				FROM	TO
2.2-18		1 2 3 4 5 6			
	8-14639	FIN ACCESS DOORS	RF	35	
- 1	8-14139-7	• DOOR INSTL, FIN BAY #1 BLEED AIR ACCESS STA 541 FOR NHA SEE FIG. 2.1-1	1	35	
	NAS333CPA6-5	• DOOR, FIN BAY #1 BLEED AIR ACCESS ATTACHING PARTS	9	35	
	NAS333CPA5	• SCREW (80205)	10	35	
	NAS333CPA4-5	• SCREW (80205)	30	35	
	8-14329-45	• RIB ASSY, FIN SPAR #2 TO #3 FOR NHA SEE FIG. 2.7-8	RF	35	
- 2	8-14329-37	• DOOR	1	35	
	NAS221-6	• ATTACHING PARTS	20	35	
- 3	8-14329-35	• SCREW (80205)	1	35	
	NAS221-6	• DOOR	18	35	
- 4	8-14329-33	• ATTACHING PARTS	1	35	
	NAS221-6	• SCREW (80205)	16	35	
- 5	8-14640-3	• DOOR INSTL, FIN EQUIPMENT PANEL STA 519 FOR NHA SEE FIG. 2.1-1	RF	35	
	8-14140-1	• DOOR ASSY, FIN EQUIPMENT PANEL REPLACED BY INTCHG WITH 8-14140-3	1	35	129
	8-14140-3	• DOOR ASSY, FIN EQUIPMENT PANEL REPLACES INTCHG WITH 8-14140-1	1	130	
	4S14-12	• SOUDY F-00ENE9 <71286> 98-58007-005	38	35	
	4S9-2	• RING, FASTENER <71286> 97-61506-004	38	35	
	4R41-1	• RECEPTACLE, FASTENER <71286> 97-31000-005	38	35	
	8-14655	• DOOR INSTL, FIN ACCESS STA 603 TO 610 FOR NHA SEE FIG. 2.1-1	RF	A	
	8-14618	• DOOR INSTL, BAY #1 LWR AFT ACCESS FOR NHA SEE FIG. 2.1-1	RF	90	277
- 6	8-14655-9	• DOOR	1	A	
	8-14116	• DOOR	1	90	277
	NAS333CPA5	• ATTACHING PARTS	12	A	
	NAS333CPA4-5	• SCREW (80205)	51	30	277
	NAS333CPA15	• SCREW (80205)	3	90	277
	NAS333CPA6-5	• SCREW (80205)	43	90	277
	8-14641-3	• DOOR INSTL, WAVEGUIDE ACCESS STA 615 FOR NHA SEE FIG. 2.1-1	RF	35	
- 7	8-14141-1	• DOOR, WAVEGUIDE ACCESS	1	35	
	NAS333CPA6	• ATTACHING PARTS	42	35	
		• SCREW (80205)			
		-----X-----			
		A AIRPLANES #35 THRU 89, 278 AND ON			

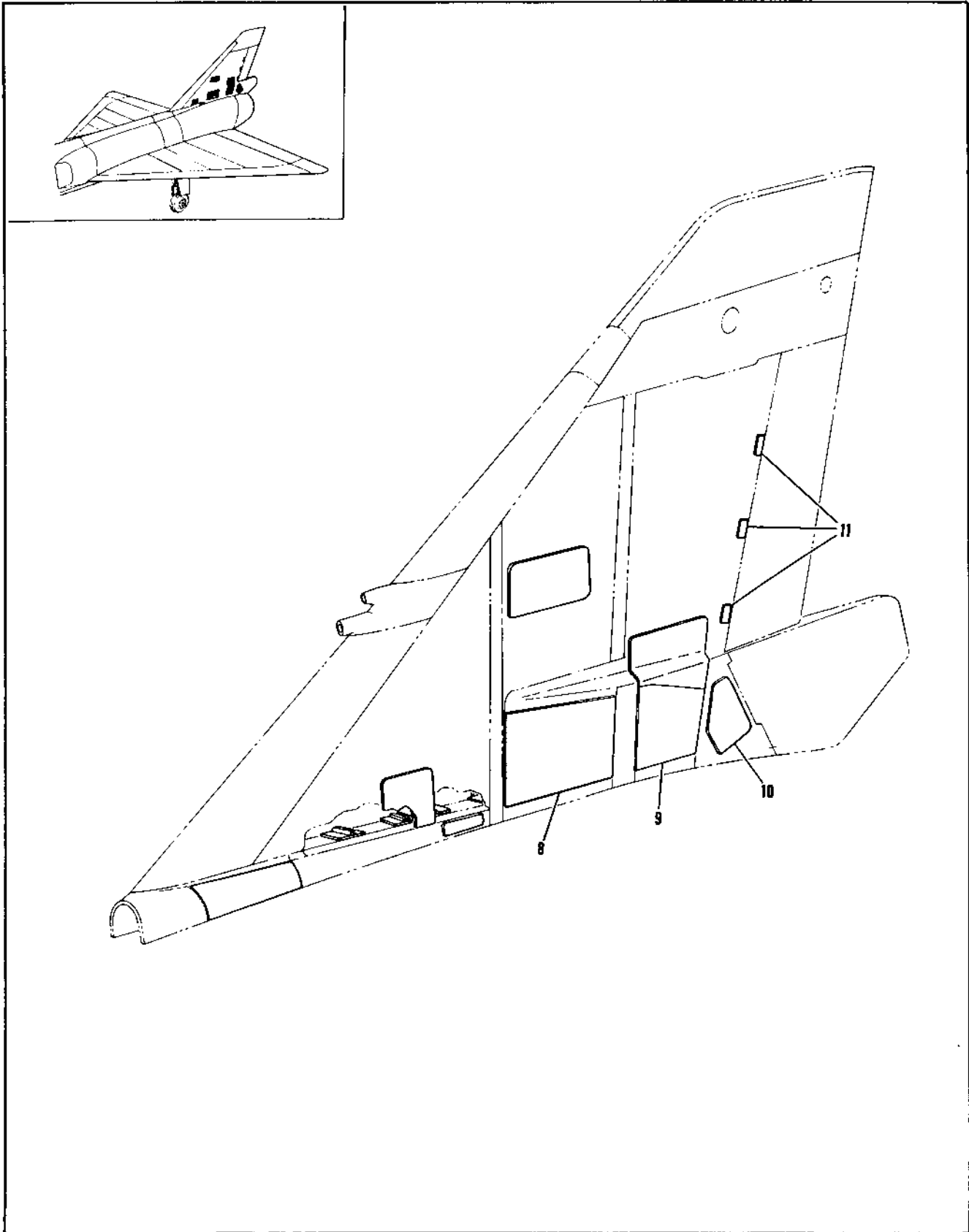

Figure 2.2-18. Fin Access Doors (Sheet 2 of 2)

FIGURE AND INDEX NUMBER	PART NUMBER	DESCRIPTION	UNITS PER ASSY.	USABLE ON CODE	
				FROM	TO
2.2-18	8-14642	• DOOR INSTL, ELECTRONIC EQUIPMENT FIN STA 6L5 FOR NHA SEE FIG. 2.1-1	RF	35	
- 8	8-14142-3	• DOOR ASSY, ELECTRONIC EQUIPMENT FIN LH HONEYCOMBED REPLACED BY INTCHG WITH 8-14142-5	1	35	129
	8-14142-5	• DOOR ASSY, ELECTRONIC EQUIPMENT FIN LH HONEYCOMBED REPLACES INTCHG WITH 8-14142-3	1	130	
	8-14142-2	• PANEL ASSY, ELECTRONIC EQUIPMENT FIN RH HONEYCOMBED RIVETED FOR NHA SEE FIG. 2.7-8	RF	35	
	4S14-4	• • • STUD, FASTENER LHC71286> 98-58007-001	45	35	
	4S9-2	• • • RING, FASTENER LHC71286> 97-61506-004	45	35	
	4R41-1	• • • RECEPTACLE, FASTENER LH <71286> 97-31000-005	45	35	
	8-14644	• DOOR INSTL, FIN RUDDER CONTROL ACCESS STA 646 FOR NHA SEE FIG. 2.1-1	RF	35	
- 9	8-14144-3	• DOOR ASSY, FIN RUDDER CONTROL ACCESS LH HONEYCOMBED	1	35	
	8-14144-2	• PANEL ASSY, FIN RUDDER CONTROL ACCESS RH HONEYCOMBED RIVETED FOR NHA SEE FIG. 2.7-8	RF	35	
	NAS333CPA4-5	• • SCREW, LH (80205)	86	35	
	NAS333CPA5	• • SCREW, LH (80205) -----X-----	1	35	
	8-74863-3	• PANEL INSTL, SPEED BRAKE SUPPORT LH STA 672 FOR NHA SEE FIG. 2.1-1	RF	35	
- 10	8-74863-13	• DOOR ASSY, SPEED BRAKE SUPPORT RIVETED WITH EXCESS MATERIAL FOR TRIM ON INSTL	1	35	
	8-74863-513	• DOOR ASSY, SPEED BRAKE SUPPORT RIVETED SPARES ASSY FOR 8-74863-13 ATTACHING PARTS	RF	35	
	NAS333CPA4	• • SCREW (80205) -----X-----	36	35	
	8-14650-1	• DOOR INSTL, RUDDER HINGE ACCESS UPPER FOR NHA SEE FIG. 2.1-1	RF	35	
	8-14650-3	• DOOR INSTL, RUDDER HINGE ACCESS CENTER FOR NHA SEE FIG. 2.1-1	RF	35	
	8-14650-5	• DOOR INSTL, RUDDER HINGE ACCESS LOWER FOR NHA SEE FIG. 2.1-1	RF	35	
- 11	8-14650-7	• DOOR, RUDDER ACCESS ATTACHING PARTS	1	35	
	NAS333CPA7-5	• • SCREW, UPPER AND CENTER (80205)	3	35	
	NAS333CPA11	• • SCREW, LOWER (80205)	1	35	
	NAS333CPA7-5	• • SCREW, LOWER (80205) -----X-----	2	35	

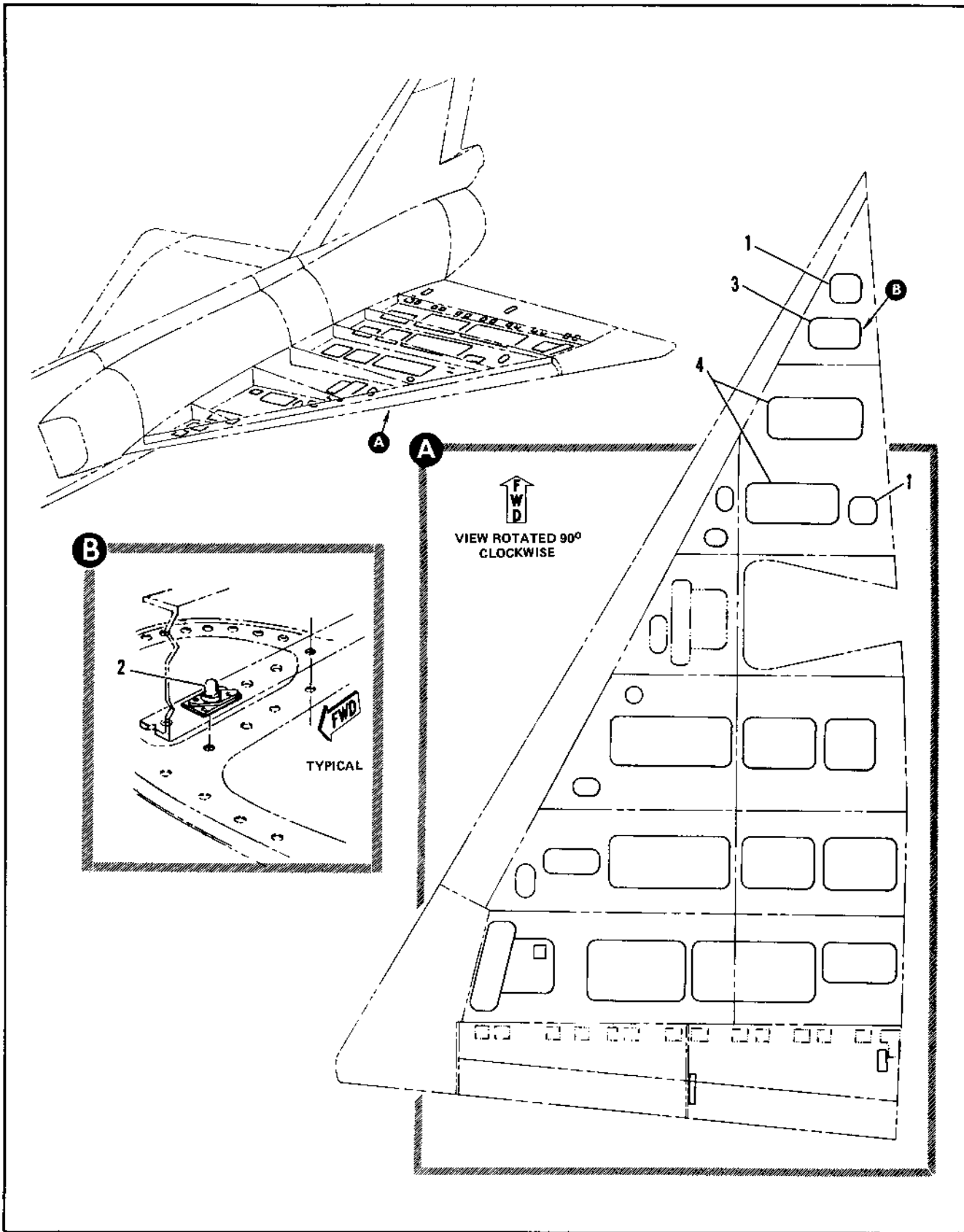

Figure 2.2-19. Lower Wing Access Doors (Sheet 1 of 7)

FIGURE AND INDEX NUMBER	PART NUMBER	DESCRIPTION	UNITS PER ASSY.	USABLE ON CODE	
				FROM	TO
		1 2 3 4 5 6			
2.2-19		LOWER WING ACCESS DOORS			
	8-18661-1	. DOOR INSTL, WING ACCESS TANK #1 BL 55 STA 337 LH FOR NHA SEE FIG. 2.6-32	RF	35	
	8-18661-803	. DOOR INSTL, WING ACCESS TANK #1 BL 47 STA 416 LH FOR NHA SEE FIG. 2.6-32	RF	35	
	8-18661-5	. DOOR INSTL, WING ACCESS TANK #1 BL 55 STA 337 RH FOR NHA SEE FIG. 2.6-32	RF	35	
	8-18661-807	. DOOR INSTL, WING ACCESS TANK #1 BL 47 STA 416 RH FOR NHA SEE FIG 2.6-32	RF	35	
- 1	8-18641-7	. . DOOR ATTACHING PARTS	1	35	
	NAS334CPA6-5	. . BOLT (80205)	31	35	
	NAS334CPA6	. . BOLT (80205)	4	35	
	NAS334CPA5-5	. . BOLT (80205) ----X----	2	35	
	8-18621-7	. . GASKET, USE WITH 8-18641-7	1	35	
	8-18661	. FRAME INSTL, WING TANK #1 ACCESS DOOR BL 55 STA 337 LH FOR NHA SEE FIG. 2.6-35	RF	35	
	8-18661-3	. FRAME INSTL, WING TANK #1 ACCESS DOOR BL 55 STA 337 RH FOR NHA SEE FIG. 2.6-35	RF	35	
	8-18661-801	. FRAME INSTL, WING TANK #1 ACCESS DOOR BL 47 STA 416 LH FOR NHA SEE FIG. 2.6-35	RF	35	
	8-18661-805	. FRAME INSTL, WING TANK #1 ACCESS DOOR BL 47 STA 416 RH FOR NHA SEE FIG. 2.6-35	RF	35	
- 2	8-18179-1	. . NUTPLATE ASSY, AFT RIVETED	1	35	
	8-18179-2	. . NUTPLATE ASSY, FWD RIVETED	1	35	
	8-18662-1	. DOOR INSTL, WING ACCESS TANK #1 BL 58 STA 352 LH FOR NHA SEE FIG. 2.6-32	RF	35	
	8-18662-5	. DOOR INSTL, WING ACCESS TANK #1 BL 58 STA 352 RH FOR NHA SEE FIG. 2.6-32	RF	35	
- 3	8-18642-7	. . DOOR ATTACHING PARTS	1	35	
	NAS334CPA6-5	. . BOLT (80205)	31	35	
	NAS334CPA6	. . BOLT (80205)	20	35	
	NAS334CPA5-5	. . BOLT (80205) ----X----	4	35	
	8-18622-7	. . GASKET, USE WITH 8-18642-7	1	35	
	8-18662	. FRAME INSTL, WING TANK #1 ACCESS DOOR BL 58 STA 352 LH FOR NHA SEE FIG. 2.6-35	RF	35	
	8-18662-3	. FRAME INSTL, WING TANK #1 ACCESS DOOR BL 58 STA 352 RH FOR NHA SEE FIG. 2.6-35	RF	35	
	8-18179-1	. . NUTPLATE ASSY, AFT RIVETED	2	35	
	8-18179-2	. . NUTPLATE ASSY, FWD RIVETED	2	35	
	8-18663-1	. DOOR INSTL, WING ACCESS TANK #1 BL 65 STA 381 LH FOR NHA SEE FIG. 2.6-32	RF	35	
	8-18663-5	. DOOR INSTL, WING ACCESS TANK #1 BL 72 STA 413 LH FOR NHA SEE FIG. 2.6-32	RF	35	
	8-18663-803	. DOOR INSTL, WING ACCESS TANK #1 BL 65 STA 381 RH FOR NHA SEE FIG. 2.6-32	RF	35	
	8-18663-807	. DOOR INSTL, WING ACCESS TANK #1 BL 72 STA 413 RH FOR NHA SEE FIG. 2.6-35	RF	35	
- 4	8-18643-7	. . DOOR ATTACHING PARTS	1	35	
	NAS334CPA6-5	. . BOLT (80205)	38	35	
	NAS334CPA6	. . BOLT (80205)	52	35	

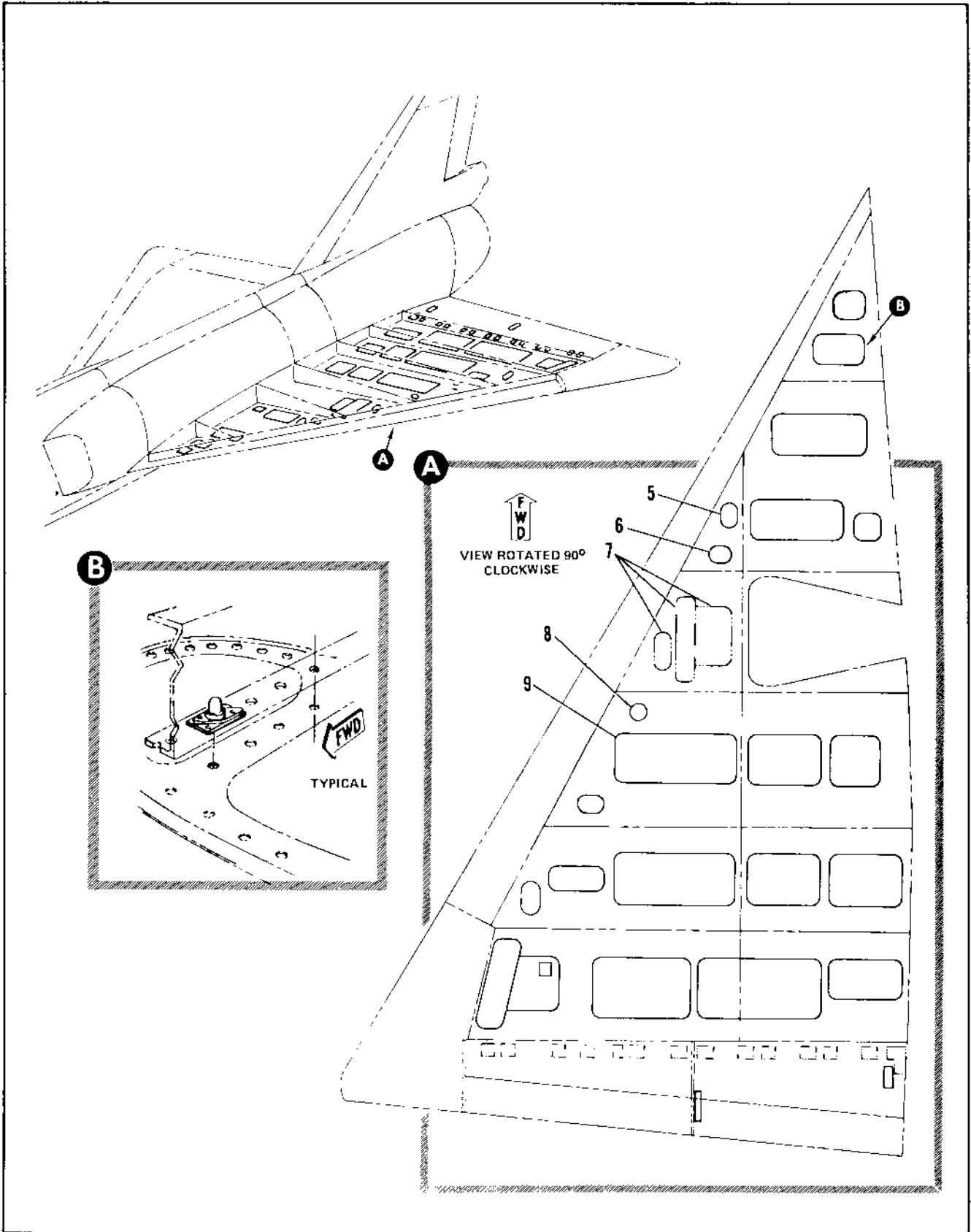

Figure 2.2-19. Lower Wing Access Doors (Sheet 2 of 7)

FIGURE AND INDEX NUMBER	PART NUMBER	DESCRIPTION 1 2 3 4 5 6	UNITS PER ASSY.	USABLE ON CODE		
				FROM	TO	
2.2-19	NAS334CPA5-5	• • BOLT -----X-----	16	35		
	8-18623-7	• • GASKET, USE WITH 8-18643-7	1	35		
	8-18663	• FRAME INSTL, WING TANK #1 ACCESS DOOR BL 65 STA 381 LH FOR NHA SEE FIG. 2.6-35	RF	35		
	8-18663-801	• FRAME INSTL, WING TANK #1 ACCESS DOOR BL 65 STA 381 RH FOR NHA SEE FIG. 2.6-35	RF	35		
	8-18663-3	• FRAME INSTL, WING TANK #1 ACCESS DOOR BL 72 STA 413 LH FOR NHA SEE FIG. 2.6-35	RF	35		
	8-18663-805	• FRAME INSTL, WING TANK #1 ACCESS DOOR BL 72 STA 413 RH FOR NHA SEE FIG. 2.6-35	RF	35		
	8-18179-1	• • NUTPLATE ASSY, AFT RIVETED	4	35		
	8-18179-2	• • NUTPLATE ASSY, FWD RIVETED	4	35		
	8-18664-1	• DOOR INSTL, WING ACCESS TANK #1 BL 96 STA 413 LH FOR NHA SEE FIG. 2.6-32	RF	35		
	8-18644-5	• DOOR INSTL, WING ACCESS TANK #1 BL 96 STA 413 RH FOR NHA SEE FIG. 2.6-32	RF	35		
	- 5	8-18644-7	• • DOOR ATTACHING PARTS	1	35	
		NAS334CPA6-5	• • BOLT (80205) -----X-----	23	35	
		8-18624-7	• • GASKET, USE WITH 8-18644-7	1	35	
		8-18664-803	• DOOR INSTL, WING ACCESS TANK #1 BL 99 STA 423 LH FOR NHA SEE FIG. 2.6-32	RF	35	
		8-18664-807	• DOOR INSTL, WING ACCESS TANK #1 BL 99 STA 423 RH FOR NHA SEE FIG. 2.6-32	RF	35	
	- 6	8-18644-7	• • DOOR ATTACHING PARTS	1	35	
		NAS334CPA6-5	• • BOLT (80205) -----X-----	23	35	
	- 7	8-18624-7	• • GASKET, USE WITH 8-18644-7	1	35	
		8-18669-803	• DOOR INSTL, WING OUTBOARD INTERMEDIATE BOX ACCESS LH SEE FIG. 2.2-21	RF	35	
		8-18669-807	• DOOR INSTL, WING ACCESS TANK #2 BL 127 LH FOR NHA SEE FIG. 2.6-32	RF	35	
- 8	8-18649-7	• • DOOR ATTACHING PARTS	1	35		
	NAS334CPA6-5	• • BOLT (80205) -----X-----	23	35		
	8-18629-7	• • GASKET, USE WITH 8-18649-7	1	35		
	8-18668-5	• DOOR INSTL, WING ACCESS TANK #2 BL 123 STA 496 LH FOR NHA SEE FIG. 2.6-32	RF	35		
	8-18668-807	• DOOR INSTL, WING ACCESS TANK #2 BL 123 STA 496 RH FOR NHA SEE FIG. 2.6-32	RF	35		
- 9	8-18648-7	• • DOOR ATTACHING PARTS	1	35		
	NAS334CPA6-5	• • BOLT (80205)	49	35		
	NAS334CPA6	• • BOLT (80205)	76	35		
	NAS334CPA5-5	• • BOLT (80205) -----X-----	35	35		
	8-18628-7	• • GASKET, USE WITH 8-18648-7	1	35		
	8-18668-3	• FRAME INSTL, WING TANK #2 ACCESS DOOR BL 123 STA 496 LH FOR NHA SEE FIG. 2.6-36	RF	35		

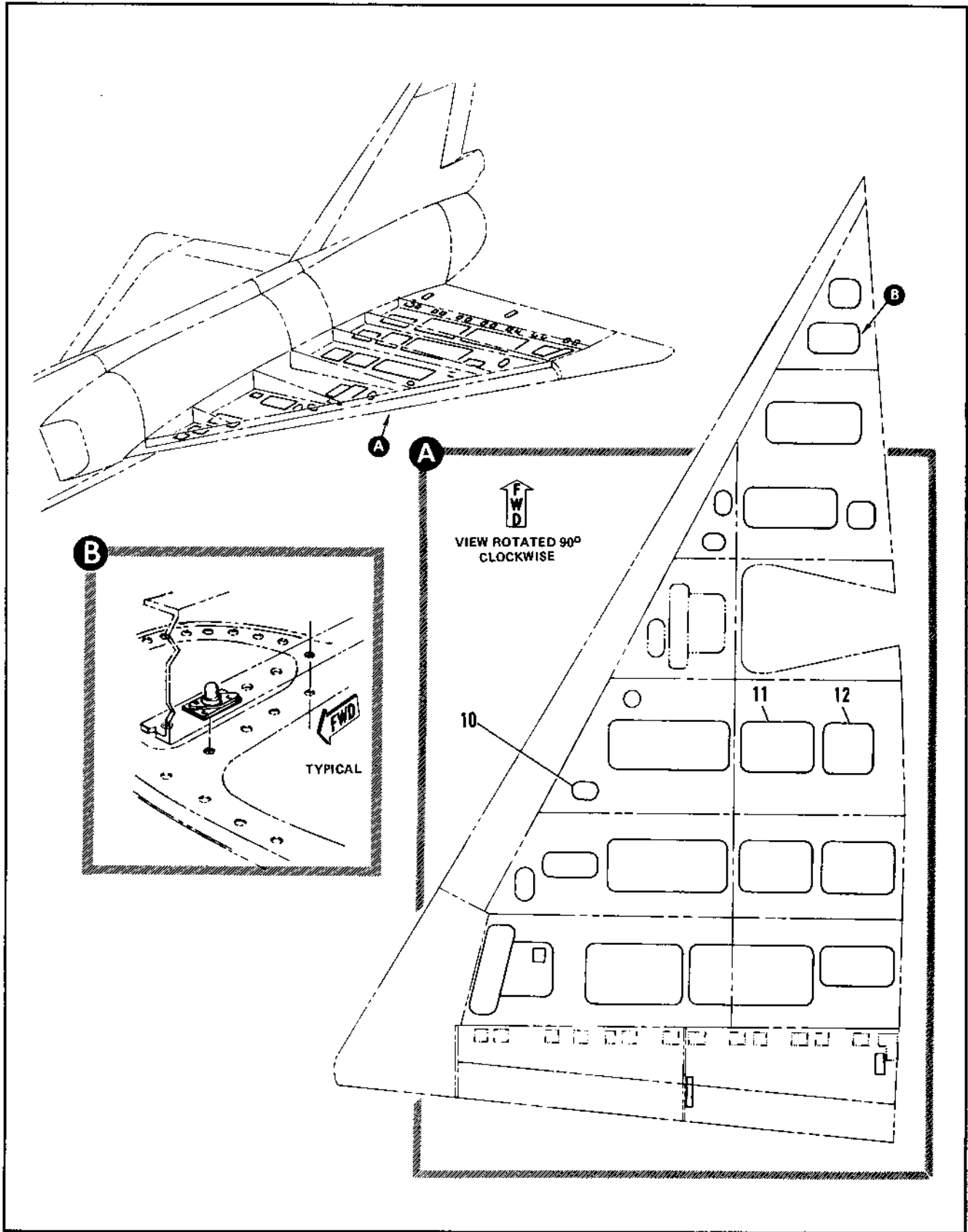

Figure 2.2-19. Lower Wing Access Doors (Sheet 3 of 7)

FIGURE AND INDEX NUMBER	PART NUMBER	DESCRIPTION	UNITS PER ASSY.	USABLE ON CODE	
				FROM	TO
		1 2 3 4 5 6			
2.2-19	8-18668-805	• FRAME INSTL, WING TANK #2 ACCESS DOOR BL 123 STA 496 RH FOR NHA SEE FIG. 2.6-36	RF	35	
	8-18179-1	• . NUTPLATE ASSY, AFT RIVETED	5	35	
	8-18179-2	• . NUTPLATE ASSY, FWD RIVETED	5	35	
	8-18672-803	• DOOR INSTL, WING ACCESS TANK #2 BL 145 LH FOR NHA SEE FIG. 2.6-32	RF	35	
	8-18672-807	• DOOR INSTL, WING ACCESS TANK #2 BL 145 RH FOR NHA SEE FIG. 2.6-32	RF	35	
- 10	8-18652-7	• . DOOR, STA 512 ATTACHING PARTS	1	35	
	NAS334CPA6-5	• . BOLT (80205) ----X----	27	35	
	8-18632-7	• . GASKET, USE WITH 8-18652-7	1	35	
	8-18667-1	• DOOR INSTL, WING ACCESS TANK #3 BL 76 LH FOR NHA SEE FIG. 2.6-32	RF	35	
	8-18667-803	• DOOR INSTL, WING ACCESS TANK #3 BL 76 RH FOR NHA SEE FIG. 2.6-32	RF	35	
- 11	8-18647-7	• . DOOR ATTACHING PARTS	1	35	
	NAS334CPA6-5	• . BOLT (80205)	46	35	
	NAS334CAP6	• . BOLT (80205)	36	35	
	NAS334CPA5-5	• . BOLT (80205) ----X----	21	35	
	8-18627-7	• . GASKET, USE WITH 8-18647-7	1	35	
	8-18667	• FRAME INSTL, WING TANK #3 ACCESS DOOR BL 76 STA 496 LH FOR NHA SEE FIG. 2.6-36	RF	35	
	8-18667-801	• FRAME INSTL, WING TANK #3 ACCESS DOOR BL 76 STA 496 RH FOR NHA SEE FIG. 2.6-36	RF	35	
	8-18179-1	• . NUTPLATE ASSY, AFT RIVETED	3	35	
	8-18179-2	• . NUTPLATE ASSY, FWD RIVETED	3	35	
	8-18666-1	• DOOR INSTL, WING ACCESS TANK #3 BL 50 LH FOR NHA SEE FIG. 2.6-32	RF	35	
	8-18666-5	• DOOR INSTL, WING ACCESS TANK #3 BL 50 RH FOR NHA SEE FIG. 2.6-32	RF	35	
- 12	8-18646-7	• . DOOR ATTACHING PARTS	1	35	
	NAS334CPA6-5	• . BOLT (80205)	48	35	
	NAS334CPA6	• . BOLT (80205)	14	35	
	NAS334CPA5-5	• . BOLT (80205) ----X----	20	35	
	8-18626-7	• . GASKET, USE WITH 8-18646-7	1	35	
	8-18666	• FRAME INSTL, WING TANK #3 ACCESS DOOR BL 50 LH FOR NHA SEE FIG. 2.6-36	RF	35	
	8-18666-3	• FRAME INSTL, WING TANK #3 ACCESS DOOR BL 50 RH FOR NHA SEE FIG. 2.6-36	RF	35	
	8-18179-1	• . NUTPLATE ASSY, AFT RIVETED	2	35	
	8-18179-2	• . NUTPLATE ASSY, FWD RIVETED	2	35	

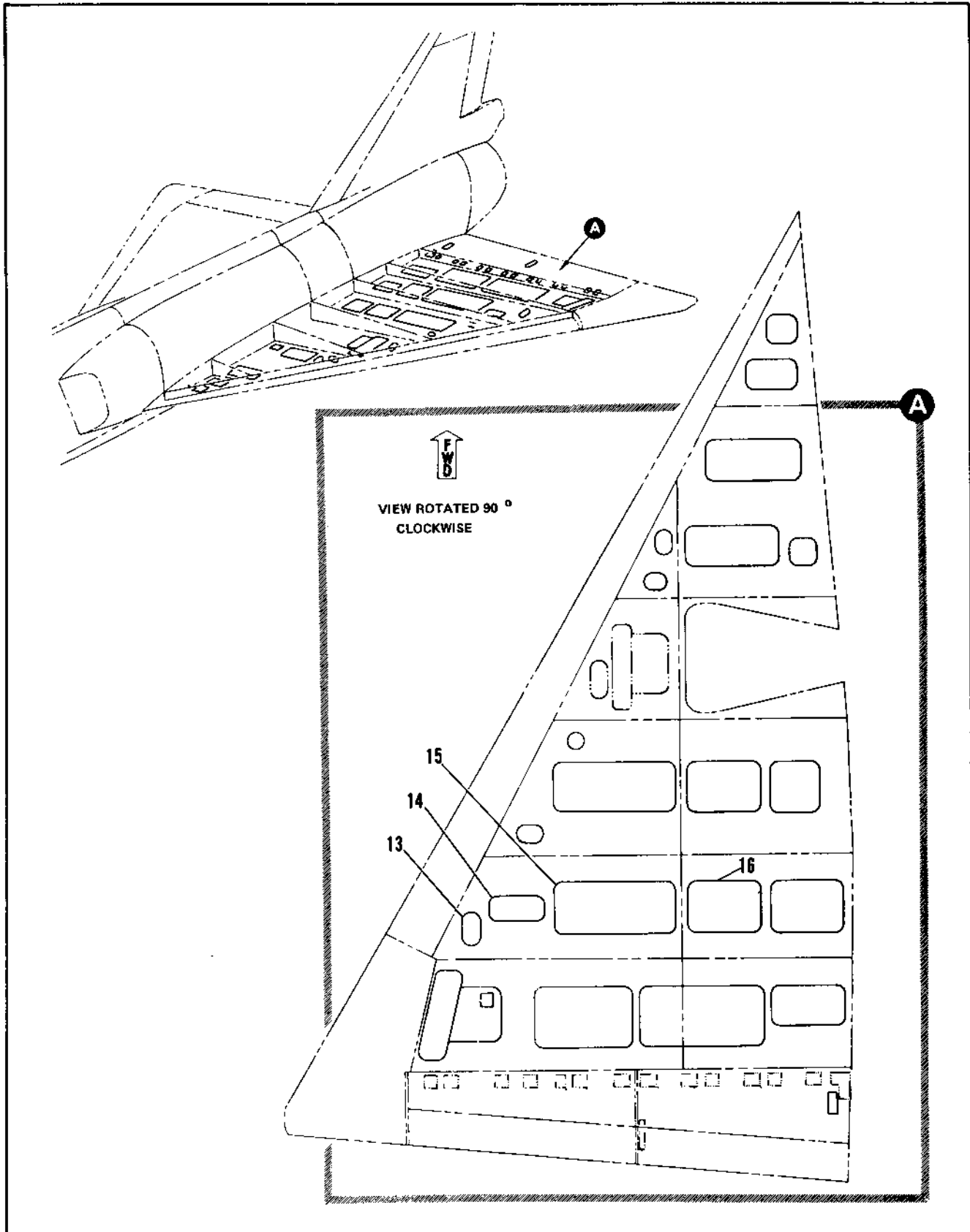

Figure 2.2-19. Lower Wing Access Doors (Sheet 4 of 7)

FIGURE AND INDEX NUMBER	PART NUMBER	DESCRIPTION	UNITS PER ASSY.	USABLE ON CODE	
				FROM	TO
		1 2 3 4 5 6			
2.2-19	8-18672-1	• DOOR INSTL, WING ACCESS TANK#2 BL 164 LH FOR NHA SEE FIG. 2.6-32	RF	35	
	8-18672-5	• DOOR INSTL, WING ACCESS TANK #2 BL 164 RH FOR NHA SEE FIG. 2.6-32	RF	35	
- 13	8-18652-7	• DOOR, STA 545 ATTACHING PARTS	1	35	
	NAS334CPA6-5	• BOLT(80205) ----X----	27	35	
	8-18632-7	• GASKET, USE WITH 8-18652-7	1	35	
	8-18671-1	• DOOR INSTL, WING ACCESS TANK #2 BL 150 LH FOR NHA SEE FIG. 2.6-32	RF	35	
	8-18671-5	• DOOR INSTL, WING ACCESS TANK #2 BL 150 RH FOR NHA SEE FIG. 2.6-32	RF	35	
- 14	8-18651-7	• DOOR, STA 538 ATTACHING PARTS	1	35	
	NAS334CPA6-5	• BOLT (80205)	33	35	
	NAS334CPA5-5	• BOLT (80205)	4	35	
	NAS334CPA6	• BOLT (80205) ----X----	20	35	
	8-18631-7	• GASKET, USE WITH 8-18651-7	1	35	
	8-18671	• FRAME INSTL, WING TANK #2 ACCESS DOOR BL 150 LH FOR NHA SEE FIG. 2.6-36	RF	35	
	8-18671-3	• FRAME INSTL, WING TANK #2 ACCESS DOOR BL 150 RH FOR NHA SEE FIG. 2.6-36	RF	35	
	8-18179-1	• NUTPLATE ASSY, AFT RIVETED	2	35	
	8-18179-2	• NUTPLATE ASSY, FWD RIVETED	2	35	
	8-18668-1	• DOOR INSTL, WING ACCESS TANK #2 BL 123 STA 538 LH FOR NHA SEE FIG. 2.6-32	RF	35	
	8-18668-803	• DOOR INSTL, WING ACCESS TANK #2 BL 123 STA 538 RH FOR NHA SEE FIG. 2.6-32	RF	35	
- 15	8-18648-7	• DOOR ATTACHING PARTS	1	35	
	NAS334CPA6-5	• BOLT (80205)	49	35	
	NAS334CPA6	• BOLT (80205)	76	35	
	NAS334CPA5-5	• BOLT (80205) ----X----	35	35	
	8-18628-7	• GASKET, USE WITH 8-18648-7	1	35	
	8-18668	• FRAME INSTL, WING TANK#2 ACCESS DOOR HL123 STA 538 LH FOR NHA SEE FIG. 2.6-36	RF	35	
	8-18668-801	• FRAME INSTL, WING TANK #2 ACCESS DOOR HL123 STA 538 RH FOR NHA SEE FIG. 2.6-36	RF	35	
	8-18179-1	• NUTPLATE ASSY, AFT RIVETED	5	35	
	8-18179-2	• NUTPLATE ASSY, FWD RIVETED	5	35	
	8-18667-5	• DOOR INSTL, WING ACCESS TANK #3 BL 76 LH FOR NHA SEE FIG. 2.6-32	RF	35	
	8-18667-807	• DOOR INSTL, WING ACCESS TANK #3 BL 76 RH FOR NHA SEE FIG. 2.6-32	RF	35	
- 16	8-18647-7	• DOOR ATTACHING PARTS	1	35	
	NAS334CPA6-5	• BOLT (80205)	46	35	
	NAS334CPA6	• BOLT (80205)	36	35	
	NAS334CPA5-5	• BOLT (80205) ----X----	21	35	
	8-18627-7	• GASKET, USE WITH 8-18647-7	1	35	

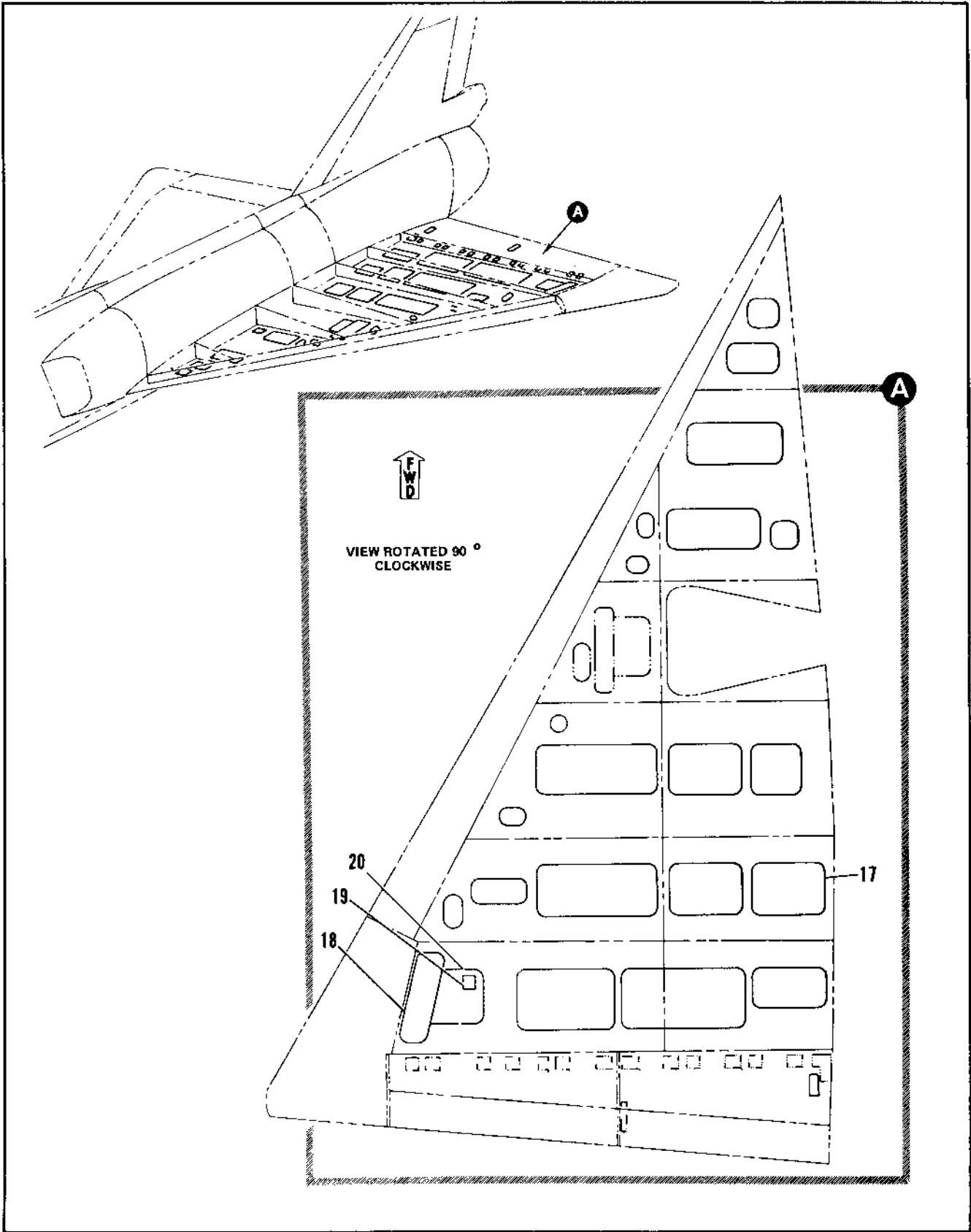

Figure 2.2-19. Lower Wing Access Doors (Sheet 5 of 7)

FIGURE AND INDEX NUMBER	PART NUMBER	DESCRIPTION	UNITS PER ASSY.	USABLE ON CODE	
				FROM	TO
		1 2 3 4 5 6			
2.2-19	8-18667-3	• FRAME INSTL, WING TANK #3 ACCESS DOOR BL 76 STA 538 LH FOR NHA SEE FIG. 2.6-36	RF	35	
	8-18667-805	• FRAME INSTL, WING TANK #3 ACCESS DOOR BL 76 STA 538 RH FOR NHA SEE FIG. 2.6-36	RF	35	
	8-18179-1	• • NUTPLATE ASSY, AFT RIVETED	3	35	
	8-18179-2	• • NUTPLATE ASSY, FWD RIVETED	3	35	
	8-18670-1	• DOOR INSTL, WING ACCESS TANK #3 BL 48 LH FOR NHA SEE FIG. 2.6-32	RF	35	
	8-18670-5	• DOOR INSTL, WING ACCESS TANK #3 BL 48 RH FOR NHA SEE FIG. 2.6-32	RF	35	
- 17	8-18650-7	• • DOOR ATTACHING PARTS	1	35	
	NAS334CPA6-5	• • BOLT (80205)	46	35	
	NAS334CPA6	• • BOLT (80205)	36	35	
	NAS334CPA5-5	• • BOLT (80205)	21	35	
		----X----			
	8-18630-7	• • GASKET, USE WITH 8-18650-7	1	35	
	8-18670	• FRAME INSTL, WING TANK #3 ACCESS DOOR BL 48 LH FOR NHA SEE FIG. 2.6-36	RF	35	
	8-18670-3	• FRAME INSTL, WING TANK #3 ACCESS DOOR BL 48 RH FOR NHA SEE FIG. 2.6-36	RF	35	
	8-18179-1	• • NUTPLATE ASSY, AFT RIVETED	3	35	
	8-18179-2	• • NUTPLATE ASSY, FWD RIVETED	3	35	
	8-18678-3	• DOOR INSTL, WING ACCESS TRAILING EDGE BL 176 LH FOR NHA SEE FIG. 2.6-32	RF	35	
	8-18678-4	• DOOR INSTL, WING ACCESS TRAILING EDGE BL 176 RH FOR NHA SEE FIG. 2.6-32	RF	35	
- 18	8-18658-7	• • DOOR, LH	1	35	
	8-18658-8	• • DOOR, RH	1	35	
		ATTACHING PARTS			
	NAS334CPA6-5	• • BOLT (80205)	48	35	
	NAS334CPA6	• • BOLT (80205)	37	35	
		----X----			
	8-18677-5	• DOOR INSTL, WING ACCESS TRAILING EDGE BL 156 LH FOR NHA SEE FIG. 2.6-32	RF	35	
	8-18677-6	• DOOR INSTL, WING ACCESS TRAILING EDGE BL 156 RH FOR NHA SEE FIG. 2.6-32	RF	35	
- 19	8-18656	• • DOOR	1	35	
		ATTACHING PARTS			
	NAS334CPA6-5	• • BOLT (80205)	6	35	
	NAS334CPA6	• • BOLT (80205)	14	35	
		----X----			
	8-18677-1	• DOOR INSTL, WING ACCESS TRAILING EDGE BL 162 LH FOR NHA SEE FIG. 2.6-32	RF	35	
	8-18677-2	• DOOR INSTL, WING ACCESS TRAILING EDGE BL 162 RH FOR NHA SEE FIG. 2.6-32	RF	35	
- 20	8-18677-19	• • DOOR ASSY, LH	1	35	
	8-18677-20	• • DOOR ASSY, RH	1	35	
		ATTACHING PARTS			
	NAS334CPA5-5	• • BOLT (80205)	44	35	
	NAS334CPA6	• • BOLT (80205)	23	35	
	NAS334CPA5	• • BOLT (80205)	14	35	
		----X----			
	8-18657-7	• • DOOR, LH	1	35	
	8-18657-8	• • DOOR, RH	1	35	

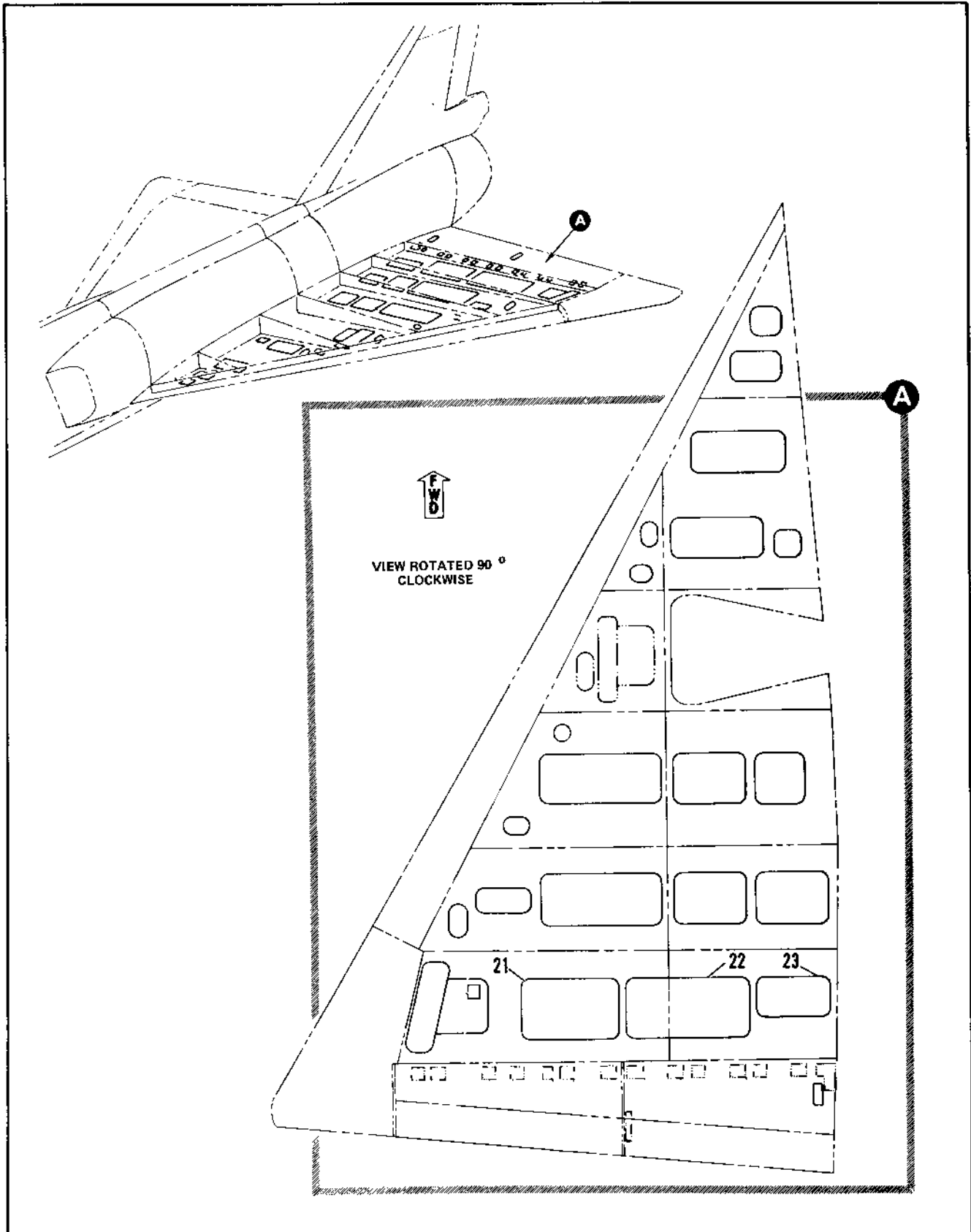

Figure 2.2-19. Lower Wing Access Doors (Sheet 6 of 7)

FIGURE AND INDEX NUMBER	PART NUMBER	DESCRIPTION	UNITS PER ASSY.	USABLE ON CODE	
				FROM	TO
		1 2 3 4 5 6			
2.2-19	8-18675-1	• DOOR INSTL, WING ACCESS TRANSFER TANK BL 126 LH FOR NHA SEE FIG. 2.6-32	RF	35	
	8-18675-5	• DOOR INSTL, WING ACCESS TRANSFER TANK BL 126 RH FOR NHA SEE FIG. 2.6-32	RF	35	
- 21	8-18675-7	• DOOR ASSEMBLY ATTACHING PARTS	1	35	
	NAS334CPA7	• BOLT (80205)	23	35	
	NAS334CPA7-5	• BOLT (80205)	23	35	
	NAS334CPA6-5	• BOLT (80205)	62	35	
	NAS334CPA6	• BOLT (80205)	56	35	
		-----X-----			
	8-18635	• GASKET, USE WITH 8-18655	1	35	
	8-18655	• DOOR	1	35	
	8-18675	• FRAME INSTL, WING TRANSFER TANK ACCESS DOOR BL 126 LH FOR NHA SEE FIG. 2.6-37	RF	A	
	8-18675-801	• FRAME INSTL, WING TRANSFER TANK ACCESS DOOR BL 126 LH FOR NHA SEE FIG. 2.6-37	RF	189	277
	8-18675-3	• FRAME INSTL, WING TRANSFER TANK ACCESS DOOR BL 126 RH FOR NHA SEE FIG. 2.6-37	RF	A	
	8-18675-803	• FRAME INSTL, WING TRANSFER TANK ACCESS DOOR BL 126 RH FOR NHA SEE FIG. 2.6-37	RF	189	277
	8-18179-1	• NUTPLATE ASSY, AFT RIVETED	8	35	
	8-18179-2	• NUTPLATE ASSY, FWD RIVETED	8	35	
	8-18674-1	• DOOR INSTL, WING ACCESS TRANSFER TANK BL 84 LH FOR NHA SEE FIG. 2.6-32	RF	35	
	8-18674-5	• DOOR INSTL, WING ACCESS TRANSFER TANK BL 84 RH FOR NHA SEE FIG. 2.6-32	RF	35	
- 22	8-18674-7	• DOOR ASSEMBLY ATTACHING PARTS	1	35	
	NAS334CPA7	• BOLT (80205)	53	35	
	NAS334CPA6	• BOLT (80205)	70	35	
	NAS334CPA6-5	• BOLT (80205)	84	35	
		-----X-----			
	8-18634	• GASKET, USE WITH 8-18654	1	35	
	8-18654	• DOOR	1	35	
	8-18674	• FRAME INSTL, WING TRANSFER TANK ACCESS DOOR BL 84 LH FOR NHA SEE FIG. 2.6-37	RF	A	
	8-18674-801	• FRAME INSTL, WING TRANSFER TANK ACCESS DOOR BL 84 LH FOR NHA SEE FIG. 2.6-37	RF	189	277
	8-18674-3	• FRAME INSTL, WING TRANSFER TANK ACCESS DOOR BL 84 RH FOR NHA SEE FIG. 2.6-37	RF	A	
	8-18674-803	• FRAME INSTL, WING TRANSFER TANK ACCESS DOOR BL 84 RH FOR NHA SEE FIG. 2.6-37	RF	189	277
	8-18179-1	• NUTPLATE ASSY, AFT RIVETED	10	35	
	8-18179-2	• NUTPLATE ASSY, FWD RIVETED	10	35	
	8-18673-1	• DOOR INSTL, WING ACCESS TRANSFER TANK BL 48 LH FOR NHA SEE FIG. 2.6-32	RF	35	
	8-18673-5	• DOOR INSTL, WING ACCESS TRANSFER TANK BL 48 RH FOR NHA SEE FIG. 2.6-32	RF	35	
- 23	8-18673-7	• DOOR ASSEMBLY ATTACHING PARTS	1	35	
	NAS334CPA7-5	• BOLT (80205)	18	35	
	NAS334CPA7	• BOLT (80205)	24	35	
	NAS334CPA6-5	• BOLT (80205)	42	35	
	NAS334CPA6	• BOLT (80205)	24	35	
		-----X-----			

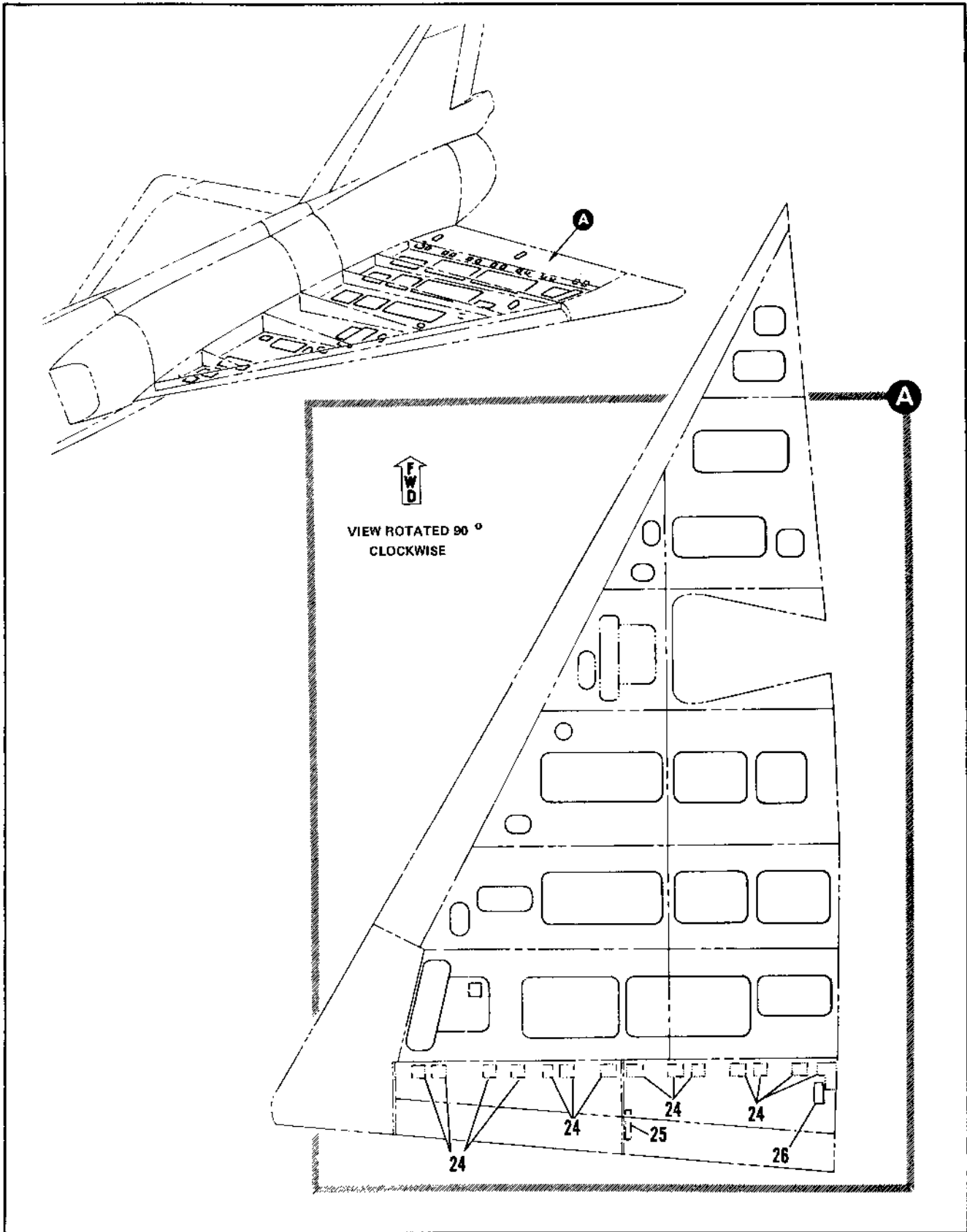

Figure 2.2-19. Lower Wing Access Doors (Sheet 7 of 7)

FIGURE AND INDEX NUMBER	PART NUMBER	DESCRIPTION	UNITS PER ASSY.	USABLE ON CODE	
				FROM	TO
		1 2 3 4 5 6			
2.2-19	8-18633	. . . GASKET, USE WITH 8-18653	1	35	
	8-18653	. . . DOOR	1	35	
	8-18673	. FRAME INSTL, WING TRANSFER TANK ACCESS DOOR	RF	A	
	8-18673-801	BL 48 LH FOR NHA SEE FIG. 2.6-37	RF	189	277
	8-18673-3	. FRAME INSTL, WING TRANSFER TANK ACCESS DOOR	RF	A	
	8-18673-803	BL 48 RH FOR NHA SEE FIG. 2.6-37	RF	189	277
	8-18179-1	. . NUTPLATE ASSY, AFT RIVETED	6	35	
- 24	8-18179-2	. . NUTPLATE ASSY, FWD RIVETED	6	35	
- 25		. DOOR INSTL, ELEVON HINGE ACCESS LH	RF		
		SEE FIG. 2.2-20			
		. DOOR ASSY, ELEVON LINK ACCESS BL 107	RF		
		RIVETED SEE FIG. 2.6-6			
	8-13601-5	. DOOR INSTL, INBOARD ELEVON ACCESS BL 40 LH	RF	35	
		FOR NHA SEE FIG. 2.6-6 AND 2.6-7			
	8-13601-6	. DOOR INSTL, INBOARD ELEVON ACCESS BL 40 RH	RF	35	
		FOR NHA SEE FIG. 2.6-6 AND 2.6-7			
- 26	8-13601-15	. . DOOR, LH	1	35	
	8-13601-16	. . DOOR, RH	1	35	
		ATTACHING PARTS			
	NAS333CPA7	. . SCREW (80205)	9	35	
	NAS333CPA4-5	. . SCREW (80205)	14	35	
		-----X-----			
		A AIRPLANES #35 THRU 188, 278 AND ON			

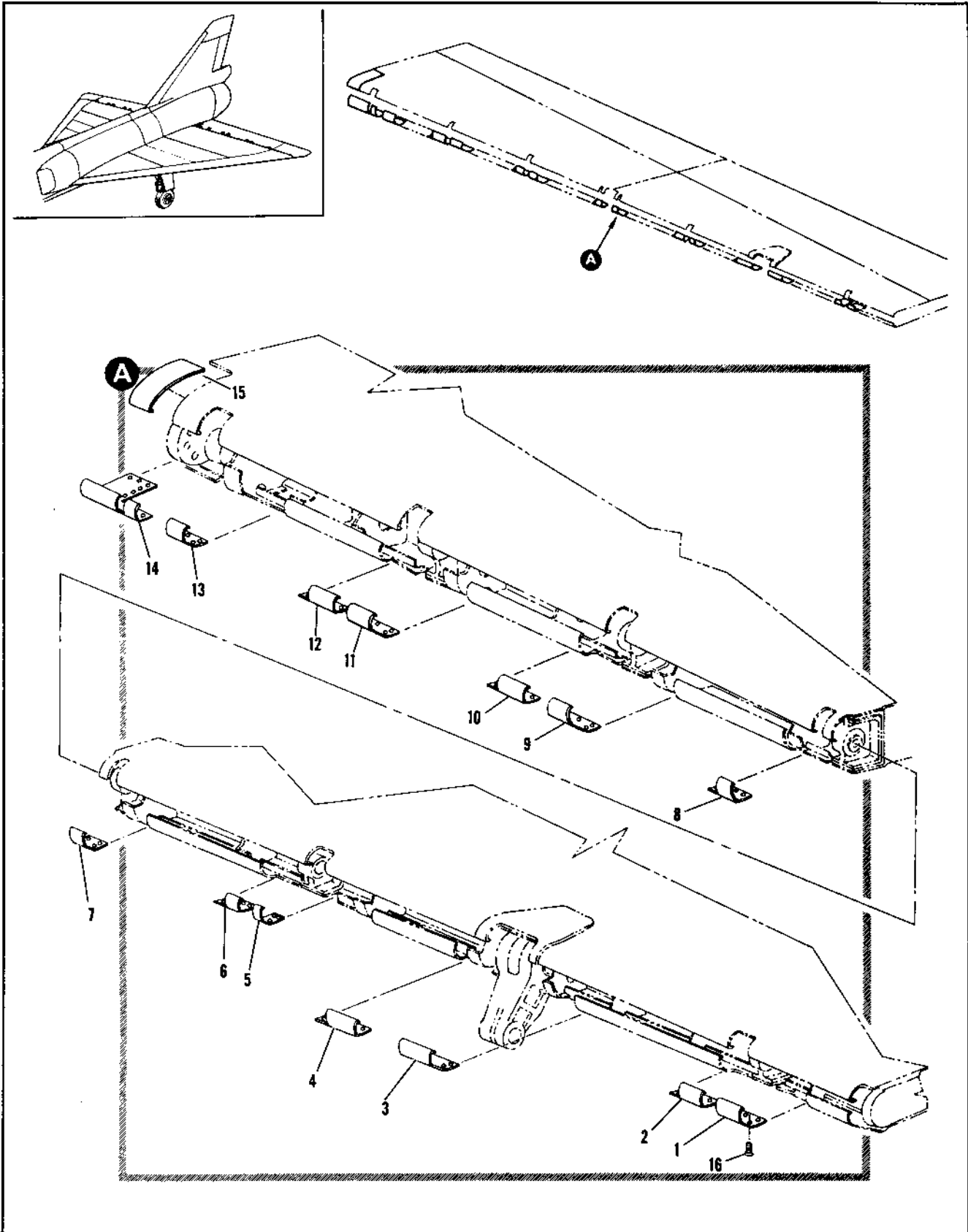

Figure 2.2-20. Elevon Hinge Access Door Installation

FIGURE AND INDEX NUMBER	PART NUMBER	DESCRIPTION 1 2 3 4 5 6	UNITS PER ASSY.	USABLE ON CODE	
				FROM	TO
2.2-20	8-13603-1	DOOR INSTALLATION, ELEVON HINGE ACCESS LH FOR NHA SEE FIG. 2.6-6 AND 2.6-7	RF	35	
	8-13603-2	DOOR INSTALLATION, ELEVON HINGE ACCESS RH FOR NHA SEE FIG. 2.6-6 AND 2.6-7	RF	35	
- 1	8-13603-35	• DOOR, ACCESS ELEVON NOSE BL 175 OUTBD LH	1	35	
	8-13603-36	• DOOR, ACCESS ELEVON NOSE BL 175 OUTBD RH	1	35	
- 2	8-13603-33	• DOOR, ACCESS ELEVON NOSE BL 175 INBD LH	1	35	
	8-13603-34	• DOOR, ACCESS ELEVON NOSE BL 175 INBD RH	1	35	
- 3	8-13603-31	• DOOR, ACCESS ELEVON NOSE BL 148 OUTBD LH	1	35	
	8-13603-32	• DOOR, ACCESS ELEVON NOSE BL 148 OUTBD RH	1	35	
- 4	8-13603-29	• DOOR, ACCESS ELEVON NOSE BL 148 INBD LH	1	35	
	8-13603-30	• DOOR, ACCESS ELEVON NOSE BL 148 INBD RH	1	35	
- 5	8-13603-27	• DOOR, ACCESS ELEVON NOSE BL 130 OUTBD LH	1	35	
	8-13603-28	• DOOR, ACCESS ELEVON NOSE BL 130 OUTBD RH	1	35	
- 6	8-13603-25	• DOOR, ACCESS ELEVON NOSE BL 130 INBD LH	1	35	
	8-13603-26	• DOOR, ACCESS ELEVON NOSE BL 130 INBD RH	1	35	
- 7	8-13603-23	• DOOR, ACCESS ELEVON NOSE BL 107 OUTBD LH	1	35	
	8-13603-24	• DOOR, ACCESS ELEVON NOSE BL 107 OUTBD RH	1	35	
- 8	8-13603-21	• DOOR, ACCESS ELEVON NOSE BL 107 INBD LH	1	35	
	8-13603-22	• DOOR, ACCESS ELEVON NOSE BL 107 INBD RH	1	35	
- 9	8-13603-19	• DOOR, ACCESS ELEVON NOSE BL 84 OUTBD LH	1	35	
	8-13603-20	• DOOR, ACCESS ELEVON NOSE BL 84 OUTBD RH	1	35	
- 10	8-13603-17	• DOOR, ACCESS ELEVON NOSE BL 84 INBD LH	1	35	
	8-13603-18	• DOOR, ACCESS ELEVON NOSE BL 84 INBD RH	1	35	
- 11	8-13603-15	• DOOR, ACCESS ELEVON NOSE BL 62 OUTBD LH	1	35	
	8-13603-16	• DOOR, ACCESS ELEVON NOSE BL 62 OUTBD RH	1	35	
- 12	8-13603-13	• DOOR, ACCESS ELEVON NOSE BL 62 INBD LH	1	35	
	8-13603-14	• DOOR, ACCESS ELEVON NOSE BL 62 INBD RH	1	35	
- 13	8-13603-11	• DOOR, ACCESS ELEVON NOSE BL 40 OUTBD LH	1	35	
	8-13603-12	• DOOR, ACCESS ELEVON NOSE BL 40 OUTBD RH	1	35	
- 14	8-13603-9	• DOOR, ACCESS ELEVON NOSE BL 40 INBD LOWER LH	1	35	
	8-13603-10	• DOOR, ACCESS ELEVON NOSE BL 40 INBD LOWER RH	1	35	
- 15	8-13603-7	• DOOR, ACCESS ELEVON NOSE BL 40 INBD UPPER LH REPLACED BY SUITABLE SUB FOR 8-13603-38	1	35	60
	8-13603-37	• DOOR, ACCESS ELEVON NOSE BL 40 INBD LOWER LH REPLACES SUITABLE SUB FOR 8-13603-7	1	61	
	8-13603-8	• DOOR, ACCESS ELEVON NOSE BL 40 INBD UPPER RH REPLACED BY SUITABLE SUB FOR 8-13603-38	1	35	60
	8-13603-38	• DOOR, ACCESS ELEVON NOSE BL 40 INBD UPPER RH REPLACES SUITABLE SUB FOR 8-13603-8	1	61	
- 16	NAS333CPA4-5	• SCREW (80205) ----X----	60	35	

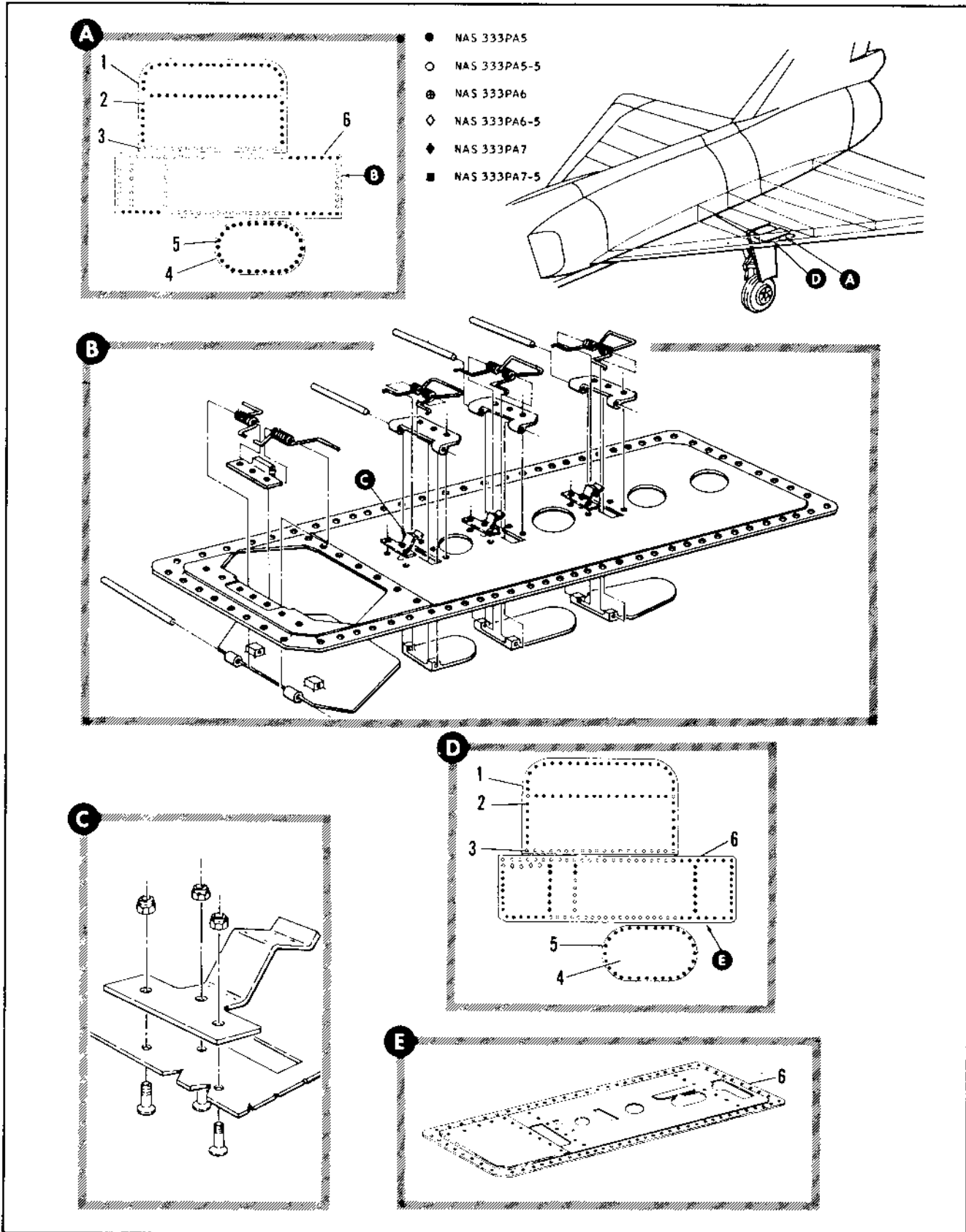

Figure 2.2-21. Wing Outbd Intermediate Box Access Door Installation (Sheet 1 of 2)

FIGURE AND INDEX NUMBER	PART NUMBER	DESCRIPTION	UNITS PER ASSY.	USABLE ON CODE		
				FROM	TO	
		1 2 3 4 5 6				
2.2-21	8-18680-801	DOOR INSTALLATION, WING OUTBOARD INTERMEDIATE	RF	A		
	8-18680-806	DOOR INSTALLATION, WING OUTBOARD INTERMEDIATE BOX ACCESS RH MODIFIED BY 8-11906-1, -5 AND 65J33342	1	B		
	8-18680-810	DOOR INSTALLATION, WING OUTBOARD INTERMEDIATE BOX ACCESS RH MODIFIED BY 8-11906-1 AND -5 FOR NHA SEE FIG. 2.6-32	RF	C		
	8-18680-810	DOOR INSTALLATION, WING OUTBOARD INTERMEDIATE BOX ACCESS RH MODIFIED BY 8-11906-1, -5 AND 65J33342 FOR NHA SEE FIG. 2.6-32 (98750) BOX ACCESS LH MODIFIED BY 8-11906-801, -3 AND -803 FOR NHA SEE FIG. 2.6-32	1	C		
	8-18680-801	DOOR INSTALLATION, WING OUTBOARD INTERMEDIATE BOX ACCESS LH MODIFIED BY 8-11906-801, -3 -803 AND 65J33342 FOR NHA SEE FIG. 2.6-32	1	A		
	8-18680-805	DOOR INSTALLATION, WING OUTBOARD INTERMEDIATE BOX ACCESS LH MODIFIED BY 8-11906-1 AND -5 FOR NHA SEE FIG. 2.6-32	RF	B		
	8-18680-805	DOOR INSTALLATION, WING OUTBOARD INTERMEDIATE BOX ACCESS LH MODIFIED BY 8-11906-1, -5 AND 65J33382 FOR NHA SEE FIG. 2.6-32	1	B		
	8-18680-809	DOOR INSTALLATION, WING OUTBOARD INTERMEDIATE BOX ACCESS LH MODIFIED BY 8-11906-1 AND -5 FOR NHA SEE FIG. 2.6-32	RF	C		
	8-18680-809	DOOR INSTALLATION, WING OUTBOARD INTERMEDIATE BOX ACCESS LH MODIFIED BY 8-11906-1, -5 AND 65J33342 FOR NHA SEE FIG. 2.6-32	1	C		
	8-18680-802	DOOR INSTALLATION, WING OUTBOARD INTERMEDIATE BOX ACCESS RH MODIFIED BY 8-11906-801, -3 AND -803 FOR NHA SEE FIG. 2.6-32	RF	A		
	8-18680-802	DOOR INSTALLATION, WING OUTBOARD INTERMEDIATE BOX ACCESS RH MODIFIED BY 8-11906-801, -3 -803 AND 65J33342 FOR NHA SEE FIG. 2.6-32	1	A		
	8-18680-806	DOOR INSTALLATION, WING OUTBOARD INTERMEDIATE BOX ACCESS RH MODIFIED BY 8-11906-1 AND -5 FOR NHA SEE FIG. 2.6-32	RF		B	
	- 1	8-18775	• DOOR, BL 102 STA 453 ATTACHING PARTS	1	35	
	- 2	NAS333CPA5	• BOLT (80205)	52	35	
	- 3	NAS333CPA5-5	• BOLT (80205)	22	35	
- 4	8-18776	• DOOR, BL 121 ATTACHING PARTS	1	35		
- 5	NAS333CPA5	• BOLT (83205)	30	35		
- 6	8-18864-801	• DOOR ASSY, BL 112 STA 456 LH	RF	35	159	
	65J33342-1	• DOOR ASSY, BL 112 STA 456 LH (98750)	1	35	159	
	8-18864-805	• DOOR ASSY, BL 112 STA 456 LH	RF	D		
	65J33342-3	• DOOR ASSY, BL 112 STA 456 LH (98750)	1	0		
	8-11906-7	• DOOR ASSY, BL 112 STA 456 LH	RF	E		
		A AIRPLANES #35 THRU 277, 287, 292 AND ON				
		B AIRPLANES #278, 280, AND 282 THRU 286				
		C AIRPLANES #279, 281, AND 288 THRU 291				
		D AIRPLANES #160 THRU 277 AND 292 THRU 301				
		E AIRPLANES #278, 279, 281 THRU 285 AND				

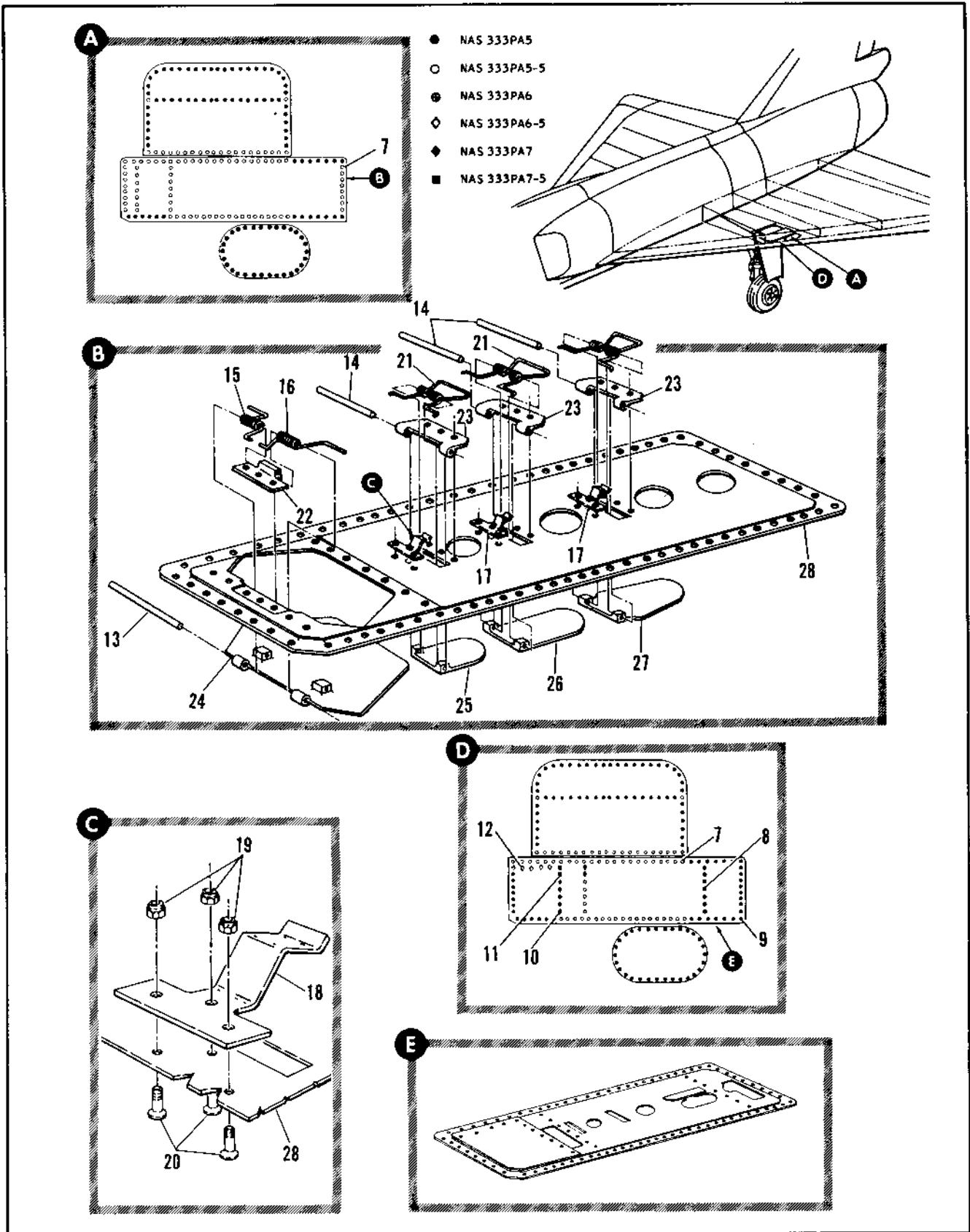

Figure 2.2-21. Wing Outboard Intermediate Box Access Door Installation (Sheet 2 of 2)

FIGURE AND INDEX NUMBER	PART NUMBER	DESCRIPTION	UNITS PER ASSY.	USABLE ON CODE	
				FROM	TO
		1 2 3 4 5 6			
2.2-21	65J33342-5	. DOOR ASSY, BL 112 STA 456 LH (98750)	1	F	
	8-11906-9	. DOOR ASSY, BL 112 STA 456 LH	RF	F	
	65J33342-5	. DOOR ASSY, BL 112 STA 456 LH (98750)	1	F	
	8-11906-11	. DOOR ASSY, BL 112 STA 456 LH	RF	G	
	65J33342-5	. DOOR ASSY, BL 112 STA 456 LH (98750)	1	G	
	8-18864-802	. DOOR ASSY, BL 112 STA 456 RH	RF	35	159
	65J33342-2	. DOOR ASSY, BL 112 STA 456 RH (98750)	1	35	159
	8-18864-806	. DOOR ASSY, BL 112 STA 456 RH	RF	D	
	65J33342-4	. DOOR ASSY, BL 112 STA 456 RH (98750)	1	D	
	8-11906-8	. DOOR ASSY, BL 112 STA 456 RH	RF	E	
	65J33342-6	. DOOR ASSY, BL 112 STA 456 RH (98750)	1	E	
	8-11906-10	. DOOR ASSY, BL 112 STA 456 RH	RF	F	
	65J33342-6	. DOOR ASSY, BL 112 STA 456 RH (98750)	1	F	
	8-11906-12	. DOOR ASSY, BL 112 STA 456 RH	RF	G	
	65J33342-6	. DOOR ASSY, BL 112 STA 456 RH (98750)	1	G	
- 7	NAS333CPA5-5	. BOLT (80205)	46	35	
- 8	NAS333CPA5	. BOLT (80205)	7	35	
- 9	NAS333CPA6	. BOLT (80205)	35	35	
- 10	NAS333CPA7	. BOLT (80205)	8	35	
- 11	NAS333CPA7-5	. BOLT (80205)	2	35	
- 12	NAS333CPA6-5	. BOLT (80205)	4	35	
- 13	MS20253-2-351	. PIN (96906)	1	35	159
	MS20253-3-462	. PIN (96906)	1	160	
- 14	MS20253-2-226	. PIN (96906)	3	35	
- 15	8-01331-1	. SPRING	RF	35	277
	8-01333-1	. SPRING	RF	278	
- 16	8-01331-2	. SPRING	1	35	
	8-01333-2	. SPRING	RF	278	
- 17	8-18799-7	. SPRING, FLAT	RF	35	
- 18	8-18799	. SPRING, FLAT	RF	35	
		ATTACHING PARTS			
- 19	NAS679A3	. NUT (80205)	RF	35	
- 20	NAS333CPA4	. BOLT (80205)	RF	35	
- 21	8-18779	. SPRING	RF	35	
- 22	8-18818	. HINGE	1	35	277
	8-18871	. HINGE	1	278	
- 23	8-18778	. HINGE	RF	35	
- 24	8-18876-15	. DOOR	1	35	277
	8-18874-7	. DOOR	1	278	
- 25	8-18876-9	. DOOR	1	35	
- 26	8-18876-7	. DOOR	1	35	
- 27	8-18710-13	. DOOR	1	35	
- 28	8-18867-11	. DOOR, LH	1	H	
	8-18867-15	. DOOR, LH	1	O	
	8-11905-7	. DOOR, LH	1	E	
	8-71130-7	. DOOR, LH	1	F	
	8-18867-12	. DOOR, RH	1	H	
	8-18867-16	. DOOR, RH	1	O	
	8-11905-8	. DOOR, RH	1	E	
	8-71130-8	. DOOR, RH	1	F	
		D AIRPLANES #160 THRU 277 AND 292 THRU 301			
		E AIRPLANES #278, 279, 281 THRU 285 AND 288 THRU 290			
		F AIRPLANES #280, 286 AND 291			
		G AIRPLANES #287, 302 AND ON			
		H AIRPLANES #35 THRU 159, 287, 302 AND ON			

FUSELAGE SUBSECTION

TABLE OF CONTENTS

Fig. No.	Title	Page	Fig. No.	Title	Page
2.3-1	Plastic Radome and Boom Assembly	2.3-2	2.3-9	Lower Barrel Assembly Sta 166 to 253	2.3-56
2.3-2	Plastic Radome Assembly	2.3-12	2.3-10	Fuselage Assembly Sta 216 to 472	2.3-58
2.3-3	General Fuselage Assembly	2.3-16	2.3-11	Equipment Assembly Sta 253 to 472	2.3-66
2.3-4	Fuselage Assembly Sta 40 to 216	2.3-32	2.3-12	Side Panel Assembly Sta 253 to 472	2.3-72
2.3-5	Fwd Radar Compartment Door and Panel Installation Sta 41 to 102	2.3-46	2.3-13	Panel Installation Sta 253 to 316	2.3-78
2.3-6	LH Side Panel Equipment Assembly Sta 102 to 172	2.3-50	2.3-14	Fuselage Assembly Sta 472 to Tail Cone	2.3-80
2.3-7	LH Panel Installation Sta 102 to 172	2.3-52	2.3-15	Panel Equipment Assembly Sta 472 to 673	2.3-90
2.3-8	RH Side Panel Equipment Assembly Sta 102 to 172	2.3-54	2.3-16	Tail Cone Assembly	2.3-94

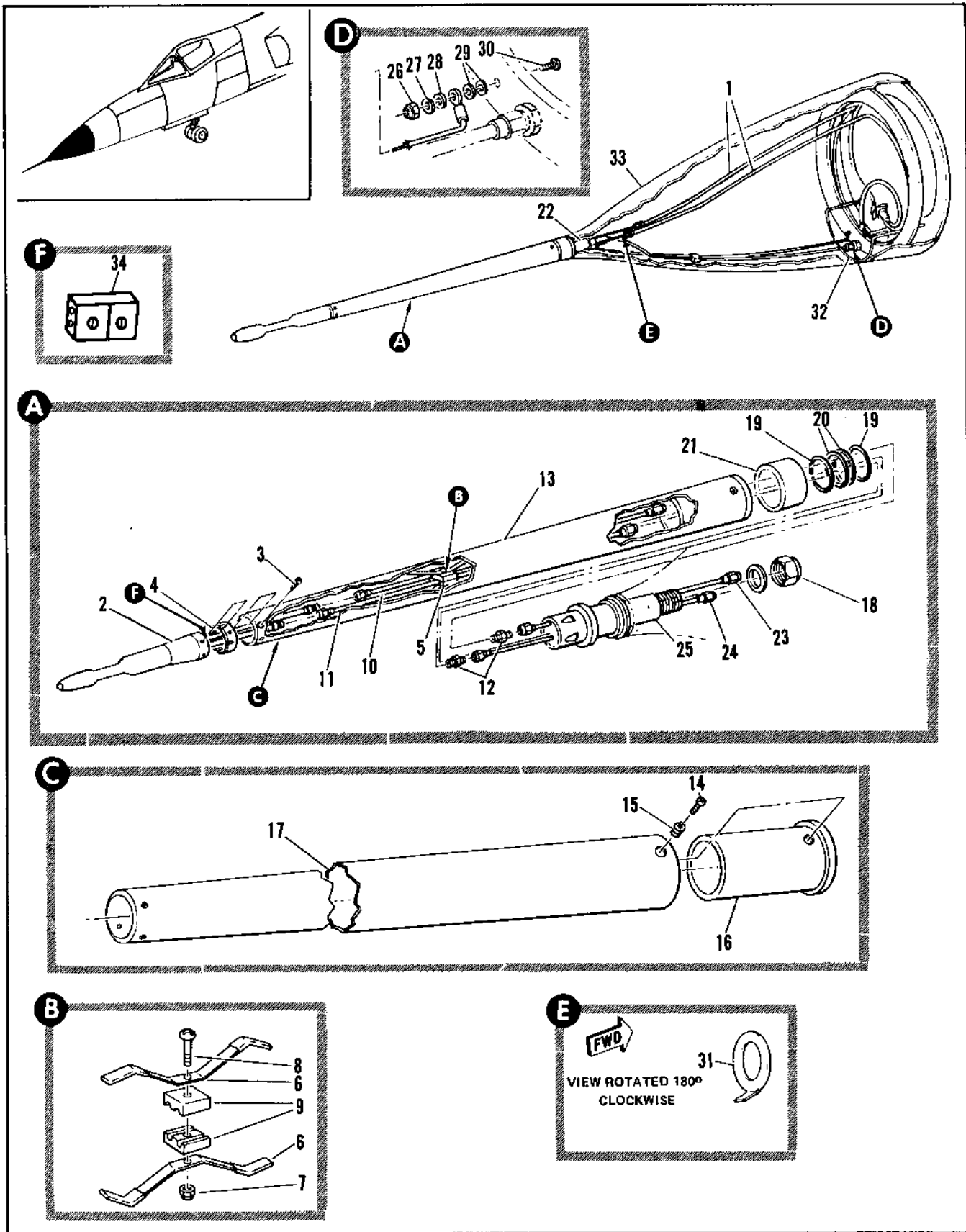

Figure 2.3-1. Plastic Radome and Boom Assembly (Sheet 1 of 5)

FIGURE AND INDEX NUMBER	PART NUMBER	DESCRIPTION 1 2 3 4 5 6	UNITS PER ASSY.	USABLE ON CODE	
				FROM	TO
2.3-1	8-74011-3	RADOME AND BOOM ASSEMBLY, PLASTIC REPLACED BY INTCHG WITH 8-74011-525 FOR NHA SEE FIG. 2.1-1	RF	35	
	8-74011-525	RADOME AND BOOM ASSEMBLY, FOR SPARES ONLY REPLACES INTCHG WITH 8-74011-3	RF	35	
	7640149	RADOME ASSEMBLY, NOSE (98750), REPLACES FOR SPARES ONLY - RADOME ONLY OF 8-74011-525	1	35	
- 1	8-38092-1	• TUBING INSTL, AIRSPEED STA -44 TO 41 FOR BREAKDOWN SEE FIG. 2.14-3	1	35	
	8-72968-3	• BOOM INSTL, NOSE	1	35	
- 2	855CR	• BOOM ASSY, NOSE SPARES • TUBE, PITOT STATIC GFAE (84274) ATTACHING PARTS	RF	35	
- 3	MS35207-226	• SCREW (96906)	RF	35	
	MS35338-41	• WASHER (96906) -----X-----	RF	35	
- 4	855-780	• SLEEVE	1	35	
	8-38092-3	• TUBING INSTL, AIRSPEED STA -103 TO -44	1	35	
- 5	8-38591	• SUPPORT ASSY, AIRSPEED TUBING	3	35	
- 6	8-38591-7	• SPRING ATTACHING PARTS	2	35	
- 7	NAS679A3	• NUT (80205)	1	35	
- 8	MS1953-54	• SCREW (96906) -----X-----	1	35	
- 9	8-38591-9	• BLOCK	2	35	
- 10	8-38092-57	• TUBE, STATIC	1	35	
- 11	8-38092-55	• TUBE, FITOF	1	35	
- 12	MS21902D4	• UNION (98906)	2	35	
- 13	8-72970	• BOOM ASSY, NOSE	1	35	
- 14	MS1964-4K	• SCREW (96906)	3	35	
- 15	3591-4CNX37K	• INSERT, <91767> 95-03003-007	3	35	
- 16	8-72970-7	• BOOM ASSY, NOSE	1	35	
- 17	8-72972-7	• FITTING, BOOM	1	35	
	8-72971-4	• BOOM	1	35	
- 18	NAS1022A20	• NUT (80205)	1	35	
- 19	AN6230B2	• GASKET (88044)	2	35	
- 20	AN6230B3	• GASKET (88044)	2	35	
- 21	1727035	• RING, NOSE BOOM ANTI-ICING	1	35	
- 22	8-36596-3	• FITTING ASSY, BOOM ATTACHMENT	1	35	
- 23	8-36596-11	• TUBE ASSEMBLY	1	35	
- 24	8-36596-13	• TUBE ASSEMBLY	1	35	
- 25	8-87295-7	• FITTING	1	35	
	8-36634	• FONDING ASSY, NOSE BOOM USED ON SPARES ASSEMBLY 8-74011-525	1	35	
- 26	NAS679A4	• NUT (80205)	1	35	
- 27	MS35338-44	• WASHER (96906)	1	35	
- 28	AN960-416L	• WASHER (88044)	1	35	
- 29	AN9610416L	• WASHER (88044)	2	35	
- 30	NAS428-4-7	• BOLT (80205)	1	35	
- 31	8-36523-7	• WASHER	1	35	
- 32	8-36224	• ANTENNA INSTL, ILAS LOCALIZER FOR BREAKDOWN SEE FIG. 2.16-7	1	35	
- 33	8-36330	• RADOME ASSY, PLASTIC USED ON SPARES ASSEMBLY 8-74011-525 FOR BREAKDOWN SEE FIG. 2.3-2	1	35	18A
	8-36330-1	• RADOME ASSY, PLASTIC FOR BREAKDOWN SEE FIG. 2.3-2	1	189	
- 34	859-27	• CONNECTOR	1	35	

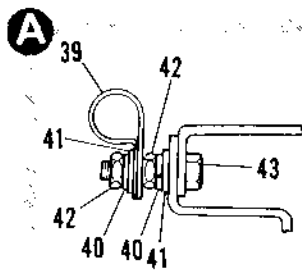
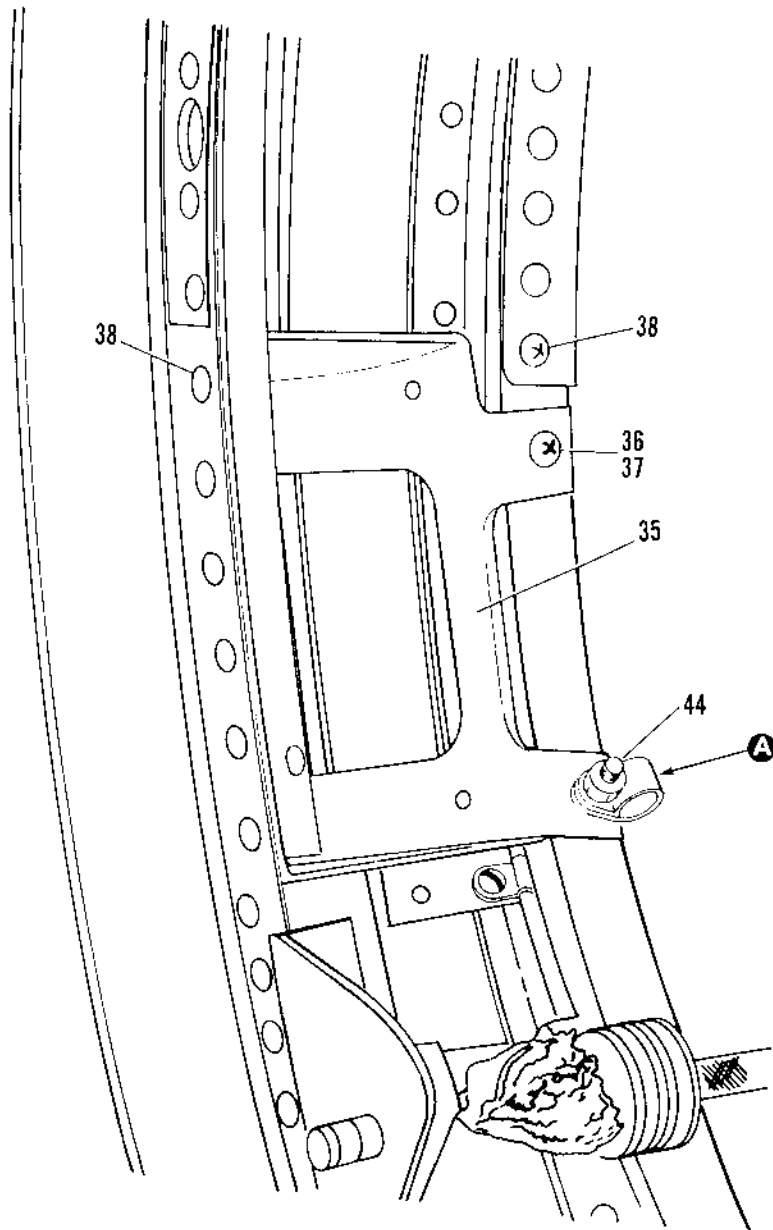

Figure 2.3-1. Plastic Radome and Boom Assembly (Sheet 2 of 5)

FIGURE AND INDEX NUMBER	PART NUMBER	DESCRIPTION	UNITS PER ASSY.	USABLE ON CODE	
				FROM	TO
		1 2 3 4 5 6			
2.3-1- 35	113D481101	• BRACKET, MTG	1	35	
- 36	10798151P4	• NUT, STAMPED	2		
- 37	MS51849-65	• SCREW, MACHINE	1		
- 38	MS2747085-7	• RIVET, SOLID	2		
- 39	9729424P4	• HARNESS CLAMP	1		
- 40	MS35338-43	• WASHER, LOCK	1		
- 41	MS27183-1	• WASHER, FLAT	3		
- 42	MS35656-302	• NUT, PLAIN HEX	2		
- 43	MS51849-66	• SCREW, MACHINE	1		
- 44	MS35207-261	• SCREW, MACH	1		

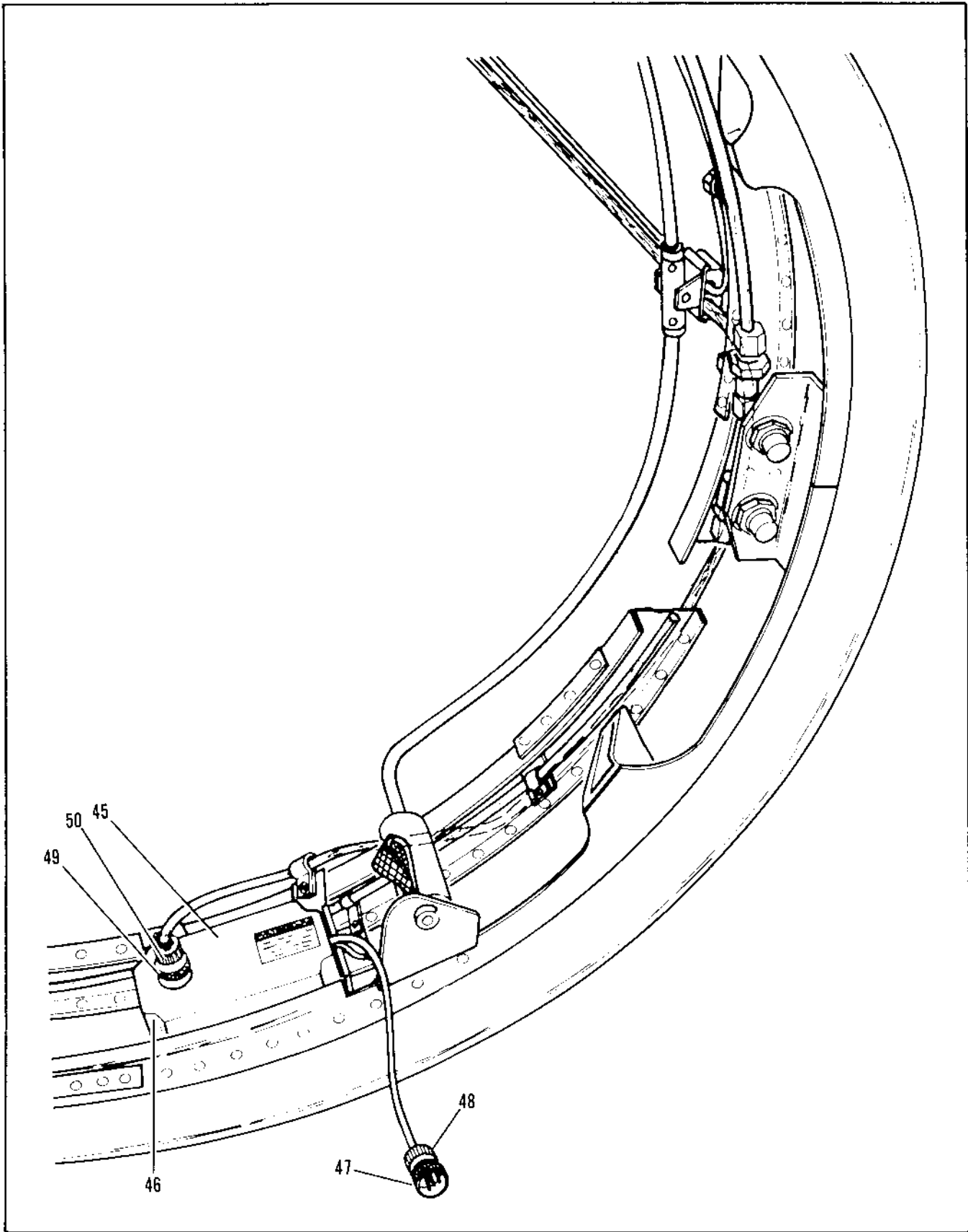

Figure 2.3-1. Plastic Radome and Boom Assembly (Sheet 3 of 5)

FIGURE AND INDEX NUMBER	PART NUMBER	DESCRIPTION	UNITS PER ASSY.	USABLE ON CODE	
				FROM	TO
		1 2 3 4 5 6			
2.3-1- 45	1230665001	• SUPPRESSOR	1		
- 46	MS35206-248	• • SCREW, MACH	4		
- 47	M83723-23R-1104N	• • CONNECTION	1		
- 48	M83723-35S-11R	• • BACKSHELL	1		
- 49	M83723-14R-1203N	• CONNECTOR	1		
- 50	M83723-15S-12	• • BACK SHELL	1		

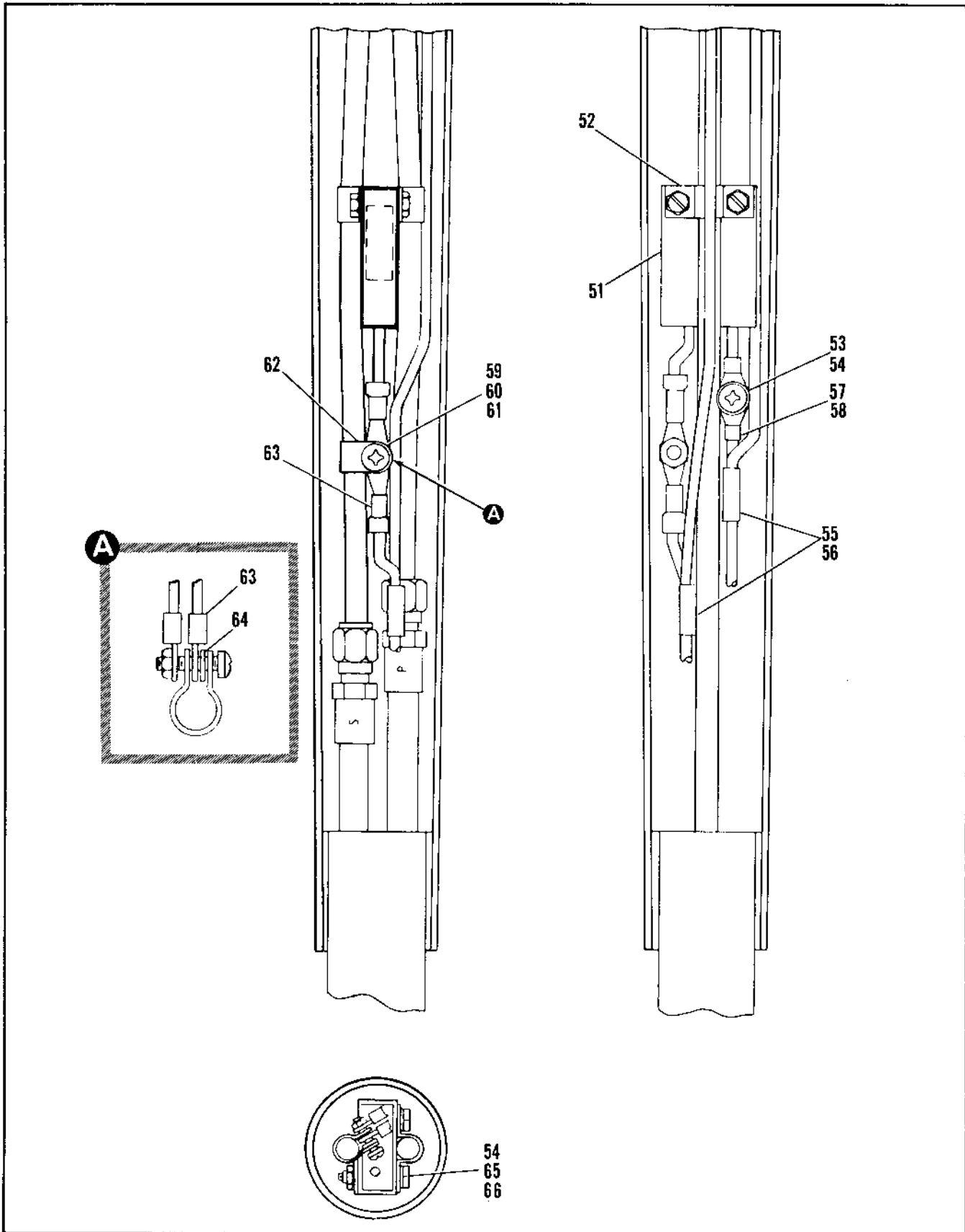

Figure 2.3-1. Plastic Radome and Boom Assembly (Sheet 4 of 5)

FIGURE AND INDEX NUMBER	PART NUMBER	DESCRIPTION 1 2 3 4 5 6	UNITS PER ASSY.	USABLE ON CODE	
				FROM	TO
2.3-1- 51	1640729061	• VARISTOR, METAL OXIDE (LEFT)	AR		
- 52	MS21315-8	• • STRAP, RETAINING	4		
- 53	MS35226-213	• • SCREW, MACH	2		
- 54	107PB151P1	• • NUT, SELF-LOCKING	3		
- 55	327025	• • SPLICE	2		
- 56	144A7375P3	• • SLEEVING	2		
- 57	34104	• • TERMINAL	1		
- 58	144A7375F1	• • SLEEVING	1		
- 59	MS27183-7	• • WASHER, FLAT	7		
- 60	MS35226-244	• • SCREW, MACH	2		
- 61	107PB151P3	• • NUT, SELF-LOCKING	2		
- 62	AN735-4	• • CLAMP, LOOP	2		
- 63	MS25036-149	• • TERMINAL, LUG	1		
- 64	MS35334-42	• • WASHER, LOCK	1		
- 65	MS27183-5	• • WASHER, FLAT	4		
- 66	MS51849-16	• • SCREW, MACH	1		

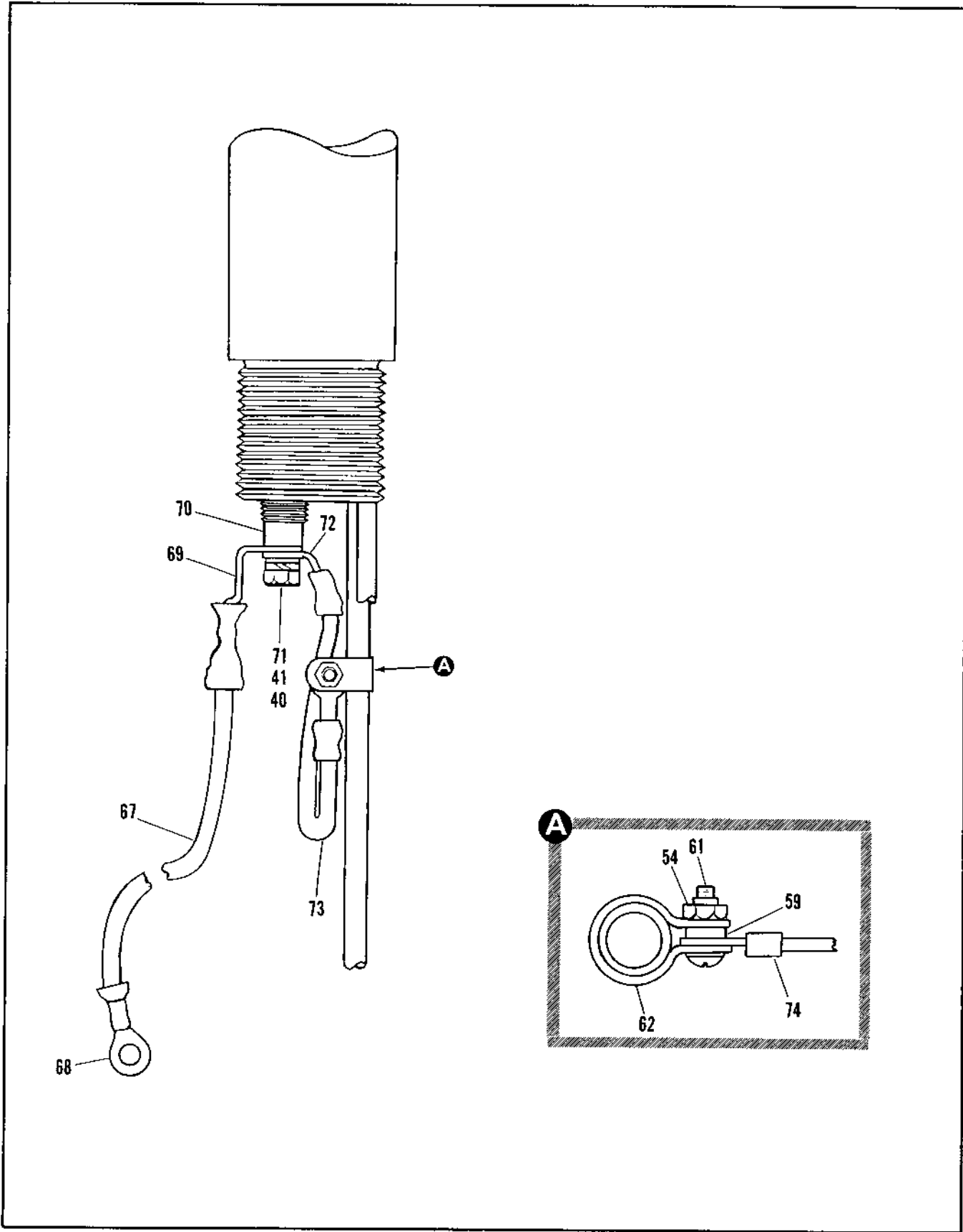

Figure 2.3-1. Plastic Radome and Boom Assembly (Sheet 5 of 5)

FIGURE AND INDEX NUMBER	PART NUMBER	DESCRIPTION	UNITS PER ASSY.	USABLE ON CODE	
				FROM	TO
		1 2 3 4 5 6			
2.3-1- 67	MS38672-P-P	• WIRE (8FT)	AR		
- 68	322049	• • TERMINAL	1		
- 69	322128	• • TERMINAL	1		
- 70	15306240P1	• • PLUG - GROUNDING ALTERED FROM MS20913-2	1		
- 71	MS51849-64	• • SCREW, MACH	2		
- 72	MS25036-1-P	• • TERMINAL, LUG	2		
- 73	MS25471-14	• • GROUND WIRE (8FT)	AR		
- 74	MS25036-153	• • TERMINAL, LUG	1		

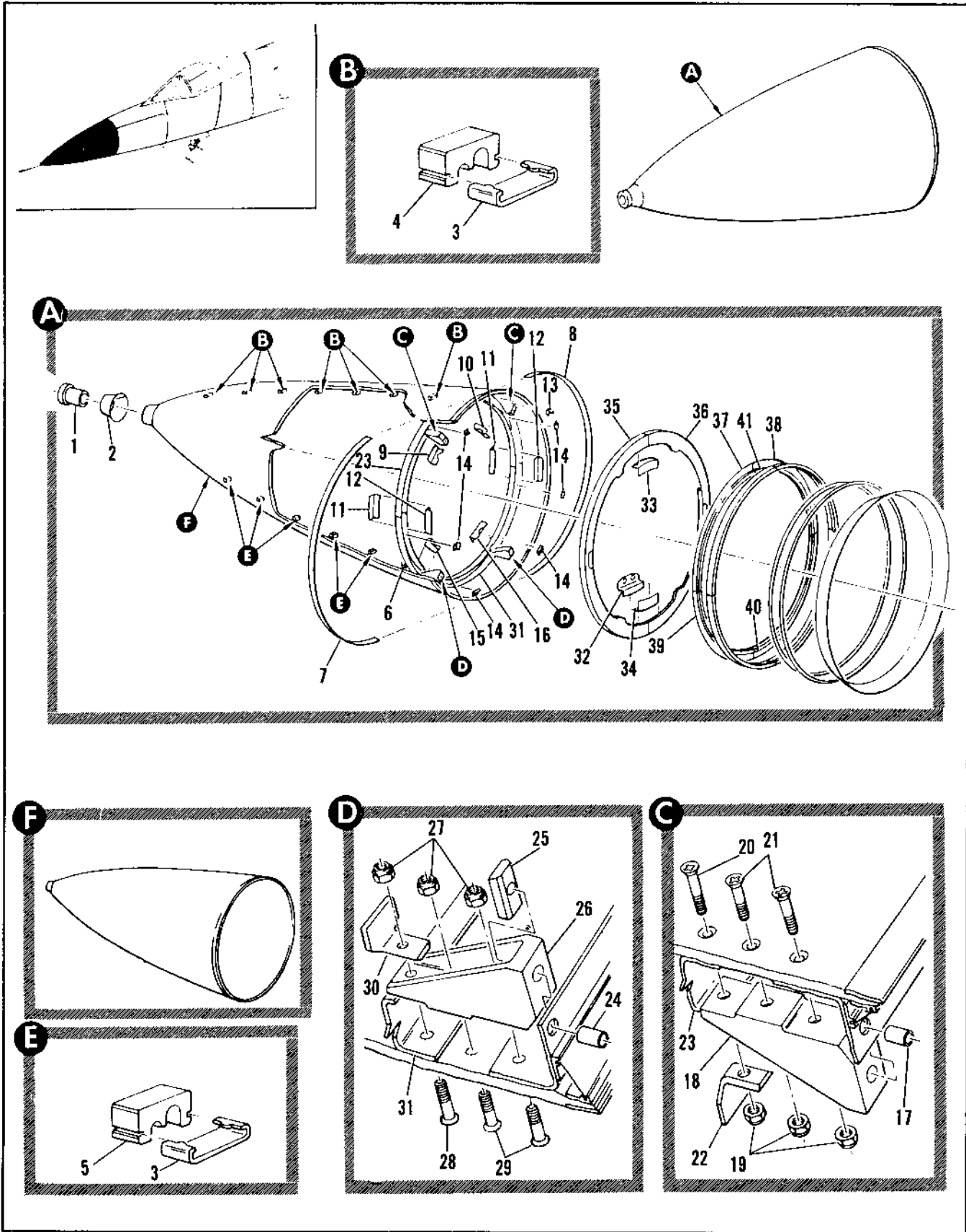

Figure 2.3-2. Plastic Radome Assembly (Sheet 1 of 2)

FIGURE AND INDEX NUMBER	PART NUMBER	DESCRIPTION	UNITS PER ASSY.	USABLE ON CODE	
				FROM	TO
2.3-2	8-36330	RADOME ASSEMBLY, PLASTIC FOR NHA SEE FIG. 2.3-1	RF	35	189
	8-36330-1	RADOME ASSEMBLY, PLASTIC FOR NHA SEE FIG. 2.3-1 USED ON SPARES ASSEMBLY 8-74011-525	RF	189	
- 1	8-72973	• FITTING, BOOM ATTACH	1	35	
- 2	8-36733	• SLEEVE	1	35	
- 3	8-37475	• RETAINER	12	35	
- 4	8-36750	• BLOCK, AIRSPEED TUBE	7	35	
- 5	15306250P1	• BLOCK SUPPORT	6	35	
- 6	8-35714	• SUPPORT ASSY, LOCALIZER ANTENNA FOR BREAKDOWN SEE FIG. 2.18-6	1	35	
- 7	8-72923-F	• STRAP, LH	1	35	
- 8	8-72923-10	• STRAP, RH	1	35	
- 9	8-36069-57	• ANGLE, LH	1	35	
- 10	8-36069-58	• ANGLE, RH	1	35	
- 11	8-36069-51	• ANGLE, FWD	2	35	
- 12	8-36069-48	• ANGLE, AFT	2	35	
- 13	8-36069-45	• CLIP, RH	1	35	
- 14	8-36330-13	• CLIP	6	35	
- 15	8-36069-55	• ANGLE, LH	1	35	
- 16	8-36069-56	• ANGLE, RH	1	35	
- 17	8-70410-31	• PUSHING	2	35	
- 18	8-73717	• FITTING, RADOME ATTACH UPPER ATTACHING PARTS	2	35	
- 19	NAS679A4	• NUT	6	35	
- 20	NAS334CPA12	• BOLT	2	35	
- 21	NAS334CPA10-5	• BOLT ----X----	4	35	
- 22	8-70410-21	• CLIP	2	35	
- 23	8-36330-9	• RING, UPPER	1	35	
- 24	8-70410-27	• PUSHING	2	35	
- 25	8-70410-29	• BLOCK	2	35	
- 26	8-73736	• FITTING, RADOME ATTACH LOWER ATTACHING PARTS	2	35	
- 27	NAS679A4	• NUT	6	35	
- 28	NAS334CPA12	• BOLT	2	35	
- 29	NAS334CPA10-5	• BOLT ----X----	4	35	
- 30	8-70410-19	• CLIP	2	35	
- 31	8-36069-53	• RING, LOWER	1	35	
	8-36094	• SUPPORT INSTL, AIRSPEED TURING	1	35	
- 32	8-38105	• SUPPORT	1	35	
	8-73597-3	• FRAME ASSY, RADOME	1	35	
- 33	8-73597-11	• ANGLE, UPPER	1	35	
- 34	8-73597-19	• ANGLE, LOWER	1	35	
	8-73597-5	• FRAME ASSY, RADOME ATTACH LH	1	35	
	8-73597-6	• FRAME ASSY, RADOME ATTACH RH	1	35	
- 35	8-73597-9	• FRAME, LH	1	35	
- 36	8-73597-10	• FRAME, RH	1	35	
- 37	8-70410-9	• RETAINER, UPPER LH	1	35	
- 38	8-70410-10	• RETAINER, UPPER RH	1	35	
- 39	8-70410-13	• RETAINER, LOWER LH	1	35	
- 40	8-70410-14	• RETAINER, LOWER RH	1	35	
- 41	8-70410-7	• RETAINER, UPPER LH	1	35	

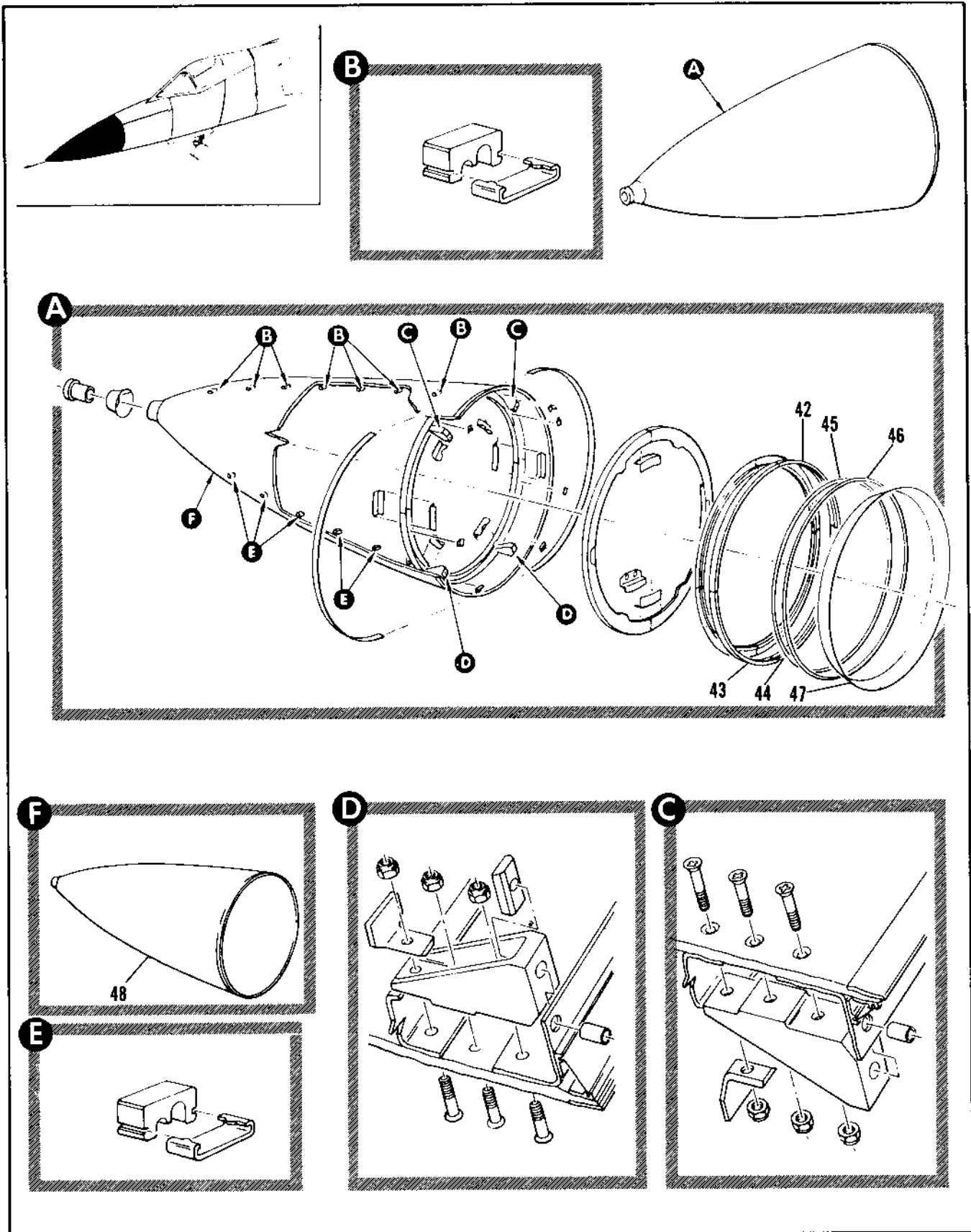

Figure 2.3-2. Plastic Radome Assembly (Sheet 2 of 2)

FIGURE AND INDEX NUMBER	PART NUMBER	DESCRIPTION	UNITS PER ASSY.	USABLE ON CODE	
				FROM	TO
		1 2 3 4 5 6			
2.3-2- 41	8-70410-9	• RETAINER, UPPER RH	1	35	
- 43	8-70410-11	• RETAINER, LOWER LH	1	35	
- 44	8-70410-12	• RETAINER, LOWER RH	1	35	
- 45	8-70410-23	• INSERT, MAKE FROM 340-8210303-9	1	35	
- 46	8-70410-25	• INSERT, MAKE FROM 340-8210303-9	1	35	
	340-8210303-9	• INSERT, EXTRUSION	RF	35	
- 47	8-70647-11	• SEAL, REPLACED BY SUITABLE SUB 8-70647-13	1	35	1 P R
	8-70647-13	• SEAL, REPLACES SUITABLE SUB FOR 8-70647-11	1	189	
- 48	8-36335-1	• PADOME	1	35	

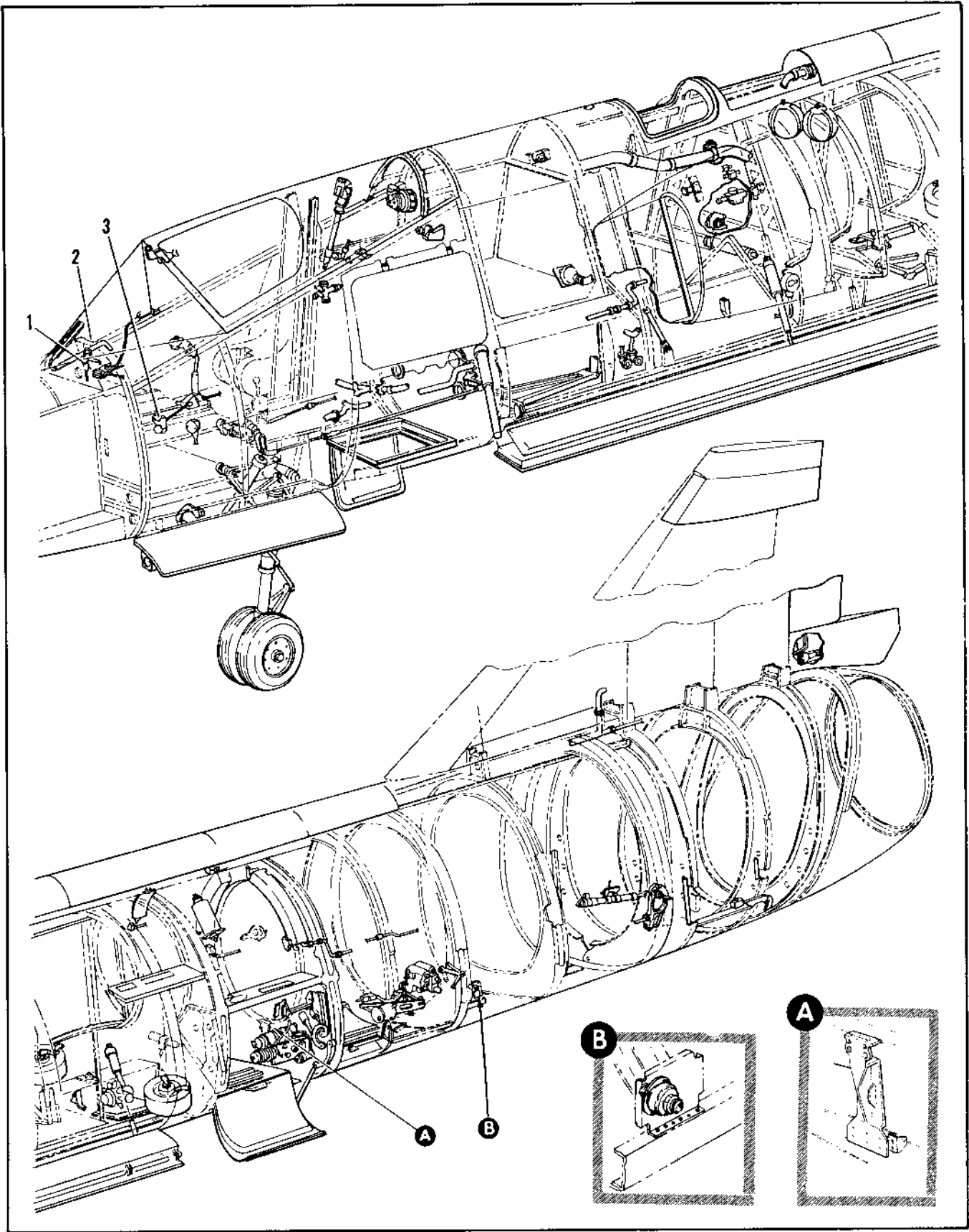

Figure 2.3-3. General Fuselage Assembly (Sheet 1 of 8)

FIGURE AND INDEX NUMBER	PART NUMBER	DESCRIPTION	UNITS PER ASSY.	USABLE ON CODE		
				FROM	TO	
2.3-3	8-74000-803	FUSELAGE ASSEMBLY, GENERAL FWD OF STA 472 FOR NHA SEE FIG. 2.1-1	RF	25	277	
	8-74000-809	FUSELAGE ASSEMBLY, GENERAL FWD OF STA 472 FOR NHA SEE FIG. 2.1-1	RF	278		
	8-74000-803	FUSELAGE ASSEMBLY, GENERAL AFT OF STA 472 FOR NHA SEE FIG. 2.1-1	RF	D		
	8-74000-1	FUSELAGE ASSEMBLY, GENERAL AFT OF STA 472 FOR NHA SEE FIG. 2.1-1	RF	278	280	
	8-74000-3	FUSELAGE ASSEMBLY, GENERAL AFT OF STA 472 FOR NHA SEE FIG. 2.1-1	RF	281	287	
	8-74000-5	FUSELAGE ASSEMBLY, GENERAL AFT OF STA 472 FOR NHA SEE FIG. 2.1-1	RF	288	293	
	- 1	8-94166-801	• HOSE INSTL, CANOPY AND SEAT JETTISON FOR BREAKDOWN SEE FIG. 2.4-6	1	A	
		8-94166-805	• HOSE INSTL, CANOPY AND SEAT JETTISON FOR BREAKDOWN SEE FIG. 2.4-7	1	C	
		8-94166-807	• HOSE INSTL, CANOPY AND SEAT JETTISON FOR BREAKDOWN SEE FIG. 2.4-7	1	H	
		8-94166-3	• HOSE INSTL, CANOPY AND SEAT JETTISON FOR BREAKDOWN SEE FIG. 2.4-7	1	278	
	- 2	8-74002-805	• FUSELAGE ASSY, STA 40 TO 216 FOR BREAKDOWN SEE FIG. 2.3-5	1	35	277
		8-74012-809	• FUSELAGE ASSY, STA 40 TO 216	1	278	
	- 3	8-42204-3	• CABLE AND LINKAGE INSTL, RUDDER FOR BREAKDOWN SEE FIG. 2.14-30	RF	A	
		8-42204-5	• CABLE AND LINKAGE INSTL, RUDDER MODIFIED BY 66J40963 FOR BREAKDOWN SEE FIG. 2.14-30	1	A	
		8-42204-801	• CABLE AND LINKAGE INSTL, RUDDER FOR BREAKDOWN SEE FIG. 2.14-30	RF	N	
8-42204-801		• CABLE AND LINKAGE INSTL, RUDDER MODIFIED BY 66J40963 FOR BREAKDOWN SEE FIG. 2.14-30	1	N		
8-42204-805		• CABLE AND LINKAGE INSTL, RUDDER FOR BREAKDOWN SEE FIG. 2.14-30	RF	278		
8-42204-805		• CABLE AND LINKAGE INSTL, RUDDER MODIFIED BY 66J40963 FOR BREAKDOWN SEE FIG. 2.14-30	1	278		
8-42229		• FAIRLEAD INSTL, RUDDER CABLE FOR BREAKDOWN SEE FIG. 2.14-31	RF	35		
8-42229		• FAIRLEAD INSTL, RUDDER CABLE MODIFIED BY 66J40963 FOR BREAKDOWN SEE FIG. 2.14-31	1	35		
		A AIRPLANES #35 THRU 47 AND 49 THRU 89 C AIRPLANES #48 AND 90 THRU 129 D AIRPLANES #35 THRU 277, 294 AND ON N AIRPLANES #48 AND 89 THRU 277 O AIRPLANES #243, 245, 248, 250 THRU 258, AND 260 THRU 277 H AIRPLANES #130 THRU 242, 244, 245, 247, 249 AND 259				

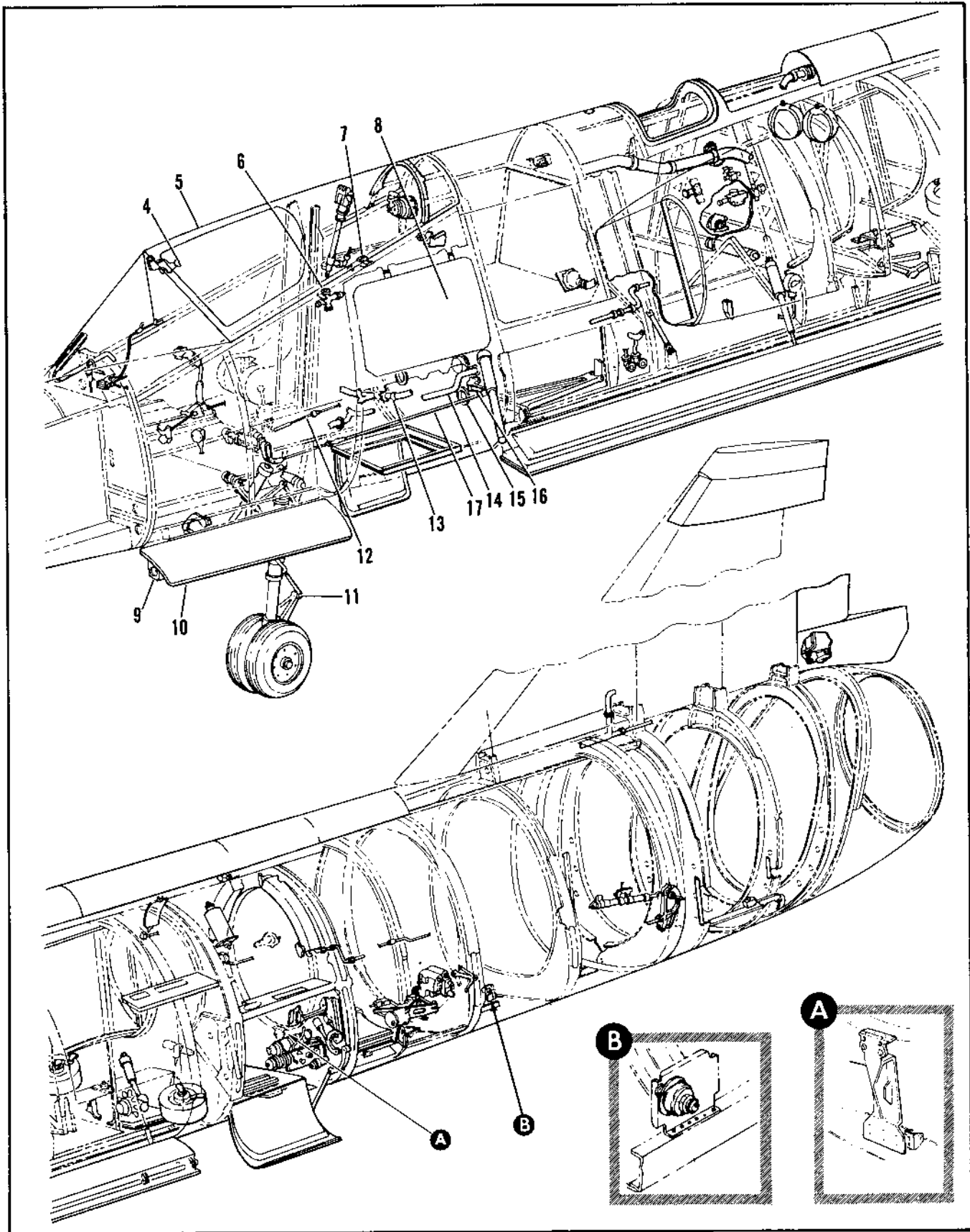

Figure 2.3-3. General Fuselage Assembly (Sheet 2 of 8)

FIGURE AND INDEX NUMBER	PART NUMBER	DESCRIPTION	UNITS PER ASSY.	USABLE ON CODE	
				FROM	TO
		1 2 3 4 5 6			
2.3-3- 4	W-74592	• SIGHT INSTL, OPTICAL	1	A	
	W-94592-7	• SIGHT INSTL, OPTICAL	1	B	
- 5	W-74633-100	• CANOPY INSTL, MOD BY 7144513-10, FOR BREAKDOWN SEE FIG. 2.4-10	1	35	
- 6	W-85045-1	• VALVE INSTL, EMER COCKPIT PRESSURIZATION FOR BREAKDOWN SEE FIG. 2.13-1	1	35	
- 7	W-45134	• LATCH AND ELECTRICAL ACTUATOR INSTL, CANOPY FOR BREAKDOWN SEE FIG. 2.4-10	1	35	
	W-23334	• VALVE INSTL, COCKPIT AIR SAFETY FOR BREAKDOWN SEE FIG. 2.13-1E	1	35	
- 8	W-74635-5	• DOOR INSTL, UPPER AFT ELECTRONIC COMPARTMENT ACCESS LH FOR BREAKDOWN SEE FIG. 2.2-5	1	35	
	W-74635-1	• DOOR INSTL, UPPER AFT ELECTRONIC COMPARTMENT ACCESS RH FOR BREAKDOWN SEE FIG. 2.2-5	1	35	
- 9	W-90705	• LIGHT INSTL, TAXI FOR BREAKDOWN SEE FIG. 2.15-6	1	35	
- 10	W-74626	• DOOR INSTL, NOSE LANDING GEAR FOR BREAKDOWN SEE FIG. 2.15-14	1	35	
	W-45110-1	• MECHANISM INSTL, NOSE LANDING GEAR DOOR FOR BREAKDOWN SEE FIG. 2.15-13	1	35	
	W-57117-5	• SWITCH INSTL, NOSE LANDING GEAR DOOR CLOSE FOR BREAKDOWN SEE FIG. 2.15-3	1	35	
- 11	W-52003-101	• GEAR INSTL, NOSE LANDING MODIFIED BY W-71135 FOR BREAKDOWN SEE FIG. 2.15-16	1	35	38
	W-52003-103	• GEAR INSTL, NOSE LANDING FOR BREAKDOWN SEE FIG. 2.15-16	1	35	217
	W-52003-105	• GEAR INSTL, NOSE LANDING FOR BREAKDOWN SEE FIG. 2.15-16	1	218	241
	W-52003-111	• GEAR INSTL, NOSE LANDING MODIFIED BY W-71135 FOR BREAKDOWN SEE FIG. 2.15-16	1	241	264
	W-52003-117	• GEAR INSTL, NOSE LANDING MODIFIED BY W-71135 FOR BREAKDOWN SEE FIG. 2.15-16	1	265	
- 12	W-42705-3	• TELEFLEX INSTL, POWER CONTROL FOR BREAKDOWN SEE FIG. 2.10-3	1	35	62
	W-42705	• TELEFLEX INSTL, POWER CONTROL FOR BREAKDOWN SEE FIG. 2.10-3	1	63	277
	W-42705-5	• TELEFLEX INSTL, POWER CONTROL FOR BREAKDOWN SEE FIG. 2.10-3	1	278	
- 13	W-23407-107	• DUCT INSTL, COCKPIT AIR STA 171 TO 22R FOR BREAKDOWN SEE FIG. 2.13-14	1	35	277
- 14	W-23407-111	• DUCT INSTL, RAIN REMOVAL STA 160 TO 227 FOR BREAKDOWN SEE FIG. 2.13-17	1	35	
- 15	W-23497	• VALVE INSTL, ELECTRONIC COMPARTMENT CHECK FOR BREAKDOWN SEE FIG. 2.13-1	1	35	
- 16	W-42507	• IDLER INSTL, ELEVATOR AND AILERON CONTROL STA 215 FOR BREAKDOWN SEE FIG. 2.14-36	1	35	
- 17	W-42504	• LINKAGE INSTL, ELEVON CONTROL FOR BREAKDOWN SEE FIG. 2.14-15	1	35	277
	W-42504-111	• LINKAGE INSTL, ELEVON CONTROL FWD OF STA 470 FOR BREAKDOWN SEE FIG. 2.14-15	1	278	
A AIRPLANES #35 THRU 47 AND 49 THRU 89 B AIRPLANES #48, 90 AND ON					

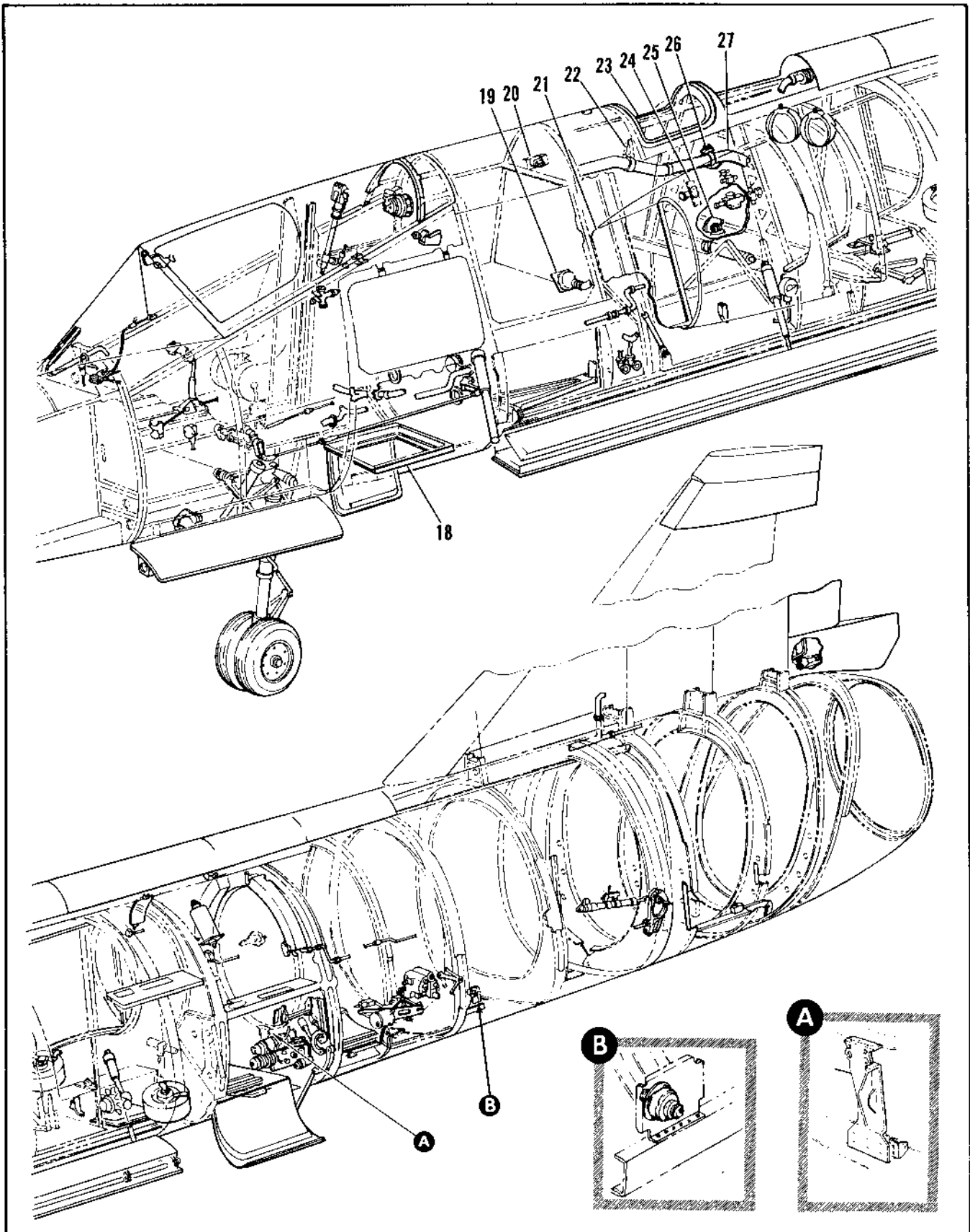

Figure 2.3-3. General Fuselage Assembly (Sheet 3 of 8)

FIGURE AND INDEX NUMBER	PART NUMBER	DESCRIPTION	UNITS PER ASSY.	USABLE ON CODE	
				FROM	TO
		1 2 3 4 5 6			
2.3-3	8-41101	• LINKAGE INSTL. ELEVON CONTROL AFT OF STA 472 FOR BREAKDOWN SEE FIG. 2.14-15	1	278	
- 18	8-74611-805	• DOOR ASSY. MIDBAY ELECTRONIC COMPARTMENT ACCESS FOR BREAKDOWN SEE FIG. 2.2-12	1	35	47
	8-74611-807	• DOOR ASSY. MIDBAY ELECTRONIC COMPARTMENT ACCESS ALT INTCHG 8-74611-805 FOR BREAKDOWN SEE FIG. 2.2-12	RF	35	47
	8-74611-821	• DOOR ASSY. MIDBAY ELECTRONIC COMPARTMENT ACCESS FOR BREAKDOWN SEE FIG. 2.2-12	1	48	49
	8-74611-823	• DOOR ASSY. MIDBAY ELECTRONIC COMPARTMENT ACCESS ALT INTCHG WITH 8-74611-821 FOR BREAKDOWN SEE FIG. 2.2-12	RF	48	49
	8-74611-809	• DOOR ASSY. MIDBAY ELECTRONIC COMPARTMENT ACCESS FOR BREAKDOWN SEE FIG. 2.2-12	1	47	57
	8-74611-827	• DOOR ASSY. MIDBAY ELECTRONIC COMPARTMENT ACCESS ALT INTCHG WITH 8-74611-809 FOR BREAKDOWN SEE FIG. 2.2-12	RF	49	57
	8-74611-517	• DOOR ASSY. MIDBAY ELECTRONIC COMPARTMENT ACCESS FOR BREAKDOWN SEE FIG. 2.2-12	1	61	59
	8-74611-519	• DOOR ASSY. MIDBAY ELECTRONIC COMPARTMENT ACCESS FOR BREAKDOWN SEE FIG. 2.2-12	1	96	277
	8-74611-829	• DOOR ASSY. MIDBAY ELECTRONIC COMPARTMENT ACCESS FOR BREAKDOWN SEE FIG. 2.2-12	1	278	
- 19	8-28274	• VALVE INSTL. PRESSURE REGULATOR REFUELING FOR BREAKDOWN SEE FIG. 2.12-53	1	35	264
	8-28274-1	• VALVE INSTL. PRESSURE REGULATOR REFUELING FOR BREAKDOWN SEE FIG. 2.12-53	1	265	
- 20	8-28367	• SWITCH INSTL. CG TRANSFER EMERGENCY PRESSURE FOR BREAKDOWN SEE FIG. 2.12-37	1	35	
- 21	8-77586-5	• DUCT INSTL. ENGINE AIR INTAKE LH FOR BREAKDOWN SEE FIG. 2.11-3	1	35	
	8-77586-6	• DUCT INSTL. ENGINE AIR INTAKE RH FOR BREAKDOWN SEE FIG. 2.11-3	1	35	
- 22	8-28281-1	• BRACKET INSTL. FUEL TRANSFER LINE FUSELAGE FOR BREAKDOWN SEE FIG. 2.12-34	1	35	50
	8-28461	• BRACKET INSTL. FUEL TRANSFER LINE FUSELAGE FOR BREAKDOWN SEE FIG. 2.12-34	1	61	
- 23	8-74003-401	• FUSELAGE ASSY. STA 216 TO 472 FOR BREAKDOWN SEE FIG. 2.3-10	1	35	277
	8-74003-813	• FUSELAGE ASSY. STA 216 TO 472 FOR BREAKDOWN SEE FIG. 2.3-10	1	278	
- 24	8-81344-1	• VALVE INSTL. SOLENOID OPERATED HYDRAULIC CHECK FOR BREAKDOWN SEE FIG. 2.8-1	1	187	
- 25	8-81315-1	• DRIVE INSTL. VARIABLE AIR PUMP INTAKE DUCT FOR BREAKDOWN SEE FIG. 2.11-1	1	35	
- 26	8-85545	• FLASK INSTL. VARIABLE AIR PUMP PNEUMATIC FOR BREAKDOWN SEE FIG. 2.11-1	1	35	
- 27	8-27470	• TUBING INSTL. FUSELAGE TANK TO WING FUEL TRANSFER FOR BREAKDOWN SEE FIG. 2.12-46	1	35	60
	8-27470-3	• TUBING INSTL. FUSELAGE TANK TO WING FUEL TRANSFER FOR BREAKDOWN SEE FIG. 2.12-46	1	61	188
	8-27470-5	• TUBING INSTL. FUSELAGE TANK TO WING FUEL TRANSFER FOR BREAKDOWN SEE FIG. 2.12-46	1	189	

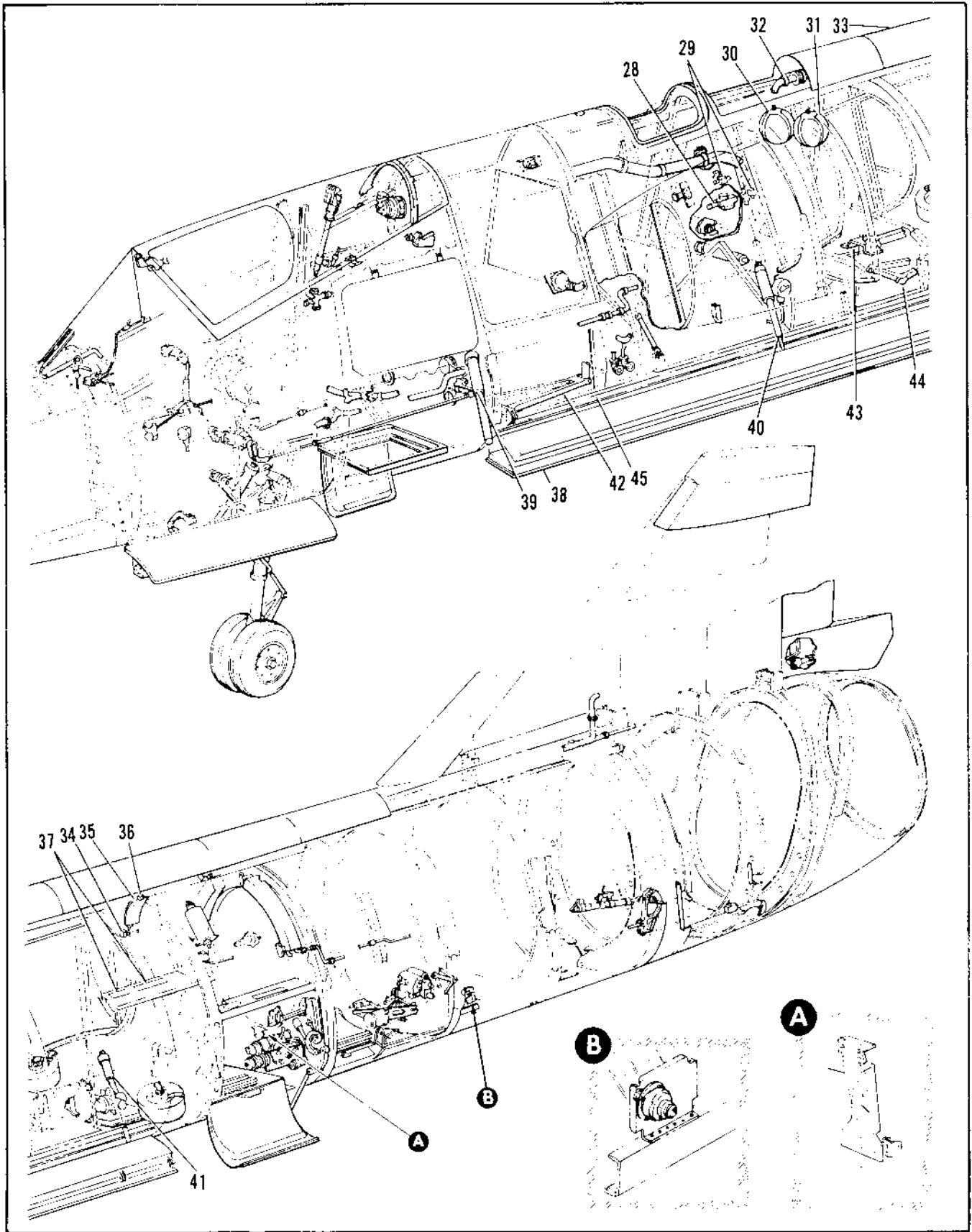

Figure 2.3-3. General Fuselage Assembly (Sheet 4 of 8)

FIGURE AND INDEX NUMBER	PART NUMBER	DESCRIPTION	UNITS PER ASSY.	USABLE ON CODE	
				FROM	TO
		1 2 3 4 5 6			
2.3-3- 28	6-81716-7	• VALVE INSTL, VARIABLE AIR RAMP INTAKE DUCT HYDRAULIC STA 287 TO 294 FOR BREAKDOWN SEE FIG. 2.11-8	1	30	
- 29	6-81316-5	• VALVE INSTL, VARIABLE AIR RAMP INTAKE DUCT HYDRAULIC STA 301 TO 317 FOR BREAKDOWN SEE FIG. 2.11-8	1	30	
- 30	9-88021-8	• SUPPORT ASSY, PNEUMATIC FLASK FWD FOR BREAKDOWN SEE FIG. 2.4-3	1	40	
- 31	6-85021-7	• SUPPORT ASSY, PNEUMATIC FLASK AFT FOR BREAKDOWN SEE FIG. 2.4-3	1	30	
- 32	6-23200	• DUCT INSTL, ENGINE BLEED AIR FOR BREAKDOWN SEE FIG. 2.13-24	RF	30	47
	6-23200-2	• DUCT INSTL, ENGINE BLEED AIR FOR BREAKDOWN SEE FIG. 2.13-24	RF	49	277
	6-23200-7	• DUCT INSTL, ENGINE BLEED AIR MODIFIED BY 66J4227 FOR BREAKDOWN SEE FIG. 2.13-26	1	49	277
	6-23200-8	• DUCT INSTL, ENGINE BLEED AIR FOR BREAKDOWN SEE FIG. 2.13-24	RF	278	
	6-23200-7	• DUCT INSTL, ENGINE BLEED AIR MODIFIED BY 66J4227 FOR BREAKDOWN SEE FIG. 2.13-26	1	8	
- 33	6-74498	• DORSAL INSTL, REMOVABLE STA 343 TO 513 FOR BREAKDOWN SEE FIG. 2.4-7	1	35	
- 34	6-27791-1	• TUBING INSTL, OIL COOLER AMBIENT AIR CONTROL RH STA 446 TO 464	1	35	61
	6-27791-001	• TUBING INSTL, OIL COOLER AMBIENT AIR CONTROL RH STA 446 TO 464	1	61	
	6-27791-0	• TUBING INSTL, OIL COOLER AMBIENT AIR CONTROL RH STA 464 TO 503	1	35	
- 35	6-27557-3	• VALVE INSTL, ACCESSORY OIL COOLER AIR FOR BREAKDOWN SEE FIG. 2.10-22	1	35	
- 36	6-27557-3	• REAPING INSTL, ACCESSORY OIL COOLER AIR VALVE FOR BREAKDOWN SEE FIG. 2.10-32	1	35	
- 37	6-74164-0-1	• DOOR INSTL, RH STA 421 TO 472 FOR BREAKDOWN SEE FIG. 2.2-7	1	35	
- 38	6-74165	• DOOR INSTL, ARMAMENT BAY STA 216 TO 412 FOR BREAKDOWN SEE FIG. 2.20-15	1	35	
- 39	6-49112-1	• ACTUATOR INSTL, ARMAMENT BAY DOOR FWD FOR BREAKDOWN SEE FIG. 2.20-11	1	35	
- 40	6-49112-2	• ACTUATOR INSTL, ARMAMENT BAY DOOR CENTER FOR BREAKDOWN SEE FIG. 2.20-11	1	35	
- 41	6-49112-3	• ACTUATOR INSTL, ARMAMENT BAY DOOR AFT FOR BREAKDOWN SEE FIG. 2.20-11	1	35	
- 42	6-57115-017	• ARMAMENT INSTL, FWD FOR BREAKDOWN SEE FIG. 2.20-13	1	35	
- 43	6-57115-0	• ARMAMENT INSTL, MB-1 FOR BREAKDOWN SEE FIG. 2.20-14	1	35	
- 44	6-57115-1	• ARMAMENT INSTL, AFT LH FOR BREAKDOWN SEE FIG. 2.20-31	1	35	
	6-57115-2	• ARMAMENT INSTL, AFT RH FOR BREAKDOWN SEE FIG. 2.20-31	1	35	
- 45	6-74163-0-1	• ATTACHMENT INSTL, ARMAMENT BAY DOOR LONGFRONT LH FOR BREAKDOWN SEE FIG. 2.20-14	1	35	
		F AIRPLACES 35 THRU 45, 278 AND ON			

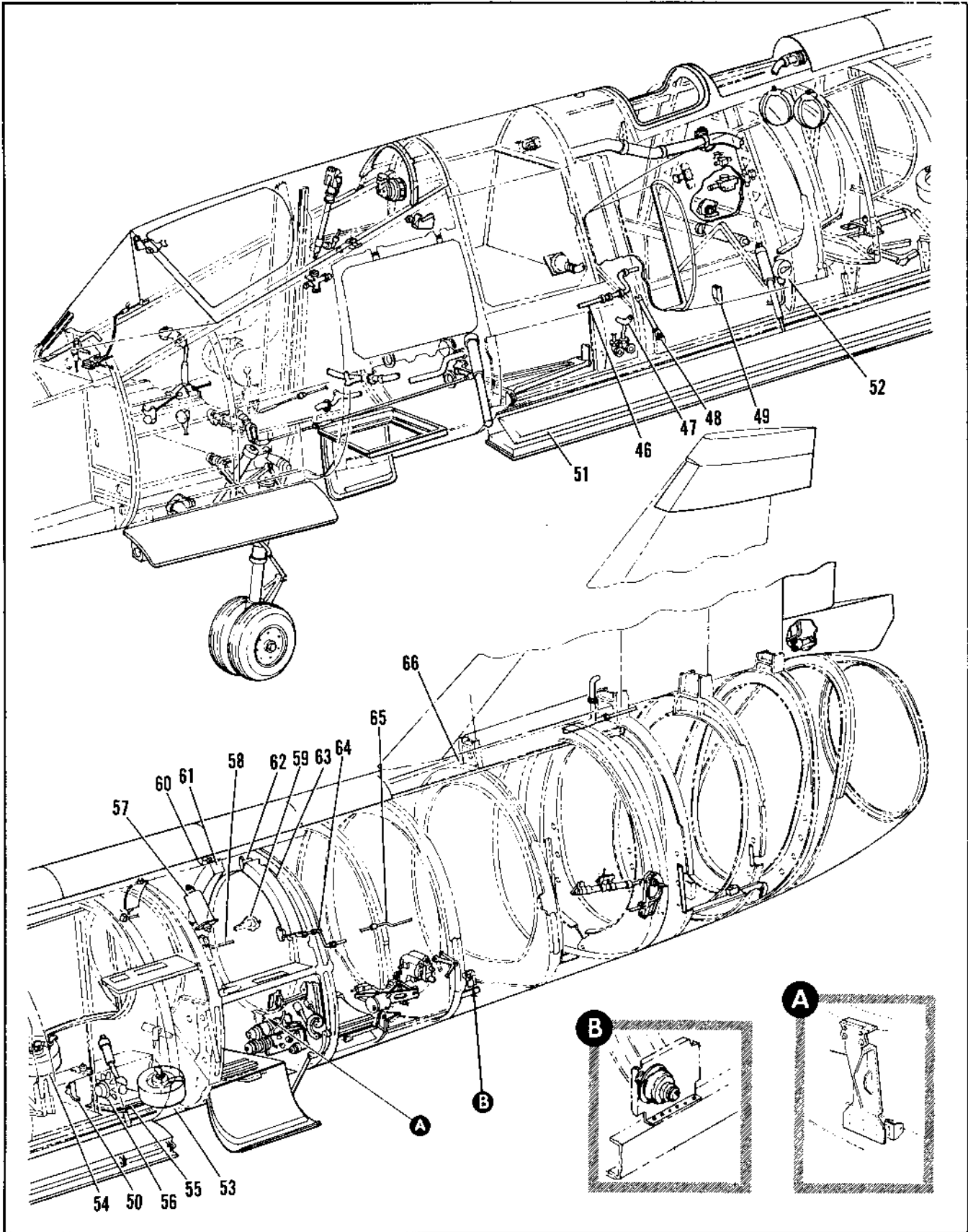

Figure 2.3-3. General Fuselage Assembly (Sheet 5 of 8)

FIGURE AND INDEX NUMBER	PART NUMBER	DESCRIPTION	UNITS PER ASSY.	USABLE ON CODE	
				FROM	TO
		1 2 3 4 5 6			
2.3-1-28	8-81716-3	• VALVE INSTL, VARIABLE AIR PUMP INTAKE DUCT HYDRAULIC STA 287 TO 294 FOR BREAKDOWN SEE FIG. 2.11-5	1	30	
- 29	8-81816-5	• VALVE INSTL, VARIABLE AIR PUMP INTAKE DUCT HYDRAULIC STA 321 TO 330 FOR BREAKDOWN SEE FIG. 2.11-7	1	30	
- 30	8-84721-8	• SUPPORT ASSY, PNEUMATIC FLASK FWD FOR BREAKDOWN SEE FIG. 2.9-3	1	40	
- 31	8-84721-7	• SUPPORT ASSY, PNEUMATIC FLASK AFT FOR BREAKDOWN SEE FIG. 2.9-3	1	70	
- 32	8-23200-1	• DUCT INSTL, ENGINE BLEED AIR FOR BREAKDOWN SEE FIG. 2.13-24	RF	30	97
	8-23200-2	• DUCT INSTL, ENGINE BLEED AIR FOR BREAKDOWN SEE FIG. 2.13-24	RF	49	277
	8-23200-3	• DUCT INSTL, ENGINE BLEED AIR MODIFIED BY 86J4228 FOR BREAKDOWN SEE FIG. 2.13-26	1	43	277
	8-23200-5	• DUCT INSTL, ENGINE BLEED AIR FOR BREAKDOWN SEE FIG. 2.13-24	RF	274	
	8-23200-7	• DUCT INSTL, ENGINE BLEED AIR MODIFIED BY 86J4228 FOR BREAKDOWN SEE FIG. 2.13-26	1	5	
- 33	8-74458	• DOOR INSTL, REMOVABLE STA 343 TO 513 FOR BREAKDOWN SEE FIG. 2.2-7	1	35	
- 34	8-27791-1	• TUBING INSTL, OIL COOLER AMBIENT AIR CONTROL RH STA 446 TO 464	1	35	61
	8-27791-111	• TUBING INSTL, OIL COOLER AMBIENT AIR CONTROL RH STA 446 TO 464	1	61	
	8-27791-3	• TUBING INSTL, OIL COOLER AMBIENT AIR CONTROL RH STA 464 TO 513	1	35	
- 35	8-27557-3	• VALVE INSTL, ACCESSORY OIL COOLER AIR FOR BREAKDOWN SEE FIG. 2.10-22	1	35	
- 36	8-27557-1	• HEATING INSTL, ACCESSORY OIL COOLER AIR VALVE FOR BREAKDOWN SEE FIG. 2.10-32	1	30	
- 37	8-74154-111	• DOOR INSTL, RH STA 421 TO 472 FOR BREAKDOWN SEE FIG. 2.2-7	1	35	
- 38	8-74665	• DOOR INSTL, ARMAMENT BAY STA 216 TO 412 FOR BREAKDOWN SEE FIG. 2.20-15	1	35	
- 39	8-49712-1	• ACTUATOR INSTL, ARMAMENT BAY DOOR FWD FOR BREAKDOWN SEE FIG. 2.20-11	1	35	
- 40	8-49712-2	• ACTUATOR INSTL, ARMAMENT BAY DOOR CENTER FOR BREAKDOWN SEE FIG. 2.20-11	1	35	
- 41	8-49712-3	• ACTUATOR INSTL, ARMAMENT BAY DOOR AFT FOR BREAKDOWN SEE FIG. 2.20-11	1	35	
- 42	8-57115-17	• ARMAMENT INSTL, FWD FOR BREAKDOWN SEE FIG. 2.20-13	1	35	
- 43	8-57115-5	• ARMAMENT INSTL, MB-1 FOR BREAKDOWN SEE FIG. 2.20-24	1	35	
- 44	8-57115-1	• ARMAMENT INSTL, AFT LH FOR BREAKDOWN SEE FIG. 2.20-31	1	35	
	8-57115-2	• ARMAMENT INSTL, AFT RH FOR BREAKDOWN SEE FIG. 2.20-31	1	35	
- 45	8-74163-1	• ATTACHMENT INSTL, ARMAMENT BAY DOOR LONGERON LH FOR BREAKDOWN SEE FIG. 2.20-14	1	35	
F AIRPLACES 15 THRU 43, 27A AND ON					

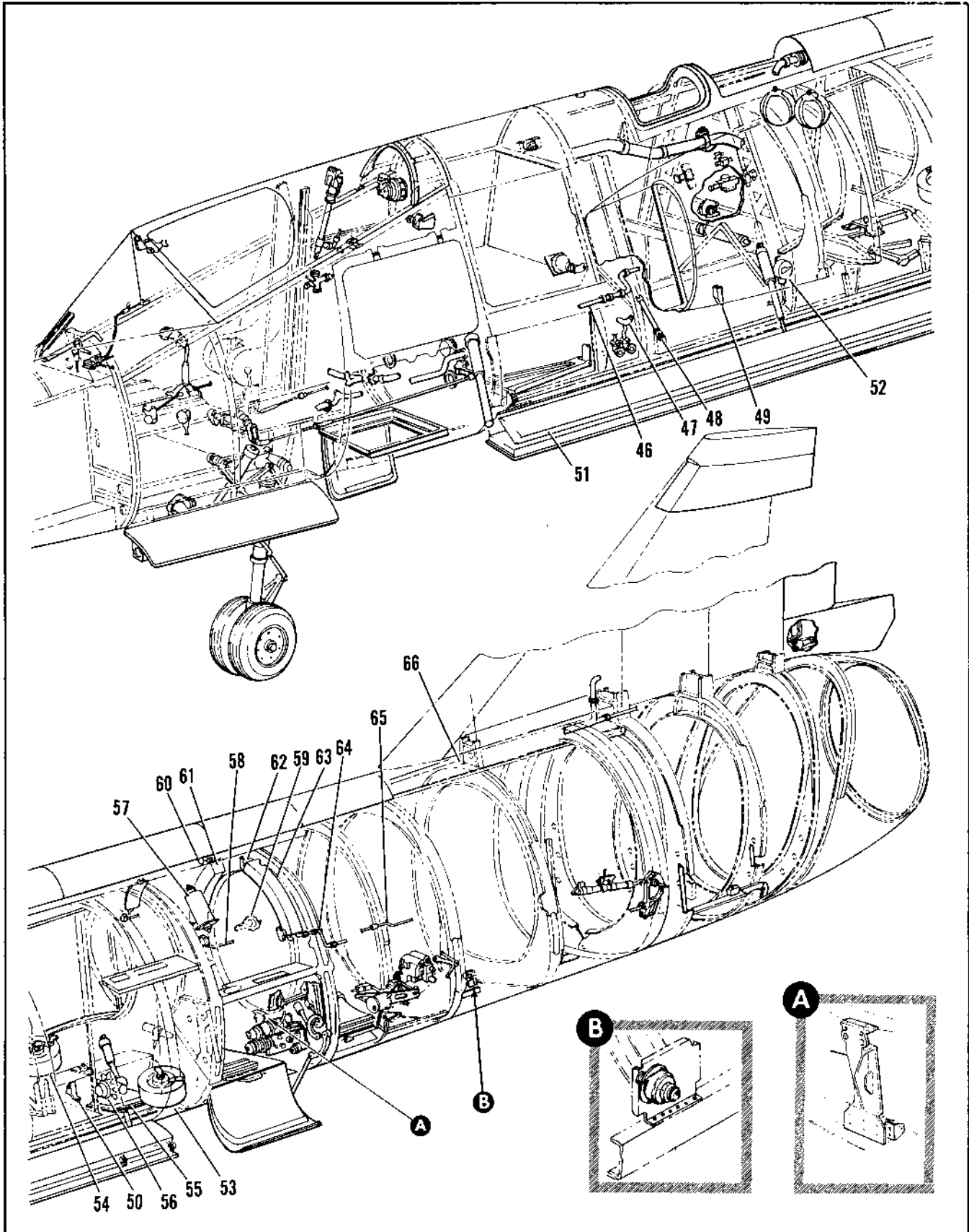

Figure 2.3-3. General Fuselage Assembly (Sheet 5 of 8)

FIGURE AND INDEX NUMBER	PART NUMBER	DESCRIPTION	UNITS PER ASSY.	USABLE ON CODE	
				FROM	TO
2.3-3	8-74163-FC2	• ATTACHMENT INSTL, ARMAMENT BAY DOOR LONGERON RH FOR BREAKDOWN SEE FIG. 2.20-14	1	35	
- 46	8-28400-1	• DUCT INSTL, WINDSHIELD RAIN REMOVAL REMOVAL STA 227 TO 295 FOR BREAKDOWN SEE FIG. 2.13-19	1	35	
- 47	8-28218-3	• TUBING INSTL, VENT FUSELAGE TANK TO WING FOR BREAKDOWN SEE FIG. 2.12-45	1	35	
- 48	8-57256-0	• REFLECTOR INSTL, ME-1 NOSE FOR BREAKDOWN SEE FIG. 2.20-17	1	35	47
- 49	8-57977-1	• CAM INSTL, ARMAMENT HOLDBACK FWD BAY LH FOR BREAKDOWN SEE FIG. 2.20-1	1	35	60
	8-57977-2	• CAM INSTL, ARMAMENT HOLDBACK FWD BAY RH FOR BREAKDOWN SEE FIG. 2.20-1	1	35	60
- 50	8-57981-1	• CAM INSTL, ARMAMENT HOLDBACK AFT BAY LH FOR BREAKDOWN SEE FIG. 2.20-1	1	35	60
	8-57981-2	• CAM INSTL, ARMAMENT HOLDBACK AFT BAY RH FOR BREAKDOWN SEE FIG. 2.20-1	1	35	60
- 51	8-85048	• FLASK INSTL, VARIABLE AIR RAMP PNEUMATIC FOR BREAKDOWN SEE FIG. 2.11-1	1	31	
- 52	8-94153-101	• INITIATOR INSTL, CANOPY JETTISON CONTROL FOR BREAKDOWN SEE FIG. 2.4-8	1	35	
- 53	8-81314-1	• RESERVOIR INSTL, PRIMARY HYDRAULIC FOR BREAKDOWN SEE FIG. 2.8-4	1	35	
- 54	8-81314-3	• RESERVOIR INSTL, SECONDARY HYDRAULIC FOR BREAKDOWN SEE FIG. 2.8-5	1	35	
- 55	8-46458	• DOOR INSTL, PAM AIR TURBINE FOR BREAKDOWN SEE FIG. 2.8-8	1	35	
- 56	8-46457	• TURBINE INSTL, PAM AIR FOR BREAKDOWN SEE FIG. 2.8-7	1	35	
- 57	8-27582-3	• VALVE INSTL, ENGINE OIL COOLER AIR FOR BREAKDOWN SEE FIG. 2.10-23	1	35	
- 58	8-27794-1	• TUBING INSTL, OIL COOLER AMBIENT AIR CONTROL LH STA 446 TO 464	1	35	277
	8-27794-3	• TUBING INSTL, OIL COOLER AMBIENT AIR CONTROL LH STA 464 TO 503	1	35	
	8-74116-1	• REAM INSTL, ENGINE THRUST STA 472 TO 522 FOR BREAKDOWN SEE FIG. 2.10-36	1	35	
- 59	8-27993	• CLAMP INSTL, ENGINE THRUST MOUNT STA 478 FOR BREAKDOWN SEE FIG. 2.10-36	1	35	
- 60	8-27545-1	• MOUNT INSTL, ACCESSORY DRIVE OIL COOLER FOR BREAKDOWN SEE FIG. 2.10-27	1	35	
- 61	8-27545	• COOLER INSTL, ACCESSORY DRIVE OIL FOR BREAKDOWN SEE FIG. 2.10-27	1	35	
- 62	8-27544-1	• MOUNT INSTL, ENGINE OIL COOLER FOR BREAKDOWN SEE FIG. 2.10-21	1	35	
- 63	8-27544	• COOLER INSTL, ENGINE OIL FOR BREAKDOWN SEE FIG. 2.10-21	1	35	
- 64	8-28267-1	• TUBING INSTL, ENGINE OIL COOLER FOR BREAKDOWN SEE FIG. 2.10-19	1	35	77
- 65	8-27795-1	• TUBING INSTL, OIL COOLER ENGINE BLEED AIR CONTROL STA 446 TO 545 FOR BREAKDOWN SEE FIG. 2.10-1	1	35	
- 66	8-74471-11	• FUSELAGE ASSY, STA 472 TO TAIL CONF FOR BREAKDOWN SEE FIG. 2.3-14	1	E	
E AIRPLANES 475 THRU 47, 294 AND ON					

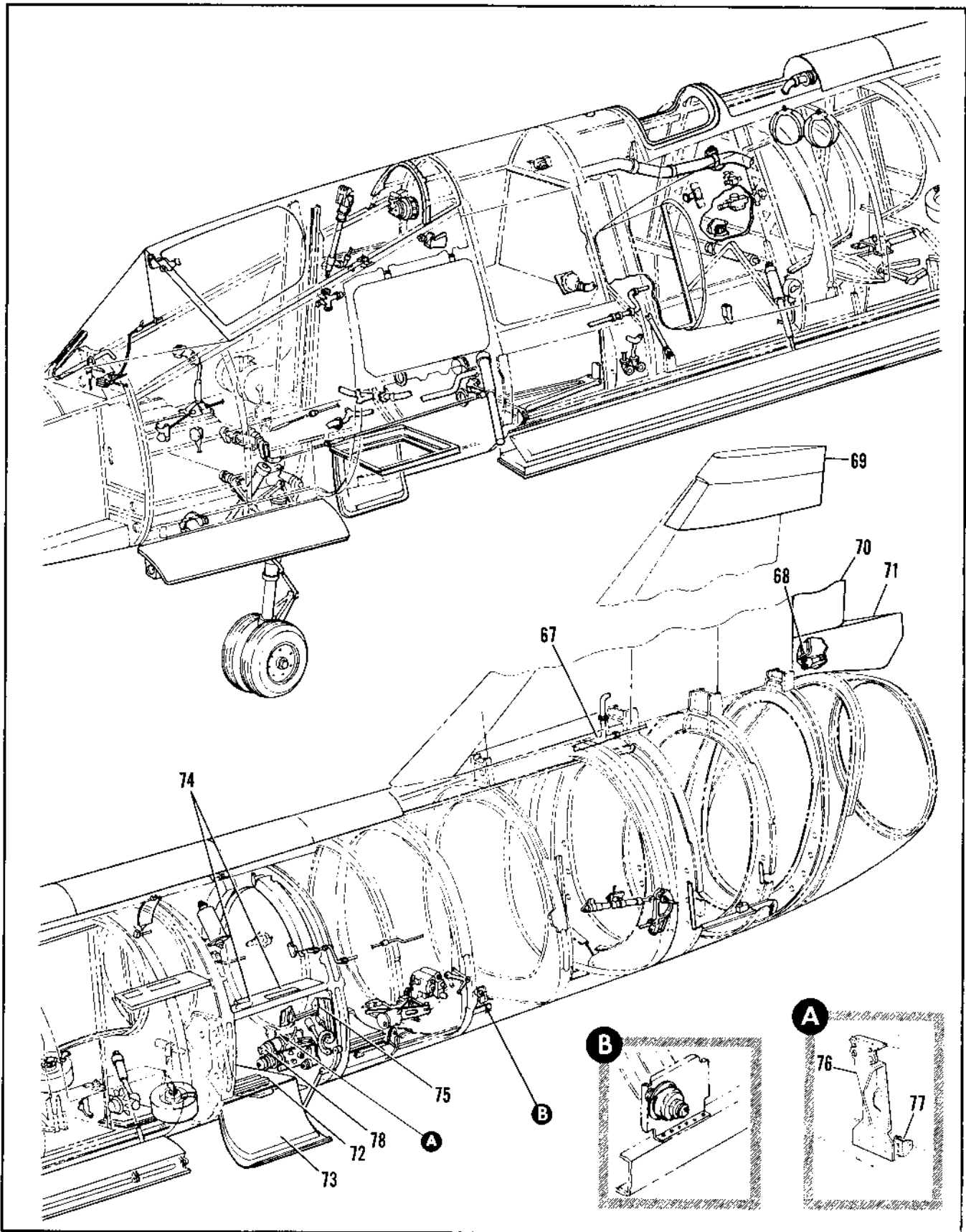

Figure 2.3-3. General Fuselage Assembly (Sheet 6 of 8)

FIGURE AND INDEX NUMBER	PART NUMBER	DESCRIPTION	UNITS PER ASSY.	USABLE ON CODE	
				FROM	TO
2.3-3	8-74470-009	• FUSELAGE ASSY, STA 472 TO TAIL CONE FOR BREAKDOWN SEE FIG. 2.3-14	1	277	277
	8-74470-011	• FUSELAGE ASSY, STA 472 TO TAIL CONE FOR BREAKDOWN SEE FIG. 42	1	288	283
- 67	8-77470	• FUSELAGE ASSY, STA 472 TO TAIL CONE FOR BREAKDOWN SEE FIG. 2.3-14	1	48	277
	8-23850-3	• DUCT INSTL, IFF COOLING STA 260 TO 628 FOR BREAKDOWN SEE FIG. 2.13-11	1	35	43
- 68	8-23850-5	• DUCT INSTL, IFF COOLING STA 260 TO 628 FOR BREAKDOWN SEE FIG. 2.13-11	1	44	277
	8-23850-031	• DUCT INSTL, IFF COOLING STA 260 TO 482 FOR BREAKDOWN SEE FIG. 2.13-11		279	
- 69	8-88300	• DUCT INSTL, IFF COOLING STA 482 TO 628 FOR BREAKDOWN SEE FIG. 2.13-11	1	278	
	8-74860-1	• SUPPORT INSTL, DRAG CHUTE ENCLOSURE FOR BREAKDOWN SEE FIG. 2.7-1	1	35	
- 70	8-14040-1	• TIP INSTL, FIN UPPER FOR BREAKDOWN SEE FIG. 2.18-2	1	35	
- 71	8-15041	• RUDDER INSTALLATION FOR BREAKDOWN SEE FIG. 2.7-5	1	35	
- 72	8-74870-1	• DOOR INSTL, SPEED BRAKE LH FOR BREAKDOWN SEE FIG. 2.7-11	1	35	
	8-74870-2	• DOOR INSTL, SPEED BRAKE RH FOR BREAKDOWN SEE FIG. 2.7-11	1	35	
- 73	8-77191	• ATTACHMENT INSTL, LONGERON LOWER STA 445 FOR BREAKDOWN SEE FIG. 2.15-32	1	61	
	8-77191-001	• HINGE INSTL, LONGERON LOWER STA 412 TO 472 FOR BREAKDOWN SEE FIG. 2.15-31	1	61	
- 74	8-77191-003	• HINGE INSTL, LONGERON LOWER STA 412 TO 472 LH FOR BREAKDOWN SEE FIG. 2.15-31	1	61	
	8-77191-004	• HINGE INSTL, LONGERON LOWER STA 412 TO 472 RH FOR BREAKDOWN SEE FIG. 2.15-31	1	61	
- 75	8-44545-5	• DOOR INSTL, MAIN LANDING GEAR FOR BREAKDOWN SEE FIG. 2.15-3	1	35	
- 76	8-74104-3	• DOOR INSTL, STA 431 TO 472 FOR BREAKDOWN SEE FIG. 2.2-7	1	35	
- 77	8-28930	• SUPPORT INSTL, REMOTE GEAR BOX ACCESSORY FOR BREAKDOWN SEE FIG. 2.10-30	1	35	
- 78	8-77310-001	• PULKHEAD INSTL, STA 472	1	61	
	8-74751-1	• ADAPTER ASSY, MLG DOOR ACTUATOR AFT FOR BREAKDOWN SEE FIG. 2.15-1	3	61	
	8-42541-11	• SUPPORT	1	61	
	8-27984-017	• DRIVE INSTL, ACCESSORY FOR BREAKDOWN SEE FIG. 2.10-25	RF	35	
	8-27984-033	• DRIVE INSTL, ACCESSORY FOR BREAKDOWN SEE FIG. 2.10-25	RF	35	277
	8-27984-5	• DRIVE INSTL, ACCESSORY FOR BREAKDOWN SEE FIG. 2.10-25	RF	35	
	8-27984-077	• DRIVE INSTL, ACCESSORY FOR BREAKDOWN SEE FIG. 2.10-25	RF	35	
	8-27984-3	• DRIVE INSTL, ACCESSORY FOR BREAKDOWN SEE FIG. 2.10-25	RF	35	
	8-27984-029	• DRIVE INSTL, ACCESSORY FOR BREAKDOWN SEE FIG. 2.10-25	RF	35	

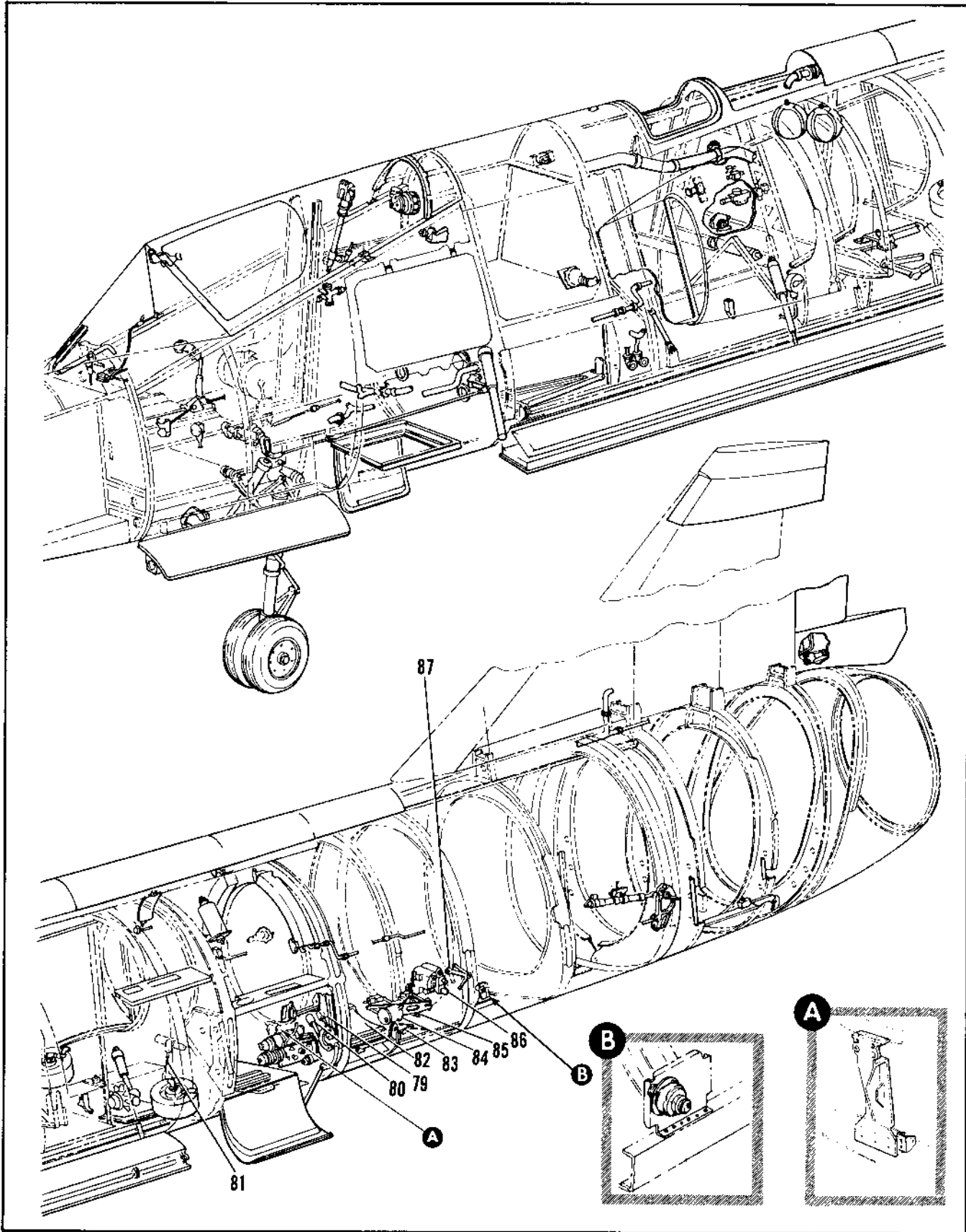

Figure 2.3-3. General Fuselage Assembly (Sheet 7 of 8)

FIGURE AND INDEX NUMBER	PART NUMBER	DESCRIPTION	UNITS PER ASSY.	USABLE ON CODE	
				FROM	TO
		1 2 3 4 5 6			
2.3-3	8-27984-927	• DRIVE INSTL, ACCESSORY FOR BREAKDOWN SEE FIG. 2.10-25	RF	35	
	8-27984-921	• DRIVE INSTL, ACCESSORY FOR BREAKDOWN SEE FIG. 2.10-25	RF	35	
	8-27984-903	• DRIVE INSTL, ACCESSORY FOR BREAKDOWN SEE FIG. 2.10-25	RF	35	
	8-27984-909	• DRIVE INSTL, ACCESSORY FOR BREAKDOWN SEE FIG. 2.10-25	RF	35	
	713095	• DRIVE INSTL, ACCESSORY (99167) FOR BREAKDOWN SEE FIG. 2.10-27	1	35	
- 79	8-44592-1	• SWITCH INSTL, MLG DOOR OPEN LH FOR BREAKDOWN SEE FIG. 2.15-32	1	35	60
	8-44592-5	• SWITCH INSTL, MLG DOOR OPEN LH FOR BREAKDOWN SEE FIG. 2.15-32	1	61	
	8-44592-2	• SWITCH INSTL, MLG DOOR OPEN RH FOR BREAKDOWN SEE FIG. 2.15-32	1	35	60
	8-44592-6	• SWITCH INSTL, MLG DOOR OPEN RH FOR BREAKDOWN SEE FIG. 2.15-32	1	61	
- 80	8-44546-3	• ACTUATOR INSTL, MAIN LANDING GEAR DOOR MODIFIED BY 8-80620 FOR BREAKDOWN SEE FIG. 2.15-22	1	35	215
	8-44546-5	• ACTUATOR INSTL, MAIN LANDING GEAR DOOR FOR BREAKDOWN SEE FIG. 2.15-23	1	215	
- 81	8-83001-1	• CABLE INSTL, MLG DOOR CYLINDER RESTRAINER LH STA 431 FOR BREAKDOWN SEE FIG. 2.15-1	1	189	
	8-83001-2	• CABLE INSTL, MLG DOOR CYLINDER RESTRAINER RH STA 431 FOR BREAKDOWN SEE FIG. 2.15-1	1	189	
	8-83001-3	• CABLE INSTL, MLG DOOR CYLINDER RESTRAINER LH STA 472 FOR BREAKDOWN SEE FIG. 2.15-1	1	189	
	8-83001-4	• CABLE INSTL, MLG DOOR CYLINDER RESTRAINER RH STA 472 FOR BREAKDOWN SEE FIG. 2.15-1	1	189	
- 82	8-74614	• DOOR INSTL, ACCESSORY DRIVE UNIT STA 472 TO 520 FOR BREAKDOWN SEE FIG. 2.2-9	1	35	
	8-74412-3	• STRUCTURE INSTL, ACCESSORY DRIVE UNIT DOOR FOR BREAKDOWN SEE FIG. 2.2-9	1	35	60
	8-74412-603	• STRUCTURE INSTL, ACCESSORY DRIVE UNIT DOOR FOR BREAKDOWN SEE FIG. 2.2-9	1	61	
- 83	8-42525	• BELL CRANK INSTL, ELEVATOR AND AILERON STA 470 FOR BREAKDOWN SEE FIG. 2.14-18	1	35	
- 84	8-42504-403	• CONTROL INSTL, ELEVON STA 472 TO 507 FOR BREAKDOWN SEE FIG. 2.14-22	1		
	8-42504-5	• CONTROL INSTL, ELEVON STA 472 TO 507 FOR BREAKDOWN SEE FIG. 2.14-22	1	K	
- 85	8-42554-1	• FITTING INSTL, ELEVON CONTROL SUPPORT FOR BREAKDOWN SEE FIG. 2.14-22	1	35	
- 86	8-27373-3	• EQUALIZER INSTL, FUEL FLOW FOR BREAKDOWN SEE FIG. 2.12-46	1	35	
- 87	8-42728-1	• SHAFT INSTL, POWER CONTROL TORQUE FOR BREAKDOWN SEE FIG. 2.10-4	1	35	
		K AIRPLANES #275, 281, AND 286 THRU 303			

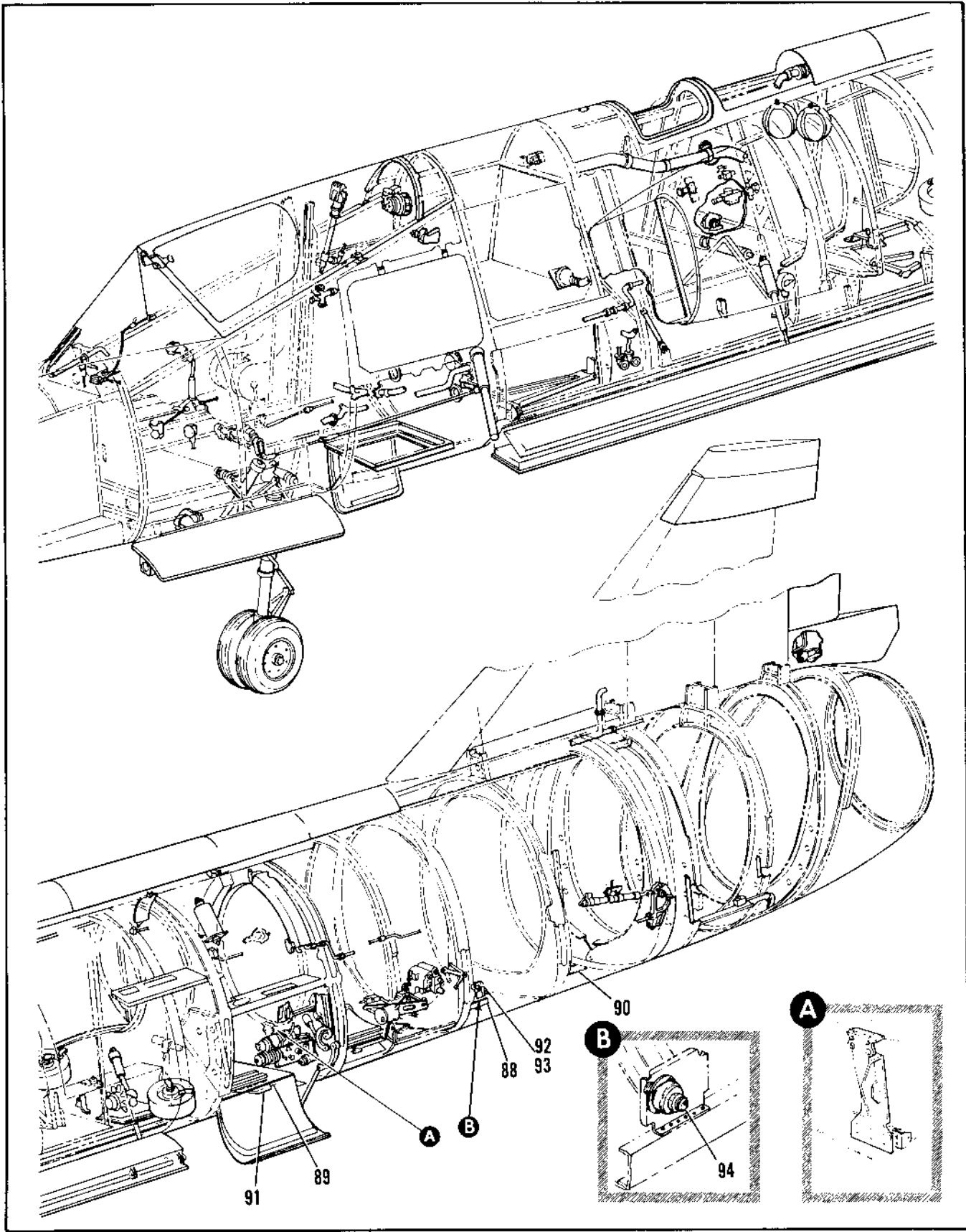

Figure 2.3-3. General Fuselage Assembly (Sheet 8 of 8)

FIGURE AND INDEX NUMBER	PART NUMBER	DESCRIPTION	UNITS PER ASSY.	USABLE ON CODE	
				FROM	TO
		1 2 3 4 5 6			
2.3-3	8-74124	• LONGERON INSTL, FUSELAGE STA 444 TO 655 MODIFIED BY 8-71163	1	M	
	8-74124-1	• LONGERON INSTL, FUSELAGE STA 472 TO 655	1	42	47
	8-74124-3	• LONGERON INSTL, FUSELAGE STA 472 TO 655 FOR NHA SEE FIG. 2.3-14	RF	44	51
	8-77124	• LONGERON INSTL, FUSELAGE STA 444 TO 655 FOR NHA SEE FIG. 2.3-14	RF	61	277
- 88	8-74124	• • LONGERON, LWR FUSELAGE STA 472 TO 607	1	35	60
	8-74132-1	• • LONGERON, LWR FUSELAGE STA 444 TO 607	1	61	123
	8-74132-3	• • LONGERON, LWR FUSELAGE STA 444 TO 607	1	130	277
	8-74742	• • BOLT, LONGERON SPLICE SHEAR STA 472	7	278	
	AN324-8	• • NUT	7	278	
- 89	8-71162-1	• • LONGERON, LWR FUSELAGE STA 444 TO 472	1	278	
- 90	8-71163-7	• • LONGERON, LWR FUSELAGE STA 472 TO 607	1	278	
- 91	8-71162-11	• • COVER, LWR FUSELAGE LONGERON ATTACHING PARTS	1	276	
	MS24654-50	• • SCREW (26926)	4	278	
	8-74124-7	• • LONGERON, LWR FUSELAGE STA 607 TO 655 REPLACED BY 8-77124-7	1	3	
	8-77124-7	• • LONGERON, LWR FUSELAGE STA 607 TO 655 REPLACES AND SUITABLE SUB FOR 8-74124-7	1	J	277
	8-81313-1	• COUPLING INSTL, HYDRAULIC PRESSURE AND SUCTION STA 531 AND 533 MOD BY 7144626-10	1	35	
- 92	3022-8D	• • COUPLING, (20624) 92-73900-006 STA 531 ATTACHING PARTS	1	35	
	NAS679A3	• • NUT (20205)	3	35	
	AN3-4A	• • BOLT (28044)	3	35	
- 93	3002-8D	• • COUPLING, (20624) 92-73900-006 STA 533 ATTACHING PARTS	RF	8	
	NAS679A3	• • NUT (20205)	RF	8	
	AN3-4A	• • BOLT (28044)	RF	8	
- 94	3022-12D	• • COUPLING, (20624) STA 533	1	8	
	MS21042L3	• • NUT (26926)	3	8	
	AN3-4A	• • BOLT (28044)	3	8	
		J AIRPLANES #35 THRU 60, 274 AND ON			
		M AIRPLANES #35 THRU 41, 274 AND ON			
		L AIRPLANES #48, 90 AND ON			

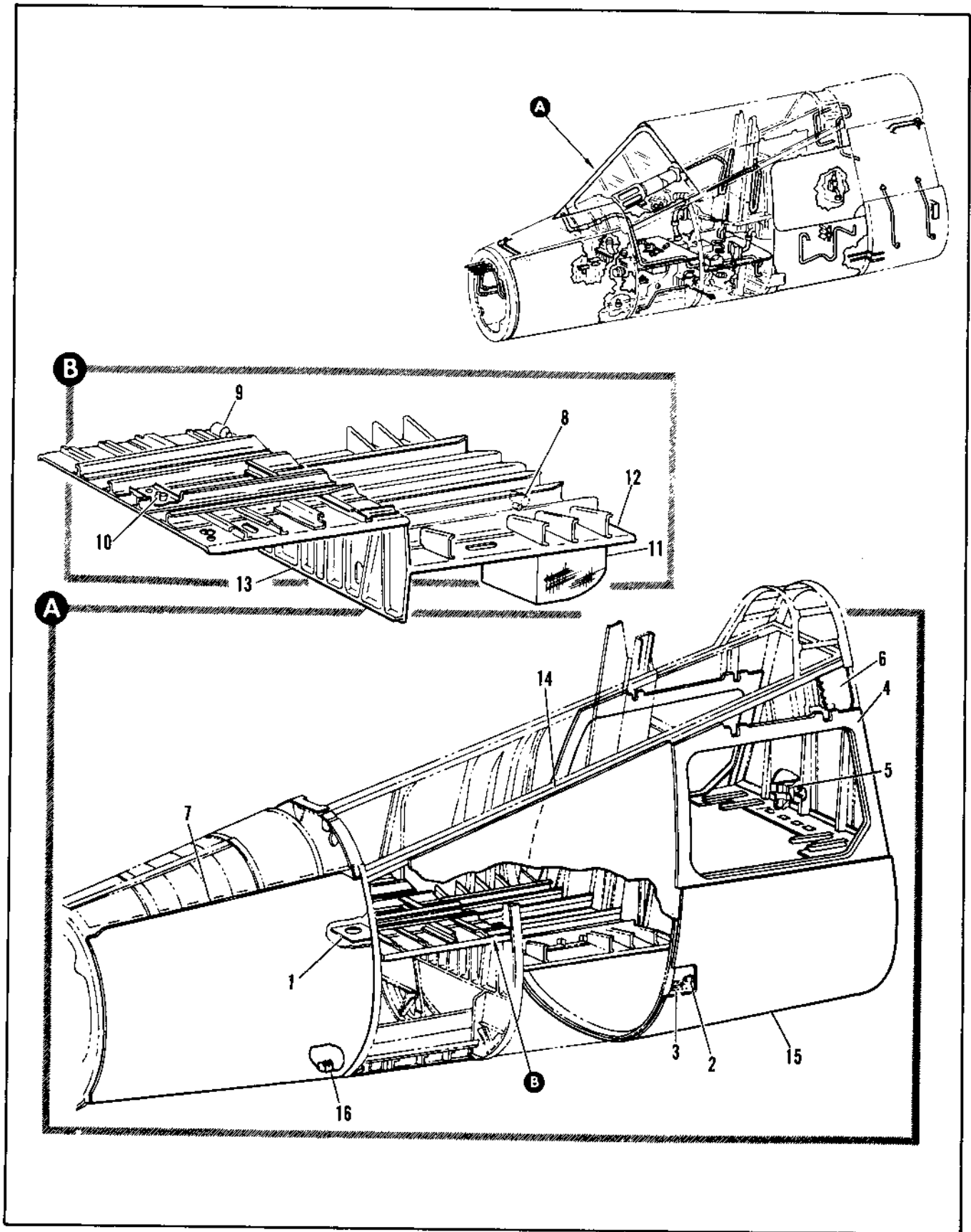

Figure 2.3-4. Fuselage Assembly Sta 40 to 216 (Sheet 1 of 6)

FIGURE AND INDEX NUMBER	PART NUMBER	DESCRIPTION	UNITS PER ASSY.	USABLE ON CODE	
				FROM	TO
2.3-4	8-74000-05	FUSELAGE ASSEMBLY, STA 40 TO 216 MODIFIED BY R-31983 FOR NHA SEE FIG. 2.3-3	RF	35	277
	8-74000-09	FUSELAGE ASSEMBLY, STA 40 TO 211 MODIFIED BY R-31983 FOR NHA SEE FIG. 2.3-3	RF	278	
- 1	8-74630	• DOOR INSTL, CABIN AIR PRESSURE REGULATOR ACCESS STA 102 TO 110 FOR BREAKDOWN SEE FIG. 2.2-1	1	A	
	8-74639	• DOOR INSTL, CABIN AIR PRESSURE REGULATOR ACCESS STA 102 TO 110 FOR BREAKDOWN SEE FIG. 2.2-1	1	B	
- 2	8-44747	• LATCH INSTL, EXTERNAL POWER ACCESS DOOR FOR BREAKDOWN SEE FIG. 2.2-6	1	35	
- 3	8-74641-1	• DOOR INSTL, ELECTRICAL POWER GROUND ACCESS STA 171 TO 175 FOR BREAKDOWN SEE FIG. 2.2-3	1	35	
- 4	8-74636-001	• FRAME INSTL, ELECTRONIC ACCESS DOOR AFT LH FOR BREAKDOWN SEE FIG. 2.2-4	1	35	
	8-74636-002	• FRAME INSTL, ELECTRONIC ACCESS DOOR AFT RH FOR BREAKDOWN SEE FIG. 2.2-4	1	35	
- 5	8-57987	• SWITCH INSTL, FWD ARMAMENT BAY LAUNCHER DOWN FOR BREAKDOWN SEE FIG. 2.20-5	1	35	
- 6	8-77409	• PANEL INSTL, CANTED UPPER STA 172 TO 217 FOR BREAKDOWN SEE FIG. 2.2-3	1	35	
- 7	8-74440-5	• DOOR AND PANEL INSTL, FWD RADAR COMPARTMENT STA 41 TO 102 FOR BREAKDOWN SEE FIG. 2.3-5	1	35	
- 8	8-74115-005	• EQUIPMENT ASSY, FLOOR STA 102 TO 172	1	35	
	8-84006	• VALVE INSTL, HYDRAULIC NOSE WHEEL STEERING FOR BREAKDOWN SEE FIG. 2.15-1	1	35	
- 9	8-23750-1	• SWITCH INSTL, COCKPIT LOW PRESS WARNING LIGHT FOR BREAKDOWN SEE FIG. 2.13-1	1	35	
- 10	8-23340-1	• FITTING INSTL, COCKPIT PRESSURE GROUND TEST FOR BREAKDOWN SEE FIG. 2.13-2	1	A	
	8-23360	• FITTING INSTL, COCKPIT PRESSURE GROUND TEST FOR BREAKDOWN SEE FIG. 2.13-3	1	B	
- 11	8-92494	• SHROUD INSTL, LIQUID OXYGEN CONVERTER FOR BREAKDOWN SEE FIG. 2.19-1	1	35	
- 12	8-74416-001	• FLOOR ASSY, COCKPIT CENTER	1	35	
- 13	8-74141-1	• FITTING ASSY, NLC DRAG STRUT FOR BREAKDOWN SEE FIG. 2.15-36	1	A	
	8-74725	• FITTING ASSY, NLC DRAG STRUT FOR BREAKDOWN SEE FIG. 2.15-36	1	F	
	8-74725-1	• FITTING ASSY, NLC DRAG STRUT FOR BREAKDOWN SEE FIG. 2.15-36	1	109	
- 14	8-74013-005	• EQUIPMENT ASSY, LH SIDE PANEL STA 102 TO 172 FOR BREAKDOWN SEE FIG. 2.3-6	1	35	
	8-74014-001	• EQUIPMENT ASSY, RH SIDE PANEL STA 102 TO 172 FOR BREAKDOWN SEE FIG. 2.3-6	1	35	
- 15	8-77406	• HARREL ASSY, STA 166 TO 253 LOWER FOR BREAKDOWN SEE FIG. 2.3-8	1	35	
- 16	8-77704-11	• SUPPORT, NOSE LANDING GEAR DOOR STOP	2	35	
	8-77700-11	• SUPPORT, NOSE LANDING GEAR DOOR STOP ALT INTCHG WITH 8-77704-11	RF	35	

A AIRPLANES #45 THRU 47 AND 49 THRU 49
 B AIRPLANES # 48, 90 AND ON
 F AIRPLANES #44, AND 99 THRU 100

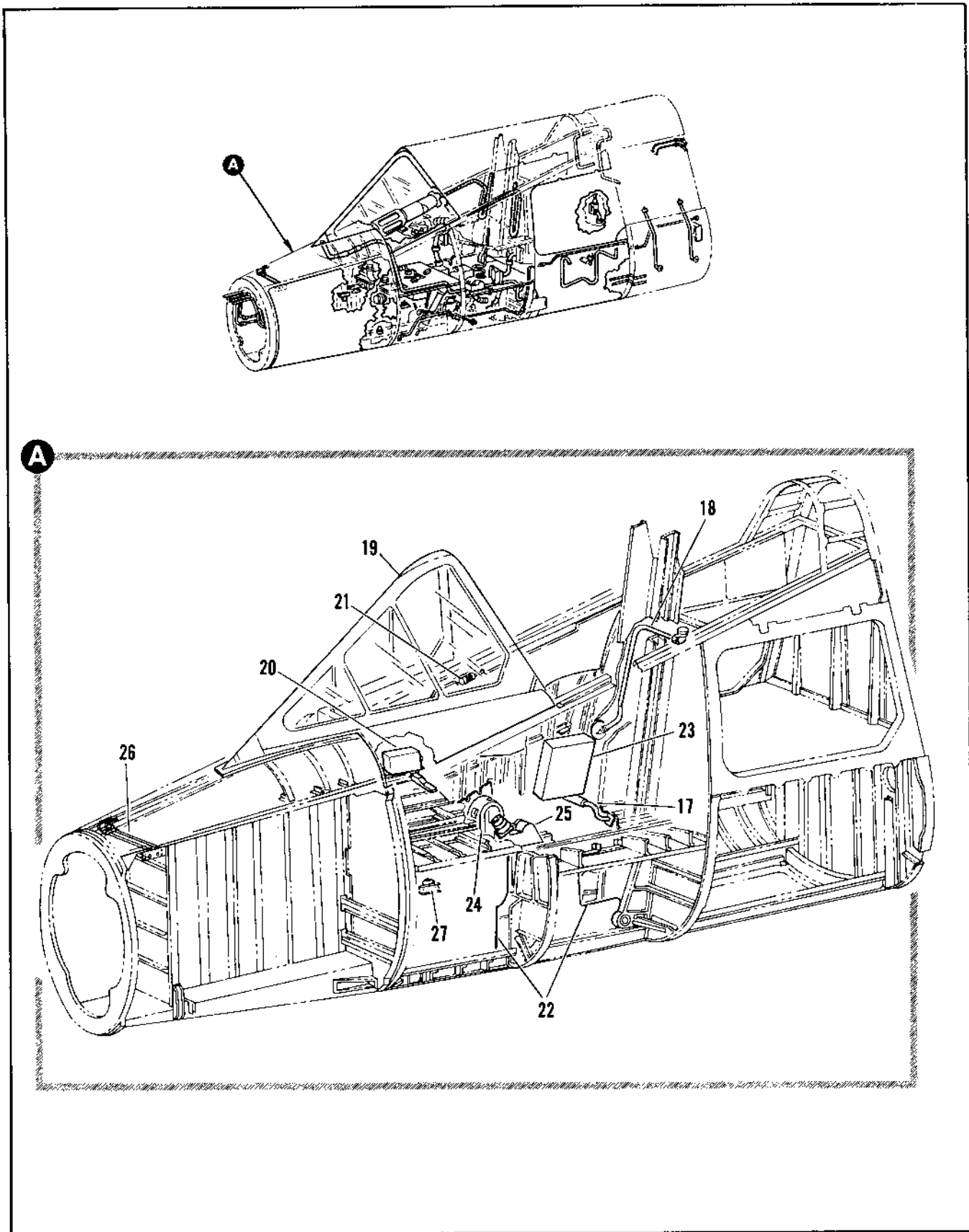

Figure 2.3-4. Fuselage Assembly Sta 40 to 216 (Sheet 2 of 6)

FIGURE AND INDEX NUMBER	PART NUMBER	DESCRIPTION	UNITS PER ASSY.	USABLE ON CODE	
				FROM	TO
		1 2 3 4 5 6			
2.3-4- 17	8-94153-103	• HOSE INSTL, CANOPY JETTISON CONTROL FOR BREAKDOWN SEE FIG. 2.4-9	1	35	
- 18	8-74955	• DRAIN INSTL, CANOPY ACTUATOR WELL FOR BREAKDOWN SEE FIG. 2.4-1	1	35	
- 19	8-74837	• WINDSHIELD INSTALLATION, FOR BREAKDOWN SEE FIG. 2.4-2	1	35	
- 20	8-95692-1	• CONTROL INSTL, WINDSHIELD ANTI-ICING FOR BREAKDOWN SEE FIG. 2.13-1	1	B	
- 21	8-94595-1	• LIGHT INSTL, MAP READING FOR BREAKDOWN SEE FIG. 2.5-1	1	35	
- 22	8-92938-205	• COVER INSTL, NOSE WHEEL WELL SPLASH FOR BREAKDOWN SEE FIG. 2.5-13	1	C	
	8-92938-217	• COVER INSTL, NOSE WHEEL WELL SPLASH FOR BREAKDOWN SEE FIG. 2.5-13	1	61	89
	8-92938-221	• COVER INSTL, NOSE WHEEL WELLSPLASH FOR BREAKDOWN SEE FIG. 2.5-13	1	D	
	8-92938-227	• COVER INSTL, NOSE WHEEL WELL SPLASH FOR BREAKDOWN SEE FIG. 2.5-13	1	165	
- 23	4-95823	• CASE INSTL, MAP AND FLIGHT REPORT FOR BREAKDOWN SEE FIG. 2.5-7	1	35	
- 24	8-94963-201	• GUARD INSTL, COCKPIT CONTROL FOR BREAKDOWN SEE FIG. 2.5-11	1	A	
	8-94983-203	• GUARD INSTL, COCKPIT CONTROL FOR BREAKDOWN SEE FIG. 2.5-11	1	H	
- 25	8-94294	• COVER INSTL, CENTER STICK CONTROL FOR BREAKDOWN SEE FIG. 2.5-11	1	35	
- 26	4-36206-1	• TUBING INSTL, RADAR PRESSURIZATION SYSTEM FOR BREAKDOWN SEE FIG. 2.18-1E	1	A	
	8-36206-3	• TUBING INSTL, RADAR PRESSURIZATION SYSTEM FOR BREAKDOWN SEE FIG. 2.18-1E	1	H	
- 27	6-95433	• SWITCH INSTL, PRESSURE INDICATED AIRSPEED FOR BREAKDOWN SEE FIG. 2.14-1	1	35	
		C AIRPLANES 435 THRU 47 AND 49 THRU 60			
		D AIRPLANES 446 AND 90 THRU 169			

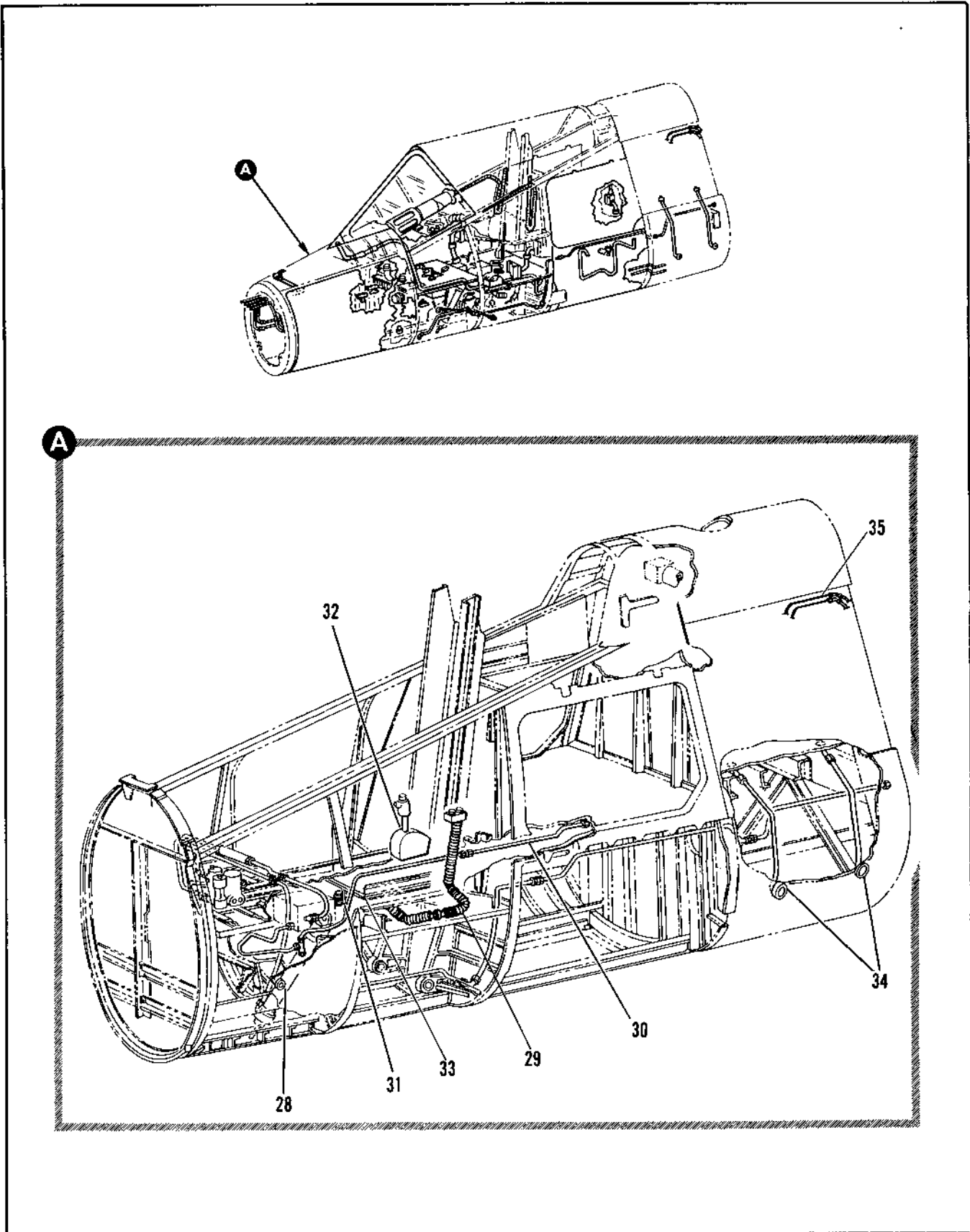

Figure 2.3-4. Fuselage Assembly Sta 40 to 216 (Sheet 3 of 6)

FIGURE AND INDEX NUMBER	PART NUMBER	DESCRIPTION	UNITS PER ASSY.	USABLE ON CODE	
				FROM	TO
		1 2 3 4 5 6			
2.3-4- 26	--21375-1	• PART INSTL, PNEUMATIC SENSING STATIC PRESSURE LH FOR BREAKDOWN SEE FIG. 2.4-1	1	35	
	--21575-2	• PART INSTL, PNEUMATIC SENSING STATIC PRESSURE RH FOR BREAKDOWN SEE FIG. 2.4-1	1	35	
- 29	ER264-21	• TUBING INSTL, ANTI-G SUIT FOR BREAKDOWN SEE FIG. 2.9-1	9F	35	
	AE350-100102	• TUBING INSTL, ANTI-G SUIT FOR BREAKDOWN SEE FIG. 2.9-1	1	35	
- 37	H-38097-20	• TUBING INSTL, PRESSURE RATIO INDICATOR STA 102 TO 215 FOR BREAKDOWN SEE FIG. 2.10-20	1	35	
- 31	--31124-4	• TRAP INSTL, PRESSURE RATIO TUBING WATER FOR BREAKDOWN SEE FIG. 2.10-20	1	35	
- 30	--42111-2	• PEEDESTAL INSTL, POWER CONTROL FOR BREAKDOWN SEE FIG. 2.10-2	1	35	123
	--42701-01	• PEEDESTAL INSTL, POWER CONTROL FOR BREAKDOWN SEE FIG. 2.10-2	1	130	
- 33	R-45273	• PANEL INSTL, PILOT FLOOR AIR SCUFF	1	5	
- 34	S-28137-1	• VALVE INSTL, FUSELAGE TANK DRAIN LH STA 225 AND 245 WL 24 FOR BREAKDOWN SEE FIG. 2.10-34	1	35	
- 35	R-92947-11	• TUBE INSTL, VARIABLE AIR RAMP PITOT STATIC CONTROL LH FOR BREAKDOWN SEE FIG. 2.11-2	1	35	
	R-92947-14	• TUBE INSTL, VARIABLE AIR RAMP PITOT STATIC CONTROL LH FOR BREAKDOWN SEE FIG. 2.11-2	1	35	
3 AIRPLANES #48, 90 AND ON					

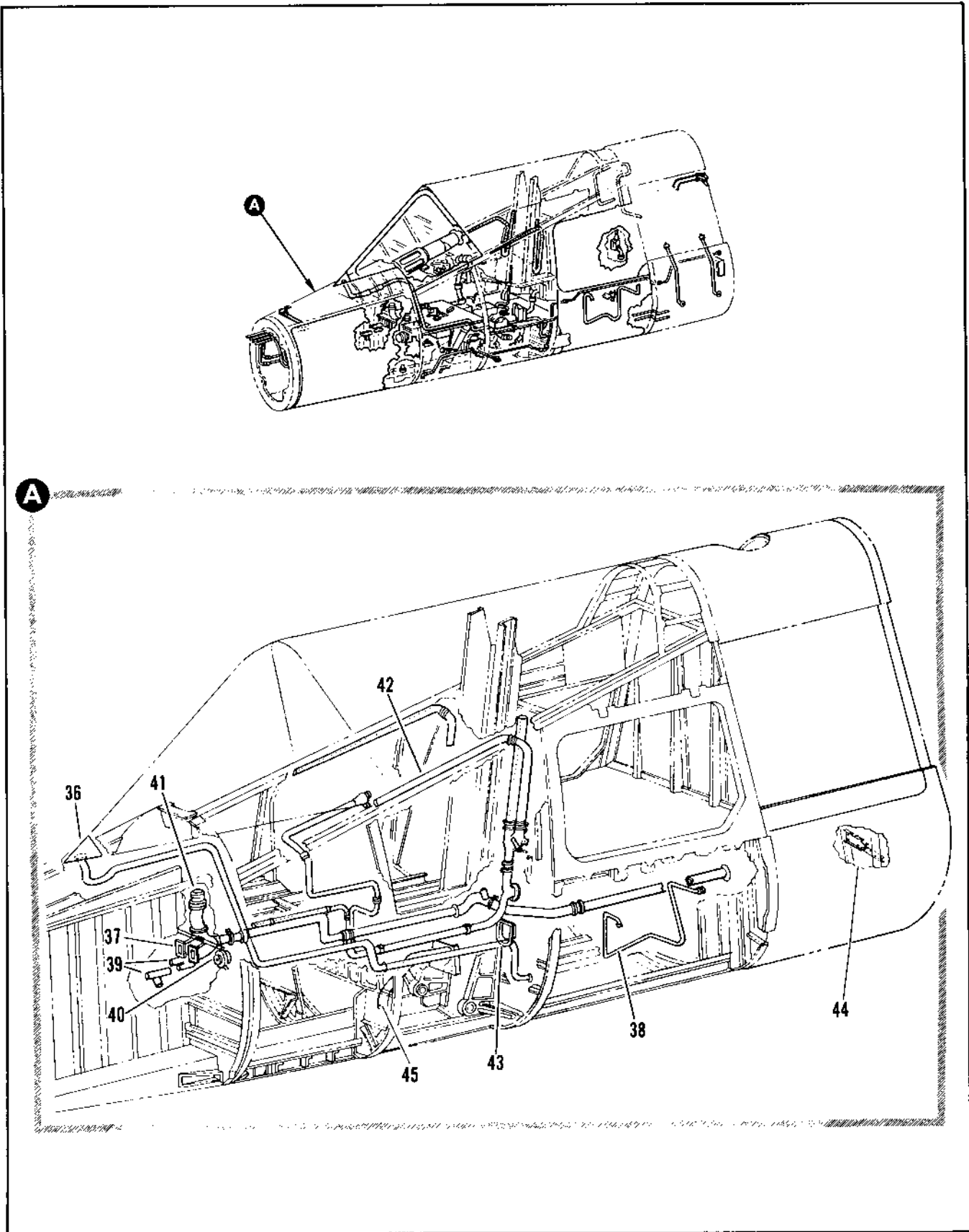
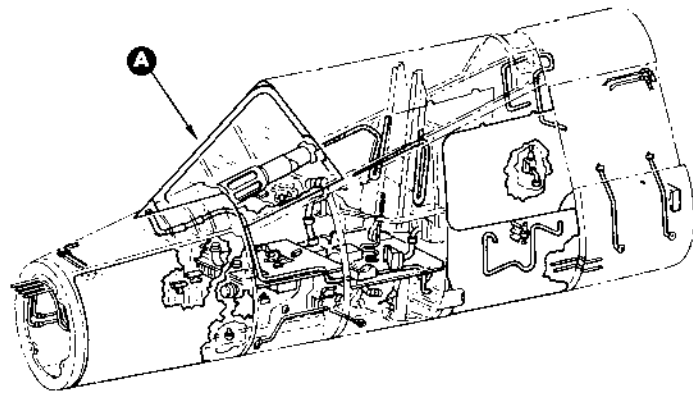

Figure 2.3-4. Fuselage Assembly Sta 40 to 216 (Sheet 4 of 6)

FIGURE AND INDEX NUMBER	PART NUMBER	DESCRIPTION	UNITS PER ASSY.	USABLE ON CODE	
				FROM	TO
		1 2 3 4 5 6			
2.3-4-36	A-23400-8	• DUCT INSTL. RAIN REMOVAL STA #4 TO 150 FOR BREAKDOWN SEE FIG. 2.13-11	PF	A	
	A-23400-9	• DUCT INSTL. RAIN REMOVAL STA #4 TO 150 MODIFIED BY 60J3841 FOR BREAKDOWN SEE FIG. 2.13-16	1	A	
	A-23400-10	• DUCT INSTL. RAIN REMOVAL STA #4 TO 150 FOR BREAKDOWN SEE FIG. 2.13-16	PF	P	
	A-23400-13	• DUCT INSTL. RAIN REMOVAL STA #4 TO 150 MODIFIED BY 60J3841 FOR BREAKDOWN SEE FIG. 2.13-16	1	P	
- 37	A-23500-11	• DUCT INSTL. FWD RADAR COMPARTMENT COOLING STA 12 TO 16P FOR BREAKDOWN SEE FIG. 2.13-5	PF	A	
	A-23500-12	• DUCT INSTL. FWD RADAR COMPARTMENT COOLING STA 12 TO 16P FOR BREAKDOWN SEE FIG. 2.13-6	PF	48	48
	A-23500-16	• DUCT INSTL. FWD RADAR COMPARTMENT COOLING STA 12 TO 16P FOR BREAKDOWN SEE FIG. 2.13-5	PF	61	49
	724276-11	• PIPE INSTL. NOSE WHEEL WELL FOR BREAKDOWN SEE FIG. 2.13-16 (99750)	1	35	
	A-23500-17	• DUCT INSTL. FWD RADAR COMPARTMENT COOLING STA 12 TO 16P FOR BREAKDOWN SEE FIG. 2.13-6	1	90	
	724276-12	• PIPE INSTL. NOSE WHEEL WELL FOR BREAKDOWN SEE FIG. 2.13-6 (99750)	1	35	
- 38	A-23640	• DUCT INSTL. AFT ELECTRONIC COMPARTMENT COOLING FOR BREAKDOWN SEE FIG. 2.13-8	1	35	
	724276-11	• DUCT INSTL. AFT ELECTRONIC EQUIPMENT COOLING FOR BREAKDOWN SEE FIG. 2.13-7 (99750)	1	35	
- 39	A-23720	• EQUIPMENT INSTL. RADOME ANTI-ICING FOR BREAKDOWN SEE FIG. 2.13-1	1	35	
- 40	A-23520	• CONTROL INSTL. COCKPIT AIR PRESSURE REGULATOR FOR BREAKDOWN SEE FIG. 2.13-4	1	A	
- 41	A-23520-1	• REGULATOR INSTL. COCKPIT AIR PRESSURE FOR BREAKDOWN SEE FIG. 2.13-4	1	A	
	A-23565	• REGULATOR INSTL. COCKPIT AIR PRESSURE FOR BREAKDOWN SEE FIG. 2.13-4	1	P	
- 42	A-23300-10	• DUCT INSTL. COCKPIT AIR-CONDITIONING FWD LH FOR BREAKDOWN SEE FIG. 2.13-10	1	A	
	A-23300-11	• DUCT INSTL. COCKPIT AIR-CONDITIONING FWD LH FOR BREAKDOWN SEE FIG. 2.13-10	1	P	
	A-23300-12	• DUCT INSTL. COCKPIT AIR-CONDITIONING FWD RH FOR BREAKDOWN SEE FIG. 2.13-12	1	A	
	A-23300-17	• DUCT INSTL. COCKPIT AIR-CONDITIONING FWD RH FOR BREAKDOWN SEE FIG. 2.13-12	1	P	
	A-23300-17	• DUCT INSTL. COCKPIT AIR-CONDITIONING AFT FOR BREAKDOWN SEE FIG. 2.13-13	1	A	
	A-23300-18	• DUCT INSTL. COCKPIT AIR-CONDITIONING AFT FOR BREAKDOWN SEE FIG. 2.13-13	1	P	
- 43	A-23637	• VALVE INSTL. PURGE AIR CHECK FOR BREAKDOWN SEE FIG. 2.13-1	1	35	
- 44	A-23525	• BRACKET INSTL. COCKPIT COOLING DUCT FOR BREAKDOWN SEE FIG. 2.13-1	PF	75	
- 45	A-92457	• SHROUD INSTL. TUBING LIQUID OXYGEN FOR BREAKDOWN SEE FIG. 2.13-1	1	30	

A AIRPLANES #1F-106A-47 AND 48 THRU 49
 B AIRPLANES #43, 90 AND ON



A

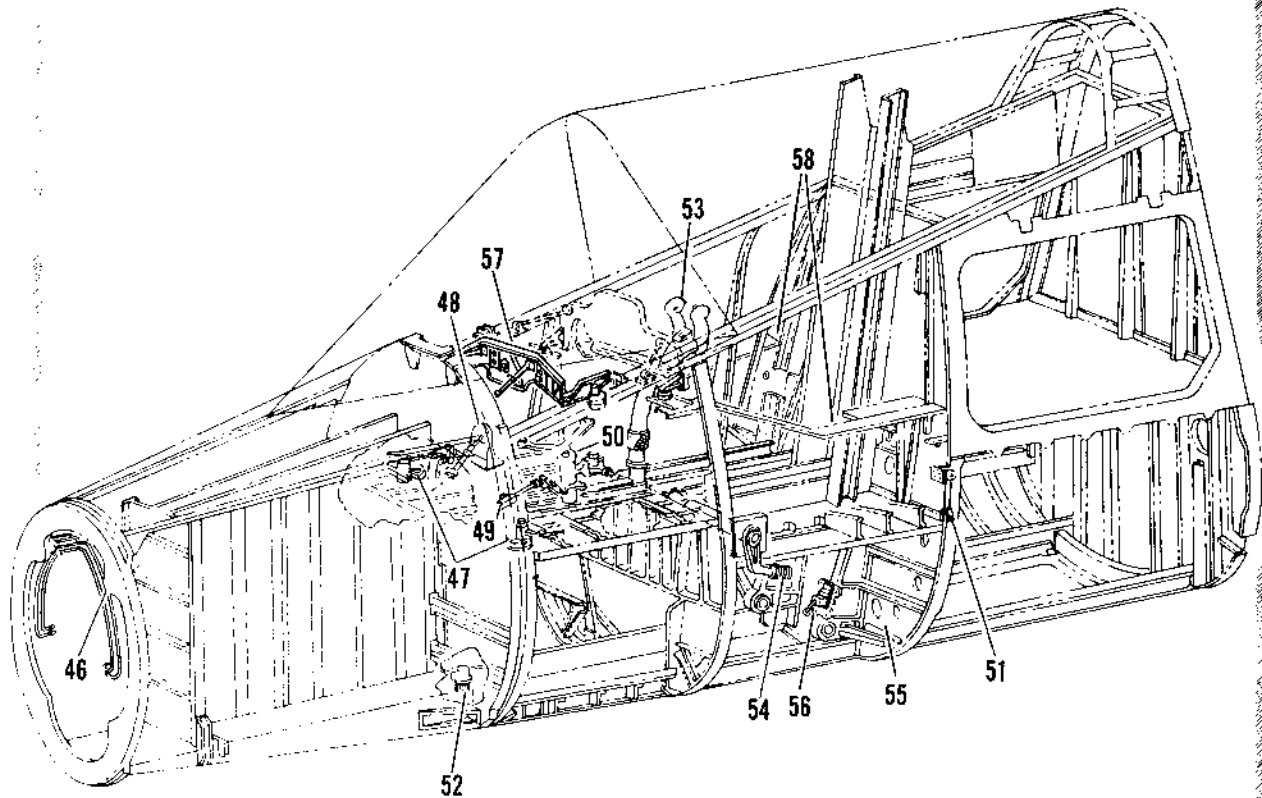

Figure 2.3-4. Fuselage Assembly Sta 40 to 216 (Sheet 5 of 6)

FIGURE AND INDEX NUMBER	PART NUMBER	DESCRIPTION	UNITS PER ASSY.	USABLE ON CODE	
				FROM	TO
		1 2 3 4 5 6			
2.3-4- 46	6-38192-5	• TUBING INSTL, AIRSPEED STA 41 TO 148 FOR BREAKDOWN SEE FIG. 2.14-4	1	35	
- 47	8-42242-1	• CONTROL INSTL, RUDDER LH STA 108 FOR BREAKDOWN SEE FIG. 2.14-32	1	A	
	8-42242-301	• CONTROL INSTL, RUDDER LH STA 108 FOR BREAKDOWN SEE FIG. 2.14-33	1	B	
	8-42242-2	• CONTROL INSTL, RUDDER RH STA 108 FOR BREAKDOWN SEE FIG. 2.14-32	1	A	
	8-42242-202	• CONTROL INSTL, RUDDER RH STA 108 FOR BREAKDOWN SEE FIG. 2.14-33	1	B	
- 48	8-42245	• PEDAL INSTL, RUDDER AND BRAKE FOR BREAKDOWN SEE FIG. 2.14-26	1	A	
	8-42245-1	• PEDAL INSTL, RUDDER AND BRAKE FOR BREAKDOWN SEE FIG. 2.14-27	1	B	
- 49	8-42417-1	• POTENTIOMETER INSTL, AILERON CONTROL STA 136 FOR BREAKDOWN SEE FIG. 2.14-2	1	35	
- 50	8-42401-5	• BELL CRANK INSTL, AILERON CONTROL STA 142 FOR BREAKDOWN SEE FIG. 2.14-12	1	35	
- 51	8-42302	• IDLER INSTL, ELEVATOR AND AILERON CONTROL STA 170 FOR BREAKDOWN SEE FIG. 2.14-13	1	35	
	8-95993-1	• GUARD INSTL, AILERON CONTROL TUBE FOR BREAKDOWN SEE FIG. 2.14-9	1	160	
	8-95657-1	• SUPPORT INSTL, ELEVATOR TORQUE TUBE FOR BREAKDOWN SEE FIG. 2.14-9	1	216	
- 52	8-38081-1	• TRAP INSTL, AIRSPEED TUBING WATER FOR BREAKDOWN SEE FIG. 2.14-5	1	35	
- 53	8-42574-1	• STICK INSTL, FLIGHT CONTROL FOR BREAKDOWN SEE FIG. 2.14-9	1	A	
	8-42574-5	• STICK INSTL, FLIGHT CONTROL FOR BREAKDOWN SEE FIG. 2.14-9	1	B	
- 54	8-42368	• COUNTERBALANCE INSTL, CONTROL STICK STA 145 FOR BREAKDOWN SEE FIG. 2.14-44	1	35	
- 55	8-77240	• BULKHEAD INSTL, FUSELAGE CAIATED STA 172 FOR BREAKDOWN SEE FIG. 2.15-1	1	35	
- 56	8-92159-1	• SWITCH INSTL, NLG UP AND DOWN FOR BREAKDOWN SEE FIG. 2.15-2	1	35	264
	8-92159-2	• SWITCH INSTL, NLG LP AND DOWN FOR BREAKDOWN SEE FIG. 2.15-2	1	265	
- 57	8-95653	• RACK INSTL, PILOT INSTRUMENT PANEL FOR BREAKDOWN SEE FIG. 2.16-3	1	B	
- 58	8-94666-813	• EQUIPMENT INSTL, PILOT CONSOLE FOR BREAKDOWN SEE FIG. 2.16-8	1	35	188
	8-94666-835	• EQUIPMENT INSTL, PILOT CONSOLE FOR BREAKDOWN SEE FIG. 2.16-8	1	189	
		A AIRPLANES #35 THRU 47 AND 49 THRU 89 B AIRPLANES #46, 98 AND ON			

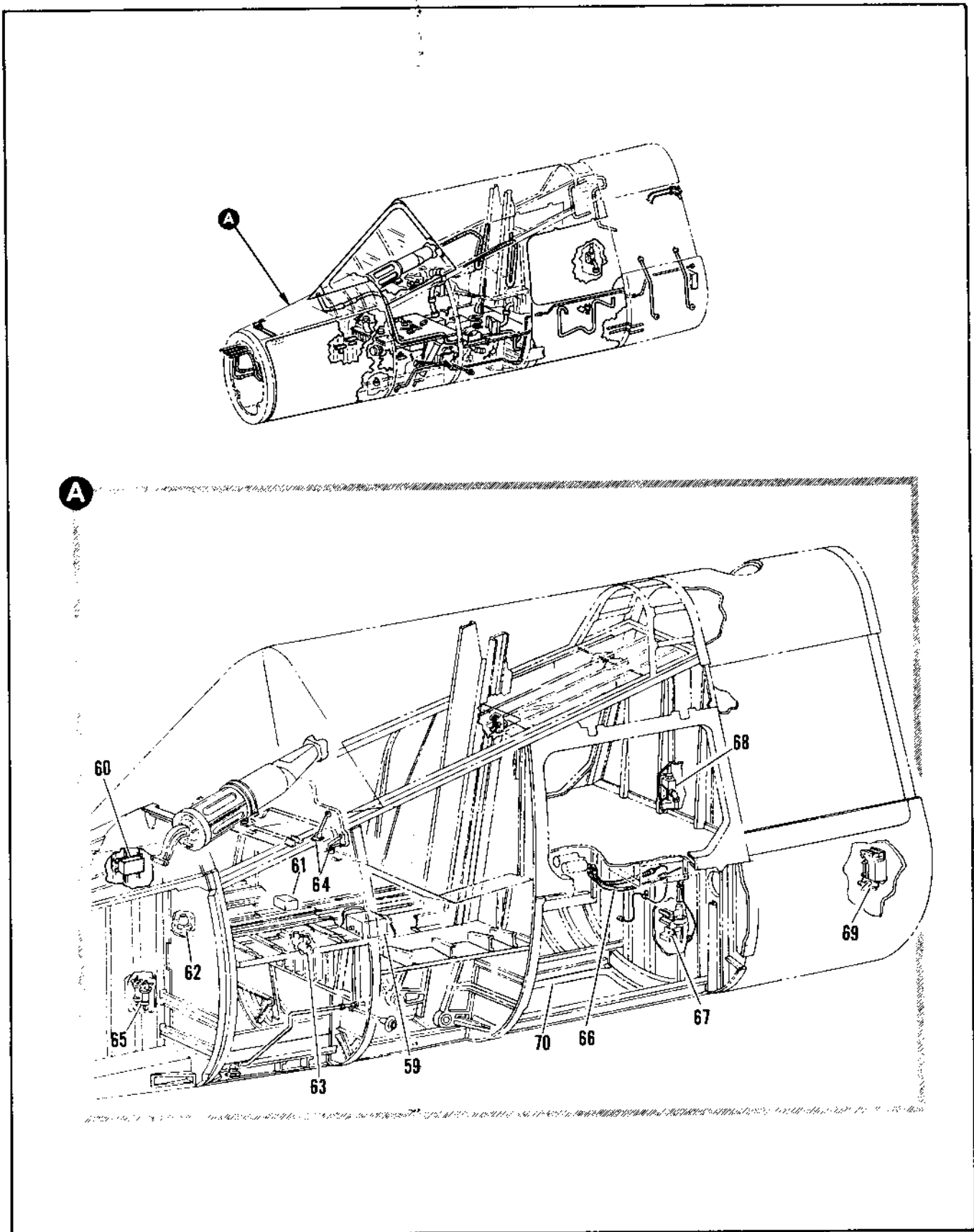

Figure 2.3-4. Fuselage Assembly Sta 40 to 216 (Sheet 6 of 6)

FIGURE AND INDEX NUMBER	PART NUMBER	DESCRIPTION	UNITS PER ASSY.	USABLE ON CODE	
				FROM	TO
		1 2 3 4 5 6			
2.3-4- 59	8-35057-3	• TRANSMITTER INSTL, ENGINE PRESSURE RATIO FOR BREAKDOWN SEE FIG. 2.17-11	1	35	
	8-35058-101	• TRANSMITTER INSTL, ANGLE OF ATTACK FOR BREAKDOWN SEE FIG. 2.18-31	1	35	
- 60	8-94543-1	• AMPLIFIER INSTL, MAGNETIC FOR BREAKDOWN SEE FIG. 2.18-19	1	A	
	8-95658-5	• AMPLIFIER INSTL, VERTICAL SPEED AIR SPEED AND ALTITUDE LH FOR BREAKDOWN SEE FIG. 2.18-19	1	B	
	8-95658-101	• AMPLIFIER INSTL, VERTICAL SPEED AIR SPEED AND ALTITUDE RH FOR BREAKDOWN SEE FIG. 2.18-19	1	B	
	8-94944	• AMPLIFIER INSTL, HORIZONTAL SITUATION INDICATOR FOR BREAKDOWN SEE FIG. 2.18-19	1	B	
- 61	8-95646-105	• SUPPORT INSTL, TACTICAL SITUATION INDICATOR FOR BREAKDOWN SEE FIG. 2.18-12	1	35	99
	8-95646-107	• SUPPORT INSTL, TACTICAL SITUATION INDICATOR FOR BREAKDOWN SEE FIG. 2.18-12	1	35	89
	3-95681-1	• DISPLAY INSTL, TACTICAL SITUATION FOR BREAKDOWN SEE FIG. 2.18-13	1	40	94
	8-95681	• DISPLAY INSTL, TACTICAL SITUATION FOR BREAKDOWN SEE FIG. 2.18-13	1	90	
- 62	8-52161	• TRANSMITTER INSTL, NOSE LANDING GEAR COMMAND FOR BREAKDOWN SEE FIG. 2.15-7	1	35	39
	8-52161	• TRANSMITTER INSTL, NOSE LANDING GEAR COMMAND FOR BREAKDOWN SEE FIG. 2.15-9	1	C	
	8-52161-1	• TRANSMITTER INSTL, NOSE LANDING GEAR COMMAND FOR BREAKDOWN SEE FIG. 2.15-11	1	B	
- 63	8-81154-1	• VALVE INSTL, NLG HYDRAULIC SELECTOR FOR BREAKDOWN SEE FIG. 2.15-1	1	A	
	8-84134	• VALVE INSTL, NLG HYDRAULIC SELECTOR FOR BREAKDOWN SEE FIG. 2.15-1	1	B	
- 64	8-38156-101	• SUPPORT INSTL, INSTRUMENT PANEL UPPER FOR BREAKDOWN SEE FIG. 2.16-6	1	A	
- 65	8-85358	• EXPANSION CHAMBER INSTL, BRAKE HYDRAULIC FOR BREAKDOWN SEE FIG. 2.9-1	1	B	
- 66	8-92945-105	• TURNING INSTL, VARIABLE AIR RAMP PITOT STATIC STA 171 TO 216 FOR BREAKDOWN SEE FIG. 2.11-11	1	35	
- 67	8-85152-1	• VALVE INSTL, ARMAMENT BAY DOOR FWD PNEUMATIC SELECTOR FOR BREAKDOWN SEE FIG. 2.20-1	1	35	
- 68	8-57119-1	• SWITCH INSTL, ARMAMENT LAUNCHER FWD UPPER FOR BREAKDOWN SEE FIG. 2.20-4	1	35	
- 69	8-57331-1	• SWITCH INSTL, ARMAMENT BAY DOOR LIMIT LH	1	35	129
	8-57331-2	• SWITCH INSTL, ARMAMENT BAY DOOR LIMIT RH	1	35	129
- 70	8-74642-5	• FRAME INSTL, NOSE LANDING GEAR DOOR SEAL LH FOR BREAKDOWN SEE FIG. 2.15-15	1	35	
	8-74457-101	• STRUCTURE INSTL, CANOPY HINGE	1	35	
		A AIRPLANES #35 THRU 47 AND 49 THRU 89			
		B AIRPLANES #48, 90 AND 09			
		C AIRPLANES #39, THRU 47 AND 49 THRU 89			

FIGURE AND INDEX NUMBER	PART NUMBER	DESCRIPTION	UNITS PER ASSY.	USABLE ON CODE	
				FROM	TO
		1 2 3 4 5 6			
2.3-4	8-74953-9	. . SUPPORT, CANOPY HINGE UPPER LH	1	35	
	8-74157-7	. . SUPPORT, CANOPY HINGE UPPER LH ALT INTCHG WITH 8-74953-9	RF	35	
	8-74953-10	. . SUPPORT, CANOPY HINGE UPPER RH	1	35	
	8-74157-8	. . SUPPORT, CANOPY HINGE UPPER RH ALT INTCHG WITH 8-74953-10	RF	35	
	8-74457-16.1	. . REAR ASSEMBLY	1	35	
	8-74167-3	. . . REAR ASSEMBLY	1	35	
- 71	8-77116-1	. . . SUPPORT ASSEMBLY	1	35	
	8-77120 SUPPORT ASSY, ALT INTCHG WITH 8-77116-1	RF	35	
	8-77116-7 SUPPORT	1	35	
	8-77120-7 SUPPORT, USE WITH 8-77120	RF	35	
	8-77116-9 BUSHING	1	35	
	8-77120-9 BUSHING, USE WITH 8-77120	RF	35	
	8-77116-11 BUSHING	1	35	
	8-77120-11 BUSHING, USE WITH 8-77120	RF	35	

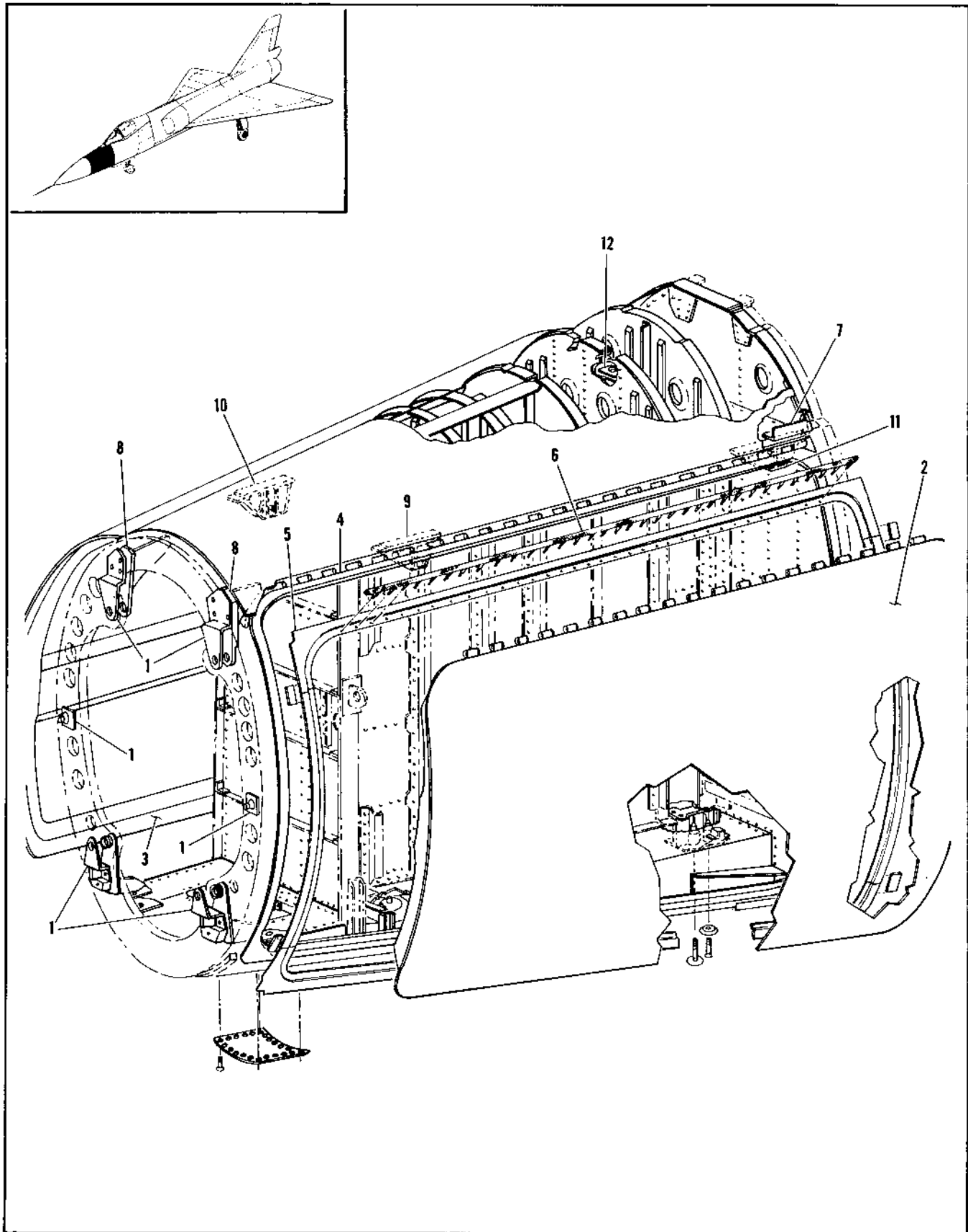

Figure 2.3-5. Fwd Radar Compartment Door and Panel Installation Sta 41 to 102 (Sheet 1 of 2)

FIGURE AND INDEX NUMBER	PART NUMBER	DESCRIPTION	UNITS PER ASSY.	USABLE ON CODE	
				FROM	TO
		1 2 3 4 5 6			
2.3-5	8-74440-3	DOOR AND PANEL INSTALLATION, FWD RADAR COMPARTMENT STA 41 TO 102 FOR NHA SEE FIG. 2.3-4	RF	35	
- 1	8-74735	• SUPPORT INSTL, RADAR ANTENNA STA 41 FOR BREAKDOWN SEE FIG. 2.18-8	1	35	
- 2	8-74600-1	• DOOR INSTL, FWD RADAR COMPARTMENT LH FOR BREAKDOWN SEE FIG. 2.2-10	1	35	
- 3	8-74600-2	• DOOR INSTL, FWD RADAR COMPARTMENT RH FOR BREAKDOWN SEE FIG. 2.2-10	1	35	
	8-74405-607	• PANEL ASSY, FWD RADAR COMPARTMENT UPPER	1	35	
- 4	8-74639-7	• HINGE, LH	1	35	
	8-74639-8	• HINGE, RH	1	35	
- 5	8-74640-7	• SEAL, DOOR FWD RADAR COMPARTMENT LH	1	35	
	8-74640-8	• SEAL, DOOR FWD RADAR COMPARTMENT RH	1	35	
- 6	4461-1	• SEAL, DOOR FWD RADAR COMPARTMENT <84914> SPEC 8-07385-1 MAKE FROM 8-71602-37	2	35	
- 7	8-74148-9	• ADAPTER, UPPER LONGERON STA 102 SPLICE LH	1	35	
	8-74148-10	• ADAPTER, UPPER LONGERON STA 102 SPLICE RH	1	35	
- 8	8-74735-1	• SUPPORT INSTL, GLIDE SLOPE ANTENNA FOR BREAKDOWN SEE FIG. 2.18-6	1	35	
- 9	8-77708-1	• SUPPORT ASSY, RADAR RACK STA 63 UPPER LH RIVETED	1	35	
- 10	8-77700-1	• SUPPORT ASSY, RADAR RACK STA 63 UPPER RH RIVETED	1	35	
- 11	8-77759-3	• SUPPORT ASSY, RADAR RACK STA 98 UPPER LH RIVETED	1	35	
- 12	8-77712-7	• SUPPORT, RADAR RACK STA 98 UPPER RH	1	35	

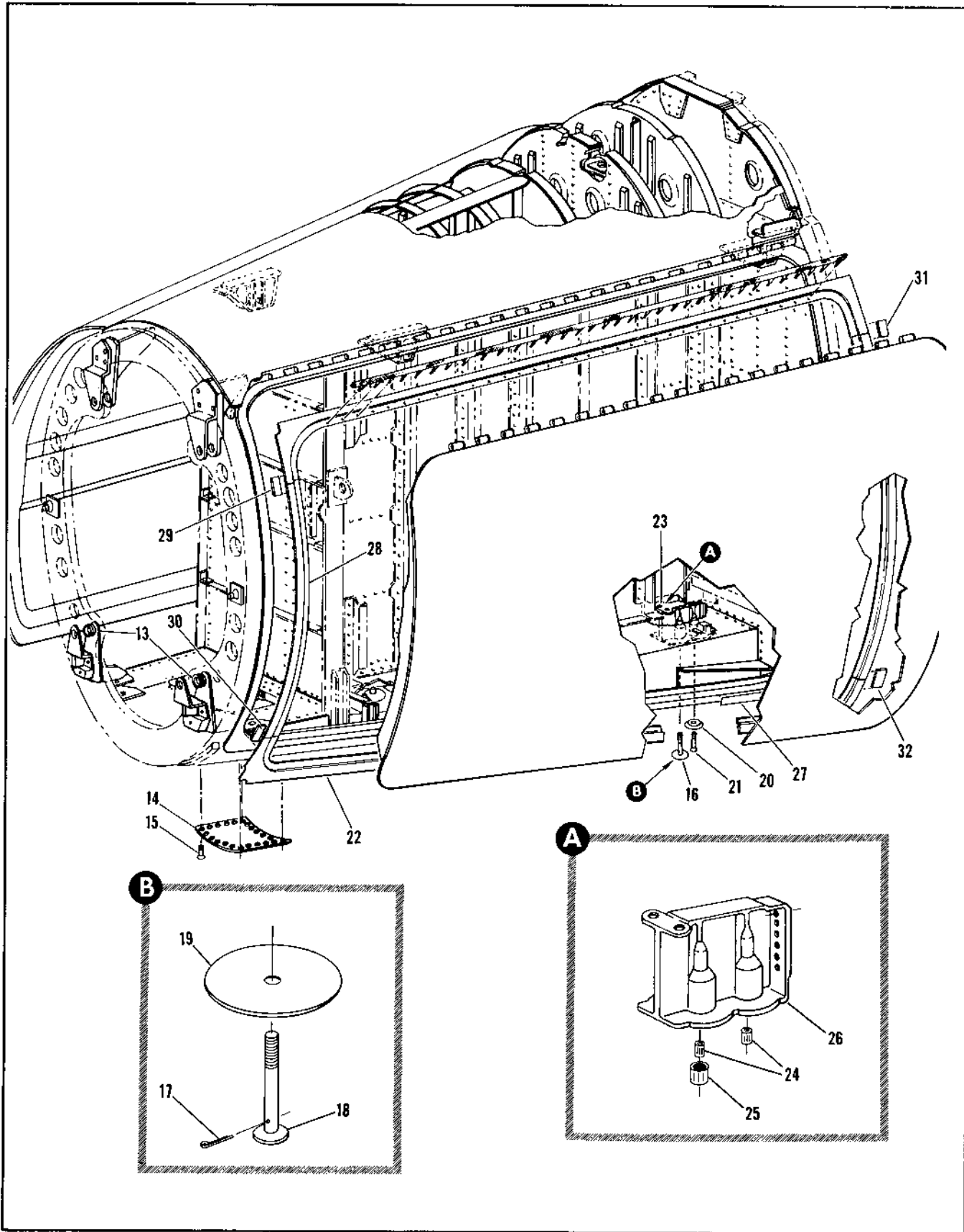

Figure 2.3-5. Fwd Radar Compartment Door and Panel Installation Sta 41 to 102 (Sheet 2 of 2)

FIGURE AND INDEX NUMBER	PART NUMBER	DESCRIPTION	UNITS PER ASSY.	USABLE ON CODE	
				FROM	TO
		1 2 3 4 5 6			
2.3-5	8-74406-3	• PANEL ASSY, FWD RADAR COMPARTMENT LWR	1	35	
- 13	8-74735-3	• • SUPPORT INSTL, LOCALIZER ANTENNA FOR BREAKDOWN SEE FIG. 2.1R-6	1	35	
- 14	8-74406-59	• • COVER ATTACHING PARTS	1	35	
- 15	MS24694-F2	• • SCREW (96906) ----X----	22	35	
- 16	8-77702	• • COVER ASSY, MOORING POINT FWD FUSELAGE	1	35	
- 17	MS24665-132	• • • PIN (96906)	1	35	
- 18	8-77702-713	• • • SCREW, ALTERED FROM AN509-1CR39	1	35	
- 19	8-77702-7	• • COVER	1	35	
- 20	8-77701	• • COVER, JACK POINT FWD BODY ATTACHING PARTS	1	35	
- 21	MS24674-21	• • SCREW (96906) ----X----	1	35	
- 22	8-74640-9	• • SEAL, DOOR FWD RADAR COMPARTMENT LH	1	35	
	8-74640-10	• • SEAL, DOOR FWD RADAR COMPARTMENT RH	1	35	
- 23	8-74759-1	• • SUPPORT ASSY, FWD MOORING AND JACK POINT	1	35	
	8-74760-1	• • SUPPORT ASSY, FWD MOORING AND JACK POINT ALT INTCHG WITH 8-74759-1	RF	35	
- 24	3591-3CNX.285	• • • INSERT, <91767> 95-03003-005	2	35	
- 25	1191-10CNX1-174	• • • INSERT, <91767> 95-03003-018	1	35	
- 26	8-74759-7	• • SUPPORT	1	35	
	8-74760-7	• • SUPPORT, ALT INTCHG WITH 8-74759-7	RF	35	
- 27	8-74406-27	• • DOUBLER, LH	1	35	
	8-74406-28	• • DOUBLER, RH	1	35	
- 28	8-74640-11	• SEAL, DOOR FWD RADAR COMPARTMENT LH	1	35	
	8-74640-12	• SEAL, DOOR FWD RADAR COMPARTMENT RH	1	35	
- 29	8-74640-15	• SPLICE SEAL FWD RADAR COMPARTMENT DOOR	2	35	
- 30	8-74640-17	• SPLICE, SEAL FWD RADAR COMPARTMENT DOOR	2	35	
- 31	8-74640-19	• SPLICE, AFT UPPER LH	1	35	
- 32	8-74640-21	• SPLICE, AFT LOWER LH	1	35	

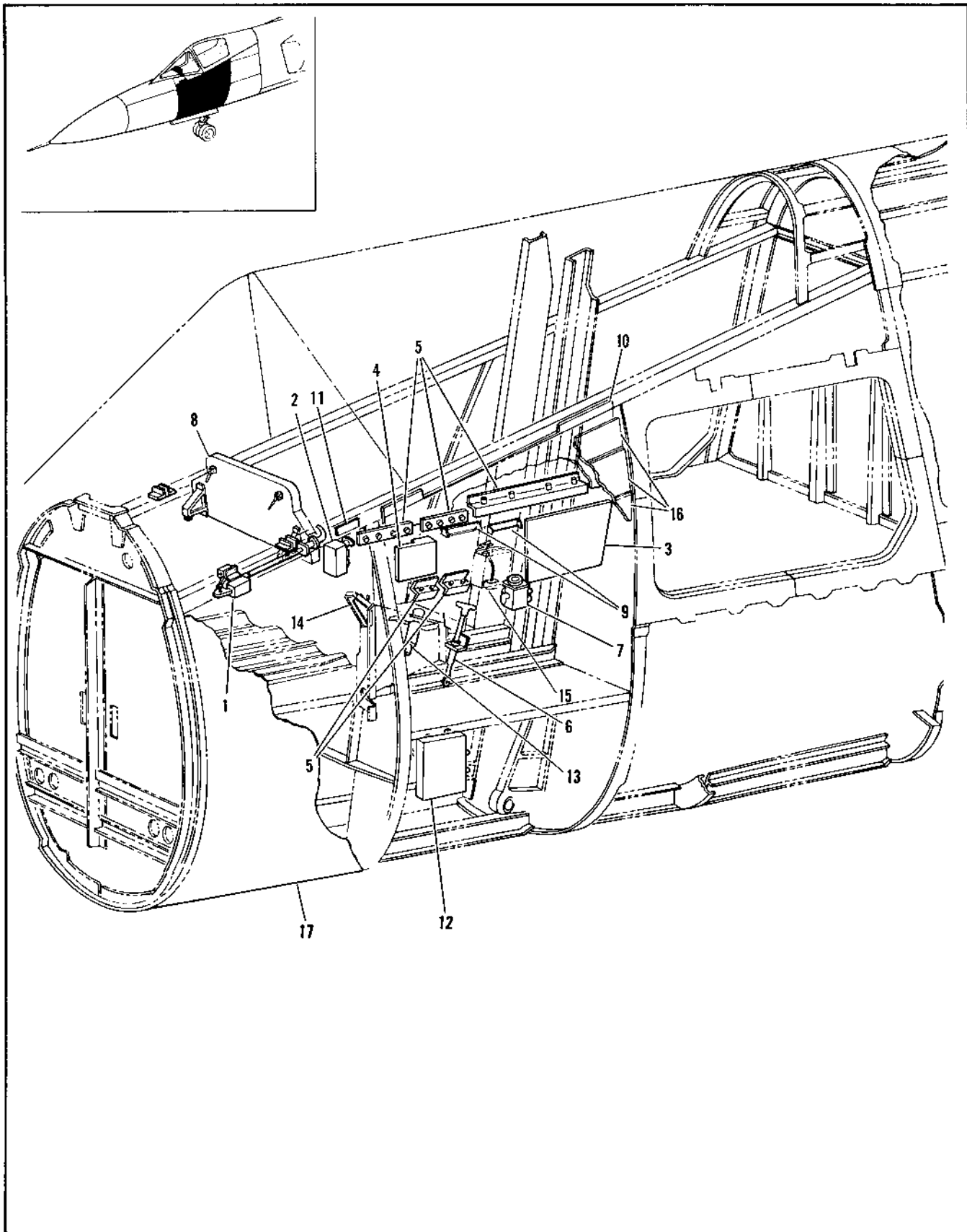

Figure 2.3-6. LH Side Panel Equipment Assembly Sta 102 to 172

FIGURE AND INDEX NUMBER	PART NUMBER	DESCRIPTION	UNITS PER ASSY.	USABLE ON CODE	
				FROM	TO
		1 2 3 4 5 6			
2.3-6 - 1	8-74013-00	EQUIPMENT ASSEMBLY, LH SIDE PANEL STA 102 TO 172 FOR NHA SEE FIG. 2.3-4	RF	35	
	8-94012-1	• CONTROL INSTL, LANDING GEAR EMERGENCY RELEASE FOR BREAKDOWN SEE FIG. 2.15-7	1	35	159
- 2	8-94012-5	• CONTROL INSTL, LANDING GEAR EMERGENCY RELEASE FOR BREAKDOWN SEE FIG. 2.15-7	1	160	
	8-94013-5	• CONTROL BOX INSTL, LANDING GEAR FOR BREAKDOWN SEE FIG. 2.15-18	1	35	159
- 3	8-94013-5	• CONTROL BOX INSTL, LANDING GEAR FOR BREAKDOWN SEE FIG. 2.15-18	1	160	
- 4	8-94655-01	• PANEL INSTL, COCKPIT FUSE LH FOR BREAKDOWN SEE FIG. 2.17-11	1	35	
- 5	8-95593	• SWITCH INSTL, TAXI AND LANDING LIGHT G SUIT AND NO FOG FOR BREAKDOWN SEE FIG. 2.15-12	1	35	
- 6	8-94976-07	• LIGHTING INSTL, COCKPIT FLOOD AND THUNDERSTORM LH FOR BREAKDOWN SEE FIG. 2.17-4	1	35	
- 7	8-95617	• CONTROL INSTL, RAM AIR TURBINE POWER FOR BREAKDOWN SEE FIG. 2.9-1	1	35	
	8-95595-1	• VALVE INSTL, ANTI-G SUIT FOR BREAKDOWN SEE FIG. 2.9-1	1	35	
- 8	8-08056-5	• SUPPORT INSTL, INSTRUMENT PANEL LOWER LH FOR BREAKDOWN SEE FIG. 2.16-7	1	A	
- 9	8-95591	• CHECK LIST INSTL, PILOT FOR BREAKDOWN SEE FIG. 2.5-4	1	35	159
- 10	8-95592-1	• TRIM INSTL, COCKPIT LH FOR BREAKDOWN SEE FIG. 2.5-9	1	35	
- 11	8-95599-1	• PLATE INSTL, EMERGENCY DRAG CHUTE INSTRUCTION FOR BREAKDOWN SEE FIG. 2.5-1	1	A	
- 12	8-92452-05	• EQUIPMENT INSTL, LIQUID OXYGEN FOR BREAKDOWN SEE FIG. 2.19-2	1	35	
- 13	8-93401	• PANEL INSTL, DUAL LIQUID OXYGEN SYSTEM FOR BREAKDOWN SEE FIG. 2.16-23	PF	61	127
- 14	8-92015-1	• VALVE INSTL, DUAL LIQUID OXYGEN SYSTEM	HF	61	127
- 15	8-95504	• SWITCH INSTL, MASK DE-FOG FOR BREAKDOWN SEE FIG. 2.16-13	1	35	
- 16	8-94812	• BLANKET INSTL, THERMAL COCKPIT LH FOR BREAKDOWN SEE FIG. 2.5-12	1	35	
- 17	8-74424-01	• PANEL ASSY, STA 102 TO 172 LH FOR BREAKDOWN SEE FIG. 2.3-7	1	35	
		A AIRPLANE #35 THRU 47 AND 49 THRU 49			

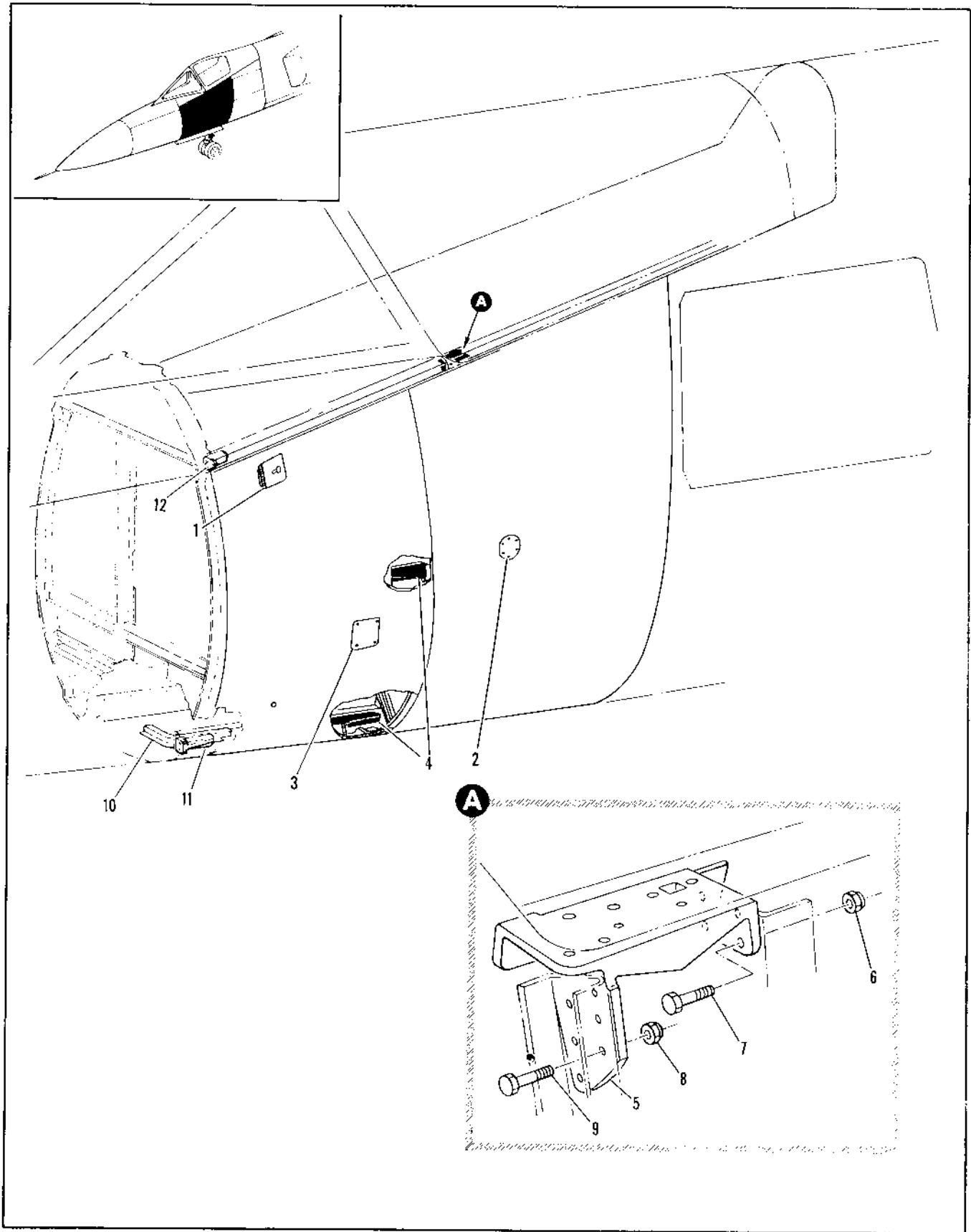

Figure 2.3-7. LH Panel Installation Sta 102 to 172

FIGURE AND INDEX NUMBER	PART NUMBER	DESCRIPTION	UNITS PER ASSY.	USABLE ON CODE	
				FROM	TO
		1 2 3 4 5 6			
2.3-7	8-74424-003	PANEL INSTALLATION, STA 102 TO 172 LH FOR NHA SEE FIG. 2.3-6	RF	35	
- 1	8-74652-3	• DOOR INSTL, EMERGENCY CANOPY RELEASE ACCESS STA 108 FOR BREAKDOWN SEE FIG. 2.2-3	1	35	
- 2	8-77629	• DOOR INSTL, TORQUE TUBE ACCESS STA 145 FOR BREAKDOWN SEE FIG. 2.2-3	1	35	
- 3	8-77635	• DOOR INSTL, LIQUID OXYGEN ACCESS STA 124 FOR BREAKDOWN SEE FIG. 2.2-3	1	35	
- 4	8-74233	• SUPPORT INSTL, NLG DOOR MECHANISM FOR BREAKDOWN SEE FIG. 2.15-1	1	35	
- 5	8-74121-11	• FITTING, CANOPY LATCH LH ATTACHING PARTS	1	35	
- 6	22FT1032	• NUT, <56878> 96-37525-002	4	35	
- 7	NAS464P3A4	• BOLT (80205)	4	35	
- 8	22FT426	• NUT, <56878> 96-37525-003	7	35	
- 9	NAS464P3A6	• BOLT (80205) -----X-----	7	35	
- 10	8-74642-1	• FRAME INSTL, NOSE LANDING GEAR DOOR SEAL LH FOR BREAKDOWN SEE FIG. 2.15-15	1	35	
- 11	8-74158-7	• ADAPTER, LOWER LONGERON STA 102 LH ALT INTCHG WITH 8-74749-9	1	35	
	8-74749-9	• ADAPTER, LOWER LONGERON STA 102 LH ALT INTCHG WITH 8-74158-7	RF	35	
- 12	8-74147-9	• FITTING UPPER LONGERON STA 102 LH	1	35	
	8-74139-9	• FITTING, UPPER LONGERON STA 102 LH ALT INTCHG WITH 8-74147-9	RF	35	

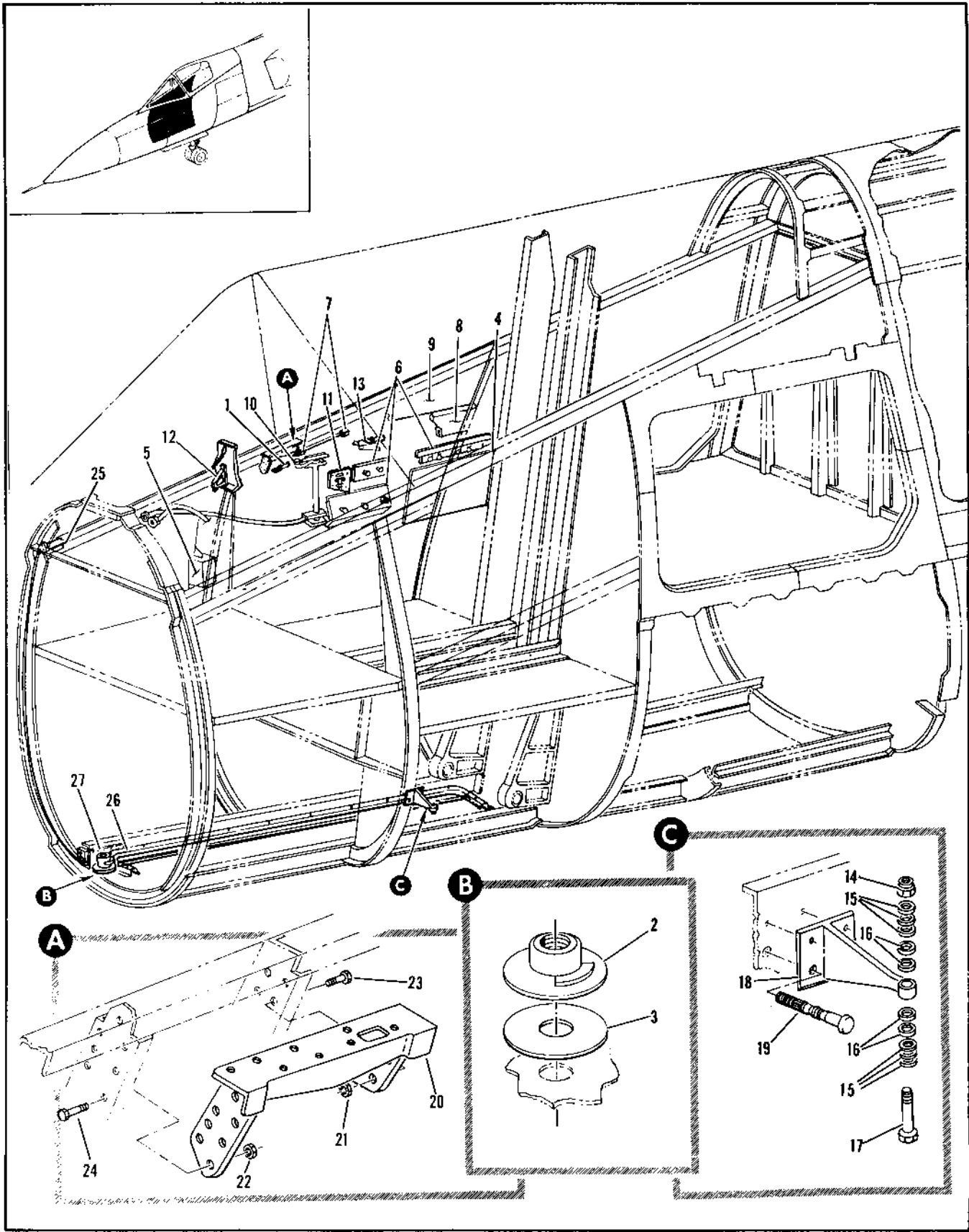

Figure 2.3-8. RH Side Panel Equipment Assembly Sta 102 to 172

FIGURE AND INDEX NUMBER	PART NUMBER	DESCRIPTION	UNITS PER ASSY.	USABLE ON CODE	
				FROM	TO
2,3-8	8-74014-001	EQUIPMENT ASSEMBLY, RH SIDE PANEL STA 102 TO 172 FOR WPA SEE FIG. 2.3-4	RF	35	
- 1	8-95619	NAMEPLATE INSTL, COCKPIT CANOPY LATCH FOR BREAKDOWN SEE FIG. 2.4-1	1	35	
- 2	8-85047	DRAIN INSTL, LANDING GEAR EMERGENCY	1	35	
- 3	8-92456	VENT, PORT	1	35	
- 4	8-94657-5	SEAL, VENT PORT	1	35	
- 5	8-95689	PANEL INSTL, COCKPIT FUSE RH FOR BREAKDOWN SEE FIG. 2.17-11	1	A	
- 6	8-94876-011	PANEL INSTL, FUSE LIGHTING FOR BREAKDOWN SEE FIG. 2.17-11	1	35	
- 7	8-84805-2	LIGHTING INSTL, COCKPIT FLOOD AND THUNDERSTORM RH FOR BREAKDOWN SEE FIG. 2.17-4	1	35	
- 8	8-94812-1	SWITCH INSTL, MAP READING LIGHT FOR BREAKDOWN SEE FIG. 2.5-1	1	35	
- 9	8-95092	BLANKET INSTL, THERMAL COCKPIT RH FOR BREAKDOWN SEE FIG. 2.5-12	1	35	
- 10	8-95013	TRIM INSTL, COCKPIT RH FOR BREAKDOWN SEE FIG. 2.5-11	1	35	129
	8-85693	CONTROL INSTL, CANOPY LATCH FOR BREAKDOWN SEE FIG. 2.4-4	1	130	
- 11	8-95501	CONTROL INSTL, CANOPY LATCH FOR BREAKDOWN SEE FIG. 2.4-5	RF	35	89
- 12	8-95091	PIN AND STREAMER INSTL, EJECTION SEAT SAFETY FOR BREAKDOWN SEE FIG. 2.5-6	1	35	
	8-34056-6	PIN AND STREAMER INSTL, EJECTION SEAT	1	P	
- 13	8-95952-001	SUPPORT INSTL, INSTRUMENT PANEL LOWER RH FOR BREAKDOWN SEE FIG. 2.18-7	1	130	
- 14	8-74425-001	PANEL INSTL, OUTBOARD SWITCH RH FOR BREAKDOWN SEE FIG. 2.17-5	1	35	
- 15	NAS179A3	PANEL INSTL, STA 102 TO 172 RH	1	35	
- 16	AN96L PD10L	NUT (61205)	6	35	
- 17	AN96L PD10	WASHER (61204)	4	35	
- 18	NAS488-3-5	WASHER (61244)	1	35	
- 19	8-77730-7	BOLT (61205)	1	35	
- 20	SALF-16-5	STOP, NOSE LANDING GEAR DOOR RH ATTACHING PARTS	1	35	
- 21	8-74121-12	LOCKBOLT, <29666> 96-79000-005	2	55	
- 22	NAS1291-3	-----X-----			
- 23	NAS1291-4	FITTING, CANOPY LATCH RH ATTACHING PARTS	1	35	
- 24	NAS46403A4	NUT, (61205) 96-37525-002	4	35	
- 25	NAS46404A6	NUT, (61205) 96-37525-003	7	35	
- 26	8-74147-17	BOLT (61205)	4	35	
- 27	8-74642-3	BOLT (61205)	7	35	
	8-74642-001	-----X-----			
- 28	8-74147-17	FITTING, UPPER LONGERON STA 102 SPLICE	1	35	
- 29	8-74642-3	FRAME INSTL, NOSE LANDING GEAR DOOR SEAL FOR BREAKDOWN SEE FIG. 2.15-15	1	35	60
- 30	8-74642-001	FRAME INSTL, NOSE LANDING GEAR DOOR SEAL FOR BREAKDOWN SEE FIG. 2.15-15	1	61	
- 31	8-74158-8	ADAPTER, LOWER LONGERON STA 102 AFT	1	35	
- 32	8-74749-13	ADAPTER, LOWER LONGERON STA 102 AFT ALT INTAKE WITH 8-74158-8	RF	35	

A AIRPLANES #47, 90 AND ON
 G AIRPLANES #35 THRU 47 AND 49 THRU 89

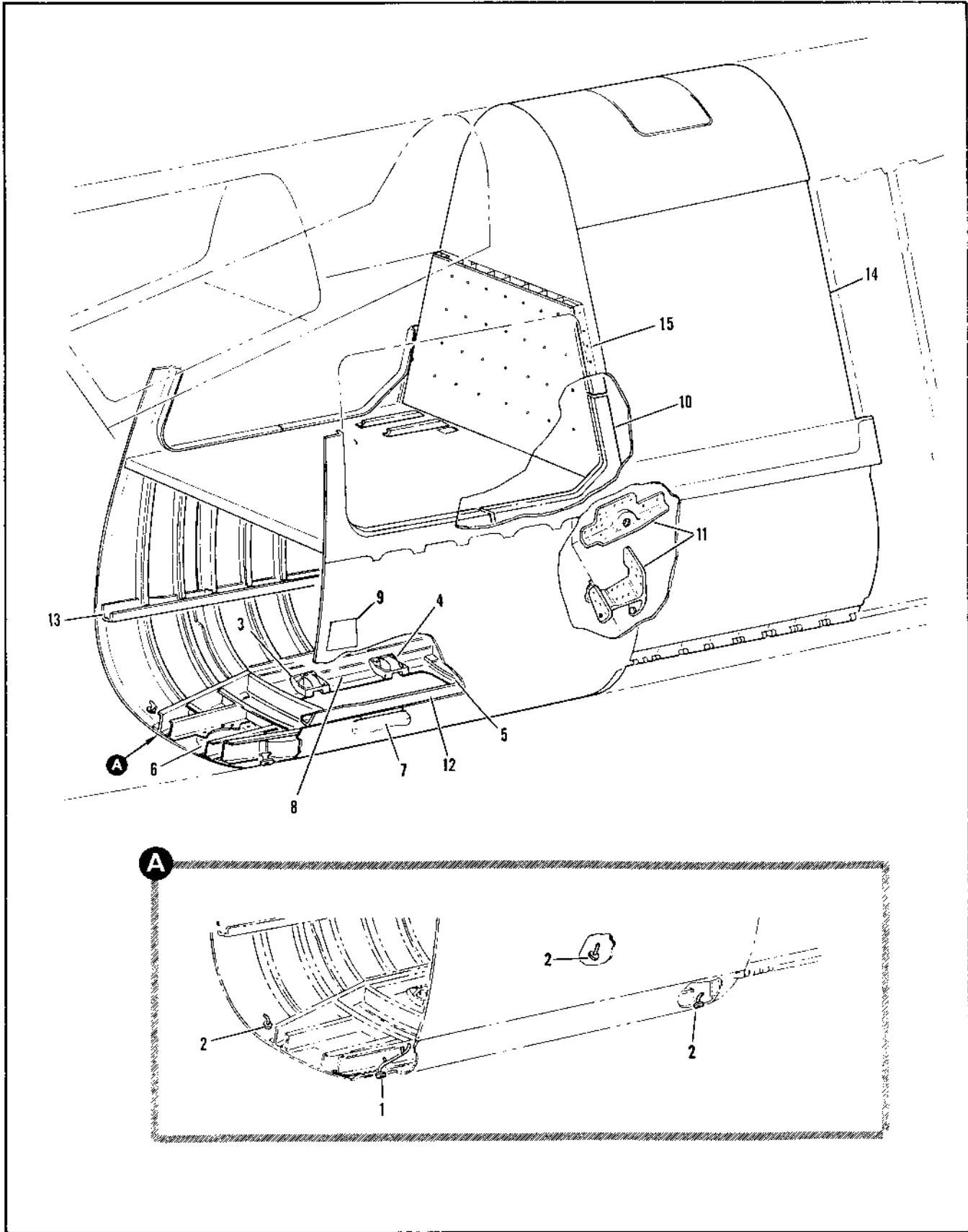

Figure 2.3-9. Lower Barrel Assembly Sta 166 to 253

FIGURE AND INDEX NUMBER	PART NUMBER	DESCRIPTION	UNITS PER ASSY.	USABLE ON CODE	
				FROM	TO
		1 2 3 4 5 6			
2.3-9	8-77406	BAPREL ASSEMBLY, STA 166 TO 253 LOWER FOR NHA SEE FIG. 2.3-4	RF	35	
	8-74408-1	• PANEL ASSY, CANTED BOTTOM STA 166 TO 216 LOWER RH	1	35	
- 1	8-81253-3	• • • LONGERON ASSY RH	1	35	
	8-81253-5	• • ADAPTER ASSY, SHROUD DRAIN STA 166 LH WELDED	1	4	
- 2	8-81253-1	• • ADAPTER ASSY, SHROUD DRAIN STA 166 LH WELDED	1	4	
- 3	8-74666-7	• • ADAPTER ASSY, SHROUD DRAIN STA 166 AND 213 WELDED	3	35	
- 4	8-74658-7	• • HINGE, MIDBAY ELECTRONIC DOOR FWD	1	35	
	8-74658-7	• • HINGE, MIDBAY ELECTRONIC DOOR AFT	1	35	
- 5	8-74658-7	• • RAMP INSTL, MIDBAY ELECTRONIC DOOR SEAL	1	35	
- 6	8-74644	• • RAMP, MIDBAY ELECTRONIC DOOR SEAL	1	35	
	8-74135-6	• • KING ASSY, ANTENNA SUPPORT STA 169.80 RIVETED	1	35	
	8-74135-6	• • LONGERON INSTL, STA 163 TO 216.50 LOWER LH	1	35	
	8-74135-6	• • LONGERON INSTL, STA 163 TO 216.50	1	35	
	8-74135-103	• • • LONGERON ASSY, LH	1	35	
	8-74135-104	• • • LONGERON ASSY, RH	1	35	
- 7	8-74135-77	• • • • ANGLE, LH	1	35	
- 8	8-74135-117	• • • • ANGLE, RH	1	35	
	8-77405	• PANEL ASSY, STA 171 TO 216 SIDE	1	35	
- 9	8-74641-5	• • PANEL ASSY, LH	1	35	
	8-74641-5	• • • PANEL INSTL, ELECTRICAL POWER GROUND ACCESS DOOR	1	35	
- 10	8-77403	• • SEAL INSTL, UPPER ELECTRONIC COMPARTMENT ACCESS DOOR FOR BREAKDOWN SEE FIG. 2.2-3	1	35	
- 11	8-57918	• SUPPORT INSTL, ARMAMENT UPPER AND LOWER DRAG ARM FOR BREAKDOWN SEE FIG. 2.2-2	1	35	
- 12	8-74163-1	• LONGERON INSTL, ARMAMENT BAY DOOR HINGE LOWER LH STA 163 TO 253 FOR BREAKDOWN SEE FIG. 2.20-29	1	35	
- 13	8-74163-3	• LONGERON INSTL, ARMAMENT BAY DOOR HINGE LOWER RH STA 163 TO 253 FOR BREAKDOWN SEE FIG. 2.20-12	1	35	
- 14	8-74403	• TANK ASSY, INTEGRAL FUEL FOR BREAKDOWN SEE FIG. 2.12-48	1	35	
- 15	8-74407-1	• BARRIER INSTL, FUSELAGE FOR BREAKDOWN SEE FIG. 2.12-61	1	35	
	8-74409-11	• SUPPORT INSTL, TRUNNION FWD	1	35	
	8-74409-125	• • DOOR ASSY, LH	1	35	48
	8-74409-211	• • DOOR ASSY, LH	1	49	
	8-74409-126	• • DOOR ASSY, RH	1	35	49
	8-74409-212	• • DOOR ASSY, RH	1	49	
		A AIRPLANES #15 THRU 47 AND 49 THRU 89			
		B AIRPLANES #48, 90 AND ON			

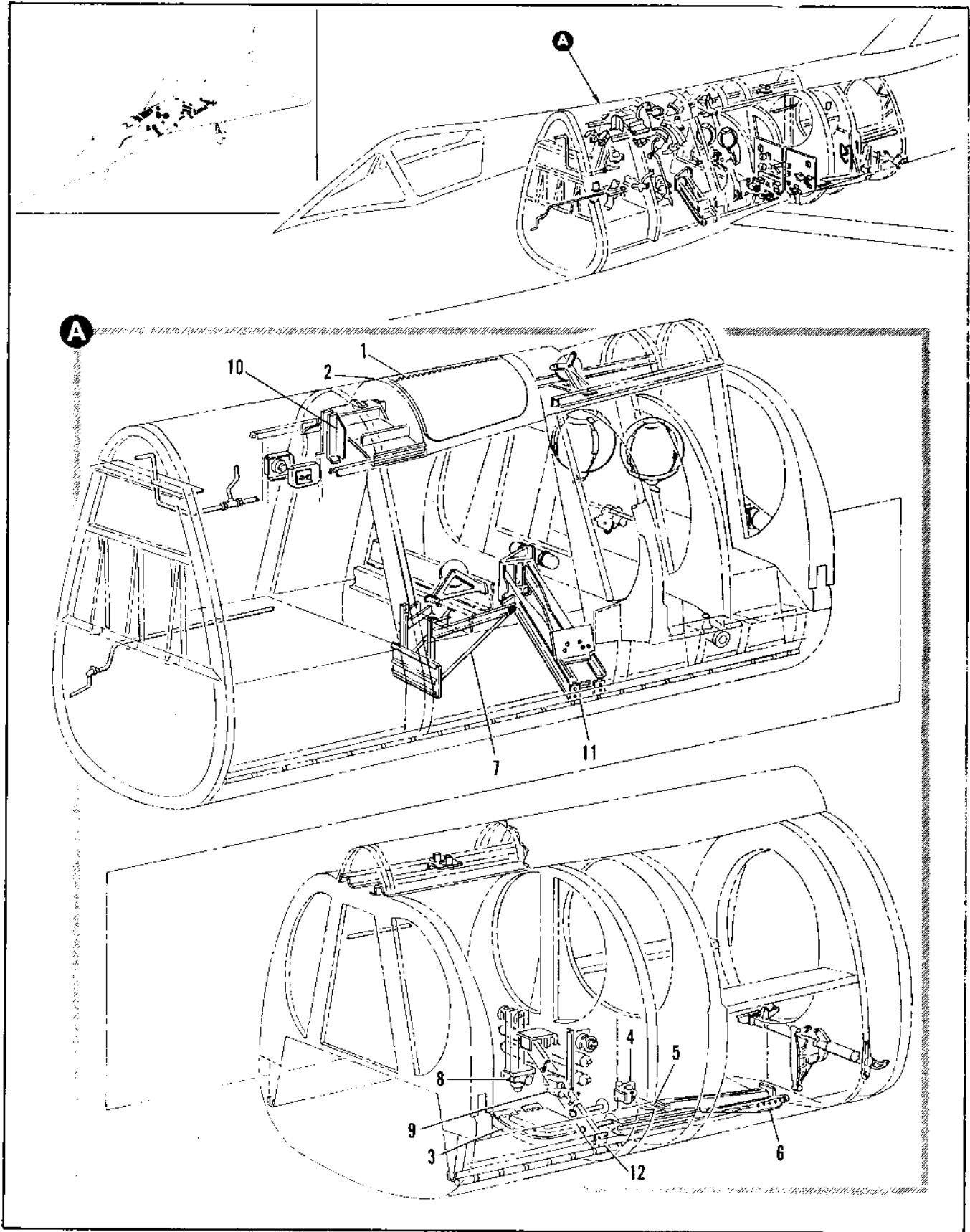

Figure 2.3-10. Fuselage Assembly Sta 216 to 472 (Sheet 1 of 4)

FIGURE AND INDEX NUMBER	PART NUMBER	DESCRIPTION 1 2 3 4 5 6	UNITS PER ASSY.	USABLE ON CODE	
				FROM	TO
2.3-10	8-74903-801	FUSELAGE ASSEMBLY, STA 216 TO 472 FOR NHA SEE FIG. 2.3-3	RF	35	277
	8-74903-813	FUSELAGE ASSEMBLY, STA 216 TO 472 FOR NHA SEE FIG. 2.3-3	RF	278	
- 1	8-74946	• DOOR INSTL, REFRIGERATION ACCESS FOR BREAKDOWN SEE FIG. 2.2-13	1	35	
- 2	8-74947	• FRAME INSTL, REFRIGERATION DOOR	1	35	
- 3	8-74947-7	• FRAME	1	35	
- 3	8-74969-1	• HINGE INSTL, HYDRAULIC ACCESS DOOR FOR BREAKDOWN SEE FIG. 2.2-7	1	35	
- 4	8-81033	• VALVE INSTL, MLG SELECTOR FOR BREAKDOWN SEE FIG. 2.15-1	1	35	67
	8-81033-1	• VALVE INSTL, MLG SELECTOR FOR BREAKDOWN SEE FIG. 2.15-1	1	61	
- 5	8-92941	• CONTAINER INSTL, MLG DOWN LOCK PINS FOR BREAKDOWN SEE FIG. 2.15-1	1	35	
- 6	8-74191-1	• LONGERON INSTL, LOWER STA 412 TO 472 FOR BREAKDOWN SEE FIG. 2.15-30	1	35	60
	8-77191-1	• LONGERON INSTL, LOWER STA 412 TO 472 FOR BREAKDOWN SEE FIG. 2.15-31	1	61	
	8-77191-5	• HINGE INSTL, LONGERON LOWER STA 412 TO 472 FOR BREAKDOWN SEE FIG. 2.15-31	1	61	
- 7	8-57053	• DEFLECTOR INSTL, MR-1 NOSE FOR BREAKDOWN SEE FIG. 2.20-21	1	90	
- 8	8-85022-1	• VALVE INSTL, ARMAMENT SELECTOR AFT FOR BREAKDOWN SEE FIG. 2.20-1	1	35	
- 9	8-85053-1	• VALVE INSTL, ARMAMENT BAY DOOR AFT PNEUMATIC SELECTOR FOR BREAKDOWN SEE FIG. 2.20-1	1	35	
- 10	8-77953	• SUPPORT INSTL, ARMAMENT EXTENSION ACTUATOR FOR BREAKDOWN SEE FIG. 2.20-1	1	35	
- 11	8-77962	• SUPPORT INSTL, ARMAMENT BAY DOOR CENTER ACTUATOR FOR BREAKDOWN SEE FIG. 2.20-10	1	35	
- 12	8-74981	• SUPPORT INSTL, ARMAMENT BAY DOOR AFT ACTUATOR FOR BREAKDOWN SEE FIG. 2.20-11	1	35	

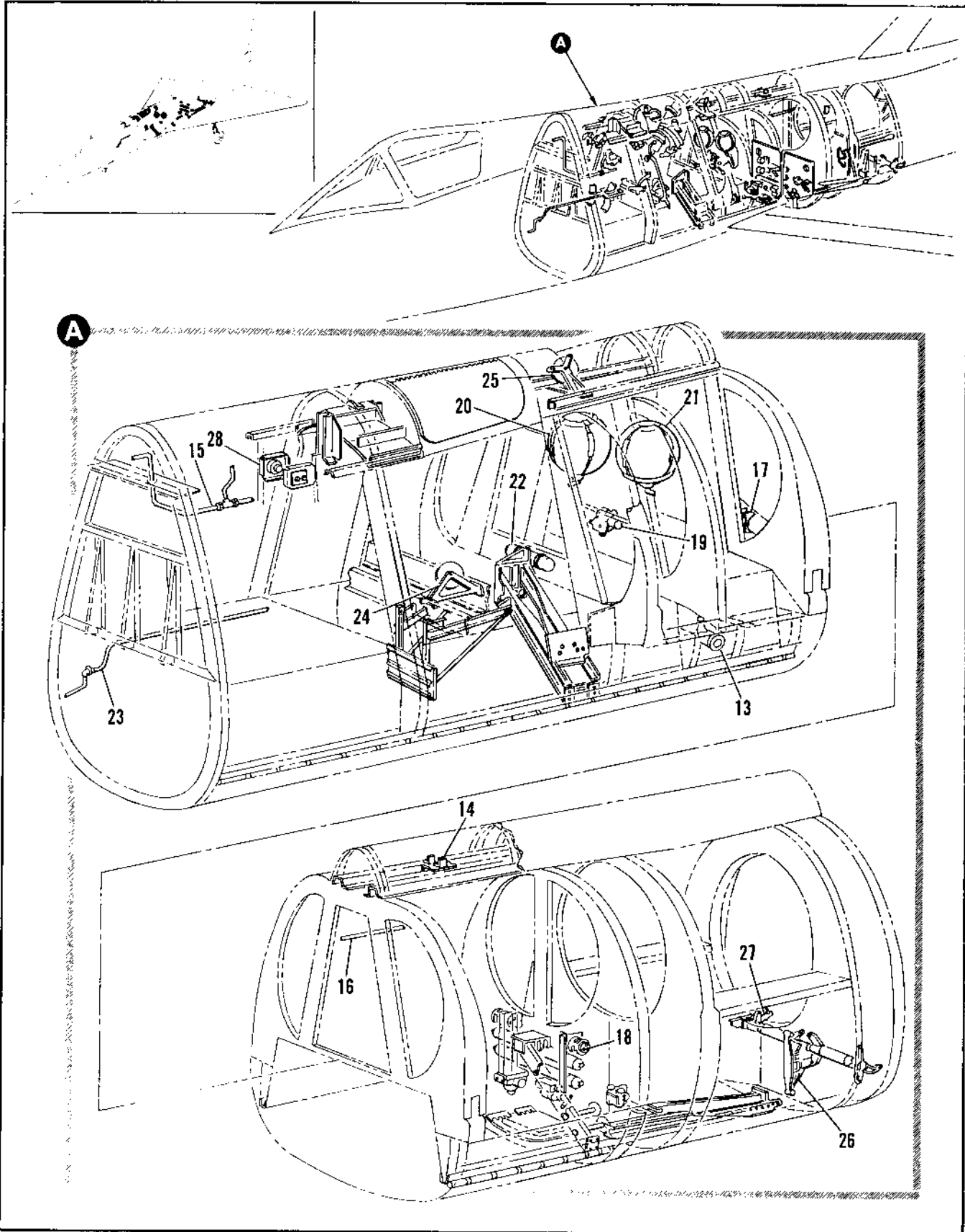

Figure 2.3-10. Fuselage Assembly Sta 216 to 472 (Sheet 2 of 4)

FIGURE AND INDEX NUMBER	PART NUMBER	DESCRIPTION	UNITS PER ASSY.	USABLE ON CODE	
				FROM	TO
		1 2 3 4 5 6			
2.3-10- 13	8-28380	• VALVE INSTL, FUEL TRANSFER DRAIN LH FOR BREAKDOWN SEE FIG. 2.12-40	1	35	
	8-28360-1	• VALVE INSTL, FUEL TRANSFER DRAIN RH FOR BREAKDOWN SEE FIG. 2.12-40	1	35	
- 14	8-28291	• SUPPORT INSTL, FUEL TANK PRESSURE MANIFOLD STA 295 TO 472 FOR BREAKDOWN SEE FIG. 2.12-5P	1	35	
- 15	8-20397-829	• TUBING INSTL, FUEL TANK PRESSURE LH STA 217 TO 253 FOR BREAKDOWN SEE FIG. 2.12-45	1	35	159
	8-20397-853	• TUBING INSTL, FUEL TANK PRESSURE LH STA 217 TO 253 FOR BREAKDOWN SEE FIG. 2.12-45	1	160	
- 16	8-20397-831	• TUBING INSTL, FUEL TANK PRESSURE STA 253 TO 472 FOR BREAKDOWN SEE FIG. 2.12-46 AND 2.12-47	1	35	42
	8-20397-841	• TUBING INSTL, FUEL TANK PRESSURE STA 253 TO 472 FOR BREAKDOWN SEE FIG. 2.12-46 AND 2.12-47	1	43	
- 17	8-28276	• BRACKET INSTL, FUEL TRANSFER LINE STA 344 FOR BREAKDOWN SEE FIG. 2.12-4	1	35	60
	8-28276-1	• BRACKET INSTL, FUEL TRANSFER LINE STA 344 FOR BREAKDOWN SEE FIG. 2.12-4	1	61	
- 18	8-81317	• ACCUMULATOR INSTL, HYDRAULIC STA 412 FOR BREAKDOWN SEE FIG. 2.9-2	1	35	
- 19	8-85024	• REGULATOR INSTL, PNEUMATIC PRESSURE FOR BREAKDOWN SEE FIG. 2.9-1	RF	35	
	66E40954-1	• REGULATOR INSTL, PNEUMATIC PRESS FOR BREAKDOWN SEE FIG. 2.9-1 (98750)	1	35	
- 20	8-85021-1	• FLASK INSTL, PNEUMATIC FWD FOR BREAKDOWN SEE FIG. 2.9-3	1	35	
- 21	8-85021	• FLASK INSTL, PNEUMATIC AFT FOR BREAKDOWN SEE FIG. 2.9-3	RF	35	
	8-85021	• FLASK INSTL, PNEUMATIC AFT MODIFIED BY 66E40416 FOR BREAKDOWN SEE FIG. 2.9-3	1	35	
- 22	8-85040-1	• SUPPORT INSTL, VARIABLE AIR RAMP FLASK FOR BREAKDOWN SEE FIG. 2.11-1	1	35	
- 23	8-39097-1	• TUBING INSTL, PRESSURE RATIO INDICATOR STA 216 TO 472 FOR BREAKDOWN SEE FIG. 2.10-20	1	35	
- 24	8-42233-1	• PULLEY INSTL, RUDDER CABLE STA 284 LH FOR BREAKDOWN SEE FIG. 2.14-34	1	35	
	8-42233-2	• PULLEY INSTL, RUDDER CABLE STA 284 RH FOR BREAKDOWN SEE FIG. 2.14-34	1	35	
- 25	8-42233-3	• PULLEY INSTL, RUDDER CABLE STA 324 FOR BREAKDOWN SEE FIG. 2.14-34	RF	35	
	8-42233-3	• PULLEY INSTL, RUDDER CABLE STA 324 MODIFIED BY 66J40963 FOR BREAKDOWN SEE FIG. 2.14-34	1	35	
- 26	8-42520-5	• TUBE INSTL, FLEWON CONTROL STA 477 MODIFIED BY 8-41111 FOR BREAKDOWN SEE FIG. 2.14-20	1	35	
- 27	8-42460	• SWITCH INSTL, AILERON LIMIT MODIFIED BY 8-42470 AND 8-42471 FOR BREAKDOWN SEE FIG. 2.14-43	1	35	
- 28	8-28414	• SWITCH INSTL, FUSELAGE TANK LOW PRESSURE AND EMERGENCY FOR BREAKDOWN SEE FIG. 2.12-41	1	35	

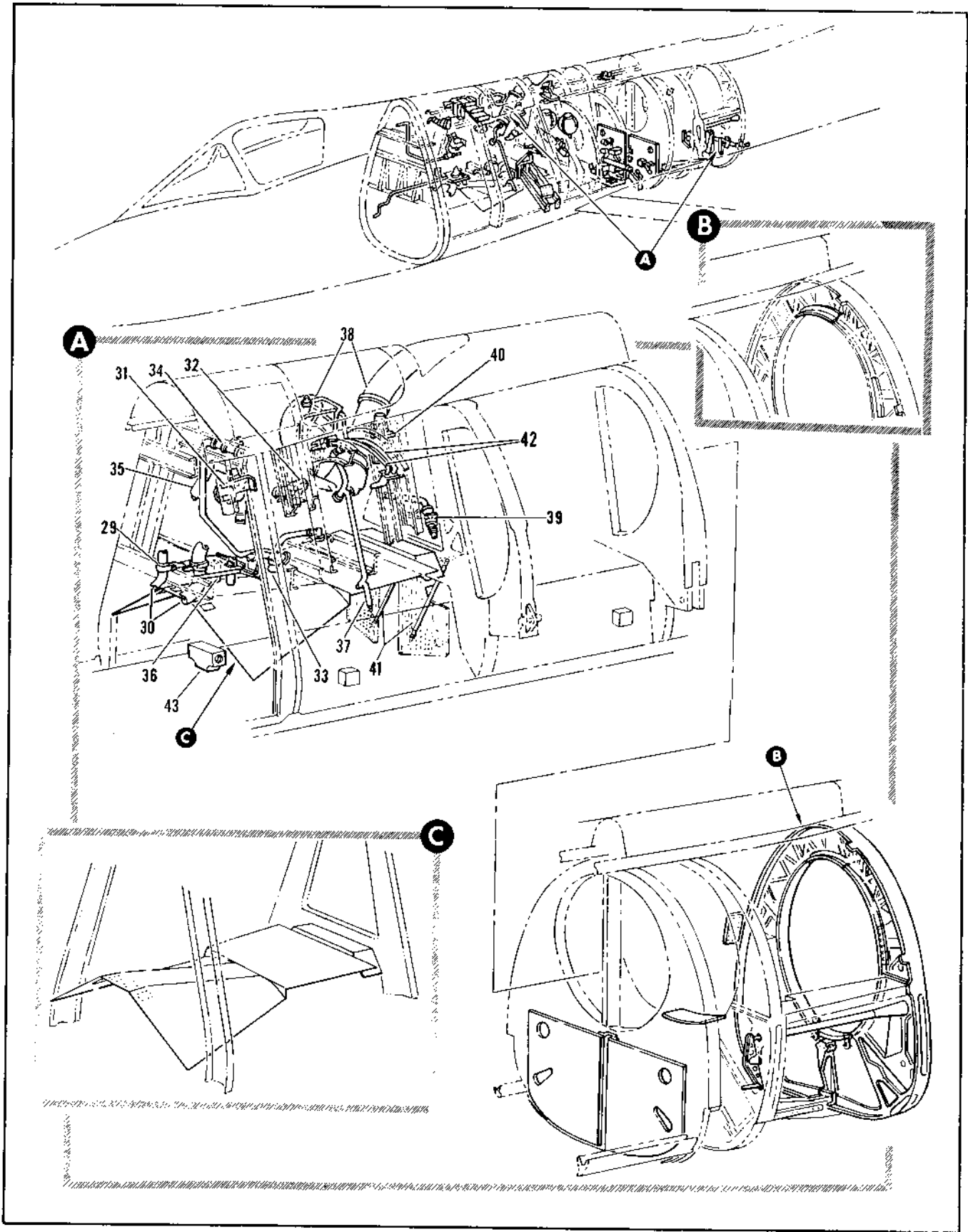

Figure 2.3-10. Fuselage Assembly Sta 216 to 472 (Sheet 3 of 4)

FIGURE AND INDEX NUMBER	PART NUMBER	DESCRIPTION 1 2 3 4 5 6	UNITS PER ASSY.	USABLE ON CODE	
				FROM	TO
2.3-10- 29	R-23524	• SUPPORT INSTL, COCKPIT AND ELECTRONIC COOLING DUCT STA 259 FOR BREAKDOWN SEE FIG. 2.13-1	1	35	
- 30	R-23521-011	• DUCT INSTL, FWD RADAR COMPARTMENT AND COCKPIT COOLING FOR BREAKDOWN SEE FIG. 2.13-1	1	35	
- 31	R-23525	• VALVE INSTL, COCKPIT DIVERTER AND SHUTOFF FOR BREAKDOWN SEE FIG. 2.13-1	1	35	
- 32	R-23522	• VALVE INSTL, ELECTRONIC COMPARTMENT COOLING FOR BREAKDOWN SEE FIG. 2.13-1	1	35	
- 33	R-2330	• DUCT INSTL, RAM AIR STA 256 TO 276 FOR BREAKDOWN SEE FIG. 2.13-1	1	35	
- 34	R-23575-1	• DUCT INSTL, COCKPIT HOT AIR BY PASS STA 267 TO 309 FOR BREAKDOWN SEE FIG. 2.13-23	1	35	
- 35	R-23595	• DUCT INSTL, EMERGENCY ELECTRONIC RAM AIR FOR BREAKDOWN SEE FIG. 2.13-1	1	35	
- 36	R-23290	• PANEL INSTL, AIR SHUTOFF VALVE AND FILTER FOR BREAKDOWN SEE FIG. 2.12-57	1	35	
- 37	R-23801	• TUBING INSTL, ANTI-ICING AIR INTAKE DUCT LIP FOR BREAKDOWN SEE FIG. 2.13-28	1	35	
- 39	R-23100-005	• REFRIGERATION UNIT INSTALLATION, FOR BREAKDOWN SEE FIG. 2.13-2	1	35	
	R-23100-011	• • HEADER INSTL, RAM AIR INLET FOR BREAKDOWN SEE FIG. 2.13-29	1	35	43
	R-23100-009	• • HEADER INSTL, RAM AIR INLET FOR BREAKDOWN SEE FIG. 2.13-29	1	44	
- 38	R-23587	• DUCT INSTL, GROUND COOLING FOR BREAKDOWN SEE FIG. 2.13-21	1	35	
- 40	R-23701	• TANK INSTL, GLYCOL RADOME ANTI-ICING FOR BREAKDOWN SEE FIG. 2.13-1	1	35	
	R-77777-003	• BAFFLE INSTL, MISSILE BAY STA 308 LH	1	0	
	R-77777-001	• BAFFLE INSTL, MISSILE BAY STA 309 LH	1	43	57
	R-77777-004	• BAFFLE INSTL, MISSILE BAY STA 308 RH	1	0	
	R-77777-002	• BAFFLE INSTL, MISSILE BAY STA 308 RH	1	43	57
- 41	R-57650	• • ROD ASSY, TRANSVERSE BAFFLE RIVETED ATTACHING PARTS	1	48	
	AN32104	• • NUT (A9244)	2	43	
	AN9610410	• • WASHER (A9244)	2	43	
	AN24-12	• • BOLT (A9244)	2	48	
- 42	R-92945-013	• TUBING INSTL, VARIABLE AIR RAMP PILOT STATIC STA 216 TO 472 FOR BREAKDOWN SEE FIG. 2.11-12	1	35	
- 43	R-92274	• VALVE INSTL, VARIABLE AIR RAMP SHUTTLE	1	A	
	R-92234-3	• VALVE INSTL, VARIABLE AIR RAMP SHUTTLE	1	B	
	20601	• • VALVE, SHUTTLE (52250) SPEC 8-08582-1 T.O. 9PT-10-5-3 REPLACED BY SUITABLE SUB 20600-1	1	A	
	20600-1	• • VALVE, SHUTTLE (92250) SPEC 8-08582-3 T.O. 9PT-10-5-3 REPLACES SUITABLE SUB FOR 20600	1	B	

A AIRPLANES 475 THRU 47 AND 49 THRU 49
 B AIRPLANES 448 AND 90 AND ON
 D AIRPLANES 448, 61 AND ON

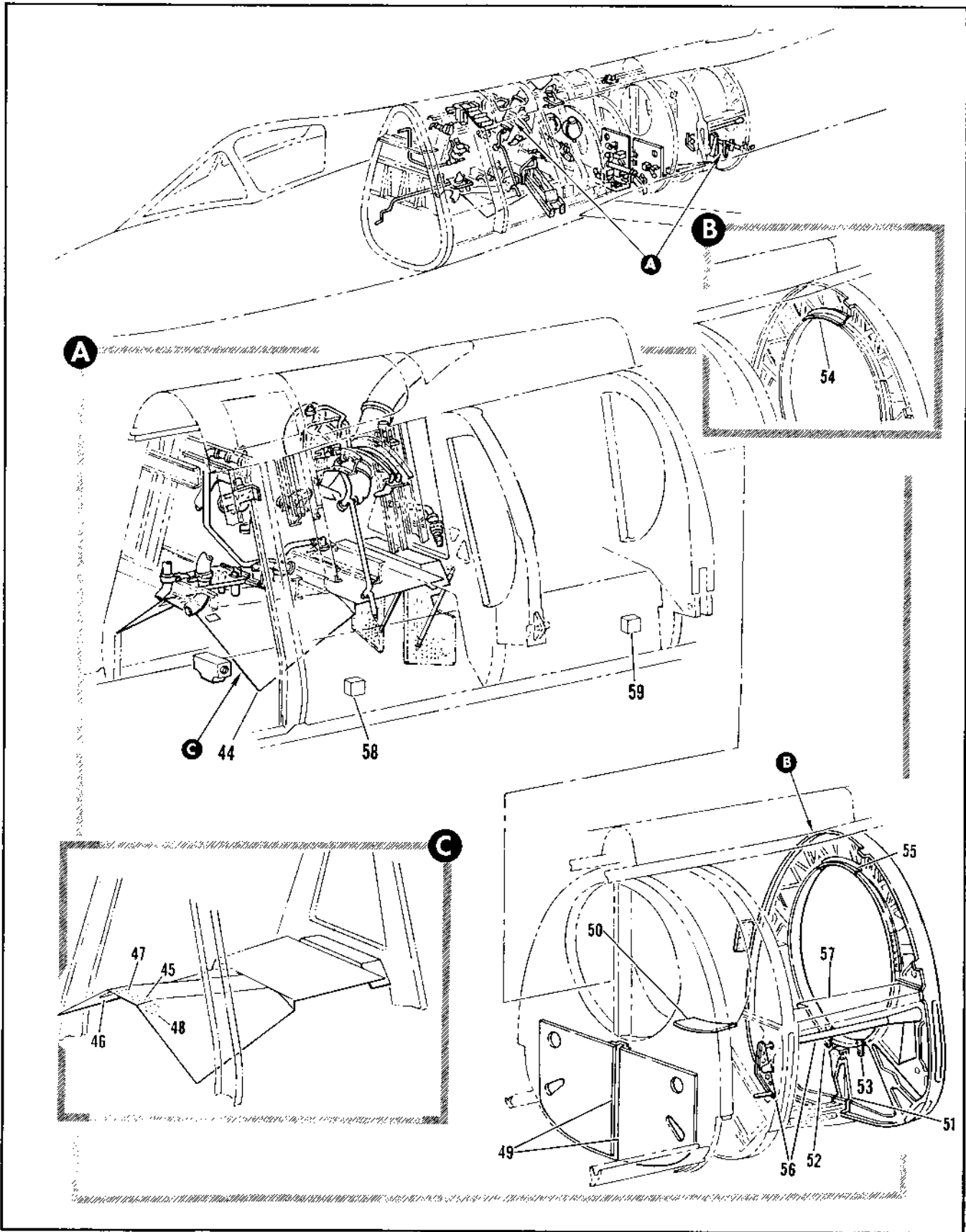

Figure 2.3-10. Fuselage Assembly Sta 216 to 472 (Sheet 4 of 4)

FIGURE AND INDEX NUMBER	PART NUMBER	DESCRIPTION	UNITS PER ASSY.	USABLE ON CODE	
				FROM	TO
		1 2 3 4 5 6			
2.3-10- 44	8-74441-3	• ROOF INSTL, ARMAMENT BAY STA 253 TO 316 MODIFIED BY 8-82396 AND 8-78594	1	35	89
	8-74441-17	• ROOF INSTL, ARMAMENT BAY STA 253 TO 316	1	99	
- 45	8-24440-21	• • NAMEPLATE	1	35	
- 46	8-24440-23	• • NAMEPLATE	1	35	
- 47	8-24440-25	• • NAMEPLATE	1	35	
- 48	8-24440-31	• • NAMEPLATE	RF	C	
	8-24440-35	• • NAMEPLATE	1	35	
- 49	8-74999-1	• SHIELD INSTL, PROTECTION STA 412 LH FOR BREAKDOWN SEE FIG. 2.5-1	1	35	
	8-74999-4	• SHIELD INSTL, PROTECTION STA 412 RH FOR BREAKDOWN SEE FIG. 2.5-1	1	35	
	8-74711-1	• SPLICE INSTL, FUSELAGE STA 412 TO 472	1	35	
- 50	8-74462-2	• • DOOR INSTL, ACCESS STA 435 FOR BREAKDOWN SEE FIG. 2.2-7	1	35	
	8-74310-17	• • BULKHEAD INSTL, FUSELAGE STA 472	1	35	60
	8-77310-5	• • BULKHEAD INSTL, FUSELAGE STA 472	1	61	
- 51	8-77115	• • • ADAPTOR ASSY, MLC ACTUATING CYLINDER STA 472 FOR BREAKDOWN SEE FIG. 2.15-1	1	35	50
- 52	8-42746	• • • BRACKET ASSY, FLEVON CONTROL COVER	1	35	
- 53	8-42746-1	• • • BRACKET ASSY, FLEVON CONTROL COVER	1	35	
- 54	8-74310-25	• • • ANGLE, ENGINE SEAL	1	35	67
- 55	8-77310-51	• • • ANGLE, ENGINE SEAL	1	61	
- 56	8-74034-213	• EQUIPMENT ASSY, STA 253 TO 472 LH FOR BREAKDOWN SEE FIG. 2.3-11	1	35	
	8-74034-215	• EQUIPMENT ASSY, STA 253 TO 472 RH FOR BREAKDOWN SEE FIG. 2.3-11	1	35	
- 57	8-74462	• ROOF INSTL, ARMAMENT BAY STA 364 TO 472 FOR BREAKDOWN SEE FIG. 2.20-35	1	A	
	8-74462-105	• ROOF INSTL, ARMAMENT BAY STA 364 TO 472 FOR BREAKDOWN SEE FIG. 2.20-35	1	B	
- 58	8-65589-1	• SWITCH INSTL, ARMAMENT BAY DOOR CLOSED LH	1	130	
	8-65589-2	• SWITCH INSTL, ARMAMENT BAY DOOR CLOSED RH	1	130	
- 59	8-65588-3	• SWITCH INSTL, ARMAMENT BAY DOOR OPEN LH	1	130	
	8-65588-4	• SWITCH INSTL, ARMAMENT BAY DOOR OPEN RH	1	130	
<p>A AIRPLANES 455 THRU 47 AND 49 THRU 49 B AIRPLANES 448 AND 40 AND 04 C AIRPLANES 448 AND 61 THRU 215</p>					

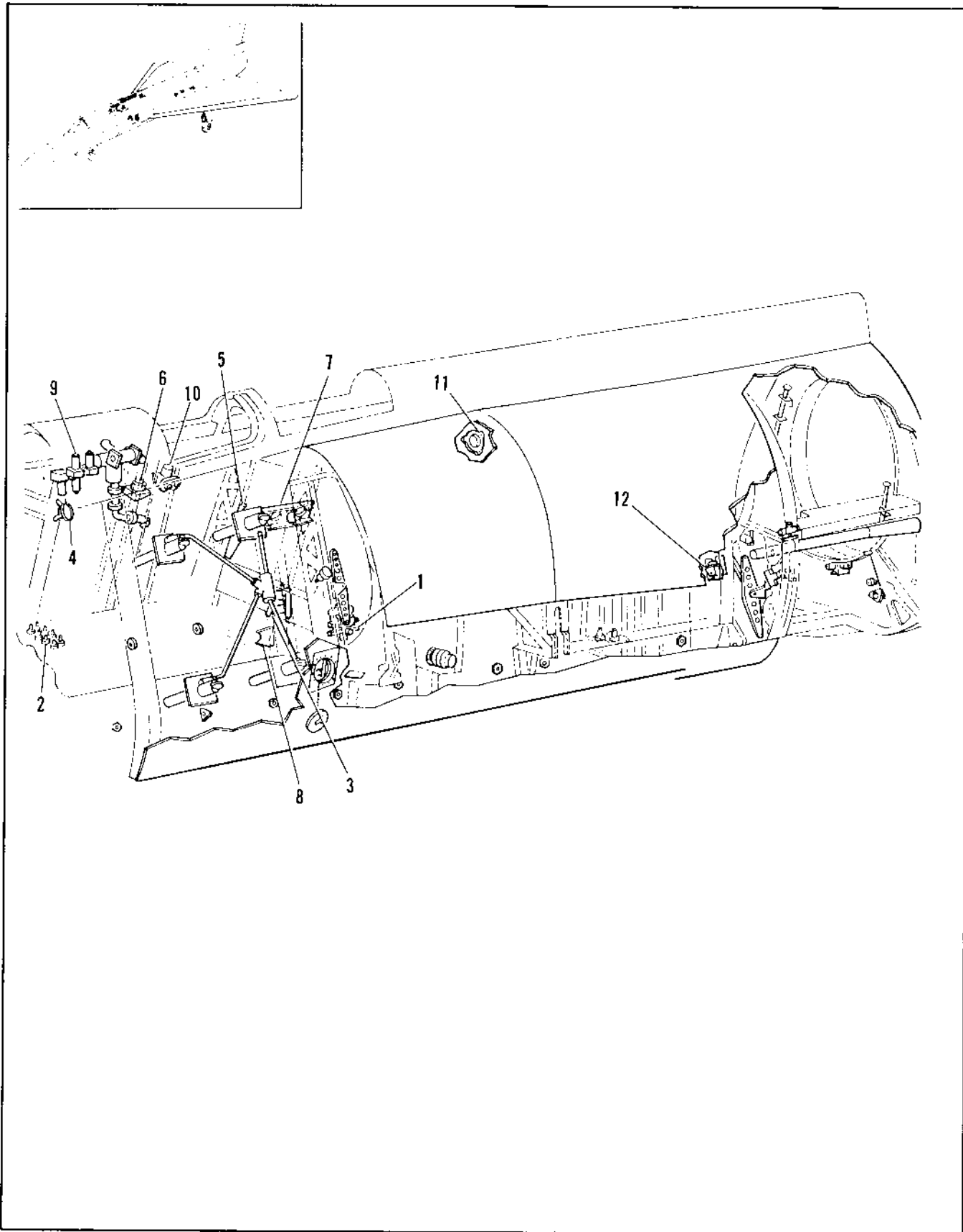

Figure 2.3-11. Equipment Assembly Sta 253 to 472 (Sheet 1 of 3)

FIGURE AND INDEX NUMBER	PART NUMBER	DESCRIPTION	UNITS PER ASSY.	USABLE ON CODE	
				FROM	TO
		1 2 3 4 5 6			
2.3-11	8-74034-813	EQUIPMENT ASSEMBLY, STA 253 TO 472 LH FOR NHA SEE FIG. 2.3-10	RF	35	
	8-74034-815	EQUIPMENT ASSEMBLY, STA 253 TO 472 RH FOR NHA SEE FIG. 2.3-10	RF	35	
- 1	8-85049-1	• VALVE INSTL, ARMAMENT BAY DOOR MASTER PNEUMATIC SELECTOR FOR BREAKDOWN SEE FIG. 2.20-9	1	35	42
	8-85023-1	• VALVE INSTL, ARMAMENT BAY DOOR MASTER PNEUMATIC SELECTOR FOR BREAKDOWN SEE FIG. 2.20-9	1	43	
- 2	8-28411	• ADAPTER INSTL, FUEL SYSTEM CHECKOUT FWD FOR BREAKDOWN SEE FIG. 2.12-40	1	A	
	8-28411-1	• ADAPTER INSTL, FUEL SYSTEM CHECKOUT FWD FOR BREAKDOWN SEE FIG. 2.12-40	1	B	
	8-28411-3	• ADAPTER INSTL, FUEL SYSTEM CHECKOUT FWD FOR BREAKDOWN SEE FIG. 2.12-40	1	216	
- 3	8-85059-1	• VALVE INSTL, ARMAMENT BAY DOOR CENTER PNEUMATIC SELECTOR FOR BREAKDOWN SEE FIG. 2.20-10	1	35	42
	8-85051-1	• VALVE INSTL, ARMAMENT BAY DOOR CENTER PNEUMATIC SELECTOR FOR BREAKDOWN SEE FIG. 2.20-10	1	43	
- 4	8-28280	• SUPPORT INSTL, CG TRANSFER TUBE STA 266 FOR BREAKDOWN SEE FIG. 2.12-36	1	35	60
	8-28460	• SUPPORT INSTL, CG TRANSFER TUBE STA 266 FOR BREAKDOWN SEE FIG. 2.12-36	1	61	
- 5	8-28462-1	• BRACKET INSTL, FUEL TRANSFER LINE FUSELAGE FOR BREAKDOWN SEE FIG. 2.12-36	1	90	
- 6	8-28377	• SWITCH INSTL, EXTERNAL FUEL TANK HIGH PRESSURE FOR BREAKDOWN SEE FIG. 2.12-36	1	35	
- 7	8-28279	• SUPPORT INSTL, CG TRANSFER TUBE STA 324 TO 344 FOR BREAKDOWN SEE FIG. 2.12-36	1	35	60
	8-28279-1	• SUPPORT INSTL, CG TRANSFER TUBE STA 324 TO 344 FOR BREAKDOWN SEE FIG. 2.12-36	1	61	
- 8	8-28282	• SUPPORT INSTL, CG TRANSFER TUBE STA 316 FOR BREAKDOWN SEE FIG. 2.12-36	1	35	
	8-28282-1	• SUPPORT INSTL, CG TRANSFER TUBE STA 316 RH FOR BREAKDOWN SEE FIG. 2.12-36	1	61	
- 9	8-28289-3	• VALVE INSTL, FUEL PRESSURE SHUTOFF STA 270 FOR BREAKDOWN SEE FIG. 2.12-52	1	35	216
	8-28289-1	• VALVE INSTL, FUEL PRESSURE SHUTOFF STA 270 FOR BREAKDOWN SEE FIG. 2.12-52	1	216	
- 10	8-85129-3	• VALVE INSTL, EMERGENCY FUEL TRANSFER FOR BREAKDOWN SEE FIG. 2.12-31	1	35	
- 11	8-28323-3	• TUBE INSTL, CG FUEL TRANSFER STA 326 LH FOR BREAKDOWN SEE FIG. 2.12-36	1	35	
	8-28323-4	• TUBE INSTL, CG FUEL TRANSFER STA 326 RH FOR BREAKDOWN SEE FIG. 2.12-36	1	35	
- 12	8-81310-1	• REGULATOR INSTL, HYDRAULIC RESERVOIR AIR PRESSURE LH FOR BREAKDOWN SEE FIG. 2.8-1	1	35	
	8-81310-3	• REGULATOR INSTL, HYDRAULIC RESERVOIR AIR PRESSURE RH FOR BREAKDOWN SEE FIG. 2.8-1	1	35	
		A AIRPLANES #35 THRU 47 AND 49 THRU 60			
		B AIRPLANES #48 AND 51 THRU 215			

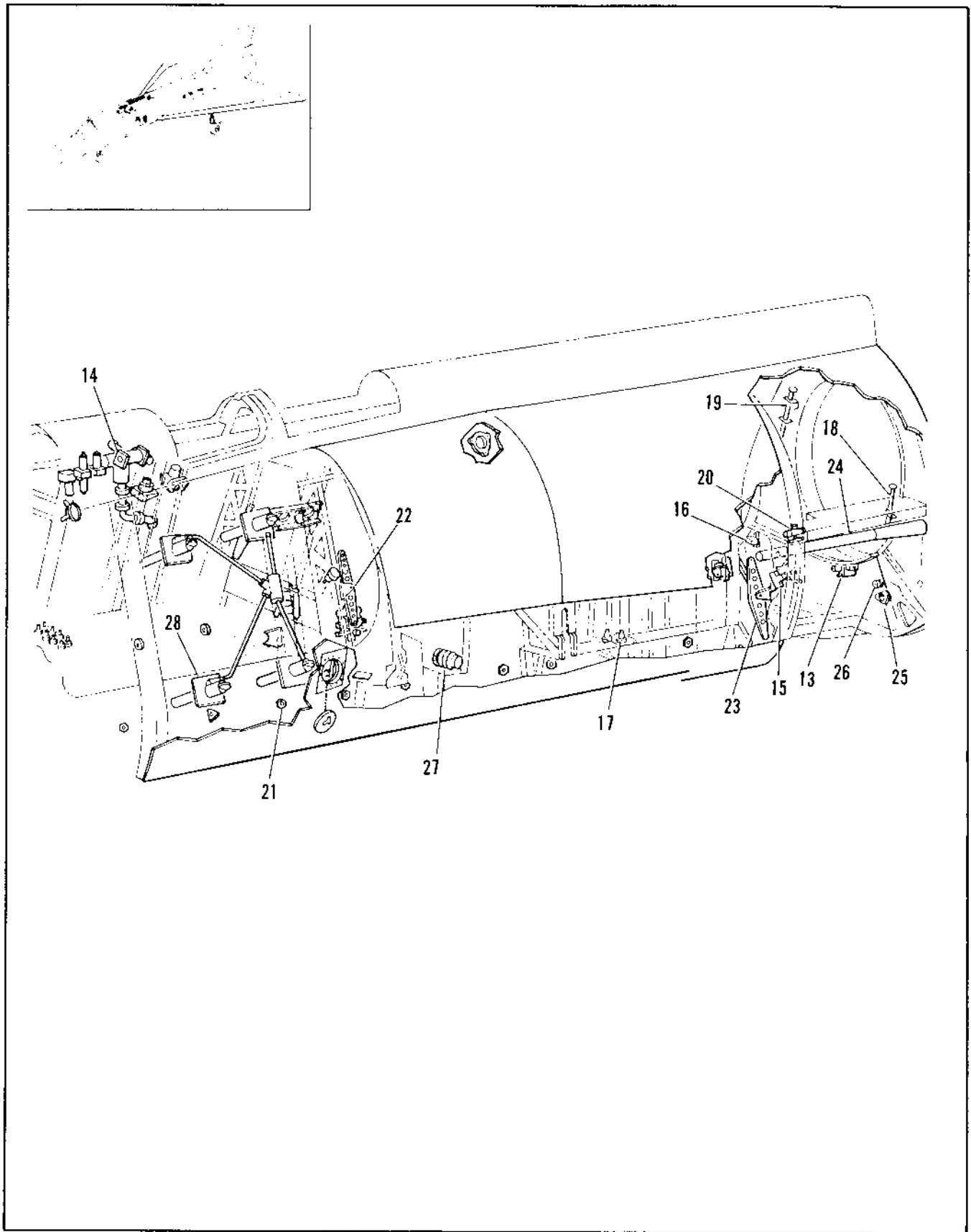

Figure 2.3-11. Equipment Assembly Sta 253 to 472 (Sheet 2 of 3)

FIGURE AND INDEX NUMBER	PART NUMBER	DESCRIPTION	UNITS PER ASSY.	USABLE ON CODE	
				FROM	TO
2.3-11- 13	8-81327-1	• VALVE INSTL, EMERGENCY GENERATOR SHUT OFF STA 468 FOR BREAKDOWN SEE FIG. 2.8-1	1	35	
- 14	8-28270-3	• REGULATOR INSTL, AIR PRESSURE FWD FOR BREAKDOWN SEE FIG. 2.9-2	1	35	
- 15	8-85046-1	• VALVE INSTL, ARMAMENT BAY DOOR MANUAL SAFETY STA 431 FOR BREAKDOWN SEE FIG. 2.20-1	1	35	
- 16	8-85058-1	• VALVE INSTL, ARMAMENT GEAR LOCK MANUAL STA 431 FOR BREAKDOWN SEE FIG. 2.20-1	1	61	
- 17	8-28419	• VALVE INSTL, REFUEL AND AIR PRESSURE LINES DRAIN STA 378 FOR BREAKDOWN SEE FIG. 2.12-25	1	35	
- 18	8-26243	• DRAIN INSTL, ENGINE OIL COOLER FOR BREAKDOWN SEE FIG. 2.10-25	1	35	
- 19	8-28245	• DRAIN INSTL, ACCESSORY DRIVE OIL COOLER STA 466 FOR BREAKDOWN SEE FIG. 2.10-1	1	35	38
	8-28245-1	• DRAIN INSTL, ACCESSORY DRIVE OIL COOLER STA 466 FOR BREAKDOWN SEE FIG. 2.10-1	1	39	
- 20	8-85130-1	• VALVE INSTL, MANUAL SHUTOFF STARTER PNEUMATIC STA 441 FOR BREAKDOWN SEE FIG. 2.10-1	1	35	
- 21	8-42557-1	• SUPPORT INSTL, ELEVON CONTROL TUBE LH STA 216 TO 431 FOR BREAKDOWN SEE FIG. 2.14-14	1	35	129
	8-42557-5	• SUPPORT INSTL, ELEVON CONTROL TUBE LH STA 216 TO 431 FOR BREAKDOWN SEE FIG. 2.14-14	1	130	
	8-42557-3	• SUPPORT INSTL, ELEVON CONTROL TUBE RH STA 216 TO 431 FOR BREAKDOWN SEE FIG. 2.14-14	1	35	129
	8-42557-201	• SUPPORT INSTL, ELEVON CONTROL TUBE RH STA 216 TO 431 FOR BREAKDOWN SEE FIG. 2.14-14	1	130	
- 22	8-42425-1	• BELL CRANK INSTL, AILERON RH STA 353 FOR BREAKDOWN SEE FIG. 2.14-16	1	35	
- 23	8-42352	• BELL CRANK INSTL, ELEVATOR LH STA 426 FOR BREAKDOWN SEE FIG. 2.14-19	1	35	
- 24	8-42560-1	• SEAL INSTL, ELEVATOR AND AILERON CONTROL TUBE LH FOR BREAKDOWN SEE FIG. 2.14-17	1	35	
	8-42560-3	• SEAL INSTL, ELEVATOR AND AILERON CONTROL TUBE RH FOR BREAKDOWN SEE FIG. 2.14-17	1	35	
- 25	8-42356	• INLET INSTL, STATIC AIR REGULATOR AIRFEEL FOR BREAKDOWN SEE FIG. 2.14-35 AND 2.14-37	1	35	
- 26	8-42347	• CONNECTOR INSTL, STATIC AIR STA 472 LH FOR BREAKDOWN SEE FIG. 2.14-1	1	35	
- 27	8-23620	• DUCT INSTL, ARMAMENT BAY GROUND AIR-CONDITIONING CONNECTOR STA 340 FOR BREAKDOWN SEE FIG. 2.13-20	1	35	
- 28	8-45028-3	• SCREW JACK INSTL, VARIABLE AIR PUMP LH FOR BREAKDOWN SEE FIG. 2.11-9	1	35	

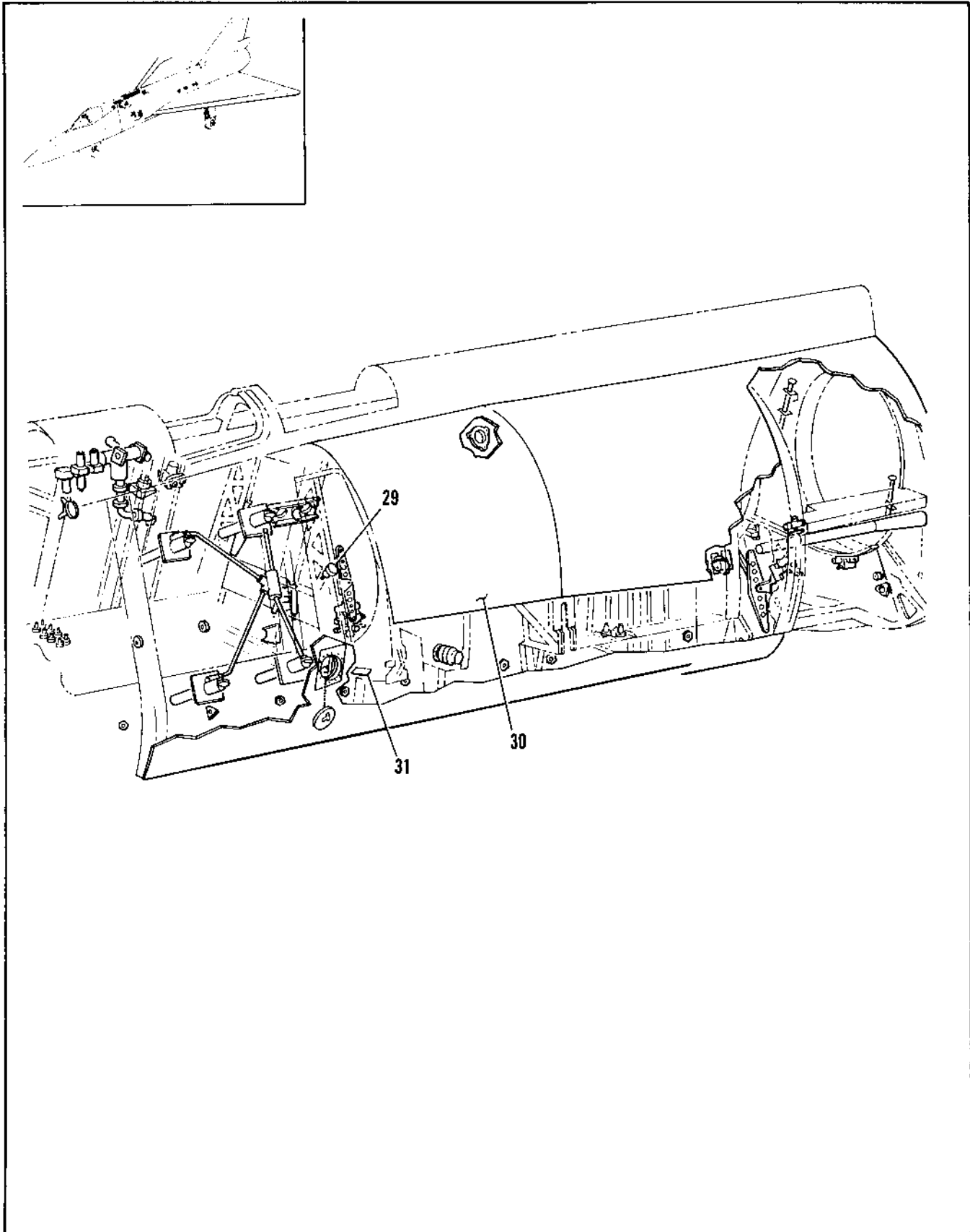

Figure 2.3-11. Equipment Assembly Sta 253 to 472 (Sheet 3 of 3)

FIGURE AND INDEX NUMBER	PART NUMBER	DESCRIPTION	UNITS PER ASSY.	USABLE ON CODE	
				FROM	TO
		1 2 3 4 5 6			
2.3-11	8-45028-5	• SCREW JACK INSTL, VARIABLE AIR RAMP RH FOR BREAKDOWN SEE FIG. 2.11-9	1	35	
- 29	8-85031-1	• VALVE INSTL, VARIABLE AIR RAMP SELECTOR FOR BREAKDOWN SEE FIG. 2.11-1	RF	35	
	66E40437-1	• VALVE INSTL, VARIABLE AIR-RAMP SELEC- TOR FOR BREAKDOWN SEE FIG. 2.11-1 (98750)	1	35	
- 30	8-74434-803	• PANEL ASSY, SIDE STA 253 TO 472 LH FOR BREAKDOWN SEE FIG. 2.3-12	1	35	
	8-74434-804	• PANEL ASSY, SIDE STA 253 TO 472 RH FOR BREAKDOWN SEE FIG. 2.3-12	1	35	
- 31	8-23510-1	• DUCT INSTL, ELECTRONIC COMPARTMENT FOR NHA SEE FIG. 2.13-1	1	35	

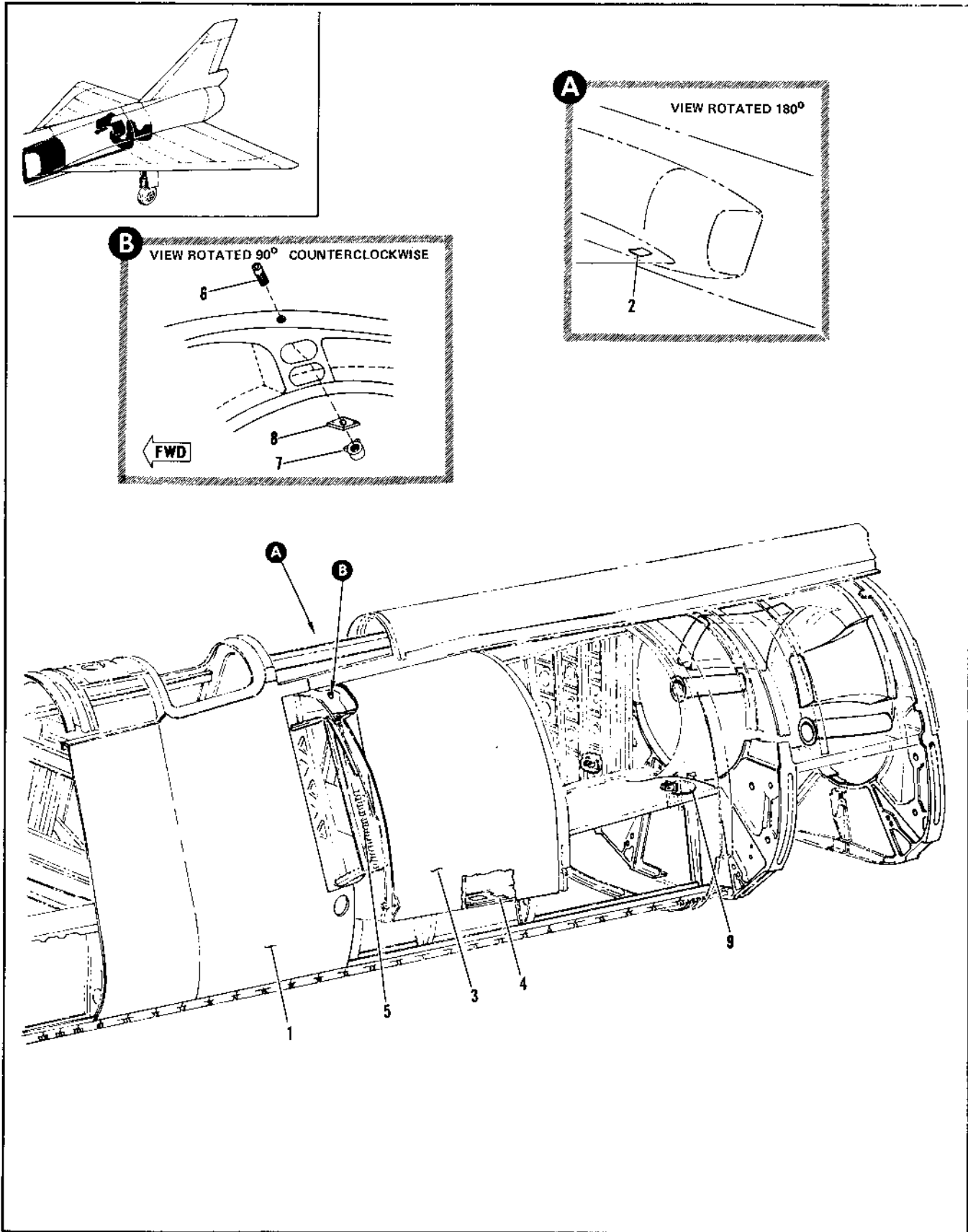

Figure 2.3-12. Side Panel Assembly Sta 253 to 472 (Sheet 1 of 3)

FIGURE AND INDEX NUMBER	PART NUMBER	DESCRIPTION	UNITS PER ASSY.	USABLE ON CODE	
				FROM	TO
2.3-12	8-74434-803	PANEL ASSEMBLY, SIDE STA 253 TO 472 LH FOR NHA SEE FIG. 2.3-11	RF	35	
	8-74434-804	PANEL ASSEMBLY, SIDE STA 253 TO 472 RH FOR NHA SEE FIG. 2.3-11	RF	35	
- 1	8-74475-805	• PANEL INSTL, SIDE STA 253 TO 316 LH FOR BREAKDOWN SEE FIG. 2.3-13	1	35	62
	8-74475-813	• PANEL INSTL, SIDE STA 253 TO 316 LH FOR BREAKDOWN SEE FIG. 2.3-13	1	63	
	8-74475-806	• PANEL INSTL, SIDE STA 253 TO 316 RH FOR BREAKDOWN SEE FIG. 2.3-13	1	35	62
	8-74475-814	• PANEL INSTL, SIDE STA 253 TO 316 RH FOR BREAKDOWN SEE FIG. 2.3-13	1	63	
- 2	8-77590	• DOOR INSTL, REFUELING STA 312 RH FOR BREAKDOWN SEE FIG. 2.2-7	1	35	
- 3	8-74476-9	• PANEL INSTL, SIDE STA 316 TO 364 LH	1	35	
	8-74476-801	• PANEL INSTL, SIDE STA 316 TO 364 RH	1	35	
- 4	8-77873	• DOUBLER, LH	1	35	
	8-77751-1	• HINGE INSTL, STA 330 TO 337 LH	1	35	
- 5	8-77751-2	• HINGE INSTL, STA 330 TO 337 RH	1	35	
	8-74974-7	• HINGE, HALF DUCT RAMP FUSELAGE LH	1	35	
	8-74974-8	• HINGE, HALF DUCT RAMP FUSELAGE RH ATTACCHING PARTS	1	35	
	NAS679A3	• NUT, (80205) 96-37545-002	1	35	
	99-51505-016	• WASHER	2	35	
	NAS464-3A19	• BOLT (80205) ----X----	1	35	
	8-74770-1	• BULKHEAD INSTL, STA 316 LH	1	35	
	8-74770-2	• BULKHEAD INSTL, STA 316 RH	1	35	
- 6	8-74748-7	• PLUG, ACFT HOIST FITTING FWD	1	35	
- 7	52NAS-108	• NUTPLATE <72962>	2	35	
- 8	8-77794-7	• RETAINER, NUTPLATE	2	35	
- 9	8-74482-1	• DOOR INSTL, STA 408 LH FOR BREAKDOWN SEE FIG. 2.2-7	1	35	42
	8-74482-803	• DOOR INSTL, STA 408 LH FOR BREAKDOWN SEE FIG. 2.2-7	1	43	
	8-74482-2	• DOOR INSTL, STA 408 RH FOR BREAKDOWN SEE FIG. 2.2-7	1	35	42
	8-74482-804	• DOOR INSTL, STA 408 RH FOR BREAKDOWN SEE FIG. 2.2-7	1	43	
	8-74434-801	• PANEL INSTL, SIDE STA 412 TO 472 LH	1	35	
	8-74434-803	• PANEL INSTL, SIDE STA 412 TO 472 RH	1	35	
	8-74300-801	• BULKHEAD INSTL, FUSELAGE STA 431 LH	1	35	60
	8-77300-1	• BULKHEAD INSTL, FUSELAGE STA 431 LH	1	61	
	8-74300-807	• BULKHEAD INSTL, FUSELAGE STA 431 RH	1	35	60
	8-77300-801	• BULKHEAD INSTL, FUSELAGE STA 431 RH	1	61	
	8-74300-243	• BULKHEAD ASSY, LH	1	35	60
	8-74300-249	• BULKHEAD ASSY, LH ALT INTCHG WITH 8-74300-243	RF	35	60
	8-77300-115	• BULKHEAD ASSY, LH	1	61	
	8-74300-267	• BULKHEAD ASSY, RH	1	35	61
	8-77300-117	• BULKHEAD ASSY, RH	1	61	69
	8-77300-119	• BULKHEAD ASSY, RH	1	90	

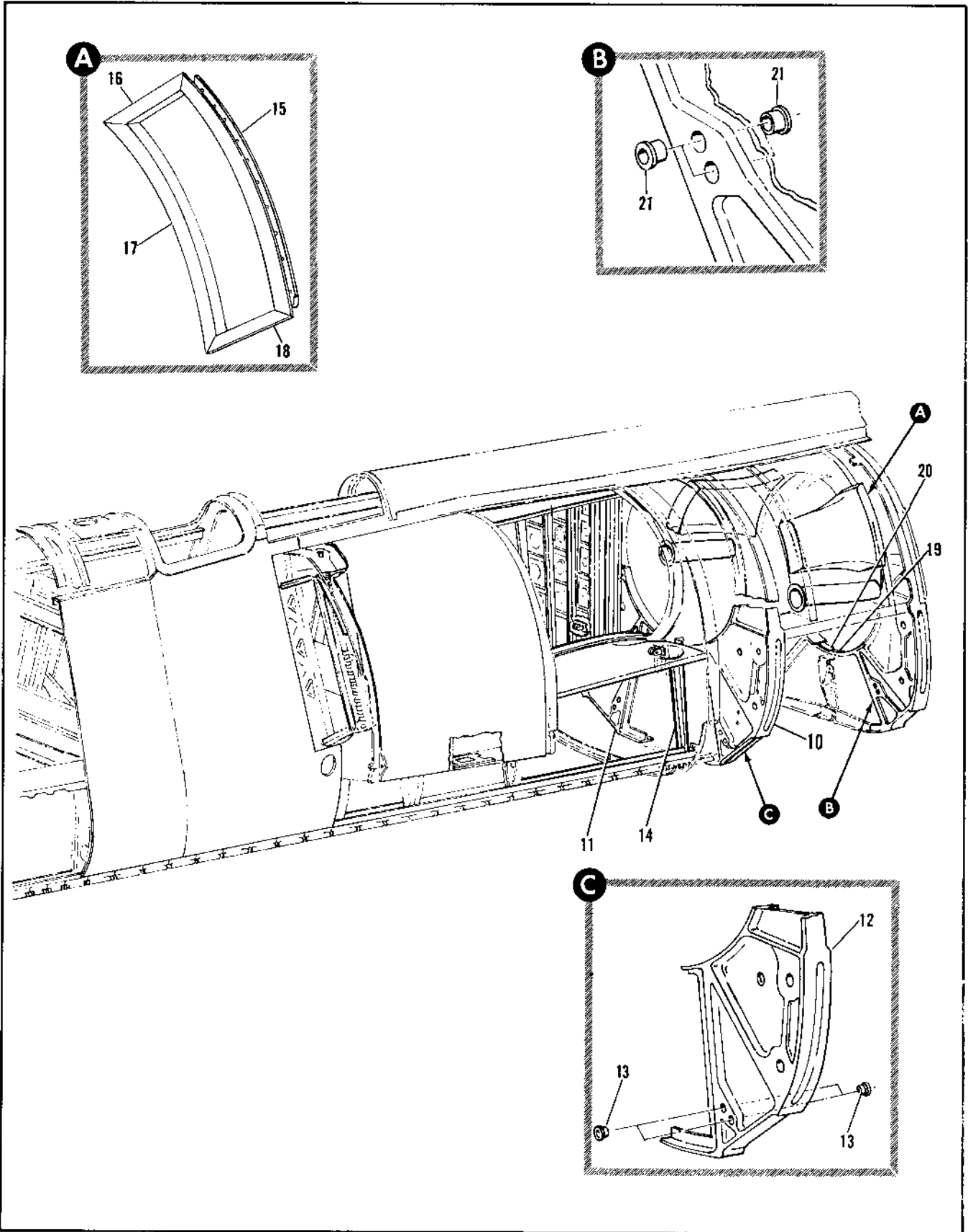

Figure 2.3-12. Side Panel Assembly Sta 253 to 472 (Sheet 2 of 3)

FIGURE AND INDEX NUMBER	PART NUMBER	DESCRIPTION	UNITS PER ASSY.	USABLE ON CODE	
				FROM	TO
		1 2 3 4 5 6			
2.3-12- 10	8-74308-3 FITTING ASSY, FUSELAGE WING ATTACH LH	1	35	60
	8-74308-805 FITTING ASSY, FUSELAGE WING ATTACH LH	1	61	
- 11	8-74309-4 FITTING ASSY, FUSELAGE WING ATTACH RH	1	35	50
	8-74309-809 FITTING ASSY, FUSELAGE WING ATTACH RH	1	61	89
	8-74309-807 FITTING ASSY, FUSELAGE WING ATTACH RH	1	90	
- 12	8-74309-11 FITTING, LH MAKE FROM 8-74306	1	35	60
	8-74308-21 FITTING, LH MAKE FROM 8-74308-3	1	61	
	8-74309-13 FITTING, RH MAKE FROM 8-74306	1	35	60
	8-74308-25 ADAPTER, RH MAKE FROM 8-74308	1	61	89
	8-74308-23 FITTING, RH MAKE FROM 8-74308-3	1	90	
	8-74306 BULLET	RF		
- 13	8-74356 BUSHING	4	35	
- 14	8-74752 SUPPORT INSTL, RAM AIR TURBINE LH FOR BREAKDOWN SEE FIG. 2.8-1	1	35	
	8-74305-1 FRAME INSTL, FUSELAGE STA 464 LH	1	35	
	8-74305-2 FRAME INSTL, FUSELAGE STA 464 RH	1	35	
	8-74305-133 FRAME ASSY, LH	1	35	
	8-74305-131 FRAME ASSY, RH	1	35	
	8-27554 FRAME ASSY, CONSTANT SPEED DRIVE OIL COOLER SUPPORT LH	1	35	
	8-27557-1 FRAME ASSY, CONSTANT SPEED DRIVE OIL COOLER SUPPORT RH	1	35	
- 15	8-27554-7 CHANNEL, LH	1	35	
	8-27557-7 CHANNEL, RH	1	35	
- 16	8-27554-9 CHANNEL, LH	1	35	
	8-27557-9 CHANNEL, RH	1	35	
- 17	8-27554-15 CHANNEL, LH	1	35	
	8-27557-15 CHANNEL, RH	1	35	
- 18	8-27554-10 CHANNEL, LH	1	35	
	8-27557-17 CHANNEL, RH	1	35	
	8-74310-403 BULKHEAD INSTL, FUSELAGE STA 472 LH	1	35	60
	8-77310-1 BULKHEAD INSTL, FUSELAGE STA 472 LH	1	61	
	8-74310-805 BULKHEAD INSTL, FUSELAGE STA 472 RH	1	35	60
	8-77310-3 BULKHEAD INSTL, FUSELAGE STA 472 RH	1	61	
	8-74310-193 BULKHEAD ASSY, LH	1	35	60
	8-77310-7 BULKHEAD ASSY, LH	1	61	
	8-74310-195 BULKHEAD ASSY, RH	1	35	60
	8-74310-199 BULKHEAD ASSY, RH	RF	35	60
		ALT JATCHG WITH 8-74310-195			
	8-77310-6 BULKHEAD ASSY, RH	1	61	
- 19	8-74310-21 ANGLE, ENGINE SEAL LH	1	35	50
	8-77310-49 ANGLE, ENGINE SEAL LH	1	61	
- 20	8-74310-22 ANGLE, ENGINE SEAL RH	1	35	50
	8-77310-50 ANGLE, ENGINE SEAL RH	1	61	
	8-74713-1 ADAPTER ASSY, LH	1	35	60
	8-74711-1 ADAPTER ASSY, LH	1	61	
	8-74713-5 ADAPTER ASSY, RH	1	35	60
	8-74711-3 ADAPTER ASSY, RH	1	61	
- 21	8-74356 BUSHING	4	35	

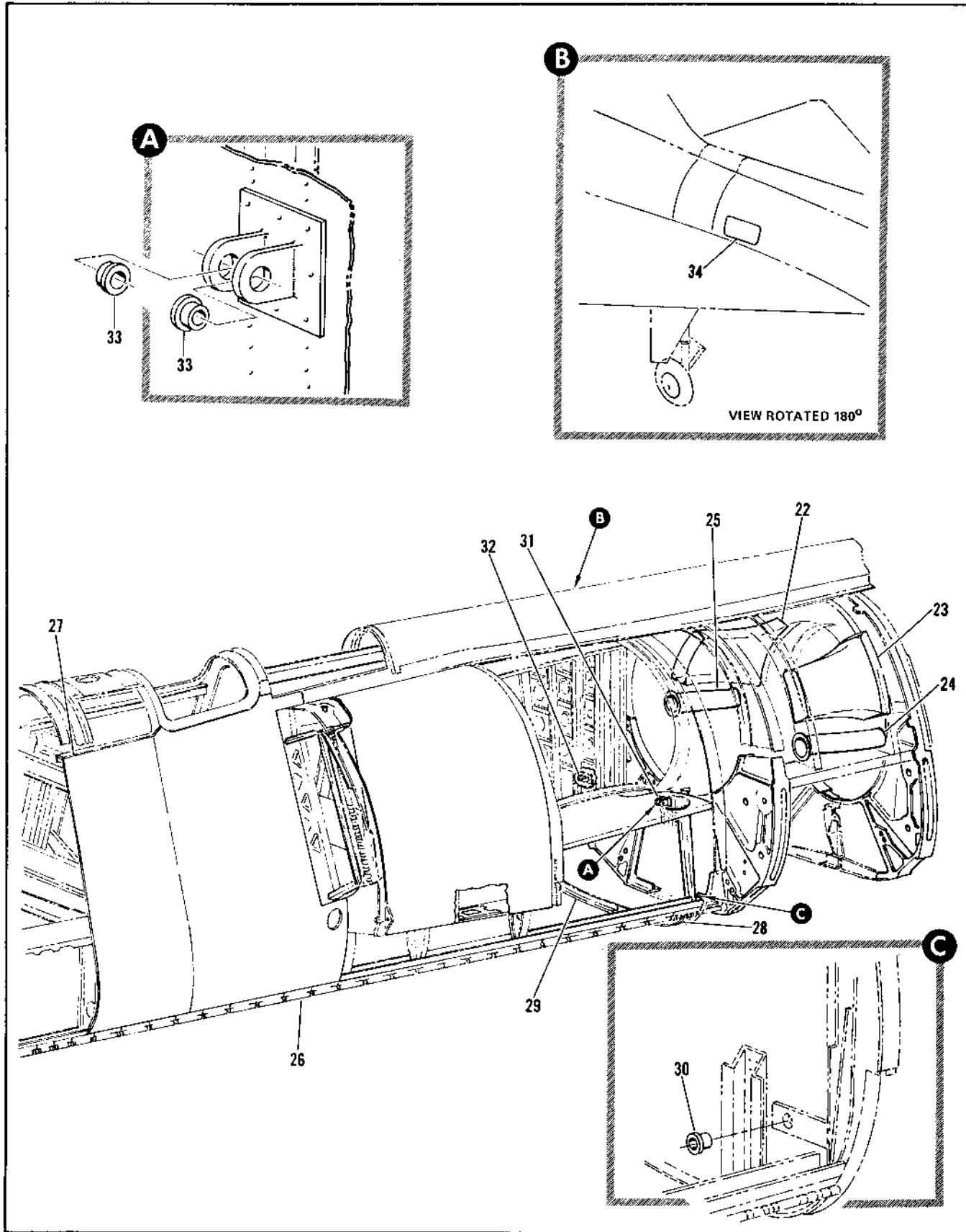

Figure 2.3-12. Side Panel Assembly Sta 253 to 472 (Sheet 3 of 3)

FIGURE AND INDEX NUMBER	PART NUMBER	DESCRIPTION	UNITS PER ASSY.	USABLE ON CODE	
				FROM	TO
2.3-12- 32	A-74473	• • DUCT ASSY, SEPARATOR DRIVE OIL COOLER SR RIVETED	1	35	
- 23	B-74472	• • DUCT ASSY, ENGINE OIL COOLER LH RIVETED	1	35	
- 24	B-74919	• • DUCT INSTL, SHROUD COOLING LH FOR BREAKDOWN SEE FIG. 2.10-1	1	35	
- 25	A-74475	• • DUCT INSTL, SHROUD COOLING RH FOR BREAKDOWN SEE FIG. 2.10-1	1	35	
- 26	A-74113-A	• LOWER DOOR INSTL, APPARENT BAY HINGE LOWER LH STA 283 TO 412 FOR BREAKDOWN SEE FIG. 2.20-14	1	35	
	A-74113-B	• LOWER DOOR INSTL, APPARENT BAY HINGE LOWER RH STA 283 TO 412 FOR BREAKDOWN SEE FIG. 2.20-14	1	35	
	A-74113-B03	• LOWER DOOR INSTL, FUELAGE TOP LH	1	35	
	A-74113-B04	• LOWER DOOR INSTL, FUELAGE TOP RH	1	35	
- 27	A-77355-7	• • PLATE, SIDE LAP LOWER DOOR UPPER STA 260	1	35	
	B-74477-7	• PANEL ASSY, SIDE STA 364 TO 412 LH	1	35	43
	A-74477-8	• PANEL ASSY, SIDE STA 364 TO 412 LH	1	44	
	B-74477-9	• PANEL ASSY, SIDE STA 364 TO 412 RH	1	35	43
	A-74477-10	• PANEL ASSY, SIDE STA 364 TO 412 RH	1	44	
	A-24417-1	• • FITTING INSTL, REFUEL AND AIR PRESSURE LINES DRAIN STA 380 LH FOR BREAKDOWN SEE FIG. 2.12-36	1	35	
	A-24418-1	• • FITTING INSTL, REFUEL AND AIR PRESSURE LINES DRAIN STA 380 RH FOR BREAKDOWN SEE FIG. 2.12-36	1	35	
	A-74747-1	• • BULKHEAD INSTL, STA 412 LH	1	35	
	A-74747-2	• • BULKHEAD INSTL, STA 412 RH	1	35	
	A-74747-1-17	• • • BULKHEAD ASSY, LH	1	35	
	A-74747-1-18	• • • BULKHEAD ASSY, LH	1	35	
	A-74747-1-17	• • • BULKHEAD ASSY, LH	1	35	
	A-74747-1-18	• • • BULKHEAD ASSY, RH	1	35	120
	A-74747-1-17	• • • BULKHEAD ASSY, RH	1	35	
- 28	B-74747-1-17	• • • • RETAINER, LH	1	35	
- 29	A-74747-1-18	• • • • RETAINER, RH	1	35	
- 30	A-77747-1-18	• • • • FUSING, MISSILE BAY DOOR MECHANISM SUPPORT	1	35	
- 31	A-77747-1	• • • • SUPPORT ASSY, AFT EXTENSION ACTUATOR STA 412 LH	1	35	
- 32	A-77747-1	• • • • SUPPORT ASSY, AFT EXTENSION ACTUATOR STA 412 RH	1	35	
	A-77747-1-1	• • • • • SUPPORT, LH	1	35	
	A-77747-1-2	• • • • • SUPPORT, RH	1	35	
- 33	A-77747-1-1	• • • • • BUSHING (R 2.5)	2	35	
- 34	A-77747-1	• DOOR INSTL, STA 384 TO 405 RH	1	35	
	A-77747-1	• DOOR ASSY, STA 384 TO 405 RH FOR BREAKDOWN SEE FIG. 2.2-7	1	35	43
	A-77747-1	• DOOR ASSY, STA 384 TO 405 RH FOR BREAKDOWN SEE FIG. 2.2-7	1	43	

A AIRPLANES #35 THRU 47 AND 49 THRU 89
 B AIRPLANES #48 AND 90 THRU 109

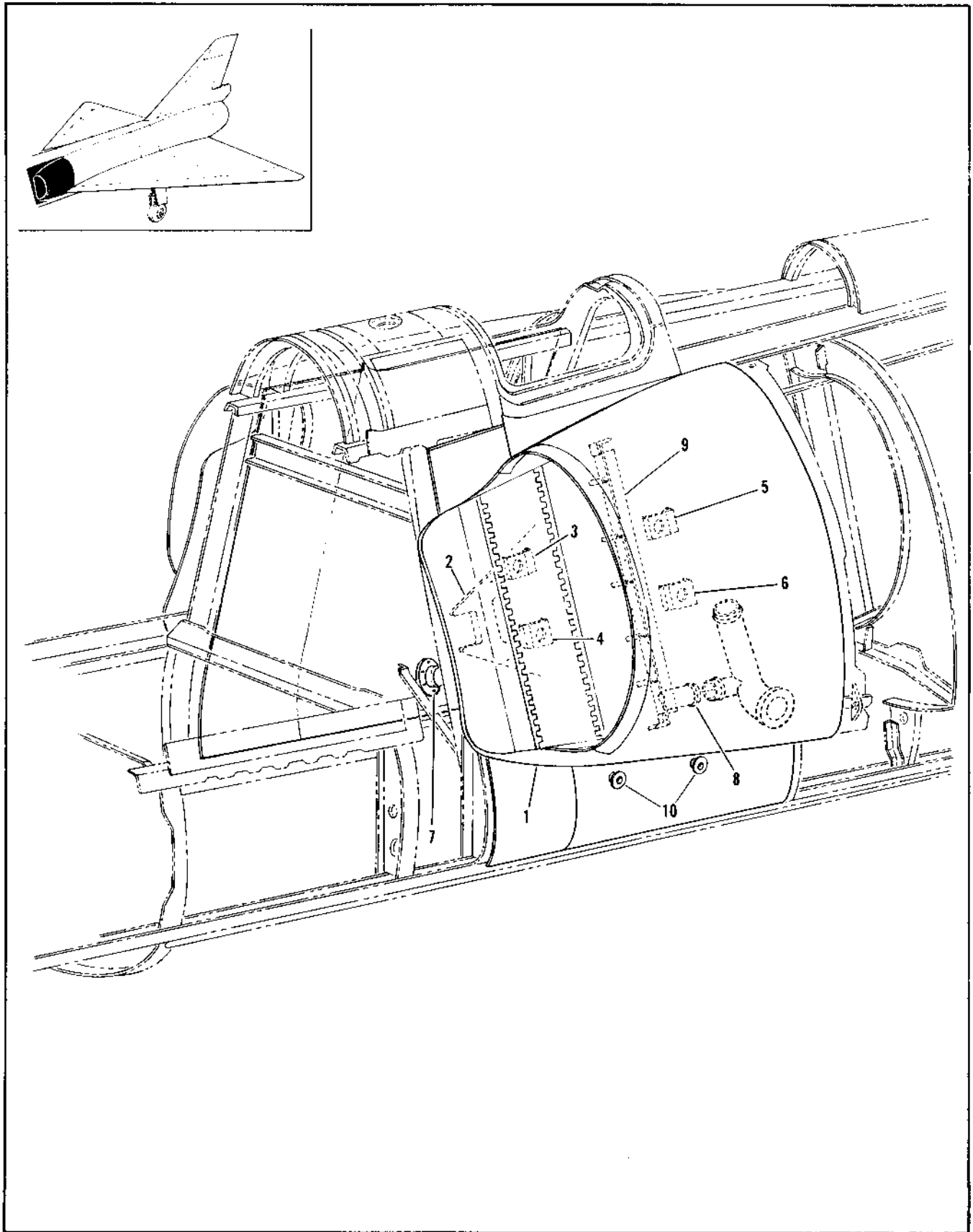

Figure 2.3-13. Panel Installation Sta 253 to 316

FIGURE AND INDEX NUMBER	PART NUMBER	DESCRIPTION	UNITS PER ASSY.	USABLE ON CODE		
				FROM	TO	
2.3-13	8-74475-205	PANEL INSTALLATION, STA 253 TO 316 LH FOR NHA SEE FIG. 2.3-12	RF	35	62	
	8-74475-213	PANEL INSTALLATION, STA 253 TO 316 LH FOR NHA SEE FIG. 2.3-12	RF	63		
	8-74475-406	PANEL INSTALLATION, STA 253 TO 316 RH FOR NHA SEE FIG. 2.3-12	RF	35	62	
	8-74475-614	PANEL INSTALLATION, STA 253 TO 316 RH FOR NHA SEE FIG. 2.3-12	RF	63		
	- 1	8-77546-1	• DUCT INSTL, ENGINE AIR INTAKE AFT LH FOR BREAKDOWN SEE FIG. 2.11-4	1	35	
		8-77546-2	• DUCT INSTL, ENGINE AIR INTAKE AFT RH FOR BREAKDOWN SEE FIG. 2.11-4	1	35	
	- 2	8-74572-1	• DUCT INSTL, BOUNDARY BLEED FWD LH FOR BREAKDOWN SEE FIG. 2.13-1	1	35	
		8-74572-2	• DUCT INSTL, BOUNDARY BLEED FWD RH FOR BREAKDOWN SEE FIG. 2.13-1	1	35	
	- 3	8-74997-1	• SUPPORT ASSY, VARIABLE AIR RAMP SCREW JACK UPPER FWD LH FOR BREAKDOWN SEE FIG. 2.11-10	1	35	
		8-74997-2	• SUPPORT ASSY, VARIABLE AIR RAMP SCREW JACK UPPER FWD RH FOR BREAKDOWN SEE FIG. 2.11-10	1	35	
- 4	8-74997-203	• SUPPORT ASSY, VARIABLE AIR RAMP SCREW JACK LOWER FWD LH FOR BREAKDOWN SEE FIG. 2.11-10	1	35	62	
	8-74997-205	• SUPPORT ASSY, VARIABLE AIR RAMP SCREW JACK LOWER FWD LH FOR BREAKDOWN SEE FIG. 2.11-10	1	63		
	8-74997-204	• SUPPORT ASSY, VARIABLE AIR RAMP SCREW JACK LOWER FWD RH FOR BREAKDOWN SEE FIG. 2.11-10	1	35	62	
	8-74997-206	• SUPPORT ASSY, VARIABLE AIR RAMP SCREW JACK LOWER FWD RH FOR BREAKDOWN SEE FIG. 2.11-10	1	63		
- 5	8-74997-5	• SUPPORT ASSY, VARIABLE AIR RAMP SCREW JACK UPPER AFT LH FOR BREAKDOWN SEE FIG. 2.11-10	1	35		
	8-74997-6	• SUPPORT ASSY, VARIABLE AIR RAMP SCREW JACK UPPER AFT RH FOR BREAKDOWN SEE FIG. 2.11-10	1	35		
- 6	8-74997-201	• SUPPORT ASSY, VARIABLE AIR RAMP SCREW JACK LOWER AFT LH FOR BREAKDOWN SEE FIG. 2.11-10	1	35		
	8-74997-202	• SUPPORT ASSY, VARIABLE AIR RAMP SCREW JACK LOWER AFT RH FOR BREAKDOWN SEE FIG. 2.11-10	1	35		
- 7	8-92783	• JACK INSTL, GROUND FUEL LOADING NOZZLE FOR BREAKDOWN SEE FIG. 2.12-37	1	35		
- 8	8-23990-1	• DUCT INSTL, GROUND AIR-CONDITIONING	1	35		
- 9	8-78732-203	• STRUCTURE INSTL, VARIABLE AIR RAMP SEAL LH	1	35	62	
	8-78732-201	• STRUCTURE INSTL, VARIABLE AIR RAMP SEAL LH	1	63		
	8-78732-204	• STRUCTURE INSTL, VARIABLE AIR RAMP SEAL RH	1	35	62	
	8-78732-202	• STRUCTURE INSTL, VARIABLE AIR RAMP SEAL RH	1	63		
	8-77264-1	• BOOT ASSY, SCREW JACK CURTAIN SEAL STITCHED	1	35		
	8-77264-3	• BOOT ASSY, SCREW JACK CURTAIN SEAL STITCHED	1	35		
- 10	8-81254	• FITTING, VARIABLE RAMP SYSTEM DRAIN	2	35		

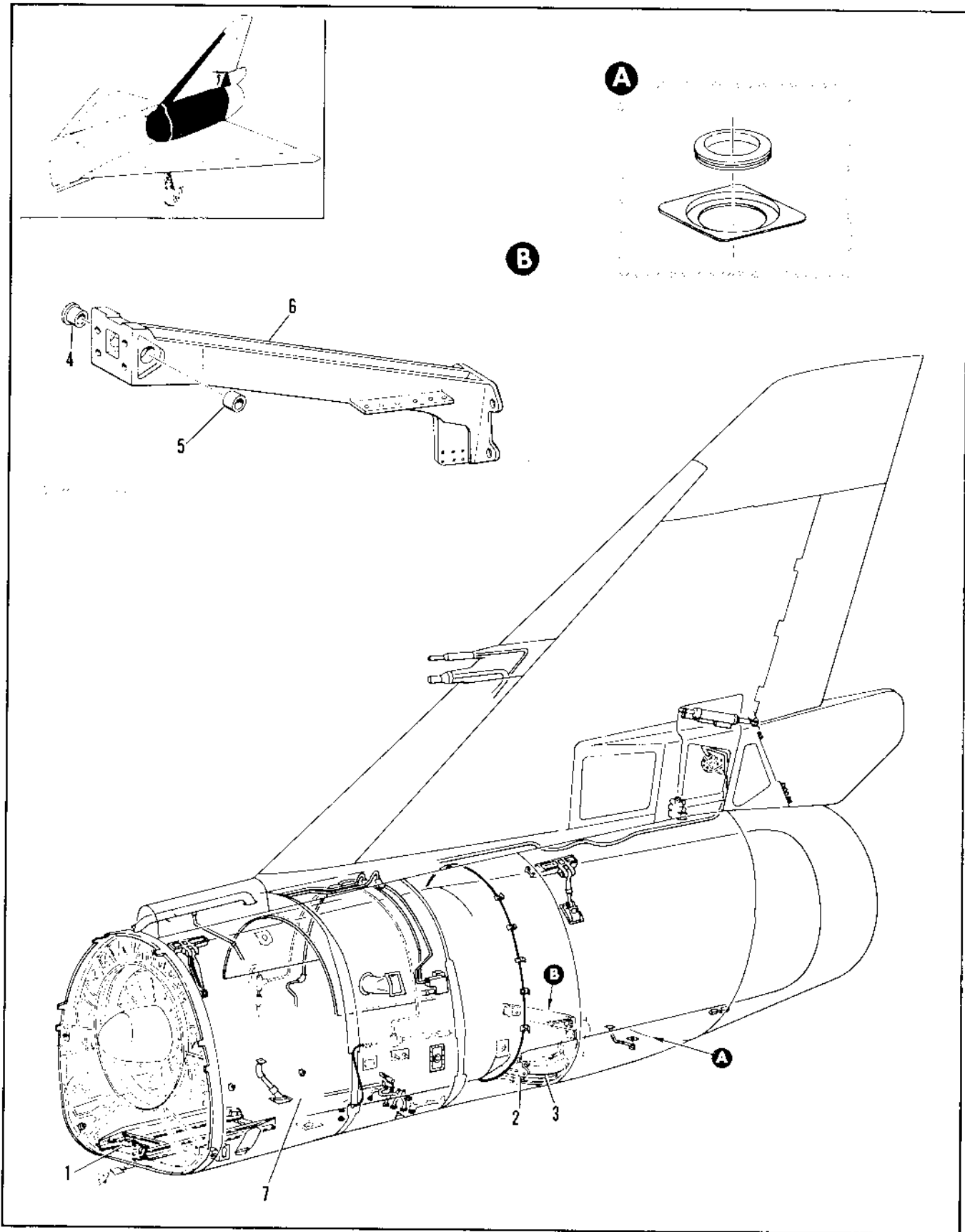

Figure 2.3-14. Fuselage Assembly Sta 472 to Tail Cone (Sheet 1 of 5)

FIGURE AND INDEX NUMBER	PART NUMBER	DESCRIPTION	UNITS PER ASSY.	USABLE ON CODE	
				FROM	TO
2.3-14	A-74470-810	FUSELAGE ASSEMBLY, STA 472 TO TAIL CONE FOR NHA SEE FIG. 2.3-5	RF	278	287
	A-74470-811	FUSELAGE ASSEMBLY, STA 472 TO TAIL CONE FOR NHA SEE FIG. 2.3-5	RF	288	293
	B-74470-810	FUSELAGE ASSEMBLY, STA 472 TO TAIL CONE FOR NHA SEE FIG. 2.3-5	RF	A	
	B-77470	FUSELAGE ASSEMBLY, STA 472 TO TAIL CONE FOR NHA SEE FIG. 2.3-5	RF	48	277
- 1	R-28413	• VALVE INSTL, ACCESSORY DRIVE UNIT VENT FOR BREAKDOWN SEE FIG. 2.10-29	RF	35	
	R-28413	• VALVE INSTL, ACCESSORY DRIVE UNIT VENT FOR BREAKDOWN SEE FIG. 2.10-29	RF	35	
	7230288-1	• PATCH INSTL, VENT CUTOFF ACCESSORY DRIVE MERIDIAN FOR BREAKDOWN SEE FIG. 2.10-29 (98750)	1	35	
	A-74470-75	• BARREL ASSEMBLY	1	A	
	A-77470-7	• BARREL ASSEMBLY	1	48	277
	A-74470-82	• BARREL ASSEMBLY	1	278	293
	A-74347	• • BULKHEAD INSTL, STA 593	1	0	
- 2	A-74374-40	• • • BULKHEAD ASSEMBLY	1	0	
	A-74374-11	• • • ADAPTER, FUSELAGE BULKHEAD LOWER STA 593	1	0	
- 3	A-74374-12	• • • ADAPTER, FUSELAGE BULKHEAD LOWER STA 593	1	0	
	A-74117-1	• • SUPPORT INSTL, ELEVON CYLINDER LH	1	0	
	B-74117-2	• • SUPPORT INSTL, ELEVON CYLINDER LH	1	42	277
	A-74117-3	• • SUPPORT INSTL, ELEVON CYLINDER RH	1	0	
	A-74117-4	• • SUPPORT INSTL, ELEVON CYLINDER RH	1	42	277
	A-74720-8	• • • STRUT ASSY, ELEVON CYLINDER SUPPORT LH	1	E	
	A-74720-9	• • • STRUT ASSY, ELEVON CYLINDER SUPPORT RH	1	E	
	A-74720-1	• • • STRUT ASSY, ELEVON CYLINDER SUPPORT	1	42	277
- 4	A-74720-1	• • • STRUT ASSY, ELEVON CYLINDER SUPPORT LH	1	278	285
	A-74720-1	• • • STRUT ASSY, ELEVON CYLINDER SUPPORT RH	1	278	285
	A-74720-7	• • • BUSHING, FLANGED ELEVON CYLINDER SUPPORT STRUT	1	278	285
- 5	A-81238	• • • STRUT, LH	1	35	
	A-74720-22	• • • STRUT, RH	1	E	
- 6	A-74720-24	• • • STRUT	1	E	
	A-74720-7	• • • STRUT	1	42	277
	A-74720-11	• • • STRUT	1	278	294
	A-74720-11	• • • STRUT	1	278	294
- 7	A-28238-873	• • DUCT INSTL, ENGINE OIL BREATHER FOR BREAKDOWN SEE FIG. 2.10-1	1	35	
	A-74470-11	• • PANEL ASSY, STA 472 TO 520 LH	1	A	
	A-77470-11	• • PANEL ASSY, STA 472 TO 520 LH	1	48	60
	A-77470-63	• • PANEL ASSY, STA 472 TO 520 LH	1	61	277
	A-74470-90	• • PANEL ASSY, STA 472 TO 520 LH	1	278	293
	A-74470-10	• • PANEL ASSY, STA 472 TO 520 RH	1	A	
	A-77470-12	• • PANEL ASSY, STA 472 TO 520 RH	1	48	5
	A-77470-24	• • PANEL ASSY, STA 472 TO 520 RH	1	61	277
	A-74470-81	• • PANEL ASSY, STA 472 TO 520 RH	1	278	293
	A-77411-1	• • • STRUCTURE INSTL, AFT END BAY STA 472 LH	1	278	300

A AIRPLANES #35 THRU 47, 294 AND ON
 Q AIRPLANES #35 THRU 41, 278 AND ON
 E AIRPLANES #35 THRU 41, 287 AND ON

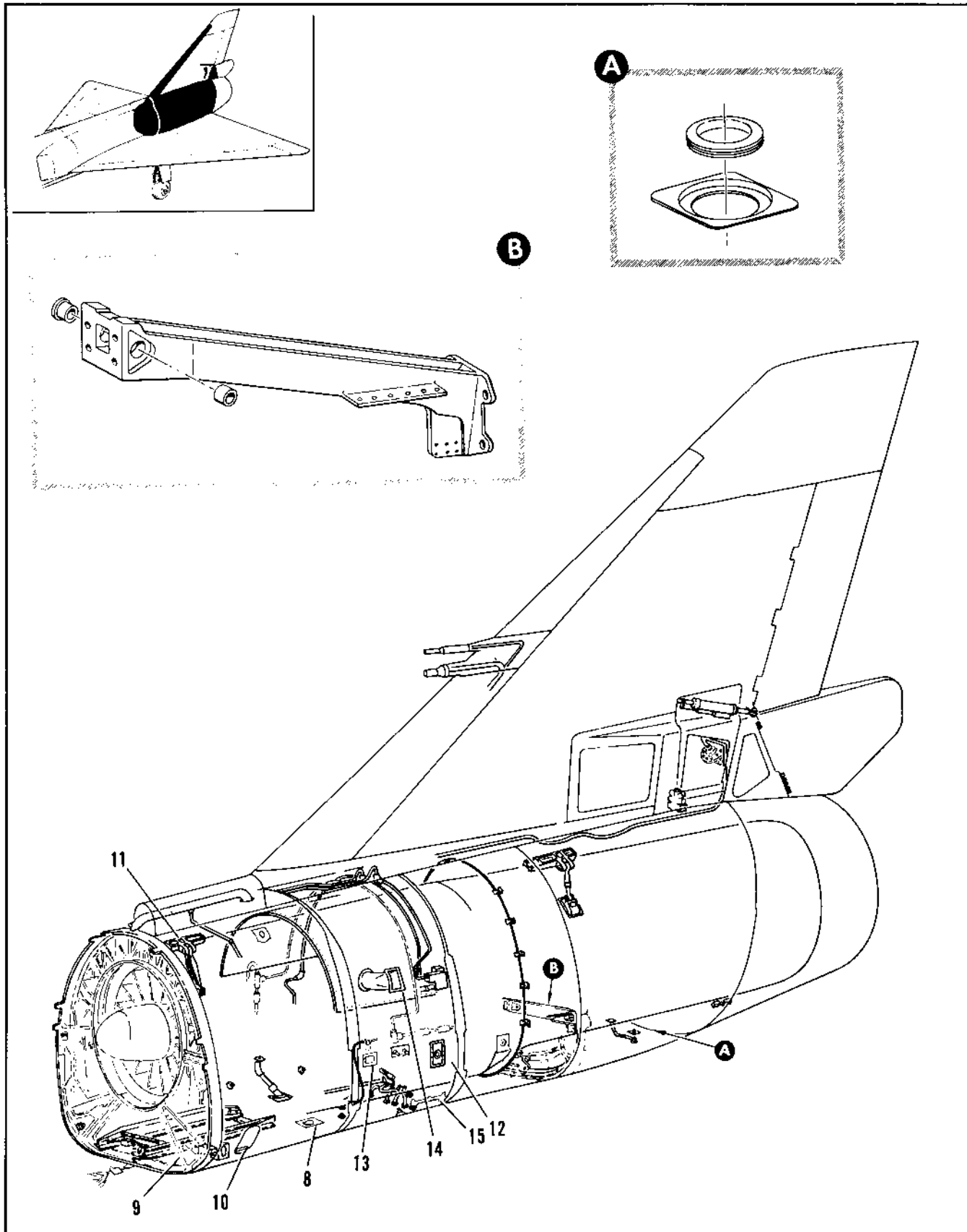

Figure 2.3-14. Fuselage Assembly Sta 472 to Tail Cone (Sheet 2 of 5)

FIGURE AND INDEX NUMBER	PART NUMBER	DESCRIPTION	UNITS PER ASSY.	USABLE ON CODE	
				FROM	TO
		1 2 3 4 5 6			
2,3-14- 8	8-77628 DOOR INSTL, PNEUMATIC STARTER FOR BREAKDOWN SEE FIG. 2.2-9	1	278	295
- 9	8-74412-1	. . . STRUCTURE INSTL, ACCESSORY DRIVE UNIT DOOR FOR BREAKDOWN SEE FIG. 2.2-9	1	A	
	8-74412-8C1	. . . STRUCTURE INSTL, ACCESSORY DRIVE UNIT DOOR FOR BREAKDOWN SEE FIG. 2.2-9	1	48	277
- 10	8-74622-1	. . . HINGE INSTL, FIRE ACCESS DOOR FOR BREAKDOWN SEE FIG. 2.2-9	1	35	
- 11	8-74115-5	. . . BEAM INSTL, ENGINE MOUNT FWD FOR BREAKDOWN SEE FIG. 2.10-1	1	35	277
	8-74115	. . . BEAM INSTL, ENGINE MOUNT FWD FOR BREAKDOWN SEE FIG. 2.10-1	1	278	
	8-74470-13	. . . PANEL ASSY, STA 520 TO 557 LH	1	C	
	8-77470-13	. . . PANEL ASSY, STA 520 TO 557 LH	1	48	277
	8-74470-14	. . . PANEL ASSY, STA 520 TO 557 RH	1	C	
	8-77470-14	. . . PANEL ASSY, STA 520 TO 557 RH	1	48	277
- 12	8-77601-7C1	. . . DOOR INSTL, FUEL SHUTOFF VALVE ACCESS LH FOR BREAKDOWN SEE FIG. 2.2-16	1	35	129
	8-77601-3	. . . DOOR INSTL, FUEL SHUTOFF VALVE ACCESS LH FOR BREAKDOWN SEE FIG. 2.2-16	1	130	
	8-77601-7C2	. . . DOOR INSTL, FUEL SHUTOFF VALVE ACCESS RH FOR BREAKDOWN SEE FIG. 2.2-16	1	35	129
	8-77601-4	. . . DOOR INSTL, FUEL SHUTOFF VALVE ACCESS RH FOR BREAKDOWN SEE FIG. 2.2-16	1	130	
- 13	8-77674-1	. . . DOOR INSTL, HYDRAULIC FLUID TUBE HEAT EXCHANGER LH FOR BREAKDOWN SEE FIG. 2.2-9	1	F	
	8-77674-2	. . . DOOR INSTL, HYDRAULIC FLUID TUBE HEAT EXCHANGER RH FOR BREAKDOWN SEE FIG. 2.2-9	1	F	
	8-77674-21	. . . DOOR ASSY, HYDRAULIC TUBE HEAT EXCHANGER FOR BREAKDOWN SEE FIG. 2.2-9	2	130	277
- 14	8-74413-1	. . . STRUCTURE INSTL, ENGINE COMPRESSOR DISCHARGE PORT LH FOR BREAKDOWN SEE FIG. 2.10-1	1	C	
	8-74413-8C1	. . . STRUCTURE INSTL, ENGINE COMPRESSOR DISCHARGE PORT LH FOR BREAKDOWN SEE FIG. 2.10-1	1	48	277
	8-74413-2	. . . STRUCTURE INSTL, ENGINE COMPRESSOR DISCHARGE PORT RH FOR BREAKDOWN SEE FIG. 2.10-1	1	C	
	8-74413-8C2	. . . STRUCTURE INSTL, ENGINE COMPRESSOR DISCHARGE PORT RH FOR BREAKDOWN SEE FIG. 2.10-1	1	48	277
	8-74619-808	. . . STRUCTURE INSTL, ENGINE ACCESS DOOR RH	1	35	
	8-74619-806	. . . STRUCTURE INSTL, ENGINE ACCESS DOOR RH ALT INTCHG WITH 8-74619-808	RF	35	
- 15	8-74647-7 DOUBLER, ENGINE ACCESS DOOR LH	1	35	
	8-74647-8 DOUBLER, ENGINE ACCESS DOOR RH REPLACED BY NOT INTCHG WITH 8-74647-9	1	C	
		A AIRPLANES #35 THRU 47, 294 AND ON			
		C AIRPLANES #35 THRU 47, 278 AND ON			
		F AIRPLANES #35 THRU 129, 278 AND ON			

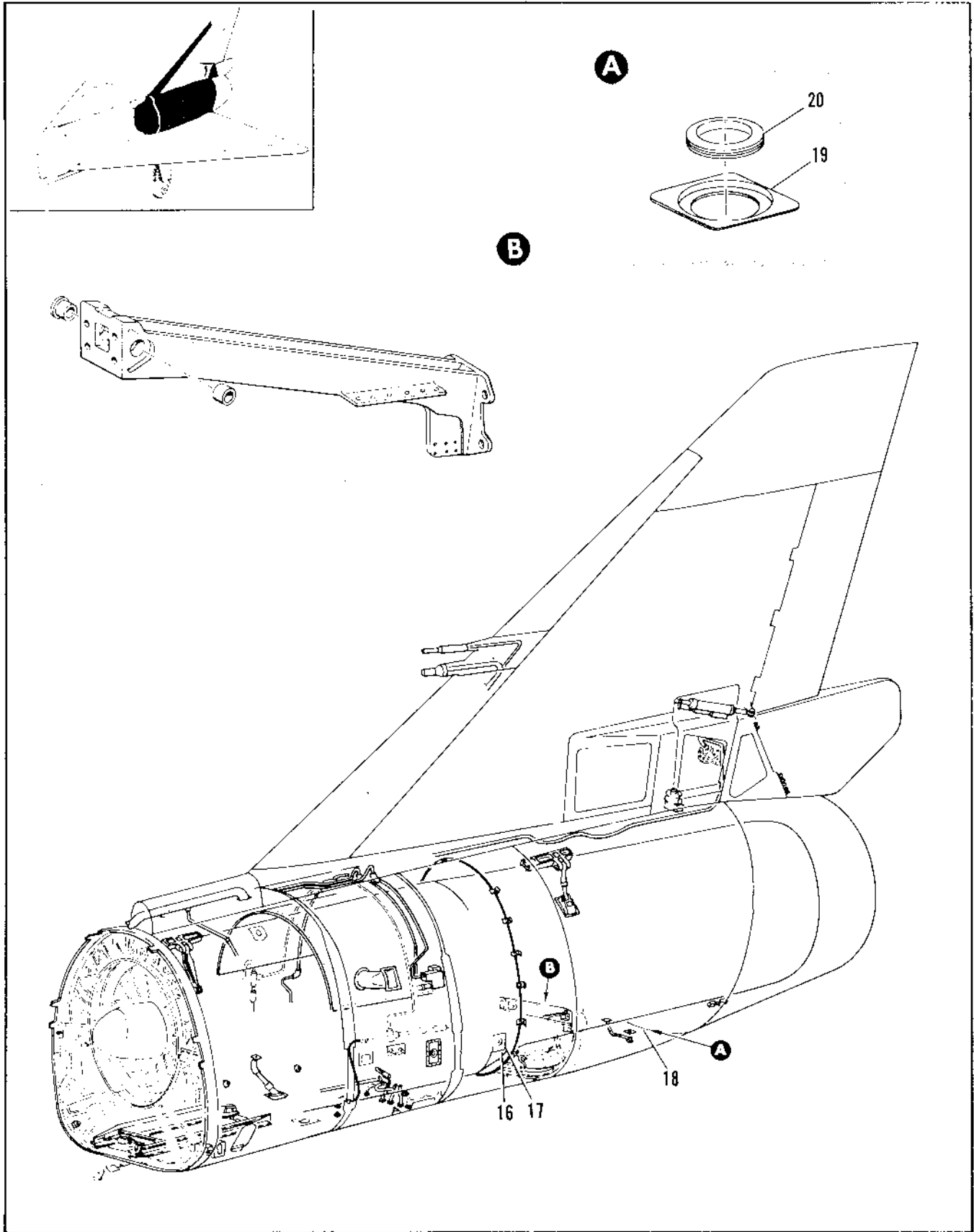

Figure 2.3-14. Fuselage Assembly Sta 472 to Tail Cone (Sheet 3 of 5)

FIGURE AND INDEX NUMBER	PART NUMBER	DESCRIPTION	UNITS PER ASSY.	USABLE ON CODE	
				FROM	TO
		1 2 3 4 5 6			
2.3-14	8-74647-9	. . . DOUBLER, ENGINE ACCESS DOOR RH REPLACES NGT INTCHG WITH 8-74647-8	1	48	277
	8-74113-3	. . LONGERON INSTL, SIDE FWD	1	35	
	8-74113-51	. . DOOR ASSY, STA 574 ATTACHING PARTS	2	35	
	NAS221-9	. . . SCREW (#6205) ----X----	44	35	
- 16	8-74113-43	. . . DOOR	1	35	
- 17	CR697-3	. . . SEAL, FLEXIBLE WING TO FUSELAGE TUBE <82A30> SPEC 8-82430-3	1	35	
	8-74470-11P	. PANEL ASSY, STA 593 TO TAIL CONE	1	C	
	8-77470-10	. PANEL ASSY, STA 593 TO TAIL CONE	1	48	277
	P-85037	. . FITTING INSTL, SPEED BRAKE VALVE VENT MFA FOR AIRPLANES #48 AND ON IS 8-77470	1	35	
- 18	8-27588-5	. . . FITTING ASSY, ENG FUEL DRAIN	1	35	
- 19	8-27588-16	. . . CAP	1	35	
- 20	8-27589-11	. . . GROMMET	1	35	
		C AIRPLANES #35 THRU 47, 278 AND ON			

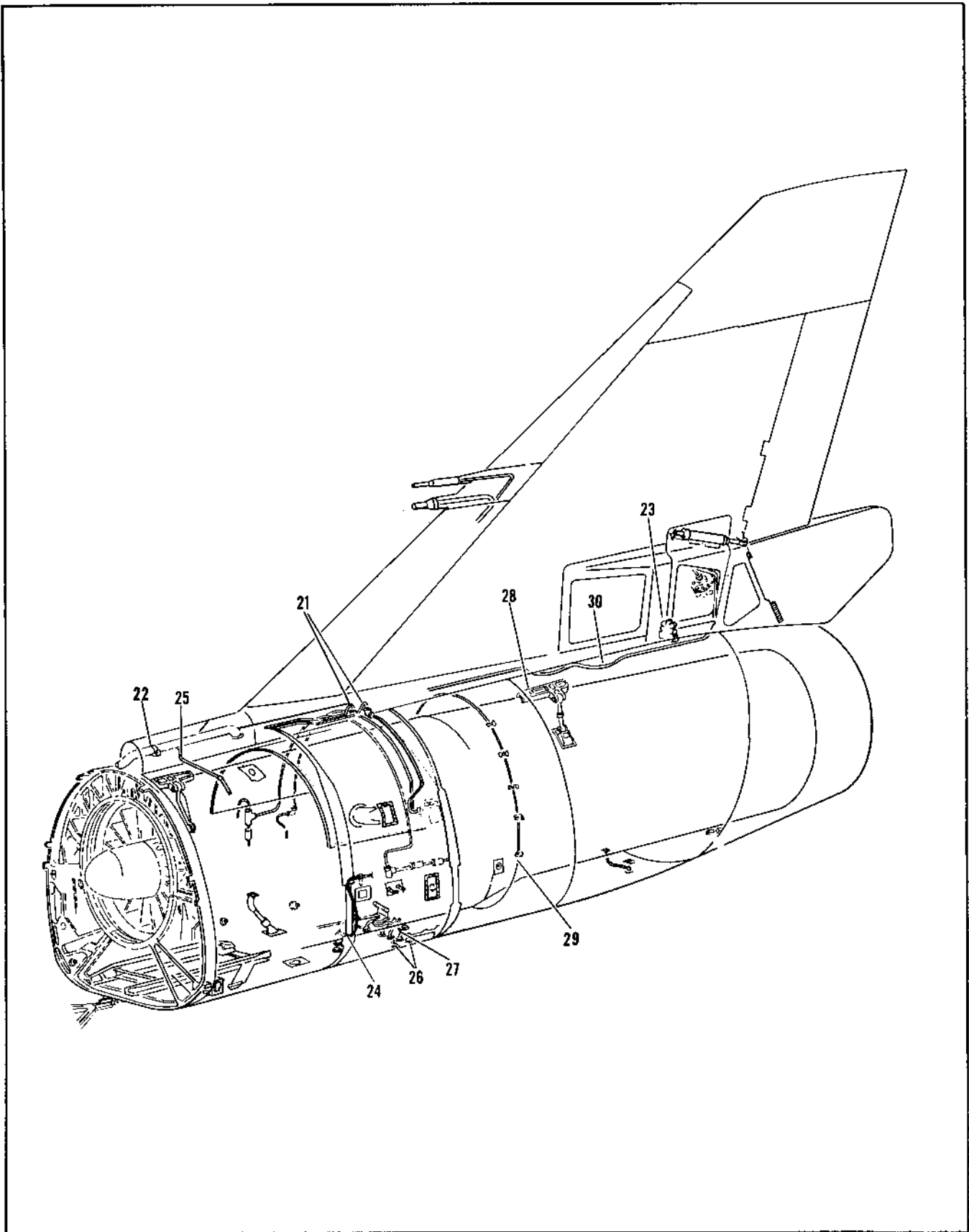

Figure 2.3-14. Fuselage Assembly Sta 472 to Tail Cone (Sheet 4 of 5)

FIGURE AND INDEX NUMBER	PART NUMBER	DESCRIPTION	UNITS PER ASSY.	USABLE ON CODE	
				FROM	TO
2.3-14- 21	8-21397-455	• TUBING INSTL, FUEL TANK PRESSURE STA 472 TO 477 FOR BREAKDOWN SEE FIG. 2.12-30 AND 2.12-48	1	35	
- 22	8-28291-1	• SUPPORT INSTL, FUEL TANK PRESSURE MANIFOLD STA 472 TO 485 FOR BREAKDOWN SEE FIG. 2.12-55	1	35	
- 23	8-82138 15050-3	• VALVE INSTL, SPEED BRAKE CONTROL HYDRAULIC • VALVE ASSY, SELECTOR SPEED BRAKE CONTROL <79294> SPEC 8-10334-3 T.O. 9H8-14-189-14 REPLACES SUITABLE SUB FOR 15050-1 ATTACHING PARTS	1 1	35 35	
- 24	AN406A AN96CPD416L	• BOLT (88044) • WASHER (88044)	1 1	35 35	
- 24	8-80030-5	• TUBING INSTL, POWER SOURCE HYDRAULIC FOR BREAKDOWN SEE FIG. 2.8-17 AND 2.8-18	1	35	
- 25	8-38097-8	• TUBING INSTL, PRESSURE RATIO INDICATOR STA 472 TO 480 FOR BREAKDOWN SEE FIG. 2.10-26	1	35	
- 26	8-27768-3	• FITTING INSTL, FUEL AND OIL VENT AND DRAIN FOR BREAKDOWN SEE FIG. 2.10-16	1	35	
- 27	8-20393	• TUBING INSTL, POWER PLANT TO FUSELAGE VENT AND DRAIN FOR BREAKDOWN SEE FIG. 2.10-18	1	35	
- 28	8-74128-1	• BEAM INSTL, ENGINE MOUNT AFT LH FOR BREAKDOWN SEE FIG. 2.10-40	1	35	
- 28	8-74128-2	• BEAM INSTL, ENGINE MOUNT AFT RH FOR BREAKDOWN SEE FIG. 2.10-40	1	35	
- 29	8-27941-801	• DETECTOR INSTL, FIRE STA 498 TO 569 FOR BREAKDOWN SEE FIG. 2.10-34	1	J	
- 29	8-27941-803	• DETECTOR INSTL, OVERHEAT STA 617 AND AFT FOR BREAKDOWN SEE FIG. 2.10-34	1	J	
- 30	8-28963	• DETECTOR INSTL, FIRE AND OVERHEAT FOR BREAKDOWN SEE FIG. 2.10-39	1	49	277
- 31	8-42103-1	• TUBING INSTL, VERTICAL STABILIZER ELEVATOR AND RUDDER AIRFEEL FOR BREAKDOWN SEE FIG. 2.14-35	1	35	
- 31	8-42103-5	• TUBING INSTL, ELEVATOR AND RUDDER AIRFEEL STA 472 TO VERTICAL STABILIZER FOR BREAKDOWN SEE FIG. 2.14-35	1	K	
- 31	8-42103-801	• TUBING INSTL, RUDDER AND ELEVATOR AIRFEEL FOR BREAKDOWN SEE FIG. 2.14-37	1	44	97
- 31	8-42103-803	• TUBING INSTL, RUDDER AND ELEVATOR AIRFEEL FOR BREAKDOWN SEE FIG. 2.14-37	1	48	277
- 31	8-37421-5	• TUBING INSTL, DORSAL AND VERTICAL STABILIZER AND ENGINE STARTER HIGH PRESSURE PNEUMATIC FOR BREAKDOWN SEE FIG. 2.9-13 AND 2.9-25	1	35	
		J AIRPLANES #35 THRU 48, 278 AND ON			
		K AIRPLANES #35 THRU 43, 278 AND ON			

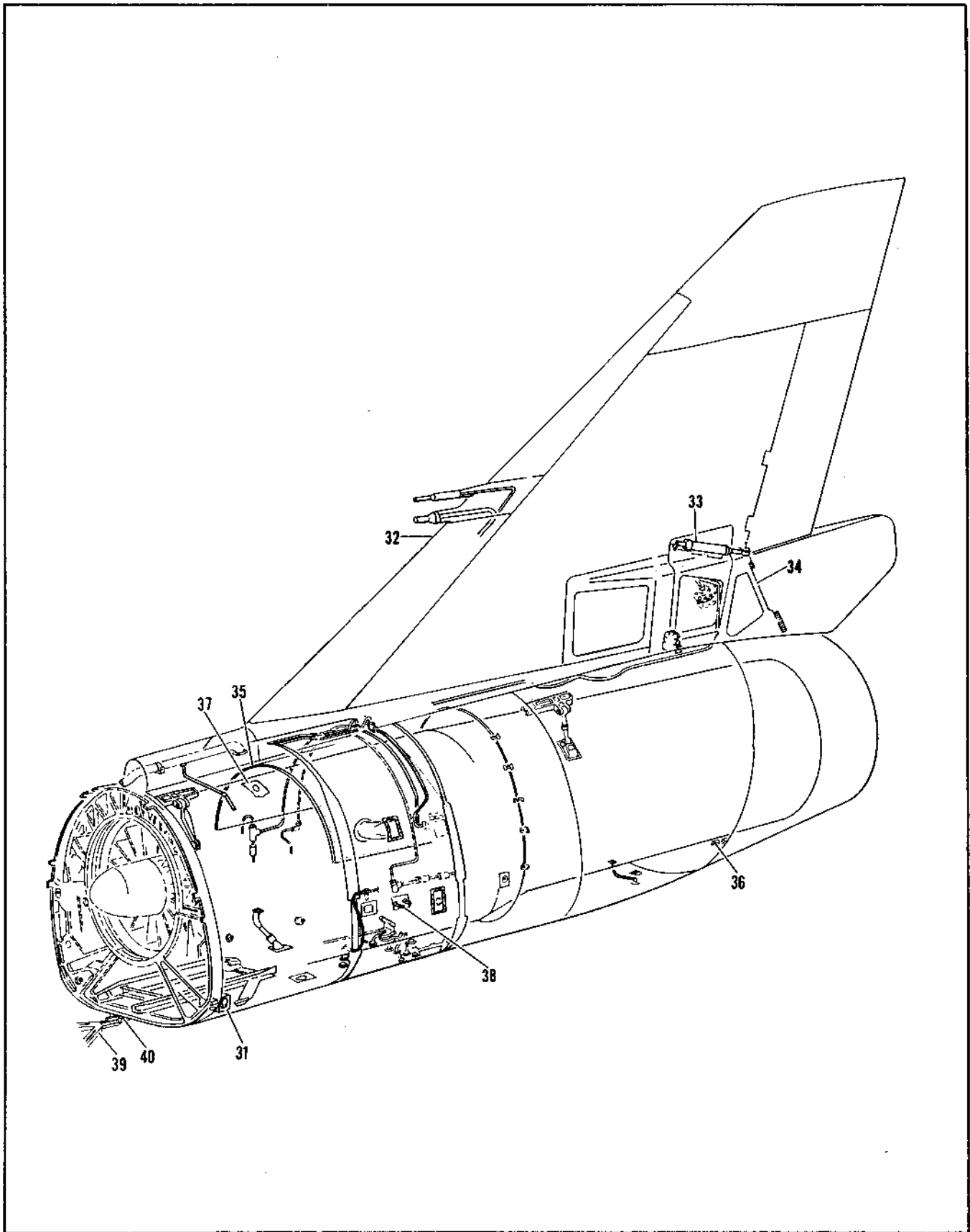

Figure 2.3-14. Fuselage Assembly Sta 472 to Tail Cone (Sheet 5 of 5)

FIGURE AND INDEX NUMBER	PART NUMBER	DESCRIPTION	UNITS PER ASSY.	USABLE ON CODE	
				FROM	TO
		1 2 3 4 5 6			
2.3-14- 31	8-42330-1	• REGULATOR INSTL, ELEVATOR AIRFEEL STA 481 TO 488 FOR BREAKDOWN SEE FIG. 2.14-21	1	35	
- 32	8-14230-5	• LEADING EDGE INSTL, FIN FOR BREAKDOWN SEE FIG. 2.7-4	1	35	
- 33	8-14025-3	• EQUIPMENT INSTL, VERTICAL STABILIZER FOR BREAKDOWN SEE FIG. 2.7-6	1	35	
- 34	8-74860	• SUPPORT INSTL, SPEED BRAKE DOOR FOR BREAKDOWN SEE FIG. 2.7-10	1	35	
- 35	8-74035-3	• EQUIPMENT ASSY, PANEL STA 472 TO 673 FOR BREAKDOWN SEE FIG. 2.3-15	1	H	
	8-74035	• EQUIPMENT ASSY, PANEL STA 472 TO 673 FOR BREAKDOWN SEE FIG. 2.3-15	1	278	287
	8-74035-1	• EQUIPMENT ASSY, PANEL STA 472 TO 673 FOR BREAKDOWN SEE FIG. 2.3-15	1	288	293
- 36	8-74745-805	• LATCH INSTL, TAIL CONE FOR BREAKDOWN SEE FIG. 2.3-16	1	6	
	8-74745-1	• LATCH INSTL, TAIL CONE FOR BREAKDOWN SEE FIG. 2.3-16	1	278	304
	8-78734	• FITTING INSTL, TAIL HOOK FOR BREAKDOWN SEE FIG. 2.15-37	1	130	277
	8-74608-1	• STRUCTURE INSTL, OIL FILLER CAP ACCESS	1	35	
- 37	8-74606-31	• PAN, LH	1	35	
- 38	8-81543-3	• FITTING INSTL, HYD HEAT EXCHANGER WING LH STA 533 FOR BREAKDOWN SEE FIG. 2.8-1	1	35	
	8-81343-4	• FITTING INSTL, HYD HEAT EXCHANGER WING RH STA 533 FOR BREAKDOWN SEE FIG. 2.8-1	1	35	
- 39	8-77191-3	• HINGE INSTL, LONGERON LOWER FUSELAGE LH STA 412 TO 472 FOR BREAKDOWN SEE FIG. 2.15-31	1	61	
	8-77191-4	• HINGE INSTL, LONGERON LOWER FUSELAGE RH STA 412 TO 472 FOR BREAKDOWN SEE FIG. 2.15-31	1	61	
- 40	8-74124-3	• LONGERON INSTL, FUSELAGE STA 472 TO 655 FOR BREAKDOWN SEE FIG. 2.3-3	1	48	65
	8-77124	• LONGERON INSTL, LWR FUSELAGE STA 444 TO 655 FOR BREAKDOWN SEE FIG. 2.3-3	1	61	277
		G AIRPLANES #35 THRU 277 AND 305			
		H AIRPLANES #35 THRU 277, 294 AND ON			

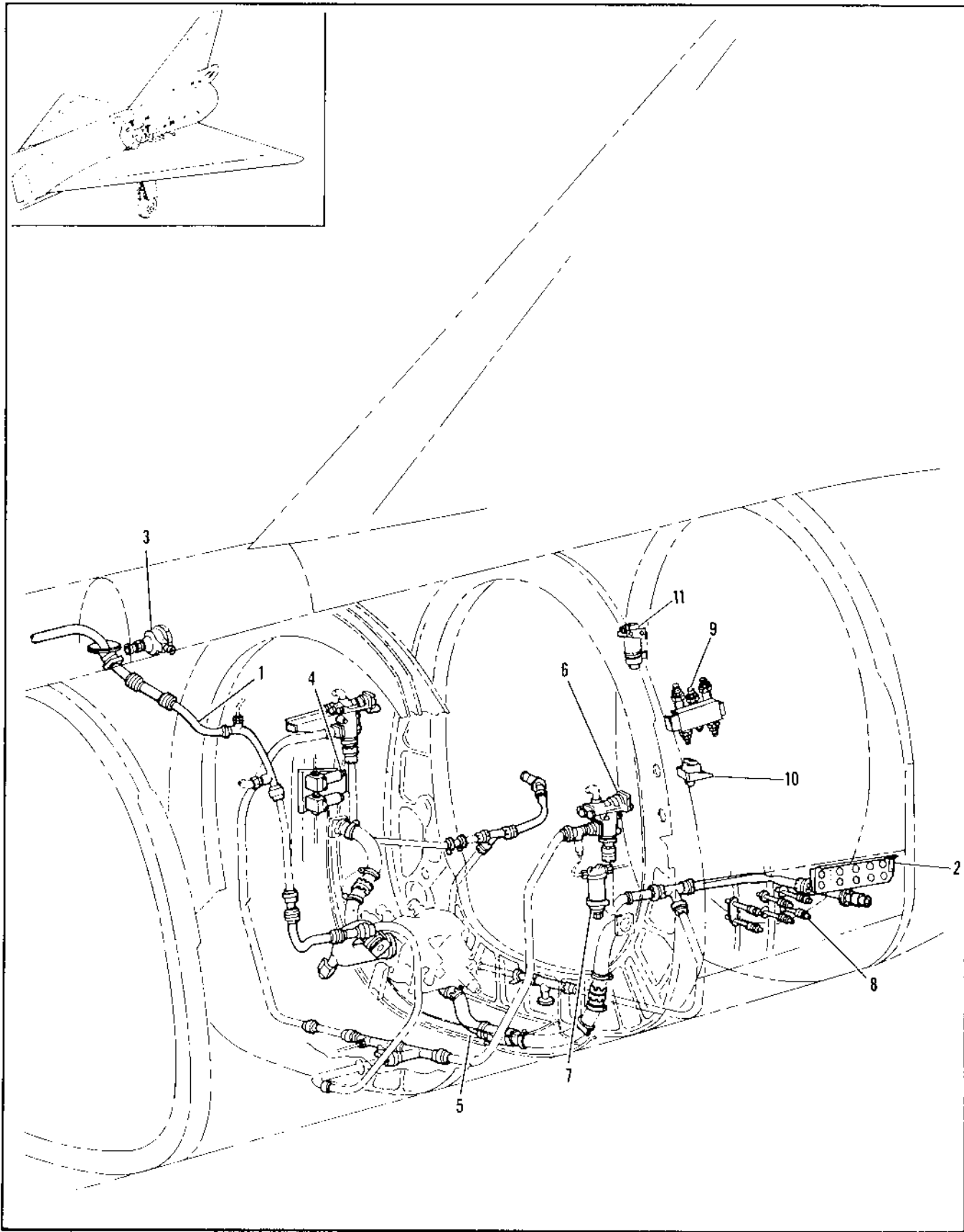

Figure 2.3-15. Panel Equipment Assembly Sta 472 to 673 (Sheet 1 of 2)

FIGURE AND INDEX NUMBER	PART NUMBER	DESCRIPTION	UNITS PER ASSY.	USABLE ON CODE	
				FROM	TO
		1 2 3 4 5 6			
2.3-15	8-74035-3	EQUIPMENT ASSEMBLY, PANEL STA 472 TO 673 FOR NHA SEE FIG. 2.3-14 MODIFIED BY 8-21834	RF	E	
	8-74035	EQUIPMENT ASSEMBLY, PANEL STA 472 TO 673 FOR NHA SEE FIG. 2.3-14 MODIFIED BY 8-21834	RF	278	287
	8-74035-1	EQUIPMENT ASSEMBLY, PANEL STA 472 TO 673 FOR NHA SEE FIG. 2.3-14 MODIFIED BY 8-21834	RF	288	293
- 1	8-27320-1	• EQUIPMENT INSTL, FUEL TANK PRESSURE FOR BREAKDOWN SEE FIG. 2.12-56	1	35	
- 2	8-28439	• PANEL INSTL, FUEL SYSTEM CHECKOUT AFT FOR BREAKDOWN SEE FIG 2.12-38	1	A	
	8-28409-1	• PANEL INSTL, FUEL SYSTEM CHECKOUT AFT FOR BREAKDOWN SEE FIG. 2.12-38	1	B	
	8-28409-3	• PANEL INSTL, FUEL SYSTEM CHECKOUT AFT FOR BREAKDOWN SEE FIG. 2.12-38	1	216	240
	8-28409-5	• PANEL INSTL, FUEL SYSTEM CHECKOUT AFT FOR BREAKDOWN SEE FIG. 2.12-38	1	241	
- 3	8-28434	• VALVE INSTL, ACCESSORY DRIVE AIR SUPPLY FOR BREAKDOWN SEE FIG. 2.10-26	1	35	
- 4	8-28266	• VALVE INSTL, SOLENOID AIR SHUTOFF RH FOR BREAKDOWN SEE FIG. 2.12-36	1	35	
- 5	8-27449-3	• TUBING INSTL, ENGINE FUEL SUPPLY FOR BREAKDOWN SEE FIG. 2.12-63	1	35	102
	8-27449-5	• TUBING INSTL, ENGINE FUEL SUPPLY FOR BREAKDOWN SEE FIG. 2.12-63	1	103	
- 6	8-27380-PC1	• REGULATOR INSTL, AIR PRESSURE TRANSFER TANK LH FOR BREAKDOWN SEE FIG. 2.12-36	1	35	
	8-27380-R02	• REGULATOR INSTL, AIR PRESSURE TRANSFER TANK RH FOR BREAKDOWN SEE FIG. 2.12-36	1	35	
- 7	8-28261-3	• FILTER INSTL, FUEL TANK PRESSURIZATION AIR FOR BREAKDOWN SEE FIG. 2.12-57	1	35	
- 8	8-21236-3	• SEAL INSTL, CG TRANSFER PRESSURE FITTING LH FOR BREAKDOWN SEE FIG. 2.12-33	1	D	
	8-21236-1	• SEAL INSTL, CG TRANSFER PRESSURE FITTING LH FOR BREAKDOWN SEE FIG. 2.12-33	1	278	303
	8-21236-5	• SEAL INSTL, CG TRANSFER PRESSURE FITTING RH FOR BREAKDOWN SEE FIG. 2.12-33	1	D	
	8-21236-2	• SEAL INSTL, CG TRANSFER PRESSURE FITTING RH FOR BREAKDOWN SEE FIG. 2.12-33	1	278	303
- 9	8-28293-1	• VALVE INSTL, FUEL TANK AIR CHECK LH FOR BREAKDOWN SEE FIG. 2.12-36	1	35	159
	8-28293-3	• VALVE INSTL, FUEL TANK AIR CHECK LH FOR BREAKDOWN SEE FIG. 2.12-36	1	160	
	8-28293-2	• VALVE INSTL, FUEL TANK AIR CHECK RH FOR BREAKDOWN SEE FIG. 2.12-36	1	35	
- 10	A-28372-1	• SWITCH INSTL, FUSELAGE FUEL TRANSFER EMERGENCY PRESSURE FOR BREAKDOWN SEE FIG. 2.12-36	1	35	159
	8-28372-7	• SWITCH INSTL, FUSELAGE FUEL TRANSFER EMERGENCY PRESSURE FOR BREAKDOWN SEE FIG. 2.12-36	1	160	
- 11	8-28376	• VALVE INSTL, FUSELAGE TANK SCAVENGE AIR PRESSURE FOR BREAKDOWN SEE FIG. 2.12-36	1	35	
		A AIRPLANES #35 THRU 47 AND 49 THRU 65 B AIRPLANES #48 AND 61 THRU 215 C AIRPLANES #25 THRU 277, 304 AND ON E AIRPLANES #35 THRU 277, 294 AND ON			

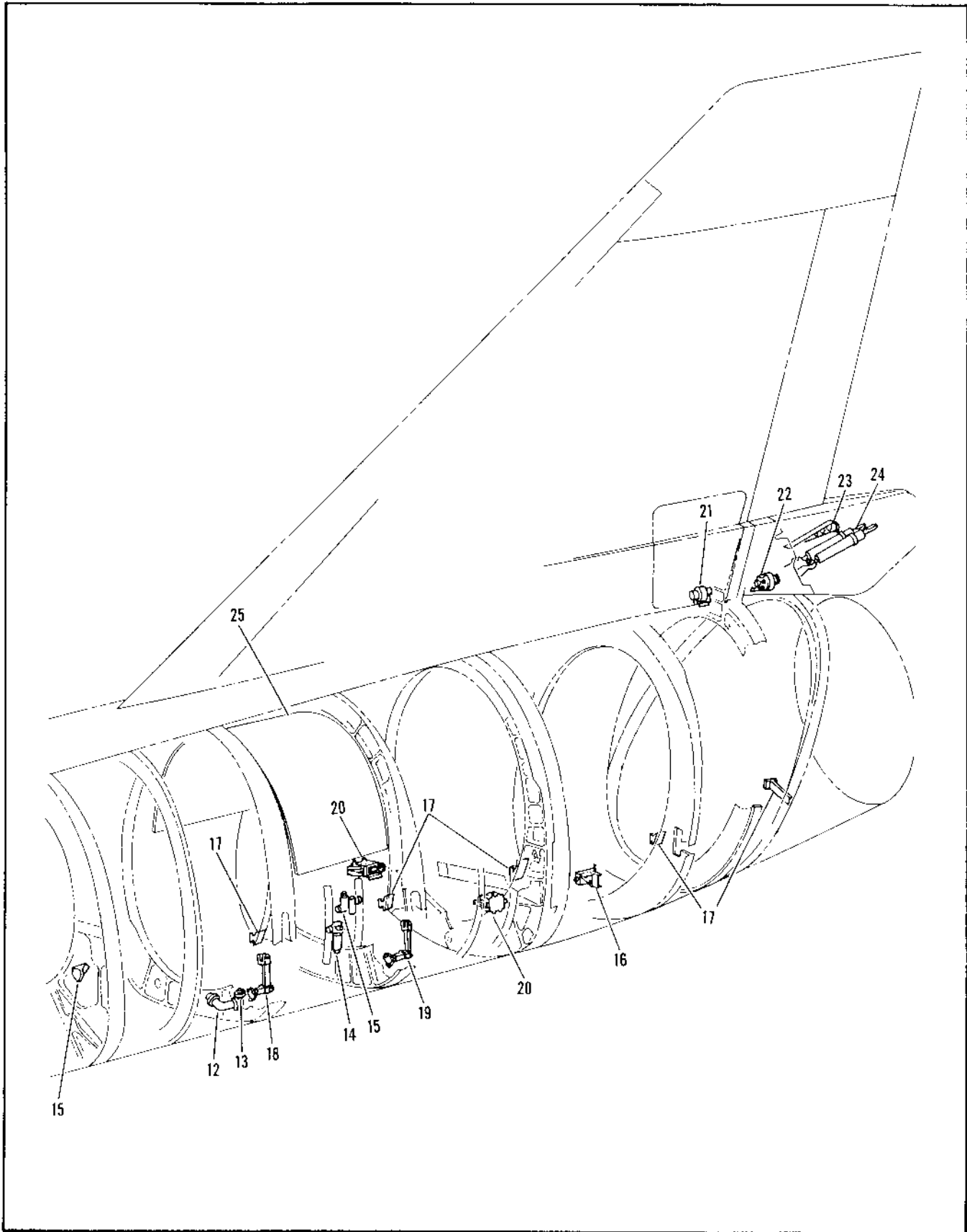

Figure 2.3-15. Panel Equipment Assembly Sta 472 to 673 (Sheet 2 of 2)

FIGURE AND INDEX NUMBER	PART NUMBER	DESCRIPTION	UNITS PER ASSY.	USABLE ON CODE	
				FROM	TO
		1 2 3 4 5 6			
2.3-15- 12	8-81313-803	• COUPLING INSTL, HYDRAULIC PRESSURE AND SUCTION STA 520 LH FOR BREAKDOWN SEE FIG. 2.8-1	1	C	
	8-81313-807	• COUPLING INSTL, HYDRAULIC PRESSURE AND SUCTION STA 520 LH FOR BREAKDOWN SEE FIG. 2.8-1	1	48	277
	8-81313-808	• COUPLING INSTL, HYDRAULIC PRESSURE AND SUCTION STA 520 RH FOR BREAKDOWN SEE FIG. 2.8-1	1	C	
	8-81313-809	• COUPLING INSTL, HYDRAULIC PRESSURE AND SUCTION STA 520 RH FOR BREAKDOWN SEE FIG. 2.8-1	1	48	277
- 13	8-81322	• FITTING INSTL, HYDRAULIC PUMP SEAL DRAIN FOR BREAKDOWN SEE FIG. 2.8-1	1	35	
- 14	8-81308-801	• FILTER INSTL, HYDRAULIC HIGH PRESSURE LH FOR BREAKDOWN SEE FIG. 2.8-1	1	35	277
	8-81308-1	• FILTER INSTL, HYDRAULIC HIGH PRESSURE LH FOR BREAKDOWN SEE FIG. 2.8-1	1	278	
	8-81308-802	• FILTER INSTL, HYDRAULIC HIGH PRESSURE RH FOR BREAKDOWN SEE FIG. 2.8-1	1	35	277
	8-81308-2	• FILTER INSTL, HYDRAULIC HIGH PRESSURE RH FOR BREAKDOWN SEE FIG. 2.8-1	1	278	
- 15	8-81326-1	• VALVE INSTL, HYDRAULIC RELIEF STA 530 LH FOR BREAKDOWN SEE FIG. 2.8-1	1	35	
	8-81326-2	• VALVE INSTL, HYDRAULIC RELIEF STA 530 RH FOR BREAKDOWN SEE FIG. 2.8-1	1	35	
- 16	8-81342-1	• SWITCH INSTL, HYDRAULIC THERMAL LH FOR BREAKDOWN SEE FIG. 2.8-1	1	90	
	8-81342-2	• SWITCH INSTL, HYDRAULIC THERMAL RH FOR BREAKDOWN SEE FIG. 2.8-1	1	90	
- 17	8-28000	• SUPPORT INSTL, ENGINE REMOVAL RAIL FOR BREAKDOWN SEE FIG. 2.10-37	1	C	
	8-28000-1	• SUPPORT INSTL, ENGINE REMOVAL RAIL FOR BREAKDOWN SEE FIG. 2.10-37	1	48	129
	8-28000-2	• SUPPORT INSTL, ENGINE REMOVAL RAIL FOR BREAKDOWN SEE FIG. 2.10-38	1	130	277
- 18	8-42504	• IDLER INSTL, ELEVON CONTROL STA 524 FOR BREAKDOWN SEE FIG. 2.14-40	1	35	
- 19	8-42503	• IDLER INSTL, ELEVON CONTROL STA 561 FOR BREAKDOWN SEE FIG. 2.14-40	1	35	
- 20	8-81405-1	• VALVE INSTL, ELEVON CONTROL FOR BREAKDOWN SEE FIG. 2.14-11	2	35	
- 21	8-85128-1	• VALVE INSTL, EMERGENCY SPEED BRAKE FOR BREAKDOWN SEE FIG. 2.7-1	1	35	
- 22	8-85132-1	• VALVE INSTL, DRAG CHUTE ACTUATING FOR BREAKDOWN SEE FIG. 2.7-1	1	35	
- 23	8-45006-1	• MECHANISM INSTL, DRAG CHUTE FOR BREAKDOWN SEE FIG. 2.7-3	1	F	
	8-45006	• MECHANISM INSTL, DRAG CHUTE FOR BREAKDOWN SEE FIG. 2.7-3	1	278	287
- 24	8-45107	• ACTUATOR INSTL, SPEED BRAKE FOR BREAKDOWN SEE FIG. 2.7-1	1	35	
- 25	8-22196	• BLANKET INSTL, FUSELAGE OVERHEAT INSULATION STA 530 TO 558 FOR BREAKDOWN SEE FIG. 2.10-15	1	35	
		C AIRPLANES #35 THRU 47, 273 AND ON			
		F AIRPLANES #75 THRU 277, 288 AND ON			

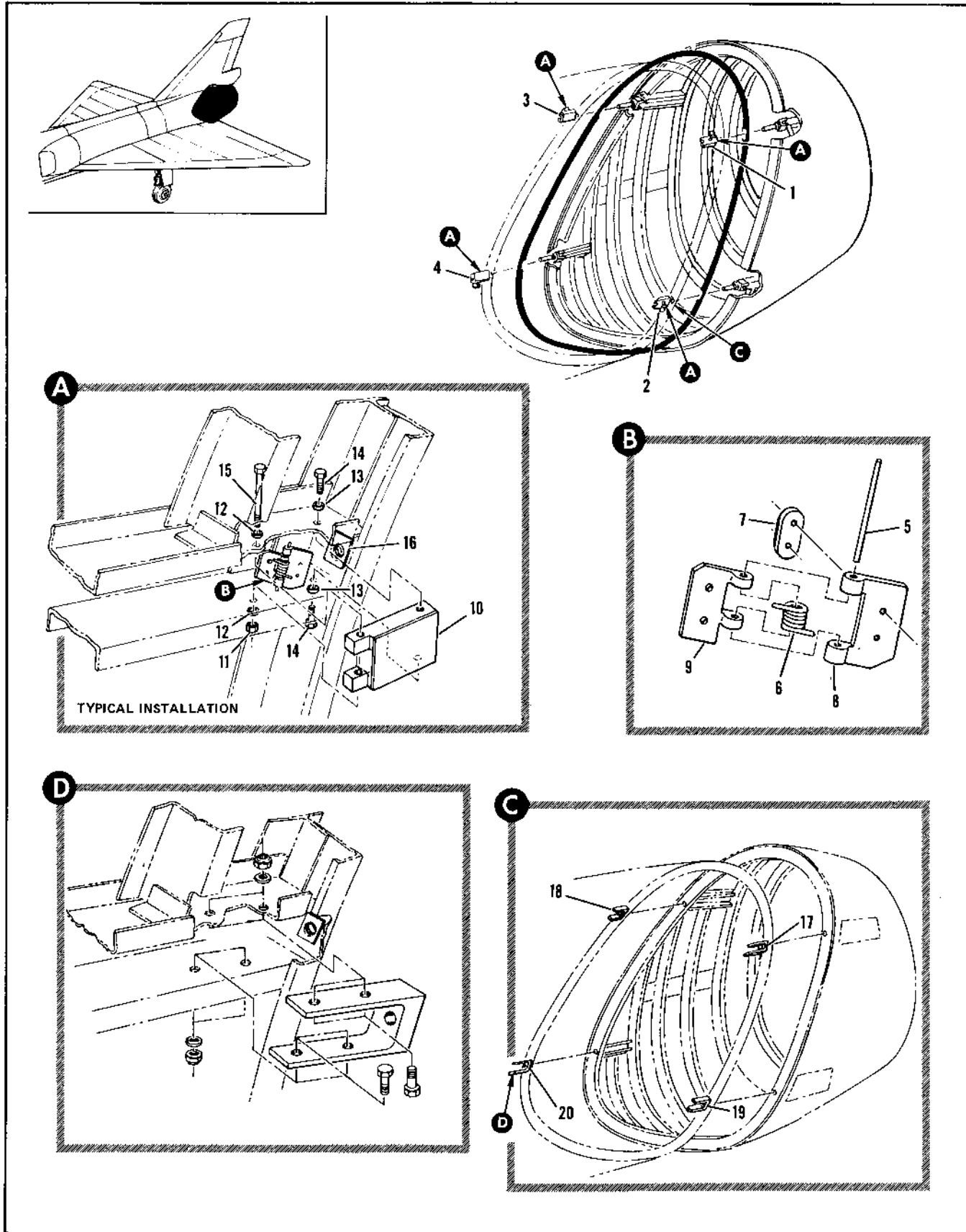

Figure 2.3-16. Tail Cone Assembly (Sheet 1 of 6)

FIGURE AND INDEX NUMBER	PART NUMBER	DESCRIPTION	UNITS PER ASSY.	USABLE ON CODE		
				FROM	TO	
2.3-16	8-74745-105	TAIL CONE ASSEMBLY	9F	A		
	8-74745-1	• LATCH INSTL, TAIL CONE FOR NHA SEE FIG. 2.3-14	RF	278	304	
	8-74678-1	• LATCH INSTL, TAIL CONE MODIFIED BY 8-71125	2	287	300	
	8-74678-2	• DOOR INSTL, TAIL CONE LATCH LH	2	287	300	
	- 1	8-74678-21	• DOOR INSTL, TAIL CONE LATCH RH	1	B	
		8-71125-13	• DOOR ASSY, UPPER LH REPLACED BY NOT INTCHG WITH 8-77388-7	1	C	
	- 2	8-74678-23	• PATCH ASSY, UPPER LH	1	D	
		8-71125-11	• DOOR ASSY, LOWER LH	1	D	
		8-71125-11	• PATCH ASSY, LOWER LH	1	296	300
	- 3	8-74678-22	• DOOR ASSY, UPPER RH	1	P	
		8-71125-14	• PATCH ASSY, UPPER RH REPLACED BY NOT INTCHG WITH 8-77388-8	1	C	
	- 4	8-74678-24	• DOOR ASSY, LOWER RH	1	R	
		8-71125-12	• PATCH ASSY, LOWER RH	1	D	
		8-71125-12	• PATCH ASSY, LOWER RH	1	296	300
	- 5	MS20253-1-125	• PIN (50205)	1	B	
	- 6	8-74678-7	• SPRING	1	R	
	- 7	8-74678-10	• PLATE, LOWER	1	B	
		8-74678-17	• PLATE, UPPER	1	B	
	- 8	8-74678-10	• HINGE, RH	1	B	
		8-74678-9	• HINGE, LH	1	B	
- 9	8-74678-12	• HINGE, RH	1	B		
	8-74678-11	• HINGE, LH	1	B		
- 10	H57-11	• HOUSING ASSY, TAIL CONE LATCH (83014) SPEC 8-17305-1	4	F		
		ATTACHING PARTS				
- 11	NAS677A3	• NUT (80205) 56-37545-102	4	E		
- 12	AN960-13L	• WASHER (8A144)	8	E		
- 13	AN960-13	• WASHER (8B144)	8	E		
- 14	NAS464-3A3	• BOLT (80205)	4	E		
- 15	NAS464-3A24	• BOLT (80205)	4	E		
		-----X-----				
- 16	8-74745-129	• PLATE LOWER RH REPLACED BY NOT INTCHG WITH 8-74745-170	1	P		
	8-74745-123	• PLATE LOWER LH REPLACED BY NOT INTCHG WITH 8-74745-149	1	B		
	8-74745-170	• PLATE UPPER RH REPLACED BY NOT INTCHG WITH 8-74745-172	1	P		
	8-74745-170	• PLATE UPPER LH REPLACED BY NOT INTCHG WITH 8-74745-171	1	B		
- 17	8-77381-7	• BRACKET, UPPER LH	1	F		
- 18	8-77381-8	• BRACKET, UPPER RH	1	F		
- 19	8-77382-7	• BRACKET, LOWER LH	1	F		
- 20	8-77382-8	• BRACKET, LOWER RH	1	F		

A AIRPLANES #25 THRU 277 AND 305
 B AIRPLANES #284, 288, AND 295
 C AIRPLANES #278 THRU 283, 285 THRU 287
 D THRU 284 AND 296 THRU 300
 E AIRPLANES #278 THRU 283, 285 THRU 287, AND 289 THRU 294
 F AIRPLANES #284 AND 288
 G AIRPLANES #25 THRU 283, 285 THRU 287, 289 THRU 294, 296 AND ON

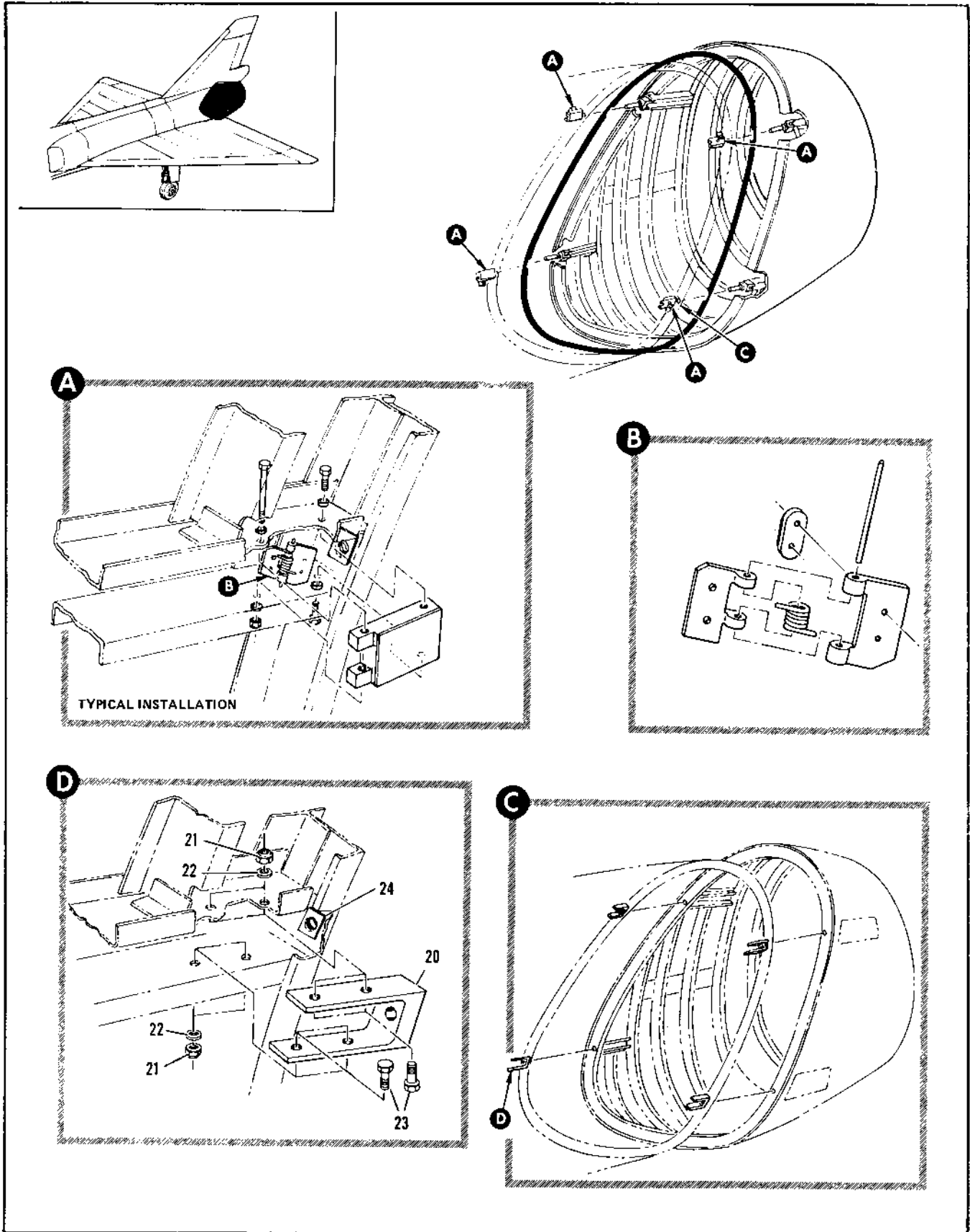

Figure 2.3-16. Tail Cone Assembly (Sheet 2 of 6)

FIGURE AND INDEX NUMBER	PART NUMBER	DESCRIPTION 1 2 3 4 5 6	UNITS PER ASSY.	USABLE ON CODE	
				FROM	TO
2.3-16		ATTACHING PARTS			
- 21	NAS679A4	• NUT (89205)	16	F	
- 22	AN56J-416	• WASHER (88344)	16	F	
- 23	AN4-5A	• BOLT (88044)	16	F	
		-----X-----			
- 24	8-74745-170	• PLATE, LOWER RH REPLACES NOT INTCHG WITH 8-74745-124	1	C	
	8-74745-169	• PLATE, LOWER LH REPLACES NOT INTCHG WITH 8-74745-123	1	C	
	8-74745-172	• PLATE, UPPER RH REPLACES NOT INTCHG WITH 8-74745-100	1	C	
	8-74745-171	• PLATE, UPPER LH REPLACES NOT INTCHG WITH 8-74745-99	1	C	
		C AIRPLANES #278, THRU 283, 285, THRU 287			
		F AIRPLANES #35 THRU 283, 285 THRU 287			
		289 THRU 294, 296 AND CN			

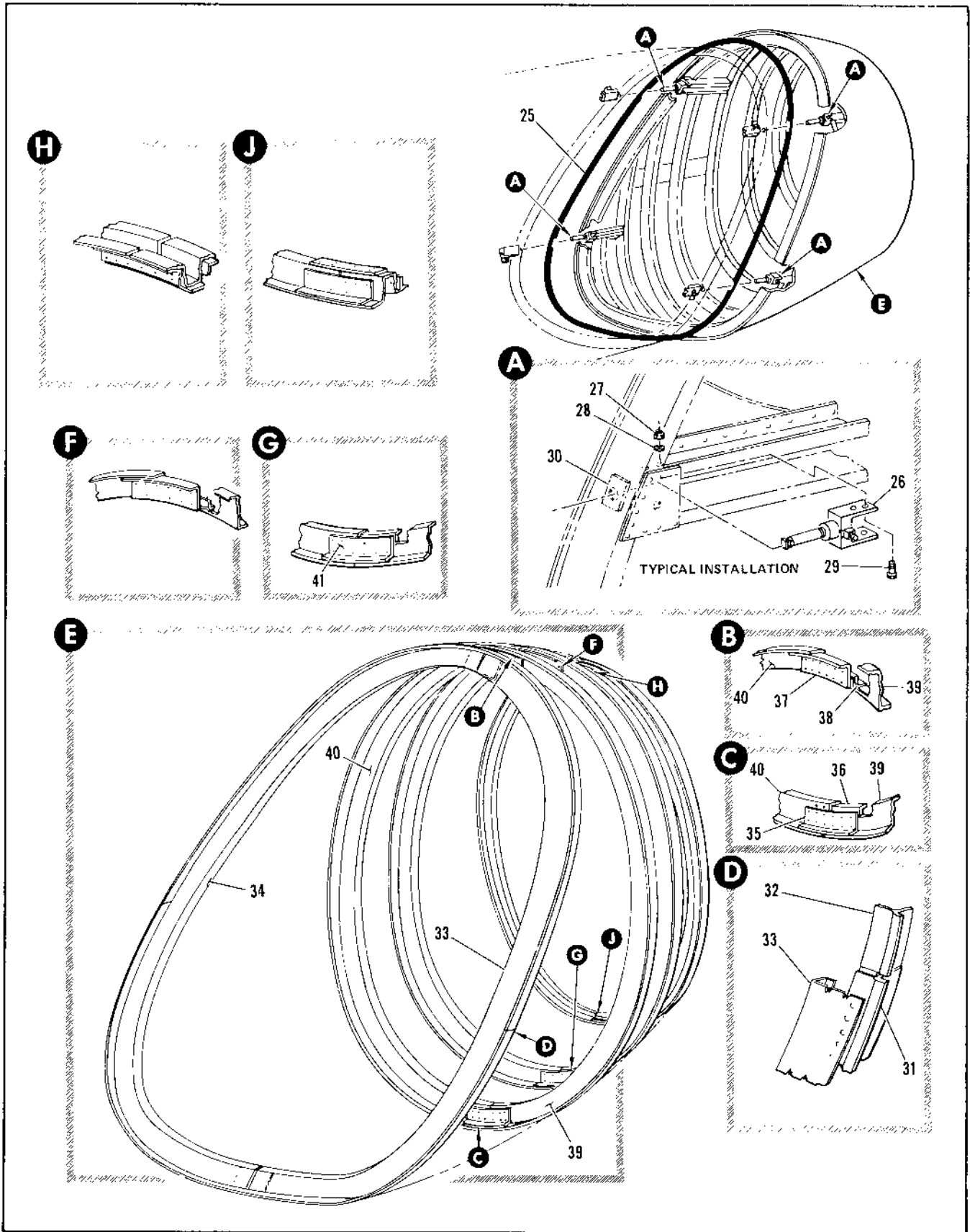

Figure 2.3-16. Tail Cone Assembly (Sheet 3 of 6)

FIGURE AND INDEX NUMBER	PART NUMBER	DESCRIPTION	UNITS PER ASSY.	USABLE ON CODE	
				FROM	TO
2.3-16	8-74490	• STRUCTURE ASSY, TAIL CONE REPLACED BY NOT INTCHG WITH 8-77309 FOR NHA SEE FIG. 2.1-1	RF	G	
- 25	8-74769-13	• • SEAL, TAIL CONE MAKE FROM 8-74769-15 AND 17 COMBINED	1	G	
- 26	8-74745-3 H57-13	• • LATCH INSTL, TAIL CONE • • • RECEPTACLE ASSY, TAIL CONE LATCH (83014) SPEC 8-77305-3 ATTACHING PARTS	1 4	G G	
- 27	NAS479A5	• • • NUT (89275)	16	G	
- 28	AN900-10	• • • WASHER (88544)	16	G	
- 29	NAS464-3A4	• • • BOLT (89265)	16	G	
- 30	8-74745-108 8-74745-109 8-74745-101 8-74745-102 8-74381	• • • PLATE, UPPER LH • • • PLATE, UPPER RH • • • PLATE, LOWER LH • • • PLATE, LOWER RH • • FRAME INSTL, TAIL CONE CANTED	1 1 1 1 1	G G G G G	
- 31	8-74381-49 8-74381-56 8-74381-9	• • • FRAME ASSEMBLY • • • FRAME ASSEMBLY • • • FLANGE LOWER REPLACED BY NOT INTCHG WITH 8-74381-53 -55 AND -57	1 1 1	E H E	
- 32	8-74381-11 8-74381-57 8-74381-53 8-74381-55 8-74381-51	• • • FLANGE, UPPER REPLACED BY NOT INTCHG WITH 8-74381-51 AND 8-74381-55 • • • FLANGE, LOWER REPLACES NOT INTCHG WITH 8-74381-9 • • • ANGLE, LOWER REPLACES NOT INTCHG WITH 8-74381-9 REPLACED BY NOT INTCHG WITH 8-77307-27 • • • FLANGE, UPPER REPLACES NOT INTCHG WITH 8-74381-9 REPLACED BY NOT INTCHG WITH 8-77307-11 • • • ANGLE, UPPER REPLACES NOT INTCHG WITH 8-74381-11 REPLACED BY NOT INTCHG WITH 8-77307-9	1 1 1 1 1	E H H H H	
- 33	8-74381-45	• • • FRAME, LH REPLACED BY NOT INTCHG WITH 8-77307-7	1	G	
- 34	8-74381-46	• • • FRAME, RH REPLACES NOT INTCHG WITH 8-77307-8	1	G	
- 35	8-74387-7	• • FRAME INSTL, TAIL CONE STA 69"	1	G	
- 36	8-74387-11	• • • FRAME ASSEMBLY	1	G	
- 37	8-74387-13	• • • ANGLE	1	G	
- 38	8-74387-15	• • • ANGLE	1	G	
- 39	8-74387-17	• • • ANGLE	1	G	
- 40	8-74387-9 8-74387-10	• • • FRAME, LH REPLACED BY SUITABLE SUB 8-74387-22 • • • FRAME, RH REPLACED BY SUITABLE SUB 8-74387-22	1 1	G G	
- 41	8-74387-7 8-74387-17	• • FRAME INSTL, TAIL CONE STA 71" • • • FRAME ASSEMBLY • • • ANGLE	1 1 1	G G G	

L AIRPLANES #284 AND 288
 C AIRPLANES #284, 288, 292, AND 295
 H AIRPLANES #292 AND 295

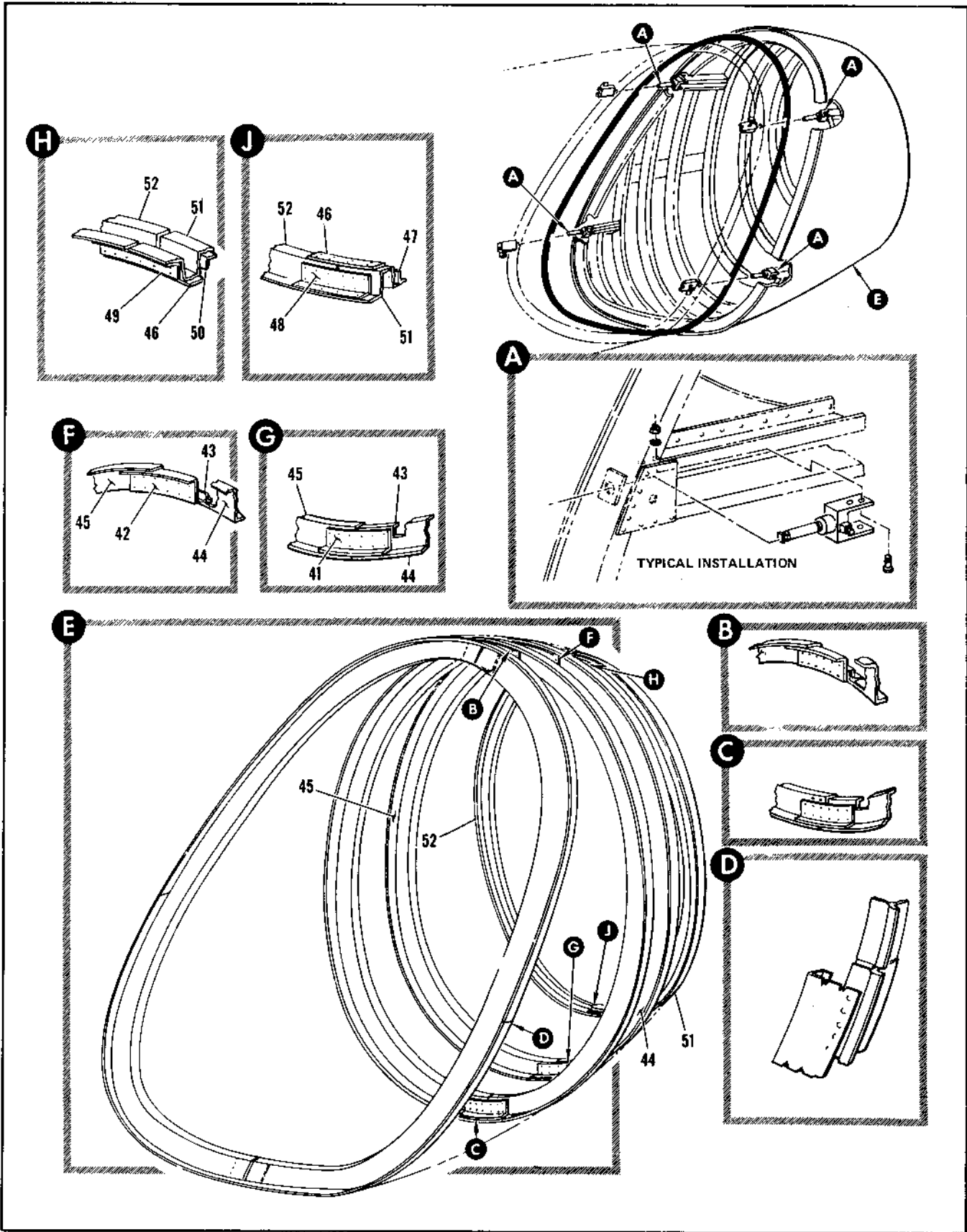

Figure 2.3-16. Tail Cone Assembly (Sheet 4 of 6)

FIGURE AND INDEX NUMBER	PART NUMBER	DESCRIPTION	UNITS PER ASSY.	USABLE ON CODE	
				FROM	TO
		1 2 3 4 5 6			
2.3-16- 42	8-74388-15 ANGLE	1	G	
- 43	8-74388-11 ANGLE	2	G	
- 44	8-74388-9 FRAME, LH	1	G	
- 45	8-74388-10 FRAME, RH	1	5	
	8-74389 FRAME INSTL, TAIL CONE STA 711	1	G	
	8-74389-14 FRAME ASSEMBLY	1	G	
- 46	8-74389-9 STRAP	2	G	
- 47	8-74389-11 ANGLE	1	G	
- 48	8-74389-13 ANGLE	1	G	
- 49	8-74389-17 ANGLE	1	G	
- 50	8-74389-23 ANGLE	1	G	
- 51	8-74389-7 FRAME, LH	1	G	
- 52	8-74389-8 FRAME, RH	1	G	
		Q AIRPLAKES 2284, 2288, 292 AND 295			

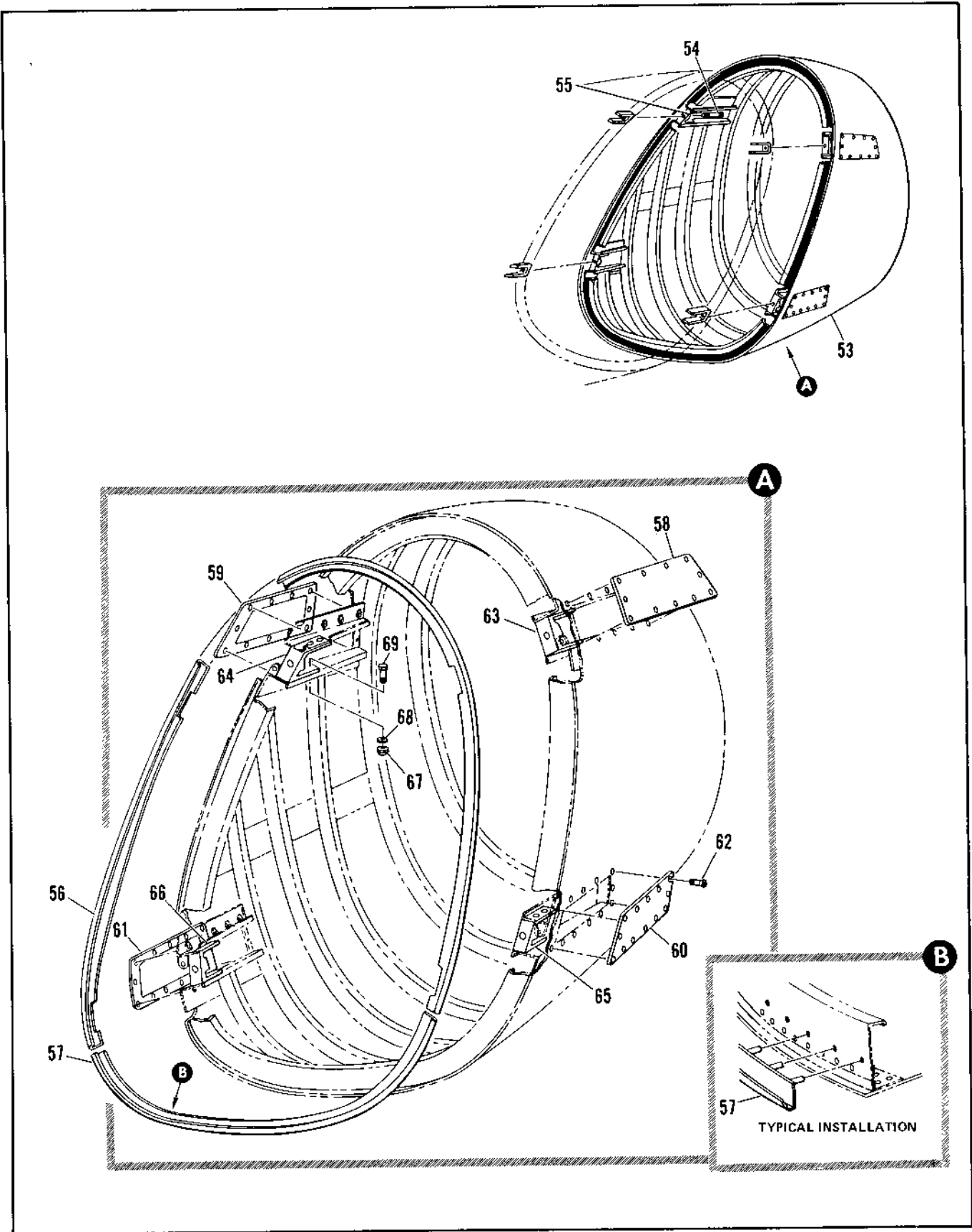

Figure 2.3-16. Tail Cone Assembly (Sheet 5 of 6)

FIGURE AND INDEX NUMBER	PART NUMBER	DESCRIPTION	UNITS PER ASSY.	USABLE ON CODE	
				FROM	TO
		1 2 3 4 5 6			
2,3-16	8-77386	• TAIL CONE INSTALLATION FOR NHA SEE FIG. 2.1-1	RF	J	
	8-77386-1	• TAIL CONE INSTALLATION FOR NHA SEE FIG. 2.1-1	RF	130	277
	8-71152-3	• TAIL CONE INSTALLATION FOR NHA SEE FIG. 2.1-1	1	P	
- 53	8-77354	• • STRUCTURE ASSY, TAIL CONE REPLACED BY SUITABLE SUB 8-77354-1	1	J	
	8-77354-1	• • STRUCTURE ASSY, TAIL CONE REPLACES SUITABLE SUB FOR 8-77354 ATTACHING PARTS	1	L	
- 54	8-77391-7	• • BOLT	4	K	
- 55	NAS143-5C	• • WASHER (20205) -----X-----	4	K	
- 56	8-74769-21	• • • SEAL, UPPER MAKE FROM 8-74769-17	1	K	
	8-74769-17	• • • SEAL	RF		
- 57	8-74769-19	• • • SEAL, LOWER MAKE FROM 8-74769-15	1	K	
	8-74769-15	• • • SEAL	RF		
- 58	8-77388-7	• • • DOOR, UPPER LH REPLACES NOT INTCHG WITH 8-74678-21	1	K	
- 59	8-77388-8	• • • DOOR, UPPER RH REPLACES NOT INTCHG WITH 8-74678-22	1	K	
- 60	8-77389-7	• • • DOOR, LOWER LH REPLACES NOT INTCHG WITH 8-74678-27	1	K	
- 61	8-77389-8	• • • DOOR, LOWER RH REPLACES NOT INTCHG WITH 8-74678-28 ATTACHING PARTS	1	K	
- 62	NAS333PA4	• • • BOLT (20205) -----X-----	24	K	
- 63	8-77383-7	• • • BRACKET, UPPER LH	1	K	
- 64	8-77383-8	• • • BRACKET, UPPER RH	1	K	
- 65	8-77383-9	• • • BRACKET, LOWER LH	1	K	
- 66	8-77383-10	• • • BRACKET, LOWER RH ATTACHING PARTS	1	K	
- 67	NAS679A4	• • • NUT (80205)	16	K	
- 68	AN960-41E	• • • WASHER (88044)	16	K	
- 69	AN4-5A	• • • BOLT (88044) -----X-----	16	K	
		J AIRPLANES #35 THRU 129, 331 AND ON			
		K AIRPLANES #35 THRU 283, 285 THRU 287, 289 THRU 291, 293, 294, 296 AND ON			
		L AIRPLANES #130 THRU 283, 285 THRU 287, 289 THRU 291, 293, 294, AND 296 THRU 300			
		P AIRPLANES #278 THRU 283, 285 THRU 287, 289 THRU 291, 293, 294, AND 296 THRU 300			

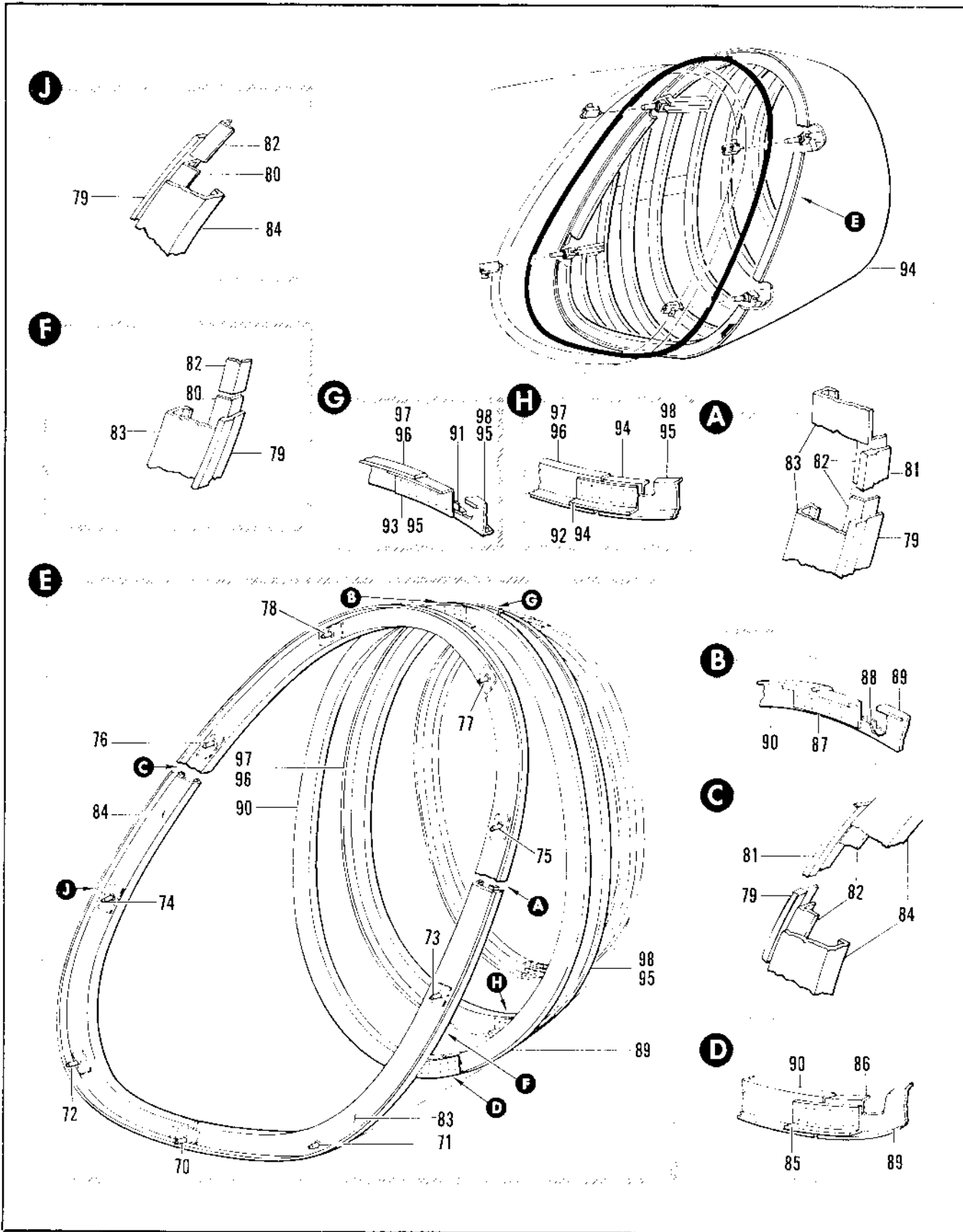

Figure 2.3-16. Tail Cone Assembly (Sheet 6 of 6)

FIGURE AND INDEX NUMBER	PART NUMBER	DESCRIPTION	UNITS PER ASSY.	USABLE ON CODE	
				FROM	TO
		1 2 3 4 5 6			
2.3-16	A-77307	FRAME INSTL, TAIL CONE CANTED	1		K
	A-77307-45	FRAME ASSEMBLY	1		K
- 73	R-77307-1	PIN ASSY, TAIL CONE SHEAR	1		K
- 71	S-77307-1	PIN ASSY, TAIL CONE SHEAR LH	1		K
- 72	S-77307-4	PIN ASSY, TAIL CONE SHEAR RH	1		K
- 73	A-77307-1	PIN ASSY, TAIL CONE SHEAR LH	1		K
- 74	A-77307-2	PIN ASSY, TAIL CONE SHEAR RH	1		K
- 75	A-77307-101	PIN ASSY, TAIL CONE SHEAR LH	1		X
- 76	A-77307-102	PIN ASSY, TAIL CONE SHEAR RH	1		K
- 77	A-77307-103	PIN ASSY, TAIL CONE SHEAR LH	1		K
- 78	A-77307-104	PIN ASSY, TAIL CONE SHEAR RH	1		K
- 79	A-77307-42	FLANGE, LOWER	1		K
- 85	A-77307-17	ANGLE, LOWER REPLACES NOT INTCHG WITH R-74381-53	1		K
- 81	A-77307-41	FLANGE, UPPER	1		K
- 82	A-77307-18	ANGLE, UPPER REPLACES NOT INTCHG WITH R-74381-51	1		K
- 83	A-77307-7	FRAME, LH REPLACES NOT INTCHG WITH R-74381-45	1		K
- 84	A-77307-8	FRAME, RH REPLACES NOT INTCHG WITH R-74381-46	1		K
- 85	A-74383	FRAME INSTL, TAIL CONE STA 670	1		K
	B-74383-9	FRAME	1		P
	A-74383-11	FRAME	1		R
	A-74383	FRAME INSTL, TAIL CONE STA 684	1		K
- 86	B-74385-9	FRAME	1		M
	B-74385-11	FRAME	1		N
	B-74385-13	FRAME	1		R
- 87	A-74386	FRAME INSTL, TAIL CONE STA 691	1		K
	A-74386-9	FRAME	1		P
	B-74386-13	FRAME	1		R
	A-74387	FRAME INSTL, TAIL CONE STA 69A	1		K
	B-74387-7	FRAME ASSEMBLY	1		P
	A-74387-19	FRAME ASSEMBLY	1		R
- 88	B-74387-11	ANGLE	1		K
- 89	B-74387-13	ANGLE	1		K
- 90	B-74387-15	ANGLE	1		K
- 91	B-74387-17	ANGLE	1		K
- 92	A-74387-1	FRAME, LH	1		P
	B-74387-11	FRAME, LH REPLACES SUITABLE SUB FOR A-74387-9	1		R
- 93	A-74387-11	FRAME, RH	1		P
	A-74387-12	FRAME, RH REPLACES SUITABLE SUB FOR A-74387-11	1		R
- 94	A-77314-17	STRUCTURE ASSY, TAIL CONE	1		K
	A-74388	FRAME INSTL, TAIL CONE STA 705	1		K
	A-74388-7	FRAME ASSEMBLY	1		K
- 95	A-74388-13	ANGLE	1		K
- 96	B-74388-15	ANGLE	1		K
- 97	B-74388-11	ANGLE	2		K
- 98	B-74388-9	FRAME, LH	1		K
- 99	B-74388-10	FRAME, RH	1		K
* AIRPLANES #75 THRU 213, 215 THRU 287, 289 THRU 291, 293, 294, 296 AND ON * AIRPLANES #278 THRU 283, 285, 286, AND 289 THRU 291 * AIRPLANES #15 THRU 277, 287, 293, 295 AND ON * AIRPLANES #278 THRU 283, 285 THRU 287, 289 THRU 291, 293, 294, AND 296 THRU 300 * AIRPLANES #25 THRU 277, 311 AND ON					

WINDSHIELD, CANOPY, AND SEAT SUBSECTION

TABLE OF CONTENTS

Fig. No.	Title	Page	Fig. No.	Title	Page
2.4-1	Windshield, Canopy and Seat.	2.4-2	2.4-7	Canopy and Seat Ejection Hose Installation.	2.4-24
2.4-2	Windshield Installation.	2.4-8	2.4-8	Canopy External Jettison Control.	2.4-34
2.4-3	Canopy Electrical Equipment	2.4-16	2.4-9	Canopy Installation	2.4-40
2.4-4	Canopy Latch Control Installation	2.4-18	2.4-10	Canopy Structure Assembly	2.4-46
2.4-5	Canopy Latch Control Installation	2.4-20	2.4-11	Ejection Seat Installation	2.4-50
2.4-6	Cartridge Powered Canopy Jettison Installation	2.4-22	2.4-12	Canopy Latch and Electrical Actuator Installation	2.4-54

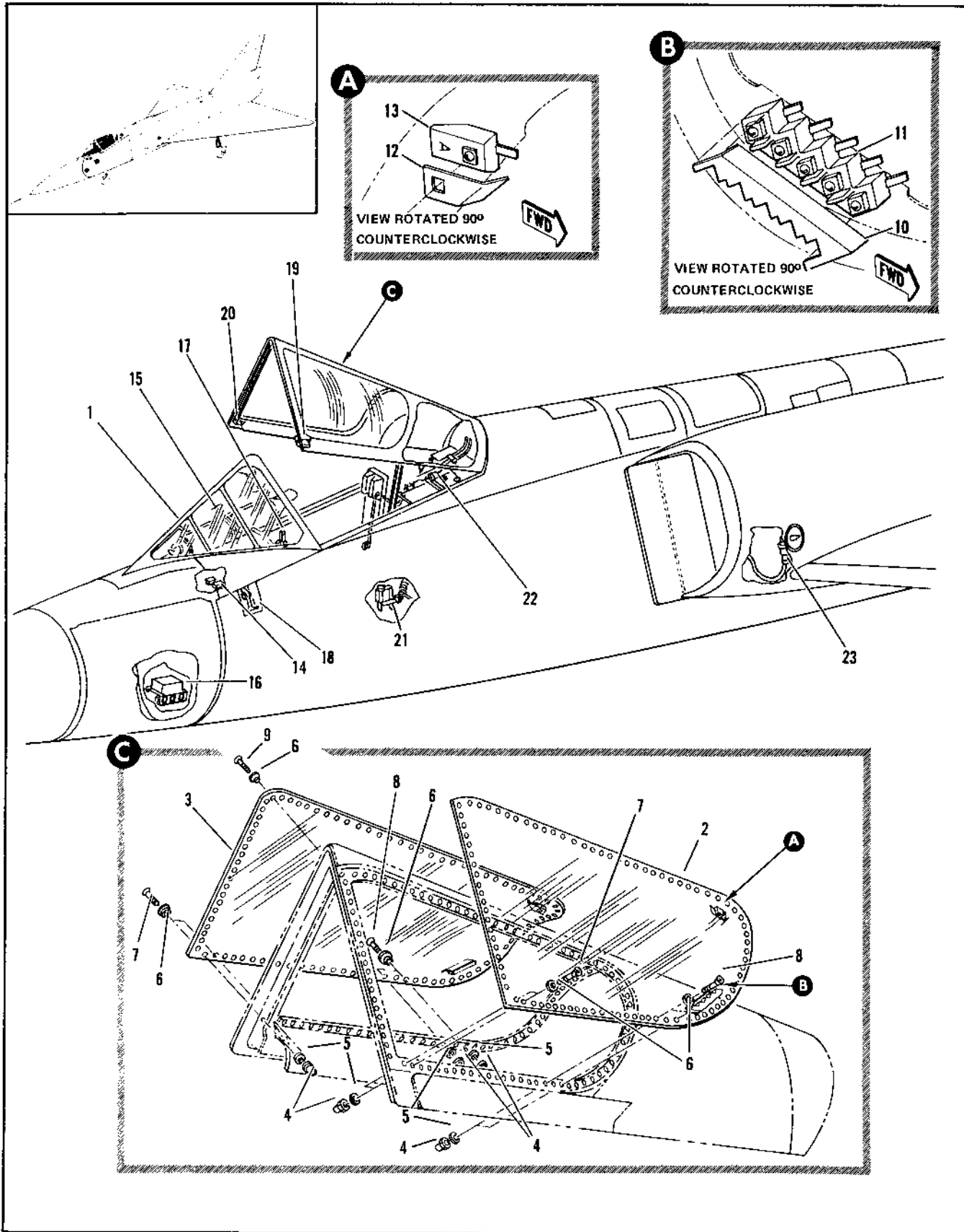

Figure 2.4-1. Windshield, Canopy and Seat (Sheet 1 of 3)

FIGURE AND INDEX NUMBER	PART NUMBER	DESCRIPTION	UNITS PER ASSY.	USABLE ON CODE	
				FROM	TO
		1 2 3 4 5 6			
2.4-1		WINDSHIELD CANOPY AND SEAT			
- 1	8-74822-1	• WINDSHIELD INSTL. SEE FIG. 2.4-2	RF		
		• WINDSHIELD INSTL. CANOPY MODIFIED BY 8-71159 FOR NHA SEE FIG. 2.1-1	RF	35	
- 2	8-74815-3	• WINDOW ASSY, LH BONDED REPLACED BY SUITABLE SUB 8-74815-5	RF	35	
	8-74815-1	• WINDOW ASSY, LH BONDED	RF	35	
		ALT INTCHG WITH 8-74815-3			
	8-74815-5	• WINDOW ASSY, LH BONDED REPLACES SUITABLE SUB FOR 8-74815-3	RF	35	
- 3	8-74815-4	• WINDOW ASSY, RH BONDED REPLACED BY SUITABLE SUB 8-74815-6	RF	35	
	8-74815-2	• WINDOW ASSY, RH BONDED	RF	35	
		ALT INTCHG WITH 8-74815-4			
	8-74815-6	• WINDOW ASSY, RH BONDED REPLACES SUITABLE SUB FOR 8-74815-4 ATTACHING PARTS	RF	35	
- 4	MS24654-37	• NUT (96906) 56-37548-002	RF	35	
- 5	89-51480-102	• WASHER	RF	35	
- 6	89-51507-003	• WASHER	RF	35	
- 7	MS24694-40	• SCREW (96906)	RF	35	
- 8	MS24694-50	• SCREW (96906)	RF	35	
- 9	MS24654-37	• SCREW (96906)	RF	35	
		-----X-----			
- 10	8-74815-27	• COVER, LOWER LH	RF	35	
	8-74815-28	• COVER, LOWER RH	RF	35	
- 11	8-74815-35	• BLOCK ASSY, LOWER LH CEMENTED	RF	35	
	8-74815-36	• BLOCK ASSY, LOWER RH CEMENTED	RF	35	
- 12	8-74815-29	• COVER, UPPER LH	RF	35	
	8-74815-30	• COVER, UPPER RH	RF	35	
- 13	8-74815-37	• BLOCK ASSY, UPPER LH CEMENTED	RF	35	
	8-74815-38	• BLOCK ASSY, UPPER RH CEMENTED	RF	35	
- 14		• TRANSFORMER INSTL. WINDSHIELD ANTI-ICE SEE FIG. 2.17-8	RF		
- 15		• BAFFLE INSTL. WINDSHIELD REFLECTION SEE FIG. 2.5-3	RF		
- 16		• CANOPY ELECTRICAL EQUIPMENT SEE FIG. 2.4-3	RF		
- 17		• CONTROL INSTL. CANOPY LATCH SEE FIG. 2.4-4	RF		
- 18		• LATCH AND ELECTRICAL ACTUATOR INSTL. CANOPY SEE FIG. 2.4-12	RF		
- 19		• FITTING, CANOPY LATCH LH SEE FIG. 2.3-7	RF		
- 20		• FITTING, CANOPY LATCH RH SEE FIG. 2.3-8	RF		
- 21		• HOSE INSTL. CANOPY AND SEAT JETTISON SEE FIG. 2.4-6	RF		
- 22		• JETTISON INSTL. CARTRIDGE POWERED CANOPY SEE FIG. 2.4-6	RF		
- 23		• CONTROL INSTL. EXTERNAL CANOPY JETTISON SEE FIG. 2.4-8	RF		

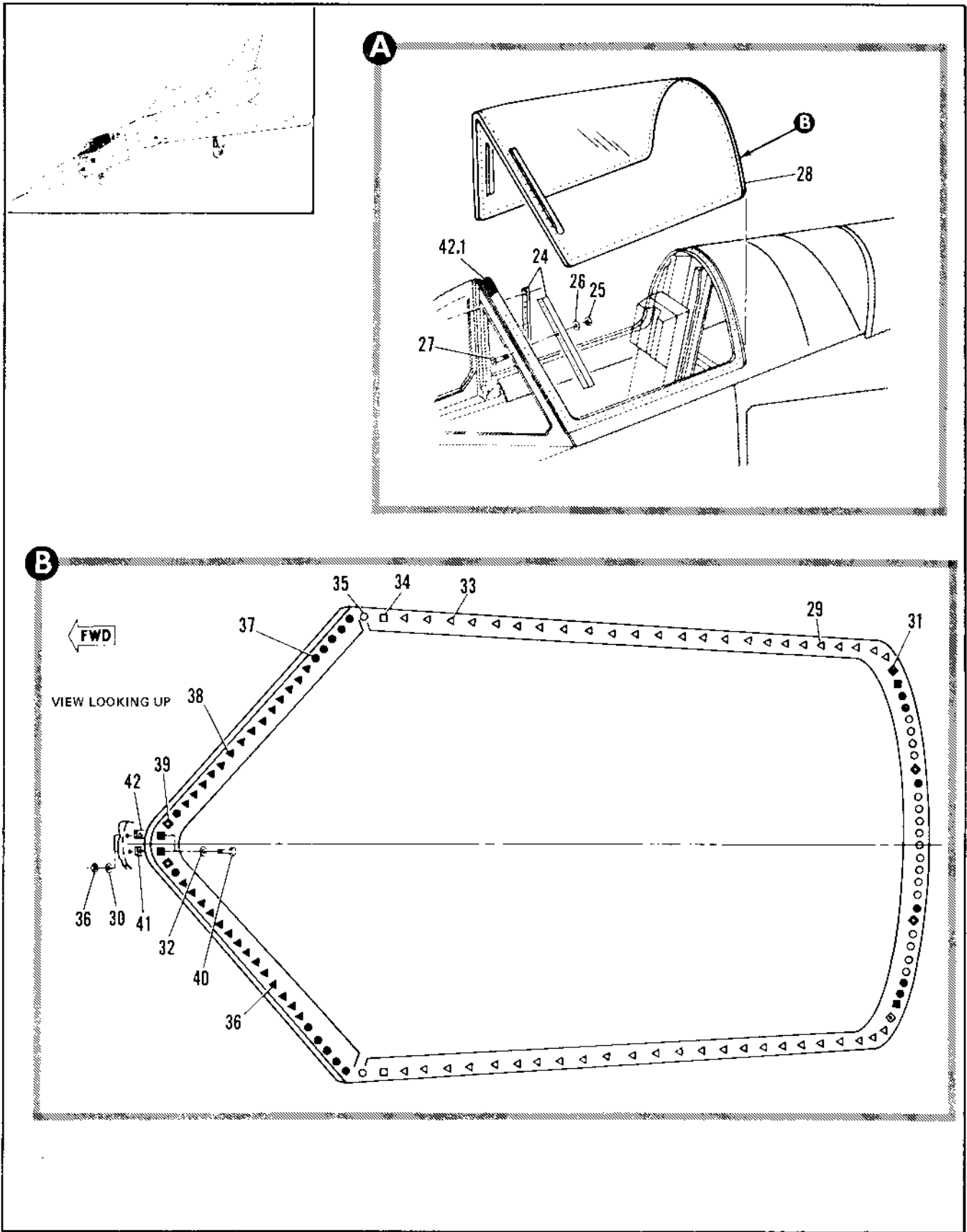

Figure 2.4-1. Windshield, Canopy and Seat (Sheet 2 of 3)

FIGURE AND INDEX NUMBER	PART NUMBER	DESCRIPTION	UNITS PER ASSY.	USABLE ON CODE	
				FROM	TO
2.4-1- 24	7144519-10	• • STIFFENER (98750) ATTACHING PARTS	2		35
- 25	MS21042-3	• • NUT (96906)	30		35
- 26	NAS1252-10L	• • WASHER (86205)	AR		35
- 27	NAS1203-5	• • BOLT (80205) -----X-----	30		35
- 28	7144506-10	• • WINDOW ASSY, CANOPY CLEAR TOP (98750) ATTACHING PARTS	1		35
- 29	H39794-3	• • NUT (15653)	41		35
- 30	AS80742-4	• • WASHER (15630)	25		35
- 31	MS24694S64	• • SCREW (96906)	2		35
- 32	99-51400-002	• • WASHER (14170)	25		35
- 33	MS24694S65	• • SCREW (96906)	48		35
- 34	MS24694S61	• • SCREW (96906)	2		35
- 35	MS24694S60	• • SCREW (96906)	19		35
- 36	MS21042L3	• • NUT (96906)	44		35
- 37	MS24694S5H	• • SCREW (96906)	18		35
- 38	MS24694S56	• • SCREW (96906)	AR		35
	MS24694S57	• • SCREW (96906)	AR		35
- 39	MS24694S59	• • SCREW (96906)	4		35
- 40	MS24694S62	• • SCREW (96906)	4		35
- 41	7144502-01	• • SPACER (98750)	1		35
- 42	7144502-02	• • SPACER (98750)	1		35
-42.1	7144516-01	• • FILLER (98750)	1		35

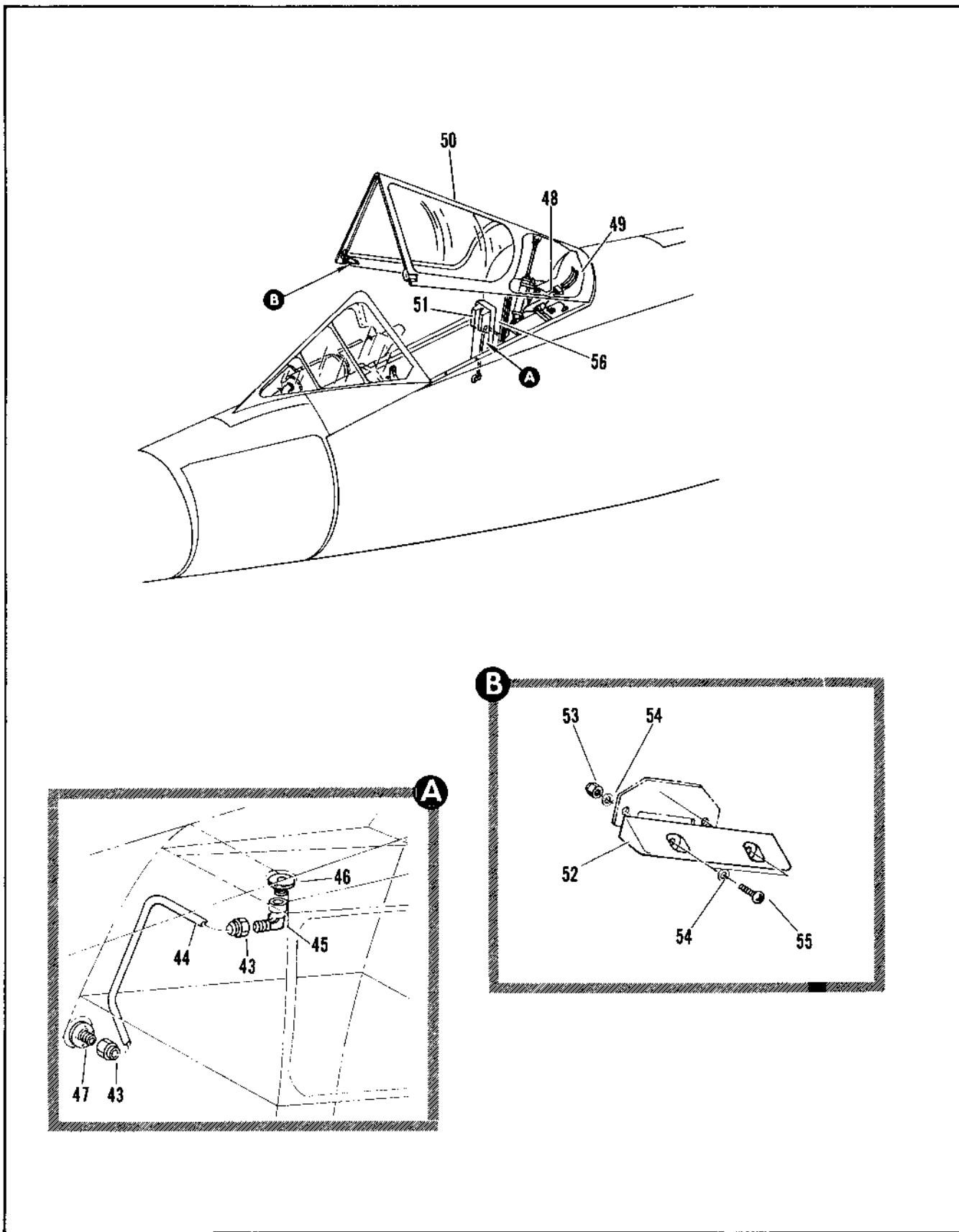

Figure 2.4-1. Windshield, Canopy and Seat (Sheet 3 of 3)

FIGURE AND INDEX NUMBER	PART NUMBER	DESCRIPTION	UNITS PER ASSY.	USABLE ON CODE	
				FROM	TO
2.4-2	R-74895	. DRAIN INSTL. CANOPY ACTUATOR WELL FOR NHA SEE FIG. 2.3-4	RF		35
- 43	TA0F6	. . NUT, <84971> 96-28507-301	2		35
- 44	R-74855-7	. . TUBE, DRAIN	1		35
- 45	TA4EF6-4	. . ELBOW, <84971> 93-39752-301	1		35
- 46	R-74856	. . FLANGE, DRAIN UPPER	1		35
- 47	R-77543	. . FLANGE, DRAIN LOWER	1		35
- 48		. TUBING INSTL, LOW PRESSURE PNEUMATIC COCKPIT PRESSURE CONTROL SEE FIG. 2.9-7	RF		
- 49		. TUBING INSTL, LOW PRESSURE PNEUMATIC CANOPY SEAL SEE FIG. 2.9-9	RF		
- 50		. CANOPY INSTL, SEE FIG. 2.4-9	RF		
- 51	803498-421 R-95619	. SEAT INSTL, EJECTION, SEE FIG. 2.4-11 . NAME PLATE INSTL, COCKPIT CANOPY LATCH FOR NHA SEE FIG. 2.3-8	RF RF		35
- 52	R-95618-7	. . NAMEPLATE ATTACHING PARTS	1		35
- 53	NAS079A3	. . NUT (90285)	2		35
- 54	AN950D6L	. . WASHER (08044)	4		35
- 55	MS35206-232	. . SCREW (96906) -----X-----	2		35
- 56	803499-407	. TRACK ASSY (92824) (SEE T.O. 13A5-18-93 FOR BREAKDOWN) (A-P)	1		

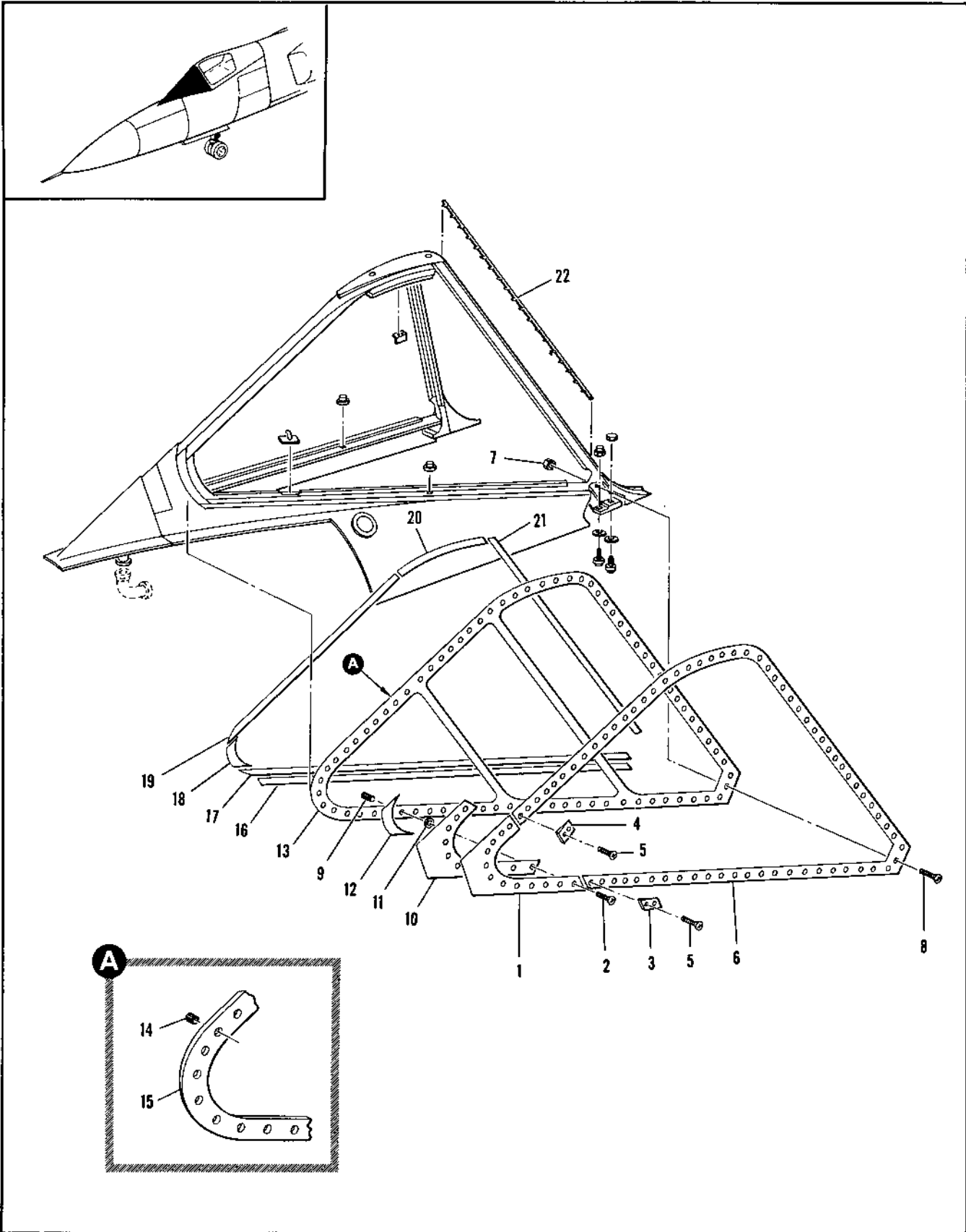

Figure 2.4-2. Windshield Installation (Sheet 1 of 3)

FIGURE AND INDEX NUMBER	PART NUMBER	DESCRIPTION	UNITS PER ASSY.	USABLE ON CODE	
				FROM	TO
2.4-2	8-74830	WINDSHIELD INSTALLATION. FOR NHA SEE FIG. 2.3-4	RF	35	
- 1	8-74850-1 8-74849-9	• GLASS INSTL, WINDSHIELD MODIFIED BY 8-74886 • RETAINER, WINDSHIELD FWD LH REPLACED BY INTCHG WITH 8-74849-11	1 1	35 35	43
	8-74849-11	• RETAINER, WINDSHIELD FWD LH REPLACES INTCHG WITH 8-74849-9	1	A	
	8-77804	• DEFLECTOR, WINDSHIELD FWD LH REPLACES NOT INTCHG WITH 8-74849-11	1	B	
- 2	MS24694-53	• SCREW (96906)	23	35	
- 3	8-77803-7	• FAIRING, WINDSHIELD RETAINER LOWER	1	B	
- 4	8-77803-9	• FAIRING, WINDSHIELD RETAINER UPPER	1	B	
- 5	MS24694-53	• SCREW (96906)	4	B	
- 6	8-73830-65	• RETAINER, WINDSHIELD LH REPLACED BY NOT INTCHG WITH 8-77806	1	C	
	8-77806	• RETAINER, WINDSHIELD LH REPLACES NOT INTCHG WITH 8-73830-65	1	B	
	8-73830-69	• RETAINER, WINDSHIELD RH	1	35	
- 7	NAS679A3	• NUT, (80205) 96-37545-002	1	35	
- 8	MS24694-53	• SCREW, LH (96906)	AR	35	
	MS24694-53	• SCREW, RH (96906)	98	35	
	MS24694-51	• SCREW, RH (96906)	6	35	
- 9	3591-3CNX.234	• INSERT, GLASS INSTALLATION WINDSHIELD <91767> 95-03003-017	AR	35	
- 10	8-74833-7	• INSULATOR, WINDSHIELD RETAINER LH REPLACED BY NOT INTCHG WITH 8-74833-9	1	35	47
	8-74833-9	• INSULATOR, WINDSHIELD RETAINER LH REPLACES NOT INTCHG WITH 8-74833-7	1	49	89
	8-77805	• INSULATOR, WINDSHIELD RETAINER REPLACES NOT INTCHG WITH 8-74833-9	1	B	
- 11	8-77769	• WASHER, WINDSHIELD GLASS	13	49	89
- 12	8-73830-43	• INSULATOR, REPLACED BY SUITABLE SUB 8-73830-71	2	35	215
	8-73830-71	• INSULATOR, REPLACES SUITABLE SUB FOR 8-73830-43	2	216	
- 13	8-73862-3	• GLASS ASSY, WINDSHIELD LH REPLACED BY INTCHG WITH 69D34546-1	1	35	
	69D34546-1	• GLASS ASSY, WINDSHIELD LH (98750) REPLACES INTCHG WITH 8-73862-3	1	35	
	69D34546-3	• GLASS ASSY, WINDSHIELD LH (98750) SUITABLE SUB FOR 69D34546-1	1	35	
	8-73862-4	• GLASS ASSY, WINDSHIELD RH REPLACED BY INTCHG WITH 69D34546-2	1	35	
	69D34546-2	• GLASS ASSY, WINDSHIELD RH (98750) REPLACES INTCHG WITH 8-73862-4	1	35	
	69D34546-4	• GLASS ASSY, WINDSHIELD RH (98750) SUITABLE SUB FOR 69D34546-2	1	35	
- 14	8-73839	• BUSHING, WINDSHIELD LH	96	35	
		A AIRPLANES #44 THRU 47 AND 49 THRU 89 B AIRPLANES #48, 90 AND ON C AIRPLANES #35 THRU 47 AND 49 THRU 89			

FIGURE AND INDEX NUMBER	PART NUMBER	DESCRIPTION	UNITS PER ASSY.	USABLE ON CODE	
				FROM	TO
		1 2 3 4 5 6			
2.4-2	B-73839	. . . BUSHING, WINDSHIELD RH	95		
- 15	B-73862-23	. . . GLASS ASSY, WINDSHIELD LH LAMINATED	1	35	
	B-73862-24	. . . GLASS ASSY, WINDSHIELD RH LAMINATED	1	35	
	B-74836	. . . SEAL INSTL, WINDSHIELD	1	35	
- 16	B-74836-17	. . . BUMPER	2	35	
- 17	B-74836-9	. . . SEAL	2	35	
- 18	B-74836-7	. . . SEAL	2	35	
- 19	B-74836-11	. . . SEAL	2	35	
- 20	B-74836-13	. . . SEAL	2	35	
- 21	B-74836-15	. . . SEAL	2	35	
- 22	B-72843-9	. SEAL, WINDSHIELD WEATHER MAKE FROM B-72841-7	1	35	
	B-72841-7	. SEAL, WINDSHIELD WEATHER	RF		

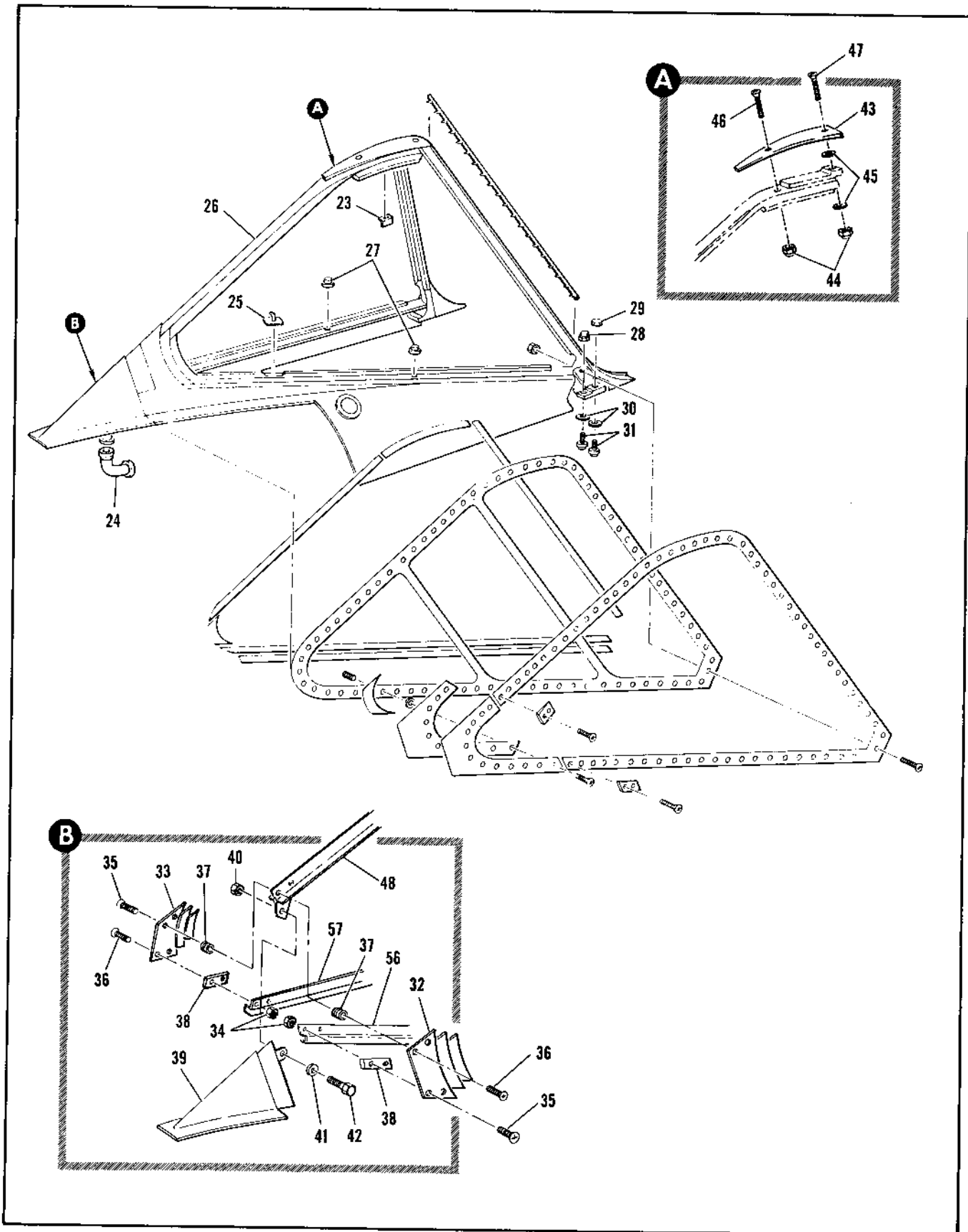

Figure 2.4-2. Windshield Installation (Sheet 2 of 3)

FIGURE AND INDEX NUMBER	PART NUMBER	DESCRIPTION	UNITS PER ASSY.	USABLE ON CODE	
				FROM	TO
2.4-2	8-74840	• STRUCTURE INSTL, WINDSHIELD	1	35	
- 23	8-94878-1	• • LATCH INSTL, WINDSHIELD REFLECTION BAFFLE	1	35	
- 24	8-94855-3	• • • LATCH ASSY, BAFFLE RIVETED	1	35	
- 25	8-94820	• • DUCT ASSY, RAIN REMOVAL NOZZLE PLENUM	PF		
- 26	8-74840-11	SEE FIG. 2.13-14			
- 27	AN227-75	• • HOOK ASSY, REFLECTION SHIELD WELDED	2	35	
- 28	8-74840-11	• • STRUCTURE ASSY, WINDSHIELD	1	C	
- 29	8-74840-11	• • STRUCTURE ASSY, WINDSHIELD	1	B	
- 30	AN227-75	ATTACHING PARTS			
- 31	AN227-75	• FASTENER (88744)	2	35	
- 32	MS24694-26	• • NUT, <78237> 96-37512-001	2	35	
- 33	MS24694-26	• • NUT, <72260> 96-37508-101	2	35	
- 34	MS24694-26	• • WASHER (96906)	4	35	
- 35	MS24694-26	• • BOLT (96906)	4	35	
- 36	8-73836-9	-----X-----			
- 37	8-73836-10	• • • FITTING, WINDSHIELD FWD LOWER LH	1	35	
- 38	8-73836-10	• • • FITTING, WINDSHIELD FWD LOWER RH	1	35	
- 39	MS24694-26	ATTACHING PARTS			
- 40	MS24694-26	• • NUT, (88205) 96-37545-002	4	35	
- 41	MS24694-26	• • SCREW (96906)	4	35	
- 42	MS24694-26	• • SCREW (96906)	4	35	
- 43	3591-30N, 234	-----X-----			
- 44	8-73840-25	• • • INSERT, <91767> 35-03003-017	2	35	
- 45	8-74840	• • • SPACER, WINDSHIELD STRUCTURE	2	35	
- 46	MS24694-26	• • • FAIRING ASSY, WINDSHIELD NOSE RIVETED	1	35	
- 47	MS24694-26	ATTACHING PARTS			
- 48	MS24694-26	• • NUT, (88205) 96-37545-002	1	35	
- 49	8-73841	• • SHIM, WINDSHIELD	1	35	
- 50	AN173-5A	• • BOLT (88044)	1	35	
- 51	8-73836-17	-----X-----			
- 52	MS24694-26	• • • FITTING, WINDSHIELD CENTER POST UPPER	1	35	
- 53	MS24694-26	ATTACHING PARTS			
- 54	MS24694-26	• • NUT, (88205) 96-37545-002	2	35	
- 55	8-73841	• • SHIM	2	35	
- 56	MS24694-26	• • SCREW (96906)	1	35	
- 57	8-73836-9	• • SCREW, ALTERED FROM AN509-10R19 (88044)	1	D	
- 58	8-73836-11	• • SCREW, ALTERED FROM AN509-10R20 (88044)	1	E	
		-----X-----			
		B AIRPLANES #48, 90 AND ON			
		C AIRPLANES #35 THRU 47 AND 49 THRU 89			
		D AIRPLANES #35 THRU 47 AND 49 THRU 60			
		E AIRPLANES #48, 51 AND ON			

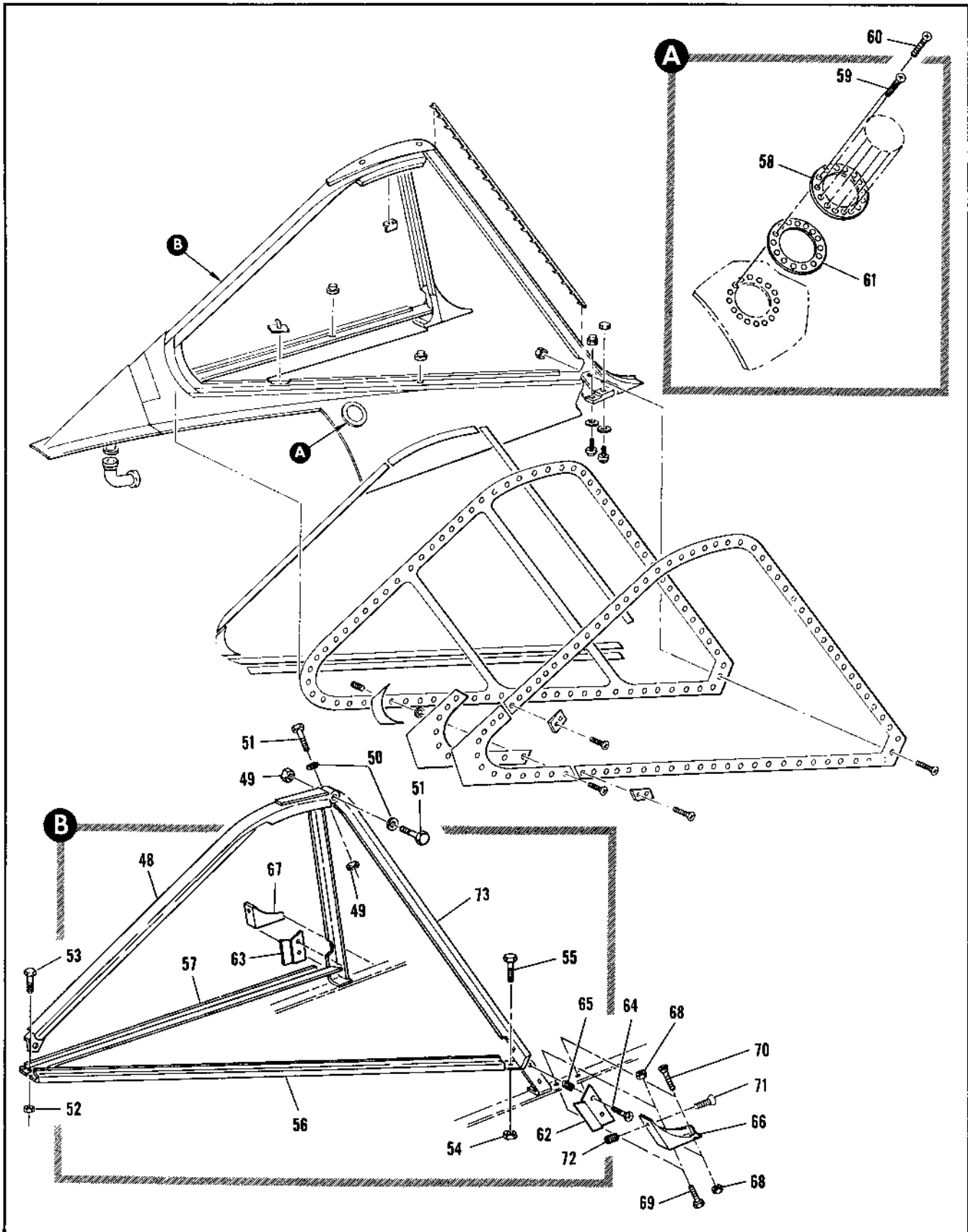

Figure 2.4-2. Windshield Installation (Sheet 3 of 3)

FIGURE AND INDEX NUMBER	PART NUMBER	DESCRIPTION	UNITS PER ASSY.	USABLE ON CODE	
				FROM	TO
2.4-2- 48	B-7343-9	. . . POST, WINDSHIELD CENTER MAKE FROM 6-73443	1	35	
	B-73443	. . . POST, WINDSHIELD CENTER ATTACHING PARTS	9F		
- 49	NAS179A3	. . . NUT, (80205) 96-37545-102	2	35	
- 50	B-73441	. . . SHIM, WINDSHIELD	2	35	
- 51	B-73559-7	. . . SCREW, ALTERED FROM NAS333PA10 ----X----	2	35	
- 52	NAS179A3	. . . NUT, (80205) 96-37545-102	24	35	
- 53	AN3-A	. . . BOLT (88044)	16	35	
	AN3-A	. . . BOLT (88044)	8	C	
	AN3-A	. . . BOLT (88044)	8	B	
- 54	NAS675A4	. . . NUT, (80205) 96-37545-103	2	35	
- 55	AN179-6A	. . . BOLT (88044)	2	35	
- 56	B-74434-7	. . . SILL, WINDSHIELD LH	1	C	
	B-74434-11	. . . SILL, WINDSHIELD LH	1	H	
- 57	B-74434-9	. . . SILL, WINDSHIELD RH	1	C	
	B-74434-12	. . . SILL, WINDSHIELD RH	1	B	
- 58	B-74440-1A	. . . BODY, LH	1	35	
	B-74440-1B	. . . BODY, RH	1	35	
	NAS333PA4	. . . BOLT, LH (80205)	9	35	
- 59	NAS333FA	. . . BOLT, LH (80205) ----X----	6	35	
- 61	B-74441-5A	. . . BASKET, LH	1	35	
	B-74441-5B	. . . BASKET, RH	1	35	
- 62	B-74445-7	. . . FILLER, WINDSHIELD FRAME LOWER AFT LH	1	35	
- 63	B-74445-10	. . . FILLER, WINDSHIELD FRAME LOWER AFT RH ATTACHING PARTS	1	35	
- 64	MS24654-01	. . . SCREW (86906) ----Y----	4	35	
- 65	3591-30NX1734	. . . INSERT, <91767> 95-03003-017	4	35	
- 66	B-74437-11	. . . FITTING, WINDSHIELD FRAME LOWER AFT LH	1	35	
- 67	B-74437-10	. . . FITTING, WINDSHIELD FRAME LOWER AFT RH ATTACHING PARTS	1	35	
- 68	NAS179A3	. . . NUT, (80205) 96-37545-102	4	35	
- 69	AN3-A	. . . BOLT (88044)	2	35	
- 70	MS24654-01	. . . SCREW (86906)	2	35	
- 71	MS24654-01	. . . SCREW (86906) ----X----	2	35	
- 72	3591-30NX1734	. . . INSERT, <91767> 95-03003-017	2	35	
- 73	B-74432	. . . FRAME, WINDSHIELD AFT	1	35	
	B-74432-7	. . . FRAME, WINDSHIELD AFT	1	9J	

-- AIRPLANES 449 50 AND ON
C AIRPLANES 435 THRU 47 AND 49 THRU 89

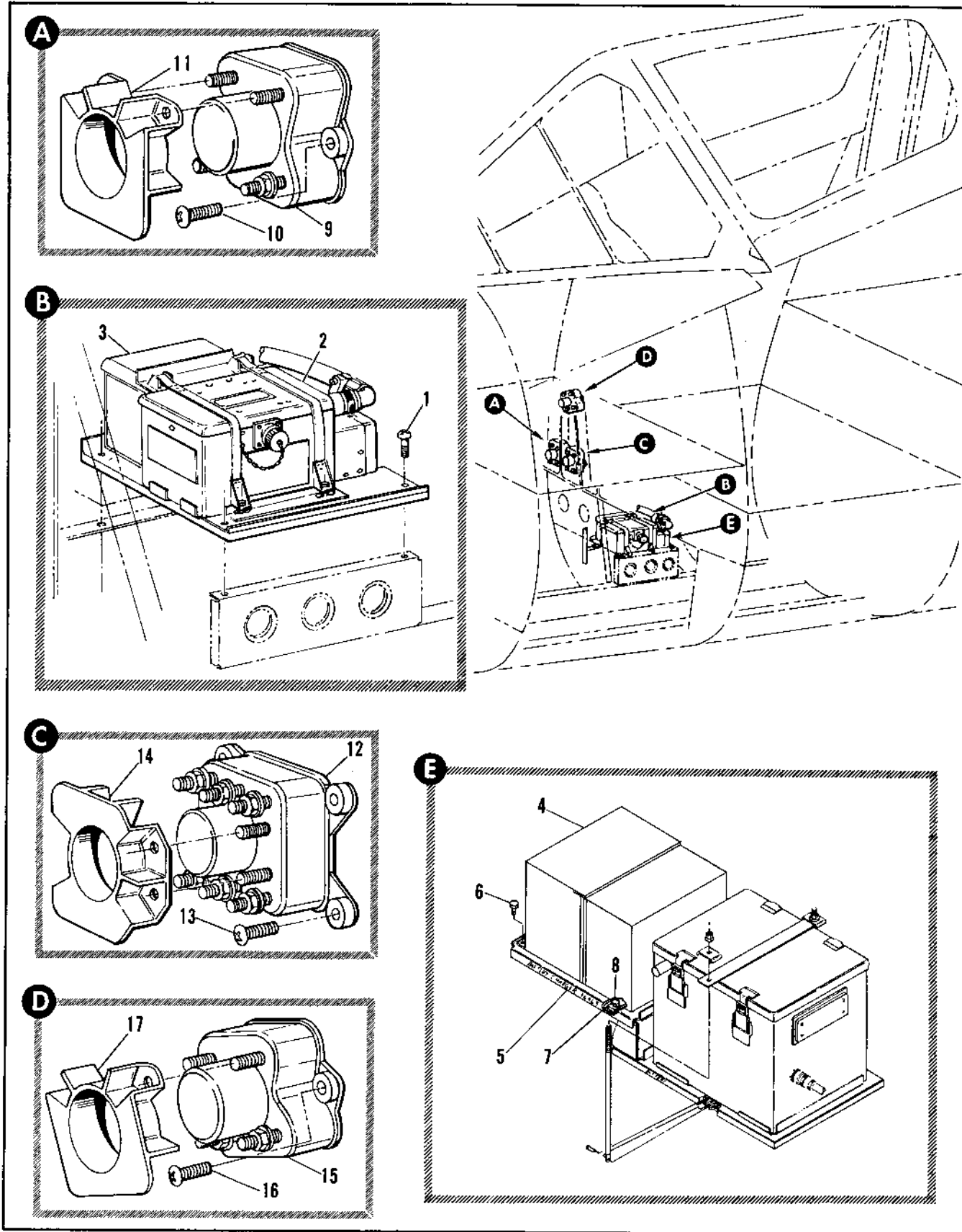

Figure 2.4-3. Canopy Electrical Equipment

FIGURE AND INDEX NUMBER	PART NUMBER	DESCRIPTION	UNITS PER ASSY.	USABLE ON CODE	
				FROM	TO
2.4-3		1 2 3 4 5 6 CANOPY ELECTRICAL EQUIPMENT			
	8-65153-1	• CONTROL UNIT INSTL, CANOPY	RF	35	
	7242435-10	• EQUIPMENT INSTL, NW LOWER (98750) MODIFICATION	1	35	
	P496A	• CONTROL UNIT ASSY, CANOPY DC POWER SUPPLY <80795> SPEC 8-66450-1	RF	35	
		ATTACHING PARTS			
- 1	MS51958-61	• SCREW (98906)	RF	35	
		----X----			
- 2	5001414	• BATTERY, <80795> SPEC 8-66450-7	RF	35	
		T.O. 1F-106A-4			
- 3	624-	• BATTERY, <87362> ALT-INTCHG WITH 5001414	RF	35	
	63E35510-1	• TRANSFORMER RECTIFIER (98750) ASSY, SPEC 8-66450-3	RF	35	
- 4	464691-100	• BATTERY CHARGER (40377) GFAF AF INSTALLED	1	35	
- 5	7242435-10	• SHELF ASSY (98750) ATTACHING PARTS	1	35	
- 6	AN3-34	• BOLT (88044)	6	35	
		----X----			
- 7	7242435-10	• SUPPORT (98750) ATTACHING PARTS	1	35	
- 8	AN3-34	• BOLT (88044)	2	35	
		----X----			
	8-65154-1	• RELAY INSTL, CANOPY	1	A	
	8-65154-3	• RELAY INSTL, CANOPY	1	B	
- 9	MS2414002	• RELAY, CANOPY DOWN ACTUATOR MOTOR (98906)	1	35	
		ATTACHING PARTS			
- 10	MS35277-204	• SCREW (98906)	2	A	
	MS2414002	• SCREW (98906)	2	B	
		----X----			
- 11	49-2467-2	• COVER, RELAY <15605> 92-74400-001	1	35	
- 12	6042H21	• RELAY ASSY, CANOPY CLUTCH DISENGAGE <15605> 97-38522-013	1	35	
		ATTACHING PARTS			
- 13	MS51958-64	• SCREW (98906)	4	A	
	MS51958-65	• SCREW (98906)	4	B	
		----X----			
- 14	49-2467-2	• COVER, RELAY <15605> 92-74400-002	1	35	
- 15	MS2414002	• RELAY, CANOPY UP ACTUATOR MOTOR (98906)	1	35	
		ATTACHING PARTS			
- 16	MS51958-64	• SCREW (98906)	2	A	
	MS35277-204	• SCREW (98906)	2	B	
		----Y----			
- 17	49-2467-2	• COVER, RELAY <15605> 92-74400-001	1	35	
		A AIRPLANES #35 THRU 47 AND 49 THRU 59			
		B AIRPLANES #98, 99 AND ON			

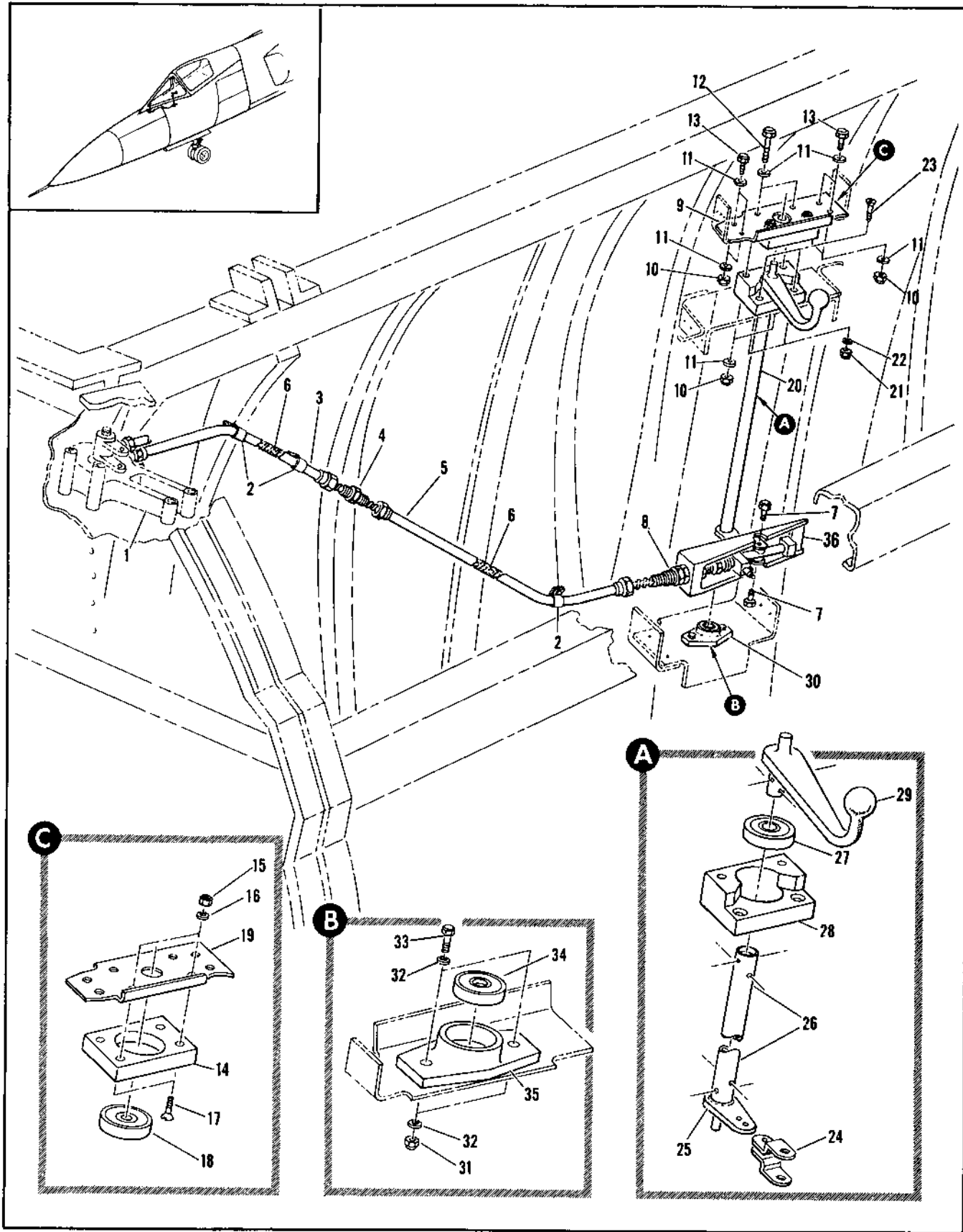

Figure 2.4-4. Canopy Latch Control Installation

FIGURE AND INDEX NUMBER	PART NUMBER	DESCRIPTION	UNITS PER ASSY.	USABLE ON CODE	
				FROM	TO
2.4-4	8-95811	CONTROL INSTALLATION, CANOPY LATCH FOR NHA SEE FIG. 2.4-8 INDEX 11	RF	35	129
- 1		• CONTROL ASSY, CANOPY LATCH TELEFLEX SEE FIG. 2.4-12 INDEX 45	RF		
- 2	45576	• SUPPORT, <78710> 98-59800-001 ATTACHING PARTS	3	35	129
	NAS679A3	• NUT (#8205)	1	35	129
	AN981PD10L	• WASHER (#89044)	3	35	129
	NAS221-7	• SCREW (#0205)	3	35	129
- 3	8-95910-07	• CONDUIT ASSEMBLY	1	35	89
- 4	8-95910-15	• CONDUIT ASSEMBLY	1	90	129
- 4	A6329	• RIFLE <78710> 96-29000-801	1	35	129
- 5	8-95910-05	• CONDUIT ASSEMBLY	1	35	89
- 5	8-95910-63	• CONDUIT ASSEMBLY	1	90	129
- 6		• CABLE, SEE FIG. 2.4-12 INDEX 5	RF		
- 7	AN3TYPE	• BOLT, FURNISHED WITH 13637	RF	35	129
- 8	13637	• CONTROL ASSY, TELESCOPIC UNIT <78710> SPEC 8-09424-9 T.O.16L1-5-14-3 REPLACED BY NOT INTCHG WITH 15663	1	35	129
- 9	8-95910-27	• BEARING ASSEMBLY ATTACHING PARTS	1	35	129
- 10	NAS679A3	• NUT (#8205)	6	35	129
- 11	AN981PD10L	• WASHER (#89044)	12	35	129
- 12	AN3C16A	• BOLT (#8044)	2	35	129
- 13	AN3-4A	• BOLT (#8044)	4	35	129
- 14	8-95917	• BLOCK, TORQUE TUBE UPPER BEARING ATTACHING PARTS	1	35	129
- 15	NAS679A3	• NUT (#8205)	2	35	129
- 16	AN981PD10L	• WASHER (#89044)	2	35	129
- 17	MS24694-052	• SCREW (#8016)	2	35	129
- 18	MS27441-6	• BEARING (#8906)	1	35	129
- 19	8-95910-11	• SUPPORT	1	35	129
- 20	8-95910-08	• HANDLE ASSY, CANOPY LATCH CONTROL ATTACHING PARTS	1	35	129
- 21	NAS679A3	• NUT (#8205)	2	35	129
- 22	AN981PD10L	• WASHER (#89044)	2	35	129
- 23	MS24694-054	• SCREW (#8016)	2	35	129
- 24	14347	• TRUNNION, <78710> SPEC 8-09424-7 T.O.16L1-5-14-3 REPLACED BY NOT INTCHG WITH 15273	2	35	129
- 25	8-95911-5	• ARM, MAKE FROM 8-95911-9	1	35	129
- 25	8-95911-9	• ARM	RF		
- 26	8-95918	• TUBE, CANOPY LATCH HANDLE TORQUE	1	35	129
- 26	8-95910-29	• BEARING ASSEMBLY	1	35	129
- 27	MS27441-3	• BEARING (#8906)	1	35	129
- 28	8-95916	• BLOCK	1	35	129
- 29	8-95915-7	• HANDLE, CANOPY LATCH RELEASE	1	35	129
- 29	8-95915-4	• SUPPORT	1	35	129
- 29	8-95910-13	• CLIP	2	35	129
- 30	8-95910-30	• BEARING ASSEMBLY ATTACHING PARTS	1	35	129
- 31	NAS679A3	• NUT (#8205)	2	35	129
- 32	AN981PD10L	• WASHER (#89044)	4	35	129
- 33	AN3-5A	• BOLT (#8044)	2	35	129
- 34	MS27445-6	• BEARING (#8906)	1	35	129
- 35	8-95913	• RETAINER, TORQUE TUBE BEARING	1	35	129
- 36	8-95922-11	• SUPPORT, CANOPY LATCH HANDLE MAKE FROM 8-95922	1	35	129
	8-95922	• SUPPORT	RF		

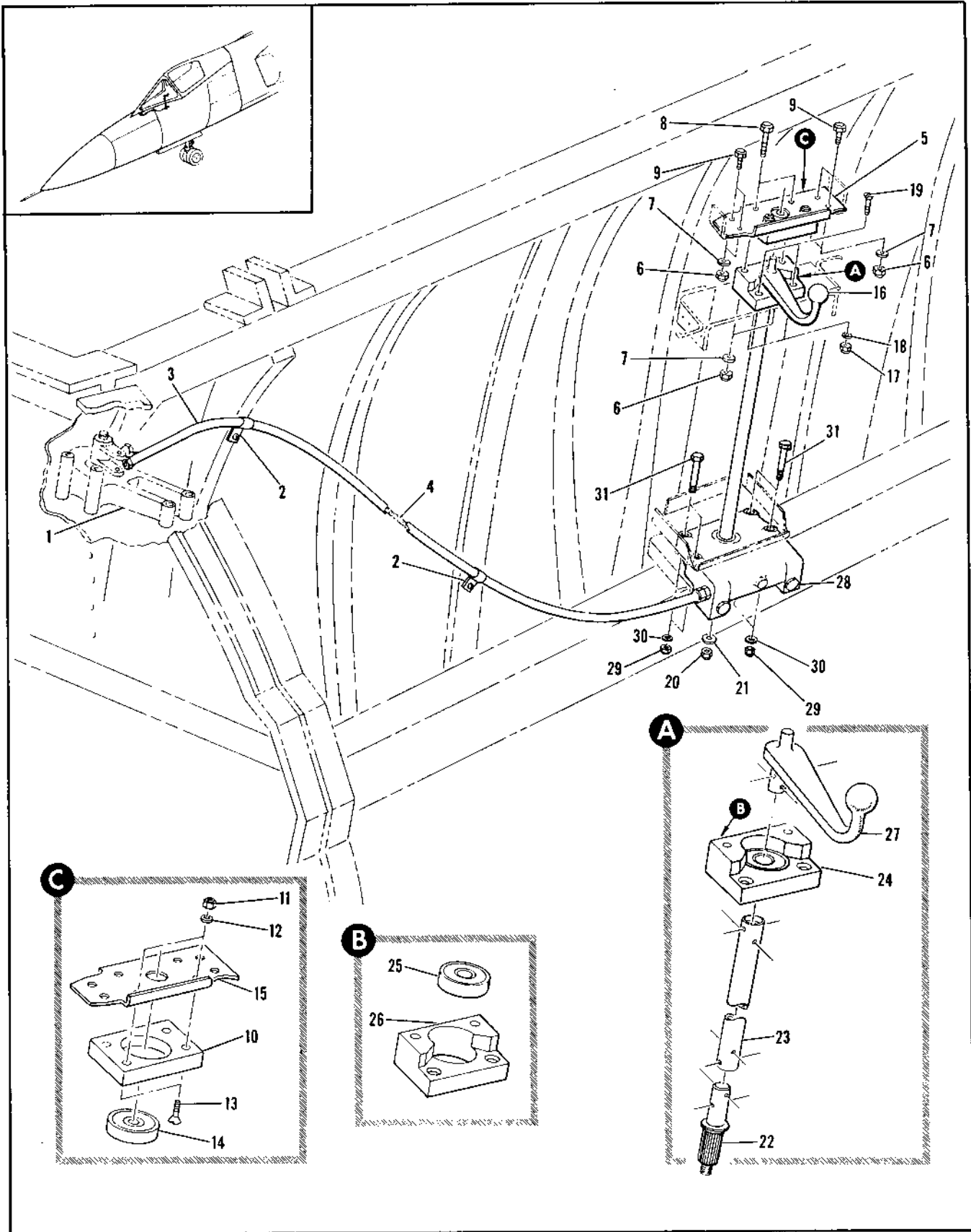

Figure 2.4-5. Canopy Latch Control Installation

FIGURE AND INDEX NUMBER	PART NUMBER	DESCRIPTION	UNITS PER ASSY.	USABLE ON CODE	
				FROM	TO
2.4-5	8-95712	CONTROL INSTALLATION, CANOPY LATCH FOR NHA SEE FIG. 2.3-H	RF	130	
- 1		• CONTROL ASSY, CANOPY LATCH TELEFLEX SEE FIG. 2.4-12 INDEX 46	RF		
- 2	AS50-	• SUPPORT, <78710> 98-59600-001 ATTACHING PARTS	2	130	
	NAS102203	• NUT (80205)	2	130	
	MS35206-67	• SCREW (96906) -----X-----	2	130	
- 3	8-95693-23	• CONDUIT ASSEMBLY	1	130	
- 4		• CABLE, SEE FIG. 2.4-12 INDEX 5	RF		
- 5	8-95910-37	• REARING ASSY, CANOPY LATCH HANDLE ATTACHING PARTS	1	130	
- 6	NAS679A7	• NUT (80205)	6	130	
- 7	AN960PD10L	• WASHER (88044)	6	130	
- 8	AN3015A	• BOLT (80044)	2	130	
- 9	AN3-4A	• BOLT (80044) -----X-----	4	130	
- 10	8-95717	• BLOCK, TORQUE TUBE UPPER REARING ATTACHING PARTS	1	130	
- 11	NAS679A3	• NUT (80205)	2	130	
- 12	AN960PD10L	• WASHER (88044)	2	130	
- 13	MS24694-49	• SCREW (96906) -----X-----	2	130	
- 14	MS27541-6	• BEARING (96906)	1	130	
- 15	8-95910-11	• SUPPORT	1	130	
- 16	8-95913-21	• HANDLE ASSEMBLY ATTACHING PARTS	1	130	
- 17	NAS679A7	• NUT (80205)	2	130	
- 18	AN960PD10L	• WASHER (88044)	2	130	
- 19	MS24694-054	• SCREW (96906)	2	130	
- 20	NAS67906	• NUT, FURNISHED WITH 15663	RF	130	
- 21	AN9600516L	• WASHER, FURNISHED WITH 15663 -----X-----	RF	130	
- 22	15663	• SHAFT, CONTROL CANOPY LATCH 100 TOOTH <78710> SPEC 8-09649-3 REPLACES NOT INTCHG WITH 13637	1	130	
- 23	8-95919-7	• TUBE, CANOPY LATCH HANDLE TORQUE	1	130	
- 24	8-95911-30	• BEARING ASSY, CANOPY LATCH HANDLE	1	130	
- 25	MS27641-8	• BEARING (96906)	1	130	
- 26	8-95716	• BLOCK, CANOPY LATCH HANDLE	1	130	
- 27	8-95915-7	• HANDLE, CANOPY LATCH RELEASE	1	130	
- 28	15273	• PKG ASSY, CONTROL CANOPY LATCH 100 TOOTH <78710> SPEC 8-09649-1 T.O. 16L1-5-15-3 REPLACES NOT INTCHG WITH 14390 ATTACHING PARTS	1	130	
- 29	NAS679A7	• NUT (80205)	4	130	
- 30	AN960PD10L	• WASHER (88044)	4	130	
- 31	AN3-13A	• BOLT (80044) -----X-----	4	130	

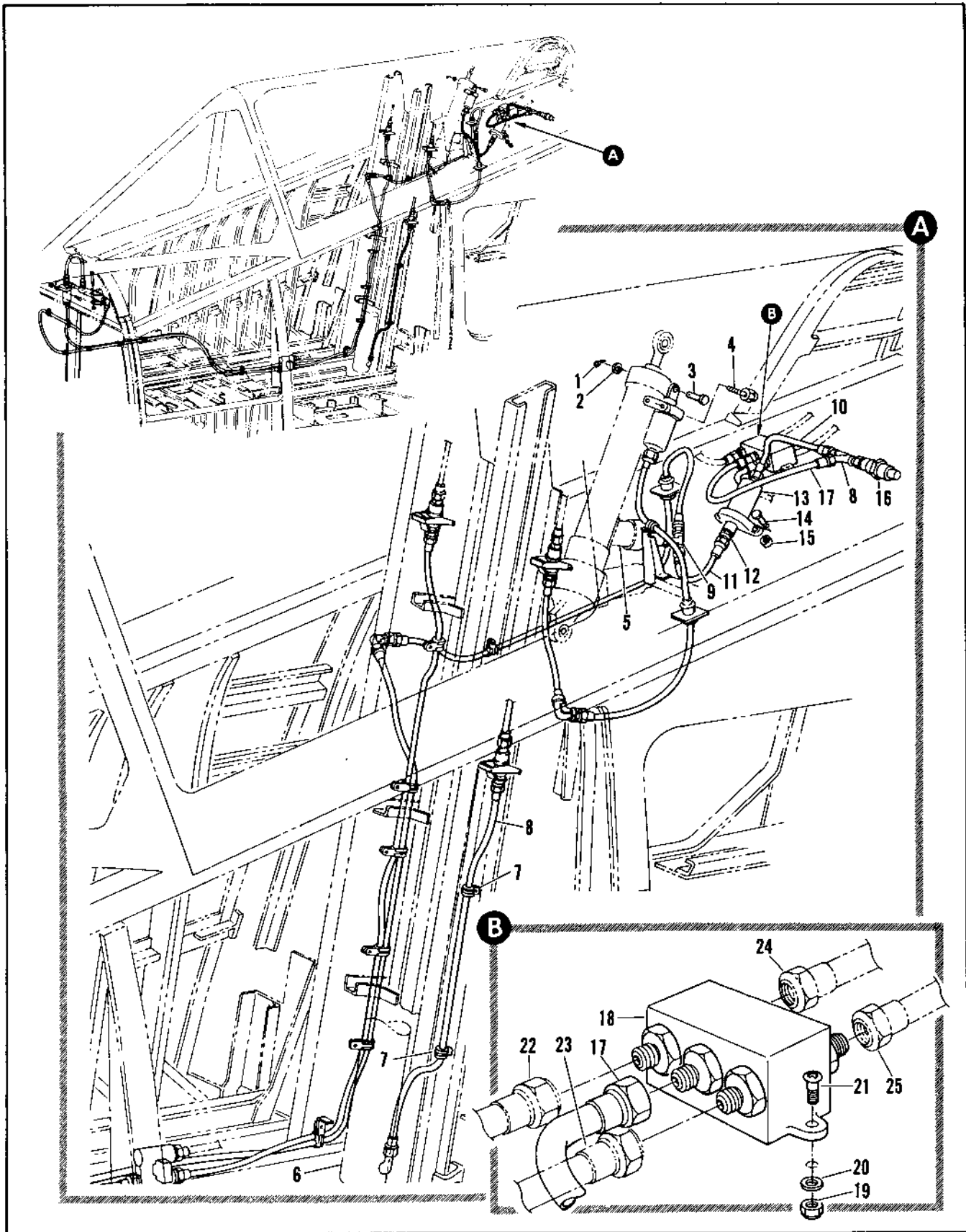

Figure 2.4-6. Cartridge Powered Canopy Jettison Installation

FIGURE AND INDEX NUMBER	PART NUMBER	DESCRIPTION	UNITS PER ASSY.	USABLE ON CODE	
				FROM	TO
2.4-6	94-3-1	• INITIATOR, M3A1 GFAC AERNO 93-0316 (19200)	1	35	
	94-3-1	• INITIATOR M3A2 GFAC AERNO 93-0316 (19200) ALT INTCHG WITH INITIATOR, M3A1 ATTACHING PARTS			
- 1	MS24669-132	• PIN (96006)	1		
- 2	AN967-10	• WASHER (88144)	1		
- 3	MS20342-2-11	• PIN (56006)	1		
- 4	AN482A	• BOLT (88044) ----X----	2		
- 5		• REMOVER, ELECTRICAL CANOPY SEE FIG. 2.4-12 INDIX 12R	RF		
- 6		• CATAPULT, EJECTION SEAT TYPE MK-1 SEE FIG. 2.4-11	RF		
- 7	MS2191900F	• CLAMP (94076) ATTACHING PARTS	2		
	NAS679A3	• NUT (80005)	2		
	AN961D10L	• WASHER (88144)	2		
	MS51958-61	• SCREW (96006) ----X----	2		
- 8	806672-401	• HOSE ASSY, SEAT JETTISON LOWER LH QUICK DISCONNECT TO MK-1 CATAPULT	1	35	
	43804-4-0340	• HOSE ASSY, TETRAFLUOROETHYLENE <50599> 94-0505-017	1	35	
- 9	MS24339-4	• TEE (96006)	2		
	AN924-4	• NUT (88144)	2		
	AN6290-4	• GASKET (88144)	2		
- 10	8-94016-107	• HOSE ASSY, CANOPY JETTISON	1		
	R3800-4-0107	• HOSE ASSY, TETRAFLUOROETHYLENE <50599> 94-0505-050	1		
- 11	8-94016-106	• HOSE ASSY, CANOPY JETTISON	1		
	R3800-4-0107	• HOSE ASSY, TETRAFLUOROETHYLENE <50599> 94-0505-053	1		
- 12	MS24190-4	• UNION (96006)	1		
		• GASKET (88144)	1		
- 13	94-3-11	• INITIATOR, M3A2 GFAC AERNO 93-0316 (19200) • INITIATOR, CARTRIDGE ACTUATED AERNO93-0318 TYPE M3A2 GFAC ALT INTCHG WITH 94-3-11 ATTACHING PARTS	RF	35	
- 14	AN4-11A	• BOLT (88144) ----X----	2		
- 15	8-94106-10	• SPACER	2		
- 16	8734	• CUTTER, CABLE <45598> SPEC 8-06437-3 T.O. 13410-2-3	1		
- 17	8-94016-106	• HOSE ASSY, CANOPY JETTISON	1		
	R3800-4-0140	• HOSE ASSY, TETRAFLUOROETHYLENE <45598> 94-0505-001	1		
- 18	8637	• FITTING ASSY, BREAKAWAY <45598> SPEC 8-02486-1 ATTACHING PARTS	1		
- 19	NAS679A3	• NUT (80005)	2		
- 20	AN960-10	• WASHER (88044)	2		
- 21	NAS221-9	• SCREW (80205) ----X----	2		
- 22		• TUBE ASSY, QUICK DISCONNECT SEE FIG. 2.9-7	RF		
- 23		• TUBE ASSY, SELECTOR VALVE SEE FIG. 2.9-7	RF		
- 24		• HOSE ASSY, COCKPIT SAFETY VALVE SEE FIG. 2.9-7	RF		
- 25		• HOSE ASSY, CANOPY SEAL SEE FIG. 2.9-9	RF		

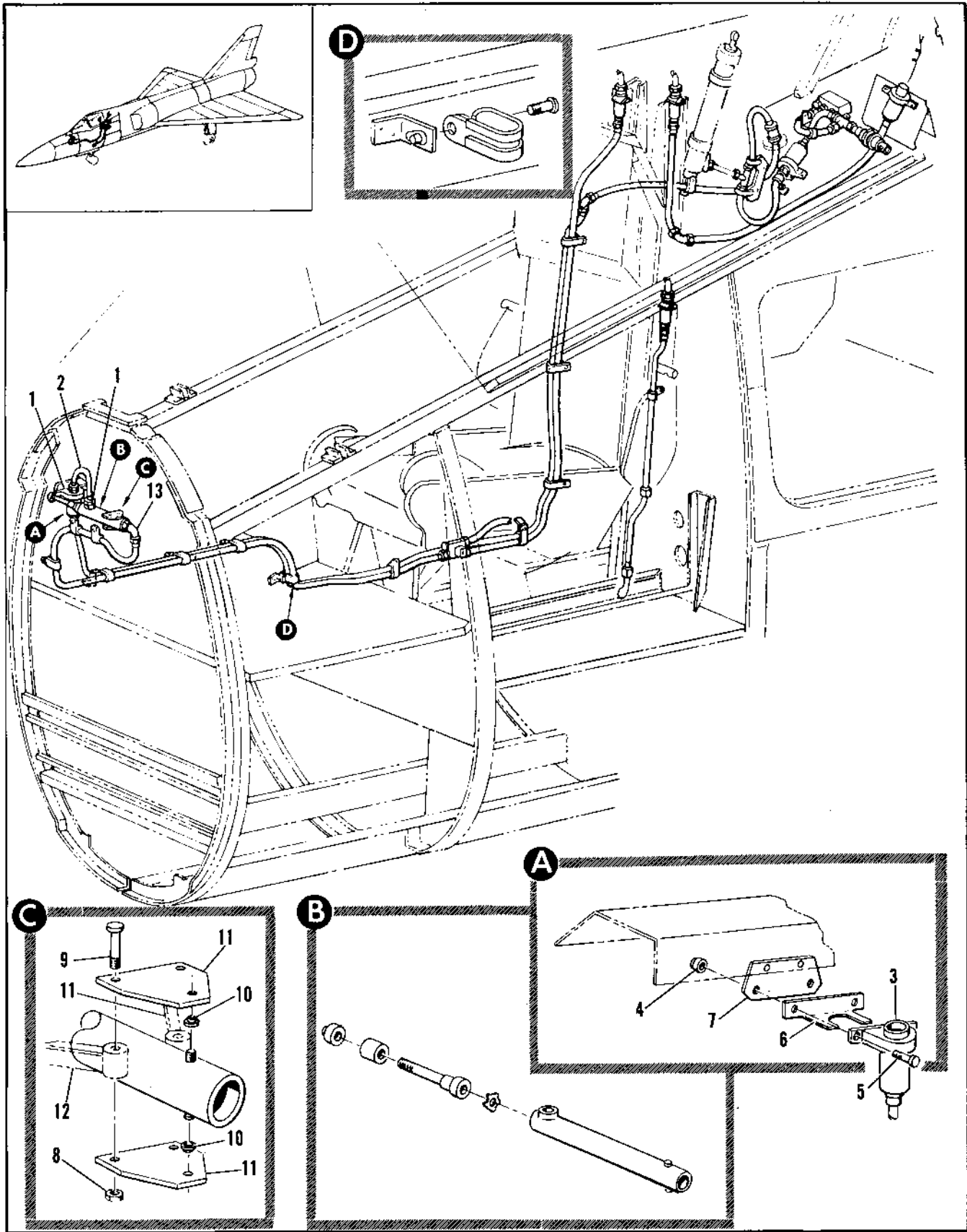

Figure 2.4-7. Canopy and Seat Ejection Hose Installation (Sheet 1 of 5)

FIGURE AND INDEX NUMBER	PART NUMBER	DESCRIPTION	UNITS PER ASSY.	USABLE ON CODE	
				FROM	TO
		1 2 3 4 5 6			
2.4-7	R-94166-001	HOSE INSTALLATION, CANOPY AND SEAT JETTISON MODIFIED BY 8-31993 FOR NHA SEE FIG. 2.3-3	1	A	
	R-94166-005	HOSE INSTALLATION, CANOPY AND SEAT JETTISON MODIFIED BY 8-31993 FOR NHA SEE FIG. 2.3-3	1	B	
	R-94166-007	HOSE INSTALLATION, CANOPY AND SEAT JETTISON MODIFIED BY 8-31993 AND 8-95882 FOR NHA SEE FIG. 2.3-3	1	C	
	R-94166-008	HOSE INSTALLATION, CANOPY AND SEAT JETTISON MODIFIED BY 8-31993 FOR NHA SEE FIG. 2.3-3	RF	D	
	R-94166-009	HOSE INSTALLATION, CANOPY AND SEAT JETTISON FOR NHA SEE FIG. 2.0-3	RF	27B	
	R-94166-010	JETTISON INSTALLATION, CARTRIDGE POWERED CANOPY FOR NHA SEE FIG. 2.1-1	1	G	
	R-94166-011	JETTISON INSTALLATION, CARTRIDGE POWERED CANOPY FOR NHA SEE FIG. 2.1-1	RF	ALL	
- 1	MS24372-4	• UNION (76906)	2	35	
	AN29-4	• GASKET (88044)	2	35	
- 2	R-94214-071	• HOSE ASSY, CANOPY JETTISON	1	35	
	R3808-4-0107	• HOSE ASSY, TETRAFLUOROETHYLENE <50599> 94-AC505-033	1	35	
- 3	94-3-11	• INITIATOR, M5A2 GFAL AERNO 93-318 (19250)	RF	35	
		• INITIATOR, CARTRIDGE ACTUATED AERNO93-3518 TYPE HEAD GFAL ALT INTCMG WITH 94-3-11 ATTACHING PARTS	RF	189	
- 4	NAS679A4	• NUT (80235)	2	35	
- 5	AN4-4	• BOLT (88044)	2	35	
		-----X-----			
- 6	R-94166-031	• BRACKET	1	35	
- 7	R-94166-032	• PLATE	1	35	
	R-94112	• PLATE ASSY, TRUNNION CANOPY LATCH MECHANISM ATTACHING PARTS	2	35	
- 8	NAS679A7	• NUT (80235)	2	35	
	MS21078-3	• NUT PLATE (96906)	2		
	MS20426D3-6	• RIVET (96956)	4	35	
- 9	AN3-17A	• BOLT (88044)	2	35	
		-----X-----			
- 10	NAS77A4-10	• RUSHING (80235)	2	35	
- 11	R-94112-7	• TRUNNION	2	35	
- 12		• CONTROL ASSY, CANOPY LATCH TELEFLEX SEE FIG. 2.4-12	RF		
- 13	MS24394-4	• ELPOW (96956)	1	35	
	AN924-4	• NUT (88044)	1	35	
	AN6290-4	• GASKET	1	35	
		A AIRPLANES #35 THRU 47 AND 49 THRU 89			
		B AIRPLANES #46 AND 90 THRU 129			
		C AIRPLANES #130 THRU 242, 244, 245, 247, 249, AND 259			
		D AIRPLANES #243, 246, 248, 250 THRU 258, AND 270 THRU 277			
		G AIRPLANES #35 THRU 242, 244, 245, 247, 249, AND 25.			

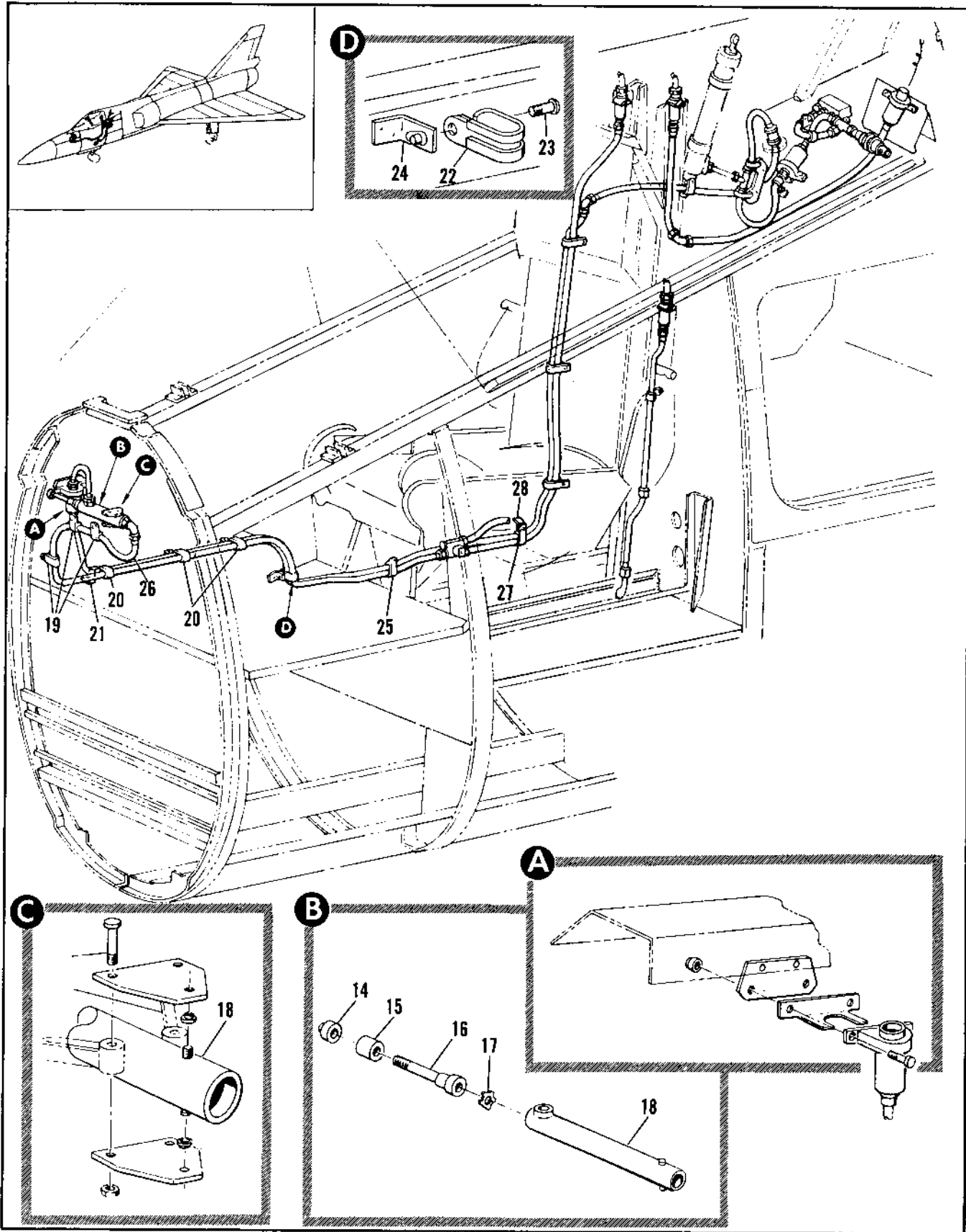

Figure 2.4-7. Canopy and Seat Ejection Hose Installation (Sheet 2 of 5)

FIGURE AND INDEX NUMBER	PART NUMBER	DESCRIPTION	UNITS PER ASSY.	USABLE ON CODE	
				FROM	TO
		1 2 3 4 5 6			
2.4-7- 14	AN310-4	• NUT (88144)	1	35	
- 15	NAS43HT4-32	• SPACER (80205)	1	35	
- 16	R-94113	• EXTENSION, CANOPY LATCH THRUSTER	1	35	
- 17	R-94118	• WASHER, THRUSTER	1	35	
- 18	94-4-14	• THRUSTER, M3A1 CANOPY JETTISON GFAE AFRNO 93-0742 (19200) WHEN RE-PLACED, INSTALL THRUSTER M3A3	1	35	
	8594491	• THRUSTER M3A2 CANOPY JETTISON GFAE AFRNO 93-074- (19200) WHEN REPLACED INSTALL THRUSTER M3A3	1	35	
	11022029	• THRUSTER, M3A3 CANOPY JETTISON GFAE AFRNO 93-0742 (19200)	1	35	
- 19	MS21915001	• CLAMP (96906) ATTACHING PARTS	3	35	
	NAS679A3	• NUT (80205)	3	35	
	AN967D11L	• WASHER (88044)	3	35	
	MS51958-F1	• SCREW (96906) -----X-----	3	35	
- 20	443-5-2-F	• CLAMP, <00502> 91-98004-001 ATTACHING PARTS	3	35	
	NAS679A3	• NUT (80205)	3	35	
	MS51958-F1	• SCREW (96906) -----X-----	3	35	
- 21	R-94166-25	• BRACKET	1	35	
- 22	443-5-2-F	• CLAMP, <00502> 91-98004-001 ATTACHING PARTS	1	35	
- 23	MS51958-F1	• SCREW (96906) -----X-----	1	35	
- 24	90-93505-001	• BRACKET, 90-93505-001	1	35	
- 25	443-5-2-F	• CLAMP <00502> 91-98004-001 ATTACHING PARTS	1	35	
	NAS679A3	• NUT (80205)	1	35	
	MS51958-F1	• SCREW (96906) -----X-----	1	35	
- 26	R-94166-24	• HOSE ASSY, CANOPY JETTISON	1	35	
	R3600-4-0830	• HOSE ASSY, TETRAFLUOROETHYLENE <50549> 94-80505-025	1	35	
- 27	443-5-2-F	• CLAMP, <00502> 91-98004-001 ATTACHING PARTS	1	35	
	NAS679A3	• NUT (80205)	1	35	
	MS51958-F1	• SCREW (96906) -----X-----	1	35	
- 28	R-94166-27	• CLIP	1	35	

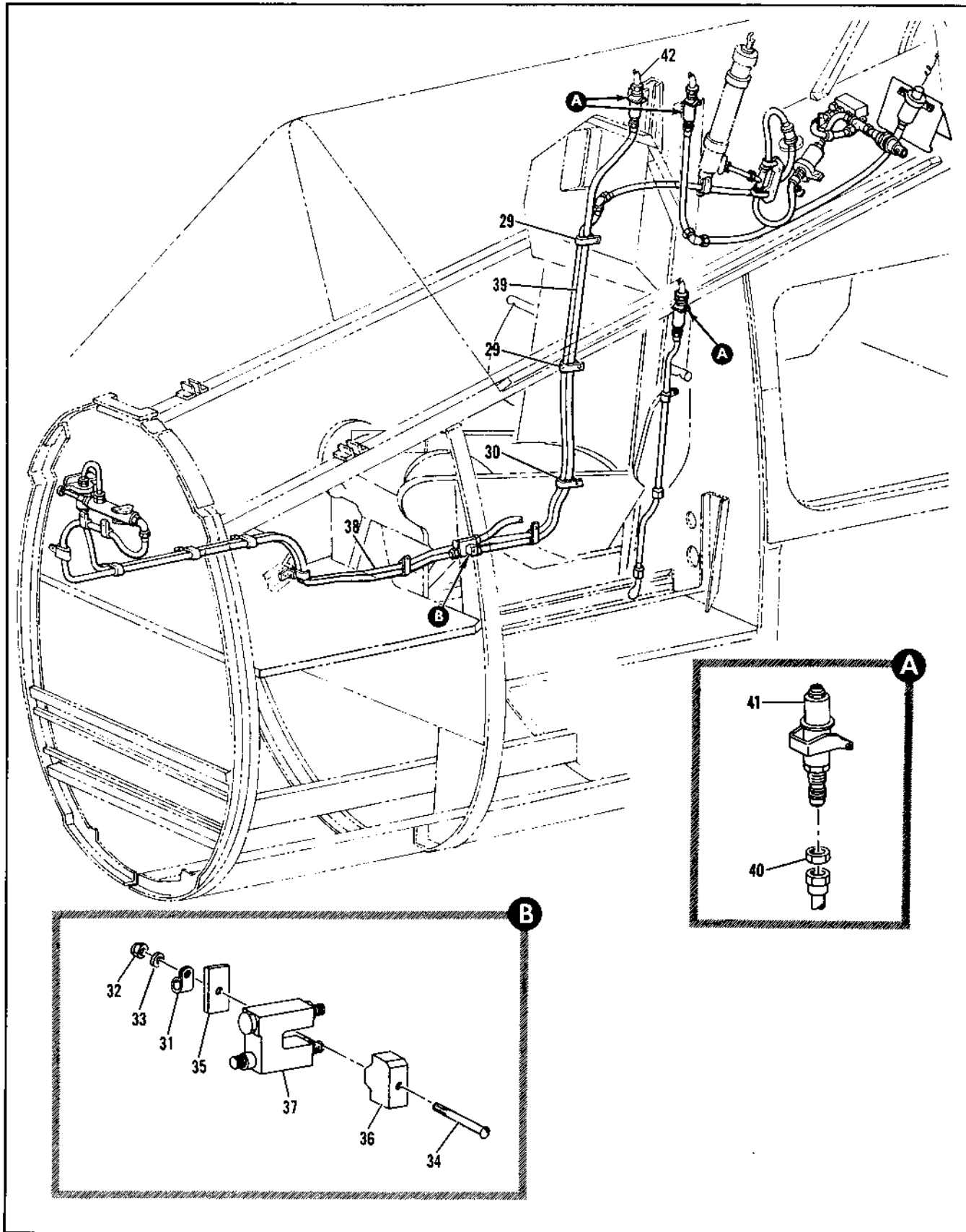

Figure 2.4-7. Canopy and Seat Ejection Hose Installation (Sheet 3 of 5)

FIGURE AND INDEX NUMBER	PART NUMBER	DESCRIPTION 1 2 3 4 5 6	UNITS PER ASSY.	USABLE ON CODE	
				FROM	TO
2.4-7- 29	443-5-2-8	• CLAMP, <00502> 91-98104-001 ATTACHING PARTS	2	35	
	MS51956-61	• SCREW (98906) ----X----	2	35	
- 30	443-5-2-8	• CLAMP, <00502> 91-98104-001 ATTACHING PARTS	1	35	
	NAS1103-1	• BOLT (80205) ----X----	1	35	
- 31	MS21919001	• CLAMP (56906) ATTACHING PARTS	1	35	
- 32	NAS470A7	• NUT (80205)	1	35	
- 33	AN565-10	• WASHER (88044)	1	35	
- 34	AN3-21A	• BOLT (88044) ----X----	1	35	
- 35	8-94166-15	• PLATE	1	35	
- 36	8-94166-13	• SPACER	1	35	
- 37	4C127-1	• VALVE ASSY, PNEUMATIC ESCAPE SYSTEM CHECK <82829> SPEC 8-09349-7 T.O. 9P5-12-31-13 REPLACES INTCHG WITH 4C127	1	35	
	4C127	• VALVE ASSY, PNEUMATIC ESCAPE SYSTEM CHECK <<82829> SPEC 8-09349-5 T.O. 9P5-12-31-13 REPLACED BY INTCHG WITH 4C127-1	RF	189	
- 38	8-94166-817	• HOSE ASSY, CANOPY JETTISON	1	35	
	R3800-4-1180	• HOSE ASSY, TETRAFLUOROETHYLENE <50599> 94-80505-021	1	35	
- 39	8-94166-897	• HOSE ASSY, CANOPY JETTISON RH QUICK DISCONNECT TO CHECK VALVE	1	35	
	R3800-4-1180	• HOSE ASSY, TETRAFLUOROETHYLENE <50519> 94-80508-016	1	35	
- 40	AN929-4	• NUT (88044)	1	35	
- 41	R401-3	• COUPLING ASSY, QUICK DISCONNECT <45598> SPEC 8-19367-1	3	35	
- 42		• HOSE ASSY, BALLISTIC	RF		

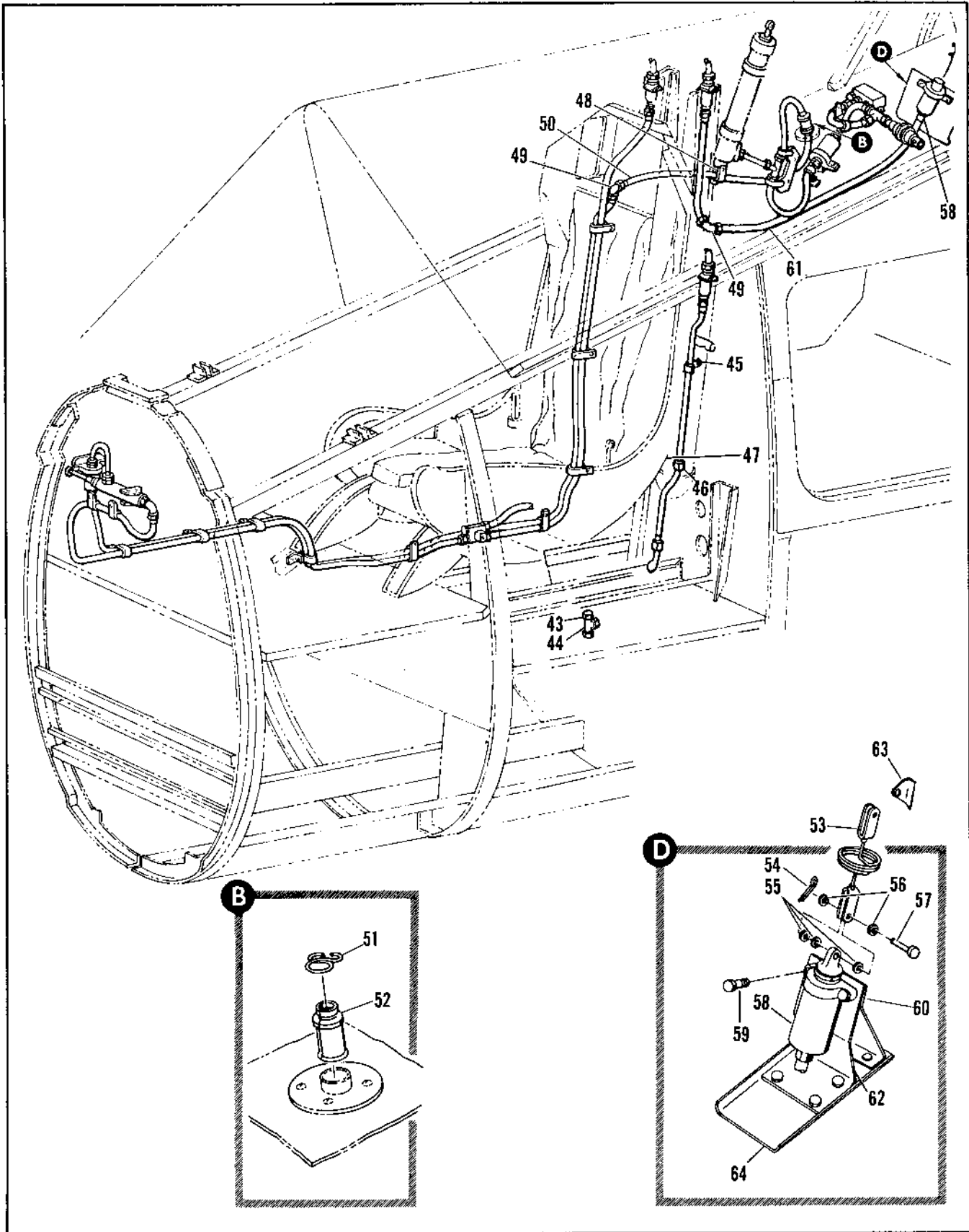

Figure 2.4-7. Canopy and Seat Ejection Hose Installation (Sheet 4 of 5)

FIGURE AND INDEX NUMBER	PART NUMBER	DESCRIPTION	UNITS PER ASSY	USABLE ON CODE	
				FROM	TO
		1 2 3 4 5 6			
2.4-7- 43	AN924-4	• CAP (88044)	1		
- 44	AN924-4	• TEE (88044)	1	35	
	AN924-4	• NUT (88044)	1	35	
	AN620-4	• GASKET (88044)	1	35	
	AN620-711L	• WASHER (88044)	2	35	
- 45	MS21919D05	• CLAMP (96906)	2	35	
- 46	MS35469-71	• GROMMET (96916)	2	35	
- 47	80349B-413	• SEAT ASSY, UPWARD EJECTION	RF		
- 48	MS21919D05	• CLAMP (96906)	1	35	
	AN924-4	• NUT (88044)	2	35	
	AN620-4	• GASKET (88044)	2	35	
	AN620-711	• WASHER (88044)	2	35	
- 49	YS24354-4	• ELBOW (96916)	2	35	
- 50	8-94816-611	• HOSE ASSY, CANOPY JETTISON	1	35	
	83601-4-136	• HOSE ASSY, TETRAFLUOROETHYLENE <50599> 94-80505-503	1	35	
- 51	511L110	• CLIP, <74687> 94-04900-001	1	35	
- 52	8-94816	• SEAL, BALLISTIC HOSE	1	35	
- 53	7239627-10	• LANYARD ASSY, SWAGED (98750)	1	35	
	64030020-1	• LANYARD ASSY (98750)	RF	35	
		ATTACHING PARTS			
- 54	MS24665-157	• PIN, CUTTER (96906)	2	35	
- 55	AN960-10	• WASHER (88044)	4	35	
- 56	AN960-10L	• WASHER (88044)	6	35	
- 57	MS20392-2-13	• PIN (96906)	2	35	
		-----X-----			
- 58	74-3-1	• INITIATOR, M5A1 OFAE AFENO 53-0316 (19200)	1	35	
		• INITIATOR M5A2 OFAE AFENO 93-0316 (19200) ALT INTER- CHANGEABLE WITH INITIATOR, M5A1			
		ATTACHING PARTS			
- 59	AN4-8A	• BOLT (88044)	2	35	
		-----X-----			
- 60	6403011-7	• BRACKET, SLAT ARMING INITIATOR (98750)	1	35	
- 61	8-94816-611	• HOSE ASSY, CANOPY JETTISON	1	35	
	83601-4-1285	• HOSE ASSY, TETRAFLUOROETHYLENE <50599> 94-80505-020	1	35	
- 62	6403011-7	• BRACKET, FORWARD, SEAT ARMING INITIATOR (98750)	1	35	
- 63	64030121-7	• BRACKET, LANYARD, SLAT ARMING INITIATOR (98750)	1	35	
- 64	64030122-7	• STIFFENER, BRACKET SEAT ARMING INITIATOR (98750)	1	35	

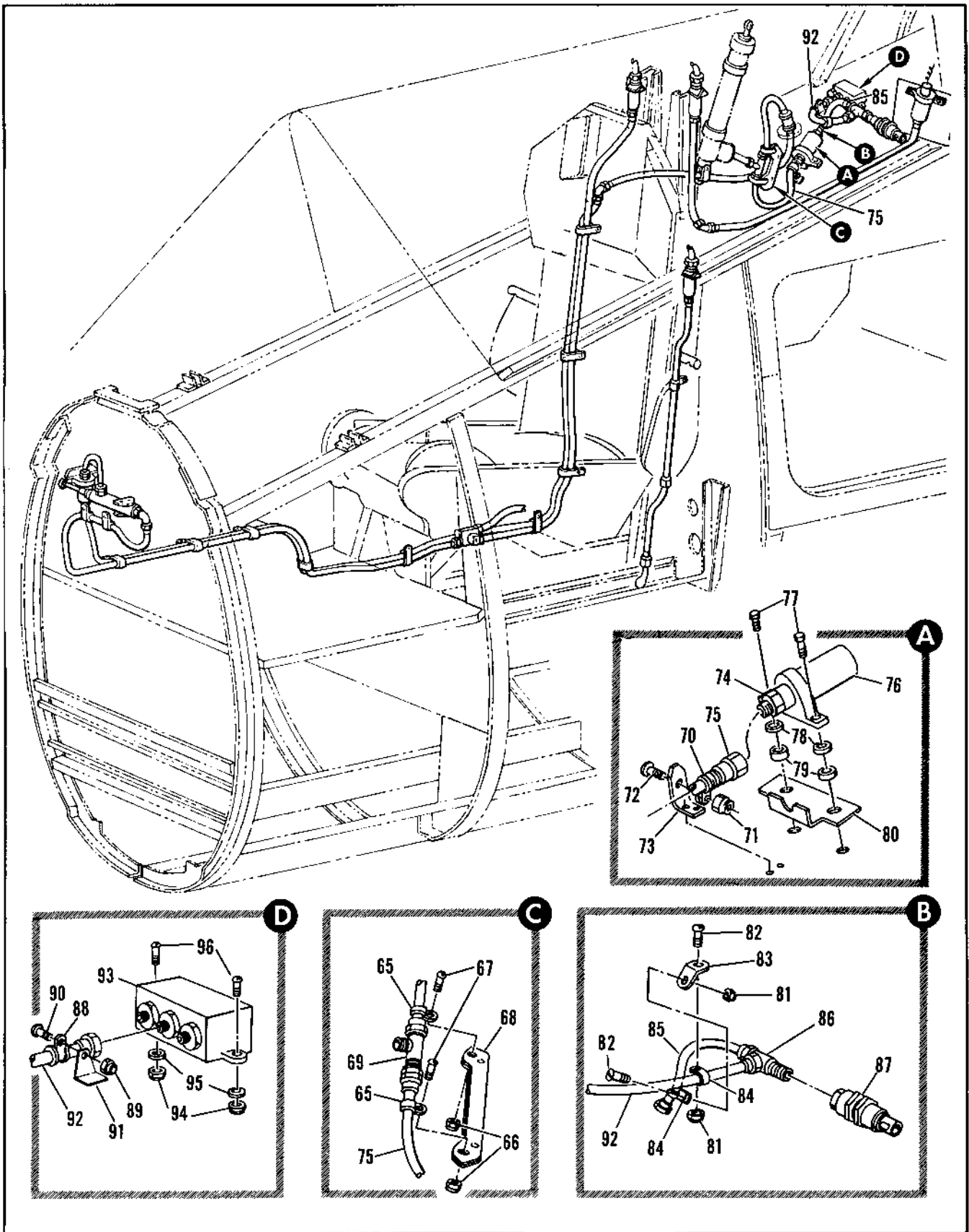

Figure 2.4-7. Canopy and Seat Ejection Hose Installation (Sheet 5 of 5)

FIGURE AND INDEX NUMBER	PART NUMBER	DESCRIPTION	UNITS PER ASSY.	USABLE ON CODE	
				FROM	TO
		1 2 3 4 5 6			
2.4-74-65	MS21919005	• CLAMP (96916)	2	35	
- 66	NAS67943	• NUT (80205)	2	35	
- 67	MS51958-48	• SCREW (96966)	2	35	
- 68	8-95105	• STRAP	2	35	
	AN929-4	• NUT (88144)	1	35	
	AN6291-4	• GASKET (88144)	1	35	
- 69	AN804-4	• TEE (88144)	1	35	
- 70	MS21919005	• CLAMP (96916)	1	35	
- 71	NAS67943	• NUT (80205)	1	35	
- 72	NAS597-1086	• SCREW (96205)	1	35	
- 73	8-94166-32	• CLIP	1	35	
- 74	AN813-4	• UNION (88144)	1	35	
	AN6291-4	• GASKET (88144)	1	35	
- 75	8-94816-607	• HOSE ASSY, CANOPY JETTISON	1	35	
	R3620-4-0107	• • HOSE ASSY, TETRAFLUOROETHYLENE <50499> 94-80505-053	1	35	
- 76	94-3-11	• INITIATOR, M5A2 GFAE AERNO 93-0318 (19203)	RF	35	
		• INITIATOR, CARTRIDGE ACTUATED AERNO93-0318 TYPE M5A2 GFAE ALT INTCHG WITH 94-3-11 ATTACHING PARTS			
- 77	AN4-11A	• BOLT (88149)	2	35	
- 78	AN960-418	• WASHER (88144)	2	35	
- 79	8-94166-15	• SPACER	2	35	
		-----X-----			
- 80	8-94166-31	• BRACKET	1	35	
- 81	NAS67943	• NUT (80205)	2	35	
- 82	MS51958-48	• SCREW (96966)	2	35	
- 83	8-94166-37	• CLIP	1	35	
- 84	MS21919005	• CLAMP (96916)	2	35	
- 85	8-94816-607	• HOSE ASSY, CANOPY JETTISON	1	35	
	R3620-4-0107	• • HOSE ASSY, TETRAFLUROETHYLENE <50599> 94-80505-150	1	35	
	AN929-4	• NUT (88144)	1	35	
	AN6291-4	• GASKET (88144)	1	35	
- 86	AN814-4	• TEE (88144)	1	35	
- 87	8734	• CUTTER, CABLE <45598> SPEC 806437-3	1	35	
- 88	MS21919005	• CLAMP (96916)	1	35	
- 89	NAS67943	• NUT (80205)	1	35	
- 90	MS51958-48	• SCREW (96966)	1	35	
- 91	8-94166-32	• CLIP	1	35	
- 92	8-94816-607	• HOSE ASSY, CANOPY JETTISON	1	35	
	R3620-4-01141	• • HOSE ASSY, TETRAFLUROETHYLENE <51099> 94-80505-001	1	35	
- 93	8637	• FITTING ASSY, BREAKAWAY <46556> SPEC 8-02498-1 ATTACHING PARTS	1	35	
- 94	NAS67943	• NUT (80205)	2	35	
- 95	AN961-11	• WASHER (88144)	2	35	
- 96	NAS221-9	• SCREW (96205)	2	35	
		-----X-----			

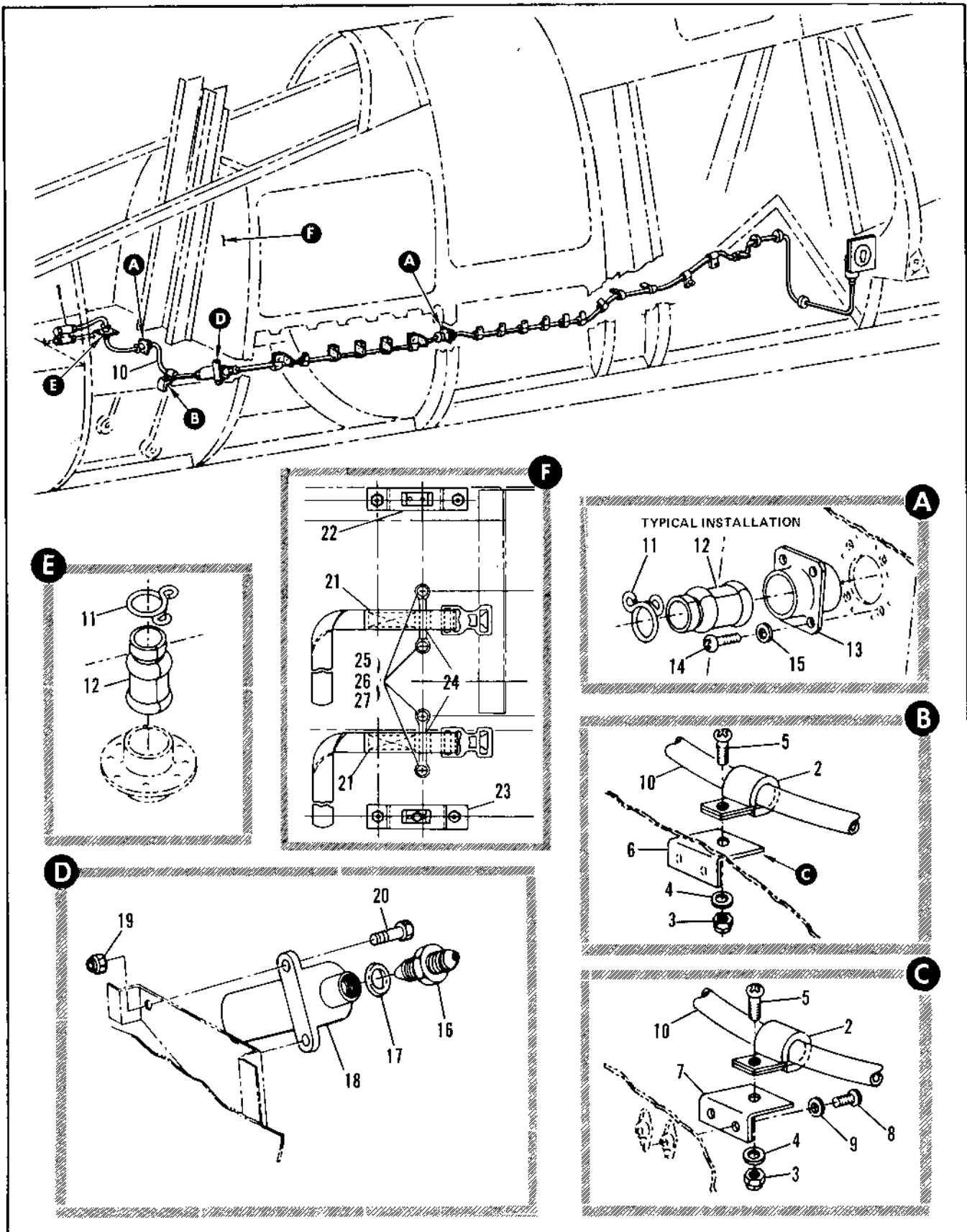

Figure 2.4-8. Canopy External Jettison Control (Sheet 1 of 3)

FIGURE AND INDEX NUMBER	PART NUMBER	DESCRIPTION	UNITS PER ASSY.	USABLE ON CODE	
				FROM	TO
2.4-8		CANOPY EXTERNAL JETTISON CONTROL			
	8-94153-F01	• INITIATOR INSTL, CANOPY JETTISON CONTROL FOR MHA SEE FIG. 2.3-3	RF	35	
	8-94153-F09	• HOSE INSTL, CANOPY JETTISON CONTROL FOR MHA SEE FIG. 2.3-4	RF	35	
	8-94153-F01	• DUOP AND CABLE INSTL, CANOPY JETTISON CONTROL FOR MHA SEE FIG. 2.11-4	RF	35	
- 1		• • VALVE ASSY, PNEUMATIC ESCAPE SYSTEM CHECK SEE FIG. 2.4-6	RF		
- 2	MS21818065	• • CLAMP (96906) (USE WITH 8-94153-F09) ATTACHING PARTS	1	35	
- 3	NAS679A3	• • NUT (80205)	1	35	
- 4	AN96001CL	• • WASHER (88044)	1	35	
- 5	MS51958-4a	• • SCREW (94906)	1	35	
		-----X-----			
- 6	8-94153-19	• • BRACKET	1	35	12°
- 7	8-94153-23	• • BRACKET ATTACHING PARTS	1	130	
- 8	MS51957-45	• • SCREW (96906)	2	130	
- 9	AN96001CL	• • WASHER (88044)	2	130	
		-----X-----			
- 10	8-94153-NP3 R3810-4-1362	• • HOSE ASSY, EXTERNAL CANOPY JETTISON • • HOSE ASSY, TETRAFLUOROETHYLENE (50599) 94-80505-003	1 1	35 35	
- 11	S11L310	• • CLIP, <74087> 92-04400-001	3	35	
- 12	8-94113	• • SEAL, BALLISTIC HOSE		3	35
- 13	8-94114	• • SUPPORT BALLISTIC HOSE ATTACHING PARTS	2	35	
- 14	MS51958-02	• • SCREW (96906)	6	35	
- 15	AN96001CL	• • WASHER (88044)	8	35	
		-----X-----			
- 16	MS24252-4	• • UNION (96906) (USE WITH 8-94153-F01)	1	35	
- 17	AN6200-4	• • CASKET (88044)	1	35	
- 18	94-3-11	• • INITIATOR, M5A2 GFAC AERNO 93-316 (19200)	1	35	
		• • INITIATOR, CARTRIDGE ACTUATED AERNO93-316 TYPE M5A2 GFAC ALT INTCHG WITH 94-3-11 ATTACHING PARTS	PF	35	
- 19	NAS679A4	• • NUT (80205)	2	35	
- 20	AN4-8A	• • BOLT (88044)	2	35	
		-----X-----			
- 21	65C34484-1	• STRAP ASSEMBLY (98750)	2	35	
- 22	65C34482-2	• BRACKET ASSEMBLY (98750)	1	35	
- 23	65C34482-1	• BRACKET ASSEMBLY (98750)	1	35	
- 24	64116	• LOOP, STRAP (72804) ATTACHING PARTS	2	35	
- 25	AN960-10	• WASHER (88044)	4	35	
- 26	MS21044N3	• NUT (94906)	4	35	
- 27	MS24654-8	• SCREW (96906)	4	35	
		-----X-----			

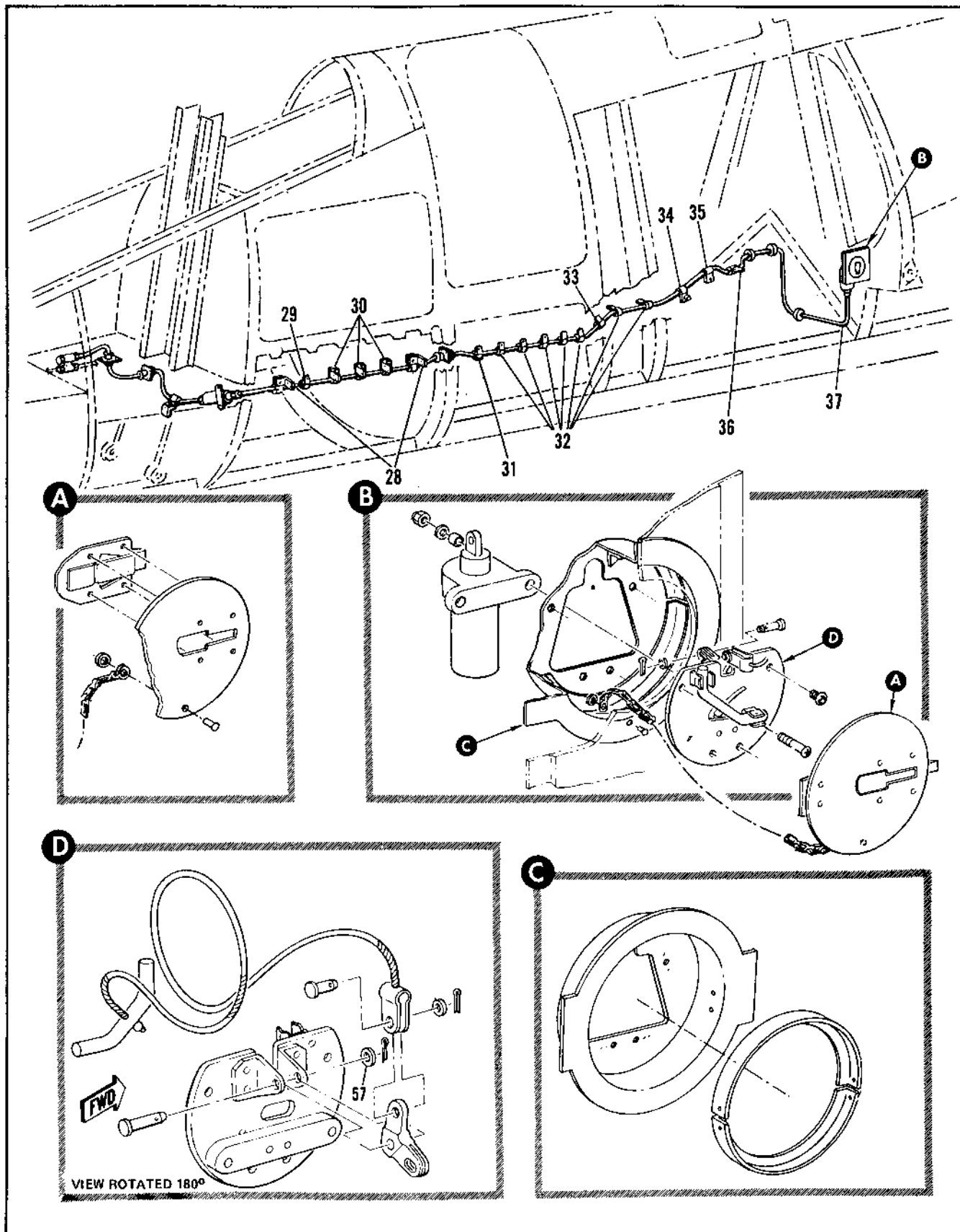

Figure 2.4-8. Canopy External Jettison Control (Sheet 2 of 3)

FIGURE AND INDEX NUMBER	PART NUMBER	DESCRIPTION	UNITS PER ASSY.	USABLE ON CODE	
				FROM	TO
		1 2 3 4 5 6			
2.4-8- 28	MS2191900F	• • CLAMP (96906) (USE WITH R-94153-809) ATTACHING PARTS	2	35	
	MS51958-48	• • SCREW (96906) -----X-----	2	35	
	90-93505-011	• • BRACKET	2	35	
- 29	MS21919005	• • CLAMP (96906) ATTACHING PARTS	1	35	
	NAS679A3	• • NUT (#0205)	1	35	
	AN960D10L	• • WASHER (#8044)	1	35	
	MS51958-48	• • SCREW (96906) -----X-----	1	35	
- 30	MS21919005	• • CLAMP (96906) ATTACHING PARTS	3	35	
	MS51958-48	• • SCREW (96906) -----X-----	3	35	
	90-93505-011	• • BRACKET	3	35	
- 31	MS21919005	• • CLAMP (96906) ATTACHING PARTS	1	35	
	NAS679A3	• • NUT (#0205)	1	35	
	NAS221-10	• • SCREW (#0205) -----X-----	1	35	
- 32	MS21919005	• • CLAMP (96906) ATTACHING PARTS	7	35	
	NAS679A3	• • NUT (#0205)	7	35	
	AN960D10L	• • WASHER (#8044)	7	35	
	MS51958-48	• • SCREW (96906) -----X-----	7	35	
- 33	MS21919005	• • CLAMP (96906) ATTACHING PARTS	1	35	
	NAS679A3	• • NUT (#0205)	1	35	
	AN960D10L	• • WASHER (#8044)	1	35	
	MS51958-48	• • SCREW (96906) -----X-----	1	35	
- 34	NAS43003-16	• • SPACER (#-205)	1	35	
	MS21919005	• • CLAMP (96906) ATTACHING PARTS	1	35	
	NAS679A3	• • NUT (#0205)	1	35	
	MS51958-64	• • SCREW (96906) -----X-----	1	35	
- 35	NAS43003-16	• • SPACER (#0205)	1	35	
	MS21919005	• • CLAMP (96906) ATTACHING PARTS	1	35	
	NAS679A3	• • NUT (#0205)	1	35	
	MS51958-62	• • SCREW (96906) -----X-----	1	35	
- 36	MS21919005	• • CLAMP (96906) ATTACHING PARTS	1	35	
	NAS679A3	• • NUT (#0205)	1	35	
	R-94153-15	• • SPACER	1	35	
	AN970-3	• • WASHER (#8044)	1	35	
	MS51953-64	• • SCREW (96906) -----X-----	1	35	
- 37	R-94816-377	• • HOSE ASSY, EXTERNAL CANOPY JETTISON	1	35	

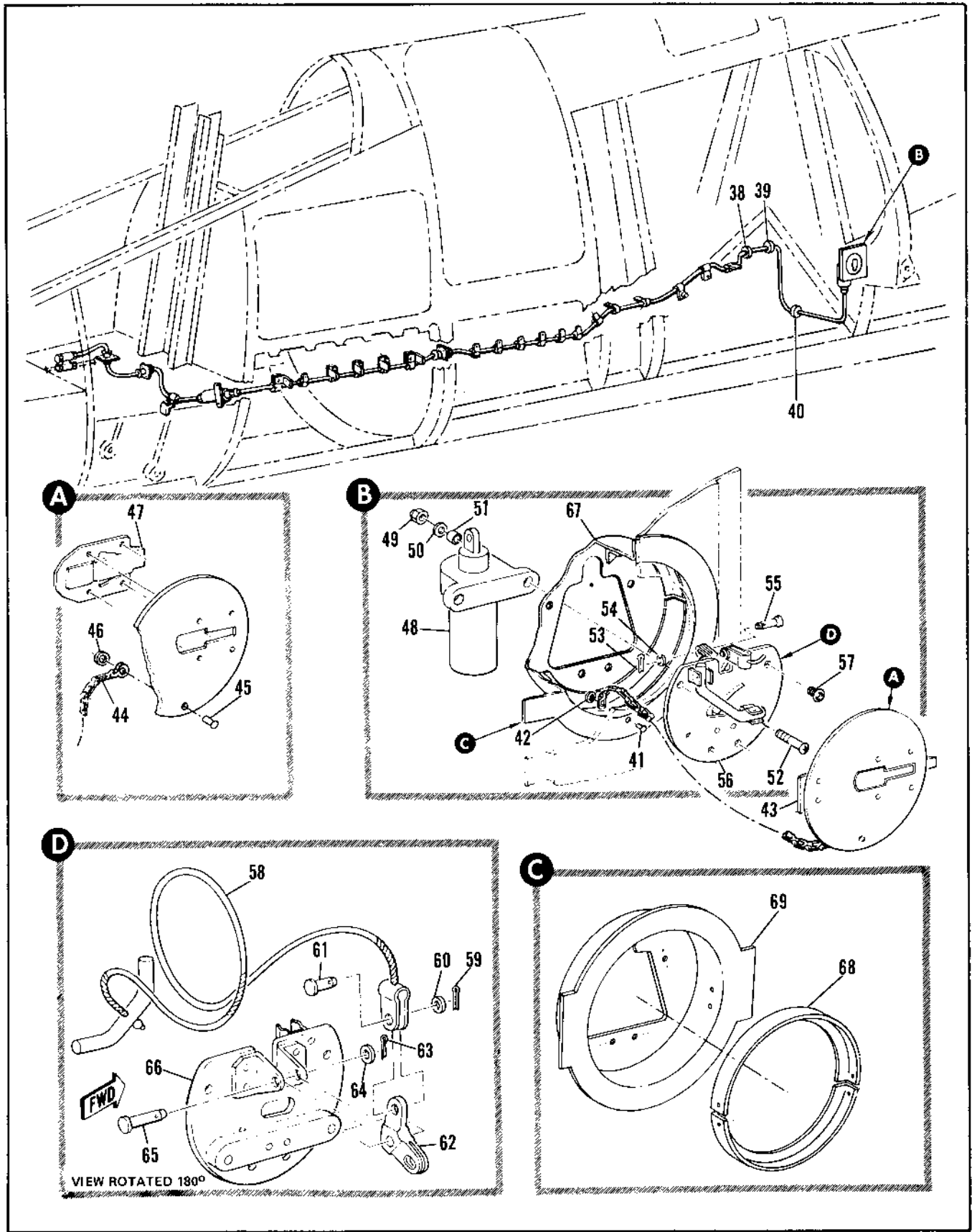

Figure 2.4-8. Canopy External Jettison Control (Sheet 3 of 3)

FIGURE AND INDEX NUMBER	PART NUMBER	DESCRIPTION	UNITS PER ASSY.	USABLE ON CODE	
				FROM	TO
				1	2
2.4-8	R3800-4-1400	. . . HOSE ASSY, TETRAFLUOROETHYLENE <50599> 94-R0505-054	1		35
- 39	AN931A559	. . . GROMMET (88044)	1		35
- 37	AN931C559	. . . GROMMET (88144)	1		35
- 40	AN931-5513	. . . GROMMET (88044)	1		35
- 41	97-67001-004	. . . RIVET	1		35
- 42	AN96102	. . . WASHER (88044)	1		35
- 43	8-92967-1	. . . DOOR ASSY, EMERGENCY CANOPY JETTISON (USE	1		35
- 44	NAF1086144	. . . CHAIN 8-94153-835) ATTACHING PARTS	1		35
- 45	MS20426A07	. . . RIVET (96906)	1		35
- 46	AN96102	. . . WASHER (88044)	1		35
- 47	MS000-040-196	. . . LATCH, <83014> 95-50500-009	1		35
- 48	94-3-1	. . . INITIATOR, M3A1 GFAE AERNO 93-0316 (19200) (USE WITH 8-94153-R01)	1		35
	94-3-1	. . . INITIATOR M3A2 GFAE AERNO 93-0316 (19200) ALT INCHG WITH INITIATOR M3A1 ATTACHING PARTS	RF		35
- 49	NAS67900A	. . . NUT (P1205)	2		35
- 50	99-51507-022	. . . WASHER	2		35
- 51	98-29503-019	. . . RUSHING	2		35
- 52	NAS623-2-2	. . . BOLT (80205)	2		35
- 53	MS24665-130	. . . PIN, COTTER (96906)	1		35
- 54	AN96101L	. . . WASHER (88044)	1		35
- 55	MS20392-11	. . . PIN (96906)	1		35
		-----X-----			
- 56	8-92964	. . . PLATE ASSY, EMERGENCY CANOPY JETTISON ATTACHING PARTS	1		35
- 57	NAS623-2-2	. . . BOLT (80205)	4		35
		-----X-----			
- 58	8-94157-41	. . . CABLE ASSY, EMERGENCY CANOPY JETTISON SWAGED ATTACHING PARTS	1		35
- 59	MS24665-132	. . . PIN, COTTER (96906)	1		35
- 60	AN96101L	. . . WASHER (88044)	1		35
- 61	MS20342-9	. . . PIN (96906)	1		35
		-----X-----			
- 62	8-92962	. . . HELL CRANK ATTACHING PARTS	1		35
- 63	MS24665-132	. . . PIN, COTTER (96906)	1		35
- 64	AN96101L	. . . WASHER (88044)	1		35
- 65	MS20392-21	. . . PIN (96906)	1		35
		-----X-----			
- 66	8-92964-11	. . . PLATE ASSY, RIVETED	1		35
	8-92963	. . . BRACKET	1		35
- 67	8-92965-1	. . . CUP ASSY, EMERGENCY CANOPY JETTISON	1		35
- 68	8-92965-9	. . . RETAINER	2		35
- 69	8-92965-11	. . . CUP	1		35

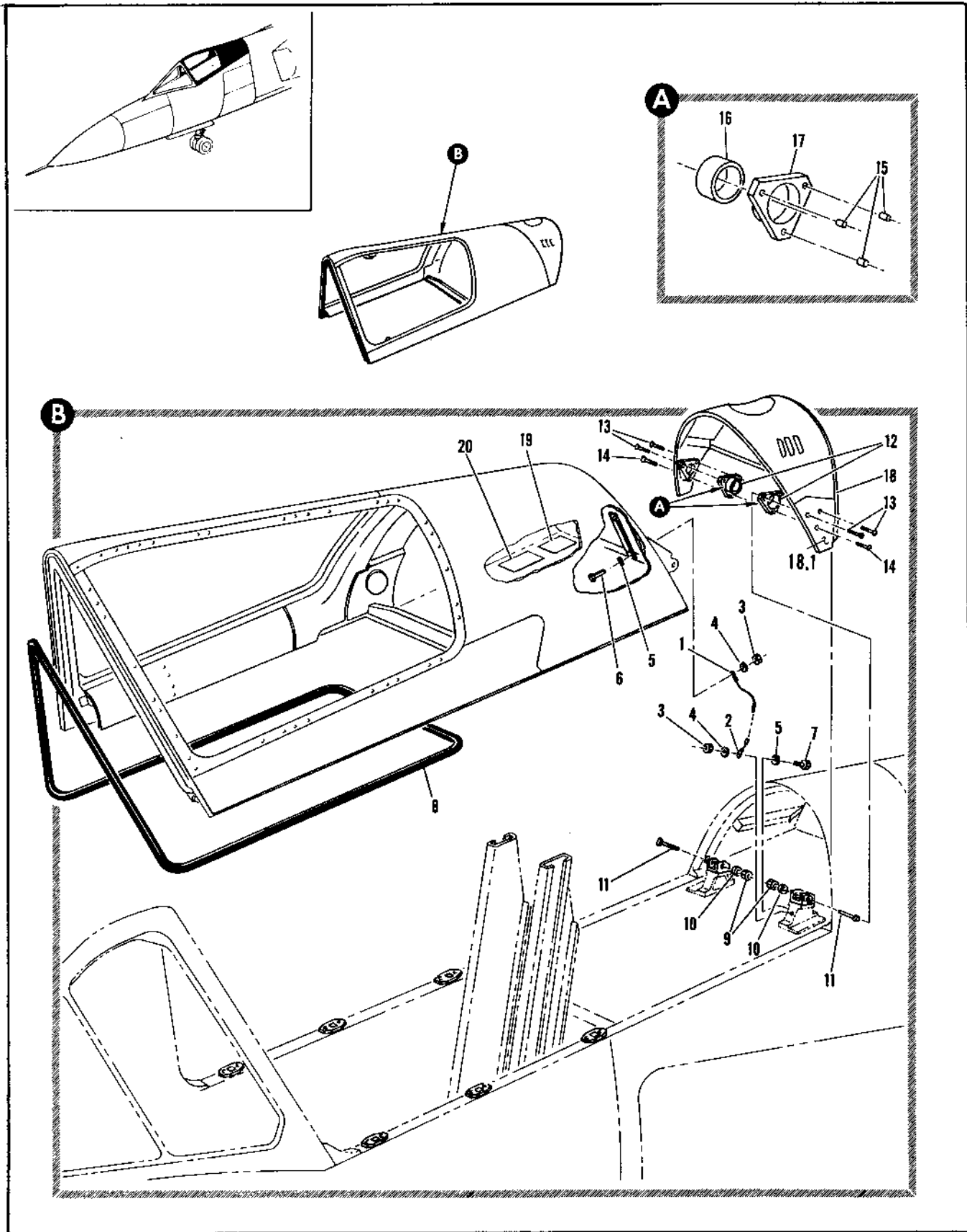

Figure 2.4-9. Canopy Installation (Sheet 1 of 2)

FIGURE AND INDEX NUMBER	PART NUMBER	DESCRIPTION	UNITS PER ASSY.	USABLE ON CODE	
				FROM	TO
2.4-9	8-74800-605	CANOPY INSTALLATION, MODIFIED BY 6-71214, 8-71159 AND 7144503-10 FOR NHA SEE FIG. 2.3-3	RF	35	
	8-74800-535	CANOPY ASSEMBLY, FOR SPARES ONLY MODIFIED BY 7144503-10 (98750)	RF	35	
- 1	MS25083-3PB6	• JUMPER (96906) USE ON 8-74800-535	1	35	
- 2	MS25083-3SB	• JUMPER (96906)	1	35	
		ATTACHING PARTS			
- 3	NAS679A3	• NUT (80205)	2	35	
- 4	MS35338-43	• WASHER (96906)	2	35	
- 5	AN963-10L	• WASHER (88044)	2	35	
- 6	AN3-4A	• BOLT (88044)	1	35	
- 7	AN3-5A	• BOLT (88044)	1	35	
		-----X-----			
- 8	E4747-1	• SEAL, <71642> SPEC 8-07304-15	1	35	
- 9	AN320-5	• NUT (88044)	2	35	
- 10	99-51505-014	• WASHER	2	35	
- 11	8-74987	• PIN, PILOTS CANOPY HINGE	2	35	
	8-74854	• FAIRING INSTL, CANOPY AFT	1	35	
- 12	8-74892	• BEARING ASSY, PILOTS CANOPY FAIRING AFT	2	35	
		ATTACHING PARTS			
- 13	NAS221-9	• SCREW (80205)	4	35	
- 14	NAS221-20	• SCREW (80205)	2	35	
		-----X-----			
- 15	3591-3CNX.285	• INSERT, <91767> 95-03003-005	3	35	
- 16	8-74892-9	• BUSHING	1	35	
- 17	8-74892-7	• RETAINER	1	35	
- 18	8-74854-65	• FAIRING ASSY, RIVETED REPLACED BY SUITABLE SUB 8-74854-67	1	35	215
	8-74854-67	• FAIRING ASSEMBLY, RIVETED REPLACES SUITABLE SUB FOR 8-74854-65	1	216	
- 18.1	8-74889-9	• FITTING, CANOPY FAIRING LOWER LH	1	35	
	8-74889-10	• FITTING, CANOPY FAIRING LOWER RH	1	35	
- 19	AN7510-1	• PLATE, IDENTIFICATION (88044)	1	35	
- 20	8-71198-1	• PLACARD, CANOPY INSTALLATION SPARES	RF	35	

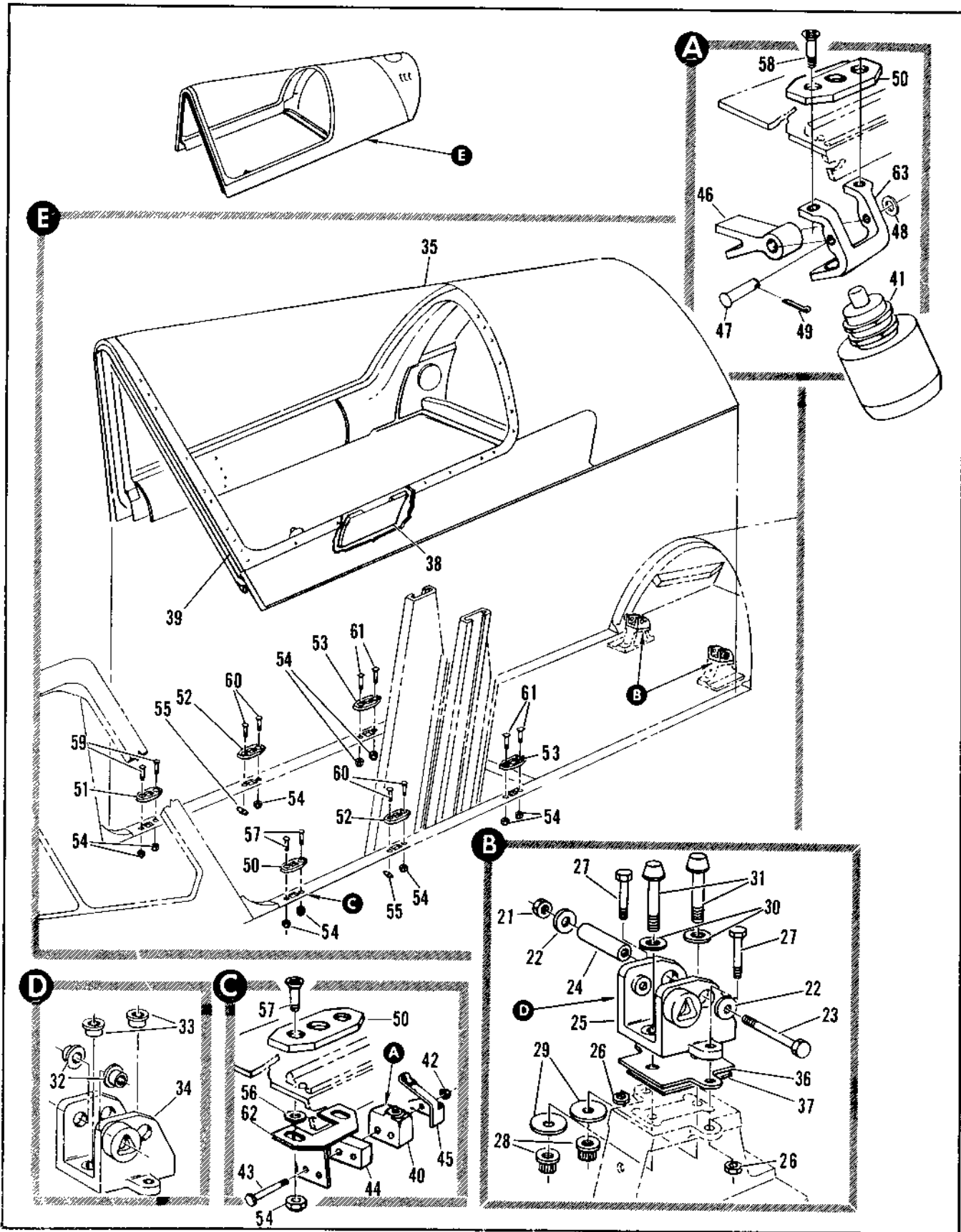

Figure 2.4-9. Canopy Installation (Sheet 2 of 2)

FIGURE AND INDEX NUMBER	PART NUMBER	DESCRIPTION	UNITS PER ASSY.	USABLE ON CODE	
				FROM	TO
		1 2 3 4 5 6			
2.4-9- 21	NAS675A4	• NUT, (R0205) 96-37545-103	2	35	
- 22	99-51505-011	• WASHER	4	35	
- 23	AN4-25A	• BOLT (R044)	2	35	
- 24	8-70952-13	• BUSHING	2	35	
- 25	8-74843-1	• HINGE ASSY, CANOPY LWR LH	1	35	
	8-74820-1	• HINGE ASSY, CANOPY LWR LH ALT INTCHG WITH 8-74843-1	RF	35	
	8-74843-2	• HINGE ASSY, CANOPY LWR RH	1	35	
	8-74820-2	• HINGE ASSY, CANOPY LWR RH ALT INTCHG WITH 8-74843-2	RF	35	
		ATTACHING PARTS			
- 26	NAS675A4	• NUT, (R0205) 96-37545-03	4	35	
- 27	AN4-11A	• BOLT (R044)	4	35	
- 28	99-51505-011	• NUT, (70562) 96-37545-152	4	35	
- 29	99-51505-013	• WASHER	4	35	
- 30	MS2103204	• WASHER (96916)	4	35	
- 31	MS20008-10	• BOLT (97506)	4	35	
		----X----			
- 32	8-74854-9	• BUSHING, HINGE PILOT CANOPY	2	35	
- 33	8-74854-11	• BUSHING, HINGE PILOT CANOPY	2	35	
- 34	8-74843-7	• HINGE, LH	1	35	
	8-74820-7	• HINGE, LH ALT INTCHG WITH 8-74843-7	RF	35	
	8-74843-8	• HINGE, RH	1	35	
	8-74820-8	• HINGE, RH ALT INTCHG WITH 8-74843-8	RF	35	
- 35	8-74817-10	• CANOPY ASSY, MODIFIED BY 8-71150 AND 7144503-10	1	35	
- 36	8-74845	• PLATE, SHEAR, CANOPY HINGE POST	2	35	
- 37	8-74846	• SHIM, PILOTS CANOPY POST	2	35	
- 38	8-90017	• HOLDER INSTL, UHF CHANNEL FREQUENCY PLATE FOR BREAKDOWN SEE FIG. 2.6-1	1	35	
- 39	8-74844-0.1	• STRUCTURE ASSY, CANOPY MODIFIED BY 7144503-10 FOR BREAKDOWN SEE FIG. 2.4-10	1	35	
	8-74844-0.2	• STRUCTURE ASSY, CANOPY FOR SPARES ONLY MODIFIED BY 7144503-10 FOR BREAKDOWN SEE	RF	35	
- 40	1SF1	• SWITCH, (91024) 96-14516-001	1	61	241
- 41	MS24551-1	• SWITCH (96806)	1	0	
		ATTACHING PARTS			
- 42	22NMSF	• NUT, (70962) 96-37545-107	2	61	241
- 43	MS35214-210	• SCREW (96803)	2	61	241
		----X----			
- 44	8-44816-9	• SPACER	1	61	241
- 45	JES	• ACTUATOR, SWITCH (91024) 96-14516-004	1	61	241
- 46	8-44817-7	• LEVER, SWITCH	1	44	44
	8-44818-7	• LEVER, SWITCH ALT INTCHG WITH 8-44817-7	RF	44	44
	8-44819-7	• LEVER, SWITCH	1	241	
		ATTACHING PARTS			
- 47	MS24067-130	• PIN (96976)	1	0	
- 48	AN90017	• WASHER (R044)	1	0	
- 49	MS21982-2-F1	• PIN, CUTTER (96976)	1	0	
		----X----			
- 50	8-74853-4	• PLATE, LH	1	35	
- 51	8-74853-5	• PLATE, RH	1	35	
- 52	8-74853-6	• PLATE	2	35	

0 AIRPLACES PAR, 241 AND ON

FIGURE AND INDEX NUMBER	PART NUMBER	DESCRIPTION	UNITS PER ASSY.	USABLE ON CODE	
				FROM	TO
		1 2 3 4 5 6			
2.4-9- 53	R-74850	• PLATE (80205)	2	35	
- 54	NAS6175A4	• NUT, (81205) 86-37541-103	10	35	
- 55	NAS618A4	• NUTPLATE, (80205) 86-37579-105	2	35	
- 56	AN941404110	• WASHER (86744)	48	61	
- 57	NAS334CPA7-5	• BOLT, LH (80205)	2	0	
- 58	NAS334CPA10	• BOLT, LH (80205)	2	0	
- 59	NAS334CPA7-5	• BOLT, RH (80205)	2	35	
- 60	NAS334CPA5-5	• BOLT (81205)	4	35	
- 61	R-74850	• BOLT	4	35	
		-----X-----			
- 62	R-44952-7	• BRACKET	1	61	24
- 63	R-44982-1	• BRACKET ASSY, RIVETED	1	0	
	R-44975-9	• BRACKET ASSY, RIVETED ALT LATCH WITH R-44952-1	RF	0	
		C AIRPLANES #48, 241 AND ON			
		D AIRPLANES #75 THRU 97, AND 49 THRU 240			

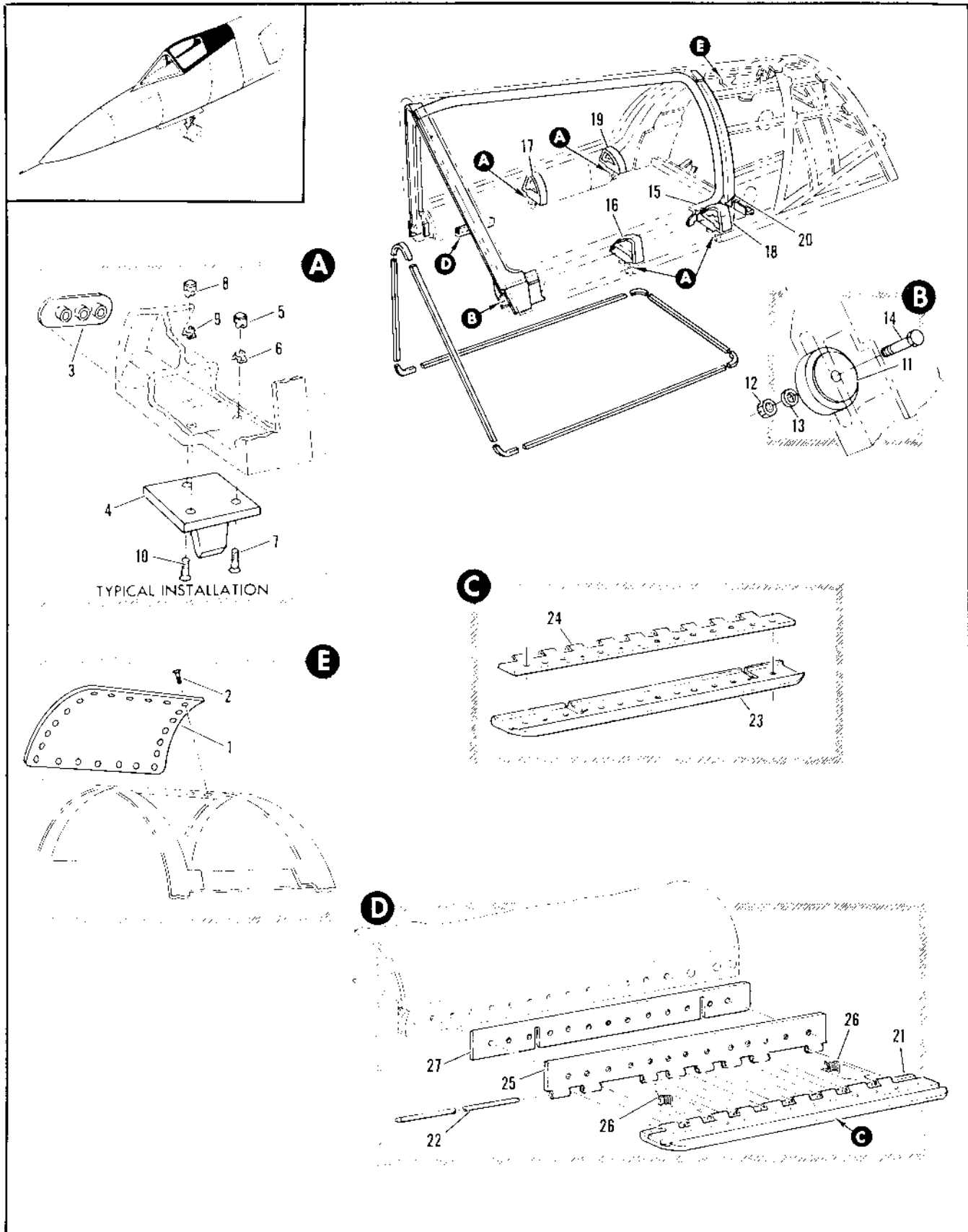

Figure 2.4-10. Canopy Structure Assembly (Sheet 1 of 2)

FIGURE AND INDEX NUMBER	PART NUMBER	DESCRIPTION	UNITS PER ASSY.	USABLE ON CODE	
				FROM	TO
		1 2 3 4 5 6			
2.4-10	8-74014-1	STRUCTURE ASSEMBLY, CANOPY MODIFIED BY 7144503-10 FOR NHA SEE FIG. 2.4-8 INDEX 40	4F	30	
	8-74014-103	STRUCTURE ASSEMBLY, CANOPY FOR SPARES ONLY MODIFIED BY 7144503-10	RF	30	
- 1	8-74045 8-74045-7	• DOOR INSTL, CANOPY ACCESS RH • DOOR	1 1	35	35
- 2	WAS353CPA4	ATTACHING PARTS • SCREW (86213) -----X-----	23	35	
- 3	8-74024	• FLUG	1	35	
- 4	8-74021-7 8-74026-8	• PLOCK, CANOPY SHEAR LH • PLOCK, CANOPY SHEAR RH ATTACHING PARTS	1 1	35	35
- 5	2452-048	• NUT, <72962> 98-3750-101	2	35	
- 6	2452-048CT	• CLIP, RETAINING <72962> 92-14000-003	2	35	
- 7	MS24674-101 MS24674-102	• SCREW, FWD (86906) • SCREW, AFT (86906)	2 2	35	35
- 8	2452-02	• NUT, <72962> 98-3750H-100	1	35	
- 9	2452-02RFT	• CLIP, RETAINING <72962> 92-14000-002	1	35	
- 10	MS24674-100 MS24674-101	• SCREW, FWD (86944) • SCREW, AFT (86944) -----X-----	1 1	35	35
- 11	LASB10-6	• BEARING (81208) ATTACHING PARTS	1	35	
- 12	AN320-8	• NUT (88144)	1	35	
- 13	AN900-610	• WASHER (88144)	2	35	
- 14	8-74047	• PIN, CANOPY LATCH RODLEP -----X-----	1	35	
	8-74010	• LONGERON INSTL, CANOPY CENTER LINE	1	A	
	8-74010-1	• LONGERON INSTL, CANOPY CENTER LINE	1	B	
- 15	8-74012-7 8-74012-8 8-74011-1 8-74011-2	• PAN, CANOPY LEDGE UPPER LH • PAN, CANOPY LEDGE UPPER RH • LONGERON INSTL, CANOPY LWR LH • LONGERON INSTL, CANOPY LWR RH	1 1 1 1	35 35 35 35	
- 16	8-74010-1	• BULKHEAD, LONGERON CANOPY STRUCTURE LWR FWD LH	1	35	
	8-74010-11	• BULKHEAD, LONGERON CANOPY STRUCTURE LWR FWD LH ALT INTCHG WITH 8-74008-9	RF	35	
- 17	8-74010-10	• BULKHEAD, LONGERON CANOPY STRUCTURE LWR FWD RH	1	35	
	8-74010-12	• BULKHEAD, LONGERON CANOPY STRUCTURE LWR FWD RH ALT INTCHG WITH 8-74008-10	RF	35	
- 18	8-74010-9	• BULKHEAD, LONGERON CANOPY STRUCTURE LWR AFT LH	1	35	
	8-74010-11	• BULKHEAD, LONGERON CANOPY STRUCTURE LWR AFT LH ALT INTCHG WITH 8-74009-9	RF	35	
- 19	8-74010-10	• BULKHEAD, LONGERON CANOPY STRUCTURE LWR AFT RH	1	35	
	8-74010-12	• BULKHEAD, LONGERON CANOPY STRUCTURE LWR AFT RH ALT INTCHG WITH 8-74009-10	RF	35	
- 20	8-74013-4 8-74013-10 8-74017	• LEDGE, CANOPY STRUCTURE LH • LEDGE, CANOPY STRUCTURE RH • HAND HOLD INSTL, PILOT CANOPY RH	1 1	35 35	
- 21	8-74017-1	• HAND HOLD ASSEMBLY	RF	35	
- 22	8-74017-9	• PIN -----X-----	RF	35	
- 23	8-74027-7	• PLATE, HAND HOLD PILOT CANOPY	RF	35	
- 24	8-74027-10	• HINGE, HALF	RF	35	
- 25	8-74027-11	• HINGE, HALF	RF	35	
- 26	8-74027-12	• SPRING, HAND HOLD	RF	35	
- 27	8-74027-7	• FILLER	RF	35	
		A AIRPLANES 475 THRU 47 AND 48 THRU 49 B AIRPLANES 848, 90 AND ON			

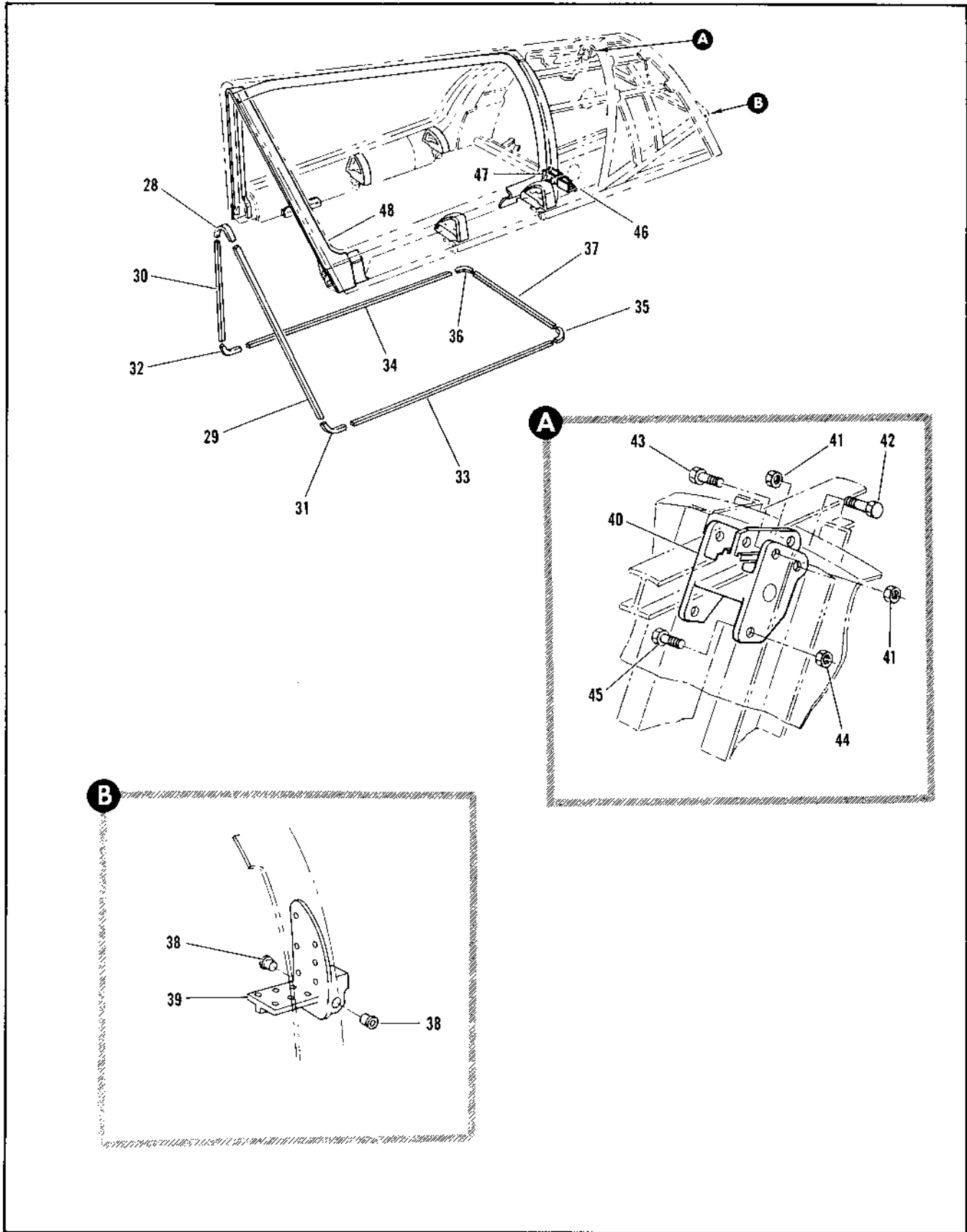

Figure 2.4-10. Canopy Structure Assembly (Sheet 2 of 2)

FIGURE AND INDEX NUMBER	PART NUMBER	DESCRIPTION	UNITS PER ASSY.	USABLE ON CODE	
				FROM	TO
		1 2 3 4 5 6			
2.4-10	8-74814	• RETAINER INSTL, CANOPY SEAL (USED ON SPARES ASSY 8-74804-503)	1	35	
- 2R	8-74829-37	• • RETAINER	1	35	
- 29	8-74829-31	• • RETAINER, LH	1	35	
- 30	8-74829-32	• • RETAINER, RH	1	35	
- 31	8-74829-29	• • RETAINER, LH REPLACED BY NOT INTCHG WITH 8-74829-39	1	35	38
	8-74829-39	• • RETAINER, LH REPLACES NOT INTCHG WITH 8-74829-29	1	39	
- 32	8-74829-30	• • RETAINER, RH REPLACED BY NOT INTCHG WITH 8-74829-40	1	35	34
	8-74829-40	• • RETAINER, RH REPLACES NOT INTCHG WITH 8-74829-30	1	39	
- 33	8-74829-27	• • RETAINER, LH	1	35	
- 34	8-74829-28	• • RETAINER, RH	1	35	
- 35	8-74829-33	• • RETAINER, LH	1	35	
- 36	8-74829-34	• • RETAINER	1	35	
- 37	8-74829-25	• • RETAINER	1	35	
	8-74817-1	• BULKHEAD INSTL, PILOT CANOPY AFT	1	35	
	8-74842-1	• • HINGE ASSY, LH	1	35	
	3-74851-1	• • HINGE ASSY, LH ALT INTCHG WITH 8-74842-1	RF	35	
	8-74842-2	• • HINGE ASSY, RH	1	35	
	6-74851-2	• • HINGE ASSY, RH ALT INTCHG WITH 8-74842-2	RF	35	
- 38	8-74858-7	• • • BUSHING	2	35	
- 39	8-74842-9	• • • HINGE, LH	1	35	
	8-74851-7	• • • HINGE, LH ALT INTCHG WITH 8-74842-9	RF	35	
	8-74842-10	• • • HINGE, RH	1	35	
	8-74851-8	• • • HINGE, RH ALT INTCHG WITH 8-74842-10	RF	35	
	8-74818-801	• BULKHEAD INSTL, PILOT CANOPY PRESSURE	1	35	
	8-74818-503	• BULKHEAD INSTL, PILOT CANOPY PRESSURE FOR SPARES ONLY (USE ON SPARE ASSY 8-74818-503)	RF	35	
- 40	8-74990-9	• • BRACKET, PILOT CANOPY ACTUATOR ATTACHING PARTS	1	35	
- 41	NAS679A4	• • NUT (80205)	6	35	
- 42	NAS1104-3	• • BOLT (80205)	2	35	
- 43	AN4-SA	• • BOLT (88044)	4	35	
- 44	NAS679A5	• • NUT (80205)	2	35	
- 45	NAS1105-3	• • BOLT (80205)	2	35	
		-----Y-----			
- 46	8-74841-9	• • BRACKET, CANOPY LOWER LONGERON LH	1	35	215
	8-74819-7	• • BRACKET, CANOPY LOWER LONGERON LH ALT INTCHG WITH 8-74841-9	RF	35	215
	8-74841-15	• • BRACKET, CANOPY LOWER LONGERON LH	1	216	
	8-74841-10	• • BRACKET, CANOPY LOWER LONGERON RH	1	35	215
	8-74819-8	• • BRACKET, CANOPY LOWER LONGERON RH ALT INTCHG WITH 8-74841-10	RF	35	215
	8-74841-16	• • BRACKET, CANOPY LOWER LONGERON RH	1	216	
- 47	8-74841-11	• • BRACKET, CANOPY LOWER LONGERON LH	1	35	215
	8-74819-9	• • BRACKET, CANOPY LOWER LONGERON LH ALT INTCHG WITH 8-74841-11	RF	35	215
	8-74841-17	• • BRACKET, CANOPY LOWER LONGERON LH	1	216	
	8-74841-12	• • BRACKET, CANOPY LOWER LONGERON RH	1	35	215
	8-74819-10	• • BRACKET, CANOPY LOWER LONGERON RH ALT INTCHG WITH 8-74841-12	RF	35	215
	8-74841-18	• • BRACKET, CANOPY LOWER LONGERON RH	1	216	
- 48	8-74805	• FRAME, PILOT CANOPY FWD MAKE FROM 8-74811	1	35	
	8-74811	• BAR, FORGED FORWARD CANOPY FRAME	RF	35	

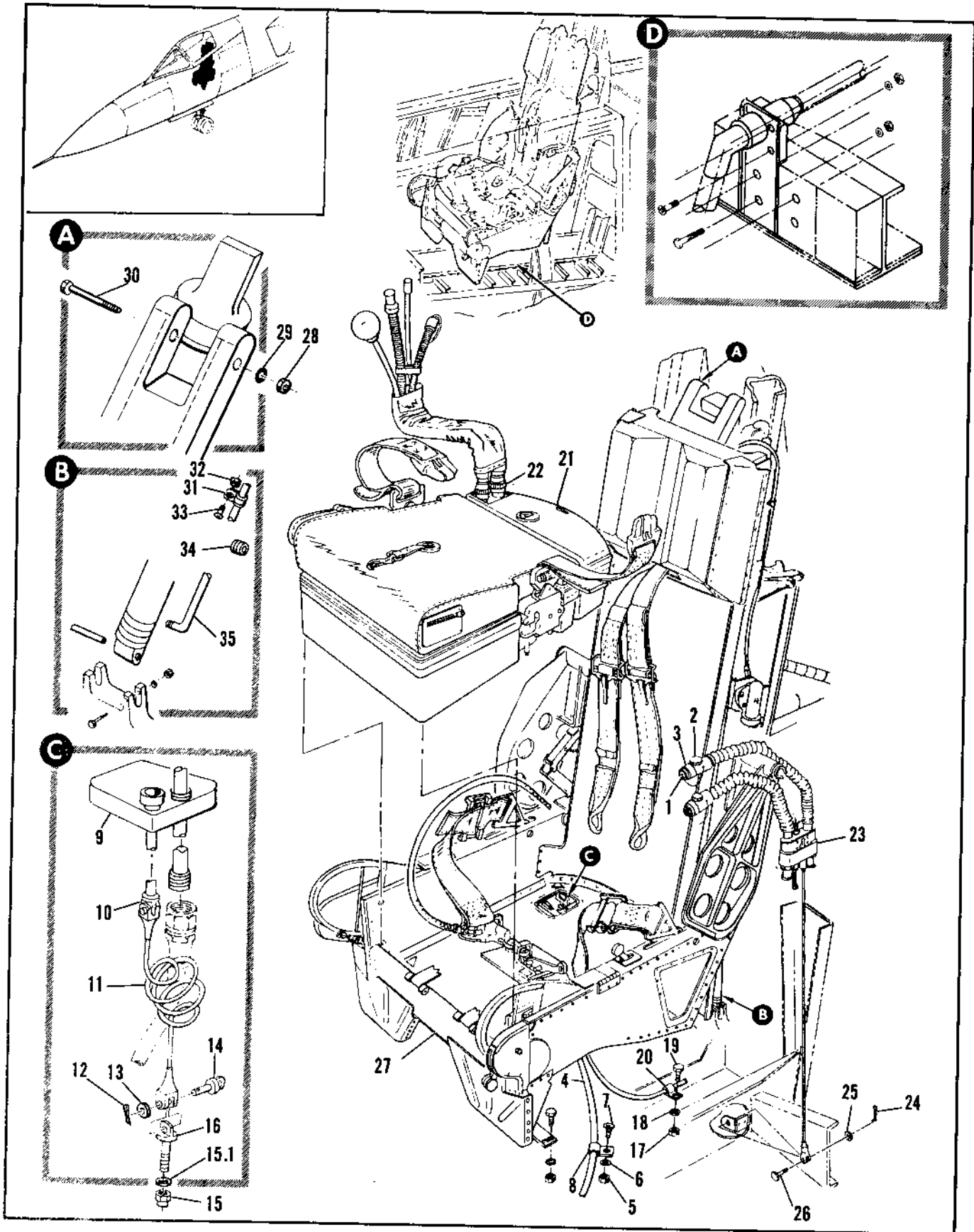

Figure 2.4-11. Ejection Seat Installation (Sheet 1 of 2)

FIGURE AND INDEX NUMBER	PART NUMBER	DESCRIPTION	UNITS PER ASSY.	USABLE ON CODE	
				FROM	TO
2.4-11	NO NUMBER	SEAT INSTL. EJECTION SEE FIG. 2.1-1 FOR MHA			
- 1	718	• CAP ASSY	1	35	
- 2	NAS397-20	• CLAMP (80205)	1		
- 3	296	• DISCONNECT ASSY	1		
- 4		• HOSE, LIQUID OXYGEN SEE FIG. 2.19-3 INDEX 34	RF		
		ATTACHING PARTS			
- 5	MS20364-1032	• NUT (96906)	1		
- 6	AN960-10L	• WASHER (88044)	1		
- 7	NAS221-10L	• SCREW (80205)	1		
- 8	AN742-20	• CLAMP (88044)	1		
		-----X-----			
- 9	F361-1121-3	• DISCONNECT ASSY, (97413) SHIP TO KIT SEE T.O. 15X-2-5-4 FOR PARTS BREAKDOWN	1	35	
- 10	F361-1361-1	• DISCONNECT, SHIP TO KIT	1	35	
- 11	F361-1003-2	• LANYARD, SHIP TO KIT	1	35	
		ATTACHING PARTS			
- 12	MS24665-151	• PIN (96906)	1		
- 13	AN960-10L	• WASHER (88044)	2		
- 14	MS20392-2-7	• PIN (96906)	1		
- 15	MS21083N3	• NUT, SELF-LOCKING (96906)	1		
- 15A	AN970-3	• WASHER (88044)	1		
- 16	AN42B3A	• EYEBOLT (88044)	1		
- 17	MS20364-1032	• NUT (96906)	1		
- 18	AN960-10L	• WASHER (88044)	1		
- 19	NAS221-10L	• SCREW (80205)	1		
- 20	AN747-16	• CLAMP (88044)	1		
- 21	140000-24 (24A)	• CONTAINER, SURVIVAL KIT	1	35	
- 22	8401-3	• COUPLING ASSY, QUICK DISCONNECT FURNISHED WITH TRACK ASSY 803499-407 (92324) PER T.O. 35A5-18-94	1	35	
- 23	762000	• DISCONNECT (98580) SEE T.O. 13A12-15-3 AND T.O. 13A12-15-4	RF	35	
	D100P	• DISCONNECT (70152) SEE T.O. 13A5-18-84	1	35	
		ATTACHING PARTS			
- 24	MS24665-151	• PIN (96906)	RF	35	
	MS24665-132	• PIN (96906)	1	35	
- 25	AN960-10L	• WASHER (88044)	RF	35	
	AN960P10	• WASHER (88044)	AR	35	
- 26	MS20392-2-7	• PIN (96906)	RF	35	
	MS20392-207	• PIN (96906)	1	35	
- 27	803498-421	• SEAT ASSY, EJECTION SEE T.O. 13A5-18-84 (92824)	1	35	
- 28	MS20364-820	• NUT (96906)	1	35	
- 29	AN960-816	• WASHER (88044)	1	35	
- 30	AN8-50A	• BOLT (88044)	1	35	
		-----X-----			
- 31	MS21919005	• CLAMP (96906)	2		
		ATTACHING PARTS			
- 32	NAS679A3	• NUT (80205)	2		
- 33	MS51958-61	• SCREW (96906)	2		
		-----X-----			
- 34	MS35469-73	• GROMMET (96906)	2		
- 35	806672-401	• HOSE ASSY, LH DISCONNECT TO ROCKET- CATAPULT (92824)	1		

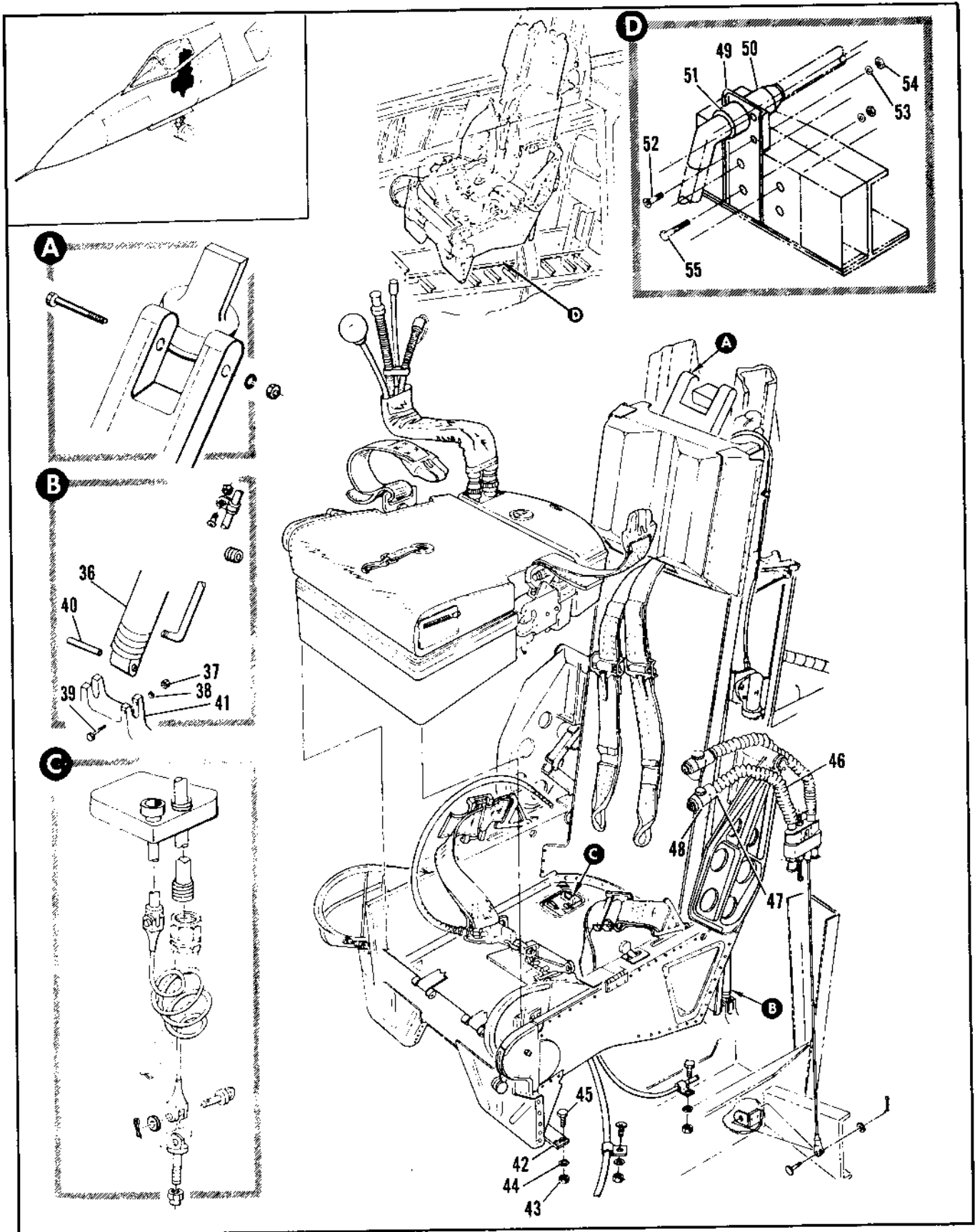

Figure 2.4-11. Ejection Seat Installation (Sheet 2 of 2)

FIGURE AND INDEX NUMBER	PART NUMBER	DESCRIPTION	UNITS PER ASSY.	USABLE ON CODE	
				FROM	TO
		1 2 3 4 5 6			
2.4-11-36	2174-518-3	• CATAPULT ROCKET (98708)	1		
	2174-518-5	• CATAPULT, PROCKET (98708) ALT INTCHS WITH CATAPULT, ROCKET 2174-518-3			35
	2174-7	• CATAPULT, ROCKET (12110) INTCHG WITH AND REPLACES CATAPULT, ROCKET P/N 2174-518-5 ATTACHING PARTS	REF		
- 37	MS20364-1072	• NUT (96906)	2		
- 38	AN960-10L	• WASHER (98744)	2		
- 39	AN3-13A	• ROLT (88744)	2		
- 40	247316-1	• PIN	1		
- 41	R-5157M-1	• ACTUATOR, SEAT ADJUSTMENT SEE T.O. 801-26-25-13 FOR PARTS BREAKDOWN -----X-----	1		
- 42	R06652-3	• STRAP ATTACHING PARTS	1		
- 43	MS20364-1032	• NUT (96906)	4		
- 44	AN960-10L	• WASHER (98744)	4		
- 45	AS221-11	• SCREW (80205) -----X-----	4		
- 46	AE335100152	• HOSE ASSY (97473) ATTACHING PARTS	1	35	
- 47	MS2044-4	• CLAMP (96906)	2	35	
- 48	AN6532-C	• CONNECTOR (98044)	1	35	
- 49	58037R93-7	• BRACKET (98750)	1	35	
- 50	PT000P-12-05	• CONNECTOR (77900)	1	35	
- 51	PT000P-12-07	• CONNECTOR (77920)	1	35	
- 52	MS35200-215	• SCREW (98714)	4	35	
- 53	AN960-4	• WASHER (98744)	4	35	
- 54	MS21144N14	• NUT (96916)	4	35	
- 55	MS27960-100	• STUD (96916)	2	35	
	MS21500-11A2	• NUT (90806)	2	35	
	AN960-10L	• WASHER (98744)	2	35	

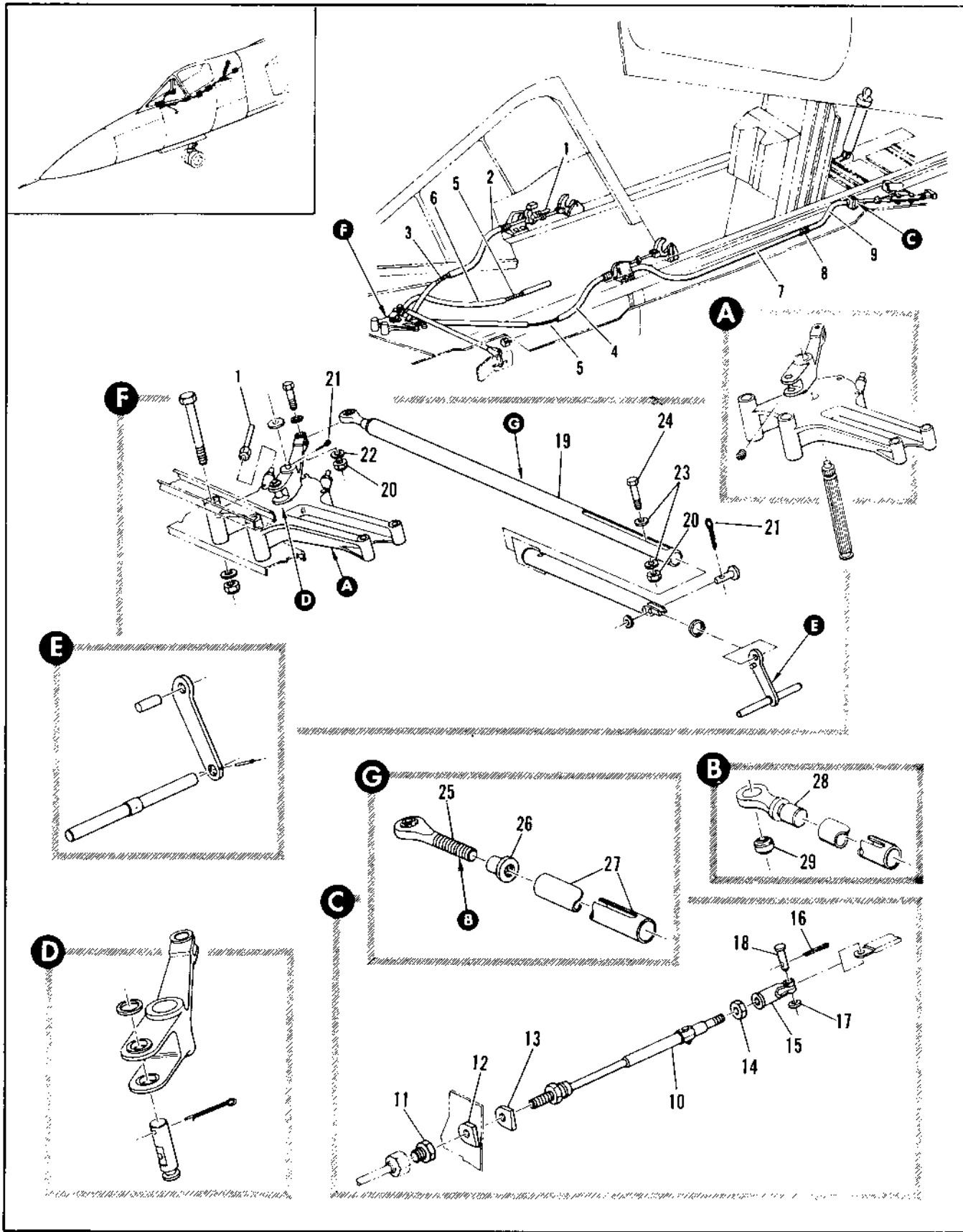

Figure 2.4-12. Canopy Latch and Electrical Actuator Installation (Sheet 1 of 5)

FIGURE AND INDEX NUMBER	PART NUMBER	DESCRIPTION	UNITS PER ASSY.	USABLE ON CODE	
				FROM	TO
2.4-12	R-4534	LATCH AND ELECTRICAL ACTUATOR INSTALLATION, CANOPY FOR AHA SEE FIG. 2.4-3	RF		35
- 1	4-4596-21	• CONDUIT ASSY, 2 INCHES LONG MAKE FROM A5123	2		35
- 2	4-4596-22	• CONDUIT ASSY, 26 INCHES LONG MAKE FROM A5123	1		35
- 3	4-4596-27	• CABLE, 25.66 INCHES LONG MAKE FROM A7416	1		35
- 4	4-4596-117	• CONDUIT ASSY, 15 INCHES LONG MAKE FROM A5123	1		35
- 5	4-4596-27 A7416	• CABLE, 163.1 INCHES LONG MAKE FROM A7416	1		35
- 6		• CABLE, STEEL <78710>	RF		
- 7	4-40466-67	• CONDUIT ASSY, SEE FIG. 2.4-4 INDEX 3	RF		
- 8	46307	• CONDUIT ASSY, 32 INCHES LONG MAKE FROM A1123	1		35
- 9	4-4596-117	• NIPPLE, <78710> 96-29009-001	1		35
- 10	C11467-1	• CONDUIT ASSEMBLY	1		35
- 11	45511	• CONTROL ASSY, CANOPY VALVE <78710> SPEC 7-14210-1 ATTACHING PARTS	1		35
- 12	8-4596-167	• NUT, <78710> FURNISHED WITH C11467-1 ----X----	1		35
- 13	8-4596-169	• SHIM	1		35
- 14	WASHER-4	• SHIM	1		35
- 15	AN447-4	• NUT (80205)	1		35
- 16	MS24665-131	• ROD END (84744)	1		35
- 17	AN960-11L	• ATTACHING PARTS			
- 18	MS24665-131	• PIN, COTTER (96906)	1		35
- 19	R-44756	• WASHER (84744)	1		35
- 20	AN327-3	• PIN (96916)	1		35
- 21	MS24665-143	• ROD ASSY, CANOPY EMERGENCY RELEASE REPLACED BY SUITABLE SUB R-44796-3 ATTACHING PARTS	1		35 129
- 22	AN960-11L	• NUT (88144)	2		35 129
- 23	AN960-11L	• PIN, COTTER (96906)	1		35 129
- 24	WAS464-3-13	• WASHER (88144)	2		35 129
- 25	HRBY155FN	• WASHER (89144)	2		35 129
- 26	8-44757	• BOLT (80205)	2		35 129
- 27	4-44756-7	• ROD ----X----	1		35 129
	R-44796-3	• ROD ASSY, CANOPY EMERGENCY RELEASE REPLACES SUITABLE SUB FOR R-44756			
	MS24665-131	• ATTACHING PARTS			
	AN327-3	• PIN (96916)	2		130
	AN960-11L	• NUT (88144)	2		130
	AN960-11L	• WASHER (88144)	2		130
	WAS464-3-13	• WASHER (89144)	2		130
	4-44753	• BOLT (80205)	2		130
- 28	8-44753-7	• END ASSEMBLY, ROD	1		130
- 29	KWB27-195	• ROD END	1		130
		• • • BEARING, <87613> 91-40715-017	1		130

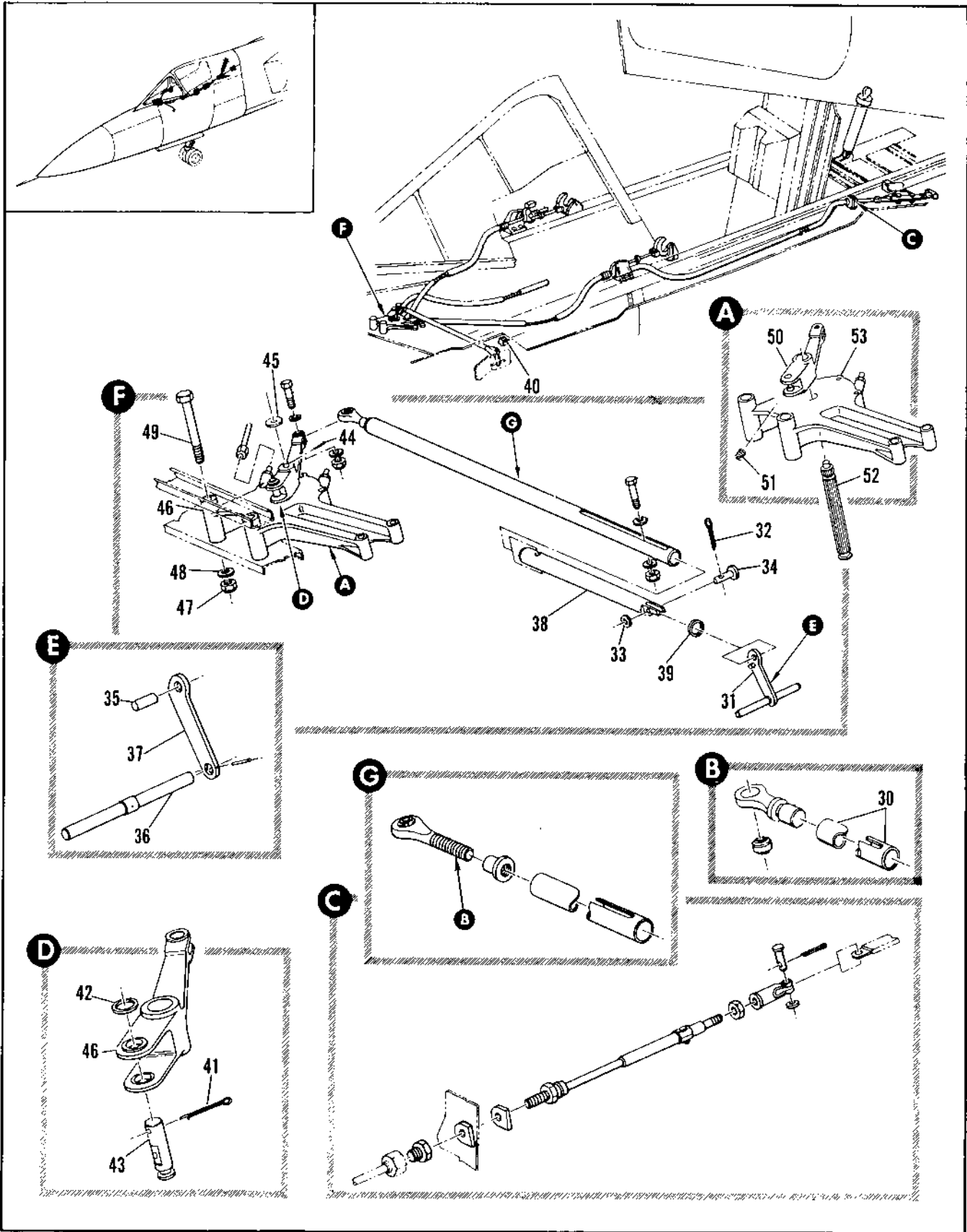

Figure 2.4-12. Canopy Latch and Electrical Actuator Installation (Sheet 2 of 5)

FIGURE AND INDEX NUMBER	PART NUMBER	DESCRIPTION	UNITS PER ASSY.	USABLE ON CODE	
				FROM	TO
		1 2 3 4 5 6			
2.4-12- 30	8-44786-9	• • ROD	1	35	
- 31	8-44781	• HANDLE ASSY, CANOPY EMERGENCY RELEASE ATTACHING PARTS	1	35	
- 32	MS24644F-134	• PIN, CUTTER (96906)	1	35	
- 33	AN961-416L	• WASHER (88044)	1	35	
- 34	AN394-19	• PIN (88044)	1	35	
- 35	96-79700-131	• • PIN	1	35	
- 36	8-44781-9	• • ROD	1	35	
- 37	8-44781-7	• • HANDLE	1	35	
- 38	8-44798	• SHAFT	1	35	
- 39	AN6207B12	• RING (88044)	1	35	
- 41	2TL16-7	• SWITCH, <91429> SPEC R-0640H-1	1	35	
- 41	MS24665-353	• PIN, CUTTER (96906)	1	35	
- 42	AN961-816L	• WASHER (88044)	1	35	
- 43	8-45189	• SHAFT, CANOPY LATCH THRUSTER MOUNT	1	35	
- 44	MS24665-380	• PIN (96906)	1	160	
- 45	AN961-716L	• WASHER (88044)	1	160	
- 46	12829	• CONTROL ASSY, CANOPY LATCH TELEFLEX <78710> SPEC R-04375-3 T.O. 1411-5-13-3 REPLACED BY SUITABLE SUB 12829-1	1	35	159
	12829-1	• CONTROL ASSY, CANOPY LATCH TELEFLEX <78710> SPEC R-04375-5 REPLACES SUITABLE SUB FOR 12829 ATTACHING PARTS	1	160	
- 47	NAS670A4	• NUT (80205)	2	35	
- 48	AN961-416L	• WASHER (88044)	2	35	
- 49	AN4-31A	• BOLT (88044)	2	35	
- 50	12829	• • BELL CRANK ASSY, FURNISHED WITH 12829	RF	35	159
- 51	AN565EC1132H5	• • • SCREW, SET FURNISHED WITH 12829	RF	35	159
	AN572-10-6	• • • SCREW, FURNISHED WITH 12829	1	8	
- 52	C11475-1	• • SHAFT, 5/8-36 SERRATIONS FURNISHED WITH 12829	RF		
	C11475-2	• • SHAFT, 5/8-36 SERRATIONS FURNISHED WITH 12829 ALT INTOCG WITH C11475-1	RF		
- 53	11441	• • BOX, CANOPY LATCH CONTROL FURNISHED WITH 12829	RF	35	159
		• AIRPLANES #35 AND 40.			

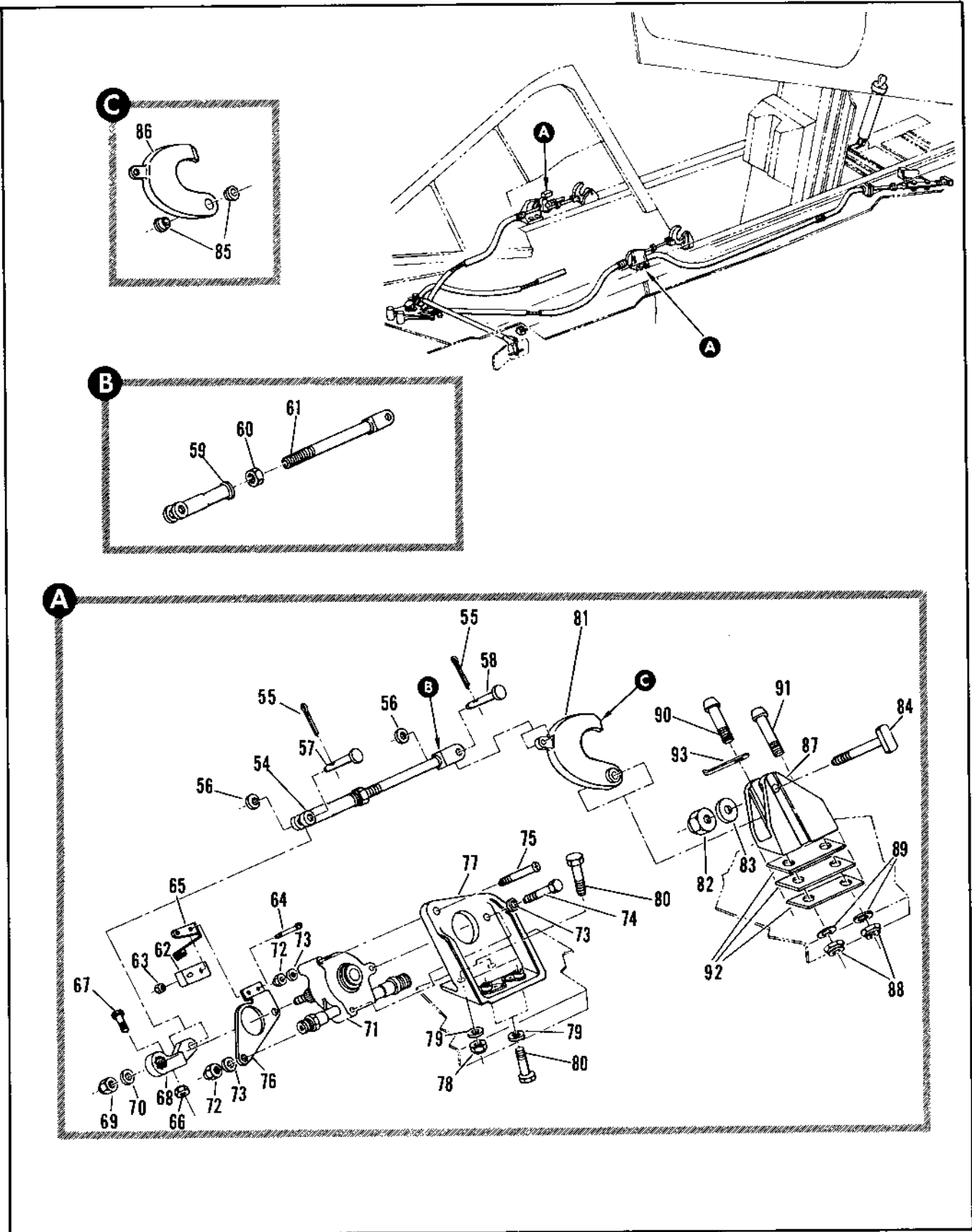

Figure 2.4-12. Canopy Latch and Electrical Actuator Installation (Sheet 3 of 5)

FIGURE AND INDEX NUMBER	PART NUMBER	DESCRIPTION	UNITS PER ASSY.	USABLE ON CODE	
				FROM	TO
2.4-12- 51	B-45198-1	• ROD ASSY, GANGY LATCH ATTACHING PARTS	2	35	
- 50	MS24965-130	• PIN, COTTER (06906)	4	35	
- 51	AN940-416L	• WASHER (88144)	4	35	
- 52	AN394-11	• PIN (88144)	2	35	
- 53	AN394-17	• PIN (88144)	2	35	
- 54	AN411-2	• ROD END (88144)	1	35	
- 55	AN311-40	• NUT (88144)	1	35	
- 56	Y-45113-7	• ROD	1	35	
- 57	ISE1	• SWITCH, <1509> 9F-54616-001 ATTACHING PARTS	2	35	
- 58	22045A	• NUT, <73552> 9A-37543-002	4	35	
- 59	AN511-2A17	• SCREW (48144)	4	35	
- 60	JEL	• ACTUATOR, SWITCH <1509> 9-46512-04	2	35	
- 61	AN341-17	• NUT	2	35	
- 62	NAS411-17	• BOLT (A-215)	2	35	
- 63	8-44718-12	• ARM, LH	1	35	
- 64	8-44719-7	• ARM, LH ALT INTCHG WITH 8-44718-13	AF	35	
- 65	8-44720-14	• ARM, RH	1	35	
- 66	8-44721-7	• ARM, RH ALT INTCHG WITH 8-44720-14 ATTACHING PARTS	AF	35	
- 67	NAS17044	• NUT (8015)	2	35	
- 68	9-81501-117	• WASHER	2	35	
- 69	0952-1	• CONTROL ASSY, <7871> SPEC R-14306-1 ATTACHING PARTS	2	35	
- 70	NAS27945	• NUT (8015)	4	35	
- 71	AN960-10L	• WASHER (88144)	10	35	
- 72	AN3133A	• BOLT (88144)	4	35	
- 73	MS24974-2	• SCREW (88144)	2	35	
- 74	8-44769-7	• BRACKET, GANGY LATCH SWITCH LH	1	35	
- 75	8-44769-8	• BRACKET, GANGY LATCH SWITCH RH	1	35	
- 76	8-44770-2	• BRACKET ASSY, LH RIVETED	1	35	
- 77	8-44770-4	• BRACKET ASSY, RH RIVETED ATTACHING PARTS	1	35	
- 78	NAS17045	• NUT (8015)	4	35	
- 79	AN941-10L	• WASHER (88144)	8	35	
- 80	AN311-4	• BOLT (88144)	8	35	
- 81	8-44787	• HOOK ASSY, GANGY LATCH ATTACHING PARTS	2	35	
- 82	AN311-4	• NUT (88144)	2	35	
- 83	AN941-10L	• WASHER (88144)	2	35	
- 84	8-44784	• BOLT	2	35	
- 85	8-44785	• PUSHING	1	35	
- 86	8-44786-7	• HOOK	1	35	
- 87	8-44789-7	• BRACKET, LH	1	35	
- 88	8-44789-8	• BRACKET, RH ATTACHING PARTS	1	35	
- 89	NAS27945	• NUT (8015)	4	35	
- 90	AN941-10L	• WASHER (88144)	4	35	
- 91	MS21125-2L	• BOLT (98915)	2	35	
- 92	MS21125-1R	• BOLT (9890F)	2	35	
- 93	8-44790-1	• SHIM	AF	35	
- 94	8-44791-1	• SHIM	AF	35	
- 95	8-44792-1	• SHIM	AF	35	
- 96	8-44793-1	• STOP	2	35	

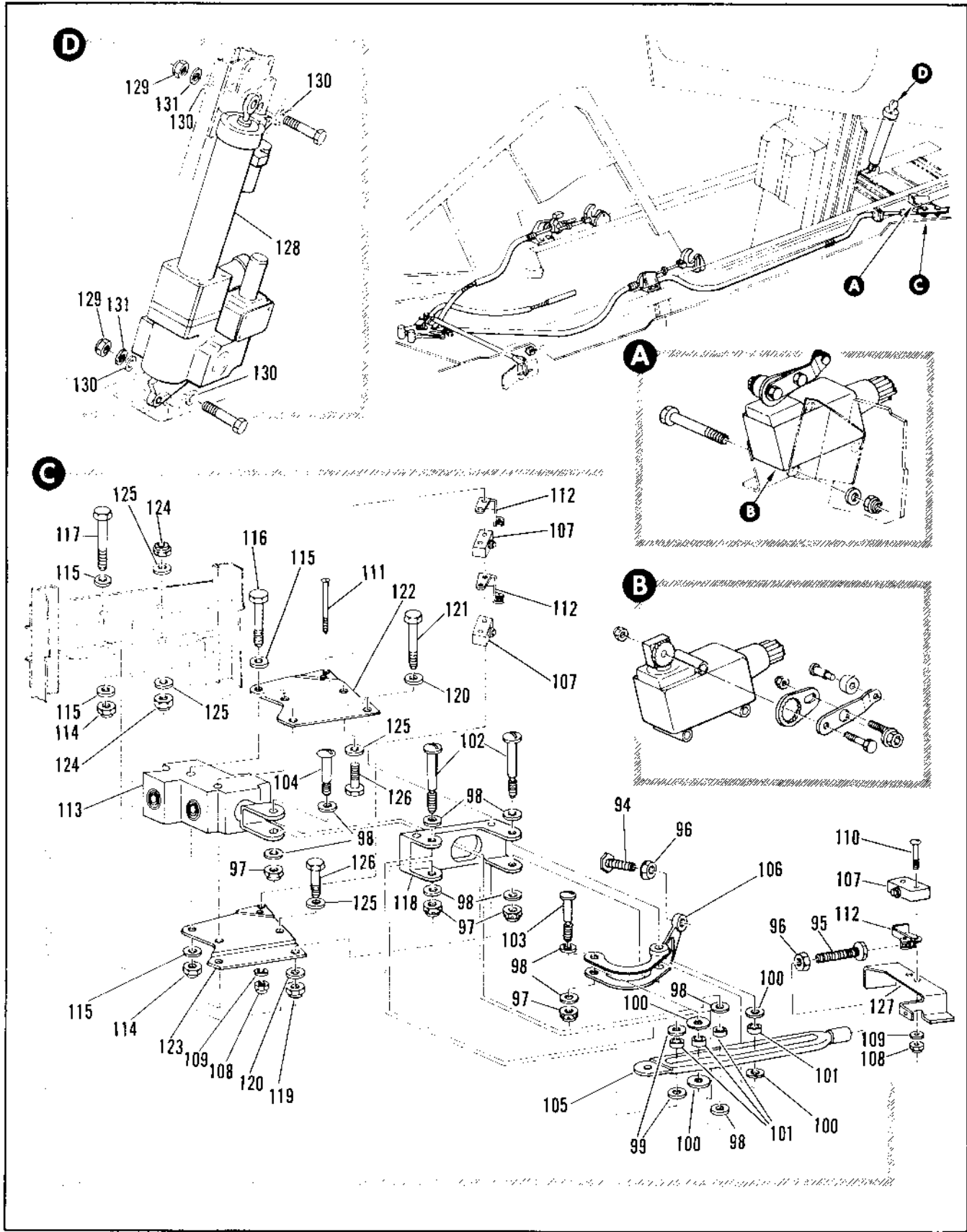

Figure 2.4-12. Canopy Latch and Electrical Actuator Installation (Sheet 4 of 5)

FIGURE AND INDEX NUMBER	PART NUMBER	DESCRIPTION	UNITS PER ASSY.	USABLE ON CODE	
				FROM	TO
		1 2 3 4 5 6			
2,4-12- 94	R-44178	• STUD	1	35	
- 95	NAS428-3-F	• BOLT (88205)	1	35	
- 96	AN345-10	• NUT (88244)	2	35	
- 97	AN327-3	• NUT (88244)	4	35	
- 98	AN961-11L	• WASHER (88244)	10	35	
- 99	R-44187	• WASHER	2	35	
-100	R9-53110-012	• WASHER	4	35	
-101	NAS205-3	• BEARING (80205)	4	35	
-102	AN23-22	• BOLT (88244)	2	35	
-103	AN23-13	• BOLT (88244)	1	35	
-104	AN23-10	• BOLT (88244)	1	35	
-105	R-44186-7	• CAM, CANOPY SEAL SWITCH AND VALVE	1	35	
	S-44187	• CAM, CANOPY SEAL SWITCH AND VALVE ALT INTCHG WITH R-44186-7	RF	35	
-106	R-44179-7	• PAWL, CANOPY LIMIT SWITCH	1	35	
	S-44180	• PAWL, CANOPY LIMIT SWITCH BRAZED ALT INTCHG WITH R-44179-7	RF	35	
-107	1SE3	• SWITCH, <8192R> 96-64516-003 ATTACHING PARTS	3	35	
-108	02NM25	• NUT, <72852> 96-37543-102	4	35	
-109	AN936A2	• WASHER (88244)	4	35	
-110	AN515-2H10	• SCREW (88244)	2	35	
-111	0-44177	• SCREW	2	35	
		-----X-----			
-112	JES	• ACTUATOR, SWITCH <8192R> 91-05302-004	3	35	
-113	2-127-101	• VALVE ASSY, CANOPY SEAL <31189> SPEC R-0R324 T.O. 995-9-8-3 ATTACHING PARTS	1	35	
-114	NAS679A3	• NUT (80205)	2	35	
-115	AN961010L	• WASHER (88244)	4	35	
-116	AN3-13A	• BOLT (88244)	1	35	
-117	AN3-14A	• BOLT (88244)	1	35	
		-----X-----			
-118	R-44185	• GUIDE, CANOPY SEAL VALVE CAM ATTACHING PARTS	1	35	
-119	NAS679A3	• NUT (80205)	2	35	
-120	AN961010L	• WASHER (88244)	4	35	
-121	AN3-14A	• BOLT (88244)	2	35	
		-----X-----			
-122	R-44185-7	• SUPPORT, CANOPY SEAL SWITCH AND VALVE	1	35	
-123	R-44185-8	• SUPPORT, CANOPY SEAL SWITCH AND VALVE ATTACHING PARTS	1	35	
-124	NAS679A3	• NUT (80205)	2	35	
-125	AN961010L	• WASHER (88244)	4	35	
-126	AN3-14A	• BOLT (88244)	2	35	
		-----X-----			
-127	R-44186-7	• BRACKET	1	35	
-128	10522538	• REMOVER, TIME? GFAL AERNO 93-0357	1	35	
	10522539	• REMOVER, M5 GFAL AERNO 93-1357	RF		
	10522538	• REMOVER, M5 GFAL AERNO 93-1357 ALT INTCHG WITH REMOVERS T18E2/M8 ATTACHING PARTS	RF		
		• NUT (88244)	2	35	
-129	AN300-5	• NUT (88244)	2	35	
-130	R9-51507-100	• WASHER	4	35	
-131	AN961051F	• WASHER (88244)	2	35	

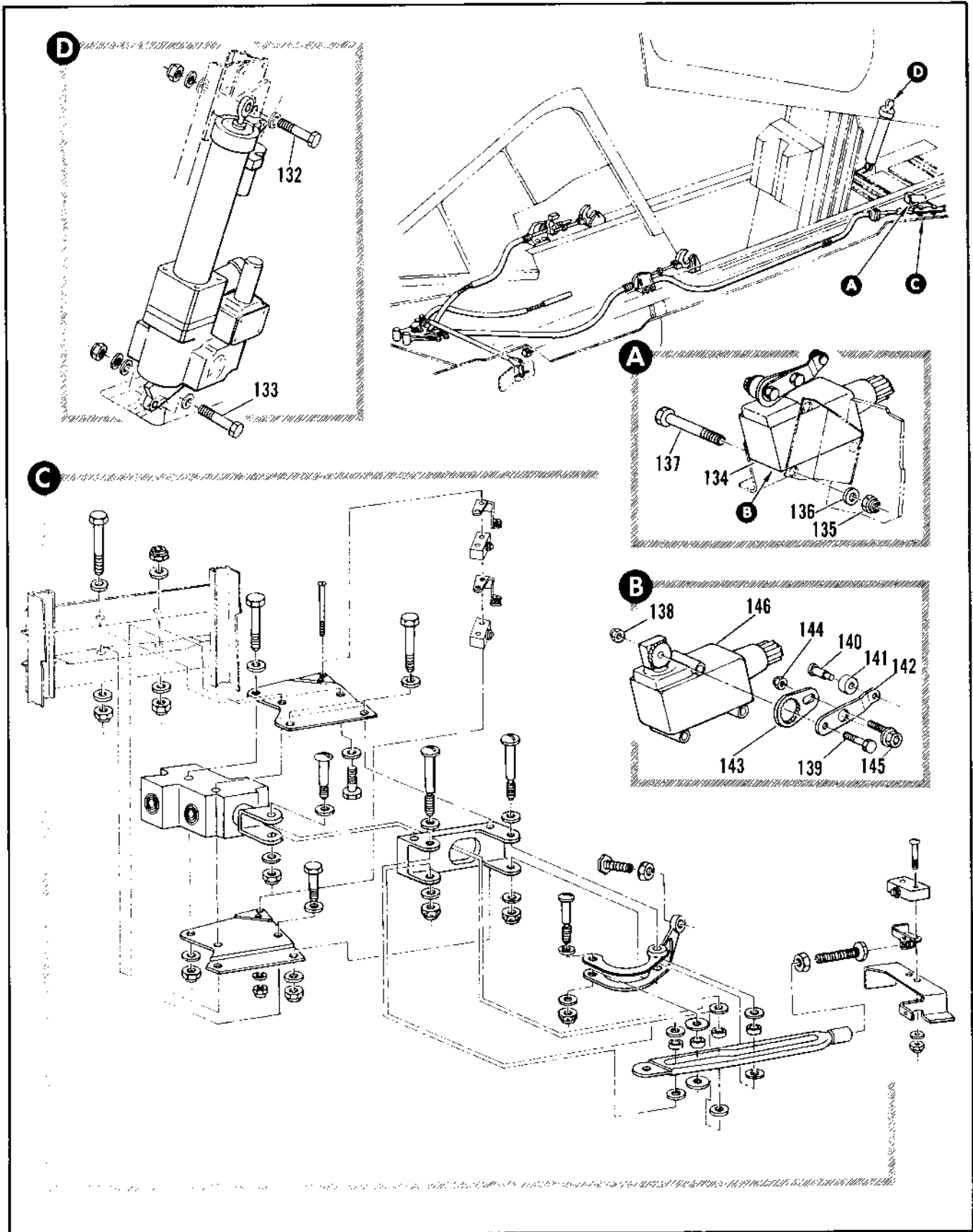

Figure 2.4-12. Canopy Latch and Electrical Actuator Installation (Sheet 5 of 5)

FIGURE AND INDEX NUMBER	PART NUMBER	DESCRIPTION	UNITS PER ASSY.	USABLE ON CODE	
				FROM	TO
		1 2 3 4 5 6			
2.4-12-132	NAS464P5-14	• BOLT (87205)	1	35	
-133	NAS464P5-17	• BOLT (87205)	1	35	
		----X----			
	LDN59-15	• • TRIGGER, INITIATOR	RF	0	
	2352-140049	• • TRIGGER, INITIATOR	RF	0	
-134	A-68130-17	• SWITCH ASSY, CANOPY LIMIT	1	35	
		ATTACHING PARTS			
-135	VAS674A1	• NUT (80205)	3	35	
-136	AN96010L	• WASHER (88344)	3	35	
-137	AN3-16A	• BOLT (88644)	3	35	
		----X----			
	8-68146-1	• • ARM ASSY, ACTUATOR	1	35	
		ATTACHING PARTS			
-138	MS21043-7	• NUT (96915)	1	35	
+139	AN3074	• BOLT (88044)	1	35	
		----X----			
-140	8-68051-6	• • • STUD, ROLLER	1	35	
-141	8-68052-6	• • • ROLLER	1	35	
-142	8-68046-7	• • • ARM	1	35	
-143	1107-509	• • PLATE, ADJUST (97918) SPEC 8-06986-7	1	35	
		ATTACHING PARTS			
-144	VAS679A1B	• NUT (80205)	1	35	
-145	8-68038-7	• BOLT, ADJUST	1	35	
		----X----			
-146	H12-27	• SWITCH, (97918) SPEC 8-06983-833	1	35	
		A AIRPLANES #35 THRU 129, 241 AND ON			
		C AIRPLANES #35 THRU 48, 61 THRU 132, 189 AND ON			

39 PAGES

FURNISHINGS SUBSECTION**TABLE OF CONTENTS**

Fig. No.	Title	Page
2.5-1	Furnishings	2.5-2
2.5-2	Instrument Panel Glare Shield Installation	2.5-6
2.5-3	Windshield Reflection Baffle Installation	2.5-8
2.5-4	Pilot Check List Installation	2.5-10
2.5-5	Ejection Seat Safety Pin and Streamer Installation	2.5-12
2.5-6	Ejection Seat Safety Pin and Streamer Installation	2.5-14
2.5-7	Map and Flight Report Case Installation	2.5-16
2.5-8	Luggage Container Installation	2.5-18
2.5-9	Cockpit Trim Installation LH.	2.5-20
2.5-10	Cockpit Trim Installation RH	2.5-22
2.5-11	Cockpit Control Guards	2.5-26
2.5-12	Thermal Cockpit Blanket Installation	2.5-30
2.5-13	Nose Wheel Well Splash Cover Installation	2.5-32
2.5-14	Canopy Breaker Tool and Storage Facility Installation	2.5-36
2.5-15	Rear View Mirror Installation	2.5-38

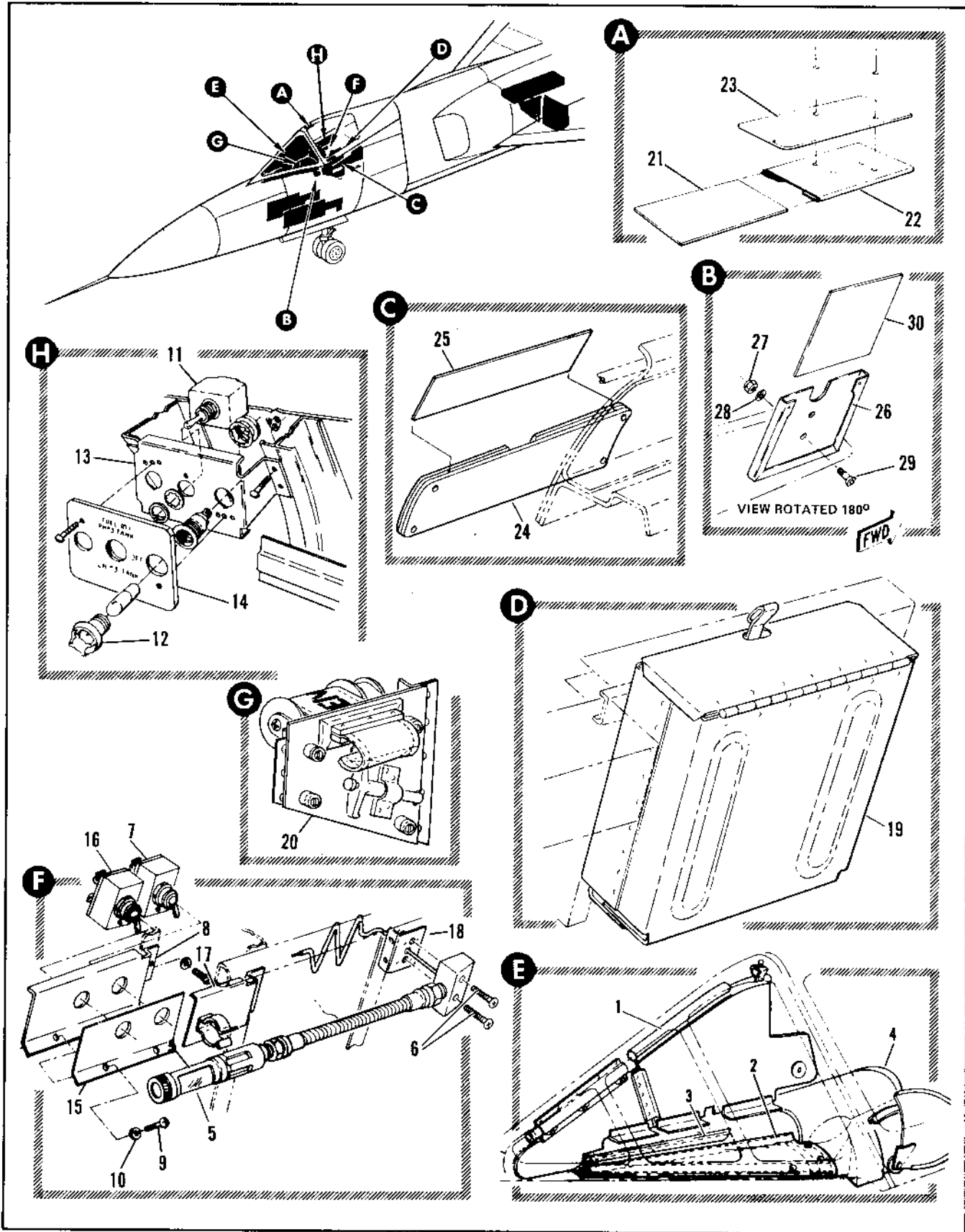

Figure 2.5-1. Furnishings (Sheet 1 of 2)

FIGURE AND INDEX NUMBER	PART NUMBER	DESCRIPTION	UNITS PER ASSY.	USABLE ON CODE	
				FROM	TO
		1 2 3 4 5 6			
2.5-1- 1		• BAFFLE INSTL, WINDSHIELD REFLECTION SEE FIG. 2.5-3	RF		
	8-94879	• SHIELD INSTL, REFLECTION STA A8 FOR NHA SEE FIG. 2.1-1	RF	35	
- 2	8-94876-2	• • SHIELD ASSY, REFLECTION STITCHED LH	1	35	
- 3	8-94876-1	• • SHIELD ASSY, REFLECTION STITCHED RH	1	35	
- 4		• SHIELD INSTL, INSTRUMENT PANEL GLARE SEE FIG. 2.5-2	RF		
	8-94895-1	• LIGHT INSTL, MAP READING FOR NHA SEE FIG. 2.3-4	RF	35	
- 5	89750-2	• • LIGHT ASSY, MAP READING <72914> SPEC 8-09285-1 ATTACHING PARTS	1	35	
- 6	MS51958-65	• • SCREW (96906) ----X----	2	35	
	8-94695-3	• SWITCH INSTL, MAP READING LIGHT FOR NHA SEE FIG. 2.3-2	RF	35	
- 7	8906K698	• • SWITCH, <15605> SPEC 8-06907-3	1	35	
- 8	8-94895-29	• • BRACKET	RF	35	
	8-94895-31	• • BRACKET	RF	35	60
	8-61453-7	• • BRACKET ATTACHING PARTS	1	35	
- 9	MS51958-61	• • SCREW (96906)	3		
- 10	AN960D10L	• • WASHER (88044)	3		
	NAS43003-40	• • SPACER (90265) ----X----	1	35	
- 11	MS24525-27	• SWITCH INSTL, FUEL QUANTITY SWITCH NO. 3 TANK (96906)	1	35	
- 12	MS25016-4A	• • LIGHT ASSEMBLY (96906)	2	35	
	MS25237-327	• • LAMP (96906)	2	35	
- 13	8-61456-7	• • PLATE	1	35	
- 14	8-61455-7	• • PANEL ATTACHING PARTS	1	35	
	MS35206-62	• • SCREW (96906)	2	35	
	MS35206-231	• • SCREW (96906) ----X----	2	35	
- 15	8-95645	• • NAMEPLATE, MAP READING LIGHT	RF	35	
	8-61457-9	• • NAMEPLATE	1	35	
- 16	MS35058-31	• • SWITCH (96906)	1	35	
- 17	8-94895-15	• • CLIP ASSY, STOWAGE MAP READING LIGHT RIVETED	1	35	
- 18	8-94895-17	• • PLATE ASSY, MAP READING LIGHT RIVETED	1	35	
- 19		• CASE INSTL, MAP AND FLIGHT REPORT SEE FIG. 2.5-7	RF		
- 20		• PIN AND STREAMER INSTL, EJECTION SEAT SAFETY SEE FIG 2.5-5 AND 2.5-6	RF		
	8-38049	• HOLDER INSTL, COMPASS CORRECTION CARD FOR NHA SEE FIG. 2.4-9	RF	A	
	8-38049-3	• HOLDER INSTL, COMPASS CORRECTION CARD FOR NHA SEE FIG. 2.4-9	RF	B	
- 21	AN5823-1	• • CARD, COMPASS CORRECTION (88044)	1	35	
- 22	AN5800-1	• • HOLDER ASSEMBLY (88044)	1	35	
- 23	8-38583-7	• • NAMEPLATE, STANDBY COMPASS CORRECTION	1	35	
- 24	8-95556	• • HOLDER ASSY, BONDED	RF	35	
- 25	8-95555	• • NAMEPLATE, STANDARD UHF CHANNELS	RF	35	
26	60M185305-1	• HOLDER, ALTIMETER CORRECTION CARD ATTACHING PARTS	1	A	
- 27	MS20365D445	• NUT (96906)	2	A	
- 28	AN96FD4	• WASHER (88044)	2	A	
- 29	MS24693-2	• SCREW (96906) ----X----	2	A	
- 30	AFTC-FCRM146	• CARD, ALTIMETER CORRECTION	1	A	
		A AIRPLANES 415 THRU 47 AND 49 THRU 89 B AIRPLANES 48, 90 AND ON			

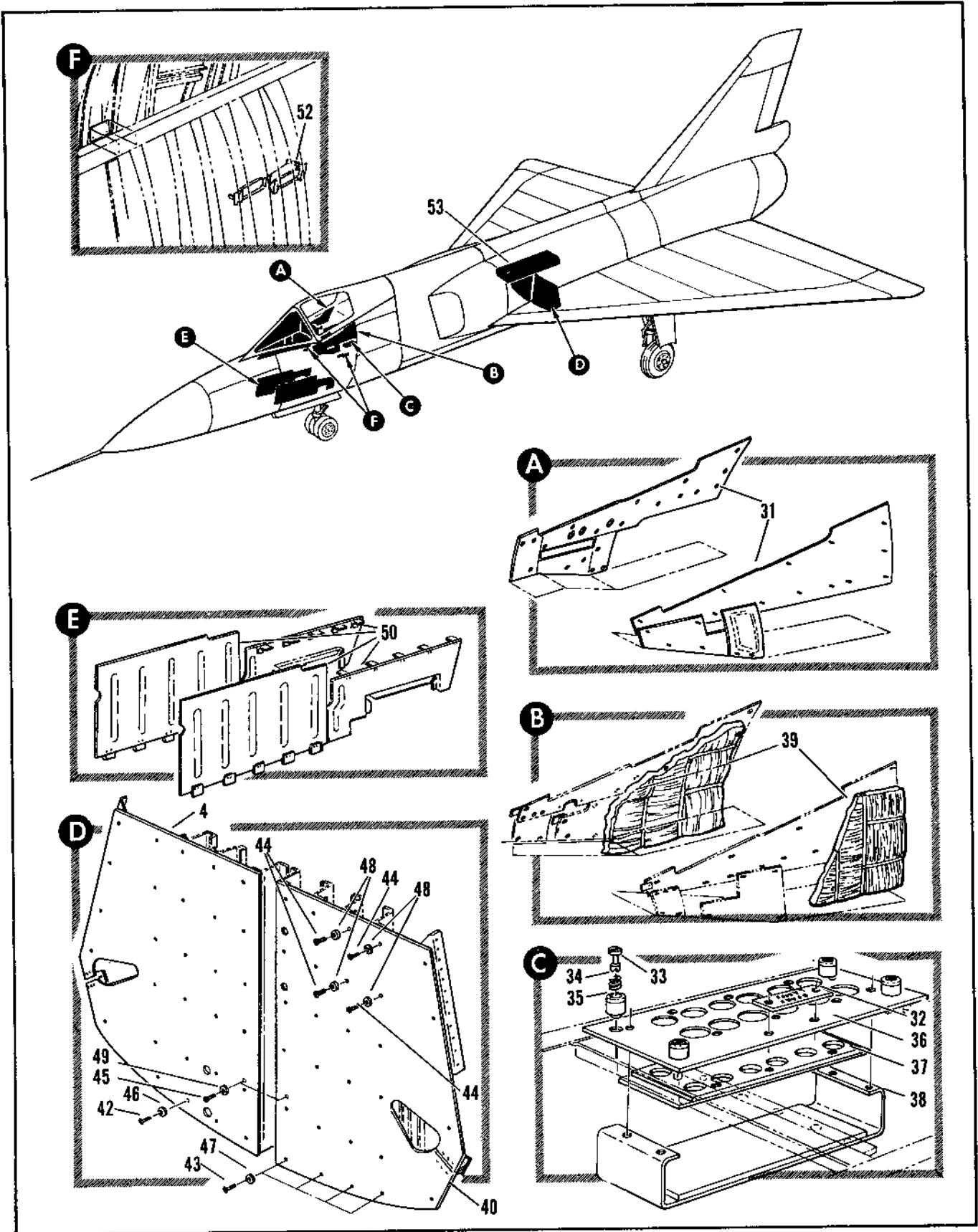

Figure 2.5-1. Furnishings (Sheet 2 of 2)

FIGURE AND INDEX NUMBER	PART NUMBER	DESCRIPTION	UNITS PER ASSY.	USABLE ON CODE	
				FROM	TO
2.5-1- 31	8-95631	• TRIM INSTL, COCKPIT SEE FIG. 2.5-9 • PANEL ASSY, SPARE LAMP STOWAGE REPLACED BY NOT INTCHG WITH 8-94681-5 FOR NHA SEE FIG. 2.16-8	RF RF	35	4A
- 32	8-92525	• NAMEPLATE SPARE LAMP	RF	35	4A
- 33	8-95632	• PANEL ASSY, MOUNTING SPARE LAMP STOWAGE	RF	35	4A
- 34	PF3-1/2-38	• • STUC, <72794> 98-56501-001	RF	35	4A
- 35	PS31/2	• • SPRING, <72794> 98-37001-003	RF	35	4A
- 36	PC3-1/2	• • RETAINER, <72794> 97-58300-001	RF	35	4A
- 35	8-95632-7	• • PANEL	RF	35	4A
- 37	8-95631-11	• RECEPTACLE ASSY, SPARE LAMP BONDED	RF	35	4A
- 38	8-95631-7	• CUSHION ASSY, SPARE LAMP BONDED	RF	35	4A
- 39		• BLANKET INSTL, THERMAL COCKPIT LH SEE FIG. 2.5-12	RF		
	8-74999-1	• SHIELD INSTL, PROTECTION STA 412 LH FOR NHA SEE FIG. 2.3-10	RF	35	
	8-74999-5	• SHIELD INSTL, PROTECTION STA 412 RH FOR NHA SEE FIG. 2.3-10	RF	35	B
- 40	8-74999-47	• SHIELD ASSY, RIVETED LH REPLACED BY SUITABLE SUB 8-74999-57	RF	B	
	8-74999-7	• SHIELD, LH ALT INTCHG WITH 8-74999-47	RF	B	
	8-74999-57	• SHIELD ASSY, RIVETED LH REPLACES SUITABLE SUB FOR 8-74999-47	RF	B	
	7144713-01	• SHIELD ASSY, (98750) RIVETED LH REPLACES 8-74999-47	1	B	
	7144713-03	• SHIELD ASSY, (98750) RIVETED LH REPLACES 8-74999-57	1	B	
- 41	8-74999-49	• SHIELD ASSY, RIVETED RH REPLACED BY SUITABLE SUB 8-74999-59	1	B	
	8-74999-9	• SHIELD, RH ALT INTCHG WITH 8-74999-49	RF	B	
	8-74999-59	• SHIELD ASSY, RIVETED RH REPLACES SUITABLE SUB FOR 8-74999-49	RF	B	
	7144713-02	• SHIELD ASSY, (98750) RIVETED RH REPLACES 8-74999-49	1	B	
	7144713-04	• SHIELD ASSY, (98750) RIVETED RH REPLACES 8-74999-59	1	B	
- 42	MS35206-62	ATTACHING PARTS	24	35	
- 43	MS35206-62	• SCREW (96906)	4	35	129
	MS24694-53	• SCREW (96906)	4	130	
- 44	MS35206-62	• SCREW (96906)	4	35	
- 45	MS35207-263	• SCREW (96906)	2	B	
- 46	99-51509-024	• WASHER	24	35	
- 47	99-51509-024	• WASHER	4	35	129
- 48	99-51406-302	• WASHER	4	130	
- 48	99-51509-024	• WASHER	4	35	
- 49	AN970-3	• WASHER	2	B	
- 50		• COVER INSTL, NOSE WHEEL WELL SPLASH SEE FIG. 2.5-13	RF		
	8-95569-1	• PLATE INSTL, EMERGENCY DRAG CHUTE INSTRUCTION FOR NHA SEE FIG. 2.3-6	RF	A	
- 51	8-95568-7	• PLATE, DRAG CHUTE INSTRUCTION	1	A	
- 52		• CHECK LIST INSTL, PILOT SEE FIG. 2.5-4	RF		
- 53		• CONTAINER INSTL, LUGGAGE SEE FIG. 2.5-8	RF		

A AIRPLANES 35 THRU 47 AND 49 THRU 89
B AIRPLANES 42, 90 AND CN

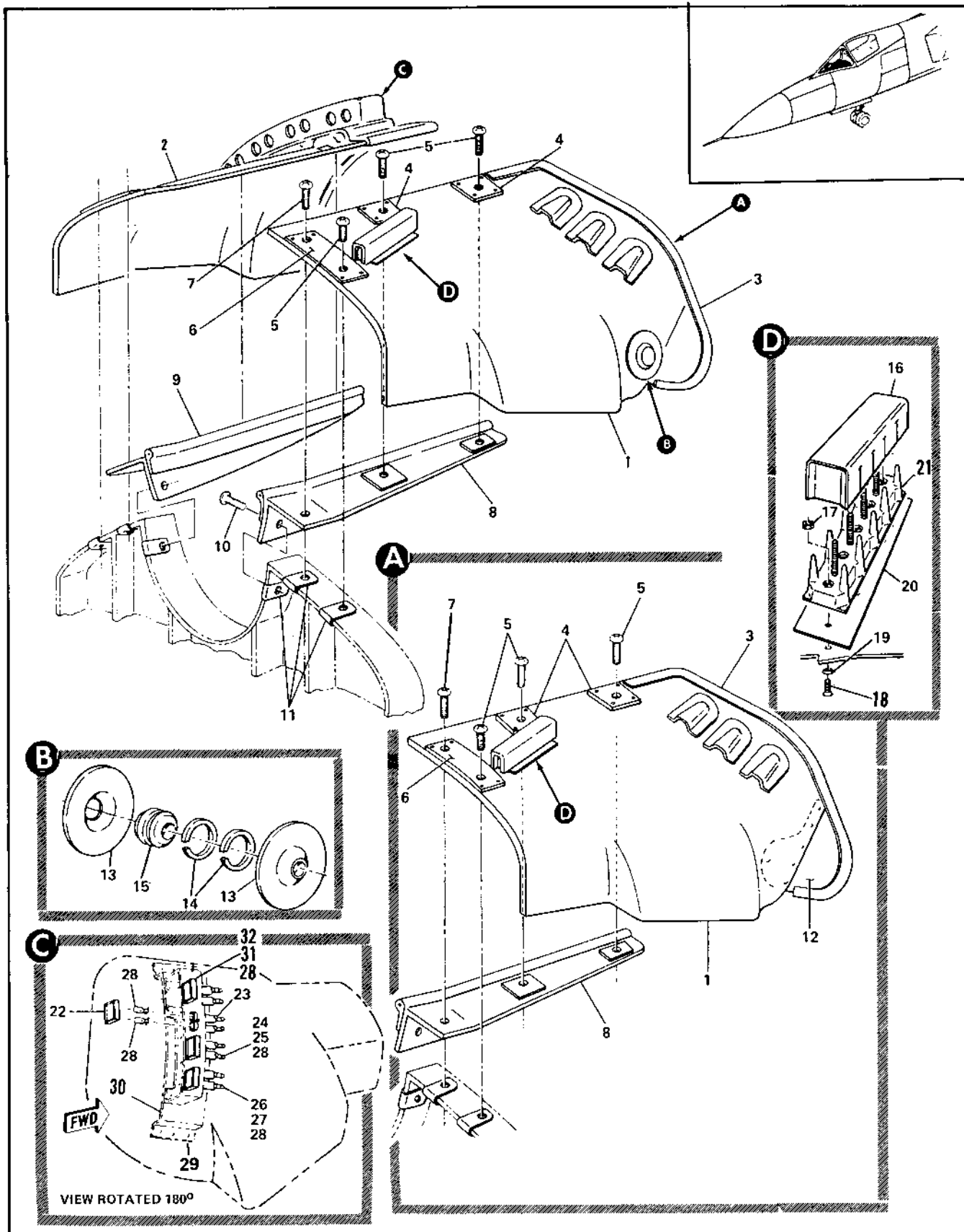

Figure 2.5-2. Instrument Panel Glare Shield Installation

FIGURE AND INDEX NUMBER	PART NUMBER	DESCRIPTION	UNITS PER ASSY.	USABLE ON CODE	
				FROM	TO
2.5-2	A-94571-1	GLARE SHIELD INSTALLATION, INSTRUMENT PANEL	1	ALL	
- 1	66E41455-9	. SHIELD ASSY, GLARE LH (98750) (WILL BE MODIFIED IN ACCORDANCE WITH 8221172-10 (98750) PRIOR TO INSTALLATION)	1	ALL	
- 2	66E41455-9	. SHIELD ASSY, GLARE RH (98750) (WILL BE MODIFIED IN ACCORDANCE WITH 8221172-20 (98750) PRIOR TO INSTALLATION)	1	ALL	
- 3	-250-01	. MOLDING (MADE FROM 81400-38-1)	1	ALL	
- 4	66E41455-7	. PLATE (98750)	2	ALL	
- 5	MS30009-243	. SCREW (94500)	3	ALL	
- 6	66E41455-8	. PLATE (98750)	1	ALL	
- 7	MS30009-243	. SCREW (94500)	1	ALL	
- 8	66D41434-1	. SUPPORT, LH (98750) (WILL BE MODIFIED IN ACCORDANCE WITH 8221171-10 (98750) PRIOR TO INSTALLATION)	1	ALL	
- 9	66D41434-2	. SUPPORT, RH (98750) (WILL BE MODIFIED IN ACCORDANCE WITH 8221171-20 (98750) PRIOR TO INSTALLATION)	1	ALL	
- 10	MS30009-243	. SCREW (94500)	2	ALL	
- 11	64972-4-12	. NUT (15653)	6	ALL	
- 12	6-9457-10	. PLATE, LH	1	ALL	
- 12	6-9457-11	. PLATE, RH	1	ALL	
- 13	6-9459-7	. PLATE, BEARING	2	ALL	
- 14	TRC827	. RING, RETAINER	2	ALL	
- 15	6-9459-8	. BEARING	1	ALL	
- 16	397-6	. COVER, TERMINAL BLOCK (74212)	1	ALL	
- 17	NAS675A24	. NUT (81590)	2	ALL	
- 18	MS24693-6	. SCREW (96906)	2	35	199
- 18	MS35201-217	. SCREW (96906)	2	200	04
- 19	69-61401-01	. WASHER	2	30	100
- 19	69-61401-02	. WASHER	2	290	04
- 20	6-67524-11	. NAMEPLATE, TERMINAL STRIP	1	35	04
- 20	6-67524-12	. NAMEPLATE, TERMINAL STRIP	1	50	04
- 21	A43436-2-4	. TERMINAL BLOCK ASSY (81590)	1	35	04
- 21	MS27212-7-6	. TERMINAL BLOCK ASSY (96906)	1	50	04
- 22	626-1573-005	. CAP, STATUS LIGHT READY (81590)	1	ALL	
- 23	642-1573-001	. BASE (81590)	1	ALL	
- 24	626-1573-002	. CAP, STATUS LIGHT CONTACT	1	ALL	
- 25	642-1573-002	. BASE (81590)	1	ALL	
- 26	626-1573-003	. CAP, STATUS LIGHT DISCONNECT	1	ALL	
- 27	642-1573-003	. BASE (81590)	1	ALL	
- 28	MS25131-213	. LAMP (96906)	8	ALL	
- 29	66D41434-1	. BRACKET ASSY (98750)	1		
- 30	7346572-01	. SHIELD, FOUR LIGHT (98750)	1		
- 31	626-1573-006	. CAP, MASTER WARNING (81590)	1	ALL	
- 32	642-1573-006	. BASE (81590)	1	ALL	

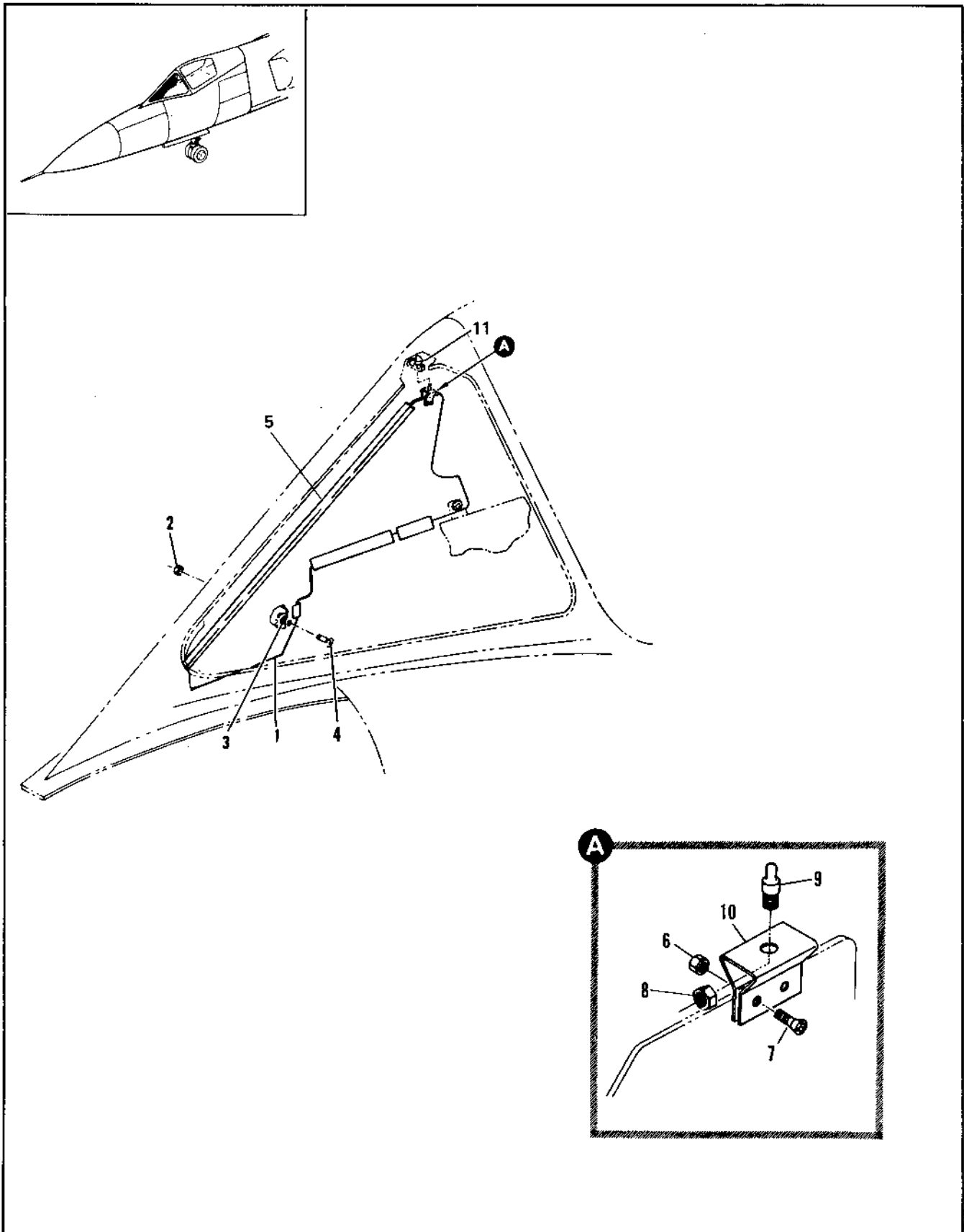

Figure 2.5-3. Windshield Reflection Baffle Installation

FIGURE AND INDEX NUMBER	PART NUMBER	DESCRIPTION	UNITS PER ASSY.	USABLE ON CODE	
				FROM	TO
		1 2 3 4 5 6			
2.3-3	1-9477-1	BAFFLE INSTALLATION, WINDSHIELD REFLECTION FOR NHA SEE FIG. 2.1-1	RF	34	44
	1-9477-2	BAFFLE INSTALLATION, WINDSHIELD REFLECTION FOR NHA SEE FIG. 2.1-1	RF	40	
- 1	66E4 011-1 77477-7-17	BAFFLE ASSEMBLY (98750) BAFFLE ASSEMBLY (98751) ATTACHING PARTS	RF 1	A 35	
- 2	NAS79A7	• NUT (10200)	1	35	
- 2	40960-10L	• WASHER (98144)	1	35	
- 4	4S35217-2-4	• SCREW (50916) -----X-----	1	35	
- 1	6-95012-11 6-946 1 6-9465-17	• SEAL, MAKE FROM 6-9486 • SEAL • LATCH ASSY, WINDSHIELD REFLECTION BAFFLE ATTACHING PARTS	1 RF 1	35 35	
- 6	NAS479A76	• NUT (10200)	2	35	
- 7	MS30266-220	• SCREW (6715) -----X-----	2	35	
- 8	NAS 79A77	• NUT (10200)	1	35	
- 9	9116-301-1-3	• STUD, TIE	1	35	
- 11	6-9465-11	• CLIP	1	35	
- 11		• LATCH ASSY, BAFFLE RIVETED SEE FIG. 2.4-2 INDEX 20	RF		
		A 37 INRU 47 AND 49 THEM 43 B 4, 51 AND 61			

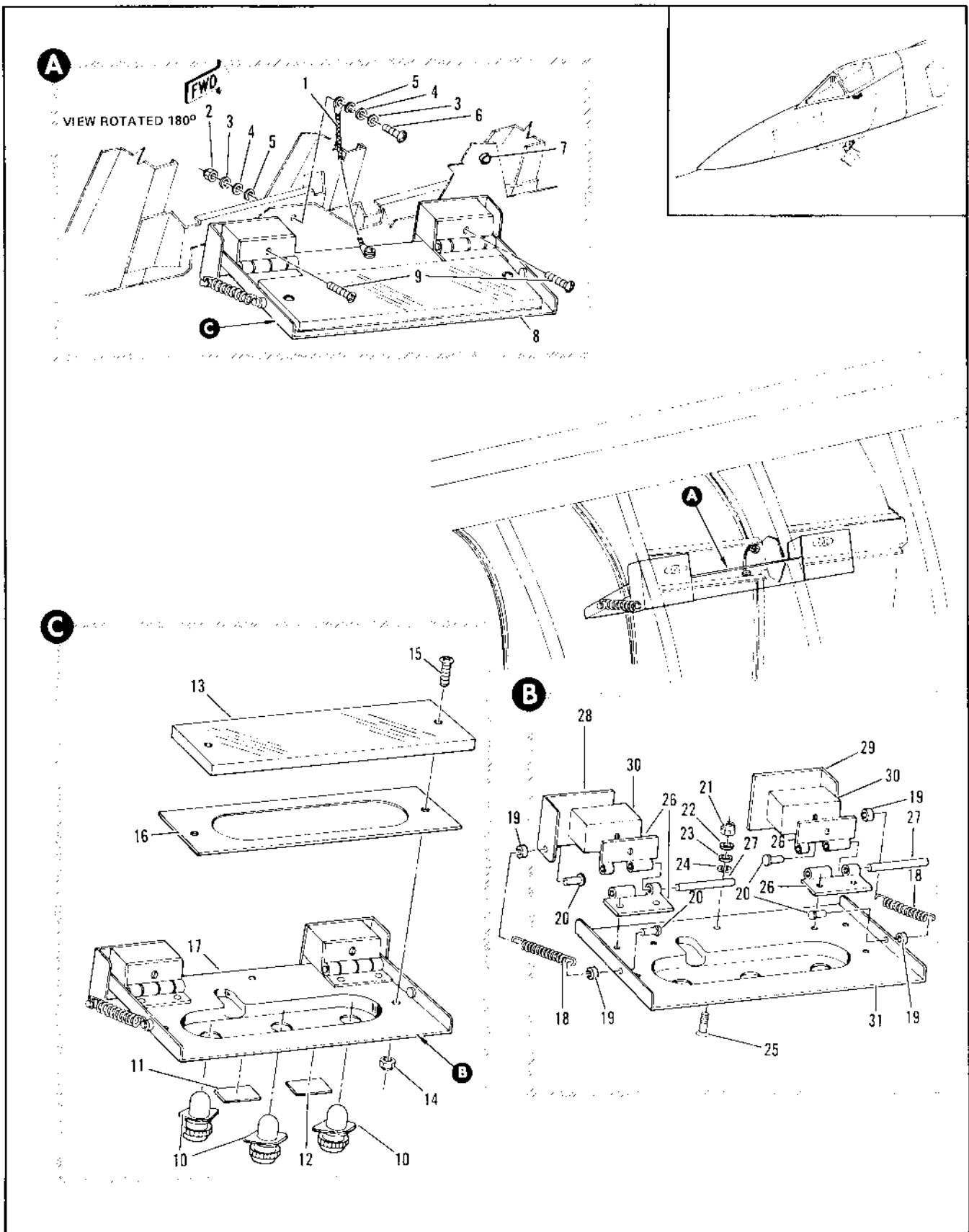

Figure 2.5-4. Pilot Check List Installation

FIGURE AND INDEX NUMBER	PART NUMBER	DESCRIPTION	UNITS PER ASSY.	USABLE ON CODE	
				FROM	TO
2.5-A	R-95071	CHECK LIST INSTALLATION, PILOT	RF	35	159
- 1	MS20113-244	FOR N/A SEE FIG. 2.5-A • JUMPER (94976)	RF	35	159
- 2	AS-7947	ATTACHING PARTS • NUT (96050)	RF	35	159
- 3	AN94731-1L	• WASHER (96144)	RF	35	159
- 4	AN94711-1L	• WASHER (96144)	RF	35	159
- 5	AS20571-47	• WASHER (96144)	RF	35	159
- 6	MS51756-62	• SCREW (96972) -----X-----	RF	35	159
- 7	R-95071-17	• JUMPER	RF	35	159
- 8	J-94717-11	• PLATE ASSY, PILOT CHECK LIST MOUNTING ATTACHING PARTS	RF	35	159
- 9	MS31117-17	• SCREW (94964) -----X-----	RF	35	159
	S-94711-14	• LAMP INSTL, PILOT CHECK LIST MOUNTING PLATE	RF	35	159
	MS20117-207	• LAMP (94966)	RF	35	159
- 11	MS20113-244	• LIGHT ASSY, (94966) 95-63512-101	RF	35	159
- 12	J-94712-7	• PLATE, CHECK	RF	35	159
- 13	J-94712-7	• PLATE, LIST	RF	35	159
- 14	J-94712-7	• PLATE, PILOT CHECK LIST ATTACHING PARTS	RF	35	159
- 15	ASL79476	• NUT (96050)	RF	35	159
- 16	MS30216-244	• SCREW (94972) -----X-----	RF	35	159
- 17	-64912	• WASHER, PILOT CHECK LIST	RF	35	159
- 18	J-94712-11	• PLATE ASSY, PILOT CHECK LIST	RF	35	159
- 19	J-64912	• SPRING, PILOT CHECK LIST	RF	35	159
- 20	AS94704-218	• SPACER (96125)	RF	35	159
- 21	MS20113-244	• PIN (94976)	RF	35	159
- 22	AS-79476	• NUT (96050)	RF	35	159
- 23	AN94731-1L	• WASHER (96144)	RF	35	159
- 24	AN94711-1L	• WASHER (96144)	RF	35	159
- 25	AS30161-41	• WASHER (94976)	RF	35	159
- 26	MS30116-217	• SCREW (94976)	RF	35	159
- 27	R-94711-1	• HINGE, BRIF MAKE FROM MS2001H1-150	RF	35	159
- 28	MS20113-244-176	• PIN, HINGE (94976)	RF	35	159
- 29	J-94717-17	• ANGLE, CH	RF	35	159
- 30	J-94717-14	• ANGLE, TH	RF	35	159
- 31	J-94716-7	• SPACER	RF	35	159
- 32	J-94711-7	• PLATE, PILOT CHECK LIST MOUNTING	RF	35	159

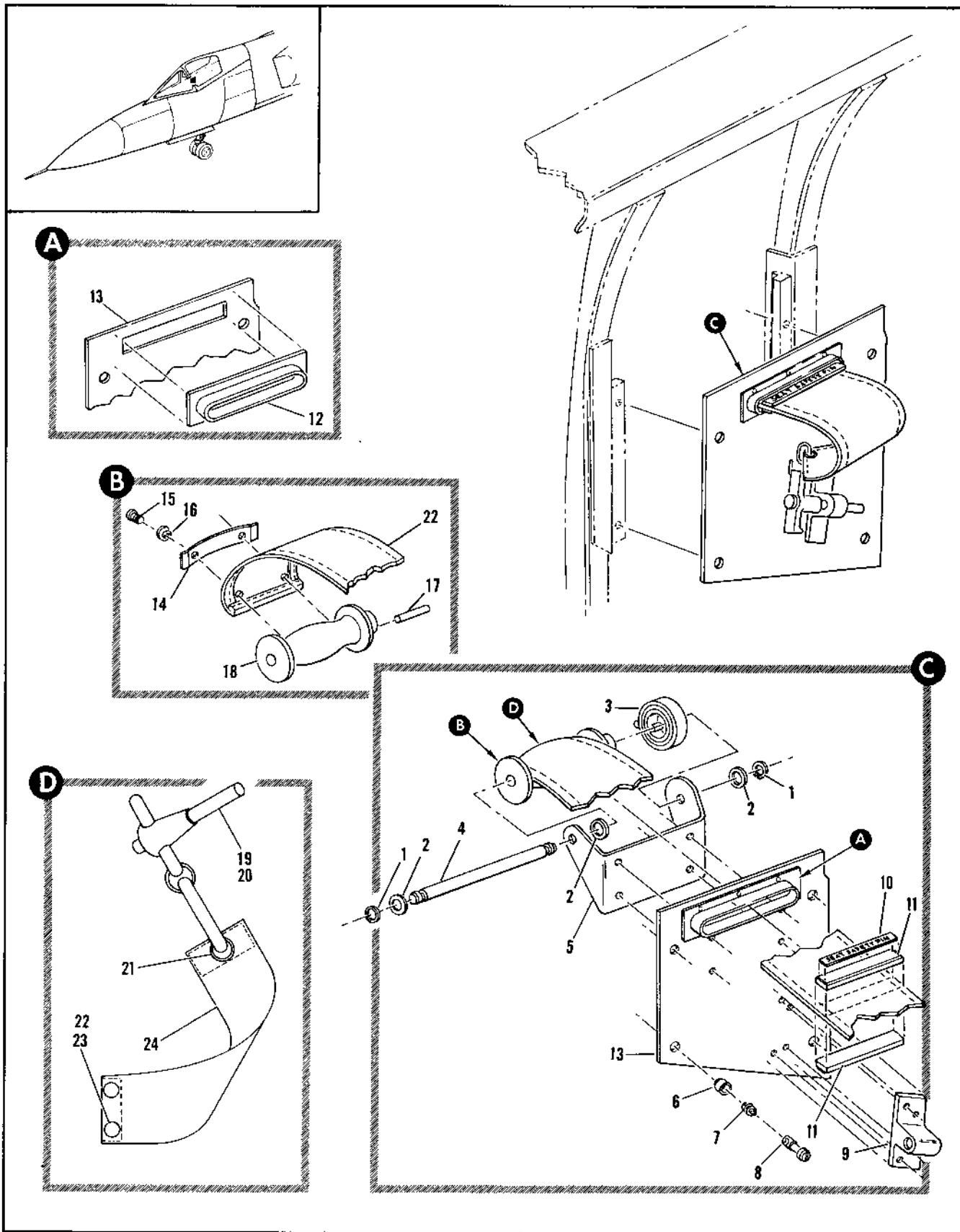

Figure 2.5-5. Ejection Seat Safety Pin and Streamer Installation

FIGURE AND INDEX NUMBER	PART NUMBER	DESCRIPTION	UNITS PER ASSY.	USABLE ON CODE	
				FROM	TO
2.5-5	W-945-1	• PIN AND STREAMER INSTALLATION, EJECTION SEAT SAFETY FOR DPA SEE FIG. 2.3-7	1	34	41
	W-951-2-1	• STREAMER ASSY, EJECTION SEAT SAFETY PIN STORAGE REPLACED BY NOT INTCHG WITH W-951-2-3	1	34	41
	W-951-2-2	• STREAMER ASSY, EJECTION SEAT SAFETY PIN STORAGE REPLACES NOT INTCHG WITH W-951-2-1 REPLACED BY NOT INTCHG WITH W-945-1	1	31	37
- 1	W-951-2-3	• RING (14201)	2	35	40
- 2	W-951-2-4	• WASHER	1	35	41
- 3	W-951-2-5	• SPRING, EJECTION SEAT SAFETY-PIN STORAGE	1	35	41
- 4	W-951-2-6	• PIN, EJECTION SEAT SAFETY PIN STORAGE	1	35	41
- 5	W-951-2-7	• BRACKET ASSY, EJECTION SEAT STORAGE WELDED	1	35	41
- 6	W-951-2-8	• RETAILING FASTENER <72794> 97-58301-01	4	35	41
- 7	W-951-2-9	• SPRING, FASTENER <72794> 96-37001-01	4	35	41
- 8	W-951-2-10	• STUD, FASTENER <72794> 98-565(1-01)	4	35	41
- 9	W-951-2-11	• BLOCK	1	35	41
- 10	W-951-2-12	• NAMEPLATE, SEAT PIN STORAGE REPLACED BY NOT INTCHG WITH W-945-2	1	35	41
- 11	W-951-2-13	• CLAMP	2	35	41
- 12	W-951-2-14	• GUIDE	1	35	41
- 13	W-951-2-15	• COVER	1	35	41
- 14	W-951-2-16	• SPOOL ASSEMBLY • CLIP ATTACHING PART	1	35	41
- 15	W-951-2-17	• SCREW (14201)	2	35	41
- 16	W-951-2-18	• WASHER (14201) -----X-----	2	35	41
- 17	W-951-2-19	• PIN	1	35	41
- 18	W-951-2-20	• SPOOL, EJECTION SEAT SAFETY PIN STORAGE	1	35	41
- 19	W-951-2-21	• STREAMER ASSY, EJECTION SEAT SAFETY PIN STORAGE (92124) PART OF SEAT ASSY 93432-413, SEE FIG. 1145-12-44	1	35	41
- 20	W-951-2-22	• PIN (54216)	1	35	41
- 21	W-951-2-23	• RING, SPLIT KEY (17266)	1	35	41
- 22	W-951-2-24	• BODY (17266)	1	35	41
- 23	W-951-2-25	• SOCKET (17266)	2	35	41
- 24	W-951-2-26	• PUTTER (17266)	2	35	41
- 25	W-951-2-27	• CLIP, STITCHED (92824) 4SPEC COMT DWG WAC 3571-33	1	35	41

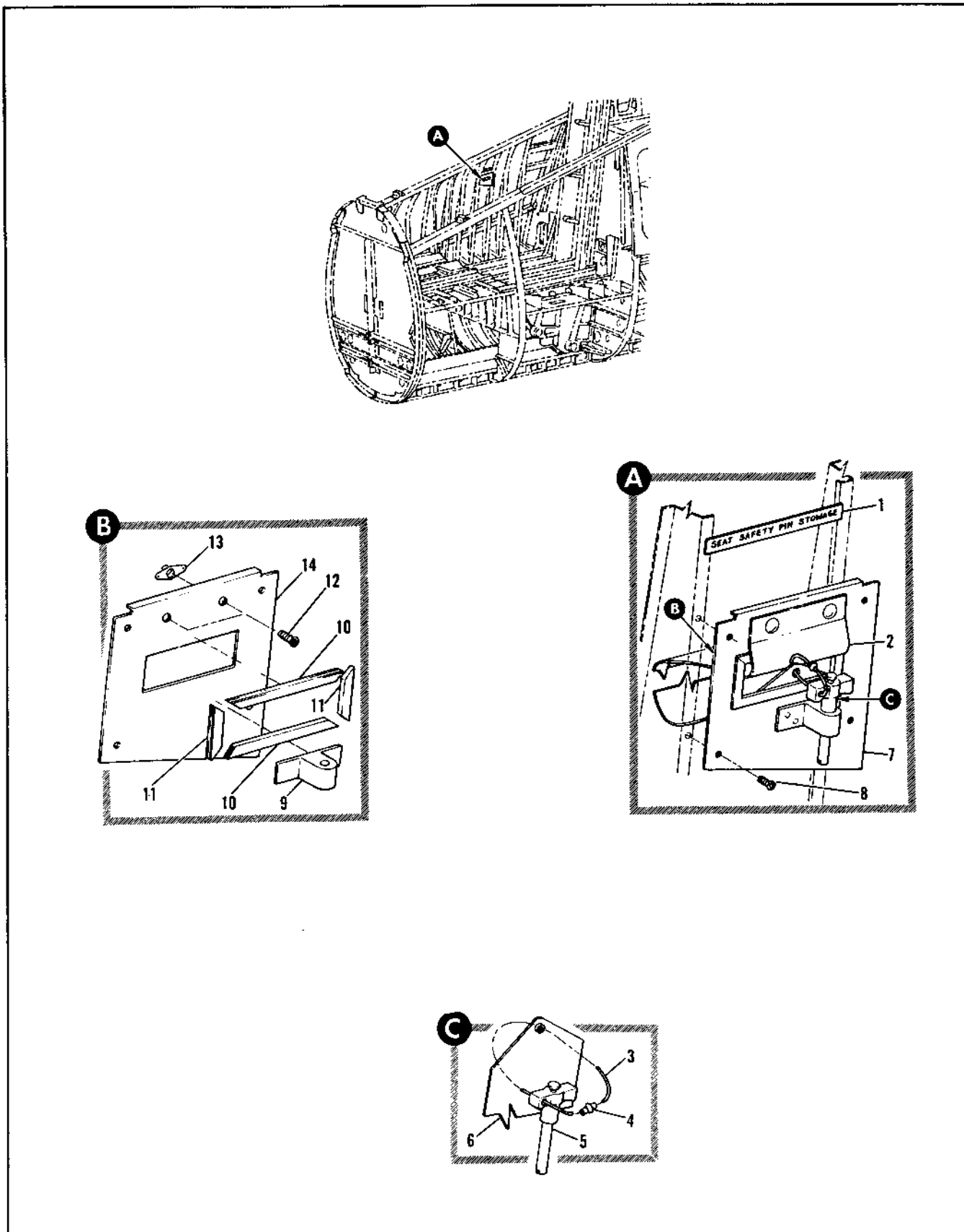

Figure 2.5-6. Ejection Seat Safety Pin and Streamer Installation

FIGURE AND INDEX NUMBER	PART NUMBER	DESCRIPTION	UNITS PER ASSY.	USABLE ON CODE	
				FROM	TO
		1 2 3 4 5 6			
2.5-b	4-95-101	PIN AND STREAMER INSTALLATION, EJECTION SEAT SAFETY FOR LPA SEE FIG. 2.3-1	1	35	
- 1	28-94510-1	• NAMEPLATE, EJECTION SEAT SAFETY PIN STORAGE REPLACES NOT INTCH	1	35	
- 2	28-94510-1	• STREAMER ASSY, EJECTION SEAT SAFETY PIN STORAGE REPLACES NOT INTCH WITH P-952ND-3 REPLACED BY SUITABLE SUB 28-94510-801 OR 28-94510-803	1	35	15-4
	28-94510-101	• STREAMER ASSY, EJECTION SEAT SAFETY PIN STORAGE REPLACES SUITABLE SUB FOR 28-94510-1 REPLACED BY SUITABLE SUB 28-94510-803	1	91	25-4
	4186-1-407	• STREAMER ASSY, EJECTION SEAT SAFETY PIN STORAGE REPLACES SUITABLE SUB FOR 28-94510-1 OR 28-94510-801	1	265	
- 3	28-94510-11	• CABLE	1	35	
- 4	AN6-100	• TERMINAL (4144)	1	35	
- 5	9447-4-14T	• PIN, BUCK RELEASE (K4255) 96-78-1-1-09	1	35	15-4
	9447-4-14T-1	• PIN, BUCK RELEASE (K4255) 96-78-1-1-03	1	51	
- 6	28-94510-1	• STREAMER ASSY, STITCHED	1	91	25-4
	28-94510-17	• STREAMER ASSY, STITCHED	1	265	
- 7	4-95-101-1	• COVER ASSY, PIVOTED ATTACHING PART	1	35	
- 8	MS3 1-1-1	• SCREW (4174)	4	35	
- 9	28-94510-2	• BLOCK, EJECTION SEAT SAFETY PIN STORAGE	1	35	
- 10	4-95-101-1	• MOULDRING	2	35	
- 11	4-95-101-11	• MOULDRING	2	35	
- 12	AN287-107	• STUD (48145)	2	31	
- 13	1AS29767	• NUT PLATE (48125)	2	35	
- 14	4-95-101-21	• COVER	1	35	

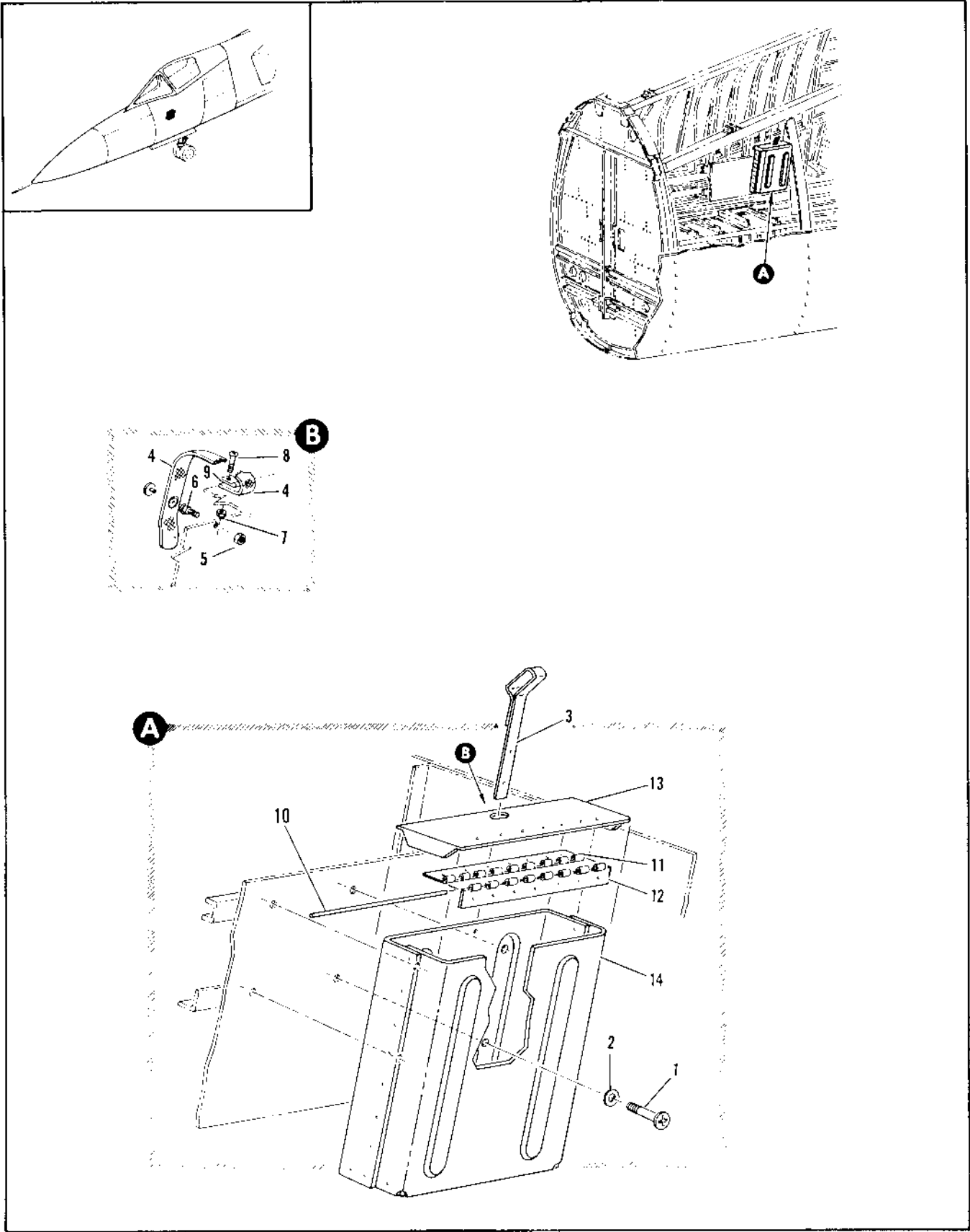

Figure 2.5-7. Map and Flight Report Case Installation

FIGURE AND INDEX NUMBER	PART NUMBER	DESCRIPTION	UNITS PER ASSY.	USABLE ON CODE	
				FROM	TO
2.5-7	--95523	CASE INSTALLATION, MAP AND FLIGHT REPORT FOR NHA SEE FIG. 2.7-4	RF	35	
	8-94971-3	• CASE ASSEMBLY	1	35	47
	8-94971-1	• CASE ASSEMBLY	1	90	
		ATTACHING PARTS			
- 1	MS3521-40	• SCREW (35908)	4	35	
- 2	4595-100	• WASHER (38744)	4	35	
		----X----			
- 5	8-94971-4	• LATCH	1	35	49
- 4	05755000	• STRAP	1	90	
		ATTACHING PARTS			
- 8	NAS47900	• NUT (40200)	1	90	
- 6	AN227-1000	• STUD (48204)	1	90	
- 7	26000	• NUT, (K1500) 96-37561-000	1	90	
- 8	NAS201-6	• SCREW (40200)	1	90	
- 9	96-40300-001	• PLATE	1	90	
		----X----			
- 10	MS20257-000	• PIN (36900)	1	35	
- 11	8-94971-7	• HINGE, HALF MAKE FROM AN257X2-835	1	35	
- 12	8-94971-9	• HINGE, HALF MAKE FROM AN257X2-835	1	35	
- 13	8-94973-7	• COVER, MAP AND FLIGHT REPORT CASE	1	35	47
		REPLACED BY SUITABLE SUB 8-94973-9			
	8-94573-4	• COVER, MAP AND FLIGHT REPORT CASE	1	90	
		REPLACES SUITABLE SUB FOR 8-94973-7			
- 14	--95518	• CASE ASSY, MAP AND FLIGHT REPORT BOWDED	1	35	
	8-94972-1	• CASE ASSY, MAP AND FLIGHT REPORT RIVETED	RF	35	
		ALT. FINISH WITH 8-55500			

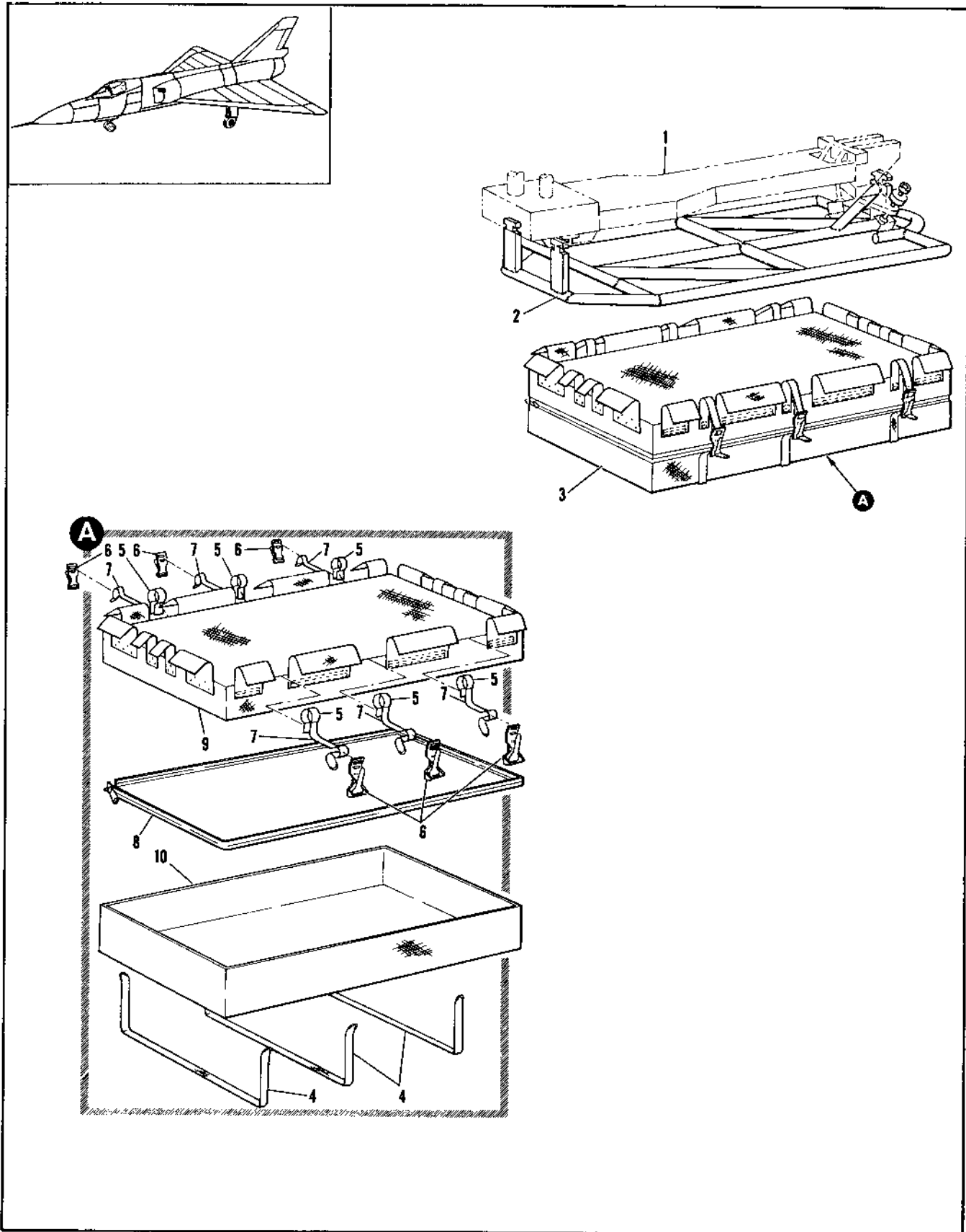

Figure 2.5-8. Luggage Container Installation

FIGURE AND INDEX NUMBER	PART NUMBER	DESCRIPTION	UNITS PER ASSY.	USABLE ON CODE	
				FROM	TO
2.5-8	4-99-14	CONTAINER INSTALLATION, LUGGAGE FOR NHA SEE FIG. 2.4-1	RF	150	
- 1		• EJECTOR ASSY. NR-1	4F		
- 2	4-99-14	• FRAME ASSY, LUGGAGE CONTAINER WELDED	1	150	
- 3	4-99-14	• CONTAINER ASSY, LUGGAGE WITH 4-99-14-7 BAG AND TIES	1	170	
- 4	99-5650-100	• • WEBBING	3	130	
- 5	91-97-10-009	• • TIP	6	130	
- 6	41-1,000-074	• • BUCKLE	4	130	
- 7	99-5650-100	• • WEBBING	6	170	
- 8	4R229-441330-1	• • FASTENER (R244)	1	170	
- 9	4-99-14-21	• • TOP	1	170	
- 10	4-99-14-6	• • BAG	1	170	

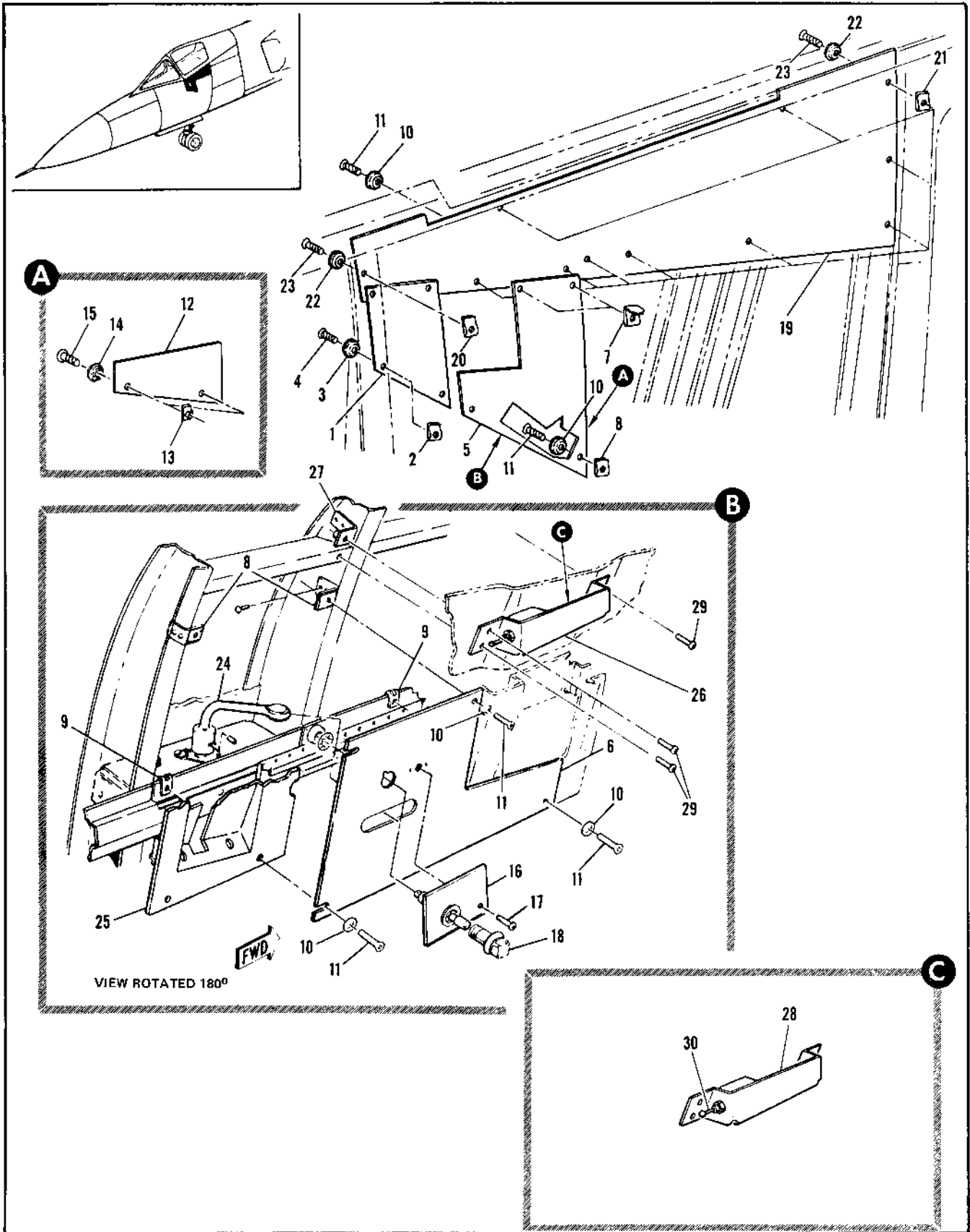

Figure 2.5-9. Cockpit Trim Installation LH

FIGURE AND INDEX NUMBER	PART NUMBER	DESCRIPTION	UNITS PER ASSY.	USABLE ON CODE	
				FROM	TO
2.5-9	8-95517-1	TRIM INSTALLATION, COCKPIT LH FOR NHA SEE FIG. 2-3-6	RF	59	
- 1	8-95517-29	• PANEL, COCKPIT TRIM LH ATTACHING PARTS	1	35	
- 2	66457-17-3	• NUT, LH <78553> 96-37302-012	4	35	
- 3	99-51404-101	• WASHER, LH	4	35	
- 4	MS24-17-22	• SCREW, LH (98906) -----X-----	4	35	
- 5	8-95517-3	• PANEL, COCKPIT TRIM LH REPLACES NUT INTCHG WITH 8-95517-23	1	A	
- 6	61024870-7	• PANEL ASSY, COCKPIT TRIM LH (98750) ATTACHING PARTS	1	35	
- 7	A8587-12-3	• NUT, <78553> 96-37303-001	2	35	
- 8	A6457-17-3	• NUT, <78553> 96-37302-002	RF	A	
	A6457-87-3	• NUT, <78553> 96-37302-002	1	35	
- 9	MS330-11-3	• NUT (80215)	1	35	
- 10	99-51404-101	• WASHER	4	35	
- 11	MS24-15-22	• SCREW (96414) -----X-----	4	35	
- 12	8-95517-23	• PANEL, COCKPIT TRIM LH REPLACES NUT INTCHG WITH 8-95517-9	RF	61	124
- 13	A6457-17-3	• NUT, <78553> 96-37302-002	RF	61	124
- 14	99-51404-101	• WASHER	RF	61	124
- 15	AN531-18R	• SCREW (86044) -----X-----	RF	61	124
- 16	62031771-1	• PANEL, COCKPIT TRIM LH (98750) ATTACHING PARTS	1	35	
- 17	MS330-16-230	• SCREW (96500)	1	A	
	MS24-19-22	• SCREW (96914) -----X-----	1	35	
- 18	MS25010-9A	• LIGHT ASSY (90906)	1	35	
	MS25037-307	• LAMP (90906)	1	35	
- 19	8-95517-27	• PANEL, COCKPIT TRIM LH REPLACES BY NUT INTCHG WITH 8-95517-43	1	35	154
	8-95517-43	• PANEL, COCKPIT TRIM LH REPLACES NUT INTCHG WITH 8-95517-27	1	160	
		ATTACHING PARTS			
- 20	A6457-17-3	• NUT, LH <78553> 96-37302-011	1	35	
- 21	A6457-17-3	• NUT, LH <78553> 96-37302-012	10	35	
- 22	99-51404-101	• WASHER, LH	11	35	
- 23	MS24-17-22	• SCREW, LH (98906) -----X-----	11	35	
- 24		• VALVE ASSY, PRESSURE SUIT MANUAL CONTROL FOR BREAKDOWN SEE FIG. 2-13-1F	RF		
- 25		• COVER ASSY, EMERGENCY HYDRAULIC POWER SEE FIG. 2-4-1	RF		
- 26	67F30622-1	• PANEL COCKPIT TRIM LH (98750)	1	35	
- 27	6604143-1	• BRACKET (98750)	1	35	
- 28	66040227-2	• CLIP ASSY, RIVETED (98750)	1	35	
- 28	6604143-1	• BRACKET (98750) ATTACHING PARTS	1	35	
- 29	MS330-17-207	• SCREW (36914) -----X-----	3	35	
- 30	MS27478-11	• SWITCH (91429)	1	35	

A AIRPLANES #25 THRU 60, 130 AND ON

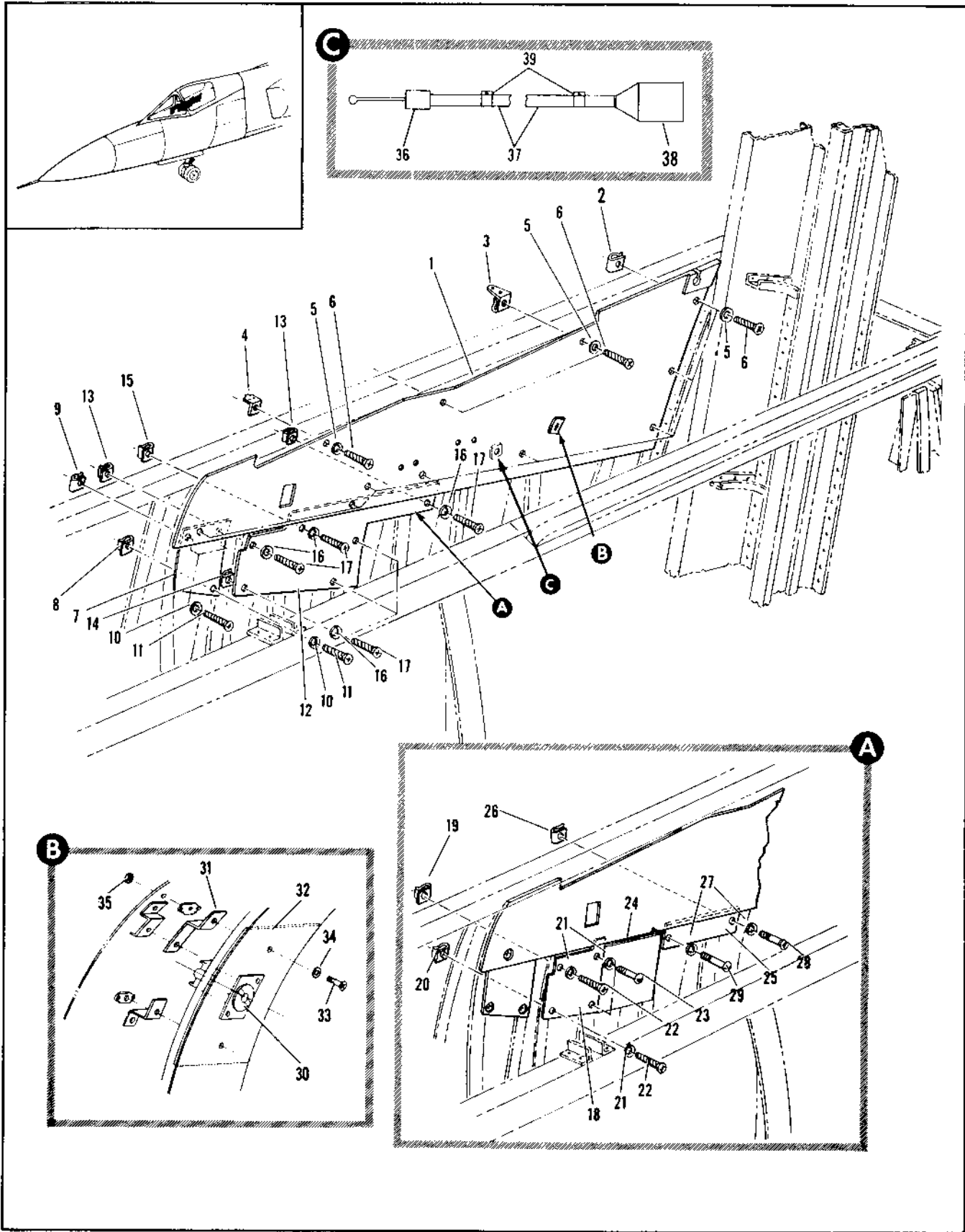

Figure 2.5-10. Cockpit Trim Installation RH

FIGURE AND INDEX NUMBER	PART NUMBER	DESCRIPTION	UNITS PER ASSY.	USABLE ON CODE	
				FROM	TO
2.5-10	489517	TRIM INSTALLATION, COCKPIT RH FOR AHA SEE FIG. 2-3-8	RF	35	
- 1	7137214-17	• PANEL, COCKPIT TRIM RH (98750)	1	35	
- 2	46449-8-23	ATTACHING PARTS			
- 3	46449-8-23	• NUT, RH <77003> 96-37302-001	8	35	
- 4	46449-8-23	• NUT, RH <77003> 96-37301-001	2	35	
- 5	46449-8-23	• NUT, RH <77003> 96-37303-001	1	35	
- 6	95-31470-101	• WASHER	11	35	
- 6	MS24717-02	• SCREW, RH (96306)	11	35	
- 7	4-90617-41	• PANEL, COCKPIT TRIM RH ATTACHING PARTS	1	35	
- 8	4-90617-41	• PANEL, COCKPIT TRIM RH	RF	35	
- 8	4-61415-01	• PANEL, LABEL QUANTITY SWITCH, NO. 1 TANK SEE FIG. 2-5-1	1	35	
- 9	46449-8-23	• NUT, RH <77003> 96-37302-001	1	35	
- 9	46449-8-23	• NUT, RH <77003> 96-37302-001	2	35	
- 10	95-31470-101	• WASHER	3	35	
- 11	MS24717-02	• SCREW (96306)	3	35	
- 12	4-90617-41	• PANEL, COCKPIT TRIM RH REPLACES NOT INCHG WITH 4-90617-39 AND 4-90617-41	1	35	40
- 13	46449-8-23	ATTACHING PARTS	RF	40	40
- 14	46449-8-23	• NUT, RH <77003> 96-37302-001	2	35	40
- 14	46449-8-23	• NUT, RH <77003> 96-37302-001	3	35	40
- 14	46449-8-23	• NUT, RH <77003> 96-37303-001	1	35	40
- 15	95-31470-101	• WASHER	6	35	40
- 17	MS24717-02	• SCREW, RH (96306)	6	35	40
- 17	4-90617-40	• PANEL, COCKPIT TRIM RH REPLACES NOT INCHG WITH 4-90617-37 REPLACED BY SUITABLE SUB FOR 4-90617-40	RF	90	120
- 17	4-90617-41	• PANEL, LOCK II TRIM RH REPLACES SUITABLE SUB FOR 4-90617-39	1	A	
- 19	46449-8-23	ATTACHING PARTS			
- 20	46449-8-23	• NUT, RH <77003> 96-37312-001	1	90	
- 20	46449-8-23	• NUT, RH <77003> 96-37312-001	1	90	
- 21	46449-8-23	• NUT PLATE (77001)	2	A	
- 21	95-31470-101	• WASHER	9	90	
- 22	MS24717-02	• SCREW (96306)	2	90	
- 23	95-31470-101	• SCREW (96306)	40	90	120
- 23	MS24694-3	• SCREW (96306)	2	A	
- 24	4-90617-41	• PANEL	1	A	
- 25	4-90617-41	• PANEL, COCKPIT TRIM RH REPLACES NOT INCHG WITH 4-90617-37	1	A	
- 26	46449-8-23	ATTACHING PARTS			
- 26	46449-8-23	• NUT, RH <77003> 96-37302-001	1	90	
- 27	46449-8-23	• NUT PLATE (77001)	1	A	
- 27	95-31470-101	• WASHER	2	90	
- 28	MS24717-02	• SCREW (96306)	1	90	
- 28	MS24717-02	• SCREW (96306)	1	A	
- 28	MS24717-02	• SCREW (96306)	1	90	120
- 28	MS24717-02	• SCREW (96306)	1	130	
		-----X-----			
		AIRPLANE NO. 90-117-00			

FIGURE AND INDEX NUMBER	PART NUMBER	DESCRIPTION	UNITS PER ASSY.	USABLE ON CODE	
				FROM	TO
		1 2 3 4 5 6			
2.5-10- 30	119352	• PHONE JACK	1	35	
- 31	7037093-1	• BRACKET	1	35	
- 32	7037092-1	• PLATE	1	35	
- 33	MS24953-24	• SCREW (98751)	2	35	
- 34	MS20159-25K	• NUT PLATE (98751)	2	35	
- 35	NAS3913-11	• WASHER (98751)	2	35	
- 36	U13470	• CONNECTOR MODIFIED TO 7037096-10 (98751)	1	35	
- 37	W1080	• CABLE INTERPHONE MODIFIED TO 7037096-10 (98751)	1	35	
- 38	U92470	• CONNECTOR MODIFIED TO 7037096-10 (98751)	1	35	
- 39	MS21102	• CLAMP MODIFIED TO 7037096-10 (98751)	2	35	

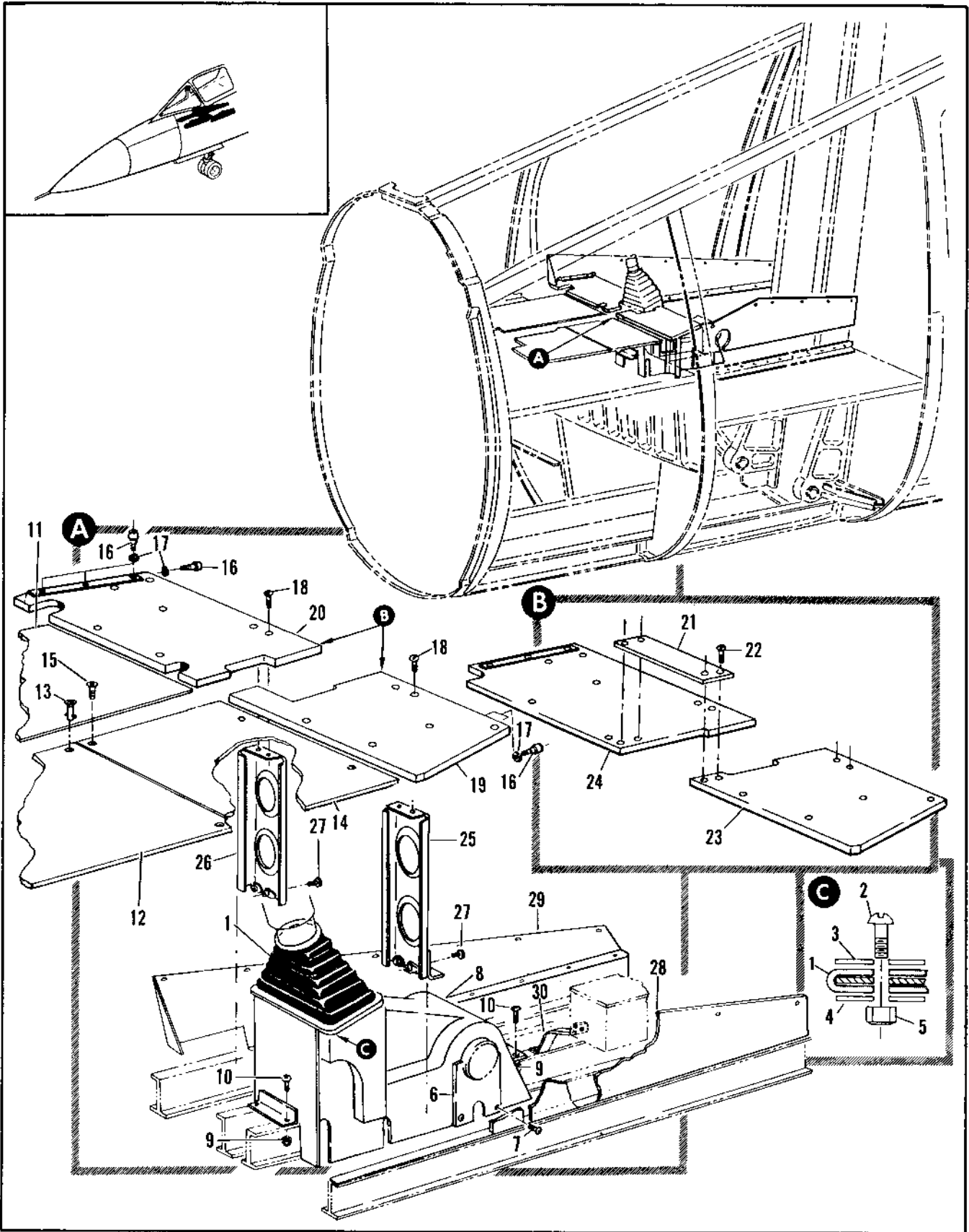

Figure 2.5-11. Cockpit Control Guards

FIGURE AND INDEX NUMBER	PART NUMBER	DESCRIPTION	UNITS PER ASSY.	USABLE ON CODE	
				FROM	TO
2.5-11		COCKPIT CONTROL GUARDS			
- 1	R-94094	• COVER INSTL, CENTER STICK CONTROL FOR NHA SEE FIG. 2.4-4	RF	7	
- 2	4261	• FOOT, CENTER STICK CONTROL (84914) SPEC R-10283-1 ATTACHING PARTS	1	5	
- 3	MS35207-007	• SCREW (PHEN)	4	3	
- 4	AN97	• WASHER (C-99)	4	3	
- 5	AN94701	• WASHER (C-99)	4	3	
- 6	MS2147-4	• NUT (PHEN)	4	3	
- 7	R-94094-1	• DOOR ATTACHING PARTS	1	5	
- 8	MS35207-007	• SCREW (PHEN)	4	3	
- 9	R-94094-1	• COVER ASSY, CENTER STICK CONTROL RIVETED	1	3	
- 10	MS35207-007	• NUT (PHEN)	4	3	
- 11	MS35207-007	• SCREW (PHEN)	4	3	
- 12	R-94094-1	• PANEL INSTL, MILITS FLOOR AND SCUFF	1	B	
- 13	R-94094-1	• PLATE ASSY, SCUFF BONDED	1	B	
- 14	R-94094-1	• PANEL ASSY, COCKPIT FLOOR LAMINATED ATTACHING PARTS	1	B	
- 15	MS35207-007	• SCREW (PHEN)	3	B	
- 16	R-94094-1	• PLATE ASSY, COCKPIT FLOOR LAMINATED ATTACHING PARTS	1	B	
- 17	MS24609-001	• SCREW (PHEN)	4	B	
- 18	R-94094-1	• GUARD INSTL, COCKPIT CONTROL FOR NHA SEE FIG. 2.4-4	RF	A	
- 19	R-94094-1	• GUARD INSTL, COCKPIT CONTROL FOR NHA SEE FIG. 2.4-4	RF	A	
- 20	AN229-1100	• STUD (PHEN)	7	3	
- 21	MS35207-007	• WASHER (C-99)	7	3	
- 22	R-94094-1	• PANEL ASSY, COCKPIT FLOOR ATTACHING PARTS	1	A	
- 23	MS35207-007	• SCREW (PHEN)	15	A	
- 24	R-94094-1	• PANEL ASSY, COCKPIT FLOOR LH BONDED REPLACED BY NGI INTCHG WITH R-94094-1	1	A	
- 25	R-94094-1	• PANEL ASSY, COCKPIT FLOOR RH BONDED REPLACED BY NGI INTCHG WITH R-94094-1	1	A	
- 26	R-94094-1	• COVER	1	B	
- 27	MS35207-007	• SCREW (PHEN)	4	B	
- 28	R-94094-1	• PANEL ASSY, COCKPIT FLOOR LH BONDED REPLACES NGI INTCHG WITH R-94094-1	1	C	
- 29	R-94094-1	• PANEL ASSY, COCKPIT FLOOR RH BONDED REPLACES NGI INTCHG WITH R-94094-1	1	C	
		REPLACED BY NGI INTCHG WITH R-94094-1			
		A AIRPLANE 84 AND 85 THROUGH			
		B AIRPLANE 84, 85 AND ON			
		C AIRPLANE 84 AND 85 THROUGH			

FIGURE AND INDEX NUMBER	PART NUMBER	DESCRIPTION	UNITS PER ASSY.	USABLE ON CODE	
				FROM	TO
2.5-11	8-95922-17	• • PANEL ASSY, COCKPIT FLOOR RH BONDED REPLACES NOT INTCHG WITH 8-95922-885	1	160	
	MS39257-010	• • SCREW (316 S)	13	R	
- 25	8-94923-49	• • SUPPORT ASSY, LH RIVETED	1	35	
- 26	8-94923-50	• • SUPPORT ASSY, RH RIVETED	1	35	
- 27	MS39256-60	• • SCREW (316 S)	4	35	
- 28	62E35018-7	• • COVER ASSY, (98791) COCKPIT CONTROL LH SWITCH	RF	35	
- 29	8-95926-17	• • COVER ASSY, COCKPIT CONTROL RH SWITCHED REPLACED BY SUITABLE SUP 8-95926-809	1	55	51
	8-95926-17	• • COVER ASSY, COCKPIT CONTROL RH SWITCHED REPLACES SUITABLE SUP FOR 8-95926-3 REPLACED BY SUITABLE SUP 8-95926-813	1	61	49
	8-95926-17	• • COVER ASSY, COCKPIT CONTROL RH SWITCHED REPLACES SUITABLE SUP FOR 8-95926-809	1	97	
- 30	8-94923-17	• • GUARD	RF	166	
	AS479A1	ATTACH. PARTS	RF	166	
	AN3-4A	• • NUT (80205)	RF	166	
		• • BOLT (88044)	RF	166	
		-----X-----			
		B AIRPLANES #48, 90 AND ON			

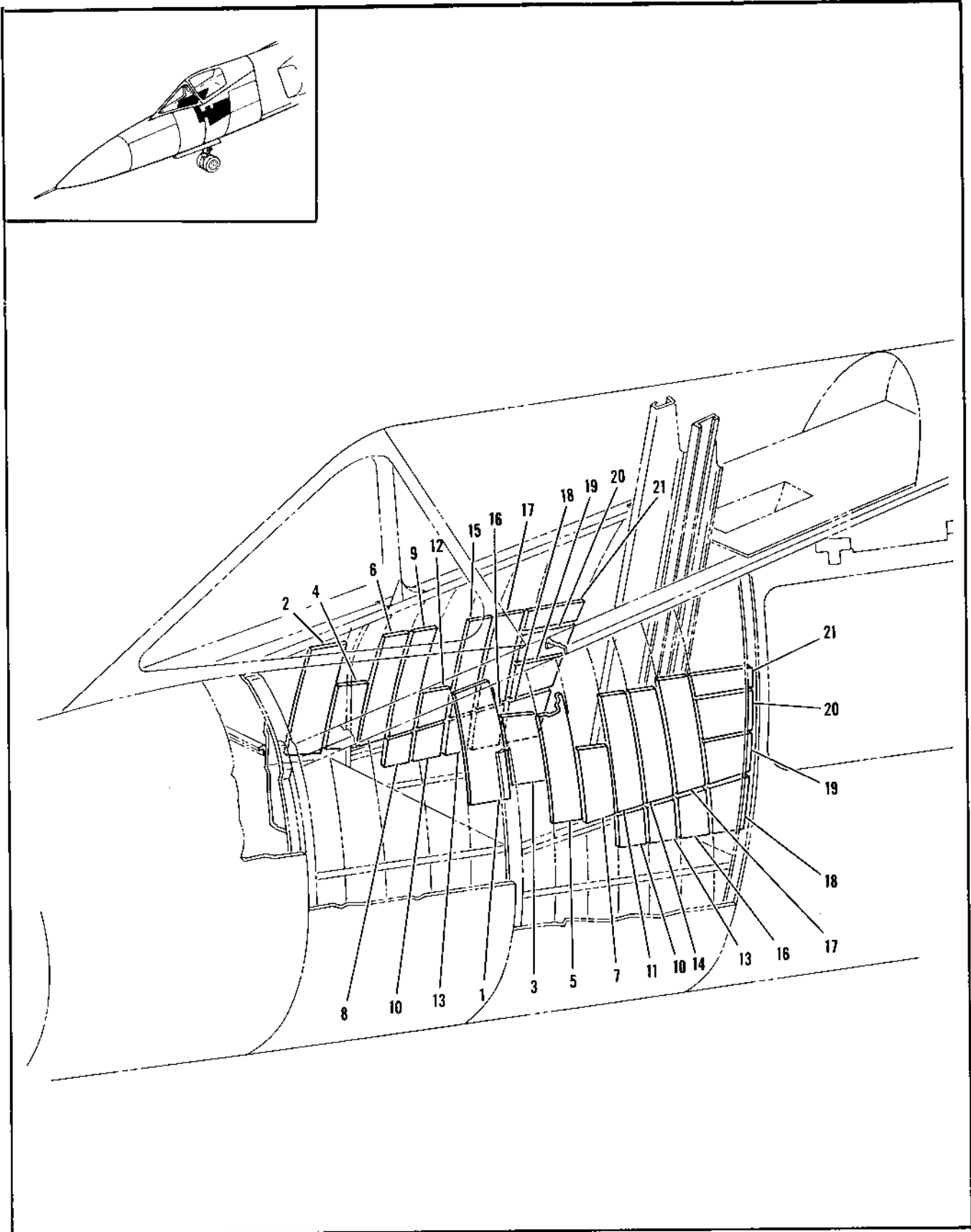

Figure 2.5-12. Thermal Cockpit Blanket Installation

FIGURE AND INDEX NUMBER	PART NUMBER	DESCRIPTION	UNITS PER ASSY.	USABLE ON CODE	
				FROM	TO
		1 2 3 4 5 6			
2.5-12	R-94812	BLANKET INSTALLATION, THERMAL COCKPIT LH FOR NHA SEE FIG. 2.3-A	9F	35	
	R-94812-1	BLANKET INSTALLATION, THERMAL COCKPIT RH FOR NHA SEE FIG. 2.3-B	9F	35	
- 1	R-94812-7	• BLANKET, LH	1	35	
- 2	R-94812-8	• BLANKET, RH	1	35	
- 3	R-94812-9	• BLANKET, LH	1	35	
- 4	R-94812-10	• BLANKET, RH	1	35	
- 5	R-94812-11	• BLANKET, LH	1	35	
- 6	R-94812-12	• BLANKET, RH	1	35	
- 7	R-94812-13	• BLANKET, LH	1	61	12
- 8	R-94812-14	• BLANKET, RH	1	35	
- 9	R-94812-15	• BLANKET, LH	1	35	
- 10	R-94812-16	• BLANKET, RH	1	35	
- 11	R-94812-17	• BLANKET, LH	1	35	
- 12	R-94812-18	• BLANKET, RH	1	35	
- 13	R-94812-19	• BLANKET, LH	1	75	
- 14	R-94812-20	• BLANKET, RH	1	35	
- 15	R-94812-21	• BLANKET, LH	1	35	
- 16	R-94812-22	• BLANKET, RH	1	35	
- 17	R-94812-23	• BLANKET, LH	1	35	
- 18	R-94812-24	• BLANKET, RH	1	35	
- 19	R-94812-25	• BLANKET, LH	1	35	
- 20	R-94812-26	• BLANKET, RH	1	35	
- 21	R-94812-27	• BLANKET, LH	1	35	

• AIRPLANES 475 THRU 60, 13, AND ON

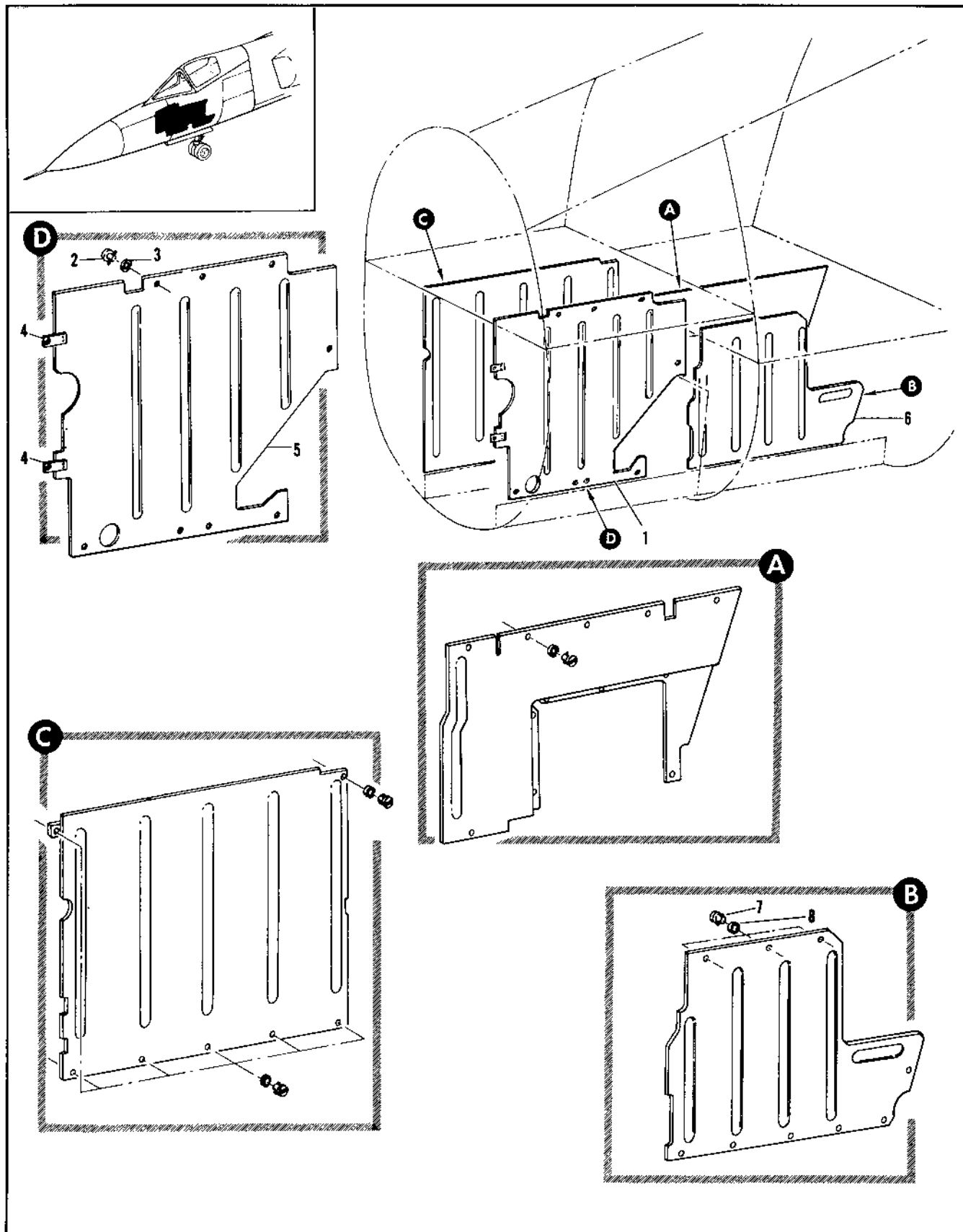

Figure 2.5-13. Nose Wheel Well Splash Cover Installation (Sheet 1 of 2)

FIGURE AND INDEX NUMBER	PART NUMBER	DESCRIPTION	UNITS PER ASSY.	USABLE ON CODE		
				FROM	TO	
2.5-13	A-92938-112	COVER INSTALLATION, NOSE WHEEL WELL SPLASH FOR NHA SEE FIG. 2.3-4	RF	B		
	A-92938-117	COVER INSTALLATION, NOSE WHEEL WELL SPLASH FOR NHA SEE FIG. 2.3-4	RF	B1	B	
	A-92938-121	COVER INSTALLATION, NOSE WHEEL WELL SPLASH FOR NHA SEE FIG. 2.3-4	RF	C		
	A-92938-125	COVER INSTALLATION, NOSE WHEEL WELL SPLASH FOR NHA SEE FIG. 2.3-4	RF	160		
	- 1	A-92939-75	• COVER ASSY, SPLASH FWD LH REPLACED BY NOT INTCHG WITH 8-92939-121	RF	35	38
		A-92939-121	• COVER ASSY, SPLASH FWD LH REPLACES NOT INTCHG WITH 8-92939-75	RF	D	
		A-92939-157	• COVER ASSY, SPLASH FWD LH REPLACED BY SUITABLE SUB 8-92974-5	RF	C	
		A-92974-5	• COVER ASSY, SPLASH FWD LH REPLACES SUITABLE SUB FOR 8-92939-157	RF	160	
		6-92974-11	• COVER	RF	B	
		64034493-1	• COVER ASSY, (98750) SPLASH FWD LH MAKE FROM 8-92939-11	1	B	
		64034495-1	• COVER ASSY, (98750) SPLASH FWD LH MAKE FROM 8-92939-157	1	C	
		64034497-1	• COVER ASSY, (98750) SPLASH FWD LH MAKE FROM 8-92939-121	1	D	
		64034499-1	• COVER ASSY, (98750) SPLASH FWD LH MAKE FROM 8-92974-5	1	160	
	- 2	5S5-1	• STUD, <71286> 98-56506-001	8	35	38
		5S5-7	• STUD, <71286> 98-56506-002	8	D	
	5S5-7	• STUD, <71286> 98-56506-002	6	C		
	5S10-4	• STUD, <71286> 98-56509-004	9	160		
- 3	5S3-1	• WASHER, <71286> 99-53600-007	6	B		
	5S3-1	• WASHER, <71286> 99-53600-003	6	C		
	5S3-1	• WASHER, <71286> 99-53600-003	9	160		
	5R2-1	• RECEPTACLE, <71286> 97-31014-001	AR	35		
- 4	A-92938-113	• CLIP ASSY, RIVETED	2	35	150	
- 5	A-92939-119	• COVER	1	A		
	A-92939-158	• COVER	1	C		
	A-92974-11	• COVER	1	160		
- 6	A-92938-113	• COVER ASSY, SPLASH AFT LH REPLACED BY NOT INTCHG WITH 8-92939-113	1	35	38	
	A-92939-113	• COVER ASSY, SPLASH AFT LH REPLACES NOT INTCHG WITH 8-92939-113	1	D		
	A-92939-163	• COVER ASSY, SPLASH AFT LH REPLACED BY NOT INTCHG WITH 8-92939-163	1	C		
	A-92974-11	• COVER ASSY, SPLASH AFT LH REPLACES SUITABLE SUB FOR 8-92939-163	1	160		
- 7	5S5-4	• STUD, <71286> 98-56506-001	9	35	38	
	5S5-7	• STUD, <71286> 98-56506-002	9	38	150	
	5S10-4	• STUD, <71286> 98-56509-004	9	160		
- 8	5S3-1	• WASHER, <71286> 99-53600-003	8	35		

A AIRPLANES #75 THRU 47 AND 49 THRU 89
 B AIRPLANES #25 THRU 47 AND 49 THRU 60
 C AIRPLANES #48 AND 51 THRU 159
 D AIRPLANES #74 THRU 47 AND 49 THRU 89

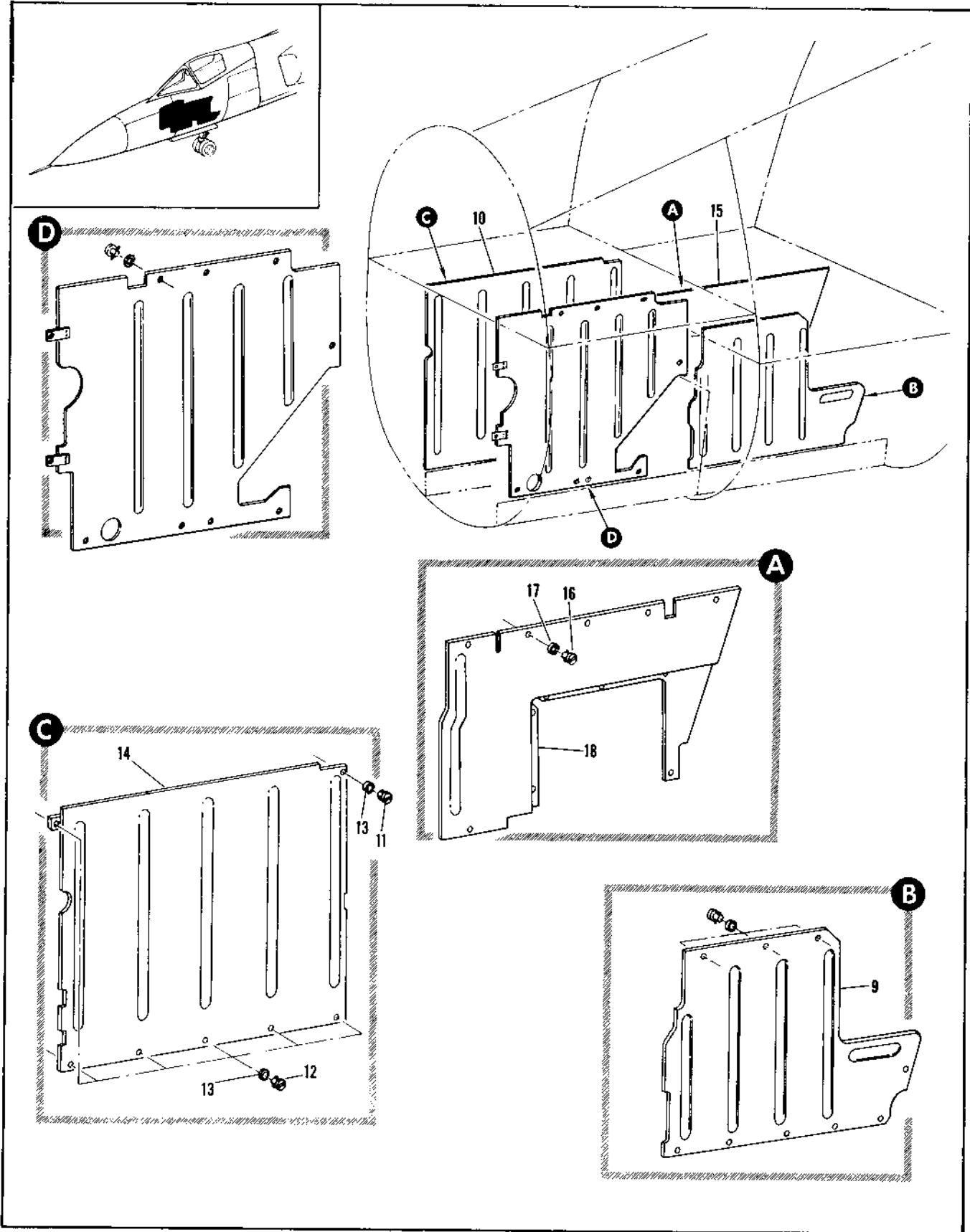

Figure 2.5-13. Nose Wheel Well Splash Cover Installation (Sheet 2 of 2)

FIGURE AND INDEX NUMBER	PART NUMBER	DESCRIPTION	UNITS PER ASSY.	USABLE ON CODE	
				FROM	TO
2.5-13	5R2-1	• • RECEPTACLE, <71266> 97-31014-101	9	50	
	8-92939-91	• • COVER	1	A	
- 9	8-92939-177	• • COVER	1	C	
	8-92974-13	• • COVER	1	160	
- 10	8-92939-77	• COVER ASSY, SPLASH FWD RH REPLACED BY NOT INTCHG WITH 8-92939-127	1	35	30
	8-92939-127	• COVER ASSY, SPLASH FWD RH REPLACES NOT INTCHG WITH 8-92939-77	1	0	
	8-92939-101	• COVER ASSY, SPLASH FWD RH REPLACED BY SUITABLE SUB 8-92974-3	1	C	
	8-92974-3	• COVER ASSY, SPLASH FWD RH REPLACES SUITABLE SUB FOR 8-92939-141	1	160	
- 11	5S5-7	• • STUD, <71266> 98-56506-010	1	35	38
- 12	5S5-7	• • STUD, <71266> 98-56506-011	6	35	38
	5S5-7	• • STUD, <71266> 98-56506-012	7	39	100
	5S11-8	• • STUD, <71266> 98-56509-006	7	160	
- 13	5S3-1	• • WASHER, <71266> 99-53600-103	7	35	
	5R2-1	• • RECEPTACLE, <71266> 97-31014-101	7	35	
- 14	8-92939-120	• • COVER	1	A	A
	8-92939-109	• • COVER	1	C	
	8-92974-9	• • COVER	1	160	
- 15	8-92939-57	• COVER ASSY, SPLASH AFT RF REPLACED BY NOT INTCHG WITH 8-92939-111	1	35	38
	8-92939-111	• COVER ASSY, SPLASH AFT RH REPLACES NOT INTCHG WITH 8-92939-57	1	E	
	8-92939-153	• COVER ASSY, SPLASH AFT RH REPLACED BY NOT INTCHG WITH 8-92939-111	1	61	89
	8-92939-165	• COVER ASSY, SPLASH AFT RH REPLACED BY NOT INTCHG WITH 8-92939-165	1	F	
	8-92939-166	• COVER ASSY, SPLASH AFT RH REPLACED BY SUITABLE SUB 8-92974-1 REPLACED BY SUITABLE SUB 8-92974-1 OR 8-92974-5	1	130	100
	8-92974-1	• COVER ASSY, SPLASH AFT RH REPLACES SUITABLE SUB FOR 8-92939-165 REPLACED BY SUITABLE SUB 8-92974-1 OR 8-92974-5	1	160	100
	8-92974-5	• COVER ASSY, SPLASH AFT RH REPLACES SUITABLE SUB FOR 8-92974-1 8-92939-165 OR 8-92939-166	1	100	
- 16	5S5-5	• • STUD, <71266> 98-56506-001	12	55	58
	5S5-7	• • STUD, <71266> 98-56506-002	12	0	
	5S5-7	• • STUD, <71266> 98-56506-002	7	0	
	5S11-8	• • STUD, <71266> 98-56509-006	11	160	
- 17	5S3-1	• • WASHER, <71266> 99-53600-103	12	A	
	5S3-1	• • WASHER, <71266> 99-53600-103	7	C	
	5S3-1	• • WASHER, <71266> 99-53600-103	11	160	
	5R2-1	• • RECEPTACLE, <71266> 97-31014-101	AR	35	
- 18	8-92939-109	• • COVER	1	F	
	8-92939-101	• • COVER	1	61	89
	8-92939-167	• • COVER	1	C	
	8-92974-7	• • COVER	1	160	100
	8-92974-10	• • COVER	1	100	
		A AIRPLANES 478 THRU 47 AND 49 THRU 89			
		B AIRPLANES 838 THRU 47 AND 49 THRU 60			
		C AIRPLANES 898 AND 93 THRU 100			
		D AIRPLANES 807 THRU 47 AND 49 THRU 89			
		E AIRPLANES 878 THRU 47 AND 49 THRU 67			
		F AIRPLANES 848 AND 97 THRU 100			

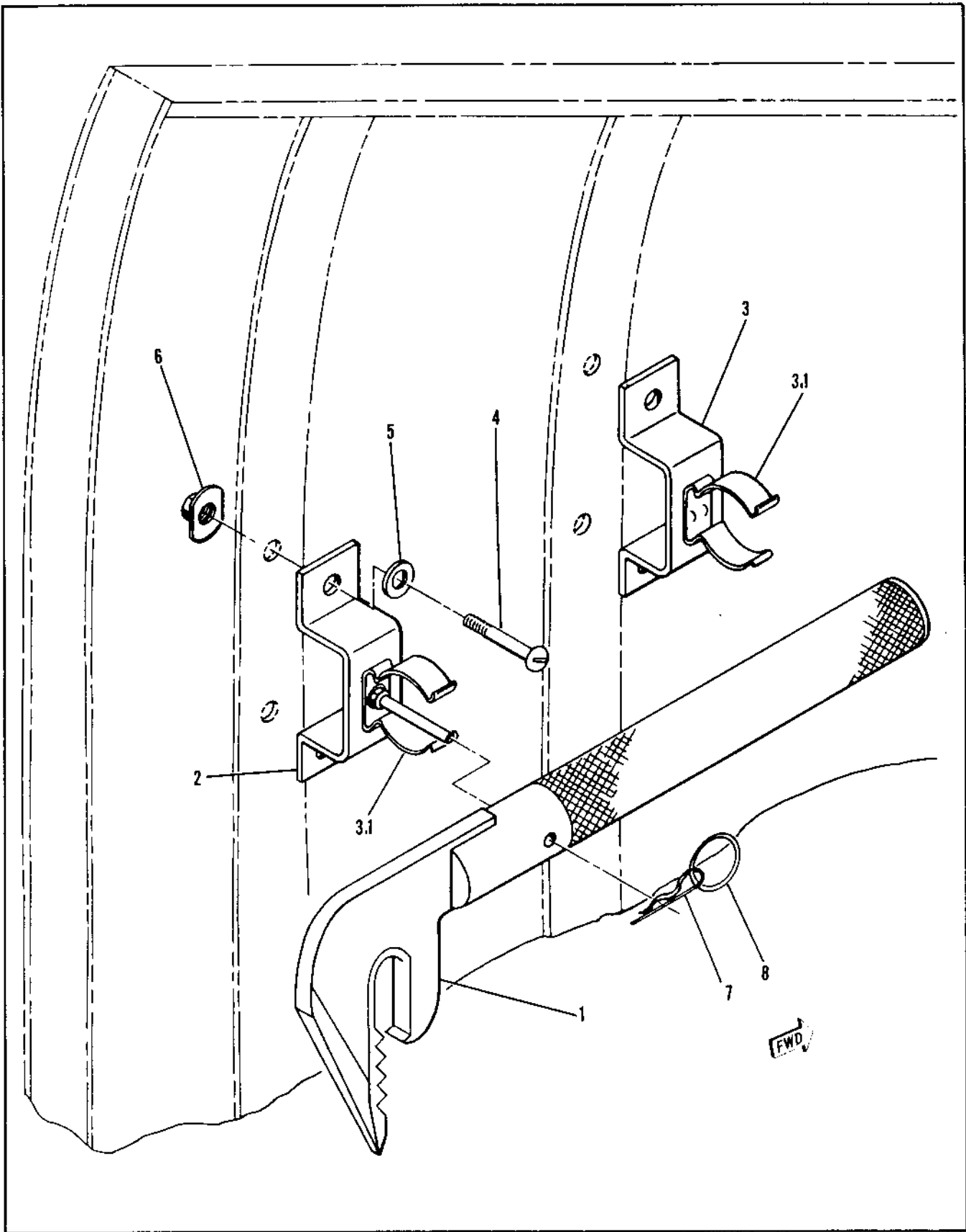

Figure 2.5-14. Canopy Breaker Tool and Storage Facility Installation

FIGURE AND INDEX NUMBER	PART NUMBER	DESCRIPTION	UNITS PER ASSY.	USABLE ON CODE	
				FROM	TO
2.5-14	66F38478	• CANOPY BREAKER TOOL AND STORAGE FACILITY INSTALLATION (98750)	1	ALL	
- 1	66F38223-3	• • TOOL (98750)	1	ALL	
- 2	7446088-10	• • BRACKET ASSEMBLY (98750)	1	ALL	
- 3	7446088-50	• • BRACKET ASSEMBLY (98750)	1	ALL	
- 3.1	100-200-15-1	• • CLIP (99378)	1	ALL	
		(ATTACHING PARTS)			
- 4	MS35207-262	• • SCREW (96906)	4	ALL	
- 5	AN960-1(L)	• • WASHER (86044)	4	ALL	
- 6	MS21059-31	• • NUT PLATE (96906)	4	ALL	
- 7	AN415-2	• • PIN (80044)	1	ALL	
- 8	14	• • RING (10266)	1	ALL	

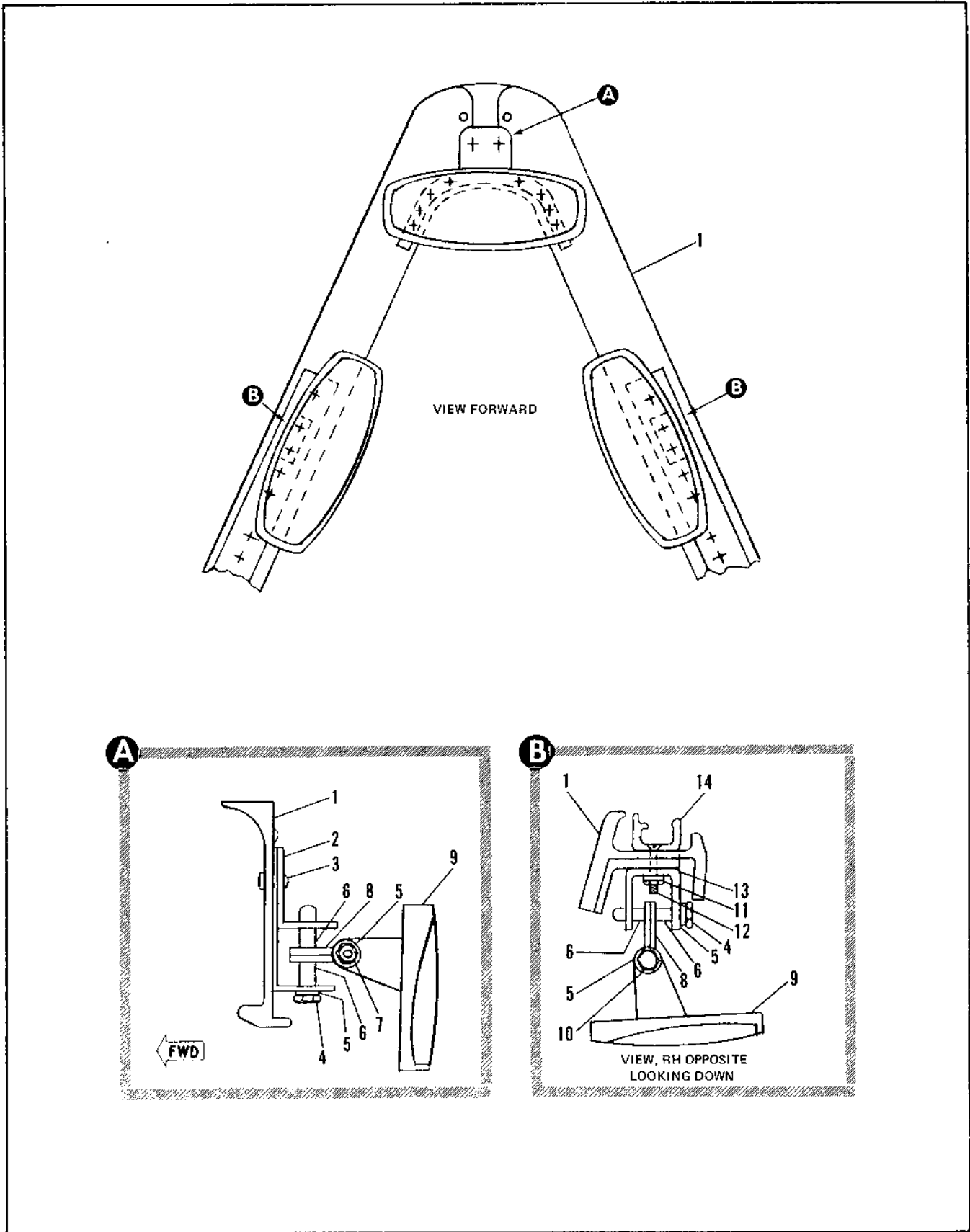

Figure 2.5-15. Rear View Mirror Installation

FIGURE AND INDEX NUMBER	PART NUMBER	DESCRIPTION	UNITS PER ASSY.	USABLE ON CODE	
				FROM	TO
		1 2 3 4 5 6			
2.5-15	NO NUMBER	• REARVIEW MIRROR INSTALLATION	RF	25	
- 1	NO NUMBER	• CANOPY FRAME	RF	30	
- 2	7545927-10	• • BRACKET (98750)	1		
- 3	MS210470ADP-10	• • RIVET (98516)	2		
- 4	NAS1017-11	• • BOLT (88205)	3		
- 5	AN9801011	• • WASHER (88144)	3		
- 6	NAS43003-10	• • SPACER (F 200)	2		
- 7	NAS47803M	• • NUT (80000)	2		
- 8	7545924-11	• • HINGE (98750)	1		
- 9	4190ML	• • MIRROR	1		
- 10	NAS1013-04	• • BOLT (88205)	1		
- 11	MS21042-03	• • NUT (46900)	2		
- 12	NAS1013-03	• • BOLT (88205)	1		
- 13	7545921-1	• • BRACKET (98750)	1		
- 14	9-74010	• • RETAINER	1		

WING SUBSECTION

TABLE OF CONTENTS

<i>Fig. No.</i>	<i>Title</i>	<i>Page</i>	<i>Fig. No.</i>	<i>Title</i>	<i>Page</i>
2.6-1	Wing Installation	2.6-2	2.6-24	Wing Leading Edge Assembly	
2.6-2	Wing Installation	2.6-6		Sta 145 to 216	2.6-100
2.6-3	Wing Assembly Spares	2.6-10	2.6-25	Wing Leading Edge Assembly	
2.6-4	Elevon Actuator Wing Fairing			Sta 145 to 216	2.6-104
	Installation	2.6-16	2.6-26	Wing Leading Edge Assembly	
2.6-5	Elevon Actuator Wing Fairing			Sta 221 to 297	2.6-108
	Installation	2.6-22	2.6-27	Wing Leading Edge Assembly	
2.6-6	Elevon Installation	2.6-24		Sta 221 to 297	2.6-112
2.6-7	Elevon Installation	2.6-28	2.6-28	Wing Slotted Leading Edge Assembly	
2.6-8	Outbd Elevon Assembly	2.6-32		Sta 301 to 334	2.6-116
2.6-9	Outbd Elevon Assembly Spares	2.6-38	2.6-29	Wing Slotted Leading Edge	
2.6-10	Inbd Elevon Assembly	2.6-42		Assembly Sta 301 to 334	2.6-118
2.6-11	Inbd Elevon Horn Seal Installation	2.6-48	2.6-30	Wing Leading Edge Assembly	
2.6-12	Inbd Elevon Assembly Spares	2.6-50		Sta 338 to 384	2.6-120
2.6-13	Wing to Fuselage Drag Angle		2.6-31	Wing Leading Edge Assembly	
	Installation	2.6-54		Sta 338 to 384	2.6-122
2.6-14	Outbd Elevon Inbd Spar Assembly	2.6-62	2.6-32	Wing Equipment Assembly	2.6-124
2.6-15	Wing to Fuselage Drag Angle		2.6-33	Wing Structure Assembly	2.6-150
	Installation	2.6-64	2.6-34	Wing Outbd Elevon Outbd	
2.6-16	Wing to Fuselage Attachment			Spar Assembly	2.6-154
	Installation	2.6-70	2.6-35	Fwd Tank Wing Structure	
2.6-17	Inbd Elevon Fitting Assembly	2.6-74		Assembly	2.6-156
2.6-18	Wing Structure and Equipment		2.6-36	Aft Tank Wing Structure	
	Assembly	2.6-76		Assembly	2.6-166
2.6-19	Wing Tips	2.6-80	2.6-37	Wing Transfer Tank Structure	
2.6-20	Wing Leading Edge Installation	2.6-84		Assembly	2.6-174
2.6-21	Wing Leading Edge Installation	2.6-90	2.6-38	Wing Spar #7 Installation	
2.6-22	Wing Cambered Stub Leading Edge			Sta 593	2.6-180
	Assembly	2.6-96	2.6-39	Wing Intermediate Box Installation	2.6-184
2.6-23	Wing Cambered Stub Leading Edge		2.6-40	Wing Tank #3 Baffle Installation	2.6-190
	Assembly	2.6-98			

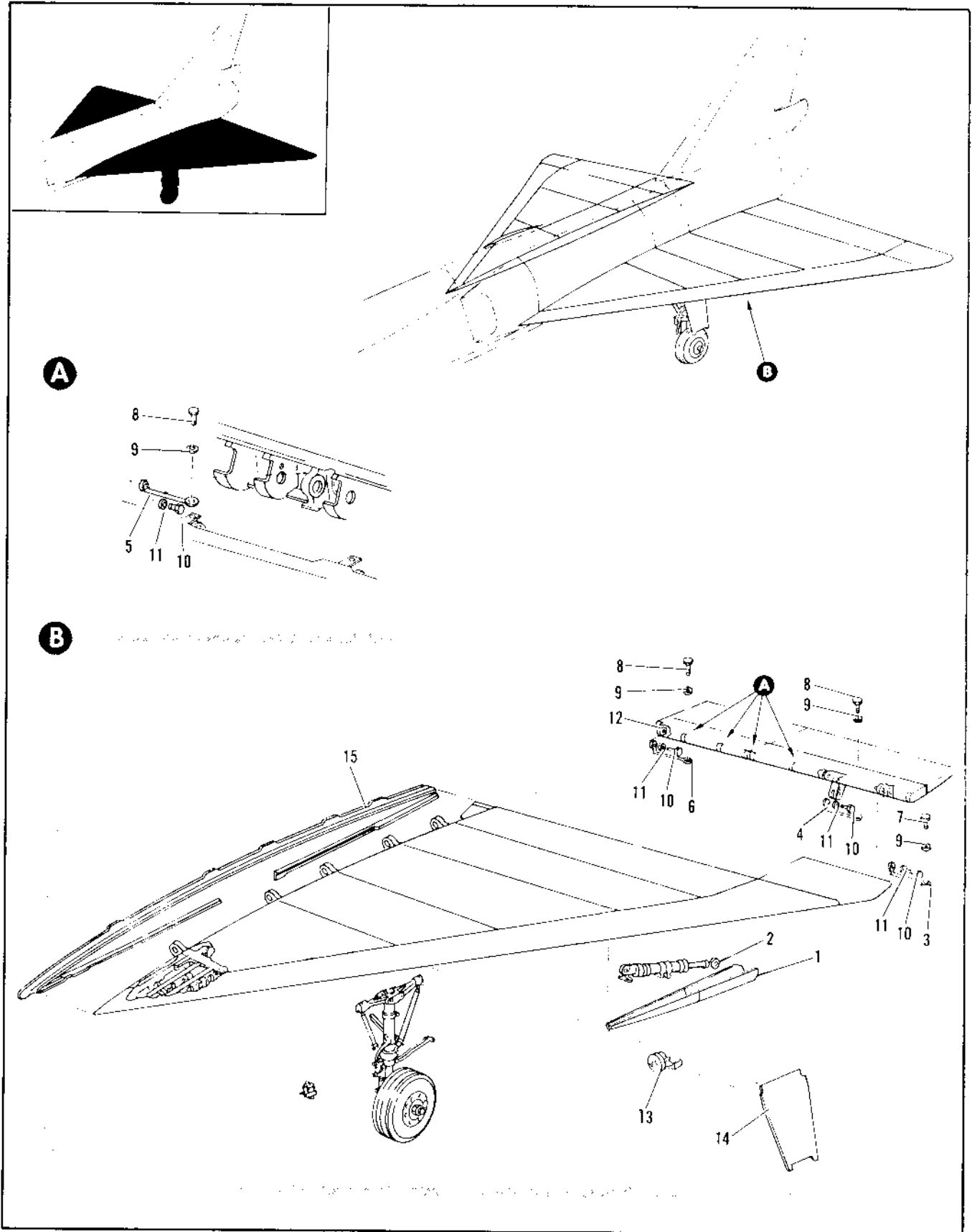

Figure 2.6-1. Wing Installation (Sheet 1 of 2)

FIGURE AND INDEX NUMBER	PART NUMBER	DESCRIPTION	UNITS PER ASSY.	USABLE ON CODE		
				FROM	TO	
2.6-1	8-10560-1	WING INSTALLATION, LH FOR NHA SEE FIG. 2.1-1	RF	R		
	8-10560-805	WING INSTALLATION, LH FOR NHA SEE FIG. 2.1-1	RF	287	287	
	8-10560-2	WING INSTALLATION, RH FOR NHA SEE FIG. 2.1-1	RF	R		
	8-10560-816	WING INSTALLATION, RH FOR NHA SEE FIG. 2.1-1	RF	287	287	
	- 1	8-18580-5	• FAIRING INSTL, ELEVON ACTUATOR WING LH FOR BREAKDOWN SEE FIG. 2.6-4	1	A	
		8-18580-6	• FAIRING INSTL, ELEVON ACTUATOR WING RH FOR BREAKDOWN SEE FIG. 2.6-4	1	A	
	- 2	8-82010-1	• ACTUATOR INSTL, ELEVON OUTRD LH FOR BREAKDOWN SEE FIG. 2.14-11	1	A	
		8-82010-2	• ACTUATOR INSTL, ELEVON OUTRD RH FOR BREAKDOWN SEE FIG. 2.14-11	1	A	
	- 3	MS25083-1FB4	• JUMPER (96906)	1	A	
	- 4	MS25083-1FB3	• JUMPER (96906)	1	A	
	- 5	MS25083-1FB7	• JUMPER (96906)	4	A	
- 6	MS25083-1FB6	• JUMPER (96906)	1	A		
		ATTACHING PARTS				
- 7	AN3-5A	• BOLT (88044)	1	A		
- 8	AN3-4A	• BOLT (88044)	6	A		
- 9	AN960-15L	• WASHER (88144)	7	A		
- 10	AN3-5A	• BOLT (88044)	7	A		
- 11	AN960-15L	• WASHER (88044)	7	A		
		-----X-----				
- 12	8-13550-1	• ELEVON INSTL, LH FOR BREAKDOWN SEE FIG. 2.6-6	1	A		
	8-13550-2	• ELEVON INSTL, RH FOR BREAKDOWN SEE FIG. 2.6-6	1	A		
- 13	8-90756-1	• LIGHT INSTL, LANDING LH FOR BREAKDOWN SEE FIG. 2.15-5	1	A		
	8-90756-2	• LIGHT INSTL, LANDING RH FOR BREAKDOWN SEE FIG. 2.15-5	1	A		
- 14	8-17630-1	• FAIRING INSTL, MAIN LANDING GEAR WING LH FOR BREAKDOWN SEE FIG. 2.15-20	1	A		
	8-17630-525	• FAIRING ASSY, MAIN LANDING GEAR WING LH SPARES FOR 8-17630-1 FOR BREAKDOWN SEE FIG. 2.15-19	RF	A		
	8-17630-2	• FAIRING INSTL, MAIN LANDING GEAR WING RH FOR BREAKDOWN SEE FIG. 2.15-19	1	A		
	8-17630-526	• FAIRING ASSY, MAIN LANDING GEAR WING RH SPARES FOR 8-17630-2 FOR BREAKDOWN SEE FIG. 2.15-19	RF	A		
- 15	8-18060-1	• DRAG ANGLE INSTL, WING TO FUSELAGE LH FOR BREAKDOWN SEE FIG. 2.6-13	1	A		
	8-18060-2	• DRAG ANGLE INSTL, WING TO FUSELAGE RH FOR BREAKDOWN SEE FIG. 2.6-13	1	A		

A AIRPLANES #35 THRU 277, 287, 292 AND ON
 R AIRPLANES #35 THRU 277, 292 AND ON

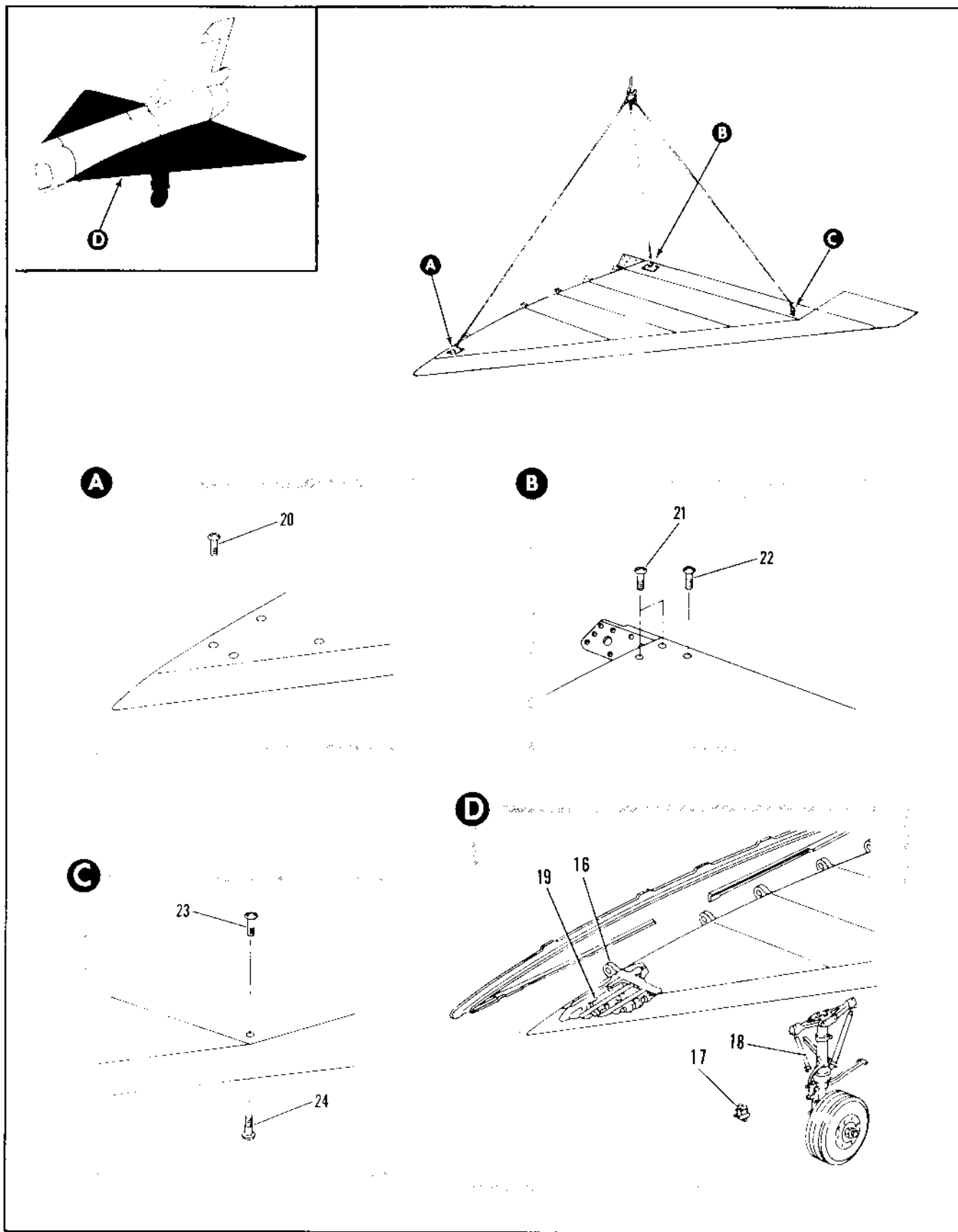

Figure 2.6-1. Wing Installation (Sheet 2 of 2)

FIGURE AND INDEX NUMBER	PART NUMBER	DESCRIPTION	UNITS PER ASSY.	USABLE ON CODE	
				FROM	TO
		1 2 3 4 5 6			
2.6-1	8-10060-3	• WING ASSY, LH MODIFIED BY 8-21833	1	B	
	8-10060-7	• WING ASSY, LH MODIFIED BY 8-21833	1	287	287
	8-10060-501	• WING ASSY, LH SPARES FOR BREAKDOWN SEE FIG. 2.6-3	RF	A	
	8-10060-505	• WING ASSY, LH SPARES REIDENTIFIED FROM 8-10060-501 FOR BREAKDOWN SEE FIG. 2.6-3	1	A	
	8-10060-4	• WING ASSY, RH MODIFIED BY 8-21833	1	B	
	8-10060-6	• WING ASSY, RH MODIFIED BY 8-21833	1	287	287
	8-10060-502	• WING ASSY, RH SPARES FOR BREAKDOWN SEE FIG. 2.6-3	RF	A	
	8-10060-506	• WING ASSY, RH SPARES REIDENTIFIED FROM 8-10060-502 FOR BREAKDOWN SEE FIG. 2.6-3 ATTACHING PARTS	1	A	
- 16	8-10070-1	• ATTACHMENT INSTL, WING TO FUSELAGE LH FOR BREAKDOWN SEE FIG. 2.6-16	1	A	
	8-10070-2	• ATTACHMENT INSTL, WING TO FUSELAGE RH FOR BREAKDOWN SEE FIG. 2.6-16	1	A	
		-----X-----			
- 17	8-86304-3	• VALVE INSTL, BRAKE RELAY LH FOR BREAKDOWN SEE FIG. 2.15-1	1	A	
	8-86304-4	• VALVE INSTL, BRAKE RELAY RH FOR BREAKDOWN SEE FIG. 2.15-1	1	A	
- 18	8-51013-3	• GEAR INSTL, MAIN LANDING LH FOR BREAKDOWN SEE FIG. 2.15-25	1	B	
	8-51013	• GEAR INSTL, MAIN LANDING LH FOR BREAKDOWN SEE FIG. 2.15-25	1	287	287
	8-51013-5	• GEAR INSTL, MAIN LANDING RH FOR BREAKDOWN SEE FIG. 2.15-25	1	B	
	8-51013-1	• GEAR INSTL, MAIN LANDING RH FOR BREAKDOWN SEE FIG. 2.15-25	1	287	287
- 19	8-10060-5	• STRUCTURE AND EQUIPMENT ASSY, WING LH FOR BREAKDOWN SEE FIG. 2.6-18	1	A	
	8-10060-6	• STRUCTURE AND EQUIPMENT ASSY, WING RH FOR BREAKDOWN SEE FIG. 2.6-18	1	A	
	8-21832-1	• BAFFLE INSTL, WING TANK #3 LH FOR BREAKDOWN SEE FIG. 2.6-40	1	A	
	8-21832-2	• BAFFLE INSTL, WING TANK #3 RH FOR BREAKDOWN SEE FIG. 2.6-40	1	A	
- 20	NAS334CPA6	• SCREW (80205)	4	35	
	NAS686A4	• NUTPLATE (80205)	4	35	
- 21	NAS334CPA6-5	• SCREW STA 593 BL 35-40 (80205)	2	35	
- 22	NAS334CPA6	• SCREW STA 593 BL 35-40 (80205)	1	35	
	NAS686A4	• NUTPLATE (80205)	3	35	
- 23	8-14906-7	• SCREW, WING HOIST <PLUG> STA 556.75	1	35	
	2452-064	• NUT, BARREL WING HOIST <72962>	1	35	
	2452-064 RET	• RETAINER, <72962> 92-L4000-105	1	35	
- 24	8-14906-9	• SCREW, AFT MOORING PLUG STA 556.75 BL172.26	1	35	
	2452-108	• NUT, BARREL MOORING <72962>	1	35	
		A AIRPLANES #35 THRU 277, 287, 292 AND ON			
		B AIRPLANES #35 THRU 277, 292 AND ON			

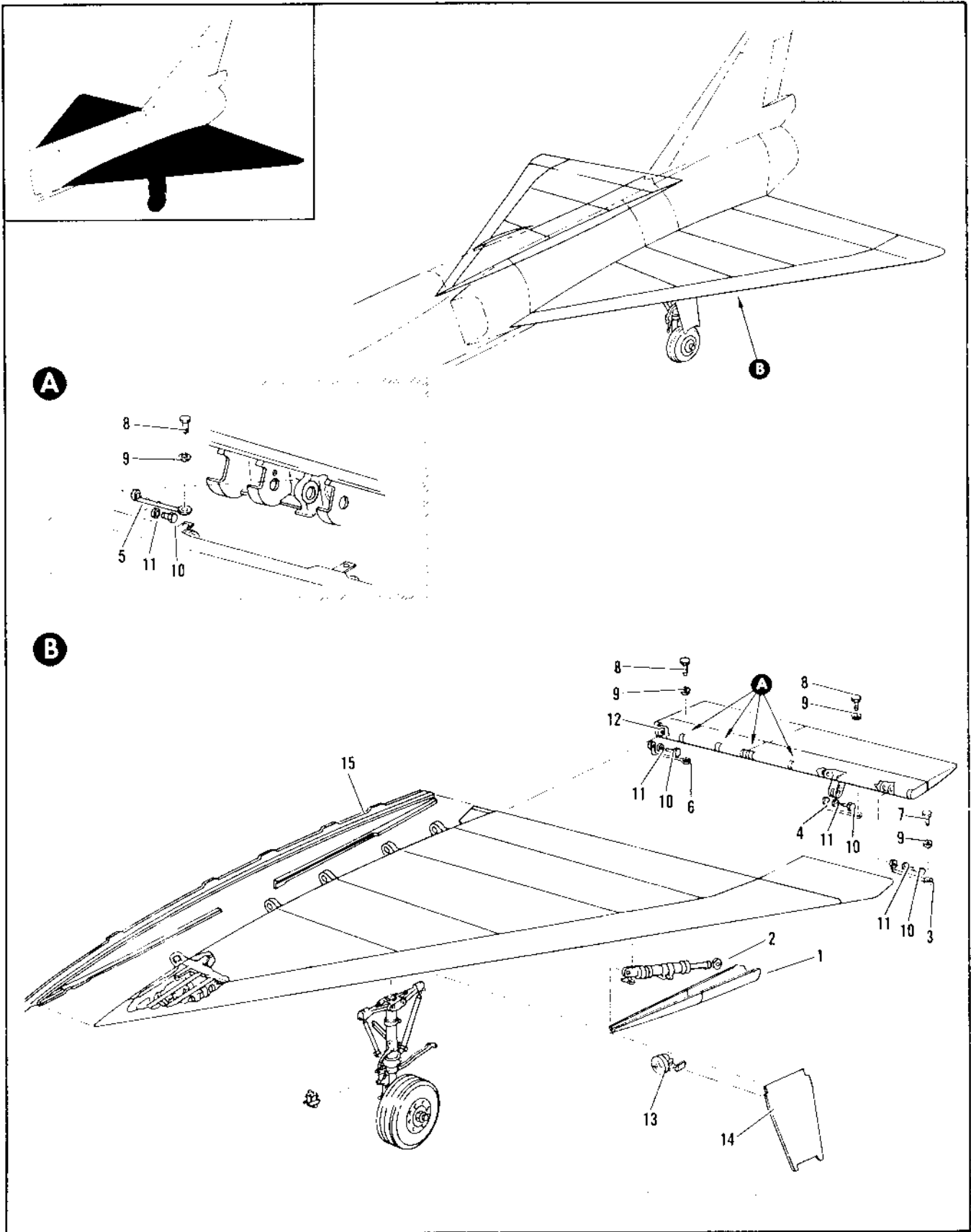

Figure 2.6-2. Wing Installation (Sheet 1 of 2)

FIGURE AND INDEX NUMBER	PART NUMBER	DESCRIPTION	UNITS PER ASSY.	USABLE ON CODE	
				FROM	TO
2.6-2	8-10040-801	WING INSTALLATION, LH FOR NHA SEE FIG. 2.1-1	RF	278	280
	8-10040-1	WING INSTALLATION, LH FOR NHA SEE FIG. 2.1-1	RF	281	286
	8-10040-805	WING INSTALLATION, LH FOR NHA SEE FIG. 2.1-1	RF	288	291
	8-10040-802	WING INSTALLATION, RH FOR NHA SEE FIG. 2.1-1	RF	278	280
	8-10040-2	WING INSTALLATION, RH FOR NHA SEE FIG. 2.1-1	RF	281	286
	8-10040-806	WING INSTALLATION, RH FOR NHA SEE FIG. 2.1-1	RF	288	291
- 1	8-18560-5	• FAIRING INSTL, ELEVON ACTUATOR WING LH FOR BREAKDOWN SEE FIG. 2.6-5	1	A	
	8-18560-6	• FAIRING INSTL, ELEVON ACTUATOR WING RH FOR BREAKDOWN SEE FIG. 2.6-5	1	A	
- 2	8-82010-1	• ACTUATOR INSTL, ELEVON OUTRD LH FOR BREAKDOWN SEE FIG. 2.14-11	1	A	
	8-82010-2	• ACTUATOR INSTL, ELEVON OUTRD RH FOR BREAKDOWN SEE FIG. 2.14-11	1	A	
- 3	MS25083-18B4	• JUMPER (96906)	1	A	
- 4	MS25083-18B3	• JUMPER (96906)	1	A	
- 5	MS25083-18B7	• JUMPER (96906)	4	A	
- 6	MS25083-18B6	• JUMPER (96906)	1	A	
		ATTACHING PARTS			
- 7	AN3-5A	• BOLT (88044)	1	A	
- 8	AN3-4A	• BOLT (88044)	6	A	
- 9	AN560-10L	• WASHER (88044)	7	A	
- 10	AN3-5A	• BOLT (88044)	7	A	
- 11	AN560-10L	• WASHER (88044)	7	A	
		----X----			
- 12	8-13020-1	• ELEVON INSTL, LH FOR BREAKDOWN SEE FIG. 2.6-7	1	A	
	8-13020-2	• ELEVON INSTL, RH FOR BREAKDOWN SEE FIG. 2.6-7	1	A	
- 13	8-90706-1	• LIGHT INSTL, LANDING LH FOR BREAKDOWN SEE FIG. 2.15-5	1	A	
	8-90706-2	• LIGHT INSTL, LANDING RH FOR BREAKDOWN SEE FIG. 2.15-5	1	A	
- 14	8-17630-1	• FAIRING INSTL, MAIN LANDING GEAR WING LH FOR BREAKDOWN SEE FIG. 2.15-19	1	A	
	8-17630-525	• FAIRING ASSY, MAIN LANDING GEAR WING LH SPARES FOR 8-17630-1 FOR BREAKDOWN SEE FIG. 2.15-19	PF	A	
	8-17630-2	• FAIRING INSTL, MAIN LANDING GEAR WING RH FOR BREAKDOWN SEE FIG. 2.15-19	1	A	
	8-17630-526	• FAIRING ASSY, MAIN LANDING GEAR WING RH SPARES FOR 8-17630-2 FOR BREAKDOWN SEE FIG. 2.15-19	PF	A	
- 15	8-18040-5	• DRAG ANGLE INSTL, WING TO FUSELAGE LH FOR BREAKDOWN SEE FIG. 2.6-15	1	A	
	8-18040-6	• DRAG ANGLE INSTL, WING TO FUSELAGE RH FOR BREAKDOWN SEE FIG. 2.6-15	1	A	
A AIRPLANES #278 THRU 286 AND 288 THRU 291					

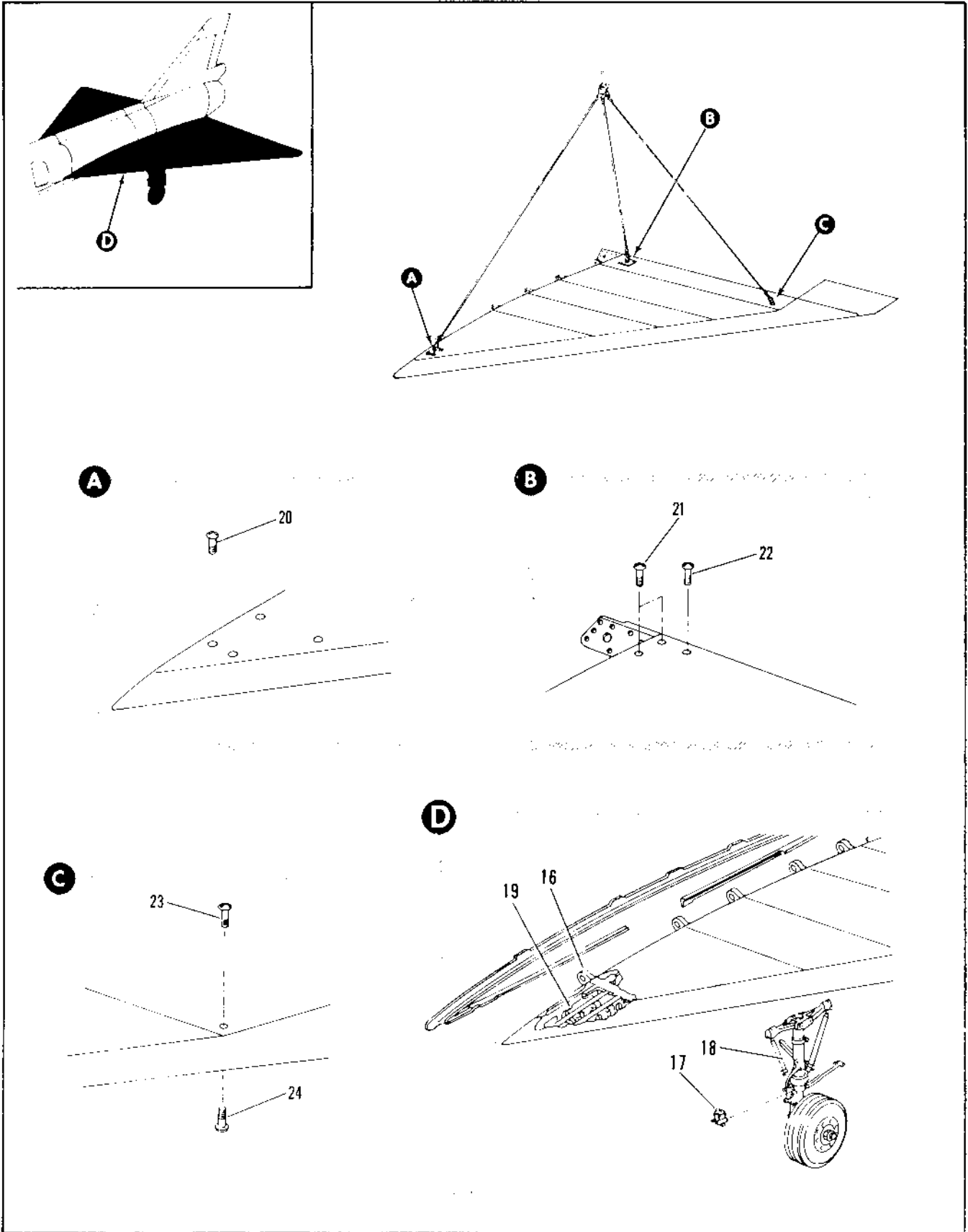

Figure 2.6-2. Wing Installation (Sheet 2 of 2)

FIGURE AND INDEX NUMBER	PART NUMBER	DESCRIPTION	UNITS PER ASSY.	USABLE ON CODE	
				FROM	TO
		1 2 3 4 5 8			
2.6-2	8-10040-813	• WING ASSY, LH MODIFIED BY 8-21833	1	278	280
	8-10040-3	• WING ASSY, LH MODIFIED BY 8-21833	1	281	286
	8-10040-7	• WING ASSY, LH MODIFIED BY 8-21833	1	288	291
	8-10040-525	• WING ASSY, LH SPARES FOR BREAKDOWN SEE FIG. 2.6-3	RF	A	
	8-10040-527	• WING ASSY, LH SPARES REIDENTIFIED FROM 8-10040-525 FOR BREAKDOWN SEE FIG. 2.6-3	1	A	
	8-10040-4	• WING ASSY, RH MODIFIED BY 8-21833	1	278	286
	8-10040-8	• WING ASSY, RH MODIFIED BY 8-21833	1	288	291
	8-10040-526	• WING ASSY, RH SPARES FOR BREAKDOWN SEE FIG. 2.6-3	RF	A	
	8-10040-528	• WING ASSY, RH SPARES REIDENTIFIED FROM 8-10040-526 FOR BREAKDOWN SEE FIG. 2.6-3	1	A	
- 16	8-10050-1	• ATTACHMENT INSTL, WING TO FUSELAGE LH FOR BREAKDOWN SEE FIG. 2.6-16	1	A	
	8-10050-2	• ATTACHMENT INSTL, WING TO FUSELAGE RH FOR BREAKDOWN SEE FIG. 2.6-16	1	A	
		-----X-----			
- 17	8-86304-3	• VALVE INSTL, BRAKE RELAY LH FOR BREAKDOWN SEE FIG. 2.15-1	1	A	
	8-86304-4	• VALVE INSTL, BRAKE RELAY RH FOR BREAKDOWN SEE FIG. 2.15-1	1	A	
- 18	8-51013	• GEAR INSTL, MAIN LANDING LH FOR BREAKDOWN SEE FIG. 2.15-25	1	278	286
	8-51013-3	• GEAR INSTL, MAIN LANDING LH FOR BREAKDOWN SEE FIG. 2.15-25	1	288	291
	8-51013-1	• GEAR INSTL, MAIN LANDING RH FOR BREAKDOWN SEE FIG. 2.15-25	1	278	286
	8-51013-5	• GEAR INSTL, MAIN LANDING RH FOR BREAKDOWN SEE FIG. 2.15-25	1	288	291
- 19	8-10040-811	• STRUCTURE AND EQUIPMENT ASSY, WING LH FOR BREAKDOWN SEE FIG. 2.6-18	1	278	280
	8-10040-5	• STRUCTURE AND EQUIPMENT ASSY, WING LH FOR BREAKDOWN SEE FIG. 2.6-18	1	B	
	8-10040-6	• STRUCTURE AND EQUIPMENT ASSY, WING RH FOR BREAKDOWN SEE FIG. 2.6-18	1	A	
	8-21832-1	• BAFFLE INSTL, WING TANK #3 LH FOR BREAKDOWN SEE FIG. 2.6-40	1	A	
	8-21832-2	• BAFFLE INSTL, WING TANK #3 RH FOR BREAKDOWN SEE FIG. 2.6-40	1	A	
- 20	NAS334CPA5	• SCREW (80205)	4	35	
	NAS686A4	• NUTPLATE (80205)	4	35	
- 21	NAS334CPA5-5	• SCREW STA 593 BL 35-40 (80205)	2	35	
- 22	NAS334CPA6	• SCREW STA 593 BL 35-40 (80205)	1	35	
	NAS686A4	• NUTPLATE (80205)	3	35	
- 23	8-18906-7	• SCREW, WING HOIST <PLUG> STA 556.75 BL 172.26	1	35	
	2452-064	• NUT, BARREL, WING HOIST <72962>	1	35	
	2452-064 RET	• RETAINER, <72962> 92-L4000-905	1	35	
- 24	8-18906-9	• SCREW, MOORING <PLUG> STA 556.75 BL 172.26	1	35	
	2452-108	• NUT, BARREL MOORING <72962>	1	35	
		A AIRPLANES #278 THRU 286 AND 288 THRU 291			
		B AIRPLANES #281 THRU 286 AND 288 THRU 291			

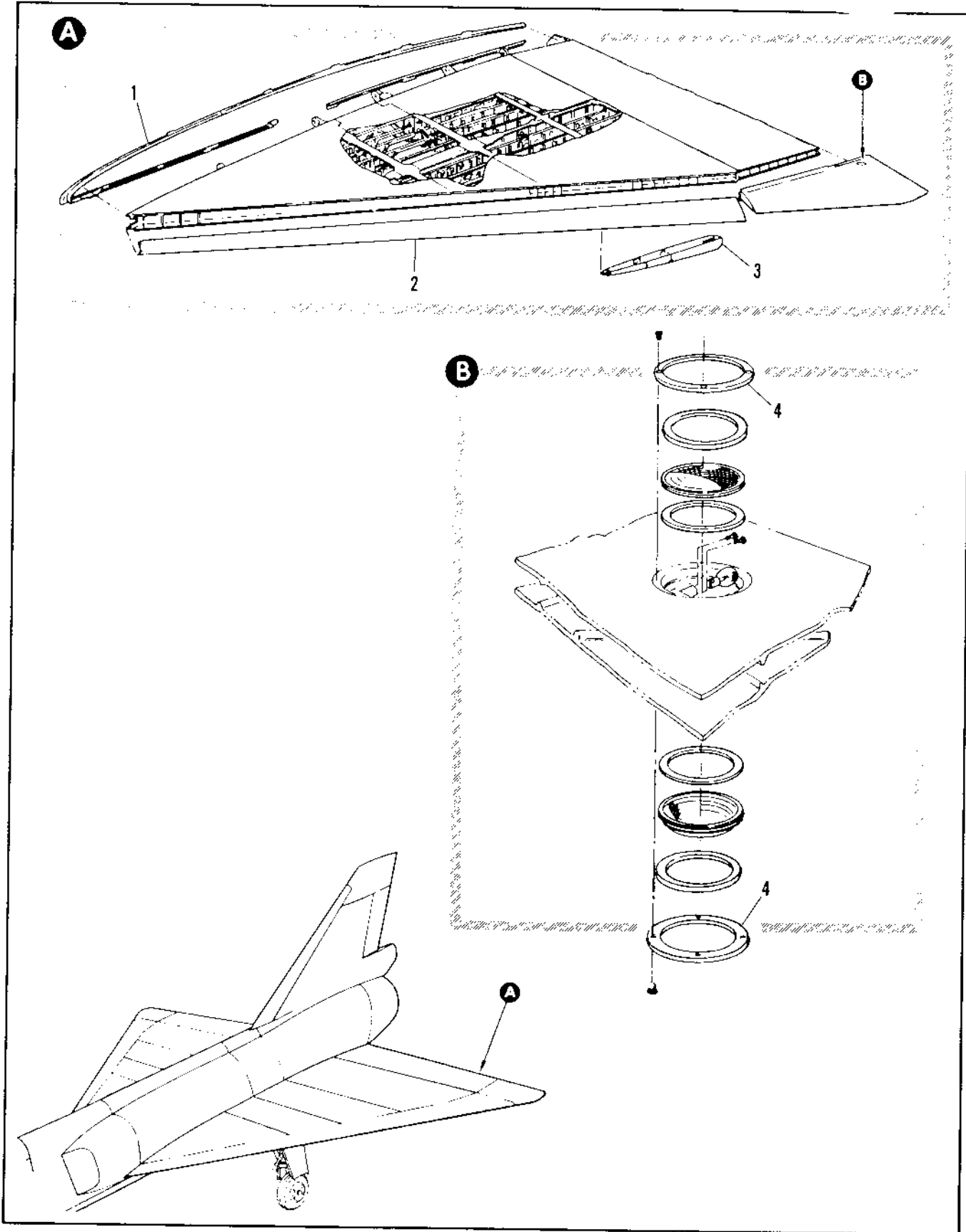

Figure 2.6-3. Wing Assembly Spares (Sheet 1 of 3)

FIGURE AND INDEX NUMBER	PART NUMBER	DESCRIPTION	UNITS PER ASSY.	USABLE ON CODE		
				FROM	TO	
2.6-3	8-10060-501	WING ASSEMBLY, LH SPARES REPLACES NOT INTCHG WITH 8-10040-525	RF	B		
	8-10060-505	WING ASSEMBLY, LH SPARES REIDENTIFIED FROM 8-10060-501	1	B		
	8-10040-525	WING ASSEMBLY, LH SPARES REPLACED BY NOT INTCHG WITH 8-10060-501 WITH 8-18201-1 8-18231-805 8-18911-1 8-18911-16 NAS333PA7 NAS333PA7-120 NAS333PA6-5 AND ALL ATTACHING HARDWARE IN 8-18040-5 DRAG ANGLE INSTL, BAGGED AND TIED	RF	A		
	8-10040-527	WING ASSEMBLY, LH SPARES REIDENTIFIED FROM 8-10040-525	1	A		
	8-10060-502	WING ASSEMBLY, RH SPARES REPLACES NOT INTCHG WITH 8-10040-526	RF	B		
	8-10060-506	WING ASSEMBLY, RH SPARES REIDENTIFIED FROM 8-10060-502	1	B		
	8-10040-526	WING ASSEMBLY, RH SPARES REPLACED BY NOT INTCHG WITH 8-10060-502 WITH 8-18201-2 8-18231-806 8-18911-2 8-18911-16 NAS333PA7 NAS333PA7-120 NAS333PA6-5 AND ALL ATTACHING HARDWARE IN 8-18040-6 DRAG ANGLE INSTL BAGGED AND TIED	RF	A		
	8-10040-529	WING ASSEMBLY, RH SPARES REIDENTIFIED FROM 8-10040-526	1	A		
	- 1	8-18060-1	• DRAG ANGLE INSTL, WING TO FUSELAGE LH FOR BREAKDOWN SEE FIG. 2.6-13	1	R	
		8-18040-5	• DRAG ANGLE INSTL, WING TO FUSELAGE LH FOR BREAKDOWN SEE FIG. 2.6-15	1	A	
		8-18060-2	• DRAG ANGLE INSTL, WING TO FUSELAGE RH FOR BREAKDOWN SEE FIG. 2.6-13	1	B	
		8-18040-6	• DRAG ANGLE INSTL, WING TO FUSELAGE RH FOR BREAKDOWN SEE FIG. 2.6-15	1	A	
	- 2	8-18280-1	• LEADING EDGE INSTL, WING LH FOR BREAKDOWN SEE FIG. 2.6-20	1	B	
		8-18230-1	• LEADING EDGE INSTL, WING LH FOR BREAKDOWN SEE FIG. 2.6-21	1	A	
		8-18280-2	• LEADING EDGE INSTL, WING RH FOR BREAKDOWN SEE FIG. 2.6-20	1	R	
		8-18230-2	• LEADING EDGE INSTL, WING RH FOR BREAKDOWN SEE FIG. 2.6-21	1	A	
	- 3	8-18580-5	• FAIRING INSTL, ELEVON ACTUATOR WING LH FOR BREAKDOWN SEE FIG. 2.6-4	1	B	
		8-18560-5	• FAIRING INSTL, ELEVON ACTUATOR WING LH FOR BREAKDOWN SEE FIG. 2.6-5	1	A	
	8-18580-6	• FAIRING INSTL, ELEVON ACTUATOR WING RH FOR BREAKDOWN SEE FIG. 2.6-4	1	B		
	8-18560-6	• FAIRING INSTL, ELEVON ACTUATOR WING RH FOR BREAKDOWN SEE FIG. 2.6-5	1	A		
	8-61036-1	• LIGHT INSTL, WING TIP POSITION LH	1	35		
- 4	8-61036-2	• LIGHT INSTL, WING TIP POSITION RH	1	35		
	A7463	• RETAINER, LENS WING AND TAIL LIGHT ASSEMBLY <72914> 97-57501-001 ATTACHING PARTS	2	35		

A AIRPLANES #278 THRU 286 AND 288 THRU 291
 B AIRPLANES #35 THRU 277, 287, 292 AND ON

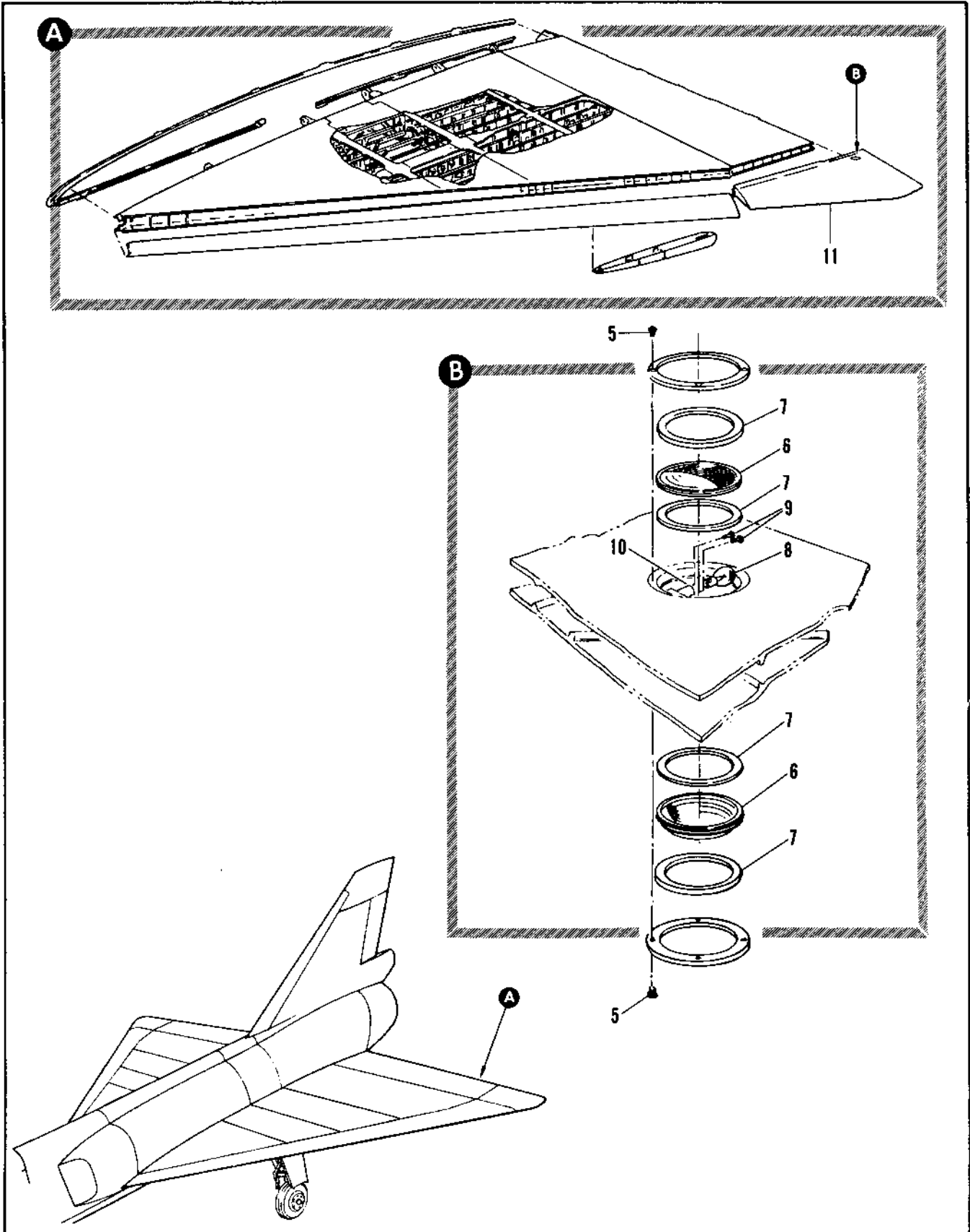

Figure 2.6-3. Wing Assembly Spares (Sheet 2 of 3)

FIGURE AND INDEX NUMBER	PART NUMBER	DESCRIPTION	UNITS PER ASSY.	USABLE ON CODE	
				FROM	TO
		1 2 3 4 5 6			
2.6-3- 5	MS24693S28	• • SCREW (96906) -----X-----	8	35	
- 6	A8087-1	• • LENS, POSITION LIGHT RED LH <72914> 95-56000-001	2	35	
	A8087-2	• • LENS, POSITION LIGHT GREEN RH <72914> 95-56000-002	2	35	
- 7	A5621	• • GASKET, LENS TAIL LIGHT ASSEMBLY	4	35	
	8-94711-29	• • LAMP INSTL, WING TIP LIGHT	1	35	
- 8	1725	• • LAMP <24455> 95-47813-006	2	35	
	1680	• • LAMP ALT INTCH WITH 1725	RF	35	
- 9	MS35206-228	• • SCREW (96906)	2	35	
- 10	8-61253	• • SOCKET, WING TIP LIGHT	1	35	
- 11	8-18410-1	• TIP INSTL, WING LH FOR BREAKDOWN SEE FIG. 2.6-18	1	B	
	8-18910-1	• TIP INSTL, WING LH FOR BREAKDOWN SEE FIG. 2.6-18	1	A	
	8-18410-2	• TIP INSTL, WING RH FOR BREAKDOWN SEE FIG. 2.6-18	1	B	
	8-18910-2	• TIP INSTL, WING RH FOR BREAKDOWN SEE FIG. 2.6-18	1	A	
	8-61551-1	• HARNESS ASSY, FUEL TANK	1	35	
	8-61551-3	• HARNESS ASSY, FUEL TANK	1	35	
	8-61551-827	• HARNESS ASSY, FUEL TANK	1	B	
	8-61551-5	• HARNESS ASSY, FUEL TANK	1	A	
	8-61551-829	• HARNESS ASSY, FUEL TANK	1	B	
	8-61551-801	• HARNESS ASSY, FUEL TANK	1	A	
	8-61551-831	• HARNESS ASSY, FUEL TANK	1	B	
	8-61551-803	• HARNESS ASSY, FUEL TANK	1	A	
	8-61551-833	• HARNESS ASSY, FUEL TANK	1	B	
	8-61551-805	• HARNESS ASSY, FUEL TANK	1	A	
	8-61551-835	• HARNESS ASSY, FUEL TANK	1	B	
	8-61551-807	• HARNESS ASSY, FUEL TANK	1	A	
	8-61551-837	• HARNESS ASSY, FUEL TANK	1	B	
	8-61551-809	• HARNESS ASSY, FUEL TANK	1	A	
		A AIRPLANES #278 THRU 286 AND 288 THRU 291 B AIRPLANES #35 THRU 277, 287, 292 AND ON			

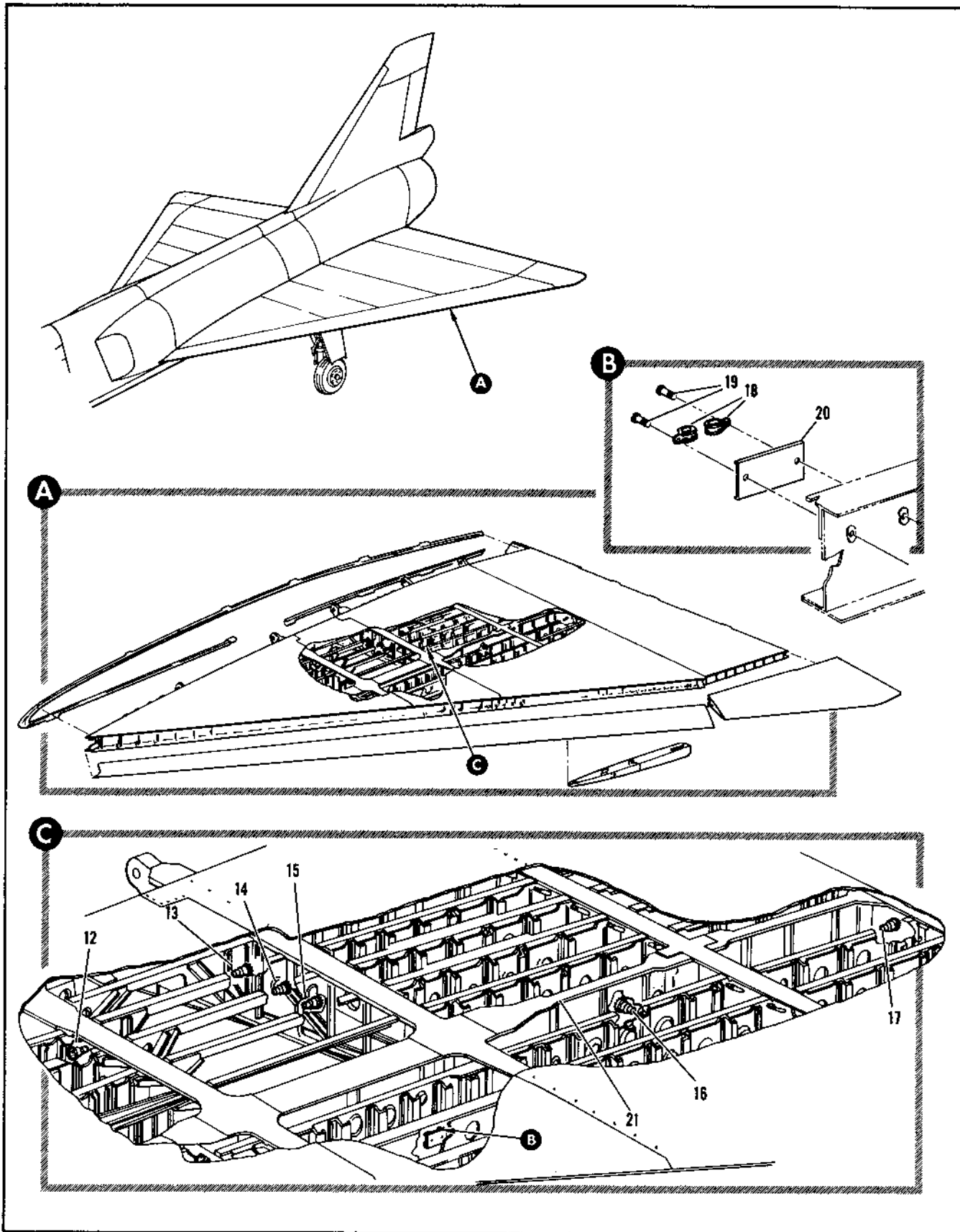

Figure 2.6-3. Wing Assembly Spares (Sheet 3 of 3)

FIGURE AND INDEX NUMBER	PART NUMBER	DESCRIPTION	UNITS PER ASSY.	USABLE ON CODE	
				FROM	TO
		1 2 3 4 5 6			
2.6-3- 12	8-61035-1	• RECEPTACLE INSTL, WING FUEL TANK ELECTRICAL STA 431 LH FOR BREAKDOWN SEE FIG. 2.12-6	1	35	
	8-61035-2	• RECEPTACLE INSTL, WING FUEL TANK ELECTRICAL STA 431 RH FOR BREAKDOWN SEE FIG. 2.12-6	1	35	
- 13	8-61035-P05	• RECEPTACLE INSTL, WING FUEL TANK ELECTRICAL STA 472 RL 52 LH FOR BREAKDOWN SEE FIG. 2.12-6	1	35	
	8-61035-P06	• RECEPTACLE INSTL, WING FUEL TANK ELECTRICAL STA 472 RL 52 RH FOR BREAKDOWN SEE FIG. 2.12-6	1	35	
- 14	8-61035-5	• RECEPTACLE INSTL, WING FUEL TANK ELECTRICAL STA 472 RL 59 LH FOR BREAKDOWN SEE FIG. 2.12-6	1	35	
	8-61035-6	• RECEPTACLE INSTL, WING FUEL TANK ELECTRICAL STA 472 RL 59 RH FOR BREAKDOWN SEE FIG. 2.12-6	1	35	
- 15	8-61035-P07	• RECEPTACLE INSTL, WING FUEL TANK ELECTRICAL STA 472 RL 66 LH FOR BREAKDOWN SEE FIG. 2.12-6	1	35	
	8-61035-P08	• RECEPTACLE INSTL, WING FUEL TANK ELECTRICAL STA 472 RL 66 RH FOR BREAKDOWN SEE FIG. 2.12-6	1	35	
- 16	8-61035-803	• RECEPTACLE INSTL, WING FUEL TANK ELECTRICAL STA 510 LH FOR BREAKDOWN SEE FIG. 2.12-6	1	35	
	8-61035-804	• RECEPTACLE INSTL, WING FUEL TANK ELECTRICAL STA 510 RH FOR BREAKDOWN SEE FIG. 2.12-6	1	35	
- 17	8-61035-P01	• RECEPTACLE INSTL, WING FUEL TANK ELECTRICAL STA 557 LH FOR BREAKDOWN SEE FIG. 2.12-6	1	35	
	8-61035-P02	• RECEPTACLE INSTL, WING FUEL TANK ELECTRICAL STA 557 RH FOR BREAKDOWN SEE FIG. 2.12-6	1	35	
	8-65019-805	• CLAMP INSTL, EXTERNAL FUEL TANK EJECTION RESISTOR	1	35	
	8-65019-807	• CLAMP INSTL, EXTERNAL FUEL TANK EJECTION RESISTOR	1	35	
- 18	MS21919D06	• • CLAMP (96906) ATTACHING PARTS	2	35	
- 19	NAS221-10	• • SCREW (R0235) -----X-----	2	35	
- 20	8-65013	• • INSULATOR, EXTERNAL FUEL TANK EJECTION RESISTOR	1	35	
- 21	8-18013-811	• EQUIPMENT ASSY, WING LH FOR BREAKDOWN SEE FIG. 2.6-32	1	B	
	8-18003-1	• EQUIPMENT ASSY, WING LH FOR BREAKDOWN SEE FIG. 2.6-32	1	A	
	8-18013-P12	• EQUIPMENT ASSY, WING RH FOR BREAKDOWN SEE FIG. 2.6-32	1	B	
	8-18003-2	• EQUIPMENT ASSY, WING RH FOR BREAKDOWN SEE FIG. 2.6-32	1	A	
		A AIRPLANES #278 THRU 296 AND 288 THRU 291			
		B AIRPLANES #35 THRU 277, 287, 292 AND ON			

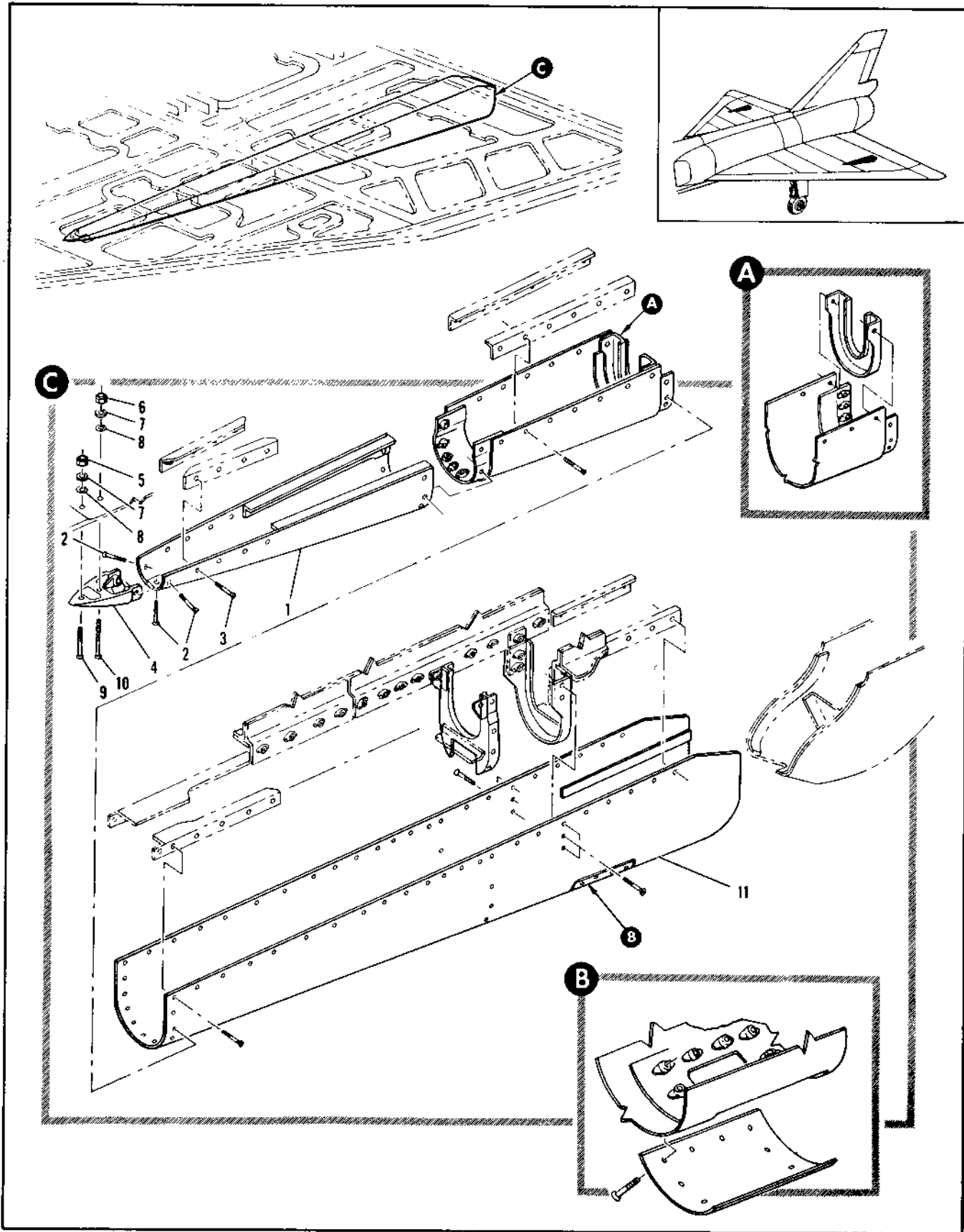

Figure 2.6-4. Elevation Actuator Wing Fairing Installation (Sheet 1 of 3)

FIGURE AND INDEX NUMBER	PART NUMBER	DESCRIPTION	UNITS PER ASSY.	USABLE ON CODE	
				FROM	TO
		1 2 3 4 5 6			
2.6-4	8-18580-5	FAIRING INSTALLATION, ELEVON ACTUATOR WING LH FOR NHA SEE FIG. 2.6-1	1	A	
	9-18580-6	FAIRING INSTALLATION, ELEVON ACTUATOR WING RH- FOR NHA SEE FIG. 2.6-1	1	A	
- 1	8-18580-89	• FAIRING ASSY, ELEVON ACTUATOR WING LH RIVETED REPLACES NOT INTCHG WITH 8-18580-69 REPLACED BY NOT INTCHG WITH 8-18580-97 WITH 0.125 EXCESS MATERIAL ON SIDES OF FAIRING WITH PARTS LIST BAGGED AND TIED	1	C	
	8-18580-97	• FAIRING ASSY, ELEVON ACTUATOR WING LH RIVETED REPLACES NOT INTCHG WITH 8-18580-89 WITH 0.25C EXCESS MATERIAL ON SIDES AND WITH ANGLES BAGGED AND TIED	1	45	277
	8-18580-69	• FAIRING ASSY, ELEVON ACTUATOR WING LH RIVETED REPLACED BY NOT INTCHG WITH 8-18580-89	1	B	
	8-18580-90	• FAIRING ASSY, ELEVON ACTUATOR WING RH RIVETED REPLACES NOT INTCHG WITH 8-18580-70 REPLACED BY NOT INTCHG WITH 8-18580-98 WITH 0.125 EXCESS MATERIAL ON SIDES OF FAIRING WITH PARTS LIST BAGGED AND TIED	1	C	
	8-18580-98	• FAIRING ASSY, ELEVON ACTUATOR WING RH RIVETED REPLACES NOT INTCHG WITH 8-18580-90 WITH 0.25C EXCESS MATERIAL ON SIDES AND WITH ANGLES BAGGED AND TIED	1	45	277
	8-18580-70	• FAIRING ASSY, ELEVON ACTUATOR WING RH RIVETED REPLACED BY NOT INTCHG WITH 8-18580-90	1	B	
- 2	MS24694-52	• SCREW (96906)	3	A	
- 3	MS24694-48	• SCREW (96906)	17	A	
		-----X-----			
- 4	8-18414	• END ASSY, ELEVON ACTUATOR FAIRING FWD RIVETED ATTACHING PARTS	1	A	
- 5	NAS679A3	• NUT (80205)	1	A	
- 6	NAS679A3	• NUT (80205)	1	A	
- 7	240-R616901-6	• WASHER	2	A	
- 8	MS29513-8	• PACKING (96906)	2	A	
- 9	MS24694-58	• SCREW (96906)	1	A	
- 10	MS24694-64	• SCREW (96906)	1	A	
		-----X-----			
- 11	8-18580-87	• FAIRING ASSY, ELEVON ACTUATOR WING LH ATTACHING PARTS REPLACES NOT INTCHG WITH 8-18580-65 REPLACED BY NOT INTCHG WITH 8-18580-95 WITH 8-18580-41 BAGGED AND TIED WITH 0.125 EXCESS MATERIAL ON SIDES LESS 0.191 HOLES	1	C	
		A AIRPLANES #35 THRU 277, 287, 292 AND ON			
		B AIRPLANES #287 AND 292 THRU 300			
		C AIRPLANES #35 THRU 44, 301 AND ON			

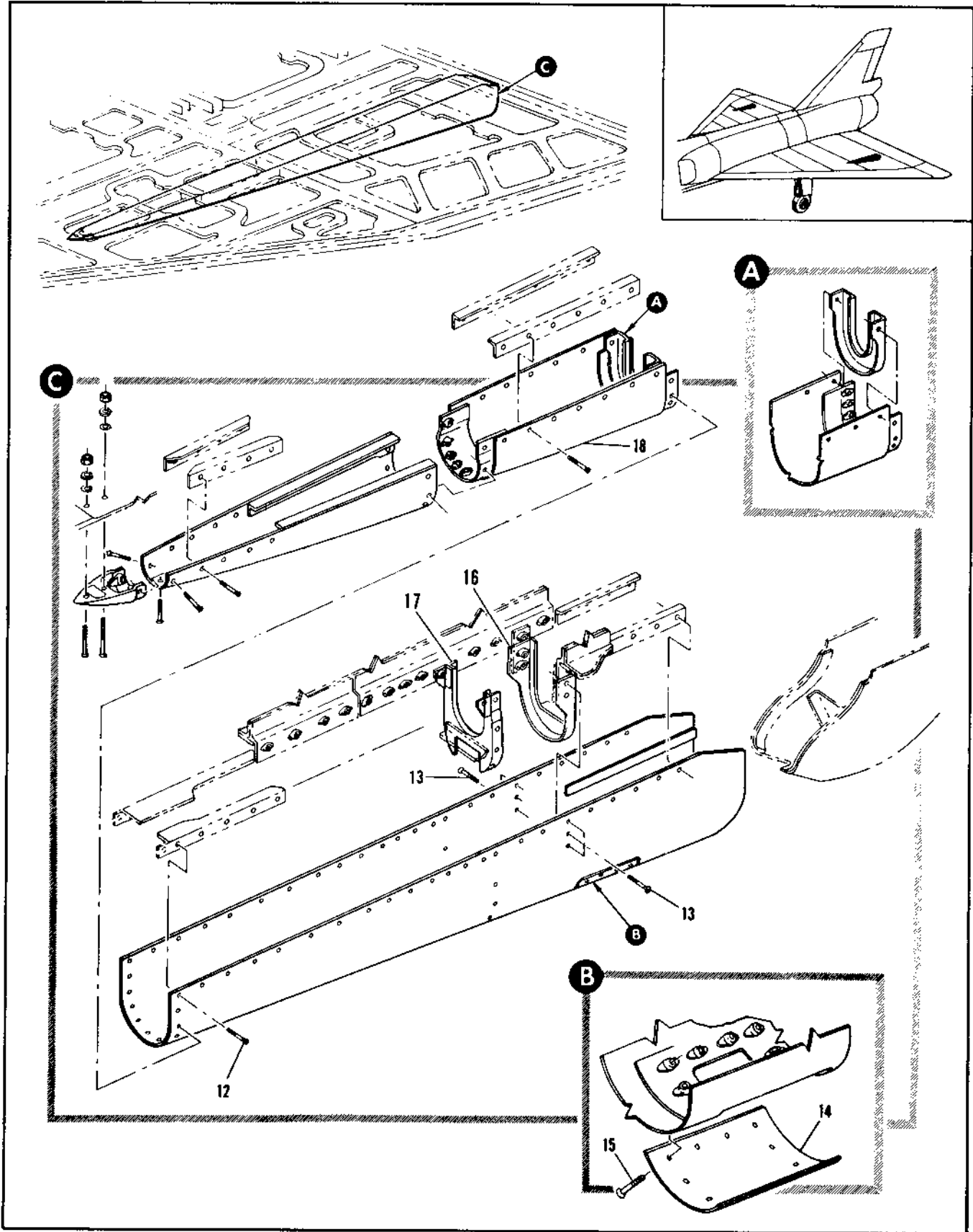

Figure 2.6-4. Elevation Actuator Wing Fairing Installation (Sheet 2 of 3)

FIGURE AND INDEX NUMBER	PART NUMBER	DESCRIPTION	UNITS PER ASSY.	USABLE ON CODE	
				FROM	TO
		1 2 3 4 5 6			
2.6-4	R-18580-95	• FAIRING ASSY, ELEVON ACTUATOR WING LH REPLACES NOT INTCHG WITH R-18580-87 WITH R-18580-41 BAGGED AND TIED WITH 0.250 EXCESS MATERIAL ON SIDES	1	45	277
	R-18580-65	• FAIRING ASSY, ELEVON ACTUATOR WING LH REPLACES NOT INTCHG WITH R-18560-65 REPLACED BY NOT INTCHG WITH R-18580-67	1		B
	R-18580-85	• FAIRING ASSY, ELEVON ACTUATOR WING RH REPLACES NOT INTCHG WITH R-18580-65 REPLACED BY NOT INTCHG WITH R-18580-96 WITH R-18580-42 BAGGED AND TIED WITH 0.125 EXCESS MATERIAL ON SIDES LESS 0.191 HOLES	1		C
	R-18580-86	• FAIRING ASSY, ELEVON ACTUATOR WING RH REPLACES NOT INTCHG WITH R-18580-88 WITH R-18580-42 BAGGED AND TIED WITH 0.250 EXCESS MATERIAL ON SIDES	1	45	277
	R-18580-66	• FAIRING ASSY, ELEVON ACTUATOR WING RH REPLACES NOT INTCHG WITH R-18560-65 REPLACED BY NOT INTCHG WITH R-18580-85	1		F
- 12	MS24694-48	• SCREW (96906)	52		A
- 13	MS24694-52	• SCREW (96906)	6		A
		----X----			
- 14	R-18560-83	• DOOR, FAIRING ACCESS	1		A
	R-18580-85	• DOOR, FAIRING ACCESS ALT INTCHG WITH R-18560-83 ATTACHING PARTS	RF		A
- 15	MS24694-48	• SCREW (96906)	12		A
		----X----			
	R-18580-63	• FAIRING ASSY, LH	1		A
	R-18580-64	• FAIRING ASSY, RH	1		A
- 16	R-18560-55	• RIB, ELEVON ACTUATOR FAIRING LH	1		A
	R-18580-55	• RIB, ELEVON ACTUATOR FAIRING LH ALT INTCHG WITH R-18560-55	RF		A
	R-18560-56	• RIB, ELEVON ACTUATOR FAIRING RH	1		A
	R-18580-56	• RIB, ELEVON ACTUATOR FAIRING RH ALT INTCHG WITH R-18560-56	RF		A
	R-18580-41	• FAIRING ASSY, LH	1		A
	R-18580-42	• FAIRING ASSY, RH	1		A
- 17	R-18560-35	• RIB, ELEVON ACTUATOR FAIRING LH	1		A
	R-18560-35	• RIB, ELEVON ACTUATOR FAIRING LH ALT INTCHG WITH R-18560-35	RF		A
	R-18560-36	• RIB, ELEVON ACTUATOR FAIRING RH	1		A
	R-18580-36	• RIB, ELEVON ACTUATOR FAIRING RH ALT INTCHG WITH R-18560-36	RF		A
- 18	R-18580-85	• FAIRING ASSY, ELEVON ACTUATOR WING LH RIVETED REPLACES NOT INTCHG WITH R-18560-44 REPLACED BY NOT INTCHG WITH R-18580-96 ATTACHING PARTS PIVETED REPLACES NOT INTCHG WITH R-18580-93 REPLACED BY NOT INTCHG WITH R-18580-93 WITH 0.250 EXCESS MATERIAL ON SIDES LESS 0.191 ATTACH HOLES AND WITH ASSEMBLY TACK RIVETED	1		D
<p>A AIRPLANES #35 THRU 277, 277, 292 AND ON F AIRPLANES #287 AND 292 THRU 311 C AIRPLANES #35 THRU 44, 301 AND ON</p>					

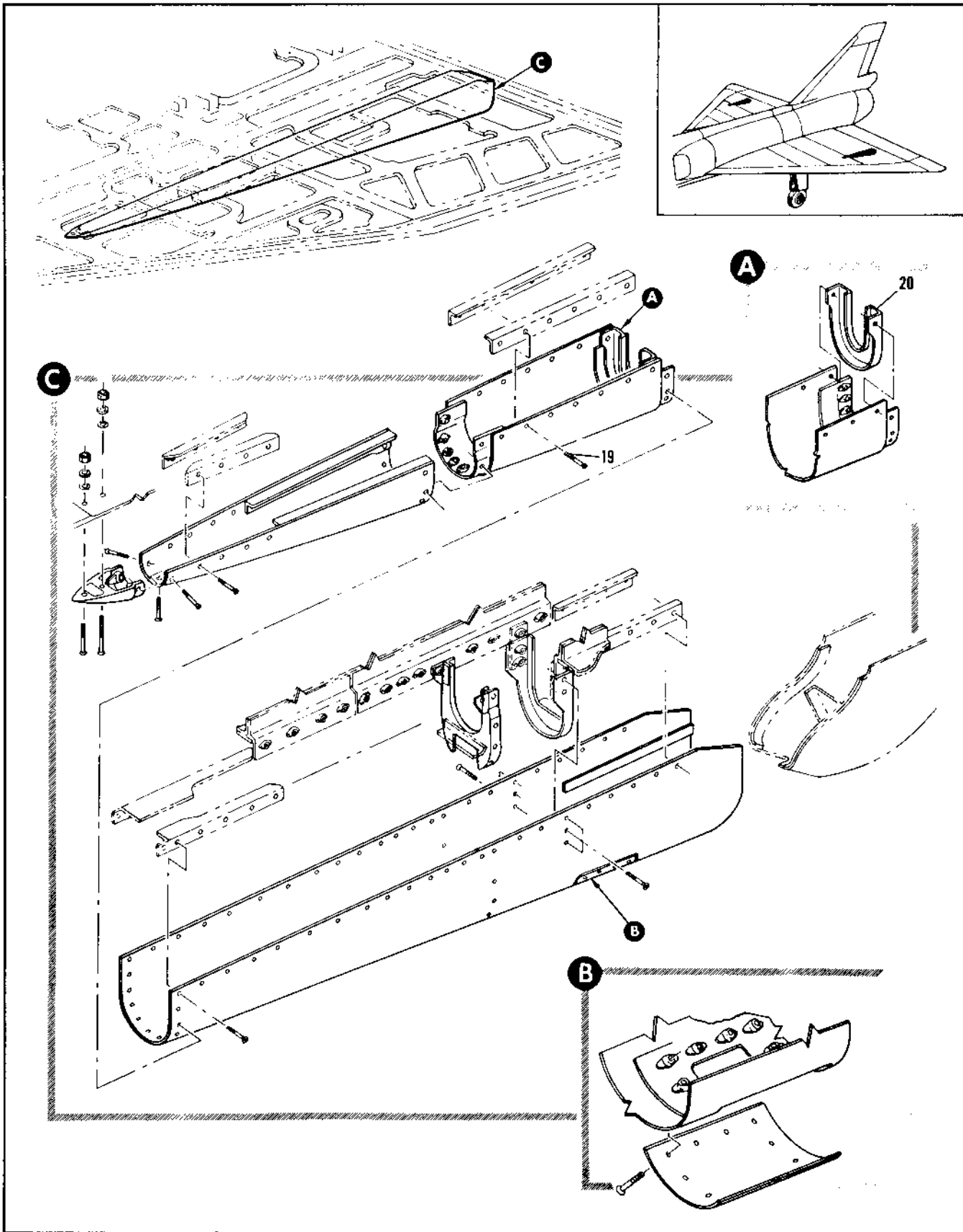

Figure 2.6-4. Elevon Actuator Wing Fairing Installation (Sheet 3 of 3)

FIGURE AND INDEX NUMBER	PART NUMBER	DESCRIPTION	UNITS PER ASSY.	USABLE ON CODE	
				FROM	TO
		1 2 3 4 5 6			
2.6-4	8-18580-93	• FAIRING ASSY, ELEVON ACTUATOR WING LH RIVETED REPLACES NOT INTCHG WITH 8-18580-85 WITH 0.250 EXCESS MATERIAL ON SIDES	1	45	277
	8-18580-43	• FAIRING ASSY, ELEVON ACTUATOR WING LH RIVETED REPLACES NOT INTCHG REPLACED BY NOT INTCHG WITH 8-18580-85 WITH 8-18560-43	1	B	
	8-18580-86	• FAIRING ASSY, ELEVON ACTUATOR WING RH RIVETED REPLACES NOT INTCHG WITH 8-18580-44 REPLACED BY NOT INTCHG WITH 8-18580-94 WITH 0.250 EXCESS MATERIAL ON SIDES LESS 0.191 ATTACH HOLES AND WITH ASSEMBLY TACK RIVETED	1	C	
	8-18580-94	• FAIRING ASSY, ELEVON ACTUATOR WING RH RIVETED REPLACES NOT INTCHG WITH 8-18580-86 WITH 0.250 EXCESS MATERIAL ON SIDES	1	45	277
	8-18580-44	• FAIRING ASSY, ELEVON ACTUATOR WING RH RIVETED REPLACES NOT INTCHG WITH 8-18560-44 REPLACED BY NOT INTCHG WITH 8-18580-86 ATTACHING PARTS	1	B	
- 19	MS24694-48	• SCREW (96906) ----X----	14	A	
- 20	8-18560-39	• RIB, ELEVON ACTUATOR FAIRING LH	1	A	
	8-18580-39	• RIB, ELEVON ACTUATOR FAIRING LH ALT INTCHG WITH 8-18560-39	RF	A	
	8-18560-40	• RIB, ELEVON ACTUATOR FAIRING RH	1	A	
	8-18580-40	• RIB, ELEVON ACTUATOR FAIRING RH ALT INTCHG WITH 8-18560-40	RF	A	
		A AIRPLANES #35 THRU 277, 287, 292 AND ON			
		P AIRPLANES #287 AND 292 THRU 300			
		C AIRPLANES #35 THRU 44, 301 AND ON			

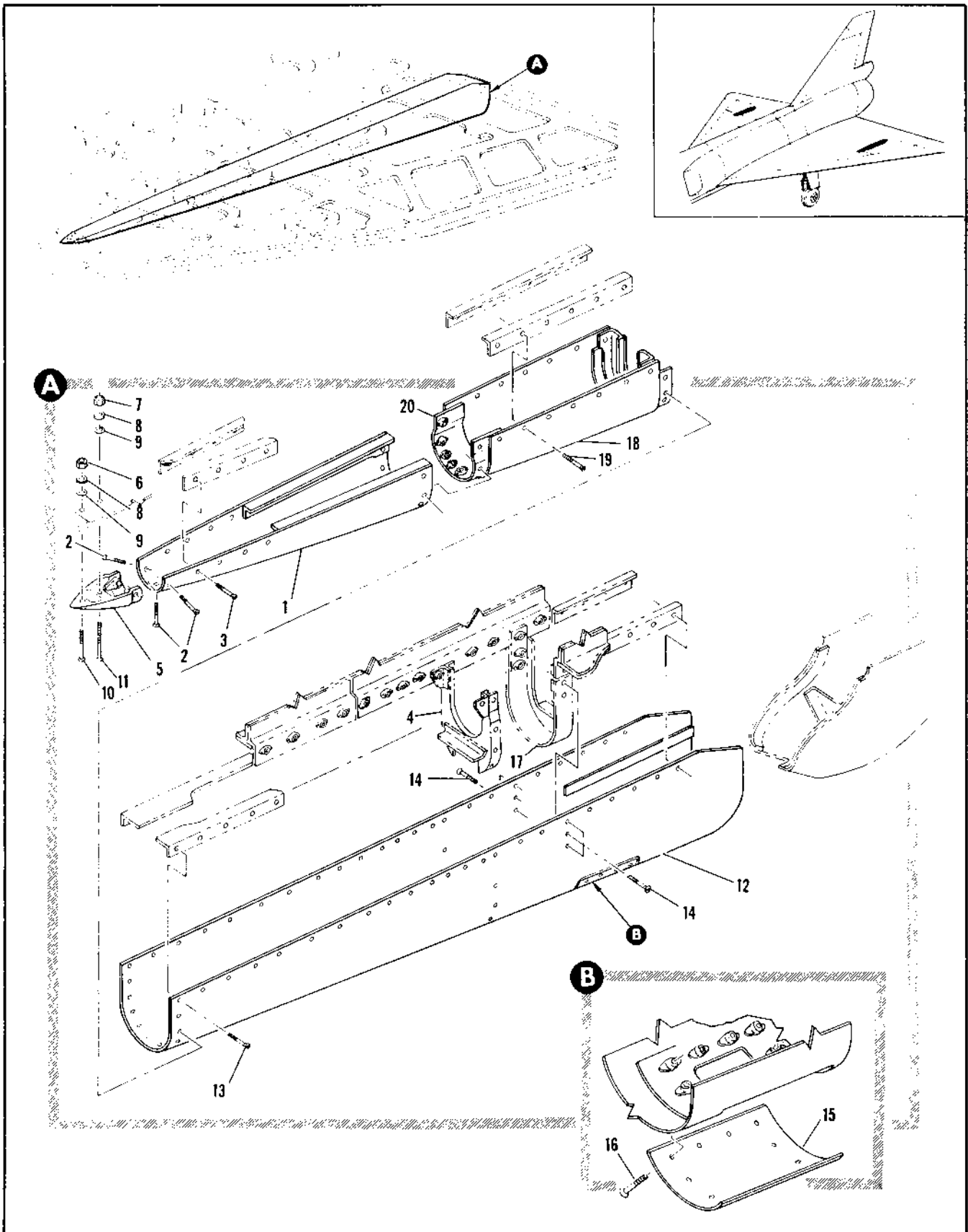

Figure 2.6-5. ELEVON ACTUATOR WING FAIRING INSTALLATION

FIGURE AND INDEX NUMBER	PART NUMBER	DESCRIPTION	UNITS PER ASSY.	USABLE ON CODE	
				FROM	TO
		1 2 3 4 5 6			
2.6-5	8-18560-5	FAIRING INSTALLATION, ELEVON ACTUATOR WING LH FOR NHA SEE FIG. 2.6-1	1	A	
	8-18560-6	FAIRING INSTALLATION, ELEVON ACTUATOR WING RH FOR NHA SEE FIG. 2.6-1	1	A	
- 1	8-18560-69	• FAIRING ASSY, ELEVON ACTUATOR LH RIVETED	1	A	
	9-18560-70	• FAIRING ASSY, ELEVON ACTUATOR RH RIVETED	1	A	
		ATTACHING PARTS			
- 2	MS24694-52	• SCREW (96906)	3	A	
- 3	MS24694-48	• SCREW (96906)	17	A	
		-----X-----			
	8-18560-41	• FAIRING ASSY, ELEVON ACTUATOR WING LH RIVETED	1	A	
	8-18560-42	• FAIRING ASSY, ELEVON ACTUATOR WING RH RIVETED	1	A	
- 4	8-18560-35	• • RIB, LH	1	A	
	8-18560-36	• • RIB, RH	1	A	
- 5	8-18554	• END ASSY, ELEVON ACTUATOR FAIRING FWD RIVETED	1	A	
		ATTACHING PARTS			
- 6	NAS679A3	• NUT (80205)	1	A	
- 7	NAS679A3	• NUT (80205)	1	A	
- 8	240-8616901-6	• WASHER	2	A	
- 9	MS29513-6	• PACKING (96906)	2	A	
- 10	MS24694-58	• SCREW (96906)	1	A	
- 11	MS24694-69	• SCREW (96906)	1	A	
		-----X-----			
- 12	8-18560-65	• FAIRING ASSY, ELEVON ACTUATOR WING LH	1	A	
	8-18560-66	• FAIRING ASSY, ELEVON ACTUATOR WING RH	1	A	
		ATTACHING PARTS			
- 13	MS24694-48	• SCREW (96906)	62	A	
- 14	MS24694-52	• SCREW (96906)	6	A	
		-----X-----			
- 15	8-18560-83	• • DOOR, FAIRING ACCESS	1	A	
		ATTACHING PARTS			
- 16	MS24694-48	• • SCREW (96906)	12	A	
		-----X-----			
	8-18560-63	• • FAIRING ASSY, LH	1	A	
	8-18560-64	• • FAIRING ASSY, RH	1	A	
- 17	8-18560-55	• • • RIB, WING ELEVON ACTUATOR LH	1	A	
	9-18560-56	• • • RIB, WING ELEVON ACTUATOR RH	1	A	
- 18	8-18560-43	• FAIRING ASSY, ELEVON ACTUATOR WING LH RIVETED	1	A	
	8-18560-44	• FAIRING ASSY, ELEVON ACTUATOR WING RH RIVETED	1	A	
		ATTACHING PARTS			
- 19	MS24694-48	• SCREW (96906)	14	A	
		-----X-----			
- 20	8-18560-39	• • RIB, LH	1	A	
	8-18560-40	• • RIB, RH	1	A	
A AIRPLANES #278 THRU 286 AND 288 THRU 291					

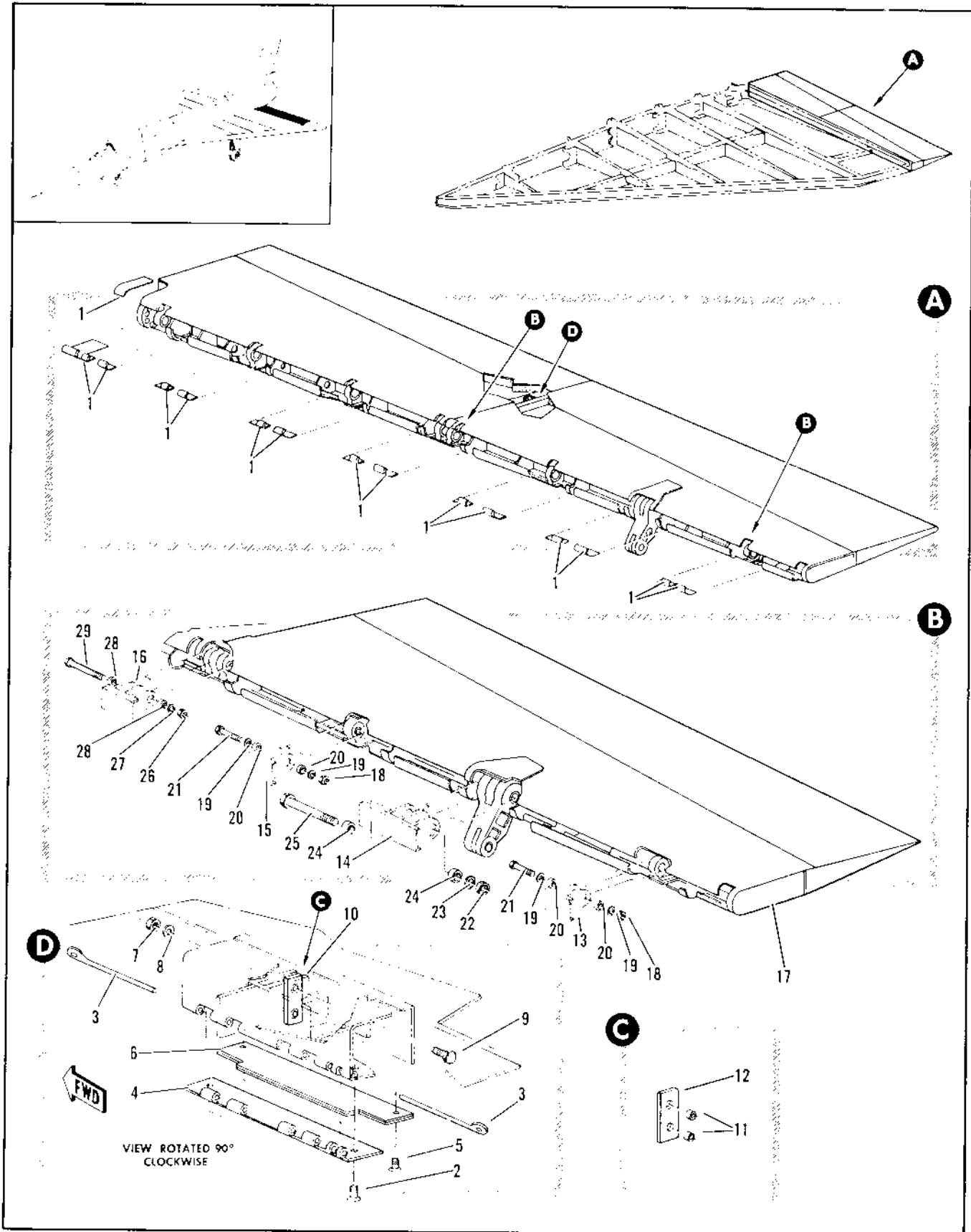

Figure 2.6-6. Elevon Installation (Sheet 1 of 2)

FIGURE AND INDEX NUMBER	PART NUMBER	DESCRIPTION	UNITS PER ASSY.	USABLE ON CODE	
				FROM	TO
		1 2 3 4 5 6			
2.6-6		FOR BREAKDOWN SEE FIG. 2.6-10			
	8-13550-1	ELEVON INSTALLATION, LH	RF	A	
	8-13550-2	ELEVON INSTALLATION, RH	RF	A	
- 1	8-13603-1	FOR NHA SEE FIG. 2.6-1 • DOOR INSTL, ELEVON HINGE ACCESS LH	1	A	
	8-13603-2	FOR BREAKDOWN SEE FIG. 2.2-20 • DOOR INSTL, ELEVON HINGE ACCESS RH	1	A	
- 2	NAS333CPA4-5	FOR BREAKDOWN SEE FIG. 2.2-20 • BOLT (81205)	2	A	
- 3	96-73502-104	• PIN	2	A	
- 4	8-13903-1	• DOOR ASSY, ELEVON LINK ACCESS LH RIVETED	1	A	
	8-13903-2	• DOOR ASSY, ELEVON LINK ACCESS RH RIVETED	1	A	
- 5	NAS333PA4-5	• BOLT (80205) 97-89004-032	2	A	
- 6	8-13901-1	• STRAP ASSY, RUH ELEVON SPLIT LH BOND	1	A	
	8-13901-2	• STRAP ASSY, RUH ELEVON SPLIT RH BOND	1	A	
- 7	AN321-4	• NUT (88044)	2	A	
- 8	AN960-416	• WASHER (88044)	2	A	
- 9	NAS464-4-17	• BOLT (81205)	1	A	
- 10	8-13703-3	• LINK ASSY, ELEVON	1	A	
- 11	8-12932-9	• BUSHING	2	A	
- 12	8-13703-9	• LINK	1	A	
- 13		• FITTING ASSY, ELEVON HINGE BL 175 SEE FIG. 2.6-38 INDEX 4	RF		
- 14		• FITTING ASSY, ELEVON HINGE BL 148 SEE FIG. 2.6-38 INDEX 6	RF		
- 15		• FITTING ASSY, ELEVON HINGE BL 130 SEE FIG. 2.6-38 INDEX 8	RF		
- 16		• FITTING ASSY, ELEVON HINGE BL 167 SEE FIG. 2.6-38 INDEX 11	RF		
- 17	8-13062-3	• ELEVON ASSY, OUTRD LH	1	E	
	8-13062-1	FOR BREAKDOWN SEE FIG. 2.6-A • ELEVON ASSY, OUTRD LH	1	P	
	8-13058-503	FOR BREAKDOWN SEE FIG. 2.6-B • ELEVON ASSY, OUTRD LH SPARES SEE FIG. 2.6-9	RF	A	
	8-13062-4	• ELEVON ASSY, OUTRD RH	1	E	
	8-13062-2	FOR BREAKDOWN SEE FIG. 2.6-B • ELEVON ASSY, OUTRD RH	1	P	
	8-13059-804	FOR BREAKDOWN SEE FIG. 2.6-B • ELEVON ASSY, OUTRD RH SPARES SEE FIG. 2.6-9	RF	A	
- 18	AN321-6	ATTACHING PARTS • NUT (88044)	2	A	
- 19	AN960-616L	• WASHER (88044)	4	A	
- 20	8-18758	• BUSHING, SPLIT CONE ELEVON HINGE	4	A	
- 21	NAS464-6-35	• BOLT (81205)	2	A	
- 22	AN321-10	• NUT (88044)	1	A	
- 23	AN960-1016L	• WASHER (88044)	1	A	
- 24	8-18759	• BUSHING, SPLIT CONE ELEVON HINGE	2	A	
- 25	NAS464-10-P1	• BOLT (81205)	1	A	
- 26	AN321-6	• NUT (88044)	1	A	
- 27	AN960-616L	• WASHER (88044)	1	A	
- 28	8-18756	• BUSHING, SPLIT CONE ELEVON HINGE	2	A	
- 29	NAS464-6-65	• BOLT (81205)	1	A	
		-----X-----			
		A AIRPLANES #25 THRU 277, 287, 292 AND ON			
		P AIRPLANES #287 AND 292 THRU 310			
		E AIRPLANES #25 THRU 277, 301 AND ON			

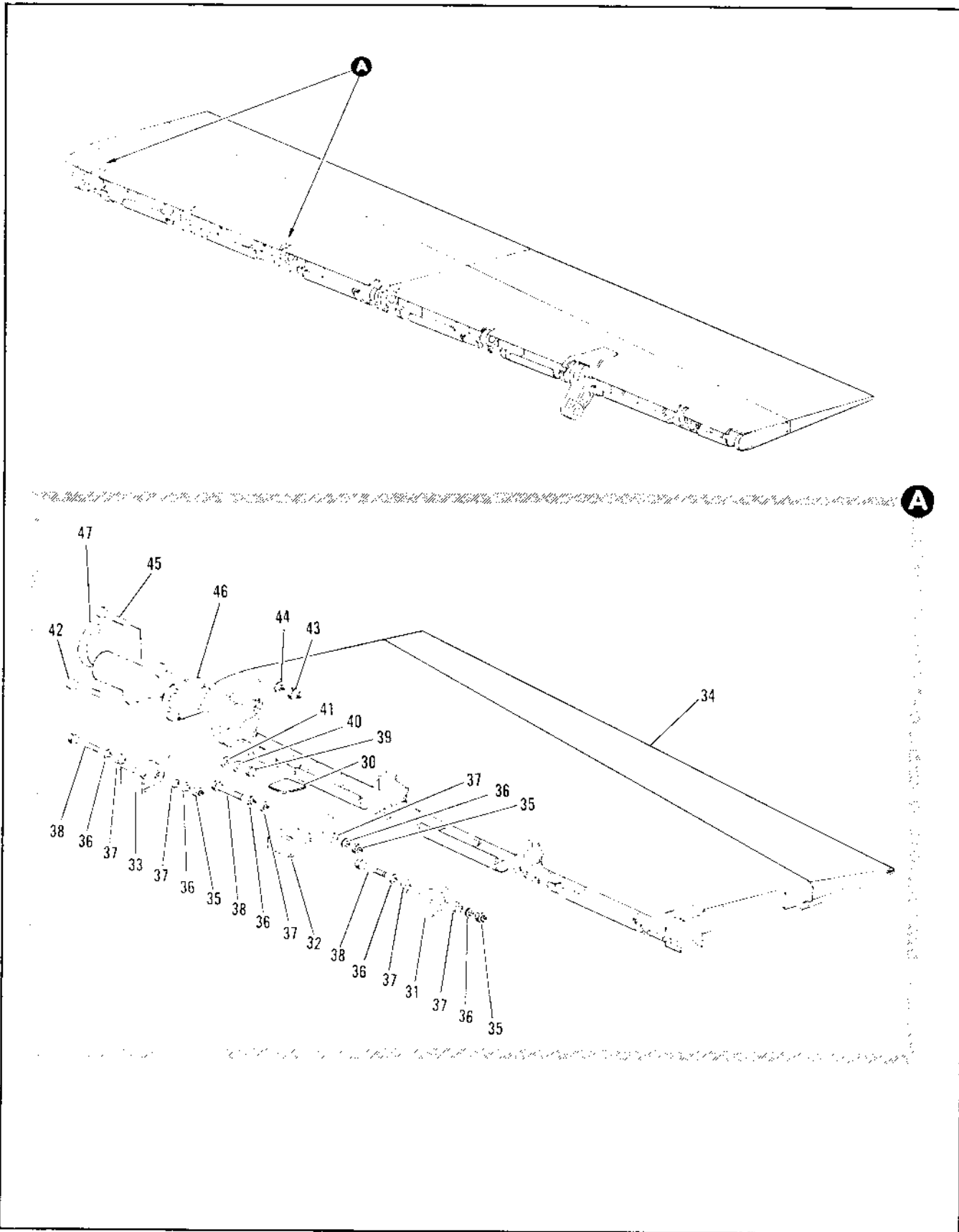

Figure 2.6-6. Elevator Installation (Sheet 2 of 2)

FIGURE AND INDEX NUMBER	PART NUMBER	DESCRIPTION	UNITS PER ASSY.	USABLE ON CODE	
				FROM	TO
		1 2 3 4 5 6			
2.6-6- 30	A-13601-5	• DOOR INSTL, INBD ELEVON ACCESS BL 40 LH FOR BREAKDOWN SEE FIG. 2.2-19	1	A	
	B-13601-6	• DOOR INSTL, INBD ELEVON ACCESS BL 40 RH FOR BREAKDOWN SEE FIG. 2.2-19	1	A	
- 31		• FITTING ASSY, ELEVON HINGE BL 84 SEE FIG. 2.6-38 INDEX 13	RF		
- 32		• FITTING ASSY, ELEVON HINGE BL 62 SEE FIG. 2.6-38 INDEX 15	RF		
- 33		• FITTING ASSY, ELEVON HINGE BL 40 SEE FIG. 2.6-38 INDEX 19	RF		
- 34	B-13031-805	• ELEVON ASSY, INBD LH FOR BREAKDOWN SEE FIG. 2.6-10	1	D	
	B-13031-807	• ELEVON ASSY, INBD LH FOR BREAKDOWN SEE FIG. 2.6-10	1	61	277
	B-13020-525	• ELEVON ASSY, INBD LH SPARES FOR BREAKDOWN SEE FIG. 2.6-12	RF	A	
	B-13031-1	• ELEVON ASSY, INBD LH FOR BREAKDOWN SEE FIG. 2.6-10	RF	C	B
	B-13031-801	• ELEVON ASSY, INBD LH FOR BREAKDOWN SEE FIG. 2.6-10	1		
	B-13031-806	• ELEVON ASSY, INBD RH FOR BREAKDOWN SEE FIG. 2.6-10	1	D	
	B-13031-808	• ELEVON ASSY, INBD RH FOR BREAKDOWN SEE FIG. 2.6-10	1	61	297
	B-13031-2	• ELEVON ASSY, INBD RH FOR BREAKDOWN SEE FIG. 2.6-10	RF	C	B
	B-13031-802	• ELEVON ASSY, INBD RH FOR BREAKDOWN SEE FIG. 2.6-10	1		B
	B-13020-526	• ELEVON ASSY, INBD RH SPARES FOR BREAKDOWN SEE FIG. 2.6-12	RF	A	
		ATTACHING PARTS			
- 35	AN320-6	• NUT (88044)	3	A	
- 36	AN950-616L	• WASHER (68044)	6	A	
- 37	B-18758	• BUSHING, SPLIT CONE ELEVON HINGE	6	A	
- 38	NAS464-6-35	• BOLT (68205)	3	A	
- 39	42FW720	• NUT, <56878> 96-37510-004	4	A	
- 40	MS20002C7	• WASHER (96906)	4	A	
- 41	MS20002-7	• WASHER (96906)	4	A	
- 42	MS20007-22	• BOLT (96936)	4	A	
- 43	42FW1018	• NUT, <56878> 96-37510-007	3	A	
- 44	MS20002C10	• WASHER (96906)	3	A	
- 45	MS20010-24	• BOLT (96936)	3	A	
		-----X-----			
- 46	B-13902-7	• SHIM, LH	AR	A	
	B-13902-9	• SHIM, RH	AR	A	
- 47		• FITTING ASSY, ELEVON IMPD HORN LH SEE FIG. 2.6-17 INDEX 11	RF		
		A AIRPLANES #35 THRU 277, 297, 292 AND ON			
		C AIRPLANES #287 AND 292 THRU 296			
		D AIRPLANES #35 THRU 60, 301 AND ON			

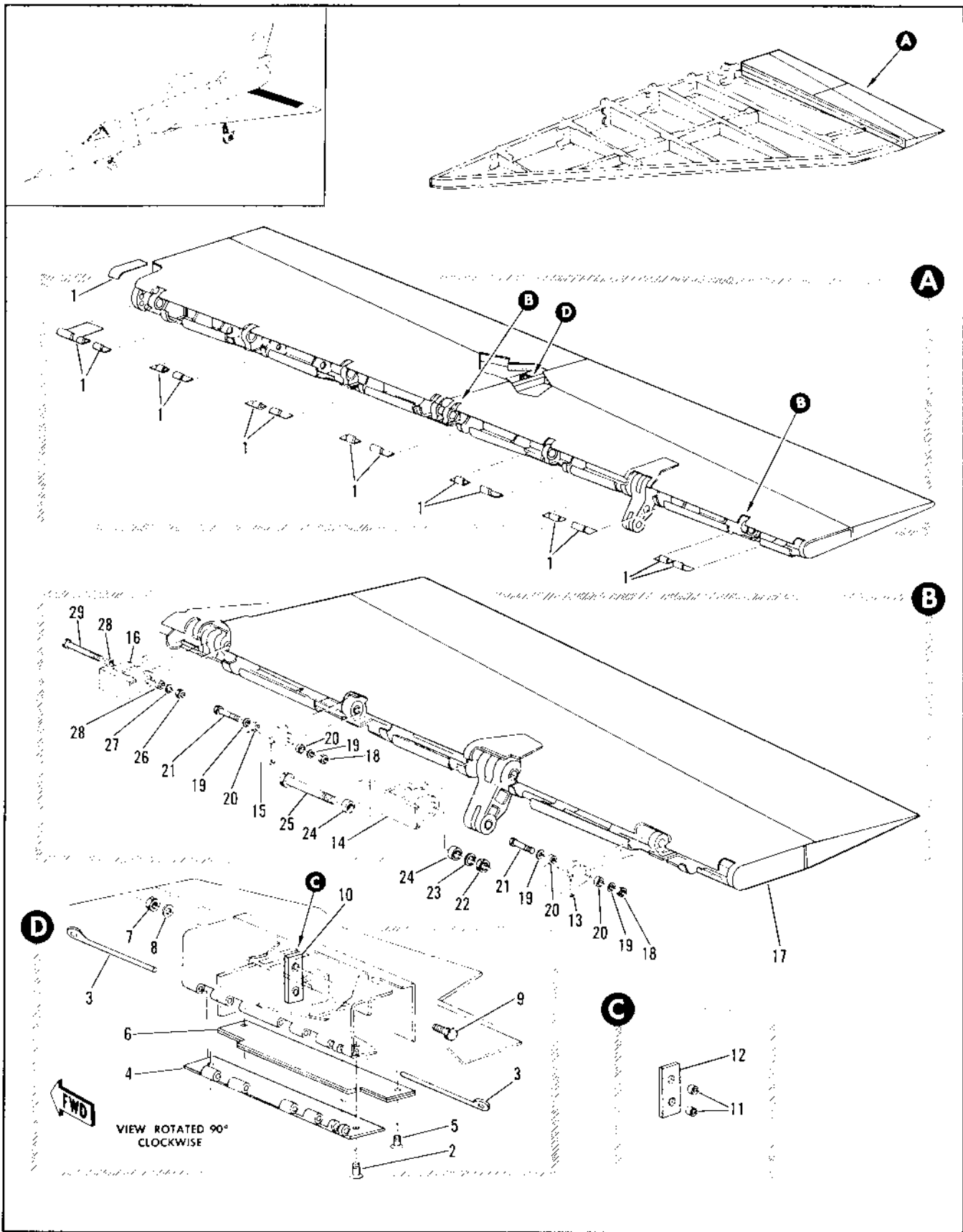

Figure 2.6-7. Elevon Installation (Sheet 1 of 2)

FIGURE AND INDEX NUMBER	PART NUMBER	DESCRIPTION	UNITS PER ASSY.	USABLE ON CODE	
				FROM	TO
		1 2 3 4 5 6			
2.6-7	8-13020-1	ELEVON INSTALLATION, LH FOR NHA SEE FIG. 2.6-2	RF	A	
	8-13020-2	ELEVON INSTALLATION, RH FOR NHA SEE FIG. 2.6-2	RF	A	
- 1	8-13603-1	• DOOR INSTL, ELEVON HINGE ACCESS LH FOR BREAKDOWN SEE FIG. 2.2-18	1	A	
	8-13603-2	• DOOR INSTL, ELEVON HINGE ACCESS RH FOR BREAKDOWN SEE FIG. 2.2-18	1	A	
- 2	NAS333CPA4-5	• BOLT (80205)	2	A	
- 3	96-78502-004	• PIN	2	A	
- 4	8-13903-1	• DOOR ASSY, ELEVON LINK ACCESS LH RIVETED	1	A	
	8-13903-2	• DOOR ASSY, ELEVON LINK ACCESS RH RIVETED	1	A	
- 5	NAS333PA4-5	• BOLT (80205)	2	A	
- 6	8-13901-1	• STRAP ASSY, RUB ELEVON SPLIT LH BONDED	1	A	
	8-13901-2	• STRAP ASSY, RUB ELEVON SPLIT RH BONDED	1	A	
- 7	AN320-4	• NUT (88044)	2	A	
- 8	AN965-416	• WASHER (88044)	2	A	
- 9	NAS464-4-17	• BOLT (80205)	2	A	
- 10	8-13703-3	• LINK ASSY, ELEVON	1	A	
- 11	8-12932-9	• BUSHING	2	A	
- 12	8-13703-9	• LINK	1	A	
- 13		• FITTING ASSY, ELEVON HINGE BL 175 SEE FIG. 2.6-38 INDEX 4	RF		
- 14		• FITTING ASSY, ELEVON HINGE BL 148 SEE FIG. 2.6-38 INDEX 6	RF		
- 15		• FITTING ASSY, ELEVON HINGE BL 130 SEE FIG. 2.6-38 INDEX 8	RF		
- 16		• FITTING ASSY, ELEVON HINGE RL 107 SEE FIG. 2.6-38 INDEX 11	RF		
- 17	8-13032-1	ELEVON ASSY, OUTBD LH FOR BREAKDOWN SEE FIG. 2.6-8	1	A	
	8-13020-527	• ELEVON ASSY, OUTBD LH SPARES SEE FIG. 2.6-9	RF	A	
	8-13032-2	• ELEVON ASSY, OUTBD RH FOR BREAKDOWN SEE FIG. 2.6-8	1	A	
	8-13020-528	• ELEVON ASSY, OUTBD RH SPARES SEE FIG. 2.6-9 ATTACHING PARTS	RF	A	
- 18	AN320-6	• NUT (88044)	2	A	
- 19	AN965-616L	• WASHER (88044)	4	A	
- 20	8-18758	• BUSHING, SPLIT CONE ELEVON HINGE	4	A	
- 21	NAS464-6-35	• BOLT (80205)	2	A	
- 22	AN320-10	• NUT (88044)	1	A	
- 23	AN965-1016L	• WASHER (88044)	1	A	
- 24	8-16759	• BUSHING, SPLIT CONE ELEVON HINGE	2	A	
- 25	NAS464-15-81	• BOLT (80205)	1	A	
- 26	AN320-6	• NUT (88044)	1	A	
- 27	AN965-616L	• WASHER (88044)	1	A	
- 28	8-18758	• BUSHING, SPLIT CONE ELEVON HINGE	2	A	
- 29	NAS464-6-65	• BOLT (80205)	1	A	
		-----X-----			
		A AIRPLANES #278 THRU 286 AND 288 THRU 291			

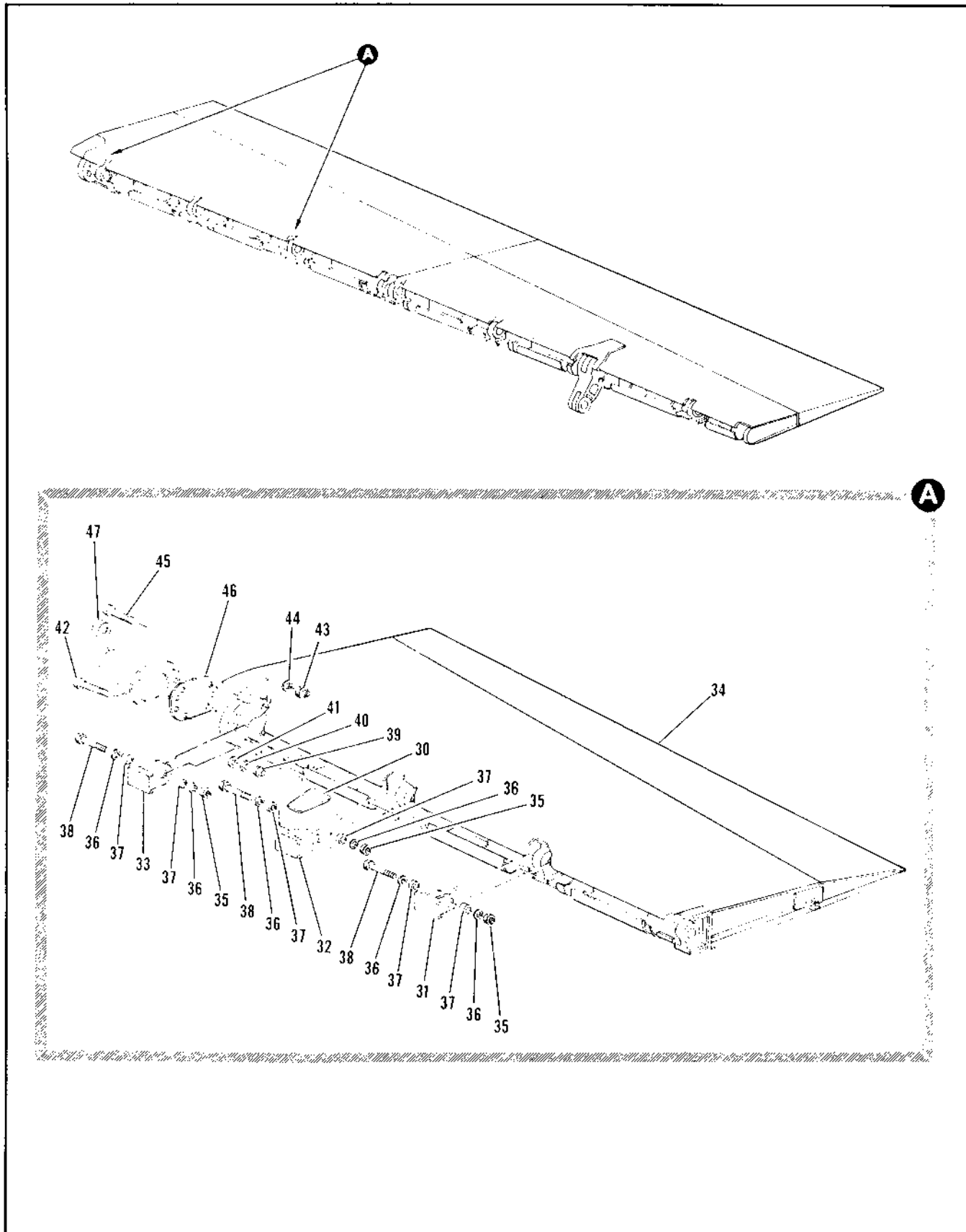

Figure 2.6-7. Elevon Installation (Sheet 2 of 2)

FIGURE AND INDEX NUMBER	PART NUMBER	DESCRIPTION	UNITS PER ASSY.	USABLE ON CODE	
				FROM	TO
		1 2 3 4 5 6			
2.6-7- 30	8-13601-5	• DOOR INSTL, INBD ELEVON ACCESS BL 40 LH FOR BREAKDOWN SEE FIG. 2.2-19	1	A	
	8-13601-6	• DOOR INSTL, INBD ELEVON ACCESS BL 40 RH FOR BREAKDOWN SEE FIG. 2.2-19	1	A	
- 31		• FITTING ASSY, WING ELEVON HINGE BL 84 SEE FIG. 2.6-38 INDEX 13	RF		
- 32		• FITTING ASSY, WING ELEVON HINGE BL 62 SEE FIG. 2.6-38 INDEX 15	RF		
- 33		• FITTING ASSY, WING ELEVON HINGE BL 40 SEE FIG. 2.6-38 INDEX 19	RF		
- 34	8-13031-1	• ELEVON ASSY, INBD LH FOR BREAKDOWN SEE FIG. 2.6-10	RF	A	
	8-13031-801	• ELEVON ASSY, INBD LH FOR BREAKDOWN SEE FIG. 2.6-10	1	A	
	8-13020-525	• ELEVON ASSY, INBD LH SPARES FOR BREAKDOWN SEE FIG. 2.6-12	RF	A	
	8-13031-2	• ELEVON ASSY, INBD RH FOR BREAKDOWN SEE FIG. 2.6-10	RF	A	
	8-13031-802	• ELEVON ASSY, INBD RH FOR BREAKDOWN SEE FIG. 2.6-10	1	A	
	8-13020-526	• ELEVON ASSY, INBD RH SPARES FOR BREAKDOWN SEE FIG. 2.6-12 ATTACHING PARTS	RF	A	
- 35	AN320-6	• NUT (88144)	3	A	
- 36	AN960-616L	• WASHER (88044)	6	A	
- 37	8-18758	• BUSHING, SPLIT CONE ELEVON HINGE	6	A	
- 38	NAS464-6-35	• BOLT (80205)	3	A	
- 39	42FW720	• NUT, <56878> 96-37510-004	4	A	
- 40	NAS143-7C	• WASHER (80205)	4	A	
- 41	NAS143-7	• WASHER (80205)	4	A	
- 42	MS20007-22	• BOLT (96906)	4	A	
- 43	42FW1018	• NUT, <56878> 96-37510-007	3	A	
- 44	NAS143-10C	• WASHER (80205)	3	A	
- 45	MS20010-24	• BOLT (96906)	3	A	
		-----X-----			
- 46	8-13902-7	• SHIM, LH	AR	A	
	8-13902-9	• SHIM, RH	AR	A	
- 47		• FITTING ASSY, ELEVON HORN INBD LH SEE FIG. 2.6-17 INDEX 11	RF		
A AIRPLANES #278 THRU 286 AND 288 THRU 291					

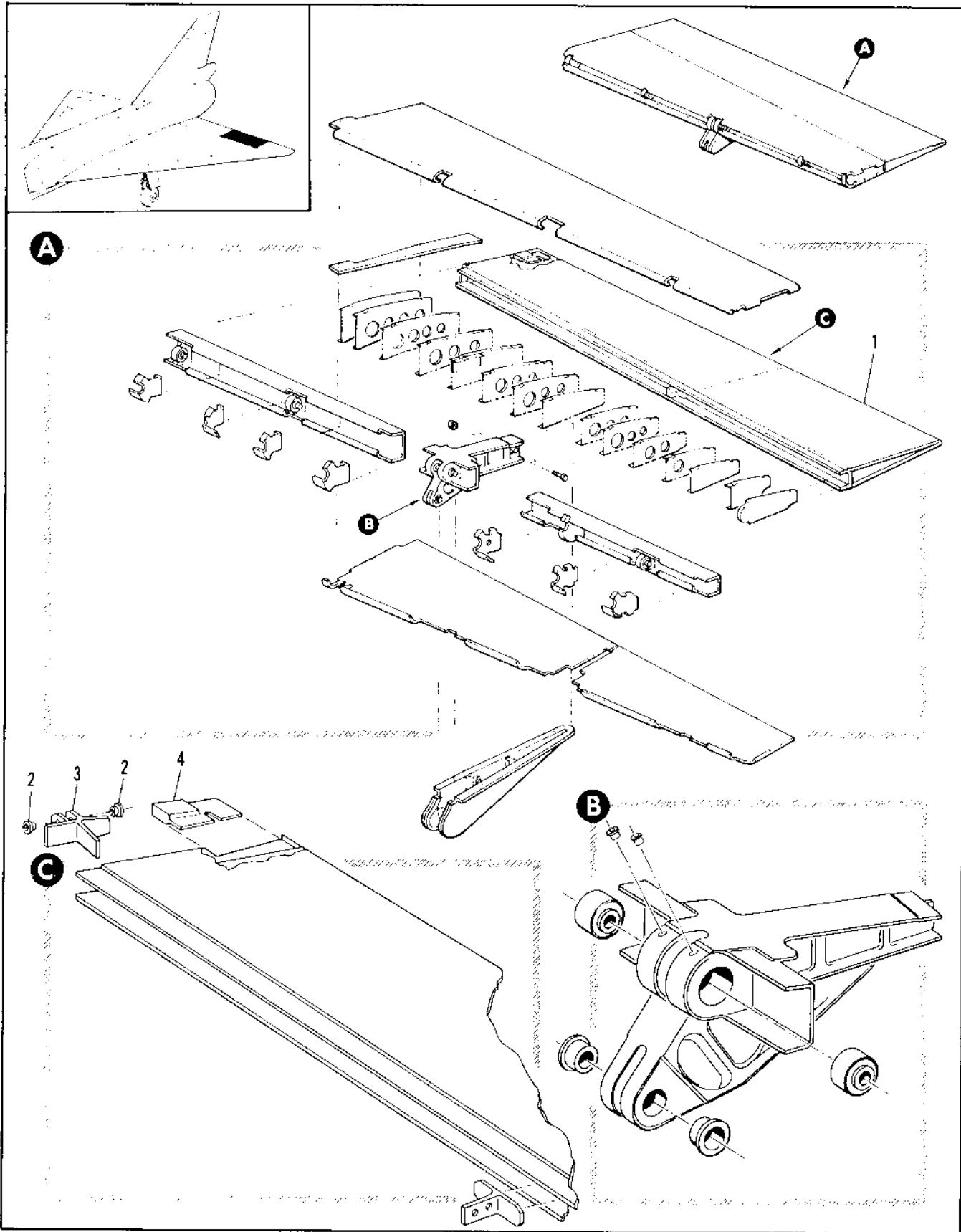

Figure 2.6-8. Outbd Elevon Assembly (Sheet 1 of 3)

FIGURE AND INDEX NUMBER	PART NUMBER	DESCRIPTION	UNITS PER ASSY.	USABLE ON CODE	
				FROM	TO
		1 2 3 4 5 6			
2.6-8	8-13062-3	ELEVON ASSEMBLY, OUTBOARD LH FOR NHA SEE FIG. 2.6-6	RF	E	
	8-13032-1	FOR SPARES ASSEMBLY SEE FIG. 2.6-3 ELEVON ASSEMBLY, OUTBOARD LH FOR NHA SEE FIG. 2.6-7	RF	A	
	8-13062-1	FOR SPARES ASSEMBLY SEE FIG. 2.6-3 ELEVON ASSEMBLY, OUTBOARD LH FOR NHA SEE FIG. 2.6-6	RF	R	
	8-13062-4	FOR SPARES ASSEMBLY SEE FIG. 2.6-3 ELEVON ASSEMBLY, OUTBOARD RH FOR NHA SEE FIG. 2.6-6	RF	E	
	8-13032-2	FOR SPARES ASSEMBLY SEE FIG. 2.6-3 ELEVON ASSEMBLY, OUTBOARD RH FOR NHA SEE FIG. 2.6-7	RF	A	
	8-13062-2	FOR SPARES ASSEMBLY SEE FIG. 2.6-3 ELEVON ASSEMBLY, OUTBOARD RH FOR NHA SEE FIG. 2.6-6	RF	R	
- 1	8-13040-805	FOR SPARES ASSEMBLY SEE FIG. 2.6-3 • TRAILING EDGE ASSY, OUTBD ELEVON LH REPLACES SUITABLE SUB FOR 8-13040-801 REPLACED BY SUITABLE SUB 8-13040-815	1	F	
	8-13040-815	• TRAILING EDGE ASSY, OUTBD ELEVON LH REPLACES SUITABLE SUB FOR 8-13040-805 REPLACED BY INTCHG WITH 8-13040-819	1	61	89
	8-13040-819	• TRAILING EDGE ASSY, OUTBD ELEVON LH REPLACES INTCHG WITH 8-13040-815	1	90	277
	8-13040-801	• TRAILING EDGE ASSY, OUTBD ELEVON LH REPLACED BY SUITABLE SUB 8-13040-805	1	278	300
	8-13040-703	• TRAILING EDGE ASSY, OUTBD ELEVON LH ALT INTCHG WITH 8-13040-801	RF	278	300
	8-13040-806	• TRAILING EDGE ASSY, OUTBD ELEVON RH REPLACES SUITABLE SUB FOR 8-13040-802 REPLACED BY SUITABLE SUB 8-13040-816	1	F	
	8-13040-816	• TRAILING EDGE ASSY, OUTBD ELEVON RH REPLACES SUITABLE SUB FOR 8-13040-806 REPLACED BY INTCHG WITH 8-13040-820	1	61	89
	8-13040-820	• TRAILING EDGE ASSY, OUTBD ELEVON RH REPLACES INTCHG WITH 8-13040-816	1	90	277
	8-13040-802	• TRAILING EDGE ASSY, OUTBD ELEVON RH REPLACED BY SUITABLE SUB 8-13040-806	1	278	300
	8-13040-704	• TRAILING EDGE ASSY, OUTBD ELEVON RH ALT INTCHG WITH 8-13040-802	RF	278	300
- 2	8-13932	• • BUSHING, ELEVON SPLICE	2	35	
- 3	8-13730-7	• • LINK, ELEVON CONNECTING LH	1	35	
	8-13730-8	• • LINK, ELEVON CONNECTING RH	1	35	
- 4	8-13724-715	• • WEDGE, ELEVON TRAILING EDGE LH REPLACED BY SUITABLE SUB 8-13724-7	1	6	
	8-13724-7	• • WEDGE, ELEVON TRAILING EDGE LH REPLACES SUITABLE SUB FOR 8-13724-715	1	90	277
		A AIRPLANES #278 THRU 286 AND 288 THRU 291			
		B AIRPLANES #287 AND 292 THRU 300			
		E AIRPLANES #35 THRU 277, 301 AND ON			
		F AIRPLANES #35 THRU 60, 301 AND ON			
		G AIRPLANES #35 THRU 89, 278 AND ON			

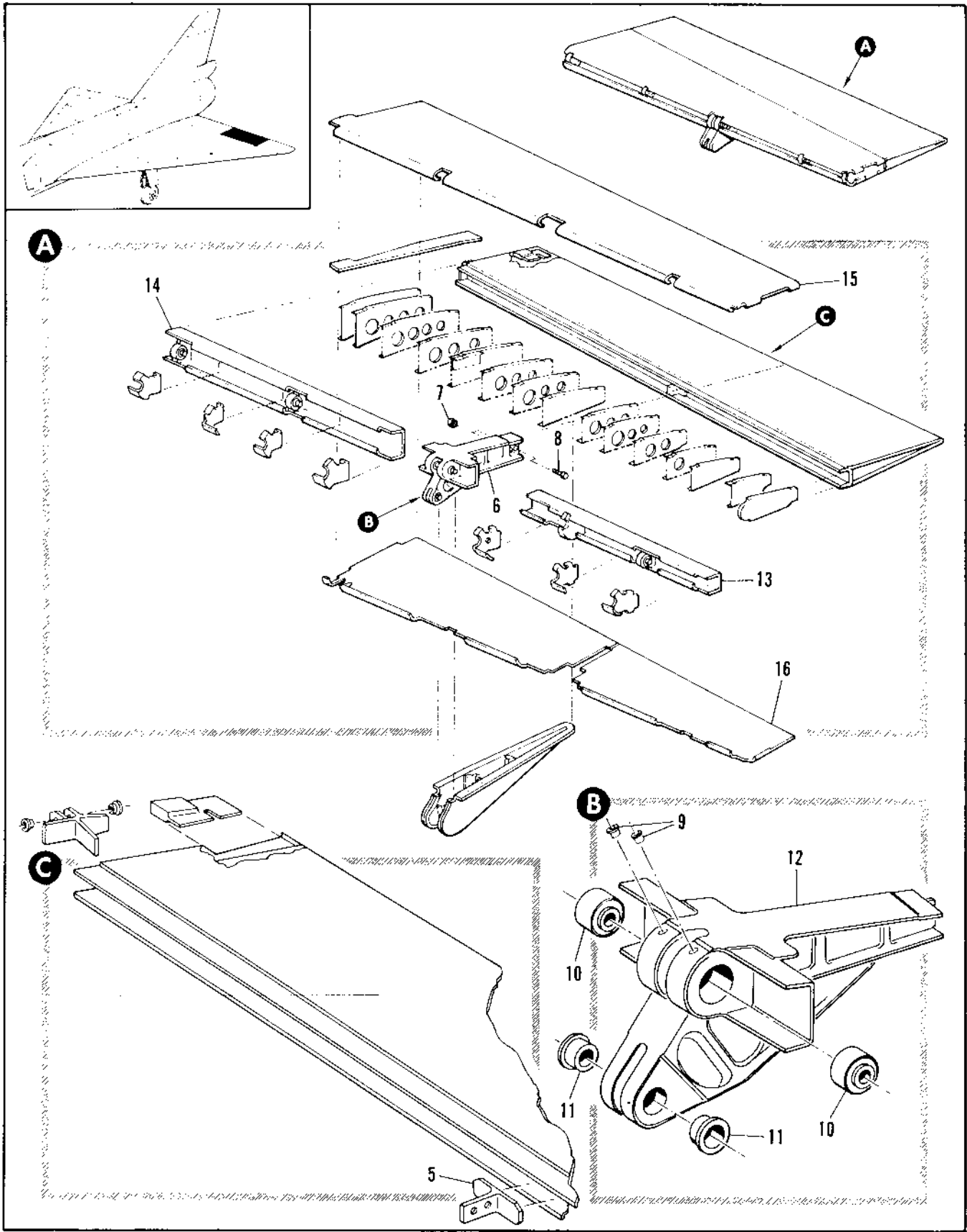

Figure 2.6-8. Outbd Elevon Assembly (Sheet 2 of 3)

FIGURE AND INDEX NUMBER	PART NUMBER	DESCRIPTION	UNITS PER ASSY.	USABLE ON CODE		
				FROM	TO	
2.6-8	8-13724-71b	• WEDGE, ELEVON TRAILING EDGE RH REPLACED BY SUITABLE SUB 8-13724-8	1	G		
	8-13724-8	• WEDGE, ELEVON TRAILING EDGE RH REPLACES SUITABLE SUB FOR 8-13724-71b	1	50	277	
- 5	8-13725-9	• WEDGE, ELEVON TRAILING EDGE	1	35		
	8-13724-13	• WEDGE, ELEVON TRAILING EDGE	1	35		
	8-13719	• CLIP, OUTRD HORN ELEVON LESS 2 HOLES 0.2500 DIA	1	35		
	8-13720-1	• HORN ASSY, OUTRD ELEVON ACTUATOR LH	1	35		
	8-13720-2	• HORN ASSY, OUTRD ELEVON ACTUATOR RH ATTACHING PARTS	1	35		
	- 7	NAS479A4	• NUT (8.205)	2	35	
	- 8	NAS4.4-4A5	• BOLT (8.205) -----X-----	2	35	
	- 9	NAS16-1	• FITTING (A0205)	2	35	
	- 10	A10H	• BEARING, <77-96> 80-60500-002	2	35	
	- 11	8-13756	• RUSHING	2	35	
	- 12	8-13720-7	• HORN, LH	1	35	
	- 13	8-13720-8	• HORN, RH	1	35	
	- 14	8-13111-5	• SPAR ASSY, OUTRD ELEVON OUTRD LH FOR BREAKDOWN SEE FIG. 2.6-34 FOR SPARES ASSEMBLY SEE FIG. 2.6-5	1	A	
8-13111-6		• SPAR ASSY, OUTRD ELEVON OUTRD RH FOR BREAKDOWN SEE FIG. 2.6-34	1	D		
8-13101-6		• SPAR ASSY, OUTRD ELEVON OUTRD RH FOR BREAKDOWN SEE FIG. 2.6-34	1	A		
8-13111-3		• SPAR ASSY, OUTRD ELEVON INRD LH FOR BREAKDOWN SEE FIG. 2.6-14	1	D		
8-13101-3		• SPAR ASSY, OUTRD ELEVON INRD LH FOR BREAKDOWN SEE FIG. 2.6-14	1	A		
8-13111-4		• SPAR ASSY, OUTRD ELEVON INRD RH FOR BREAKDOWN SEE FIG. 2.6-14	1	D		
8-13101-4		• SPAR ASSY, OUTRD ELEVON INRD RH FOR BREAKDOWN SEE FIG. 2.6-14	1	A		
8-13152-7		• SKIN, OUTRD ELEVON UPPER LH REPLACES NOT INTCHG WITH 8-13142-7	1	D		
8-13142-7		• SKIN, OUTRD ELEVON UPPER LH REPLACED BY NOT INTCHG WITH 8-13152-7	1	A		
8-13152-8		• SKIN, OUTRD ELEVON UPPER RH REPLACES NOT INTCHG WITH 8-13142-8	1	D		
8-13142-8		• SKIN, OUTRD ELEVON UPPER RH REPLACED BY NOT INTCHG WITH 8-13152-8	1	A		
8-13153-7		• SKIN, OUTRD ELEVON LOWER LH REPLACES NOT INTCHG WITH 8-13143-7	1	D		
8-13143-7		• SKIN, OUTRD ELEVON LOWER LH REPLACED BY NOT INTCHG WITH 8-13153-7	1	A		
8-13153-8	• SKIN, OUTRD ELEVON LOWER RH REPLACES NOT INTCHG WITH 8-13143-8	1	D			
8-13143-8	• SKIN, OUTRD ELEVON LOWER RH REPLACED BY NOT INTCHG WITH 8-13153-8	1	A			
<p>A AIRPLANES #278 THRU 286 AND 288 THRU 291 B AIRPLANES #35 THRU 277, 2-7, 282 AND ON C AIRPLANES #35 THRU 89, 278 AND ON</p>						

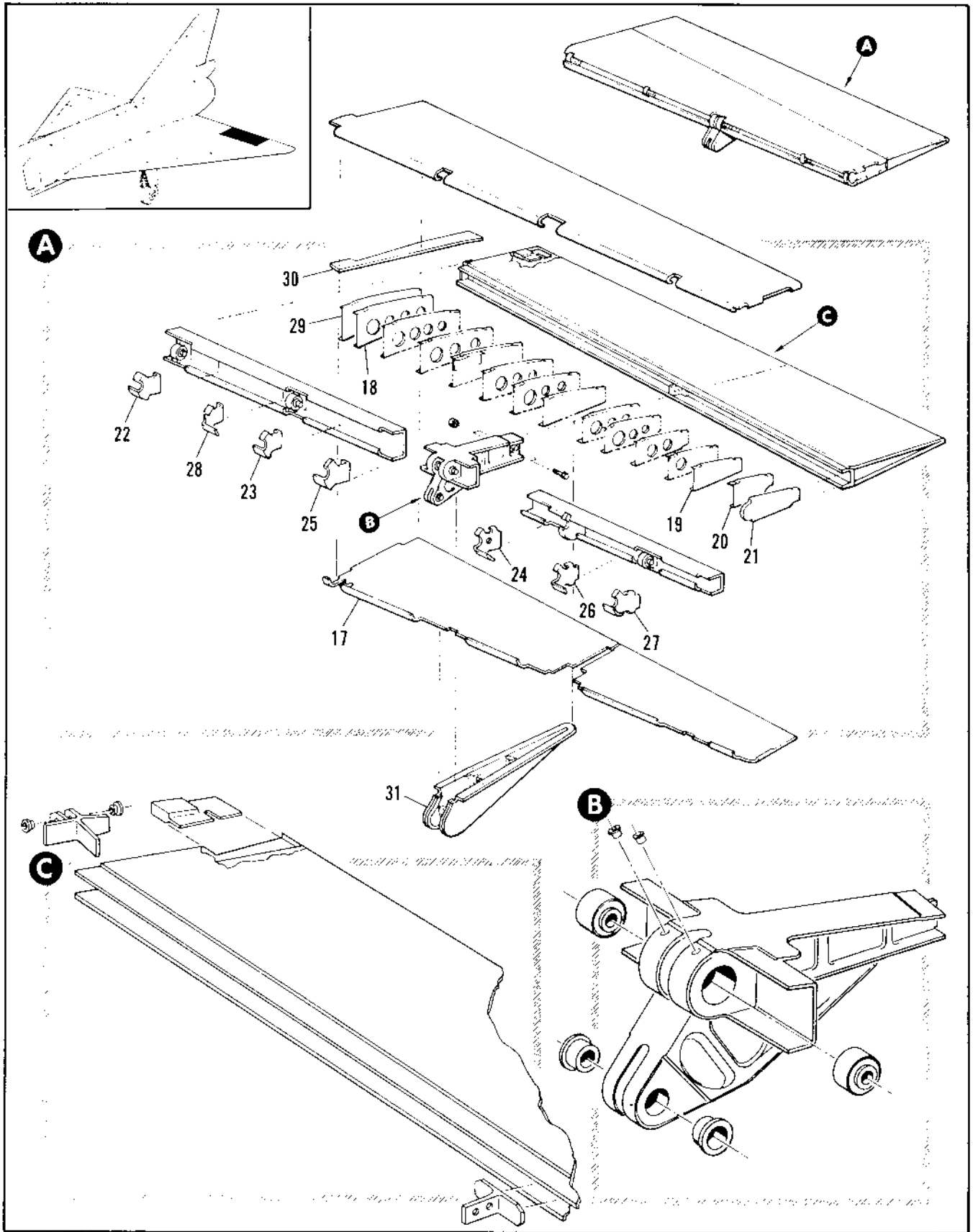

Figure 2.6-8. Outbd Elevon Assembly (Sheet 3 of 3)

FIGURE AND INDEX NUMBER	PART NUMBER	DESCRIPTION	UNITS PER ASSY.	USABLE ON CODE	
				FROM	TO
2.6-8- 17	8-13153-9	• SKIN, OUTBD ELEVON LOWER LH REPLACES NOT INTCHG WITH 8-13143-9	1		D
	8-13143-9	• SKIN, OUTBD ELEVON LOWER LH REPLACED BY NOT INTCHG WITH 8-13153-9	1		A
	8-13153-10	• SKIN, OUTBD ELEVON LOWER RH REPLACES NOT INTCHG WITH 8-13143-10	1		D
	8-13143-10	• SKIN, OUTBD ELEVON LOWER RH REPLACED BY NOT INTCHG WITH 8-13153-10	1		A
- 18	8-13365-9	• RIB	1		35
- 19	8-13376-7	• RIB	1		35
- 20	8-13387-7	• RIB, LH REPLACES NOT INTCHG WITH 8-13377-7	1		D
	8-13387-8	• RIB, RH REPLACES NOT INTCHG WITH 8-13377-7	1		D
- 21	8-13388-7	• RIB, LH REPLACES NOT INTCHG WITH 8-13378-7 REPLACED BY SUITABLE SUB 8-13388-9	1		C
	8-13388-9	• RIB, LH REPLACES SUITABLE SUB FOR 8-13388-7	1	61	277
	8-13377-7	• RIB, REPLACED BY NOT INTCHG WITH 8-13387-7 AND 8-13387-8	1		A
	8-13388-8	• RIB, RH REPLACES NOT INTCHG WITH 8-13378-7 REPLACED BY SUITABLE SUB 8-13388-10	1		C
	8-13388-10	• RIB, RH REPLACES SUITABLE SUB FOR 8-13388-8	1	61	277
	8-13378-7	• RIB, REPLACED BY NOT INTCHG WITH 8-13388-7 AND 8-13388-8	1		A
- 22	8-13379-13	• RIB ASSY, ELEVON LH RIVETED	1		35
	8-13379-14	• RIB ASSY, ELEVON RH RIVETED	1		35
- 23	8-13379-15	• RIB ASSY, ELEVON LH RIVETED	1		35
	8-13379-16	• RIB ASSY, ELEVON RH RIVETED	1		35
- 24	8-13379-47	• RIB, ELEVON NOSE LH	1		35
	8-13379-48	• RIB, ELEVON NOSE RH	1		35
- 25	8-13379-45	• RIB, ELEVON NOSE LH	1		D
	8-13379-59	• RIB ASSY, ELEVON NOSE LH RIVETED	1		A
	8-13379-46	• RIB, ELEVON NOSE RH	1		D
- 26	8-13379-60	• RIB ASSY, ELEVON NOSE RH RIVETED	1		A
	8-13379-51	• RIB, ELEVON NOSE LH	1		35
	8-13379-52	• RIB, ELEVON NOSE RH	1		35
- 27	8-13379-63	• RIB, ELEVON NOSE LH	1		D
	8-13379-19	• RIB ASSY, ELEVON NOSE LH RIVETED	1		A
	8-13379-64	• RIB, ELEVON NOSE RH	1		D
	8-13379-20	• RIB ASSY, ELEVON NOSE RH RIVETED	1		A
- 28	8-13379-41	• RIB, ELEVON NOSE LH	1		35
	8-13379-42	• RIB, ELEVON NOSE RH	1		35
	8-13364-1	• RIB ASSY, ELEVON LH	1		35
	8-13364-2	• RIB ASSY, ELEVON RH	1		35
- 29	8-13364-17	• RIB	1		35
- 30	8-13364-19	• STRIP, RUBBING ELEVON LH LESS ALL HOLES	1		35
	8-13364-20	• STRIP, RUBBING ELEVON RH LESS ALL HOLES	1		35
	8-18580-801	• FAIRING INSTL, ELEVON ACTUATOR LH	1		D
	8-18560-801	• FAIRING INSTL, ELEVON ACTUATOR LH	1		A
	8-18580-802	• FAIRING INSTL, ELEVON ACTUATOR RH	1		D
	8-18560-802	• FAIRING INSTL, ELEVON ACTUATOR RH	1		A
- 31	8-18580-77	• FAIRING ASSY, ELEVON ACTUATOR LH RIVETED REPLACES NOT INTCHG WITH 8-18560-77	1		D
	8-18560-77	• FAIRING ASSY, ELEVON ACTUATOR LH RIVETED REPLACED BY NOT INTCHG WITH 8-18580-77	1		A
	8-18580-78	• FAIRING ASSY, ELEVON ACTUATOR RH RIVETED REPLACES NOT INTCHG WITH 8-18560-78	1		D
	8-18560-78	• FAIRING ASSY, ELEVON ACTUATOR RH RIVETED REPLACED BY NOT INTCHG WITH 8-18580-78	1		A

A AIRPLANES #278 THRU 286 AND 288 THRU 291
 C AIRPLANES #35 THRU 60, 287, 292 AND ON
 D AIRPLANES #35 THRU 277, 287, 292 AND ON

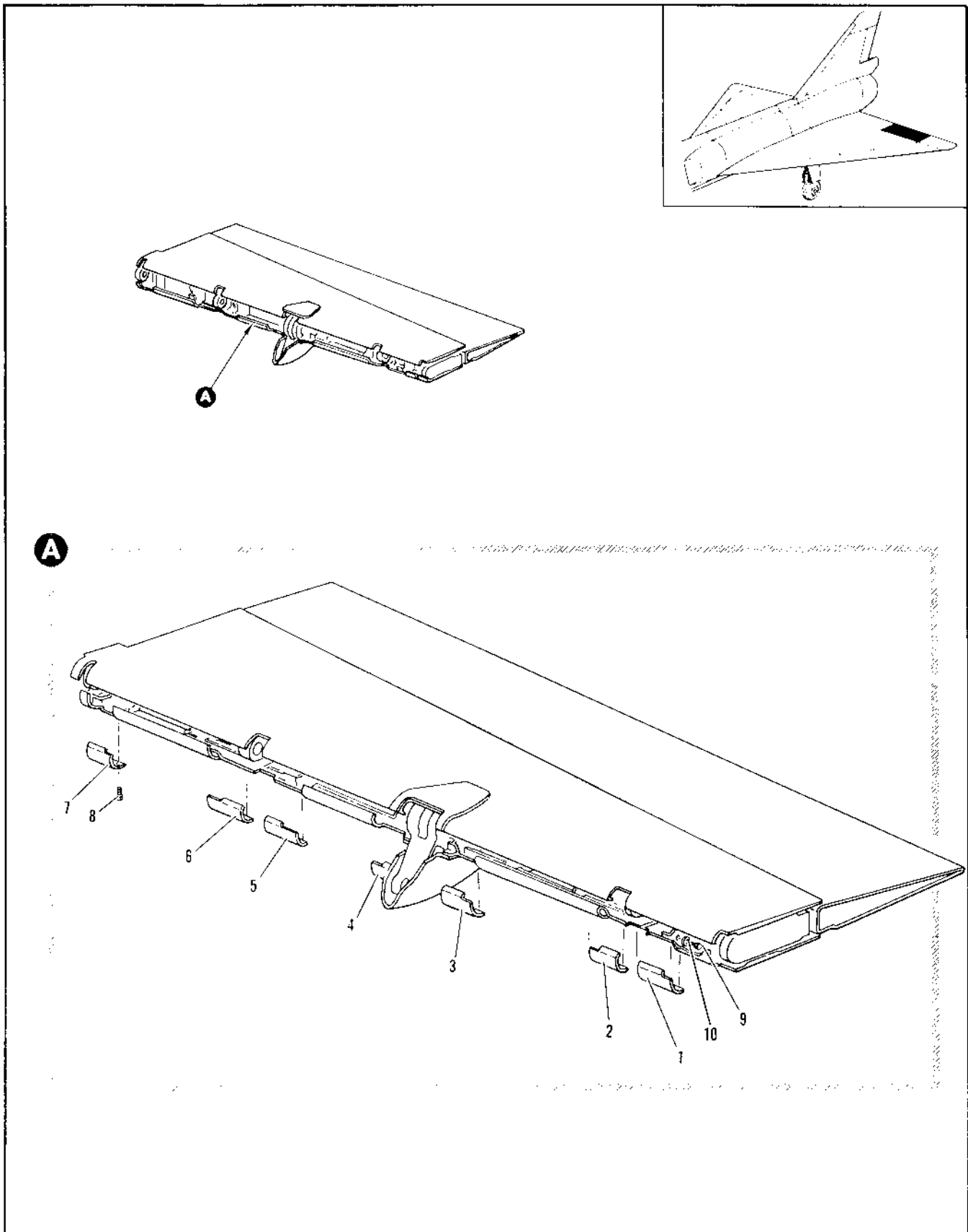

Figure 2.6-9. Outbd Elevon Assembly Spares (Sheet 1 of 2)

FIGURE AND INDEX NUMBER	PART NUMBER	DESCRIPTION	UNITS PER ASSY.	USABLE ON CODE	
				FROM	TO
		1 2 3 4 5 6			
2.6-9	8-13050-503	FOR BREAKDOWN SEE FIG. 2.6-8 ELEVON ASSEMBLY, OUTBD LH SPARES	RF	B	
	8-13020-527	REPLACES NOT INTCHG WITH 8-13020-527 ELEVON ASSEMBLY, OUTBD LH SPARES	RF	A	
	8-13050-504	REPLACED BY NOT INTCHG WITH 8-13020-503 ELEVON ASSEMBLY, OUTBD RH SPARES	RF	B	
	8-13020-528	REPLACES NOT INTCHG WITH 8-13020-528 ELEVON ASSEMBLY, OUTBD RH SPARES	RF	A	
- 1	8-13603-35	• DOOR, ELEVON HINGE ACCESS LH	1	35	
	8-13603-36	• DOOR, ELEVON HINGE ACCESS RH	1	35	
- 2	8-13603-33	• DOOR, ELEVON HINGE ACCESS LH	1	35	
	8-13603-34	• DOOR, ELEVON HINGE ACCESS RH	1	35	
- 3	8-13603-31	• DOOR, ELEVON HINGE ACCESS LH	1	35	
	8-13603-32	• DOOR, ELEVON HINGE ACCESS RH	1	35	
- 4	8-13603-29	• DOOR, ELEVON HINGE ACCESS LH	1	35	
	8-13603-30	• DOOR, ELEVON HINGE ACCESS RH	1	35	
- 5	8-13603-27	• DOOR, ELEVON HINGE ACCESS LH	1	35	
	8-13603-28	• DOOR, ELEVON HINGE ACCESS RH	1	35	
- 6	8-13603-25	• DOOR, ELEVON HINGE ACCESS LH	1	35	
	8-13603-26	• DOOR, ELEVON HINGE ACCESS RH	1	35	
- 7	8-13603-23	• DOOR, ELEVON HINGE ACCESS LH	1	35	
	8-13603-24	• DOOR, ELEVON HINGE ACCESS RH	1	35	
- 8	NAS333PA4	ATTACHING PARTS • BOLT (88205)	24	35	
		-----X-----			
- 9	AN3-5A	• BOLT (88044)	4	35	
- 10	AN960-10L	• WASHER (88044)	4	35	
		A AIRPLANES #278 THRU 286 AND 288 THRU 291 B AIRPLANES #35 THRU 277, 287, 292 AND ON			

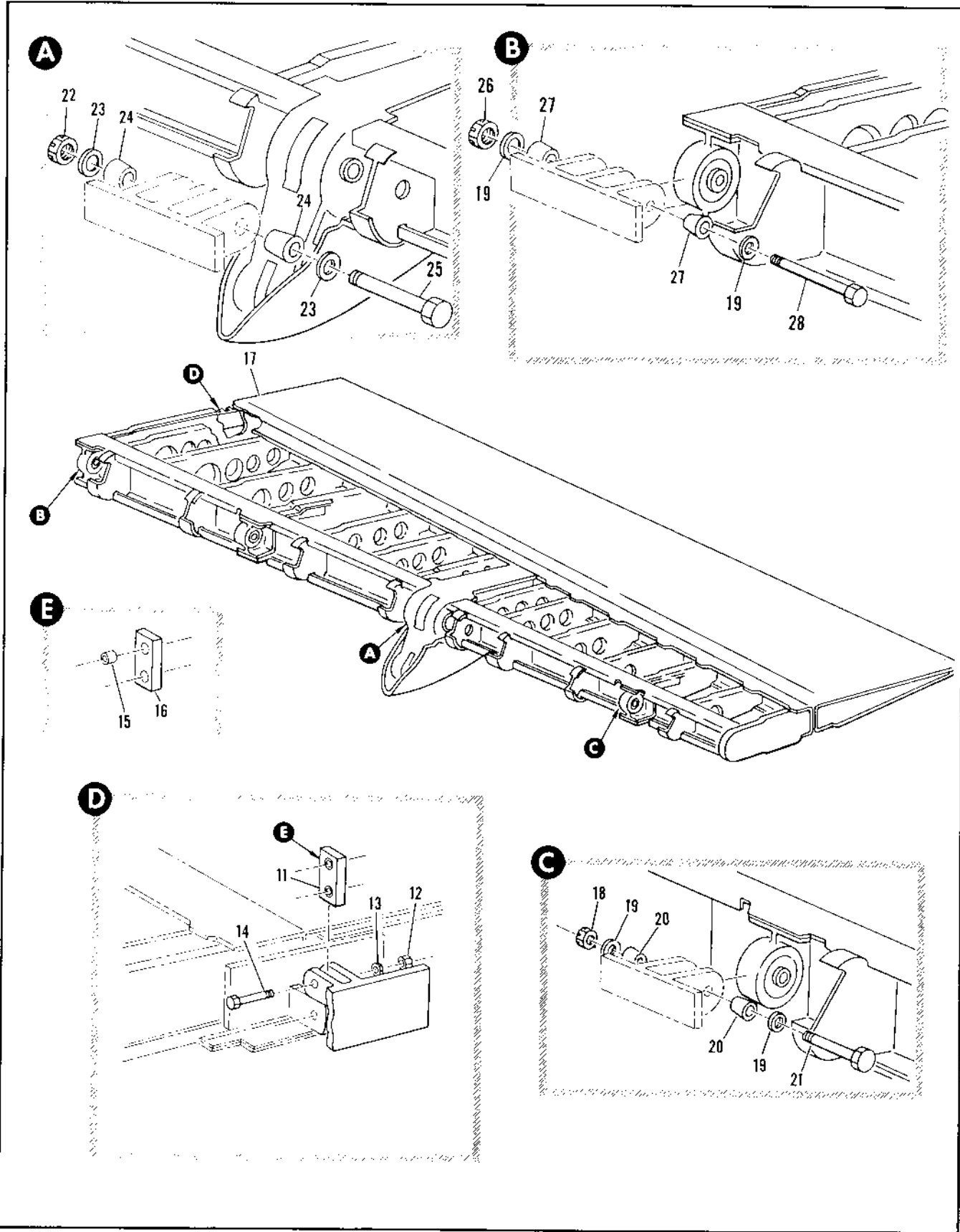

Figure 2.6-9. Outbd Elevon Assembly Spares (Sheet 2 of 2)

FIGURE AND INDEX NUMBER	PART NUMBER	DESCRIPTION	UNITS PER ASSY.	USABLE ON CODE	
				FROM	TO
		1 2 3 4 5 6			
2.6-9- 11	A-13753-3	• LINK ASSY, ELEVON ATTACHING PARTS	1	35	
- 12	AN320-4	• NUT (88.44)	2	35	
- 13	AN950-416	• WASHER (88044)	2	35	
- 14	NAS464-4-17	• BOLT (81205) -----X-----	2	35	
- 15	A-12732-0	• • PUSHING	2	35	
- 16	A-13753-0	• • LINK	1	35	
- 17	A-13062-3	• ELEVON ASSY, OUTBD LH FOR BREAKDOWN SEE FIG. 2.6-8	RF	0	
	A-13032-1	• ELEVON ASSY, OUTBD LH FOR BREAKDOWN SEE FIG. 2.6-8	RF	A	
	A-13062-1	• ELEVON ASSY, OUTBD LH FOR BREAKDOWN SEE FIG. 2.6-8	RF	C	
	A-13062-4	• ELEVON ASSY, OUTBD RH FOR BREAKDOWN SEE FIG. 2.6-8	RF	D	
	A-13032-2	• ELEVON ASSY, OUTBD RH FOR BREAKDOWN SEE FIG. 2.6-8	RF	A	
	A-13062-2	• ELEVON ASSY, OUTBD RH FOR BREAKDOWN SEE FIG. 2.6-8 ATTACHING PARTS	RF	C	
- 18	AN320-6	• NUT (88.44)	2	35	
- 19	AN950-614L	• WASHER (88044)	4	35	
- 20	A-14759	• PUSHING	4	35	
- 21	NAS464-4-35	• BOLT (81205)	2	35	
- 22	AN320-10	• NUT (88.44)	1	35	
- 23	AN950-1016L	• WASHER (88044)	4	35	
- 24	A-14759	• PUSHING	2	35	
- 25	NAS464-10-81	• BOLT (81205)	1	35	
- 26	AN320-6	• NUT (88.44)	1	35	
- 27	A-14758	• BUSHING	1	35	
- 28	NAS464-6-65	• BOLT (81205) -----X-----	1	35	
		A AIRPLANES #278 THRU 286 AND 288 THRU 291			
		C AIRPLANES #287 AND 292 THRU 300			
		D AIRPLANES #75 THRU 177, 301 AND ON			

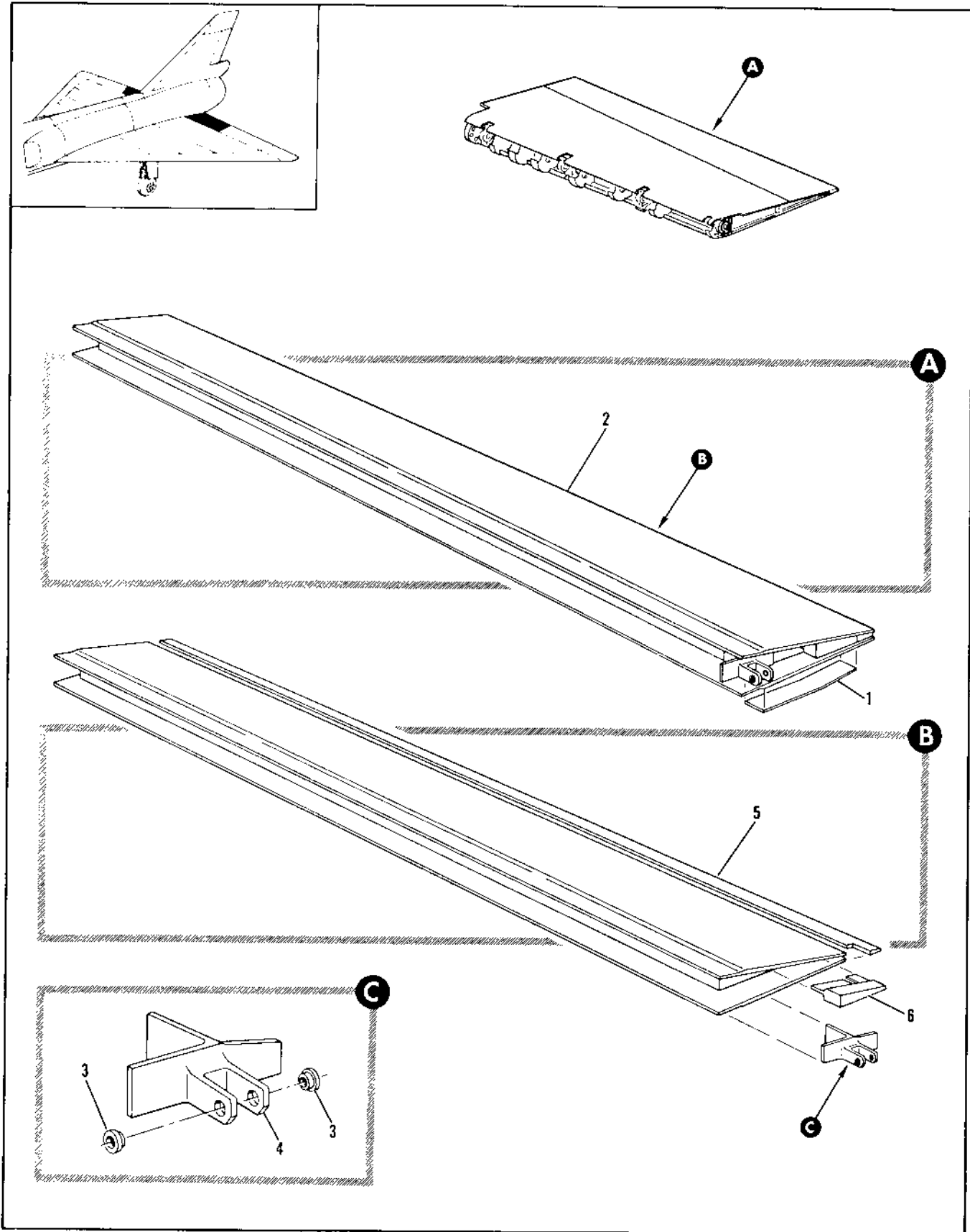

Figure 2.6-10. Inbd Elevon Assembly (Sheet 1 of 3)

FIGURE AND INDEX NUMBER	PART NUMBER	DESCRIPTION	UNITS PER ASSY.	USABLE ON CODE	
				FROM	TO
		1 2 3 4 5 6			
2.6-10	8-13031-805	ELEVON ASSEMBLY, INBOARD LH FOR NHA SEE FIG. 2.6-6	RF	0	
	8-13031-807	ELEVON ASSEMBLY, INBOARD LH FOR NHA SEE FIG. 2.6-6	RF	61	277
	8-13031-1	ELEVON ASSEMBLY, INBOARD LH FOR NHA SEE FIG. 2.6-6	RF	278	296
	8-13031-R01	ELEVON ASSEMBLY, INBOARD LH FOR NHA SEE FIG. 2.6-6	1	278	300
	8-13031-R06	ELEVON ASSEMBLY, INBOARD RH FOR NHA SEE FIG. 2.6-6	1	B	
	8-13031-P06	ELEVON ASSEMBLY, INBOARD RH FOR NHA SEE FIG. 2.6-6	RF	61	277
	8-13031-2	ELEVON ASSEMBLY, INBOARD RH FOR NHA SEE FIG. 2.6-6	RF	278	296
	8-13031-802	ELEVON ASSEMBLY, INBOARD RH FOR NHA SEE FIG. 2.6-6	RF	278	300
- 1	8-13031-15	• STRIP	1	35	
	8-13040-809	• TRAILING EDGE ASSY, INRD ELEVON LH REPLACED BY SUITABLE SUB 8-13040-813	1	A	
- 2	8-13040-813	• TRAILING EDGE ASSY, INRD ELEVON LH ALT INTCHG WITH 8-13040-808 REPLACES SUITABLE SUB FOR 8-13040-809 AND 8-13040-701 REPLACED BY INTCHG WITH 8-13040-817	1	61	89
	8-13040-817	• TRAILING EDGE ASSY, INRD ELEVON LH REPLACES INTCHG WITH 8-13040-813	1	90	277
	8-13040-5	• TRAILING EDGE ASSY, INRD ELEVON LH	1	278	296
	8-13040-701	• TRAILING EDGE ASSY, INRD ELEVON LH ALT INTCHG WITH 8-13040-5 REPLACED BY SUITABLE SUB 8-13040-813	RF	278	296
	8-13040-807	• TRAILING EDGE ASSY, INRD ELEVON LH	1	297	300
	8-13040-811	• TRAILING EDGE ASSY, INRD ELEVON LH ALT INTCHG WITH 8-13040-807	RF	297	300
	8-13040-810	• TRAILING EDGE ASSY, INRD ELEVON RH REPLACED BY SUITABLE SUB 8-13040-814	1	A	
	8-13040-814	• TRAILING EDGE ASSY, INRD ELEVON RH REPLACES SUITABLE SUB FOR 8-13040-810 AND 8-13040-702 REPLACED BY INTCHG WITH 8-13040-818	1	61	89
	8-13040-818	• TRAILING EDGE ASSY, INRD ELEVON RH REPLACES INTCHG WITH 8-13040-814	1	90	277
	8-13040-C	• TRAILING EDGE ASSY, INRD ELEVON RH	1	278	296
	8-13040-702	• TRAILING EDGE ASSY, INRD ELEVON RH ALT INTCHG WITH 8-13040-5 REPLACED BY SUITABLE SUB 8-13040-814	RF	278	296
	8-13040-808	• TRAILING EDGE ASSY, INRD ELEVON RH	1	297	300
	8-13040-812	• TRAILING EDGE ASSY, INRD ELEVON RH	RF	297	300
- 3	8-13932	• • PUSHING	2	35	
- 4	8-13730-9	• • LINK, ELEVON CONNECTING LH	1	35	
	8-13730-10	• • LINK, ELEVON CONNECTING RH	1	35	
- 5	8-13725-7	• • WEDGE, ELEVON CLOSING	1	B	
	8-13725-11	• • WEDGE, ELEVON CLOSING	1	61	277
- 6	8-13724-713	• • WEDGE, ELEVON TRAILING EDGE LH	1	C	
	8-13724-9	• • WEDGE, ELEVON TRAILING EDGE LH	3	90	277
	8-13724-714	• • WEDGE, ELEVON TRAILING EDGE RH	1	C	
	8-13724-10	• • WEDGE, ELEVON TRAILING EDGE RH	1	90	277
		A AIRPLANES #35 THRU 60, 301 AND ON			
		B AIRPLANES #35 THRU 60, 278 AND ON			
		C AIRPLANES #35 THRU 89, 278 AND ON			

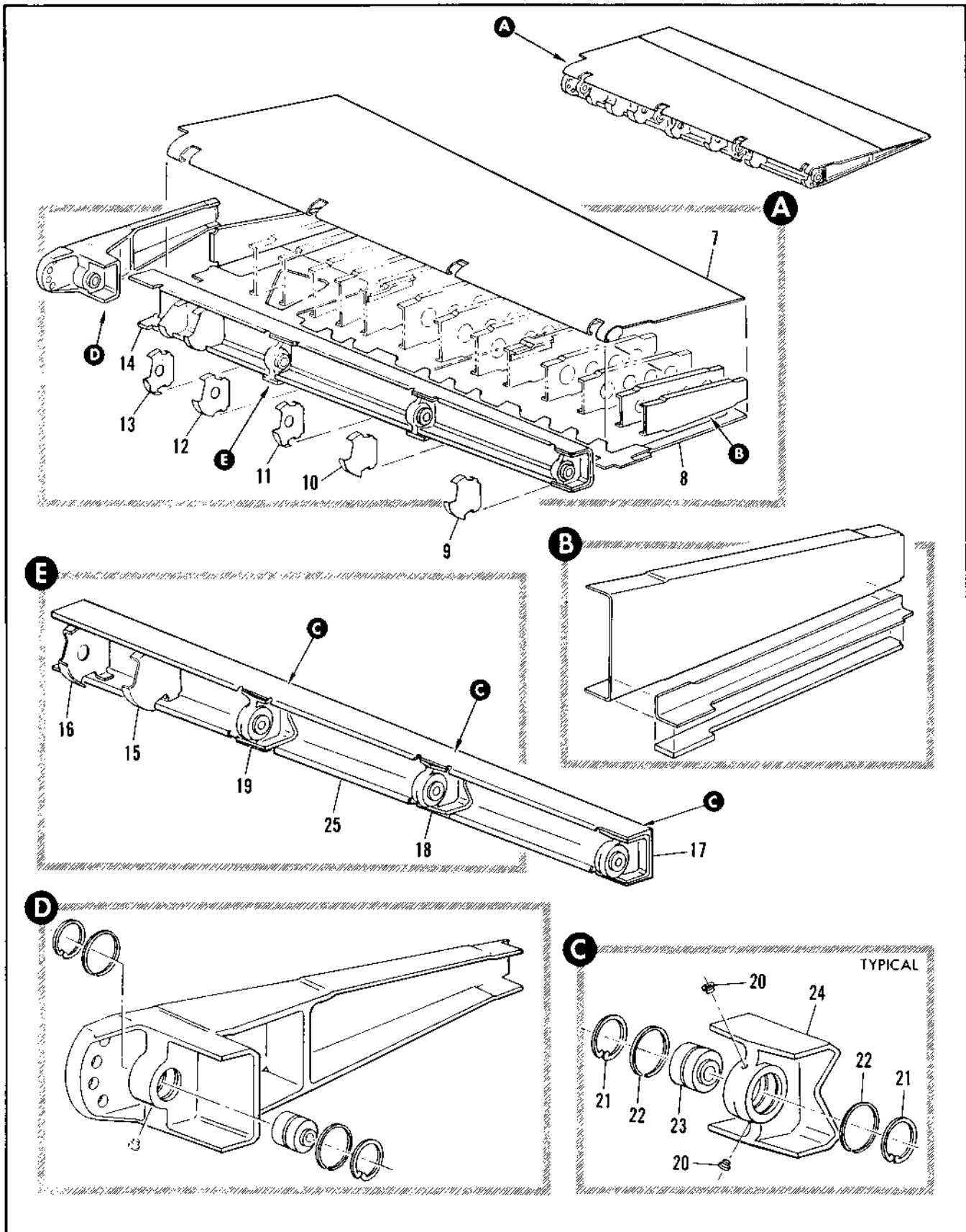

Figure 2.6-10. Inbd Elevon Assembly (Sheet 2 of 3)

FIGURE AND INDEX NUMBER	PART NUMBER	DESCRIPTION	UNITS PER ASSY.	USABLE ON CODE	
				FROM	TO
2.6-10- 7	A-13140-7	• SKIN, ELEVON UPPER INBD LH REPLACES BY NOT INTCHG WITH A-13140-8	1		
	A-13140-8	• SKIN, ELEVON UPPER INBD LH REPLACES NOT INTCHG WITH A-13140-7	1	61	277
	A-13140-9	• SKIN, ELEVON UPPER INBD RH REPLACES BY NOT INTCHG WITH A-13140-10	1		
	A-13140-10	• SKIN, ELEVON UPPER INBD RH REPLACES NOT INTCHG WITH A-13140-9	1	61	277
	B-13141-7	• SKIN, ELEVON LOWER INBD LH REPLACES BY NOT INTCHG WITH B-13141-8	1		
	B-13141-8	• SKIN, ELEVON LOWER INBD LH REPLACES NOT INTCHG WITH B-13141-7	1	61	277
	B-13141-9	• SKIN, ELEVON LOWER INBD RH REPLACES BY NOT INTCHG WITH B-13141-10	1		
	B-13141-10	• SKIN, ELEVON LOWER INBD RH REPLACES NOT INTCHG WITH B-13141-9	1	61	277
- 9	A-13379-37	• RIB, ELEVON NOSE LH	1		35
	A-13379-38	• RIB, ELEVON NOSE RH	1		35
	A-13379-39	• RIB, ELEVON NOSE LH	1		35
- 11	A-13379-30	• RIB, ELEVON NOSE RH	1		35
	A-13379-31	• RIB ASSY, ELEVON NOSE LH	1		35
	A-13379-32	• RIB ASSY, ELEVON NOSE RH	1		35
	A-13379-33	• RIB ASSY, ELEVON NOSE LH	1		35
	A-13379-34	• RIB ASSY, ELEVON NOSE RH	1		35
- 12	A-13379-27	• RIB, LH	1		35
	A-13379-28	• RIB, RH	1		35
	A-13379-29	• RIB, ELEVON NOSE LH	1		35
- 13	A-13101-1	• RIB, ELEVON NOSE RH	1		35
	A-13101-2	• SPAR ASSY, INBD ELEVON LH	1		35
	A-13101-3	• SPAR ASSY, INBD ELEVON RH	1		35
- 14	A-13379-23	• RIB, ELEVON NOSE LH	1		35
	A-13379-24	• RIB, ELEVON NOSE RH	1		35
	A-13379-25	• RIB ASSY, ELEVON NOSE LH RIVETED	1		35
- 15	A-13379-26	• RIB ASSY, ELEVON NOSE RH RIVETED	1		35
	A-13777-1	• HINGE ASSY, INBD ELEVON BL 176	1		35
	A-13777-2	• HINGE ASSY, INBD ELEVON BL 176 ALT INTCHG WITH A-13777-1	RF		35
- 18	A-13751-1	• HINGE ASSY, INBD ELEVON BL 84	1		35
- 19	A-13751-2	• HINGE ASSY, INBD ELEVON BL 62	1		35
- 20	FAS514-1	• FITTING (#5205)	2		35
- 21	FAS514-15	• RETAINER (#5205)	2		35
- 22	A-15541-7	• RING	2		35
- 23	A6H	• BEARING, <77896> 97-60510-001	1		35
	A-13777-7	• HINGE, ELEVON BL 176	1		35
	A-13751-7	• HINGE, ELEVON BL 176 USE WITH A-13758	RF		35
- 24	A-13751-8	• HINGE, ELEVON BL 84	1		35
	A-13751-9	• HINGE, ELEVON BL 62	1		35
	A-15101-7	• CHANNEL	1		35

- AIRPLANES #35 I-RU 01, 276 AND ON

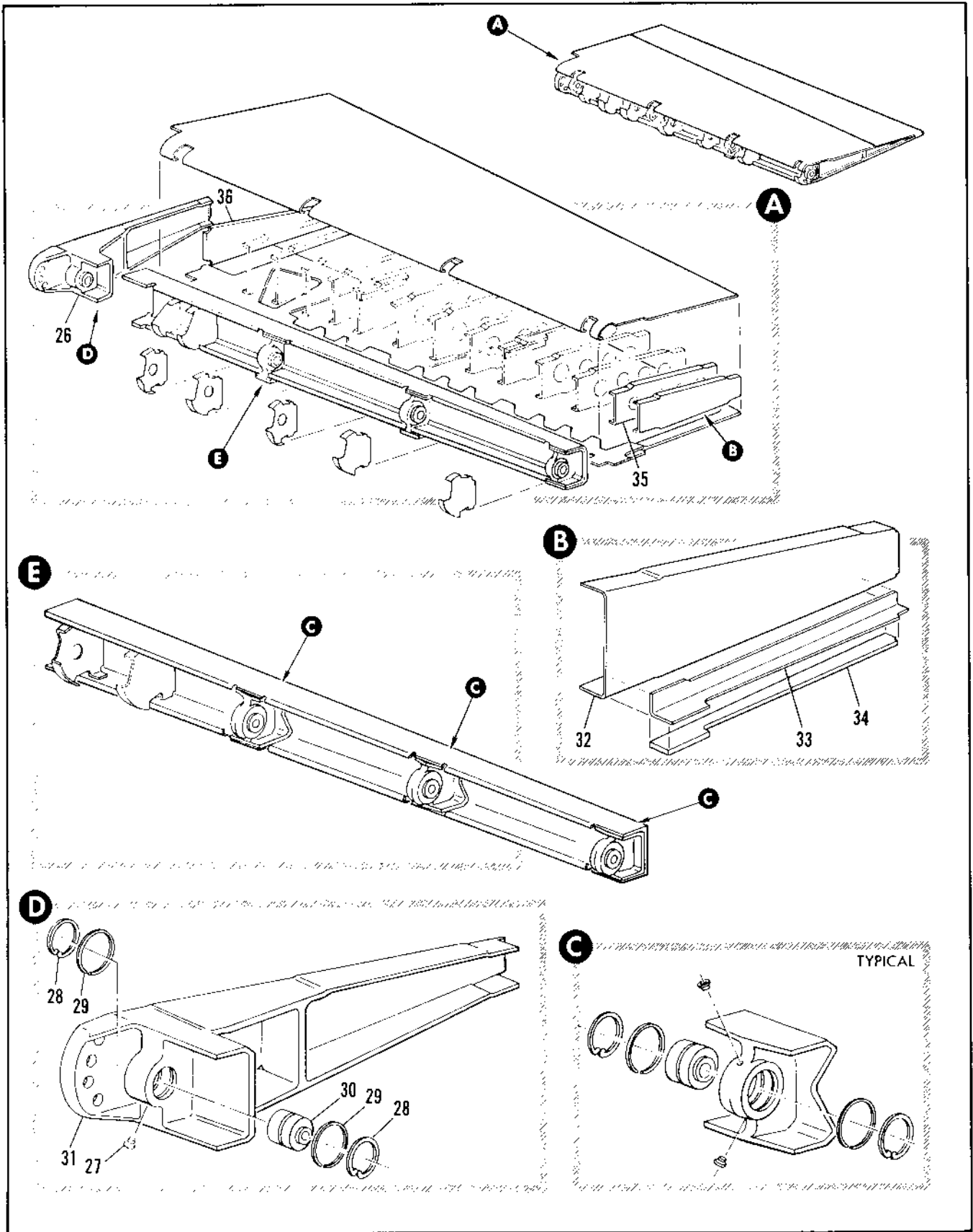

Figure 2.6-10. Inbd Elevon Assembly (Sheet 3 of 3)

FIGURE AND INDEX NUMBER	PART NUMBER	DESCRIPTION	UNITS PER ASSY.	USABLE ON CODE	
				FROM	TO
		1 2 3 4 5 6			
2.6-10- 26	H-13700-1	• HINGE ASSY, ELEVON ACTUATOR ATTACHMENT BL 37 LH	1	35	
	H-13700-2	• HINGE ASSY, ELEVON ACTUATOR ATTACHMENT BL 37 RH	1	35	
- 27	NAS516-1	• • LUBRICATOR, (R0205) 93-80100-050	1	35	
- 28	NAS51-156	• • RETAINER, (R0205) 97-61503-024	2	35	
- 29	8-15840-7	• • RING	2	35	
- 30	AbH	• • BEARINGS, <77896> 90-60500-001	1	35	
- 31	8-13700-11	• • HINGE, ELEVON BL 37 LH	1	0	
	8-13700-12	• • HINGE, ELEVON BL 37 LH	1	49	277
	8-13700-12	• • HINGE, ELEVON BL 37 RH	1	0	
	8-13700-14	• • HINGE, ELEVON BL 37 RH	1	49	277
	8-13363-1	• RIB ASSY, ELEVON LH	1	35	
	8-13363-2	• RIB ASSY, ELEVON RH	1	35	
- 32	8-13363-7	• • RIB	1	35	
- 33	8-13363-9	• • ANGLE, LH	1	35	
	8-13363-10	• • ANGLE, RH	1	35	
- 34	8-13363-11	• • STRIP, RUBBING LH	1	35	
	8-13363-12	• • STRIP, RUBBING RH	1	35	
- 35	8-13362	• RIB	1	35	
- 36	8-13380-1	• RIB ASSEMBLY	1	35	
D AIRPLANES #35 THRU 48, 278 AND ON					

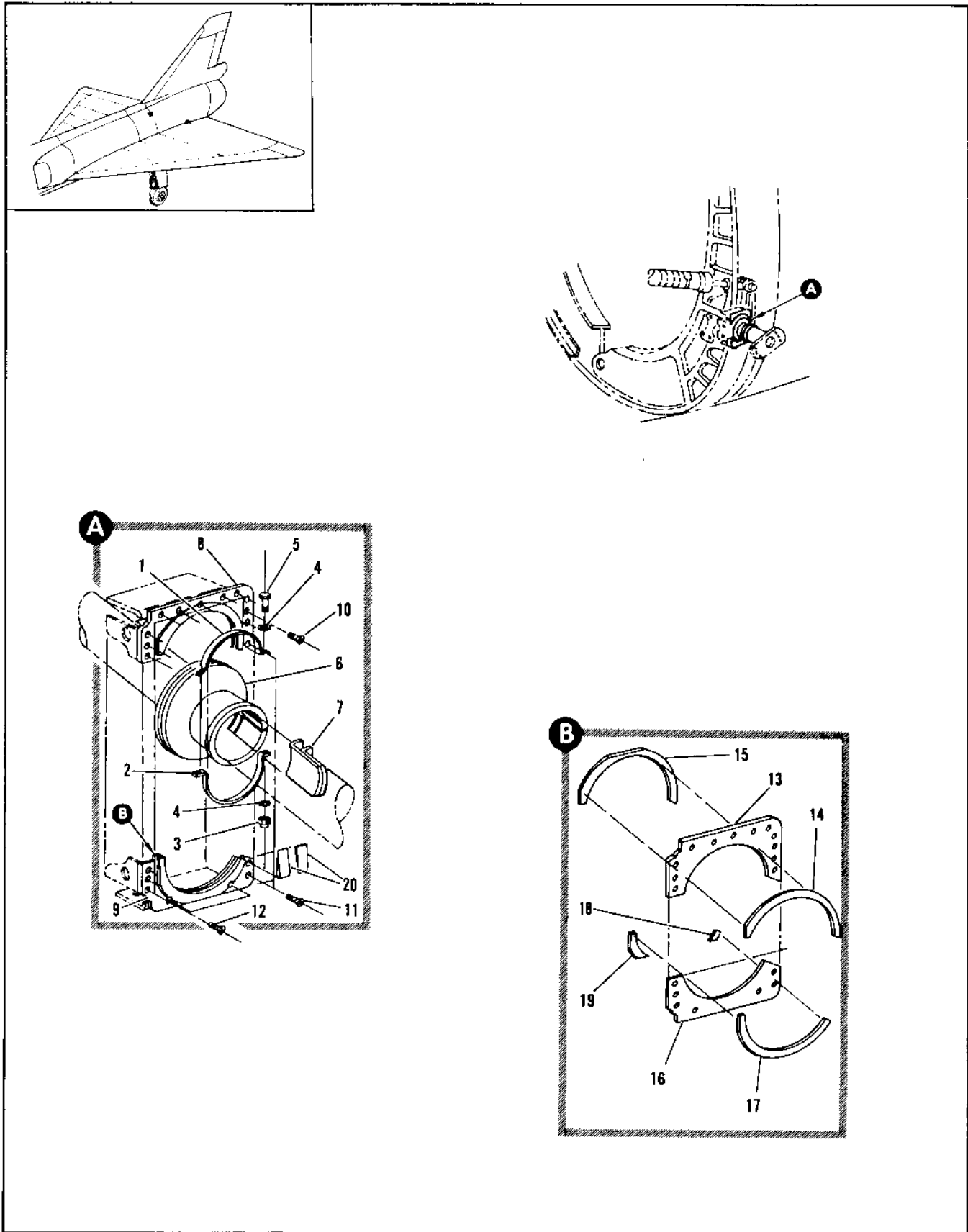

Figure 2.6-11. Inbd Elevon Horn Seal Installation

FIGURE AND INDEX NUMBER	PART NUMBER	DESCRIPTION	UNITS PER ASSY.	USABLE ON CODE	
				FROM	TO
		1 2 3 4 5 6			
2.6-11	8-13939-1	SEAL INSTALLATION, INBOARD ELEVON HORN LH FOR NHA SEE FIG. 2.6-1b	RF	35	
	8-13939-2	SEAL INSTALLATION, INBOARD ELEVON HORN RH FOR NHA SEE FIG. 2.6-1b	RF	35	
- 1	8-13940-39	• CLAMP, UPPER	1	35	
- 2	8-13940-41	• CLAMP, LOWER	1	35	
		ATTACHING PARTS			
- 3	NAS679A3	• NUT, (R3205) 96-37545-102	1	35	
- 4	AN96L-10L	• WASHER (88044)	2	35	
- 5	AN3-7A	• BOLT (89044)	1	35	
		-----X-----			
- 6	4497-1	• SEAL, (71643) SPEC 8-01325-1	1	35	
- 7	8-13940-47	• FITTING ASSY, SEAL W/FLD	1	35	
- 8	8-13940-81	• DOOR ASSY, SEAL BAFFLE UPPER LH	1	35	
- 9	8-13940-82	• DOOR ASSY, SEAL BAFFLE UPPER RH	1	35	
- 9	8-13940-73	• DOOR ASSY, SEAL BAFFLE LOWER LH	1	35	
- 9	8-13940-74	• DOOR ASSY, SEAL BAFFLE LOWER RH	1	35	
		ATTACHING PARTS			
- 10	MS24694-52	• SCREW (96906)	3	35	
- 11	MS24694-55	• SCREW (96909)	5	35	
- 12	MS24694-46	• SCREW (96906)	11	35	
- 13	8-13940-75	• DOOR, UPPER	1	35	
- 14	8-13940-77	• SEAL, UPPER LH	1	35	
- 14	8-13940-78	• SEAL, UPPER RH	1	35	
- 15	8-13940-79	• SEAL, UPPER LH	1	35	
- 15	8-13940-80	• SEAL, UPPER RH	1	35	
- 16	8-13940-87	• DOOR, LOWER	1	35	
- 17	8-13940-69	• SEAL, LOWER LH	1	35	
- 17	8-13940-70	• SEAL, LOWER RH	1	35	
- 18	8-13940-71	• SEAL, LOWER LH	1	35	
- 18	8-13940-72	• SEAL, LOWER RH	1	35	
- 19	8-13940-91	• SEAL, LOWER LH	1	35	
- 19	8-13940-92	• SEAL, LOWER RH	1	35	
- 20	8-13938	• FILLER	2	35	

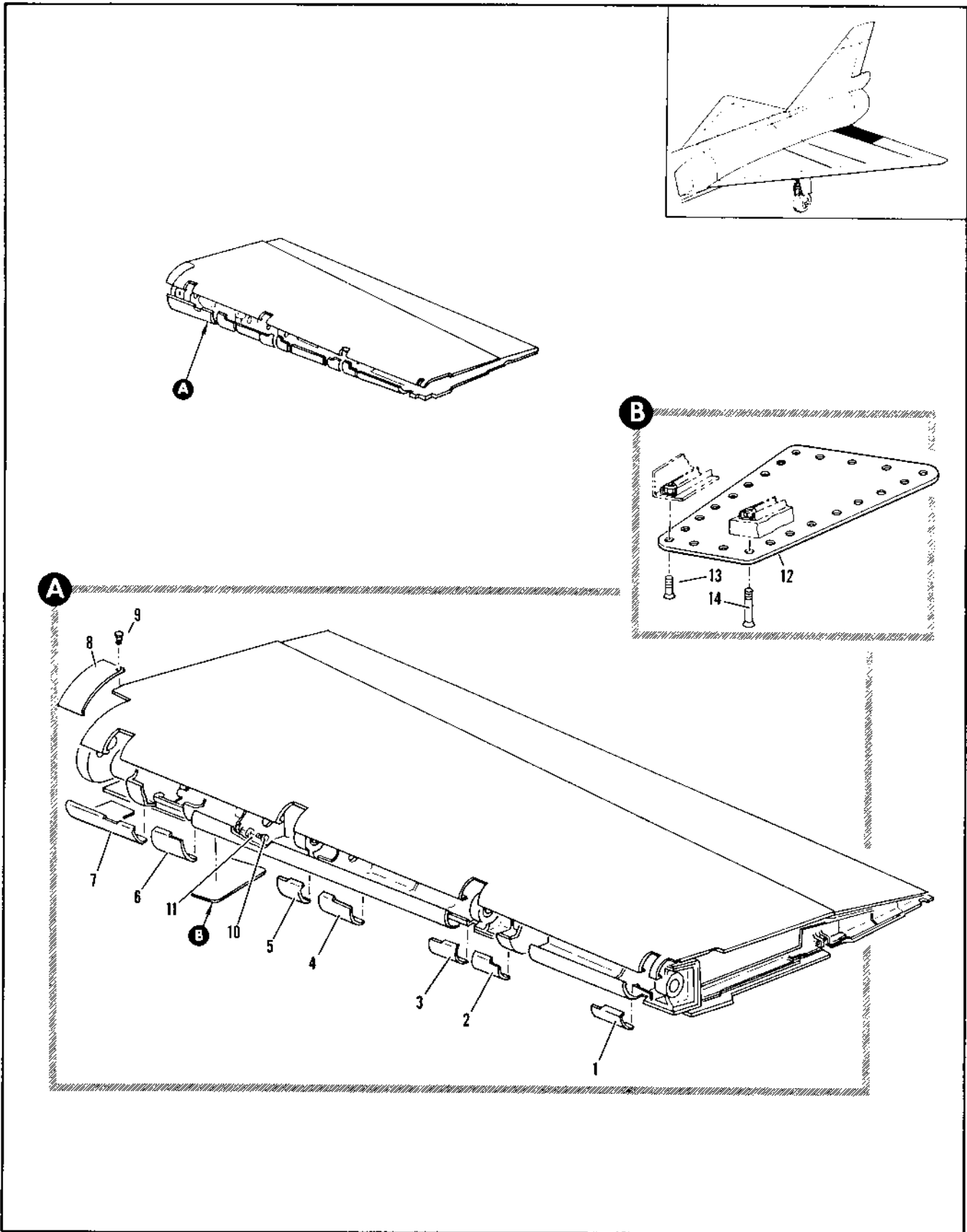

Figure 2.6-12. Inbd Elevon Assembly Spares (Sheet 1 of 2)

FIGURE AND INDEX NUMBER	PART NUMBER	DESCRIPTION	UNITS PER ASSY.	USABLE ON CODE	
				FROM	TO
		1 2 3 4 5 6			
2.6-12	8-13620-525	ELEVON ASSEMBLY, INBD LH SPARES	RF	35	
	8-13620-526	ELEVON ASSEMBLY, INBD RH SPARES	RF	35	
- 1	8-13603-21	• DOOR, ELEVON HINGE ACCESS LH	1	35	
	8-13603-22	• DOOR, ELEVON HINGE ACCESS RH	1	35	
- 2	8-13603-19	• DOOR, ELEVON HINGE ACCESS LH	1	35	
	8-13603-20	• DOOR, ELEVON HINGE ACCESS RH	1	35	
- 3	8-13603-17	• DOOR, ELEVON HINGE ACCESS LH	1	35	
	8-13603-18	• DOOR, ELEVON HINGE ACCESS RH	1	35	
- 4	8-13603-15	• DOOR, ELEVON HINGE ACCESS LH	1	35	
	8-13603-16	• DOOR, ELEVON HINGE ACCESS RH	1	35	
- 5	8-13603-13	• DOOR, ELEVON HINGE ACCESS LH	1	35	
	8-13603-14	• DOOR, ELEVON HINGE ACCESS RH	1	35	
- 6	8-13603-11	• DOOR, ELEVON HINGE ACCESS LH	1	35	
	8-13603-12	• DOOR, ELEVON HINGE ACCESS RH	1	35	
- 7	8-13603-9	• DOOR, ELEVON HINGE ACCESS LWR LH	1	35	
	8-13603-10	• DOOR, ELEVON HINGE ACCESS LWR RH	1	35	
- 8	8-13603-7	• DOOR, ELEVON HINGE ACCESS UPPER LH	1	35	
	8-13603-8	• DOOR, ELEVON HINGE ACCESS UPPER RH	1	35	
- 9	NAS333CPA4	• ATTACHING PARTS • BOLT (80205)	36	35	
- 10	AN3-SA	• BOLT (88044)	3	35	
- 11	AN960-10L	• WASHER (88044)	3	35	
	8-13601-5	• DOOR INSTL, ELEVON INBD LH	1	35	
	8-13601-6	• DOOR INSTL, ELEVON INBD RH	1	35	
- 12	3-13601-15	• DOOR, LH	1	35	
	8-13601-10	• DOOR, RH	1	35	
- 13	NAS333CPA4-5	• ATTACHING PARTS • BOLT (80205)	14	35	
- 14	NAS333CPA7	• BOLT (80205)	9	35	

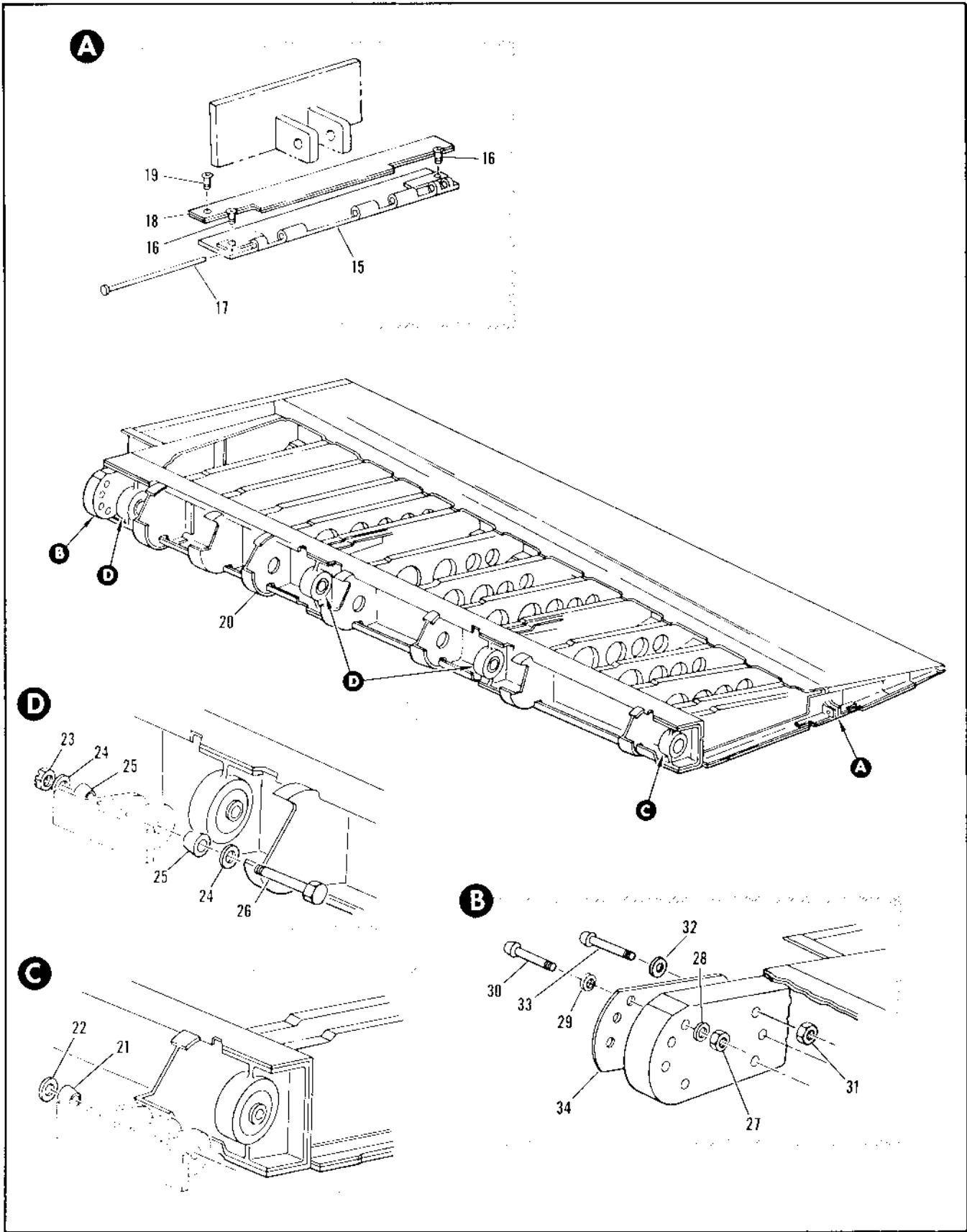

Figure 2.6-12. Inbd Elevon Assembly Spares (Sheet 2 of 2)

FIGURE AND INDEX NUMBER	PART NUMBER	DESCRIPTION	UNITS PER ASSY.	USABLE ON CODE	
				FROM	TO
		1 2 3 4 5 6			
2.6-12- 15	8-13903-1	• DOOR ASSY, ELEVON LINK ACCESS LH RIVETED	1	35	
	8-13903-2	• DOOR ASSY, ELEVON LINK ACCESS RH RIVETED	1	35	
- 16	NAS333CPA4-5	• BOLT (80205) -----X-----	2	35	
- 17	96-78502-104	• PIN	2	35	
- 18	8-13901-1	• STRAP, ELEVON LINK DOOR LH	1	35	
	8-13901-2	• STRAP, ELEVON LINK DOOR RH	1	35	
- 19	NAS333CPA4-5	• BOLT (80205) -----X-----	2	35	
- 20	8-13031-1	• ELEVON ASSY, INBD LH FOR BREAKDOWN SEE FIG. 2.6-10	1	35	
	8-13031-2	• ELEVON ASSY, INBD RH FOR BREAKDOWN SEE FIG. 2.6-10	1	35	
- 21	8-18758	• BUSHING	1	35	
- 22	AN960-616L	• WASHER (88044)	1	35	
- 23	AN320-6	• NUT (88044)	3	35	
- 24	AN960-616L	• WASHER (88044)	6	35	
- 25	8-18758	• BUSHING	6	35	
- 26	NAS464-6-35	• BOLT (80205)	3	35	
- 27	42FW720	• NUT, <56878> 96-37510-004	4	35	
- 28	NAS143-7	• WASHER (80205)	4	35	
- 29	NAS143-7C	• WASHER (80205)	4	35	
- 30	MS20007-22	• BOLT (96916)	4	35	
- 31	42FW1018	• NUT, <56878> 96-37510-007	3	35	
- 32	NAS143-10C	• WASHER (80205)	3	35	
- 33	MS20010-24	• BOLT (96916) -----X-----	3	35	
- 34	8-13902-7	• SHIM, LH	1	35	
	8-13902-9	• SHIM, RH	1	35	

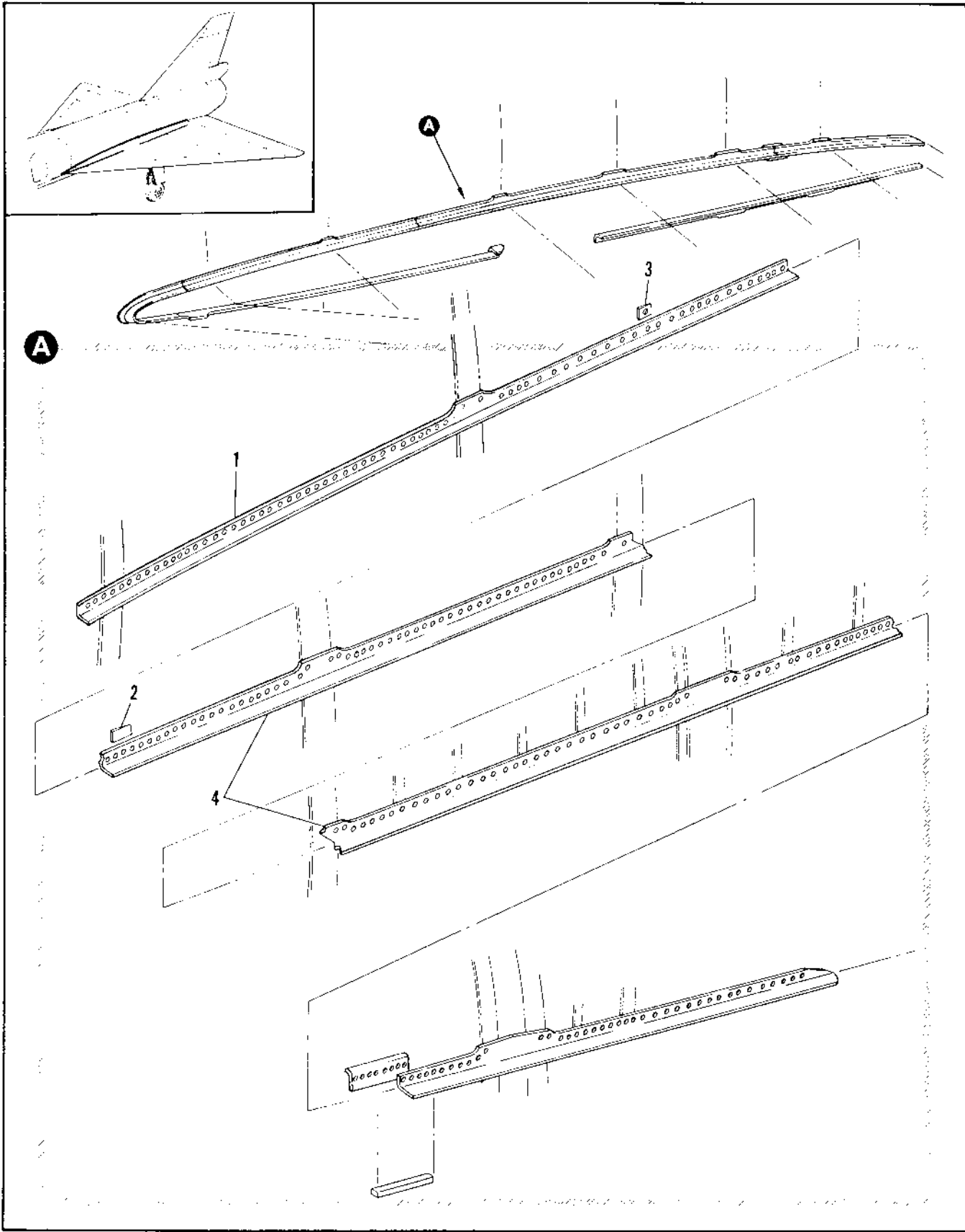

Figure 2.6-13. Wing to Fuselage Drag Angle Installation (Sheet 1 of 4)

FIGURE AND INDEX NUMBER	PART NUMBER	DESCRIPTION	UNITS PER ASSY.	USABLE ON CODE	
				FROM	TO
2.6-13	8-18060-1	DRAG ANGLE INSTALLATION, WING TO FUSELAGE LH MODIFIED BY R-11904 FOR NHA SEE FIG. 2.6-1 USED ON SPARES ASSEMBLY R-10060-501	RF	A	
	8-18060-2	DRAG ANGLE INSTALLATION, WING TO FUSELAGE RH MODIFIED BY R-11904 FOR NHA SEE FIG. 2.6-1 USED ON SPARES ASSEMBLY R-10060-502	RF RF	A A	
- 1	8-18040-17	• ANGLE, UPPER DRAG LH REPLACED BY NOT INTCHG WITH 8-18040-67	1	F	
	8-18060-17	• ANGLE, UPPER DRAG LH ALT INTCHG WITH 8-18040-17	F	F	
	8-18060-53	• ANGLE, UPPER DRAG LH	1	50	277
	8-18040-18	• ANGLE, UPPER DRAG RH REPLACED BY NOT INTCHG WITH 8-18040-68	1	C	
	8-18060-18	• ANGLE, UPPER DRAG RH ALT INTCHG WITH 8-18040-18	F	E	
	8-18060-77	• ANGLE, UPPER DRAG RH REPLACES NOT INTCHG WITH 8-18060-18	1	45	277
	NAS679A3	• NUT (R1205) 66-37545-02	AP	A	
	NAS333CPA4	• BOLT (R1205)	AP	A	
	NAS333CPA5	• BOLT (R1205)	AP	A	
	NAS333CPA5-5	• BOLT (R1205)	AP	A	
NAS333CPA6	• BOLT (R1205)	AP	A		
NAS333CPA6-5	• BOLT (R1205)	AP	A		
97-67004-1.1	• JC-BOLT	AP	A		
97-63004-10L	• JC-BOLT	AP	A		
	-----X-----				
- 2	8-18160-81	• SPACER, LH	1	L	
- 3	8-18160-85	• SPACER, LH	1	K	
- 4	8-18160-15	• ANGLE, UPPER DRAG LH -----X----- REPLACES NOT INTCHG WITH 8-18040-15 REPLACED BY NOT INTCHG WITH 8-18060-73	1	H	
	8-18060-73	• ANGLE, UPPER DRAG LH REPLACES NOT INTCHG WITH 8-18040-15	1	44	277
	8-18060-73	• ANGLE, UPPER DRAG LH	1	50	277
	8-18060-18	• ANGLE, UPPER DRAG RH REPLACES NOT INTCHG WITH 8-18040-18 REPLACED BY NOT INTCHG WITH 8-18060-74	1	4	
	8-18060-74	• ANGLE, UPPER DRAG RH REPLACES NOT INTCHG WITH 8-18160-15	1	44	277
	NAS679A3	• NUT (R1205)	AP	A	
	NAS333CPA4	• BOLT (R1205)	AP	A	
	NAS333CPA4-5	• BOLT (R1205)	AP	A	
	NAS333CPA5	• BOLT (R1205)	AP	A	
	NAS333CPA5-5	• BOLT (R1205)	AP	A	
	NAS333CPA6	• BOLT (R1205)	AP	A	
	NAS333CPA6-5	• BOLT (R1205)	AP	A	
	MS24694-37	• SCREW (R4506)	AP	A	
	MS24694-56	• SCREW (R4506)	AP	A	
	MS24694-57	• SCREW (R5016)	AP	A	

A AIRPLANES #35 THRU 277, 287, 292 AND ON
 B AIRPLANES #15 THRU 47, 287, 292 AND ON
 E AIRPLANES #35 THRU 44, 287, 292 AND ON
 F AIRPLANES #35 THRU 89, 287, 292 AND ON
 K AIRPLANES #48 AND 90 THRU 277
 L AIRPLANES #48, 90 THRU 277, 287, 301 AND ON

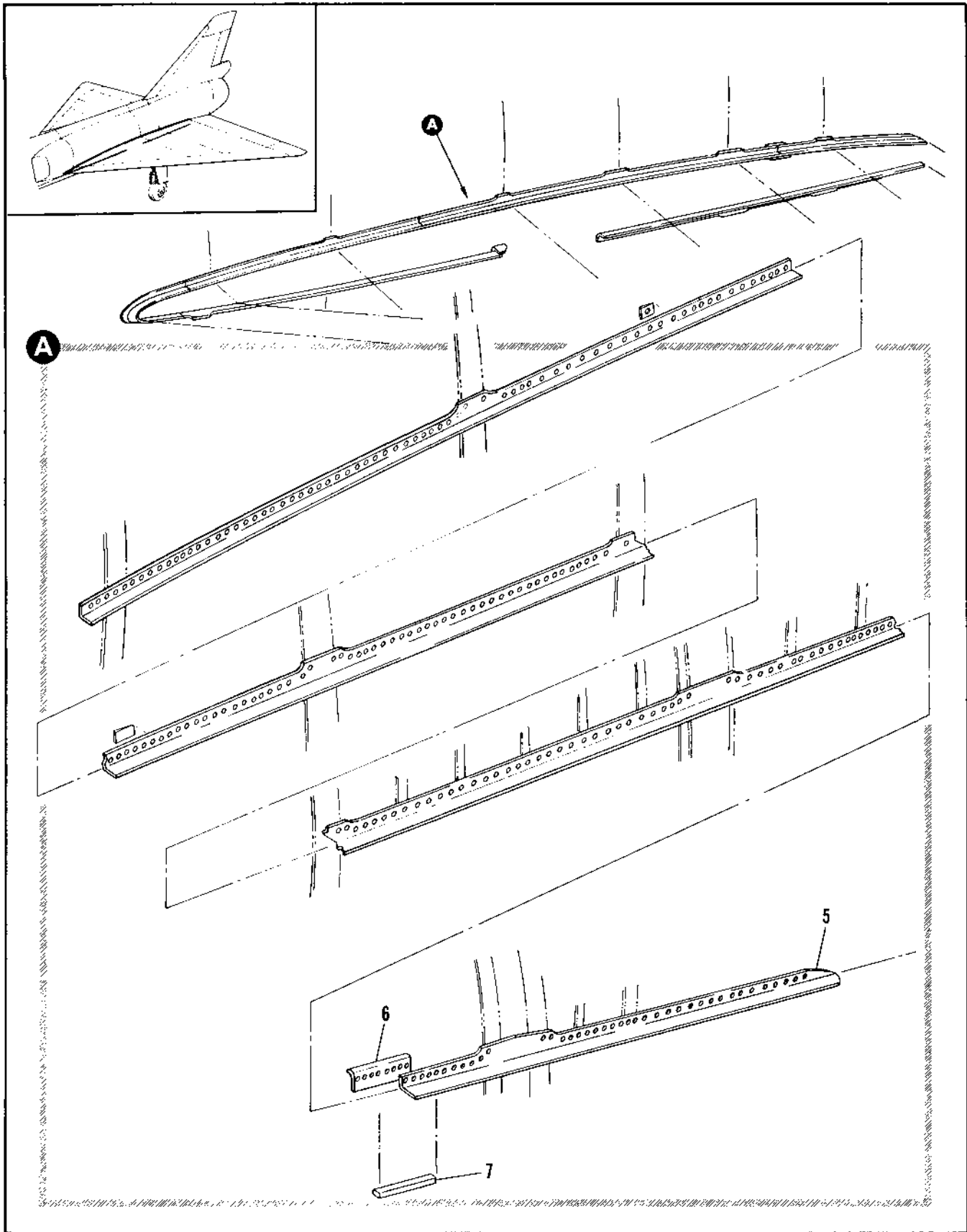

Figure 2.6-13. Wing to Fuselage Drag Angle Installation (Sheet 2 of 4)

FIGURE AND INDEX NUMBER	PART NUMBER	DESCRIPTION	UNITS PER ASSY.	USABLE ON CODE	
				FROM	TO
2.6-13- 5	8-18060-11	• ANGLE, UPPER DRAG LH REPLACED BY NOT INTCHG WITH 8-18060-71	1	B	
	8-18060-71	• ANGLE, UPPER DRAG LH REPLACES NOT INTCHG WITH 8-18060-11	1	48	277
	8-18060-12	• ANGLE, UPPER DRAG RH REPLACED BY NOT INTCHG WITH 8-18060-72	1	B	
	8-18060-72	• ANGLE, UPPER DRAG RH REPLACES NOT INTCHG WITH 8-18060-12	1	48	277
	NAS679A3	• NUT (81205)	AR	A	
	NAS333CPA6	• BOLT (81205)	AR	A	
	NAS333CPA6-5	• BOLT (81205)	AR	A	
	NAS333CPA7	• BOLT (81205)	AR	A	
	NAS334CPA4-5	• BOLT (81205)	AR	A	
	NAS334CPA7-5	• BOLT (81205)	AR	A	
NAS334CPA11	• BOLT (81205) -----X-----	AR	A		
- 6	8-18060-27	• PLATE	1	D	
- 7	8-18060-47	• PLATE	1	44	277
	8-18040-31	• PLATE	1	A	
	8-18060-31	• PLATE, ALT INTCHG WITH 8-18040-31	RF	A	
		A AIRPLANES #35 THRU 277, 287, 292 AND ON			
		B AIRPLANES #35 THRU 47, 287, 292 AND ON			
		D AIRPLANES #35 THRU 43, 287, 292 AND ON			

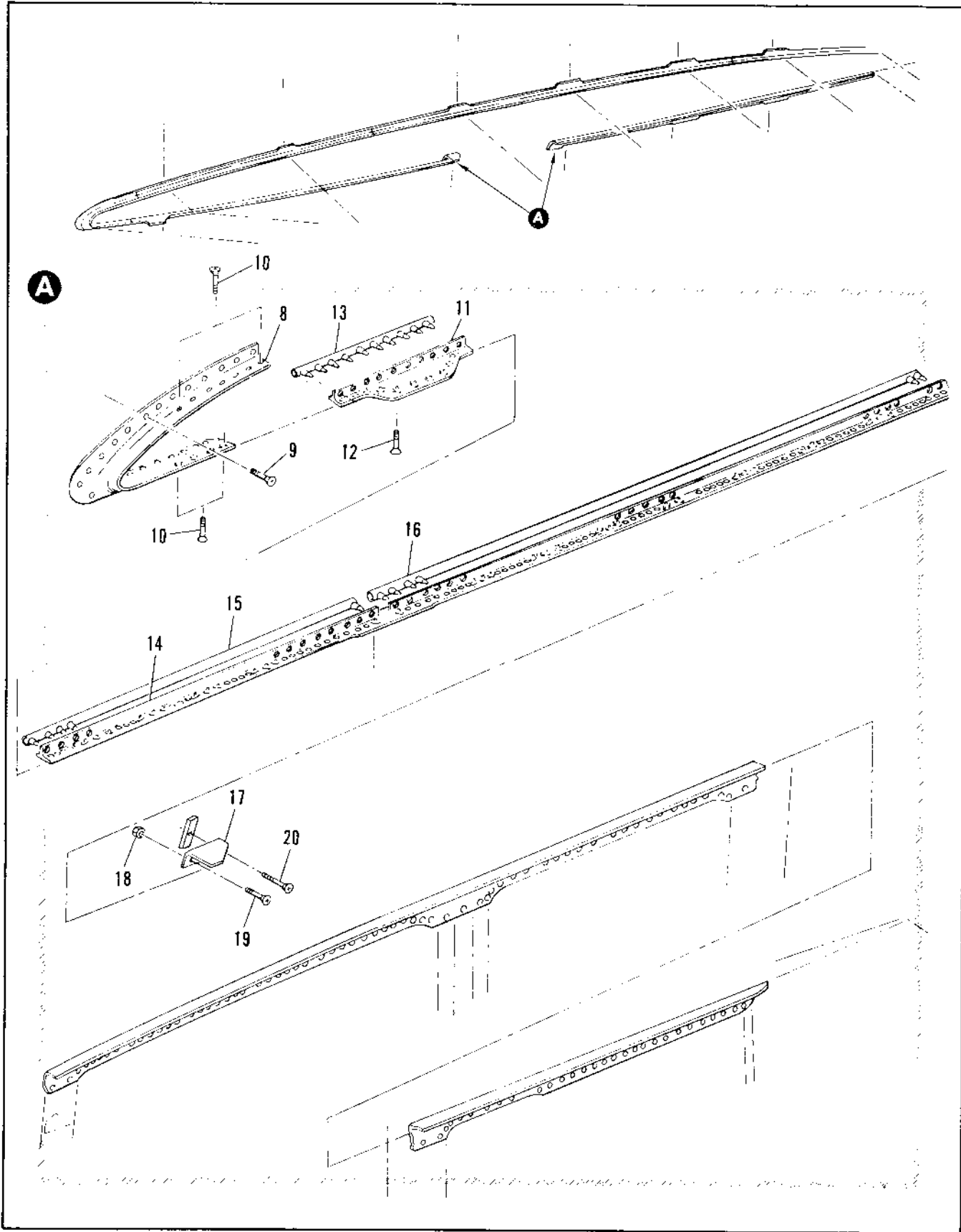

Figure 2.6-13. Wing to Fuselage Drag Angle Installation (Sheet 3 of 4)

FIGURE AND INDEX NUMBER	PART NUMBER	DESCRIPTION	UNITS PER ASSY.	USABLE ON CODE		
				FROM	TO	
2.6-13- 8	8-18004-9	• ANGLE, NOSE DRAG LH	1		C	
	8-11904-9	• ANGLE, NOSE DRAG LH	1		M	
	8-18004-10	• ANGLE, NOSE DRAG RH	1		C	
	8-11904-10	• ANGLE, NOSE DRAG RH	1		M	
		ATTACHING PARTS				
	- 9	NAS333CPA4-5	• BOLT (80205)	23		A
	- 10	NAS333CPA5-5	• BOLT (80205)	11		A
		-----X-----				
	- 11	8-18989-1	• ANGLE ASSY, LOWER DRAG LH RIVETED	1		M
		8-18989-3	• ANGLE ASSY, LOWER DRAG LH RIVETED	1	190	277
		8-18913-7	• ANGLE, LOWER DRAG LH	1	292	300
		8-18989-2	• ANGLE ASSY, LOWER DRAG RH RIVETED	1		H
		8-18989-4	• ANGLE ASSY, LOWER DRAG LH RIVETED	1	190	277
		8-18913-8	• ANGLE, LOWER DRAG RH	1	292	300
		ATTACHING PARTS				
	- 12	NAS333CPA5-5	• BOLT (80205)	12		A
		-----X-----				
	- 13	8-18040-43	• SEAL, ALTERED FROM 8-71602-37	1		G
		6-18060-43	• SEAL, ALTERED FROM 8-71602-37	RF		G
		ALT INTCHG WITH 8-18040-43				
	8-71602-37	• SEAL	RF			
- 14	8-18040-83	• RETAINER, LOWER LH	1		A	
	6-18060-25	• RETAINER, LOWER LH	RF		A	
	ALT INTCHG WITH 8-18040-83					
	8-18040-84	• RETAINER, LOWER RH	1		A	
	8-18060-26	• RETAINER, LOWER RH	RF		A	
	ALT INTCHG WITH 8-18040-84					
	ATTACHING PARTS					
	NAS333CPA5-5	• BOLT (80205)	AR		A	
	NAS333CPA6	• BOLT (80205)	AR		A	
	NAS333CPA7	• BOLT (80205)	AR		A	
	-----X-----					
- 15	8-18040-79	• SEAL	1		A	
	8-18060-45	• SEAL, ALTERED FROM 8-71602-37	RF		A	
	ALT INTCHG WITH 8-18040-79					
- 16	8-18040-85	• SEAL	1		A	
	8-18060-47	• SEAL, ALTERED FROM 8-71602-37	RF		A	
	ALT INTCHG WITH 8-18040-85					
	8-71602-37	• SEAL	RF			
- 17	8-18040-89	• PLATE, LH	1		A	
	8-18060-67	• PLATE, LH ALT INTCHG WITH 8-18040-89	RF		A	
	8-18040-90	• PLATE, RH	1		A	
	8-18060-68	• PLATE, RH ALT INTCHG WITH 8-18040-90	RF		A	
	ATTACHING PARTS					
- 18	NAS679A3	• NUT (80205)	2		A	
- 19	MS24694-55	• SCREW, FWD (96906)	1		J	
	NAS333CPA6	• SCREW, FWD (80205)	1	61	277	
- 20	MS24694-55	• SCREW, AFT (96906)	1		J	
	NAS333CPA6-5	• SCREW, AFT	1	61	277	
	-----X-----					
	A AIRPLANES #35 THRU 277, 287, 292 AND ON					
	C AIRPLANES #35 THRU 277, 287, 295,					
	301 AND ON					
	G AIRPLANES #35 THRU 189, 287, 292 AND ON					
	H AIRPLANES #35 THRU 189, 287, 301 AND ON					
	J AIRPLANES #35 THRU 60, 287, 301 AND ON					
	M AIRPLANES #292 THRU 294 AND 296 THRU 300					

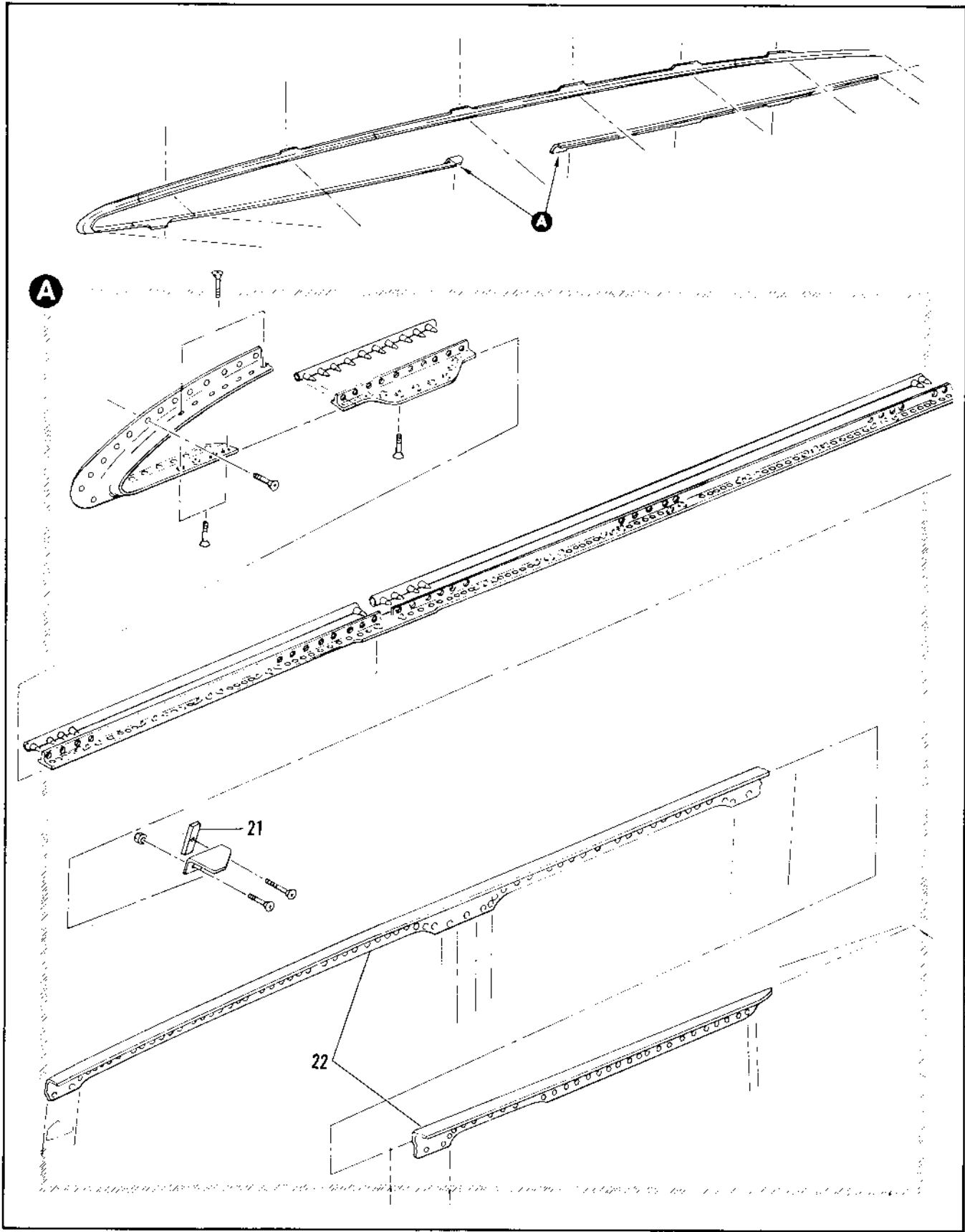

Figure 2.6-13. Wing to Fuselage Drag Angle Installation (Sheet 4 of 4)

FIGURE AND INDEX NUMBER	PART NUMBER	DESCRIPTION	UNITS PER ASSY.	USABLE ON CODE	
				FROM	TO
2.6-13- 21 - 22	8-18060-75	• RADIUS BLOCK	1	21	277
	8-18060-9	• ANGLE, LOWER DRAG LH REPLACED BY NOT INTCHG WITH 8-18060-69	1	B	
	8-18060-69	• ANGLE, LOWER DRAG LH REPLACES NOT INTCHG WITH 8-18060-9	1	48	277
	8-18060-10	• ANGLE, LOWER DRAG RH REPLACED BY NOT INTCHG WITH 8-18060-70	1	B	
	8-18060-70	• ANGLE, LOWER DRAG RH REPLACES NOT INTCHG WITH 8-18060-10	1	48	277
	NAS679A3	ATTACHING PARTS	AR	A	
	NAS333CPA4-5	• NUT (80205)	AR	A	
	NAS333CPA5	• BOLT (80205)	AR	A	
	NAS333CPA5-5	• BOLT (80205)	AR	A	
	NAS333CPA6-5	• BOLT (80205)	AR	A	
	NAS333CPA7-5	• BOLT (80205)	AR	A	
	NAS333CPA11	• BOLT (80205)	AR	A	
	MS24694-57	• SCREW (96906)	AR	A	
		-----X-----			
		A AIRPLANES #35 THRU 277, 287, 292 AND ON			
	B AIRPLANES #35 THRU 47, 287, 292 AND ON				

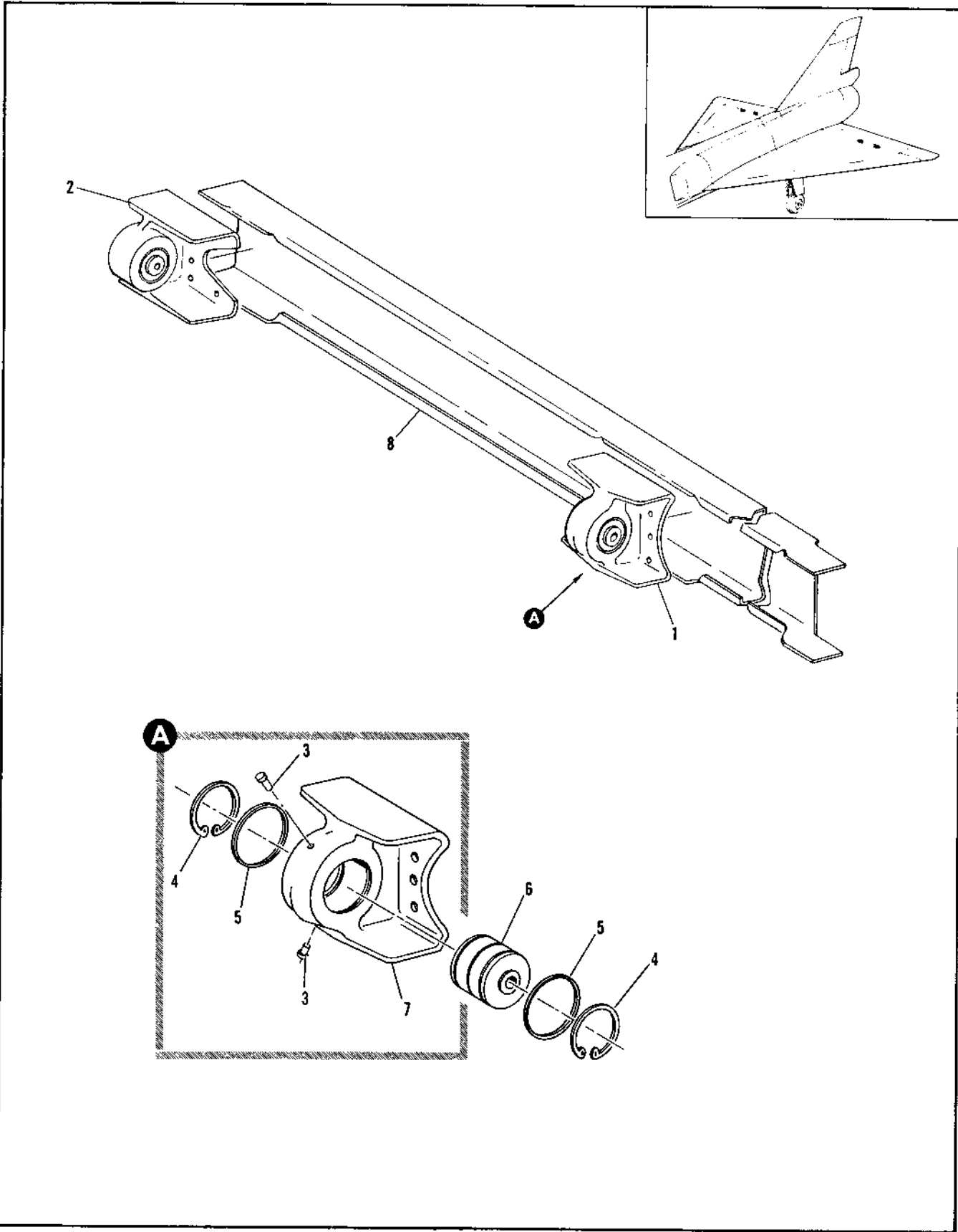

Figure 2.6-14. Outbd Elevon Inbd Spar Assembly

FIGURE AND INDEX NUMBER	PART NUMBER	DESCRIPTION	UNITS PER ASSY.	USABLE ON CODE	
				FROM	TO
		1 2 3 4 5 6			
2.6-14	8-13111-3	SPAR ASSEMBLY, OUTBOARD ELEVON INBOARD LH FOR NHA SEE FIG. 2.6-8	RF	A	
	8-13101-3	SPAR ASSEMBLY, OUTBOARD ELEVON INBOARD LH FOR NHA SEE FIG. 2.6-8	RF	B	
	8-13111-4	SPAR ASSEMBLY, OUTBOARD ELEVON INBOARD RH FOR NHA SEE FIG. 2.6-8	RF	A	
	8-13101-4	SPAR ASSEMBLY, OUTBOARD ELEVON INBOARD RH FOR NHA SEE FIG. 2.6-8	RF	B	
- 1	8-13753-1	• HINGE ASSY, OUTBD ELEVON INBD BL 130	1	35	
- 2	8-13778-1	• HINGE ASSY, OUTBD ELEVON INBD BL 108 ALT INTCHG WITH 8-13757	RF	35	
	8-13757	• HINGE ASSY, OUTBD ELEVON INBD BL 108 ALT INTCHG WITH 8-13778-1	RF	35	
- 3	NAS516-1	• LUBRICATOR (80205)	2	35	
- 4	NAS53-156	• RETAINER (80205)	2	35	
- 5	8-15440-7	• RING, RETAINER HINGE BEARING	2	35	
- 6	A6H	• BEARING, <77896> 92-80500-001	1	35	
- 7	8-13753-9	• HINGE, ELEVON BL 130	1	35	
	8-13778-7	• HINGE, ELEVON BL 108	1	35	
	8-13758-7	• HINGE, ELEVON BL 108 ALT INTCHG WITH 8-13778-7	RF	35	
- 8	8-13111-9	• CHANNEL	1	A	
	8-13101-9	• CHANNEL	1	B	
		A AIRPLANES #35 THRU 277, 287, 292 AND ON			
		B AIRPLANES #278 THRU 286 AND 288 THRU 291			

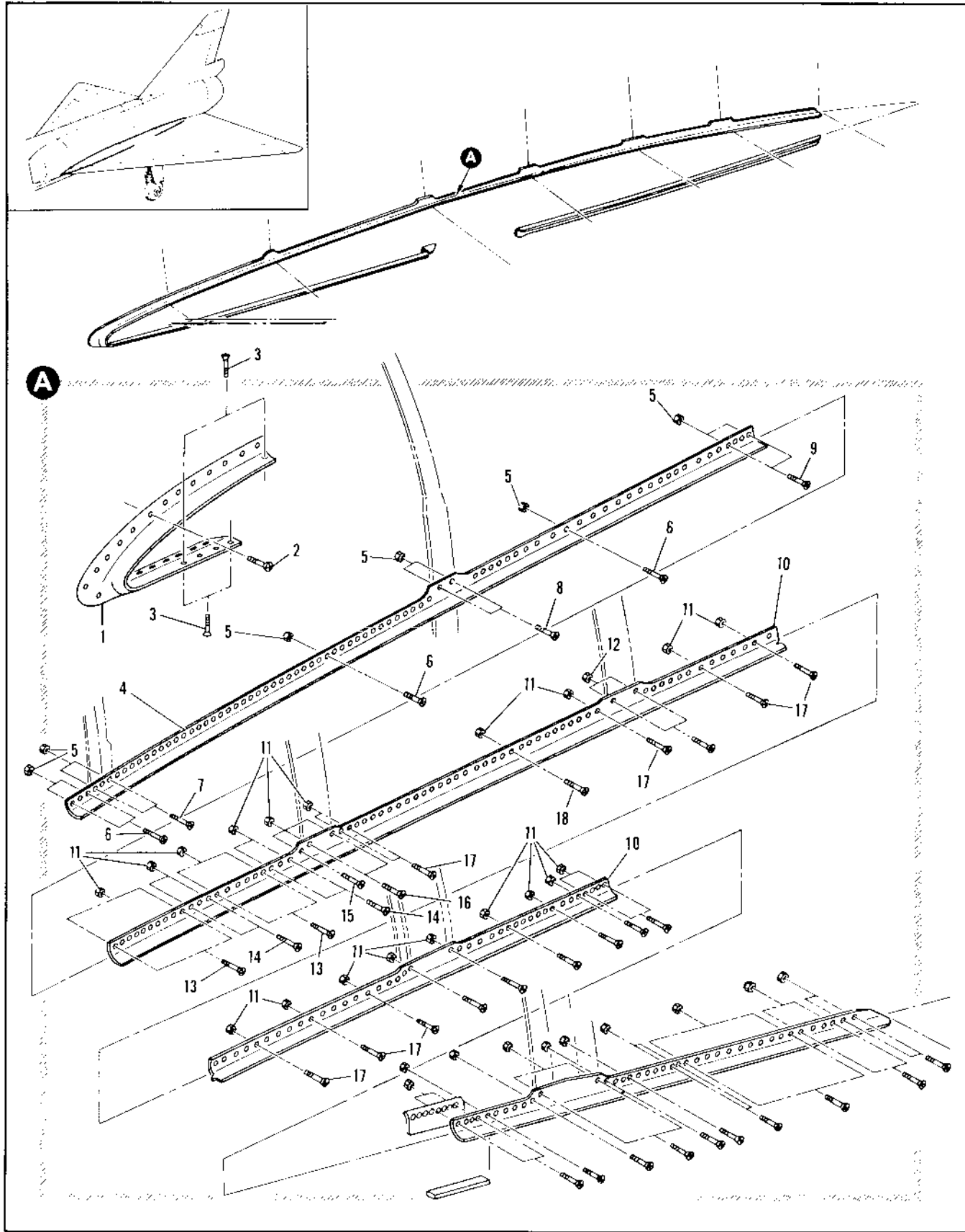

Figure 2.6-15. Wing to Fuselage Drag Angle Installation (Sheet 1 of 3)

FIGURE AND INDEX NUMBER	PART NUMBER	DESCRIPTION 1 2 3 4 5 6	UNITS PER ASSY.	USABLE ON CODE		
				FROM	TO	
2.6-15	8-18040-5	DRAG ANGLE INSTALLATION, WING TO FUSELAGE LH FOR NHA SEE FIG. 2.6-2 USED ON SPARES ASSEMBLY 8-10040-525	RF	A		
	8-18040-6	DRAG ANGLE INSTALLATION, WING TO FUSELAGE RH FOR NHA SEE FIG. 2.6-2 USED ON SPARES ASSEMBLY 8-10040-526	RF	A		
	- 1	8-18041-7 8-18004-7	• ANGLE, NOSE DRAG LH • ANGLE, NOSE DRAG LH REPLACED BY NOT INTCHG WITH 8-18004-9	1 1	B 283	283
		8-18041-8 8-18004-8	• ANGLE, NOSE DRAG RH • ANGLE, NOSE DRAG RH REPLACED BY NOT INTCHG WITH 8-18004-10 ATTACHING PARTS	1 1	B 283	283
	- 2	NAS333CPA4-5	• BOLT (80205)	23	A	
	- 3	NAS333CPA5-5	• BOLT (80205) ----X----	11	A	
	- 4	8-18040-67 8-18040-68	• ANGLE, UPPER DRAG LH • ANGLE, UPPER DRAG RH ATTACHING PARTS	1 1	A A	
	- 5	NAS679A3	• NUT, (80205) 96-37545-002	74	A	
	- 6	NAS333CPA4	• BOLT (80205)	66	A	
	- 7	NAS333CPA5-5	• BOLT (80205)	2	A	
	- 8	NAS333CPA6-5	• BOLT (80205)	2	A	
	- 9	NAS333CPA4-5	• BOLT (80205) ----X----	4	A	
	- 10	8-18040-15 8-18040-16	• ANGLE, UPPER DRAG LH REPLACED BY NOT INTCHG WITH 8-18060-15 • ANGLE, UPPER DRAG RH REPLACED BY NOT INTCHG WITH 8-18060-16 ATTACHING PARTS	1 1	A A	
	- 11	NAS679A3 NAS679A3	• NUT, LH (80205) 96-37545-002 • NUT, RH (80205) 96-37545-002	AR 91	A A	
	- 12	NAS679A3	• NUT (80205)	2	A	
	- 13	NAS333CPA4-5	• BOLT (80205)	16	A	
	- 14	NAS333CPA4	• BOLT (80205)	6	A	
	- 15	MS24694-53	• SCREW (96906)	1	A	
- 16	MS24694-57	• SCREW (96906)	2	A		
- 17	NAS333CPA5-5	• BOLT, LH (80205)	8	A		
- 18	NAS333CPA5 NAS333CPA5 NAS333CPA5-5 NAS333CPA6-5	• BOLT, LH (80205) • BOLT, RH (80205) • BOLT, RH (80205) • BOLT, RH (80205)	55 11 26 9	A A A A		

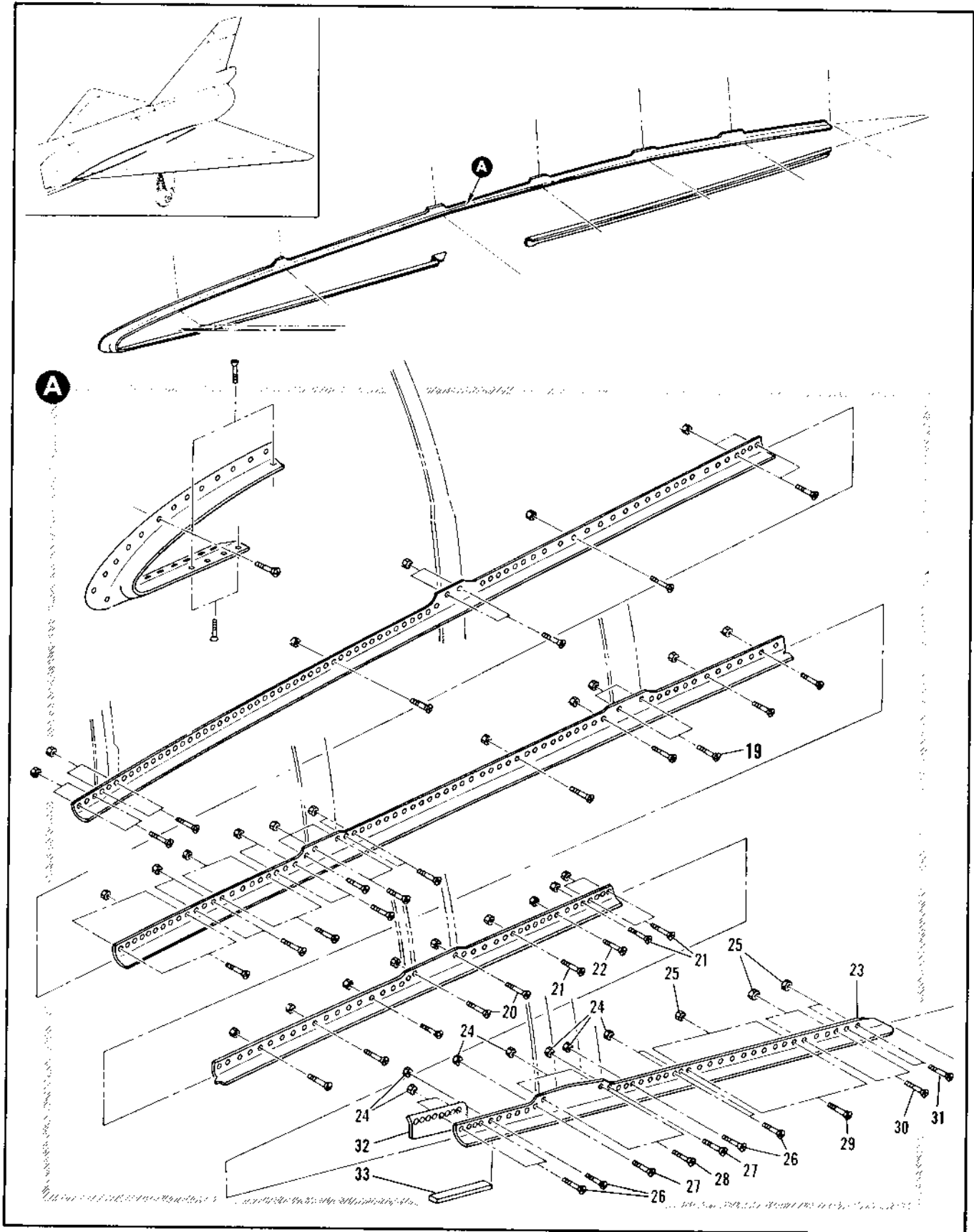

Figure 2.6-15. Wing to Fuselage Drag Angle Installation (Sheet 2 of 3)

FIGURE AND INDEX NUMBER	PART NUMBER	DESCRIPTION	UNITS PER ASSY.	USABLE ON CODE	
				FROM	TO
		1 2 3 4 5 6			
2,6-15- 19	MS24694-F6	• SCREW (76906)	2	A	
- 20	NAS333CPA6-5	• BOLT (81205)	2	A	
- 21	NAS333CPA6-5	• BOLT (81205)	6	A	
- 22	NAS333CPA5	• BOLT (81205)	12	A	
		-----X-----			
- 23	8-18040-87	• ANGLE, UPPER DRAG LH REPLACED BY NOT INTCHE WITH 8-18060-11	1	A	
	8-18040-88	• ANGLE, UPPER DRAG RH REPLACED BY NOT INTCHE WITH 8-18060-12 ATTACHING PARTS	1	A	
- 24	NAS679A3	• NUT, (81205) 96-37545-102	22	A	
- 25	NAS679A4	• NUT, (81205) 96-37545-103	17	A	
- 26	NAS333CPA5-5	• BOLT (81205)	8	A	
- 27	NAS333CPA5	• BOLT (81205)	12	A	
- 28	NAS333CPA7	• BOLT (81205)	2	A	
- 29	NAS334CPA6-5	• BOLT (81205)	11	A	
- 30	NAS334CPA7-5	• BOLT (81205)	4	A	
- 31	NAS334CPA10	• BOLT (81205)	2	A	
		-----X-----			
- 32	8-18040-39	• PLATE	1	A	
- 33	8-18040-31	• PLATE	1	A	
		A AIRPLANES #278 THRU 286 AND 288 THRU 291 B AIRPLANES #278 THRU 282, 284 THRU 286, AND 288 THRU 291			

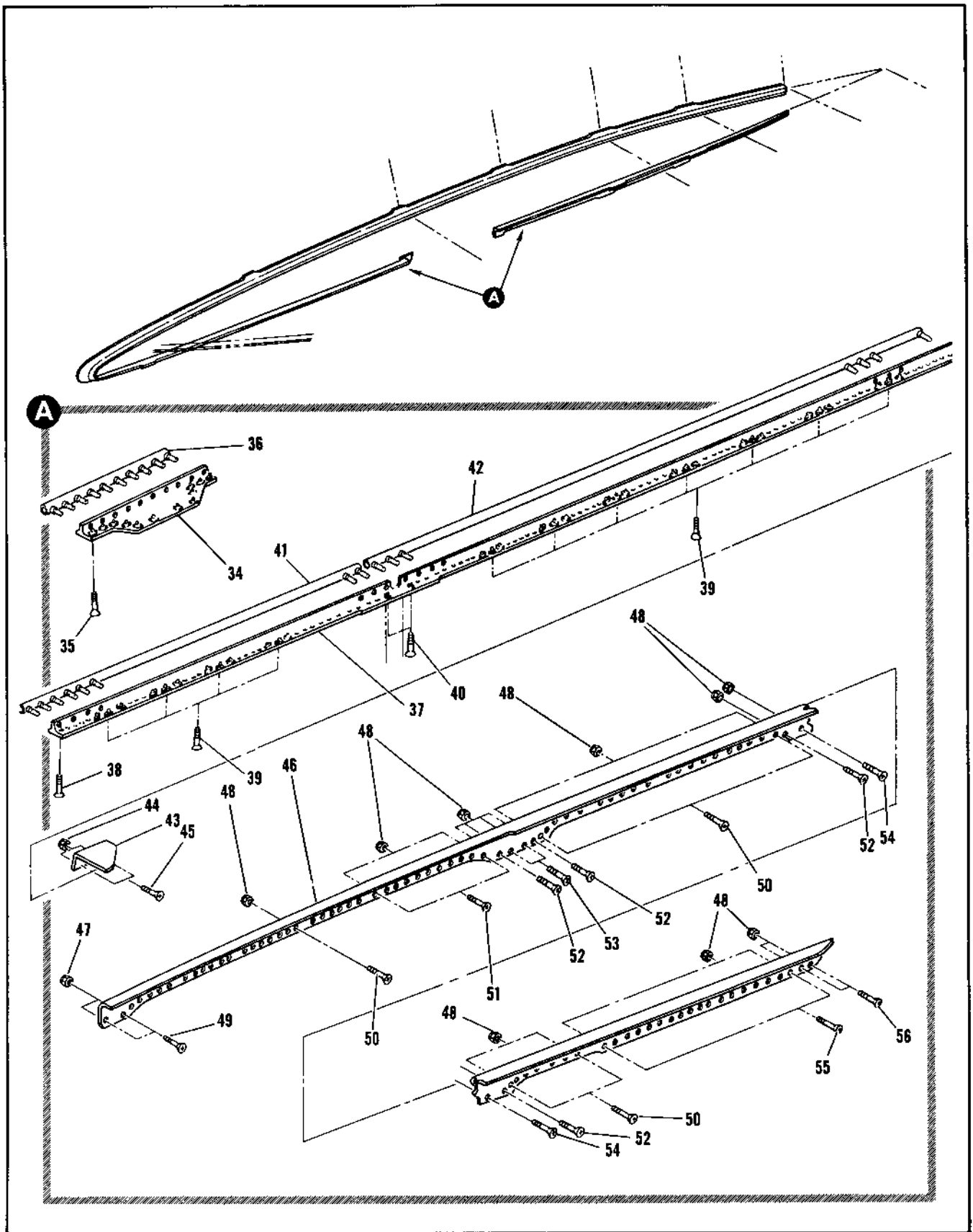

Figure 2.6-15. Wing to Fuselage Drag Angle Installation (Sheet 3 of 3)

FIGURE AND INDEX NUMBER	PART NUMBER	DESCRIPTION	UNITS PER ASSY.	USABLE ON CODE	
				FROM	TO
2.6-15- 34	8-18913-7	• ANGLE, LOWER DRAG LH	1	B	
	8-18989-1	• ANGLE ASSY, LOWER DRAG LH RIVETED	1	283	283
	8-18913-8	• ANGLE, LOWER DRAG RH	1	B	
	8-18989-2	• ANGLE ASSY, LOWER DRAG RH RIVETED	1	283	283
		ATTACHING PARTS			
- 35	NAS333CPA5-5	• BOLT (80205)	12	A	
		----X----			
- 36	8-18040-43	• SEAL, ALTERED FROM 8-71602-37	1	A	
	8-71602-37	• SEAL	RF		
- 37	8-18040-83	• RETAINER, LOWER LH	1	A	
	8-18040-84	• RETAINER, LOWER RH	1	A	
		ATTACHING PARTS			
- 38	NAS333CPA5-5	• BOLT (80205)	70	A	
- 39	NAS333CPA6	• BOLT (80205)	11	A	
- 40	NAS333CPA7	• BOLT (80205)	2	A	
		----X----			
- 41	8-18040-79	• SEAL, ALTERED FROM 8-71602-37	1	A	
- 42	8-18040-85	• SEAL, ALTERED FROM 8-71602-37	1	A	
	8-71602-37	• SEAL	RF		
- 43	8-18040-89	• PLATE, LH	1	A	
	8-18040-90	• PLATE, RH	1	A	
		ATTACHING PARTS			
- 44	NAS679A3	• NUT (80205)	2	A	
- 45	MS24694-56	• SCREW (96906)	2	A	
		----X----			
- 46	8-18040-69	• ANGLE, LOWER DRAG LH	1	A	
	8-18040-70	• ANGLE, LOWER DRAG RH	1	A	
		ATTACHING PARTS			
- 47	NAS679A3	• NUT (80205)	2	A	
- 48	NAS679A3	• NUT, LH (80205) 96-37545-002	91	A	
	NAS679A3	• NUT, RH (80205) 96-37545-002	92	A	
- 49	MS24694-57	• SCREW (96906)	2	A	
- 50	NAS333CPA4-5	• BOLT (80205)	52	A	
- 51	NAS333CPA6-5	• BOLT, LH (80205)	11	A	
	NAS333CPA4-5	• BOLT, RH (80205)	12	A	
- 52	NAS333CPA6-5	• BOLT (80205)	4	A	
- 53	NAS333CPA7-5	• BOLT (80205)	2	A	
- 54	NAS333CPA11	• BOLT (80205)	2	A	
- 55	NAS333CPA5	• BOLT (80205)	18	A	
- 56	NAS333CPA5-5	• BOLT (80205)	2	A	
		----X----			

A AIRPLANES #278 THRU 286 AND 288 THRU 291
 B AIRPLANES #278 THRU 282, 284 THRU 286,
 AND 288 THRU 291

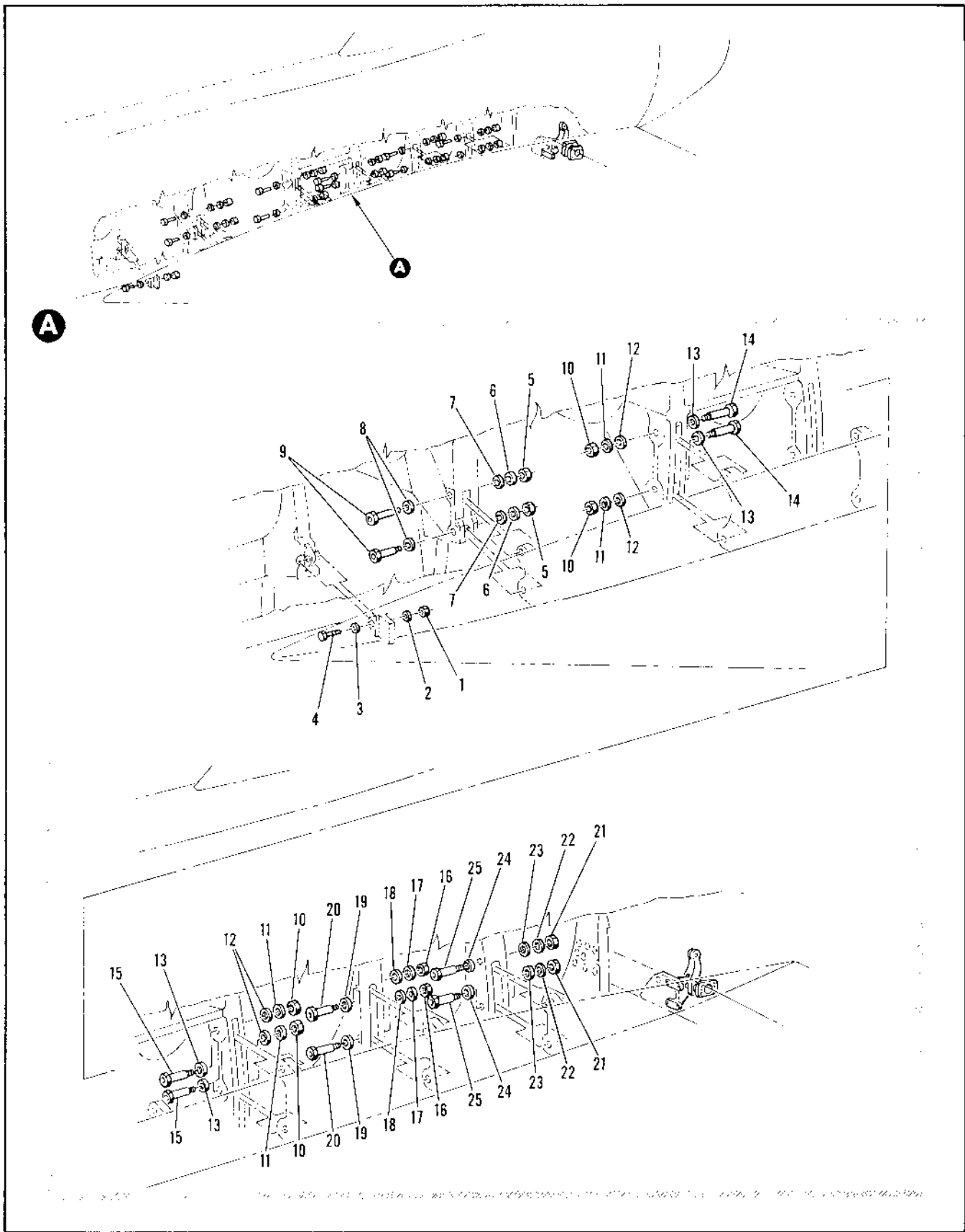

Figure 2.6-16. Wing to Fuselage Attachment Installation (Sheet 1 of 2)

FIGURE AND INDEX NUMBER	PART NUMBER	DESCRIPTION	UNITS PER ASSY.	USABLE ON CODE	
				FROM	TO
		1 2 3 4 5 6			
2.6-16	8-13070-1	ATTACHMENT INSTALLATION, WING TO FUSELAGE LH FOR NHA SEE FIG. 2.6-1	RF	B	
	8-13050-1	ATTACHMENT INSTALLATION, WING TO FUSELAGE LH FOR NHA SEE FIG. 2.6-2	RF	A	
	8-13070-2	ATTACHMENT INSTALLATION, WING TO FUSELAGE RH FOR NHA SEE FIG. 2.6-1	RF	B	
	8-10650-2	ATTACHMENT INSTALLATION, WING TO FUSELAGE RH FOR NHA SEE FIG. 2.6-2	RF	A	
- 1	AN320-8	• NUT (88144)	1	35	
- 2	AN960-816	• WASHER (88044)	1	35	
- 3	MS20002C08	• WASHER (96906)	1	35	
- 4	NAS464-8-22	• BOLT (81205)	1	35	
- 5	AN320-14	• NUT (88144)	2	35	
- 6	AN960-1416L	• WASHER (88044)	2	35	
- 7	8-18930-11	• WASHER	2	35	
- 8	MS20002C16	• WASHER (96906)	2	35	
- 9	8-18941-15	• BOLT	2	35	
- 10	AN320-20	• NUT (88144)	4	35	
- 11	AN960-2016L	• WASHER (88044)	4	35	
- 12	8-17975-13	• WASHER	4	35	
- 13	8-17975-7	• WASHER	4	35	
- 14	8-18941-13	• BOLT	2	35	
- 15	8-18941-11	• BOLT	2	35	
- 16	AN320-16	• NUT (88244)	2	35	
- 17	AN960-1616L	• WASHER (88044)	2	35	
- 18	8-18930-9	• WASHER	2	35	
- 19	MS20002C20	• WASHER (96906)	2	35	
- 20	8-18941-9	• BOLT, REPLACED BY NOT INTCHG WITH 8-18941-19	2	0	
	8-18941-19	• BOLT, REPLACES NOT INTCHG WITH 8-18941-9	2	48	277
- 21	AN320-20	• NUT (88144)	2	35	
- 22	AN960-2016L	• WASHER (88044)	2	35	
- 23	8-18930-7	• WASHER	2	35	
- 24	8-18930-13	• WASHER	2	35	
- 25	8-18941-7	• BOLT, REPLACED BY NOT INTCHG WITH 8-18941-17	2	0	
	8-18941-17	• BOLT, REPLACES NOT INTCHG WITH 8-18941-7	2	48	277
		A AIRPLANES #278 THRU 286 AND 288 THRU 291			
		B AIRPLANES #35 THRU 277, 287, 292 AND ON			
		D AIRPLANES #35 THRU 47, 276 AND ON			

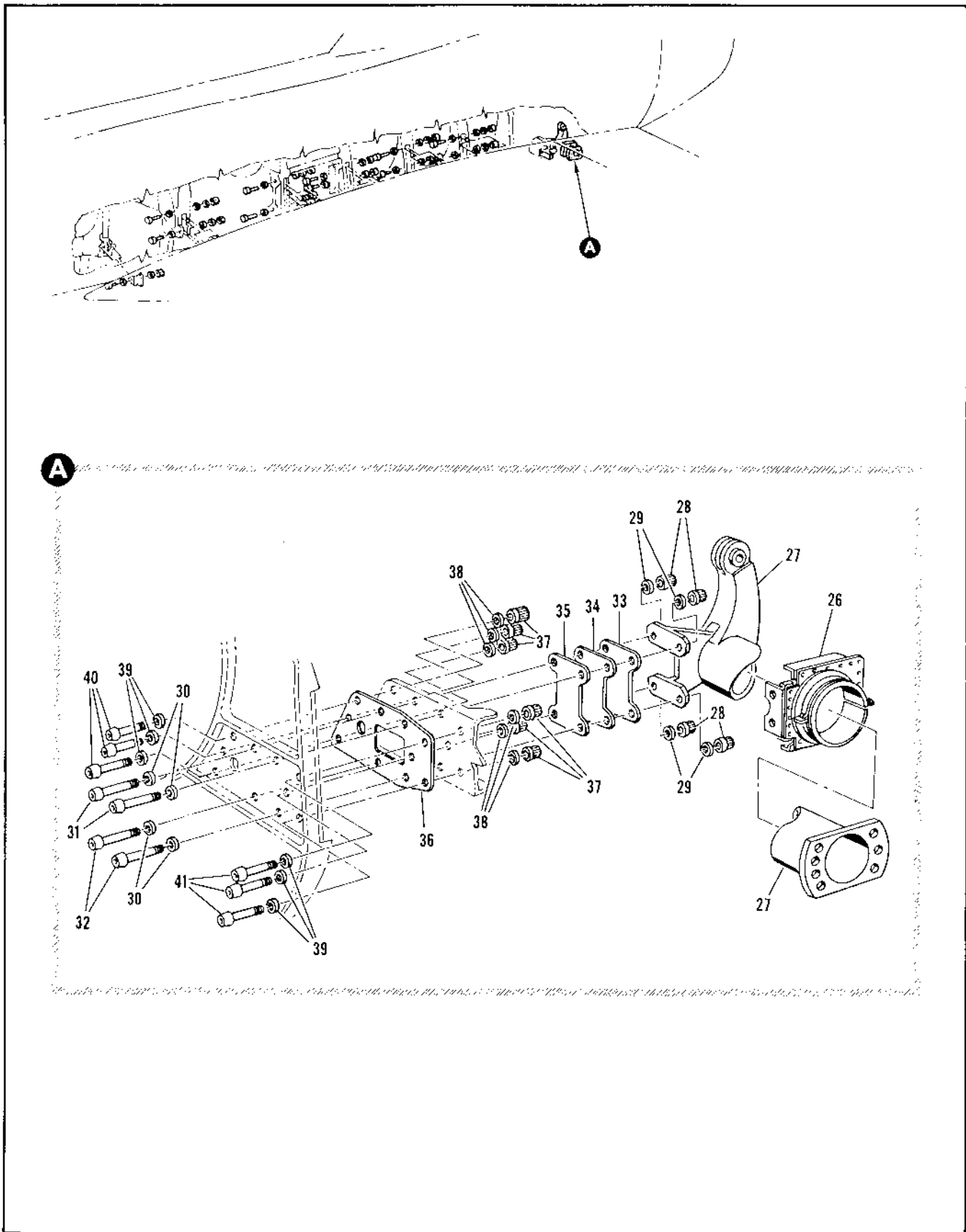

Figure 2.6-16. Wing to Fuselage Attachment Installation(Sheet 2 of 2)

FIGURE AND INDEX NUMBER	PART NUMBER	DESCRIPTION	UNITS PER ASSY.	USABLE ON CODE	
				FROM	TO
2.6-16- 26	8-13939-1	• SEAL INSTL, INBD ELEVON HORN LH FOR BRFAKDOWN SEE FIG. 2.6-11	1	35	
	8-13939-2	• SEAL INSTL, INBD ELEVON HORN RH FOR BREAKDOWN SEE FIG. 2.6-11	1	35	
- 27	8-10070-17	• FITTING ASSY, INBD ELEVON LH FOR BREAKDOWN SEE FIG. 2.6-17	1	E	
	8-10050-7	• FITTING ASSY, INBD ELEVON LH FOR BREAKDOWN SEE FIG. 2.6-17	1	A	
	8-10070-7	• FITTING ASSY, INBD ELEVON LH FOR BREAKDOWN SEE FIG. 2.6-17	1	C	
	8-10070-18	• FITTING ASSY, INBD ELEVON RH FOR BREAKDOWN SEE FIG. 2.6-17	1	E	
	8-10050-8	• FITTING ASSY, INBD ELEVON RH FOR BREAKDOWN SEE FIG. 2.6-17	1	A	
	8-10070-8	• FITTING ASSY, INBD ELEVON RH FOR BREAKDOWN SEE FIG. 2.6-17	1	C	
		ATTACHING PARTS			
- 28	42FW1018	• NUT, <56878> 96-37510-007	4	35	
- 29	MS20002-10	• WASHER (96906)	4	35	
- 30	MS20002C10	• WASHER (96906)	4	35	
- 31	MS20010H30	• BOLT (96906)	2	35	
- 32	MS20010H28	• BOLT (96906)	2	35	
		-----X-----			
- 33	8-10050-13	• SHIM	AR	35	
	8-10070-13	• SHIM, ALT INTCHG WITH 8-10050-13	RF	35	
- 34	8-10050-11	• SHIM	AR	35	
	8-10070-11	• SHIM, ALT INTCHG WITH 8-10050-11	RF	35	
- 35	8-10050-9	• SHIM	AR	35	
	8-10070-9	• SHIM, ALT INTCHG WITH 8-10050-9	RF	35	
- 36	8-10050-15	• SHIM	AR	35	
	8-10070-15	• SHIM, ALT INTCHG WITH 8-10050-15	RF	35	
		ATTACHING PARTS			
- 37	42FW1216	• NUT, <56878> 96-37510-108	6	35	
- 38	MS20002-12	• WASHER (96906)	6	35	
- 39	MS20002C12	• WASHER (96906)	6	35	
- 40	MS20012-18	• BOLT (96906)	3	35	
- 41	MS20012-22	• BOLT (96906)	3	35	
		-----X-----			
		A AIRPLANES #278 THRU 286 AND 288 THRU 291			
		C AIRPLANES #287 AND 292 THRU 300			
		E AIRPLANES #35 THRU 277, 301 AND ON			

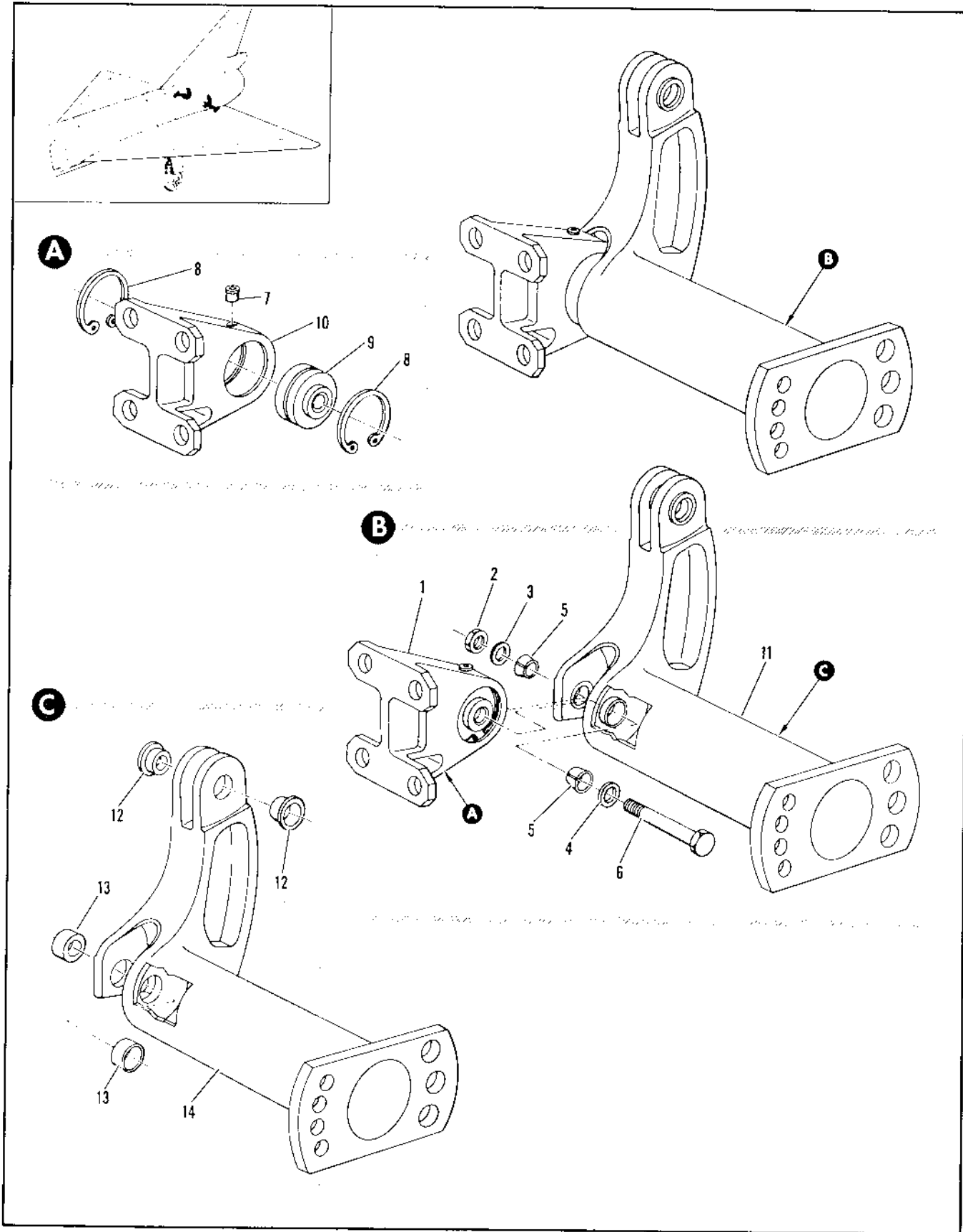

Figure 2.6-17. Inbd Elevon Fitting Assembly

FIGURE AND INDEX NUMBER	PART NUMBER	DESCRIPTION	UNITS PER ASSY.	USABLE ON CODE	
				FROM	TO
		1 2 3 4 5 6			
2.6-17	8-10070-17	FITTING ASSEMBLY, INBOARD ELEVON LH FOR NHA SEE FIG. 2.6-16	RF	C	
	8-10050-7	FITTING ASSEMBLY, INBOARD ELEVON LH FOR NHA SEE FIG. 2.6-16	RF	A	
	8-10070-7	FITTING ASSEMBLY, INBOARD ELEVON LH FOR NHA SEE FIG. 2.6-16	RF	B	
	8-10070-18	FITTING ASSEMBLY, INBOARD ELEVON RH FOR NHA SEE FIG. 2.6-16	RF	C	
	8-10050-8	FITTING ASSEMBLY, INBOARD ELEVON RH FOR NHA SEE FIG. 2.6-16	RF	A	
	8-10070-8	FITTING ASSEMBLY, INBOARD ELEVON RH FOR NHA SEE FIG. 2.6-16	RF	B	
- 1	8-18763-1	• FITTING ASSY, ELEVON ACTUATOR HORN BEARING SUPPORT	1	35	
	8-18764	• FITTING ASSY, ELEVON ACTUATOR HORN BEARING SUPPORT ALT INCHES WITH 8-18763-1 ATTACHING PARTS	RF	35	
- 2	AN320-12	• NUT (80244)	1	35	
- 3	MS20502-12	• WASHER (96906)	1	35	
- 4	MS20502C12	• WASHER (96906)	1	35	
- 5	8-13722	• BUSHING	2	35	
- 6	8-17947	• BOLT	1	35	
		-----X-----			
- 7	NAS516-1	• LUBRICATOR (80205)	1	35	
- 8	NAS669-262	• RETAINER (80205)	2	35	
- 9	A12H	• BEARING, <77896> 90-60500-003	1	35	
- 10	8-18763-7	• FITTING	1	35	
	8-18764-7	• FITTING, USE WITH 8-18764	RF	35	
- 11	8-13749-3	• FITTING ASSY, INBD ELEVON HORN LH	1	C	
	8-13749-1	• FITTING ASSY, INBD ELEVON HORN LH	1	278	300
	8-13749-4	• FITTING ASSY, INBD ELEVON HORN RH	1	C	
	8-13749-2	• FITTING ASSY, INBD ELEVON HORN RH	1	278	300
- 12	8-13717	• PUSHING	2	35	
- 13	8-13721	• PUSHING	2	35	
- 14	8-13749-9	• FITTING, LH	1	35	
	8-13749-10	• FITTING, RH	1	35	
		A AIRPLANES #278 THRU 286 AND 288 THRU 291			
		B AIRPLANES #287 AND 292 THRU 300			
		C AIRPLANES #35 THRU 277, 301 AND ON			

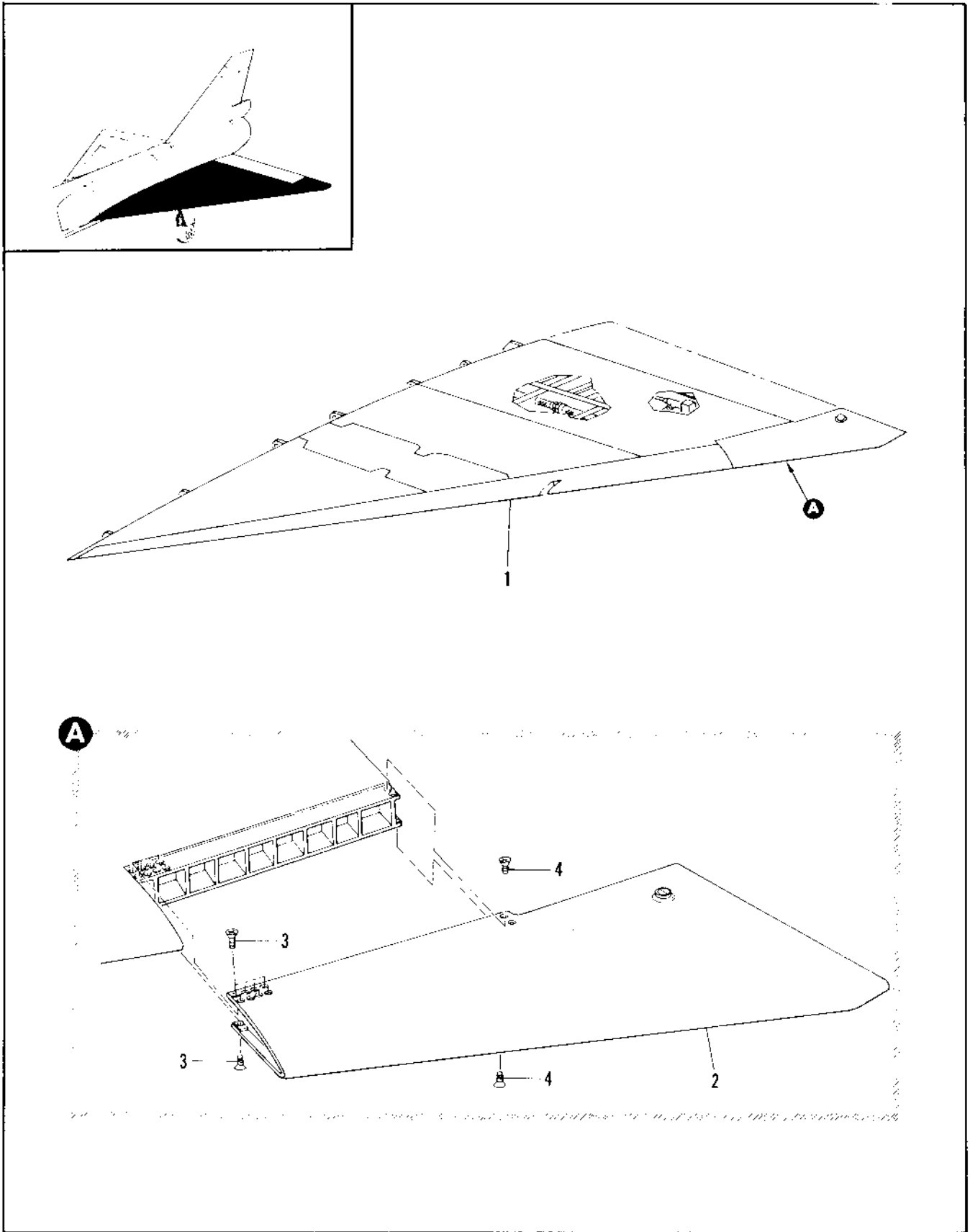

Figure 2.6-18. Wing Structure and Equipment Assembly (Sheet 1 of 2)

FIGURE AND INDEX NUMBER	PART NUMBER	DESCRIPTION	UNITS PER ASSY.	USABLE ON CODE	
				FROM	TO
		1 2 3 4 5 6			
2.6-18	8-10060-5	STRUCTURE AND EQUIPMENT ASSEMBLY, WING LH FOR NHA SEE FIG. 2.6-1	RF	A	
	8-10040-811	STRUCTURE AND EQUIPMENT ASSEMBLY, WING LH FOR NHA SEE FIG. 2.6-2	RF	278	280
	8-10040-5	STRUCTURE AND EQUIPMENT ASSEMBLY, WING LH FOR NHA SEE FIG. 2.6-2	RF	B	
	8-10060-6	STRUCTURE AND EQUIPMENT ASSEMBLY, WING RH FOR NHA SEE FIG. 2.6-1	RF	A	
	8-10040-6	STRUCTURE AND EQUIPMENT ASSEMBLY, WING RH FOR NHA SEE FIG. 2.6-2	RF	C	
- 1	8-18280-1	• LEADING EDGE INSTL, WING LH FOR BREAKDOWN SEE FIG. 2.6-20	1	A	
	8-18230-1	• LEADING EDGE INSTL, WING LH FOR BREAKDOWN SEE FIG. 2.6-21	1	B	
	8-18280-2	• LEADING EDGE INSTL, WING RH FOR BREAKDOWN SEE FIG. 2.6-20	1	A	
	8-18230-2	• LEADING EDGE INSTL, WING RH FOR BREAKDOWN SEE FIG. 2.6-21	1	B	
	8-18410-1	• TIP INSTL, WING LH USED ON SPARES ASSEMBLY 8-10060-501	1	A	
	8-18910-1	• TIP INSTL, WING LH USED ON SPARES ASSEMBLY 8-10060-502	1	B	
	8-18410-2	• TIP INSTL, WING RH USED ON SPARES ASSEMBLY 8-10040-525	1	A	
	8-18910-2	• TIP INSTL, WING RH USED ON SPARES ASSEMBLY 8-10040-526	1	B	
- 2	8-18411-1	• • TIP ASSY, WING LH FOR BREAKDOWN SEE FIG. 2.6-19	1	A	
	8-18911-1	• • TIP ASSY, WING LH FOR BREAKDOWN SEE FIG. 2.6-19	1	B	
	8-18411-2	• • TIP ASSY, WING RH FOR BREAKDOWN SEE FIG. 2.6-19	1	A	
	8-18911-2	• • TIP ASSY, WING RH FOR BREAKDOWN SEE FIG. 2.6-19	1	B	
- 3	NAS333CPA7	• • BOLT (A3295)	16	35	
- 4	NAS333CPA6-5	• • BOLT (A3205)	AP	35	
		----X----			
		A AIRPLANES #35 THRU 277, 287, 292 AND ON			
		B AIRPLANES #281 THRU 286 AND 288 THRU 291			
		C AIRPLANES #278 THRU 286 AND 288 THRU 291			

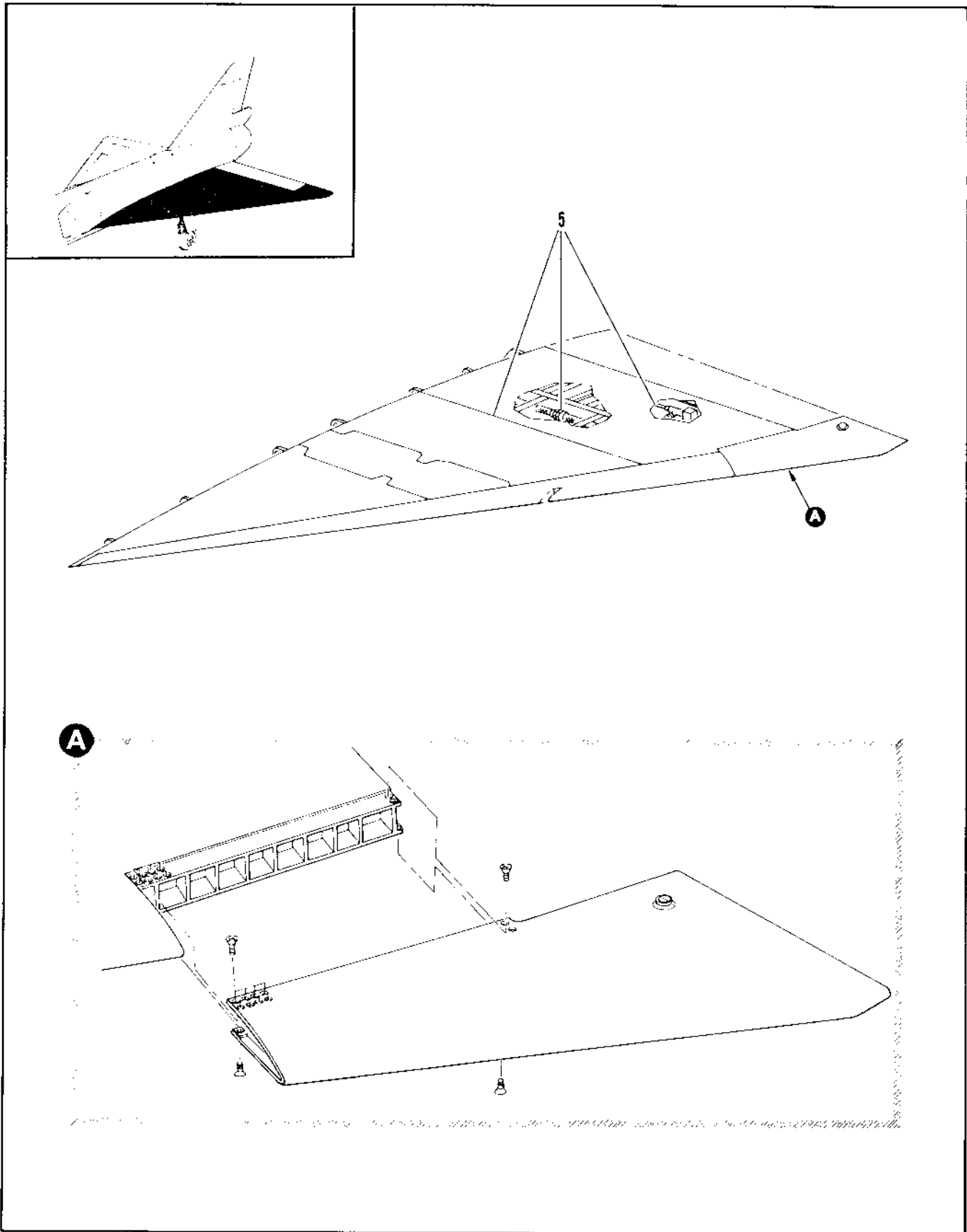

Figure 2.6-18. Wing Structure and Equipment Assembly (Sheet 2 of 2)

FIGURE AND INDEX NUMBER	PART NUMBER	DESCRIPTION	UNITS PER ASSY.	USABLE ON CODE		
				FROM	TO	
2.6-18- 5	8-18013-811	• EQUIPMENT ASSY, WING LH	1	35	89	
	8-18013-809	• EQUIPMENT ASSY, WING LH FOR BREAKDOWN SEE FIG. 2.6-32	1	90	159	
	8-18013-815	• EQUIPMENT ASSY, WING LH FOR BREAKDOWN SEE FIG. 2.6-32	1	169	188	
	8-18013-827	• EQUIPMENT ASSY, WING LH FOR BREAKDOWN SEE FIG. 2.6-32	1	189	277	
	8-18003-803	• EQUIPMENT ASSY, WING LH FOR BREAKDOWN SEE FIG. 2.6-32	1	278	286	
	8-18003-1	• EQUIPMENT ASSY, WING LH FOR BREAKDOWN SEE FIG. 2.6-32	1		B	
	8-18013-1	• EQUIPMENT ASSY, WING LH FOR BREAKDOWN SEE FIG. 2.6-32	1		D	
	8-18013-801	• EQUIPMENT ASSY, WING LH FOR BREAKDOWN SEE FIG. 2.6-32	1	302	303	
	8-18013-805	• EQUIPMENT ASSY, WING LH FOR BREAKDOWN SEE FIG. 2.6-32	1	304		
	8-18013-812	• EQUIPMENT ASSY, WING RH FOR BREAKDOWN SEE FIG. 2.6-32	1	35	89	
	8-18013-810	• EQUIPMENT ASSY, WING RH FOR BREAKDOWN SEE FIG. 2.6-32	1	90	159	
	8-18013-816	• EQUIPMENT ASSY, WING RH FOR BREAKDOWN SEE FIG. 2.6-32	1	160	188	
	8-18013-819	• EQUIPMENT ASSY, WING RH FOR BREAKDOWN SEE FIG. 2.6-32	1	189	277	
	8-18003-2	• EQUIPMENT ASSY, WING RH FOR BREAKDOWN SEE FIG. 2.6-32	1		C	
	8-18013-2	• EQUIPMENT ASSY, WING RH FOR BREAKDOWN SEE FIG. 2.6-32	1		D	
	8-18013-802	• EQUIPMENT ASSY, WING RH FOR BREAKDOWN SEE FIG. 2.6-32	1	302	313	
	8-18013-816	• EQUIPMENT ASSY, WING RH FOR BREAKDOWN SEE FIG. 2.6-32	1	330		
	B AIRPLANES #281 THRU 286 AND 288 THRU 291 C AIRPLANES #278 THRU 286 AND 288 THRU 291 D AIRPLANES #287 AND 292 THRU 311					

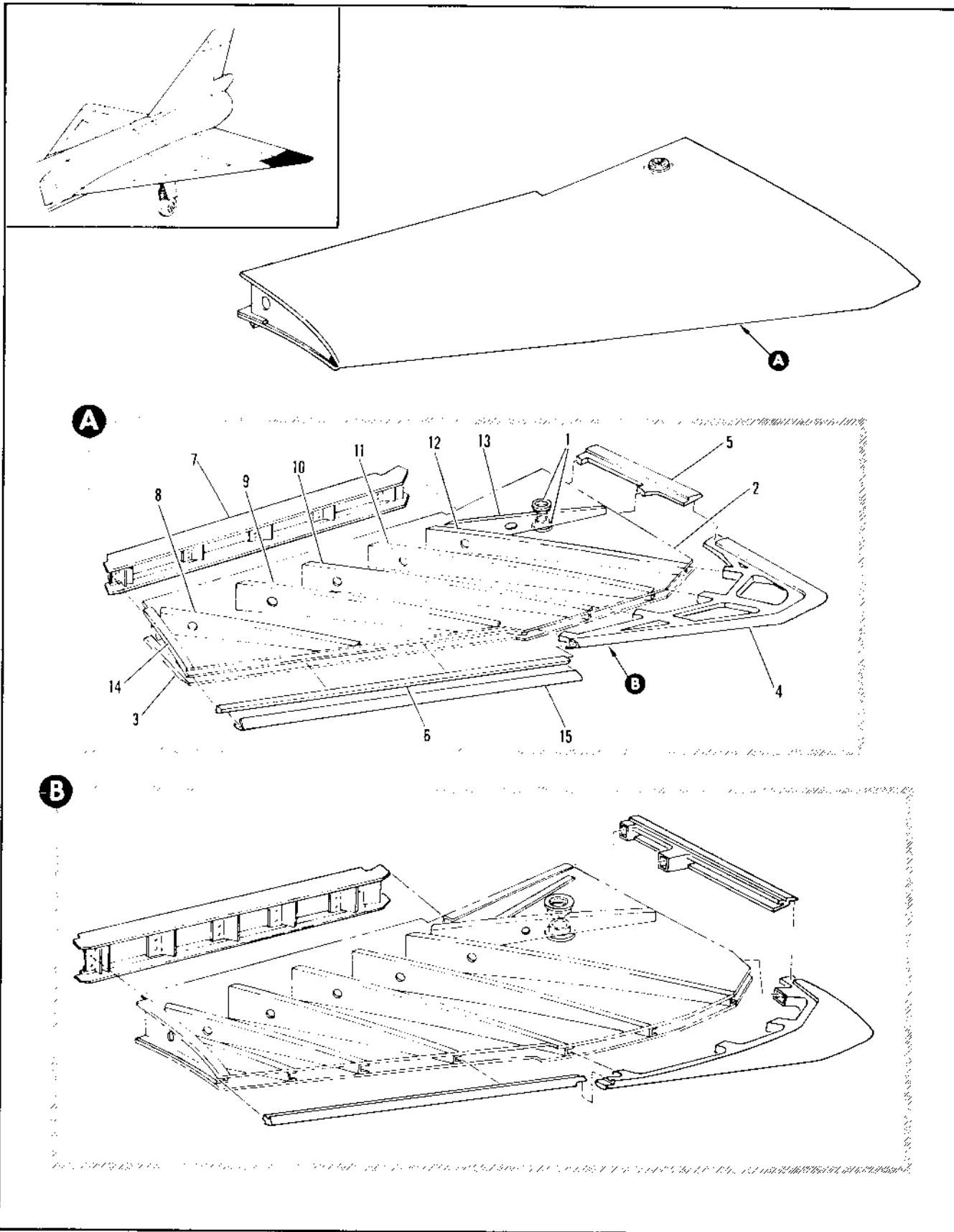

Figure 2.6-19. Wing Tips (Sheet 1 of 2)

FIGURE AND INDEX NUMBER	PART NUMBER	DESCRIPTION	UNITS PER ASSY.	USABLE ON CODE	
				FROM	TO
		1 2 3 4 5 6			
2.6-19		WING TIPS			
	8-18411-1	. TIP ASSEMBLY, WING LH FOR NHA SEE FIG. 2.6-18	RF	A	
	8-18911-1	. TIP ASSEMBLY, WING LH FOR NHA SEE FIG. 2.6-18	RF	B	
	8-18411-2	. TIP ASSEMBLY, WING RH FOR NHA SEE FIG. 2.6-18	RF	A	
	8-18911-2	. TIP ASSEMBLY, WING RH FOR NHA SEE FIG. 2.6-18	RF	B	
- 1	D6272-1	. . RETAINER, LENS <72914> 97-57500-001	2	A	
- 2	8-18401-7	. . SKIN, WING TIP PANEL UPPER LH	1	A	
	8-18401-8	. . SKIN, WING TIP PANEL UPPER RH	1	A	
- 3	8-18401-9	. . SKIN, WING TIP PANEL LOWER LH	1	A	
	8-18401-10	. . SKIN, WING TIP PANEL LOWER RH	1	A	
- 4	8-18402-13	. . WEDGE, LH REPLACE BY INTCHG WITH 8-18402-15	1	C	
	8-18402-15	. . WEDGE, LH REPLACES NOT INTCHG WITH 8-18402-13	1	39	277
	8-18402-14	. . WEDGE, RH REPLACED BY NOT INTCHG WITH 8-18402-16	1	C	
	8-18402-16	. . WEDGE, RH REPLACES NOT INTCHG WITH 8-18402-14	1	39	277
- 5	8-18402-9	. . WEDGE, LH REPLACES NOT INTCHG WITH 8-18902-9	1	A	
	8-18402-10	. . WEDGE, RH REPLACES NOT INTCHG WITH 8-18902-10	1	A	
- 6	8-18402-11	. . WEDGE, LH REPLACES NOT INTCHG WITH 8-18902-11	1	C	
	8-18402-12	. . WEDGE, RH REPLACES NOT INTCHG WITH 8-18902-12	1	C	
- 7	8-18403-1	. . SPAR ASSY, WING TIP LH	1	A	
	8-18403-2	. . SPAR ASSY, WING TIP RH	1	A	
	8-18403-7	. . . RAIL, LH	1	A	
	8-18403-8	. . . RAIL, RH	1	A	
	8-18403-9	. . . RAIL, LH	1	A	
	8-18403-10	. . . RAIL, RH	1	A	
- 8	8-18404-25	. . RIB ASSY, WING TIP LH	1	A	
	8-18404-26	. . RIB ASSY, WING TIP RH	1	A	
- 9	8-18404-27	. . RIB ASSY, WING TIP LH	1	A	
	8-18404-28	. . RIB ASSY, WING TIP RH	1	A	
- 10	8-18404-29	. . RIB ASSY, WING TIP LH	1	A	
	8-18404-30	. . RIB ASSY, WING TIP RH	1	A	
- 11	8-18404-31	. . RIB ASSY, WING TIP LH	1	A	
	8-18404-32	. . RIB ASSY, WING TIP RH	1	A	
- 12	8-18404-33	. . RIB ASSY, WING TIP LH	1	A	
	8-18404-34	. . RIB ASSY, WING TIP RH	1	A	
- 13	8-18404-35	. . RIB ASSY, WING TIP LH	1	A	
	8-18404-36	. . RIB ASSY, WING TIP RH	1	A	
- 14	8-18404-37	. . RIB ASSY, WING TIP LH	1	A	
	8-18404-38	. . RIB ASSY, WING TIP RH	1	A	
- 15	8-18411-15	. . CAP, LH	1	A	
	8-18411-16	. . CAP, RH	1	A	

A AIRPLANES #35 THRU 277, 287, 292 AND ON
 B AIRPLANES #278 THRU 286 AND 288 THRU 291
 C AIRPLANES #35 THRU 38, 287, 292 AND ON

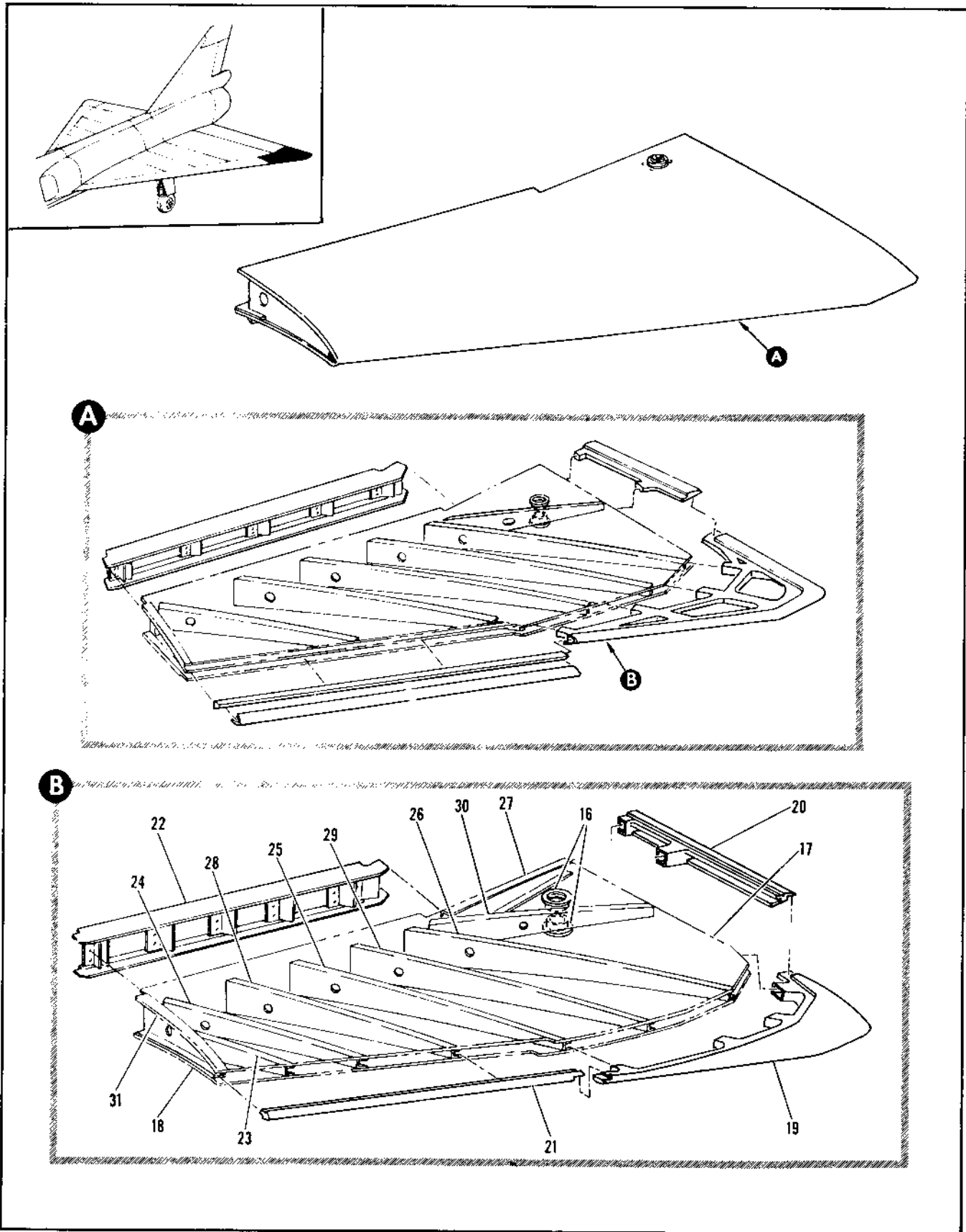

Figure 2.6-19. Wing Tips (Sheet 2 of 2)

FIGURE AND INDEX NUMBER	PART NUMBER	DESCRIPTION	UNITS PER ASSY.	USABLE ON CODE	
				FROM	TO
		1 2 3 4 5 6			
2.6-19- 16	D0272-1	. . . RETAINER, LENS <72514> 97-57500.101	1	B	
- 17	8-18901-7	. . . SKIN, WING TIP PANEL UPPER LH	1	R	
	8-18901-8	. . . SKIN, WING TIP PANEL UPPER RH	1	R	
- 18	8-18901-9	. . . SKIN, WING TIP PANEL LOWER LH	1	B	
	8-18901-10	. . . SKIN, WING TIP PANEL LOWER RH	1	R	
- 19	8-18902-7	. . . WEDGE, WING TIP LH	1	B	
	8-18902-8	. . . WEDGE, WING TIP RH	1	B	
- 20	8-18902-9	. . . WEDGE, WING TIP LH REPLACED BY NOT INTCHG WITH 8-18402-9	1	B	
	8-18902-10	. . . WEDGE, WING TIP RH REPLACED BY NOT INTCHG WITH 8-18402-10	1	P	
- 21	8-18902-11	. . . WEDGE, WING TIP LH REPLACED BY NOT INTCHG WITH 8-18402-11	1	R	
	8-18902-12	. . . WEDGE, WING TIP RH REPLACED BY NOT INTCHG WITH 8-18402-12	1	B	
- 22	8-18903-1	. . . SPAR ASSY, WING TIP LH	1	R	
	8-18903-2	. . . SPAR ASSY, WING TIP RH	1	B	
	8-18903-3	. . . RAIL, LH	1	R	
	8-18903-4	. . . RAIL, RH	1	R	
	8-18903-5	. . . RAIL, LH	1	B	
	8-18903-6	. . . RAIL, RH	1	R	
- 23	8-18904-7	. . . RIB, LH	1	B	
	8-18904-8	. . . RIB, RH	1	R	
- 24	8-18904-9	. . . RIB, LH	1	B	
	8-18904-10	. . . RIB, RH	1	R	
- 25	8-18904-11	. . . RIB, LH	1	B	
	8-18904-12	. . . RIB, RH	1	R	
- 26	8-18904-13	. . . RIB, LH	1	B	
	8-18904-14	. . . RIB, RH	1	R	
- 27	8-18904-15	. . . RIB, LH	1	B	
	8-18904-16	. . . RIB, RH	1	R	
- 28	8-18904-17	. . . RIB ASSY, WING TIP LH	1	B	
	8-18904-18	. . . RIB ASSY, WING TIP RH	1	R	
	8-18904-19	. . . RIB, LH	1	B	
	8-18904-20	. . . RIB, RH	1	R	
- 29	8-18904-21	. . . RIB ASSY, WING TIP LH	1	B	
	8-18904-22	. . . RIB ASSY, WING TIP RH	1	R	
	8-18904-23	. . . RIB, LH	1	B	
	8-18904-24	. . . RIB, RH	1	R	
- 30	8-18904-25	. . . RIB ASSY, WING TIP LH	1	B	
	8-18904-26	. . . RIB ASSY, WING TIP RH	1	R	
	8-18904-27	. . . RIB, LH	1	B	
	8-18904-28	. . . RIB, RH	1	R	
- 31	8-18904-29	. . . RIB ASSY, WING TIP LH	1	B	
	8-18904-30	. . . RIB ASSY, WING TIP RH	1	R	
	8-18904-31	. . . RIB, LH	1	B	
	8-18904-32	. . . RIB, RH	1	R	
	8-18904-33	. . . RIB, LH	1	B	
	8-18904-34	. . . RIB, RH	1	R	
		R AIRPLANES #276 THRU 286 AND 288 THRU 291			

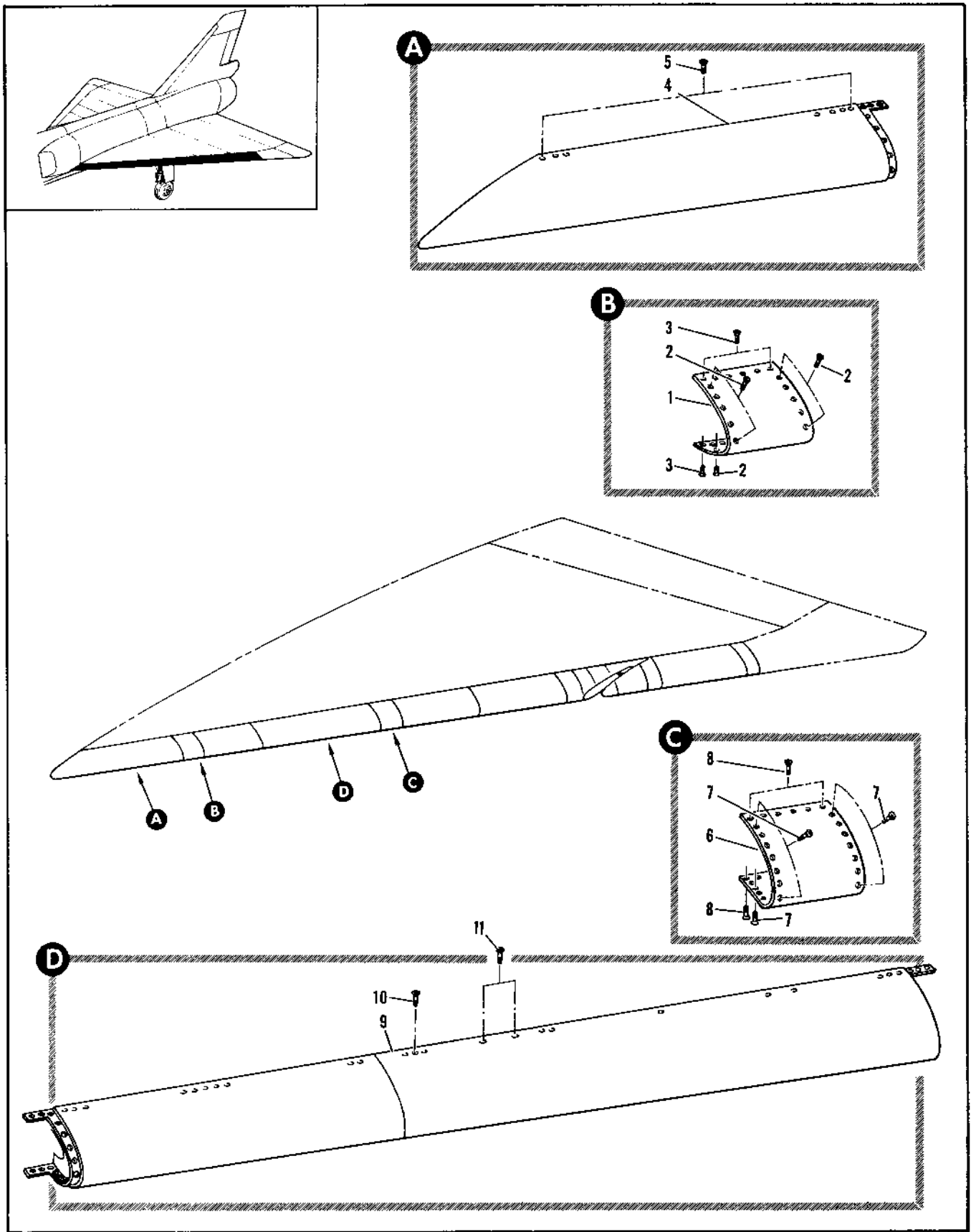

Figure 2.6-20. Wing Leading Edge Installation (Sheet 1 of 3)

FIGURE AND INDEX NUMBER	PART NUMBER	DESCRIPTION	UNITS PER ASSY.	USABLE ON CODE	
				FROM	TO
2.6-20	8-18280-1	LEADING EDGE INSTALLATION, WING LH MODIFIED BY 8-11904 FOR NHA SEE FIG. 2.6-1P USED ON SPARES ASSEMBLY 8-10060-501	6F		A
	8-18280-2	LEADING EDGE INSTALLATION, WING RH MODIFIED BY 8-11904 FOR NHA SEE FIG. 2.6-1R USED ON SPARES ASSEMBLY 8-10060-502	RF		A
- 1	8-18281-7	• PANEL, LH	1		A
	8-18281-8	• PANEL, RH	1		A
		ATTACHING PARTS			
- 2	NAS333CPA4	• BOLT (#205)	18		A
	NAS333CPA5	• BOLT (#205)	12		A
		-----X-----			
- 4	8-18251-1	• LEADING EDGE ASSY, CAMBERED STUP LH FOR BREAKDOWN SEE FIG. 2.6-22	1		A
	8-18251-2	• LEADING EDGE ASSY, CAMBERED STUP RH FOR BREAKDOWN SEE FIG. 2.6-22	1		A
		ATTACHING PARTS			
- 5	NAS333CPA5	• BOLT (#205)	48		A
		-----X-----			
- 6	8-18281-9	• PANEL, LH	1		A
	8-18281-10	• PANEL, RH	1		A
		ATTACHING PARTS			
- 7	NAS333CPA4	• BOLT (#205)	26		A
	NAS333CPA5	• BOLT (#205)	12		A
		-----X-----			
- 9	8-18252-3	• LEADING EDGE ASSY, STA 145 TO 216 LH REPLACED BY NOT INTCHG WITH 8-18252-5 MODIFIED BY 8-18992 FOR BREAKDOWN SEE FIG. 2.6-24	1		B
	8-18252-1	• LEADING EDGE ASSY, STA 145 TO 216 LH ALT INTCHG WITH 8-18252-3 FOR BREAKDOWN SEE FIG. 2.6-24	RF		B
	8-18252-5	• LEADING EDGE ASSY, STA 145 TO 216 LH REPLACES NOT INTCHG WITH 8-18252-3 FOR BREAKDOWN SEE FIG. 2.6-24	1	49	277
	8-18252-4	• LEADING EDGE ASSY, STA 145 TO 216 RH REPLACED BY NOT INTCHG WITH 8-18252-6 MODIFIED BY 8-18992 FOR BREAKDOWN SEE FIG. 2.6-24	1		B
	8-18252-2	• LEADING EDGE ASSY, STA 145 TO 216 RH ALT INTCHG WITH 8-18252-4 FOR BREAKDOWN SEE FIG. 2.6-24	RF		B
	8-18252-6	• LEADING EDGE ASSY, STA 145 TO 216 RH REPLACES NOT INTCHG WITH 8-18252-4 FOR BREAKDOWN SEE FIG. 2.6-24	1	49	277
		ATTACHING PARTS			
- 10	NAS333CPA5	• BOLT (#205)	6R		A
	NAS333CPA6	• BOLT, UPPER (#205)	2		A
		-----X-----			
		A AIRPLANES #35 THRU 277, 287, 292 AND ON			
		B AIRPLANES #35 THRU 48, 287, 292 AND ON			

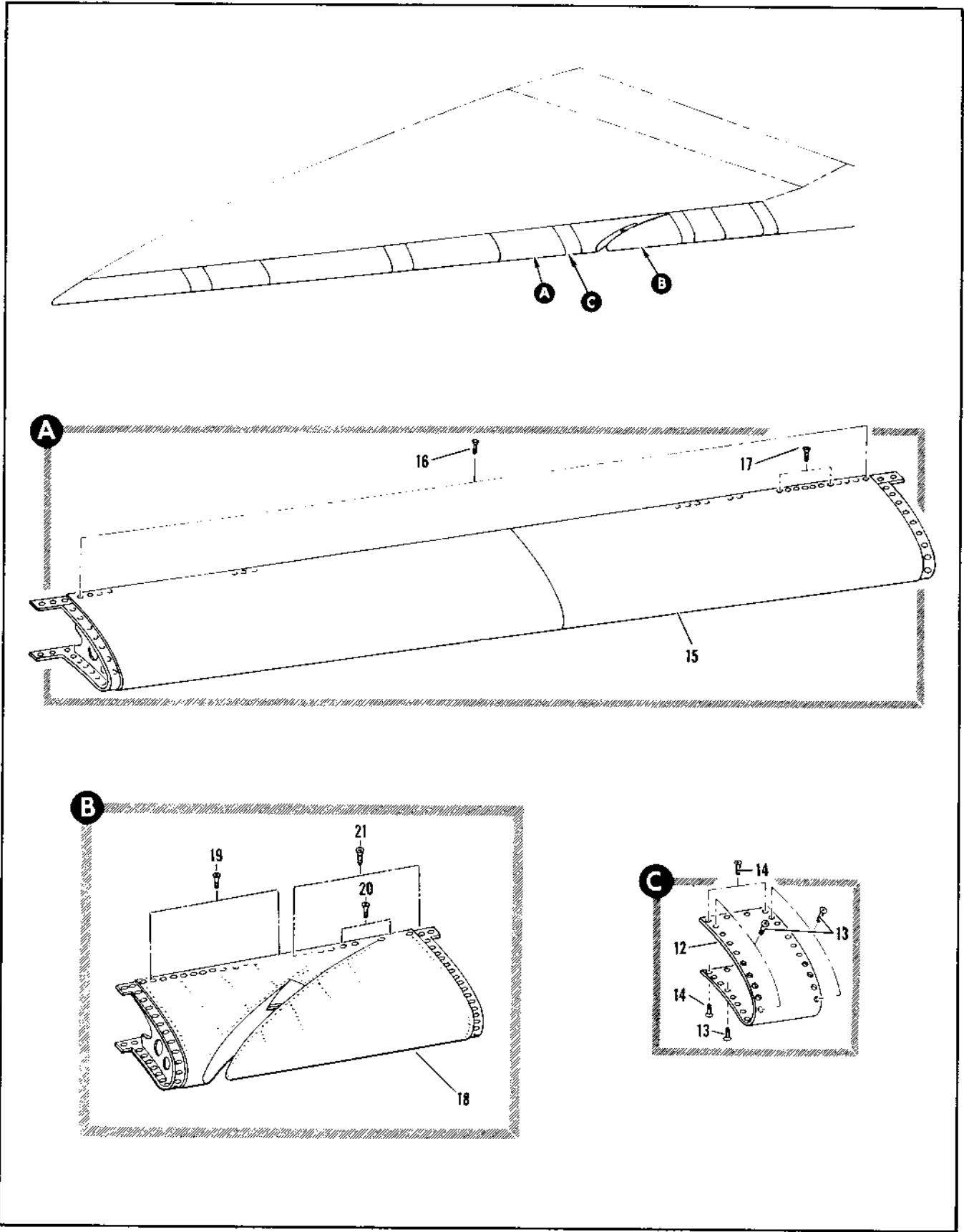

Figure 2.6-20. Wing Leading Edge Installation (Sheet 2 of 3)

FIGURE AND INDEX NUMBER	PART NUMBER	DESCRIPTION	UNITS PER ASSY.	USABLE ON CODE	
				FROM	TO
		1 2 3 4 5 6			
2.6-20- 12	8-18281-11	• PANEL, LH	1	A	
	8-18281-12	• PANEL, RH	1	A	
- 13	NAS333CPA4	ATTACHING PARTS	36	A	
- 14	NAS333CPA5	• BOLT (80205)	8	A	
		• BOLT (80205)			
		-----X-----			
- 15	8-18253-3	• LEADING EDGE ASSY, STA 221 TO 297 LH FOR BREAKDOWN SEE FIG. 2.6-26	1	A	
	8-18253-1	• LEADING EDGE ASSY, STA 221 TO 297 LH ALT INTCHG WITH 8-18253-3 FOR BREAKDOWN SEE FIG. 2.6-26	RF	A	
	8-18253-4	• LEADING EDGE ASSY, STA 221 TO 297 RH FOR BREAKDOWN SEE FIG. 2.6-26	1	A	
	8-18253-2	• LEADING EDGE ASSY, STA 221 TO 297 RH ALT INTCHG WITH 8-18253-4 FOR BREAKDOWN SEE FIG. 2.6-26	RF	A	
		ATTACHING PARTS			
- 16	NAS333CPA5	• BOLT (80205)	94	A	
- 17	NAS333CPA6	• BOLT (80205)	14	A	
		-----X-----			
- 18	8-18254-3	• LEADING EDGE ASSY, SLOTTED STA 301 TO 334 LH FOR BREAKDOWN SEE FIG. 2.6-28	1	35	48
	8-18256-1	• LEADING EDGE ASSY, SLOTTED STA 301 TO 334 LH FOR BREAKDOWN SEE FIG. 2.6-28	1	C	
	8-18254-4	• LEADING EDGE ASSY, SLOTTED STA 301 TO 334 RH FOR BREAKDOWN SEE FIG. 2.6-28	1	35	48
	8-18256-2	• LEADING EDGE ASSY, SLOTTED STA 301 TO 334 RH FOR BREAKDOWN SEE FIG. 2.6-28	1	C	
		ATTACHING PARTS			
- 19	NAS333CPA5	• BOLT (80205)	42	A	
- 20	NAS333CPA6	• BOLT, UPPER (80205)	2	A	
- 21	NAS333CPA5	• BOLT, UPPER (80205)	4	B	
	NAS333CPA5	• BOLT, LOWER (80205)	8	B	
		-----X-----			
		A AIRPLANES #35 THRU 277, 287, 292 AND ON			
		B AIRPLANES #35 THRU 48, 287, 292 AND ON			
		C AIRPLANES #49 THRU 277, 287, 292 AND ON			

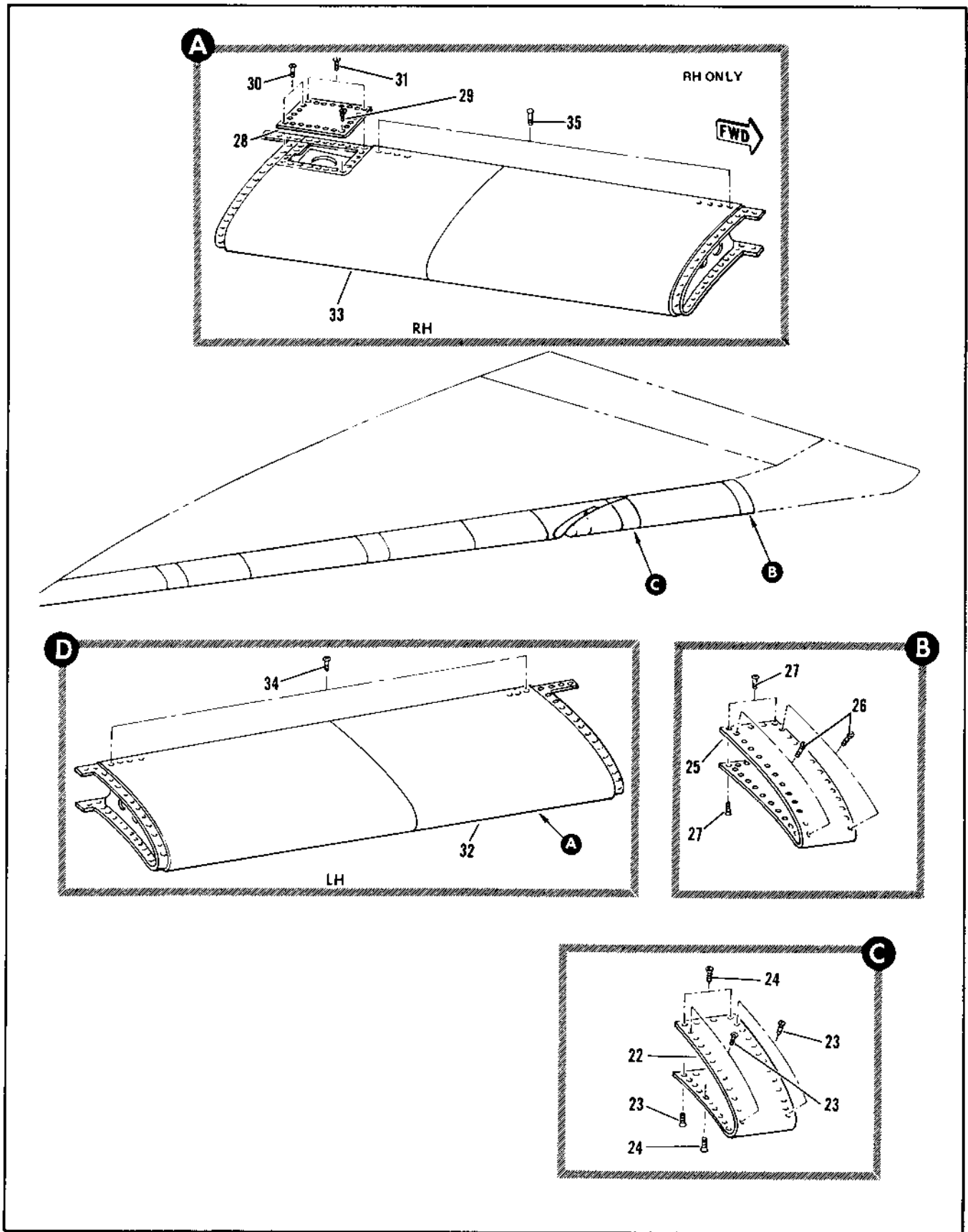

Figure 2.6-20. Wing Leading Edge Installation (Sheet 3 of 3)

FIGURE AND INDEX NUMBER	PART NUMBER	DESCRIPTION	UNITS PER ASSY.	USABLE ON CODE	
				FROM	TO
		1 2 3 4 5 6			
2.6-20- 22	8-18281-13 8-18281-14	• PANEL, LH • PANEL, RH	1 1	A A	
- 23	NAS333CPA4	ATTACHING PARTS • BOLT (80205)	42	A	
- 24	NAS333CPA5	• BOLT (80205) -----X-----	8	A	
- 25	8-18281-1 8-18281-2	• PANEL ASSY, LH RIVETED • PANEL ASSY, RH RIVETED	1 1	A A	
- 26	NAS333CPA4	ATTACHING PARTS • BOLT (80205)	46	A	
- 27	NAS333CPA5	• BOLT (80205) -----X-----	8	A	
- 28	8-18281-15	• DOOR, UPPER RH ATTACHING PARTS	1	A	
- 29	NAS560HK-3-1	• SCREW (80205)	11	A	
- 30	NAS560HK-3P2	• SCREW (80205)	6	A	
- 31	NAS560HK-3-3	• SCREW (80205) -----X-----	10	A	
- 32	8-18255-3 8-18255-1	• LEADING EDGE ASSY, STA 339 TO 384 LH FOR BREAKDOWN SEE FIG. 2.6-30 • LEADING EDGE ASSY, STA 339 TO 384 LH ALT INTCHG WITH 8-18255-3 FOR BREAKDOWN SEE FIG. 2.6-30	1 RF	A A	
- 33	8-18255-4 8-18255-2	• LEADING EDGE ASSY, STA 339 TO 384 RH FOR BREAKDOWN SEE FIG. 2.6-30 • LEADING EDGE ASSY, STA 339 TO 384 RH ALT INTCHG WITH 8-18255-4 FOR BREAKDOWN SEE FIG. 2.6-30 ATTACHING PARTS	1 RF	A A	
- 34	NAS333CPA5	• BOLT, LH (80205)	AR	A	
- 35	NAS333CPA5	• BOLT, RH (80205) -----X-----	86	A	
A AIRPLANES #35 THRU 277, 287, 292 AND ON					

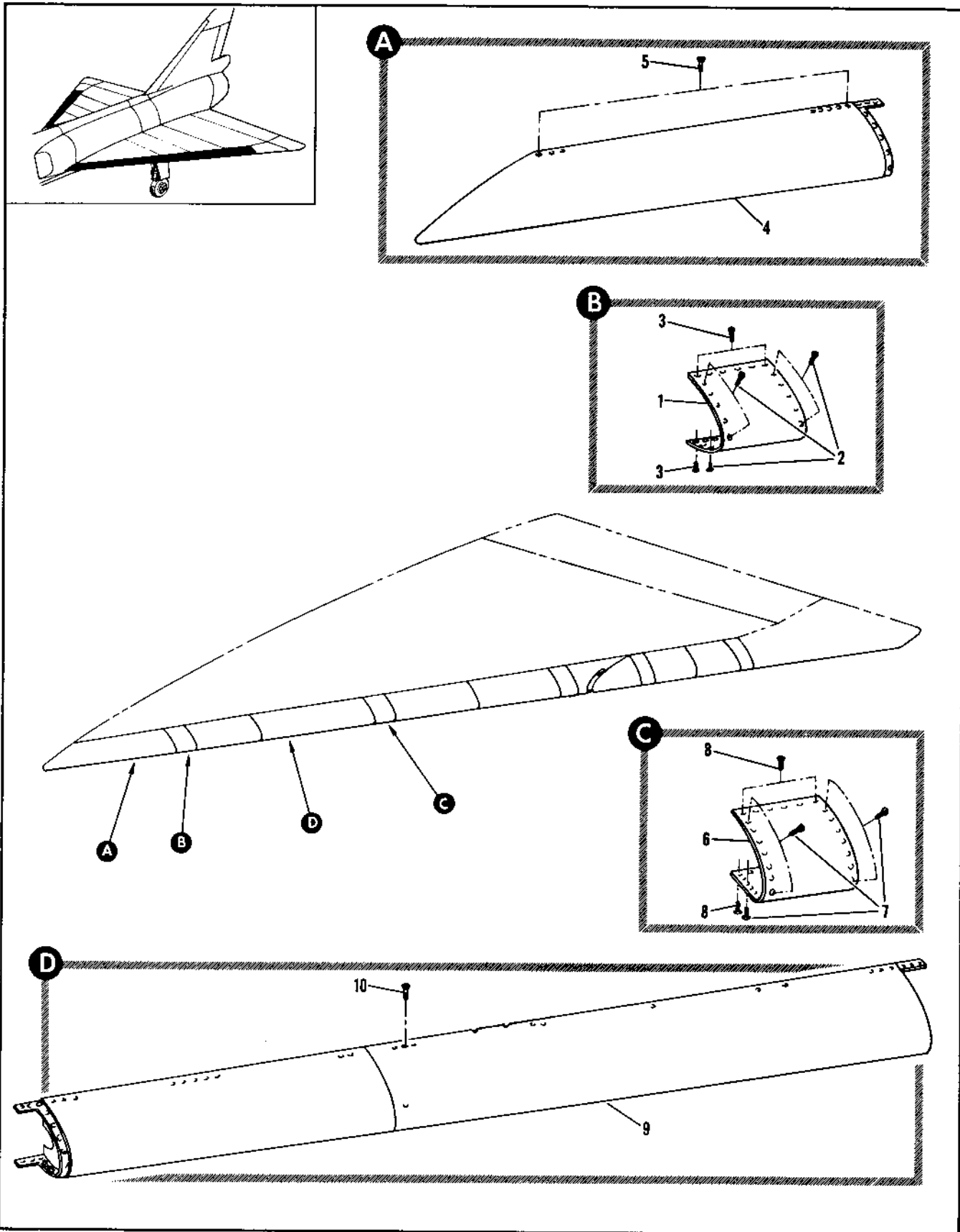

Figure 2.6-21. Wing Leading Edge Installation (Sheet 1 of 3)

FIGURE AND INDEX NUMBER	PART NUMBER	DESCRIPTION	UNITS PER ASSY.	USABLE ON CODE		
				FROM	TO	
2.6-21	8-18230-1	LEADING EDGE INSTALLATION, WING LH FOR NHA SEE FIG. 2.6-18 USED ON SPARES ASSEMBLY 9-10040-525	RF		A	
	8-18230-2	LEADING EDGE INSTALLATION, WING RH FOR NHA SEE FIG. 2.6-18 USED ON SPARES ASSEMBLY 9-10040-526	RF		A	
	- 1	8-18231-1 8-18231-007	• PANEL ASSY, LH BONDED • PANEL ASSY, LH WELDED ALT INTCHG WITH 8-18231-1	1 RF		A A
	- 2	8-18231-2 8-18231-008	• PANEL ASSY, RH BONDED • PANEL ASSY, RH WELDED ALT INTCHG WITH 8-18231-2	1 RF		A A
	- 3	NAS333CPA4	• ATTACHING PARTS • SCREW (C0205)	1R		A
	- 4	NAS333CPA5	• SCREW (C0205) -----X-----	12		A
	- 5	8-18201-1	• LEADING EDGE ASSY, CAMBERED STUF LH FOR BREAKDOWN SEE FIG. 2.6-23	1		A
	- 6	8-18201-2	• LEADING EDGE ASSY, CAMBERED STUF RH FOR BREAKDOWN SEE FIG. 2.6-23 ATTACHING PARTS	1		A
	- 7	NAS333CPA5	• SCREW (C0205) -----X-----	4R		A
	- 8	8-18231-3 8-18231-009	• PANEL ASSY, LH BONDED • PANEL ASSY, LH WELDED ALT INTCHG WITH 8-18231-3	1 RF		A A
	- 9	8-18231-4 8-18231-010	• PANEL ASSY, RH BONDED • PANEL ASSY, RH WELDED ALT INTCHG WITH 8-18231-4 ATTACHING PARTS	1 RF		A A
	- 10	NAS333CPA4	• SCREW (C0205)	26		A
	- 11	NAS333CPA5	• SCREW (C0205) -----X-----	12		A
	- 12	8-18202-1	• LEADING EDGE ASSY, STA 144 TO 216 L MODIFIED BY 8-18990-1 FOR BREAKDOWN SEE FIG. 2.6-25	1		A
	- 13	8-18202-2	• LEADING EDGE ASSY, STA 144 TO 216 RH MODIFIED BY 8-18990-4 NOT INTCHG WITH 8-18202-502 FOR BREAKDOWN SEE FIG. 2.6-25 ATTACHING PARTS	1		A
- 14	NAS333CPA5	• SCREW (C0205) -----X-----	AR		A	

A AIRPLANES #278 THRU 286 AND 288 THRU 291

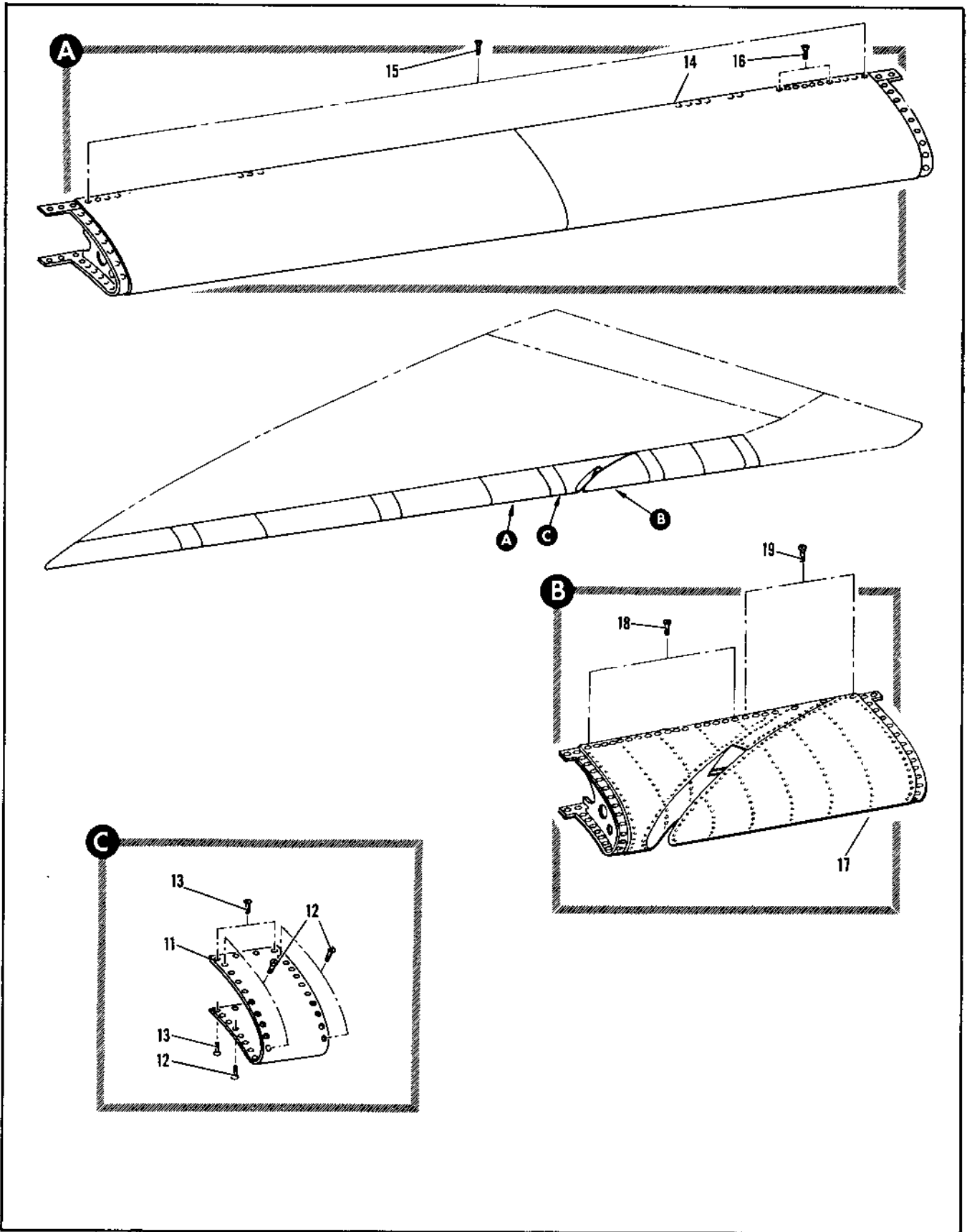

Figure 2.6-21. Wing Leading Edge Installation (Sheet 2 of 3)

FIGURE AND INDEX NUMBER	PART NUMBER	DESCRIPTION 1 2 3 4 5 6	UNITS PER ASSY.	USABLE ON CODE	
				FROM	TO
2.6-21- 11	8-18231-5	• PANEL ASSY, LH BONDED	1	A	
	8-18231-811	• PANEL ASSY, LH WELDED ALT INTCHG WITH 8-18231-5	RF	A	
	8-18231-6	• PANEL ASSY, RH BONDED	1	A	
	8-18231-812	• PANEL ASSY, RH WELDED ALT INTCHG WITH 8-18231-6	RF	A	
		ATTACHING PARTS			
- 12	NAS333CPA4	• SCREW (#2205)	36	A	
- 13	NAS333CPA5	• SCREW (#2205)	8	A	
		----X----			
- 14	8-18203-1	• LEADING EDGE ASSY, STA 221 TO 297 LH FOR BREAKDOWN SEE FIG. 2.6-27	1	A	
	8-18203-2	• LEADING EDGE ASSY, STA 221 TO 297 RH FOR BREAKDOWN SEE FIG. 2.6-27	1	A	
		ATTACHING PARTS			
- 15	NAS333CPA5	• SCREW (#2205)	94	A	
- 16	NAS333CPA6	• SCREW (#2205)	14	A	
		----X----			
- 17	8-18204-3	• LEADING EDGE ASSY, SLOTTED STA 301 TO 334 LH FOR BREAKDOWN SEE FIG. 2.6-29	1	A	
	8-18204-4	• LEADING EDGE ASSY, SLOTTED STA 301 TO 334 RH MODIFIED BY 8-18990 FOR BREAKDOWN SEE FIG. 2.6-29	1	A	
		ATTACHING PARTS			
- 18	NAS333CPA5	• SCREW (#2205)	42	A	
- 19	NAS333CPA5	• SCREW, UPPER (#2205)	6	A	
	NAS333CPA5	• SCREW, LOWER (#2205)	8	A	
		----X----			
A AIRPLANES #278 THRU 286 AND 288 THRU 291					

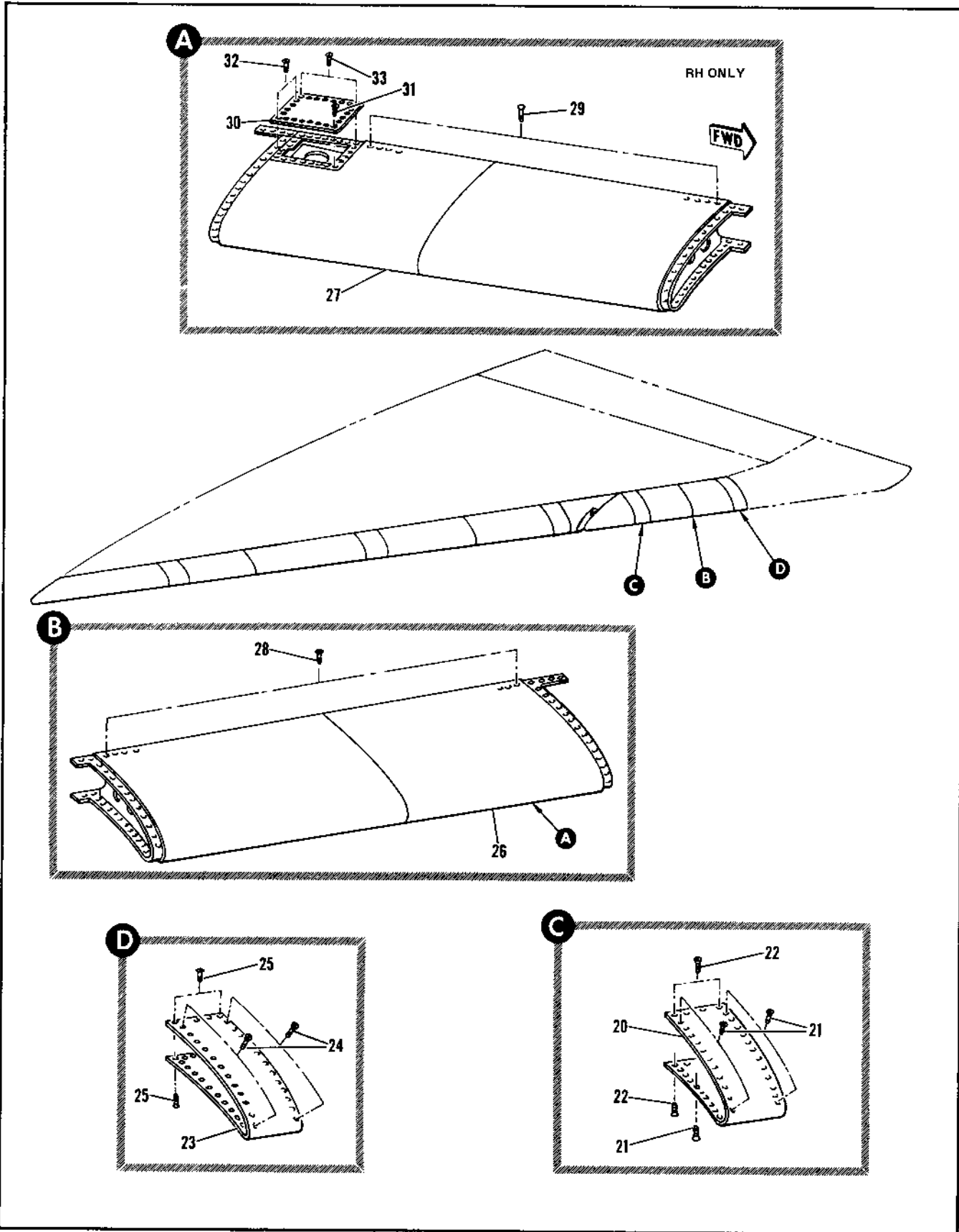

Figure 2.6-21. Wing Leading Edge Installation (Sheet 3 of 3)

FIGURE AND INDEX NUMBER	PART NUMBER	DESCRIPTION	UNITS PER ASSY.	USABLE ON CODE	
				FROM	TO
		1 2 3 4 5 6			
2.6-21- 20	8-18231-801 8-18231-813	• PANEL ASSY, LH BONDED • PANEL ASSY, LH WELDED ALT INTCHG WITH 8-18231-801	1 RF	A A	
	8-18231-802 8-18231-814	• PANEL ASSY, RH BONDED • PANEL ASSY, RH WELDED ALT INTCHG WITH 8-18231-802	1 RF	A A	
- 21	NAS333CPA4	• SCREW (#0205)	42	A	
- 22	NAS333CPA5	• SCREW (#0205) ----X----	8	A	
- 23	8-18231-805 8-18231-817	• PANEL ASSY, LH BONDED • PANEL ASSY, LH WELDED ALT INTCHG WITH 8-18231-805	1 RF	A A	
	8-18231-806 8-18231-818	• PANEL ASSY, RH BONDED • PANEL ASSY, RH WELDED ALT INTCHG WITH 8-18231-806	1 RF	A A	
- 24	NAS333CPA4	• SCREW (#0205)	46	A	
- 25	NAS333CPA5	• SCREW (#0205) ----X----	8	A	
- 26	8-18205-1	• LEADING EDGE ASSY, STA 338 TO 364 LH FOR BREAKDOWN SEE FIG. 2.6-31	1	A	
- 27	8-18205-2	• LEADING EDGE ASSY, STA 338 TO 364 RH FOR BREAKDOWN SEE FIG. 2.6-31	1	A	
		ATTACHING PARTS			
- 28	NAS333CPA5	• SCREW, LH (#0205)	90	A	
- 29	NAS333CPA5	• SCREW, RH (#0205) ----X----	74	A	
- 30	8-18231-803 8-18231-815	• DOOR ASSY, UPPER RH BONDED • DOOR ASSY, UPPER RH WELDED ALT INTCHG WITH 8-18231-803	1 RF	A A	
		ATTACHING PARTS			
- 31	NAS560HK-3-1	• SCREW (#0205)	11	A	
- 32	NAS560HK-3P2	• SCREW (#0205)	6	A	
- 33	NAS560HK-3-3	• SCREW (#0205) ----X----	8	A	
A AIRPLANES #278 THRU 286 AND 288 THRU 291					

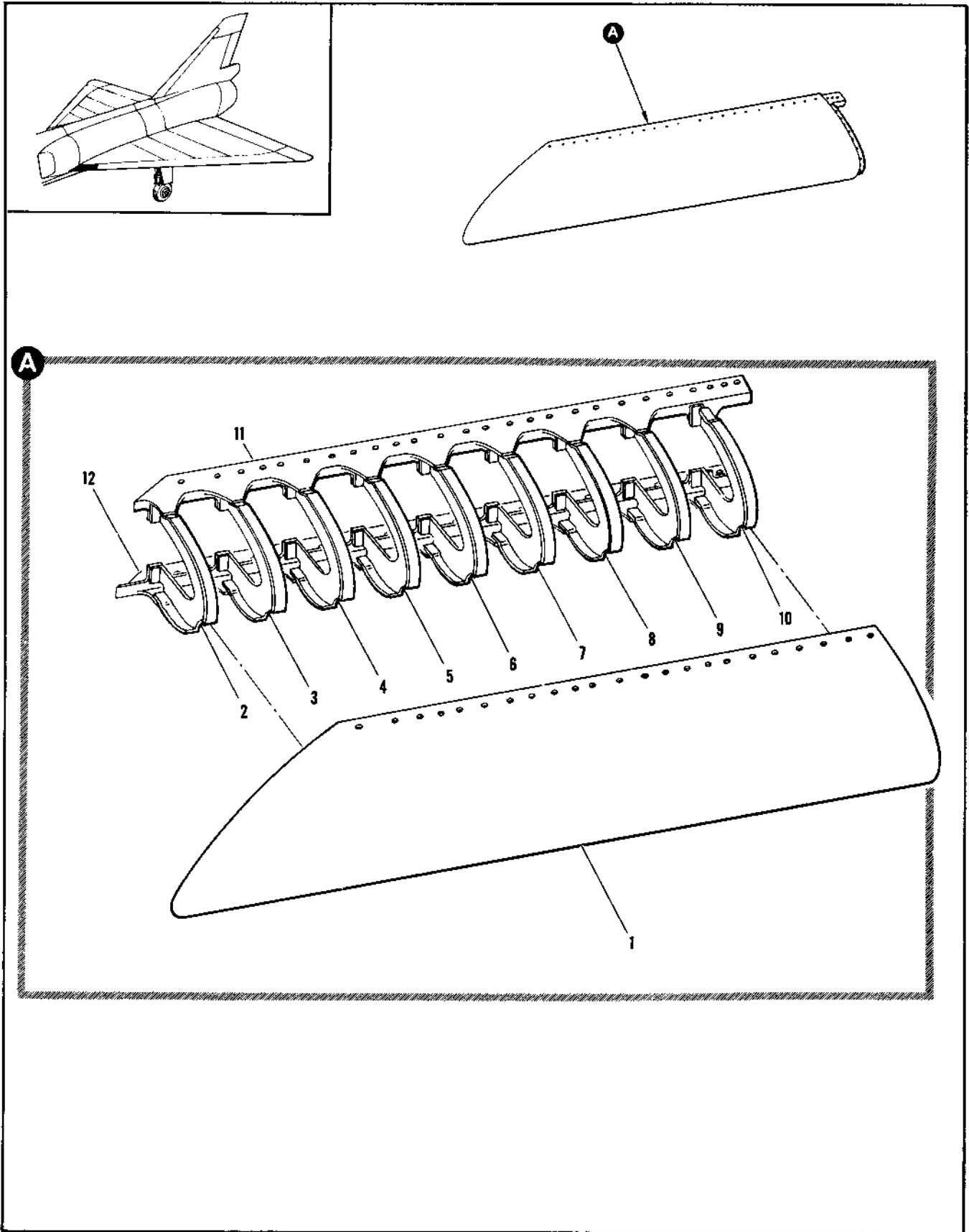

Figure 2.6-22. Wing Cambered Stub Leading Edge Assembly

FIGURE AND INDEX NUMBER	PART NUMBER	DESCRIPTION	UNITS PER ASSY.	USABLE ON CODE	
				FROM	TO
2.6-22	8-18251-1	LEADING EDGE ASSEMBLY, WING CAMBERED STUB LH FOR NHA SEE FIG. 2.6-20	RF	A	
	8-18251-2	LEADING EDGE ASSEMBLY, WING CAMBERED STUB RH FOR NHA SEE FIG. 2.6-20	RF	A	
	- 1	8-18251-7 • SKIN, LH	1	A	
		8-18251-8 • SKIN, RH	1	A	
	- 2	8-18261-7 • RIB, LH	1	A	
		8-18261-8 • RIB, RH	1	A	
	- 3	8-18261-9 • RIB, LH	1	A	
		8-18261-10 • RIB, RH	1	A	
	- 4	8-18261-11 • RIB, LH	1	A	
		8-18261-12 • RIB, RH	1	A	
	- 5	8-18261-13 • RIB, LH	1	A	
		8-18261-14 • RIB, RH	1	A	
	- 6	8-18261-15 • RIB, LH	1	A	
	8-18261-16 • RIB, RH	1	A		
- 7	8-18261-17 • RIB, LH	1	A		
	8-18261-18 • RIB, RH	1	A		
- 8	8-18261-19 • RIB, LH	1	A		
	8-18261-20 • RIB, RH	1	A		
- 9	8-18261-21 • RIB, LH	1	A		
	8-18261-22 • RIB, RH	1	A		
- 10	8-18261-23 • RIB, LH	1	A		
	8-18261-24 • RIB, RH	1	A		
- 11	8-18271-7 • RAIL, LH	1	A		
	8-18271-8 • RAIL, RH	1	A		
- 12	8-18271-9 • RAIL, LH	1	A		
	8-18271-10 • RAIL, RH	1	A		

A AIRPLANES #35 THRU 277, 297, 292 AND ON

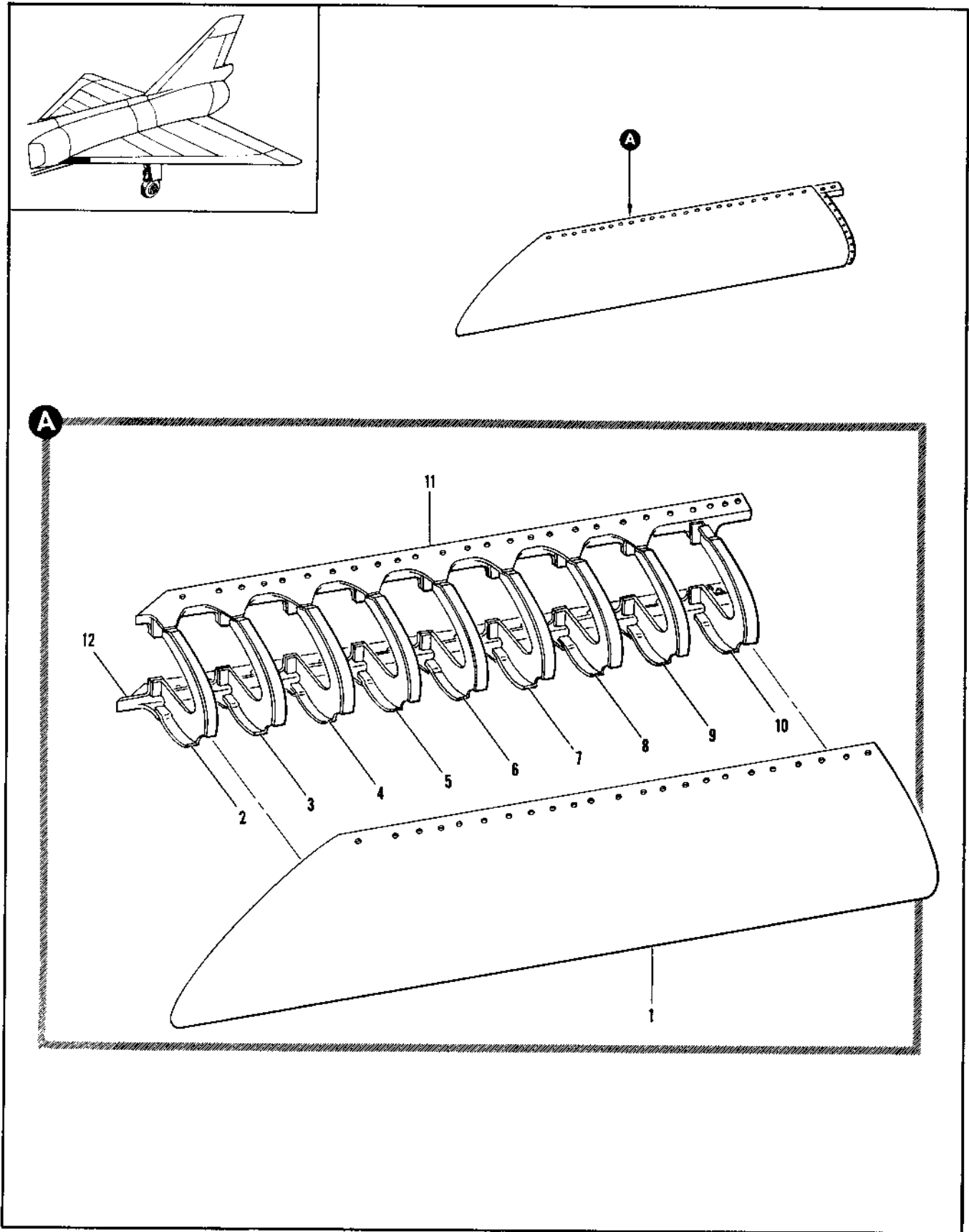

Figure 2.6-23. Wing Cambered Stub Leading Edge Assembly

FIGURE AND INDEX NUMBER	PART NUMBER	DESCRIPTION	UNITS PER ASSY.	USABLE ON CODE	
				FROM	TO
		1 2 3 4 5 6			
2.6-23	8-18201-1	LEADING EDGE ASSEMBLY, WING CAMBERED STUB LH FOR NHA SEE FIG. 2.6-20	RF	A	
	8-18201-2	LEADING EDGE ASSEMBLY, WING CAMBERED STUB RH FOR NHA SEE FIG. 2.6-20	RF	A	
- 1	8-18201-7	. SKIN, LH	1	A	
	8-18201-8	. SKIN, RH	1	A	
- 2	8-18211-7	. RIB, LH	1	A	
	8-18211-8	. RIB, RH	1	A	
- 3	8-18211-9	. RIB, LH	1	A	
	8-18211-10	. RIB, RH	1	A	
- 4	8-18211-11	. RIB, LH	1	A	
	8-18211-12	. RIB, RH	1	A	
- 5	8-18211-13	. RIB, LH	1	A	
	8-18211-14	. RIB, RH	1	A	
- 6	8-18211-15	. RIB, LH	1	A	
	8-18211-16	. RIB, RH	1	A	
- 7	8-18211-17	. RIB, LH	1	A	
	8-18211-18	. RIB, RH	1	A	
- 8	8-18211-19	. RIB, LH	1	A	
	8-18211-20	. RIB, RH	1	A	
- 9	8-18211-21	. RIB, LH	1	A	
	8-18211-22	. RIB, RH	1	A	
- 10	8-18211-23	. RIB, LH	1	A	
	8-18211-24	. RIB, RH	1	A	
- 11	8-18221-7	. RAIL, LH	1	A	
	8-18221-8	. RAIL, RH	1	A	
- 12	8-18221-9	. RAIL, LH	1	A	
	8-18221-10	. RAIL, RH	1	A	
A AIRPLANES #278 THRU 286 AND 288 THRU 291					

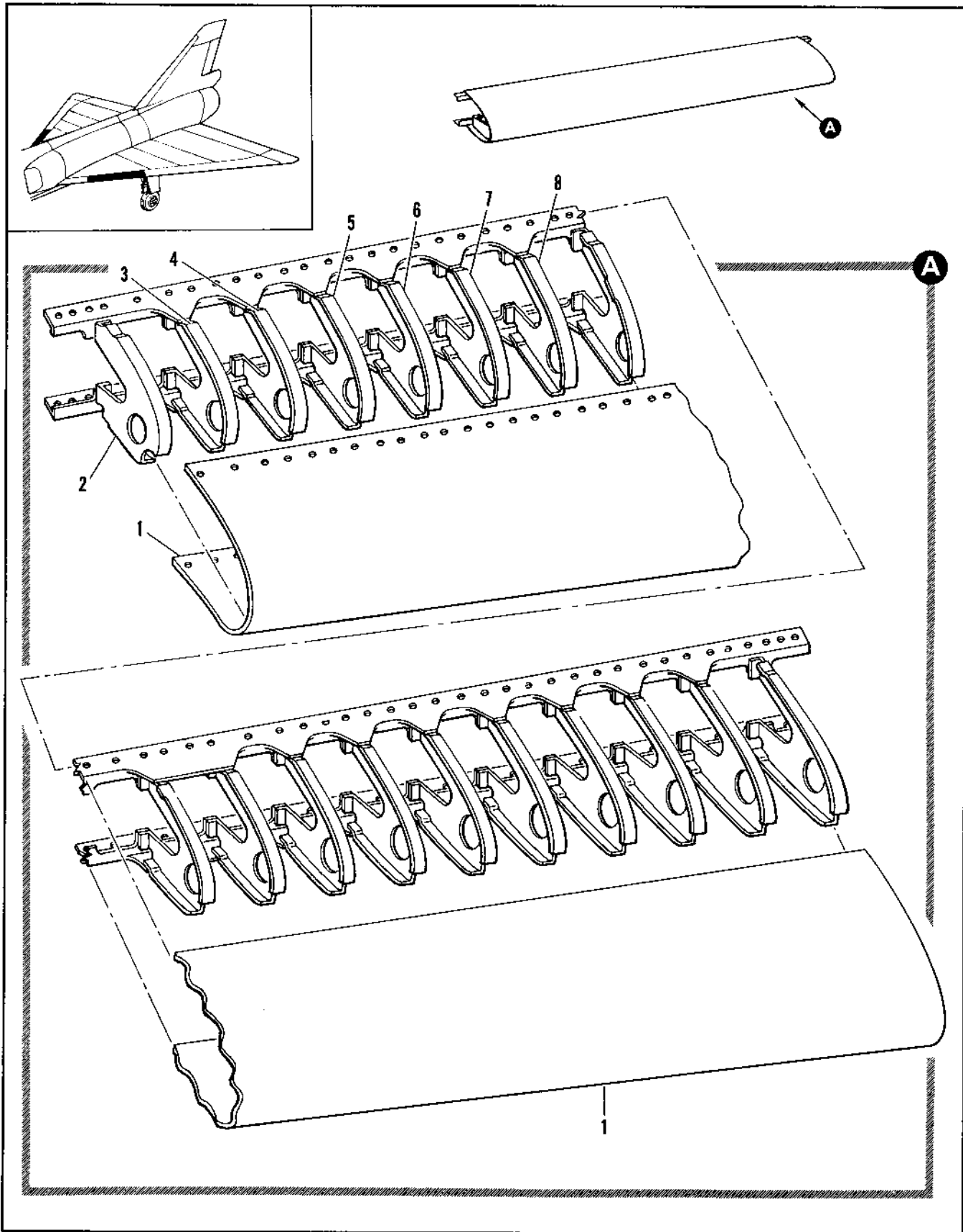

Figure 2.6-24. Wing Leading Edge Assembly Sta 145 to 216 (Sheet 1 of 2)

FIGURE AND INDEX NUMBER	PART NUMBER	DESCRIPTION	UNITS PER ASSY.	USABLE ON CODE	
				FROM	TO
		1 2 3 4 5 6			
2.6-24	8-18252-3	LEADING EDGE ASSEMBLY, WING STA 145 TO 216 LH REPLACED BY NOT INTCHG WITH 8-18252-5 MODIFIED BY R-18992 FOR NHA SEE FIG. 2.6-21	RF	B	
	8-18252-1	LEADING EDGE ASSEMBLY, WING STA 145 TO 216 LH ALT INTCHG WITH 8-18252-3 FOR NHA SEE FIG. 2.6-20	RF	B	
	8-18252-5	LEADING EDGE ASSEMBLY, WING STA 145 TO 216 LH REPLACES NOT INTCHG WITH 8-18252-3 FOR NHA SEE FIG. 2.6-20	RF	49	277
	8-18252-4	LEADING EDGE ASSEMBLY, WING STA 145 TO 216 RH REPLACED BY NOT INTCHG WITH 8-18252-6 MODIFIED BY R-18992 FOR NHA SEE FIG. 2.6-20	RF	B	
	8-18252-2	LEADING EDGE ASSEMBLY, WING STA 145 TO 216 RH ALT INTCHG WITH 8-18252-4 FOR NHA SEE FIG. 2.6-20	RF	B	
	8-18252-6	LEADING EDGE ASSEMBLY, WING STA 145 TO 216 RH REPLACES NOT INTCHG WITH 8-18252-4 FOR NHA SEE FIG. 2.6-20	RF	49	277
- 1	8-18252-23	• SKIN, LH REPLACED BY NOT INTCHG WITH 8-18252-29	1	B	
	8-18252-7	• SKIN, LH USE WITH 8-18252-1	RF	B	
	8-18252-9	• SKIN, LH USE WITH 8-18252-1	RF	B	
	8-18252-29	• SKIN, LH REPLACES NOT INTCHG WITH 8-18252-23	1		277
	8-18252-24	• SKIN, RH REPLACED BY NOT INTCHG WITH 8-18252-30	1	B	
	8-18252-8	• SKIN, RH USE WITH 8-18252-2	RF	B	
	8-18252-10	• SKIN, RH USE WITH 8-18252-2	RF	B	
	8-18252-30	• SKIN, RH REPLACES NOT INTCHG WITH 8-18252-24	1	49	277
- 2	8-18262-7	• RIB, LH REPLACES NOT INTCHG WITH 8-18212-7	1	A	
	8-18262-8	• RIB, RH REPLACES NOT INTCHG WITH 8-18212-8	1	A	
- 3	8-18262-9	• RIB, LH REPLACES NOT INTCHG WITH 8-18212-9	1	A	
	8-18262-10	• RIB, RH REPLACES NOT INTCHG WITH 8-18212-10	1	A	
- 4	8-18262-11	• RIB, LH REPLACES NOT INTCHG WITH 8-18212-11	1	A	
	8-18262-12	• RIB, RH REPLACES NOT INTCHG WITH 8-18212-12	1	A	
- 5	8-18262-13	• RIB, LH REPLACES NOT INTCHG WITH 8-18212-13	1	A	
	8-18262-14	• RIB, RH REPLACES NOT INTCHG WITH 8-18212-14	1	A	
- 6	8-18262-15	• RIB, LH REPLACES NOT INTCHG WITH 8-18212-15	1	A	
	8-18262-16	• RIB, RH REPLACES NOT INTCHG WITH 8-18212-16	1	A	
- 7	8-18262-17	• RIB, LH REPLACES NOT INTCHG WITH 8-18212-17	1	A	
	8-18262-18	• RIB, RH REPLACES NOT INTCHG WITH 8-18212-18	1	A	
- 8	8-18262-19	• RIB, LH REPLACES NOT INTCHG WITH 8-18212-19	1	A	
	8-18262-20	• RIB, RH REPLACES NOT INTCHG WITH 8-18212-20	1	A	
		A AIRPLANES #35 THRU 277, 287, 292 AND ON B AIRPLANES #35 THRU 48, 287, 292 AND ON			

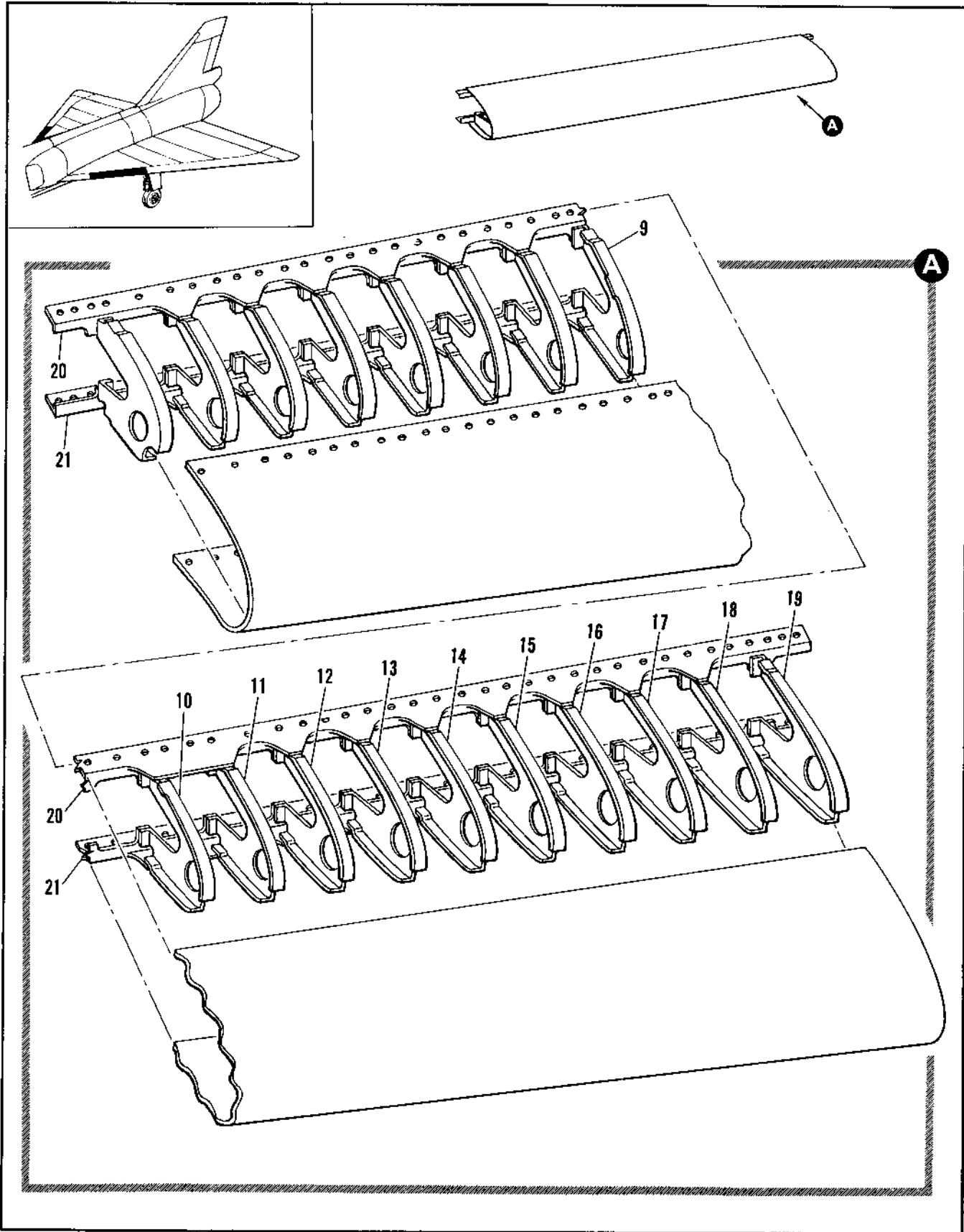

Figure 2.6-24. Wing Leading Edge Assembly Sta 145 to 216 (Sheet 2 of 2)

FIGURE AND INDEX NUMBER	PART NUMBER	DESCRIPTION	UNITS PER ASSY.	USABLE ON CODE	
				FROM	TO
		1 2 3 4 5 6			
2.6-24- 9	8-18262-43	• RIB, LH REPLACES NOT INTCHG WITH 8-18262-21	1	B	
	8-18262-21	• RIB, LH REPLACED BY NOT INTCHG WITH 8-18262-43 USE WITH 8-18252-1	RF	B	
	8-18262-45	• RIB, LH	1	49	277
	8-18262-44	• RIB, RH REPLACES NOT INTCHG WITH 8-18262-22	1	B	
	8-18262-22	• RIB, RH REPLACED BY NOT INTCHG WITH 8-18262-44 USE WITH 8-18252-2	RF	B	
	8-18262-46	• RIB, RH	1	49	277
- 10	8-18262-23	• RIB, LH REPLACES NOT INTCHG WITH 8-18212-23	1	B	
	8-18262-47	• RIB, LH	1	49	277
	8-18262-24	• RIB, RH REPLACES NOT INTCHG WITH 8-18212-24	1	B	
	8-18262-48	• RIB, RH	1	49	277
- 11	8-18262-25	• RIB, LH REPLACES NOT INTCHG WITH 8-18212-25	1	B	
	8-18262-49	• RIB, LH	1	49	277
	8-18262-26	• RIB, RH REPLACES NOT INTCHG WITH 8-18212-26	1	B	
	8-18262-50	• RIB, RH	1	49	277
- 12	8-18262-27	• RIB, LH REPLACES NOT INTCHG WITH 8-18212-27	1	A	
	8-18262-28	• RIB, RH REPLACES NOT INTCHG WITH 8-18212-28	1	A	
- 13	8-18262-29	• RIB, LH REPLACES NOT INTCHG WITH 8-18212-29	1	A	
	8-18262-30	• RIB, RH REPLACES NOT INTCHG WITH 8-18212-30	1	A	
- 14	8-18262-31	• RIB, LH REPLACES NOT INTCHG WITH 8-18212-31	1	A	
	8-18262-32	• RIB, RH REPLACES NOT INTCHG WITH 8-18212-32	1	A	
- 15	8-18262-33	• RIB, LH REPLACES NOT INTCHG WITH 8-18212-33	1	A	
	8-18262-34	• RIB, RH REPLACES NOT INTCHG WITH 8-18212-34	1	B	
- 16	8-18262-35	• RIB, LH REPLACES NOT INTCHG WITH 8-18212-35	1	A	
	8-18262-36	• RIB, RH REPLACES NOT INTCHG WITH 8-18212-36	1	A	
- 17	8-18262-37	• RIB, LH REPLACES NOT INTCHG WITH 8-18212-37	1	A	
	8-18262-38	• RIB, RH REPLACES NOT INTCHG WITH 8-18212-38	1	A	
- 18	8-18262-39	• RIB, LH REPLACES NOT INTCHG WITH 8-18212-39	1	A	
	8-18262-40	• RIB, RH REPLACES NOT INTCHG WITH 8-18212-40	1	A	
- 19	8-18262-41	• RIB, LH REPLACES NOT INTCHG WITH 8-18212-41	1	A	
	8-18262-42	• RIB, RH REPLACES NOT INTCHG WITH 8-18212-42	1	A	
- 20	8-18271-33	• RAIL, LH REPLACED BY NOT INTCHG WITH 8-18273-11	1	B	
	8-18271-11	• RAIL, LH USE WITH 8-18252-1	RF	B	
	8-18273-11	• RAIL, LH REPLACES NOT INTCHG WITH 8-18271-33	1	49	277
	8-18271-34	• RAIL, RH REPLACED BY NOT INTCHG WITH 8-18273-12	1	B	
	8-18271-12	• RAIL, RH USE WITH 8-18252-2	RF	B	
	8-18273-12	• RAIL, RH REPLACES NOT INTCHG WITH 8-18271-34	1	49	277
- 21	8-18271-31	• RAIL, LH	1	A	
	8-18271-13	• RAIL, LH USE WITH 8-18252-1	RF	A	
	8-18271-32	• RAIL, RH	1	A	
	8-18271-14	• RAIL, RH USE WITH 8-18252-2	RF	A	

A AIRPLANES #35 THRU 277, 287, 292 AND ON
 R AIRPLANES #35 THRU 48, 287, 292 AND ON

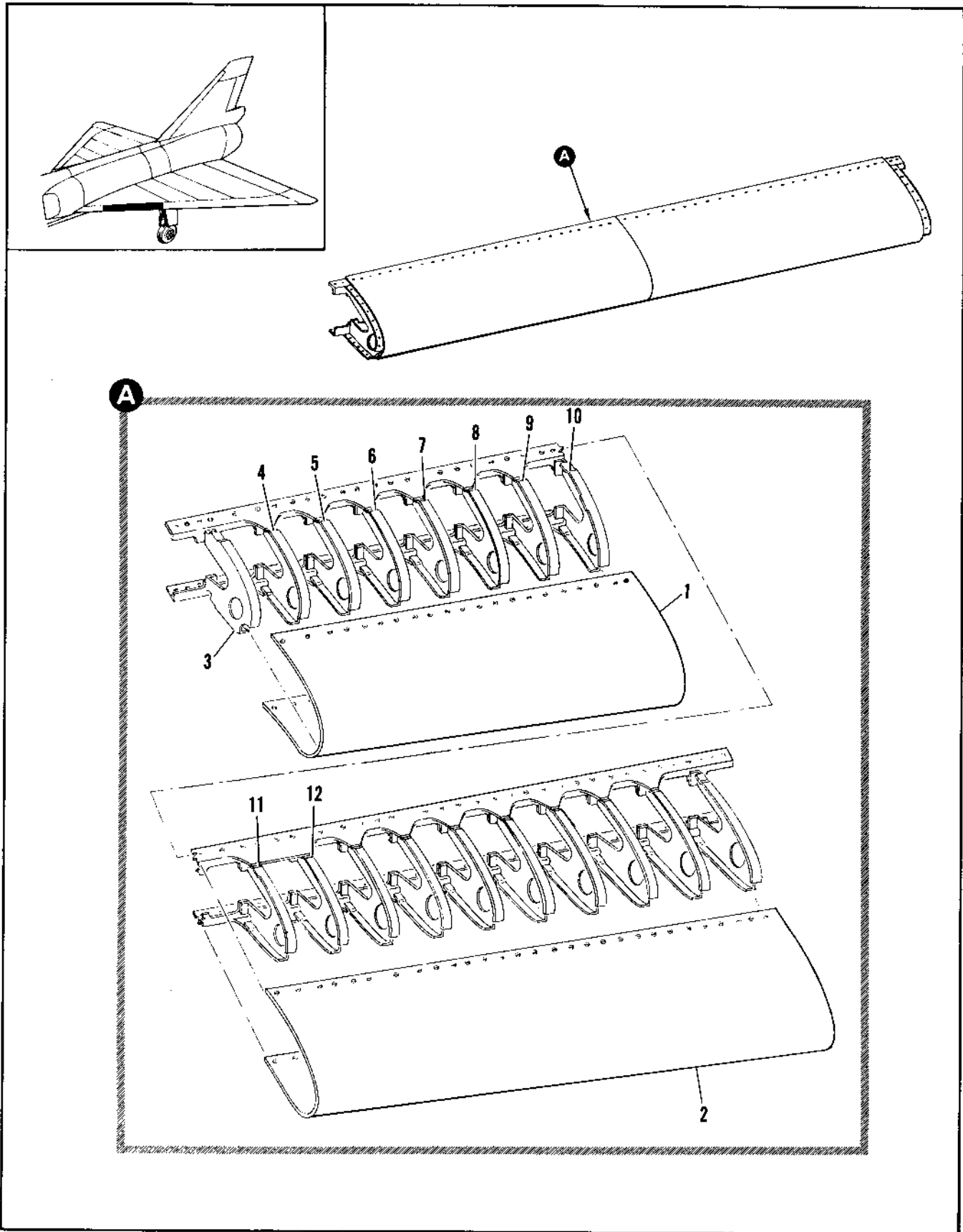

Figure 2.6-25. Wing Leading Edge Assembly Sta 221 to 297 (Sheet 1 of 2)

FIGURE AND INDEX NUMBER	PART NUMBER	DESCRIPTION	UNITS PER ASSY.	USABLE ON CODE	
				FROM	TO
		1 2 3 4 5 6			
2.6-25	8-18202-1	LEADING EDGE ASSEMBLY, WING STA 145 TO 216 LH MODIFIED BY 8-18990 FOR NHA SEE FIG. 2.6-21	RF	A	
	8-18202-2	LEADING EDGE ASSEMBLY, WING STA 145 TO 216 RH MODIFIED BY 8-18990 FOR NHA SEE FIG. 2.6-21	RF	A	
- 1	8-18202-7	• SKIN, LH	1	A	
	8-18202-8	• SKIN, RH	1	A	
	8-18202-9	• SKIN, LH	1	A	
	8-18202-10	• SKIN, RH	1	A	
- 3	8-18212-7	• RIB, LH REPLACED BY NOT INTCHG WITH 8-18262-7	1	A	
	8-18212-8	• RIB, RH REPLACED BY NOT INTCHG WITH 8-18262-8	1	A	
- 4	8-18212-9	• RIB, LH REPLACED BY NOT INTCHG WITH 8-18262-9	1	A	
	8-18212-10	• RIB, RH REPLACED BY NOT INTCHG WITH 8-18262-10	1	A	
- 5	8-18212-11	• RIB, LH REPLACED BY NOT INTCHG WITH 8-18262-11	1	A	
	8-18212-12	• RIB, RH REPLACED BY NOT INTCHG WITH 8-18262-12	1	A	
- 6	8-18212-13	• RIB, LH REPLACED BY NOT INTCHG WITH 8-18262-13	1	A	
	8-18212-14	• RIB, RH REPLACED BY NOT INTCHG WITH 8-18262-14	1	A	
- 7	8-18212-15	• RIB, LH REPLACED BY NOT INTCHG WITH 8-18262-15	1	A	
	8-18212-16	• RIB, RH REPLACED BY NOT INTCHG WITH 8-18262-16	1	A	
- 8	8-18212-17	• RIB, LH REPLACED BY NOT INTCHG WITH 8-18262-17	1	A	
	8-18212-18	• RIB, RH REPLACED BY NOT INTCHG WITH 8-18262-18	1	A	
- 9	8-18212-19	• RIB, LH REPLACED BY NOT INTCHG WITH 8-18262-19	1	A	
	8-18212-20	• RIB, RH REPLACED BY NOT INTCHG WITH 8-18262-20	1	A	
- 10	8-18212-21	• RIB, LH	1	A	
	8-18212-22	• RIB, RH	1	A	
- 11	8-18212-23	• RIB, LH REPLACED BY NOT INTCHG WITH 8-18262-23	1	A	
	8-18212-24	• RIB, RH REPLACED BY NOT INTCHG WITH 8-18262-24	1	A	
- 12	8-18212-25	• RIB, LH REPLACED BY NOT INTCHG WITH 8-18262-25	1	A	
	8-18212-26	• RIB, RH REPLACED BY NOT INTCHG WITH 8-18262-26	1	A	
A AIRPLANES #278 THRU 286 AND 288 THRU 291					

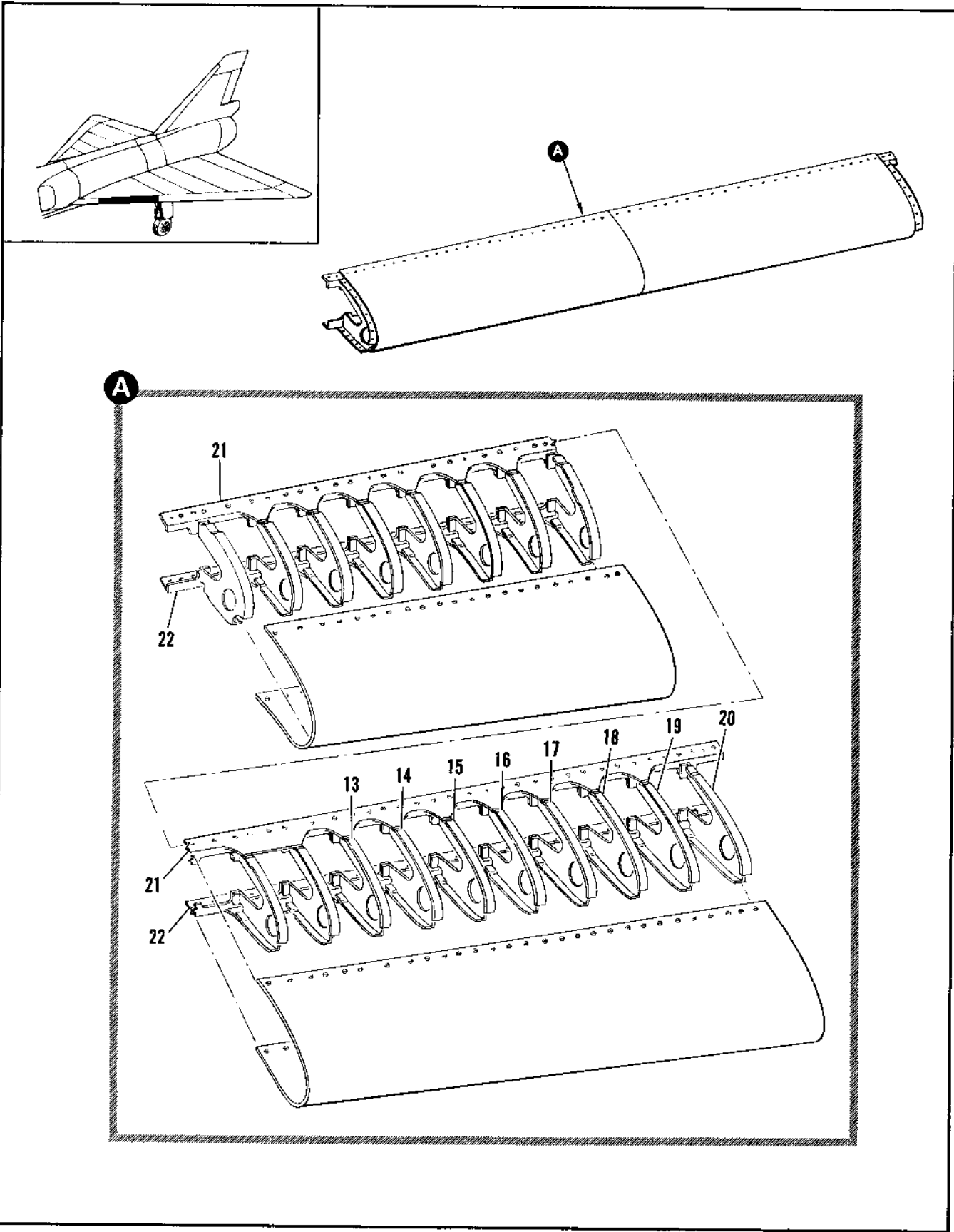

Figure 2.6-25. Wing Leading Edge Assembly Sta 145 to 216 (Sheet 2 of 2)

FIGURE AND INDEX NUMBER	PART NUMBER	DESCRIPTION 1 2 3 4 5 6	UNITS PER ASSY.	USABLE ON CODE	
				FROM	TO
2.6-25- 13	8-18212-27	• RIB, LH REPLACED BY NOT INTCHG WITH 8-18262-27	1	A	
	8-18212-28	• RIB, RH REPLACED BY NOT INTCHG WITH 8-18262-28	1	A	
- 14	8-18212-29	• RIB, LH REPLACED BY NOT INTCHG WITH 8-18262-29	1	A	
	8-18212-30	• RIB, RH REPLACED BY NOT INTCHG WITH 8-18262-30	1	A	
- 15	8-18212-31	• RIB, LH REPLACED BY NOT INTCHG WITH 8-18262-31	1	A	
	8-18212-32	• RIB, RH REPLACED BY NOT INTCHG WITH 8-18262-32	1	A	
- 16	8-18212-33	• RIB, LH REPLACED BY NOT INTCHG WITH 8-18262-33	1	A	
	8-18212-34	• RIB, RH REPLACED BY NOT INTCHG WITH 8-18262-34	1	A	
- 17	8-18212-35	• RIB, LH REPLACED BY NOT INTCHG WITH 8-18262-35	1	A	
	8-18212-36	• RIB, RH REPLACED BY NOT INTCHG WITH 8-18262-36	1	A	
- 18	8-18212-37	• RIB, LH REPLACED BY NOT INTCHG WITH 8-18262-37	1	A	
	8-18212-38	• RIB, RH REPLACED BY NOT INTCHG WITH 8-18262-38	1	A	
- 19	8-18212-39	• RIB, LH REPLACED BY NOT INTCHG WITH 8-18262-39	1	A	
	8-18212-40	• RIB, RH REPLACED BY NOT INTCHG WITH 8-18262-40	1	A	
- 20	8-18212-41	• RIB, LH REPLACED BY NOT INTCHG WITH 8-18262-41	1	A	
	8-18212-42	• RIB, RH REPLACED BY NOT INTCHG WITH 8-18262-42	1	A	
- 21	8-18221-11	• RAIL, LH	1	A	
	8-18221-12	• RAIL, RH	1	A	
- 22	8-18221-13	• RAIL, LH	1	A	
	8-18221-14	• RAIL, RH	1	A	
A AIRPLANES #278 THRU 286 AND 288 THRU 291					

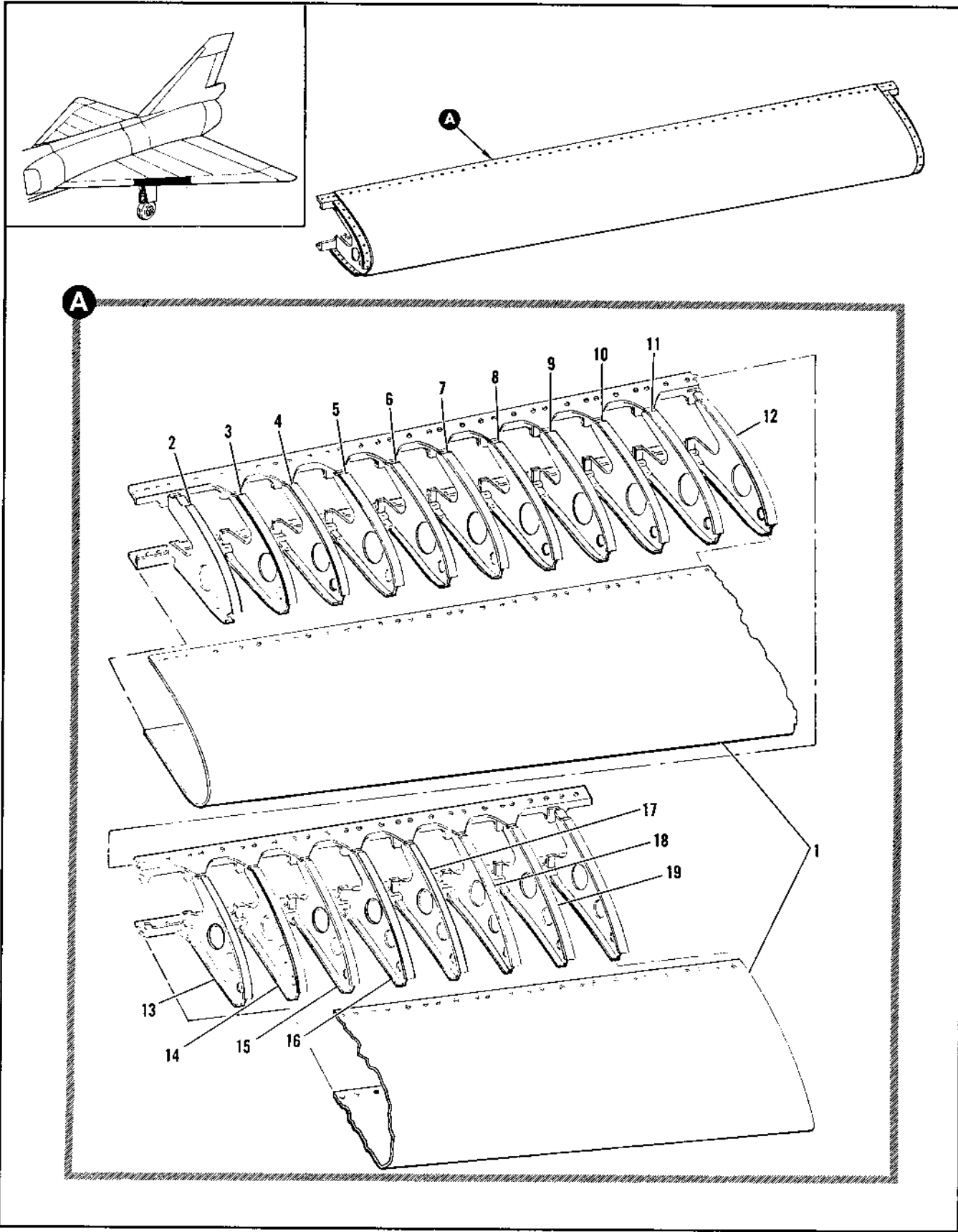

Figure 2.6-26. Wing Leading Edge Assembly Sta 221 to 297 (Sheet 1 of 2)

FIGURE AND INDEX NUMBER	PART NUMBER	DESCRIPTION	UNITS PER ASSY.	USABLE ON CODE		
				FROM	TO	
2.6-26	8-18253-3	LEADING EDGE ASSEMBLY, WING STA 221 TO 297 LH FOR NHA SEE FIG. 2.6-21	RF	A		
	8-18253-1	LEADING EDGE ASSEMBLY, WING STA 221 TO 297 LH ALT INTCHG WITH 8-18253-3	RF	A		
	8-18253-4	LEADING EDGE ASSEMBLY, WING STA 221 TO 297 RH FOR NHA SEE FIG. 2.6-21	RF	A		
	8-18253-2	LEADING EDGE ASSEMBLY, WING STA 221 TO 297 RH ALT INTCHG WITH 8-18253-4	RF	A		
	- 1	8-18253-23	• SKIN, LH	1	A	
		8-18253-7	• SKIN, LH USE WITH 8-18253-1	RF	A	
		8-18253-9	• SKIN, LH USE WITH 8-18253-1	RF	A	
		8-18253-24	• SKIN, RH	1	A	
		8-18253-8	• SKIN, RH USE WITH 8-18253-2	RF	A	
		8-18253-10	• SKIN, RH USE WITH 8-18253-2	RF	A	
	- 2	8-18263-7	• RIP, LH REPLACES NOT INTCHG WITH 8-18213-7	1	A	
		8-18263-8	• RIP, RH REPLACES NOT INTCHG WITH 8-18213-8	1	A	
	- 3	8-18263-9	• RIP, LH REPLACES NOT INTCHG WITH 8-18213-9	1	A	
		8-18263-10	• RIP, RH REPLACES NOT INTCHG WITH 8-18213-10	1	A	
	- 4	8-18263-11	• RIP, LH REPLACES NOT INTCHG WITH 8-18213-11	1	A	
		8-18263-12	• RIP, RH REPLACES NOT INTCHG WITH 8-18213-12	1	A	
	- 5	8-18263-13	• RIP, LH REPLACES NOT INTCHG WITH 8-18213-13	1	A	
		8-18263-14	• RIP, RH REPLACES NOT INTCHG WITH 8-18213-14	1	A	
	- 6	8-18263-15	• RIP, LH REPLACES NOT INTCHG WITH 8-18213-15	1	A	
		8-18263-16	• RIP, RH REPLACES NOT INTCHG WITH 8-18213-16	1	A	
- 7	8-18263-17	• RIP, LH REPLACES NOT INTCHG WITH 8-18213-17	1	A		
	8-18263-18	• RIP, RH REPLACES NOT INTCHG WITH 8-18213-18	1	A		
- 8	8-18263-19	• RIP, LH REPLACES NOT INTCHG WITH 8-18213-19	1	A		
	8-18263-20	• RIP, RH REPLACES NOT INTCHG WITH 8-18213-20	1	A		
- 9	8-18263-21	• RIP, LH REPLACES NOT INTCHG WITH 8-18213-21	1	A		
	8-18263-22	• RIP, RH REPLACES NOT INTCHG WITH 8-18213-22	1	A		
- 10	8-18263-23	• RIP, LH REPLACES NOT INTCHG WITH 8-18213-23	1	A		
	8-18263-24	• RIP, RH REPLACES NOT INTCHG WITH 8-18213-24	1	A		
- 11	8-18263-25	• RIP, LH REPLACES NOT INTCHG WITH 8-18213-25	1	A		
	8-18263-26	• RIP, RH REPLACES NOT INTCHG WITH 8-18213-26	1	A		
- 12	8-18263-27	• RIP, LH	1	A		
	8-18263-27	• RIP, LH USE WITH 8-18253-1 REPLACES NOT INTCHG WITH 8-18213-27	RF	A		
	8-18263-46	• RIP, RH	1	A		
	8-18263-28	• RIP, RH USE WITH 8-18253-2 REPLACES NOT INTCHG WITH 8-18213-28	RF	A		
- 13	8-18263-29	• RIP, LH REPLACES NOT INTCHG WITH 8-18213-29	1	A		
	8-18263-30	• RIP, RH REPLACES NOT INTCHG WITH 8-18213-30	1	A		
- 14	8-18263-31	• RIP, LH REPLACES NOT INTCHG WITH 8-18213-31	1	A		
	8-18263-32	• RIP, RH REPLACES NOT INTCHG WITH 8-18213-32	1	A		
- 15	8-18263-33	• RIP, LH REPLACES NOT INTCHG WITH 8-18213-33	1	A		
	8-18263-34	• RIP, RH REPLACES NOT INTCHG WITH 8-18213-34	1	A		
- 16	8-18263-35	• RIP, LH REPLACES NOT INTCHG WITH 8-18213-35	1	A		
	8-18263-36	• RIP, RH REPLACES NOT INTCHG WITH 8-18213-36	1	A		
- 17	8-18263-37	• RIP, LH REPLACES NOT INTCHG WITH 8-18213-37	1	A		
	8-18263-38	• RIP, RH REPLACES NOT INTCHG WITH 8-18213-38	1	A		
- 18	8-18263-39	• RIP, LH REPLACES NOT INTCHG WITH 8-18213-39	1	A		
	8-18263-40	• RIP, RH REPLACES NOT INTCHG WITH 8-18213-40	1	A		
- 19	8-18263-41	• RIP, LH REPLACES NOT INTCHG WITH 8-18213-41	1	A		
	8-18263-42	• RIP, RH REPLACES NOT INTCHG WITH 8-18213-42	1	A		
		• REPLACES #35 THRU 277, 297, 298 AND ON				

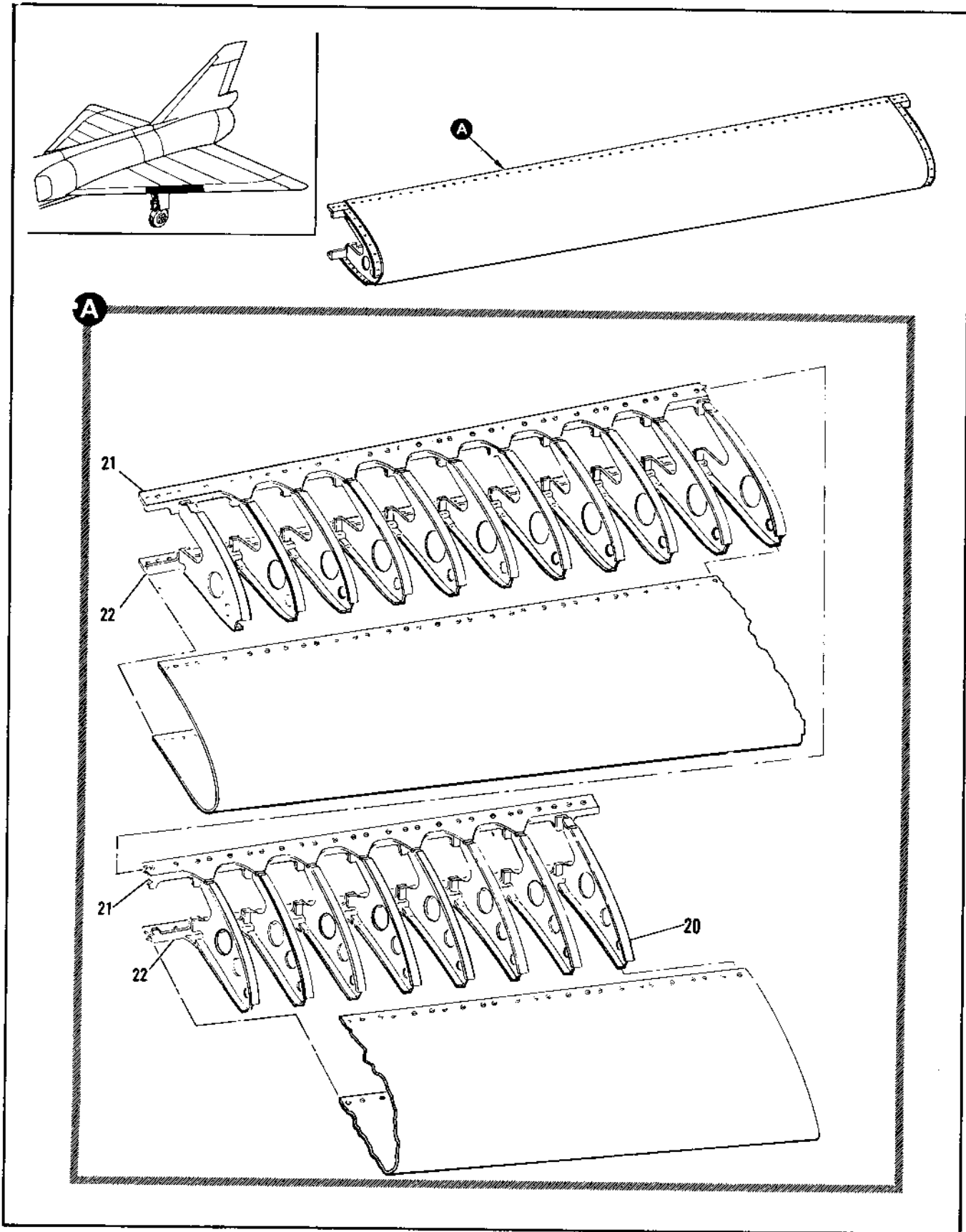

Figure 2.6-26. Wing Leading Edge Assembly Sta 221 to 297 (Sheet 2 of 2)

FIGURE AND INDEX NUMBER	PART NUMBER	DESCRIPTION	UNITS PER ASSY.	USABLE ON CODE	
				FROM	TO
		1 2 3 4 5 6			
2.6-26- 20	8-18263-43	• RIR, LH REPLACES NOT INTCHG WITH 8-18213-43	1	A	
	8-18263-44	• RIR, RH REPLACES NOT INTCHG WITH 8-18213-44	1	A	
- 21	8-18271-35	• RAIL, LH	1	A	
	8-18271-15	• RAIL, LH USE WITH 8-18253-1	RF	A	
	8-18271-36	• RAIL, RH	1	A	
	8-18271-16	• RAIL, RH USE WITH 8-18253-2	RF	A	
- 22	8-18271-37	• RAIL, LH	1	A	
	8-18271-17	• RAIL, LH USE WITH 8-18253-1	RF	A	
	8-18271-38	• RAIL, RH	1	A	
	8-18271-18	• RAIL, RH USE WITH 8-18253-2	RF	A	
		A AIRPLANES #35 THRU 277, 287, 292 AND ON			

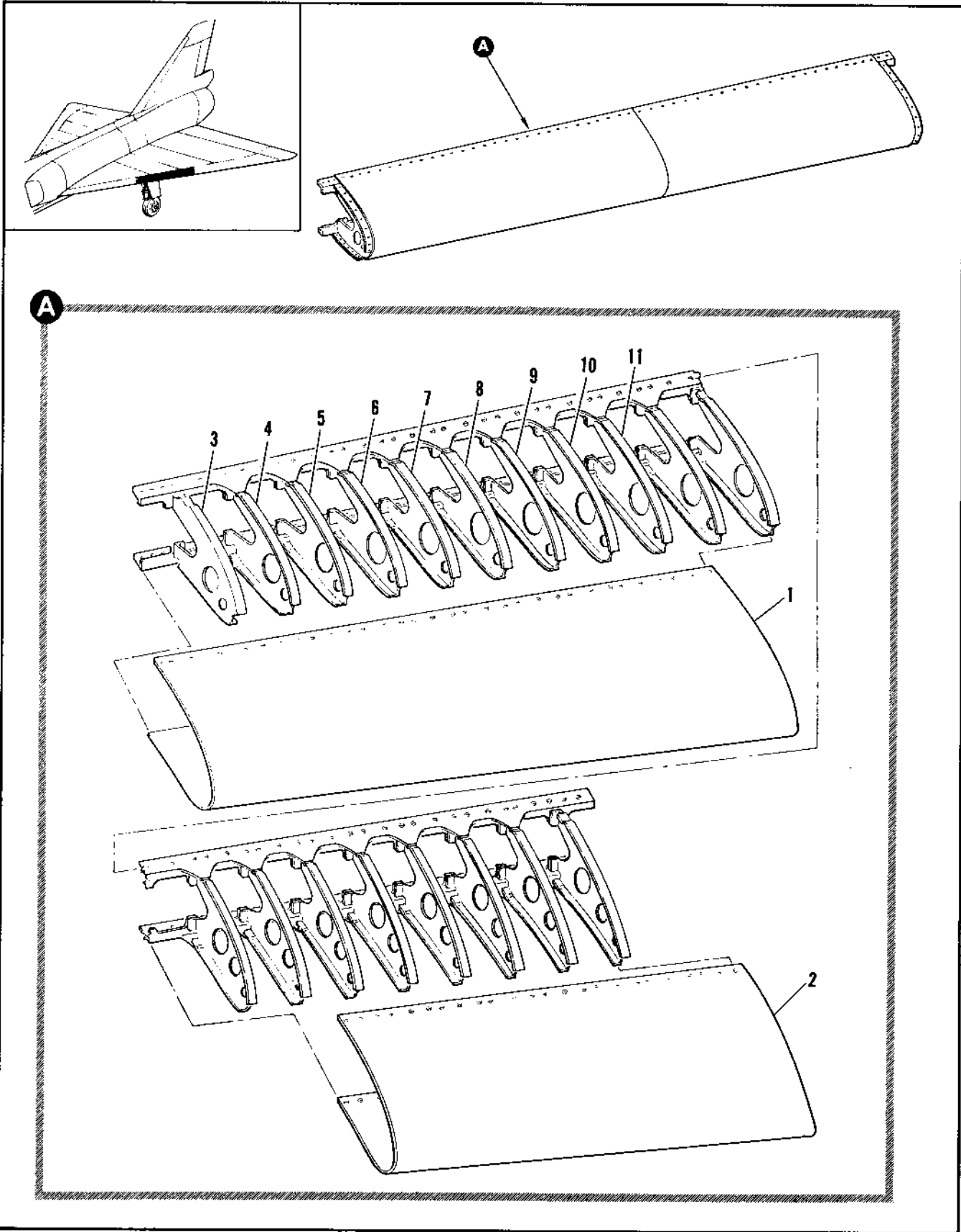

Figure 2.6-27. Wing Leading Edge Assembly Sta 221 to 297 (Sheet 1 of 2)

FIGURE AND INDEX NUMBER	PART NUMBER	DESCRIPTION	UNITS PER ASSY.	USABLE ON CODE	
				FROM	TO
2.6-27	8-18203-1	LEADING EDGE ASSEMBLY, WING STA 221 TO 297 LH FOR NHA SEE FIG. 2.6-21	RF	A	
	8-18203-2	LEADING EDGE ASSEMBLY, WING STA 221 TO 297 RH	RF	A	
- 1	8-18203-7	• SKIN, LH	1	A	
	8-18203-8	• SKIN, RH	1	A	
- 2	8-18203-9	• SKIN, LH	1	A	
	8-18203-10	• SKIN, RH	1	A	
- 3	8-18213-7	• RIB, LH REPLACED BY NOT INTCHG WITH 8-18263-7	1	A	
	8-18213-8	• RIB, RH REPLACED BY NOT INTCHG WITH 8-18263-8	1	A	
- 4	8-18213-9	• RIB, LH REPLACED BY NOT INTCHG WITH 8-18263-9	1	A	
	8-18213-10	• RIB, RH REPLACED BY NOT INTCHG WITH 8-18263-10	1	A	
- 5	8-18213-11	• RIB, LH REPLACED BY NOT INTCHG WITH 8-18263-11	1	A	
	8-18213-12	• RIB, RH REPLACED BY NOT INTCHG WITH 8-18263-12	1	A	
- 6	8-18213-13	• RIB, LH REPLACED BY NOT INTCHG WITH 8-18263-13	1	A	
	8-18213-14	• RIB, RH REPLACED BY NOT INTCHG WITH 8-18263-14	1	A	
- 7	8-18213-15	• RIB, LH REPLACED BY NOT INTCHG WITH 8-18263-15	1	A	
	8-18213-16	• RIB, RH REPLACED BY NOT INTCHG WITH 8-18263-16	1	A	
- 8	8-18213-17	• RIB, LH REPLACED BY NOT INTCHG WITH 8-18263-17	1	A	
	8-18213-18	• RIB, RH REPLACED BY NOT INTCHG WITH 8-18263-18	1	A	
- 9	8-18213-19	• RIB, LH REPLACED BY NOT INTCHG WITH 8-18263-19	1	A	
	8-18213-20	• RIB, RH REPLACED BY NOT INTCHG WITH 8-18263-20	1	A	
- 10	8-18213-21	• RIB, LH REPLACED BY NOT INTCHG WITH 8-18263-21	1	A	
	8-18213-22	• RIB, RH REPLACED BY NOT INTCHG WITH 8-18263-22	1	A	
- 11	8-18213-23	• RIB, LH REPLACED BY NOT INTCHG WITH 8-18263-23	1	A	
	8-18213-24	• RIB, RH REPLACED BY NOT INTCHG WITH 8-18263-24	1	A	
A AIRPLANES #278 THRU 286 AND 288 THRU 291					

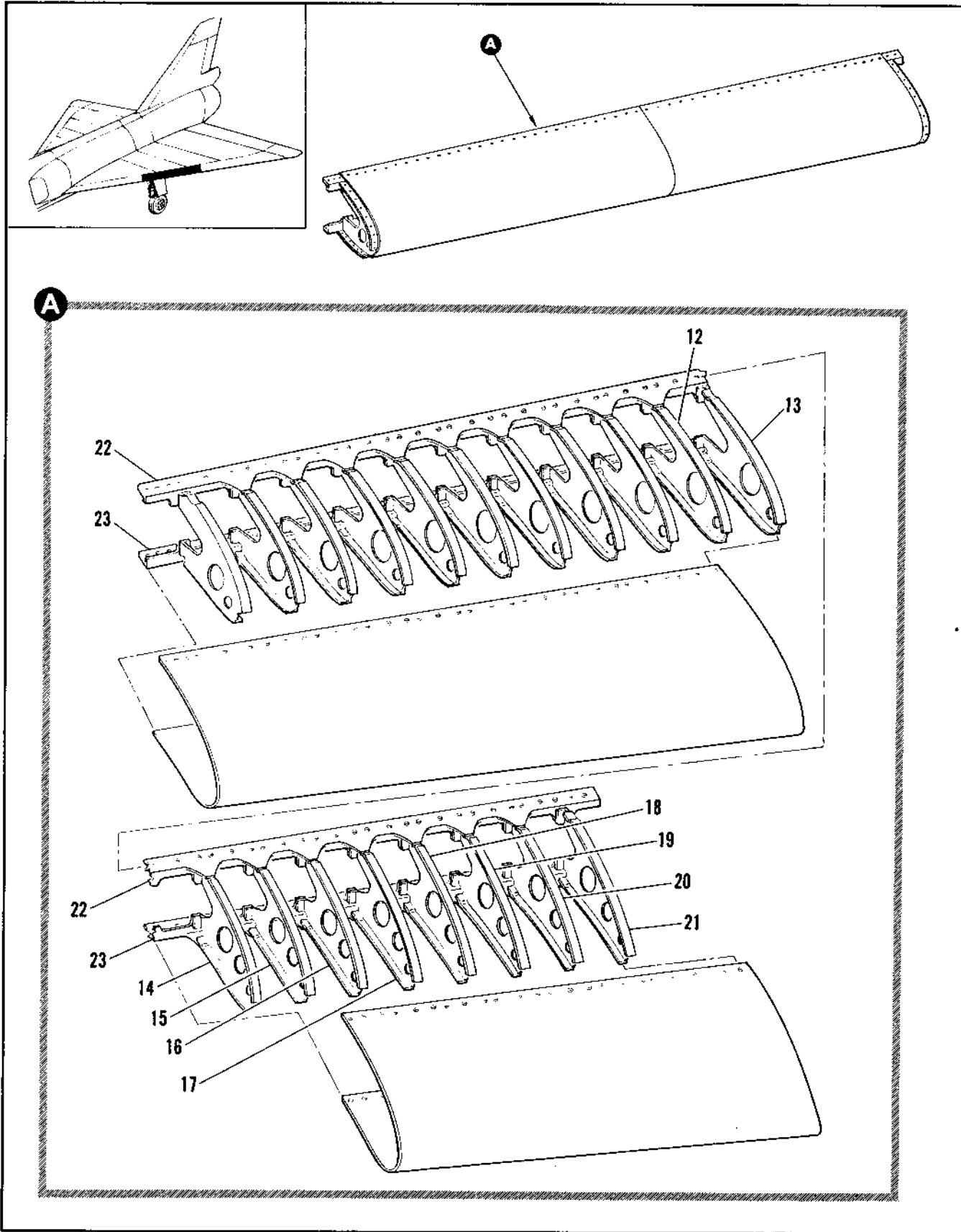

Figure 2.6-27. Wing Leading Edge Assembly Sta 221 to 297 (Sheet 2 of 2)

FIGURE AND INDEX NUMBER	PART NUMBER	DESCRIPTION	UNITS PER ASSY.	USABLE ON CODE	
				FROM	TO
		1 2 3 4 5 6			
2,6-27- 12	8-18213-25	• RIB, LH REPLACED BY NOT INTCHG WITH 8-18263-25	1	A	
	8-18213-26	• RIB, RH REPLACED BY NOT INTCHG WITH 8-18263-26	1	A	
- 13	8-18213-27	• RIB, LH REPLACED BY NOT INTCHG WITH 8-18263-27	1	A	
	8-18213-28	• RIB, RH REPLACED BY NOT INTCHG WITH 8-18263-28	1	A	
- 14	8-18213-29	• RIB, LH REPLACED BY NOT INTCHG WITH 8-18263-29	1	A	
	8-18213-30	• RIB, RH REPLACED BY NOT INTCHG WITH 8-18263-30	1	A	
- 15	8-18213-31	• RIB, LH REPLACED BY NOT INTCHG WITH 8-18263-31	1	A	
	8-18213-32	• RIB, RH REPLACED BY NOT INTCHG WITH 8-18263-32	1	A	
- 16	8-18213-33	• RIB, LH REPLACED BY NOT INTCHG WITH 8-18263-33	1	A	
	8-18213-34	• RIB, RH REPLACED BY NOT INTCHG WITH 8-18263-34	1	A	
- 17	8-18213-35	• RIB, LH REPLACED BY NOT INTCHG WITH 8-18263-35	1	A	
	8-18213-36	• RIB, RH REPLACED BY NOT INTCHG WITH 8-18263-36	1	A	
- 18	8-18213-37	• RIB, LH REPLACED BY NOT INTCHG WITH 8-18263-37	1	A	
	8-18213-38	• RIB, RH REPLACED BY NOT INTCHG WITH 8-18263-38	1	A	
- 19	8-18213-39	• RIB, LH REPLACED BY NOT INTCHG WITH 8-18263-39	1	A	
	8-18213-40	• RIB, RH REPLACED BY NOT INTCHG WITH 8-18263-40	1	A	
- 20	8-18213-41	• RIB, LH REPLACED BY NOT INTCHG WITH 8-18263-41	1	A	
	8-18213-42	• RIB, RH REPLACED BY NOT INTCHG WITH 8-18263-42	1	A	
- 21	8-18213-43	• RIB, LH REPLACED BY NOT INTCHG WITH 8-18263-43	1	A	
	8-18213-44	• RIB, RH REPLACED BY NOT INTCHG WITH 8-18263-44	1	A	
- 22	8-18221-15	• RAIL, LH	1	A	
	8-18221-16	• RAIL, RH	1	A	
- 23	8-18221-17	• RAIL, LH	1	A	
	8-18221-18	• RAIL, RH	1	A	
A AIRPLANES 278 THRU 286 AND 288 THRU 291					

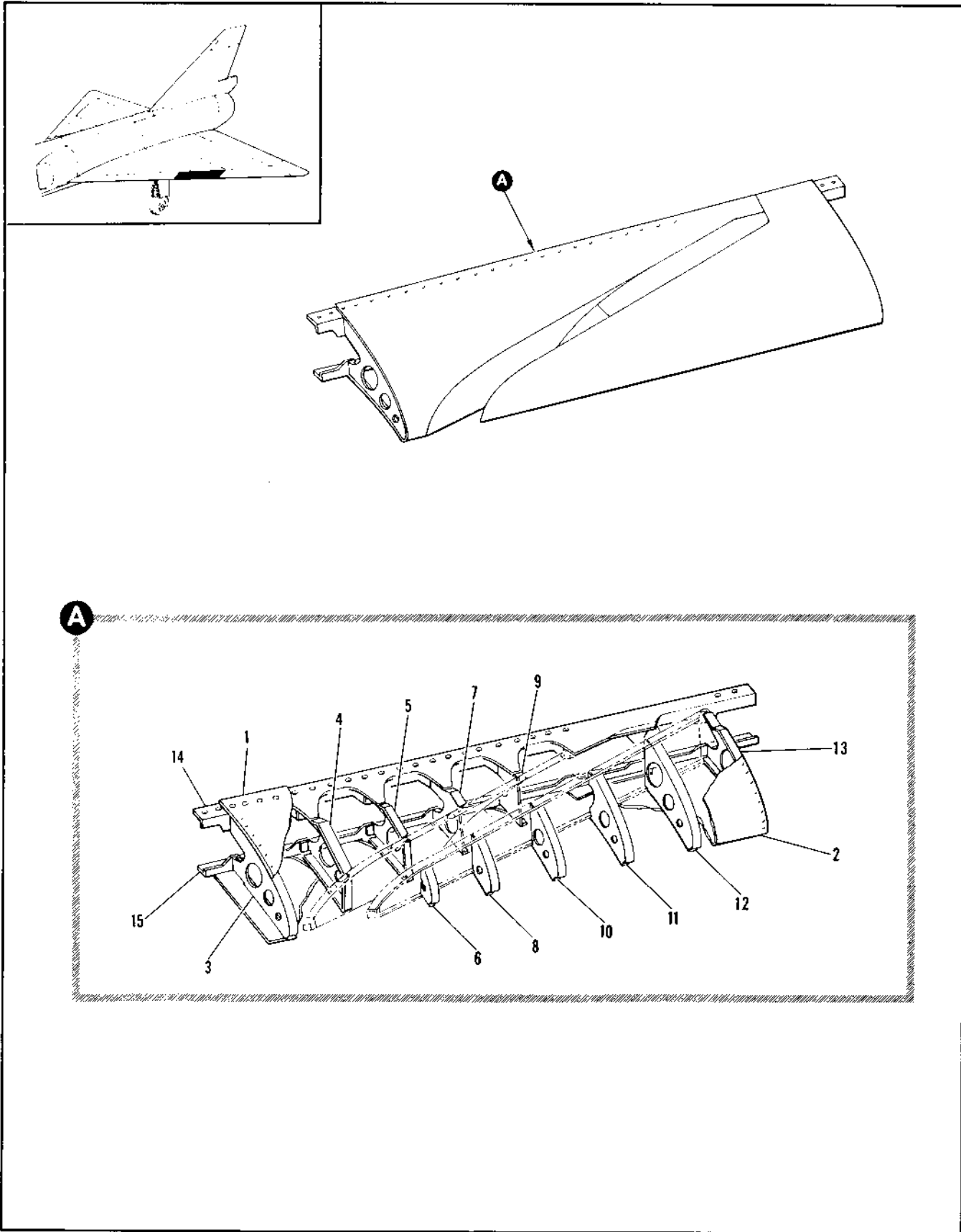

Figure 2.6-28. Wing Slotted Leading Edge Assembly Sta 301 to 334

FIGURE AND INDEX NUMBER	PART NUMBER	DESCRIPTION	UNITS PER ASSY.	USABLE ON CODE	
				FROM	TO
2.6-28	8-18254-3	LEADING EDGE ASSEMBLY, WING SLOTTED STA 301 TO 334 LH FOR NHA SEE FIG. 2.6-20	RF	35	49
	8-18256-1	LEADING EDGE ASSEMBLY, WING SLOTTED STA 301 TO 334 LH FOR NHA SEE FIG. 2.6-20	RF	A	
	8-18254-4	LEADING EDGE ASSEMBLY, WING SLOTTED STA 301 TO 334 RH FOR NHA SEE FIG. 2.6-20	RF	35	49
	8-18256-2	LEADING EDGE ASSEMBLY, WING SLOTTED STA 301 TO 334 RH FOR NHA SEE FIG. 2.6-20	RF	A	
- 1	8-18254-41	• SKIN, LH	1	35	49
	8-18256-7	• SKIN, LH	1	A	
- 2	8-18254-42	• SKIN, RH	1	35	48
	8-18256-8	• SKIN, RH	1	A	
- 3	8-18254-39	• SKIN, LH	1	35	48
	8-18254-40	• SKIN, RH	1	35	48
- 4	8-18264-7	• RIB, LH REPLACES NOT INTCHG WITH 8-18214-7	1	35	48
	8-18266-11	• RIB, LH	1	A	
	8-18264-8	• RIB, RH REPLACES NOT INTCHG WITH 8-18214-8	1	35	48
	8-18266-12	• RIB, RH	1	A	
- 5	8-18264-9	• RIB, LH REPLACES NOT INTCHG WITH 8-18214-9	1	35	48
	8-18266-13	• RIB, LH	1	A	
	8-18264-10	• RIB, RH REPLACES NOT INTCHG WITH 8-18214-10	1	35	48
	8-18266-14	• RIB, RH	1	A	
- 6	8-18264-11	• RIB, LH REPLACES NOT INTCHG WITH 8-18214-11	1	35	48
	8-18266-15	• RIB, LH	1	A	
	8-18264-12	• RIB, RH REPLACES NOT INTCHG WITH 8-18214-12	1	35	48
	8-18266-16	• RIB, RH	1	A	
- 7	8-18264-29	• RIB, LH	1	35	48
	8-18266-17	• RIB, LH	1	A	
	8-18264-30	• RIB, RH	1	35	48
	8-18266-18	• RIB, RH	1	A	
- 8	8-18264-33	• RIB, LH	1	35	48
	8-18266-21	• RIB, LH	1	A	
	8-18264-34	• RIB, RH	1	35	48
	8-18266-22	• RIB, RH	1	A	
- 9	8-18264-31	• RIB, LH	1	35	48
	8-18266-19	• RIB, LH	1	A	
	8-18264-32	• RIB, RH	1	35	48
	8-18266-20	• RIB, RH	1	A	
- 10	8-18264-37	• RIB, LH	1	35	48
	8-18266-25	• RIB, LH	1	A	
	8-18264-35	• RIB, RH	1	35	48
	8-18266-26	• RIB, RH	1	A	
- 11	8-18264-35	• RIB, LH	1	35	48
	8-18266-23	• RIB, LH	1	A	
	8-18264-36	• RIB, RH	1	35	48
	8-18266-24	• RIB, RH	1	A	
- 12	8-18264-38	• RIB, LH	1	35	48
	8-18266-27	• RIB, LH	1	A	
	8-18264-40	• RIB, RH	1	35	48
	8-18266-28	• RIB, RH	1	A	
- 13	8-18264-41	• RIB, LH	1	35	48
	8-18266-29	• RIB, LH	1	A	
	8-18264-42	• RIB, RH	1	35	48
	8-18266-30	• RIB, RH	1	A	
- 14	8-18264-43	• RIB, LH REPLACES NOT INTCHG WITH 8-18214-24	1	35	48
	8-18266-31	• RIB, LH	1	A	
	8-18264-44	• RIB, RH	1	35	48
	8-18266-32	• RIB, RH	1	A	
- 15	8-18271-47	• RAIL, UPPER LH	1	35	48
	8-18273-7	• RAIL, UPPER LH	1	A	
	8-18271-48	• RAIL, UPPER RH	1	35	48
	8-18273-8	• RAIL, UPPER RH	1	A	
- 16	8-18271-49	• RAIL, LOWER LH	1	35	48
	8-18273-9	• RAIL, LOWER LH	1	A	
	8-18271-50	• RAIL, LOWER RH	1	35	48
	8-18273-10	• RAIL, LOWER RH	1	A	

A AIRPLANES #49 THRU 277, 287, 292 AND ON

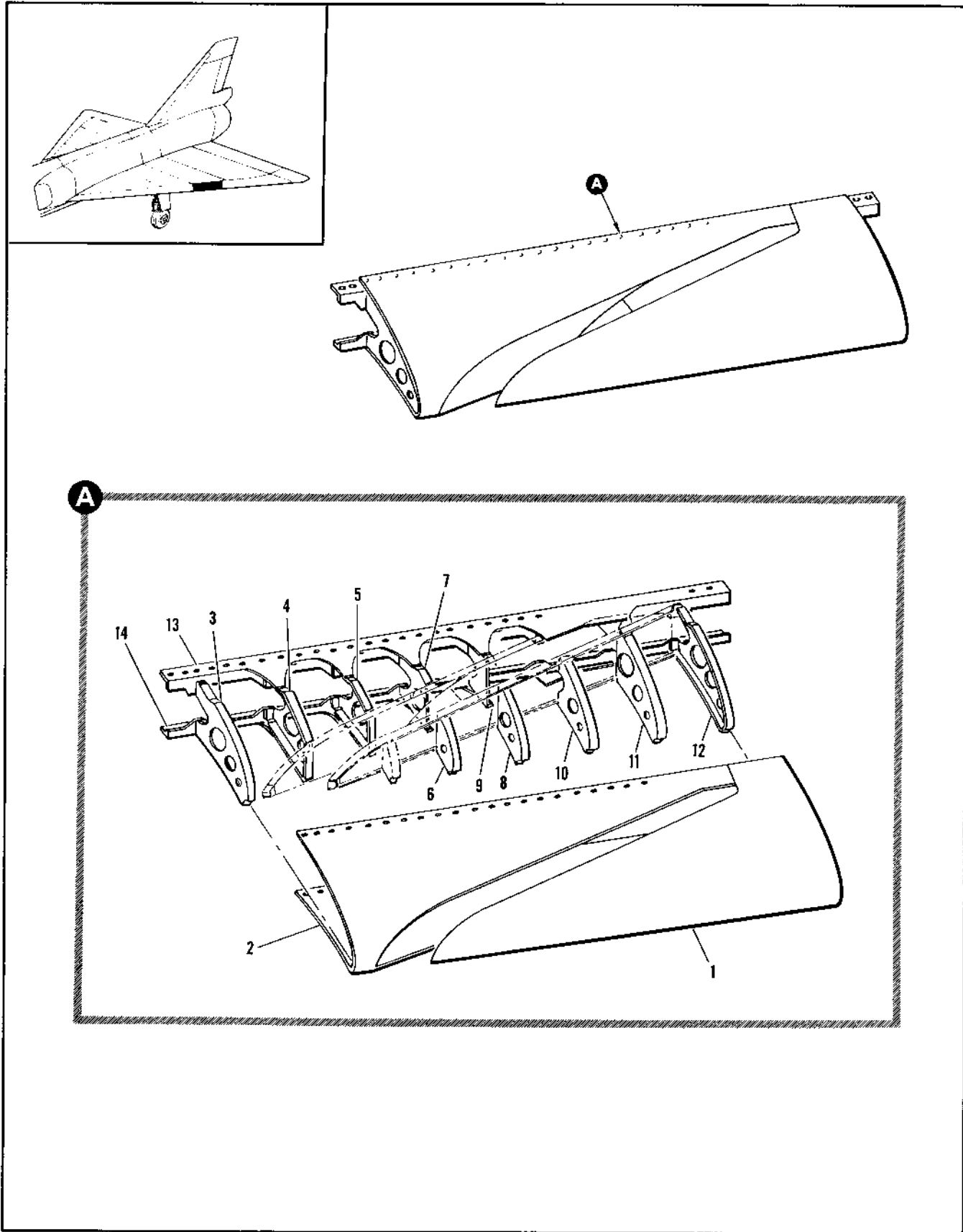

Figure 2.6-29. Wing Slotted Leading Edge Assembly Sta 301 to 334

FIGURE AND INDEX NUMBER	PART NUMBER	DESCRIPTION	UNITS PER ASSY.	USABLE ON CODE	
				FROM	TO
2.6-29	8-18204-3	LEADING EDGE ASSEMBLY, WING SLOTTED STA 301 TO 334 LH MODIFIED BY 8-18990 FOR NHA SEE FIG. 2.6-21	RF	A	
	8-18204-4	LEADING EDGE ASSEMBLY, WING SLOTTED STA 301 TO 334 RH MODIFIED BY 8-18990 FOR NHA SEE FIG. 2.6-21	RF	A	
- 1	8-18990-7	• SKIN, LH	1	A	
	8-18990-8	• SKIN, RH	1	A	
- 2	8-18990-9	• SKIN, LH ALTERED FROM 8-18204-7	1	A	
	8-18204-7	• SKIN	RF	A	
- 3	8-18990-10	• SKIN, RH ALTERED FROM 8-18204-8	1	A	
	8-18204-8	• SKIN	RF	A	
- 4	8-18214-7	• RIB, LH REPLACED BY NOT INTCHG WITH 8-18264-7	1	A	
	8-18214-8	• RIB, RH REPLACED BY NOT INTCHG WITH 8-18264-8	1	A	
- 5	8-18990-23	• RIB, LH ALTERED FROM 8-18214-9	1	278	279
	8-18214-9	• RIB, LH REPLACED BY NOT INTCHG WITH 8-18264-9	1	B	
- 6	8-18990-24	• RIB, RH ALTERED FROM 8-18214-10	1	278	278
	8-18214-10	• RIB, RH REPLACED BY NOT INTCHG WITH 8-18264-10	1	R	
- 7	8-18214-11	• RIB, LH REPLACED BY NOT INTCHG WITH 8-18264-11	1	A	
	8-18214-12	• RIB, RH REPLACED BY NOT INTCHG WITH 8-18264-12	1	A	
- 8	8-18990-27	• RIB, LH ALTERED FROM 8-18214-15	1	A	
	8-18990-29	• RIB, LH ALTERED FROM 8-18214-15	1	A	
- 9	8-18214-15	• RIB	RF	A	
	8-18990-28	• RIB, RH ALTERED FROM 8-18214-16	1	A	
- 10	8-18990-30	• RIB, RH ALTERED FROM 8-18214-16	1	A	
	8-18214-16	• RIB	RF	A	
- 11	8-18990-31	• RIB, LH ALTERED FROM 8-18214-17	1	A	
	8-18990-33	• RIB, LH ALTERED FROM 8-18214-17	1	A	
- 12	8-18214-17	• RIB	RF	A	
	8-16990-32	• RIB, RH ALTERED FROM 8-18214-18	1	A	
- 13	8-18990-34	• RIB, RH ALTERED FROM 8-18214-18	1	A	
	8-18214-18	• RIB	RF	A	
- 14	8-18990-35	• RIB, LH ALTERED FROM 8-18214-19	1	A	
	8-18214-19	• RIB	RF	A	
- 15	8-18990-36	• RIB, RH ALTERED FROM 8-18214-20	1	A	
	8-18214-20	• RIB	RF	A	
- 16	8-18990-37	• RIB, LH ALTERED FROM 8-18214-21	1	A	
	8-18214-21	• RIB	RF	A	
- 17	8-18990-38	• RIB, RH ALTERED FROM 8-18214-22	1	A	
	8-18214-22	• RIB	RF	A	
- 18	8-18214-23	• RIB, LH	1	A	
	8-18214-24	• RIB, RH	1	A	
- 19	8-18990-67	• RAIL, UPPER LH ALTERED FROM 8-18221-19	1	A	
	8-18221-19	• RAIL	RF	A	
- 20	8-18990-68	• RAIL, UPPER RH ALTERED FROM 8-18221-20	1	A	
	8-18221-20	• RAIL	RF	A	
- 21	8-18990-69	• RAIL, LOWER LH ALTERED FROM 8-18221-21	1	A	
	8-18221-21	• RAIL	RF	A	
- 22	8-18990-70	• RAIL, LOWER RH ALTERED FROM 8-18221-22	1	A	
	8-18221-22	• RAIL	RF	A	

A AIRPLANES #278 THRU 286 AND 288 THRU 291
 R AIRPLANES #279 THRU 286 AND 288 THRU 291

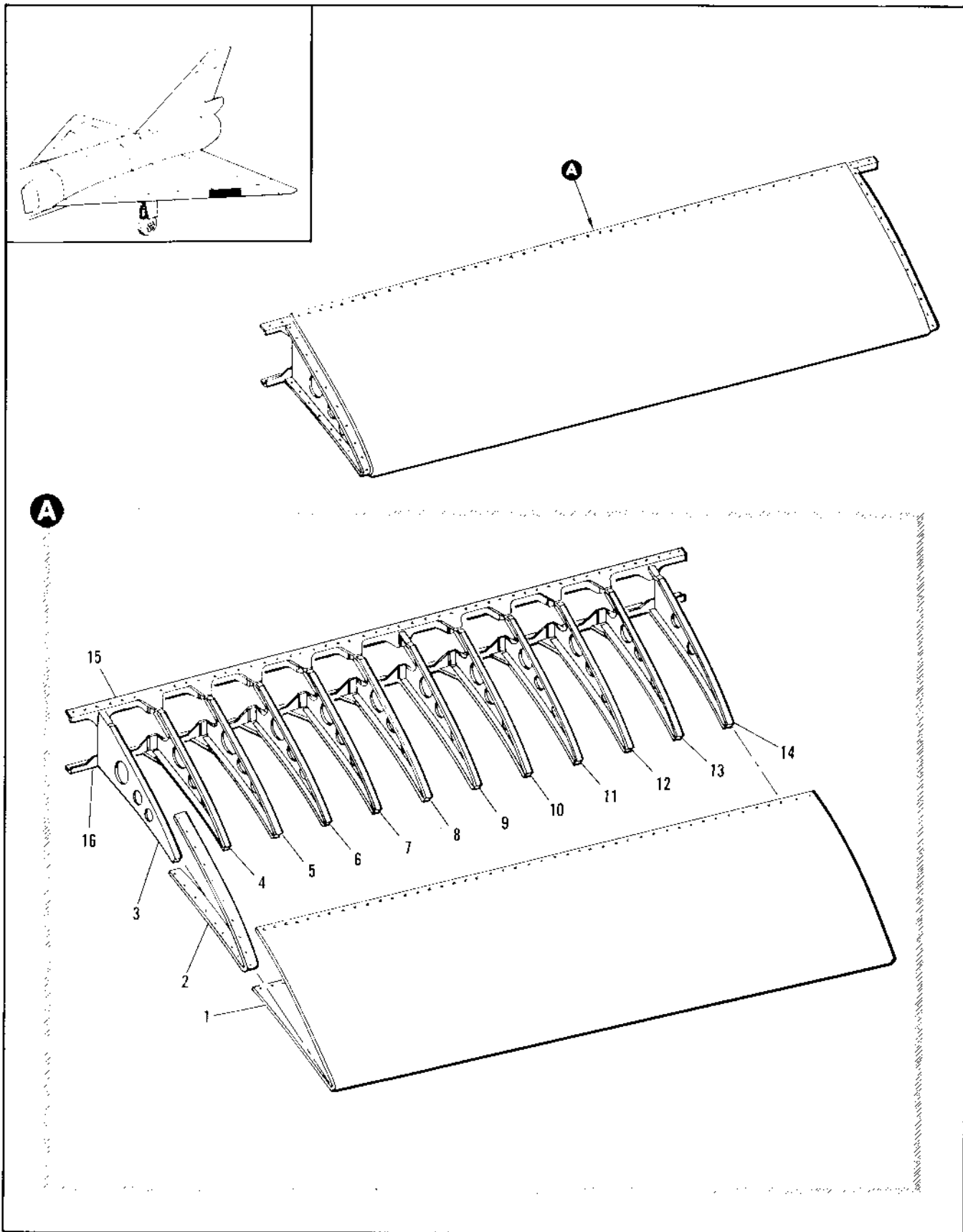

Figure 2.6-30. Wing Leading Edge Assembly Sta 338 to 384

FIGURE AND INDEX NUMBER	PART NUMBER	DESCRIPTION	UNITS PER ASSY.	USABLE ON CODE	
				FROM	TO
		1 2 3 4 5 6			
2.6-30	8-18255-3	LEADING EDGE ASSEMBLY, WING STA 338 TO 384 LH FOR NHA SEE FIG. 2.6-20	RF	A	
	8-18255-1	LEADING EDGE ASSEMBLY, WING STA 338 TO 384 LH ALT INTCHG WITH 8-18255-3	RF	A	
	8-18255-4	LEADING EDGE ASSEMBLY, WING STA 338 TO 384 RH FOR NHA SEE FIG. 2.6-20	RF	A	
	8-18255-2	LEADING EDGE ASSEMBLY, WING STA 338 TO 384 RH ALT INTCHG WITH 8-18255-4	RF	A	
- 1	8-18255-57	• SKIN, LH REPLACES NOT INTCHG WITH 8-18255-7	1	A	
	8-18255-7	• SKIN, LH USE WITH 8-18255-1 REPLACED BY NOT INTCHG WITH 8-18255-57	RF	A	
	8-18255-9	• SKIN, LH USE WITH 8-18255-1	RF	A	
	8-18255-61	• SKIN, RH REPLACES NOT INTCHG WITH 8-18255-8 AND 8-18255-11	1	A	
	8-18255-8	• SKIN, RH USE WITH 8-18255-2 REPLACED BY NOT INTCHG WITH 8-18255-61	RF	A	
	8-18255-11	• SKIN, RH USE WITH 8-18255-2 REPLACED BY NOT INTCHG WITH 8-18255-61	RF	A	
- 2	8-18255-19	• DOUBLER, LH	1	A	
	8-18255-13	• DOUBLER, RH	1	A	
- 3	8-18265-7	• RIB, LH REPLACES NOT INTCHG WITH 8-18215-7	1	A	
	8-18265-8	• RIB, RH REPLACES NOT INTCHG WITH 8-18215-8	1	A	
- 4	8-18265-9	• RIB, LH REPLACES NOT INTCHG WITH 8-18215-9	1	A	
	8-18265-10	• RIB, RH REPLACES NOT INTCHG WITH 8-18215-10	1	A	
- 5	8-18265-11	• RIB, LH REPLACES NOT INTCHG WITH 8-18215-11	1	A	
	8-18265-12	• RIB, RH REPLACES NOT INTCHG WITH 8-18215-12	1	A	
- 6	8-18265-13	• RIB, LH REPLACES NOT INTCHG WITH 8-18215-13	1	A	
	8-18265-14	• RIB, RH REPLACES NOT INTCHG WITH 8-18215-14	1	A	
- 7	8-18265-15	• RIB, LH REPLACES NOT INTCHG WITH 8-18215-15	1	A	
	8-18265-16	• RIB, RH REPLACES NOT INTCHG WITH 8-18215-16	1	A	
- 8	8-18265-17	• RIB, LH REPLACES NOT INTCHG WITH 8-18215-17	1	A	
	8-18265-18	• RIB, RH REPLACES NOT INTCHG WITH 8-18215-18	1	A	
- 9	8-18265-37	• RIB, LH REPLACES NOT INTCHG WITH 8-18265-19	1	A	
	8-18265-19	• RIB, LH REPLACED BY NOT INTCHG WITH 8-18265-37 USE WITH 8-18265-1	RF	A	
	8-18265-20	• RIB, RH REPLACES NOT INTCHG WITH 8-18265-20	1	A	
	8-18265-21	• RIB, RH REPLACED BY NOT INTCHG WITH 8-18265-37 USE WITH 8-18265-2	RF	A	
- 10	8-18265-21	• RIB, LH REPLACES NOT INTCHG WITH 8-18215-21	1	A	
	8-18265-22	• RIB, RH REPLACES NOT INTCHG WITH 8-18215-22	1	A	
- 11	8-18265-23	• RIB, LH REPLACES NOT INTCHG WITH 8-18215-23	1	A	
	8-18265-24	• RIB, RH REPLACES NOT INTCHG WITH 8-18215-24	1	A	
- 12	8-18265-25	• RIB, LH REPLACES NOT INTCHG WITH 8-18215-25	1	A	
	8-18265-31	• RIB, RH REPLACES NOT INTCHG WITH 8-18215-31	1	A	
- 13	8-18265-27	• RIB, LH REPLACES NOT INTCHG WITH 8-18215-27	1	A	
	8-18265-33	• RIB, RH REPLACES NOT INTCHG WITH 8-18215-33	1	A	
- 14	8-18265-29	• RIB, LH REPLACES NOT INTCHG WITH 8-18215-29	1	A	
	8-18265-35	• RIB, RH	1	A	
- 15	8-18271-39	• RAIL, LH REPLACES NOT INTCHG WITH 8-18271-23	1	A	
	8-18271-23	• RAIL, LH USE WITH 8-18255-1 REPLACED BY NOT INTCHG WITH 8-18271-39	RF	A	
	8-18271-43	• RAIL, RH	1	A	
	8-18271-27	• RAIL, RH USE WITH 8-18255-2	RF	A	
- 16	8-18271-41	• RAIL, LH	1	A	
	8-18271-45	• RAIL, LH USE WITH 8-18255-1	RF	A	
	8-18271-46	• RAIL, RH REPLACES NOT INTCHG WITH 8-18271-29	1	A	
	8-18271-29	• RAIL, RH USE WITH 8-18255-2 REPLACED BY NOT INTCHG WITH 8-18271-46	RF	A	
A AIRPLANES #35 THRU 277, 287, 292 AND ON					

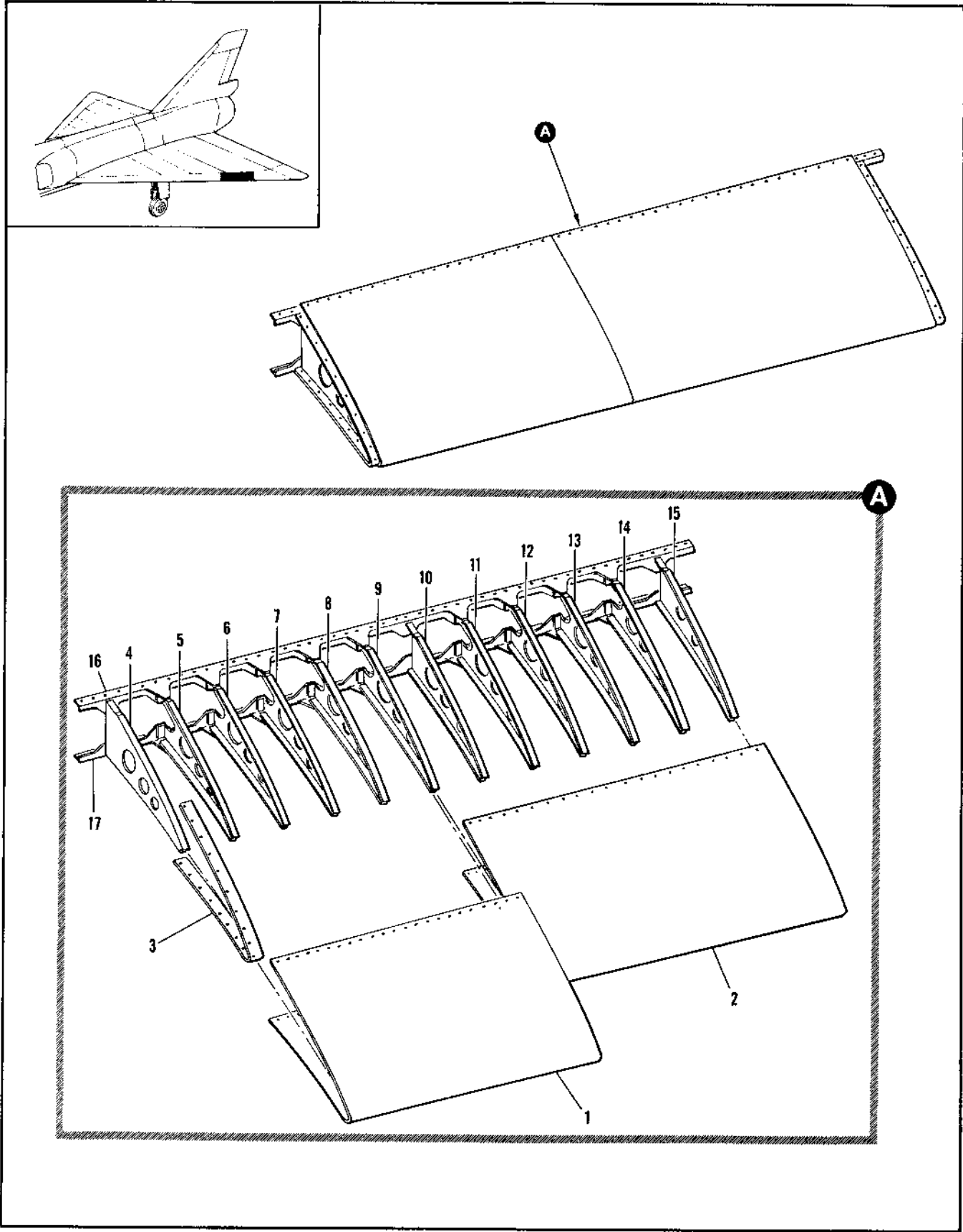

Figure 2.6-31. Wing Leading Edge Assembly Sta 338 to 384

FIGURE AND INDEX NUMBER	PART NUMBER	DESCRIPTION	UNITS PER ASSY.	USABLE ON CODE	
				FROM	TO
		1 2 3 4 5 6			
2.6-31	8-18205-1	LEADING EDGE ASSEMBLY, WING STA 338 TO 384 LH FOR NHA SEE FIG. 2.6-21	RF	A	
	8-18205-2	LEADING EDGE ASSEMBLY, WING STA 338 TO 384 RH FOR NHA SEE FIG. 2.6-21	RF	A	
- 1	8-18205-7	• SKIN, LH	1	A	
	8-18205-8	• SKIN, RH	1	A	
- 2	8-18205-9	• SKIN, LH	1	A	
	8-18205-11	• SKIN, RH	1	A	
- 3	8-18205-15	• DOUBLER, LH	1	A	
	8-18205-13	• DOUBLER, RH	1	A	
- 4	8-18215-7	• RIB, LH REPLACED BY NOT INTCHG WITH 8-18265-7	1	A	
	8-18215-8	• RIB, RH REPLACED BY NOT INTCHG WITH 8-18265-8	1	A	
- 5	8-18215-9	• RIB, LH REPLACED BY NOT INTCHG WITH 8-18265-9	1	A	
	8-18215-10	• RIB, RH REPLACED BY NOT INTCHG WITH 8-18265-10	1	A	
- 6	8-18215-11	• RIB, LH REPLACED BY NOT INTCHG WITH 8-18265-11	1	A	
	8-18215-12	• RIB, RH REPLACED BY NOT INTCHG WITH 8-18265-12	1	A	
- 7	8-18215-13	• RIB, LH REPLACED BY NOT INTCHG WITH 8-18265-13	1	A	
	8-18215-14	• RIB, RH REPLACED BY NOT INTCHG WITH 8-18265-14	1	A	
- 9	8-18215-15	• RIB, LH REPLACED BY NOT INTCHG WITH 8-18265-15	1	A	
	8-18215-16	• RIB, RH REPLACED BY NOT INTCHG WITH 8-18265-16	1	A	
- 10	8-18215-17	• RIB, LH REPLACED BY NOT INTCHG WITH 8-18265-17	1	A	
	8-18215-18	• RIB, RH REPLACED BY NOT INTCHG WITH 8-18265-18	1	A	
- 11	8-18215-35	• RIB, LH	1	A	
	8-18215-40	• RIB, RH	1	A	
- 11	8-18215-21	• RIB, LH REPLACED BY NOT INTCHG WITH 8-18265-21	1	A	
	8-18215-22	• RIB, RH REPLACED BY NOT INTCHG WITH 8-18265-22	1	A	
- 12	8-18215-23	• RIB, LH REPLACED BY NOT INTCHG WITH 8-18265-23	1	A	
	8-18215-24	• RIB, RH REPLACED BY NOT INTCHG WITH 8-18265-24	1	A	
- 13	8-18215-25	• RIB, LH REPLACED BY NOT INTCHG WITH 8-18265-25	1	A	
	8-18215-31	• RIB, RH REPLACED BY NOT INTCHG WITH 8-18265-31	1	A	
- 14	8-18215-27	• RIB, LH REPLACED BY NOT INTCHG WITH 8-18265-27	1	A	
	8-18215-33	• RIB, RH REPLACED BY NOT INTCHG WITH 8-18265-33	1	A	
- 15	8-18215-29	• RIB, LH REPLACED BY NOT INTCHG WITH 8-18265-29	1	A	
	8-18215-37	• RIB, RH REPLACES NOT INTCHG WITH 8-18265-37	1	A	
- 16	8-18221-25	• RAIL, LH	1	A	
	8-18221-27	• RAIL, RH	1	A	
- 17	8-18221-25	• RAIL, LH	1	A	
	8-18221-27	• RAIL, RH	1	A	
A AIRPLANES #278 THRU 286 AND 288 THRU 291					

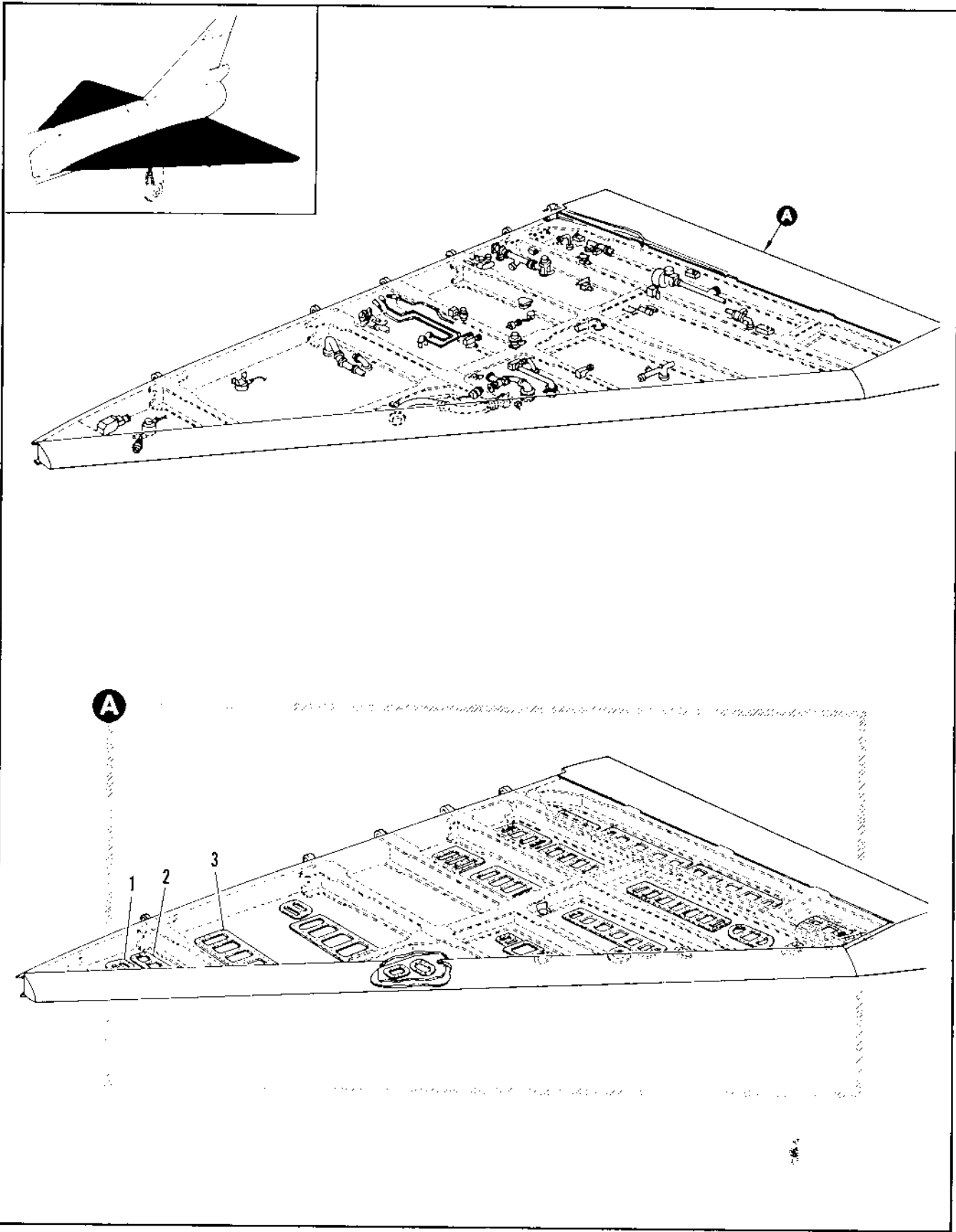

Figure 2.6-32. Wing Equipment Assembly (Sheet 1 of 13)

FIGURE AND INDEX NUMBER	PART NUMBER	DESCRIPTION	UNITS PER ASSY.	USABLE ON CODE	
				FROM	TO
		1 2 3 4 5 6			
2.6-32	8-18013-R11	EQUIPMENT ASSEMBLY, WING LH FOR NHA SEE FIG. 2.6-18	RF	35	89
	8-18013-R09	EQUIPMENT ASSEMBLY, WING LH FOR NHA SEE FIG. 2.6-18	RF	90	159
	8-18013-R15	EQUIPMENT ASSEMBLY, WING LH FOR NHA SEE FIG. 2.6-18	RF	160	188
	8-18013-R27	EQUIPMENT ASSEMBLY, WING LH FOR NHA SEE FIG. 2.6-18	RF	189	277
	8-18003-R03	EQUIPMENT ASSEMBLY, WING LH FOR NHA SEE FIG. 2.6-18 MODIFIED BY 8-21835 8-21837 AND 8-11906	RF	278	280
	8-18003-1	EQUIPMENT ASSEMBLY, WING LH FOR NHA SEE FIG. 2.6-18 MODIFIED BY 8-21835 8-21837 AND 8-11906	RF		K
	8-18013-1	EQUIPMENT ASSEMBLY, WING LH FOR NHA SEE FIG. 2.6-18 MODIFIED BY 8-21835 8-21837 AND 8-11906	RF		L
	8-18013-801	EQUIPMENT ASSEMBLY, WING LH FOR NHA SEE FIG. 2.6-18 MODIFIED BY 8-21835 8-21837 AND 8-11906	RF	302	303
	8-18013-805	EQUIPMENT ASSEMBLY, WING LH FOR NHA SEE FIG. 2.6-18	RF	304	
	8-18013-R12	EQUIPMENT ASSEMBLY, WING RH FOR NHA SEE FIG. 2.6-18	RF	35	89
	8-18013-R10	EQUIPMENT ASSEMBLY, WING RH FOR NHA SEE FIG. 2.6-18	RF	93	159
	8-18013-R16	EQUIPMENT ASSEMBLY, WING RH FOR NHA SEE FIG. 2.6-18	RF	160	198
	8-18013-R19	EQUIPMENT ASSEMBLY, WING RH FOR NHA SEE FIG. 2.6-18	RF	189	227
	8-18003-2	EQUIPMENT ASSEMBLY, WING RH FOR NHA SEE FIG. 2.6-18	RF		0
	8-18013-2	EQUIPMENT ASSEMBLY, WING RH FOR NHA SEE FIG. 2.6-18	RF		L
	8-18013-802	EQUIPMENT ASSEMBLY, WING RH FOR NHA SEE FIG. 2.6-18 MODIFIED BY 8-21838 AND 8-11906-1	RF	302	303
	8-18013-806	EQUIPMENT ASSEMBLY, WING RH FOR NHA SEE FIG. 2.6-18 MODIFIED BY 8-21838 AND 8-11906-1	RF	304	
- 1	8-18661-1	• DOOR INSTL, WING ACCESS TANK #1 BL 55 STA 337 LH FOR BREAKDOWN SEE FIG. 2.2-19	1	35	
	8-18661-5	• DOOR INSTL, WING ACCESS TANK #1 BL 55 STA 337 RH FOR BREAKDOWN SEE FIG. 2.2-19	1	35	
- 2	8-18662-1	• DOOR INSTL, WING ACCESS TANK #1 BL 58 STA 352 LH FOR BREAKDOWN SEE FIG. 2.2-19	1	35	
	8-18662-5	• DOOR INSTL, WING ACCESS TANK #1 BL 58 STA 352 RH FOR BREAKDOWN SEE FIG. 2.2-19	1	35	
- 3	8-18663-1	• DOOR INSTL, WING ACCESS TANK #1 BL 65 STA 341 LH FOR BREAKDOWN SEE FIG. 2.2-19	1	35	
		Q AIRPLANES #278 THRU 286 AND 288 THRU 291			
		K AIRPLANES #281 THRU 286 AND 288 THRU 291			
		L AIRPLANES #287 AND 288 THRU 301			

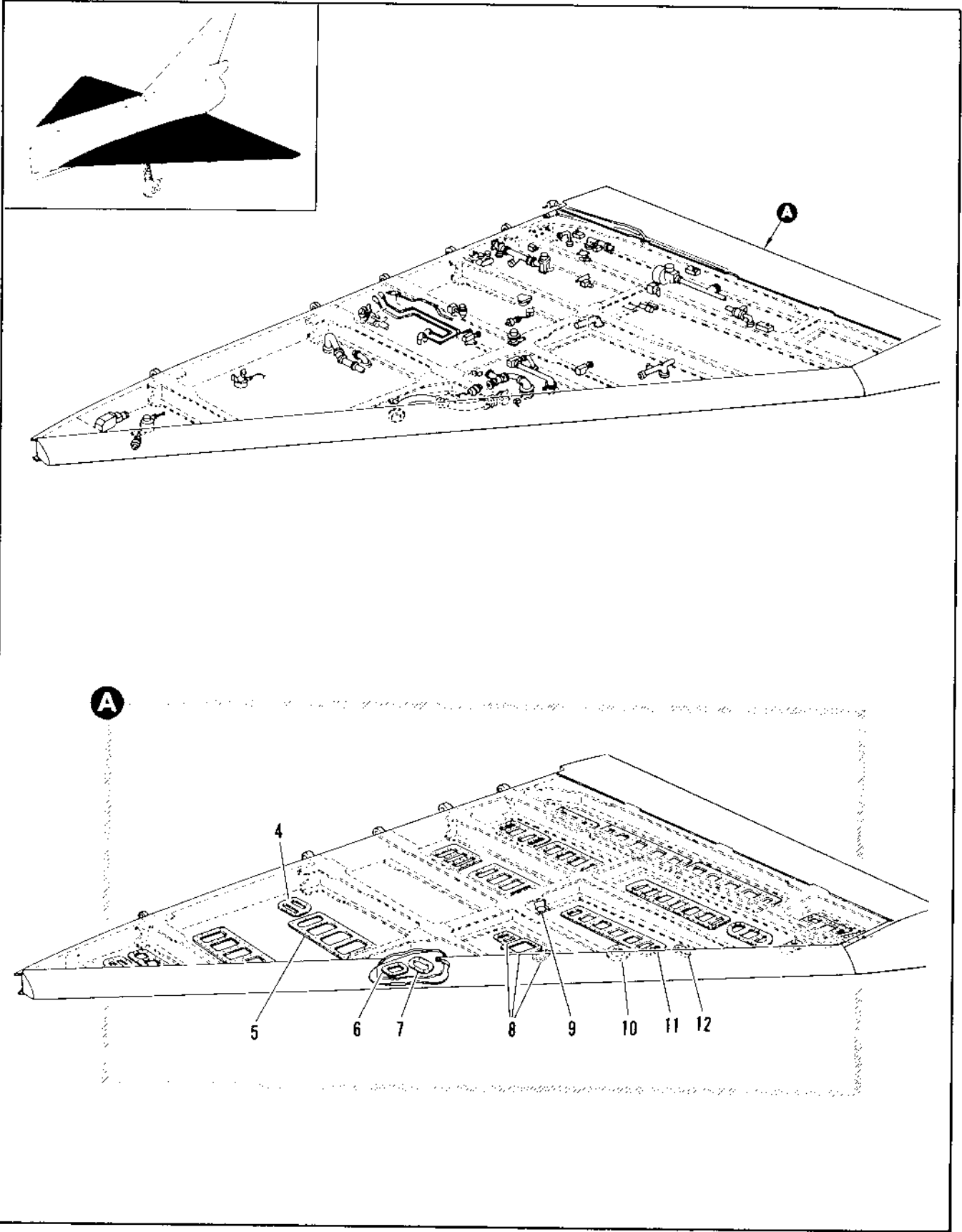

Figure 2.6-32. Wing Equipment Assembly (Sheet 2 of 13)

FIGURE AND INDEX NUMBER	PART NUMBER	DESCRIPTION	UNITS PER ASSY.	USABLE ON CODE	
				FROM	TO
		1 2 3 4 5 6			
2.6-32	8-18663-803	• DOOR INSTL, WING ACCESS TANK #1 BL 65 STA 381 RH FOR BREAKDOWN SEE FIG. 2.2-19	1	35	
- 4	8-18661-803	• DOOR INSTL, WING ACCESS TANK #1 BL 47 STA 416 LH FOR BREAKDOWN SEE FIG. 2.2-19	1	35	
	8-18661-807	• DOOR INSTL, WING ACCESS TANK #1 BL 47 STA 416 RH FOR BREAKDOWN SEE FIG. 2.2-19	1	35	
- 5	8-18663-5	• DOOR INSTL, WING ACCESS TANK #1 BL 72 STA 413 LH FOR BREAKDOWN SEE FIG. 2.2-19	1	35	
	8-18663-807	• DOOR INSTL, WING ACCESS TANK #1 BL 72 STA 413 RH FOR BREAKDOWN SEE FIG. 2.2-19	1	35	
- 6	8-18664-1	• DOOR INSTL, WING ACCESS TANK #1 BL 96 STA 413 LH FOR BREAKDOWN SEE FIG. 2.2-19	1	35	
	8-18664-5	• DOOR INSTL, WING ACCESS TANK #1 BL 96 STA 413 RH FOR BREAKDOWN SEE FIG. 2.2-19	1	35	
- 7	8-18664-803	• DOOR INSTL, WING ACCESS TANK #1 BL 99 STA 423 LH FOR BREAKDOWN SEE FIG. 2.2-19	1	35	
	8-18664-807	• DOOR INSTL, WING ACCESS TANK #1 BL 99 STA 423 RH FOR BREAKDOWN SEE FIG. 2.2-19	1	35	
- 8	8-18680-801	• DOOR INSTL, WING OUTRD INTERMEDIATE BOX ACCESS LH FOR BREAKDOWN SEE FIG. 2.2-21	1	A	
	8-18680-805	• DOOR INSTL, WING OUTRD INTERMEDIATE BOX ACCESS LH FOR BREAKDOWN SEE FIG. 2.2-21	1	B	
	8-18680-809	• DOOR INSTL, WING OUTRD INTERMEDIATE BOX ACCESS LH FOR BREAKDOWN SEE FIG. 2.2-21	1	C	
	8-18680-802	• DOOR INSTL, WING OUTRD INTERMEDIATE BOX ACCESS RH FOR BREAKDOWN SEE FIG. 2.2-21	1	A	
	8-18680-806	• DOOR INSTL, WING OUTRD INTERMEDIATE BOX ACCESS RH FOR BREAKDOWN SEE FIG. 2.2-21	1	B	
	8-18680-810	• DOOR INSTL, WING OUTRD INTERMEDIATE BOX ACCESS RH FOR BREAKDOWN SEE FIG. 2.2-21	1	C	
- 9	8-18784	• COVER PLATE, JACK POINT WING	1	35	
- 10	8-18669-803	• DOOR INSTL, WING ACCESS TANK #2 BL 127 LH FOR BREAKDOWN SEE FIG. 2.2-19	1	35	303
	8-18669-807	• DOOR INSTL, WING ACCESS TANK #2 BL 127 RH FOR BREAKDOWN SEE FIG. 2.2-19	1	35	
- 11	8-18664-5	• DOOR INSTL, WING ACCESS TANK #2 BL 123 STA 426 LH FOR BREAKDOWN SEE FIG. 2.2-19	1	35	
	8-18664-807	• DOOR INSTL, WING ACCESS TANK #2 BL 123 STA 426 RH FOR BREAKDOWN SEE FIG. 2.2-19	1	35	
- 12	8-18672-803	• DOOR INSTL, WING ACCESS TANK #2 BL 145 LH FOR BREAKDOWN SEE FIG. 2.2-19	1	35	
<p>A AIRPLANES #75 THRU 277, 297, 292 AND ON B AIRPLANES #278, 280 AND 282 THRU 286 C AIRPLANES #279, 281 AND 284 THRU 291</p>					

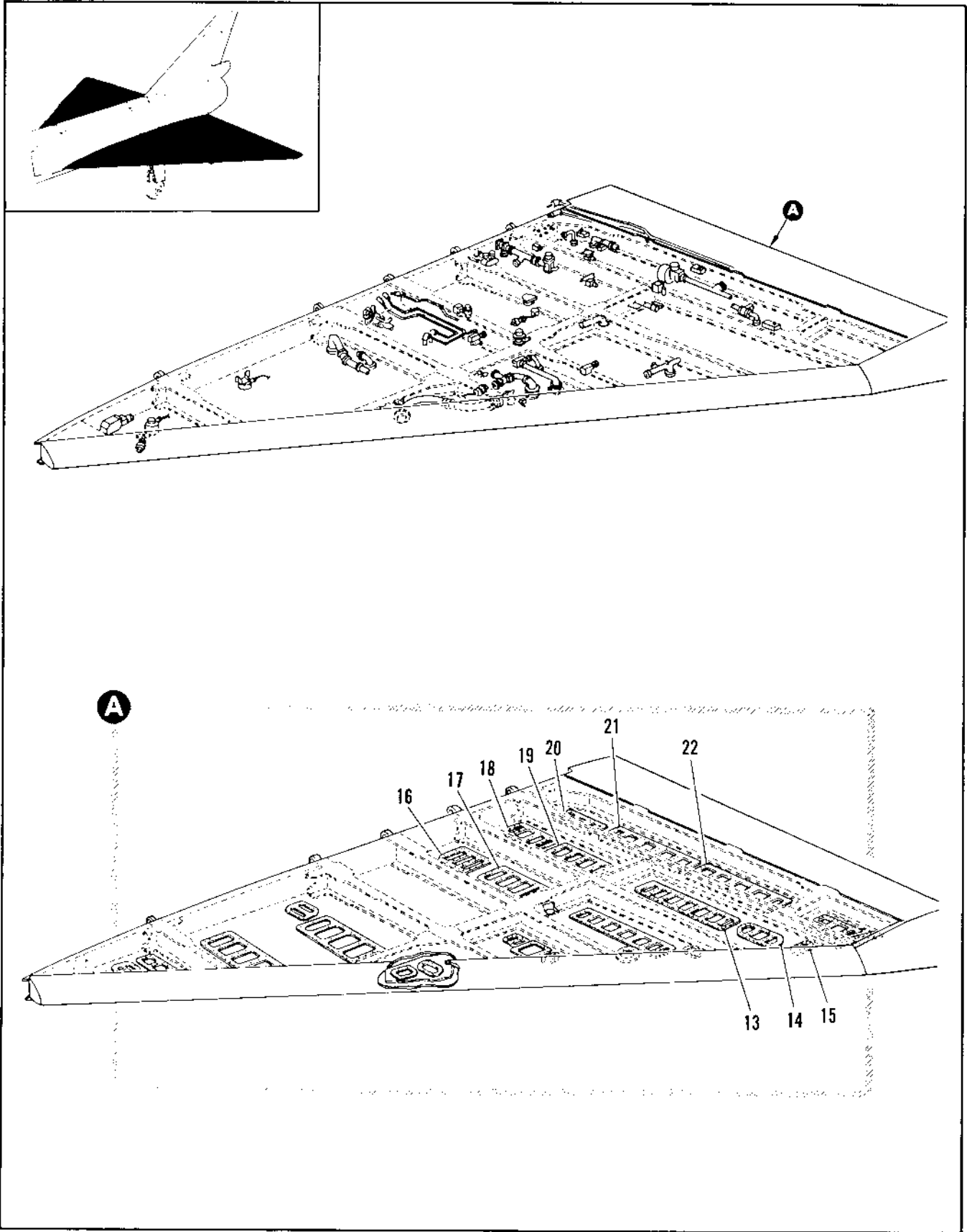

Figure 2.6-32. Wing Equipment Assembly (Sheet 3 of 13)

FIGURE AND INDEX NUMBER	PART NUMBER	DESCRIPTION	UNITS PER ASSY.	USABLE ON CODE	
				FROM	TO
2.6-32	R-18672-807	• DOOR INSTL, WING ACCESS TANK #2 BL 145 RH FOR BREAKDOWN SEE FIG. 2.2-19	1	35	
- 13	R-18668-1	• DOOR INSTL, WING ACCESS TANK #2 BL 123 STA 53B LH FOR BREAKDOWN SEE FIG. 2.2-19	1	35	
	R-18668-803	• DOOR INSTL, WING ACCESS TANK #2 BL 123 STA 57B RH FOR BREAKDOWN SEE FIG. 2.2-19	1	35	
- 14	R-18671-1	• DOOR INSTL, WING ACCESS TANK #2 BL 150 LH FOR BREAKDOWN SEE FIG. 2.2-19	1	35	
	R-18671-5	• DOOR INSTL, WING ACCESS TANK #2 BL 150 RH FOR BREAKDOWN SEE FIG. 2.2-19	1	35	
- 15	R-18672-1	• DOOR INSTL, WING ACCESS TANK #2 BL 164 LH FOR BREAKDOWN SEE FIG. 2.2-19	1	35	
	R-18672-5	• DOOR INSTL, WING ACCESS TANK #2 BL 164 RH FOR BREAKDOWN SEE FIG. 2.2-19	1	35	
- 16	R-18666-1	• DOOR INSTL, WING ACCESS TANK #3 BL 50 LH FOR BREAKDOWN SEE FIG. 2.2-19	1	35	
	R-18666-5	• DOOR INSTL, WING ACCESS TANK #3 BL 50 RH FOR BREAKDOWN SEE FIG. 2.2-19	1	35	
- 17	R-18667-1	• DOOR INSTL, WING ACCESS TANK #3 BL 76 LH FOR BREAKDOWN SEE FIG. 2.2-19	1	35	
	R-18667-803	• DOOR INSTL, WING ACCESS TANK #3 BL 76 RH FOR BREAKDOWN SEE FIG. 2.2-19	1	35	
- 18	R-18670-1	• DOOR INSTL, WING ACCESS TANK #3 BL 98 LH FOR BREAKDOWN SEE FIG. 2.2-19	1	35	
	R-18670-5	• DOOR INSTL, WING ACCESS TANK #3 BL 98 RH FOR BREAKDOWN SEE FIG. 2.2-19	1	35	
- 19	R-18667-5	• DOOR INSTL, WING ACCESS TANK #3 BL 76 LH FOR BREAKDOWN SEE FIG. 2.2-19	1	35	
	R-18667-807	• DOOR INSTL, WING ACCESS TANK #3 BL 76 RH FOR BREAKDOWN SEE FIG. 2.2-19	1	35	
- 20	R-18673-1	• DOOR INSTL, WING ACCESS TRANSFER TANK BL 46 LH FOR BREAKDOWN SEE FIG. 2.2-19	1	35	
	R-18673-5	• DOOR INSTL, WING ACCESS TRANSFER TANK BL 48 RH FOR BREAKDOWN SEE FIG. 2.2-19	1	35	
- 21	R-18674-1	• DOOR INSTL, WING ACCESS TRANSFER TANK BL 84 LH FOR BREAKDOWN SEE FIG. 2.2-19	1	35	
	R-18674-5	• DOOR INSTL, WING ACCESS TRANSFER TANK BL 84 RH FOR BREAKDOWN SEE FIG. 2.2-19	1	35	
- 22	R-18675-1	• DOOR INSTL, WING ACCESS TRANSFER TANK BL 126 LH FOR BREAKDOWN SEE FIG. 2.2-19	1	35	

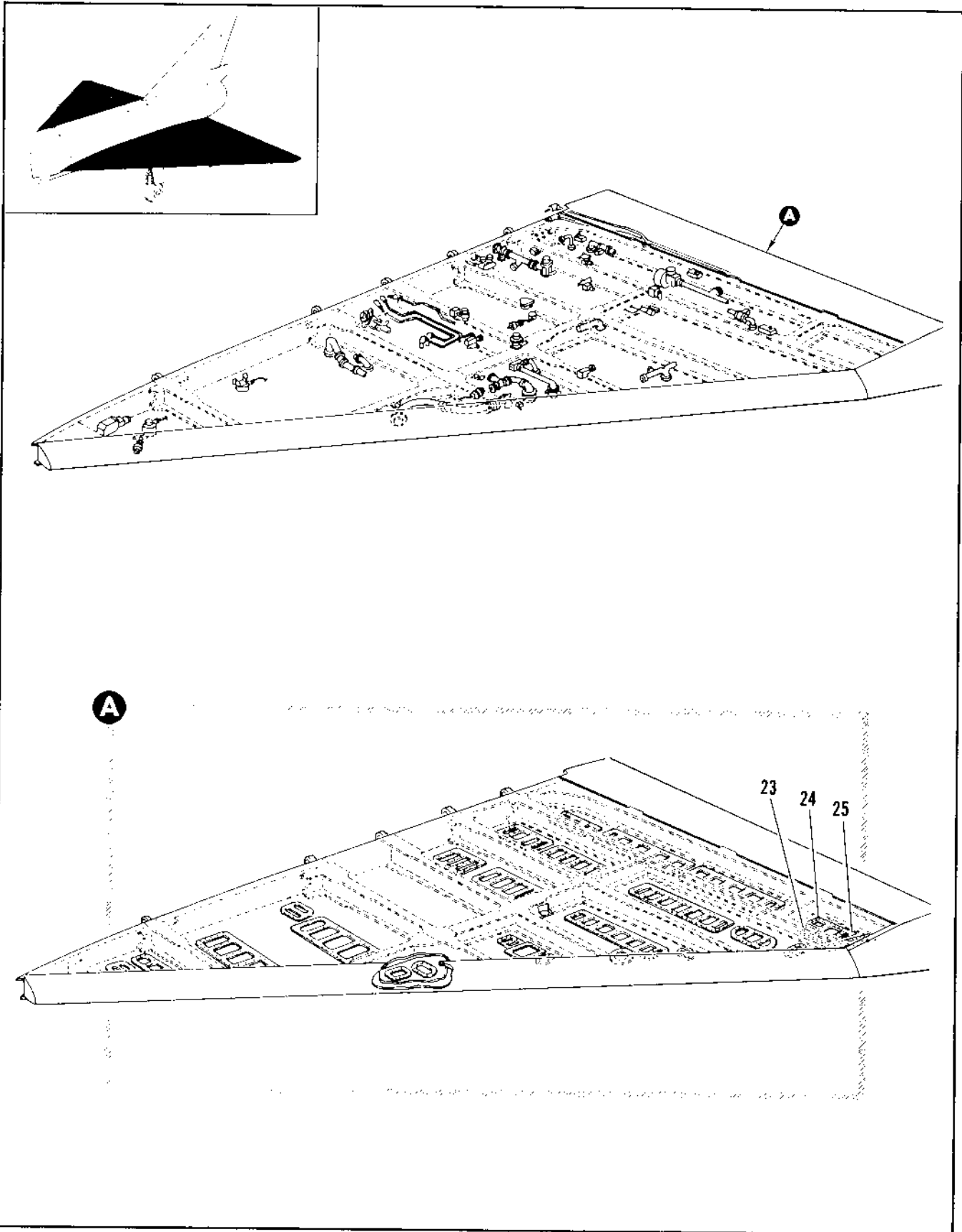

Figure 2.6-32. Wing Equipment Assembly (Sheet 4 of 13)

FIGURE AND INDEX NUMBER	PART NUMBER	DESCRIPTION	UNITS PER ASSY.	USABLE ON CODE	
				FROM	TO
		1 2 3 4 5 6			
2.6-32	R-18675-5	• DOOR INSTL, WING ACCESS TRANSFER TANK BL 126 RH FOR BREAKDOWN SEE FIG. 2.2-19	1	35	
- 23	A-18677-5	• DOOR INSTL, WING ACCESS TRAILING EDGE BL 156 LH FOR BREAKDOWN SEE FIG. 2.2-19	1	35	
	R-18677-6	• DOOR INSTL, WING ACCESS TRAILING EDGE BL 156 RH FOR BREAKDOWN SEE FIG. 2.2-19	1	35	
- 24	R-18677-1	• DOOR INSTL, WING ACCESS TRAILING EDGE BL 162 LH FOR BREAKDOWN SEE FIG. 2.2-19	1	35	
	S-18677-2	• DOOR INSTL, WING ACCESS TRAILING EDGE BL 162 RH FOR BREAKDOWN SEE FIG. 2.2-19	1	35	
- 25	R-18678-3	• DOOR INSTL, WING ACCESS TRAILING EDGE BL 176 LH FOR BREAKDOWN SEE FIG. 2.2-19	1	35	
	R-18678-4	• DOOR INSTL, WING ACCESS TRAILING EDGE BL 176 RH FOR BREAKDOWN SEE FIG. 2.2-19	1	35	

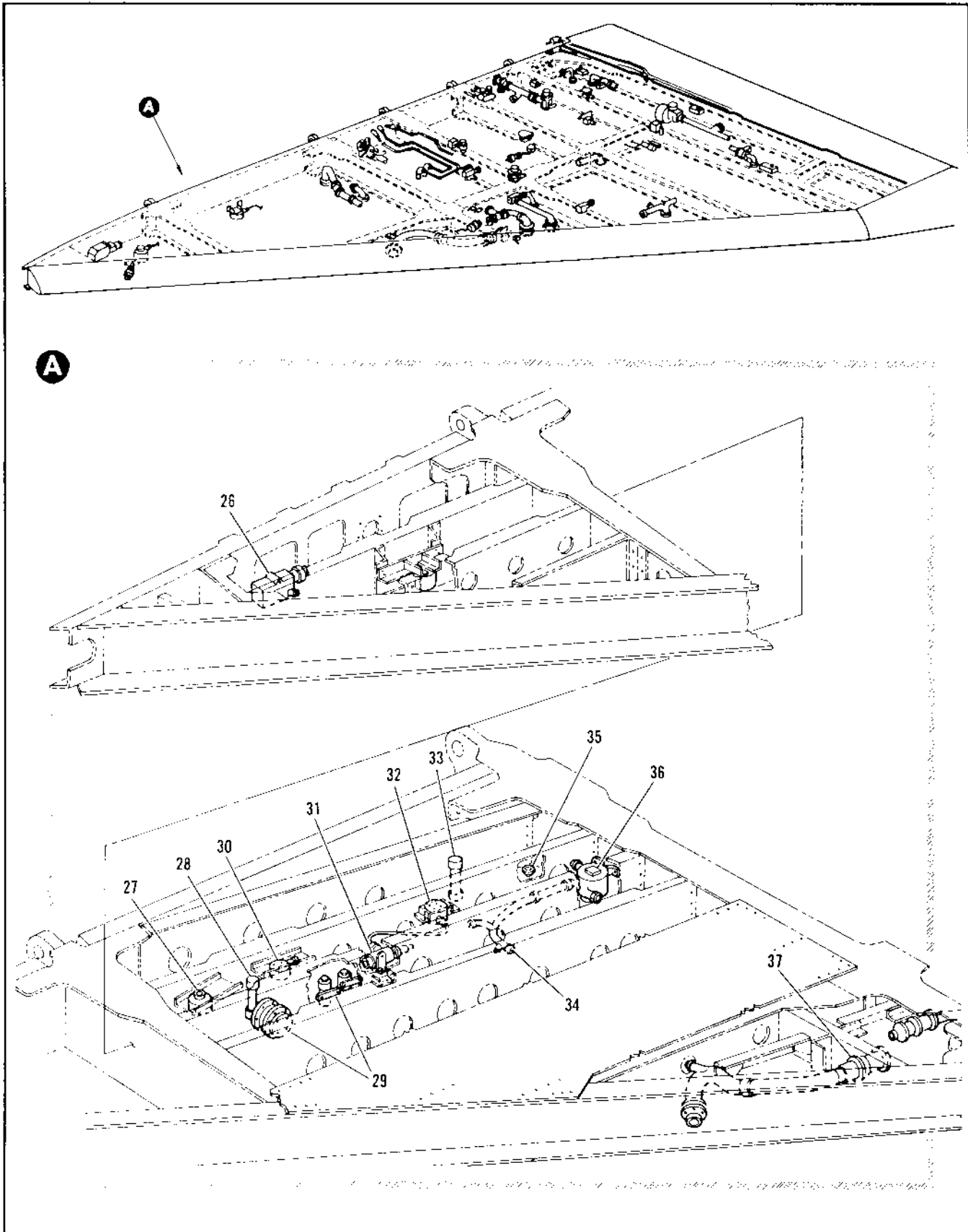

Figure 2.6-32. Wing Equipment Assembly (Sheet 5 of 13)

FIGURE AND INDEX NUMBER	PART NUMBER	DESCRIPTION	UNITS PER ASSY.	USABLE ON CODE	
				FROM	TO
2.6-32- 26	8-21188-1	• VALVE INSTL, FUEL TANK #1 PRESSURE RELIEF LH FOR BREAKDOWN SEE FIG. 2.12-1	1	35	
	8-21188-2	• VALVE INSTL, FUEL TANK #1 PRESSURE RELIEF RH FOR BREAKDOWN SEE FIG. 2.12-1	1	35	
- 27	8-21192-1	• VALVE INSTL, TANK #1 REFUEL PILOT LH FOR BREAKDOWN SEE FIG. 2.12-1	1	35	
	8-21192-2	• VALVE INSTL, TANK #1 REFUEL PILOT RH FOR BREAKDOWN SEE FIG. 2.12-1	1	35	
- 28	8-21104-3	• PROPE INSTL, FUEL QUANTITY TANK #1 STA 377 LH FOR BREAKDOWN SEE FIG. 2.12-7	1	35	
	8-21104-4	• PROPE INSTL, FUEL QUANTITY TANK #1 STA 377 RH FOR BREAKDOWN SEE FIG. 2.12-7	1	35	
- 29	8-21176-1	• DRAIN INSTL, M/G WHEEL WELL FUEL TUBING LH FOR BREAKDOWN SEE FIG. 2.12-1	1	35	
	8-21176-3	• DRAIN INSTL, M/G WHEEL WELL FUEL TUBING RH FOR BREAKDOWN SEE FIG. 2.12-1	1	35	
- 30	8-21194-1	• VALVE INSTL, TANK #1 REFUEL SHUTOFF LH FOR BREAKDOWN SEE FIG. 2.12-22	1	35	
	8-21194-2	• VALVE INSTL, TANK #1 REFUEL SHUTOFF RH FOR BREAKDOWN SEE FIG. 2.12-22	1	35	
- 31	8-21193-1	• VALVE INSTL, TANK #1 REFUEL PILOT LH FOR BREAKDOWN SEE FIG. 2.12-1	1	35	
	8-21193-2	• VALVE INSTL, TANK #1 REFUEL PILOT RH FOR BREAKDOWN SEE FIG. 2.12-1	1	35	
- 32	8-21191-1	• VALVE INSTL, TANK #1 REFUEL PRESSURE PILOT LH FOR BREAKDOWN SEE FIG. 2.12-1	1	35	
	8-21191-2	• VALVE INSTL, TANK #1 REFUEL PRESSURE PILOT RH FOR BREAKDOWN SEE FIG. 2.12-1	1	35	
- 33	8-21186-1	• VALVE INSTL, TANK #1 REFUEL PILOT LH FOR BREAKDOWN SEE FIG. 2.12-1	1	35	
	8-21186-2	• VALVE INSTL, TANK #1 REFUEL PILOT RH FOR BREAKDOWN SEE FIG. 2.12-1	1	35	
- 34	8-21104-1	• PROPE INSTL, TANK #1 FUEL QUANTITY STA 410 LH FOR BREAKDOWN SEE FIG. 2.12-7	1	35	
	8-21104-2	• PROPE INSTL, TANK #1 FUEL QUANTITY STA 410 RH FOR BREAKDOWN SEE FIG. 2.12-7	1	35	
- 35	8-21190-1	• TUBING INSTL, TANK #1 VENT LINE LH FOR BREAKDOWN SEE FIG. 2.12-1	1	35	
	8-21190-2	• TUBING INSTL, TANK #1 VENT LINE RH FOR BREAKDOWN SEE FIG. 2.12-1	1	35	
- 36	60112-1	• VALVE ASSY, FUEL DRAIN (42829) 92-12500-005	4	35	
	8-21542-1	• VALVE INSTL, TANK #1 REFUELING VENT LH FOR BREAKDOWN SEE FIG. 2.12-1	1	35	
- 37	8-21542-2	• VALVE INSTL, TANK #1 REFUELING VENT RH FOR BREAKDOWN SEE FIG. 2.12-1	1	35	
	8-21294-3	• VALVE INSTL, TANK #1 SUCTION RELIEF LH FOR BREAKDOWN SEE FIG. 2.12-21	1	4	

A AIRPLANES #35 THRU 277, 287, 292 AND ON
 B AIRPLANES #078 THRU 286 AND 288 THRU 291

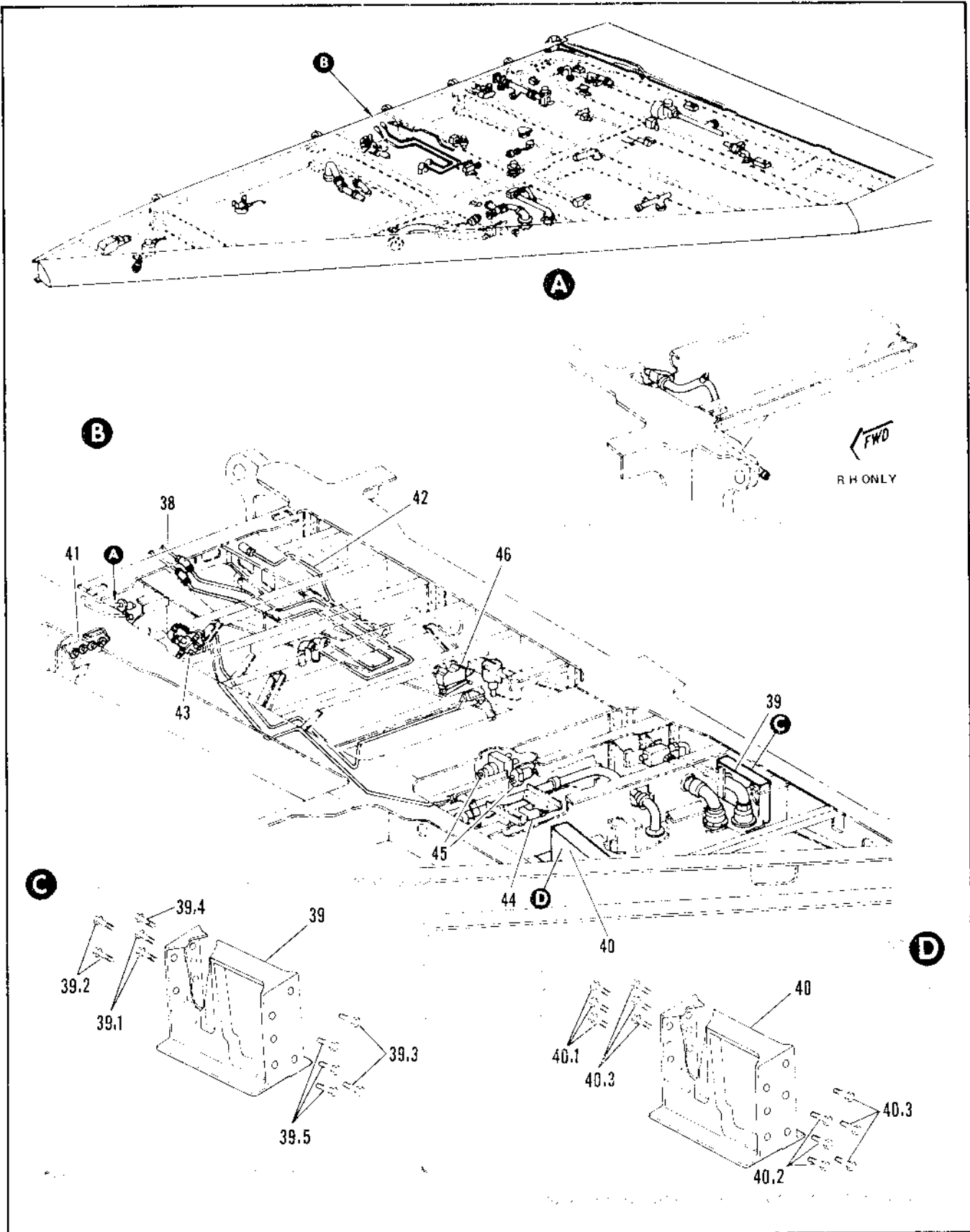

Figure 2.6-32. Wing Equipment Assembly (Sheet 6 of 13)

FIGURE AND INDEX NUMBER	PART NUMBER	DESCRIPTION	UNITS PER ASSY.	USABLE ON CODE	
				FROM	TO
		1 2 3 4 5 6			
2.6-32	8-21294-1	. VALVE INSTL, TANK #1 SUCTION RELIEF LH FOR BREAKDOWN SEE FIG. 2.12-21	1	D	
	8-21294-4	. VALVE INSTL, TANK#1 SUCTION RELIEF RH FOR BREAKDOWN SEE FIG. 2.12-21	1	A	
	8-21294-2	. VALVE INSTL, TANK #1 SUCTION RELIEF RH FOR BREAKDOWN SEE FIG. 2.12-21	1	B	
- 38	8-80031-805	. TUBING INSTL, HYDRAULIC MAIN LANDING GEAR ACTUATOR LH FOR BREAKDOWN SEE FIG. 2.15-23	1	49	277
	8-80031-807	. TUBING INSTL, HYDRAULIC MAIN LANDING GEAR ACTUATOR RH FOR BREAKDOWN SEE FIG. 2.15-23	1	49	277
- 39	65E33322-1	. BEAM SUPPORT LH (98750)	1	35	
	65E33322-2	. BEAM SUPPORT RH (98750)	1	35	
		(ATTACHING PARTS)			
- 39.1	NAS6203-11	. . BOLT	4		
	AN960D10L	. . WASHER	4		
	MS21059-L3	. . NUT	4		
- 39.2	NAS6205-9	. . BOLT	4		
	K19301-5	. . WASHER	4		
	H19300-5	. . NUT	4		
- 39.3	NAS6205-10	. . BOLT	4		
	MS21061-L5	. . NUT	4		
- 39.4	NAS6205-11	. . BOLT	2		
	AN960PD516L	. . WASHER	2		
	MS21061-5	. . NUT	2		
- 39.5	NAS6205-10	. . BOLT	6		
	K19301-5	. . WASHER	6		
	H19300-5	. . NUT	6		
		----X----			

FIGURE AND INDEX NUMBER	PART NUMBER	DESCRIPTION	UNITS PER ASSY.	USABLE ON CODE	
				FROM	TO
2.6-32					
- 40	65E33321-3	• BEAM SUPPORT LP (98750)	1	35	
	65E33321-4	• BEAM SUPPORT RH (98750) (ATTACHING PARTS)	1	35	
- 40.1	NAS6206-11	• BOLT	12		
	K19301-6	• WASHER	12		
	H19300-6	• NUT	12		
- 40.2	NAS6203-6	• BOLT	6		
	K19301-6	• WASHER	6		
	H19300-6	• NUT	6		
- 40.3	NAS6203-7	• BOLT	6		
	K19301-7	• WASHER	6		
	H19300-7	• NUT	6		
		-----X-----			
- 41	8-28413-1	• PANEL INSTL, FUEL SYSTEM CHECK OUT INTERMEDIATE LH FOR BREAKDOWN SEE FIG. 2.12-47	1	35	
	8-28413-2	• PANEL INSTL, FUEL SYSTEM CHECK OUT INTERMEDIATE RH FOR BREAKDOWN SEE FIG. 2.12-47	1	35	
- 42	8-80429-807	• TUBING INSTL, HIGH PRESSURE PNEUMATIC LH FOR BREAKDOWN SEE FIG. 2.9-11	1	35	49
	8-80429-819	• TUBING INSTL, HIGH PRESSURE PNEUMATIC LH FOR BREAKDOWN SEE FIG. 2.9-11	1	49	
	8-80429-809	• TUBING INSTL, HIGH PRESSURE PNEUMATIC RH FOR BREAKDOWN SEE FIG. 2.9-11	1	35	48
	8-80429-821	• TUBING INSTL, HIGH PRESSURE PNEUMATIC RH FOR BREAKDOWN SEE FIG. 2.9-11	1	49	
- 43	8-21521-1	REGULATOR INSTL, WING FUEL TANK PRESSURE LH FOR BREAKDOWN SEE FIG. 2.12-1	1	35	
	8-21521-2	• REGULATOR INSTL, WING FUEL TANK PRESSURE RH FOR BREAKDOWN SEE FIG. 2.12-1	1	35	
- 44	8-21524-1	• VALVE INSTL, EXTERNAL TANK SHUTOFF LH STA 442 TO 450 FOR BREAKDOWN SEE FIG. 2.12-13	1	35	
	8-21524-2	• VALVE INSTL, EXTERNAL TANK SHUTOFF RH STA 442 TO 450 FOR BREAKDOWN SEE FIG. 2.12-13	1	35	
- 45	8-21458-3	• SWITCH INSTL, TANK AND BOOST PUMP LOW PRESSURE WARNING LH FOR BREAKDOWN SEE FIG. 2.12-1	1	35	
	8-21458-4	• SWITCH INSTL, TANK AND BOOST PUMP LOW PRESSURE WARNING RH FOR BREAKDOWN SEE FIG. 2.12-1 FUEL INLET DISCONNECT RH FOR BREAKDOWN SEE FIG. 2.12-1	1	35	
- 46	8-51016-3	• SWITCH INSTL, MLG UP LH FOR BREAKDOWN SEE FIG. 2.15-4	1	G	
	8-51016-5	• SWITCH INSTL, MLG UP LH FOR BREAKDOWN SEE FIG. 2.15-4	1	49	277
		A AIRPLANE #35 THRU 277, 297, 292 AND ON			
		D AIRPLANE #278 THRU 286 AND 288 THRU 291			
		G AIRPLANES #35 THRU 48, 288 AND ON			

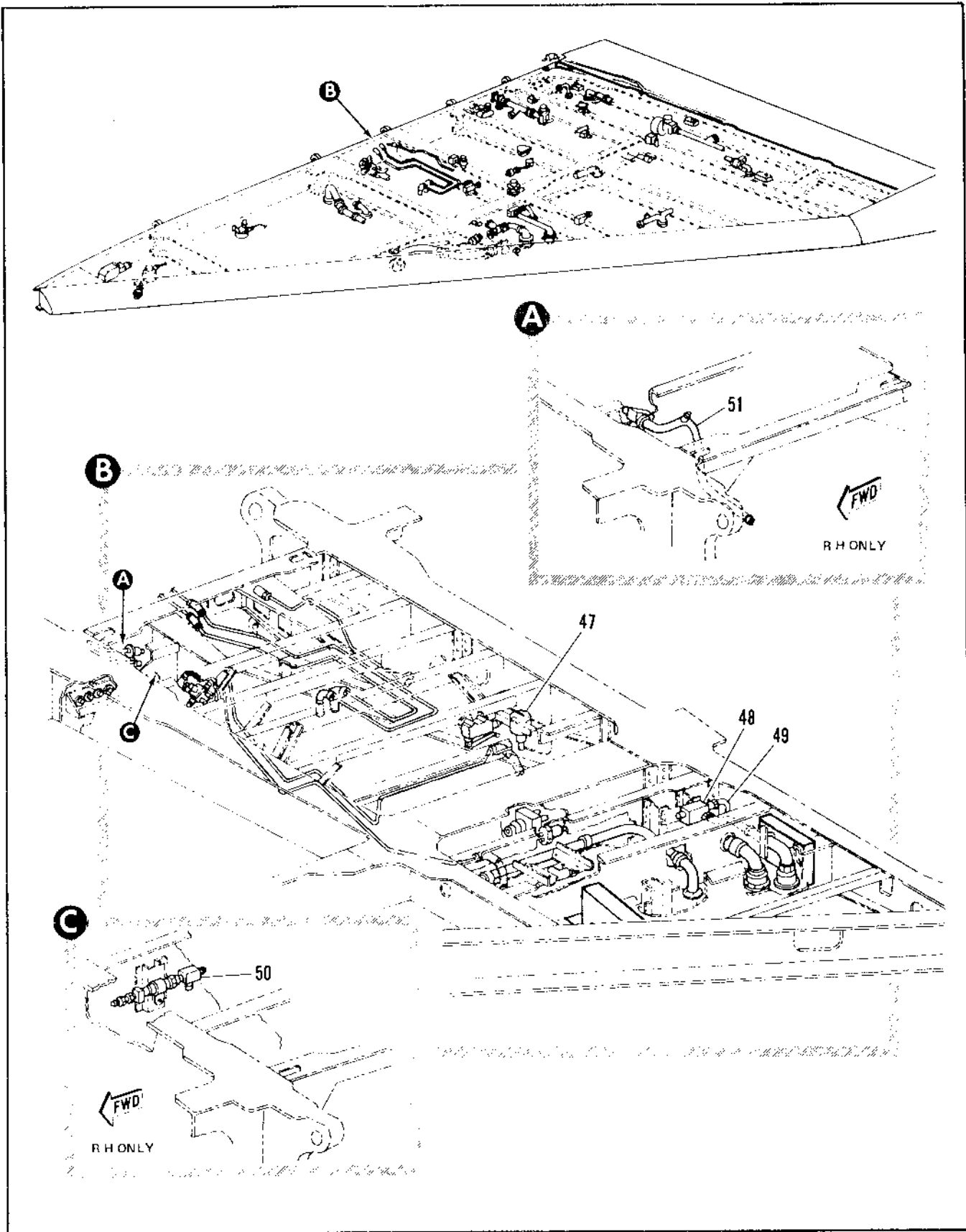

Figure 2.6-32. Wing Equipment Assembly (Sheet 7 of 13)

FIGURE AND INDEX NUMBER	PART NUMBER	DESCRIPTION	UNITS PER ASSY.	USABLE ON CODE	
				FROM	TO
		1 2 3 4 5 6			
2.6-32	8-51016-1	• SWITCH INSTL, M/G UP LH FOR BREAKDOWN SEE FIG. 2.15-4	1	278	287
	8-1015-4	• SWITCH INSTL, M/G UP RH FOR BREAKDOWN SEE FIG. 2.15-4	1	6	
	8-51016-6	• SWITCH INSTL, M/G UP RH FOR BREAKDOWN SEE FIG. 2.15-4	1	49	277
	8-51016-2	• SWITCH INSTL, M/G UP RH FOR BREAKDOWN SEE FIG. 2.15-4	1	278	287
- 47	8-85017-1	• CONNECTOR INSTL, PNEUMATIC GROUND FILLER LH FOR BREAKDOWN SEE FIG. 2.9-1	1	35	
- 48	8-21288-1	• VALVE INSTL, EXTERNAL FUEL TANK CHECK AND PRESSURE LH FOR BREAKDOWN SEE FIG. 2.12-1	1	35	
	8-21288-2	• VALVE INSTL, EXTERNAL FUEL TANK CHECK AND PRESSURE RH FOR BREAKDOWN SEE FIG. 2.12-1	1	35	
- 49	8-21166-1	• TUBING INSTL, EXTERNAL TANK PRESSURE RE- LIEF LH MODIFIED BY 65J35879 (98750)	1	35	
	8-21166-2	• TUBING INSTL, EXTERNAL TANK PRESSURE RE- LIEF RH MODIFIED BY 65J35879 (98750) FOR BREAKDOWN SEE FIG. 2.12-12	1	35	
- 50	8-21199-1	• VALVE INSTL, MANUAL REFUEL SELECTOR RH FOR BREAKDOWN SEE FIG. 2.12-3	1	35	69
	8-21199-3	• VALVE INSTL, MANUAL REFUEL SELECTOR RH FOR BREAKDOWN SEE FIG. 2.12-3	1	90	
- 51	8-21167-801	• TUBING INSTL, FUEL TANK AIR PRESSURE RH FOR BREAKDOWN SEE FIG. 2.12-1	1	35	
C AIRPLANES #35 THRU 40, 288 AND ON					

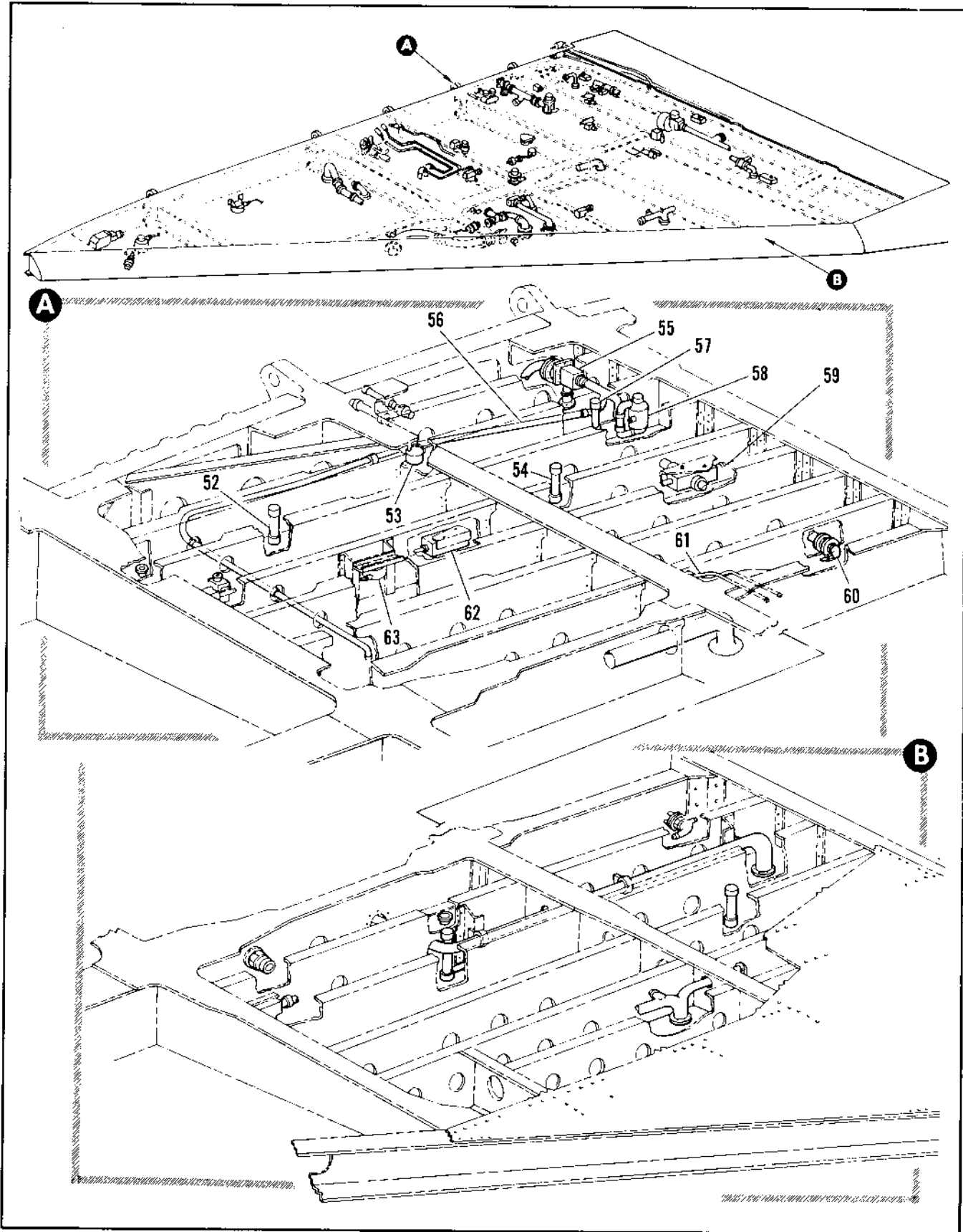

Figure 2.6-32. Wing Equipment Assembly (Sheet 8 of 13)

FIGURE AND INDEX NUMBER	PART NUMBER	DESCRIPTION	UNITS PER ASSY.	USABLE ON CODE	
				FROM	TO
2.6-32- 52	8-21106-5	• PROBE INSTL, FUEL QUANTITY TANK #3 STA 491 LH FOR BREAKDOWN SEE FIG. 2.12-8	1	35	
	8-21106-6	• PROBE INSTL, FUEL QUANTITY TANK #3 STA 491 RH FOR BREAKDOWN SEE FIG. 2.12-8	1	35	
- 53	8-21369	• COMPENSATOR INSTL, FUEL QUANTITY PROBE LH FOR BREAKDOWN SEE FIG. 2.12-1	1	35	
- 54	8-21106-3	• PROBE INSTL, FUEL QUANTITY TANK #3 STA 529 LH FOR BREAKDOWN SEE FIG. 2.12-8	1	35	
	8-21106-4	• PROBE INSTL, FUEL QUANTITY TANK #3 STA 529 RH FOR BREAKDOWN SEE FIG. 2.12-8	1	35	
- 55	8-21532-1	• VALVE INSTL, SHUTOFF AND CHECK LH FOR BREAKDOWN SEE FIG. 2.12-16	1	35	
	8-21532-3	• VALVE INSTL, SHUTOFF AND CHECK RH FOR BREAKDOWN SEE FIG. 2.12-16	1	35	
- 56	8-21540-1	• TUBING INSTL, ENGINE FUEL SUPPLY WING LH FOR BREAKDOWN SEE FIG. 2.12-59	1	35	
	8-21540-2	• TUBING INSTL, ENGINE FUEL SUPPLY WING RH FOR BREAKDOWN SEE FIG. 2.12-59	1	35	
- 57	8-21106-1	• PROBE INSTL, FUEL QUANTITY TANK #3 STA 544 LH FOR BREAKDOWN SEE FIG. 2.12-8	1	35	
	8-21106-2	• PROBE INSTL, FUEL QUANTITY TANK #3 STA 544 RH FOR BREAKDOWN SEE FIG. 2.12-8	1	35	
- 58	8-22310-1	• PUMP INSTL, FUEL BOOST LH FOR BREAKDOWN SEE FIG. 2.12-1	1	35	
	8-22310-2	• PUMP INSTL, FUEL BOOST RH FOR BREAKDOWN SEE FIG. 2.12-1	1	35	
- 59	8-21537-801	• VALVE INSTL, CG TRANSFER LINE SHUTOFF LH FOR BREAKDOWN SEE FIG. 2.12-34	1	35	
	8-21537-802	• VALVE INSTL, CG TRANSFER LINE SHUTOFF RH FOR BREAKDOWN SEE FIG. 2.12-34	1	35	
- 63	8-21534-809	• VALVE INSTL, TANK #3 REFUEL SHUTOFF AND PILOT LH FOR BREAKDOWN SEE FIG. 2.12-15	1	35	
	8-21534-811	• VALVE INSTL, TANK #3 REFUEL SHUTOFF AND PILOT RH FOR BREAKDOWN SEE FIG. 2.12-15	1	35	
- 61	8-20397-837	• TUBING INSTL, WING FUEL CONTROL LH FOR BREAKDOWN SEE FIG. 2.12-13	1	35	159
	8-20397-855	• TUBING INSTL, WING FUEL CONTROL LH FOR BREAKDOWN SEE FIG. 2.12-14	1	160	189
	8-20397-865	• TUBING INSTL, WING FUEL CONTROL LH FOR BREAKDOWN SEE FIG. 2.12-14	1	190	
	8-20397-839	• TUBING INSTL, WING FUEL CONTROL RH FOR BREAKDOWN SEE FIG. 2.12-13	1	35	159
	8-20397-857	• TUBING INSTL, WING FUEL CONTROL RH FOR BREAKDOWN SEE FIG. 2.12-14	1	160	189
	8-20397-867	• TUBING INSTL, WING FUEL CONTROL RH FOR BREAKDOWN SEE FIG. 2.12-14	1	190	
- 62	8-21255-1	• SWITCH INSTL, FUEL LOW LEVEL WARNING LH FOR BREAKDOWN SEE FIG. 2.12-1	1	35	
	8-21255-3	• SWITCH INSTL, FUEL LOW LEVEL WARNING RH FOR BREAKDOWN SEE FIG. 2.12-1	1	35	
- 63	8-21181-1	• VALVE INSTL, TANK #3 REFUEL PILOT LH FOR BREAKDOWN SEE FIG. 2.12-1	1	35	43
	8-21181-811	• VALVE INSTL, TANK #3 REFUEL PILOT LH FOR BREAKDOWN SEE FIG. 2.12-1	1	44	
	8-21181-3	• VALVE INSTL, TANK #3 REFUEL PILOT RH FOR BREAKDOWN SEE FIG. 2.12-1	1	35	43

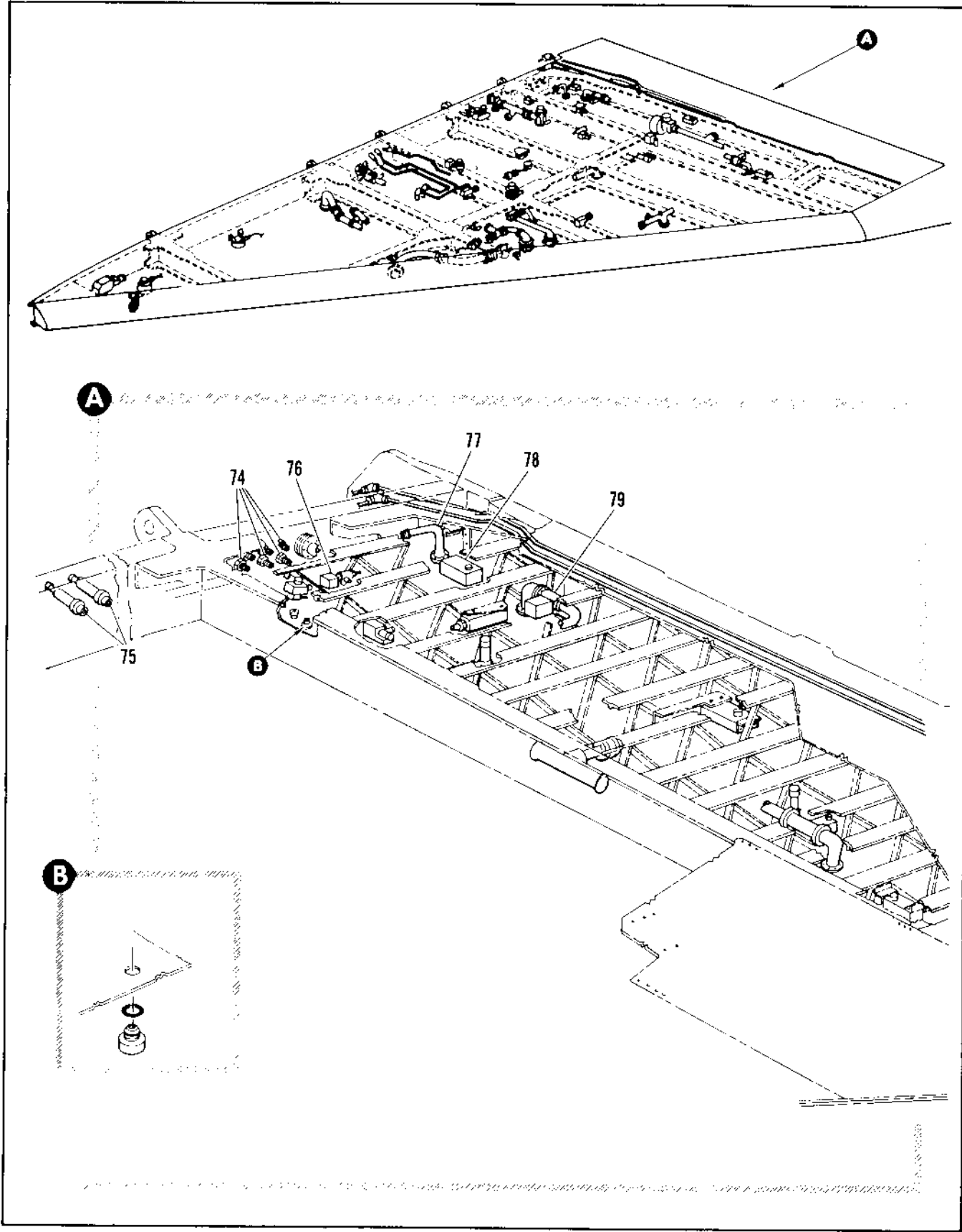

Figure 2.6-32. Wing Equipment Assembly (Sheet 10 of 13)

FIGURE AND INDEX NUMBER	PART NUMBER	DESCRIPTION	UNITS PER ASSY.	USABLE ON CODE		
				FROM	TO	
2.6-32- 74	8-21236-801	• FITTING INSTL, CG TRANSFER PRESSURE WING TRANSFER TANK LH FOR BREAKDOWN SEE FIG. 2.12-33	1	M		
	8-21236-811	• FITTING INSTL, CG TRANSFER PRESSURE WING TRANSFER TANK LH FOR BREAKDOWN SEE FIG. 2.12-33	1	189	277	
	8-21236-805	• FITTING INSTL, CG TRANSFER PRESSURE WING TRANSFER TANK LH MODIFIED BY 8-21834 AND 8-21938 FOR BREAKDOWN SEE FIG. 2.12-33	1	278	303	
	8-21236-803	• FITTING INSTL, CG TRANSFER PRESSURE WING TRANSFER TANK RH FOR BREAKDOWN SEE FIG. 2.12-33	1	M		
	8-21236-813	• FITTING INSTL, CG TRANSFER PRESSURE WING TRANSFER TANK RH FOR BREAKDOWN SEE FIG. 2.12-33	1	189	277	
	8-21236-806	• FITTING INSTL, CG TRANSFER PRESSURE WING TRANSFER TANK RH MODIFIED BY 8-21834 AND 8-21838 FOR BREAKDOWN SEE FIG. 2.12-33	1	278	303	
	- 75	8-81343-1	• FITTING INSTL, HYDRAULIC HEAT EXCHANGER LH FOR BREAKDOWN SEE FIG. 2.8-1	1	35	
		8-81343-2	• FITTING INSTL, HYDRAULIC HEAT EXCHANGER RH FOR BREAKDOWN SEE FIG. 2.8-1	1	35	
- 76	8-21183-1	• VALVE INSTL, TRANSFER TANK REFUEL PILOT AND VENT LH FOR BREAKDOWN SEE FIG. 2.12-24	1	H		
	8-21183-801	• VALVE INSTL, TRANSFER TANK REFUEL PILOT AND VENT LH FOR BREAKDOWN SEE FIG. 2.12-24	1	189	277	
- 77	8-21183-3	• VALVE INSTL, TRANSFER TANK REFUEL PILOT AND VENT RH FOR BREAKDOWN SEE FIG. 2.12-24	1	H		
	8-21183-803	• VALVE INSTL, TRANSFER TANK REFUEL PILOT AND VENT RH FOR BREAKDOWN SEE FIG. 2.12-24	1	189	277	
	8-21158-3	• BELLMOUTH INSTL, TRANSFER TANK FUEL SCAVENGE LH FOR BREAKDOWN SEE FIG. 2.12-1	1	35		
- 78	8-21158-4	• BELLMOUTH INSTL, TRANSFER TANK FUEL SCAVENGE RH FOR BREAKDOWN SEE FIG. 2.12-1	1	35		
	8-21179-1	• VALVE INSTL, TRANSFER TANK INBD PILOT LH FOR BREAKDOWN SEE FIG. 2.12-26	1	35	188	
	8-21179-3	• VALVE INSTL, TRANSFER TANK INBD PILOT LH FOR BREAKDOWN SEE FIG. 2.12-26	1	189	277	
	8-21179-5	• VALVE INSTL, TRANSFER TANK INBD PILOT LH FOR BREAKDOWN SEE FIG. 2.12-26	1	278		
	8-21179-2	• VALVE INSTL, TRANSFER TANK INBD PILOT RH FOR BREAKDOWN SEE FIG. 2.12-26	1	35	188	
	8-21179-4	• VALVE INSTL, TRANSFER TANK INBD PILOT RH FOR BREAKDOWN SEE FIG. 2.12-26	1	189	277	
	8-21179-6	• VALVE INSTL, TRANSFER TANK INBD PILOT RH FOR BREAKDOWN SEE FIG. 2.12-26	1	278		
	- 79	8-21525-3	• VALVE INSTL, TRANSFER TANK INBD SHUTOFF LH FOR BREAKDOWN SEE FIG. 2.12-28	1	H	
8-21525-5		• VALVE INSTL, TRANSFER TANK INBD SHUTOFF LH FOR BREAKDOWN SEE FIG. 2.12-28	1	189	277	

H AIRPLANES 475 THRU 184, 278 AND ON
 Y AIRPLANES 835 THRU 184, 374, AND ON

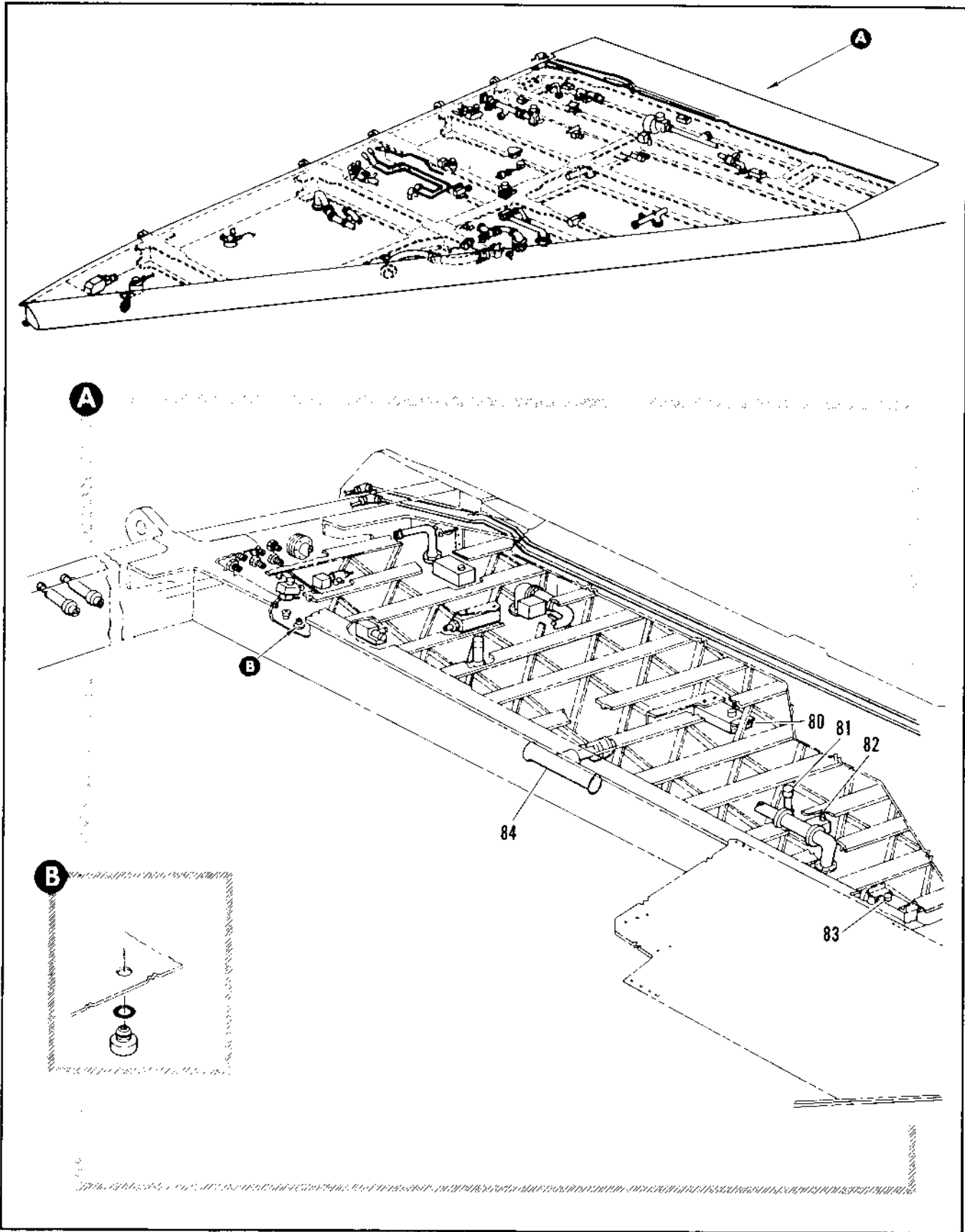

Figure 2.6-32. Wing Equipment Assembly (Sheet 11 of 13)

FIGURE AND INDEX NUMBER	PART NUMBER	DESCRIPTION	UNITS PER ASSY.	USABLE ON CODE	
				FROM	TO
		1 2 3 4 5 8			
2.6-32	8-21525-4	• VALVE INSTL, TRANSFER TANK INBD SHUTOFF RH FOR BREAKDOWN SEE FIG. 2.12-28	1	H	
	8-21525-6	• VALVE INSTL, TRANSFER TANK INBD SHUTOFF RH FOR BREAKDOWN SEE FIG. 2.12-29	1	189	277
- 80	8-21168-1	• VALVE INSTL, TRANSFER TANK EMERGENCY PILOT LH FOR BREAKDOWN SEE FIG. 2.12-32	1	35	189
	8-21168-3	• VALVE INSTL, TRANSFER TANK EMERGENCY PILOT LH FOR BREAKDOWN SEE FIG. 2.12-32	1	189	277
	8-21168-5	• VALVE INSTL, TRANSFER TANK EMERGENCY PILOT LH FOR BREAKDOWN SEE FIG. 2.12-32	1	278	
	8-21168-2	• VALVE INSTL, TRANSFER TANK EMERGENCY PILOT RH FOR BREAKDOWN SEE FIG. 2.12-32	1	35	188
	8-21168-4	• VALVE INSTL, TRANSFER TANK EMERGENCY PILOT RH FOR BREAKDOWN SEE FIG. 2.12-32	1	189	277
	8-21168-6	• VALVE INSTL, TRANSFER TANK EMERGENCY PILOT RH FOR BREAKDOWN SEE FIG. 2.12-32	1	278	
- 81	8-21107-3	• PROBE INSTL, FUEL QUANTITY TRANSFER TANK STA 568 LH FOR BREAKDOWN SEE FIG. 2.12-8	1	35	188
	8-21107-803	• PROBE INSTL, FUEL QUANTITY TRANSFER TANK STA 568 LH FOR BREAKDOWN SEE FIG. 2.12-8	1	189	
	8-21107-4	• PROBE INSTL, FUEL QUANTITY TRANSFER TANK STA 568 RH FOR BREAKDOWN SEE FIG. 2.12-8	1	35	188
	8-21107-804	• PROBE INSTL, FUEL QUANTITY TRANSFER TANK STA 568 RH FOR BREAKDOWN SEE FIG. 2.12-8	1	189	
- 82	8-21271-3	• VALVE INSTL, TRANSFER TANK OUTBD SHUTOFF LH FOR BREAKDOWN SEE FIG. 2.12-25	1	H	
	8-21271-801	• VALVE INSTL, TRANSFER TANK OUTBD SHUTOFF LH FOR BREAKDOWN SEE FIG. 2.12-25	1	189	277
	8-21271-4	• VALVE INSTL, TRANSFER TANK OUTBD SHUTOFF RH FOR BREAKDOWN SEE FIG. 2.12-25	1	H	
	8-21271-802	• VALVE INSTL, TRANSFER TANK OUTBD SHUTOFF RH FOR BREAKDOWN SEE FIG. 2.12-25	1	189	277
- 83	8-21180-1	• VALVE INSTL, TRANSFER TANK OUTPD PILOT LH FOR BREAKDOWN SEE FIG. 2.12-27	1	35	189
	8-21180-3	• VALVE INSTL, TRANSFER TANK OUTBD PILOT LH FOR BREAKDOWN SEE FIG. 2.12-27	1	189	277
	8-21180-5	• VALVE INSTL, TRANSFER TANK OUTPD PILOT LH FOR BREAKDOWN SEE FIG. 2.12-27	1	278	
	8-21180-2	• VALVE INSTL, TRANSFER TANK OUTPD PILOT RH FOR BREAKDOWN SEE FIG. 2.12-27	1	35	188
	8-21180-4	• VALVE INSTL, TRANSFER TANK OUTPD PILOT RH FOR BREAKDOWN SEE FIG. 2.12-27	1	189	277
	8-21180-6	• VALVE INSTL, TRANSFER TANK OUTBD PILOT RH FOR BREAKDOWN SEE FIG. 2.12-27	1	278	
- 84	8-21147-3	• VALVE INSTL, REFUELING SHUTOFF TRANSFER TANK LH FOR BREAKDOWN SEE FIG. 2.12-2	1	35	89
	8-21147-5	• VALVE INSTL, REFUELING SHUTOFF TRANSFER TANK LH FOR BREAKDOWN SEE FIG. 2.12-2	1	J	
	8-21147-801	• VALVE INSTL, REFUELING SHUTOFF TRANSFER TANK LH FOR BREAKDOWN SEE FIG. 2.12-2	1	189	277
	8-21147-4	• VALVE INSTL, REFUELING SHUTOFF TRANSFER TANK RH FOR BREAKDOWN SEE FIG. 2.12-2	1	35	89

H AIRPLANES #35 THRU 124, 278 AND ON
 J AIRPLANES #90 THRU 188, 278 AND ON

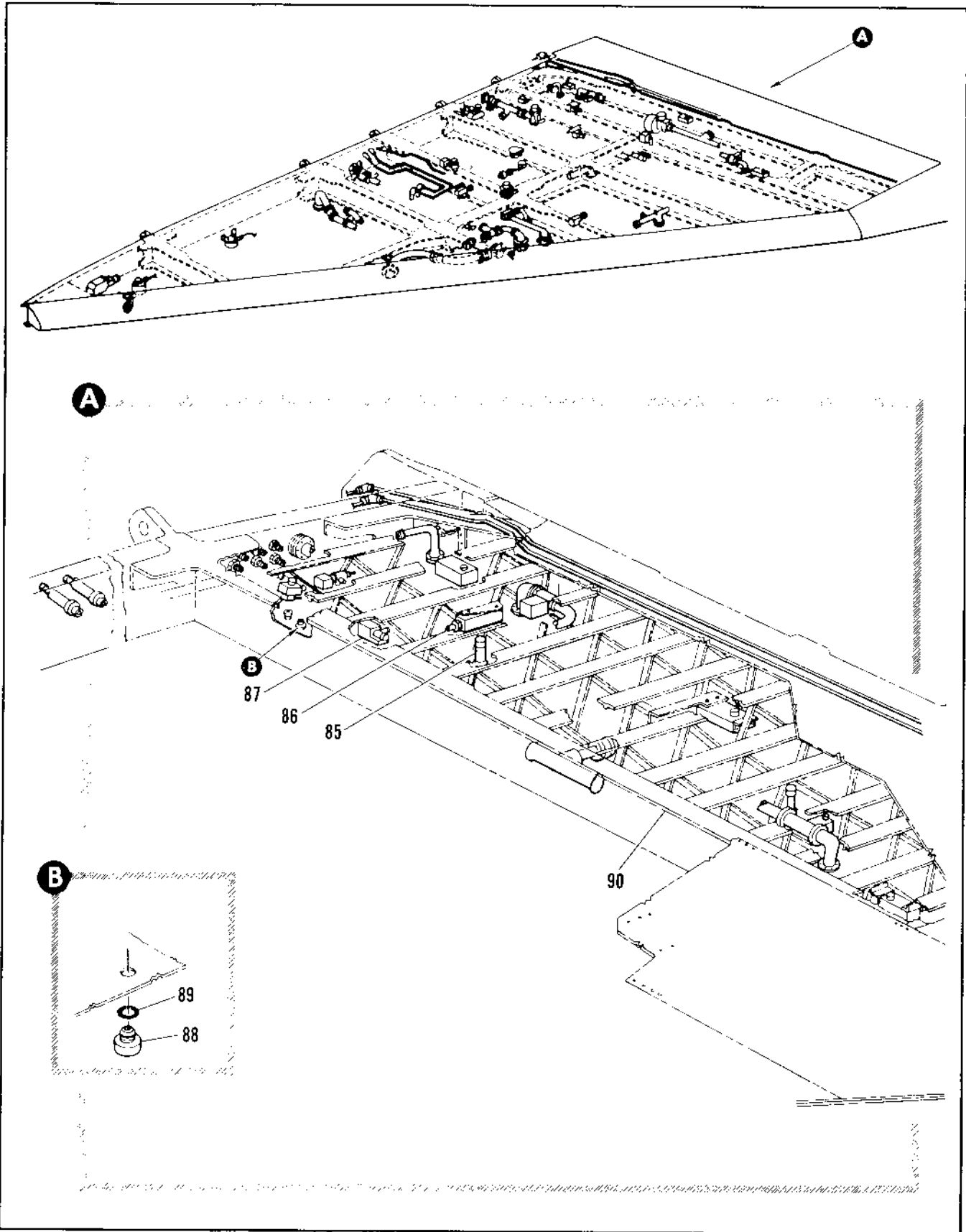

Figure 2.6-32. Wing Equipment Assembly (Sheet 12 of 13)

FIGURE AND INDEX NUMBER	PART NUMBER	DESCRIPTION	UNITS PER ASSY.	USABLE ON CODE	
				FROM	TO
		1 2 3 4 5 6			
2.6-32	8-21147-6	• VALVE INSTL, REFUELING SHUTOFF TRANSFER TANK RH FOR BREAKDOWN SEE FIG. 2.12-2	1	J	
	8-21147-802	• VALVE INSTL, REFUELING SHUTOFF TRANSFER TANK RH FOR BREAKDOWN SEE FIG. 2.12-2	1	189	277
- 85	8-21107-1	• PROBE INSTL, FUEL QUANTITY TRANSFER TANK STA 578 LH FOR BREAKDOWN SEE FIG. 2.12-8	1	35	188
	8-21107-801	• PROBE INSTL, FUEL QUANTITY TRANSFER TANK STA 578 LH FOR BREAKDOWN SEE FIG. 2.12-8	1	189	
	8-21107-2	• PROBE INSTL, FUEL QUANTITY TRANSFER TANK STA 578 RH FOR BREAKDOWN SEE FIG. 2.12-8	1	35	188
	8-21107-802	• PROBE INSTL, FUEL QUANTITY TRANSFER TANK STA 578 RH FOR BREAKDOWN SEE FIG. 2.12-8	1	189	
- 86	8-21187-1	• SWITCH INSTL, TRANSFER TANK FUEL LOW LEVEL LH FOR BREAKDOWN SEE FIG. 2.12-1	1	H	
	8-21187-5	• SWITCH INSTL, TRANSFER TANK FUEL LOW LEVEL LH FOR BREAKDOWN SEE FIG. 2.12-1	1	189	277
	8-21187-3	• SWITCH INSTL, TRANSFER TANK FUEL LOW LEVEL RH FOR BREAKDOWN SEE FIG. 2.12-1	1	H	
	8-21187-801	• SWITCH INSTL, TRANSFER TANK FUEL LOW LEVEL RH FOR BREAKDOWN SEE FIG. 2.12-1	1	189	277
- 87	8-21163-801	• VALVE INSTL, TRANSFER TANK VENT LH FOR BREAKDOWN SEE FIG. 2.12-23	1	35	188
	8-21163-803	• VALVE INSTL, TRANSFER TANK VENT LH FOR BREAKDOWN SEE FIG. 2.12-23	1	189	277
	8-21163-805	• VALVE INSTL, TRANSFER TANK VENT LH FOR BREAKDOWN SEE FIG. 2.12-23	1	278	
	8-21163-802	• VALVE INSTL, TRANSFER TANK VENT RH FOR BREAKDOWN SEE FIG. 2.12-23	1	35	188
	8-21163-804	• VALVE INSTL, TRANSFER TANK VENT RH FOR BREAKDOWN SEE FIG. 2.12-23	1	189	277
	8-21163-806	• VALVE INSTL, TRANSFER TANK VENT RH FOR BREAKDOWN SEE FIG. 2.12-23		278	
	8-21887	• VALVE INSTL, TRANSFER TANK PRESSURE RELIEF LH FOR BREAKDOWN SEE FIG. 2.12-1	1	48	49
	8-21182-5	• VALVE INSTL, TRANSFER TANK PRESSURE RELIEF LH FOR BREAKDOWN SEE FIG. 2.12-1	1	F	
	8-21887	• VALVE INSTL, TRANSFER TANK PRESSURE RELIEF RH FOR BREAKDOWN SEE FIG. 2.12-1	1	48	49
	8-21182-6	• VALVE INSTL, TRANSFER TANK PRESSURE RELIEF RH FOR BREAKDOWN SEE FIG. 2.12-1	1	F	
- 88	1508	• VALVE ASSY, FUEL DRAIN (91511) 92-12531-002	2	35	
- 89	MS29512-6	• GASKET (96906)	1	35	
- 90	8-18012-807	• STRUCTURE ASSY, WING LH FOR BREAKDOWN SEE FIG. 2.6-29	1	35	159
	8-18012-811	• STRUCTURE ASSY, WING LH FOR BREAKDOWN SEE FIG. 2.6-29	1	160	188
	8-18012-817	• STRUCTURE ASSY, WING LH FOR BREAKDOWN SEE FIG. 2.6-29	1	189	277
		D AIRPLANES #278 THRU 296 AND 288 THRU 291			
		E AIRPLANES #287 AND 292 THRU 303			
		F AIRPLANES 35 THRU 47 AND 49 AND ON			
		H AIRPLANES #35 THRU 188, 278 AND ON			
		J AIRPLANES #90 THRU 188, 278 AND ON			

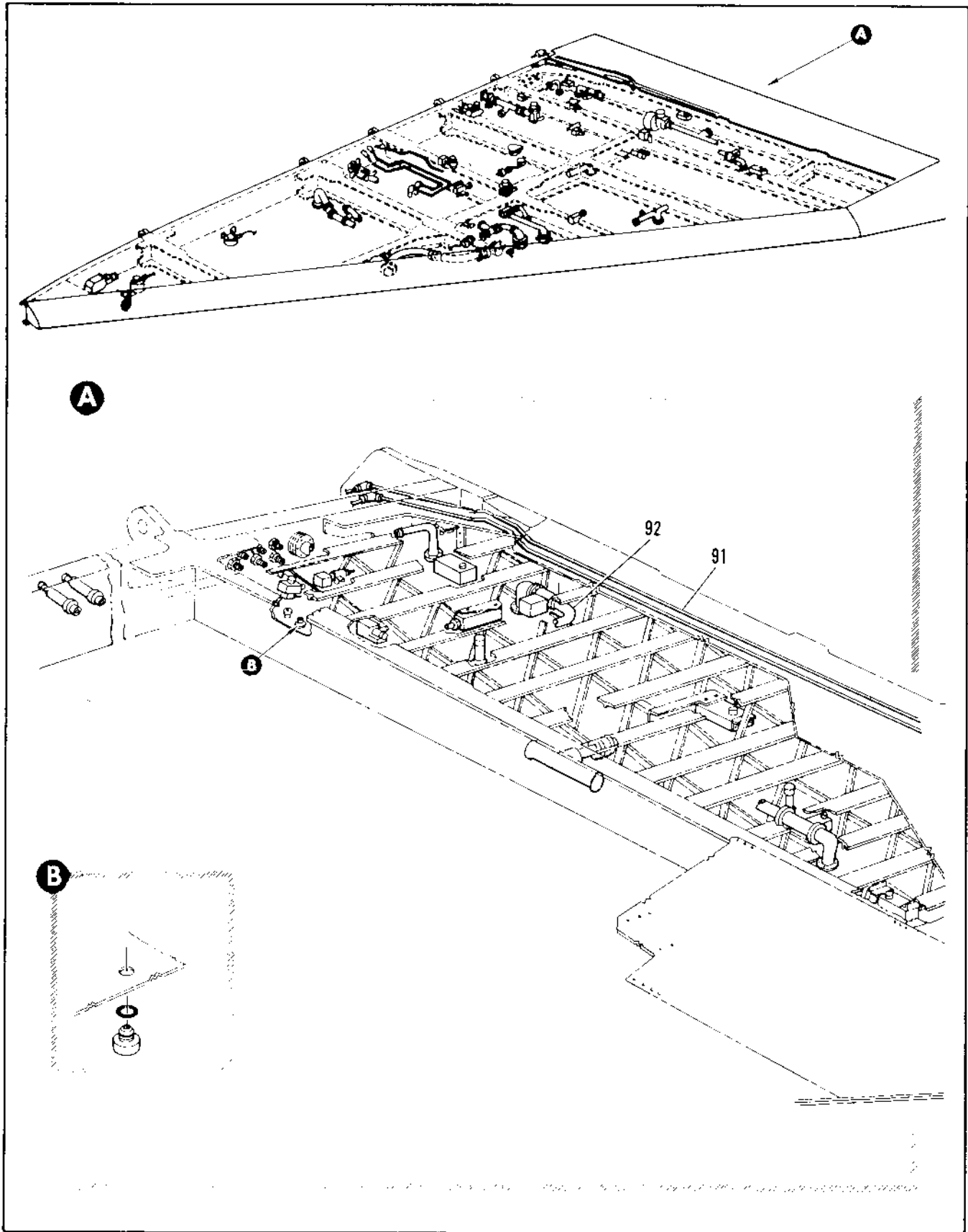

Figure 2.6-32. Wing Equipment Assembly (Sheet 13 of 13)

FIGURE AND INDEX NUMBER	PART NUMBER	DESCRIPTION	UNITS PER ASSY.	USABLE ON CODE		
				FROM	TO	
2.6-32	8-18022-1	• STRUCTURE ASSY, WING LH MODIFIED BY 8-18990 FOR BREAKDOWN SEE FIG. 2.6-29	1	D		
	8-18012-1	• STRUCTURE ASSY, WING LH MODIFIED BY 8-18992 FOR BREAKDOWN SEE FIG. 2.6-29	1	E		
	8-18012-803	• STRUCTURE ASSY, WING LH FOR BREAKDOWN SEE FIG. 2.6-29	1	304		
	8-18012-801	• STRUCTURE ASSY, WING LH ALT INTCHG WITH 8-18012-803 FOR BREAKDOWN SEE FIG. 2.6-29	RF	304		
	8-18012-80F	• STRUCTURE ASSY, WING RH FOR BREAKDOWN SEE FIG. 2.6-29	1	35	159	
	8-18012-812	• STRUCTURE ASSY, WING RH FOR BREAKDOWN SEE FIG. 2.6-29	1	189	188	
	8-18012-819	• STRUCTURE ASSY, WING RH FOR BREAKDOWN SEE FIG. 2.6-29	1	189	277	
	8-18002-2	• STRUCTURE ASSY, WING RH MODIFIED BY 8-18990 FOR BREAKDOWN SEE FIG. 2.6-29	1	E		
	8-18012-2	• STRUCTURE ASSY, WING RH MODIFIED BY 8-18992 FOR BREAKDOWN SEE FIG. 2.6-29	1	E		
	8-18012-804	• STRUCTURE ASSY, WING RH FOR BREAKDOWN SEE FIG. 2.6-29	1	304		
	8-18012-804	• STRUCTURE ASSY, WING RH FOR BREAKDOWN SEE FIG. 2.6-29	RF	304		
	8-18012-802	• STRUCTURE ASSY, WING RH ALT INTCHG WITH 8-18012-804 FOR BREAKDOWN SEE FIG. 2.6-29				
	- 91	8-80029	• TUBING INSTL, WING ELEVON HYDRAULIC LH FOR BREAKDOWN SEE FIG. 2.8-14	1	35	
		8-80029-1	• TUBING INSTL, WING ELEVON HYDRAULIC RH FOR BREAKDOWN SEE FIG. 2.8-14	1	35	
- 92	8-21622-1	• TUBING INSTL, CG FUEL TRANSFER LH FOR BREAKDOWN SEE FIG. 2.12-1	1	189	277	
	8-21622-2	• TUBING INSTL, CG FUEL TRANSFER RH FOR BREAKDOWN SEE FIG. 2.12-1	1	189	277	
		D AIRPLANES #278 THRU 284 AND 286 THRU 291				
		E AIRPLANES #287 AND 292 THRU 303				
		F AIRPLANES 35 THRU 47 AND 49 AND ON				

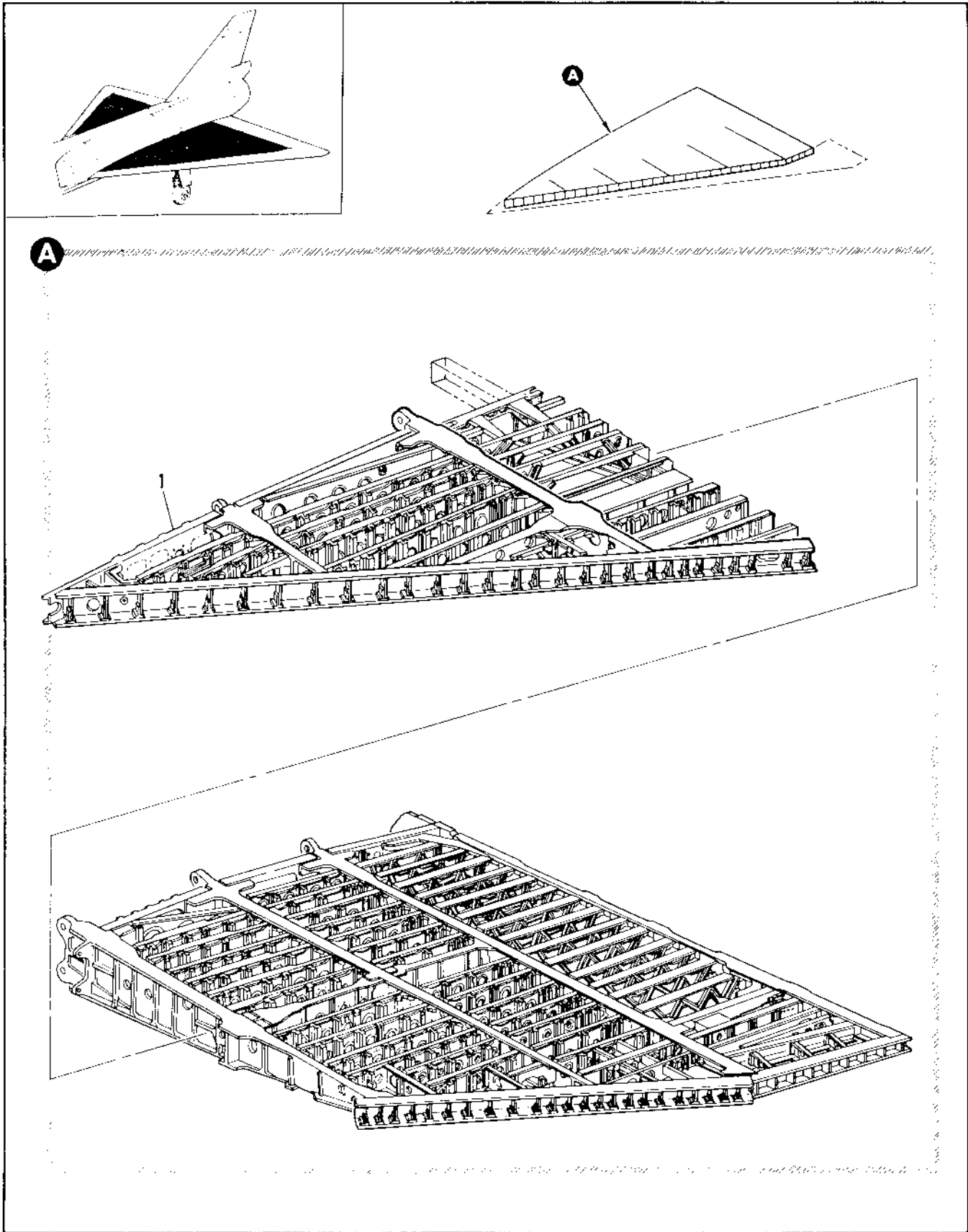

Figure 2.6-33. Wing Structure Assembly (Sheet 1 of 2)

FIGURE AND INDEX NUMBER	PART NUMBER	DESCRIPTION	UNITS PER ASSY.	USABLE ON CODE	
				FROM	TO
2.6-33	R-18012-807	STRUCTURE ASSEMBLY, WING LH R-18012-804 FOR NHA SEE FIG. 2.6-32	RF	35	149
	R-18012-811	STRUCTURE ASSEMBLY, WING LH FOR NHA SEE FIG. 2.6-32	RF	163	148
	R-18012-817	STRUCTURE ASSEMBLY, WING LH FOR NHA SEE FIG. 2.6-32	RF	189	277
	R-18012-81	STRUCTURE ASSEMBLY, WING LH MODIFIED BY R-18992 FOR NHA SEE FIG. 2.6-32	RF	A	
	R-18012-81	STRUCTURE ASSEMBLY, WING LH MODIFIED BY R-18992 FOR NHA SEE FIG. 2.6-32	RF	B	
	R-18012-817	STRUCTURE ASSEMBLY, WING LH FOR NHA SEE FIG. 2.6-32	RF	314	
	R-18012-801	STRUCTURE ASSEMBLY, WING LH ALT INTCHG WITH R-18012-803	RF	304	
	R-18012-808	STRUCTURE ASSEMBLY, WING RH FOR NHA SEE FIG. 2.6-32	RF	35	159
	R-18012-810	STRUCTURE ASSEMBLY, WING RH FOR NHA SEE FIG. 2.6-32	RF	163	148
	R-18012-818	STRUCTURE ASSEMBLY, WING RH FOR NHA SEE FIG. 2.6-32	RF	189	277
	R-18012-82	STRUCTURE ASSEMBLY, WING RH MODIFIED BY R-18992 FOR NHA SEE FIG. 2.6-32	RF	A	
	R-18012-82	STRUCTURE ASSEMBLY, WING RH MODIFIED BY R-18992 FOR NHA SEE FIG. 2.6-32	RF	B	
	R-18012-804	STRUCTURE ASSEMBLY, WING RH FOR NHA SEE FIG. 2.6-32	RF	314	
	R-18012-802	STRUCTURE ASSEMBLY, WING RH ALT INTCHG WITH	RF	314	
	R-18070-801	• STRUCTURE ASSY, FWD TANK LH FOR BREAKDOWN SEE FIG. 2.6-35	1		
	R-18070-811	• STRUCTURE ASSY, FWD TANK LH FOR BREAKDOWN SEE FIG. 2.6-35	1	163	277
	R-18070-81	• STRUCTURE ASSY, FWD TANK LH FOR BREAKDOWN SEE FIG. 2.6-35	1	A	
	R-18070-81	• STRUCTURE ASSY, FWD TANK LH FOR BREAKDOWN SEE FIG. 2.6-35	1	B	
	R-18070-88	• STRUCTURE ASSY, FWD TANK LH USE WITH R-18012-801 FOR BREAKDOWN SEE FIG. 2.6-35	1	304	
	R-18070-802	• STRUCTURE ASSY, FWD TANK RH FOR BREAKDOWN SEE FIG. 2.6-35	1		
R-18070-810	• STRUCTURE ASSY, FWD TANK RH FOR BREAKDOWN SEE FIG. 2.6-35	1	163	148	
R-18070-818	• STRUCTURE ASSY, FWD TANK RH FOR BREAKDOWN SEE FIG. 2.6-35	1	189	277	
R-18070-82	• STRUCTURE ASSY, FWD TANK RH FOR BREAKDOWN SEE FIG. 2.6-35	1	A		
R-18070-82	• STRUCTURE ASSY, FWD TANK RH FOR BREAKDOWN SEE FIG. 2.6-35	1	B		
R-18070-82	• STRUCTURE ASSY, FWD TANK RH USE WITH R-18012-802 FOR BREAKDOWN SEE FIG. 2.6-35	1	304		

A AIRPLANES #278 THRU 286 AND 288 THRU 291
 B AIRPLANES #287 AND 289 THRU 312
 C AIRPLANES #35 THRU 148, 304 AND ON

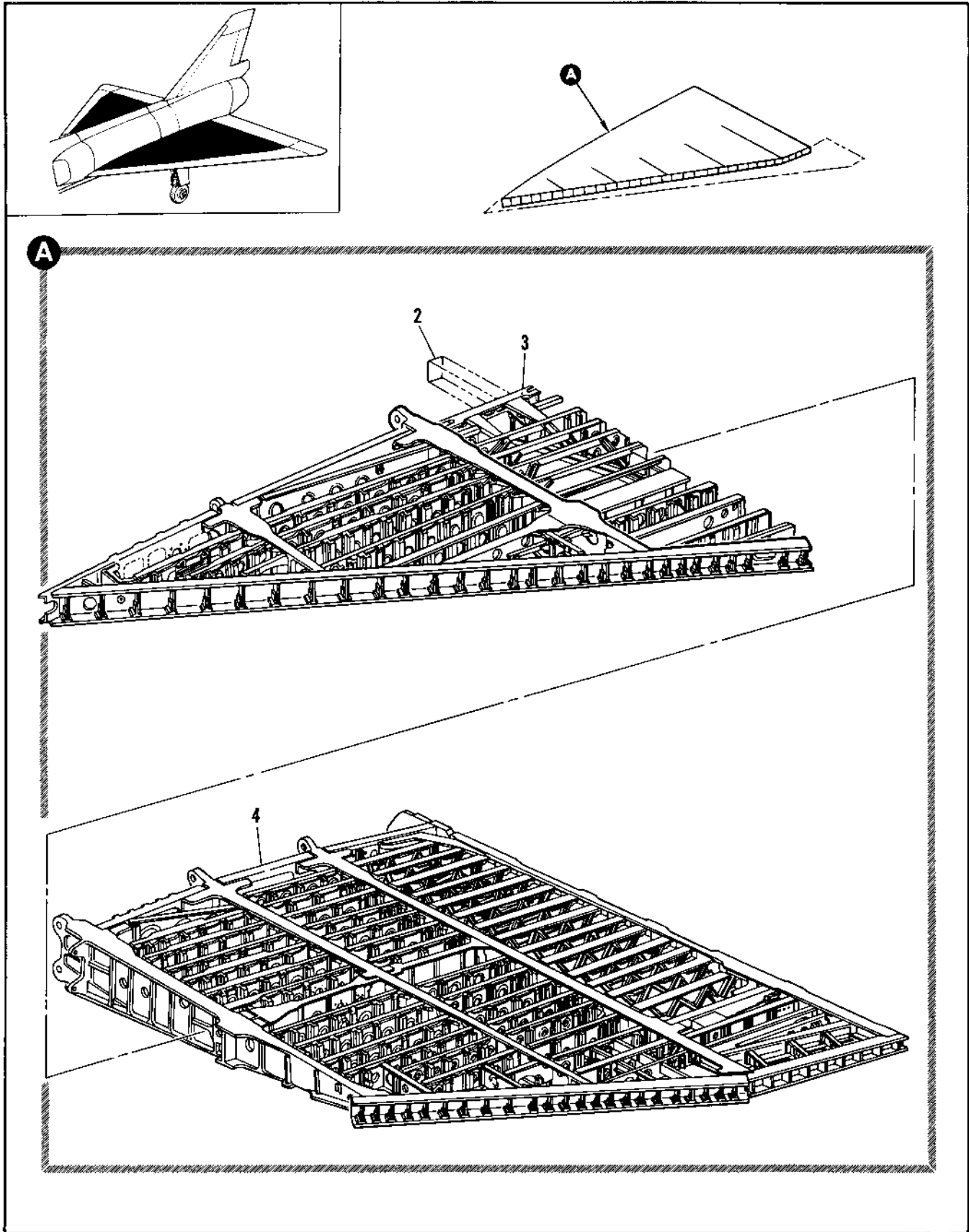

Figure 2.6-33. Wing Structure Assembly (Sheet 2 of 2)

FIGURE AND INDEX NUMBER	PART NUMBER	DESCRIPTION	UNITS PER ASSY.	USABLE ON CODE		
				FROM	TO	
2.6-33- 2 - 3	MS27253-1	NAMEPLATE, IDENTIFICATION (96905)	1	F		
	A-18071-3	BOX INSTL, WING INTERMEDIATE LH FOR BREAK-DOWN SEE FIG. 2.6-39	9F	E		
	B-18071-3	BOX INSTL, WING INTERMEDIATE LH MODIFIED BY 65J15279 FOR BREAKDOWN SEE FIG. 2.12-11	1	F		
	A-18071-3C	BOX INSTL, WING INTERMEDIATE LH FOR BREAK-DOWN SEE FIG. 2.6-39	9F	C		
	A-18071-3B	BOX INSTL, WING INTERMEDIATE LH MODIFIED BY 65J15279 FOR BREAKDOWN SEE FIG. 2.12-11	1	C		
	B-18031-5	BOX INSTL, WING INTERMEDIATE LH FOR BREAK-DOWN SEE FIG. 2.6-39	9F	A		
	B-18031-5	BOX INSTL, WING INTERMEDIATE LH MODIFIED BY 65J15279 FOR BREAKDOWN SEE FIG. 2.12-11	1	A		
	A-18071-1	BOX INSTL, WING INTERMEDIATE LH MODIFIED BY 1-11906 AND B-71119 FOR BREAKDOWN SEE FIG. 2.6-39	9F	R		
	B-18071-1	BOX INSTL, WING INTERMEDIATE LH MODIFIED BY 1-11906, B-71119 AND 65J15279 FOR BREAK-DOWN SEE FIG. 2.12-11	1	R		
	A-18071-4	BOX INSTL, WING INTERMEDIATE RH FOR BREAK-DOWN SEE FIG. 2.6-39	9F	E		
	B-18071-4	BOX INSTL, WING INTERMEDIATE RH MODIFIED BY 65J15279 FOR BREAKDOWN SEE FIG. 2.12-11	1	F		
	A-18071-4C	BOX INSTL, WING INTERMEDIATE RH FOR BREAK-DOWN SEE FIG. 2.6-39	9F	C		
	B-18071-4B	BOX INSTL, WING INTERMEDIATE RH MODIFIED BY 65J15279 FOR BREAKDOWN SEE FIG. 2.12-11	1	C		
	A-18031-6	BOX INSTL, WING INTERMEDIATE RH FOR BREAK-DOWN SEE FIG. 2.6-39	9F	A		
	B-18031-6	BOX INSTL, WING INTERMEDIATE RH MODIFIED BY 65J15279 FOR BREAKDOWN SEE FIG. 2.12-11	1	A		
	A-18071-2	BOX INSTL, WING INTERMEDIATE RH FROM BREAKDOWN SEE FIG. 2.6-39	9F	B		
	B-18071-2	BOX INSTL, WING INTERMEDIATE RH MODIFIED BY 65J15279 FOR BREAKDOWN SEE FIG. 2.12-11	1	B		
4	B-18072-803	STRUCTURE ASSY, AFT TANK LH FOR BREAKDOWN SEE FIG. 2.6-36	1	59	159	
	B-18072-816	STRUCTURE ASSY, AFT TANK LH FOR BREAKDOWN SEE FIG. 2.6-36	1	160	191	
	B-18072-809	STRUCTURE ASSY, AFT TANK LH FOR BREAKDOWN SEE FIG. 2.6-36	1	189	277	
	B-18032-1	STRUCTURE ASSY, AFT TANK LH FOR BREAKDOWN SEE FIG. 2.6-36	1	A		
	B-18072-1	STRUCTURE ASSY, AFT TANK LH FOR BREAKDOWN SEE FIG. 2.6-36	1	B		
	B-18072-5	STRUCTURE ASSY, AFT TANK LH FOR BREAKDOWN SEE FIG. 2.6-36	1	304		
	B-18072-814	STRUCTURE ASSY, AFT TANK RH FOR BREAKDOWN SEE FIG. 2.6-36	1	35	159	
	B-18072-816	STRUCTURE ASSY, AFT TANK RH FOR BREAKDOWN SEE FIG. 2.6-36	1	35	159	
	B-18072-816	STRUCTURE ASSY, AFT TANK RH FOR BREAKDOWN SEE FIG. 2.6-36	1	160	189	
	B-18072-810	STRUCTURE ASSY, AFT TANK RH FOR BREAKDOWN SEE FIG. 2.6-36	1	159	277	
	B-18032-2	STRUCTURE ASSY, AFT TANK RH FOR BREAKDOWN SEE FIG. 2.6-36	1	A		
	B-18072-2	STRUCTURE ASSY, AFT TANK RH FOR BREAKDOWN SEE FIG. 2.6-36	1	B		
	B-18072-6	STRUCTURE ASSY, AFT TANK RH FOR BREAKDOWN SEE FIG. 2.6-36	1	304		
			A AIRPLANES #278 THRU 294 AND 298 THRU 291			
			B AIRPLANES #287 AND 292 THRU 303			
			C AIRPLANES #40, 54, 55, 167 THRU 227			
		E AIRPLANES #35 THRU 39, 41 THRU 53, 56 THRU 159, 304 AND ON				
		F AIRPLANES #39 THRU 177, 297 AND ON				

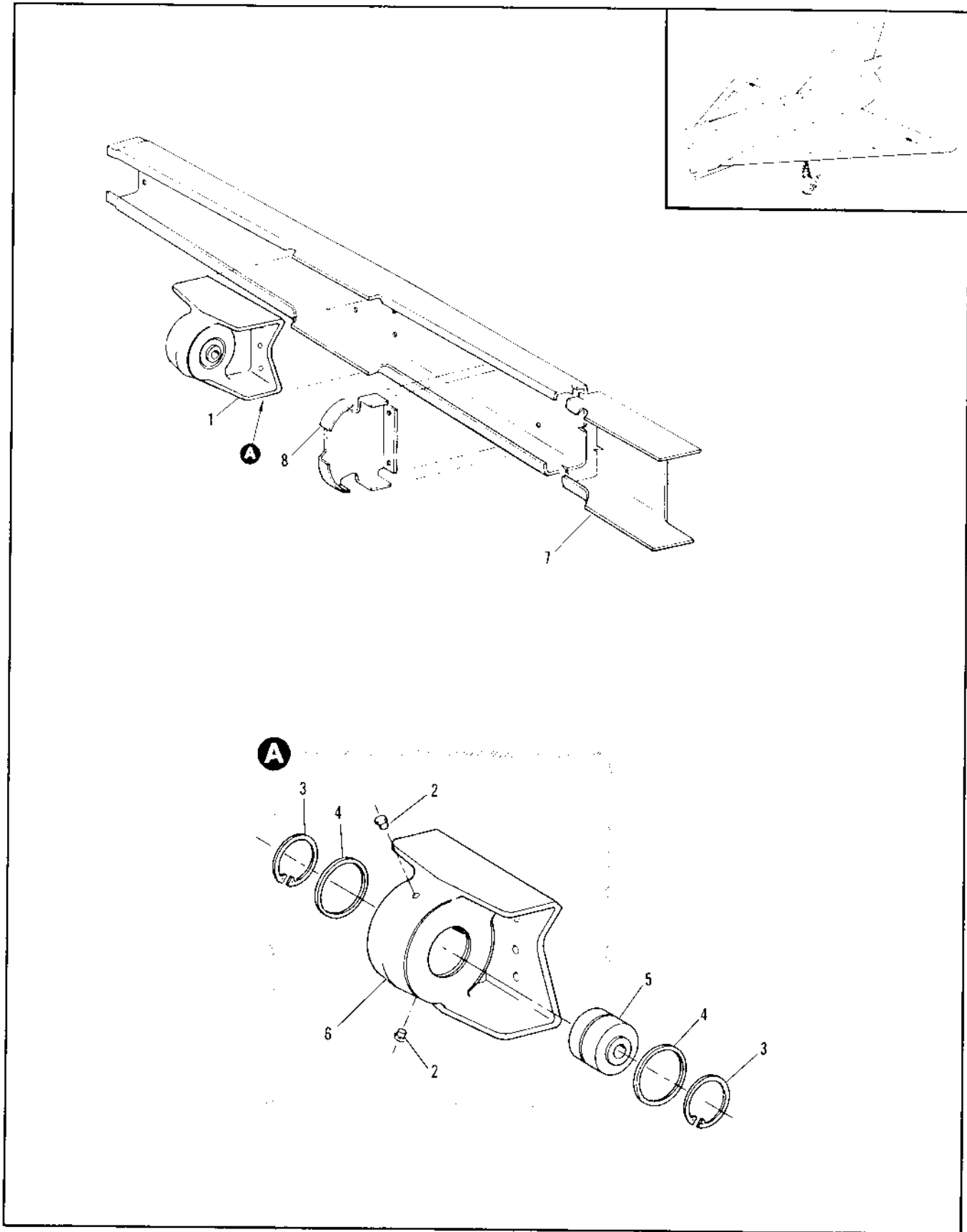

Figure 2.6-34. Wing Outbd Elevon Outbd Spar Assembly

FIGURE AND INDEX NUMBER	PART NUMBER	DESCRIPTION	UNITS PER ASSY.	USABLE ON CODE	
				FROM	TO
		1 2 3 4 5 6			
2.6-34	R-13111-5	SPAR ASSEMBLY, WING OUTBOARD ELEVON OUTBOARD LH FOR NHA SEE FIG. 2.6-8	RF	A	
	R-13101-5	SPAR ASSEMBLY, WING OUTBOARD ELEVON OUTBOARD LH FOR NHA SEE FIG. 2.6-8	RF	B	
	R-13111-6	SPAR ASSEMBLY, WING OUTBOARD ELEVON OUTBOARD RH FOR NHA SEE FIG. 2.6-8	RF	A	
	R-13101-6	SPAR ASSEMBLY, WING OUTBOARD ELEVON OUTBOARD RH FOR NHA SEE FIG. 2.6-8	RF	B	
- 1	R-13754-1	• HINGE ASSY, OUTBD ELEVON OUTBD PL 175	1	35	
- 2	NAS516-1	• • LUBRICATOR (80205)	2	35	
- 3	NAS52-156	• • RETAINER (80205)	2	35	
- 4	8-15840-7	• • RING, RETAINER HINGE BEARING	2	35	
- 5	A6H	• • BEARING, <71896> 90-60500-301	1	35	
- 6	R-13754-9	• • HINGE, ELEVON BL 175 MAKE FROM 8-12706-11	1	35	
	8-12706-11	• • HINGE	RF		
- 7	R-13101-11	• CHANNEL	1	A	
	8-13111-11	• CHANNEL, LH	1	B	
	8-13111-12	• CHANNEL, RH	1	A	
- "	R-13379-45	• RIB, ELEVON NOSE LH	1	35	
	8-13379-50	• RIB, ELEVON NOSE RH	1	35	
		A AIRPLANES #35 THRU 277, 297, 292 AND ON			
		R AIRPLANES #278 THRU 266 AND 288 THRU 291			

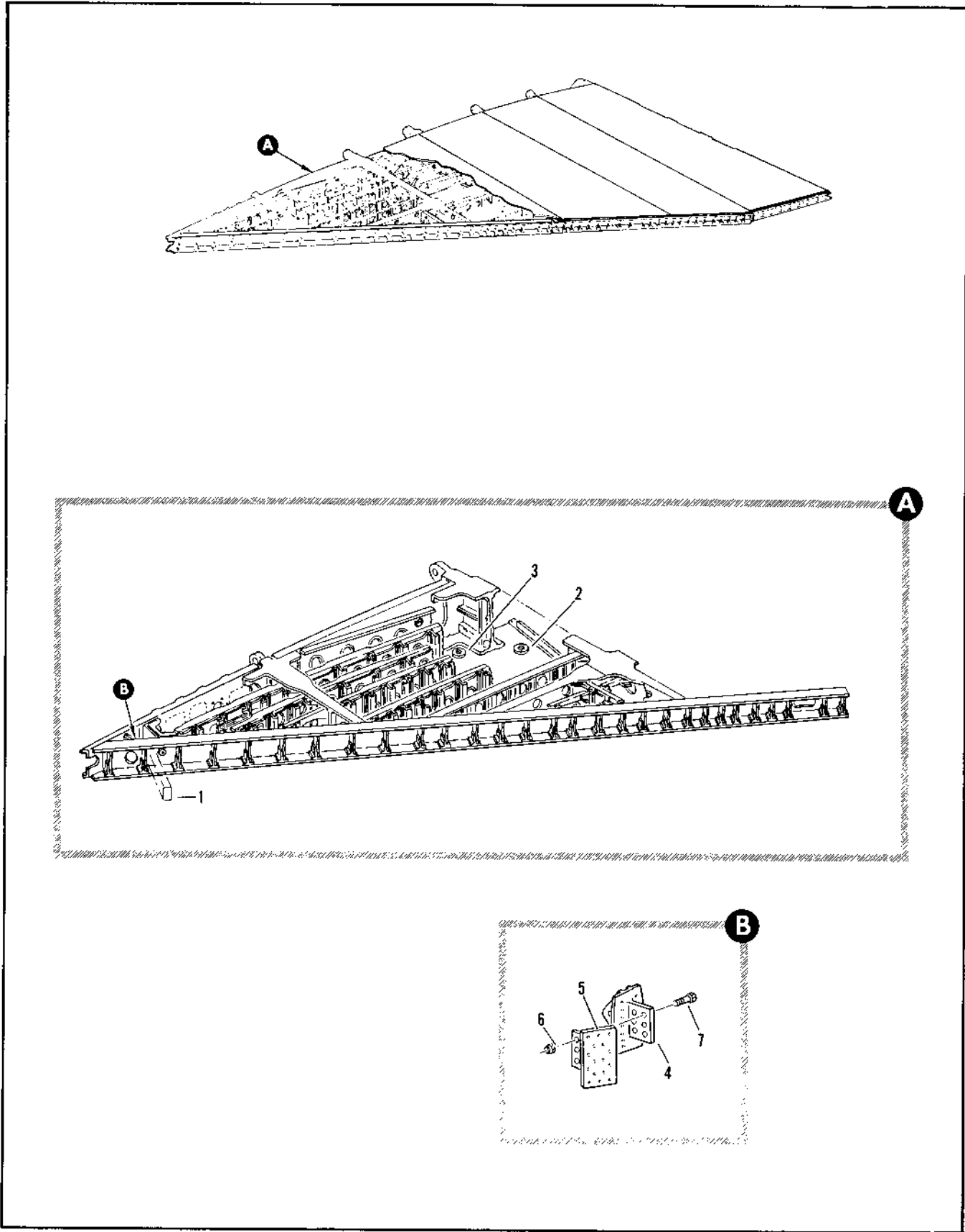

Figure 2.6-35. Fwd Tank Wing Structure Assembly (Sheet 1 of 5)

FIGURE AND INDEX NUMBER	PART NUMBER	DESCRIPTION	UNITS PER ASSY.	USABLE ON CODE	
				FROM	TO
		1 2 3 4 5 6			
2.6-35	8-14070-R01	STRUCTURE ASSEMBLY, WING FWD TANK LH FOR NHA SEE FIG. 2.6-33	RF	35	159
	8-14070-R11	STRUCTURE ASSEMBLY, WING FWD TANK LH FOR NHA SEE FIG. 2.6-33	RF	160	277
	8-14030-1	STRUCTURE ASSEMBLY, WING FWD TANK LH FOR NHA SEE FIG. 2.6-33	RF	A	
	8-14070-1	STRUCTURE ASSEMBLY, WING FWD TANK LH FOR NHA SEE FIG. 2.6-33	RF	R	
	8-14070-5	STRUCTURE ASSEMBLY, WING FWD TANK LH USE WITH 9-18012-R01 FOR NHA SEE FIG. 2.6-33	RF	304	
	8-14070-R02	STRUCTURE ASSEMBLY, WING FWD TANK RH FOR NHA SEE FIG. 2.6-33	RF	35	159
	8-14070-R12	STRUCTURE ASSEMBLY, WING FWD TANK RH FOR NHA SEE FIG. 2.6-33	RF	160	189
	8-14070-R15	STRUCTURE ASSEMBLY, WING FWD TANK RH FOR NHA SEE FIG. 2.6-33	RF	189	277
	8-14030-2	STRUCTURE ASSEMBLY, WING FWD TANK RH FOR NHA SEE FIG. 2.6-33	RF	A	
	8-14070-2	STRUCTURE ASSEMBLY, WING FWD TANK RH FOR NHA SEE FIG. 2.6-33	RF	R	
	8-14070-6	STRUCTURE ASSEMBLY, WING FWD TANK RH USE WITH 9-18012-R02 FOR NHA SEE FIG. 2.6-33	RF	314	
- 1	MS27253-1	NAMEPLATE, IDENTIFICATION AND MODIFICATION (56916)	1	35	
- 2	8-21562	FLANGE, PRESSURE RELIEF OUTLET	1	35	
- 3	19712	FLANGE, DRAIN V (75361) 93-43300-002 REPLACES SUITABLE SUP FOR 43362	1	H	
	43342	FLANGE, DRAIN V (75361) 93-43300-001 REPLACED BY SUITABLE SUB 19712	1	277	295
	8-14430-1	SUPPORT INSTL, WING STA 316 LH	1	D	
	8-14430-1	SUPPORT INSTL, WING STA 316 LH	1	A	
	8-14430-2	SUPPORT INSTL, WING STA 316 RH	1	D	
	8-14430-2	SUPPORT INSTL, WING STA 316 RH	1	A	
- 4	8-12744-7	SUPPORT	1	35	
- 5	8-12745-7	ADAPTER	1	35	
		ATTACHING PARTS			
- 6	WAS47044	NUT (82205)	6	35	
- 7	A74-6A	BOLT (82144)	6	35	
		-----X-----			
		A AIRPLANES #276 THRU 286 AND 288 THRU 291			
		R AIRPLANES #287 AND 289 THRU 303			
		D AIRPLANES #35, THRU 277, 287, 292 AND ON			
		H AIRPLANES #35 THRU 277, 297 AND ON			

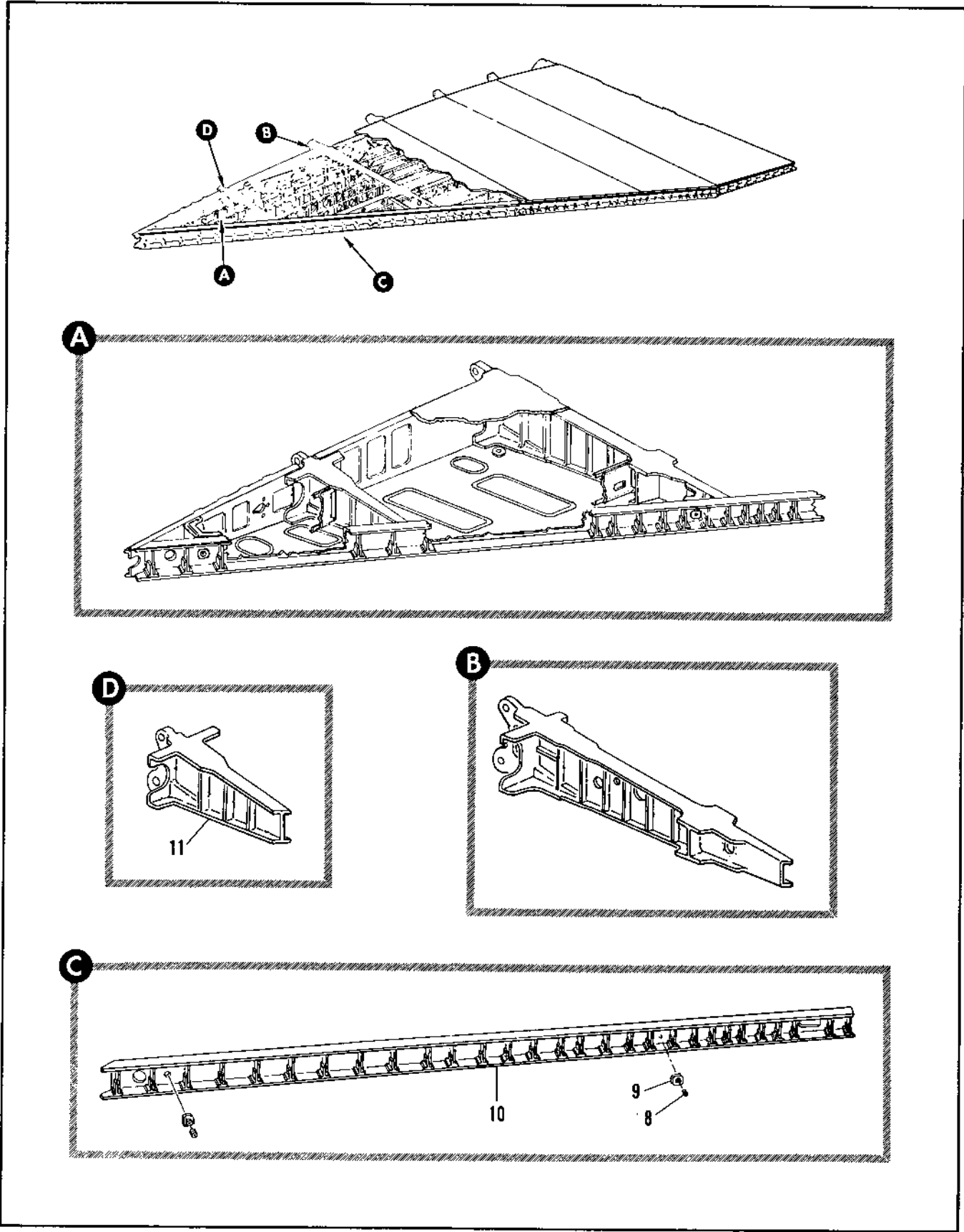

Figure 2.6-35. Fwd Tank Wing Structure Assembly (Sheet 2 of 5)

FIGURE AND INDEX NUMBER	PART NUMBER	DESCRIPTION	UNITS PER ASSY.	USABLE ON CODE		
				FROM	TO	
2.6-35	8-18121-5	• SPAR INSTL, WING FWD TANK LH	1	J		
	8-18121-1	• SPAR INSTL, WING FWD TANK LH	1	A		
	8-18121-1	• SPAR INSTL, WING FWD TANK LH	1	E		
	8-18121-3	• SPAR INSTL, WING FWD TANK LH	1	301	333	
	8-18121-6	• SPAR INSTL, WING FWD TANK RH	1	J		
	8-18121-2	• SPAR INSTL, WING FWD TANK RH	1	A		
	8-18121-2	• SPAR INSTL, WING FWD TANK RH	1	E		
	8-18121-4	• SPAR INSTL, WING FWD TANK RH	1	301	333	
	- 8	AN93302	• • FLUG (89,44)	1	35	
	- 9	4-17354-17	• • FITTING, GASTIGHT INJECTION	1	O	
		4-17354-9	• • FITTING, GASTIGHT INJECTION	1	A	
	- 1	8-18121-165	• • SPAR ASSY, LH RIVETED	1	J	
		8-18121-63	• • SPAR ASSY, LH RIVETED	1	A	
		8-18121-91	• • SPAR ASSY, LH RIVETED	1	F	
		8-18121-97	• • SPAR ASSY, LH RIVETED	1	301	333
		8-18121-166	• • SPAR ASSY, RH RIVETED	1	J	
		8-18121-84	• • SPAR ASSY, RH RIVETED	1	A	
		8-18121-92	• • SPAR ASSY, RH RIVETED	1	E	
		8-18121-96	• • SPAR ASSY, RH RIVETED	1	301	333
		8-18157-9	• • • SPAR, WING FWD TANK LH	1	J	
		8-18137-7	• • • SPAR, WING FWD TANK LH	1	A	
		8-18157-7	• • • SPAR, WING FWD TANK LH	1	R	
		8-18157-10	• • • SPAR, WING FWD TANK RH	1	J	
		8-18137-8	• • • SPAR, WING FWD TANK RH	1	A	
		8-18157-8	• • • SPAR, WING FWD TANK RH	1	P	
		8-18122-801	• SPAR INSTL, WING STA 363 LH	1	J	
		8-18102-1	• SPAR INSTL, WING STA 363 LH	1	A	
		8-18122-1	• SPAR INSTL, WING STA 363 LH	1	R	
		8-18122-802	• SPAR INSTL, WING STA 363 RH	1	K	
		8-18122-803	• SPAR INSTL, WING STA 363 RH	1	189	277
		8-18102-2	• SPAR INSTL, WING STA 363 RH	1	A	
		8-18122-2	• SPAR INSTL, WING STA 363 RH	1	R	
	- 11	8-18122-27	• • SPAR ASSY, LH RIVETED	1	J	
		8-18122-7	• • SPAR ASSY, LH RIVETED	1	A	
		8-18122-7	• • SPAR ASSY, LH RIVETED	1	R	
		8-18122-28	• • SPAR ASSY, RH RIVETED	1	K	
		8-18122-31	• • SPAR ASSY, RH RIVETED	1	189	277
		8-18102-8	• • SPAR ASSY, RH RIVETED	1	A	
		8-18122-2	• • SPAR ASSY, RH RIVETED	1	R	
		8-18792-11	• • • SPAR, LH	1	J	
		8-18792-10	• • • SPAR, LH ALT INTCHG WITH 8-18792-11	RF	J	
		8-18792-11	• • • SPAR, LH	1	A	
		8-18792-7	• • • SPAR, LH	1	R	
		8-18792-11	• • • SPAR, LH ALT INTCHG WITH 8-18792-7	RF	R	
		8-18792-12	• • • SPAR, RH	1	K	
	8-18792-15	• • • SPAR, RH	1	189	277	
	8-18792-15	• • • SPAR, RH ALT INTCHG WITH 8-18792-15	RF	189	277	
	8-18792-12	• • • SPAR, RH	1	A		
	8-18792-8	• • • SPAR, RH	1	P		

A AIRPLANES #278 THRU 286 AND 288 THRU 291
 P AIRPLANES #287 AND 292 THRU 303
 O AIRPLANES #35 THRU 277, 287, 292 AND ON
 E AIRPLANES #287 AND 292 THRU 306
 J AIRPLANES #35 THRU 277, 314 AND ON
 K AIRPLANES #35 THRU 189, 306 AND ON

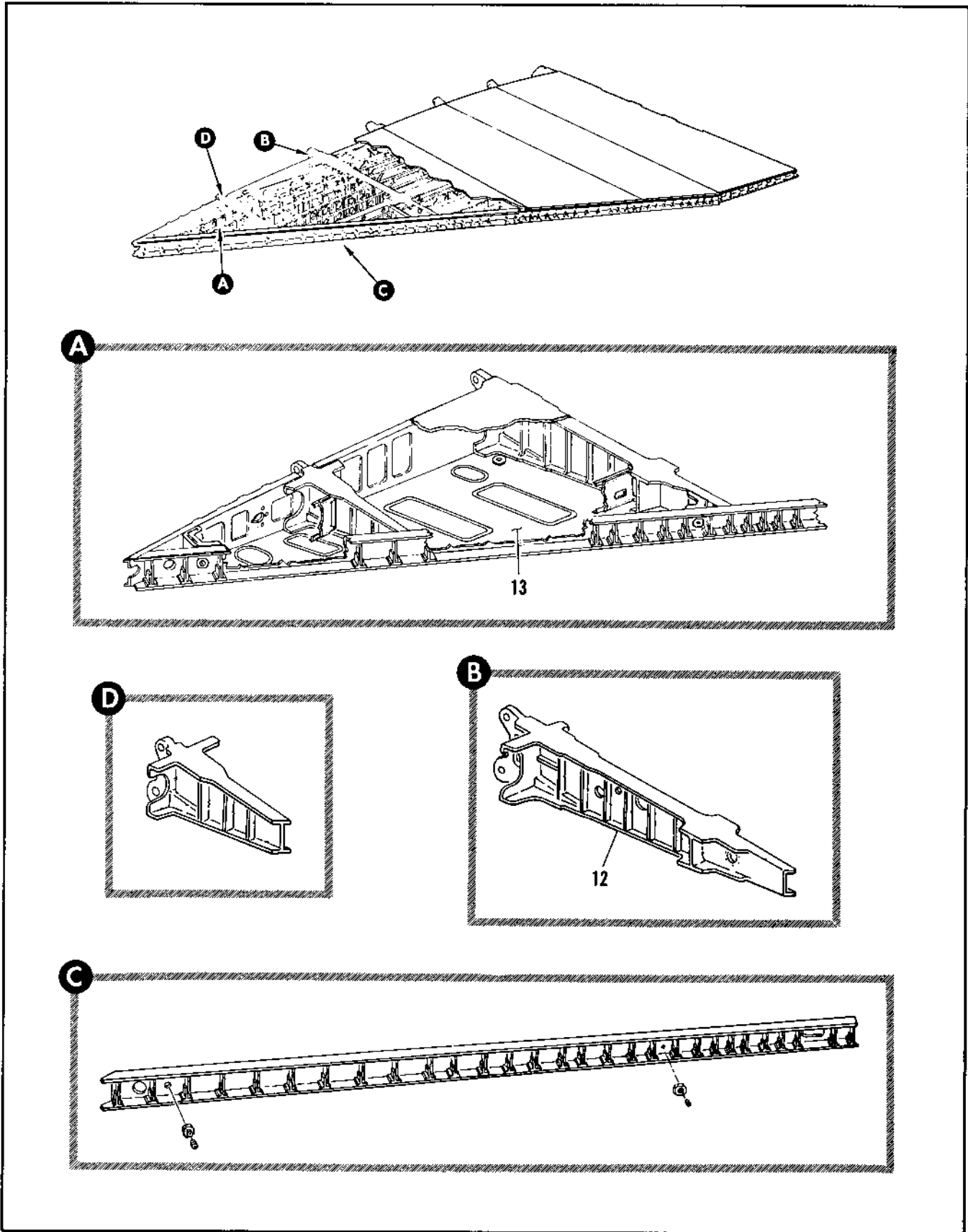

Figure 2.6-35. Fwd Tank Wing Structure Assembly (Sheet 3 of 5)

FIGURE AND INDEX NUMBER	PART NUMBER	DESCRIPTION	UNITS PER ASSY.	USABLE ON CODE		
				FROM	TO	
2.6-35	R-18122-12	• • • SPAR, RH ALT INTCHG WITH R-18792-8	9F	B		
	R-18123-5	• SPAR INSTL, WING STA 431 LH	1	L		
	R-18123-603	• SPAR INSTL, WING STA 431 LH	1	167	277	
	R-18103-1	• SPAR INSTL, WING STA 431 LH	1	A		
	R-18123-1	• SPAR INSTL, WING STA 431 LH	1	E		
	R-18123-3	• SPAR INSTL, WING STA 431 LH	1	301	303	
	R-18123-6	• SPAR INSTL, WING STA 431 RH	1	L		
	R-18123-604	• SPAR INSTL, WING STA 431 RH	1	167	189	
	R-18123-607	• SPAR INSTL, WING STA 431 RH	1	189	277	
	R-18103-2	• SPAR INSTL, WING STA 431 RH	1	A		
	R-18123-2	• SPAR INSTL, WING STA 431 RH	1	F		
	R-18123-4	• SPAR INSTL, WING STA 431 RH	1	301	303	
	R-18123-43	• • SPAR ASSY, LH RIVETED	1	L		
	R-18123-47	• • SPAR ASSY, LH RIVETED	1	160	277	
	R-18123-44	• • SPAR ASSY, RH RIVETED	1	L		
	R-18123-48	• • SPAR ASSY, RH RIVETED	1	160	189	
	R-18123-53	• • SPAR ASSY, RH RIVETED	1	189	277	
	R-18103-7	• • SPAR ASSY, LH RIVETED	1	A		
	R-18103-8	• • SPAR ASSY, RH RIVETED	1	A		
	R-18123-7	• • SPAR ASSY, LH RIVETED	1	E		
	R-18123-8	• • SPAR ASSY, RH RIVETED	1	E		
	R-18123-9	• • SPAR ASSY, LH RIVETED	1	301	303	
	R-18123-10	• • SPAR ASSY, RH RIVETED	1	301	303	
	R-18793-9	• • • SPAR, LH	1	L		
	R-18793-13	• • • SPAR, LH	1	160	277	
	R-18703-13	• • • SPAR, LH	1	A		
	R-18793-12	• • • SPAR, LH	1	F		
	R-18793-7	• • • SPAR, LH	1	301	303	
	R-18793-10	• • • SPAR, RH	1	L		
	R-18793-14	• • • SPAR, RH	1	160	277	
	R-18703-14	• • • SPAR, RH	1	A		
	R-18723-12	• • • SPAR, RH	1	C		
	R-18793-8	• • • SPAR, RH	1	301	303	
	- 12	R-18161-11	• SKIN, LH	J	J	
		R-18141-13	• SKIN, LH	1	G	
R-18141-15		• SKIN, LH	1	283	283	
R-18161-9		• SKIN, LH	1	C		
R-18161-7		• SKIN, LH	1	292	300	
R-18161-12		• SKIN, RH	1	J		
R-18141-14		• SKIN, RH	1	G		
R-18141-20		• SKIN, RH	1	283	283	
R-18161-10		• SKIN, RH	1	C		
R-18141-8		• SKIN, RH	1	292	300	
R-18079-23		• STRUCTURE ASSY, LH	1	J		
R-18030-15		• STRUCTURE ASSY, LH	1	A		
- 13		A AIRPLANES #278 THRU 286 AND 288 THRU 291				
		B AIRPLANES #287 AND 292 THRU 303				
		C AIRPLANES #287 AND 301 THRU 303				
		D AIRPLANES #35 THRU 277, 287, 292 AND ON				
	E AIRPLANES #287 AND 292 THRU 300					
	F AIRPLANES #278 THRU 282, 284 THRU 286, AND 288 THRU 291					
	G AIRPLANES #35 THRU 277, 304 AND ON					
	H AIRPLANES #35 THRU 189, 304 AND ON					
	I AIRPLANES #35 THRU 150, 304 AND ON					

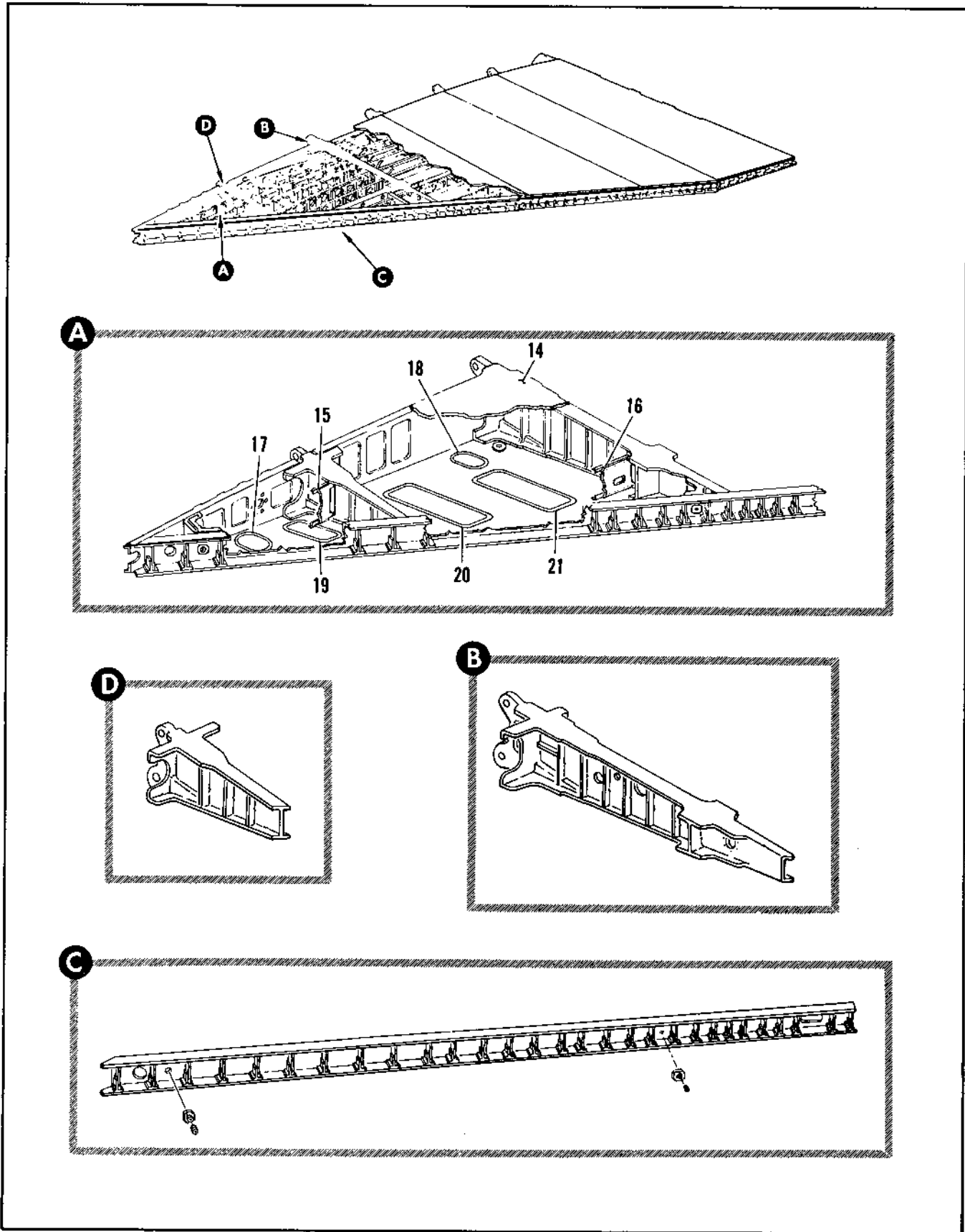

Figure 2.6-35. Fwd Tank Wing Structure Assembly (Sheet 4 of 5)

FIGURE AND INDEX NUMBER	PART NUMBER	DESCRIPTION	UNITS PER ASSY.	USABLE ON CODE	
				FROM	TO
		1 2 3 4 5 6			
2.6-35	P-18070-7	• STRUCTURE ASSY, LH	1	R	
	R-18070-24	• STRUCTURE ASSY, RH	1	J	
	P-18086-16	• STRUCTURE ASSY, RH	1	A	
	R-18070-9	• STRUCTURE ASSY, RH	1	R	
- 14	R-18170-7	• SKIN, LH	1	D	
	R-18180-7	• SKIN, LH	1	A	
	R-18170-6	• SKIN, RH	1	D	
	R-18180-8	• SKIN, RH	1	A	
- 15	A-18302-7	• FIB ASSY, LH	1	J	
	P-18312-1	• RIB ASSY, LH	1	278	353
	R-18312-4	• RIB ASSY, RH	1	K	
	R-18382-201	• RIB ASSY, RH	1	189	277
	R-18382-2	• RIB ASSY, RH	1	278	353
	R-18510-201	• RIB ASSY, SPAR #3 FWD WING LH	1	M	
	R-18510-202	• RIB ASSY, SPAR #3 FWD WING LH	1	49	277
	R-18510-3	• RIB ASSY, SPAR #3 FWD WING LH	1	A	
	R-18510-1	• RIB ASSY, SPAR #3 FWD WING RH	1	R	
	R-18510-204	• RIB ASSY, SPAR #3 FWD WING RH	1	49	277
	R-18510-4	• RIB ASSY, SPAR #3 FWD WING RH	1	A	
	R-18510-2	• RIB ASSY, SPAR #3 FWD WING RH	1	R	
- 16	R-18510-16	• RAIL LH	1	D	
	R-18510-59	• RAIL, LH	1	A	
	R-18510-20	• RAIL, RH	1	D	
	R-18510-60	• RAIL, RH	1	A	
	R-18510-21	• RAIL, LH	1	F	
	R-18510-22	• RAIL, LH	1	A	
	R-18510-23	• RAIL, LH	1	49	277
	R-18510-24	• RAIL, RH	1	F	
	R-18510-36	• RAIL, RH	1	49	277
	R-18510-34	• RAIL, RH	1	A	
- 17	R-18661	• FRAME INSTL, WING TANK #1 ACCESS DOOR BL 55 STA 337 LH FOR BREAKDOWN SEE FIG. 2.2-19	1	35	
	R-18661-3	• FRAME INSTL, WING TANK #1 ACCESS DOOR BL 55 STA 337 RH FOR BREAKDOWN SEE FIG. 2.2-19	1	35	
- 18	R-18661-401	• FRAME INSTL, WING TANK #1 ACCESS DOOR BL 47 STA 416 LH FOR BREAKDOWN SEE FIG. 2.2-19	1	35	
	R-18661-402	• FRAME INSTL, WING TANK #1 ACCESS DOOR BL 47 STA 416 RH FOR BREAKDOWN SEE FIG. 2.2-19	1	35	
- 19	R-18662	• FRAME INSTL, WING TANK #1 ACCESS DOOR BL 58 STA 352 LH FOR BREAKDOWN SEE FIG. 2.2-19	1	35	
	R-18662-3	• FRAME INSTL, WING TANK #1 ACCESS DOOR BL 58 STA 352 RH FOR BREAKDOWN SEE FIG. 2.2-19	1	35	
- 20	R-18663	• FRAME INSTL, WING TANK #1 ACCESS DOOR BL 65 STA 391 LH FOR BREAKDOWN SEE FIG. 2.2-19	1	35	
	R-18663-201	• FRAME INSTL, WING TANK #1 ACCESS DOOR BL 65 STA 391 RH FOR BREAKDOWN SEE FIG. 2.2-19	1	35	
- 21	R-18663-3	• FRAME INSTL, WING TANK #1 ACCESS DOOR BL 72 STA 413 LH FOR BREAKDOWN SEE FIG. 2.2-19	1	35	
	R-18663-204	• FRAME INSTL, WING TANK #1 ACCESS DOOR BL 72 STA 413 RH FOR BREAKDOWN SEE FIG. 2.2-19	1	35	
		A AIRPLANES #278 THRU 296, AND 288 THRU 291			
		F AIRPLANES #287 AND 292 THRU 313			
		D AIRPLANES #15 THRU 277, 287, 292 AND ON			
		J AIRPLANES #35 THRU 277, 304 AND ON			
		K AIRPLANES #35 THRU 188, 304 AND ON			
		F AIRPLANES #35 THRU 49, 287, 292 AND ON			
		M AIRPLANES #35 THRU 49, 304 AND ON			

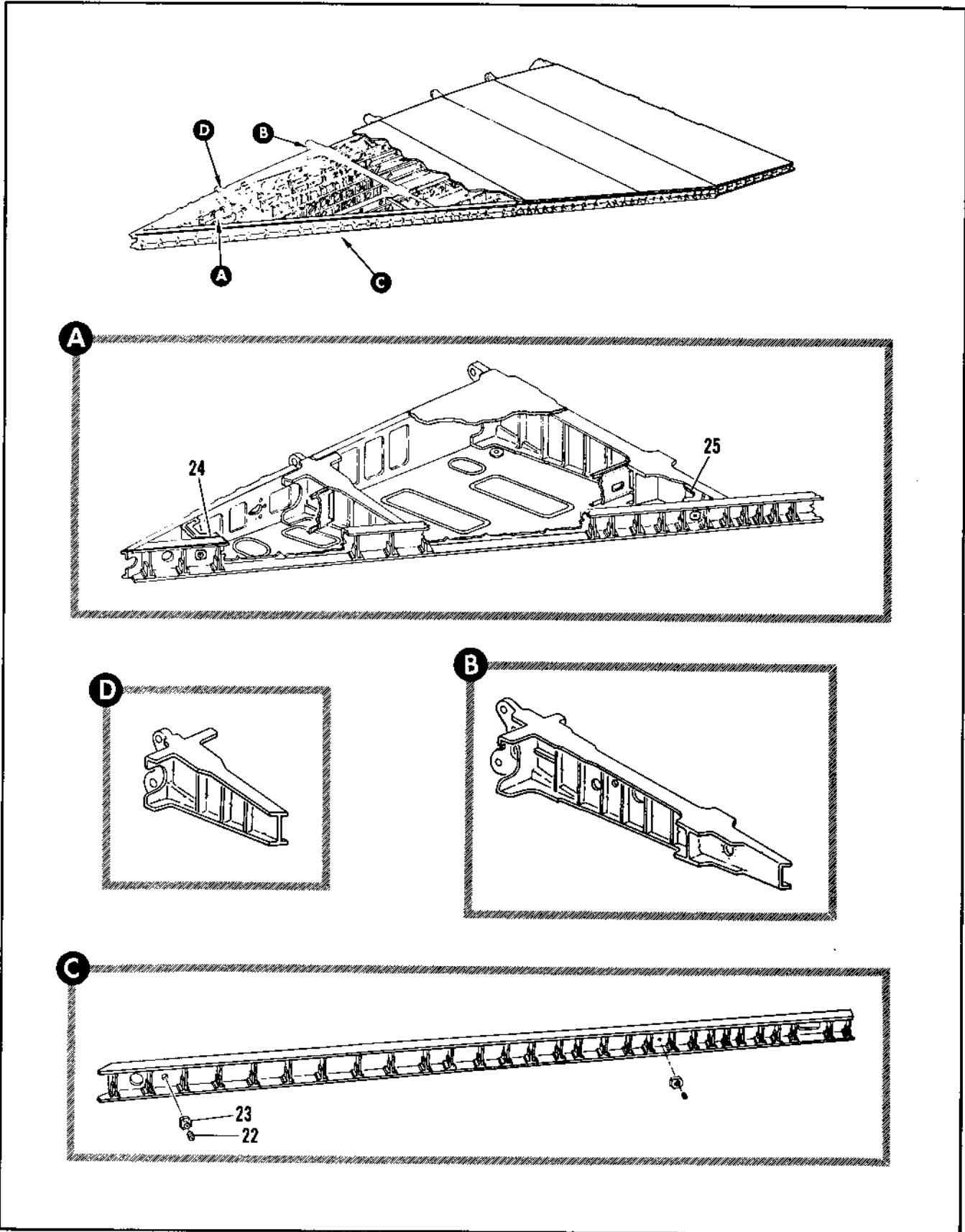

Figure 2.6-35. Fwd Tank Wing Structure Assembly (Sheet 5 of 5)

FIGURE AND INDEX NUMBER	PART NUMBER	DESCRIPTION	UNITS PER ASSY.	USABLE ON CODE	
				FROM	TO
		1 2 3 4 5 6			
2.6-35	8-18431-1	• CORNER INSTL. WING TANK #2 FWD FUEL TIGHT LH	1	D	
	8-18931-1	• CORNER INSTL. WING TANK #2 FWD FUEL TIGHT LH	1	A	
	8-18431-2	• CORNER INSTL. WING TANK #2 FWD FUEL TIGHT RH	1	D	
	8-18931-2	• CORNER INSTL. WING TANK #2 FWD FUEL TIGHT RH	1	A	
- 22	AN932D2	• • PLUG (38844)	1	35	
- 23	8-17854-11	• • FITTING, GAS TIGHT CORNER INJECTION	1	35	
- 24	8-18472-7	• • FITTING, LH	1	D	
	3-18572-8	• • FITTING, RH	1	D	
	8-18732	• • FITTING	1	A	
	8-18439-1	• CORNER INSTL. FUEL TANK #2 AFT OUTBD LH	1	D	
	8-18939-1	• CORNER INSTL. FUEL TANK #2 AFT OUTBD LH	1	A	
	8-18439-2	• CORNER INSTL. FUEL TANK #2 AFT OUTBD RH	1	D	
	8-18939-2	• CORNER INSTL. FUEL TANK #2 AFT OUTBD RH	1	A	
- 25	8-18850-7	• • FITTING, LH	1	D	
	8-18730-7	• • FITTING, LH	1	A	
	8-18850-8	• • FITTING, RH	1	D	
	8-18730-8	• • FITTING, RH	1	A	
		A AIRPLANES #278 THRU 286, AND 288 THRU 291			
		B AIRPLANES #287 AND 292 THRU 303			
		D AIRPLANES #35 THRU 277, 287, 292 AND ON			
		F AIRPLANES #35 THRU 48, 287, 292 AND ON			
		M AIRPLANES #35 THRU 48, 304 AND ON			

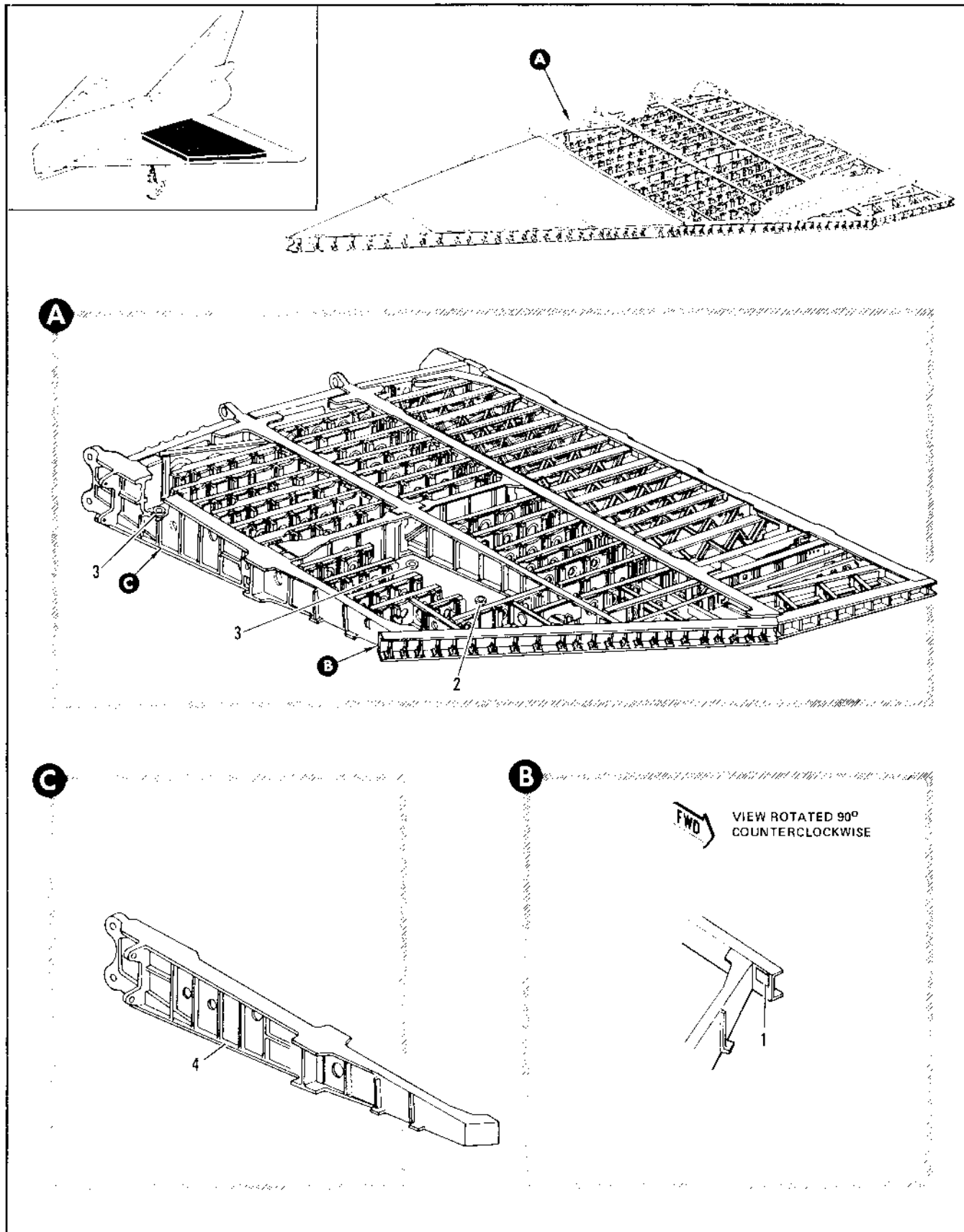

Figure 2.6-36. Aft Tank Wing Structure Assembly (Sheet 1 of 4)

FIGURE AND INDEX NUMBER	PART NUMBER	DESCRIPTION	UNITS PER ASSY.	USABLE ON CODE		
				FROM	TO	
2.6-36	8-18072-803	STRUCTURE ASSEMBLY, WING AFT TANK LH FOR NHA SEE FIG. 2.6-33	RF	35	159	
	8-18072-805	STRUCTURE ASSEMBLY, WING AFT TANK LH FOR NHA SEE FIG. 2.6-33	RF	160	189	
	8-18072-809	STRUCTURE ASSEMBLY, WING AFT TANK LH FOR NHA SEE FIG. 2.6-33	RF	189	277	
	8-18032-1	STRUCTURE ASSEMBLY, WING AFT TANK LH FOR NHA SEE FIG. 2.6-33	RF		A	
	8-18072-1	STRUCTURE ASSEMBLY, WING AFT TANK LH FOR NHA SEE FIG. 2.6-33	RF		B	
	8-18072-5	STRUCTURE ASSEMBLY, WING AFT TANK LH FOR NHA SEE FIG. 2.6-33	RF	304		
	8-18072-804	STRUCTURE ASSEMBLY, WING AFT TANK RH FOR NHA SEE FIG. 2.6-33	RF	35	159	
	8-18072-806	STRUCTURE ASSEMBLY, WING AFT TANK RH FOR NHA SEE FIG. 2.6-33	RF	160	189	
	8-18072-810	STRUCTURE ASSEMBLY, WING AFT TANK RH FOR NHA SEE FIG. 2.6-33	RF	189	277	
	8-18032-2	STRUCTURE ASSEMBLY, WING AFT TANK RH FOR NHA SEE FIG. 2.6-33	RF			
	8-18072-2	STRUCTURE ASSEMBLY, WING AFT TANK RH FOR NHA SEE FIG. 2.6-33	RF		B	
	8-18072-6	STRUCTURE ASSEMBLY, WING AFT TANK RH FOR NHA SEE FIG. 2.6-33	RF	304		
	- 1	MS27253-1	NAMEPLATE, IDENTIFICATION AND MODIFICATION (P6906)	1	35	
	- 2	8-21249-7 8-21550	FLANGE, SENSING OUTLET RL 126 FLANGE, SENSING OUTLET RL 126 ALT INTCHG WITH 8-21249-7	1 RF	35 35	
	- 3	19712 43382	FLANGE, DRAIN VALVE BL 39 AND 94 <75361> 93-83300-002 REPLACES SUITABLE SUP FOR 43382 FLANGE, DRAIN VALVE BL 39 AND 94 <75361> 93-83300-001 REPLACED BY SUITABLE SUP 19712	2 2	C 278	276
	- 4	8-18124-803	SPAR INSTL, WING STA 472 LH	1		D
		8-18104-3	SPAR INSTL, WING STA 472 LH	1		A
		8-18124-1	SPAR INSTL, WING STA 472 LH	1		F
8-18124-804		SPAR INSTL, WING STA 472 RH	1		D	
8-18104-4		SPAR INSTL, WING STA 472 RH	1		H	
8-18124-2		SPAR INSTL, WING STA 472 RH	1		A	
8-18124-67		SPAR ASSY, STA 472 LH RIVETED	1		D	
8-18104-53		SPAR ASSY, STA 472 LH RIVETED	1		A	
8-18124-7		SPAR ASSY, STA 472 LH RIVETED	1		F	
8-18124-64		SPAR ASSY, STA 472 RH RIVETED	1		D	
8-18104-54		SPAR ASSY, STA 472 RH RIVETED	1		B	
8-13124-8		SPAR ASSY, STA 472 RH RIVETED	1		B	
8-18794-13		SPAR, STA 472 LH	1		D	
8-18824-17		SPAR, STA 472 LH ALT INTCHG WITH 8-18794-13	RF		D	
8-18704-15		SPAR, STA 472 LH	1		A	
8-18794-7		SPAR, STA 472 LH	1		B	
8-18824-11		SPAR, STA 472 LH ALT INTCHG WITH 8-18794-7	RF		B	
8-18794-14		SPAR, STA 472 RH	1		D	
8-18824-18	SPAR, STA 472 RH ALT INTCHG WITH 8-18794-14	RF		D		
8-18734-16	SPAR, STA 472 RH	1		A		
8-18794-8	SPAR, STA 472 RH	1		C		
8-18824-12	SPAR, STA 472 RH ALT INTCHG WITH 8-18794-8	RF		B		

A AIRPLANES #278 THRU 296 AND 298 THRU 291
 B AIRPLANES #287 AND 299 THRU 313
 C AIRPLANES #35 THRU 277, 297 AND ON
 D AIRPLANES #35 THRU 277, 304 AND ON

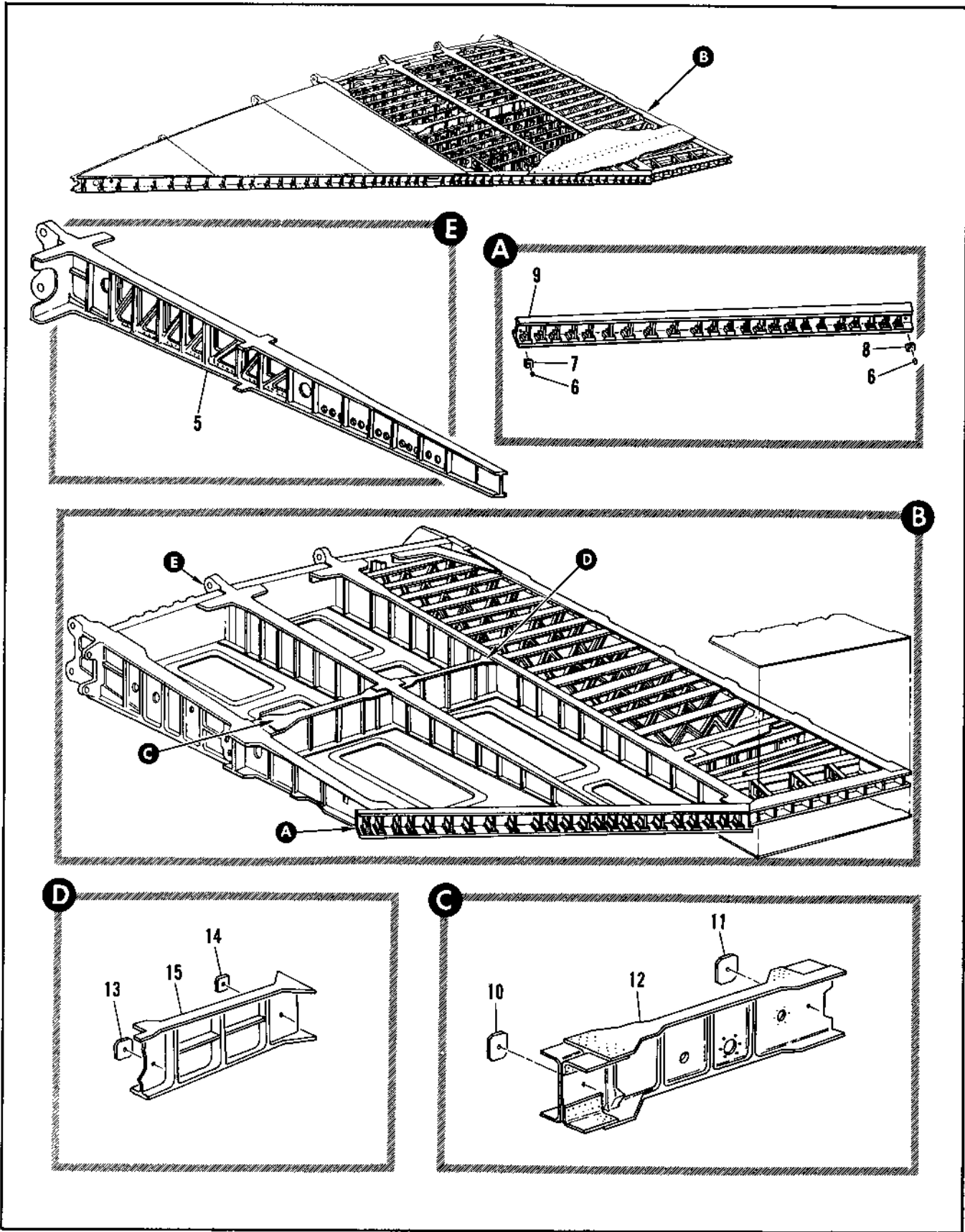

Figure 2.6-36. Aft Tank Wing Structure Assembly (Sheet 2 of 4)

FIGURE AND INDEX NUMBER	PART NUMBER	DESCRIPTION	UNITS PER ASSY.	USABLE ON CODE	
				FROM	TO
		1 2 3 4 5 6			
2.6-36	8-18125-801	• SPAR INSTL, WING STA 520 LH	1	D	
	8-18105-1	• SPAR INSTL, WING STA 520 LH	1	A	
	8-18125-1	• SPAR INSTL, WING STA 520 LH	1	A	
	8-18125-802	• SPAR INSTL, WING STA 520 RH	1	A	
	8-18105-2	• SPAR INSTL, WING STA 520 RH	1	A	
	8-18125-2	• SPAR INSTL, WING STA 520 RH	1	R	
- 5	4-18125-7	• • SPAR ASSY, STA 520 LH RIVETED	1	E	
	8-18125-69	• • SPAR ASSY, STA 520 LH RIVETED	1	A	
	8-18125-8	• • SPAR ASSY, STA 520 RH RIVETED	1	E	
	8-18105-70	• • SPAR ASSY, STA 520 RH RIVETED	1	A	
	8-18795-7	• • • SPAR, STA 520 LH	1	E	
	8-18825-11	• • • SPAR, STA 520 LH ALT INTCHG WITH 8-18795-7	RF	E	
	8-18705-11	• • • SPAR, STA 520 LH	1	A	
	4-18795-8	• • • SPAR, STA 520 RH	1	F	
	8-18825-12	• • • SPAR, STA 520 RH ALT INTCHG WITH 8-18795-8	RF	E	
	8-18705-12	• • • SPAR, STA 520 LH	1	A	
	8-18131-1	• SPAR INSTL, AFT TANK LH	1	E	
	8-18111-1	• SPAR INSTL, AFT TANK LH	1	A	
	8-18131-2	• SPAR INSTL, AFT TANK RH	1	E	
	8-18111-2	• SPAR INSTL, AFT TANK RH	1	A	
- 6	AN93202	• • PLUG (88044)	2	35	
- 7	8-17854-9	• • FITTING, GASTIGHT INJECTION FWD	1	35	
- 8	8-17854-10	• • FITTING, GASTIGHT INJECTION AFT	1	E	
	8-17854-9	• • FITTING, GASTIGHT INJECTION AFT	1	A	
- 9	8-18131-63	• • SPAR ASSY, LH RIVETED	1	E	
	8-18131-64	• • SPAR ASSY, RH RIVETED	1	E	
	8-18111-63	• • SPAR ASSY, RIVETED	1	A	
	8-18158-7	• • • SPAR, LH	1	F	
	8-18158-8	• • • SPAR, RH	1	E	
	8-18138	• • • SPAR	1	A	
	8-18337-3	• RIB INSTL, SPAR #4 TO 5 BL 91 LH	1	35	
	8-18337-4	• RIB INSTL, SPAR #4 TO 5 BL 91 RH	1	35	
- 10	8-17854-21	• • FITTING, GASTIGHT INJECTION	1	35	
- 11	8-17854-11	• • FITTING, GASTIGHT INJECTION	1	35	
- 12	8-18782-1	• • RIB ASSY, SPAR #4 TO 5 BL 91 LH	1	35	
	8-18743-3	• • RIB ASSY, SPAR #4 TO 5 BL 91 LH ALT INTCHG WITH 8-18782-1	RF	35	
	8-18782-2	• • RIB ASSY, SPAR #4 TO 5 BL 91 RH	1	35	
	8-18743-4	• • RIB ASSY, SPAR #4 TO 5 BL 91 RH ALT INTCHG WITH 8-18782-2	RF	35	
	8-18743-9	• • • RIB, SPAR #4 TO 5 LH USE WITH 8-18743-3	RF	35	
	8-18743-10	• • • RIB, SPAR #4 TO 5 RH USE WITH 8-18743-4	RF	35	
	8-18358-3	• RIB INSTL, SPAR #5 TO 6 BL 91 LH	1	35	
	8-18358-4	• RIB INSTL, SPAR #5 TO 6 BL 91 RH	1	35	
- 13	8-17854-11	• • FITTING, GASTIGHT INJECTION	1	35	
- 14	8-17854-17	• • FITTING, GASTIGHT INJECTION	1	35	
- 15	8-18783-7	• • RIB, SPAR #5 TO 6 LH	1	35	
	8-18739-9	• • RIB, SPAR #5 TO 6 LH ALT INTCHG WITH 8-18783-7	RF	35	
		A AIRPLANES #278 THRU 286 AND 288 THRU 291			
		D AIRPLANES #287 AND 292 THRU 303			
		G AIRPLANES #35 THRU 277, 304 AND ON			
		E AIRPLANES #35 THRU 277, 287, 292 AND ON			

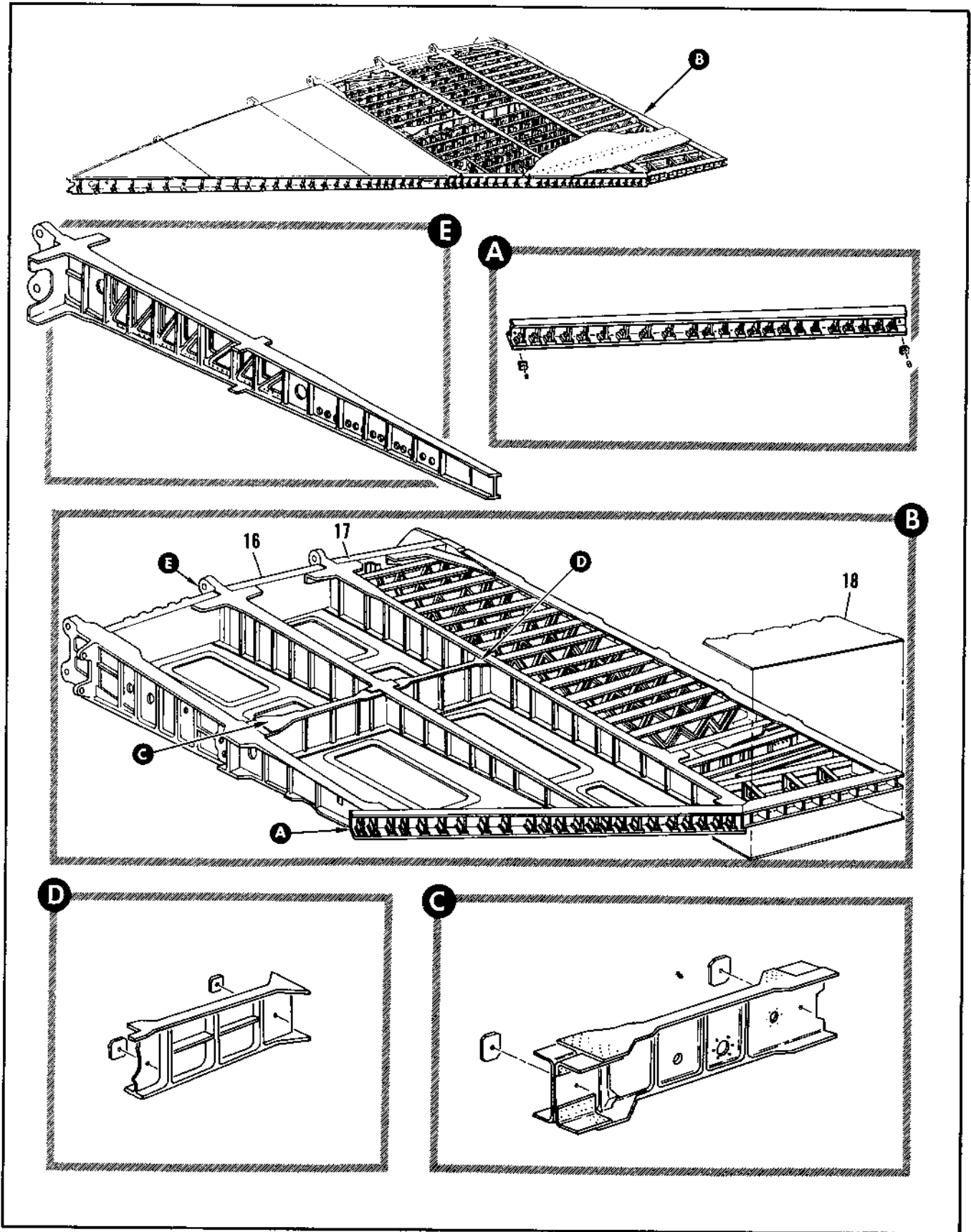

Figure 2.6-36. Aft Tank Wing Structure Assembly (Sheet 3 of 4)

FIGURE AND INDEX NUMBER	PART NUMBER	DESCRIPTION	UNITS PER ASSY.	USABLE ON CODE		
				FROM	TO	
		1 2 3 4 5 6				
2.6-36	8-18783-A	• RIB, SPAR #5 TO 6 RH	1	35		
	8-18739-10	• RIB, SPAR #5 TO 6 RH ALT INTCHG WITH 8-18783-B	RF	35		
	8-18350-3	• RIB INSTL, CLOSING SPAR #5 TO 6 WING LH	1	35	159	
	8-18350-401	• RIB INSTL, CLOSING SPAR #5 TO 6 WING LH	1	160	277	
	8-18350-1	• RIB INSTL, CLOSING SPAR #5 TO 6 WING LH	1	278		
	8-18350-4	• RIB INSTL, CLOSING SPAR #5 TO 6 WING RH	1	35	159	
	8-18350-212	• RIB INSTL, CLOSING SPAR #5 TO 6 WING RH	1	160	277	
	8-18350-2	• RIB INSTL, CLOSING SPAR #5 TO 6 WING RH	1	278		
	- 16	8-18350-21	• RIB ASSY, LH	1	35	159
		8-18350-27	• RIB ASSY, LH	1	160	277
		8-18350-17	• RIB ASSY, LH	1	278	
		8-18350-28	• RIB ASSY, RH	1	35	159
		8-18350-28	• RIB ASSY, RH	1	160	277
	- 17	8-18350-18	• RIB ASSY, RH	1	278	
		8-19073-5	• STRUCTURE ASSY, WING TRANSFER TANK LH FOR BREAKDOWN SEE FIG. 2.6-37	1	F	
8-19073-303		• STRUCTURE ASSY, WING TRANSFER TANK LH FOR BREAKDOWN SEE FIG. 2.6-37	1	60	136	
8-19073-1		• STRUCTURE ASSY, WING TRANSFER TANK LH FOR BREAKDOWN SEE FIG. 2.6-37	1	189	277	
8-19033-1		• STRUCTURE ASSY, WING TRANSFER TANK LH FOR BREAKDOWN SEE FIG. 2.6-37	1	A		
8-19073-1		• STRUCTURE ASSY, WING TRANSFER TANK LH FOR BREAKDOWN SEE FIG. 2.6-37	1	R		
8-19073-6		• STRUCTURE ASSY, WING TRANSFER TANK RH FOR BREAKDOWN SEE FIG. 2.6-37	1	F		
8-19073-304		• STRUCTURE ASSY, WING TRANSFER TANK RH FOR BREAKDOWN SEE FIG. 2.6-37	1	60	186	
8-19073-2		• STRUCTURE ASSY, WING TRANSFER TANK RH FOR BREAKDOWN SEE FIG. 2.6-37	1	189	277	
8-19033-2		• STRUCTURE ASSY, WING TRANSFER TANK RH FOR BREAKDOWN SEE FIG. 2.6-37	1	A		
8-19073-2		• STRUCTURE ASSY, WING TRANSFER TANK RH FOR BREAKDOWN SEE FIG. 2.6-37	1	R		
- 18		8-18072-29	• STRUCTURE ASSY, WING LH	1	35	159
	8-18072-33	• STRUCTURE ASSY, WING LH	1	160	277	
	8-18032-31	• STRUCTURE ASSY, WING LH	1	A		
	8-18072-7	• STRUCTURE ASSY, WING LH	1	H		
	8-18072-25	• STRUCTURE ASSY, WING LH	1	304		
	8-18072-30	• STRUCTURE ASSY, WING RH	1	35	159	
	8-18072-34	• STRUCTURE ASSY, WING RH	1	160	277	
	8-18032-32	• STRUCTURE ASSY, WING RH	1	A		
	8-18072-8	• STRUCTURE ASSY, WING RH	1	R		
	8-18072-26	• STRUCTURE ASSY, WING RH	1	304		
	8-18162-7	• SKIN, MACH AFT BOX UPPER FWD LH	1	E		
	8-18142-11	• SKIN, MACH AFT BOX UPPER FWD LH	1	A		
	8-18142-15	• SKIN, MACH AFT BOX UPPER FWD LH ALT INTCHG WITH 8-18142-11	RF	A		
	8-18162-8	• SKIN, MACH AFT BOX UPPER FWD RH	1	E		
	8-18142-12	• SKIN, MACH AFT BOX UPPER FWD RH	1	A		

A AIRPLANES #278 THRU 285 AND 288 THRU 291
 P AIRPLANES #287 AND 292 THRU 313
 E AIRPLANES #75 THRU 277, 277, 292 AND ON
 F AIRPLANES #35 THRU 159, 304 AND ON

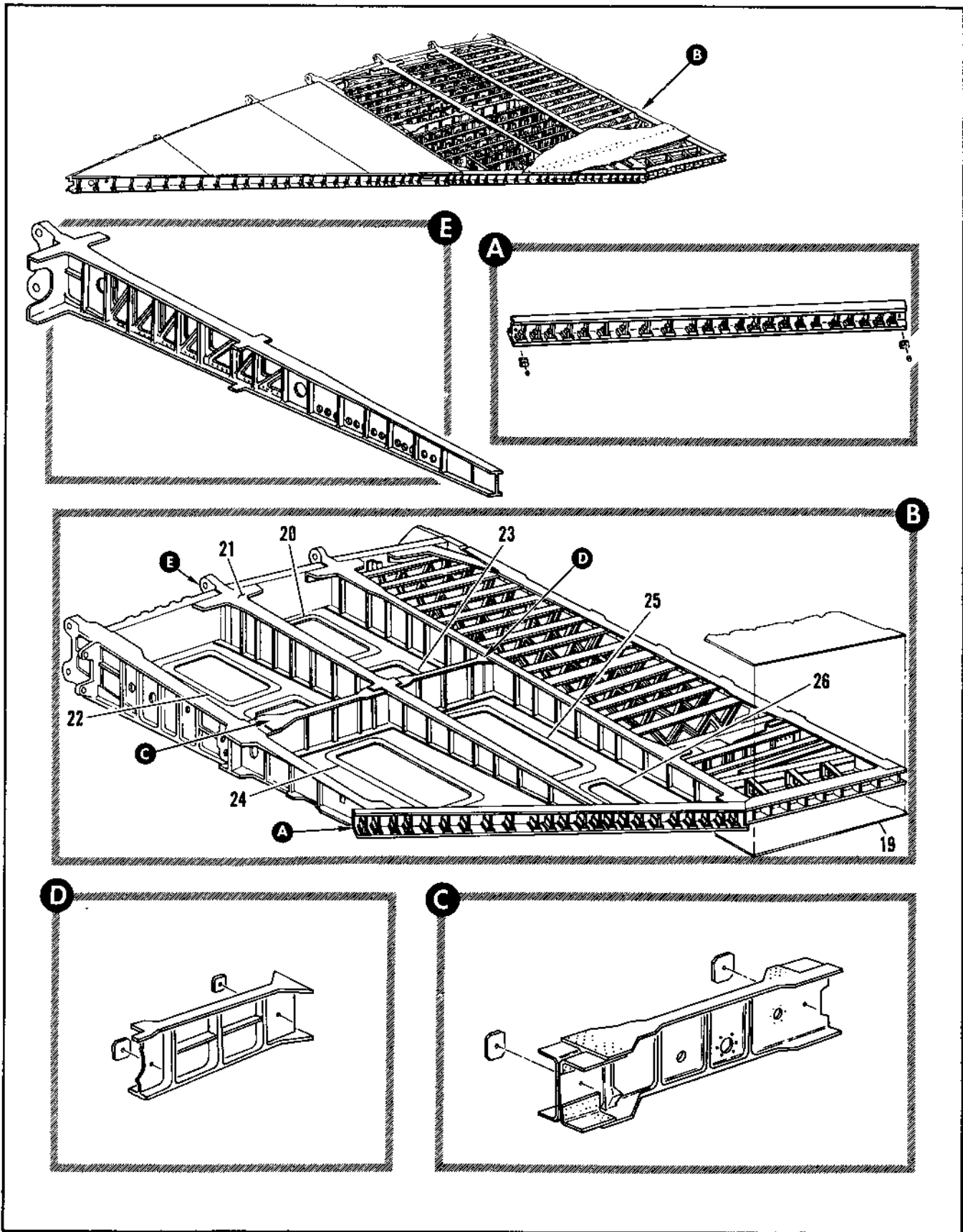

Figure 2.6-36. Aft Tank Wing Structure Assembly (Sheet 4 of 4)

FIGURE AND INDEX NUMBER	PART NUMBER	DESCRIPTION	UNITS PER ASSY.	USABLE ON CODE	
				FROM	TO
2.6-36	8-18142-16	• SKIN, MACH AFT BOX UPPER FWD RH ALT INTCHG WITH 8-18142-12	RF	A	
- 19	8-18163-7	• SKIN, AFT BOX LOWER FWD LH	1	E	
	8-18143-13	• SKIN, AFT BOX LOWER FWD LH	1	A	
	P-18163-8	• SKIN, AFT BOX LOWER FWD RH	1	E	
	8-18143-14	• SKIN, AFT BOX LOWER FWD RH	1	A	
- 20	8-18670	• FRAME INSTL, WING TANK #3 ACCESS DOOR BL 48 LH FOR BREAKDOWN SEE FIG. 2.2-19	1	35	
	8-18670-3	• FRAME INSTL, WING TANK #3 ACCESS DOOR BL 48 RH FOR BREAKDOWN SEE FIG. 2.2-19	1	35	
- 21	8-18666	• FRAME INSTL, WING TANK #3 ACCESS DOOR BL 50 LH FOR BREAKDOWN SEE FIG. 2.2-19	1	35	
	8-18666-3	• FRAME INSTL, WING TANK #3 ACCESS DOOR BL 50 RH FOR BREAKDOWN SEE FIG. 2.2-19	1	35	
- 22	8-18667	• FRAME INSTL, WING TANK #3 ACCESS DOOR BL 76 STA 496 LH FOR BREAKDOWN SEE FIG. 2.2-19	1	35	
	8-18667-801	• FRAME INSTL, WING TANK #3 ACCESS DOOR BL 76 STA 496 RH FOR BREAKDOWN SEE FIG. 2.2-19	1	35	
- 23	8-18667-3	• FRAME INSTL, WING TANK #3 ACCESS DOOR BL 76 STA 518 LH FOR BREAKDOWN SEE FIG. 2.2-19	1	35	
	8-18667-605	• FRAME INSTL, WING TANK #3 ACCESS DOOR BL 76 STA 538 RH FOR BREAKDOWN SEE FIG. 2.2-19	1	35	
- 24	8-18668-3	• FRAME INSTL, WING TANK #2 ACCESS DOOR BL 123 STA 496 LH FOR BREAKDOWN SEE FIG. 2.2-19	1	35	
	8-18668-805	• FRAME INSTL, WING TANK #2 ACCESS DOOR BL 123 STA 496 RH FOR BREAKDOWN SEE FIG. 2.2-19	1	35	
- 25	8-18668	• FRAME INSTL, WING TANK #2 ACCESS DOOR BL 123 STA 538 LH FOR BREAKDOWN SEE FIG. 2.2-19	1	35	
	8-18668-801	• FRAME INSTL, WING TANK #2 ACCESS DOOR BL 123 STA 538 RH FOR BREAKDOWN SEE FIG. 2.2-19	1	35	
- 26	8-18671	• FRAME INSTL, WING TANK #2 ACCESS DOOR BL 150 LH FOR BREAKDOWN SEE FIG. 2.2-19	1	35	
	8-18671-3	• FRAME INSTL, WING TANK #2 ACCESS DOOR BL 150 RH FOR BREAKDOWN SEE FIG. 2.2-19	1	35	
		A AIRPLANES #278 THRU 286 AND 288 THRU 291 E AIRPLANES #35 THRU 277, 287, 292 AND ON			

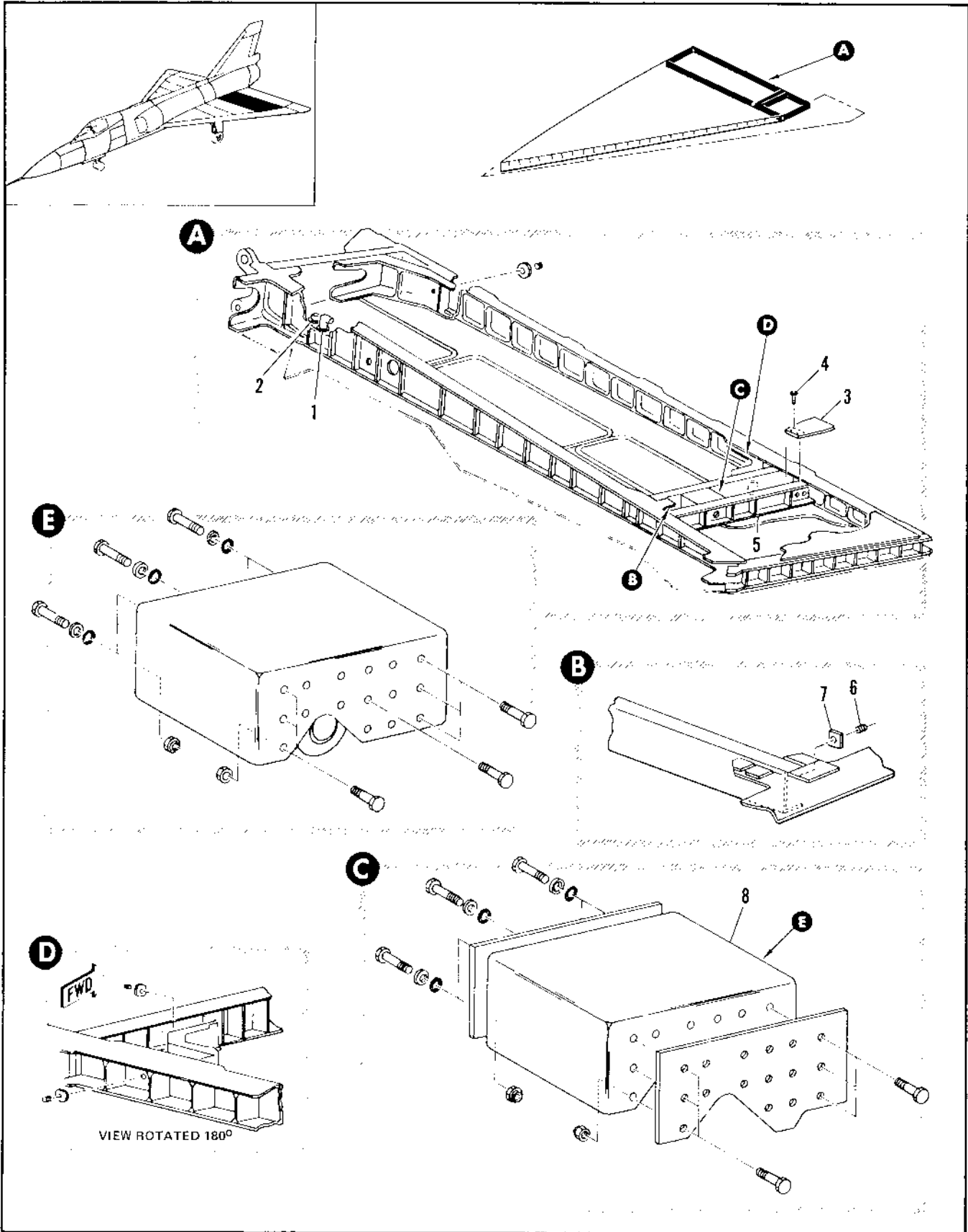

Figure 2.6-37. Wing Transfer Tank Structure Assembly (Sheet 1 of 3)

FIGURE AND INDEX NUMBER	PART NUMBER	DESCRIPTION	UNITS PER ASSY.	USABLE ON CODE	
				FROM	TO
		1 2 3 4 5 6			
2.6-37	8-18073-5	STRUCTURE ASSEMBLY, WING TRANSFER TANK LH FOR NHA SEE FIG. 2.6-36	RF	G	
	8-18073-853	STRUCTURE ASSEMBLY, WING TRANSFER TANK LH FOR NHA SEE FIG. 2.6-36	RF	163	189
	8-19073-1	STRUCTURE ASSEMBLY, WING TRANSFER TANK LH FOR NHA SEE FIG. 2.6-36	RF	189	277
	8-18033-1	STRUCTURE ASSEMBLY, WING TRANSFER TANK LH FOR NHA SEE FIG. 2.6-36	RF	A	
	8-18073-1	STRUCTURE ASSEMBLY, WING TRANSFER TANK LH FOR NHA SEE FIG. 2.6-36	RF	B	
	8-19073-6	STRUCTURE ASSEMBLY, WING TRANSFER TANK RH FOR NHA SEE FIG. 2.6-36	RF	G	
	8-18073-804	STRUCTURE ASSEMBLY, WING TRANSFER TANK RH FOR NHA SEE FIG. 2.6-36	RF	160	188
	8-19073-2	STRUCTURE ASSEMBLY, WING TRANSFER TANK RH FOR NHA SEE FIG. 2.6-36	RF	189	277
	8-18033-2	STRUCTURE ASSEMBLY, WING TRANSFER TANK RH FOR NHA SEE FIG. 2.6-36	RF	A	
	8-18073-2	STRUCTURE ASSEMBLY, WING TRANSFER TANK RH FOR NHA SEE FIG. 2.6-36	RF	B	
- 1	8-21248-7	• FLANGE, TRANSFER LINE DRAIN BL 45	1	35	
	8-21238	• FLANGE, TRANSFER LINE DRAIN BL 45 ALT INTCHG WITH 8-21248-7	RF	H	
- 2	8-21171	• FLANGE, DRAIN OUTLET BL 43 REPLACES SUITABLE SUB FOR 8-21204	1	J	
	8-21204	• FLANGE, DRAIN OUTLET BL 43 REPLACED BY SUITABLE SUB 8-21171 REPLACED BY NOT INTCHG WITH 8-18552	1	278	296
- 3	8-18552-9	• FAIRING, ELEVON HINGE BL 148	1	265	277
	8-18552	• FAIRING, ELEVON HINGE BL 148 REPLACED BY NOT INTCHG WITH 8-18552-7	1	C	
	8-18552-7	• FAIRING, ELEVON HINGE BL 148 REPLACES NOT INTCHG WITH 8-18552	1	K	
- 4	BB351-8-9	• ATTACHING PARTS • BOLT, BLIND (73397) 97-63023-033 ----X----	6	35	
- 5	8-18386-3	• RIB ASSY, SPAR #6 TO 7 BL 151 LH RIVETED	1	L	
	8-18386-5	• RIB ASSY, SPAR #6 TO 7 BL 151 LH RIVETED	1	49	277
	8-18386-4	• RIB ASSY, SPAR #6 TO 7 PL 151 PH RIVETED	1	L	
	8-18386-6	• RIB ASSY, SPAR #6 TO 7 PL 151 PH RIVETED	1	49	277
	8-18385-3	• RIB INSTL, SPAR #6 TO 7 BL 146 LH	1	35	
	8-18385-4	• RIB INSTL, SPAR #6 TO 7 BL 146 RH	1	35	
- 6	AN93202	• PLUG (8AC44)	1	35	
- 7	8-17854-11	• FITTING, GASTIGHT INJECTION	1	35	
	8-18781-1	• SUPPORT INSTL, ELEVON ACTUATOR BL 148	1	35	
- 8	8-18709-1	• SUPPORT	1	35	
	8-18719-1	• SUPPORT, ALT INTCHG WITH 8-18709-1	RF	35	
		A AIRPLANES #278 THRU 296 AND 298 THRU 291			
		F AIRPLANES #287 AND 292 THRU 303			
		C AIRPLANES #279, 281 AND 284 THRU 303			
		G AIRPLANES #35 THRU 155, 304 AND ON			
		H AIRPLANES #35 THRU 188, 278 AND ON			
		J AIRPLANES #35 THRU 277, 297 AND ON			
		K AIRPLANES #35 THRU 264, 304 AND ON			
		L AIRPLANES #35 THRU 48, 278 AND ON			
		ATTACHING PARTS			

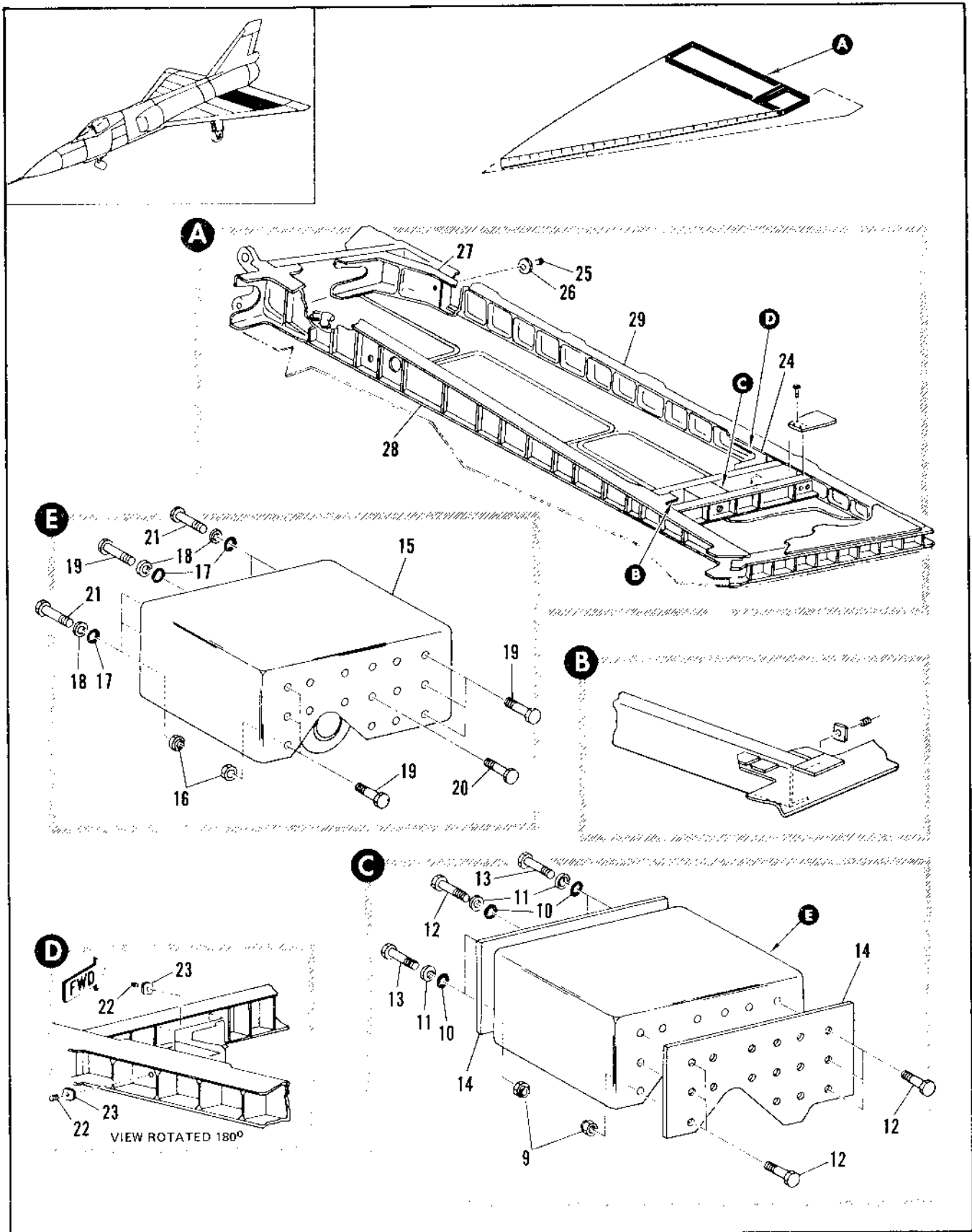

Figure 2.6-37. Wing Transfer Tank Structure Assembly (Sheet 2 of 3)

FIGURE AND INDEX NUMBER	PART NUMBER	DESCRIPTION	UNITS PER ASSY.	USABLE ON CODE	
				FROM	TO
		1 2 3 4 5 6			
2.6-37- 9	NASE7944	• • NUT, (80205) 96-37545-003	32	35	
- 11	MS29513-10	• • GASKET (96906)	16	35	
- 11	240-8616901-10	• • WASHER	16	35	
- 12	AN174-6A	• • BOLT (88044)	26	35	
- 13	AN174-7A	• • BOLT (88044)	6	35	
		----X----			
	8-18719-8	• • • SUPPORT	RF	35	
	8-18768	• • • PUSHING, FLANGED CONE ELEVON ACTUATOR	2	35	
- 14	8-18981-7	• • FILLER	2	35	
	8-18981	• SUPPORT INSTL, ELEVON ACTUATOR BL 148	RF	35	
		ALT INTCHG WITH 8-18981-1			
- 15	8-18719	• • SUPPORT ASSEMBLY	RF	35	
		ATTACHING PARTS			
- 16	NASE7944	• • NUT, (80205) 96-37545-003	32	35	
- 17	MS29513-10	• • GASKET (96906)	16	35	
- 18	240-8616901-10	• • WASHER	16	35	
- 19	AN174-6A	• • BOLT (88044)	16	35	
- 20	AN174-5A	• • BOLT (88044)	10	35	
- 21	AN174-7A	• • BOLT (88044)	6	35	
		----X----			
	8-18719-7	• • • SUPPORT	RF	35	
	8-18768	• • • PUSHING FLANGED CONE ELEVONACTUATOR	2	35	
	8-18938-1	• CORNER INSTL, TRANSFER TANK BL 146 LH	1	H	
	8-18938-3	• CORNER INSTL, TRANSFER TANK BL 146 LH	1	189	277
	8-18938-2	• CORNER INSTL, TRANSFER TANK BL 146 RH	1	H	
	8-18938-4	• CORNER INSTL, TRANSFER TANK BL 146 RH	1	189	277
- 22	AN93202	• • PLUG	2	35	
- 23	8-17854-11	• • FITTING, GASTIGHT INJECTION	2	35	
- 24	8-18747-7	• • FITTING, FUEL TANK OUTBD SPAR #7 LH	1	35	
	8-18748-7	• • FITTING, FUEL TANK OUTBD SPAR #7 LH	RF	35	
		ALT INTCHG WITH 8-18747-7			
	8-18747-8	• • FITTING, FUEL TANK OUTBD SPAR #7 RH	1	35	
	8-18748-8	• • FITTING, FUEL TANK OUTBD SPAR #7 RH	RF	35	
		ALT INTCHG WITH 8-18747-8			
	8-18932-1	• CORNER INSTL, TRANSFER TANK BL 40 LH	1	H	
	8-18932-811	• CORNER INSTL, TRANSFER TANK BL 40 LH	1	189	277
	8-18932-2	• CORNER INSTL, TRANSFER TANK BL 40 RH	1	H	
	8-18932-802	• CORNER INSTL, TRANSFER TANK BL 40 RH	1	189	277
- 25	AN93202	• • PLUG (88044)	1	H	
- 26	8-17854-11	• • FITTING, GASTIGHT INJECTION	1	H	
- 27	8-18733-7	• • FITTING, FUEL TANK INBD SPAR #7	1	35	
	8-18734	• • FITTING, ALT INTCHG WITH 8-18733-7	RF	35	
	8-18126-801	• SPAR INSTL, WING STA 556 LH	1	G	
	8-18126-805	• SPAR INSTL, WING STA 556 LH	1	160	188
	8-19126-1	• SPAR INSTL, WING STA 556 LH	1	189	277
	8-18126-1	• SPAR INSTL, WING STA 556 LH	1	A	
	8-18126-1	• SPAR INSTL, WING STA 556 LH	1	B	
	8-18126-802	• SPAR INSTL, WING STA 556 RH	1	G	
	8-18126-806	• SPAR INSTL, WING STA 556 RH	1	160	188
	8-19126-2	• SPAR INSTL, WING STA 556 RH	1	189	277
	8-18126-2	• SPAR INSTL, WING STA 556 RH	1	A	
	8-18126-2	• SPAR INSTL, WING STA 556 RH	1	B	
- 28	8-18126-283	• • SPAR ASSY, STA 556 LH RIVETED	1	G	
	8-18126-281	• • SPAR ASSY, STA 556 LH RIVETED	1	160	188

A AIRPLANES #278 THRU 286 AND 288 THRU 291
 B AIRPLANES #287 AND 292 THRU 303
 C AIRPLANES #35 THRU 159, 304 AND ON
 H AIRPLANES #35 THRU 188, 278 AND ON

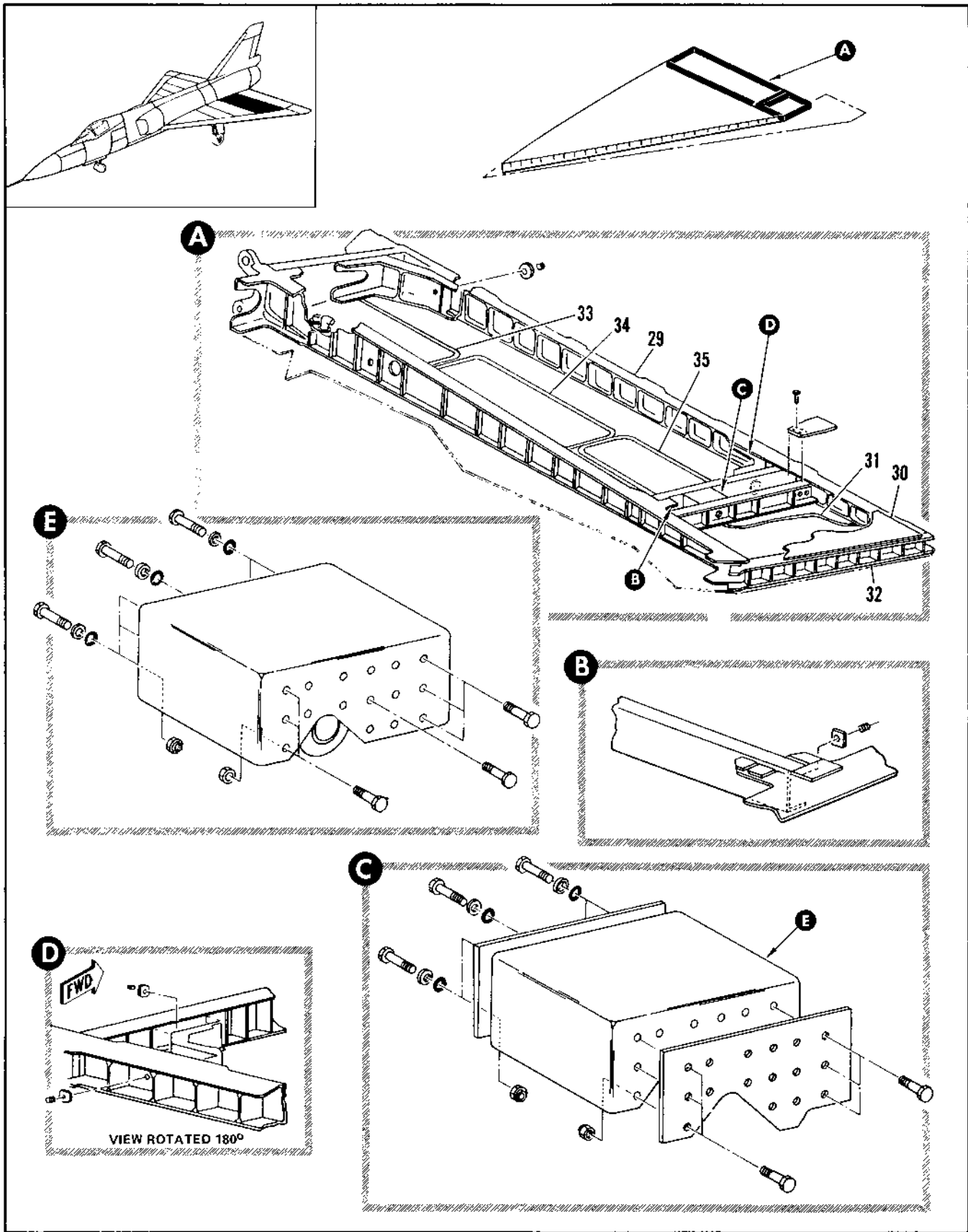

Figure 2.6-37. Wing Transfer Tank Structure Assembly (Sheet 3 of 3)

FIGURE AND INDEX NUMBER	PART NUMBER	DESCRIPTION	UNITS PER ASSY.	USABLE ON CODE	
				FROM	TO
2.6-37- 29	8-19127-1	• SPAR INSTL, WING STA 593 LH FOR BREAKDOWN SEE FIG. 2.6-34	1	F	
	8-19127-1	• SPAR INSTL, WING STA 597 LH FOR BREAKDOWN SEE FIG. 2.6-34	1	189	277
	8-19127-1	• SPAR INSTL, WING STA 597 LH FOR BREAKDOWN SEE FIG. 2.6-34	1	A	
	8-19127-2	• SPAR INSTL, WING STA 593 RH FOR BREAKDOWN SEE FIG. 2.6-34	1	F	
	8-19127-2	• SPAR INSTL, WING STA 593 RH FOR BREAKDOWN SEE FIG. 2.6-34	1	189	277
	8-19127-2	• SPAR INSTL, WING STA 593 RH FOR BREAKDOWN SEE FIG. 2.6-34	1	A	
- 31	8-19168-9	• SKIN, UPPER TRANSFER TANK LH	1	M	
	8-19168-11	• SKIN, UPPER TRANSFER TANK LH	1	97	194
	8-19168-13	• SKIN, UPPER TRANSFER TANK LH	1	189	277
	8-19168-11	• SKIN, UPPER TRANSFER TANK LH	1	A	
	8-19168-7	• SKIN, UPPER TRANSFER TANK LH	1	F	
	8-19168-10	• SKIN, UPPER TRANSFER TANK RH	1	M	
	8-19168-12	• SKIN, UPPER TRANSFER TANK RH	1	97	194
	8-19168-14	• SKIN, UPPER TRANSFER TANK RH	1	189	277
	8-18148-12	• SKIN, UPPER TRANSFER TANK RH	1	A	
	8-18148-4	• SKIN, UPPER TRANSFER TANK RH	1	C	
- 31	8-18147-7	• SKIN, LOWER TRANSFER TANK LH	1	D	
	8-18147-13	• SKIN, LOWER TRANSFER TANK LH	1	A	
	8-18147-8	• SKIN, LOWER TRANSFER TANK RH	1	D	
	8-18147-19	• SKIN, LOWER TRANSFER TANK RH	1	A	
	8-18590-1	• RIB ASSY, WING SPAR #6 TO 7 LH	1	D	
	8-18590-1	• RIB ASSY, WING SPAR #6 TO 7 LH	1	A	
	8-18590-2	• RIB ASSY, WING SPAR #6 TO 7 RH	1	D	
	8-18590-2	• RIB ASSY, WING SPAR #6 TO 7 RH	1	A	
- 32	8-18562-2	• RIB, WING SPAR #6, LH	1	D	
	8-18562-7	• RIB, ALT INTCHG WITH 8-18562-5	RF	0	
	8-18572	• RIB, WING SPAR #6	1	A	
	8-18562-10	• RIB, WING SPAR #6, RH	1	D	
- 33	8-18592-8	• RIB, ALT INTCHG WITH 8-18562-10	RF	0	
	8-18573	• FRAME INSTL, WING TRANSFER TANK ACCESS DOOR PL 48 LH FOR BREAKDOWN SEE FIG. 2.2-19	1	H	
	8-18673-801	• FRAME INSTL, WING TRANSFER TANK ACCESS DOOR PL 48 LH FOR BREAKDOWN SEE FIG. 2.2-19	1	189	277
	8-18673-3	• FRAME INSTL, WING TRANSFER TANK ACCESS DOOR PL 48 RH FOR BREAKDOWN SEE FIG. 2.2-19	1	H	
	8-18673-113	• FRAME INSTL, WING TRANSFER TANK ACCESS DOOR PL 48 RH FOR BREAKDOWN SEE FIG. 2.2-19	1	189	
	8-18674	• FRAME INSTL, WING TRANSFER TANK ACCESS DOOR PL 84 LH FOR BREAKDOWN SEE FIG. 2.2-19	1	H	
- 34	8-18674-801	• FRAME INSTL, WING TRANSFER TANK ACCESS DOOR PL 84 LH FOR BREAKDOWN SEE FIG. 2.2-19	1	189	277
	8-18674-3	• FRAME INSTL, WING TRANSFER TANK ACCESS DOOR PL 84 RH FOR BREAKDOWN SEE FIG. 2.2-19	1	H	
	8-18674-113	• FRAME INSTL, WING TRANSFER TANK ACCESS DOOR PL 84 RH FOR BREAKDOWN SEE FIG. 2.2-19	1	189	277
	8-18675	• FRAME INSTL, WING TRANSFER TANK ACCESS DOOR PL 120 LH FOR BREAKDOWN SEE FIG. 2.2-19	1	H	
- 35	8-18675-801	• FRAME INSTL, WING TRANSFER TANK ACCESS DOOR PL 120 LH FOR BREAKDOWN SEE FIG. 2.2-19	1	189	277
	8-18675-3	• FRAME INSTL, WING TRANSFER TANK ACCESS DOOR PL 120 RH FOR BREAKDOWN SEE FIG. 2.2-19	1	H	
	8-18675-113	• FRAME INSTL, WING TRANSFER TANK ACCESS DOOR PL 120 RH FOR BREAKDOWN SEE FIG. 2.2-19	1	189	277

A AIRPLANES #278 THRU 286 AND 288 THRU 291
 F AIRPLANES #215 THRU 277, 287, 292 AND ON
 E AIRPLANES #297 AND 292 THRU 296
 F AIRPLANES #35 THRU 165, 227, 292 AND ON
 M AIRPLANES #75 THRU 89, 297 AND ON

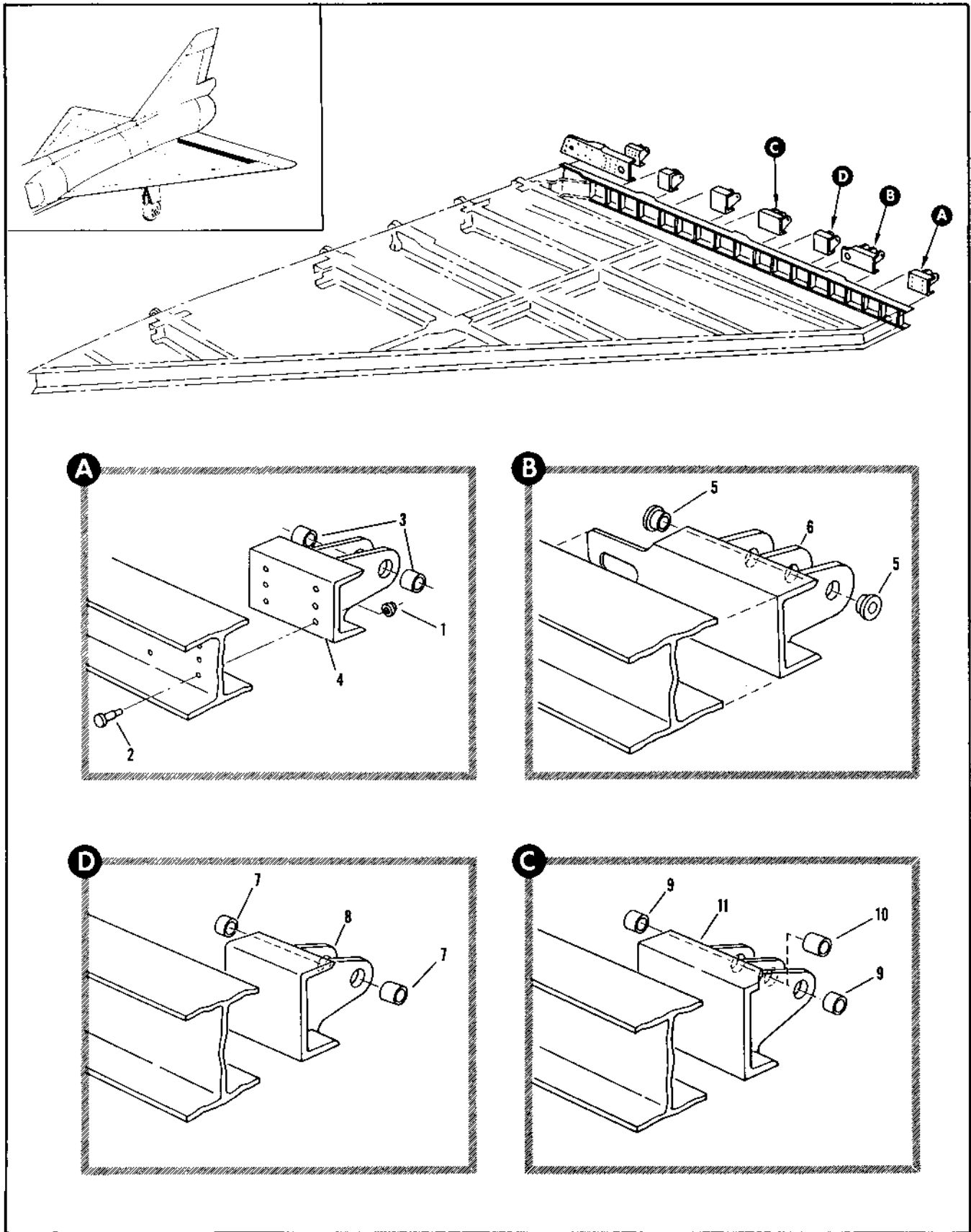

Figure 2.6-38. Wing Spar #7 Installation Sta 593 (Sheet 1 of 2)

FIGURE AND INDEX NUMBER	PART NUMBER	DESCRIPTION	UNITS PER ASSY.	USABLE ON CODE	
				FROM	TO
		1 2 3 4 5 6			
2.6-38	8-19127-1	SPAR INSTALLATION, #7 WING STA 593 LH FOR NHA SEE FIG. 2.6-37	RF	B	
	8-19127-1	SPAR INSTALLATION, #7 WING STA 593 LH FOR NHA SEE FIG. 2.6-37	RF	189	277
	8-19107-1	SPAR INSTALLATION, #7 WING STA 593 LH FOR NHA SEE FIG. 2.6-37	RF	A	
	8-19127-2	SPAR INSTALLATION, #7 WING STA 593 RH FOR NHA SEE FIG. 2.6-37	RF	R	
	8-19127-2	SPAR INSTALLATION, #7 WING STA 593 RH FOR NHA SEE FIG. 2.6-37	RF	189	277
	8-19107-2	SPAR INSTALLATION, #7 WING STA 593 RH FOR NHA SEE FIG. 2.6-37	RF	A	
	8-18809-1	• FITTING ASSY, ELEVON HINGE BL 175	1	35	
	8-18720	• FITTING ASSY, ELEVON HINGE BL 175 ALT INTCHG WITH 8-18809-1 ATTACHING PARTS	RF	35	
- 1	LC-C6	• COLLAR, <29666> 92-17000-001	6	35	
- 2	ALPPH-T6-5	• LOCKBOLT, <29666> 96-79002-604 -----X-----	6	35	
- 3	8-18761	• • RUSHING	2	35	
- 4	8-18809-7	• • FITTING, ELEVON HINGE BL 175	1	35	
	8-18720-7	• • FITTING, ELEVON HINGE BL 175 ALT INTCHG WITH 8-18809-7	RF	35	
	8-18808-1	• FITTING ASSY, ELEVON HINGE BL 148	1	35	
	8-18729	• FITTING ASSY, ELEVON HINGE BL 148 ALT INTCHG WITH 8-18808-1	RF	35	
- 5	8-18760-7	• • RUSHING	2	35	
	8-18760	• • RUSHING, ALT INTCHG WITH 8-18760-7	RF	35	
- 6	8-18808-7	• • FITTING, ELEVON HINGE BL 148	1	35	
	8-18729-7	• • FITTING, ELEVON HINGE BL 148 ALT INTCHG WITH 8-18808-7	RF	35	
	8-18807-1	• FITTING ASSY, ELEVON HINGE BL 130	1	35	
	8-18725	• FITTING ASSY, ELEVON HINGE BL 130 ALT INTCHG WITH 8-18807-1	RF	35	
- 7	8-18761	• • RUSHING	2	35	
- 8	8-18807-7	• • FITTING, ELEVON HINGE BL 130	1	35	
	8-18725-7	• • FITTING, ELEVON HINGE BL 130 ALT INTCHG WITH 8-18807-7	RF	35	
	8-18806-1	• FITTING ASSY, ELEVON HINGE BL 107	1	35	
	8-18726	• FITTING ASSY, ELEVON HINGE BL 107 ALT INTCHG WITH 8-18806-1	RF	35	
- 9	8-18761	• • RUSHING	2	35	
- 10	8-18757	• • RUSHING	1	35	
- 11	8-18806-7	• • FITTING, ELEVON HINGE BL 107	1	35	
	8-18726-7	• • FITTING, ELEVON HINGE BL 107 ALT INTCHG WITH 8-18806-7	RF	35	
		A AIRPLANES #27A THRU 296 AND 288 THRU 291 B AIRPLANES #35 THRU 189, 287, 292 AND ON			

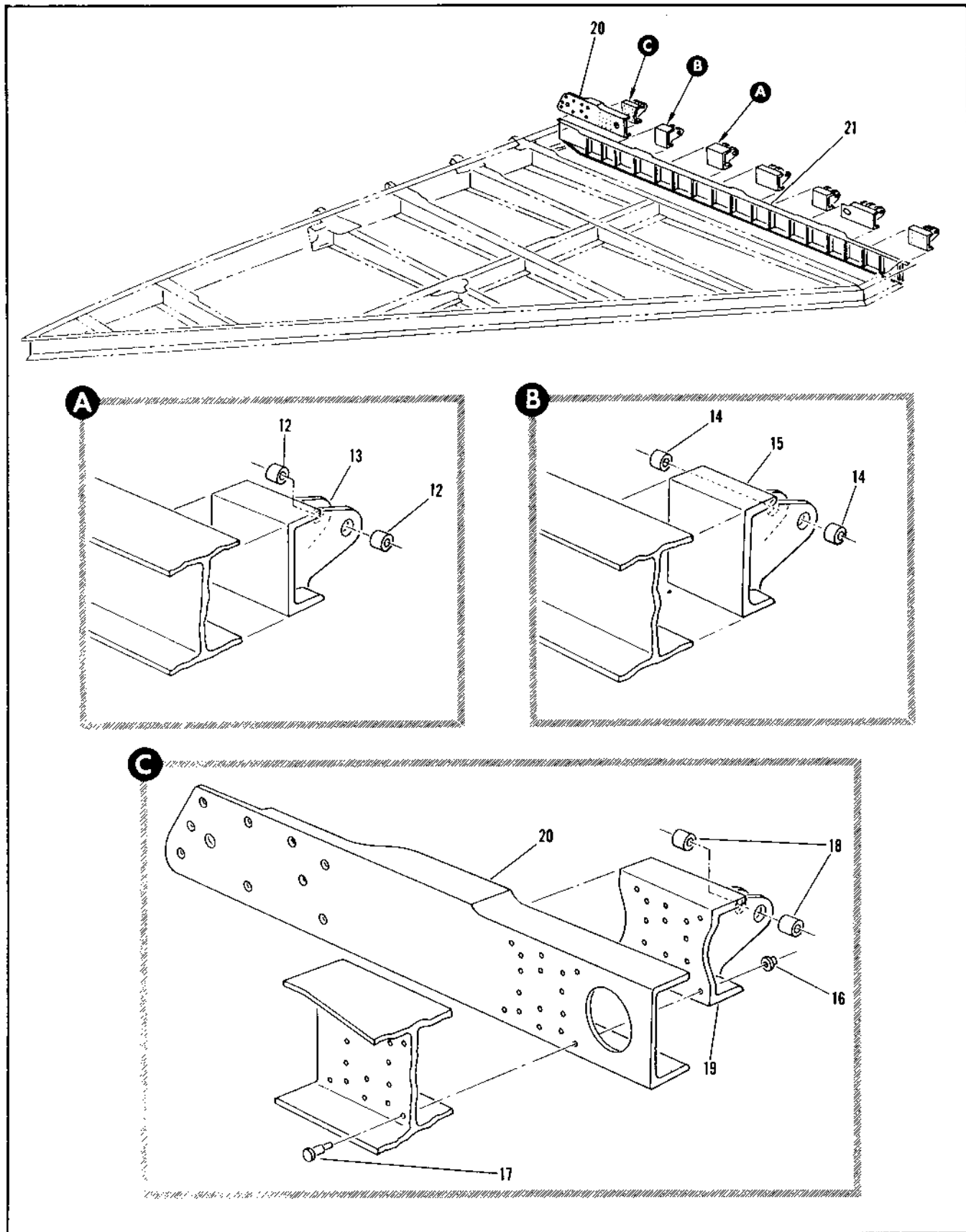

Figure 2.6-38. Wing Spar #7 Installation Sta 593 (Sheet 2 of 2)

FIGURE AND INDEX NUMBER	PART NUMBER	DESCRIPTION	UNITS PER ASSY.	USABLE ON CODE	
				FROM	TO
		1 2 3 4 5 6			
2.6-38	R-18905-1 R-18727	• FITTING ASSY, ELEVON HINGE PL 64 • FITTING ASSY, ELEVON HINGE PL 64 ALT INTCHG WITH R-18905-1	1 RF	35 35	
- 12	R-18761	• • PUSHING	2	35	
- 13	R-18905-7 R-18727-7	• • FITTING, ELEVON HINGE PL 64 • • FITTING, ELEVON HINGE PL 64 ALT INTCHG WITH R-18905-7	1 RF	35 35	
	R-18904-1 R-18728	• FITTING ASSY, ELEVON HINGE PL 62 • FITTING ASSY, ELEVON HINGE PL 62 ALT INTCHG WITH R-18904-1	1 RF	35 35	
- 14	R-18761	• • PUSHING	2	35	
- 15	R-18904-7 R-18728-7	• • FITTING, ELEVON HINGE PL 62 • • FITTING, ELEVON HINGE PL 62 ALT INTCHG WITH R-18904-7	1 RF	35 35	
	R-18903-1 R-18721	• FITTING ASSY, ELEVON HINGE PL 40 • FITTING ASSY, ELEVON HINGE PL 40 ALT INTCHG WITH R-18903-1	1 RF	35 35	
		ATTACHING PARTS			
- 16	LC-06	• COLLAR, <29666> 92-17330-001	16	35	
- 17	ALPPH-16-6	• LOCKBOLT, <29666> 90-77002-605	16	35	

	R-18761	• • PUSHING	2	35	
- 18	R-18903-7	• • FITTING, ELEVON HINGE PL 40	1	35	
- 19	R-18721-7	• • FITTING, ELEVON HINGE PL 40 ALT INTCHG WITH R-18903-7	RF	35	
- 20	R-18910-7 R-18723-11	• FITTING, WING ATTACH STA 593 LH • FITTING, WING ATTACH STA 593 LH ALT INTCHG WITH R-18910-7	1 RF	C C	
	R-18723-9 R-18910-9 R-18723-12	• FITTING, WING ATTACH STA 593 LH • FITTING, WING ATTACH STA 593 RH • FITTING, WING ATTACH STA 593 RH ALT INTCHG WITH R-18910-9	1 1 RF	278 C C	282
	R-18723-10	• FITTING, WING ATTACH STA 593 RH	1	278	281
- 21	R-18127-95 R-18127-7 R-18107-7A R-18127-7B R-18127-7C R-18107-7D	• SPAR ASSY, #7 WING STA 593 LH RIVETED • SPAR ASSY, #7 WING STA 593 LH RIVETED • SPAR ASSY, #7 WING STA 593 LH RIVETED • SPAR ASSY, #7 WING STA 593 RH RIVETED • SPAR ASSY, #7 WING STA 593 RH RIVETED • SPAR ASSY, #7 WING STA 593 RH RIVETED • SPAR ASSY, #7 WING STA 593 RH RIVETED	1 1 1 1 1 1	5 189 A B 189 A	277 277

A AIRPLANES #278 THRU 286 AND 288 THRU 291
 B AIRPLANES #35 THRU 188, 287, 292 AND ON
 C AIRPLANES #75 THRU 277, 283 AND ON

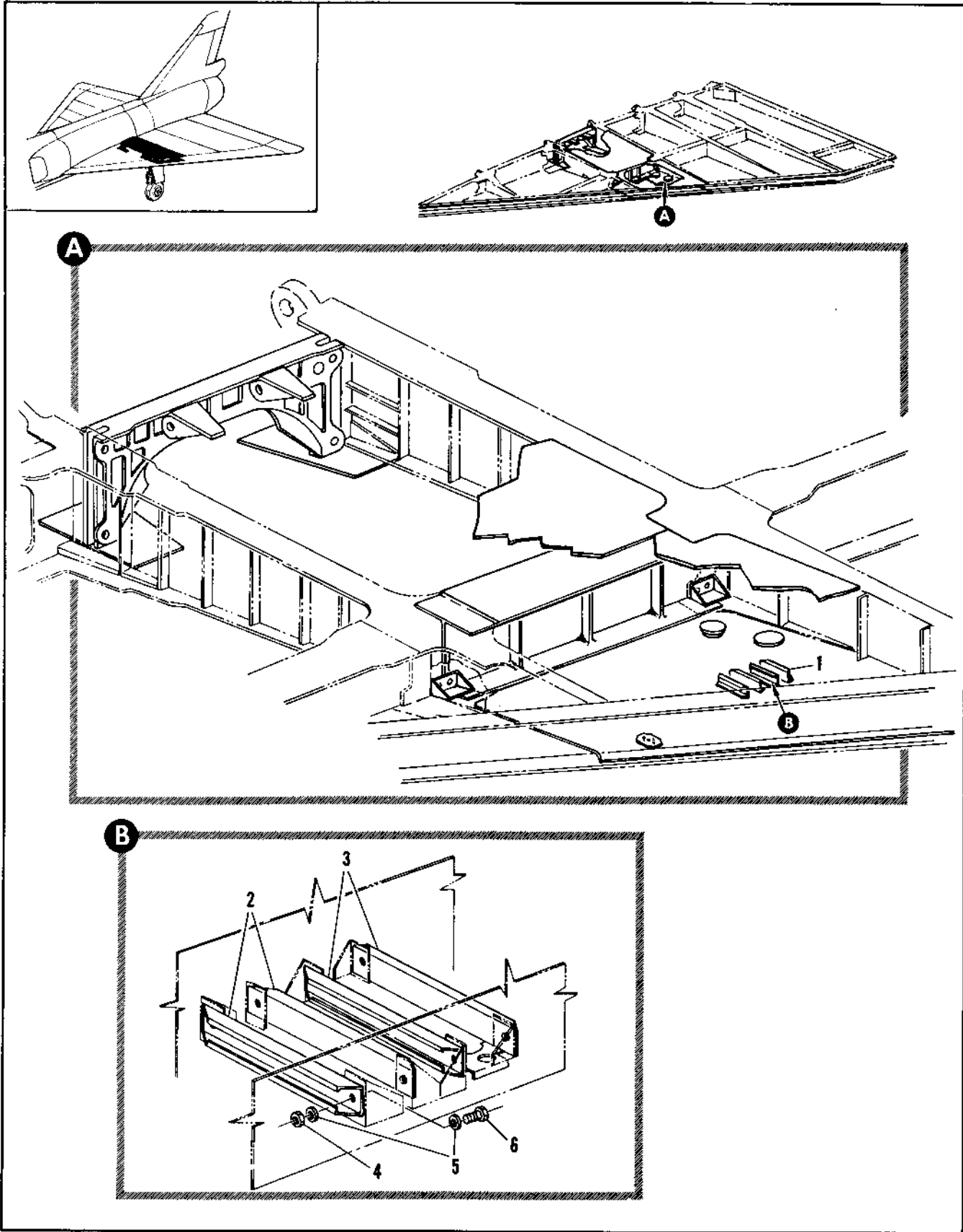

Figure 2.6-39. Wing Intermediate Box Installation (Sheet 1 of 3)

FIGURE AND INDEX NUMBER	PART NUMBER	DESCRIPTION	UNITS PER ASSY.	USABLE ON CODE	
				FROM	TO
		1 2 3 4 5 6			
2.6-39	8-18071-3	BOX INSTALLATION, WING INTERMEDIATE LH FOR NHA SEE FIG. 2.6-33	RF	C	
	8-18071-3	BOX INSTALLATION, WING INTERMEDIATE LH MODIFIED BY 65J35879 FOR NHA SEE FIG. 2.6-33	1	C	
	8-18071-803	BOX INSTALLATION, WING INTERMEDIATE LH FOR NHA SEE FIG. 2.6-33	RF	E	
	8-18071-803	BOX INSTALLATION, WING INTERMEDIATE LH MODIFIED BY 65J35879 FOR NHA SEE FIG. 2.6-33	1	E	
	8-18031-5	BOX INSTALLATION, WING INTERMEDIATE LH FOR NHA SEE FIG. 2.6-33	RF	A	
	8-18031-5	BOX INSTALLATION, WING INTERMEDIATE LH MODIFIED BY 65J35879 FOR NHA SEE FIG. 2.6-33	1	A	
	8-18071-1	BOX INSTALLATION, WING INTERMEDIATE LH MODIFIED BY 8-11906 AND 8-71119 FOR NHA SEE FIG. 2.6-33	RF	R	
	8-18071-1	BOX INSTALLATION, WING INTERMEDIATE LH MODIFIED BY 8-11906, 8-71119 AND 65J35879 FOR NHA SEE FIG. 2.6-33	1	R	
	8-18071-4	BOX INSTALLATION, WING INTERMEDIATE RH FOR NHA SEE FIG. 2.6-33	RF	C	
	8-18071-4	BOX INSTALLATION, WING INTERMEDIATE RH MODIFIED BY 65J35879 FOR NHA SEE FIG. 2.6-33	1	C	
	8-18071-804	BOX INSTALLATION, WING INTERMEDIATE RH FOR NHA SEE FIG. 2.6-33	RF	E	
	8-18071-804	BOX INSTALLATION, WING INTERMEDIATE RH MODIFIED BY 65J35879 FOR NHA SEE FIG. 2.6-33	1	E	
	8-18031-6	BOX INSTALLATION, WING INTERMEDIATE RH FOR NHA SEE FIG. 2.6-33	RF	A	
	8-18031-6	BOX INSTALLATION, WING INTERMEDIATE RH MODIFIED BY 65J35879 FOR NHA SEE FIG. 2.6-33	1	A	
	8-18071-2	BOX INSTALLATION, WING INTERMEDIATE RH FOR NHA SEE FIG. 2.6-33	RF	B	
	8-18071-2	BOX INSTALLATION, WING INTERMEDIATE RH MODIFIED BY 65J35879 FOR NHA SEE FIG. 2.6-33	1	B	
- 1	8-21532-1	• SUPPORT INSTL, EXTERNAL TANK FUEL AND AIR DISCONNECT LH	RF	35	
	8-21532-2	• SUPPORT INSTL, EXTERNAL TANK FUEL AND AIR DISCONNECT RH	RF	35	
- 2	8-21532-7	• • SUPPORT	RF	35	
- 3	8-21532-13	• • SUPPORT ATTACHING PARTS	RF	35	
- 4	NAS679A3	• • NUT (80205)	RF	35	
- 5	AN960D10	• • WASHER (80044)	RF	35	
	AN3-5A	• • BOLT (80044)	RF	35	
		A AIRPLANES #278 THRU 286 AND 288 THRU 291			
		B AIRPLANES #287 AND 292 THRU 303			
		C AIRPLANES #35 THRU 39, 41 THRU 53, 56 THRU 159, 319 AND ON			
		E AIRPLANES #40, 54, 55, AND 160 THRU 277			

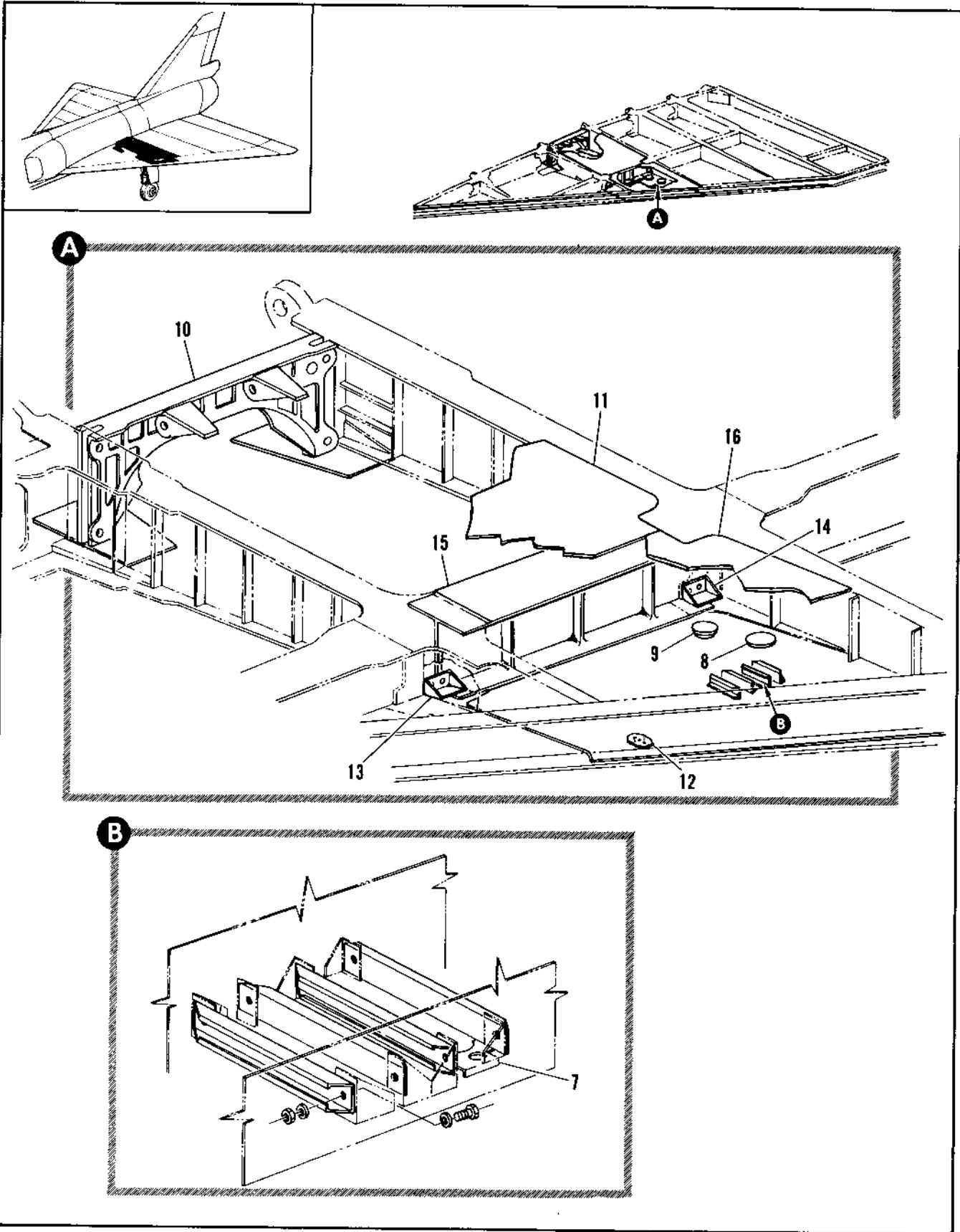

Figure 2.6-39. Wing Intermediate Box Installation (Sheet 2 of 3)

FIGURE AND INDEX NUMBER	PART NUMBER	DESCRIPTION	UNITS PER ASSY.	USABLE ON CODE	
				FROM	TO
		1 2 3 4 5 6			
2.6-39- 7	8-21332-17	• • BRACKET, LH	RF	35	
	8-21332-18	• • BRACKET, RH	RF	35	
- R	A-21276	• FLANGE, BOOST PUMP PRESSURE SWITCH VENT	1	35	
- R	8-21133	• FLANGE, EXTERNAL TANK VENT OUTLET	1	35	
- 11	8-18320-1	• FITTING INSTL, MAIN LANDING GEAR RL 38 LH FOR BREAKDOWN SEE FIG. 2.15-28	1	35	
	8-18320-2	• FITTING INSTL, MAIN LANDING GEAR RL 38 RH FOR BREAKDOWN SEE FIG. 2.15-28	1	35	
- 11	8-18031-7	• SKIN, LH	1	35	
	8-18071-11	• SKIN, LH ALT INTCHG WITH 8-18031-7	RF	35	
	8-18031-8	• SKIN, RH	1	35	
	8-18071-12	• SKIN, RH ALT INTCHG WITH 8-18031-8	RF	35	
	8-18071-9	• BOX ASSY, WING INTERMEDIATE LH	1	C	
	8-18071-10	• BOX ASSY, WING INTERMEDIATE LH	1	E	
	8-18031-59	• BOX ASSY, WING INTERMEDIATE LH	1	A	
	8-18071-7	• BOX ASSY, WING INTERMEDIATE LH	1	B	
	8-18071-10	• BOX ASSY, WING INTERMEDIATE RH	1	C	
	8-18071-10	• BOX ASSY, WING INTERMEDIATE RH	1	E	
	8-18031-60	• BOX ASSY, WING INTERMEDIATE RH	1	A	
	8-18071-8	• BOX ASSY, WING INTERMEDIATE RH	1	B	
- 12	8-18071-71	• • SOCKET ASSY, WING INTERMEDIATE BOX	1	E	
	8-180804	• • • SOCKET	1	F	
	MS24694-55	• • • ATTACHING PARTS SCREW (96926) ----X----	2	F	
	8-18526-3	• • BULKHEAD INSTL, INTERMEDIATE BOX LH	1	G	
	8-18526-1	• • BULKHEAD INSTL, INTERMEDIATE BOX LH	1	278	303
	8-18526-4	• • BULKHEAD INSTL, INTERMEDIATE BOX RH	1	G	
- 13	8-18526-2	• • BULKHEAD INSTL, INTERMEDIATE BOX RH	1	278	303
	8-18785-7	• • • SUPPORT, MAIN LANDING GEAR FAIRING HINGE LH LESS TWO 0.3125 DIA HOLES	1	35	
	8-18785-8	• • • SUPPORT, MAIN LANDING GEAR FAIRING HINGE RH LESS TWO 0.3125 DIA HOLES	1	35	
- 14	8-18785-9	• • • SUPPORT, MAIN LANDING GEAR FAIRING HINGE LH LESS TWO 0.3125 DIA HOLES	1	35	
	8-18785-10	• • • SUPPORT, MAIN LANDING GEAR FAIRING HINGE RH LESS TWO 0.3125 DIA HOLES	1	35	
- 15	8-18751-9	• • • BULKHEAD, LH	1	G	
	8-18751-7	• • • BULKHEAD, LH	1	278	303
	8-18741-9	• • • BULKHEAD, LH ALT INTCHG WITH 8-18751-7	RF	278	303
	8-18751-10	• • • BULKHEAD, RH	1	G	
	8-18751-8	• • • BULKHEAD, RH	1	278	303
	8-18741-10	• • • BULKHEAD, RH ALT INTCHG WITH 8-18751-8	RF	278	303
- 16	8-18166-7	• • SKIN, LH	1	0	
	8-18146-8	• • SKIN, LH	1	A	
	8-18166-8	• • SKIN, RH	1	0	
	8-18146-10	• • SKIN, RH	1	A	

A AIRPLANES #278 THRU 286 AND 288 THRU 291
 B AIRPLANES #287 AND 292 THRU 303
 C AIRPLANES #35 THRU 39, 41 THRU 53, 56 THRU 159,
 304 AND ON
 D AIRPLANES #35 THRU 277, 287, 292 AND ON
 E AIRPLANES #40, 54, 55, AND 160 THRU 277
 G AIRPLANES #35 THRU 277, 304 AND ON

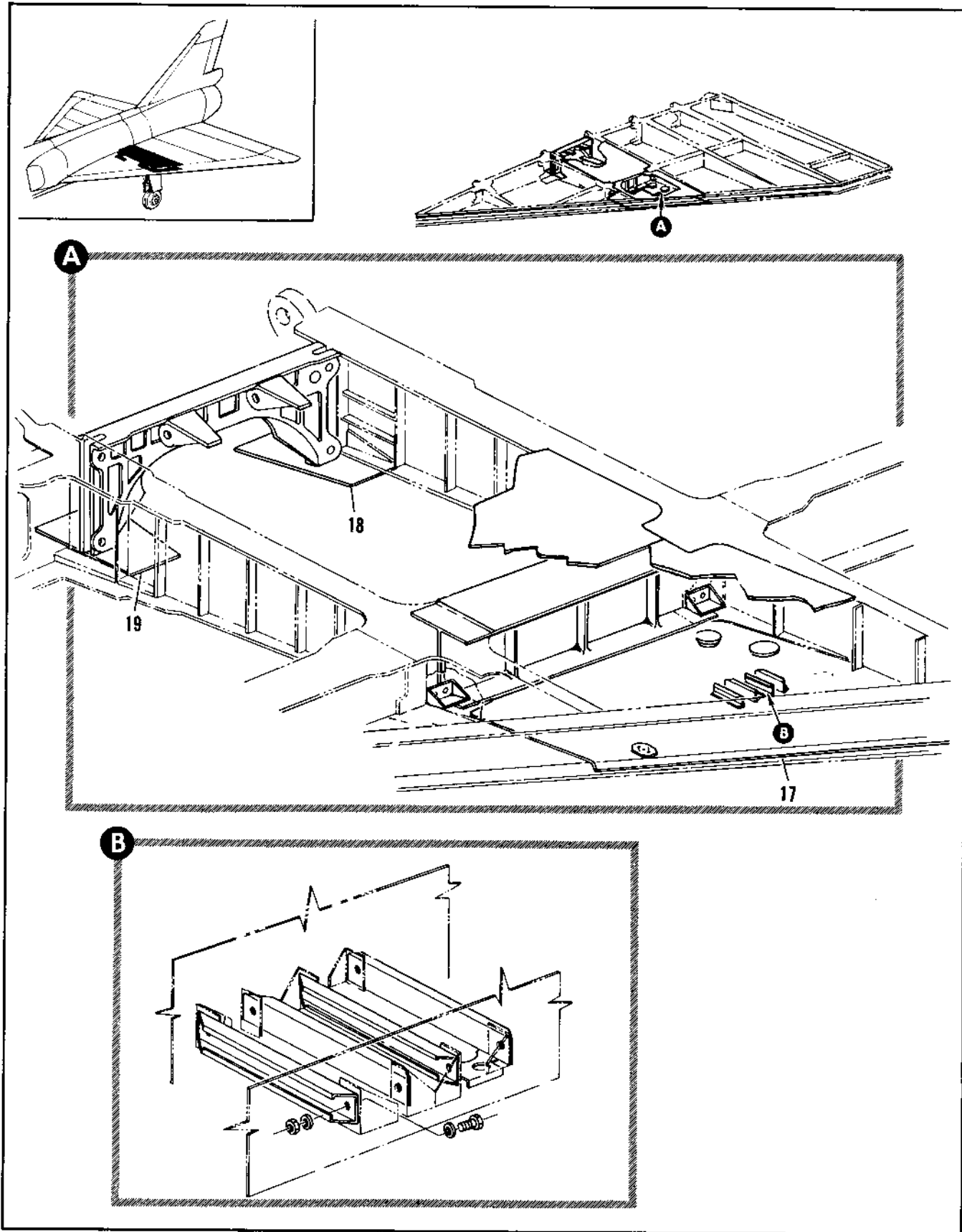

Figure 2-6.39. Wing Intermediate Box Installation (Sheet 3 of 3)

FIGURE AND INDEX NUMBER	PART NUMBER	DESCRIPTION	UNITS PER ASSY.	USABLE ON CODE	
				FROM	TO
		1 2 3 4 5 8			
2.6-39- 17 - 18 - 19	8-18164-11	• • SKIN, LH	1		H
	8-18164-15	• • SKIN, LH ALT INTCHG WITH 8-18164-11	RF		H
	8-18144-17	• • SKIN, LH	1		A
	8-18144-11	• • SKIN, LH ALT INTCHG WITH 8-18144-17	RF		A
	8-18164-7	• • SKIN, LH	1		F
	8-18164-13	• • SKIN, RH	1		H
	8-18164-17	• • SKIN, RH ALT INTCHG WITH 8-18164-13	RF		H
	8-18144-19	• • SKIN, RH	1		A
	8-18144-13	• • SKIN, RH ALT INTCHG WITH 8-18144-19	RF		A
	8-18164-9	• • SKIN, RH	1		F
	8-18151-7	• SKIN, INTERMEDIATE BOX LOWER LH	1		35
	8-18151-8	• SKIN, INTERMEDIATE BOX LOWER RH	1		35
	8-18151-11	• SKIN, INTERMEDIATE BOX LOWER LH	1		D
	8-18151-9	• SKIN, INTERMEDIATE BOX LOWER LH	1		A
	8-18151-12	• SKIN, INTERMEDIATE BOX LOWER RH	1		D
	8-18151-10	• SKIN, INTERMEDIATE BOX LOWER RH	1		A
			A AIRPLANES #278 THRU 296 AND 298 THRU 291		
		D AIRPLANES #35 THRU 277, 287, 292 AND ON			
		F AIRPLANES #287 AND 292 THRU 301			
		S AIRPLANES #35 THRU 277, 304 AND ON			
		H AIRPLANES #35 THRU 277, 302 AND ON			

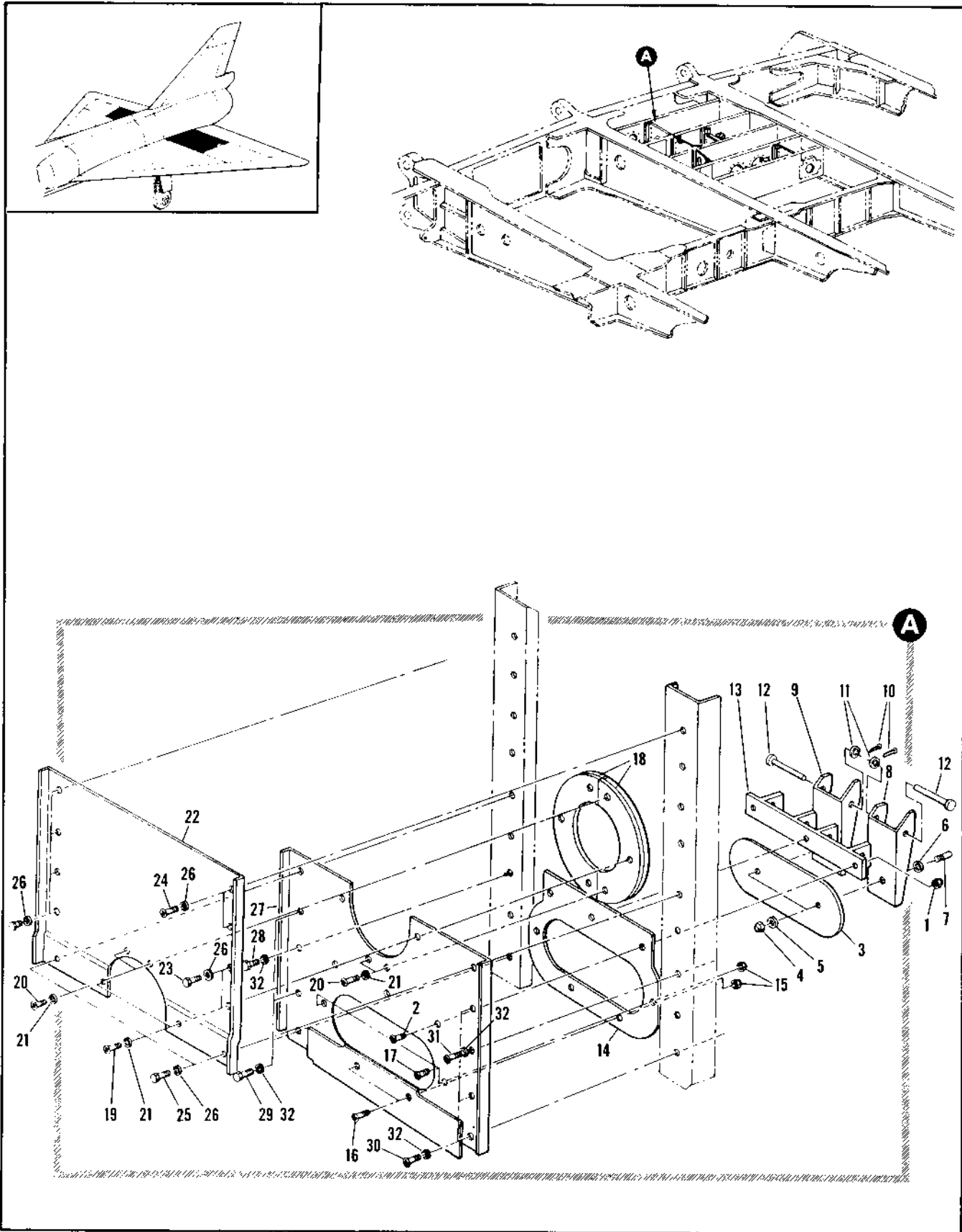

Figure 2.6-40. Wing Tank #3 Baffle Installation (Sheet 1 of 4)

FIGURE AND INDEX NUMBER	PART NUMBER	DESCRIPTION	UNITS PER ASSY.	USABLE ON CODE		
				FROM	TO	
2.6-40	8-21832-1	BAFFLE INSTALLATION, WING TANK #3 LH FOR AHA SEE FIG. 2.6-1 AND 2.6-2	1	35		
	A-21832-101	BAFFLE ASSEMBLY, WING TANK #3 LH SPARES	1	A		
	8-21832-5	BAFFLE ASSEMBLY, WING TANK #3 LH SPARES	1	P		
	8-21832-2	BAFFLE INSTALLATION, WING TANK #3 RH FOR AHA SEE FIG. 2.6-1 AND 2.6-2	1	35		
	8-21832-2	BAFFLE ASSEMBLY, WING TANK #3 RH SPARES	1	A		
	8-21832-6	BAFFLE ASSEMBLY, WING TANK #3 RH SPARES	1	B		
	8-21846-1	• VALVE ASSY, FLAPPER CHECK ATTACHING PARTS	1	35		
	- 1	NAS1291-3	• NUT (#2205)	3	35	
	- 2	NAS623-3-4	• SCREW (#2205)	3	35	
			-----X-----			
	- 3	8-21843-7	• FLAPPER, CHECK VALVE	1	35	
		8-21848-7	• FLAPPER, ALT INTCNG WITH 8-21843-7 ATTACHING PARTS	RF	35	
	- 4	NAS1291-3	• NUT (#2205)	2	35	
	- 5	AN960D10	• WASHER (#8044)	2	35	
	- 6	99-51559-023	• WASHER	2	35	
	- 7	NAS623-3-6	• SCREW (#2205)	2	35	
			-----X-----			
	- 9	8-21842-6	• ARM	1	35	
	- 9	8-21842-7	• ARM	1	35	
			ATTACHING PARTS			
	- 10	MS24665-132	• PIN, COTTER (#6906)	2	35	
	- 11	AN960D10	• WASHER (#8044)	2	35	
	- 12	MS20192-2-41	• PIN (#6906)	2	35	
			-----X-----			
	- 13	8-21844-7	• BRACKET	1	35	
	- 14	8-21845-7	• SEAT, FLAPPER CHECK VALVE ATTACHING PARTS	1	35	
	- 15	NAS1291-3	• NUT (#2205)	4	35	
	- 16	NAS623-3-4	• SCREW (#2205)	2	35	
	- 17	NAS623-3-2	• SCREW (#2205)	2	35	
			-----X-----			
	- 18	8-21831-1	• SEAL ASSY, TUPE ATTACHING PARTS	2	35	
	- 19	NAS623-3-5	• SCREW (#2205)	2	35	
- 20	NAS623-3-4	• SCREW (#2205)	4	35		
- 21	AN960D10	• WASHER (#8044)	6	35		
		-----X-----				
- 22	8-21832-15	• BAFFLE ASSY, LH	1	35		
	8-21832-20	• BAFFLE ASSY, RH ATTACHING PARTS	1	35		
- 23	AN3-3A	• BOLT (#8044)	6	35		
- 24	NAS623-3-2	• SCREW (#2205)	2	35		
- 25	AN3-4A	• BOLT (#8044)	2	35		
- 26	AN960D10	• WASHER (#8044)	10	35		
		-----Y-----				
- 27	8-21832-11	• BAFFLE ASSY, LH	1	35		
	8-21832-12	• BAFFLE ASSY, RH ATTACHING PARTS	1	35		
- 28	AN3-4A	• BOLT	1	35		
- 29	AN3-3A	• BOLT	3	35		
- 30	NAS623-3-2	• SCREW	3	35		
- 31	NAS623-3-3	• SCREW (#2205)	1	35		
- 32	AN960D10	• WASHER (#8044)	10	35		
		-----X-----				
		A AIRPLANES #35 THRU 277, 287, 292 AND ON				
		B AIRPLANES #278 THRU 286 AND 288 THRU 291				

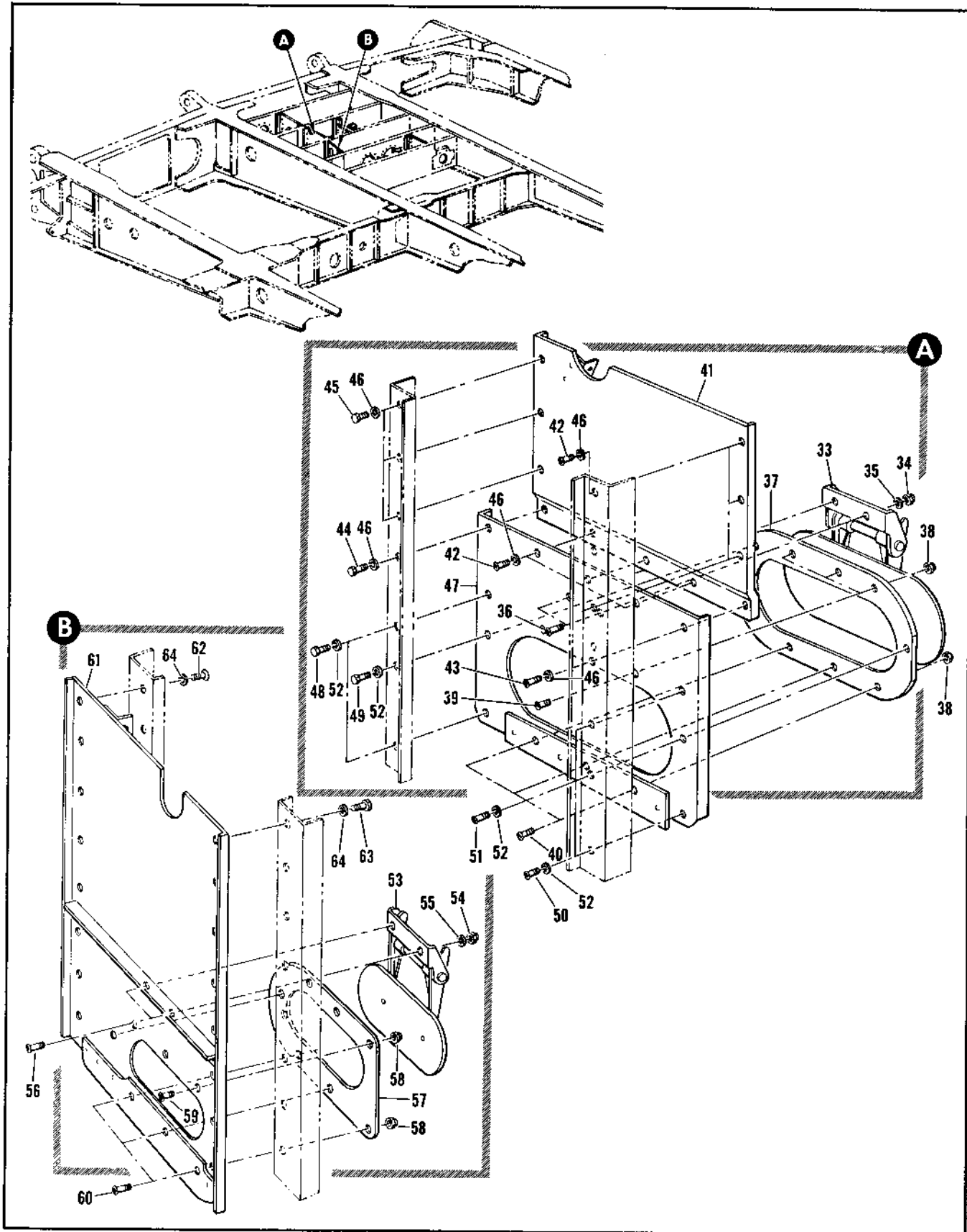

Figure 2.6-40. Wing Tank #3 Baffle Installation (Sheet 2 of 4)

FIGURE AND INDEX NUMBER	PART NUMBER	DESCRIPTION	UNITS PER ASSY.	USABLE ON CODE	
				FROM	TO
		1 2 3 4 5 6			
2.6-40- 33	330450-1	• VALVE <96124> 99-37075-003 ATTACHING PARTS	1	35	
- 34	NAS1291-3	• NUT (80205)	2	35	
- 35	AN960D10	• WASHER (88044)	2	35	
- 36	NAS623-3-4	• SCREW (80205) -----X-----	2	35	
- 37	8-21845-21	• SEAT, FLAPPER CHECK VALVE ATTACHING PARTS	1	35	
- 38	NAS1291-3	• NUT (80205)	6	35	
- 39	NAS623-3-2	• SCREW (80205)	3	35	
- 40	NAS623-3-4	• SCREW (80205) -----X-----	3	35	
- 41	8-21832-93 8-21832-94	• BAFFLE ASSY, LH • BAFFLE ASSY, RH ATTACHING PARTS	1 1	35 35	
- 42	NAS623-3-2	• SCREW (80205)	6	35	
- 43	NAS623-3-3	• SCREW (80205)	1	35	
- 44	AN3-4A	• BOLT (88044)	1	35	
- 45	AN3-3A	• BOLT (88044)	3	35	
- 46	AN960D10	• WASHER (88044) -----X-----	11	35	
- 47	8-21832-149 8-21832-150	• BAFFLE ASSY, LH • BAFFLE ASSY, RH ATTACHING PARTS	1 1	35 35	
- 48	AN3-3A	• BOLT (88044)	2	35	
- 49	AN3-4A	• BOLT (88044)	1	35	
- 50	NAS623-3-2	• SCREW (80205)	2	35	
- 51	NAS623-3-4	• SCREW (80205)	1	35	
- 52	AN960D10	• WASHER (88044) -----X-----	6	35	
- 53	330600-1	• VALVE, <96124> 99-37075-002 ATTACHING PARTS	1	35	
- 54	NAS1291-3	• NUT (80205)	2	35	
- 55	AN960D10	• WASHER (88044)	2	35	
- 56	NAS623-3-4	• SCREW (80205) -----X-----	2	35	
- 57	8-21845-11	• SEAT, FLAPPER CHECK VALVE ATTACHING PARTS	1	35	
- 58	NAS1291-3	• NUT (80205)	7	35	
- 59	NAS623-3-2	• SCREW (80205)	4	35	
- 60	NAS623-3-4	• SCREW (80205) -----X-----	3	35	
- 61	8-21832-41 8-21832-42	• BAFFLE ASSY, LH • BAFFLE ASSY, RH ATTACHING PARTS	1 1	35 35	
- 62	NAS623-3-2	• SCREW	8	35	
- 63	AN3-3A	• BOLT	8	35	
- 64	AN960D10	• WASHER -----X-----	16	35	

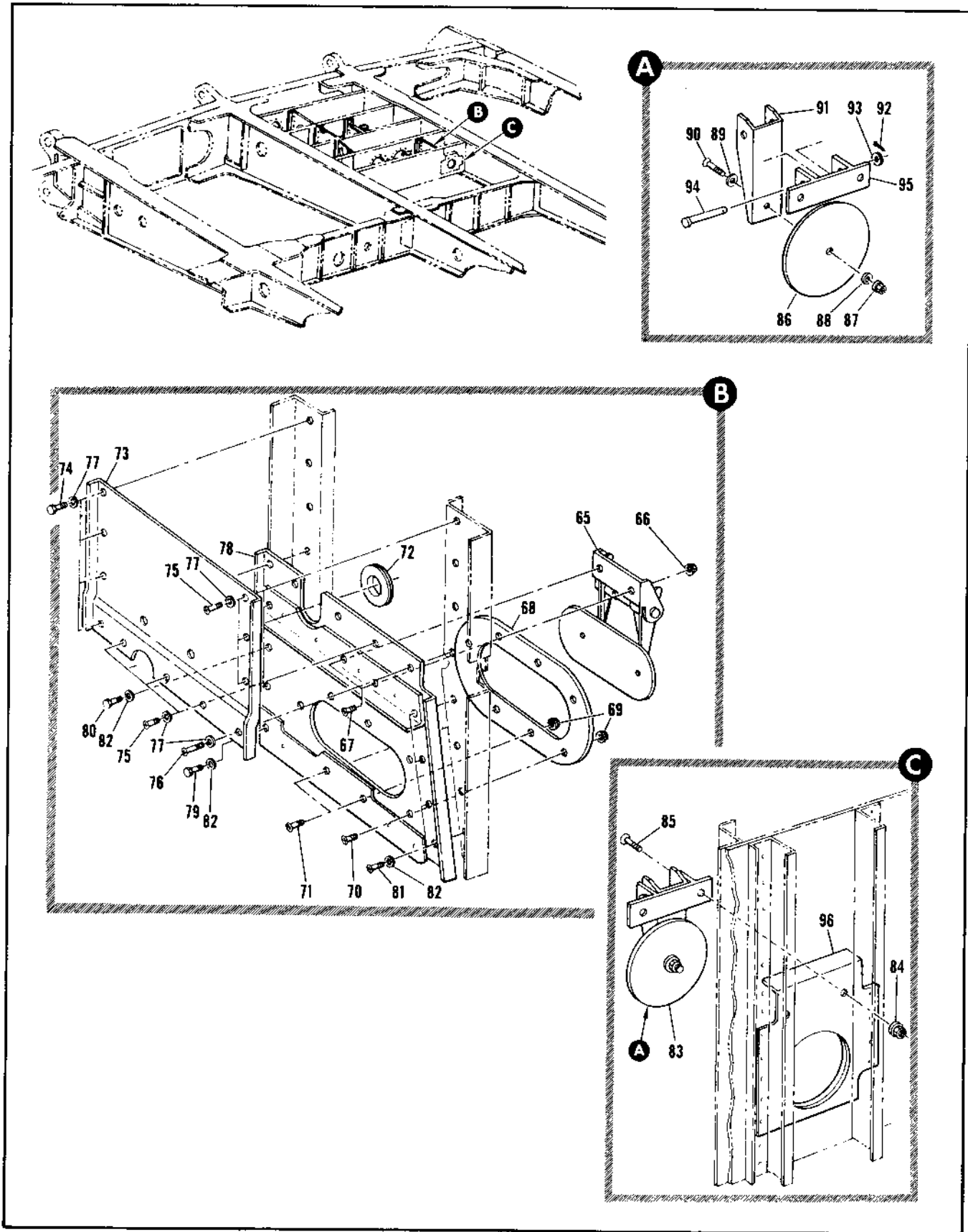

Figure 2.6-40. Wing Tank #3 Baffle Installation (Sheet 3 of 4)

FIGURE AND INDEX NUMBER	PART NUMBER	DESCRIPTION	UNITS PER ASSY.	USABLE ON CODE	
				FROM	TO
2.6-40- 65	333600-1	• VALVE, <96124> 99-57375-002 ATTACHING PARTS	1	35	
- 66	NAS1291-3	• NUT (80205)	2	35	
- 67	NAS623-3-3	• SCREW (80205) -----X-----	2	35	
- 68	R-21845-19	• SEAT, FLAPPER CHECK VALVE ATTACHING PARTS	1	35	
- 69	NAS1291-3	• NUT (80205)	7	35	
- 70	NAS623-3-4	• SCREW (80205)	2	35	
- 71	NAS623-3-3	• SCREW (80205) -----X-----	5	35	
- 72	MS21266-3T	• GROMMET, ELASTIC (96906)	1	35	
- 73	R-21832-56	• BAFFLE, LH	1	35	
	R-21832-56	• BAFFLE, RH ATTACHING PARTS	1	35	
- 74	AN3-3A	• BOLT (80044)	4	35	
- 75	NAS623-3-2	• SCREW (80205)	6	35	
- 76	NAS623-3-3	• SCREW (80205)	1	35	
- 77	AN961010	• WASHER (80044) -----X-----	11	35	
- 78	R-21832-F1	• BAFFLE ASSY, LH	1	35	
	R-21832-62	• BAFFLE ASSY, RH ATTACHING PARTS	1	35	
- 79	AN3-4A	• BOLT (80044)	1	35	
- 80	AN3-3A	• BOLT (80044)	3	35	
- 81	NAS623-3-2	• SCREW (80205)	4	35	
- 82	AN961010	• WASHER (80044) -----X-----	8	35	
- 83	R-21830-1	• VALVE ASSY, ROUND CHECK ATTACHING PARTS	1	35	
- 84	NAS1291-3	• NUT (80205)	2	35	
- 85	NAS623-3-4	• SCREW (80205) -----X-----	2	35	
- 86	R-21849-7	• FLAPPER, CHECK VALVE ATTACHING PARTS	1	35	
- 87	NAS1291-3	• NUT (80205)	1	35	
- 88	AN961010	• WASHER (80044)	1	35	
- 89	AN961010	• WASHER (80044)	1	35	
- 90	NAS623-3-6	• SCREW (80205) -----X-----	1	35	
- 91	R-21850-7	• ARM, CHECK VALVE ATTACHING PARTS	1	35	
- 92	MS29065-132	• PIN, COTTER (96906)	1	35	
- 93	AN961010	• WASHER (80044)	1	35	
- 94	MS21832-2-41	• PIN (96906) -----X-----	1	35	
- 95	R-21851-7	• BRACKET, CHECK VALVE	1	35	
- 96	R-21832-71	• SEAT, LH	1	35	
	R-21832-72	• SEAT, RH	1	35	

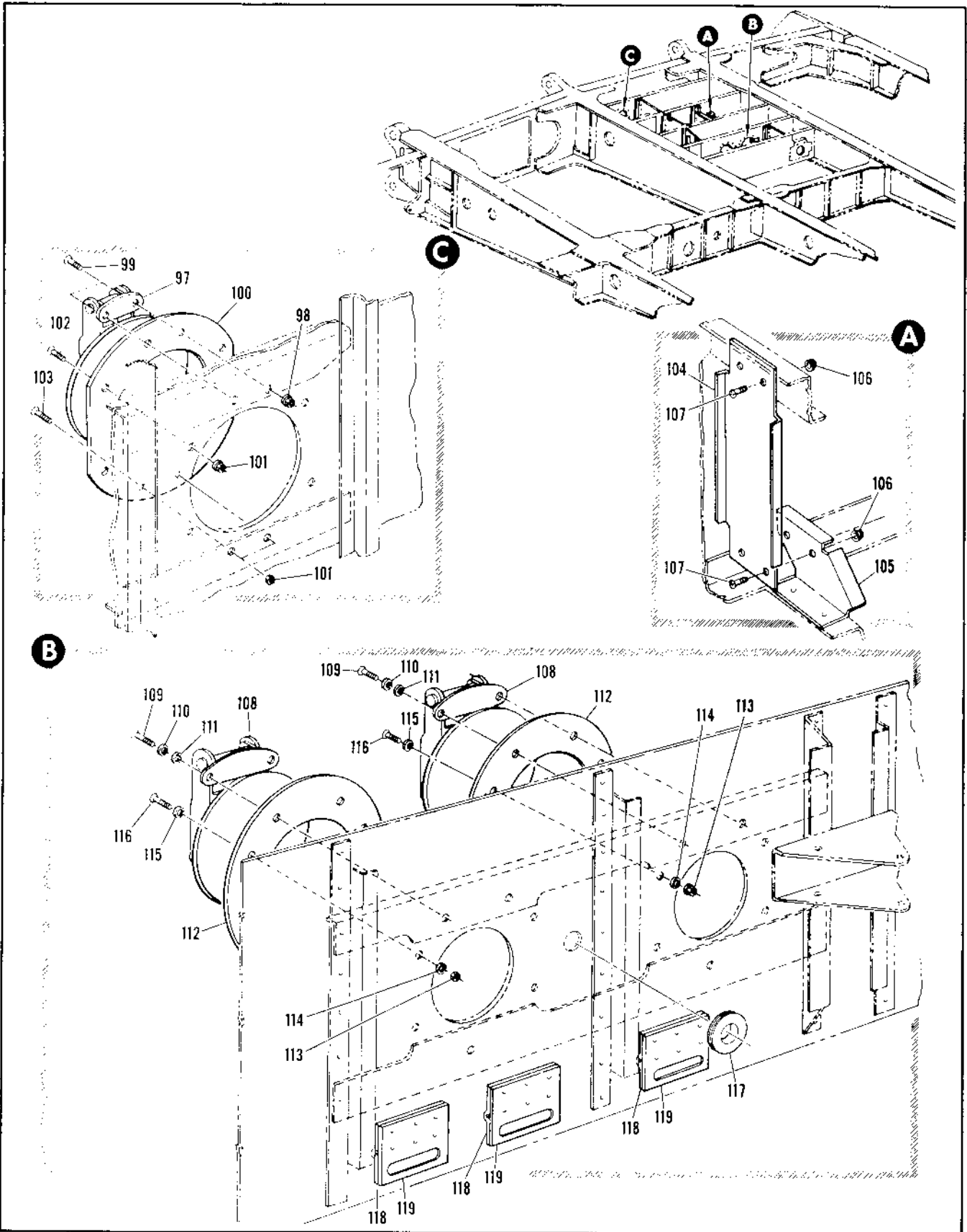

Figure 2.6-40. Wing Tank #3 Baffle Installation (Sheet 4 of 4)

FIGURE AND INDEX NUMBER	PART NUMBER	DESCRIPTION 1 2 3 4 5 6	UNITS PER ASSY.	USABLE ON CODE	
				FROM	TO
2.6-40- 97	31900-1	• VALVE, <96124> 99-37175-001 ATTACHING PARTS	1	35	
- 98	NAS1291-3	• NUT (80205)	2	35	
- 99	NAS623-3-3	• SCREW (80205) -----Y-----	2	35	
-100	8-21845-17	• SEAT ATTACHING PARTS	1	35	
-101	NAS1291-3	• NUT (80205)	6	35	
-102	NAS623-3-1	• SCREW (80205)	4	35	
-103	NAS623-3-2	• SCREW (80205) -----X-----	2	35	
-104	8-21889-13	• BRACKET, LH	1	27	30
-105	8-21832-89	• BRACKET, LH ATTACHING PARTS	1	35	
-106	NAS1291-3	• NUT (80205)	4	35	
-107	NAS623-3-2	• SCREW (80205) -----Y-----	4	35	
-108	3199-0-1	• VALVE, <96124> 99-37175-001 ATTACHING PARTS	2	35	
-109	NAS623-3-5	• SCREW (80205)	4	35	
-110	AN95010L	• WASHER (88044)	4	35	
-111	AN95010	• WASHER (88044) -----X-----	4	35	
-112	8-21845-15	• SEAT ATTACHING PARTS	2	35	
-113	NAS1291-3	• NUT (80205)	10	35	
-114	AN96010L	• WASHER (88044)	10	35	
-115	AN96010	• WASHER (88044)	10	35	
-116	NAS623-3-3	• SCREW (80205) -----X-----	10	35	
-117	94-35006-052	• GROMMET	1	35	
-118	8-21832-125	• HINGE ASSEMBLY	3	35	
-119	8-21845-13	• SEAT	3	35	

38741000

VERTICAL STABILIZER, SPEED BRAKE AND DRAG CHUTE SUBSECTION**TABLE OF CONTENTS**

Fig. No.	Title	Page	Fig. No.	Title	Page
2.7-1	Vertical Stabilizer, Speed Brake and Drag Chute	2.7-2	2.7-7	Spar #3 and #4 Fin Shroud	2.7-22
2.7-2	Drag Chute Installation	2.7-6	2.7-8	Vertical Stabilizer Structure Assembly	2.7-24
2.7-3	Drag Chute Mechanism Installation	2.7-8	2.7-9	Rudder Assembly Spares	2.7-28
2.7-4	Fin Leading Edge Installation	2.7-16	2.7-10	Speed Brake Door Support Installation	2.7-30
2.7-5	Rudder Installation	2.7-18	2.7-11	Speed Brake Door Installation	2.7-32
2.7-6	Vertical Stabilizer Equipment Installation	2.7-20			

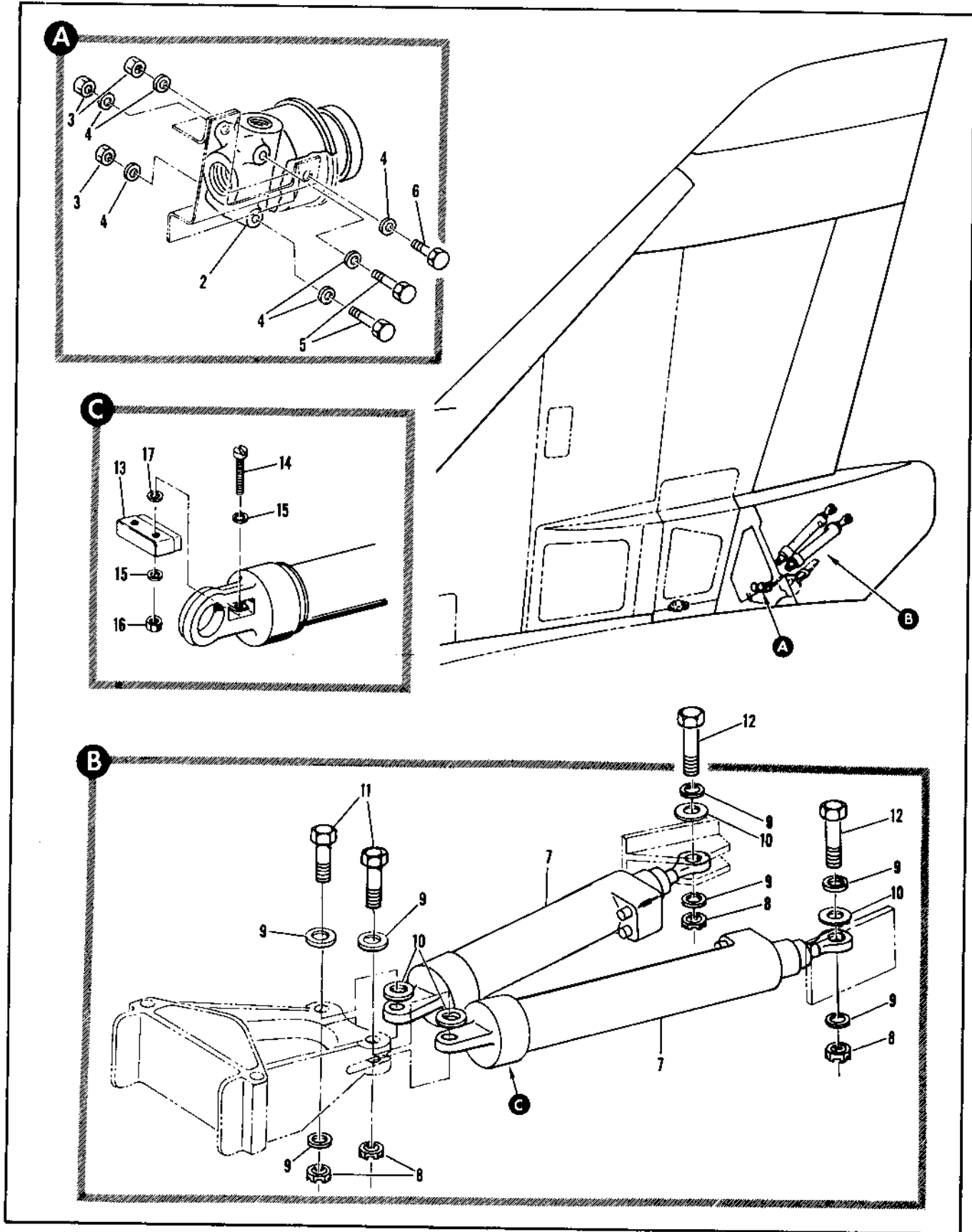

Figure 2.7-1. Vertical Stabilizer, Speed Brake and Drag Chute (Sheet 1 of 2)

FIGURE AND INDEX NUMBER	PART NUMBER	DESCRIPTION 1 2 3 4 5 6	UNITS PER ASSY.	USABLE ON CODE	
				FROM	TO
2.7-1		VERTICAL STABILIZER, SPEED BRAKE AND DRAG CHUTE			
- 1	R-85J32-1	• MECHANISM INSTL, DRAG CHUTE SEE FIG. 2.7-3	RF		
		• VALVE INSTL, DRAG CHUTE ACTUATING MODIFIED BY 8-80503 FOR NHA SEE FIG. 2.3-16		35	
- 2	HP5421G6-1	• VALVE ASSY, SELECTOR (84685) SPEC 8-00403-1, T.O. 9P5-5-21-3 NOT INTERCHANGEABLE WITH 12650-3	1	35	47
	12650-3	• VALVE ASSY, SELECTOR (84685) SPEC 8-06580, T.O. 9P5-9-31-3	1	48	
		ATTACHING PARTS			
- 3	NAS678A3	• NUT (80205)	3	35	
- 4	AN96JD10L	• WASHER (88044)	6	35	
- 5	AN3-13A	• BOLT (88044)	2	35	
- 6	AN3-5A	• BOLT (88044)	1	35	
		-----X-----			
	R-45907	• ACTUATOR INSTL, SPEED BRAKE MODIFIED BY 8-44802 FOR NHA SEE FIG. 2.3-15		35	
- 7	27J800-1	• ACTUATOR ASSY, SPEED BRAKE (89660) SPEC 8-08483, T.O. 9H2-5-115-3 REPLACES K51581-2 AND K51581-3	2	35	
		ATTACHING PARTS			
- 8	AN320-10	• NUT (88044)	4	35	
- 9	AN960D1016	• WASHER (88044)	7	35	
- 10	R-45017-7	• WASHER	4	35	
- 11	NAS454P10-31	• BOLT (80205)	2	35	
- 12	NAS454P10-33	• BOLT (80205)	2	35	
		-----X-----			
- 13	MS20111-1	• SWITCH, MICRO (96906)	2		
		ATTACHING PARTS			
- 14	AN500A6-18	• SCREW (88044)	2		
- 15	AN960-6	• WASHER (88044)	4		
- 16	MS21364D632	• NUT, SELF LOCKING (96906)	2		
- 17	AN93456	• WASHER (88044)	2		
		-----X-----			

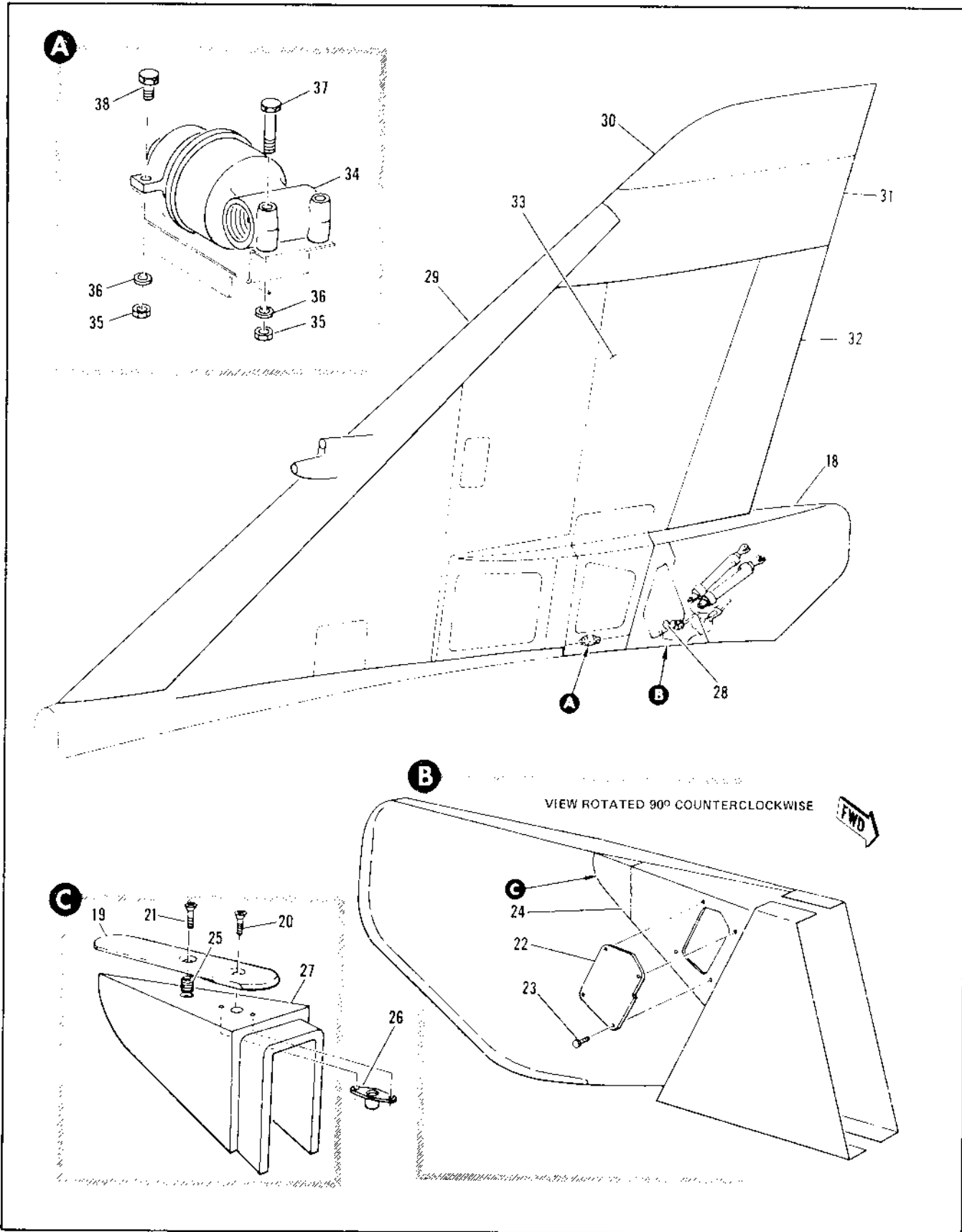

Figure 2.7-1. Vertical Stabilizer, Speed Brake and Drag Chute (Sheet 2 of 2)

FIGURE AND INDEX NUMBER	PART NUMBER	DESCRIPTION	UNITS PER ASSY.	USABLE ON CODE	
				FROM	TO
		1 2 3 4 5 6			
2.7-1	8-RH12H-1	• VALVE INSTL, EMERGENCY SPEED BRAKE FOR NHA SEE FIG. 2.3-15	RF	35	
		• DOOP INSTL, SPEED BRAKE LH SEE FIG. 2.7-11	RF		
- 18	8-74860-1	• SUPPORT INSTL, DRAG CHUTE ENCLOSURE FOR NHA SEE FIG. 2.3-3	RF	35	
- 19	8-42241	• PLATE, RUDDER STREAMLINE POSITION ATTACHING PARTS	1	35	
- 20	AN509-10R11	• SCREW (88044)	1	35	
- 21	AN509-10R10	• SCREW (88044)	1	35	
		-----X-----			
- 22	8-74860-81	• SUPPORT ASSY, DRAG CHUTE ENCLOSURE	1	35	
	8-74860-83	• DOOR ATTACHING PARTS	1	35	
- 23	NAS464P3AF	• BOLT (80205)	17	35	
		-----Y-----			
- 24	8-74863-1	• TIP ASSY, DRAG CHUTE ENCLOSURE SUPPORT	1	35	
- 25	3591-30MY.380	• INSERT, <91767> 95-03003-006	1	35	
- 26	F5000-10-1032	• NUTPLATE, <75237> 96-37502-003	1	35	
- 27	8-74863-9	• TIP	1	35	
- 28		• SUPPORT INSTL, SPEED BRAKE DOOP SEE FIG. 2.7-10	RF		
- 29		• LEADING EDGE INSTL, FIN SEE FIG. 2.7-4	RF		
- 30		• TIP INSTL, FIN UPPER SEE FIG. 2.18-2	RF		
- 31		• TIP INSTL, FIN LOWER SEE FIG. 2.18-3	RF		
- 32		• RUDDER INSTL, SEE FIG. 2.7-5	RF		
- 33		• EQUIPMENT INSTL, VERTICAL STABILIZER SEE FIG. 2.7-6	RF		
- 34	HP542100-3	• VALVE ASSY, EMERGENCY SPEED BRAKE SELECTOR SPEC 8-00400-3 T.O. 9P5-9-21-3 ATTACHING PARTS	1	35	
- 35	NAS679A3	• NUT (85205)	3	35	
- 36	AN960D10L	• WASHER (88044)	3	35	
- 37	AN3-12A	• BOLT (86344)	2	35	
- 38	AN3-4A	• BOLT (88044)	1	35	
		-----X-----			

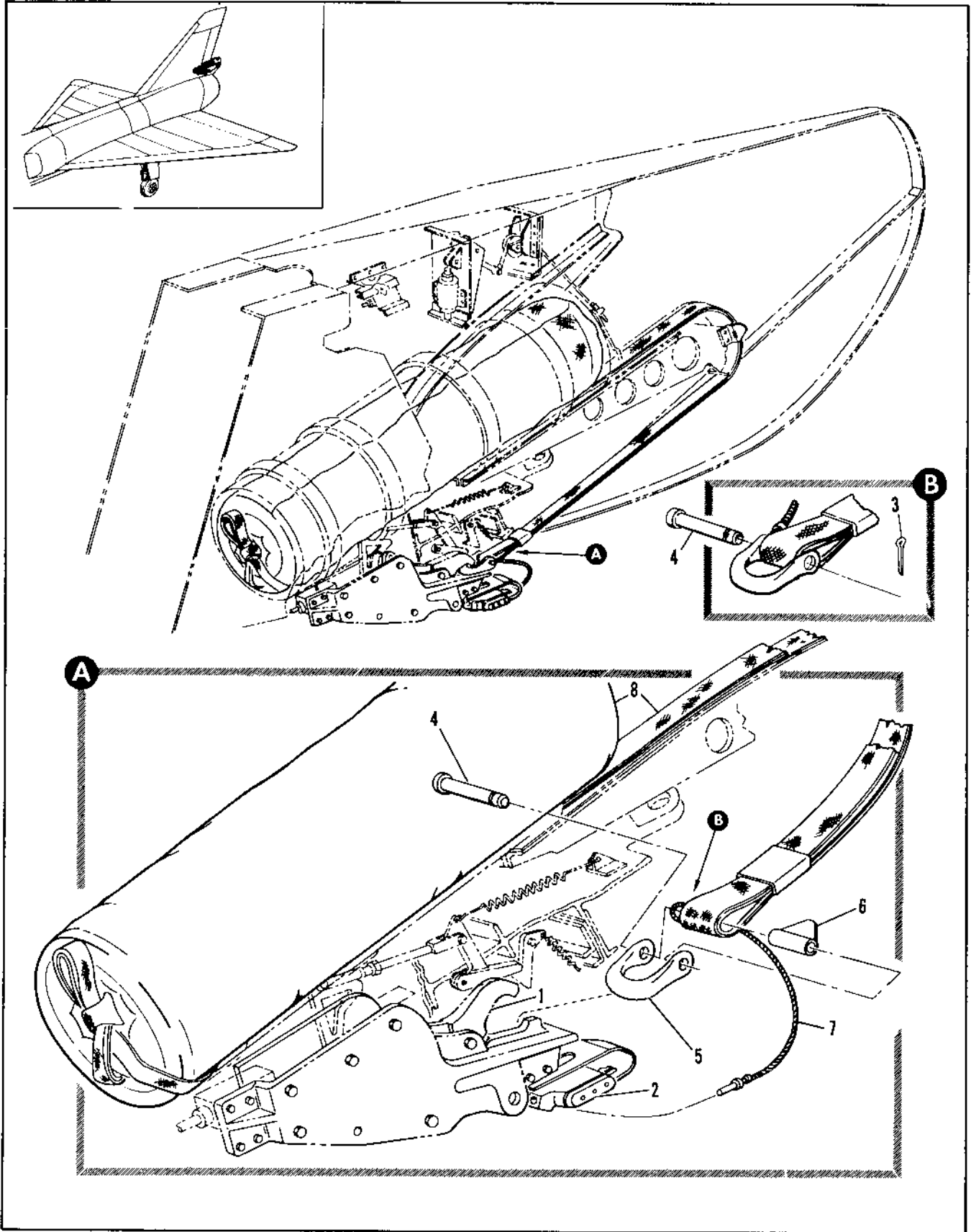

Figure 2.7-2. Drag Chute Installation

FIGURE AND INDEX NUMBER	PART NUMBER	DESCRIPTION	UNITS PER ASSY.	USABLE ON CODE	
				FROM	TO
		1 2 3 4 5 8			
2.7-2	8-45011-11	DRAG CHUTE INSTALLATION. FOR NHA SEE FIG. 2.1-1	RF	35	
	8-45011-19	DRAG CHUTE ASSY, SPARES FOR 8-45011-11	RF	35	
- 1		• HOOK, SEE FIG. 2.7-3 INDEX 46	RF		
- 2		• SWITCH ASSY, DRAG CHUTE JETTISON SEE FIG. 2.7-3	RF		
	8-45011-13	• DRAG CHUTE ASSY, REPLACED BY SUITABLE SUB 8-45011-21	1	35	
	8-45011-21	• DRAG CHUTE ASSY, SPARES REPLACES SUITABLE SUB FOR 8-45011-13	RF	35	
- 3	AN381-2-R	• • PIN, COTTER (88044)	1		
- 4	8-44498	• • PIN, DRAG CHUTE	1	35	
- 5	8-44456-11	• • D RING	1	35	
	8-44457-15	• • D RING, ALT INTCHG WITH 8-44456-11	RF	35	
- 6	8-44454-9	• • SPACER	1	35	
	8-44454-15	• • SPACER, ALT INTCHG WITH 8-44454-9	RF	35	
- 7	8-45343	• • CABLE ASSY, DRAG CHUTE SWAGED	1	35	
- 8	C4108-4	• • DRAG CHUTE, <87567> SPEC 8-04378-7	1	35	

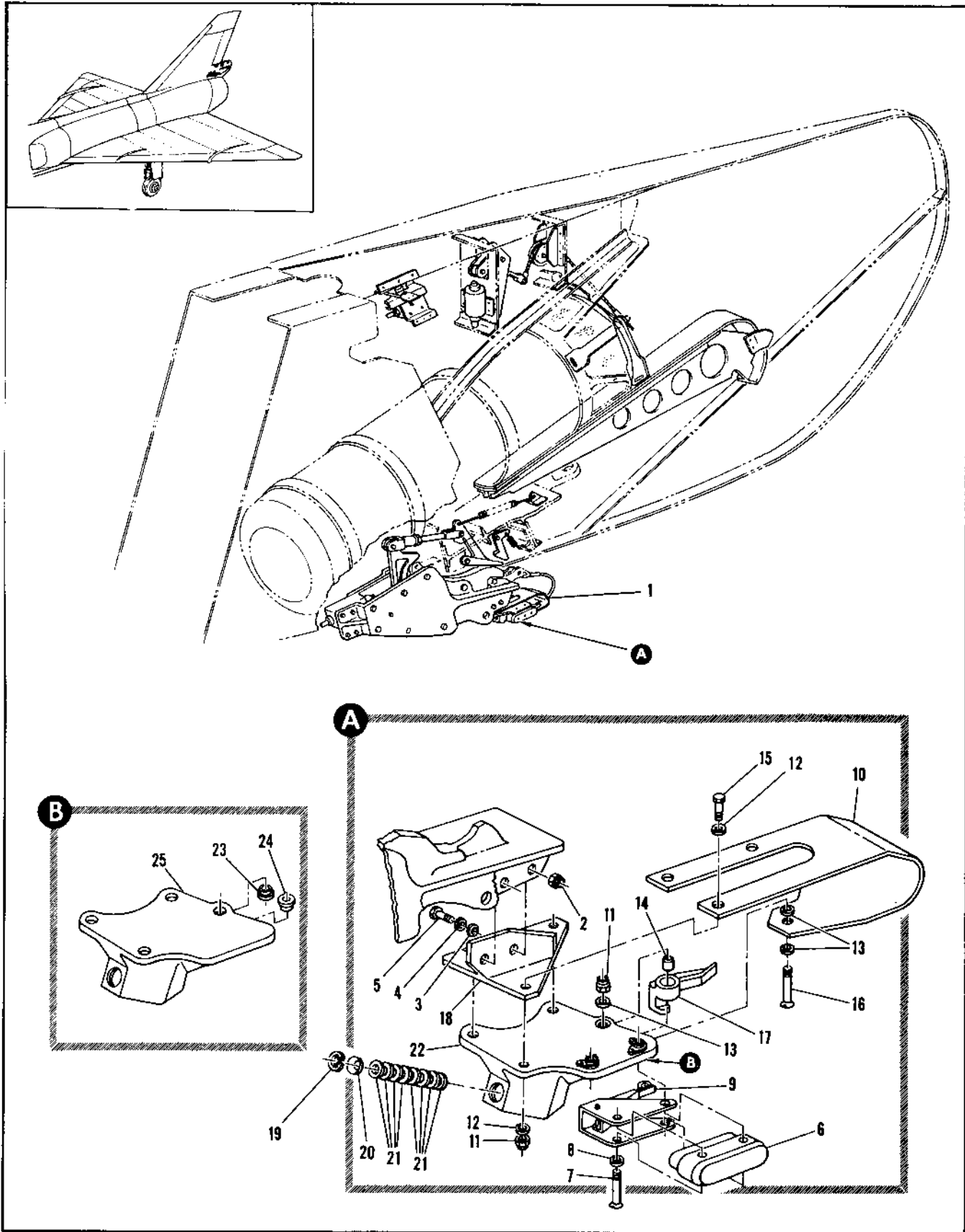

Figure 2.7-3. Drag Chute Mechanism Installation (Sheet 1 of 4)

FIGURE AND INDEX NUMBER	PART NUMBER	DESCRIPTION	UNITS PER ASSY.	USABLE ON CODE	
				FROM	TO
2.7-3	8-45006-1	MECHANISM INSTALLATION, DRAG CHUTE MODIFIED BY FOR NHA SEE FIG. 2.3-15 FOR NHA SEE 030160AS100	RF	A	
	8-45006	MECHANISM INSTALLATION, DRAG CHUTE MODIFIED BY 8-44804 FOR NHA SEE FIG. 2.3-15	RF	278	287
- 1	R-44388-1	• CABLE ASSY, DRAG CHUTE SEE FIG. 2.7-2	RF		
	8-44388	• SWITCH ASSY, DRAG CHUTE JETTISON • SWITCH ASSY, DRAG CHUTE JETTISON ATTACHING PARTS	1	35	277
- 2	NAS679A3	• NUT (80205)	2	35	
- 3	AN960D10	• WASHER (88044)	2	35	
- 4	AN960D10L	• WASHER (88044)	2	35	
- 5	AN3-5A	• BOLT (88044)	2	35	
- 6	101HS1	• SWITCH, <91929> 9-84503-001 ATTACHING PARTS	1	35	
- 7	AN515-6R1A	• SCREW (88044)	2	35	
- 8	AN960-6L	• WASHER (88044)	2	35	
- 9	AN3109-1	• ACTUATOR ASSEMBLY (88044)	1	35	
- 10	8-45389-7	• SHIELD ATTACHING PARTS	1	35	
- 11	NAS679A3	• NUT (80205)	4	35	
- 12	AN960D10	• WASHER (88044)	6	35	
- 13	AN960-10L	• WASHER (88044)	3	35	
- 14	NAS72-3-007	• BUSHING (80205)	1	35	
- 15	AN3-6A	• BOLT (88044)	3	35	
- 16	AN23-21A	• BOLT, CLEVIS (88044)	1	35	
- 17	8-45357	• LEVER	1	35	
- 18	8-45356	• LEVER, ALT INTCHG WITH 8-45357	RF	35	
- 19	8-45395	• SUPPORT	1	35	
- 20	MS16625-1(56)	• RETAINER (96906)	1	35	
- 21	8-45364	• DISC	1	35	
- 21	8-45365-7	• WASHER, REPLACES SUITABLE SUP FOR 8-54365	8	35	277
- 21	8-45365	• WASHER, REPLACED BY SUITABLE SUP	8	278	
- 22	8-45355-1	• FITTING ASSY, DRAG CHUTE	1	35	
- 22	8-45354-1	• FITTING ASSY, DRAG CHUTE ALT INTCHG WITH 8-45355-1	RF	35	
- 23	8-45363-4	• BUSHING	1	35	
- 24	8-45363-7	• BUSHING	1	35	
- 25	8-45355-2	• FITTING	1	35	
- 25	8-45355-7	• FITTING	1	35	
- 25	8-45354-7	• FITTING, ALT INTCHG WITH 8-45355-9	RF	35	
A AIRPLANES WAS THRU 277, 288 AND ON					

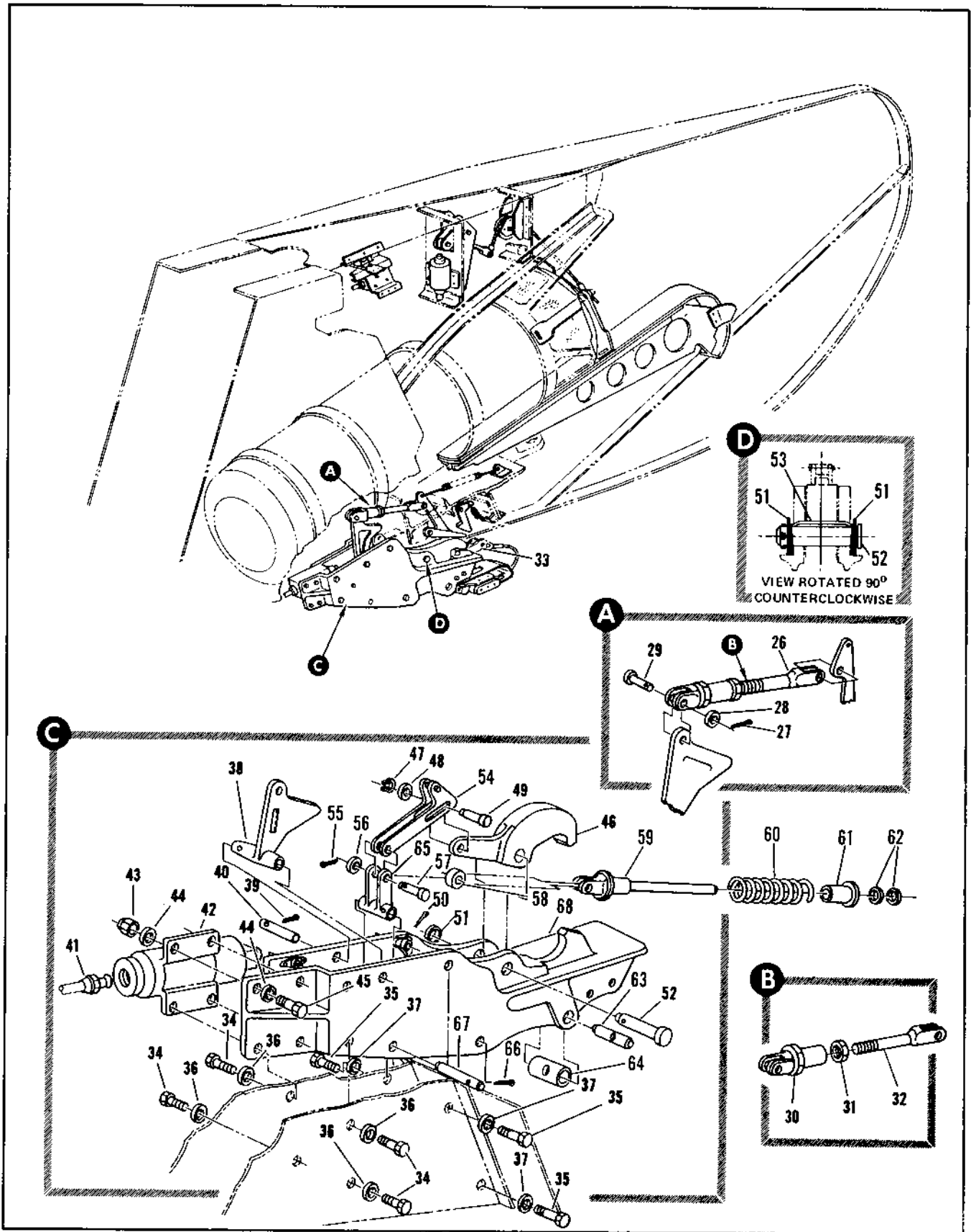

Figure 2.7-3. Drag Chute Mechanism Installation (Sheet 2 of 4)

FIGURE AND INDEX NUMBER	PART NUMBER	DESCRIPTION	UNITS PER ASSY.	USABLE ON CODE	
				FROM	TO
2.7-3- 26	8-45377	• LINK ASSY. DRAG CHUTE REPLACED BY SUITABLE SUB 8-45377-1	1	35	129
	8-45377-1	• LINK ASSY. DRAG CHUTE REPLACES SUITABLE SUB FOR 8-45377 ATTACHING PARTS	1	130	277
- 27	AN380-1-1	• PIN, COTTER (88044)	2	35	
- 28	AN960-8	• WASHER (88044)	2	35	
- 29	8-44377-11	• PIN -----X-----	2	35	
- 30	8-45375	• CLEVIS	1	35	
- 31	AN315-3R	• NUT (88044)	1	35	129
- 32	8-45378	• FORK	1	35	
	8-45378-7	• FORK	1	130	
- 33	8-44378-3	• D RING, DRAG CHUTE SEE FIG. 2.7-2 INDEX 6 • RELEASE ASSY. DRAG CHUTE REPLACES SUITABLE SUB FOR 8-44378-1 ATTACHING PARTS	RF	1	160
- 34	NAS454P4A7	• BOLT (80205)	4	35	
- 35	NAS454P5A7	• BOLT (80205)	4	35	
- 36	AN960D416	• WASHER (88044)	4	35	
- 37	AN960D516	• WASHER (88044) -----X-----	4	35	
- 38	8-45383-507 8-44346	• LINK, SPARES FOR 8-45383-7 • LINK ASSY. REPLACES SUITABLE SUB FOR 8-45383-7 ATTACHING PARTS	RF	35	159
			1	160	
- 39	AN381-1-12	• PIN, COTTER (88044)	1	35	
- 40	8-44374-11	• SHAFT -----X-----	1	35	
- 41		• TUBE ASSY. DRAG CHUTE SEE FIG. 2.9-25 INDEX 69	RF	35	
- 42	501700	• ACTUATOR ASSY. DRAG CHUTE RELEASE <96124> SPEC 8-00309 T.O. 9P2-3-27-3	1	35	
- 43	NAS578A3	• NUT (90295)	4	35	
- 44	AN960-10L	• WASHER (88044)	8	35	
- 45	AN3-5A	• BOLT (88044)	4	35	
- 46	8-44379	• HOOK	1	35	
- 47	NAS51-31	• RETAINER (80205)	1	35	
- 48	AN960-516L	• WASHER (88044)	1	35	
- 49	8-45386	• PIN	1	35	
- 50	AN381-3-12	• PIN, COTTER	1	35	
- 51	AN960C816L	• WASHER (88044)	2	35	
- 52	MS20392-7C55	• PIN 1 (96906)			
- 53	62034801	• SPRING 1			
- 54	8-45376	• GUIDE ASSY. RIVETED	1	35	
- 55	AN381-2-P	• PIN, COTTER (88044)	1	35	
- 56	AN960-516L	• WASHER (88044)	1	35	
- 57	8-44377-9	• PIN	1	35	
- 58	8-44375	• ROLLER	1	35	
- 59	8-45341	• GUIDE	1	35	
- 60	8-45372	• SPRING	1	35	
- 61	8-45342	• RETAINER	1	35	
- 62	AN960-416L	• WASHER (88044)	AR	35	
- 63	8-44374-13	• SHAFT	1	35	
- 64	8-44374-7	• COLLAR	1	35	
- 65	8-45384-7 8-44349	• ARM • ARM, ALT INTCHG WITH 8-4534-7	RF	35	
- 66	AN381-2-16	• PIN, COTTER	1	35	
- 67	8-44374-9	• SHAFT	1	35	
- 68	8-45382 8-44390	• HOUSING ASSEMBLY • HOUSING ASSY. ALT INTCHG WITH 8-45382	RF	35	

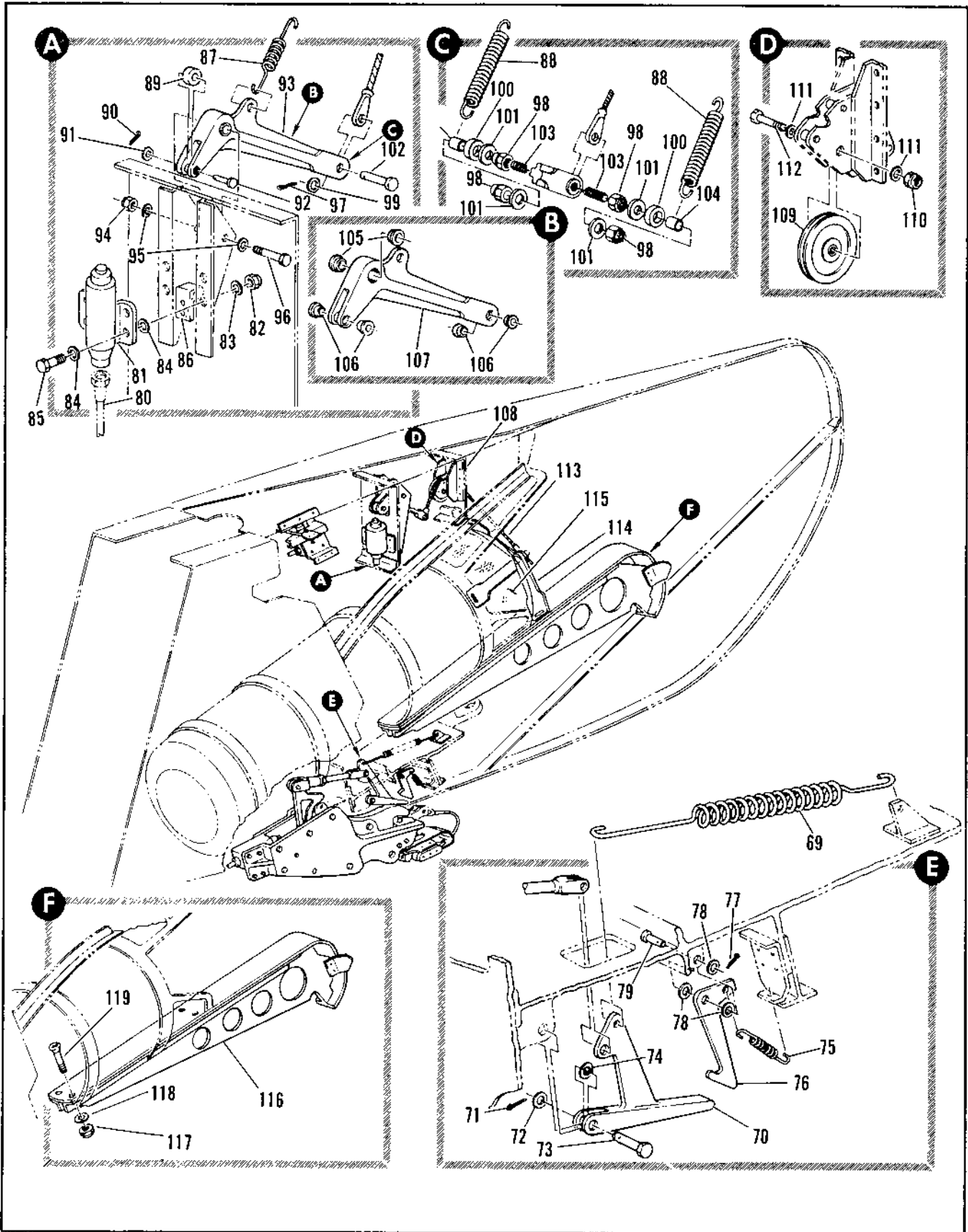

Figure 2.7-3. Drag Chute Mechanism Installation (Sheet 3 of 4)

FIGURE AND INDEX NUMBER	PART NUMBER	DESCRIPTION	UNITS PER ASSY.	USABLE ON CODE	
				FROM	TO
2.7-3- 69	8-44369	• SPRING	1	35	
- 70	8-45370-7	• ARM	1	35	
- 71	AN380-1-2	• PIN, COTTER	1	35	
- 72	AN960D10L	• WASHER	1	35	
- 73	8-44377-13	• PIN	1	35	
- 74	AN960D10L	• WASHER (88044)	AR		
- 75	8-45120	• SPRING	1	35	
- 76	8-45371	• PAWL	1	35	
- 77	AN380-1-1	• PIN, COTTER (88044)	1	35	
- 78	AN960D8	• WASHER (88044)	AR	35	
- 79	8-44377-15	• PIN	1	35	
- 80		• TUBE ASSY, DRAG CHUTE SEE FIG. 2.9-25 INDEX 70	RF		
- 81	501700	• CYLINDER ASSY, DRAG CHUTE RELEASE <96124> SPEC 8-00312	1	35	
- 82	NAS679A3	• NUT (80205)	4	35	
- 83	AN960D10L	• WASHER (88044)	4	35	
- 84	AN960D10	• WASHER (88044)	8	35	
- 85	AN3-5A	• BOLT (88044)	4	35	
- 86	8-44391	• BUMPER	1	35	
- 87	8-44448-7	• SPRING, REPLACED BY NOT INTCHG WITH 93	1	R	
- 88	93	• SPRING, <71447> 98-36503-058 REPLACES NOT INTCHG WITH 8-44448-7	2	160	277
- 89	8-44398	• ROLLER	1	35	
- 90	AN380-2-2	• PIN, COTTER (88044)	1	35	
- 91	AN960D10L	• WASHER (88044)	1	35	
- 92	MS20392-2C23	• PIN (96906)	1	35	
- 93	8-44382-3	• ARM ASSY, REPLACES SUITABLE SUB FOR 8-44382-1 ATTACHING PARTS	1	C	
- 94	AN320-4	• NUT (88044)	1	35	
- 95	AN960D416L	• WASHER (88044)	2	35	
- 96	AN24-22	• BOLT (88044)	1	35	
- 97	AN380-2-2	• PIN, COTTER (88044)	1	R	
- 98	NAS679A3	• NUT (80205)	4	160	277
- 99	AN960D10L	• WASHER (88044)	1	R	
-100	99-51505-030	• WASHER	2	160	277
-101	99-51505-026	• WASHER	4	160	277
-102	MS20392-2C19	• PIN (96906)	1	R	
-103	8-44344	• PIN	1	160	277
-104	NAS43-3-15	• SPACER (80205) -----X-----	2	160	277
-105	NAS77A4-15	• BUSHING (80205)	2	35	
-106	NAS77A3-14	• BUSHING (80205)	4	35	
-107	8-44382-9	• ARM	1	C	
	8-44382-7	• ARM	1	278	303
-108	8-44383	• PULLEY ASSY, DRAG CHUTE	1	35	47
	8-44348	• PULLEY ASSY, DRAG CHUTE	1	48	
-109	AN219-2	• PULLEY (88044)	1	35	47
	MS20219A2	• PULLEY (96906)	1	48	
-110	NAS679A4	• NUT (80205)	1	35	
-111	AN960D41F	• WASHER (88044)	2	35	
-112	AN4-11A	• BOLT (88044)	1	35	
-113	8-45393	• CABLE ASSY	1	35	47
	8-44347	• CABLE ASSY	1	48	
-114	8-45373	• STRAP ASSY, RIVETED	3	35	
-115		• DRAG CHUTE, SEE FIG. 2.7-2 INDEX 8	RF		
-116	8-44387-1	• GUIDE ASSY, RIVETED	1	35	
-117	AN365-428	• NUT (88044)	4	35	
-118	AN960D416	• WASHER (88044)	4	35	
-119	AN509-416R12	• SCREW (88044)	4	35	

B AIRPLANES #35 THRU 150, 278 AND ON
C AIRPLANES #35 THRU 277, 304, AND 305

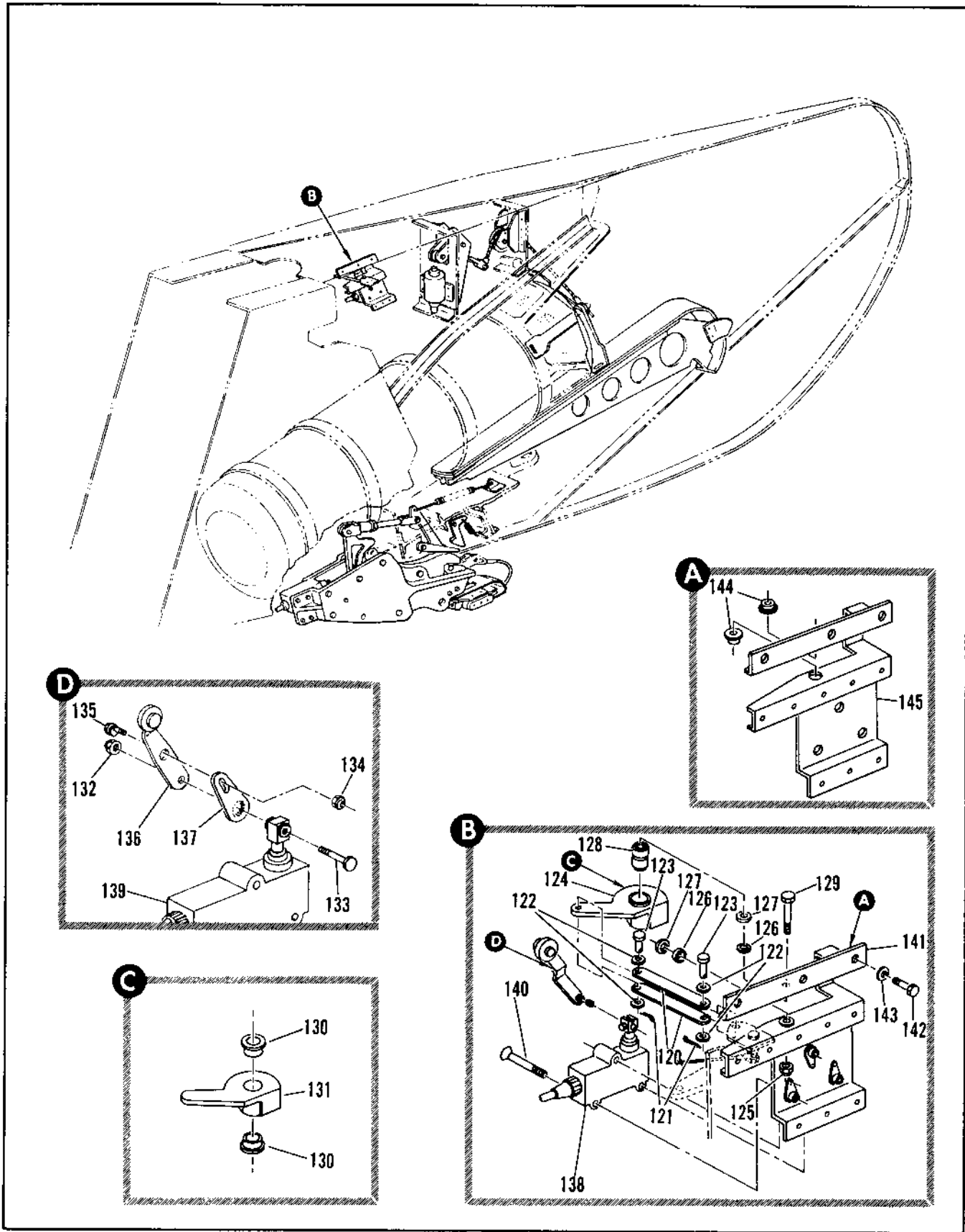

Figure 2.7-3. Drag Chute Mechanism Installation (Sheet 4 of 4)

FIGURE AND INDEX NUMBER	PART NUMBER	DESCRIPTION	UNITS PER ASSY.	USABLE ON CODE	
				FROM	TO
2,7-3-120	8-44385	• LINK ATTACHING PARTS	2	35	
-121	AN387-2-2	• PIN, COTTER (88044)	2	35	
-122	AN967-10L	• WASHER (88044)	4	35	
-123	MS20392-207	• PIN (96906) -----X-----	2	35	
-124	8-44386	• CAM ASSEMBLY ATTACHING PARTS	1	35	
-125	NAS679A3	• NUT (80205)	1	35	
-126	AN967010L	• WASHER (88044)	2	35	
-127	AN9670616	• WASHER (88044)	2	35	
-128	NAS73-3-009	• BUSHING (80205)	1	35	
-129	AN3-12A	• BOLT (88044) -----X-----	1	35	
-130	NAS77A6-12	• BUSHING (80205)	2	35	
-131	8-44386-7	• CAM ATTACHING PARTS	1	35	
-132	NAS679C3	• NUT (80205)	1	35	
-133	AN307A	• BOLT (88044)	1	35	
-134	NAS679AC8	• NUT (80205)	1	35	
-135	8-68138-7	• BOLT -----X-----	1	35	
-136	8-68843-1	• ARM ASSY, SPEED BRAKE POSITION SWITCH REPLACES 1107SA9-7	1	35	
-137	G12742	• PLATE (86149)	1	35	
-138	H12-1000	• SWITCH, SPEED BRAKE POSITION	1	35	
-139	H12-1001	• SWITCH, SPEED BRAKE POSITION SUITABLE SUB FOR H12-1000 ATTACHING PARTS	RF		
-140	AN520-10R26	• SCREW (49044) -----X-----	3	35	
-141	8-44384	• BRACKET ASSEMBLY ATTACHING PARTS	1	35	
-142	AN3-4A	• BOLT (88044)	3	35	
-143	AN967010L	• WASHER (88044) -----X-----	3	35	
-144	NAS77A3-09	• BUSHING (80205)	2	35	
-145	8-44384-7	• BRACKET	1	35	

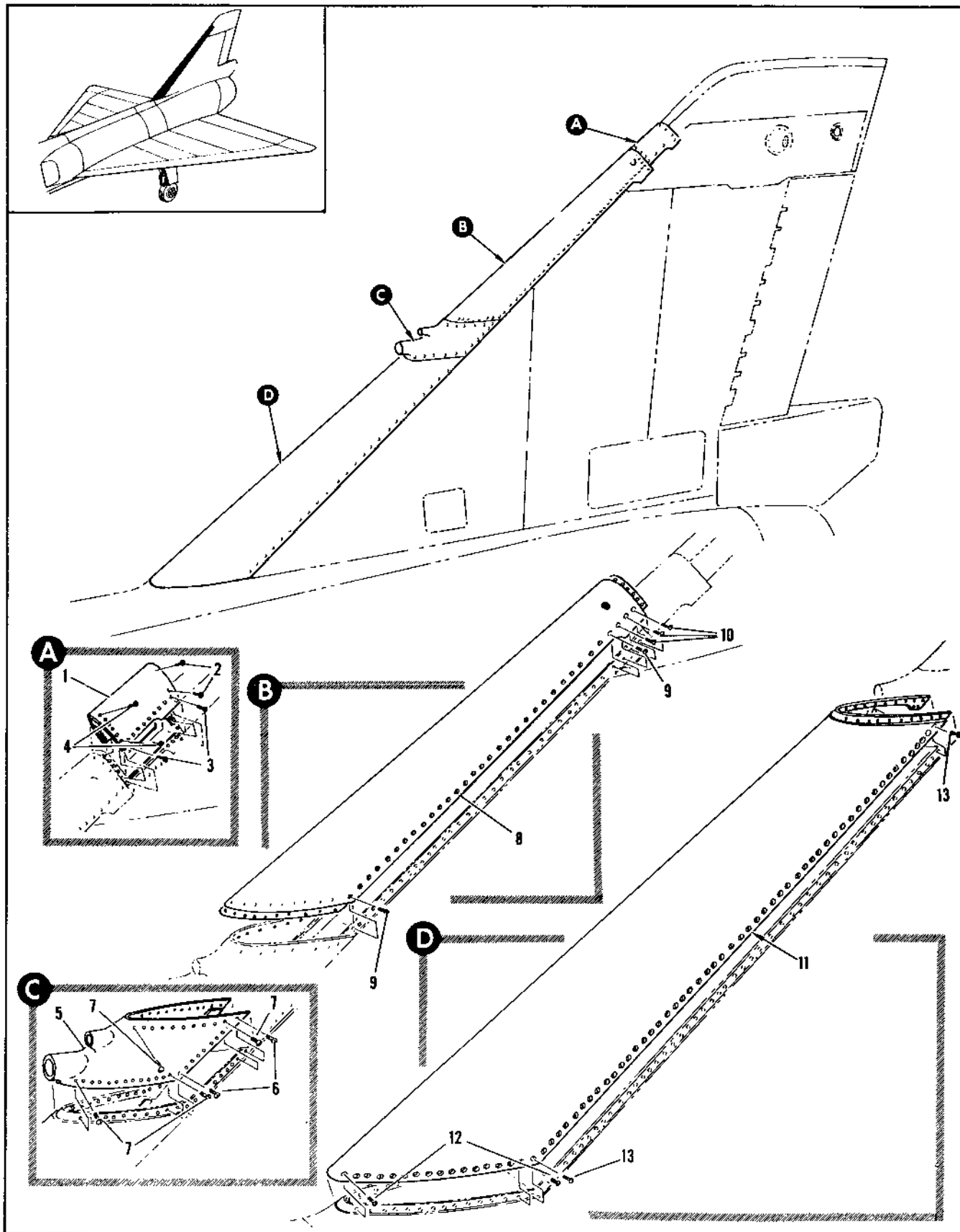

Figure 2.7-4. Fin Leading Edge Installations

FIGURE AND INDEX NUMBER	PART NUMBER	DESCRIPTION	UNITS PER ASSY.	USABLE ON CODE	
				FROM	TO
		1 2 3 4 5 6			
2.7-4	8-14230-5	LEADING EDGE INSTALLATION, FIN FOR NHA SEE FIG. 2.3-14	RF	35	
- 1	8-14228	• LEADING EDGE ASSY, FIN UPPER RIVETED ATTACHING PARTS	1	35	
- 2	NAS333CPA4-5	• SCREW	8	35	
- 3	NAS333CPA5-5	• SCREW	22	35	
- 4	NAS333CPA4	• SCREW	10	35	
		-----X-----			
- 5	8-14233-P31	• LEADING EDGE ASSY, FIN LOWER CENTER RIVETED ATTACHING PARTS	1	35	
- 6	NAS333CPA6-5	• SCREW	18	35	
- 7	NAS333CPA4-5	• SCREW	46	35	
		-----X-----			
- 8	8-14234-1	• LEADING EDGE ASSY, FIN CENTER RIVETED ATTACHING PARTS	1	35	
- 9	NAS333CPA6-5	• SCREW	72	35	
- 10	NAS333CPA5-5	• SCREW	6	35	
		-----X-----			
- 11	6-14232	• LEADING EDGE ASSY, FIN LOWER RIVETED ATTACHING PARTS	1	35	
- 12	NAS333CPA4-5	• SCREW	34	35	
- 13	NAS333CPA6-5	• SCREW	98	35	
		-----X-----			

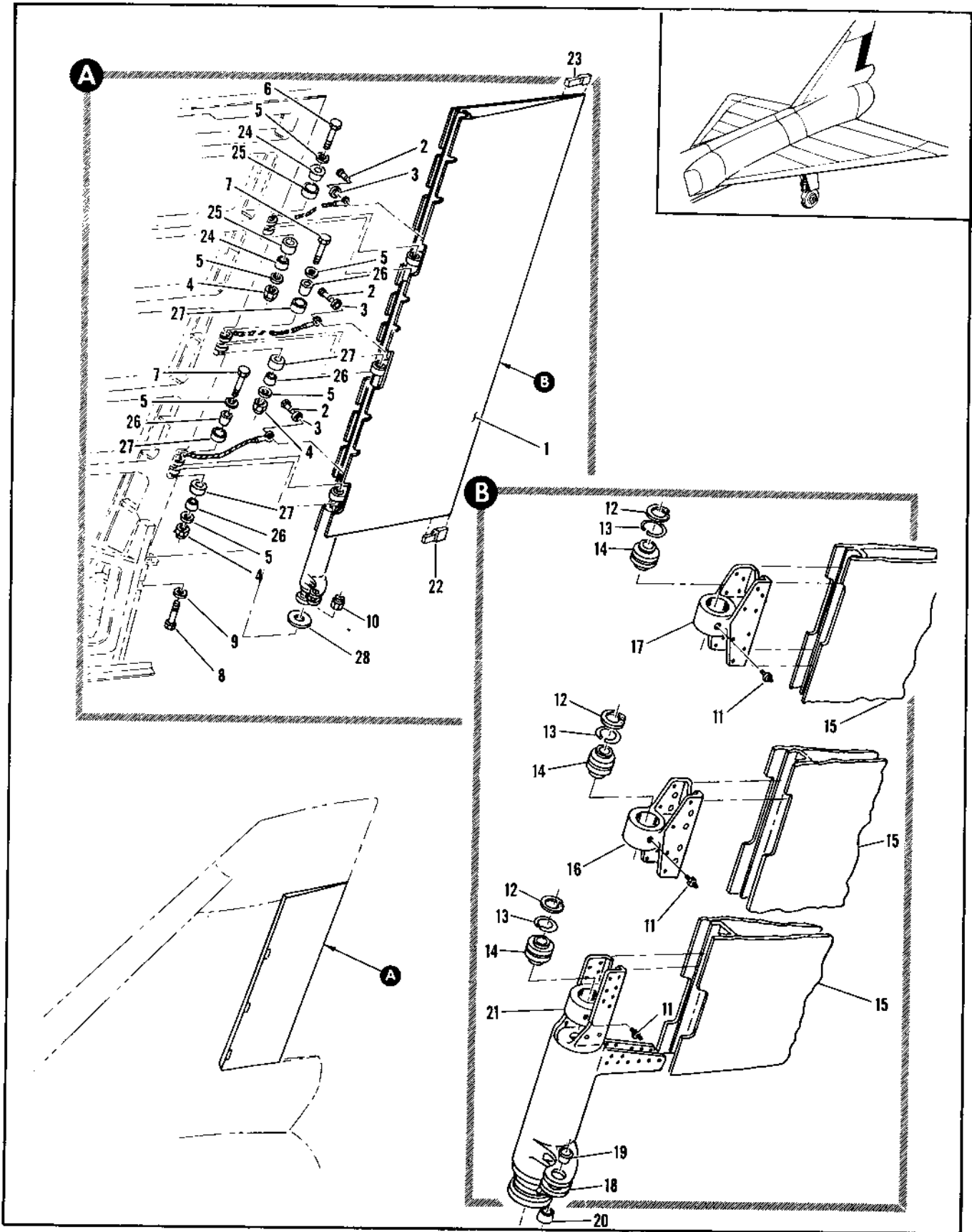

Figure 2.7-5. Rudder Installation

FIGURE AND INDEX NUMBER	PART NUMBER	DESCRIPTION	UNITS PER ASSY.	USABLE ON CODE	
				FROM	TO
2.7-5	4-15141	RUDDER INSTALLATION, FOR NHA SEE FIG. 2.3-3	RF	35	
- 1	8-15140-1 8-15143-527	• RUDDER ASSEMBLY • RUDDER ASSEMBLY, SPARES FOR 8-15140-1 FOR BREAKDOWN SEE FIG. 2.7-9 ATTACHING PARTS	1 RF	35 35	
- 2	AN3-4A	• BOLT	3	35	
- 3	AN960-10L	• WASHER	4	35	
- 4	NAS77947	• NUT	3	35	
- 5	AN961-71LL	• WASHER	6	35	
- 6	NAS4-4-7A44	• BOLT	1	35	
- 7	NAS4-4-7A50	• BOLT	2	35	
- 8	MS20012H14	• BOLT	1	35	
- 9	MS20022C17	• WASHER	1	35	
- 10	2452-126	• NUT, BARREL <72962> 36-37509-108 -----Y-----	1	35	
- 11	NAS516-1 *1	• LUBRICATOR	3	35	
- 12	MS16025-1200 *1	• KING, RETAINING	3	35	
- 13	8-15140-13	• SPACER	1	35	
- 14	8-15142-15 *1	• PLATE ASSEMBLY	1	35	
- 15	A7H *1	• BEARING, <77896> 90-60000-007	3	35	
- 16	8-15140 *1	• RUDDER ASSY, RIVETED	1	35	
- 17	8-15142-13 *1	• SPAR ASSEMBLY	1	35	
- 18	8-15731-13 *1	• SUPPORT, RUDDER HINGE	1	35	
- 19	8-15730-11 *1	• SUPPORT, RUDDER HINGE ALT INTCHG WITH 8-15731-13	RF	35	
- 20	8-15745-9 *1	• SUPPORT, RUDDER HINGE	1	35	
- 21	8-15730-13 *1	• SUPPORT, RUDDER HINGE ALT INTCHG WITH 8-15745-9	RF	35	
- 22	8-15737-9 *1	• ACTUATOR, RUDDER SEE FIG. 2.14-4.7	1	35	
- 23	8-15702-9 *1	• HORN ASSY, RUDDER ACTUATOR	1	35	
- 24	8-15703 *1	• BUSHING, UPPER	1	35	
- 25	8-15737-13 *1	• BUSHING, LOWER	1	35	
- 26	8-15750 *1	• HORN	1	35	
- 27	8-15703 *1	• HORN ASSY, RUDDER ACTUATOR ALT INTCHG WITH 8-15737-9	RF	35	
- 28	8-15702-9 *1	• BUSHING, LOWER	1	35	
- 29	8-15702-9 *1	• BUSHING, UPPER	1	35	
- 30	8-15760 *1	• PLUS	1	35	
- 31	8-15761 *1	• HORN	1	35	
- 32	8-15738 *1	• FITTING	1	35	
- 33	8-15739 *1	• FITTING	1	35	
- 34	8-15806 *1	• BUSHING	2	35	
- 35	8-15805 *1	• BUSHING	2	35	
- 36	8-15809 *1	• BUSHING	4	35	
- 37	8-15810 *1	• BUSHING	4	35	
- 38	8-14823-C *1	• SHIM	1	35	

*1 USED ON SPARES ASSEMBLY 8-15040-527 FOR AIRPLANES #35 AND ON

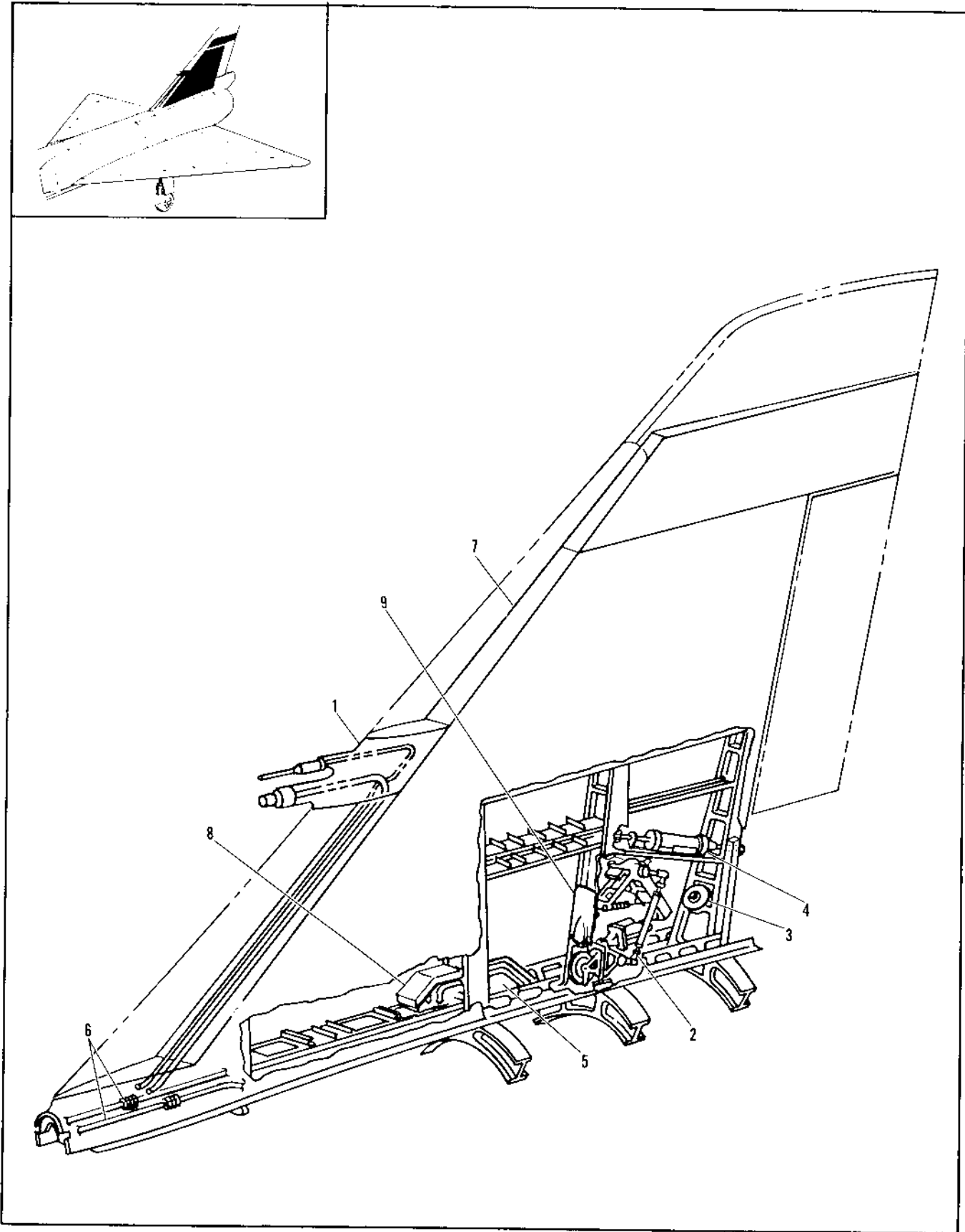

Figure 2.7-6. Vertical Stabilizer Equipment Installation

FIGURE AND INDEX NUMBER	PART NUMBER	DESCRIPTION	UNITS PER ASSY.	USABLE ON CODE	
				FROM	TO
		1 2 3 4 5 6			
2.7-6	8-14025-3	EQUIPMENT INSTALLATION, VERTICAL STABILIZER MODIFIED BY 8-41111, 8-41113 AND 8-41109 FOR NHA SEE FIG. 2.3-14	RF	35	
- 1	8-42332-1	• INTAKE INSTL, ELEVATOR AND RUDDER AIRFEEL FOR BREAKDOWN SEE FIG. 2.14-38	1	35	
- 2	8-42209-3	• CONTROL INSTL, RUDDER TRIM AND FEEL FOR BREAKDOWN SEE FIG. 2.14-41	1	35	
- 3	8-85010-3	• REGULATOR INSTL, VARIABLE AIR PRESSURE FOR BREAKDOWN SEE FIG. 2.14-1	1	35	
- 4	8-82067	• ACTUATOR INSTL, SERVO VALVE RUDDER FOR BREAKDOWN SEE FIG. 2.14-43	1	35	
- 5	8-80024	• TUBING INSTL, HYDRAULIC VERTICAL STABILIZER FOR BREAKDOWN SEE FIG. 2.8-12	1	35	
- 6	8-80421	• TUBING INSTL, SPEED BRAKE AND DRAG CHUTE PNEUMATIC FOR BREAKDOWN SEE FIG. 2.9-25	1	35	
- 7	8-14035-1	• STRUCTURE ASSY, VERTICAL STABILIZER FOR BREAKDOWN SEE FIG. 2.7-8	1	C	
	8-14035-801	• STRUCTURE ASSY, VERTICAL STABILIZER FOR BREAKDOWN SEE FIG. 2.7-8	1	90	277
	8-14035	• STRUCTURE ASSY, VERTICAL STABILIZER FOR BREAKDOWN SEE FIG. 2.7-8	1	278	304
- 8	8-81319-1	• SHROUD INSTL, SPAR #3 FIN FOR BREAKDOWN SEE FIG. 2.7-7	1	D	
	8-81319	• SHROUD INSTL, SPAR #3 FIN FOR BREAKDOWN SEE FIG. 2.7-7	1	278	304
- 9	8-81318-1	• SHROUD INSTL, SPAR #4 FIN FOR BREAKDOWN SEE FIG. 2.7-7	1	B	
	8-81318-3	• SHROUD INSTL, SPAR #4 FIN FOR BREAKDOWN SEE FIG. 2.7-7	1	130	277
	8-81318	• SHROUD INSTL, SPAR #4 FIN FOR BREAKDOWN SEE FIG. 2.7-7	1	A	
		A AIRPLANES #278, 280, AND 282 THRU 285			
		R AIRPLANES #35 THRU 120, 279, 281, 286 AND ON			
		C AIRPLANES #35 THRU 89 AND 305			
		D AIRPLANES #35 THRU 277 AND 305			

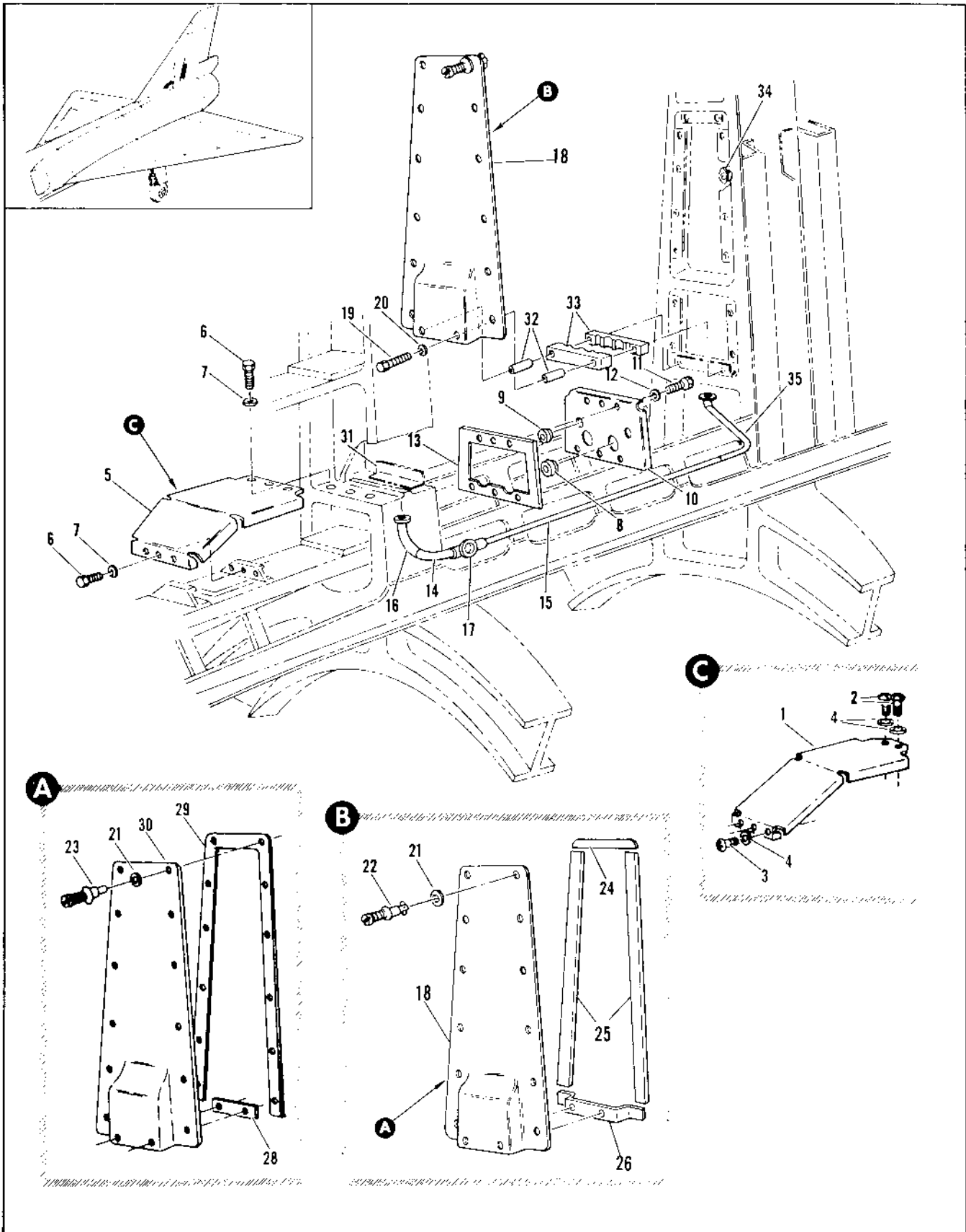

Figure 2.7-7. Spar #3 and #4 Fin Shroud

FIGURE AND INDEX NUMBER	PART NUMBER	DESCRIPTION	UNITS PER ASSY.	USABLE ON CODE	
				FROM	TO
2.7-7		SPAR #3 AND #4 FIN SPROUD			
	8-81319-1	• SHROUD INSTL, SPAR #3 FIN FOR NHA SEE FIG. 2.7-6	RF	D	
	8-81319	• SHROUD INSTL, SPAR #3 FIN MODIFIED BY 8-80131-801 AND 8-80131-5 FOR NHA SEE FIG. 2.7-6	RF	278	304
- 1	8-81319-13	• SHROUD ATTACHING PARTS	1	D	
- 2	AN520-10R7	• SCREW	2	D	
- 3	AN520-10R6	• SCREW	2	D	
- 4	AN960D10L	• WASHER	5	D	
		-----X-----			
- 5	8-81319-11	• SHROUD ATTACHING PARTS	1	278	304
- 6	AN3-3A	• BOLT	6	278	304
- 7	AN960PD10	• WASHER	6	278	304
		-----X-----			
- 8	AN931-6S16	• GROMMET	2	35	
- 9	AN931-4S12	• GROMMET	2	35	
- 10	8-81319-15	• PLATE	1	D	
	8-81319-7	• PLATE ATTACHING PARTS	1	278	304
- 11	AN520-10R6	• SCREW	6	D	
	AN3-3A	• BOLT	6	278	304
- 12	AN960D10L	• WASHER	6	D	
	AN960PD10	• WASHER	6	278	304
		-----X-----			
- 13	8-81319-9	• GASKET	1	35	
- 14	8-80024-131	• TUBE ASSY, SHROUD DRAIN TRANSPARENT	1	35	
- 15	8-80024-133	• TUBE ASSY, SHROUD DRAIN TRANSPARENT	1	35	
- 16	8-81253	• ADAPTER ASSY, SHROUD DRAIN WELDED	1	35	
- 17	8-81253-1	• ADAPTER ASSY, SHROUD DRAIN WELDED	1	35	
	8-81318-1	• SHROUD INSTL, SPAR #4 FIN FOR NHA SEE FIG. 2.7-6	RF	B	
	8-81318-3	• SHROUD INSTL, SPAR #4 FIN FOR NHA SEE FIG. 2.7-6	RF	130	277
	8-81318	• SHROUD INSTL, SPAR #4 FIN MODIFIED BY 8-80131-803 FOR NHA SEE FIG. 2.7-6	RF	A	
- 18	8-81318-21	• SHROUD ASSY, SPAR #4 FIN ATTACHING PARTS	1	35	
- 19	AN3-15A	• BOLT	2	35	
- 20	AN960D10L	• WASHER	2	35	
		-----X-----			
- 21	2600SW2	• WASHER, <71286> 99-53600-004	12	A	
- 22	2600-3	• STUD ASSY, <71286> 98-58001-002	12	E	
- 23	2600-1	• STUD ASSY, <71286> 98-58001-004	12	140	277
- 24	8-81318-19	• GASKET	1	F	
- 25	8-81318-17	• GASKET	2	F	
- 26	8-81318-15	• GASKET	1	F	
- 27	8-81248	• SHROUD ASSY, HYDRAULIC TUBING	1	F	
	8-81248-1	• SHROUD ASSY, HYDRAULIC TUBING	1	160	277
- 28	8-81248-11	• GASKET	1	160	277
- 29	8-81248-9	• GASKET	1	160	277
- 30	8-81248-7	• SHROUD	1	160	277
- 31	8-81318-13	• ANGLE	1	35	
- 32	NAS43003-80	• SPACER	2	35	
- 33	8-81249	• BLOCK ASSY, HYDRAULIC TUBING MOUNTING MOLDED	1	35	
		-----X-----			
- 34	212-12A	• RECEPTACLE, <71284> 97-31007-001	12	C	
	212-12AD	• RECEPTACLE, <71284> 97-31007-002	12	A	
- 35	8-81502	• ADAPTER ASSY, SHROUD DRAIN WELDED	1	35	
		A AIRPLANES #278, 280, AND 282 THRU 285			
		R AIRPLANES #35 THRU 129, 275, 281, 286 AND ON			
		C AIRPLANES #35 THRU 277, 279, 281, 286 AND ON			
		D AIRPLANES #35 THRU 277 AND 305			
		E AIRPLANES #35 THRU 139, 278 AND ON			
		F AIRPLANES #35 THRU 159, 278 AND ON			

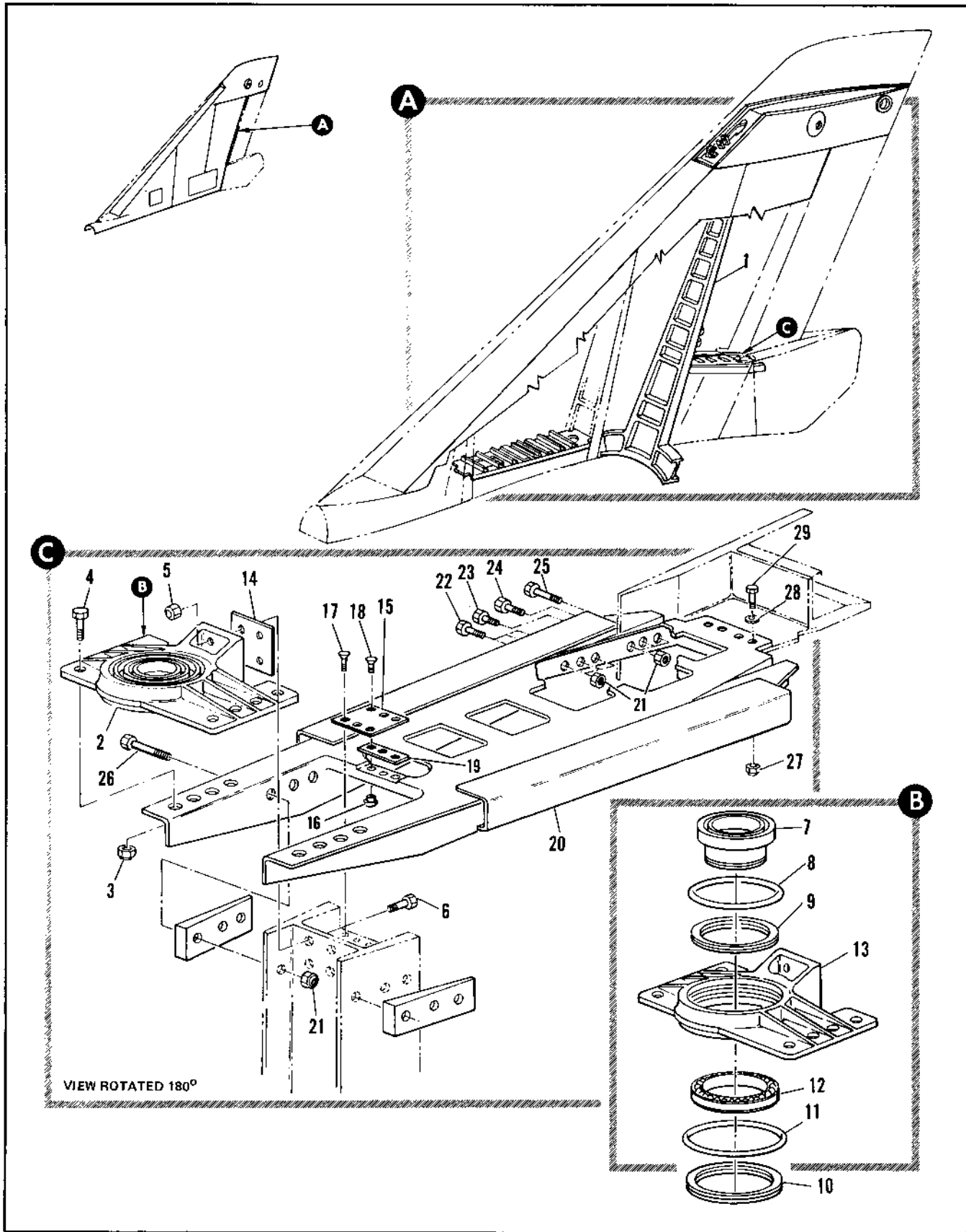

Figure 2.7-8. Vertical Stabilizer Structure Assembly (Sheet 1 of 2)

FIGURE AND INDEX NUMBER	PART NUMBER	DESCRIPTION	UNITS PER ASSY.	USABLE ON CODE	
				FROM	TO
		1 2 3 4 5 6			
2.7-8	8-14035-1	STRUCTURE ASSEMBLY, VERTICAL STABILIZER FOR NHA SEE FIG. 2.7-6	RF	C	
	8-14035-801	STRUCTURE ASSEMBLY, VERTICAL STABILIZER FOR NHA SEE FIG. 2.7-6	RF	90	277
	8-14035	STRUCTURE ASSEMBLY, VERTICAL STABILIZER FOR NHA SEE FIG. 2.7-6	RF	278	334
- 1	8-14035-29	• SPAR ASSY, #4 VERTICAL STABILIZER FOR BREAKDOWN SEE FIG. 2.14-1	1	D	
	8-14035-7	• SPAR ASSY, #4 VERTICAL STABILIZER FOR BREAKDOWN SEE FIG. 2.14-1	1	278	304
	8-14318	• RIB INSTL, FIN BAY #3 CANTED WL 49	1	35	
- 2	8-14318-15	• FITTING ASSY, RUDDER SUPPORT ATTACHING PARTS	1	35	
- 3	NAS679A4	• NUT	8	35	
- 4	NAS464P4A7	• BOLT	8	35	
- 5	NAS679A3	• NUT	4	35	
- 6	AN173-7A	• BOLT	4	35	
		-----X-----			
- 7	8-15741-1	• INSERT ASSY, RUDDER SUPPORT BEARING RIVETED REPLACES SUITABLE SUB FOR 8-15741	1	B	
- 8	8-15941-9	• SPACER, HINGE BEARING RETAINER RING	1	35	
- 9	RR433	• RING, RETAINING <80756> 97-61505-002	1	35	
- 10	RST306	• RING, RETAINING <86849> 97-61508-001	1	35	
- 11	8-15841-7	• SPACER, HINGE BEARING RETAINER RING	1	35	
- 12	KP49BS	• BEARING, <21335> 90-58006-001	1	35	
- 13	8-15750-7	• FITTING, RUDDER SUPPORT	1	35	
	8-15740	• FITTING, RUDDER SUPPORT ALT INTCHG WITH 8-15750-7	RF	35	
- 14	8-14823-7	• SHIM, RUDDER ACTUATOR FITTING	1	35	
- 15	8-14318-11	• PLATE ATTACHING PARTS	1	35	
- 16	LC-C6	• COLLAR, <29666> 92-17000-001	6	35	
- 17	ALSF-T6-3	• BOLT, <29666> 96-79002-003	3	35	
- 18	ACT509H-T8-4	• BOLT, <29666> 96-79002-452	3	35	
		-----X-----			
- 19	8-14823-715	• SHIM	AR	35	
- 20	8-14318-17	• RIB ASSY, RUDDER SUPPORT RIVETED ATTACHING PARTS	1	35	
- 21	NAS679A4	• NUT	18	35	
- 22	AN174-6A	• BOLT	6	35	
- 23	AN174-7A	• BOLT	2	35	
- 24	AN174-10A	• BOLT	2	35	
- 25	AN174-11A	• BOLT	2	35	
- 26	AN174-15A	• BOLT	6	35	
- 27	NAS679A3	• NUT	4	35	
- 28	AN960-1CL	• WASHER	4	35	
- 29	NAS464P3A4	• BOLT	4	35	
		-----X-----			
	8-14791-7	• RIB, BAY #3 CANTED WL 49	1	35	
		A AIRPLANES #278 THRU 280, 282 THRU 286, AND 298			
		B AIRPLANES #281, 287, 289 AND ON			
		C AIRPLANES #35 THRU 89 AND 305			
		D AIRPLANES #35 THRU 277 AND 305			

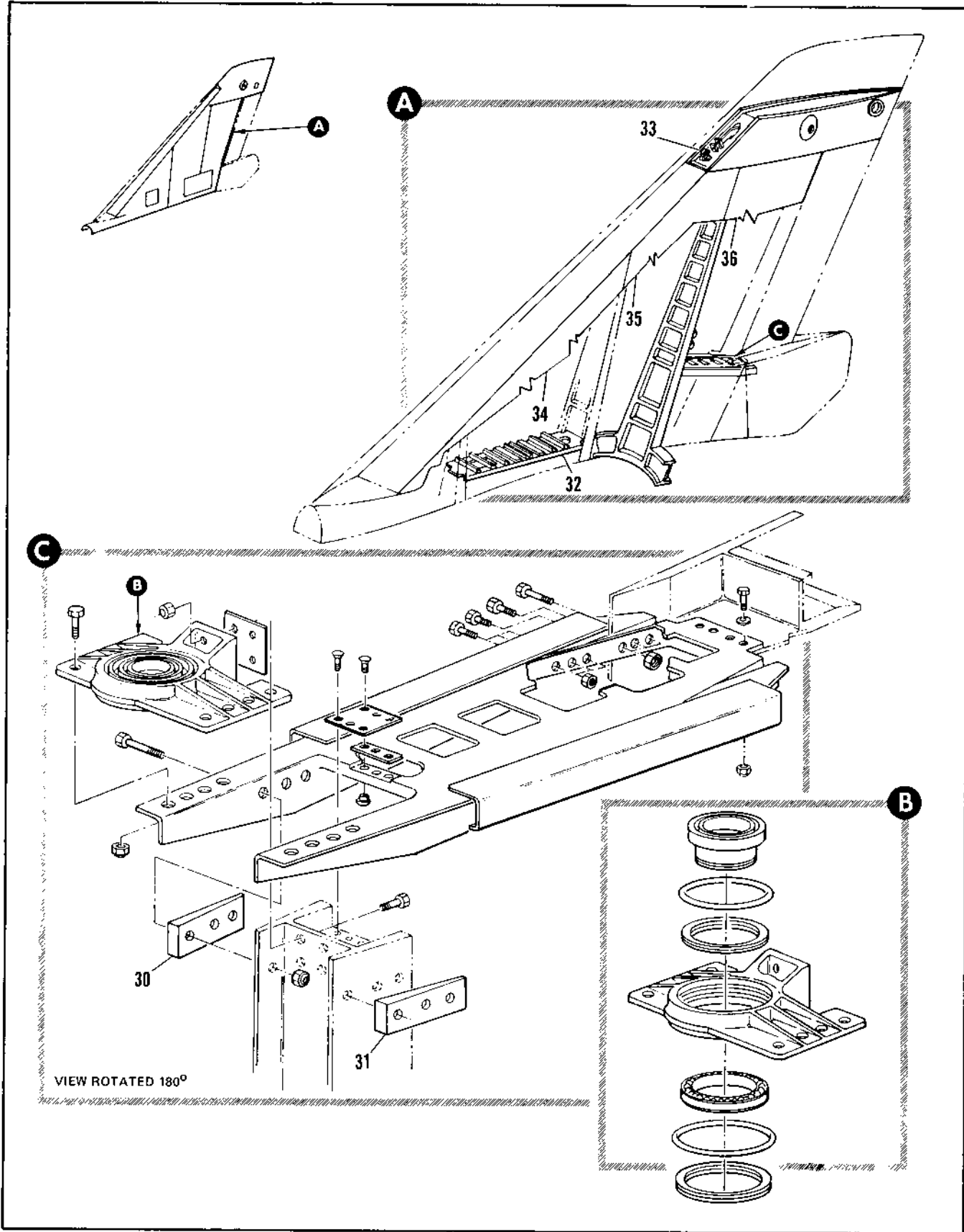

Figure 2.7-8. Vertical Stabilizer Structure Assembly (Sheet 2 of 2)

FIGURE AND INDEX NUMBER	PART NUMBER	DESCRIPTION	UNITS PER ASSY.	USABLE ON CODE	
				FROM	TO
		1 2 3 4 5 6			
2.7-8	8-14769	. . . RIP, BAY #3 CANTED WL 48 ALT INTCHG WITH 8-14791-7	RF	35	
- 30	8-14733-7	. . FILLER	1	35	
- 31	8-14733-8	. . FILLER	1	35	
	8-14329	. RIB INSTL, FIN SPAR #2 TO #3	1	35	
- 32	8-14329-45	. . RIB ASSY, FIN SPAR#2 TO #3 FOR BREAKDOWN SEE FIG. 2.2-18	1	35	
- 33	8-14540	. TIP INSTL, FIN LOWER FOR BREAKDOWN SEE FIG. 2.18-2	1	35	
+ 34	8-14150-3	. PANEL ASSY, FIN SKIN FWD LH ALTERED FROM 8-14150-103 REPLACED BY NOT INTCHG WITH 8-14150-801	1	E	
	8-14150-103	. PANEL ASSY, FIN SKIN	RF		
	8-14150-801	. PANEL ASSY, FIN SKIN FWD LH ALTERED FROM 8-14150-109 REPLACES NOT INTCHG WITH 8-14150-3	1	90	277
	8-14150-109	. PANEL ASSY, FIN SKIN FWD LH	RF		
	8-14150-4	. PANEL ASSY, FIN SKIN FWD RH ALTERED FROM 8-14150-104	1	35	
	8-14150-104	. PANEL ASSY, FIN SKIN	RF		
- 35	8-14151-5	. PANEL ASSY, FIN SKIN CENTER LH ALTERED FROM 8-14151-105	1	35	
	8-14151-105	. PANEL ASSY, FIN SKIN	RF		
	8-14151-4	. PANEL ASSY, FIN SKIN CENTER RH ALTERED FROM 8-14151-104	1	35	
	8-14151-104	. PANEL ASSY, FIN SKIN	RF		
- 36	8-14152-3	. PANEL ASSY, FIN SKIN AFT LH ALTERED FROM 8-14152-103	1	35	
	8-14152-103	. PANEL ASSY, FIN SKIN	RF		
	8-14152-4	. PANEL ASSY, FIN SKIN AFT RH ALTERED FROM 8-14152-104	1	35	
	8-14152-104	. PANEL ASSY, FIN SKIN	RF		
	8-14142-2	. PANEL ASSY, ELECTRONIC EQUIPMENT FIN RH HONEY COMBED FOR BREAKDOWN SEE FIG. 2.2-18	1	35	
	8-14144-2	. PANEL ASSY, FIN RUDDER CONTROL ACCESS RH HONEYCOMBED FOR BREAKDOWN SEE FIG. 2.2-18	1	35	
		E AIRPLANE #35 THRU #9, 278 AND ON			

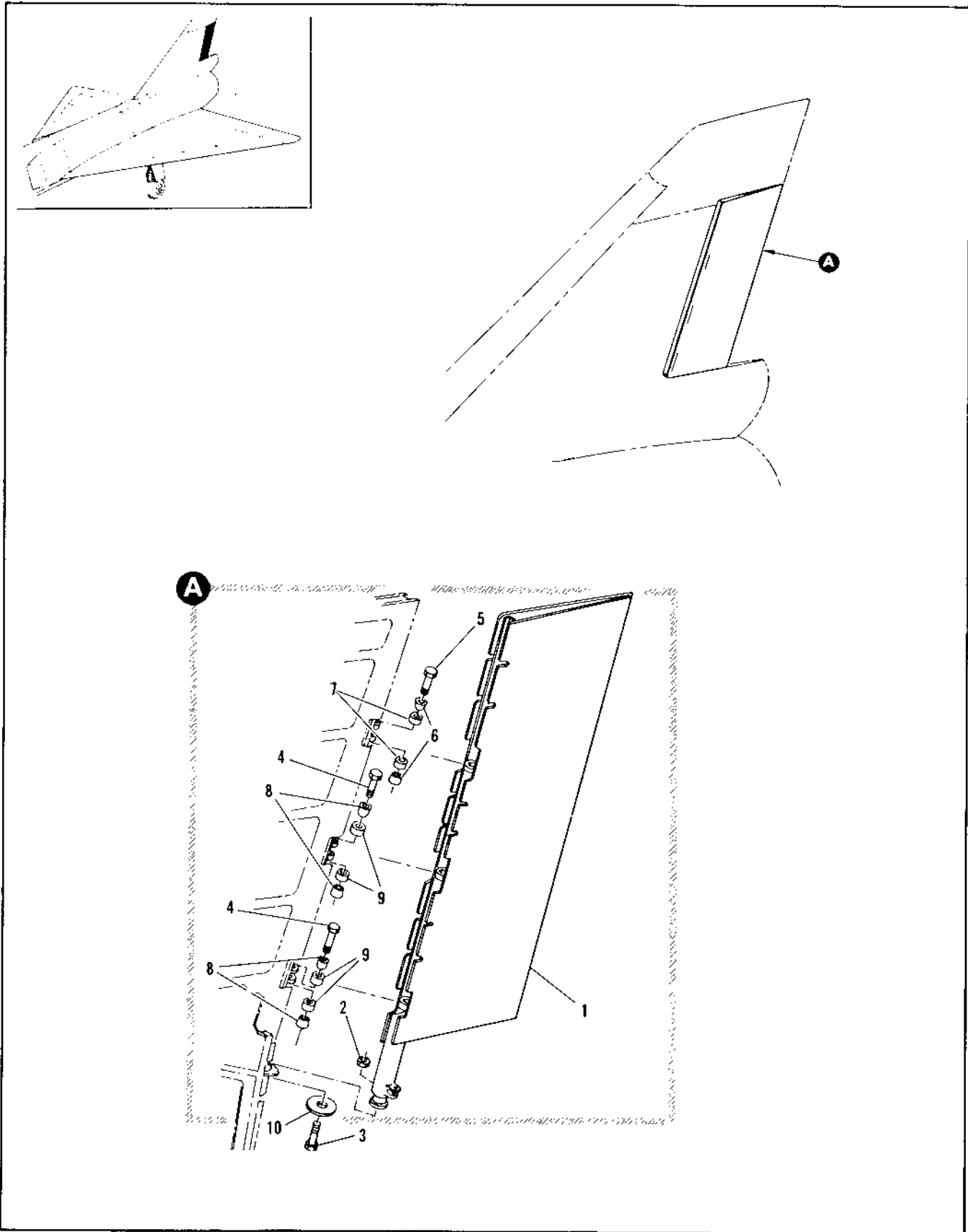

Figure 2.7-9. Rudder Assembly Spares

FIGURE AND INDEX NUMBER	PART NUMBER	DESCRIPTION	UNITS PER ASSY.	USABLE ON CODE	
				FROM	TO
		1 2 3 4 5 6			
2.7-9	8-15040-527	RUDDER ASSEMBLY, SPARE FOR 8-15040-1	RF		
- 1	8-15040-1	• RUDDER ASSY, FOR BREAKDOWN SEE FIG. 2.7-5	1	35	
		ATTACHING PARTS			
- 2	2452-126	• NUT, BARREL (72962) 9E-37508-10A	1	35	
- 3	NAS501-12F24A	• BOLT	1	35	
- 4	NAS464-7A50	• BOLT	2	35	
- 5	NAS464-7A44	• BOLT	1	35	
		-----X-----			
- 6	8-15806	• BUSHING	2	35	
- 7	8-15805	• BUSHING	2	35	
- 8	8-15809	• BUSHING	4	35	
- 9	8-15810	• BUSHING	4	35	
- 10	8-14823-9	• SHIM	1	35	

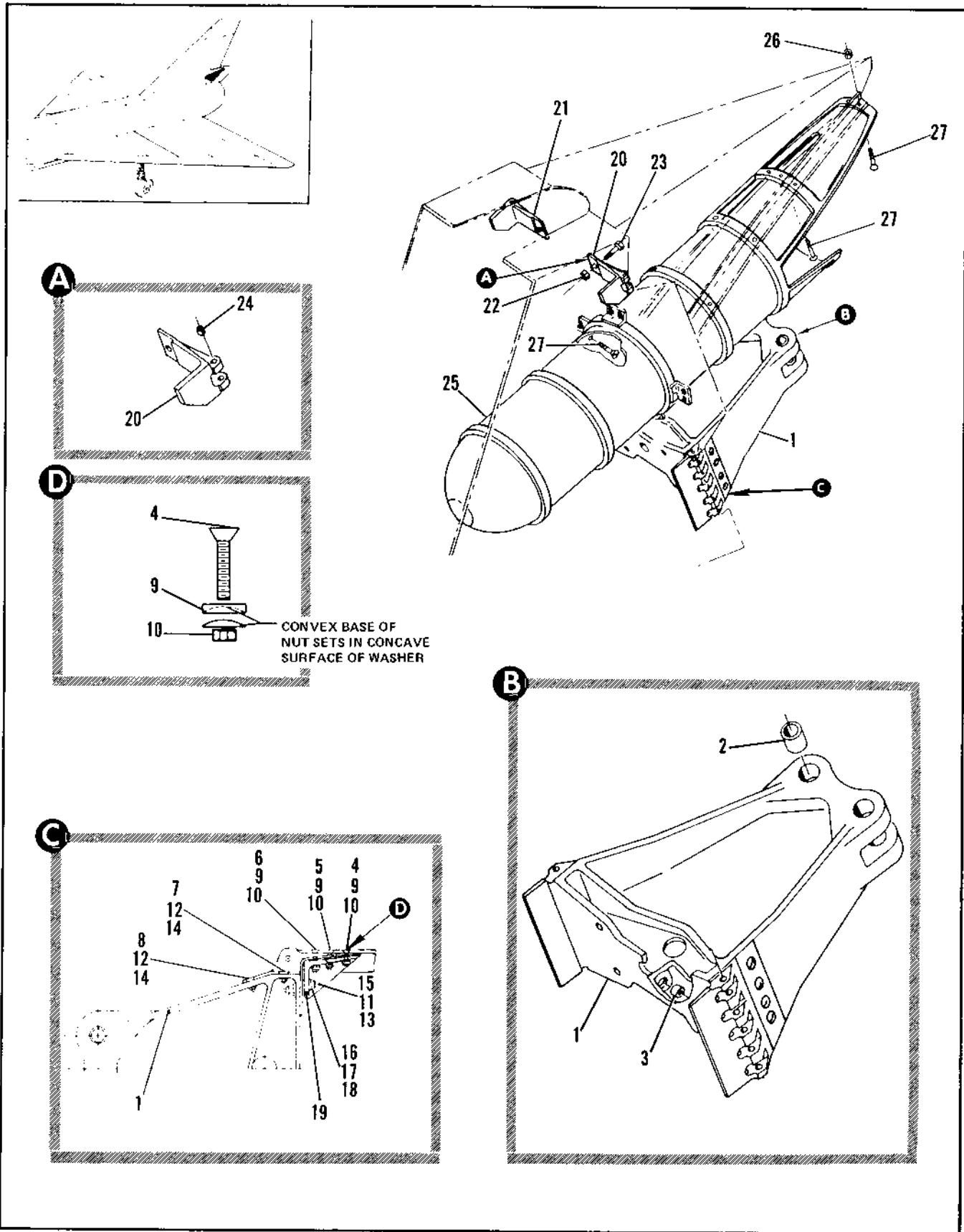

Figure 2.7-10. Speed Brake Door Support Installation

FIGURE AND INDEX NUMBER	PART NUMBER	DESCRIPTION 1 2 3 4 5 6	UNITS PER ASSY.	USABLE ON CODE	
				FROM	TO
2.7-10	8-74860	SUPPORT INSTALLATION, LOWER BRAKE DOOR MODIFIED BY 8-71151 FOR NHA SEE FIG. 2-3-14	RF	35	
- 1	68F37502-1	• HINGE ASSY, LOWER REPLACES NOT INTCHG WITH 8-74861-5	1	35	
- 2	NAS75-10-021	• • BUSHING	4	35	
- 3	NAS75-3-005	• • BUSHING	1	35	
- 4	NAS517-3-7	• SCREW	8	35	
- 5	NAS517-3-8	• SCREW	12	35	
- 6	NAS517-3-11	• SCREW	12	35	
- 7	NAS1154E5	• BOLT	8	35	
- 8	NAS1154E7	• BOLT	8	35	
- 9	2935-0	• WASHER	32	35	
- 10	F52LH4367-02	• NUT	32	35	
- 11	AN960-10	• WASHER	8	35	
- 12	AN960-416	• WASHER	16	35	
- 13	MS21044N3	• NUT	8	35	
- 14	MS21043-4	• NUT			
- 15	NAS1203-8	• SCREW	8	35	
- 16	AN174-10A	• BOLT	4	35	
- 17	AN960-416L	• WASHER	4	35	
- 18	MS21044N4	• NUT	4	35	
- 19	66D38738-7	• SUPPORT RH	1	35	
	66D38738-8	• SUPPORT LH	1	35	
- 20	8-74862-3	• HINGE ASSY, UPPER LH REPLACES NOT INTCHG WITH 8-74862-1	1	35	
- 21	8-74862-4	• HINGE ASSY UPPER RH REPLACES NOT INTCHG WITH 8-74862-2 ATTACHING PARTS	1	35	
- 22	NAS679A3	• NUT	1	35	
- 23	NAS454P3A5	• BOLT	1	35	
- 24	8-74974-19	• • BUSHING ----X----	2	35	
- 25	8-74881-3	• ENCLOSURE ASSY, DRAG CHUTE BONDED REPLACED BY SUITABLE SUB 8-74881-1 ATTACHING PARTS	1	35	
- 26	NAS679A3	• NUT	8	35	
- 27	NAS333PA4	• SCREW ----X----	15	35	

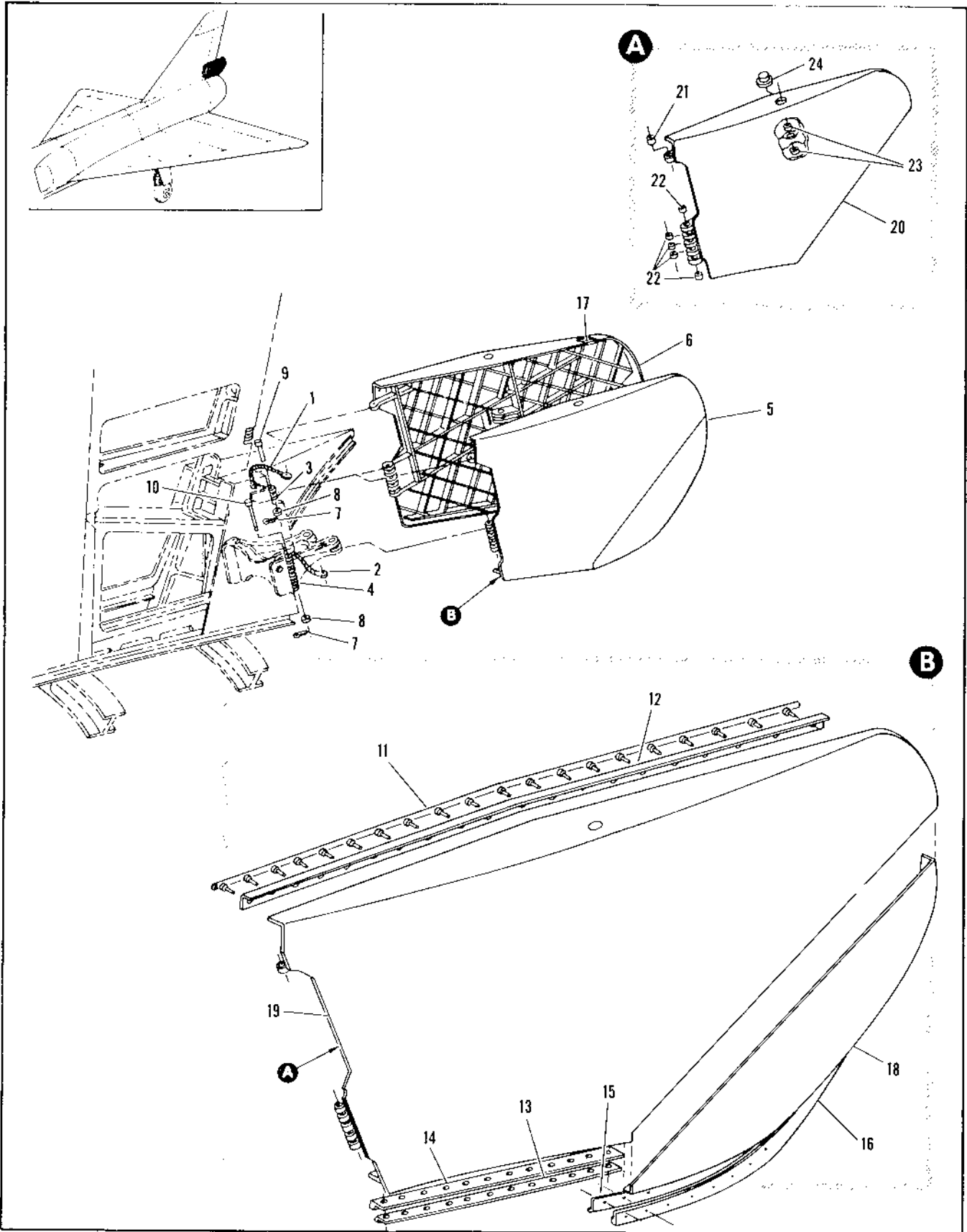

Figure 2.7-11. Speed Brake Door Installation

FIGURE AND INDEX NUMBER	PART NUMBER	DESCRIPTION	UNITS PER ASSY.	USABLE ON CODE	
				FROM	TO
2.7-11	R-74870-1	DOOR INSTALLATION, SPEED BRAKE LH MODIFIED BY R-71156 FOR NHA SEE FIG. 2.3-3	RF		35
	R-74870-2	DOOR INSTALLATION, SPEED BRAKE RH MODIFIED BY R-71156 FOR NHA SEE FIG. 2.3-3	RF		35
- 1	MS25083-1R67	• JUMPER	1		35
		ATTACHING PARTS			
	NAS679A3	• NUT, GROUND STUD	1		35
	AN960D13L	• WASHER, GROUND STUD	2		35
	AN3-4A	• BOLT, GROUND STUD	1		35
	NAS679A3	• NUT, 96-37545-002 GROUND STUD	1		35
	NAS5464P3A3	• BOLT, GROUND STUD	1		35
		-----X-----			
- 2	MS25083-1054	• JUMPER	1		35
		ATTACHING PARTS			
	NAS679A3	• NUT, 96-37545-002 GROUND STUD	2		35
	AN960D13L	• WASHER, GROUND STUD	4		35
	AN3-4A	• BOLT, GROUND STUD	1		35
	AN3-5A	• BOLT, GROUND STUD	1		35
		-----X-----			
- 3		• HINGE ASSY, UPPER SEE FIG. 2.7-10 INDEX 20	RF		
- 4		• HINGE ASSY, LOWER SEE 2.7-10 INDEX 1	RF		
- 5	R-74870-47	• DOOR ASSY, SPEED BRAKE LH	1		35
- 6	R-74870-48	• DOOR ASSY, SPEED BRAKE RH	1		35
		ATTACHING PARTS			
- 7	AN381-2-16	• PIN, COTTER	2		35
- 8	AN960P041AL	• WASHER	2		35
- 9	R-74875-7	• PIN, SPEED BRAKE DOOR HINGE UPPER	1		35
- 10	R-74875-13	• PIN, SPEED BRAKE DOOR HINGE LOWER REPLACES NOT INTCHG WITH R-74875-11	1		35
		-----X-----			
- 11	R-74876-13	• SEAL, SPEED BRAKE DOOR LH	1		35
	R-74876-11	• SEAL, SPEED BRAKE DOOR RH	1		35
- 12	R-74870-9	• ANGLE, SPEED BRAKE DOOR LH	1		35
- 13	R-74870-11	• RETAINER, LH	1		35
	R-74870-12	• RETAINER, RH	1		35
- 14	R-74870-19	• SEAL, MAKE FROM MX4181-3/R-1	2		35
	MX4181-3/R-1	• SEAL, X36 BULK <<1700>>	RF		
- 15	R-74870-29	• RETAINER, LH	1		35
	R-74870-31	• RETAINER, RH	1		35
- 16	R-74870-21	• SEAL, LH MAKE FROM MX4181-3/R-1	1		35
	MX4181-3/R-1	• SEAL, X76 BULK <<1700>>	RF		
	R-74870-23	• SEAL, RH MAKE FROM MX4181-3/R-1	1		35
	MX4181-3/R-1	• SEAL, X36 BULK	RF		
- 17	R-74870-27	• ANGLE, SPEED BRAKE DOOR RH	1		35
	R-74872-1	• CAP INSTL, SPEED BRAKE DOOR LH	1		35
	R-74872-2	• CAP INSTL, SPEED BRAKE DOOR RH	1		35
- 18	R-74872-33	• CAP ASSY, SPEED BRAKE DOOR LH RIVETED REPLACES BY SUITABLE SUB R-74872-49	1		4
	R-74872-49	• CAP ASSY, SPEED BRAKE DOOR LH RIVETED REPLACES SUITABLE FOR R-74872-33	1		4
		A AIRPLANES #178 THRU 2-2, 204 THRU 286 AND 288 THRU 300			
		B AIRPLANES #35 THRU 277, 283, 287 311 AND ON			
		C AIRPLANES #35 THRU 277, 287 AND ON			

FIGURE AND INDEX NUMBER	PART NUMBER	DESCRIPTION	UNITS PER ASSY.	USABLE ON CODE	
				FROM	TO
2.7-11	R-74872-37	• • • CAP ASSY, SPEED BRAKE DOOR RH RIVETED REPLACED BY SUITABLE SUB R-74872-51	1	A	
	R-74872-51	• • • CAP ASSY, SPEED BRAKE DOOR RH RIVETED REPLACES SUITABLE SUB FOR R-74872-37	1	B	
- 19	R-74871-19	• • • DOOR ASSY, SPEED BRAKE LH	1	C	
	R-71156-3	• • • DOOR ASSY, SPEED BRAKE LH	1	278	286
	R-74871-413	• • • DOOR ASSY, SPEED BRAKE RH	1	C	
	R-71156-4	• • • DOOR ASSY, SPEED BRAKE RH	1	278	286
- 20	R-74871-28	• • • DOOR, LH MAKE FROM R-74871-15	1	C	
	R-74871-15	• • • DOOR	PF		
	R-71156-7	• • • DOOR, MAKE FROM R-74871-13 AND R-71156-23	1	278	286
	R-74871-13	• • • DOOR	RF		
	R-71156-23	• • • DOOR	RF		
	R-74871-30	• • • DOOR, RH MAKE FROM R-74871-16	1	C	
	R-71156-8	• • • DOOR, MAKE FROM R-74871-16 AND R-71156-24	1	278	286
	R-74871-16	• • • DOOR	RF		
	R-71156-24	• • • DOOR	RF		
- 21	R-74874-21	• • • BUSHING, UPPER	1	35	
- 22	R-74874-17	• • • BUSHING, LOWER	5	35	
- 23	WAS75-19-123	• • • BUSHING	2	35	
- 24	R-74873	• • • FLUG, SPEED BRAKE DOOR	1	35	
		A AIRPLANES #278 THRU 282, 284 THRU 286 AND 288 THRU 300			
		B AIRPLANES #35 THRU 277, 283, 287, 301 AND ON			
		C AIRPLANES #35 THRU 277, 287 AND ON			

HYDRAULIC SUBSECTION

TABLE OF CONTENTS

<i>Fig. No.</i>	<i>Title</i>	<i>Page</i>	<i>Fig. No.</i>	<i>Title</i>	<i>Page</i>
2.8-1	Hydraulic Equipment	2.8-2	2.8-17	Variable Air Ramp Hydraulic Tubing Installation	2.8-82
2.8-2	Hydraulic Filter	2.8-10	2.8-18	Elevon Actuator Hydraulic Tubing Installation Sta 556 to 605	2.8-86
2.8-3	Hydraulic Accumulator Installation Sta 412	2.8-12	2.8-19	Wing Elevon Hydraulic Tubing Installation	2.8-94
2.8-4	Primary Hydraulic Reservoir Installation	2.8-14	2.8-20	Rudder Actuator Hydraulic Tubing Installation	2.8-104
2.8-5	Secondary Hydraulic Reservoir Installation	2.8-16	2.8-21	Speed Brake Hydraulic Tubing Installation	2.8-106
2.8-6	Hydraulic Reservoir Pressure Panel	2.8-18	2.8-22	Nose Landing Gear Hydraulic Tubing Installation Sta 126 to 162	2.8-110
2.8-7	Ram Air Turbine Installation	2.8-20	2.8-23	Rapid Tune Magnetron Hydraulic Equipment	2.8-116
2.8-8	Ram Air Turbine Door Installation	2.8-22	2.8-24	Rapid Tune Magnetron Hydraulic Tubing Installation Sta 47 to 102 ..	2.8-120
2.8-9	Power Source Refrigeration Compartment Hydraulic Tubing Installation Sta 216 to 336	2.8-24	2.8-25	Rapid Tune Magnetron Hydraulic Tubing Installation Sta 102 to 216	2.8-122
2.8-10	Power Source Hydraulic Tubing Installation Sta 316 to 472	2.8-26	2.8-26	Rapid Tune Magnetron Hydraulic Tubing Installation Sta 216 to 412	2.8-124
2.8-11	Power Source Hydraulic Tubing Installation Sta 431 to 472	2.8-42	2.8-27	Rapid Tune Magnetron Hydraulic Tubing Installation Sta 412 to 540	2.8-126
2.8-12	Power Source Hydraulic Tubing Installation Sta 472 to 605	2.8-50	2.8-28	Aerial Refueling Hydraulic Equipment	2.8-130
2.8-13	Power Source Hydraulic Tubing Installation Sta 615 to 711	2.8-64	2.8-29	Aerial Refueling Hydraulic Tubing Installation	2.8-132
2.8-14	Nose Landing Gear Hydraulic Tubing Installation Sta 132 to 169..	2.8-68			
2.8-15	Nose Landing Gear Hydraulic Tubing Installation Sta 169 to 216..	2.8-72			
2.8-16	Main Landing Gear Hydraulic Tubing Installation	2.8-74			

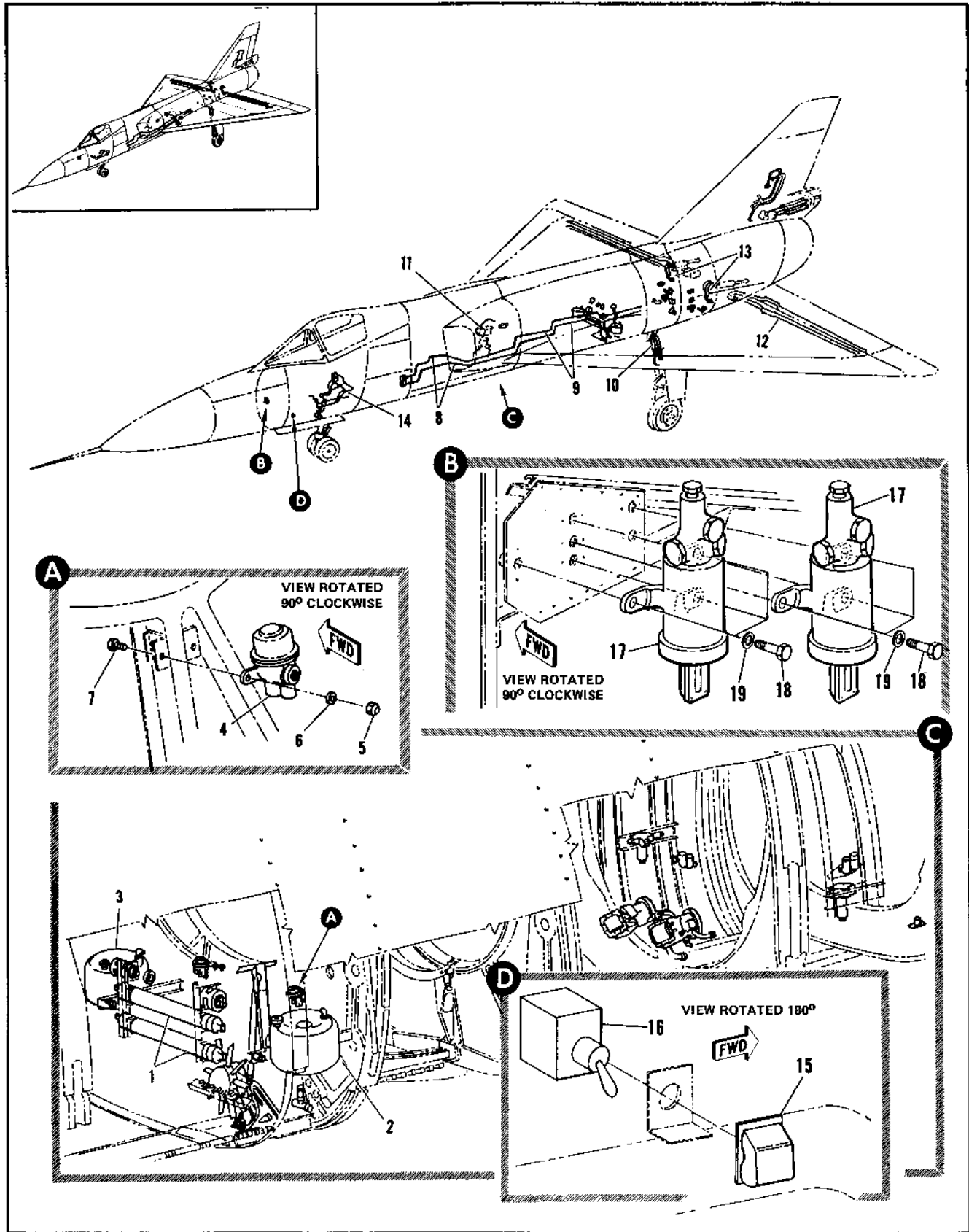

Figure 2.8-1. Hydraulic Equipment (Sheet 1 of 4)

FIGURE AND INDEX NUMBER	PART NUMBER	DESCRIPTION	UNITS PER ASSY.	USABLE ON CODE	
				FROM	TO
		1 2 3 4 5 6			
2.8-1		HYDRAULIC EQUIPMENT			
- 1		• ACCUMULATOR INSTL, HYDRAULIC STA 412 SEE FIG. 2.8-3	RF		
- 2		• RESERVOIR INSTL, PRIMARY HYDRAULIC SEE FIG. 2.8-4	RF		
- 3		• RESERVOIR INSTL, SECONDARY HYDRAULIC SEE FIG. 2.8-5	RF		
	8-81310-1	• REGULATOR INSTL, HYDRAULIC RESERVOIR AIR PRESSURE RH MODIFIED BY 8-82403 FOR NHA SEE FIG. 2.3-13	RF	75	
	8-81310-3	• REGULATOR INSTL, HYDRAULIC RESERVOIR AIR PRESSURE RH MODIFIED BY 8-82403 FOR NHA SEE FIG. 2.3-13	RF	35	
- 4	108100-5	• REGULATOR ASSY, HYDRAULIC RESERVOIR AIR PRESSURE <94124> SPEC 8-10370-5 T.O. 985-3-23-E3 ATTACHING PARTS	1	0	
- 5	NAS679A3	• NUT	2	35	
- 6	AN966PD10L	• WASHER	2	35	
- 7	AN3-5A	• BOLT	2	35	
		----X----			
- 8		• TUBING INSTL, POWER SOURCE HYDRAULIC STA 216 TO 336 SEE FIG. 2.8-9	RF		
- 9		• TUBING INSTL, POWER SOURCE HYDRAULIC 316 TO 472 SEE FIG. 2.8-10		RF	
- 10		• TUBING INSTL, MAIN LANDING GEAR HYDRAULIC SEE FIG. 2.8-16	RF		
- 11		• TUBING INSTL, VARIABLE AIR RAMP HYDRAULIC SEE FIG. 2.8-17	RF		
- 12		• TUBING INSTL, WING ELEVON HYDRAULIC SEE FIG. 2.8-19	RF		
- 13		• TUBING INSTL, ELEVON ACTUATOR HYDRAULIC SEE FIG. 2.8-18	RF		
- 14		• TUBING INSTL, NOSE LANDING GEAR HYDRAULIC STA 126 TO 216 SEE FIG. 2.8-22	RF		
- 15	8-32931-1	• SWITCH INSTL, RAPID TUNE MAGNETRON	1		
- 16	MS25224-3	• GUARD	1		
	MS3535F-21	• SWITCH	1		
	8-85358	• EXPANSION CHAMBER INSTL, BRAKE HYDRAULIC FOR NHA SEE FIG. 2.3-4	RF	B	
- 17	17877	• CHAMBER, BRAKE HYDRAULIC EXPANSION <79294> SPEC 8-38655-1 T.O. 48A10-2-3 ATTACHING PARTS	2	B	
- 18	NAS1104-5	• BOLT	6	B	
- 19	AN9610414L	• WASHER	6	B	
		----X----			
		R AIRPLANES #48, 90 AND ON			
		O AIRPLANES #247, 248, 291, 295 THRU 297, 299, AND 302			

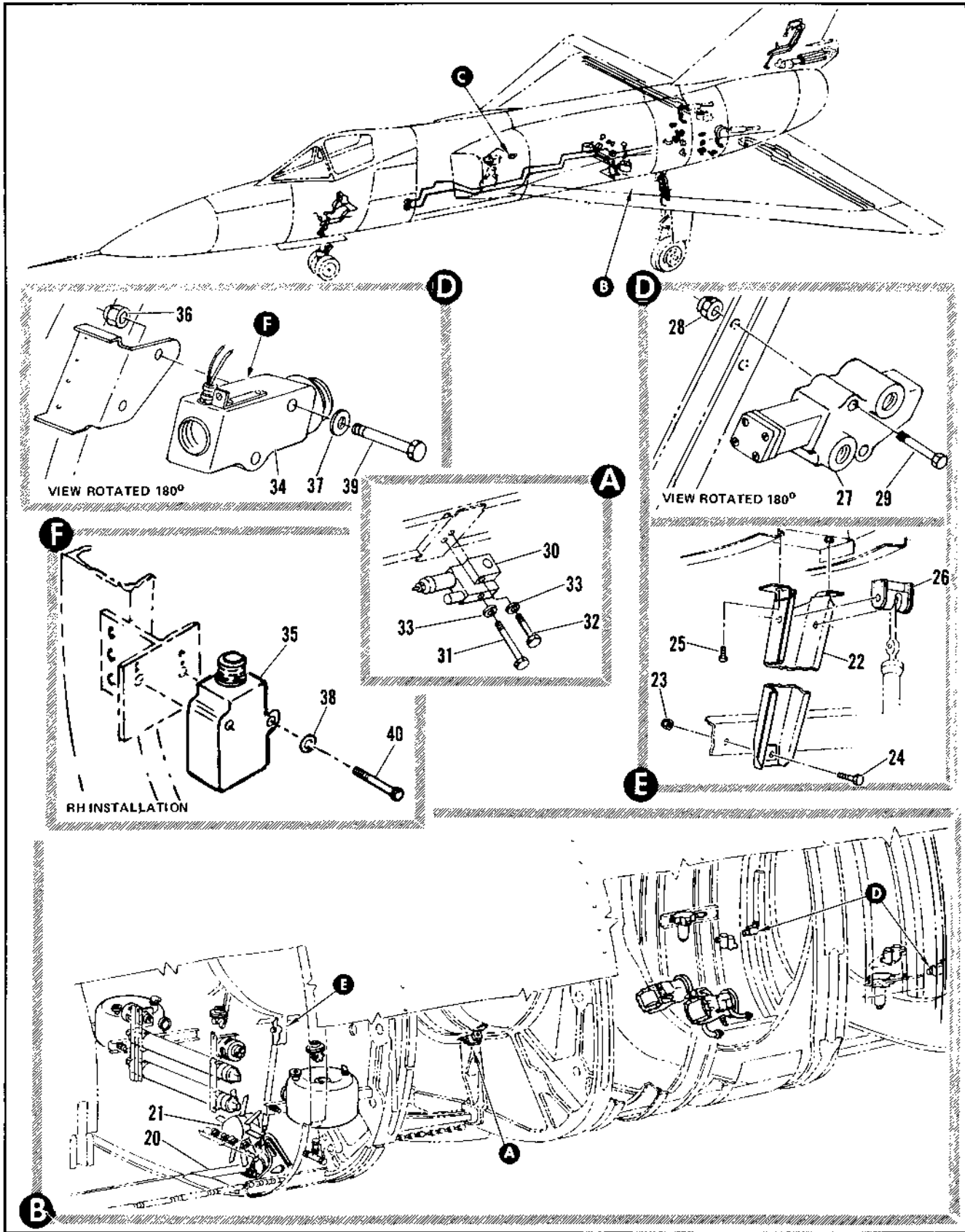

Figure 2.8-1. Hydraulic Equipment (Sheet 2 of 4)

FIGURE AND INDEX NUMBER	PART NUMBER	DESCRIPTION 1 2 3 4 5 6	UNITS PER ASSY.	USABLE ON CODE	
				FROM	TO
2.8-1-20		• TURBINE INSTL, RAM AIR SEE FIG. 2.8-7	RF		
- 21	8-74752	• TURBINE INSTL, RAM AIR SEE FIG. 2.8-7	RF		
		• SUPPORT INSTL, RAM AIR TURBINE LH FOR NHA SEE FIG. 2.3-14	RF	35	
- 22	8-74752-17	• SUPPORT ASSY, RAM AIR TURBINE ATTACHING PARTS	1	35	
- 23	NAS679A4	• NUT	1	35	
- 24	AN4-5A	• BOLT	1	35	
- 25	AN4-3A	• BOLT	2	35	
		-----X-----			
- 26	8-74156-9	• SUPPORT	1	35	
	8-81344-1	• VALVE INSTL, SOLENOID OPERATED HYDRAULIC CHECK FOR NHA SEE FIG. 2.3-3	RF	189	
- 27	15810	• VALVE ASSY, SOLENOID OPERATED HYDRAULIC CHECK STA 361 <99643> SPEC R-08574-1 T.O. 9P5-12-44-3 ATTACHING PARTS	1	189	
- 28	NAS679A3	• NUT	2	189	
	NAS1292-3	• NUT	2		
- 29	NAS1103-16	• BOLT	2	189	
		-----X-----			
	8-81327-1	• VALVE INSTL, EMERGENCY GENERATOR SHUTOFF STA 465 FOR NHA SEE FIG. 2.3-11	RF	35	
- 30	52449-61	• VALVE ASSY, HYDRAULIC SHUTOFF <00502> SPEC R-30389-5 T.O. 9H3-14-99-53 ATTACHING PARTS	1	35	
- 31	AN3-24A	• BOLT	1	35	
- 32	AN3-14A	• BOLT	1	35	
- 33	AN960D10	• WASHER	2	35	
		-----X-----			
	8-81342-1	• SWITCH INSTL, HYDRAULIC THERMAL LH FOR NHA SEE FIG. 2.3-15	RF	90	
	8-81342-2	• SWITCH INSTL, HYDRAULIC THERMAL RH MOD BY 7144621-50 FOR NHA SEE FIG. 2.3-15	RF	90	
- 34	1044-2	• SWITCH, THERMOSTATIC <80234> SPEC R-40659-3	1	90	
- 35	1044-2	• SWITCH, THERMOSTATIC <80234> ATTACHING PARTS	1		
- 36	NAS679A3	• NUT	2	90	
- 37	AN960-15L	• WASHER	2	90	
- 38	AN960-10	• WASHER, RH	2		
- 39	AN3-17A	• BOLT, LH	2		
	NAS1103-18	• BOLT, LH	2	90	
	NAS1103-18	• BOLT, RH	2	90	
- 40	NAS1103-20	• BOLT, RH	2		
		-----X-----			

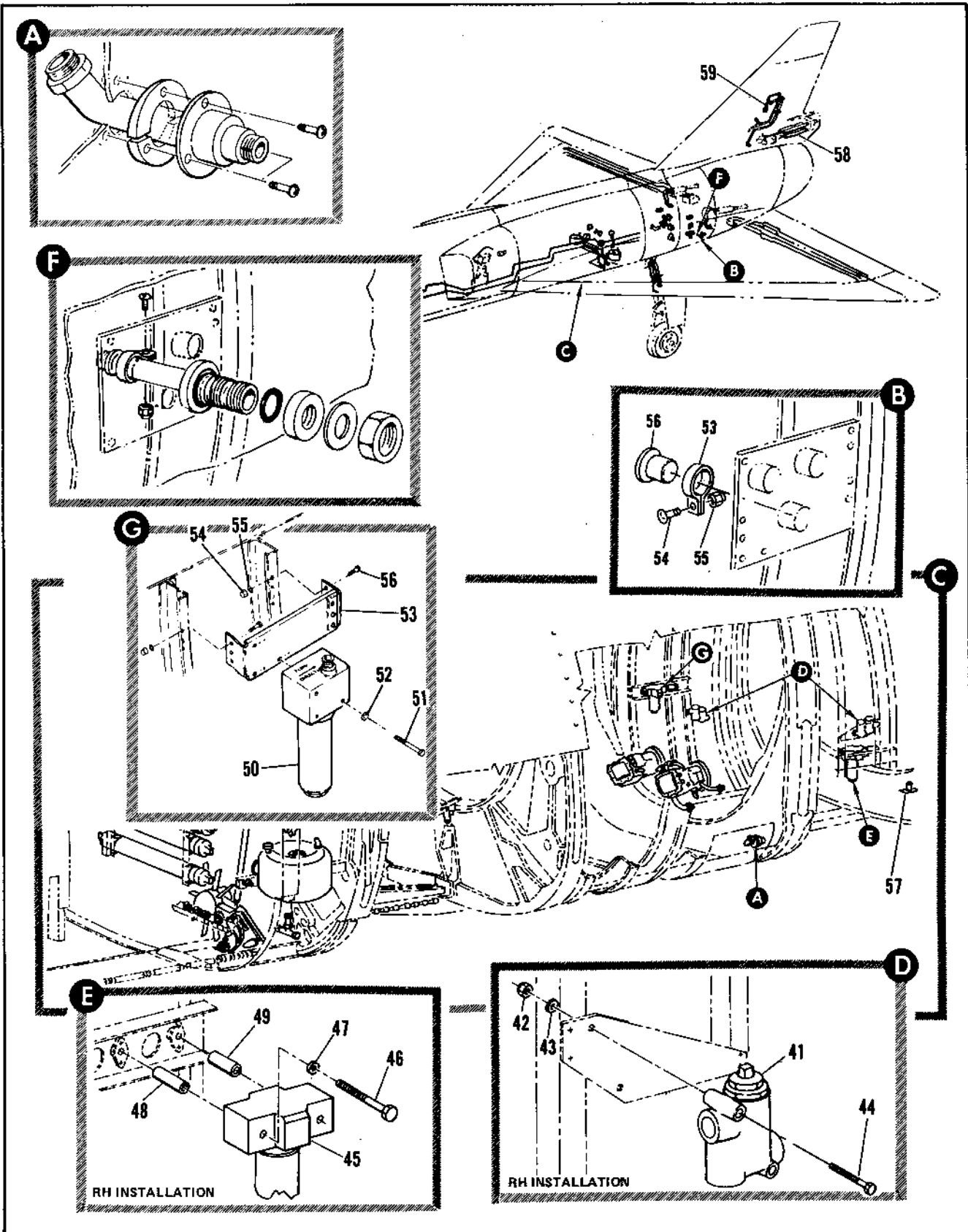

Figure 2.8-1. Hydraulic Equipment (Sheet 3 of 4)

FIGURE AND INDEX NUMBER	PART NUMBER	DESCRIPTION	UNITS PER ASSY.	USABLE ON CODE	
				FROM	TO
2.8-1	8-81326-1	• VALVE INSTL, HYDRAULIC RELIEF STA 530 LH MODIFIED BY 8-80132 FOR NHA SEE FIG. 2.3-15	RF	35	
	8-81326-3	• VALVE INSTL, HYDRAULIC RELIEF STA 530 RH MODIFIED BY 8-80132 FOR NHA SEE FIG. 2.3-15	RF	35	
- 41	EA50004-3	• VALVE ASSY, HYDRAULIC RELIEF (80048) SPEC 8-00329-3 T.O. 9H8-2-110-13 (EA50004-6 IS SUITABLE SUB)	1	35	160
	FA50004-6	• VALVE ASSY, HYDRAULIC RELIEF (80048) SPEC 8-00329-3 T.O. 9H8-2-110-13 (SUITABLE SUB FOR EA50004-5)	1	160	
		ATTACHING PARTS			
- 42	NAS679A4	• NUT (80205)	2	35	
- 43	AN963-416L	• WASHER (88044)	2	35	
- 44	AN4-22A	• BOLT (88044)	2	35	
		-----X-----			
	8-81308-801	• FILTER INSTL, HYDRAULIC HIGH PRESSURE LH FOR NHA SEE FIG. 2.3-15	RF	35	277
	8-81308-1	• FILTER INSTL, HYDRAULIC HIGH PRESSURE LH FOR NHA SEE FIG. 2.3-15	RF	278	
	8-81308-802	• FILTER INSTL, HYDRAULIC HIGH PRESSURE RH MOD BY 7144628-30 FOR NHA SEE FIG. 2.3-15	RF	35	277
	8-81308-2	• FILTER INSTL, HYDRAULIC HIGH PRESSURE RH MOD BY 7144628-30 FOR NHA SEE FIG. 2.3-15	RF	278	
- 45	AC840-81	• FILTER ASSY, (01414) SPEC 8-08452-801 REF T.O. 9H3-3-39-33; USE FILTER ELEMENT AC 860L-12, FSN 1650-555-1615 CLEAN ELEMENT PER 9H3-1-1, USE PARTS KIT AC840-81KC UNTIL EXHAUSTED, THEN USE AA863-12KC.	2	35	
		ATTACHING PARTS			
- 46	AN4-26A	• BOLT (88044)	2	35	
- 47	AN963PD416	• WASHER (88044)	2	35	
- 48	8-81243	• SPACER	1	35	
- 49	8-81243-1	• SPACER	1	35	
		-----X-----			
- 50	AC3255-12HM	• FILTER ASSY (01414) RH SIDE ONLY SEE FIG. 2.8-2 FOR BREAKDOWN	1	1	
		ATTACHING PARTS			
- 51	NAS1104-44	• BOLT, RH (80205)	3		
- 52	AN963-416	• WASHER, RH (88044)	3		
		-----X-----			
- 53	7144628-83	• CLIP, FILTER MTG, RH (98750)	1		
		ATTACHING PARTS			
- 54	MS21042L3	• NUT, RH (96906)	4		
- 55	AN960-10	• WASHER, RH (88044)	4		
- 56	NAS1103-3	• BOLT, RH (80205)	4		
		-----X-----			
	8-81322	• FITTING INSTL, HYDRAULIC PUMP SEAL DRAIN FOR NHA SEE FIG. 2.3-16	RF	35	
- 57	8-80209	• FITTING	1	35	
- 58		• TUBING INSTL, SPEED BRAKE HYDRAULIC SEE FIG. 2.8-19	RF		
- 59		• TUBING INSTL, VERTICAL STABILIZER HYDRAULIC SEE FIG. 2.8-11 AND 2.8-18	RF		
	8-81313-803	• COUPLING INSTL, HYDRAULIC PRESSURE AND SUCTION STA 520 LH MODIFIED BY 8-80132 FOR NHA SEE FIG. 2.3-16	RF	A	

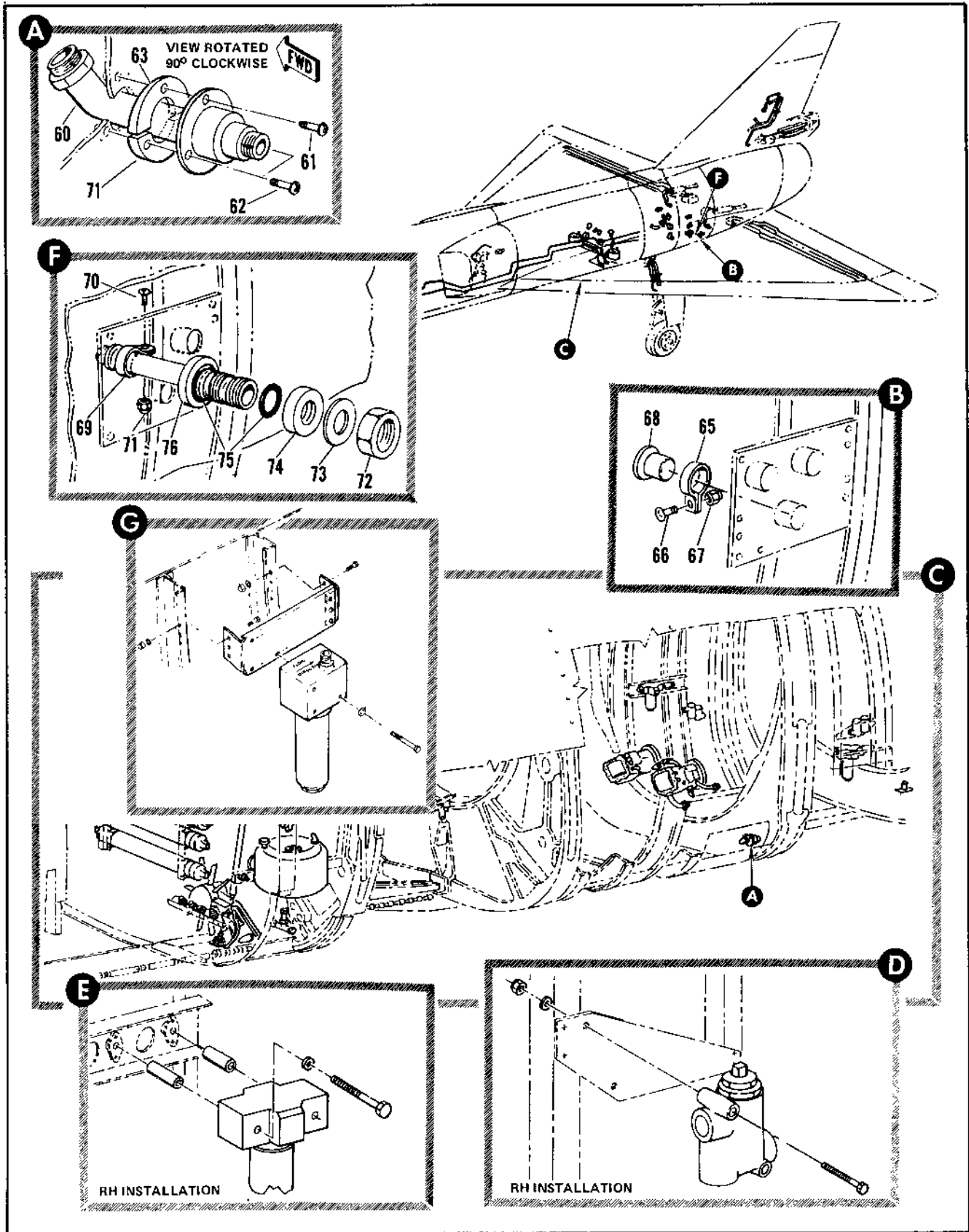

Figure 2.8-1. Hydraulic Equipment (Sheet 4 of 4)

FIGURE AND INDEX NUMBER	PART NUMBER	DESCRIPTION	UNITS PER ASSY.	USABLE ON CODE	
				FROM	TO
		1 2 3 4 5 6			
2.8-1	8-81313-807	• COUPLING INSTL, HYDRAULIC PRESSURE AND SUCTION STA 520 LH FOR NHA SEE FIG. 2.3-15	RF	48	277
	8-81313-305	• COUPLING INSTL, HYDRAULIC PRESSURE AND SUCTION STA 520 RH MODIFIED BY 8-80132 FOR NHA SEE FIG. 2.3-15	RF	A	
	8-81313-809	• COUPLING INSTL, HYDRAULIC PRESSURE AND SUCTION STA 520 RH FOR NHA SEE FIG. 2.3-15	RF	48	277
- 60	307534-16D	• • COUPLING ASSY, <0624> 92-73903-001 ATTACHING PARTS	1	35	
- 61	NAS221-8	• • SCREW	1	35	277
	NAS221-9	• • SCREW	1	278	
- 62	NAS221-8	• • SCREW	1	35	277
	AN502-10-10	• • SCREW	1	278	
	NAS221-10	• • SCREW	1	278	
	AN502-10-10	• • SCREW	1	278	
		----X----			
- 63	8-80132-7	• • SHIM, COUPLING ASSEMBLY	1	278	
- 64	8-80132-9	• • SHIM, COUPLING ASSEMBLY	1	278	
	8-81343-3	• FITTING INSTL, HYDRAULIC HEAT EXCHANGER WING LH STA 533 MODIFIED BY 8-80125 FOR NHA SEE FIG. 2.3-14	RF	35	
	8-81343-4	• FITTING INSTL, HYDRAULIC HEAT EXCHANGER WING RH STA 533 MODIFIED BY 8-80125 FOR NHA SEE FIG. 2.3-14	RF	35	
- 65	AN735012	• • CLAMP ATTACHING PARTS	1	35	159
- 66	NAS221-8	• • SCREW	1	35	159
- 67	NAS679A3	• • NUT ----X----	1	35	159
- 68	H-81505	• • PLUG	1	35	159
- 69	AN735012	• • CLAMP ATTACHING PARTS	2	35	
- 70	NAS221-8	• • SCREW	2	35	
- 71	NAS679A3	• • NUT ----X----	2	35	
	8-81343-1	• FITTING INSTL, HYDRAULIC HEAT EXCHANGER WING LH STA 534 FOR NHA SEE FIG. 2.6-32	RF	35	
	8-81343-2	• FITTING INSTL, HYDRAULIC HEAT EXCHANGER WING RH STA 534 FOR NHA SEE FIG. 2.6-32	RF	35	
- 72	AN924-100	• • NUT	2	35	
- 73	AN960U1416	• • WASHER	2	35	
- 74	9-21311-05	• • WASHER	2	35	
- 75	MS29513-20	• • PACKING	4	35	
- 76	8-81506-7	• • FITTING	2	35	
A AIRPLANES #45 THRU 47, 278 AND ON					

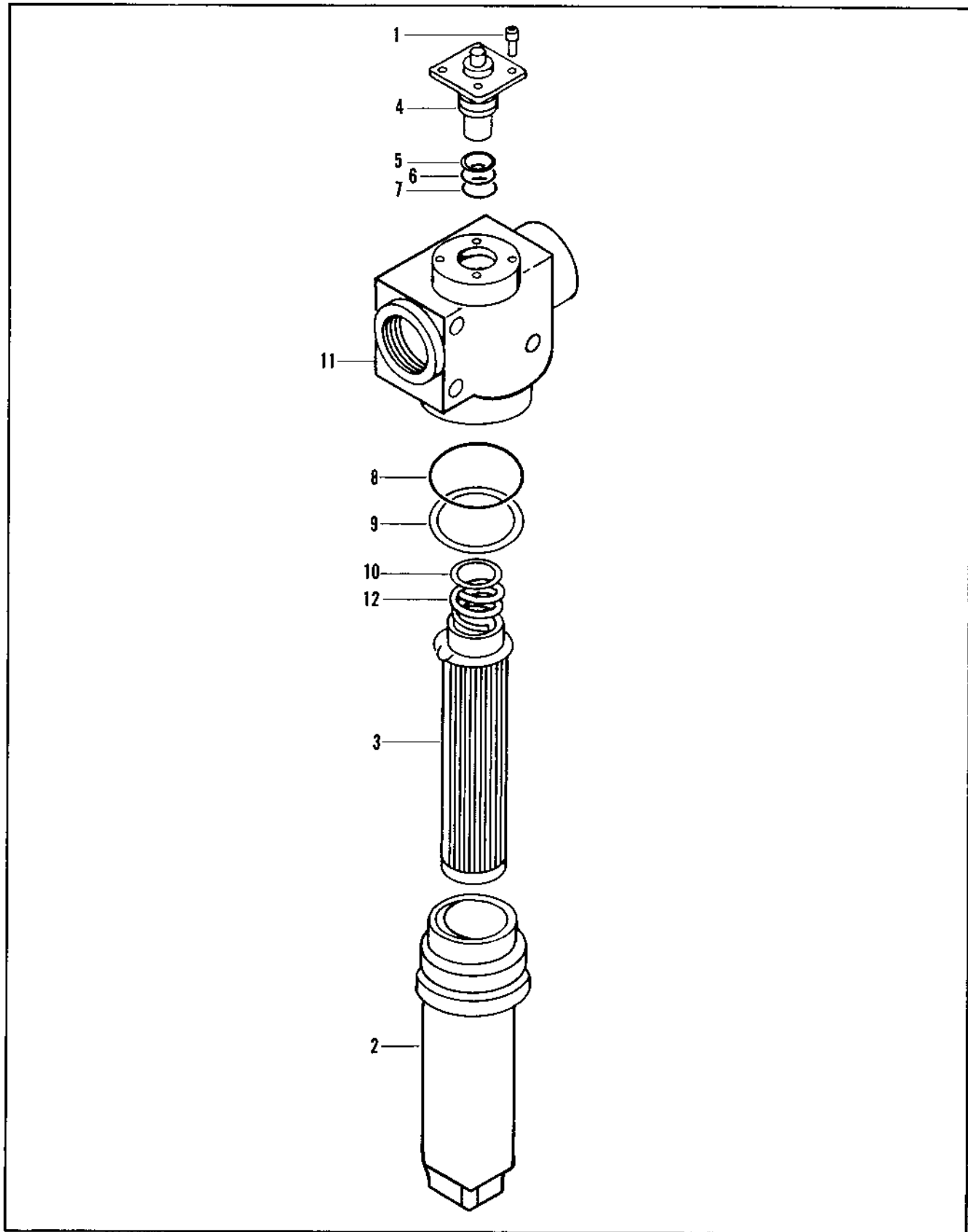

Figure 2.8-2. Hydraulic Filter

FIGURE AND INDEX NUMBER	PART NUMBER	DESCRIPTION	UNITS PER ASSY.	USABLE ON CODE	
				FROM	TO
2.8-2-2		1 2 3 4 5 6			
- 2	AA2100-11099	• SOCKET HEAD CAP SCREW	4		
- 3	AC-3255-12H02	• FILTER BOWL	1		
- 4	AC-3255-12	• FILTER ELEMENT	1		
- 5	RC193PH096	• PRESSURE INDICATOR	1		
- 6	MS28774-215	• RETAINER	1		
- 7	MS28775-215	• PACKING	1		
- 8	MS28774-114	• PACKING	1		
- 9	MS28775-132	• PACKING	1		
- 10	MS28774-132	• PACKING	1		
- 11	MS28775-024	• PACKING	1		
- 12	AA-3255-12HMD1A	• FILTER HEAD	1		
	AA-3258-1201	• SPRING, ELEMENT, REMOVAL	1		

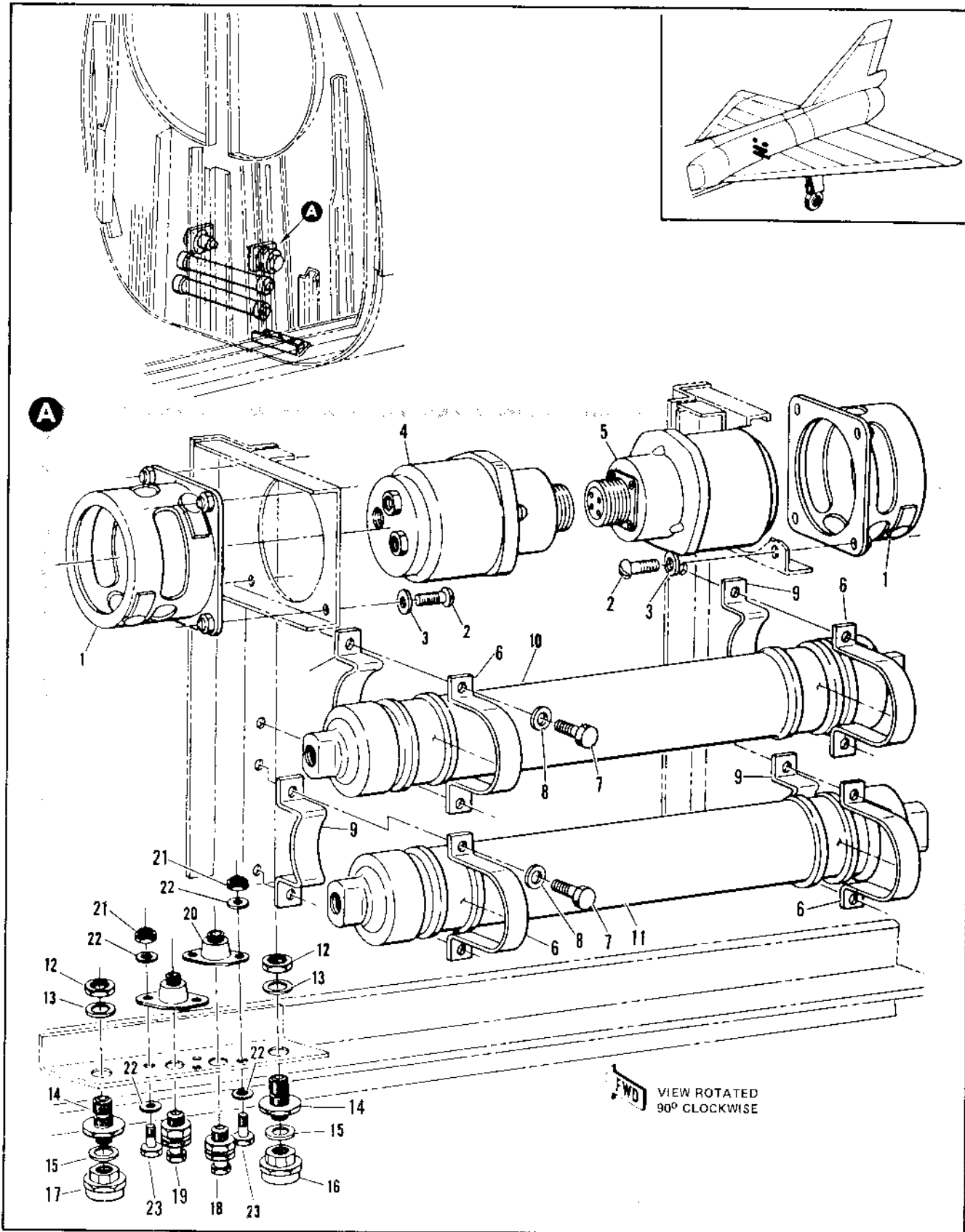

Figure 2.8-3. Hydraulic Accumulator Installation Sta 412

FIGURE AND INDEX NUMBER	PART NUMBER	DESCRIPTION	UNITS PER ASSY.	USABLE ON CODE	
				FROM	TO
		1 2 3 4 5 6			
2.8-3	8-81317	ACCUMULATOR INSTALLATION, HYDRAULIC STA 412 FOR NHA SEE FIG. 2.3-10	RF	35	
- 1	K297-6	• MOUNT, <51116> 96-07503-001 ATTACHING PARTS	2	35	
- 2	AN515-8R6	• SCREW	8	35	
- 3	AN960D8L	• WASHER	6	35	
		-----X-----			
- 4	7615-3785-1	• TRANSMITTER AND SWITCH ASSY, PRIMARY PRESSURE <19315> SPEC 8-08456 T.O. 9P5-3-30-3 ALT INTCHG WITH 7615-37A5-1	RF	35	
- 5	7615-3785-1	• TRANSMITTER AND SWITCH ASSY, SECONDARY PRESSURE <19315> SPEC 8-08456 T.O. 9P5-3-30-3 ALT INTCHG WITH 7615-37A5-1	RF	35	
- 6	8-81057-7	• CLAMP ATTACHING PARTS	4	35	
- 7	AN3-6A	• BOLT	8	35	
- 8	AN960PD10L	• WASHER	8	35	
		-----X-----			
- 9	8-81057-9	• SADDLE	4	35	
- 10	1356-553818	• ACCUMULATOR ASSY, PRIMARY HYDRAULIC <92003> SPEC 8-08453 T.O. 9H1-2-5-43	1	35	
	08-8422-030	• ACCUMULATOR ASSY, PRIMARY HYDRAULIC (81616) SUITABLE SUB FOR 1356-553818 T.O. 9H1-2-46-3	1	35	
- 11	1356-553818	• ACCUMULATOR ASSY, SECONDARY HYDRAULIC <92003> SPEC 8-08453 T.O. 9H1-2-5-43	1	35	
	08-8422-030	• ACCUMULATOR ASSY, SECONDARY HYDRAULIC (81616) SUITABLE SUB FOR 1356-553818 T.O. 9H1-2-46-3	1	35	
- 12	AN924-4D	• NUT	2	35	
- 13	AN960PD716	• WASHER	2	35	
- 14	MS21903D4	• UNION	2	35	
- 15	AN6290-4	• GASKET	2	35	
- 16	AW1026AEC1	• GAUGE, DIRECT INDICATING PRIMARY PRESSURE <61349> AERN061-2341 TYPE MS2447A-2 GFAE	1	35	
- 17	AW1026AEC31	• GAUGE, DIRECT INDICATING SECONDARY PRESSURE <61349> AERN061-2341 TYPE MS2447A-2 GFAE	1	35	
- 18	MS28889-1	• VALVE, PRIMARY HIGH PRESSURE CHARGING 99-34801-001	1	35	
- 19	MS28889-1	• VALVE, SECONDARY HIGH PRESSURE CHARGING 99-34801-001	1	35	
- 20	8-81236-11	• ADAPTER ATTACHING PARTS	2	35	
- 21	AN363-1032	• NUT	2	35	
- 22	AN960PD10L	• WASHER	4	35	
- 23	AN3-3A	• BOLT	2	35	
		-----X-----			

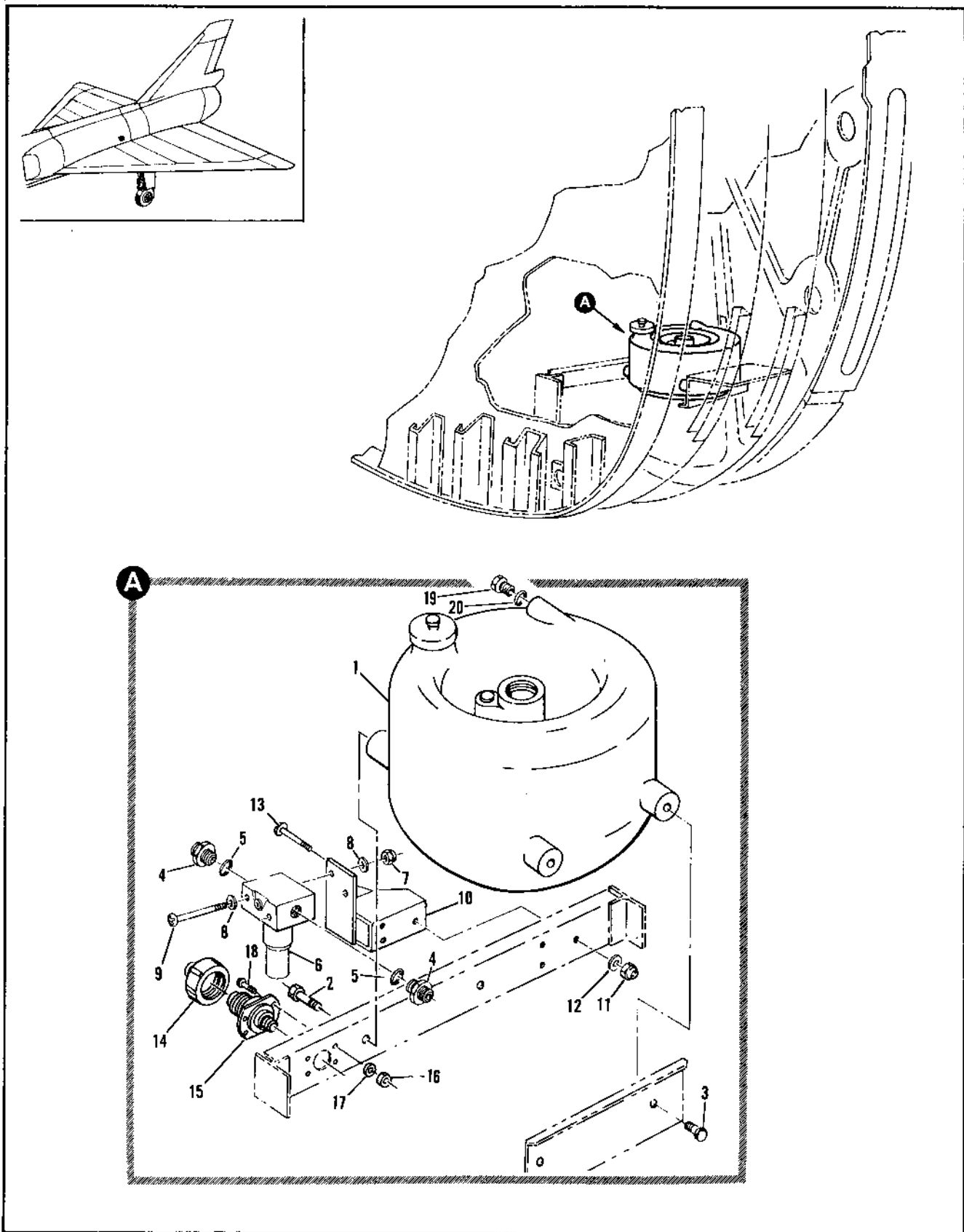

Figure 2.8-4. Primary Hydraulic Reservoir Installation

FIGURE AND INDEX NUMBER	PART NUMBER	DESCRIPTION	UNITS PER ASSY.	USABLE ON CODE	
				FROM	TO
		1 2 3 4 5 6			
2.8-4	8-81314-1	RESERVOIR INSTALLATION, PRIMARY HYDRAULIC MODIFIED BY 8-80109 AND 8-82403 FOR NHA SEE FIG. 2.3-3	RF	35	
- 1	6300-1	• RESERVOIR ASSY, PRIMARY HYDRAULIC <81896> SPEC 8-06485-7 T.O. 9H5-3-17-3 ATTACHING PARTS	1	35	
- 2	AN5H4A	• BOLT	2	35	
- 3	NK5-4	• BOLT, <92615> 90-84000-003 -----X-----	2	35	
	63-06036-1	• SEAL, O-RING FURNISHED WITH 6300-1	RF	35	
- 4	MS21916D6-4	• REDUCER	2	35	
- 5	AN6290-4	• GASKET	2	35	
- 6	AC1526-4	• FILTER ASSY, (01414) SPEC 8-00460-1 T.O. 9H3-3-43-3 REQUIRES FILTER ELEMENT AC1526-E4, STOCK NUMBER 1650-684-9717, T.O. 9H3-1-1 ATTACHING PARTS	1	35	
- 7	NAS679A3	• NUT	2	35	
- 8	AN960PD10	• WASHER	4	35	
- 9	AN520-10R36	• SCREW -----X-----	2	35	
- 10	8-81314-45	• SUPPORT ASSY, FILTER WELDED ATTACHING PARTS	1	35	
- 11	NAS679A3	• NUT	3	35	
- 12	AN960PD10L	• WASHER	3	35	215
	AN960-10L	• WASHER	3	216	
- 13	NAS2210D7	• SCREW	3	35	215
	NAS221-7	• SCREW -----X-----	3	216	
- 14	155-S7-5D	• CAP, <00624> 91-52300-006	1	35	
- 15	3024S4-4D	• COUPLING, PRIMARY QUICK DISCONNECT <00624> SPEC 8-00455-1 ATTACHING PARTS	1	35	
- 16	NAS679A3	• NUT	4	35	
- 17	AN960PD10L	• WASHER	4	35	
- 18	AN520-10R6	• SCREW -----X-----	4	35	
- 19	MS21913D4	• CAP	1	A	
- 20	AN6290-4	• GASKET	1	A	
		A AIRPLANES #287, 288, 291, 295 THRU 297, 299, AND 302			

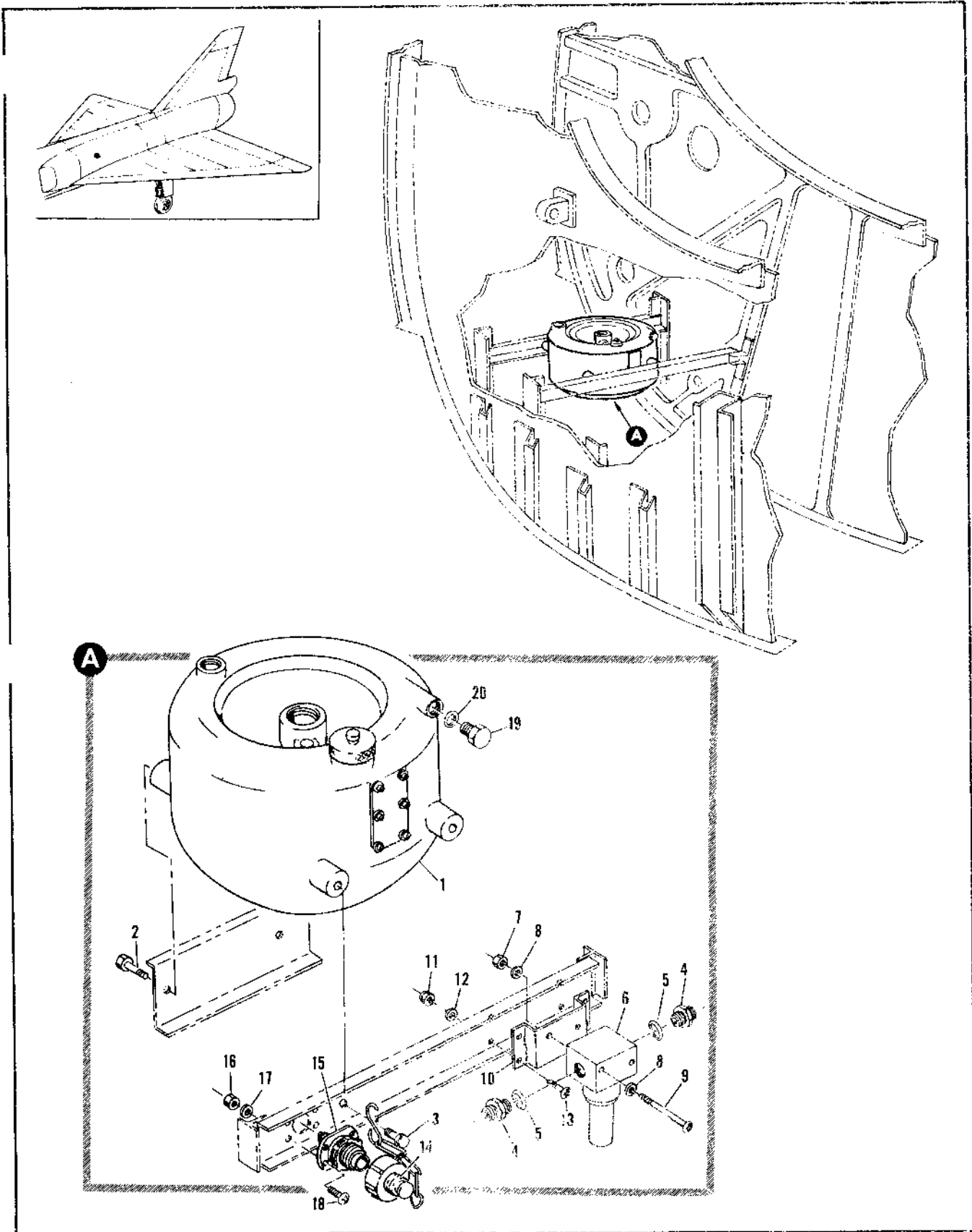

Figure 2.8-5. Secondary Hydraulic Reservoir Installation

FIGURE AND INDEX NUMBER	PART NUMBER	DESCRIPTION 1 2 3 4 5 6	UNITS PER ASSY.	USABLE ON CODE	
				FROM	TO
2,8-5	8-81314-3	RESERVOIR INSTALLATION, SECONDARY HYDRAULIC MODIFIED BY 8-80109 AND 8-82463 FOR NHA SEE FIG. 2.3-3	RF	35	
- 1	7144533-10	RESERVOIR ASSY, SECONDARY HYDRAULIC ALTERED FROM (81896) PART NO. 6301-1 T.O. 9H5-3-17-3	1		
- 2	NK5-4	ATTACHING PARTS	2	35	
- 3	AN5H4A	• BOLT, <J2615> 97-R4000-C03 • BOLT	2	35	
		-----X-----			
- 4	63-30036-1	• SEAL, O-RING FURNISHED WITH 6301-1	RF	35	
- 5	MS21916D6-4	• REDUCER	2	35	
- 6	AN6290-4	• GASKET	2	35	
- 7	AC1526-4	• FILTER ASSY, (01414) T.O. 9H3-3-43-3	1	35	
- 8	NAS679A3	• NUT	2	35	
- 9	AN960PD10	• WASHER	4	35	
- 10	AN520-1GR36	• SCREW	2	35	
		-----X-----			
- 10	8-81314-47	• SUPPGRT, FILTER ATTACHING PARTS	1	35	
- 11	NAS679A3	• NUT	4	35	
- 12	AN960PD10L	• WASHER	4	35	159
- 13	AN960-19L	• WASHER	4	160	
- 13	NAS221DD7	• SCREW	4	35	159
- 13	NAS1103-2	• BOLT	4	160	
		-----X-----			
- 14	155-S7-50	• CAP, <00624> 91-52300-006	1	35	
- 15	3624S4-40	• COUPLING, SECONDARY QUICK DISCONNECT <00624> SPEC 8-00455-1	1	35	
		ATTACHING PARTS			
- 16	NAS679A3	• NUT	4	35	
- 17	AN960PD10L	• WASHER	4	35	
- 18	AN520-1DR6	• SCREW	4	35	
		-----X-----			
- 19	MS21913D4	• CAP	1	35	
- 20	AN6290-4	• GASKET	1	35	

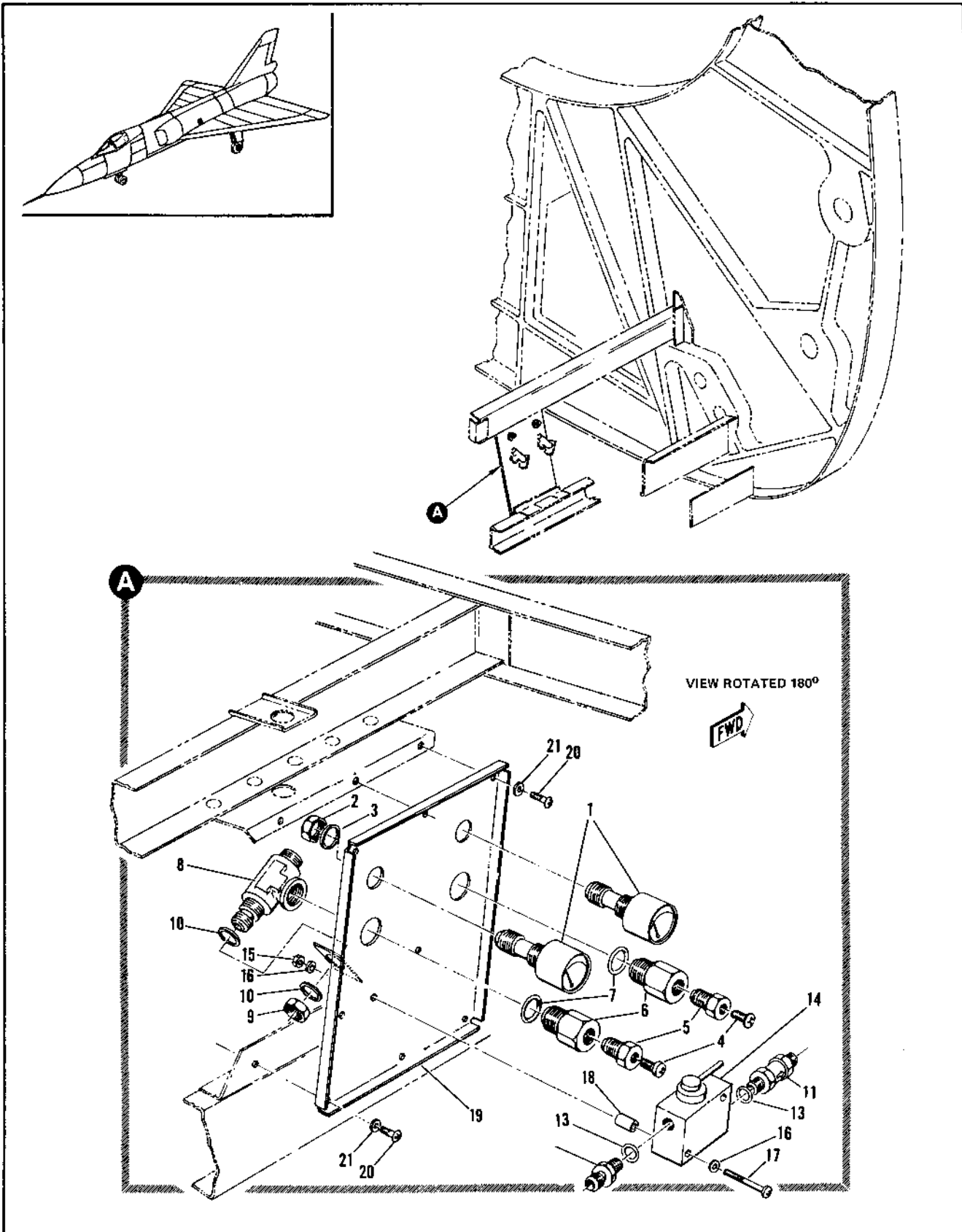

Figure 2.8-6. Hydraulic Reservoir Pressure Panel

FIGURE AND INDEX NUMBER	PART NUMBER	DESCRIPTION 1 2 3 4 5 6	UNITS PER ASSY.	USABLE ON CODE	
				FROM	TO
2.8-6		HYDRAULIC RESERVOIR PRESSURE PANEL			
- 1	6918-707	• GAGE, PNEUMATIC LOW PRESSURE <51240> SPEC 8-08678-1 ATTACHING PARTS	2	RF	A
- 2	AN924-3D	• NUT	2	A	
- 3	AN963PD616	• WASHER -----X-----	2	A	
- 4	AN501AC10-6	• SCREW	2	A	
- 5	AN6204-1	• VALVE, HYDRAULIC BLEEDER	2	A	
- 6	8-82406	• ADAPTER, BLEED FITTING	2	A	
- 7	AN6290-3	• GASKET	2	A	
- 8	MS21910D3	• TEE	2	A	
- 9	AN924-3D	• NUT	2	A	
- 10	AN963PD616	• WASHER	4	A	
- 11	P12-319	• VALVE, PNEUMATIC HIGH PRESSURE CHECK <91816> SPEC 8-00430-11	1	A	
- 12	MS21916D4-3	• REDUCER	1	A	
- 13	AN6290-4	• GASKET	1	A	
- 14	P16-416	• VALVE, PNEUMATIC HIGH PRESSURE <91816> SPEC 8-06677-1 ATTACHING PARTS	1	A	
- 15	NAS1291-3	• NUT	2	A	
- 16	AN960-10L	• WASHER	4	A	
- 17	NAS221-24	• SCREW -----X-----	2	A	
- 18	NAS43DD3-16	• SPACER	2	A	
- 19	8-82403-21	• PANEL ASSY, HYDRAULIC RESERVOIR PRESSURE RIVETED ATTACHING PARTS	1	A	
- 20	NAS2219	• SCREW	6	A	
- 21	AN960-10L	• WASHER -----X-----	6	A	
		A AIRPLANES #287, 288, 291, 295 THRU 297, 299, AND 302			

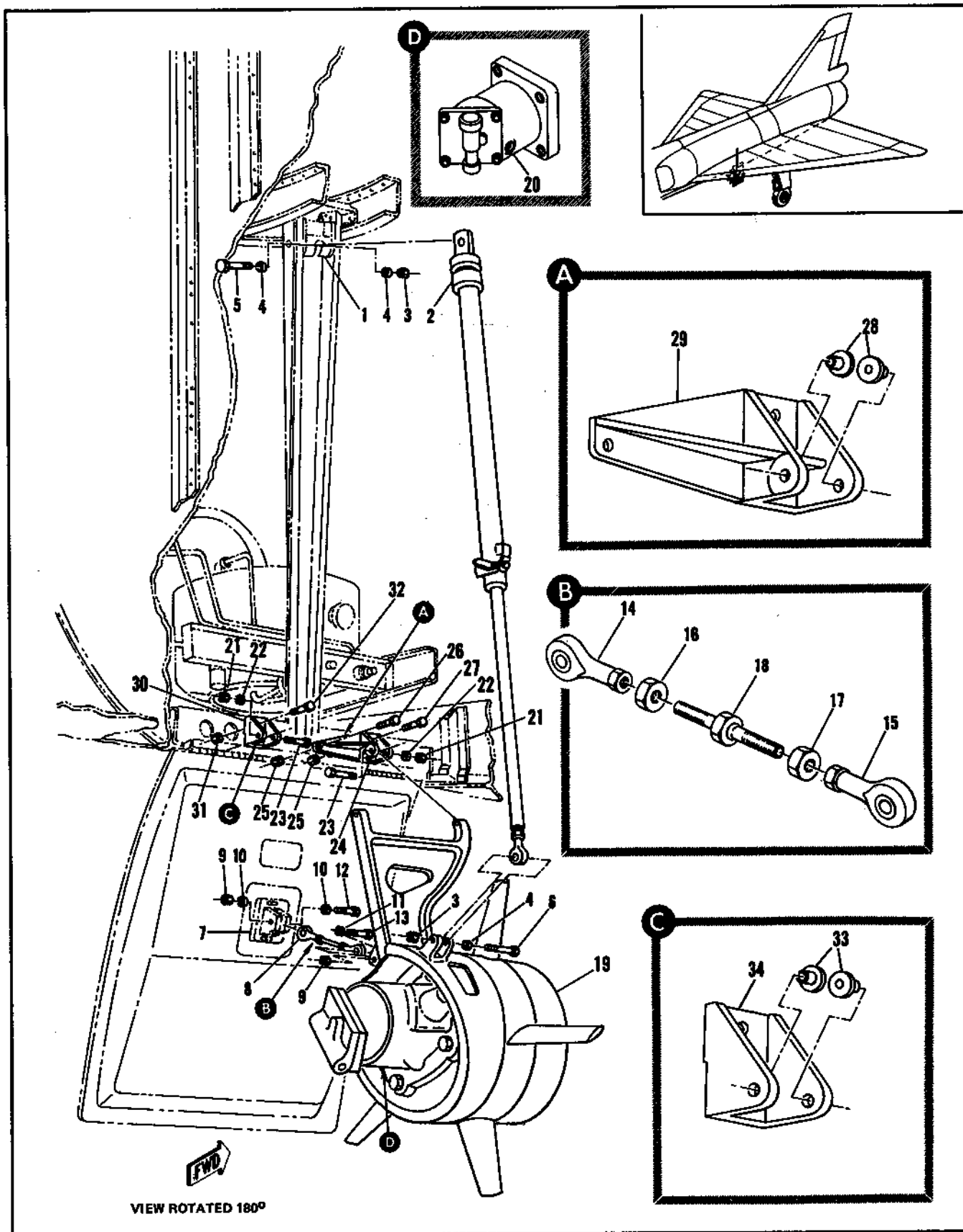

Figure 2.8-7. Ram Air Turbine Installation

FIGURE AND INDEX NUMBER	PART NUMBER	DESCRIPTION 1 2 3 4 5 6	UNITS PER ASSY.	USABLE ON CODE	
				FROM	TO
2.8-7	R-45957	TURBINE INSTALLATION, RAM AIR FOR NHA SEE FIG. 2.3-3	RF	35	
- 1		• SUPPORT, SEE FIG. 2.4-1 INDEX 24	RF		
- 2	10906	• ACTUATOR ASSY, <97395> SPEC R-18945-1 T.O. 9P2-3-29-3 ATTACHING PARTS	1	35	
- 3	NAS679A3	• NUT	2	35	
- 4	AN960916	• WASHER	3	35	
- 5	NAS464-4A34	• BOLT	1	35	
- 5	NAS464-4A14	• BOLT	1	35	
- 7		-----X----- • BRACKET ASSY, TURBINE DOOR LINK ATTACHMENT SEE FIG. 2.F-8 INDEX 15	RF		
- 8	R-44902-1	• ROD ASSY, RAM AIR TURBINE ATTACHING PARTS	1	35	
- 9	NAS679A3	• NUT	2	35	
- 10	AN960-10L	• WASHER	2	35	
- 11	AN960D10	• WASHER	1	35	
- 12	AN3-10A	• BOLT	1	35	
- 13	AN3-12A	• BOLT	1	35	
- 14	HF36	• BEARING <73134> 99-60001-001	1	35	
- 15	HFL3	• BEARING, <73134> 99-60001-002	1	35	
- 16	S8079-205P	• NUT	1	35	
- 17	S8079-206L	• NUT	1	35	
- 18	R-44902-11	• ROD	1	35	
- 19	44102-1	• TURBINE ASSY, HYDRAULIC RAM AIR <70210> SPEC R-00310-1 T.O. 9H7-3-4-14	1	35	
- 20	PF76-3907-30S354	• PUMP, RAM AIR TURBINE T.O. 9H4-5-3-3 ATTACHING PARTS	1	35	
- 21	AN320-4	• NUT	2	35	
- 22	AN960916	• WASHER	2	35	
- 23	NAS464-4-1P	• BOLT	2	35	
- 24	R-45966-1	• FITTING ASSY, RAM AIR TURBINE ATTACHING PARTS	1	35	
- 25	NAS679A3	• NUT	3	35	
- 26	AN3-6A	• BOLT	1	35	
- 27	AN3-6A	• BOLT	2	35	
- 28	91-26003-001	• BUSHING	2	35	
- 29	R-45960-7	• FITTING	1	35	
- 30	R-45963	• FITTING ASSY, RAM AIR TURBINE ATTACHING PARTS	1	35	
- 31	NAS679A3	• NUT	2	35	
- 32	AN3-6A	• BOLT	2	35	
- 33	91-26003-001	• BUSHING	2	35	
- 34	R-45969-7	• FITTING	1	35	

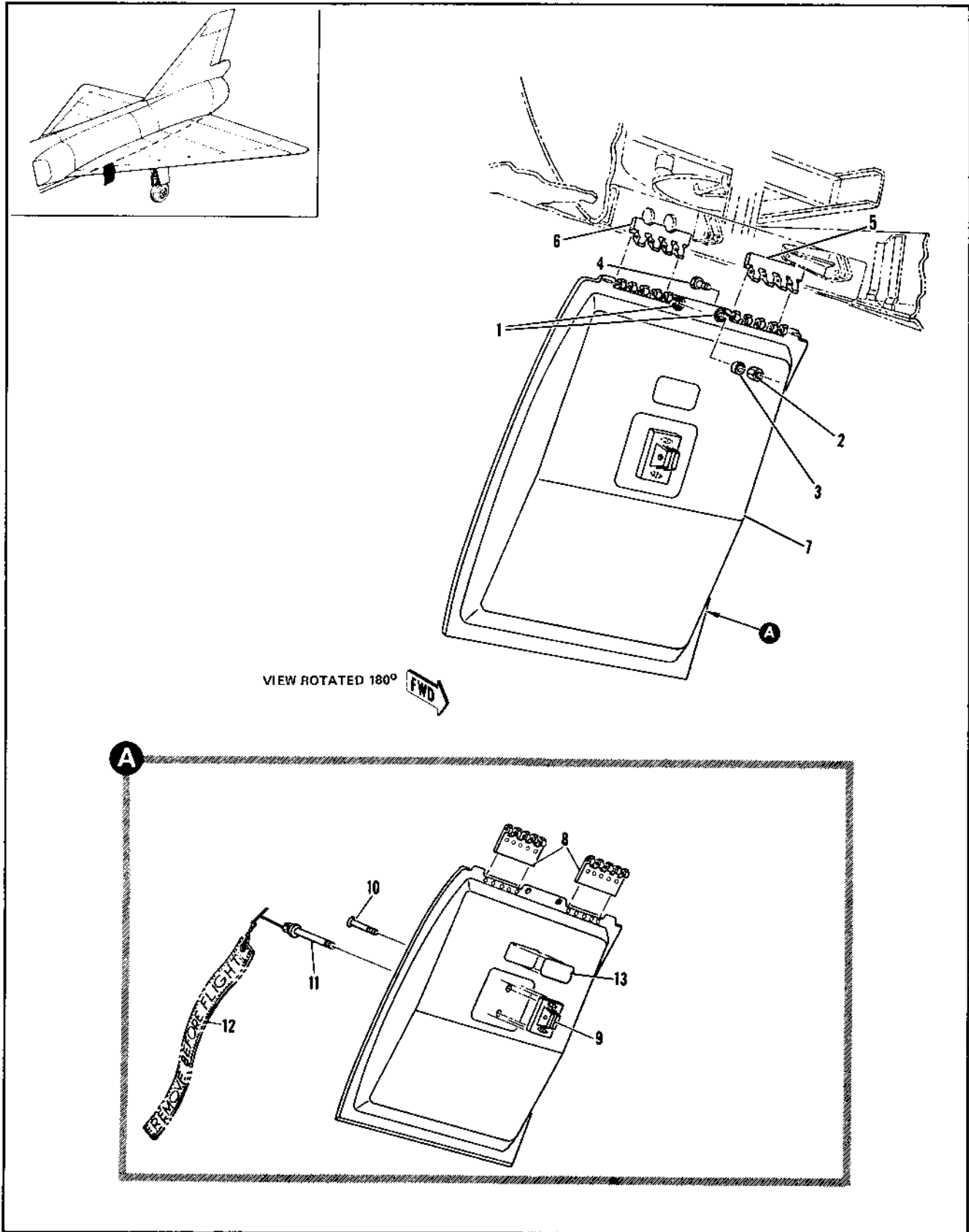

Figure 2.8-8. Ram Air Turbine Door Installation

FIGURE AND INDEX NUMBER	PART NUMBER	DESCRIPTION	UNITS PER ASSY.	USABLE ON CODE	
				FROM	TO
2.8-8	A-45958	DOOR INSTALLATION, RAM AIR TURBINE MODIFIED BY P-44803 FOR NHA SEE FIG. 2.3-3	1	35	
- 1	A-45971	• PIN, HINGE ATTACHING PARTS	2	35	
- 2	NASS79A08	• NUT	2	35	
- 3	AN980-8L	• WASHER	2	35	
- 4	AN539-8R6	• BOLT ----X----	2	35	
- 5	A-45962-7	• HINGE, HALF	1	35	
- 6	A-45962	• HINGE, HALF	1	35	
- 7	A-45958-31	• DOOR ASSY, RAM AIR TURBINE REPLACES SUITABLE SUB FOR A-45958-29	1	61	
- 8	A-45961	• HINGE, HALF	2	35	
- 9	A-45931-3	• BRACKET ASSY, TURBINE DOOR LINK ATTACHMENT RIVETED ATTACHING PARTS	1	35	
- 10	AN509-10929	• SCREW	1	35	
- 11	A-44772	• EYEBOLT ----X----	1	35	
- 12	63052550-1	• TEE HANDLE ASSY, RAM AIR TURBINE, SEE FIG. 2.15-1 INDEX 6	1	35	
- 13	AN7510-1	• NAMEPLATE	1	35	

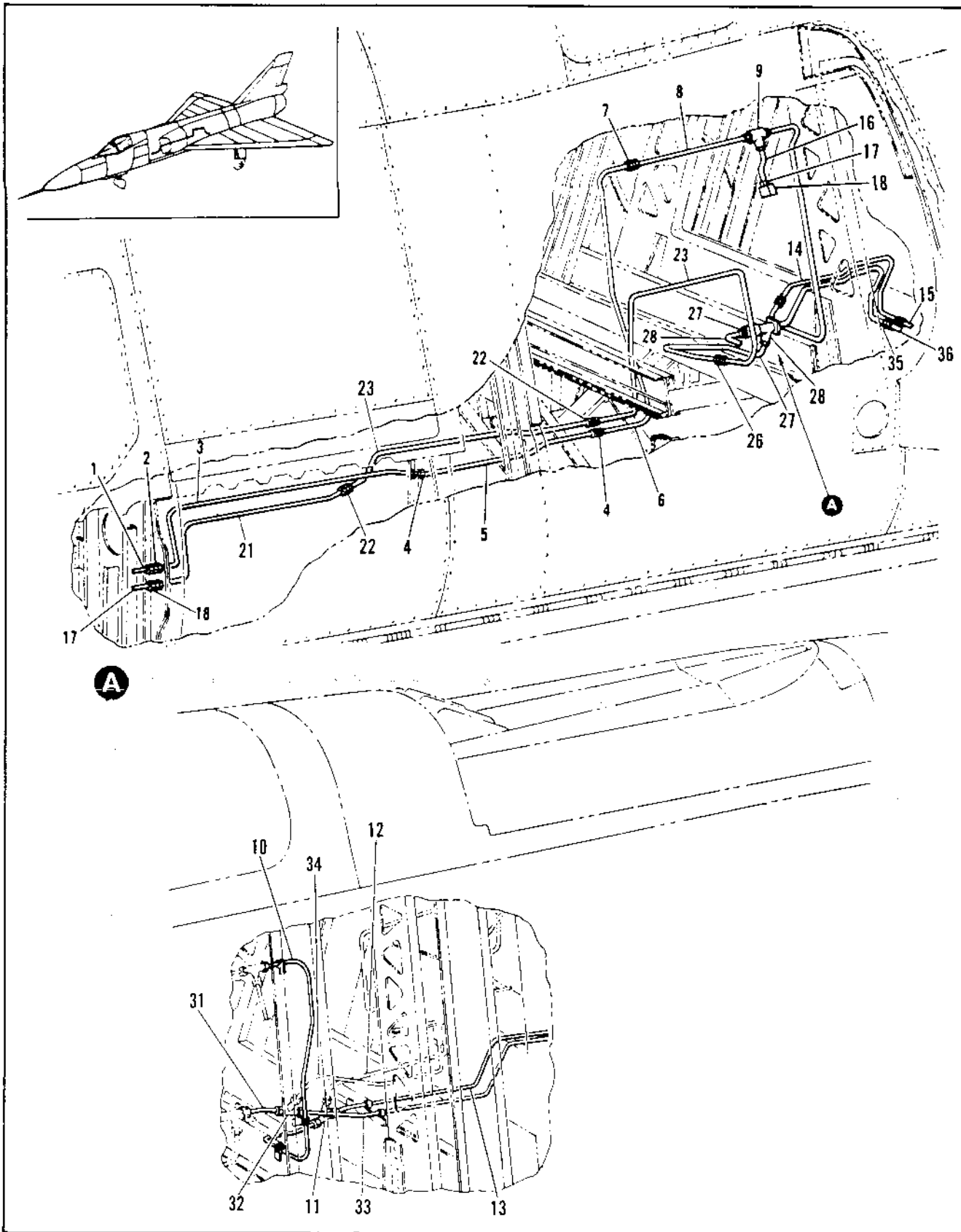

Figure 2.8-9. Power Source Refrigeration Compartment Hydraulic Tubing Installation Sta 216 to 336

FIGURE AND INDEX NUMBER	PART NUMBER	DESCRIPTION	UNITS PER ASSY.	USABLE ON CODE	
				FROM	TO
		1 2 3 4 5 6			
2.8-9	R-80031-R01	TUBING INSTL. POWER SOURCE REFRIGERA- TION COMPARTMENT HYDRAULIC STATION 216 TO 336 MODIFIED BY 66J40297	PF		
	R-80031-R03	TUBING INSTL. POWER SOURCE REFRIGERA- TION COMPARTMENT HYDRAULIC STATION 216 TO 336 MODIFIED BY 66J40277	PF		
	R-80031-R09	TUBING INSTL. POWER SOURCE REFRIGERA- TION COMPARTMENT HYDRAULIC STATION 216 TO 336 MODIFIED BY 66J40297	PF		
- 1		• TUBE ASSY. SEE FIG. 2.8-15 INDEX 22	PF		
- 2	MS21924D4	• UNION	1		35
	AN924-40	• NUT	1		35
	AN9610716	• WASHER	1		35
- 3	R-80031-203	• TUBE ASSEMBLY	1		35
- 4	MS21902D4	• UNION	2		35
	64A34210-1	• TUBE ASSY. HYDRAULIC SYSTEM	1		
- 5	R-80031-305	• TUBE ASSEMBLY	1		35
- 6	R-80031-309	• TUBE ASSEMBLY	1		35
- 7	MS21902D4	• UNION	1		35
- 8	R-80031-301	• TUBE ASSEMBLY	1		35
- 9	MS21905D4	• TEE	1		35
- 11	66A39620-1	• TUBE ASSY	1		
- 11	MS21905D4	• TEE	1		
- 12		• TUBE ASSY. SEE FIG. 2.8-20 INDEX 32	PF		
- 13	66A39617-1	• TUBE ASSY	1		
- 14	R-80031-107	• TUBE ASSEMBLY	1		35
- 15		• TUBE ASSY. SEE FIG. 2.8-10 INDEX 34	PF		
- 16	R-80031-103	• TUBE ASSEMBLY	1		35
- 17	MS21916D6-4	• REDUCER	2		35
	A66290-6	• GASKET	1		35
- 18		• VALVE ASSY. HYDRAULIC SHUT OFF STA 308 SPEC FIG. 2.11-8 INDEX 5	PF		
- 19		• TUBE ASSY. SEE FIG. 2.8-15 INDEX 19	PF		
- 20	MS21924D4	• UNION	1		35
	AN924-40	• NUT	1		35
	AN9610716L	• WASHER	1		35
- 21	R-80031-221	• TUBE ASSEMBLY	1		35
- 22	MS21902D4	• UNION	1		35
- 23	64A34210-1	• TUBE ASSY. HYDRAULIC SYSTEM	1		
- 24	MS21902D4	• UNION	1		35
- 25	R-80031-105	• TUBE ASSEMBLY	1		35
- 26	MS21916D6-4	• REDUCER	1		35
- 27	R-80031-303	• TUBE ASSEMBLY	1		35
- 28	MS21911D4	• TEE	1		35
	AN924-60	• NUT	1		35
	AN9610911L	• WASHER	1		35
	A66290-6	• GASKET	1		35
- 29	1112-589401	• VALVE ASSY. CHECK (92.13) SPEC R-08450-106 T.O. 9H6-6-6-23	1		35
- 30		• TUBE ASSY. SEE FIG. 2.8-17 INDEX 36	PF		
- 31	66A39619-1	• TUBE ASSY	1		
- 32	ER81406-5-4	• TEE (92103)	1		
- 33	66A39618-1	• TUBE ASSY	1		
- 34		• TUBE ASSY. SEE FIG. 2.8-29 INDEX 2	PF		
- 35	MS21912D6	• UNION	1		35
- 36		• TUBE ASSY. SEE FIG. 2.8-10 INDEX 3	PF		

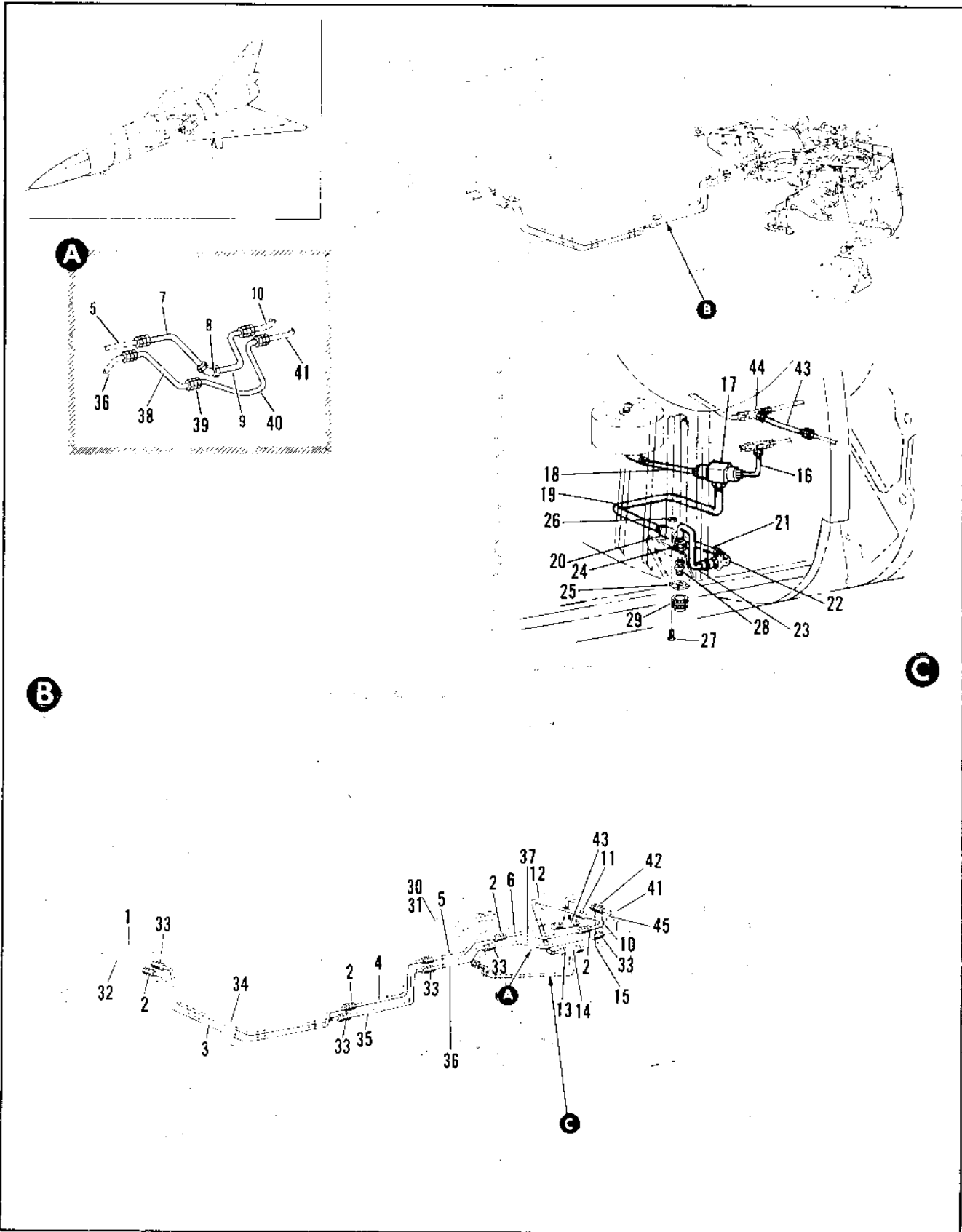

Figure 2.8-10. Power Source Hydraulic Tubing Installation Sta 316 to 472 (Sheet 1 of 8)

FIGURE AND INDEX NUMBER	PART NUMBER	DESCRIPTION	UNITS PER ASSY.	USABLE ON CODE	
				FROM	TO
2.8-10	8-80031-801	TUBING INSTALLATION, POWER SOURCE HYDRAULIC STA 316 TO 472 MODIFIED BY 8-80109	PF	35	49
	8-80031-803	TUBING INSTALLATION, POWER SOURCE HYDRAULIC STA 316 TO 472	PF	49	61
	8-80031-809	TUBING INSTALLATION, POWER SOURCE HYDRAULIC STA 316 TO 472	PF	61	
- 1		• TUFF ASSY, SEE FIG. 2.8-3 INDEX 30	PF		
- 2	MS21902D6	• UNION	5	35	
- 3	8-80031-91	• TUBE ASSEMBLY	1	35	
- 4	8-80031-85	• TUBE ASSEMBLY	1	35	
- 5	8-80031-87	• TUBE ASSEMBLY	1	35	
- 6	8-80031-89	• TUBE ASSEMBLY	1	35	89
- 7	8-80031-553	• TUBE ASSEMBLY	1	90	
- 8	MS21907D6	• ELBOW	1	90	
	AN924-60	• NUT	1	90	
	AN960D916	• WASHER	1	90	
- 9	8-80031-555	• TUBE ASSEMBLY	1	90	
- 10	8-80031-41	• TUBE ASSEMBLY	1	35	
- 11	MS21902D6	• UNION	1	35	
- 12	8-80031-39	• TUBE ASSEMBLY	1	35	
- 13	MS21916D10-6	• REDUCER	1	35	
	AN6290-10	• BASKET	1	35	
- 14	MS21911D10	• TEE	1	35	
	AN924-100	• NUT	1	35	
	AN96101416	• WASHER	1	35	
- 15		• TUBE ASSY, SEE FIG. 2.8-11 INDEX 44	PF		
- 16	7144813-01	• TUBE ASSY	1		
- 17	ER8240101016	• TEE (92003)	1		
- 18	7144812-01	• TUBE ASSY	1		
- 19	7144814-01	• TUBE ASSY	1		
- 20	MS28892-16	• VALVE, CHECK	1		
- 21	7144815-01	• TUBE ASSY	1		
- 22	MS21908D1E	• ELBOW	1		
	AN924-160	• NUT	1		
	AN96101416	• WASHER	1		
- 23	7144814-01	• TUBE ASSY	1		
- 24	AN924-160	• NUT	1		
- 25	MS24335-16	• FLANGE	1		
		ATTACHING PARTS			
- 26	MS21042L3	• NUT	4		
- 27	AN502-15-6	• SCREW	4		
		-----X-----			
- 28	3302-16	• COUPLING, HALF (10624)	1		
- 29	3207-16	• CAP, GUST. PRESSURE (10624)	1		
- 30	MS21902D19	• UNION	1	35	
- 31	AN6290-10	• BASKET	1	35	
		• RESERVOIR ASSY, SECONDARY HYDRAULIC SEE FIG. 2.8-3	PF		
- 32		• TUBE ASSY, SEE FIG. 2.8-9 INDEX 14	PF		
- 33	MS21902D4	• UNION	5	35	
- 34	8-80031-93	• TUBE ASSEMBLY	1	35	
- 35	8-80031-95	• TUBE ASSEMBLY	1	35	
- 36	8-80031-97	• TUBE ASSEMBLY	1	35	
- 37	8-80031-99	• TUBE ASSEMBLY	1	35	39
- 38	8-80031-557	• TUBE ASSEMBLY	1	35	

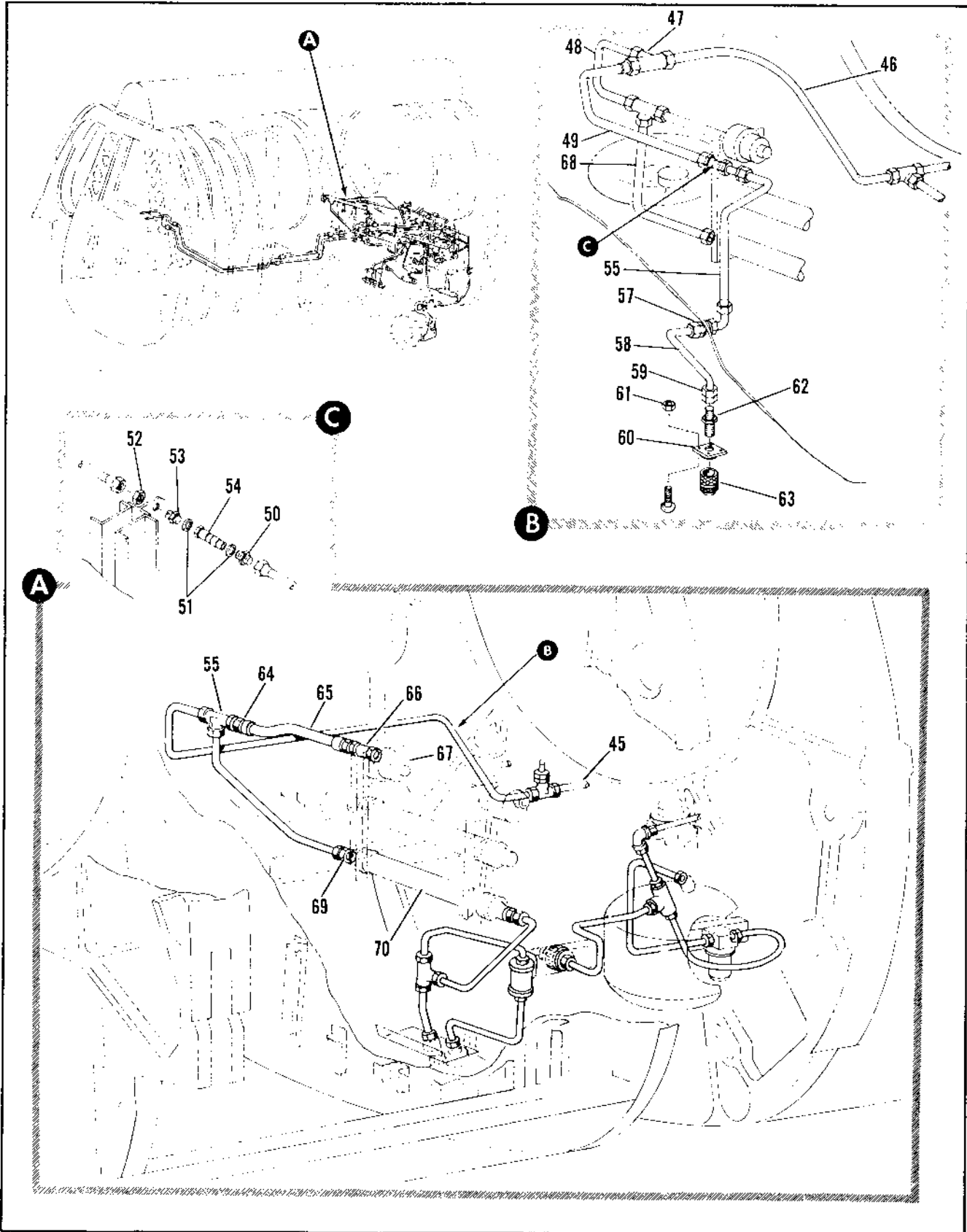

Figure 2.8-10. Power Source Hydraulic Tubing Installation Sta 316 to 472 (Sheet 2 of 8)

FIGURE AND INDEX NUMBER	PART NUMBER	DESCRIPTION	UNITS PER ASSY.	USABLE ON CODE	
				FROM	TO
2.8-10-39	MS2190304	• UNION	1	90	
	AN924-40	• NUT	1	90	
	AN9600716	• WASHER	1	90	
- 40	8-80031-50	• TUBE ASSEMBLY	1	35	
- 41	8-80031-33	• TUBE ASSEMBLY	1	35	
- 42	MS2190204	• UNION	1	35	
- 43	7144805-01	• TUBE ASSY	1		
- 44	ER9240121204	• TEE (92103)	1		
	AN924-12	• NUT	1		
	AN9600716	• WASHER	1		
- 45		• TUBE ASSY, SEE FIG. 2.8-11	1		
- 46	7144808-01	• TUBE ASSY	1		
- 47	ER9240121204	• TEE (92103)	1		
- 48	7144808-01	• TUBE ASSY	1		
- 49	7144810-01	• TUBE ASSY	1		
	7144827-10	• VALVE INSTL, HYDRAULIC, FLOW CONTROL	1		
- 50	MS21902D12	• UNION	1		
- 51	MS29778-12	• PACKING	1		
- 52	AN924-12	• NUT	1		
	NAS1252-1716H	• WASHER	1		
- 53	MS22924012	• UNION	1		
- 54	4845	• VALVE CONTROL, HYD FLOW (99643)	1		
- 55	7144811-01	• TUBE ASSY	1		
- 56	MS2191108	• TEE	1		
	AN924-80	• NUT	1		
	AN56101216	• WASHER	1		
- 57	MS21908D12	• ELBOW	1		
	NAS1252-1716H	• WASHER	1		
	AN924-120	• NUT	1		
- 58	7144817-01	• TUBE ASSY	1		
- 59	AN924-120	• NUT	1		
- 60	MS24535-12	• FLANGE	1		
		ATTACHING PARTS			
- 61	MS21142L3	• NUT	4		
	AN502-10-6	• SCREW	4		
- 62	3392-12	• COUPLING, HALF (02624)	1		
- 63	3207-12	• CAP, DUST, PRESSURE (00524)	1		
- 64	MS2191600-4	• REDUCER	1	35	
	AN6290-8	• GASKET	1	35	
- 65	R295200-4-0062	• HOSE ASSY, <50599> 94-81542-001	1	35	
	677732-4-0062	• HOSE ASSY, <10599> 94-87548-124 ALT INTCHG WITH R295200-4-0062	1	35	
- 66	S7441	• SNOOBER ASSY, <91207> SPEC 1-80245	1	35	
	AN6290-4	• GASKET	1	35	
- 67		• TRANSMITTER AND SWITCH ASSY, SECONDARY HYDRAULIC PRESSURE SEE FIG. 2.8-2 INDEX 5	1		
- 68	7144807-01	• TUBE ASSY	1	35	
- 69	MS2190208	• UNION	1	35	
	AN6290-8	• GASKET	1	35	
- 70		• ACCUMULATOR ASSY, SECONDARY HYDRAULIC SEE FIG. 2.8-2 INDEX 11	1		
		A AIRPLANES 435 THRU 246, 249, 290, 292 THRU 294, 298, 300, 310, 313 AND ON			
		B AIRPLANES 2247, 225, 241, 205 THRU 257, 259, AND 302			

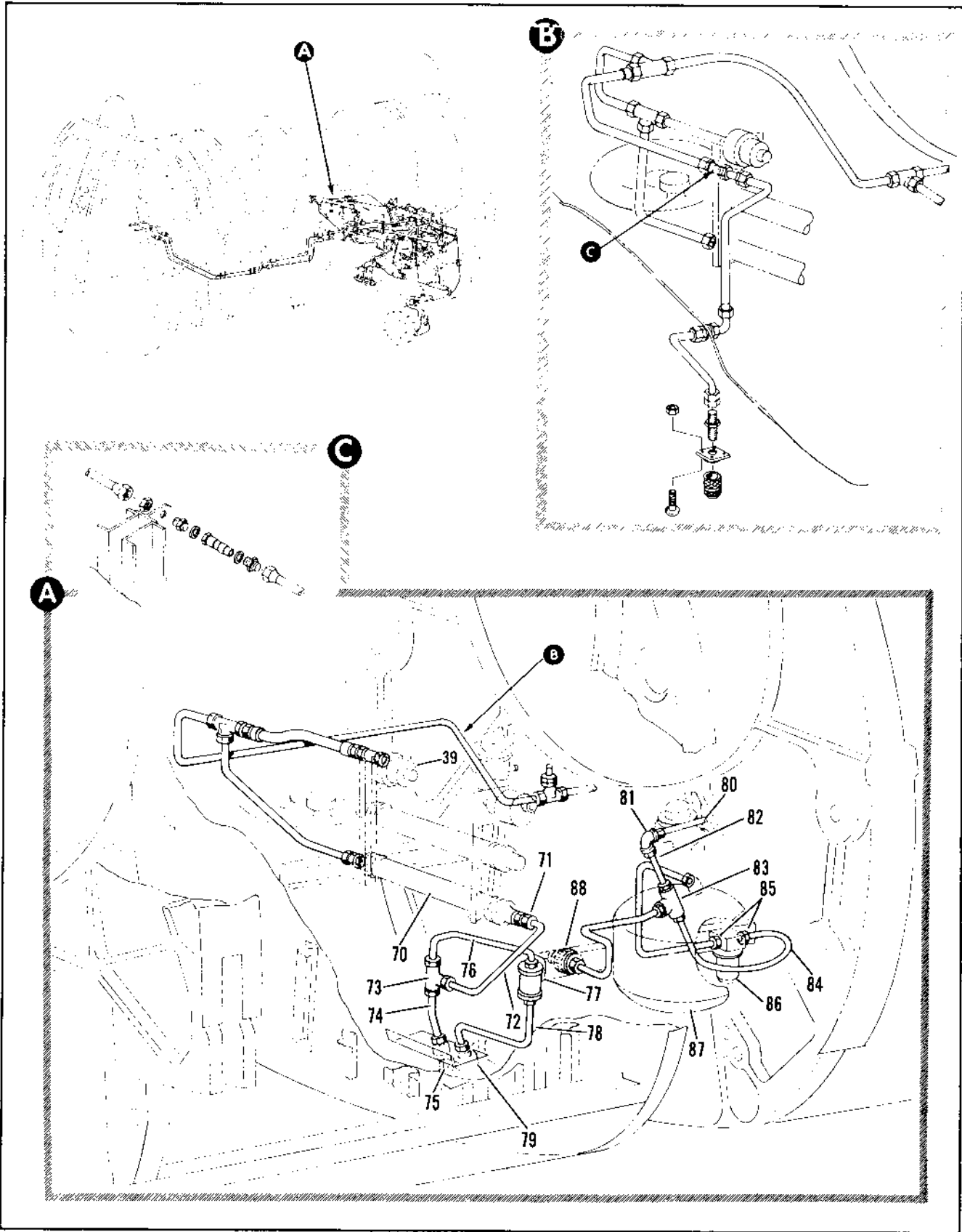

Figure 2.8-10. Power Source Hydraulic Tubing Installation Sta 316 to 472 (Sheet 3 of 8)

FIGURE AND INDEX NUMBER	PART NUMBER	DESCRIPTION 1 2 3 4 5 6	UNITS PER ASSY.	USABLE ON CODE	
				FROM	TO
2.8-10- 71	MS2191605-4	• REDUCER	1	35	
- 72	AN6299-5	• GASKET	1	35	
- 73	8-80031-327	• TUBE ASSEMBLY	1	35	60
- 74	8-80031-577	• TUBE ASSEMBLY	1	61	
- 75	MS2190504	• TEE	1	35	
- 76	8-80031-323	• TUBE ASSEMBLY	1	35	60
- 77	8-80031-573	• TUBE ASSEMBLY	1	61	
- 78	8-80031-349	• VALVE ASSY, HIGH PRESSURE CHARGING SEE FIG. 2.8-3 INDEX 20	PF		
- 79	8-80031-349	• TUBE ASSEMBLY	1	35	60
- 80	8-80031-583	• TUBE ASSEMBLY	1	61	
- 81	S1443	• DAMPENER, <91277> 92-91393-103	1	35	
- 82	8-80031-325	• TUBE ASSEMBLY	1	35	60
- 83	8-80031-575	• TUBE ASSEMBLY	1	61	
- 84	MS2190706	• GAUGE, SECONDARY HYDRAULIC PRESSURE ACCUMULATOR SEE FIG. 2.8-3 INDEX 17	PF		
- 85	AN924-60	• TUBE ASSY SEE FIG. 2.8-11 INDEX 74	PF		
- 86	AN9600916	• ELBOW	1	35	
- 87	8-80031-443	• NUT	1	35	
- 88	ER8240061604	• WASHER	1	35	
- 89	8-80031-447	• TUBE ASSEMBLY	1	35	
- 90	MS2191605-4	• TEE, <92103> 98-90017-009	1	35	
- 91	AN6299-4	• TUBE ASSEMBLY	1	35	
- 92	8-82433-121	• REDUCER	2	35	
- 93		• GASKET	2	35	
- 94		• FILTER ASSY, SEE FIG. 2.8-4 INDEX 4	PF		
- 95		• RESERVOIR ASSY, PRIMARY HYDRAULIC SEE FIG. 2.8-4 INDEX 1	PF		
- 96		• TUBE ASSEMBLY	1		F
- 97		• COUPLING, PRIMARY QUICK DISCONNECT SEE FIG. 2.8-3 INDEX 15	PF		

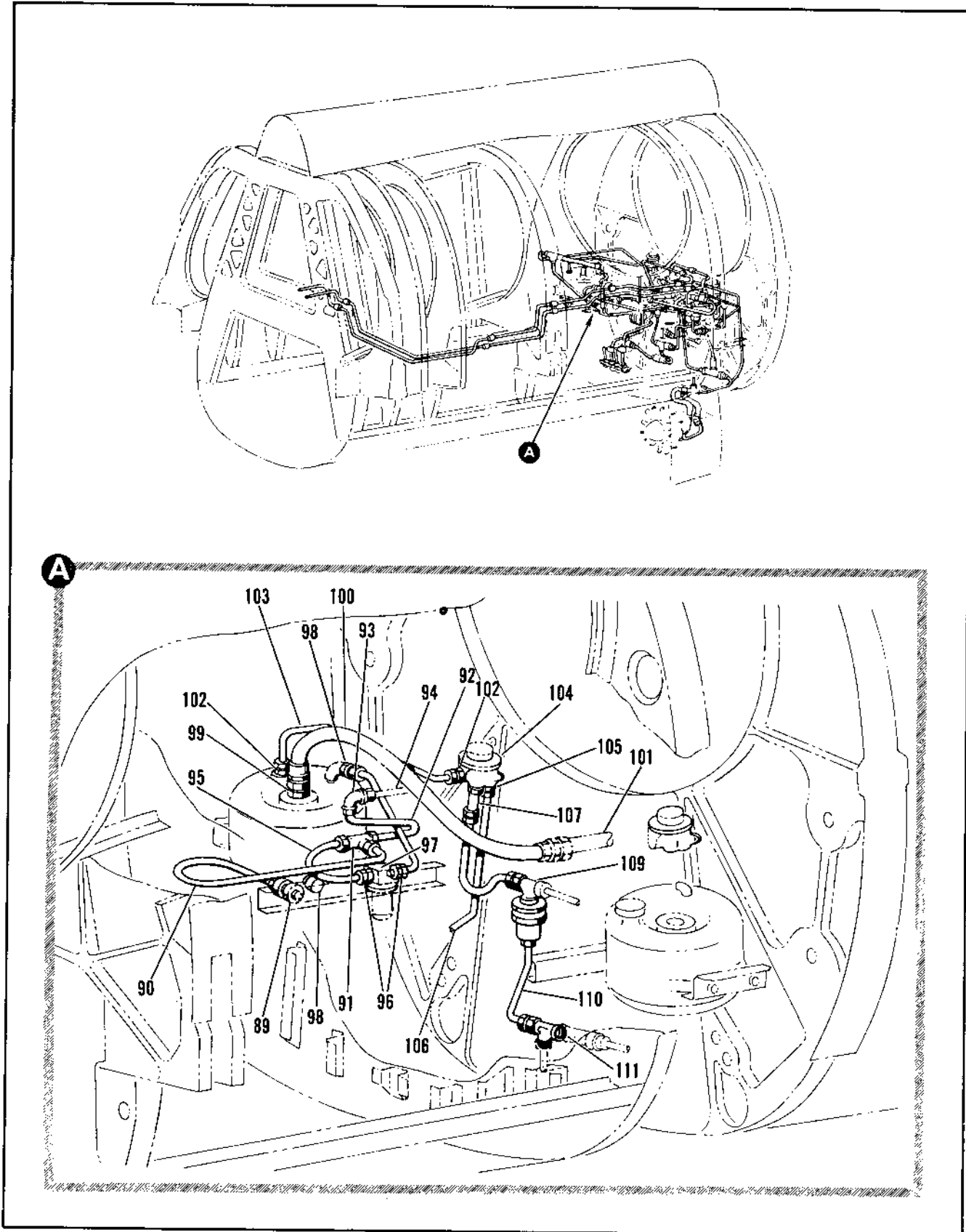

Figure 2.8-10. Power Source Hydraulic Tubing Installation Sta 316 to 472 (Sheet 4 of 8)

FIGURE AND INDEX NUMBER	PART NUMBER	DESCRIPTION	UNITS PER ASSY.	USABLE ON CODE	
				FROM	TO
2.8-10- 89		• COUPLING, SECONDARY QUICK DISCONNECT SEE FIG. 2.8-4 INDEX 15	BF		
- 90	R-80331-441	• TUBE ASSEMBLY	1	35	
- 91	ERR240861604	• TEE, <92137> 90-90319-108	1	35	40
- 92	R-80331-453	• TUBE ASSEMBLY	1	35	
	8-80331-547	• TUBE ASSEMBLY	1	31	
- 93	MS21907D6	• ELBOW	1	35	
	AN924-00	• NUT	1	37	
	AN9610914	• WASHER	1	35	
- 94		• TUBE ASSY, SEE FIG. 2.8-10 INDEX 90	BF		
- 95	R-80331-457	• TUBE ASSEMBLY	1	35	
- 96	MS21916D6-4	• REDUCER	2	35	
	AN6290-4	• GASKET	2	35	
- 97		• FILTER ASSY, SEE FIG. 2.8-4 INDEX 6	BF		
- 98	MS21913D6	• PLUG	1	35	
	AN6290-6	• GASKET	1	35	
- 99	MS21902D16	• UNION	1	30	
	AN6290-14	• GASKET	1	30	
-100	R203-7-3	• HOSE ASSY, SECONDARY HYDRAULIC RESERVOIR SUCTION <81599> SPEC 4-21400-3	1	35	
-101		• TUBE ASSY, SEE FIG. 2.8-11 INDEX 90	BF		
-102	MS21912D4	• UNION	2	35	
	AN6290-5	• GASKET	2	35	
-103	R-80331-293	• TUBE ASSEMBLY	1	35	
-104		• REGULATOR ASSY, SECONDARY HYDRAULIC RESERVOIR AIR PRESSURE SEE FIG. 2.8-11 INDEX 9	BF		
-105	MS21916D11-8	• REDUCER	1	35	
	AN6290-8	• GASKET	1	35	
-106	R-80331-477	• TUBE ASSEMBLY	1	35	
-107	300830-1	• VALVE ASSY, PNEUMATIC CHECK <99224> SPEC 4-20420-1 T.O. 308-12-30-13	1	35	
	AN6290-4	• GASKET	1	35	
-108	R-80331-17	• TUBE ASSEMBLY	1	35	40
	6-80331-473	• TUBE ASSEMBLY	1	31	
-109	MS21913D9	• TEE	1	35	
	AN904-40	• NUT	1	35	
	AN9610916	• WASHER	1	35	
-110	R-80331-13	• TUBE ASSEMBLY	1	35	50
-111	MS21911D4	• TEE	1	35	50
	MS21913D4	• TEE	1	31	
	AN9610917	• WASHER	2	35	
	AN6290-4	• GASKET	2	35	
		A AIRPLANE 835 THRU 286, 289, 290, 292 THRU 294, 299, 300, 301, 303 AND ON			
		C AIRPLANE 861 THRU 286, 290, 291, 292 THRU 294, 299, 300, 301, 303 AND ON			

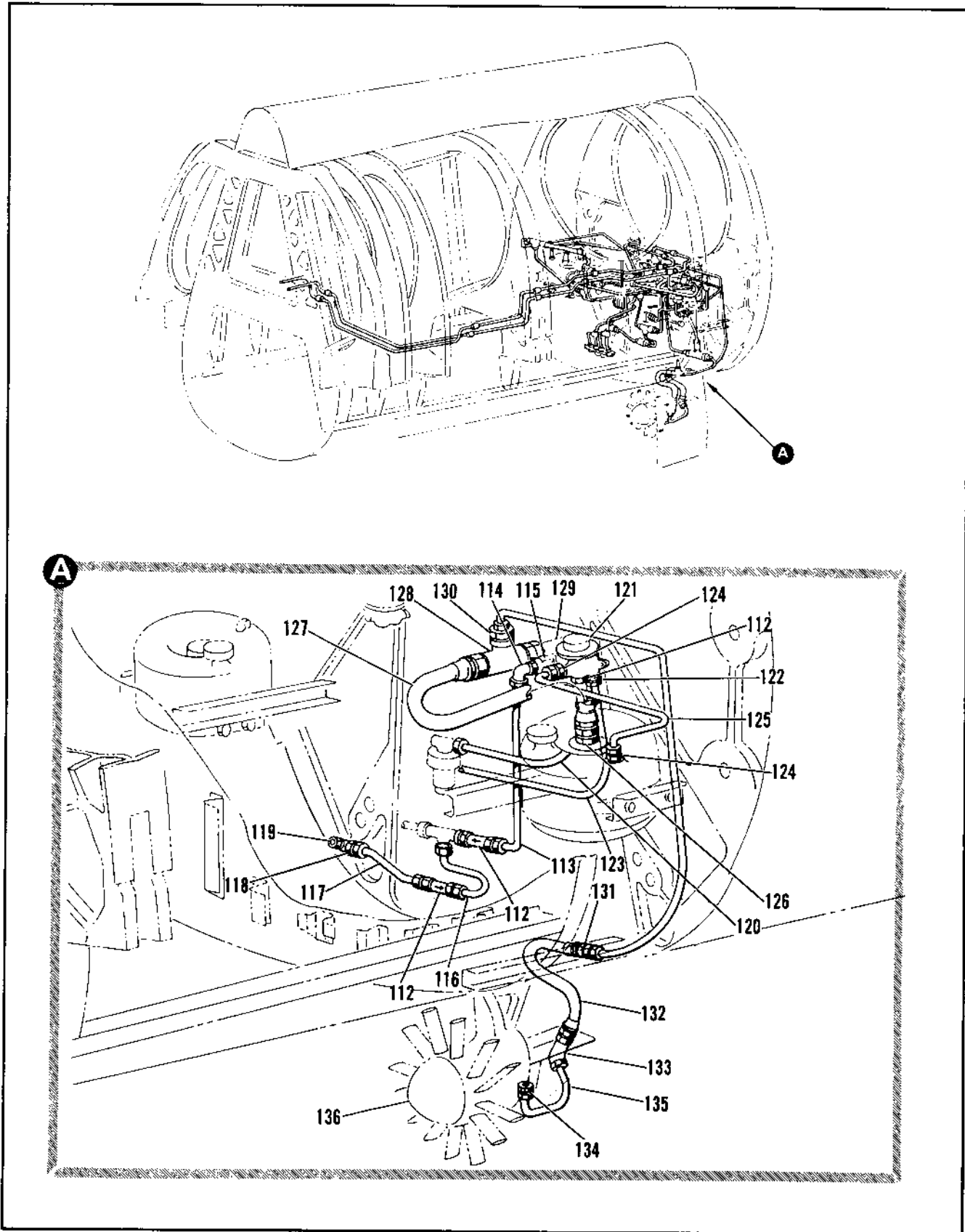

Figure 2.8-10. Power Source Hydraulic Tubing Installation Sta 316 to 472 (Sheet 5 of 8)

FIGURE AND INDEX NUMBER	PART NUMBER	DESCRIPTION	UNITS PER ASSY.	USABLE ON CODE	
				FROM	TO
2.8-10-112	360330-1	• VALVE ASSY, PNEUMATIC CHECK <99224> SPEC R-01430-1 T.O. 8P5-12-36-13	3	35	
-113	R-80031-7	• TUBE ASSEMBLY	1	35	60
	R-80031-463	• TUBE ASSEMBLY	1	61	49
	R-80031-561	• TUBE ASSEMBLY	1	40	
-114	MS21907D4	• ELBOW	1	35	
	AN924-40	• NUT	1	35	
	AN9510716	• WASHER	1	35	
-115		• TUBE ASSY, SEE FIG. 2.8-11 INDEX 69	PF		
-116	R-80031-465	• TUBE ASSEMBLY	1	61	
-117	R-80031-11	• TUBE ASSEMBLY	1	35	6
	R-80031-467	• TUBE ASSEMBLY	1	61	
-118	MS21908D4	• ELBOW	1	35	
	AN924-40	• NUT	1	35	
	AN9510716	• WASHER	1	35	
-119	MS21914-4	• CAP	1	35	
-120	R-80031-373	• TUBE ASSEMBLY	1	35	60
	R-80031-471	• TUBE ASSEMBLY	1	61	
-121		• REGULATOR ASSY, PRIMARY HYDRAULIC RESERVOIR AIR PRESSURE SEE FIG. 2.8-1 INDEX 4	PF		
-122	MS21916D10-R	• REDUCER	1	35	
	AN6290-8	• GASKET	1	35	
-123	R-80031-475	• TUBE ASSEMBLY	1	35	
-124	MS21902D8	• UNION	2	35	
	AN6290-8	• GASKET	2	35	
-125	R-80031-375	• TUBE ASSEMBLY	1	35	
-126	MS21902D16	• UNION	1	35	
	AN6290-16	• GASKET	1	35	
-127	R20017-4	• HOSE ASSY, PRIMARY HYDRAULIC RESERVOIR SUCTION <50559> SPEC R-01451-4	1	35	
-128	MS21917D18	• TEE	1	35	
	AN924-160	• NUT	1	35	
	AN95102116	• WASHER	1	35	
-129		• TUBE ASSY, SEE FIG. 2.8-11 INDEX 69	PF		
-130	MS21916D16-10	• REDUCER	1	35	
	AN6290-16	• GASKET	1	35	
-131	MS21903D10	• UNION	1	35	
	AN924-100	• NUT	1	35	
	AN95101414	• WASHER	1	35	
-132	R9870-10-0154	• HOSE ASSY, <50559> 94--1522-129	1	35	
-133	MS21907D10	• ELBOW	1	35	
	AN924-100	• NUT	1	35	
	AN95101414	• WASHER	1	35	
-134	MS21916D12-R	• REDUCER	1	35	
	AN6290-8	• GASKET	1	35	
-135	R-80031-55	• TUBE ASSEMBLY	1	35	
-136		• TURBINE ASSY, HYDRAULIC RAM AIR SEE FIG. 2.8-7 INDEX 2.	PF		
		C AIRPLACES #81 THRU 286, 289, 290, 292 THRU 294, 296, 300, 301, 303 AND ON			

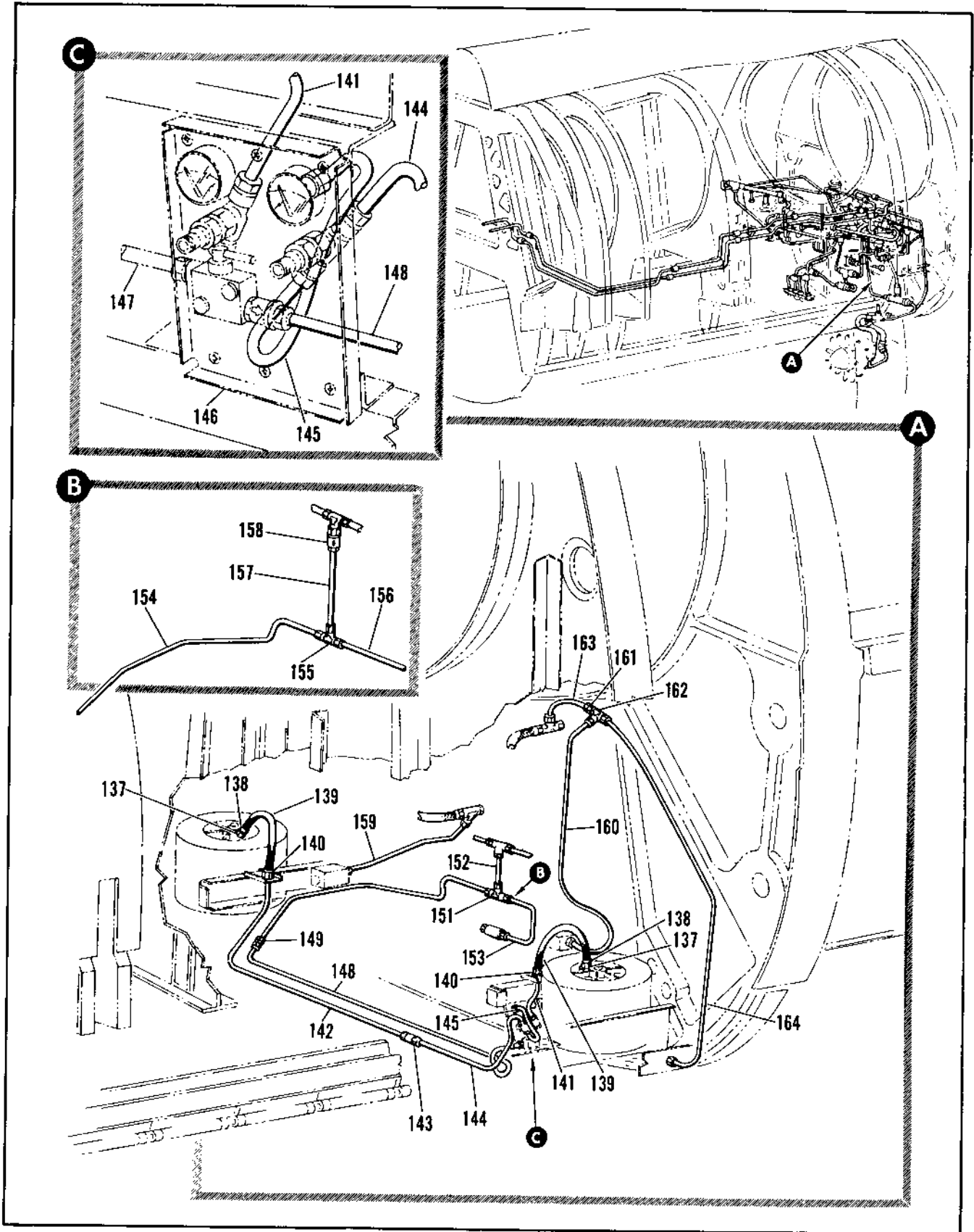

Figure 2.8-10. Power Source Hydraulic Tubing Installation Sta 316 to 472 (Sheet 6 of 8)

FIGURE AND INDEX NUMBER	PART NUMBER	DESCRIPTION	UNITS PER ASSY.	USABLE ON CODE	
				FROM	TO
		1 2 3 4 5 6			
2.8-10-137	AN815-30	• UNION	2		
-138	8-82404	• ADAPTER, HYDRAULIC RESERVOIR TUBE FITTING	2		
	AN6290-4	• GASKET	2		
-139	MS28741-3-1094	• HOSE ASSEMBLY, MANUFACTURE FROM #4 BULK HOSE AND #3 FITTINGS	2		
-140	MS21923D3	• UNION	2		
	AN924-3D	• NUT	2		
	AN961061b	• WASHER	2		
-141	8-82403-135	• TUBE ASSEMBLY	1		
-142	8-82403-127	• TUBE ASSEMBLY	1		
-143	MS21902D3	• UNION	1		
-144	8-82403-125	• TUBE ASSEMBLY	1		
-145	8-82403-131	• TUBE ASSEMBLY	1		
-146		• PANEL ASSY, HYDRAULIC RESERVOIR PRESSURE SEE FIG. 2.8-6 INDEX 19	WF		
-147	8-82403-123	• TUBE ASSY, HYDRAULIC HOIST SEE FIG. 2.9-32 INDEX 27	WF		
-148	8-82403-129	• TUBE ASSEMBLY	1		
-149	MS21916D4-3	• REDUCER	1		
-150	8-82403-97	• TUBE ASSEMBLY	1		
-151	MS21905D4	• TEE	1		
-152	8-82403-98	• TUBE ASSEMBLY	1		
-153	8-82403-99	• TUBE ASSY	1		
-154	8-82403-115	• TUBE ASSEMBLY	1		
-155	MS21905D4	• TEE	1		
-156	8-82403-111	• TUBE ASSEMBLY	1		
-157	8-82403-113	• TUBE ASSEMBLY	1		
-158	5H567-1	• FILTER ASSY, AIR (<1321> SPEC R-28679-1 (ASSEMBLE FROM)	1		
	5H567	• FILTER	1		
	750000	• ELEMENT	1		
	AN6290-12	• GASKET	1		
	MS28775-3-16	• PACKING	1		
-159	8-82403-107	• TUBE ASSEMBLY	1		
-160	8-82403-105	• TUBE ASSEMBLY	1		
-161	MS21916D17-6	• REDUCER	1		
	AN6290-10	• GASKET	1		
-162	MS21910F10	• TEE	1		
-163	8-82403-103	• TUBE ASSEMBLY	1		
-164	8-82403-101	• TUBE ASSEMBLY	1		
		B AIRPLANES #287, 288, 291, 295 THRU 297 299, AND 302			

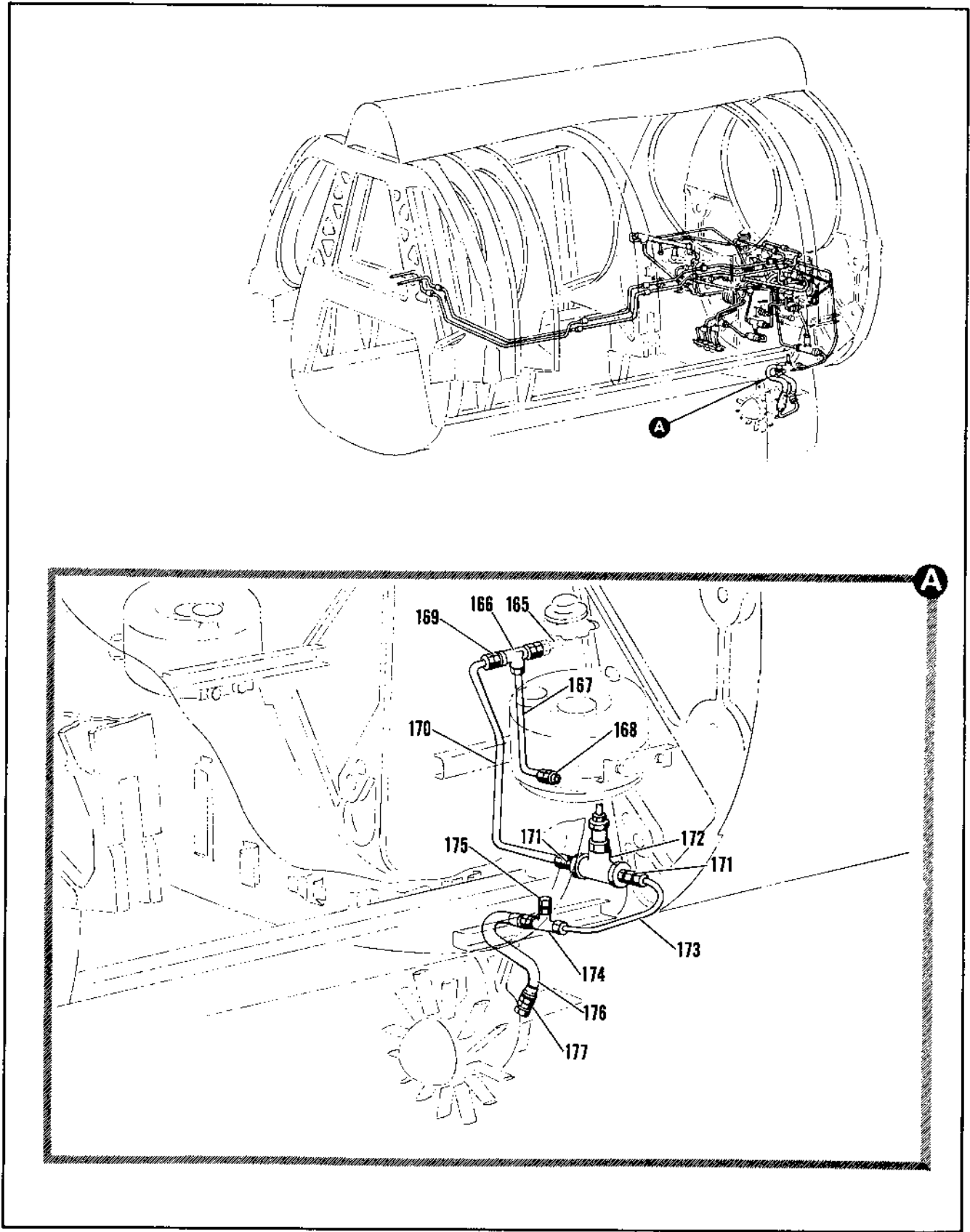

Figure 2.8-10. Power Source Hydraulic Tubing Installation Sta 316 to 472 (Sheet 7 of 8)

FIGURE AND INDEX NUMBER	PART NUMBER	DESCRIPTION	UNITS PER ASSY.	USABLE ON CODE	
				FROM	TO
		1 2 3 4 5 6			
2.8-10-165		• TUBE ASSY. SEE FIG. 2.8-11 INDEX 75	RF		
-166	MS21911010	• TEE	1	35	
	AN924-100	• NUT	1	35	
	AN96101419	• WASHER	1	35	
-167	R-80031-303	• TUBE ASSEMBLY	1	35	
-168	MS21902010	• UNION	1	35	
	AN6290-10	• GASKET	1	35	
-169	MS21918D10-6	• REDUCER	1	35	
	AN6290-10	• GASKET	1	35	
-170	R-80031-49	• TUBE ASSEMBLY	1	35	60
	R-80031-44B	• TUBE ASSEMBLY	1	61	
-171	MS2190306	• UNION	2	35	
	AN924-60	• NUT	2	35	
	AN9610916	• WASHER	2	35	
	AN6290-6	• GASKET	2	35	
-172	12400-1	• REGULATOR ASSY. HYD SENSITIVE PRESSURE <79294> SPEC 8-88462-1 T.O. 9HR-16-25-13	1	35	
-173	R-80031-58	• TUBE ASSEMBLY	1	35	60
	R-80031-409	• TUBE ASSEMBLY	1	61	
-174	MS2191206	• TEE	1	35	
	AN924-60	• NUT	1	35	
	AN9610916	• WASHER	1	35	
-175	MS21914-6	• CAP	1	35	
-176	R295800-8-0160	• HOSE ASSY. <90599> 94-80542-012 REPLACES INTCH6 WITH YR5P10-6-0160	1	35	
	677032-6-0160	• HOSE ASSY. <00624> 94-90554-081 ALT INTCH6 WITH R295800-8-0160	RF	35	
-177	MS2190306	• UNION	1	35	
	AN924-60	• NUT	1	35	
	AN6290-6	• GASKET	1	35	

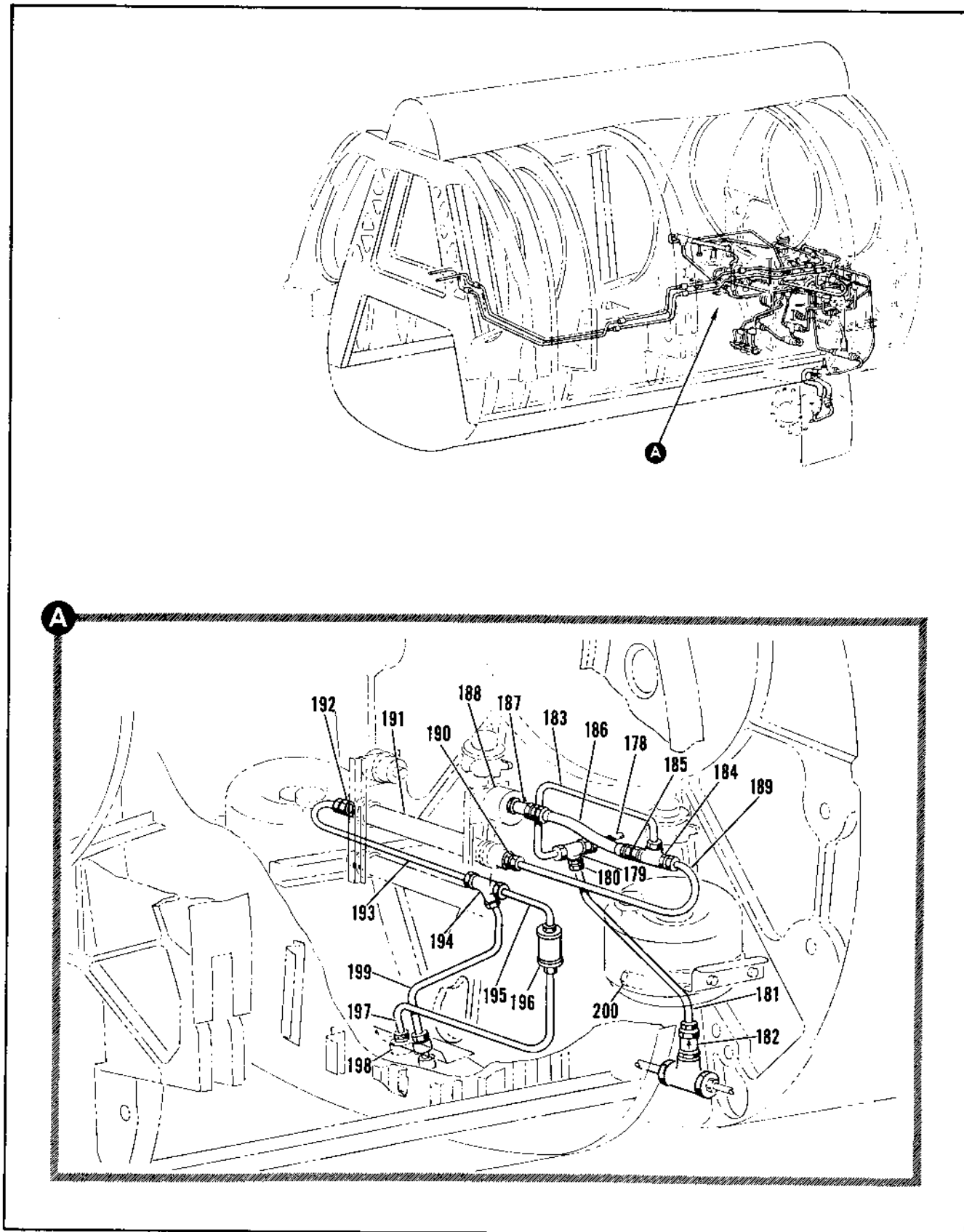

Figure 2.8-10. Power Source Hydraulic Tubing Installation Sta 316 to 472 (Sheet 8 of 8)

FIGURE AND INDEX NUMBER	PART NUMBER	DESCRIPTION	UNITS PER ASSY.	USABLE ON CODE	
				FROM	TO
2.8-10-178			40		
-175	MS219100A	• TUBE ASSY, SEE FIG. 2.4-11 INDEX 65	1	45	
	AN924-80	• TEE	1	35	
	AN9670121A	• NUT	1	35	
-180	MS219160A-6	• WASHER	1	35	
	AN6290-8	• REDUCER	1	35	
-181	8-80031-57	• GASKET	1	35	
	8-80031-487	• TUBE ASSEMBLY	1	35	63
-182	4CV464	• TUBE ASSEMBLY	1	61	
		• VALVE ASSY, CHECK <91207> SPEC 8-06450-506 7.0.9M9-6-50-3	1	35	
	AN6290-8	• GASKET	1	35	
-183	8-80031-47	• TUBE ASSEMBLY	1	35	63
	8-80031-493	• TUBE ASSEMBLY	1	61	
-184	MS219110A	• TEE	1	35	
	AN924-80	• NUT	1	35	
	AN9670121A	• WASHER	1	35	
-185	MS219160A-4	• REDUCER	1	35	
	AN6290-8	• GASKET	1	35	
-186	929500-4-1062	• HOSE ASSY, <51999> 94-40542-101 REPLACES INTCHG WITH 477332-4-1062	1	35	
	677032-4-1062	• HOSE ASSY, <00624> 94-40542-124 ALT INTCHG WITH 829500-4-1062	95	35	
-187	S7441	• SMOOTHER ASSY, <91207> SPEC 8-40245	1	35	
-188		• TRANSMITTER AND SWITCH ASSY, PRIMARY HYDRAULIC PRESSURE SEE FIG. 2.4-3 INDEX 4	40		
-189	8-80031-45	• TUBE ASSEMBLY	1	35	63
	8-80031-551	• TUBE ASSEMBLY	1	61	
-190	MS219120A	• UNION	1	35	
	AN6890-8	• GASKET	1	35	
-191		• ACCUMULATOR ASSY, PRIMARY HYDRAULIC SEE FIG. 2.4-3 INDEX 11	61		
-192	MS219160A-4	• REDUCER	1	35	
	AN6290-8	• GASKET	1	35	
-193	714400-10	• TUBE ASSY	1		
-194	MS219050A	• TEE	1	35	
-195	8-80031-447	• TUBE ASSEMBLY	1	35	
-196	21441	• DAMPER, <91207> 92-87300-003	1	35	
-197	8-80031-340	• TUBE ASSEMBLY	1	35	63
	8-80031-179	• TUBE ASSEMBLY	1	61	
-198		• GAGE, HYDRAULIC PRIMARY PRESSURE ACCUMULATOR SEE FIG. 2.4-3 INDEX 16	40		
-199	8-80031-543	• TUBE ASSEMBLY	1	35	63
	8-80031-581	• TUBE ASSEMBLY	2	61	
-200	MS219130A	• PLUG	1	35	
	AN6290-8	• GASKET	1	35	

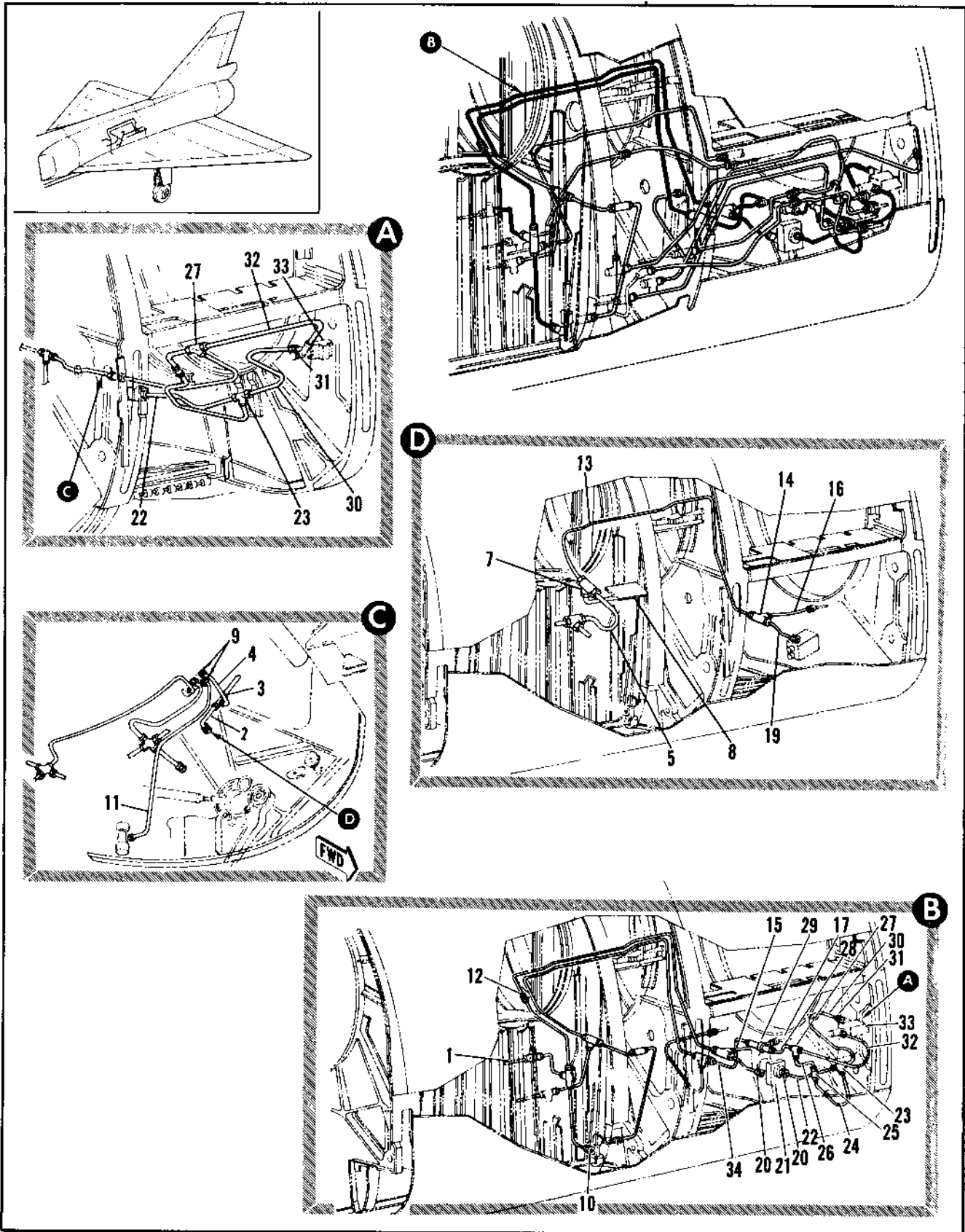

Figure 2.8-11. Power Source Hydraulic Tubing Installation Sta 431 to 472 (Sheet 1 of 3)

FIGURE AND INDEX NUMBER	PART NUMBER	DESCRIPTION	UNITS PER ASSY.	USABLE ON CODE	
				FROM	TO
2.8-11	8-80031-801	TUBING INSTALLATION, POWER SOURCE HYDRAULIC STATION 431 TO 472 MODIFIED BY 8-80109	RF	35	4-
	8-80031-803	TUBING INSTALLATION, POWER SOURCE HYDRAULIC STATION 431 TO 472	RF	49	4-
	8-80031-809	TUBING INSTALLATION, POWER SOURCE HYDRAULIC STATION 431 TO 472	RF	51	
- 1		• TUBE ASSY, SEE FIG. 2.8-10 INDEX 33	RF		
- 2	65A33291-1	• TUBE ASSY, HYDRAULIC BYPASS VALVE	1		
	64A34514-1	• TUBE ASSY, HYDRAULIC BYPASS VALVE	1		
- 3	MS21905DB	• TEE	1		
- 4	64A34516-1	• TUBE ASSY, HYDRAULIC BYPASS VALVE	1		
- 5	MS21916DB-6	• REDUCER	2		
	MS28778-F	• PACKING	2		
- 6	7144803-11	• TUBE ASSY, HYDRAULIC BYPASS VALVE	1		
- 7	ER824012012	• TEE (10024)	1		
- 8	7144802-01	• TUBE ASSY, HYDRAULIC	1		
- 9	MS21916DB-6	• REDUCER	2		
	MS28778-6	• PACKING	2		
- 10	MS21916DB-6	• REDUCER	1	35	
	AN6290-F	• GASKET	1	35	
- 11	64A34518-1	• TUBE ASSY, HYDRAULIC BYPASS VALVE	1		
- 12	MS21902DB	• UNION	1	35	
- 13	7144801-01	• TUBE ASSY	1		
	AN6290-F	• GASKET	1	35	
- 14	ER8240120112	• TEE (92 03)	1		
- 15	8-80031-320	• TUBE ASSEMBLY	1	35	4-
	8-80031-509	• TUBE ASSEMBLY	1	51	
- 16	7144803-01	• TUBE ASSY	1		
- 17		• TUBE ASSY, SEE FIG. 2.8-12	1		
- 18		• TUBE ASSY, SEE FIG. 2.8-12 INDEX 143	RF		
- 19	7144799-11	• TUBE ASSY	1		
- 20	MS21902DB	• UNION	1	35	
	AN6290-F	• GASKET	1	35	
- 21		• VALVE ASSY, HYDRAULIC SHUTOFF (SEE FIG. 2.8-11 INDEX 33)	RF		
- 22	8-80031-789	• TUBE ASSEMBLY	1	35	
- 23	MS21905DB	• TEE	1	35	
- 24	8-80031-347	• TUBE ASSEMBLY	1	35	4-
- 25	4CV484	• VALVE ASSY, CHECK (92107) SPEC 8-09450-806 T.O. 998-6-91-3	1	35	4-
- 26	8-80031-343	• TUBE ASSEMBLY	1	35	4-
- 27	MS21905DB	• TEE	1	35	
- 28	8-80031-341	• TUBE ASSEMBLY	1	35	4-
- 29	1112-5589911	• VALVE ASSY, CHECK (92107) SPEC 8-09450-336 T.O. 998-6-91-3	1	35	4-
- 30	8-80031-365	• TUBE ASSEMBLY	1	35	
- 31	MS21902DB	• UNION	1	35	
	AN6290-F	• GASKET	1	35	
- 32	8-80031-359	• TUBE ASSEMBLY	1	35	
- 33		SEE FIG. 2.17-B INDEX 33	RF		
		SEE FIG. 2.17-B INDEX 24	RF		
- 34	8-80031-151	• TUBE ASSEMBLY	1	35	4-

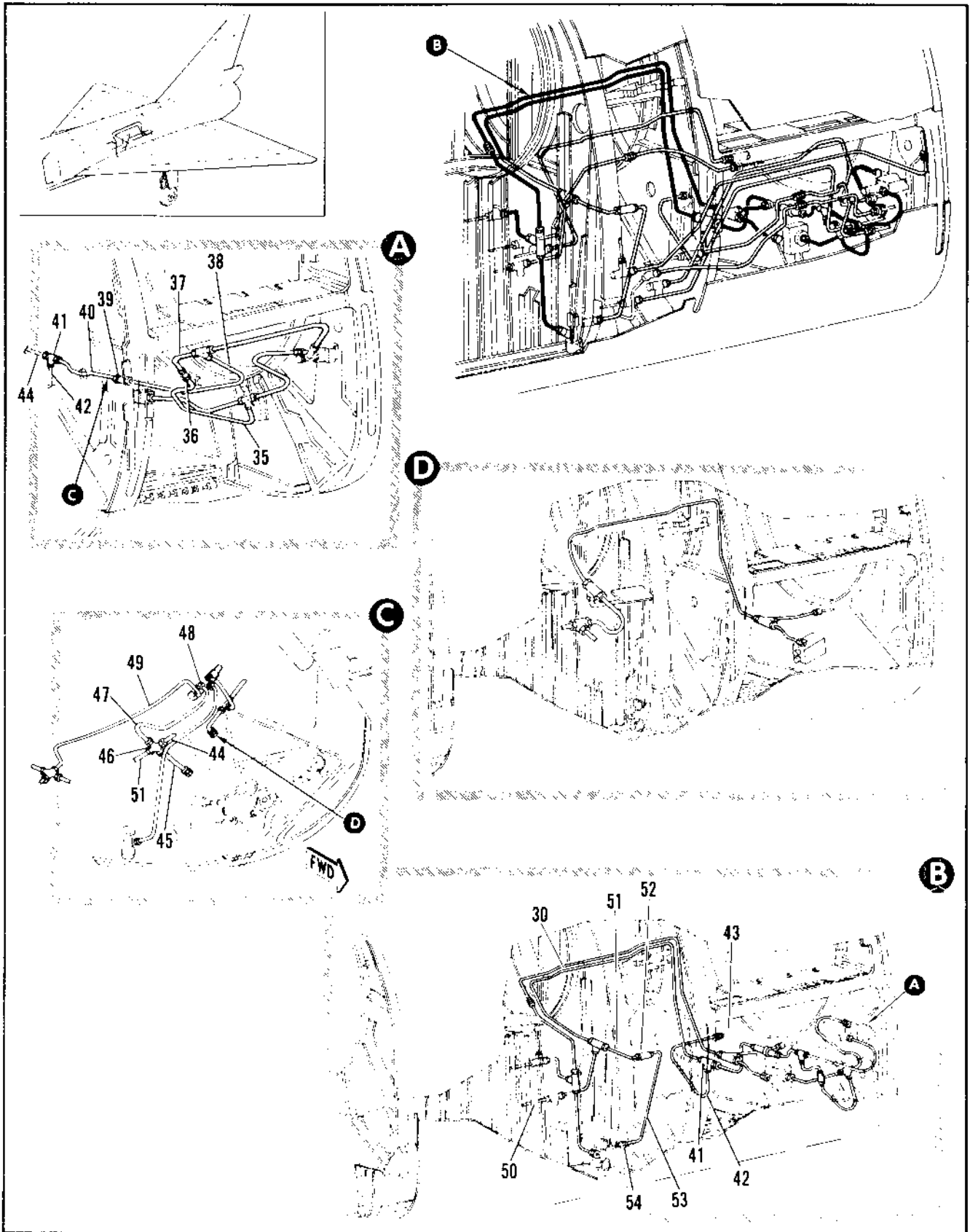

Figure 2.8-11. Power Source Hydraulic Tubing Installation Sta 431 to 472 (Sheet 2 of 3)

FIGURE AND INDEX NUMBER	PART NUMBER	DESCRIPTION 1 2 3 4 5 6	UNITS PER ASSY.	USABLE ON CODE	
				FROM	TO
2.8-11- 35	8-80031-437	• TUBE ASSEMBLY	1	49	
- 36	4CV464	• VALVE ASSY. CHECK <91207> SPEC 8-08450-606 T.O. 9H8-6-50-3	1	49	
- 37	8-80031-435	• TUBE ASSEMBLY	1	49	
- 38	8-80031-433	• TUBE ASSEMBLY	1	49	
- 39	1112-568951	• VALVE ASSY. CHECK <92003> SPEC 8-08450-306 T.O. 9H8-6-6-23	1	49	
- 41	2-80031-431	• TUBE ASSEMBLY	1	49	
- 41	MS21911D10	• TEE	1	35	
	MS21916D10	• REDUCER	1	35	
	AN6290-10	• GASKET	1	35	
- 42	8-80031-531	• TUBE ASSEMBLY	1	35	
- 43		• TUBE ASSY. SEE FIG. 2.8-12 INDEX 173	PF		
- 44	8-80031-111	• TUBE ASSEMBLY	1	35	
- 45	64A34515-1	• TUBE ASSY. HYDRAULIC BYPASS VALVE	1		
- 46	MS21906D10	• CROSS	1		
- 47	64A34517-1	• TUBE ASSY. HYDPAULIC BYPASS VALVE	1		
- 48	MS21916D10-6	• REDUCER	1		
	MS28778-6	• PACKING	1		
	MS28778-4	• PACKING	1		
- 49		• TUBE ASSY. PNEUMATIC BYPASS VALVE SEE FIG. 2.8-17 INDEX 34	PF		
- 51		• TUBE ASSY. SEE FIG. 2.8-9 INDEX 12	1	35	
- 51	8-80031-115	• TUBE ASSEMBLY	1	35	
- 52	1112-565171	• VALVE ASSY. CHECK <92003> SPEC 8-08450-210	1	35	
- 53	8-80031-155	• TUBE ASSEMBLY	1	35	57
	8-80031-517	• TUBE ASSEMBLY	1	35	
- 54	MS21916D10-6	• REDUCER	1	35	
	AN6290-6	• GASKET	1	35	

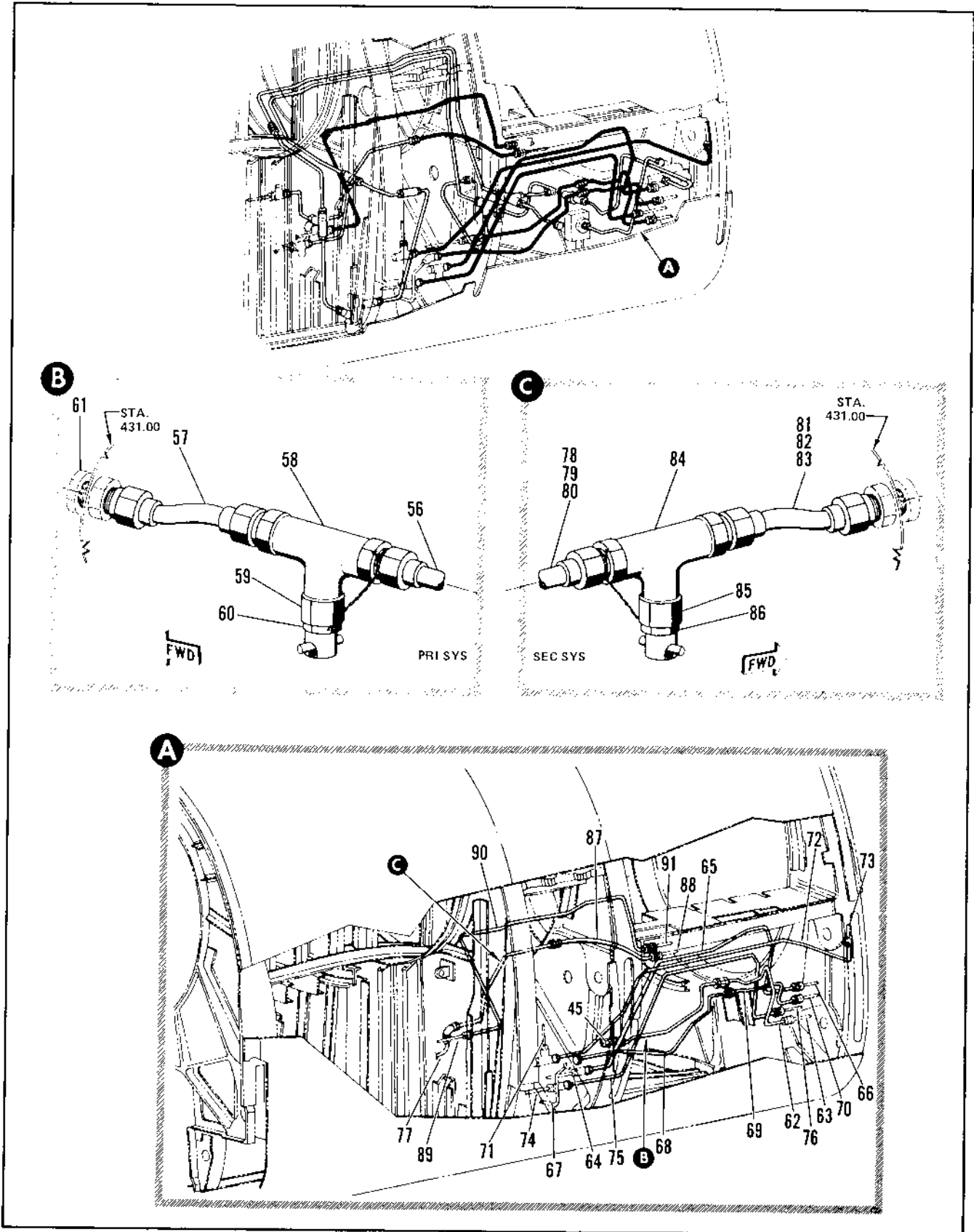

Figure 2.8-11. Power Source Hydraulic Tubing Installation Sta 431 to 472 (Sheet 3 of 3)

FIGURE AND INDEX NUMBER	PART NUMBER	DESCRIPTION	UNITS PER ASSY.	USABLE ON CODE	
				FROM	TO
		1 2 3 4 5 6			
2.8-11- 55		• TUBE ASSY, SEE FIG. 2.8-10 INDEX 82	4F		N
- 56	66038121-11	• TUBE ASSY, PRIMARY PUMP CASE DRAIN	1	35	30
	MS28778-6	• PACKING	2	35	04
- 57	66A38120	• TUBE ASSY, PRIMARY PUMP CASE DRAIN	1	35	04
- 58	AN938-6	• TEE	1	35	04
- 59	AN893-20	• BUSHING	1	35	04
	MS28778-6	• PACKING	1	35	04
- 60	MS29528-4	• VALVE	1	35	04
	MS28778-4	• PACKING	1	35	04
- 61	8-80031-443	• TUBE ASSY, SEE FIGURE 2.8-10 REF INDEX 52	1	35	
- 62	8-80031-451	• TUBE ASSEMBLY	1	35	
- 63		• TUBE ASSY, SEE FIG. 2.8-12 INDEX 75	2F		
- 64		• TUBE ASSY, SEE FIG. 2.8-10 INDEX 155	2F		
- 65	8-80031-153	• TUBE ASSEMBLY	1	35	60
	8-80031-515	• TUBE ASSEMBLY	1	61	
- 66		• TUBE ASSY, SEE FIG. 2.8-12 INDEX 23	2F		
- 67		• TUBE ASSY, SEE FIG. 2.8-10 INDEX 114	2F		
- 68	8-80031-177	• TUBE ASSEMBLY	1	35	60
	8-80031-523	• TUBE ASSEMBLY	1	61	29
	8-80031-557	• TUBE ASSEMBLY	1	90	
- 69	8-80031-179	• TUBE ASSEMBLY	1	35	60
	8-80031-525	• TUBE ASSEMBLY	1	61	
- 70		• TUBE ASSY, SEE FIG. 2.8-12 INDEX 83	2F		
- 71		• TUBE ASSY, SEE FIG. 2.8-10	2F		
- 72	8-80031-171	• TUBE ASSEMBLY	1	35	
- 73		• TUBE ASSY, SEE FIG. 2.8-12 INDEX 93	2F		
- 74		• TUBE ASSY, SEE FIG. 2.8-10 INDEX 142	2F		
- 75	8-80031-169	• TUBE ASSEMBLY	1	35	60
	8-80031-521	• TUBE ASSEMBLY	1	61	
- 76		• TUBE ASSY, SEE FIG. 2.8-12 INDEX 3	2F		
- 77		• TUBE ASSY, SEE FIG. 2.8-10 INDEX 92	2F		
- 78	66038121-15	• TUBE ASSY, SECONDARY PUMP CASE DRAIN	1	0	
- 79	66038121-17	• TUBE ASSY, SECONDARY PUMP CASE DRAIN	1	0	
- 80	66038121-13	• TUBE ASSY, SECONDARY PUMP CASE DRAIN	1	0	
- 81	66A38282	• TUBE ASSY, SECONDARY PUMP CASE DRAIN	1	0	
- 82	66A38347	• TUBE ASSY, SECONDARY PUMP CASE DRAIN	1	0	
- 83	66A38039	• TUBE ASSY, SECONDARY PUMP CASE DRAIN	1	0	
	MS28778-6	• PACKING	2	COE	
- 84	AN938-6	• TEE	1	COE	
- 85	AN893-20	• BUSHING	1	COE	
	MS28778-6	• PACKING	1	COE	
		A AIRPLANES #35 THRU 286, 289, 290, 292 THRU 294, 298, 300, 311, 313 AND ON			
		B AIRPLANES #257, 280, 291, 295 THRU 297, 299, AND 302			
		C AIRPLANES 35, 36, 38, 41, 43, 44, 46, THRU 50, 52, 53, 55, 56, 58 THRU 60.			
		D AIRPLANES 39, 40, 42.			
		E AIRPLANES 61, 63, 64 THRU 66, 68 THRU 70, 73 THRU 80, 82 THRU 91, 95 THRU 97, 103 THRU 119, 121 THRU 124, 126, 128, 130 THRU 141, 143 THRU 145, 147 THRU 157, 159 THRU 167, 169 THRU 173, 175 THRU 178, 180 THRU 183, 185, THRU 198, 200, 201, 203 THRU 215, 217 THRU 220, 222, THRU 235, 237 239, 241, 244, 245, 247, 248, 250 THRU 252, 254 THRU 267, 269, 270, 272 THRU 279, 281 THRU 286, 288 THRU 293, 295 THRU 299, 301 THRU 305, AND AIRPLANE 56-455.			

FIGURE AND INDEX NUMBER	PART NUMBER	DESCRIPTION	UNITS PER ASSY.	USABLE ON CODE	
				FROM	TO
		1 2 3 4 5 6			
2.8-1- 86	MS29528-4	• VALVE	1	00E	
	MS28778-4	• PACKING	1	00E	
- 87	H-80031-401	• TUBE ASSEMBLY	1	35	
- 88		• TUBE ASSY. SEE FIG. 2.8-11 INDEX 127	0F		
- 89		• HOSE ASSY. HYDRAULIC RESERVOIR SEE FIG. 2.8-10 INDEX 100	0F		
	AN924-160	• NUT	1	35	
	AN9502110	• WASHER	1	35	
	98-91319-037	• TEE	1	0	
- 90	H-80031-117	• TUBE ASSEMBLY	1	35	
- 91		• TUBE ASSY. SEE FIG. 2.8-12 INDEX 137	0F		

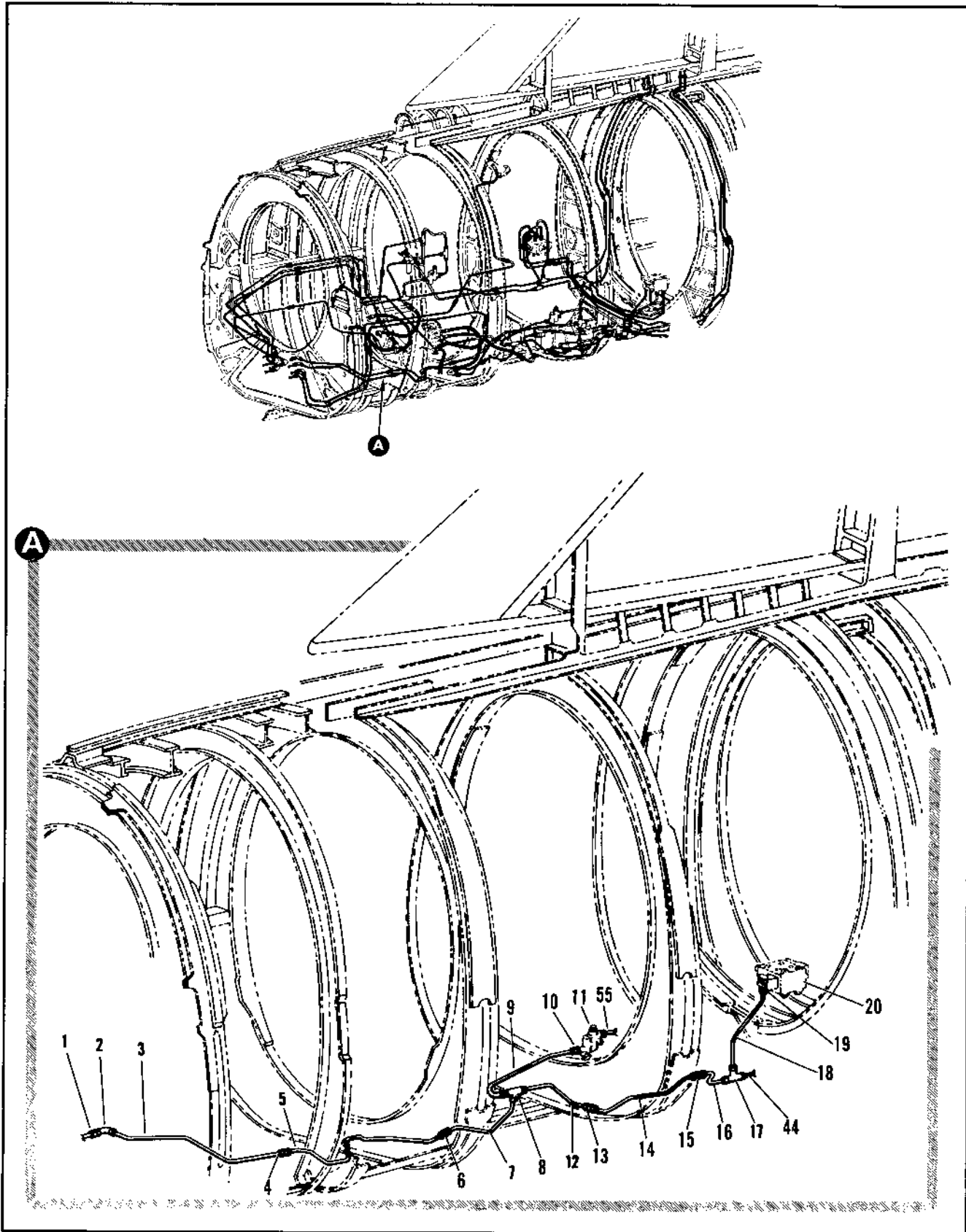

Figure 2.8-12. Power Source Hydraulic Tubing Installation Sta 472 to 605 (Sheet 1 of 7)

FIGURE AND INDEX NUMBER	PART NUMBER	DESCRIPTION	UNITS PER ASSY.	USABLE ON CODE	
				FROM	TO
2.8-12	8-80030-F	TUBING INSTALLATION, POWER SOURCE HYDPAULIC STA 472 TO 635 MODIFIED BY P-80109 AND 8-80134	RF	A	
	8-80030	TUBING INSTALLATION, POWER SOURCE HYDRAULIC STA 472 TO 635 MODIFIED BY 8-80134	RF	278	287
	8-80030-1	TUBING INSTALLATION, POWER SOURCE HYDRAULIC STA 472 TO 635 MODIFIED BY 8-80134	RF	288	293
	8-80030-3	TUBING INSTALLATION, POWER SOURCE HYDRAULIC STA 472 TO 635 MODIFIED BY 8-80134	RF	294	303
- 1	MS21907010	• TUBE ASSY, SEE FIG. 2.8-11 INDEX 75	RF		
- 2	AN924-100	• ELBOW	1	35	
	AN96701416	• NUT	1	35	
	AN96701416	• WASHER	1	35	
- 3	8-80030-251	• TUBE ASSEMBLY	1	35	
- 4	MS21902010	• UNION	1	35	
- 5	8-80030-257	• TUBE ASSEMBLY	1	35	
- 6	MS21903010	• UNION	1	35	
	AN924-100	• NUT	1	35	
	AN96701416	• WASHER	1	35	
- 7	8-80030-29	• TUBE ASSY	1		
- 8	MS21905010	• TEE	1	35	
- 9	8-80030-31	• TUBE ASSY	1		
- 10	MS21916010-A	• REDUCER	1	35	
	AN5290-2	• GASKET	1	35	
- 11		• VALVE ASSY, HYDRAULIC RELIEF SEE FIG. 2.8-1 INDEX 41	RF		
- 12	8-80030-32	• TUBE ASSY	1		
- 13	MS21902010	• UNION	1	35	
- 14	8-80030-257	• TUBE ASSEMBLY	1	35	
- 15	MS21924010	• UNION	1	35	
	AN924-100	• NUT	1	35	
	AN96701416	• WASHER	1	35	
- 16	8-80030-21	• TUBE ASSEMBLY	1	35	
- 17	FR3240100606	• TEE, REDUCING <92003> 88-97319-002	1	35	
- 18	8-80030-123	• TUBE ASSY	1	35	
- 19	MS2190306	• UNION	1	35	
	AN924-6D	• NUT	1	35	
	AN9570916L	• WASHER	1	35	
	AN6290-6	• GASKET	1	35	
- 20		• VALVE ASSY, ELEVON CONTROL SEE FIG. 2.14-11 INDEX 32	RF		

A AIRPLANES #25 THRU 277, 374 AND ON

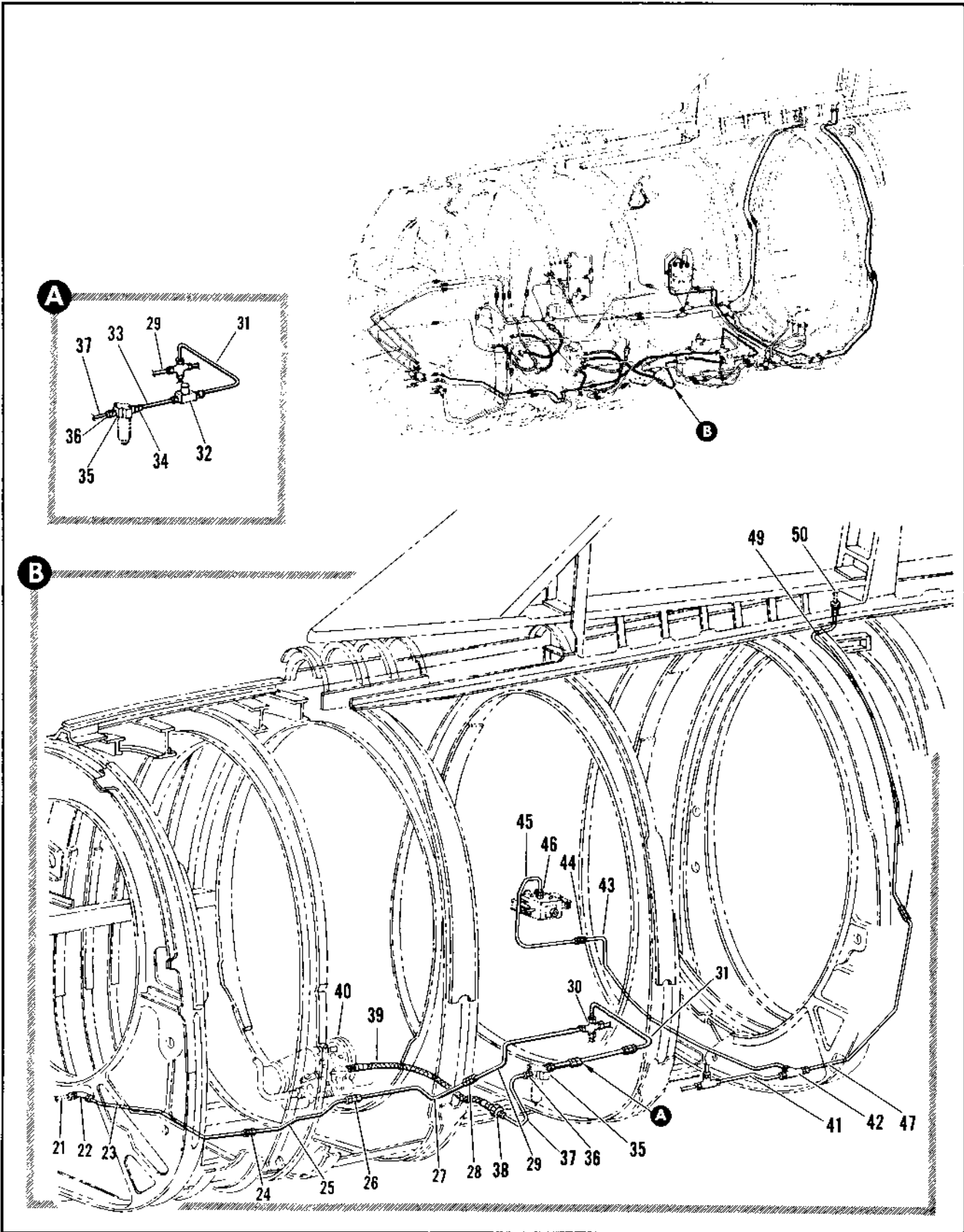

Figure 2.8-12. Power Source Hydraulic Tubing Installation Sta 472 to 605 (Sheet 2 of 7)

FIGURE AND INDEX NUMBER	PART NUMBER	DESCRIPTION	UNITS PER ASSY.	USABLE ON CODE	
				FROM	TO
		1 2 3 4 5 6			
2.8-12- 21		• TUBE ASSY, SEE FIG. 2.4-11 INDEX 67	AF	45	
- 22	MS2191704	• ELBOW	1	55	
	AN929-80	• NUT	1	55	
	AN967 D1210	• WASHER	1	55	
- 23	R-87130-973	• TUBE ASSEMBLY	1	55	
- 24	MS2190204	• UNION	1	55	
- 25	R-87130-204	• TUBE ASSEMBLY	1	55	
- 26	MS2191307	• UNION	1	55	
	AN929-80	• NUT	1	55	
	AN967 D1210	• WASHER	1	55	
- 27	R-87130-301	• TUBE ASSEMBLY	1	55	
- 28	MS2191204	• UNION	1	55	
- 29	R-87130-303	• TUBE ASSY	1		
	R-87130-303	• TUBE ASSY	1		
- 31	MS2191604	• CROSS	1	55	
- 31	R-87130-310	• TUBE ASSY	1	45	
- 32		• SWITCH, THERMOSTATIC SEE FIG. 2.4-1 INDEX 24	AF	45	
- 33	R-87130-341	• TUBE ASSEMBLY	1	55	
- 34	MS2191204	• UNION	1	55	
	AN929-80	• WASHER	1	55	
- 35		• FILTER ASSY, SEE FIG. 2.4-1 INDEX 45	AF		
- 36	MS2190204	• UNION	1	55	
	AN929-80	• WASHER	1	55	
- 37	R-87130-37	• TUBE ASSY	1	55	
- 38		• COUPLING, SEE FIG. 2.3-4 INDEX 40	AF		
- 39	677132-R-1144	• HOSE ASSY, PRIMARY PUMP PRESSURE, SEE FIG. 2.10-7 INDEX 122	1	55	
- 40		• PUMP ASSY, PRIMARY LH SEE FIG. 2.10-7 INDEX 31	1		
- 41	R-87130-115	• TUBE ASSEMBLY	1	55	
- 42	MS2191204	• UNION	1	55	
	AN929-80	• NUT	1	55	
	AN967 D3141	• WASHER	1	55	
- 43	R-87130-121	• TUBE ASSEMBLY	1	55	
- 44	MS2190204	• UNION	1	55	
- 45	R-87130-113	• TUBE ASSEMBLY	1	55	
- 46	MS2191204	• UNION	1	55	
	TA061849	• PLUCK CLAMP	1	55	
	AN929-80	• WASHER	1	55	
- 47	R-87130-113	• TUBE ASSEMBLY	1	55	
- 48	MS2191604-4	• REDUCER	1	55	
- 49	R-87130-111	• TUBE ASSEMBLY	1	55	
- 50		• TUBE ASSY, SEE FIG. 2.4-14 INDEX 3	1		

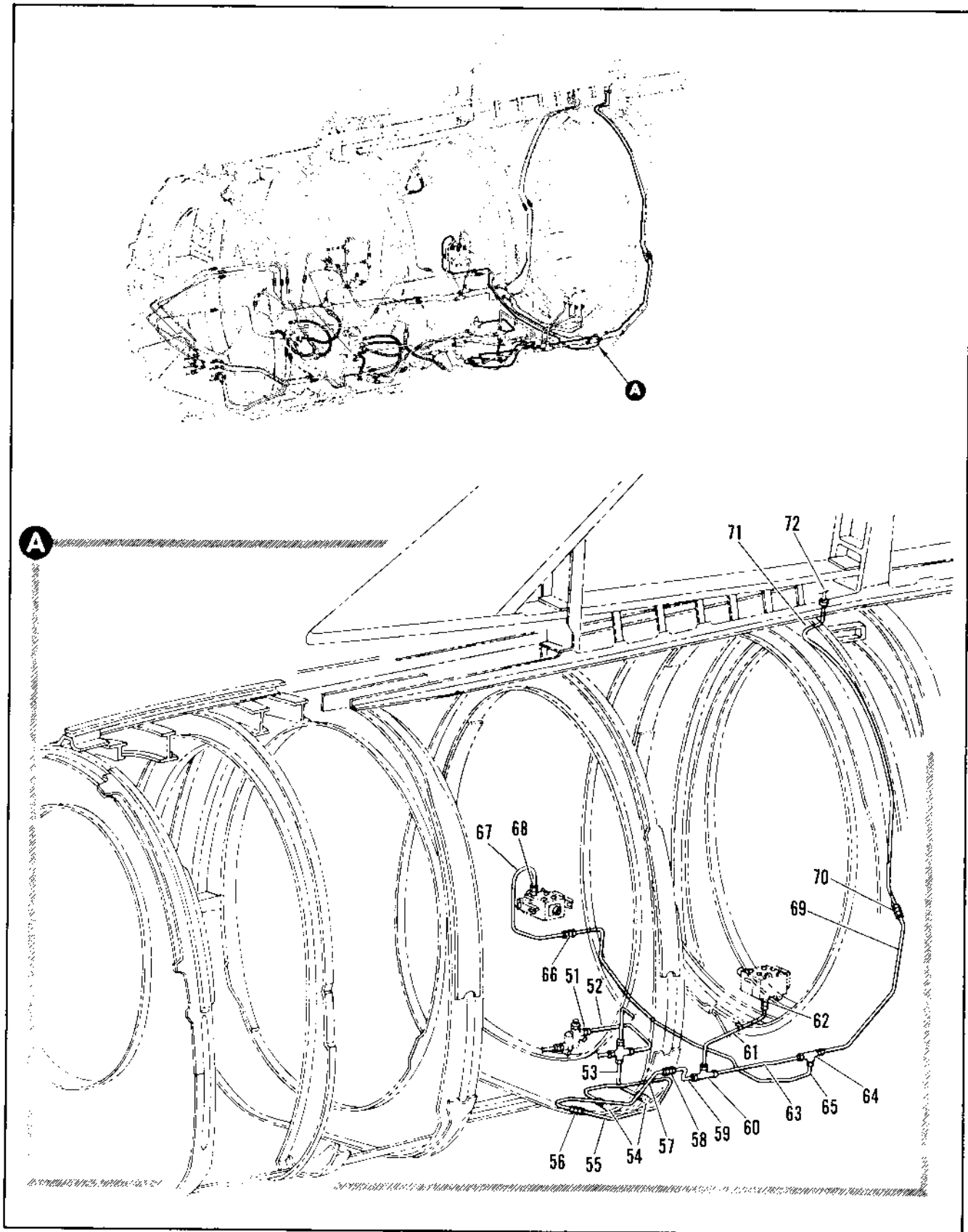

Figure 2.8-12. Power Source Hydraulic Tubing Installation Sta 472 to 605 (Sheet 3 of 7)

FIGURE AND INDEX NUMBER	PART NUMBER	DESCRIPTION	UNITS PER ASSY.	USABLE ON CODE	
				FROM	TO
		1 2 3 4 5 6			
2.8-12- 51	MS21922D4	• UNION	1	35	
	AN6290-8	• GASKET	1	35	
- 52	R-80130-317	• TUBE ASSEMBLY	1	35	
- 53	R-80130-321	• TUBE ASSEMBLY	1	35	
- 54		• FITTING, AFT SEE FIG. 2.8-1 INDEX 75	1	35	
- 55	R-80130-325	• TUBE ASSEMBLY	1	35	
- 56	MS21922D4	• UNION	1	35	
- 57	R-80030-271	• TUBE ASSEMBLY	1	35	
- 58	MS21924B4	• UNION	1	35	
	AN924-8D	• NUT	1	35	
	AN96101216	• WASHER	1	35	
- 59	R-80130-211	• TUBE ASSEMBLY	1	35	
- 60	1R92400886696	• TEE, REDUCING (92165) R-90319-003	1	35	
- 61	R-80130-125	• TUBE ASSEMBLY	1	35	
- 62	MS21922D6	• UNION	1	35	
	AN6290-6	• GASKET	1	35	
- 63	R-80130-117	• TUBE ASSEMBLY	1	35	
- 64	MS21912D6	• TEE	1	35	
	AN924-6D	• NUT	1	35	
	AN96109161	• WASHER	1	35	41
- 65	R-80030-119	• TUBE ASSEMBLY	1	42	
	R-80030-145	• TUBE ASSEMBLY	1	35	41
	TAL6LS49	• BLOCK CLAMP	1	35	
- 66	MS21922D4	• UNION	1	35	
- 67	R-80130-151	• TUBE ASSEMBLY	1	35	
- 68	MS21922D4	• UNION	1	35	
	AN6290-6	• GASKET	1	35	
- 69	R-80130-279	• TUBE ASSEMBLY	1	35	
- 70	MS21914D9-4	• REDUCER	1	35	
- 71	R-80130-237	• TUBE ASSEMBLY	1	35	
- 72		• TUBE ASSY, SEE FIG. 2.8-13 INDEX 14	1	35	

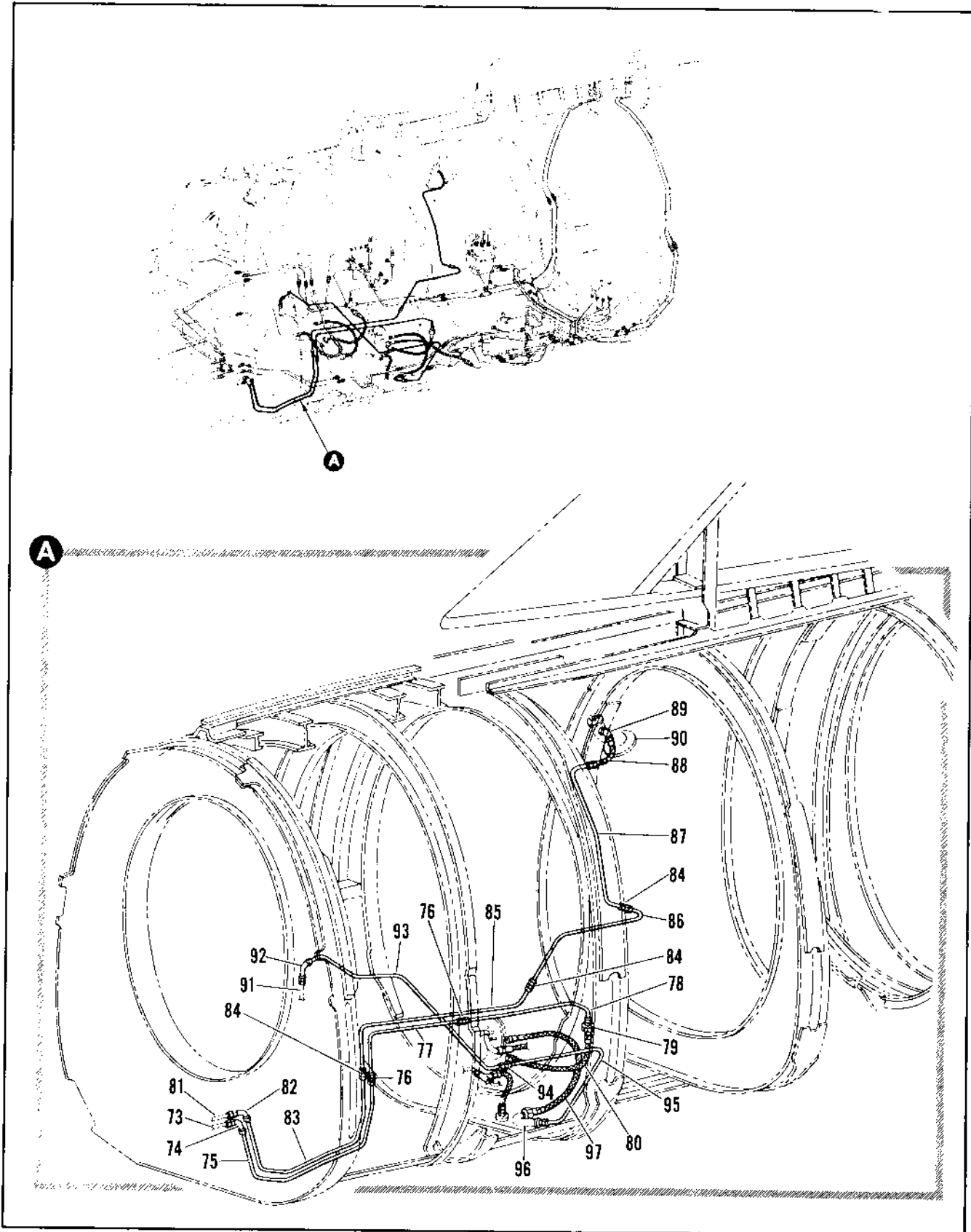

Figure 2.8-12. Power Source Hydraulic Tubing Installation Sta 472 to 605 (Sheet 4 of 7)

FIGURE AND INDEX NUMBER	PART NUMBER	DESCRIPTION	UNITS PER ASSY.	USABLE ON CODE	
				FROM	TO
2.8-12- 73		• TUBE ASSY, SEE FIG. 2.7-11 INDEX 63	1		
- 74	MS2191809	• ELBOW	1	35	
	AN924-40	• NUT	1	35	
	AN9310917	• WASHER	1	35	
- 75	R-80130-271	• TUBE ASSEMBLY	1	35	
- 77	MS2112100	• UNION	1	35	
- 77	R-80130-213	• TUBE ASSEMBLY	1	35	
- 76	R-80130-270	• TUBE ASSEMBLY	1	35	
- 79	3022-80	• COUPLING ASSY, SELF SEALING < 7624 > SPEC R-16384-1	1	35	
- 81	666371-B-0184	• HOSE ASSY, PRIMARY (UMI) CASE DRAIN SEE FIG. 2.10-7 INDEX 116	1	35	
- 81		• TUBE ASSY, SEE FIG. 2.7-11 INDEX 63	1		
- 81	MS2191809	• ELBOW	1	35	
	AN924-40	• NUT	1	35	
	AN9610716L	• WASHER	1	277	
- 83	R-80130-113	• TUBE ASSEMBLY	1	35	
- 84	MS2191209	• UNION	1	35	
- 84	R-80130-118	• TUBE ASSEMBLY	1	35	
- 84	R-80130-119	• TUBE ASSEMBLY	1	35	47
- 84	R-80130-113	• TUBE ASSEMBLY	1	35	
- 87	R-80314-43	• TUBE ASSY	1	44	
	R-80314-38	• TUBE ASSY	1		
	MS2191809	• ELBOW	1	35	
	AN924-40	• NUT	1	35	
	AN9610716L	• WASHER	1	35	
- 88	09111	• HOSE ASSY, FLEXIBLE STEEL (P1481) SPEC R-16384-1B	1	35	
- 89	4190-178113	• ELBOW < 92 1/2 93-4 014-002	1	35	
- 90		• DUCT ASSY, FLEED AIR SEE FIG. 2.13-25 INDEX 16	1		
- 91		• TUBE ASSY, SEE FIG. 2.7-11 INDEX 63	1		
- 92	MS21917016	• ELBOW	1	35	
	AN924-160	• NUT	1	35	
	AN921-12A	• WASHER	1	277	
	AN9610716L	• WASHER	1	277	
- 93	R-80130-213	• TUBE ASSEMBLY	1	35	277
	R-80130-270	• TUBE ASSEMBLY	1	35	277
- 94	MS21102011	• UNION	1	35	277
- 94	R-80130-213	• TUBE ASSEMBLY	1	35	277
- 94	R-80130-241	• TUBE ASSEMBLY	1	35	277
- 94	R-80130-270	• TUBE ASSEMBLY	1	35	277
- 97		• COUPLING ASSY, SEE FIG. 2.9-1 INDEX 60	1		
- 97		• HOSE ASSY, PRIMARY PUMP SUCTION SEE FIG. 2.11-7 INDEX 123	1		

AIRPLANE 75 THRU 184, 278 AND ON

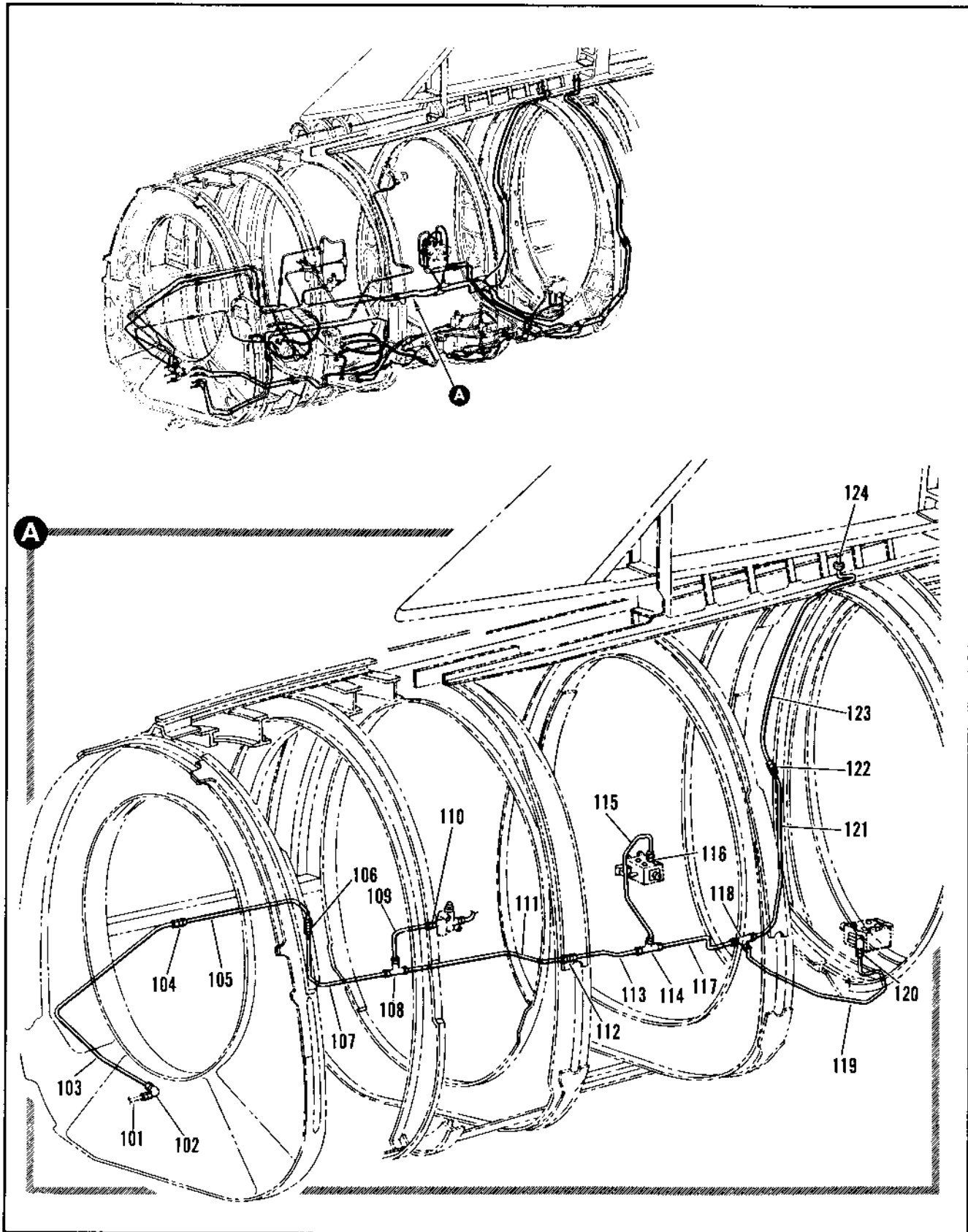

Figure 2.8-12. Power Source Hydraulic Tubing Installation Sta 472 to 605 (Sheet 5 of 7)

FIGURE AND INDEX NUMBER	PART NUMBER	DESCRIPTION	UNITS PER ASSY.	USABLE ON CODE	
				FROM	TO
2.8-12- 98	R9300-4-0090	• HOSE ASSY, PUMP SEAL DRAIN <S:599> 94-86606-047	1	35	
- 99			9F		
-100		• TUBE ASSY, SEE FIG. 2.10-7 INDEX 101	9F		
-101		• TUBE ASSY, SEE FIG. 2.10-7 INDEX 97	9F		
-102	MS21907010	• TUBE ASSY, SEE FIG. 2.8-11 INDEX 42	1	35	
	AN924-100	• ELBOW	1	35	
	AN96001416	• NUT	1	35	
-103	8-80030-57	• WASHER	1	275	
	8-80030-347	• TUBE ASSEMBLY	1	35	125
-104	MS21902010	• TUBE ASSEMBLY	1	130	
-105	8-80030-225	• UNION	1	35	
	8-80030-275	• TUBE ASSEMBLY	1	35	48
-106	MS21903010	• TUBE ASSEMBLY	1	49	
	AN924-100	• UNION	1	35	48
	AN96001416	• NUT	1	35	48
	MS21902010	• WASHER	1	35	48
-107	8-80030-227	• UNION	1	49	
	8-80030-277	• TUBE ASSEMBLY	1	35	48
-108	MS21905010	• TUBE ASSEMBLY	1	49	
-109	8-80030-63	• TEE	1	35	
-110	MS21916010-8	• TUBE ASSEMBLY	1	35	
	AN6290-8	• REDUCER	1	35	
-111	8-80030-65	• GASKET	1	35	
-112	MS21903010	• TUBE ASSEMBLY	1	35	
	AN924-100	• UNION	1	35	
	AN96001416	• NUT	1	35	
-113	8-80030-67	• WASHER	1	35	
-114	ER6240100606	• TUBE ASSEMBLY	1	35	
-115	8-80030-355	• TEE, <92003> 99-30317-302	1	35	
-116	MS2190206	• TUBE ASSEMBLY	1	0	
	AN6290-6	• UNION	1	35	
-117	8-80030-105	• GASKET	1	35	
-118	MS2191206	• TUBE ASSEMBLY	1	35	
	AN924-60	• TEE	1	35	
	AN9600916L	• NUT	1	35	
-119	8-80030-97	• WASHER	1	35	
	TA06LS49	• TUBE ASSEMBLY	1	35	
-120	MS2190306	• BLOCK CLAMP	2	35	
	AN924-60	• UNION	1	35	
	AN9600916L	• NUT	1	35	
	AN6290-6	• WASHER	1	35	
-121	8-80030-101	• GASKET	1	35	
-122	MS2190206	• TUBE ASSEMBLY	1	35	
-123	8-80030-59	• UNION	1	35	
-124		• TUBE ASSEMBLY	1	35	
		• TUBE ASSY, SEE FIG. 2.8-12 INDEX 40	9F		
		C AIRPLANES #35 THRU 47 AND 49 THRU 49			
		D AIRPLANES #48, 50 AND ON			

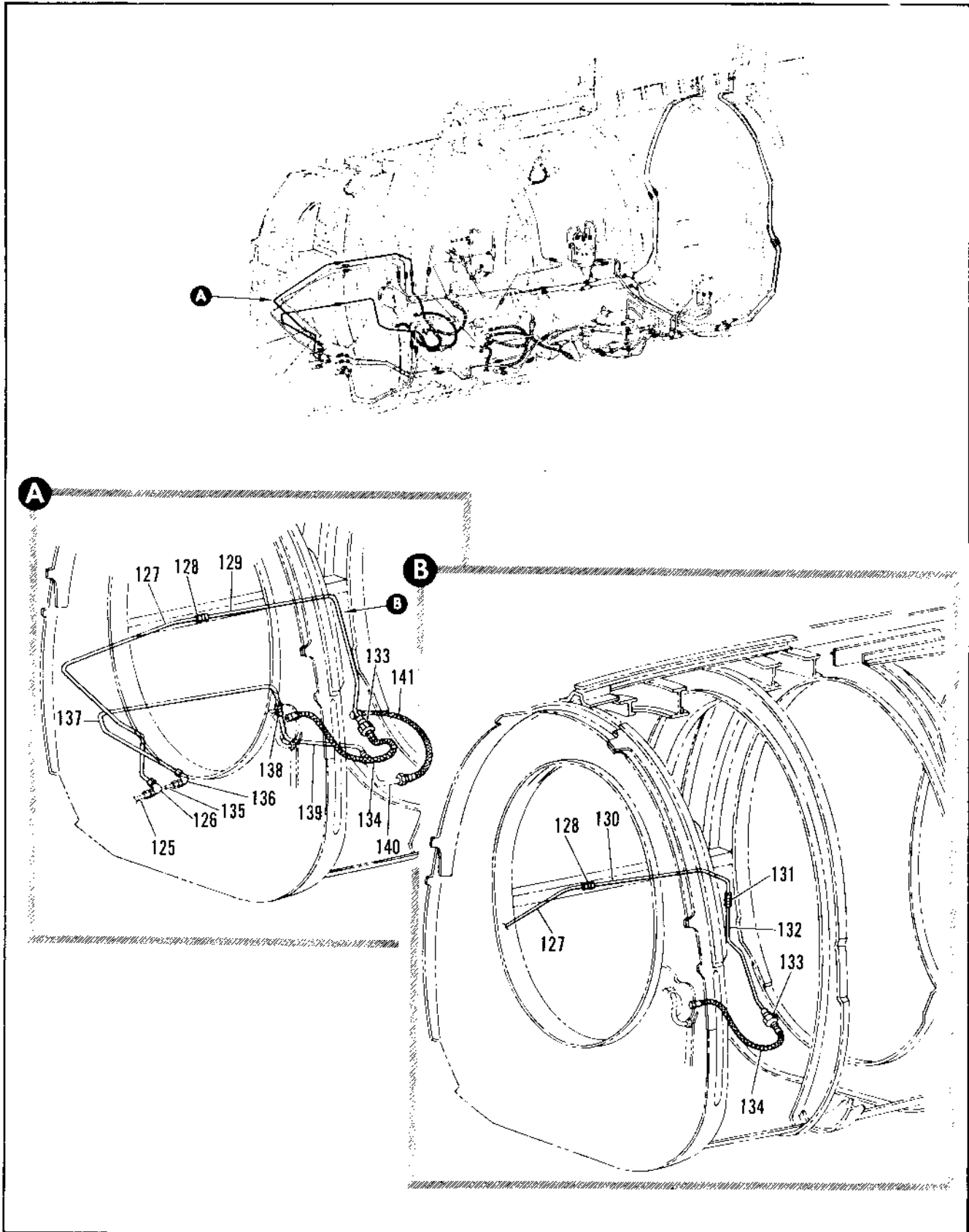

Figure 2.8-12. Power Source Hydraulic Tubing Installation Sta 472 to 605 (Sheet 6 of 7)

FIGURE AND INDEX NUMBER	PART NUMBER	DESCRIPTION	UNITS PER ASSY.	USABLE ON CODE	
				FROM	TO
		1 2 3 4 5 6			
2.8-12-125		• TUBE ASSY, SEE FIG. 2.4-11 INDEX 87	PF		
-126	MS2190706	• ELBOW	1	35	
	AN924-60	• NUT	1	35	
	AN9600916	• WASHER	1	35	
-127	R-80030-265	• TUBE ASSEMBLY	1	E	
	R-80109-21	• TUBE ASSEMBLY	1	48	40
	R-80030-351	• TUBE ASSEMBLY	1	130	
-128	MS2190206	• UNION	1	35	
-129	R-80030-287	• TUBE ASSEMBLY	1	F	
-130	R-80109-23	• TUBE ASSEMBLY	1	47	40
-131	MS2190306	• UNION	1	47	40
	AN924-60	• NUT	1	44	44
	AN9600916L	• WASHER	1	48	40
-132	R-80109-25	• TUBE ASSEMBLY	1	48	40
-133	3022-60	• COUPLING ASSY, SELF SEALING <J0624> SPEC Y-J8586-1	1	35	
-134	566319-60174	• HOSE ASSY, SECONDARY PUMP CASE DRAIN SEE FIG. 2.10-7 INDEX 117	1	35	
-135		• TUBE ASSY, SEE FIG. 2.4-11 INDEX 90	PF		
-136	MS21907016	• ELBOW	1	35	
	AN924-160	• NUT	1	35	
-137	R-80030-253	• TUBE ASSEMBLY	1	35	120
	R-80030-349	• TUBE ASSEMBLY	1	130	
-138	MS21902016	• UNION	1	35	
-139	R-80030-267	• TUBE ASSEMBLY	1	G	
	R-80030-269	• TUBE ASSEMBLY	1	48	277
-140		• COUPLING ASSY, SEE FIG. 2.4-1 INDEX 60	PF		
-141	R23698-2	• HOSE ASSY, SECONDARY PUMP SUCTION SEE FIG. 2.10-7 INDEX 124 AND INDEX 125	1	35	
		E AIRPLANES #35 THRU 47 AND 49 THRU 129			
		F AIRPLANES #35 THRU 47, 49 AND ON			
		G AIRPLANES #35 THRU 47, 275 AND ON			

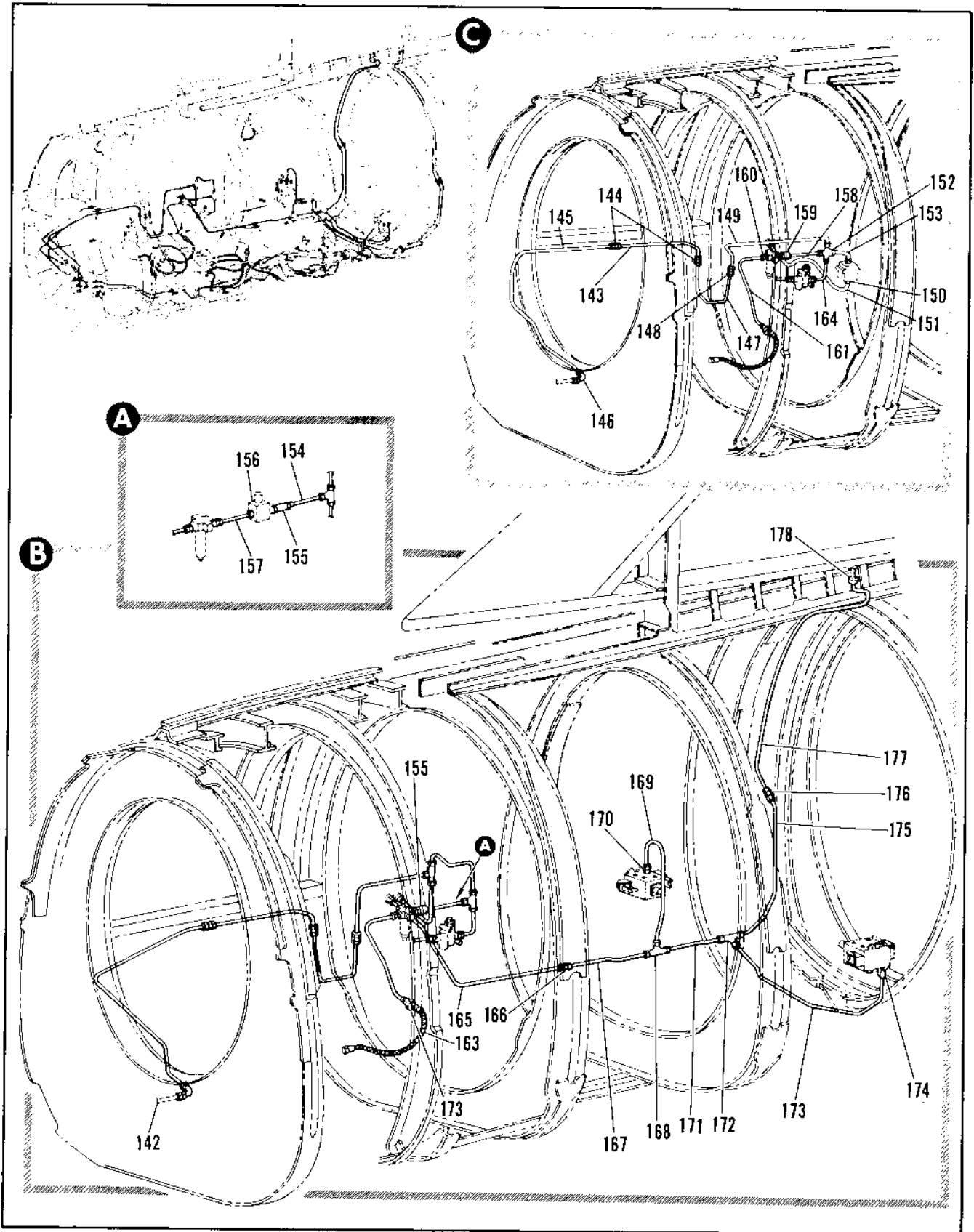

Figure 2.8-12. Power Source Hydraulic Tubing Installation Sta 472 to 605 (Sheet 7 of 7)

FIGURE AND INDEX NUMBER	PART NUMBER	DESCRIPTION	UNITS PER ASSY.	USABLE ON CODE	
				FROM	TO
2.8-12-142		• TUBE ASSY, SEE FIG. 2.8-11 INDEX 15	RF		
-143	7144797-01	• TUBE ASSY (98750)	1		
-144	MS21902D12	• UNION (96906)	2		
-145	7144798-01	• TUBE ASSY (98750)	1		
-146	MS21907C12	• ELBOW (96906)	1		
	AN924-120	• NUT (88044)	1		
	AN960D1716	• WASHER (88044)	1		
-147	7144797-01	• TUBE ASSY (98750)	1		
-148	MS21902D12	• UNION (96906)	1		
-149	7144795-01	• TUBE ASSY (98750)	1		
-150	MS21902D6	• UNION (96906)	1		
	MS28778-8	• PACKING (96906)	1		
-151	7144791-01	• TUBE ASSY (98750)	1		
-152	ER827D12081208	• CROSS (92003)	1		
-153	7144789-01	• TUBE ASSY (98750)	1		
-154	8-80030-345	• TUBE ASSEMBLY	1	90	
-155	4CV482	• VALVE ASSY, CHECK <91207> SPEC 8-08450-608 T.O. 9H8-6-50-3	1	35	
-156		• SWITCH, THERMOSTATIC SEE FIG. 2.8-1 INDEX 34	RF		
-157	8-80030-343	• TUBE ASSEMBLY	1	90	
-158	7144794-01	• TUBE ASSY (98750)	1		
-159	MS28892-12	• VALVE, CHECK (96906)	1		
	MS28778-12	• PACKING (96906)	1		
-160	MS21902-12	• UNION (96906)	1		
	MS28778-12	• PACKING (96906)	1		
-161	7144793-01	• TUBE ASSY (98750)	1		
-162		• COUPLING ASSY, SEE FIG. 2.3-4 INDEX 93	RF		
-163	MS27369-H-0214	• HOSE ASSY, SECONDARY PUMP PRESSURE SEE FIG. 2.10-7 INDEX 194.1	1	35	
-164	7144790-01	• TUBE ASSY (98750)	1		
-165	8-80030-321	• TUBE ASSEMBLY	1	35	
-166	MS21903D8	• UNION (96906)	1	35	
	AN924-80	• NUT (88044)	1	35	
	AN960D1216	• WASHER (88044)	1	35	
-167	8-80030-203	• TUBE ASSEMBLY	1	35	
-168	ER824D080606	• TEE, REDUCER <82003> 98-90319-003	1	35	
-169	8-80030-353	• TUBE ASSEMBLY	1	35	
-170	MS21902D6	• UNION (96906)	1	35	
	AN6290-6	• GASKET (88044)	1	35	
-171	8-80030-97	• TUBE ASSEMBLY	1	35	
-172	MS21912D6	• TEE (96906)	1	35	
	AN924-60	• NUT (88044)	1	35	
	AN960D916L	• WASHER (88044)	1	35	
-173	8-80030-95	• TUBE ASSEMBLY	1	35	
	TA06LS49	• BLOCK CLAMP	1	35	
-174	MS21902D6	• UNION (96906)	1	35	
	AN6290-6	• GASKET (88044)	1	35	
-175	8-80030-233	• TUBE ASSEMBLY	1	35	
-176	MS21902D6	• UNION (96906)	1	35	
-177	8-80030-235	• TUBE ASSEMBLY	1	35	
-178		• TUBE ASSY, SEE FIG. 2.8-13 INDEX 27	RF		

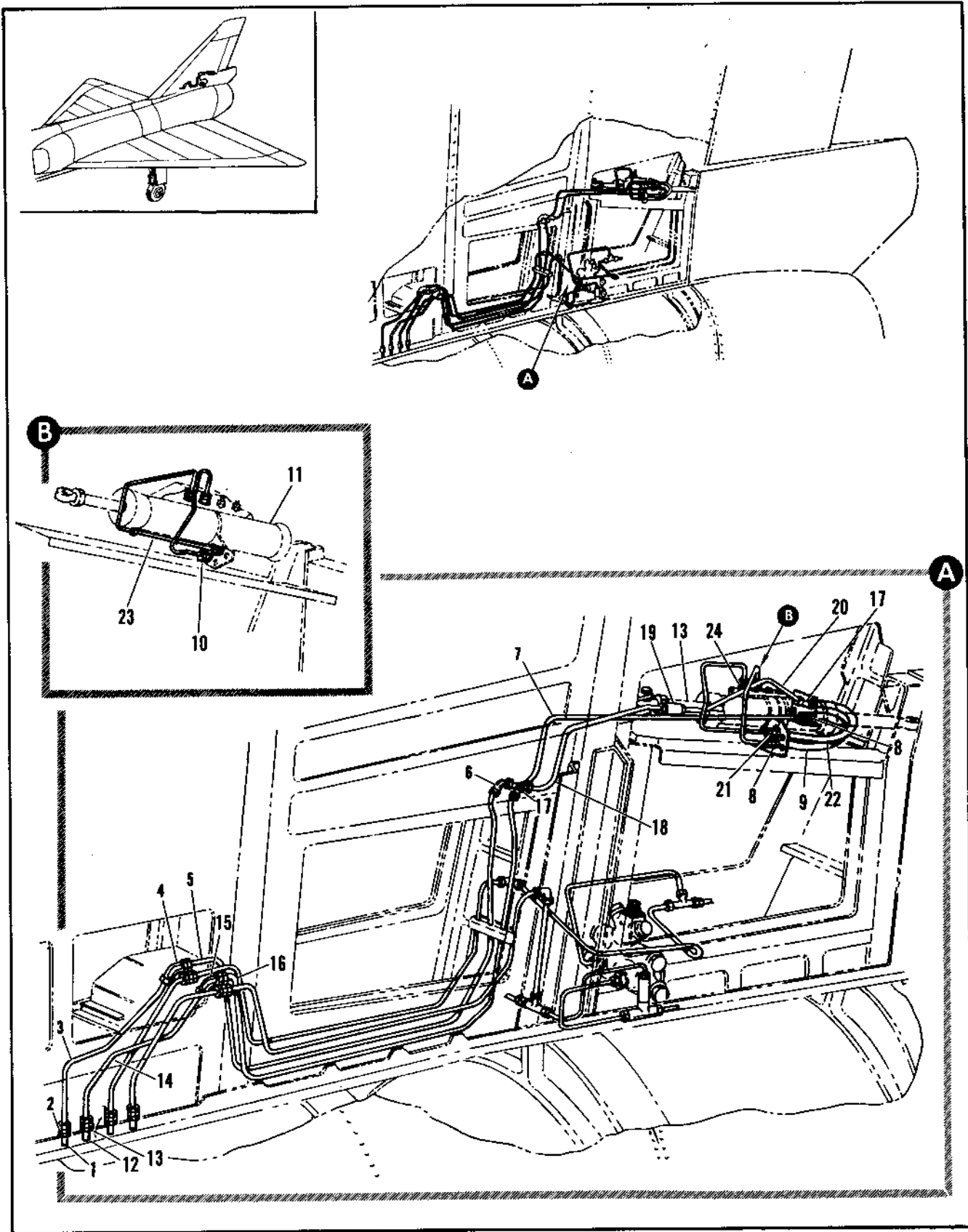

Figure 2.8-13. Power Source Hydraulic Tubing Installation Sta 615 to 711 (Sheet 1 of 2)

FIGURE AND INDEX NUMBER	PART NUMBER	DESCRIPTION	UNITS PER ASSY.	USABLE ON CODE	
				FROM	TO
2.8-13	R-80024	TUBING INSTALLATION, POWER SOURCE HYDRAULIC STA 615 TO 711 MODIFIED BY 8-80131-5 FOR NHA SEE FIG. 2.7-6	RF	35	
- 1		• TUBE ASSY, SEE FIG. 2.8-12 INDEX 49	RF		
- 2	MS2190304	• UNION	1	35	
	AN924-4D	• NUT	1	35	
- 3	8-80024-117	• TUBE ASSEMBLY	1	35	
- 4	MS2190704	• ELBOW	1	35	
	AN924-4D	• NUT	1	35	
	AN9670716	• WASHER	1	35	
- 5	R-80024-141	• TUBE ASSEMBLY	1	35	
- 6	MS2190704	• ELBOW	1	35	
	AN924-4D	• NUT	1	35	
- 7	8-80024-167	• TUBE ASSEMBLY	1	35	
- 8	MS2190304	• UNION	2	35	
	AN924-4D	• NUT	2	35	
- 9	CR295870-4-0134	• HOSE ASSY, <50599> SPEC 8-00358-134	1	35	
- 10	8-80024-179	• TUBE ASSEMBLY	1	35	124
	8-80024-159	• TUBE ASSEMBLY	1	130	
- 11		• ACTUATOR ASSY, SERVO VALVE CONTROL RUDDER SEE FIG. 2.14-44 INDEX 2	RF		
- 12		• TUBE ASSY, SEE FIG. 2.8-12 INDEX 50	RF		
- 13	MS2190304	• UNION	1	35	
	AN924-4D	• NUT	1	35	
- 14	8-80024-121	• TUBE ASSEMBLY	1	35	
- 15	MS2190704	• ELBOW	1	35	
	AN924-4D	• NUT	1	35	
	AN9670716	• WASHER	1	35	
- 16	8-80024-143	• TUBE ASSEMBLY	1	35	
- 17	MS2190704	• ELBOW	2	35	
	AN924-4D	• NUT	2	35	
- 18	8-80024-163	• TUBE ASSEMBLY	1	35	
- 19	6J844	• FILTER ASSY, <R1321> SPEC 8-00492-1	1	35	
- 20	8-80024-165	• TUBE ASSEMBLY	1	35	
- 21	MS2190304	• UNION	1	35	
	AN924-4D	• NUT	1	35	
- 22	CR29587000-4-0136	• HOSE ASSY, <50599> SPEC 8-00356-134	1	35	
- 23	8-80024-177	• TUBE ASSEMBLY	1	61	
- 24	MS2190204	• UNION	1	35	
	AN6295-4	• GASKET	1	35	

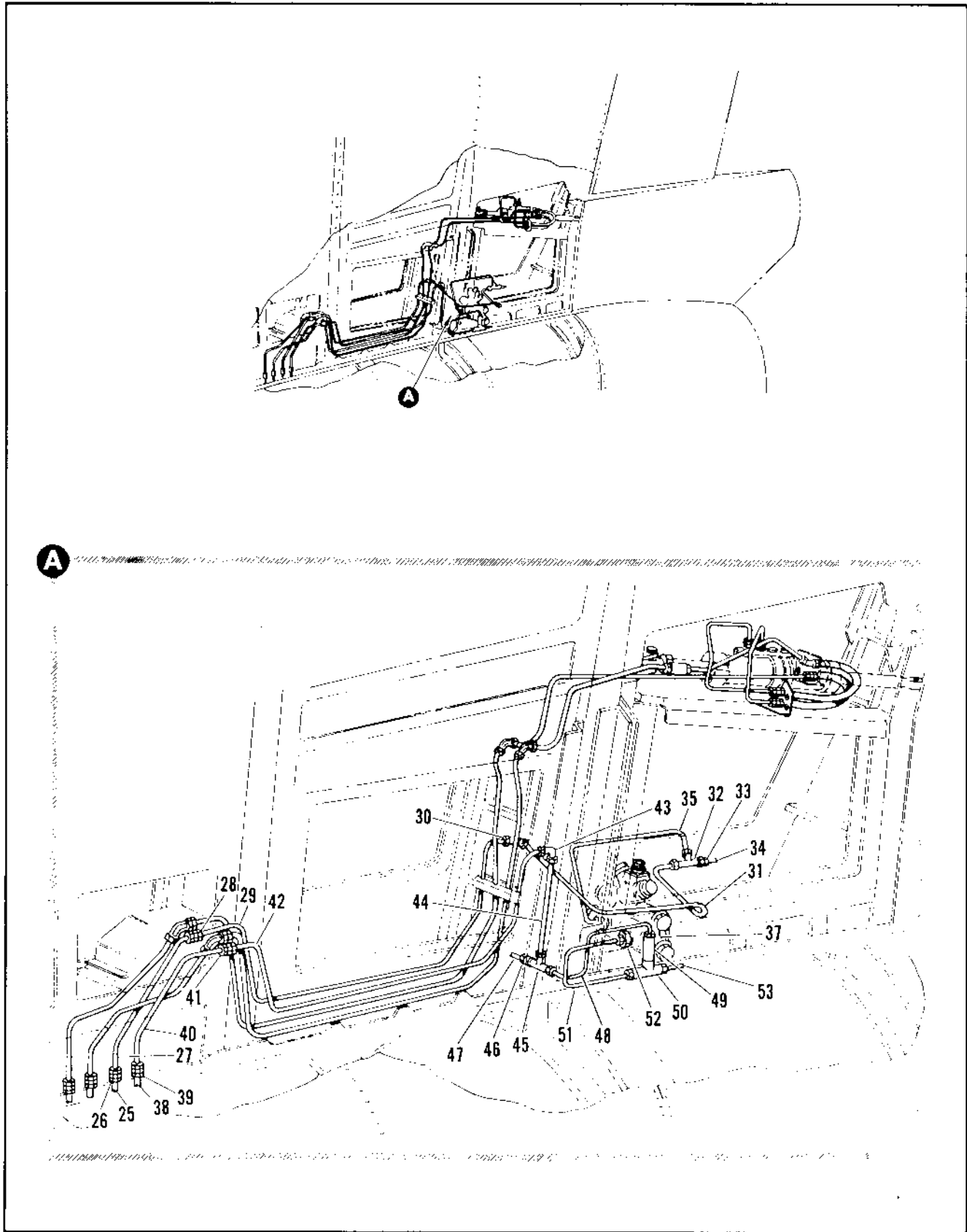

Figure 2.8-13. Power Source Hydraulic Tubing Installation Sta 615 to 711 (Sheet 2 of 2)

FIGURE AND INDEX NUMBER	PART NUMBER	DESCRIPTION	UNITS PER ASSY.	USABLE ON CODE	
				FROM	TO
		1 2 3 4 5 6			
2.8-13- 25		• TUBE ASSY, SEE FIG. 2.8-12	RF		
- 26	MS21903D6	• UNION	1	35	
	AN924-60	• NUT	1	35	
	AN960D916	• WASHER	1	35	
- 27	8-80024-137	• TUBE ASSEMBLY	1	35	
- 28	MS21903D6	• UNION	1	35	
	AN924-60	• NUT	1	35	
- 29	8-80024-139	• TUBE ASSEMBLY	1	35	277
	8-80024-11	• TUBE ASSEMBLY	1	278	
- 30	MS21908D6	• ELBOW	1	35	
	AN924-60	• NUT	1	35	
- 31	8-80024-151	• TUBE ASSEMBLY	1	35	
- 32	MS21911D6	• TEE	1	35	
	AN924-60	• NUT	1	35	
	AN960D916	• WASHER	1	35	
- 33	MS21916D6-4	• REDUCER	1	35	
- 34		• TUBE ASSY, SEE FIG. 2.8-20 INDEX 3	RF		
	AN6290-6	• GASKET	1	35	
- 35	8-80024-25	• TUBE ASSEMBLY	1	35	
- 36	MS21902D6	• UNION	1	35	
	AN6290-6	• GASKET	1	35	
- 37		• VALVE ASSY, SELECTOR SPEED BRAKE CONTROL SEE FIG. 2.3-15 INDEX 23	RF		
- 38		• TUBE ASSY, SEE FIG. 2.8-12 INDEX 71	RF		
- 39	MS21903D6	• UNION	1	35	
	AN924-60	• NUT	1	35	
	AN960D916	• WASHER	1	35	
- 40	8-80024-9	• TUBE ASSEMBLY	1	35	
- 41	MS21903D6	• UNION	1	35	
	AN924-60	• NUT	1	35	
- 42	8-80024-135	• TUBE ASSEMBLY	1	35	277
	8-80024-7	• TUBE ASSEMBLY	1	278	
- 43	MS210706	• ELBOW	1	35	
	AN924-60	• NUT	1	35	
- 44	8-80024-149	• TUBE ASSEMBLY	1	35	
- 45	MS21911D6	• TEE	1	35	
	AN924-160	• NUT	1	35	
	AN960D916	• WASHER	1	35	
- 46	MS21916D6-4	• REDUCER	1	35	
	AN6290-6	• GASKET	1	35	
- 47		• TUBE ASSY, SEE FIG. 2.8-20 INDEX 15	RF		
- 48	8-80024-95	• TUBE ASSEMBLY	1	35	
- 49	1112-558951	• VALVE ASSY, CHECK <9203> SPEC 8-08450-306 1.0.9H8-6-6-23	1	35	
	AN6290-6	• GASKET	1	35	
- 50	MS21910D6	• TEE	1	35	
	AN924-60	• NUT	1	35	
	AN960D916	• WASHER	1	35	
- 51	8-80024-97	• TUBE ASSEMBLY	1	35	
- 52	MS21902D6	• UNION	1	35	
	AN6290-6	• GASKET	1	35	
- 53		• TUBE ASSY, SEE FIG. 2.8-20 INDEX 5	RF		

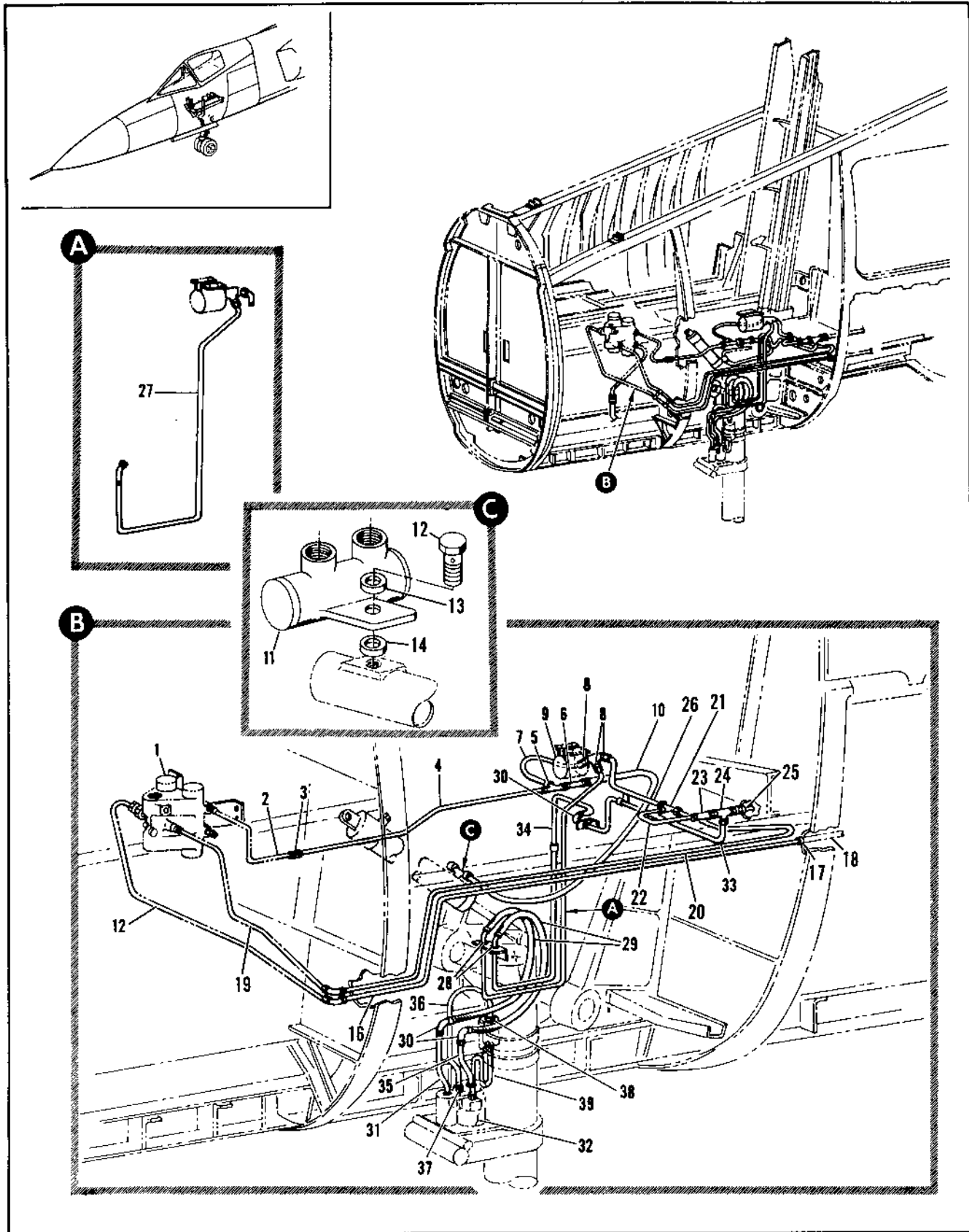

Figure 2.8-14. Nose Landing Gear Hydraulic Tubing Installation Sta 132 to 169

FIGURE AND INDEX NUMBER	PART NUMBER	DESCRIPTION	UNITS PER ASSY.	USABLE ON CODE	
				FROM	TO
2.8-14	8-80032-801	TURING INSTALLATION, NOSE LANDING GEAR HYDRAULIC STA 132 TO 169 MODIFIED BY 8-80160	PF	35	
- 1		• VALVE ASSY, NLC HYDRAULIC CONTROL SEE FIG. 2.15-1 INDEX 2	PF		
- 2		• TUBE ASSY, SEE FIG. 2.8-22 INDEX 1 ^A	PF		
- 3	MS2192404	• UNION	1	35	
	AN924-40	• NUT	1	35	
	AN9600716	• WASHER	1	35	
- 4	3-80032-43	• TUBE ASSEMBLY	1	35	
- 5	MS2191104	• TEE	1	35	
	AN924-40	• NUT	1	35	
	AN9600716	• WASHER	1	35	
	AN6290-4	• GASKET	1	35	
- 6	2R2441-1	• RESTRICTOR ASSY, <P1287> SPEC 8-28476-204 T.O. 988-8-20-3	1	35	
- 7	8-80032-45	• TUBE ASSEMBLY	1	35	
- 8	MS2190204	• UNION	3	35	
	AN6290-4	• GASKET	3	35	
- 9		• VALVE ASSY, HYDRAULIC CONTROL NOSE WHEEL STEERING SEE FIG. 2.15-1 INDEX 17	PF		
- 10	R295800-4-0180	• HOSE ASSY, <50599> 94-01542-007	1	35	
- 11	02675	• VALVE ASSY, SHUTTLE <0502> SPEC 8-00361 T.O. 988-5-50-3	1	35	
- 12	8-80208	• BOLT	1	35	
- 13	MS28775-011	• PACKING	1	35	
- 14	MS28778-4	• GASKET	1	35	
- 15		• TUBE ASSY, SEE FIG. 2.8-22 INDEX 39	PF		
- 16	8-80032-77	• TUBE ASSEMBLY	1	35	60
	8-80032-235	• TUBE ASSEMBLY	1	61	
- 17	MS2190204	• UNION	1	35	
	AN924-40	• NUT	1	35	
	AN6290-4	• GASKET	1	35	
- 18		• TUBE ASSY, SEE FIG. 2.8-15 INDEX 13	PF		
- 19		• TUBE ASSY, SEE FIG. 2.8-22	PF		
- 20	8-80032-109	• TUBE ASSEMBLY	1	35	60
	8-80032-237	• TUBE ASSEMBLY	1	61	188
	8-80032-257	• TUBE ASSEMBLY	1	189	
- 21	MS2190504	• TEE	1	35	
- 22	8-80032-171	• TUBE ASSEMBLY	1	35	188
	3-80032-251	• TUBE ASSEMBLY	1	189	
- 23	1112-568864	• VALVE ASSY, CHECK <22003> SPEC 8-08450-304	1	35	
- 24	MS2191104	• TEE	1	35	
	AN924-40	• NUT	1	35	
	AN9600716	• WASHER	1	35	
	AN6290-4	• GASKET	1	35	
- 25		• TUBE ASSY, SEE FIG. 2.8-15 INDEX 13	PF		
- 26	8-80032-175	• TUBE ASSEMBLY	1	35	188
	3-80032-253	• TUBE ASSEMBLY	1	189	
- 27	8-80032-259	• TUBE ASSEMBLY	1	0	
- 28	MS2190704	• FLANG	2	35	
	AN924-40	• NUT	2	35	
	AN9600716	• WASHER	2	35	

A AIRPLANES #35 THRU 110, 112 THRU 121, AND 123
 B AIRPLANES #111, 122, 124 AND ON

FIGURE AND INDEX NUMBER	PART NUMBER	DESCRIPTION 1 2 3 4 5 6	UNITS PER ASSY.	USABLE ON CODE	
				FROM	TO
2.8-14- 29	R295800-4-0217	• HOSE ASSY. <53599> 94-80542-008	2	35	
- 30	MS21908D4	• ELBOW	3	35	
	AN924-4D	• UNION	3	35	
	AN9690716	• WASHER	3	35	
- 31	8-80032-137	• TUBE ASSEMBLY	1	35	
- 32		• STEER-DAMP UNIT ASSEMBLY SEE FIG. 2.15-18 INDEX 17	FF		
- 33	8-80032-175	• TUBE ASSEMBLY	1	35	
- 34	8-80032-165	• TUBE ASSEMBLY	1	35	
- 35	8-80032-139	• TUBE ASSEMBLY	1	35	
- 36	8-80032-261	• TUBE ASSEMBLY	1	241	
- 37	MS21916-6-4	• REDUCER	2	241	
	AN6290-4	• GASKET	2	241	
- 38		• RESTRICTOR ASSY. SEE FIG. 2.15-17 INDEX 80	FF		
- 39	8-80032-2F3	• TUBE ASSEMBLY	1	241	

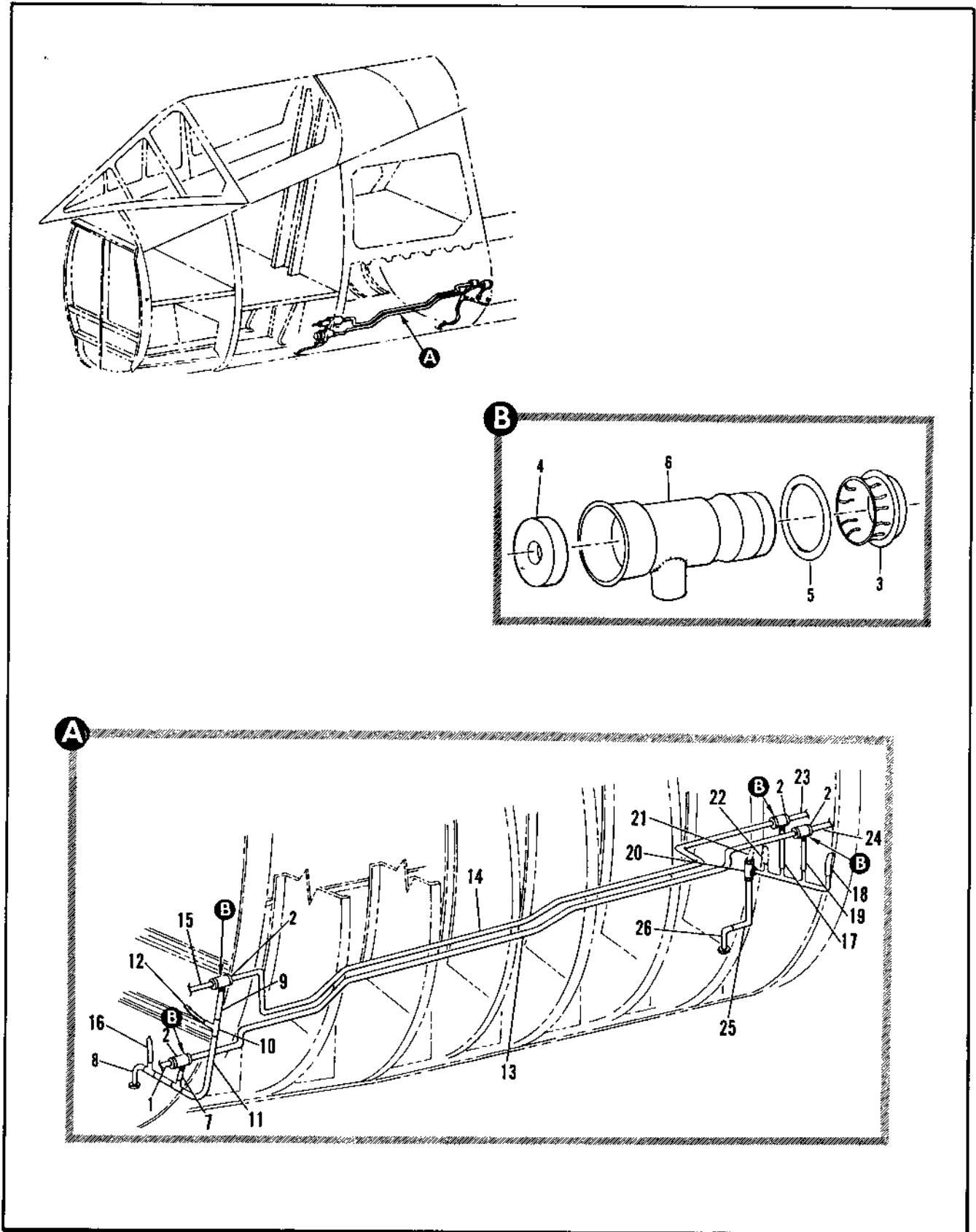

FIGURE AND INDEX NUMBER	PART NUMBER	DESCRIPTION	UNITS PER ASSY.	USABLE ON CODE	
				FROM	TO
		1 2 3 4 5 8			
2.8-15	8-80032-8C1	TUBING INSTALLATION, NOSE LANDING GEAR HYDRAULIC STA 169 TO 216	RF	35	
- 1		• TUBE ASSY, SEE FIG. 2.8-14 INDEX 16	RF		
- 2	8-81331	• SHROUD ASSY, HYDRAULIC	4	35	
- 3	8-81257	• • RECEPTACLE	1	35	
- 4	8-81258	• • GROMMET	1	35	
- 5	AN6227-19	• • PACKING	1	35	
- 6	8-81331-7	• • CASE ASSY, WELDED	1	35	
- 7	8-80032-213	• TUBE, DRAIN	1		
	8-80032-233	• TUBE, DRAIN	1		
- 8	8-81253-3	• ADAPTER ASSEMBLY	1	35	
- 9	8-84224-7	• TUBE, DRAIN	1		
- 10	8-81259	• TEE ASSY, WELDED	1		
- 11	8-84224-19	• TUBE, DRAIN	1		
- 12		• TUBE, DRAIN SEE FIG. 2.8-25 INDEX 27	RF		
- 13	8-80032-211	• TUBE ASSEMBLY	1	35	
- 14	8-80032-209	• TUBE ASSEMBLY	1	35	
- 15		• TUBE ASSY, SEE FIG. 2.8-14 INDEX 17	RF		
- 16		• TUBE ASSY, SEE FIG. 2.9-14 INDEX 20	RF		
- 17	8-84224-21	• TUBE, DRAIN	1		
- 18		• TUBE ASSY, SEE FIG. 2.9-13 INDEX 18	RF		
- 19	8-84224-17	• TUBE, DRAIN	1		
- 20	8-84225-1	• MANIFOLD ASSEMBLY	1		
- 21		• TUBE, DRAIN SEE FIG. 2.8-25 INDEX 29	RF		
- 22		• TUBE, DRAIN SEE FIG. 2.8-25 INDEX 30	RF		
- 23		• TUBE ASSY, SEE FIG. 2.8-9 INDEX 21	RF		
- 24		• TUBE ASSY, SEE FIG. 2.9-9 INDEX 3	RF		
- 25	8-84224-27	• TUBE, DRAIN	1		
- 26	8-81253-1	• ADAPTER ASSEMBLY	1	35	

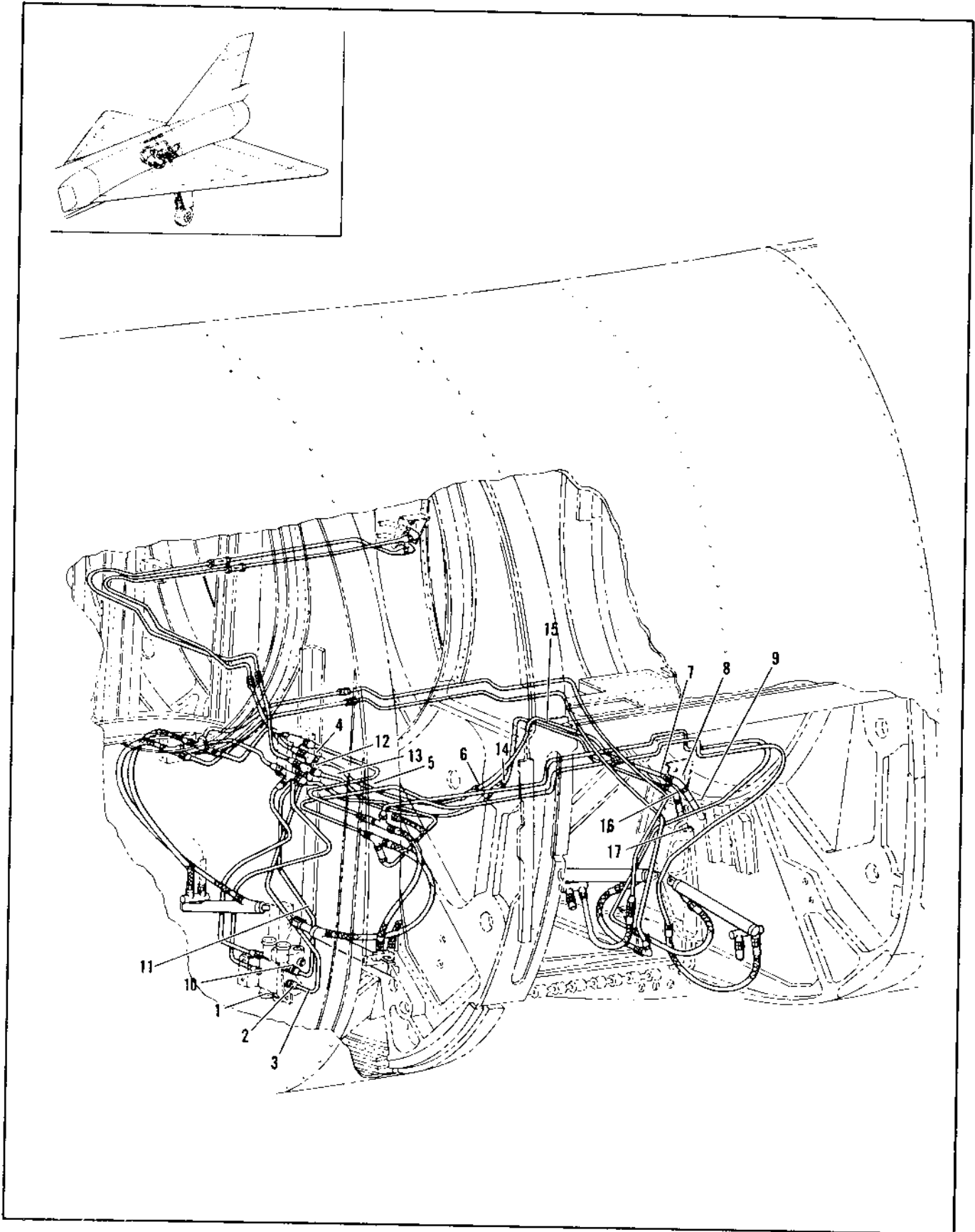

Figure 2.8-16. Main Landing Gear Hydraulic Tubing Installation (Sheet 1 of 4)

FIGURE AND INDEX NUMBER	PART NUMBER	DESCRIPTION	UNITS PER ASSY.	USABLE ON CODE		
				FROM	TO	
2.8-16	8-80031-801	TUBING INSTALLATION, HYDRAULIC MAIN LANDING GEAR	PF	35	48	
	8-80031-803	TUBING INSTALLATION, HYDRAULIC MAIN LANDING GEAR	PF	49	61	
	8-80031-809	TUBING INSTALLATION, HYDRAULIC MAIN LANDING GEAR	PF	61		
	- 1	1371-579106	• VALVE, MLG SELECTOR SEE FIG. 2.15-1 INDEX 37	PF		
	- 2	MS21916D10-6	• REDUCER	1	35	
		AN6290-6	• GASKET	1	35	
	- 3	8-80031-157	• TUBE ASSY, MLG DOWN	1	35	60
		8-80031-519	• TUBE ASSY, MLG DOWN	1	61	
	- 4	MS21910D6	• TEE	1	35	
		AN924-6D	• NUT	1	35	
		AN960D916	• WASHER	1	35	
		MS21916D8-6	• REDUCER	1	35	
		AN6290-6	• GASKET	1	35	
	- 5	8-80031-165	• TUBE ASSY, MLG DOWN	1	35	38
		8-80031-405	• TUBE ASSY, MLG DOWN	1	30	
	- 6	4CV464-70-30	• RESTRICTOR, VALVE <91207> SPEC 8-00247-670	1	35	
	- 7	8-80031-167	• TUBE ASSY, MLG DOWN	1	35	38
	8-80031-407	• TUBE ASSY, MLG DOWN	1	39		
- 8	MS21907D6	• ELBOW	1	35		
	AN924-6D	• NUT	1	35		
	AN960D916	• WASHER	1	35		
- 9		• HOSE ASSY, SEE FIG. 2.15-25 INDEX 9	PF			
- 10	MS21916D10-6	• REDUCER	1	35		
	AN6290-6	• GASKET	1	35		
- 11	8-80031-251	• TUBE ASSY, MLG UP	1	35	60	
	8-80031-535	• TUBE ASSY, MLG UP	1	61		
- 12	MS21910D6	• TEE	1	35		
	AN924-6D	• NUT	1	35		
	AN960D916	• WASHER	1	35		
	MS21916D8-6	• REDUCER	1	35		
	AN6290-6	• GASKET	1	35		
- 13	8-80031-161	• TUBE ASSY, MLG UP	1	35	38	
	8-80031-411	• TUBE ASSY, MLG UP	1	39		
- 14	4CV464-70-30	• RESTRICTOR, VALVE <91207> SPEC 8-00247-670	1	35		
- 15	8-80031-163	• TUBE ASSY, MLG UP	1	35	38	
	8-80031-403	• TUBE ASSY, MLG UP	1	39		
- 16	MS21907D6	• ELBOW	1	35		
	AN924-6D	• NUT	1	35		
	AN960D916	• WASHER	1	35		
- 17		• HOSE ASSY, SEE FIG. 2.15-25 INDEX 6	PF			

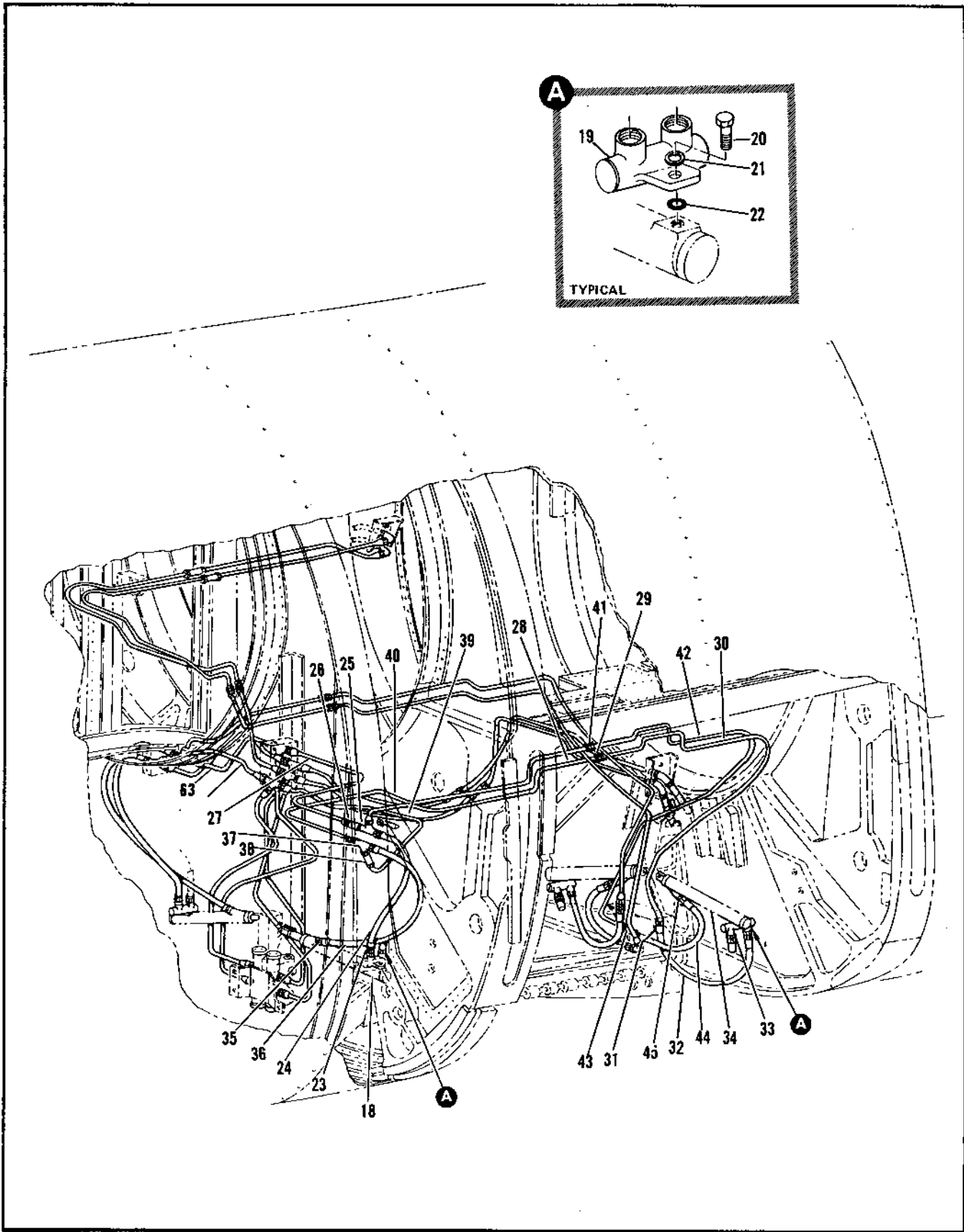

Figure 2.8-16. Main Landing Gear Hydraulic Tubing Installation (Sheet 2 of 4)

FIGURE AND INDEX NUMBER	PART NUMBER	DESCRIPTION 1 2 3 4 5 6	UNITS PER ASSY.	USABLE ON CODE	
				FROM	TO
2.8-16- 18		• ACTUATOR ASSY, MLG DOOR FWD SEE FIG. 2.15-22 INDEX 2	RF		
- 19	385DA1	• VALVE ASSY, SHUTTLE <78062> SPEC 8-00364-1 T.O.9H8-5-51-3 ATTACHING PARTS	2	35	
- 20	8-80208	• BOLT	2	35	
- 21	MS28775-011	• PACKING	2	35	
- 22	MS28778-4	• GASKET -----X----	2	35	
- 23	MS2190204 AN6290-4	• UNION • GASKET	1	35	
- 24	CR295870-4-0136 YR5870-4-0136	• HOSE ASSY, FWD <50599> SPEC 8-00358-136 • HOSE ASSY, FWD <50599> SPEC 8-00358-136	1	35	48
- 25	MS2191104 AN924-40 AN9600716L	• TEE • NUT • WASHER	1	35	
- 26	2R2441-3	• RESTRICTOR, VALVE <91207> SPEC 8-08476-404 T.O.9H8-6-20-3	1	35	
- 27	8-80031-271 8-80031-531	• TUBE ASSY, MLG DOOR OPEN • TUBE ASSY, MLG DOOR OPEN	1	35	60
- 28	8-80031-273 8-80031-533	• TUBE ASSY, MLG DOOR OPEN • TUBE ASSY, MLG DOOR OPEN	1	35	60
- 29	MS2190304	• UNION	1	35	
- 30	8-80031-335 8-80031-535	• TUBE ASSY, MLG DOOR OPEN • TUBE ASSY, MLG DOOR OPEN	1	35	60
- 31	MS2192404 AN924-40 AN9600716L	• UNION • NUT • WASHER	1	35	
- 32	CR295870-4-0136	• HOSE ASSY, AFT <50599> SPEC 8-00358-136	1	35	
- 33	MS2190204 AN6290-4	• UNION • GASKET	1	35	
- 34		• ACTUATOR ASSY, MLG DOOR AFT SEE FIG. 2.15-22 INDEX 4	RF		
- 35	MS2190204 AN6290-4	• UNION • GASKET	1	35	
- 36	CR295870-4-0180 YR5870-4-0180	• HOSE ASSY, FWD <50599> SPEC 8-00358-180 • HOSE ASSY, FWD <50599> SPEC 8-00358-180	1	35	48
- 37	MS2191104 AN924-40 AN9600716L	• TEE • NUT • WASHER	1	35	
- 38	2R2441-3	• RESTRICTOR, VALVE <91207> SPEC 8-08476-404 T.O.9H8-6-20-3	1	35	
- 39	8-80031-265 8-80031-527	• TUBE ASSY, MLG DOOR CLOSE • TUBE ASSY, MLG DOOR CLOSE	1	35	60
- 40	8-80031-267 8-80031-529	• TUBE ASSY, MLG DOOR CLOSE • TUBE ASSY, MLG DOOR CLOSE	1	35	60
- 41	MS2190204	• UNION	1	35	
- 42	8-80031-333 8-80031-537	• TUBE ASSY, MLG DOOR CLOSE • TUBE ASSY, MLG DOOR CLOSE	1	35	60
- 43	MS2190704 AN924-40 AN9600716L	• ELBOW • NUT • WASHER	1	35	
- 44	R295800-4-0122	• HOSE ASSY, <50599> 94-80542-015	1	35	
- 45	MS2190204 AN6290-4	• UNION • GASKET	1	35	

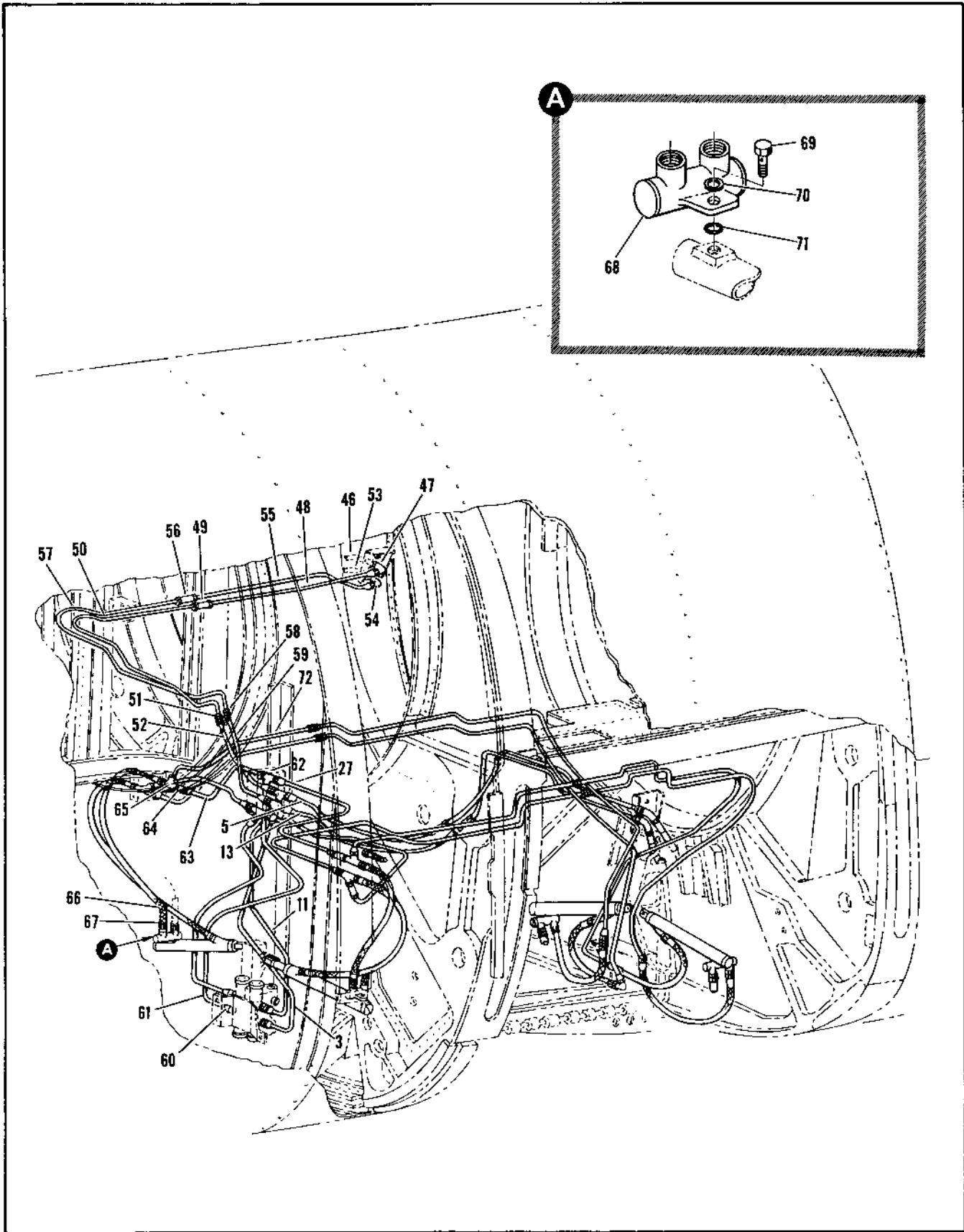

Figure 2.8-16. Main Landing Gear Hydraulic Tubing Installation (Sheet 3 of 4)

FIGURE AND INDEX NUMBER	PART NUMBER	DESCRIPTION	UNITS PER ASSY.	USABLE ON CODE	
				FROM	TO
2.8-16- 46		• HOSE ASSEMBLY 2.15-26 INDEX 9	RF		
- 47	MS21908D6	• ELBOW	1	35	
	AN924-6D	• NUT	1	35	
	AN960D916	• WASHER	1	35	
- 48	8-80031-135	• TUBE ASSY, MLG DOWN	1	35	48
	8-80031-423	• TUBE ASSY, MLG DOWN	1	49	
- 49	4CV464-70-30	• RESTRICTOR, VALVE <91207> SPEC 8-00247-670	1	35	
- 50	8-80031-133	• TUBE ASSY, MLG DOWN	1	35	
- 51	MS21902D6	• UNION	1	35	
- 52	8-80031-131	• TUBE ASSY, MLG DOWN	1	35	60
	8-80031-545	• TUBE ASSY, MLG DOWN	1	61	
- 53		• HOSE ASSY, SEE FIG. 2.15-26 INDEX 6	RF		
- 54	MS21908D6	• ELBOW	1	35	
	AN924-6D	• NUT	1	35	
	AN960D916	• WASHER	1	35	
- 55	8-80031-141	• TUBE ASSY, MLG UP	1	35	48
	8-80031-417	• TUBE ASSY, MLG UP	1	49	
- 56	4CV464-70-30	• RESTRICTOR, VALVE <91207> SPEC 8-00247-670	1	35	
- 57	8-80031-139	• TUBE ASSY, MLG UP	1	35	60
	8-80031-585	• TUBE ASSY, MLG UP	1	61	
- 58	MS21902D6	• UNION	1	35	
- 59	8-80031-137	• TUBE ASSY, MLG UP	1	35	60
	8-80031-543	• TUBE ASSY, MLG UP	1	61	
- 60	MS21902D6	• UNION	1	35	
	AN6290-6	• GASKET	1	35	
- 61	8-80031-121	• TUBE ASSY, MLG DOOR OPEN	1	35	60
	8-80031-499	• TUBE ASSY, MLG DOOR OPEN	1	61	
- 62	MS21910D4	• TEE	1	35	
	AN924-4D	• NUT	1	35	
	AN960D716	• WASHER	1	35	
	MS21916D4	• REDUCER	1	35	
	AN6290-4	• GASKET	1	35	
- 63	8-80031-123	• TUBE ASSY, MLG DOOR OPEN	1	35	60
	8-80031-561	• TUBE ASSY, MLG DOOR OPEN	1	61	
- 64	2R2441-3	• RESTRICTOR, VALVE <91207> SPEC 8-08476-404 T.O.9H8-6-20-3	1	35	
- 65	MS21911D4	• TEE	1	35	
	AN924-4D	• NUT	1	35	
	AN960D716	• WASHER	1	35	
	AN6290-4	• GASKET	1	35	
- 66	CR295870-4-0143	• HOSE ASSY, FWD <50599> SPEC 8-00358-143	1	35	48
	YR5870-4-0143	• HOSE ASSY, FWD <50599> SPEC 8-00358-143	1	49	
- 67	MS21902D4	• UNION	1	35	
	AN6290-4	• GASKET	1	35	
- 68	385DA1	• VALVE ASSY, SHUTTLE <78062> SPEC 8-00364-1 T.O.9H8-5-51-3	1	35	
- 69	8-80208	• BOLT	1	35	
		ATTACHING PARTS			
- 70	MS28775-011	• PACKING	1	35	
- 71	MS28778-4	• GASKET	1	35	
		----X----			

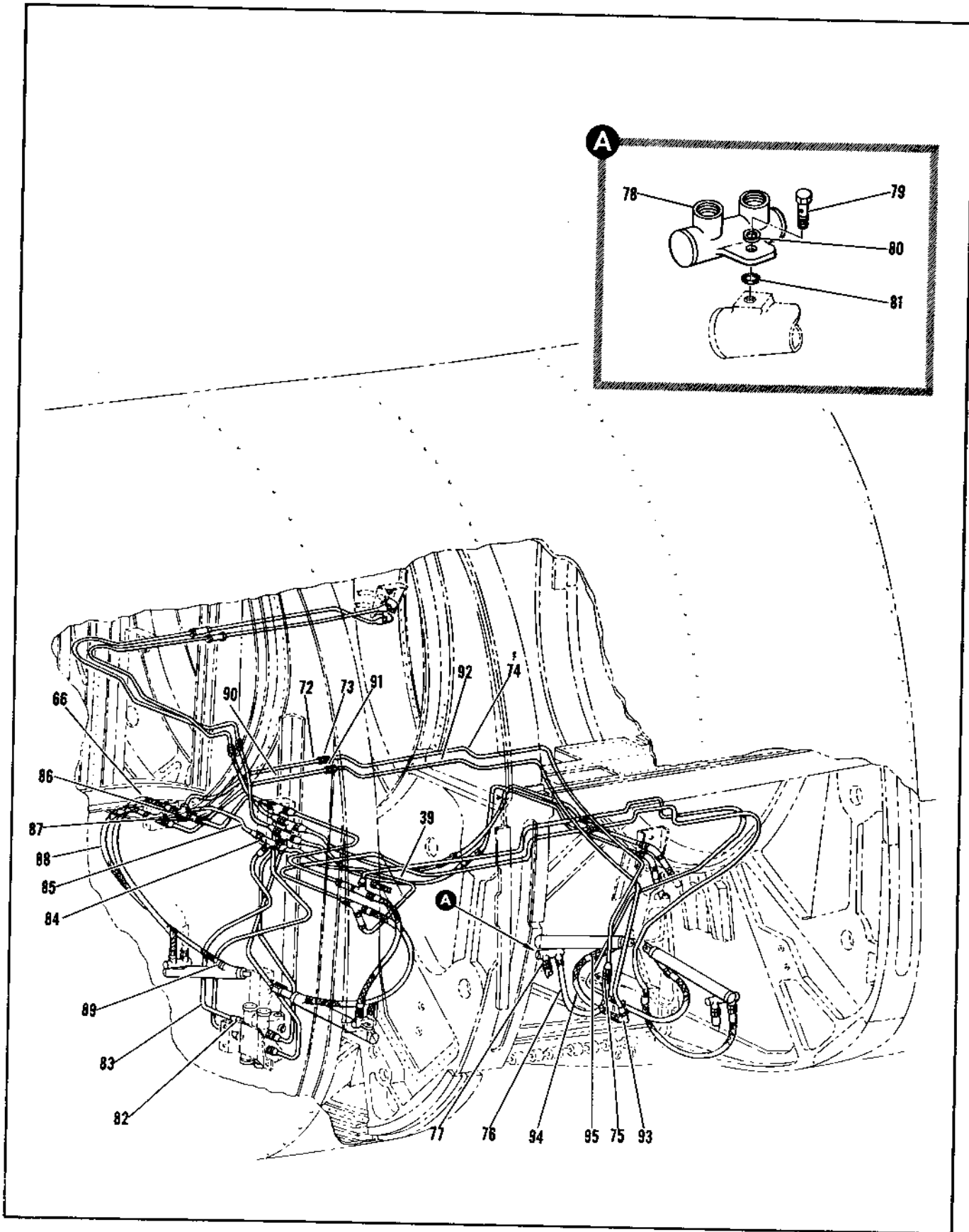

Figure 2.8-16. Main Landing Gear Hydraulic Tubing Installation (Sheet 4 of 4)

FIGURE AND INDEX NUMBER	PART NUMBER	DESCRIPTION	UNITS PER ASSY.	USABLE ON CODE	
				FROM	TO
2.8-16- 72	8-80031-281	• TUBE ASSY, MLG DOOR OPEN	1	35	61
- 73	8-80031-503	• TUBE ASSY, MLG DOOR OPEN	1	61	
- 74	MS2190204	• UNION	1	35	
- 74	8-80031-283	• TUBE ASSY, MLG DOOR OPEN	1	35	61
- 75	8-80031-507	• TUBE ASSY, MLG DOOR OPEN	1	61	
- 75	MS2192404	• UNION	1	35	
- 75	AN924-40	• NUT	1	35	
- 75	AN9610716	• WASHER	1	35	
- 76	CR205873-4-0136	• HOSE ASSY, <50599> SPEC 8-10358-136	1	35	
- 77	MS2190204	• UNION	1	35	
- 77	AN6290-4	• GASKET	1	35	
- 78	3350A1	• VALVE ASSY, SHUTTLE <78162> SPEC 8-00364-1 I.O.918-5-01-3 ATTACHING PARTS	1	35	
- 79	8-80208	• BOLT	1	35	
- 80	MS28775-011	• PACKING	1	35	
- 81	MS28778-4	• GASKET	1	35	
- 82	MS2190206	• UNION	1	35	
- 82	AN6290-6	• GASKET	1	35	
- 83	8-80031-125	• TUBE ASSY, MLG DOOR CLOSE	1	35	61
- 83	8-84794-7	• TUBE ASSY, MLG DOOR CLOSE	1	61	
- 84	MS2191004	• TEE	1	35	
- 84	AN924-40	• NUT	1	35	
- 84	AN9610716	• WASHER	1	35	
- 84	MS2191606-4	• REDUCER	1	35	
- 84	AN6290-6	• GASKET	1	35	
- 85	8-80031-127	• TUBE ASSY, MLG DOOR CLOSE	1	35	61
- 85	8-80031-457	• TUBE ASSY, MLG DOOR CLOSE	1	61	
- 86	282441-3	• RESTRICTOR, VALVE <31207> SPEC 8-08476-404 I.O.918-1-20-3	1	35	
- 87	MS2191004	• TEE	1	35	
- 87	AN924-40	• NUT	1	35	
- 87	AN9610716	• WASHER	1	35	
- 87	AN6290-4	• GASKET	1	35	
- 88	CR295873-4-0180	• HOSE ASSY, FWD <50599> SPEC 8-10358-180	1	35	49
- 88	YR5470-4-1180	• HOSE ASSY, FWD <50599> SPEC 8-10358-180	1	49	
- 89	MS2190204	• UNION	1	35	
- 89	AN6290-4	• GASKET	1	35	
- 90	8-80031-077	• TUBE ASSY, MLG DOOR CLOSE	1	35	61
- 90	8-80031-505	• TUBE ASSY, MLG DOOR CLOSE	1	61	
- 91	MS2190204	• UNION	1	35	
- 92	8-80031-027	• TUBE ASSY, MLG DOOR CLOSE	1	35	61
- 92	8-80031-511	• TUBE ASSY, MLG DOOR CLOSE	1	61	
- 93	MS2190804	• ELBOW	1	35	
- 93	AN924-40	• NUT	1	35	
- 93	AN9610716	• WASHER	1	35	
- 94	CR295873-4-0122	• HOSE ASSY, <50599> 84-87542-015	1	35	
- 95	MS2190204	• UNION	1	35	
- 95	AN6290-4	• GASKET	1	35	

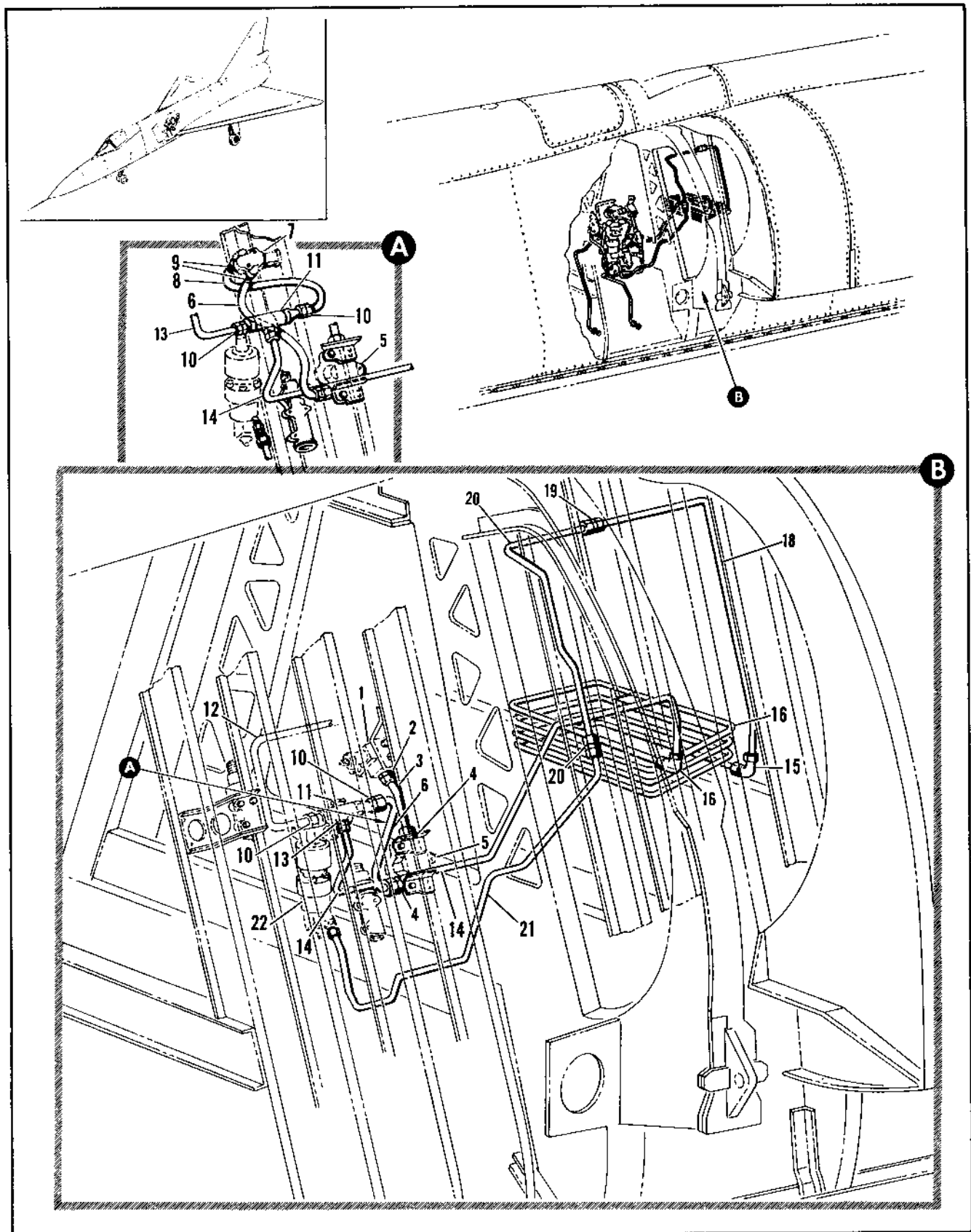

Figure 2.8-17. Variable Air Ramp Hydraulic Tubing Installation (Sheet 1 of 2)

FIGURE AND INDEX NUMBER	PART NUMBER	DESCRIPTION 1 2 3 4 5 6	UNITS PER ASSY.	USABLE ON CODE	
				FROM	TO
2.8-17	8-80031-801	TUBING INSTL. VARIABLE AIR RAMP HYDRAULIC MODIFIED BY 66J41297			
	8-80031-803	TUBING INSTL. VARIABLE AIR RAMP HYDRAULIC MODIFIED BY 66J41297			
	8-80031-809	TUBING INSTL. VARIABLE AIR RAMP HYDRAULIC MODIFIED BY 66J41297			
- 1		• VALVE ASSY, HYDRAULIC SHUTOFF STA 30A SEE FIG. 2.11-8 INDEX 5	RF		
- 2	MS2191606-4	• REDUCER	1	35	
	AN6290-6	• GASKET	1	35	
- 3	8-80031-377	• TUBE ASSEMBLY	1	35	
- 4	MS2190204	• UNION	2	35	
	AN6290-4	• GASKET	2	35	
- 5		• VALVE ASSY, VARIABLE AIR RAMP SERVO CONTROL RF STA 30R SEE FIG. 2.11-8 INDEX 10			
- 6	8-80031-601	• TUBE ASSEMBLY	1	189	
- 7		• VALVE ASSY, SOLENOID OPERATED HYDRAULIC CHECK SEE FIG. 2.8-1 INDEX 27	RF		
- 8	8-80031-899	• TUBE ASSEMBLY	1	189	
- 9	MS2190204	• UNION	2	189	
	AN6290-4	• GASKET	2	189	
- 10	MS2190204	• UNION	2	35	
	AN6290-4	• GASKET	2	35	
- 11		• VALVE ASSY, SHUTTLE STA 301 SEE FIG. 2.11-8 INDEX 14	RF		
- 12		• TUBE ASSY, VARIABLE AIR RAMP DRIVE UNIT SEE FIG. 2.9-19 INDEX 12	RF		
- 13	MS2191603-4	• REDUCER	1	35	
	AN6290-4	• GASKET	1	35	
- 14	66A39645-1	• TUBE ASSY	1		
- 15	MS2190204	• UNION	2		
- 16	8-80031-253	• TUBE ASSY	1	35	
- 17	66A39644-1	• TUBE ASSY	1		
- 18	MS2191600-4	• REDUCER	1	35	
- 19	66A39661-1	• TUBE ASSY	1		
- 20	MS2190204	• UNION	1	35	
- 21	8-80031-371	• TUBE ASSEMBLY	1	35	
- 22		• DRIVE UNIT ASSY, VARIABLE AIR RAMP INTAKE DUCT SEE FIG. 2.11-1 INDEX 3	RF		

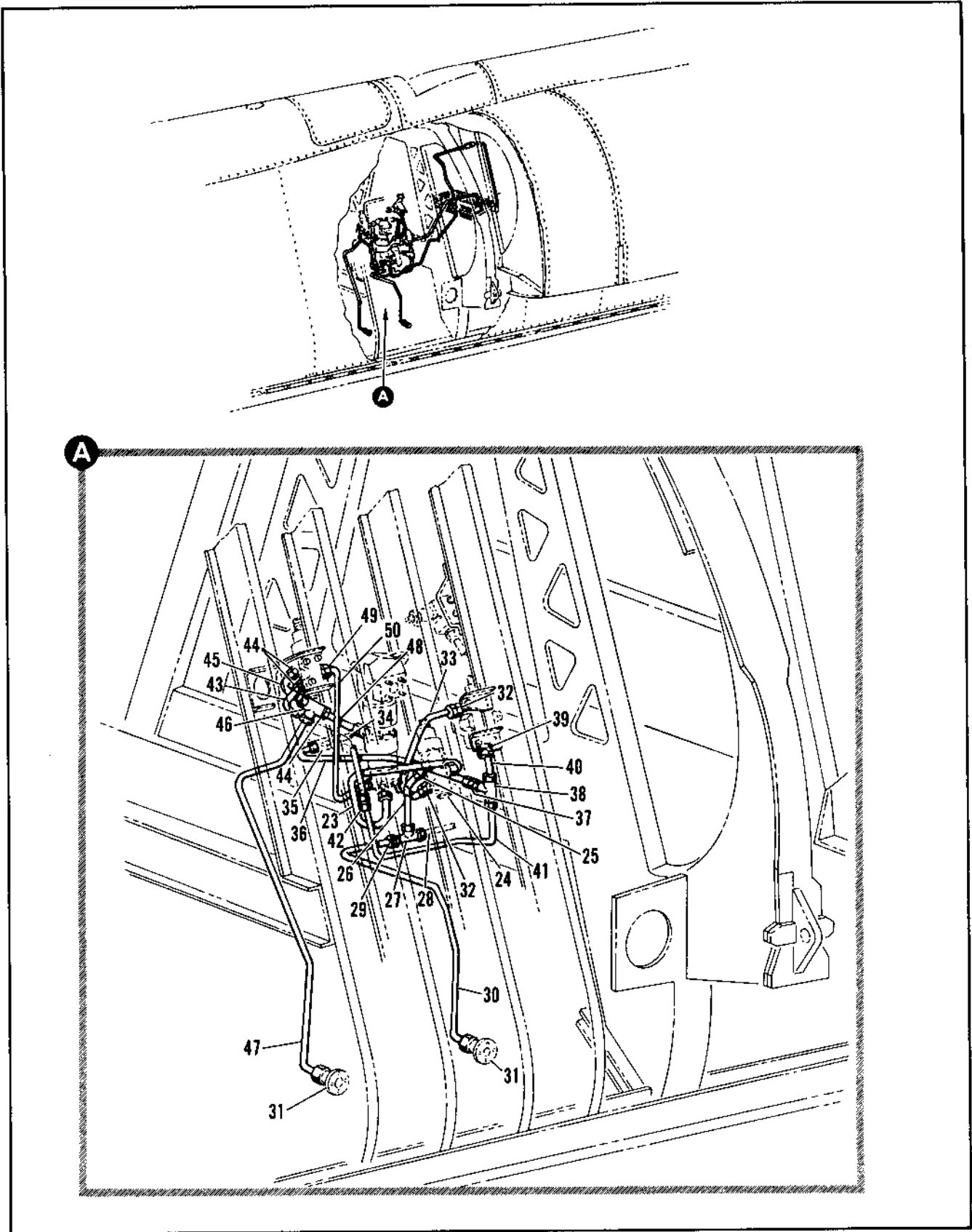

Figure 2.8-17. Variable Air Ramp Hydraulic Tubing Installation (Sheet 2 of 2)

FIGURE AND INDEX NUMBER	PART NUMBER	DESCRIPTION	UNITS PER ASSY.	USABLE ON CODE	
				FROM	TO
2.8-17- 23	R-80031-339	• TUBE ASSEMBLY	1	35	
- 24		• VALVE, HYDRAULIC BYPASS STA 287 TO 294 SEE FIG. 2.11-8 INDEX 1	PF		
- 25	MS2191606-4	• REDUCER	1	35	
	AN6290-6	• GASKET	1	35	
- 26	R-80031-315	• TUBE ASSEMBLY	1	35	
- 27	MS2191106	• TEE	1	35	
- 28		• TUBE ASSY, VARIABLE AIR RAMP VENT SEE FIG. 2.9-18 INDEX 21	PF		
- 29	MS2191606-4	• REDUCER	1	35	
	AN924-60	• NUT	1	35	
	AN9610910L	• WASHER	1	35	
	AN6290-6	• GASKET	1	35	
- 30	R-80031-239	• TUBE ASSEMBLY	1	35	
- 31		• FITTING, VARIABLE AIR RAMP SYSTEM DRAIN SEE FIG. 2.3-14 INDEX 10	PF		
- 32	MS2190204	• UNION	2	35	
	AN6290-4	• GASKET	2	35	
- 33	R-80031-331	• TUBE ASSEMBLY	1	35	
- 34		• TUBE ASSY, SEE FIG. 2.4-4 INDEX 42	PF		
- 35	1112-558951	• VALVE ASSY, CHECK (C02017) SPEC R-24452-306 T.O. 9H8-6-8-23	1	35	
- 36	R-80031-227	• TUBE ASSEMBLY	1	35	
- 37	MS2190204	• UNION	2	35	
- 38	MS2191104	• TEE	1	35	
	AN924-40	• NUT	1	35	
	AN9610716L	• WASHER	1	35	
- 39	MS2191606-4	• REDUCER	1	35	
	AN6290-4	• GASKET	1	35	
- 40	R-80031-231	• TUBE ASSEMBLY	1	35	
- 41	R-80031-201	• TUBE ASSEMBLY	1	35	
- 42	MS2190204	• UNION	1	35	
	AN6290-4	• GASKET	1	35	
- 43	R-80031-243	• TUBE ASSEMBLY	1	35	
- 44	MS2191606-4	• REDUCER	2	35	
	AN6290-4	• GASKET	2	35	
- 45	R-80031-311	• TUBE ASSEMBLY	1	35	
- 46	MS2191106	• TEE	1	35	
- 47	R-80031-249	• TUBE ASSEMBLY	1	35	
- 48	R-80031-307	• TUBE ASSEMBLY	1	35	
- 49	MS2190204	• UNION	1	35	
	AN6290-4	• GASKET	1	35	
- 50	R-80031-317	• TUBE ASSEMBLY	1	35	

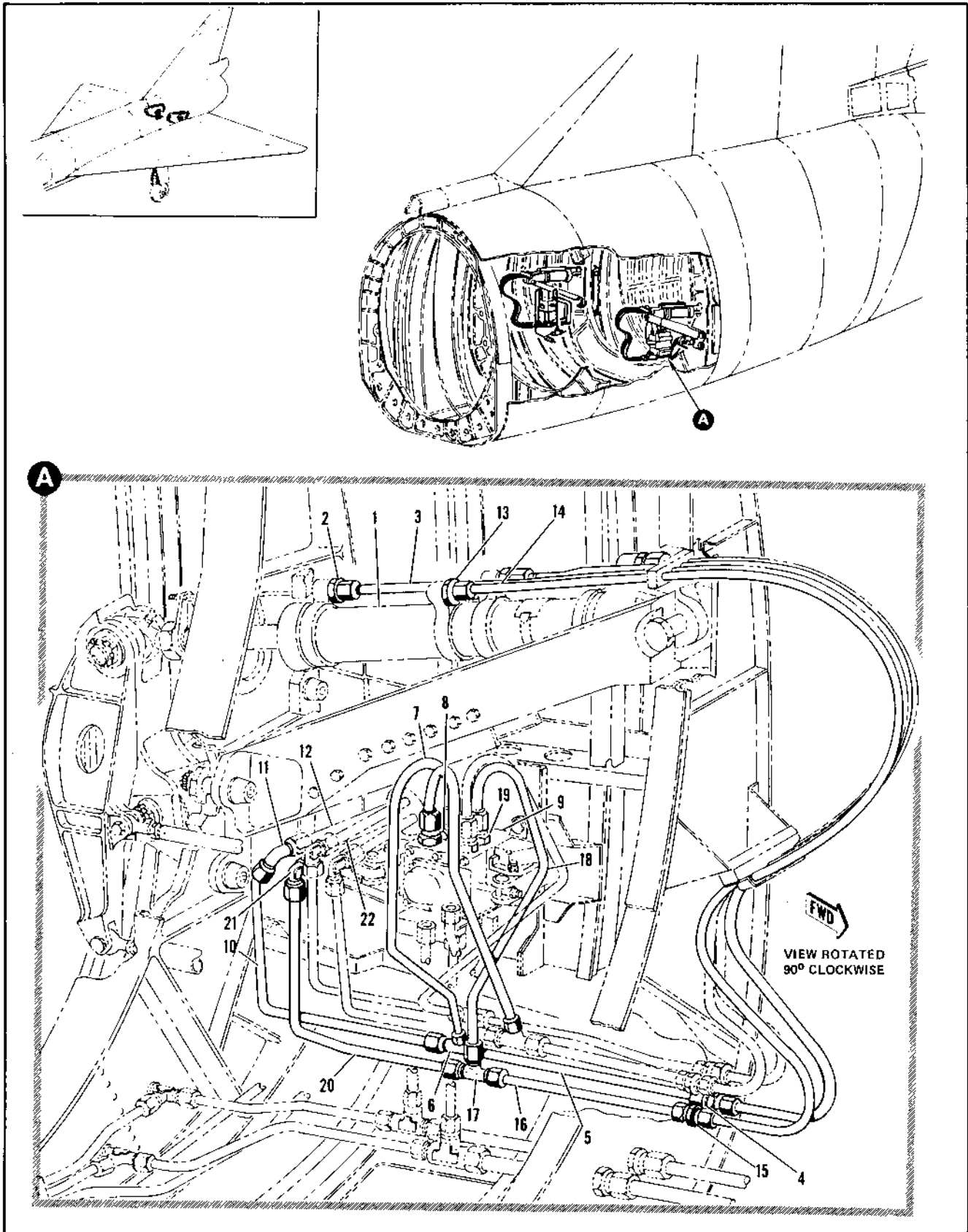

Figure 2.8-18. Elevon Actuator Hydraulic Tubing Installation Sta 556 to 605 (Sheet 1 of 4)

FIGURE AND INDEX NUMBER	PART NUMBER	DESCRIPTION	UNITS PER ASSY.	USABLE ON CODE	
				FROM	TO
2.8-18	R-80130-3	TURBINE INSTALLATION, ELEVON ACTUATOR HYDRAULIC STA 556 TO 555 MODIFIED BY R-80134	1		A
	6-80030	TURBINE INSTALLATION, ELEVON ACTUATOR HYDRAULIC STA 556 TO 555 MODIFIED BY 6-80134	1	273	297
	R-80130-1	TURBINE INSTALLATION, ELEVON ACTUATOR HYDRAULIC STA 556 TO 555 MODIFIED BY R-80134	1	284	293
	R-80130-3	TURBINE INSTALLATION, ELEVON ACTUATOR HYDRAULIC STA 556 TO 555 MODIFIED BY R-80134	1	294	303
- 1		• ACTUATOR ASSY, ELEVON OUTBOARD SEE FIG. 2.14-11 INDEX 35	1		F
- 2	MS21902-40	• UNION	1	35	
	AN6290-6	• GASKET	1	35	
- 3	R-81401	• TUBE ASSEMBLY	1	35	
- 4	MS2190306	• UNION	1	35	
	AN924	• NUT	1	35	
	AN960-917L	• WASHER	1	35	
- 5	R-80130-137	• TUBE ASSEMBLY	1	35	
- 6	MS2190506	• TEE	1	35	
- 7	R-80030-359	• TUBE ASSEMBLY	1		C
- 8	MS2190206	• UNION	1	35	
	AN6290-6	• GASKET	1	35	
- 9		• VALVE ASSY, ELEVON CONTROL SEE FIG. 2.14-11 INDEX 32	1		F
- 10	R-80130-187	• TUBE ASSY, LH	1	35	
- 11	MS2190406	• FLEDM	1	35	
- 12		• TUBE ASSY, LH SEE FIG. 2.8-19 INDEX 2	1		F
- 13	MS21902-40	• UNION	1	35	
	AN6290-6	• GASKET	1	35	
- 14	R-81403	• TUBE ASSEMBLY	1	35	
- 15	MS2190306	• UNION	1	35	
	AN924-6	• NUT	1	35	
	AN960-918L	• WASHER	1	35	
- 16	R-80130-175	• TUBE ASSEMBLY	1	35	
- 17	MS2190506	• TEE	1	35	
- 18	R-80030-205	• TUBE ASSEMBLY	1	35	
- 19	MS2190206	• UNION	1	35	
	AN6290-6	• GASKET	1	35	
- 20	R-80130-189	• TUBE ASSY, LH	1	35	
- 21	MS2190406	• FLEDM	1	35	
- 22		• TUBE ASSY, LH SEE FIG. 2.8-19 INDEX 45	1		F
		A AIRPLANES 435 THRU 477, 504 AND 515			
		F AIRPLANES 475 THRU 477 AND 480 THRU 489			
		C AIRPLANES 448, 450 AND ON			

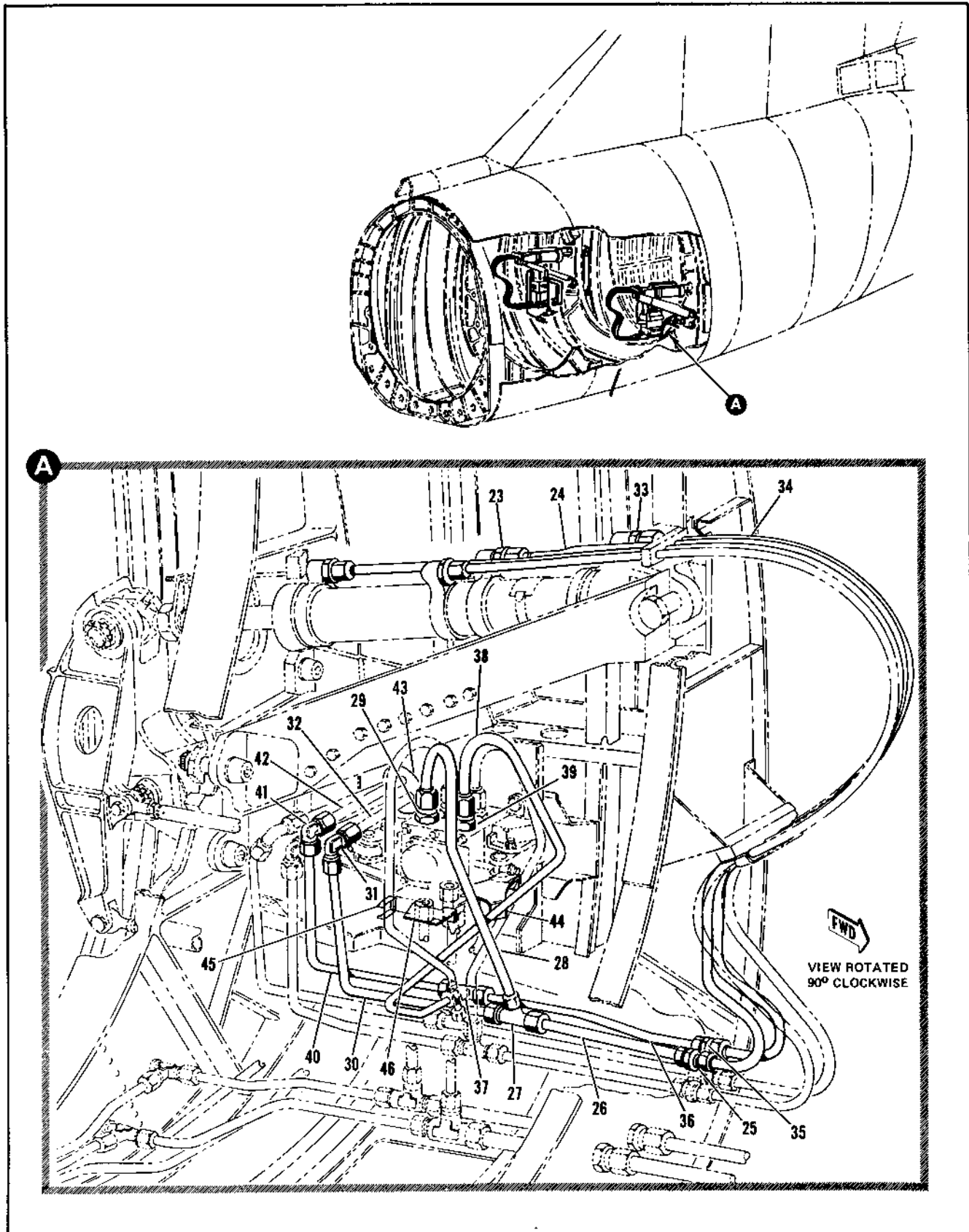

Figure 2.8-18. Elevon Actuator Hydraulic Tubing Installation Sta 556 to 605 (Sheet 2 of 4)

FIGURE AND INDEX NUMBER	PART NUMBER	DESCRIPTION	UNITS PER ASSY.	USABLE ON CODE	
				FROM	TO
		1 2 3 4 5 6			
2.8-18- 23	MS21902-6C	• UNION	1	35	
	AN6290-6	• GASKET	1	35	
- 24	8-81405	• TUBE ASSEMBLY	1	35	
- 25	MS21903D6	• UNION	1	35	
	AN924-6	• NUT	1	35	
	AN960-915L	• WASHER	1	35	
- 26	8-80030-139	• TUBE ASSEMBLY	1	35	
- 27	MS21905D6	• TEE	1	35	
- 28	8-80030-357	• TUBE ASSEMBLY	1	C	
- 29	MS21902D6	• UNION	1	35	
	AN6290-6	• GASKET	1	35	
- 30	8-80030-165	• TUBE ASSY, LH	1	35	
- 31	MS21904D6	• ELBOW	1	35	
- 32		• TUBE ASSY, LH SEE FIG. 2.8-19 INDEX 27	RF		
- 33	MS21902-6C	• UNION	1	35	
	AN6290-6	• GASKET	1	35	
- 34	8-81407	• TUBE ASSEMBLY	1	35	
- 35	MS21903D6	• UNION	1	35	
	AN924-6	• NUT	1	35	
	AN960-915L	• WASHER	1	35	
- 36	8-80030-141	• TUBE ASSEMBLY	1	35	
- 37	MS21905D6	• TEE	1	35	
- 38	8-80030-361	• TUBE ASSEMBLY	1	189	
- 39	MS21902D6	• UNION	1	35	
	AN6290-6	• GASKET	1	35	
- 40	8-80030-163	• TUBE ASSY, LH	1	35	
- 41	MS21904D6	• ELBOW	1	35	
- 42		• TUBE ASSY, LH SEE FIG. 2.8-19 INDEX 37	RF		
- 43	4289	• GROMMET, <84914> SPEC 8-00434-3	1	35	
- 44	8-69004-495	• BRACKET ASSY, RIVETED	1	179	
- 45	8-28964-167	• BRACKET ASSY, RIVETED	1	C	
- 46	8-69013-367	• BRACKET	1	C	
		B AIRPLANES #35 THRU 47 AND 49 THRU 29			
		C AIRPLANES #48, 90 AND ON			

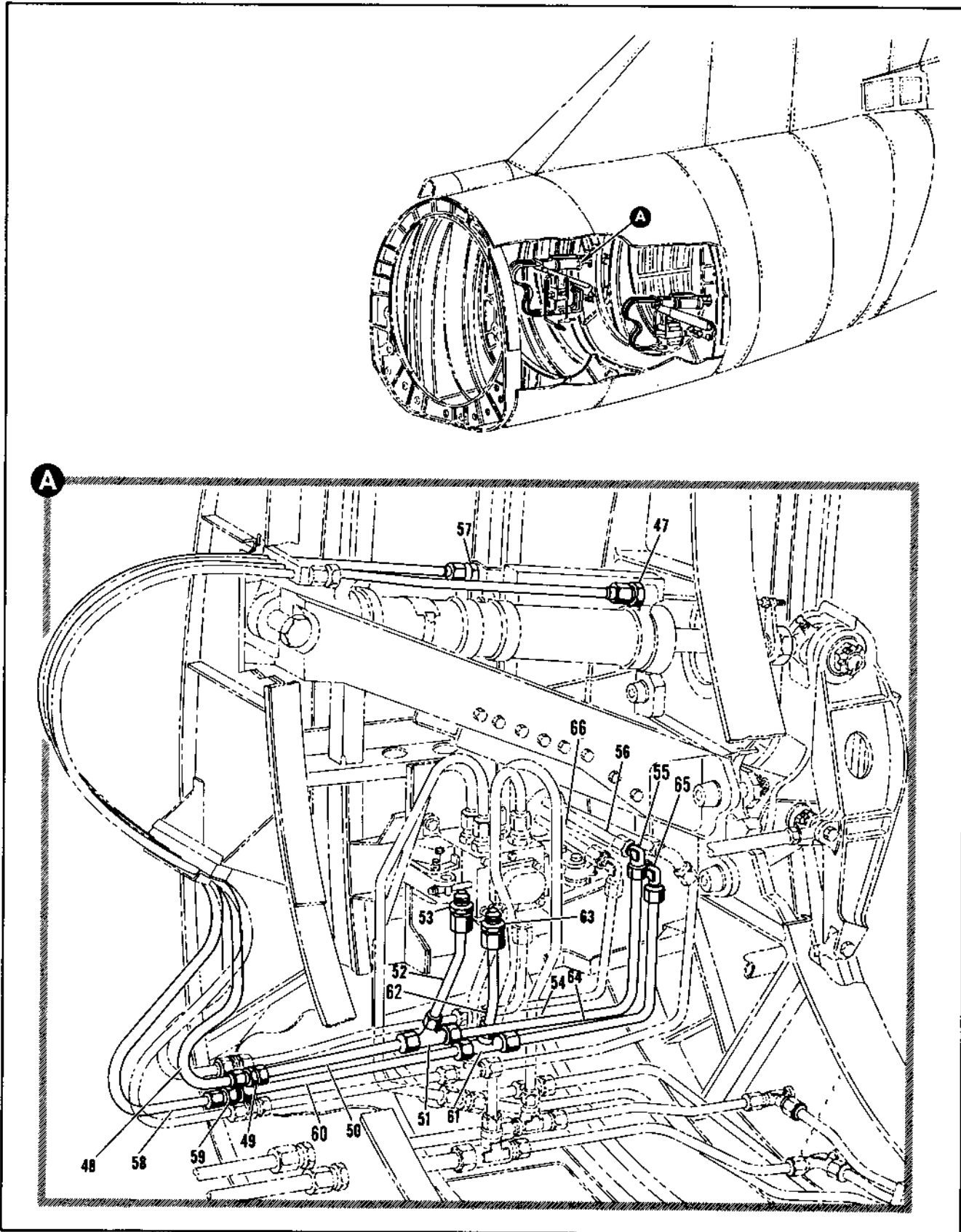

Figure 2.8-18. Elevon Actuator Hydraulic Tubing Installation Sta 556 to 605 (Sheet 3 of 4)

FIGURE AND INDEX NUMBER	PART NUMBER	DESCRIPTION	UNITS PER ASSY.	USABLE ON CODE	
				FROM	TO
2.8-18- 47	MS21902-60	• UNION	1	35	
	AN6290-6	• GASKET	1	35	
- 48	R-81403	• TUBE ASSEMBLY	1	35	
- 49	MS2190306	• UNION	1	35	
	AN924-6	• NUT	1	35	
	AN960-916	• WASHER	1	35	
- 50	R-80030-157	• TUBE ASSEMBLY	1	35	
- 51	MS2190406	• TEE	1	35	
- 52	R-80030-143	• TUBE ASSEMBLY	1	35	
- 53	MS2190306	• UNION	1	35	
	AN924-60	• NUT	1	35	
	AN9600916L	• WASHER	1	35	
	AN6290-6	• GASKET	1	35	
- 54	R-80030-171	• TUBE ASSY, RH	1	35	
- 55	MS2190406	• ELBOW	1	35	
- 56		• TUBE ASSY, RH SEE FIG. 2.8-19 INDEX 55	FF		
- 57	MS21902-60	• UNION	1	35	
	AN6290-6	• GASKET	1	35	
- 58	R-81403	• TUBE ASSEMBLY	1	35	
- 59	MS2190306	• UNION	1	35	
	AN924-6	• NUT	1	35	
	AN960-916	• WASHER	1	35	
- 60	R-80030-159	• TUBE ASSEMBLY	1	35	
- 61	MS2190506	• TEE	1	35	
- 62	R-80030-145	• TUBE ASSEMBLY	1	35	
- 63	MS2190206	• UNION	1	35	
	AN6290-6	• GASKET	1	35	
- 64	R-80030-173	• TUBE ASSY, RH	1	35	
- 65	MS2190406	• ELBOW	1	35	
- 66		• TUBE ASSY, RH SEE FIG. 2.8-19 INDEX 61	FF		

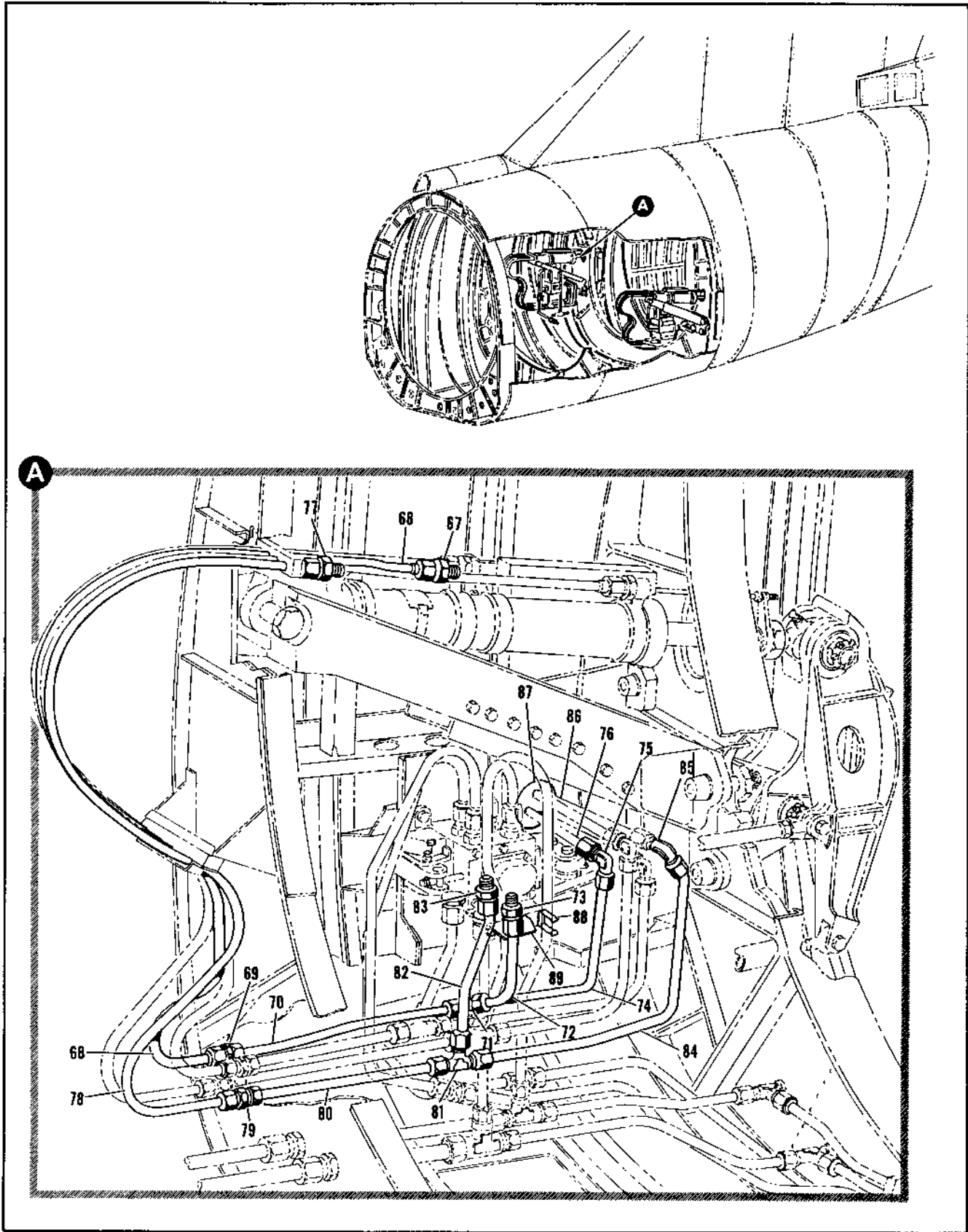

Figure 2.8-18. Elevon Actuator Hydraulic Tubing Installation Sta 556 to 605 (Sheet 4 of 4)

FIGURE AND INDEX NUMBER	PART NUMBER	DESCRIPTION	UNITS PER ASSY.	USABLE ON CODE	
				FROM	TO
2.8-18- 67	MS21932-60	• UNION	1	35	
	AN6290-6	• GASKET	1	35	
- 68	R-81405	• TUBE ASSEMBLY	1	35	
- 69	MS21933D6	• UNION	1	35	
	AN924-6	• NUT	1	35	
	AN960-918	• WASHER	1	35	
- 70	3-80030-161	• TUBE ASSEMBLY	1	35	
- 71	MS21935D6	• TEE	1	35	
- 72	R-80011-149	• TUBE ASSEMBLY	1	35	
- 73	MS2190306	• UNION	1	35	
	AN924-60	• NUT	1	35	
	AN96 091eL	• WASHER	1	35	
	AN6290-6	• GASKET	1	35	
- 74	R-80030-267	• TUBE ASSY. RH	1	35	
- 75	MS21904DA	• ELBOW	1	35	
- 76		• TUBE ASSY. RH SEE FIG. 2.8-19 INDEX 91	1	35	
- 77	MS21902-60	• UNION	1	35	
	AN6290-6	• GASKET	1	35	
- 78	R-81407	• TUBE ASSEMBLY	1	35	
- 79	MS21903D6	• UNION	1	35	
	AN924-6	• NUT	1	35	
	AN960-918	• WASHER	1	35	
- 80	3-80030-155	• TUBE ASSEMBLY	1	35	
- 81	MS21908D6	• TEE	1	35	
- 82	R-80030-147	• TUBE ASSEMBLY	1	35	
- 83	MS21902D6	• UNION	1	35	
	AN6290-6	• GASKET	1	35	
- 84	R-80030-177	• TUBE ASSY. RH	1	35	
- 85	MS21904DA	• ELBOW	1	35	
- 86		• TUBE ASSY. RH SEE FIG. 2.8-19 INDEX 100	1	35	
- 87	4289	• GROMMET, 664914> SPEC R-70434-3	1	35	
- 88	R-28964-171	• BRACKET ASSY, RIVETED	1	C	
- 89	R-69013-389	• BRACKET	1	C	
		B AIRPLANES #35 THRU 47 AND 49 THRU 89			
		C AIRPLANES #48, 90 AND ON			

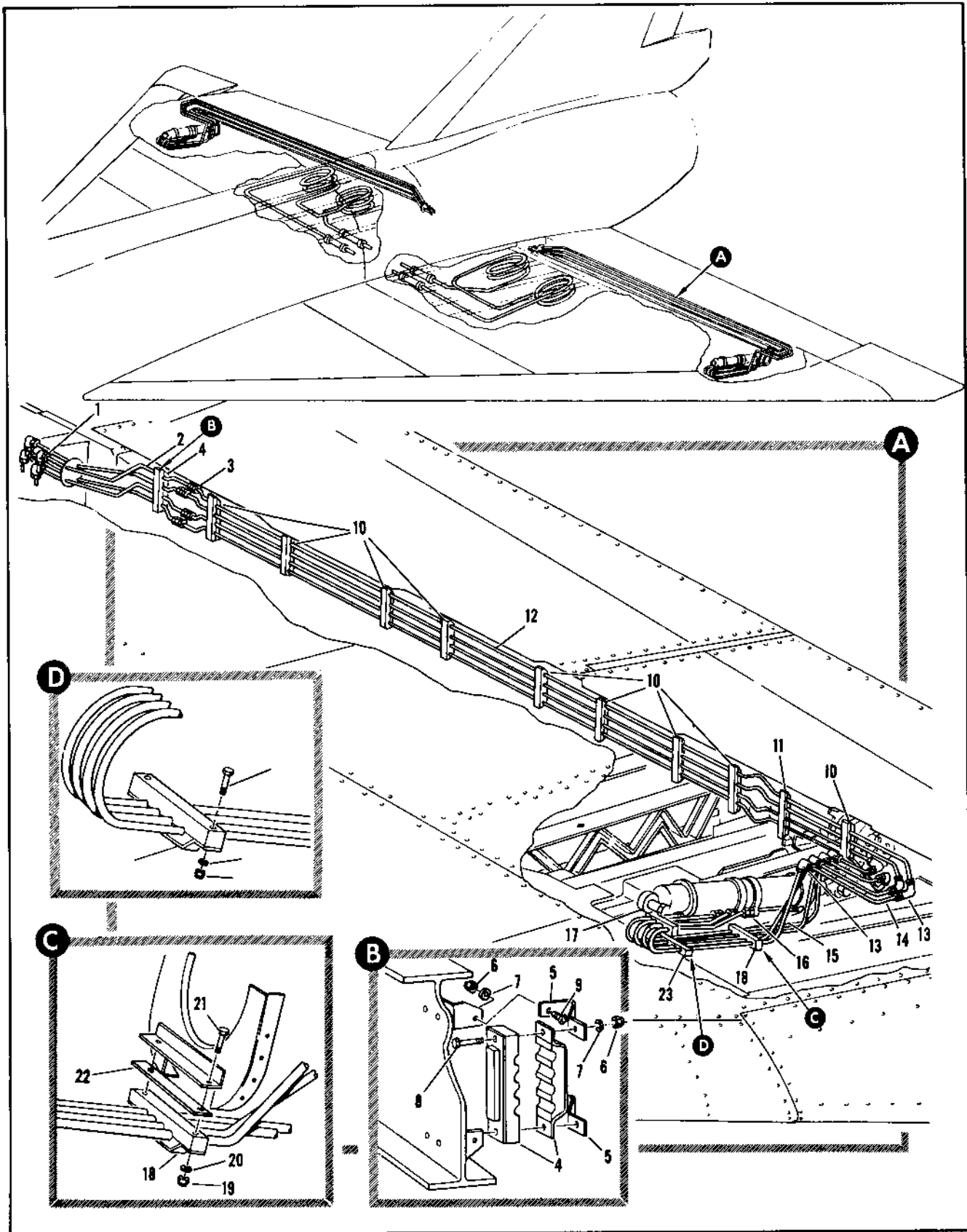

Figure 2.8-19. Wing Elevon Hydraulic Tubing Installation (Sheet 1 of 5)

FIGURE AND INDEX NUMBER	PART NUMBER	DESCRIPTION	UNITS PER ASSY.	USABLE ON CODE	
				FROM	TO
2.8-19	8-80029	TUBING INSTALLATION, WING ELEVON HYDRAULIC LH MODIFIED BY 8-80133 AND 8-80125 FOR NHA SEE FIG. 2.6-32	WF	35	
	8-80029-1	TUBING INSTALLATION, WING ELEVON HYDRAULIC RH MODIFIED BY 8-80133 AND 8-80125 FOR NHA SEE FIG. 2.6-32	WF	35	
- 1	8-81029-57	• TUBE ASSY, LH SEE FIG. 2.8-18 INDEX 10	WF		
- 2	MS2193206	• TUBE ASSY, LH	1	35	
- 3	TAGLS52	• UNION, LH	1	35	
- 4	8-80023-8	• SUPPORT, TUBE LH <84971> 98-61200-032	1	35	
- 5		• CLIP, LH	2	35	
		ATTACHING PARTS			
- 6	NAS679A3	• NUT	4	35	
- 7	AN96D10L	• WASHER	4	35	
- 8	AN3-6A	• BOLT	2	35	
- 9	AN524-1032R4	• SCREW	2	35	
		-----X-----			
- 10	TAGLS51	• SUPPORT, TUBE LH <84971> 98-61200-031	9	35	
- 11	TAGLS53	• SUPPORT, TUBE LH <84971> 98-61200-033	1	35	
		ATTACHING PARTS			
	NAS679A3	• NUT	20	35	
	AN96D10L	• WASHER	20	35	
	AN3-6A	• BOLT	20	35	
		-----X-----			
- 12	8-80129-21	• TUBE ASSY, LH	1	35	
- 13	MS21908D6	• ELBOW, LH	1	35	
	AN924-6D	• NUT, LH	2	35	
	AN96D9161	• WASHER, LH	2	35	
- 14	8-80129-7	• TUBE ASSY, LH	1	35	
- 15	8-82111	• TUBE ASSY, OUTRD ELEVON LH	1	35	
- 16	MS21902-6C	• UNION, LH	1	35	
	AN5295-6	• GASKET, LH	1	35	
- 17		• ACTUATOR ASSY, ELEVON SEE FIG. 2.14-11 INDEX 21	1		
- 18	TAGLS53	• SUPPORT, TUBE LH <84971> 98-61200-033	1	35	
		ATTACHING PARTS			
- 19	NAS679A3	• NUT	2	35	
- 20	AN96D10L	• WASHER	1	35	
- 21	AN3-7A	• BOLT	2	35	
		-----X-----			
- 22	8-80029-82	• FILLER, LH	1	35	
- 23	TAGLS52	• SUPPORT, TUBE LH <84971> 98-61200-032	1	35	
		ATTACHING PARTS			
- 24	NAS679A3	• NUT	2	35	
- 25	AN96D10L	• WASHER	2	35	
- 26	AN3-6A	• BOLT	2	35	
		-----X-----			

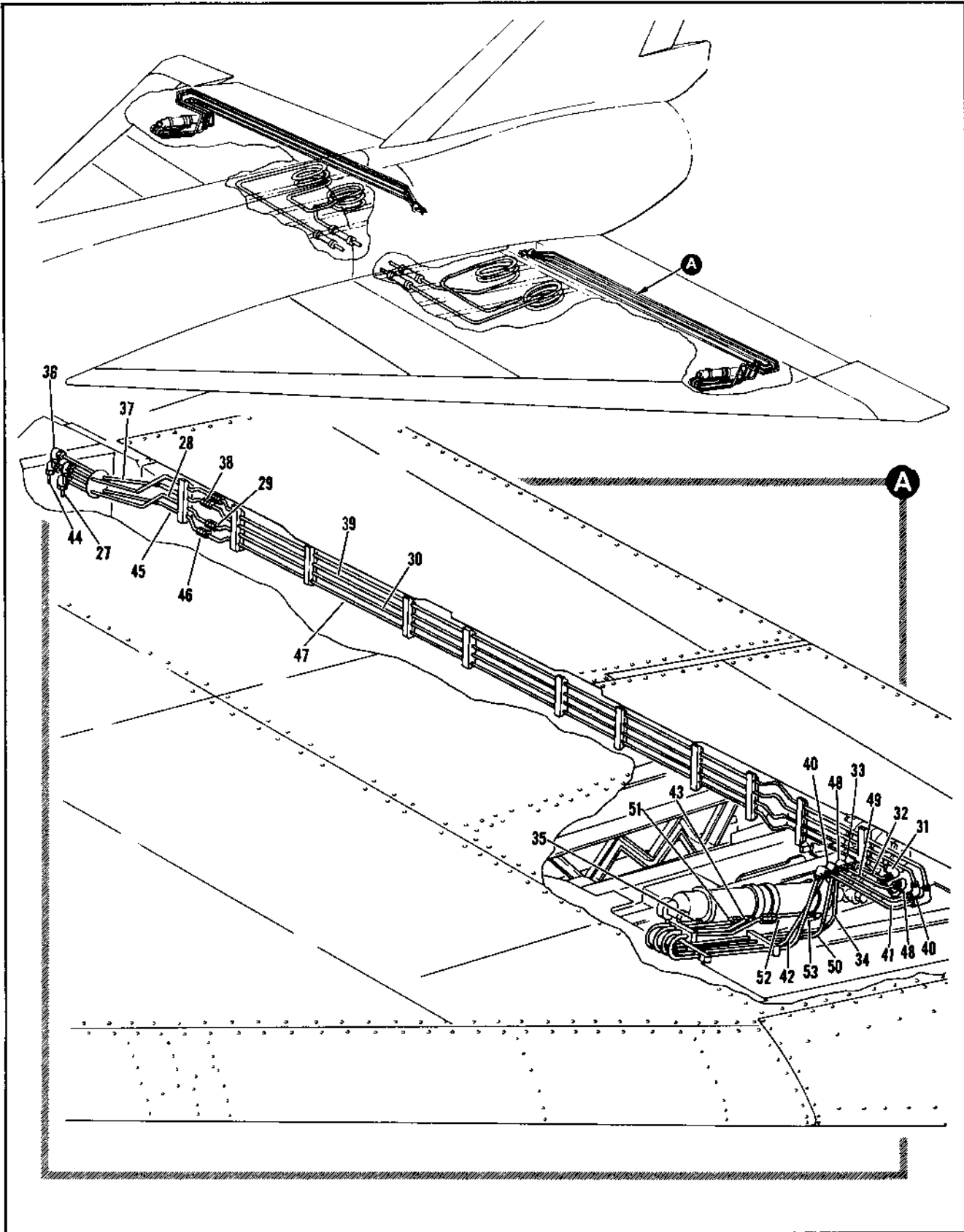

Figure 2.8-19. Wing Elevon Hydraulic Tubing Installation (Sheet 2 of 5)

FIGURE AND INDEX NUMBER	PART NUMBER	DESCRIPTION	UNITS PER ASSY.	USABLE ON CODE	
				FROM	TO
		1 2 3 4 5 6			
2.8-19- 54		• TUBE ASSY, RH SEE FIG. 2.8-18 INDEX 54	9F		
- 55	8-80029-53	• TUBE ASSY, RH	1	35	
- 56	MS21902D6	• UNION, RH	1	35	
- 57	TA6LS52	• SUPPORT, TUBE RH <84971> 98-61200-002	1	35	
- 58	8-80003-9	• CLIP, RH	2	35	
		ATTACHING PARTS			
- 59	NAS679A3	• NUT	4	35	
- 60	AN960D16L	• WASHER	4	35	
- 61	AN3-6A	• BOLT	2	35	
- 62	AN526-1032R6	• SCREW	2	35	
		-----X-----			
- 63	TA6LS51	• SUPPORT, TUBE RH <84971> 98-61200-001	9	35	
- 64	TA6LS53	• SUPPORT, TUBE RH <84971> 98-61200-003	1	35	
		ATTACHING PARTS			
	NAS679A3	• NUT	20	35	
	AN960D16L	• WASHER	20	35	
	AN3-6A	• BOLT	20	35	
		-----X-----			
- 65	8-80029-21	• TUBE ASSY, RH	1	35	
- 66	MS21908D6	• ELBOW, RH	1	35	
	AN924-6D	• NUT,	1	35	
	AN960D916L	• WASHER,	1	35	
- 67	8-80029-43	• TUBE ASSY, RH	1	35	
- 68	MS21903D6	• UNION, RH	1	35	
	AN924-6D	• NUT	1	35	
	AN960D916L	• WASHER	1	35	
- 69	8-82112	• TUBE ASSY, CUTBD ELEVCR RH	1	35	
- 70	MS21902-6C	• UNION, RH	1	35	
	AN629C-6	• GASKET, RH	1	35	
- 71	TA6LS53	• SUPPORT, TUBE RH <84971> 98-61200-003	1	35	
		ATTACHING PARTS			
- 72	NAS679A3	• NUT	2	35	
- 73	AN960D16L	• WASHER	2	35	
- 74	AN3-7A	• BOLT	2	35	
		-----X-----			
- 75	8-80029-83	• FILLER, RH	1	35	
- 76	TA6LS52	• SUPPORT, TUBE RH <84971> 98-61200-002	1	35	
		ATTACHING PARTS			
- 77	NAS679A3	• NUT	2	35	
- 78	AN960D16L	• WASHER	2	35	
- 79	AN3-5A	• BOLT	2	35	
		-----X-----			

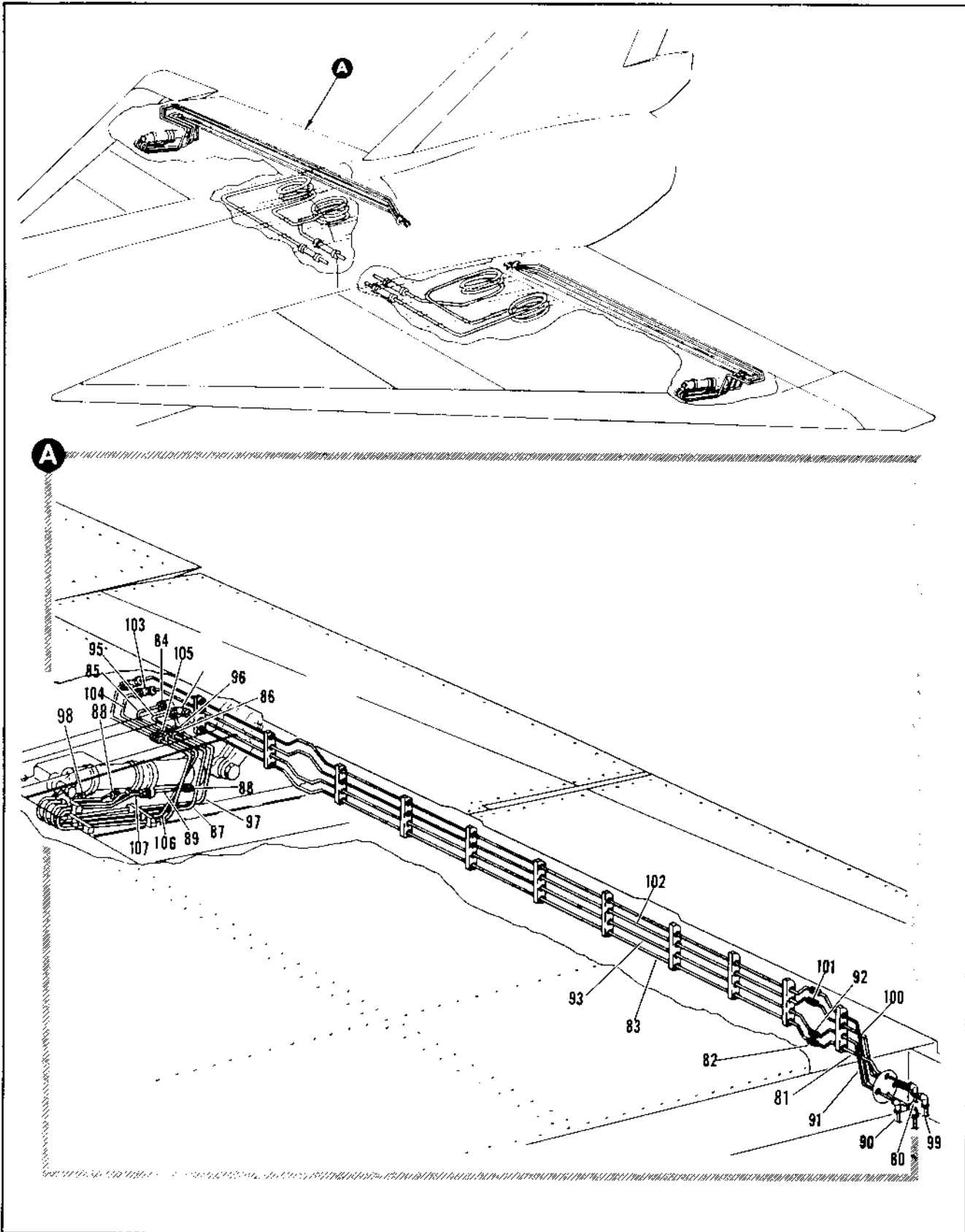

Figure 2.8-19. Wing Elevon Hydraulic Tubing Installation (Sheet 4 of 5)

FIGURE AND INDEX NUMBER	PART NUMBER	DESCRIPTION	UNITS PER ASSY.	USABLE ON CODE	
				FROM	TO
		1 2 3 4 5 6			
2.8-19- 80		• TUBE ASSY, RH SEE FIG. 2.8-18 INDEX 64	RF		
- 81	8-80029-31	• TUBE ASSY, RH	1	35	
- 82	MS21902D6	• UNION, RH	1	35	
- 83	8-80029-19	• TUBE ASSY, RH	1	35	
- 84	MS21908D6	• ELBOW, RH	1	35	
	AN924-6D	• NUT, RH	1	35	
	AN960D916L	• WASHER, RH	1	35	
- 85	8-80029-47	• TUBE ASSY, RH	1	35	
- 86	MS21903D6	• UNION, RH	1	35	
	AN924-6D	• NUT, RH	1	35	
	AN960D916L	• WASHER, RH	1	35	
- 87	8-82108-1	• TUBE ASSY, OUTRD ELEVON RH	1	35	
- 88	MS21902-6C	• UNION, RH	2	35	
	AN6290-6	• GASKET, RH	2	35	
- 89	8-82113	• TUBE ASSY, OUTRD ELEVON RH	1	35	
- 90		• TUBE ASSY, RH SEE FIG. 2.8-18 INDEX 74	RF		
- 91	8-80029-39	• TUBE ASSY, RH	1	35	
- 92	MS21902D6	• UNION, RH	1	35	
- 93	8-80029-17	• TUBE ASSY, RH	1	35	
- 94	MS21908D6	• ELBOW, RH	1	35	
	AN924-6D	• NUT, RH	1	35	
	AN960D916L	• WASHER, RH	1	35	
- 95	8-80029-49	• TUBE ASSY, RH	1	35	
- 96	MS21903D6	• UNION, RH	1	35	
	AN924-6D	• NUT, RH	1	35	
	AN960D916L	• WASHER, RH	1	35	
- 97	8-82106	• TUBE ASSY, OUTRD ELEVCA RH	1	35	
- 98	MS21902-6C	• UNION, RH	1	35	
	AN6290-6	• GASKET, RH	1	35	
- 99		• TUBE ASSY, RH SEE FIG. 2.8-17 INDEX 84	RF		
-100	8-80029-41	• TUBE ASSY, RH	1	35	
-101	MS21902D6	• UNION, RH	1	35	
-102	8-80029-19	• TUBE ASSY, RH	1	35	
-103	MS21908D6	• ELBOW, RH	1	35	
	AN924-6D	• NUT, RH	1	35	
	AN960D916L	• WASHER, RH	1	35	
-104	8-80029-45	• TUBE ASSY, RH	1	35	
-105	MS21903D6	• UNION, RH	1	35	
	AN924-6D	• NUT, RH	1	35	
	AN960D916L	• WASHER, RH	1	35	
-106	8-82113	• TUBE ASSY, OUTRD ELEVCA RH	1	35	
-107	MS21902-6C	• UNION, RH	1	35	
	AN6290-6	• GASKET, RH	1	35	

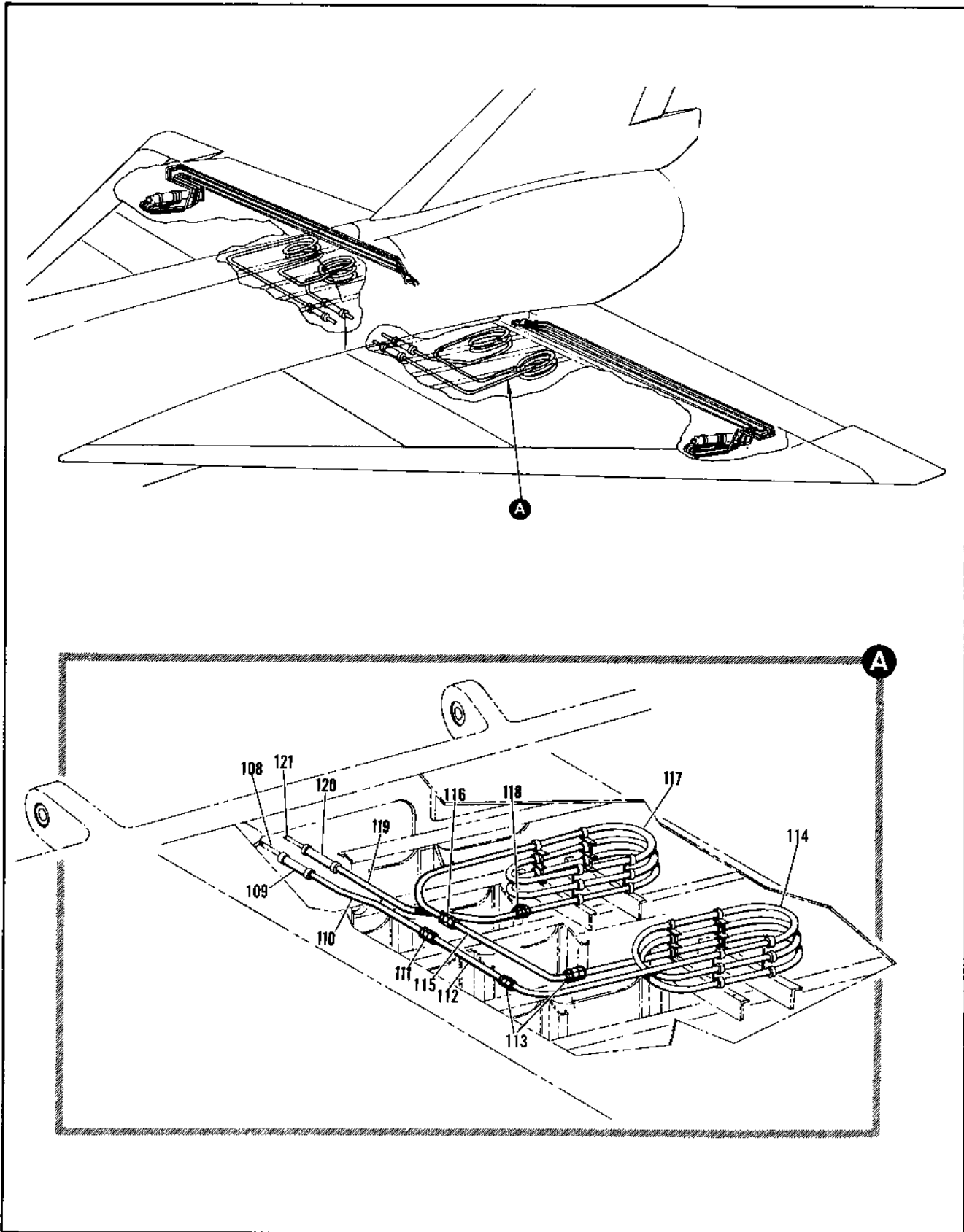

Figure 2.8-19. Wing Elevon Hydraulic Tubing Installation (Sheet 5 of 5)

FIGURE AND INDEX NUMBER	PART NUMBER	DESCRIPTION	UNITS PER ASSY.	USABLE ON CODE	
				FROM	TO
2.8-19-108		• TUBE ASSY, LH SEE FIG. 2.8-11 INDEX 52	RF		
-109		• FITTING, SEE FIG. 2.8-1 INDEX 76	RF		
-110	8-80029-69	• TUBE ASSY, LH	1	35	
	8-80029-81	• TUBE ASSY, RH	1	35	
-111	MS21903D10	• UNION	1	35	
	AN924-100	• NUT	1	35	
-112	8-80029-67	• TUBE ASSY, LH	1	35	
	8-80029-79	• TUBE ASSY, RH	1	35	
-113	MS21902D10	• UNION	2	35	
-114	8-80029-65	• TUBE ASSY, LH	1	35	
	8-80029-77	• TUBE ASSY, RH	1	35	
-115	8-80029-63	• TUBE ASSY, LH	1	35	
	8-80029-75	• TUBE ASSY, RH	1	35	
-116	MS21903D10	• UNION	1	35	
	AN924-100	• NUT	1	35	
-117	8-80029-61	• TUBE ASSY, LH	1	35	
	8-80029-73	• TUBE ASSY, RH	1	35	
-118	MS21902D10	• UNION	1	35	
-119	8-80029-59	• TUBE ASSY, LH	1	35	
	8-80029-71	• TUBE ASSY, RH	1	35	
-120		• FITTING, SEE FIG. 2.8-1 INDEX 76	RF		
-121		• TUBE ASSY, LH SEE FIG. 2.8-11 INDEX 53	RF		

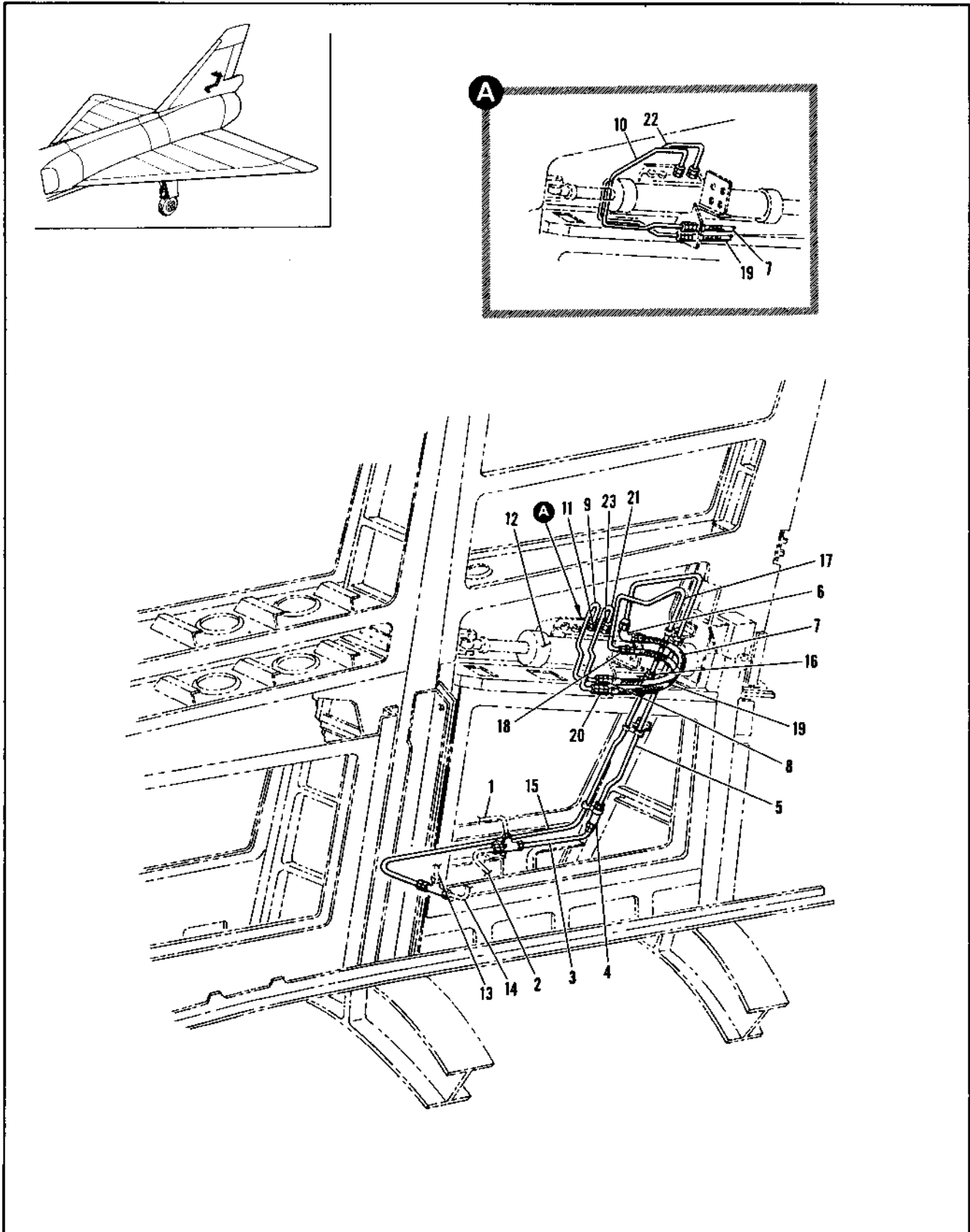

Figure 2.8-20. Rudder Actuator Hydraulic Tubing Installation

FIGURE AND INDEX NUMBER	PART NUMBER	DESCRIPTION	UNITS PER ASSY.	USABLE ON CODE	
				FROM	TO
2.8-20	8-80024	TUBING INSTALLATION, RUDDER ACTUATOR HYDRAULIC MODIFIED BY 8-80131-5 FOR NHA SEE FIG. 2.7-6	FF	35	
- 1		• TUBE ASSY, SEE FIG. 2.8-13 INDEX 35	PF		
- 2		• TUBE ASSY, SEE FIG. 2.8-13 INDEX 30	FF		
- 3	8-80024-171	• TUBE ASSEMBLY	1	35	
- 4	MS21902D4	• UNION	1	35	
- 5	8-80024-173	• TUBE ASSEMBLY	1	35	
- 6	MS21907D4	• ELBOW	1	35	
	AN924-40	• NUT	1	35	
- 7	CR295H700C4-0156	• HOSE ASSY	1	35	
- 8	MS21903D4	• UNION	1	35	
	AN924-40	• NUT	1	35	
- 9	8-80024-189	• TUBE ASSY, PRIMARY PRESSURE	1	35	60
- 10	8-80024-181	• TUBE ASSY, PRIMARY PRESSURE	1	61	120
	8-80024-201	• TUBE ASSY, PRIMARY PRESSURE	1	135	
- 11	MS21902D4	• UNION	1	35	
	AN6290-4	• GASKET	1	35	
- 12		• ACTUATOR ASSY, SERVO VALVE CONTROL RUDDER SEE FIG. 2.14-44 INDEX 2	FF		
- 13		• TUBE ASSY, SEE FIG. 2.8-13 INDEX 44	FF		
- 14		• TUBE ASSY, SEE FIG. 2.8-13 INDEX 48	FF		
- 15	9-80024-43	• TUBE ASSEMBLY	1	35	
- 16	MS21902D4	• UNION	1	35	
- 17	8-80024-189	• TUBE ASSEMBLY	1	35	
- 18	MS21903D4	• UNION	1	35	
	AN924-40	• NUT	1	35	
- 19	CR295H700C4-0156	• HOSE ASSY	1	35	
- 20	MS21903D4	• UNION	1	35	
	AN924-40	• NUT	1	35	
- 21	8-80024-181	• TUBE ASSY, PRIMARY RETURN	1	35	60
- 22	8-80024-183	• TUBE ASSY, PRIMARY RETURN	1	61	
	8-80024-203	• TUBE ASSY, PRIMARY RETURN	1	135	
- 23	MS21902D4	• UNION	1	35	
	AN6290-4	• GASKET	1	35	

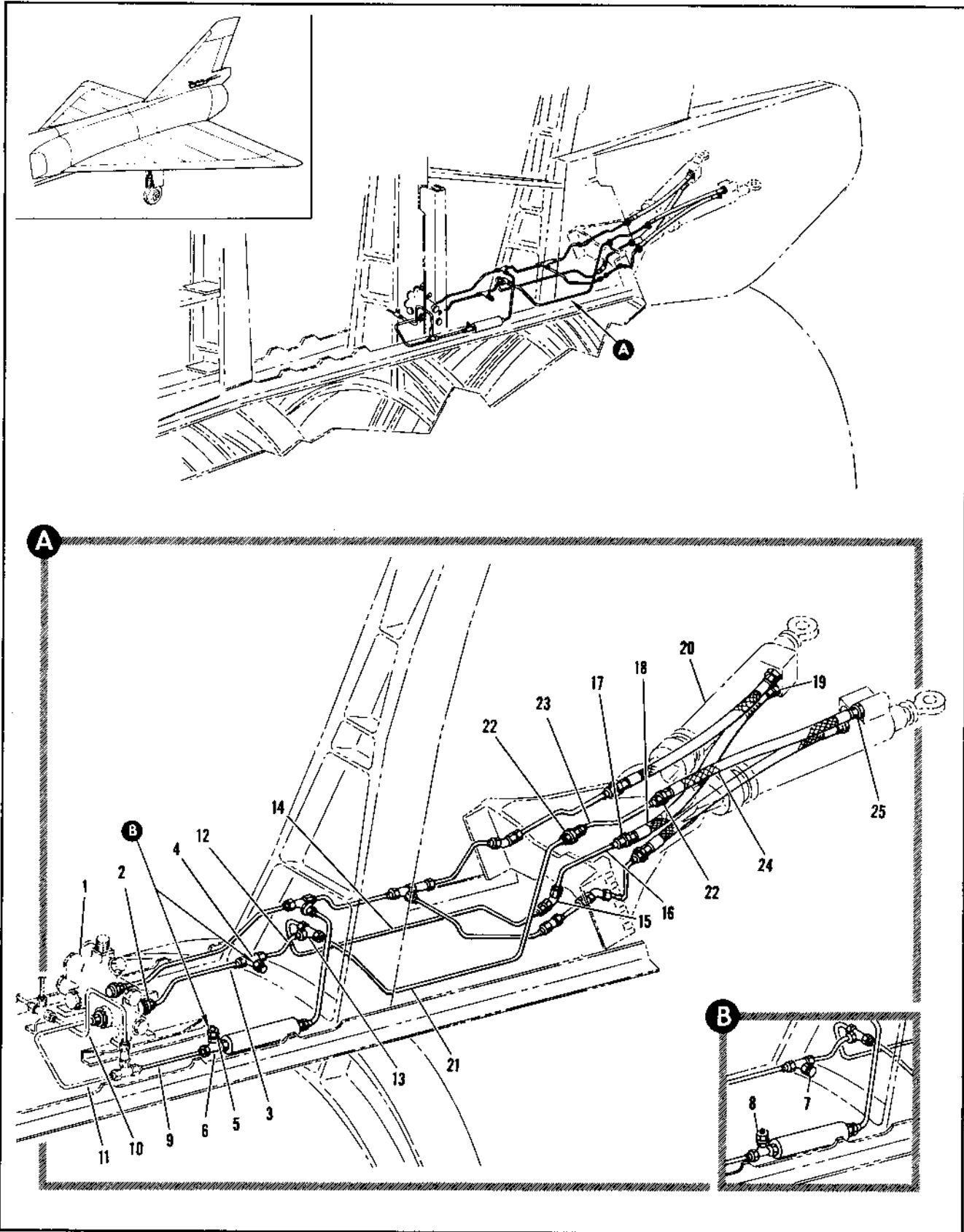

Figure 2.8-21. Speed Brake Hydraulic Tubing Installation (Sheet 1 of 2)

FIGURE AND INDEX NUMBER	PART NUMBER	DESCRIPTION	UNITS PER ASSY.	USABLE ON CODE	
				FROM	TO
2.8-21	8-80024	TUBING INSTALLATION, SPEED BRAKE HYDRAULIC MODIFIED BY 8-80131-5 FOR NHA SEE FIG. 2.7-6	RF	35	
- 1		• VALVE ASSY, SELECTOR SPEED BRAKE CONTROL SEE FIG. 2.3-14 INDEX 23	RF		
- 2	MS21916D6-4	• REDUCER	1	35	
	AN6293-6	• GASKET	1	35	
- 3	8-80024-107	• TUBE ASSEMBLY	1	35	
- 4	MS21910D4	• TEE	1	35	
	AN924-4D	• NUT	1	35	
	AN961D716	• WASHER	1	35	
	AN6293-4	• GASKET	1	35	
- 5	MS21916D6-4	• REDUCER	1	35	
- 6	MS21910D6	• TEE	1	35	
	AN924-6D	• NUT	1	35	
	AN961D916	• WASHER	1	35	
	AN6293-6	• GASKET	1	35	
- 7	MS21913D4	• PLUS	1	35	
- 8	MS21914D4	• CAP	1	35	
- 9	8-80024-95	• TUBE ASSEMBLY	1	35	
- 10		• TUBE ASSY, SEE FIG. 2.4-13 INDEX 51	RF		
- 11		• TUBE ASSY, SEE FIG. 2.4-13 INDEX 48	RF		
- 12	8-80024-109	• TUBE ASSEMBLY	1	35	
- 13	MS21919D4	• TEE	1	35	
	AN924-4D	• NUT	1	35	
- 14	8-80024-47	• TUBE ASSEMBLY	1	35	
- 15	MS21907D4	• ELBOW	1	35	
	AN924-4D	• NUT	1	35	
- 16	8-80024-73	• TUBE ASSEMBLY	1	35	
- 17	MS21903D4	• UNION	1	35	
	AN924-4D	• NUT	1	35	
- 18	CR295873CC4-0152	• HOSE ASSY	1	35	
- 19	MS21902D4	• UNION	1	35	
	AN6293-4	• GASKET	1	35	
- 20		• ACTUATOR ASSY, SPEED BRAKE SEE FIG. 2.7-1 INDEX 7	RF		
- 21	8-80024-153	• TUBE ASSEMBLY	1	35	
- 22	MS21903D4	• UNION	1	35	
	AN924-4D	• NUT	2	35	
- 23	8-80024-129	• TUBE ASSEMBLY	1	35	
- 24	CR295873CC4-0146	• HOSE ASSY	1	35	
- 25	MS21902D4	• UNION	1	35	
	AN6293-4	• GASKET	1	35	

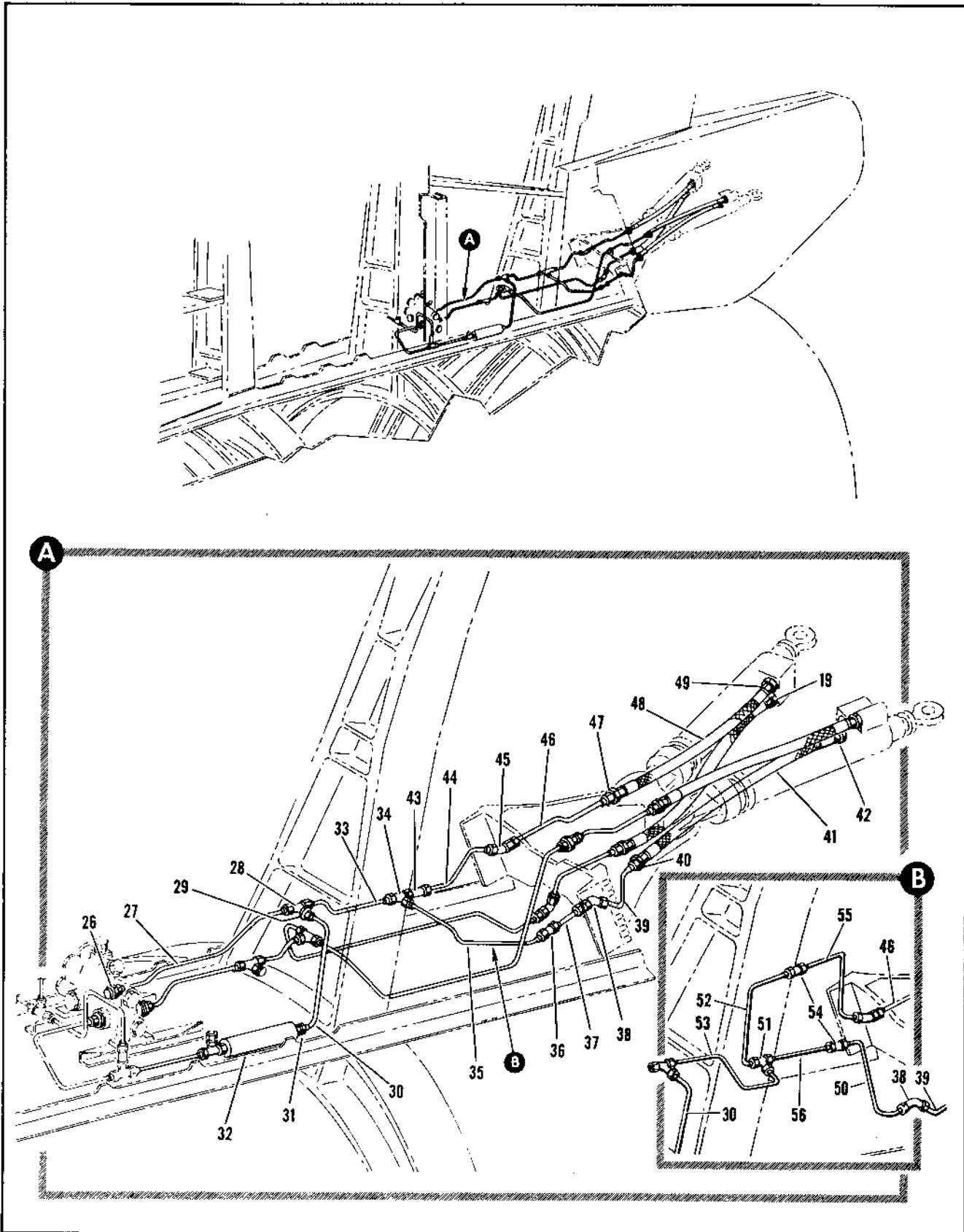

Figure 2.8-21. Speed Brake Hydraulic Tubing Installation (Sheet 2 of 2)

FIGURE AND INDEX NUMBER	PART NUMBER	DESCRIPTION	UNITS PER ASSY.	USABLE ON CODE	
				FROM	TO
		1 2 3 4 5 6			
2.8-21- 26	MS21916D6-4	• REDUCER	1	35	
	AN6290-6	• GASKET	1	35	
- 27	8-80024-53	• TUBE ASSEMBLY	1	35	
- 28	MS21910D4	• TEE	1	35	
	AN924-4D	• NUT	1	35	
- 29	MS21916D6-4	• REDUCER	1	35	
	AN6290-4	• GASKET	1	35	
- 30	8-80024-105	• TUBE ASSEMBLY	1	35	
- 31	MS21903D6	• UNION	1	35	
	AN924-6D	• NUT	1	35	
	AN960D916	• WASHER	1	35	
	AN6290-6	• GASKET	1	35	
- 32	HP457100-1	• VALVE ASSY, SPEED BRAKE RELIEF			
	HP595100-1	• VALVE ASSY, SPEED BRAKE RELIEF, ALT INTCMG WITH HP457100-1	1		
- 33	8-80024-57	• TUBE ASSEMBLY	1	35	60
- 34	MS21911D4	• TEE	1	35	60
	AN6290-4	• GASKET	1	35	60
- 35	8-80024-55	• TUBE ASSEMBLY	1	35	43
	8-80024-175	• TUBE ASSEMBLY	1	45	50
- 36	2R2441-4	• RESTRICTOR ASSY, <91207> SPEC 8-08476-704 T.O.9H8-R-20-3	1	35	60
- 37	8-80024-61	• TUBE ASSEMBLY	1	35	60
- 38	MS21907D4	• ELBOW	1	35	
	AN924-4D	• NUT	1	35	
- 39	8-80024-71	• TUBE ASSEMBLY	1	35	
- 40	MS21903D4	• UNION	1	35	
	AN924-4D	• NUT	1	35	
- 41	CR295870CC4-0156	• HOSE ASSY	1	35	
- 42	MS21902D4	• UNION	1	35	
	AN6290-4	• GASKET	1	35	
- 43	2R2441-4	• RESTRICTOR ASSY, <91207> SPEC 8-08476-704 T.O.9H8-R-20-3	1	35	60
- 44	8-80024-63	• TUBE ASSEMBLY	1	35	60
- 45	MS21907D4	• ELBOW	1	35	
	AN924-4D	• NUT	1	35	
- 46	8-80024-127	• TUBE ASSEMBLY	1	35	
- 47	MS21903D4	• UNION	1	35	
	AN924-4D	• NUT	1	35	
- 48	CR295870CC4-0156	• HOSE ASSY	1	35	
- 49	MS21902D4	• UNION	1	35	
	AN6290-4	• GASKET	1	35	
- 50	8-80024-157	• TUBE ASSEMBLY	1	61	
- 51	MS21912D4	• TEE	1	61	
	AN960D716	• WASHER	1	61	
	AN924-4D	• NUT	1	61	
- 52	8-80024-191	• TUBE ASSEMBLY	1	61	
- 53	8-80024-193	• TUBE ASSEMBLY	1	61	
- 54	2R2441-4	• RESTRICTOR ASSY, <91207> SPEC 8-08476-704 T.O.9H8-R-20-3	2	61	
- 55	8-80024-187	• TUBE ASSEMBLY	1	61	
- 56	8-80024-195	• TUBE ASSEMBLY	1	61	

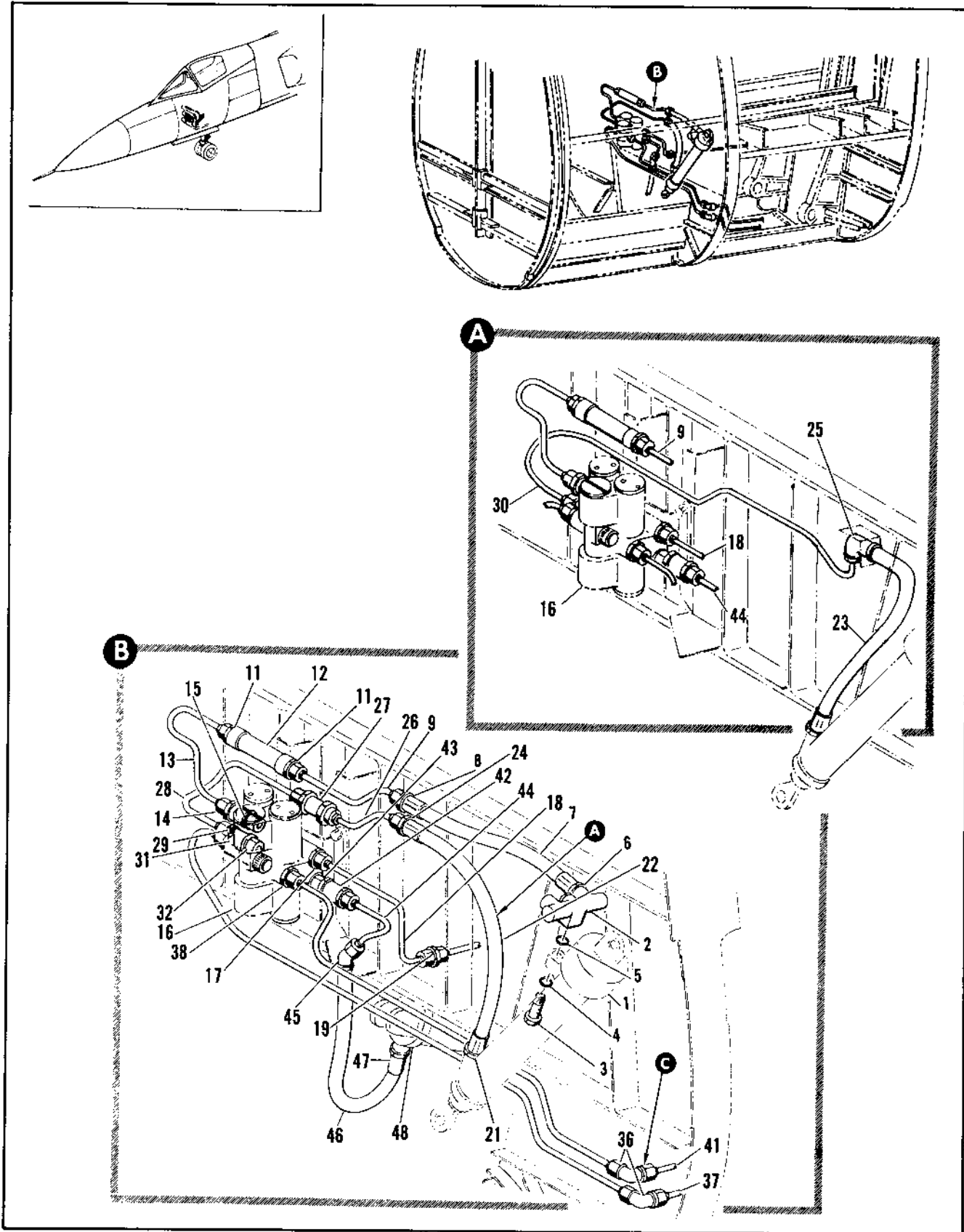

Figure 2.8-22. Nose Landing Gear Hydraulic Tubing Installation Sta 126 to 162 (Sheet 1 of 2)

FIGURE AND INDEX NUMBER	PART NUMBER	DESCRIPTION	UNITS PER ASSY.	USABLE ON CODE	
				FROM	TO
2.8-22	8-81932-001	TURING INSTALLATION, NOSE LANDING GEAR HYDRAULIC STA 126 TO 162	RF	35	
- 1		• ACTUATOR ASSY, NOSE LANDING GEAR DOOR SEE FIG. 2.15-13 INDEX 31	RF		
- 2	3850A1	• VALVE ASSY, SHUTTLE <78462> SPEC 8-00364-1 T.O.9H8-5-51-3 ATTACHING PARTS	1	35	
- 3	8-80208	• BOLT, UNIVERSAL FITTING -----X-----	1	35	
- 4	MS28775-011	• PACKING	1	35	
- 5	MS28778-4	• GASKET	2	35	
- 6	MS2190204	• UNION	1	35	
	AN6290-4	• GASKET	1	35	
- 7	R295800-4-0093	• HOSE ASSY, <50599> 94-80542-002 REPLACED BY NOT INTCHG WITH R295805-4-0106	1	A	
	R295805-4-0106	• HOSE ASSY, <50599> 94-80562-001 REPLACES NOT INTCHG WITH R295800-4-0093	1	A	
- 8	MS2190304	• UNION	1	35	
	AN924-40	• NUT	1	35	
	AN96.D716	• WASHER	1	35	
- 9	8-80032-177	• TUBE ASSEMBLY	1	A	
- 10	65A33170-1	• TUBE ASSY, HYDRAULIC BYPASS VALVE	1	B	
- 11	MS2190304	• UNION	2	35	
	AN924-40	• NUT	2	35	
	AN6290-4	• GASKET	2	35	
- 12	A70079	• VALVE ASSY, PRIORITY <91130> SPEC 8-00499-1 T.O.9H8-26-13-3	1	35	
- 13	8-80032-179	• TUBE ASSEMBLY	1	A	
	8-80032-217	• TUBE ASSEMBLY	1	48	48
	8-80032-239	• TUBE ASSEMBLY	1	40	
- 14	2R2441-3	• RESTRICTOR ASSY, VALVE <91207> SPEC 8-08476-404 T.O.9H8-R-20-3	1	35	
- 15	AN893-20	• BUSHING	1	35	
	AN6290-4	• GASKET	1	35	
	AN6290-6	• GASKET	1	35	
- 16		• VALVE ASSY, NOSE LANDING GEAR HYDRAULIC CONTROL SEE FIG. 2.15-1 INDEX 2	RF		
- 17	MS2191606-4	• REDUCER	1	35	
	AN6290-6	• GASKET	1	35	
- 18	8-80032-167	• TUBE ASSEMBLY	1	A	
	8-80032-227	• TUBE ASSEMBLY	1	44	43
	8-80032-245	• TUBE ASSEMBLY	1	40	
- 19	MS2190304	• UNION	1	35	
	AN924-40	• NUT	1	35	
	AN96.D716	• WASHER	1	35	
- 20		• TUBE ASSY, SEE FIG. 2.8-14 INDEX 4	RF		
- 21	MS2190204	• UNION	1	35	
	AN6290-4	• GASKET	1	35	
- 22	R295800-4-0172	• HOSE ASSY, <50599> 94-80542-006 REPLACED BY NOT INTCHG WITH R295805-4-0134	1	A	

A AIRPLANES 15 THRU 47 AND 49 THRU 89
 B AIRPLANES 48, 90 AND ON

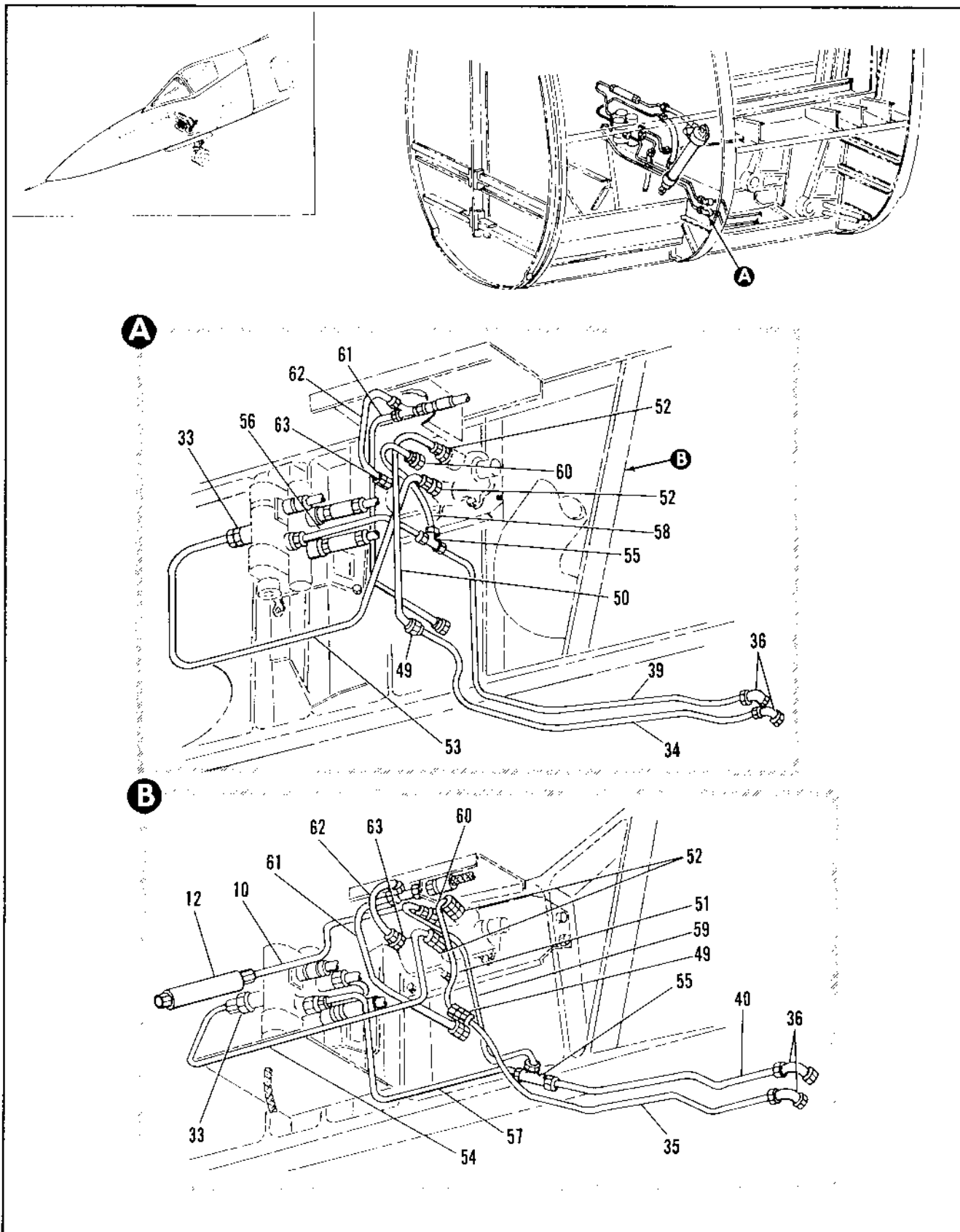

Figure 2.8-22. Nose Landing Gear Hydraulic Tubing Installation Sta 126 to 162 (Sheet 2 of 2)

FIGURE AND INDEX NUMBER	PART NUMBER	DESCRIPTION	UNITS PER ASSY.	USABLE ON CODE	
				FROM	TO
		1 2 3 4 5 6			
2.8-22- 23	R295805-4-0134	• HOSE ASSY, <50599> 94-80562-002 REPLACES NOT INTCHG WITH R295800-4-0172	1	9	
- 24	MS21903D4	• UNION	1	A	
- 25	MS21908D4	• ELBOW	1	B	
	AN924-40	• NUT	1	35	
	AN96 D716	• WASHER	1	35	
- 26	R-80032-193	• TUBE ASSEMBLY	1	4	
- 27	2R2441-2	• RESTRICTOR ASSY, VALVE <91207> SPEC R-08476-324 T.O. 1F-108-8-20-3	1	A	
- 28	R-80032-181	• TUBE ASSEMBLY	1	A	
- 29	MS21916D6	• REDUCER	1	A	
- 30	R-80032-229	• TUBE ASSEMBLY	1	4R	4R
	R-80032-247	• TUBE ASSEMBLY	1	4R	
- 31	2R2441-2	• RESTRICTOR ASSY, VALVE <91207> SPEC R-08476-324 T.O. 1F-108-8-20-3	1	B	
- 32	AN893-20	• RUSHING	1	4	
	AN6290-4	• GASKET	1	3	
	AN6290-6	• GASKET	1	3	
- 33	MS21952D6	• UNION	1		
	MS28778-6	• PACKING	1		
- 34	64A3452H-1	• TUBE ASSY, HYDRAULIC BYPASS VALVE	1	A	
- 35	64A3450R-1	• TUBE ASSY, HYDRAULIC BYPASS VALVE	1	B	
- 36	MS21908D4	• ELBOW	2	35	
	AN924-40	• NUT	2	35	
	AN96 D716	• WASHER	2	35	
- 37		• TUBE ASSY, SEE FIG. 2.8-14 INDEX 16	1		
- 38	MS21916D6-4	• REDUCER	1	35	
	AN6290-6	• GASKET	1	35	
- 39	64A34529-1	• TUBE ASSY, HYDRAULIC BYPASS VALVE	1	A	
- 40	64A34507-1	• TUBE ASSY, HYDRAULIC BYPASS VALVE	1	A	
- 41		• TUBE ASSY, SEE FIG. 2.8-14 INDEX 25	1		
- 42	2R2441-2	• RESTRICTOR ASSY, VALVE <91207> SPEC R-08476-324 T.O. 1F-108-8-20-3	1	35	
- 43	AN843-20	• RUSHING	1	35	
	AN6290-4	• GASKET	3	35	
	AN6290-6	• GASKET	1	35	
- 44	R-80032-187	• TUBE ASSEMBLY	1	A	
	R-80032-225	• TUBE ASSEMBLY	1	A	
- 45	AN21907D4	• ELBOW	1	35	
	AN924-40	• NUT	1	35	
	AN96 D716	• WASHER	1	35	
- 46	R295800-4-0133	• HOSE ASSY, <50599> 94-80542-003 REPLACED BY NOT INTCHG WITH R295800-4-0193	1	4	
	R295800-4-0143	• HOSE ASSY, <50599> 94-80562-005 REPLACES NOT INTCHG WITH R295800-4-0133	1	B	
- 47	MS21902D4	• UNION	1	35	
	AN6290-4	• GASKET	1	35	
- 48		• ACTUATOR ASSY, NOSE LANDING GEAR SEE FIG. 2.15-16 INDEX 59	1		
- 49	MS21926D6-4	• REDUCER	1		
- 50	64A34522-1	• TUBE ASSY, HYDRAULIC BYPASS VALVE	1		
- 51	64A34510-1	• TUBE ASSY, HYDRAULIC BYPASS VALVE	1		

A AIRPLANES #35 THRU 47 AND 49 THRU 89
H AIRPLANES #48, 90 AND 91

FIGURE AND INDEX NUMBER	PART NUMBER	DESCRIPTION	UNITS PER ASSY.	USABLE ON CODE	
				FROM	TO
		1 2 3 4 5 6			
2.8-22- 52	MS2190206	• UNION	2		
	MS28778-6	• PACKING	2		
- 53	64A34524-1	• TUBE ASSY, HYDRAULIC BYPASS VALVE	1		
- 54	64A34512-1	• TUBE ASSY, HYDRAULIC BYPASS VALVE	1		
- 55	MS2190504	• TEE	1		
- 56	64A34523-1	• TUBE ASSY, HYDRAULIC BYPASS VALVE	1		
- 57	64A34509-1	• TUBE ASSY, HYDRAULIC BYPASS VALVE	1		
- 58	64A34525-1	• TUBE ASSY, HYDRAULIC BYPASS VALVE	1		
- 59	64A34511-1	• TUBE ASSY, HYDRAULIC BYPASS VALVE	1		
- 60	MS2191006-4	• REDUCER	1		
	MS28778-6	• PACKING	1		
- 61		SEE FIG. 2.9-16	RF		
		SEE FIG. 2.9-15 INDEX 12			
- 62		• TUBE ASSY, PNEUMATIC BYPASS VALVE	RF		
		SEE FIG. 2.9-16			
- 63	MS2190204	• UNION	1		
	MS28778-4	• PACKING	1		

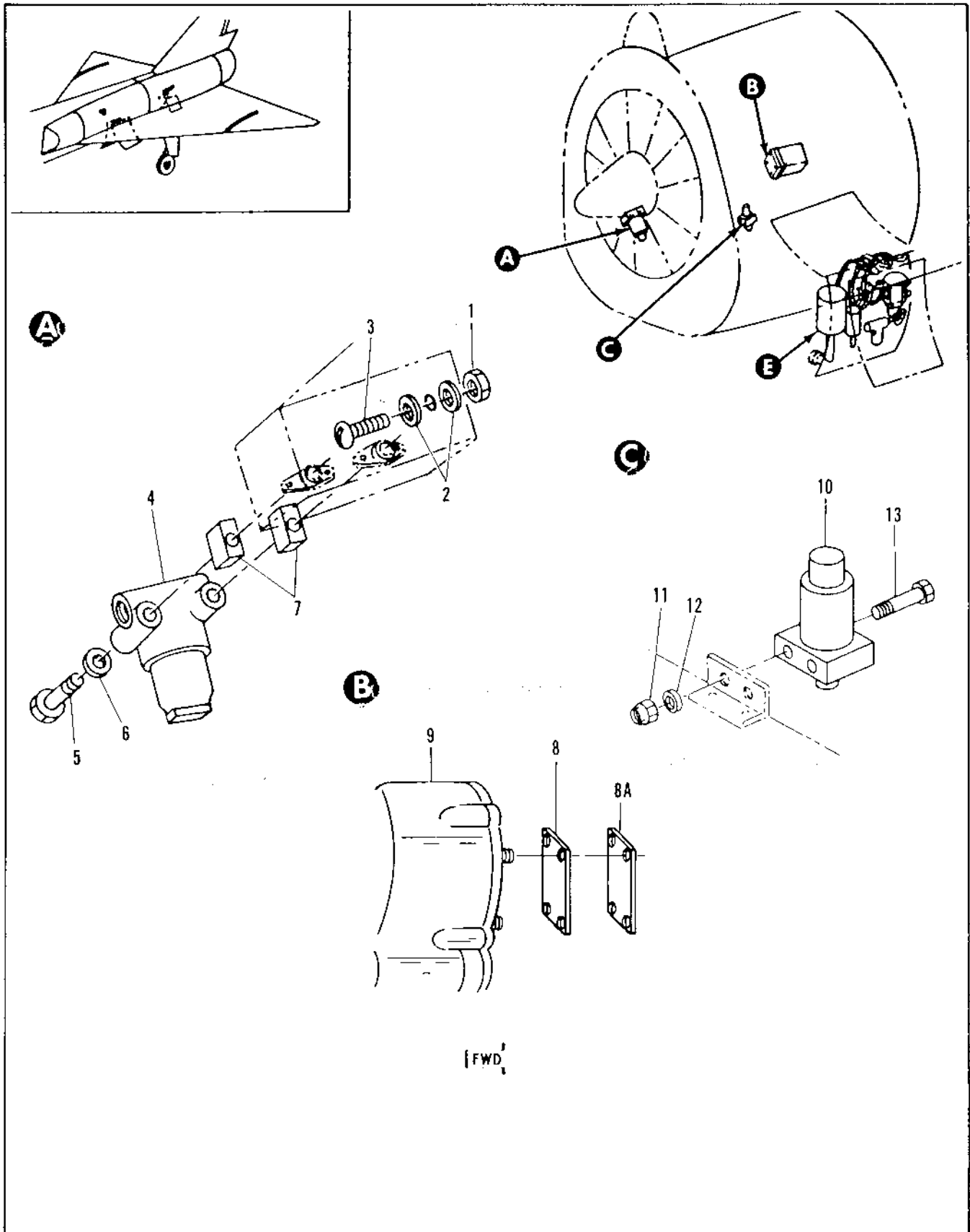

Figure 2.8-23. Rapid Tune Magnetron Hydraulic Equipment (Sheet 1 of 2)

FIGURE AND INDEX NUMBER	PART NUMBER	DESCRIPTION 1 2 3 4 5 6	UNITS PER ASSY.	USABLE ON CODE	
				FROM	TO
2.8-23		RAPID TUNE MAN RAPID TUNE MAGNETRON HYDRAULIC EQUIPMENT	RF		
- 1	8-83604-1	. FILTER INSTL, RAPID TUNE MAGNETRON	1		
- 2	AN345-10	. . NUT, GROUND STUD	1		
- 3	AN965-13L	. . WASHER, GROUND STUD	2		
- 4	ANS26-1032R12	. . SCREW, GROUND STUD	1		
- 4	AC840-81	. . FILTER ASSY, HYDRAULIC OIL (01414) SPEC 8-68452-801 T.O. 9H3-3-39-33 ATTACHING PARTS	1		
- 5	AN4-12A	. . BOLT	2		
- 6	AN9600416L	. . WASHER -----X-----	2		
- 7	3-84238-1	. . SPACER, HYDRAULIC FILTER	2		
- 7	8-83002-1	. PUMP INSTL, HYDRAULIC, RAPID TUNE MAGNETRON	1		
- 8	MS9134-01	. . GASKET (96906)	1		
- 8A	AN100043	. . COVER (88044)	1		
- 9		. . ENGINE ASSY, SEE FIG. 2.10-7 INDEX 169	OF		
- 10	95020	. . SWITCH PRESSURE ACTUATED (09049) 98-62805-024 ATTACHING PARTS	1		
- 11	MS21042L3	. . NUT	2		
- 12	AN96501GL	. . WASHER	2		
- 13	AN3-17A	. . BOLT -----X-----	2		

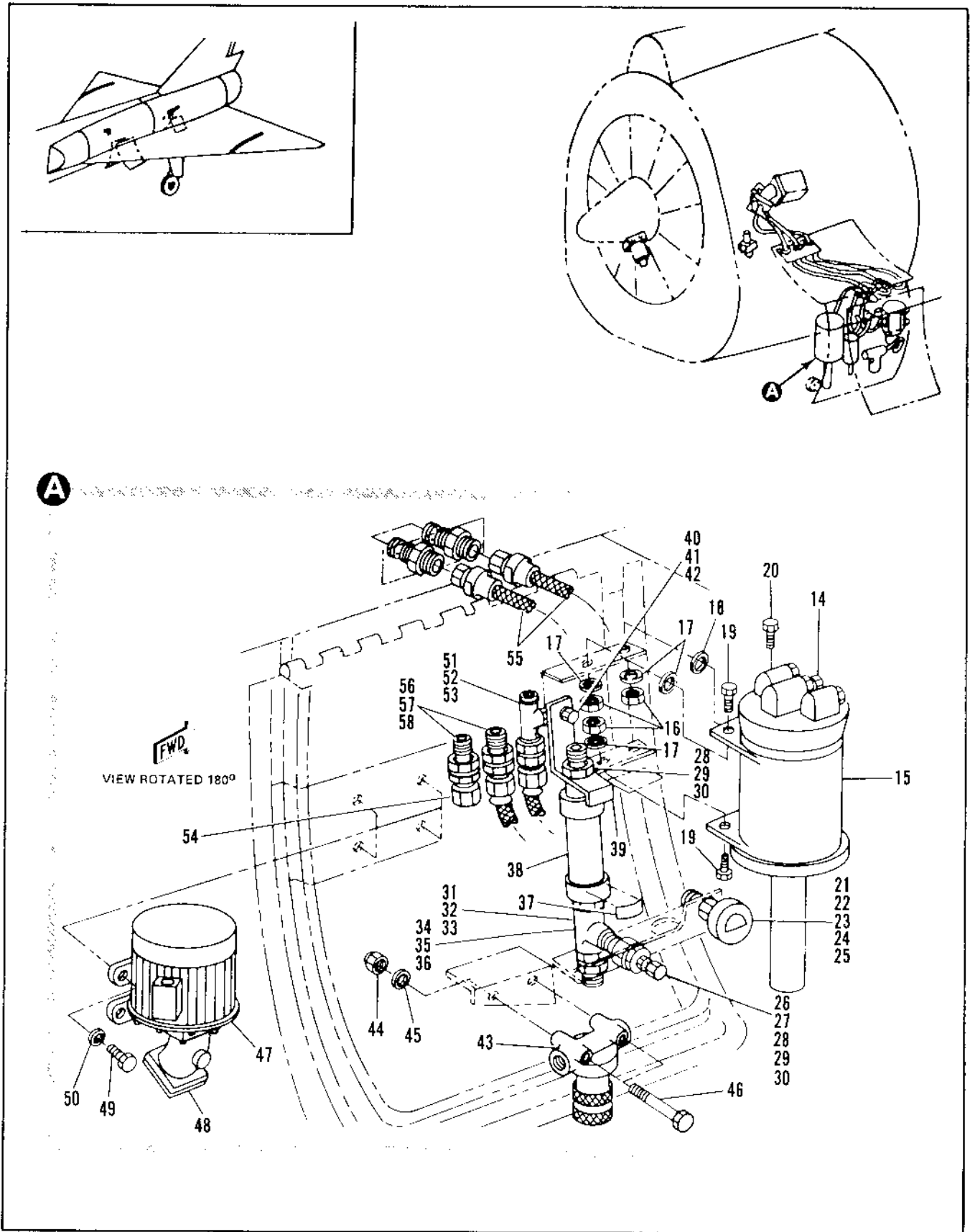

Figure 2.8-23. Rapid Tune Magnetron Hydraulic Equipment (Sheet 2 of 2)

FIGURE AND INDEX NUMBER	PART NUMBER	DESCRIPTION	UNITS PER ASSY.	USABLE ON CODE	
				FROM	TO
		1 2 3 4 5 6			
2,8-23	8-83003-1	• EQUIPMENT INSTL, HYDRAULIC RAPID TUNE MAGNETRON	1		
- 14	27020	• • VALVE, LOW PRESSURE RELIEF (99643) SPEC 8-CR697-1 T.O. 9H8-2-160-2	1		
- 15	8-84231-5	• • RESERVOIR ASSY, HYDRAULIC PRESSURIZED T.O. 9H5-3-40-3 ATTACHING PARTS	1		
- 16	MS21042L4	• • NUT	4		
- 17	AN9600416L	• • WASHER	5		
- 18	NAS1401-4C3	• • WASHER	1		
- 19	AN4-4A	• • BOLT	4		
- 20	AN4-5A	• • BOLT	1		
		-----X-----			
- 21	MS2192404	• • UNION	1		
- 22	AN924-4D	• • NUT	1		
- 23	AN9600716L	• • WASHER	1		
- 24	MS28778-4	• • PACKING	1		
- 25	MS24478-2	• • GAGE	1		
- 26	MS28889-1	• • VALVE	1		
- 27	ER83200405	• • NIPPLE, REDUCING (45681)	1		
- 28	AN924-4D	• • NUT	1		
- 29	AN9600716L	• • WASHER	1		
- 30	MS28778-5	• • PACKING	3		
- 31	AN93805	• • TEE	1		
- 32	MS2190205	• • UNION	1		
- 33	MS21924D4	• • UNION	1		
- 34	AN924-4D	• • NUT	1		
- 35	AN9600716L	• • WASHER	1		
- 36	MS28778-4	• • PACKING	1		
- 37	8-84242-7	• • PLACARD	1		
- 38	1356-593105	• • ACCUMULATOR, HYDRAULIC (09523) 98-03500-004 T.O. 9H1-2-44-3	1		
- 39	8-83003-55	• • CLIP ATTACHING PARTS	1		
- 40	MS21042L3	• • NUT	2		
- 41	AN960010L	• • WASHER	2		
- 42	AN3-4A	• • BOLT	2		
		-----X-----			
- 43	AC1526-4	• • FILTER ASSY, HYDRAULIC LOW PRESSURE (J1414) SPEC 8-00460-1 T.O. 9H3-3-43-3 ATTACHING PARTS	1		
- 44	MS21042L3	• • NUT	2		
- 45	AN960010L	• • WASHER	2		
- 46	AN3-21A	• • BOLT	2		
		-----X-----			
- 47	EA1565-541	• • MOTOR PUMP PACKAGE, ELECTRIC MOTOR DRIVEN, HYDRAULIC VARIABLE DELIVERY PUMP (06538) SPEC 8-08687-1 T.O. 9H4-3-57-3	1		
	443MC1	• • ELECTRIC MOTOR (00462)			
	PV006R030P	• • PUMP, HYDRAULIC VARIABLE DELIVERY (62983)			
- 48	284417	• • COUPLING, SHAFT (62983) T.O. 9H4-3-57-4 ATTACHING PARTS			
- 49	AN4-6A	• • BOLT	4		
- 50	AN9600416L	• • WASHER	4		
		-----X-----			
- 51	MS2191204	• • TEE	1		
- 52	AN924-4D	• • NUT	1		
- 53	AN9600716L	• • WASHER	1		
- 54	MS21914-6A	• • CAP	1		35
- 55	R295800-4-0280	• • HOSE	2		
- 56	ER83200604	• • NIPPLE, REDUCING	2		
- 57	AN9600916L	• • WASHER	2		
- 58	AN924-6D	• • NUT	2		

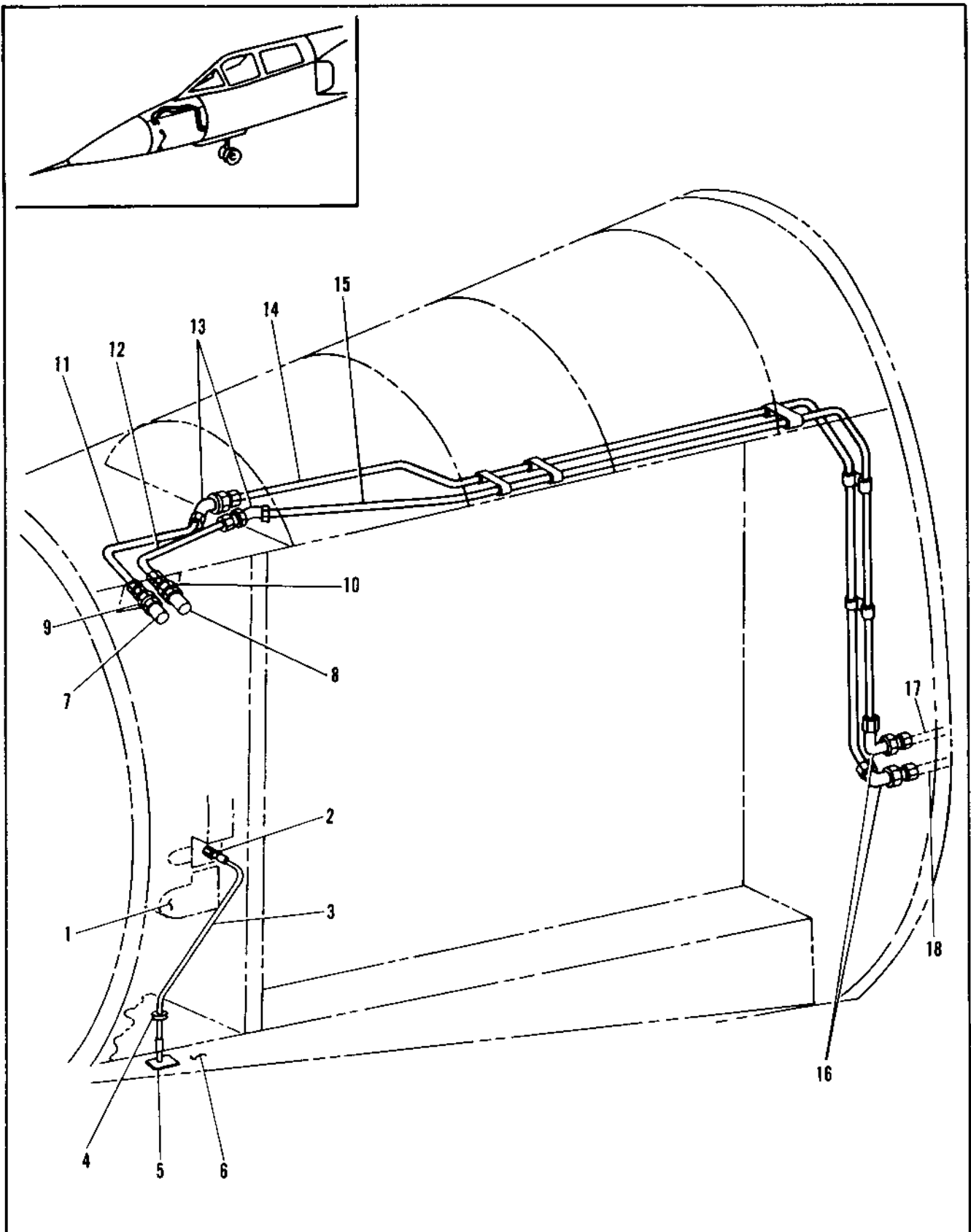

Figure 2.8-24. Rapid Tune Magnetron Hydraulic Tubing Installation Sta 47 to 102

FIGURE AND INDEX NUMBER	PART NUMBER	DESCRIPTION	UNITS PER ASSY.	USABLE ON CODE	
				FROM	TO
2.8-24	8-84224-3	TUBING INSTL, HYDRAULIC, RAPID TUNE MAGNETRON, STA 47 TO 102	1		
- 1		• RECEIVER-TRANSMITTER, RADAR SEE FIG. 2.18-16	9F		
- 2	8-84224-79	• TUBE ASSY, DRAIN	1		
- 3	8-84224-71	• TUBE, DRAIN	1		
- 4	MS35489-4	• GROMMET	1		
- 5	8-84224-73	• PLATE ASSY, WELDED	1		
- 6		• PANEL ASSY, FWD RADAR COMPARTMENT LWR SEE FIG. 2.3-5	9F		
	8-84236-1	• BRACKET INSTL, HYDRAULIC QUICK DISCONNECT FITTING	1		
- 7	3202-6	• COUPLING, QUICK DISCONNECT (00624) 92-74029-002	1		
	AN924-120	• NUT	1		
- 8	3202-4	• COUPLING, QUICK DISCONNECT (00624) 92-74029-001	1		
	AN924-100	• NUT	1		
- 9	MS21902D6	• UNION	1		
	MS28778-6	• PACKING	1		
- 10	MS21916D6-4	• REDUCER	1		
	MS28778-4	• PACKING	1		
- 11	8-84747-9	• TUBE ASSEMBLY	1		
- 12	8-84748-9	• TUBE ASSEMBLY	1		
- 13	MS21907D6	• ELBOW	2		
	AN924-6D	• NUT	2		
	AN960916	• WASHER	2		
- 14	8-84746-7	• TUBE ASSEMBLY	1		
- 15	8-84745-9	• TUBE ASSEMBLY	1		
- 16	MS21908D6	• ELBOW	2		
	AN924-6D	• NUT	2		
	AN960916	• WASHER	2F		
- 17		• TUBE ASSY, SEE FIG. 2.8-25 INDEX 3	9F		
- 18		• TUBE ASSY, SEE FIG. 2.8-25 INDEX 4	9F		

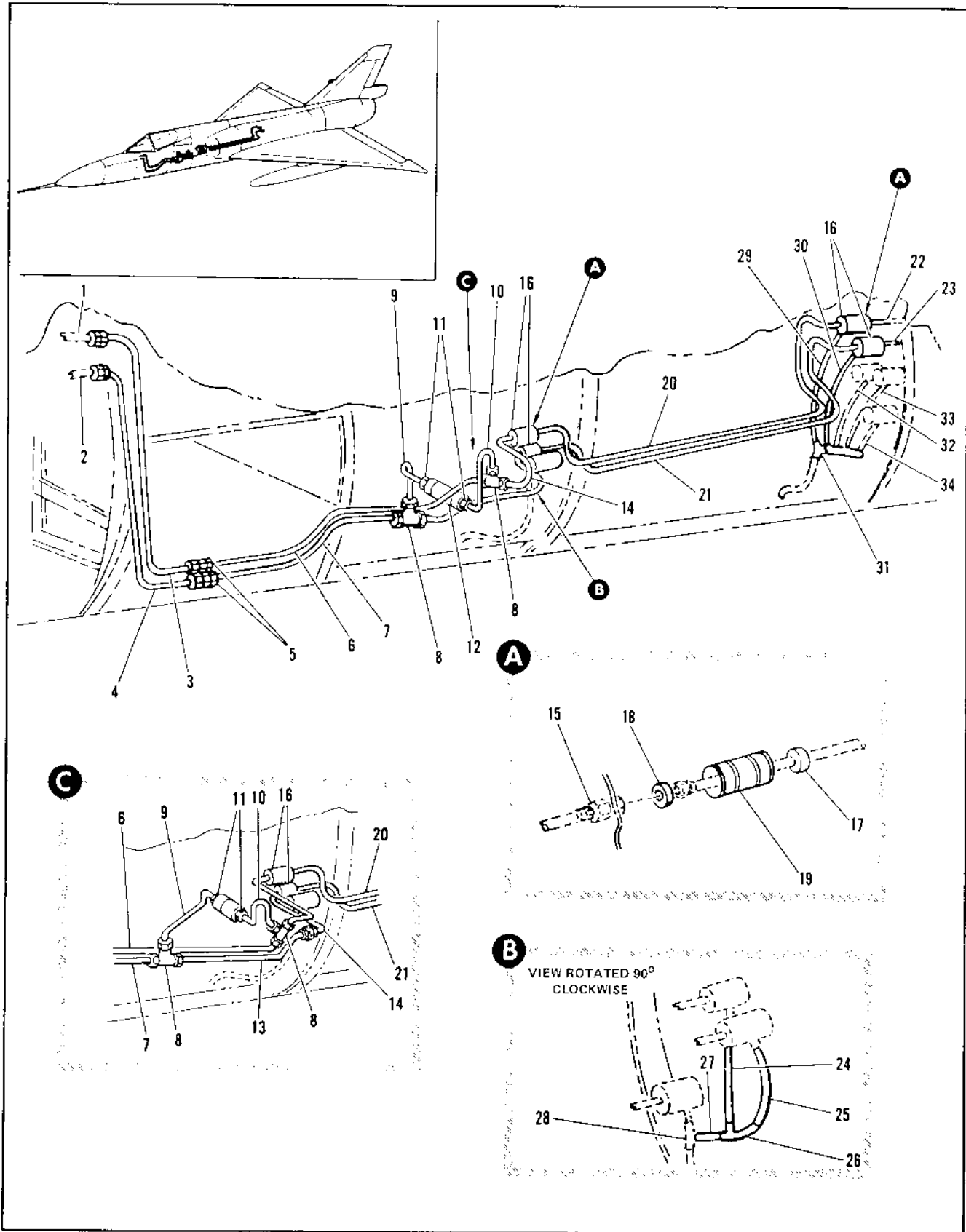

Figure 2.8-25. Rapid Tune Magnetron Hydraulic Tubing Installation Sta 102 to 216

FIGURE AND INDEX NUMBER	PART NUMBER	DESCRIPTION	UNITS PER ASSY.	USABLE ON CODE	
				FROM	TO
2,8-25	8-84224-1	TUBING INSTL, HYDRAULIC RAPID TUNE MAGNETRON STA 12 TO 21A	1		
- 1		• TUBE ASSY, SEE FIG. 2.8-24 INDEX 14	RF		
- 2		• TUBE ASSY, SEE FIG. 2.8-24 INDEX 15	RF		
- 3	8-84744-7	• TUBE ASSEMBLY	1		
- 4	8-84743-7	• TUBE ASSEMBLY	1		
- 5	MS21902D6	• UNION	2		
- 6	8-84740-7	• TUBE ASSEMBLY	1		
	67A36611-1	• TUBE, HYDRAULIC PRESSURE FWD	1		
- 7	8-84742-7	• TUBE ASSEMBLY	1		
- 8	98-90319-L08	• TEE, (14170)	2		
- 9	8-84741-7	• TUBE ASSEMBLY	1		
- 10	8-84738-7	• TUBE ASSEMBLY	1		
	67A36609-1	• TUBE HYDRAULIC INFLT RELIEF VALVE	1		
- 11	MS21902D4	• UNION	2		
	MS28778-4	• PACKING	2		
- 12	MS28893D4	• VALVE, RELIEF	1		
- 13	8-84739-7	• TUBE ASSEMBLY	1		
	67A36608-1	• TUBE, HYDRAULIC RETURN RAPID TUNE MAGNETRON	1		
- 14	8-84737-7	• TUBE ASSEMBLY	1		
	67A36610-1	• TUBE, HYDRAULIC PRESSURE AFT	1		
- 15	MS21924D6	• UNION	2		
	AN924-6D	• NUT	2		
	AN950916	• WASHER	2		
- 16	8-84241-1	• SHROUD ASSY, HYDRAULIC DRAIN TUBE	4		
- 17	8-84241-11	• GROMMET	1		
- 18	8-84241-12	• GROMMET	1		
- 19	8-84241-7	• CASE ASSEMBLY	1		
- 20	8-84735-7	• TUBE ASSEMBLY	1		
- 21	8-84736-7	• TUBE ASSEMBLY	1		
- 22		• TUBE ASSY, SEE FIG. 2.8-26 INDEX 3	RF		
- 23		• TUBE ASSY, SEE FIG. 2.8-26 INDEX 4	RF		
- 24	8-84224-81	• TUBE, DRAIN	1		
- 25	8-84224-9	• TUBE, DRAIN	1		
- 26	8-81504	• FITTING ASSEMBLY	1		
- 27	8-84224-13	• TUBE, DRAIN	1		
- 28		• TEE ASSY, SEE FIG. 2.8-15 INDEX 10	RF		
- 29	8-84224-17	• TUBE DRAIN	1		
- 30	8-84224-19	• TUBE, DRAIN	1		
- 31		• MANIFOLD ASSY, SEE FIG. 2.8-15 INDEX 20	RF		
- 32		• TUBE, DRAIN SEE FIG. 2.8-15 INDEX 17	RF		
- 33		• TUBE, DRAIN SEE FIG. 2.8-15 INDEX 19	RF		
- 34		• TUBE, DRAIN SEE FIG. 2.8-14 INDEX 23	RF		

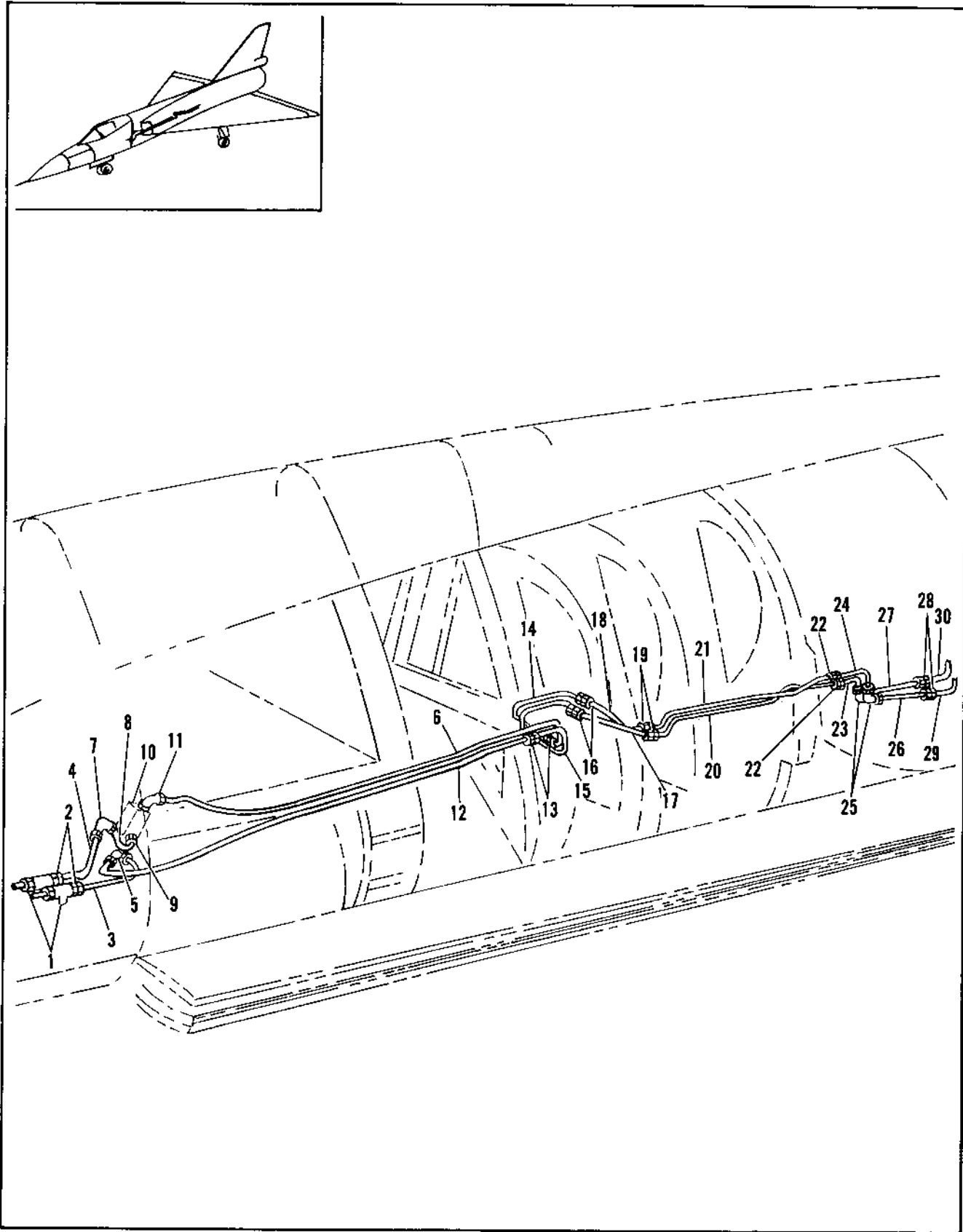

Figure 2.8-26. Rapid Tune Magnetron Hydraulic Tubing Installation Sta 216 to 412

FIGURE AND INDEX NUMBER	PART NUMBER	DESCRIPTION	UNITS PER ASSY.	USABLE ON CODE	
				FROM	TO
		1 2 3 4 5 6			
2,8-26	8-84234-803	TUBING INSTL, HYDRAULIC RAPID TUNE MAGNETRON MISSILE BAY STA 216 TO 412	1		
	8-84234-811	TUBING INSTL, HYDRAULIC RAPID TUNE MAGNETRON MISSILE BAY STA 216 TO 412	1		
	8-84234-801	TUBING INSTL, HYDRAULIC RAPID TUNE MAGNETRON MISSILE BAY STA 216 TO 412	1		
	8-84234-8	TUBING INSTL, HYDRAULIC RAPID TUNE MAGNETRON MISSILE BAY STA 216 TO 412	1		
	8-84234-809	TUBING INSTL, HYDRAULIC RAPID TUNE MAGNETRON MISSILE BAY STA 216 TO 412	1		
	8-84234-1	TUBING INSTL, HYDRAULIC RAPID TUNE MAGNETRON MISSILE BAY STA 216 TO 412	1		
- 1		• SHROUD ASSY, SEE FIG. 2.8-27 INDEX 16	RF		
- 2	MS21924D6	• UNION	2		
	AN924-6D	• NUT	2		
	AN9670916	• WASHER	2		
- 3	8-84733-7	• TUBE ASSEMBLY	1		
- 4	8-84734-7	• TUBE ASSEMBLY	1		
- 5	MS21908D6	• ELBOW	1		
	AN924-6D	• NUT	1		
	AN9670916	• WASHER	1		
- 6	66A38334-1	• TUBE ASSEMBLY	1	75	
- 7	MS21907D6	• ELBOW	1		
	AN924-6D	• NUT	1		
	AN9670916	• WASHER	1		
- 8	8-84732-9	• TUBE ASSEMBLY	1		
- 9	MS21902D6	• UNION	1		
	MS28778-6	• PACKING	1		
- 10		• COOLER, AIR-OIL SEE FIG. 2.13-9 INDEX 16	RF		
- 11	MS21908D6	• ELBOW	1		
	AN924-6D	• NUT	1		
	MS23778-6	• PACKING	1		
- 12	66A38336-1	• TUBE ASSEMBLY	1	75	
- 13	MS21902D6	• UNION	2	75	
- 14	66A38333-1	• TUBE ASSEMBLY	1	75	
- 15	66A38335-1	• TUBE ASSEMBLY	1	75	
- 16	MS21924D6	• UNION	2		
	AN924-6D	• NUT	2		
	AN9670916	• WASHER	2		
- 17	8-84726-11	• TUBE ASSEMBLY	1		
- 18	8-84727-11	• TUBE ASSEMBLY	1		
- 19	MS21902D6	• UNION	2		
- 20	8-84724-11	• TUBE ASSEMBLY	1		
- 21	8-84725-11	• TUBE ASSEMBLY	1		
- 22	MS21902D6	• UNION	1		
- 23	8-84722-9	• TUBE ASSEMBLY	1		
- 24	8-84723-9	• TUBE ASSEMBLY	1		
- 25	MS21908D6	• ELBOW	2		
	AN924-6D	• NUT	2		
- 26	8-84720-7	• TUBE ASSEMBLY	1		
- 27	8-84721-7	• TUBE ASSEMBLY	1		
- 28	MS21902D6	• UNION	2		
- 29		• TUBE ASSY, SEE FIG. 2.8-21 INDEX 3	RF		
- 30		• TUBE ASSY, SEE FIG. 2.8-21 INDEX 4	RF		

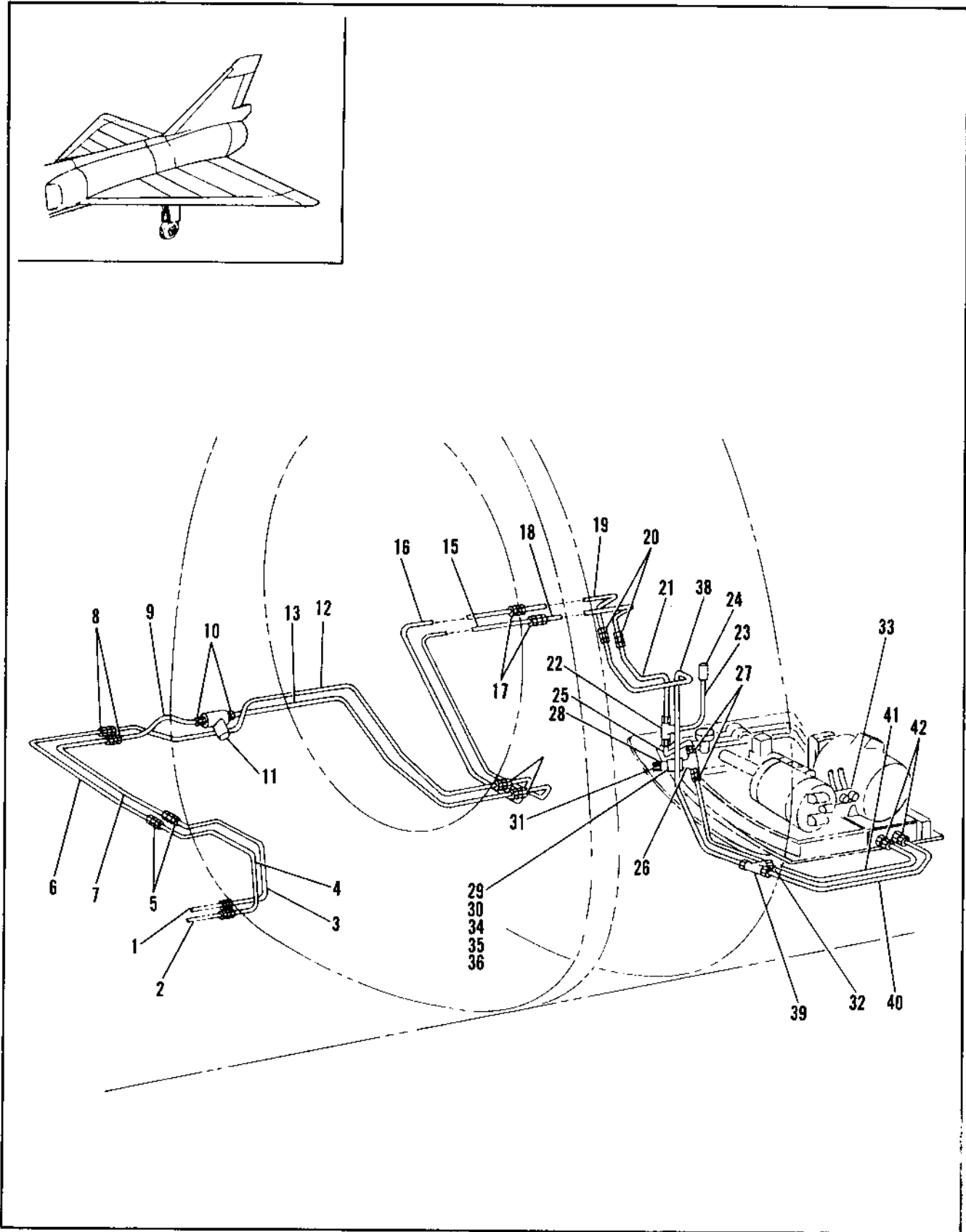

Figure 2.8-27. Rapid Tune Magnetron Hydraulic Tubing Installation Sta 412 to 540 (Sheet 1 of 2)

FIGURE AND INDEX NUMBER	PART NUMBER	DESCRIPTION	UNITS PER ASSY.	USABLE ON CODE	
				FROM	TO
2.8-27	8-84235-5	TUBING INSTL, HYDRAULIC RAPID TUNE MAGNETRON STA 412 TO 54.	1		
- 1		• TUBE ASSY, SEE FIG. 2.8-26 INDEX 26	PF		
- 2		• TUBE ASSY, SEE FIG. 2.8-26 INDEX 27	PF		
- 3	8-84718-7	• TUBE ASSEMBLY	1		
- 4	8-84719-7	• TUBE ASSEMBLY	1		
- 5	MS21902D6	• UNION	2		
- 6	8-84717-7	• TUBE ASSEMBLY	1		
	8-84795-7	• TUBE ASSEMBLY	1		
- 7	8-84716-7	• TUBE ASSEMBLY	1		
	8-84796-7	• TUBE ASSEMBLY	1		
- 8	96-29810-00	• NIPPLE	2		
	AN924-6D	• NUT	2		
	AN961D91E1	• WASHER	2		
- 9	8-84715-8	• TUBE ASSEMBLY	1		
- 10	MS21916D8-6	• REDUCER	2		
	MS28778-8	• PACKING	2		
- 11		• FILTER ASSY, HYDRAULIC OIL SEE FIG. 2.8-23 INDEX 4	PF		
- 12	8-84714-7	• TUBE ASSEMBLY	1		
- 13	8-84713-7	• TUBE ASSEMBLY	1		
- 14	MS21924D6	• UNION	2		
	AN924-6D	• NUT	2		
	AN961D91E	• WASHER	2		
- 15	8-84711-7	• TUBE ASSEMBLY	1		
- 16	8-84712-7	• TUBE ASSEMBLY	1		
- 17	MS21902D6	• UNION	2		
- 18	8-84709-7	• TUBE ASSEMBLY	1		
- 19	8-84710-7	• TUBE ASSEMBLY	1		
- 20	MS21902D6	• UNION	2		
- 21	8-84707-8	• TUBE ASSEMBLY	1		
- 22	96-90319-008	• TEE	1		
- 23	8-84706-9	• TUBE ASSEMBLY	1		
- 24		• SWITCH, PRESSURE ACTUATED SEE FIG. 2.8-23 INDEX 17	PF		
- 25	8-84704-7	• TUBE ASSEMBLY	1		
- 26	AN938D6	• TEE	1		
- 27	MS21902D6	• UNION	2		
	MS28778-6	• PACKING	2		
- 28	4CV454	• VALVE, CHECK HYDRAULIC (91277) SPEC P-08455-606 T.O. 988-6-50-3	1		
- 29	91-98126-015	• CLAMP	1		
		ATTACHING PARTS			
- 30	AN520-10PF	• SCREW	1		
- 31	MS21914-64	• CAP	1		
- 32	MS21914-44	• CAP	1		
- 33	MS21914-64	• CAP	1		
		-----X-----			
- 34	8-69002-67	• BRACKET	1		
		ATTACHING PARTS			
- 35	MS21042L3	• NUT	2		
- 36	AN520-10R10	• SCREW	2		
- 37		• COUPLING ASSY, SELF-SEALING SEE FIG. 2.8-23	PF		
- 38	8-84703-9	• TUBE ASSEMBLY	1		
- 39	96-90319-008	• TEE	1		
- 40	8-84705-11	• TUBE ASSEMBLY	1		
- 41	8-84701-11	• TUBE ASSEMBLY	1		
- 42		• NIPPLE, SEE FIG. 2.8-23	2		

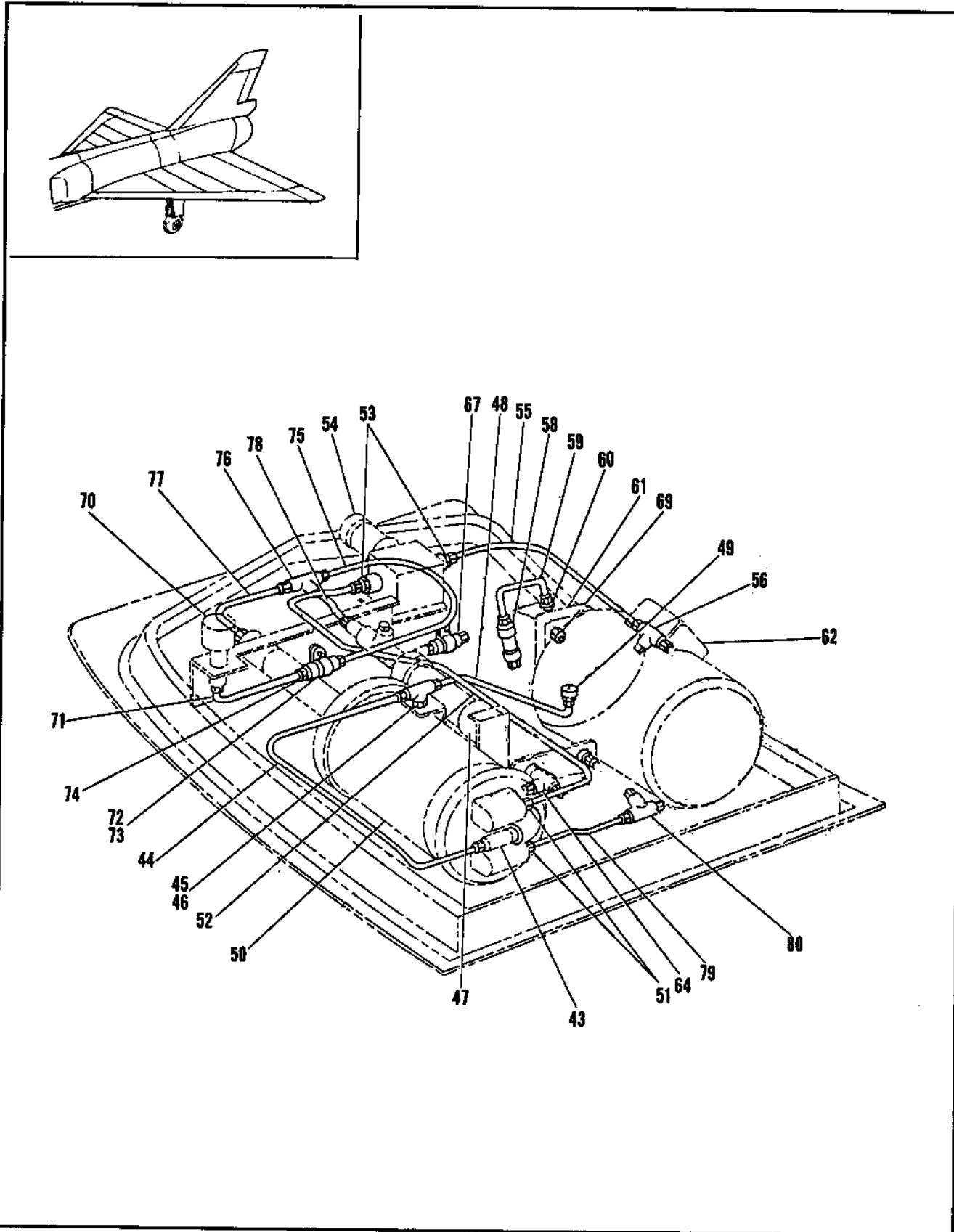

Figure 2.8-27. Rapid Tune Magnetron Hydraulic Tubing Installation Sta 412 to 540 (Sheet 2 of 2)

FIGURE AND INDEX NUMBER	PART NUMBER	DESCRIPTION	UNITS PER ASSY.	USABLE ON CODE	
				FROM	TO
2.8-27- 43		• VALVE, LOW PRESSURE RELIEF SEE FIG. 2.8-23 INDEX 14	RF		
- 44	R-84791-11	• TUBE ASSEMBLY SEAL DRAIN	1		
- 45	MS21909D3	• TEE	1		
- 46	AN924-3C	• NUT	1		
- 47		• ACCUMULATOR, HYDRAULIC SEE FIG. 2.8-23 INDEX 38	RF		
- 48	R-84792-7	• TUBE ASSEMBLY SEAL DRAIN	1		
- 49	MS21916D4-3	• REDUCER	1		
	MS28778-6	• PACKING	1		
- 50		• RESERVOIR ASSY, HYDRAULIC PRESSURIZED SEE FIG. 2.8-23 INDEX 15	RF		
- 51	MS21902D6	• UNION	1		
	MS28778-6	• PACKING	1		
- 52	R-84782-9	• TUBE ASSEMBLY	1		
	7243609-01	• TUBE ASSY, CASE DRAIN	1		
- 53	MS21916D6-4	• REDUCER	2		
	MS28778-4	• PACKING	RF		
- 54		• FILTER ASSY, HYDRAULIC LOW PRESSURE SEE FIG. 2.8-23 INDEX 43			
- 55	R-84781	• TUBE ASSEMBLY, CASE DRAIN	1		
- 56	98-90319-038	• TEE	1		
- 57	R-84783-7	• TUBE ASSEMBLY, CASE DRAIN	1		
- 58	1112-568664	• VALVE, CHECK HYDRAULIC (92103) SPEC R-38450-304	1		
- 59	R-84784-7	• TUBE ASSEMBLY, CASE DRAIN	1		
- 60	MS21902D4	• UNION	1		
	MS28778-4	• PACKING	RF		
- 61		• PUMP, ELECTRIC MOTOR DRIVEN HYDRAULIC VARIABLE DELIVERY SEE FIG. 2.8-23 INDEX 47			
- 62		• ELECTRIC MOTOR, SEE FIG. 2.8-23 INDEX 47	RF		
- 63	R-84783-11	• TUBE ASSEMBLY, CASE DRAIN	1		
- 64		• TEE SEE FIG. 2.8-23 INDEX 50	RF		
- 65	R-84785-4	• TUBE ASSEMBLY, PRESSURE	1		
- 66	R-84786-11	• TUBE ASSEMBLY, PRESSURE	1		
- 67	4CV442	• VALVE, CHECK HYDRAULIC (91207) SPEC R-38450-634	1		
- 68	R-84787-9	• TUBE ASSEMBLY, PRESSURE	1		
- 69	MS21916D6-4	• REDUCER	1		
	MS28778-6	• PACKING	1		
- 70		• GAGE, SEE FIG. 2.8-23 INDEX 25	RF		
- 71	R-84783-7	• TUBE ASSEMBLY, AIR PRESSURE	1		
- 72	91-48026-011	• CLAMP	1		
		ATTACHING PARTS			
- 73	MS21942L3	• NUT	1		
	AN96.0111	• WASHER	1		
	4N527-10R14	• SCREW	1		
		-----X-----			
- 74	VAS430D3-16	• SPACER	1		
	31493	• DAMPENER, FLUID PRESSURE (91207) 92-91300-103	1		
- 75	R-84788-7	• TUBE ASSEMBLY, AIR PRESSURE	1		
- 76	MS21905D4	• TEE	1		
- 77	R-84789-9	• TUBE ASSEMBLY, AIR PRESSURE	1		
- 78	R-84790-7	• TUBE ASSEMBLY, AIR PRESSURE	1		
- 79	R-84770-11	• TUBE ASSEMBLY, SUCTION	1		
- 80	MS21905D6	• TEE	1		
- 81	R-84779-11	• TUBE ASSEMBLY, SUCTION	1		

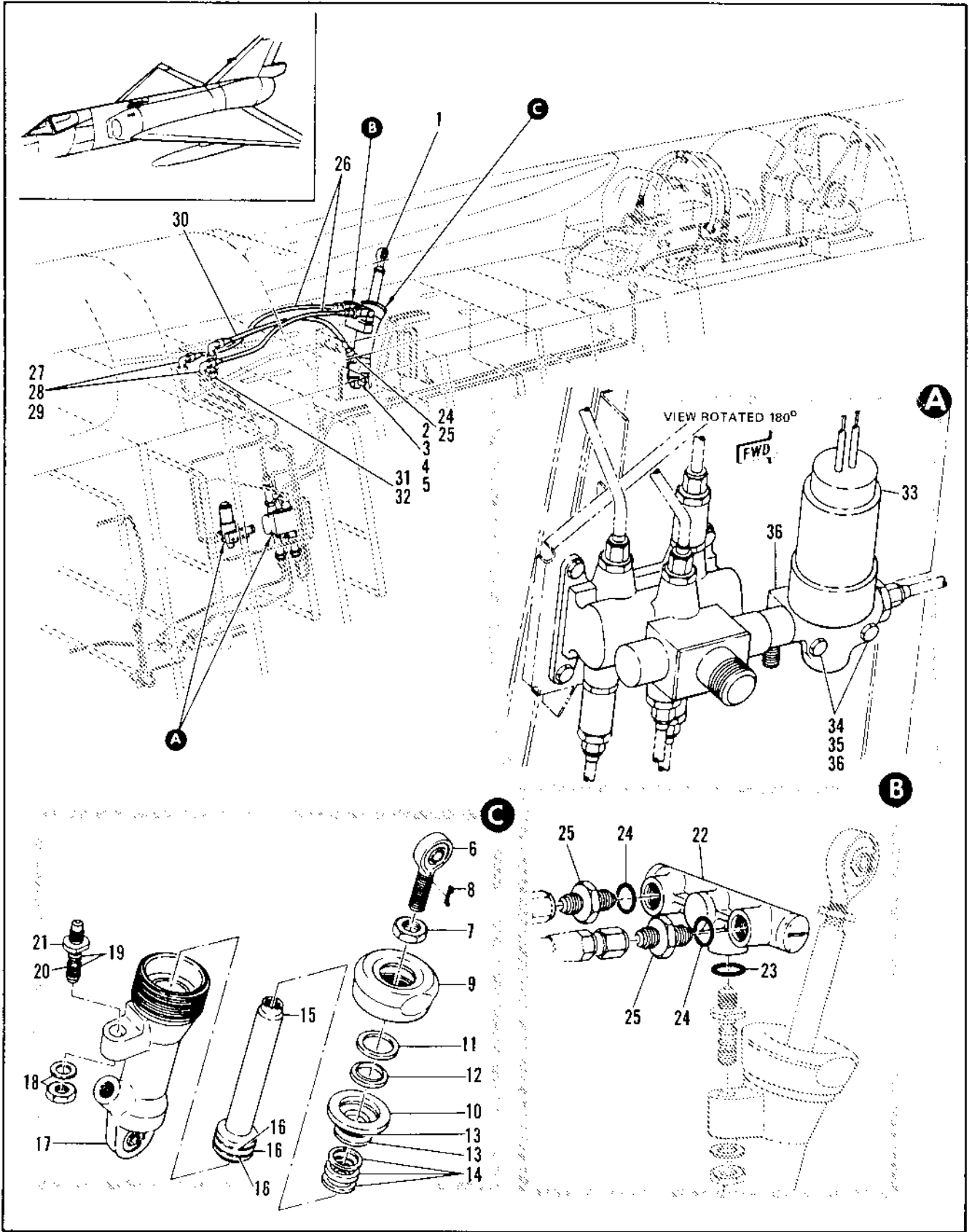

Figure 2.8-28. Aerial Refueling Hydraulic Equipment (Sheet 1 of 2)

FIGURE AND INDEX NUMBER	PART NUMBER	DESCRIPTION	UNITS PER ASSY.	USABLE ON CODE	
				FROM	TO
		1 2 3 4 5 6			
2.8-28		AERIAL REFUELING HYDRAULIC EQUIPMENT			
- 1	66J41593-1 66E40607-1	. ACTUATOR INSTL, SLIPWAY . . CYLINDER, ACTUATING ATTACHING PARTS	1 1		
- 2	MS24665-285	. . COYTER PIN	1		
- 3	AN360-6	. . NUT	1		
- 4	AN960-616	. . WASHER	1		
- 5	NAS1106-230	. . BOLT	1		
- 6	DREMHDS-6-065	-----X----- . . . ROD END (81376)	1		
- 7	NAS509-7	. . . NUT	1		
- 8	NAS559-3	. . . LOCK, ROD END	1		
- 9	66E40627-1	. . . END CAP	1		
- 17	66E40628-1	. . . RETAINER	1		
- 11	66B40629-1	. . . WASHER	1		
- 12	MS28776M-4	. . . SCRAPER	1		
- 13	MS28775-218 MS28774-218	. . . PACKING . . . RETAINER	1 1		
- 14	MS28774-113 MS28778-115	. . . PACKING . . . RETAINER	1 2		
- 15	66E40643-1	. . . PISTON	1		
- 16	MS28775-212 MS28774-212	. . . PACKING . . . RETAINER	1 2		
- 17	66E40626-3	. . . CYLINDER	1		
- 18	NAS509-7 AN960-716L	. . . NUT . . . WASHER	1 1		
- 19	MS28775-011	. . . PACKING	2		
- 20	MS28774-011	. . . RETAINER	1		
- 21	66D40592-1	. . . FITTING	1		
- 22	3850A1	. . VALVE ASSY, SHUTTLE (78062) SPEC 8-73564-1 T.O. 1F-106A-5-51-3	1		
- 23	MS28775-011	. . PACKING	1		
- 24	MS28776-4	. . PACKING	1		
- 25	MS21902-4C	. . UNION	3		
- 26	66D39700-1	. . HOSE	2		
- 27	MS21908-4C	. . ELBOW ATTACHING PARTS	2		
- 28	AN960-716	. . WASHER	2		
- 29	AN924-4C	. . NUT -----X-----	2		
- 30	66D39700-4	. . HOSE	1		
- 31	MS21924-4C	. . UNION ATTACHING PARTS	1		
- 32	AN924-4C	. . NUT -----X-----	1		
- 33	66E40978-2 HP542100-3	. VALVE INSTL, HYD-PNEU AIR REFUEL . VALVE ASSY, SOLENOID SELECTOR (84485) SPEC 8-20400-5 T.O. 1F-106A-5-9-21-3 ATTACHING PARTS	1 1		
- 34	MS21042L3	. . NUT	2		
- 35	AN960010L	. . WASHER	2		
- 36	66B40302-1	. . SPACER	1		
- 37	NAS1303-24	. . BOLT -----X-----	1		

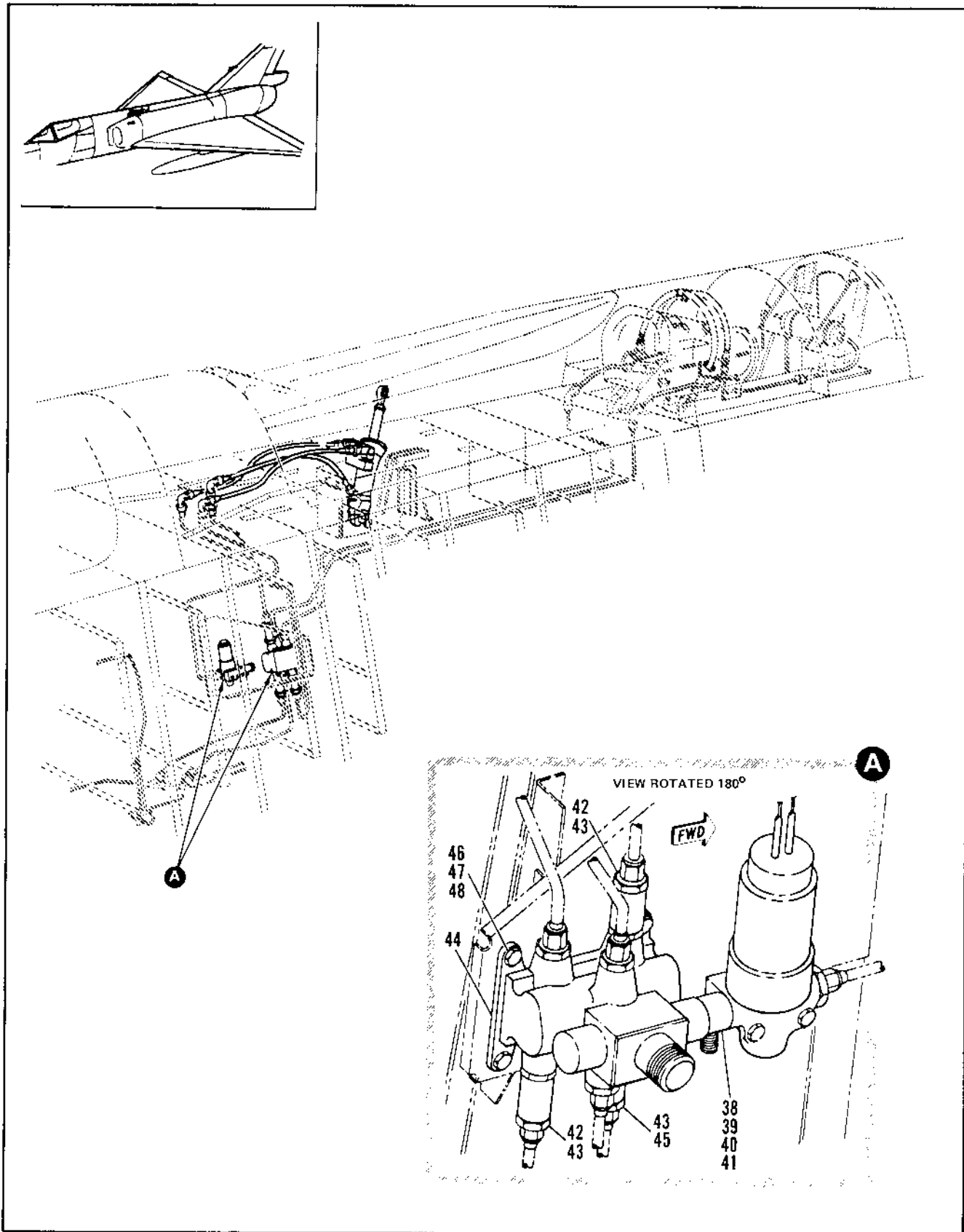

Figure 2.8-28. Aerial Refueling Hydraulic Equipment (Sheet 2 of 2)

FIGURE AND INDEX NUMBER	PART NUMBER	DESCRIPTION	UNITS PER ASSY.	USABLE ON CODE	
				FROM	TO
		1 2 3 4 5 6			
2.8-28- 38	NAS1237A4	• • ELBOW ATTACHING PARTS	1		
- 39	NAS551-4D	• • BOLT	1		
- 40	MS28775-511	• • PACKING	1		
- 41	MS28778-4	• • PACKING	1		
		-----X-----			
- 42	2R2441-9	• • VALVE, RESTRICTOR (91207)	2		
- 43	MS28778-4	• • PACKING	3		
- 44	HP865100	• • VALVE, CONTROL (84685)			
- 45	MS28892-4	• • VALVE ATTACHING PARTS	1		
- 46	MS21042L3	• • NUT	4		
- 47	AN965010L	• • WASHER	4		
- 48	NAS1303-6	• • BOLT	4		

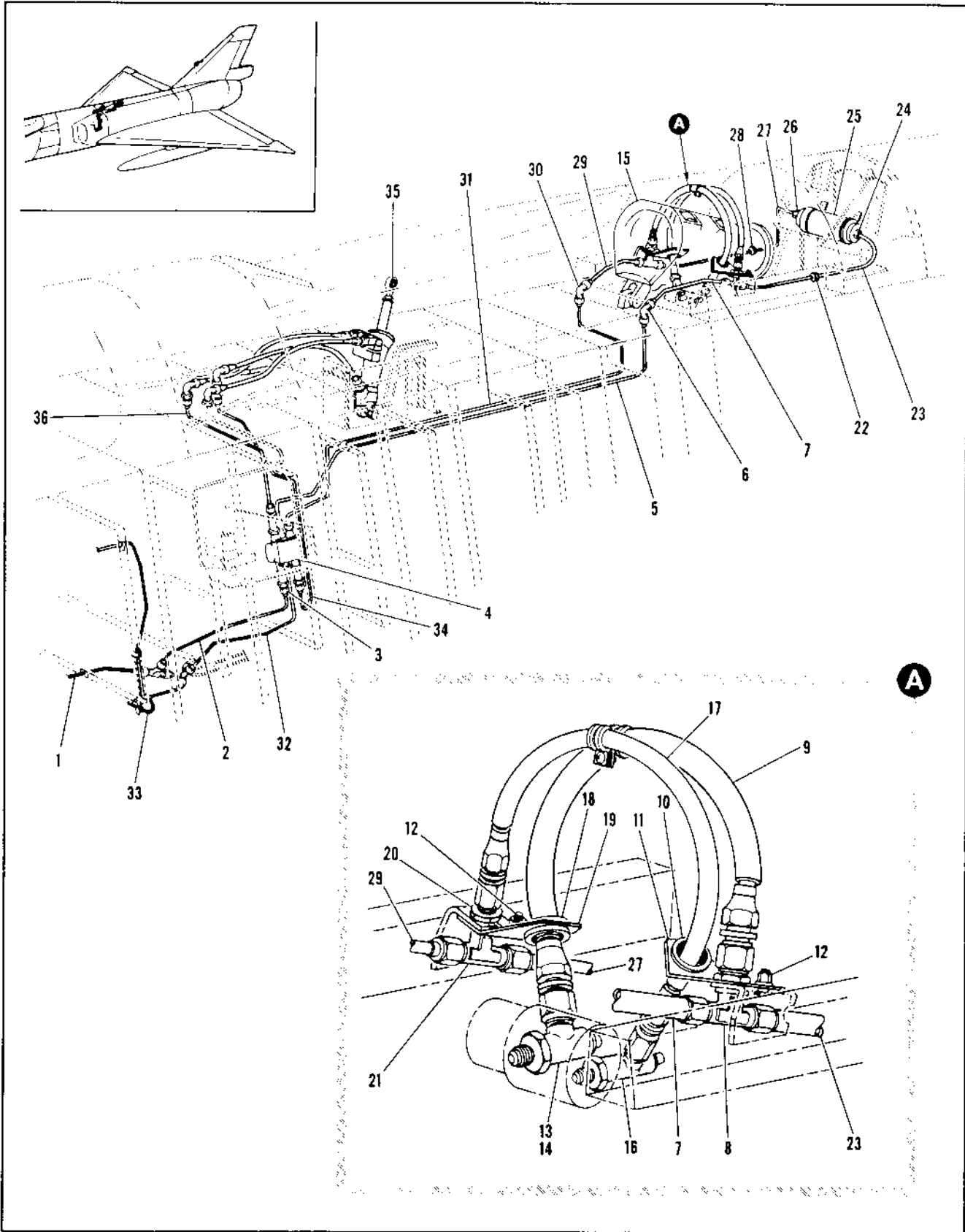

Figure 2.8-29. Aerial Refueling Hydraulic Tubing Installation

FIGURE AND INDEX NUMBER	PART NUMBER	DESCRIPTION	UNITS PER ASSY.	USABLE ON CODE	
				FROM	TO
2.8-29	66J40297-2	TUBING INSTALLATION, AIR REFUELING HYDRAULIC	FF		
- 1		• TUBE ASSY, SEE FIG. 2.8-9 INDEX 31	9F		
- 2	66A39622-1	• TUBE ASSY	1		
- 3	MS2190204	• UNION	1		
	MS28778-4	• PACKING	1		
- 4		• VALVE, AIR REFUELING SEE FIG. 2.8-28 INDEX 33	FF		
- 5	66A39626-1	• TUBE ASSEMBLY	1		
- 6	MS2190706	• ELBOW	1		
	AN924-6D	• NUT	1		
- 7	66A39655-1	• TUBE ASSEMBLY	1		
	66J40435-2	• LATCH HOSE INSTALLATION	1		
- 8	MS2190906	• TEE	1		
	AN924-6D	• NUT	1		
- 9	66D39700-3	• HOSE ASSEMBLY	1		
- 10	MS21266-1T	• GROMMET (97520)	1		
- 11	66C40651-1	• FAIRLEAD	1		
- 12	MS21442L3	• NUT	2		
	AN960D10L	• WASHER	2		
	NAS1103-3	• BOLT	2		
- 13	66D40613-2	• SWIVEL	1		
- 14	MS28778-6	• O-RING	1		
- 15		• REFUELING RECEPTACLE, SEE FIG. 2.12-66	9F		
- 16	66D40613-1	• SWIVEL	1		
	MS28778-4	• O-RING	1		
- 17	66D39700-2	• HOSE ASSEMBLY	1		
- 18	MS21266-1T	• GROMMET (97520)	1		
- 19	66C40650-1	• FAIRLEAD	2		
- 20	AN924-4D	• NUT	1		
	AN960D716	• WASHER	1		
- 21	MS21909D4	• TEE	1		
- 22	66B40363-2	• TUBE ASSEMBLY	1		
- 23	66A39657-1	• TUBE ASSEMBLY	1		
- 24	MS21916D8-6	• REDUCER	1		
	MS28778-c	• PACKING	1		
- 25	1205-5	• VALVE, RELIEF (06177)	1		
- 26	MS21916D8-4	• REDUCER	1		
	MS28778-8	• PACKING	1		
- 27	66A39658-1	• TUBE ASSEMBLY	2		
- 28	66B40363-1	• GROMMET	1		
- 29	66A39656-1	• TUBE ASSEMBLY	1		
- 30	MS21907D4	• ELBOW	1		
	AN924-4D	• NUT	1		
- 31	66A39625-1	• TUBE ASSEMBLY	1		
- 32	66A39621-1	• TUBE ASSEMBLY	1		
- 33		• TUBE ASSEMBLY SEE FIG. 2.8-9 INDEX 17	9F		
- 34	66A39662-1	• TUBE ASSEMBLY	1		
- 35		• ACTUATOR INSTL, SEE FIG. 2.8-28	FF		
- 36	66A39663-1	• TUBE ASSEMBLY	1		

PNEUMATIC SUBSECTION

TABLE OF CONTENTS

<i>Fig. No.</i>	<i>Title</i>	<i>Page</i>	<i>Fig. No.</i>	<i>Title</i>	<i>Page</i>
2.9-1	Pneumatic System	2.9-2	2.9-19	High Pressure Pneumatic Variable Air Ramp Drive Unit	
2.9-2	Air Pressure Fwd Regulator Installation	2.9-6		Tubing Installation	2.9-84
2.9-3	Pneumatic Flask Installation	2.9-12	2.9-20	High Pressure Pneumatic Emergency Landing Gear Selector Valve	
2.9-4	Low Pressure Pneumatic Radome Anti-Icing Tubing Installation	2.9-14		Main Line and Vent Tubing Installation	2.9-86
2.9-5	Low Pressure Pneumatic G Suit and Flow Tubing Installation	2.9-20	2.9-21	High Pressure Pneumatic Ram Air Tubing Installation	2.9-90
2.9-6	Low Pressure Pneumatic Variable Air Ramp Seal Tubing Installation	2.9-22	2.9-22	High Pressure Pneumatic Bleed Tubing Installation	2.9-94
2.9-7	Low Pressure Pneumatic Cockpit Pressure Control Tubing Installation	2.9-24	2.9-23	High Pressure Pneumatic Filler and Pressure Gauge Tubing Installation	2.9-96
2.9-8	Low Pressure Pneumatic Refrigera- tion Unit Bleed Air Sensing Tubing Installation	2.9-30	2.9-24	High Pressure Pneumatic Speed Brake and Drag Chute Tubing Installation	2.9-100
2.9-9	Low Pressure Pneumatic Canopy Seal Tubing Installation	2.9-32	2.9-25	High Pressure Pneumatic Vertical Stabilizer and Dorsal Tubing	2.9-102
2.9-10	Low Pressure Pneumatic Electronic Cooling Hot Air By-Pass Tubing Installation	2.9-38	2.9-26	High Pressure Pneumatic Fuel Transfer and Armament Supply Tubing Installation	2.9-108
2.9-11	High Pressure Pneumatic Emergency Cockpit Pressurization Tubing Installation	2.9-44	2.9-27	High Pressure Pneumatic Armament Door Actuator Shuttle Valve Tubing Installation	2.9-110
2.9-12	Tubing Installation High Pressure Pneumatic Infrared Seeker	2.9-48	2.9-28	High Pressure Pneumatic Armament Door Fwd Actuator Tubing Installation	2.9-112
2.9-13	Engine Starter High Pressure Pneumatic Tubing Installation	2.9-52	2.9-29	High Pressure Pneumatic Armament Door Center Actuator Tubing Installation	2.9-118
2.9-14	Pneumatic Master Brake Cylinder to Wheel Brake Relay Valve Tubing Installation LH	2.9-54	2.9-30	High Pressure Pneumatic Armament Door Aft Actuator Tubing Installation	2.9-124
2.9-15	Pneumatic Master Brake Cylinder to Wheel Brake Relay Valve Tubing Installation RH	2.9-58	2.9-31	High Pressure Pneumatic Fwd Armament Displacement Tubing Installation	2.9-130
2.9-16	High Pressure Pneumatic Nose Landing Gear Tubing Installation	2.9-62	2.9-32	High Pressure Pneumatic Armament Gear Lock Tubing Installation	2.9-132
2.9-17	High Pressure Pneumatic Main Landing Gear Tubing Installation	2.9-66	2.9-33	High Pressure Pneumatic Aft Armament Displacement Tubing Installation	2.9-134
2.9-18	High Pressure Pneumatic Main Landing Gear Brake Supply Tubing Installation	2.9-76			

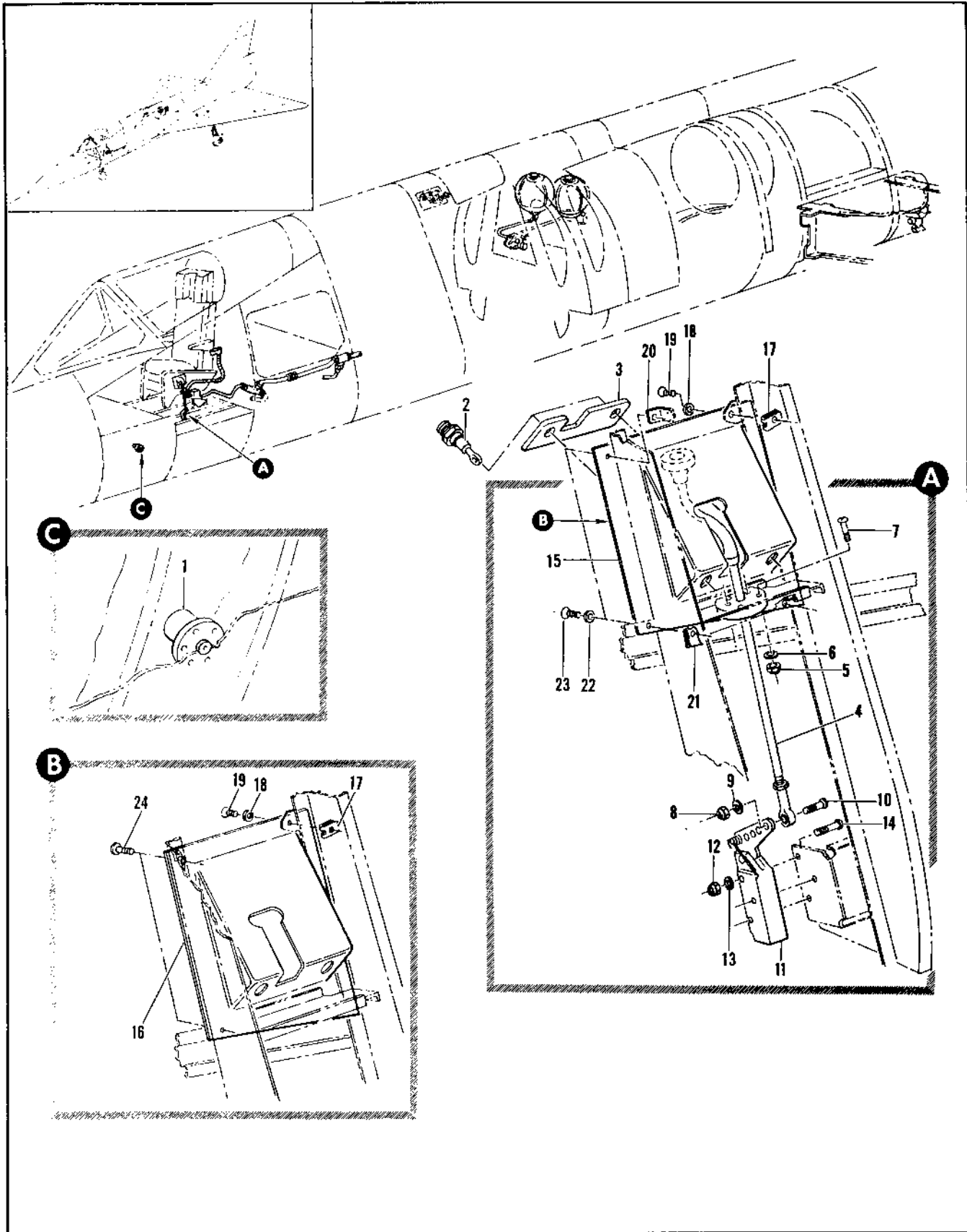

Figure 2.9-1. Pneumatic System (Sheet 1 of 2)

FIGURE AND INDEX NUMBER	PART NUMBER	DESCRIPTION	UNITS PER ASSY.	USABLE ON CODE	
				FROM	TO
		1 2 3 4 5 6			
2.9-1	8-23375-1	PNEUMATIC SYSTEM	RF	35	
	8-23375-2	• PORT INSTL, PNEUMATIC SENSING STATIC PRESSURE LH FOR NHA SEE FIG. 2.3-4	RF	35	
- 1	8-23327-1	• PORT INSTL, PNEUMATIC SENSING STATIC PRESSURE RH FOR NHA SEE FIG. 2.3-4	1	35	
	8-95615	• • FLANGE, PNEUMATIC SENSING STATIC PRESSURE	RF	35	
	8-94711-219	• CONTROL INSTL, RAM AIR TURBINE POWER FOR NHA SEE FIG. 2.3-6	1	35	
	AN3140-327	• • LAMP INSTL, EMERGENCY HYDRAULIC POWER	2	35	
- 2	20715-327	• • LAMP	2	35	89
	MS25010-4A	• • LIGHT ASSY, PANEL PLASTIC PLATE <72914> SPEC 8-09441-1 REPLACED BY SUITABLE SUB MS25010-4A	2	90	
- 3	8-95616-1	• • LIGHT, REPLACES SUITABLE SUB FOR 20715-327	1	35	
- 4	13636-1	• • PLATE, EMERGENCY HYDRAULIC POWER DESIGNATION	1	35	
- 5	NAS679A3	• • CONTROL ASSY, EMERGENCY HYDRAULIC POWER <78710> SPEC 8-09294-3 T.O.16C1-23-2-3	3	35	
- 6	AN969-1C	• • NUT	3	35	
- 7	NAS221-17	• • WASHER	3	35	
- 8	NAS679A3	• • SCREW	1	35	
- 9	AN960-10	• • NUT	1	35	
- 10	NAS221-17	• • WASHER	1	35	
- 11	871823	• • SCREW	1	35	
- 12	NAS679A3	• • VALVE ASSY, EMERGENCY HYDRAULIC POWER <33525> SPEC 8-00401-3 T.O.9P5-9-9-13	3	35	
- 13	AN960-10L	• • NUT	3	35	
- 14	NAS221-23	• • WASHER	3	35	
- 15	8-95615	• • SCREW	1	A	
- 16	8-95615-1	• • COVER ASSY, EMERGENCY HYDRAULIC POWER REPLACED SUITABLE SUB 8-95615-1	1	61	129
- 17	A6459-823	• • COVER ASSY, EMERGENCY HYDRAULIC POWER REPLACES SUITABLE SUB FOR 8-95615 ATTACHING PARTS	2	35	
- 18	99-51400-001	• • NUT, <78553> 96-37302-001	2	35	
- 19	AN531-8R6	• • WASHER	2	35	
- 20	A8567-823	• • SCREW	1	A	
- 21	A6452-823	• • NUT, <78553> 96-37303-001	1	A	
- 22	99-51400-001	• • NUT, <78553> 96-37302-002	2	A	
- 23	AN531-8R6	• • WASHER	2	A	
- 24	AN526-832R4	• • SCREW	2	61	129
		-----X-----			
		A AIRPLANES #35 THRU 60, 130 AND ON			

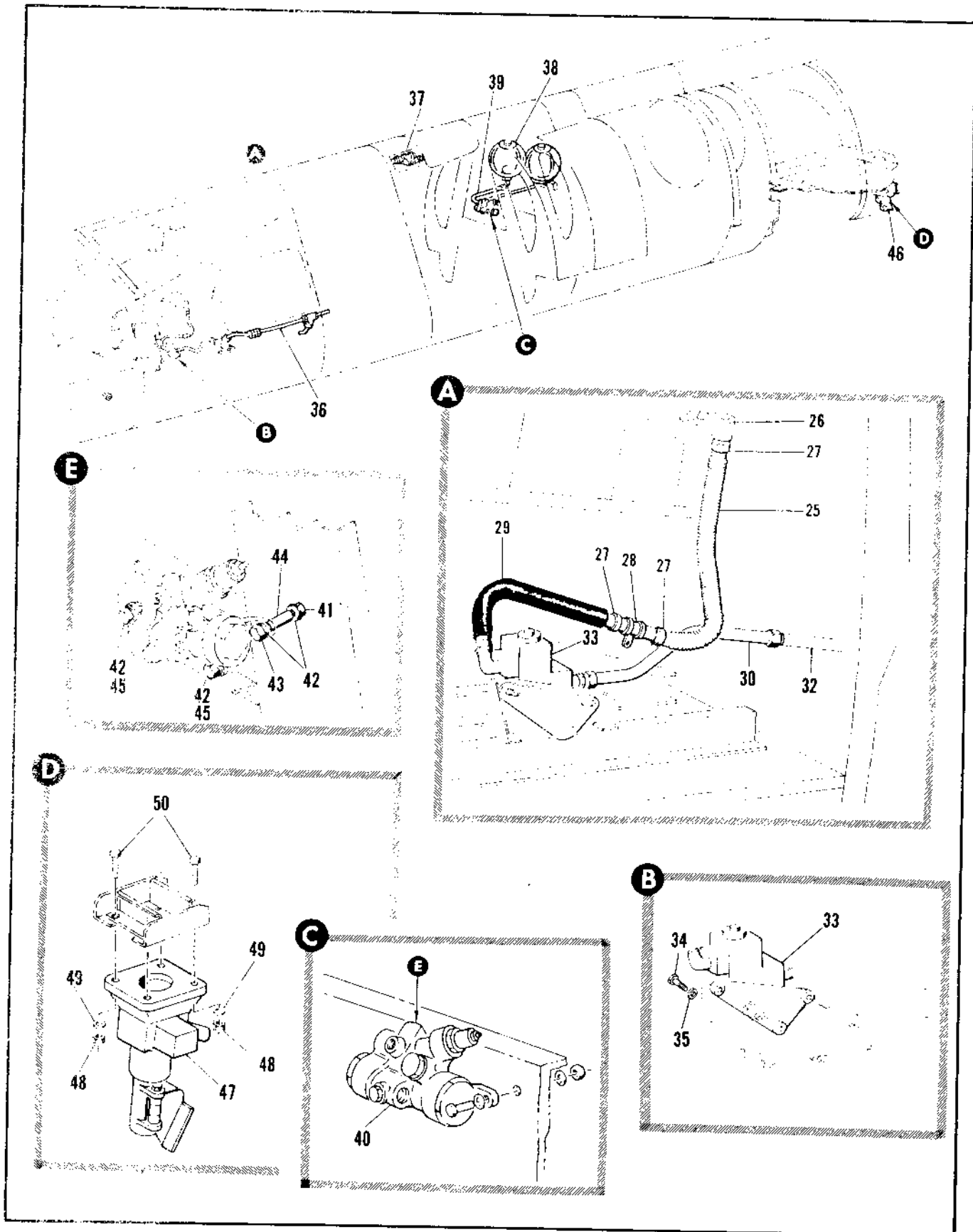

Figure 2.9-1. Pneumatic System (Sheet 2 of 2)

FIGURE AND INDEX NUMBER	PART NUMBER	DESCRIPTION 1 2 3 4 5 6	UNITS PER ASSY.	USABLE ON CODE	
				FROM	TO
2.9-1	8-94825-3	• TUBING INSTL, ANTI-G SUIT MODIFIED BY 8-310R3 FOR NHA SEE FIG. 2.3-4	RF	35	
- 25	DC266-23	• HOSE ASSY, ANTI-G SUIT	1	35	
- 26	AE335-10C152 D100U	• HOSE ASSY, ANTI-G SUIT • DISCONNECT ASSY SEE FIG. 2.4-11 INDEX 2	RF	35	
- 27	NAS397-14	• CLAMP	1	35	
- 28	MS22364-4 AN742010	• CLAMP • CLAMP	2	35	
		ATTACHING PARTS	1		
	AN963010	• WASHER	1		
	MS27039-1-09	• SCREW	1		
- 29	68A37759-3	• TUBE ASSEMBLY	1	35	
	7036819-1	• TUBE ASSEMBLY	1	35	
- 30	8-94825-27	• TUBE ASSEMBLY	1	35	
- 31		• TUBE ASSEMBLY	1	189	
- 32		• TUBE ASSY, RADOME ANTI-ICING SEE FIG. 2.9-4 INDEX 29	RF	35	
	R-95599-1	• VALVE INSTL, ANTI-G SUIT FOR NHA SEE FIG. 2.3-6	RF	35	
- 33	5503040	• VALVE ASSY, ANTI-G SUIT <70491> 99-34859-001 T.O.15X8-7-3 ATTACHING PARTS	1	35	
- 34	AN4-7A	• BOLT	3	35	
- 35	AN9600416	• WASHER	3	35	
		-----X-----			
- 36		• TUBING INSTL, LOW PRESSURE PNEUMATIC SEE FIG. 2.9-4 THRU 2.3-10	RF		
- 37		• REGULATOR INSTL, AIR PRESSURE FWD SEE FIG. 2.9-2	RF		
- 38		• FLASK INSTL, PNEUMATIC SEE FIG. 2.9-3	RF		
- 39		• TUBING INSTL, HIGH PRESSURE PNEUMATIC SEE FIG. 2.9-11	RF		
	66E40984-1	• REGULATOR INSTL, PNEUMATIC PRESSURE FOR NHA SEE FIG. 2.3-10	RF		
- 40	15700-1	• REGULATOR ASSY, PNEUMATIC PRESSURE <79294> SPEC 8-02264-3 T.O.9P503-73-3 ATTACHING PARTS	1	35	
- 41	MS21042L4	• NUT	1		
- 42	AN9600416L	• WASHER	4		
- 43	NAS1104-23	• BOLT	1		
- 44	NAS43004-68	• SPACER	1		
- 45	NAS1104-6	• BOLT	2		
- 46	8-85017-1	• CONNECTOR INSTL, PNEUMATIC GROUND FILLER LH FOR NHA SEE FIG. 2.6-32	RF	35	
- 47	56380-3	• CONNECTOR, HIGH PRESSURE GROUND FILLER (08093)	1	35	
	56140-3	• CONNECTOR, HIGH PRESSURE GROUND FILLER (08093) SPEC 8-00431-9 T.O. 9P8-4-3, ALT, INTCHG WITH 56380-3 ATTACHING PARTS	4	35	
- 48	NAS679A4	• NUT	4	35	
- 49	AN9600416	• WASHER	4	35	
- 50	AN4-6A	• BOLT	4	35	
		-----X-----			

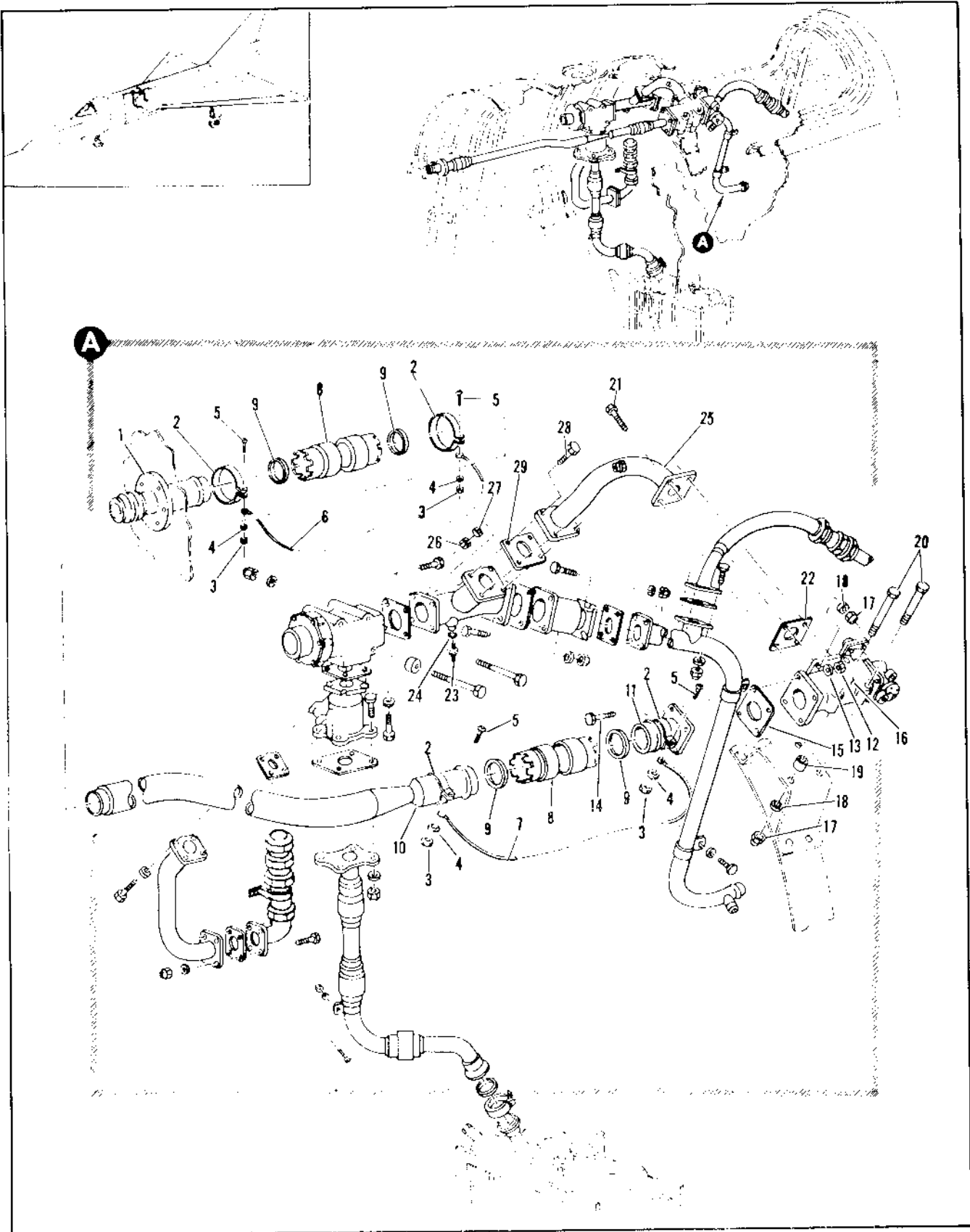

Figure 2.9-2. Air Pressure Forward Regulator Installation (Sheet 1 of 3)

FIGURE AND INDEX NUMBER	PART NUMBER	DESCRIPTION	UNITS PER ASSY.	USABLE ON CODE	
				FROM	TO
2.9-2	8-28270-3	REGULATOR INSTALLATION, AIR PRESSURE FORWARD FOR NMA SEE FIG. 2.3-11	RF	35	
- 1		• FLANGE ASSY, AIR INTAKE SEE FIG. 2.12-49	RF		
- 2	AN735D24	• CLAMP ATTACHING PARTS	4	35	
- 3	NAS679A3	• NUT	4	35	
- 4	AN960D10L	• WASHER	4	35	
- 5	AN525-1032R6	• SCREW	4	35	
- 6	MS25083-1EB6	• JUMPER	1	35	
- 7	MS25083-1FB4	• JUMPER	1	35	
- 8	3621200	• COUPLING, <97326> 92-72500-006	2	35	
- 9	MS219513-218	• PACKING	4	35	
- 10	8-28360-807	• TUBE ASSY, WELDED REPLACES NOT INCHG WITH 8-28360-803	1	35	
- 11	AN757D20-24	• CONNECTOR ATTACHING PARTS	1	35	
- 12	NAS679A4	• NUT	4	35	
- 13	AN961PD416L	• WASHER	4	35	
- 14	AN4-11A	• BOLT	4	35	
- 15	460-615-24	• SEAL, <43259> 97-93503-003	1	35	
- 16	114100-27	• REGULATOR ASSY, AIR PRESSURE <96124> SPEC 8-25377-27 ATTACHING PARTS	1	35	
- 17	NAS679A4	• NUT	7	35	
- 18	AN960PD416L	• WASHER	7	35	
- 19	NAS430D4-12	• SPACER	3	35	
- 20	AN4-21A	• BOLT	3	35	
- 21	AN4-10A	• BOLT	4	35	
- 22	460-615-24	• SEAL, <43259> 97-93503-003	1	35	
- 23	8-28388-7	• UNION, PRESSURE LINE DRAIN RESTRICTOR	1	35	
- 24	NAS617-6	• GASKET	1	35	
- 25	8-28392	• TUBE ASSY, WELDED ATTACHING PARTS	1	35	
- 26	NAS679A4	• NUT	4	35	
- 27	AN961PD416L	• WASHER	4	35	
- 28	AN4-7	• BOLT	4	35	
- 29	460-630-20	• SEAL, <83259> 97-93505-004	1	35	

A AIRPLANES #35 THRU 47 AND 49 THRU 60
B AIRPLANES #42, 61 AND 69

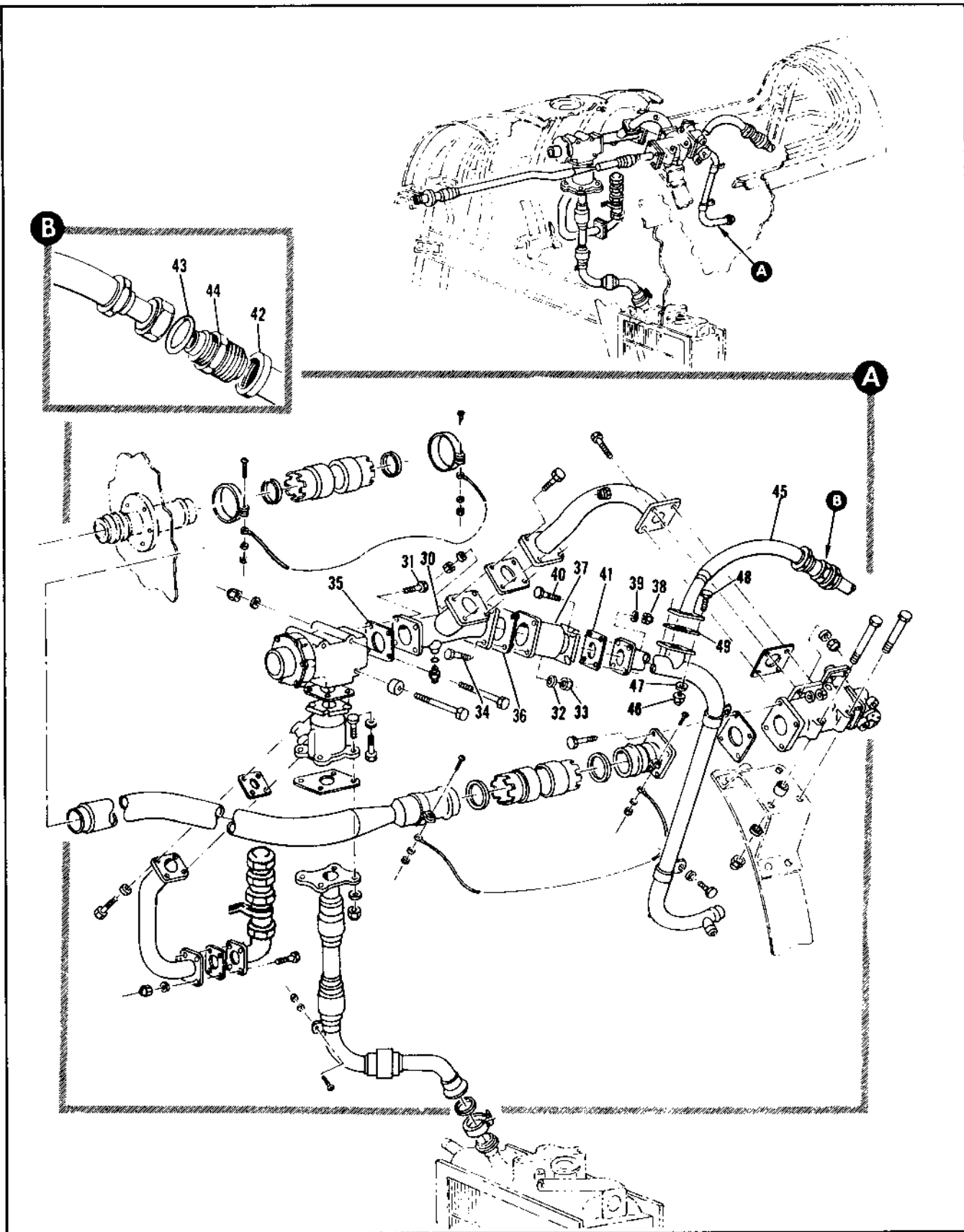

Figure 2.9-2. Air Pressure Forward Regulator Installation (Sheet 2 of 3)

FIGURE AND INDEX NUMBER	PART NUMBER	DESCRIPTION	UNITS PER ASSY.	USABLE ON CODE	
				FROM	TO
2.9-2- 50	91-98026-023	• CLAMP ATTACHING PARTS			35
- 51	AN3-4A	• BOLT	2		35
- 52	AN960PD10L	• WASHER	2		35
		-----X-----			
- 53	NAS617-4	• GASKET	1		35
- 54	160B	• VALVE ASSY, <91511> 92-12501-003	1		35
- 55	8-28330-5	• TUBE ASSY, FUEL TANK PRESSURE WELDED	1		35
- 56	8-28325	• ELBOW ASSY, DEFUEL ADAPTER WELDED ATTACHING PARTS	1		35
- 57	AN3H5A	• BOLT	4		35
- 58	AN960PD10L	• WASHER	12		35
- 59	NAS679A3	• NUT	4		35
- 60	AN3-10A	• BOLT	4		35
		-----X-----			
- 61	460-630-16	• SEAL, <83259> 97-93503-007	2		35
- 62	MS20756D16	• FLANGE	1		35
- 63	MS20762D16	• ELBOW	1		35
- 64	64A33336-1	• TUBE ASSEMBLY	1		35
- 65	AN815-16D	• UNION	1		35
- 66	MS21919H16	• CLAMP	1		35
- 67	AN929-16	• CAP	1		35
- 68	91-98026-024	• CLAMP ATTACHING PARTS	1		35
- 69	NAS679A3	• NUT	1		35
- 70	AN960PD10L	• WASHER	1		35
- 71	NAS221-9	• SCREW	1		35
- 72	4464C257M	• COUPLING, <98625> 92-73012-001	1		35
- 73	074956A 2749	• SEAL, <73240> SPEC 8-00277-1 • SEAL (98159) SPEC 8-00277-1 ALT INTCHG WITH 074956	1 1		35 35
- 74	20442	• HOSE ASSY, HEAT EXCHANGE OUTLET <55820> SPEC 8-02492-5 ATTACHING PARTS	1		35
- 75	NAS679A4	• NUT	4		35
- 76	AN960PD416L	• WASHER	4		35
- 77	AN4-7A	• BOLT	4		35
- 78		• HEAT EXCHANGER ASSY, REFRIGERATION UNIT SEE FIG. 2.13-31 INDEX 53	RF		
- 79	075056 WC95-1-1/2D	• SEAL, <83259> SPEC 8-00278-1	1		35
- 80	WC95-1-1/2E	• VALVE ASSY, DUAL AIR CHECK <96138> SPEC 8-02494-3 T.O.P5-12-37-3 ATTACHING PARTS	1		35
- 81	AN4H5A	• BOLT	4		35
- 82	AN960PD416L	• WASHER	4		35
		-----X-----			
- 83	460-615-24	• SEAL, <83259> 97-93505-003	1		35
- 84	5063-1	• REGULATOR ASSY, AIR PRESSURE CG CONTROL <98439> 8-00945-1 T.C. 9P5-3-65-3 ATTACHING PARTS	1		35
- 85	NAS679A4	• NUT	3		35
- 86	AN960PD416L	• WASHER	3		35
- 87	NAS43DD4-12	• SPACER	1		35
- 88	AN4-36A	• BOLT	1		35
- 89	AN4-35A	• BOLT	2		35
		-----X-----			

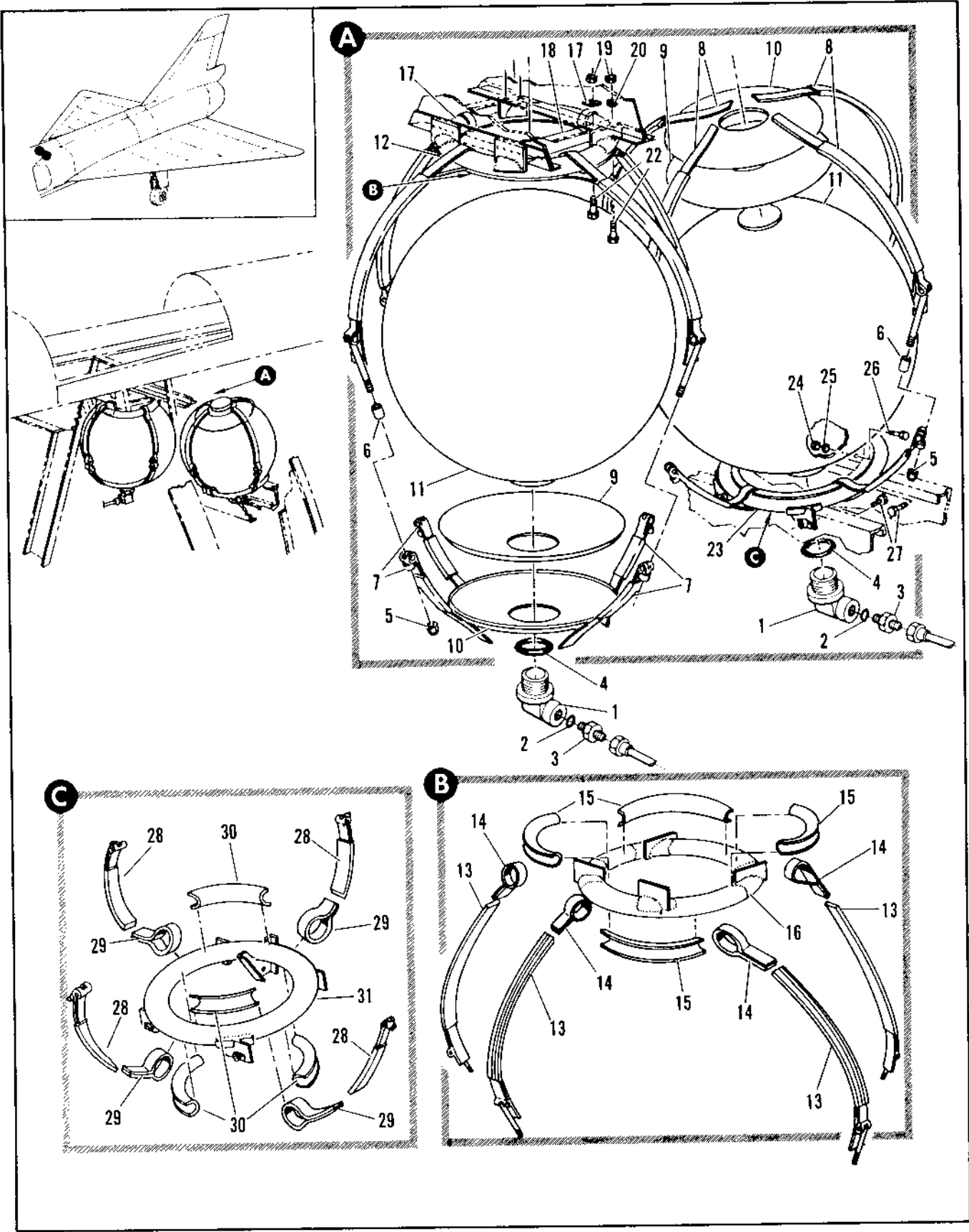

Figure 2.9-3. Pneumatic Flask Installation

FIGURE AND INDEX NUMBER	PART NUMBER	DESCRIPTION	UNITS PER ASSY.	USABLE ON CODE	
				FROM	TO
2.9-3	8-85021-1	FLASK INSTALLATION, PNEUMATIC FWD FOR NHA SEE FIG. 2.3-1G	PF	35	
	8-85021	FLASK INSTALLATION, PNEUMATIC AFT FOR NHA SEE FIG. 2.3-1C	PF	35	
	8-85021	FLASK INSTL. PNEUMATIC AFT MODIFIED BY 66E40416 FOR NHA SEE FIG. 2.3-1C	PF		
- 1	67C34350-7	• ELROW, BLEED AIR FLASK	1	35	
- 2	MS28778-12	• GASKET	1	35	
- 3	MS21916D12-10	• UNION	1	35	
- 4	AN6290-22	• GASKET	1	35	
- 5	NAS679A3	• NUT, FURNISHED WITH STRAP 98-54500-005 AND 98-54500-004 FOR NHA SEE FIG. 2.3-5	PF	35	
- 6	NAS43003-40	• SUPPORT ASSY, PNEUMATIC FLASK FWD FOR NHA SEE FIG. 2.3-3	4	35	
	8-85021-9	• SUPPORT ASSY, PNEUMATIC FLASK AFT FOR NHA SEE FIG. 2.3-3	PF	35	
	8-85021-7	• SUPPORT ASSY, PNEUMATIC FLASK AFT FOR NHA SEE FIG. 2.3-3	PF	35	
- 7	50190-28-875	• STRAP, LOWER FORWARD <98625> 98-54501-003	4	35	
- 8	50190-30-1600S	• STRAP, UPPER AFT <98625> 98-54500-004	4	35	
- 9	8-85021-11	• PAD	1	35	
- 10	8-85021-13	• CUP	1	35	
- 11	ASFW2550	• FLASK, AIR STORAGE	1	35	
	ASFW2550	• FLASK AIR STORAGE (179318) ALT INTCHG WITH 873161 830310 AND 876947	1	35	
	873161	• FLASK AIR STORAGE (33525) ALT INTCHG WITH ASFW2550, 830310 AND 876947	PF		
	830310	• FLASK AIR STORAGE (17996) ALT INTCHG WITH ASFW2550, 873161 AND 876947	PF		
	876947	• FLASK AIR STORAGE (33525) ALT INTCHG WITH ASFW2550, 873161 AND 830310	PF		
- 12	8-85106-3	• BRACKET ASSY, PNEUMATIC FLASK FWD	1	35	
- 13	50190-30-1325S	• STRAP, UPPER FWD <98625> 98-54500-005	4	35	
- 14	8-85106-25	• CLIP	4	35	
- 15	8-85106-27	• PAD	4	35	
- 16	8-85106-7	• BRACKET ASSY, FWD WELDED	1	35	
- 17	8-85021-15	• TEE, FWD RH	1	35	
- 18	8-85021-20	• TEE, FWD LH	1	35	
		ATTACHING PARTS			
- 19	NAS1022N3	• NUT	4	35	
- 20	AN961P010	• WASHER	2	35	
- 21	8-85021-15	• NUT	2	35	
- 22	AN173-5A	• BOLT	4	35	
		-----X-----			
- 23	8-85106-1	• CRADLE ASSY, PNEUMATIC FLASK AFT	1	35	
	66C47667-1	• CRADLE ASSY, PNEUMATIC FLASK AFT	1		
		ATTACHING PARTS			
- 24	NAS1022N3	• NUT	4	35	
	MS21942L3	• NUT	5		
- 25	AN961PD1032L	• WASHER	1	35	
	AN961D10L	• WASHER	10		
- 26	AN173-4A	• BOLT	5		
	NAS1103-2	• BOLT	4	35	
- 27	AN173-5A	• BOLT	4	35	
		-----X-----			
- 28	50190-28-300	• STRAP, LOWER AFT <98625> 98-54501-004	4	35	
- 29	8-85106-25	• CLIP	4	35	
- 30	8-85106-27	• PAD	4	35	
- 31	8-85106-5	• BRACKET ASSY, AFT WELDED	1	35	

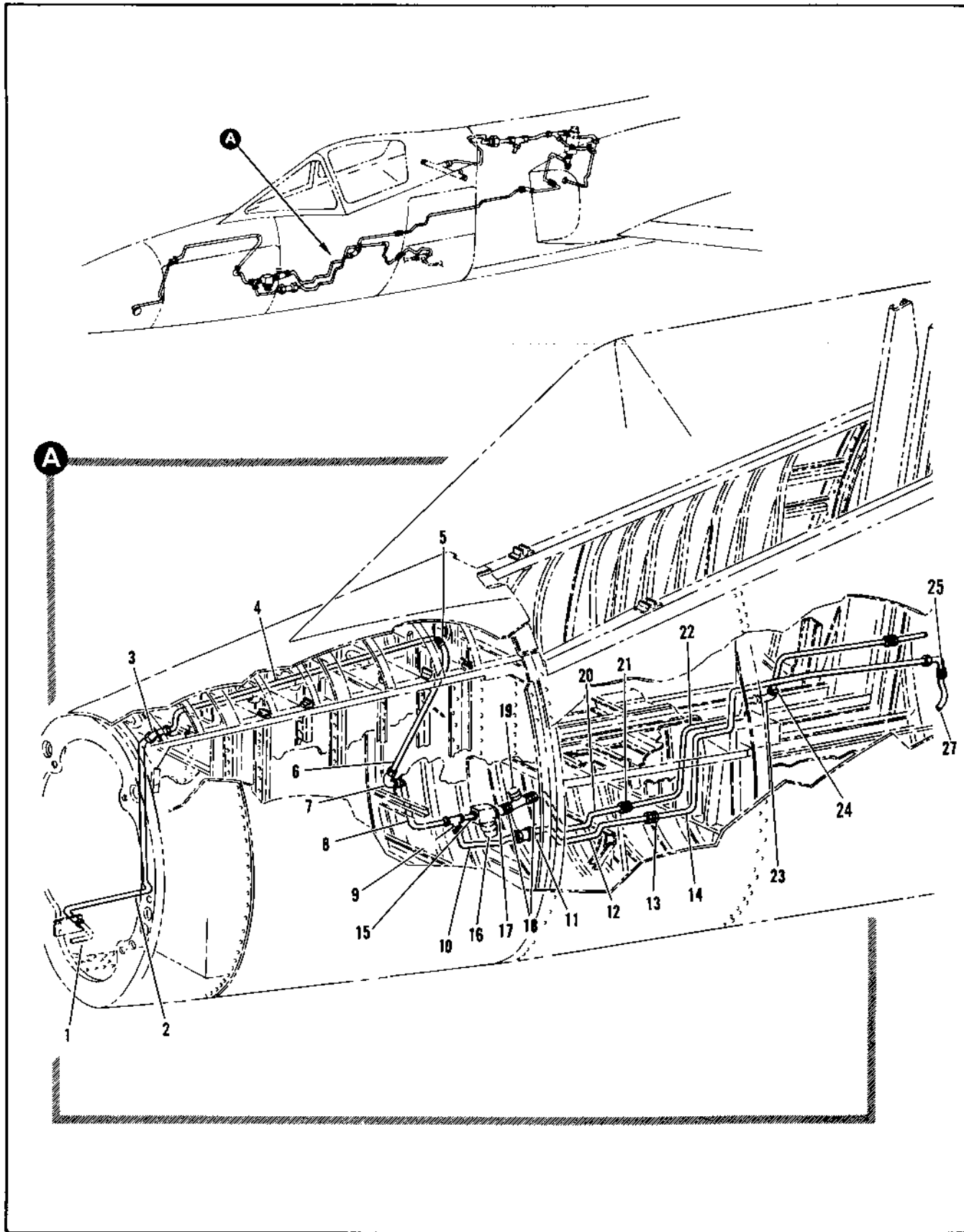

Figure 2.9-4. Low Pressure Pneumatic Radome Anti-Icing Tubing Installation (Sheet 1 of 3)

FIGURE AND INDEX NUMBER	PART NUMBER	DESCRIPTION	UNITS PER ASSY.	USABLE ON CODE	
				FROM	TO
2.9-4	8-83610	TURING INSTALLATION, LOW PRESSURE PNEUMATIC RADOME ANTI-ICING	1	35	
- 1		• HOSE ASSY	RF 1	35	
- 2	8-80610-309	• TUBE ASSY, DISCONNECT	1	35	
- 3	MS21908D6	• ELBOW	1	35	
	AN924-6D	• NUT	1	35	
	AN960D916L	• WASHER	1	A	
- 4	8-80610-11	• TUBE ASSY, DISCONNECT	1	8	
	8-80610-439	• TUBE ASSY, DISCONNECT	1	35	
- 5	MS21902D6	• UNION	1	A	
- 6	8-80610-13	• TUBE ASSY, DISCONNECT	1	9	
- 7	8-80610-437	• TUBE ASSY, DISCONNECT	1	35	
	MS21908D6	• ELBOW	1	35	
	AN924-6D	• NUT	1	35	
	AN960D916L	• WASHER	1	35	
- 8	8-80610-337	• TUBE ASSY, DISCONNECT	1	35	
- 9	MS21910D6	• TEE	1	35	
	MS21916D6-4	• REDUCER	1	35	
	AN6290-6	• GASKET	1	35	
- 10	8-80610-339	• TUBE ASSY, DISCONNECT	1	35	
- 11	1909	• VALVE ASSY, <81896> 97-54900-004	1	35	
- 12	8-80610-27	• TUBE ASSY, RADOME ANTI-ICING	1	35	
- 13	MS21902D4	• UNION	1	35	1A8
- 14	8-80610-29	• TUBE ASSY, RADOME ANTI-ICING	1	189	
	8-80610-473	• TUBE ASSY, RADOME ANTI-ICING	1	35	
- 15	8-80610-17	• TUBE ASSY, FILTER	2	35	
	MS21916D6-4	• REDUCER	2	35	
	AN6290-6	• GASKET	RF		
- 16		• FILTER, RADOME ANTI-ICING SEE FIG. 2.13-1 INDEX 3	1	35	
- 17	8-80610-15	• TUBE ASSY, ANTI-ICING VALVE	2	35	
- 18	MS21902D6	• UNION	2	35	
	AN6290-6	• GASKET	RF		
- 19		• VALVE ASSY, RADOME ANTI-ICING SEE FIG. 2.13-1 INDEX 11	1	35	
- 20	8-80610-21	• TUBE ASSY, GLYCOL TANK	1	35	
- 21	MS21902D6	• UNION	1	35	
- 22	8-80610-23	• TUBE ASSY, GLYCOL TANK	1	35	
- 23	MS21908D6	• ELBOW	1	35	
	AN924-6D	• NUT	1	35	
	AN960D916	• WASHER	1	35	
- 24	MS21914D6	• CAP	1	35	
- 25	MS21902D6	• UNION	1	35	
- 26	MS21907D4	• ELBOW	1	35	
	AN924-4D	• NUT	1	35	
	AN960D716	• WASHER	1	35	

A AIRPLANES #35 THRU 47 AND 49 THRU 89
 B AIRPLANES #48, 90 AND ON

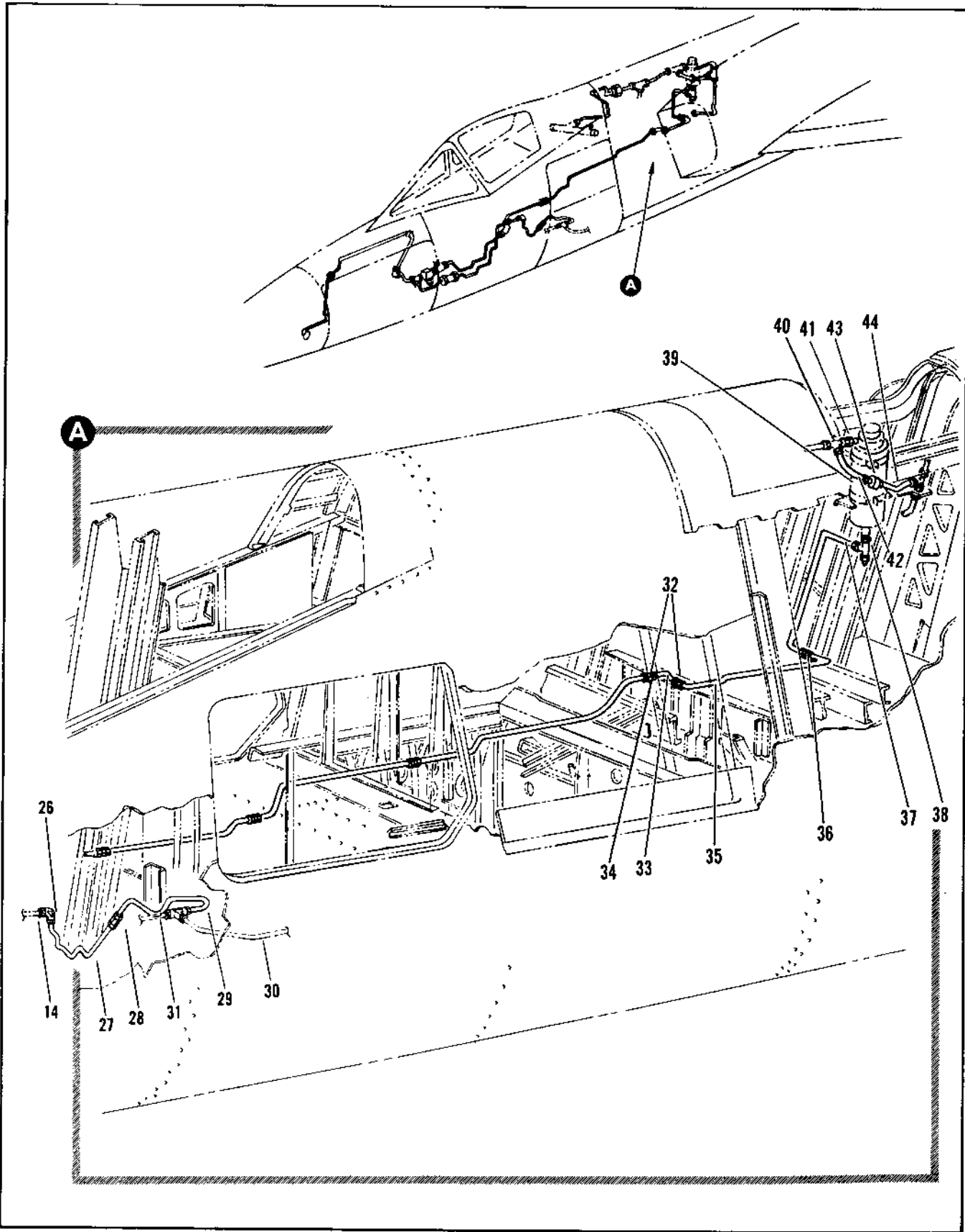

Figure 2.9-4. Low Pressure Pneumatic Radome Anti-Icing Tubing Installation (Sheet 2 of 3)

FIGURE AND INDEX NUMBER	PART NUMBER	DESCRIPTION	UNITS PER ASSY.	USABLE ON CODE	
				FROM	TO
		1 2 3 4 5 6			
2.9-4- 45	MS21902D6	• UNION	1	35	
- 46	8-80610-267	• TUBE ASSY, TANK DRAIN	1	35	
- 47	MS21910D6	• TEE	1	35	
	AN924-60	• NUT	1	35	
	AN960D916L	• WASHER	1	35	
	MS21916D6-3	• REDUCER	1	35	
	AN6290-6	• GASKET	1	35	
- 48	8-80610-145	• TUBE ASSY, TANK DRAIN	1	35	
	MS21902D6	• UNION	1	35	
	AN6290-6	• GASKET	1	35	
- 49	8-80610-263	• TUBE ASSY, MANIFOLD	1	35	
- 50	7S2191004	• TEE	1	35	
	AN924-40	• NUT	1	35	
	AN960D716L	• WASHER	1	35	
- 51	R347	• VALVE ASSY, SAFETY <07811> SPEC 8-C8367-801 T.O.15A2-9-11-13	1	35	
	AN6290-4	• GASKET	1	35	
- 52	K1280-4-2	• VALVE ASSY, CHECK <75361> 99-33102-005	1	35	
	51280-4	• VALVE ASSY, CHECK <75361> 99-33102-001 ALT INTCHG WITH K1280-4-2	RF	35	
	AN6290-4	• GASKET	2	35	
- 53	1908	• RESTRICTOR, FILTERED <81896> 97-54900-103	1	35	
- 54	8-80610-135	• TUBE ASSY, MANIFOLD	1	35	
- 55	MS21902D4	• UNION	1	35	
- 56	8-80610-255	• TUBE ASSY, MANIFOLD	1	35	
- 57	MS21902D4	• UNION	1	35	
	AN6290-4	• GASKET	1	35	
- 58		• MANIFOLD ASSY, SEE FIG. 2.9-5 INDEX 18	RF		

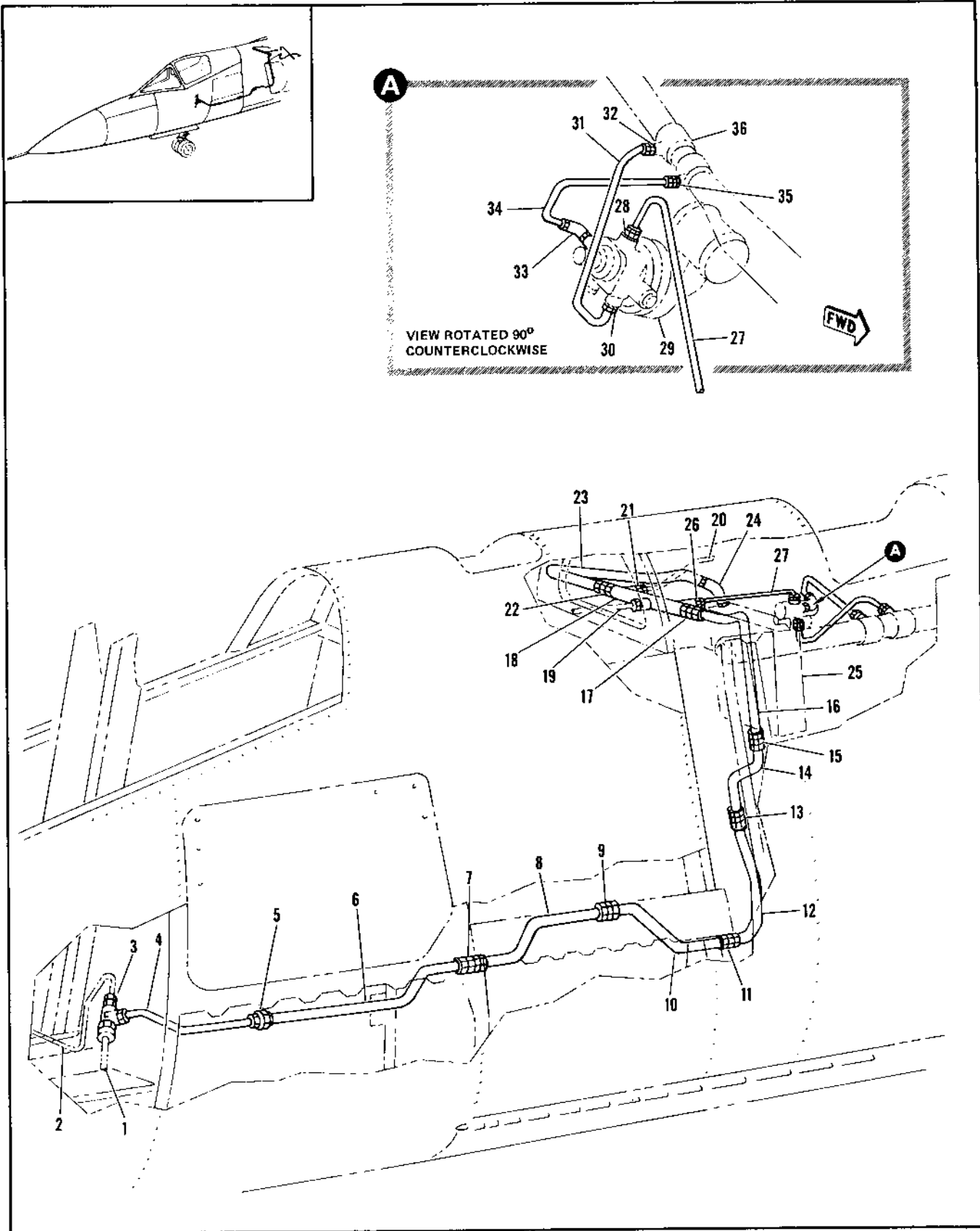

Figure 2.9-5. Low Pressure Pneumatic G Suit and Flow Tubing Installation

FIGURE AND INDEX NUMBER	PART NUMBER	DESCRIPTION	UNITS PER ASSY.	USABLE ON CODE	
				FROM	TO
2.9-5	8-80610	TUBING INSTALLATION, LOW PRESSURE PNEUMATIC G SUIT AND FLOW CONTROL	1	35	
- 1		• TUBE ASSY, G SUIT SEE FIG. 2.9-1 INDEX 30	RF		
- 2		• TUBE ASSY, RADOME ANTI-ICING SEE FIG. 2.9-4 INDEX 29	RF		
- 3	MS21910010	• TEE	1	35	
	N924-100	• NUT	1	35	
	8-80610-409	• WASHER, ALTERED FROM AN6301416	1	35	
	MS21916010-4	• REDUCER	1	35	
	AN6290-10	• GASKET	1	35	
- 4	8-80610-357	• TUBE ASSY, G SUIT	1	35	
- 5	MS21916012-10	• REDUCER	1	35	
- 6	62A35023-1	• TUBE ASSY, G SUIT SEE FIG. 2.13-15 INDEX 42			
- 7	MS21903012	• UNION	1	35	
	AN924-120	• NUT	1	35	
	AN96101716	• WASHER	1	35	
- 8	8-80610-121	• TUBE ASSY, MANIFOLD	1	35	
- 9	MS21902012	• UNION	1	35	
- 10	8-80610-401	• TUBE ASSY, MANIFOLD	1	35	
- 11	MS2190204	• UNION	1	35	
- 12	8-80610-403	• TUBE ASSY, MANIFOLD	1	35	
- 13	MS21902012	• UNION	1	35	
- 14	8-80610-355	• TUBE ASSY, MANIFOLD	1	35	
- 15	MS21902012	• UNION	1	35	
- 16	8-80610-357	• TUBE ASSY, MANIFOLD	1	35	
- 17	MS21902012	• UNION	1	35	
- 18	8-23715	• MANIFOLD ASSY, WELDED	1	35	
- 19		• TUBE ASSY, VARIABLE AIR RAMP SEE FIG. 2.9-6 INDEX 3	RF		
- 20		• TUBE ASSY, MANIFOLD SEE FIG. 2.9-4 INDEX 56	RF		
- 21	MS2190204	• UNION	1	35	
	AN6290-4	• GASKET	1	35	
- 22	MS1902012	• UNION	1	35	
- 23	8-80610-259	• TUBE ASSY, REFRIGERATION	1	35	
- 24	MS21908012	• ELBOW	1	35	
	AN6289012	• NUT	1	35	
	AN6290-12	• GASKET	1	35	
	AN6291-12	• RING	1	35	
- 25		• HEAT EXCHANGER ASSY, RF SEE FIG. 2.13-33 INDEX 51	RF		
- 26	MS2190206	• UNION	1	35	
	AN6290-6	• GASKET	1	35	
- 27	8-80610-415	• TUBE ASSY, FLOW CONTROL	1	35	
- 28	MS2190706	• ELBOW	1	35	
	AN924-60	• NUT	1	35	
	AN6290-6	• GASKET	1	35	
- 29		• VALVE ASSY, FLOW DIVIDER SEE FIG. 2.13-1 INDEX 121	RF		
- 30	MS2190204	• UNION	1	35	
	AN6290-4	• GASKET	1	35	
- 31	8-80610-367	• TUBE ASSY, AIR FLOW SENSOR	1	35	
- 32	MS2190204	• UNION	1	35	
	AN6290-4	• GASKET	1	35	
- 33	MS2190805	• ELBOW	1	35	
	AN924-50	• NUT	1	35	
	AN6290-5	• GASKET	1	35	
- 34	7036970-10	• TUBE ASSY, AIR FLOW SENSOR	1	35	
- 35	MS2190205	• UNION	1	35	
	AN6290-5	• GASKET	1	35	
- 36		• DUCT ASSY, COCKPIT HOT AIR BYPASS WELDED	RF		

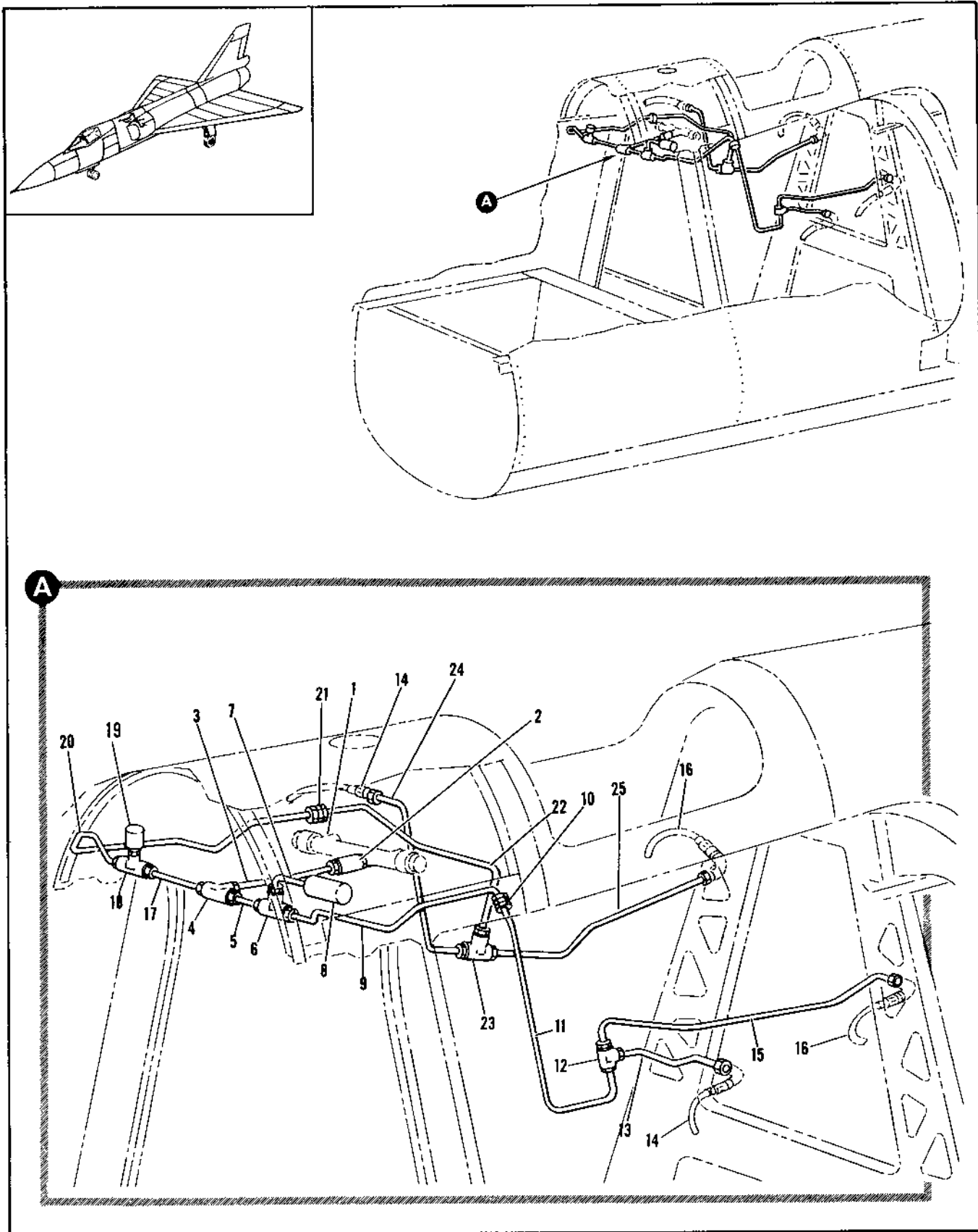

Figure 2.9-6. Low Pressure Pneumatic Variable Air Ramp Seal Tubing Installation

FIGURE AND INDEX NUMBER	PART NUMBER	DESCRIPTION 1 2 3 4 5 6	UNITS PER ASSY.	USABLE ON CODE	
				FROM	TO
2.9-6	8-80610	TUBING INSTALLATION, LOW PRESSURE PNEUMATIC VARIABLE AIR RAMP SEAL	1	35	
- 1		• MANIFOLD ASSEMBLY SEE FIG. 2.9-5 INDEX 19	RF		
- 2	1908	• RESTRICTOR, FILTERED <81R96> 97-54900-003	1	35	
	AN6290-4	• GASKET	1	35	
- 3	8-80610-303	• TUBE ASSY, VARIABLE AIR RAMP	1	35	
- 4	MS2190504	• TEE	1	35	
- 5	8-80610-177	• TUBE ASSY, LH	1	35	
- 6	MS2191004	• TEE	1	35	
	AN924-40	• NUT	1	35	
	AN9600716L	• WASHER	1	35	
	MS2191505-4	• REDUCER	1	35	
	AN6290-4	• GASKET	1	35	
- 7	8-80610-179	• TUBE ASSY, SAFETY VALVE	1	35	
- 8	R348	• VALVE ASSY, SAFETY <07R11> SPEC 8-C8367-803	1	35	
- 9	8-80610-181	• TUBE ASSY, LH	1	35	
- 10	MS2190204	• UNION	1	35	
- 11	8-80610-183	• TUBE ASSY, LH	1	35	
- 12	MS2190504	• TEE	1	35	
- 13	8-80610-363	• TUBE ASSY, UPPER SEAL LH	1	35	
- 14		• HOSE ASSY, VARIABLE AIR RAMP SEAL FWD SEE FIG. 2.11-7 INDEX 2	RF		
- 15	8-80610-389	• TUBE ASSY, LWR SEAL LP	1	35	
- 16		• HOSE ASSY, VARIABLE AIR RAMP SEAL AFT SEE FIG. 2.11-7 INDEX 3	RF		
- 17	8-80610-173	• TUBE ASSY, RH	1	35	
- 18	MS2191004	• TEE	1	35	
	AN924-40	• NUT	1	35	
	AN9600716L	• WASHER	1	35	
- 19	R347	• VALVE ASSY, SAFETY <07R11> SPEC 8-C8367-801 T.O. 15A2-9-11-13	1	35	
	AN6290-4	• GASKET	1	35	
- 20	8-80610-195	• TUBE ASSY, RH	1	35	
- 21	MS2190204	• UNION	1	35	
- 22	8-80610-467	• TUBE ASSY, RH	1	61	
- 23	MS2190504	• TEE	1	35	
- 24	8-80610-365	• TUBE ASSY, UPPER SEAL LH	1	35	
- 25	8-80610-455	• TUBE ASSY, LWR SEAL RH	1	61	

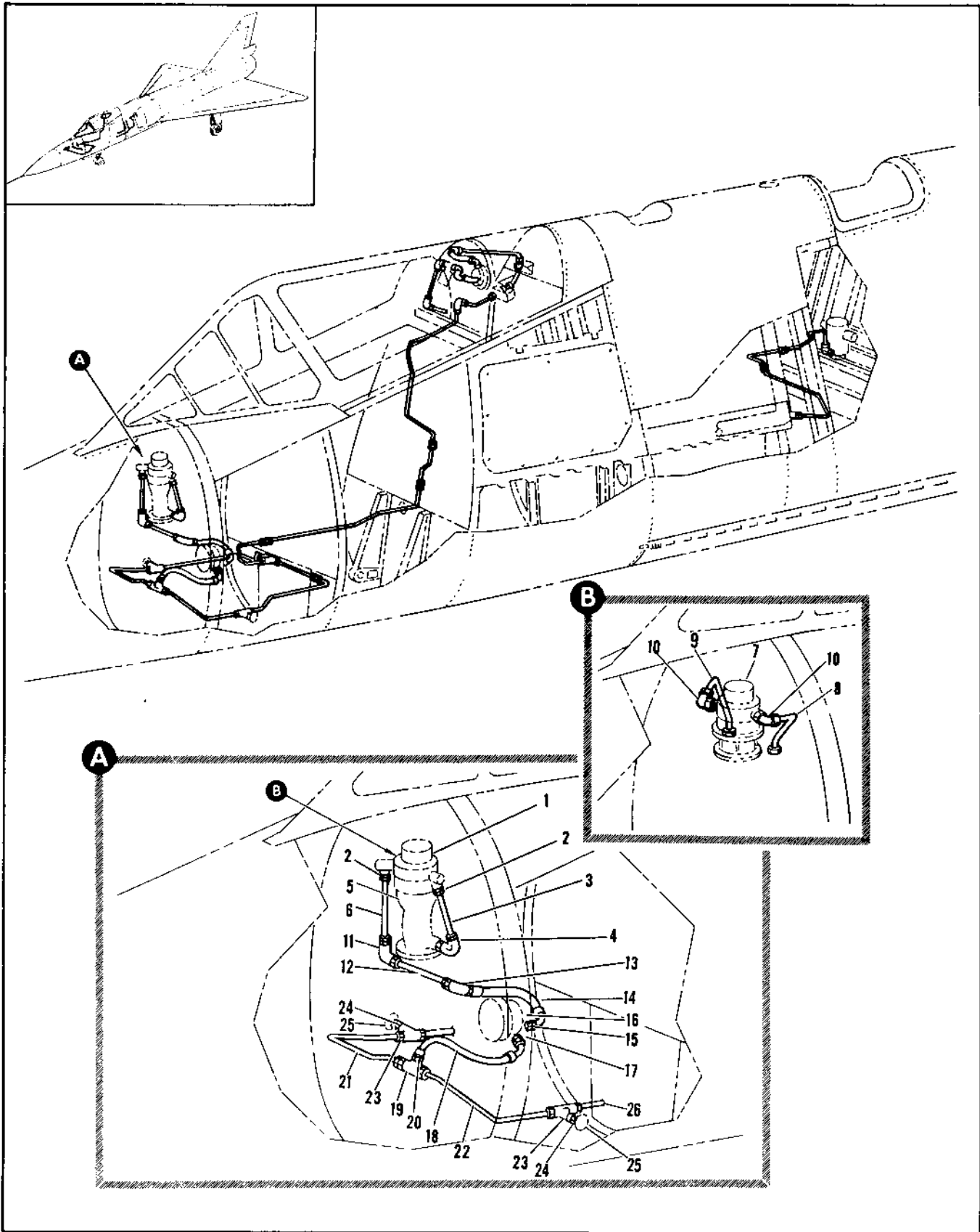

Figure 2.9-7. Low Pressure Pneumatic Cockpit Pressure Control Tubing Installation (Sheet 1 of 3)

FIGURE AND INDEX NUMBER	PART NUMBER	DESCRIPTION	UNITS PER ASSY.	USABLE ON CODE	
				FROM	TO
2.9-7	8-80610	TUBING INSTALLATION, LOW PRESSURE PNEUMATIC COCKPIT PRESSURE CONTROL	1	35	
- 1		• VALVE ASSY, OUTFLOW COCKPIT AIR SEE FIG. 2.13-4 INDEX 1	RF		
- 2	MS2190204	• UNION	2	A	
	AN6293-4	• GASKET	2	A	
- 3	8-80610-81	• TUBE ASSY, PRESSURE OLT FLOW	1	A	
- 4	MS2190804	• ELBOW	1	A	
	AN924-4D	• NUT	1	A	
	AN6293-4	• GASKET	1	A	
- 5		• SUPPORT, SEE FIG. 2.13-4 INDEX 5	RF		
- 6	8-80610-83	• TUBE ASSY, PRESSURE CONTROL	1	A	
- 7		• VALVE ASSY, OUTFLOW AIR SEE FIG. 2.13-4 INDEX 14	RF		
- 8	8-80610-459	• TUBE ASSY, PRESSURE OUT FLOW	1	R	
- 9	8-80610-461	• TUBE ASSY, PRESSURE CONTROL	1	R	
- 10	MS2190804	• ELBOW	2	R	
	AN924-4D	• NUT	2	R	
- 11	MS2190804	• ELBOW	1	35	
	AN924-4D	• NUT	1	35	
	AN9650716L	• WASHER	1	35	
- 12	8-80610-197	• TUBE ASSY, PRESSURE CONTROL	1	A	
	8-80610-441	• TUBE ASSY, PRESSURE CONTROL	1	48	49
	8-80610-471	• TUBE ASSY, PRESSURE CONTROL	1	48	
- 13	MS2190804	• ELBOW	1	A	
	MS2190304	• UNION	1	R	
	AN924-4D	• NUT	1	35	
	AN9650716L	• WASHER	1	35	
- 14	616048-4-0106	• HOSE ASSY, <00624> 94-80517-020 REPLACED BY NOT INTCHG WITH 616048-4-0070	1	A	
	616048-4-0070	• HOSE ASSY, <00624> 94-80517-030 REPLACES NOT INTCHG WITH 616048-4-0106	1	R	
- 15	MS2190204	• UNION	1	35	
- 16		• CONTROL, COCKPIT AIR PRESSURE REGULATOR SEE FIG. 2.13-4 INDEX 10	RF		
- 17	MS2190204	• UNION	1	35	
- 18	616048-4-0090	• HOSE ASSY, <00624> 94-80517-010 REPLACED BY NOT INTCHG WITH 616046-4-0132	1	A	
	616046-4-0132	• HOSE ASSY, <00624> 94-80517-012 REPLACES NOT INTCHG WITH 616048-4-0090	1	R	
- 19	MS2191506	• TEE	1	35	
	AN924-6D	• NUT	1	35	
	AN9650916L	• WASHER	1	35	
- 20	MS2191606-4	• REDUCER	1	35	
	AN6293-6	• GASKET	1	35	
- 21	8-44899-83	• TUBE ASSY, INFRARED SEEKER	1	35	
- 22	8-80610-201	• TUBE ASSY, STATIC PORT	1	A	
	8-80610-443	• TUBE ASSY, STATIC PORT	1	A	
- 23	MS191506	• TEE	1	35	
- 24	MS2190204	• UNION	2	35	
	AN6293-6	• GASKET	2	35	
- 25		• FLANGE, PNEUMATIC SENSING STATIC PRESSURE SEE FIG. 2.9-1 INDEX 1	RF		

A AIRPLANES #35 THRU 47 AND 49 THRU 89
B AIRPLANES #48, 90 AND 91

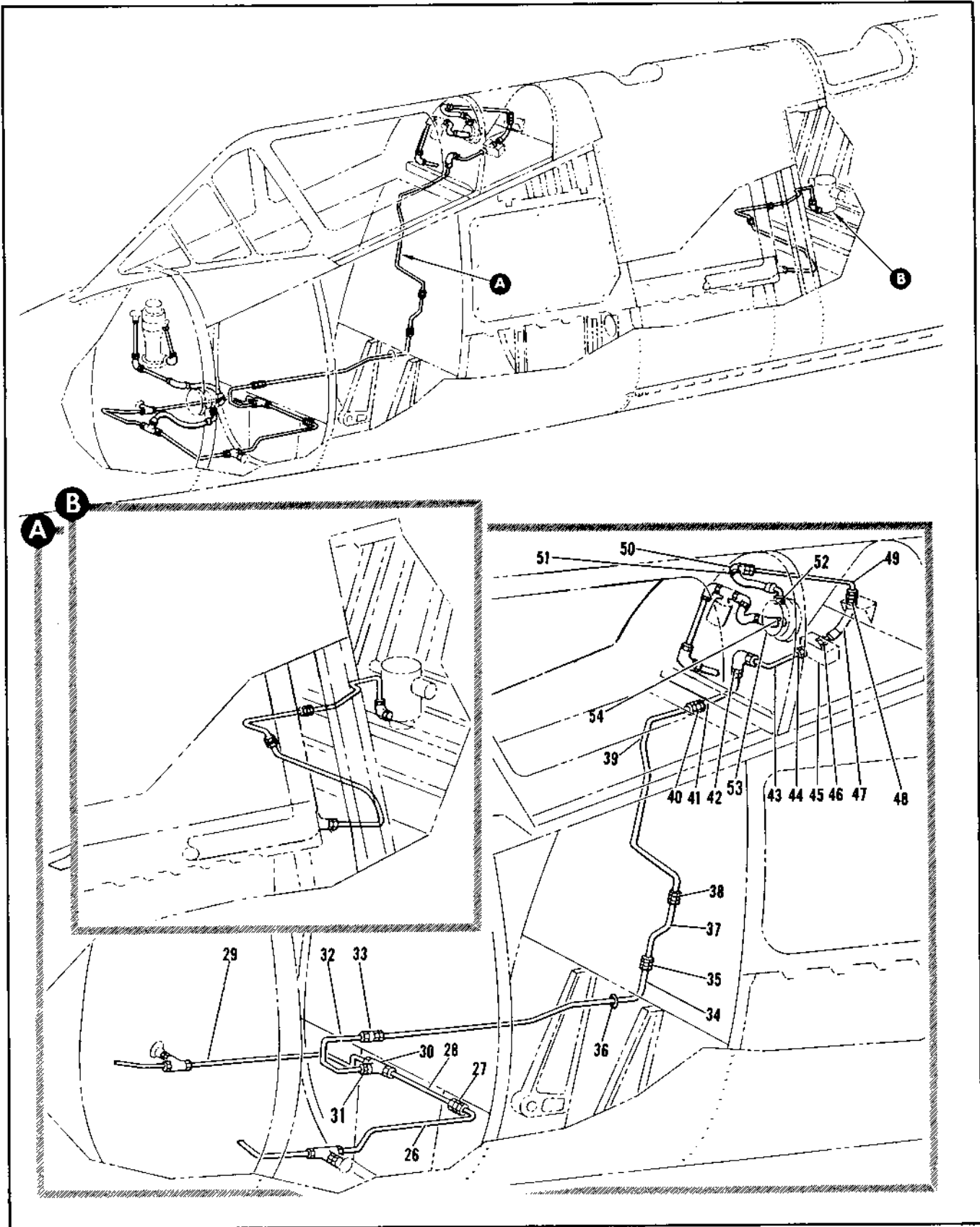

Figure 2.9-7. Low Pressure Pneumatic Cockpit Pressure Control Tubing Installation (Sheet 2 of 3)

FIGURE AND INDEX NUMBER	PART NUMBER	DESCRIPTION	UNITS PER ASSY.	USABLE ON CODE	
				FROM	TO
		1 2 3 4 5 6			
2.9-7- 26	8-80610-323	• TUBE ASSY, STATIC PORT	1	A	
	8-80610-445	• TUBE ASSY, STATIC PORT	1	R	
- 27	MS2190206	• UNION	1	35	
- 28	8-80610-325	• TUBE ASSY, STATIC PORT	1	A	
	8-80610-447	• TUBE ASSY, STATIC PORT	1	3	
- 29	8-80610-327	• TUBE ASSY, STATIC PORT	1	A	
	8-80610-469	• TUBE ASSY, STATIC PORT	1	R	
- 30	MS2191606	• TEE	1	35	
	AN924-60	• NUT	1	35	
	AN9600916L	• WASHER	1	35	
- 31	MS2191606-4	• REDUCER	1	35	
	AN6290-6	• GASKET	1	35	
- 32	8-80610-333	• TUBE ASSY, QUICK DISCONNECT	1	A	
	8-80610-451	• TUBE ASSY, QUICK DISCONNECT	1	B	
- 33	MS2190304	• UNION	1	35	
	AN924-40	• NUT	1	35	
	AN9600716	• WASHER	1	35	
- 34	8-80610-427	• TUBE ASSY, QUICK DISCONNECT	1	35	
- 35	MS2190204	• UNION	1	35	
- 36	AN931-4-12	• GROMMET	1	35	
- 37	8-80610-35	• TUBE ASSY, QUICK DISCONNECT	1	35	
- 38	MS2190304	• UNION	1	35	
	AN924-40	• NUT	1	35	
	AN9600716L	• WASHER	1	35	
- 39	7037026-10	• TUBE ASSY, QUICK DISCONNECT	1	35	
- 40	MS2190204	• UNION	1	35	
- 41	8-80610-73	• TUBE ASSY, QUICK DISCONNECT	1	35	
- 42	MS2190805	• ELBOW	1	35	
	AN924-50	• NUT	1	35	
	AN9600816	• WASHER	1	35	
- 43	8-80610-85	• TUBE ASSY, QUICK DISCONNECT	1	35	
- 44	MS2190205	• UNION	1	35	
	AN6290-5	• GASKET	1	35	
- 45		• FITTING ASSY, BREAKAWAY SEE FIG. 2.4-6 INDEX 72	PF		
- 46	MS2190204	• UNION	1	75	
	AN6290-4	• GASKET	1	35	
- 47	616048-4-0082	• HOSE ASSY, <00624> 94-80517-008	1	35	
- 48	MS2190304	• UNION	1	35	
	AN924-40	• NUT	1	35	
	AN9600716	• WASHER	1	35	
- 49	8-80610-353	• TUBE ASSY, COCKPIT SAFETY VALVE	1	35	
- 50	MS2190704	• ELBOW	1	35	
	AN924-40	• NUT	1	35	
	AN9600716	• WASHER	1	35	
- 51	616043-4-0147	• HOSE ASSY, <00624> 94-80517-061	1	189	
- 52	MS2190204	• UNION	1		189
	MS21926-4C	• ELBOW	1	189	
	AN924-40	• NUT	1	189	
	AN6290-4	• GASKET	1	35	
- 53	103080-4C	• VALVE ASSY, SEE FIG. 2.13-19 INDEX 1	PF		189
- 54	MS21926-6C	• ELBOW	1	189	
	AN924-60	• NUT	1	189	
	AN6290-6	• GASKET	1	35	

A AIRPLANES #35 THRU 47 AND 49 THRU 89
 B AIRPLANES #48, 90 AND ON

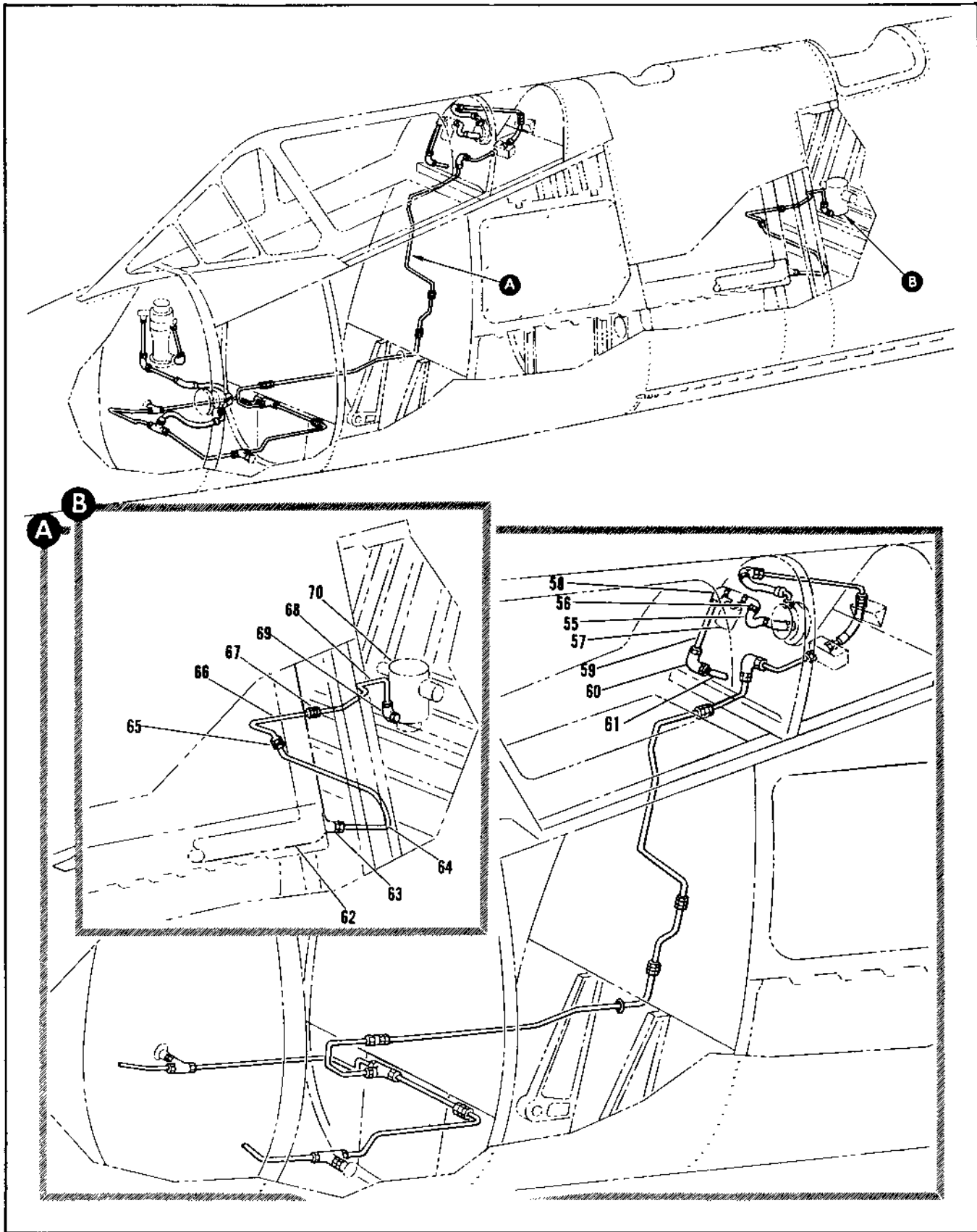

Figure 2.9-7. Low Pressure Pneumatic Cockpit Pressure Control Tubing Installation (Sheet 3 of 3)

FIGURE AND INDEX NUMBER	PART NUMBER	DESCRIPTION	UNITS PER ASSY.	USABLE ON CODE	
				FROM	TO
2.9-7- 55	616043-6-0122	• HOSE ASSY, <C0624> 94-AC517-062	1	189	
- 56	MS21908D6	• ELBOW	1	35	
	AN924-6D		1	35	
	AN6290-6	• GASKET	1	35	
- 57		• VALVE ASSY, SOLENOID SEE FIG. 2.13-19 INDEX 5	PF		
- 58	MS21908D6	• ELBOW	1	35	
	AN924-6D	• NUT	1	35	
	AN6290-6	• GASKET	1	35	
- 59	8-80610-101	• TUBE ASSY, SAFETY VENT	1	35	
- 60	MS21908D6	• ELBOW	1	35	
	AN924-6D	• NUT	1	35	
	AN960D916	• WASHER	1	35	
- 61	8-80610-103	• TUBE ASSY, SAFETY VENT	1	35	
- 62		• DUCT ASSY, COCKPIT COOLING SEE FIG. 2.13-9 INDEX 60	RF		
- 63	MS21902D4	• UNION	1	35	
	AN6290-4	• GASKET	1	35	
- 64	64A34214-1	• TUBE ASSY, LOW PRESSURE PNEUMATIC	1		
- 65	MS21902D4	• UNION	1	35	
- 66	8-80610-169	• TUBE ASSY, SHUTOFF VALVE	1	35	
- 67	MS21902D4	• UNION	1	35	
- 68	8-80610-431	• TUBE ASSY, SHUTOFF VALVE	1	35	
- 69	MS21908D6	• ELBOW	1	35	
	AN924-4D	• NUT	1	35	
	AN6290-4	• GASKET	1	35	
- 70		• VALVE ASSY, REGULATOR AND SHUTOFF HOT AIR PRESSURE STA 298 SEE FIG. 2.13-24 INDEX 16	PF		

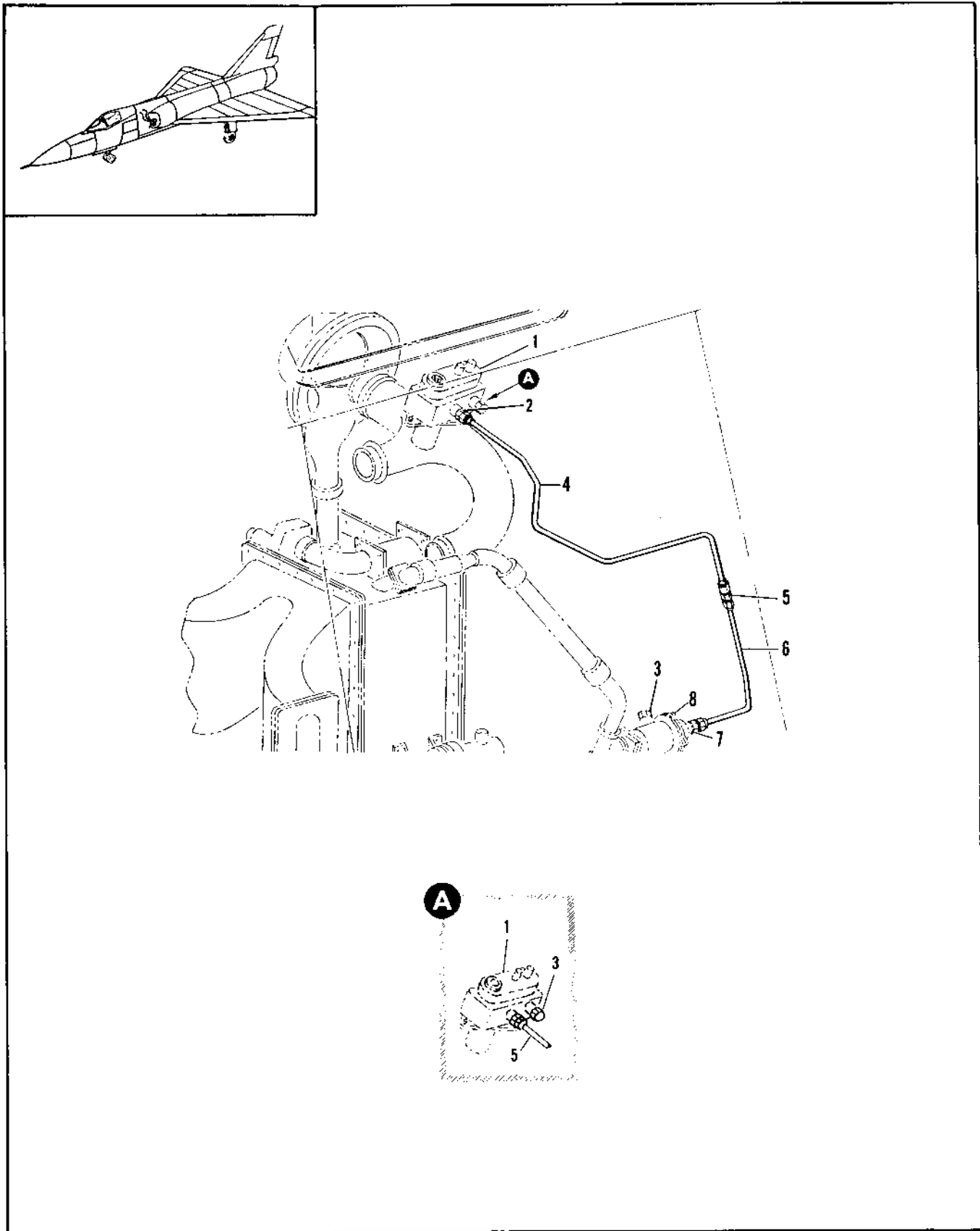

Figure 2.9-8. Low Pressure Pneumatic Refrigeration Unit Bleed Air Sensing Tubing Installation

FIGURE AND INDEX NUMBER	PART NUMBER	DESCRIPTION	UNITS PER ASSY.	USABLE ON CODE	
				FROM	TO
2.9-8	P-80610	TUBING INSTALLATION, LOW PRESSURE PNEUMATIC REFRIGERATION UNIT BLEED AIR SENSING	1	35	
- 1		• THERMOSTAT, TURBINE DISCHARGE SEE FIG. 2.13-30 INDEX 4	PF		
- 2	MS21902D4	• UNION	2	35	240
	AN6290-4	• GASKET	2	35	240
- 3	AN929-4	• CAP	2		
- 5	MS21902D4	• UNION	1	35	
- 6	8-80610-419	• TUBE ASSY, BLEED AIR SENSING	1	35	
- 7	MS21902D4	• UNION	1	35	240
	AN6290-4	• GASKET	1	35	240
- 8		• VALVE, BYPASS HEAT EXCHANGER SEE FIG. 2.13-30 INDEX 11	PF		

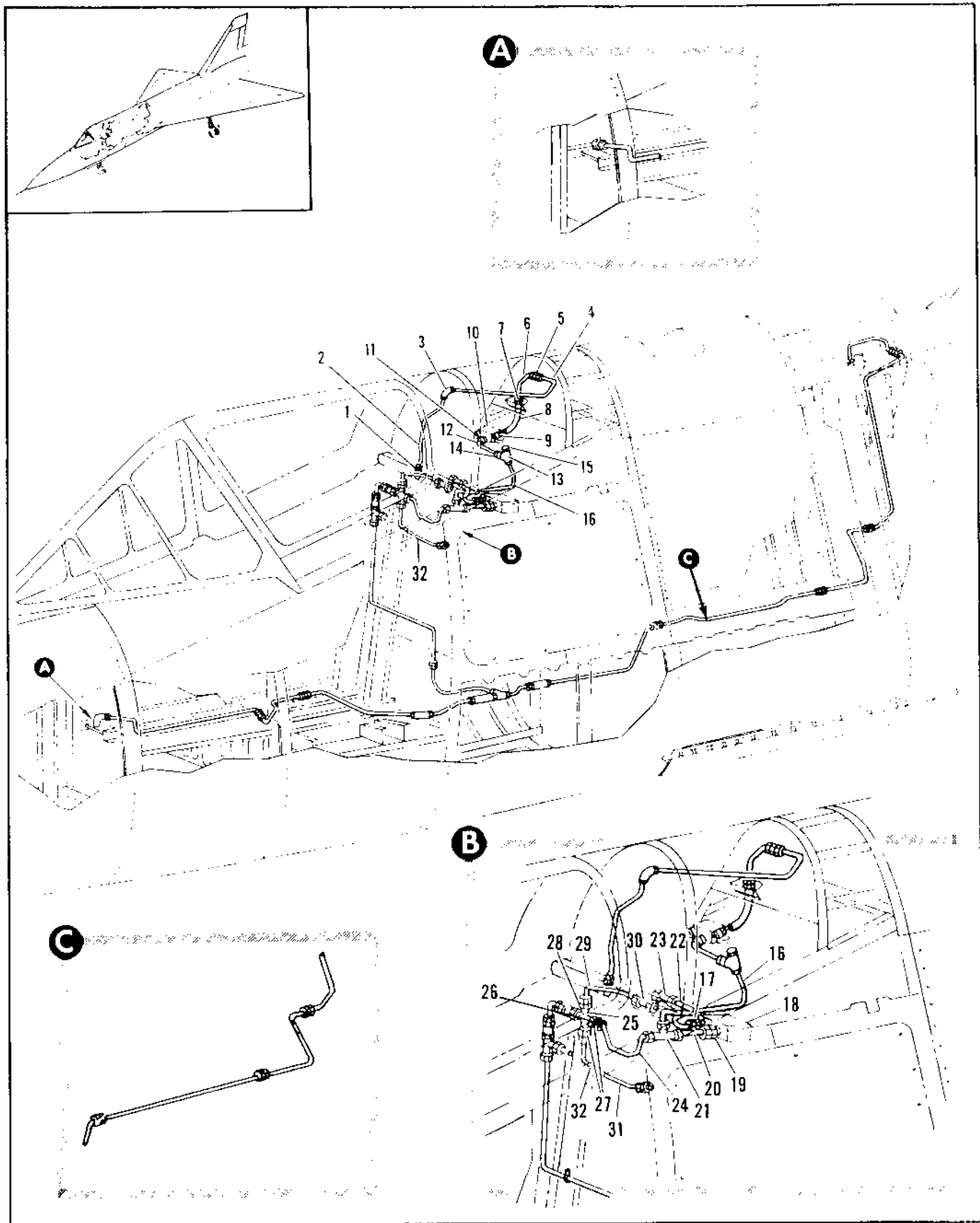

Figure 2.9-9. Low Pressure Pneumatic Canopy Seal Tubing Installation (Sheet 1 of 3)

FIGURE AND INDEX NUMBER	PART NUMBER	DESCRIPTION	UNITS PER ASSY.	USABLE ON CODE	
				FROM	TO
2.9-9	R-80610	TUBING INSTL. LOW PRESSURE PNEUMATIC CANOPY SEAL MODIFIED BY 66E40089	1		
- 1		• SEAL, SEE FIG. 2.4-9 INDEX 8	RF		
- 2	8-80610-111	• TUBE ASSY, CANOPY SEAL	1	35	
- 3	MS21908D4	• ELBOW	1	35	
	AN924-40	• NUT	1	35	
	AN963D716	• WASHER	1	35	
- 4	8-80610-109	• TUBE ASSY, CANOPY SEAL	1	35	
- 5	MS21916D6-4	• REDUCER	1	35	
- 6	4-80610-107	• TUBE ASSY, CANOPY SEAL	1	35	
- 7	MS21903D6	• UNION	1	35	
	AN924-60	• NUT	1	35	
	AN963D916	• WASHER	1	35	
- 8	616048-600080				
- 9	MS21902D6	• UNION	1	35	
	AN6290-6	• GASKET	1	35	
- 10		• FITTING ASSY, BREAKAWAY SEE FIG. 2.4-6 INDEX 18	RF		
- 11	MS21902D5	• UNION	1	35	
	AN6290-5	• GASKET	1	35	
- 12	8-80610-253	• TUBE ASSY, SELECTOR VALVE	1	35	
- 13	MS21911D5	• TEE	1	35	
	AN924-50	• NUT	1	35	
	AN963D816	• WASHER	1	35	
- 14	AN919-3D	• REDUCER	1	35	
	AN6290-5	• GASKET	1	35	
- 15	AN929-4	• CAP	1	35	
- 16	67A36607-1	• TUBE ASSY, PNEUMATIC CANOPY SEAL	1		
- 17	MS21916D5-4	• REDUCER	1	35	
	AN6290-4	• GASKET	2	35	
- 18		• VALVE ASSY, CANOPY SEAL SEE FIG. 2.4-12 INDEX 113	RF		
- 19	MS21902D4	• UNION	1	35	
	AN6290-4	• GASKET	1	35	
- 20	8-80610-275	• TUBE ASSY, FILTERED RESTRICTOR	1	35	
- 21	MS21905D4	• TEE	1	35	
- 22	8-80610-291	• TUBE ASSY, RELIEF VALVE	1	35	
- 23	R347	• VALVE ASSY, SAFETY <07A11> SPEC 8-08367-801 T.O. 15A2-9-11-13	1	35	
- 24	7037029-10	• TUBE ASSY, FILTERED RESTRICTOR	1	35	
- 25	AN937D4	• CROSS	1	35	
- 26	7037044	• CLIP	1	35	
- 27	MS21902D4	• UNION	2	35	
	AN6290-4	• GASKET	2	35	
- 28	MS21916D5-4	• REDUCER	1	35	
	AN6290-4	• GASKET	2	35	
- 29	7037025-10	• TUBE ASSY, SAFETY VALVE	1	35	
- 30	R348	• VALVE ASSY, SAFETY <70811> SPEC 8-08367-803	1	35	
- 31	7037028-10	• TUBE ASSY, GROUND TEST	1	35	
- 32	MS21919D64	• CLAMP	1	35	
	MS35207-263	• SCREW	1	35	
	MS21744N3	• NUT	1	35	

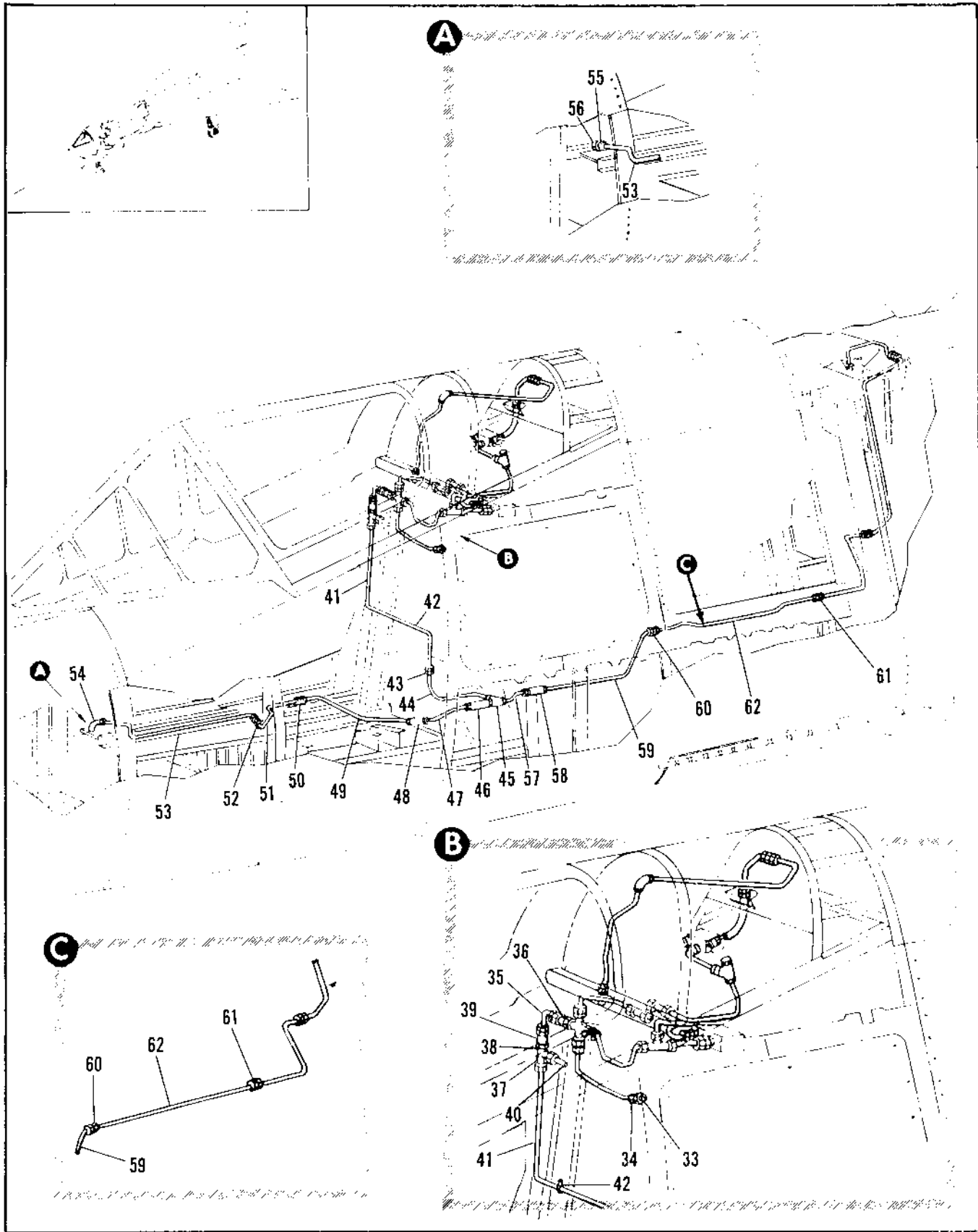

Figure 2.9-9. Low Pressure Pneumatic Canopy Seal Tubing Installation (Sheet 2 of 3)

FIGURE AND INDEX NUMBER	PART NUMBER	DESCRIPTION	UNITS PER ASSY.	USABLE ON CODE	
				FROM	TO
2.9-9	AN960-10L	• WASHER	1	35	
- 33	AN929-4	• CAP	1	35	
- 34	MS2190004	• UNION	1	35	
- 35	7037031-10	• TUBE ASSY, LOW PRESSURE PNEUMATIC	1	35	
- 36	1908	• RESTRICTOR, FILTERED <R1896> 97-54900-003	1	35	
- 37	MS2191004	• TEE	1	35	
- 38	7037043-01	• CLIP	1	35	
- 39	9R7442-1	• RESTRICTOR, FIXED PNEUMATIC <91207> SPEC R-00429-1	1	35	
- 40		• TUBE ASSY, SEE FIG. 2.9-11 INDEX 6	RF		
- 41	703727-10	• TUBE ASSY, LOW PRESSURE PNEUMATIC	1		
- 42	MS21919004	• CLAMP	1	35	
	MS35207-265	• SCREW	1	35	
	MS21044N3	• NUT	1	35	
	AN960-10L	• WASHER	1	35	
- 43	MS2192404	• UNION	1	35	
	AN924-4D	• NUT	1	35	
	AN9600716	• NUT	1	35	
- 44	8-80610-379	• TUBE ASSY, CHECK VALVE	1	35	42
	8-80610-435	• TUBE ASSY, CHECK VALVE	1	47	
- 45	MS2191104	• TEE	1	35	
	AN924-4D	• NUT	1	35	
	AN9600716	• WASHER	1	35	
	AN6290-4	• GASKET	1	35	
- 46	K1353-4-3	• VALVE ASSY, CHECK <34199> 99-33108-003	1	35	
	AN6290-4	• GASKET	1	35	
- 47	8-80610-373	• TUBE ASSY, GROUND CHECK	1	35	60
	8-80610-457	• TUBE ASSY, GROUND CHECK	1	61	
- 48	MS21907D	• ELBOW	1	35	
	AN924-4D	• NUT	1	35	
	AN9600716	• WASHER	1	35	
- 49	8-80610-347	• TUBE ASSY, GROUND CHECK	1	35	
- 50	MS2190204	• UNION	1	35	
- 51	8-80610-345	• TUBE ASSY, GROUND CHECK	1	A	
	8-80610-465	• TUBE ASSY, GROUND CHECK	1	B	
- 52	MS2190204	• UNION	1	35	
- 53	8-80610-261	• TUBE ASSY, GROUND CHECK	1	A	
	8-80610-463	• TUBE ASSY, GROUND CHECK	1	B	
- 54		• FITTING, COCKPIT PRESSURE GROUND TEST SEE FIG. 2.13-2 INDEX 3	RF		
- 55	MS2190304	• UNION	1	B	
	AN924-4D	• NUT	1	B	
	AN9600716	• WASHER	1	B	
- 56	MS21914-4	• CAP	1	B	
- 57	62A35022-1	• TUBE	1		
- 58	K1353-4-3	• VALVE ASSY, CHECK <34199> 99-33108-003	1	35	
- 59	62A35021-1	• TUBE	1		
- 60	MS2190304	• UNION	1	35	
	AN924-4D	• NUT	1	35	
	AN9600716	• WASHER	1	35	
- 61	MS2190204	• UNION	1	35	
- 62	64A34200-1	• TUBE ASSY, LOW PRESSURE PNEUMATIC	1		

A AIRPLANES #35 THRU 47 AND 49 THRU 69
 B AIRPLANES #48, 90 AND 04

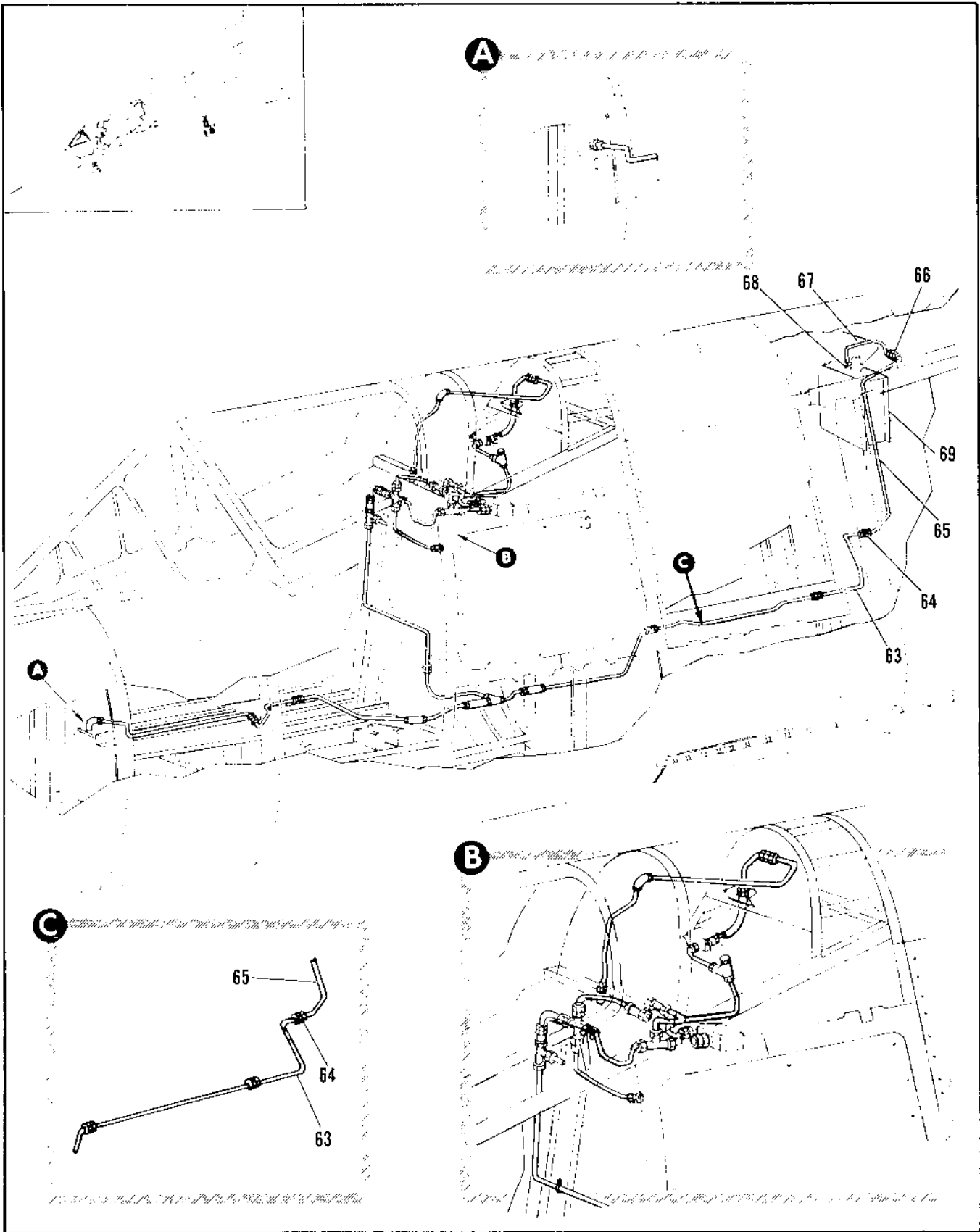

Figure 2.9-9. Low Pressure Pneumatic Canopy Seal Tubing Installation (Sheet 3 of 3)

FIGURE AND INDEX NUMBER	PART NUMBER	DESCRIPTION	UNITS PER ASSY.	USABLE ON CODE	
				FROM	TO
		1 2 3 4 5 6			
2.9-9- 63	64A34201-1	• TUBE ASSY, LOW PRESSURE PNEUMATIC	1		
- 64	MS21903D4	• UNION	1	35	
- 65	8-80610-411	• TUBE ASSY, HEAT EXCHANGER	1	35	
- 66	MS21902D4	• UNION	1	35	
- 67	8-80610-413	• TUBE ASSY, HEAT EXCHANGER	1	35	
- 68	MS21916DA-4	• REDUCER	1	35	
- 69	AN6290-8	• GASKET	1	35	
		• HEAT EXCHANGER ASSY, SEE FIG. 2.13-31	FF		

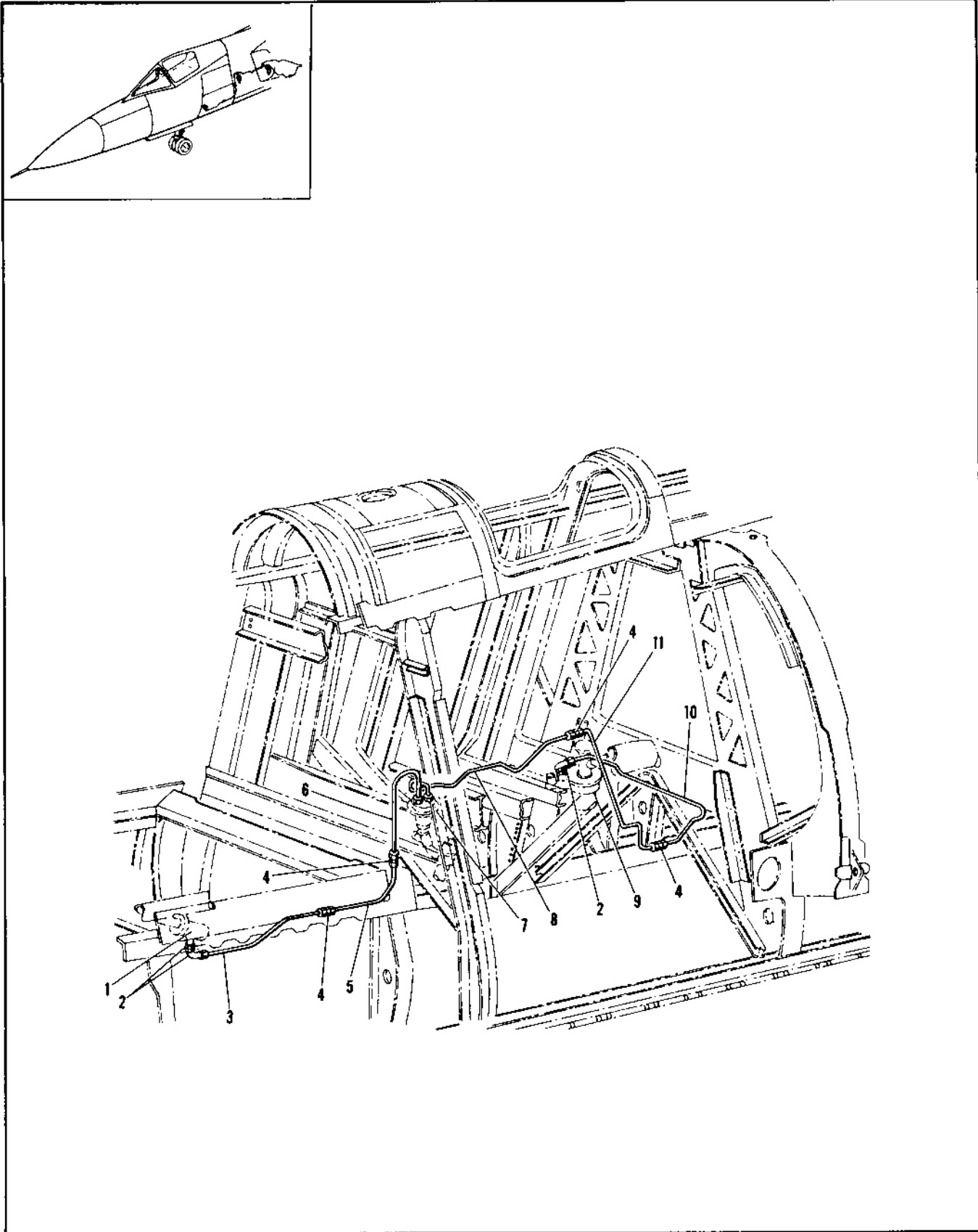

Figure 2.9-10. Low Pressure Pneumatic Electronic Cooling Hot Air By-Pass Tubing Installation (Sheet 1 of 3)

FIGURE AND INDEX NUMBER	PART NUMBER	DESCRIPTION	UNITS PER ASSY.	USABLE ON CODE	
				FROM	TO
2.9-10	R-80610	TUBING INSTALLATION, LOW PRESSURE PNEUMATIC ELECTRONIC COOLING HOT AIR BYPASS • THERMOSTAT ASSY, ELECTRONIC COOLING BYPASS SEE FIG. 2.13-9 INDEX 3	1	241	
- 1			WF		
- 2	MS21908-4	• ELBOW	2	241	
	AN924-4	• NUT	2	241	
	AN6290-4	• GASKET	2	241	
- 3	J-80610-451	• TUBE ASSY, THERMOSTAT	1	241	
- 4	MS21702-4	• UNION	4	241	
- 5	R-80610-489	• TUBE ASSY, THERMOSTAT	1	241	
- 6	R-80610-487	• TUBE ASSY, THERMOSTAT	1	241	
- 7		• VALVE ASSY, ELECTRONIC COOLING BYPASS SEE FIG. 2.13-8 INDEX 24	WF		
- 8	R-80610-485	• TUBE ASSY, SUPPLY	1	241	
- 9		• VALVE ASSY, REGULATOR AND SHUTOFF HOT AIR SEE FIG. 2.13-24 INDEX 16	WF		
- 10	R-80610-481	• TUBE ASSY, SUPPLY	1	241	
- 11	R-80610-483	• TUBE ASSY, SUPPLY	1	241	

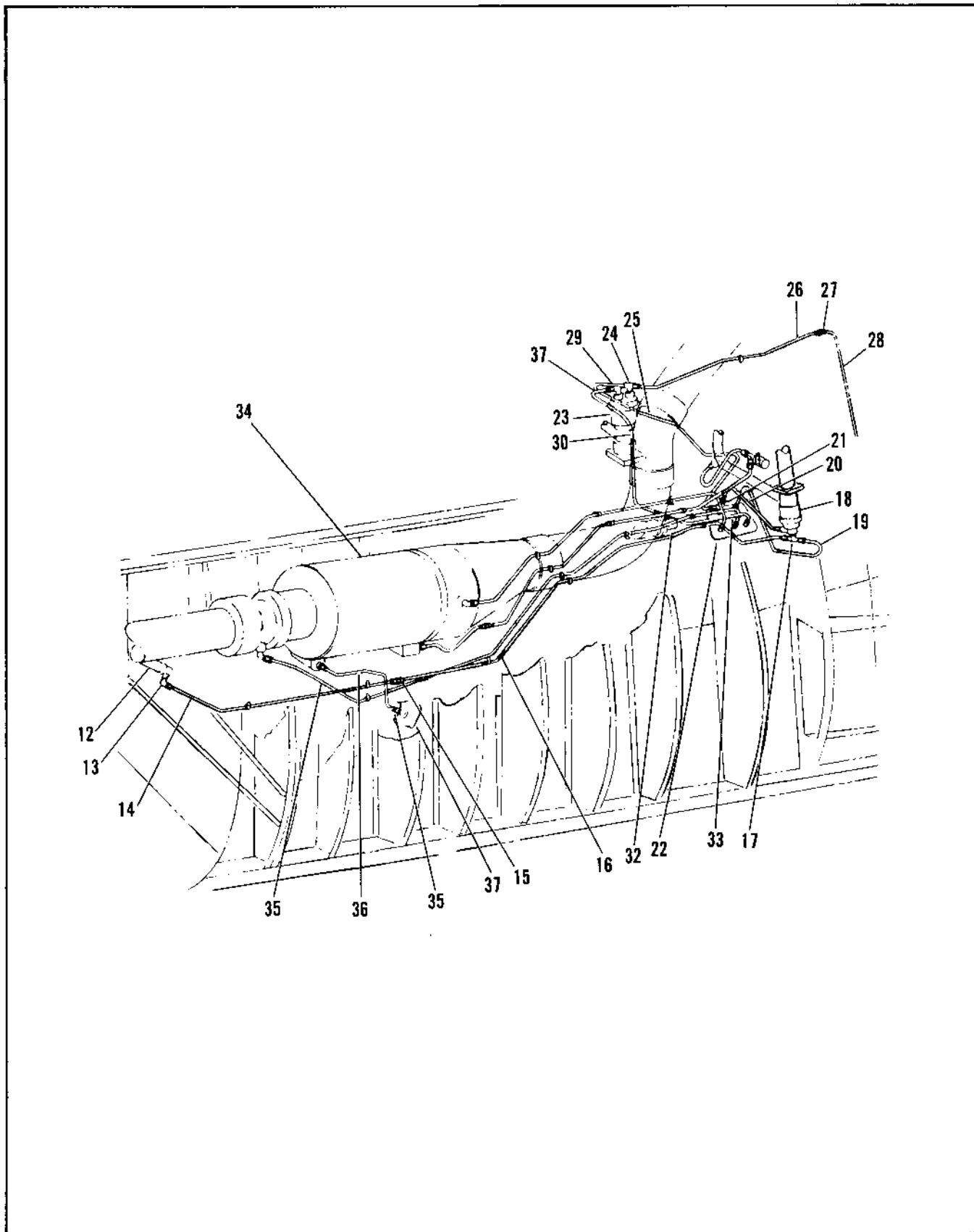

Figure 2.9-10. Low Pressure Pneumatic Electronic Cooling Hot Air By-Pass Tubing Installation (Sheet 2 of 3)

FIGURE AND INDEX NUMBER	PART NUMBER	DESCRIPTION	UNITS PER ASSY.	USABLE ON CODE	
				FROM	TO
2.9-10		TUBING INSTALLATION, MOISTURE SEPARATOR	RF		
- 12	10789C-1	• THERMOSTAT ASSY, MOISTURE SEPARATOR OUTLET HOT AIR BYPASS SEE FIG. 2.13-9 INDEX 8	RF		
- 13	MS21908D4	• ELBOW	1		
	AN924-4D	• NUT	1		
	MS28778-4	• GASKET	1		
- 14	64A34216-1	• TUBE ASSY, LOW PRESSURE PNEUMATIC	1		
- 15	MS21902D4	• UNION	1		
- 16	64A34215-1	• TUBE ASSY, LOW PRESSURE PNEUMATIC	1		
- 17	MS21909D4	• TEE	1		
	AN924-4	• NUT	1		
	MS28778-4	• GASKET	1		
- 18	106780-1	• VALVE ASSY, MOISTURE SEPARATOR INLET SEE FIG. 2.13-9 INDEX 67	RF		
- 19	64A34226-1	• TUBE ASSY, LOW PRESSURE PNEUMATIC	1		
- 20	64A34225-1	• TUBE ASSY, LOW PRESSURE PNEUMATIC	1		
- 21	MS21912D4	• TEE	RF		
- 22	64E34185-1	• PANEL ASSY, TEST ENVIRONMENTAL CONTROL SYSTEM INDEX 10.6	RF		
- 23	10678-1	• VALVE ASSY, MOISTURE SEPARATOR OUTLET HOT AIR BYPASS SEE FIG. 2.13-9 INDEX 51	RF		
- 24	MS21909D4	• TEE	1		
	AN924-4D	• NUT	1		
	MS28778-4	• GASKET	1		
- 25	64E34224-1	• TUBE ASSY, LOW PRESSURE PNEUMATIC	1		
- 26	64E34213-1	• TUBE ASSY, LOW PRESSURE PNEUMATIC	1		
- 27	MS21902D4	• UNION	1		
- 28	8-80510-483	• TUBE ASSY, SUPPLY SEE FIG. 2.9-10 INDEX 22	RF		
- 29	MS21908D4	• ELBOW	1		
	AN924-4D	• NUT	1		
	MS28778-4	• GASKET	1		
- 30	64A34212-1	• TUBE ASSY, LOW PRESSURE PNEUMATIC	1		
- 31	MS21909D4	• TEE	1		
	AN924-4D	• NUT	1		
	MS28778-4	• GASKET	1		
- 32	107890-6	• THERMOSTAT ASSY, MOISTURE SEPARATOR INLET HOT AIR BYPASS SEE FIG. 2.13-9 INDEX 78	RF		
- 33	64A34232-1	• TUBE ASSY, LOW PRESSURE PNEUMATIC	1		
- 34	595350-1	• SEPARATOR, MOISTURE AIRCRAFT AIR CONDITIONING SYSTEM SEE FIG. 2.13-1 INDEX 79	RF		
- 35	MS21902D6	• UNION	2		
	MS28778-6	• GASKET	2		
- 36	64A34233-1	• TUBE ASSY, DRAIN AIR CONDITIONING	1		
- 37	8-81254	• FITTING, MOISTURE SEPARATOR DRAIN PORT	1		

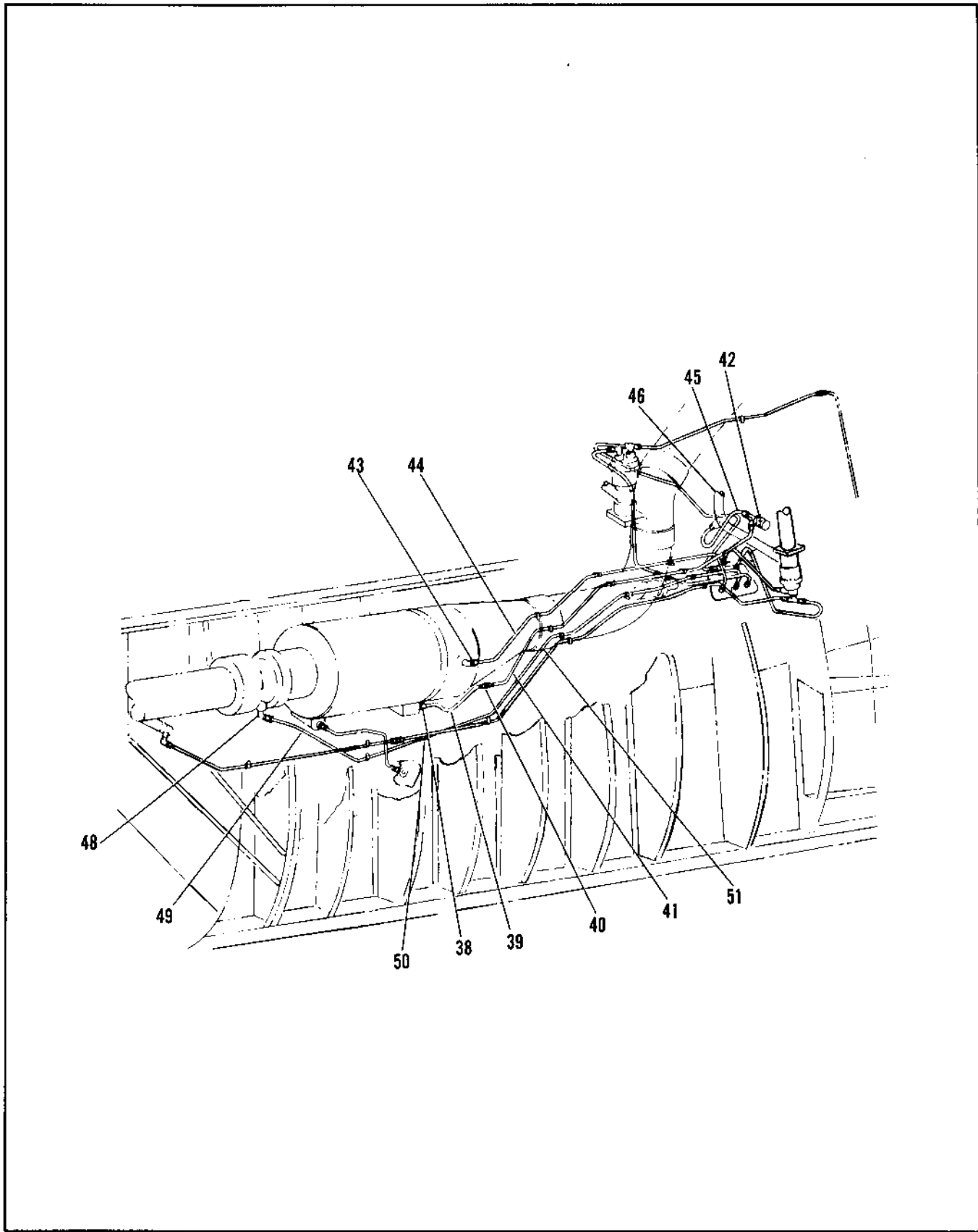

Figure 2.9-10. Low Pressure Pneumatic Electronic Cooling Hot Air By-Pass Tubing Installation (Sheet 3 of 3)

FIGURE AND INDEX NUMBER	PART NUMBER	DESCRIPTION	UNITS PER ASSY.	USABLE ON CODE	
				FROM	TO
		1 2 3 4 5 6			
2.9-10- 38	MS21902D4	• UNION	1		
- 39	MS28778-4 64A34234-1	• GASKET • TUBE ASSY, LOW PRESSURE PNEUMATIC	1 1		
- 40	MS21902D4	• UNION	1		
- 41	64A34231-1	• TUBE ASSY, LOW PRESSURE PNEUMATIC	1		
- 42	27900	• VALVE ASSY, MOISTURE SEPARA- TOR SERVO BYPASS SEE FIG. 2.13-1 INDEX R4	RF		
- 43	MS2190804	• ELBOW	1		
	AN924-4D	• NUT	1		
	MS28778-4	• GASKET	1		
- 44	64A34229-1	• TUBE ASSY LOW PRESSURE PNEUMATIC	1		
- 45	64A34230-1	• TUBE ASSY, LOW PRESSURE PNEUMATIC	1		
- 46	63E35696-1	• DUCT ASSY, ELECTORNIC HOT AIR BYPASS SEE FIG. 2.13-9 INDEX 66	RF		
- 47	64E34054-1	• DUCT ASSY, MOISTURE SEPARA- TOR SEE FIG. 2.13-9 INDEX 38	RF		
- 48	MS2190804	• ELBOW	1		
	AN924-4D	• NUT	1		
	MS28778-4	• GASKET	1		
- 49	64A34227-1	• TUBE ASSY, LOW PRESSURE PNEUMATIC	1		
- 50	MS21902D4	• UNION	1		
- 51	64A34228-1	• TUBE ASSY, LOW PRESSURE PNEUMATIC	1		

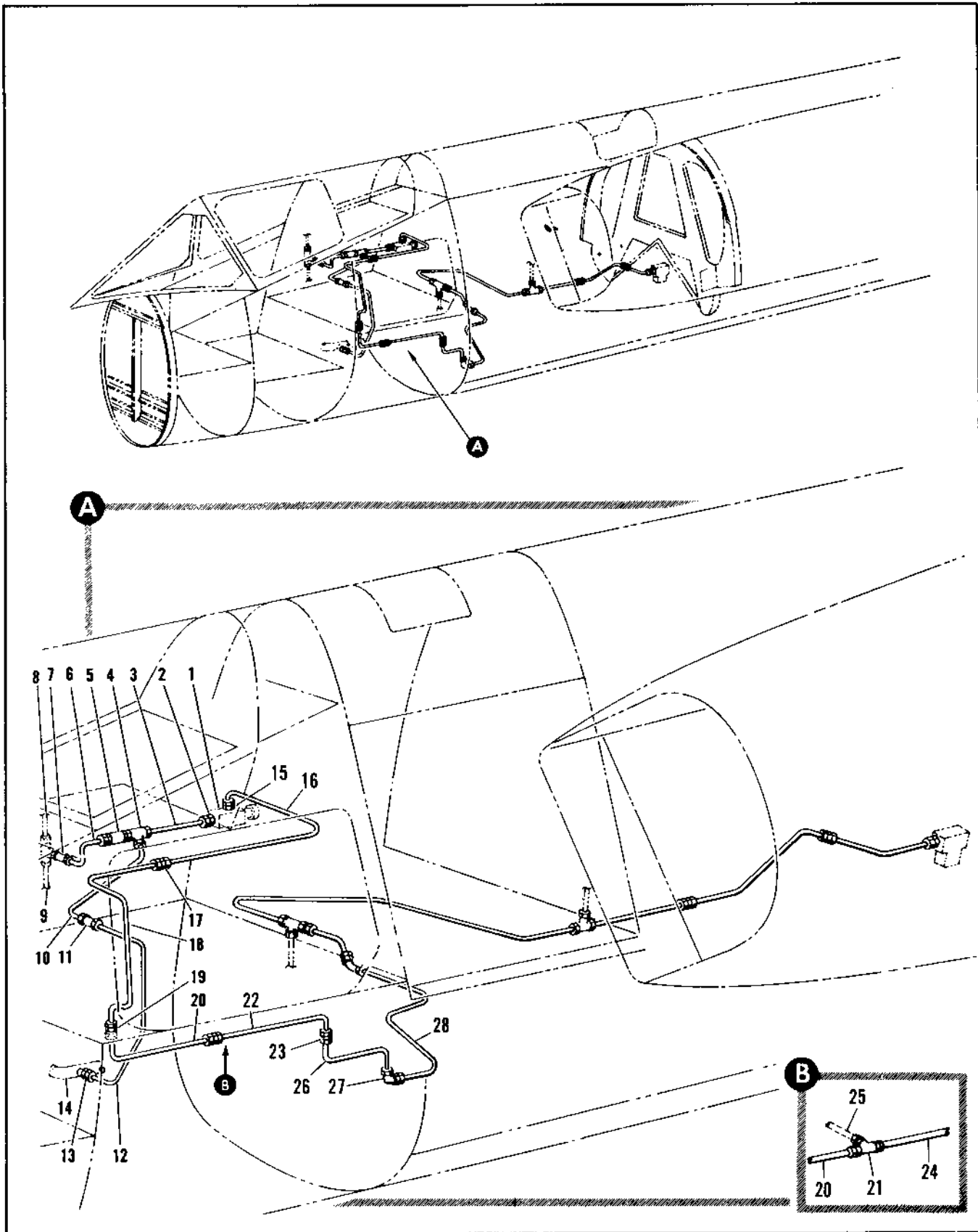

Figure 2.9-11. High Pressure Pneumatic Emergency Cockpit Pressurization Tubing Installation (Sheet 1 of 2)

FIGURE AND INDEX NUMBER	PART NUMBER	DESCRIPTION	UNITS PER ASSY.	USABLE ON CODE	
				FROM	TO
2.9-11	8-80430	TUBING INSTALLATION, HIGH PRESSURE PNEUMATIC EMERGENCY COCKPIT PRESSURIZATION	1	35	
	8-80429	TUBING INSTALLATION, HIGH PRESSURE PNEUMATIC EMERGENCY COCKPIT PRESSURIZATION	1	35	
- 1		• VALVE, EMERGENCY COCKPIT PRESSURIZATION SHUT OFF 2.13-1 INDEX	RF		
- 2	MS21902D4	• UNION	1	35	
	AN6290-4	• GASKET	1	35	
- 3	8-80430-203	• TUBE ASSY, PRESSURIZATION VALVE	1	35	
- 4	MS21911D4	• TEE	1	35	
	AN6290-4	• GASKET	1	35	
- 5	155140-2	• VALVE ASSY, CHECK <91864> SPEC 8-00430-3 T.O. 9P5-12-35-0	1	35	
- 6	7037030-10	• TUBE ASSY, EMERGENCY COCKPIT PRESSURIZATION	1	35	
- 7		• RESTRICTOR, FIXED SEE FIG. 2.9-9 INDEX 39	RF		
- 8		• TUBE ASSY, LOW PRESSURE PNEUMATIC SEE FIG. 2.9-9 INDEX 35	RF		
- 9		• TUBE ASSY, LOW PRESSURE PNEUMATIC SEE FIG. 2.9-9 INDEX 41	RF		
- 10	8-80430-207	• TUBE ASSY, EMERGENCY COCKPIT PRESSURIZATION	1	35	
- 11	9R7442-13	• RESTRICTOR, FIXED <91207> SPEC 8-00429-13	1	35	
- 12	8-80430-341	• TUBE ASSY, EMERGENCY COCKPIT PRESSURIZATION	1	35	
- 13	MS21902D4	• UNION	1	35	
	AN6290-4	• GASKET	1	35	
- 14		• DUCT ASSY, COCKPIT AIR CONDITIONING SEE FIG. 2.13-13 INDEX 63	RF		
- 15	MS21916D4-3	• REDUCER	1	35	
	AN6290-4	• GASKET	1	35	
- 16	8-80430-201	• TUBE ASSY, PRESSURIZATION VALVE	1	35	
- 17	MS21902D3	• UNION	1	35	
- 18	8-80430-179	• TUBE ASSY, EMERGENCY COCKPIT PRESSURIZATION	1	35	
- 19	MS21903D3	• UNION	1	35	
	AN924-3D	• NUT	1	35	
	AN960D616	• WASHER	1	35	
- 20	8-80430-327	• TUBE ASSY, EMERGENCY COCKPIT PRESSURIZATION	1	35	
- 21	MS21905D3	• TEE	1		
- 22	62A35029-1	• TUBE ASSY, EMERGENCY COCKPIT PRESSURIZATION	1		
- 23	MS21902D3	• UNION			
- 24	8-44899-109	• TUBE ASSY, INFRARED SEEKER	1		
- 25		• TUBE ASSY, INFRARED SEEKER	RF		
- 26	8-80430-331	• TUBE ASSY, EMERGENCY COCKPIT PRESSURIZATION	1	4	
	8-80430-373	• TUBE ASSY, EMERGENCY COCKPIT PRESSURIZATION	1	8	
- 27	MS21908D3	• ELBOW	1	35	
	AN924-3D	• NUT	1	35	
	AN960D616	• WASHER	1	35	
- 28	64A34217-1	• TUBE ASSY, HIGH PRESSURE PNEUMATIC	1		
- 29	MS21907D3	• ELBOW	1	35	
	AN924-3D	• NUT	1	35	
	AN960D616L	• WASHER	1	35	
- 30	8-80429-255	• TUBE ASSY, EMERGENCY COCKPIT PRESSURIZATION	1	35	

A AIRPLANES #35 THRU 47, 49 THRU 89
 B AIRPLANES #48, 90 AND ON

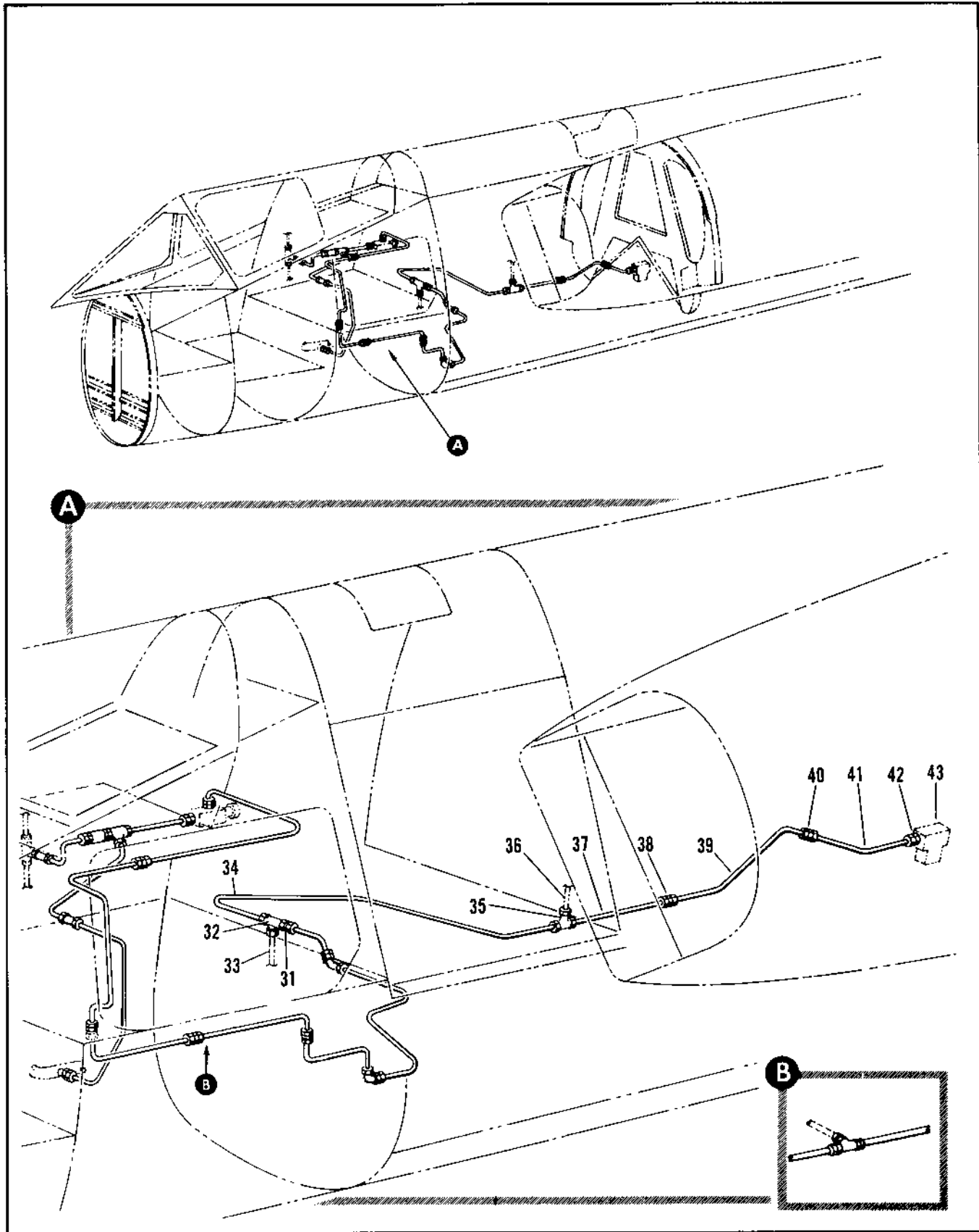

Figure 2.9-11. High Pressure Pneumatic Emergency Cockpit Pressurization Tubing Installation (Sheet 2 of 2)

FIGURE AND INDEX NUMBER	PART NUMBER	DESCRIPTION	UNITS PER ASSY.	USABLE ON CODE	
				FROM	TO
		1 2 3 4 5 6			
2.9-11- 31	MS2191608-4	• REDUCER	1	35	
- 32	AN6290-8	• GASKET	1	35	
- 33	MS2191108	• TEE	1	35	
		• TUBE ASSY, FWD SELECTOR VALVE SEE FIG. 2.9-28 INDEX 14	PF		
- 34	8-80429-487	• TUBE ASSY, EMERGENCY COCKPIT PRESSURIZATION	1	35	1FR
	8-80429-1375	• TUBE ASSY, EMERGENCY COCKPIT PRESSURIZATION	1	189	
- 35	MS2190908	• TEE	1	35	
	AN924-80	• NUT	1	35	
	AN9600121E	• WASHER	1	35	
- 36		• TUBE ASSY, FWD ARMAMENT DISPLACEMENT SEE FIG. 2.9-31 INDEX 27	PF		
- 37	8-80429-1123	• TUBE ASSY, EMERGENCY COCKPIT PRESSURIZATION	1	35	
- 38	MS2190208	• UNION	1	35	
- 39	8-80429-1161	• TUBE ASSY, EMERGENCY COCKPIT PRESSURIZATION	1	35	
- 40	MS2190208	• UNION	1	35	
- 41	8-80429-1159	• TUBE ASSY, EMERGENCY COCKPIT PRESSURIZATION	1	35	42
	8-80429-1309	• TUBE ASSY, EMERGENCY COCKPIT PRESSURIZATION	1	35	
- 42	MS2190208	• UNION	1	35	
	AN6290-8	• GASKET	1	35	
- 43		• VALVE ASSY, ARMAMENT BAY DOOR SELECTOR SEE FIG. 2.20-9 INDEX 1	PF		
			1		

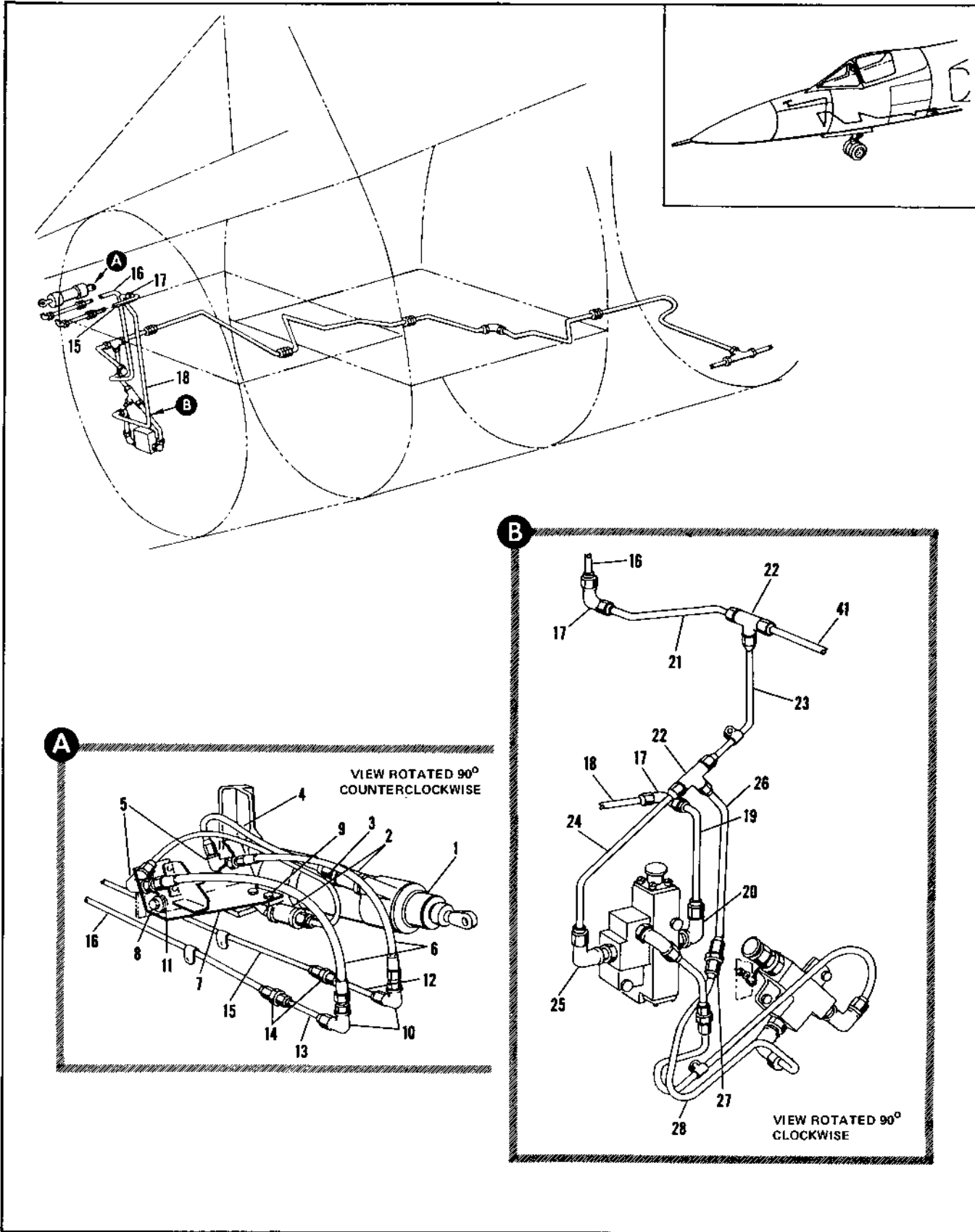

Figure 2.9-12. Tubing Installation High Pressure Pneumatic Infrared Seeker (Sheet 1 of 2)

FIGURE AND INDEX NUMBER	PART NUMBER	DESCRIPTION	UNITS PER ASSY.	USABLE ON CODE	
				FROM	TO
2.9-12	8-44865-R03	TUBING INSTALLATION, HIGH PRESSURE PNEUMATIC INFRARED SEEKER	1		
	8-44865-3	TUBING INSTALLATION, HIGH PRESSURE PNEUMATIC INFRARED SEEKER	1		
- 1		• CYLINDER, PNEUMATIC INFRARED SEEKER SEE FIG. 2-20-4B INDEX 52	1		
- 2	FSCM12439	• RESTRICTOR, PNEUMATIC FIXED <12439> SPEC 8-06429-17	2		
	MS28778-4	• PACKING	2		
- 3	8-44899-21	• TUBE ASSY, INFRARED SEEKER	1		
- 4	8-44899-71	• TUBE ASSY, INFRARED SEEKER	1		
- 5	MS2190803	• ELBOW	2		
	AN924-30	• NUT	2		
	AN9630616	• WASHER	2		
- 6	124223-3DC197	• HOSE ASSY, HIGH PRESSURE PNEUMATIC <98441> SPEC 8-08535-R3	2		
- 7	8-44865-7	• BRACKET ASSY, RIVETED ATTACHING PARTS	1		
- 8	AN4-6	• BOLT	1		
	AN960-416	• WASHER	1		
- 9	AN3-5A	• BOLT	2		
	AN960-416L	• WASHER	1		
	AN3-5A	• BOLT	2		
	NAS1291-3	• NUT	2		
	NA963010	• WASHER	2		
		-----X-----			
- 10	MS2190803	• ELBOW	2		
	AN924-30	• NUT	2		
	AN9630616	• WASHER	2		
- 11	94-35036-062	• GROMMET	1		
- 12	8-44899-135	• TUBE ASSY, INFRARED SEEKER	1		
- 13	8-44899-137	• TUBE ASSY, INFRARED SEEKER	1		
- 14	MS2191604-3	• REDUCER	2		
- 15	8-44899-69	• TUBE ASSY, INFRARED SEEKER	1		
- 16	8-44899-129	• TUBE ASSY, INFRARED SEEKER	1		
	8-44899-31	• TUBE ASSY, INFRARED SEEKER	1		
- 17	MS2190804	• ELBOW	3		
	AN924-40	• NUT	3		
	AN9630716	• WASHER	3		
- 18	8-44899-127	• TUBE ASSY, INFRARED SEEKER	1		
	8-44899-61	• TUBE ASSY, INFRARED SEEKER	1		
- 19	8-44899-29	• TUBE ASSY, INFRARED SEEKER	1		
- 20	MS2190804	• ELBOW	1		
	AN924-40	• NUT	1		
	MS28778-4	• PACKING	1		
- 21	8-44899-59	• TUBE ASSY, INFRARED SEEKER	1		
- 22	MS2190504	• TEE	2		
- 23	8-44899-57	• TUBE ASSY, INFRARED SEEKER	1		
- 24	8-44899-113	• TUBE ASSY, INFRARED SEEKER	1		
- 25	MS2180804	• ELBOW	1		
	AN924-40	• NUT	1		
	MS28778-4	• PACKING	1		
- 26	8-44899-25	• TUBE ASSY, INFRARED SEEKER	1		
- 27	MS2191604-3	• REDUCER	1		
- 28	8-44899-77	• TUBE ASSY, INFRARED SEEKER	1		

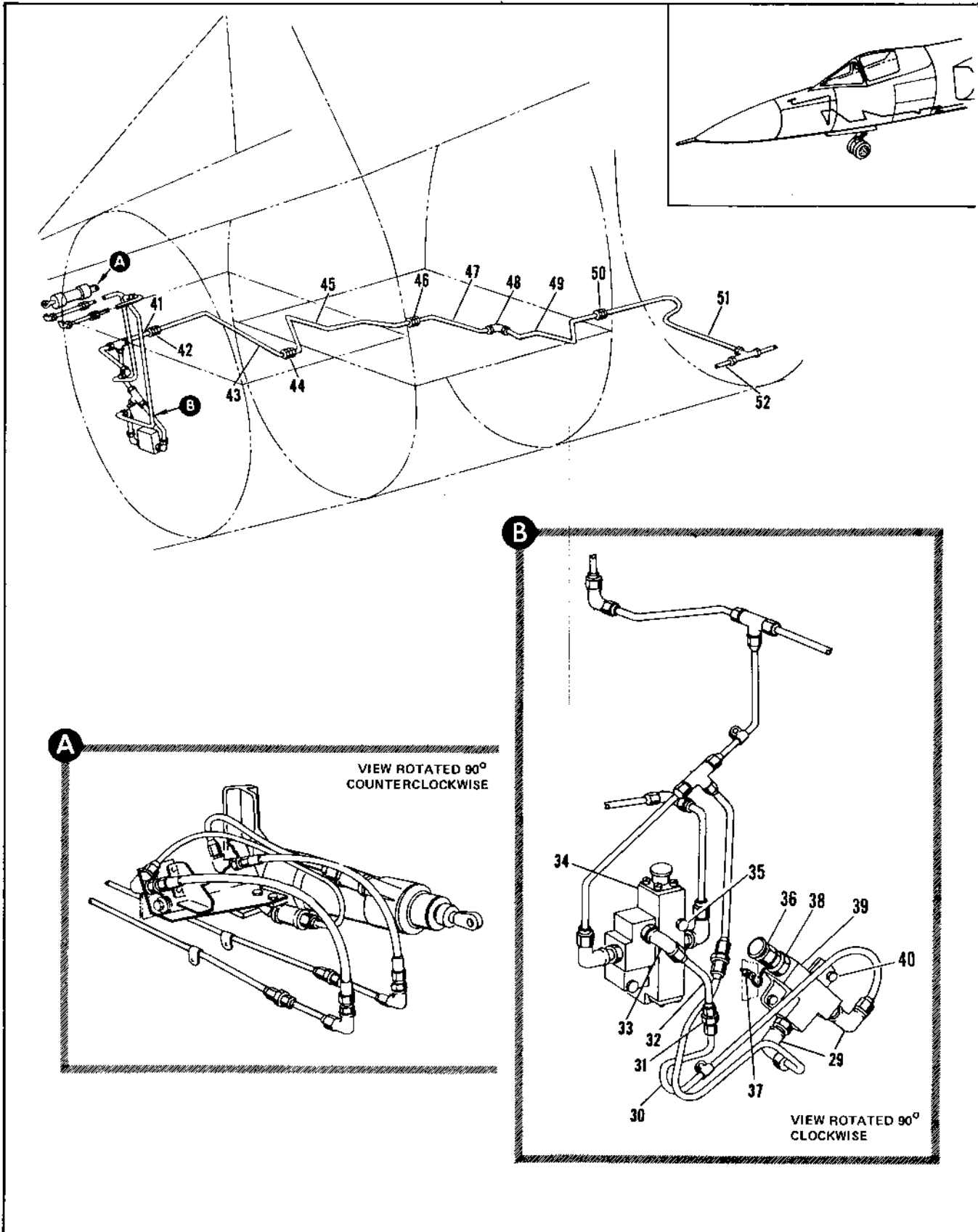

Figure 2.9-12. Tubing Installation High Pressure Pneumatic Infrared Seeker (Sheet 2 of 2)

FIGURE AND INDEX NUMBER	PART NUMBER	DESCRIPTION	UNITS PER ASSY.	USABLE ON CODE	
				FROM	TO
		1 2 3 4 5 6			
2.9-12- 29	MS2190803	• ELBOW	2		
	AN924-3D	• NUT	2		
	MS28778-3	• PACKING	2		
- 30	8-44899-75	• TUBE ASSY, INFRARED SEEKER	1		
- 31	MS21916D4-3	• REDUCER	1		
- 32	8-44899-23	• TUBE ASSY, INFRARED SEEKER	1		
- 33	MS2190804	• ELBOW	1		
	AN924-4D	• PACKING	1		
- 34	16150	• CONTROL VALVE, SOLENOID OPERATED INFRARED SEEKER SPEC 8-08666-1 ATTACHING PARTS	1		
- 35	AN4-16A	• BOLT	1		
	AN4-27A	• BOLT	1		
	AN960-416L	• WASHER	1		
- 36	7325048-01	• CAP, FWD <75294> ARMAMENT DISPLACEMENT CYLINDER VENT SPEC 8-08572-1 ATTACHING PARTS	1		
- 37	AN520-10R7	• SCREW	1		
	NAS1291-3	• NUT	1		
	AN960-10L	• WASHER	1		
- 38	MS21916D6-4	• REDUCER	1		
	MS28778-4	• PACKING	1		
- 39	214AA3	• VALVE, MANUAL CONTROL INFRARED SEEKER <05214> SPEC 8-00494-7 ATTACHING PARTS	1		
- 40	AN3-6A	• BOLT	2		
	NAS1291-3	• NUT	2		
	AN960D10	• WASHER	2		
- 41	8-44899-97	• TUBE ASSY, INFRARED SEEKER	1		
- 42	MS21916D4-3	• REDUCER	1		
- 43	8-44899-99	• TUBE ASSY, INFRARED SEEKER	1		
- 44	MS2192403	• UNION	1		
	AN924-3D	• NUT	1		
	AN960D616	• WASHER	1		
- 45	8-44899-101	• TUBE ASSY, INFRARED SEEKER	1		
- 46	MS21902D3	• UNION	1		
- 47	8-44899-103	• TUBE ASSY, INFRARED SEEKER	1		
- 48	MS21907D3	• ELBOW	1		
	AN924-3D	• NUT	1		
	AN960D616	• WASHER	1		
- 49	8-44899-105	• TUBE ASSY, INFRARED SEEKER	1		
- 50	MS21902D3	• UNION	1		
- 51	8-44899-107	• TUBE ASSY, INFRARED SEEKER	1		
- 52		• TUBE ASSY, INFRARED SEEKER SEE FIG. 2.9-11	RF		

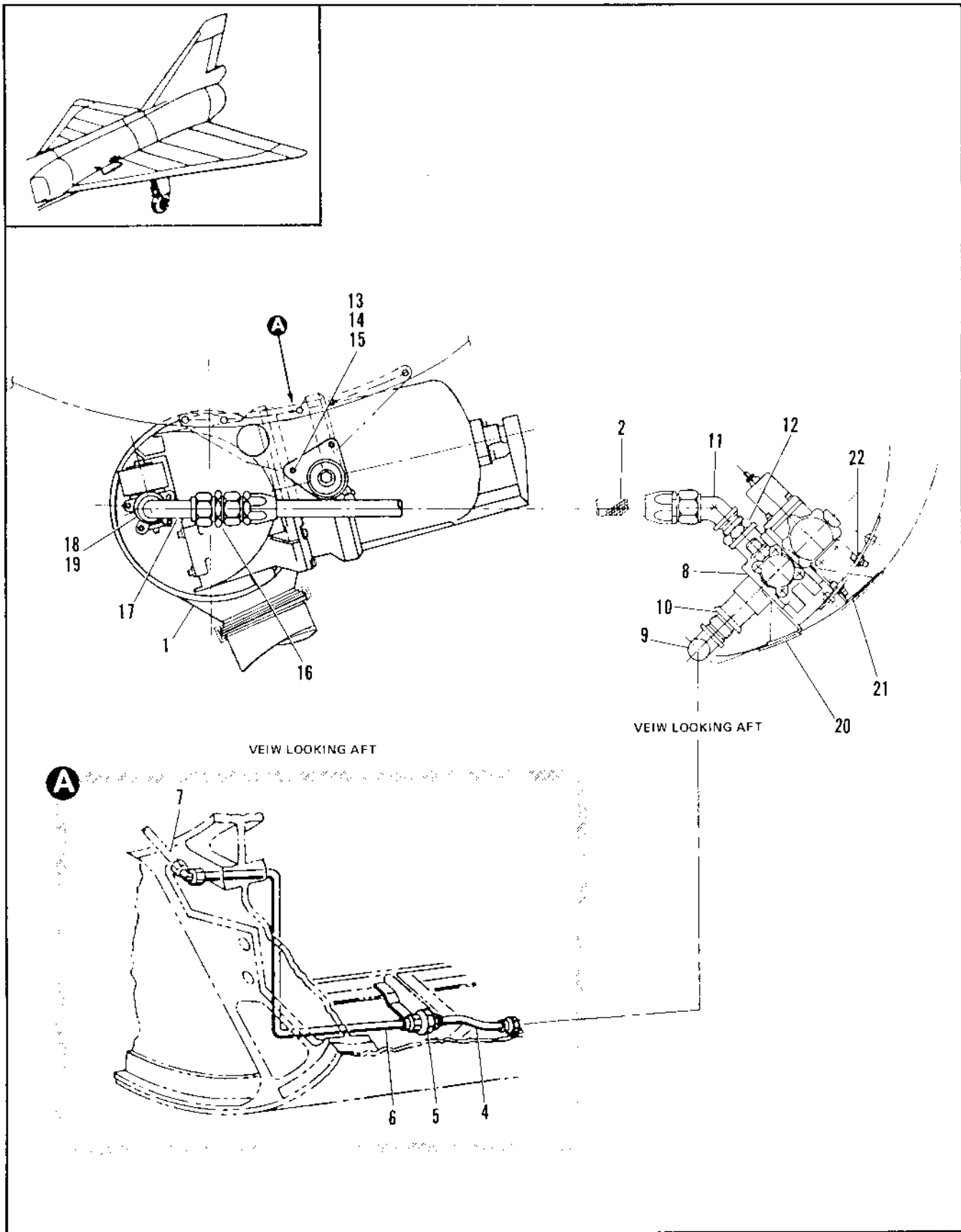

Figure 2.9-13. Engine Starter High Pressure Pneumatic Tubing Installation

FIGURE AND INDEX NUMBER	PART NUMBER	DESCRIPTION	UNITS PER ASSY.	USABLE ON CODE	
				FROM	TO
2.9-13	8-80421-5	TUBING INSTL, ENGINE STARTER HIGH PRESSURE PNEUMATIC MODIFIED BY 3501172 (99193) FOR NHA SEE FIG. 2.3-14	RF	35	
- 1	*1	* STARTER, COMBUSTION, SEE FIG. 2.10-7 INDEX 73	RF		
	*2	* STARTER CARTRIDGE/PNEUMATIC SEE INDEX 73	RF		
- 2	11204-12-0163	* HOSE ASSY, (98441) SPEC 8-08538-13	1	35	
- 3	MS21908012	* ELBOW	1	35	
	AN924-120	* NUT	1	35	
	AN960D716	* WASHER	1	35	
- 4	8-80421-99	* TUBE ASSY, STARTER	1	35	60
	3501663-1	* TUBE ASSY VALVE INLET	1	35	60
	8-80421-127	* TUBE ASSY, STARTER	1	61	
	3167776-1	* TUBE ASSY VALVE INLET	1	61	
- 5	MS21916D12-10	* REDUCER	1	35	
- 6	8-80421-97	* TUBE ASSY, STARTER	1	35	60
	8-80421-125	* TUBE ASSY, STARTER	1	61	
- 7		* TUBE ASSY, FILLER SEE FIG. 2.9-23 INDEX 25	RF		
- 8	3214050-1-1	* VALVE, STARTER CONTROL	1	35	
- 9	MS21908D12	* ELBOW 90 DEGREE	1	35	
- 10	AN924-12C	* NUT	1	35	
	MS28778-12	* PACKING	1	35	
- 11	MS21907-D12	* ELBOW 45 DEGREE	1	35	
- 12	AN924-12D	* NUT	1	35	
	MS28778-12	* PACKING	1	35	
- 13	MS21280-C7	* BOLT	2	35	
- 14	MS16212-12	* WASHER	3	35	
- 15	MS21043-4	* NUT	2	35	
- 16	MS21909D12	UNION	1	35	
- 17	3167777-1	TUBE ASSY, STARTER INLET	1	35	
- 18	MS21902D12	UNION	1	35	
- 19	59990-612	PACKING	1	35	
- 20		* BRACKET, VALVE INBOARD AFT MOUNTING	1	35	
	MS21279-08	* BOLT	3	35	
- 21		* BRACKET, VALVE OUTBOARD AFT MOUNTING	1	35	
	MS21979-08	* BOLT	3	35	
- 22	3169437-1	BRACKET, VALVE FWD MOUNTING	1	35	
	MS21279-08	* BOLT	2	35	
		*1 REMOVED PER TCTO 1F-106-1110.			
		*2 ADDED PER TCTO 1F-106-1110			

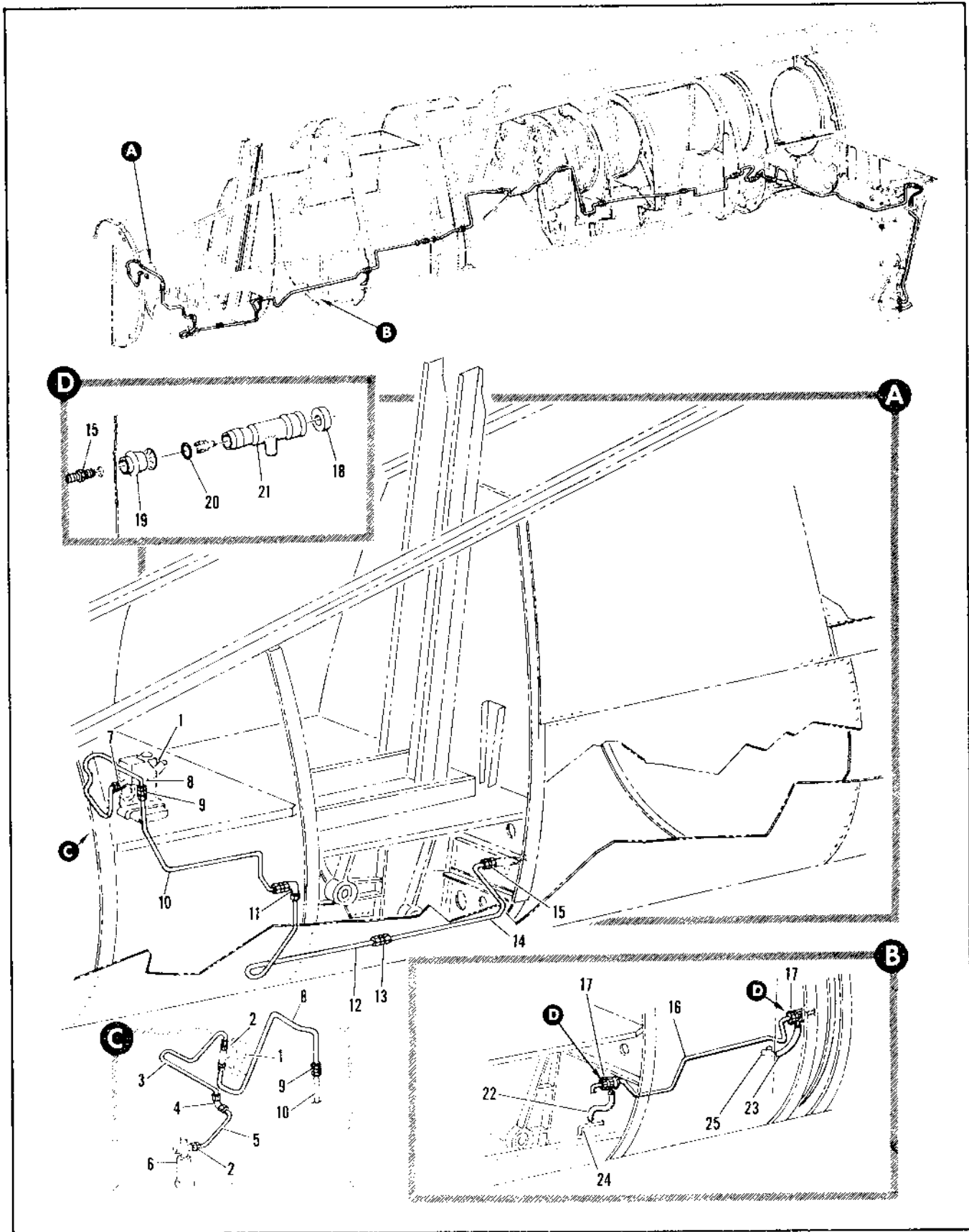

Figure 2.9-14. Pneumatic Master Brake Cylinder to Wheel Brake Relay Valve Tubing Installation LH (Sheet 1 of 2)

FIGURE AND INDEX NUMBER	PART NUMBER	DESCRIPTION	UNITS PER ASSY.	USABLE ON CODE	
				FROM	TO
2.9-14	8-80430	TUBING INSTL. PNEUMATIC MASTER BRAKE CYLINDER TO WHEEL BRAKE RELAY VALVE LH MODIFIED BY 66J48297	1		
	8-80429	TUBING INSTALLATION. PNEUMATIC MASTER BRAKE CYLINDER TO WHEEL BRAKE RELAY VALVE LH MODIFIED BY 2-80534	1	35	
- 1		• CYLINDER, MASTER BRAKE SEE FIG. 2.14-26 INDEX 12	PF		
- 2	MS2190203	• UNION	2	B	
	AN6290-3	• GASKET	2	B	
- 3	8-80430-381	• TUBE ASSY, EXPANSION CHAMBER	1	49	45
	8-80430-389	• TUBE ASSY, EXPANSION CHAMBER	1	49	
- 4	MS2190803	• ELBOW	1	B	
	AN924-30	• NUT	1	B	
	AN9600616	• WASHER	1	B	
- 5	8-80430-385	• TUBE ASSY, EXPANSION CHAMBER	1	49	48
	8-80430-395	• TUBE ASSY, EXPANSION CHAMBER	1	49	
- 6		• EXPANSION CHAMBER, BRAKE HYDRAULIC SEE FIG. 2.8-1 INDEX 15	PF		
- 7	MS2190203	• UNION	1	35	
	AN6290-3	• GASKET	1	35	
- 8	8-80430-273	• TUBE ASSEMBLY	1	A	
	8-80430-351	• TUBE ASSEMBLY	1	B	
- 9	MS2190303	• UNION	1	35	
	AN924-30	• NUT	1	35	
	AN9600616	• WASHER	1	35	
- 10	8-80430-293	• TUBE ASSEMBLY	1	35	
- 11	MS2190803	• ELBOW	1	35	
	AN924-30	• NUT	1	35	
	AN9600616	• WASHER	1	35	
- 12	8-80430-337	• TUBE ASSEMBLY	1	35	47
	8-80430-347	• TUBE ASSEMBLY	1	49	89
	8-80430-367	• TUBE ASSEMBLY	1	B	
- 13	MS2190203	• UNION	1	35	
- 14	8-80430-339	• TUBE ASSY, BRAKE	1	35	47
	8-80430-349	• TUBE ASSY, BRAKE	1	49	89
	8-80430-369	• TUBE ASSY, BRAKE	1	B	
- 15	MS2190303	• UNION	2	35	
	AN924-30	• NUT	1	35	
	AN9600616	• WASHER	1	35	
- 16	8-80430-315	• TUBE ASSEMBLY	1	35	
- 17	8-81331-1	• SHROUD ASSY, HYDRAULIC TUBE	2	35	
- 18	8-1258-7	• GROMMET	1	35	
- 19	8-81257-7	• RECEPTACLE	1	35	
- 20	AN6227-19	• PACKING	1	35	
- 21	8-81331-7	• SHROUD ASSY, WELDED	1	35	
- 22	8-80430-319	• TUBE ASSEMBLY	1	35	
- 23	6-34224-9	• TUBE, DRAIN	1		
- 24		• ADAPTER ASSY, SHROUD DRAIN SEE FIG. 2.8-15 INDEX 8	PF		
- 25		MANIFOLD ASSY, SEE FIG. 2.8-15 INDEX 21	PF		

A AIRPLANES #35 THRU 47 AND 49 THRU 89
 B AIRPLANES #48, 50 AND ON

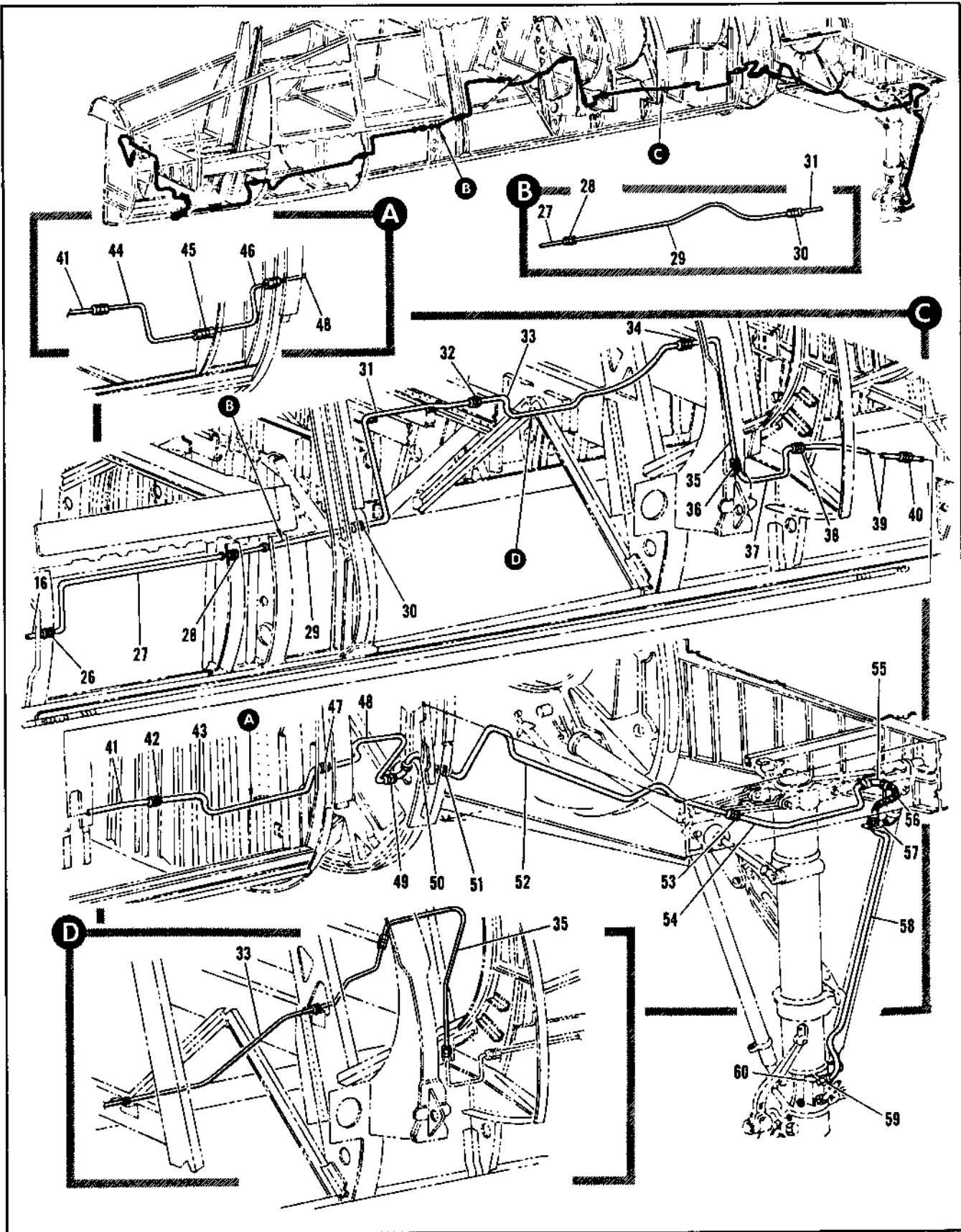

Figure 2.9-14. Pneumatic Master Brake Cylinder to Wheel Brake Relay Valve Tubing Installation LH (Sheet 2 of 2)

FIGURE AND INDEX NUMBER	PART NUMBER	DESCRIPTION 1 2 3 4 5 6	UNITS PER ASSY.	USABLE ON CODE	
				FROM	TO
2.9-14- 26	MS2190303	• UNION	1	35	
	AN924-30	• UNION	1	35	
	AN9600616	• WASHER	1	35	
- 27	8-80429-35	• TUBE ASSEMBLY	1	35	
- 28	MS2190203	• UNION	1	35	
- 29	64A34211-1	• TUBE ASSY, HIGH PRESSURE PNEUMATIC	1	35	
- 30	MS2190203	• UNION	1	35	
- 31	8-80429-1077	• TUBE ASSEMBLY	1	35	
- 32	MS2190203	• UNION	1	35	
- 33	66A39628-1	• TUBE ASSY	1		
- 34	MS2190203	• UNION	1	35	
- 35	66A39629-1	• TUBE ASSY	1		
- 36	MS2190203	• UNION	1	35	
- 37	8-80429-59	• TUBE ASSEMBLY	1	35	
- 38	MS2190203	• UNION	1	35	
- 39	8-80429-61	• TUBE ASSEMBLY	1	35	
- 40	MS2190203	• UNION	1	35	
- 41	8-80429-63	• TUBE ASSEMBLY	1	35	
- 42	MS2190203	• UNION	1	35	
- 43	8-80429-65	• TUBE ASSEMBLY	1	A	
- 44	8-80429-1305	• TUBE ASSEMBLY	1	B	
- 45	MS2190303	• UNION	1	B	
	AN924-30	• NUT	1	B	
	AN9600616	• WASHER	1	B	
- 46	8-80429-1307	• TUBE ASSEMBLY	1	B	
- 47	MS2190203	• UNION	1	35	
- 48	8-80429-9	• TUBE ASSEMBLY	1	35	
- 49	MS2190703	• ELBOW	1	35	
	AN924-30	• NUT	1	35	
	AN9600616	• WASHER	1	35	
- 50	8-80429-1387	• TUBE ASSEMBLY	1	241	
- 51	MS2190203	• UNION	1	35	
- 52	65A33101-1	• TUBE ASSEMBLY	1	35	
	MS21942L3	• NUT	3		
	AN520-10R14	• SCREW	3		
	WAS43003-27	• SPACER	3		
- 53	MS2190203	• UNION	1	35	
- 54	8-80429-301	• TUBE ASSEMBLY	1	35	
- 55	MS2190803	• ELBOW	1	35	
	AN924-30	• NUT	1	35	
	AN9600616	• WASHER	1	35	
- 56	666035-3-0170	• HOSE ASSY, <13624> 94-80520-089 REPLACED BY SUITABLE SUR 124223-300170	1	C	
	124223-300170	• HOSE ASSY, <98441> SPEC 8-28538-31 REPLACES SUITABLE SUR FOR 666035-3-0170	1	D	
- 57	MS2190303	• UNION	1	35	
	AN924-30	• NUT	1	35	
	AN9600616L	• WASHER	1	35	
- 58	8-80429-637	• TUBE ASSEMBLY	1	35	102
	8-80429-1327	• TUBE ASSEMBLY	1	103	
- 59	MS2191604-3	• REDUCER	1	35	
	AN6290-4	• GASKET	1	35	
- 60		• VALVE ASSY, BRAKE RELAY SEE FIG. 2-15-1 INDEX 50	RF		

C AIRPLANES #35 THRU 38 AND 49 THRU 102
D AIRPLANES #39 THRU 48, 103 AND ON

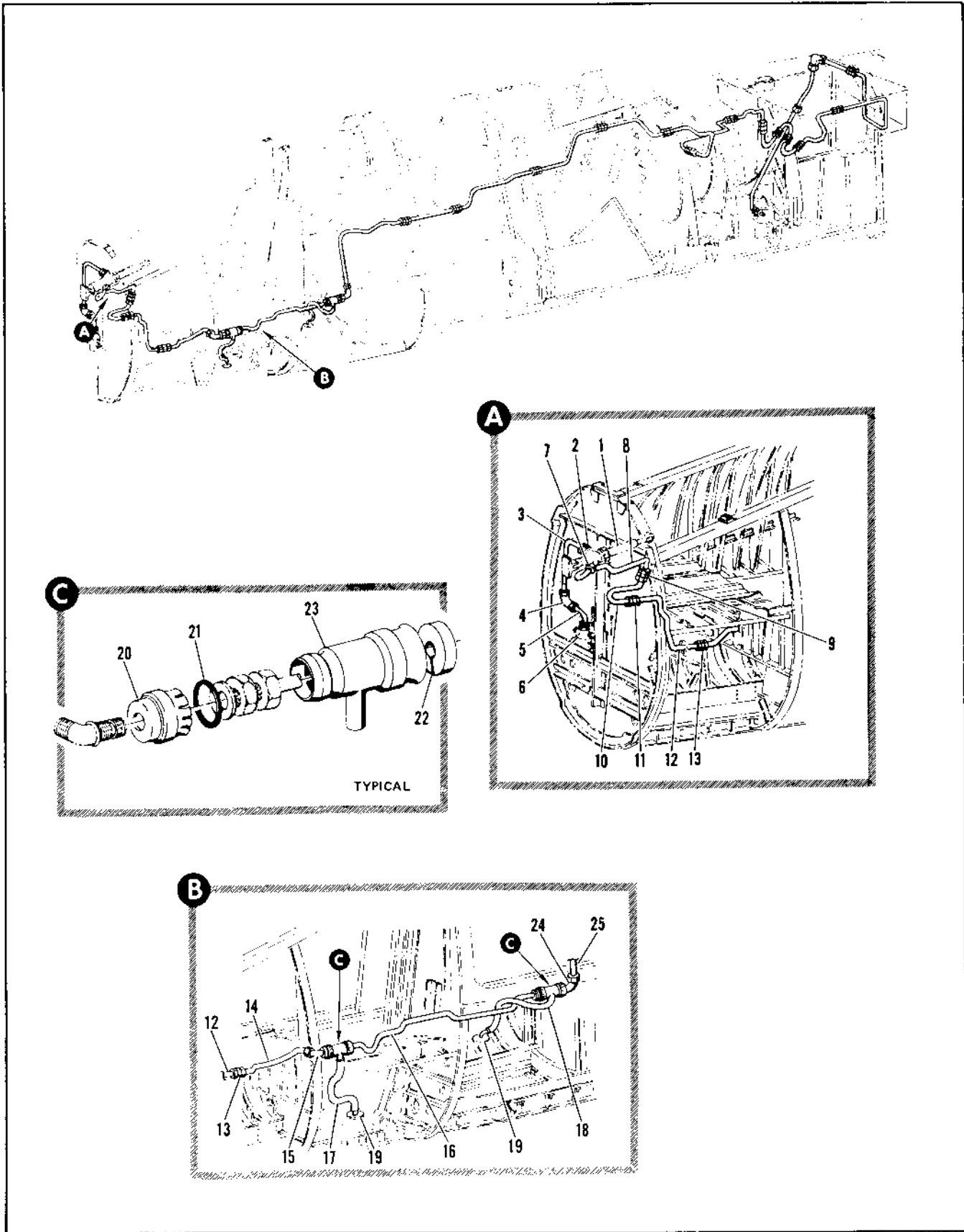

Figure 2.9-15. Pneumatic Master Brake Cylinder to Wheel Brake Relay Valve Tubing Installation RH (Sheet 1 of 2)

FIGURE AND INDEX NUMBER	PART NUMBER	DESCRIPTION 1 2 3 4 5 6	UNITS PER ASSY.	USABLE ON CODE	
				FROM	TO
2.9-15	8-80430	TUBING INSTALLATION, PNEUMATIC MASTER BRAKE CYLINDER TO WHEEL BRAKE RELAY VALVE RH	1	35	
	8-80429	TUBING INSTALLATION, PNEUMATIC MASTER BRAKE CYLINDER TO WHEEL BRAKE RELAY VALVE RH MODIFIED BY 8-80504	1	35	
- 1		• CYLINDER, MASTER BRAKE SEE FIG. 2.14-26 INDEX 12	RF		
- 2	MS2190203	• UNION	2	8	
	AN6290-3	• GASKET	2	8	
- 3	8-80430-383	• TUBE ASSY, EXPANSION CHAMBER	1	48	48
	8-80430-391	• TUBE ASSY, EXPANSION CHAMBER	1	90	
- 4	MS2190803	• ELBOW	1	8	
	AN9600616	• WASHER	1	8	
	AN924-30	• NUT	1	48	48
- 5	8-80430-387	• TUBE ASSY, EXPANSION CHAMBER	1	48	48
	8-80430-393	• TUBE ASSY, EXPANSION CHAMBER	1	90	
- 6		• EXPANSION CHAMBER, BRAKE HYDRAULIC SEE FIG. 2.8-1 INDEX 15	RF		
- 7	MS2190203	• UNION	1	35	
	AN6920-3	• GASKET	1	35	
- 8	8-80430-279	• TUBE ASSEMBLY	1	A	
	8-80430-355	• TUBE ASSEMBLY	1	8	
- 9	MS2190303	• UNION	1	35	
	AN924-30	• NUT	1	35	
	AN9600616	• WASHER	1	35	
- 10	8-80430-183	• TUBE ASSEMBLY	1	A	
	8-80430-377	• TUBE ASSEMBLY	1	8	
- 11	MS2190203	• UNION	1	35	
- 12	8-80430-131	• TUBE ASSEMBLY	1	A	
	8-80430-379	• TUBE ASSEMBLY	1	8	
- 13	MS2190303	• UNION	1	35	
	AN924-30	• NUT	1	35	
	AN9600616	• WASHER	1	35	
- 14	8-80430-307	• TUBE ASSY, DRAIN	1	35	
- 15	MS2190703	• ELBOW	1	35	
	AN924-30	• NUT	1	35	
	AN9600616	• WASHER	1	35	
- 16	8-80430-311	• TUBE ASSEMBLY	1	A	
	8-80430-375	• TUBE ASSEMBLY	1	8	
- 17	8-80430-309	• TUBE ASSY, DRAIN	1	35	
- 18	8-80430-313	• TUBE ASSY, DRAIN	1	35	
- 19		• ADAPTER ASSY, SHROUD DRAIN SEE FIG. 2.3-9 INDEX 2	RF		
	8-81331-1	• SHROUD ASSY, TUBING	2	35	
- 20	8-81257-7	• RECEPTACLE	1	35	
- 21	AN6227-19	• PACKING	1	35	
- 22	8-81258-7	• GROMMET	1	35	
- 23	8-81331-7	• SHROUD ASSY, WELDED	1	35	
- 24	MS2190803	• ELBOW	135		
	AN924-30	• NUT	1	35	
	AN9600616	• WASHER	1	35	
<p>A AIRPLANES #35 THRU 47 AND 49 THRU 89 B AIRPLANES #48, 90 AND ON</p>					

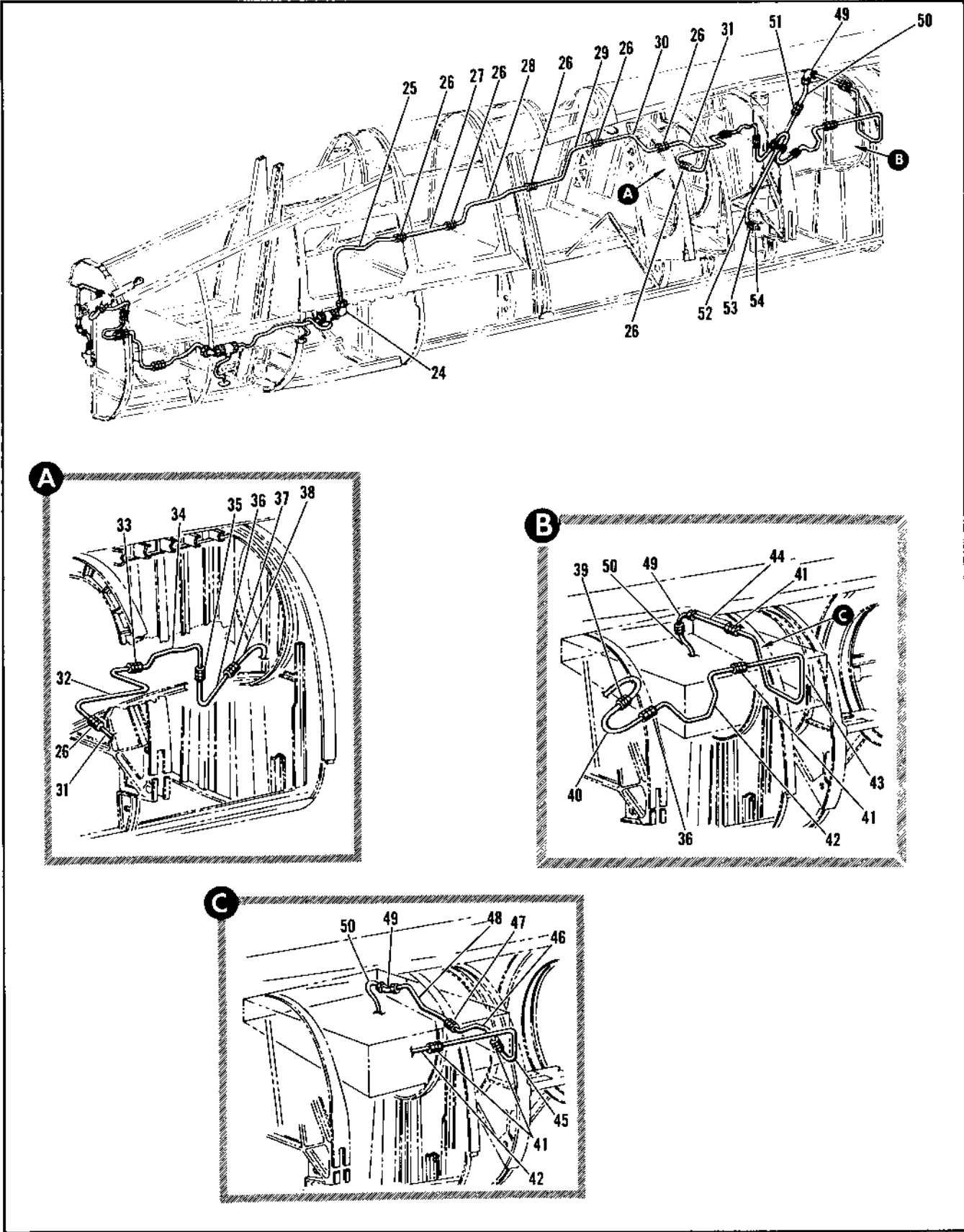

Figure 2.9-15. Pneumatic Master Brake Cylinder to Wheel Brake Relay Valve Tubing Installation RH (Sheet 2 of 2)

FIGURE AND INDEX NUMBER	PART NUMBER	DESCRIPTION	UNITS PER ASSY.	USABLE ON CODE	
				FROM	TO
		1 2 3 4 5 6			
2.9-15- 25	8-80429-411	• TUBE ASSEMBLY	1	35	
- 26	MS21902D3	• UNION	6	35	
- 27	8-80429-41	• TUBE ASSEMBLY	1	35	
- 28	8-80429-1075	• TUBE ASSEMBLY	1	35	
- 29	8-80429-387	• TUBE ASSEMBLY	1	35	
- 30	8-80429-385	• TUBE ASSEMBLY	1	35	
- 31	8-80429-59	• TUBE ASSEMBLY	1	35	
- 32	8-80429-1193	• TUBE ASSEMBLY	1	35	
- 33	MS2190303	• UNION	1	35	
	AN924-30	• NUT	1	35	
	AN960D616	• WASHER	1	35	
- 34	8-80429-1195	• TUBE ASSEMBLY	1	35	
- 35	MS21903D3	• UNION	1	35	
- 36	8-80429-1197	• TUBE ASSEMBLY	1	35	
- 37	MS21902D3	• UNION	1	35	
- 38	8-80429-541	• TUBE ASSEMBLY	1	35	50
	8-80429-1251	• TUBE ASSEMBLY	1	61	
- 39	MS2190303	• UNION	1	35	
	AN924-30	• NUT	1	35	
	AN960D616	• WASHER	1	35	
- 40	8-80429-1113	• TUBE ASSEMBLY	1	35	60
	8-80429-1263	• TUBE ASSEMBLY	1	61	
- 41	MS21902D3	• UNION	3	35	
- 42	8-80429-1111	• TUBE ASSEMBLY	1	35	
- 43	9-80429-663	• TUBE ASSEMBLY	1	35	48
- 44	8-80429-661	• TUBE ASSEMBLY	1	35	49
- 45	8-80429-1209	• TUBE ASSEMBLY	1	49	
- 46	8-80429-1211	• TUBE ASSEMBLY	1	49	
- 47	MS21902D3	• UNION	1	49	
- 48	8-80429-1213	• TUBE ASSEMBLY	1	49	
- 49	MS21907D3	• ELBOW	1	35	
	AN924-30	• NUT	1	35	
	AN960D616	• WASHER	1	35	
- 50	666035-3-6170	• HOSE ASSY, <00624> 94-80520-089	1	35	32
	SF124223-3D0170	• HOSE ASSY, <98441> SPEC 8-08538-31	1	35	
- 51	MS21903D3	• UNION	1	35	
	AN924-30	• NUT	1	35	
	AN960D716L	• WASHER	1	35	
- 52	8-80429-629	• TUBE ASSEMBLY	1	35	102
	8-80429-1335	• TUBE ASSEMBLY	1	103	
- 53	MS21916D4-3	• REDUCER	1	35	
	AN6290-4	• GASKET	1	35	
- 54		• VALVE ASSY, BRAKE RELAY SEE FIG. 2.15-1 INDEX 50	FF		

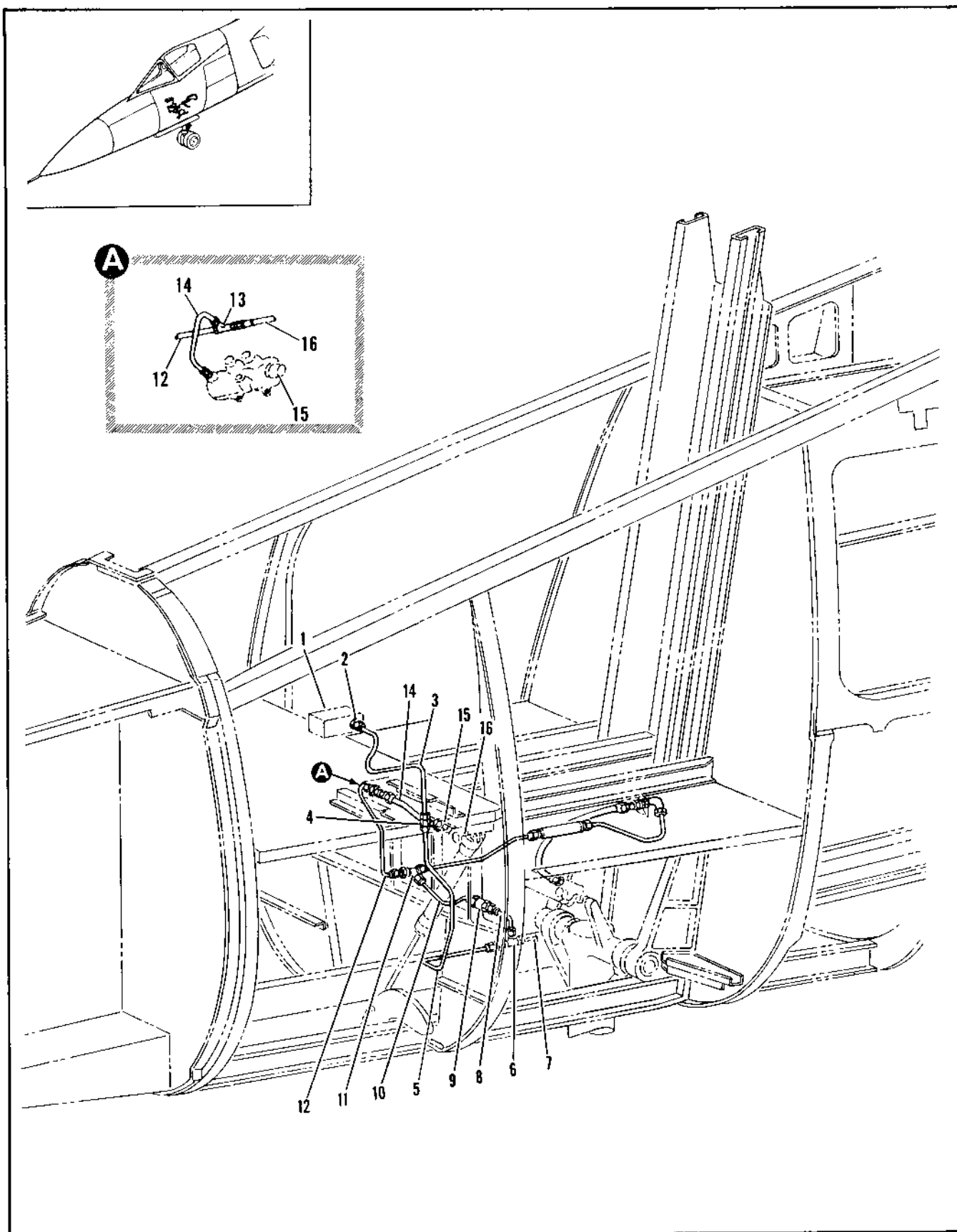

Figure 2.9-16. High Pressure Pneumatic Nose Landing Gear Tubing Installation (Sheet 1 of 2)

FIGURE AND INDEX NUMBER	PART NUMBER	DESCRIPTION	UNITS PER ASSY.	USABLE ON CODE	
				FROM	TO
2.9-16	8-80430	TURING INSTALLATION, HIGH PRESSURE PNEUMATIC NCSE LANDING GEAR	1	35	
- 1		• VALVE ASSY, SEE FIG. 2.15-7 INDEX 15	PF		
- 2	MS21902D4	• UNION	1	35	
	AN6290-4	• GASKET	1	35	
- 3	8-80430-345	• TUBE ASSY, NLG ACTUATOR	1	35	159
	8-80430-405	• TUBE ASSY, NLG ACTUATOR	1	160	
- 4	MS21903D4	• UNION	1	35	
	AN924-4	• NUT	1	35	
	AN9600716	• WASHER	1	35	
- 5	8-80430-295	• TUBE ASSY, NLG ACTUATOR	1	35	
- 6	MS21912D4	• TEE	1	35	
	AN924-4D	• NUT	1	35	
	AN9600716	• WASHER	1	35	
- 7		• TUBE ASSY, NLG ACTUATOR SEE FIG. 2.9-16 INDEX 3	PF		
- 8	8-80430-287	• TUBE ASSY, NLG ACTUATOR	1	A	
	8-80430-357	• TUBE ASSY, NLG ACTUATOR	1	B	
- 9	8R7448-5	• VALVE ASSY, CHECK NLG <91207> SPEC 8-00428-5 T.O. 9P5-13-3-13	1	35	
- 10	8-80430-289	• TUBE ASSY, NLG ACTUATOR	1	A	
	8-80430-359	• TUBE ASSY, NLG ACTUATOR	1	B	
- 11	MS21912D4	• TEE	1	35	
	AN924-4D	• NUT	1	35	
	AN9600716	• WASHER	1	35	
- 12	8-80430-291	• TUBE ASSY, NLG DOOR ACTUATOR	1	A	
	8-80430-361	• TUBE ASSY, NLG DOOR ACTUATOR	1	B	
- 13	MS21912D4	• TEE	1		
	AN924-4D	• NUT	1	35	
	AN9600716	• WASHER	1	35	
- 14	64A34527-1	• TUBE ASSY, PNEUMATIC BYPASS VALVE	1		
	64A34513-1	• TUBE ASSY, PNEUMATIC BYPASS VALVE	1		
- 15		• VALVE, EMERGENCY BYPASS SEE FIG. 2.15-1 INDEX 5	PF		
- 16	MS8001E093A	• HOSE ASSY, NLG DOOR EMERGENCY OPEN (ASSEMBLE FROM)	1	C	
	MIL-H-27267-4	• • HOSE, BULK, MED. PRESS. TEFLON	AR		
	R5400-.460	• • GUARD, CHAFE	AR		
	MS27381-4C	• • ADAPTER ASSY, FLARELESS, STRAIGHT	2		
	MS8001E110B	• HOSE ASSY, NLG DOOR EMERGENCY OPEN (ASSEMBLE FROM)	1	B	
	MIL-H-27267-4	• • HOSE, BULK, MED PRESS TEFLON	AR		
	R5400-.460	• • GUARD, CHAFE	AR		
	MS27381-4C	• • ADAPTER ASSY, FLARELESS, STRAIGHT	1		
	MS27384-4C	• • ADAPTER ASSY, FLARELESS, 45 DEGREE ELBOW	1		
- 17	MS21902D4	• UNION	1	35	
	AN6290-4	• GASKET	1	35	
- 18		• ACTUATOR ASSY, NLG DOOR SEE FIG. 2.15-13 INDEX 31	PF		
		A AIRPLANES #35 THRU 47 AND 49 THRU 89			
		B AIRPLANES #48, 90 AND ON			
		C AIRPLANES 35 THRU 47 AND 49 THRU 89			

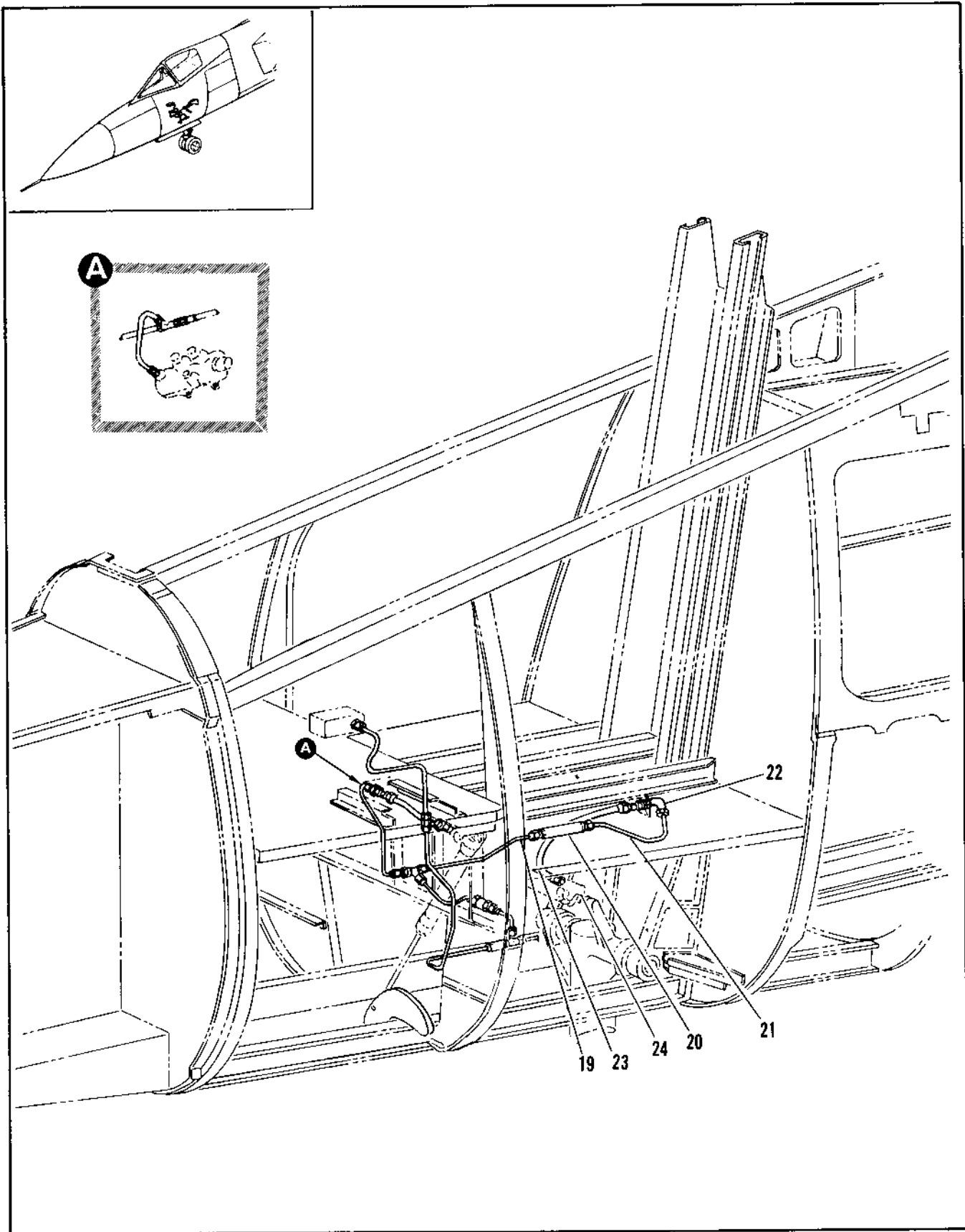

Figure 2.9-16. High Pressure Pneumatic Nose Landing Gear Tubing Installation (Sheet 2 of 2)

FIGURE AND INDEX NUMBER	PART NUMBER	DESCRIPTION	UNITS PER ASSY.	USABLE ON CODE	
				FROM	TO
		1 2 3 4 5 6			
2.9-16- 19	6-8C430-31	• TUBE ASSY, NLG ACTUATOR	1	35	
- 20	41930-3	• VALVE ASSY, HIGH PRESS PRIORITY PNEUMATIC <R1873> SPEC R-00305-P T.O. 9P5-7-6-3 REPLACED BY SUITABLE SUB 41930-13	1	35	70
	41930-13	• VALVE ASSY, HIGH PRESS PRIORITY PNEUMATIC <R1873> SPEC R-00305-13 REPLACES SUITABLE SUP FOR 41930-3	1	71	
- 21	8-80430-159	• TUBE ASSY, NLG ACTUATOR	1	35	
- 22	MS21504D4	• ELBOW	1	35	
	AN924-40	• NUT	1	35	
	AN9610716	• WASHER	1	35	
- 23	MSH001E16CA	• HOSE ASSY, NLG STRUT EMERGENCY EXTEND (ASSEMBLE FROM)	1	45	
	MIL-H-27267-4	• HOSE, BULK, MED, PRESS, TEFLOX	RF		
- 24	MS27381-4C	• ADAPTER ASSY, FLARELESS, STRAIGHT • ACTUATOR ASSY, NLG SEE FIG. 2.15-16 INDEX 59	2 RF		

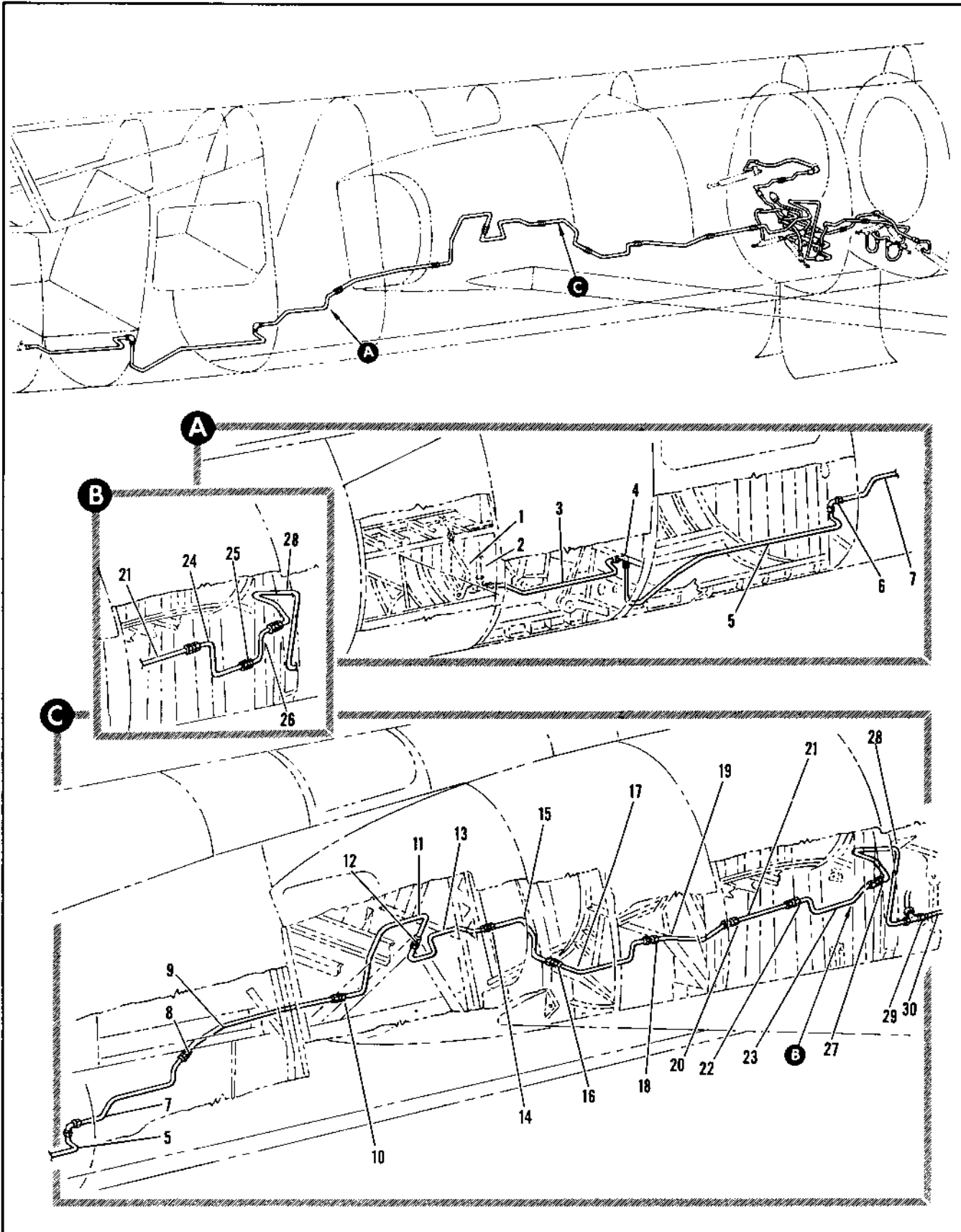

Figure 2.9-17. High Pressure Pneumatic Main Landing Gear Tubing Installation (Sheet 1 of 5)

FIGURE AND INDEX NUMBER	PART NUMBER	DESCRIPTION	UNITS PER ASSY.	USABLE ON CODE	
				FROM	TO
		1 2 3 4 5 6			
2.9-17	8-80430	TUBING INSTALLATION, HIGH PRESSURE PNEUMATIC MAIN LANDING GEAR	1	35	
	8-80429	TUBING INSTALLATION, HIGH PRESSURE PNEUMATIC MAIN LANDING GEAR MODIFIED BY 8-80504	1	35	
- 1		• TUBE ASSY, MLG ACTUATOR SEE FIG. 2.9-15 INDEX 5	RF		
- 2		• TUBE ASSY, MLG ACTUATOR SEE FIG. 2.9-15 INDEX 8	RF		
- 3	8-80430-37	• TUBE ASSY, MLG ACTUATOR	1	35	
- 4	MS21907D4	• ELBOW	1	35	
	AN924-40	• NUT	1	35	
	AN9600716	• WASHER	1	35	
- 5	8-80430-323	• TUBE ASSY, MLG ACTUATOR	1	35	
- 6	MS21907D4	• ELBOW	1	35	
	AN924-40	• NUT	1	35	
	AN9600716	• WASHER	1	35	
- 7	64A34208-1	• TUBE ASSY, HIGH PRESSURE PNEUMATIC	1		
- 8	MS21902D4	• UNION	1	35	
- 9	64A34207-1	• TUBE ASSY, HIGH PRESSURE PNEUMATIC	1		
- 10	MS21902D4	• UNION	1	35	
- 11	8-80429-1083	• TUBE ASSY, MLG ACTUATOR	1	35	
- 12	MS21902D4	• UNION	1	35	
- 13	8-80429-1065	• TUBE ASSY, MLG ACTUATOR	1	35	
- 14	MS21902D4	• UNION	1	35	
- 15	8-80429-363	• TUBE ASSY, MLG ACTUATOR	1	35	
- 16	MS21902D4	• UNION	1	35	
- 17	8-80429-51	• TUBE ASSY, MLG ACTUATOR	1	35	
- 18	MS21902D4	• UNION	1	35	
- 19	8-80429-53	• TUBE ASSY, MLG ACTUATOR	1	35	
- 20	MS21902D4	• UNION	1	35	
- 21	8-80429-55	• TUBE ASSY, MLG ACTUATOR	1	35	
- 22	MS21902D4	• UNION	1	35	
- 23	8-80429-57	• TUBE ASSY, MLG ACTUATOR	1	4	
- 24	8-80429-1297	• TUBE ASSY, MLG ACTUATOR	1	B	
- 25	MS21903D4	• UNION	1	B	
	AN924-30	• NUT	1	B	
	AN9600716	• WASHER	1	B	
- 26	8-80429-1299	• TUBE ASSY, MLG ACTUATOR	1	B	
- 27	MS21902D4	• UNION	1	35	
- 28	8-80429-11	• TUBE ASSY, MLG ACTUATOR	1	35	
- 29	MS21912D4	• TEE	1	35	
	AN924-40	• NUT	1	35	
	AN9600716	• WASHER	1	35	
		A AIRPLANES #35 THRU 47 AND 49 THRU 89 B AIRPLANES #48, 90 AND ON			

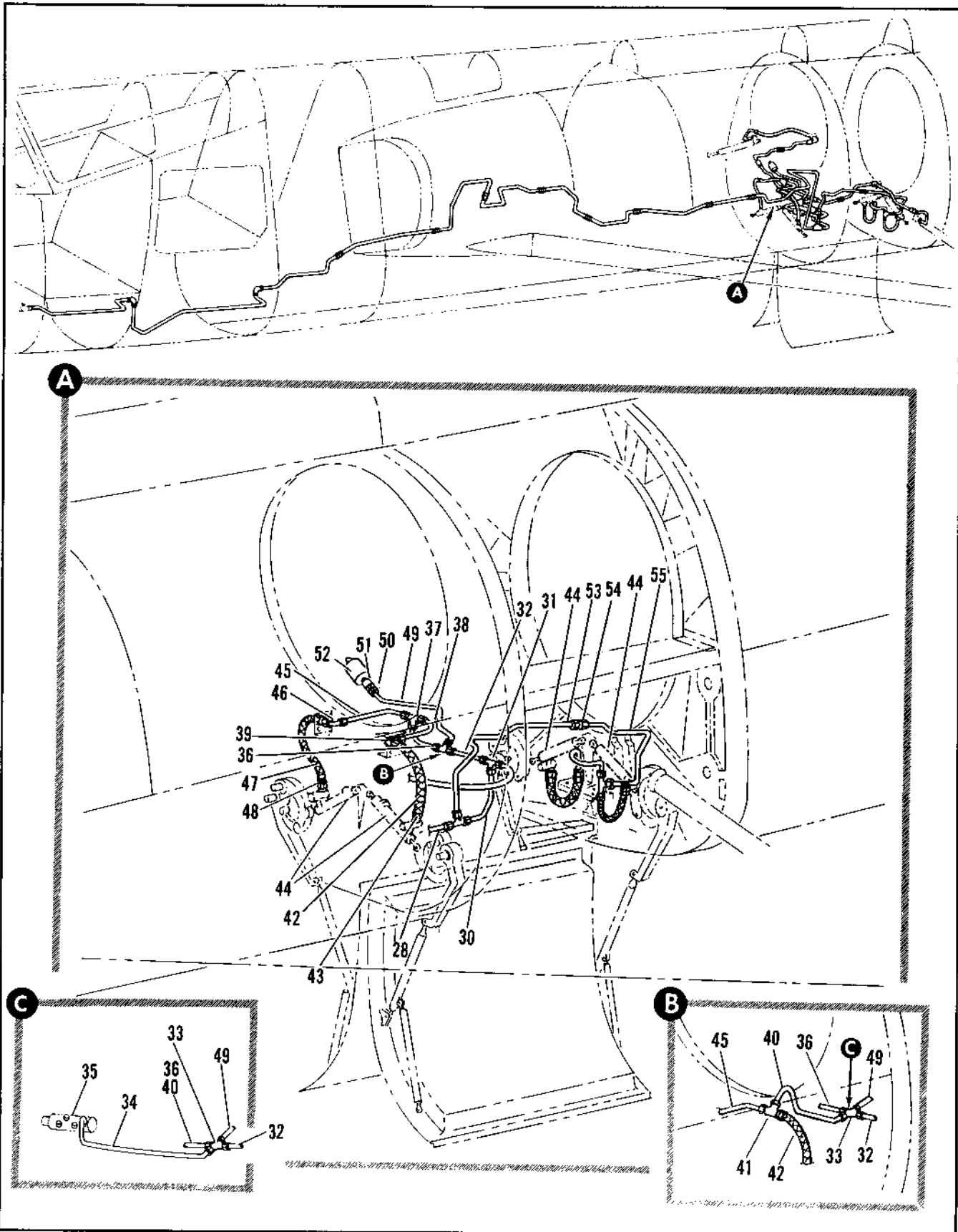

Figure 2.9-17. High Pressure Pneumatic Main Landing Gear Tubing Installation (Sheet 2 of 5)

FIGURE AND INDEX NUMBER	PART NUMBER	DESCRIPTION	UNITS PER ASSY.	USABLE ON CODE	
				FROM	TO
		1 2 3 4 5 6			
2.9-17- 30	8-80429-157	. TUBE ASSY, FWD MLG DOOR ACTUATOR	1	35	
- 31	MS21905D4	. TEE	1	35	
- 32	8-80429-133	. TUBE ASSY, FWD MLG DOOR ACTUATOR	1	35	
- 33	MS21906D4	. CROSS	1		
- 34	64A34519-1	. TUBE ASSY, PNEUMATIC BYPASS VALVE	1		
- 35		. VALVE, EMERGENCY BYPASS SEE FIG. 2.15-1 INDEX 64	PF		
- 36	8-80429-159	. TUBE ASSY, FWD MLG DOOR ACTUATOR	1	35	60
- 37	MS21905D4	. TEE	1	35	60
- 38	8-80429-161	. TUBE ASSY, FWD MLG DOOR ACTUATOR	1	35	60
- 39	MS21908D4	. ELBOW	1	35	60
	AN924-4D	. NUT	1	35	60
	AN960D716	. WASHER	1	35	60
- 40	8-80429-1269	. TUBE ASSY, FWD MLG DOOR ACTUATOR	1	61	
- 41	MS21912D4	. TEE	1	61	
	AN924-4D	. NUT	1	61	
	AN960D716	. WASHER	1	61	
- 42	MS8001E143A	. HOSE ASSY, LH MLG DOOR (FWD) EMERGENCY OPEN (ASSEMBLE FROM)	1	35	
	MIL-H-27267-4	. HOSE, BULK, MED. PRESS, TEFLON	AR		
	MS27381-4C	. ADAPTER ASSY, FLARELESS, STRAIGHT	2		
- 43	MS21902D4	. UNION	1	35	
	AN6290-4	. GASKET	1	35	
- 44		. ACTUATOR ASSY, MLG DOOR SEE FIG. 2.15-22 INDEX 2	PF		
- 45	8-80429-97	. TUBE ASSY, FWD MLG DOOR ACTUATOR RH	1	35	60
- 46	8-80429-1257	. TUBE ASSY, FWD MLG DOOR ACTUATOR RH	1	61	
	MS21908D4	. ELBOW	1	35	60
	MS21907D4	. ELBOW	1	61	
	AN924-4D	. NUT	1	35	
	AN960D716L	. WASHER	1	35	
- 47	MS8001E143A	. HOSE ASSY, RH MLG DOOR (FWD) EMERGENCY OPEN (ASSEMBLE FROM)	1	35	
	MIL-H-27267-4	. HOSE, BULK, MED PRESS TEFLON	AR		
	MS27381-4C	. ADAPTER ASSY, FLARELESS, STRAIGHT	2		
	MIL-H-27267-4	. HOSE, BULK, MED. PRESS, TEFLON	AR		
	MS27381-4C	. ADAPTER ASSY, FLARELESS, STRAIGHT	2		
- 48	MS21902D4	. UNION	1	35	
	AN6290-4	. GASKET	1	35	
- 49	8-80429-167	. TUBE ASSY, PRESSURE SWITCH	1	35	
- 50	MS21902D4	. UNION	2	35	
	AN6290-4	. GASKET	3	35	
- 51	9R7442-1	. RESTRICTOR, FIXED PNEUMATIC <91207> SPEC 8-80429-1	1	35	
- 52	95400-3	. SWITCH ASSY, PRESSURE <81873> SPEC 8-10404-3 T.O. 852-3-49-13	1	35	
- 53	8-80429-307	. TUBE ASSY, AFT MLG DOOR ACTUATOR	1	35	
- 54	MS21902D4	. UNION	1	35	
- 55	8-80429-627	. TUBE ASSY, AFT MLG DOOR ACTUATOR	1	35	60

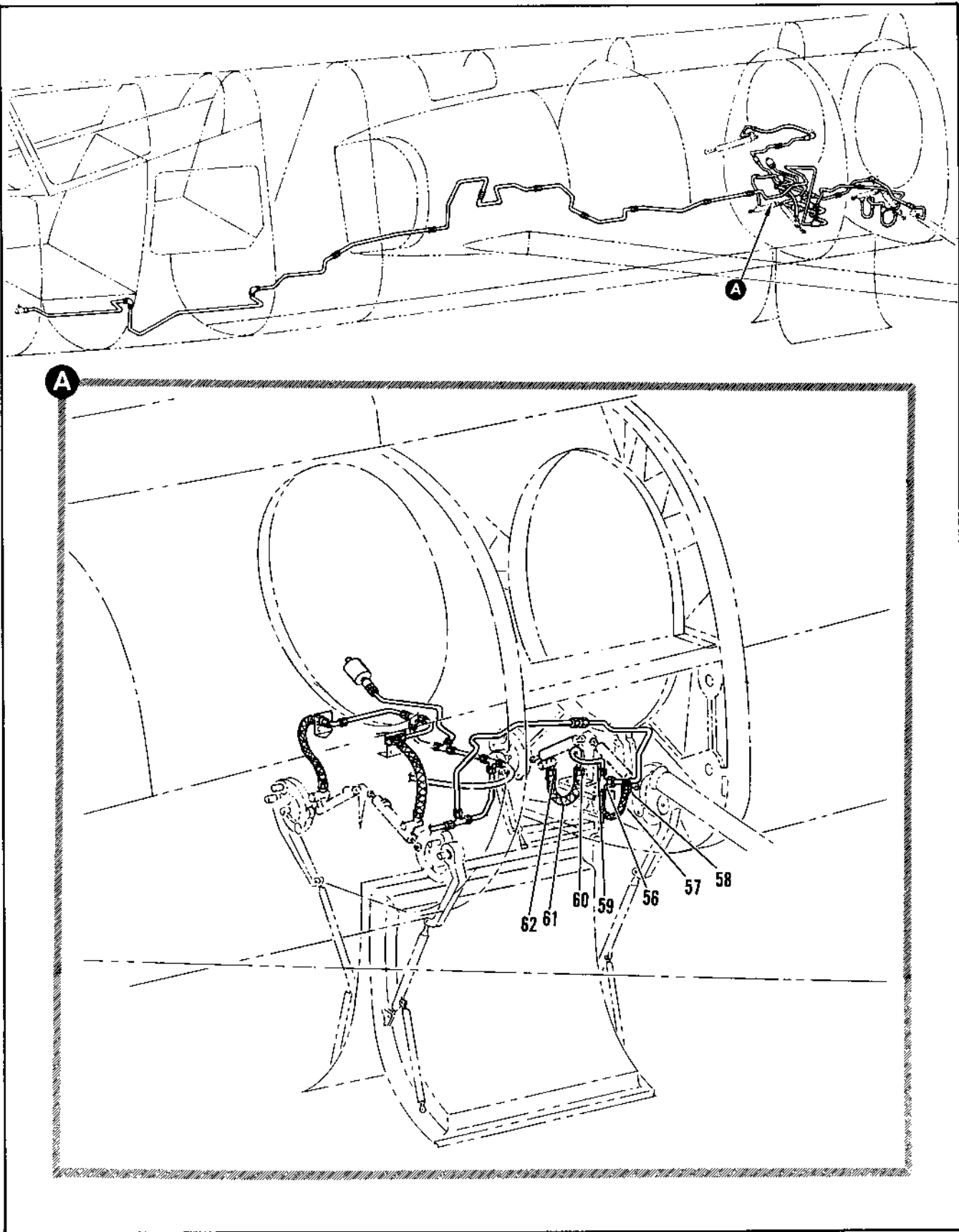

Figure 2.9-17. High Pressure Pneumatic Main Landing Gear Tubing Installation (Sheet 3 of 5)

FIGURE AND INDEX NUMBER	PART NUMBER	DESCRIPTION 1 2 3 4 5 6	UNITS PER ASSY.	USABLE ON CODE	
				FROM	TO
2.9-17	8-80429-1275	• TUBE ASSY, AFT MLG DOOR ACTUATOR	1	61	
- 56	MS21912D4	• TEE	1	35	
	AN924-4D	• NUT	1	35	
	AN9600716L	• WASHER	1	35	
- 57	MSB001E135A	• HOSE ASSY, LH MLG DOOR (AFT) EMERGENCY OPEN (ASSEMBLE FROM)	1	35	
	MIL-H-27267-4	• HOSE, BULK, MED. PRESS, TEFLON	AP		
	MS27381-4C	• ADAPTER ASSY, FLARELESS, STRAIGHT	2		
- 58	MS21902D4	• UNION	1	35	
	AN6290-4	• GASKET	1	35	
- 59	8-80429-623	• TUBE ASSY, AFT MLG DOOR ACTUATOR RH	1	35	53
	8-80429-1261	• TUBE ASSY, AFT MLG DOOR ACTUATOR RH	1	61	
- 60	MS21903D4	• UNION	1	35	
	AN924-4D	• NUT	1	35	
	AN9600716L	• WASHER	1	35	
- 61	MSB001E135A	• HOSE ASSY, RH MLG DOOR (AFT) EMERGENCY OPEN (ASSEMBLE FROM)	1	35	
	MIL-H-27267-4	• HOSE, BULK, MED. PRESS TEFLON	AR		
	MS27381-4C	• ADAPTER ASSY, FLARELESS, STRAIGHT	2		
- 62	MS21902D4	• UNION	1	35	
	AN6290-4	• GASKET	1	35	

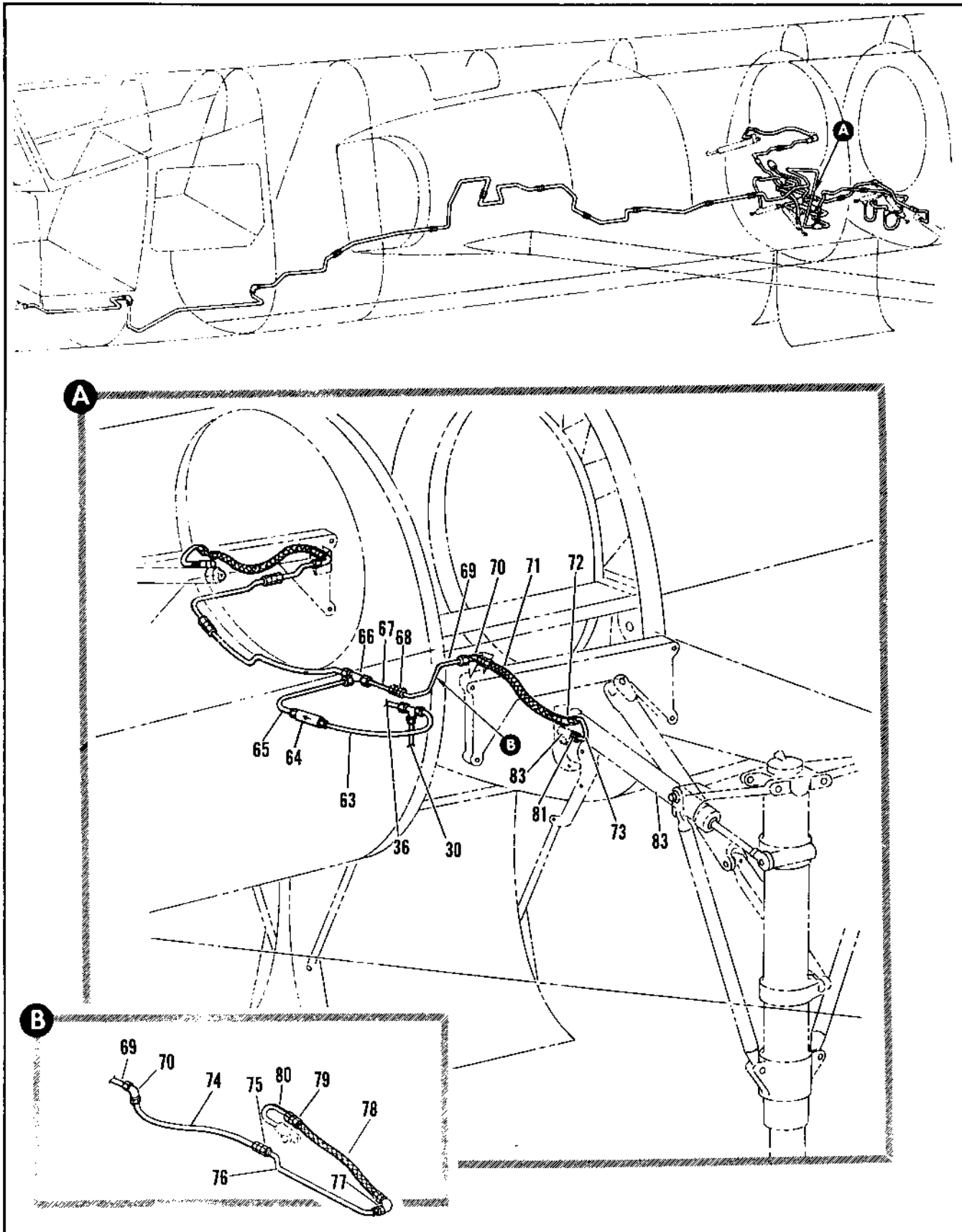

Figure 2.9-17. High Pressure Pneumatic Main Landing Gear Tubing Installation (Sheet 4 of 5)

FIGURE AND INDEX NUMBER	PART NUMBER	DESCRIPTION	UNITS PER ASSY.	USABLE ON CODE	
				FROM	TO
2.9-17- 63	8-80429-145	• TUBE ASSY, MLG ACTUATOR	1	35	60
- 64	8-80429-1265 41930-7	• TUBE ASSY, MLG ACTUATOR • VALVE ASSY, PRIORITY HIGH PRESSURE <81873> SPEC 8-00305-11 T.O.9P5-7-6-3	1 1	61 35	
- 65	8-80429-151	• TUBE ASSY, MLG ACTUATOR	1	35	60
- 66	8-80429-1267	• TUBE ASSY, MLG ACTUATOR	1	61	
- 67	MS21905D4	• TEE	1	35	
- 68	8-80429-153	• TUBE ASSY, MLG ACTUATOR LH	1	35	
- 69	MS21902D4	• UNION	1	35	
- 70	8-80429-155 8-80429-1107	• TUBE ASSY, MLG ACTUATOR LH • TUBE ASSY, MLG ACTUATOR LH	1 1	35 39	39
- 71	MS21907D4 AN924-40 AN960D716 MS8001E133A	• ELBOW • NUT • WASHER • HOSE ASSY, LH MLG STRUT, EMERGENCY EXTEND	1 1 1 1	35 35 35 35	38
	MIL-H-27267-4	(ASSEMBLE FROM) • HOSE, BULK, MED. PRESS TEFLON	AR		
	RS400-.460	• GUARD, CHAFF	AR		
- 72	MS27381-4C MS21907D4 AN924-40 AN960D716L	• ADAPTER ASSY, FLARELESS, STRAIGHT • ELBOW • NUT • WASHER	2 1 1 1	35 35 35 38	38
- 73	8-80429-319	• TUBE ASSY, MLG ACTUATOR LH	1	35	38
- 74	8-80429-297 8-80429-1199	• TUBE ASSY, MLG ACTUATOR LH • TUBE ASSY, MLG ACTUATOR LH	1 1	39 49	48
- 75	MS21902D4	• UNION	1	39	
- 76	8-80429-1099 8-80429-1201	• TUBE ASSY, MLG ACTUATOR LH • TUBE ASSY, MLG ACTUATOR LH	1 1	39 47	48 129
- 77	8-80429-1359 MS21903D4 AN924-40 AN960D716L	• TUBE ASSY, MLG ACTUATOR LH • UNION • NUT • WASHER	1 1 1 1	130 39 39 39	
- 78	MS8001E14200	• HOSE ASSY, LH MLG STRUT, EMERGENCY EXTEND (ASSEMBLE FROM)	1	39	48
	MIL-H-27267-4	• HOSE, BULK, MED. PRESS TEFLON	AR		
	RS400-.460	• GUARD, CHAFF	AR		
	MS27384-4C	• ADAPTER ASSY, FLARELESS 45 DEGREE ELBOW	2		
	MS8001E1460	• HOSE ASSY, LH MLG STRUT, EMERGENCY EXTEND (ASSEMBLE FROM)	1	49	
	MIL-H-27267-4	• HOSE, BULK, MED. PRESS TEFLON	AR		
	RS400-.460	• GUARD, CHAFF	AR		
- 79	MS27381-4C MS27384-4C MS21903D4 AN924-40 AN960D716L	• ADAPTER ASSY, FLARELESS, STRAIGHT • ADAPTER ASSY, FLARELESS, 45 DEGREE ELBOW • UNION • NUT • WASHER	1 1 1 1 1	1 1 1 1 39	
- 80	8-80429-1207	• TUBE ASSY, MLG ACTUATOR LH	1	39	
- 81	MS21915D6-4 AN629D-6	• REDUCER • GASKET	1 1	35 35	
- 82		• VALVE ASSY, SHUTTLE SEE FIG. 2.15-26 INDEX 13	PF		
- 83		• ACTUATOR ASSY, MLG SEE FIG. 2.15-25 INDEX 21	PF		

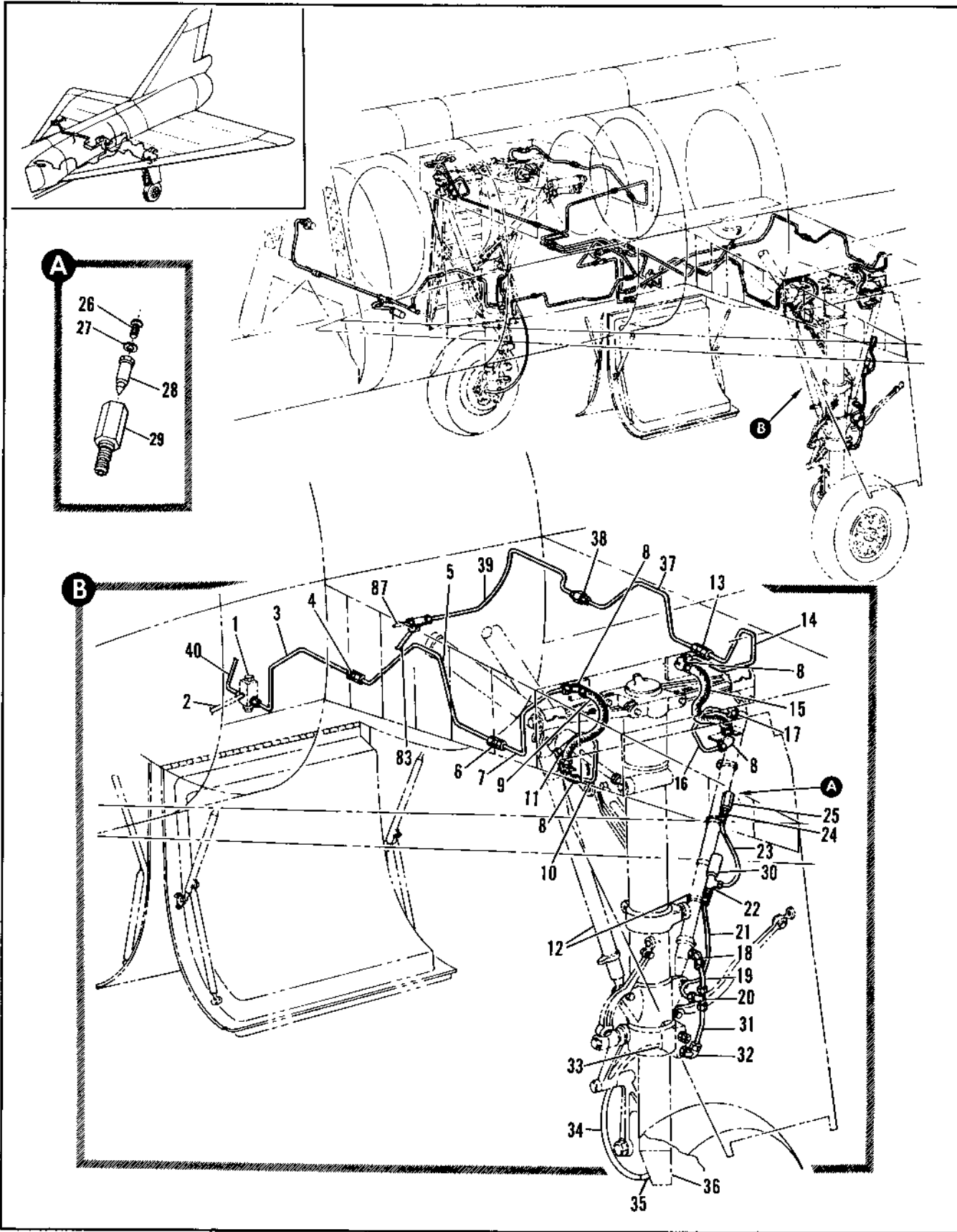

Figure 2.9-18. High Pressure Pneumatic Main Landing Gear Brake Supply Tubing Installation (Sheet 1 of 4)

FIGURE AND INDEX NUMBER	PART NUMBER	DESCRIPTION	UNITS PER ASSY.	USABLE ON CODE	
				FROM	TO
2.9-18	8-80429	TURING INSTL, HIGH PRESSURE PNEUMATIC MAIN LANDING GEAR BRAKE SUPPLY MONI- FIED BY 8-80504 AND 66J40297	1	35	
- 1		• VALVE ASSY, SEE FIG. 2.9-22 INDEX 19	RF		
- 2		• TUBE ASSY, BLEED SEE FIG. 2.9-22 INDEX 18	RF		
- 3	8-80429-1385	• TUBE ASSY, FWD DRAG BRACE LH	1	241	
- 4	MS21902D4	• UNION	1	35	
- 5	65A33102-1	• TUBE ASSY, LH	1	35	
- 6	MS21902D4	• UNION	1	35	
- 7	8-80429-753	• TUBE ASSY, FWD DRAG BRACE LH	1	35	
- 8	MS21908D4	• ELBOW	4	35	
	AN924-4D	• NUT	4	35	
	AN961D716L	• WASHER	4	35	
- 9	127012-4CR0170	• HOSE ASSY, FWD DRAG BRACE SERVICING <9H441>	1	35	
- 10	8-80429-629	• TUBE ASSY, FWD DRAG BRACE LH	1	35	102
	8-80429-1333	• TUBE ASSY, FWD DRAG BRACE LH	1	103	
- 11	MS21902D4	• UNION	1	35	
	AN6290-4	• GASKET	1	35	
- 12		• SHOCK STRUT, MLG., SEE FIG. 2.15-25 INDEX 82	RF		
- 13	MS21902D4	• UNION	1	35	
- 14	8-80429-153	• TUBE ASSY, AFT DRAG BRACE LH	1	35	
- 15	127012-4CR0170	• HOSE ASSY, AFT DRAG BRACE SERVICING <9H441>	1	35	
- 16	8-80429-755	• TUBE ASSY, AFT DRAG BRACE LH	1	35	102
	8-80429-1331	• TUBE ASSY, AFT DRAG BRACE LH	1	103	
- 17	155140-2	• VALVE, CHECK <91864> SPEC 4-35430-3 T.O.9P5-12-35-3	1	35	
	AN6290-4	• GASKET	1	35	
- 18	4190-565491	• ELBOW, <92003> 93-40014-001	1	35	
- 19	8-80429-757	• TUBE ASSY, AFT DRAG BRACE LH	1	35	
- 20	MS21905D4	• TEE	1	35	
- 21	8-80429-761	• TUBE ASSY, RELIEF VALVE LH	1	35	
- 22	MS21911D4	• TEE	1	A	
	AN6290-4	• GASKET	1	A	
- 23	8-80429-8	• TUBE ASSY, BLEED VALVE		A	
- 24	AN924-4D	• NUT	1	A	
	AN961D716	• WASHER	1	A	
- 25	8-85107	• PLUG ASSY, BLEEDER	1	A	
- 26	AN520C10R6	• SCREW	1	A	
- 27	AN935-10L	• WASHER	1	A	
- 28	AN6204-1	• VALVE	1	A	
- 29	8-85107-7	• PLUG	1	A	
- 30	MC1624-3450	• VALVE ASSY, RELIEF <74000> SPEC 6-08336-7 T.O.9P5-2-39-3	1	35	
- 31	8-80429-759	• TUBE ASSY, AFT DRAG BRACE LH		35	
- 32	4190-565491	• ELBOW, <92003> 93-40014-001	1	35	
- 33		• VALVE ASSY, BRAKE RELAY SEE FIG. 2.15-1 INDEX 47	RF		
- 34	MS8001E230A	• HOSE ASSY, LH BRAKE (ASSEMBLE FROM)	1	35	
	MIL-H-27267-4	• HOSE, RULK, MED. PRESS. TEFLO	AP		
	MS27381-4C	• ADAPTER ASSY, FLANGELESS, STRAIGHT	2		
- 35	MS21902-4	• UNION	1	35	
	AN6290-4	• GASKET	1	35	
- 36		• BRAKE, MLG., SEE FIG. 2.15-26 INDEX 74	RF		
- 37	8-80429-751	• TUBE ASSY, DRAG BRACE LH	1	35	
- 38	MS21902D4	• UNION	1	35	
- 39	8-80429-1009	• TUBE ASSY, DRAG BRACE LH	1	35	

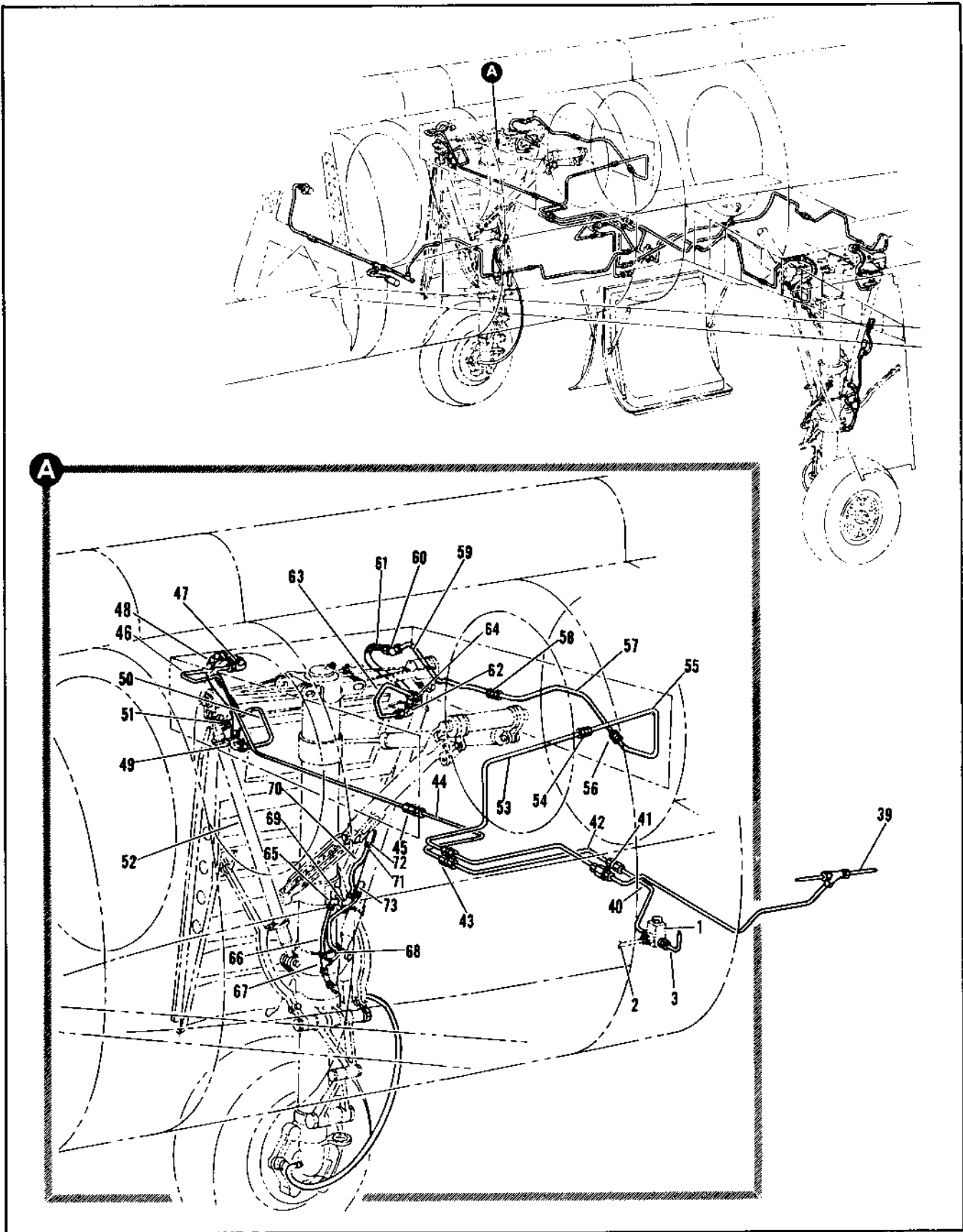

Figure 2.9-18. High Pressure Pneumatic Main Landing Gear Brake Supply Tubing Installation (Sheet 2 of 4)

FIGURE AND INDEX NUMBER	PART NUMBER	DESCRIPTION	UNITS PER ASSY.	USABLE ON CODE	
				FROM	TO
		1 2 3 4 5 6			
2.9-18- 40	8-80429-587	• TUBE ASSY, FWD DRAG BRACE RH	1	35	
- 41	MS21902D4	• UNION	1	35	
- 42	8-80429-1383	• TUBE ASSY, FWD DRAG BRACE RH	1	241	
- 43	MS21902D4	• UNION	1	35	
- 44	8-80429-1115	• TUBE ASSY, FWD DRAG BRACE RH	1	35	
- 45	MS21902D4	• UNION	1	35	
- 46	8-80429-1001	• TUBE ASSY, FWD DRAG BRACE RH	1	35	
- 47	MS21908D4	• ELBOW	1	35	
	AN924-4D	• NUT	1	35	
	AN9600716L	• WASHER	1	35	
- 48	127012-4CR0170	• HOSE ASSY, FWD DRAG BRACE SERVICING <98441>	1	35	
- 49	MS21908D4	• ELBOW	1	35	
	AN924-4D	• NUT	1	35	
	AN9600716L	• WASHER	1	35	
- 50	8-80429-641	• TUBE ASSY, FWD DRAG BRACE RH	1	35	102
	8-80429-1337	• TUBE ASSY, FWD DRAG BRACE RH	1	103	
- 51	MS21902D4	• UNION	1	35	
	AN6290-4	• GASKET	1	35	
- 52		• SHOCK STRUT, MLG, SEE FIG. 2-15-25 INDEX 82	RF		
- 53	8-80429-1117	• TUBE ASSY, AFT DRAG BRACE RH	1	35	
- 54	MS21902D4	• UNION	1	35	
- 55	8-80429-683	• TUBE ASSY, AFT DRAG BRACE RH	1	35	46
	8-80429-1215	• TUBE ASSY, AFT DRAG BRACE RH	1	49	
- 56	MS21902D4	• UNION	1	35	
- 57	8-80429-669	• TUBE ASSY, AFT DRAG BRACE RH	1	35	48
	8-80429-1217	• TUBE ASSY, AFT DRAG BRACE RH	1	49	
- 58	MS21902D4	• UNION	1	35	
- 59	8-80429-799	• TUBE ASSY, AFT DRAG BRACE RH	1	35	48
	8-80429-1219	• TUBE ASSY, AFT DRAG BRACE RH	1	49	
- 60	MS21907D4	• ELBOW	1	35	
	AN924-4D	• NUT	1	35	
	AN9600716L	• WASHER	1	35	
- 61	127012-4CR0170	• HOSE ASSY, AFT DRAG BRACE SERVICING <98441>	1	35	
- 62	MS21908D4	• ELBOW	1	35	
	AN924-4D	• NUT	1	35	
	AN9600716L	• WASHER	1	35	
- 63	8-80429-777	• TUBE ASSY, AFT DRAG BRACE RH	1	35	102
	8-80429-1329	• TUBE ASSY, AFT DRAG BRACE RH	1	103	
- 64	MS21902D4	• UNION	1	35	
	AN6290-4	• GASKET	1	35	
- 65	4190-565491	• ELBOW, <92003> 93-43014-001	1	35	
- 66	8-80429-779	• TUBE ASSY, AFT DRAG BRACE RH	1	35	
- 67	MS21905D4	• TEE	1	35	
- 68	8-80429-783	• TUBE ASSY, RELIEF VALVE	1	35	
- 69	MS21911D4	• TEE	1	A	
	AN6290-4	• GASKET	1	A	
- 70	8-80429-1279	• TUBE ASSY, BLEED VALVE RH	1	A	
- 71	AN924-4D	• NUT	1	A	
	AN9600716	• WASHER	1	A	
- 72	8-85107	• PLUG ASSY, BLEEDER	1	A	
	AN520C10RE	• SCREW	1	A	
	AN935-10L	• WASHER	1	A	
	AN6294-1	• VALVE	1	A	
	8-85107-7	• PLUG	1	A	
- 73	MC1624-3450	• VALVE ASSY, RELIEF <76050> SPEC 8-08336-7 T.O. 9P5-2-38-3	1	35	

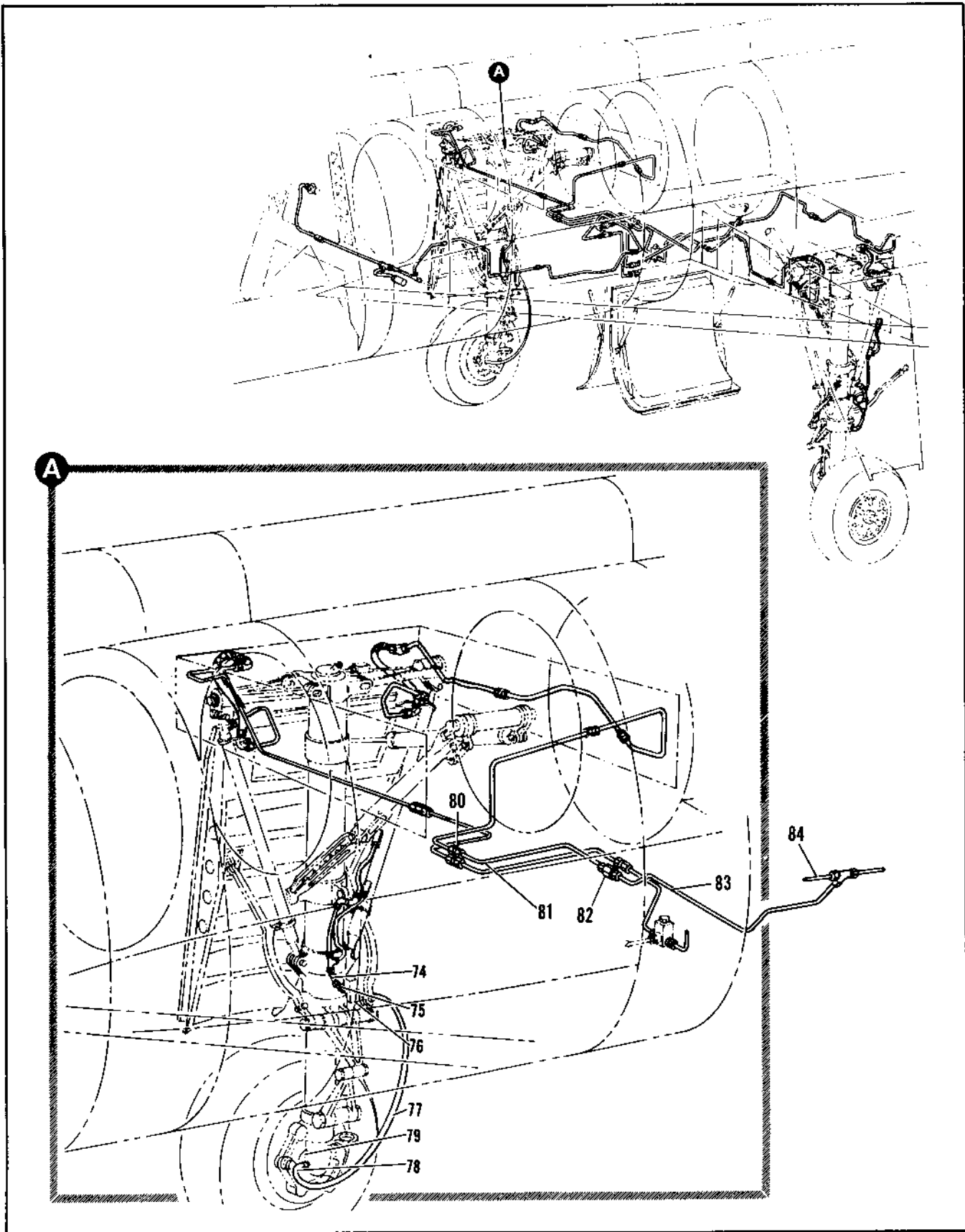

Figure 2.9-18. High Pressure Pneumatic Main Landing Gear Brake Supply Tubing Installation (Sheet 3 of 4)

FIGURE AND INDEX NUMBER	PART NUMBER	DESCRIPTION	UNITS PER ASSY.	USABLE ON CODE	
				FROM	TO
		1 2 3 4 5 8			
2.9-18- 74	8-80429-781	• TUBE ASSY, AFT DRAG BRACE RH	1	35	
- 75	4190-565491	• ELBOW, <92003> 93-40014-001	1	35	
- 76		• VALVE ASSY, BRAKE RELAY SEE FIG. 2.15-1 INDEX 47	RF		
- 77	MS8001E234A	(ASSEMBLE FROM)	1	35	
	MIL-H-27267-4	(ASSEMBLY FROM)			
		• HOSE, BULK, MED. PRFSS. TEFLOW	AR		
	MS27381-4C	• ADAPTER ASSY, FLARELESS, STRAIGHT	2		
- 78	MS21902-4	• UNION	1	35	
	AN6290-4	• GASKET	1	35	
- 79		• BRAKE, MLG, SEE FIG. 2.15-25 INDEX 74	RF		
- 80	MS21902D4	• UNION	1	35	
- 81	8-80429-1381	• TUBE ASSY, DRAG BRACE RH	1	241	
- 82	MS21902D4	• UNION	1		
- 83	8-80429-311	• TUBE ASSY, DRAG BRACE RH	1	35	
- 84		• TUBE ASSY, FILLER, SEE FIG. 2.9-23 INDEX 36	RF		
A AIRPLANES #48, 61 AND ON					

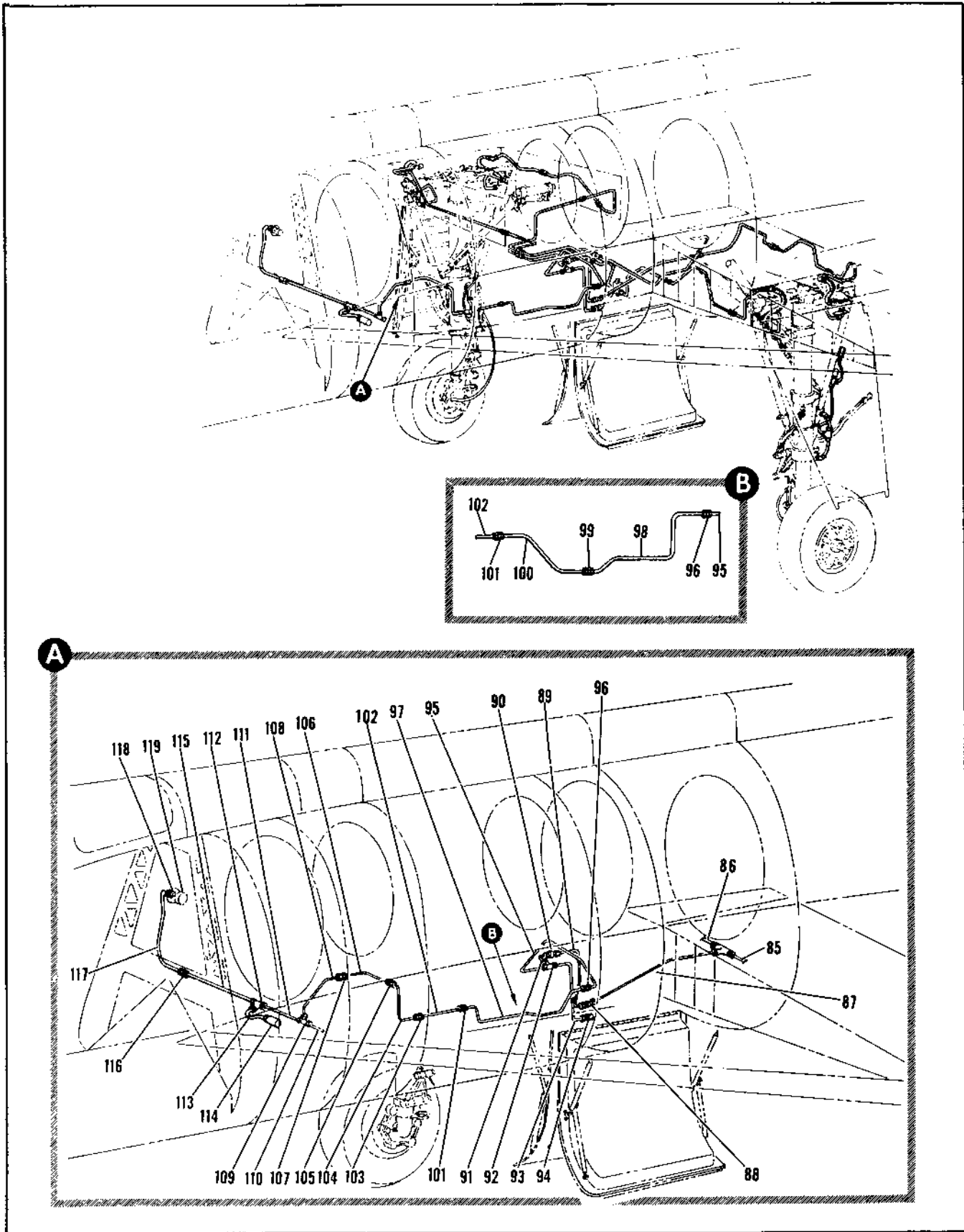

Figure 2.9-18. High Pressure Pneumatic Main Landing Gear Brake Supply Tubing Installation (Sheet 4 of 4)

FIGURE AND INDEX NUMBER	PART NUMBER	DESCRIPTION	UNITS PER ASSY.	USABLE ON CODE	
				FROM	TO
2.9-18- 85					
- 86		• TUBE ASSY, FILTER SEE FIG. 2.9-23 INDEX 43	RF		
- 87		• TUBE ASSY, FILTER SEE FIG. 2.9-23 INDEX 41	RF		
- 88	8-80429-765	• TUBE ASSY, SUPPLY	1	35	
	MS21907D4	• ELBOW	1	35	
	AN924-4D	• NUT	1	35	
	AN960716	• WASHER	1	35	
- 89	8-80429-523	• TUBE ASSY, SUPPLY	1	35	
- 90	155140-2	• VALVE ASSY, CHECK <91864> SPEC R-00430-0 T.O. 9P5-12-35-3	1	35	
- 91	8-80429-511	• TUBE ASSY, SUPPLY	1	35	
- 92	MS21905D4	• TEE	1	35	
- 93	8-80429-329	• TUBE ASSY, PLUG	1	35	
	AN924-4D	• NUT	1	35	
	AN960716	• WASHER	1	35	
- 94	8-85107	• PLUG ASSEMBLY	1	35	
	AN520C10R6	• SCREW	1	35	
	AN935-10L	• WASHER	1	35	
	AN6204-1	• VALVE	1	35	
	8-85107-7	• PLUG	1	35	
- 95	8-80429-89	• TUBE ASSY, SUPPLY	1	35	
- 96	MS21902D4	• UNION	1	35	
- 97	8-80429-81	• TUBE ASSY, SUPPLY	1	B	
- 98	8-80429-1291	• TUBE ASSY, SUPPLY	1	C	
- 99	MS21902D4	• UNION	1	C	
	AN924-4D	• NUT	1	C	
	AN960716	• WASHER	1	C	
-100	8-80429-1289	• TUBE ASSY, SUPPLY	1	C	
-101	MS21902D4	• UNION	1	C	
-102	8-80429-79	• TUBE ASSY, SUPPLY	1	35	
-103	MS21902D4	• UNION	1	35	
-104	8-80429-77	• TUBE ASSY, SUPPLY	1	35	
-105	MS21902D4	• UNION	1	35	
-106	8-80429-75	• TUBE ASSY, SUPPLY	1	35	
-107	MS21902D4	• UNION	1	35	
-108	66A39638-1	• TUBE ASSY	1		
-109	MS21905D4	• TEE	1	35	
-110		• TUBE ASSY, VARIABLE AIR RAMP DRIVE UNIT SEE FIG. 2.9-19 INDEX 3	RF		
-111	8-80429-613	• TUBE ASSY, MLG BRAKE SUPPLY	1	35	
-112	MS21905D4	• TEE	1	35	
-113	8-80429-611	• TUBE ASSY, RELIEF VALVE	1	35	
-114	MC1624-3450	• VALVE ASSY, RELIEF <76050> SPEC 8-08336-7 T.O. 9P5-2-38-3	1	35	
-115	8-80429-615	• TUBE ASSY, MLG BRAKE SUPPLY	1	35	
-116	MS21902D4	• UNION	1	35	
-117	8-80429-617	• TUBE ASSY, MLG BRAKE SUPPLY	1	35	
-118	MS21916D8-4	• REDUCER	1	35	
	AN6290-8	• GASKET	1	35	
-119		• FLASK, AIR STORAGE VARIABLE AIR RAMP SEE FIG. 2.11-1 INDEX 38	RF		
		B AIRPLANES #35 THRU 47 AND 49 THRU 89			
		C AIRPLANES #48, 90 AND ON			

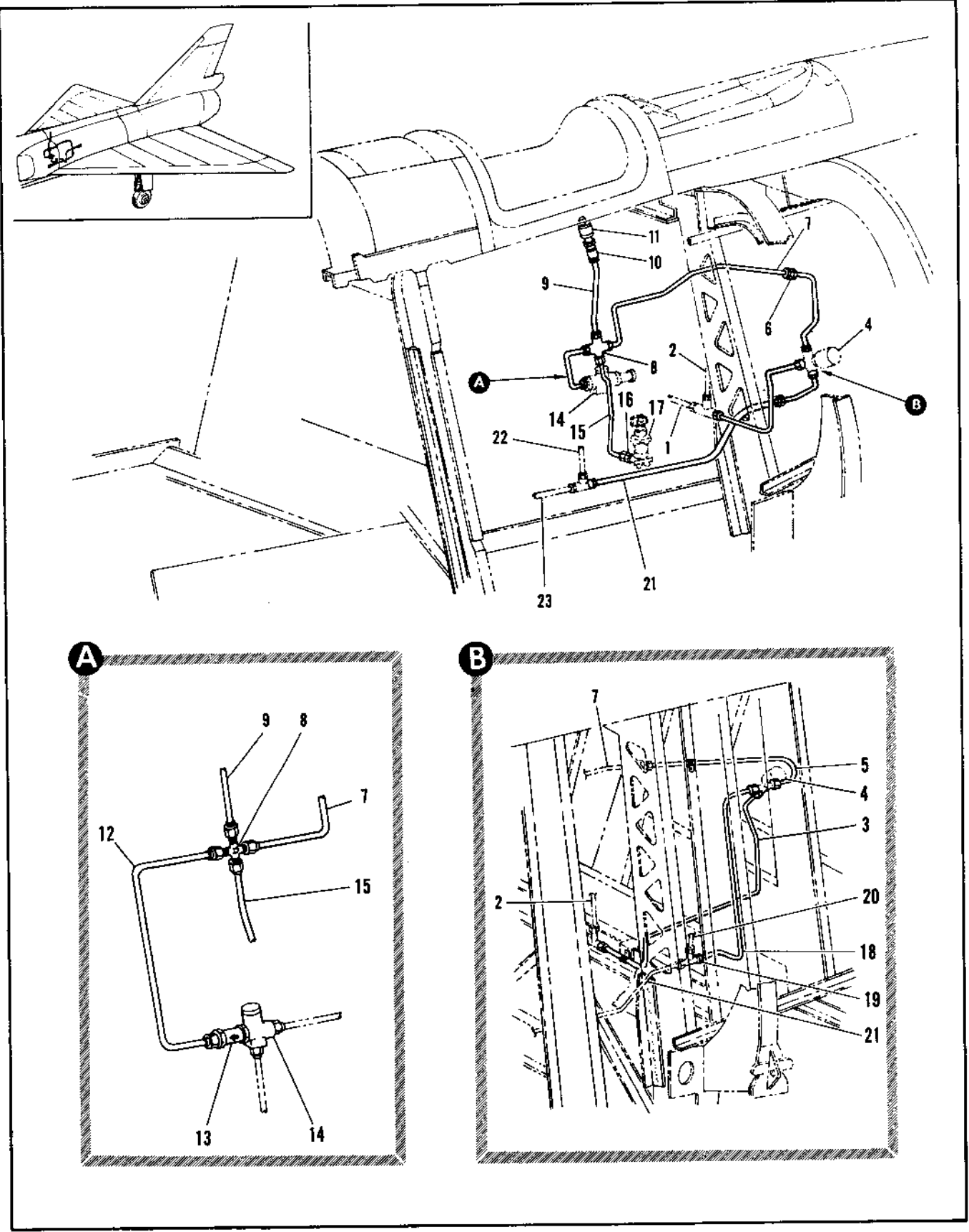

Figure 2.9-19. High Pressure Pneumatic Variable Air Ramp Drive Unit Tubing Installation

FIGURE AND INDEX NUMBER	PART NUMBER	DESCRIPTION	UNITS PER ASSY.	USABLE ON CODE	
				FROM	TO
		1 2 3 4 5 6			
2.9-19	8-80429	VARIABLE AIR RAMP DRIVE UNIT TURING INSTL. HIGH PRESSURE PNEUMATIC VARIABLE AIR RAMP DRIVE UNIT MODIFIED BY 66J43297	1		
- 1		. TUBE ASSY, SEE FIG. 2.9-17 INDEX 111	RF		
- 2		. TUBE ASSY, SEE FIG. 2.9-17 INDEX 108	RF		
- 3	66A39635-1	. TUBE ASSY, VARIABLE AIR RAMP DRIVE UNIT	1		
- 4		. VALVE ASSY, VARIABLE AIR RAMP SELECTOR SOLENOID OPERATED SEE FIG. 2.11-1 INDEX 18	RF		
- 5	66A39633-1	. TUBE ASSY, VARIABLE AIR RAMP DRIVE UNIT	1		
- 6	MS21902D4	. UNION	1	35	
- 7	8-80429-1177	. TUBE ASSY, VARIABLE AIR RAMP DRIVE UNIT	1	35	
- 8	MS21906D4	. CROSS	1	35	
- 9	8-80429-533	. TUBE ASSY, PRESSURE SWITCH	1	35	
- 10	9R7442-1	. RESTRICTOR ASSY, FIXED <91207> SPEC 8-80429-	1	35	
- 11	95400-3	. SWITCH ASSY, PRESSURE <81873> SPEC 8-80404-3 T.O. 8S2-3-49-13	1	35	
- 12	8-82407-7	. TUBE ASSY, VARIABLE AIR RAMP DRIVE UNIT	1		
- 13	8R7448-3	. RESTRICTOR	1		
	AN6290-4	. GASKET	1		
- 14		. VALVE ASSY, SHUTTLE STA 301 SEE FIG. 2.11-8 INDEX 14	RF	RF	
- 15	8-80429-1103	. TUBE ASSY, VARIABLE AIR RAMP DRIVE UNIT	1	35	
- 16	MS2191604-2	. REDUCER	1	35	
	AN6290-4	. GASKET	1	35	
- 17		. DRIVE UNIT, VARIABLE AIR RAMP INTAKE DUCT SEE FIG. 2.11-1 INDEX 3	RF		
- 18	66A39634-1	. TUBE ASSY, VARIABLE AIR RAMP VENT	1		
- 19	MS21905D4	. TEE	1		
- 20		. TUBE ASSY,	PF		
- 21	8-80429-505	. TUBE ASSY, VARIABLE AIR RAMP VENT	1	35	
- 22		. TUBE ASSY, SEE FIG. 2.8-17 INDEX 26	RF		
- 23		. TUBE ASSY, SEE FIG. 2.8-17 INDEX 30	RF		

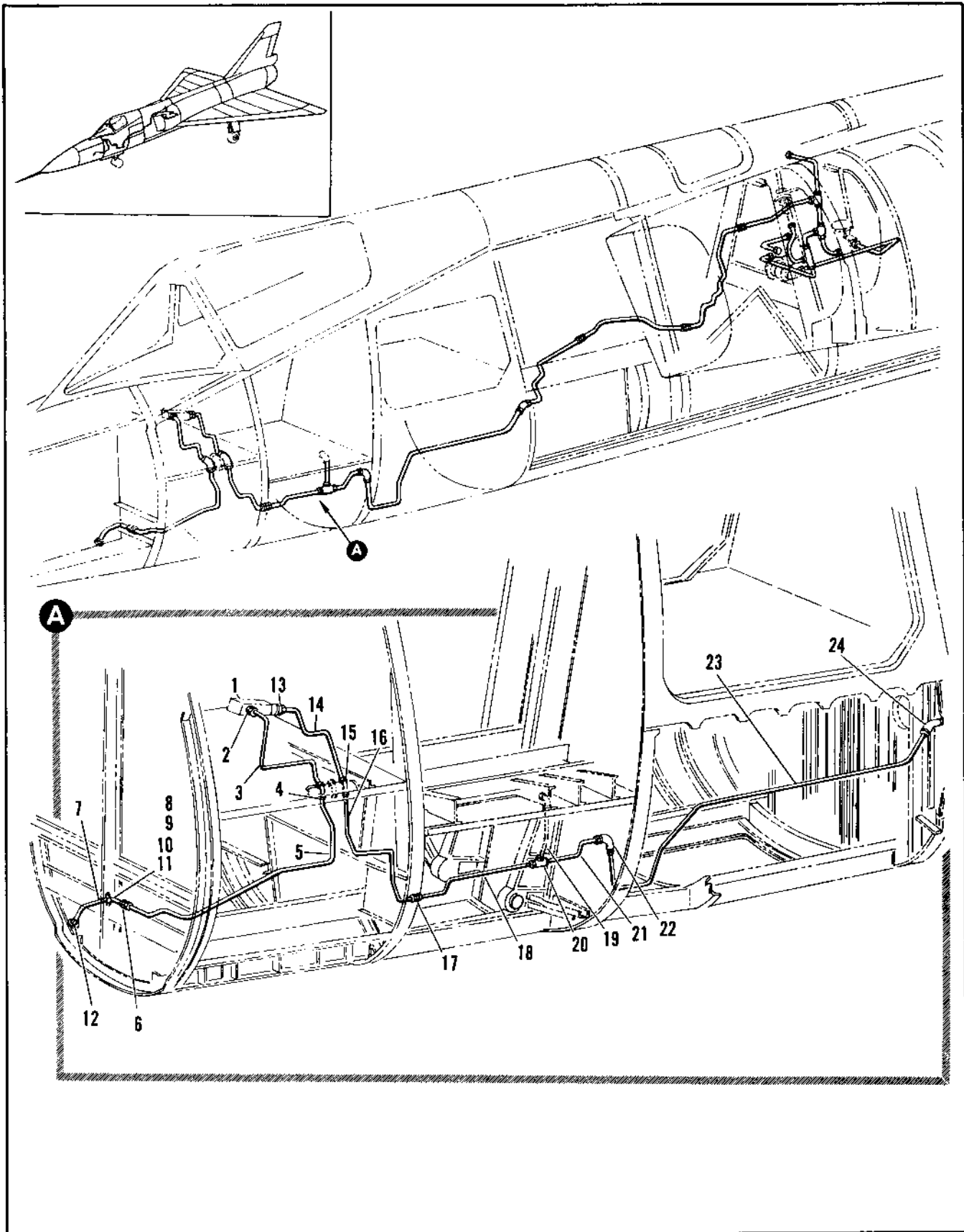

Figure 2.9-20. High Pressure Pneumatic Emergency Landing Gear Selector Valve Main Line and Vent Tubing Installation (Sheet 1 of 2)

FIGURE AND INDEX NUMBER	PART NUMBER	DESCRIPTION	UNITS PER ASSY.	USABLE ON CODE	
				FROM	TO
		1 2 3 4 5 6			
2.9-20	8-80430	TUBING INSTL, HIGH PRESSURE PNEUMATIC EMERGENCY LANDING GEAR SELECTOR VALVE MAIN LINE AND VENT MODIFIED BY 66J40297	1	35	
	8-80429	TUBING INSTL, HIGH PRESSURE PNEUMATIC EMERGENCY LANDING GEAR SELECTOR VALVE MAIN LINE AND VENT MODIFIED BY 66J40297	1	35	
- 1		. VALVE ASSY, SEE FIG. 2.15-7 INDEX 15	RF		
- 2	MS21902D4	. UNION	1	35	
	AN6290-4	. GASKET	1	35	
- 3	8-80430-343	. TUBE ASSY, VENT	1	A	
	8-80430-365	. TUBE ASSY, VENT	1	A	
	8-80430-403	. TUBE ASSY, VENT	1	160	
- 4	MS21903D4	. UNION	1	35	
	AN924-40	. NUT	1	35	
	AN9600716	. WASHER	1	35	
- 5	8-80430-335	. TUBE ASSY, VENT	1	A	
	8-80430-363	. TUBE ASSY, VENT	1	C	
- 6	ER81600406	. UNION, <92003> 90-04929-005	1	35	
- 7	7140212-10	. TUBE ASSY, INFRARED SEEKER	1	35	
- 8	MS219190G4	. CLAMP	1	35	
- 9	NAS43003-26	. SPACER	1	35	
- 10	MS35207-029	. SCREW	1	35	
- 11	MS21142L3	. NUT	1	35	
- 12		. VENT, PORT, SEE FIG. 2.3-8 INDEX 2	RF		
- 13	155140-2	. VALVE ASSY, MAIN LINE CHECK <91864> SPEC 8-80430-3 T.O. 9P5-12-35-3	1	35	
- 14	8-80430-277	. TUBE ASSY, MAIN LINE	1	A	
	8-80430-353	. TUBE ASSY, MAIN LINE	1	R	
	8-80430-399	. TUBE ASSY, MAIN LINE	1	160	
- 15	MS21907D4	. ELBOW	1	35	
	AN924-40	. NUT	1	35	
	AN9600716	. WASHER	1	35	
- 16	8-80430-257	. TUBE ASSY, MAIN LINE	1	35	
- 17	MS21903D4	. UNION	1	35	
	AN924-40	. NUT	1	35	
	AN9600716	. WASHER	1	35	
- 18	8-80430-153	. TUBE ASSY, MAIN LINE	1	35	
- 19		. TUBE ASSY, SEE FIG. 2.9-21 INDEX 5	RF		
- 20	MS21905D4	. TEE	1	35	
- 21	8-80430-23	. TUBE ASSY, MAIN LINE PRESSURE REGULATOR	1	35	
- 22	MS21907D4	. ELBOW	1	35	
	AN924-40	. NUT	1	35	
	AN9600716	. WASHER	1	35	
- 23	8-80430-325	. TUBE ASSY, MAIN LINE	1	35	
- 24	MS21907D4	. ELBOW	1	35	
	AN924-40	. NUT	1	35	
	AN9600716	. WASHER	1	35	
		A AIRPLANES #35 THRU 47 AND 49 THRU 89			
		R AIRPLANES #48 AND 90 THRU 159			
		C AIRPLANES #49, 90 AND ON			

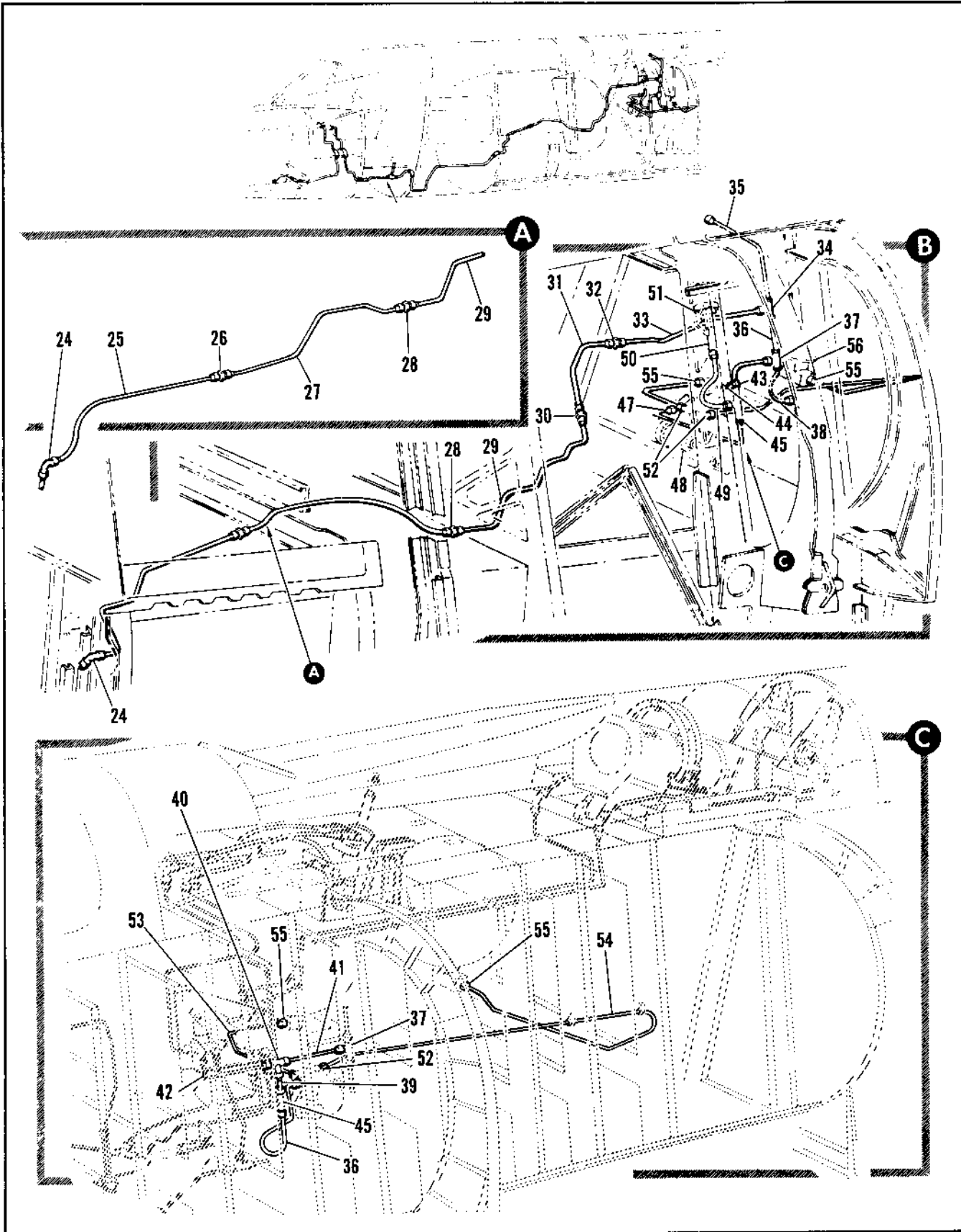

Figure 2.9-20. High Pressure Pneumatic Emergency Landing Gear Selector Valve Main Line and Vent Tubing Installation (Sheet 2 of 2)

FIGURE AND INDEX NUMBER	PART NUMBER	DESCRIPTION	UNITS PER ASSY.	USABLE ON CODE	
				FROM	TO
		1 2 3 4 5 6			
2.9-20- 25	64A34206-1	• TUBE ASSY, HIGH PRESSURE PNEUMATIC	1		
- 26	MS2190204	• UNION	1	35	
- 27	64A34205-1	• TUBE ASSY, HIGH PRESSURE PNEUMATIC	1		
- 28	MS2190204	• UNION	1	35	
- 29	8-80429-1089	• TUBE ASSY, MAIN LINE	1	35	
- 30	MS2190204	• UNION	1	35	
- 31	8-80429-1091	• TUBE ASSY, MAIN LINE	1	35	
- 32	MS2190204	• UNION	1	35	
- 33	66A39646-1	• TUBE ASSY, MAIN LINE	1		
- 34	MS2190504	• TEE	1	35	
- 35		• TUBE ASSY, DRAG CHUTE SEE FIG. 2.9-24 INDEX 4	RF		
- 36	8-80429-339	• TUBE ASSY, MAIN LINE	1	35	
- 37	MS2190504	• TEE	1	35	
- 38		• TUBE ASSY, BLEED SEE FIG. 2.9-22 INDEX 3	RF		
- 39	66A39637-1	• TUBE ASSY, MAIN LINE	1		
- 40	MS2190504	• TEE	1		
- 41	66A39631-1	• TUBE ASSY	1		
- 42		• TUBE	RF		
- 43	155140-2	• VALVE ASSY, CHECK (91864) SPEC 8-00430-3 T.O. 9P5-12-35-3	1	35	
- 44	NAS43003-24	• SPACER	1	35	
- 45	MS2191104	• TEE	1	35	
	AN6290-4	• GASKET	1	35	
- 46	66A39636-1	• TUBE ASSY, MAIN LINE	1		
- 47	MS2190204	• UNION	1	35	
	AN6290-4	• GASKET	1	35	
- 48		• REGULATOR ASSY, PNEUMATIC PRESSURE SEE FIG. 2.9-1 INDEX 40	RF		
- 49	8-80429-361	• TUBE ASSY, PRESSURE SWITCH	1	35	
- 50	9R7442-1	• RESTRICTOR, FIXED <91207> SPEC 8-00429-1	1	35	
- 51	95400-1	• SWITCH ASSY, PRESSURE <R1873> SPEC 8-00404-1 T.O. 9S2-3-49-13	1	35	
- 52	800627	• SWITCH ASSY, PRESSURE ALT PART	1		
	MS21902010	• UNION	2	35	
	AN6290-10	• GASKET	2	35	
- 53	66A39641-1	• TUBE ASSY, AIR FLASK	1		
- 54	66A39642-1	• TUBE ASSY, AIR FLASK	1		
- 55	MS21916012-10	• REDUCER	2	35	
	AN6290-12	• GASKET	2	35	
- 56		• FLASK, SEE FIG. 2.9-3 INDEX 11	RF		

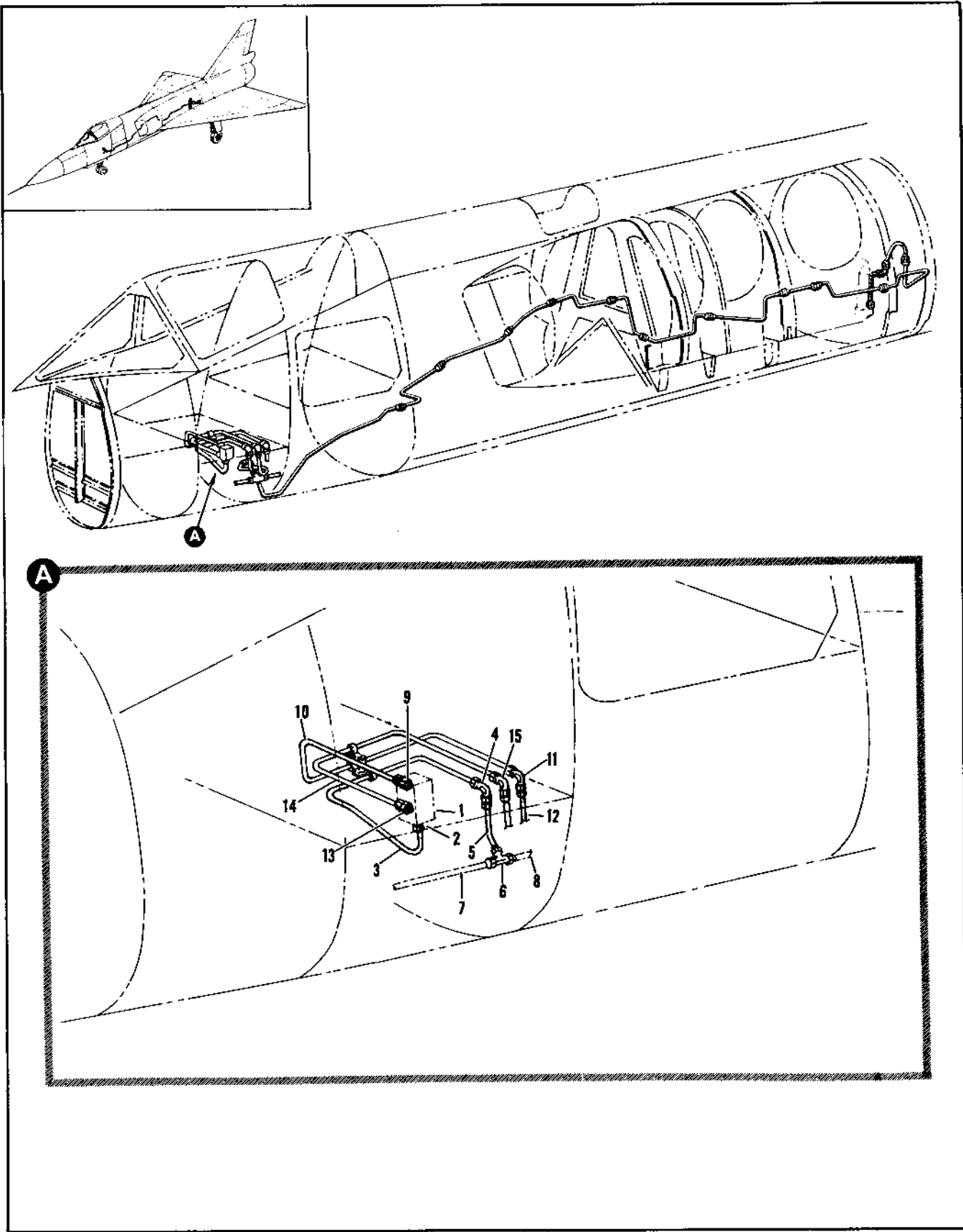

Figure 2.9-21. High Pressure Pneumatic Ram Air Tubing Installation (Sheet 1 of 2)

FIGURE AND INDEX NUMBER	PART NUMBER	DESCRIPTION	UNITS PER ASSY.	USABLE ON CODE	
				FROM	TO
2.9-21	R-80430	TUBING INSTALLATION, HIGH PRESSURE PNEUMATIC RAM AIR	1	35	
	R-80429	TUBING INSTALLATION, HIGH PRESSURE PNEUMATIC RAM AIR	1	35	
- 1		• VALVE ASSY, EMERGENCY HYDRAULIC POWER SEE FIG. 2.9-1 INDEX 11	RF		
- 2	MS2190204	• UNION	1	35	
	AN6290-4	• GASKET	1	35	
- 3	R-80430-281	• TUBE ASSY, MAIN LINE	1	35	
- 4	MS2190804	• ELBOW	1	35	
	AN924-40	• NUT	1	35	
	AN9600716	• WASHER	1	35	
- 5	R-80430-25	• TUBE ASSY, MAIN LINE	1	35	
- 6	MS2190504	• TEE	1	35	
- 7		• TUBE ASSY, MAIN LINE SEE FIG. 2.9-20 INDEX 18	RF		
- 8		• TUBE ASSY, MAIN LINE PRESSURE REGULATOR SEE FIG. 2.9-20 INDEX 21	RF		
- 9	MS2190204	• UNION	1	35	
	AN6290-4	• GASKET	1	35	
- 10	R-80430-283	• TUBE ASSY, VENT	1	35	
- 11	MS2190804	• ELBOW	1	35	
	AN924-40	• NUT	1	35	
	AN9600716	• WASHER	1	35	
- 12	R-80430-42	• TUBE ASSY, VENT	1	35	
- 13	MS2190604-3	• REDUCER	1	35	
	AN6290-4	• GASKET	1	35	
- 14	R-80430-269	• TUBE ASSY, ACTUATOR	1	35	
- 15	MS2190803	• ELBOW	1	35	
	AN924-30	• NUT	1	35	
	AN9600616	• WASHER	1	35	

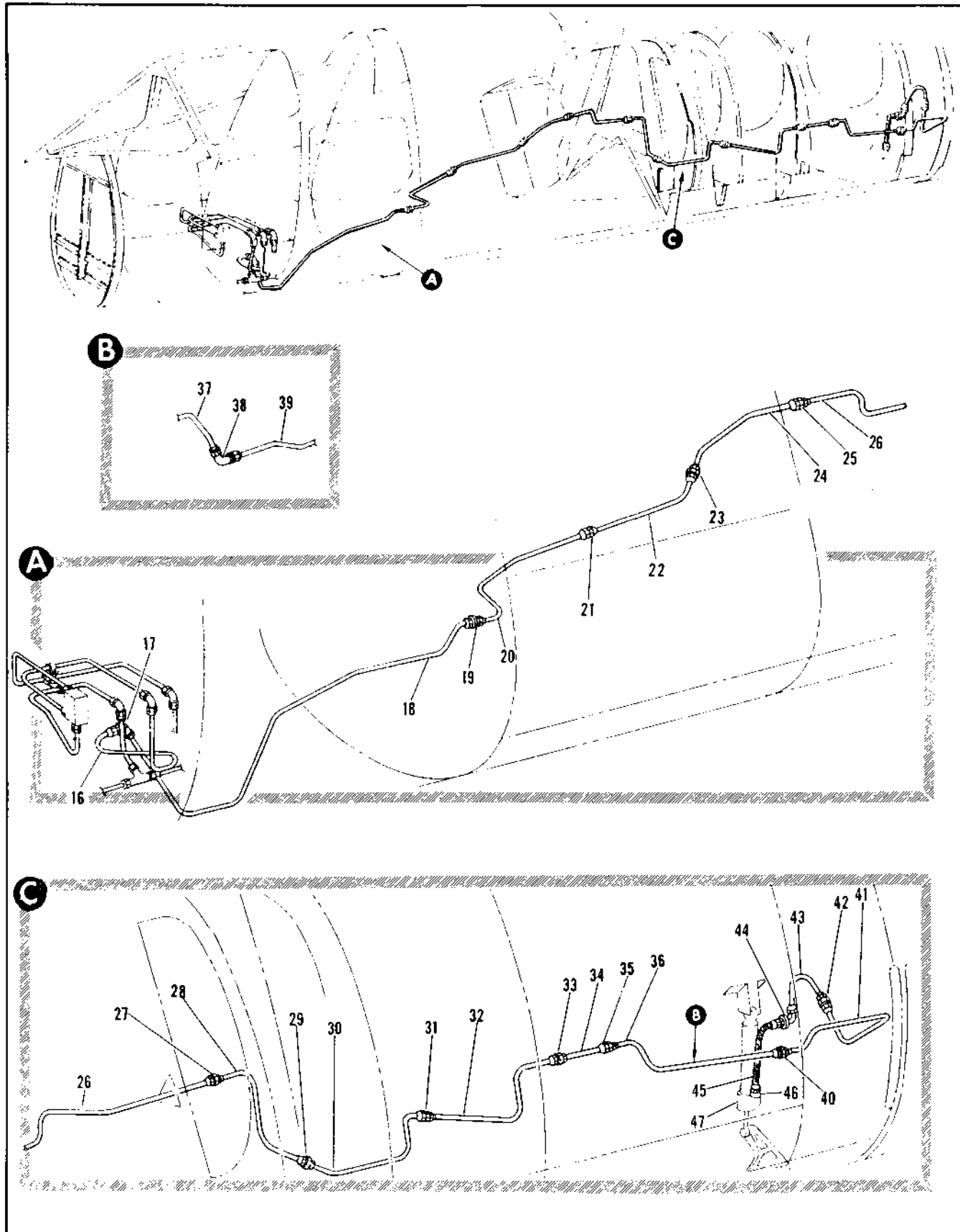

Figure 2.9-21. High Pressure Pneumatic Ram Air Tubing Installation (Sheet 2 of 2)

FIGURE AND INDEX NUMBER	PART NUMBER	DESCRIPTION	UNITS PER ASSY.	USABLE ON CODE	
				FROM	TO
		1 2 3 4 5 6			
2.9-21- 16	8-80430-47	• TUBE ASSY, ACTUATOR	1	35	
- 17	MS21907D3	• ELBOW	1	35	
	AN924-3D	• NUT	1	35	
	AN960D616	• WASHER	1	35	
- 18	8-80430-317	• TUBE ASSY, ACTUATOR	1	35	
- 19	MS21903D3	• UNION	1	35	
	AN960D616	• WASHER	1	35	
- 20	8-80429-21	• TUBE ASSY, ACTUATOR	1	35	
- 21	MS21902D3	• UNION	1	35	
- 22	8-80429-23	• TUBE ASSY, ACTUATOR	1	35	
- 23	MS21902D3	• UNION	1	35	
- 24	8-80429-1079	• TUBE ASSY, ACTUATOR	1	35	
- 25	MS21902D3	• UNION	1	35	
- 26	8-80429-373	• TUBE ASSY, ACTUATOR	1	35	
- 27	MS21902D3	• UNION	1	35	
- 28	8-80429-371	• TUBE ASSY, ACTUATOR	1	35	
- 29	MS21902D3	• UNION	1	35	
- 30	8-80429-43	• TUBE ASSY, ACTUATOR	1	35	
- 31	MS21902D3	• UNION	1	35	
- 32	8-80429-45	• TUBE ASSY ACTUATOR	1	35	
- 33	MS21902D3	• UNION	1	35	
- 34	8-80429-47	• TUBE ASSY, ACTUATOR	1	35	
- 35	MS21902D3	• UNION	1	35	
- 36	8-80429-49	• TUBE ASSY, ACTUATOR	1	A	
- 37	8-80429-1301	• TUBE ASSY, ACTUATOR	1	B	
- 38	MS21907D3	• ELBOW	1	B	
	AN924-100	• NUT	1	B	
	AN960D616	• WASHER	1	B	
- 39	8-80429-1303	• TUBE ASSY, ACTUATOR	1	B	
- 40	MS21902D3	• UNION	1	35	
- 41	8-80429-15	• TUBE ASSY, ACTUATOR	1	35	
- 42	MS21916D4-3	• REDUCER	1	35	
- 43	8-80429-17	• TUBE ASSY, ACTUATOR	1	35	
- 44	MS21908D4	• ELBOW	1	35	
	AN924-4D	• NUT	1	35	
	AN960D716	• WASHER	1	35	
- 45	CR295870-CC4-D156	• HOSE ASSY, (50599) SPEC 8-00358-156	1	35	
- 46	BR7448-3	• RESTRICTOR, PNEUMATIC (91207) SPEC 8-00428-3 T.O. 9P5-13-3-13	1	35	
- 47		• ACTUATOR ASSY, SEE FIG. 2.8-6 INDEX 2	RF		
		A AIRPLANES #35 THRU 47 AND 49 THRU 89			
		B AIRPLANES #48, 90 AND ON			

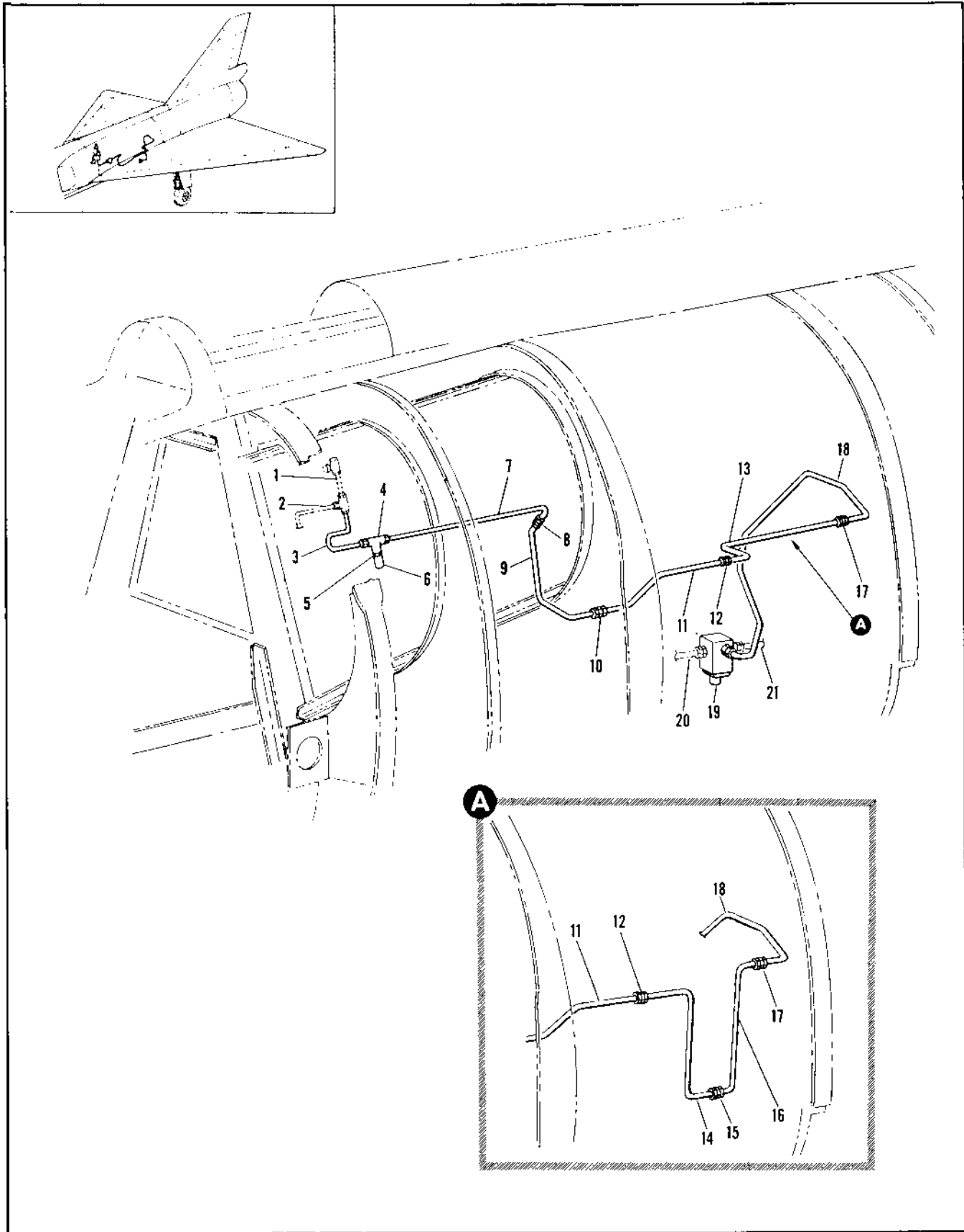

Figure 2.9-22. High Pressure Pneumatic Bleed Tubing Installation

FIGURE AND INDEX NUMBER	PART NUMBER	DESCRIPTION	UNITS PER ASSY.	USABLE ON CODE	
				FROM	TO
		1 2 3 4 5 6			
2.9-22	8-80429	TUBING INSTALLATION, HIGH PRESSURE PNEUMATIC BLEED	1	35	
- 1		• TUBE ASSY, MAIN LINE SEE FIG. 2.9-20 INDEX 36	RF		
- 2		• TUBE ASSY, MAIN LINE SEE FIG. 2.9-20 INDEX 38	RF		
- 3	8-80429-381	• TUBE ASSY, PLEED	1	35	
- 4	MS21910D4	• TEE	1	35	
	AN924-4D	• NUT	1	35	
	AN960D716	• WASHER	1	35	
- 5	MS21902D4	• UNION	1	35	
	AN6290-4	• GASKET	2	35	
- 6	MC1624-3450	• VALVE ASSY, RELIEF <76050> SPEC 8-08336-7 T.O. 9P5-2-38-3	1	35	
- 7	8-80429-383	• TUBE ASSY, BLEED	1	35	
- 8	MS21902D4	• UNION	1	35	
- 9	8-80429-87	• TUBE ASSY, BLEED	1	35	
- 10	MS21902D4	• UNION	1	35	
- 11	8-80429-85	• TUBE ASSY, BLEED	1	35	
- 12	MS21902D4	• UNION	1	35	
- 13	8-80429-83	• TUBE ASSY, BLEED	1	A	
- 14	8-80429-1293	• TUBE ASSY, BLEED	1	B	
- 15	MS21903D4	• UNION	1	B	
	AN924-4D	• NUT	1	R	
	AN960D716	• WASHER	1	R	
- 16	8-80429-1295	• TUBE ASSY, BLEED	1	8	
- 17	MS21902D4	• UNION	1	35	
- 18	8-80429-317	• TUBE ASSY, BLEED	1	35	
- 19	301552	• VALVE ASSY, BLEED CONTROL <05214> SPEC 8-00458-1 T.O. 9P5-5-84-3	1	35	
	AN924-4D	• NUT	1	35	
	AN960D716L	• WASHER	1	35	
- 20		• TUBE ASSY, FWD DRAG BRACE LH SEE FIG. 2.9-18 INDEX 3	RF		
- 21		• TUBE ASSY, FWD DRAG BRACE RH SEE FIG. 2.9-17 INDEX 40	RF		
		A AIRPLANES 35 THRU 47 AND 49 THRU 89 B AIRPLANES #48, 90 AND ON			

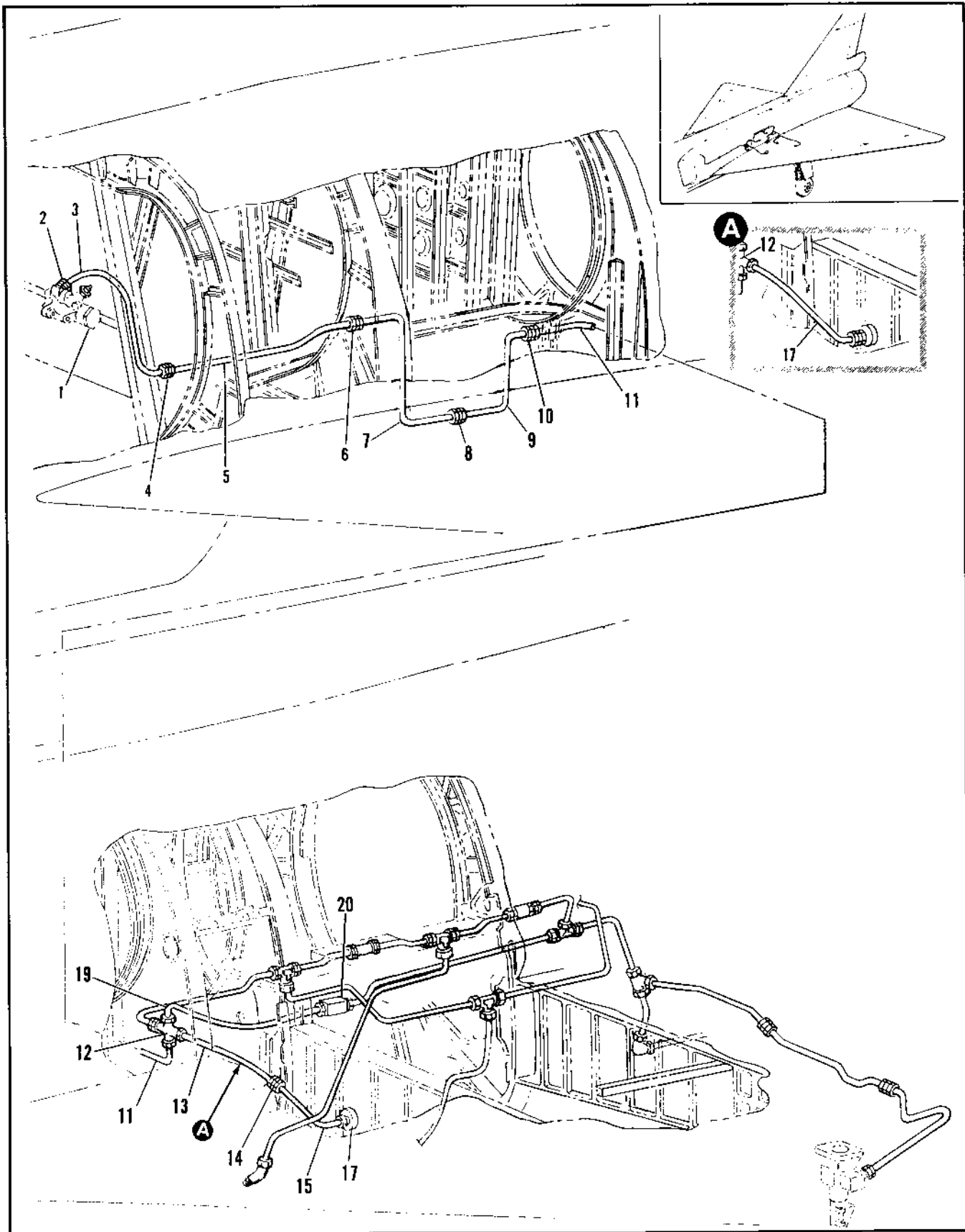

Figure 2.9-23. High Pressure Pneumatic Filler and Pressure Gauge Tubing Installation (Sheet 1 of 2)

FIGURE AND INDEX NUMBER	PART NUMBER	DESCRIPTION	UNITS PER ASSY.	USABLE ON CODE	
				FROM	TO
		1 2 3 4 5 6			
2.9-23	8-80429	TUBING INSTL, HIGH PRESSURE PNEUMATIC FILLER AND PRESSURE GAUGE MODIFIED BY 8-80504	1	35	
	8-80429	TUBING INSTL, HIGH PRESSURE PNEUMATIC FILLER AND PRESSURE GAUGE MODIFIED BY 66J40297-2	1		
- 1		• REGULATOR ASSY, PNEUMATIC PRESSURE SEE FIG. 2.9-1 INDEX 40	RF		
- 2	MS21902D10	• UNION	1	35	
	AN6290-10	• GASKET	1	35	
- 3	66A39643-1	• TUBE ASSY	1	35	
- 4	MS21902D10	• UNION	1	35	
- 5	8-80429-1105	• TUBE ASSY, FILLER	1	35	
- 6	MS21902D10	• UNION	1	35	
- 7	8-80429-1285	• TUBE ASSY, FILLER	1	8	
	8-71284-53	• TUBE ASSY, FILLER	1		
- 8	MS21903D10	• UNION	1	8	
	MS21902-10	• UNION	1		
	AN924-100	• NUT	1	9	
	AN960D1416	• WASHER	1	8	
- 9	8-80429-1287	• TUBE ASSY, FILLER	1	8	
	8-71284-55	• TUBE ASSY, FILLER	1		
- 10	MS21902D10	• UNION	1	35	
- 11	8-80429-19	• TUBE ASSY, FILLER	1	35	
- 12	4126-565774	• CROSS, <92003> 92-79005-001	1	35	
	AN924-100	• NUT	1	35	
	AN9670D1416	• WASHER	1	35	
- 13	8-80429-127	• TUBE ASSY, PRESSURE GAUGE	1	35	89
- 14	MS21902D4	• UNION	1	35	89
- 15	65A33198-1	• TUBE ASSY, PNEUMATIC	1	8	
- 16	8-80429-1347	• TUBE ASSY, PRESSURE GAUGE	1	90	
- 17	AW1026AEG01	• GAUGE, PRESSURE <61349> ACRN061-2341 TYPE MS24478-2	1	35	
- 18	MS21903D4	• UNION	1	90	
	AN924-40	• NUT	1	90	
	AN690-4	• GASKET	1	90	
- 19	8-80429-609	• TUBE ASSY, FILLER	1	35	60
	8-80429-1349	• TUBE ASSY, FILLER	1	61	
- 20		• VALVE ASSY, MANUAL SHUTOFF SEE FIG. 2.10-1 INDEX 6	RF		

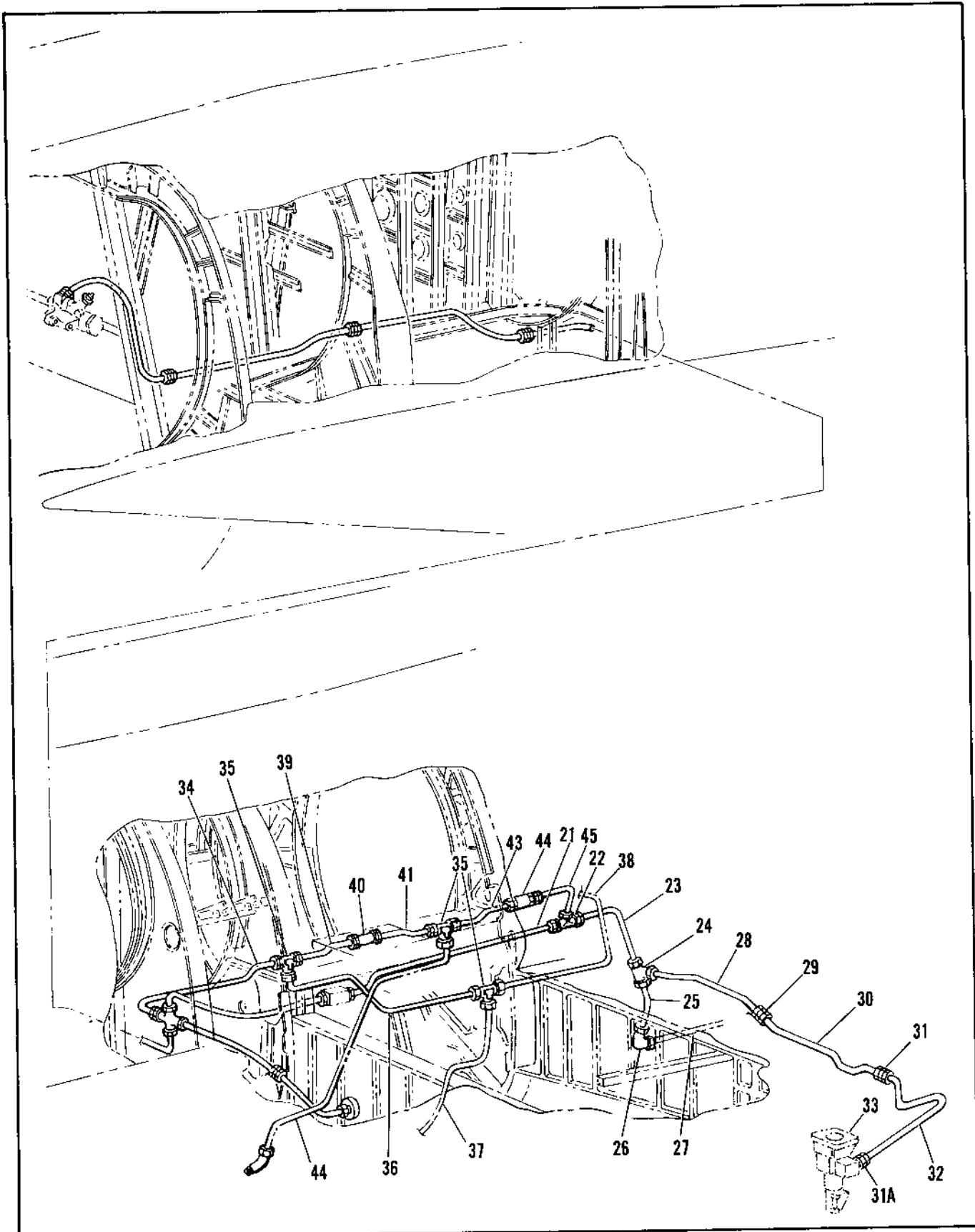

Figure 2.9-23. High Pressure Pneumatic Filler and Pressure Gauge Tubing Installation (Sheet 2 of 2)

FIGURE AND INDEX NUMBER	PART NUMBER	DESCRIPTION	UNITS PER ASSY.	USABLE ON CODE	
				FROM	TO
		1 2 3 4 5 6			
2.9-23- 21	8-80429-111	. TUBE ASSY, FILLER	1	35	
- 22	ER824D101004	. TEE, <92003> 98-90319-001	1	35	
- 23	8-80429-625	. TUBE ASSY, FILLER	1	35	60
	8-80429-1273	. TUBE ASSY, FILLER	1	61	
- 24	MS21905010	. TEE	1	35	
- 25	8-80429-619	. TUBE ASSY, FILLER	1	35	
- 26	MS21907010	. ELBOW	1	35	
	AN924-100	. NUT	1	35	
	AN960D1416	. WASHER	1	35	
- 27		. TUBE ASSY, STARTER SEE FIG. 2.9-15 INDEX 6	RF		
- 28	8-80429-147	. TUBE ASSY, FILLER	1	35	
- 29	MS21902010	. UNION	1	35	
- 30	8-80429-1535	. TUBE ASSY, FILLER	1	35	
- 31	MS31902010	. UNION	1	35	
- 31A	MS21916010-8	. REDUCER	1		
- 32	8-80429-143	. TUBE ASSY, FILLER	1	35	
- 33		. CONNECTOR, HIGH PRESSURE PNEUMATIC GROUND FILLER SEE FIG. 2.9-1	RF		
- 34	8-80429-763	. TUBE ASSY, FILLER	1	35	
- 35	MS2190504	. TEE	3	35	
- 36	8-80429-769	. TUBE ASSY, FILLER	1	35	
- 37		. TUBE ASSY, DRAG BRACE RH SEE FIG. 2.9-18 INDEX 83	RF		
- 38		. TUBE ASSY, DRAG BRACE LH SEE FIG. 2.9-18 INDEX 42	RF		
- 39	8-80429-775	. TUBE ASSY, FILTER	1	35	
- 40	155140-2	. VALVE ASSY, CHECK <91864> SPEC 8-00430-3 T.O. 9P5-12-35-3	1	35	
- 41	8-80429-767	. TUBE ASSY, FILTER	1	35	
- 42		. TUBE ASSY, SUPPLY SEE FIG. 2.9-18 INDEX 87	RF		
- 43	8-80429-771	. TUBE ASSY, FILTER	1	35	
- 44	AC1146-4	. FILTER ASSY, AIRCRAFT (31414) SPEC 8-00298-1 T.O. 9P6-2-7-3 REQUIRES FILTER ELEMENT AC1146-E4, STOCK NUMBER 1650-541-7818, T.O. 9H3-1-1	1	35	
- 45	8-80429-121	. TUBE ASSY, FILTER	1	35	

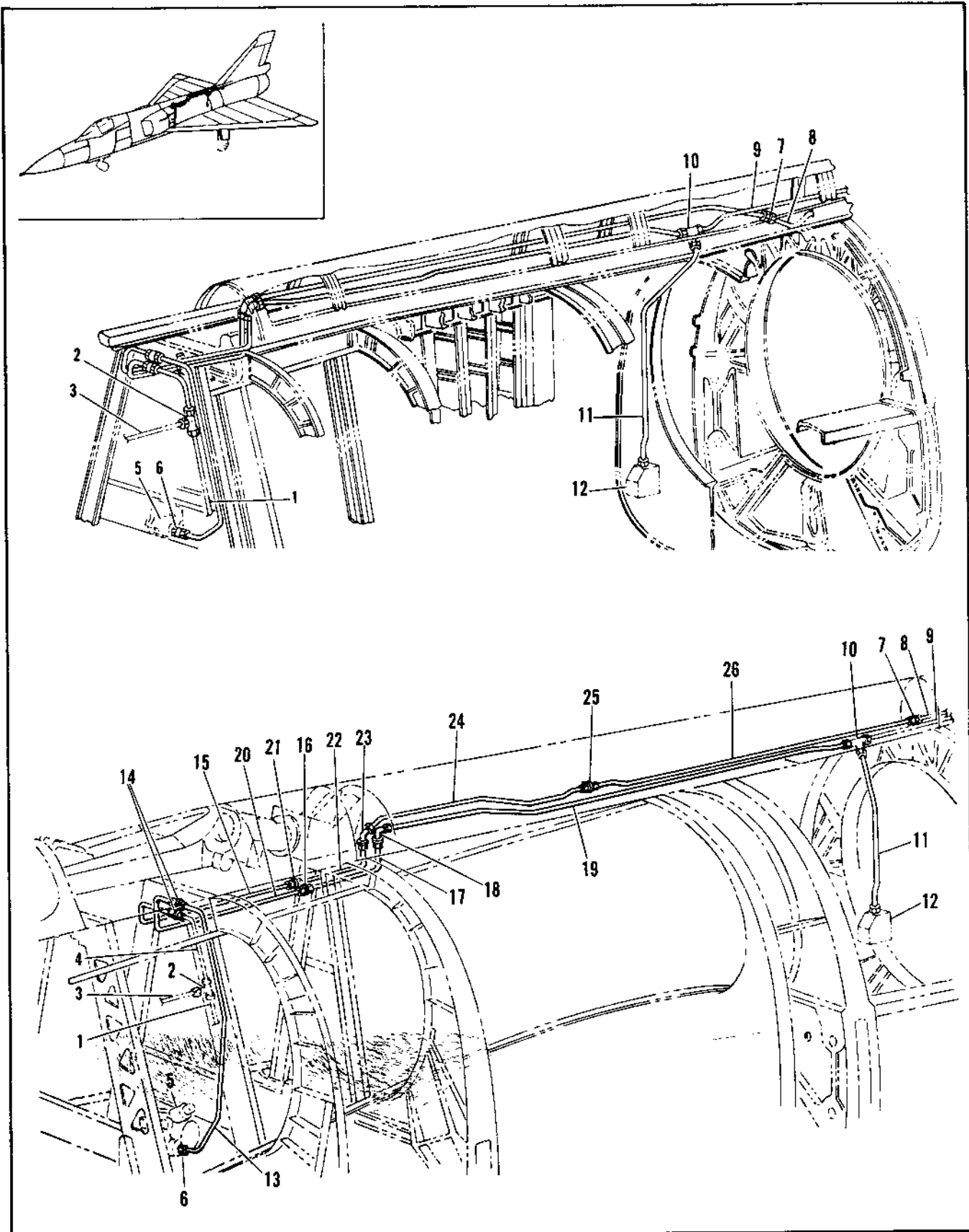

Figure 2.9-24. High Pressure Pneumatic Speed Brake and Drag Chute Tubing Installation

FIGURE AND INDEX NUMBER	PART NUMBER	DESCRIPTION	UNITS PER ASSY.	USABLE ON CODE	
				FROM	TO
2.9-24	8-80429	TUBING INSTL. HIGH PRESSURE PNEUMATIC SPEED BRAKE AND DRAG CHUTE	1	35	
	8-80429	TUBING INSTL. HIGH PRESSURE PNEUMATIC SPEED BRAKE AND DRAG CHUTE MODIFIED BY 66J41297	1		
- 1		• TUBE ASSY. MAIN LINE SEE FIG. 2.9-20 INDEX 36	RF		
- 2	MS2190504	• TEE	1	35	
- 3		• TUBE ASSY. MAIN LINE SEE FIG. 2.9-20 INDEX 33	RF		
- 4	8-80429-347	• TUBE ASSY. DRAG CHUTE	1	35	
- 5		• REGULATOR, PNEUMATIC PRESSURE SEE FIG. 2.9-1 INDEX 39	RF		
- 6	MS2191604-3	• REDUCER	1	35	
	AN6290-4	• GASKET	1	35	
- 7	MS2190204	• UNION	1	35	
- 8		• TUBE ASSY. DRAG CHUTE SEE FIG. 2.9-25 INDEX 8	RF		
- 9		• TUBE ASSY. VARIABLE AIR SEE FIG. 2.9-24 INDEX 3	RF		
- 10	MS2190903	• TEE	1	35	
	AN924-3D	• NUT	1	35	
	AN9610616L	• WASHER	1	35	
- 11	8-80429-483	• TUBE ASSY. PRESSURE CONTROL SENSOR	1	35	
- 12		• SENSOR ASSY. ENGINE COMPARTMENT EMERGENCY PRESSURE CONTROL SEE FIG. 2.10-22	RF		
- 13	66A39630-1	• TUBE ASSY. VARIABLE AIR	1	35	
- 14	MS2191604-3	• REDUCER	2	35	
- 15	66A39660-1	• TUBE ASSY	1	35	
- 16	MS2192403	• UNION	1		
	AN924-3D	• NUT	1		
- 17	66A39650-1	• TUBE ASSY	1		
- 18	MS2190803	• ELBOW	1		
	AN924-3D	• NUT	1		
- 19	66A39648-1	• TUBE ASSY	1		
- 20	66A39659-1	• TUBE ASSY	1		
- 21	MS2192404	• UNION	1		
	AN924-4D	• NUT	1		
- 22	66A39627-1	• TUBE ASSY	1		
- 23	MS2190704	• ELBOW	1		
	AN924-4C	• NUT	1		
- 24	66A39649-1	• TUBE ASSY	1		
- 25	MS2190204	• UNION	1		
- 26	66A39647-1	• TUBE ASSY	1		

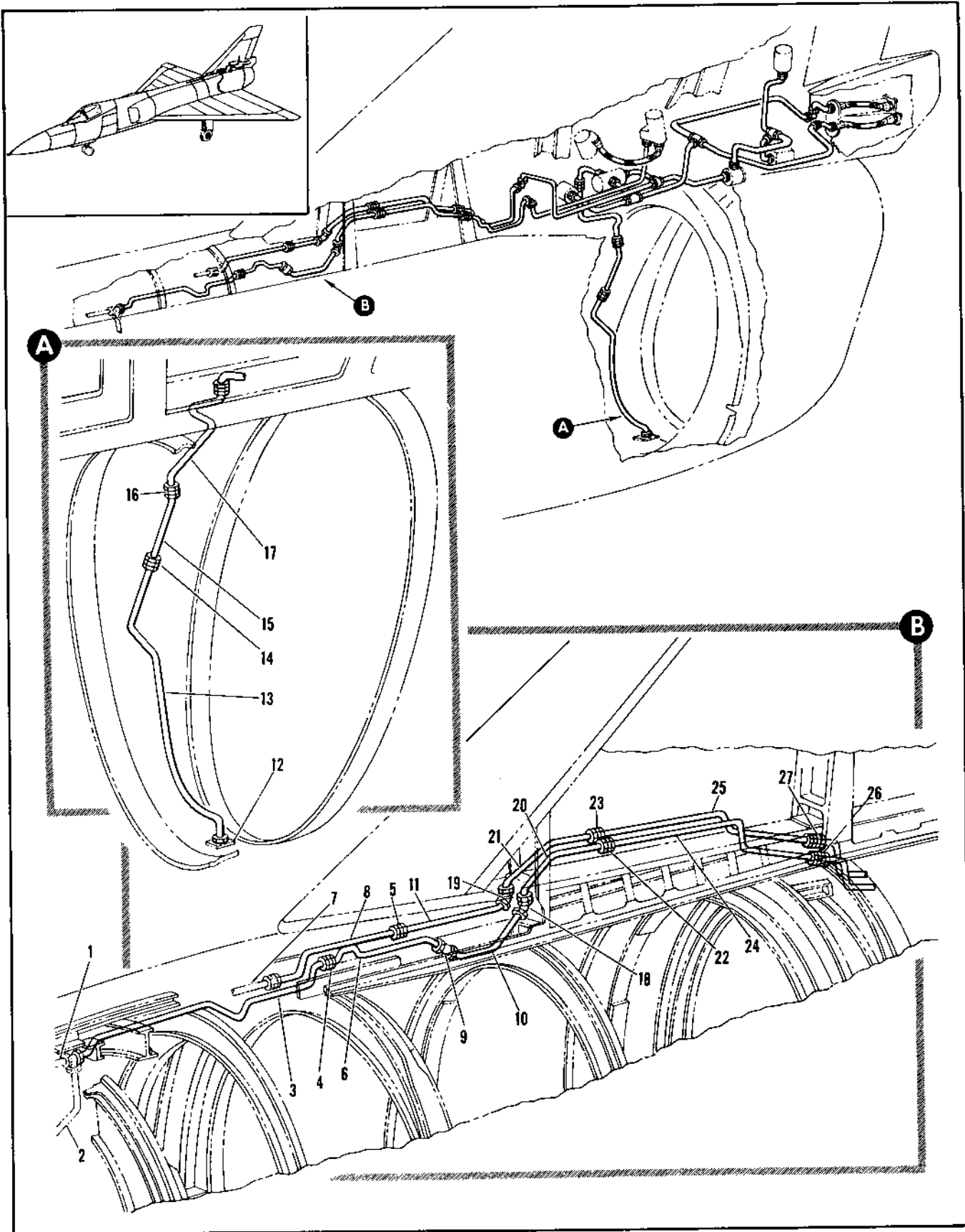

Figure 2.9-25. High Pressure Pneumatic Vertical Stabilizer and Dorsal Tubing (Sheet 1 of 3)

FIGURE AND INDEX NUMBER	PART NUMBER	DESCRIPTION	UNITS PER ASSY.	USABLE ON CODE	
				FROM	TO
2.9-25		1 2 3 4 5 6 HIGH PRESSURE PNEUMATIC VERTICAL STABILIZER AND DORSAL TUBING			
	8-80421-5		RF	35	
	8-80421-5	• TUBING INSTL, DORSAL AND VERTICAL STABILIZER HIGH PRESSURE PNEUMATIC MODIFIED BY 8-80503 FOR NHA SEE FIG. 2.3-15	RF	35	
- 1		• • TUBE ASSY, VARIABLE AIR SEE FIG. 2.9-23 INDEX 1K	RF		
- 2		• • TUBE ASSY, PRESSURE CONTROL SENSOR SEE FIG. 2.9-23 INDEX 20	RF		
- 3	8-80421-17	• • TUBE ASSEMBLY	1	35	
- 4	MS21902D3	• • UNION	1	35	
- 5	MS21902D4	• • UNION	1	35	
- 6	8-80421-85	• • TUBE ASSEMBLY	1	35	
- 7		• • TUBE ASSY, DRAG CHUTE SEE FIG. 2.9-24 INDEX 24	RF		
- 8	8-80421-89	• • TUBE ASSEMBLY	1	35	
- 9	155160-2	• • VALVE, CHECK <91864> SPEC 8-00430-9 T.O.9P5-12-35-3	1	35	
- 10	8-80421-87	• • TUBE ASSEMBLY	1	35	
- 11	8-80421-91	• • TUBE ASSEMBLY	1	35	
- 12		• • FITTING ASSY, ENGINE FUEL DRAIN SEE FIG. 2.3-15 INDEX 18	RF		
- 13	8-80421-79	• • TUBE ASSEMBLY	1	35	
- 14	MS21902D4	• • UNION	1	35	
- 15	8-80421-77	• • TUBE ASSEMBLY	1	35	
- 16	MS2190304	• • UNION	1	35	
	AN924-4D	• • NUT	1	35	
	AN960D716	• • WASHER	1	35	
- 17	8-80421-75	• • TUBE ASSEMBLY	1	35	
	8-80421	• TUBING INSTL, SPEED BRAKE AND DRAG CHUTE HIGH PRESSURE PNEUMATIC MODIFIED BY 8-80503 FOR NHA SEE FIG. 2.7-6	RF	35	
- 18	MS21907D3	• • ELBOW	1	35	
	AN924-3D	• • NUT	1	35	
	AN960D616	• • WASHER	1	35	
- 19	MS21907D4	• • ELBOW	1	35	
	AN924-4D	• • NUT	1	35	
	AN960D716	• • WASHER	1	35	
- 20	8-80421-21	• • TUBE ASSEMBLY	1	35	
- 21	8-80421-31	• • TUBE ASSEMBLY	1	35	
- 22	MS21902D3	• • UNION	1	35	
- 23	MS21902D4	• • UNION	1	35	
- 24	8-80421-23	• • TUBE ASSEMBLY	1	35	
- 25	8-80421-33	• • TUBE ASSEMBLY	1	35	
- 26	MS2190303	• • UNION	1	35	
	AN924-3D	• • NUT	1	35	
- 27	MS21903D4	• • UNION	1	35	
	AN924-4D	• • NUT	1	35	

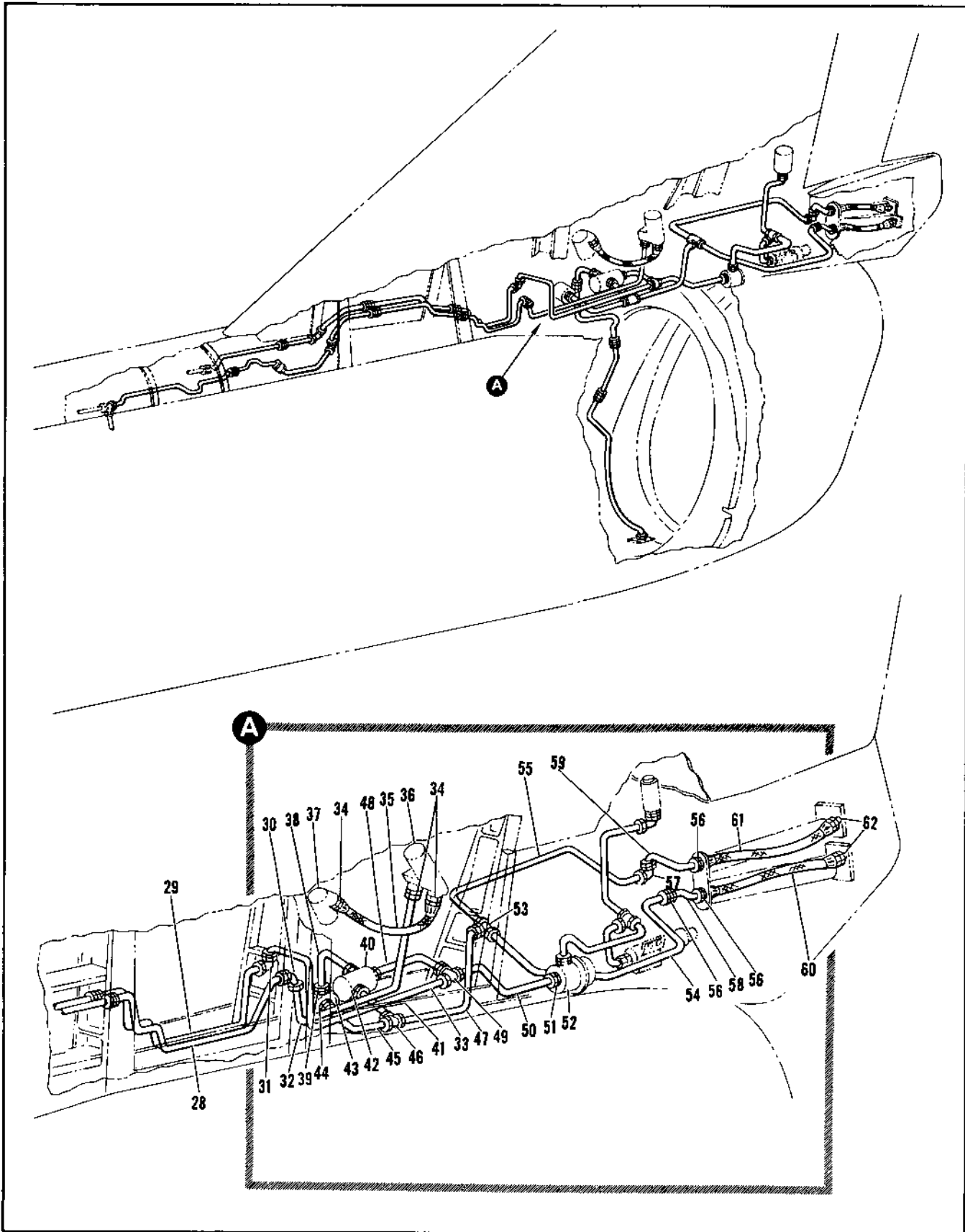

Figure 2.9-25. High Pressure Pneumatic Vertical Stabilizer and Dorsal Tubing (Sheet 2 of 3)

FIGURE AND INDEX NUMBER	PART NUMBER	DESCRIPTION	UNITS PER ASSY.	USABLE ON CODE	
				FROM	TO
		1 2 3 4 5 6			
2.9-25- 28	8-80421-25	• • TUBE ASSEMBLY	1	35	
- 29	8-80421-35	• • TUBE ASSEMBLY	1	35	
- 30	MS21907D3	• • ELBOW	1	35	
	AN924-3D	• • NUT	1	35	
- 31	MS21908D4	• • ELBOW	1	35	
	AN924-4D	• • NUT	1	35	
- 32	8-80421-101	• • TUBE ASSEMBLY	1	35	
- 33	8-80421-105	• • TUBE ASSEMBLY	1	35	
- 34	MS21916D4-3	• • REDUCER	3	35	
	AN6290-4	• • GASKET	2	35	
- 35	124221-4D0150	• • HOSE ASSY, <98441> SPEC 8-08538-39	1	35	
- 36		• • REGULATOR ASSY, VARIABLE AIR PRESSURE SEE FIG. 2.14-1 INDEX 21	RF		
- 37		• • CYLINDER ASSY, RUDDER FEEL SEE FIG. 2.14-41 INDEX 30	RF		
- 38	8-80421-73	• • TUBE ASSEMBLY	1	35	
- 39	MS21903D4	• • UNION	1	35	
	AN924-4D	• • NUT	1	35	
	AN960D716	• • WASHER	1	35	
- 40		• • VALVE ASSY, EMER SPEED BRAKE SELECTOR SEE FIG. 2.7-1 INDEX 13	RF		
- 41	8-80421-43	• • TUBE ASSEMBLY	1	35	
- 42	MS21902D4	• • UNION	1	35	
	AN6290-4	• • GASKET	1	35	
- 43		• • VALVE ASSY, SELECTOR SPEED BRAKE CONTROL SEE FIG. 2.3-15 INDEX 23	RF		
- 44	MS21916D4-3	• • REDUCER	1	35	
	AN6290-3	• • GASKET	1	35	
- 45	8-80421-45	• • TUBE ASSEMBLY	1	35	
- 46	MS21905D4	• • TEE	1	35	
- 47	8-80421-47	• • TUBE ASSEMBLY	1	35	
- 48	8-80421-67	• • TUBE ASSEMBLY	1	35	
- 49	MS21912D4	• • TEE	1	35	
	AN924-4D	• • NUT	1	35	
- 50	8-80421-103	• • TUBE ASSEMBLY	1	35	
- 51	MS21902D4	• • UNION	1	35	
	AN6290-4	• • GASKET	1	35	
- 52		• • VALVE ASSY, DRAG CHUTE SELECTOR SEE FIG. 2.7-1 INDEX 2	RF		
- 53	MS21909D4	• • TEE	1	35	
	AN924-4D	• • NUT	1	35	
- 54	8-80421-107	• • TUBE ASSEMBLY	1	35	
	AN8-80421-123	• • TUBE ASSEMBLY	1	61	
- 55	8-80421-51	• • TUBE ASSEMBLY	1	35	
- 56	MS21903D4	• • UNION	3	35	
	AN924-4D	• • NUT	3	35	
- 57	MS21907D4	• • ELBOW	1	35	
	AN924-4D	• • NUT	1	35	
- 58	8-80421-93	• • TUBE ASSEMBLY	1	35	
- 59	8-80421-95	• • TUBE ASSEMBLY	1	35	
- 60	CR295870-4-0150	• • HOSE ASSY, TEFLON OR EQUAL REPLACES 112040-4-C150			
- 61	CR295870-4-0155	• • HOSE ASSY, TEFLON OR EQUAL REPLACES 112040-4-0155			
- 62	MS21902D4	• • UNION	2	35	

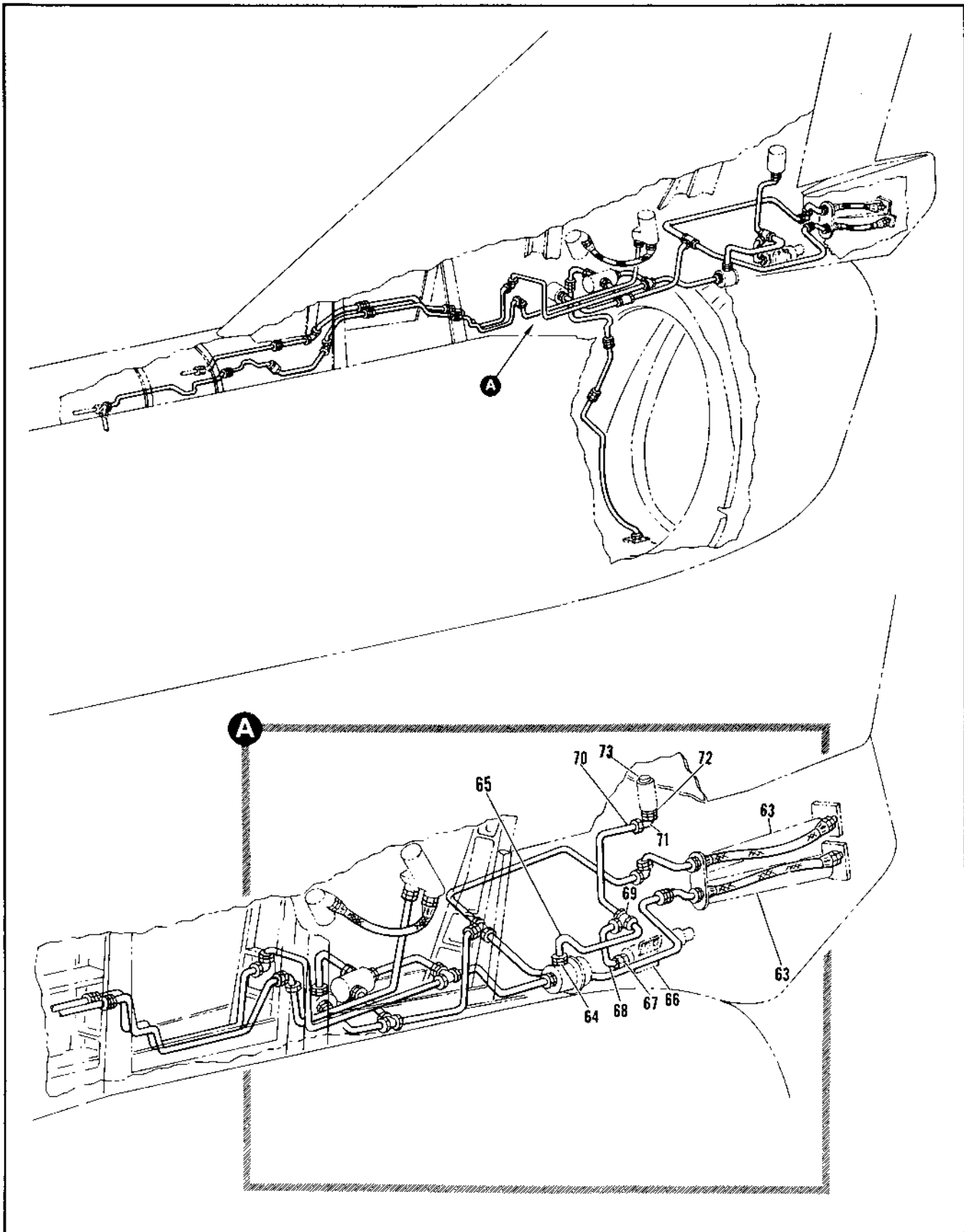

Figure 2.9-25. High Pressure Pneumatic Vertical Stabilizer and Dorsal Tubing (Sheet 3 of 3)

FIGURE AND INDEX NUMBER	PART NUMBER	DESCRIPTION	UNITS PER ASSY.	USABLE ON CODE	
				FROM	TO
		1 2 3 4 5 6			
2.9-25	AN6290-4	<ul style="list-style-type: none"> • GASKET • ACTUATOR ASSY, SPEED BRAKE SEE FIG. 2-7-1 INDEX 7 	2 RF	35	
- 63					
- 64	MS2191604-3	<ul style="list-style-type: none"> • REDUCER 	1	35	
	AN6290-4	<ul style="list-style-type: none"> • GASKET 	1	35	
- 65	8-80421-55	<ul style="list-style-type: none"> • TUBE ASSEMBLY 	1	35	48
	8-80421-121	<ul style="list-style-type: none"> • TUBE ASSEMBLY • ACTUATOR ASSY, DRAG CHUTE RELEASE SEE FIG. 2-7-3 INDEX 42 	1 RF	49	
- 66					
- 67	MS2190203	<ul style="list-style-type: none"> • UNION 	1	35	
	AN6290-3	<ul style="list-style-type: none"> • GASKET 	1	35	
- 68	8-80421-55	<ul style="list-style-type: none"> • TUBE ASSEMBLY 	1	35	
- 69	MS2190503	<ul style="list-style-type: none"> • TEE 	1	35	
- 70	8-80421-119	<ul style="list-style-type: none"> • TUBE ASSEMBLY 	1	35	
- 71	ER1833-3	<ul style="list-style-type: none"> • ELBOW, <92003> 93-40014-006 	1	35	
- 72	MS2190203	<ul style="list-style-type: none"> • UNION 	1	35	
	AN6290-3	<ul style="list-style-type: none"> • GASKET • CYLINDER ASSY, DRAG CHUTE RELEASE SEE FIG. 2-7-3 INDEX 81 	1 RF	35	
- 73					

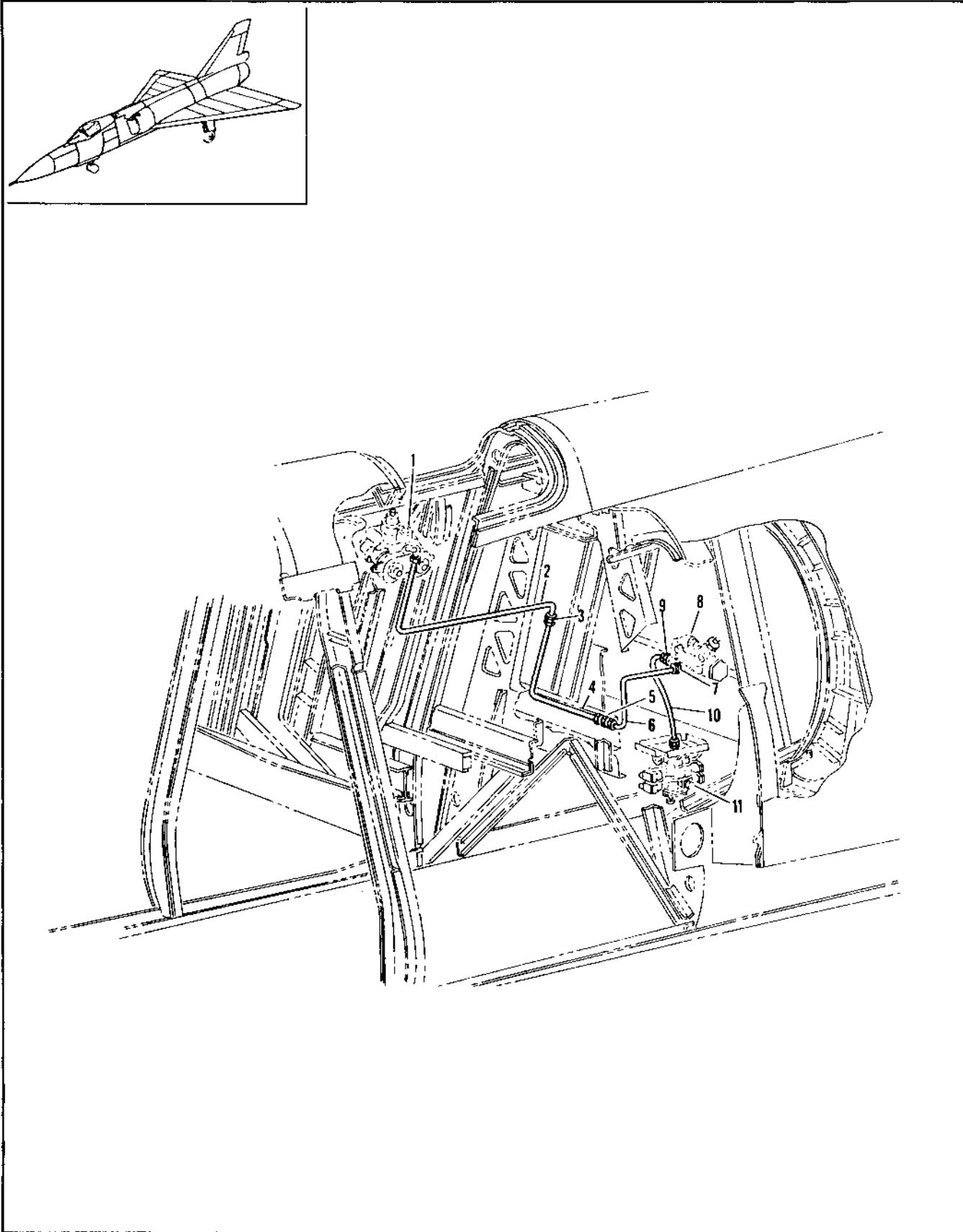

Figure 2.9-26. High Pressure Pneumatic Fuel Transfer and Armament Supply Tubing Installation

FIGURE AND INDEX NUMBER	PART NUMBER	DESCRIPTION	UNITS PER ASSY.	USABLE ON CODE	
				FROM	TO
2.9-26	8-80249	TUBING INSTL, HIGH PRESSURE PNEUMATIC FUEL TRANSFER AND ARMAMENT SUPPLY	1		
- 1		• VALVE ASSY, FUEL TRANSFER REGULATOR AND RELIEF SEE FIG. 2-12-33 INDEX 1	RF		
- 2	8-80429-359	• TUBE ASSY, FUEL TRANSFER	1	35	
- 3	MS21902D6	• UNION	1	35	
- 4	8-80429-357	• TUBE ASSY, FUEL TRANSFER	1	35	
- 5	MS21902D6	• UNION MODIFIED BY 66J40297	1	35	
- 6	66A39640-1	• TUBE ASSY, FUEL TRANSFER	1		
- 7	MS21902D6	• UNION	1	35	
- 8	AN6290-6	• GASKET	1	35	
- 8		• REGULATOR ASSY, PNEUMATIC PRESSURE SEE FIG. 2.9-1 INDEX 40	RF		
- 9	MS21902D12	• UNION	1	35	
- 9	AN6290-12	• GASKET	1	35	
- 10	66A39639-1	• TUBE ASSY, FUEL TRANSFER	1		
- 11		• VALVE ASSY, ARMAMENT BAY DOOR SELECTOR SEE FIG. 2-20-10 INDEX 1	RF		

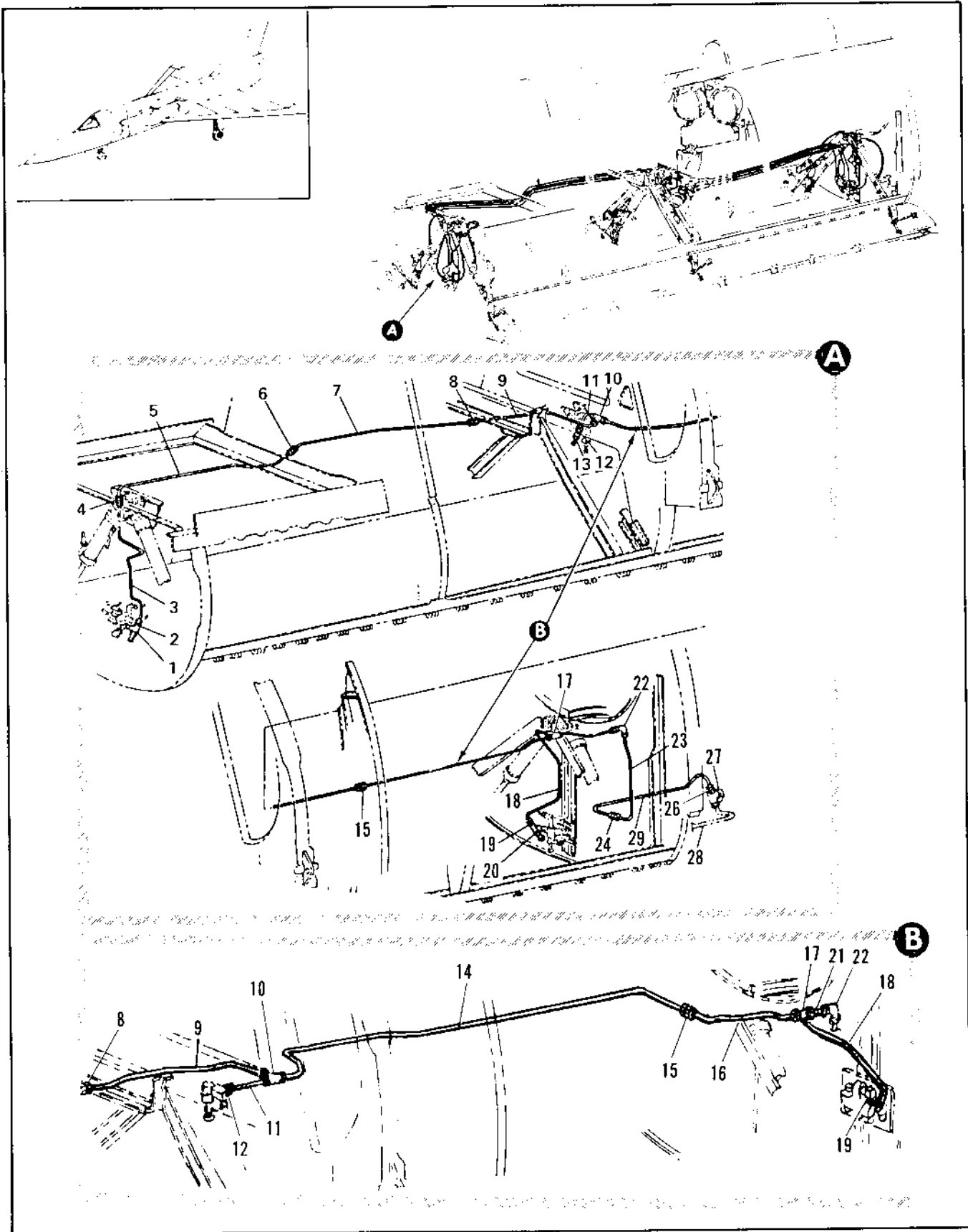

Figure 2.9-27. High Pressure Pneumatic Armament Door Actuator Shuttle Valve Tubing Installation

FIGURE AND INDEX NUMBER	PART NUMBER	DESCRIPTION 1 2 3 4 5 6	UNITS PER ASSY.	USABLE ON CODE	
				FROM	TO
2.9-27	8-80429	TUBING INSTALLATION, HIGH PRESSURE PNEUMATIC ARMAMENT DOOR ACTUATOR SHUTTLE VALVE	1	35	
- 1		• VALVE ASSY, SELECTOR FWD SEE FIG. 2.20-1 INDEX 4	RF		
- 2	MS2190203	• UNION	1	35	
	AN6290-3	• GASKET	1	35	
- 3	8-80429-1071	• TUBE ASSY, FWD SHUTTLE VALVE	1	35	
- 4	MS2190203	• UNION	1	35	
- 5	8-80429-497	• TUBE ASSY, FWD SHUTTLE VALVE	1	35	188
	8-80429-1369	• TUBE ASSY, FWD SHUTTLE VALVE	1	189	
- 6	MS2190203	• UNION	1	35	
- 7	8-80429-1129	• TUBE ASSY, FWD SHUTTLE VALVE	1	35	
- 8	MS2190203	• UNION	1	35	
- 9	7144906-01	• TUBE ASSY, FWD SHUTTLE VALVE	1		
- 10	MS2190503	• TEE	1	35	
- 11	7144909-01	• TUBE ASSY, CENTER SHUTTLE VALVE	1		
- 12	MS2190203	• UNION	1	35	
	MS28778-3	• PACKING	1		
- 13		• VALVE ASSY, PRESSURE OPERATED SELECTOR SEE FIG. 2.20-8 INDEX 1	RF		
- 14	7144876-01	• TUBE ASSY, AFT SHUTTLE VALVE	1		
- 15	MS2190203	• UNION	1	35	
- 16	7144874-01	• TUBE ASSY, AFT SHUTTLE VALVE	1		
- 17	MS2190503	• TEE	1	35	
- 18	7144875-01	• TUBE ASSY, AFT SHUTTLE VALVE	1		
	MS28778-3	• PACKING	1		
- 19	MS2190203	• UNION	1	35	
- 20		• VALVE ASSY, SELECTOR AFT SEE FIG. 2.20-1 INDEX 6	RF		
- 21	7144904-01	• TUBE ASSY, ARMAMENT BAY DOOR AFT VALVE	1		
- 22	MS2190804	• ELBOW	1	35	
	AN924-30	• NUT	1	35	
	AN9610616L	• WASHER	1	35	
- 23	8-80429-405	• TUBE ASSY, ARMAMENT BAY DOOR AFT VALVE	1	35	
- 24	MS2190203	• UNION	1	35	
- 25	8-80429-407	• TUBE ASSY, ARMAMENT BAY DOOR AFT VALVE	1	35	60
	8-80429-1255	• TUBE ASSY, ARMAMENT BAY DOOR AFT VALVE	1	61	
- 26	MS2190203	• UNION	1	35	
	AN6290-3	• GASKET	1	35	
- 27		• VALVE ASSY, ARMAMENT BAY DOOR MANUAL SAFETY SEE FIG. 2.20-1 INDEX 11	RF		
- 28		• TUBE ASSY, PNEUMATIC PRESSURE SEE FIG. 2.9-32 INDEX 14	RF		

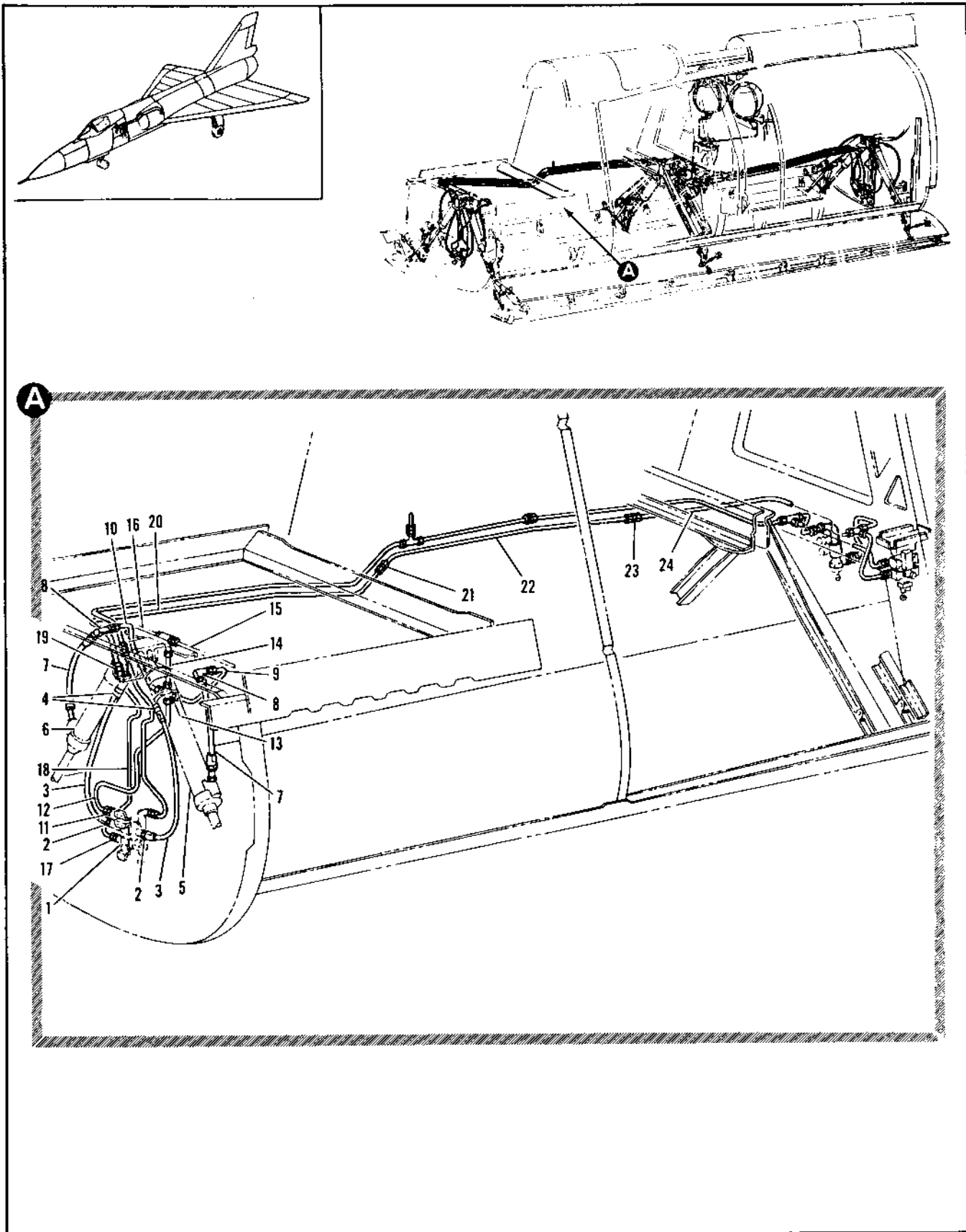

Figure 2.9-28. High Pressure Pneumatic Armament Door Forward Actuator Tubing Installation (Sheet 1 of 3)

FIGURE AND INDEX NUMBER	PART NUMBER	DESCRIPTION	UNITS PER ASSY.	USABLE ON CODE	
				FROM	TO
		1 2 3 4 5 8			
2.9-28	8-80429	TUBING INSTALLATION, HIGH PRESSURE PNEUMATIC ARMAMENT DOOR FWD ACTUATOR	1	35	
- 1		• VALVE ASSY, PNEUMATIC SELECTOR SEE FIG. 2.20-1 INDEX 4	RF		
- 2	MS2191608-6	• REDUCER	2	35	
	AN6290-8	• GASKET	2	35	
- 3	666035-6-0192	• HOSE ASSY, <00624> 94-80522-107	2	35	
- 4	MS2190206	• UNION	2	35	
	AN6290-6	• GASKET	2	35	
- 5		• ACTUATOR ASSY, ARMAMENT BAY DOOR FWD LH SEE FIG. 2.20-11 INDEX 1	RF		
- 6		• ACTUATOR ASSY, ARMAMENT BAY DOOR FWD RH SEE FIG. 2.20-11 INDEX 2	RF		
- 7	666035-6-0125	• HOSE ASSY, <00624> 94-80522-054 REPLACED BY SUITABLE SUB 124223-600125	2	35	38
	124223-600125	• HOSE ASSY, <90441> SPEC 8-08538-23 REPLACES SUITABLE SUB FOR 666035-6-0125	1	39	
- 8	4126-577250	• ELBOW <92003> 93-40015-001	2	35	
	AN924-60	• NUT	2	35	
	AN9600916L	• WASHER	2	35	
- 9	8-80429-251	• TUBE ASSY, FWD ACTUATOR LH	1	35	
- 10	8-80429-253	• TUBE ASSY, FWD ACTUATOR RH	1	35	
- 11	9R0481-7	• RESTRICTOR, FIXED <91207> SPEC 8-00429-7	1	35	
	AN6290-8	• GASKET	1	35	
- 12	8-80429-1067	• TUBE ASSY, FWD SELECTOR VALVE	1	35	
- 13	4126-569800	• CROSS, <92003> 92-79005-002	1	35	
- 14	8-80429-247	• TUBE ASSY, FWD SELECTOR VALVE	1	35	
- 15		• TUBE ASSY, EMERGENCY COCKPIT PRESSURIZATION SEE FIG. 2.9-11 INDEX 27	RF		
- 16		• TUBE ASSY, EMERGENCY COCKPIT PRESSURIZATION SEE FIG. 2.9-11 INDEX 31	RF		
- 17	MS2190203	• UNION	1	35	
	AN6290-3	• GASKET	1	35	
- 18	8-80429-1065	• TUBE ASSY, FWD SELECTOR VALVE	1	35	
- 19	MS2190203	• UNION	1	35	
- 20	8-80429-505	• TUBE ASSY, FWD SELECTOR VALVE	1	35	188
	8-80429-1373	• TUBE ASSY, FWD SELECTOR VALVE	1	35	
- 21	MS2190203	• UNION	1	35	
- 22	8-80429-1127	• TUBE ASSY, FWD SELECTOR VALVE	1	35	
- 23	MS2190203	• UNION	1	35	
- 24	8-80429-1165	• TUBE ASSY, FWD SELECTOR VALVE	1	35	

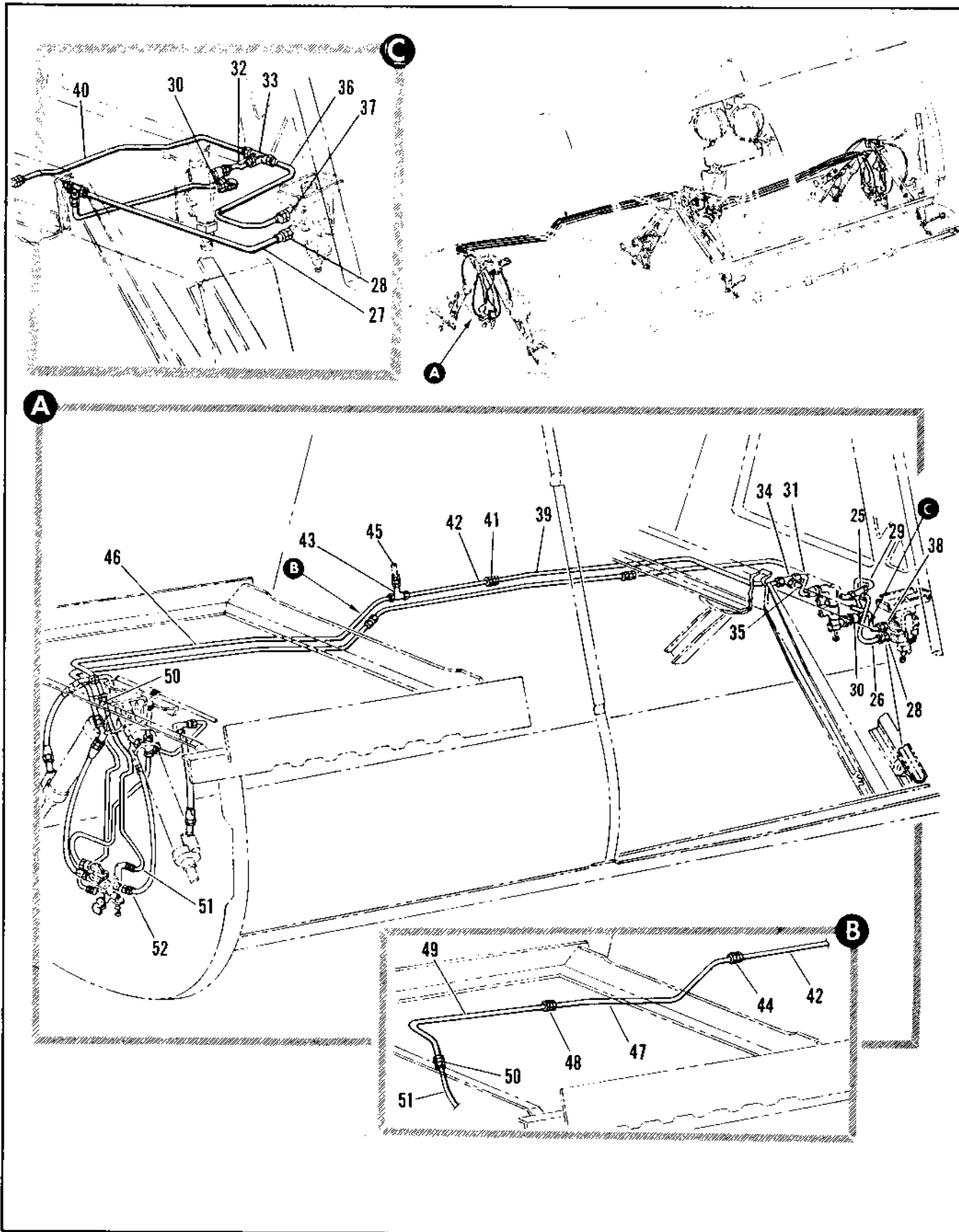

Figure 2.9-28. High Pressure Pneumatic Armament Door Forward Actuator Tubing Installation (Sheet 2 of 3)

FIGURE AND INDEX NUMBER	PART NUMBER	DESCRIPTION	UNITS PER ASSY.	USABLE ON CODE	
				FROM	TO
		1 2 3 4 5 6			
2.9-28- 25	MS21912D3	• TEE	1	35	
	AN924-3D	• NUT	1	35	
	AN9630616	• WASHER	1	35	
- 26	8-80429-1311	• TUBE ASSY, FWD SELECTOR VALVE	1	43	
- 27	7144821-01	• TUBE ASSY, FWD SELECTOR VALVE	1	35	42
- 28	MS21902D3	• UNION	1	35	
	MS21902D3	• PACKING	1	35	42
- 29	8-80429-1153	• TUBE ASSY, CENTER SELECTOR VALVE	1	35	39
	8-80429-1283	• TUBE ASSY, CENTER SELECTOR VALVE	1	90	
- 30	9R7431-5	• RESTRICTOR, FIXED (91207) SPEC 8-00429-3	1	35	
- 31	8-80429-1155	• TUBE ASSY, CENTER SELECTOR VALVE	1	35	
- 32	7144907-01	• TUBE ASSY, CENTER SELECTOR VALVE	1		
- 33	MS21902D4	• TEE	1		
	MS28778-4	• PACKING	1		
- 34	MS21905D4	• TEE	1	35	
- 35	8-80429-1313	• TUBE ASSY, FWD SELECTOR VALVE	1	43	
- 36	7144548-01	• TUBE ASSY, FWD SELECTOR VALVE	1	35	42
- 37	MS21902D4	• UNION	1		
	MS28778-4	• PACKING	1		
- 38	MS21916D4-3	• REDUCER	1	35	42
- 39	8-80429-1167	• TUBE ASSY, FWD SELECTOR VALVE	1	35	
- 40	7144910-01	• TUBE ASSY, FWD SELECTOR VALVE	1	35	42
- 41	MS21902D4	• UNION	1	35	
- 42	8-80429-1125	• TUBE ASSY, FWD SELECTOR VALVE	1	48	4R
	8-80429-1225	• TUBE ASSY, FWD SELECTOR VALVE	1	4	
- 43	MS21909D4	• TEE	1	4R	4P
	AN924-4D	• NUT	1	48	4P
	AN9630716L	• WASHER	1	48	4R
- 44	MS21902D4	• UNION	1	A	
- 45		• TUBE ASSY, FWD ARMAMENT DISPLACEMENT SEE FIG. 2.9-30 INDEX 3	PF		
- 46	8-80429-491	• TUBE ASSY, FWD SELECTOR VALVE	1	4R	4P
	8-80429-1371	• TUBE ASSY, FWD SELECTOR VALVE	1	189	
- 47	8-80429-1223	• TUBE ASSY, FWD SELECTOR VALVE	1	B	
- 48	MS21902D4	• UNION	1	B	
- 49	8-80429-1277	• TUBE ASSY, FWD SELECTOR VALVE	1	B	
- 50	MS21902D4	• UNION	1	35	
- 51	8-80429-1069	• TUBE ASSY, FWD SELECTOR VALVE	1	35	
- 52	MS21902D4	• UNION	1	35	

A AIRPLANES #35 THRU 44, 49 AND ON
R AIRPLANES #35 THRU 44, 49 THRU 188

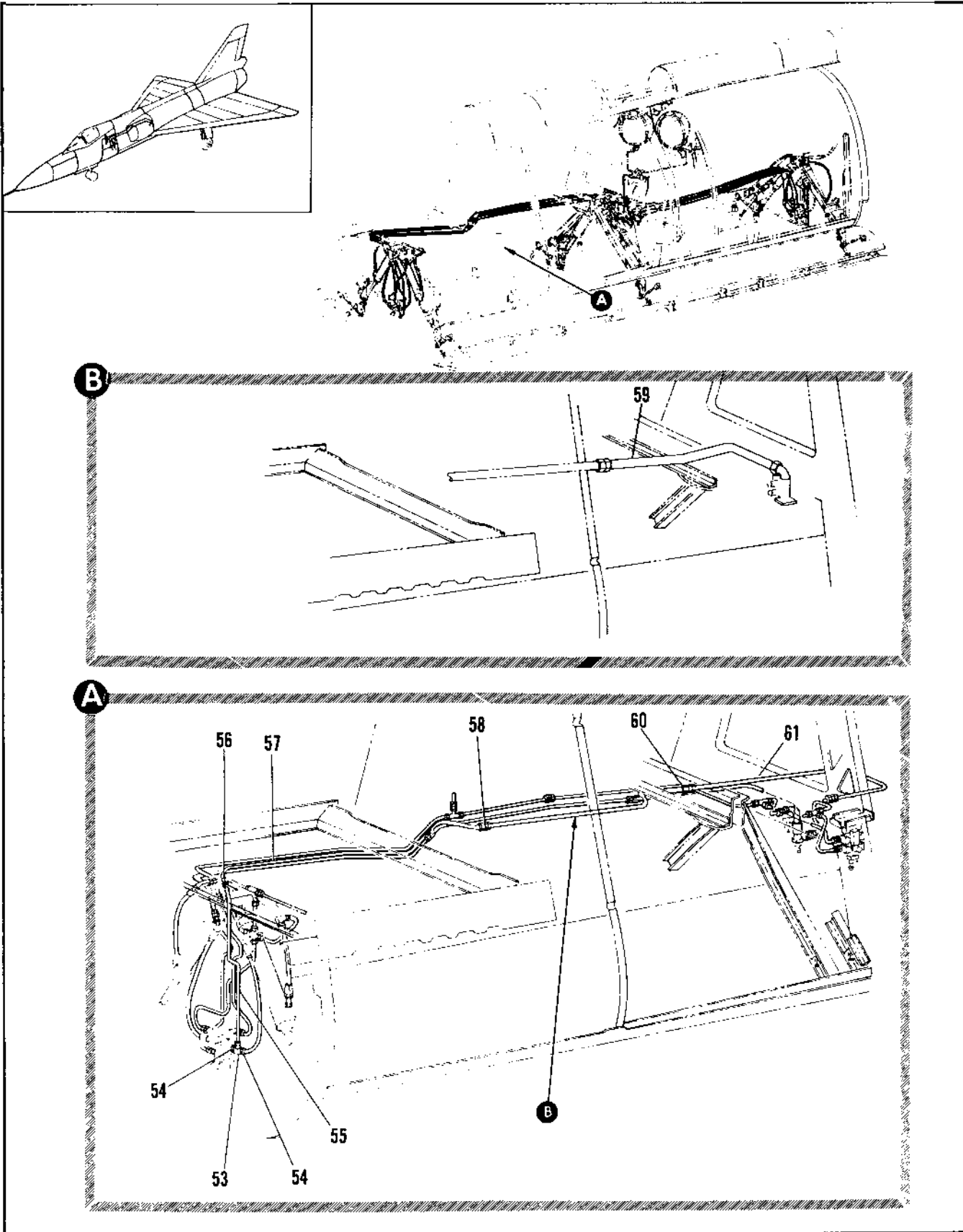

Figure 2.9-28. High Pressure Pneumatic Armament Door Forward Actuator Tubing Installation (Sheet 3 of 3)

FIGURE AND INDEX NUMBER	PART NUMBER	DESCRIPTION	UNITS PER ASSY.	USABLE ON CODE	
				FROM	TO
		1 2 3 4 5 6			
2.9-28- 53	AN938D6	• TEE REPLACED BY A SUITABLE SUB MS21912D6	1		
	MS21912D6	• TEE	1		
- 54	MS21902D6	• • UNION	3		
	MS28778-6	• • PACKING	4		
	AN924-60	• • NUT	1		
- 55	67A34045-1	• TUBE ASSY	1		
	7947437-10	• TUBE ASSY (AFTER TCTO 1F-106-1159)	1		
- 56	MS21922D6	• UNION	1		
- 57	67A34045-6	• TUBE ASSY	1		
- 58	MS21922D6	• UNION	1		
- 59	7144903-01	• TUBE ASSY	1		
- 60	MS21922D6	• UNION	1		
- 61	67A34045-3	• TUBE ASSY	1		

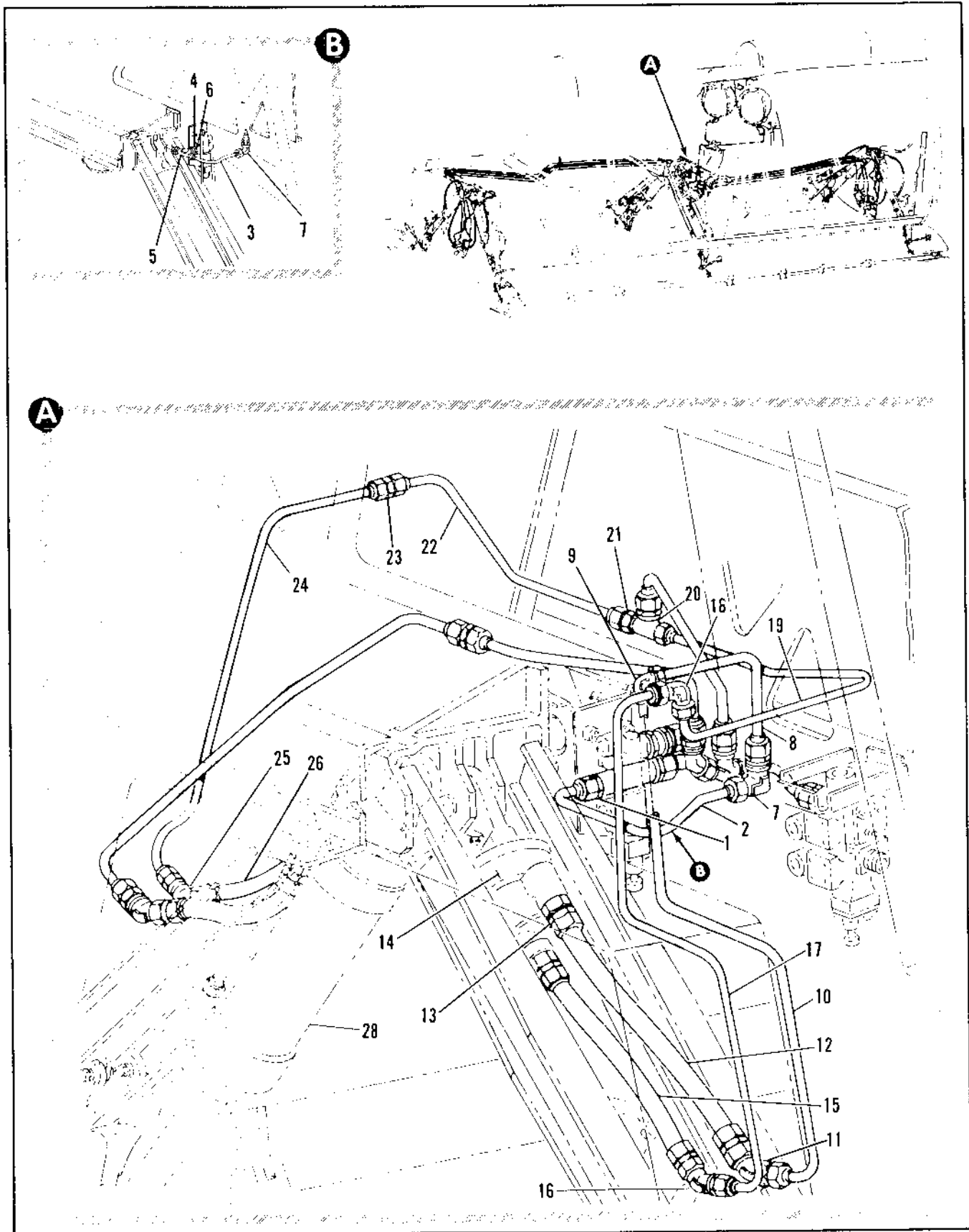

Figure 2.9-29. High Pressure Pneumatic Armament Door Center Actuator Tubing Installation (Sheet 1 of 3)

FIGURE AND INDEX NUMBER	PART NUMBER	DESCRIPTION	UNITS PER ASSY.	USABLE ON CODE	
				FROM	TO
2.9-29	8-80429	TUBING INSTALLATION, HIGH PRESSURE PNEUMATIC ARMAMENT DOOR DOOR CENTER ACTUATOR	1	35	
- 1	MS21902D8 AN6290-8	• UNION	1	35	
- 2	8-80429-1059	• GASKET	1	35	
- 3	7144897-31	• TUBE ASSY, CENTER ACTUATOR LH	1	35	
- 4	AN924-100	• TUBE ASSY, CENTER ACTUATOR LH	1		
- 5	ER0340080610	• NUT	1		
- 6	MS28778-10	• TEE (92003)	1		
- 7	MS21908D8 AN924-8D	• PACKING	1		
	AN96001216	• ELBOW	1	35	
- 8	8-80429-1145	• NUT	1	35	
- 9	MS21907D8 AN924-8D	• WASHER	1	35	
	AN96001216	• TUBE ASSY, CENTER ACTUATOR LH	1	35	
- 10	8-80429-1147	• ELBOW	1	35	
- 11	MS21907D8 AN924-8D	• NUT	1	35	
	AN96001216	• WASHER	1	35	
- 12	666035-8-0147	• TUBE ASSY, CENTER ACTUATOR LH	1	35	
	124223-800147	• HOSE ASSY, <00624> 94-80537-072 REPLACED BY SUITABLE SUB 124223-800147	1	35	38
- 13	MS21902D8 AN6290-8	• HOSE ASSY, <98441> SPEC 8-0538-29 REPLACES SUITABLE SUB FOR 666035-8-0147	1	39	
- 14		• UNION	1	35	
		• GASKET	1	35	
- 15	666035-6-0145	• ACTUATOR ASSY, ARMAMENT BAY DOOR CENTER LH SEE FIG. 2.20-11 INDEX 48	RF		
	124223-600145	• HOSE ASSY, <00624> 94-80522-070 REPLACED BY SUITABLE SUB 124223-600145	1	35	38
- 16	MS21907D6 AN924-6D	• HOSE ASSY, <98441> SPEC 8-08538-27 REPLACES SUITABLE SUB FOR 666035-6-0145	1	39	
- 17	AN9600916L	• ELBOW	1	35	
- 18	8-80429-1143	• NUT	1	35	
	MS21907D6	• WASHER	1	35	
- 19	AN924-6D	• TUBE ASSY, CENTER SELECTOR LH	1	35	
- 20	AN9600916	• ELBOW	1	35	
- 21	8-80429-1141	• NUT	1	35	
- 22	MS21910D6	• WASHER	1	35	
- 23	MS21916D8-6	• TUBE ASSY, CENTER SELECTOR LH	1	35	
- 24	AN6290-6	• TEE	1	35	
- 25	8-80429-275	• REDUCER	1	35	
- 26	MS21902D6	• GASKET	1	35	
- 27	8-80429-1101	• TUBE ASSY, CENTER ACTUATOR RH	1	35	
	MS21907D6	• UNION	1	35	
	AN924-6D	• TUBE ASSY, CENTER ACTUATOR RH	1	35	
	AN9600916	• ELBOW	1	35	
- 28	666035-6-0145	• NUT	1	35	
	124223-600145	• WASHER	1	35	
		• HOSE ASSY, <00624> 94-80522-070 REPLACED BY SUITABLE SUB 124223-600145	1	35	38
		• HOSE ASSY, <98441> SPEC 8-08538-27 REPLACES SUITABLE SUB FOR 666035-66-0145	1	35	38
- 28		• ACTUATOR ASSY, ARMAMENT BAY DOOR CENTER RH SEE FIG. 2.20-11	RF		

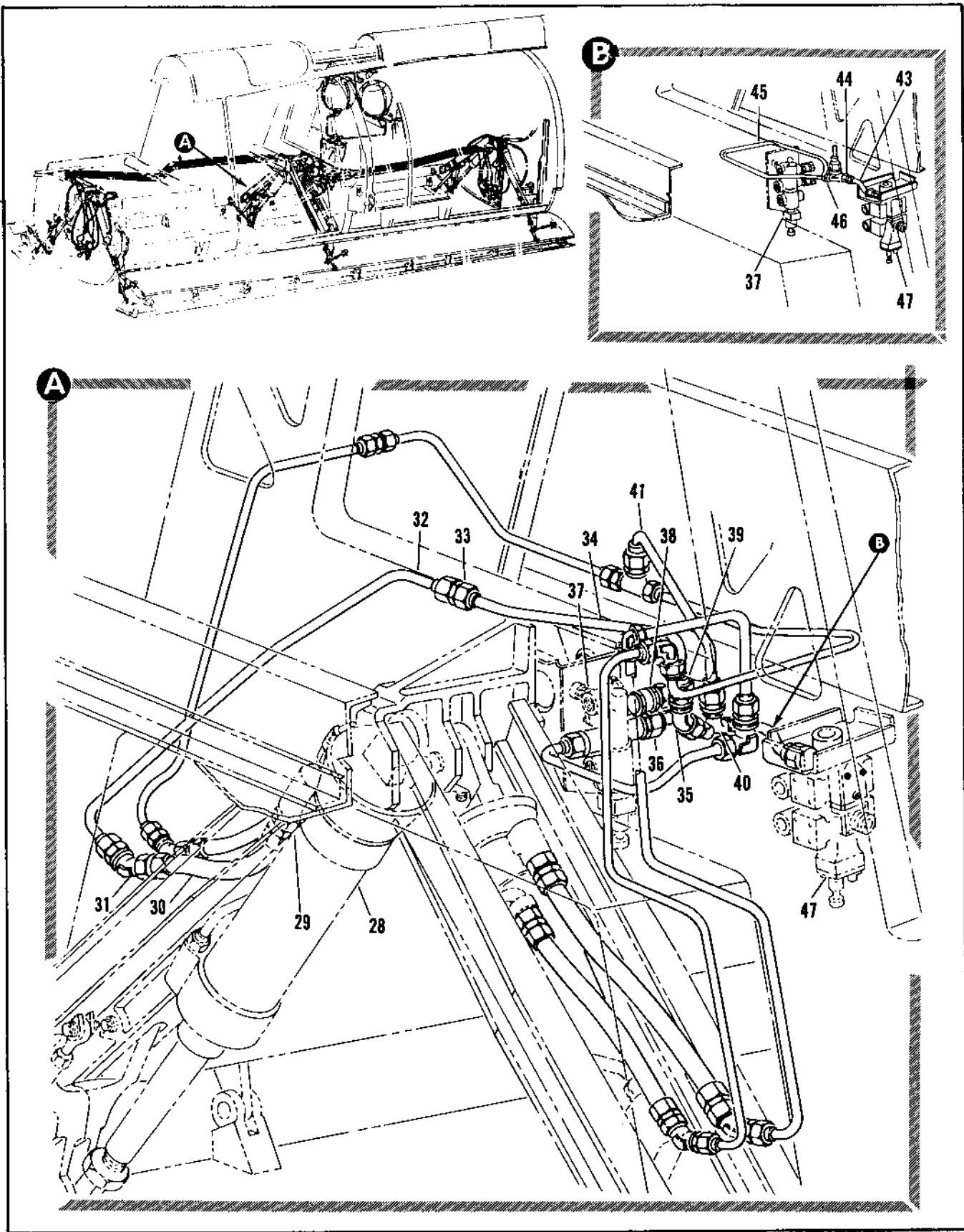

Figure 2.9-29. High Pressure Pneumatic Armament Door Center Actuator Tubing Installation (Sheet 2 of 3)

FIGURE AND INDEX NUMBER	PART NUMBER	DESCRIPTION 1 2 3 4 5 6	UNITS PER ASSY.	USABLE ON CODE	
				FROM	TO
2.9-29- 29	MS21902D8	• UNION	1	35	
- 30	AN6290-8	• GASKET	1	35	
	666035-8-1147	• HOSE ASSY, <00624> 94-80537-072 REPLACED BY SUITABLE SUB 124223-800147	1	35	38
	124223-8D0147	• HOSE ASSY, <98441> SPEC 9-08538-29 REPLACES SUITABLE SUB FOR 666035-8-0147	1	39	
- 31	MS21907D8	• ELBOW	1	35	
	AN924-8D	• NUT	1	35	
	AN960D1216	• WASHER	1	35	
- 32	8-80429-1151	• TUBE ASSY, CENTER ACTUATOR RH	1	35	
- 33	MS21902D8	• UNION	1	35	
- 34	8-80429-1149	• TUBE ASSY, CENTER ACTUATOR RH	1	35	264
	8-80429-1395	• TUBE ASSY, CENTER ACTUATOR RH	1	265	
- 35	MS21907D8	• ELBOW	1	35	
	AN924-8D	• NUT	1	35	
	AN960D1216	• WASHER	1	35	
- 36	MS21916D10-8	• REDUCER	1	35	
	AN6290-10	• GASKET	1	35	
- 37		• VALVE ASSY, PNEUMATIC SELECTOR SEE FIG. 2.20-8 INDEX 1	RF		
- 38	9R0481-9	• RESTRICTOR, FIXED <91207> SPEC 8-00429-9	1	35	
	AN6290-8	• GASKET	1	35	
- 39	8-80429-1277	• TUBE ASSY, CENTER SELECTOR VALVE	1	35	
- 40	MS21909D8	• TEE	1	35	
	AN924-8D	• NUT	1	35	
	AN960D1216	• WASHER	1	35	
- 41	8-80429-733	• TUBE ASSY, CENTER SELECTOR VALVE	1	35	
- 42	8-80429-467	• TUBE ASSY, ARMAMENT SELECTOR VALVE	1	43	
- 43	7144822-01	• TUBE ASSY, CENTER SELECTOR VALVE	1	35	42
- 44	MS21902D8	• UNION	1		
	MS28778-8	• PACKING	1		
- 45	7144908-01	• TUBE ASSY	1		
- 46	MS21902D8	• UNION	1		
	MS28778-8	• PACKING	1		
- 47		• VALVE ASSY, ARMAMENT BAY DOOR SELECTOR SEE FIG. 2.20-9 INDEX 1	RF		

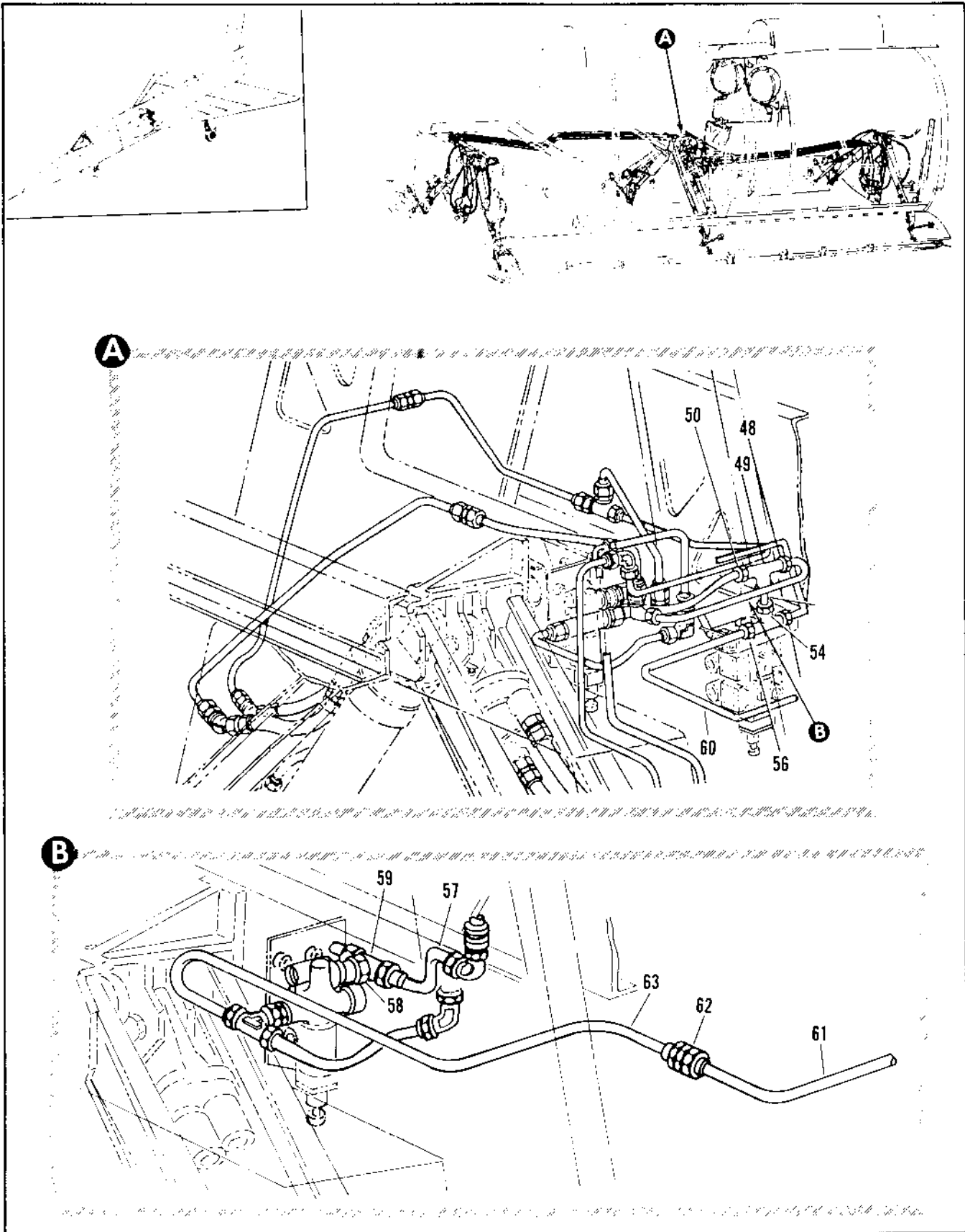

Figure 2.9-29. High Pressure Pneumatic Armament Door Center Actuator Tubing Installation (Sheet 3 of 3)

FIGURE AND INDEX NUMBER	PART NUMBER	DESCRIPTION	UNITS PER ASSY.	USABLE ON CODE	
				FROM	TO
		1 2 3 4 5 6			
2.9-29- 48	67A34045-3	• TUBE ASSY. SEE FIG. 2.9-28 INDEX 61	RFF		
- 49	AN93808	• TEE	1		
- 50	MS21902D8	• UNION	2		
- 51	MS28778-8	• PACKING	2		
- 52	AN893-12D	• BUSHING	1		
- 53	MS28778-8	• PACKING	1		
- 54	AN924-6D	• NUT	1		
- 55	MS21909D6	• TEE	1		
- 56	MS28778-6	• PACKING	1		
- 57	7144896-01	• TUBE ASSY	1		
- 58	AN924-10D	• NUT	1		
- 59	CR834D080E10	• TEE (92003)	1		
- 60	67A34045-5	• TUBE ASSY	1		
- 61	7144901-01	• TUBE ASSY	1		
- 62	MS21902D6	• UNION	1		
- 63	7144902-01	• TUBE ASSY	1		

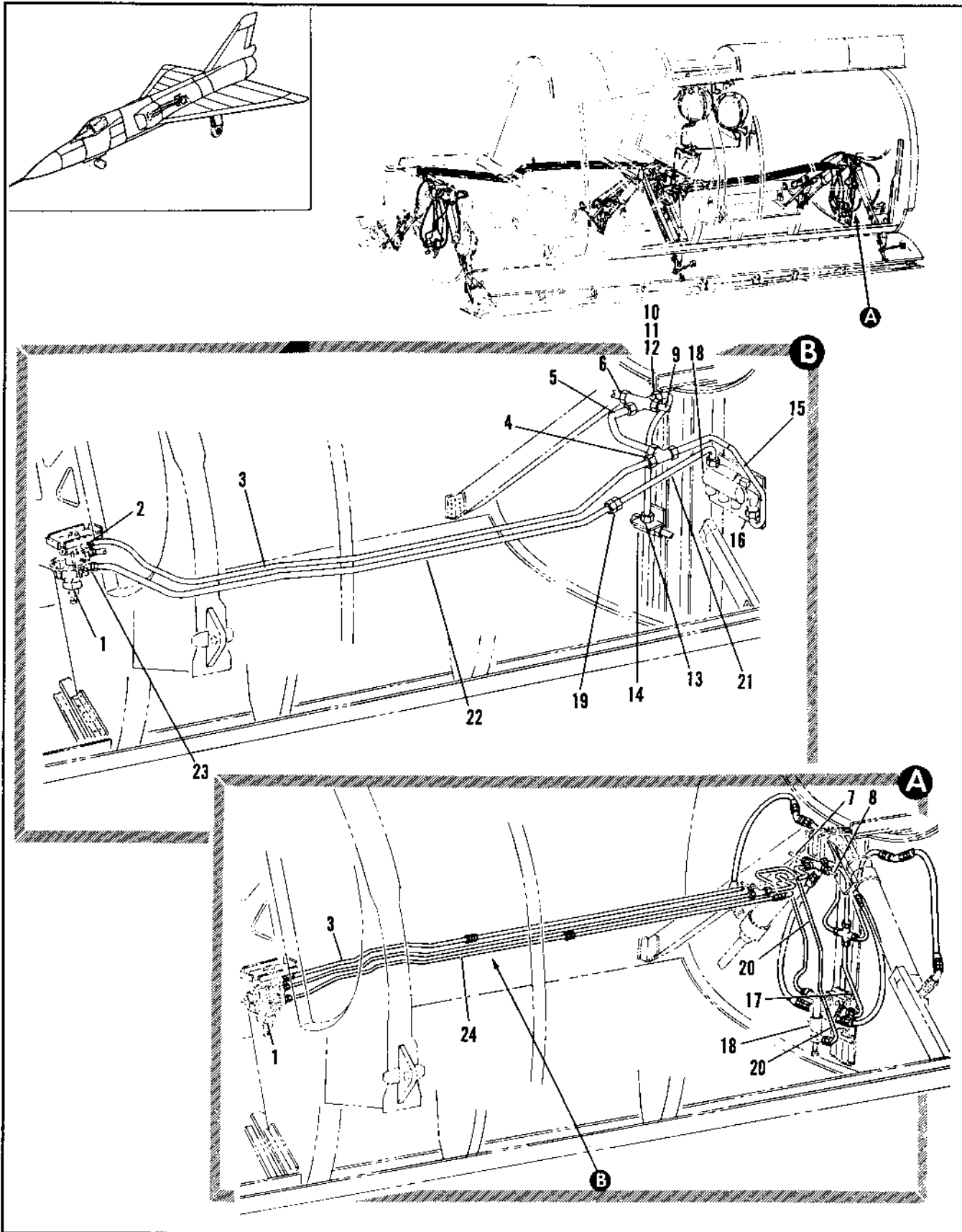

Figure 2.9-30. High Pressure Pneumatic Armament Door Aft Actuator Tubing Installation (Sheet 1 of 3)

FIGURE AND INDEX NUMBER	PART NUMBER	DESCRIPTION	UNITS PER ASSY.	USABLE ON CODE	
				FROM	TO
		1 2 3 4 5 6			
2.9-30	8-80429	TUBING INSTALLATION, HIGH PRESSURE PNEUMATIC ARMAMENT DOOR AFT ACTUATOR	1	35	
- 1		• VALVE ASSY, ARMAMENT BAY DOOR SELECTOR SEE FIG. 2.20-9 INDEX 1	RF		
- 2	MS21902D8	• UNION	1		
	MS28778-8	• PACKING	1		
- 3	8-80429-725	• TUBE ASSY, AFT SELECTOR VALVE	1	35	42
	7144894-51	• TUBE ASSY, AFT SELECTOR VALVE	1		
- 4	MS2190508	• TEE	1		
- 5	7144893-01	• TUBE ASSY, AFT SELECTOR VALVE	1		
- 6	MS21902D8	• UNION	1		
	MS28778-8	• PACKING	1		
- 7		• TUBE ASSY, AFT ACTUATOR SEE FIG. 2.9-32 INDEX 35	RF		
- 8		• TUBE ASSY, AFT ACTUATOR SEE FIG. 2.9-32 INDEX 32	RF		
- 9	7144892-01	• TUBE ASSY, AFT SELECTOR VALVE	1		
- 10	AN924-8D	• NUT	1		
- 11	MS21924D8	• UNION	1		
- 12	MS28778-8	• PACKING	1		
- 13	NA924-8D	• NUT	1		
- 14	ER834D060608	• TEE	1		
- 15	7144895-01	• TUBE ASSY, AFT SELECTOR VALVE	1		
- 16	MS21902D8	• UNION	1		
	MS28778-8	• PACKING	1		
- 17	9R0481-11	• RESTRICTOR, FIXED <91267> SPEC 8-00429-11	1	35	
	AN6293-8	• GASKET	1	35	
- 18		• VALVE ASSY, SEE FIG. 2.20-1 INDEX 4	RF		
- 19	MS21902D2	• UNION	1		
	MS28778-3	• PACKING	1		
- 20	8-80429-1379	• TUBE ASSY, AFT SELECTOR VALVE	1	206	
- 21	7144877-01	• TUBE ASSY, AFT SELECTOR VALVE	1		
- 22	7144878-01	• TUBE ASSY, AFT SELECTOR VALVE	1		
- 23	MS21902D3	• UNION	1		
	MS28778-8	• PACKING	1		
- 24	8-80429-651	• TUBE ASSY, AFT SELECTOR VALVE	1	35	42

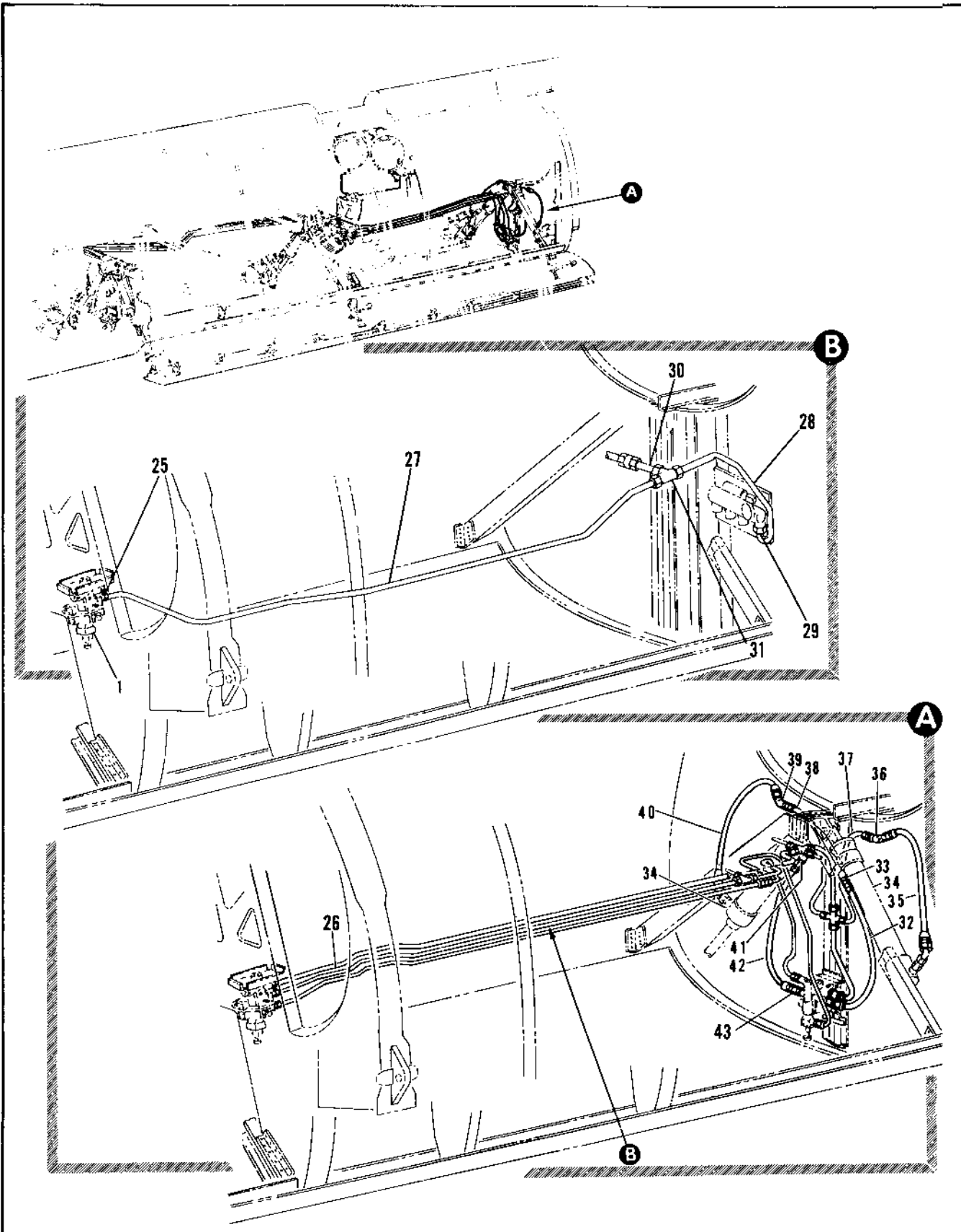

Figure 2.9-30. High Pressure Pneumatic Armament Door Aft Actuator Tubing Installation (Sheet 2 of 3)

FIGURE AND INDEX NUMBER	PART NUMBER	DESCRIPTION	UNITS PER ASSY.	USABLE ON CODE	
				FROM	TO
		1 2 3 4 5 6			
2.9-30- 25	MS2190204	• UNION	1		
	MS28778-4	• PACKING	1		
- 26	8-80429-7C3	• TUBE ASSY, AFT SELECTOR VALVE	1	35	42
- 27	7144881-101	• TUBE ASSY, AFT SELECTOR VALVE	1		
- 28	7144879-01	• TUBE ASSY, AFT SELECTOR VALVE	1		
- 29	MS2190204	• UNION	1		
	MS28778-4	• PACKING	1		
- 30	7144880-01	• TUBE ASSY	1		
- 31	MS2190504	• TEE	1		
- 32	666035-6-0200	• HOSE ASSY, <00624> 94-80522-113	1	35	38
		REPLACED BY SUITABLE SUB 124223-600200			
	124223-600200	• HOSE ASSY, <98441> SPEC 8-08538-35	1	39	
		REPLACES SUITABLE SUB FOR 666035-6-0200			
- 33	MS2190206	• UNION	1	35	
	AN6290-6	• GASKET	1	35	
- 34		• ACTUATOR ASSY, ARMAMENT BAY DOOR AFT	RF		
		SEE FIG. 2-20-11 INDEX 85			
- 35	666320-6-0166	• HOSE ASSY, <00624> 94-80509-003	1	35	38
		REPLACED BY SUITABLE SUB 124221-600166			
	124221-600166	• HOSE ASSY, <98441> SPEC 8-08538-41	1	39	
		REPLACES SUITABLE SUB FOR 666320-6-0166			
- 36	MS2190706	• ELBOW	1	35	
	AN924-6D	• NUT	1	35	
	AN960916L	• WASHER	1	35	
- 37	8-80429-565	• TUBE ASSY, AFT ACTUATOR LH	1	35	
- 38	8-80429-567	• TUBE ASSY, AFT ACTUATOR RH	1	35	
- 39	MS2190706	• ELBOW	1	35	
	AN924-6D	• NUT	1	35	
	AN960916L	• WASHER	1	35	
- 40	666320-6-0166	• HOSE ASSY, <00624> 94-80509-003	1	35	38
		REPLACED BY SUITABLE SUB 124221-600166			
	124221-600166	• HOSE ASSY, <98441> SPEC 8-08538-41	1	39	
		REPLACES SUITABLE SUB FOR 666320-6-0166			
- 41	MS2190206	• UNION	1	35	
	AN6290-6	• GASKET	1	35	
- 42	666035-6-0200	• HOSE ASSY, <00624> 94-80522-113	1	35	38
		REPLACED BY SUITABLE SUB 124223-600200			
	124223-600200	• HOSE ASSY, <98441> SPEC 8-08538-35	1	39	
		REPLACES SUITABLE SUB FOR 666035-6-0200			
- 43	MS21916DR-6	• REDUCER	1	35	
	AN6290-8	• GASKET	1	35	
		A AIRPLANES #35 THRU 47, 49 AND ON			

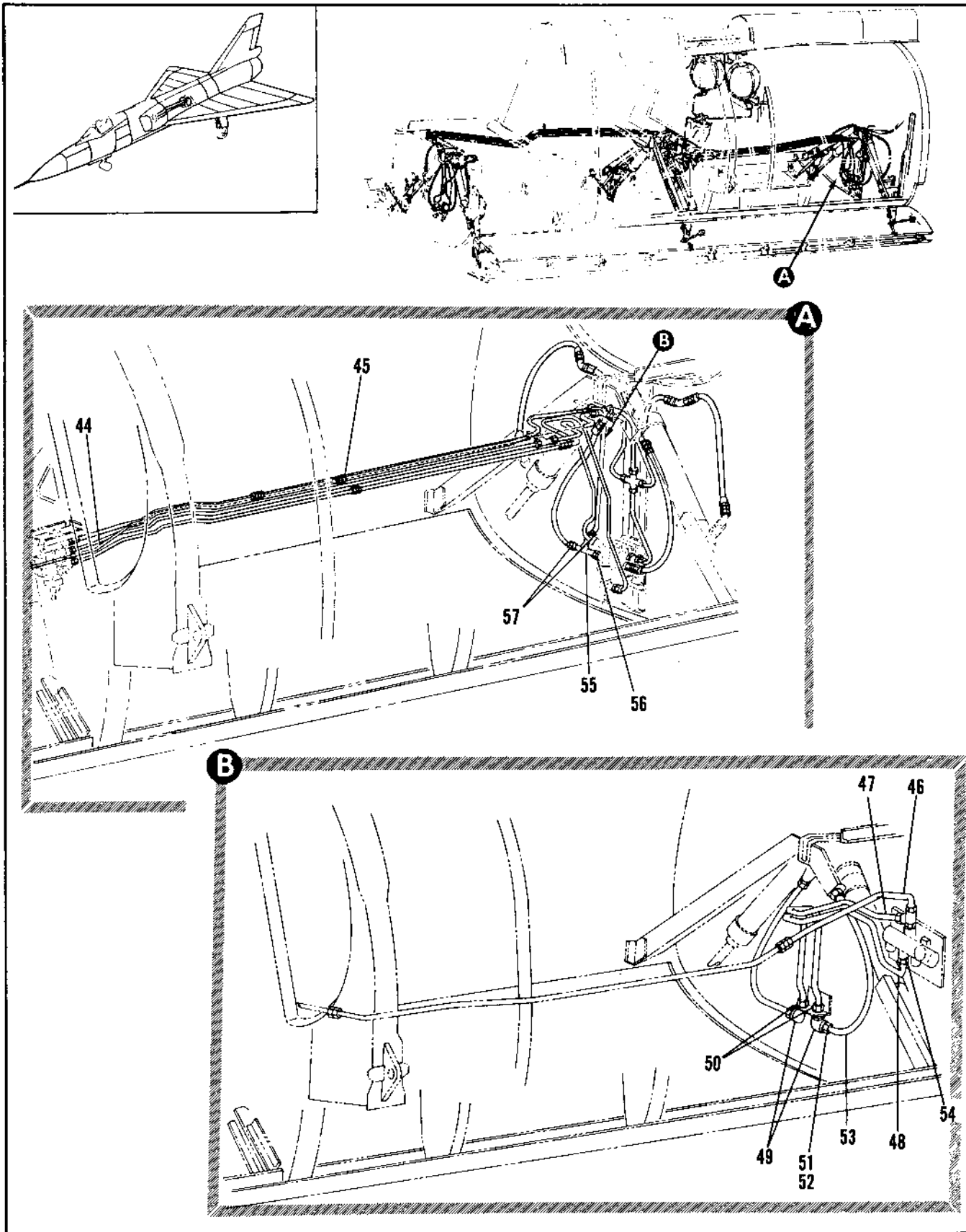

Figure 2.9-30. High Pressure Pneumatic Armament Door Aft Actuator Tubing Installation (Sheet 3 of 3)

FIGURE AND INDEX NUMBER	PART NUMBER	DESCRIPTION 1 2 3 4 5 6	UNITS PER ASSY.	USABLE ON CODE	
				FROM	TO
2.9-30- 44	67A34045-5	• TUBE ASSY (SEE FIG. 2.9-29 IND 60)	RFF		
- 45	MS21902D6	• UNION	1		
- 46	7144900-01	• TUBE ASSY	1		
- 47	7144899-01	• TUBE ASSY	1		
- 48	7144898-01	• TUBE ASSY	1		
- 49	MS21908-06	• ELBOW	2		
- 50	AN924-6D	• NUT	2		
- 51	MS21902D6	• UNION	2		
- 52	MS28778-6	• PACKING	2		
- 53	124223-600145	• HOSE ASSY, (98441)	2		
- 54	MS21902D6	• UNION	1		
	MS28778-6	• PACKING	1		
- 55	MS21912D6	• TEE	1		
- 56	MS2439D121	• REDUCER	1		
- 57	AN924-6D	• NUT	1		
	MS28778-6	• PACKING	2		

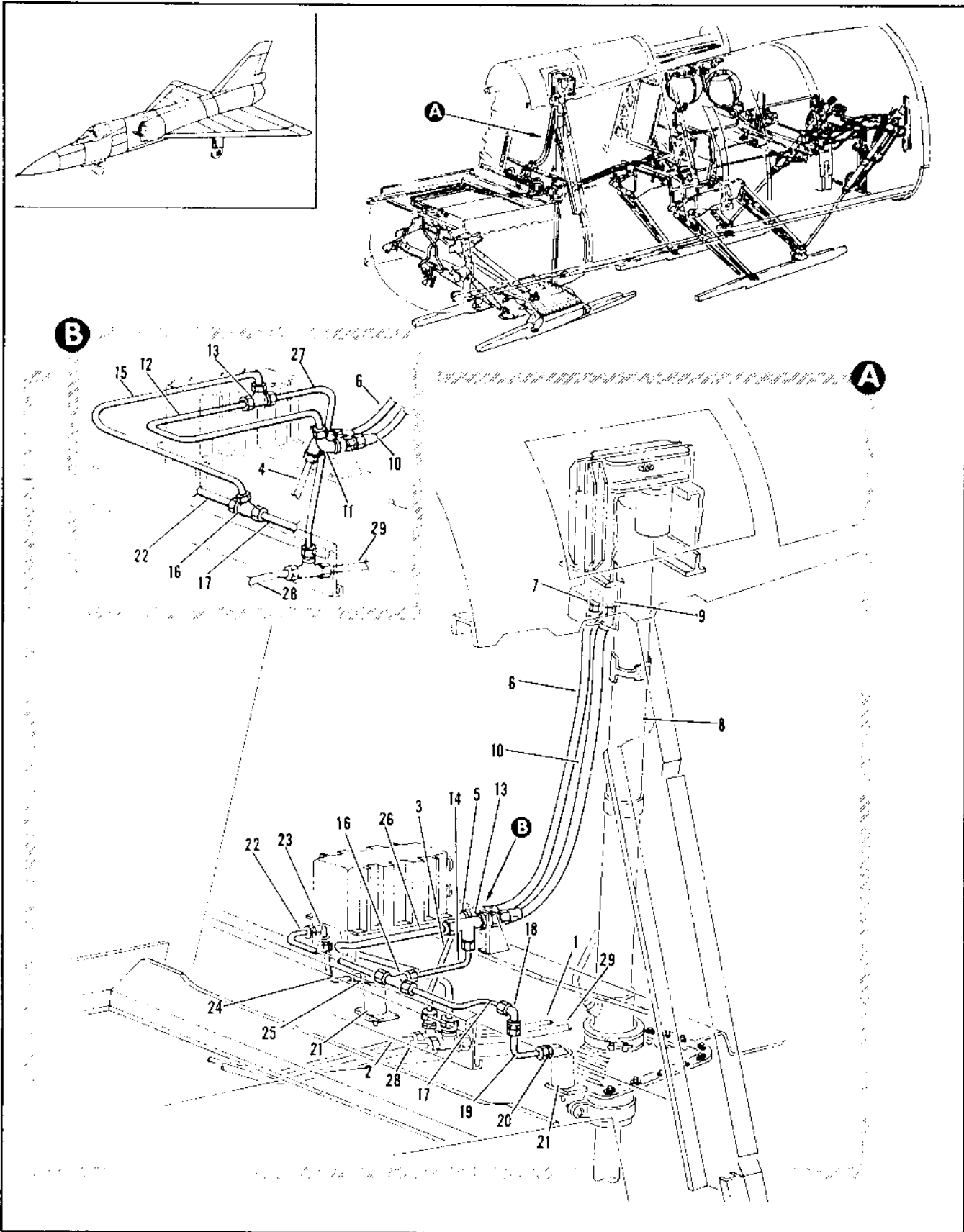

Figure 2.9-31. High Pressure Pneumatic Forward Armament Displacement Tubing Installation

FIGURE AND INDEX NUMBER	PART NUMBER	DESCRIPTION	UNITS PER ASSY.	USABLE ON CODE	
				FROM	TO
		1 2 3 4 5 6			
2.9-31	8-80429	TUBING INSTALLATION, HIGH PRESSURE PNEUMATIC FWD ARMAMENT DISPLACEMENT	1	35	
- 1		• TUBE ASSY, FWD SELECTOR VALVE SEE FIG. 2.9-28 INDEX 42	RF		
- 2		• TUBE ASSY, FWD SELECTOR VALVE SEE FIG. 2.9-29 INDEX 46	RF		
- 3	8-80429-515	• TUBE ASSY, FWD ARMAMENT DISPLACEMENT	1	35	60
- 4		• TUBE ASSY, ARMAMENT GEAR LOCK SEE FIG. 2.9-32 INDEX 2	RF		
- 5	MS2190704	• ELBOW	1	48	44
	MS2190804	• ELBOW	1	A	
	AN924-4D	• NUT	1	35	
	AN960D716L	• WASHER	1	35	
- 6	666320-4-C215	• HOSE ASSY, <00624> 94-80509-005 REPLACED BY SUITABLE SUB 124221-4D0215	1	35	38
	124221-4D0215	• HOSE ASSY, <98441> SPEC 08538-43 REPLACES SUITABLE SUB FOR 666320-4-0215	1	39	
- 7	21243-4-10	• FILTER, INLINE (REPLACES MS21902 UNION)	1	B	
	AN6290-4	• GASKET	1	35	
- 8		• ACTUATOR ASSY, FWD ARMAMENT DISPLACEMENT SEE FIG. 2.20-23 INDEX 55	RF		
- 9	MS21902D6	• UNION	1	35	
	AN6290-6	• GASKET	1	35	
- 10	666320-6-C225	• HOSE ASSY, <00624> 94-80509-004 REPLACED BY SUITABLE SUB 124221-6CR0226	1	35	38
	124221-6CR0226	• HOSE ASSY, <98441> SPEC 8-08538-45 REPLACES SUITABLE SUB FOR 666320-6-0225	1	39	
- 11	MS2190706	• ELBOW	1	90	
	AN924-6D	• NUT	1	90	
	AN960D916	• WASHER	1	90	
- 12	8-80429-1325	• TUBE ASSY, FWD ARMAMENT DISPLACEMENT	1	90	
- 13	ER8240060804	• TEE, <92003> 98-90319-004	1	35	
	AN924-6D	• NUT	1	35	
	AN960D916L	• WASHER	1	35	
- 14	8-80429-517	• TUBE ASSY, FWD ARMAMENT DISPLACEMENT	1	35	89
- 15	8-80429-1321	• TUBE ASSY, FWD ARMAMENT DISPLACEMENT	1	90	
- 16	MS2190504	• TEE	1	35	
- 17	8-80429-519	• TUBE ASSY, FWD SNUBBER LH	1	35	
- 18	MS2190604	• ELBOW	1	35	
	AN924-4D	• NUT	1	35	
	AN960D716L	• WASHER	1	35	
- 19	8-80429-527	• TUBE ASSY, FWD SNUBBER LH	1	35	
- 20	MS21902D4	• UNION	1	35	
	AN6290-4	• GASKET	1	35	
- 21		• SNUBBER, FWD ARMAMENT RETRACT SEE FIG. 2.20-23 INDEX 49	RF		
- 22	8-80429-521	• TUBE ASSY, FWD SNUBBER RH	1	35	
- 23	MS2190804	• ELBOW	1	35	
	AN924-4D	• NUT	1	35	
	AN960D716L	• WASHER	1	35	
- 24	8-80429-525	• TUBE ASSY, FWD SNUBBER RH	1	35	
- 25	MS21902D4	• UNION	1	35	
	AN6290-4	• GASKET	1	35	
- 26	8-80429-543	• TUBE ASSY, FWD ARMAMENT DISPLACEMENT	1	35	89
- 27	8-80429-1323	• TUBE ASSY, FWD ARMAMENT DISPLACEMENT	1	90	
- 28		• TUBE ASSY, EMERGENCY COCKPIT PRESSURIZATION SEE FIG. 2.9-11 INDEX 31	RF		
- 29		• TUBE ASSY, EMERGENCY COCKPIT PRESSURIZATION SEE FIG. 2.9-11 INDEX 34	RF		
		A AIRPLANES #35 THRU 47, 49 AND ON			

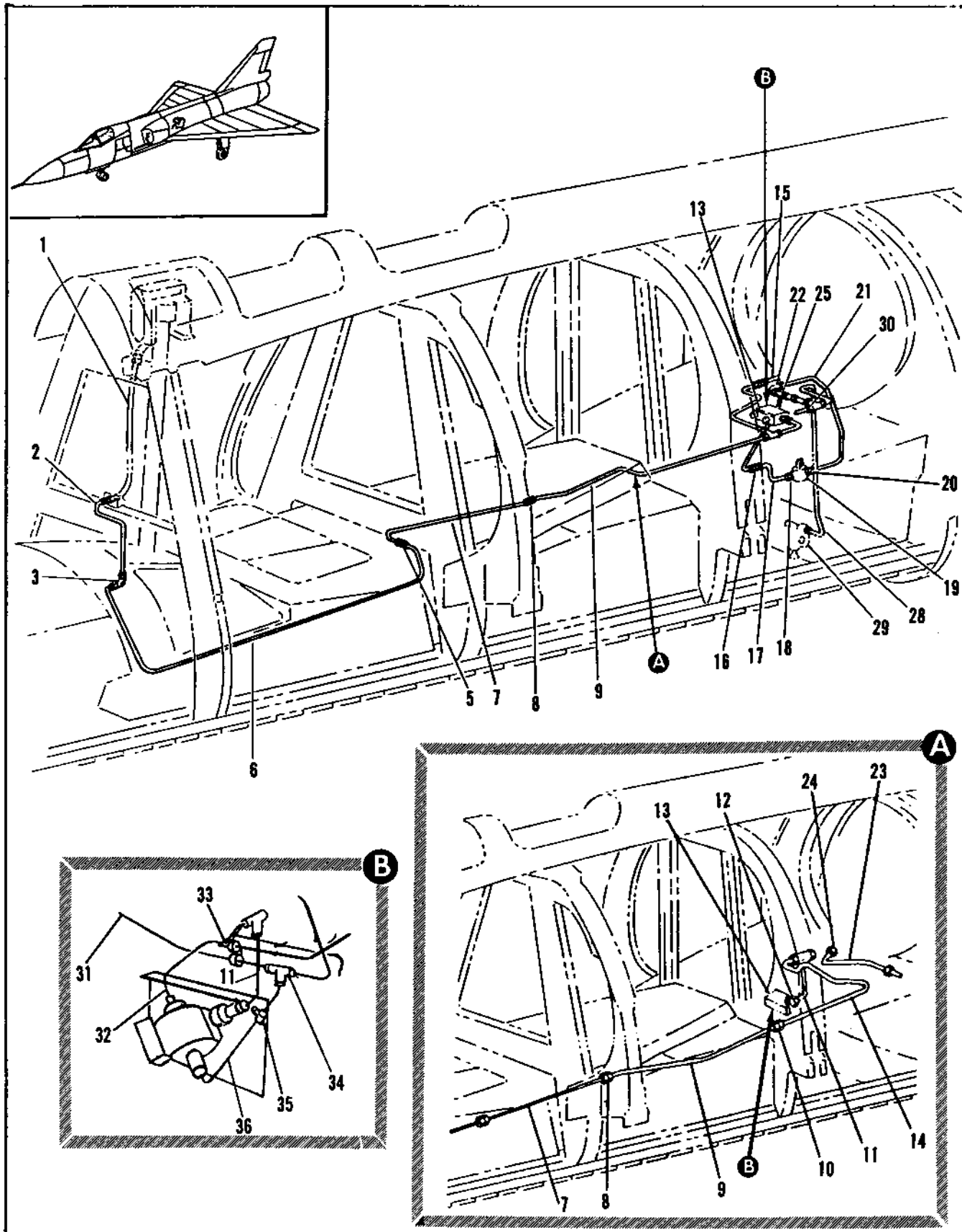

Figure 2.9-32. High Pressure Pneumatic Armament Gear Lock Tubing Installation

FIGURE AND INDEX NUMBER	PART NUMBER	DESCRIPTION	UNITS PER ASSY.	USABLE ON CODE	
				FROM	TO
2.9-32	8-80429	TUBING INSTALLATION, HIGH PRESSURE PNEUMATIC ARMAMENT GEAR LOCK	1	61	
- 1		. HOSE ASSY, SEE FIG. 2.9-31 INDEX 6	PF		
- 2	8-80429-1221	. TUBE ASSY, ARMAMENT GEAR LOCK	1	A	
- 3	MS21908D4	. ELBOW (96906)	1	A	
	AN924-4D	. NUT (88044)	1	A	
	AN967PD716	. WASHER (88044)	2	A	
- 4	8-80429-1389	. TUBE ASSY, ARMAMENT GEAR LOCK BY T.C.T.C. 1F-106A-549)	1	35	
- 5	MS2190204	. UNION (96906)	3	A	
- 6	66A36345-1	. TUBE ASSY, ARMAMENT GEAR LOCK (98750)			
- 7	7144905-01	. TUBE ASSY, ARMAMENT GEAR LOCK (98750)	1		
- 8	MS21902D4	. UNION (96906)	1		
- 9	7144884-01	. TUBE ASSY, ARMAMENT GEAR LOCK (98750)	1		
- 10	MS2190204	. UNION (96906)	1		
- 11	7144885-01	. TUBE ASSY, ARMAMENT GEAR LOCK (98750)	1		
- 12	MS21902D4	. UNION (96906)	1		
- 13	MS28778-4	. PACKING (96906)	1		
		. VALVE ASSY, SOLENOID OPERATED SELECTOR SEE FIG. 2.20-1 INDEX 10	RF		
- 14	7144883-01	. TUBE ASSY, ARMAMENT GEAR LOCK (98750)	1		
- 15	7144804-C1	. TUBE ASSY, ARMAMENT GEAR LOCK (98750)	1		
- 16	MS21902D4	. UNION (96906)	1	A	
- 17	8-80429-1249	. TUBE ASSY, ARMAMENT GEAR LOCK	1	A	
- 18	MS2191604-3	. REDUCER (96906)	1	A	
	AN6290-3	. GASKET (88044)	1	A	
- 19		. VALVE, ARMAMENT GEAR LOCK MANUAL SEE FIG. 2.20-1 INDEX 16	RF		
- 20	MS2190204	. UNION (96906)	1	A	
	AN6290-4	. GASKET (88044)	1	A	
- 21	8-80429-1245	. TUBE ASSY, ARMAMENT GEAR LOCK	1	A	
- 22	MS21907D4	. ELBOW (96906)	1	A	
	AN924-4D	. NUT (88044)	1	A	
	AN967PD716	. WASHER (88044)	1	A	
- 23	7144882-01	. TUBE ASSY, ARMAMENT GEAR LOCK (98750)	1		
- 24	AN924-4D	. NUT (88044)	1		
	MS2192404	. UNION (96906)	1		
- 25	PR7448-7	. RESTRICTOR, <91207> SPEC 8-0042E-7	1	A	
- 26		. TUBE ASSY, AFT SELECTOR VALVE SEE FIG. 2.9-30 INDEX 28	RF		
- 27		. VALVE ASSY, PNEUMATIC SELECTOR AFT SEE FIG. 2.20-1 INDEX 4	PF		
- 28		. TUBE ASSY, AFT SELECTOR VALVE SEE FIG. 2.9-30 INDEX 27	RF		
- 29	7144871-01	. TUBE ASSEMBLY (98750)	1		
	MS21122-3	. CLAMP (96906)	2		
	NAS1403-2	. SCREW (80205)	1		
- 30	7144886-01	. TUBE ASSEMBLY (98750)	1		
	MS2191608-4	. REDUCER (96906)	1		
	MS28778-8	. PACKING (96906)	1		
	MS21122-4	. CLAMP (96906)	3		
	NAS1403-3	. SCREW (80205)	3		
- 31	7144871-01	. TUBE ASSEMBLY (98750)	1		
	MS21122-3	. CLAMP (96906)	1		
	NAS1403-2	. SCREW (80205)	1		
- 32	71448861-01	. TUBE ASSEMBLY (98750)	1		
	MS2191608-4	. REDUCER (96906)	1		
	MS28778-8	. PACKING (96906)	1		
	MS21122-4	. CLAMP (96906)	1		
	NAS1403-3	. SCREW (80205)	1		
- 33	MS21912D-4	. UNION (96906)	1		
	AN924-4D	. NUT (88044)	1		
	AN960D-716	. WASHER (88044)	1		
- 34	MS21905D3	. TEE (96906)	1		
- 35	MS21122-3	. CLAMP (96906)	1		
- 36	7144872-01	. TUBE ASSEMBLY (98750)	1		
	MS2191608-3	. REDUCER (96906)	1		
	MS28778-8	. PACKING (96906)	1		
		A AIRPLANES #35 THRU 47, 49 AND ON			
		B AIRPLANES #35 THRU 47, 49 THRU 60			
		C AIRPLANES #35 THRU 47, 49 THRU 89			

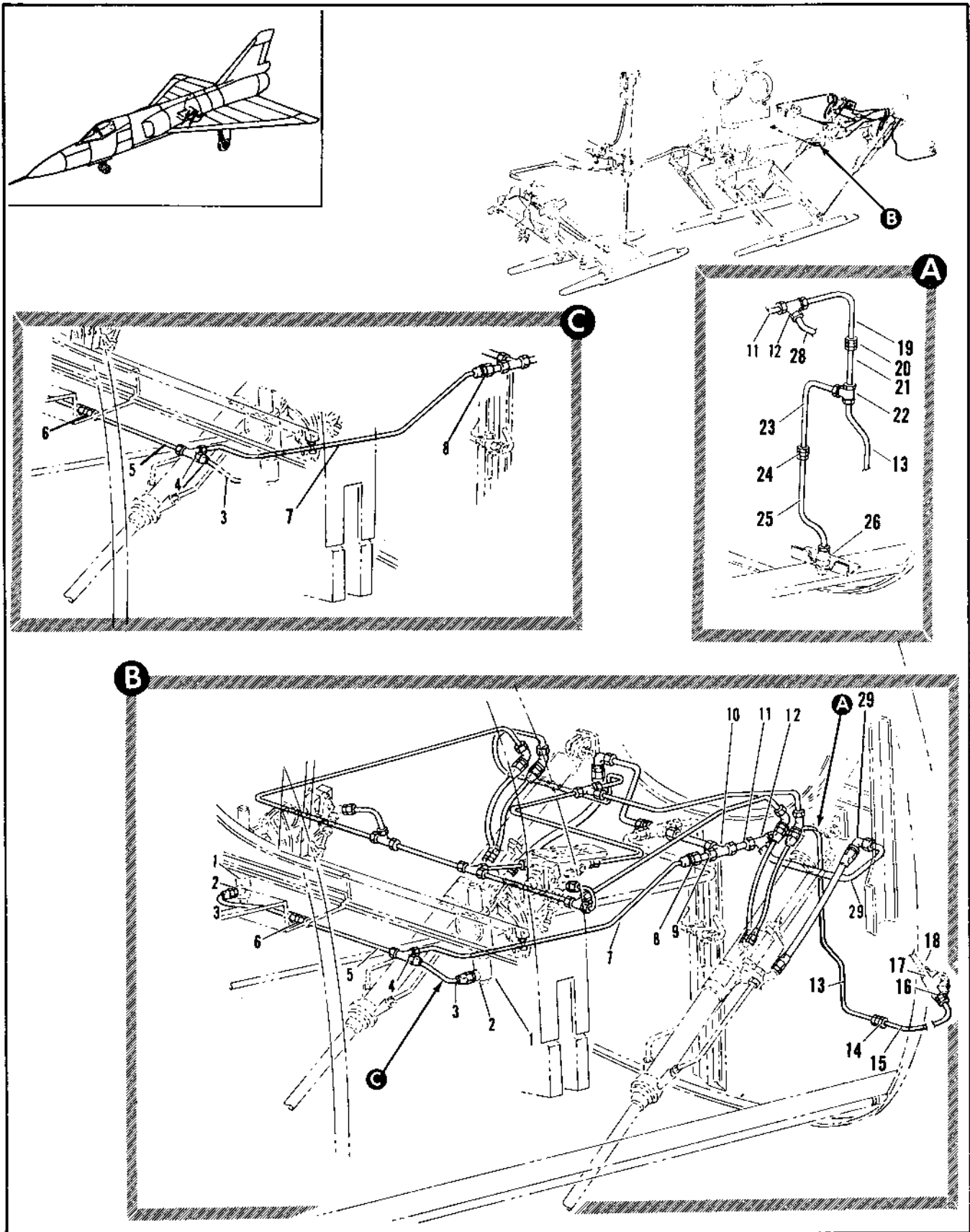

Figure 2.9-33. High Pressure Pneumatic Aft Armament Displacement Tubing Installation (Sheet 1 of 3)

FIGURE AND INDEX NUMBER	PART NUMBER	DESCRIPTION	UNITS PER ASSY.	USABLE ON CODE	
				FROM	TO
		1 2 3 4 5 6			
2.9-33	R-80429	• TUBING INSTALLATION, HIGH PRESSURE • PNEUMATIC AFT ARMAMENT DISPLACEMENT • SNUBBER, AFT ARMAMENT RETRACT SEE FIG. 2.20-33 INDEX 1	1	35	
- 1			RF		
- 2	MS21902D4 AN6290-4	• UNION • GASKET	2	35	
- 3	666319-4-0076 124222-4D0076	• HOSE ASSY <06624> 94-80510-004 REPLACED BY SUITABLE SUR 124222-4D0076 • HOSE ASSY <98441> SPEC 8-0853A-37 REPLACES SUITABLE SUR FOR 666319-4-0076	2	35	3A
- 4	MS21905D4	• TEE	1	35	
- 5	8-80429-595 7144889-01	• TUBE ASSY, SNUBBER RH • TUBE ASSY, SNUBBER RH	1	35	40
- 6	MS21902D4 AN6290-4	• UNION • GASKET	1	35	
- 7	8-80429-1029 7144888-01	• TUBE ASSY, SNUBBER • TUBE ASSY, SNUBBER	1	35	40
- 8	MS21916D6-4	• REDUCER	1	35	
- 9	8-80429-453	• TUBE ASSY, SNUBBER	1	35	
- 10	MS21905D6	• TEE	1	35	
- 11	8-80429-447	• TUBE ASSY, AFT ACTUATOR LH	1	35	
- 12	MS21912D6 AN924-6D	• NUT	1	35	
- 13	AN961D916L	• WASHER	1	35	
- 14	8-80429-401	• TUBE ASSY, MANUAL SAFETY VALVE	1	35	
- 15	MS21902D4	• UNION	1	35	50
- 16	8-80429-403 8-80429-1253	• TUBE ASSY, MANUAL SAFETY VALVE • TUBE ASSY, MANUAL SAFETY VALVE	1	35	
- 17	MS21902D4 AN6290-4	• UNION • GASKET	1	35	
- 18		• VALVE ASSY, MANUAL SAFETY SEE FIG. 2.20-1 INDEX 40	RF		
- 19	8-82403-109	• TUBE ASSY, ARMAMENT BAY DOOR AFT VALVE SEE FIG. 2.9-27 INDEX 25	1	A	
- 20	MS21916D4-3	• TUBE ASSY, HYDRAULIC BOOST	1	A	
- 21	8-82403-119	• REDUCER	1	A	
- 22	MS21905D4	• TUBE ASSY, HYDRAULIC BOOST	1	A	
- 23	8-82403-117	• TEE	1	A	
- 24	MS21916D4-3	• TUBE ASSY, HYDRAULIC BOOST	1	A	
- 25	8-82403-127	• REDUCER	1	A	
- 26		• TUBE ASSY, HYDRAULIC BOOST • VALVE, PNEUMATIC HIGH PRESSURE CHECK SEE FIG. 2.8-6 INDEX 11	RF		
- 27	8-80429-1005	• TUBE ASSY, AFT ACTUATOR LH	1	35	
- 28	8-80429-1005	• ELPOW	1	35	
- 29	MS21905D6 AN924-6D AN961D916L	• NUT • WASHER	1	35	
		A AIRPLANES #287, 288, 291, 295 THRU 297, 299, AND 302			
		B AIRPLANES #35 THRU 92, 94 THRU 286, 289, 290, 292 THRU 294, 298, 300, 301, 303 AND ON			

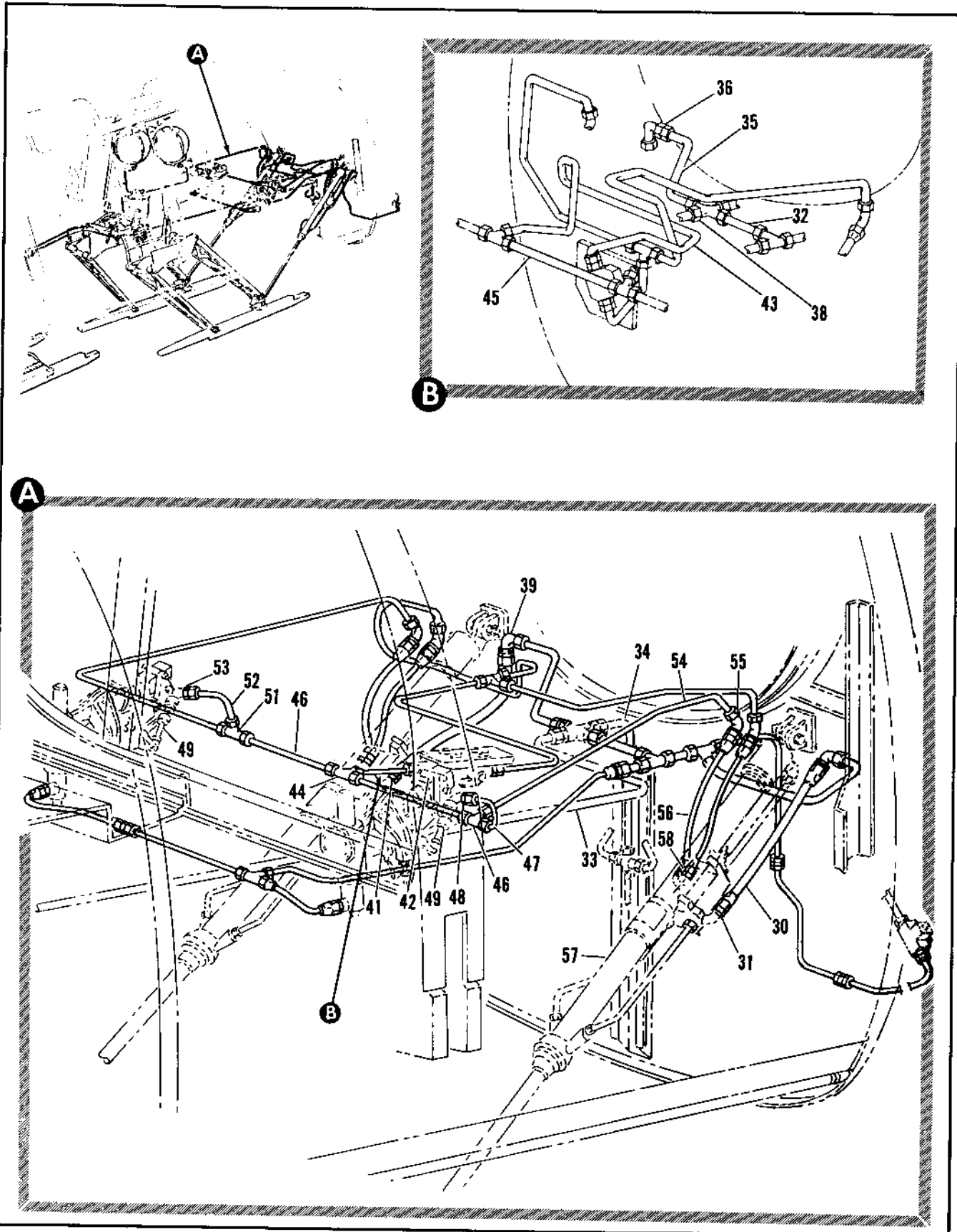

Figure 2.9-33. High Pressure Pneumatic Aft Armament Displacement Tubing Installation (Sheet 2 of 3)

FIGURE AND INDEX NUMBER	PART NUMBER	DESCRIPTION	UNITS PER ASSY.	USABLE ON CODE	
				FROM	TO
		1 2 3 4 5 6			
2.9-33	R-80429	• TUBING INSTALLATION, HIGH PRESSURE • PNEUMATIC AFT ARMAMENT DISPLACEMENT • SNURBER, AFT ARMAMENT RETRACT SEE FIG. 2.20-33 INDEX 1	1	35	
- 1			AF		
- 2	MS21902D4	• UNION	2	35	
	AN6290-4	• GASKET	2	35	
- 3	666319-4-1076	• HOSE ASSY <<6624> 94-R1510-004 REPLACED BY SUITABLE SUB 124222-400076	2	35	34
	124222-400076	• HOSE ASSY, <98441> SPEC R-08538-37 REPLACES SUITABLE SUP FOR 666319-4-1076	2	39	
- 4	MS21905D4	• TEE	1	35	
- 5	R-80429-595	• TUBE ASSY, SNURBER RH	1	35	40
	7144889-01	• TUBE ASSY, SNURBER RH	1		
- 6	MS21902D4	• UNION	1	35	
	AN6290-4	• GASKET	1	35	
- 7	R-80429-1029	• TUBE ASSY, SNURBER	1	35	41
	7144888-01	• TUBE ASSY, SNURBER	1		
- 8	MS21916D6-4	• REDUCER	1	35	
- 9	R-80429-453	• TUBE ASSY, SNURBER	1	35	
- 10	MS21905D6	• TEE	1	35	
- 11	R-80429-447	• TUBE ASSY, AFT ACTUATOR LH	1	35	
- 12	MS21912D6		1	35	
	AN924-60	• NUT	1	35	
	AN9610916L	• WASHER	1	35	
- 13	R-80429-401	• TUBE ASSY, MANUAL SAFETY VALVE	1	35	
- 14	MS21902D4	• UNION	1	35	60
- 15	R-80429-413	• TUBE ASSY, MANUAL SAFETY VALVE	1	35	
	R-80429-1253	• TUBE ASSY, MANUAL SAFETY VALVE	1	35	
- 16	MS21902D4	• UNION	1	35	
	AN6290-4	• GASKET	1	35	
- 17		• VALVE ASSY, MANUAL SAFETY SEE FIG. 2.20-1 INDEX 40	AF		
- 18		• TUBE ASSY, ARMAMENT BAY DOOR AFT VALVE SEE FIG. 2.9-27 INDEX 25	AF		
- 19	R-82403-109	• TUBE ASSY, HYDRAULIC BOOST	1	A	
- 20	MS21916D4-3	• REDUCER	1	A	
- 21	R-82403-119	• TUBE ASSY, HYDRAULIC BOOST	1	A	
- 22	MS21905D4	• TEE	1	A	
- 23	R-82403-117	• TUBE ASSY, HYDRAULIC BOOST	1	A	
- 24	MS21916D4-3	• REDUCER	1	A	
- 25	R-82403-127	• TUBE ASSY, HYDRAULIC BOOST	1	A	
- 26		• VALVE, PNEUMATIC HIGH PRESSURE CHECK SEE FIG. 2.8-6 INDEX 11	AF		
- 27	R-80429-1005		1	35	
- 28	R-80429-1005	• TUBE ASSY, AFT ACTUATOR LH	1	35	
- 29	MS21902D6	• ELPOW	1	35	
	AN924-60	• NUT	1	35	
	AN9610916L	• WASHER	1	35	
		A AIRPLANES #287, 288, 291, 295 THRU 297, 299, AND 312			
		B AIRPLANES #35 THRU 92, 94 THRU 286, 289, 290, 292 THRU 294, 298, 310, 311, 313 AND ON			

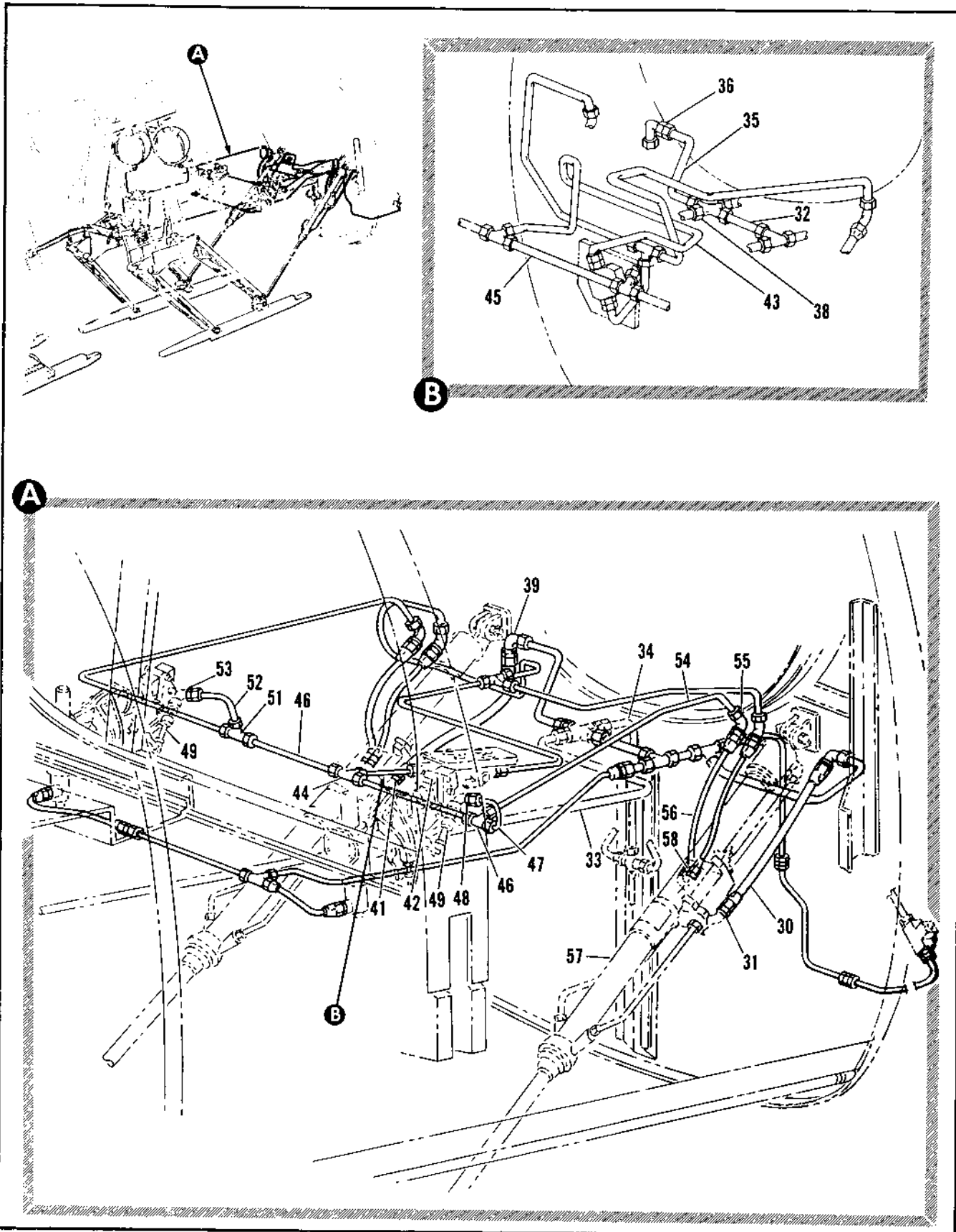

Figure 2.9-33. High Pressure Pneumatic Aft Armament Displacement Tubing Installation (Sheet 2 of 3)

FIGURE AND INDEX NUMBER	PART NUMBER	DESCRIPTION	UNITS PER ASSY.	USABLE ON CODE	
				FROM	TO
2.9-33- 30	666335-6-0134	• HOSE ASSY, <00624> 94-HF522-061 REPLACED BY SUITABLE SUB 124223-400134	1	30	34
	124223-400134	• HOSE ASSY, <98441> SPEC 8-08038-25 REPLACES SUITABLE SUB FOR 666335-6-0134	1	30	
- 31	MS2190206	• UNION	1	35	
	AN6290-6	• GASKET	1	35	
- 32	7144890-01	• TUBE ASSY, AFT ACTUATOR	1		
- 33		• TUBE ASSY, AFT SELECTOR VALVE SEE FIG. 2.9-30 INDEX 3	RF		
- 34		• TUBE ASSY, AFT SELECTOR VALVE SEE FIG. 2.9-30 INDEX 3	RF		
- 35	7144891-01	• TUBE ASSY, AFT ACTUATOR	1		
- 36	MS2190206	• UNION	1		
	MS28778-6	• PACKING	1		
- 37	MS2191608-6	• REDUCER	1		
	MS28778-8	• PACKING	1		
- 38	AN93708	• CROSS	1		
- 39	MS2190806	• ELBOW	1	35	
	AN924-60	• NUT	1	35	
	AN9610916L	• WASHER	1	35	
- 40	666335-6-0134	• HOSE ASSY, <00624> 94-HF522-061 REPLACED BY SUITABLE SUB 124223-400134	1	30	34
	124223-400134	• HOSE ASSY, <98441> SPEC 8-08038-25 REPLACES SUITABLE SUB FOR 666335-6-0134	1	30	
- 41	MS2190206	• UNION	1	35	
	AN6290-6	• GASKET	1	35	
- 42		• VALVE ASSY, HIGH PRESS PNEUMATIC SOLENOID OPERATED ARMAMENT SELECTOR SEE FIG. 2.20-1 INDEX 7	RF		
- 43	7144886-01	• TUBE ASSY, AFT SELECTOR VALVE	1		
- 44	MS2190504	• TEE	1	35	
- 45	7144877-01	• TUBE ASSY, AFT SELECTOR VALVE	1		
- 46	MS2190504	• TEE	1	35	
- 47	8-80429-1023	• TUBE ASSY, UP-LATCH LH	1	35	
- 48	MS2190204	• UNION	1	35	
	AN6290-4	• GASKET	1	35	
- 49		• ACTUATOR ASSY, UP-LATCH SEE FIG. 2.20-33 INDEX 57	RF		
- 50	8-80429-1017	• TUBE ASSY, AFT SELECTOR VALVE	1	35	
- 51	MS2190504	• TEE	1	35	
- 52	8-80429-1027	• TUBE ASSY, UP-LATCH RH	1	35	
- 53	MS2190204	• UNION	1	35	
	AN6290-4	• GASKET	1	35	
- 54	8-80429-1025	• TUBE ASSY, AFT ACTUATOR LH	1	35	
- 55	MS2190804	• ELBOW	1	35	
	AN924-40	• NUT	1	35	
	AN9610916L	• WASHER	1	35	
- 56	666335-4-0120	• HOSE ASSY, <00624> 94-HF521-049 REPLACED BY SUITABLE SUB 124223-400120	1	30	34
	124223-400120	• HOSE ASSY, <98441> SPEC 8-08038-21 REPLACES SUITABLE SUB FOR 666335-4-0120	1	30	
- 57		• ACTUATOR ASSY, AFT DISPLACEMENT GEAR SEE FIG. 2.20-31 INDEX 97	RF		
- 58	MS2190203	• UNION	1	35	
	AN6290-3	• GASKET	1	35	

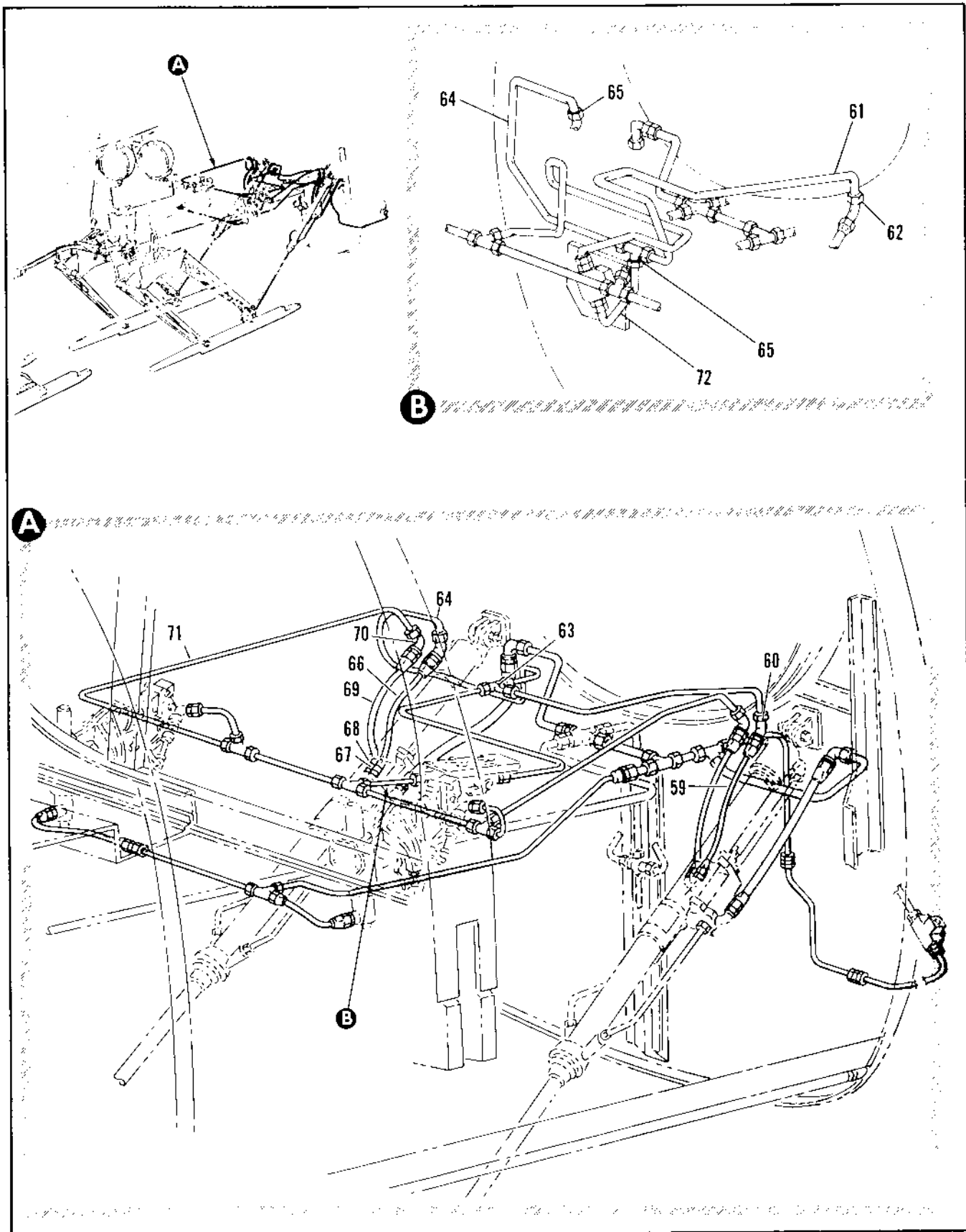

Figure 2.9-33. High Pressure Pneumatic Aft Armament Displacement Tubing Installation (Sheet 3 of 3)

FIGURE AND INDEX NUMBER	PART NUMBER	DESCRIPTION	UNITS PER ASSY.	USABLE ON CODE	
				FROM	TO
2.9-33- 59	666035-3-0120	• HOSE <00624> 94-80520-049 REPLACED BY SUITABLE SUB 124223-300120	1	35	38
	124223-300120	• HOSE ASSY, <98441> SPEC 8-08538-19 REPLACES SUITABLE SUB FOR 666035-3-0120	1	39	
- 60	MS2190703	• ELBOW	1	35	
	AN924-30	• NUT	1	35	
	AN9600616	• WASHER	1	35	
- 61	7144873-01	• TUBE ASSY, AFT ACTUATOR LH	1		
- 62	MS2190203	• UNION	1		
	MS28778-3	• PACKING	1		
- 63	MS2190503	• TEE	1	35	
- 64	7144871-01	• TUBE ASSY, AFT ACUTATOR RH	1		
- 65	MS2190503	• TEE	1		
- 66	666035-3-0120	• HOSE ASSY, <00624> 94-80520-049 REPLACED BY SUITABLE SUB 124223-300120	1	35	38
	124223-300120	• HOSE ASSY, <98441> SPEC 8-08538-19 REPLACES SUITABLE SUB FOR 666035-3-0120	1	39	
- 67	MS2190203	• UNION	1	35	
	AN6290-3	• GASKET	1	35	
- 68	MS2190204	• UNION	1	35	
	AN6290-4	• GASKET	1	35	
- 69	666035-4-0120	• HOSE ASSY, <00624> 94-80521-049 REPLACED BY SUITABLE SUB 124223-400120	1	35	38
	124223-400120	• HOSE ASSY, <98441> SPEC 8-08538-21 REPLACES SUITABLE SUB FOR 666035-4-0120	1	39	
- 70	MS2190804	• ELBOW	1	35	
	AN924-40	• NUT	1	35	
	AN9600716L	• WASHER	1	55	
- 71	9-80429-1015	• TUBE ASSY, AFT ACTUATOR RH	1	35	
- 72	7144872-01	• TUBE ASSY, AFT SELECTOR VALVE	1		

123 126 50

POWER PLANT SUBSECTION**TABLE OF CONTENTS**

<i>Fig. No.</i>	<i>Title</i>	<i>Page</i>	<i>Fig. No.</i>	<i>Title</i>	<i>Page</i>
2.10-1	Power Plant	2,10-2	2.10-20	Pressure Ratio Tubing	2,10-76
2.10-2	Power Control Pedestal Installation	2,10-8	2.10-21	Engine Oil Cooler	2,10-80
2.10-3	Power Control Teleflex Installation	2,10-10	2.10-22	Accessory Oil Cooler Air Valve Installation	2,10-82
2.10-4	Power Control Torque Shaft Installation	2,10-12	2.10-23	Engine Oil Cooler Air Valve Installation	2,10-86
2.10-5	Power Control Bell Crank Installation	2,10-14	2.10-24	Engine Oil Tubing Installation	2,10-90
2.10-6	Power Plant Installation	2,10-16	2.10-25	CSD Transmission/Generator Assembly Installation	2,10-92
2.10-7	Turbojet Engine Assembly	2,10-22	2.10-26	Engine Oil Cooler Drain Installation	2,10-94
2.10-8	Engine Cooling Air Supply Duct Installation Sta 487 to 560	2,10-40	2.10-27	Accessory Drive Oil Cooler	2,10-96
2.10-9	Engine Fire Seal Adapter Installation	2,10-46	2.10-28	Accessory Drive Oil Cooler Equipment Installation	2,10-98
2.10-10	Ram Air Shroud Cooling Check Valve Assembly	2,10-48	2.10-29	Accessory Drive External Filter and Assembly	2,10-100
2.10-11	Shroud Ground Cooling Duct Installation	2,10-50	2.10-30	Remote Gearbox Accessory Drive Support Installation	2,10-102
2.10-12	Engine Air Cooling Shroud Installation	2,10-52	2.10-31	CSD Oil Cooler Bypass Valve Installation	2,10-104
2.10-13	Engine Cooling Shroud Assembly	2,10-60	2.10-32	Engine Mounted Gearbox Installation	2,10-106
2.10-14	Engine Shroud Blanket Installation	2,10-64	2.10-33	CSD Drive Shaft Cover, Drive Shaft and Internal Filter Installation	2,10-108
2.10-15	Fuselage Overheat Insulation Blanket Installation Sta 530 to 556	2,10-66	2.10-34	Fire and Overheat Detector	2,10-110
2.10-16	Fuel and Oil Vent and Drain Fitting Installation	2,10-68	2.10-35	Fire and Overheat Detector Installation	2,10-112
2.10-17	Power Plant Vent and Drain Tubing Assembly Spares	2,10-70	2.10-36	Engine Thrust Bearing Support and Clamp	2,10-114
2.10-18	Power Plant Vent and Drain Tubing	2,10-72	2.10-37	Engine Removal Rail Support Installation	2,10-116
2.10-19	Engine Oil Cooler Tubing Installation	2,10-74	2.10-38	Engine Removal Rail Support Installation	2,10-118
			2.10-39	Engine Aft Roller Installation	2,10-120
			2.10-40	Engine Mount Beam Installation Aft	2,10-122

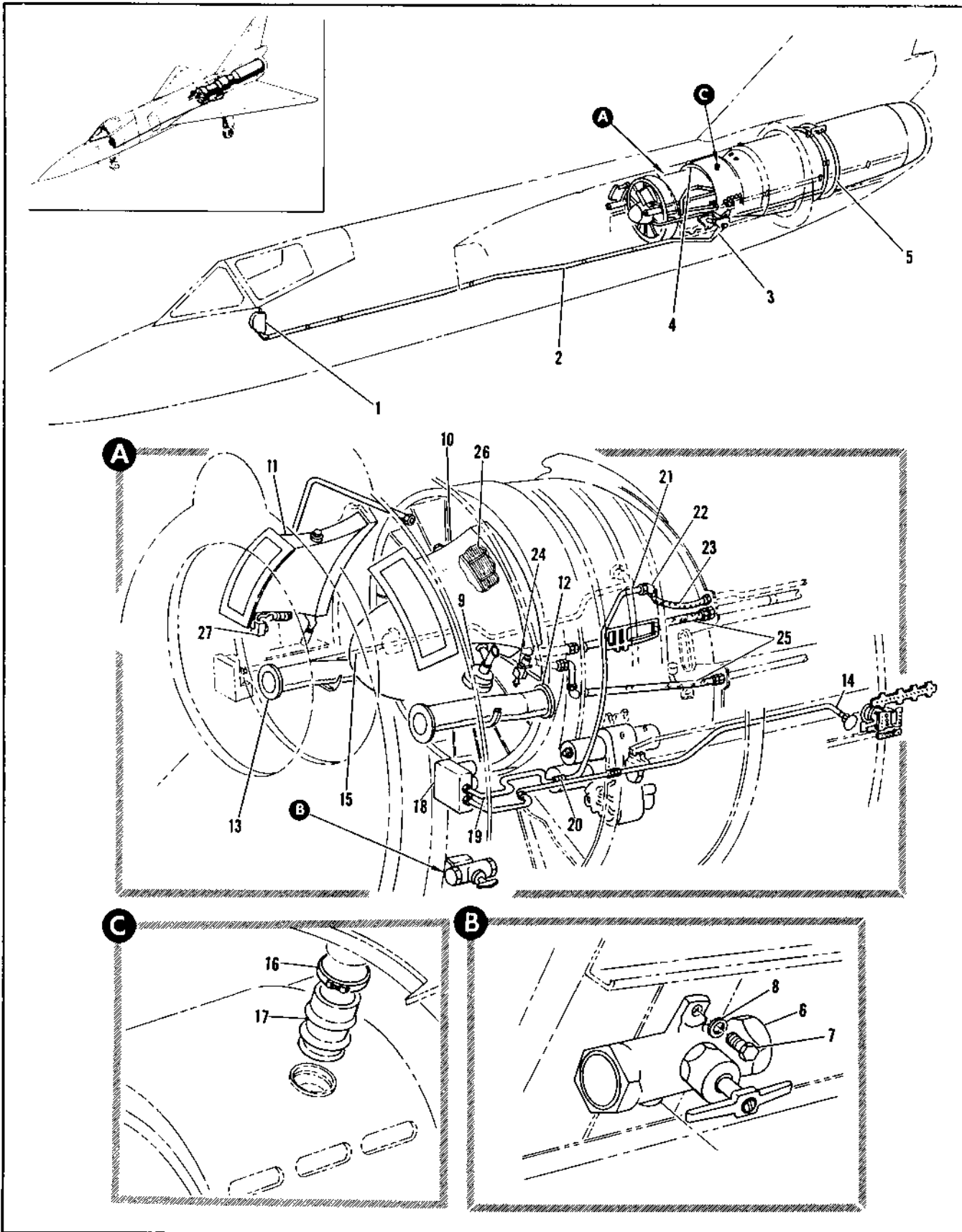

Figure 2.10-1. Power Plant (Sheet 1 of 3)

FIGURE AND INDEX NUMBER	PART NUMBER	DESCRIPTION	UNITS PER ASSY.	USABLE ON CODE	
				FROM	TO
		1 2 3 4 5 6			
2.10-1		POWER PLANT			
- 1		• PEDESTAL INSTL, POWER CONTROL SEE FIG. 2.10-2	RF		
- 2		• TELEFLEX INSTL, POWER CONTROL SEE FIG. 2.10-3	RF		
- 3		• SHAFT INSTL, POWER CONTROL TORQUE SEE FIG. 2.10-4	RF		
- 4		• POWER PLANT INSTL, SEE FIG. 2.10-6	RF		
- 5		• PRESSURE RATIO INDICATOR TUBING SEE FIG. 2.10-20	RF		
	8-85039-1	• VALVE INSTL, MANUAL SHUTOFF STARTER PNEUMATIC STA 441 FOR NHA SEE FIG. 2.3-11	RF	35	
- 6	10610-2	• VALVE ASSY, MANUAL SHUTOFF <99034> SPEC 8-0040A-1 T.O. 9P5-9-22-23 ATTACHING PARTS	1	35	
- 7	AN3-5A	• BOLT	2	35	
- 8	AN965010	• WASHER -----X-----	2	35	
- 9		• VALVE INSTL, ENGINE OIL COOLER AIR SEE FIG. 2.10-23	RF		
- 10	8-74472	• DUCT ASSY, ENGINE OIL COOLER LH SEE FIG. 2.3-13 INDEX 23	RF		
- 11	8-74473	• DUCT ASSY, GENERATOR OIL COOLER RH SEE FIG. 2.3-13 INDEX 22	RF		
	8-74919	• DUCT INSTL, SHROUD COOLING LH FOR NHA SEE FIG. 2.3-13-24	RF	35	
	8-74920	• DUCT INSTL, SHROUD COOLING RH FOR NHA SEE FIG. 2.3-13-24	RF	35	
- 12	8-74919-23	• DUCT ASSY, SHROUD COOLING LH WELDED	1	35	
- 13	8-74920-13	• DUCT ASSY, SHROUD COOLING RH WELDED	1	35	
- 14		• TUBING INSTL, OIL COOLER AMBIENT AIR CONTROL LH STA 446 TO 503 SEE FIG. 2.10-23	RF		
- 15		• TUBING INSTL, OIL COOLER AMBIENT AIR CONTROL RH STA 446 TO 503 SEE FIG. 2.10-23	RF		
	8-27561-3	• BELLOWS INSTL, ENGINE OIL TANK SCUPPER FOR NHA SEE FIG. 2.1-1 INDEX 50	RF	35	
- 16	326-62-612S	• CLAMP, <98625> 91-97801-014	1	35	
- 17	423A-3	• BELLOWS, <84191> SPEC 8-02476-3	1	35	
	8-27795-5	• TUBING INSTL, OIL COOLER ENGINE BLEED AIR CONTROL STA 445 TO 545 FOR NHA SEE FIG. 2.3-3	RF	35	
- 18		• SENSOR ASSY, ENGINE COMPARTMENT PRESSURE CONTROL ENVELOPE SEE FIG. 2.10-23 INDEX 22	RF		
- 19	8-27795-17	• TUBE ASSEMBLY	1	35	
- 20	MS21902D5	• UNION	1	35	
- 21	8-27795-29	• TUBE ASSEMBLY - (5/16 O.D. x 0.035 x 34.0 - 5052 AL ALLOY, WW-T-787) OPPOSITE TUBE END SWAGE TO 1/4 O.D.	1	35	
- 22	MS21908-4	• ELBOW	1	35	
	AN924-4	• NUT	1	35	
	AN960-716	• WASHER	1	35	
- 23		• HOSE ASSY, SEE FIG. 2.10-7 INDEX 48	RF		
- 24		• DRAIN INSTL, ENGINE OIL COOLER SEE FIG. 2.10-26	RF		
- 25		• TUBING INSTL, ENGINE OIL COOLER SEE FIG. 2.10-19	RF		
- 26		• COOLER ASSY, ENGINE OIL SEE FIG. 2.10-21 INDEX 1	RF		
- 27		• VALVE INSTL, ACCESSORY OIL COOLER AIR SEE FIG. 2.10-22	RF		

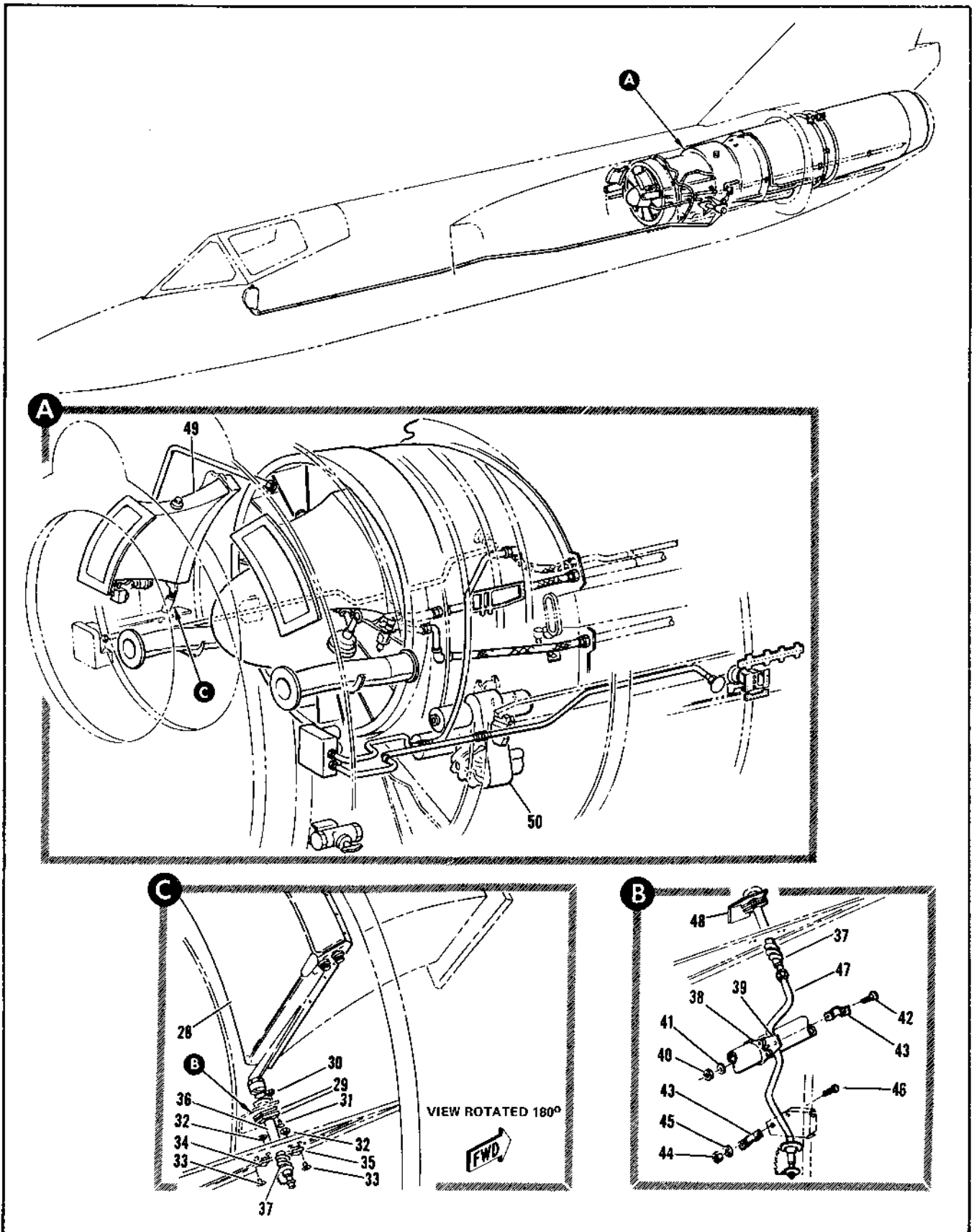

Figure 2.10-1. Power Plant (Sheet 2 of 3)

FIGURE AND INDEX NUMBER	PART NUMBER	DESCRIPTION	UNITS PER ASSY.	USABLE ON CODE	
				FROM	TO
2.10-1	8-28245	. DRAIN INSTL, ACCESSORY DRIVE OIL COOLER STA 466 FOR NHA SEE FIG. 2.3-11	RF	35	38
	8-28245-1	. DRAIN INSTL, ACCESSORY DRIVE OIL COOLER STA 466 FOR NHA SEE FIG. 2.3-11	RF	39	
- 28		. . COOLER ASSY, ACCESSORY DRIVE OIL SEE FIG. 2.10-28 INDEX 1	RF		
- 29	8-27570	. . GUIDE, ENGINE OIL COOLER DRAIN ATTACHING PARTS	2	35	
- 30	MS21042L3	. . NUT	2	35	
- 31	AN520-10R8	. . SCREW	2	35	
	8-28236	. . GUIDE ASSY, DRAIN OIL COOLER ACCESSORY DRIVE	1	35	
	8-28247	. . GUIDE ASSY, DRAIN OIL COOLER ACCESSORY DRIVE ALT INTCHG WITH 8-28236 ATTACHING PARTS	RF	35	
- 32	MS21042L3	. . NUT	4	35	
- 33	AN520-10R6	. . SCREW	4	35	
- 34	8-28236-7	. . . GUIDE, LH	1	35	
	8-28247-7	. . . GUIDE, LH USE WITH 8-28247	RF	35	
- 35	8-28236-8	. . . GUIDE, RH	1	35	
	8-28247-8	. . . GUIDE, RH USE WITH 8-28247	RF	35	
- 36	8-28246-3	. . DRAIN ASSY, OIL COOLER WELDED	1	35	
- 37	8-44119	. . . SPRING, ACTUATING VALVE LATCH MECHANISM	1	35	
- 38	901-398-2-5A	. . SUPPORT, <98625> 98-60000-017	1	35	
- 39	8-26718	. . SUPPORT ASSY, COOLING AIR RIVETED ATTACHING PARTS	1	35	
- 40	MS21042L3	. . NUT	1	35	
- 41	AN960-10L	. . WASHER	1	35	
- 42	AN520-10R7	. . SCREW	1	35	
- 43	8-28396	. . FAIR-LEAD, ENGINE OIL COOLER DRAIN ATTACHING PARTS	4	35	
- 44	MS21042L3	. . NUT	2	39	
- 45	AN960-10L	. . WASHER	2	39	
- 46	AN520-10R7	. . SCREW	2	39	
- 47	8-28395	. . TUBE ASSY, DRAIN OIL COOLER ACCESSORY DRIVE WELDED	1	35	
- 48	8-28248	. . BRACKET INSTL, OIL COOLER DRAIN ACCESSORY DRIVE RIVETED	1	35	89
	8-28248-1	. . BRACKET INSTL, OIL COOLER DRAIN ACCESSORY DRIVE RIVETED	1	90	
- 49		. ACCESSORY DRIVE OIL COOLER SEE FIG. 2.10-27	RF		
- 50		. DRIVE INSTL, ACCESSORY SEE FIG. 2.10-25	RF		

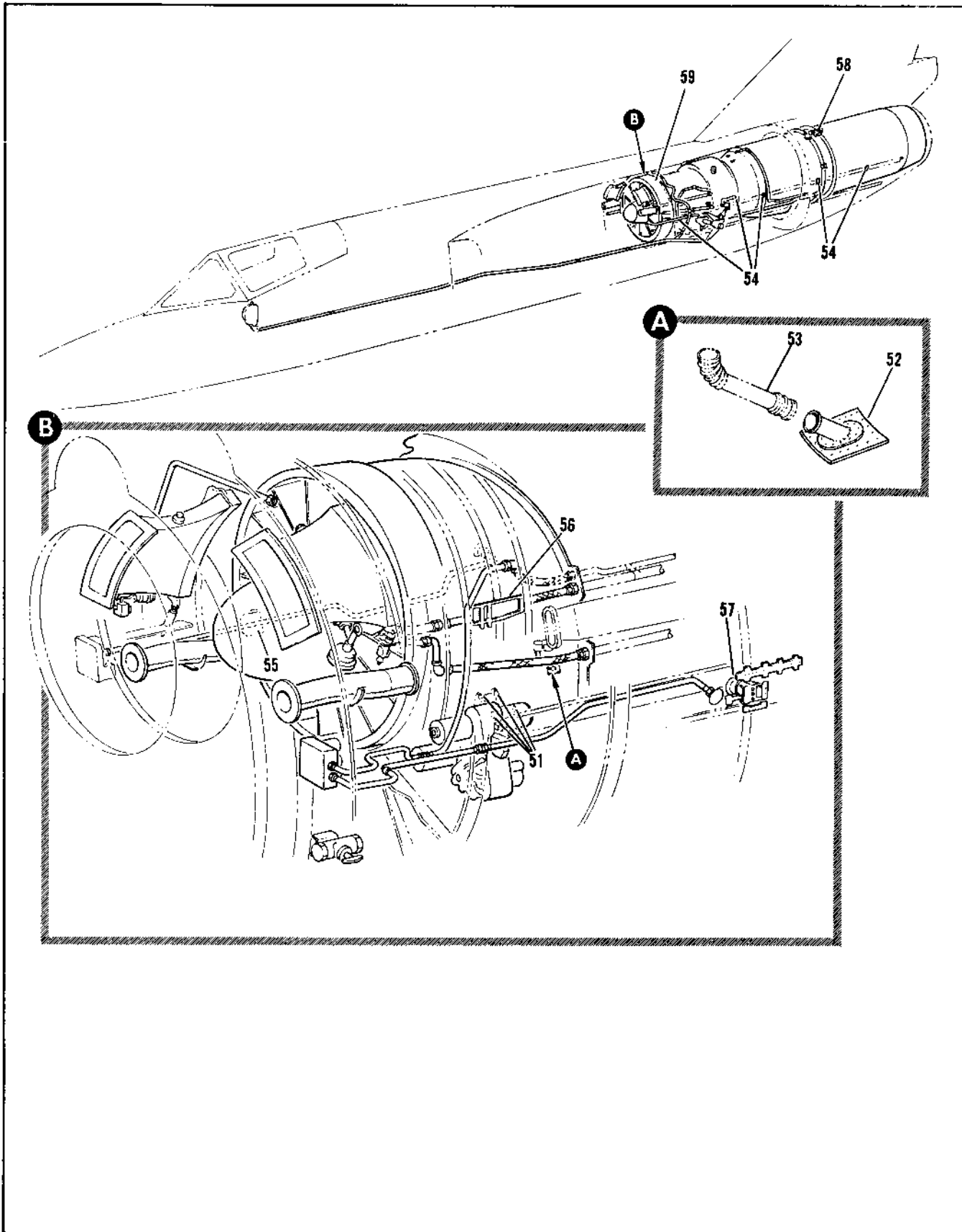

Figure 2.10-1. Power Plant (Sheet 3 of 3)

FIGURE AND INDEX NUMBER	PART NUMBER	DESCRIPTION	UNITS PER ASSY.	USABLE ON CODE	
				FROM	TO
2.10-1	8-28245	• DRAIN INSTL, ACCESSORY DRIVE OIL COOLER STA 466 FOR NHA SEE FIG. 2.3-11	RF	35	38
	8-28245-1	• DRAIN INSTL, ACCESSORY DRIVE OIL COOLER STA 466 FOR NHA SEE FIG. 2.3-11	RF	39	
- 28		• • COOLER ASSY, ACCESSORY DRIVE OIL SEE FIG. 2.10-28 INDEX 1	RF		
- 29	8-27570	• • GUIDE, ENGINE OIL COOLER DRAIN ATTACHING PARTS	2	35	
- 30	MS21042L3	• • NUT	2	35	
- 31	AN520-10R8	• • SCREW	2	35	
		-----X-----			
	8-28236	• • GUIDE ASSY, DRAIN OIL COOLER ACCESSORY DRIVE	1	35	
	8-28247	• • GUIDE ASSY, DRAIN OIL COOLER ACCESSORY DRIVE ALT INTCHG WITH 8-28236 ATTACHING PARTS	RF	35	
- 32	MS21042L3	• • NUT	4	35	
- 33	AN520-10R8	• • SCREW	4	35	
		-----X-----			
- 34	8-28236-7	• • • GUIDE, LH	1	35	
	8-28247-7	• • • GUIDE, LH USE WITH 8-28247	RF	35	
- 35	8-28236-8	• • • GUIDE, RH	1	35	
	8-28247-8	• • • GUIDE, RH USE WITH 8-28247	RF	35	
- 36	8-28246-3	• • DRAIN ASSY, OIL COOLER WELDED	1	35	
- 37	8-44119	• • • SPRING, ACTUATING VALVE LATCH MECHANISM	1	35	
- 38	901-390-2-5A	• • SUPPORT, <98625> 98-60000-017	1	35	
- 39	8-26718	• • SUPPORT ASSY, COOLING AIR RIVETED ATTACHING PARTS	1	35	
- 40	MS21042L3	• • NUT	1	35	
- 41	AN960-10L	• • WASHER	1	35	
- 42	AN520-10R7	• • SCREW	1	35	
		-----X-----			
- 43	8-28396	• • FAIR-LEAD, ENGINE OIL COOLER DRAIN ATTACHING PARTS	4	35	
- 44	MS21042L3	• • NUT	2	39	
- 45	AN960-10L	• • WASHER	2	39	
- 46	AN520-10R7	• • SCREW	2	39	
		-----X-----			
- 47	8-28395	• • TUBE ASSY, DRAIN OIL COOLER ACCESSORY DRIVE WELDED	1	35	
- 48	8-28248	• • BRACKET INSTL, OIL COOLER DRAIN ACCESSORY DRIVE RIVETED	1	35	89
	8-28248-1	• • BRACKET INSTL, OIL COOLER DRAIN ACCESSORY DRIVE RIVETED	1	90	
- 49		• ACCESSORY DRIVE OIL COOLER SEE FIG. 2.10-27	RF		
- 50		• DRIVE INSTL, ACCESSORY SEE FIG. 2.10-25	RF		

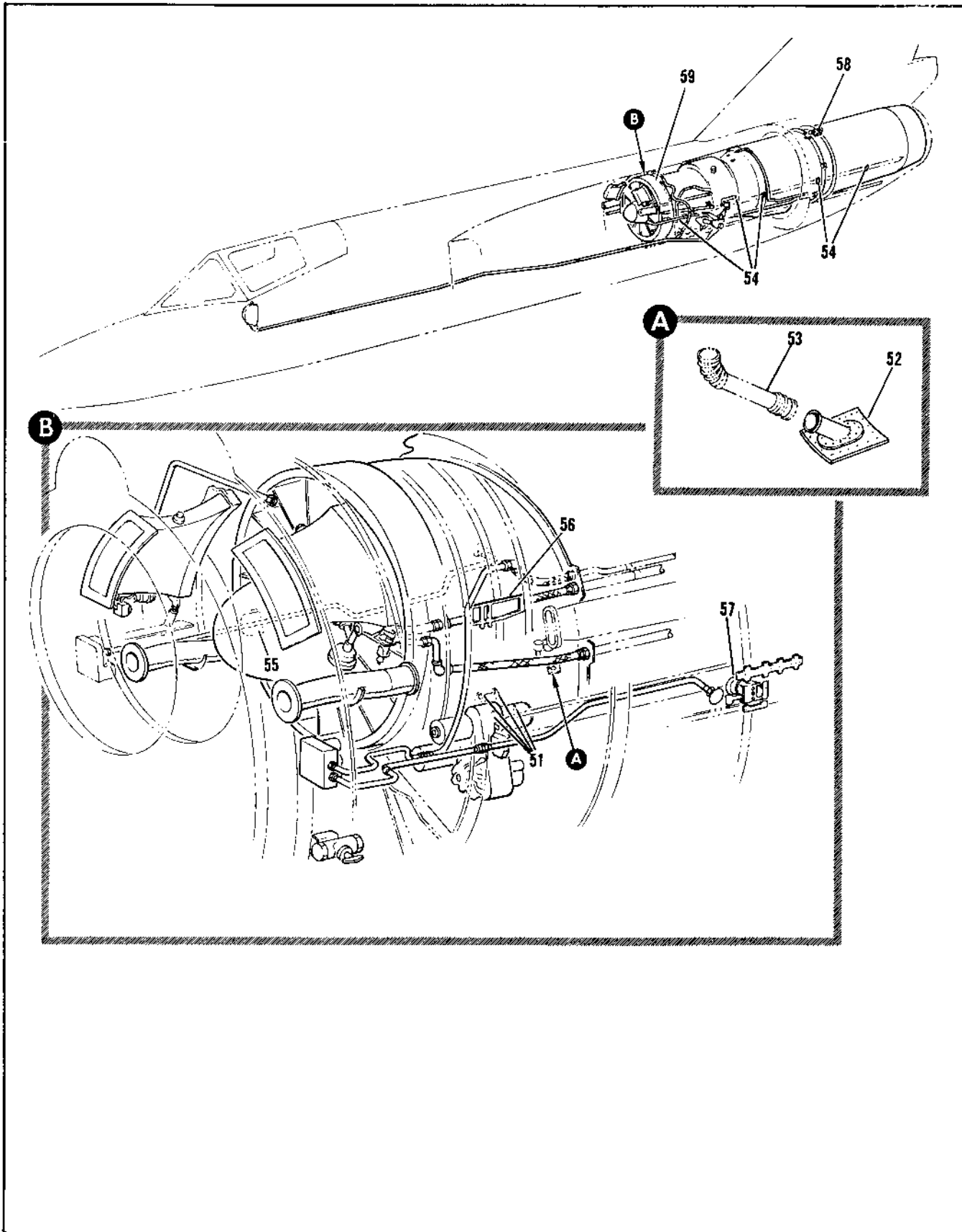

Figure 2.10-1. Power Plant (Sheet 3 of 3)

FIGURE AND INDEX NUMBER	PART NUMBER	DESCRIPTION	UNITS PER ASSY.	USABLE ON CODE	
				FROM	TO
		1 2 3 4 5 6			
2.10-1- 51		• SUPPORT INSTL, REMOTE GEARBOX ACCESSORY SEE FIG. 2.10-30	RF		
	8-28238-803	• DUCT INSTL, ENGINE OIL BREATHER MODIFIED BY 8-21914 FOR NHA SEE FIG. 2.10-6	RF	35	
- 52	8-22813-1	• • DUCT ASSY, ENGINE OIL BREATHER LWR WELDED	1	35	
- 53		• • DUCT ASSY, ENGINE OIL BREATHER SEE FIG. 2.10-6 INDEX 73	RF		
- 54		• SUPPORT INSTL, ENGINE REMOVAL RAIL SEE FIG. 2.10-37	RF		
- 55		• CLAMP INSTL, ENGINE THRUST MOUNT STA 478 SEE FIG. 2.10-36	RF		
	8-74115-5	• BEAM INSTL, ENGINE MOUNT FWD FOR NHA SEE FIG. 2.3-14	RF	35	277
	8-74115	• BEAM INSTL, ENGINE MOUNT FWD FOR NHA SEE FIG. 2.3-14	RF	278	
- 56	8-74184-7	• • BEAM, ENGINE MOUNT FWD REPLACES INTCHG WITH 8-74119-7	1	35	
	8-74119-11	• • BEAM, ENGINE MOUNT FWD ALT INTCHG WITH 8-74184-7	RF	A	
	8-74119-1	• • BEAM ASSY, ENGINE MOUNT FWD ALT INTCHG WITH 8-74184-7 AND 8-74119-11	RF	B	
	8-74119-7	• • • BEAM, ENGINE MOUNT FWD REPLACED BY NOT INTCHG WITH 8-74184-7	RF	B	
	8-74413-1	• STRUCTURE INSTL, ENGINE COMPRESSOR DISCHARGE PORT LH FOR NHA SEE FIG. 2.3-14	RF	C	
	8-74413-801	• STRUCTURE INSTL, ENGINE COMPRESSOR DISCHARGE PORT LH FOR NHA SEE FIG. 2.3-14	RF	48	277
	8-74413-2	• STRUCTURE INSTL, ENGINE COMPRESSOR DISCHARGE PORT RH FOR NHA SEE FIG. 2.3-14	RF	C	
	8-74413-802	• STRUCTURE INSTL, ENGINE COMPRESSOR DISCHARGE PORT RH FOR NHA SEE FIG. 2.3-14	RF	48	277
- 57	8-22736-5	• • DUCT ASSY, WELDED LH	1		
- 58	8-22736-6	• • DUCT ASSY, WELDED RH	1		
		• BEAM INSTL, ENGINE MOUNT AFT SEE FIG. 2.10-40	RF		
- 59		• FIRE AND OVERHEAT DETECTOR SEE FIG. 2.10-34	RF		
		A AIRPLANES #35 THRU 277, 279, 281, 287 AND ON			
		B AIRPLANES #278, 280, 282 THRU 286			
		C AIRPLANES #35 THRU 47, 279 AND ON			
		D AIRPLANES #35 THRU 39, 279 AND ON			

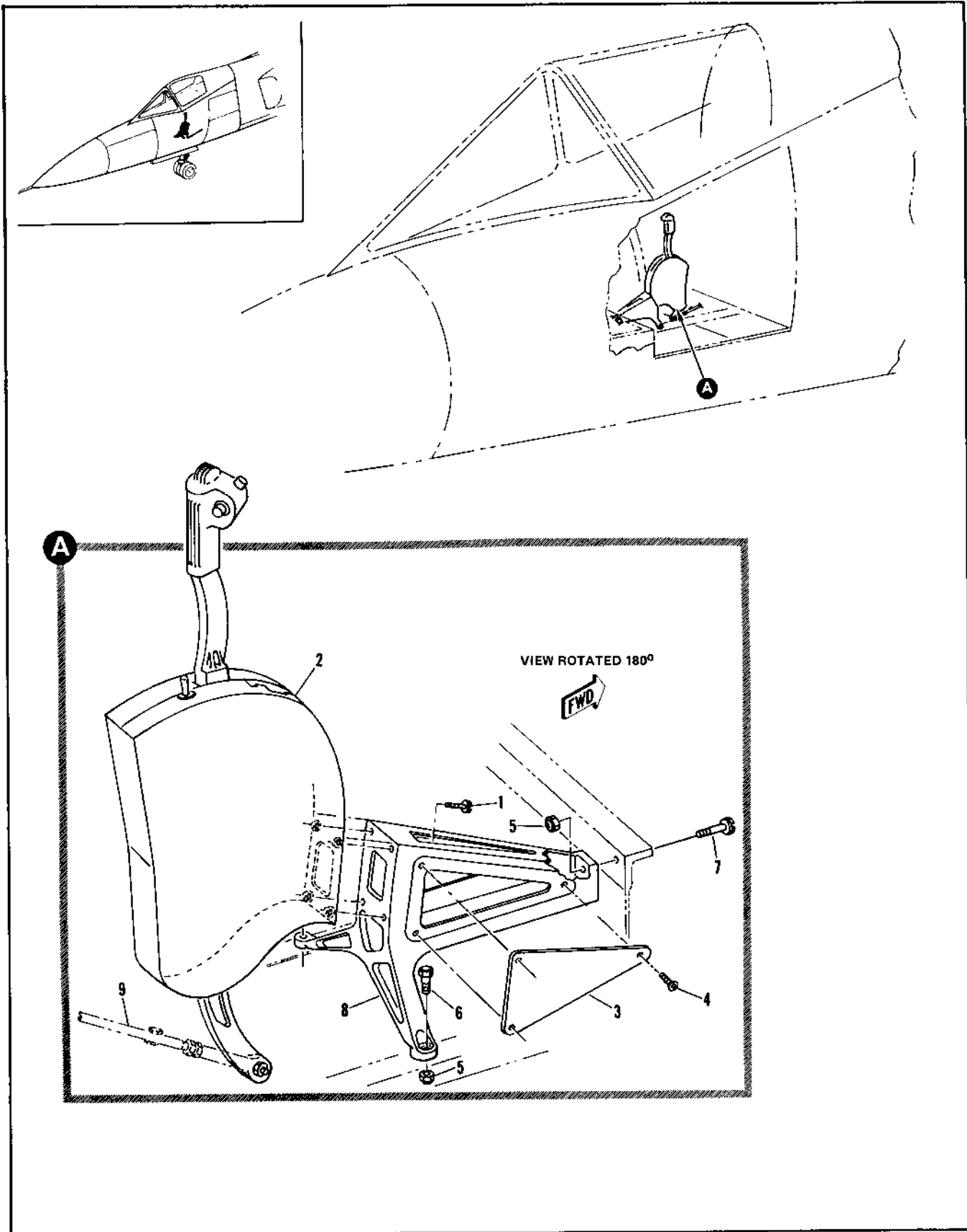

Figure 2.10-2. Power Control Pedestal Installation

FIGURE AND INDEX NUMBER	PART NUMBER	DESCRIPTION	UNITS PER ASSY.	USABLE ON CODE		
				FROM	TO	
2.10-2	8-42701-5	PEDESTAL INSTALLATION, POWER CONTROL FOR NHA SEE FIG. 2.3-5	RF	35	129	
	8-42701-801	PEDESTAL INSTALLATION, POWER CKL FOR NHA SEE FIG. 2.3-5	RF	130		
	- 1	AN23-11A	• BOLT	4	35	43
		NAS464-3A6	• BOLT	4	44	
	- 2	5L4300-803	• QUADRANT ASSY, PILOT POWER CONTROL (78062); T.O. 1ER1-3-22-4; REPLACES 5L4300-3, -3A, -3A1, -3B, -3AB, -3A1B, -5, -801, -801A, -5B, -801B AND -801AB; INTERCHANGEABLE AND SUITABLE SUB FOR 5L4300-3ABC.	1	35	
	- 3	8-42716	• COVER, QUADRANT SUPPORT ATTACHING PARTS	1	35	
	- 4	AN227-10M6	• STUD, FASTENER	3	35	
		8-42673-5	• SUPPORT ASSY, PILOT POWER CONTROL QUADRANT RIVETED REPLACED BY SUITABLE SUB 8-42673-801	1	35	60
		8-42673-801	• SUPPORT ASSY, PILOT POWER CONTROL QUADRANT RIVETED REPLACES SUITABLE SUB FOR 8-42673-5 ATTACHING PARTS	1	61	
	- 5	MS21042L4	• NUT	3	35	
	- 6	AN4-6A	• BOLT	2	35	
	- 7	AN4-7A	• BOLT	1	35	
	- 8	8-42673-13	• SUPPORT, MAKE FROM 8-42673-11	1	35	60
		8-42673-15	• SUPPORT, MAKE FROM 8-42673-11	1	61	
- 9	8-42673-11	• SUPPORT • CONTROL ASSY, TELESCOPIC POWER SEE FIG. 2.10-3	RF RF			

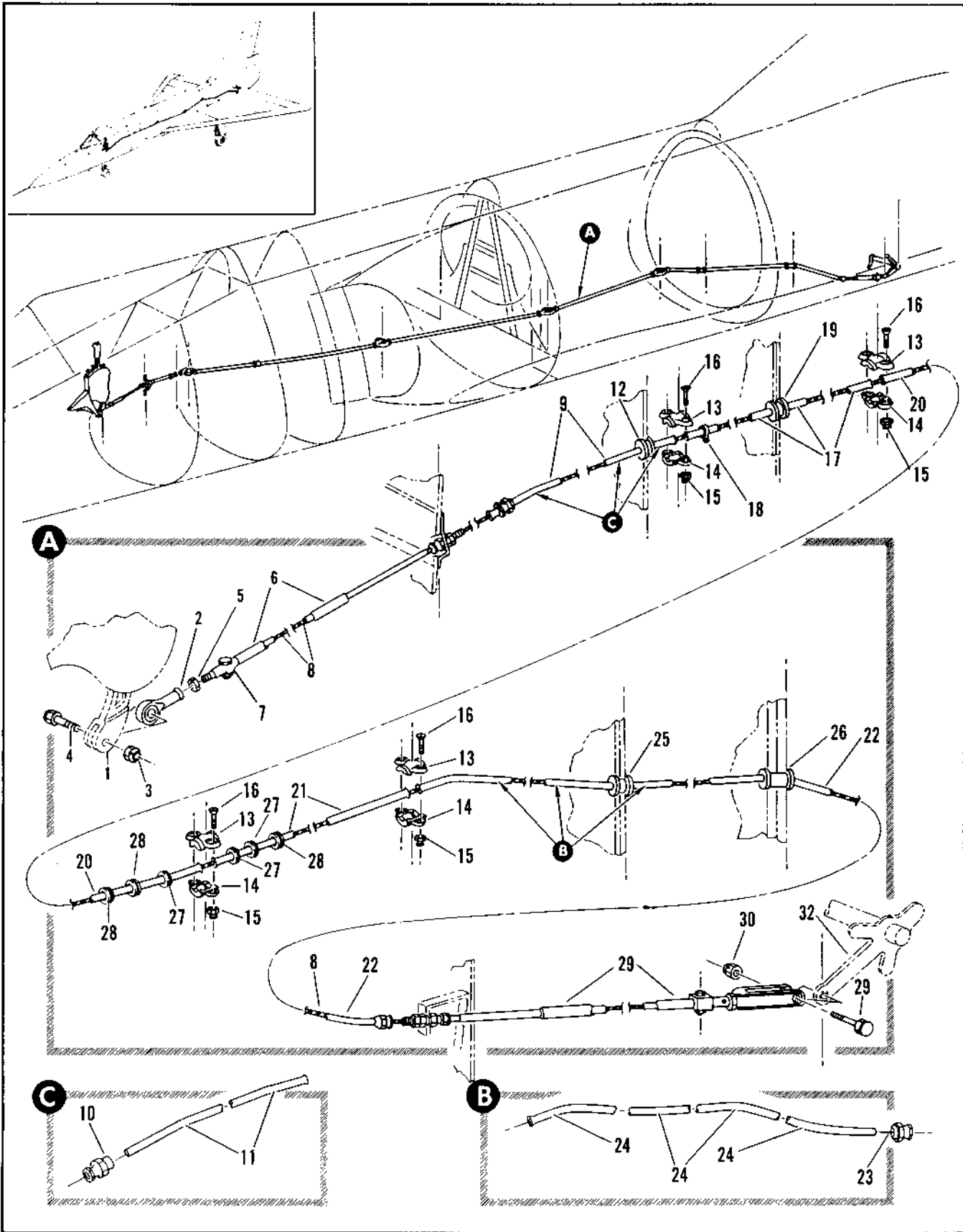

Figure 2.10-3. Power Control Teleflex Installation

FIGURE AND INDEX NUMBER	PART NUMBER	DESCRIPTION	UNITS PER ASSY.	USABLE ON CODE	
				FROM	TO
2.10 3	8-42705-3	TELEFLEX INSTALLATION, POWER CONTROL FOR NHA SEE FIG. 2.3-3	RF	35	62
	8-42705	TELEFLEX INSTALLATION, POWER CONTROL FOR NHA SEE FIG. 2.3-3	RF	63	277
	8-42705-5	TELEFLEX INSTALLATION, POWER CONTROL FOR NHA SEE FIG. 2.3-3	RF	278	
- 1		• QUADRANT ASSY, PILOT POWER CONTROL SEE FIG. 2.10-2 INDEX 2	RF		
- 2	REAF5E7416	• BEARING, ROD END <21335> 90-60002-010 ATTACHING PARTS	1	35	
- 3	MS21244-4	• NUT	1	35	
- 4	MS27576-4-19	• BOLT	1	35	
		-----X-----			
- 5	AN316-5R	• NUT	1	35	
- 6	16207	• CONTROL ASSY, TELESCOPIC POWER <78710> 92-65800-018	1	35	
- 7	5034	• BOLT	1		
	MS2104603	• NUT	1		
- 8	8-42705-19	• CABLE, POWER CONTROL ALTERED FROM A7793	1	35	
	A7793	• CABLE, CONTROL <78710>	RF		
- 9	8-42705-21	• CONDUIT ASSY, TELEFLEX POWER CONTROL	1	35	
- 10	A6338	• NUT, <78710> 96-36503-001	1	35	
- 11	8-42705-7	• CONDUIT	1	35	
- 12	8-42714-17	• GROMMET, TELEFLEX SUPPORT POWER CONTROL	1	35	
- 13	C7505-2	• CONNECTOR, <78710> 92-35000-001	4	35	
- 14	C7505	• CONNECTOR, <78710> 92-35000-003 ATTACHING PARTS	4	35	
- 15	22FT1032	• NUT, <56878> 96-37525-002	8	35	
- 16	AN509-10R16	• SCREW	8	35	
		-----X-----			
- 17	8-42705-27	• CONDUIT, TELEFLEX POWER CONTROL	1	35	
- 18	AN735-4	• CLAMP STA 240	1		
- 19	8-42714-19	• GROMMET	1	35	
- 20	8-42705-29	• CONDUIT, TELEFLEX POWER CONTROL	1	63	
	C7505-2	• CONNECTOR, <78710> 92-35000-001	1	35	62
	C7505	• CONNECTOR, <78710> 92-35000-003 ATTACHING PARTS	1	35	62
	22FT1032	• NUT, <56878> 96-37525-002	2	35	62
	AN509-10R16	• SCREW	2	35	62
		-----X-----			
	8-42705-35	• CONDUIT, TELEFLEX POWER CONTROL	1	35	62
	8-42705-37	• CONDUIT, TELEFLEX POWER CONTROL	1	35	62
- 21	8-42705-31	• CONDUIT, TELEFLEX POWER CONTROL	1	35	
- 22	8-42705-23	• CONDUIT ASSY, TELEFLEX POWER CONTROL	1	35	
- 23	A6338	• NUT, <78710> 96-36503-001	1	35	
- 24	8-42705-17	• CONDUIT	1	35	
- 25	8-42714-21	• GROMMET	1	35	
- 26	8-42714-23	• GROMMET	1	35	
- 27	8-49115	• FAIRLEAD, CONTROL CABLE	3	90	
- 28	8-49115-7	• FAIRLEAD, CONTROL CABLE	3	90	
- 29	11679-1	• TELESCOPIC ASSY, POWER CONTROL <78710> SPEC 4-34285 T.O.2JAR-9-3	1	35	
+ 30	MS21244-4	• NUT	1	35	
- 31	MS27576-4-07	• BOLT	1	35	
- 32		• BELL CRANK ASSY, TORQUE SHAFT OUTBOARD SEE FIG. 2.10-4 INDEX 6	RF		

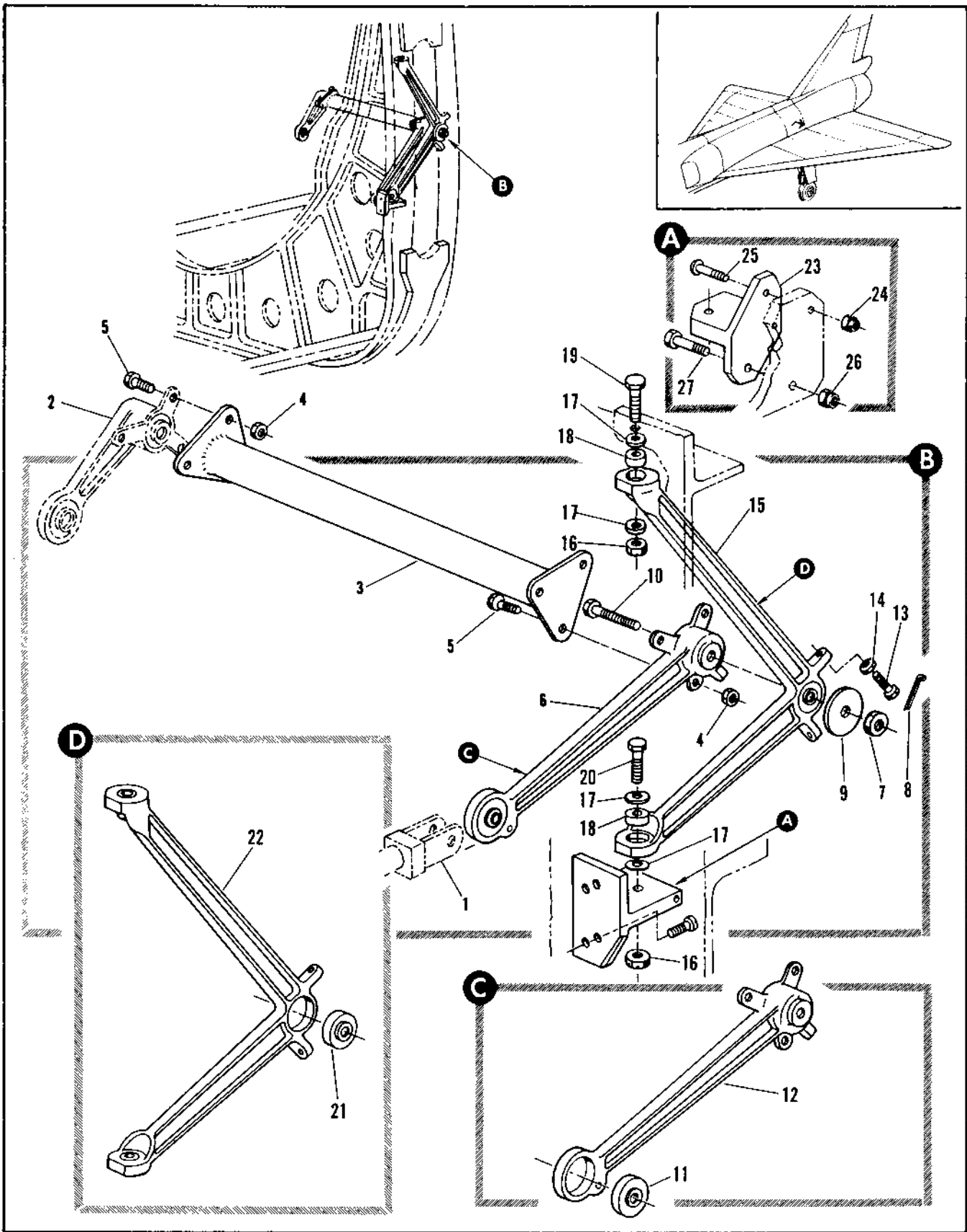

Figure 2.10-4. Power Control Torque Shaft Installation

FIGURE AND INDEX NUMBER	PART NUMBER	DESCRIPTION	UNITS PER ASSY.	USABLE ON CODE	
				FROM	TO
		1 2 3 4 5 6			
2.10-4	8-42728-1	SHAFT INSTALLATION, POWER CONTROL TORQUE FOR NHA SEE FIG. 2.3-3	RF	35	
- 1		• CONTROL ASSY, TELESCOPIC POWER SEE FIG. 2.10-3	RF		
- 2		• BELL CRANK ASSY, POWER CONTROL SEE FIG. 2.10-5	RF		
- 3	8-42729-1	• SHAFT ASSY, TORQUE POWER CONTROL WELDED ATTACHING PARTS	1	35	
- 4	MS21042L4	• NUT	6	35	
- 5	NAS464P4A3	• BOLT	6	35	
		-----X-----			
- 6	8-42676-5	• BELL CRANK ASSY, TORQUE SHAFT OUTBOARD ATTACHING PARTS	1	35	
- 7	AN310C4	• NUT			
- 8	MS24665-153	• PIN, COTTER	1	9	
- 9	AN970-4	• WASHER			
- 10	NAS464P4-11	• BOLT			
		-----X-----			
- 11	KS4AE7416	• BEARING, <21335> 90-58001-018	1	35	
- 12	8-42676-7	• BELL CRANK	1	35	
- 13	NAS42PK3-6	• BOLT	2	35	
- 14	AN310C3R	• NUT	2	35	
- 15	8-42674-5	• SUPPORT ASSY, TORQUE SHAFT OUTBOARD	1	35	
	8-42719-3	• SUPPORT ASSY, TORQUE SHAFT ALT INTCHG WITH 8-42674-5 ATTACHING PARTS	RF	35	
- 16	AN310C4	• NUT	2	35	
- 17	AN560C416L	• WASHER	4	35	
- 18	8-42725	• PUSHING, OUTBD TORQUE SHAFT SUPPORT	2	35	
- 19	NAS464P4-7	• BOLT, UPPER	1	35	
- 20	NAS464P4-9	• BOLT, LOWER	1	35	
		-----X-----			
- 21	KS4E7416	• BEARING, <21665> 90-58001-016	1	35	
- 22	8-42674-7	• SUPPORT	1	35	
	8-42719-7	• SUPPORT, USE WITH 8-42719-1	RF	35	
- 23	8-42750	• BRACKET, TORQUE SHAFT SUPPORT ATTACHING PARTS	1	35	
- 24	MS21042L3	• NUT	1	35	
- 25	NAS221-13	• SCREW	1	35	
- 26	NAS679A4	• NUT	1	35	
- 27	NAS1104-6	• BOLT	1	35	
		-----X-----			

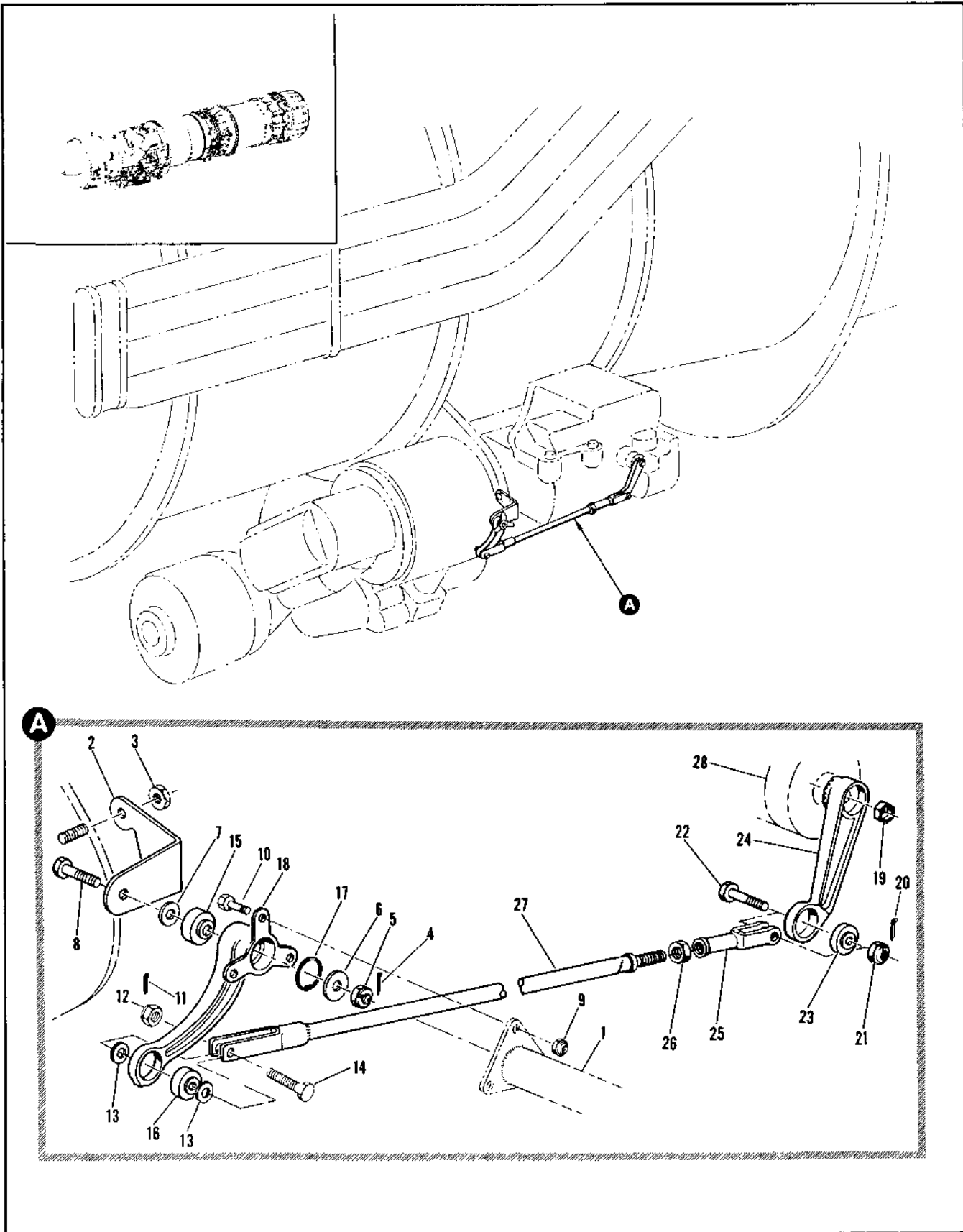

Figure 2.10-5. Power Control Bell Crank Installation

FIGURE AND INDEX NUMBER	PART NUMBER	DESCRIPTION	UNITS PER ASSY.	USABLE ON CODE	
				FROM	TO
		1 2 3 4 5 6			
2.10-4	8-42728-1	SHAFT INSTALLATION, POWER CONTROL TORQUE FOR NMA SEE FIG. 2.3-3	RF	35	
- 1		• CONTROL ASSY, TELESCOPIC POWER SEE FIG. 2.10-3	RF		
- 2		• BELL CRANK ASSY, POWER CONTROL SEE FIG. 2.10-5	RF		
- 3	8-42729-1	• SHAFT ASSY, TORQUE POWER CONTROL WELDED ATTACHING PARTS	1	35	
- 4	MS21042L4	• NUT	6	35	
- 5	NAS464P4A3	• BOLT	6	35	
		-----X-----			
- 6	8-42676-5	• BELL CRANK ASSY, TORQUE SHAFT OUTBOARD ATTACHING PARTS	1	35	
- 7	AN310C4	• NUT			
- 8	MS24665-153	• PIN, COTTER	1	9	
- 9	AN97C-4	• WASHER			
- 10	NAS464P4-11	• BOLT			
		-----X-----			
- 11	KS4AF7416	• BEARING, <21335> 90-58001-018	1	35	
- 12	8-42676-7	• BELL CRANK	1	35	
- 13	NAS42PK3-6	• BOLT	2	35	
- 14	AN315C3R	• NUT	2	35	
- 15	8-42674-5	• SUPPORT ASSY, TORQUE SHAFT OUTBOARD	1	35	
	8-42719-3	• SUPPORT ASSY, TORQUE SHAFT ALT INTCHG WITH 8-42674-5 ATTACHING PARTS	RF	35	
- 16	AN313C4	• NUT	2	35	
- 17	AN560C416L	• WASHER	4	35	
- 18	8-42725	• BUSHING, OUTRD TORQUE SHAFT SUPPORT	2	35	
- 19	NAS454P4-7	• BOLT, UPPER	1	35	
- 20	NAS454P4-9	• BOLT, LOWER	1	35	
		-----X-----			
- 21	KS4E7416	• BEARING, <21665> 90-58001-016	1	35	
- 22	8-42674-7	• SUPPORT	1	35	
	8-42719-7	• SUPPORT, USE WITH 8-42719-1	RF	35	
- 23	8-42750	• BRACKET, TORQUE SHAFT SUPPORT ATTACHING PARTS	1	35	
- 24	MS21042L3	• NUT	1	35	
- 25	NAS221-13	• SCREW	1	35	
- 26	NAS679A4	• NUT	1	35	
- 27	NAS1104-6	• BOLT	1	35	
		-----X-----			

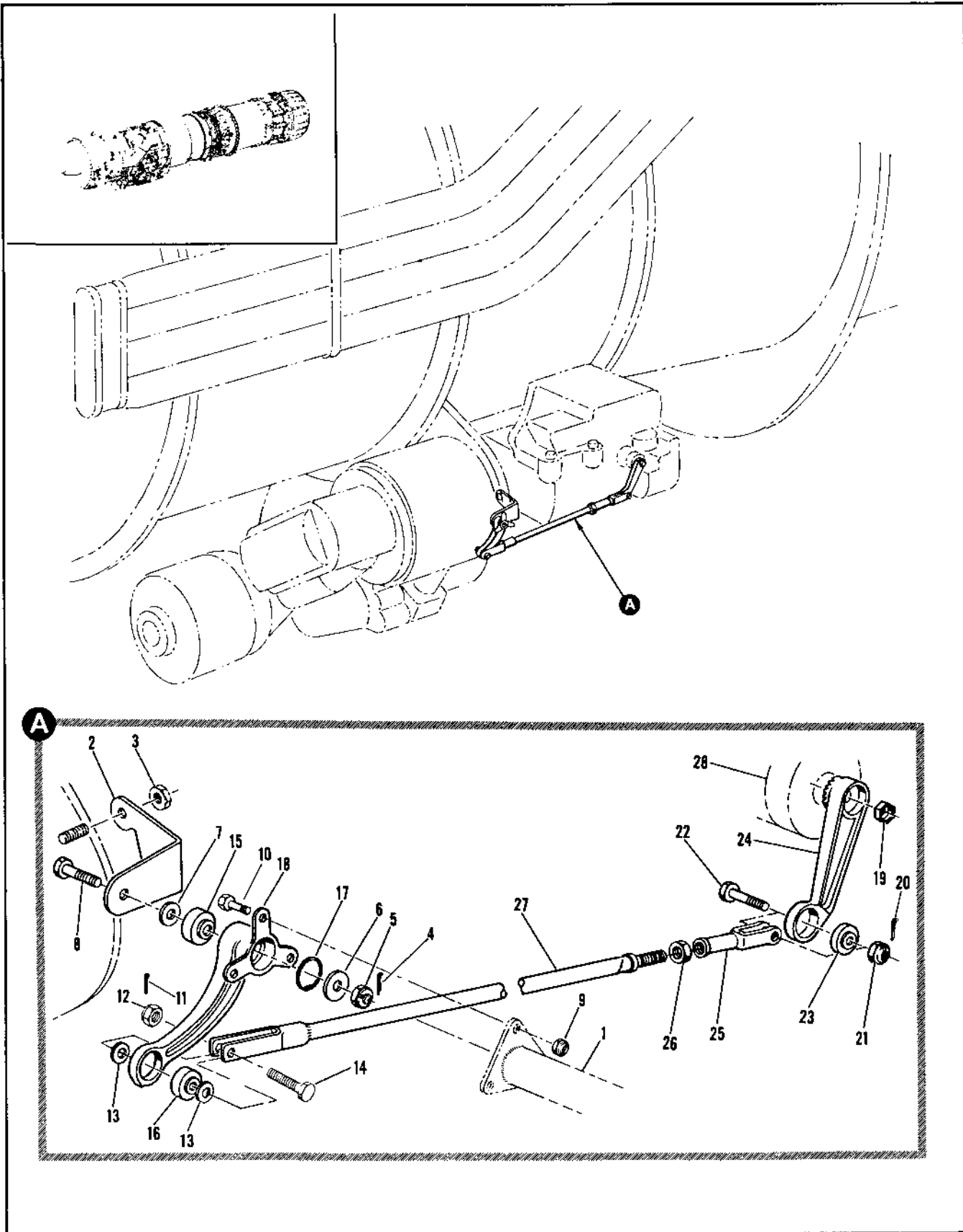

Figure 2.10-5. Power Control Bell Crank Installation

FIGURE AND INDEX NUMBER	PART NUMBER	DESCRIPTION	UNITS PER ASSY.	USABLE ON CODE	
				FROM	TO
		1 2 3 4 5 6			
2.10-5	8-42728-5	BELL CRANK INSTALLATION, POWER CONTROL FOR NHA SEE FIG. 2.10-7	RF	35	
- 1		• SHAFT ASSY, TORQUE POWER CONTROL SEE FIG. 2.10-4 INDEX 3	RF		
- 2	351769A *1	• BRACKET	RF	35	
	8-42731-7 *2	• BRACKET	1	35	
		ATTACHING PARTS			
- 3	281703 *1	• NUT, PW	RF	35	
- 4	MS24665-153	• PIN, COTTER	1	35	
- 5	MS21244-4	• NUT	1	35	
- 6	8-42736	• WASHER	1	35	
- 7	AN960C416L	• WASHER	1	35	
- 8	MS27576-4-8	• BOLT	1	35	
	8-42690-801	• BELL CRANK ASSY, POWER CONTROL ATTACHING PARTS	1	35	
- 9	MS21042L4	• NUT	3	35	
- 10	NAS464P4A3	• BOLT	3	35	
- 11	MS24665-153	• PIN, COTTER	1	35	
- 12	MS21244-4	• NUT	1	35	
- 13	AN960C416	• WASHER	2	35	
- 14	MS27576-4-8	• BOLT	1	35	
		• BOLT, ALTERNATE	1	35	
- 15	KS4AE7416	• BEARING, <21335> 90-58001-018	1	35	
- 16	KS4E7416	• BEARING, <21335> 50-58031-016	1	35	
- 17	NAS50-90	• RING	1	35	
- 18	8-42690-11	• BELL CRANK	1	35	
	8-42744-7	• BELL CRANK, USE WITH 8-42744-1	RF	35	129
	8-42691-5	• BELL CRANK ASSY, FUEL CONTROL REPLACED BY INTCHG WITH 8-42691-801	1	35	
	8-42743-1	• BELL CRANK ASSY, FUEL CONTROL ALT INTCHG WITH 8-42691-5	RF	35	
	8-42691-801	• BELL CRANK ASSY, FUEL CONTROL REPLACES INTCHG WITH 8-42691-5 ATTACHING PARTS	1	130	
- 19	51142-42P	• NUT, <5627P> 95-37576-101	1	35	
- 20	MS24665-153	• PIN, COTTER	1	35	
- 21	MS21244-4	• NUT	1	35	
- 22	MS27576-4-8P	• BOLT	1	35	
- 23	KS4AE7416	• BEARING, <21335> 90-58001-018	1		
- 24	8-42691-13	• BELL CRANK, MAKE FROM 8-42691-9	1	35	
	8-42691-9	• BELL CRANK	RF		
	8-42743-9	• BELL CRANK, USE WITH 8-42743-1	RF	35	129
- 25	AN486-1	• CLEVIS	1	35	
- 26	AN316C4R	• NUT	1	35	
- 27	8-42735-1	• ROD ASSY, FUEL CONTROL POWER CONTROL WELDED	1	35	
- 28		• ENGINE ASSY, SEE FIG. 2.10-7	RF		
		*1 FURNISHED WITH PRATT AND WHITNEY ENGINE			
		*2 MAY BE SUBSTITUTED FOR PW BRACKET P/N 351769A REF T.O. 1F-106A-10 SECTION V			

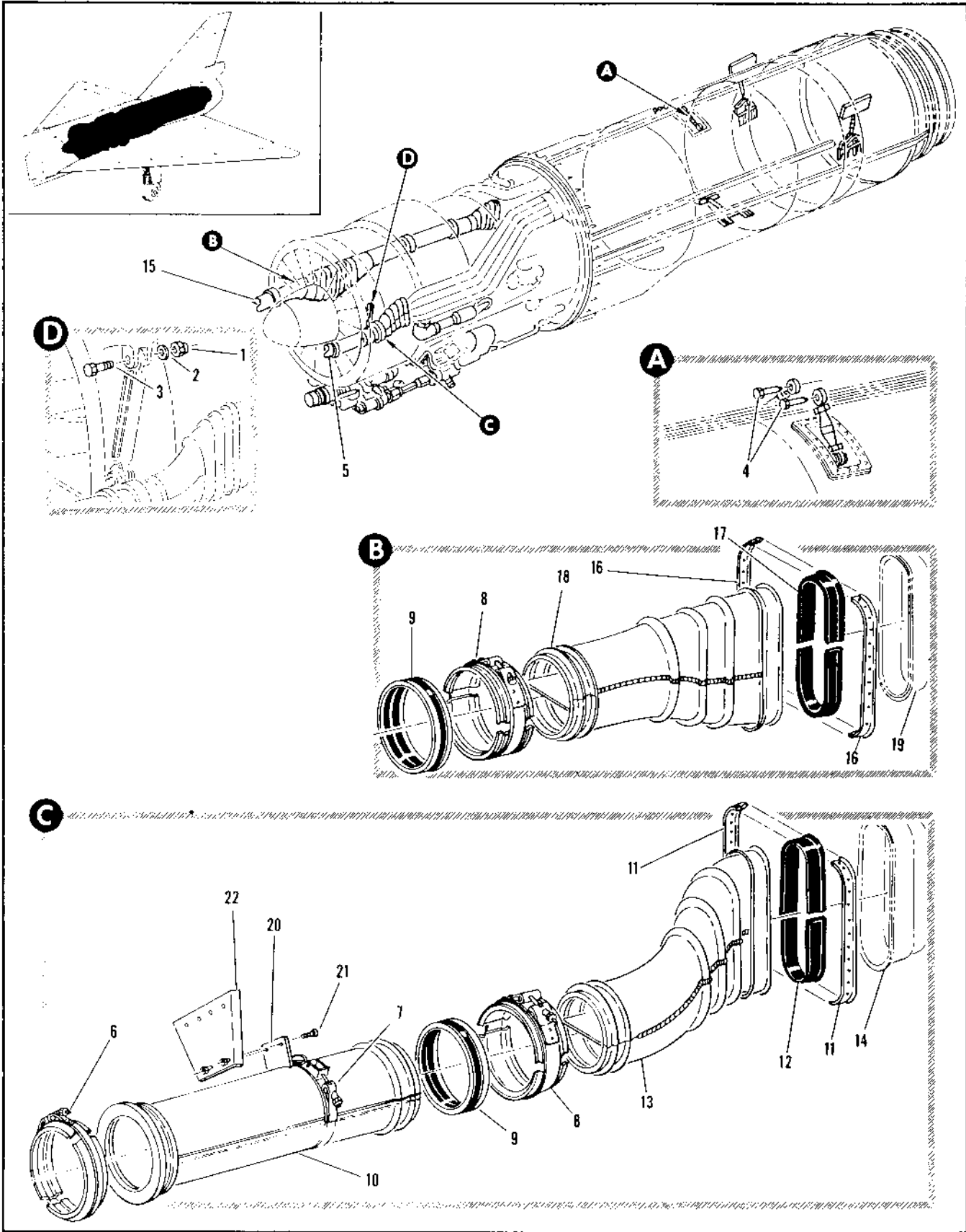

Figure 2.10-6. Power Plant Installation (Sheet 1 of 3)

FIGURE AND INDEX NUMBER	PART NUMBER	DESCRIPTION	UNITS PER ASSY.	USABLE ON CODE	
				FROM	TO
2.10-6	8-22094-807	POWER PLANT INSTALLATION FOR NHA SEE FIG. 2.1-1	RF	35	
- 1	AN32CC10	• NUT	1	35	
- 2	AN960C1016L	• WASHER	1	35	
- 3	8-26003	• BOLT	1	35	
- 4	8-26957	• BOLT, AFT ENGINE MOUNT	2	35	
- 5	8-22759-3	• DUCT INSTL, ENGINE AIR COOLING • DUCT ASSY, SHROUD COOLING LH SEE FIG. 2.10-1 INDEX 12	RF	35	
- 6	17313-448SH	• COUPLING, <98625> 92-73005-007	1	35	
- 7	451-75-406SH	• CLAMP, <98625> 91-97806-001	1	35	
- 8	53861	• COUPLING, <98625> 92-73007-002	2	35	
- 9	19388-400	• SLEEVE, <98625> 98-13800-001	2	35	
- 10	8-22750-1 8-22751	• DUCT ASSY, ENGINE AIR COOLING LH WELDED • DUCT ASSY, ENGINE AIR COOLING INTERMEDIATE LH	1 1	35 35	
- 11	8-22751-19	• RETAINER	2	35	
- 12	8-22751-21	• SEAL	1	35	
- 13	8-22751-7	• DUCT ASSY, WELDED	1	35	
- 14		• DUCT ASSY, COOLING AIR SUPPLY LH SEE FIG. 2.10-8 INDEX 2	RF		
- 15		• DUCT ASSY, SHROUD COOLING RH SEE FIG. 2.10-1 INDEX 13	RF		
	8-22752	• DUCT ASSY, AIR COOLING INTERMEDIATE RH	1	35	
- 16	8-22751-19	• RETAINER	2	35	
- 17	8-22751-21	• SEAL	1	35	
- 18	8-22752-15	• DUCT ASSY, WELDED	1	35	
- 19		• DUCT ASSY, COOLING AIR SUPPLY RH SEE FIG. 2.10-8 INDEX 48	RF		
- 20	8-22761-713	• SUPPORT ATTACHING PARTS	1	35	
- 21	AN520-10RB	• SCREW -----X-----	2	35	
- 22	8-22760	• BRACKET ASSY, RIVETED	1	35	

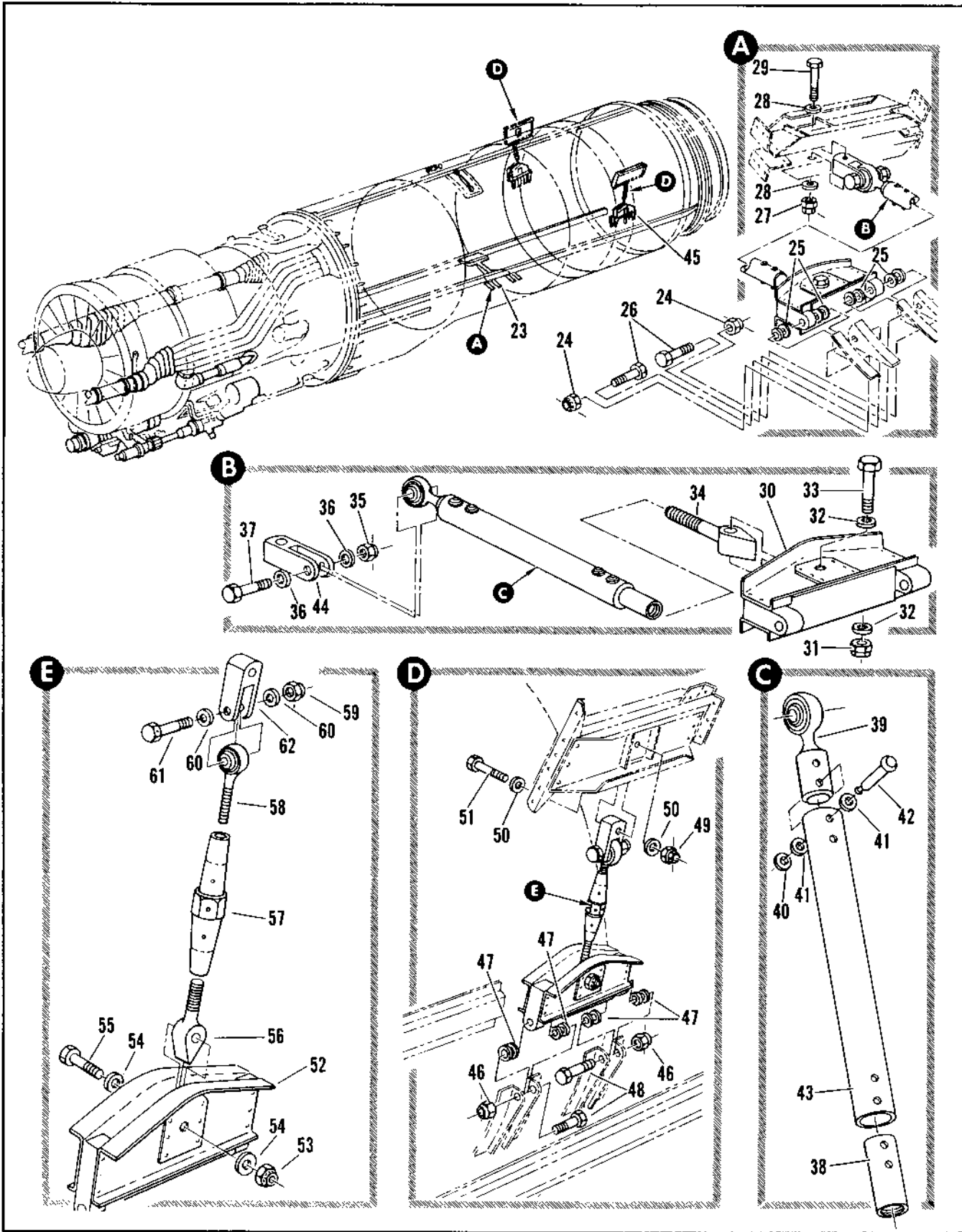

Figure 2.10-6. Power Plant Installation (Sheet 2 of 3)

FIGURE AND INDEX NUMBER	PART NUMBER	DESCRIPTION	UNITS PER ASSY.	USABLE ON CODE	
				FROM	TO
		1 2 3 4 5 6			
2.10-6	8-22684-1	• SUPPORT INSTL, ENGINE COOLING SHROUD	1	35	
- 23	8-22684-7	• • STRUT ASSY, ENGINE COOLING ATTACHING PARTS	1	35	
- 24	AN310-3	• • NUT	2	35	
- 25	AN960-10L	• • WASHER	8	35	
- 26	AN173-11	• • BOLT	2	35	
- 27	AN310-4	• • NUT	1	35	
- 28	AN960-416L	• • WASHER	2	35	
- 29	AN174-14	• • BOLT	1	35	
		-----X-----			
- 30	8-22684-13	• • • BEAM ASSY, ENGINE COOLING SHROUD WELDED ATTACHING PARTS	1	35	
- 31	AN310-4	• • • NUT	1	35	
- 32	AN960-416L	• • • WASHER	2	35	
- 33	AN174-10	• • • BOLT	1	35	
		-----X-----			
	8-22692-7	• • • • SPACER, ENGINE SHROUD SUPPORT	2	35	
	8-22692-9	• • • • SPACER, ENGINE SHROUD SUPPORT	2	35	
- 34	8-22695-9	• • • BOLT, EYE ENGINE SHROUD SUPPORT TURNBUCKLE	1	35	
	8-22684-49	• • • ROD ASSY, ENGINE COOLING SHROUD ATTACHING PARTS	1	35	
- 35	AN310-4	• • • NUT	1	35	
- 36	AN960-416L	• • • WASHER	2	35	
- 37	AN174-11	• • • BOLT	1	35	
		-----X-----			
- 38	8-22693	• • • • ADAPTER	1	35	
- 39	8-22694	• • • • ADAPTER ATTACHING PARTS	1	35	
- 40	LC-R6	• • • • COLLAR, <29666> 92-17000-200	4	35	
- 41	AN960-10L	• • • • WASHER	8	35	
- 42	ALPPH-T6-14	• • • • LOCKBOLT, <29666> 96-79002-613	4	35	
		-----X-----			
- 43	8-22684-37	• • • • ROD	1	35	
- 44	8-22690-7	• • • UNIVERSAL	1	35	
	8-22683-3	• SUPPORT INSTL, UPPER ENGINE COOLING SHROUD	1	35	
- 45	8-22683-23	• • SUPPORT ASSY, UPPER ENGINE COOLING SHROUD ATTACHING PARTS	2	35	
- 46	AN310-3	• • NUT	4	35	
- 47	AN960-10L	• • WASHER	16	35	
- 48	AN173-11	• • BOLT	4	35	
- 49	AN310-4	• • NUT	2	35	
- 50	AN960-416L	• • WASHER	4	35	
- 51	AN174-14	• • BOLT	2	35	
		-----X-----			
- 52	8-22684-13	• • • BEAM ASSY, ENGINE COOLING ATTACHING PARTS	1	35	
- 53	AN310-4	• • • NUT	1	35	
- 54	AN960-416L	• • • WASHER	2	35	
- 55	AN174H10	• • • BOLT	1	35	
		-----X-----			
- 56	8-22695-7	• • • BOLT, EYE SHROUD SUPPORT TURNBUCKLE	1	35	
- 57	8-22689	• • • BARREL, ENG SHROUD SUPPORT TURNBUCKLE	1	35	
- 58	8-22691	• • • BOLT, EYE ENGINE SHROUD SUPPORT TURNBUCKLE ATTACHING PARTS	1	35	
- 59	AN310-4	• • • NUT	1	35	
- 60	AN960-416L	• • • WASHER	2	35	
- 61	AN174H11	• • • BOLT	1	35	
		-----X-----			
- 62	8-22690-7	• • • UNIVERSAL	1	35	

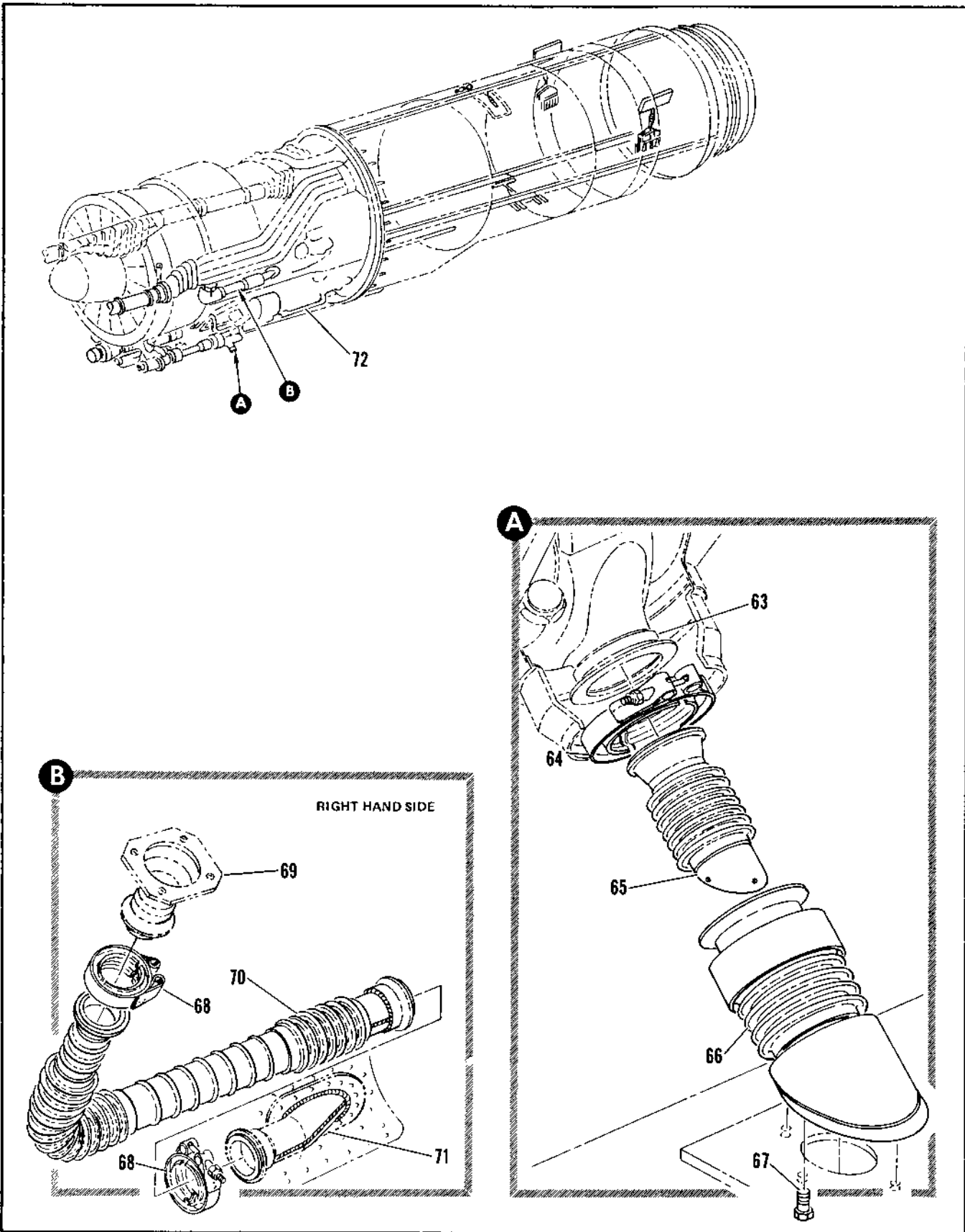

Figure 2.10-6. Power Plant Installation (Sheet 3 of 3)

FIGURE AND INDEX NUMBER	PART NUMBER	DESCRIPTION	UNITS PER ASSY.	USABLE ON CODE	
				FROM	TO
		1 2 3 4 5 6			
2.10-6	8-22808-803	• DUCT INSTL, COMBUSTION STARTER EXHAUST	1	35	
- 63		• • STARTER, CARTRIDGE/PNEUMATIC SEE FIG. 2.10-7, INDEX 73	RF		
- 64	4404-450M	• • COUPLING, <98625> 92-73003-008	1	35	
- 65	400B1003	• • DUCT ASSY, <04958> SPEC 8-00250	1	35	
- 66	403B1002	• • DUCT ASSY, <04958> SPEC 8-00251	1	35	
		ATTACHING PARTS			
- 67	NAS333PAS-5	• • BOLT	7	35	
		-----X----			
	8-20238-801	• DUCT INSTL, ENGINE OIL BREATHER	1	35	
- 68	16965-173	• • COUPLING, <98625> 92-73003-011	2	35	
- 69		• • FLANGE, OIL BREATHER DUCT UPPER	RF	35	
		SEE FIG. 2.10-7 INDEX 30			
- 70	8-22316	• • DUCT ASSY, ENGINE OIL BREATHER WELDED	1	35	
	8-22316-1	• • DUCT ASSY, ENGINE OIL BREATHER WELDED ALT INTCHG WITH 8-22316	RF	35	
- 71		• • DUCT ASSY, ENGINE OIL BREATHER LWR	RF		
		SEE FIG. 10-1 INDEX 51			
- 72	8-22095-827	• ENGINE ASSY, J75P17 TURBOJET	1	35	38
		FOR BREAKDOWN SEE FIG. 2.10-7			
	8-22095-857	• ENGINE ASSY, J75P17 TURBOJET	1	39	43
		FOR BREAKDOWN SEE FIG. 2.10-7			
	8-22095-855	• ENGINE ASSY, J75P17 TURBOJET	1	A	
		FOR BREAKDOWN SEE FIG. 2.10-7			
	8-22095-869	• ENGINE ASSY, J75P17 TURBOJET	1	8	
		FOR BREAKDOWN SEE FIG. 2.10-7			
	8-22095-853	• ENGINE ASSY, J75P17 TURBOJET	1	61	89
		FOR BREAKDOWN SEE FIG. 2.10-7			
	8-22095-867	• ENGINE ASSY, J75P17 TURBOJET	1	90	102
		FOR BREAKDOWN SEE FIG. 2.10-7			
	8-22095-861	• ENGINE ASSY, J75P17 TURBOJET	1	103	129
		FOR BREAKDOWN SEE FIG. 2.10-7			
	8-22095-863	• ENGINE ASSY, J75P17 TURBOJET	1	130	159
		FOR BREAKDOWN SEE FIG. 2.10-7			
	8-22095-871	• ENGINE ASSY, J75P17 TURBOJET	1	160	188
		FOR BREAKDOWN SEE FIG. 2.10-7			
	8-22095-873	• ENGINE ASSY, J75P17 TURBOJET	1	189	
		FOR BREAKDOWN SEE FIG. 2.10-7			
		A AIRPLANES #44 THRU 51 AND 54			
		B AIRPLANES #52, 53, AND 55 THRU 60			

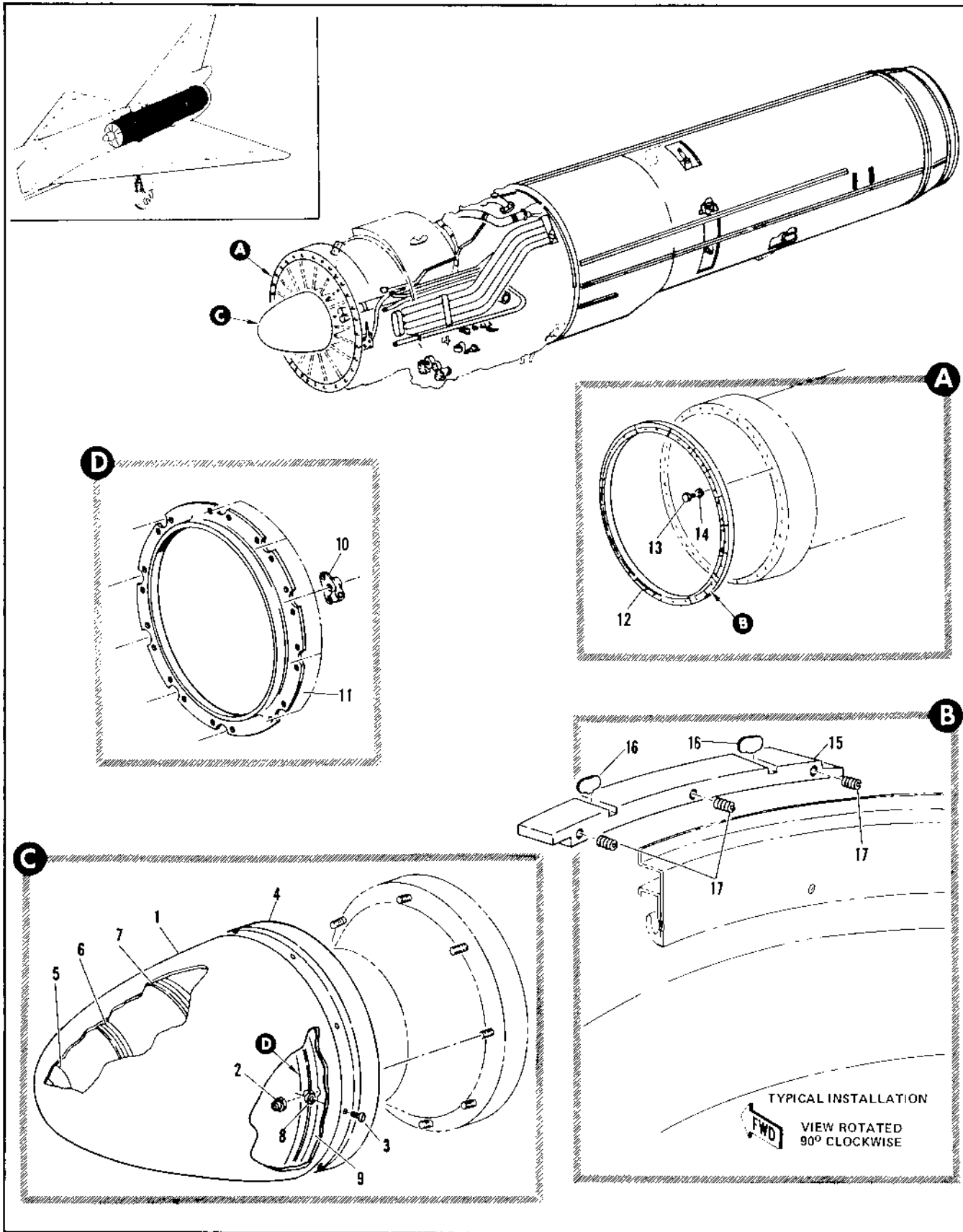

Figure 2.10-7. Turbojet Engine Assembly (Sheet 1 of 9)

FIGURE AND INDEX NUMBER	PART NUMBER	DESCRIPTION	UNITS PER ASSY.	USABLE ON CODE	
				FROM	TO
		1 2 3 4 5 6			
2.10-7	8-22195-827	ENGINE ASSEMBLY, J75P17 TURBOJET FOR NHA SEE FIG. 2.10-6	RF	35	34
	8-22195-857	ENGINE ASSEMBLY, J75P17 TURBOJET FOR NHA SEE FIG. 2.10-6	RF	39	43
	8-22195-855	ENGINE ASSEMBLY, J75P17 TURBOJET MODIFIED BY 8-71986 FOR NHA SEE FIG. 2.10-6	RF	A	
	8-22195-869	ENGINE ASSEMBLY, J75P17 TURBOJET FOR NHA SEE FIG. 2.10-6	RF	B	
	8-22195-853	ENGINE ASSEMBLY, J75P17 TURBOJET FOR NHA SEE FIG. 2.10-6	RF	61	69
	8-22195-867	ENGINE ASSEMBLY, J75P17 TURBOJET FOR NHA SEE FIG. 2.10-6	RF	90	102
	8-22195-861	ENGINE ASSEMBLY, J75P17 TURBOJET FOR NHA SEE FIG. 2.10-6	RF	103	129
	8-22195-867	ENGINE ASSEMBLY, J75P17 TURBOJET FOR NHA SEE FIG. 2.10-6	RF	130	159
	8-22195-871	ENGINE ASSEMBLY, J75P17 TURBOJET FOR NHA SEE FIG. 2.10-6	RF	160	188
	8-22195-873	ENGINE ASSEMBLY, J75P17 TURBOJET FOR NHA SEE FIG. 2.10-6	RF	189	
	500-00800A	KIT A, ENGINE BUILDUP SEE T.O. 1F-106A-10	RF	35	
	500-00800B	KIT B, ENGINE BUILDUP SEE T.O. 1F-106A-10	RF	35	102
	500-00800C	KIT C, ENGINE BUILDUP SEE T.O. 1F-106A-10	RF	44	
	500-00800D	KIT D, ENGINE BUILDUP SEE T.O. 1F-106A-10	RF	103	
	500-00800E	KIT E, ENGINE BUILDUP SEE T.O. 1F-106A-10	RF	35	43
	500-00800F	KIT F, ENGINE BUILDUP SEE T.O. 1F-106A-10	RF	35	65
	8-22118	FAIRING INSTL, ENGINE AIR INTAKE	1	35	
- 1	8-22118-29	• • CONE ASSY	1	160	
		• • ATTACHING PARTS			
- 2	MS21742L4	*1 • • NUT	10	35	174
	AN75A10	*2 • • BOLT (REPLACED BY MS20074-05-11, NOT INTERCHG WITH AN75A10)	10	35	174
	MS20074-05-11	• • BOLT, USE WITH FRONT SUPPORTS EQUIPPED WITH TWINSERV ONLY	10	35	
- 3	AN502-416-6	• • SCREW	10	35	174
		-----X-----			
- 4	8-22119	• • RING	1	35	89
	8-22119-1	• • RING	1	90	192
	8-22119-3	• • RING	1	103	
	8-22121	• • LINER ASSY, J75 ENGINE FAIRING RIVETED	1	35	
- 5	8-22123	• • CAP	1	35	
- 6	8-22125	• • RING, STIFFENER J75 ENGINE FAIRING	1	35	
	8-22125-15	• • RING, STIFFENER J75 ENGINE FAIRING ALT INTCHG WITH 8-22125	RF	35	
- 7	8-22125-1	• • RING, STIFFENER J75 ENGINE FAIRING	1	35	
	8-22125-17	• • RING, STIFFENER J75 ENGINE FAIRING ALT INTCHG WITH 8-22125-1	RF	35	
- 8	8-22127	• • SPACER	20	35	
	8-22111-1	• • CONE	1	35	
- 9	8-22124	*1 • • RING ASSY, ENGINE AIR INTAKE REPLACED BY NOT INTCHG WITH 8-22124-1	1	35	174
	8-22124-1	• • RING ASSY, ENGINE AIR INTAKE REPLACES NOT INTCHG WITH 8-22124	1	177	
- 10	8-22120-7	• • FITTING	10	35	
	8-22122	• • FITTING, ALT INTCHG WITH 8-22120-7	RF	35	
- 11	8-22124-7	• • RING	1	35	
- 12	3-22105-1	• SEAL ASSY, ENGINE AIR INTAKE ATTACHING PARTS	1	35	
- 13	AN13807	• BOLT	40	35	
- 14	AN966PC416L	• WASHER	40	35	
		-----X-----			
- 15	8-22106	• SEAL	16	35	
- 16	8-22107-7	• STOP	32	35	
- 17	8-22108	• SPRING	48	35	
		A AIRPLANES #44 THRU #1 AND 54			
		B AIRPLANES #12, 53, AND 55 THRU 60			
		*1 USE WITH ENGINES WITH STUDS			
		*2 USE WITH ENGINES WITHOUT STUDS			

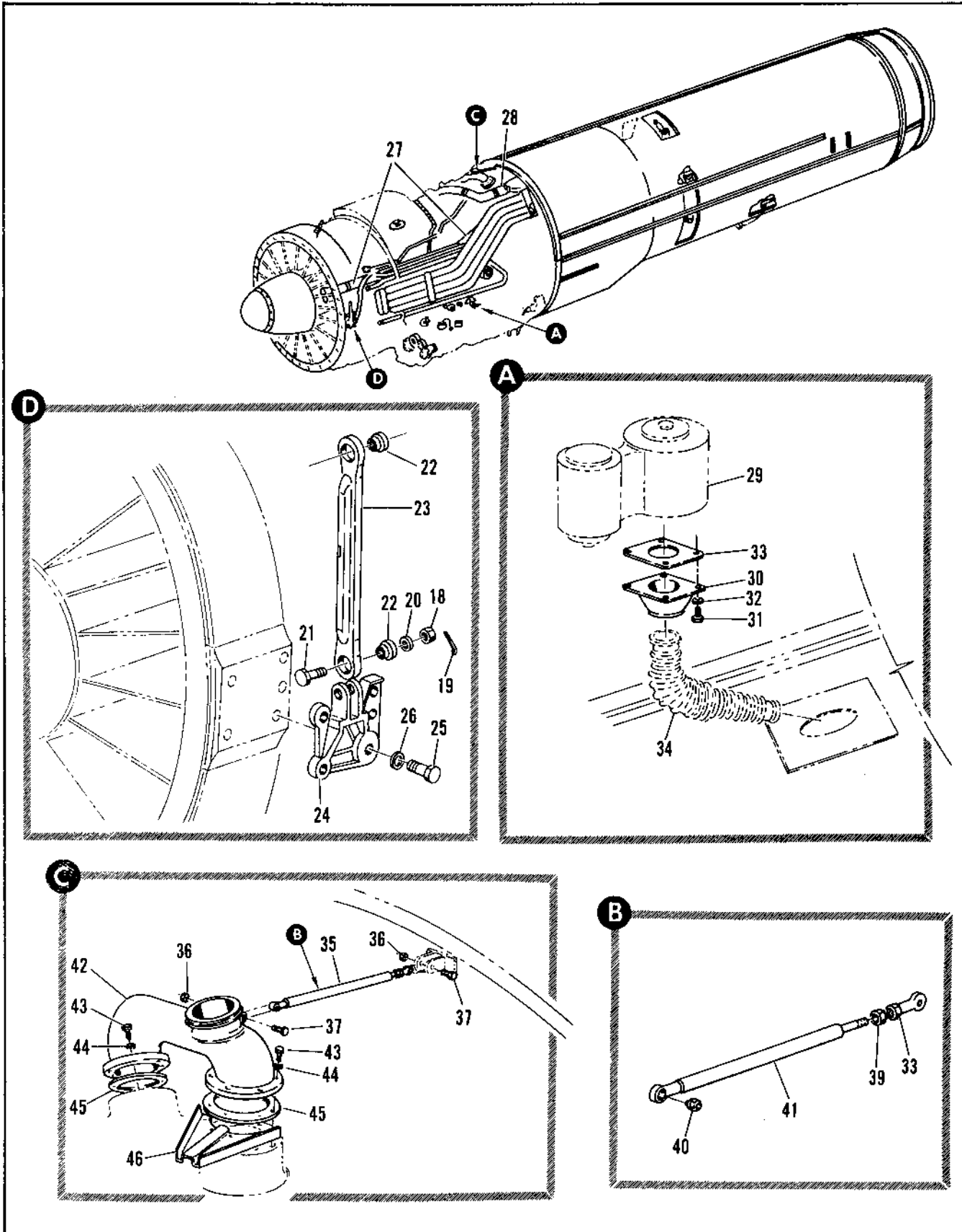

Figure 2.10-7. Turbojet Engine Assembly (Sheet 2 of 9)

FIGURE AND INDEX NUMBER	PART NUMBER	DESCRIPTION	UNITS PER ASSY.	USABLE ON CODE	
				FROM	TO
2.10-7	8-22969-1 8-22964	• LINK ASSY, ENGINE SUPPORT LH • LINK ASSY, ENGINE SUPPORT LH ALT INTCHG WITH 8-22969-1 ATTACHING PARTS	1 RF	35 35	
- 18	AN327C10	• WASHER	1	35	
- 19	AN381-4-24	• PIN, COTTER	1	1	35
- 20	AN960C1316L	• NUT	1	35	
- 21	8-26003	• BOLT	1	35	
		-----X-----			
- 22	BSSN10545	• BEARING, <81376> 90-60003-001	2	35	
- 23	8-22969-7 8-22969 8-22964-7 8-22968-7 8-22967	• LINK, MAKE FROM 8-22969 • LINK • LINK, ALT INTCHG WITH 8-22969-7 • SUPPORT, ENGINE FWD LH • SUPPORT, ENGINE FWD LH ALT INTCHG WITH 8-22968-7	1 RF RF RF RF	35 35 35 35 35	
- 25	MS20009H8	• BOLT	5	35	
- 26	MS20002C9	• WASHER	5	35	
- 27	8-22799-1	• DUCT INSTL, ENGINE COOLING AIR SUPPLY STA 487 TO 562 FOR BREAKDOWN SEE FIG. 2.10-8	1	35	60
	8-22799-5	• DUCT INSTL, ENGINE COOLING AIR SUPPLY STA 487 TO 562 FOR BREAKDOWN SEE FIG. 2.10-8	1	61	
- 28	8-22762	• DUCT INSTL, SHROUD GROUND COOLING FOR BREAKDOWN SEE FIG. 2.10-11	1	35	3A
	8-22762-1	• DUCT INSTL, SHROUD GROUND COOLING FOR BREAKDOWN SEE FIG. 2.10-11	1	39	
	8-28238-5 279900	• DUCT INSTL, ENGINE OIL BREATHER • VALVE ASSY, BREATHER PRESSURE PW FURNISHED WITH J75P17 ENGINE	1 RF	35 35	
- 29	8-22315-7	• FLANGE, OIL BREATHER DUCT UPPER ATTACHING PARTS	1	35	
- 31	AN7446	• BOLT	4	35	
- 32	AN960C416	• WASHER	4	35	
		-----X-----			
- 33	8-22317	• GASKET	1	35	
- 34		• DUCT ASSY, ENGINE OIL BREATHER SEE FIG. 2.10-6 INDEX 73	RF		
	8-23240-1	• DUCT INSTL, ENGINE BLEED AIR MANIFOLD	1	35	
- 35	8-23227	• ROD ASSY, MANIFOLD BLEED AIR DUCT SUPPORT ATTACHING PARTS	1	35	
- 36	MS20500-428	• NUT	2	35	
- 37	AN4C13A	• BOLT	2	35	
		-----X-----			
- 38	H4CR	• BEARING <P1629> 90-60016-001	1	35	
- 39	AN315C5R	• NUT	1	35	
	8-23227-7	• ROD ASSY, SUPPORT	1	35	
- 40	HSBY4CR	• BEARING <81629> 90-60011-003	1	35	
- 41	8-23227-9	• ROD ASSY, RIVETED	1	35	
- 42	8-23213-1	• DUCT ASSY, ENGINE BLEED AIR MANIFOLD WELDED ATTACHING PARTS	1	35	
- 43	AN5CH5A	• BOLT	12	35	
- 44	AN960C516	• WASHER	12	35	
		-----X-----			
- 45	C3125C	• SEAL, <97968> 94-16013-013	2	35	
- 46	8-22798	• SUPPORT	1	35	

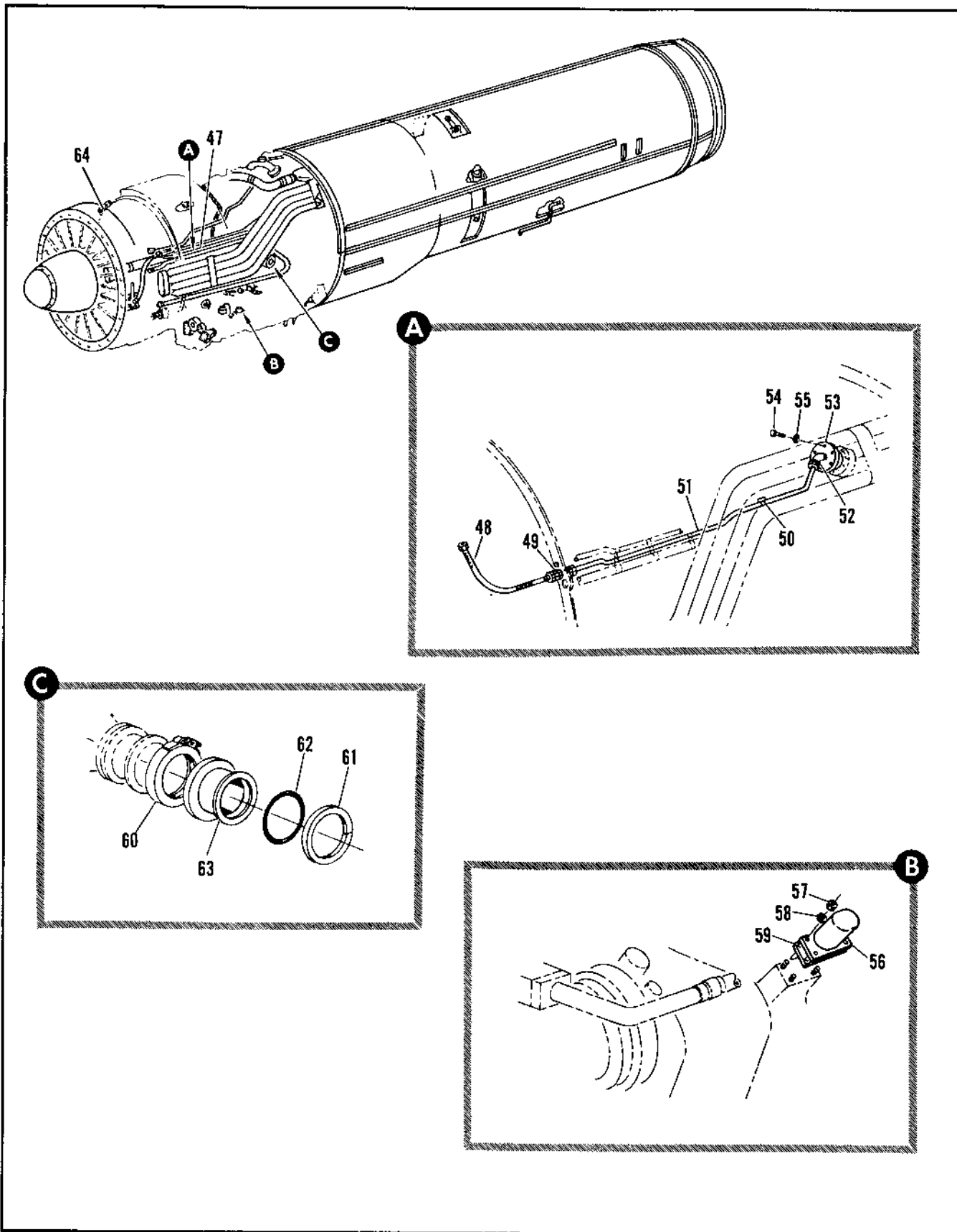

Figure 2.10-7. Turbojet Engine Assembly (Sheet 3 of 9)

FIGURE AND INDEX NUMBER	PART NUMBER	DESCRIPTION	UNITS PER ASSY.	USABLE ON CODE	
				FROM	TO
2.10-7- 47	8-38097-801	• TUBING INSTL, PRESSURE RATIO INDICATOR STA 481 AND AFT FOR BREAKDOWN SEE FIG. 2.10-20	1	35	43
	8-38097-807	• TUBING INSTL, PRESSURE RATIO INDICATOR STA 481 AND AFT FOR BREAKDOWN SEE FIG. 2.10-20	1	44	
	8-26700-1	• TUBING INSTL, ENGINE BLEED AIR CONTROL OIL COOLER STA 487 TO 544	1	35	
- 48	R9800S4-0176	• HOSE ASSY, <50599> 94-80545-G05	1	35	
- 49	MS21903-4	• UNION	1	35	
	95-71003-003	• NUT	1	35	
- 50	8-26700-17	• BRACKET	1	35	
- 51	8-26700-11	• TUBE ASSY, BLEED AIR	1	35	
- 52	MS21908-4	• ELBOW	1	35	
	95-71003-003	• NUT	1	35	
	AN900-7	• GASKET	1	35	
- 53	8-22795	• ADAPTER, ENGINE BLEED AIR PORT ATTACHING PARTS	1	35	
- 54	AN5CH5A	• BOLT	6	35	
- 55	AN960C516	• WASHER	6	35	
		-----X-----			
- 56	MS28054-2	• GENERATOR, TACHOMETER AERN061-8731 GFAE	1	0	
	22A554	• GENERATOR, TACHOMETER <25140> TYPE GEU-71A AERN061-8732 GFAE ATTACHING PARTS	1	160	277
- 57	MS21042L4	• NUT, 96-37545-003	4	35	
- 58	AN960PD416	• WASHER	4	35	
		-----X-----			
- 59	AN4045-1	• GASKET	1	35	
- 60	17266-609SH	• COUPLING, <98625> 92-73010-005	2	35	
	8-22737	• ADAPTER ASSY, COMPRESSOR BLEED	1	35	
- 61	8-22737-15	• RING	1	35	
- 62	8-27764	• SEAL	1	35	
- 63	8-22737-17	• DUCT ASSY, WELDED	1	35	
	8-65146	• BRACKET INSTL, ENGINE MOUNTING HARNESS	1	35	89
	8-65146-5	• BRACKET INSTL, ENGINE MOUNTING HARNESS	1	90	129
	8-65146-3	• BRACKET INSTL, ENGINE MOUNTING HARNESS	1	130	
	8-65146-7	• GROUND STUD ASSEMBLY	1	35	
	NAS679A4	• NUT, GROUND STUD	1	35	
	AN516-4R	• NUT, GROUND STUD	1	35	
	AN935-416L	• WASHER, GROUND STUD	2	35	
	AN960C416L	• WASHER, GROUND STUD	4	35	
	NAS428-4-12	• BOLT, GROUND STUD	1	35	
- 64	8-65145-11	• BRACKET	1	35	129
	8-65145-13	• BRACKET	1	130	
	8-67420-7	• CLIP, ENGINE SUPPORT HARNESS	10	35	
	8-67420-9	• CLIP, ENGINE SUPPORT HARNESS	3	35	
D AIRPLANES #35 THRU 159, 278 AND ON					

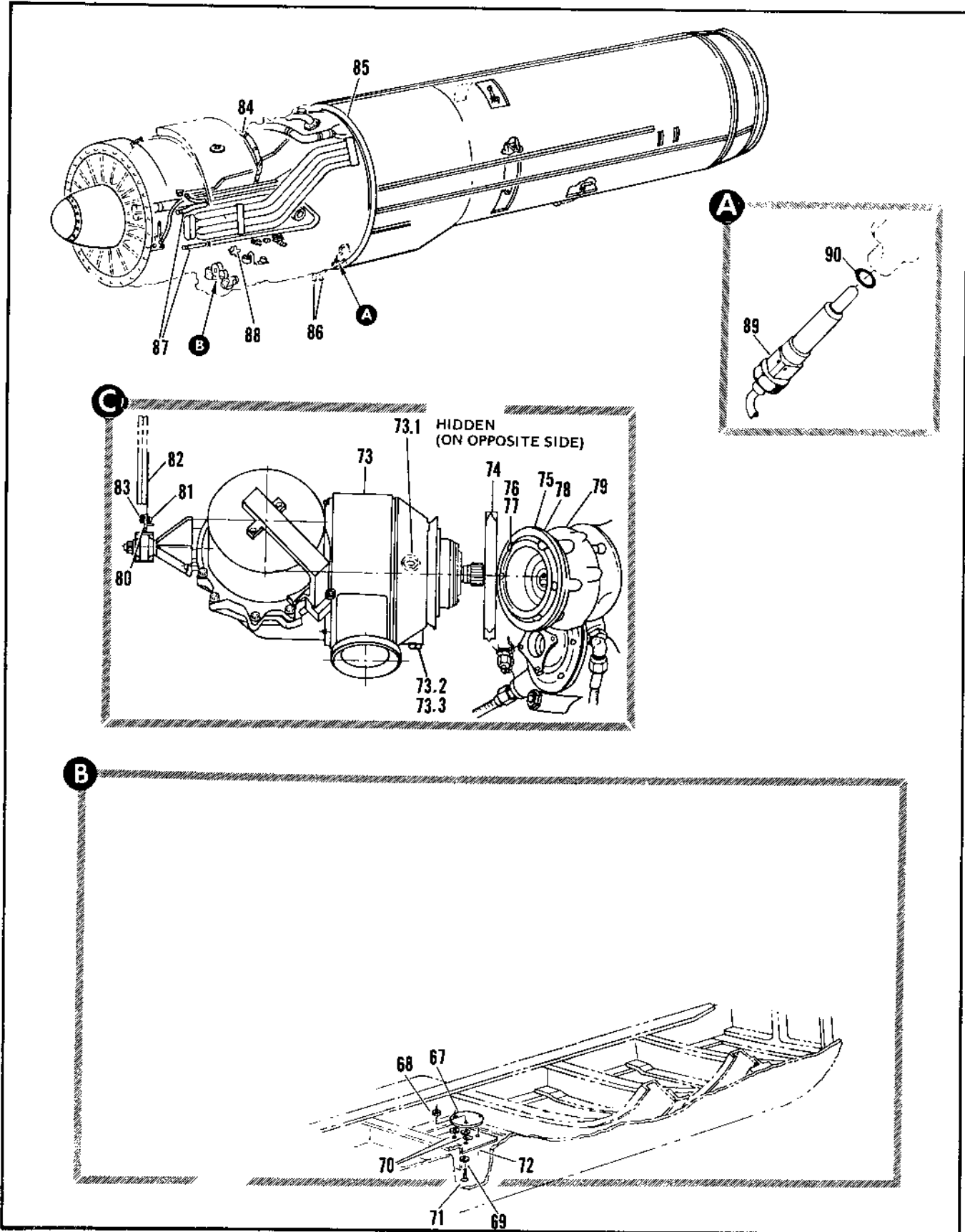

Figure 2.10-7. Turbojet Engine Assembly (Sheet 4 of 9)

FIGURE AND INDEX NUMBER	PART NUMBER	DESCRIPTION 1 2 3 4 5 6	UNITS PER ASSY.	USABLE ON CODE	
				FROM	TO
2.10-7	8-22808-8C1	• STARTER INSTL, MODIFIED BY 3501172 (99193)	1	35	
- 65	DELETED				
- 66	DELETED				
- 67	3501656-1	• COVER ATTACHING PARTS	1		
- 68	MS20365-1032	• • NUT SELF LOCKING	3		
- 69	AN960-10	• • WASHER	3		
- 70	DELETED				
- 71	MS24694C53	• • SCREW -----X-----	3		
- 72	60874066	• • PLATE, DRAIN VALVE RIVETED	1		
- 73	3505056-1-1	• STARTER CARTRIDGE-PNEUMATIC (99193)	1	35	
- 73.1	S9413-111	• O-RING SEAL, OIL LEVEL FILLER PLUG	1		
- 73.2	AN814-4	• DRAIN PLUG	1		
- 73.3	S9143-110	• O-RING SEAL, DRAIN PLUG	1		
- 74	234-514-9016	• • CLAMP	1	35	
- 75	353992	• • FLANGE, ADAPTER STARTER ATTACHING PARTS	1	35	
- 76	NAS679A6	• • NUT	6	35	
- 77	AN960-616L	• • WASHER	6	35	
- 78	AN4047-1	• • GASKET	1	35	
- 79	708682	• GEARBOX ASSY, ENGINE MOUNTED FOR BREAKDOWN SEE FIG. 2.10-32	1	35	
- 80	3501518-1	• BRACKET	1	35	
- 81	MS21280-67	• • BOLT	2	35	
- 82	MS16212-12	• • WASHER	3	35	
- 83	MS21043-4	• • NUT	2	35	
- 84	8-20393-1	• TUBING INSTL, POWER PLANT VENT AND DRAIN FOR BREAKDOWN SEE FIG. 2.10-18	1	35	
	8-20393-3	• TUBING ASSY, POWER PLANT VENT AND DRAIN FOR BREAKDOWN SEE FIG. 2.10-17			
- 85	8-22739-1	• ADAPTER INSTL, ENGINE FIRE SEAL FOR BREAKDOWN SEE FIG. 2.10-9			
- 86	8-20397-835	• TUBING INSTL, ENGINE FUEL PRESS FOR BREAKDOWN SEE FIG. 2.12-60			
- 87	8-28267-5	• TUBING INSTL, ENGINE OIL FOR BREAKDOWN SEE FIG. 2.10-15			
- 88	8-42728-5	• BELL CRANK INSTL, POWER CONTROL FOR BREAKDOWN SEE FIG. 2.10-5			
- 89	25633151	• SENSOR, ENGINE FUEL TEMP ENVELOPE 80234 SPEC 8-00912 T.O. 803-10-6-13 REPLACED BY SUITABLE SUB 25633151-01			
	25633151-01	• SENSOR, ENGINE FUEL TEMP ENVELOPE 80234 SPEC 8-00912 T.O. 803-10-6-13 REPLACES 25633151			
- 90	MS29512-12	• GASKET	1	35	

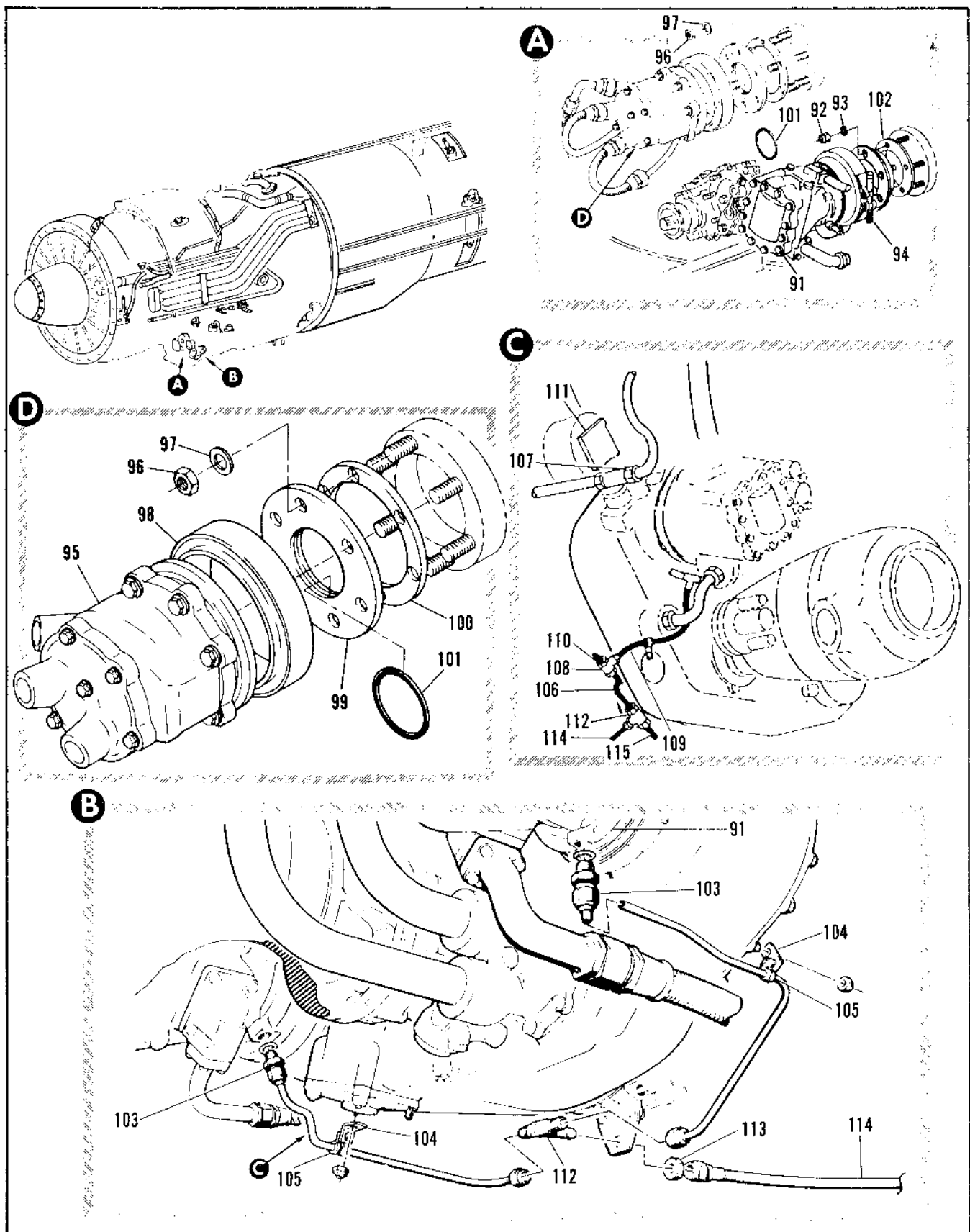

Figure 2.10-7. Turbojet Engine Assembly (Sheet 5 of 9)

FIGURE AND INDEX NUMBER	PART NUMBER	DESCRIPTION	UNITS PER ASSY.	USABLE ON CODE	
				FROM	TO
		1 2 3 4 5 6			
2.10-7	8-81320-3	• PUMP INSTL, HYDRAULIC	1	35	
- 91	AA60691L6A	• . PUMP ASSY, PRIMARY LH (62983) SPEC 8-08478-11 T.O. 9H4-2-36-63	1	35	
		ATTACHING PARTS			
- 92	NAS679A6	• . . NUT	6	35	
- 93	AN960-616L	• . . WASHER	6	35	
		-----X-----			
- 94	192667	• . . CLAMP (62983), FURNISHED WITH PUMP	R		
	186628	• . . ADAPTER	1		
	MS28775-235	• . . PACKING	1		
- 95	297617	• . PUMP ASSY, SECONDARY RH (62983) MODEL PVB-205-2 T.O. 9H4-2-85-4	1		
		ATTACHING PARTS			
- 96	MS21042L-6	• . . NUT	6		
- 97	AN960-616L	• . . WASHER	6	35	
		-----X-----			
- 98	315473	• . . CLAMP, (62983) USE WITH 297617 PUMP	1		
- 99	315472	• . . ADAPTER (62983)	1		
-100	MS9136-01	• . . GASKET	1		
-101	NAS1593-156	• . . PACKING	1		
-102	AN4047-1	• . . GASKET, USE WITH AA60691L6A PUMP	1	35	
	8-80030-801	• TUBING INSTL, HYD STATION 472 TO TAIL CONE	1	35	
-103	MS21902-4	• . UNION	2	35	
	AN6290-4	• . GASKET	2	35	
-104	8-67420-9	• . CLIP	2	35	
-105	91-98026-003	• . CLAMP	2	35	
-106	8-84774-9	• . TUBE ASSY	1	35	
-107	MS21907-4	• . ELBOW	1	35	
	AN924-4	• . NUT	1	35	
	MS28778-4	• . PACKING	1	35	
-108	MS21905-4	• . TEE	1	35	
-109	8-84775-9	• . TUBE ASSY	1	35	
-110	MS21914-4M	• . CAP, TUBING	1	35	
-111	AN100043	• . COVER	1	35	
-112	MS21909-4	• . TEE	1	35	
-113	AN924-4	• . NUT	1	35	
	AN960-716L	• . WASHER	1	35	
-114	R9800-4-CC90	• HOSE ASSY SEAL DRAIN SEE FIG. 2.8-11 INDEX 102	1	35	

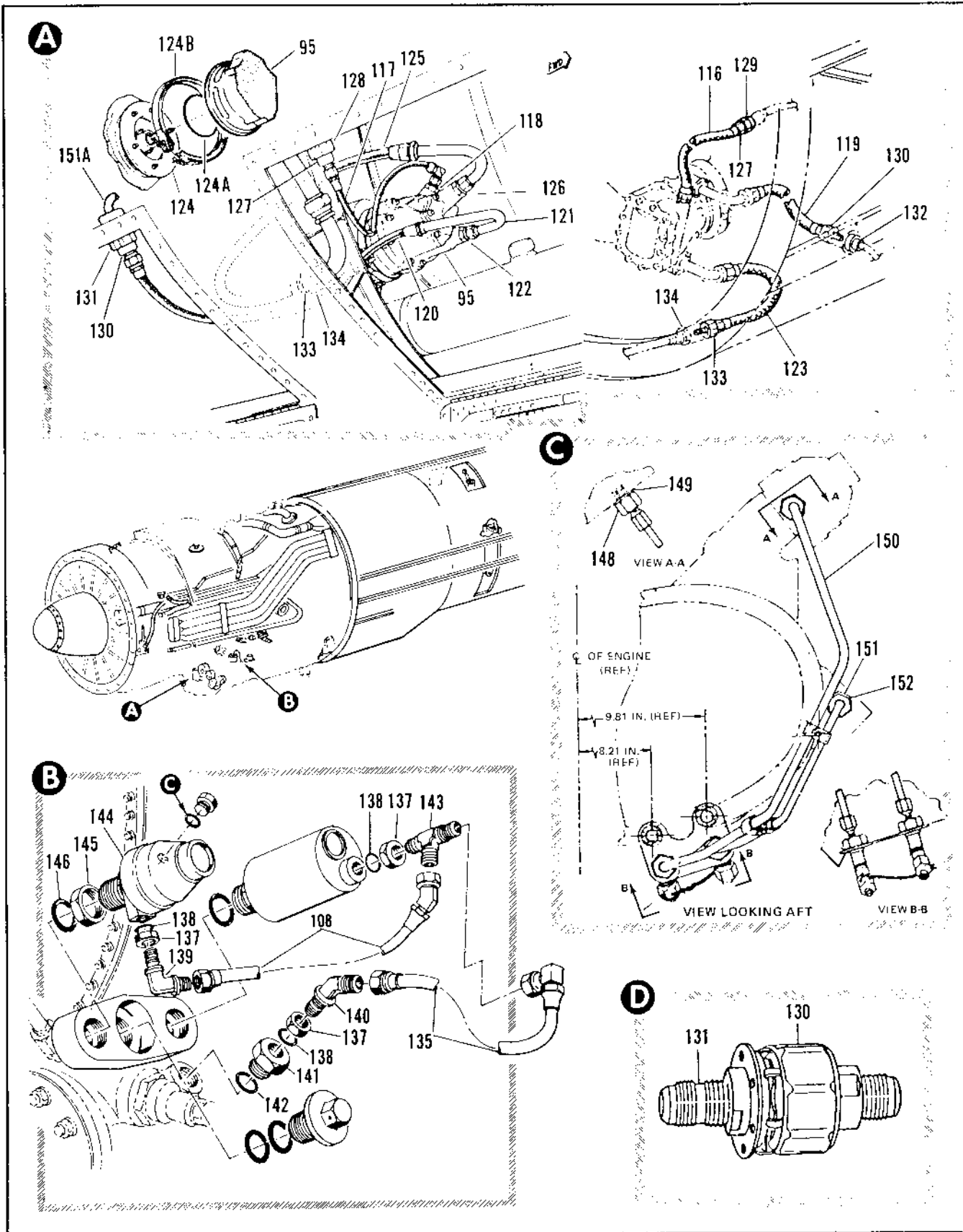

Figure 2.10-7. Turbojet Engine Assembly (Sheet 6 of 9)

FIGURE AND INDEX NUMBER	PART NUMBER	DESCRIPTION	UNITS PER ASSY.	USABLE ON CODE	
				FROM	TO
2.10-7-115	8-P5035-239	• TUBE ASSY (14170)	1	35	
-116	666371-6-0164	• HOSE ASSY, PRIMARY PUMP CASE DRAIN (00624)	1	35	
-117	666315-6-1174	• HOSE ASSY, SECONDARY PUMP CASE DRAIN (00624)	1	35	
-118	MS21902-6	• UNION (96906)	1		
	MS28778-6	• PACKING (96906)	1		
-119	677032-8-0164	• HOSE ASSY, PRIMARY PUMP PRESSURE	1	35	
-120	R295012-00-15214	• HOSE ASSY, SECONDARY PUMP PRESSURE REPLACED BY BUT NOT INTERCHANGING WITH 8043964-10 AND 7947451-10	RF	35	
	8043964-10	• HOSE ASSY, SECONDARY HYDRAULIC PUMP (98750)	1		
-121	7947451-10	• TUBE ASSY, SECONDARY HYDRAULIC PUMP (98750)	1		
-122	MS21902-12	• UNION (96906)	1		
	MS28778-12	• PACKING (96906)	1		
-123	R20006	• HOSE ASSY, PRIMARY PUMP SUCTION (50599)	1	35	
-124	315472	• ADAPTER (62983)	1	35	
-124A	NAS1595	• SEAL (80205)	1	35	
-124B	315473	• CLAMP (62983)	1	35	
-125	AE702254-1	• HOSE ASSY, SECONDARY PUMP SUCTION (00624)	1		
	MS21902-10	• UNION (96906)	1		
-126	MS28778-10	• PACKING (96906)	1		
-127	3065-S5-6L	• QUICK DISCONNECT, HOSE HALF (00624)	2	35	
-128	TR3015-S4-FD	• QUICK DISCONNECT, BULKHEAD HALF (00624)	2	35	
-129	3018S4-6D	• QUICK DISCONNECT, BULKHEAD HALF (00624)	1	35	
-130	3065-S5-8D	• QUICK DISCONNECT, HOSE HALF (00624)	2	35	
-131	3018S4-12D	• QUICK DISCONNECT, BULKHEAD HALF (00624)	1	35	
-132	3018S4-8D	• QUICK DISCONNECT, BULKHEAD HALF (00624)	1	35	
-133	3065S5-16D	• COUPLING, HALF, SELF SEALING STRAIGHT TUBULAR VALVE (00624) 92-74007-005	2		
	155-25-16L	• NUT, UNION SELF SEALING COUPLING	2		
-134	307534-16D	• QUICK DISCONNECT, BULKHEAD HALF (00624)	2	35	
	8-22544	• SWITCH AND TRANSMITTER INSTL, ENGINE OIL PRESSURE	1	35	
-135	R9806S4-0096	• HOSE ASSY, (50599) 94-80510-005	1	35	
-136	R9806S4-0084	• HOSE ASSY, (50599) 94-80509-009	1	35	
-137	AN924-4	• NUT (88044)	3	35	
-138	NAS617-4	• GASKET (80205)	3	35	
-139	MS21907-4	• ELBOW (96906)	1	35	
-140	MS21907-4	• ELBOW (96906)	1	35	
-141	AN892-30	• REDUCER (88044)	1	35	
-142	NAS617-8	• GASKET (80205)	1	35	
-143	MS21912D4	• TEE (96906)	1	35	
-144	40121-1A	• SWITCH, (98750) SPEC A-62989-7 T.O. 982-3-57-63	1	35	
-145	AN924-120	• NUT (88044)	1	35	
-146	NAS617-12	• GASKET (80205)	1	35	
-147	MS21916-4-30	• REDUCER (96906)	1	9	
-148	MS29512-3	• GASKET (96906)	1	9	
-149	65A34165-1	• TUBING ASSEMBLY (98750)	1	9	
-150	MS21902-40	• UNION (96906)	1	9	
-151	MS29512-4	• GASKET (96906)	1	9	
-151A	7640015-10	• TUBE ASSY, HYDRAULIC (98750)	1	35	

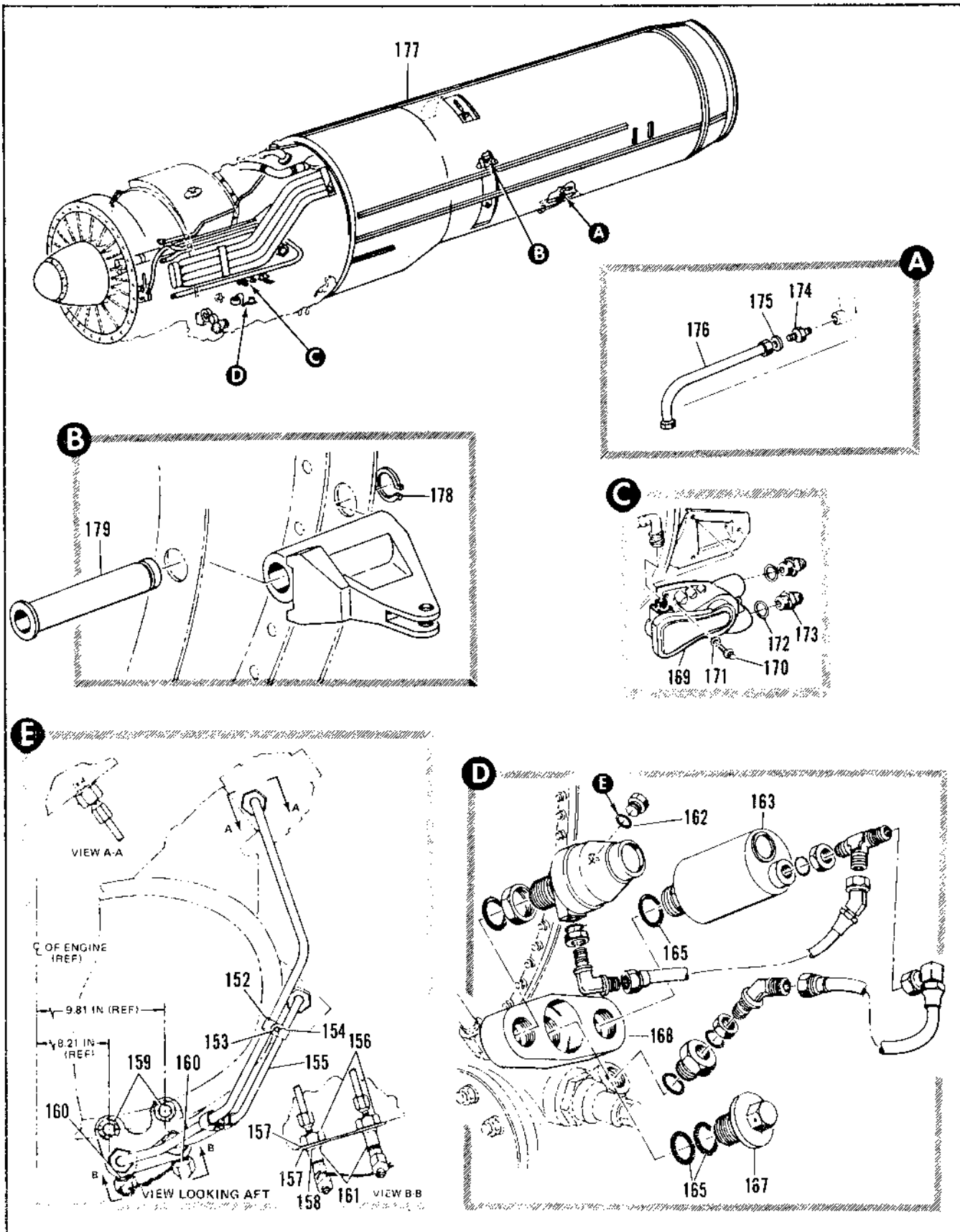

Figure 2.10-7. Turbojet Engine Assembly (Sheet 7 of 9)

FIGURE AND INDEX NUMBER	PART NUMBER	DESCRIPTION	UNITS PER ASSY.	USABLE ON CODE	
				FROM	TO
		1 2 3 4 5 6			
2.10-7-152	MS122902	• CLAMP (REPLACED BY MS21919HA, NOT INTCHG) ATTACHING PARTS	4	9	
-153	AN520C10R8	• SCREW	2	9	
-154	MS21043-3	• NUT	2	9	
		-----X-----			
-155	65A34166-1	• TUBING ASSEMBLY	1	9	
-156	AN924-4C	• NUT	2	9	
-157	AN960-716	• WASHER	4	9	
-158	65B34008-7	• BRACKET	1	9	
		ATTACHING PARTS			
	NO NUMBER	• STUD (INSTALLED ON HOUSING)	2	9	
-159	MS35335-62	• WASHER, LOCK	2	9	
		• NUT (USE EXISTING HARDWARE)	2	9	
		-----X-----			
-160	MS21914-4C	• CAP, PRESSURE	2	9	
-161	MS21907-4C	• ELBOW	2	9	
-162	NAS617-3	• GASKET	1	35	
-163	ST504A	• TRANSMITTER, OIL PRESSURE 61249 REPLACED BY (NOT INTCHG WITH) 18-1718-3A OR 3567750-3001A	1	35	
	18-1718-3A	• TRANSMITTER, OIL PRESSURE 96774 REPLACES (NOT INTCHG WITH) ST504A	1	35	
	3567750-3001A	• TRANSMITTER, OIL PRESSURE, REPLACES (NOT INTCHG WITH) ST504A	1	35	
-164	AN123971	• GASKET	1	35	
-165	NAS617-12	• GASKET	3	35	
-166	AN123971	• GASKET	1	35	
-167	8-22565-1	• BOLT	1	35	
-168	8-22566-1	• ADAPTER PLATE, SWITCH	1	35	
-169	9121-21A1	• TRANSMITTER, RATE OF FUEL FLOW <19315> AERN061-2456 TYPE MA-1 GFAE ATTACHING PARTS	1	35	
-170	AN4-13A	• BOLT	3	35	
-171	AN960PD416	• WASHER	3	35	
-172	MS902C-20	• PACKING	2	35	
-173	227435	• UNION, USED WITH RIGID FUEL LINES	2	35	
	400374	• UNION, USED WITH FLEX TYPE FUEL LINES	2	35	
		-----X-----			
-174	MS21902-6C	• UNION	1	35	
-175	AN901-6C	• WASHER	1	35	
-176	C8886	• HOSE ASSY, AFTERBURNER DRAIN <81481> 94-80513-004	1	35	
-177	8-22679-803	• SHROUD INSTL, ENGINE AIR COOLING FOR BREAKDOWN SEE FIG. 2.10-12	1	M	
	8-22679-805	• SHROUD INSTL, ENGINE AIR COOLING FOR BREAKDOWN SEE FIG. 2.10-12	1	A	
	8-22679-811	• SHROUD INSTL, ENGINE AIR COOLING FOR BREAKDOWN SEE FIG. 2.10-12	1	C	
	8-22679-809	• SHROUD INSTL, ENGINE AIR COOLING FOR BREAKDOWN SEE FIG. 2.10-12	1	189	277
	8-26679-3	• SHROUD INSTL, ENGINE AIR COOLING FOR BREAKDOWN SEE FIG. 2.10-12	1	E	
	8-26679-5	• SHROUD INSTL, ENGINE AIR COOLING FOR BREAKDOWN SEE FIG. 2.10-12	1	F	
	8-26679-801	• SHROUD INSTL, ENGINE AIR COOLING FOR BREAKDOWN SEE FIG. 2.10-12	1	G	
-178	5100-75W	• RING, RETAINING <79136> 97-61509-001	2	35	
-179	8-22084	• PIN	2	35	
		A AIRPLANES #44 THRU 51 AND 54 C AIRPLANES #52, 53, AND 55 THRU 188 E AIRPLANES #279 THRU 281 AND 286 F AIRPLANES #278, 282, 285, AND 288 THRU 300 G AIRPLANES #283, 287, AND 301 THRU 303 H AIRPLANES #35 THRU 43, 304 AND ON			

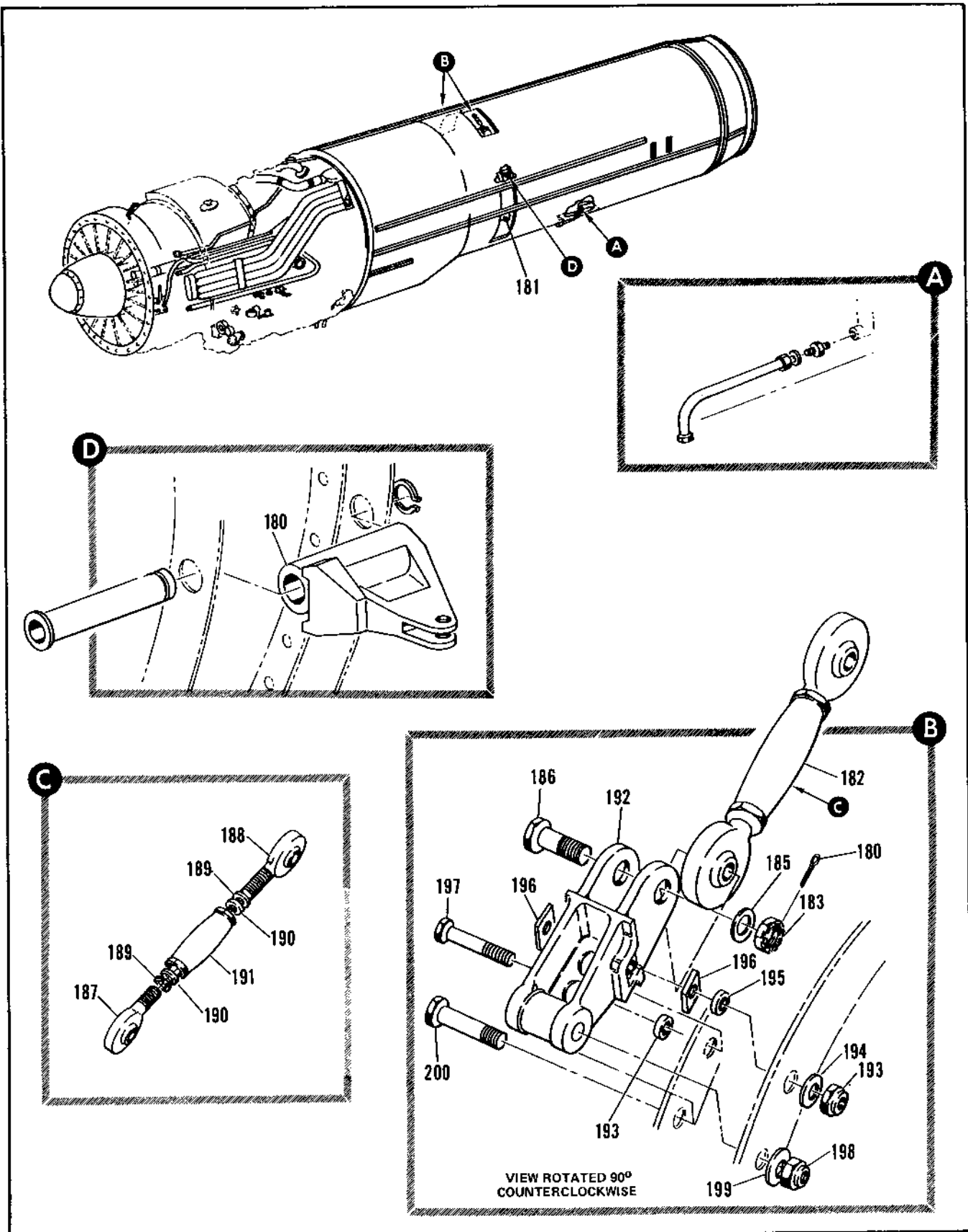

Figure 2.10-7. Turbojet Engine Assembly (Sheet 8 of 9)

FIGURE AND INDEX NUMBER	PART NUMBER	DESCRIPTION	UNITS PER ASSY.	USABLE ON CODE	
				FROM	TO
		1 2 3 4 5 6			
2.10-7-180	8-22669-17	• SUPPORT, ENGINE COOLING SHROUD UPPER LH MAKE FROM 8-22669-15	1	35	
	8-22669-15	• SUPPORT	RF		
	8-22670-9	• SUPPORT, ENGINE COOLING SHROUD UPPER LH ALT INTCHG WITH 8-22669-17	RF	35	
	8-22669-18	• SUPPORT, ENGINE COOLING SHROUD UPPER RH MAKE FROM 8-22669-15	1	35	
	8-22669-16	• SUPPORT	RF		
	8-22670-13	• SUPPORT, ENGINE COOLING SHROUD UPPER RH ALT INTCHG WITH 8-22669-18	RF	35	
-181	8-22680-1	• ROLLER INSTL, ENGINE AFT LH FOR BREAKDOWN SEE FIG. 2.10-39	1	35	
	8-22680-2	• ROLLER INSTL, ENGINE AFT RH FOR BREAKDOWN SEE FIG. 2.10-39	1	35	
	8-22976	• MOUNT INSTL, ENGINE AFT	1	35	
-182	8-22962-1	• TURNBUCKLE ASSY, ENGINE MOUNT AFT ATTACHING PARTS	RF	35	
-183	8-26951	• NUT	2	35	
-184	AN381-4-20	• COTTER PIN	2	35	
-185	AN960C916	• WASHER	2	35	
-186	8-22984-7	• BOLT, REPLACED BY NOT INTCHG WITH 8-26957	2	35	89
	8-26957	• BOLT, REPLACES NOT INTCHG WITH 8-22984-7	2	90	
		-----X-----			
-187	8RE14285	• EYE BOLT, ENGINE SUPPORT AFT <81376> SPEC 8-12272-7	1	35	
-188	8RE14290	• EYE BOLT, ENGINE SUPPORT AFT <81376> SPEC 8-02272-9	1	35	
-189	5008-125*	• RING, RETAINING <79136> 97-61511-001	2	35	
-190	8-22983	• WASHER	2	35	
-191	8-22982-7	• NUT	1	35	
-192	8-22978-7	• SUPPORT, ENGINE MOUNT AFT	2	35	
	8-22977	• SUPPCNT, ENGINE MOUNT AFT ALT INTCHG WITH 8-22978-7	RF	35	
-193	99F12-624	• NUT, <56878> 96-37536-001	2	35	
-194	AN960C616	• WASHER	2	35	
-195	8-22980	• BUSHING	4	35	
-196	8-22981	• BLOCK	4	35	
-197	8-22925	• FOLT	2	35	
-198	MS20500-1216	• NUT, <56878> 96-37536-002	2	35	
-199	AN960C1216L	• WASHER	2	35	
-200	8-22979	• FOLT	2	35	

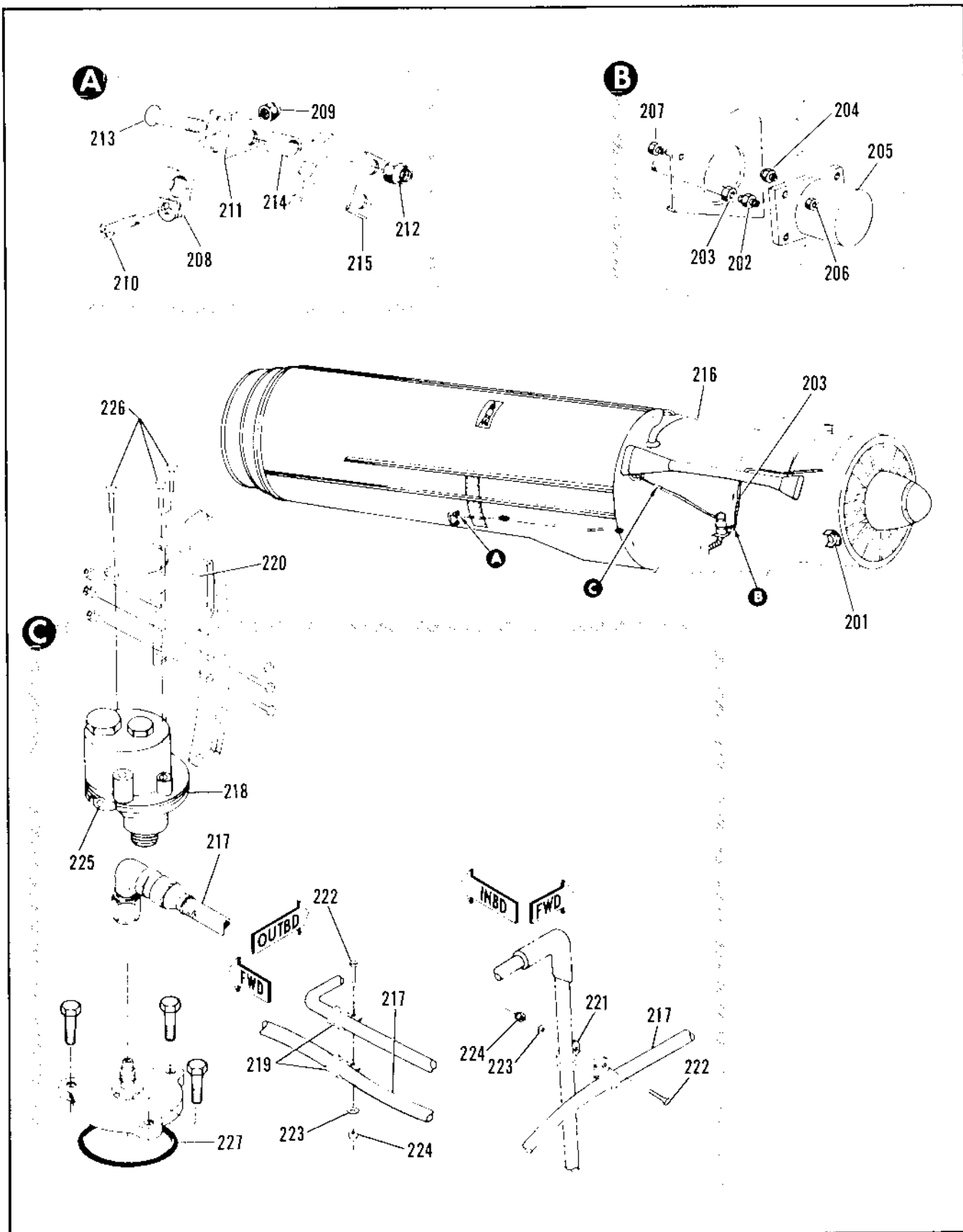

Figure 2.10-7. Turbojet Engine Assembly (Sheet 9 of 9)

FIGURE AND INDEX NUMBER	PART NUMBER	DESCRIPTION	UNITS PER ASSY.	USABLE ON CODE	
				FROM	TO
		1 2 3 4 5 6			
2.10-7-201	8-22961	• SUPPORT ASSY, ENGINE THRUST BEARING FOR BREAKDOWN SEE FIG. 2.10-36	1	35	
	8-22736-5	• SWITCH INSTL, SHROUD PPESSURE	1	35	
-202	MS21902-4	• • UNION	1	35	
	0327-7	• • PACKING, <45581> 96-58500-J13	1	35	
-203	8-22738-11	• TUBE ASSY, FLARED	1	35	
-204	8-22796	• • PLUG, SHROUD PPESSURE SWITCH ALTERED FROM AN806-4	1	35	
	0327-7	• • PACKING, <45681> 96-58500-C13	1	35	
-205	41004	• • SWITCH, DIFFERENTIAL PPESSURE COOLING AIR <98505> SPEC 8-02990 T.O. 8S2-3-57-33 REPLACED BY SUITABLE SUB 41004-1	1	35	89
	41004-1	• • SWITCH, DIFFERENTIAL PPESSURE COOLING AIR <98505> SPEC 8-02990-1 T.O. 8S2-3-57-112 REPLACES SUITABLE SUB FOR 41004 ATTACHING PARTS	1	90	
-206	NAS679A3	• • NUT	4	35	
-207	AN3-4A	• • BOLT	4	35	
		-----X-----			
	8-67420-9	• • CLIP, ENGINE SUPPORT HARNES	1	35	
	8-26349-1	• TUBING INSTL, AFTERRURNER IGNITER DRAIN VALVE	1	35	
-208	MS21919H5	• CLAMP	1	35	
		ATTACHING PARTS			
-209	NAS679C3	• NUT	1	35	
-210	AN520C10R7	• SCREW	1	35	
		-----X-----			
-211	8-26950	• PRACKET	1	35	
		ATTACHING PARTS			
-212	NAS679C3	• NUT	2	35	
-213	AN520C10R18	• SCREW	2	35	
		-----X-----			
-214	NAS72-3-G10	• PUSHING	2	35	
-215	8-26949-15	• FLATE	1	35	
-216	J75P17	• ENGINE ASSY, <77445> AEPN035-6066 GFAE	1	35	
-217	7346560-10	• HOSE ASSY	1	ALL	
-218	10-374058-2	• SWITCH	1	ALL	
-219	MS21919H5	• CLAMP	3	ALL	
-220	7346561-01	• PRACKET	1	ALL	
-221	MS21919H5	• CLAMP	1	ALL	
-222	MS9316-04	• SCREW	2	ALL	
-223	AN960-10L	• WASHER	2	ALL	
-224	MS21145C3	• NUT	2	ALL	
-225	10-382465-2	• ADAPTER ASSY	1	ALL	
-226	MS24678-21	• BOLT	3	ALL	
-227	MS9575-039	• PACKING	1	ALL	

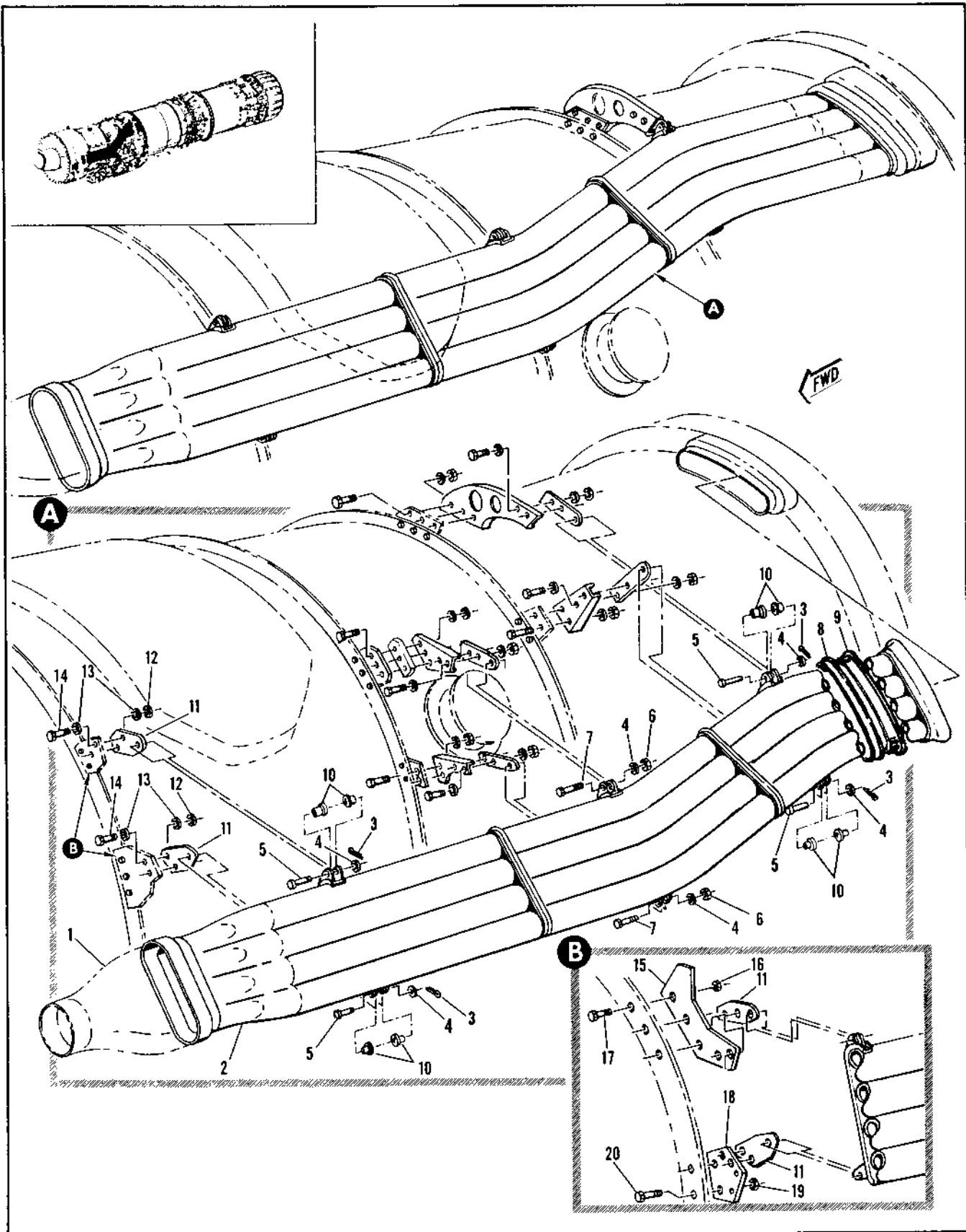

Figure 2.10-8. Engine Cooling Air Supply Duct Installation Sta 487 to 560 (Sheet 1 of 3)

FIGURE AND INDEX NUMBER	PART NUMBER	DESCRIPTION	UNITS PER ASSY.	USABLE ON CODE	
				FROM	TO
		1 2 3 4 5 6			
2.10-8	8-22799-1	DUCT INSTALLATION, ENGINE COOLING AIR SUPPLY STA 487 TO 560 FOR NHA SEE FIG. 2.10-7	RF	35	60
	8-22799-5	DUCT INSTALLATION, ENGINE COOLING AIR SUPPLY STA 487 TO 560 FOR NHA SEE FIG. 2.10-7	RF	61	
- 1		• DUCT ASSY, AIR COOLING INTERMEDIATE LH SEE FIG. 2.10-7 INDEX 13	RF		
- 2	8-26717	• DUCT ASSY, COOLING AIR SUPPLY LH WELDED	1	35	
		ATTACHING PARTS			
- 3	MS24665-132	• PIN, COTTER	4	35	
- 4	AN960-10L	• WASHER	6	35	
- 5	MS20392-2-25	• PIN	4	35	
- 6	MS21042L3	• PIN	2	35	
- 7	AN3-4A	• NUT	2	35	
		-----X-----			
- 8	8-26717-33	• RETAINER	1	61	
- 9	8-26717-69	• SEAL	1	61	
- 10	8-26719	• BUSHING	8	61	
- 11	8-22759	• CLIP, LH	2	35	
		ATTACHING PARTS			
- 12	MS21042L4	• NUT, LH	4	35	
- 13	AN960-416	• WASHER, LH	8	35	
- 14	AN4-5A	• BOLT	4	35	
		-----X-----			
- 15	8-22786-41	• BRACKET, UPPER LH	1	35	
		ATTACHING PARTS			
- 16	MS21042L5	• NUT, LH	3	35	
- 17	AN5-5A	• BOLT, LH	3	35	
		-----X-----			
- 18	8-22786-29	• BRACKET, LOWER LH	1	35	
		ATTACHING PARTS			
- 19	MS21042L5	• NUT, LH	2	35	
- 20	AN5-5A	• BOLT, LH	2	35	
		-----X-----			

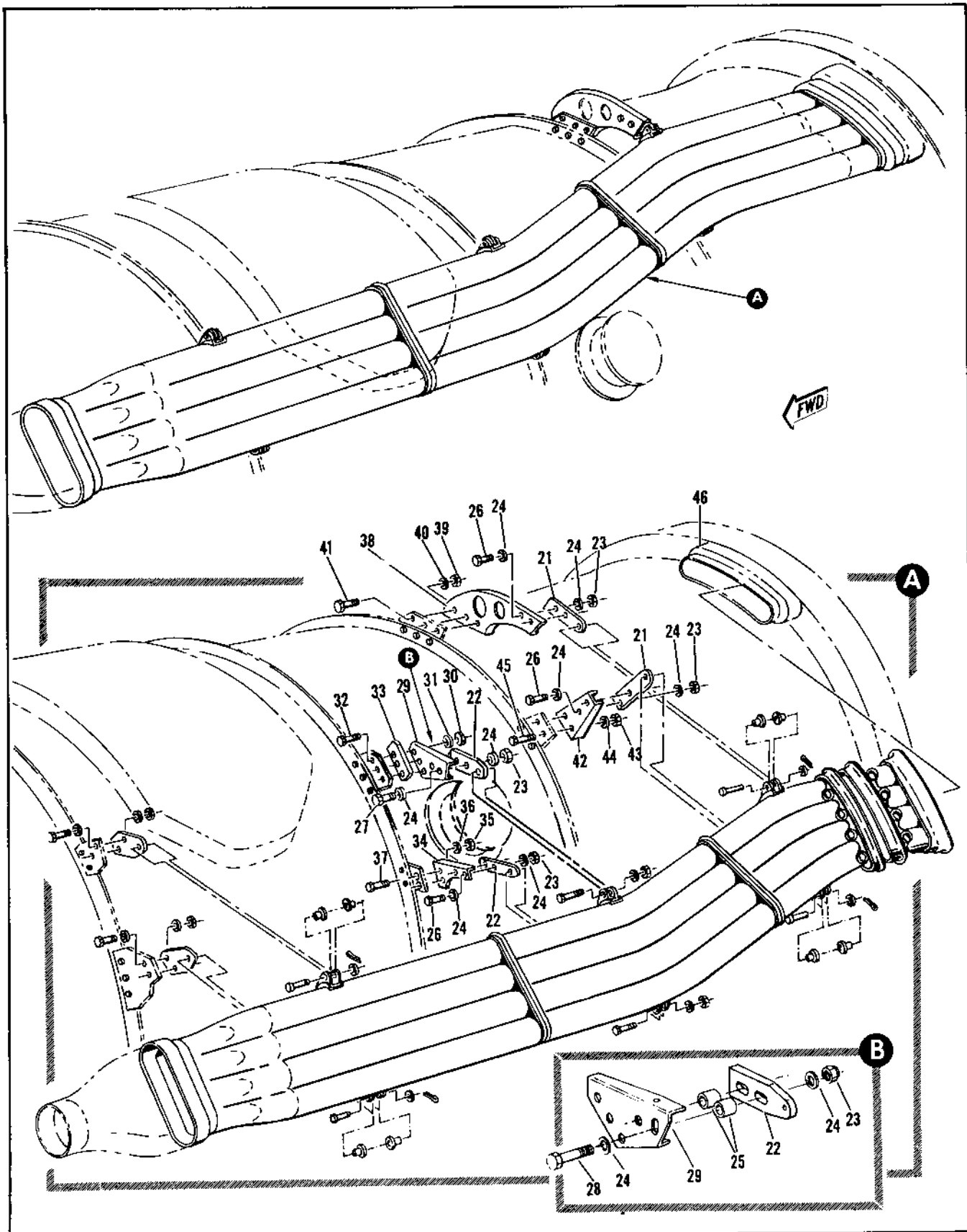

Figure 2.10-8. Engine Cooling Air Supply Duct Installation Sta 487 to 560 (Sheet 2 of 3)

FIGURE AND INDEX NUMBER	PART NUMBER	DESCRIPTION	UNITS PER ASSY.	USABLE ON CODE	
				FROM	TO
		1 2 3 4 5 6			
2.10-8- 21	8-22757	• CLIP, LH	2	35	
- 22	8-26708	• CLIP, UPPER LH	1	35	
	8-22767	• CLIP, LOWER LH	1	35	
		ATTACHING PARTS			
- 23	MS21042L4	• NUT, LH	8	35	
- 24	AN960-416	• WASHER, LH	16	35	
- 25	NAS42HT8-12	• SPACER	2	61	
- 26	AN4-5A	• BOLT, LH	6	35	
- 27	AN4-5A	• BOLT, LH	2	35	60
- 28	AN4-6A	• BOLT, LH	2	61	
		-----X-----			
- 29	8-26707-7	• BRACKET, COOLING AIR DUCT INTERMEDIATE UPPER LH	1	35	
		ATTACHING PARTS			
- 30	MS21042L3	• NUT	3	35	
- 31	AN960-10L	• WASHER	3	35	
- 32	AN3-4A	• BOLT	3	35	
		-----X-----			
- 33	8-26707-9	• SPACER	1	35	60
- 34	8-26706-9	• BRACKET, COOLING AIR DUCT INTERMEDIATE LWR	1	35	
		ATTACHING PARTS			
- 35	MS21042L3	• NUT	2	35	
- 36	AN960-10L	• WASHER	2	35	
- 37	AN3-4A	• BOLT	2	35	
		-----X-----			
- 38	8-22754-7	• BRACKET, UPPER LH	1	35	
		ATTACHING PARTS			
- 39	MS21042L3	• NUT	3	35	
- 40	AN960-10L	• WASHER	3	35	
- 41	AN3-4A	• BOLT	3	35	
		-----X-----			
- 42	8-26701	• BRACKET, LOWER LH	1	35	
		ATTACHING PARTS			
- 43	MS21042L3	• NUT	2	35	
- 44	AN960-10L	• WASHER	2	35	
- 45	AN3-4A	• BOLT	2	35	
		-----X-----			
- 46		• VALVE ASSY, RAM AIR SHROUD COOLING CHECK LH	RF		
		SEE FIG. 2.10-10			

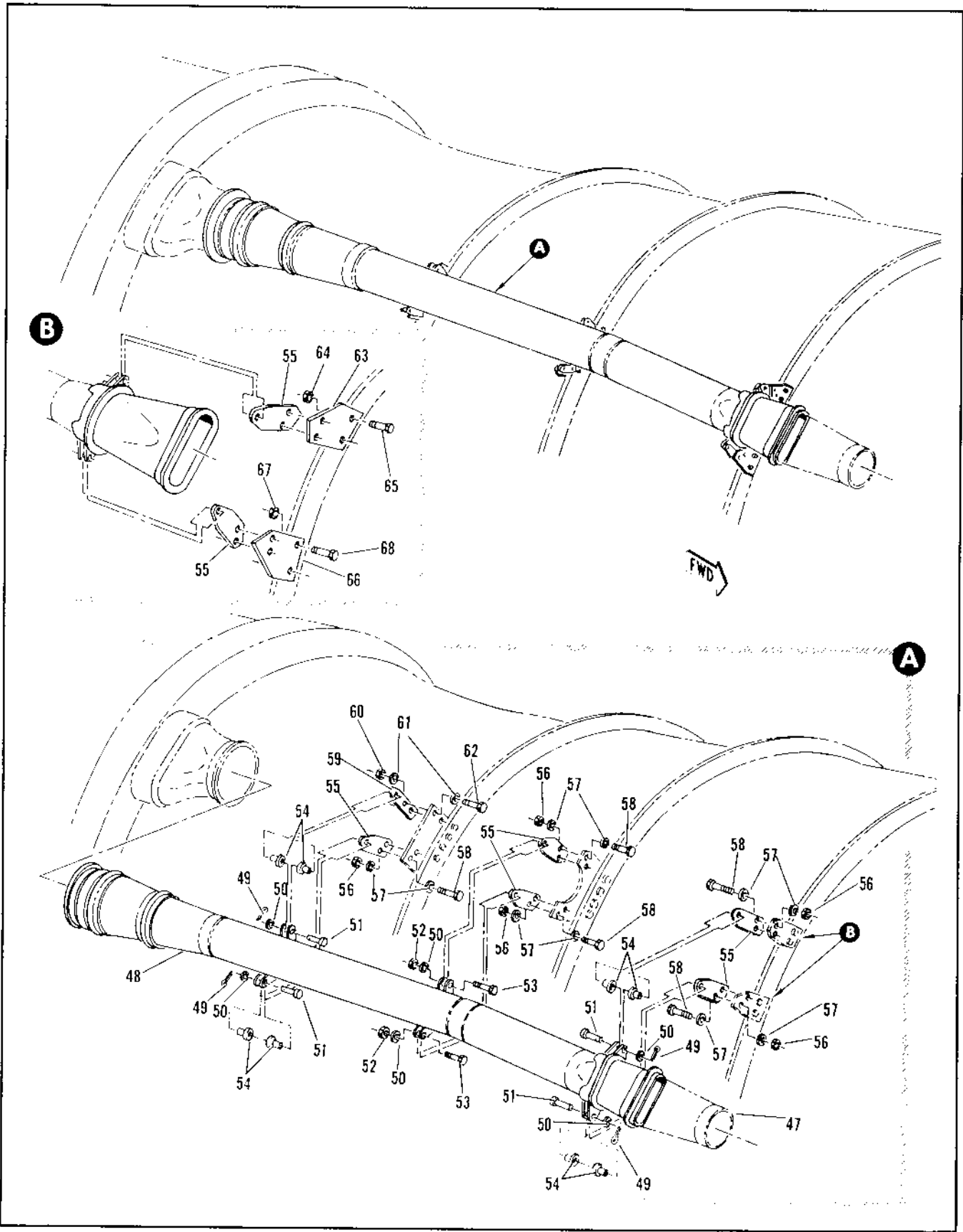

Figure 2.10-8. Engine Cooling Air Supply Duct Installation Sta 487 to 560 (Sheet 3 of 3)

FIGURE AND INDEX NUMBER	PART NUMBER	DESCRIPTION	UNITS PER ASSY.	USABLE ON CODE	
				FROM	TO
		1 2 3 4 5 6			
2.10-8- 47		• DUCT ASSY, AIR COOLING INTERMEDIATE RH SEE FIG. 2.10-6 INDEX 18	RF		
- 48	8-26720 8-26703	• DUCT ASSY, COOLING AIR SUPPLY RH WELDED • DUCT ASSY, COOLING AIR SUPPLY RH WELDED ALT INTCHG WITH 8-26720	1 RF	35 35	
		ATTACHING PARTS			
- 49	MS24665-132	• PIN, COILER	4	35	
- 50	AN960-10L	• WASHER	6	35	
- 51	MS20392-2-25	• PIN	4	35	
- 52	MS21042L3	• NUT	2	35	
- 53	AN3-4A	• BOLT	2	35	
		----X----			
- 54	8-26719	• BUSHING	8	35	
- 55	8-22759	• CLIP, RH	5	35	
		ATTACHING PARTS			
- 56	MS21042L4	• NUT,	10	35	
- 57	AN960-416	• WASHER	20	35	
- 58	AN4-5A AN4-5A AN4-6A	• BOLT • BOLT • BOLT	10 8 2	35 61 61	60
		----X----			
- 59	8-22757	• CLIP, RH	1	35	
		ATTACHING PARTS			
- 60	MS21042L4	• NUT,	2	35	
- 61	AN960-416	• WASHER,	4	35	
- 62	AN4-5A	• BOLT, RH	2	35	
		----X----			
- 63	8-22786-31	• BRACKET, UPPER RH	1	35	
		ATTACHING PARTS			
- 64	MS21042L5	• NUT,	2	35	
- 65	AN5-5A	• BOLT,	2	35	
		----X----			
- 66	8-22786-33	• BRACKET, LOWER RH	1	35	
		ATTACHING PARTS			
- 67	MS21042L5	• NUT,	2	35	
- 68	AN5-5A	• BOLT,	2	35	
		----X----			

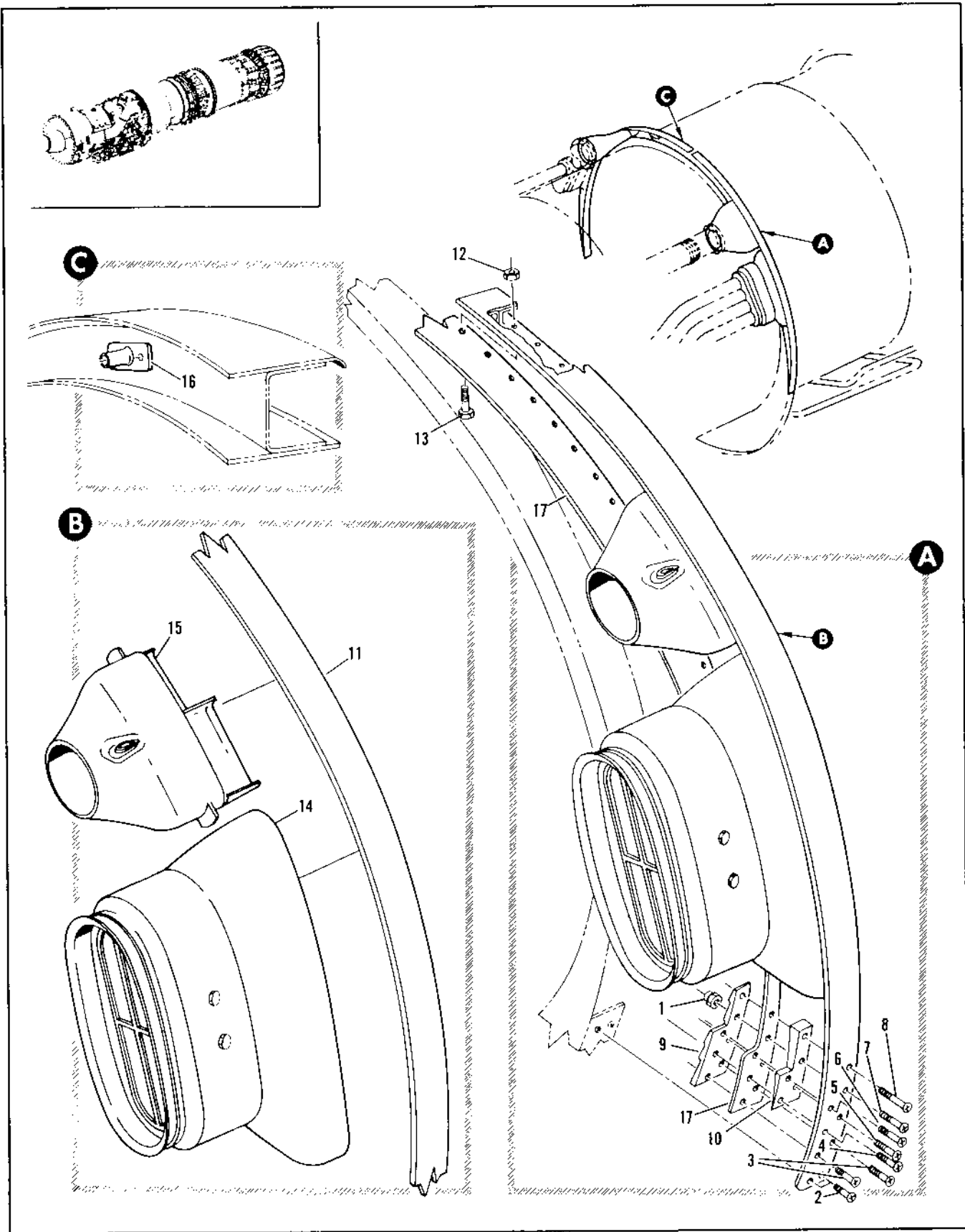

Figure 2.10-9. Engine Fire Seal Adapter Installation

FIGURE AND INDEX NUMBER	PART NUMBER	DESCRIPTION	UNITS PER ASSY.	USABLE ON CODE	
				FROM	TO
		1 2 3 4 5 6			
2.10-9	8-22739-1	ADAPTER INSTALLATION, ENGINE FIRE SEAL FOR NHA SEE FIG. 2.10-7	RF	35	
- 1	702MC2	• NUT, <72962> 96-27550-001	18	35	
- 2	AN507C1032R7	• SCREW	4	35	
- 3	AN509C10R12	• SCREW	4	35	
- 4	AN509C10R13	• SCREW	2	35	
- 5	AN509C10R14	• SCREW	2	35	
- 6	AN509C10R16	• SCREW	2	35	
- 7	AN509C10R17	• SCREW	2	35	
- 8	AN509C10R20	• SCREW	2	35	
- 9	8-22779-9	• ADAPTER, LH	1	35	
	8-22779-19	• ADAPTER, RH	1	35	
- 10	8-22765-7	• WEDGE, LH	1	35	
	8-22765-8	• WEDGE, RH	1	35	
- 11	8-22739-27	• ADAPTER ASSY, ENGINE FIRE SEAL LH	1	35	
	8-22739-29	• ADAPTER ASSY, ENGINE FIRE SEAL RH	1	35	
		ATTACHING PARTS			
- 12	Z1200-02	• NUT, <72962> 96-37549-001	66	35	
	Z1200-02	• NUT, <72962> 96-37549-001 RH	2	35	
- 13	AN106410	• BOLT	66	35	
	AN106410	• BOLT, RH	2	35	
		-----X-----			
- 14	8-26714-1	• VALVE ASSY, RAM AIR SHROUD COOLING CHECK LH FOR BREAKDOWN SEE FIG. 2.10-10	1	35	
	8-26714-3	• VALVE ASSY, RAM AIR SHROUD COOLING CHECK RH FOR BREAKDOWN SEE FIG. 2.10-10	1	35	
- 15	8-22763	• DUCT ASSY, SHROUD COOLING TRANSITION LH WELDED	1	35	
	8-22764	• DUCT ASSY, SHROUD COOLING TRANSITION RH WELDED	1	35	
- 16	8-22797	• GUIDE, TUBE SHROUD PRESSURE SWITCH RH	1	35	
- 17	8-22739-19	• SEAL, ENGINE FIRE	1	35	

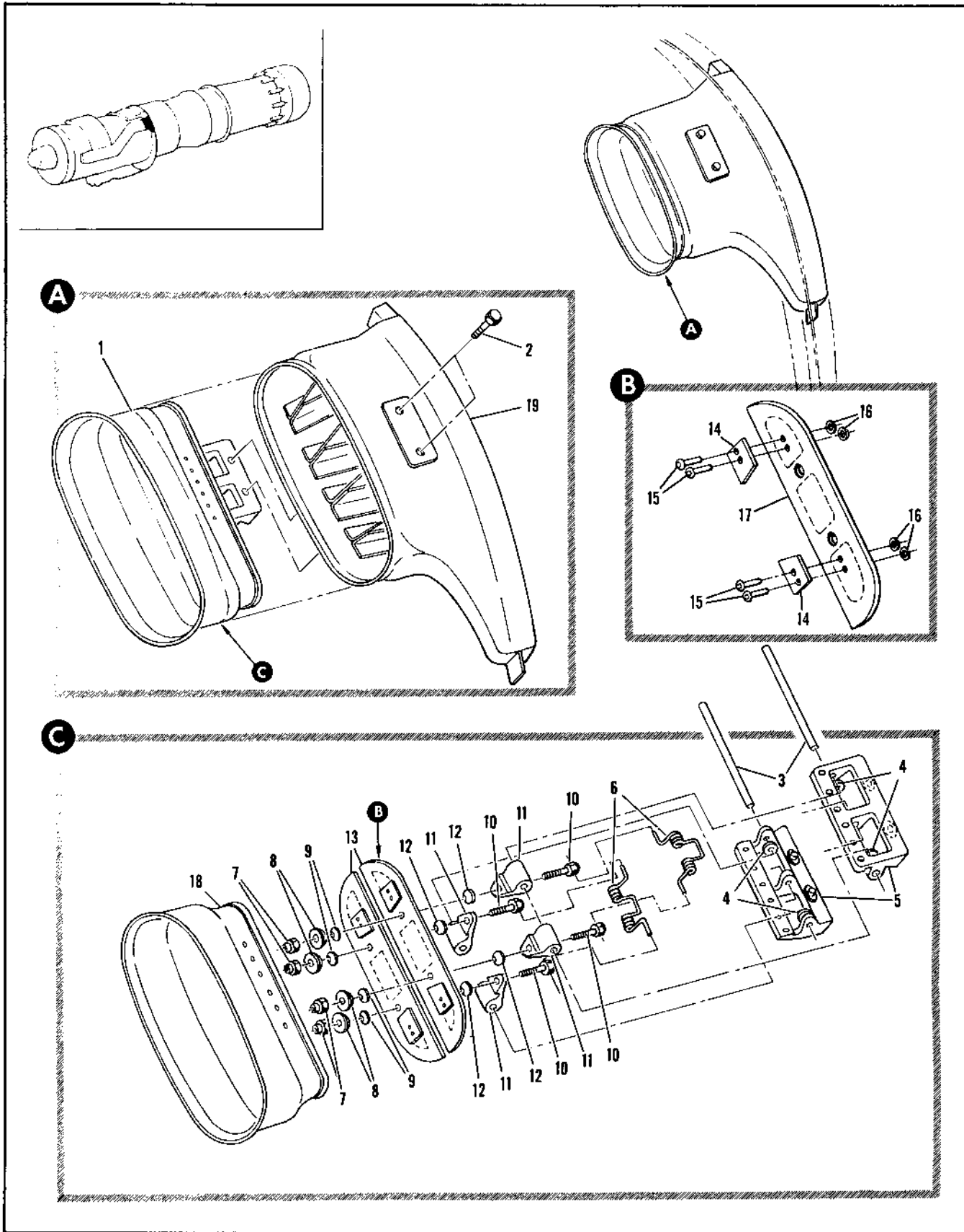

Figure 2.10-10. Ram Air Shroud Cooling Check Valve Assembly

FIGURE AND INDEX NUMBER	PART NUMBER	DESCRIPTION 1 2 3 4 5 6	UNITS PER ASSY.	USABLE ON CODE	
				FROM	TO
2.10-10	8-26714-1	VALVE ASSEMBLY, RAM AIR SHROUD COOLING CHECK LH FOR NHA SEE FIG. 2.10-9	RF	35	
	8-26714-3	VALVE ASSEMBLY, RAM AIR SHROUD COOLING CHECK RH FOR NHA SEE FIG. 2.10-9	RF	35	
- 1	8-26712	MECHANISM ASSY, SHROUD COOLING CHECK VALVE ATTACHING PARTS	1	35	
- 2	AN4-5A	BOLT -----X-----	4	35	
- 3	8-22745	PIN	2	35	
- 4	99-51507-C08	WASHER	AR	35	
- 5	8-26715	HINGE	2	35	
	8-26711	HINGE, ALT INTCHG WITH 8-26715	RF	35	
- 6	8-30967	SPRING, FLAPPER CHECK VALVE	2	35	
- 7	NAS679C3	NUT	4	35	
- 8	AF95C-3	WASHER	4	35	
- 9	8-22787	WASHER	4	35	
- 10	AN3CH6A	BOLT	4	35	
- 11	8-22743	LEAF, BUTT HINGE	4	35	
- 12	AF955-3	WASHER	4	35	
- 13	8-26712-9	FLAPPER ASSY, BUTT HINGE	2	35	
- 14	8-26712-7	BUMPER ATTACHING PARTS	2	35	
- 15	NAS5J8M3	RIVET	4	35	
- 16	AN960C2	WASHER -----X-----	4	35	
- 17	8-22741-9	FLAPPER, BUTT HINGE CHECK VALVE	1	35	
- 18	8-22778-1	SEAT ASSY, VALVE WELDED	1	35	
- 19	8-26713-1	SHROUD ASSY, RAM AIR CHECK VALVE LH WELDED	1	35	
	8-26713-3	SHROUD ASSY, RAM AIR CHECK VALVE RH WELDED	1	35	

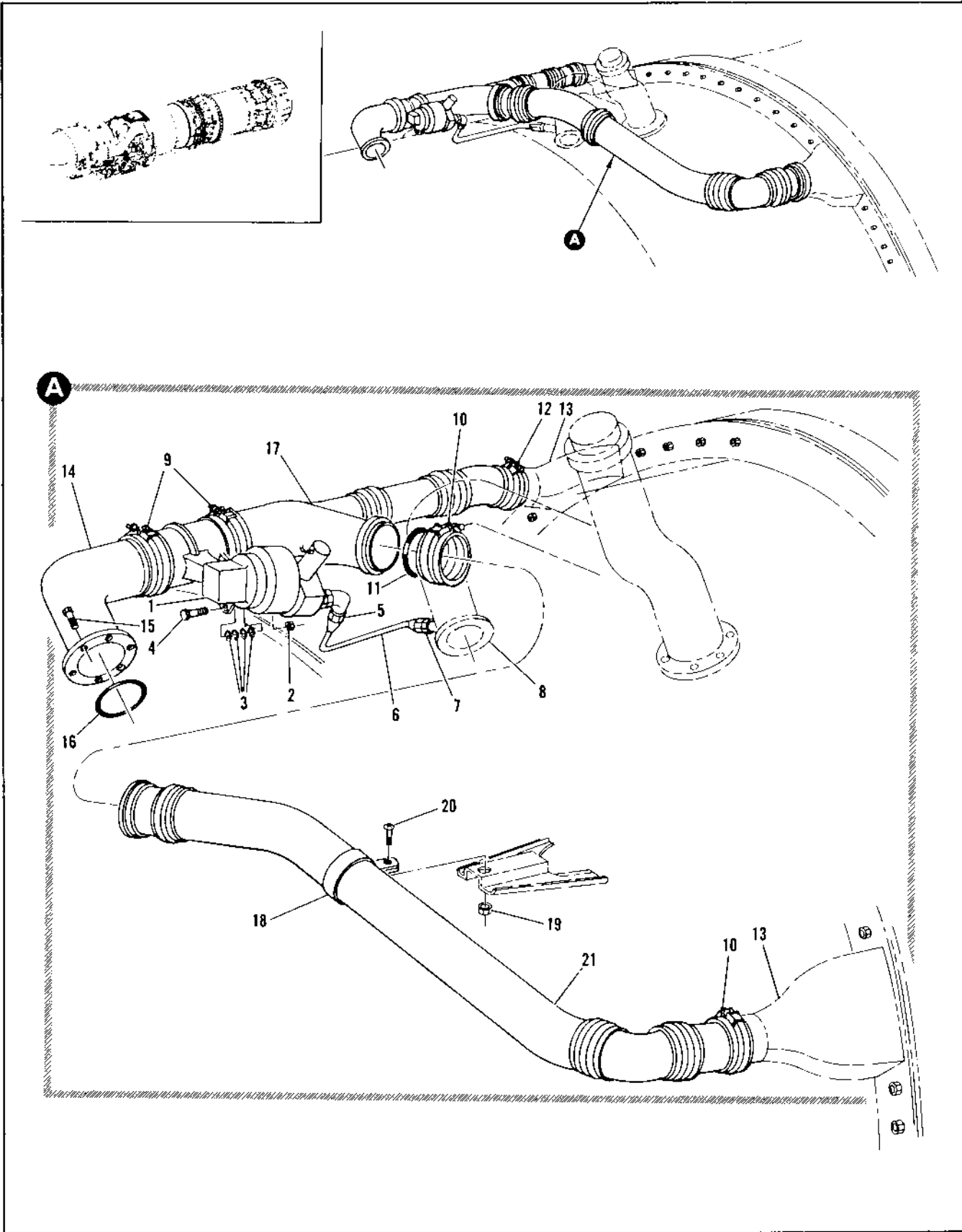

Figure 2.10-11. Shroud Ground Cooling Duct Installation

FIGURE AND INDEX NUMBER	PART NUMBER	DESCRIPTION	UNITS PER ASSY.	USABLE ON CODE	
				FROM	TO
2.10-11	A-22762	DUCT INSTALLATION, SHROUD GROUND COOLING FOR NHA SEE FIG. 2.10-7	RF	35	38
	B-22762-1	DUCT INSTALLATION, SHROUD GROUND COOLING FOR NHA SEE FIG. 2.10-7	RF	39	
- 1	1364-575740	* VALVE ASSY, AIR SHUTOFF <92003> SPEC B-02966 T.O. 9P5-82-13 ATTACHING PARTS	RF	35	
- 2	MS21043-4	* NUT	2	35	
- 3	AN960C416L	* WASHER	6	35	
- 4	AN406A	* BOLT -----X-----	2	35	
- 5	MS21908-4	* ELBOW	1	35	
	AN924-4	* NUT	1	35	215
	95-71003-033	* NUT	1	216	
	AN901-4C	* GASKET	1	35	
- 6	B-22762-9	* TUBE	1	35	1
- 7	MS21902-4	* UNION	1	35	
	MS21921-4	* NUT	2	35	215
	4121-579638	* NUT, <92003> 96-38508-203	2	216	
	MS21922-4	* SLEEVE	2	35	
	AN901-4C	* GASKET	1	35	
- 6		* DUCT ASSY, ENGINE BLEED AIR MANIFOLD SEE FIG. 2.10-7 INDEX 42	RF		
- 9	4265-382SH	* COUPLING, <98625> 92-73003-316	2	35	1
	PRP9230-12-7180	* PACKING, <86579> 96-58500-006	2	35	1
- 10	4275-331M	* COUPLING, <98625> 92-73010-007	2	35	1
- 11	PRP909-8	* PACKING, O-RING <86579> 96-58500-005	2	35	
- 12	4275-307M	* COUPLING, <98625> 92-73010-006	1	35	1
	PRP909-6	* PACKING, O-RING <86579> 96-58500-004	1	35	
- 13		* ADAPTER ASSY, ENGINE FIRE SEAL SEE FIG. 2.10-9 INDEX 11	RF		
- 14	B-22770	* ELBOW ASSY, GROUND COOLING AIR ENGINE MOUNT WELDED ATTACHING PARTS	1	35	
- 15	AN5CH5A	* BOLT -----X-----	6	35	
- 16	A3000	* SEAL, DUCT INSTL GROUND COOLING <97968> 94-16513-024	1	35	
- 17	B-22769-3	* DUCT ASSY, GROUND COOLING AIR LH WELDED	1	35	
- 18	JP0625SH40	* CLAMP, <0598> 91-98037-037 ATTACHING PARTS	1	35	1
- 19	MS21043-3	* NUT	1	35	
- 20	AN520C10R7	* SCREW -----X-----	1	35	
- 21	B-22766-1	* DUCT ASSY, GROUND COOLING AIR CROSS-OVER RH WELDED	1	35	

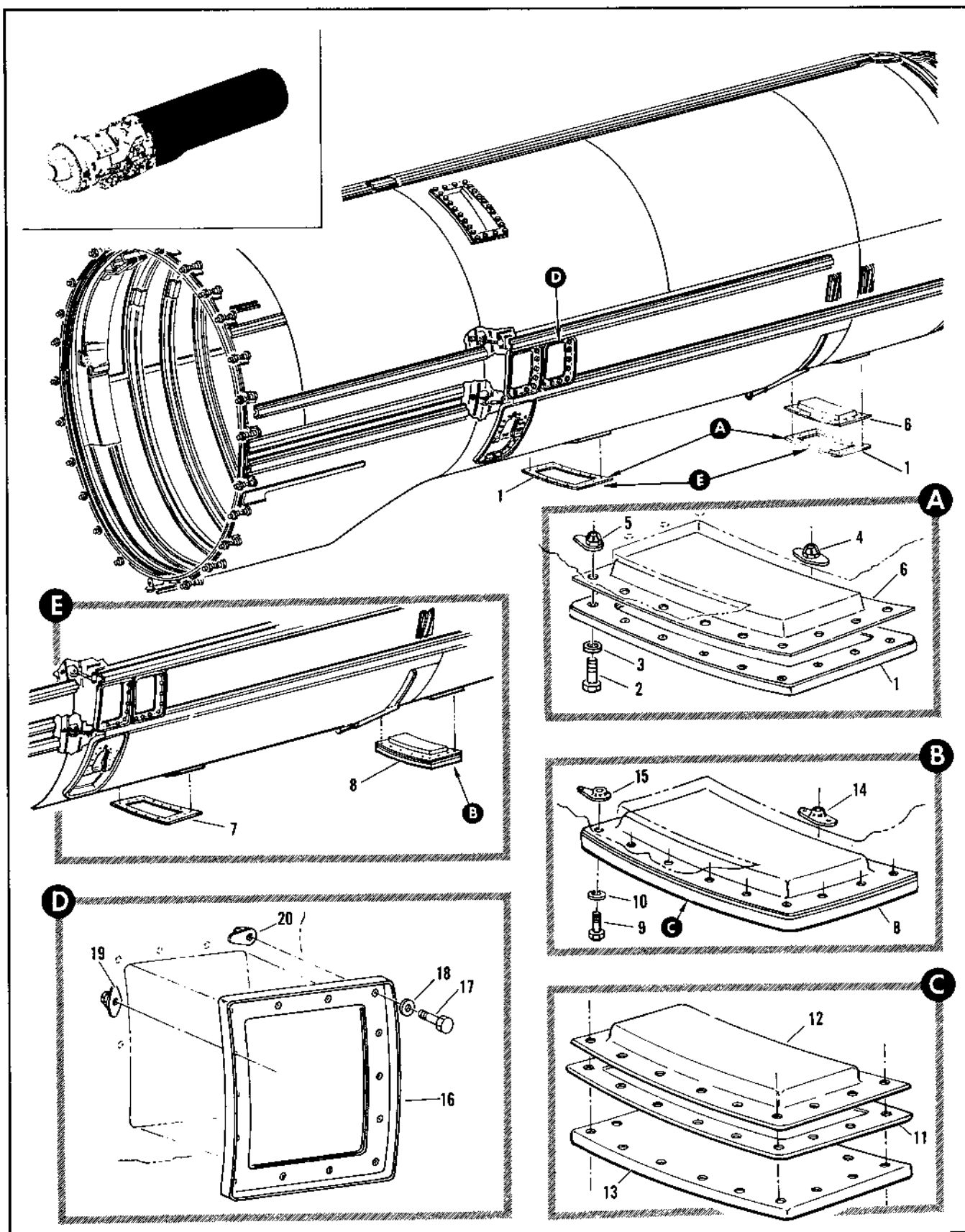

Figure 2.10-12. Engine Air Cooling Shroud Installation (Sheet 1 of 4)

FIGURE AND INDEX NUMBER	PART NUMBER	DESCRIPTION	UNITS PER ASSY.	USABLE ON CODE	
				FROM	TO
		1 2 3 4 5 8			
2.10-12	8-22679-803	SHROUD INSTALLATION, ENGINE AIR COOLING MODIFIED BY R-21902 FOR NHA SEE FIG. 2.10-7	RF	G	
	8-22679-805	SHROUD INSTALLATION, ENGINE AIR COOLING FOR NHA SEE FIG. 2.10-7	RF	C	
	8-22679-811	SHROUD INSTALLATION, ENGINE AIR COOLING FOR NHA SEE FIG. 2.10-7	RF	D	
	8-22679-809	SHROUD INSTALLATION, ENGINE AIR COOLING FOR NHA SEE FIG. 2.10-7	RF	189	
	8-22679-3	SHROUD INSTALLATION, ENGINE AIR COOLING MODIFIED BY R-26030 AND R-21902 FOR NHA SEE FIG. 2.10-7	RF	F	
	8-22679-5	SHROUD INSTALLATION, ENGINE AIR COOLING MODIFIED BY R-26030 AND R-21902 FOR NHA SEE FIG. 2.10-7	RF	H	
	8-22679-801	SHROUD INSTALLATION, ENGINE AIR COOLING MODIFIED BY R-26030 AND R-21902 FOR NHA SEE FIG. 2.10-7	RF	J	
- 1	8-22659	• DOOR ASSY, ENGINE ACCESS WELDED REPLACED BY NOT INTCHG WITH R-22659-3 AND R-22659-5	2	A	
	8-22659-1	• DOOR ASSY, ENGINE ACCESS WELDED ALT INTCHG WITH R-22659 ATTACHING PARTS	RF	A	
- 2	AN106410	• BOLT	32	A	
- 3	AN960C10L	• WASHER	32	A	
		-----X-----			
- 4	MS21048L3	• NUTPLATE, <72962> 96-37527-001	24	A	
- 5	MS21052-3	• NUTPLATE, <72962> 96-37528-001	8	A	
- 6	18-21958-69	• BLANKET ASSY, ENGINE SHROUD INSULATION <78741> SPEC R-00541-69	1	A	
- 7	8-22659-3	• DOOR ASSY, ENGINE ACCESS FWD REPLACES NOT INTCHG WITH R-22659	1	B	
- 8	8-22659-5	• DOOR ASSY, ENGINE ACCESS AFT REPLACES NOT INTCHG WITH R-22659 ATTACHING PARTS	1	B	
- 9	AN106410	• BOLT	32	B	
- 10	AN960C10L	• WASHER	32	B	
		-----X-----			
- 11	8-22659-13	• SEAL	1	B	
- 12	18-21958-69	• BLANKET ASSY, AFT ENGINE SHROUD INSULATION <78741> SPEC R-00541-69	1	B	
- 13	8-22659	• DOOR ASSY, WELDED	1	B	
- 14	MS21048L3	• NUTPLATE, <72962> 96-37527-001	24	B	
- 15	MS21052-3	• NUTPLATE, <72962> 96-37528-001	8	B	
- 16	8-22620-1	• DOOR ASSY, DRAG FITTING SHROUD ACCESS STA 605 WELDED ATTACHING PARTS	2	35	
- 17	AN106410	• BOLT	28	35	
- 18	AN960C10L	• WASHER	28	35	
		-----X-----			
- 19	MS21048L3	• NUTPLATE, <72962> 96-37527-001	20	35	
- 20	MS21052-3	• NUTPLATE, <72962> 96-37528-001	8	35	

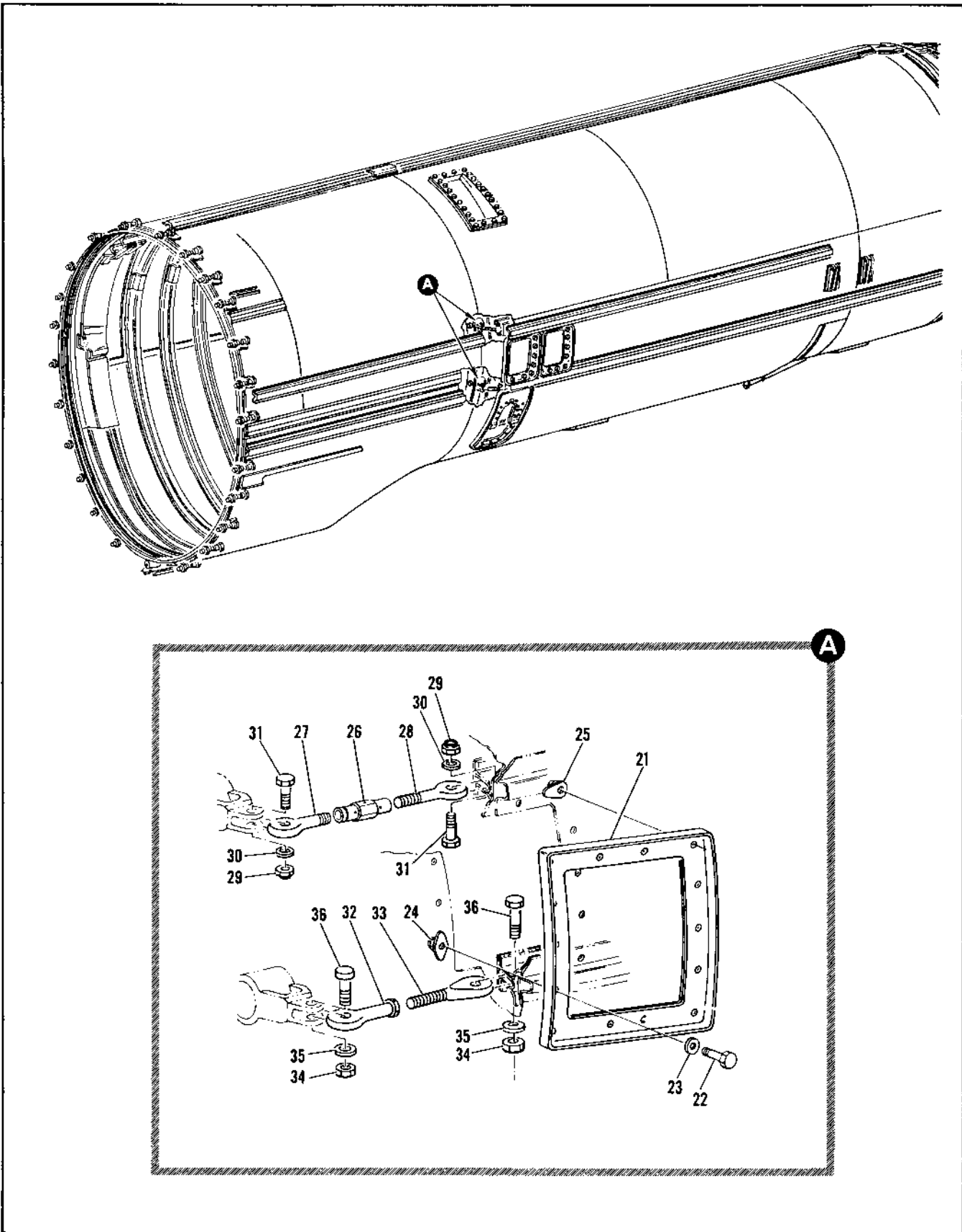

Figure 2.10-12. Engine Air Cooling Shroud Installation (Sheet 2 of 4)

FIGURE AND INDEX NUMBER	PART NUMBER	DESCRIPTION	UNITS PER ASSY.	USABLE ON CODE	
				FROM	TO
		1 2 3 4 5 6			
2.10-12- 21	8-22660-1	• DOOR ASSY, DRAG FITTING SHROUD ACCESS STA 612 WELDED REPLACED BY NOT INTCHG WITH 8-22660-3	2	A	
	8-22660-3	• DOOR ASSY, DRAG FITTING SHROUD ACCESS STA 612 WELDED REPLACES NOT INTCHG WITH 8-22660-1 ATTACHING PARTS	2	B	
- 22	AN106410	• BOLT	28	35	
- 23	AN960C10L	• WASHER -----X-----	28	35	
- 24	MS21048L3	• NUTPLATE, <72962> 96-37527-001	14	35	
- 25	MS21052-3	• NUTPLATE, <72962> 96-37528-001	14	35	
- 26	8-22672	• NUT, SLEEVE	2	35	
- 27	8-22671-7	• EYEBOLT, ENGINE COOLING SHROUD	2	35	
- 28	8-22671	• EYEBOLT, ENGINE COOLING SHROUD ATTACHING PARTS	2	35	
- 29	MS20500-42A	• NUT	4	35	
- 30	AN960C416	• WASHER	4	35	
- 31	12A428-4H	• BOLT, <B2831> 90-82016-001 -----X-----	4	35	
- 32	BRE5630	• BEARING, <B1376> 90-60008-001	2	35	
- 33	BRE5635	• BEARING, <B1376> 90-60007-001 ATTACHING PARTS	2	35	
- 34	MS20500-52A	• NUT	4	35	
- 35	AN960C516	• WASHER	4	35	
- 36	12A524-5	• BOLT, <B2831> 90-83016-002 -----X-----	4	35	
		A AIRPLANES #35 THRU 51 AND 54 B AIRPLANES #52, 53, 55 AND ON C AIRPLANES #44 THRU 51 AND 54 D AIRPLANES #52, 53, AND 55 THRU 180 E AIRPLANES #279 THRU 281 AND 286 F AIRPLANES #35 THRU 43, 304 AND ON G AIRPLANES #278, 282, 284, 285, AND 288 THRU 300 J AIRPLANES #283, 287, AND 301 THRU 303			

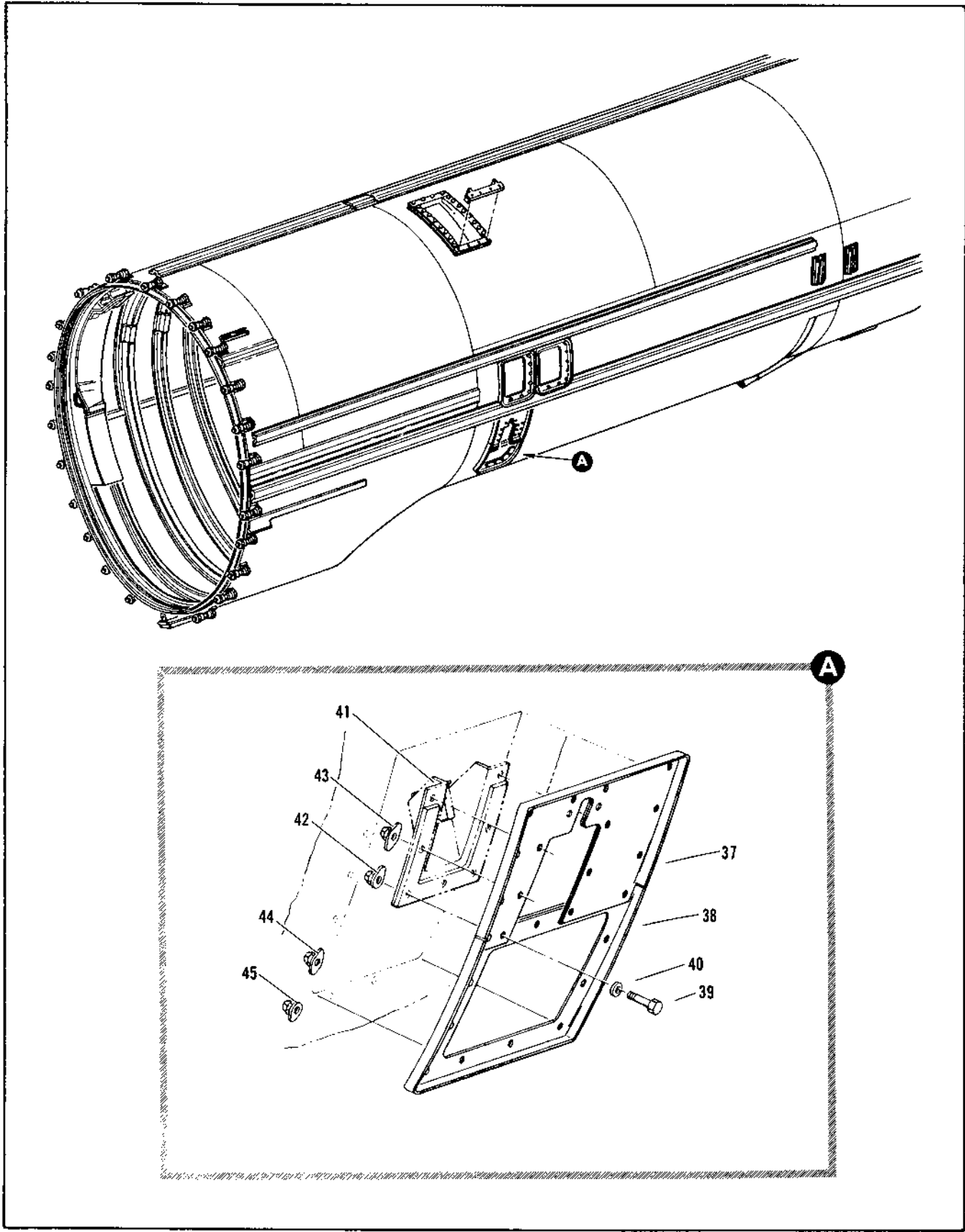

Figure 2.10-12. Engine Air Cooling Shroud Installation (Sheet 3 of 4)

FIGURE AND INDEX NUMBER	PART NUMBER	DESCRIPTION	UNITS PER ASSY.	USABLE ON CODE	
				FROM	TO
		1 2 3 4 5 6			
2.10-12- 37	8-22661-5	• DOOR ASSY, ROLLER BRACKET ACCESS UPPER LH WELDED	1	35	
	8-22661-6	• DOOR ASSY, ROLLER BRACKET ACCESS UPPER RH WELDED	1	35	
- 3R	8-22621-3	• DOOR ASSY, ROLLER BRACKET ACCESS LOWER LH WELDED	1	35	
	8-22621-4	• DOOR ASSY, ROLLER BRACKET ACCESS LOWER RH WELDED	1	35	
		ATTACHING PARTS			
- 39	AN166410	• BOLT	6.0	35	
- 40	AN960010L	• WASHER	6.0	35	
		-----X-----			
- 41		• SEAL ASSY, ENGINE COOLING SHROUD SEE FIG. 2.10-39 INDEX 19	RF		
- 42	ZA21-1200-02BC	• NUTPLATE, <72962> 96-37526-001	6	35	
- 43	ZA217-1200-02BC	• NUTPLATE, <72962> 96-37529-001	8	35	
- 44	MS21048L3	• NUTPLATE, <72962> 96-37527-001	32	35	
- 45	MS21052-3	• NUTPLATE, <72962> 96-37528-001	10	35	

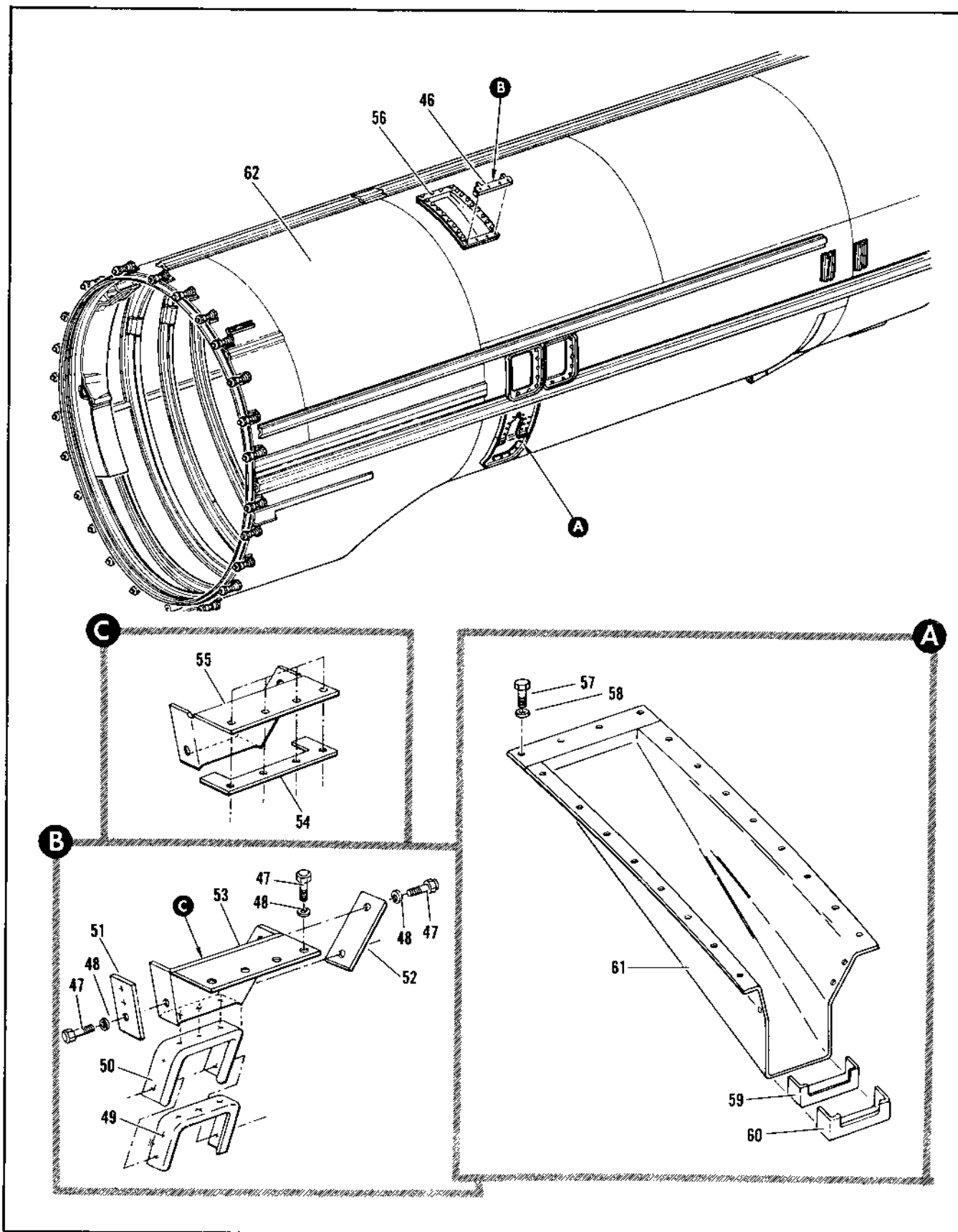

Figure 2.10-12. Engine Air Cooling Shroud Installation (Sheet 4 of 4)

FIGURE AND INDEX NUMBER	PART NUMBER	DESCRIPTION	UNITS PER ASSY.	USABLE ON CODE	
				FROM	TO
		1 2 3 4 5 6			
2.10-12- 46	8-22663-E01 8-22663-E02	• SEAL ASSY, ENGINE MOUNT AFT LH • SEAL ASSY, ENGINE MOUNT AFT RH ATTACHING PARTS	1 1	35 35	
- 47	AN106410	• BOLT	14	35	
- 48	AN960C10L	• WASHER -----X-----	14	35	
- 49	8-22663-39	• • RETAINER	1	35	
- 50	8-22663-21	• • SEAL	1	35	
- 51	8-22663-23	• • SEAL	1	35	
- 52	8-22663-25	• • SEAL	1	35	
- 53	8-22663-41	• • SEAL	1	8	
- 54	8-22663-37	• • SUPPORT ASSY, LH WELDED	1	35	
	8-22663-38	• • SUPPORT ASSY, RH WELDED	1	35	
- 55	8-22662-3	• PAN ASSY, ENGINE MOUNT AFT LH	1	35	
	8-22662-4	• PAN ASSY, ENGINE MOUNT AFT RH ATTACHING PARTS	1	35	
- 56	AN106410	• BOLT	40	35	
- 57	AN960C10L	• WASHER -----X-----	40	35	
- 58	8-22662-15	• • RETAINER	1	35	
- 59	8-22662-17	• • SEAL	1	35	
- 63	8-22662-7	• • PAN ASSY, LH WELDED	1	35	
	8-22662-8	• • PAN ASSY, RH WELDED	1	35	
- 61	8-22654-803	• SHROUD ASSY, ENGINE COOLING FOR BREAKDOWN SEE FIG. 2.10-13	1	E	
	8-22654-809	• SHROUD ASSY, ENGINE COOLING FOR BREAKDOWN SEE FIG. 2.10-13	1	35	277
	8-22654-5	• SHROUD ASSY, ENGINE COOLING FOR BREAKDOWN SEE FIG. 2.10-13	1	F	
	8-22654-R01	• SHROUD ASSY, ENGINE COOLING FOR BREAKDOWN SEE FIG. 2.10-13	1	H	
		E AIRPLANES #35 THRU #3, 283, 287, 301 AND ON			
		F AIRPLANES #279 THRU 281 AND 286			
		H AIRPLANES #278, 282, 284, 285, AND 288 THRU 300			

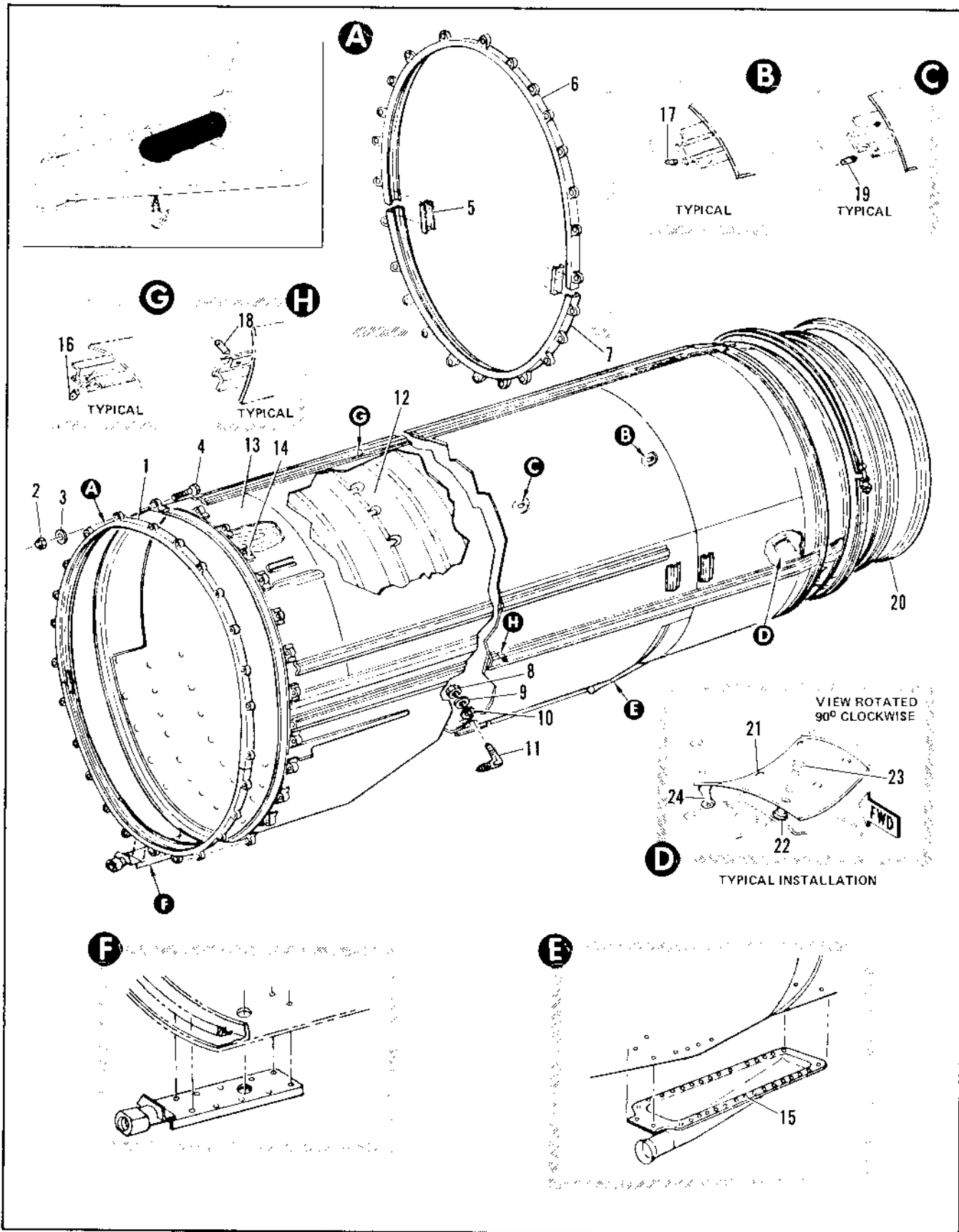

Figure 2.10-13. Engine Cooling Shroud Assembly (Sheet 1 of 2)

FIGURE AND INDEX NUMBER	PART NUMBER	DESCRIPTION	UNITS PER ASSY.	USABLE ON CODE	
				FROM	TO
		1 2 3 4 5 6			
2.10-13	8-22654-803	SHROUD ASSEMBLY, ENGINE COOLING MODIFIED BY 8-26030 AND 8-21902 REPLACES SUITABLE SUB FOR 8-22654-801 FOR NHA SEE FIG. 2.10-12	RF	A	
	8-22654-809	SHROUD ASSEMBLY, ENGINE COOLING FOR NHA SEE FIG. 2.10-12	RF	35	
	8-22654-5	SHROUD ASSEMBLY, ENGINE COOLING MODIFIED BY 8-26030 AND 8-21902 REPLACES SUITABLE SUB FOR 8-22654-801 FOR NHA SEE FIG. 2.10-12	RF	D	
	8-22654-801	SHROUD ASSEMBLY, ENGINE COOLING MODIFIED BY 8-26030 AND 8-21902 REPLACES SUITABLE SUB FOR 8-22654-5 REPLACES SUITABLE SUB 8-22654-803 FOR NHA SEE FIG. 2.10-12	RF	E	
- 1	8-22666-1	• RETAINER ASSY, SEAL FWD SHROUD ATTACHING PARTS	1	35	
- 2	NAS679C4	• NUT	25	35	
- 3	AN9610416L	• WASHER	25	35	
- 4	8-22673	• BOLT	25	35	
		----X----			
- 5	8-22666-15	• • SPLICE	2	35	
- 6	8-22666-19	• • RETAINER ASSY, WELDED REPLACES	1	35	
- 7	8-22666-21	• • RETAINER ASSY, WELDED REPLACES	1	35	
- 8	AN924-6C	• NUT	1	35	
- 9	AN9600916L	• WASHER	1	35	
- 10	AN9600916	• WASHER	1	35	
- 11	MS21908-6C	• ELBOW	1	35	
- 12	8-22655-801	• BLANKET INSTL, ENGINE SHROUD FOR BREAKDOWN SEE FIG. 2.10-14	1	35	
- 13	8-22654-467	• SHROUD ASSY,	1	35	
	8-22654-15	• SHROUD ASSEMBLY	1	D	
	8-22654-379	• SHROUD ASSEMBLY	1	E	
- 14	8-22664	• • BRACKET ASSY, RETAINER FWD ENGINE SHROUD RIVETED	25	35	
	8-22668	• • TROUGH INSTL, SHROUD DRAIN	1	35	
- 15	8-22668-7	• • • TROUGH ASSY, WELDED	1	35	
- 16	8-22665	• • STUD, 5/16 PLANKET ATTACHMENT	AR	35	
- 17	8-22640-25	• • STUD, BLANKET ATTACHMENT	44	35	
- 18	8-22640-27	• • STUD, BLANKET ATTACHMENT	AR	35	
- 19	8-22640-17	• • STUD, PLANKET ATTACHMENT	24	35	
- 20	8-26610	• • EJECTOR ASSY, ENGINE SHROUD WELDED	1	H	
	8-26610-3	• • EJECTOR ASSY, ENGINE SHROUD WELDED	1	K	
- 21	8-26054-7	• • • INSERT, ENGINE SHROUD EJECTOR THROAT	35	188	
- 22	8-26055-7	• • • SPOOL, ENGINE SHROUD EJECTOR INSERT AFT	35	188	
- 23	AN-123529	• • • RIVET	36	189	
	NAS56C-HK310	• • • SCREW, ALT INTCHG WITH AN-123529	36	189	
	MS20500-1032	• • • NUT, USE WITH NAS56C-HK310	36	189	
- 24	8-26056-7	• • • SPOOL, ENGINE SHROUD EJECTOR INSERT FWD	35	188	
	8-22698	• • TROUGH INSTL, FWD ENGINE SHROUD	1	35	
		1 REMOVED FROM AIRPLANES #35 THRU 43 FOR AIRPLANES #283, 287, 301 AND ON ORDER 8-22654-809			
		5 REMOVED FROM AIRPLANES #35 THRU 188			

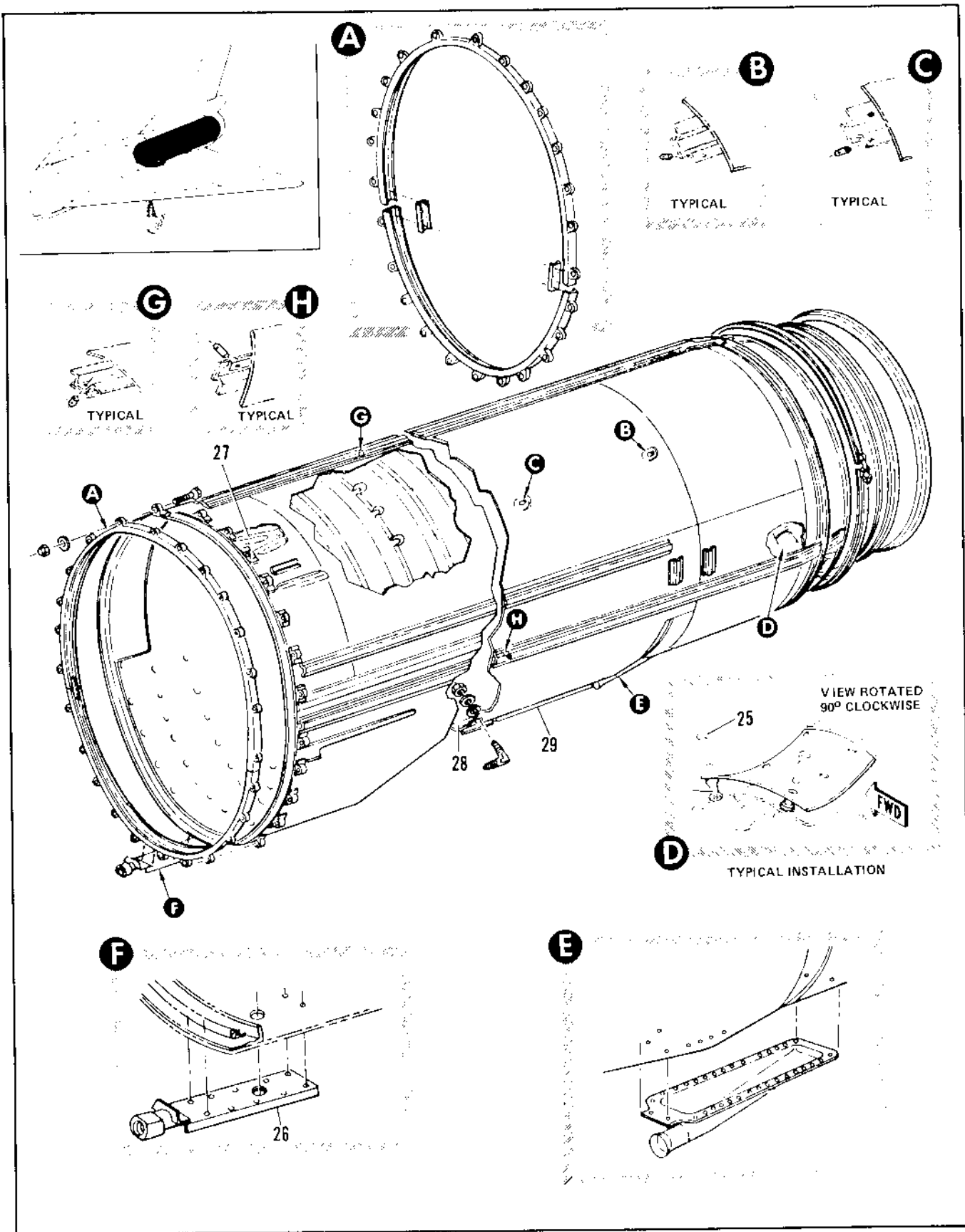

Figure 2.10-13. Engine Cooling Shroud Assembly (Sheet 2 of 2)

FIGURE AND INDEX NUMBER	PART NUMBER	DESCRIPTION	UNITS PER ASSY.	USABLE ON CODE	
				FROM	TO
		1 2 3 4 5 6			
2.10-13- 25	AN-123526	. . . RIVET	36	189	
	NAS560-HK315	. . . SCREW, ALT INTCHG WITH AN-123526	36	189	
- 26	MS22500-1032	. . . NUT, USE WITH NAS560-HK315	36	189	
- 27	8-22698-15	. . . TROUGH ASSY, WELDED	1	35	
	8-26600-1	. . DEFLECTOR ASSY, ENGINE COOLING SHROUD LH WELDED	1	35	
	8-26600-2	. . DEFLECTOR ASSY, ENGINE COOLING SHROUD RH WELDED	1	35	
- 28	8-22654-431	. . SHROUD ASSY, WELDED	1	J	
- 29	8-22654-419	. . . LONGERON	4	J	
	8-22654-439	. . . LONGERON	1	J	
		A AIRPLANES #35 THRU 43, 283, 287, 301 AND ON			
		D AIRPLANES #279 THRU 281 AND 286			
		E AIRPLANES #276, 282, 284, 285, AND 288 THRU 300			
		H AIRPLANES #35 THRU 188, 283, 287, 301 AND ON			
		J AIRPLANES #35 THRU 277, 283, 287, 301 AND ON			
		K AIRPLANES #35 THRU 282, 284 THRU 286, 288 THRU 300			

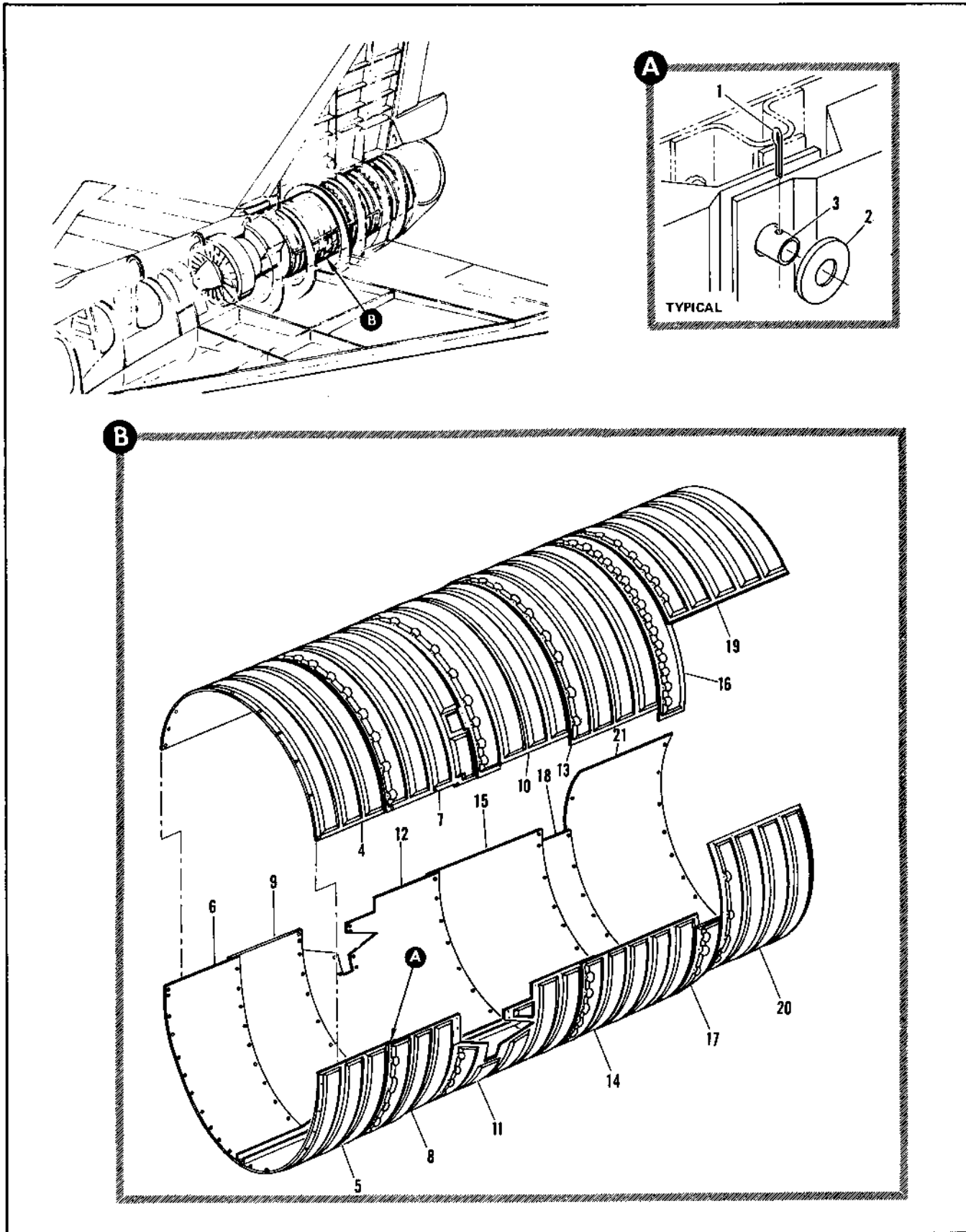

Figure 2.10-14. Engine Shroud Blanket Installation

FIGURE AND INDEX NUMBER	PART NUMBER	DESCRIPTION	UNITS PER ASSY.	USABLE ON CODE	
				FROM	TO
2.10-14	8-22655-801	BLANKET INSTALLATION, ENGINE SHROUD FOR NHA SEE FIG. 2.10-13	RF	35	
- 1	AN381-2-12	• PIN, COTTER	AR	35	
- 2	8-22644	• WASHER	AR	35	
	8-22644-7	• WASHER, ENGINE SHROUD COOLING BLANKET	AR	35	
	AN427M3	• RIVET	AR	35	
- 3	8-22640-27	• STUD, BLANKET ATTACH	AR	35	
	8-22640-25	• STUD, BLANKET ATTACH	AR	35	
	8-22640-23	• STUD, BLANKET ATTACH	AR	35	
- 4	18-21958-79	• BLANKET ASSY, ENGINE SHROUD UPPER <78741> SPEC 8-00541-79	1	35	
- 5	18-21958-81	• BLANKET ASSY, ENGINE SHROUD LOWER LH <78741> SPEC 8-00541-81	1	35	
- 6	18-21958-82	• BLANKET ASSY, ENGINE SHROUD LOWER RH <78741> SPEC 8-00541-82	1	35	
- 7	18-21958-47	• BLANKET ASSY, ENGINE SHROUD UPPER <78741> SPEC 8-00541-47	1	35	
- 8	18-21958-95	• BLANKET ASSY, ENGINE SHROUD LOWER LH <78741> SPEC 8-00541-95	1	35	
- 9	18-21958-96	• BLANKET ASSY, ENGINE SHROUD LOWER RH <78741> SPEC 8-00541-96	1	35	
- 10	18-21958-61	• BLANKET ASSY, ENGINE SHROUD UPPER <78741> SPEC 8-00541-61	1	35	
- 11	18-21958-83	• BLANKET ASSY, ENGINE SHROUD LOWER LH <78741> SPEC 8-00541-83	1	35	
- 12	18-21958-84	• BLANKET ASSY, ENGINE SHROUD LOWER RH <78741> SPEC 8-00541-84	1	35	
- 13	18-21958-91	• BLANKET ASSY, ENGINE SHROUD UPPER <78741> SPEC 8-00541-91	1	35	
- 14	18-21958-89	• BLANKET ASSY, ENGINE SHROUD LOWER LH <78741> SPEC 8-00541-89	1	35	
- 15	18-21958-93	• BLANKET ASSY, ENGINE SHROUD LOWER RH <78741> SPEC 8-00541-93	1	35	
- 16	18-21958-85	• BLANKET ASSY, ENGINE SHROUD UPPER <78741> SPEC 8-00541-85	1	35	
- 17	18-21958-87	• BLANKET ASSY, ENGINE SHROUD LOWER LH <78741> SPEC 8-00541-87	1	35	
- 18	18-21958-88	• BLANKET ASSY, ENGINE SHROUD LOWER RH <78741> SPEC 8-00541-88	1	35	
- 19	18-21958-63	• BLANKET ASSY, ENGINE SHROUD UPPER <78741> SPEC 8-00541-63	1	35	
- 20	18-21958-93	• BLANKET ASSY, ENGINE SHROUD LOWER LH <78741> SPEC 8-00541-93	1	35	
- 21	18-21958-94	• BLANKET ASSY, ENGINE SHROUD LOWER RH <78741> SPEC 8-00541-94	1	35	

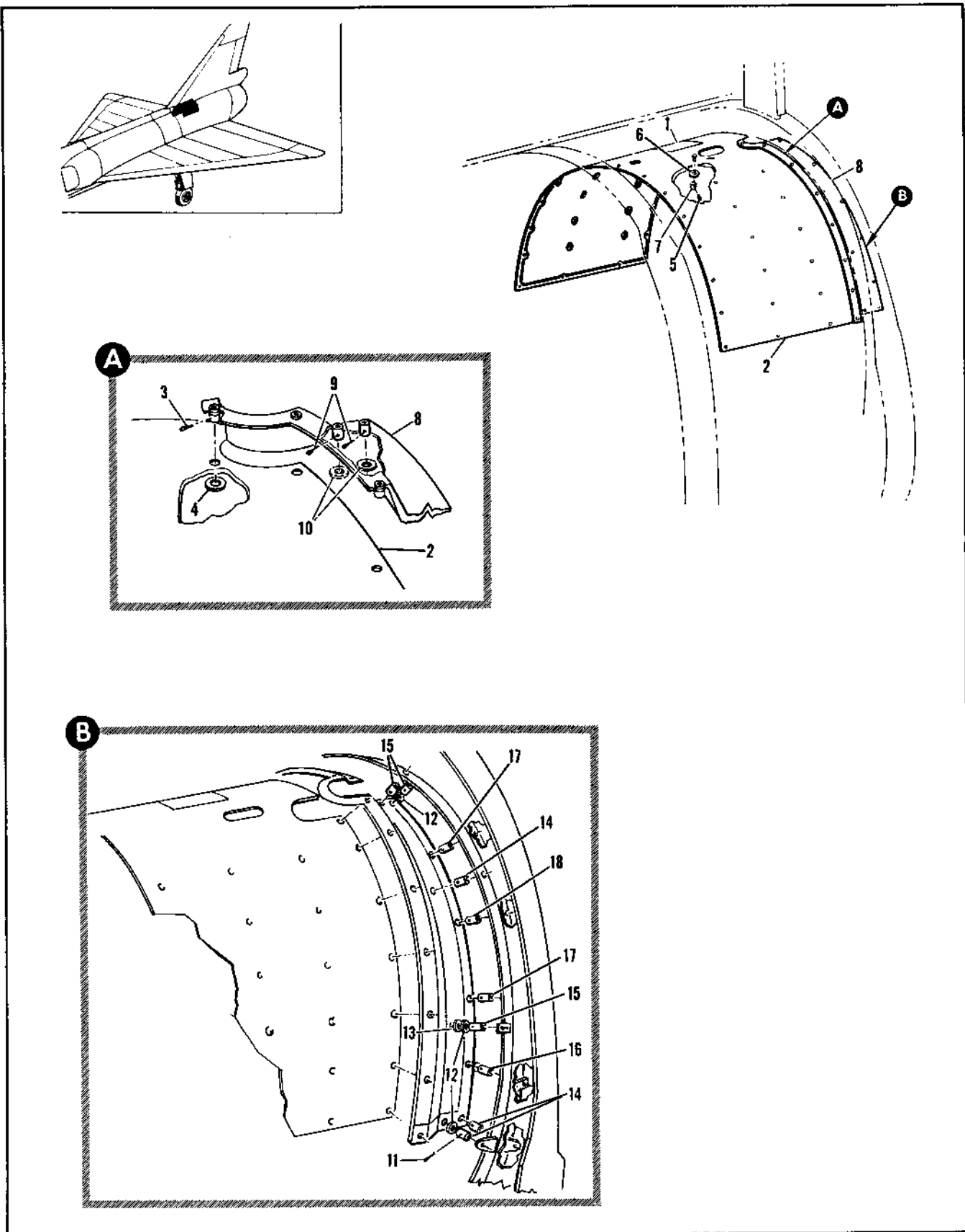

Figure 2.10-15. Fuselage Overheat Insulation Blanket Installation Sta 530 to 556

FIGURE AND INDEX NUMBER	PART NUMBER	DESCRIPTION	UNITS PER ASSY.	USABLE ON CODE	
				FROM	TO
		1 2 3 4 5 6			
2.10-15	8-22096	BLANKET INSTALLATION, FUSELAGE OVERHEAT INSULATION STA 530 TO 556 FOR NHA SEE FIG. 2.3-15 INDEX 25	PF	35	
- 1	18-22074-9	• BLANKET, FUSELAGE OVERHEAT INSULATION DOOR RH <78741> SPEC 8-00424-9	1	35	
- 2	18-22074-7	• BLANKET, FUSELAGE OVERHEAT INSULATION <78741> SPEC 8-00424-7	1	35	
		ATTACHING PARTS			
- 3	MS24665-153	• PIN, COTTER	15	35	
- 4	8-22644-9	• WASHER	15	35	
- 5	MS24665-153	• PIN, COTTER	42	35	
- 6	8-22644	• WASHER	42	35	
- 7	8-22640-19	• STUD, 1/4 BLANKET ATTACHING	42	35	
		----X----			
- 8	18-22074-11	• BLANKET, FUSELAGE OVERHEAT INSULATION LH <78741> SPEC 8-00424-11	1	35	
	18-22074-12	• BLANKET, FUSELAGE OVERHEAT INSULATION RH <78741> SPEC 8-00424-12	1	35	
		ATTACHING PARTS			
- 9	MS24665-153	• PIN, COTTER	2	35	
- 10	8-22644-9	• WASHER	2	35	
- 11	MS24665-153	• PIN, COTTER	20	35	
- 12	8-22644	• WASHER	20	35	
- 13	8-22644	• WASHER	2	48	
- 14	8-22640-19	• STUD, 1/4 BLANKET ATTACHING	6	35	
- 15	8-22640-29	• STUD, 1/4 BLANKET ATTACHING	6	35	
- 16	8-22640-11	• STUD, 1/4 BLANKET ATTACHING	2	35	
- 17	8-22640-31	• STUD, 1/4 BLANKET ATTACHING	4	35	
- 18	8-22640-31	• STUD, 1/4 BLANKET ATTACHING LH	1	35	
	8-22640-31	• STUD, 1/4 BLANKET ATTACHING RH	1	35	
		----X----			

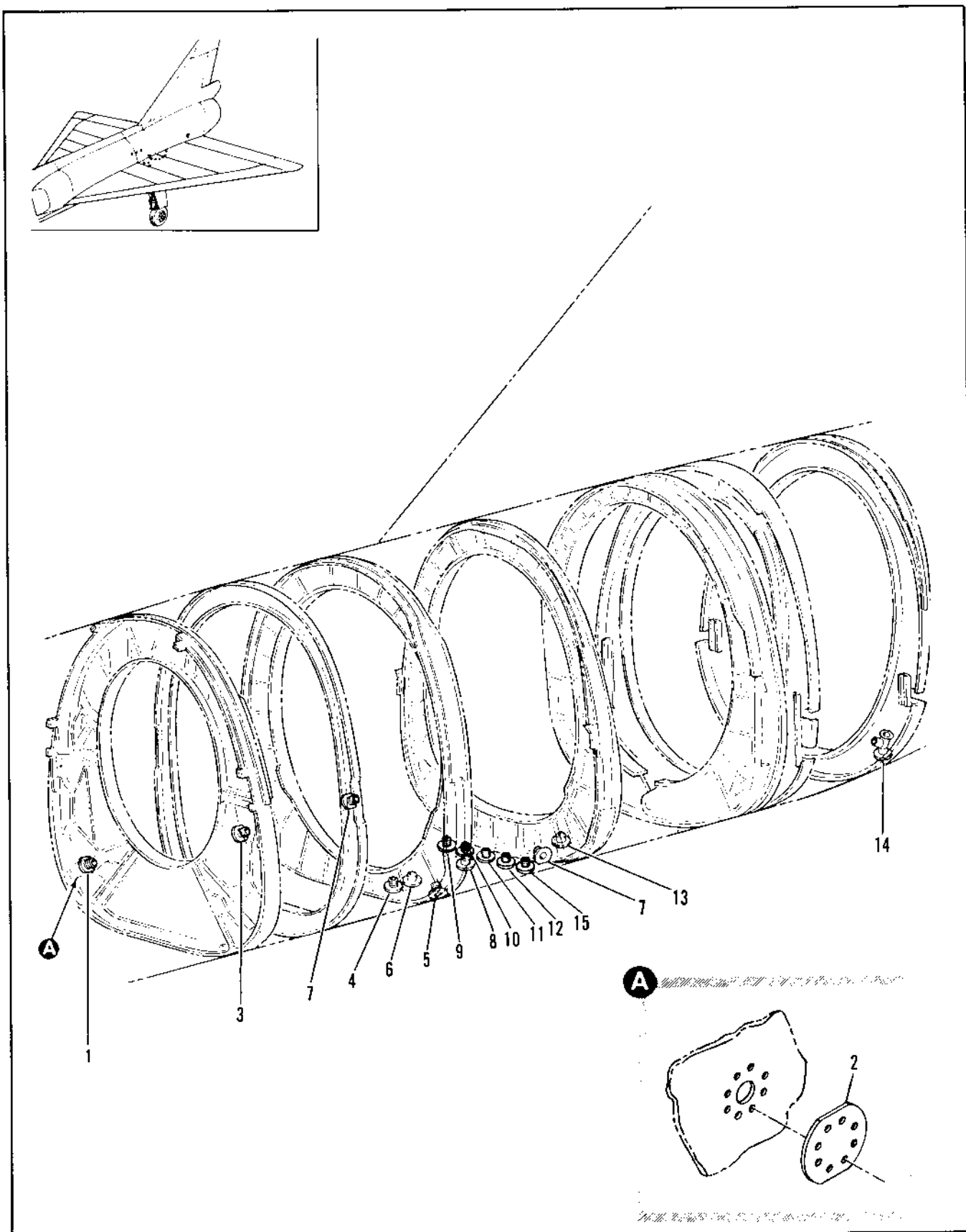

Figure 2.10-16. Fuel and Oil Vent and Drain Fitting Installation

FIGURE AND INDEX NUMBER	PART NUMBER	DESCRIPTION	UNITS PER ASSY.	USABLE ON CODE	
				FROM	TO
2.10-16	8-27768-3	FITTING INSTALLATION, FUEL AND OIL VENT AND DRAIN MODIFIED BY P-28516 8-21918 8-21920 AND 8-21910 FOR NHA SEE FIG. 2.3-14	RF	35	
- 1	8-28954-9	• ADAPTER, CONSTANT SPEED DRIVE GEARBOX VENT STA 476	1	278	296
	8-28951-13	• ADAPTER, CONSTANT SPEED DRIVE GEARBOX VENT STA 476 ALT INTCHG WITH 8-28954-9	RF	278	296
	7239289-10	• PATCH INSTL, ADAPTER OVERBOARD DRAIN HOLE	1	278	296
- 2	7239289-01	• PATCH	1	278	296
- 3	8-28954-7	• ADAPTER, CONSTANT SPEED DRIVE GENERATOR VENT STA 514	1	35	
- 4	8-26005-11	• ADAPTER, STARTER SEAL DRAIN STA 524	1	44	
- 5	8-26005-9	• ADAPTER, OIL SCUPPER DRAIN STA 525	1	35	
- 6	8-28254	• ADAPTER, TRANSFER TANK REGULATOR CROSSOVER TUBE DRAIN STA 527	1	35	
- 7	8-28954-9	• ADAPTER, TRANSFER TANK AIR PRESSURE REGULATOR BLEED DRAIN STA 542	2	278	296
	8-28951-13	• ADAPTER, TRANSFER TANK AIR PRESSURE REGULATOR BLEED DRAIN ALT INTCHG WITH 8-28954-9	RF	278	296
- 8	8-28254	• ADAPTER, ENGINE FUEL SUPPLY TUBE DRAIN STA 549	1	35	
- 9	8-26005-13	• ADAPTER, AFTERBURNER FUEL MANIFOLD DRAIN STA 551 BL 4.25	1	35	
- 10	8-26005-11	• ADAPTER, ENGINE FUEL CONTROL DRAIN STA 551 BL 6.50	1	35	
- 11	8-26005-9	• ADAPTER, FWD SHROUD DRAIN STA 551 BL 10.25	1	35	
- 12	8-28337	• ADAPTER, COMBUSTION MANIFOLD DRAIN STA 551 BL 14	1	35	
- 13	8-28254	• ADAPTER, TRANSFER TANK CROSSOVER DRAIN STA 562	1	35	
- 14	8-27637-13	• DRAIN ASSY, AFT SHROUD AND AFTERBURNER DUCT DRAIN STA 646 WELDED	1	35	
- 15	8-27457-19	• ADAPTER, EXHAUST NOZZLE CONTROL SEAL DRAIN	1	35	

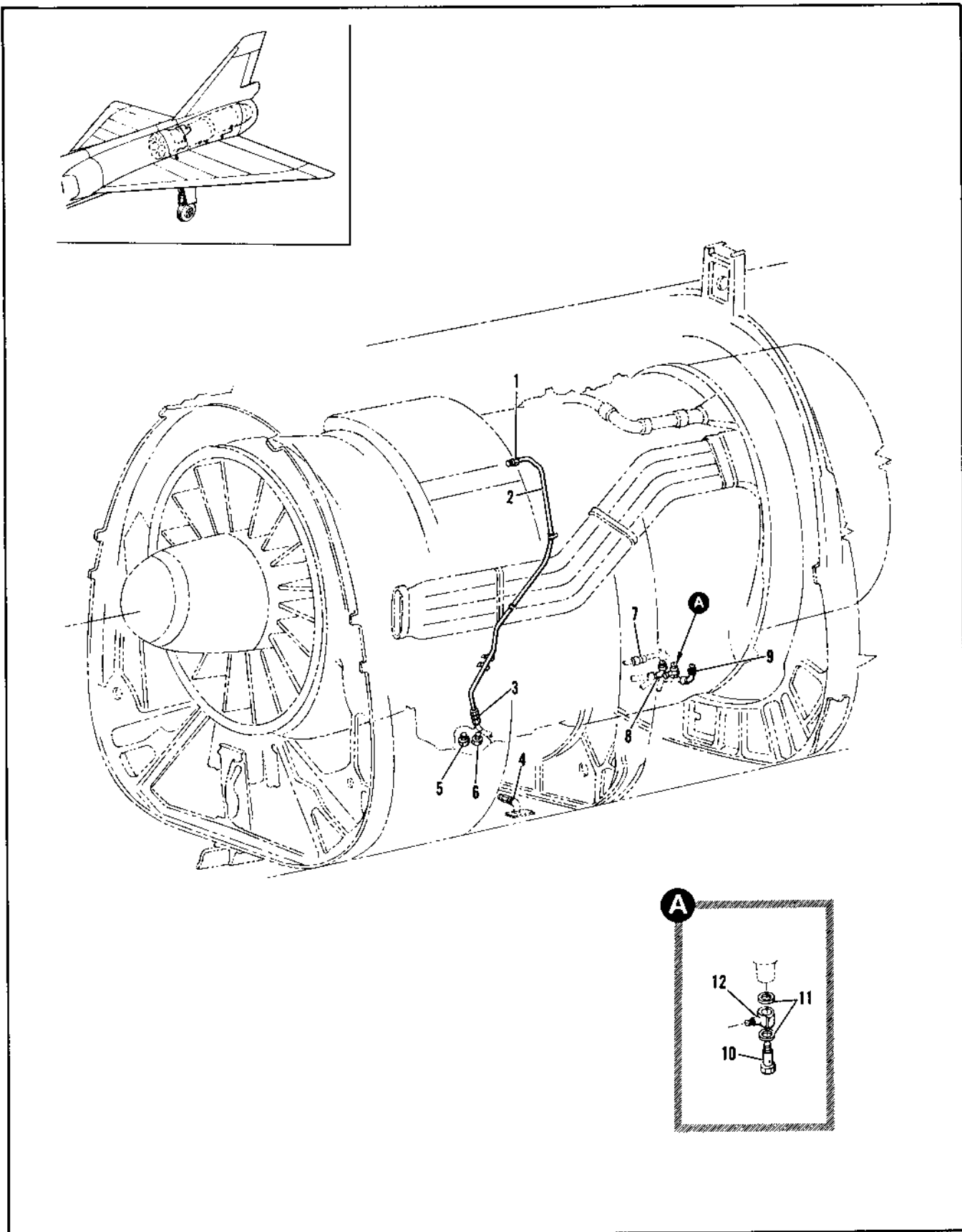

Figure 2.10-17. Power Plant Vent and Drain Tubing Assembly Spares

FIGURE AND INDEX NUMBER	PART NUMBER	DESCRIPTION	UNITS PER ASSY.	USABLE ON CODE	
				FROM	TO
2.10-17	8-20393-3	TUBING ASSEMBLY, POWER PLANT VENT AND DRAIN SPARES	PF	35	
- 1	MS21916-H-6	• REDUCER	1	35	
	MS29512-8	• GASKET	1	35	
- 2	8-20393-9	• TUBE ASSEMBLY	1	35	
- 3	MS21916-E-6	• REDUCER	1	35	
- 4	MS21916D6-4	• REDUCER	1	35	
	AN924-4	• NUT	2	35	
- 5	AN814-4D	• PLUG	2	35	
- 6	AN814-6D	• PLUG	2	35	
	MS21916D6-4	• REDUCER	2	35	
	MS29512-6	• GASKET	2	35	
- 7	MS21502-2	• UNION	1	35	
	MS29512-8	• GASKET	1	35	
- 8	MS21907-8	• ELBOW	1	A	
	AN924-8	• NUT	1	A	
	MS29512-8	• GASKET	1	A	
- 9	MS21908-4	• ELBOW	1	35	
	AN924-4	• NUT	1	35	
	MS21512-4	• GASKET	1	35	
- 10	AN775-12	• BOLT	1	35	
- 11	AN901-12C	• WASHER	2	35	
- 12	ER776-12	• ELBOW, UNIVERSAL <79470> 93-40013-003	1	35	
	91-98026-005	• CLAMP	3	35	43
	JP0025SH06	• CLAMP, <00986> 91-98037-004	4	44	
	JP0025SH08	• CLAMP, <00986> 91-98037-006	1	44	
	JP0025SH16	• CLAMP, <00986> 91-98037-014	2	44	
		USAGE GOVERNED BY SEARBOX			
		A AIRPLANES #35 THRU 208 AND 210			

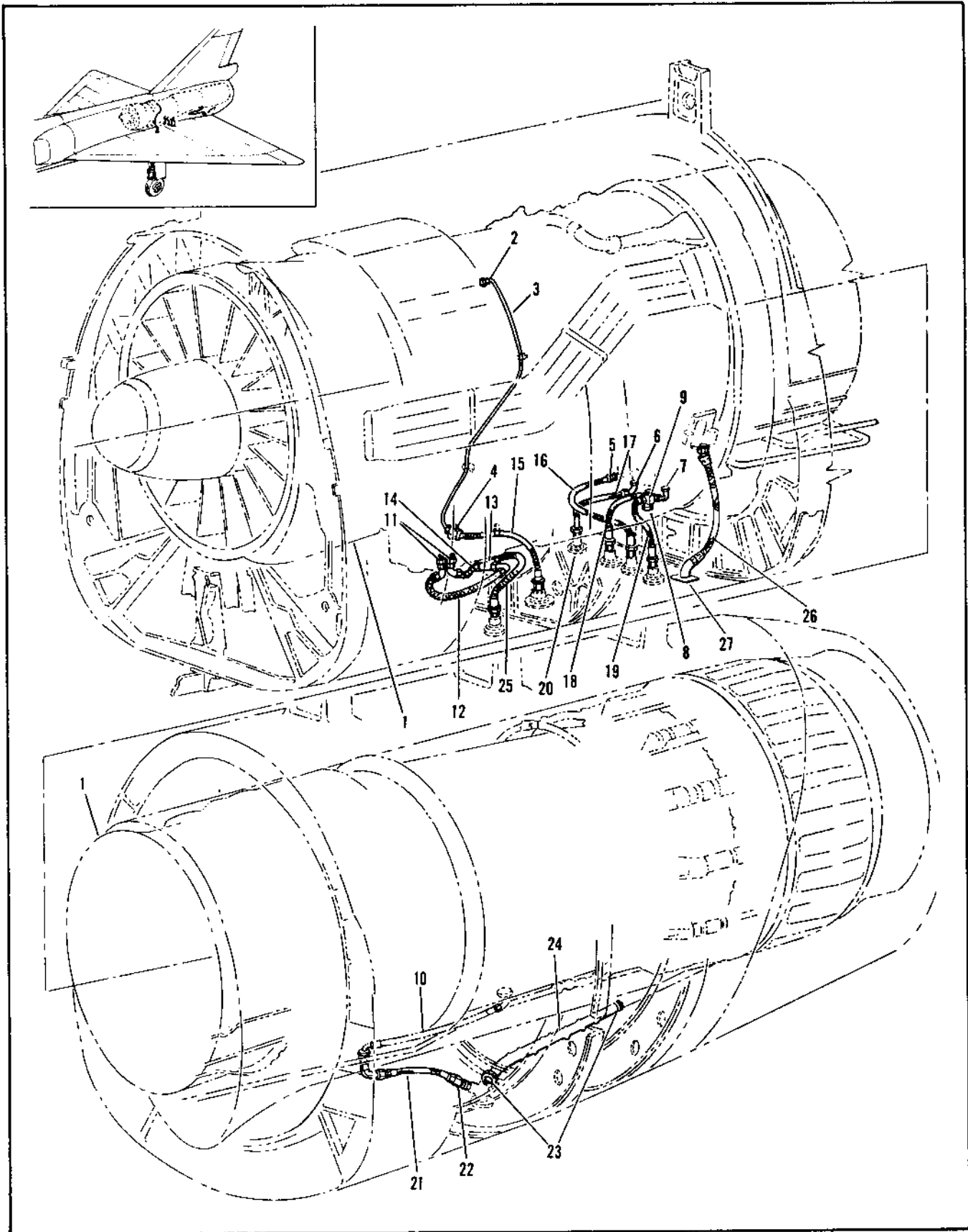

Figure 2.10-18. Power Plant Vent and Drain Tubing

FIGURE AND INDEX NUMBER	PART NUMBER	DESCRIPTION	UNITS PER ASSY.	USABLE ON CODE	
				FROM	TO
		1 2 3 4 5 6			
2.10-18	8-20393-1	POWER PLANT VENT AND DRAIN TUBING • TUBING INSTL, POWER PLANT VENT AND DRAIN FOR NHA SEE FIG. 2.10-7	RF	35	
- 1		• ENGINE ASSY, SEE FIG. 2.10-7 INDEX 212	RF		
- 2	MS21916-8-6	• REDUCER	1	35	
	MS29512-8	• GASKET	1	35	
- 3	8-20393-9	• TUBE ASSEMBLY	1	35	
- 4	MS21916-R-6	• REDUCER	1	35	
- 5	MS21902-8	• UNION	1	35	
	MS29512-8	• GASKET	1	35	
- 6	MS21907-8	• ELBOW	1	A	
	AN924-8	• NUT	1	A	
	MS29512-8	• GASKET	1	A	
- 7	MS21908-4	• ELBOW	1	35	
	AN924-4	• NUT	1	35	
	MS29512-4	• GASKET	1	35	
- 8	AN775-12	• BOLT	1	35	
- 9	ER776-12	• ELBOW, UNIVERSAL <79470> 93-40013-003	1	35	
	AN901-12C	• WASHER	2	35	
- 10		• HOSE ASSY, AFTERBURNER DRAIN SEE FIG. 2.10-7 INDEX 172	RF		
- 11	MS2190204	• UNION	2	44	
	MS29512-4	• GASKET	2	44	
- 12	R9844S4-C111-90	• HOSE ASSY, VENT AND DRAIN <50599> 94-80549-002	1	44	
- 13	MS2190904	• TEE	1	44	
	AN924-40	• NUT	1	44	
	AN9670716L	• WASHER	1	44	
- 14	R9836S4-0055	• HOSE ASSY, VENT AND DRAIN <51599> 94-80510-019	1	44	
	8-20393	• TUBING INSTL, POWER PLANT TO FUSELAGE VENT AND DRAIN FOR NHA SEE FIG. 2.3-14	RF	35	
- 15	C9660	• HOSE ASSY, OIL SCUPPER DRAIN <81481> 94-80513-006	1	35	
- 16	C9660	• HOSE ASSY, FWD SHROUD DRAIN <81481> 94-80513-006	1	35	
- 17	260-860605J	• HOSE ASSY, 0124-MANIFOLD DRAIN FUEL	1	35	
- 18	R9805S4-0120	• HOSE ASSY, ENGINE FUEL CONTROL DRAIN <50599> 94-80509-010	1	35	
- 19	R9805DDS12-0120	• HOSE ASSY, COMBUSTION MANIFOLD DRAIN <50599> 94-80509-011	1	35	
- 20		• ADAPTER, AFTERBURNER FUEL MANIFOLD DRAIN STA 551 BL 40 SEE FIG. 2.10-16	RF		
- 21	C888F	• HOSE ASSY, AFTERBURNER DRAIN <81481> 94-80514-005	1	35	
- 22	MS21902-6	• UNION	1	35	
	MS29512-6	• GASKET	1	35	
- 23	4265-1560	• COUPLING, <58625> 92-73003-012	2	35	
- 24	8-22648-1	• TUBE ASSY, ENGINE SHROUD DRAIN WELDED	1	35	
- 25	R9800-CCA4-0074	• HOSE ASSY, VENT AND DRAIN <50599> 94-80545-007	1	44	
- 26	R3R25S4-0124	• HOSE ASSY, 160 ENGINE EXHAUST CONTROL SEAL DRAIN <50599> 94-80544-005	1	35	
	AN929-4	• CAP	1		
- 27		• ADAPTER, EXHAUST NOZZLE CONTROL SEAL DRAIN STA 551 BL 18.25 SEE FIG. 2.10-16 ENGINES WITHOUT DRAIN PROVISIONS SHALL REQUIRE THE DRAIN ADAPTER TO BE CAPPED AND HOSE RETURNED TO STOCK AIRPLANES #35 THRU 208 AND 210 AIRPLANES #209, 211 AND ON	RF		

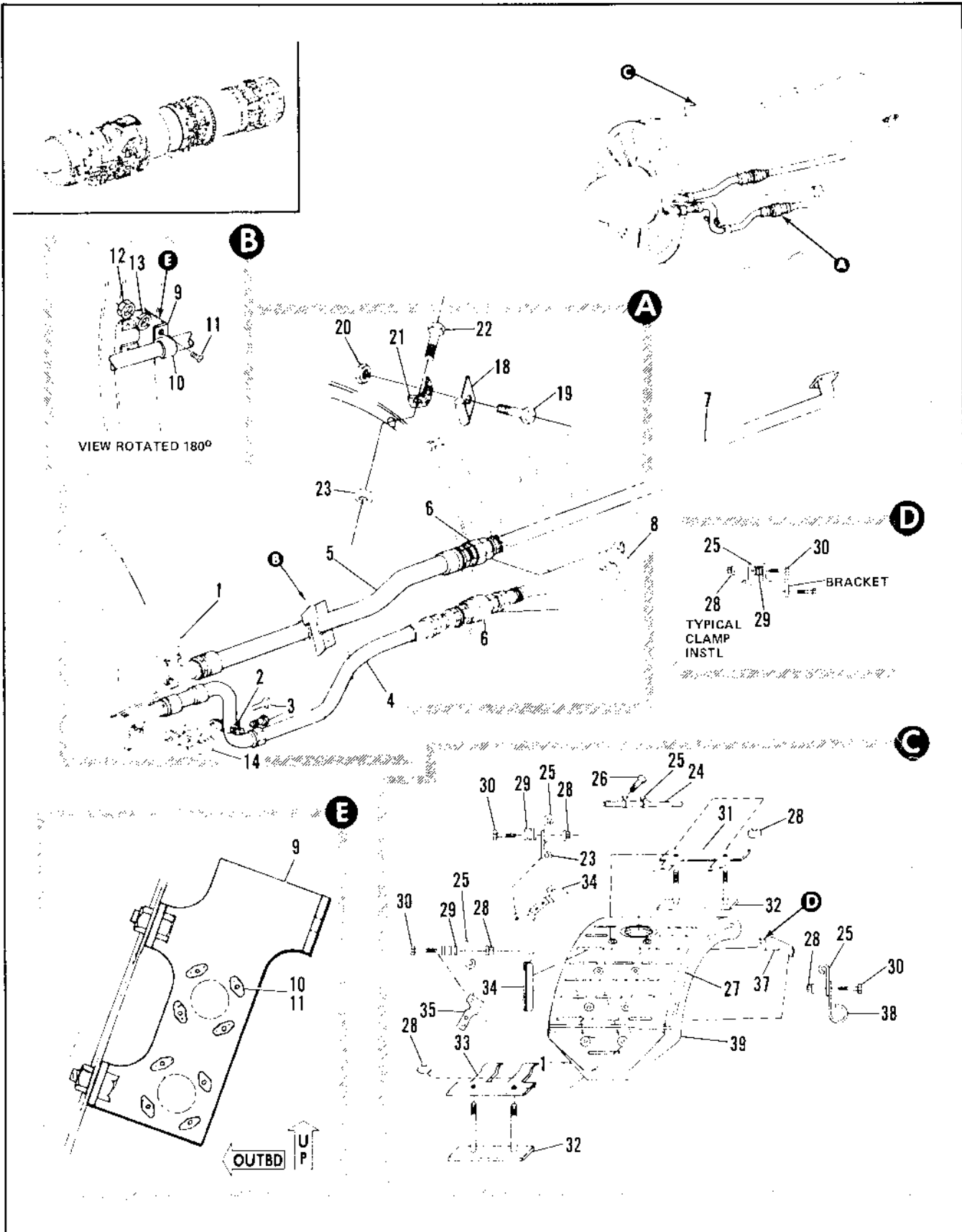

Figure 2.10-19. Engine Oil Cooler Tubing Installation

FIGURE AND INDEX NUMBER	PART NUMBER	DESCRIPTION	UNITS PER ASSY.	USABLE ON CODE	
				FROM	TO
2.10-19	R-28247-1	TUBING INSTALLATION, ENGINE OIL COOLER FOR NHA SEE FIG. 2.3-3	RF	35	
- 1	R-27544-21	• COOLER ASSY, ENGINE OIL SEE FIG. 2.10-21 INDEX 1	RF		
- 2	TA4057D16T	• CLAMP	1	35	
- 3	AN304A	• BOLT	1	35	
- 4	R10233	• HOSE ASSY, ENGINE OIL OUTLET (50599)	1	35	
	R10233B	• HOSE ASSY, ENGINE OIL OUTLET (50599)	1	35	
	HR10233	• HOSE ASSY, ENGINE OIL OUTLET (50599) REPLACES/INTCHG WITH R10233, R10233B	1	35	
- 5	R9800DDS16-0273	• HOSE ASSY, ENGINE OIL INLET (50599) 94-80547-001	1	35	
	R9800CC16-0274	• HOSE ASSY, ENGINE OIL INLET, SUITABLE SUB FOR R9800DDS16-0273	1	35	
- 6	AE94502M	• COUPLING, HALF	2	35	
- 7		• TUBE ASSY, ENGINE OIL INLET SEE FIG. 2.10-24 INDEX 19	RF		
- 8		• TUBE ASSY, ENGINE OIL OUTLET SEE FIG. 2.10-24 INDEX 10	RF		
- 9	65033074-7	• BRACKET	1	35	
- 10	MS21073-4	• NUT PLATE	8	ALL	
- 11	MS20470AD3-6	• RIVETS	16	ALL	
- 12	MS219190G17	• CLAMP	1	35	
- 13	AN3-5A	• BOLT	1	35	
- 14	AN365-10320	• NUT	1	35	
- 15	AN960-10	• WASHER	1	35	
- 16	66034047	• BRACKET	1	35	
- 17	67034033	• UNION	1	35	
- 18	400W0S2	• CLAMP (0P512) ATTACHING PARTS	4		
- 19	NAS135103-6	• SCREW	4		
- 20	MS21043-3	• NUT -----X-----	4		
- 21	MS9103-02	• BRACKET	4		
- 22	NAS135105-4	• SCREW	4		
- 23	MS21043-5	• NUT, LOCK	4		
- 24	1007-00-400-1	• DETECTOR ASSY, RADIATION (24494)	1		
- 25	MS21919H5	• CLAMP ATTACHING PARTS	10		
- 26	NAS135103H6	• SCREW -----X-----	2		
- 27	1007-00-300-1	• RADIATION SOURCE ASSY (24494)	1		
- 28	MS21042-3	• NUT	10		
- 29	AN960-10L	• WASHER	40		
- 30	AN303A	• BOLT	6		
- 31	7037316	• BRACKET, DETECTOR TUBE	1		
- 32	7037469	• HOLDER	2		
- 33	7037314	• BRACKET, LOWER TANK	1		
- 34	7037312	• SPACER	4		
- 35	7037311	• BRACKET, LOWER	1		
- 36	7037313	• BRACKET, UPPER	1		
- 37	7037315	• BRACKET, REAR	2		
- 38	JP002ESH16	• CLAMP, LOOP	1		
- 39	SW11-4	• SPIRAL WRAP	1		

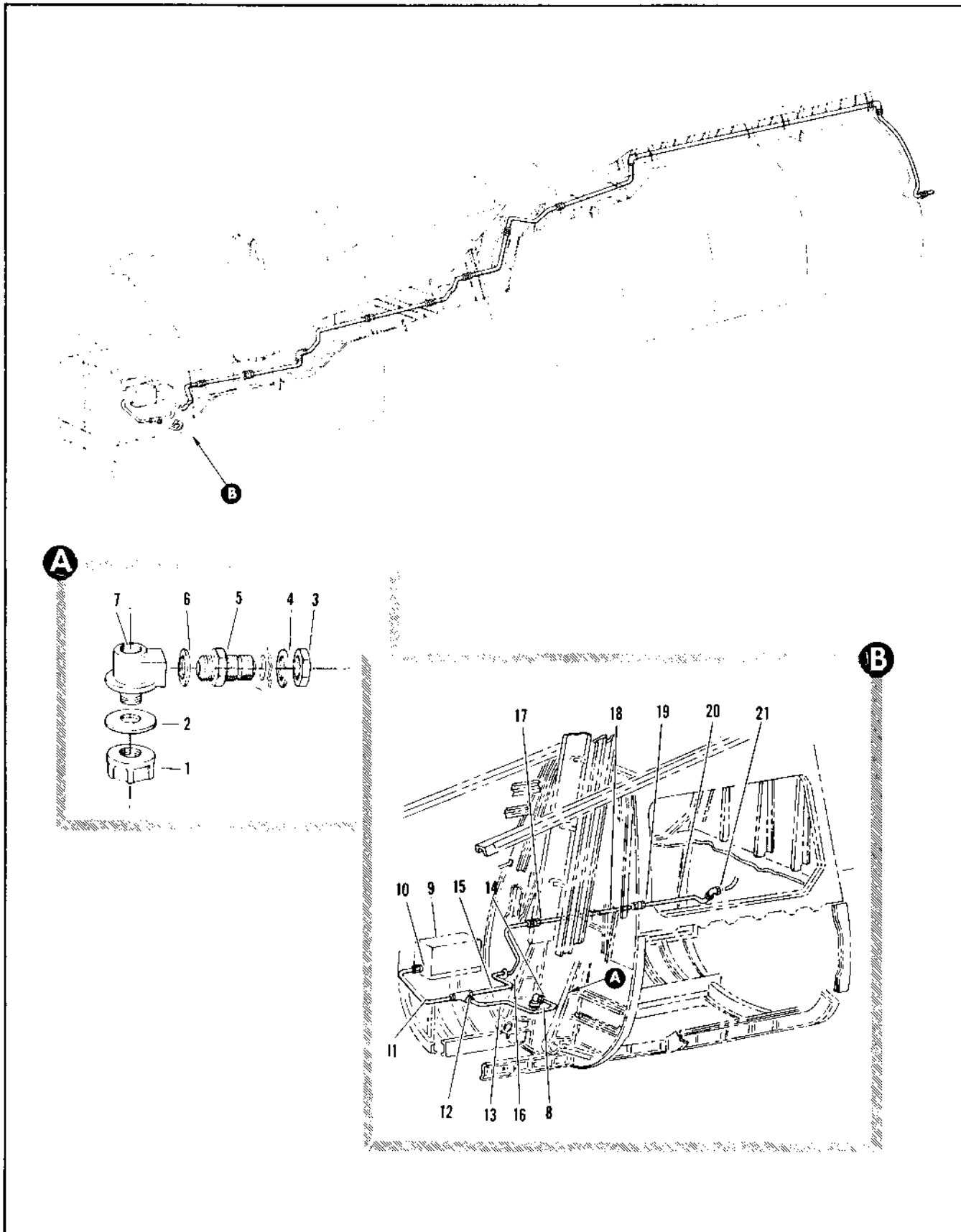

Figure 2.10-20. Pressure Ratio Tubing (Sheet 1 of 2)

FIGURE AND INDEX NUMBER	PART NUMBER	DESCRIPTION	UNITS PER ASSY.	USABLE ON CODE	
				FROM	TO
2.10-20	8-38084-3	PRESSURE RATIO TUBING • TRAF INSTL, PRESSURE RATIO TUBING WATER FOR NHA SEE FIG. 2.3-4	RF	35	
- 1	8-38080	• • CAP, WATER TRAP	1	35	
- 2	AN6290-12	• • GASKET	1	35	
- 3	AN924-4D	• • NUT	1	35	
- 4	AN9600716	• • WASHER	1	35	
- 5	MS2190304	• • FITTING, BULKHEAD	1	35	
- 6	AN6290-4	• • GASKET	1	35	
- 7	8-38082-9	• • BODY, WATER TRAP	RF	35	
- 8	8-38079-4	• • BODY, WATER TRAP ALT INTCHG WITH 8-38082-9	1	35	
- 8	MS2191404	• • CAP	RF	35	
- 8	8-38097-605	• TUBING INSTL, PRESSURE RATIO INDICATOR STA 102 TO 216 FOR NHA SEE FIG. 2.3-4			
- 9		• • TRANSMITTER, PRESSURE RATIO SEE FIG. 2.17-5 INDEX 1	RF		
- 10	MS21902D4	• • UNION	1	35	
- 10	AN6290-4	• • GASKET	2	35	
- 10	AN924-4D	• • NUT	1	35	
- 11	8-38097-59	• • TUBE ASSEMBLY	1	35	
- 12	MS21912D4	• • TEE	1	35	
- 13	8-38097-65	• • TUBE ASSEMBLY	1	35	
- 14	MS21908D4	• • ELBOW	1	35	
- 15	8-38097-61	• • TUBE ASSEMBLY	1	35	
- 16	AN931-4-12	• • GROMMET	1	35	
- 17	MS21902D4	• • UNION	1	35	
- 18	8-38097-39	• • TUBE ASSEMBLY	1	35	
- 19	MS21902D4	• • UNION	1	35	
- 20	8-38097-37	• • TUBE ASSEMBLY	1	35	189
- 20	8-38097-71	• • TUBE ASSEMBLY	1	35	
- 21	MS21908D4	• • ELBOW	1	35	
- 21	AN924-4D	• • NUT	1	35	
- 21	AN9600716L	• • WASHER	1	35	

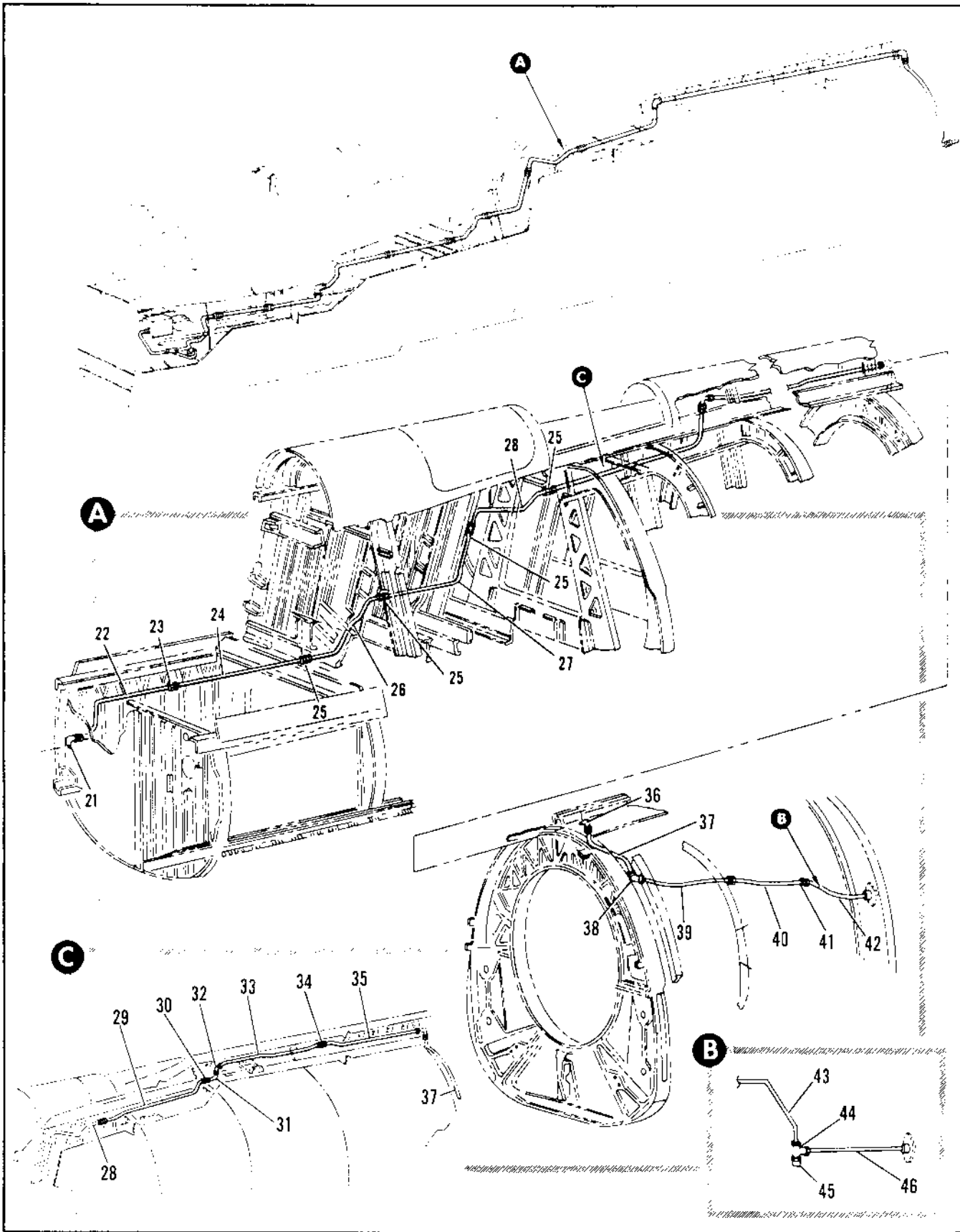

Figure 2.10-20. Pressure Ratio Tubing (Sheet 2 of 2)

FIGURE AND INDEX NUMBER	PART NUMBER	DESCRIPTION	UNITS PER ASSY.	USABLE ON CODE	
				FROM	TO
2.10-20	8-38097-1	• TUBING INSTL, PRESSURE RATIO INDICATOR STA 214 TO 472 MODIFIED BY 66D40638-1 FOR NHA SEE FIG. 2.3-10	RF	35	
- 22	8-38097-13	• • TUBE ASSEMBLY	1	35	188
	8-38097-69	• • TUBE ASSEMBLY	1	189	
- 23	MS21902D4	• • UNION	1	35	
- 24	8-38097-15	• • TUBE ASSEMBLY	1	35	
- 25	MS21902D4	• • UNION	4	35	
- 26	8-38097-43	• • TUBE ASSEMBLY	1	35	
- 27	8-38097-45	• • TUBE ASSEMBLY	1	35	
- 28	8-38097-35	• • TUBE ASSEMBLY	1	35	
- 29	66A40639-1	• • TUBE ASSY	1	35	
- 30	MS21924D4	• • UNION, PULKHEAD	1	35	
	AN924-4D	• • NUT	1	35	
	AN960D716L	• • WASHER	1	35	
- 31	66A40640-1	• • TUBE ASSY	1	35	
- 32	MS21907D4	• • ELBOW, 45	1	35	
	AN924-4D	• • NUT	1	35	
	AN960D716	• • WASHER	1	35	
- 33	66A40641-1	• • TUBE ASSY	1	35	
- 34	MS21902D4	• • UNION	1	35	
- 35	66A40642-1	• • TUBE ASSY	1	35	
- 36	MS21906D4	• • ELBOW	1	35	
	AN924-4D	• • NUT	1	35	
	AN960D716L	• • WASHER	1	35	
- 37	8-38097-17	• • TUBE ASSEMBLY	1	35	
- 38	MS21907D4	• • ELBOW	1	35	
	AN924-4D	• • NUT	1	35	
	AN960D716L	• • WASHER	1	35	
	8-38097-801	• TUBING INSTL, PRESSURE RATIO INDICATOR STA 481 AND AFT FOR NHA SEE FIG. 2.10-7	RF	35	43
	8-38097-607	• TUBING INSTL, PRESSURE RATIO INDICATOR STA 481 AND AFT FOR NHA SEE FIG. 2.10-7	RF	44	
- 39	R9800-4-C176	• • HOSE ASSY, <E0599> 94-80506-027	1	35	
- 40	8-38097-33	• • TUBE ASSEMBLY	1	35	
- 41	MS21902D4	• • UNION	1	35	43
- 42	8-38097-31	• • TUBE ASSEMBLY	1	35	
- 43	8-38097-51	• • TUBE ASSEMBLY	1	44	
- 44	AN824-4D	• • TEE	1	44	
- 45	AN929-4	• • CAP	1	44	
- 46	8-38097-53	• • TUBE ASSEMBLY	1	44	

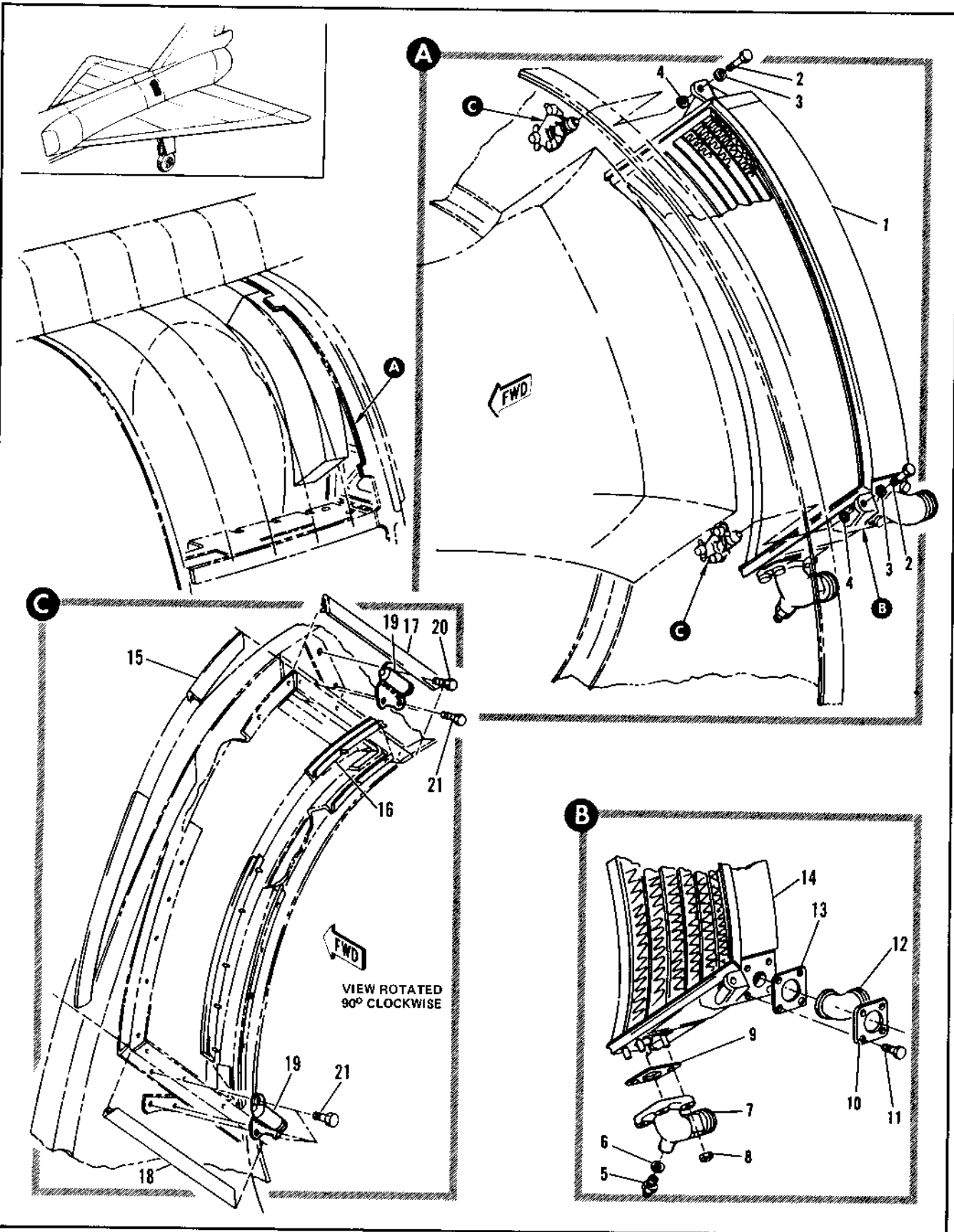

Figure 2.10-21. Engine Oil Cooler

FIGURE AND INDEX NUMBER	PART NUMBER	DESCRIPTION	UNITS PER ASSY.	USABLE ON CODE	
				FROM	TO
2.10-21	8-27544	ENGINE OIL COOLER • COOLER INSTALLATION, ENGINE OIL FOR NHA SEE FIG. 2.3-3	RF	35	
- 1	8-27544-21	• COOLER ASSY, ENGINE OIL ATTACHING PARTS	1	35	
- 2	AN4H7A	• • BOLT	2	35	
- 3	AN960-416L	• • WASHER	2	35	
- 4	AN960-416	• • WASHER	2	35	
- 5	RJ1000ASIM21	• • • VALVE ASSY, DRAIN OIL COOLER <91511> SPEC 8-00901	1	35	
- 6	NAS617-4	• • • PACKING	1	35	
- 7	8-27551-7	• • • ELBOW, ENGINE OIL COOLER INLET	1	35	
	8-27549-7	• • • ELBOW, ENGINE OIL COOLER INLET ALT INTCHG WITH 8-27551-7 ATTACHING PARTS	RF	35	
- 8	NAS679A3	• • • NUT	4	35	
- 9	460-715-16	• • • SEAL, <M3259> 97-93503-001	1	35	
- 10	AN756016	• • • FLANGE ATTACHING PARTS	1	35	
- 11	AN3H5A	• • • BOLT	4	35	
- 12	4126-565484	• • • ELBOW, COOLER OUTLET <92003> 93-39902-001	1	35	
- 13	460-715-16	• • • SEAL <83259> 97-93503-001	1	35	
- 14	8525264	• • • COOLER ASSY, ENGINE OIL <27462> SPEC 8-00324 T.O. 7J1-7-83	1	35	
	8-27544-1	• MOUNT INSTL, ENGINE OIL COOLER FOR NHA SEE FIG. 2.3-3	RF	35	
- 15	8-27544-7	• • SEAL, OIL COOLER DUCT FLANGE ALTERED FROM 8-27556	1	35	
- 16	8-27556	• • SEAL	RF		
	8-27544-9	• • SEAL, OIL COOLER DUCT FLANGE ALTERED FROM 8-27555	1	35	
- 17	8-27555	• • SEAL	RF		
	8-27544-11	• • SEAL, OIL COOLER DUCT FLANGE ALTERED FROM 8-27556	1	35	
- 18	8-27556	• • SEAL	RF		
	8-27544-12	• • SEAL, OIL COOLER DUCT FLANGE ALTERED FROM 8-27556	1	35	
- 19	8-27556	• • SEAL	RF		
	J7204-1	• • MOUNT ASSY, OIL COOLER SHOCK <76005> SPEC 8-00900 ATTACHING PARTS	2	35	
- 20	AN3H5A	• • BOLT	1	35	
- 21	AN3-5A	• • BOLT	5	35	
		• • • • • -----X-----			
		*1 FOR USE WITH ENGINES HAVING CONSTANT RISE OIL SYSTEM			

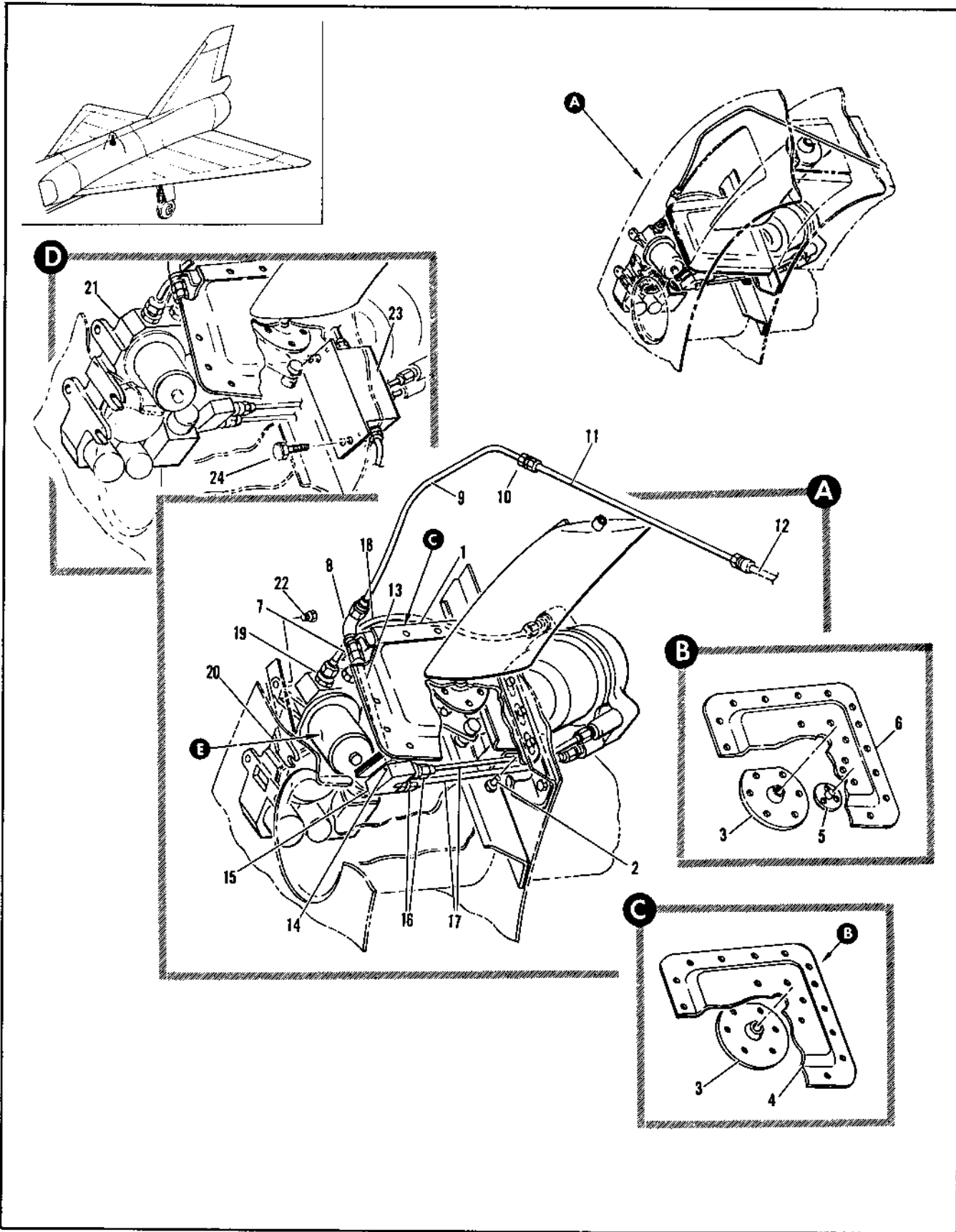

Figure 2.10-22. Accessory Oil Cooler Air Valve Installation (Sheet 1 of 2)

FIGURE AND INDEX NUMBER	PART NUMBER	DESCRIPTION	UNITS PER ASSY.	USABLE ON CODE	
				FROM	TO
2.10-21	3-27553-3	VALVE INSTALLATION, ACCESSORY OIL COOLER AIR FOR NHA SEE FIG. 2.3-5	RF	35	
- 1	8-27560-3	• DCCP ASSY, AIR CONTROL OIL COOLER VALVE REPLACED BY SUITABLE SUB 8-27560-5	1	35	38
	8-27560-5	• DOOR ASSY, AIR CONTROL OIL COOLER VALVE REPLACED SUITABLE SUB FOR 8-27560-3	1	39	129
	8-27560-801	• DCCP ASSY, AIR CONTROL OIL COOLER VALVE REPLACES SUITABLE SUB FOR 8-27560-5	1	130	
- 2	AN3-5A	• BOLT -----X-----	17	35	
- 3	BSR6880	• BEARING, <R1376> SPEC 8-80949	1	35	
- 4	8-27560-13	• DOOR	1	35	38
- 5	8-28398	• BOSS	1	39	129
	8-28398-7	• BOSS	1	130	
- 6	8-27560-15	• DOOR	1	39	
- 7	AN924-4D	• NUT	1	35	
	AN9600716	• WASHER	1	35	
- 8	MS21902D4	• ELBOW	1	35	
- 9	8-27553-29	• TUBE ASSY, ACTUATOR CONTROL LINE	1	35	
- 10	MS21902D4	• UNION	1	35	
- 11	8-27553-25	• TUBE ASSY, ACTUATOR CONTROL LINE	1	35	
- 12		• TUBE ASSY, ACTUATOR CONTROL LINE SEE FIG. 2.10-23 INDEX 13	RF		
- 13	R9800-4-0034	• HOSE ASSY, <50599> 94-80506-032	1	35	
- 14	AN924-4D	• NUT	1	35	
- 15	8-27793	• FITTING ASSY, EMERGENCY AIR SUPPLY LINE WELDED	1	35	
- 16	MS21902D4	• UNION	2	35	
	AN6290-4	• GASKET	2	35	
- 17	R9800-4-0064	• HOSE ASSY, <50599> 94-80506-003	2	35	
- 18	R5800-4-0100	• HOSE ASSY, <50599> 94-80506-020	1	35	
- 19	MS21902D4	• UNION	1	35	
	AN6290-4	• GASKET	1	35	
- 20	25640580-01	• SENSOR ASSY, ENGINE COMPARTMENT EMERGENCY PRESSURE CONTROL <R0234> SPEC 8-00928-1 T.O. 803-10-6-23 REPLACED BY SUITABLE SUB 25640580-02	1	35	129
- 21	25640580-02	• SENSOR ASSY, ENGINE COMPARTMENT EMERGENCY PRESSURE CONTROL <R0234> SPEC 8-00928-3 T.O. 803-10-6-23 REPLACES SUITABLE SUB FOR 25640580-01	1	130	
- 22	AN3-5A	• BOLT -----X-----	5	35	
	8-65315	• FILTER INSTL, NHA IS 8-67031	1	130	
- 23	2542-130	• FILTER ASSY, RADIO NOISE <R0234> SPEC 8-76423-1	1	130	
- 24	AN3-3A	• BOLT -----X-----	2	130	

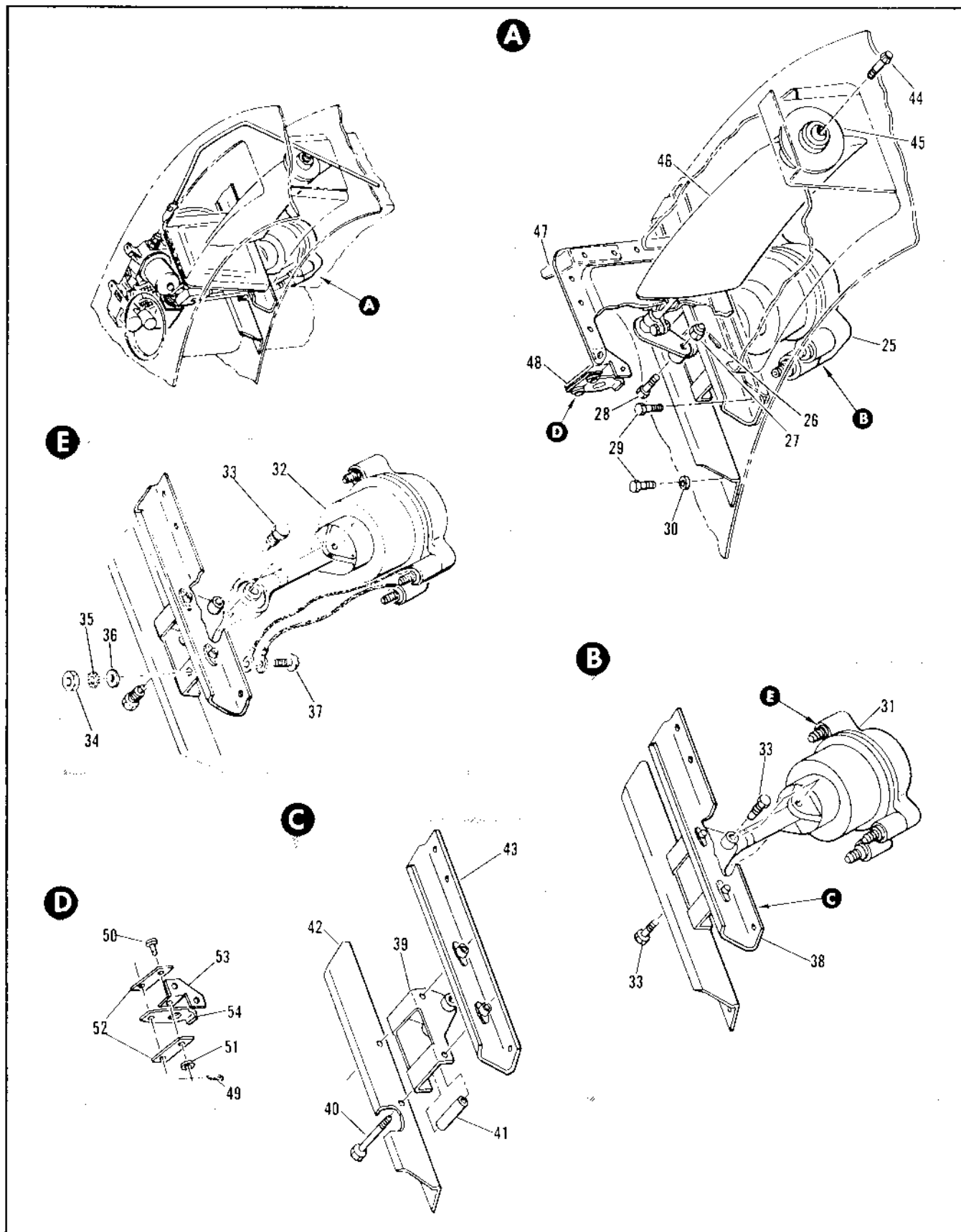

Figure 2.10-22. Accessory Oil Cooler Air Valve Installation (Sheet 2 of 2)

FIGURE AND INDEX NUMBER	PART NUMBER	DESCRIPTION	UNITS PER ASSY.	USABLE ON CODE	
				FROM	TO
2.10-22- 35	8-27553-7	• ACTUATOR ASSY, ACCESSORY OIL COOLER	1	35	129
	8-27553-33	• ACTUATOR ASSY, ACCESSORY OIL COOLER ATTACHING PARTS	1	130	
	- 26 AN380-2-3	• PIN, COTTER	1	35	
	- 27 AN310-4	• NUT	1	35	
	- 28 AN174-10	• BOLT	1	35	
- 29 AN3-5A	• BOLT	6	35		
- 30 AN960-10	• WASHER	3	35		
- 31 25640004-01	• • ACTUATOR ASSY, ACCESSORY OIL COOLER AIR VALVE <80234> SPEC 8-00915-1 T.O. 7J6-6-12-33 REPLACED BY SUITABLE SUB 25640004-02	1	35		
- 32 25640004-02	• • ACTUATOR ASSY, ACCESSORY OIL COOLER AIR VALVE <80234> SPEC 8-00915-3 T.O. 7J6-6-12-33 REPLACES SUITABLE SUB FOR 25640004-01 ATTACHING PARTS	1	130		
- 33 8-27586	• • PIN	2	35		
- 34 NAS679A3	• • NUT	1	130		
- 35 AN960-10L	• • WASHER	1	130		
- 36 AN935-10	• • WASHER	1	130		
- 37 AN521-10-6	• • SCREW	1	130		
- 38 8-27589-1	• • SUPPORT ASSY, OIL COOLER ACTUATOR	1	35	129	
8-27589-3	• • SUPPORT ASSY, OIL COOLER ACTUATOR	1	130		
- 39 8-27587	• • • MOUNT ASSY, ACTUATOR AIR VALVE OIL COOLER WELDED REPLACED BY SUITABLE SUB 8-27587-1	1	35	129	
8-27587-1	• • • MOUNT ASSY, ACTUATOR AIR VALVE OIL COOLER WELDED REPLACES SUITABLE SUB FOR 8-27587 ATTACHING PARTS	1	130		
- 40 AN173-22A	• • • BOLT	2	35		
- 41 NAS43DD3-10 ³	• • • SPACER	2	35		
- 42 8-27589-13	• • • SUPPORT	1	35		
- 43 8-27589-19	• • • SUPPORT ASSY, RIVETED	1	35		
- 44 8-27553-1	• BOLT, FURNISHED WITH 25643753 <80234> • BEARING INSTL, ACCESSORY OIL COOLER AIR VALVE FOR NHA, SEE FIG. 2.3-3	RF	RF	35	
- 45 BSR6880	• • BEARING, <81378> SPEC 8-10946	1	35		
- 46 25643753-01	• VALVE ASSY, AIR CONTROL <80234> SPEC 8-00253-1 T.O. 7J6-6-12-13	1	35		
- 47 8-27794-11	• SUPPORT, SUPPLY LINE EMERGENCY AIR	1	35		
- 48 8-27794-1	• SUPPORT ASSY, SUPPLY LINE EMERGENCY AIR	1	35		
- 49 AN385-2-2	• • PIN, COTTER	2	35		
- 50 AN392-7	• • PIN	2	35		
- 51 AN960D4	• • WASHER	4	35		
- 52 8-27794-17	• • LINK	2	35		
- 53 8-27794-13	• • CLIP	1	35		
- 54 8-27794-15	• • PLATE	1	35		

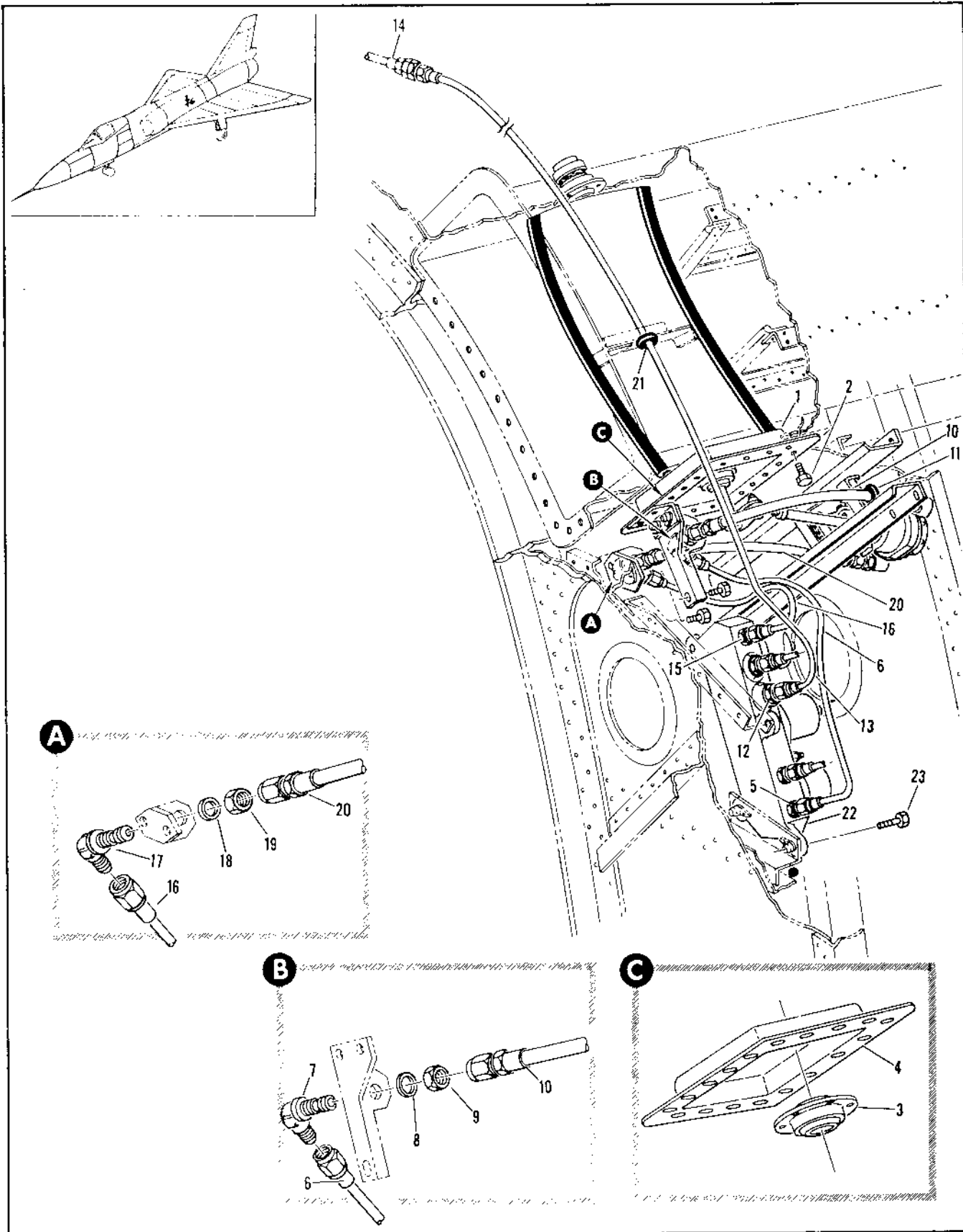

Figure 2.10-23. Engine Oil Cooler Air Valve Installation (Sheet 1 of 2)

FIGURE AND INDEX NUMBER	PART NUMBER	DESCRIPTION	UNITS PER ASSY.	USABLE ON CODE	
				FROM	TO
		1 2 3 4 5 6			
2.10-23	8-27552-3	VALVE INSTALLATION, ENGINE OIL COOLER AIR FOR NHA SEE FIG. 2.3-3	RF	35	
- 1	8-27559	• DOOR ASSY, AIR CONTROL VALVE ENGINE OIL COOLER ATTACHING PARTS	1	35	
- 2	AN3-5A	• BOLT	18	35	
- 3	BSR6480	• BEARING, <41376> SPEC 8-00449	1	35	
- 4	8-27559-7	• DOOR	1	35	
- 5	MS2191604-2	• UNION	1	35	
	AN6290-2	• GASKET	1	35	
- 6	8-27552-21	• TUBE ASSY, ACTUATOR CONTROL LINE PRESSURE EXHAUST	1	35	
- 7	MS2190804	• ELBOW	1	35	
- 8	AN9600716	• WASHER	1	35	
- 9	AN924-4D	• NUT	1	35	
- 10	R9800-4-0090	• HOSE ASSY, ENGINE OIL COOLER AIR VALVE ACTUATOR <50599> 94-80502-033	1	35	
- 11	295967-7	• GROMMET, <76530> SPEC 8-221K7-7	1	35	
- 12	MS2190204	• UNION	1	35	
- 13	8-27552-35	• TUBE ASSY, ACTUATOR CONTROL LINE	1	35	
- 14		• TUBE ASSY, ACTUATOR CONTROL LINE SEE FIG. 2.10-22 INDEX 9	RF		
- 15	MS2190204	• UNION	1	35	
	AN6290-4	• GASKET	1	35	
- 16	8-27552-29	• TUBE ASSY, ACTUATOR CONTROL LINE	1	35	
- 17	MS2190804	• ELBOW	1	35	
- 18	AN9600716	• WASHER	1	35	
- 19	AN924-4D	• NUT	1	35	
- 20	R9800-4-0133	• HOSE ASSY, <50599> 94-80502-013	1	35	
- 21	295967-7	• GROMMET, <76530> SPEC 8-021R7-7	1	35	
- 22	25640555	• SENSOR ASSY, ENGINE COMPARTMENT PRESSURE CONTROL ENVELOPE <80234> SPEC 8-00913 T.O. PD3-15-2-3 REPLACES SUITABLE SUB 25640555-01	1	35	129
	25640555-01	• SENSOR ASSY, ENGINE COMPARTMENT PRESSURE CONTROL ENVELOPE <80234> SPEC 8-00913-1 T.O. PD3-15-2-3 REPLACES SUITABLE SUB FOR 25640555 ATTACHING PARTS	1	130	
- 23	AN3-5A	• BOLT	4	35	

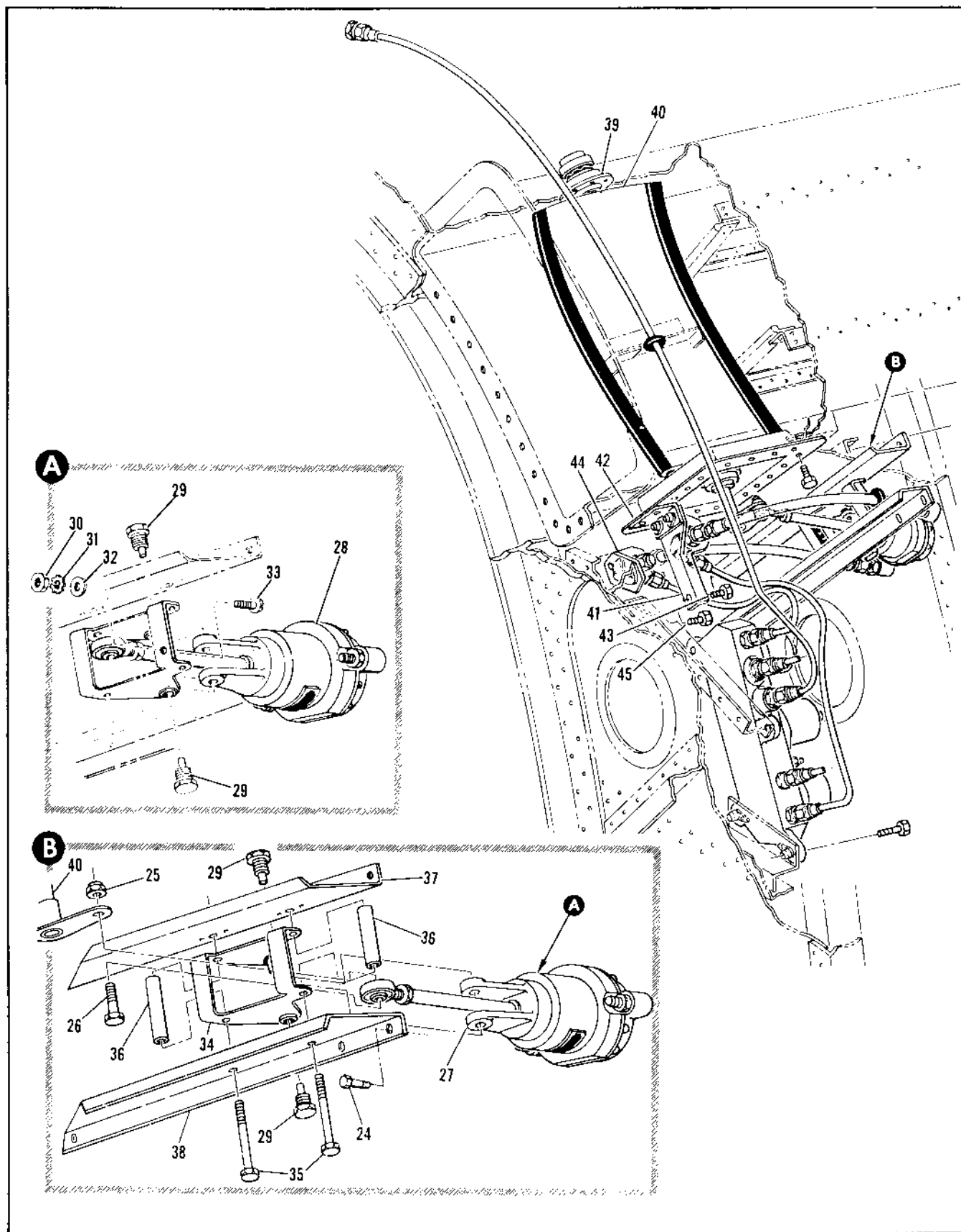

Figure 2.10-23. Engine Oil Cooler Air Valve Installation (Sheet 2 of 2)

FIGURE AND INDEX NUMBER	PART NUMBER	DESCRIPTION	UNITS PER ASSY.	USABLE ON CODE	
				FROM	TO
2.10-23	8-27552-7	• ACTUATOR ASSY, ENGINE OIL COOLER AIR VALVE	1	35	129
	8-27552-39	• ACTUATOR ASSY, ENGINE OIL COOLER AIR VALVE ATTACHING PARTS	1	130	
- 24	AN3-5A	• BOLT	6	35	
- 25	AN310-4	• NUT	1	35	
- 26	AN174-10	• BOLT	1	35	
		----X----			
- 27	25640003	• ACTUATOR, ENGINE OIL COOLER AIR VALVE <R0234> SPEC R-00914 T.O. 7J6-6-12-43 REPLACED BY SUITABLE SUB 25640003-01	1	35	129
- 28	25640003-01	• ACTUATOR, ENGINE OIL COOLER AIR VALVE <R0234> SPEC R-00914-1 T.O. 7J6-6-12-43 REPLACES SUITABLE SUB FOR 25640003 ATTACHING PARTS	1	130	
- 29	8-27586	• PIN, OIL COOLER AIR VALVE ACTUATOR SUPPORT	2	35	
- 30	MS2142L3	• NUT	1	130	
- 31	AN935-10	• WASHER, LOCK	1	130	
- 32	AN960-10L	• WASHER	1	130	
- 33	AN520-10-6	• SCREW	1	130	
		----X----			
	8-27586-1	• SUPPORT ASSY, ACTUATOR AIR VALVE ENGINE OIL COOLER	1	35	
- 34	8-27587-1	• MOUNT ASSY, OIL COOLER AIR VALVE ACTUATOR ATTACHING PARTS	1	35	
- 35	NAS464P3A30	• BOLT	2	35	
- 36	NAS43003-103	• SPACER	2	35	
		----X----			
- 37	8-27588-11	• SUPPORT ASSY, RIVETED	1	35	
- 38	8-27588-9	• SUPPORT	1	35	
- 39	BSR6A80	• BEARING, <R1376> SPEC R-00949	1	35	
- 40	25643752-01	• VALVE ASSY, ENGINE OIL COOLER AIR CONTROL <R0234> SPEC R-00254 T.O. 7J6-6-12-23	1	35	
- 41	8-27797-11	• SUPPORT, EXHAUST LINE AIR CONTROL ACTUATOR ENGINE OIL COOLER	1	35	
- 42		• SUPPORT, EXHAUST LINE AIR	1	35	
- 43	R-27797-3 AN3-5A	• BOLT	3	35	
		----X----			
- 44	R-27796-1	• SUPPORT, CONTROL LINE AIR VALVE ACTUATOR ENGINE OIL COOLER ATTACHING PARTS	1	35	
- 45	AN3-5A	• BOLT	2	35	
		----X----			

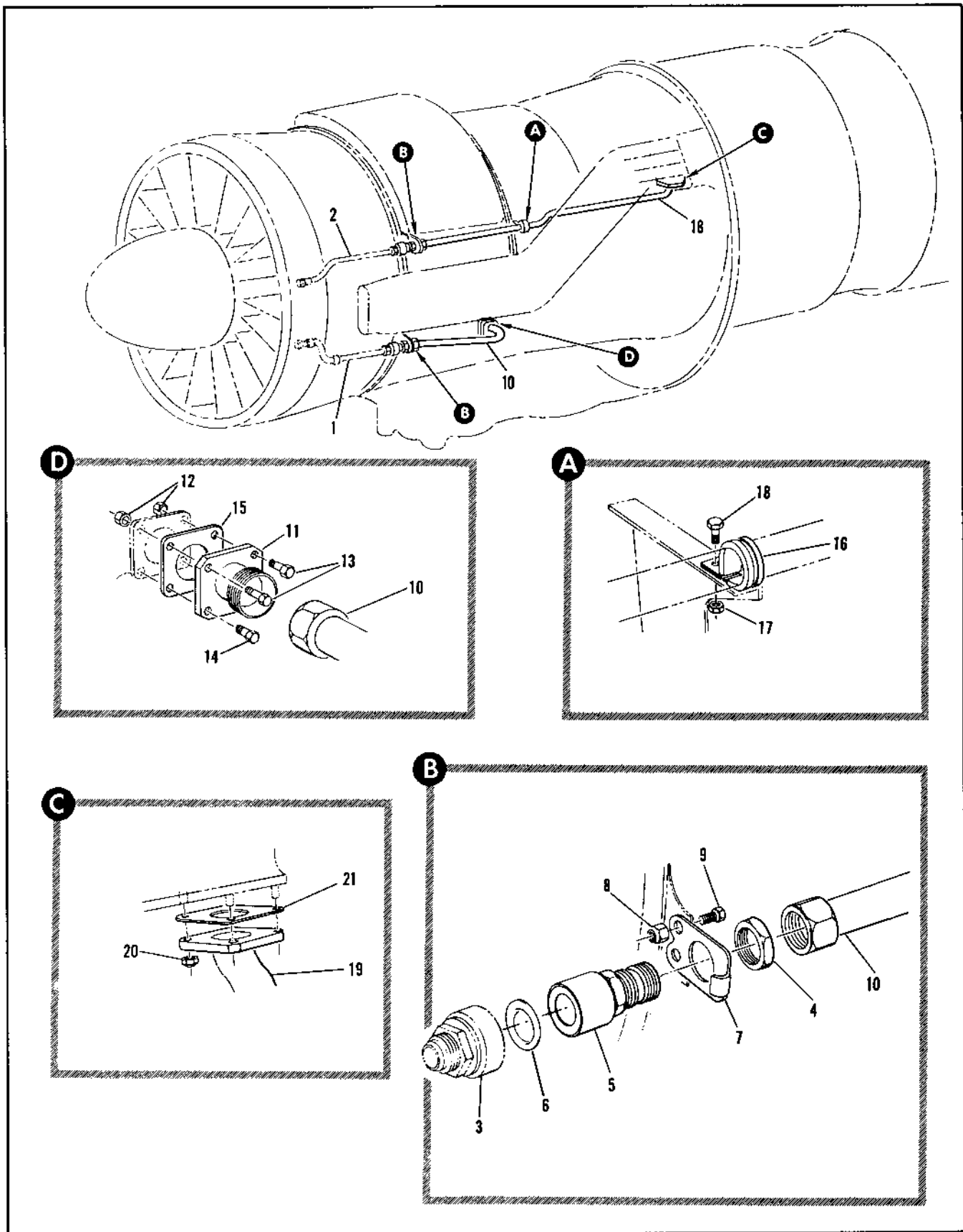

Figure 2.10-24. Engine Oil Tubing Installation

FIGURE AND INDEX NUMBER	PART NUMBER	DESCRIPTION 1 2 3 4 5 6	UNITS PER ASSY.	USABLE ON CODE	
				FROM	TO
2.10-24	8-28267-5	TUBING INSTALLATION, ENGINE OIL FOR NHA SEE FIG. 2.10-7	RF	35	
- 1		• HOSE ASSY, ENGINE OIL OUTLET SEE FIG. 2.10-19 INDEX 4	RF		
- 2		• HOSE ASSY, ENGINE OIL INLET SEE FIG. 2.10-19 INDEX 5	RF		
- 3	AE94532M	• COUPLING, HALF	2	35	
- 4	95-71903-024	• NUT	2	35	
- 5	375213-16	• COUPLING, HALF	2	35	
- 6	MS9388-213	• O-RING	2	1	
- 7	3-27548-13	• SUPPORT	2	35	
		ATTACHING PARTS			
- 8	NAS679A3	• NUT	4	35	
- 9	AN3-4A	• BOLT	4	35	
		-----X-----			
- 10	8-28267-17	• TUBE ASSY, ENGINE OIL OUTLET	1	35	
- 11	8-27547	• FITTING	1	35	
		ATTACHING PARTS			
- 12	NAS679A4	• NUT	2	35	
- 13	AN4-10A	• BOLT	2	35	
- 14	AN4H6A	• BOLT	2	35	
		-----X-----			
- 15	8-27564	• SEAL	1	35	
- 16	JP0025SH16	• CLAMP, .U-., 70M-/UJ	1	35	
		• CLAMP, 91-96037-014			
- 17	NASE79A3	• NUT	1	35	
- 18	AN3-4A	• BOLT	1	35	
		-----X-----			
- 19	8-22545-5	• TUBE ASSY, ENGINE OIL INLET WELDED	1	35	
		ATTACHING PARTS			
- 20	NAS679A4	• NUT	4	35	
		-----X-----			
- 21	8-27564	• SEAL	1	35	

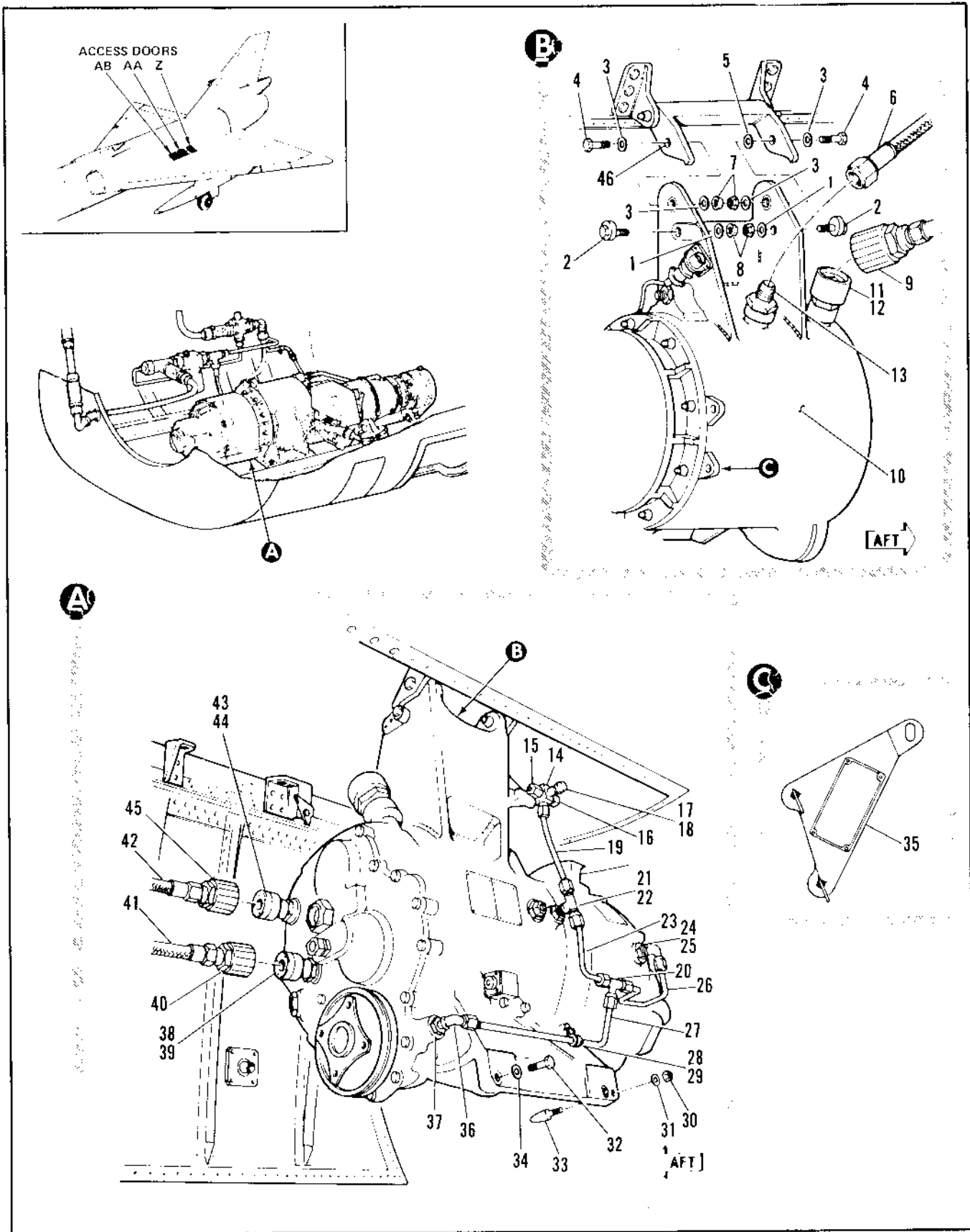

Figure 2.10-25. CSD Transmission/Generator Assembly Installation

FIGURE AND INDEX NUMBER	PART NUMBER	DESCRIPTION	UNITS PER ASSY.	USABLE ON CODE	
				FROM	TO
2.10-25	713591	DRIVE INSTL. ACCESSORY (99167)	RF	35	
- 1	AN963-416L	• WASHER P/N 37513-1F USED WITH 37550P-1C ONLY	2	35	
- 2	8-28933	• STOP BOLT	2	35	
- 3	99-51505-007	• WASHER	4	35	
- 4	AN4-14A	• BOLT	2	35	
- 5	99-51505-009	• WASHER	1	35	
- 6	MS8001H044B	• HOSE ASSY	1		
- 7	NAS679A4	• NUT	2		
- 8	NAS679A4	• NUT (96-37545-003)	2		
- 9	56428	• SOCKET (405-00913-33201) REPLACED BY P/N 37550R-1C NOT INTERCHANGEABLE WITH 56428. P/N 37550R-1C USED WITH 375213-1C ONLY	1		
- 10	708645B	• CSD TRANSMISSION	1		
- 11	56427	• NIPPLE (405-00912-33201) REPLACED BY P/N 375213-1C NOT INTCHG WITH 56427 P/N 375213-1C USED WITH 37550R-10 ONLY	1		
- 12	MS9387-10	• PACKING	1		
- 13	MS21902-80 MS9387-08	• UNION • PACKING	1 1		
- 14	8-28452	• SEAL DRAIN MANIFOLD	1		
- 15	MS21914-J4	• CAP PRESSURE SEAL	1		
- 16	NAS1352-6-16P	• SCREW CAP SOC HD	1		
- 17	8-28443-7	• FLANGE	1		
- 18	MS9388-110	• PACKING	1		
- 19	7124H1	• TUBE	1		
- 20	MS21905-J4	• TEE, FLARELESS TUBE	1		
- 21	MS21909-J4	• TEE, BULKHEAD	1		
- 22	AN924-4J MS9388-111	• NUT, BULKHEAD • PACKING	1 1		
- 23	7124R9	• TUBE ASSY	1		
- 24	MS21908-J4	• ELBOW, BULKHEAD 90 DEG FCFES	1		
- 25	AN924-4J MS9388-111	• NUT, BULKHEAD • PACKING	1 1		
- 26	7124H2	• TUBE ASSY	1		
- 27	7124R0	• TUBE ASSY	1		
- 28	MS21919-H4	• CLAMP, CUSHION, SUPPORT	1		
- 29	NAS1352-3-HJ	• SCREW, CAP, SOCKET, HEAD	1		
- 30	NAS679A4	• NUT	1		
- 31	99-51505-022	• WASHER	1		
- 32	AN5-14A	• BOLT	1	35	
- 33	8-28932-7	• PIN	1		
- 34	99-51505-021	• WASHER	1		
- 35	7130R3	• ADAPTER PLATE (USED IN REMOVING AND INSTALLING CSD TRANSMISSION AND GENER- ATOR)	1		
- 36	MS21908-J4	• ELBOW, BULKHEAD	1		
- 37	MS9387-04	• PACKING	1		
- 38	56423	• NIPPLE (405-00922-33200) REPLACED BY P/N 375213-4 NOT INTCHG WITH 56423. P/N 375213-4 USED WITH 37550R-6 ONLY	1		
- 39	MS9387-06	• PACKING	1		
- 40	56424	• SOCKET (405-00923-33200) REPLACED BY P/N 37550R-4 NOT INTCHG WITH 56424. P/N 37550R-4 USED WITH 375213-6 ONLY.	1		
- 41	MS8001G126A	• HOSE ASSY	1		
- 42	MS8001E156A	• HOSE ASSY	1		
- 43	56421	• NIPPLE (405-00492-33200) REPLACED BY P/N 375213-4 NOT INTCHG WITH 56421. P/N 375213-4 USED WITH 37550R-4 ONLY.	1		
- 44	MS9387-04	• PACKING	1		
- 45	56422	• SOCKET (405-00493-33200) REPLACED BY P/N 37550R-4 NOT INTCHG WITH 56422. P/N 37550R-4 USED WITH 375213-4 ONLY.	1		
- 46	8-28931	• BUSHING	2		

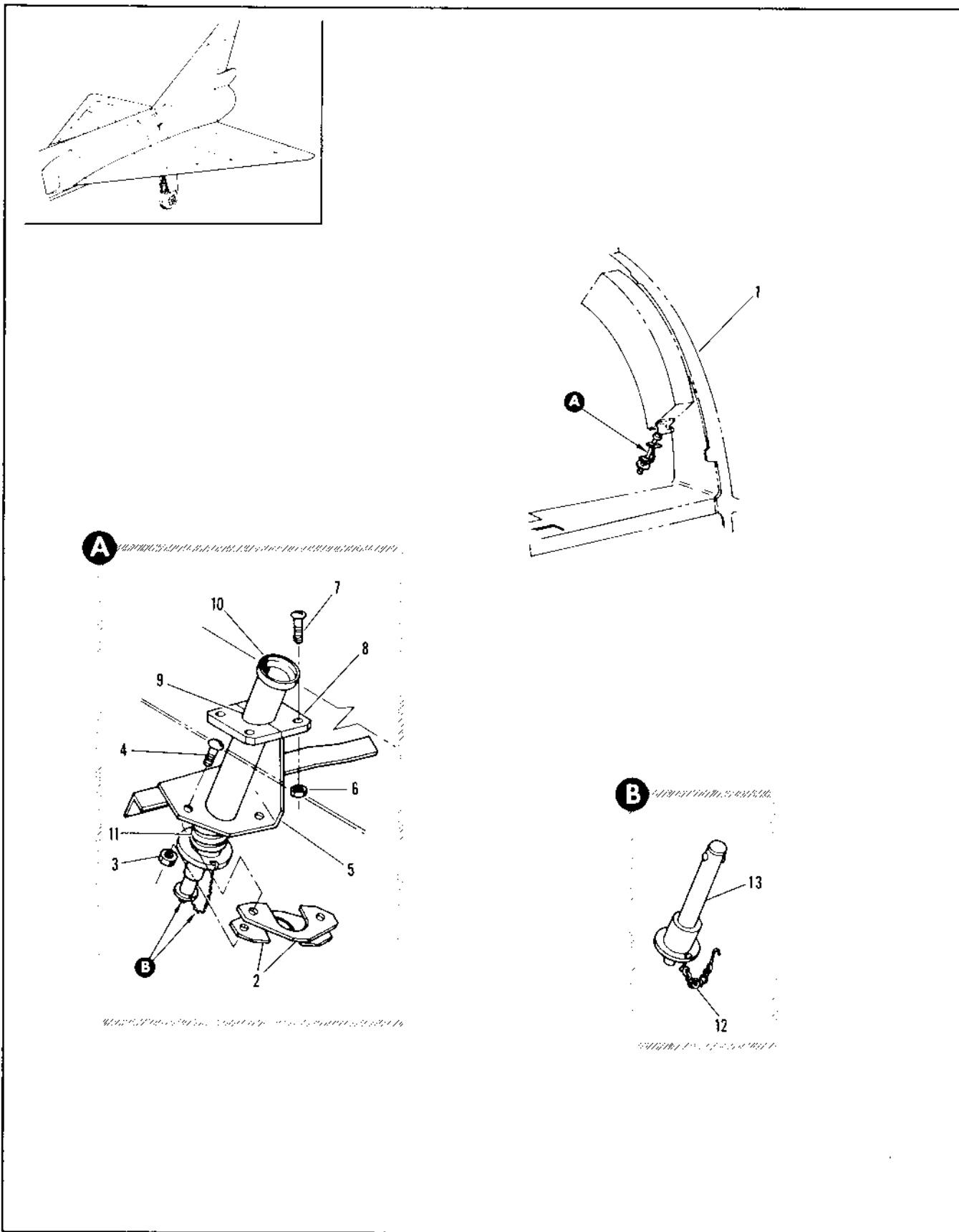

Figure 2.10-26. Engine Oil Cooler Drain Installation

FIGURE AND INDEX NUMBER	PART NUMBER	DESCRIPTION	UNITS PER ASSY.	USABLE ON CODE	
				FROM	TO
2.10-26	8-28243	DRAIN INSTALLATION, ENGINE OIL COOLER FOR NHA SEE FIG. 2.3-11	RF	35	
- 1		• COOLER ASSY, ENGINE OIL SEE FIG. 2.10-21 INDEX 1	RF		
- 2	8-27570	• GUIDE ATTACHING PARTS	2	35	
- 3	NAS679A3	• NUT	2	35	
- 4	AN528-10R8	• SCREW -----X-----	2	35	
	8-28244	• BRACKET INSTL, ENGINE OIL COOLER DRAIN	1	35	
- 5	8-28244-11	• BRACKET ASSY, RIVETED	1	35	
	8-27571 *1	• SUPPORT ASSEMBLY ATTACHING PARTS	1	35	
- 6	NAS679A3	• NUT	4	35	
- 7	AN528-10R8	• SCREW -----X-----	4	35	
- 8	8-27571-1 *1	• SUPPORT	1	35	
- 9	8-27571-3 *1	• SUPPORT	1	35	
- 10	8-28222	• DRAIN ASSY, ENGINE OIL COOLER	1	35	
- 11	8-44119	• SPRING, ACTUATING VALVE LATCH MECHANISM	1	35	
- 12	NAF1088-1A3	• CHAIN	1	35	
- 13	5440-4-036-R	• PIN, QUICK RELEASE <#4256> 96-78805-001	1	35	
		*1 8-27571-1 AND 8-27571-3 IS A MATCHED SET. DO NOT USE SEPARATELY, ORDER 8-27571			

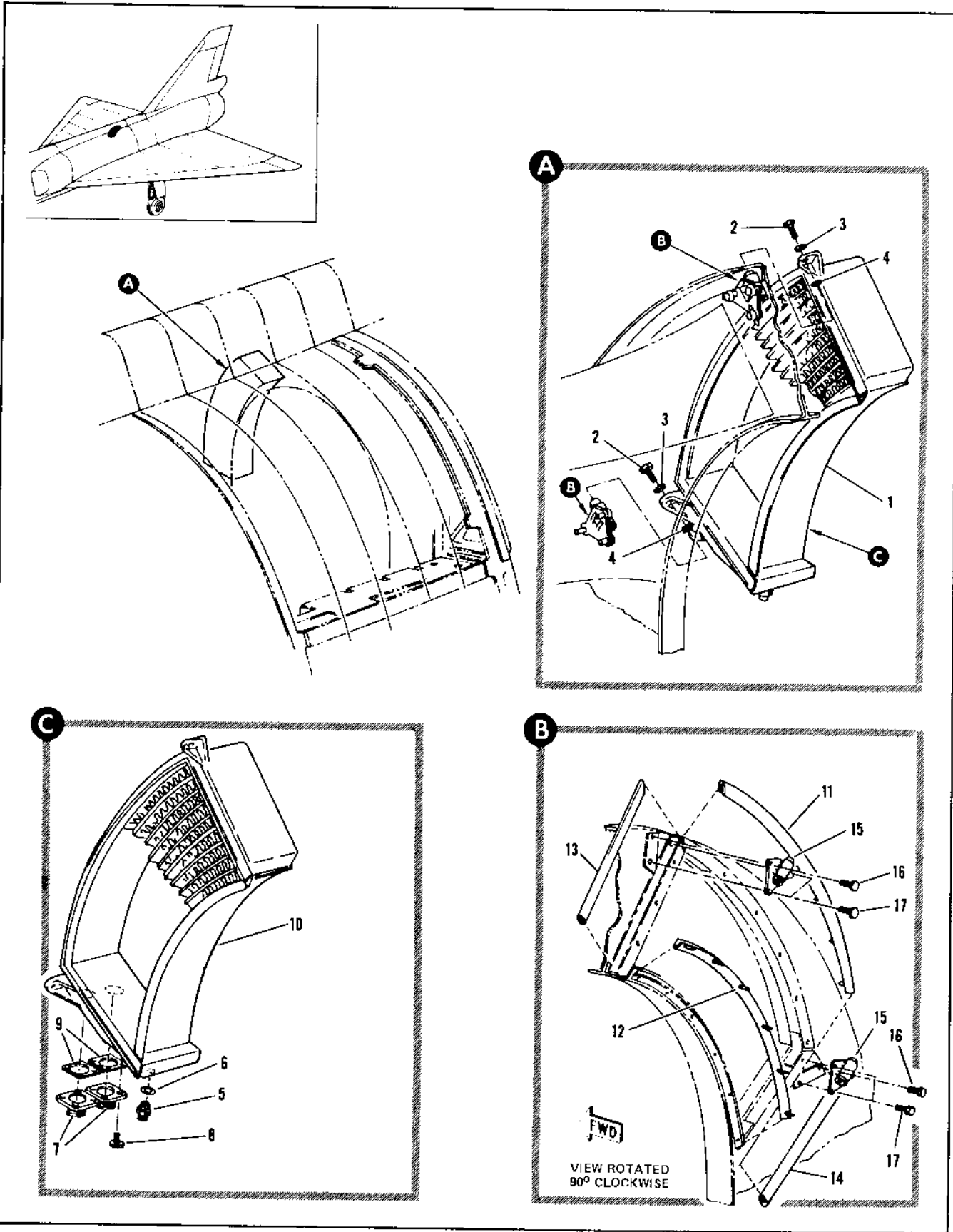

Figure 2.10-27. Accessory Drive Oil Cooler

FIGURE AND INDEX NUMBER	PART NUMBER	DESCRIPTION	UNITS PER ASSY.	USABLE ON CODE	
				FROM	TO
2.10-27	8-27545	ACCESSORY DRIVE OIL COOLER • COOLER INSTALLATION, ACCESSORY DRIVE OIL FOR NHA SEE FIG. 2.3-3	RF	35	
- 1	8-27545-15	• • COOLER ASSY, ACCESSORY DRIVE OIL ATTACHING PARTS	1	35	
- 2	AN4H7A	• • BOLT	2	35	
- 3	AN960-416L	• • WASHER	AR	35	
- 4	AN960-416	• • WASHER	2	35	
		-----X-----			
- 5	BJ1000ASIM71	• • VALVE ASSY, DRAIN <91511> SPEC 8-00901	1	35	
- 6	NAS617-4	• • PACKING	1	35	
- 7	8-27569	• • FITTING, CONSTANT SPEED DRIVE OIL COOLER LINE CONNECTOR ATTACHING PARTS	2	35	
- 8	AN3H5A	• • BOLT	8	35	
		-----X-----			
- 9	460-715-16	• • SEAL, <83259> 97-53503-001	2	35	
- 10	8525265	• • COOLER ASSY, ACCESSORY DRIVE OIL <27462> SPEC 8-00323 T.O. 7J1-26-3	1	35	
	8-27545-1	• MOUNT INSTL, ACCESSORY DRIVE OIL COOLER FOR NHA SEE FIG. 2.3-3	RF	35	
- 11	8-27545-7	• • SEAL, OIL COOLER DUCT FLANGE	1	35	
	8-27556	• • SEAL, OIL COOLER DUCT FLANGE	RF		
- 12	8-27545-9	• • SEAL, OIL COOLER DUCT FLANGE MAKE FROM 8-27555	1	35	
	8-27555	• • SEAL, OIL COOLER DUCT FLANGE	RF		
- 13	8-27545-11	• • SEAL, OIL COOLER DUCT FLANGE MAKE FROM 8-27556	1	35	
	8-27556	• • SEAL, OIL COOLER DUCT FLANGE	RF		
- 14	8-27545-12	• • SEAL, OIL COOLER DUCT FLANGE MAKE FROM 8-27556	1	35	
	8-27556	• • SEAL, OIL COOLER DUCT FLANGE	RF		
- 15	J7234-1	• • MOUNT ASSY, OIL COOLER SHOCK <76005> SPEC 8-00900 ATTACHING PARTS	2	35	
- 16	AN3H4A	• • BOLT	2	35	
- 17	AN3-4A	• • BOLT	4	35	
		-----X-----			

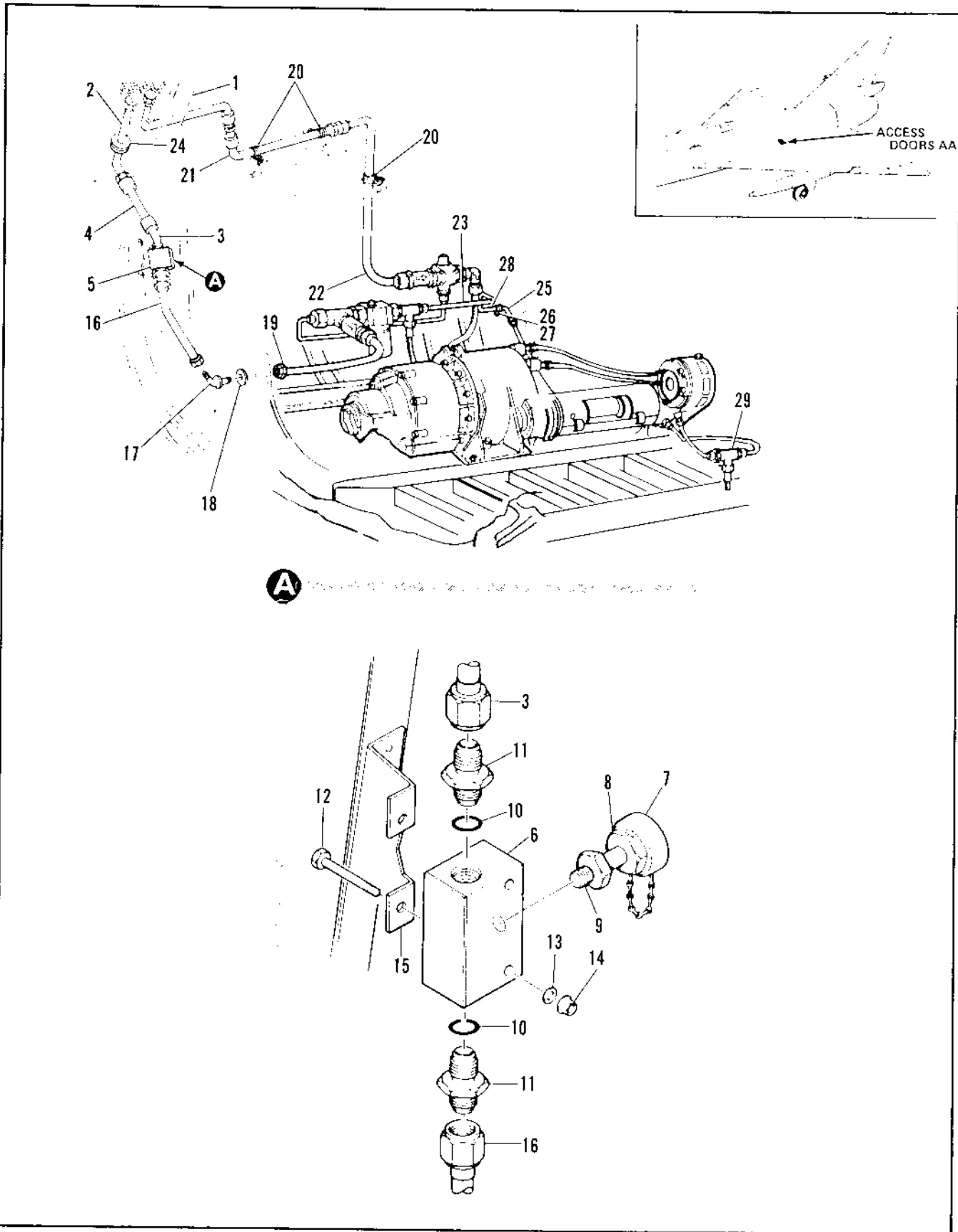

Figure 2.10-28. Accessory Drive Oil Cooler Equipment Installation

FIGURE AND INDEX NUMBER	PART NUMBER	DESCRIPTION	UNITS PER ASSY.	USABLE ON CODE	
				FROM	TO
2.10-26		TUBING INSTALLATION, ACCESSORY DRIVE EQUIPMENT FOR NHA SEE FIG. 2.10-25	RF	35	
- 1		• COOLER ASSY, ACCESSORY DRIVE OIL SEE FIG. 2.10-27 INDEX 1	RF	35	
- 2	8-27572-21	• TUBE ASSY, OIL COOLER INLET	1	35	
- 3	713363	• TUBE, INLET ASSY	1		
- 4	R10316	• HOSE ASSY, OIL COOLER INLET (50599) SPEC 8-00283-7	1	35	
- 5	8-09296-7	• CHECK VALVE	1		
- 6	713364	• TEE, INTERNAL SCREW	1		
- 7	MS244761	• NIPPLE & PRESSURE CAP ASSY (NCC40FE8)	1		
- 8	AN924-8D	• NUT, BULKHEAD	1		
- 9	MS9387-08	• PACKING	1		
- 10	MS9387-16	• PACKING	1		
- 11	MS21992-016	• UNION, FLARELESS	1		
- 12	AN4-21A	• BOLT, MACHINE	2		
- 13	AN960PD416	• WASHER	2		
- 14	NAS1291-4	• NUT	2		
- 15	8-21098-25	• BRACKET	1		
- 16	8-21098-23	• TUBE ASSY	1		
- 17	8-21951	• FITTING ASSY	1		
- 18	AN96002116	• WASHER	1		
- 19	AN924-16	• NUT	1		
- 20	JP0025SH016	• CLAMP HOSE SUPPORT (00986) SPEC 91-98037-014	3	35	
	NAS679A3	• NUT	3	35	
	AN960016L	• WASHER	5	35	
	NAS221-10	• SCREW	3	35	
- 21	R10556	• HOSE ASSY, OIL COOLER OUTLET (50599) SPEC 8-00286-3	1	35	
- 22	8-27576-45	• TUBE ASSY, OIL COOLER OUTLET	1	35	
- 23	712492	• TUBE ASSY	1		
- 24	94-35065-001	• GROMMET	1		
- 25	MS21919-116	• CLAMP, CUSHION, SUPPORT	1		
- 26	MS16996-9	• SCREW, CAP, SOC HD	1		
- 27	MS21043-3	• NUT, SELF LOCKING	1		
- 28	713070	• BRACKET	1		
- 29	MS2190904	• TEE, BULKHEAD	1		

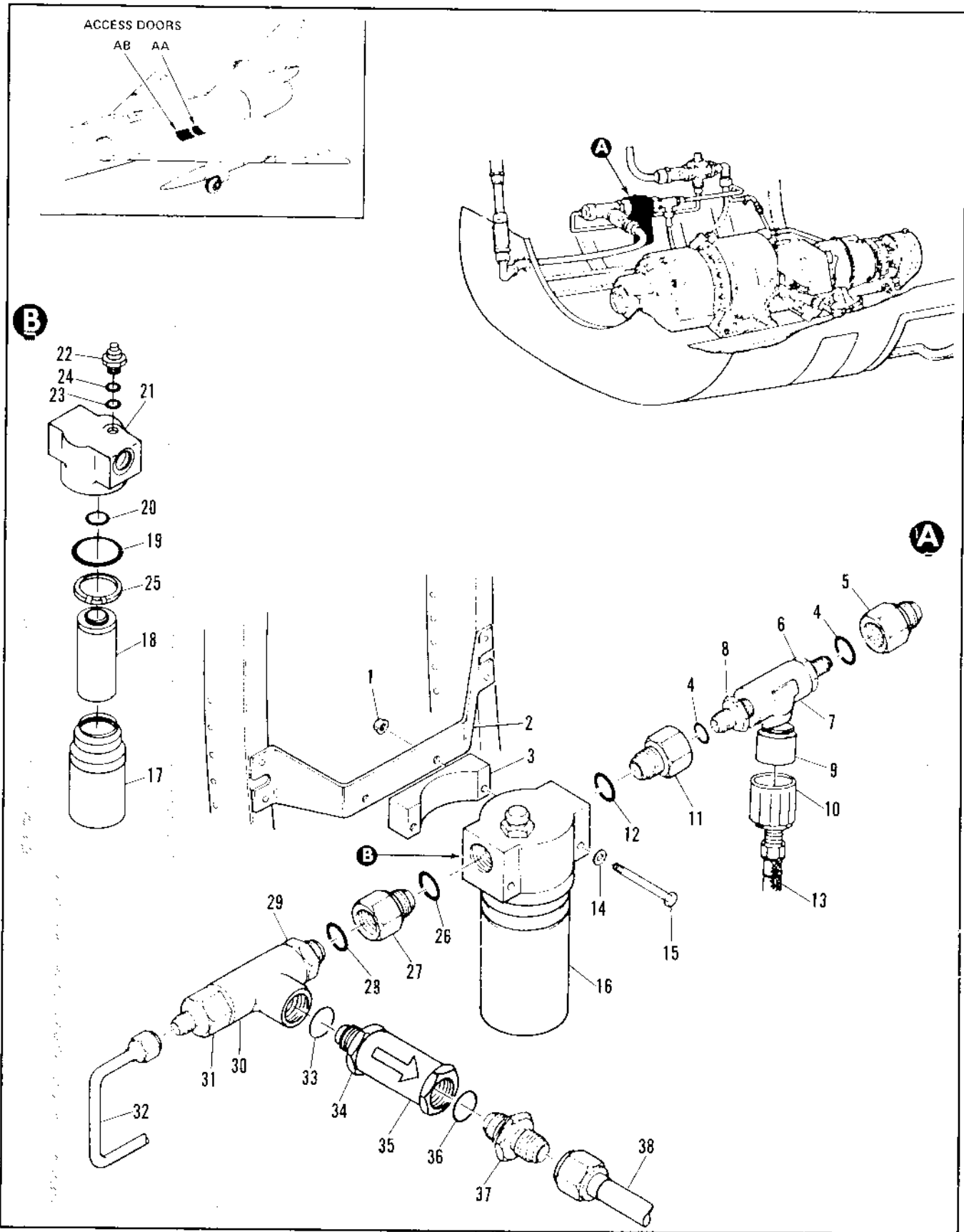

Figure 2.10-29. Accessory Drive External Filter and Assembly

FIGURE AND INDEX NUMBER	PART NUMBER	DESCRIPTION 1 2 3 4 5 6	UNITS PER ASSY.	USABLE ON CODE	
				FROM	TO
2.10-29		ACCESSORY DRIVE EXTERNAL FILTER EQUIPMENT AND INSTALLATION	RF		
- 1	MS21043-4	• NUT, SELFLOCKING	2	35	
- 2	713048	• BRACKET, INSEP ASSY	1		
- 3	713069	• SPACER	1		
- 4	MS9387-08	• PACKING	2		
- 5	MS21915-08-6	• REDUCER	1		
- 6	AN924-BD	• JAMB NUT	1		
- 7	MS21910-R	• TEE	1		
- 8	AN924-BD	• UNION	1		
- 9	56425	• NIPPLE (405-20222-33201) REPLACED BY P/N 375213-8 NOT INTCHG WITH 56425. P/N 375213-8 USED WITH 375508-8 ONLY.	1		
- 10	56426	• SOCKET (405-20223-33201) REPLACED BY P/N 375508-8 NOT INTCHG WITH 56426. P/N 375508-8 USED WITH 375213-8 ONLY.	1		
- 11	MS21915-C8-6	• BUSHING, SCR THD, REDUCER	1		
- 12	MS9387-12	• PACKING	1		
- 13	MS8001HC94B	• HOSE ASSY	1		
- 14	AN964C-416L	• WASHER	2		
- 15	MS20073-34-30	• BOLT, MACHINE	2		
- 16	56429	• FILTER ASSY	RF		
- 17	56429-3	• • BOWL, FILTER	1		
- 18	56429-1	• • ELEMENT, FILTER (P1414, P/N AC-6091F12Y8)			
- 19	MS9388-136	• • PACKING, PREFORMED (MR3248/1-136)	1		
- 20	MS9388-214	• • PACKING, PREFORMED (MR3248/1-214)	1		
- 21	56429-4	• • HEAD, FILTER	1		
- 22	56429-2	• • INDICATOR, PRESSURE DIFFERENTIAL	1		
- 23	MS9388-14	• • PACKING, PREFORMED (MR3248/1-14)	1		
- 24	MS9387-08	• • PACKING, PREFORMED (MR3248/1-908)	1		
- 25	MS28774-136	• • BACKUP RING	1		
- 26	MS9387-12	• PACKING	1		
- 27	MS21615-D16-12	• BUSHING, SCR THD, EXPANDER	1		
- 28	MS9387-16	• PACKING	1		
- 29	MS21915-D16-8	• BUSHING, SCR THD, EXPANDER	1		
- 30	MS21910-D16	• TEE, FLARELESS TUBE, INTERNAL THD ON RUN	1		
- 31	MS21915-D16-8	• BUSHING, SCR THD, EXPANDER	1		
	MS9387-16	• PACKING	1		
- 32	712494	• TUBE INSEPARABLE ASSY	1	35	
- 33	MS9387-16	• PACKING	1		
- 34	MS21902-D16	• UNION	1		
- 35	A-09296-5	• CHECK VALVE	1		
- 36	MS9387-16	• PACKING	1		
- 37	MS21922-D16	• UNION, FLARELESS TUBE	1		
- 38	712493	• TUBE ASSY	1		

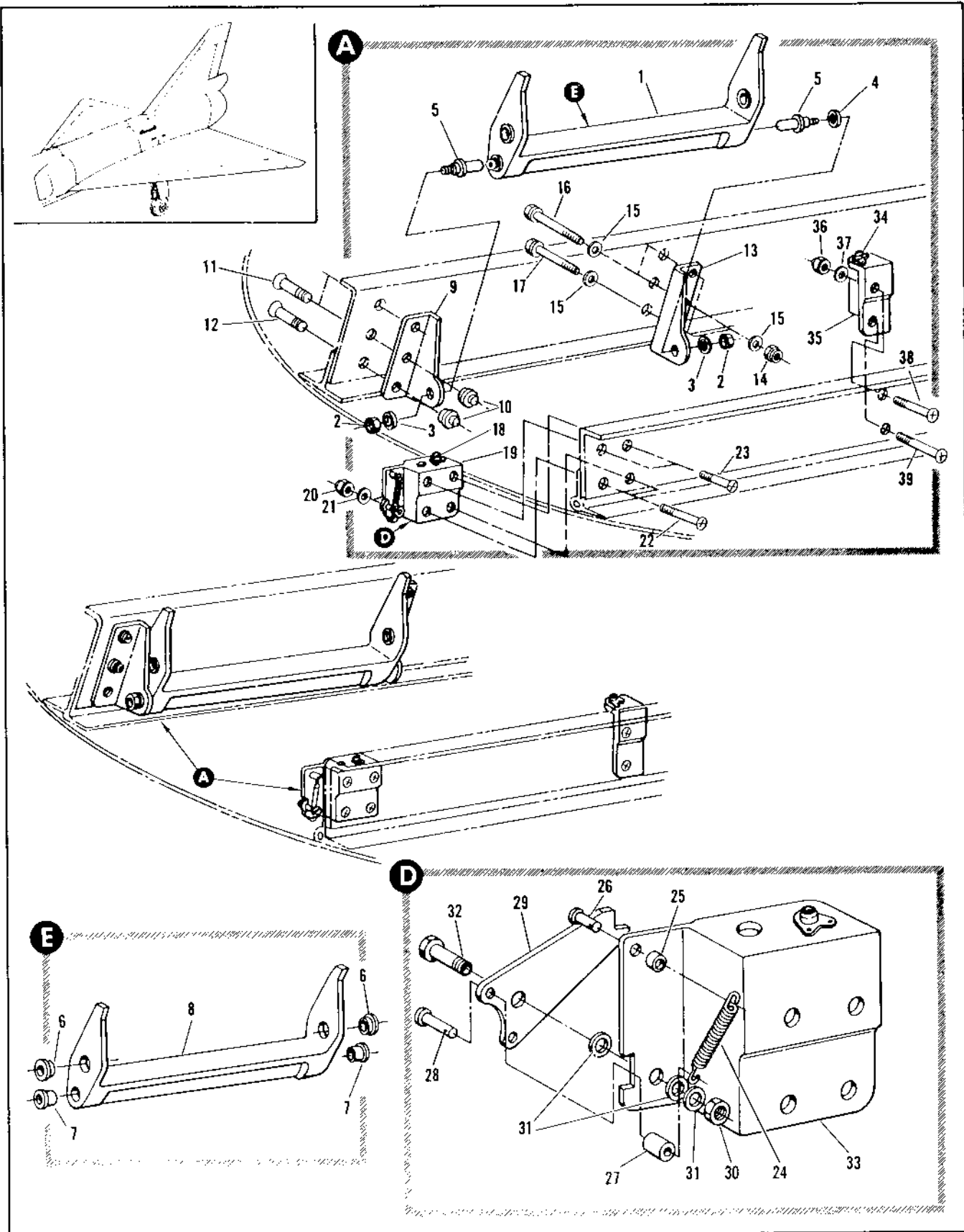

Figure 2.10-30. Remote Gearbox Accessory Drive Support Installation

FIGURE AND INDEX NUMBER	PART NUMBER	DESCRIPTION	UNITS PER ASSY.	USABLE ON CODE	
				FROM	TO
2.10-30	8-28930	SUPPORT INSTALLATION, REMOTE GEARBOX ACCESSORY DRIVE FOR NHA SEE FIG. 2.3-3	RF	35	
- 1	8-28944	• CLEVIS ASSY, OUTBD SUPPORT	1	35	
	8-28936	• CLEVIS ASSY, OUTBD SUPPORT ALT INTCHG WITH 8-29944 ATTACHING PARTS	RF	35	
- 2	NAS679A4	• NUT	2	35	
- 3	99-51505-087	• WASHER	2	35	
- 4	99-51507-010	• WASHER	AR	35	
- 5	8-28941	• PIN, HINGE OUTBD SUPPORT ----X----	2	35	
- 6	NAS53F-7P32	• BUSHING	2	35	
- 7	NAS53B-6P67	• BUSHING	2	35	
- 8	8-28944-9	• CLEVIS	1	35	
	8-28936-7	• CLEVIS, USE WITH 8-28936	RF	35	
- 9	8-28940-9	• BRACKET	1	35	
- 10	LC-CF	• COLLAR, FWD <29666> 92-17600-002	3	35	
- 11	ALPH-T8-6	• LOCKBOLT, FWD <29666> 96-79102-645	2	35	
- 12	ALPH-T8-8	• LOCKBOLT, FWD <29666> 96-79102-647	1	35	
- 13	8-28940-10	• PRACKET, AFT	1	35	
- 14	NAS679A4	• NUT, AFT	3	35	
- 15	AN960-416	• WASHER, AFT	6	35	
- 16	NAS454-4A7	• BOLT, AFT	2	35	
- 17	NAS464-4A10	• BOLT, AFT	1	35	
- 18	NAS684A5	• NUTPLATE	1	B	
	NAS686A5	• NUTPLATE	1	189	277
- 19	8-28934-1	• BRACKET ASSY, FWD INBD SUPPORT GEARBOX ATTACHING PARTS	1	49	277
- 20	NAS679A4	• NUT	4	35	
- 21	AN960-416	• WASHER	4	35	
- 22	NAS334PA11	• SCREW	2	35	
- 23	NAS334FA7	• SCREW ----X----	2	35	
- 24	8-64374	• SPRING, PILOTS CHECK LIST	1	35	
- 25	NAS420D4-10	• SPACER	1	35	
- 26	AN392-11	• FIN	1	35	
- 27	NAS420D4-24	• SPACER	1	35	
- 28	MS20392-1021	• PIN	1	35	
- 29	8-28939-7	• PLATE, LATCH INBD SUPPORT	1	35	
- 30	AN320-4	• NUT	1	35	
- 31	AN960-416L	• WASHER	3	35	
- 32	AN24-13	• BOLT, CLEVIS	1	35	
- 33	8-28946	• BRACKET, FWD INBD SUPPORT GEARBOX REPLACED BY SUITABLE SUB 8-28946-9	1	A	
	8-28938-7	• BRACKET, FWD INBD SUPPORT GEARBOX ALT INTCHG WITH 8-28946	RF	A	
	8-28946-9	• BRACKET, FWD INBD SUPPORT GEARBOX REPLACES SUITABLE SUB FOR 8-28946	1	49	277
	8-28938-9	• BRACKET, FWD INBD SUPPORT GEARBOX ALT INTCHG WITH 8-28946-9	RF	49	277
- 34	NAS684A5	• NUTPLATE	1	B	
	NAS686A5	• NUTPLATE	1	189	277
- 35	8-28945	• BRACKET, SUPPORT REMOTE GEARBOX ACCESSORY DRIVE REPLACED BY SUITABLE SUB 8-28945-9	1	A	
	8-28935-7	• BRACKET, SUPPORT REMOTE GEARBOX ACCESSORY DRIVE ALT INTCHG WITH 8-28945	RF	A	
	8-28945-9	• BRACKET, SUPPORT REMOTE GEAR BOX ACCESSORY DRIVE REPLACES SUITABLE SUB FOR 8-28945	1	49	277
	8-28935-9	• BRACKET, SUPPORT REMOTE GEARBOX ACCESSORY DRIVE ALT INTCHG WITH 8-28945-9 ATTACHING PARTS	RF	49	277
- 36	NAS679A4	• NUT	2	35	
- 37	AN960-416	• WASHER	2	35	
- 38	NAS334PA11	• BOLT	1	35	
- 39	NAS334PA7	• BOLT ----X----	1	35	
		A AIRPLANES #15 THRU 4A, 27A AND ON			
		B AIRPLANES #35 THRU 18A, 27A AND ON			

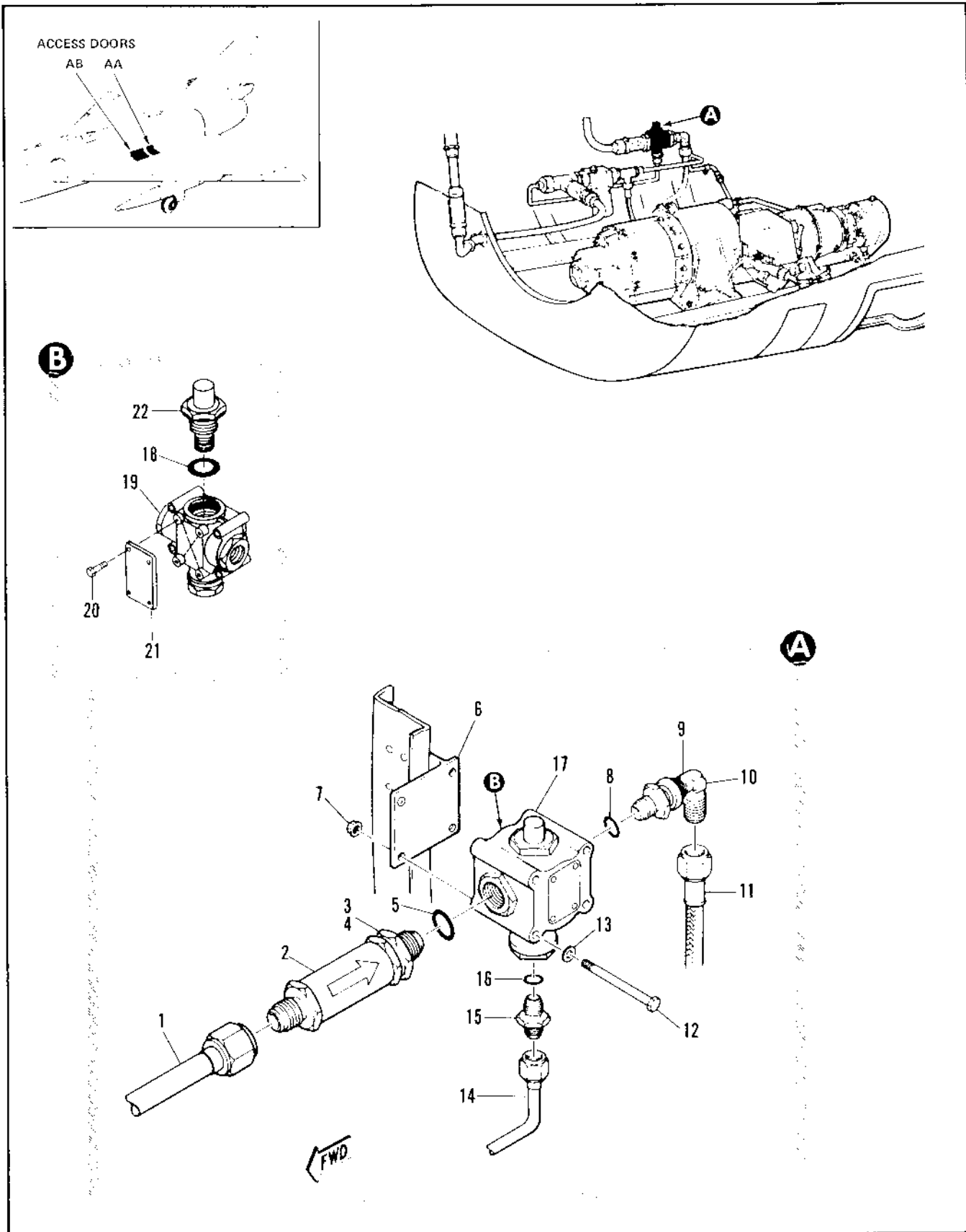

Figure 2.10-31. CSD Oil Cooler Bypass Valve Installation

FIGURE AND INDEX NUMBER	PART NUMBER	DESCRIPTION	UNITS PER ASSY.	USABLE ON CODE	
				FROM	TO
		1 2 3 4 5 6			
2.10-31		CSD OIL COOLER BYPASS VALVE INSTALLATION	RF	35	
- 1	8-27576-45	• TUBE ASSY	1		
- 2	8-09296-3	• CHECK VALVE	1		
- 3	MS21916-D16-10	• REDUCER, EXTERNAL THD	1		
- 4	MS9387-16	• PACKING	1		
- 5	MS9387-10	• PACKING	1		
- 6	713065	• BRACKET ASSY	1		
- 7	MS21343-4	• NUT, SELFLOCKING	4		
- 8	MS9387-10	• PACKING	1		
- 9	AN924-100	• NUT HEX	1		
- 10	MS21968D10	• ELBOW, BULKHEAD 90 DEGREES	1		
- 11	MS8001J152C	• HOSE ASSY	1		
- 12	MS16598-50	• SCREW, CAP, SOC HD	4		
- 13	AN968C-416L	• WASHER	4		
- 14	712494	• TUBE ASSY	1		
- 15	MS21962-C8	• UNION, FLAPELESS TUBE	1		
- 16	MS9387-C8	• PACKING	1		
- 17	712009	• COOLER BYPASS VALVE ASSEMBLY	RF		
- 18	MS9387-16	• • PACKING	1		
- 19	712795	• • HOUSING ASSY	1		
- 20	NAS1352-04-4P	• • SCREW, CAP	4		
- 21	712974	• • PLATE, ID	1		
- 22	56541	• • VALVE, TEMPERATURE REGULATOR	1		

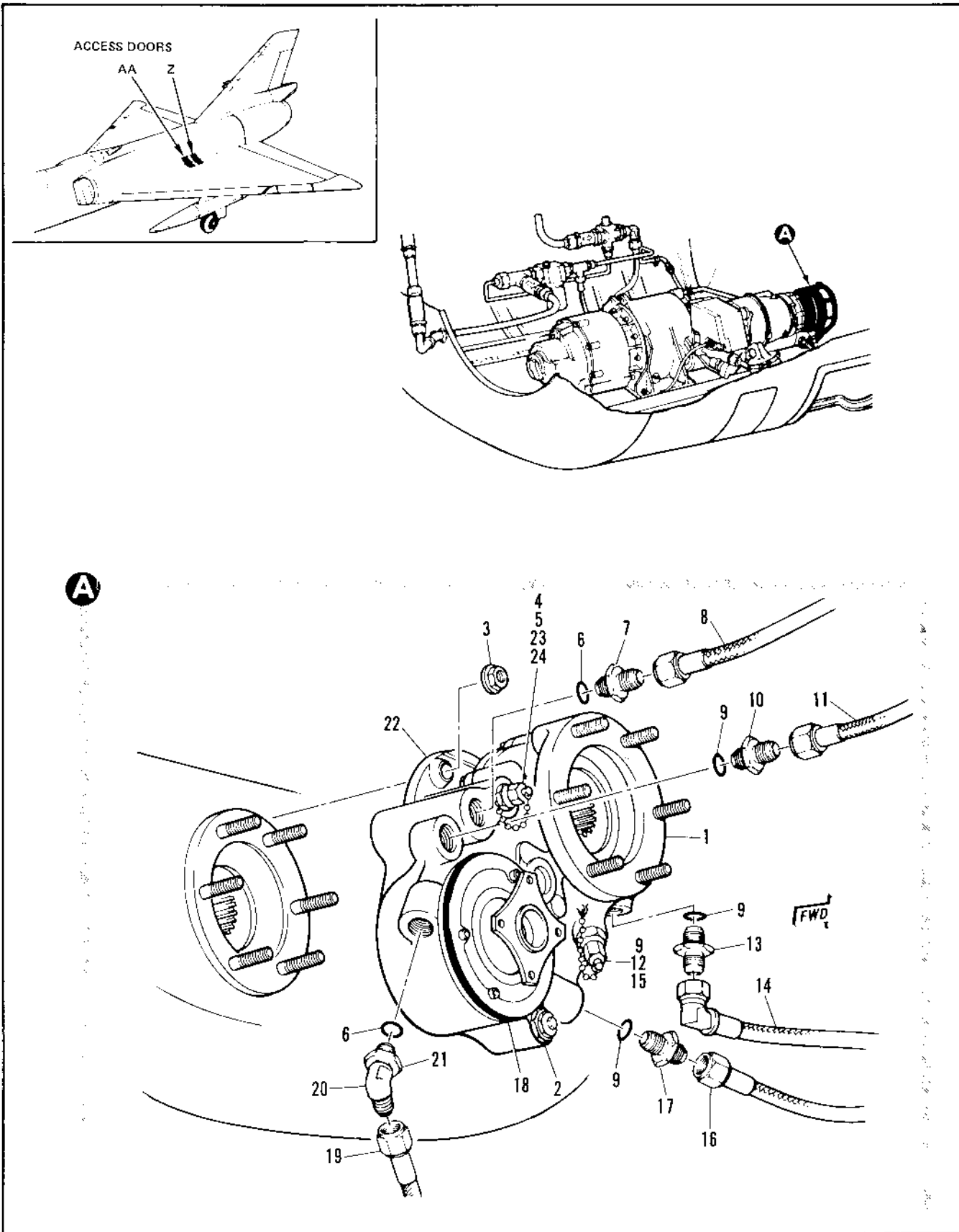

Figure 2.10-32. Engine Mounted Gearbox Installation

FIGURE AND INDEX NUMBER	PART NUMBER	DESCRIPTION	UNITS PER ASSY.	USABLE ON CODE	
				FROM	TO
		1 2 3 4 5 6			
2.10-32		ENGINE MOUNTED GEARBOX INSTALLATION	RF	35	
- 1	7086A2C	• GEARBOX	1		
- 2	4064J	• PLUG ASSY, DRAIN SELF-CLOSING, MAGNETIC	1		
- 3	NAS1291-6	• NUT, SELF-LOCKING	1		
- 4	MS21914-2J	• CAP, PRESSURE SEAL	1		
- 5	S6553	• CHAIN SAFETY	1		
- 6	MS5387-06	• PACKING	1		
- 7	MS21924J6	• UNION, BULKHEAD	1		
- 8	MS801612EA	• HOSE ASSY	1		
- 9	MS9387-04	• PACKING	1		
- 10	MS21902D4	• UNION, FLARELESS TUBE	1		
- 11	MS8001E156A	• HOSE ASSY	1		
- 12	MS24423-4	• VALVE, CHECK	1		
- 13	MS21902-D4	• UNION, FLARELESS TUBE	1		
- 14	R9844S4-0111-90	• HOSE ASSY, VENT & DRAIN 94-PC949-002	1		
- 15	MS21914-J4	• CAP, PRESSURE TUBE	1		
- 16	MS8001E064A	• HOSE ASSY	1		
- 17	MS2192-D4	• UNION, FLARELESS TUBE	1		
- 18	MS9388-247	• PACKING	1		
- 19	MS8001G206A *	• HOSE ASSY	1		
- 20	MS21907-D6	• ELBOW, BULKHEAD 45 DEGREE UNIVERSAL	1		
- 21	AN924-6D	• NUT, HEX	1		
- 22	MS9388-155	• SEAL	1		
- 23	MS21902-2C	• UNION	1		
- 24	MS9387-02	• PACKING	1		
		* THIS HOSE MUST BE USED IN COMBINATION WITH A MS21902J6 UNION TO REPLACE THE 712487 HOSE ASSEMBLY			

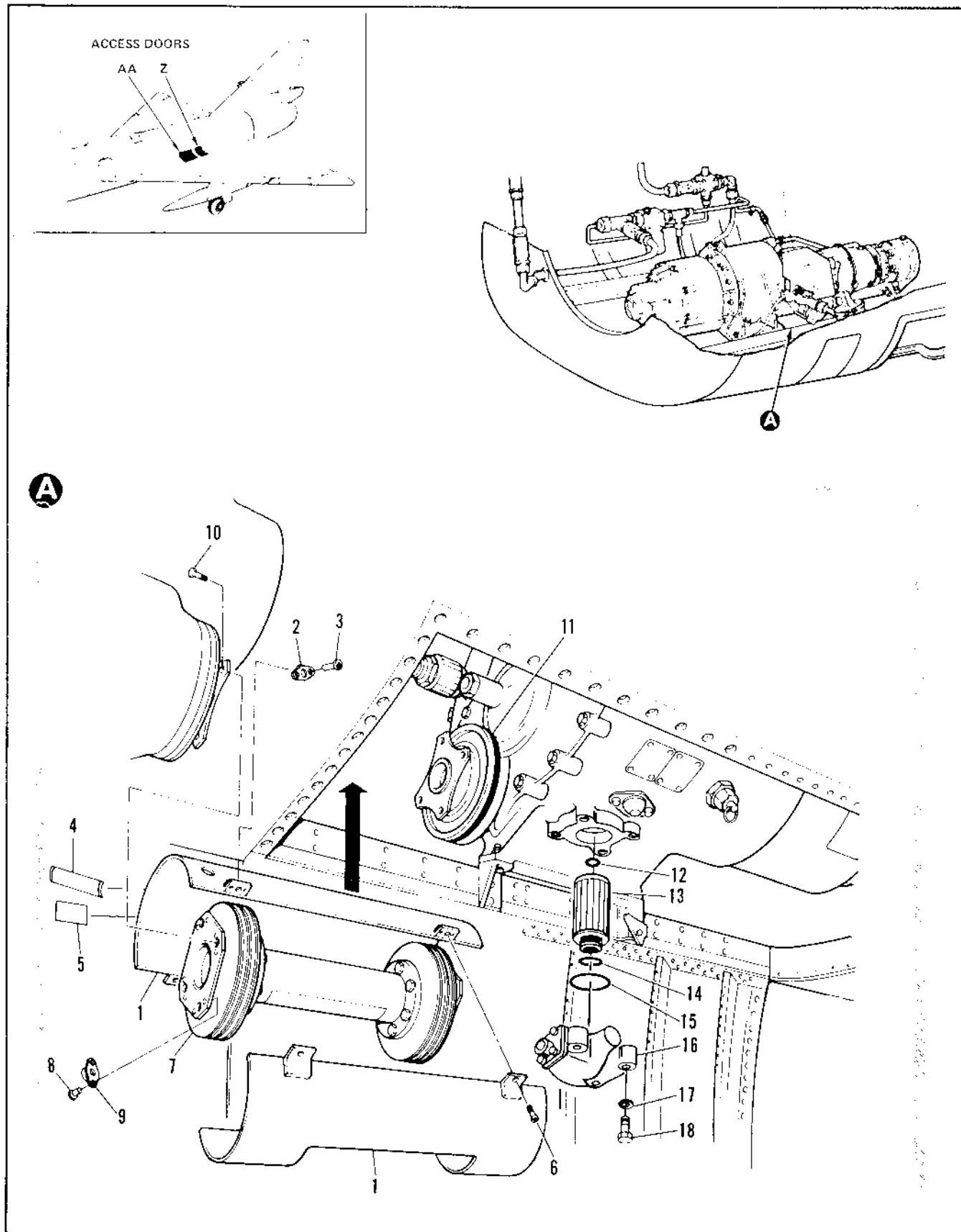

Figure 2.10-33. CSD Drive Shaft Cover, Drive Shaft and Internal Filter Installation

FIGURE AND INDEX NUMBER	PART NUMBER	DESCRIPTION	UNITS PER ASSY.	USABLE ON CODE	
				FROM	TO
2.10-33		CSD DRIVE SHAFT COVER, DRIVE SHAFT AND INTERNAL FILTER ASSEMBLY	RF		
- 1	711867	• COVER, ASSEMBLY	1	35	
- 2	MS21075-3	• • PLATE NUT	4		
- 3	MS20426A3-5	• • RIVET	8		
- 4	715774	• • PLATE, CAUTION	1		
- 5	5200266	• • PLATE, ID	1		
- 6	NAS135103-R	• SCREW, CAP	4		
- 7	708646	• DRIVE SHAFT ASSY	1		
- 8	MS20605MP4W4	• • RIVET	16		
- 9	MS21075-3	• • NUT LOCK FLOAT	8		
- 10	NAS464P-5L-A4	• BOLT, MACHINE	8		
- 11	MS9388-245	• PACKING	1		
- 12	MS9388-014	• PACKING	1		
- 13	M70-002-4	• FILTER ASSY	1		
- 14	MS9388-016	• PACKING	1		
- 15	MS9388-128	• PACKING	1		
- 16	708595	• CAP ASSY, FILTER			
- 17	AN9600416L	• WASHER, FLAT	4		
- 18	NAS1352-4-14P	• SCREW, CAP, SOCKET HEAD	4		

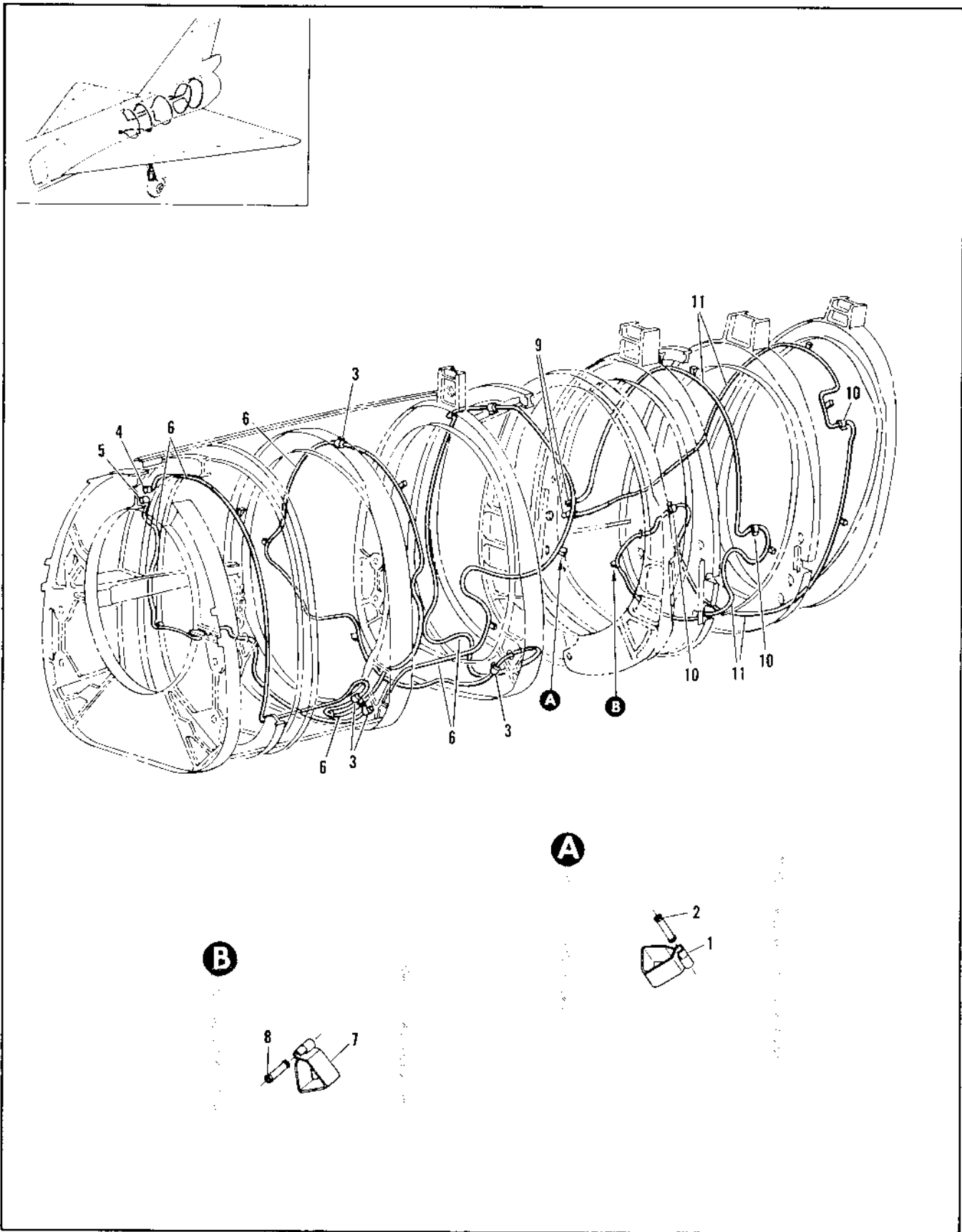

Figure 2.10-34. Fire and Overheat Detector

FIGURE AND INDEX NUMBER	PART NUMBER	DESCRIPTION	UNITS PER ASSY.	USABLE ON CODE	
				FROM	TO
		1 2 3 4 5 6			
2.10-34	8-27981-801	FIRE AND OVERHEAT DETECTOR • DETECTOR INSTL, FIRE STA 487 TO 569 FOR NHA SEE FIG. 2.3-14	RF	35	48
- 1	22466	• • CLAMP, <97196> 92-05100-001	AR	35	48
- 2	23541	• • BUSHING, <97196> 91-26901-001	AR	35	48
- 3	41604	• • CONNECTOR, <97196> 92-50074-002 REPLACED BY NOT INTCHG WITH 41799	5	35	48
- 4	41234	• • CONNECTOR, <97196> 92-50031-001	1	35	43
	41941	• • RECEPTACLE, FIRE DETECTOR <19500> SPEC 8-09481-1	1	44	48
	8-27981-151	• • RECEPTACLE ASSY, FIRE DETECTOR ALT INTCHG WITH 41941	RF	44	48
	41234	• • • CONNECTOR, <97196> 92-50031-001	1	44	48
	EX06-B51S	• • • RECEPTACLE, <18355> SPEC 8-06283	1	44	48
- 5	41236	• • CONNECTOR, <97196> 92-50031-025	1	35	43
	41941	• • RECEPTACLE, FIRE DETECTOR <19500> SPEC 8-09481-1	1	44	48
	8-27981-151	• • RECEPTACLE ASSY, FIRE DETECTOR ALT INTCHG WITH 41941	RF	44	48
- 6	234-54610	• • CABLE, <97196> 91-38031-003	6	35	48
	8-27981-803	• DETECTOR INSTL, OVERHEAT STA 617 AND AFT FOR NHA SEE FIG. 2.3-14	RF	35	48
- 7	22466	• • CLAMP, <97196> 92-05100-001	12	35	48
- 8	23541	• • BUSHING, <97196> 91-26901-001	73	35	48
- 9	41234	• • CONNECTOR, <97196> 92-50031-001	2	35	43
	41241	• • RECEPTACLE, FIRE DETECTOR <15500> SPEC 8-09481-1	2	44	48
	8-27981-151	• • RECEPTACLE ASSY, FIRE DETECTOR ALT INTCHG WITH 41941	RF	44	48
- 10	41604	• • CONNECTOR, <97196> 92-50074-002 REPLACED BY NOT INTCHG WITH 41799	3	35	48
- 11	234-54610	• • CABLE, <97196> 91-38031-003	4	35	48

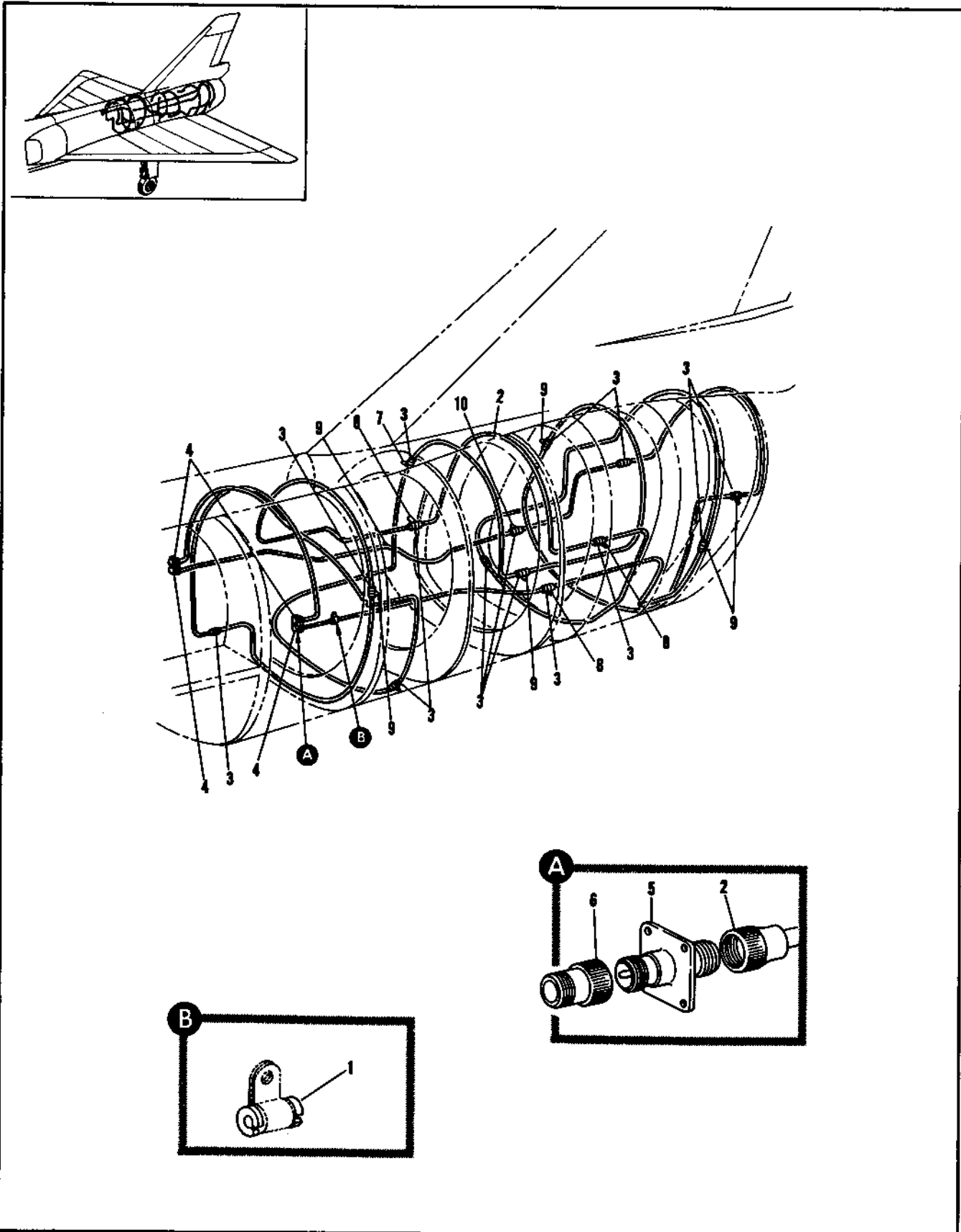

Figure 2.10-35. Fire and Overheat Detector Installation

FIGURE AND INDEX NUMBER	PART NUMBER	DESCRIPTION	UNITS PER ASSY.	USABLE ON CODE	
				FROM	TO
		1 2 3 4 5 6			
2.10-35	8-28963	DETECTOR INSTALLATION, FIRE AND OVERHEAT FOR NHA SEE FIG. 2.3-14	RF	49	
- 1	23541	• BUSHING, <19500> 91-26901-001	AR	49	
- 2	234-54610	• CABLE ASSY, FIRE DETECTOR <19500> 91-38000-003 REPLACED BY SUITABLE SUB 2940546120	16	49	60
	2940546120	• CABLE ASSY, FIRE DETECTOR <19500> 91-38000-004 REPLACES SUITABLE SUB FOR 234-54610	16	61	
- 3	41604	• CONNECTOR, FIRE DETECTOR <19500> 92-50074-002 REPLACED BY SUITABLE SUB 41799	14	49	60
	41799	• CONNECTOR, FIRE DETECTOR <19500> 92-50074-003 REPLACES SUITABLE SUB FOR 41604	14	61	
- 4	41941	• RECEPTACLE, <19500> SPEC 8-09481-1	4	49	
- 5	41234	• RECEPTACLE, <19500> 92-50001-001	1	49	
- 6	EX06-8S1S	• CONNECTOR, <71462> SPEC 8-06283	1	49	
- 7	NAS43DD3-16	• SPACER	1	49	
- 8	NAS43DD3-20	• SPACER	4	49	
- 9	NAS43DD3-24	• SPACER	6	49	
- 10	NAS43DD3-48	• SPACER	1	49	

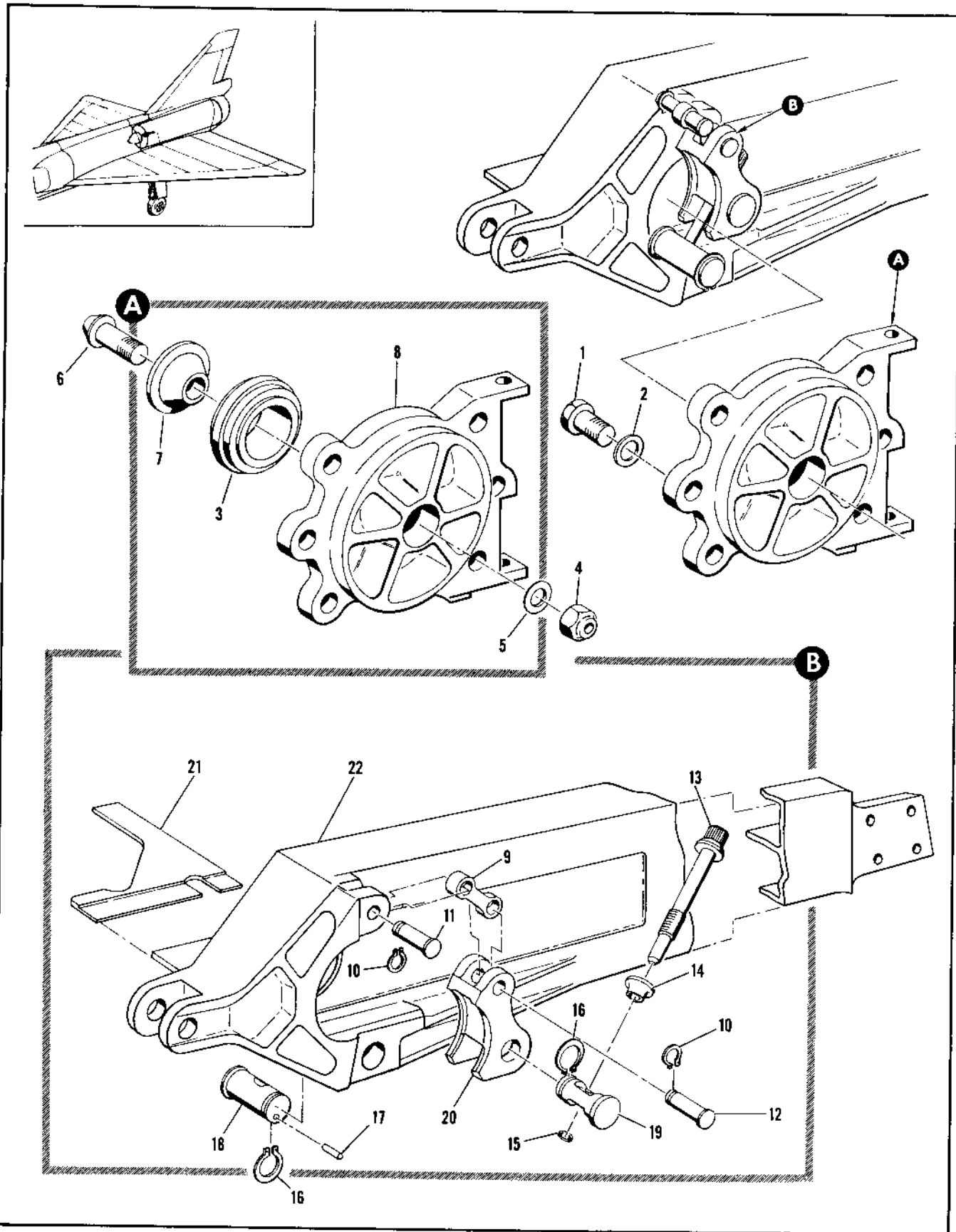

Figure 2.10-36. Engine Thrust Bearing Support and Clamp

FIGURE AND INDEX NUMBER	PART NUMBER	DESCRIPTION	UNITS PER ASSY.	USABLE ON CODE	
				FROM	TO
2.10-36	B-22961	ENGINE THRUST BEARING SUPPORT AND CLAMP • SUPPORT ASSY, ENGINE THRUST BEARING FOR NHA SEE FIG. 2.10-7 ATTACHING PARTS	RF	35	
- 1	NAS1305-3M	• BOLT	6	35	
- 2	AN960-916L	• WASHER	6	35	
		-----X-----			
- 3	BSSR29005	• BEARING ASSY, ENGINE THRUST MOUNT <81376> SPEC 8-02271 ATTACHING PARTS	1	35	
- 4	NAS679A6	• NUT	1	35	
- 5	AN960-616L	• WASHER	1	35	
- 6	MS20006-20	• BOLT	1	35	
		-----X-----			
- 7	8-22965	• WASHER	1	35	
- 8	8-22960-7	• SUPPORT	1	35	
	8-22959	• SUPPORT, ALT INTCHG WITH 8-22960-7	RF	35	
	8-27993	• CLAMP INSTL, ENGINE THRUST MOUNT STA 478 FOR NHA SEE FIG. 2.3-3	RF	35	
- 9	8-27994	• LINK, ENGINE THRUST MOUNT CLAMP ATTACHING PARTS	1	35	
- 10	NAS670-43	• RING	2	35	
- 11	8-27995-7	• PIN, ENGINE THRUST MOUNT CLAMP	1	35	
- 12	8-27995	• PIN, ENGINE THRUST MOUNT CLAMP	1	35	
		-----X-----			
- 13	P-27999-7	• SCREW	1	A	
	8-28005	• SCREW, ALT INTCHG WITH 8-27999-7	RF	A	
	8-28005	• SCREW	1	B	
- 14	P-28006	• SPACER, SCREW ENGINE CLAMP	1	35	
- 15	8-27989	• RING, ENGINE THRUST MOUNT CLAMP	1	35	
- 16	NAS670-87	• RING	2	35	
- 17	79-022-094-075	• PIN, <72962> 96-79301-001	1	35	
- 18	8-27996	• NUT, ENGINE THRUST MOUNT CLAMP	1	35	
- 19	8-27997	• TRUNNION, ENGINE THRUST MOUNT CLAMP	1	35	
- 20	8-27996	• CLAMP, ENGINE THRUST MOUNT	1	35	
	8-74116-L	• BEAM INSTL, ENGINE THRUST STA 472 TO 520 FOR NHA SEE FIG. 2.3-3	RF	35	
- 21	8-74956	• FILLER, ENGINE THRUST BEAM	1	35	
- 22	8-74172-7	• BEAM, ENGINE THRUST	1	C	
	8-74123	• BEAM, ENGINE THRUST ALT INTCHG WITH 8-74172-7	RF	C	
	8-74172-11	• BEAM, ENGINE THRUST	1	90	277
		A AIRPLANES #35 THRU 286, 288, 297 AND ON			
		B AIRPLANES #287 AND 289 THRU 296			
		C AIRPLANES #35 THRU 89, 278 AND ON			

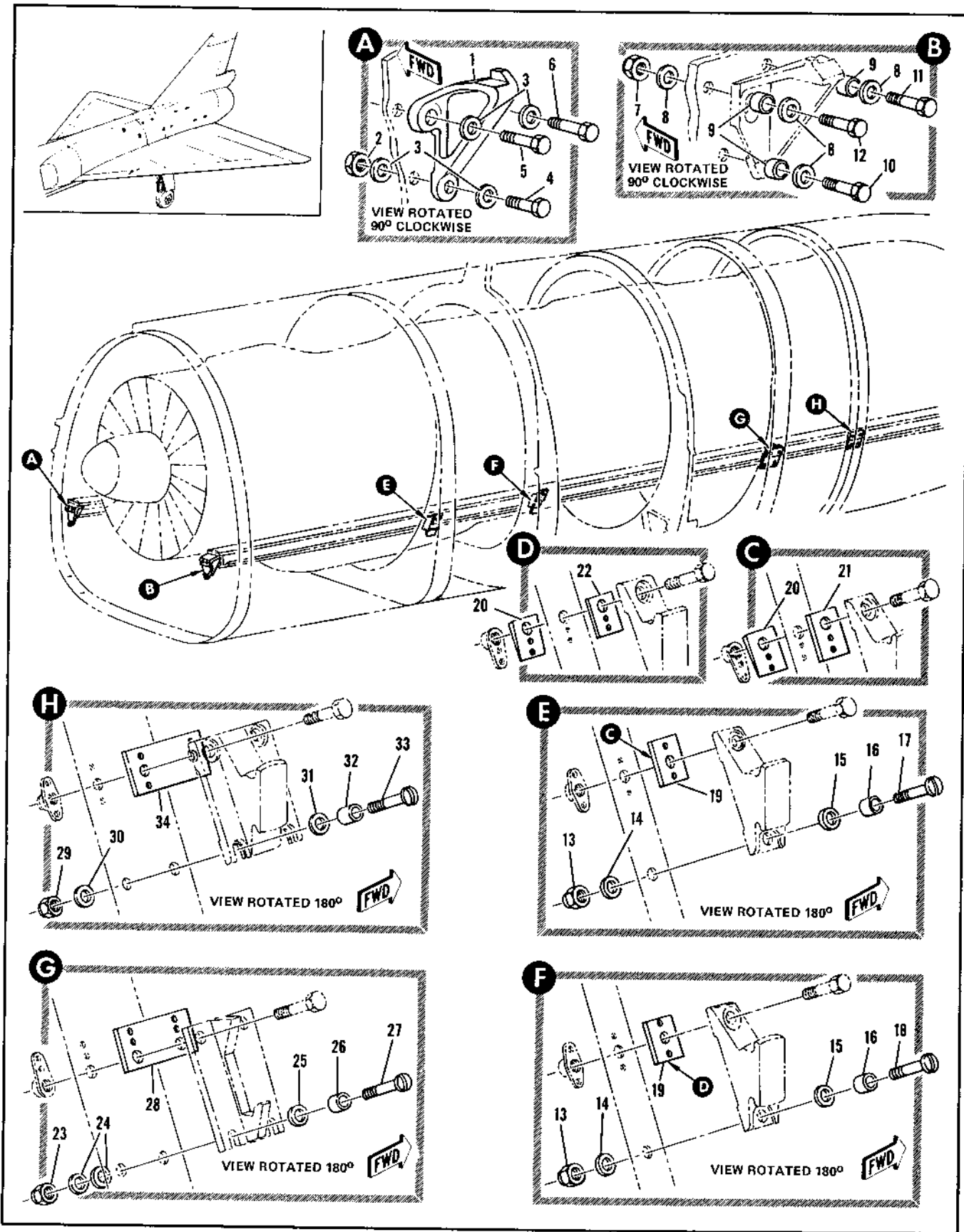

Figure 2.10-37. Engine Removal Rail Support Installation

FIGURE AND INDEX NUMBER	PART NUMBER	DESCRIPTION	UNITS PER ASSY.	USABLE ON CODE	
				FROM	TO
		1 2 3 4 5 6			
2.10-37	8-28000	SUPPORT INSTALLATION, ENGINE REMOVAL RAIL FOR NHA SEE FIG. 2.3-15	PF	A	
	8-28000-1	SUPPORT INSTALLATION, ENGINE REMOVAL RAIL FOR NHA SEE FIG. 2.3-15	PF	48	129
- 1	8-28003-7	• SUPPORT, ENGINE REMOVAL RAIL RH REPLACED BY NOT INTCHG WITH 8-28008-10	1	B	
	8-28002	• SUPPORT, ENGINE REMOVAL RAIL RH ALT INTCHG WITH 8-28003-7 ATTACHING PARTS	PF	B	
- 2	NAS679A4	• NUT	3	B	
- 3	AN960-416L	• WASHER	6	B	
- 4	AN4-12A	• BOLT	1	A	
	AN4-14A	• BOLT	1	48	129
- 5	AN4-13A	• BOLT	1	A	
	AN4-14A	• BOLT	1	48	129
- 6	AN4-15A	• BOLT	1	A	
	AN4-16A	• BOLT	1	48	129
		-----X-----			
- 7	NAS679A4	• NUT	3	B	
- 8	AN960-416	• WASHER	6	B	
- 9	NAS43HT4-20	• SPACER	3	B	
- 10	AN4-13A	• BOLT	1	A	
	AN4-14A	• BOLT	1	48	129
- 11	AN4-14A	• BOLT	1	B	
- 12	AN4-16A	• BOLT	1	H	
- 13	22FT524	• NUT, <5687P> 56-37525-024	4	A	
	52LH2935-C54	• NUT, <70962> 96-37542-101	4	48	129
- 14	AN960-516	• WASHER	AR	A	
	2935-05	• WASHER, <72942> 99-51701-001	4	48	129
- 15	99-51505-010	• WASHER	4	B	
	99-51505-F10	• WASHER	2	48	129
- 16	NAS43HT5-11	• SPACER	2	B	
- 17	AN25-19A	• BOLT	2	A	
	AN25-17A	• BOLT	2	48	129
- 18	AN25-14A	• BOLT	2	A	
	AN25-22A	• BOLT	2	48	129
- 19	8-28000-7	• SHIM	4	A	
- 20	8-28004	• SHIM	4	48	129
- 21	8-28000-17	• SHIM	2	48	129
- 22	8-28000-16	• SHIM	2	48	129
- 23	22FT425	• NUT, <5687P> 96-37525-003	4	B	
- 24	AN960-416	• WASHER	8	B	
- 25	99-51505-009	• WASHER	4	B	
- 26	NAS43HT4-10	• SPACER	4	R	
- 27	AN24-13A	• BOLT	4	R	
- 28	9-28000-9	• SHIM	2	5	
- 29	22FT524	• NUT, <5687P> 96-37525-004	4	B	
- 30	AN960-516	• WASHER	AR	B	
- 31	99-51505-013	• WASHER	4	B	
- 32	NAS43HT5-11	• SPACER	4	B	
- 33	AN25-11A	• BOLT	4	R	
- 34	8-28000-11	• SHIM	2	B	

A AIRPLANES #35 THRU 47, 27R AND ON
 B AIRPLANES #35 THRU 125, 27R AND ON

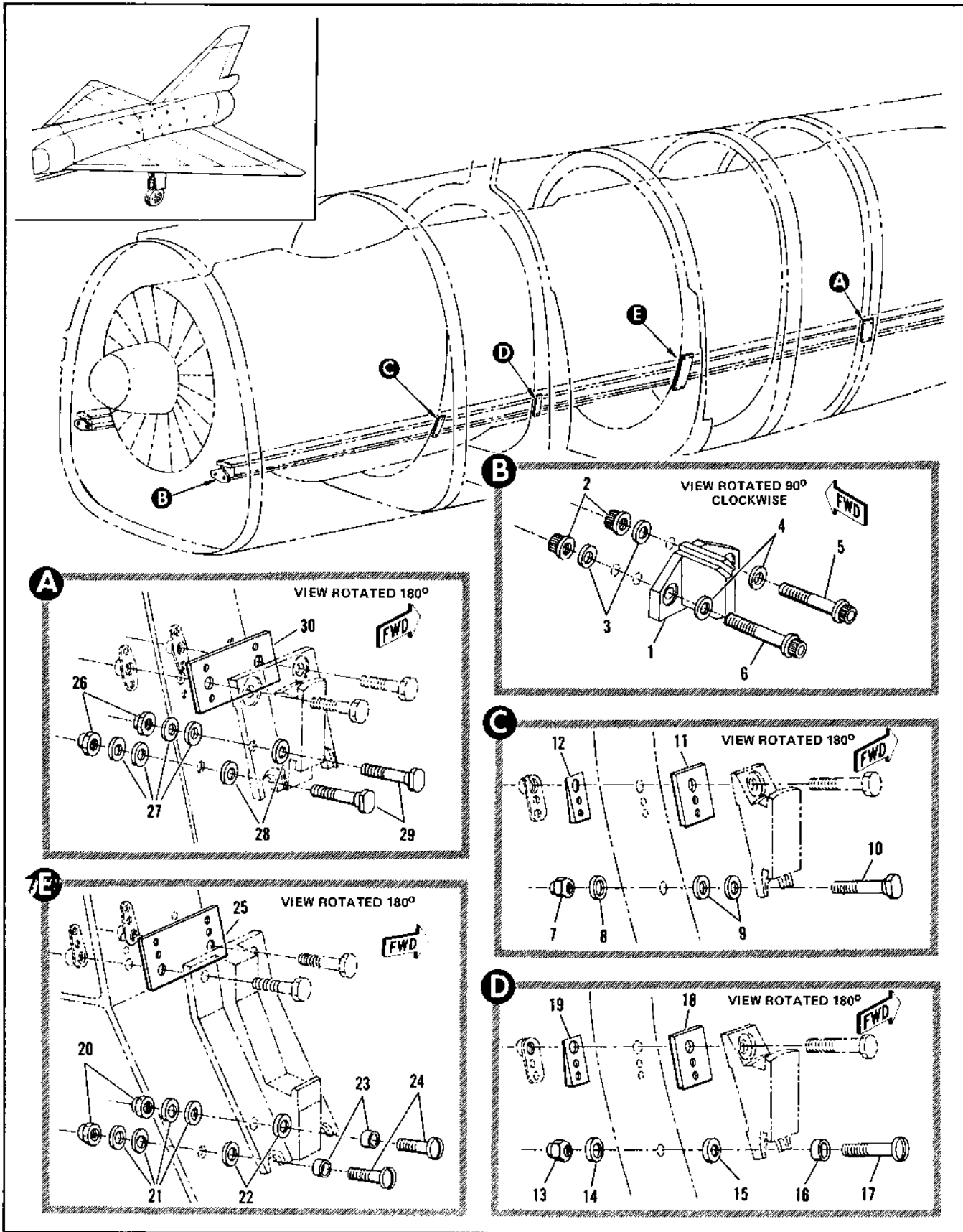

Figure 2.10-38. Engine Removal Rail Support Installation

FIGURE AND INDEX NUMBER	PART NUMBER	DESCRIPTION	UNITS PER ASSY.	USABLE ON CODE	
				FROM	TO
2.10-38	R-28000-3	SUPPORT INSTALLATION, ENGINE REMOVAL RAIL FOR MHA SEE FIG. 2.3-1F	RF	130	277
- 1	R-28008-9 R-28008-10	• SUPPORT, ENGINE REMOVAL RAIL LH • SUPPORT, ENGINE REMOVAL RAIL RH REPLACES NOT INTCHG WITH R-28003-7 ATTACHING PARTS	1 1	130	277 277
- 2	EWN22-4	• NUT, <56874> 96-37590-101	4	130	277
- 3	MS20002-4	• WASHER	4	130	277
- 4	MS20002-04	• WASHER	4	130	277
- 5	EWN22-4-19	• BOLT, <56874> 90-82024-025	2	130	277
- 6	EWN22-4-22	• BOLT, <56874> 90-82024-044 -----X-----	2	130	277
- 7	52LH2935-C54	• NUT, <72962> 96-37592-101	2	130	277
- 8	2935-05	• WASHER, <72962> 99-51201-001	2	130	277
- 9	99-51505-C10	• WASHER	4	130	277
- 10	8-28009-9	• BOLT	2	130	277
- 11	R-28000-17	• SHIM	2	130	277
- 12	8-28004	• SHIM	2	130	277
- 13	52LH2935-054	• NUT, <72962> 96-37592-101	2	130	277
- 14	2935-05	• WASHER, <72962> 99-51201-001	2	130	277
- 15	99-51505-010	• WASHER	2	130	277
- 16	NAS43HT5-10	• SPACER	2	130	277
- 17	AN25-22A	• BOLT	2	130	277
- 18	8-28000-15	• SHIM	2	130	277
- 19	8-28004	• SHIM	2	130	277
- 20	NAS1291-4	• NUT	4	130	277
- 21	AN962-416	• WASHER	6	130	277
- 22	99-51505-009	• WASHER	4	130	277
- 23	NAS43HT4-10	• SPACER	4	130	277
- 24	AN24-13A	• BOLT	4	130	277
- 25	8-28000-9	• SHIM	2	130	277
- 26	NAS1251-5	• NUT	4	130	277
- 27	AN962-516	• WASHER	AR	130	277
- 28	99-51505-010	• WASHER	2	130	277
- 29	8-28009-7	• BOLT, REPLACES NOT INTCHG WITH AN25-11A	4	130	277
- 30	8-28000-11	• SHIM	2	130	277

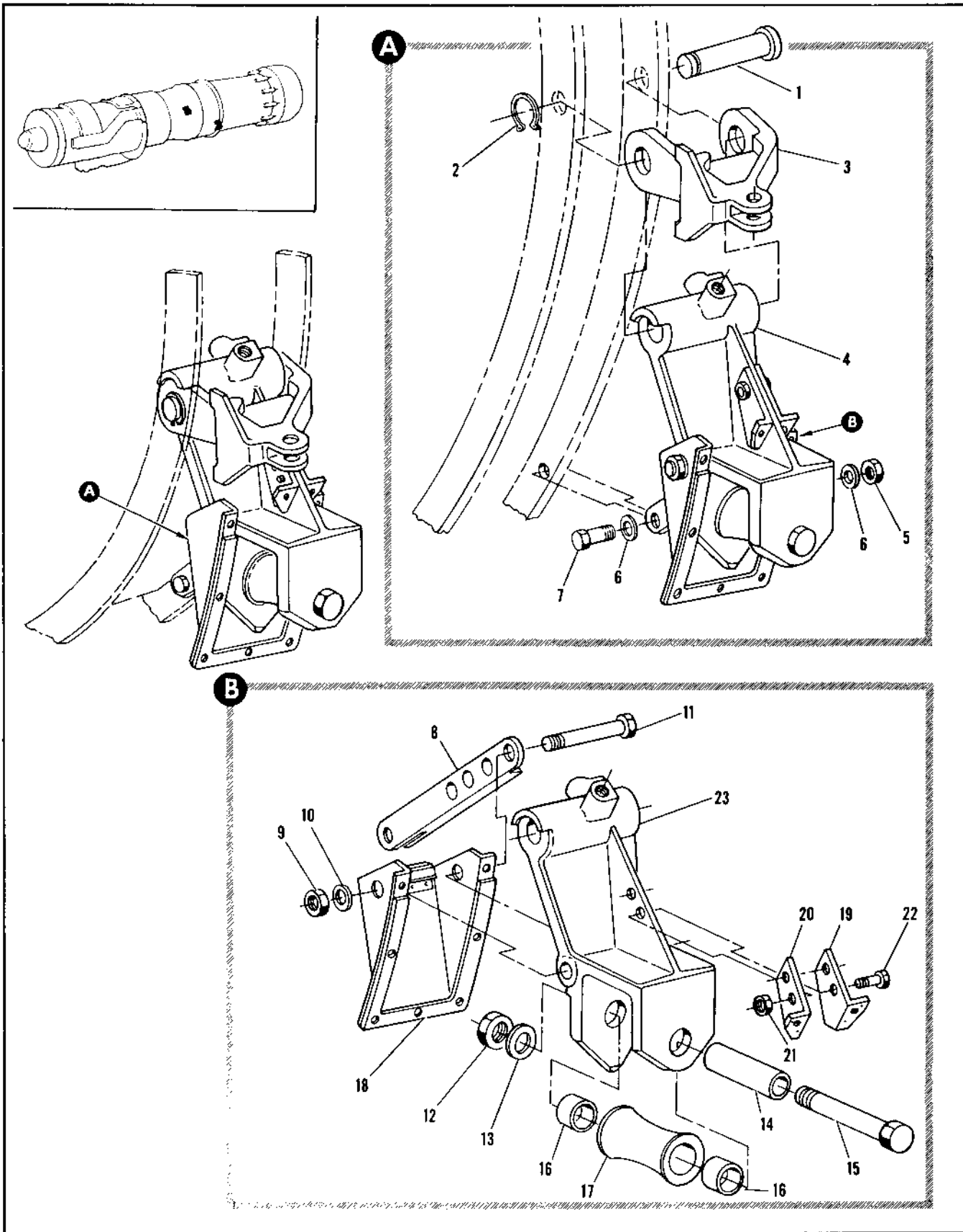

Figure 2.10-39. Engine Aft Roller Installation

FIGURE AND INDEX NUMBER	PART NUMBER	DESCRIPTION	UNITS PER ASSY.	USABLE ON CODE	
				FROM	TO
		1 2 3 4 5 6			
2.10-39	8-22080-1	ROLLER INSTALLATION, ENGINE AFT LH FOR NHA SEE FIG. 2.10-7	RF	35	
	8-22080-2	ROLLER INSTALLATION, ENGINE AFT RH FOR NHA SEE FIG. 2.10-7	RF	35	
- 1	8-22084	• PIN, ENGINE AFT ROLLER	1	35	
- 2	5100-75	• RING, RETAINER <79130> 97-61500-001	1	35	
- 3	8-22018-7	• SUPPORT, ENGINE COOLING SHROUD	1	35	
	8-22617	• SUPPORT, ENGINE COOLING SHROUD ALT INTCHG WITH 8-22618-7	RF	35	
- 4	8-22086-7	• ROLLER ASSY, LH	1	35	
	8-22080-6	• ROLLER ASSY, RH ATTACHING PARTS	1	35	
- 5	AN310C6	• NUT	1	35	
- 6	AN960-616	• WASHER	2	35	
- 7	NAS501-6-12	• BOLT	1	35	
		----X----			
- 8	8-22083-7	• LINK, ENGINE AFT ROLLER BRACKET LH	1	35	
	8-22083-8	• LINK, ENGINE AFT ROLLER BRACKET RH ATTACHING PARTS	1	35	
- 9	AN320C7	• NUT	1	35	
- 10	AN960-716	• WASHER	1	35	
- 11	NAS501-7-22	• BOLT	1	35	
		----X----			
	8-22082	• ROLLER ASSY, ENGINE AFT ATTACHING PARTS	1	35	
- 12	AN320C2	• NUT	1	35	
- 13	AN960-716	• WASHER	1	35	
- 14	8-22069	• SPACER, ENGINE SUPPORT ROLLER	1	35	
- 15	8-22085	• BOLT, ENGINE AFT ROLLER BRACKET SHEAR	1	35	
		----X----			
- 16	NAS295-1JA	• BEARING	2	35	
- 17	8-22082-7	• ROLLER	1	35	
- 18	8-22615	• SEAL ASSY, ENGINE COOLING SHROUD RIVETED	1	35	
- 19	8-22616-3	• SUPPORT ASSY, ENGINE COOLING SHROUD PIVETED	1	35	
- 20	8-22616-4	• SUPPORT ASSY, ENGINE COOLING SHROUD RIVETED ATTACHING PARTS	1	35	
- 21	99F12-1632	• NUT, <56878> 96-37534-193	2	35	
- 22	AN305A	• BOLT	2	35	
		----X----			
- 23	8-22081-19	• BRACKET, ENGINE AFT ROLLER LH	1	35	
	8-22086-17	• BRACKET, ENGINE AFT ROLLER LH ALT INTCHG WITH 8-22081-19	RF	35	
	8-22081-21	• BRACKET, ENGINE AFT ROLLER RH	1	35	
	8-22086-19	• BRACKET, ENGINE AFT ROLLER RH ALT INTCHG WITH 8-22081-21	RF	35	

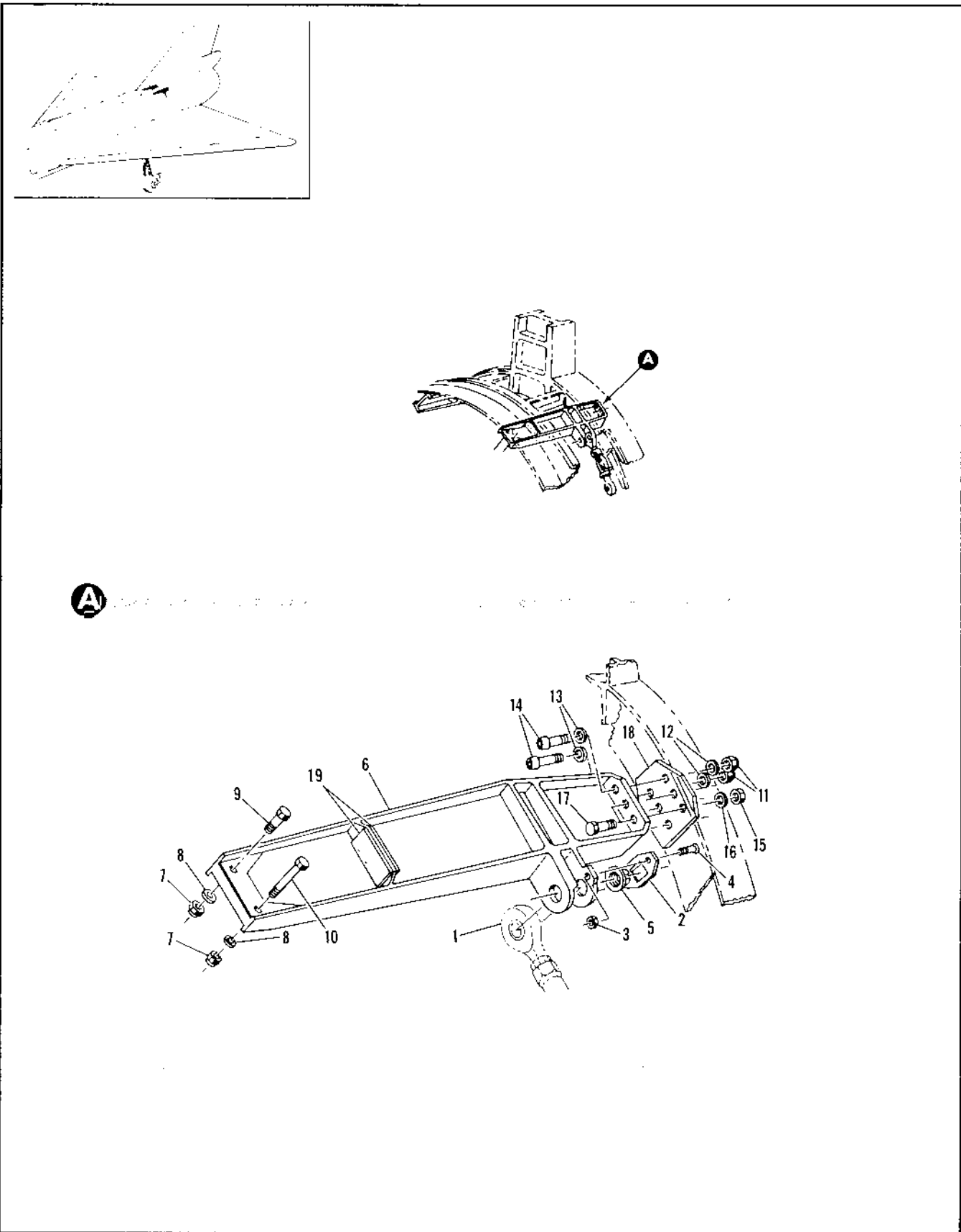

Figure 2.10-40. Engine Mount Beam Installation Aft

FIGURE AND INDEX NUMBER	PART NUMBER	DESCRIPTION	UNITS PER ASSY.	USABLE ON CODE	
				FROM	TO
		1 2 3 4 5 6			
2.10-40	8-74128-1	BEAM INSTALLATION, ENGINE MOUNT AFT LH FOR NHA SEE FIG. 2.3-14	RF	35	
	8-74128-2	BEAM INSTALLATION, ENGINE MOUNT AFT RH FOR NHA SEE FIG. 2.3-14	RF	35	
- 1		• TURNBUCKLE ASSY, SEE FIG. 2.10-7 INDEX 178	RF		
- 2	8-74128-7	• RETAINER	1	35	
- 3	NAS679A3	• NUT	2	35	
- 4	NAS221-11	• SCREW	2	35	
- 5	8-27985	• NUT, ENGINE MOUNT	1	35	
- 6	8-74722-11	• BEAM, LH MAKE FROM 8-74724 REPLACED BY INTCHG WITH 8-74726-7	1	A	
	8-74726-7	• BEAM, LH REPLACES INTCHG WITH 8-74722-11	1	278	293
	8-77766-7	• BEAM, LH MAKE FROM 8-74724-7 ALT INTCHG WITH 8-74722-11 AND 8-74726-7	RF	35	
	8-74722-12	• BEAM, RH MAKE FROM 8-74724 REPLACED BY INTCHG WITH 8-74726-8	1	A	
	8-74726-8	• BEAM, RH REPLACES INTCHG WITH 8-74722-12	1	278	293
	8-74724	• BILLET, MAKES ONE 8-74722-11 AND -12 BEAM	RF		
	8-77766-8	• BEAM, RH MAKE FROM 8-74724-7 ALT INTCHG WITH 8-74722-12 AND 8-74726-8	RF	35	
	8-74724-7	• BILLET, MAKES ONE 8-77766-7 AND -8 BEAM	RF		
- 7	NAS679A6	• NUT	2	B	
	NAS1291-6	• NUT	2	39	277
- 8	MS20002-6	• WASHER	2	35	
- 9	NAS464-6A10	• BOLT	1	35	
- 10	NAS464-6A24	• BOLT	1	35	
- 11	42FW624	• NUT, <56876> 96-37510-103	2	35	
- 12	MS20002-6	• WASHER	2	35	
- 13	MS20002C6	• WASHER	2	35	
- 14	MS20006-10	• BOLT	2	35	
- 15	22FT524	• NUT, <56876> 96-37525-004	4	35	
- 16	MS20002-8	• WASHER	4	35	
- 17	NAS464-5A8	• BOLT	4	35	
- 18	8-74128-9	• SHIM	AR	35	
- 19	8-74128-11	• SHIM	AR	35	
<p>A AIRPLANES #35 THRU 277, 294 AND ON B AIRPLANES #35 THRU 39, 278 AND ON</p>					

VARIABLE AIR RAMP SUBSECTION**TABLE OF CONTENTS**

<i>Fig. No.</i>	<i>Title</i>	<i>Page</i>	<i>Fig. No.</i>	<i>Title</i>	<i>Page</i>
2.11-1	Variable Air Ramp System	2.11-2	2.11-8	Variable Air Ramp Intake Duct Hydraulic Valve Installation	
2.11-2	Variable Air Ramp Pitot Static System	2.11-6		Sta 287 to 294	2.11-24
2.11-3	Engine Air Intake Duct Installation..	2.11-8	2.11-9	Variable Air Ramp Screw Jack Installation	2.11-26
2.11-4	Engine Air Intake Duct Installation..	2.11-12	2.11-10	Variable Air Ramp Screw Jack Support Assembly	2.11-32
2.11-5	Air Intake Duct Adapter Installation Sta 280	2.11-14	2.11-11	Variable Air Ramp Pitot Static Tubing Installation Sta 171 to 216..	2.11-34
2.11-6	Variable Air Intake Duct Ramp Installation	2.11-16	2.11-12	Variable Air Ramp Pitot Static Tubing Installation Sta 216 to 472..	2.11-36
2.11-7	Variable Air Ramp Seal Installation	2.11-22			

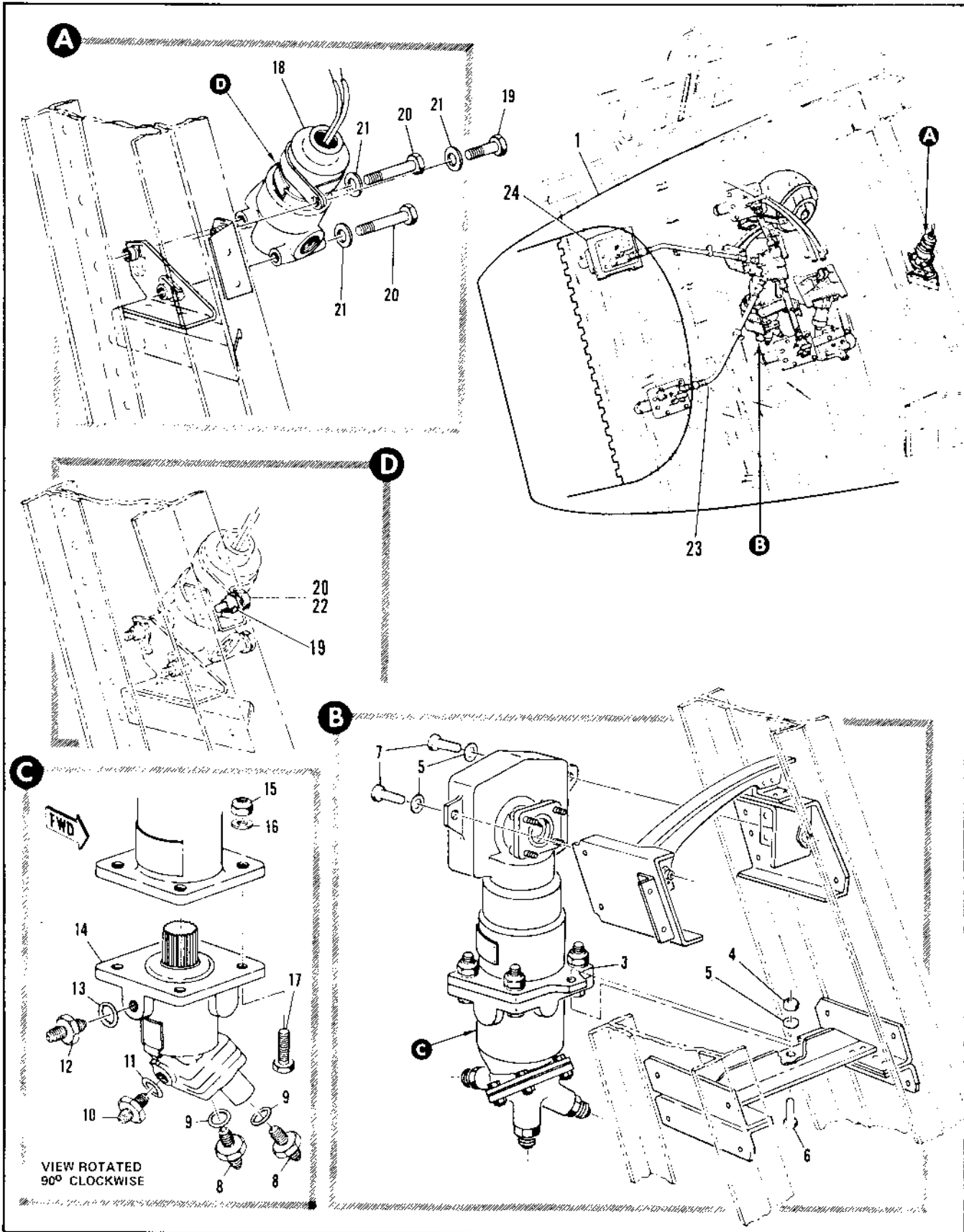

Figure 2.11-1. Variable Air Ramp System (Sheet 1 of 2)

FIGURE AND INDEX NUMBER	PART NUMBER	DESCRIPTION	UNITS PER ASSY.	USABLE ON CODE	
				FROM	TO
		1 2 3 4 5 6			
2.11-1		VARIABLE AIR RAMP SYSTEM			
- 1		• DUCT INSTL, ENGINE AIR INTAKE SEE FIG. 2.11-3	RF		
- 2		• VARIABLE AIR RAMP PITOT STATIC SYSTEM SEE FIG. 2.11-2	RF		
	8-81315-1	• DRIVE INSTL, VARIABLE AIR RAMP INTAKE DUCT MODIFIED BY 8-71122 FOR NHA SEE FIG. 2.3-3	RF	35	
- 3	1063052	• DRIVE UNIT ASSY, VARIABLE AIR RAMP INTAKE DUCT <R2402> SPEC 8-90355-5 T.O. 16G2-2-25-3 REPLACES SUITABLE SUB 1C63072	1	35	38
	1063072	• DRIVE UNIT ASSY, VARIABLE AIR RAMP INTAKE DUCT <R2402> SPEC 8-90355-7 T.O. 16G2-2-25-3 REPLACES SUITABLE SUB FOR 1063052 REPLACED BY SUITABLE SUB 1C63085	1	39	159
	1063085	• DRIVE UNIT ASSY, VARIABLE AIR RAMP INTAKE DUCT <R2402> SPEC 8-90355-9 T.O. 16G2-2-25-3 REPLACES SUITABLE SUB FOR 1063072 ATTACHING PARTS	1	160	
- 4	NAS679A4	• NUT	1	35	
- 5	AN960PD416	• WASHER	3	35	
- 6	AN4-7A	• BOLT	1	35	
- 7	AN4-8A	• BOLT	2	35	
		-----X-----			
- 8	1063032	• ADAPTER, TUBING	2	35	
- 9	AN6290-5	• GASKET	2	35	
- 10	1063031	• ADAPTER, TUBING	1	35	
- 11	AN6290	• GASKET	1	35	
- 12	1063033	• ADAPTER, TUBING	1	35	
- 13	AN6290-3	• GASKET	1	35	
- 14	MF98-3906-30	• MOTOR, S397-4 HYDRAULIC <R2402> DWG 1863054	1	35	38
	MF98-3906-30	• MOTOR, S397-4 HYDRAULIC <R2402> DWG 1763071	3	39	
	MF98-3906-30	• MOTOR, S457-4 HYDRAULIC <R2402> DWG 1863071 ALTERNATE FOR MF98-3906-30-S397-4 ATTACHING PARTS	RF	39	
- 15	AN364-428C	• NUT	4	35	
- 16	AN960-416L	• WASHER	4	35	
- 17	AN4-7A	• BOLT	4	35	
		-----X-----			
	66E40437-1	• VALVE INSTL, VARIABLE AIR RAMP SELECTOR FOR NHA SEE FIG. 2.3-11	RF	35	
- 18	HP542100-3	• VALVE ASSY, VARIABLE AIR RAMP SELECTOR SOLENOID OPERATED (84685) SPEC 8-00400-3 T.O. 9P5-9-21-3	1	35	
	12650-3	• VALVE ASSY, SELECTOR (84665) SPEC 8-08580, T.O. 9P5-9-31-3 ATTACHING PARTS	RF		
- 19	MS21042L3	• NUT	1		
- 20	AN3-5A	• BOLT	1	35	
- 21	AN3-16A	• BOLT	2	35	
- 22	AN963010	• WASHER	3	35	
		-----X-----			
- 23		• SCREW JACK INSTL, VARIABLE AIR RAMP LH SEE FIG. 2.11-9	RF		
- 24		• SUPPORT ASSY, VARIABLE AIR RAMP SCREW JACK UPPER FWD LH SEE FIG. 2.11-10	RF		
		*1 FURNISHED WITH DRIVE UNIT ASSEMBLY			

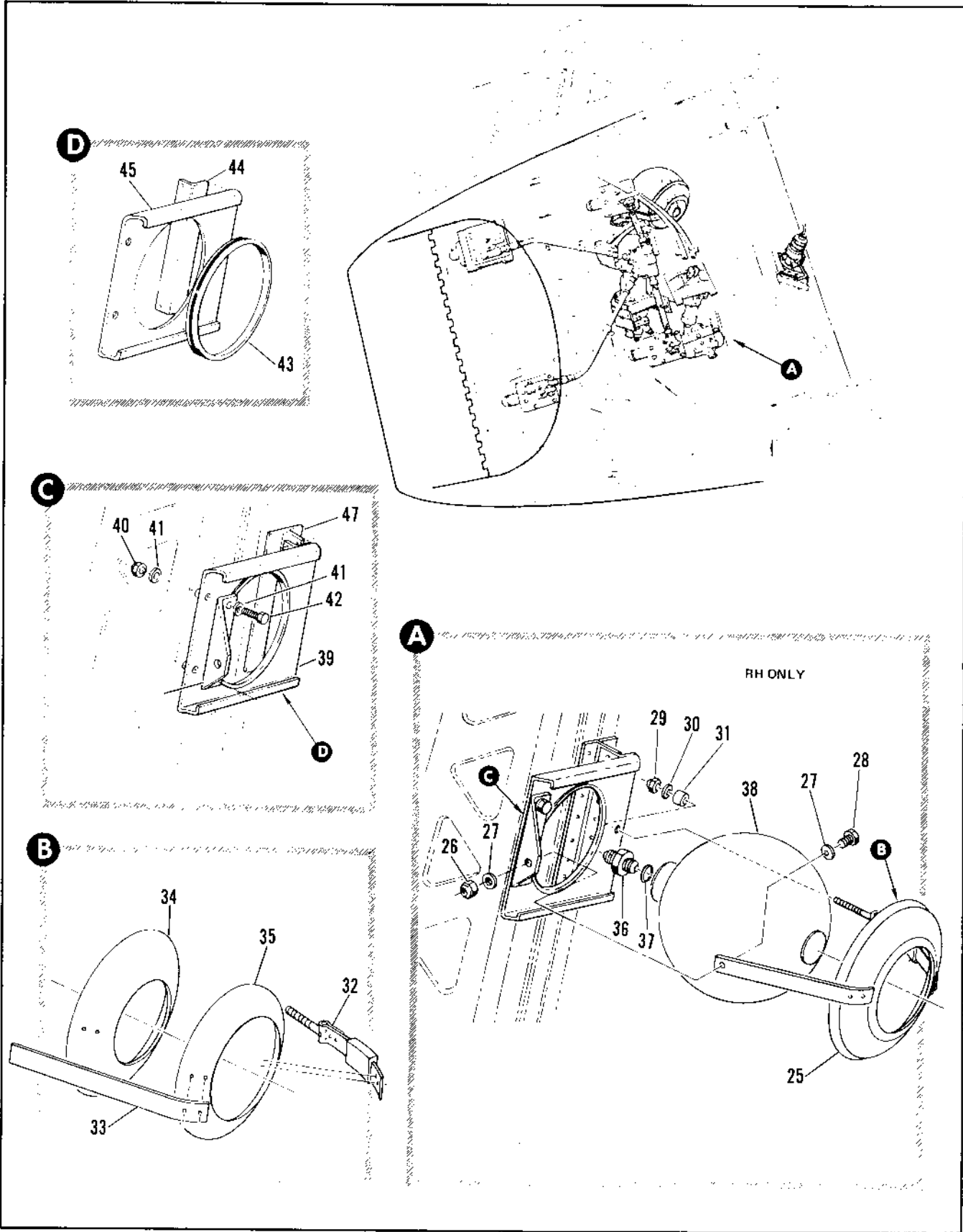

Figure 2.11-1. Variable Air Ramp System (Sheet 2 of 2)

FIGURE AND INDEX NUMBER	PART NUMBER	DESCRIPTION	UNITS PER ASSY.	USABLE ON CODE	
				FROM	TO
		1 2 3 4 5 6			
2.11-1	8-85048	• FLASK INSTL, VARIABLE AIR RAMP PNEUMATIC FOR NHA SEE FIG. 2.3-3	RF	35	
- 25	8-85346-25	• • SUPPORT ASSY, VARIABLE AIR RAMP FLASK ATTACHING PARTS	1	35	
- 26	NAS679A3	• • NUT	1	35	
- 27	AN960-PD-10L	• • WASHER	2	35	
- 28	AN3-4A	• • BOLT	1	35	
		-----X-----			
- 29	NAS679A3	• • • NUT	1	35	
- 30	AN960-PD-10L	• • • WASHER	1	35	
- 31	NAS430D3-16	• • • SPACER	1	35	
- 32	19839	• • • STRAP, <98625> 98-54500-002	1	35	
- 33	8-85048-15	• • • STRAP	1	35	
- 34	8-85048-19	• • • PAD	1	35	
- 35	8-85048-17	• • • CUP	1	35	
- 36	MS21916D8-4	• • REDUCER, TUBE	1	35	
- 37	AN6290-8	• • GASKET	1	35	
- 38	873420	• • FLASK, AIR STORAGE VARIABLE AIR RAMP <33525> SPEC 8-00411-5	1	35	
	8-85048-1	• SUPPORT INSTL, VARIABLE AIR RAMP FLASK FOR NHA SEE FIG. 2.3-10	1	35	
- 39	8-85048-23	• • BRACKET ASSEMBLY ATTACHING PARTS	1	35	
- 40	NAS679A3	• • NUT	2	35	
- 41	AN960-PD-10L	• • WASHER	4	35	
- 42	AN3-5A	• • BOLT	2	35	
		-----X-----			
- 43	8-85048-21	• • • PAD	1	35	
- 44	8-85048-9	• • • ANGLE	1	35	
- 45	8-85048-7	• • • MOUNT	1	35	
- 46	8-85048-27	• • ANGLE	1	35	
- 47	8-85048-11	• • TEE	1	35	

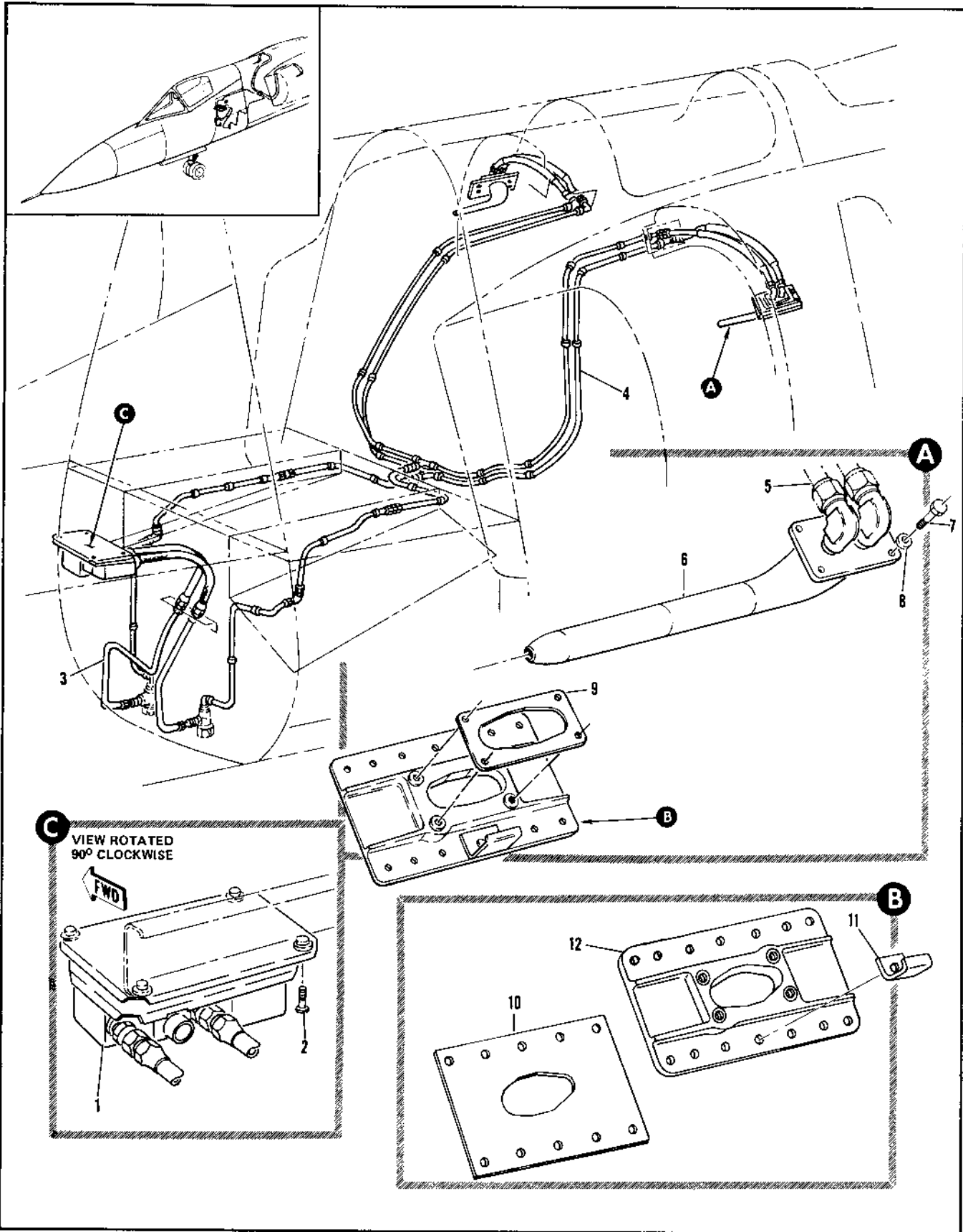

Figure 2.11-2. Variable Air Ramp Pitot Static System

FIGURE AND INDEX NUMBER	PART NUMBER	DESCRIPTION	UNITS PER ASSY.	USABLE ON CODE	
				FROM	TO
		1 2 3 4 5 6			
2.11-2		VARIABLE AIR RAMP PITOT STATIC SYSTEM			
- 1	24650	• CONTROL INSTL, VARIABLE AIR INLET	1	35	
	48112-2	• CONTROL UNIT, VARIABLE AIR <72737> SPEC 8-06474-3 T.O. 803-10-3-14	1	35	129
	34760	• CONTROL UNIT, VARIABLE AIR <72737> SPEC 8-06474-5 T.O. 5A8-23-2-4	1	130	
		• CONTROL UNIT, VARIABLE AIR <72737> SPEC 8-06474-7 T.O. 5A8-23-2-4 ALT INTCHG WITH 48112-2	RF	130	
- 2	AN520-1CR7	• ATTACHING PARTS • SCREW -----X-----	4	35	
- 3		• TUBING INSTL, VARIABLE AIR RAMP PITOT STATIC STA 171 TO 216 SEE FIG. 2.11-11	RF		
- 4		• TUBING INSTL, VARIABLE AIR RAMP PITOT STATIC STA 216 TO 472 SEE FIG. 2.11-12	RF		
- 5	8-92947-803	• TUBE INSTL, VARIABLE AIR RAMP CONTROL PITOT STATIC LH FOR NMA SEE FIG. 2.3-4	RF	35	
	8-92947-804	• TUBE INSTL, VARIABLE AIR RAMP CONTROL PITOT STATIC RH FOR NMA SEE FIG. 2.3-4	RF	35	
- 6	HS4004	• TUBE, PITOT STATIC LH <04849> SPEC 8-09292-1	1	35	
	PST751L	• TUBE, PITOT STATIC LH <70134> SPEC 8-09292-1 ALT INTCHG WITH HS4004	RF	35	
	HS4005	• TUBE, PITOT STATIC RH <04849> SPEC 8-09292-2	1	35	
	PST751R	• TUBE, PITOT STATIC RH <70134> SPEC 8-09292-2 ALT INTCHG WITH HS4005	RF	35	
- 7	AN3HEA	• ATTACHING PARTS • BOLT	4	35	
- 8	AN96101CL	• WASHER -----X-----	4	35	
- 9	8-92950	• GASKET	1	35	
	8-92947-801	• MOUNT INSTL, PITOT STATIC TUBE LH FOR NMA SEE FIG. 2.11-4	RF	35	
	8-92947-802	• MOUNT INSTL, PITOT STATIC TUBE RH FOR NMA SEE FIG. 2.11-4	RF	35	
- 10	8-92947-21	• FILLER, LH	1	35	
	8-92947-22	• FILLER, RH	1	35	
- 11	8-92947-4	• CLIP, GROUNDING	1	35	
- 12	8-92961-1	• MOUNT ASSY, LH	1	35	
	8-92961-1	• MOUNT ASSY, LH ALT INTCHG WITH 8-92961-1	RF	35	
	8-92961-2	• MOUNT ASSY, RH	1	35	
	8-92961-2	• MOUNT ASSY, RH ALT INTCHG WITH 8-92961-2	RF	35	

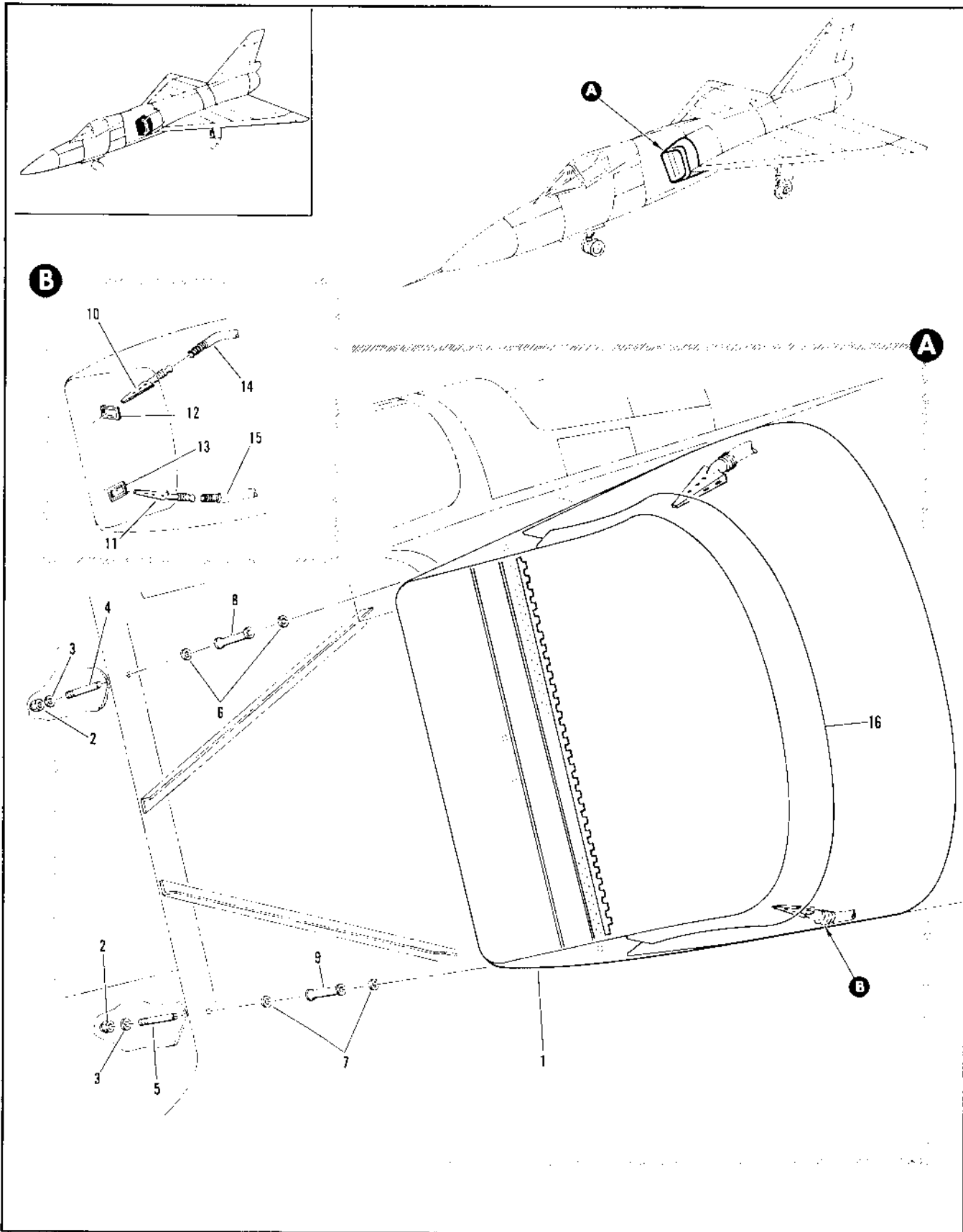

Figure 2.11-3. Engine Air Intake Duct Installation (Sheet 1 of 2)

FIGURE AND INDEX NUMBER	PART NUMBER	DESCRIPTION	UNITS PER ASSY.	USABLE ON CODE	
				FROM	TO
		1 2 3 4 5 6			
2.11-3	8-77586-5	DUCT INSTALLATION, ENGINE AIR INTAKE LH FOR NHA SEE FIG. 2.3-3	RF	35	
	8-77586-6	DUCT INSTALLATION, ENGINE AIR INTAKE RH FOR NHA SEE FIG. 2.3-3	RF	35	
- 1	8-77585-1	• DUCT ASSY, ENGINE AIR INTAKE	1	35	
	8-77585-2	• DUCT ASSY, ENGINE AIR INTAKE RH ATTACHING PARTS	1	35	
	MS20006H16	• BOLT	AR	35	
	MS20002C6	• WASHER	AR	35	
	AN3H5A	• BOLT	AR	35	
	AN3-7A	• BOLT	AR	35	
	AN3H6A	• BOLT	AR	35	
- 2	FN22M624	• NUT, <56878> 96-37510-052	2	35	
- 3	AN96C-616	• WASHER	AR	35	
- 4	8-77050-13	• STUD, ENGINE AIR INTAKE DUCT UPPER	1	35	
- 5	8-77050-15	• STUD, ENGINE AIR INTAKE DUCT LOWER	1	35	
- 6	99-51505-018	• WASHER, UPPER	AR	35	
- 7	99-51505-019	• WASHER, LOWER	AR	35	
- 8	8-77058-7	• SPACER, ENGINE AIR INTAKE DUCT UPPER	1	35	
- 9	8-77058-9	• SPACER, ENGINE AIR INTAKE DUCT LOWER	1	35	
	FN22M524	• NUT, <56878> 96-37510-051	2	35	
	MS20052C5	• WASHER	2	35	
	MS20005H16	• BOLT	2	35	
		-----X-----			
	8-77583-801	• LEADING EDGE INSTL, LH	1	35	129
	8-77583-3	• LEADING EDGE INSTL, LH ALT INTCHG WITH 8-77583-801	RF	35	129
	8-77583-803	• LEADING EDGE INSTL, LH	1	130	
	8-77583-805	• LEADING EDGE INSTL, LH ALT INTCHG WITH 8-77583-803	RF	130	
	8-77583-802	• LEADING EDGE INSTL, RH	1	35	129
	8-77583-4	• LEADING EDGE INSTL, RH ALT INTCHG WITH 8-77583-802	RF	35	129
	8-77583-804	• LEADING EDGE INSTL, RH	1	130	
	8-77583-806	• LEADING EDGE INSTL, RH ALT INTCHG WITH 8-77583-804	RF	130	
	8-77584-5	• TUBING INSTL, DUCT LEADING EDGE LH	1	35	129
	8-77584-805	• TUBING INSTL, DUCT LEADING EDGE LH	1	130	
	8-77584-6	• TUBING INSTL, DUCT LEADING EDGE RH	1	35	129
	8-77584-806	• TUBING INSTL, DUCT LEADING EDGE RH	1	130	
- 10	8-77584-19	• TUBE ASSY, UPPER LH WELDED	1	35	129
	8-77584-121	• TUBE ASSY, UPPER LH WELDED	1	130	159
	8-77584-133	• TUBE ASSY, UPPER LH WELDED	1	160	
	8-77584-20	• TUBE ASSY, UPPER RH WELDED	1	35	129
	8-77584-122	• TUBE ASSY, UPPER RH WELDED	1	130	159
	8-77584-134	• TUBE ASSY, UPPER RH WELDED	1	160	
- 11	8-77584-23	• TUBE ASSY, LOWER LH WELDED	1	35	129
	8-77584-123	• TUBE ASSY, LOWER LH WELDED	1	130	159
	8-77584-135	• TUBE ASSY, LOWER LH WELDED	1	160	
	8-77584-24	• TUBE ASSY, LOWER RH WELDED	1	35	129
	8-77584-124	• TUBE ASSY, LOWER RH WELDED	1	130	159
	8-77584-136	• TUBE ASSY, LOWER RH WELDED	1	160	
- 12	8-77584-33	• GASKET	1	35	
- 13	8-77584-29	• GASKET	1	35	
- 14		• TUBE ASSY, UPPER SEE FIG. 2.13-27	RF		
- 15		• TUBE ASSY, LOWER SEE FIG. 2.13-27	RF		
	8-77583-51	• SKIN ASSY, ENGINE AIR INTAKE DUCT LH USED WITH 8-77583-801	1	35	129
	8-77583-52	• SKIN ASSY, ENGINE AIR INTAKE DUCT RH USED WITH 8-77583-802	1	35	129
- 16	8-77583-49	• SKIN ASSY, LH	1	35	129
	8-77583-50	• SKIN ASSY, RH	1	35	129

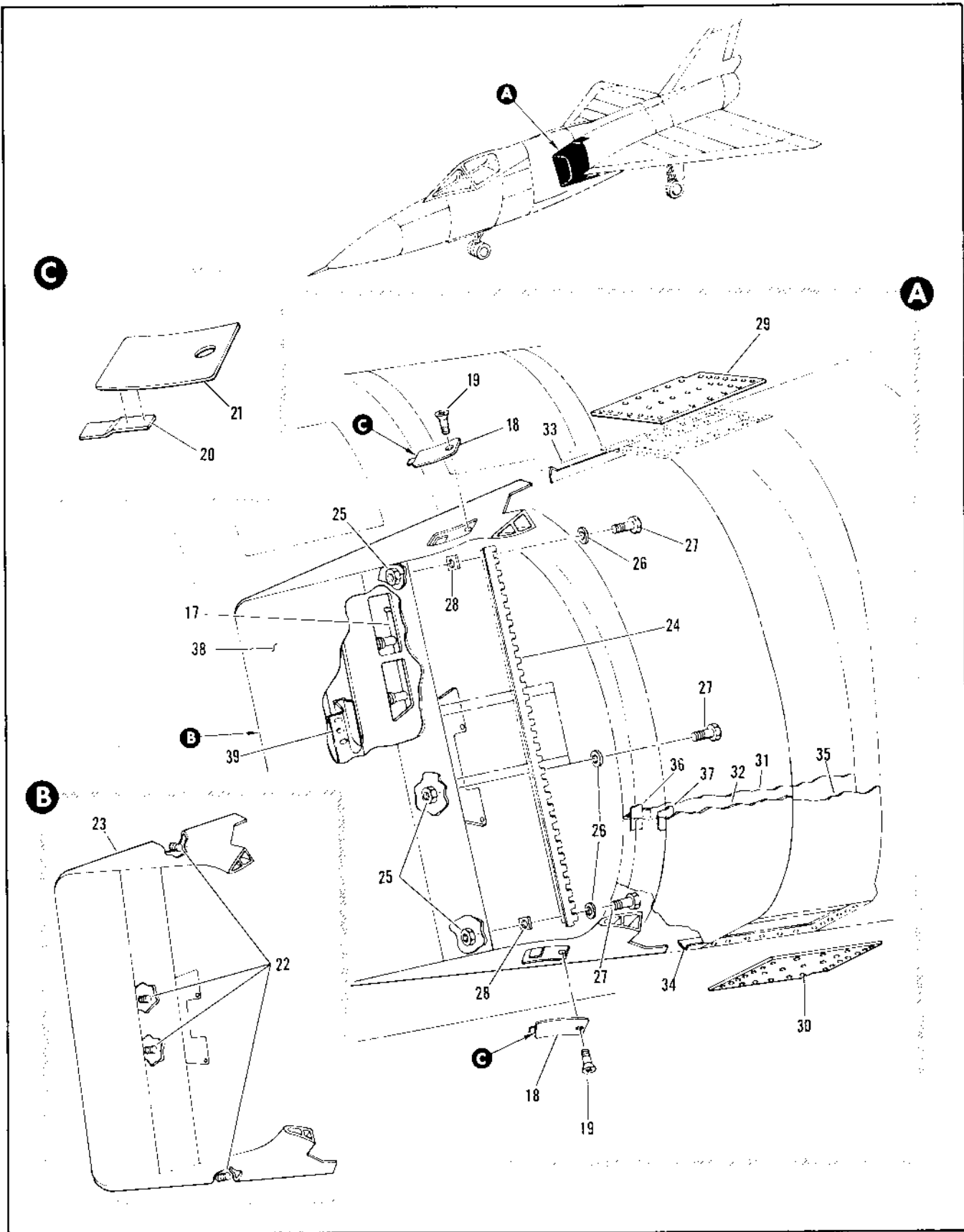

Figure 2.11-3. Engine Air Intake Duct Installation (Sheet 2 of 2)

FIGURE AND INDEX NUMBER	PART NUMBER	DESCRIPTION 1 2 3 4 5 6	UNITS PER ASSY.	USABLE ON CODE	
				FROM	TO
2.11-3- 17	8-77584-1	. . TUBING INSTL, LEADING EDGE DUCT ANTI-ICING LH FOR BREAKDOWN SEE FIG. 2.13-27	1	35	
	8-77584-2	. . TUBING INSTL, LEADING EDGE DUCT ANTI-ICING RH FOR BREAKDOWN SEE FIG. 2.13-27	1	35	
- 18	8-77585-61	. . PLATE ASSY, ENGINE AIR INTAKE DUCT ATTACHING PARTS	2	35	
- 19	NAS333PA4	. . SCREW -----X-----	1	35	
- 20	8-77585-59	. . . RETAINER, ENGINE AIR INTAKE DUCT	1	35	
- 21	8-77585-35	. . . PLATE, ENGINE AIR INTAKE DUCT	1	35	
	8-77587-1	. . RAMP ASSY, ENGINE AIR INTAKE DUCT LH	1	35	
	8-77587-2	. . RAMP ASSY, ENGINE AIR INTAKE DUCT RH	1	35	
- 22	1191-9CNY3/4	. . . INSERT, <91767> 95-13003-016	4	35	
- 23	8-77587-11	. . . RAMP, ENGINE AIR INTAKE DUCT LH	1	35	
	8-77587-12	. . . RAMP, ENGINE AIR INTAKE DUCT RH	1	35	
- 24	8-74536-15	. . HINGE, ENGINE AIR INTAKE DUCT ATTACHING PARTS	1	35	
- 25	NAS679A3	. . NUT	6	35	
- 26	AN960-10L	. . WASHER	6	35	
- 27	NAS464-3A4	. . BOLT -----X-----	6	35	
- 28	8-77585-109	. . SHIM	2	35	
- 29	8-77585-11	. . DOOR, ENGINE AIR INTAKE DUCT UPPER LH	1	35	
	8-77585-12	. . DOOR, ENGINE AIR INTAKE DUCT UPPER RH	1	35	
- 30	8-77585-25	. . DOOR, ENGINE AIR INTAKE DUCT LOWER LH	1	35	
	8-77585-26	. . DOOR, ENGINE AIR INTAKE DUCT LOWER RH ATTACHING PARTS	1	35	
	NAS333PA4	. . SCREW	AR	35	
	NAS333PA7	. . SCREW	AR	35	
	NAS333PA5	. . SCREW	AR	35	
	NAS333PA6	. . SCREW -----X-----	AR	35	
- 31	8-77585-7	. . SKIN, INNER LH	1	35	
	8-77585-8	. . SKIN, INNER RH	1	35	
- 32	8-77585-9	. . SKIN, OUTER LH	1	35	
	8-77585-10	. . SKIN, OUTER RH	1	35	
- 33	8-77585-19	. . SKIN, LH	1	35	
	8-77585-20	. . SKIN, RH	1	35	
- 34	8-77585-21	. . SKIN, LH	1	35	
	8-77585-22	. . SKIN, RH	1	35	
- 35	8-77585-123	. . SKIN, LH	1	35	
	8-77585-124	. . SKIN, RH	1	35	
- 36	8-74583-11	. . SKIN, LH	1	35	
	8-74583-12	. . SKIN, RH	1	35	
- 37	8-74583-13	. . SKIN, LH	1	35	
	8-74583-14	. . SKIN, RH	1	35	
- 38	8-77585-79	. . WELD ASSY, ENGINE AIR INTAKE DUCT LH	1	35	
	8-77585-80	. . WELD ASSY, ENGINE AIR INTAKE DUCT RH	1	35	
- 39	8-77585-87	. . DUCT ASSY, ENGINE AIR INTAKE WELDED LH	1	35	
	8-77585-86	. . DUCT ASSY, ENGINE AIR INTAKE WELDED RH	1	35	

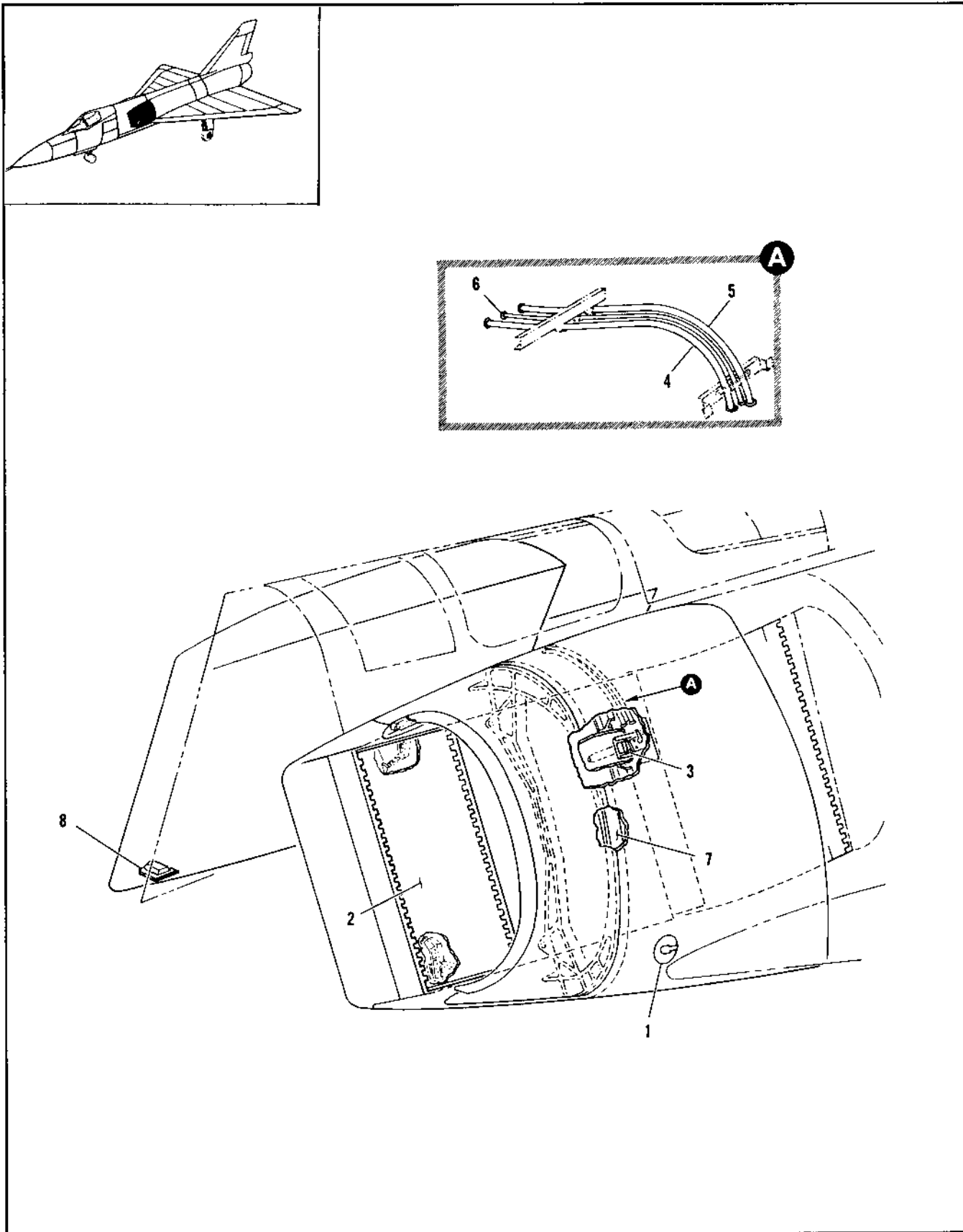

Figure 2.11-4. Engine Air Intake Duct Installation

FIGURE AND INDEX NUMBER	PART NUMBER	DESCRIPTION	UNITS PER ASSY.	USABLE ON CODE	
				FROM	TO
		1 2 3 4 5 6			
2.11-4	8-77586-1	DUCT INSTALLATION, ENGINE AIR INTAKE LH FOR NHA SEE FIG. 2.3-13	RF	35	
	8-77586-2	DUCT INSTALLATION, ENGINE AIR INTAKE RH FOR NHA SEE FIG. 2.3-13	RF	35	
- 1	8-94153-805	• DOOR AND CABLE INSTL, CANOPY JETTISON CONTROL FOR BREAKDOWN SEE FIG. 2.4-9	1	35	
- 2	8-74568-5	• RAMP INSTL, VARIABLE AIR INTAKE DUCT LH FOR BREAKDOWN SEE FIG. 2.11-6	1	35	35
	8-74568-801	• RAMP INSTL, VARIABLE AIR INTAKE DUCT LH FOR BREAKDOWN SEE FIG. 2.11-6	1	36	
	8-74568-6	• RAMP INSTL, VARIABLE AIR INTAKE DUCT RH FOR BREAKDOWN SEE FIG. 2.11-6	1	35	35
	8-74568-802	• RAMP INSTL, VARIABLE AIR INTAKE DUCT RH FOR BREAKDOWN SEE FIG. 2.11-6	1	36	
- 3	8-92947-801	• MOUNT INSTL, PITOT STATIC TUBE LH FOR BREAKDOWN SEE FIG. 2.11-2	1	35	
	8-92947-802	• MOUNT INSTL, PITOT STATIC TUBE RH FOR BREAKDOWN SEE FIG. 2.11-2	1	35	
	8-92948-3	• CONDUIT INSTL, PITOT AND STATIC TUBE LH	1	35	
	8-92948-4	• CONDUIT INSTL, PITOT AND STATIC TUBE	1	35	
- 4	8-92948-31	• • CONDUIT, PITOT	1	35	
- 5	8-92948-33	• • CONDUIT, PITOT	1	35	
- 6	8-92948-35	• • CONDUIT, PITOT	1	35	
- 7	8-77567-1	• ADAPTER INSTL, DUCT STA 281 LH FOR BREAKDOWN SEE FIG. 2.11-5	1	35	
		• ADAPTER INSTL, DUCT STA 281 RH FOR BREAKDOWN SEE FIG. 2.11-5	1	35	
- 8	8-77590-1	• SUPPORT INSTL, REFUEL DOOR STA 312 RH FOR BREAKDOWN SEE FIG. 2.2-7	1	35	

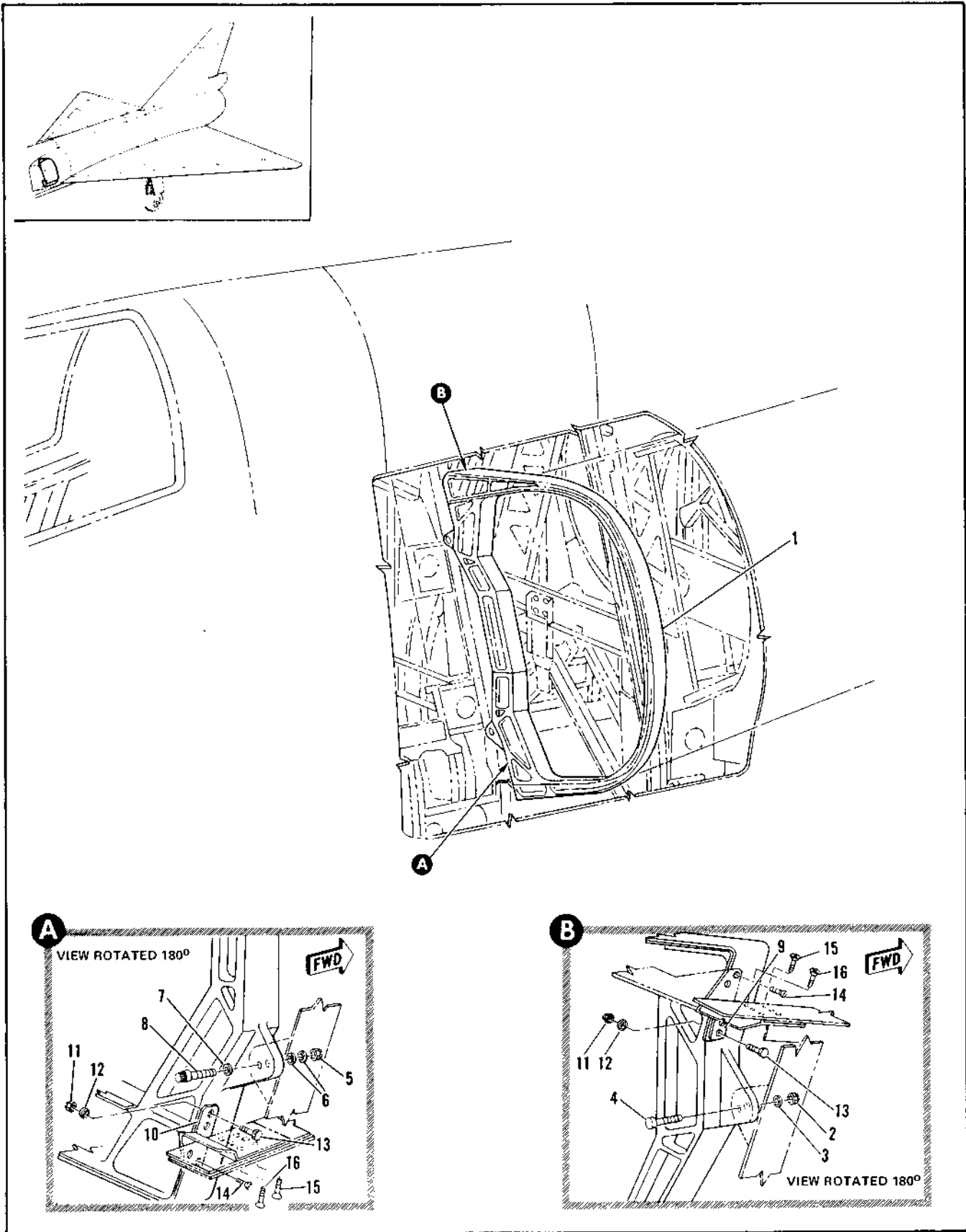

Figure 2.11-5. Air Intake Duct Adapter Installation Sta 280

FIGURE AND INDEX NUMBER	PART NUMBER	DESCRIPTION	UNITS PER ASSY.	USABLE ON CODE	
				FROM	TO
		1 2 3 4 5 6			
2.11-5	8-77567-1	ADAPTER INSTALLATION, AIR INTAKE DUCT STA 281 LH FOR NHA SEE FIG. 2.11-4	RF	35	
	8-77567-2	ADAPTER INSTALLATION, AIR INTAKE DUCT STA 281 RH FOR NHA SEE FIG. 2.11-4	RF	35	
	NAS679A7	• NUT	AR	35	
	AN509-10R10	• SCREW	AR	35	
	AN509-10R11	• SCREW	AR	35	114
	AN509-10R12	• SCREW	AR	35	
	AN509-10R14	• SCREW	AR	35	
	AN509-10R15	• SCREW	AR	35	
	AN509-10R16	• SCREW	AR	35	
	AN509-10R17	• SCREW	AR	35	
	AN509-10R18	• SCREW	AR	35	
	AN509-10R19	• SCREW	AR	35	
- 1	8-77568-7	• ADAPTER LH, MAKE FROM 8-77569	1	35	
	8-77568-8	• ADAPTER RH, MAKE FROM 8-77569	1	35	
	8-77569	• ADAPTER	RF		
		ATTACHING PARTS			
- 2	AN320-7	• NUT, UPPER	1	35	
- 3	AN960-716	• WASHER, UPPER	1	35	
- 4	NAS464-7-16	• BOLT, UPPER	1	35	
- 5	EW22-7	• NUT, <5687A> 96-37541-104 LOWER	1	35	
- 6	AN960-716L	• WASHER, LOWER	2	35	
- 7	MS2100207	• WASHER, LOWER	1	35	
- 8	EW22-7-25	• BOLT, <5687A> 96-82024-042 LOWER	1	35	60
	8-74528	• BOLT, LOWER	1	61	
		-----X-----			
- 9	8-74587-15	• TEE, UPPER LH	1	35	
	8-74587-16	• TEE, UPPER RH	1	35	
- 10	8-74587-13	• TEE, LOWER LH	1	35	
	8-74587-14	• TEE, LOWER RH	1	35	
		ATTACHING PARTS			
- 11	AN310-3	• NUT	4	35	
- 12	AN960 PD10	• WASHER	4	35	
- 13	AN3-10	• BOLT	4	35	
- 14	AN509-10R13	• SCREW	4	35	
- 15	AN509-10R11	• SCREW	6	35	
- 16	AN509-10R10	• SCREW	6	35	
		-----X-----			

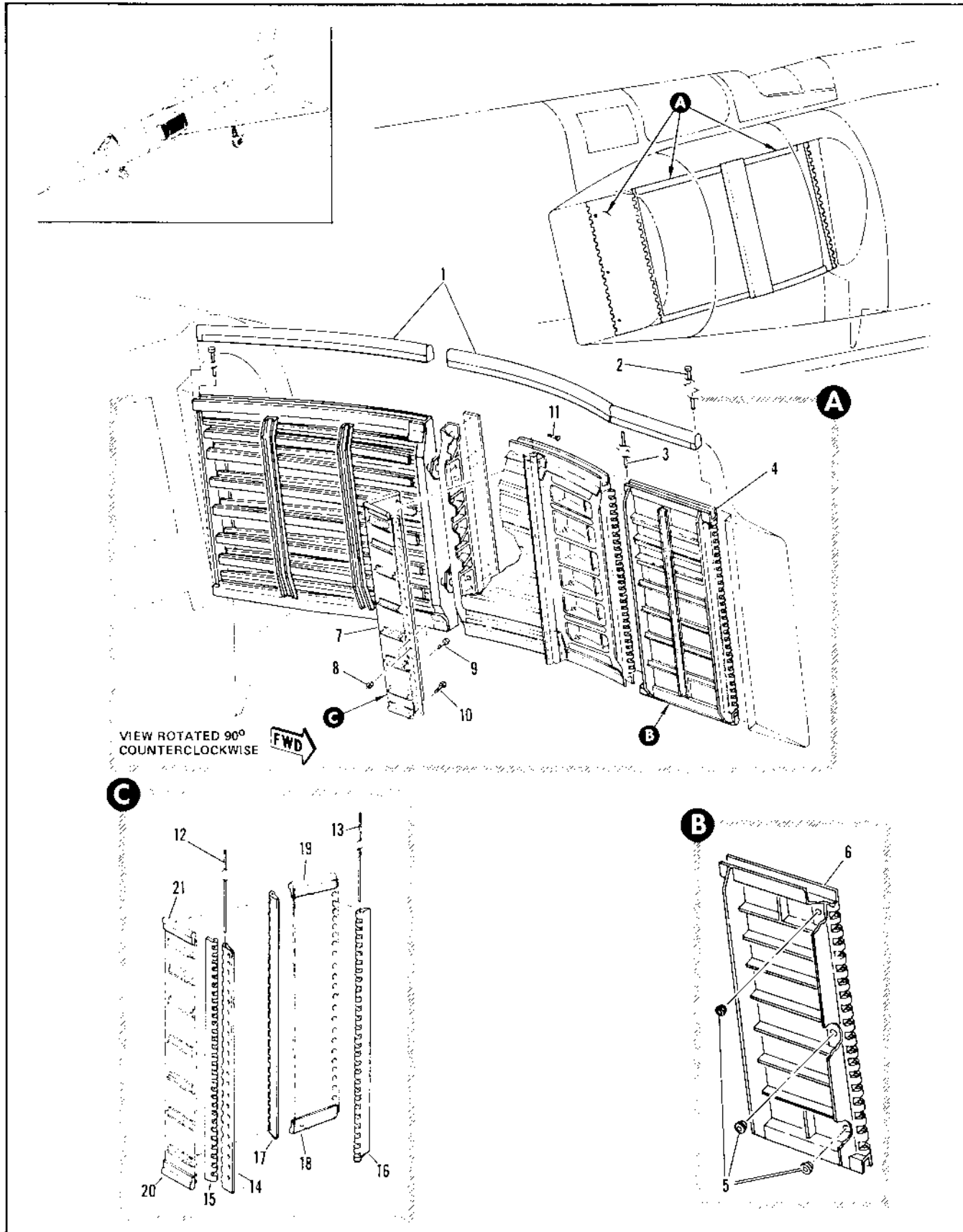

FIGURE AND INDEX NUMBER	PART NUMBER	DESCRIPTION	UNITS PER ASSY.	USABLE ON CODE		
				FROM	TO	
2.11-6	8-74568-5	RAMP INSTALLATION, VARIABLE AIR INTAKE DUCT LH FOR NHA SEE FIG. 2.11-4	RF	35	35	
	8-74568-101	RAMP INSTALLATION, VARIABLE AIR INTAKE DUCT LH FOR NHA SEE FIG. 2.11-4	RF	36		
	8-74568-6	RAMP INSTALLATION, VARIABLE AIR INTAKE DUCT RH FOR NHA SEE FIG. 2.11-4	RF	35	35	
	8-74568-102	RAMP INSTALLATION, VARIABLE AIR INTAKE DUCT RH FOR NHA SEE FIG. 2.11-4	RF	36		
	- 1	P-77534-3	• SEAL INSTL, VARIABLE AIR RAMP LH FOR BREAKDOWN SEE FIG. 2.11-7	1	35	
		8-77534-4	• SEAL INSTL, VARIABLE AIR RAMP RH FOR BREAKDOWN SEE FIG. 2.11-7	1	35	
	- 2	8-74599-7	• PIN, RAMP PANEL HINGE FWD	1	35	
	- 3	8-74599-9	• PIN, RAMP PANEL HINGE INTERMEDIATE	1	35	
	- 4	8-78509-1	• RAMP ASSY, VARIABLE AIR FWD LH RIVETED	1	35	
		8-78509-2	• RAMP ASSY, VARIABLE AIR FWD RH RIVETED	1	35	
		8-74586-3	• PANEL ASSY, LH	1	35	
		8-74586-4	• PANEL ASSY, RH	1	35	
	- 5	91-26034-001	• BUSHING	3	35	
	- 6	8-74586-9	• PANEL, LH	1	35	60
		8-74586-11	• PANEL, LH	1	61	
		8-74586-10	• PANEL, RH	1	35	60
		8-74586-12	• PANEL, RH	1	61	
	- 7	8-78703-1	• SEAL ASSY, VARIABLE AIR RAMP LH	1	35	240
		8-78703-3	• SEAL ASSY, VARIABLE AIR RAMP LH	1	241	
		8-78703-2	• SEAL ASSY, VARIABLE AIR RAMP RH	1	35	240
		8-78703-4	• SEAL ASSY, VARIABLE AIR RAMP RH	1	241	
		ATTACHING PARTS				
- 8	AN310-4	• NUT	2	35		
- 9	AN4-13	• BOLT	2	35		
- 10	AN3HCA	• BOLT	22	35		
- 11	AN3HSA	• BOLT	23	35		
		-----X-----				
- 12	AN253-4-3418	• PIN	1	35		
- 13	AN253-2-3418	• PIN	1	35		
- 14	8-78703-43	• HINGE, HALF LH	1	35		
	8-78703-44	• HINGE, HALF RH	1	35		
- 15	8-78703-41	• HINGE, HALF LH	1	35		
	8-78703-42	• HINGE, HALF RH	1	35		
- 16	8-78703-21	• HINGE, HALF	1	35		
- 17	8-78703-23	• HINGE, HALF	1	35		
	8-78703-7	• PANEL ASSY, VARIABLE AIR RAMP SEAL	1	35	240	
	8-78703-44	• PANEL ASSY, VARIABLE AIR RAMP SEAL	1	241		
	8-78703-8	• PANEL ASSY, VARIABLE AIR RAMP SEAL	1	35		
- 18	8-78703-31	• SEAL, VARIABLE AIR RAMP PANEL LOWER	1	35		
- 19	8-78703-32	• SEAL, VARIABLE AIR RAMP PANEL	1	35		
- 20	8-78703-33	• SEAL, VARIABLE AIR RAMP PANEL LOWER	1	35		
- 21	8-78703-34	• SEAL, VARIABLE AIR RAMP PANEL UPPER	1	35		

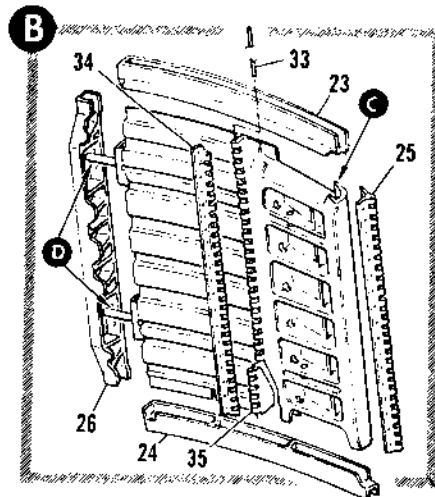
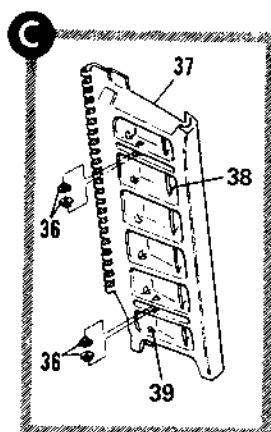
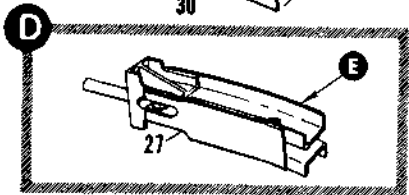
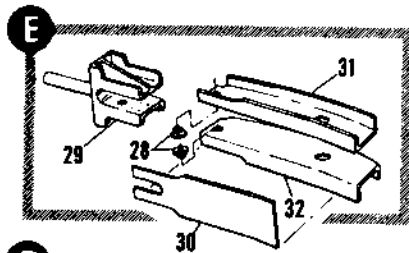
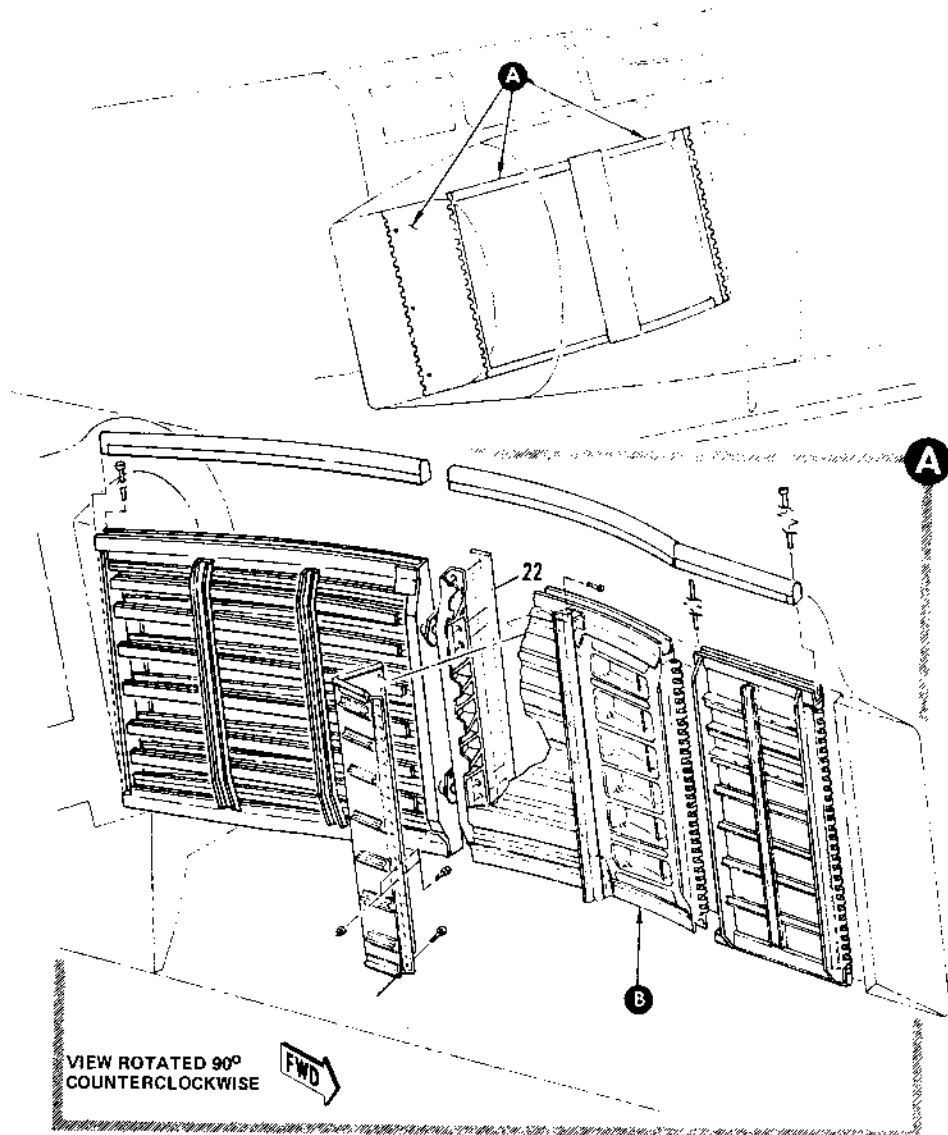

Figure 2.11-6. Variable Air Intake Duct Ramp Installation (Sheet 2 of 3)

FIGURE AND INDEX NUMBER	PART NUMBER	DESCRIPTION	UNITS PER ASSY.	USABLE ON CODE	
				FROM	TO
		1 2 3 4 5 6			
2.11-6	8-78501-3 8-78501-805	• PANEL ASSY, VARIABLE AIR RAMP INTERMEDIATE • PANEL ASSY, VARIABLE AIR RAMP INTERMEDIATE ALT INTCHG WITH 8-78501-3	1 RF	35 35	
- 22	8-74593-13	• • SPRING, SLIP JOINT SEAL	1	35	
- 23	8-74593-13	• • ADAPTER, RAMP BORDER LOWER LH UPPER RH	1	35	
- 24	8-74593-14	• • ADAPTER, RAMP BORDER UPPER LH LOWER RH	1	35	
- 25	8-78503	• • HINGE, RAMP INTERMEDIATE	1	35	
- 26	8-77515-7	• • FITTING, RAMP EDGE INTERMEDIATE SLIP JOINT MAKE FROM 8-77515	1	35	
	8-77515	• • FITTING	RF		
	8-74594-9	• • FITTING, RAMP EDGE INTERMEDIATE SLIP JOINT ALT INTCHG WITH 8-77515-7	RF	35	
	8-78501-77	• • PANEL ASSY, VARIABLE AIR RAMP INTERMEDIATE	1	35	
- 27	8-76501-79	• • • BEAM ASSY, VARIABLE AIR RAMP INTERMEDIATE PANEL	2	35	
- 28	8-74547-13	• • • BUSHING	2	35	
- 29	8-77517-7	• • • ADAPTER, VARIABLE AIR RAMP SLIP JOINT REPLACED BY SUITABLE SUR 8-77517-1	1	35	60
	8-74591	• • • ADAPTER, VARIABLE AIR RAMP SLIP JOINT ALT INTCHG WITH 8-77517-7	RF	35	60
	8-77517-1	• • • ADAPTER, VARIABLE AIR RAMP SLIP JOINT REPLACES SUITABLE SUR FOR 8-77517-7	1	61	
	8-74591-1	• • • ADAPTER, VARIABLE AIR RAMP SLIP JOINT ALT INTCHG WITH 8-77517-1	RF	61	
- 30	8-78501-21	• • • STRAP	1	35	
- 31	8-78501-11	• • • BEAM, VARIABLE AIR RAMP INTERMEDIATE PANEL LH	1	35	
- 32	8-78501-12	• • • BEAM, VARIABLE AIR RAMP INTERMEDIATE PANEL RH	1	35	
- 33	AN253-2-341H	• • PIN	1	35	
- 34	8-78501-47	• • HINGE, HALF	1	35	
- 35	8-78501-45	• • HINGE, HALF LH	1	35	
	8-78501-46	• • HINGE, HALF RH	1	35	
	8-78502-1	• • FITTING ASSY, VARIABLE AIR RAMP INTERMEDIATE	1	35	
- 36	8-78547-15	• • BUSHING, RAMP ACTUATOR ADAPTER	4	35	
- 37	8-78502-9	• • FITTING	1	35	
- 38	8-78501-95	• • FAIRING FWD	1		
- 39	8-78501-117	• • FAIRING AFT	1		

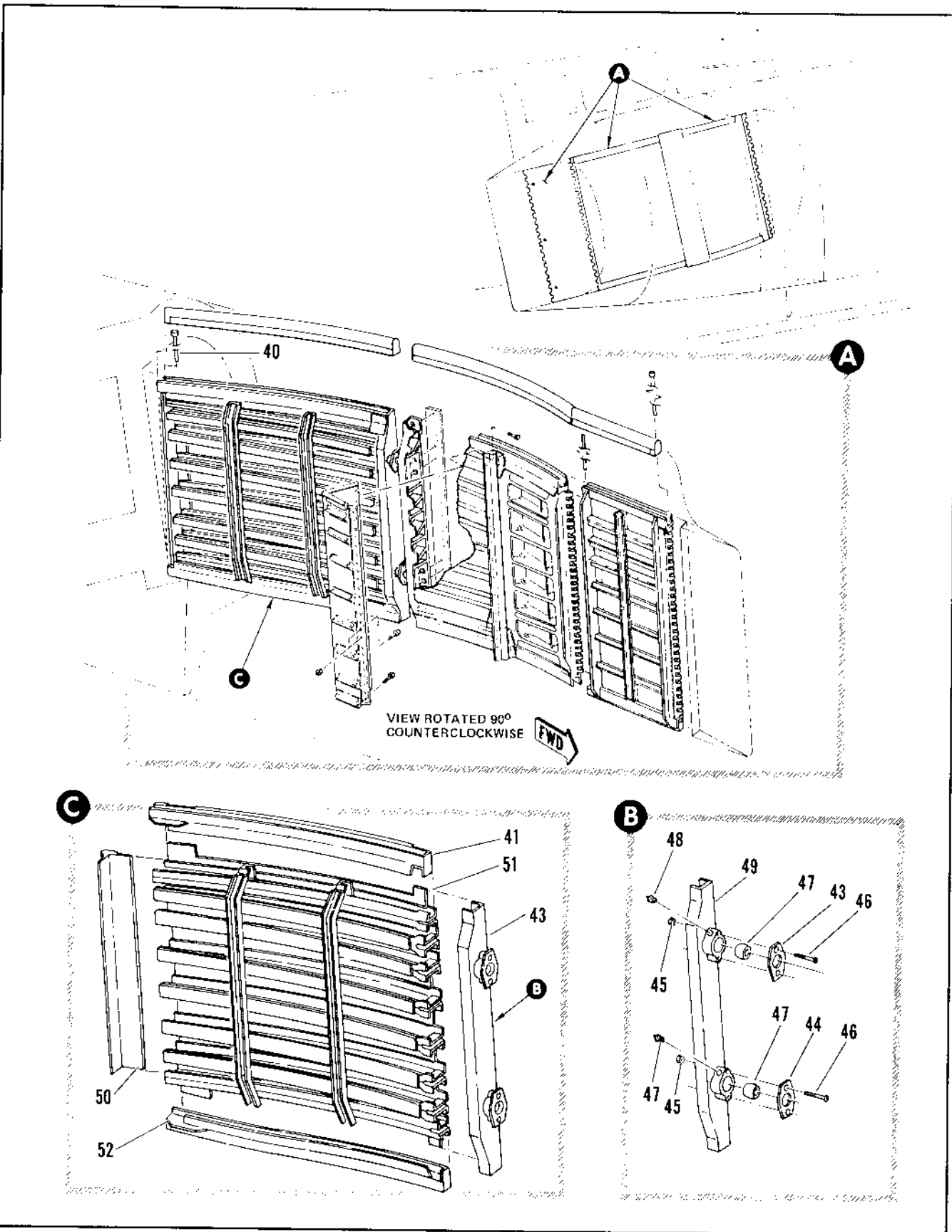

Figure 2.11-6. Variable Air Intake Duct Ramp Installation (Sheet 3 of 3)

FIGURE AND INDEX NUMBER	PART NUMBER	DESCRIPTION	UNITS PER ASSY.	USABLE ON CODE	
				FROM	TO
		1 2 3 4 5 6			
2.11-6- 40	8-74599-11 8-74571-5	• PIN, RAMP PANEL HINGE AFT • RAMP ASSY, VARIABLE AIR AFT LH MODIFIED BY R-71127 REPLACED BY NOT INTCHG WITH 8-74571-3	1 1	35 35	35
	8-74571-3	• RAMP ASSY, VARIABLE AIR AFT LH REPLACES NOT INTCHG WITH 8-7457-5	1	36	
	8-74571-6	• RAMP ASSY, VARIABLE AIR AFT RH MODIFIED BY R-71127 REPLACED NOT INTCHG WITH 8-7457-4	1	35	35
	8-74571-4	• RAMP ASSY, VARIABLE AIR AFT RH REPLACES NOT INTCHG WITH 8-74571-6	1	35	
- 41	8-74596-9	• ADAPTER, RAMP BORDER UPPER LH	1	35	
	8-74596-10	• ADAPTER, RAMP BORDER UPPER RH	1	35	
- 42	8-74589-9	• ADAPTER, RAMP BORDER LOWER LH	1	35	
	8-74589-10	• ADAPTER, RAMP BORDER LOWER RH	1	35	
- 43	8-77514-1	• POST ASSY, RAMP EDGE SLIP JOINT AFT LH	1	35	89
	8-77514-3	• POST ASSY, RAMP EDGE SLIP JOINT AFT LH	1	98	
	8-74595-1	• POST ASSY, RAMP EDGE SLIP JOINT AFT LH ALT INTCHG WITH 8-77514-1 AND 8-77514-3	RF	35	
	8-77514-2	• POST ASSY, RAMP EDGE SLIP JOINT AFT RH	1	35	89
	8-77514-4	• POST ASSY, RAMP EDGE SLIP JOINT AFT RH	1	98	
	8-74595-2	• POST ASSY, RAMP EDGE SLIP JOINT AFT RH ALT INTCHG WITH 8-77514-2 AND 8-77514-4	RF	35	
- 44	8-77514-9	• COVER, SLIP JOINT BEARING	2	35	
	8-77595-9	• COVER, SLIP JOINT BEARING ALT INTCHG WITH 8-77514-9	RF	35	
		ATTACHING PARTS			
- 45	AN310-3	• NUT	4	35	
- 46	NAS333P13-5	• BOLT	4	35	
		-----X-----			
- 47	KS16-2	• BEARING, <97613> 97-60009-169	2	35	
- 48	MS15001-1	• FITTING	2	35	
- 49	8-77514-7	• POST, LH MAKE FROM 8-77514	1	35	89
	8-74595-7	• POST, LH USE WITH 8-74595-1	RF	35	
	8-77514-8	• POST, RH MAKE FROM 8-77514	1	35	89
	8-74595-8	• POST, RH USE WITH 8-74595-2	RF	35	
	8-77514-13	• POST, LH MAKE FROM 8-77514	1	98	
	8-77514-14	• POST, RH MAKE FROM 8-77514	1	90	
	8-77514	• POST	RF	35	
- 50	8-74596-7	• HINGE, RAMP AFT LH	1	278	
	8-74598-8	• HINGE, RAMP AFT RH	1	278	
- 51	8-74571-63	• BEAM ASSY, LH RIVETED	1	35	35
	8-74571-93	• BEAM ASSY, LH METALBONDED	1	A	
	8-74571-97	• BEAM ASSY, LH METALBONDED	1	61	89
	8-74571-64	• BEAM ASSY, RH RIVETED	1	35	
	8-74571-94	• BEAM ASSY, RH METALBONDED	1	A	
	8-74571-98	• BEAM ASSY, RH METALBONDED	1	61	89
A AIRPLANES #36 THRU 60, 93 AND ON					

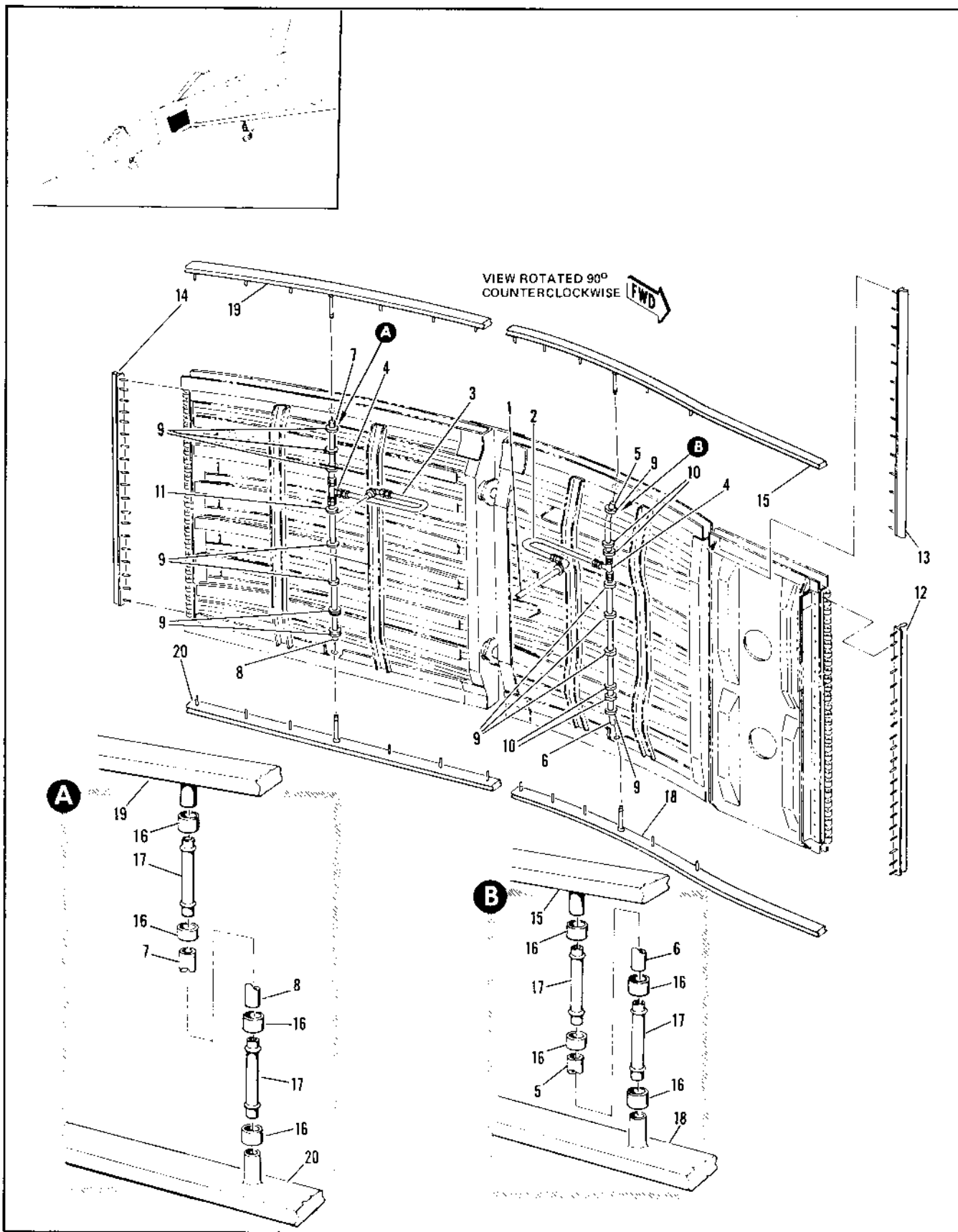

Figure 2.11-7. Variable Air Ramp Seal Installation

FIGURE AND INDEX NUMBER	PART NUMBER	DESCRIPTION	UNITS PER ASSY.	USABLE ON CODE	
				FROM	TO
		1 2 3 4 5 6			
2.11-7	8-77504-3	SEAL INSTALLATION, VARIABLE AIR RAMP LH FOR NHA SEE FIG. 2.11-6	RF	35	
	8-77504-4	SEAL INSTALLATION, VARIABLE AIR RAMP RH FOR NHA SEE FIG. 2.11-6	RF	35	
- 1	8-77504-23	• TUBE ASSY, LWK SEAL LH SEE FIG. 2.9-6	RF	35	
- 2	8-77504-11	• HOSE ASSY, VARIABLE AIR RAMP SEAL FWD	1	35	
	MS27404-4	• HOSE	1	35	
- 3	8-77504-24	• ADAPTER, <79470> 90-04950-002	1	35	
	8-77504-17	• HOSE ASSY, VARIABLE AIR RAMP SEAL AFT	1	35	
	MS27404-4	• HOSE	1	35	
- 4	MS21905D4	• ADAPTER, <79470> 90-04950-002	2	35	
- 5	8-77504-19	• TEE	1	35	
	8-77504-7	• HOSE ASSY, VARIABLE AIR RAMP SEAL	1	35	
	MS27404-4	• HOSE	1	35	
- 6	8-77504-21	• ADAPTER, <79470> 90-04950-002	1	35	
	8-77504-9	• HOSE ASSY, VARIABLE AIR RAMP SEAL	1	35	
	MS27404-4	• HOSE	1	35	
- 7	8-77504-25	• ADAPTER, <79470> 90-04950-002	1	35	
	8-77504-13	• HOSE ASSY, VARIABLE AIR RAMP SEAL	1	35	
	MS27404-4	• HOSE	1	35	
- 8	8-77504-27	• ADAPTER, <79470> 90-04950-002	1	35	
	8-77504-15	• HOSE ASSY, VARIABLE AIR RAMP SEAL	1	35	
	MS27404-4	• HOSE	1	35	
- 9	A4931A8-13	• ADAPTER, <79470> 90-04950-002	12	35	
- 10	AN931-8-13	• GROMMET	4	35	
- 11	AN931A10-14	• GROMMET	1	35	
- 12	8-74555-19	• GROMMET	1	35	
- 13	8-74555-15	• SEAL, RAMP HINGE FWD	1	35	
- 14	8-74555-17	• SEAL, RAMP HINGE INTERMEDIATE	1	35	
- 15	4763-19	• SEAL, RAMP HINGE AFT	1	35	43
	4763-23	• SEAL, RAMP EDGE UPPER FWD LH <71643> SPEC 8-07330-19 REPLACED BY SUITABLE SUB 4763-23	1	44	
	4763-20	• SEAL, RAMP EDGE UPPER FWD LH <71643> SPEC 8-07330-23 REPLACES SUITABLE SUB FOR 4763-19	1	35	43
	4763-24	• SEAL, RAMP EDGE UPPER FWD RH <71643> SPEC 8-07330-20 REPLACED BY SUITABLE SUB 4763-24	1	44	
- 16	AN737TW22	• SEAL, RAMP EDGE UPPER FWD RH <71643> SPEC 8-07330-24 REPLACES SUITABLE SUB FOR 4763-20	8	35	
- 17	8-77504-31	• CLAMP	4	35	60
	8-77504-713	• TUBE	RF	35	60
	8-77504-55	• TUBE, ALT INTCHG WITH 8-77504-31	4	61	
- 18	4763-20	• TUBE	1	35	43
	4763-19	• SEAL, RAMP EDGE LOWER FWD LH <71643> SPEC 8-07330-20 REPLACED BY SUITABLE SUB 4763-24	1	35	43
- 19	4763-15	• SEAL, RAMP EDGE LOWER FWD RH <71643> SPEC 8-07330-19 REPLACED BY SUITABLE SUB 4763-23	1	35	
	4763-16	• SEAL, RAMP EDGE UPPER AFT LH <71643> SPEC 8-07330-15	1	35	
- 20	4763-17	• SEAL, RAMP EDGE UPPER AFT RH <71643> SPEC 8-07330-16	1	35	
	4763-18	• SEAL, RAMP EDGE LOWER AFT LH <71643> SPEC 8-07330-17	1	35	
		• SEAL, RAMP EDGE LOWER AFT RH <71643> SPEC 8-07330-18	1	35	

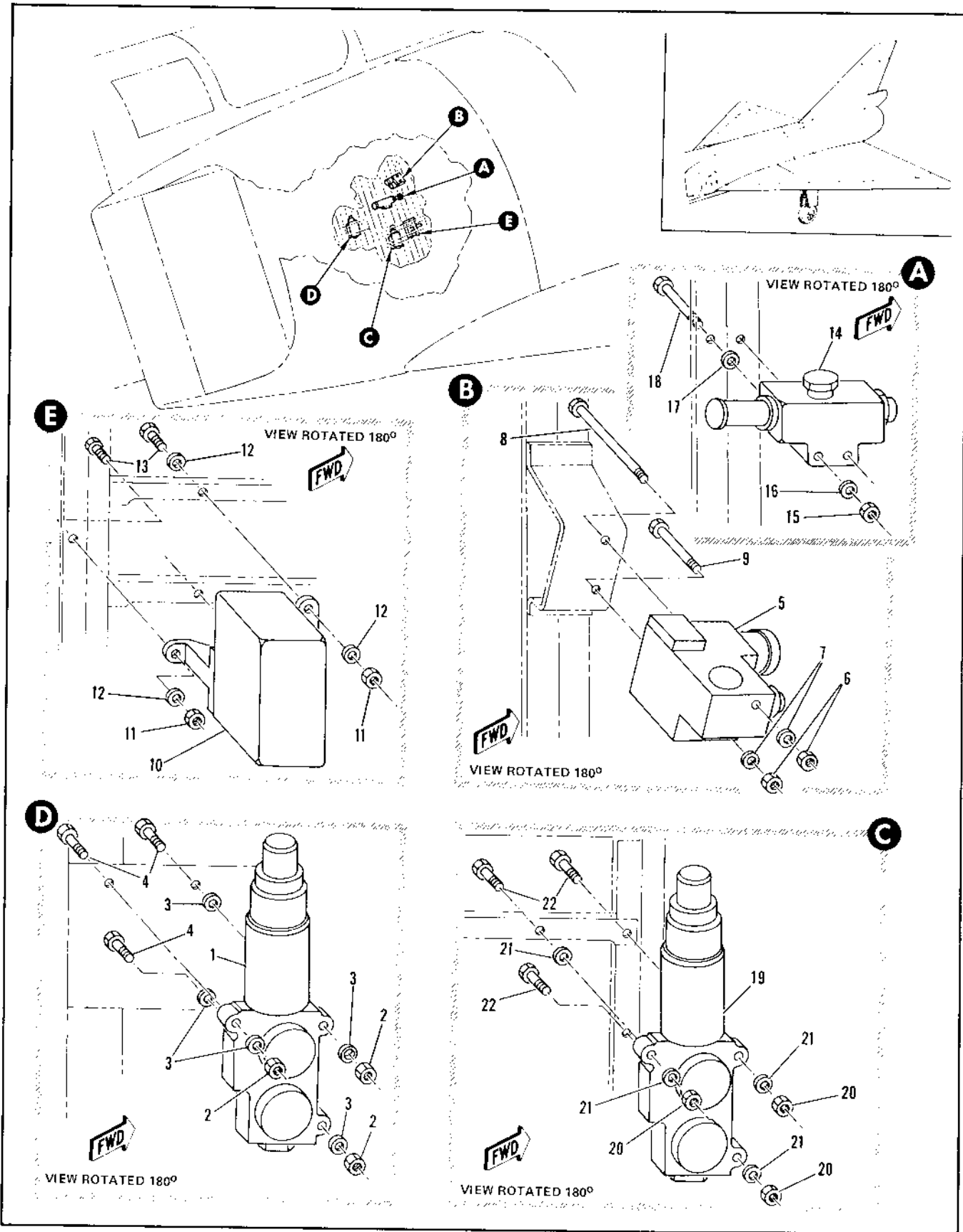

Figure 2.11-8. Variable Air Ramp Intake Duct Hydraulic Valve Installation Sta 287 to 294

FIGURE AND INDEX NUMBER	PART NUMBER	DESCRIPTION	UNITS PER ASSY.	USABLE ON CODE	
				FROM	TO
		1 2 3 4 5 6			
2.11-8	8-81316-5	VALVE INSTALLATION, VARIABLE AIR RAMP INTAKE DUCT HYDRAULIC STA 287 TO 294 FOR NHA SEE FIG. 2-3-3	RF	35	
	8-81316-5	VALVE INSTALLATION, VARIABLE AIR RAMP INTAKE DUCT HYDRAULIC STA 301 TO 308 FOR NHA SEE FIG. 2-3-3	RF	35	
- 1	MC1766-1	VALVE, HYDRAULIC BYPASS STA 287 TO 294 <76050> SPEC 8-00991-1 T.O. 9H8-11-33-3 ATTACHING PARTS	1	35	
- 2	NAS679A3	NUT	3	35	
- 3	AN960D10	WASHER	5	35	
- 4	AN3-5A	BOLT	3	35	
		-----X-----			
- 5	52449-61	VALVE ASSY, HYDRAULIC SHUTOFF STA 308 <00532> SPEC 8-00389-5 T.O. 9H8-14-99-53 ATTACHING PARTS	1	35	
- 6	NAS679A3	NUT	2	35	
- 7	AN960D10	WASHER	2	35	
- 8	AN3-24A	BOLT	1	35	
- 9	AN3-14A	BOLT	1	35	
		-----X-----			
- 10	FC2-173	VALVE ASSY, VARIABLE AIR RAMP SERVO CONTROL <10237> SPEC 8-00367-1 T.O. 9H8-14-198-4 REPLACED BY SUITABLE SUB FC2-173A	1	35	89
	FC2-73	VALVE ASSY, SERVO CONTROL <10237> SPEC 8-00367 ALT INTCHG WITH FC2-173 T.O. 9H8-14-198-4	RF	35	89
	FC2-173A	VALVE ASSY, VARIABLE AIR RAMP SERVO CONTROL <10237> SPEC 8-00367-5 T.O. 9H8-14-198-4 REPLACES SUITABLE SUB FOR FC2-173	1	90	
	FC2-73A	VALVE ASSY, VARIABLE AIR RAMP SERVO CONTROL <10237> SPEC 8-00367-3 T.O. 9H8-14-198-4 ALT INTCHG WITH FC2-173A ATTACHING PARTS	RF	90	
	22206570	VALVE ASSY, VARIABLE AIR RAMP SERVO CONTROL MODEL 20 (81873) ALT INTCHG WITH FC2-73A	1	35	
	11735	MANIFOLD, VALVE MOUNTING (10237)	1	35	
	MS35276-270	BOLT (96906)	2	35	
	MS35276-266	BOLT (96906)	2	35	
	AN960-10L	WASHER (88044)	4	35	
	MS21042-3	NUT (96906)	4	35	
- 11	NAS679A3	NUT	3	35	
- 12	AN960D10	WASHER	5	35	
- 13	AN3-5A	BOLT	3	35	
		-----X-----			
- 14	HP521100	VALVE ASSY, SHUTTLE STA 301 <84685> SPEC 8-00365 T.O. 9H8-5-47-3 ATTACHING PARTS	1	35	
- 15	NAS679A3	NUT	2	35	
- 16	AN960D10	WASHER	2	35	
- 17	NAS43DD3-10	SPACER	2	35	
- 18	AN3-14A	BOLT	2	35	
		-----X-----			
- 19	MC1766-1	VALVE, HYDRAULIC BYPASS STA 301 <76050> SPEC 8-00991-1 T.O. 9H8-11-33-3 ATTACHING PARTS	1	35	
- 20	NAS679A3	NUT	3	35	
- 21	AN960D10	WASHER	4	35	
- 22	AN3-5A	BOLT	3	35	
		-----X-----			

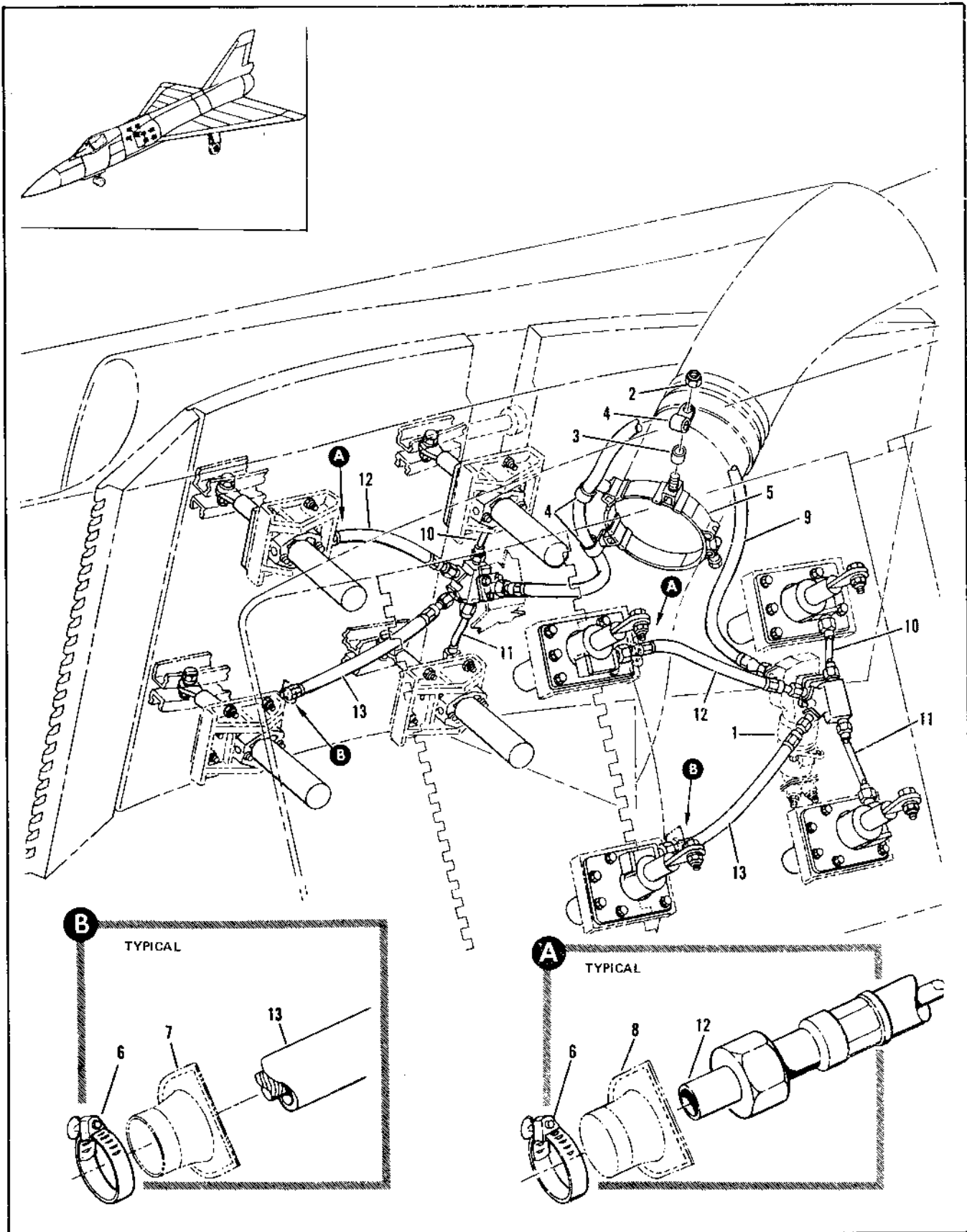

Figure 2.11-9. Variable Air Ramp Screw Jack Installation (Sheet 1 of 3)

FIGURE AND INDEX NUMBER	PART NUMBER	DESCRIPTION	UNITS PER ASSY.	USABLE ON CODE	
				FROM	TO
		1 2 3 4 5 6			
2.11-9	8-45028-3	SCREW JACK INSTALLATION, VARIABLE AIR RAMP LH FOR NHA SEE FIG. 2.3-11	RF	35	
	8-45028-5	SCREW JACK INSTALLATION, VARIABLE AIR RAMP RH FOR NHA SEE FIG. 2.3-11	RF	35	
- 1		• DRIVE UNIT ASSY, VARIABLE AIR RAMP INTAKE DUCT SEE FIG. 2.11-1 INDEX 3	RF		
- 2	NAS679A3	• NUT, RH	3	35	
- 3	NAS43HT3-24	• SPACER, RH	3	35	
- 4	MS21919G12	• CLAMP, PH	3	35	
- 5	900-850-3-74	• SUPPORT, RH <98625> 98-50004-001	1	35	
- 6	AN757TW38	• CLAMP	2	35	
- 7		• BOOT ASSY, SCREW JACK CURTAIN SEAL SEE FIG. 2.3-13	RF		
- 8		• BOOT ASSY, SCREW JACK CURTAIN SEAL SEE FIG. 2.3-13	RF		
- 9	8-45028-9	• SHAFT ASSY, SCREW JACK RH	1	35	60
	127669-042-16	• • SHAFT ASSY, SCREW JACK FLEXIBLE RH <35351> SPEC 8-14963-17	1	35	60
	127669-042-16	• SHAFT ASSY, SCREW JACK FLEXIBLE RH <35351> SPEC 8-14963-17	1	61	
- 10	121283-01	• SHAFT ASSY, SCREW JACK UNIVERSAL JOINT <35351> SPEC 8-04292-3 REPLACED BY NOT INTCHG WITH 139429-01	1	35	48
	129429-01	• SHAFT ASSY, SCREW JACK UNIVERSAL JOINT <35351> SPEC 8-04964-3 REPLACES NOT INTCHG WITH 121283-01	1	49	
- 11	121284-01	• SHAFT ASSY, SCREW JACK UNIVERSAL JOINT <35351> SPEC 8-04292-5 REPLACED BY NOT INTCHG WITH 129429-02	1	35	48
	129429-02	• SHAFT ASSY, SCREW JACK UNIVERSAL JOINT <35351> SPEC 8-04964-1 REPLACES NOT INTCHG WITH 121284-01	1	49	
- 12	127668-018-24	• SHAFT ASSY, SCREW JACK FLEXIBLE <35351> SPEC 8-14963-19	1	35	
- 13	127668-019-24	• SHAFT ASSY, SCREW JACK FLEXIBLE <35351> SPEC 8-14963-21	1	35	

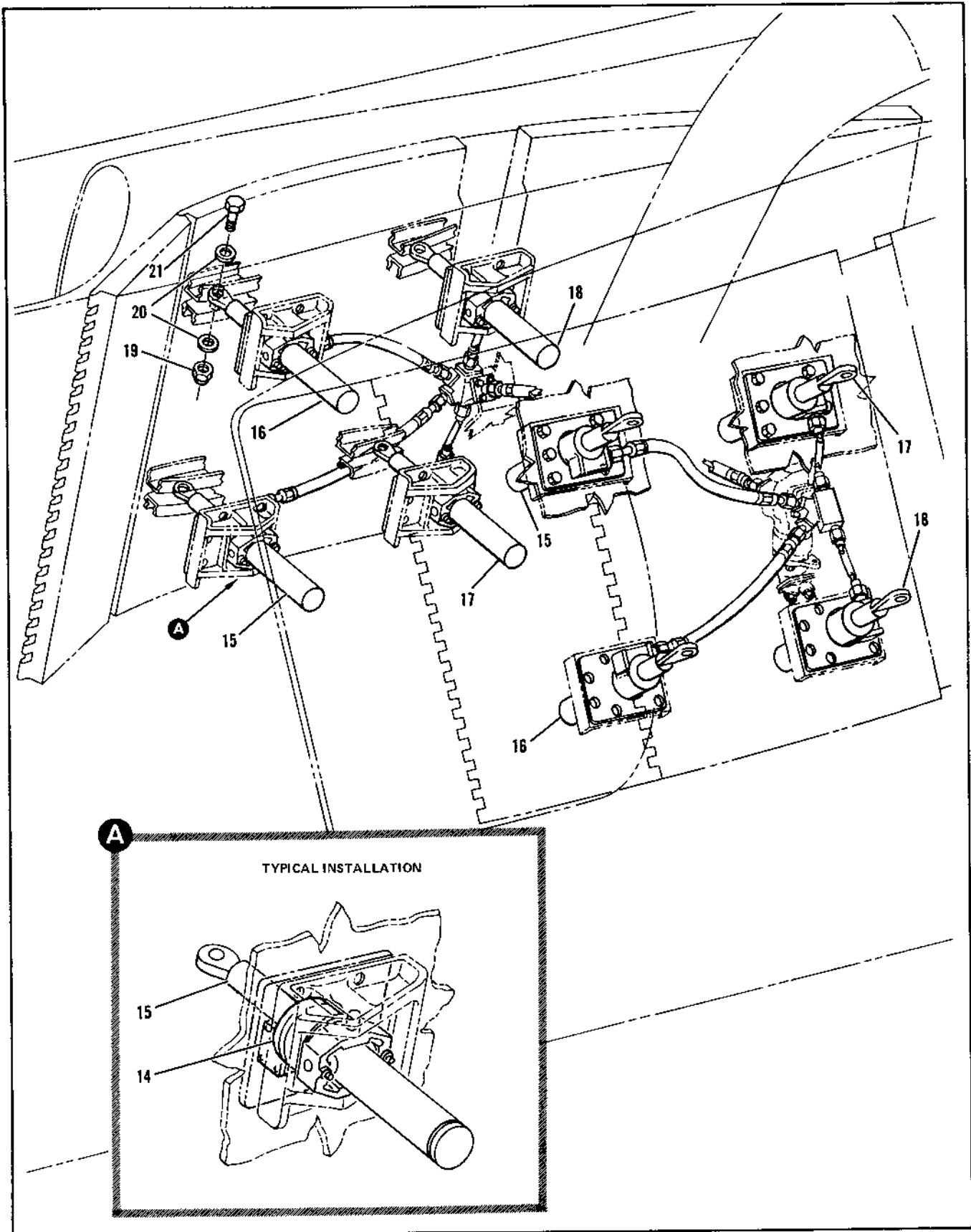

Figure 2.11-9. Variable Air Ramp Screw Jack Installation (Sheet 2 of 3)

FIGURE AND INDEX NUMBER	PART NUMBER	DESCRIPTION	UNITS PER ASSY.	USABLE ON CODE	
				FROM	TO
		1 2 3 4 5 6			
2.11-9- 14	8-45035	• CLAMP ASSY, RIVETED ALTFRED FROM NAS397-34 USE WITH 4227 AND 4437 BOOTS	4	35	21-
- 15	129342-02	• SCREW JACK ASSY, VARIABLE AIR UPPER LH FWD LOWER RH FWD <35351> SPEC R-04293-5 T.O. 1603-2-41-53	2	35	
- 16	129342-01	JACK ASSY, VARIABLE AIR LOWER LH UPPER RH FWD <35351> SPEC R-04293-6 T.O. 1603-2-41-53	2	35	
- 17	129500-01	• SCREW JACK ASSY, VARIABLE AIR UPPER LH LOWER RH AFT <35351> SPEC R-04294-4 T.O. 1603-2-41-63	2	35	60
	131100-01	REPLACED BY SUITABLE SUB 131100-01	2	61	
- 18	129500-02	• SCREW JACK ASSY, VARIABLE AIR LOWER LH UPPER RH <35351> SPEC R-04293-3 T.O. 1603-2-41-63	2	35	60
	131100-02	REPLACED BY SUITABLE SUB 131100-02	2	61	
- 19	AN320-6	• NUT	4	35	
- 20	AN960-616	• WASHER	8	35	
- 21	NAS464-6-14	• BOLT, FWD	2	35	
	NAS464-6-18	• BOLT, AFT	2	35	
		-----X-----			

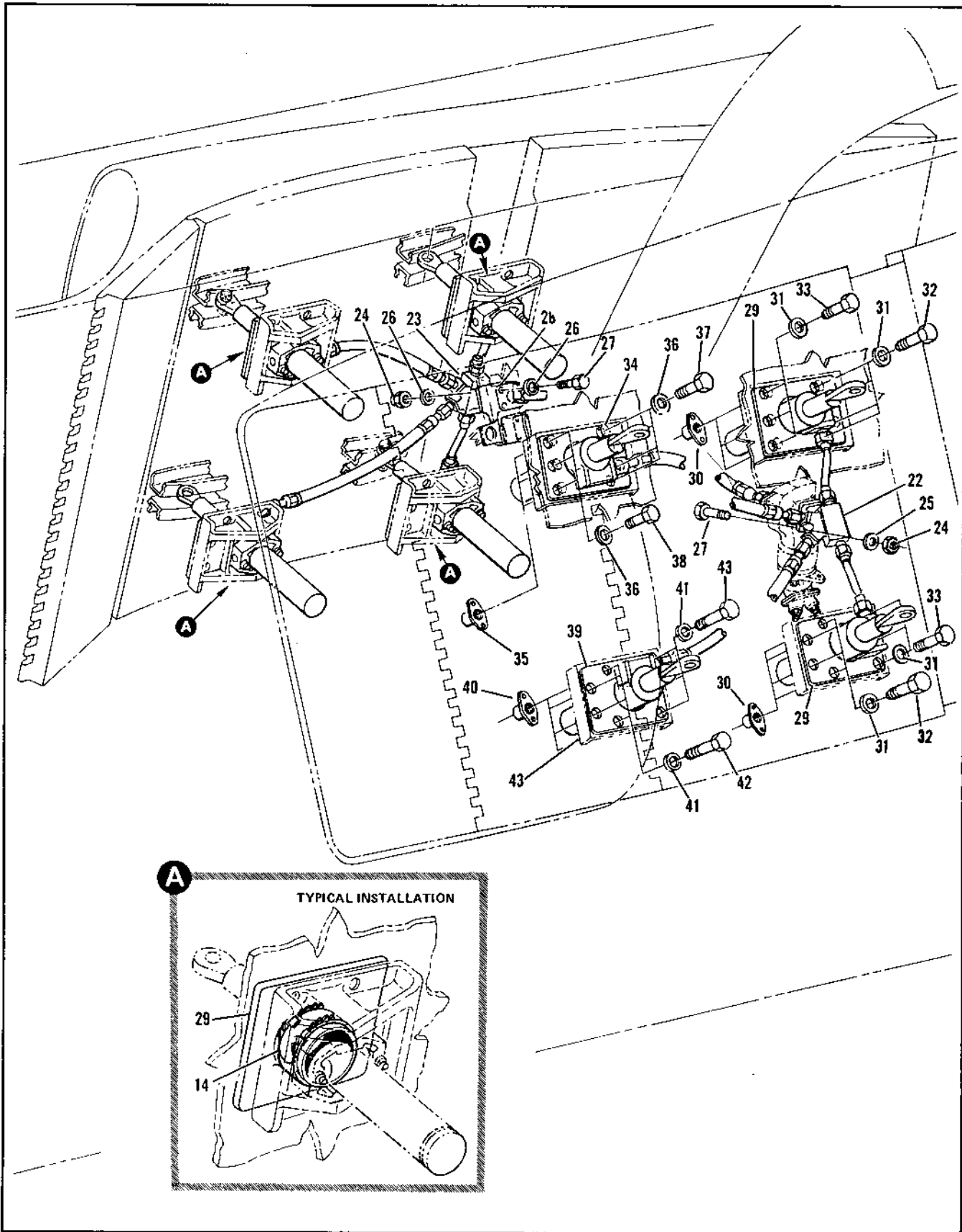

Figure 2.11-9. Variable Air Ramp Screw Jack Installation (Sheet 3 of 3)

FIGURE AND INDEX NUMBER	PART NUMBER	DESCRIPTION	UNITS PER ASSY.	USABLE ON CODE	
				FROM	TO
2.11-9- 22	122196-02	• GEARBOX ASSY, VARIABLE AIR RAMP SCREW JACK LH <35351> SPEC 8-04399-9 T.O. 1661-73-3	1	35	
	118330-04	• GEARBOX ASSY, VARIABLE AIR RAMP SCREW JACK LH <35351> SPEC 8-04399-7 ALT INTCHG WITH 122196-02	PF	35	
- 23	122196-01	• GEARBOX ASSY, VARIABLE AIR RAMP SCREW JACK RH <35351> SPEC 8-04399-10 T.O. 1661-73-3	1	35	
	118330-03	• GEARBOX ASSY, VARIABLE AIR RAMP SCREW JACK RH <35351> SPEC 8-04399-8 ALT INTCHG WITH 122196-01 ATTACHING PARTS	PF	35	
- 24	AN310-3	• NUT			
- 25	AN960-10	• WASHER, LH	4	35	
- 26	AN960-10	• WASHER, RH	8	35	
- 27	AN3-25	• BOLT	4	35	
- 28	128997-01	• GEARBOX, INLET DUCT RH <35351> SPEC 8-04962-1 T.O. 403-19-2-3	1	35	
- 29	4227	• BOLT, VARIABLE AIR RAMP SCREW JACK AFT <84914> SPEC 8-04296-1 ATTACHING PARTS	2	35	
- 31	NAS666A3	• NUTPLATE	14	35	
- 31	AN960-10	• WASHER	14	35	
- 32	AN3H5A	• BOLT	8	35	
- 33	AN3H6A	• BOLT	6	35	
- 34	4227	• BOLT, VARIABLE AIR RAMP SCREW JACK FWD UPPER <84914> SPEC 8-04296-1 ATTACHING PARTS	1	35	
- 35	NAS666A3	• NUTPLATE	7	35	
- 36	AN960-10	• WASHER	7	35	
- 37	AN3H5A	• BOLT	4	35	
- 38	AN3H6A	• BOLT	3	35	
- 39	4437	• BOLT, VARIABLE AIR RAMP SCREW JACK FWD LOWER <84914> SPEC 8-04296-3 ATTACHING PARTS	1	35	
- 40	NAS666A3	• NUTPLATE	7	35	
- 41	AN3H5A	• BOLT	4	35	
- 42	AN3H10A	• BOLT	3	35	
- 43		• SUPPORT, UPPER FWD LH SEE FIG. 2.11-10 INDEX 3	PF		

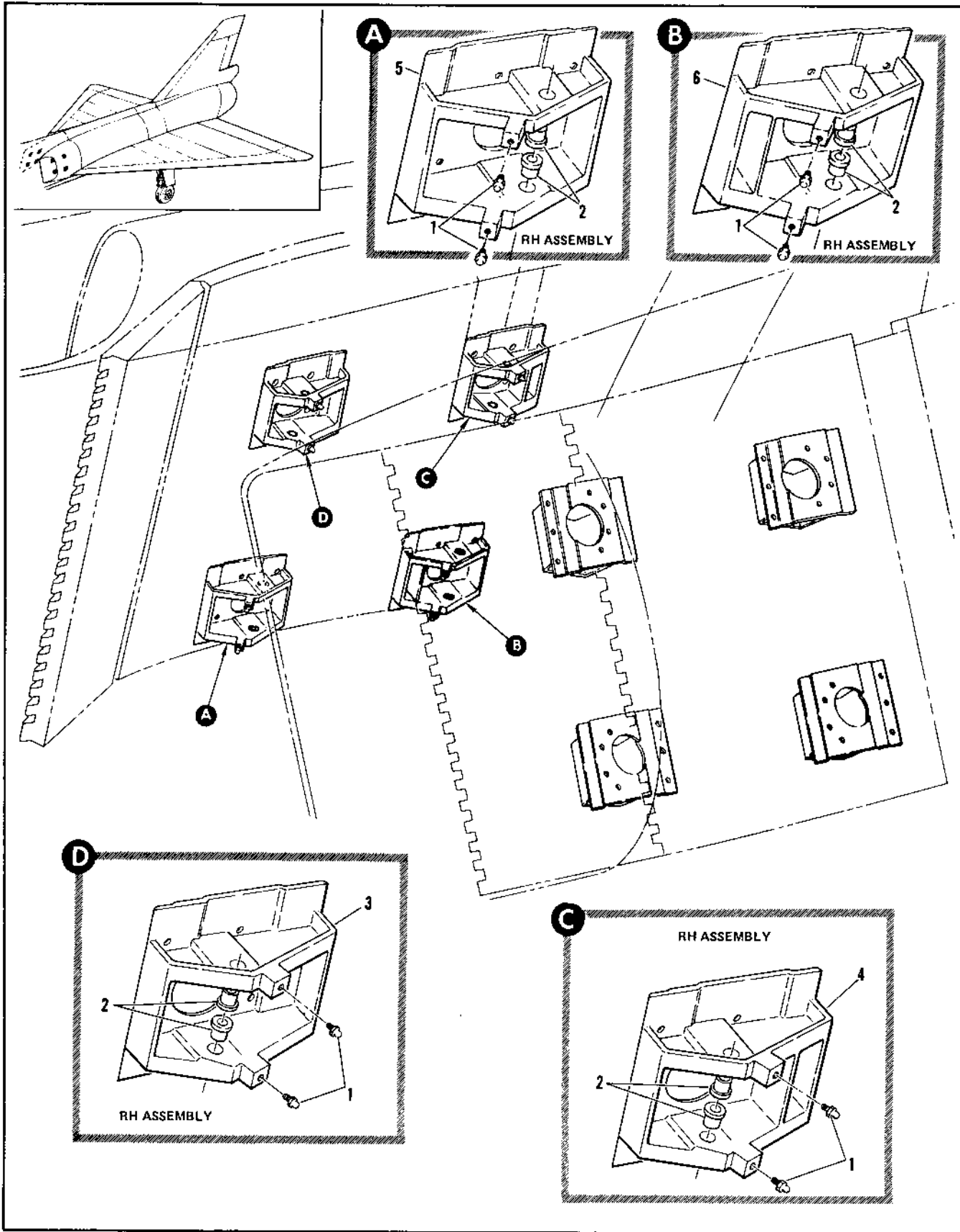

Figure 2.11-10. Variable Air Ramp Screw Jack Support Assembly

FIGURE AND INDEX NUMBER	PART NUMBER	DESCRIPTION	UNITS PER ASSY.	USABLE ON CODE		
				FROM	TO	
2.11-10	8-74997-1	SUPPORT ASSEMBLY, VARIABLE AIR RAMP SCREW JACK UPPER FWD LH FOR NHA SEE FIG. 2.3-13	RF	35		
	8-74997-2	SUPPORT ASSEMBLY, VARIABLE AIR RAMP SCREW JACK UPPER FWD RH FOR NHA SEE FIG. 2.3-13	RF	35		
	8-74997-803	SUPPORT ASSEMBLY, VARIABLE AIR RAMP SCREW JACK LOWER FWD LH FOR NHA SEE FIG. 2.3-13	RF	35	62	
	8-74997-805	SUPPORT ASSEMBLY, VARIABLE AIR RAMP SCREW JACK LOWER FWD LH FOR NHA SEE FIG. 2.3-13	RF	63		
	8-74997-804	SUPPORT ASSEMBLY, VARIABLE AIR RAMP SCREW JACK LOWER FWD RH FOR NHA SEE FIG. 2.3-13	RF	35	62	
	8-74997-806	SUPPORT ASSEMBLY, VARIABLE AIR RAMP SCREW JACK LOWER FWD RH FOR NHA SEE FIG. 2.3-13	RF	63		
	8-74997-5	SUPPORT ASSEMBLY, VARIABLE AIR RAMP SCREW JACK UPPER AFT LH FOR NHA SEE FIG. 2.3-13	RF	35		
	8-74997-6	SUPPORT ASSEMBLY, VARIABLE AIR RAMP SCREW JACK UPPER AFT RH FOR NHA SEE FIG. 2.3-13	RF	35		
	8-74997-801	SUPPORT ASSEMBLY, VARIABLE AIR RAMP SCREW JACK LOWER AFT LH FOR NHA SEE FIG. 2.3-13	RF	35		
	8-74997-802	SUPPORT ASSEMBLY, VARIABLE AIR RAMP SCREW JACK LOWER AFT RH FOR NHA SEE FIG. 2.3-13	RF	35		
	- 1	MS15061-1	• LUBRICATOR	2	35	
	- 2	8-74997-25	• BUSHING, ALTERED FROM 8-44718-7	2	35	
		8-44718-7	• BUSHING	RF		
		8-74997-37	• SUPPORT, UPPER FWD LH	1	35	
	- 3	8-74997-38	• SUPPORT, UPPER FWD RH	1	35	
		8-74997-31	• SUPPORT, UPPER AFT LH	1	35	
	- 4	8-74997-32	• SUPPORT, UPPER AFT RH	1	35	
		8-74997-39	• SUPPORT, LOWER FWD LH	1	35	62
		8-74997-41	• SUPPORT, LOWER FWD RH	1	63	
- 5	8-74997-40	• SUPPORT, LOWER FWD LH	1	35	62	
	8-74997-42	• SUPPORT, LOWER FWD RH	1	63		
	8-74997-33	• SUPPORT, LOWER AFT LH	1	35		
- 6	8-74997-34	• SUPPORT, LOWER AFT RH	1	35		

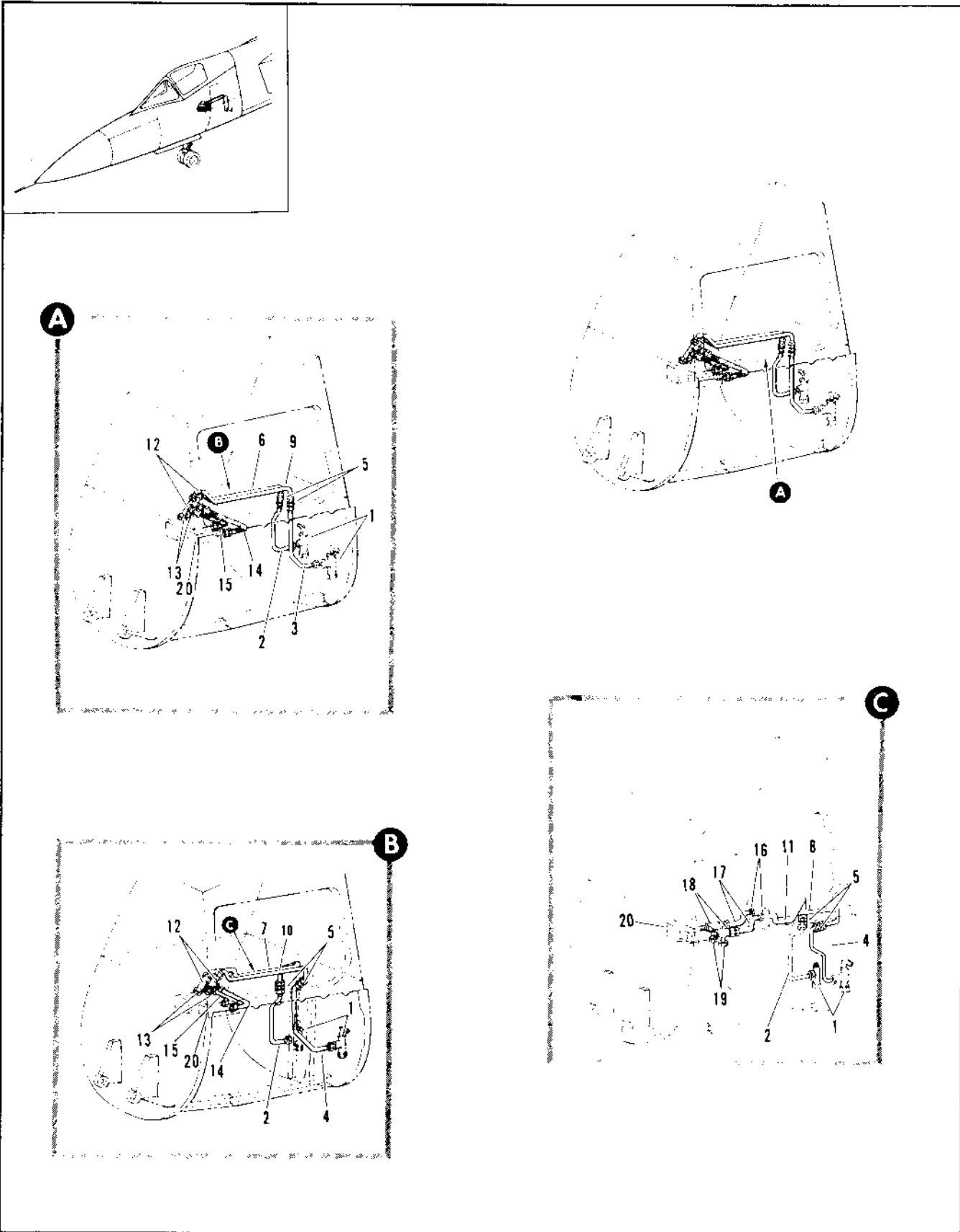

Figure 2.11-11. Variable Air Ramp Pitot Static Tubing Installation Sta 171 to 216

FIGURE AND INDEX NUMBER	PART NUMBER	DESCRIPTION	UNITS PER ASSY.	USABLE ON CODE	
				FROM	TO
2.11-11	8-92945-805	TUBING INSTALLATION, VARIABLE AIR RAMP PITOT STATIC STA 171 TO 216 MOD BY 7144644-10 FOR NHA SEE FIG. 2.3-4	RF	35	
- 1		• TRAP, WATER SEE FIG. 2.11-12 INDEX 7	RF		
- 2	8-92945-143	• TUBE ASSY, PITOT	1	35	
- 3	8-92945-145	• TUBE ASSY, STATIC	1	A	
- 4	7144645-10	• TUBE ASSY, STATIC	1		
- 5	MS2190206	• UNION	2	35	
- 6	8-92945-123	• TUBE ASSY, PITOT	1	A	
- 7	8-92945-149	• TUBE ASSY, PITOT	1	C	
- 8	8-92945-169	• TUBE ASSY, PITOT	1	130	
- 9	8-92945-125	• TUBE ASSY, STATIC	1	A	
- 10	8-92945-147	• TUBE ASSY, STATIC	1	C	
- 11	8-92945-171	• TUBE ASSY, STATIC	1	130	
- 12	AN834-6D	• TEE	2	35	129
- 13	AN929-6	• CAP	2	35	129
	AN924-6D	• NUT	2	35	129
	AN9600916	• WASHER	2	35	129
- 14	306015-6D0094	• HOSE ASSY, <30624> 94-80557-001 REPLACED BY NOT INTCHG WITH 616044-6-0063	1	35	129
- 15	950312-6D0044	• HOSE ASSY, <30624> 94-80556-004 REPLACED BY INTCHG WITH 616044-6-0063	1	35	129
- 16	MS2190306	• UNION	2	130	
	AN924-6D	• NUT	2	130	
- 17	616044-6-0063	• HOSE ASSY, <30624> 94-80517-054 REPLACES NOT INTCHG WITH 950312-6D0044 AND 306015-6D0094	2	130	
- 18	4126-5970-63D	• TEE	2	130	
	AN924-6D	• NUT	2	130	
- 19	MS2191406	• CAP	2	130	
- 20	AN6290-5	• GASKET	2	130	
		• CONTROL UNIT, SEE FIG. 2.11-2 INDEX 1	RF		
		A AIRPLANES #35 THRU 47 AND 49 THRU 89			
		B AIRPLANES #48, 90 AND ON			
		C AIRPLANES #48 AND 90 THRU 129			

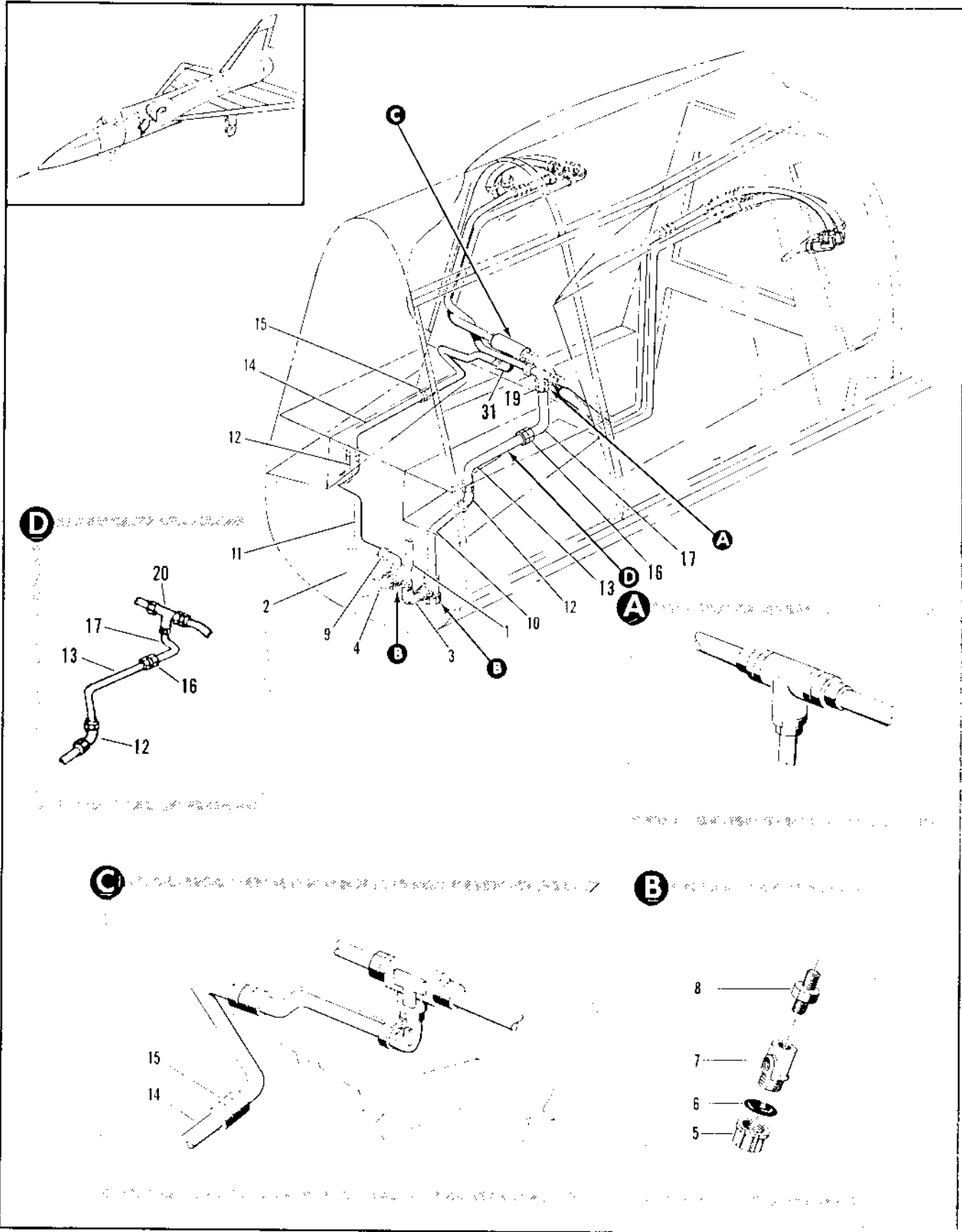

Figure 2.11-12. Variable Air Ramp Pitot Static Tubing Installation Sta 216 to 472 (Sheet 1 of 2)

FIGURE AND INDEX NUMBER	PART NUMBER	DESCRIPTION	UNITS PER ASSY.	USABLE ON CODE	
				FROM	TO
2.11-12	8-92945-603	TUBING INSTALLATION, VARIABLE AIR RAMP PITOT STATIC STA 216 TO 472 FOR NHA SEE FIG. 2.3-10	RF	35	
- 1		• TUBE ASSY, PITOT SEE FIG. 2.11-11 INDEX 2	RF		
- 2		• TUBE ASSY, STATIC SEE FIG. 2.11-11 INDEX 3	RF		
- 3	MS21908D6	• ELBOW, LH	1	35	
- 4	MS21903D6	• UNION, RH	1	35	
	AN924-6D	• NUT	2	35	
	AN6290-6	• GASKET	2	35	
- 5	R-38082	• CAP	2	35	
- 6	AN6290-12	• GASKET	2	35	
- 7	R-38082-7	• TRAP, AIRSPEED WATER	2	35	
- 8	MS21902D6	• UNION, LH	1	35	
	AN6290-6	• GASKET, LH	1	35	
- 9	MS21908D6	• ELBOW, RH	1	35	
	AN924-6D	• NUT, LH	1	35	
	AN6290-6	• GASKET, RH	1	35	
- 10	8-92945-81	• TUBE ASSY, STATIC LH	1	35	
- 11	8-92945-39	• TUBE ASSY, PITOT RH	1	35	
- 12	MS21908D6	• ELBOW	2	35	
	AN924-6D	• NUT	2	35	
	AN9600916L	• WASHER	2	35	
- 13	64A34218-1	• TUBE ASSY, PITOT STATIC VARIABLE RAMP LH	1	35	
- 14	8-92945-15	• TUBE ASSY, STATIC RH	1	35	
- 15	MS21902D6	• UNION	1	35	
- 16	MS21902D6	• UNION	1	35	
- 17	64A34219-1	• TUBE ASSY, PITOT STATIC VARIABLE RAMP	1		
- 18	8-92945-165	• TUBE ASSY, PITOT	1	189	215
	8-92945-167	• TUBE ASSY, PITOT	1	216	
- 19	MS21902D6	• UNION	1		
	AN6290-6	• GASKET	1		

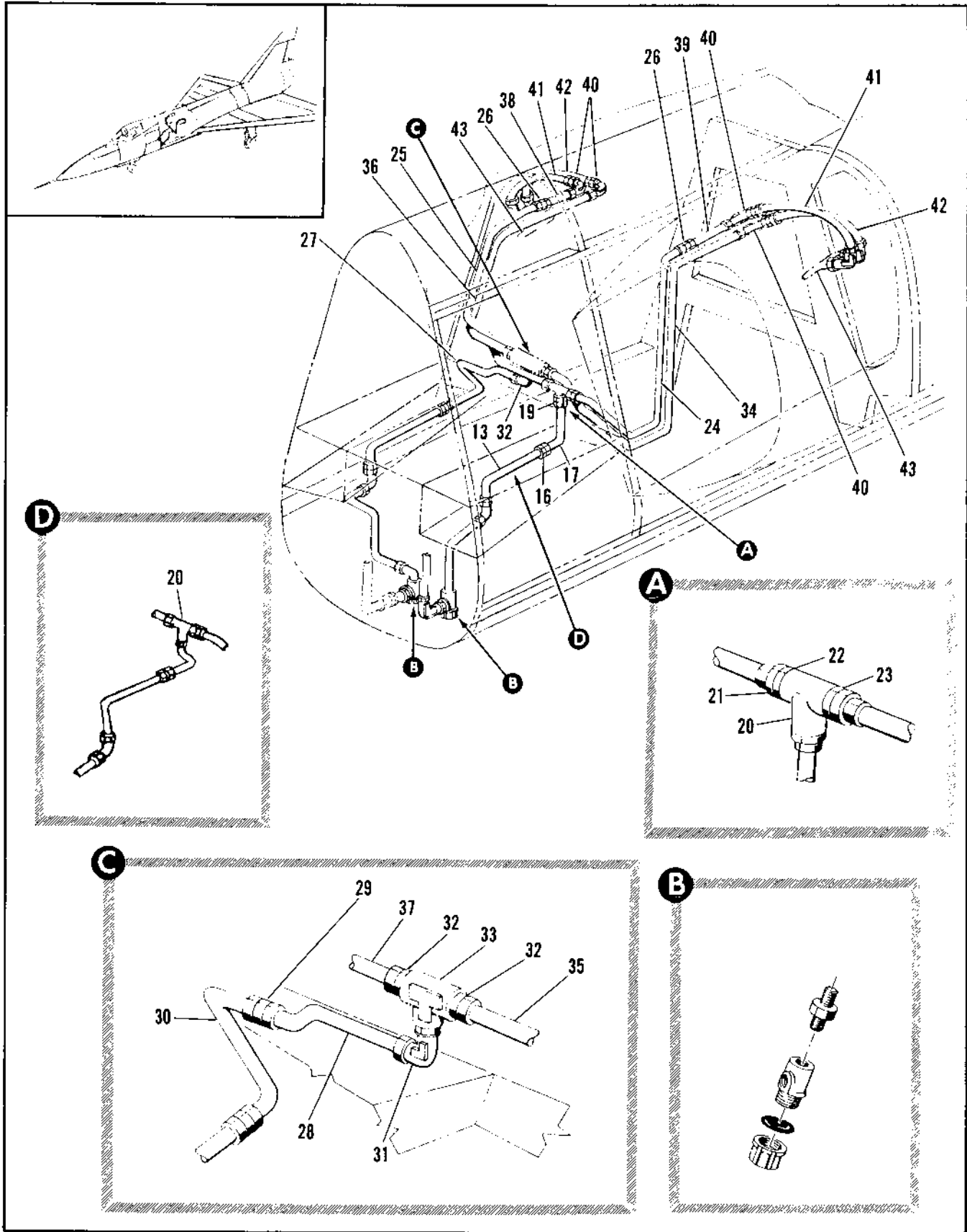
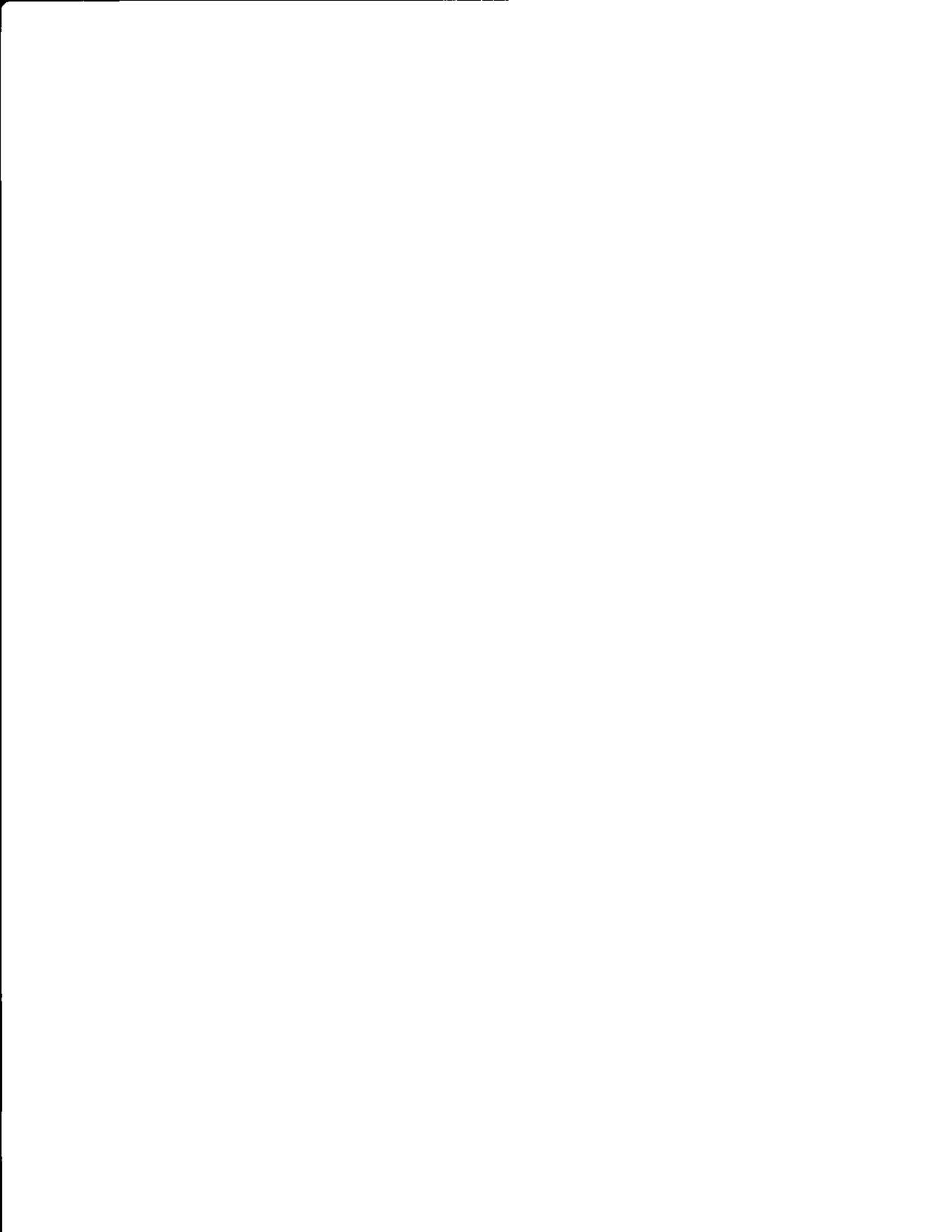

Figure 2.11-12. Variable Air Ramp Pitot Static Tubing Installation Sta 216 to 472 (Sheet 2 of 2)

FIGURE AND INDEX NUMBER	PART NUMBER	DESCRIPTION	UNITS PER ASSY.	USABLE ON CODE	
				FROM	TO
2.11-12- 20	14130	• VALVE ASSY, SHUTTLE (99643) SPEC R-C6593 T.O. 9P5-10-6-3	1	189	
- 21	MS219-15D6-4 AN6290-6	• REDUCER • GASKET	1 1	189 189	
- 22	MS21903D6 AN924-6D AN960D716 AN6290-6	• UNION • NUT • WASHER • GASKET	1 1 3 1	189 189 189 189	
- 23	MS21916D6-4 AN6290-6	• REDUCER • GASKET	1 1	189 189	
- 24	8-92945-69	• TUBE ASSY, PITOT	1	35	
- 25	8-92945-91	• TUBE ASSY, PITOT	1	35	
- 26	MS21903D4 AN924-4D AN960D716	• UNION • NUT • WASHER	2 2 2	35 35 35	
- 27	8-92945-103	• TUBE ASSY, STATIC	1	35	129
- 28	8-92945-157	• TUBE ASSY, STATIC	1	130	
- 29	MS21902D6	• UNION	1	130	
- 30	8-92945-159	• TUBE ASSY, STATIC	1	130	
- 31	MS21968D4 AN924-6D AN6290-6	• ELBOW • NUT • GASKET	1 1 3	35 35 35	
- 32	MS21916D6-4	• REDUCER	2	35	
- 33		• VALVE INSTL, SHUTTLE VARIABLE AIR RAMP SEE FIG. 2.3-11 INDEX 36	RF		
- 34	8-92945-95	• TUBE ASSY, STATIC	1	35	129
- 35	8-92945-155	• TUBE ASSY, STATIC	1	130	
- 36	8-92945-151	• TUBE ASSY, STATIC	1	35	129
- 37	8-92945-153	• TUBE ASSY, STATIC	1	130	
- 38	8-92945-55	• TUBE ASSY, PITOT	1	35	
- 39	8-92945-59	• TUBE ASSY, PITOT	1	35	
- 40	MS21908D4 AN924-4D AN960D716L	• ELBOW • NUT • WASHER	4 4 4	35 35 35	
- 41	8-92945-77	• TUBE ASSY, PITOT	2	35	
- 42	8-92945-79	• TUBE ASSY, STATIC	2	35	
- 43		• TUBE, SEE FIG. 2.11-2 INDEX 6	RF		



391 PAGES

FUEL SYSTEM SUBSECTION

TABLE OF CONTENTS

<i>Fig. No.</i>	<i>Title</i>	<i>Page</i>	<i>Fig. No.</i>	<i>Title</i>	<i>Page</i>
2.12-1	Wing Fuel System	2.12-4	2.12-27	Transfer Tank Outbd Shutoff Valve Installation	2.12-172
2.12-2	Refueling Shutoff Transfer Tank Valve Installation	2.12-20	2.12-28	Transfer Tank Inbd Pilot Valve Installation	2.12-174
2.12-3	Manual Refuel Selector Valve Installation RH	2.12-22	2.12-29	Transfer Tank Outbd Pilot Valve Installation	2.12-176
2.12-4	Fuel Transfer Line Bracket Installation Sta 343	2.12-24	2.12-30	Transfer Tank Inbd Shutoff Valve Installation	2.12-178
2.12-5	Wing Fuel Electrical	2.12-26	2.12-31	Transfer Tank Inbd Shutoff Valve Installation	2.12-180
2.12-6	Wing Tank Electrical Receptacle Installation	2.12-28	2.12-32	Fuel Tank Pressure Tubing Installation RH Sta 472 to 577	2.12-182
2.12-7	Tank #1 and #2 Fuel Quantity Probes	2.12-30	2.12-33	Emergency Fuel Transfer Valve Installation	2.12-190
2.12-8	Transfer and #3 Tank Fuel Quantity Probes	2.12-32	2.12-34	Transfer Tank Emergency Pilot Valve Installation	2.12-192
2.12-9	Pylon Installation and External Fuel Tank Release	2.12-34	2.12-35	CG Transfer Tank Pressure Fitting Sta 569	2.12-194
2.12-10	External Fuel Tank Assembly	2.12-42	2.12-36	CG Transfer Line Shutoff Valve Installation	2.12-198
2.12-11	External Fuel Tank and Vent Line Tubing Installation Intermediate Wing Box	2.12-52	2.12-37	MLG Wheel Well Fuel Control Tubing Installation	2.12-200
2.12-12	External Tank Pressure Relief Tubing Installation	2.12-54	2.12-38	Fuselage Fuel System	2.12-220
2.12-13	External Tank Shutoff Valve Installation Sta 442 to 450	2.12-56	2.12-39	Fuselage Fuel Electrical	2.12-230
2.12-14	Fuel Flow Wing Tubing Installation	2.12-58	2.12-40	Fuel System Checkout Panel Aft Installation	2.12-236
2.12-15	Wing Tank #1 Fuel Control Tubing Installation	2.12-70	2.12-41	Fuel System Checkout Intermediate Panel Installation	2.12-238
2.12-16	Wing Tank #1 Fuel Control Tubing Installation	2.12-92	2.12-42	Fuel System Checkout Adapter Installation Fwd	2.12-240
2.12-17	Tank #3 Refuel Shutoff and Pilot Valve Installation	2.12-112	2.12-43	Fuel Tank Pressure Tubing Installation Sta 217 to 253	2.12-242
2.12-18	Shutoff and Check Valve Installation	2.12-114	2.12-44	Fuel Tank Pressure Tubing Installation Sta 253 to 472 LH	2.12-260
2.12-19	Wing Tank #2 Fuel Control Tubing Installation	2.12-116	2.12-45	Fuel Tank Pressure Tubing Installation Sta 253 to 472 RH	2.12-274
2.12-20	Wing Tank #3 Fuel Control Tubing Installation	2.12-122	2.12-46	Fuel Tank Pressure Tubing Installation LH Sta 472 to 577	2.12-296
2.12-21	Wing Transfer Tank Fuel Control Tubing Installation	2.12-128	2.12-47	Vent Fuselage Tank to Wing Tubing Installation	2.12-312
2.12-22	Wing Transfer Tank Fuel Control Tubing Installation	2.12-148	2.12-48	Fuselage Tank to Wing Fuel Transfer Tubing Installation	2.12-314
2.12-23	Tank #1 Suction Relief Valve Installation	2.12-162	2.12-49	Fuselage Fuel Tank Vent Tubing Installation	2.12-320
2.12-24	Tank #1 Refuel Shutoff Valve Installation LH	2.12-164	2.12-50	Fuselage Fuel Tank Assembly	2.12-326
2.12-25	Transfer Tank Vent Valve Installation	2.12-166	2.12-51	Fuselage Fuel Tank Structure Assembly	2.12-328
2.12-26	Transfer Tank Refuel Pilot and Vent Valve Installation LH	2.12-170	2.12-52	Fuselage Tank Fuel Transfer Equipment Installation	2.12-330
			2.12-53	Fuselage Fuel Tank Vent Valve Installation	2.12-344
			2.12-54	Fuel Pressure Valve	2.12-346

FUEL SYSTEM SUBSECTION

TABLE OF CONTENTS (Cont.)

2.12-55	Pressure Regulator Refueling Valve Installation	2.12-348	2.12-62	Engine Fuel Pressure Tubing Installation	2.12-366
2.12-56	2.12-56 Pressure Refueling Valve	2.12-350	2.12-63	Fuselage Fuel Tank Fume Barrier Installation	2.12-368
2.12-57	Fuel Tank Pressure Manifold Tubing Support	2.12-352	2.12-64	Air Shutoff Valve and Filter Panel Installation	2.12-370
2.12-58	Fuel Tank Pressure Equipment Installation	2.12-356	2.12-65	Engine Fuel Supply Tubing and Strainer	2.12-372
2.12-59	Fuel Tank Pressurization Air Filter Installation	2.12-360	2.12-66	Wing Fuel Fitting	2.12-376
2.12-60	Fuel Flow Equalizer Installation	2.12-362	2.12-67	Aerial Refueling Fuel Tank Pressure Tubing Installation	2.12-382
2.12-61	Engine Fuel Supply Wing Tubing Installation	2.12-364	2.12-68	Aerial Refueling Equipment Dorsal Area	2.12-386

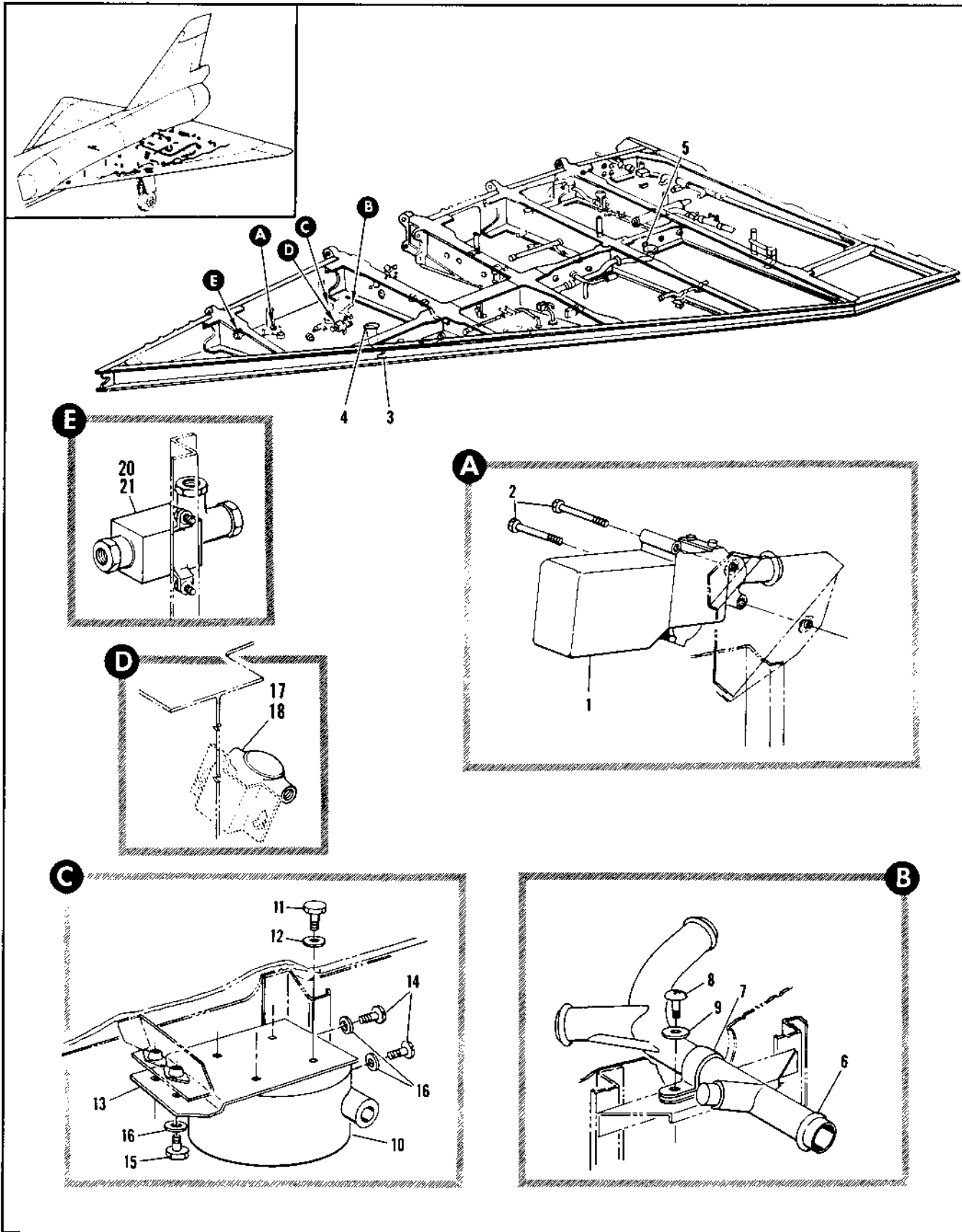

Figure 2.12-1. Wing Fuel System (Sheet 1 of 8)

FIGURE AND INDEX NUMBER	PART NUMBER	DESCRIPTION 1 2 3 4 5 6	UNITS PER ASSY.	USABLE ON CODE	
				FROM	TO
2.12-1	8-21188-1	WING FUEL SYSTEM • VALVE INSTL, FUEL, TANK #1 PRESSURE RELIEF LH FOR NHA SEE FIG. 2-6-32	RF	35	
	8-21188-2	• VALVE INSTL, FUEL TANK #1 PRESSURE RELIEF RH FOR NHA SEE FIG. 2-6-32	RF	35	
- 1	14-356-51	• VALVE ASSY, PRESSURE RELIEF TANK #1 <82267> SPEC 8-00394-1 T.O. 6J15-8-63-13 REPLACED BY INTCHG WITH 14-356-101 ATTACHING PARTS	1	35	
- 2	NAS3-27A	• BOLT	2	35	
		-----X-----			
- 3		• VALVE INSTL, TANK #1 SUCTION RELIEF LH SEE FIG. 2.12-23	RF		
- 4		• TUBING INSTL, FUEL FLOW WING LH SEE FIG. 2.12-14	RF		
- 5		• FITTING INSTL, WING BULKHEAD FUEL TUBING LH SEE FIG. 2.12-66	RF		
	8-21190-1	• TUBING INSTL, TANK #1 VENT LINE LH FOR NHA SEE FIG. 2.6-32	RF	35	
	8-21190-2	• TUBING INSTL, TANK #1 VENT LINE RH FOR NHA SEE FIG. 2.6-32	RF	35	
- 6	8-21189-1	• TUBE ASSY, TANK #1 TEE VENT LINE LH	1	35	
- 7	8-21189-2	• TUBE ASSY, TANK #1 TEE VENT LINE RH	1	35	
	91-98026-015	• CLAMP ATTACHING PARTS	1	35	
- 8	NAS221-9	• SCREW	1	35	
- 9	AN960D10L	• WASHER	1	35	
		-----X-----			
	8-21186-1	• VALVE INSTL, TANK #1 REFUEL PILOT LH FOR NHA SEE FIG. 2.6-32	RF	35	
	8-21186-2	• VALVE INSTL, TANK #1 REFUEL PILOT RH FOR NHA SEE FIG. 2.6-32	RF	35	
- 10	16-356-1	• VALVE ASSY, FUEL TANK PILOT FLOAT (92003) SPEC 8-00904 T.O. 6J15-5-19-3	1	35	
	909555	• VALVE ASSY, FUEL TANK PILOT FLOAT (92003) SPEC 8-00904 T.O. 6J15-3-75-13 ATTACHING PARTS	1	35	
- 11	AN3H3A	• BOLT	4	35	
- 12	AN960D10L	• WASHER	4	35	
		-----X-----			
- 13	8-21186-7	• BRACKET ASSY, LH RIVETED	1	35	
	8-21186-8	• BRACKET ASSY, RH RIVETED ATTACHING PARTS	1	35	
- 14	NAS221-8	• SCREW	2	35	
- 15	AN3-4A	• BOLT	2	35	
- 16	AN960D10L	• WASHER	4	35	
		-----X-----			
- 17	104700	• VALVE ASSY, FUEL TANK VENT (96124) SPEC 8-02915 T.O. 6J15-8-35-3 ATTACHING PARTS	1	35	
- 18	AN4-5A	• BOLT	2	35	
		-----X-----			

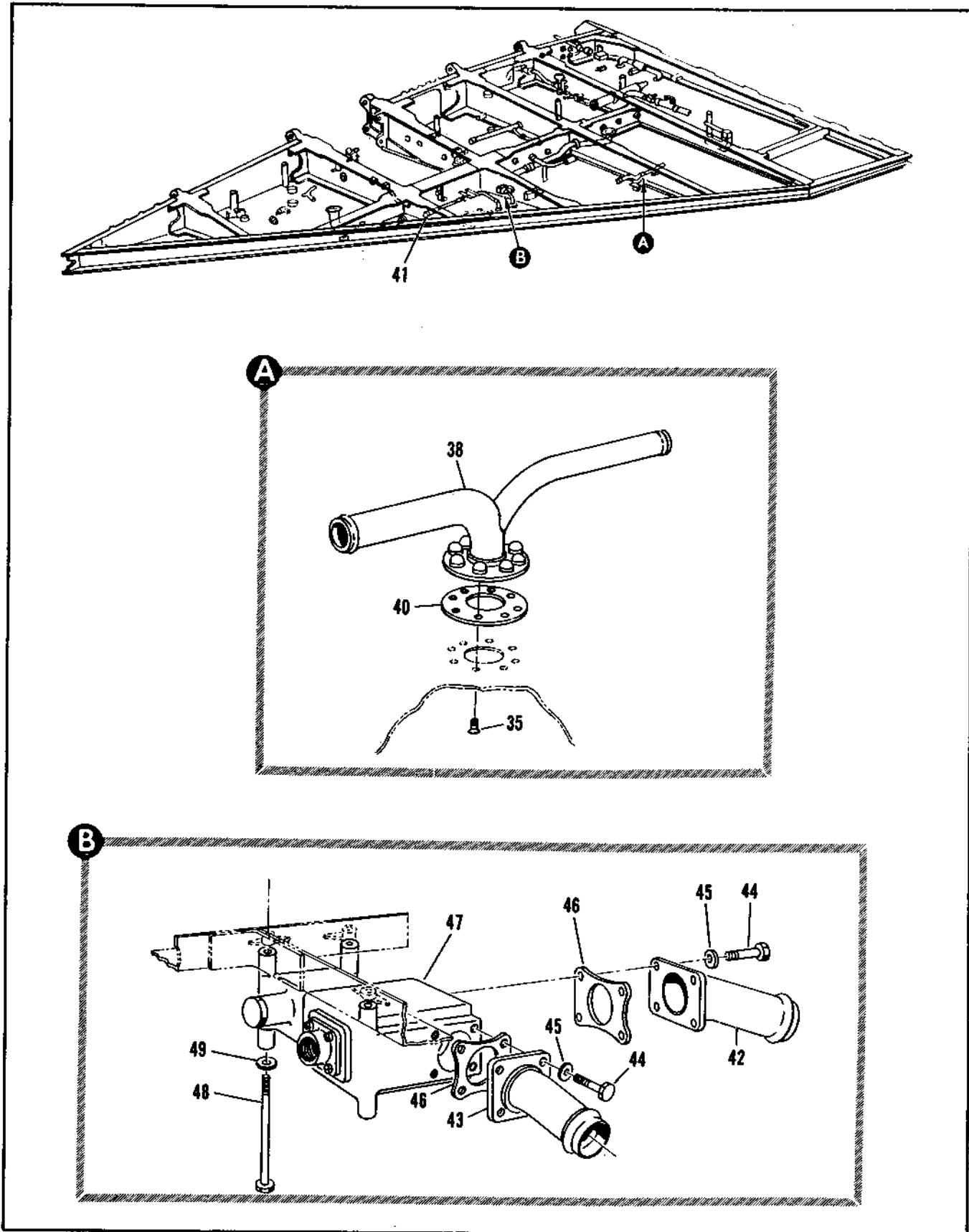

Figure 2.12-1. Wing Fuel System (Sheet 3 of 8)

FIGURE AND INDEX NUMBER	PART NUMBER	DESCRIPTION	UNITS PER ASSY.	USABLE ON CODE	
				FROM	TO
		1 2 3 4 5 6			
2.12-1	A-21282-1	• OUTLET INSTL, FUEL TANK VENT LH FOR NMA SEE FIG. 2.6-32	RF	35	
	B-21282-2	• OUTLET INSTL, FUEL TANK VENT RH FOR NMA SEE FIG. 2.6-32	RF	35	
- 38	B-21548-3	• • OUTLET ASSY, FUEL TANK #2 VENT LH WELDED	1	35	
	B-21548-4	• • OUTLET ASSY, FUEL TANK #2 VENT RH WELDED ATTACHING PARTS	1	35	
- 39	NAS334PA10	• • SCREW	6	35	
		-----X-----			
	B-21548-23	• • • TUBE ASSY, LH WELDED	1	35	
	A-21548-24	• • • TUBE ASSY, RH WELDED	1	35	
- 40	075456	• • GASKET, <A3289> SPEC 2-02290-1	1	35	
- 41		• VALVE INSTL, EXTERNAL FUEL TANK SHUTOFF AND CHECK SEE FIG. 2.12-11 INDEX 1	RF		
- 42	B-21109	• • TUBE ASSY, EXTERNAL TANK WING VENT OUTLET WELDED	1	35	
- 43	B-21108-3	• • TUBE ASSY, AIR PRESSURE EXTERNAL TANK WELDED ATTACHING PARTS	1	35	
- 44	AN3-2A	• • BOLT	8	35	
- 45	AN961-10	• • WASHER	8	35	
		-----X-----			
- 46	075356-5	• • GASKET, <A3289> SPEC 3-02289-9	2	35	
- 47	PR332-100	• • VALVE ASSY, CHECK AND PRESSURE INDICATOR <A4987> SPEC 8-02938-1 T.O. 6J15-F-75-3 ATTACHING PARTS	1	35	
- 48	AN3-27A	• • BOLT	3	35	
- 49	AN961-10	• • WASHER	3	35	
		-----X-----			

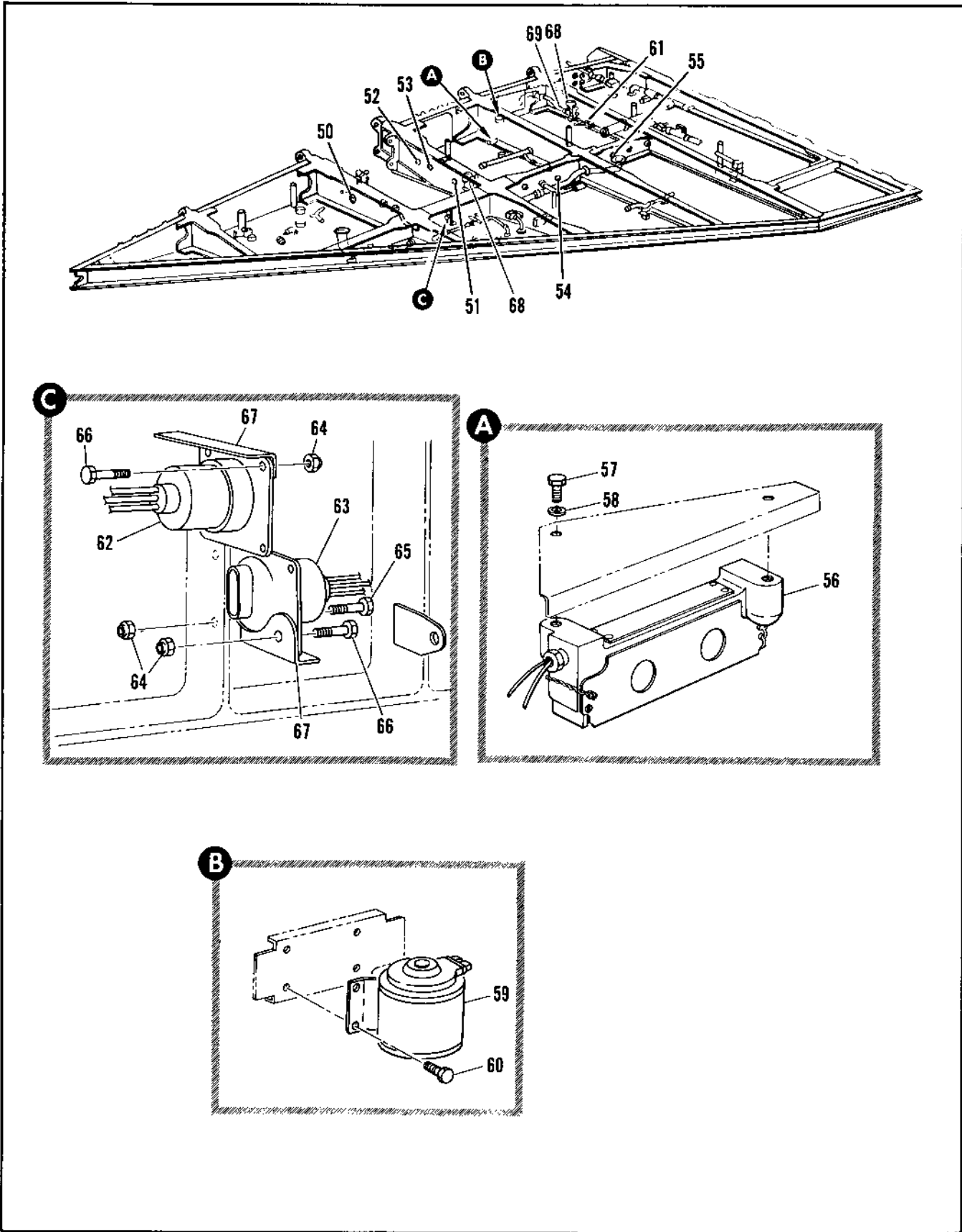

Figure 2.12-1. Wing Fuel System (Sheet 4 of 8)

FIGURE AND INDEX NUMBER	PART NUMBER	DESCRIPTION	UNITS PER ASSY.	USABLE ON CODE	
				FROM	TO
		1 2 3 4 5 6			
2.12-1- 50		• RECEPTACLE INSTL, WING FUEL TANK ELECTRICAL STA 431 SEE FIG. 2.12-6	RF		
- 51		• RECEPTACLE INSTL, WING FUEL TANK ELECTRICAL STA 472 BL 52 SEE FIG. 2.12-6	RF		
- 52		• RECEPTACLE INSTL, WING FUEL TANK ELECTRICAL STA 472 BL 59 SEE FIG. 2.12-6	RF		
- 53		• RECEPTACLE INSTL, WING FUEL TANK ELECTRICAL STA 472 BL 66 SEE FIG. 2.12-6	RF		
- 54		• RECEPTACLE INSTL, WING FUEL TANK ELECTRICAL STA 519 SEE FIG. 2.12-6	RF		
- 55		• RECEPTACLE INSTL, WING FUEL TANK ELECTRICAL STA 557 SEE FIG. 2.12-6	RF		
	8-21255-1	• SWITCH INSTL, FUEL LOW LEVEL WARNING LH FOR NHA SEE FIG. 2.6-32	RF	35	
	8-21255-3	• SWITCH INSTL, FUEL LOW LEVEL WARNING FOR NHA SEE FIG. 2.6-32	RF	35	
- 56	F7890	• SWITCH, <50625> 98-62000-101 T.O. 8S1-2-24-23 ATTACHING PARTS	1	35	
- 57	AN3H3A	• BOLT	2	35	
- 58	AN96C01C	• WASHER ----X----	2	35	
	8-21309	• COMPENSATOR INSTL, FUEL QUANTITY PROBE LH FOR NHA SEE FIG. 2.6-32	RF	35	
- 59	FG1A1A	• COMPENSATOR, <48931> 92-22506-001 T.O. 5L5-2-6-4 ATTACHING PARTS	1	35	
- 60	AN3-3A	• BOLT ----X----	4	35	
- 61		• VALVE INSTL, CO TRANSFER LINE SHUTOFF LH SEE FIG. 2.12-38	PF		
	8-21458-3	• SWITCH INSTL, TANK AND BOOST PUMP LOW PRESSURE WARNING LH FOR NHA SEE FIG. 2.6-32	RF	35	
	8-21458-4	• SWITCH INSTL, TANK AND BOOST PUMP LOW PRESSURE WARNING RH FOR NHA SEE FIG. 2.6-32	RF	35	
- 62	40064-1	• SWITCH ASSY, BOOST PUMP PRESSURE <98635> SPEC 8-02986-7 T.O. 8S2-3-57-73	1	35	
- 63	40065	• SWITCH ASSY, TANK PRESSURE <98505> SPEC 8-02986-3 T.O. 8S2-3-57-73 ATTACHING PARTS	1	35	
- 64	NAS679A3	• NUT, 96-37545-002	6	35	
- 65	AN3-5A	• BOLT	4	35	
- 66	AN3-5A	• BOLT ----X----	2	35	
- 67	8-21275-1	• BRACKET ASSY, LH RIVETED	2	35	
	8-21275-2	• BRACKET ASSY, RH RIVETED	2	35	
	8-22310-1	• PUMP INSTL, FUEL BOOST LH FOR NHA SEE FIG. 2.6-32	RF	35	
	8-22310-2	• PUMP INSTL, FUEL BOOST RH FOR NHA SEE FIG. 2.6-32	PF	35	
- 68	TB129700	• PUMP ASSY, FUEL BOOST <82700> SPEC 8-02975 T.O. 6J10-3-63-4 REPLACED BY SUITABLE SUB TB129700-5	2	35	35
	TB129700-5	• PUMP ASSY, FUEL BOOST <82700> SPEC 8-02975-1 T.O. 6J10-3-63-4 REPLACES SUITABLE SUB FOR TB129700	2	36	
	TB129700-8	• PUMP ASSY, FUEL BOOST <82700> SPEC 8-02975-1 T.O. 6J10-3-63-4 ALT INTCHG WITH TB129700-5 ATTACHING PARTS	2	35	
	AN4-6A	• BOLT ----X----	8	35	
- 69		• TUBING INSTL, ENGINE FUEL SUPPLY WING SEE FIG. 2.12-61	RF		

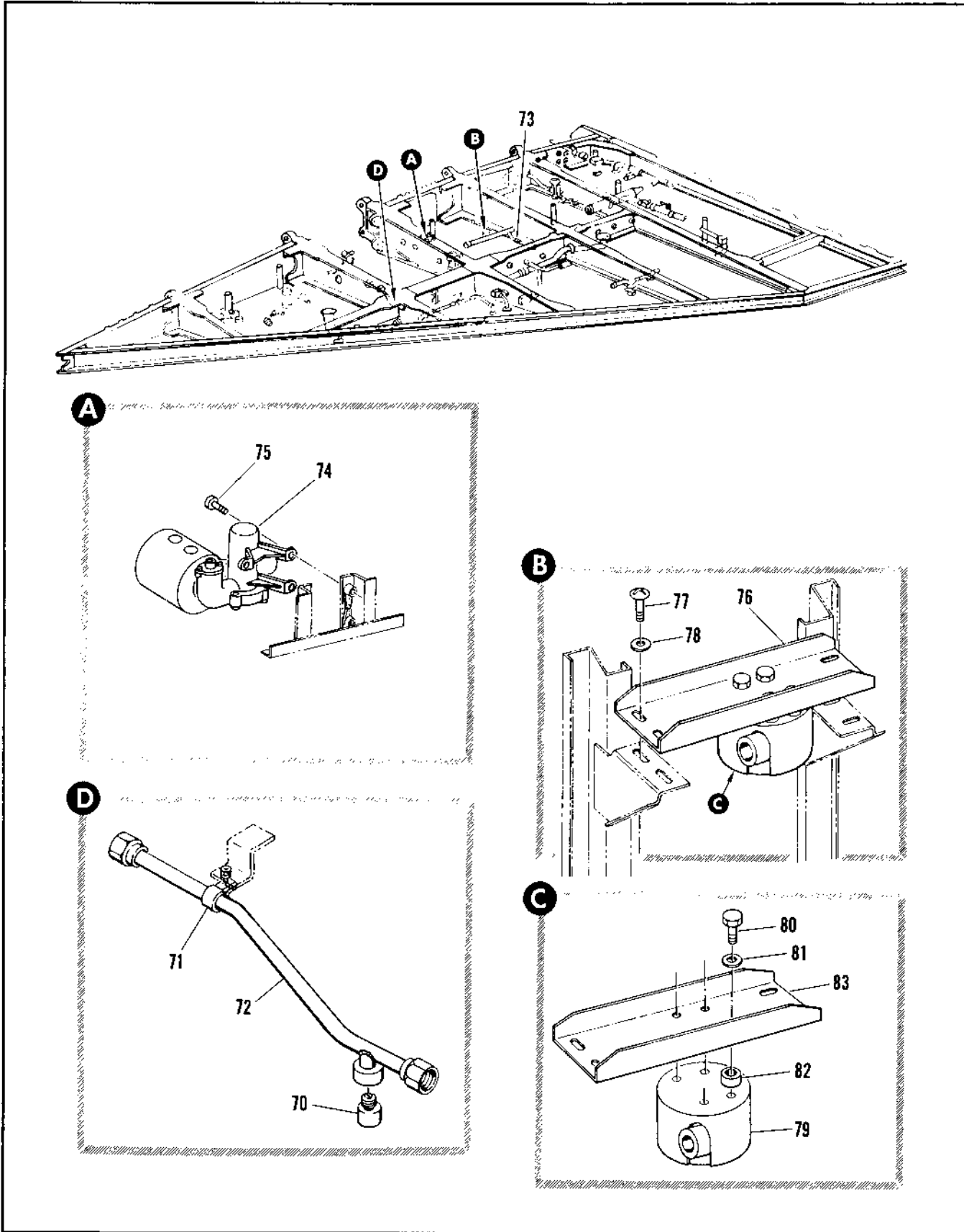

Figure 2.12-1. Wing Fuel System (Sheet 5 of 8)

FIGURE AND INDEX NUMBER	PART NUMBER	DESCRIPTION	UNITS PER ASSY.	USABLE ON CODE	
				FROM	TO
2.12-1	8-21176-1	• DRAIN INSTL. M/G WHEEL WELL FUEL TUBING LH FOR NHA SEE FIG. 2.6-32	RF	35	
	8-21176-3	• DRAIN INSTL. M/G WHEEL WELL FUEL TUBING RH FOR NHA SEE FIG. 2.6-32	RF	35	
- 70	1608	• • VALVE, <91511> 92-12501-003	1	35	
- 71	91-98026-007	• • CLAMP, LH	1	35	60
	NAS221-9	• • BOLT	1	35	60
	AN963PD10L	• • WASHER	1	35	60
	91-98026-007	• • CLAMP, RH	1	35	
	NAS221-9	• • BOLT	1	35	
	AN963PD10L	• • WASHER	1	35	
- 72	8-21175	• TUBE ASSY, WELDED	1	35	
- 73		• VALVE INSTL. TANK #3 REFUEL SHUTOFF AND PILOT SEE FIG. 2.12-19	RF		
	8-21527-1	• VALVE INSTL. TANK #3 VENT RELIEF LH FOR NHA SEE FIG. 2.6-32	RF	35	186
	8-21527-5	• VALVE INSTL. TANK #3 VENT RELIEF LH FOR NHA SEE FIG. 2.6-32	RF	187	
	8-21527-3	• VALVE INSTL. TANK #3 VENT RELIEF RH FOR NHA SEE FIG. 2.6-32	RF	35	186
	8-21527-801	• VALVE INSTL. TANK #3 VENT RELIEF RH FOR NHA SEE FIG. 2.6-32	RF	187	
- 74	8-105155	• • VALVE ASSY, TANK #3 VENT RELIEF <75361> SPEC 8-02200-3 REPLACES SUITABLE SUB FOR 8-104155	1	D	
	8-104155	• • VALVE ASSY, TANK #3 VENT RELIEF <75361> SPEC 8-02200-1 REPLACED BY SUITABLE SUB 8-105155	1	C	
		ATTACHING PARTS			
- 75	AN3-4A	• • BOLT	3	35	
		-----X-----			
	8-21181-1	• VALVE INSTL. TANK #3 REFUEL PILOT LH FOR NHA SEE FIG. 2.6-32	RF	35	43
	8-21181-801	• VALVE INSTL. TANK #3 REFUEL PILOT LH FOR NHA SEE FIG. 2.6-32	RF	44	
	8-21181-3	• VALVE INSTL. TANK #3 REFUEL PILOT RH FOR NHA SEE FIG. 2.6-32	RF	35	43
	8-21181-803	• VALVE INSTL. TANK #3 REFUEL PILOT RH FOR NHA SEE FIG. 2.6-32	RF	44	
- 76	8-21181-13	• • VALVE ASSY, LH	1	35	43
	8-21181-15	• • VALVE ASSY, LH	1	44	
	8-21181-15	• • VALVE ASSY, RH	1	35	43
	8-21181-21	• • VALVE ASSY, RH	1	44	
		ATTACHING PARTS			
- 77	NAS221-6	• • SCREW	4	35	
- 78	AN960D10L	• • WASHER	4	35	
		-----X-----			
- 79	16-336-1	• • • VALVE ASSY, TANK #3 REFUEL PILOT SHUTOFF (92003) SPEC 8-00904 T.O. 6J15-5-19-3	1	35	
	909555	• • • VALVE ASSY, FUEL TANK PILOT FLOAT (92003) SPEC 8-00904 T.O. 6J15-3-75-13	1	35	
		ATTACHING PARTS			
- 80	AN3M3A	• • • BOLT	4	35	
- 81	AN960D10L	• • • WASHER	4	35	
- 82	NAS430D3-8	• • • SPACER	4	35	
		-----X-----			
- 83	8-21181-7	• • • CHANNEL	1	35	43
	8-21181-23	• • • CHANNEL ASSY, RIVETED	1	44	
		C AIRPLANES #187 THRU 199 AND 226 THRU 231			
		D AIRPLANES #35 THRU 225, 232 AND ON			

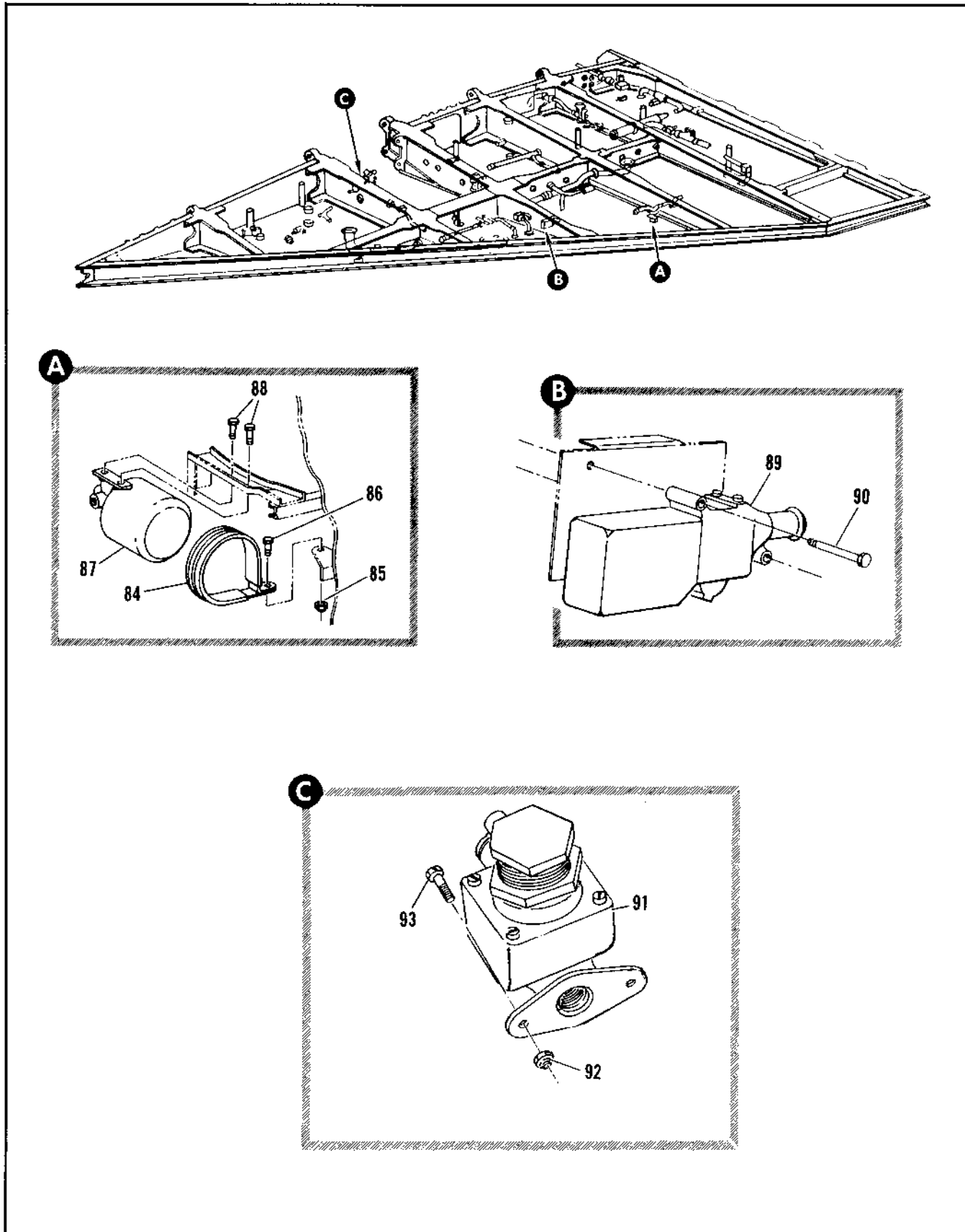

Figure 2.12-1. Wing Fuel System (Sheet 6 of 8)

FIGURE AND INDEX NUMBER	PART NUMBER	DESCRIPTION	UNITS PER ASSY.	USABLE ON CODE	
				FROM	TO
		1 2 3 4 5 6			
2.12-1	8-21211-1	• VALVE INSTL. TANK #2 FLOAT PILOT LH FOR NHA SEE FIG. 2.6-32	RF	35	
	8-21211-3	• VALVE INSTL. TANK #2 FLOAT PILOT RH FOR NHA SEE FIG. 2.6-32	RF	35	
- 84	MS21919DF-54	• • CLAMP	1	35	
- 85	NAS679A3	• • NUT, 96-37545-002	1	35	
- 86	AN3-4A	• • BOLT	1	35	
- 87	5-556-1	• • VALVE ASSY, TANK #2 PILOT FLOAT <R2267> SPEC 8-00908 T.O. 9P5-5-67-3	1	35	
- 88	AN3-4A	• • BOLT	2	35	
	8-21528-3	• VALVE INSTL. FUEL TANK #2 PRESSURE RELIEF LH FOR NHA SEE FIG. 2.6-32	RF	35	188
	8-21528-5	• VALVE INSTL. FUEL TANK #2 PRESSURE RELIEF LH FOR NHA SEE FIG. 2.6-32	RF	189	
	8-21528-4	• VALVE INSTL. FUEL TANK #2 PRESSURE RELIEF RH FOR NHA SEE FIG. 2.6-32	RF	35	188
	8-21528-6	• VALVE INSTL. FUEL TANK #2 PRESSURE RELIEF RH FOR NHA SEE FIG. 2.6-32	RF	189	
- 89	14-356-151	• VALVE ASSY, TANK #2 PRESSURE RELIEF <R2267> SPEC 8-00394-5 T.O. 6J15-63-13	1	35	
- 90	AN3-27A	• • BOLT	2	35	
- 91	5069	• • REGULATOR, FUEL TANK PRESSURE <98439> SPEC 8-00379 T.O. 6J15-7-24-13	1	35	
		ATTACHING PARTS			
- 92	NAS679A4	• • NUT, 96-37545-003	2	35	
- 93	AN4-5A	• • BOLT	2	35	
		-----X-----			

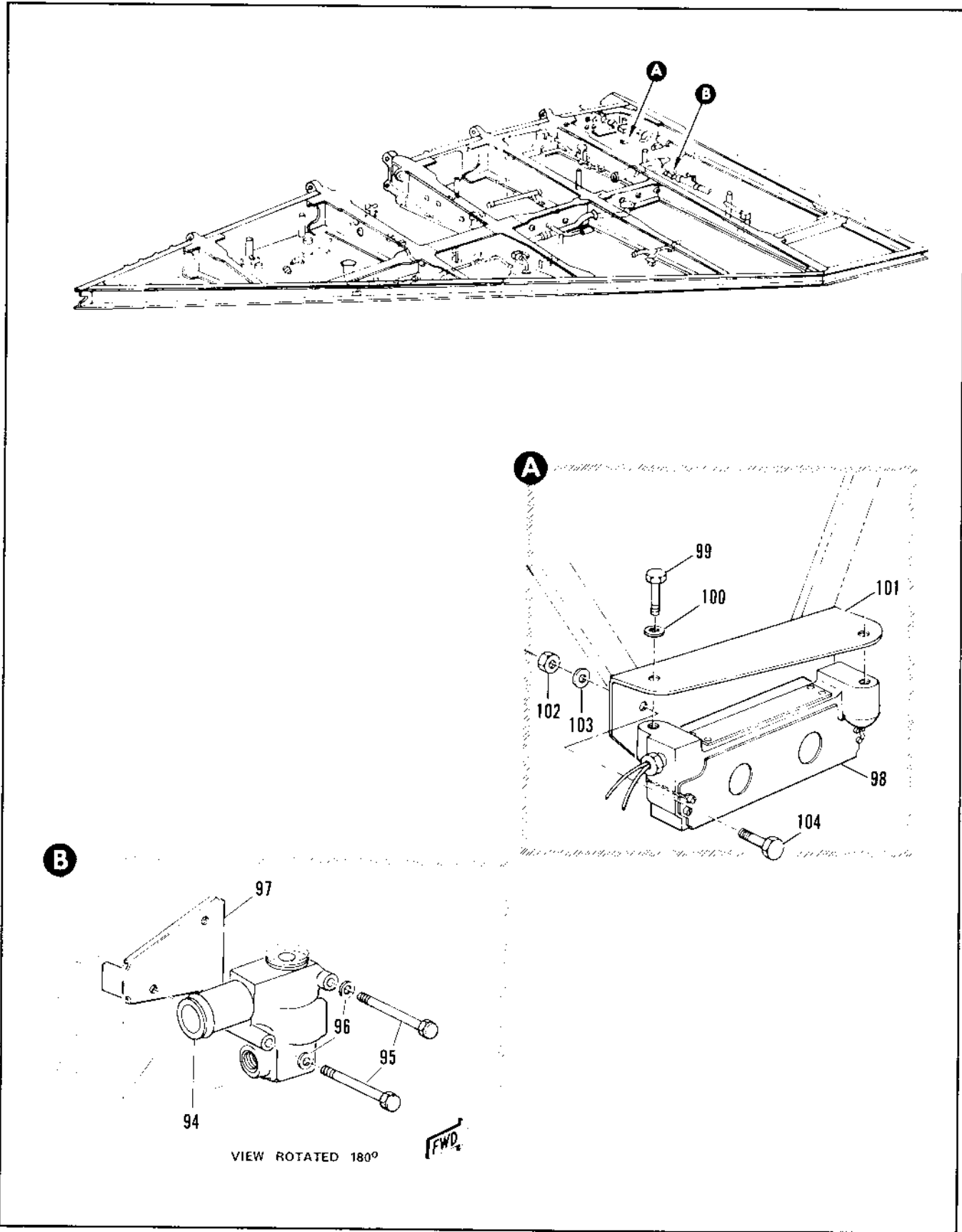

Figure 2.12-1. Wing Fuel System (Sheet 7 of 8)

FIGURE AND INDEX NUMBER	PART NUMBER	DESCRIPTION	UNITS PER ASSY.	USABLE ON CODE	
				FROM	TO
		1 2 3 4 5 6			
2.12-1	8-21887	• VALVE INSTL, TRANSFER TANK PRESSURE RELIEF LH FOR NHA SEE FIG. 2.6-32	RF	48	48
	8-21182-5	• VALVE INSTL, TRANSFER TANK PRESSURE RELIEF LH FOR NHA SEE FIG. 2.6-32	RF	A	
	8-21887	• VALVE INSTL, TRANSFER TANK PRESSURE RELIEF RH FOR NHA SEE FIG. 2.6-32	RF	48	48
	8-21182-6	• VALVE INSTL, TRANSFER TANK PRESSURE RELIEF RH FOR NHA SEE FIG. 2.6-32	RF	A	
- 94	19-356-91	• VALVE ASSY, TRANSFER TANK PRESSURE RELIEF <82267> SPEC 8-JJ354-13 T.O. 6J15-2-64-24 REPLACES SUITABLE SUB FOR 19-356-71 ATTACHING PARTS	1	35	
- 95	AN3-29A	• BOLT	2	35	
- 96	AN960D10L AN960D10	• WASHER • WASHER -----X-----	2 2	35 35	
	MS29513-21	• PACKING	2	48	48
	MS29512-4	• GASKET	1	48	48
- 97	8-21182-9	• SUPPORT ASSY, TRANSFER TANK PRESSURE RELIEF VALVE LH RIVETED NHA IS 8-18126	1	E	
	8-21182-11	• SUPPORT ASSY, TRANSFER TANK PRESSURE RELIEF VALVE LH RIVETED NHA IS 8-18926	1	189	277
	8-21182-10	• SUPPORT ASSY, TRANSFER TANK PRESSURE RELIEF VALVE RH RIVETED NHA IS 8-18126	1	E	
	8-21182-12	• SUPPORT ASSY, TRANSFER TANK PRESSURE RELIEF VALVE RH RIVETED NHA IS 8-18926	1	189	277
	8-21187-1	• SWITCH INSTL, TRANSFER TANK FUEL LOW LEVEL LH FOR NHA SEE FIG. 2.6-32	RF	E	
	8-21187-5	• SWITCH INSTL, TRANSFER TANK FUEL LOW LEVEL LH FOR NHA SEE FIG. 2.6-32	RF	189	277
	8-21187-3	• SWITCH INSTL, TRANSFER TANK FUEL LOW LEVEL RH FOR NHA SEE FIG. 2.6-32	RF	E	
	8-21187-801	• SWITCH INSTL, TRANSFER TANK FUEL LOW LEVEL RH FOR NHA SEE FIG. 2.6-32	RF	189	277
- 98	F7897	• SWITCH, FUEL LEVEL FLOAT <06862> 96-82000-001 ATTACHING PARTS	1	35	
- 99	AN3H3A	• BOLT	2	35	
- 100	AN960PD10L	• WASHER -----X-----	2	35	
- 101	8-21187-7	• BRACKET	1	E	
	8-21187-17	• BRACKET ASSY, LH	1	189	277
	8-21187-19	• BRACKET ASSY, RH ATTACHING PARTS	1	189	277
- 102	NAS679A3	• NUT	4	35	
- 103	AN960PD10L	• WASHER	4	35	
- 104	AN3-7A	• BOLT -----X-----	4	35	
<p>A AIRPLANES #35 THRU 47 AND 49 THRU 89 B AIRPLANES #48, 90 AND 30 C AIRPLANES #75 THRU 124, 279 AND ON</p>					

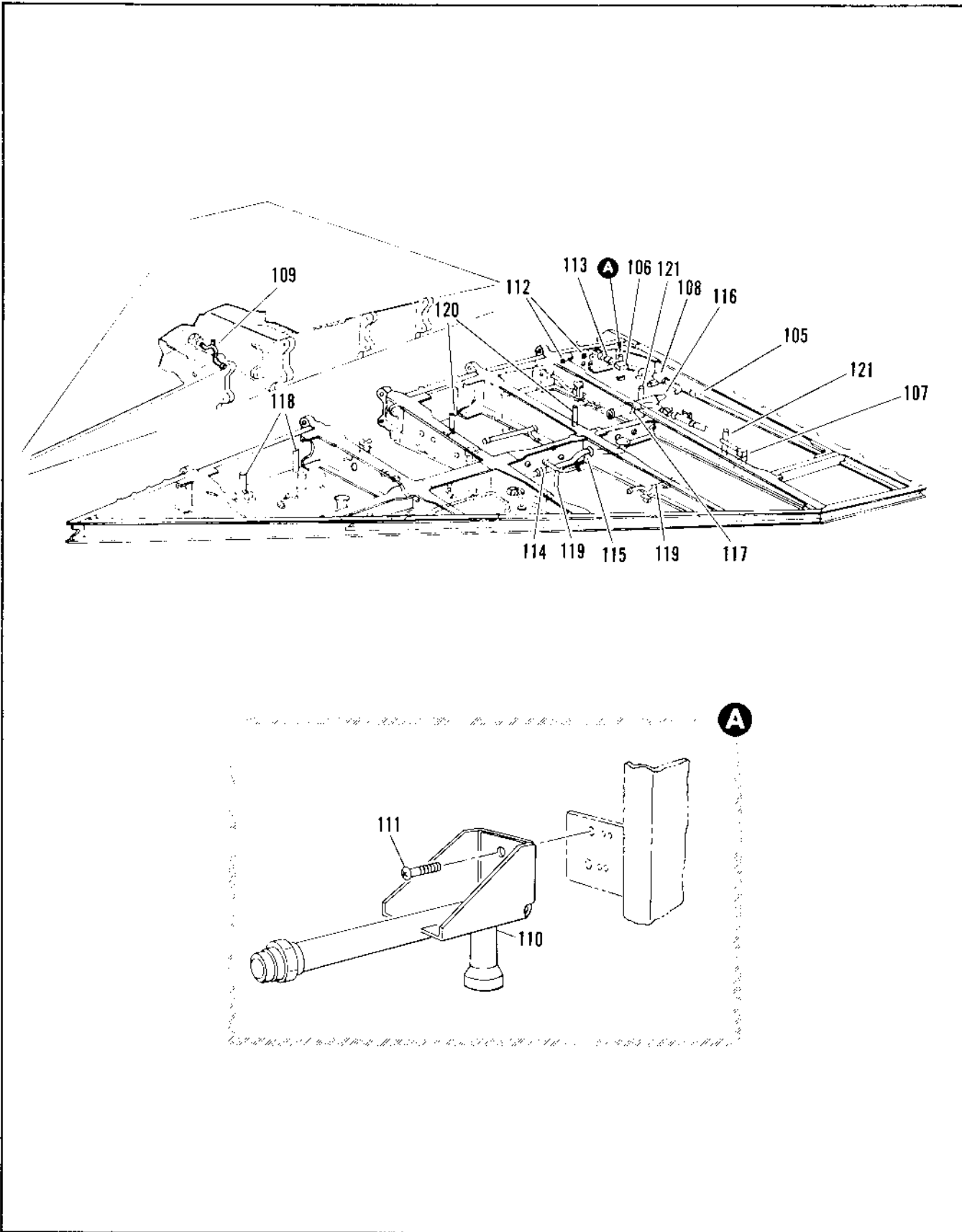

Figure 2.12-1. Wing Fuel System (Sheet 8 of 8)

FIGURE AND INDEX NUMBER	PART NUMBER	DESCRIPTION	UNITS PER ASSY.	USABLE ON CODE	
				FROM	TO
		1 2 3 4 5 6			
2.12-1-105		• VALVE INSTL, TRANSFER TANK EMERGENCY PILOT SEE FIG. 2.12-34	RF		
-106		• VALVE INSTL, TRANSFER TANK INBD PILOT SEE FIG. 2.12-28	RF		
-107		• VALVE INSTL, TRANSFER TANK OUTPD SHUTOFF SEE FIG. 2.12-27	RF		
-108		• VALVE INSTL, TRANSFER TANK INBD SHUTOFF SEE FIG. 2.12-32	RF		
	B-21167-801	• TUBING INSTL, WING FUEL TANK AIR PRESSURE RH FOR NHA SEE FIG. 2.6-32	RF	35	
-109	B-28390	• . TUBE ASSY, WING FUEL TANK AIR PRESSURE WELDED	1	35	
	B-21155-3	• BELLMOUTH INSTL, TRANSFER TANK FUEL SCAVENGE LH FOR NHA SEE FIG. 2.6-32	RF	35	
	B-21155-4	• BELLMOUTH INSTL, TRANSFER TANK FUEL SCAVENGE RH FOR NHA SEE FIG. 2.6-32	RF	35	
-110	B-21154-1	• . BELLMOUTH ASSY, TRANSFER TANK FUEL SCAVENGE ATTACHING PARTS	1	35	
-111	AN520010R7	• . . BELLMOUTH ASSEMBLY -----X-----	2	35	
	B-21154-15	• . . BELLMOUTH ASSEMBLY	1	35	
	B-21156-7	• . . FITTING	1	35	
-112		• SEAL INSTL, CG TRANSFER PRESSURE FITTING SEE FIG. 2.1237	RF		
-113		• FITTING INSTL, CG TRANSFER PRESSURE WING TRANSFER TANK SEE FIG. 2.12-35	RF		
	B-21612-1	• BELLMOUTH INSTL, TANK #2 FUEL TRANSFER FWD LH FOR NHA SEE FIG. 2.6-32	RF	160	277
	B-21612-2	• BELLMOUTH INSTL, TANK #2 FUEL TRANSFER FWD RH FOR NHA SEE FIG. 2.6-32	RF	160	277
-114	3605-400	• . COUPLING, <79326> B2-72501-015	1	160	277
	MS29513-533	• . PACKING	2	160	277
-115	B-21613-1	• . BELLMOUTH ASSY, FUEL TRANSFER TANK #2 FWD LH WELDED REPLACES NOT INTCHG WITH B-21571-1	1	160	277
	B-21613-2	• . BELLMOUTH ASSY, FUEL TRANSFER TANK #2 FWD RH WELDED REPLACES NOT INTCHG WITH B-21571-2	1	160	277
	AN3-4A	• . BOLT -----X-----	2	160	277
	B-21622-1	• TUBE INSTL, CG FUEL TRANSFER SPAR #6 LH FOR NHA SEE FIG. 2.6-32	RF	189	277
	B-21622-2	• TUBE INSTL, CG FUEL TRANSFER SPAR #6 RH FOR NHA SEE FIG. 2.6-32	RF	189	277
-116	B-21593-801	• . TUBE ASSY, CG FUEL TRANSFER LH WELDED	1	189	277
	B-21593-802	• . TUBE ASSY, CG FUEL TRANSFER RH WELDED ATTACHING PARTS	1	189	277
	NAS1104-9	• . BOLT	6	189	277
	NAS623-3-4	• . SCREW	2	160	
	AN96-0416L	• . WASHER	6	189	277
	AN96010L	• . WASHER	2	189	277
-117	J75156-2	• . GASKET, <83259> SPEC 8-02287-3	1	189	277
-118		• PROBE INSTL, FUEL QUANTITY TANK #1 STA 413 SEE FIG. 2.12-7	RF		
-119		• PROBE INSTL, FUEL QUANTITY TANK #2 STA 538 SEE FIG. 2.12-7	RF		
-120		• PROBE INSTL, FUEL QUANTITY TANK #3 STA 544 SEE FIG. 2.12-8	RF		
-121		• PROBE INSTL, FUEL QUANTITY TRANSFER TANK STA 578 SEE FIG. 2.12-8	RF		

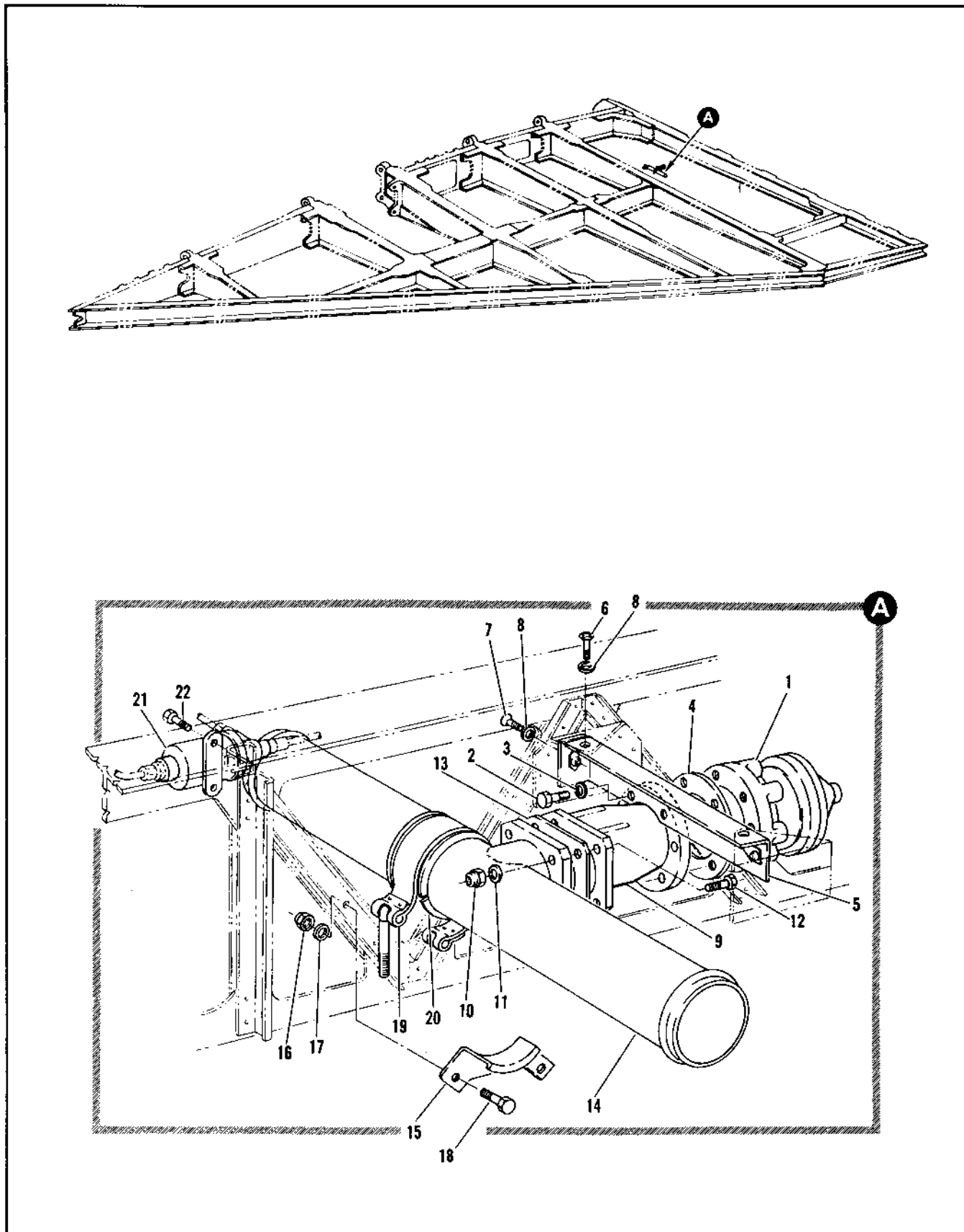

Figure 2.12-2. Refueling Shutoff Transfer Tank Valve Installation

FIGURE AND INDEX NUMBER	PART NUMBER	DESCRIPTION	UNITS PER ASSY.	USABLE ON CODE		
				FROM	TO	
2.12-2	8-21147-3	VALVE INSTALLATION, REFUELING SHUTOFF TRANSFER TANK LH FOR NHA SEE FIG. 2-6-32	RF	35	89	
	8-21147-5	VALVE INSTALLATION, REFUELING SHUTOFF TRANSFER TANK LH FOR NHA SEE FIG. 2-6-32	RF	A		
	8-21147-801	VALVE INSTALLATION, REFUELING SHUTOFF TRANSFER TANK LH FOR NHA SEE FIG. 2-6-32	RF	189	277	
	8-21147-4	VALVE INSTALLATION, REFUELING SHUTOFF TRANSFER TANK RH FOR NHA SEE FIG. 2-6-32	RF	35	89	
	8-21147-6	VALVE INSTALLATION, REFUELING SHUTOFF TRANSFER TANK RH FOR NHA SEE FIG. 2-6-32	RF	A		
	8-21147-802	VALVE INSTALLATION, REFUELING SHUTOFF TRANSFER TANK RH FOR NHA SEE FIG. 2-6-32	RF	189	277	
	- 1	15-356-101	VALVE, FUEL TANK PILOT OPERATED SHUTOFF <82257> SPEC 8-019J3-1 ATTACHING PARTS	1	35	
	- 2	AN4-5A	• BOLT	6	35	
	- 3	AN9600416L	• WASHER	6	35	
			-----X-----			
	- 4	075156-4	• GASKET, FUEL SYSTEM FLANGE <83259> SPEC 8-02287-7	1	35	
	- 5	8-21177-17	• BRACKET ASSY, TRANSFER TANK REFUELING VALVES SUPPORT LH	1	35	
		8-21177-18	• BRACKET ASSY, TRANSFER TANK REFUELING VALVES SUPPORT RH ATTACHING PARTS	1	35	
	- 6	MS24694-A62	• SCREW	3	35	89
		AN3-6A	• BOLT	3	90	
	- 7	NAS221-6	• SCREW	1	35	
	- 8	AN960010L	• WASHER	4	35	
			-----X-----			
	- 9	25-6500-3	• VALVE, FUEL CHECK <96736> SPEC 8-00954 ATTACHING PARTS	1	35	
	- 10	NAS679A4	• NUT	4	35	
	- 11	AN9600416L	• WASHER	4	35	
	- 12	AN4-11A	• BOLT	4	35	
		-----X-----				
- 13	075356-6	• GASKET, FUEL SYSTEM FLANGE <83259> SPEC 8-02289-11 REPLACES NOT IN CHG WITH 075356-1	1	35		
- 14	8-21143-1	• TUBE ASSY, TRANSFER TANK WELDED	1	35	240	
	8-21143-3	• TUBE ASSY, TRANSFER TANK WELDED	1	241		
- 15	8-21118-11	• BRACKET, TRANSFER TANK TUBE LH	1	8		
	8-21118-17	• BRACKET, TRANSFER TANK TUBE LH	1	89	277	
	8-21118-12	• BRACKET, TRANSFER TANK TUBE RH	1	8		
	8-21118-18	• BRACKET, TRANSFER TANK TUBE RH ATTACHING PARTS	1	189	277	
- 16	NAS679A3	• NUT	2	35		
- 17	AN960010L	• WASHER	2	35		
- 18	AN3-10A	• BOLT	2	8		
	AN3-4A	• BOLT	2	189	277	
		-----X-----				
- 19	MS21920-22	• CLAMP, SPEC 91-97802-041	1	35		
- 20	R-28277-7	• PAD	1	35		
- 21	PV293-110	• VALVE, PRESSURE OPERATED PILOT <84987> SPEC 8-02275 T.O. 6J15-3-80-3 REPLACES, IS SUITABLE SUB FOR PV293-120	1	35		
	PV293-120	• VALVE ASSY, PRESSURE OPERATED PILOT <84987> SPEC 8-02275 T.O. 6J15-3-80-3 REPLACES, IS SUITABLE SUB FOR PV293-110 ATTACHING PARTS	RF	35		
- 22	AN3-6A	• BOLT	2	35		
		-----X-----				
		A AIRPLANES #90 THRU 182, 278 AND ON				
		B AIRPLANES #35 THRU 182, 278 AND ON				

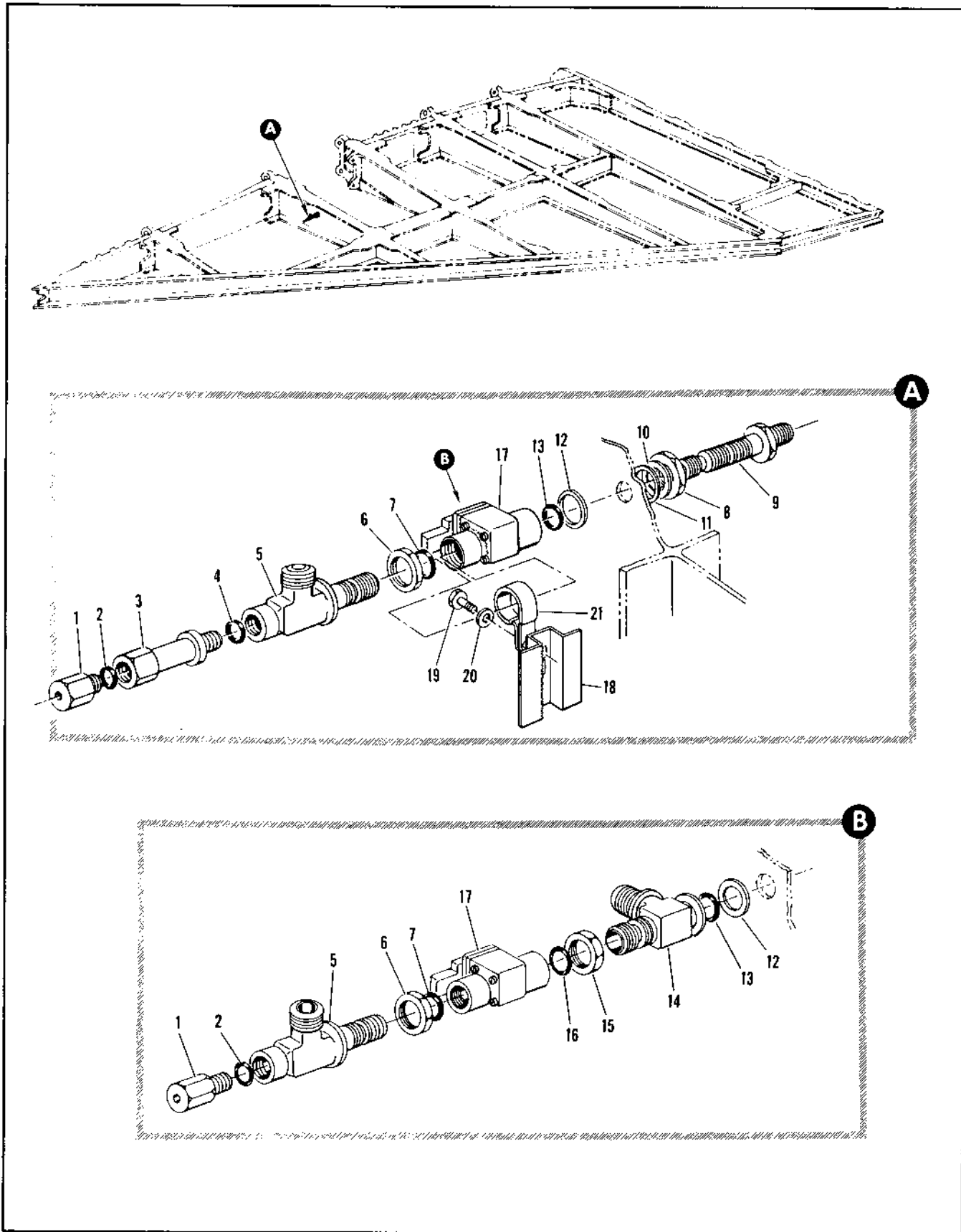

Figure 2.12-3. Manual Refuel Selector Valve Installation RH

FIGURE AND INDEX NUMBER	PART NUMBER	DESCRIPTION	UNITS PER ASSY.	USABLE ON CODE	
				FROM	TO
		1 2 3 4 5 6			
2.12-3	P-21199-1	VALVE INSTALLATION, MANUAL REFUEL SELECTOR PH FOR NHA SEE FIG. 2-6-32	RF	35	89
	8-2119-3	VALVE INSTALLATION, MANUAL REFUEL SELECTOR PH FOR NHA SEE FIG. 2-6-32	RF	90	
- 1	160B	• VALVE, DRAIN SELF-LOCKING FLUSH TYPE <51511> 92-12501-033	1	35	
- 2	MS29512-4	• GASKET	1	35	
- 3	8-2833E	• FITTING, DRAIN TANK #2 PILOT VALVE PRESSURE LINE	1	35	89
- 4	MS29512-4	• GASKET	1	35	
- 5	MS21911D4	• TEE	1	35	
- 6	AN924-4D	• NUT	1	35	
- 7	MS29512-5	• GASKET	1	35	
- 8	AN924-4D	• NUT	1	35	
- 9	8-20307-27	• FITTING	1	35	
- 10	AN961D716	• WASHER	1	35	
- 11	8-21311-7	• WASHER	1	35	
- 12	8-21311-7	• WASHER	1	35	
- 13	MS29512-4	• GASKET	1	35	
- 14	MS21911D4	• TEE	1	90	
- 15	AN924-4D	• NUT	1	90	
- 16	MS21512-4	• GASKET	1	90	
- 17	3-368E	• COCK, PLUS DRAIN SELF-LOCKING <75361> 92-13000-304 T.O. 6J15-9-21-3	1	35	
- 18	8-21199-3	• BRACKET ASSY, RIVETED	1	35	
- 19	NAS221-7	• SCREW	1	35	
- 20	AN961D19L	• WASHER	1	35	
- 21	AN742012	• CLAMP	1	35	89
	MS21919D611	• CLAMP	1	90	

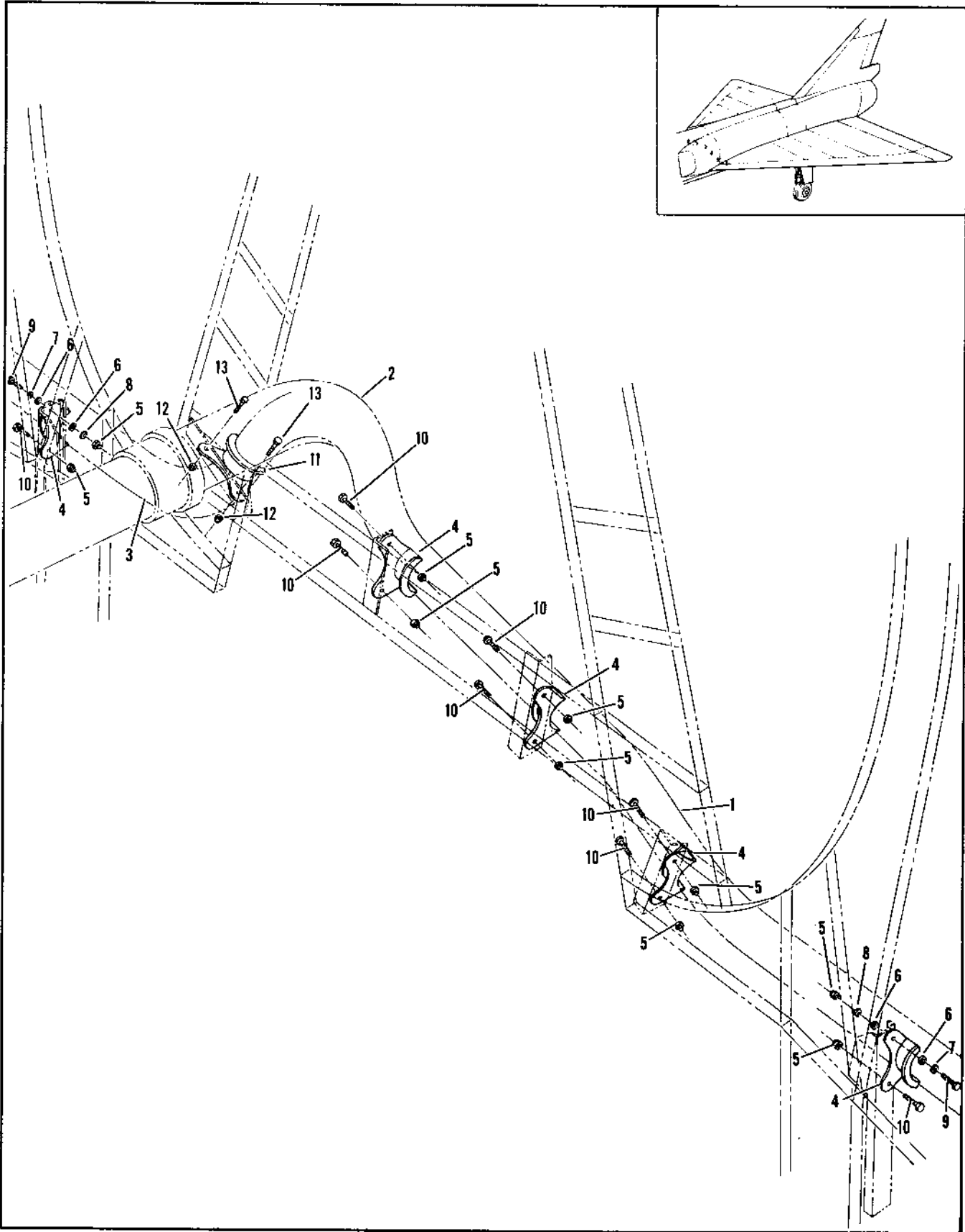

Figure 2.12-4. Fuel Transfer Line Bracket Installation Sta 343

FIGURE AND INDEX NUMBER	PART NUMBER	DESCRIPTION	UNITS PER ASSY.	USABLE ON CODE		
				FROM	TO	
2.12-4	8-28276	BRACKET INSTALLATION, FUEL TRANSFER LINE STA 344 FOR NHA SEE FIG. 2.3-10	RF	35	60	
	8-28276-1	BRACKET INSTALLATION, FUEL TRANSFER LINE STA 344 FOR NHA SEE FIG. 2.3-11	RF	61		
	- 1	• TUBE ASSY, WING FUEL TRANSFER LH SEE FIG. 2.12-48 INDEX 34	RF			
	- 2	• TEE ASSY, WING FUEL TRANSFER SEE FIG. 2.12-48 INDEX 30	RF			
	- 3	• TUBE ASSY, WING FUEL TRANSFER SEE FIG. 2.12-48 INDEX 35	RF			
	- 4	8-28278	• BRACKET, 3 DIA TUBE REPLACED BY NOT INTCHG WITH 8-28469	5	35	60
		8-28469	• BRACKET, REPLACES NOT INTCHG WITH 8-28278 ATTACHING PARTS	5	61	
	- 5	NAS679A3	• NUT	10	35	
	- 6	AN960D13L	• WASHER	4	35	
		AN960D13L	• WASHER	AR	61	
	- 7	AN960-10L	• WASHER	2	35	
	- 8	AN935-10L	• WASHER	2	35	
	- 9	AN3-6A	• BOLT	2	35	
	- 10	AN3-4A	• BOLT	8	35	
	- 11	8-28278-7	• BRACKET, REPLACED BY NOT INTCHG WITH 8-28469	1	35	60
	8-28469	• BRACKET, REPLACES NOT INTCHG WITH 8-28278-7 ATTACHING PARTS	1	61		
- 12	NAS679A3	• NUT	2	35		
- 13	AN3-4A	• BOLT	2	35		

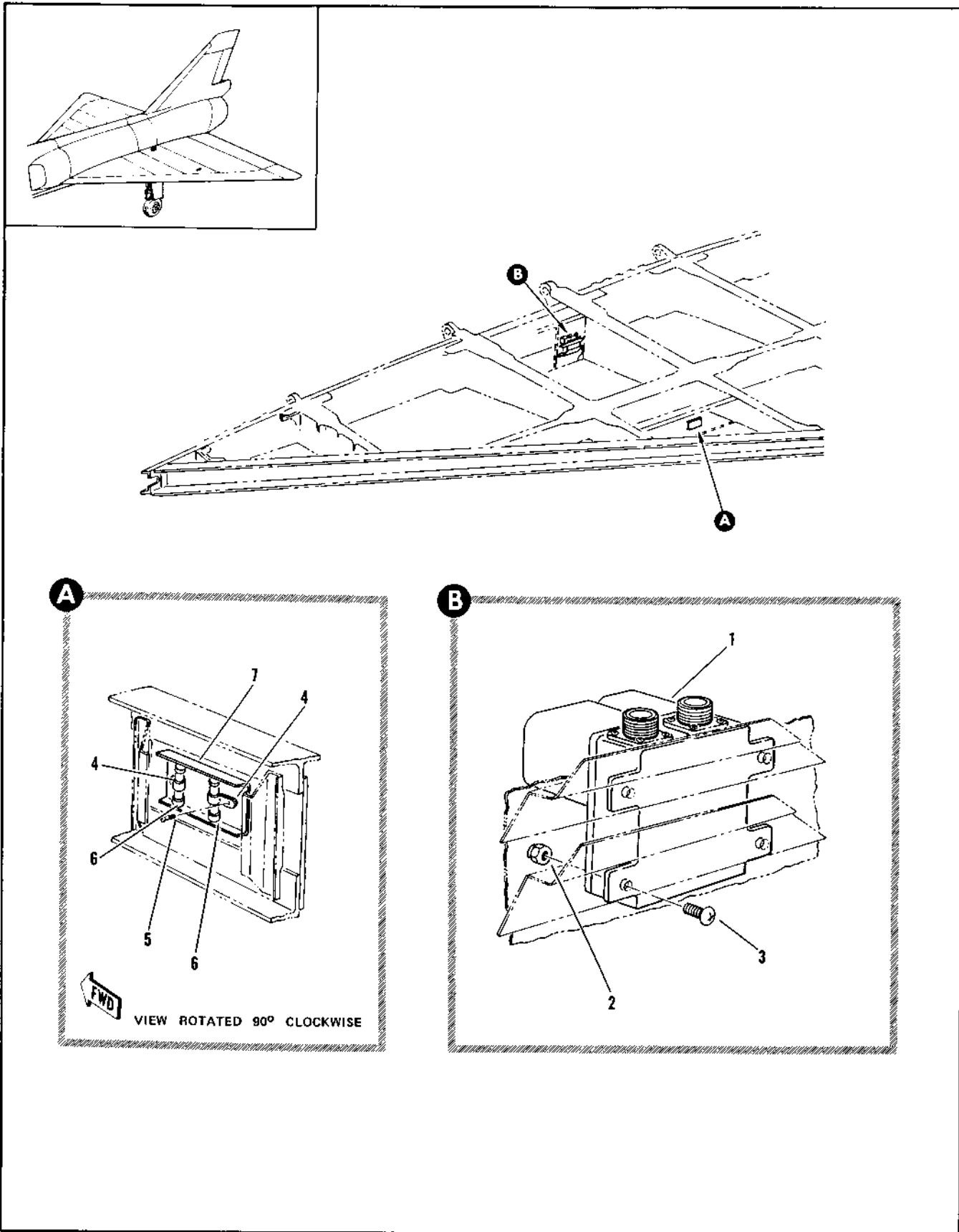

Figure 2.12-5. Wing Fuel Electrical

FIGURE AND INDEX NUMBER	PART NUMBER	DESCRIPTION	UNITS PER ASSY.	USABLE ON CODE	
				FROM	TO
		1 2 3 4 5 6			
2.12-5		WING FUEL ELECTRICAL			
		• WING FUEL SYSTEM SEE FIG. 2.12-1	RF		
		• WING FUEL TANK ELECTRICAL RECEPTACLES SEE FIG. 2.12-6	RF		
- 1	8-65046	• BOX INSTL, ENGINE FUEL TEMPERATURE CONTROL	RF	35	
	25630131	• CONTROL BOX ASSY, ENGINE FUEL TEMPERATURE <80234> SPEC 8-10911 T.O. 803-10-6-3 REPLACED BY SUITABLE SUB 25630131-01	1	35	129
	25630131-01	• CONTROL BOX ASSY, ENGINE FUEL TEMPERATURE <80234> SPEC 8-00911-1 T.O. 803-10-6-3 REPLACES SUITABLE SUB FOR 25630131 ATTACHING PARTS	1	130	
- 2	NAS679A3	• NUT	4	35	
- 3	NAS221-10	• SCREW	4	35	
		-----X-----			
	8-65119-805	• RESISTOR INSTL, EXTERNAL FUEL TANK EJECTION LH	1	35	
	8-65119-807	• RESISTOR INSTL, EXTERNAL FUEL TANK EJECTION RH	1	35	
- 4	MS21919D66	• CLAMP	2	35	
		ATTACHING PARTS			
- 5	NAS221-10	• SCREW	2	35	
		-----X-----			
- 6	RW29F4R0	• RESISTOR, RW 4 OHMS 97-47053-001 REPLACED BY RW29V3R9	2	35	
	RW29V3R9	• RESISTOR, REPLACES RW29F4R0	2	35	
- 7	8-65013	• INSULATOR, RESISTOR EJECTION FUEL TANK	1	35	
	8-65009-801	• HARNESS ASSY, MAIN WHEEL WELL TO WING	1	35	
	14760-75	• CONNECTOR, <17419> SPEC 8-26985-9	2	35	
	EX620SC	• CONTACT, ELECTRICAL CONNECTOR <71468> SPEC 8-66253-879	1	35	
	RW29V4R0	• RESISTOR, 97-47053-002	4	35	

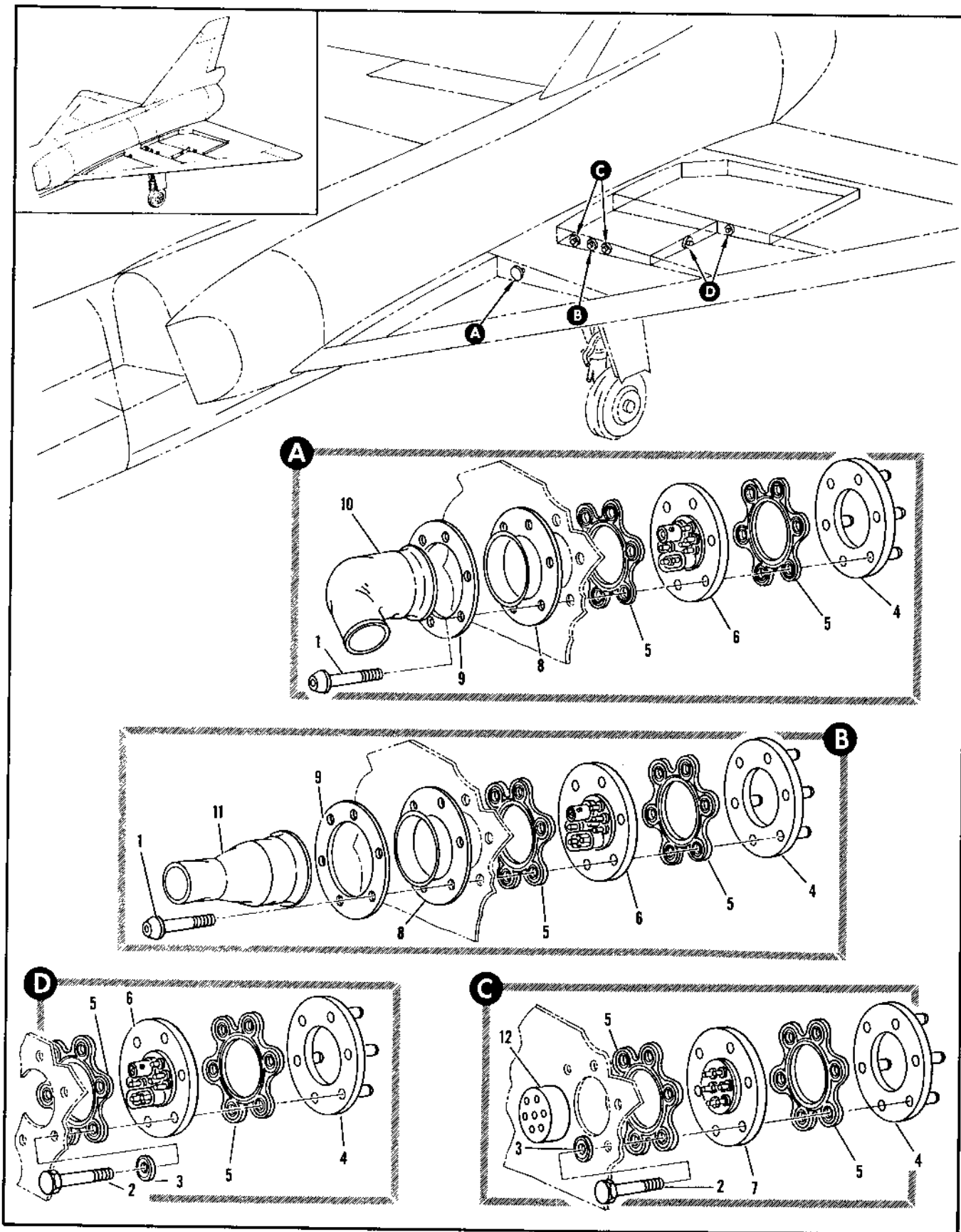

Figure 2.12-6. Wing Fuel Tank Electrical Receptacle Installation

FIGURE AND INDEX NUMBER	PART NUMBER	1	2	3	4	5	6	DESCRIPTION	UNITS PER ASSY.	USABLE ON CODE	
										FROM	TO
										2.12-6	8-61035-1
	8-61035-2,	*2	RECEPTACLE INSTL, WING FUEL TANK ELECTRICAL STA 431 RH	1	35						
	8-61035-5	*1	RECEPTACLE INSTL, WING FUEL TANK ELECTRICAL STA 472 BL 59 LH	1	35						
	8-61035-6	*2	RECEPTACLE INSTL, WING FUEL TANK ELECTRICAL STA 472 BL 59 RH	1	35						
	8-61035-805*1		RECEPTACLE INSTL, WING FUEL TANK ELECTRICAL STA 472 BL 52 LH	1	35						
	8-61035-806	*2	RECEPTACLE INSTL, WING FUEL TANK ELECTRICAL STA 472 BL 52 RH	1	35						
	8-61035-807	*1	RECEPTACLE INSTL, WING FUEL TANK ELECTRICAL STA 472 BL 66 LH	1	35						
	8-61035-808	*2	RECEPTACLE INST, WING FUEL TANK ELECTRICAL STA 472 BL 66 RH	1	35						
	8-61035-803		RECEPTACLE INSTL, WING FUEL TANK ELECTRICAL STA 510 LH	1	35						
	8-61035-804		RECEPTACLE INSTL, WING FUEL TANK ELECTRICAL STA 510 RH	1	35						
	8-61035-801	*1	RECEPTACLE INSTL, WING FUEL TANK ELECTRICAL STA 557 LH	1	35						
	8-61035-802	*2	RECEPTACLE INSTL, WING FUEL TANK ELECTRICAL STA 557 RH	1	35						
- 1	MS20004-14		• BOLT, STA 431 AND 472 BL 59	6	35						
- 2	AN4-12A		• BOLT, STA 472 BL 52 AND 66 STA 510 AND 557	6	35						
- 3	MS20902C4		• WASHER, STA 472 BL 52 AND BL 66 STA 510 AND 557	6	35						
- 4	8-21321		• FLANGE ASSY, RIVETED	1	35						
- 5	100154-1		• SEAL, O-RING FUEL TANK RECEPTACLE <83259> SPEC 8-02396	2	35						
- 6	YHS8M2		• RECEPTACLE ASSY, FUEL CELL ELECTRICAL STA 431 AND 472 BL 59 STA 510 AND 557 <09922> SPEC 8-06315 <09922> SPEC 8-06315	1	35						
- 7	YHS7M4		• RECEPTACLE ASSY, FUEL CELL ELECTRICAL STA 472 BL 52 AND BL 66 <09922> SPEC 8-06281	1	35						
8	6719		• RING, MOUNTING PRESSURE DISK PANEL STA 431 AND 472 BL 59 <97820> SPEC 8-06242	1	35						
- 9	8-68273		• RETAINER, BOOT STA 431 AND 472 BL 59	1	35						
- 10	YHS828R		• BOOT, STA 431 <09922> 91-38301-001	1	35						
- 11	YHS828		• BOOT, STRAIGHT CONNECTOR <09922> 91-38301-002 STA 472 BL 59	1	35						
- 12	8-68355-7		• INSULATOR, BURNDY CONNECTOR PANEL STA 472 RL 52 AND BL 66	1	35						
		*1	USED ON SPARES ASSEMBLY 8-10040-525 AND 8-10060-501 FOR AIRPLANES #35 AND ON								
		*2	USED ON SPARES ASSEMBLY 8-10040-526 AND 8-10060-502 FOR AIRPLANES #35 AND ON								

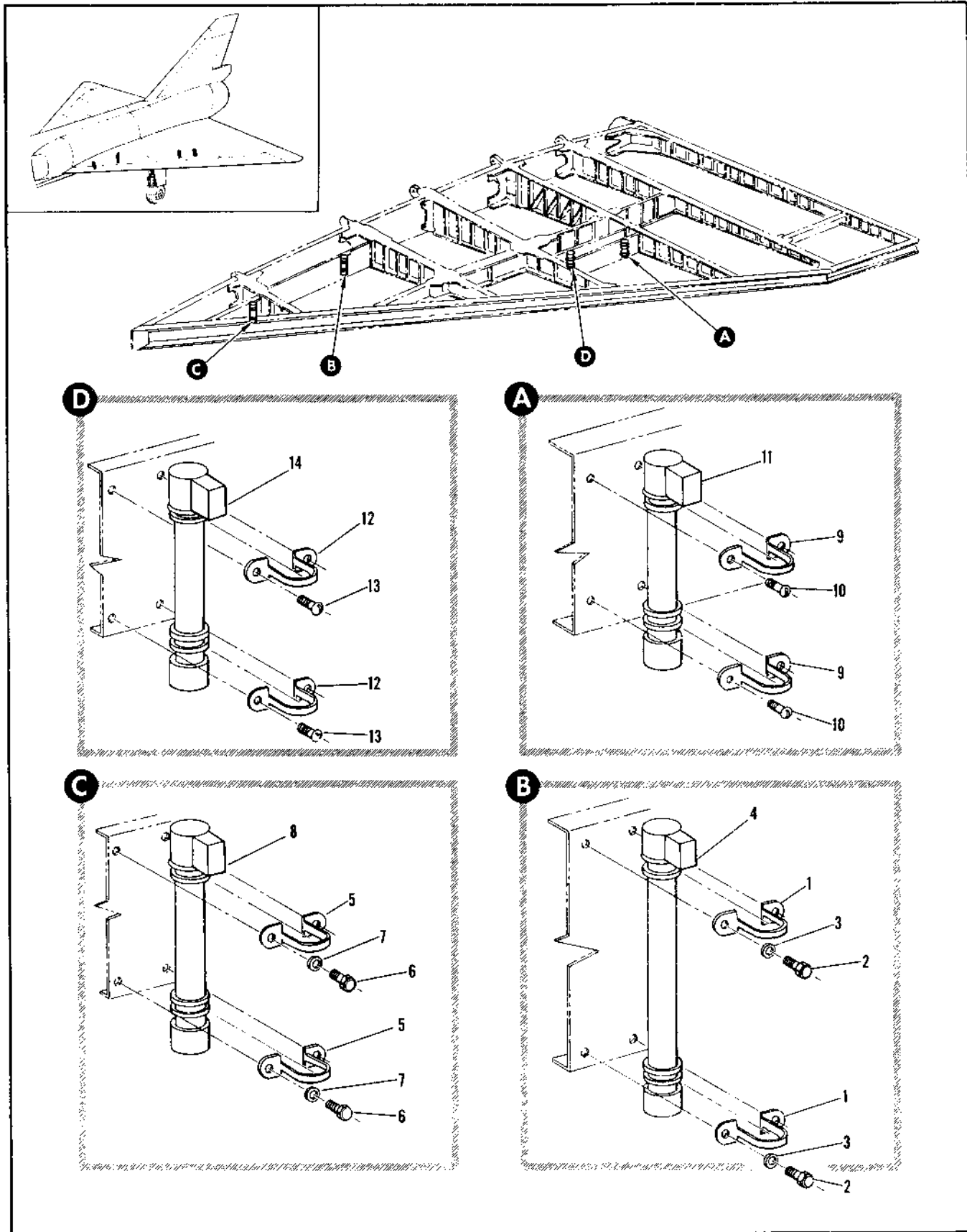

Figure 2.12-7. Tank #1 and #2 Fuel Quantity Probes

FIGURE AND INDEX NUMBER	PART NUMBER	DESCRIPTION	UNITS PER ASSY.	USABLE ON CODE	
				FROM	TO
2.12-7		1 2 3 4 5 6			
	8-21104-1	TANK #1 AND 2 FUEL QUANTITY PROBES • PROBE INSTL, FUEL QUANTITY TANK #1 STA 413 LH FOR NHA SEE FIG. 2.6-32	RF	35	
	8-21104-2	• PROBE INSTL, FUEL QUANTITY TANK #1 STA 410 RH FOR NHA SEE FIG. 2.6-32	RF	35	
- 1	8-21114-7	• • CLAMP ATTACHING PARTS	2	35	
- 2	AN3-4A	• • BOLT	4	35	
- 3	AN960010	• • WASHER	4	35	
		-----X-----			
- 4	FG221A61	• • PROBE, <41931> SPEC A-00995-9 T.O. 5L14-3-21-13	1	35	
	8-21104-3	• PROBE INSTL, FUEL QUANTITY TANK #1 STA 377 LH FOR NHA SEE FIG. 2.6-32	PF	35	
	8-21104-4	• PROBE INSTL, FUEL QUANTITY TANK #1 STA 377 RH FOR NHA SEE FIG. 2.6-32	RF	35	
- 5	8-21114-7	• • CLAMP ATTACHING PARTS	2	35	
- 6	AN3-4A	• • BOLT	4	35	
- 7	AN960010	• • WASHER	4	35	
		-----X-----			
- 8	FG221A60	• • PROBE, <40931> SPEC A-00995-7 T.O. 5L14-3-21-13	1	35	
	8-21105-1	• PROBE INSTL, FUEL QUANTITY TANK #2 STA 536 LH FOR NHA SEE FIG. 2.6-32	RF	35	
	8-21105-2	• PROBE INSTL, FUEL QUANTITY TANK #2 STA 536 RH FOR NHA SEE FIG. 2.6-32	RF	35	
- 9	8-21114-7	• • CLAMP ATTACHING PARTS	2	35	
- 10	AN520-10R6	• • SCREW	4	35	
		-----X-----			
- 11	FG221A63	• • PROBE, <41631> SPEC A-00995-13 T.O. 5L14-3-21-13	1	35	
	8-21105-3	• PROBE INSTL, FUEL QUANTITY TANK #2 STA 502 LH FOR NHA SEE FIG. 2.6-32	RF	35	
	8-21105-4	• PROBE INSTL, FUEL QUANTITY TANK #2 STA 502 RH FOR NHA SEE FIG. 2.6-32	RF	35	
- 12	8-21114-7	• • CLAMP ATTACHING PARTS	2	35	
- 13	AN520-10R6	• • SCREW	4	35	
		-----X-----			
- 14	FG220A62	• • PROBE, <40931> SPEC A-00995-11 T.O. 5L14-3-21-13	1	35	

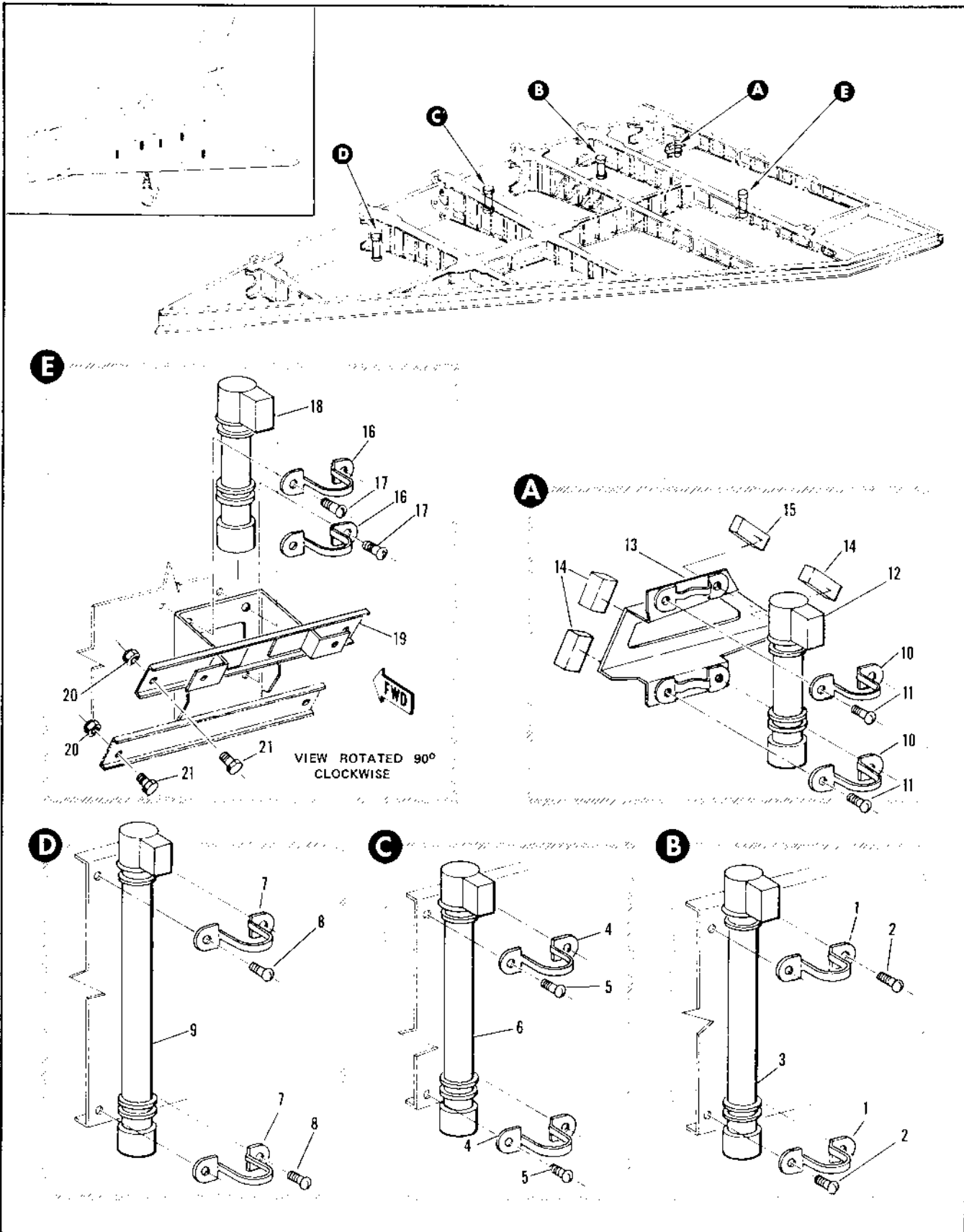

Figure 2.12-8. Transfer and #3 Tank Fuel Quantity Probes

FIGURE AND INDEX NUMBER	PART NUMBER	DESCRIPTION	UNITS PER ASSY.	USABLE ON CODE						
				FROM	TO					
				1	2	3	4	5	6	
2.12-8	8-21106-1	TRANSFER AND #3 TANK FUEL QUANTITY PROBES								
	8-21106-2	• PROBE INSTL, FUEL QUANTITY TANK #3 STA 544 LH FOR NHA SEE FIG. 2.6-32	RF		35					
- 1	8-21114-7	• PROBE INSTL, FUEL QUANTITY TANK #3 STA 544 RH FOR NHA SEE FIG. 2.6-32	RF		35					
- 2	AN520-10P6	• CLAMP	2		35					
- 3	FG220A75	• ATTACHING PARTS	4		35					
	FG220A76	• SCREW	1		35					
	8-21106-3	• PROBE, LH <40931> SPEC R-00995-25 T.O. 5L14-3-21-13	1		35					
	8-21106-4	• PROBE, RH <40931> SPEC R-00995-27 T.O. 5L14-3-21-13	1		35					
- 4	8-21114-7	• PROBE INSTL, FUEL QUANTITY TANK #3 STA 529 LH FOR NHA SEE FIG. 2.6-32	RF		35					
- 5	AN520-10P6	• PROBE INSTL, FUEL QUANTITY TANK #3 STA 529 RH FOR NHA SEE FIG. 2.6-32	RF		35					
- 6	FG220A65	• CLAMP	2		35					
	8-21106-5	• SCREW	4		35					
	8-21106-6	• PROBE, <40931> SPEC R-00995-17 T.O. 5L14-3-21-13	1		35					
- 7	8-21114-7	• PROBE INSTL, FUEL QUANTITY TANK #3 STA 491 LH FOR NHA SEE FIG. 2.6-32	RF		35					
- 8	AN520-10R6	• PROBE INSTL, FUEL QUANTITY TANK #3 STA 491 RH FOR NHA SEE FIG. 2.6-32	RF		35					
- 9	FG220A64	• CLAMP	2		35					
	8-21107-1	• SCREW	4		35					
	8-21107-1	• PROBE, <40931> SPEC R-00995-15 T.O. 5L14-3-21-13	1		35					
	8-21107-PC1	• PROBE INSTL, FUEL QUANTITY TRANSFER TANK STA 578 LH FOR NHA SEE FIG. 2.6-32	RF		A					
	8-21107-2	• PROBE INSTL, FUEL QUANTITY TRANSFER TANK STA 578 LH FOR NHA SEE FIG. 2.6-32	RF	189	277					
	8-21107-P02	• PROBE INSTL, FUEL QUANTITY TRANSFER TANK STA 578 RH FOR NHA SEE FIG. 2.6-32	RF		A					
- 10	8-21114-7	• PROBE INSTL, FUEL QUANTITY TRANSFER TANK STA 578 RH FOR NHA SEE FIG. 2.6-32	RF	189	277					
- 11	AN520-10R6	• CLAMP	2		35					
- 12	FG220A68	• SCREW	4		35					
- 13	8-21107-7	• PROBE, <40631> SPEC R-00995-23 T.O. 5L14-3-21-13	1		35					
	8-21107-25	• BRACKET ASSY, LH RIVETED	1		A					
	8-21107-8	• BRACKET ASSY, LH RIVETED	1	189	277					
	8-21107-26	• BRACKET ASSY, RH RIVETED	1		A					
- 14	8-21277-4	• BRACKET ASSY, RH RIVETED	1	189	277					
- 15	8-21277-15	• SPACER	3		A					
	8-21107-3	• SPACER	1		A					
	8-21107-B03	• PROBE INSTL, FUEL QUANTITY TRANSFER TANK STA 568 LH FOR NHA SEE FIG. 2.6-32	RF		A					
	8-21107-4	• PROBE INSTL, FUEL QUANTITY TRANSFER TANK STA 568 LH FOR NHA SEE FIG. 2.6-32	RF	189	277					
	8-21107-RC4	• PROBE INSTL, FUEL QUANTITY TRANSFER TANK STA 568 RH FOR NHA SEE FIG. 2.6-32	RF		A					
- 16	8-21114-7	• PROBE INSTL, FUEL QUANTITY TRANSFER TANK STA 568 RH FOR NHA SEE FIG. 2.6-32	RF	189	277					
- 17	AN520-10R6	• CLAMP	2		35					
- 18	FG220A66	• SCREW	4		35	333				
- 19	8-21107-23	• PROBE, <409317> SPEC R-00995-19 T.O. 5L14-3-21-13	1		35					
	8-21107-29	• BRACKET ASSY, LH RIVETED	1		R					
	8-21107-9	• BRACKET ASSY, LH RIVETED	1	189	277					
	8-21107-24	• BRACKET ASSY, LH RIVETED	1	278	333					
	8-21107-30	• BRACKET ASSY, RH RIVETED	1		B					
	8-21107-10	• BRACKET ASSY, RH RIVETED	1	189	277					
- 20	NAS679A3	• BRACKET ASSY, RH RIVETED	1	278	333					
- 21	AN3-4A	• ATTACHING PARTS	4		35					
		• NUT	4		35					
		• BOLT	4		35					
		-----X-----								
		A AIRPLANES #35 THRU 100, 270 AND ON								
		F AIRPLANES #35 THRU 100, 270 AND ON								

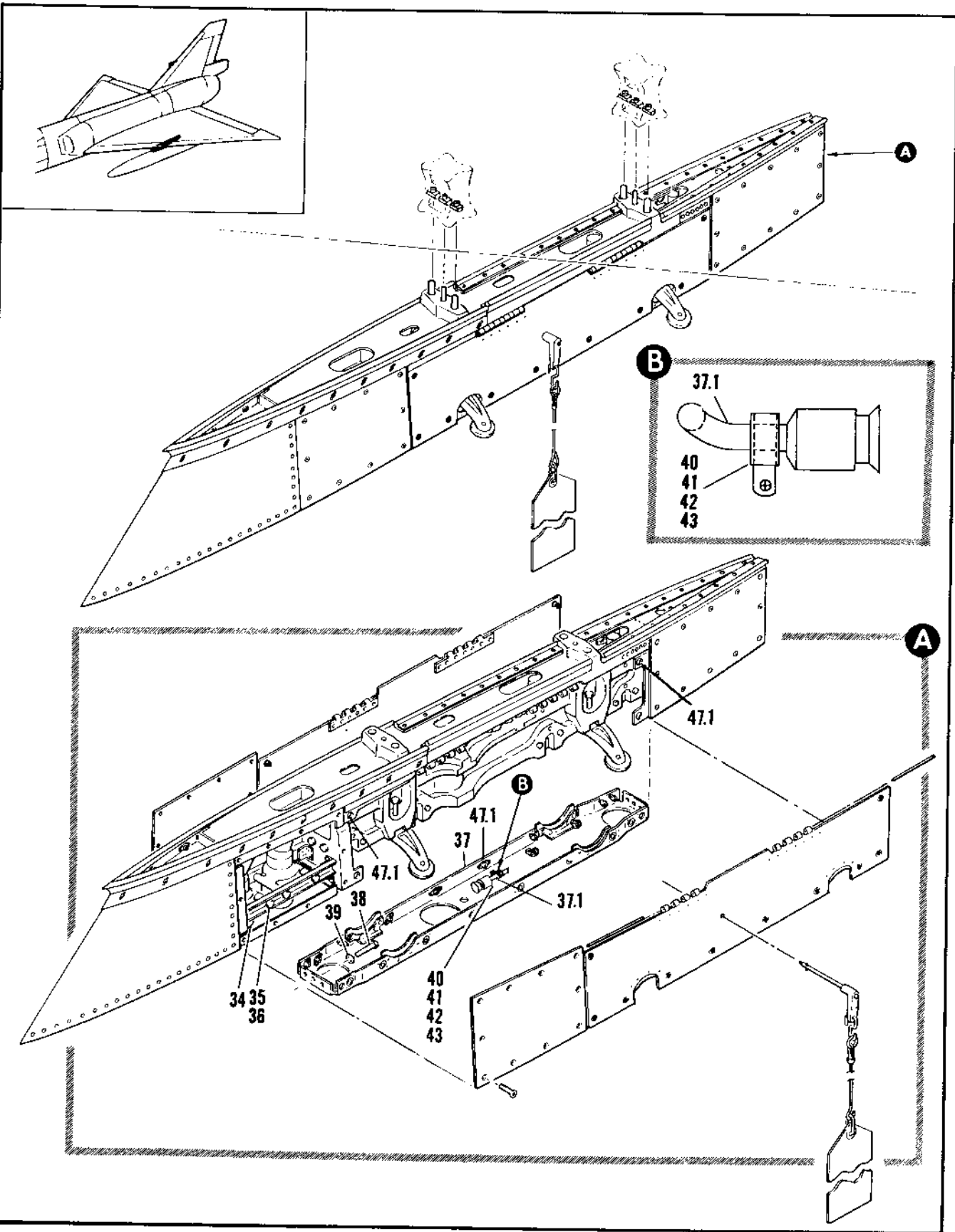

Figure 2.12-9. Pylon Installation and External Fuel Tank Release (Sheet 2 of 4)

FIGURE AND INDEX NUMBER	PART NUMBER	DESCRIPTION	UNITS PER ASSY.	USABLE ON CODE	
				FROM	TO
		1 2 3 4 5 6			
2.12-9- 34	6510-200 6708-055	. . COUPLING (95161) . . . SEAL ATTACHING PARTS	1 1		
- 35	MS2104264	. . NUT (96906)	2		
- 36	NAS1304-50	. . BOLT (80205) -----X-----	2		
- 37	65E33313-1	. . RIB, AFT PYLON	1		
- 37.1	7747251-10	. . HARNESS ASSY ATTACHING PARTS	1		
- 38	NAS1303-3	. . BOLT	6		
- 39	AN960PD1CL	. . WASHER	6		
- 40	MS21919D68	. . CLAMP ATTACHING PARTS			
- 41	MS24693-272	. . SCREW	1		
- 42	AN960-10-L	. . WASHER	1		
- 43	MS21044N5	. . NUT -----X-----	1		
- 44	60A52J1 5444622-511	. . EJECTOR RACK, GFAE AERO-7A1 . . EJECTOR RACK, GFAE AERO-7A REPLACES, NOT INTCHG WITH 60A52J1 AERO-7A1 (T.O. 11829- 3-14-2 ATTACHING PARTS	1 1		
- 45	NAS1304-3	. . BOLT	4		
- 46	AN960PD416	. . WASHER	4		
- 47	65J33320-25	. . SHIM -----X-----	2		
- 47.1	212-125	. . RECEPTACLE, DOOR ACCESS PYLON	20		

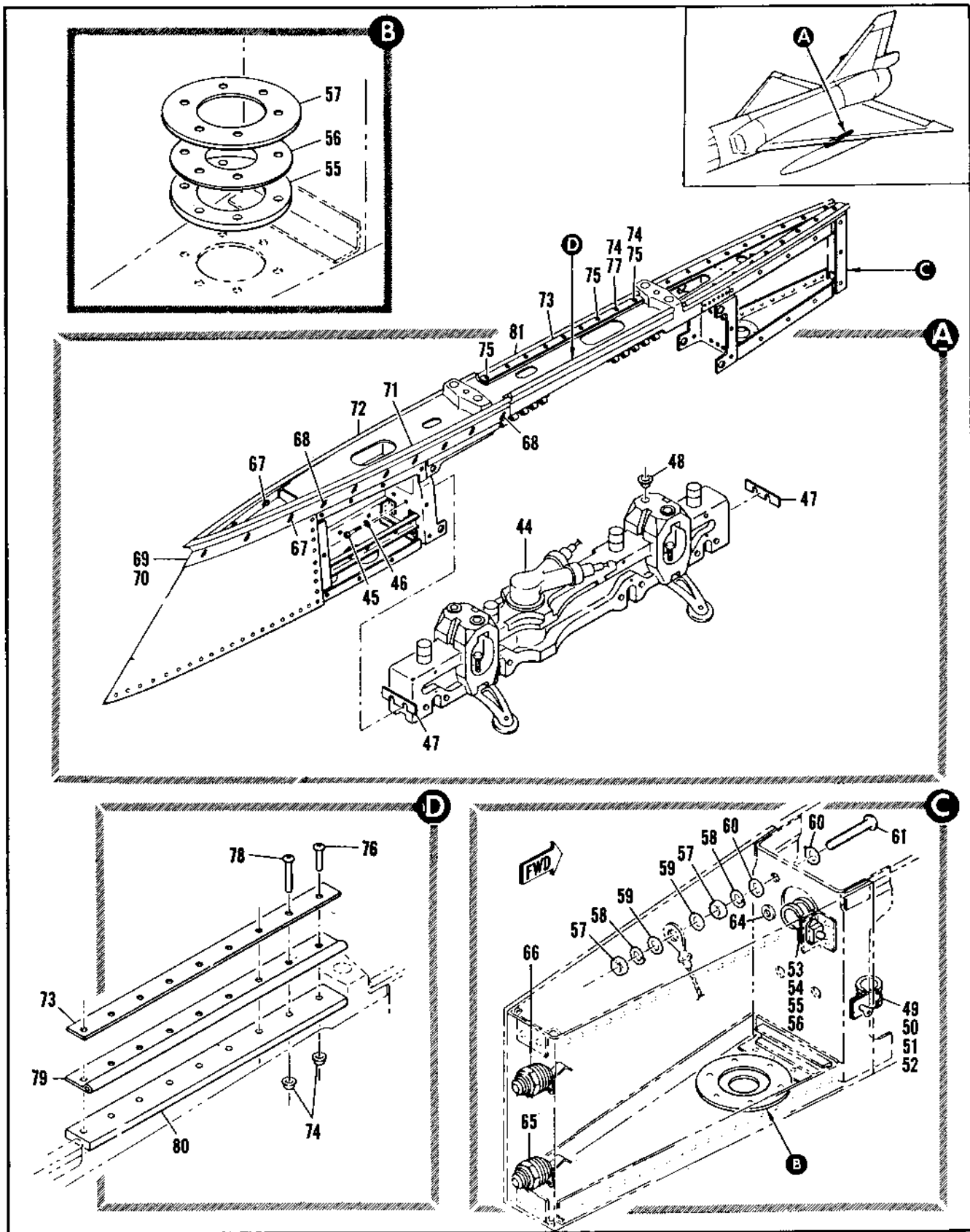

Figure 2.12-9. Pylon Installation and External Fuel Tank Release (Sheet 3 of 4)

FIGURE AND INDEX NUMBER	PART NUMBER	DESCRIPTION	UNITS PER ASSY.	USABLE ON CODE	
				FROM	TO
2.12-9- 48	65C33334-1	. . BUSHING, RELEASE RACK EXTERNAL FUEL TANK	4	35	
- 49	MS21919DF8	. . CLAMP ATTACHING PARTS	3	35	
- 50	MS21042L3	. . NUT	3	35	
- 51	AN960PD10L	. . WASHER	3	35	
- 52	AN509-10R4	. . SCREW	3	35	
	65D35855-1	-----X----- . . HARNESS ASSY	1	35	
- 53	MS21919DF6	. . CLAMP ATTACHING PARTS	1	35	
- 54	NAS1068A3	. . NUT	1	35	
- 55	AN960PD10L	. . WASHER	1	35	
- 56	MS35207-262	. . SCREW	1	35	
		-----X-----			
- 57	AN345-10	. . NUT	2	35	
- 58	AN935-10	. . WASHER	2	35	
- 59	AN960-10L	. . WASHER	2	35	
- 60	AN960D10L	. . WASHER	2	35	
- 61	MS35207-265	. . SCREW	1	35	
- 62	65C33301-3	. . WASHER, FLAT	1	35	
- 63	65C33300-2	. . WASHER, NONMETALIC		35	
- 64	65C33301-5	. . WASHER, FLAT	1	35	
	65D35856-1	. . HARNESS ASSY (98750) DWG 65D35856, T.O. 11B29-3-14-2	1	35	
- 65	AN3117-1	. . RECEPTACLE ATTACHING PARTS	1	35	
- 66	MS90298-1	. . RECEPTACLE (AN3117-1 ALT) ATTACHING PARTS	1	35	
	AN935-616L	. . WASHER, LOCK	1	35	
	68D37746-7	. . DECAL (EARTH GROUND)	1	35	
	67D34662-5	. . DECAL (FUEL NOZZLE GROUND FOR -58)	1	35	
- 67	MS35207-262	. . SCREW	6	35	
- 68	MS35207-264	. . SCREW	14	35	
		-----X-----			
- 69	65E33341-1	. . FAIRING LH ASSEMBLY	2	278	291
	65E33341-3	. . FAIRING LH ASSEMBLY	2	A	
- 70	65E33341-2	. . FAIRING RH ASSEMBLY	2	278	291
	65E33341-4	. . FAIRING RH ASSEMBLY	2	A	
- 71	65E33341-9	. . SEAL MAKE FROM PART NUMBER 5516-1 (84914)	1	35	
- 72	65E33341-9	. . SEAL MAKE FROM PART NUMBER 5516-1 (84914)	1	35	
- 73	65J33320-41	. . RETAINER ATTACHING PARTS	2	35	
- 74	MS21042L08	. . NUT	4		
- 75	MS35206-246	. . SCREW	8		
- 76	MS35206-247	. . SCREW	8		
- 77	MS35206-248	. . SCREW	1		
- 78	MS35206-250	. . SCREW	1		
		-----X-----			
- 79	65J33320-29	. . SEAL, OUTBD (84914)	1		
- 80	65J33320-11	. . FILLER, OUTBD	1		
- 81	65J33320-30	. . SEAL, INBD (84914)	1		

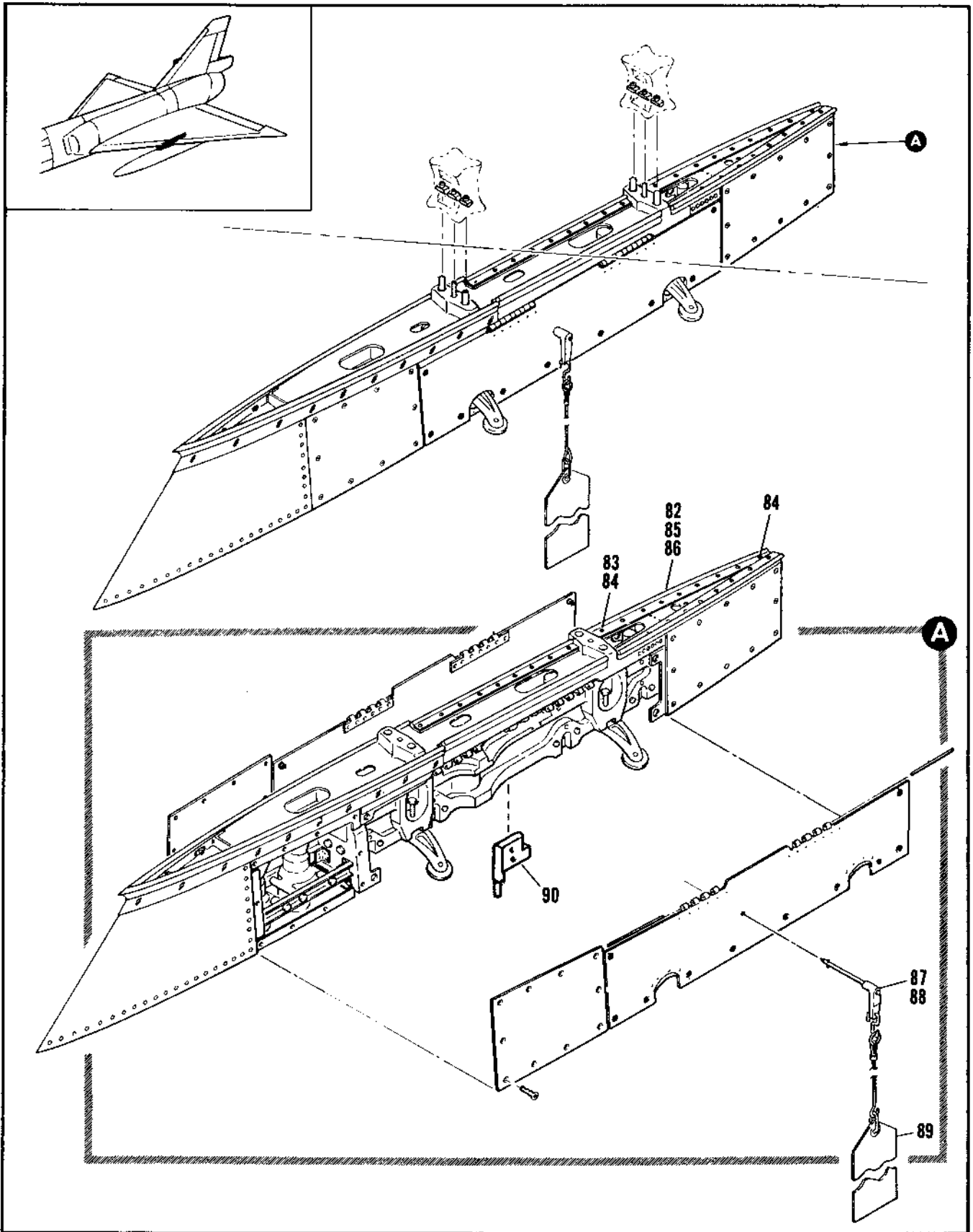

Figure 2.12-9. Pylon Installation and External Fuel Tank Release (Sheet 4 of 4)

FIGURE AND INDEX NUMBER	PART NUMBER	DESCRIPTION	UNITS PER ASSY.	USABLE ON CODE	
				FROM	TO
		1 2 3 4 5 6			
2.12-9- 82	65J33320-39	. . . RETAINER	2	35	
		. . . ATTACHING PARTS			
- 83	MS210611.08	. . . NUT	1	35	
- 84	MS35206-246	. . . SCREW	9	35	
- 85	65J33320-31	. . . SEAL	2	35	
- 86	65J33320-15	. . . FILLER, OUTBD	1	35	
- 87	65C33295-1	. . . SAFETY PIN ASSEMBLY, EXTERNAL TANK	1	A	
- 88	51343	. . . PIN (84256)	1	A	
- 89	NAS1091-30H	. . . STREAMER ASSEMBLY	1	A	
- 90	3447449	. . . SWITCH ASSEMBLY	1	35	
		A ADDED ON AIRPLANES #35 THRU 277, 292 AND ON			

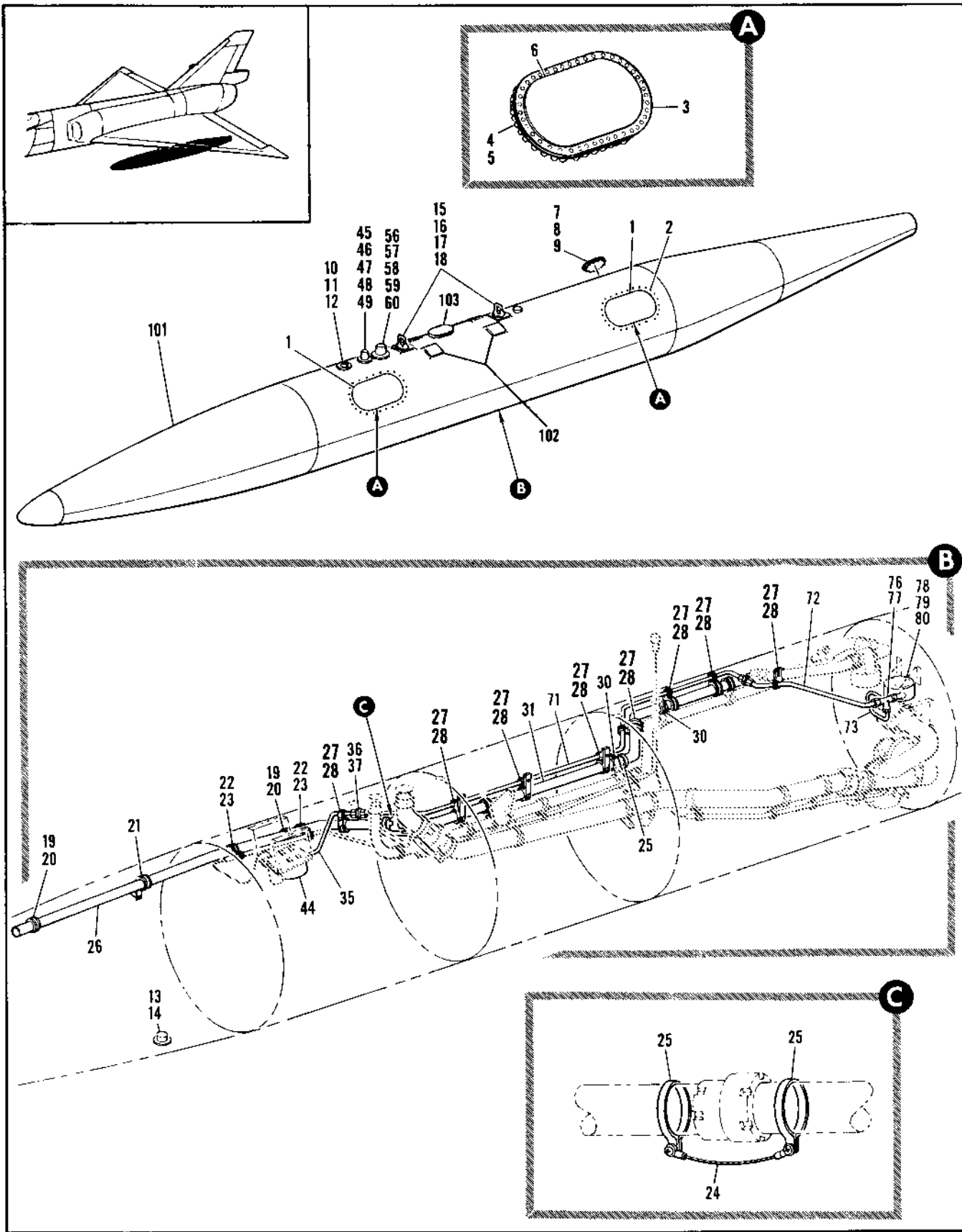

Figure 2.12-10. External Fuel Tank Assembly (Sheet 1 of 5)

2.12-10	65J33310-1	TANK ASSY, FUEL EXTERNAL FOR NHA SEE FIG. 2.1-1	RF	35
- 1	65E33312-1	• DOOR ASSY, ACCESS EXTERNAL FUEL TANK	2	35
- 2	NAS334CPA6	ATTACHING PARTS ----X----	43	35
- 3	65E33312-5	• SEAL (90056)	1	35
- 4	14630H-048	• • DOME NUT (80539) ATTACHING PARTS	43	35
- 5	MS20426AD3-7	• • RIVET ----X----	86	35
- 6	65E33312-3	• • DOOR	1	35
- 7	65C35933-1	• SEAL ATTACHING PARTS	1	35
- 8	NAS333CPA4	• SCREW ----X----	12	35
- 9	FV400-77 FV756	• CAP ASSY, FILLER (98817) • • COVER CAP	1	35
- 10	65B35907-1	• ADAPTER, VACUUM RELIEF VALVE	1	35
- 11	66840836-1	• SEAL, FUEL RESISTANT, 2.5 INCH	1	35
- 12	1111-56A371M1	• VALVE, VACUUM RELIEF (83259) SPEC 8-02999-5	1	35
- 13	19722	• VALVE, DRAIN (753617)	1	35
- 14	65C34875-1	• ADAPTER, DRAIN EXTERNAL TANK REPLACED BY SUITABLE SUB 65C35909-1	1	35
	65C35909-1	• ADAPTER, DRAIN EXTERNAL TANK REPLACES SUIT- ABLE SUB FOR 65C34875-1	1	35
- 15	65D33325-1	• ATTACHMENT LUG, EXTERNAL FUEL TANK ATTACHING PARTS	2	35
- 16	42FW1614	• NUT (56878)	1	35
- 17	MS20002-16	• WASHER ----X----	1	35
- 18	MS9021-033	• PACKING	2	35
	65J35891-1	• FUEL SYSTEM INSTL, AIRCRAFT EXTERNAL TANK	1	35
- 19	S169DT16	• • CLAMP (92196) ATTACHING PARTS	2	35
- 20	AN520-10R10	• • SCREW ----X----	2	35
- 21	S169DT16	• • CLAMP (92196) ATTACHING PARTS	1	35
	AN520-10R10	• • SCREW	1	35
	NAS43DD3-20	• • SPACER ----X----	1	35
- 22	S169DT16	• • CLAMP (92196)	6	35
- 23	S169DT7	• • CLAMP (92196) ATTACHING PARTS	6	35
	MS21042L3	• • NUT	1	35
	AN520-10R10	• • SCREW ----X----	1	35
- 24	MS25083-28B3	• • JUMPER	2	35
- 25	AN735D16	• • CLAMP ATTACHING PARTS	6	35
	MS21042L3	• • NUT	6	35
	AN960-10L	• • WASHER	12	35
	AN526-1032R8	• • SCREW	6	35
- 26	65A35913-1	• • TUBE, PRESSURIZATION FWD EXTERNAL TANK ATTACHING PARTS	1	35
	3605-160	• • COUPLING (79326)	1	
	MS29513-214	• • PACKING ----X----	2	
- 27	S169DT16	• • CLAMP (92196)	8	
- 28	S169DT4	• • CLAMP (92196)	8	

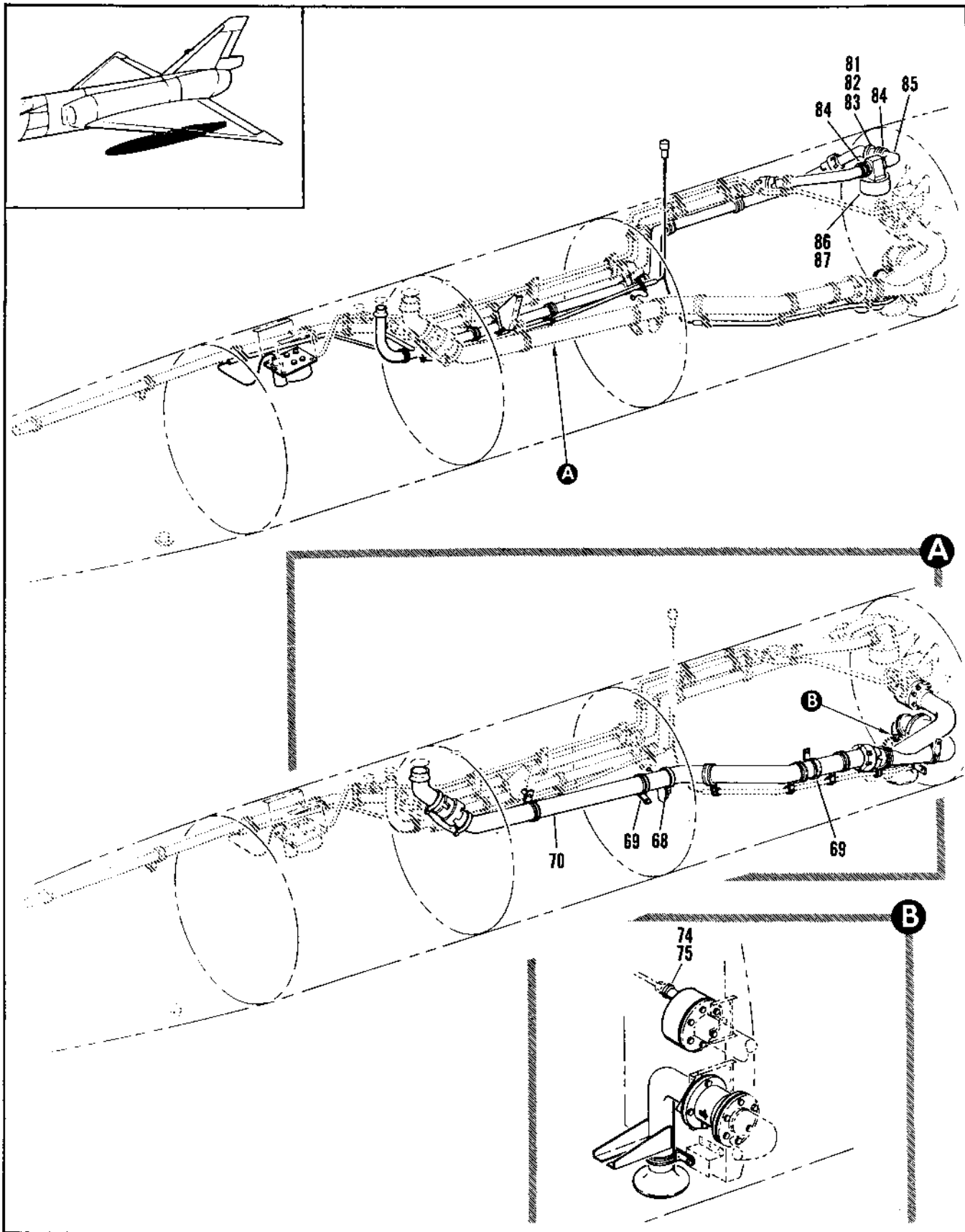

Figure 2.12-10. External Fuel Tank Assembly (Sheet 4 of 5)

FIGURE AND INDEX NUMBER	PART NUMBER	DESCRIPTION	UNITS PER ASSY.	USABLE ON CODE	
				FROM	TO
		1 2 3 4 5 6			
2.12-10- 68	AN735024	• • CLAMP ATTACHING PARTS	1		
	MS2142L3	• • NUT	1		
	AN960-10L	• • WASHER	2		
	AN526-1032RA	• • SCREW	1		
- 64	MS21919DF24	• • CLAMP (92196) ATTACHING PARTS	2		
	AN520-10F10	• • SCREW	2		
- 70	65A35917-1	• • TUBE, FUEL TRANSFER AFT EXTERNAL TANK ATTACHING PARTS	1		
	3605-24D	• • COUPLING (79326)	1		
	MS29513-325	• • PACKING	2		
- 71	66A40028-1	• • TUBE, REFUEL SENSING CENTER ATTACHING PARTS	1		
	MS21902D4	• • UNION	1		
- 72	66A40029-1	• • TUBE, REFUEL SENSING AFT	1		
- 73	66A40018-1	• • TUBE, REFUELING PRESSURE SENSING ATTACHING PARTS	1		
- 74	MS21902D4	• • UNION	1		
- 75	MS29512-4	• • PACKING	1		
- 76	MS2192D4	• • TEE ATTACHING PARTS	1		
- 77	AN924-4D	• • NUT	1		
	MS29512-4	• • PACKING	1		
- 78	16-356-1	• • VALVE, SINGLE LEVEL PILOT (A2267) SPEC R-1004 ATTACHING PARTS	1		
- 79	AN3H3A	• • BOLT	4		
- 80	AN939-10	• • WASHER	4		
- 81	MS25783-2883	• • JUMPER	1		
- 82	AN715D1C	• • CLAMP ATTACHING PARTS	1		
- 83	MS2142L3	• • NUT	2		
	AN960-10L	• • WASHER	2		
	AN960-10L	• • WASHER	2		
	AN939-10	• • WASHER	1		
	AN526-103217	• • SCREW	2		
- 84	S1690T16	• • CLAMP (92196) ATTACHING PARTS	2		
	AN520-10F10	• • SCREW	1		
- 85	65E35911-1	• • TUBE ASSY, FUEL VENT, AFT EXTERNAL TANK WELDED	1		
- 86	6660415	• • VALVE (92103) ATTACHING PARTS	1		
- 87	MS29512-16	• • PACKING	1		

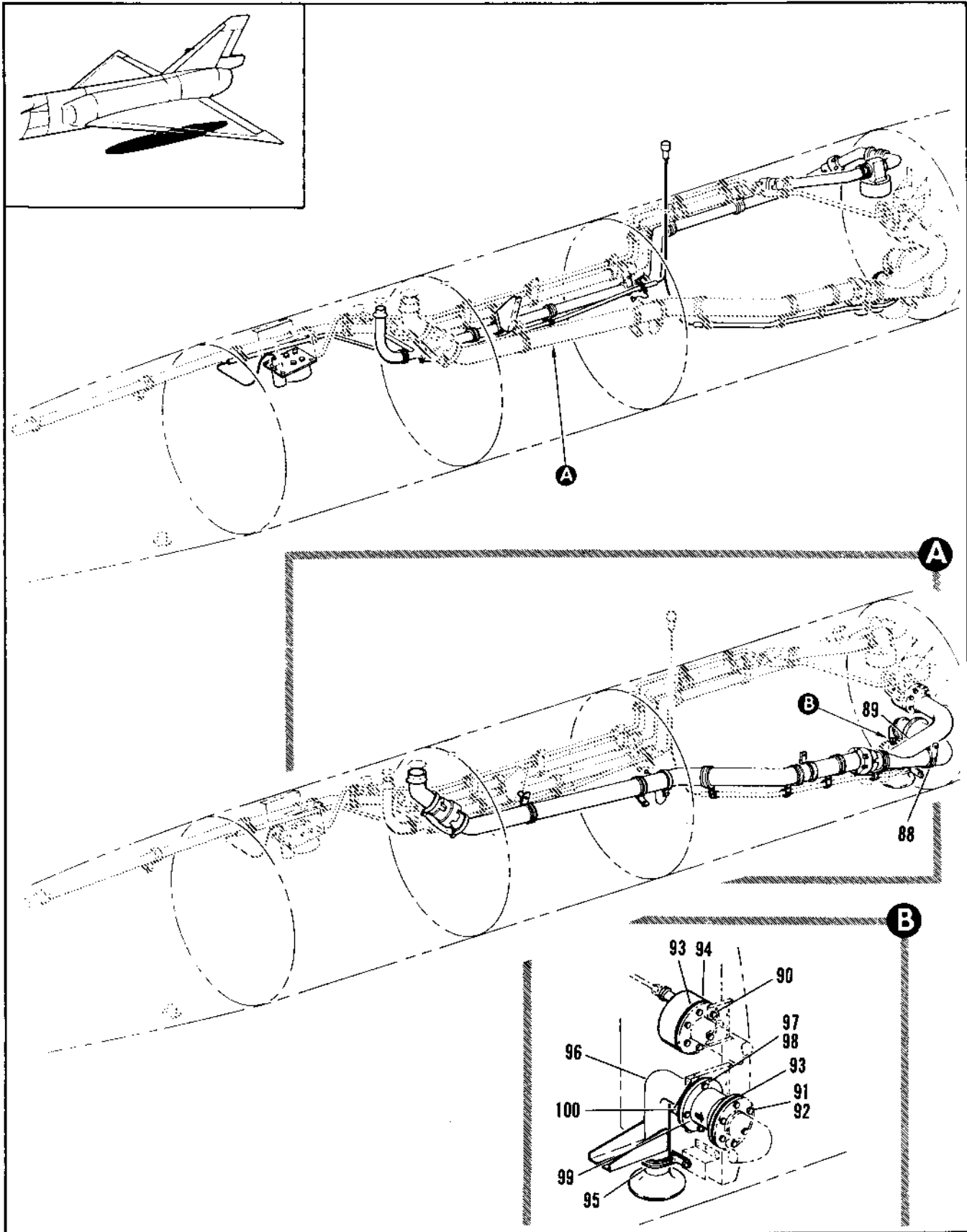

Figure 2.12-10. External Fuel Tank Assembly (Sheet 5 of 5)

FIGURE AND INDEX NUMBER	PART NUMBER	DESCRIPTION	UNITS PER ASSY.	USABLE ON CODE	
				FROM	TO
		1 2 3 4 5 6			
2.12-10- 88	S1690T24	• • CLAMP (92196) ATTACHING PARTS	1		
	AN520-10R10	• • SCREW	1		
- 89	65E35889-1	• • TUBE ASSY, FUEL DISCHARGE AND INTAKE WELDED ATTACHING PARTS	1		
- 90	AN4-5A	• • BOLT	6		
- 91	MS21042L4	• • NUT	6		
- 92	AN4-7A	• • BOLT	6		
- 93	075156-4	• • SEAL (83259) SPEC 8-02287-7	2		
- 94	15-356-101	• • VALVE (22267) SPEC 8-00903-1	1		
- 95	S1690T24	• • CLAMP (92196) ATTACHING PARTS	1		
	AN520-10R10	• • SCREW	1		
- 96	65D35882-1	• • ELBOW ASSY, FUEL INLET EXTERNAL TANK WELDED	1		
- 97	MS21042L4	• • NUT	2		
- 98	AN4-11A	• • BOLT	4		
- 99	25-6500-3	• • VALVE (96736) SPEC 8-00954	1		
-100	MS27198-24	• • SEAL	1		
-101	65J33310-3	• • TANK, FUEL EXTERNAL WELDED	1		
-102	65C33336-3	• • PAD, EXTERNAL TANK	4		
-103	57C30602	• • ADAPTER PLATE, RAM	1		

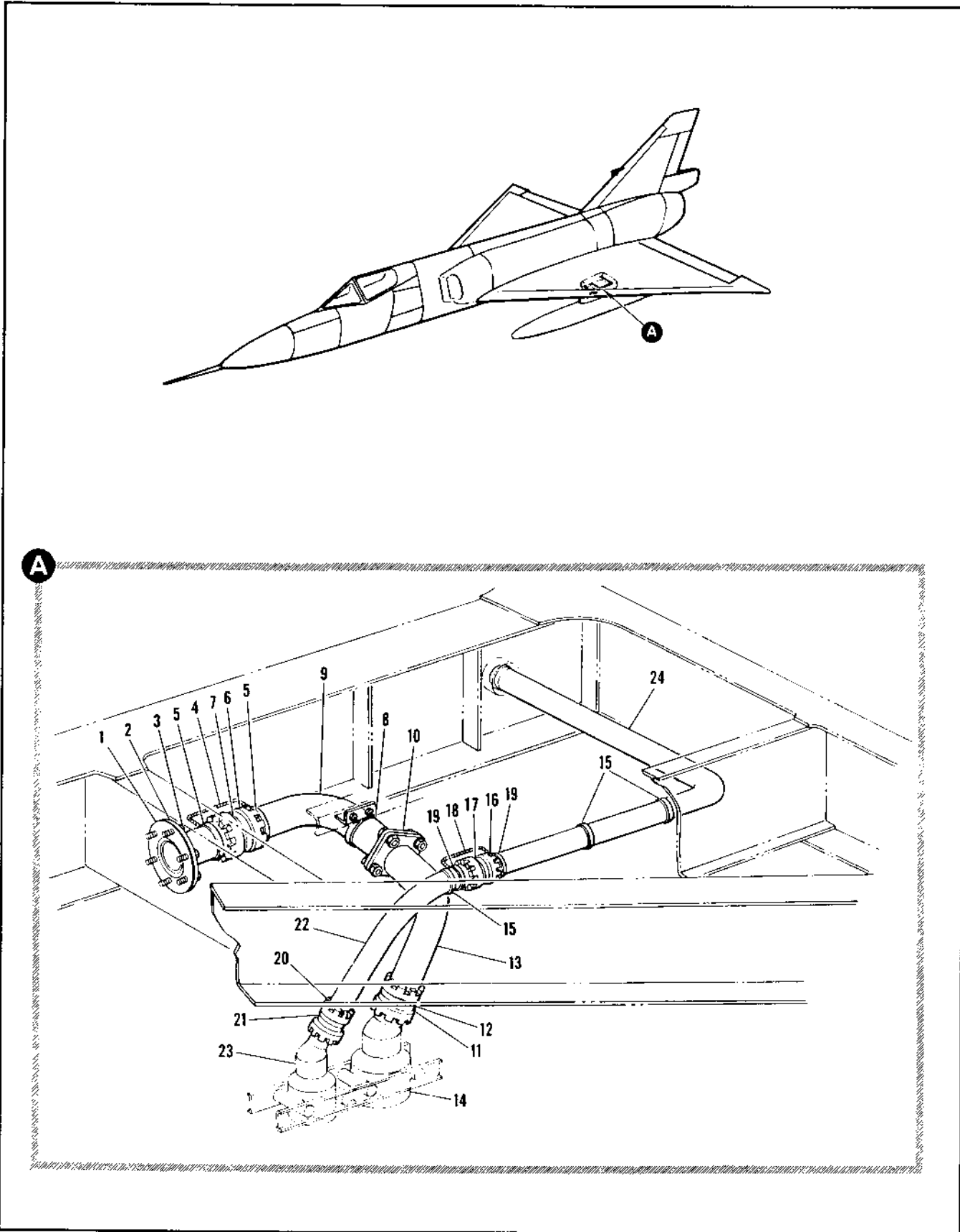

Figure 2.12-11. External Fuel Tank and Vent Line Tubing Installation Intermediate Wing Box

FIGURE AND INDEX NUMBER	PART NUMBER	DESCRIPTION	UNITS PER ASSY.	USABLE ON CODE	
				FROM	TO
2.12-11	65J35879-1	FUEL SYSTEM INSTALLATION, INTERMEDIATE WING BOX LH FOR NHA SEE FIG. 2.6-33	RF		
	65J35879-2	FUEL SYSTEM INSTALLATION, INTERMEDIATE WING BOX RH FOR NHA SEE FIG. 2.6-33	RF		
- 1	65C35875-1	• TUBE ASSEMBLY, 6 BOLT FLANGE WELDED	1		
- 2	J75156-4	• SEAL (89259) SPEC 9-00287-7 ATTACHING PARTS	1		
- 3	AN4-11A	• BOLT -----X-----	6		
- 4	MS25083-2BB4	• JUMPER	1		
- 5	AN735D24	• CLAMP ATTACHING PARTS	2		
	MS21042L3	• NUT	2		
	AN526-1032R7	• SCREW -----X-----	2		
- 6	3605-24D	• COUPLING (79326) 92-72500-003	1		
- 7	MS29513-325	• PACKING	2		
- 8	S169DT24	• CLAMP (92196) ATTACHING PARTS	1		
- 9	65C35876-1	• TUBE ASSEMBLY, 4 BOLT FLANGE LH	1		
	65C35876-2	• TUBE ASSEMBLY, 4 BOLT FLANGE RH	1		
- 10	MS27198-24	• SEAL ATTACHING PARTS	1		
	MS21042L4	• NUT	4		
	AN4-5A	• BOLT -----X-----	4		
- 11	3605-24D	• COUPLING (79326) 92-72500-003	1		
- 12	MS29513-325	• PACKING	2		
- 13	65C35877-1	• TUBE ASSEMBLY, 4 BOLT FLANGE PYLON WELDED	1		
- 14		• COUPLING (91561) SEE FIG. 2.12-9 INDEX 33	RF		
- 15	MS21919DF16	• CLAMP (92196) ATTACHING PARTS	1		
	MS21042L3	• NUT	3		
	AN526-1038	• SCREW -----X-----	3		
- 16	3605-16D	• COUPLING (79326) 92-72500-001	1		
- 17	MS29513-214	• PACKING	2		
- 18	MS25083-2BB3	• JUMPER	1		
- 19	AN735-D16	• CLAMP ATTACHING PARTS	2		
	MS21042L3	• NUT	2		
	AN526-1032R7	• SCREW -----X-----	2		
- 20	3605-16D	• COUPLING (79326) 92-72500-001	1		
- 21	MS29513-214	• PACKING	2		
- 22	65A35902-1	• TUBE, VENT 1.00 INCH LH	1		
	66A41644-1	• TUBE, VENT 1.00 INCH RH	1		
- 23		• COUPLING (91561) SEE FIG. 2.12-9 INDEX 34	RF		
- 24	65A35901-1	• TUBE, VENT 1.00 INCH LH	1		
	66A41633-1	• TUBE, VENT 1.00 INCH RH	1		

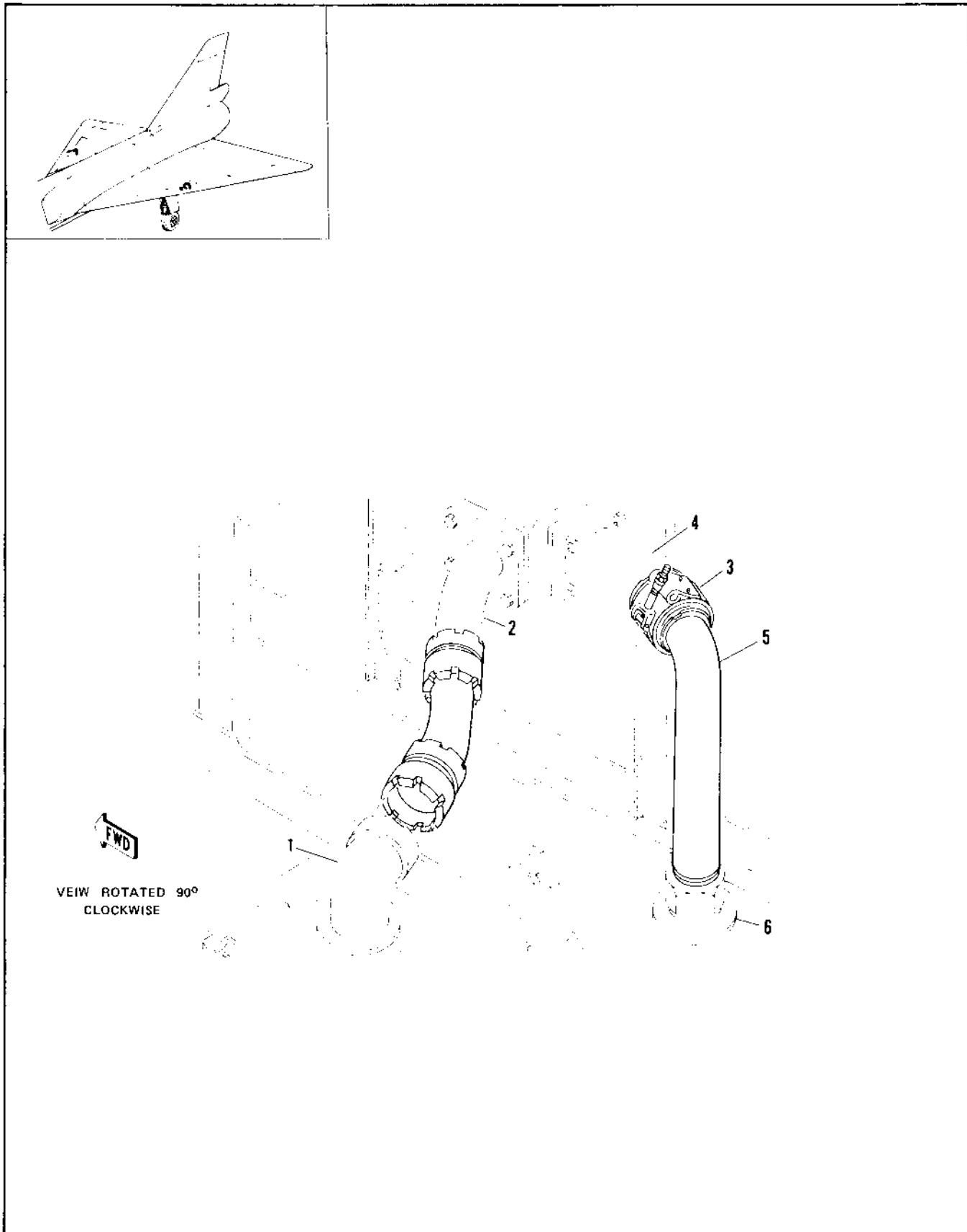

Figure 2.12-12. External Tank Pressure Relief Tubing Installation

FIGURE AND INDEX NUMBER	PART NUMBER	DESCRIPTION 1 2 3 4 5 6	UNITS PER ASSY.	USABLE ON CODE	
				FROM	TO
2.12-12 - 1 - 2 - 3 - 4 - 5 - 6	8-21166-2	TUBING INSTALLATION, EXTERNAL TANK PRESSURE RELIEF RH FOR NHA SEE FIG. 2.6-32	RF	35	
		• COUPLING, SEE FIG. 2.12-1	RF		
		• TUBE ASSY, AIR PRESSURE EXTERNAL TANK SEE FIG. 2.12-1 INDEX 45	RF		
	CF14-100	• COUPLING, <98625> 52-73308-005 REPLACED BY SUITABLE SUB 51500-2-100	1	35	69
	51500-2-100	• COUPLING, <98625> 52-73308-012 REPLACES SUITABLE SUP FOR CF14-100	1	61	
		• TUBE ASSY, EXTERNAL TANK WING VENT OUTLET SEE FIG. 2.12-1 INDEX 42	RF		
	8-21150-1	• TUBE	1	35	
		• FLANGE, EXTERNAL TANK VENT OUTLET	RF		

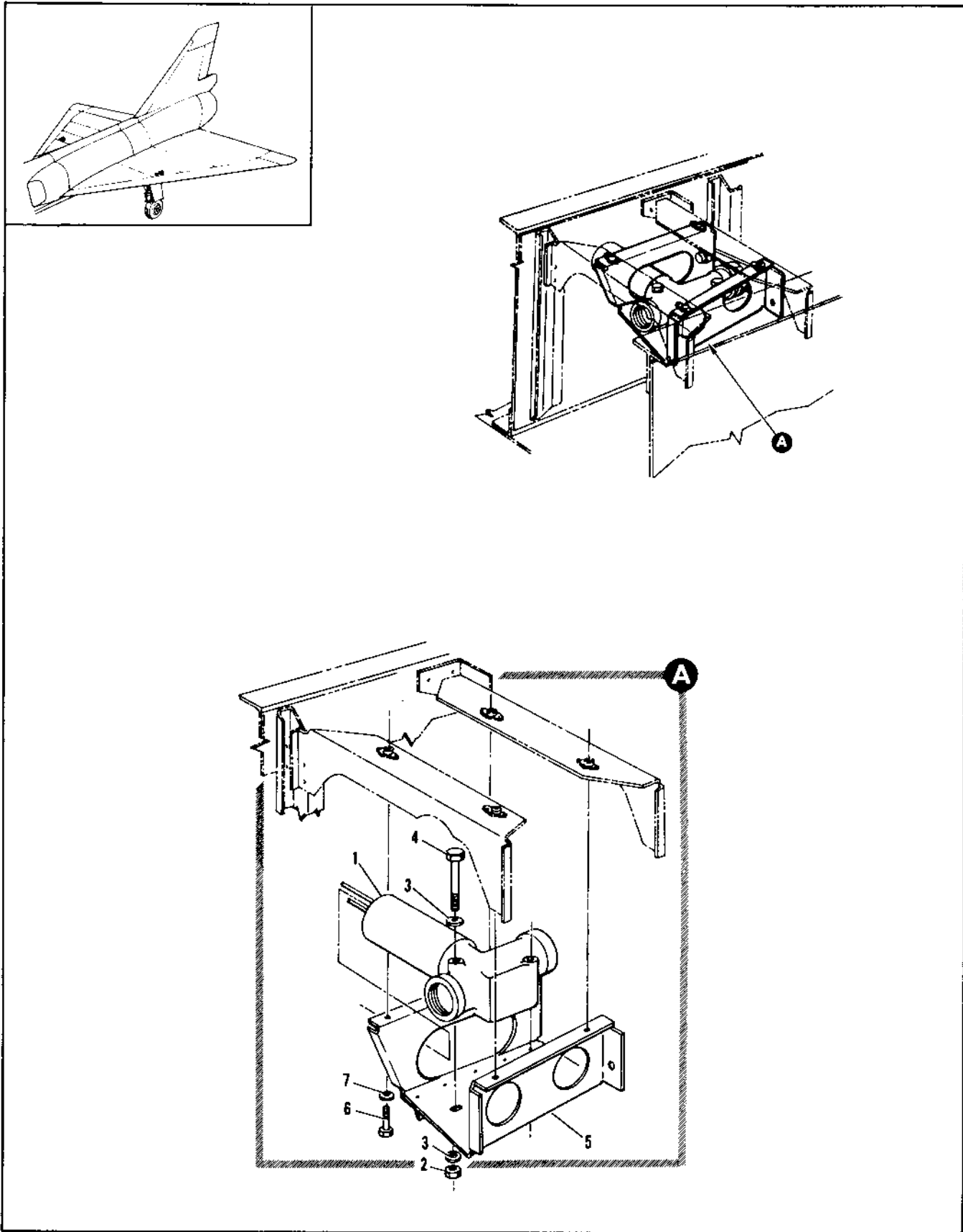

Figure 2.12-13. External Tank Shutoff Valve Installation Sta 442 to 450

FIGURE AND INDEX NUMBER	PART NUMBER	DESCRIPTION	UNITS PER ASSY.	USABLE ON CODE	
				FROM	TO
		1 2 3 4 5 6			
2.12-13	8-21524-1	SEE FIG. 2-6-39 INDEX 7 VALVE INSTALLATION, EXTERNAL TANK SHUTOFF STA 442 TO 450 LH FOR NHA SEE FIG. 2-6-32	RF	35	
	8-21524-2	VALVE INSTALLATION, EXTERNAL TANK SHUTOFF STA 442 TO 450 RH FOR NHA SEE FIG. 2-6-32	RF	35	
- 1	2326-101	• VALVE ASSY, SHUTOFF <31189> SPEC 8-00971-3 T.O. 6J15-10-111-3 REPLACED BY SUITABLE SUB 2326-105	1	35	18A
	2326-105	• VALVE ASSY, SHUTOFF <31189> SPEC 8-00971-5 T.O. 6J15-10-111-3 REPLACES SUITABLE SUB FOR 2326-101 ATTACHING PARTS	1	189	
- 2	NAS679A3	• NUT	2	35	
- 3	AN969-10	• WASHER	4	35	
- 4	AN3-20A	• BOLT	2	35	
		-----X-----			
- 5	8-21524-33	• SUPPORT ASSY, LH RIVETED	1	35	
	8-21524-34	• SUPPORT ASSY, RH RIVETED ATTACHING PARTS	1	35	
- 6	AN3-4A	• BOLT	4	35	
- 7	AN969-10	• WASHER	4	35	
		-----X-----			

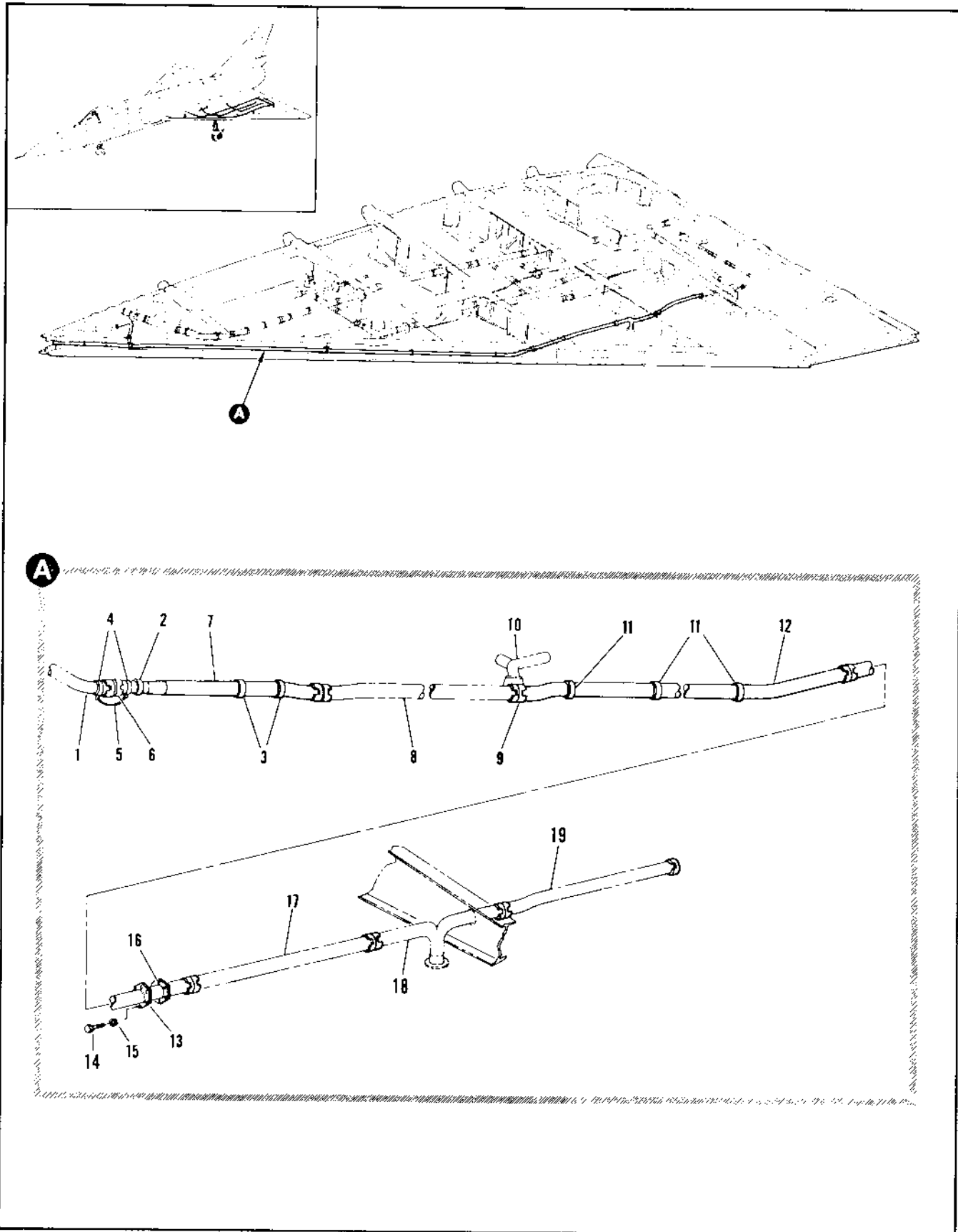

Figure 2.12-14. Fuel Flow Wing Tubing Installation (Sheet 1 of 6)

FIGURE AND INDEX NUMBER	PART NUMBER	DESCRIPTION	UNITS PER ASSY.	USABLE ON CODE	
				FROM	TO
		1 2 3 4 5 6			
2.12-13	8-21524-1	SEE FIG. 2-6-39 INDEX 9 VALVE INSTALLATION, EXTERNAL TANK SHUTOFF STA 442 TO 450 LH FOR NHA SEE FIG. 2-6-32	RF	35	
	R-21524-2	VALVE INSTALLATION, EXTERNAL TANK SHUTOFF STA 442 TO 453 RH FOR NHA SEE FIG. 2-6-32	RF	35	
- 1	2326-101	• VALVE ASSY, SHUTOFF <31189> SPEC 8-00971-3 T.O. 6J15-10-111-3 REPLACED BY SUITABLE SUB 2326-105	1	35	188
	2326-105	• VALVE ASSY, SHUTOFF <31189> SPEC 8-00971-5 T.O. 6J15-10-111-3 REPLACES SUITABLE SUB FOR 2326-101 ATTACHING PARTS	1	189	
- 2	NAS679A3	• NUT	2	35	
- 3	AN960-10	• WASHER	4	35	
- 4	AN3-20A	• BOLT	2	35	
		-----X-----			
- 5	8-21524-33	• SUPPORT ASSY, LH RIVETED	1	35	
	9-21524-34	• SUPPORT ASSY, RH RIVETED ATTACHING PARTS	1	35	
- 6	AN3-4A	• BOLT	4	35	
- 7	AN960-10	• WASHER	4	35	
		-----X-----			

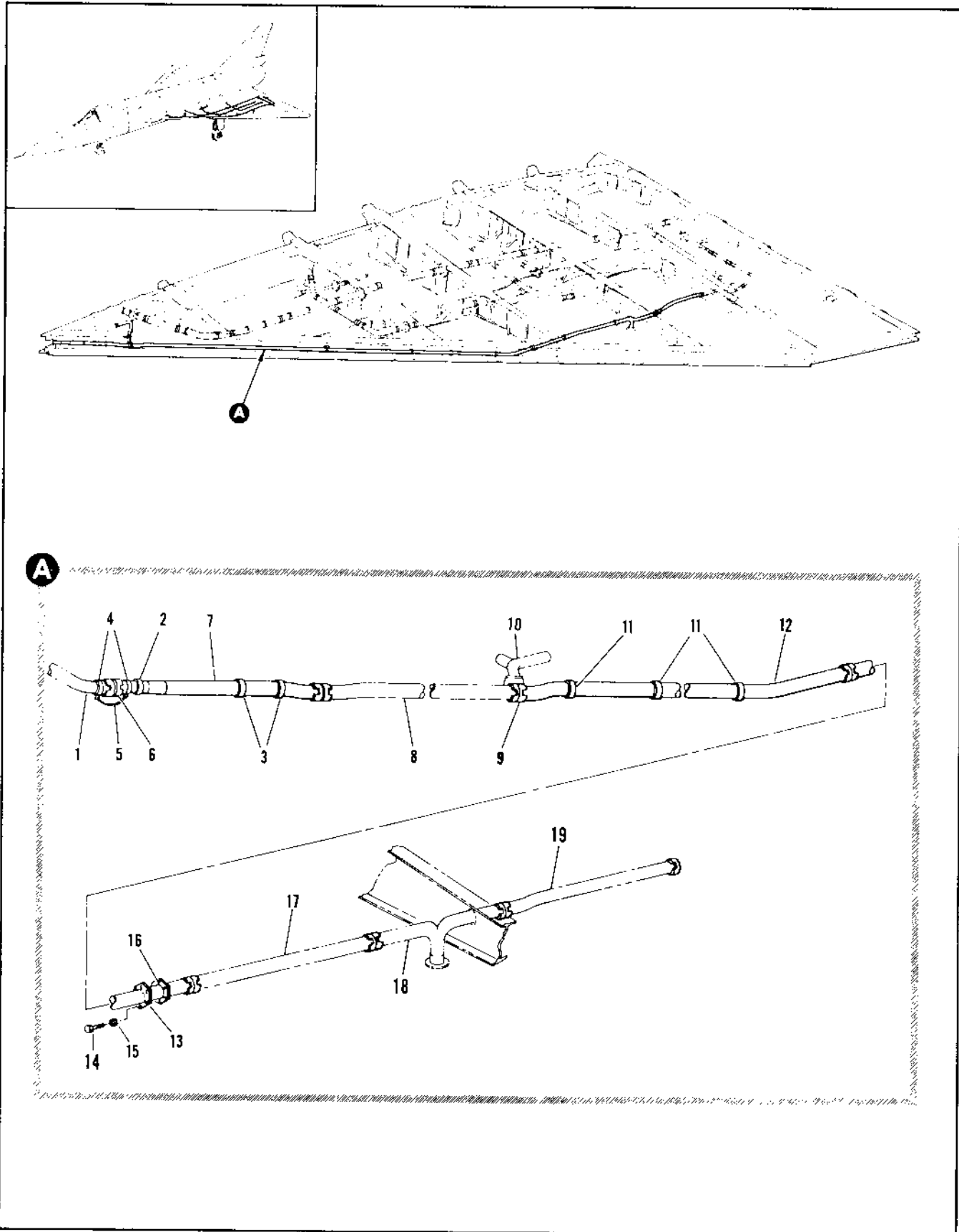

Figure 2.12-14. Fuel Flow Wing Tubing Installation (Sheet 1 of 6)

FIGURE AND INDEX NUMBER	PART NUMBER	DESCRIPTION	UNITS PER ASSY.	USABLE ON CODE		
				FROM	TO	
2.12-14	8-20324-813	TUBING INSTALLATION, FUEL FLOW WING LH FOR NHA SEE FIG. 2.6-32	RF	35	189	
	8-20324-825	TUBING INSTALLATION, FUEL FLOW WING LH FOR NHA SEE FIG. 2.6-32	RF	189		
	8-20324-815	TUBING INSTALLATION, FUEL FLOW WING RH FOR NHA SEE FIG. 2.6-32	RF	35	188	
	8-20324-827	TUBING INSTALLATION, FUEL FLOW WING RH FOR NHA SEE FIG. 2.6-32	RF	189		
	- 1		• TUBE ASSY, SEE FIG. 2.12-49 INDEX 16	RF		
	- 2	91-98026-023	• CLAMP	1	35	
	- 3	MS21919DF32	• CLAMP	2	35	
		NAS679A3	ATTACHING PARTS	3	35	
		AN525-10R6	• NUT, 96-37545-002	3	35	
			• SCREW			
			-----X-----			
	- 4	AN735024	• CLAMP	2	35	
			ATTACHING PARTS			
		NAS679A3	• NUT	2	35	
		AN960D16L	• WASHER	2	35	
		AN526-1032R6	• SCREW	2	35	
			-----X-----			
	- 5	MS25083-1P84	• JUMPER	1	35	
- 6	3805-240	• COUPLING, <79326> 92-72500-003	2	35		
	MS29513-325	• PACKING	1	A		
- 7	8-21135-11	• TUBE, LEADING EDGE VENT FWD LH	1	B		
	8-21592-11	• TUBE, LEADING EDGE VENT FWD RH	RF			
- 8		• TUBE ASSY, SEE FIG. 2.12-18 INDEX A	1	35		
- 9	3655-200	• COUPLING, <79326> 92-72501-004	1	35		
	MS29513-218	• PACKING	RF			
- 10		• TUBE ASSY, VENT SUCTION RELIEF SEE FIG. 2.12-25 INDEX 2	3	35		
- 11	MS21919DF32	• CLAMP				
		ATTACHING PARTS				
	NAS679A3	• NUT, 96-37545-002	3	35		
	AN520-10R8	• SCREW	3	35		
		-----X-----				
- 12	8-21134-5	• TUBE ASSY, LEADING EDGE VENT AFT LH WELDED	1	A		
	8-21134-6	• TUBE ASSY, LEADING EDGE VENT AFT RH WELDED	1	B		
	8-21296-1	• TUBE ASSY, LEADING EDGE VENT AFT WELDED	1	35		
- 13	8-21593	• TUBE ASSY, VENT WELDED				
		ATTACHING PARTS				
- 14	AN4-11A	• BOLT	6	35		
- 15	AN960G416	• WASHER	6	35		
		-----X-----				
- 16	075156-1	• GASKET, <83259> SPEC R-12287-1	1	35		
- 17		• TUBE ASSY, SEE FIG. 2.12-19 INDEX 42	RF			
- 18		• OUTLET ASSY, FUEL TANK #2 VENT SEE FIG. 2.12-1	RF			
- 19		• TUBE ASSY, SEE FIG. 2.12-18 INDEX 49	RF			

A AIRPLANES #35 THRU 277, 287, 292 AND ON
 B AIRPLANES #279 THRU 286 AND 288 THRU 291

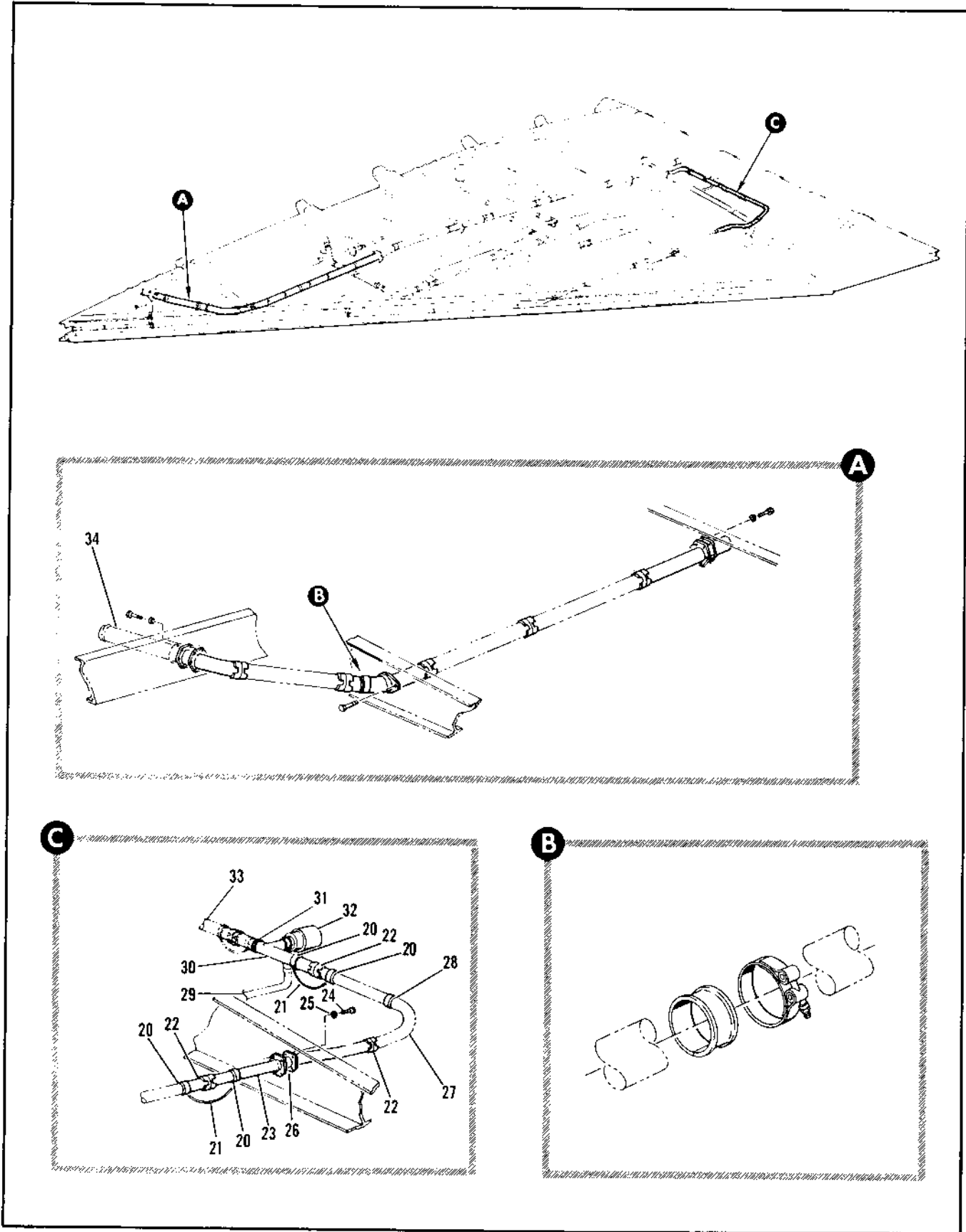

Figure 2.12-14. Fuel Flow Wing Tubing Installation (Sheet 2 of 6)

FIGURE AND INDEX NUMBER	PART NUMBER	DESCRIPTION	UNITS PER ASSY.	USABLE ON CODE	
				FROM	TO
		1 2 3 4 5 6			
2.12-14- 20	91-98026-027	• CLAMP ATTACHING PARTS	6	35	
	NAS679A3	• NUT	6	35	
	AN961010L	• WASHER	6	35	
	AN526-1032R6	• SCREW	6	35	
		----X----			
- 21	MS25283-1EB3	• JUNPER	3	35	
- 22	3605-240	• COUPLING, <79326> 92-72500-003	4	35	
	MS29513-325	• PACKING	8	35	
- 23	R-21596	• TUBE ASSY, TRANSFER TANK VENT WELDED ATTACHING PARTS	1	35	
- 24	AN4-10A	• BOLT	4	35	
- 25	AN960D416	• WASHER	4	35	
		----X----			
- 26	075556-2	• GASKET, <95259> SPEC A-02291-3	1	35	
- 27		• TUBE ASSY, SEE FIG. 2.12-21 INDEX 200	RF		
- 28	91-98026-023	• CLAMP ATTACHING PARTS	1	35	
	NAS679A3	• NUT, 96-37545-302	1	35	
	AN526-1032RA	• SCREW	1	35	
		----X----			
- 29		• ELBOW, SEE FIG. 2.12-21 INDEX 155	RF		
- 30	R-21094-1	• TUBE ASSY, VACUUM AND PRESSURE RELIEF LH WELDED	1	35	
	R-21094-2	• TUBE ASSY, VACUUM AND PRESSURE RELIEF	1	35	
		• RH WELD			
- 31	91-98026-027	• CLAMP ATTACHING PARTS	1	35	
	AN520-1032R9	• SCREW	1	35	
		----X----			
- 32	MS29512-16	• GASKET	1	35	
	312210	• VALVE ASSY, RELIEF VACUUM <96124> SPEC A-02397 T.O. 6J15-0-91-3	1	35	
- 33		• TUBE ASSY, SEE FIG. 2.12-22 INDEX 160	RF		
- 34		• TUBE ASSY, LH SEE FIG. 2.12-4R INDEX 34	RF		

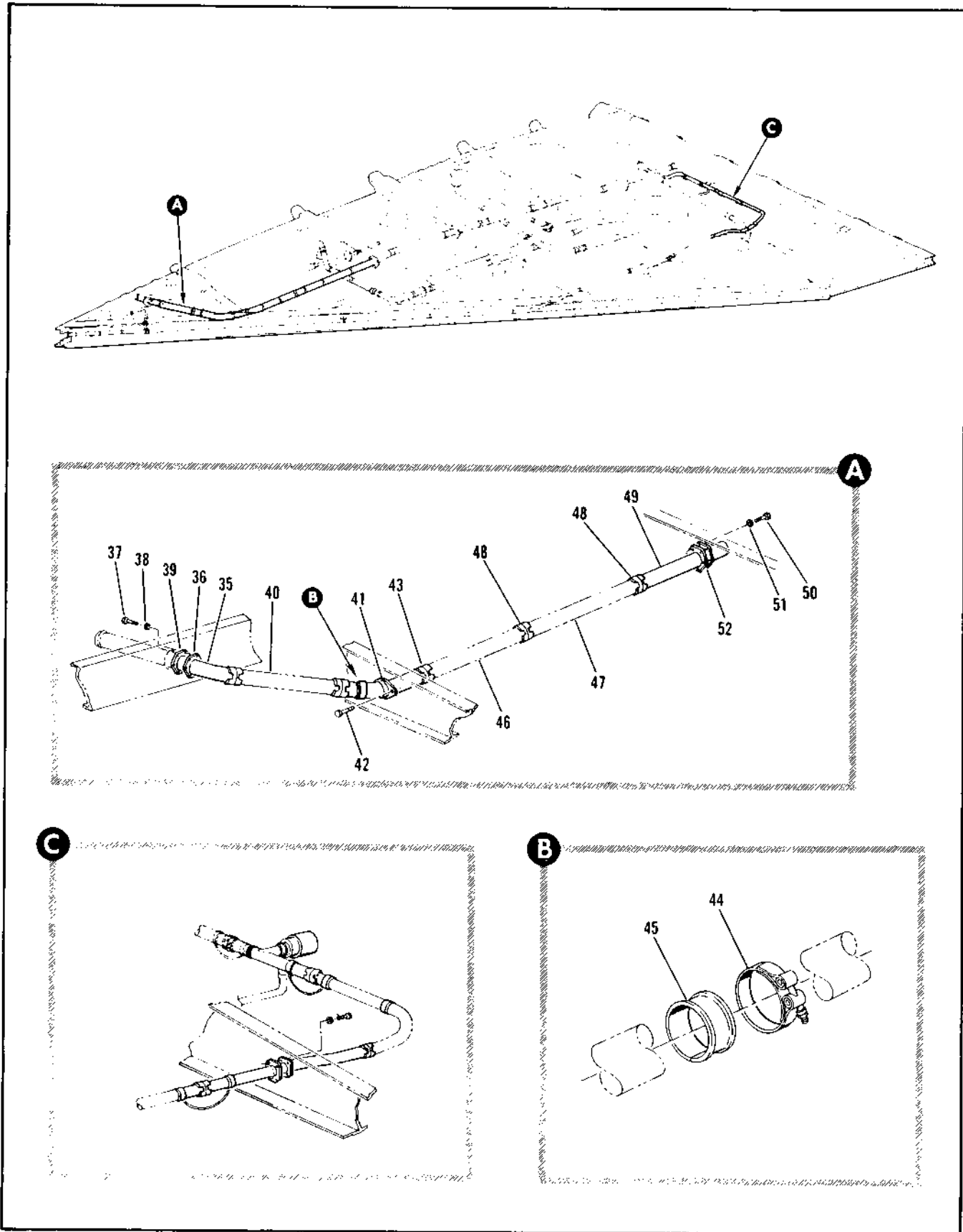

Figure 2.12-14. Fuel Flow Wing Tubing Installation (Sheet 3 of 6)

FIGURE AND INDEX NUMBER	PART NUMBER	DESCRIPTION	UNITS PER ASSY.	USABLE ON CODE		
				FROM	TO	
2.12-14- 35	8-21580-5	• TUBE ASSY, CG FUEL TRANSFER LH WELDED REPLACED BY NOT INTCHG WITH 8-21580-801	1	35	188	
	8-21580-803	• TUBE ASSY, CG FUEL TRANSFER LH WELDED REPLACES SUITABLE SUB FOR 8-21580-801	1	241		
	8-21580-3	• TUBE ASSY, CG FUEL TRANSFER RH WELDED REPLACED BY NOT INTCHG WITH 8-21580-802	1	35	188	
	8-21580-804	• TUBE ASSY, CG FUEL TRANSFER RH WELDED REPLACES SUITABLE SUB FOR 8-21580-802	1	241		
	- 36	8-21273-9	• PLATE ATTACHING PARTS	1	35	
	- 37	AN4-11A	• BOLT	6	35	
	- 38	AN960D416L	• WASHER -----X-----	6	35	
	- 39	075156-2	• GASKET, <83259> SPEC 8-02287-3	1	35	
	- 40		• TUBE ASSY, SEE FIG. 2.12-15 INDEX 50	RF		
	- 41	8-21582 8-21582-1	• TUBE ASSY, CG FUEL TRANSFER SPAR #2 WELDED • TUBE ASSY, CG FUEL TRANSFER SPAR #2 WELDED ATTACHING PARTS	1	35	240
	- 41			1	241	
	- 42	AN3-7A	• BOLT -----X-----	2	35	
- 43	3605-48D	• COUPLING, <79326> 92-72500-005	1	35		
- 43	MS29513-337	• PACKING	1	35		
- 44	50230C75-30PM	• CLAMP, <98625> 91-97802-039	1	35		
- 45	8-28277-9	• PAD	1	35		
- 46		• TUBE ASSY,	RF			
- 47		• TUBE ASSY,	RF			
- 48	3605-48D	• COUPLING, <79326> 92-72500-005	1	35		
- 48	MS29513-337	• PACKING	1	35		
- 49	8-21581-3	• TUBE ASSY, WELDED REPLACES SUITABLE SUB FOR 8-21581 ATTACHING PARTS	1	35		
- 50	AN4-11A	• BOLT	6	35		
- 51	AN960D416L	• WASHER -----X-----	6	35		
- 52	075156-2	• GASKET, <83259> SPEC 8-02287-3	1	35		

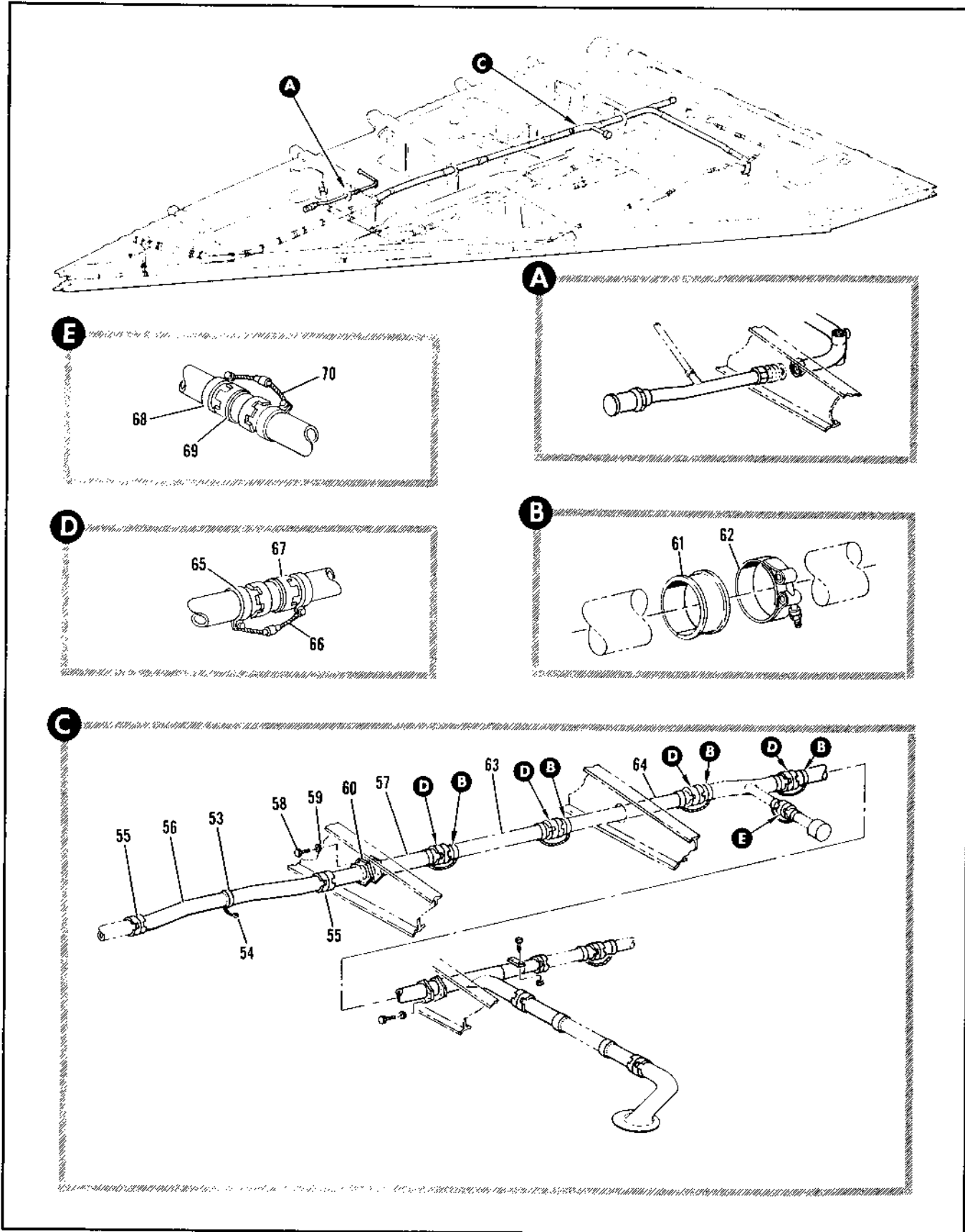

Figure 2.12-14. Fuel Flow Wing Tubing Installation (Sheet 4 of 6)

FIGURE AND INDEX NUMBER	PART NUMBER	DESCRIPTION	UNITS PER ASSY.	USABLE ON CODE	
				FROM	TO
2.12-14- 53	AN735D4R	• CLAMP ATTACHING PARTS	1	35	
	NAS679A3 AN960D10L AN526-1032	• NUT • WASHER • SCREW	1 2 1	35 35 35	
- 54	MS250R3-26R4	-----X----- • JUMPER ATTACHING PARTS	1	35	
	NAS679A3 AN935-10L AN960-10L AN960D10L NAS428-3-4	• NUT • WASHER • WASHER • WASHER • BOLT	1 1 1 2 1	35 35 35 35 35	
- 55	3605-480	• COUPLING, <79326> 72-72500-205	2	35	
- 56	MS29513-337	• PACKING	2	35	
	8-21564 8-21564-1	• TUBE ASSY, CG FUEL TRANSFER LH • TUBE ASSY, CG FUEL TRANSFER LH WELDED ALT INTCHS WITH 8-21564	1 PF 35	35 240	
- 57	8-21564-23 8-21564-15 8-21564-3	• TUBE ASSY, CG FUEL TRANSFER LH WELDED • TUBE ASSY, CG FUEL TRANSFER RH • TUBE ASSY, CG FUEL TRANSFER RH WELDED ALT INTCHS WITH 8-21564-15	1 1 PF 35	241 35 240	
	8-21564-25 8-215R-5	• TUBE ASSY, CG FUEL TRANSFER RH WELDED • TUBE ASSY, WELDED ATTACHING PARTS	1 1	241	
- 58	AN4-11A AN4-10A	• BOLT • BOLT	6 6	35 278	277
- 59	AN960D416L AN960D416	• WASHER • WASHER	6 6	35 278	277
- 60	075156-2	-----X----- • GASKET, <80959> SPEC 80-2247-3	1	35	
- 61	50250075-306M	• CLAMP, <97675> 91-57802-339	3	35	
- 62	8-26277-9	• PAC	3	35	
- 63	AN735D4R	• TUBE ASSY, SEE FIG. 2.12-20 INDEX 23	PF		
- 64		• TUBE ASSY, SEE FIG. 2.12-20 INDEX 24	PF		
- 65		• CLAMP ATTACHING PARTS	4	35	
- 66	NAS679A3	• NUT	4	35	
- 67	AN960D10L	• WASHER	4	35	
- 68	AN526-1032R6	• SCREW	4	35	
- 66	MS250R3-18R4	-----X----- • JUMPER	2	35	
- 67	3605-480	• COUPLING, <79326> 92-72500-115	2	35	
- 68	MS29513-337	• PACKING	1	35	
	AN735D24	• CLAMP ATTACHING PARTS	2	35	
	NAS679A3	• NUT	2	35	
	AN960D10L	• WASHER	2	35	
	AN526-1032R6	• SCREW	2	35	
- 69	MS250R3-18R4	-----X----- • JUMPER	1	35	
- 70	3605-240	• COUPLING, <79326> 92-72500-003	1	35	
	MS29513-337	• PACKING	1	35	

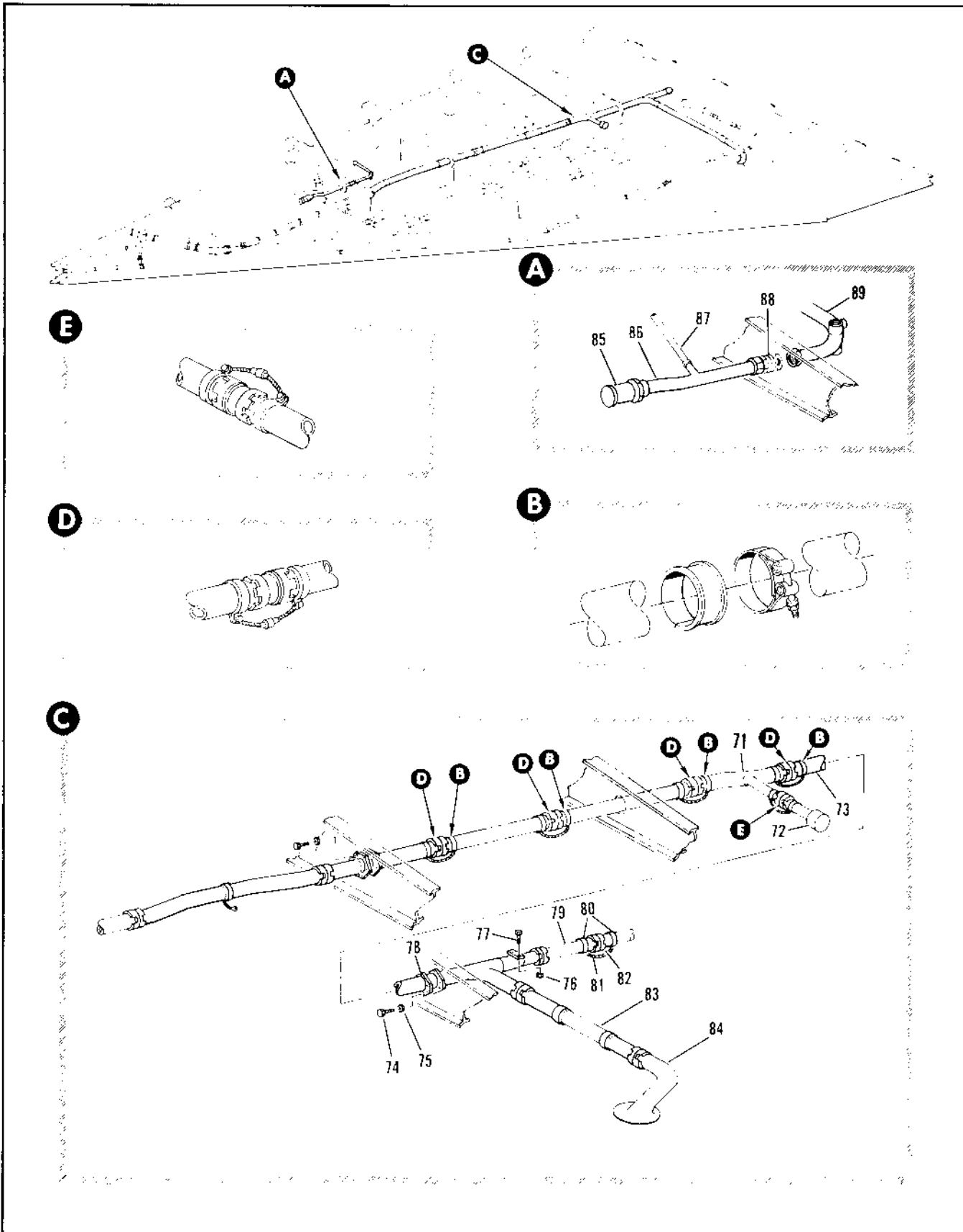

Figure 2.12-14. Fuel Flow Wing Tubing Installation (Sheet 5 of 6)

FIGURE AND INDEX NUMBER	PART NUMBER	DESCRIPTION	UNITS PER ASSY.	USABLE ON CODE	
				FROM	TO
2.12-14- 71		• TUBE ASSY, CG FUEL TRANSFER SEE FIG. 2.12-17 INDEX 5	RF		
- 72		• VALVE ASSY, SHUTOFF STA 542 SEE FIG. 2.12-17 INDEX 1	RF		
- 73	8-21583-1	• TUBE ASSY, LH MODIFIED BY 8-20321	1	35	
	8-21583-2	• TUBE ASSY, RH ATTACHING PARTS	1	35	
- 74	AN4-10A	• BOLT	6	35	
- 75	AN963D416L	• WASHER	6	35	
- 76	NAS679A3	• NUT, 96-37545-0L2	2	35	
- 77	AN3-4A	• BOLT -----X-----	2	35	
	8-21118-11	• SUPPORT, REPLACED BY NOT INTCHG WITH 8-21118-17	1	35	188
	8-21118-12	• SUPPORT, REPLACED BY NOT INTCHG WITH 8-21118-18	1	35	188
- 78	75156-2	• GASKET, <83259> SPEC 8-02297-3	1	35	
- 79		• TUBE ASSY, SEE FIG. 2.12-21 INDEX 12C	RF		
- 80	AN735D40	• CLAMP ATTACHING PARTS	2	35	
	NAS679A3	• NUT	2	35	
	AN963D10L	• WASHER	2	35	
	AN526-1032R6	• SCREW -----X-----	2	35	
- 81	MS25083-1884	• JUMPER	1	35	
- 82	3605-40D	• COUPLING, <79326> 92-72500-054	1	35	
	MS29513-333	• PACKING	2	35	
- 83		• TUBE ASSY, SEE FIG. 2.12-23 INDEX 19	RF		
- 84		• BELLMOUTH ASSY, SEE FIG. 2.12-27 INDEX 3	RF		
- 85	1111-568372	• VALVE ASSY, <92033> SPEC 8-02299-1 T.O. 6J15-2-105-32	1	35	
- 86	8-21121-1	• TUBE ASSY, TANK #1 LH	1	35	
	8-21121-2	• TUBE ASSY, TANK #1 RH	1	35	
- 87		• TUBE ASSY, LH SEE FIG. 2.12-16 INDEX 25	RF		
- 88		• UNION, SPAR #3 BL 43 AND 44 SEE FIG. 2.12-66 INDEX 4	RF		
- 89	8-21597-3	• TUBE ASSY, FUEL TANK PRESSURE MLG. WHEEL WELL LH	1	35	
	8-21597-4	• TUBE ASSY, FUEL TANK PRESSURE MLG. WHEEL WELL RH	1	35	

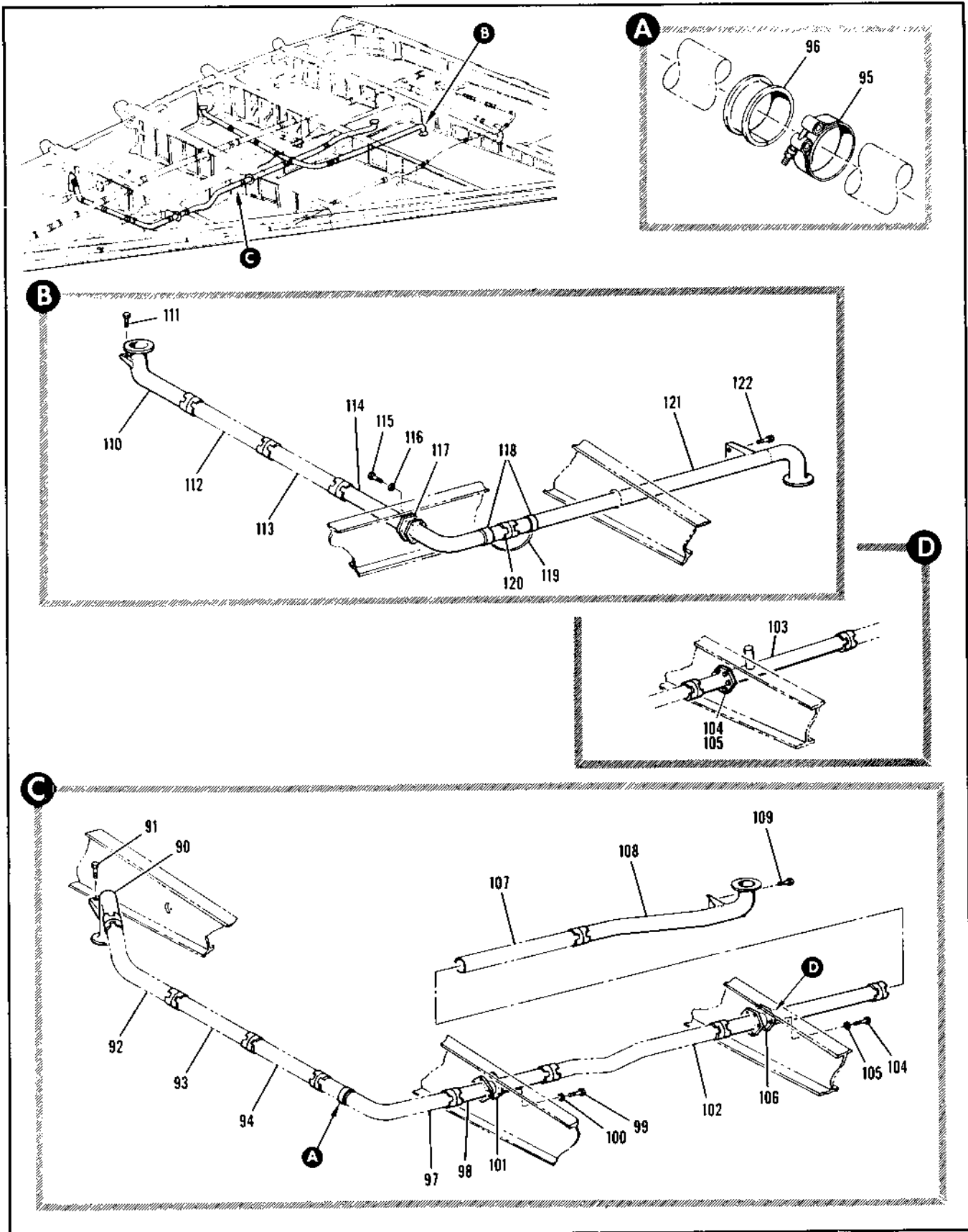

Figure 2.12-14. Fuel Flow Wing Tubing Installation (Sheet 6 of 6)

FIGURE AND INDEX NUMBER	PART NUMBER	DESCRIPTION	UNITS PER ASSY.	USABLE ON CODE	
				FROM	TO
		1 2 3 4 5 6			
2.12-14- 90	8-21570-1	• BELLMOUTH ASSY, TANK #1 LH	1	35	
	8-21570-2	• BELLMOUTH ASSY, TANK #1 RH ATTACHING PARTS	1	35	
- 91	AN3-4A	• BOLT -----X-----	2	35	
- 92		• TUBE ASSY, SEE FIG. 2.12-15 INDEX 221	PF		
- 93		• TUBE ASSY, SEE FIG. 2.12-15 INDEX 222	PF		
- 94		• TUBE ASSY, SEE FIG. 2.12-15 INDEX 223	PF		
- 95	MS21919DF-42	• CLAMP	1	35	
- 96	8-23277-7	• PAL	1	35	
- 97		• TUBE ASSY, SEE FIG. 2.12-15 INDEX 224	PF		
- 98	8-21572	• TUBE ASSY, WELDED ATTACHING PARTS	1	35	
- 99	AN4-11A	• BOLT	6	35	
-100	AN960D416	• WASHER -----X-----	6	35	
-101	075156-3	• GASKET, <83259> SPEC 8-02287-5	1	35	
-102		• TUBE ASSY, LH SEE FIG. 2.12-37 INDEX 110	PF		
-103	66E40985-1	• TUBE ASSY, WELDED ALTERED FROM 8-21539 ATTACHING PARTS	1		
-104	AN4-10A	• BOLT	3	35	
-105	AN960D41CL	• WASHER -----X-----	3	35	
-106	075156-3	• GASKET, <83259> SPEC 8-02287-5	1	35	
-107		• TUBE ASSY, LH SEE FIG. 2.12-19 INDEX 58	PF		
-108	8-21571-1	• BELLMOUTH ASSY, TANK #2 LH REPLACED BY NOT INTCHG WITH 8-21613-1	1	C	
	8-21572	• BELLMOUTH ASSY, TANK #2 RH REPLACED BY NOT INTCHG WITH 8-21613-2 ATTACHING PARTS	1	C	
-109	AN3-4A	• BOLT -----Y-----	2	C	
-110	8-21577	• BELLMOUTH ASSY, TANK #7 ATTACHING PARTS	1	35	
-111	AN3-4A	• BOLT -----X-----	2	35	
-112		• TUBE ASSY, SEE FIG. 2.12-20 INDEX 70	PF		
-113		• TUBE ASSY, SEE FIG. 2.12-20 INDEX 80	PF		
-114	8-21578-1	• TUBE ASSY, LH	1	35	
	8-21578-2	• TUBE ASSY, RH ATTACHING PARTS	1	35	
-115	AN4-10A	• BOLT	6	35	
-116	AN9610416L	• WASHER -----X-----	6	35	
-117	075156-3	• GASKET, <83259> SPEC 8-02287-5	1	35	
-118	AN730040	• CLAMP ATTACHING PARTS	2	35	
	NAS679A3	• NUT	2	35	
	AN962010L	• WASHER	2	35	
	AN526-103246	• SCREW -----X-----	2	35	
-119	MS25043-1PP4	• JUMPER	1	35	
-120	3605-4JD	• COUPLING, <79326> 12-72400-004	1	35	
	MS29513-333	• PACKING	2	35	
-121	8-21574-1	• BELLMOUTH ASSY, AFT TANK #2 LH	1	35	
	8-21574-2	• BELLMOUTH ASSY, AFT TANK #2 RH ATTACHING PARTS	1	35	
-122	AN3-4A	• BOLT -----X-----	2	35	
		C AIRPLANES #35 THRU 159, 278 AND ON			

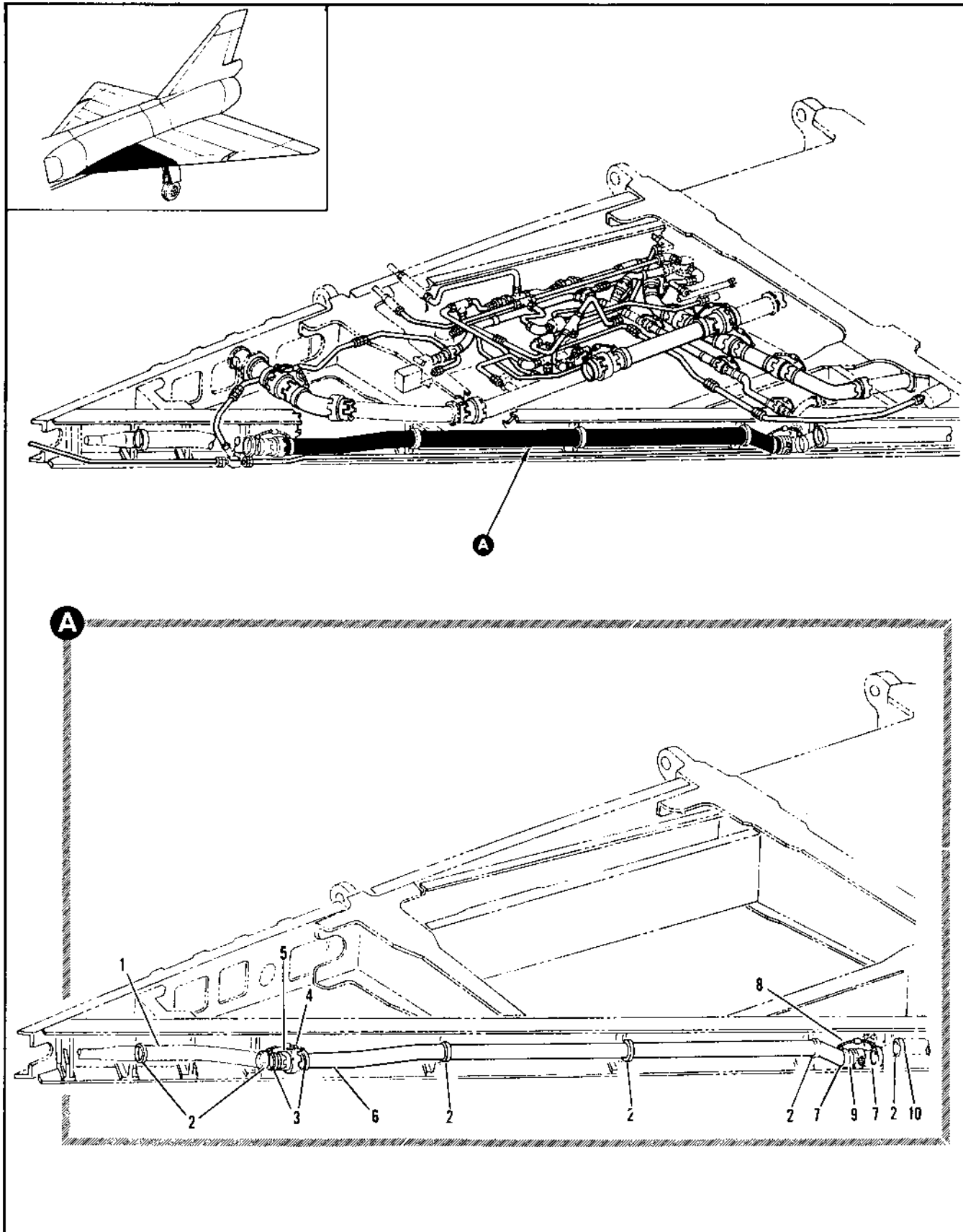

Figure 2.12-15. Wing Tank #1 Fuel Control Tubing Installation (Sheet 1 of 11)

FIGURE AND INDEX NUMBER	PART NUMBER	DESCRIPTION 1 2 3 4 5 6	UNITS PER ASSY.	USABLE ON CODE		
				FROM	TO	
2.12-15	8-20397-F37	TUBING INSTL, WING TANK #1 FUEL CONTROL LH MODIFIED BY 65035874 AND 66040393 FOR NHA SEE FIG. 2.6-32	RF			
	8-20397-F39	TUBING INSTL, WING TANK #1 FUEL CONTROL RH MODIFIED BY 65035874 AND 66040393	RF	35	159	
	- 1	• TUBE, LEADING EDGE VENT FWD SEE FIG. 2.12-14 INDEX 7	6	35	159	
	- 2	• CLAMP	2	35	159	
	- 3	• CLAMP ATTACHING PARTS	2	35	159	
		• NUT	2	35	159	
		• WASHER	2	35	159	
		• SCREW -----X-----	1	35	159	
	- 4	MS20543-10B4	• JUMPER	1	35	159
	- 5	3605-37P	• COUPLING, <79326> 92-73078-002	1	35	159
		MS20513-32R	• PACKING	1	35	159
	- 6	8-21397-324	• TUBE ASSY, LEADING EDGE VENT	2	35	159
	- 7	AN775F32	• CLAMP ATTACHING PARTS	2	35	159
	AN526-15R	• SCREW	2	35	159	
	AN960D101	• WASHER -----X-----	2	35	159	
- 8	MS20543-11B4	• JUMPER	1	35	62	
- 9	CF14-200	• COUPLING, <98425> 92-73078-006 REPLACED BY SUITABLE SUB -1507-2-200	1	61	159	
	81564-2-200	• COUPLING, <98625> 92-73078-016 REPLACES SUITABLE SUB FOR CF14-200	1	61	159	
- 10		• TUBE ASSY, LEADING EDGE VENT AFT LH SEE FIG. 2.12-14 INDEX 12	RF			

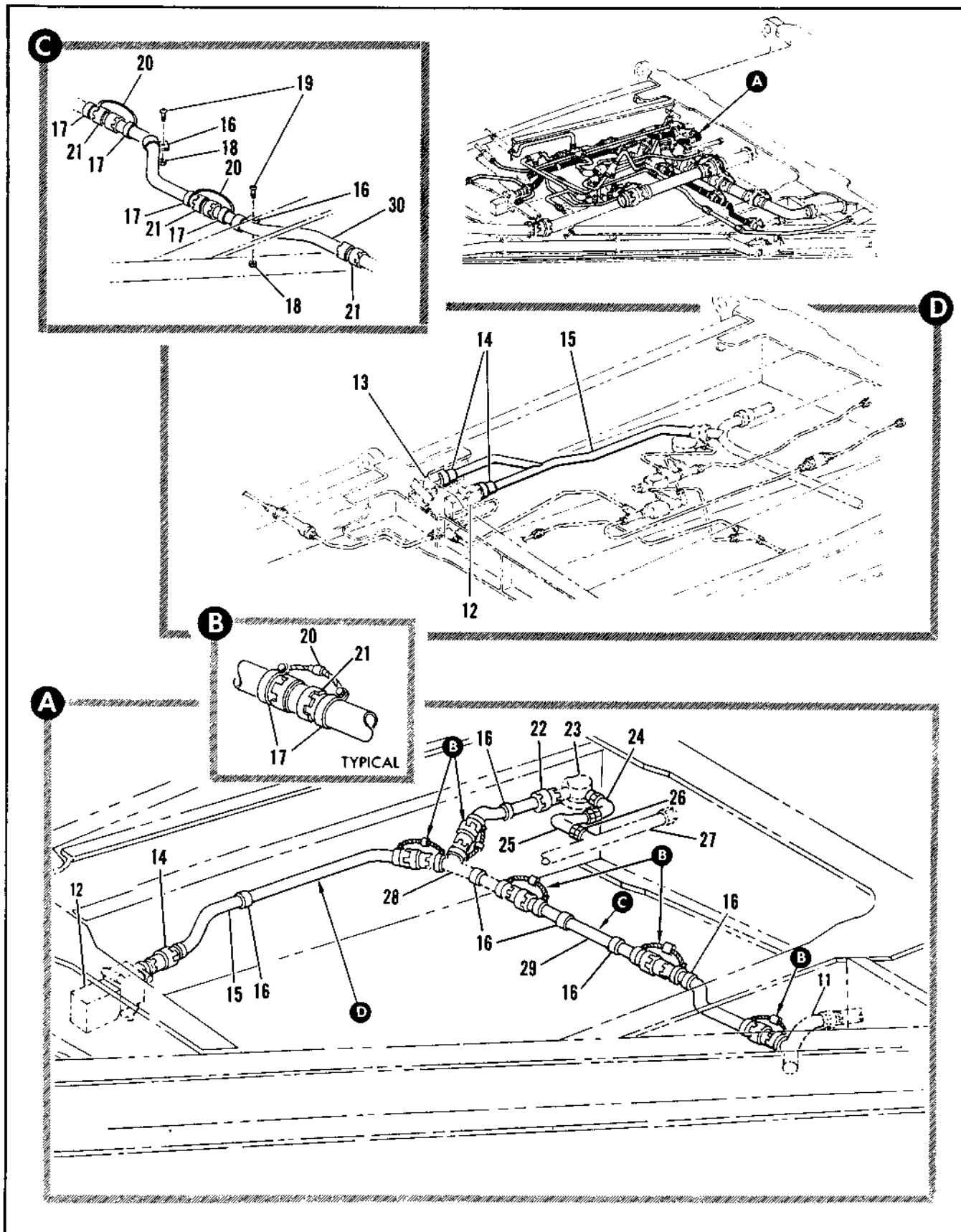

Figure 2.12-15. Wing Tank #1 Fuel Control Tubing Installation (Sheet 2 of 11)

FIGURE AND INDEX NUMBER	PART NUMBER	DESCRIPTION	UNITS PER ASSY.	USABLE ON CODE	
				FROM	TO
		1 2 3 4 5 6			
2.12-15- 11		• TUBE ASSY, VENT SUCTION RELIEF SEE FIG. 2.12-23 INDEX 2	RF		
- 12		• VALVE ASSY, PRESSURE RELIEF TANK #1 SEE FIG. 2.12-1 INDEX 3	RF		
- 13		• VALVE INSTL, FUEL TANK VENT SEE FIG. 2.12-1 INDEX 17	RF		
- 14	3605-160	• COUPLING, <79326> 92-72500-001	2	35	159
	MS29513-214	• PACKING	4	35	159
- 15	66J40320-1	• TUBE ASSY, LH	1		
	66J40320-2	• TUBE ASSY, RH		35	159
	8-20397-1767	• TUBE ASSY, RF	1	35	159
- 16	91-98026-015	• CLAMP	4		
- 17	AN735016	• CLAMP	6		
		ATTACHING PARTS			
	NAS679A3	• NUT	6		
- 18	MS21043-3	• NUT	2		
	AN960010L	• WASHER	6		
	AN526-1032R6	• SCREW	6		
- 19	AN520-1098	• SCREW	2		
		-----X-----			
- 20	MS5083-1RB3	• JUMPER	4		
- 21	3605-160	• COUPLING <79326> 92-72500-001 REPLACES INTCHG WITH 3601-160	3	35	159
	3605-160	• COUPLING, <79326> 92-72500-001	1	35	159
- 22	MS29513-214	• PACKING	1	35	159
- 23		• VALVE ASSY, FUEL TANK VENT REFUELING SEE FIG. 2.12-1 INDEX 36 AND FIG. 2.12-26 INDEX 3	RF		
	AN924-40	• NUT	1	35	159
- 24	MS2190804	• ELBOW	1	35	159
	MS29512-34	• GASKET	1	35	159
- 25	8-20397-367	• TUBE ASSY, LH	1	35	159
	8-20397-142	• TUBE ASSY, RH	1	35	159
- 26	MS2190204	• UNION	1	35	159
	MS29512-4	• GASKET	1	35	159
- 27		• TUBE ASSY, TANK #1 LH SEE FIG. 2.12-14 INDEX 86	RF		
- 28		• TUBE ASSY, TANK #1 TEE VENT LINE LH SEE FIG. 2.12-1 INDEX 6	RF		
- 29	65A35899-1	• TUBE, VENT ONE INCH TANK	1		
- 30	65A35698-1	• TUBE, VENT ONE INCH TANK	1		

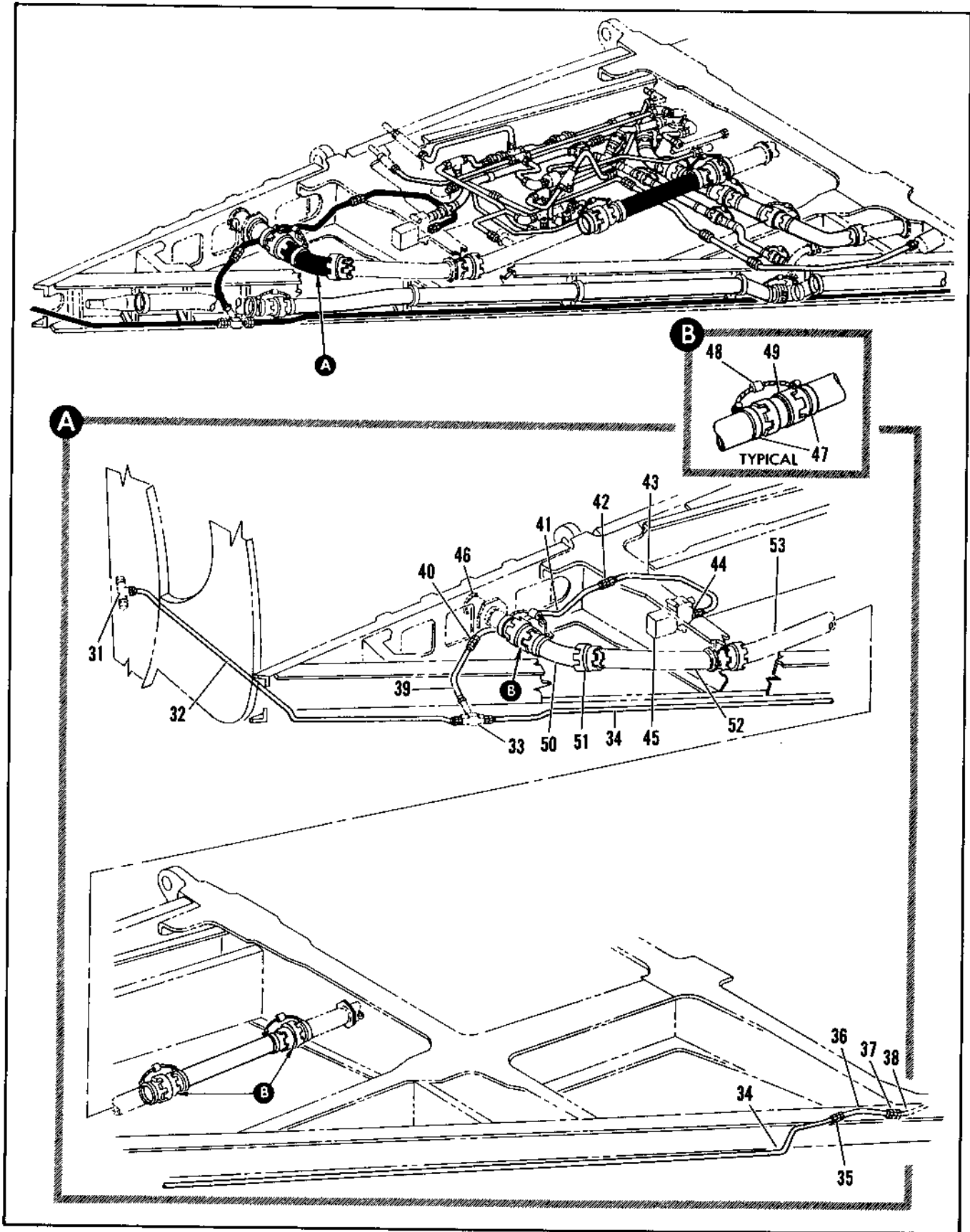

Figure 2.12-15. Wing Tank #1 Fuel Control Tubing Installation (Sheet 3 of 11)

FIGURE AND INDEX NUMBER	PART NUMBER	DESCRIPTION 1 2 3 4 5 6	UNITS PER ASSY.	USABLE ON CODE	
				FROM	TO
2.12-15- 31		• TEE, SEE FIG. 2.12-45 INDEX 137	RF		
- 32	8-20397-330	• TUBE ASSY, LH	1	35	159
	8-20397-788	• TUBE ASSY, RH	1	35	159
- 33		• CONNECTOR, VENT VALVE TANK #1 STA 138 LEADING EDGE SEE FIG. 2.12-66 INDEX 1	RF		
- 34	8-20397-155	• TUBE ASSEMBLY	1	35	159
- 35	MS21902D6	• UNION	1	35	159
- 36	8-20397-153	• TUBE ASSEMBLY	1	35	159
- 37		• UNION, SPAR #4 BL 129 SEE FIG. 2.12-66 INDEX 14	RF		
- 38		• TUBE ASSY, SEE FIG. 2.12-21 INDEX 16	RF		
- 39	8-20397-1561	• TUBE ASSY, LH	1	35	159
	8-20397-1727	• TUBE ASSY, RH	1	35	159
- 40	MS21902D4	• UNION	1	35	159
- 41	8-20397-1563	• TUBE ASSY, LH	1	35	159
	8-20397-1726	• TUBE ASSY, RH	1	35	159
	AN924-40	• NUT	1	35	159
	AN9610716	• WASHER	1	35	159
- 42	MS21903D4	• UNION	1	35	159
- 43	8-20397-1555	• TUBE ASSY, LH	1	35	159
- 44	MS21902D4	• UNION	1	35	159
	MS29512-4	• GASKET	1	35	159
- 45		• VALVE ASSY, PRESSURE RELIEF TANK #1 SEE FIG. 2.12-1 INDEX 1	RF		
- 46		• TUBE ASSY, CG FUEL TRANSFER LH SEE FIG. 2.12-14 INDEX 35	RF		
- 47	AN735048	• CLAMP	6	35	159
		ATTACHING PARTS			
	NAS679A3	• NUT	6	35	159
	AN960010L	• WASHER	6	35	159
	ANS26-1032R5	• SCREW	6	35	159
		-----X-----			
- 48	MS25083-18B4	• JUMPER	3	35	159
- 49	3605-48D	• COUPLING (79324) 92-72500-005	3	35	159
	MS29513-337	• PACKING	4	35	159
- 50	8-20397-95	• TUBE ASSEMBLY	1	35	159
- 52		• TUBE ASSY, CG FUEL TRANSFER SPAR #2 SEE FIG. 2.12-14 INDEX 41	RF		
- 53		• TUBE ASSY, FUEL TRANSFER AND REFUELING LH SEE FIG. 2.12-1	RF		

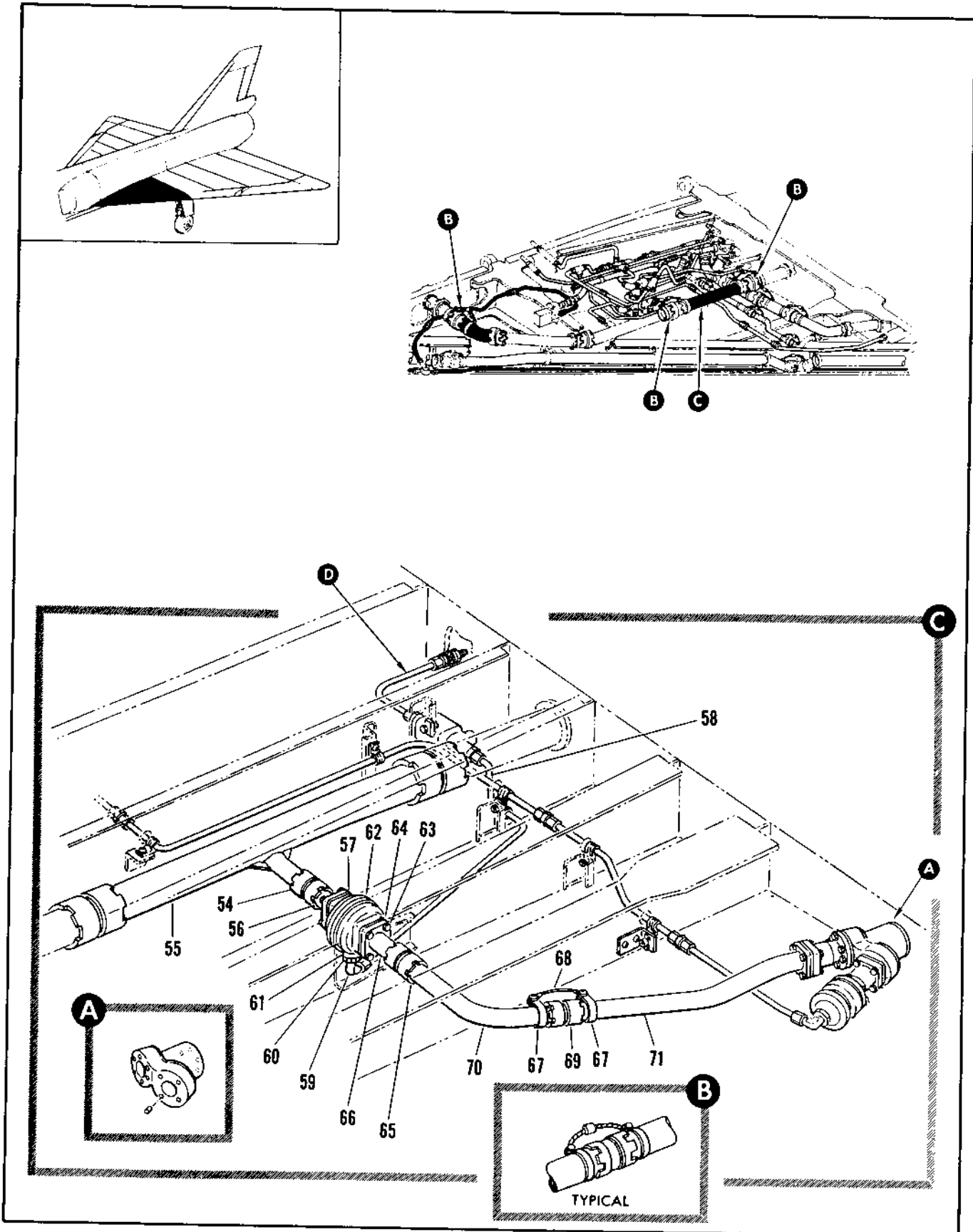

Figure 2.12-15. Wing Tank #1 Fuel Control Tubing Installation (Sheet 4 of 11)

FIGURE AND INDEX NUMBER	PART NUMBER	DESCRIPTION	UNITS PER ASSY.	USABLE ON CODE	
				FROM	TO
2.12-15- 54	3605-240	• COUPLING (79326) 92-72500-003	1	35	159
	MS29513-325	• PACKING	2	35	159
- 55	65E35970-1	• TUBE ASSY, 3.0 INCH FUEL TRANSFER LH WELDED	1	35	159
	65F35870-2	• TUBE ASSY, 3.0 INCH FUEL TRANSFER RH WELDED	1	35	159
- 56	65C35869-1	• TUBE ASSY, 4 BOLT FLANGE WELDED ATTACHING PARTS	4	35	159
	AN4H-5A	• BOLT	4	35	159
	AN960D416L	• WASHER -----X-----	1	35	159
- 57	MS27198-24	• SEAL	1	35	159
- 58	65A35930-1	• TUBE ASSY, SHUTOFF VALVE BLEED	1	35	159
- 59	MS2190804	• ELBOW ATTACHING PARTS	1	35	159
- 60	AN924-40	• NUT -----X-----	1	35	159
- 61	MS29512-4	• GASKET	1	35	159
- 62	737600-3	• VALVE ASSY, N96124) REPLACES 730800-1 ATTACHING PARTS	4	35	159
- 63	AN4H-6A	• BOLT	4	35	159
	AN960D16	• WASHER -----Y-----	1	35	159
- 64	MS27198-24	• SEAL	1	35	159
- 65	3605-240	• COUPLING (79326) 92-72500-003	2	35	159
	MS29513-325	• PACKING	1	35	159
- 66	65C35869-1	• TUBE ASSY, 4 BOLT FLANGE WELDED	2	35	159
- 67	AN755024	• CLAMP ATTACHING PARTS	2	35	159
	MS21142L3	• NUT	2	35	159
	AN526-1032R6	• SCREW -----X-----	1	35	159
- 68	MS250P3-2884	• JUMPER	1	35	159
- 69	3605-240	• COUPLING (79326) 92-72500-003	2	35	159
	MS29513-325	• PACKING	1	35	159
- 70	66A40859-1	• TUBE, FUEL TRANSFER TANK 1	1	35	159
- 71	66D39362-1	• TUBE ASSY, FUEL SYSTEM WELDED LH	1	35	159
	66D39462-2	• TUBE ASSY, FUEL SYSTEM WELDED RH	1	35	159

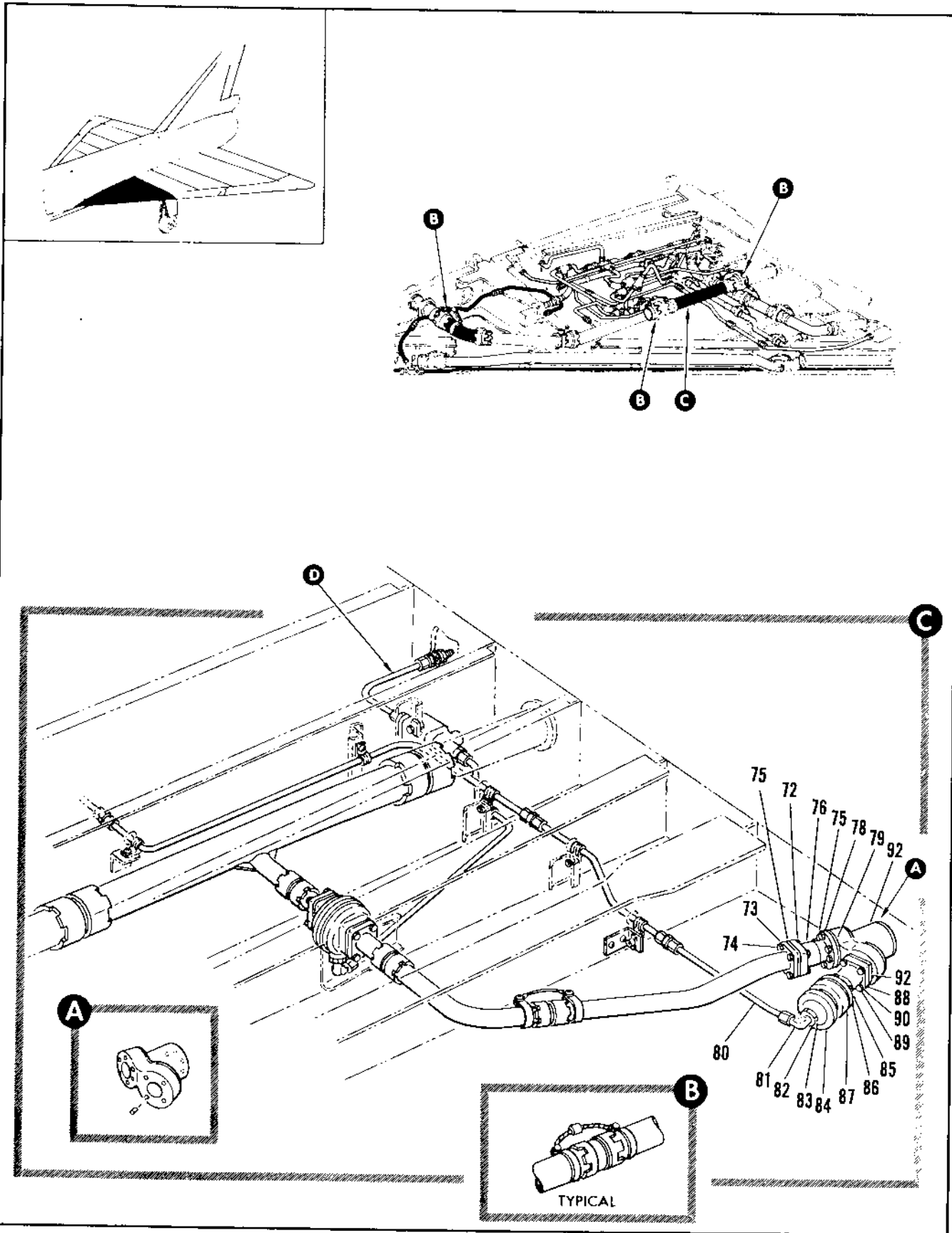

Figure 2.12-15. Wing Tank #1 Fuel Control Tubing Installation (Sheet 5 of 11)

FIGURE AND INDEX NUMBER	PART NUMBER	DESCRIPTION 1 2 3 4 5 6	UNITS PER ASSY.	USABLE ON CODE	
				FROM	TO
2.12-15		ATTACHING PARTS			
- 72	S21042L4	• NUT	4	35	159
- 77	AN9600416L	• WASHER	4	35	159
- 74	AN4-11A	• BOLT -----X-----	1	35	159
- 75	MS27198-24	• SEAL	1	35	159
- 76	25-6503-3	• VALVE ASSY, FUEL CHECK (96736) SPEC 8-00954 T.O. 6SJ15-2-111-3	CF	35	159
	25-6500	• VALVE ASSY, FUEL CHECK (96736) SPEC 8-00954 T.O. 6SJ15-2-111-3 ALT INTCHG WITH 25-6500-3			
		ATTACHING PARTS			
- 77	AN4H-5A	• BOLT	6	35	159
- 78	AN960-0416L	• WASHER -----X-----	6	35	159
- 79	075156-4	• SEAL (89259) SPEC 8-02287-7	1	35	159
- 80	65A35925-1	• TUBE, PILOT VALVE SENSING	1	35	159
	66A40632-1	• TUBE, PILOT VALVE SENSING RH	1	35	159
- 81	MS2198R04	• FLPOW			
		ATTACHING PARTS			
- 82	AN924-40	• NUT -----X-----	1	35	159
- 83	MS29512-4	• GASKET	1	35	159
- 84	15-356-101	• VALVE ASSY, SHUTOFF (82267) SPEC 8-00903-1 T.O. 6J15-10-106A-13	HF	35	159
	15-356-51	• VALVE ASSY, SHUTOFF (82267) SPEC 8-00903-1 T.O. 6J15-10-106A-13 ALT INTCHG WITH 15-356-101			
		ATTACHING PARTS			
- 85	AN4H-5A	• BOLT	6	35	159
- 84	AN960-0416L	• WASHER -----X-----	6	35	159
- 87	075156-4	• SEAL (89259) SPEC 8-02287-7	1	35	159
- 88	25-6500-3	• VALVE ASSY, FUEL CHECK (96736) SPEC 8-00954 T.O. 6J15-2-111-3	RF	35	159
	25-6500	• VALVE ASSY, FUEL CHECK (96736) SPEC 8-00954 T.O. 6J15-2-111-3 ALT INTCHG WITH 25-6500-3			
		ATTACHING PARTS			
- 89	AN4H-7A	• BOLT	4	35	159
- 90	AN960-0416L	• WASHER -----X-----	4	35	159
- 91	MS27198-24	• SEAL	1	35	159
- 92	66E47834-1	• ADAPTER ASSEMBLY, TANK NO. 1 FUEL SYSTEM	1	35	159
	66E47833-1	• ADAPTER ASSEMBLY, TANK NO. 1 FUEL SYSTEM ALT PART FOR 66E47834-1	HF	35	159

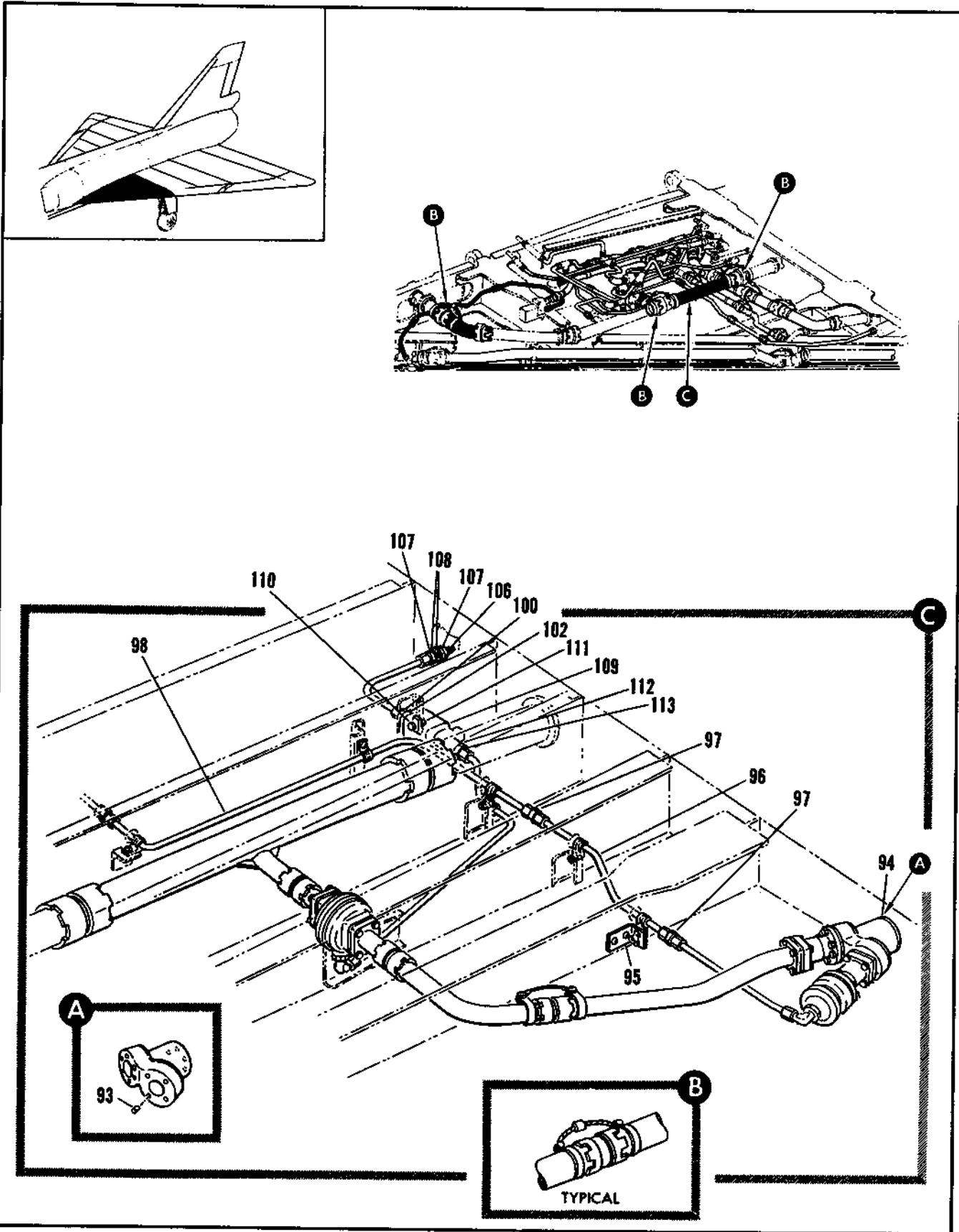

Figure 2.12-15. Wing Tank #1 Fuel Control Tubing Installation (Sheet 6 of 11)

FIGURE AND INDEX NUMBER	PART NUMBER	DESCRIPTION 1 2 3 4 5 6	UNITS PER ASSY.	USABLE ON CODE	
				FROM	TO
2.12-15- 93	MS21288F4-15	• • INSERT	16	35	159
- 94	075156-4	• SEAL (49259) SPEC 9-22227-7	1	35	159
- 95	65C35873-1	• BRACKET, TUBE SUPPORT WING VENT ATTACHING PARTS	1	35	159
	MS21042L3	• NUT	2	35	159
	AN520-10R8	• SCREW	3	35	159
		-----X-----			
- 96	65A35926-1	• TUBE, SHUTOFF VALVE	1	35	159
- 97	MS21902D4	• UNION	2	35	159
- 98	66A4086C-1	• TUBE, VALVE SENSING	1	35	159
	66A40631-1	• TUBE, VALVE SENSING RH	1	35	159
- 99	66A40487-1	• TUBE ASSY, LH	1	35	159
	66A40307-1	• TUBE ASSY, RH	1	35	159
-100	MS21902D4	• UNION	1		
-101	MS21912D4	• TEE	1	35	159
-102	MS219512-4	• GASKET	1	35	159
-103	AN924-40	• NUT	1	35	159
-104	66B40304-1	• CAP	1	35	159
-105		• TUBE ASSY, LH SEE FIG. 2.12-37 INDEX 76	RF	35	159
-106	8-20307-27	• UNION	1	35	159
-107	8-21311-7	• WASHER	2	35	159
-108	MS29512-4	• GASKET	2	35	159
		ATTACHING PARTS			
	AN924-40	• NUT	1	35	159
	AN9600716	• WASHER	1	35	159
		-----X-----			
-109	PV-293-130	• VALVE ASSY (84987) SPEC 9-02275 (REPLACES PV-293-120) ATTACHING PARTS	1	35	159
-110	MS21042L3	• NUT	2	35	159
-111	AN3-4A	• BOLT	2	35	159
		-----X-----			
-112	MS21902D4	• UNION	1	35	159
-113	MS29512-4	• GASKET	1	35	159
-114	MS21908D4	• ELBOW	1	35	159
	AN924-40	• NUT	1	35	159
	MS29512-4	• PACKING	1	35	159
-115	MS21910DF4	• CLAMP	3	35	159
	71-89926-001	• CLAMP	3	35	159
	NAS41003-40	• SPACER	3	35	159
		ATTACHING PARTS			
	MS21042L3	• NUT	3	35	159
	MS35207-265	• SCREW	3	35	159
		-----X-----			

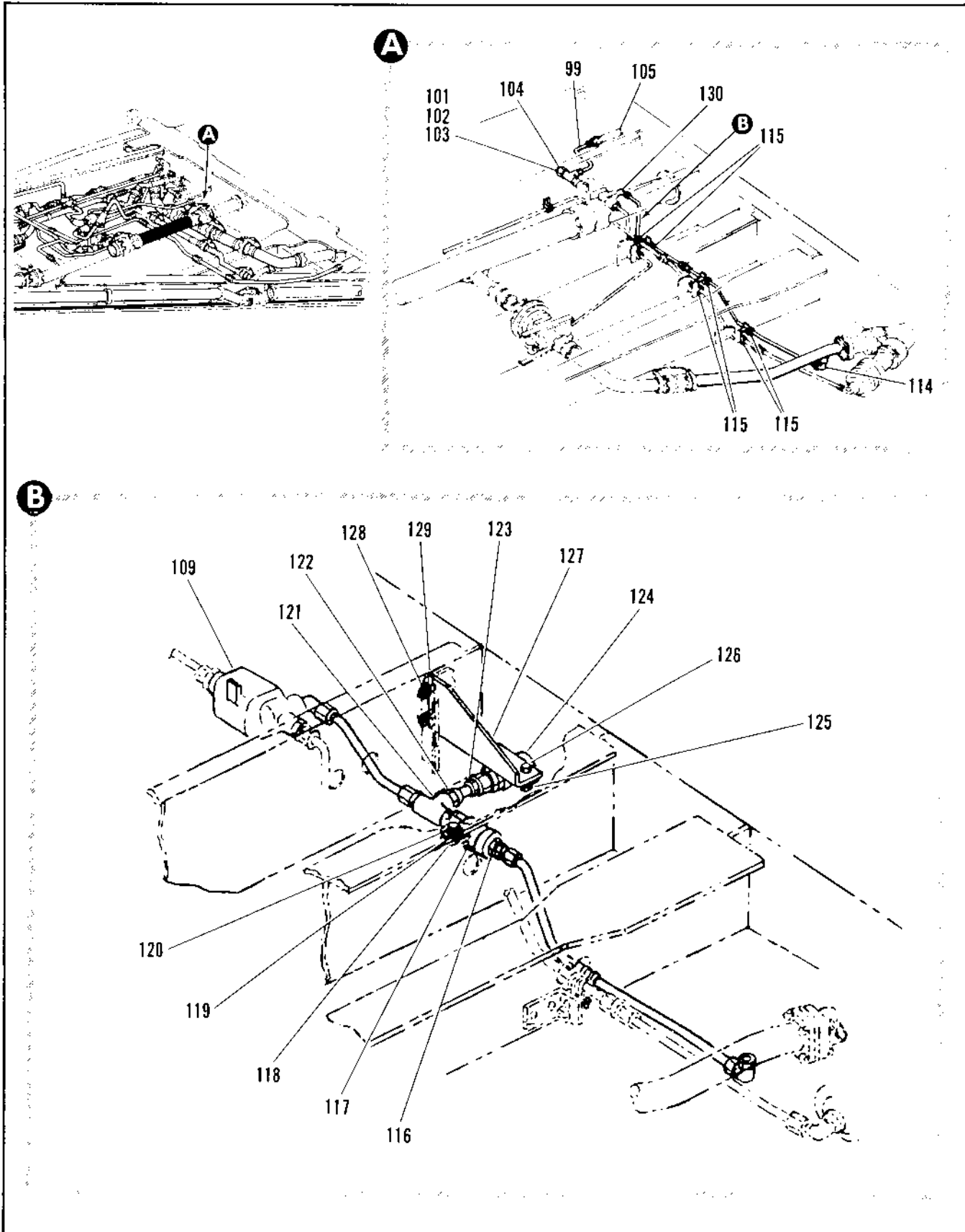

Figure 2.12-15. Wing Tank #1 Fuel Control Tubing Installation (Sheet 7 of 11)

FIGURE AND INDEX NUMBER	PART NUMBER	DESCRIPTION 1 2 3 4 5 6	UNITS PER ASSY.	USABLE ON CODE	
				FROM	TO
2.12-15-116	MS21916D6-4	• REDUCER	1	35	
	MS29512-36	• GASKET	1	35	
-117	MS35-3/8F	• VALVE (29524) ATTACHING PARTS	1	35	
-118	MS21942L3	• NUT	1	35	
-119	AN967D10	• WASHER	1	35	
-120	AN3-3A	• BOLT -----X-----	1	35	
	MS29512-36	• PACKING	1	35	
	MS29512-04	• PACKING	1	35	
	AN924D4	• NUT	1	35	
-121	MS21910D4	• TEE	1	35	
	MS29512-J4	• PACKING	1	35	
-122	MS21924D4	• UNION	1	35	
	AN924D4	• NUT	1	35	
-123	AN893-20	• BUSHING	1	35	
	MS29512-04	• PACKING	1	35	
-124	MS35-3/8F	• VALVE	1	35	
	MS29512-06	• PACKING ATTACHING PARTS	1	35	
-125	MS21042L3	• NUT	1	35	
-126	AN3-3A	• BOLT -----X-----	1	35	
-127	69D36693-01	• BRACKET, LH	1	35	
	69D36693-03	• BRACKET, RH ATTACHING PARTS	1	35	
-128	MS21042L3	• NUT	2	35	
-129	AN3-3A	• BOLT -----X-----	2	35	
-130	MS21926D4	• FLOW	1	35	159
	MS29512-4	• PACKING	1	35	159
	AN924-40	• NUT	1	35	159

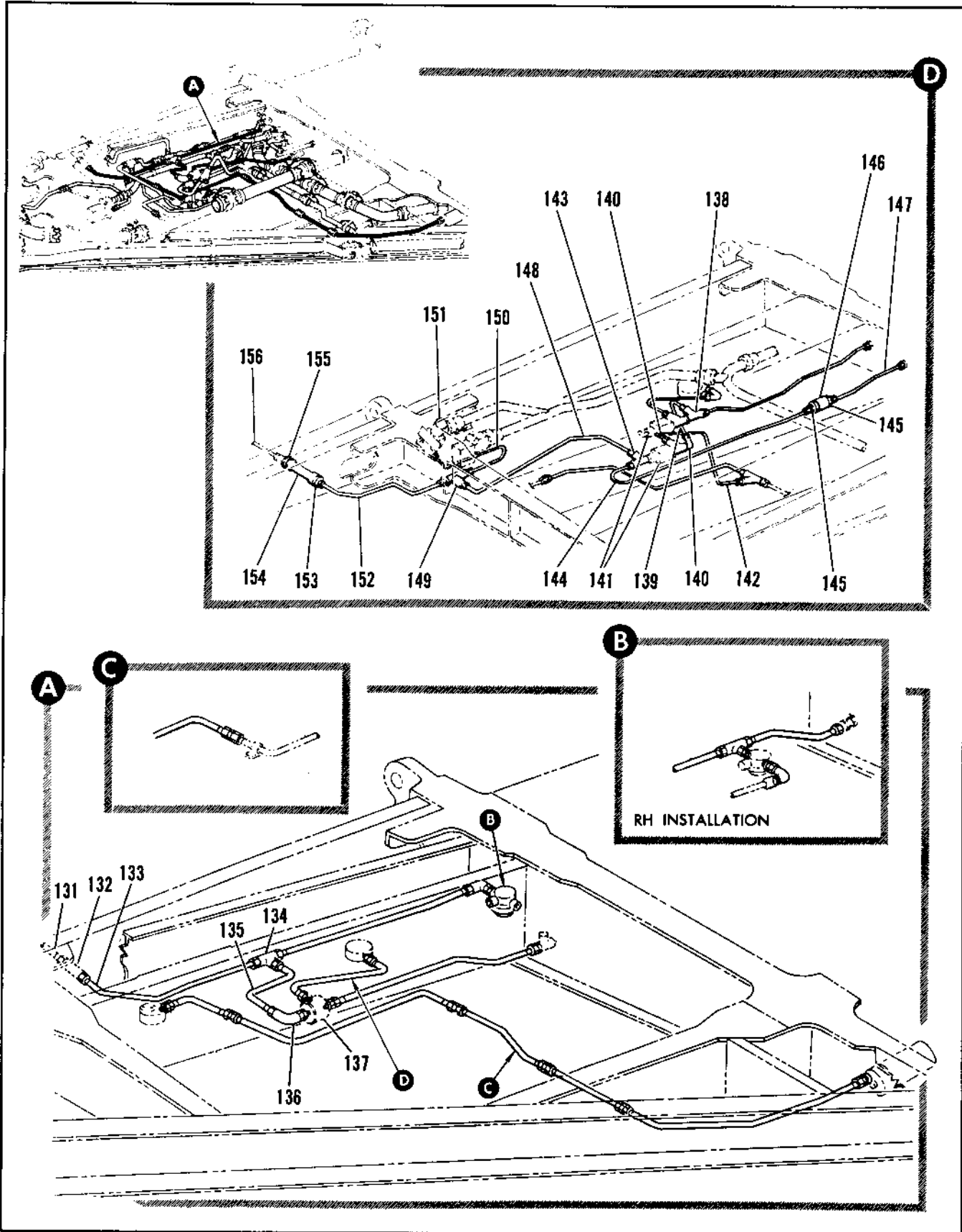

Figure 2.12-15. Wing Tank #1 Fuel Control Tubing Installation (Sheet 8 of 11)

FIGURE AND INDEX NUMBER	PART NUMBER	DESCRIPTION	UNITS PER ASSY.	USABLE ON CODE	
				FROM	TO
		1 2 3 4 5 6			
2.12-15-131		• TUBE ASSY, FUEL TANK PRESSURE SEE FIG. 2.12-45 INDEX 1-2	PF		
-132		• FITTING, STA 380 SEE FIG. 2.12-66 INDEX 2	RF		
-133	8-20397-1539	• TUBE ASSY, LH	1	35	159
	8-20397-1737	• TUBE ASSY, RH	1	35	159
-134	MS2190804	• TEE	1	35	159
-135	8-20397-1543	• TUBE ASSY, LH	1	35	159
	8-20397-1751	• TUBE ASSY, RH	1	35	159
	AN924-40	• NUT	1	35	159
-136	MS2190804	• ELBOW	1	35	159
	MS29512-4	• GASKET	1	35	159
-137		• VALVE ASSY, PRESSURE OPERATED PILOT SEE FIG. 2.12-1 INDEX 19	PF		
-138	MS2191204	• TEE	1	35	159
	AN924-40	• NUT	1	35	159
	MS29512-04	• GASKET	1	35	159
-139	66A40308-1	• TUBE ASSY	1	35	159
-140	MS2190804	• ELBOW	2	35	159
	AN924-40	• NUT	2	35	159
	MS29512-4	• GASKET	2	35	159
	S163014	• CLAMP (92196)	2	35	159
		ATTACHING PARTS			
	MS2114213	• NUT	1	35	159
	NAS43003-2	• SPACER	1	35	159
	MS35207-264	• SCREW	1	35	159
		-----X-----			
-141	PV-293-110	• VALVE INSTL, PRESSURE OPERATED PILOT SEE FIG. 2.12-1 INDEX 19			
-142	66A40309-1	• TUBE ASSY	1	35	159
-143	MS2191204	• TEE, LH	1	35	159
	MS2190804	• ELBOW, RH	1	35	159
	AN924-40	• NUT	1	35	159
	MS29512-4	• GASKET	1	35	159
-144	66A40311-1	• TUBE ASSY, LH	2	35	159
-145	MS2191606-4	• REDUCER	2	35	159
	MS29512-6	• GASKET	1	35	159
-146	MS35-37PF	• VALVE, AIR CHECK LH (9138) SFFC 9-02998-13	1	35	159
-147	66A40312-1	• TUBE ASSY	1	35	159
-148	66A40313-1	• TUBE ASSY	1	35	159
-149	MS2191204	• TEE	1	35	159
	AN924-40	• NUT	1	35	159
-150	66A40317-1	• TUBE ASSY, RH	1	35	159
	66A40316-1	• TUBE ASSY, LH	1	35	159
-151	104710	• VALVE ASSY, FULL TANK VENT SEE FIG. 2.12-7 INDEX 17			
-152	66A40318-1	• TUBE ASSY, LH	1	35	159
	66A40316-1	• TUBE ASSY, RH	1	35	159
-153	AN924-60	• NUT	1	35	159
	AN9509910	• WASHER	1	35	159
	MS29513-15	• PACKING	1	35	159
	8-21311-19	• WASHER	1	35	159
-154	8-21263-7	• FITTING	1	35	159
-155	8-21127-1	• O-RING	1	35	159
-156		• TUBE ASSY, SEE FIG. 2.12-67 INDEX 11	PF	35	159

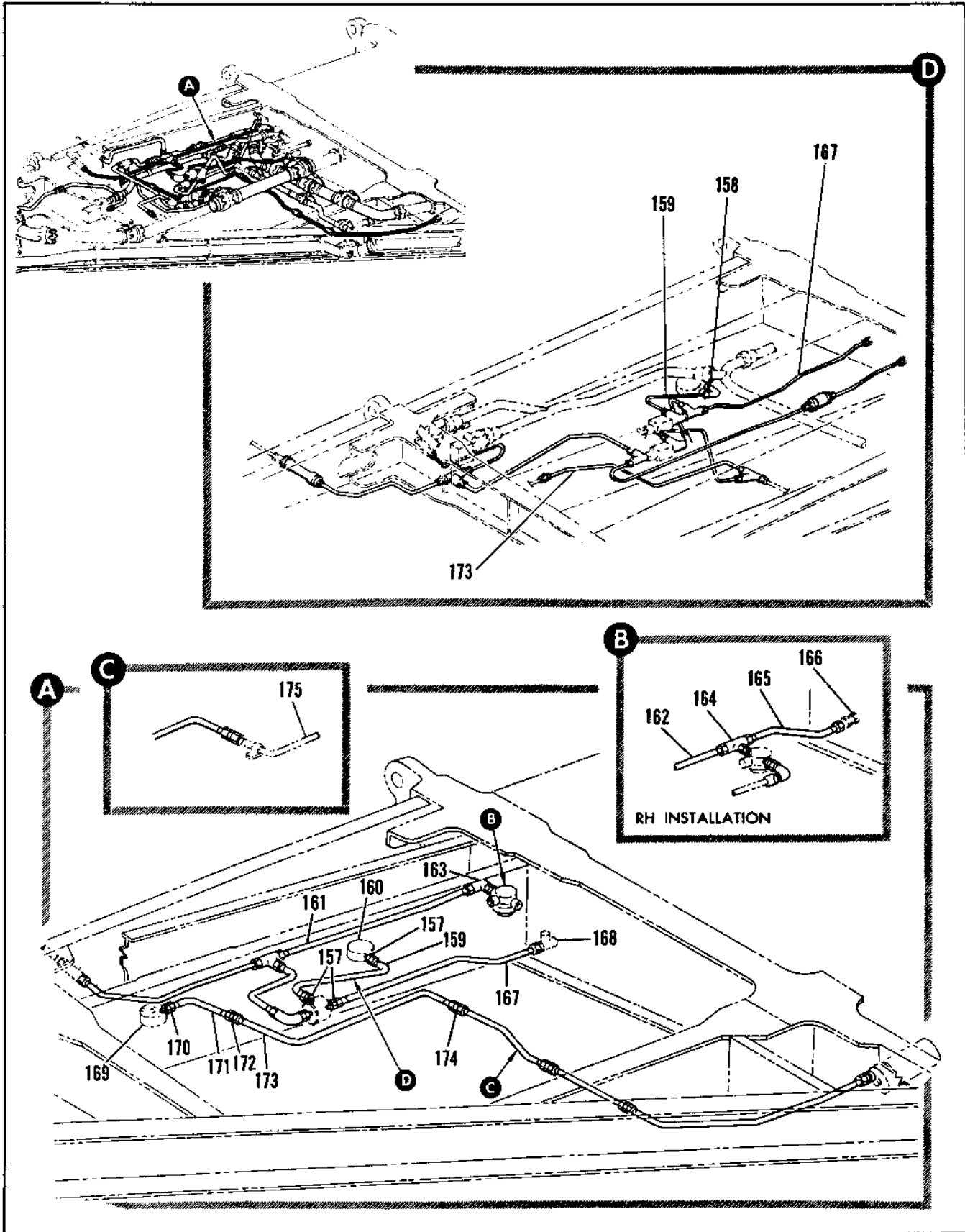

Figure 2.12-15. Wing Tank #1 Fuel Control Tubing Installation (Sheet 9 of 11)

FIGURE AND INDEX NUMBER	PART NUMBER	DESCRIPTION	UNITS PER ASSY.	USABLE ON CODE	
				FROM	TO
2.12-15-157	MS2190204	• UNION	1	35	159
	MS29512-4	• GASKET	1	35	159
-159	AN924-40	• NUT	1	35	159
	MS29512-04	• GASKET	1	35	159
	MS2190804	• ELBOW	1	35	159
-159	66A40034-1	• TUBE ASSY, RH	1	35	159
-160		• VALVE ASSY, FUEL TANK PILOT FLOAT SEE FIG. 2.12-1 INDEX 10	RF		
-161	8-20397-1537	• TUBE ASSY, LH	1	35	159
-162	8-20397-1747	• TUBE ASSY, RH	1	35	159
	AN924-40	• NUT	1	35	159
-163	MS2190804	• ELBOW, LH	1	35	159
-164	MS2190904	• TEE, RH	1	35	159
	AN924-40	• GASKET	1	35	159
-165	8-20397-1733	• TUBE ASSY, RH	1	35	159
-166		• UNION, SPAR #3 RH SEE FIG. 2.12-66	RF		
-167	66A40306-1	• TUBE ASSY, LH	1	35	159
	66A40306-1	• TUBE ASSY, RH	1	35	159
-168		• UNION, SPAR #3 SEE FIG. 2.12-66	RF		
-169		• VALVE ASSY, FUEL TANK PILOT FLOAT SEE FIG. 2.12-1 INDEX 25	RF		
-170	MS2190204	• UNION	1	35	159
	MS29512-4	• GASKET	1	35	159
-171	8-20397-1519	• TUBE ASSY, LH	1	35	159
	8-20397-1739	• TUBE ASSY, RH	1	35	159
-172	MS2190204	• UNION	1	35	159
-173	66A40319-1	• TUBE ASSY	1	35	159
-174	MS2190504	• TEE	1	35	159
-175		• TUBE, VALVE SENSING SEE FIG. 2.12-15 INDEX 98	RF		

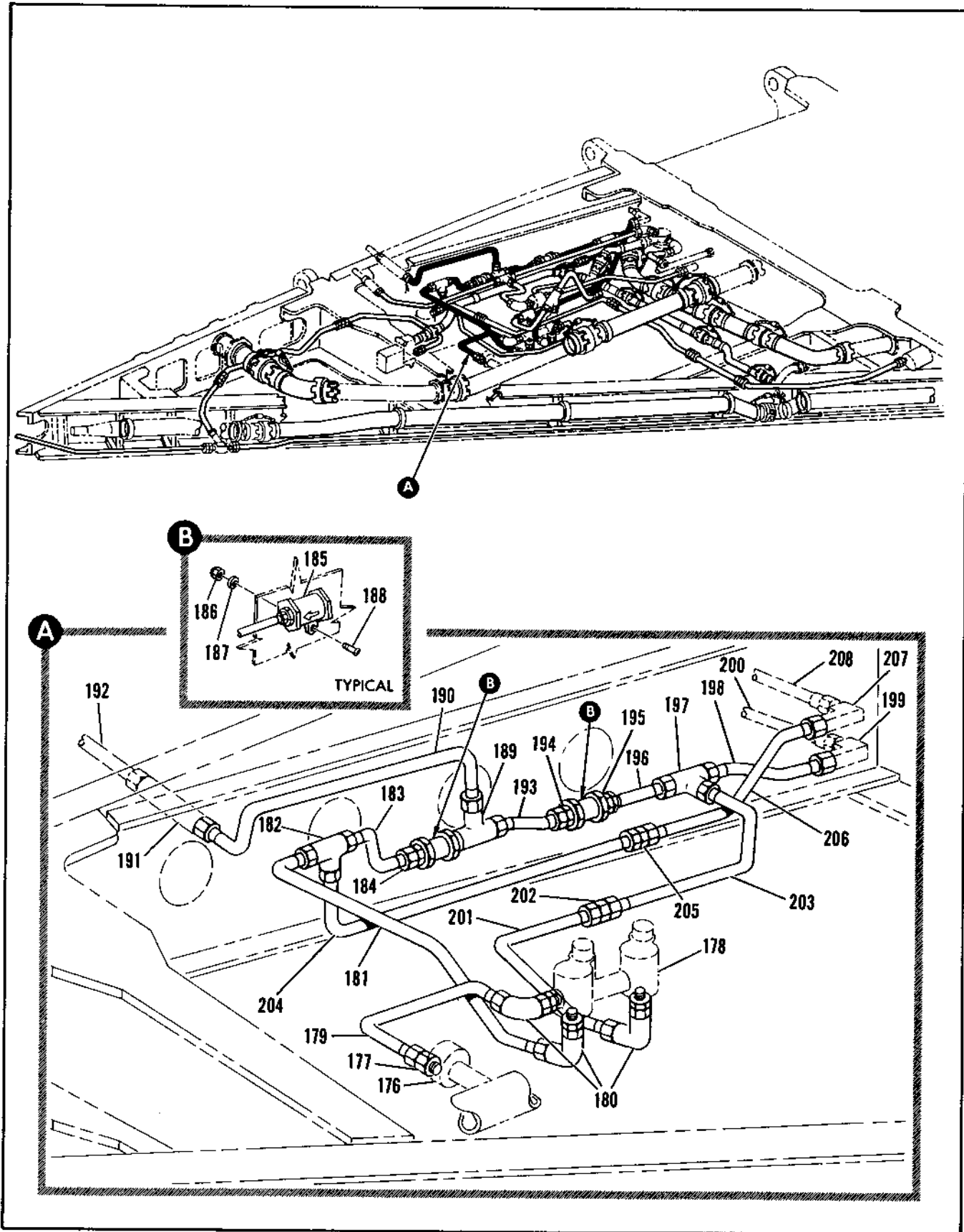

Figure 2.12-15. Wing Tank #1 Fuel Control Tubing Installation (Sheet 10 of 11)

FIGURE AND INDEX NUMBER	PART NUMBER	DESCRIPTION	UNITS PER ASSY.	USABLE ON CODE	
				FROM	TO
		1 2 3 4 5 6			
2.12-15-175		• VALVE ASSY, PILOT OPERATED SHUTOFF SEE FIG. 2.12-26 INDEX 1	RF		
-177	MS2199754	• UNION	1	35	159
	MS29512-4	• GASKET	1	35	159
-178		• VALVE ASSY, FUEL SHUTOFF SEE FIG. 2.12-24 INDEX	RF		
-179	R-20397-1551	• TUBE ASSEMBLY	1	35	159
	AN924-40	• NUT	1	35	159
-180	MS2199704	• ELBOW	3	35	159
	MS29512-4	• GASKET	3	35	159
-181	R-20397-1527	• TUBE ASSY, LH	1	35	159
	R-20397-1735	• TUBE ASSY, RH	1	35	159
	AN924-40	• NUT	1	35	159
	AN9670716	• WASHER	1	35	159
-182	MS2191204	• TEE	1	35	159
-183	R-20397-1525	• TUBE ASSY, LH	1	35	159
	R-20397-1745	• TUBE ASSY, RH	1	35	159
-184	MS2191606-4	• REDUCER	1	35	159
	MS29512-4	• GASKET	1	35	159
-185	MS35-3746	• VALVE, AIR CHECK (99-13) SPEC 9-259H-13 REPLACES SUITABLE SUP FOR MS35-3746 ATTACHING PARTS	2	35	159
-186	MS46-2A3	• NUT, <70000> 96-17534-105	2	35	159
-187	AN9670716	• WASHER, SPEC 99-51579-125	2	35	159
-188	AN3-54	• BOLT	2	35	159

	AN924-40	• NUT	1	35	159
-189	MS2191204	• TEE	1	35	159
	MS29512-4	• GASKET	1	35	159
-190	R-20397-1523	• TUBE ASSY, LH	1	35	159
	R-20397-1719	• TUBE ASSY, RH	1	35	159
-191		• FITTING, STA 341 SEE FIG. 2.12-66 INDEX 7	RF		
-192		• TUBE ASSY, SEE FIG. 2.12-47 INDEX 21	RF		
-193	R-20397-1528	• TUBE ASSY, LH	1	35	159
	R-20397-1721	• TUBE ASSY, RH	1	35	159
-194	MS2199704	• UNION	1	35	159
	MS29512-4	• GASKET	1	35	159
-195	MS2191606-4	• REDUCER	1	35	159
	MS29512-4	• GASKET	1	35	159
-196	R-20397-1531	• TUBE ASSEMBLY	1	35	159
	AN924-40	• NUT	1	35	159
	AN9670716	• WASHER	1	35	159
-197	MS2191204	• TEE	1	35	159
-198	R-20397-1511	• TUBE ASSY, LH	1	35	159
	R-20397-1753	• TUBE ASSY, RH	1	35	159
-199		• UNION, SPAR #3 SEE FIG. 2.12-66	RF		
-200	R-20397-1534	• TUBE ASSY, LH SEE FIG. 2.12 INDEX 2	RF		
-201	R-20397-1534	• TUBE ASSEMBLY	1	35	159
-202	MS2199704	• UNION	1	35	159
-203	R-20397-1533	• TUBE ASSY, LH	1	35	159
	R-20397-1755	• TUBE ASSY, RH	1	35	159
-204	R-20397-1507	• TUBE ASSEMBLY	1	35	159
-205	MS2191204	• UNION	1	35	159
-206	R-20397-1510	• TUBE ASSY, LH	1	35	159
	R-20397-1711	• TUBE ASSY, RH	1	35	159
-207		• UNION, SPAR #3 SEE FIG. 2.12-66	RF		
-208		• TUBE ASSY, LH SEE FIG. 2.12-57 INDEX 1	RF		

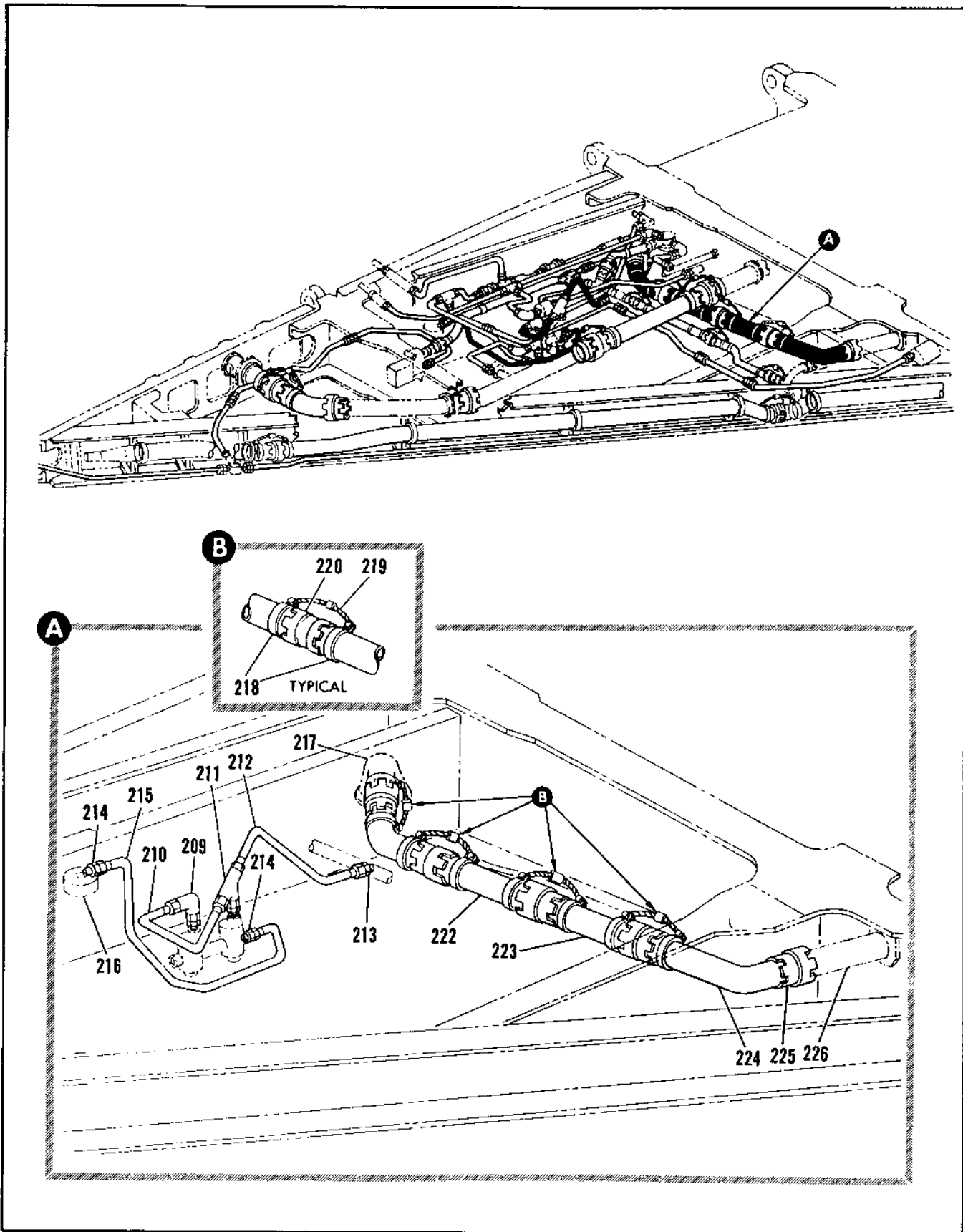

Figure 2.12-15. Wing Tank #1 Fuel Control Tubing Installation (Sheet 11 of 11)

FIGURE AND INDEX NUMBER	PART NUMBER	DESCRIPTION 1 2 3 4 5 6	UNITS PER ASSY.	USABLE ON CODE	
				FROM	TO
2.12-15	AN924-60	• NUT	1	35	159
-209	MS2190806	• ELBOW	1	35	159
	MS29512-6	• GASKET	1	35	159
-211	R-20397-1875	• TUBE ASSEMBLY	1	35	159
	AN924-60	• NUT	1	35	159
-211	MS2190906	• TEE	1	35	159
	MS29512-6	• GASKET	1	35	159
-212	R-20397-1549	• TUBE ASSY. LH	1	35	159
	R-20397-1723	• TUBE ASSY. RH	1	35	159
-213	MS2190206	• UNION	1	35	159
	MS29512-6	• GASKET	2	35	159
-214	MS2190209	• UNION	2	35	159
	MS29512-6	• GASKET	1	35	159
-215	R-20397-1549	• TUBE ASSY. LH	1	35	159
	R-20397-1749	• TUBE ASSY. RH	1	35	159
-216		• VALVE ASSY. SEE FIG. 2.12-1 INDEX 36	1		
-217		• BELLMOUTH ASSY. TANK #1 LH SEE FIG. 2.12-14 INDEX 98	1		
-217	AN735040	• CLAMP ATTACHING PARTS	8	35	159
	AN364-10320	• NUT	8	35	159
	AN96 010L	• WASHER	6	35	159
	AN526-103286	• SCREW -----X-----	4	35	159
-219	MS29513-333	• JUMPER	4	35	159
-221	3605-400	• COUPLING, <70326> R2-72500-004	4	35	159
	MS29513-333	• PACKING	1	35	159
-221	R-20397-19	• TUBE ASSEMBLY	1	35	159
-222	R-20397-21	• TUBE ASSEMBLY	1	35	159
-223	R-20397-23	• TUBE ASSEMBLY	1	35	159
-224	R-20397-25	• TUBE ASSEMBLY	1	35	159
-225	3605-400	• COUPLING, <70326> R2-72500-004	1	35	159
	MS29513-333	• PACKING	1	35	159
-226		• TUBE ASSY. SEE FIG. 2.12-14 INDEX 98	1		

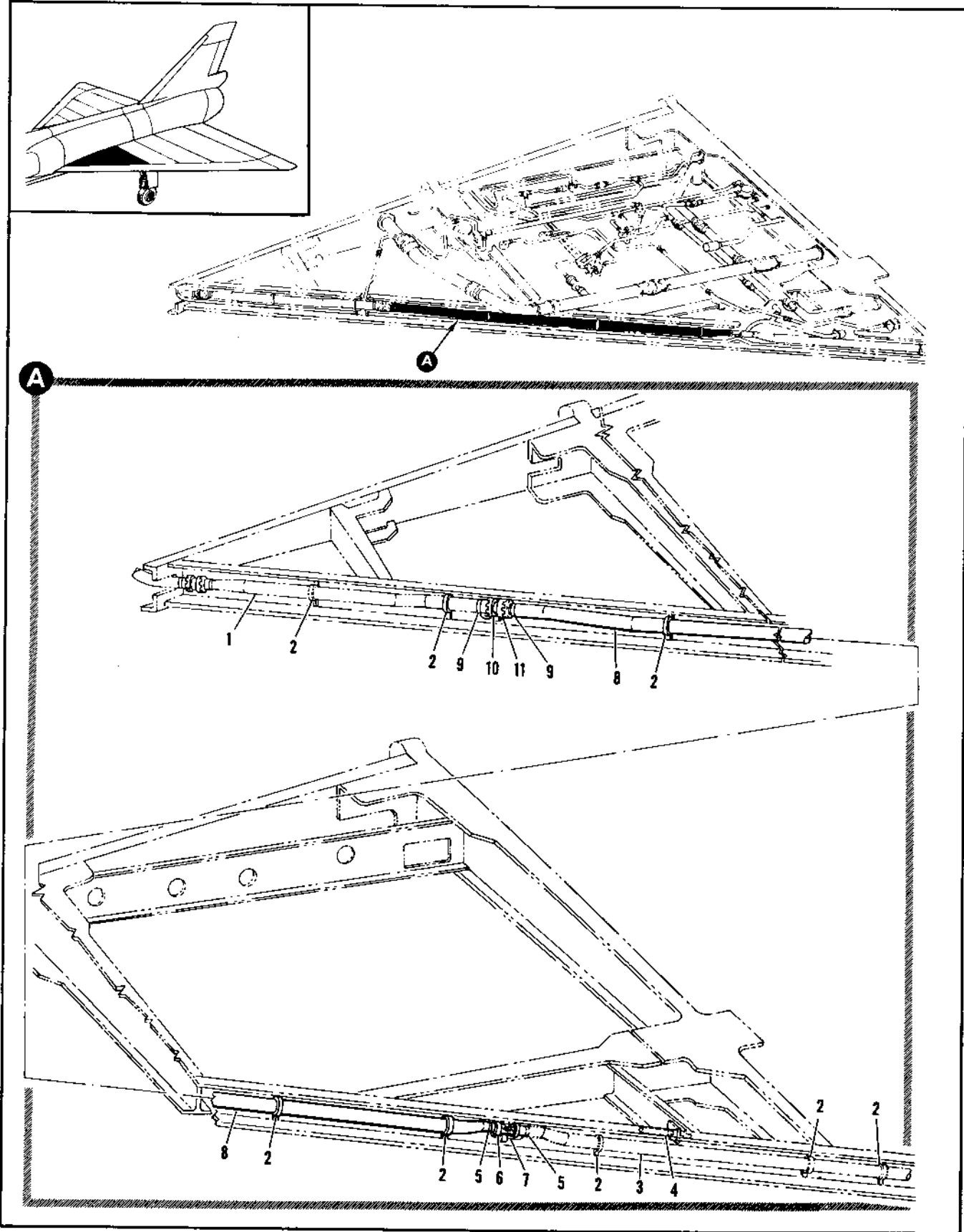

Figure 2.12-16. Wing Tank #1 Fuel Control Tubing Installation (Sheet 1 of 10)

FIGURE AND INDEX NUMBER	PART NUMBER	DESCRIPTION	UNITS PER ASSY.	USABLE ON CODE	
				FROM	TO
		1 2 3 4 5 6			
2.12-16	8-20397-855	TUBING INSTL, WING TANK #1 FUEL CONTROL LH MODIFIED BY 65135874 AND 66J40303 FOR NHA SEE FIG. 2.6-32	RF	165	189
	8-20397-865	TUBING INSTL, WING TANK #1 FUEL CONTROL LH MODIFIED BY 65J35874 AND 66J40303 FOR NHA SEE FIG. 2.6-32	RF	190	
	8-20397-857	TUBING TANK #1 FUEL CONTROL RH MODIFIED BY 65J35374 AND 66J40303 FOR NHA SEE FIG. 2.6-32	RF		
	8-20397-857	TUBING INSTL, WING TANK #1 FUEL CONTROL RH MODIFIED BY 65J35874 AND 66J40303 FOR NHA SEE FIG. 2.6-32	RF		
- 1		• TUBE ASSY, LEADING EDGE VENT FWD SEE FIG. 2.12-14 INDEX 7	RF		
- 2	91-98026-031	• CLAMP	8	160	
- 3		• TUBE ASSY, LEADING EDGE VENT AFT LH SEE FIG. 2.12-14 INDEX 12	RF		
- 4		• TUBE ASSY, VENT SUCTION RELIEF SEE FIG. 2.12-23 INDEX 11	RF		
- 5	AN735D32	• CLAMP	2	160	
	NAS679A3	ATTACHING PARTS	2	160	
	AN960D10L	• NUT	2	160	
	AN526-1032R6	• WASHER	2	160	
		• SCREW	2	160	
- 6	51500-2-200	• COUPLING, <98625> 92-73008-016	1	160	
- 7	MS25083-1885	• JUMPER	1	160	
	MS29513-329	• PACKING	1	160	
- 8	8-27397-324	• TUBE ASSY, LEADING EDGE VENT	1	1	
	8-20397-595	• TUBING ASSY, LEADING EDGE VENT	1	1	
- 9	AN735D32	• CLAMP	2	160	
	NAS679A3	ATTACHING PARTS	2	160	
	AN960D10L	• NUT	2	160	
	AN526-1032R6	• WASHER	2	160	
		• SCREW	2	160	
- 10	3605-32D	• COUPLING, <79326> 92-72500-002	1	160	
- 11	MS25083-1884	• JUMPER		160	
		A AIRPLANES #160 THRU 277, 287, 292, AND ON B AIRPLANES #278 THRU 286 AND 288 THRU 291			

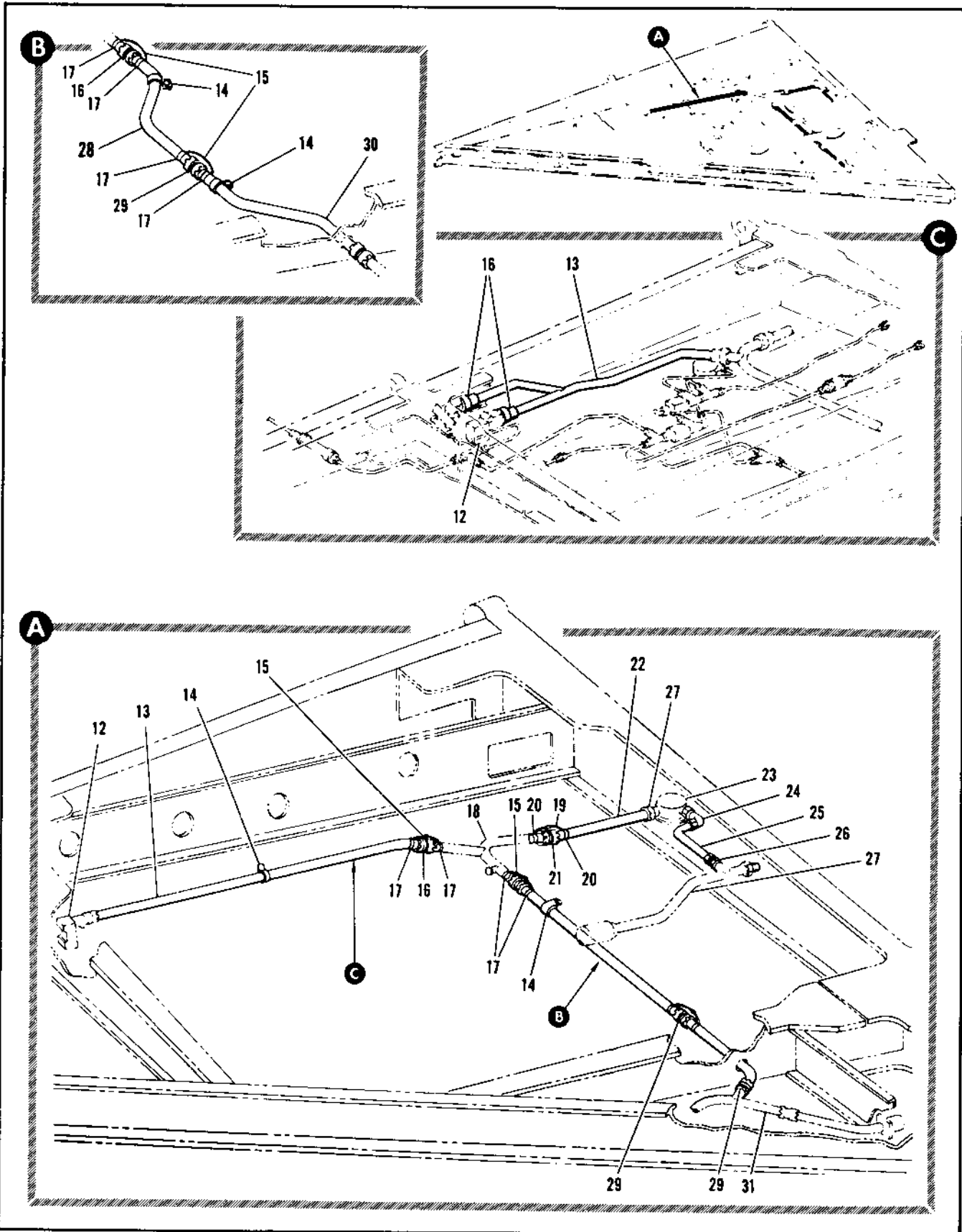

Figure 2.12-16. Wing Tank #1 Fuel Control Tubing Installation (Sheet 2 of 10)

FIGURE AND INDEX NUMBER	PART NUMBER	DESCRIPTION	UNITS PER ASSY.	USABLE ON CODE	
				FROM	TO
2.12-16- 12		<ul style="list-style-type: none"> • VALVE ASSY, PRESSURE RELIEF TANK #1 • TUBE ASSY, FUEL TANK PRESSURE SEE FIG. 2.12-1 INDEX 1 			
- 13	66J40320-1	• TUBE ASSY, LH	1	160	
	66J40320-2	• TUBE ASSY, RH	1	160	
- 14	91-98026-015	• CLAMP	2	160	
- 15	MS25183-18B3	• JUMPER	2	160	
- 16	3605-160	• COUPLING, (79326) 92-72500-001	2	160	
	MS29513-214	• PACKING			
- 17	AN735016	• CLAMP	4	160	
		ATTACHING PARTS			
	NAS679A3	• NUT	4	160	
	AN960D1CL	• WASHER	4	160	
	AN526-1032RE	• SCREW	4	160	
- 18		• TUBE ASSY, TANK #1 TEE VENT LINE SEE FIG. 2.12-1 INDEX 6	RF	160	
- 19	MS25083-1PP6	• JUMPER	1	160	
- 20	3605-160	• COUPLING, (79326) 92-72500-001	1	160	
	MS29513-214	• PACKING	1	160	
- 21	AN735016	• CLAMP	2	160	
		ATTACHING PARTS			
	NAS679A3	• NUT	2	160	
	AN957D13L	• WASHER	2	160	
	AN526-1032R6	• SCREW		160	
- 22	R-20397-1557	• TUBE ASSY, LH	1	160	
	R-20397-1765	• TUBE ASSY, RH	1	160	
- 23		• VALVE ASSY, FUEL TANK VENT SEE FIG. 2.12-1 INDEX 36	RF		
- 24	MS21908D4	• ELBOW	1	160	
	AN924-40	• NUT	1	160	
	MS29512-4	• GASKET	1	160	
- 25	R-20397-2371	• TUBE ASSY, LH	1	160	
	R-20397-2367	• TUBE ASSY, RH	1	160	
- 26	MS21902D4	• UNION	1	160	
	MS21912-4	• GASKET	1	160	
- 27		• TUBE ASSY, WELDED SEE FIG. 2.12-14 INDEX 86	RF		
- 28	65A35899-1	• TUBE, VENT ONE INCH TANK	1	160	
- 29	3605-160	• COUPLING (79326) 92-72500-001 REPLACES INCHS WITH 3601-160	1	160	
- 30	65A35898-1	• TUBE, VENT ONE INCH TANK	1	160	
- 31		• TUBE ASSY, VENT SUCTION RELIEF SEE FIG. 2.12-21 INDEX 2	RF		

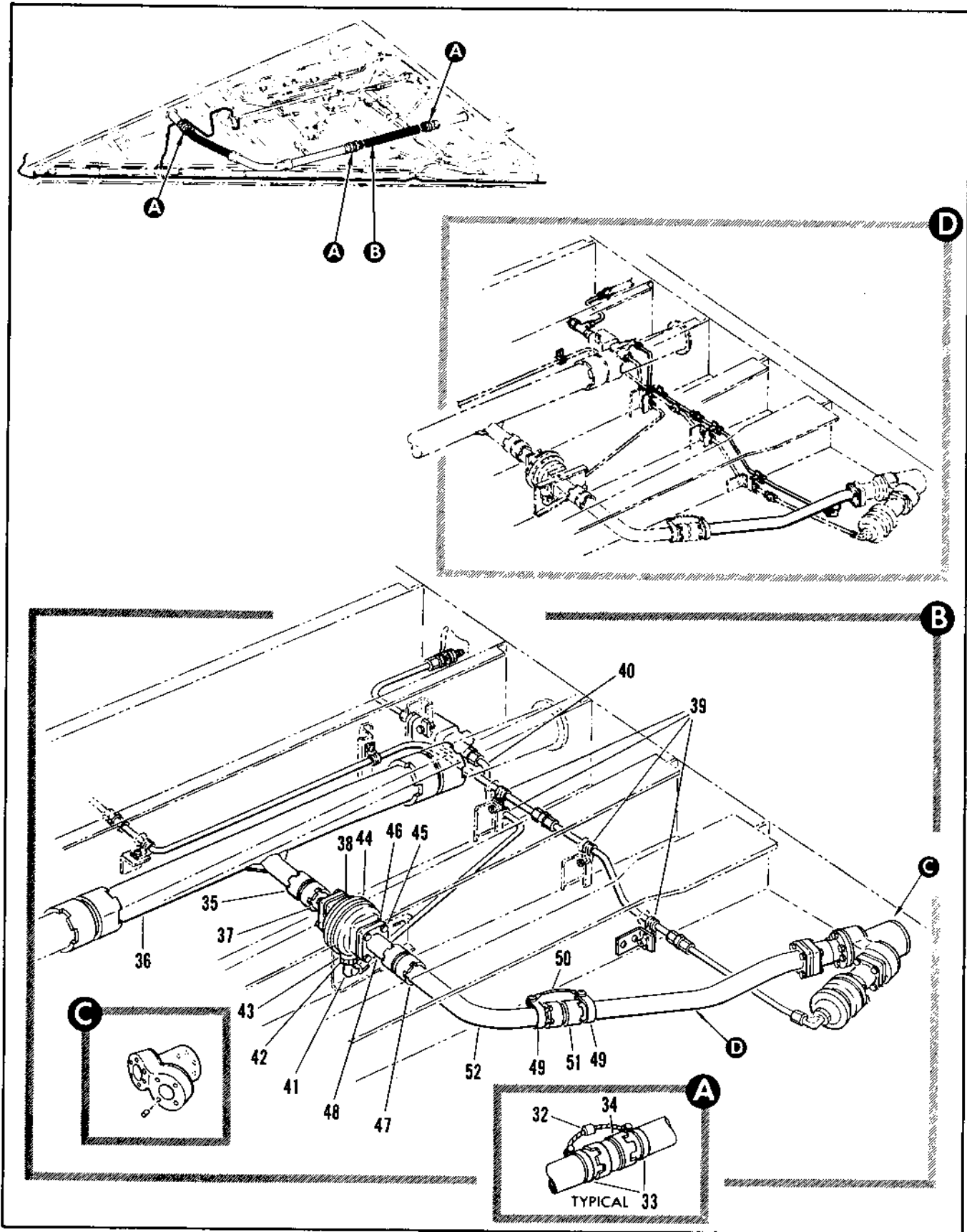

Figure 2.12-16. Wing Tank #1 Fuel Control Tubing Installation (Sheet 3 of 10)

FIGURE AND INDEX NUMBER	PART NUMBER	DESCRIPTION	UNITS PER ASSY.	USABLE ON CODE	
				FROM	TO
2.12-16-32 - 33	MS250R3-1809	• JUMPER	3	160	
	AN735D48	• CLAMP	6	160	
- 34	MS250R3-1809	• ATTACHING PARTS	6	160	
	MS29513-337	• NUT	6	160	
- 35	3605-24D	• WASHER	6	160	
	MS29513-325	• SCREW	6	160	
- 36	65E35870-1	-----X-----			
	65E35870-2	• COUPLING (79326) 92-72500-005	3	160	
- 37	65C35869-1	• PACKING	4	160	
		• COUPLING (79326) 92-72500-033	1	160	
		• PACKING	2	160	
		• TUBE ASSY, 3.0 INCH FUEL TRANSFER LH WELDED	1	160	
		• TUBE ASSY, 3.0 INCH FUEL TRANSFER RH WELDED	1	160	
		• TUBE ASSY, 4 BOLT FLANGE WELDED	1	160	
		• ATTACHING PARTS	4	160	
	AN4H-5A	• BOLT	4	160	
	AN9610416L	• WASHER	4	160	
		-----X-----			
- 38	MS27198-24	• SEAL	1	160	
- 30	MS21919DF4	• CLAMP (72196)	5	160	
		• ATTACHING PARTS	5	160	
	MS21042L3	• NUT	1	160	
	AN520-10R10	• SCREW	1	160	
	AN521-10R8	• SCREW	6	160	
		-----X-----			
- 40	65A35930-1	• TUBE ASSY, SHUTOFF VALVE BLEED	1	160	
- 41	MS21908D4	• FLOW	1	160	
		• ATTACHING PARTS	1	160	
- 42	AN924-4D	• NUT	1	160	
		-----X-----			
- 43	MS29512-4	• GASKET	1	160	
- 44	733600-3	• VALVE ASSY (96124) REPLACES NOT INTERG WITH 733600-1 AND 733600	RF	160	
		• ATTACHING PARTS	4	160	
- 45	AN4H-6A	• BOLT	4	160	
	AN961016	• WASHER	4	160	
		-----X-----			
- 46	MS27198-24	• SEAL	1	160	
- 47	3605-24D	• COUPLING (79326) 92-72500-003	1	35	
	MS29513-325	• PACKING	2	160	
- 48	65C35869-1	• TUBE ASSY, 4 BOLT FLANGE WELDED	1	160	
- 49	AN735D24	• CLAMP	2	160	
		• ATTACHING PARTS	2	160	
	MS21042L3	• NUT	2	160	
	AN520-10R2R6	• SCREW	2	160	
		-----X-----			
- 50	MS250R3-2454	• JUMPER	1	160	
- 51	3605-24D	• COUPLING (79326) 92-72500-003	1	160	
	MS29513-325	• PACKING	2	160	
- 52	66A47859-1	• TUBE, FUEL TRANSFER TANK NO. 1	1	160	

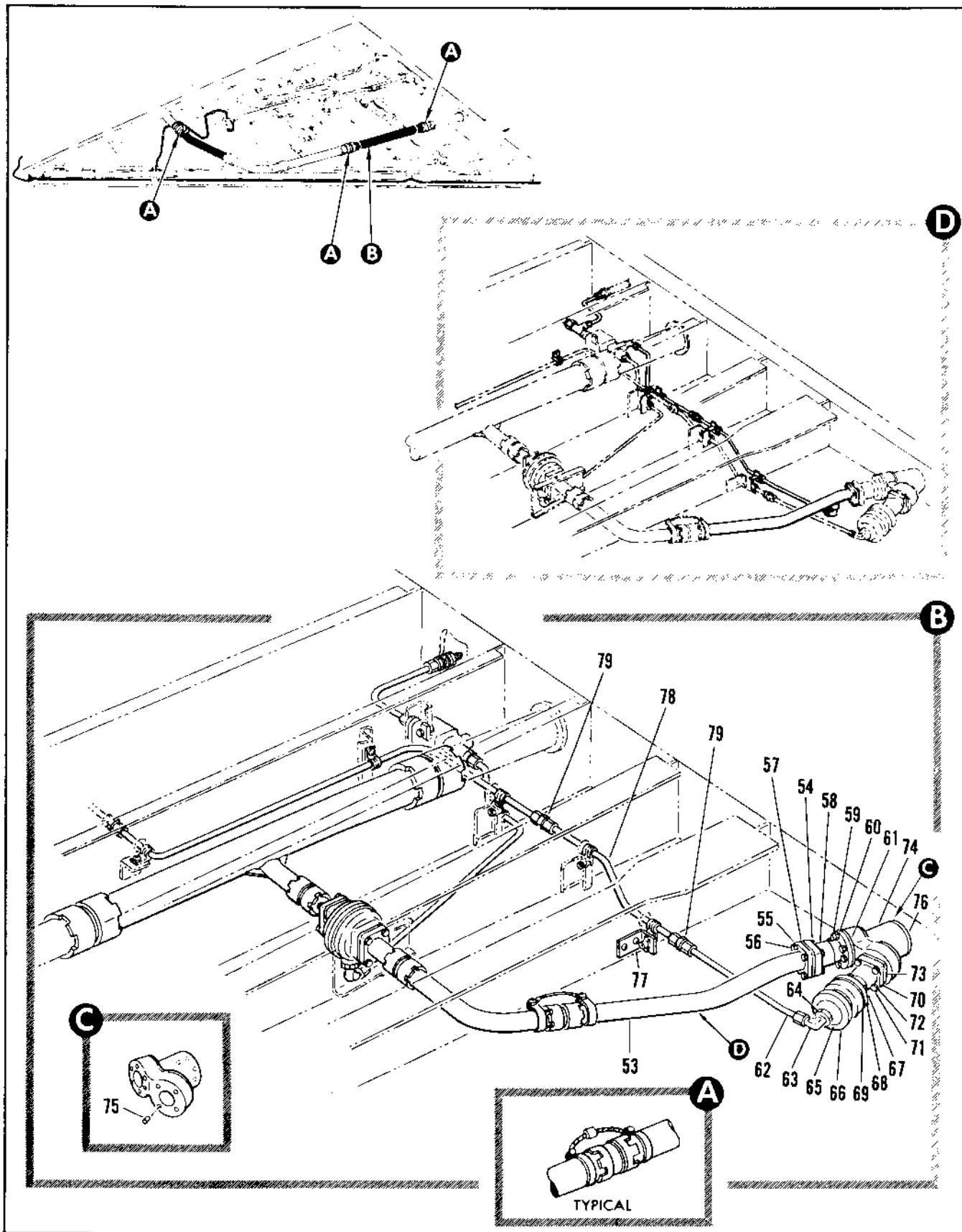

Figure 2.12-16. Wing Tank #1 Fuel Control Tubing Installation (Sheet 4 of 10)

FIGURE AND INDEX NUMBER	PART NUMBER	DESCRIPTION	UNITS PER ASSY.	USABLE ON CODE	
				FROM	TO
2.12-16- 53	66039862-1 66039862-2	• TUBE ASSY, FUEL SYSTEM WELDED LH • TUBE ASSY, FUEL SYSTEM WELDED RH ATTACHING PARTS	1 1	160 160	
- 54	MS21042L3	• NUT	4	160	
- 55	AN960-D416L	• WASHER	4	160	
- 56	AN4-11A	• BOLT	4	160	
		-----X-----			
- 57	MS27198-24	• SEAL	1	160	
- 58	25-6500-3	• VALVE ASSY, FUEL CHECK (96736) SPEC 8-00954 T.O. 6J15-2-111-3	1	160	
	25-6500	• VALVE ASSY, FUEL CHECK (96736) SPEC 8-00954 T.O. 6J15-2-111-3 ALT INTCHG WITH 25-6500-3 ATTACHING PARTS	RF	160	
- 59	AN4H-5A	• BOLT	6	160	
- 60	AN960-D416L	• WASHER	6	160	
		-----X-----			
- 61	075156-4	• SEAL (89259) SPEC R-02287-7	1	160	
- 62	65A35925-1	• TUBE, PILOT VALVE SENSING	1	160	
	66A41532-1	• TUBE, PILOT VALVE SENSING RH	1	160	
- 63	MS2190804	• ELBOW	1	160	
		ATTACHING PARTS			
- 64	AN924-40	• NUT	1	160	
		-----X-----			
- 65	MS29512-4	• GASKET	1	160	
- 66	15-356-101	• VALVE ASSY, SHUTOFF (A2267) SPEC 8-00903-1 T.O. 6J15-10-106A13	1	160	
	15-356-51	• VALVE ASSY, SHUTOFF (A2267) SPEC R-00903-1 T.O. 6J15-10-106A-13 ALT INTCHG WITH 15-356-101 ATTACHING PARTS	RF	160	
- 67	AN4H-5A	• BOLT	6	160	
- 68	AN960-D416L	• WASHER	6	160	
		-----X-----			
- 69	075156-4	• SEAL (89259) SPEC R-02287-7	1	160	
- 70	25-6500-3	• VALVE ASSY, FUEL CHECK (96736) SPEC 8-00954 T.O. 6J15-2-111-3	1	160	
	25-6500	• VALVE ASSY, FUEL CHECK (96736) SPEC 8-00954 T.O. 6J15-2-111-3 ALT INTCHG WITH 25-6500-3 ATTACHING PARTS	RF	160	
- 71	AN4H-7A	• BOLT	4	160	
- 72	AN960-D416L	• WASHER	4	160	
		-----X-----			
- 73	MS27198-24	• SEAL	1	160	
- 74	66E41834-1 66E41834-1	• ADAPTER ASSEMBLY, TANK NO. 1 FUEL SYSTEM • ADAPTER ASSEMBLY, TANK NO. 1 FUEL SYSTEM ALT PART FOR 66E41834-1	RF	160	
- 75	MS2120PF4-10	• INSERT	16	160	
- 76	075156-4	• SEAL (89259) SPEC R-02287-7	1	160	
- 77	65C35P73-1	• BRACKET, TUBE SUPPORT WING VENT ATTACHING PARTS	1	160	
	MS21042L3	• NUT	2	160	
	AN520-10RH	• SCREW	3	160	
		-----X-----			
- 78	65A35926-1	• TUBE, SHUTOFF VALVE	1	160	
- 79	MS2193204	• UNION	2	160	

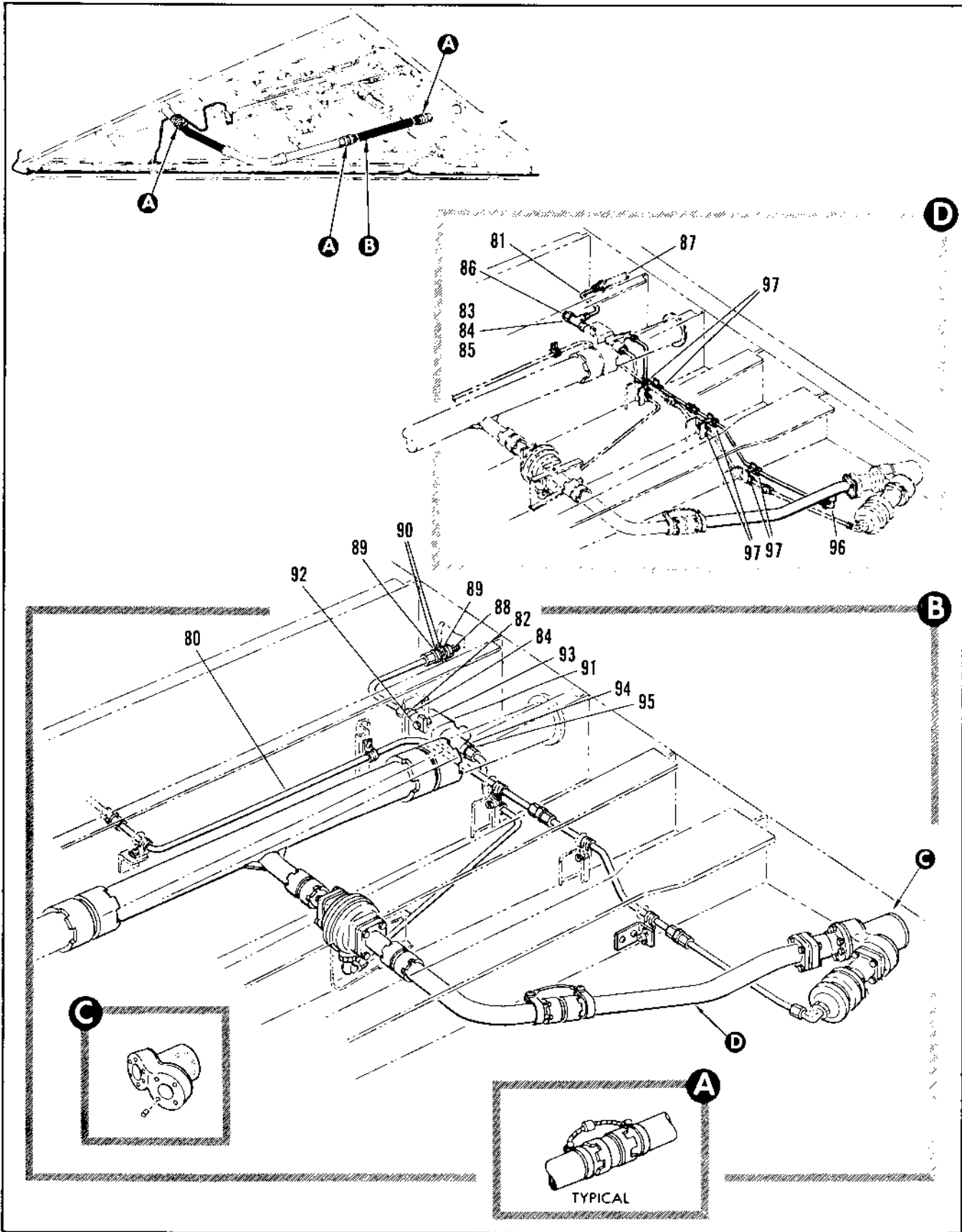

Figure 2.12-16. Wing Tank #1 Fuel Control Tubing Installation (Sheet 5 of 10)

FIGURE AND INDEX NUMBER	PART NUMBER	DESCRIPTION 1 2 3 4 5 6	UNITS PER ASSY.	USABLE ON CODE	
				FROM	TO
2.12-16- 80 - 81 - 82 - 83 - 84 - 85 - 86 - 87 - 88 - 89 - 90 - 91 - 92 - 93 - 94 - 95 - 96 - 97	66A41800-1	• TUBE, VALVE SENSING	1	160	
	66A41631-1	• TUBE, VALVE SENSING RH	1	160	
	66A41487-1	• TUBE ASSY, LH	1	160	
	66A41307-1	• TUBE ASSY, RH	1	160	
	MS2190204	• UNION	1	160	
	MS2191204	• TEE	2	160	
	MS219512-4	• GASKET	1	160	
	AN924-40	• NUT	1	160	
	66H43304-1	• CAP	1	160	
	R-20307-27	• TUBE ASSY, 1/8" SEE FIG. 2.12-37 INDEX 74	97	160	
	R-21311-7	• UNION	1	160	
	MS29812-0	• WASHER	2	160	
		• GASKET	2	160	
		ATTACHING PARTS			
		• NUT	1	160	
		• WASHER	1	160	
		-----X-----			
		• VALVE ASSY (44987)	1	160	
		SPEC 3-2275			
	ATTACHING PARTS				
	• NUT	2	160		
	• BOLT	2	160		
	-----X-----				
	• UNION	1	160		
	• GASKET	1	160		
	• ELBOW	1	160		
	• NUT	1	160		
	• PACKING	1	160		
	• CLAMP (32196)	3	160		
	• CLAMP	3	160		
	• SPACER	3	160		
	ATTACHING PARTS				
	• NUT	3	160		
	• SCREW	3	160		
	-----X-----				

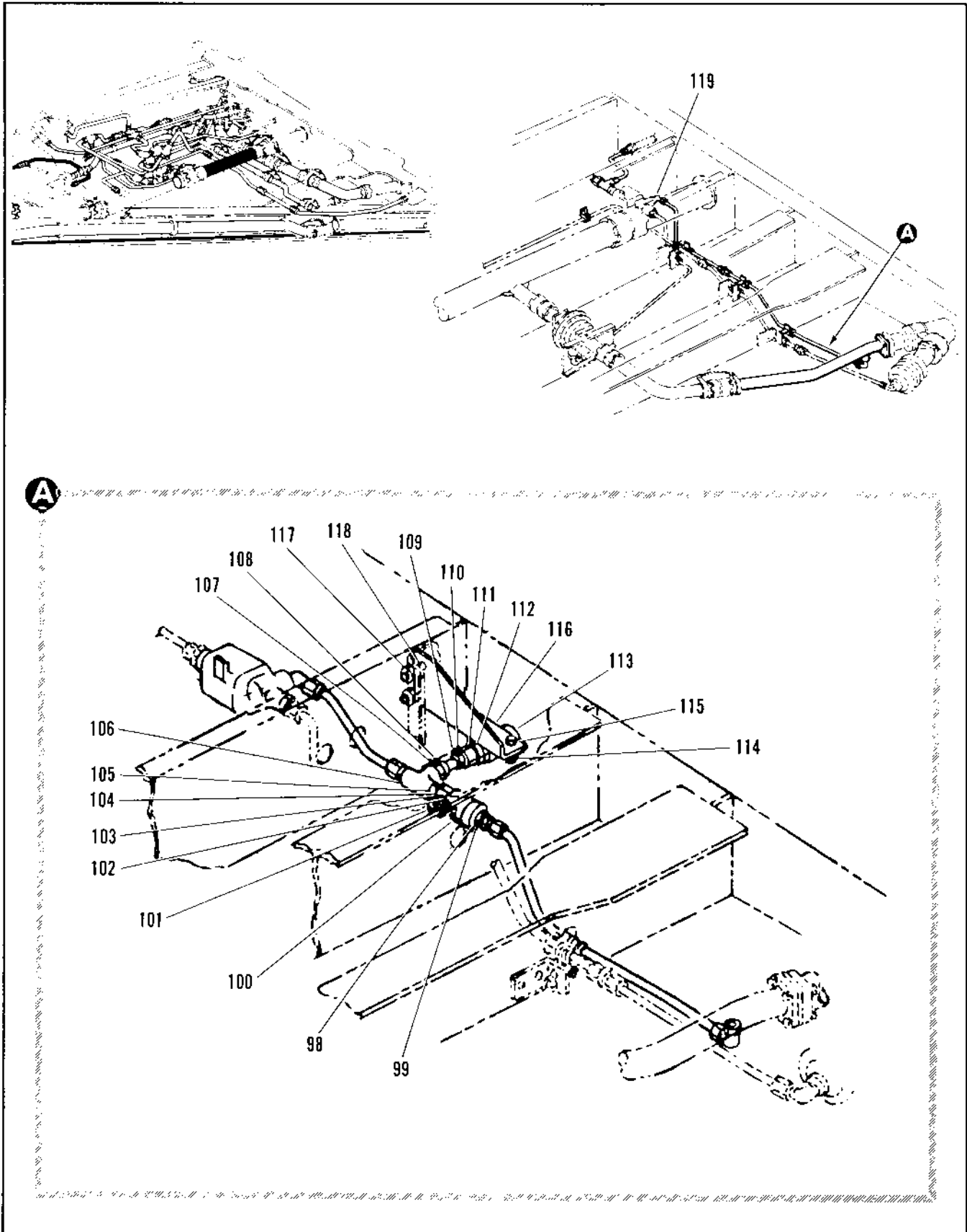

Figure 2.12-16. Wing Tank #1 Fuel Control Tubing Installation (Sheet 6 of 10)

FIGURE AND INDEX NUMBER	PART NUMBER	DESCRIPTION 1 2 3 4 5 6	UNITS PER ASSY.	USABLE ON CODE	
				FROM	TO
2.12-16- 98	MS21916D6-4	• REDUCER	1	160	
- 99	MS29512-06	• GASKET	1	160	
-100	W535-3/8F	• VALVE (26624) ATTACHING PARTS	1	160	
-101	MS21042L3	• NUT	1	160	
	AN960D10	• WASHER	1	160	
	AN3-3A	• BOLT -----X-----	1	160	
-102	MS2951206	• PACKING	1	160	
-103	AN893-2D	• BUSHING	1	160	
-104	MS29512-04	• PACKING	1	160	
-105	AN924D4	• NUT	1	160	
-106	MS21910D4	• TEE	1	160	
-107	MS29512-04	• PACKING	1	160	
-108	MS21924D4	• UNION	1	160	
-109	AN924D4	• NUT	1	160	
-110	MS29512-04	• PACKING	1	160	
-111	AN893-2D	• REDUCER	1	160	
-112	MS29512-06	• PACKING	1	160	
-113	W535-3/8F	• VALVE ATTACHING PARTS	1	160	
-114	MS21042L3	• NUT	1	160	
-115	AN3-3A	• BOLT -----X-----	1	160	
-116	69D36693-01	• BRACKET, LH	1	160	
	69D36693-03	• BRACKET, RH ATTACHING PARTS	1	160	
-117	MS21042L3	• NUT	2	160	
-118	AN3-3A	• BOLT -----X-----	2	160	
-119	MS21926D4	• ELBOW	1	160	
	MS29512-4	• PACKING	1	160	
	AN924-4D	• NUT	1	160	

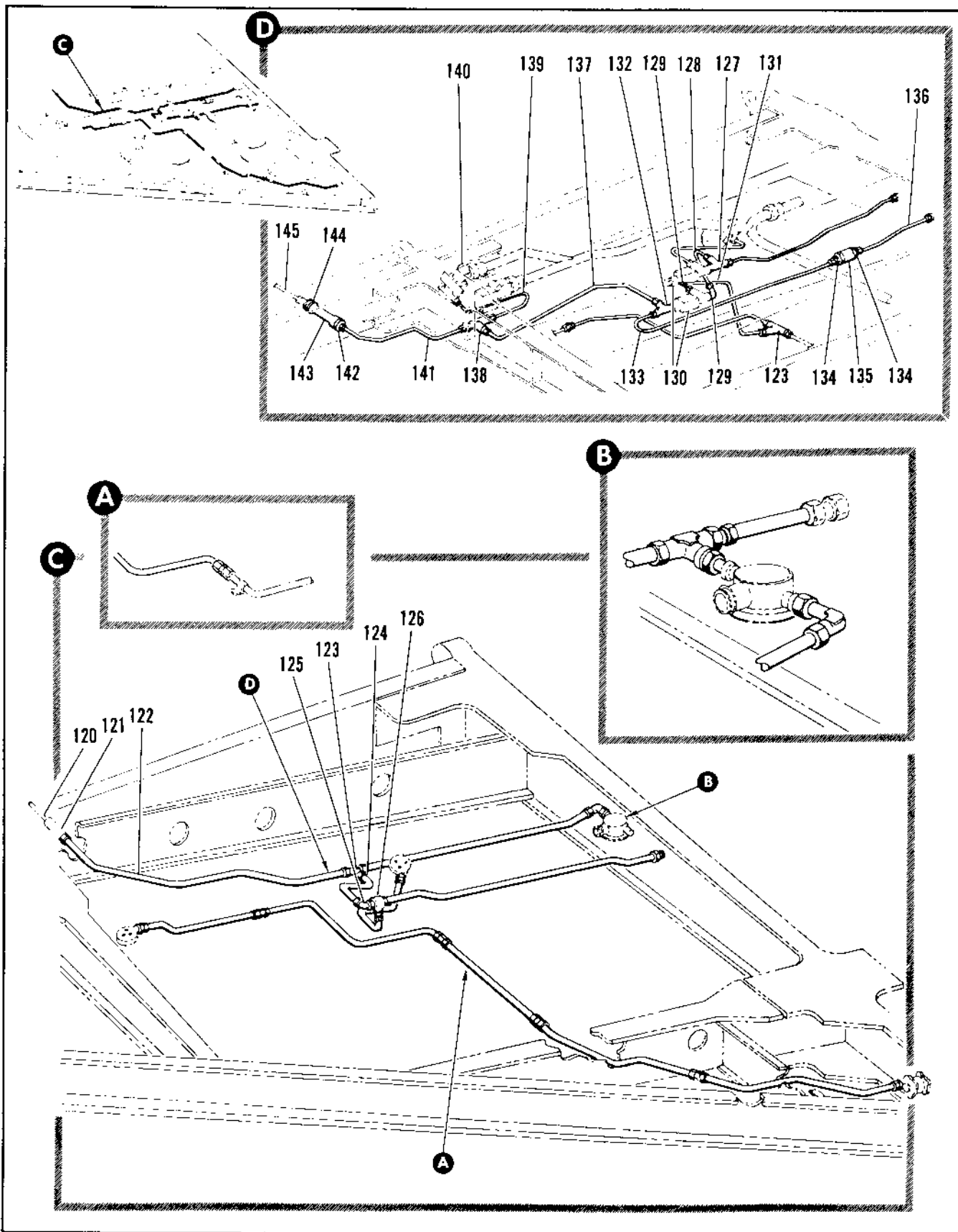

Figure 2.12-16. Wing Tank #1 Fuel Control Tubing Installation (Sheet 7 of 10)

FIGURE AND INDEX NUMBER	PART NUMBER	DESCRIPTION	UNITS PER ASSY.	USABLE ON CODE	
				FROM	TO
2.12-16- 98 - 99 -100 -101 -102 -103 -104 -105 -106 -107 -108 -109 -110 -111 -112 -113	MS21916D6-4	• REDUCER	1	160	
	MS29512-06	• GASKET	1	160	
	W535-378F	• VALVE (26624) ATTACHING PARTS	1	160	
	MS21042L3	• NUT	1	160	
	AN960D10	• WASHER	1	160	
	AN3-3A	• BOLT	1	160	
		-----X-----			
	MS2951206	• PACKING	1	160	
	AN895-2D	• BUSHING	1	160	
	MS29512-04	• PACKING	1	160	
	AN92404	• NUT	1	160	
	MS21910D4	• TFE	1	160	
	MS29512-04	• PACKING	1	160	
MS2192404	• UNION	1	160		
AN92404	• NUT	1	160		
MS29512-04	• PACKING	1	160		
AN895-2D	• REDUCER	1	160		
MS29512-06	• PACKING	1	160		
W535-378F	• VALVE ATTACHING PARTS	1	160		
MS21042L3	• NUT	1	160		
AN3-3A	• BOLT	1	160		
	-----X-----				
69D36593-01	• BRACKET, LM	1	160		
69D36593-03	• BRACKET, RM ATTACHING PARTS	1	160		
MS21042L3	• NUT	2	160		
AN3-3A	• BOLT	2	160		
	-----X-----				
MS21926D4	• FLOW	1	160		
MS29512-4	• PACKING	1	160		
AN924-40	• NUT	1	160		

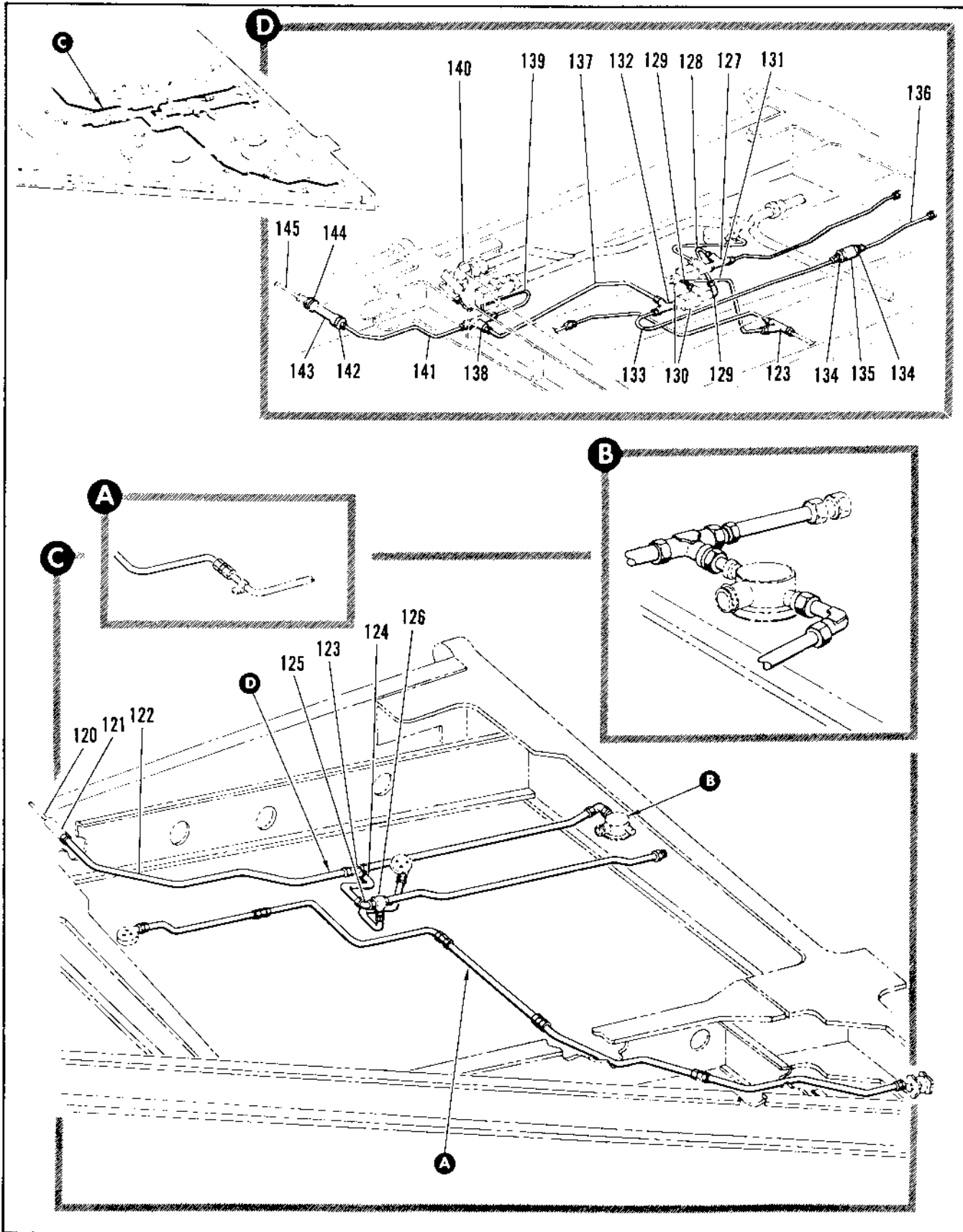

Figure 2.12-16. Wing Tank #1 Fuel Control Tubing Installation (Sheet 7 of 10)

FIGURE AND INDEX NUMBER	PART NUMBER	DESCRIPTION 1 2 3 4 5 6	UNITS PER ASSY.	USABLE ON CODE	
				FROM	TO
2.12-16-120		• TUBE ASSY, FUEL TANK PRESSURE SEE FIG. 2.12-45 INDEX 132	RF		
-121		• FITTING, STA 3RD BL 63 SEE FIG. 2.12-66 INDEX 2	RF		
-122	8-20397-2257 8-20397-2425	• TUBE ASSY, LH • TUBE ASSY, RH	1 1	160	
-123	MS2190504 MS2190504	• TEE • TEE	2 1	160	
-124	8-20397-2261 8-20397-2449	• TUBE ASSY, LH • TUBE ASSY, RH	1 1	160	
-125	MS2190804 AN924-40 MS29512-4	• ELBOW • NUT • GASKET	1 1 1	160	
-126		• VALVE ASSY, PRESSURE OPERATED PILOT SEE FIG. 2.12-1 INDEX 19	RF	160	
-127	MS2191204 AN92402 MS29512-4	• TEE • NUT • GASKET	1 1 1	160	
-128	66A40308-1	• TUBE ASSY	2	160	
-129	MS2190904 AN924-40 MS29512-4 S1690T4	• ELBOW • NUT • GASKET • CLAMP (92196) ATTACHING PARTS	2 2 2 1	160	
	MS21942L3 NAS43003-20 MS35227-264	• NUT • SPACER • SCREW	1 1 1	160	
-130		-----X----- • VALVE INSTL, PRESSURE OPERATED PILOT SEE FIG. 2.12-1 INDEX 19	RF		
-131	66A40309-1	• TUBE ASSY	1	160	
-132	MS2191204 MS2190304 AN924-40 MS29512-4	• TEE, LH • ELBOW, RH • NUT • GASKET	1 1 1 1	160	
-133	66A40311	• TUBE ASSY, LH	2	160	
-134	MS2191406-4 MS29512-4	• REDUCER, LH • GASKET, LH	2 1	160	
-135	W535-378F	• VALVE, AIR CHECK LH (96139) SPEC	1	160	
-136	66A40312-1	• TUBE ASSY, LH	1	160	
-137	66A40313-1	• TUBE ASSY	1	160	
-138	MS2191204 AN924-40	• TEE • NUT	1 1	160	
-139	66A40317-1 66A40316-1	• TUBE ASSY, LH • TUBE ASSY, RH	1 1	160	
-140		• VALVE ASSY, FUEL TANK VENT SEE FIG. 2.12-1 INDEX 17	RF	160	
-141	66A40318-1 66A40386-1	• TUBE ASSY, LH • TUBE ASSY, RH	1 1	160	
-142	AN92406 AN9610916 MS29513-15 8-21311-19	• NUT • WASHER • PACKING • WASHER	1 2 1 1	160	
-143	3-21260-7	• FITTING	1	160	
-144	8-21128-1	• BROMMET	1	160	
-145		• TUBE ASSY, SEE FIG. 2.12-67 INDEX 11	RF	160	

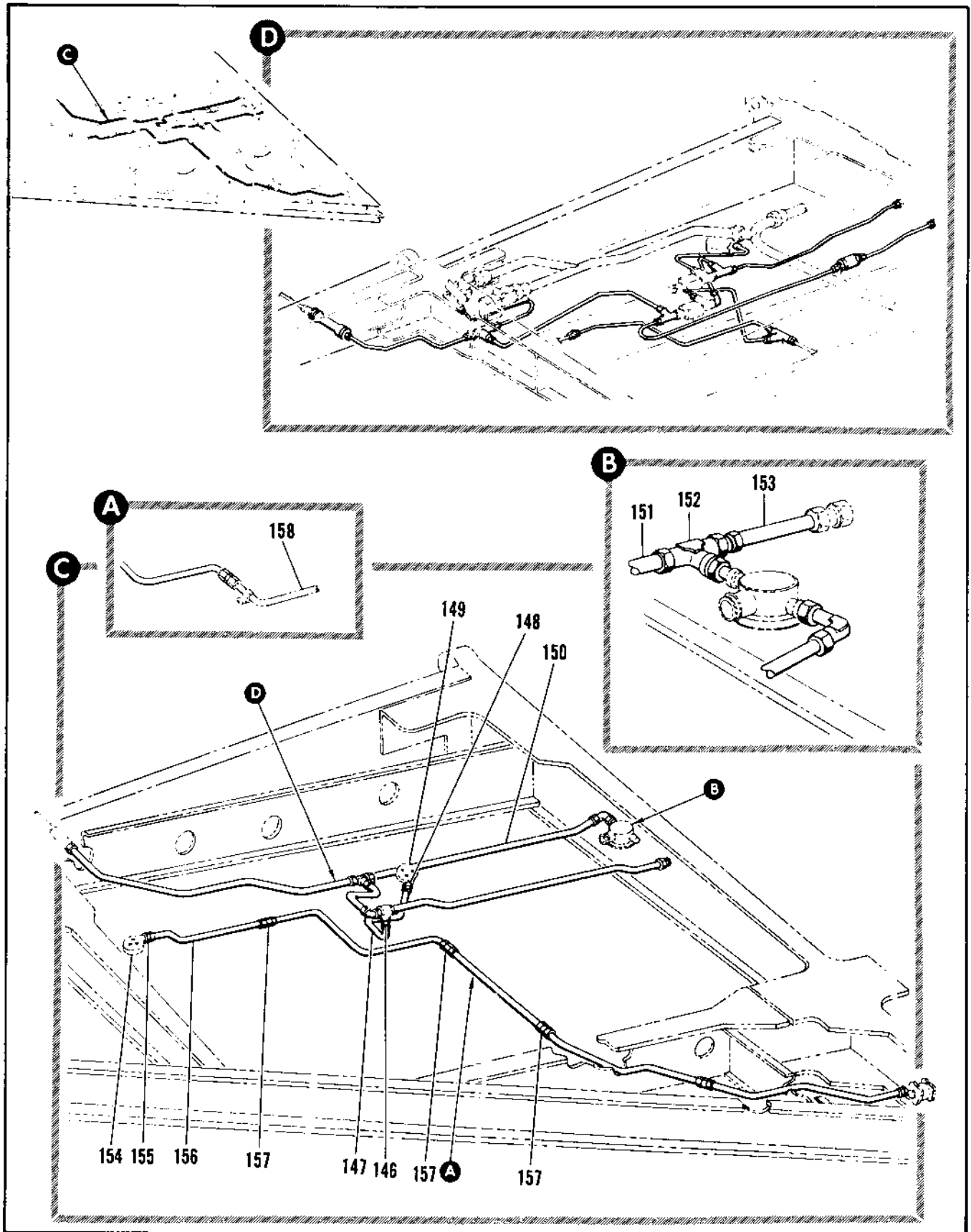

Figure 2.12-16. Wing Tank #1 Fuel Control Tubing Installation (Sheet 8 of 10)

FIGURE AND INDEX NUMBER	PART NUMBER	DESCRIPTION	UNITS PER ASSY.	USABLE ON CODE	
				FROM	TO
		1 2 3 4 5 6			
2.12-16-146	MS21902D4	• UNION	1	160	
	MS29812-4	• GASKET	1	160	
-147	R-20397-2259	• TUBE ASSY, LH	1	160	
	66A47134-1	• TUBE ASSY, RH	1	160	
-148	MS21908D4	• FLOW	1	160	
	AN924-40	• NUT	1	160	
	MS29812-04	• PACKING	1	160	
-149		• VALVE ASSY, FUEL TANK PILOT FLOAT SEE FIG. 2.12-1 INDEX 21	RF	160	
-150	R-20397-2403	• TUBE ASSY, LH	1	160	
-151	R-20397-2435	• TUBE ASSY, RH	1	160	
-152	MS21909D4	• TEE	1	160	
	AN924-40	• NUT	1	160	
	MS29812-4	• GASKET	1	160	
-153	R-20397-2421	• TUBE ASSY, RH	1	160	277
	R-21836-9	• TUBE ASSY, RH	1	278	
-154		• VALVE ASSY, FUEL TANK PILOT FLOAT SEE FIG. 2.12-1 INDEX 32	RF	160	
-155	MS21904D4	• UNION	1	160	
	MS29812-4	• GASKET	1	160	
-156	R-20397-2387	• TUBE ASSY, LH	1	160	
	R-20397-2427	• TUBE ASSY, RH	1	160	
-157	MS21902D4	• UNION	3	160	
-158		• TUBE, VALVE SENSING	RF	160	

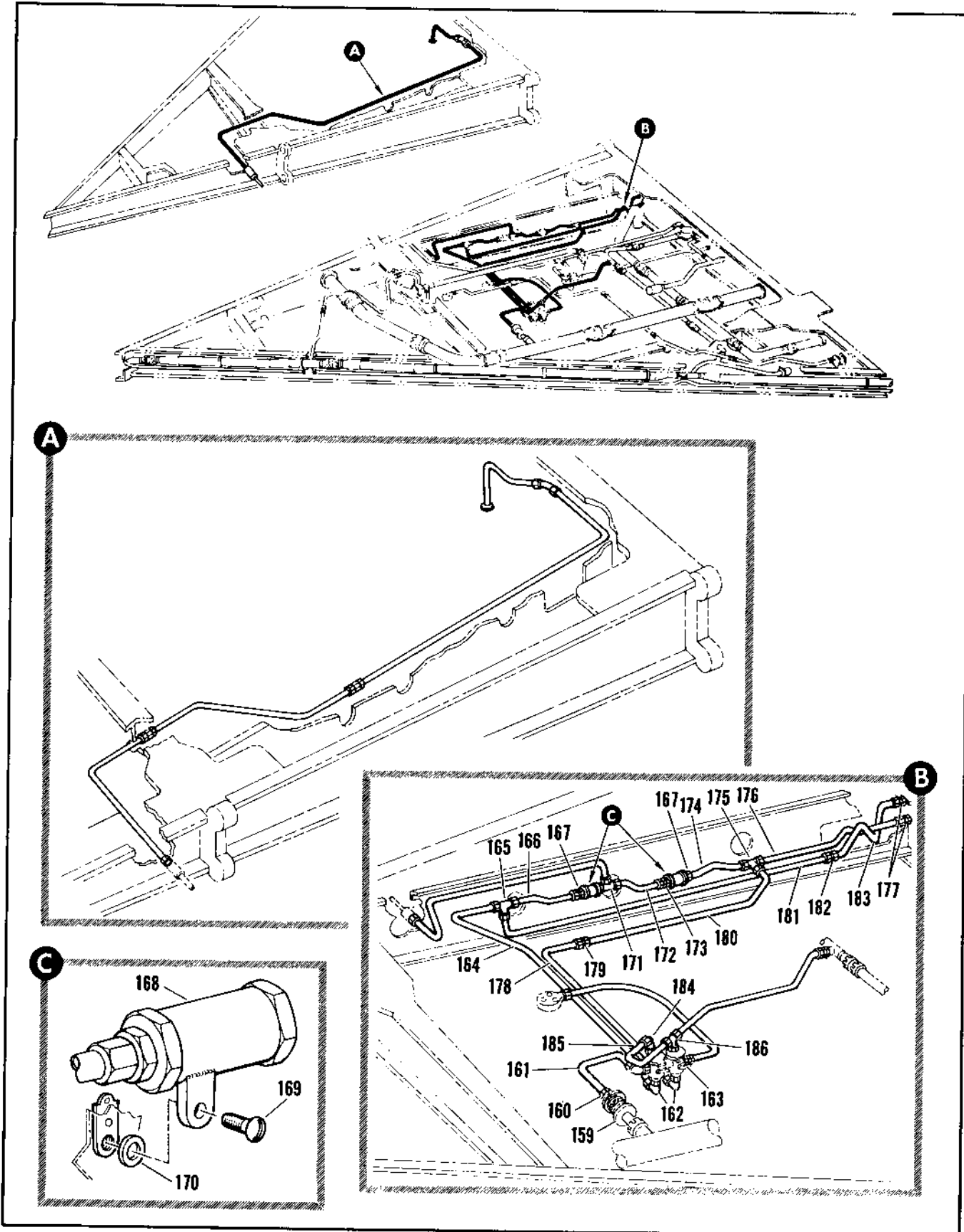

Figure 2.12-16. Wing Tank #1 Fuel Control Tubing Installation (Sheet 9 of 10)

FIGURE AND INDEX NUMBER	PART NUMBER	DESCRIPTION	UNITS PER ASSY.	USABLE ON CODE	
				FROM	TO
2.12-16-159					
-160	MS2190204	• VALVE ASSY, PILOT OPERATED SHUTOFF	RF		
	MS29512-4	• UNION	1	160	
	MS29512-4	• GASKET	1	160	
-161	R-20397-2265	• TUBE ASSEMBLY	1	160	
-162	MS2190804	• ELBOW	3	160	
	MS29512-4	• GASKET	3	160	
	AN924-40	• NUT	3	160	
-163		• VALVE ASSY, FULL SHUTOFF	RF		
		SEE FIG. 2.12-1 INDEX 47			
-164	R-20397-2393	• TUBE ASSY, LH	1	160	
	R-20397-2423	• TUBE ASSY, RH	1	160	
-165	MS2191204	• TEE	1	160	
	AN924-40	• NUT	1	160	
	AN9600716	• WASHER	1	160	
-166	R-20397-2391	• TUBE ASSY, LH	1	160	
	R-20397-2433	• TUBE ASSY, RH	1	160	
-167	MS2191606	• REDUCER	2	160	
	MS29512-6	• GASKET	2	160	
-168	MS35-37RF	• VALVE, AIR CHECK (5813P) SPEC R-02998-13	2	160	
		ATTACHING PARTS			
-169	AN3-0A	• BOLT	1	160	
-170	99-51609-020	• WASHER	1	160	
		-----X-----			
	AN924-60	• NUT	2	160	
-171	MS2191206	• TEE	2	160	
	MS29512-6	• GASKET	1	160	
-172	R-20397-2395	• TUBE ASSY, LH	1	160	
	R-20397-2411	• TUBE ASSY, RH	1	160	
-173	MS2190206	• UNION	1	160	
	MS29512-6	• GASKET	1	160	
-174	R-20397-2397	• TUBE ASSEMBLY	1	160	
	AN924-40	• NUT	1	160	
	AN9600716	• WASHER	1	160	
-175	MS1191204	• TEE	1	160	
-176	R-20397-2379	• TUBE ASSY, LH	1	160	
	R-20397-2441	• TUBE ASSY, RH	1	160	
-177		• UNION, SPAR #3 BL 44	RF		
		SEE FIG. 2.12-56 INDEX 4			
-178	R-20397-2401	• TUBE ASSEMBLY	1	160	
-179	MS2190404	• UNION	1	160	
-180	R-20397-2399	• TUBE ASSY, LH	1	160	
	R-20397-2443	• TUBE ASSY, RH	1	160	
-181	R-20397-2375	• TUBE ASSEMBLY	1	160	
-182	MS2191606-4	• REDUCER	1	160	
	MS29512-6	• GASKET	1	160	
-183	R-20397-2377	• TUBE ASSY, LH	1	160	
	R-20397-2439	• TUBE ASSY, RH	1	160	
	AN924-60	• NUT	1	160	
-184	MS2190806	• ELBOW	1	160	
	MS29512-6	• GASKET	1	160	
-185	R-20397-2451	• TUBE ASSEMBLY	1	160	
	AN924-60	• NUT	1	160	
-186	MS2190906	• TEE	1	160	
	MS29512-6	• GASKET	1	160	

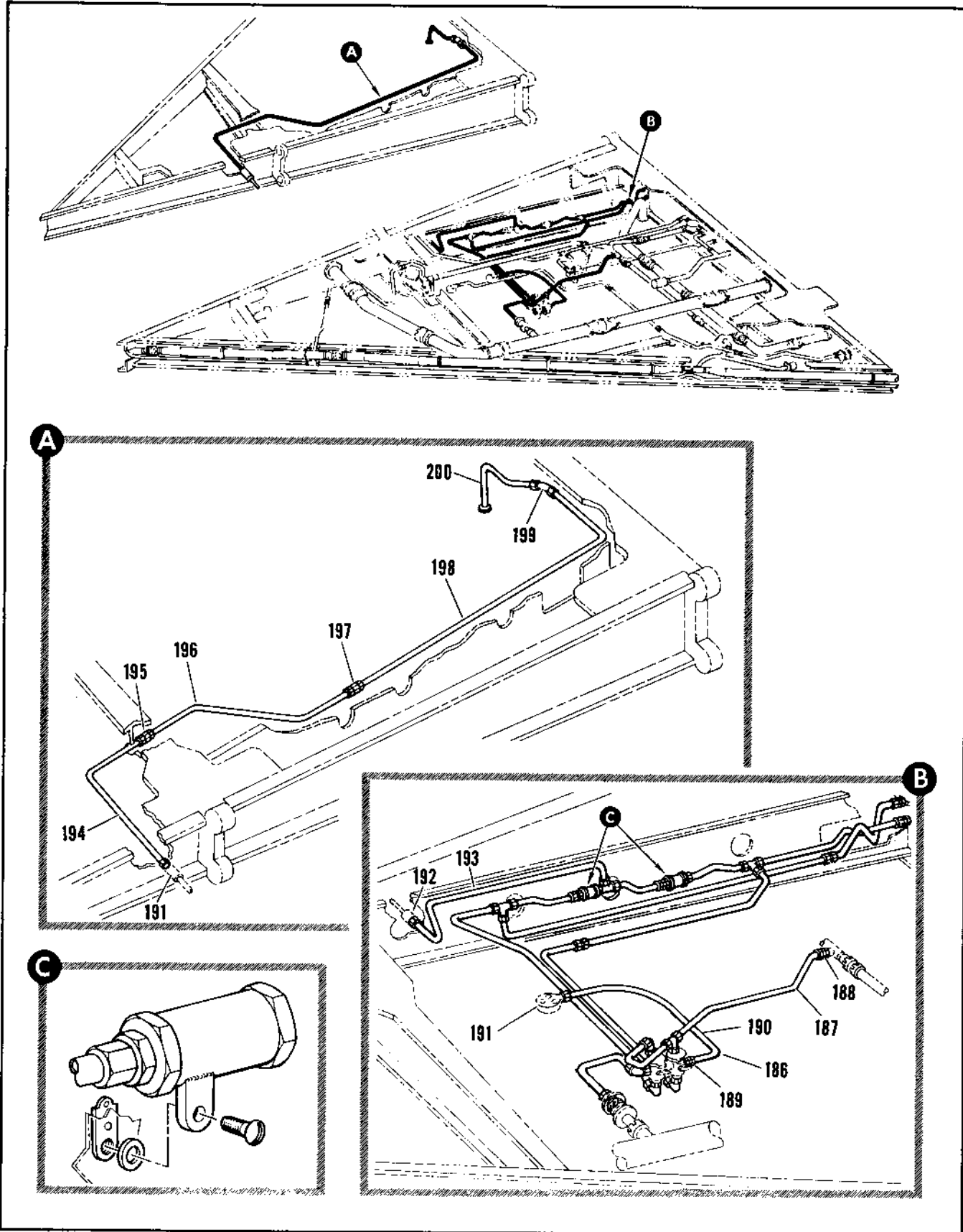

Figure 2.12-16. Wing Tank #1 Fuel Control Tubing Installation (Sheet 10 of 10)

FIGURE AND INDEX NUMBER	PART NUMBER	DESCRIPTION	UNITS PER ASSY.	USABLE ON CODE	
				FROM	TO
		1 2 3 4 5 6			
2.12-16-187	R-20397-2257	• TUBE ASSY, LH	1	160	
	R-20397-2413	• TUBE ASSY, RH	1	160	
-188	MS21902D6	• UNION	1	160	
	MS29512-6	• GASKET	1	160	
-189	MS21902D4	• UNION	2	160	
	MS29512-4	• GASKET	2	160	
-190	R-20397-2265	• TUBE ASSY, LH	1	160	
	R-20397-2437	• TUBE ASSY, RH	1	160	
-191		• VALVE ASSY, FUEL TANK PILOT FLOAT SEE FIG. 2-12-1 INDEX 32	RF		
-192		• UNION, SEE FIG. 2-12-66	RF		
-193	R-20397-2389	• TUBE ASSY, LH	1	160	
	R-20397-2439	• TUBE ASSY, RH	1	160	189
	R-20397-2655	• TUBE ASSY, RH	1	190	215
	R-20397-2459	• TUBE ASSY, RH	1	216	
-194	R-20397-2637	• TUBE ASSY, RH	1	190	
-195	MS21903D6	• UNION	1	190	
	AN924-60	• NUT	1	190	
	AN967D6	• WASHER	1	190	
-196	R-20397-2639	• TUBE ASSY, RH	1	190	
-197	MS21902D6	• UNION	1	190	
-198	R-20397-2651	• TUBE ASSY, RH	1	190	
-199	MS21967D6	• ELBOW	1	190	
	AN924-60	• NUT	1	190	
	AN967D6	• WASHER	1	190	
-200	R-20397-2653	• TUBE ASSY, RH	1	190	

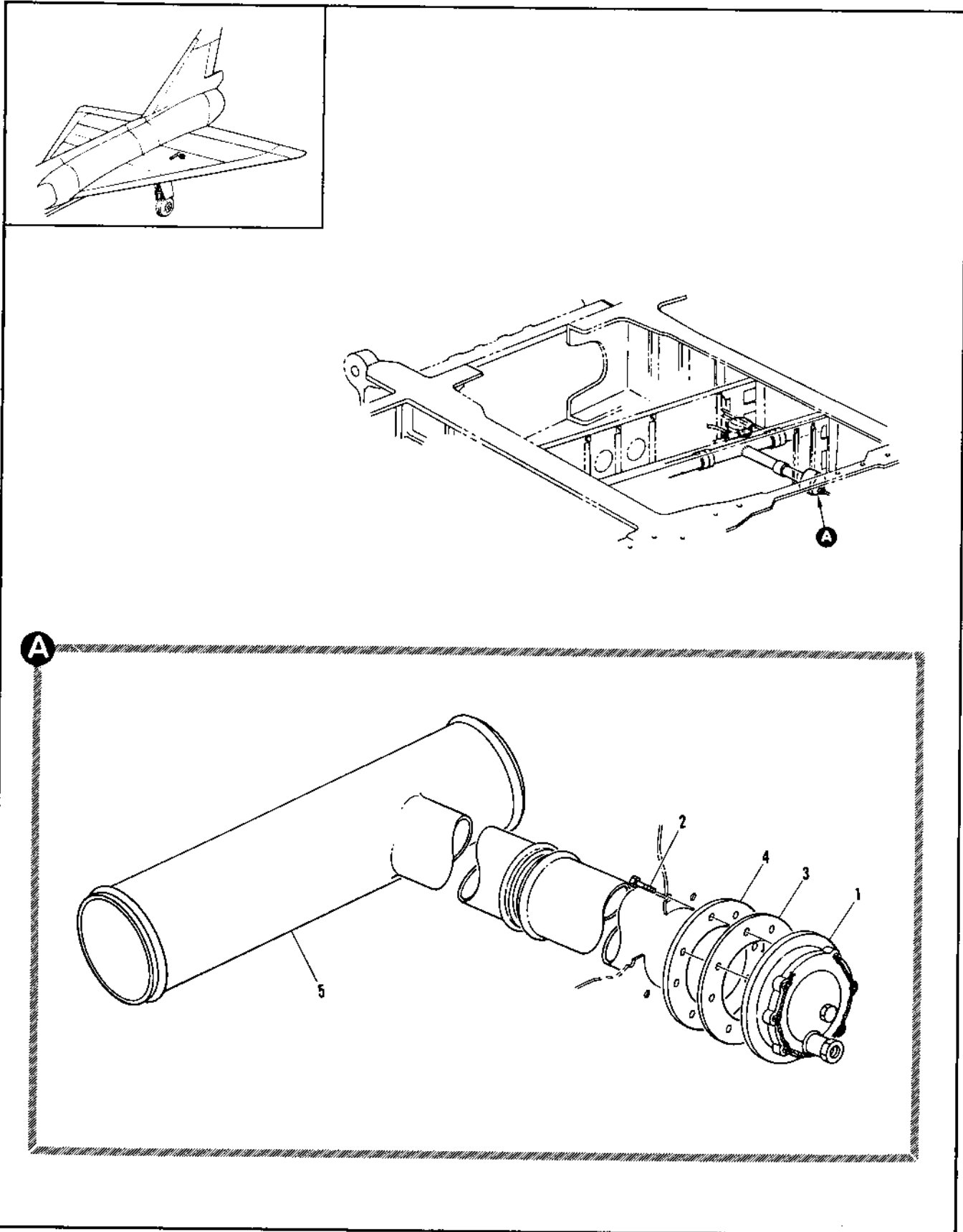

Figure 2.12-17. Tank #3 Refuel Shutoff and Pilot Valve Installation

FIGURE AND INDEX NUMBER	PART NUMBER	DESCRIPTION	UNITS PER ASSY.	USABLE ON CODE	
				FROM	TO
2.12-17 - 1 - 2 - 3 - 4 - 5	8-21534-P39	VALVE INSTALLATION, TANK #3 REFUEL SHUTOFF AND PILOT LH FOR NHA SEE FIG. 2.6-32	RF	35	
	8-21534-811	VALVE INSTALLATION, TANK #3 REFUEL SHUTOFF AND PILOT RH FOR NHA SEE FIG. 2.6-32	RF	35	
	15-356-101	• VALVE ASSY, SHUTOFF STA 542 <82267> SPEC 8-00903-1 T.O. 6J15-10-106-13	1	35	
	15-356-51	• VALVE ASSY, SHUTOFF STA 542 <82267> SPEC 8-00903-1 ALT INTCHG WITH 15-356-101 ATTACHING PARTS	RF	35	
	AN4H5A	• BOLT -----X-----	6	35	
	175156-4	• GASKET, <83259> SPEC 8-02287-7	1	35	
	8-21526	• FITTING ASSY, TANK #3 REFUELING WELDED	1	35	
	6-21170	• TUBE ASSY, LH WELDED REPLACED BY SUITABLE SUB 6-21170-3	1	35	188
	8-21170-3	• TUBE ASSY, LH WELDED REPLACES SUITABLE SUB FOR 4-21170	1	189	
	8-21170-1	• TUBE ASSY, RH WELDED REPLACED BY SUITABLE SUB 6-21170-4	1	35	188
	8-21170-4	• TUBE ASSY, RH WELDED REPLACES SUITABLE SUB FOR 4-21170-1	1	189	

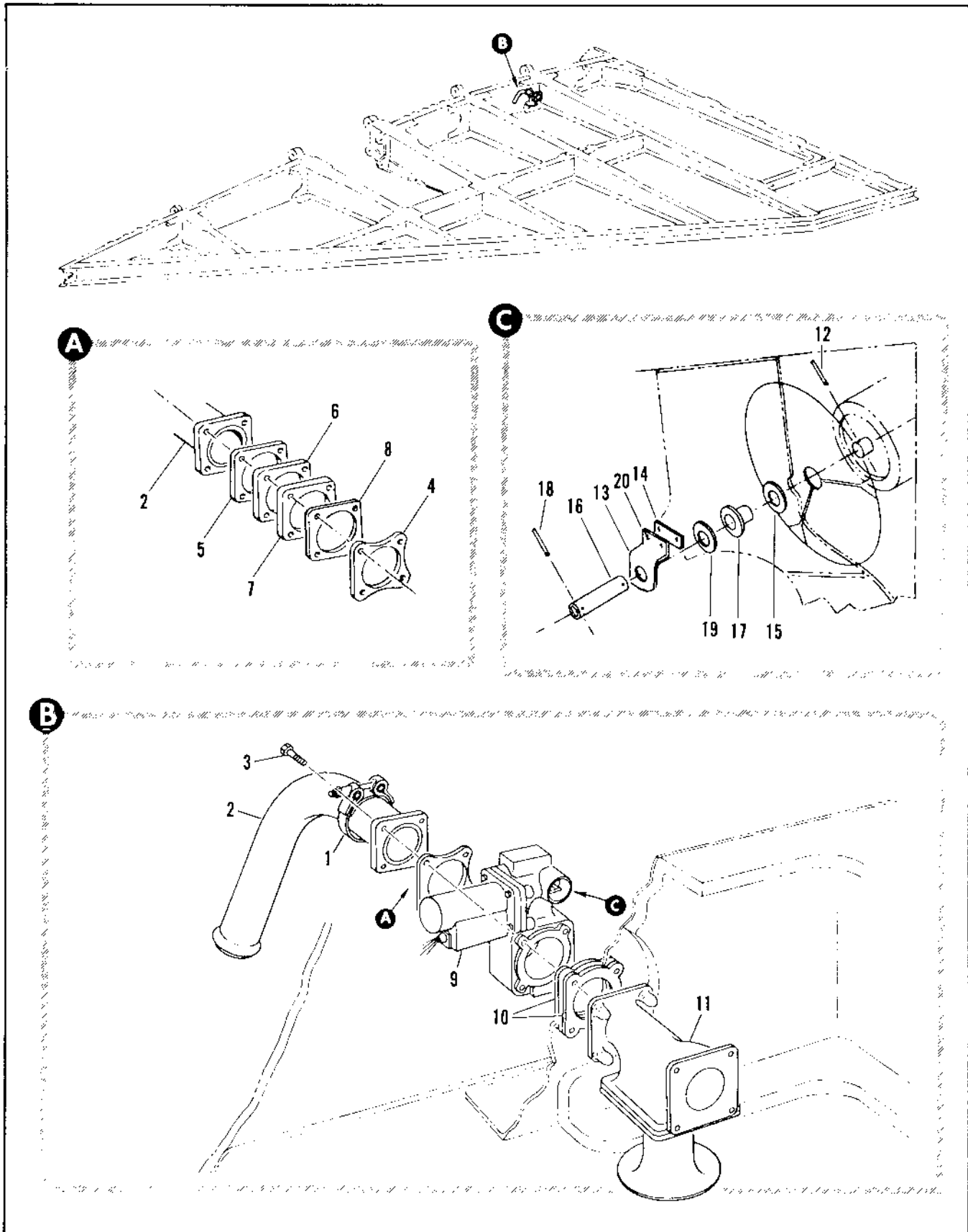

Figure 2.12-18. Shutoff and Check Valve Installation

FIGURE AND INDEX NUMBER	PART NUMBER	DESCRIPTION	UNITS PER ASSY.	USABLE ON CODE	
				FROM	TO
		1 2 3 4 5 6			
2.12-18	8-21538-1	VALVE INSTALLATION, SHUTOFF AND CHECK LH FOR NHA SEE FIG. 2.6-32	RF	35	
	8-21538-3	VALVE INSTALLATION, SHUTOFF AND CHECK RH FOR NHA SEE FIG. 2.6-32	RF	35	
- 1	320-62-2125	• CLAMP, MAR 91-97802-022	1	35	
- 2		• TUBE ASSY, ENGINE FUEL SUPPLY LH AND RH SEE FIG. 2.12-65 INDEX 32	RF		
		ATTACHING PARTS			
- 3	AN5H23A	• BOLT	4	35	
		----X----			
- 4	275356-2	• GASKET, <R3259> SPEC 8-02289-3	2	61	
- 5	8-21610-7	• SHIM	AR	61	
- 6	8-21610-9	• SHIM	AR	61	
- 7	8-21610-11	• SHIM	AR	61	
- 8	8-21610-13	• SHIM	AR	61	
- 9	132415-1	• VALVE ASSY, SHUTOFF <79318> SPEC 8-00959-3	1	35	277
	132305-1	• VALVE ASSY, SHUTOFF <79318> SPEC 8-00959-3 ALT INTCHG WITH 130415-1 REPLACES NOT INTCHG WITH 130415	RF	35	277
	K41866	• VALVE ASSY, SHUTOFF <R2700> SPEC 8-00959-3 ALT INTCHG WITH 130415-1	RF	55	277
	K41866-1	• VALVE ASSY, SHUTOFF <R2700> SPEC 8-00959-5	1	278	
	132305-1	• VALVE ASSY, SHUTOFF <79318> SPEC 8-00959-3 ALT INTCHG WITH K41866-1	RF	278	
- 10	075556-3	• GASKET, <R3259> SPEC 8-02291-5	2	35	
- 11	312800	INSTALLATION, T.O. 6J15-2-50-13 REPLACED BY SUITABLE SUP 312800-1	1	35	188
	312800-1	• VALVE ASSY, CHECK <96124> SPEC 8-02968-1 REPLACES SUITABLE SUP FOR 312800	1	189	
	69F35365	INSTALLATION VALVE INDICATOR	RF	35	
- 12	MS206665-22	• PIN, CUTTER (USED WITH THOMPSON VALVE)	1	35	
	MS171433	• PIN, SPRING (USED WITH WHITTAKER VALVE)	1	35	
- 13	7036809-1	• RETAINER	1	35	
- 14	7036911-01	• FILLER	1	35	
- 15	7036812-01	• WASHER	1	35	
- 16	7036813-01	• SHAFT	1	35	
- 17	7036914-01	• SEAL	1	35	
- 18	MS171442	• PIN	1	35	
- 19	AN965-416L	• WASHER	1	35	
- 20	MS20435F4-5	• RIVET	2	35	

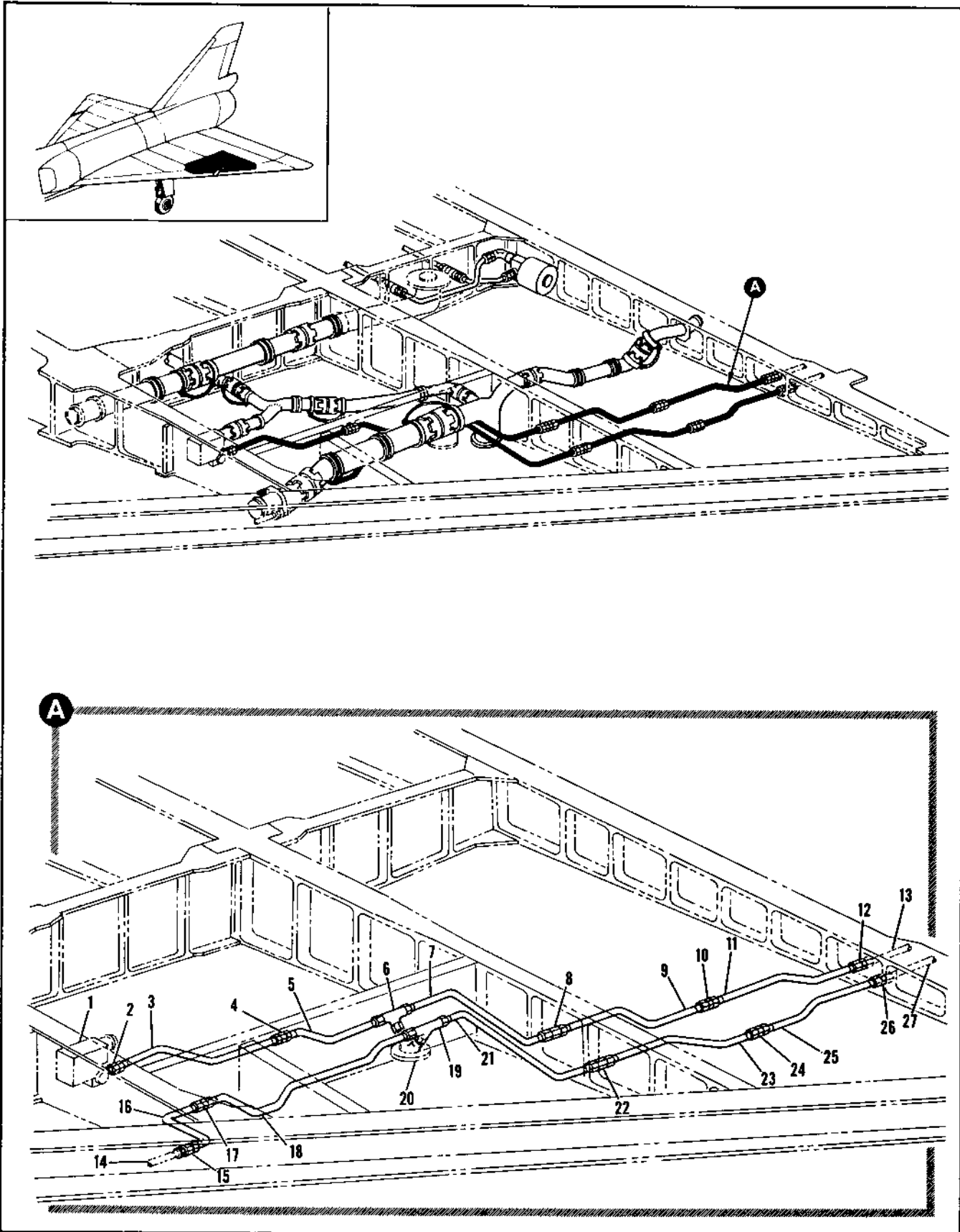

Figure 2.12-19. Wing Tank #2 Fuel Control Tubing Installation (Sheet 1 of 3)

FIGURE AND INDEX NUMBER	PART NUMBER	DESCRIPTION	UNITS PER ASSY.	USABLE ON CODE	
				FROM	TO
2.12-19	8-20397-837	TUBING INSTALLATION, WING TANK #2 FUEL CONTROL LH FOR NHA SEE FIG. 2.6-32	RF	35	159
	8-20397-855	TUBING INSTALLATION, WING TANK #2 FUEL CONTROL LH FOR NHA SEE FIG. 2.6-32	RF	160	189
	8-20397-865	TUBING INSTALLATION, WING TANK #2 FUEL CONTROL LH FOR NHA SEE FIG. 2.6-32	RF	190	
	8-20397-839	TUBING INSTALLATION, WING TANK #2 FUEL CONTROL RH FOR NHA SEE FIG. 2.6-32	RF	35	159
	8-20397-857	TUBING INSTALLATION, WING TANK #2 FUEL CONTROL RH FOR NHA SEE FIG. 2.6-32	RF	160	189
	8-20397-867	TUBING INSTALLATION, WING TANK #2 FUEL CONTROL RH FOR NHA SEE FIG. 2.6-32	RF	190	
- 1		• VALVE ASSY, TANK #2 PRESSURE RELIEF SEE FIG. 2.12-1 INDEX 88	RF		
- 2	MS2190204	• UNION	1	35	
	MS29512-9	• GASKET	1	35	
- 3	8-20397-53	• TUBE ASSEMBLY	1	35	159
	8-20397-2229	• TUBE ASSEMBLY	1	160	
- 4	MS2190204	• UNION	1	35	
- 5	8-20397-51	• TUBE ASSY, LH	1	35	159
	8-20397-2227	• TUBE ASSY, LH	1	160	
	8-20397-149	• TUBE ASSY, RH	1	35	159
	8-20397-2231	• TUBE ASSY, RH	1	160	
- 6	MS2190904	• TEE	1	35	
- 7	8-20397-241	• TUBE ASSY, LH	1	35	159
	8-20397-2241	• TUBE ASSY, LH	1	160	
	8-20397-247	• TUBE ASSY, RH	1	35	159
	8-20397-2247	• TUBE ASSY, RH	1	160	
	AN924-40	• NUT	1	35	
	AN9610716	• WASHER	1	35	
- 8	MS2190304	• UNION	1	35	
- 9	8-20397-243	• TUBE ASSEMBLY	1	35	159
	8-20397-2243	• TUBE ASSEMBLY	1	160	
- 10	MS2190204	• UNION	1	35	
- 11	8-20397-245	• TUBE ASSEMBLY	1	35	159
	8-20397-2245	• TUBE ASSEMBLY	1	160	
- 12		• UNION, SPAR #6 BL 142 SEE FIG. 2.12-68 INDEX 18	RF		
- 13		• TUBE ASSY, SEE FIG. 2.12-21 INDEX 73	RF		
- 14		• TUBE ASSY, SEE FIG. 2.12-15 INDEX 36	RF		
- 15		• UNION, SPAR #4 BL 120 SEE FIG. 2.12-66 INDEX 14	RF		
- 16	8-20397-47	• TUBE ASSEMBLY	1	35	159
	8-20397-2223	• TUBE ASSEMBLY	1	160	
- 17	MS2190206	• UNION	1	35	
- 18	8-20397-49	• TUBE ASSEMBLY	1	35	159
	8-20397-2225	• TUBE ASSEMBLY	1	160	
	AN924-60	• NUT	2	35	
- 19	MS2190906	• TEE	2	35	
	MS29512-5	• GASKET	2	35	
- 20		• FLANGE, SENSING OUTLET BL 126 SEE FIG. 296-36 INDEX 2	RF		
- 21	8-20397-174	• TUBE ASSY, LH	1	35	159
	8-20397-2233	• TUBE ASSY, LH	1	160	
	8-20397-202	• TUBE ASSY, RH	1	35	159
	8-20397-2235	• TUBE ASSY, RH	1	160	
	AN924-60	• NUT	1	35	
	AN9610916	• WASHER	1	35	
- 22	MS2190306	• UNION	1	35	
- 23	8-20397-304	• TUBE ASSEMBLY	1	35	
	8-20397-2251	• TUBE ASSEMBLY	1	160	189
	8-20397-2907	• TUBE ASSEMBLY	1	190	
- 24	MS2190206	• UNION	1	35	
- 25	8-20397-302	• TUBE ASSEMBLY	1	35	159
	8-20397-2249	• TUBE ASSEMBLY	1	160	
- 26		• UNION, SPAR #6 BL 143 SEE FIG. 2.12-66 INDEX 18	RF		
- 27		• TUBE ASSY, LH SEE FIG. 2.12-21 INDEX 72	RF		

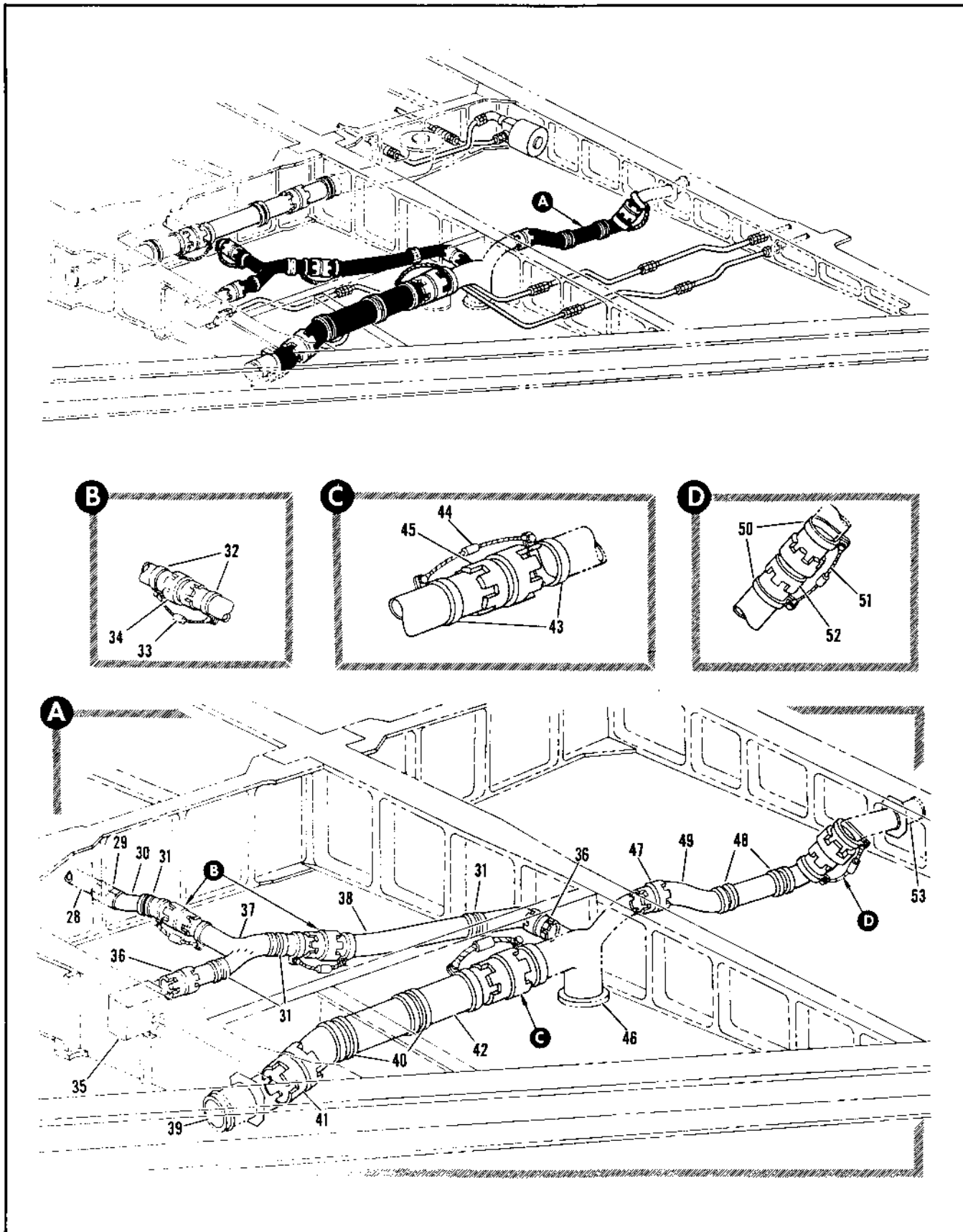

Figure 2.12-19. Wing Tank #2 Fuel Control Tubing Installation (Sheet 2 of 3)

FIGURE AND INDEX NUMBER	PART NUMBER	DESCRIPTION	UNITS PER ASSY.	USABLE ON CODE	
				FROM	TO
		1 2 3 4 5 6			
2.12-19- 28		• TUBE ASSY, SEE FIG. 2.12-20 INDEX 71	RF		
- 29		• UNION, STA 492 RL 92 SEE FIG. 2.12-56 INDEX 29	RF		
- 30	8-20397-43	• TUBE ASSEMBLY	1	35	
- 31	91-98026-015	• CLAMP	4	35	
- 32	AN735016	• CLAMP	4	35	
	NAS679A3	ATTACHING PARTS	4	35	
	AN960010L	• NUT	4	35	
	AN526-103R6	• WASHER	4	35	
		• SCREW			
		----X----			
- 33	MS25083-1BB3	• JUMPER	2	35	
- 34	3605-16D	• COUPLING, <79326> 92-72500-001	2	35	
- 35		• VALVE ASSY, TANK #2 PRESSURE RELIEF SEE FIG. 2.12-1 INDEX 88	RF		
	MS29513-214	• PACKING	3	35	
- 36	3605-16D	• COUPLING, <79326> 92-72500-001	2	35	
	MS29513-214	• PACKING	1	35	
- 37	8-21594-3	• TUBE ASSY, LH	1	35	
	8-21594-4	• TUBE ASSY, RH	1	35	
- 38	8-20397-45	• TUBE ASSEMBLY	1	35	
	8-20397-151	• TUBE ASSEMBLY	1	35	
- 39		• TUBE ASSY, VENT SEE FIG. 2.12-23 INDEX 2	RF		
- 40	MS21919DF-32	• CLAMP	2	35	
- 41	3605-32D	• COUPLING, <79326> 92-72500-002	1	35	
	MS29513-32B	• PACKING	1	35	
- 42	8-20397-507	• TUBE ASSEMBLY	1	35	
- 43	AN735032	• CLAMP	2	35	
	NAS679A3	ATTACHING PARTS	2	35	
	AN960010L	• NUT	2	35	
	AN526-1032R6	• WASHER	2	35	
		• SCREW			
		----X----			
- 44	MS25083-1BB4	• JUMPER	1	35	
- 45	3605-32D	• COUPLING, WIG 92-72500-002	1	35	
	MS29513-329	• PACKING	1	35	
- 46		• OUTLET ASSY, FUEL TANK #2 VENT LH SEE FIG. 2.12-1 INDEX 38	RF		
	3605-24D	• COUPLING, <79326> 92-72500-003	1	35	
- 47	MS29513-325	• PACKING	1	35	
	91-98026-023	• CLAMP	2	35	
- 48	8-20397-157	• TUBE ASSEMBLY	1	35	
- 49	AN735024	• CLAMP	2	35	
- 50		ATTACHING PARTS	2	35	
	NAS679A3	• NUT	2	35	
	AN960010L	• WASHER	2	35	
	AN526-1032R6	• SCREW	2	35	
		----X----			
- 51	MS25083-1BB4	• JUMPER	1	35	
- 52	3605-24D	• COUPLING, <79326> 92-72500-003	1	35	
	MS29513-325	• PACKING	1	35	
- 53		• TUBE ASSY, TRANSFER TANK VENT SEE FIG 2.12-14 INDEX 31	RF		

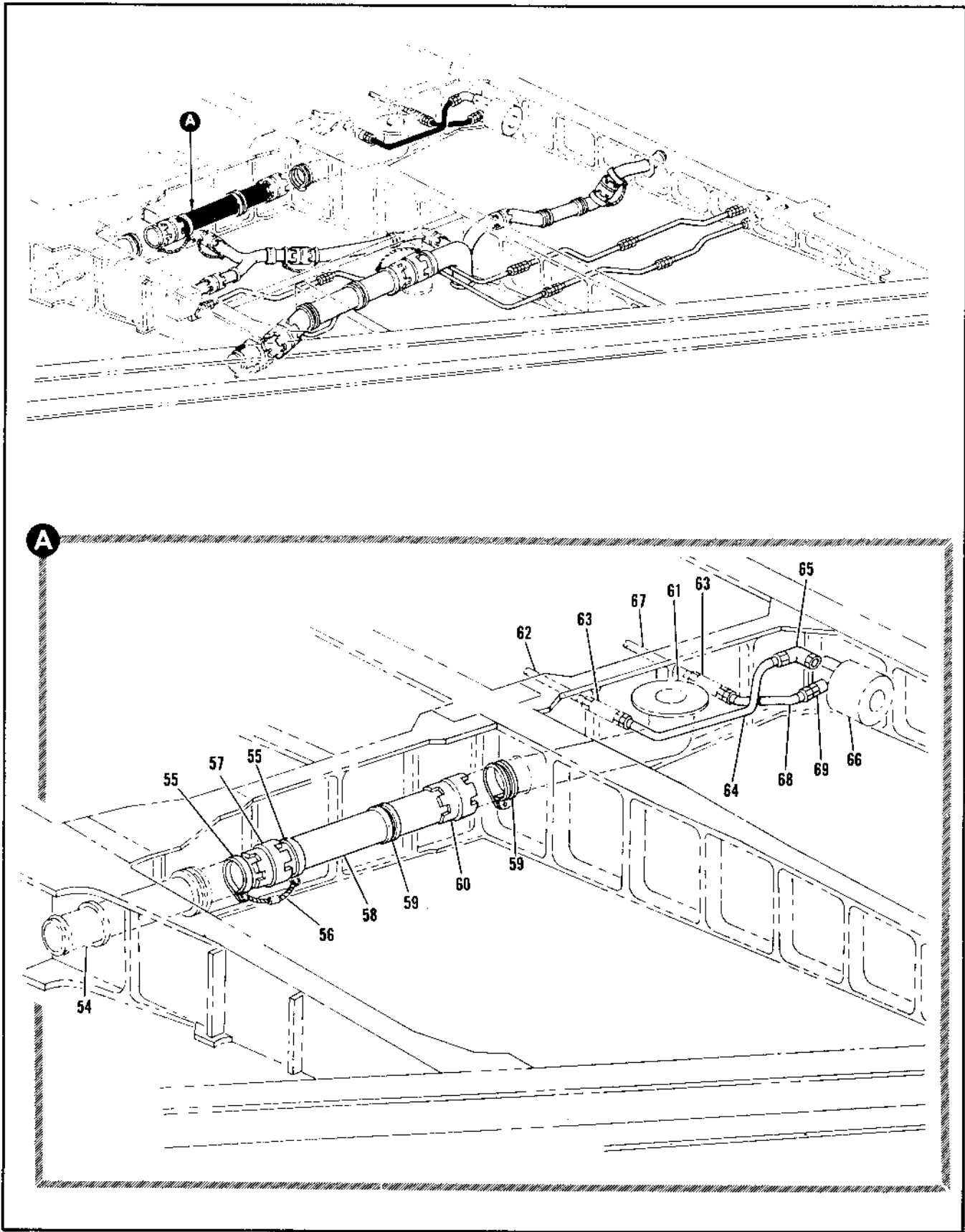

Figure 2.12-19. Wing Tank #2 Fuel Control Tubing Installation (Sheet 3 of 3)

FIGURE AND INDEX NUMBER	PART NUMBER	DESCRIPTION	UNITS PER ASSY.	USABLE ON CODE	
				FROM	TO
2.12-19- 54 - 55	AN735D40 NAS679A3 AN967D19L AN526-1032R6	1 • TUBE ASSY, SEE FIG. 2.12-16 INDEX 103 2 • CLAMP 3 ATTACHING PARTS 4 • NUT 5 • WASHER 6 • SCREW -----X-----	RF 4	35	
- 56	MS25083-1884	• JUMPER	2	35	
- 57	3635-43D MS29513-333	• COUPLING, <79326> 92-72500-004 • PACKING	2 2	35 35	
- 58	8-20397-39 8-20397-77	• TUBE ASSY, LH • TUBE ASSY, RH	1 1	35 35	
- 59	MS21122-40 NAS430D3-24	• CLAMP • SPACER	4 1	35 35	
- 60	3635-40D MS29513-333	• COUPLING, <79326> 92-72500-004 • PACKING	1 1	35 35	
- 61		• BELLMOUTH ASSY, TANK #2 LH SEE FIG. 2.12-14 INDEX UUL	RF		
- 62		• TUBE ASSY, LH SEE FIG. 2.12-26 INDEX LI	RF		
- 63		• UNION, STA 532 AND 542 PL 92 SEE FIG. 2.12-66 INDEX 19	RF		
- 64	8-20397-411 8-20397-2253 8-20397-413 8-20397-2237	• TUBE ASSY, LH • TUBE ASSY, LH • TUBE ASSY, RH • TUBE ASSY, RH	1 1 1 1	35 160 35 160	159 159
- 65	MS21902D4 MS29512-4	• ELEW • GASKET	1 1	35 35	
- 66		• VALVE ASSY, TANK #2 PILOT FLOAT SEE FIG. 2.12-1 INDEX 86	RF		
- 67		• TUBE ASSY, LH SEE FIG. 2.12-20 INDEX 52	1	35	159
- 68	8-20397-415 8-20397-2255 8-20397-417 8-20397-2239	• TUBE ASSY, LH • TUBE ASSY, LH • TUBE ASSY, RH • TUBE ASSY, RH	1 1 1 1	35 160 35 160	159 159
- 69	MS21902D4 MS29512-4 AN924-4D	• UNION • GASKET • NUT	1 1 1	35 35 35	

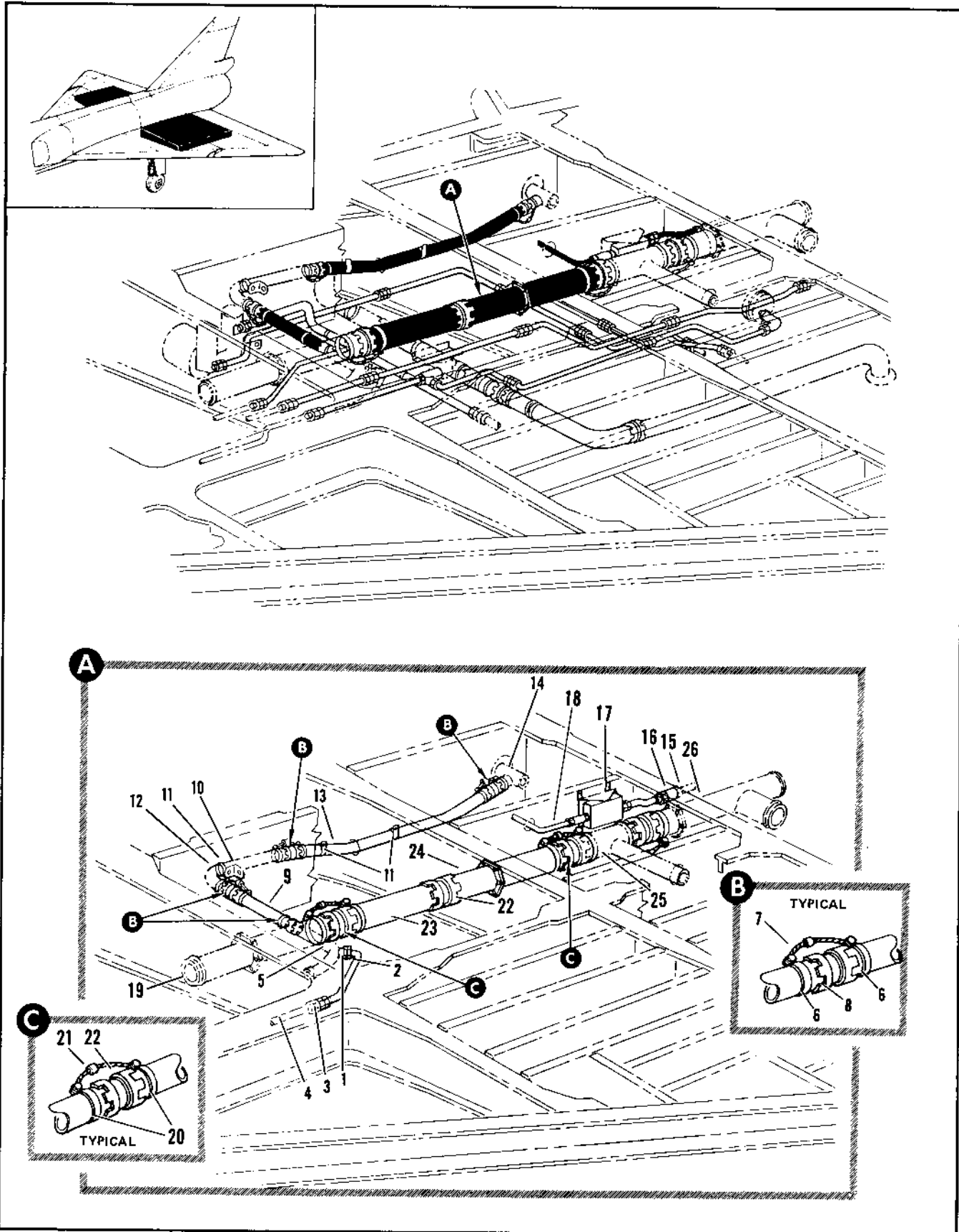

Figure 2.12-20. Wing Tank #3 Fuel Control Tubing Installation (Sheet 1 of 3)

FIGURE AND INDEX NUMBER	PART NUMBER	DESCRIPTION	UNITS PER ASSY.	USABLE ON CODE		
				FROM	TO	
2.12-20	8-20397-837	TUBING INSTALLATION, WING TANK #3 FUEL CONTROL LH FOR NHA SEE FIG. 2.6-32	RF	35	159	
	8-20397-855	TUBING INSTALLATION, WING TANK #3 FUEL CONTROL LH FOR NHA SEE FIG. 2.6-32	RF	160	189	
	8-20397-465	TUBING INSTALLATION, WING TANK #3 FUEL CONTROL LH FOR NHA SEE FIG. 2.6-32	RF	190		
	8-20397-839	TUBING INSTALLATION, WING TANK #3 FUEL CONTROL RH FOR NHA SEE FIG. 2.6-32	RF	35	159	
	8-20397-857	TUBING INSTALLATION, WING TANK #3 FUEL CONTROL RH FOR NHA SEE FIG. 2.6-32	RF	160	189	
	8-20397-867	TUBING INSTALLATION, WING TANK #3 FUEL CONTROL RH FOR NHA SEE FIG. 2.6-32	RF	190		
	- 1	MS21902D4	• UNION	1	35	159
		MS29512-A	• GASKET	1	35	159
	- 2	8-20397-395	• TUBE ASSY, LH	1	35	159
		8-20397-2321	• TUBE ASSY, LH	1	160	
		8-20397-423	• TUBE ASSY, RH	1	35	159
		8-20397-2325	• TUBE ASSY, RH	1	160	
	- 3		• UNION, SPAR #4 PL 89 SEE FIG. 2.12-66 INDEX 13	RF		
	- 4		• TUBE ASSY, LH SEE FIG. 2.12-37 INDEX 93	RF		
	- 5		• TUBE ASSY, LH SEE FIG. 2.12-61 INDEX 7	RF		
	- 6	AN735D32	• CLAMP	8	35	
		NAS679A3	• NUT	8	35	
		AN967D10L	• WASHER	8	35	
		AN526-1032R6	• SCREW	8	35	
	- 7	MS25083-10B4	• JUMPER	4	35	
	- 8	3605-32D	• COUPLING, <79326> 92-72500-802	4	35	
		MS29513-32D	• PACKING	4	35	
	- 9	8-20397-405	• TUBE ASSEMBLY	1	35	
	- 10	AN743-12	• BRACKET	1	35	
	- 11	91-580226-031	• CLAMP	3	35	
- 12		• ELBOW, SEE FIG. 2.12-61 INDEX 9	RF			
- 13	8-20397-403	• TUBE ASSEMBLY, LH	1	35		
	8-20397-425	• TUBE ASSY, RH	1	35		
- 14		• TUBE ASSY, SEE FIG. 2.12-61 INDEX 11	RF			
- 15		• TUBE ASSY, LH SEE FIG. 2.12-21 INDEX 34	RF			
- 16		• UNION, SPAR #4 PL 46 SEE FIG. 2.12-66 INDEX 17	RF			
- 17		• VALVE ASSY, SHUTOFF SEE FIG. 2.12-36 INDEX 3	RF			
- 18	8-21847-13	• TUBE ASSEMBLY	1			
	8-21847-11	• TUBE ASSEMBLY	1			
- 19		• TUBE ASSY, SEE FIG. 2.12-14 INDEX 57	RF			
- 20	AN735D48	• CLAMP	4	35		
	NAS679A3	• NUT	4	35		
	AN960010L	• WASHER	4	35		
	AN526-1032R6	• SCREW	4	35		
- 21	MS25083-10B4	• JUMPER	2	35		
- 22	3605-48D	• COUPLING, <79326> 92-72500-105	3	35		
	MS29513-337	• PACKING	3	35		
- 23	8-20397-774	• TUBE ASSEMBLY	1	35		
- 24	8-20397-772	• TUBE ASSY, LH	1	35		
	8-20397-1791	• TUBE ASSY, RH	1	35		
- 25		• TUBE ASSY, LH SEE FIG. 2.12-17 INDEX 5	RF			
- 26		• TUBE ASSY, LH SEE FIG. 2.12-14 INDEX 73	RF			

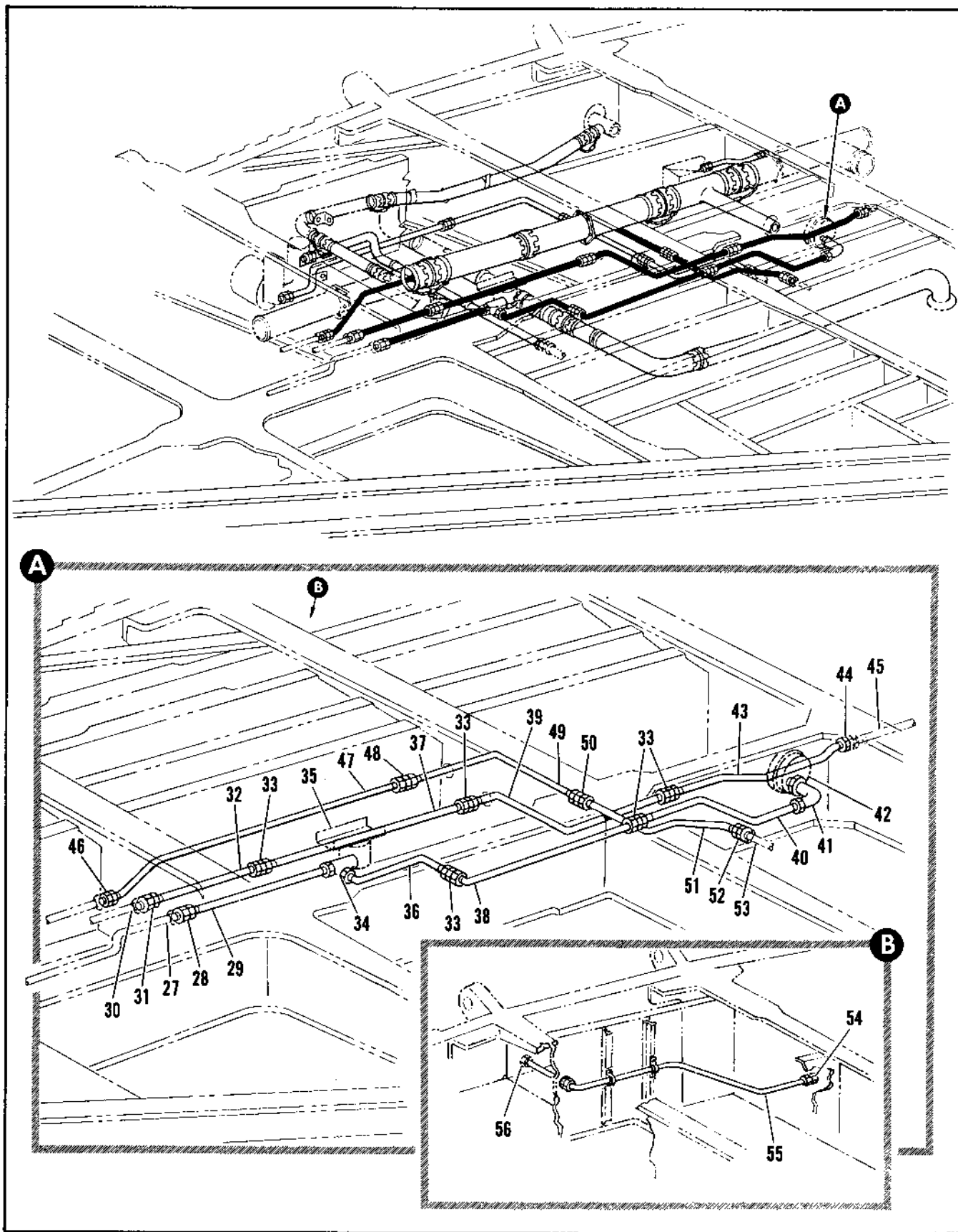

Figure 2.12-20. Wing Tank #3 Fuel Control Tubing Installation (Sheet 2 of 3)

FIGURE AND INDEX NUMBER	PART NUMBER	DESCRIPTION	UNITS PER ASSY.	USABLE ON CODE	
				FROM	TO
2.12-20- 27		• TUBE ASSY, LH SEE FIG. 2.12-37 INDEX 42	RF		
- 28		• UNION, SPAR #4 BL 66 SEE FIG. 2.12-66	RF		
- 29	8-20397-1479	• TUBE ASSY, LH	1	35	159
	8-20397-2325	• TUBE ASSY, LH	1	160	
	8-20397-1783	• TUBE ASSY, RH	1	35	159
	8-20397-2357	• TUBE ASSY, RH	1	160	
- 30		• TUBE ASSY, LH SEE FIG. 2.12-32	RF		
- 31		• UNION, SPAR #4 BL 68 SEE FIG. 2.12-66	RF		
- 32	8-20397-1481	• TUBE ASSY, LH	1	35	159
	8-20397-2337	• TUBE ASSY, LH	1	160	
	8-20397-1775	• TUBE ASSY, RH	1	35	159
	8-20397-2349	• TUBE ASSY, RH	1	160	
- 33	MS2190204	• UNION	5	35	
	AN924-40	• NUT	1	35	
- 34	MS2191204	• TEE	1	35	
	MS29512-4	• GASKET	1	35	
- 35		• VALVE ASSY, TANK #3 REFUEL PILOT LH SEE FIG. 2.12-1 INDEX 76	RF		
- 36	8-20397-1477	• TUBE ASSY, LH	1	35	159
	8-20397-2333	• TUBE ASSY, LH	1	160	
	8-20397-1781	• TUBE ASSY, RH	1	35	159
	8-20397-2355	• TUBE ASSY, RH	1	160	
- 37	8-20397-344	• TUBE ASSEMBLY	1	35	159
	8-20397-2317	• TUBE ASSEMBLY	1	160	
- 38	8-20397-1475	• TUBE ASSEMBLY	1	35	159
	8-20397-2331	• TUBE ASSEMBLY	1	160	
- 39	8-20397-350	• TUBE ASSY, LH	1	35	159
	8-20397-2319	• TUBE ASSY, LH	1	160	
	8-20397-19A	• TUBE ASSY, RH	1	35	159
	8-20397-2315	• TUBE ASSY, RH	1	160	
- 40	8-20397-562	• TUBE ASSY, LH	1	35	159
	8-20397-2327	• TUBE ASSY, LH	1	160	
	8-20397-1779	• TUBE ASSY, RH	1	35	159
	8-20397-2353	• TUBE ASSY, RH	1	160	
	AN924-40	• NUT	1	35	
- 41	MS2190804	• ELBOW	1	35	
	MS29512-4	• GASKET	1	35	
- 42		• VALVE ASSY, SHUTOFF STA 542 SEE FIG. 2.12-19 INDEX 1	RF		
- 43	8-20397-570	• TUBE ASSY, LH	1	35	159
	8-20397-2329	• TUBE ASSY, LH	1	160	
	8-20397-1777	• TUBE ASSY, RH	1	35	159
	8-20397-2351	• TUBE ASSY, RH	1	160	
- 44		• UNION, SPAR #6 BL 67 SEE FIG. 2.12-66	RF		
- 45		• TUBE ASSY, LH SEE FIG. 2.12-18	RF		
- 46		• UNION, SPAR #4 BL 68 SEE FIG. 2.12-66	RF		
- 47	8-20397-127	• TUBE ASSEMBLY	1	35	159
	8-20397-2307	• TUBE ASSEMBLY	1	160	
- 48	MS2190204	• UNION	1	35	
- 49	8-20397-129	• TUBE ASSY, LH	1	35	159
	8-20397-2309	• TUBE ASSY, LH	1	160	
	8-20397-1771	• TUBE ASSY, RH	1	35	159
	8-20397-2345	• TUBE ASSY, RH	1	160	
	AN924-40	• NUT	1	35	
	AN9600716	• WASHER	1	35	
- 50	MS2190304	• UNION	1	35	
- 51	8-20397-150	• TUBE ASSY, LH	1	35	159
	8-20397-2313	• TUBE ASSY, LH	1	160	
	8-20397-1773	• TUBE ASSY, RH	1	35	159
	8-20397-2347	• TUBE ASSY, RH	1	160	
- 52		• UNION, STA 532 AND 542 BL 92 SEE FIG. 2.12-66 INDEX 19	RF		
- 53		• TUBE ASSY, LH SEE FIG. 2.12-19 INDEX 68	RF		
- 54		• UNION, SPAR #6 BL 143 SEE FIG. 2.12-66	RF		
- 55	8-20397-2363	• TUBE ASSY, LH	1	160	
	8-20397-2365	• TUBE ASSY, RH	1	160	
- 56		• FITTING, TRANSFER TANK PRESSURE SENSING STA 534 SEE FIG. 2.12-55 INDEX 21	RF		

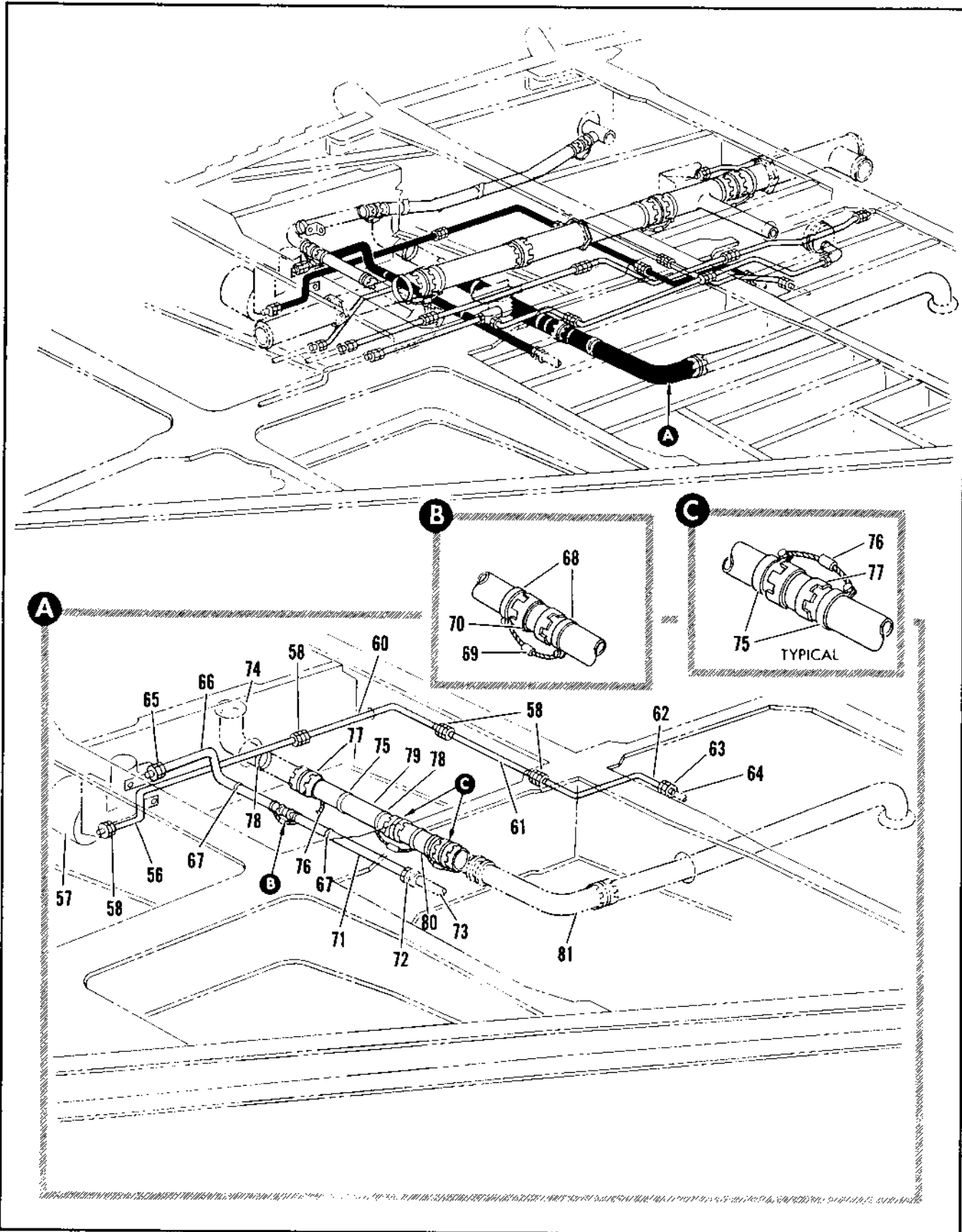

Figure 2.12-20. Wing Tank #3 Fuel Control Tubing Installation (Sheet 3 of 3)

FIGURE AND INDEX NUMBER	PART NUMBER	DESCRIPTION 1 2 3 4 5 6	UNITS PER ASSY.	USABLE ON CODE	
				FROM	TO
2.12-20- 57		• VALVE ASSY, TANK #3 VENT RELIEF SEE FIG. 2.12-1 INDEX 73	RF		
- 58	MS2190204	• UNION	4	35	
	MS29512-4	• GASKET	1	35	
- 59	8-20397-1683	• TUBE ASSY, LH	1	35	159
	8-20397-2341	• TUBE ASSY, LH	1	160	
	8-20397-1796	• TUBE ASSY, RH	1	35	159
	8-20397-2343	• TUBE ASSY, RH	1	160	
- 60	8-21847-9	• TUBE ASSEMBLY	1	35	
	8-21847-10	• TUBE ASSEMBLY	1	35	
- 61	8-21847-7	• TUBE ASSEMBLY	1	35	
- 62	8-20397-148	• TUBE ASSY, LH	1	35	159
	8-20397-2311	• TUBE ASSY, LH	1	160	
	8-20397-1785	• TUBE ASSY, RH	1	35	159
	8-20397-2359	• TUBE ASSY, RH	1	160	
- 63		• UNION, STA 532 AND 542 BL 92 SEE FIG. 2.12-66	RF		
- 64		• TUBE ASSY, LH SEE FIG. 2.12-19 INDEX 64	RF		
- 65	MS21916016-12	• REDUCER	1	35	
	MS29512-16	• GASKET	1	35	
- 66	8-20397-399	• TUBE ASSY, LH	1	35	
	8-20397-421	• TUBE ASSY, RH	1	35	
- 67	91-98026-015	• CLAMP	2	35	
- 68	AN735D16	• CLAMP	2	35	
		ATTACHING PARTS			
	NAS679A3	• NUT	2	35	
	AN960D10L	• WASHER	2	35	
	AN526-1C32R6	• SCREW	2	35	
		-----X-----			
- 69	MS250A3-1BB3	• JUMPER	1	35	
- 70	3605-160	• COUPLING, <79326> 92-72500-001	1	35	
	MS29513-214	• PACKING	1	35	
	8-20397-409	• TUBE ASSEMBLY	1	35	
- 71		• UNION, STA 492 BL 92 SEE FIG. 2.12-66	RF		
- 72		• TUBE ASSY, SEE FIG. 2.12-19 INDEX 30	RF		
- 73		• BELLMOUTH ASSY, TANK #3	RF		
- 74		SEE FIG. 2.12-16 INDEX 110			
- 75	AN735D40	• CLAMP	5	35	
		ATTACHING PARTS			
	NAS679A3	• NUT	5	35	
	AN960D10L	• WASHER	5	35	
	AN526-1C32R6	• SCREW	5	35	
		-----X-----			
- 76	MS250B3-1BB4	• JUMPER	3	35	
- 77	3605-400	• COUPLING, <79326> 92-72500-004	3	35	
	MS29513-333	• PACKING	3	35	
- 78	91-98026-038	• CLAMP	3	35	
- 79	8-20397-81	• TUBE ASSEMBLY	1	35	
- 80	8-20397-83	• TUBE ASSEMBLY	1	35	
- 81		• TUBE ASSY, LH SEE FIG. 2.12-14 INDEX 114	RF		

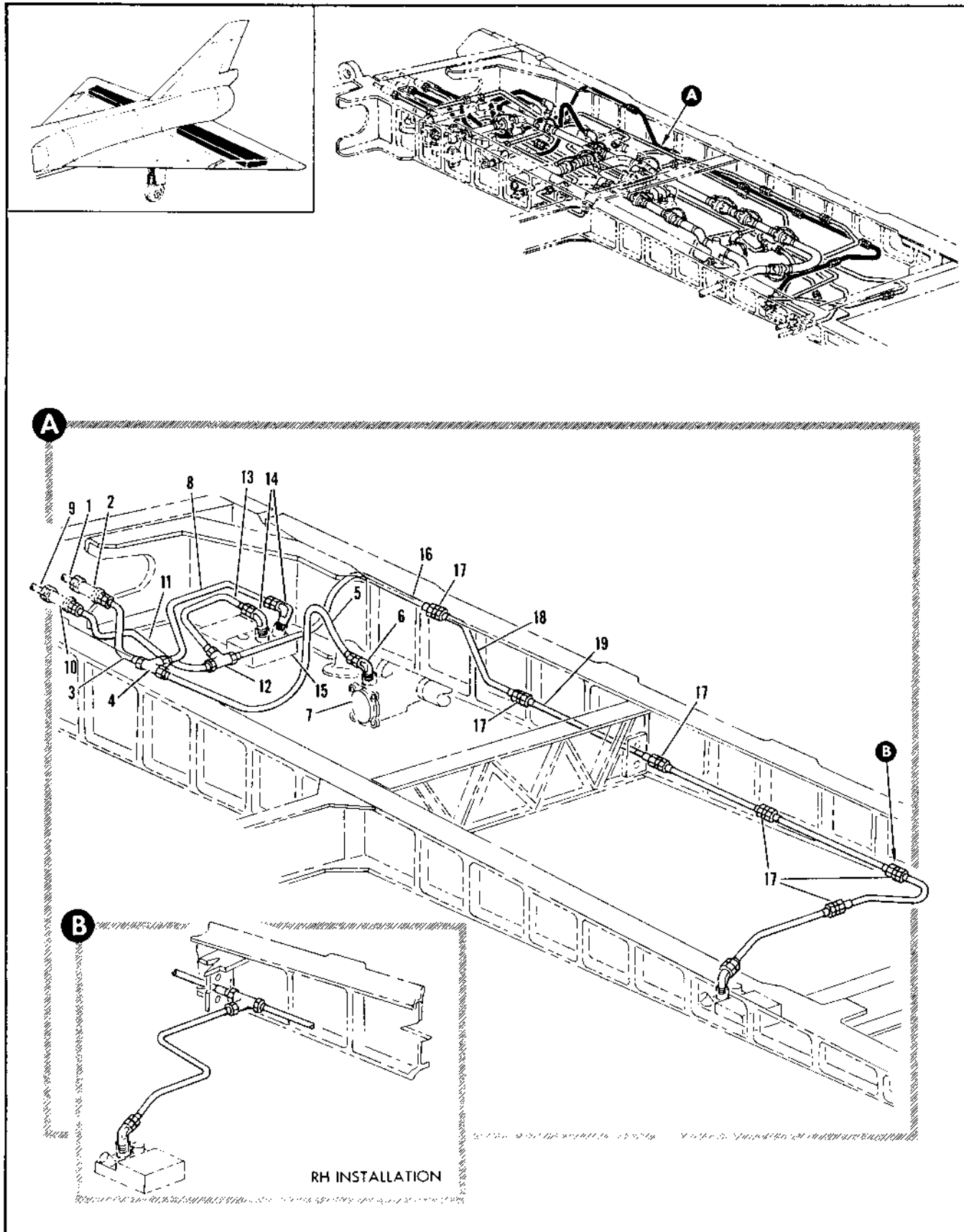

Figure 2.12-21. Wing Transfer Tank Fuel Control Tubing Installation (Sheet 1 of 10)

FIGURE AND INDEX NUMBER	PART NUMBER	DESCRIPTION	UNITS PER ASSY.	USABLE ON CODE	
				FROM	TO
		1 2 3 4 5 6			
2.12-21	8-20397-837	TUBING INSTALLATION, WING TRANSFER TANK FUEL CONTROL LH FOR NHA SEE FIG. 2.6-32	RF	35	159
	8-20397-855	TUBING INSTALLATION, WING TRANSFER TANK FUEL CONTROL FOR NHA SEE FIG. 2.6-32	RF	B	
	8-20397-839	TUBING INSTALLATION, WING TRANSFER TANK FUEL CONTROL RH FOR NHA SEE FIG. 2.6-32	RF	35	159
	8-20397-857	TUBING INSTALLATION, WING TRANSFER TANK FUEL CONTROL FOR NHA SEE FIG. 2.6-32	RF	B	
- 1		• TUBE ASSY. SEE FIG. 2.12-46 INDEX 170	RF		
- 2		• FITTING, TRANSFER AMBIENT TANK PRESSURE SENSING SEE FIG. 2.12-35 INDEX 7	RF		
- 3	8-20397-467	• TUBE ASSY, LOW LEVEL PILOT VALVE PRESSURE	1	35	159
	8-20397-2201	• TUBE ASSEMBLY	1	B	
- 4	MS2190506	• TEE	1	35	159
- 5	8-20397-1161	• TUBE ASSY, LH	1	35	159
	8-20397-2555	• TUBE ASSY, LH	1	B	
	8-20397-1163	• TUBE ASSY, RH	1	35	159
	8-20397-2557	• TUBE ASSY, RH	1	B	
	AN924-6D	• NUT	1	A	
- 6	MS2190806	• ELBOW	1	A	
	MS29512-6	• GASKET	1	A	
- 7		• VALVE ASSY, TRANSFER TANK INRD SHUTOFF SEE FIG. 2.12-30 INDEX 4	RF		
- 8	8-20397-1079	• TUBE ASSY, LH	1	35	159
	8-20397-2539	• TUBE ASSY, LH	1	B	
	8-20397-1839	• TUBE ASSY, RH	1	35	159
	8-20397-2171	• TUBE ASSY, RH	1	B	
- 9		• TUBE ASSY, LH SEE FIG. 2.12-46 INDEX 4A	RF		
		• TUBE ASSY, RH SEE FIG. 2.12-32 INDEX 8B	RF		
- 10		• FITTING, TRANSFER AMBIENT TANK PRESSURE SENSING SEE FIG. 2.12-35 INDEX 7	RF		
- 11	8-20397-473	• TUBE ASSY, LOW LEVEL PILOT VALVE PRESSURE	1	35	159
	8-20397-2483	• TUBE ASSY, LH	1	B	
	8-20397-503	• TUBE ASSY, LOW LEVEL PILOT VALVE PRESSURE	1	35	159
	8-20397-2485	• TUBE ASSY, RH	1	B	
- 12	MS2190506	• TEE	1	A	
- 13	8-20397-1081	• TUBE ASSY, LH	1	A	
	8-20397-2541	• TUBE ASSY, LH	1	B	
	8-20397-1841	• TUBE ASSY, RH	1	35	159
	8-20397-2173	• TUBE ASSY, RH	1	B	
	AN924-6D	• NUT	2	A	
- 14	MS2190806	• ELBOW	2	A	
	MS29512-6	• GASKET	2	A	
- 15		• VALVE ASSY, FUEL TRANSFER PILOT SEE FIG. 2.12-28 INDEX 6	RF		
- 16	8-20397-1085	• TUBE ASSEMBLY	1	35	159
	8-20397-2211	• TUBE ASSEMBLY	1	B	
- 17	MS2190206	• UNION	6	A	
- 18	8-20397-1083	• TUBE ASSEMBLY	1	35	159
	8-20397-2209	• TUBE ASSEMBLY	1	B	
		A AIRPLANES #35 THRU 188, 279 AND ON R AIRPLANES #163 THRU 199, 278 AND ON			

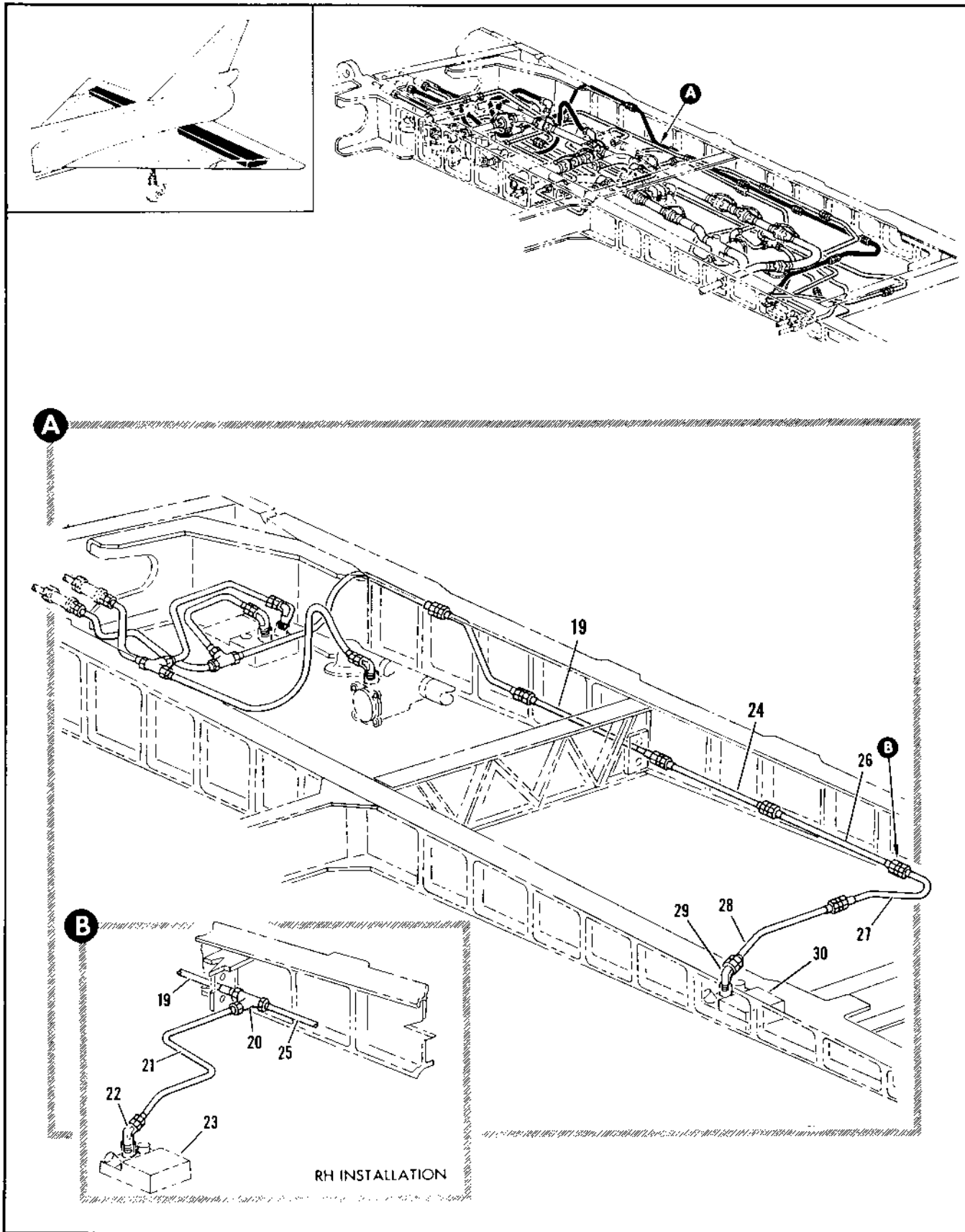

Figure 2.12-21. Wing Transfer Tank Fuel Control Tubing Installation (Sheet 2 of 10)

FIGURE AND INDEX NUMBER	PART NUMBER	DESCRIPTION	UNITS PER ASSY.	USABLE ON CODE	
				FROM	TO
2.12-21- 19	8-20397-179	• TUBE ASSEMBLY	1	35	159
- 20	8-20397-2191	• TUBE ASSEMBLY	1	B	
- 21	MS21905D6	• TEE, RH	1	A	
	8-20397-1817	• TUBE ASSY, RH	1	35	60
	8-20397-1927	• TUBE ASSY, RH	1	61	159
	8-20397-2187	• TUBE ASSY, RH	1	B	
	AN924-60	• NUT, RH	1	A	
- 22	MS21908D6	• ELBOW, RH	1	A	
- 23	MS29512-6	• GASKET, RH	1	A	
		• VALVE ASSY, FUEL TRANSFER PILOT RH SEE FIG. 2.12-34 INDEX 11	RF		
- 24	8-20397-183	• TUBE ASSY, LH	1	35	159
	8-20397-2465	• TUBE ASSY, LH	1	B	
- 25	8-20397-644	• TUBE ASSY, RH	1	35	159
	8-20397-2497	• TUBE ASSY, RH	1	B	
- 26	8-20397-185	• TUBE ASSEMBLY	1	35	159
	8-20397-2193	• TUBE ASSEMBLY	1	9	
- 27	8-20397-1667	• TUBE ASSY, LH	1	35	159
	8-20397-2153	• TUBE ASSY, LH	1	B	
	8-20397-1811	• TUBE ASSY, RH	1	35	159
	8-20397-2585	• TUBE ASSY, RH	1	B	
- 28	8-20397-1077	• TUBE ASSY, LH	1	35	159
	8-20397-2537	• TUBE ASSY, LH	1	B	
	8-20397-1799	• TUBE ASSY, RH	1	35	159
	8-20397-2461	• TUBE ASSY, RH	1	B	
- 29	AN924-60	• NUT	1	A	
	MS21908D6	• ELBOW	1	A	
- 30	MS29512-6	• GASKET	1	A	
		• VALVE ASSY, FUEL TRANSFER PILOT SEE FIG. 2.12-29 INDEX R	RF		

A AIRPLANES #35 THRU 188, 278 AND ON
R AIRPLANES #160 THRU 188, 278 AND ON

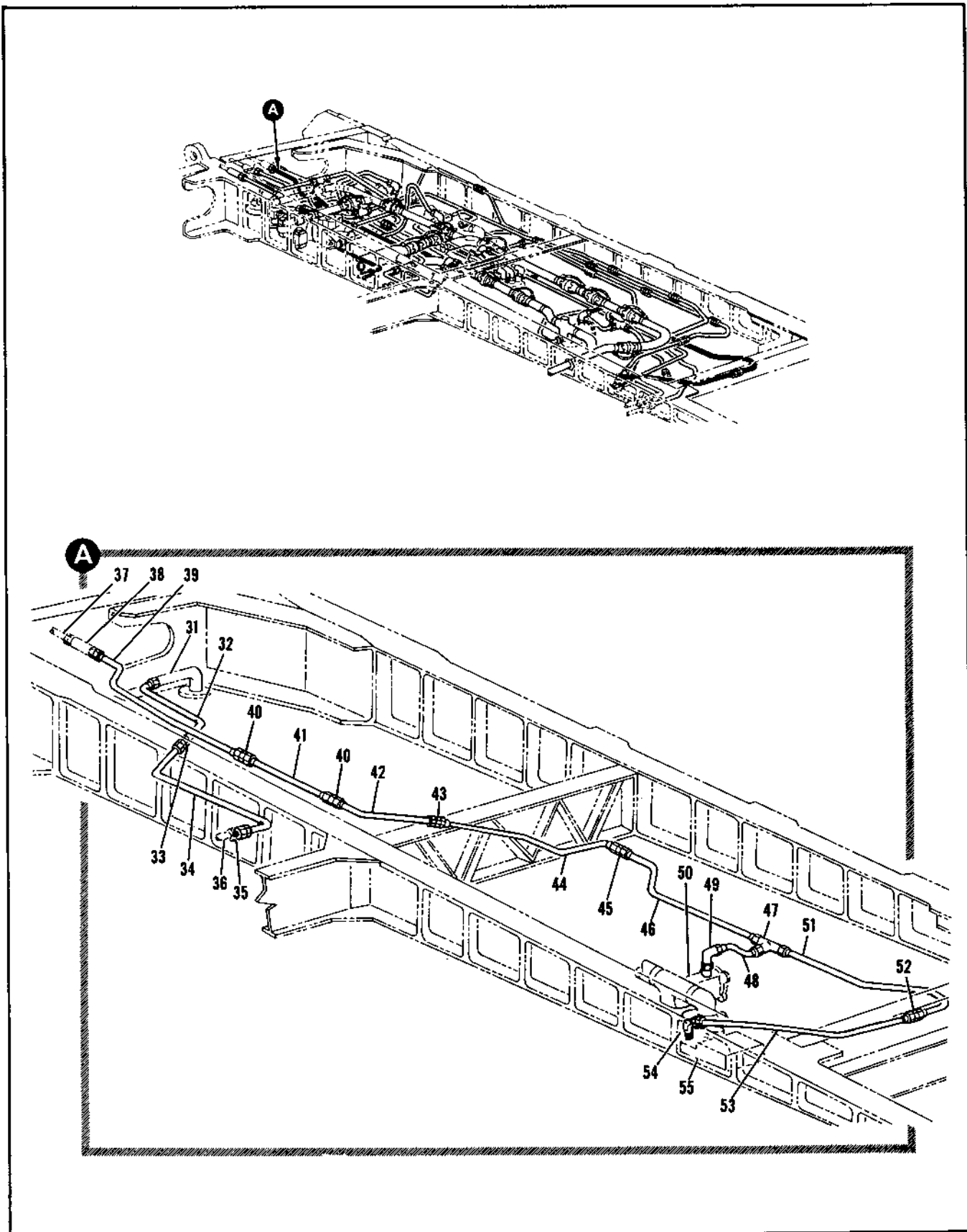

Figure 2.12-21. Wing Transfer Tank Fuel Control Tubing Installation (Sheet 3 of 10)

FIGURE AND INDEX NUMBER	PART NUMBER	DESCRIPTION	UNITS PER ASSY.	USABLE ON CODE	
				FROM	TO
2.12-21- 31		• BELLMOUTH ASSY, TRANSFER TANK FUEL SCAVENGE SEE FIG. 2.12-1 INDEX 110	RF		
- 32	8-20397-494	• TUBE ASSY, LH	1	35	159
	8-20397-2611	• TUBE ASSY, LH	1	B	
	8-20397-628	• TUBE ASSY, RH	1	35	159
	8-20397-2613	• TUBE ASSY, RH	1	B	
- 33	MS21902D8	• UNION	1	A	
- 34	8-20397-492	• TUBE ASSY, LH	1	35	159
	8-20397-2609	• TUBE ASSY, LH	1	R	
	8-20397-646	• TUBE ASSY, RH	1	35	159
	8-20397-2637	• TUBE ASSY, RH	1	R	
- 35		• UNION, SPAR #6 RL 66 SEE FIG. 2.12-66	RF		
- 36		• TUBE ASSY, SEE FIG. 2.12-22	RF		
- 37		• TUBE ASSY, LH SEE FIG. 2.12-4A INDEX 168	RF		
- 38		• FITTING, TRANSFER AMBIENT TANK PRESSURE SENSING SEE FIG. 2.12-35 INDEX 7	RF		
- 39	8-20397-471	• TUBE ASSEMBLY	1	35	159
	8-20397-2203	• TUBE ASSEMBLY	1	B	
- 40	MS21902D6	• UNION	2	A	
- 41	8-20397-526	• TUBE ASSEMBLY	1	35	159
	8-20397-2205	• TUBE ASSEMBLY	1	B	
- 42	8-20397-608	• TUBE ASSY, LH	1	35	159
	8-20397-2493	• TUBE ASSY, LH	1	B	
	8-20397-1019	• TUBE ASSY, RH	1	35	159
	8-20397-2517	• TUBE ASSY, RH	1	B	
- 43	MS21902D6	• UNION	1	A	
- 44	8-20397-606	• TUBE ASSY, LH	1	35	159
	8-20397-2491	• TUBE ASSY, LH	1	B	
	8-20397-1851	• TUBE ASSY, RH	1	35	159
	8-20397-2183	• TUBE ASSY, RH	1	R	
- 45	MS21902D6	• UNION	1	A	
- 46	8-20397-604	• TUBE ASSY, LH	1	35	159
	8-20397-2489	• TUBE ASSY, LH	1	B	
	8-20397-1021	• TUBE ASSY, PH	1	35	159
	8-20397-2519	• TUBE ASSY, PH	1	9	
- 47	MS21095D6	• TEE	1	A	
- 48	8-20397-1027	• TUBE ASSY, LH	1	35	159
	8-20397-2467	• TUBE ASSY, LH	1	R	
	8-20397-1809	• TUBE ASSY, RH	1	35	159
	8-20397-2583	• TUBE ASSY, RH	1	B	
	AN924-6D	• NUT	1	A	
- 49	MS21908D6	• ELBOW	1	A	
	MS29512-6	• GASKET	1	A	
- 50		• VALVE ASSY, TRANSFER TANK OUTBD SHUTOFF SEE FIG. 2.12-27 INDEX 6	RF		
- 51	8-20397-1071	• TUBE ASSY, LH	1	35	159
	8-20397-2531	• TUBE ASSY, LH	1	B	
	8-20397-1801	• TUBE ASSY, RH	1	35	159
	8-20397-2577	• TUBE ASSY, RH	1	B	
- 52	MS21902D6	• UNION	1	A	
- 53	8-20397-1073	• TUBE ASSY, LH	1	35	159
	8-20397-2533	• TUBE ASSY, LH	1	B	
	8-20397-1795	• TUBE ASSY, RH	1	35	159
	8-20397-2457	• TUBE ASSY, PH	1	B	
	AN924-6D	• NUT	1	A	
- 54	MS21908D6	• ELBOW	1	A	
	MS29512-6	• GASKET	1	A	
- 55		• VALVE ASSY, FUEL TRANSFER PILOT SEE FIG. 2.12-29 INDEX 9	RF		

A AIRPLANES #35 THRU 18A, 27H AND ON
R AIRPLANES #160 THRU 1PA, 278 AND ON

FIGURE AND INDEX NUMBER	PART NUMBER	DESCRIPTION	UNITS PER ASSY.	USABLE ON CODE	
				FROM	TO
2.12-21- 56		• TUBE ASSY, SEE FIG. 2.12-46 INDEX 135	RF		
- 57		• TUBE ASSY, SEE FIG. 2.12-32 INDEX 79	RF		
- 58	8-20397-616	• FITTING, TRANSFER AMBIENT TANK PRESSURE SENSING SEE FIG. 2.12-35 INDEX 7	RF		
- 59	8-20397-2495	• TUBE ASSY, VENT VALVE PRESSURE LH	1	35	159
- 60	8-20397-1023	• TUBE ASSY, LH	1	B	
- 61	8-20397-2521	• TUBE ASSY, VENT VALVE PRESSURE RH	1	35	159
- 62	MS21962D6	• TUBE ASSY, RH	1	B	
- 63	8-20397-1025	• UNION, RH	1	35	159
- 64	8-20397-2523	• TUBE ASSY, RH	1	B	
- 65	MS21962D6	• UNION	1	A	
- 66	MS29512-6	• GASKET	1	A	
- 67		• VALVE ASSY, TRANSFER TANK VENT SEE FIG. 2.12-25 INDEX 1	RF		
- 68	MS21902D4	• UNION	1	A	
- 69	MS29512-4	• GASKET	1	A	
- 70	8-20397-1661	• TUBE ASSY, LH	1	35	159
- 71	8-20397-2151	• TUBE ASSY, LH	1	B	
- 72	8-20397-1485	• TUBE ASSY, RH	1	35	159
- 73	8-20397-2561	• TUBE ASSY, RH	1	B	
- 74	MS21902D4	• UNION	1	A	
- 75	8-20397-1659	• TUBE ASSY, LH	1	35	159
- 76	8-20397-2140	• TUBE ASSY, LH	1	B	
- 77	8-20397-1483	• TUBE ASSY, RH	1	35	159
- 78	8-20397-2559	• TUBE ASSY, RH	1	B	
- 79	MS21916D6-4	• REDUCER	1	A	
- 80	8-20397-1671	• TUBE ASSY, LH	1	35	159
- 81	8-20397-2155	• TUBE ASSY, LH	1	B	
- 82	8-20397-1013	• TUBE ASSY, RH	1	35	159
- 83	8-20397-2515	• TUBE ASSY, RH	1	B	
- 84	MS21902D6	• UNION	3	A	
- 85	8-20397-164	• TUBE ASSEMBLY	1	35	159
- 86	8-20397-2189	• TUBE ASSEMBLY	1	B	
- 87	8-20397-1677	• TUBE ASSY, LH	1	35	159
- 88	8-20397-2159	• TUBE ASSY, LH	1	B	
- 89	8-20397-1813	• TUBE ASSY, RH	1	35	159
- 90	8-20397-2587	• TUBE ASSY, RH	1	B	
- 91	8-20397-168	• TUBE ASSY, LH	1	35	159
- 92	8-20397-2463	• TUBE ASSY, LH	1	B	
- 93	8-20397-1803	• TUBE ASSY, RH	1	35	159
- 94	8-20397-2579	• TUBE ASSY, RH	1	B	
- 95		• UNION, SPAP #6 BL 143 SEE FIG. 2.12-66	RF		
- 96		• TUBE ASSY, SEE FIG. 2.12-19 INDEX 25	RF		
- 97		• TUBE ASSY, SEE FIG. 2.12-46 INDEX 131	RF		
- 98		• FITTING, LH SEE FIG. 2.12-35 INDEX 24	RF		
- 99	8-20397-664	• TUBE ASSY, EMERGENCY PILOT VALVE PRESS LH	1	35	159
- 100	8-20397-2503	• TUBE ASSY, EMERGENCY PILOT VALVE PRESS LH	1	B	
- 101	MS21902D6	• UNION, LH	2	A	
- 102	8-20397-684	• TUBE ASSY, LH	1	35	159
- 103	8-20397-2525	• TUBE ASSY, LH	1	B	

A AIRPLANES #35 THRU 1PP, 27P AND ON
 B AIRPLANES #150 THRU 1PP, 27P AND ON

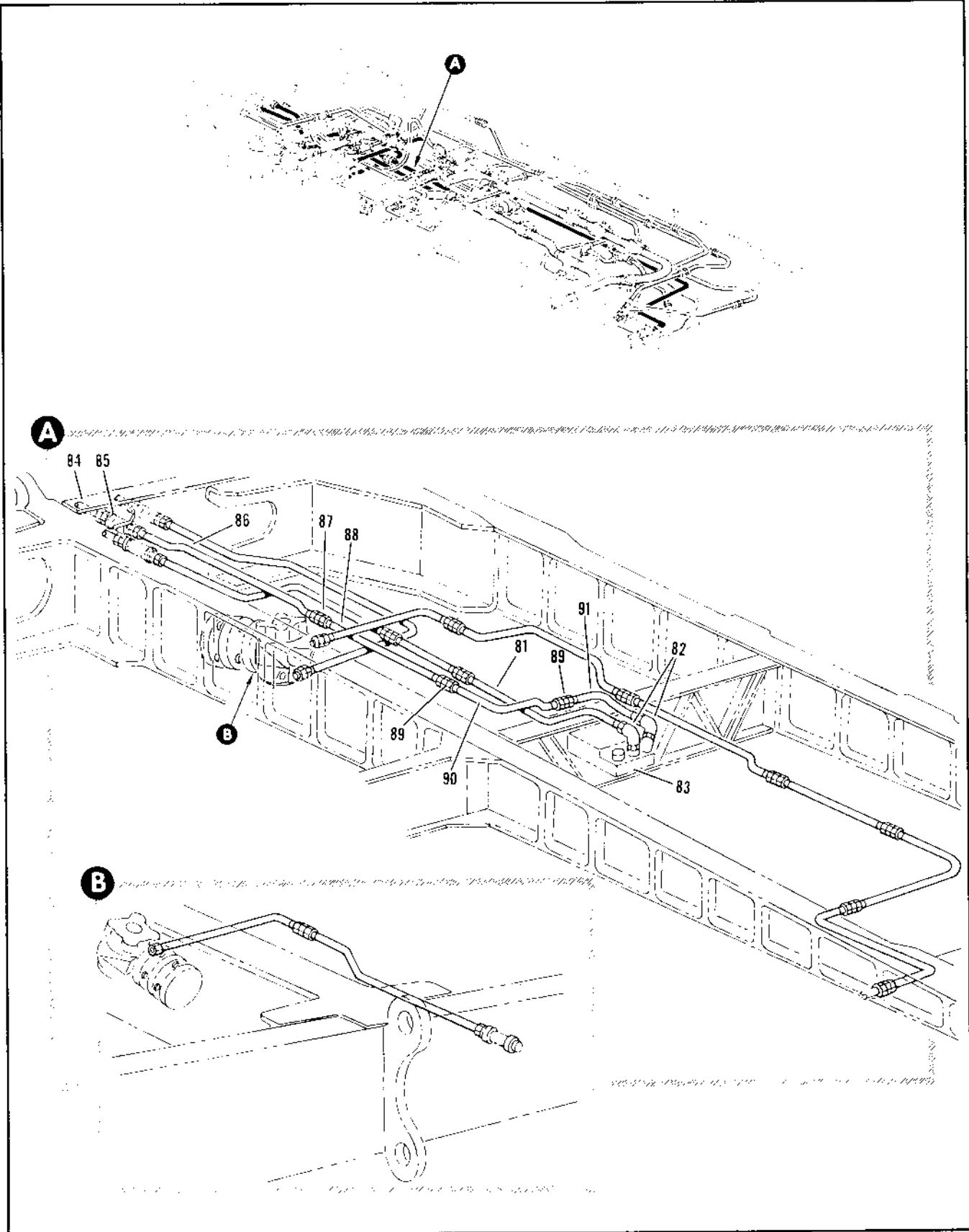

Figure 2.12-21. Wing Transfer Tank Fuel Control Tubing Installation (Sheet 5 of 10)

FIGURE AND INDEX NUMBER	PART NUMBER	DESCRIPTION	UNITS PER ASSY.	USABLE ON CODE	
				FROM	TO
2.12-21- 81	8-20397-1655	• TUBE ASSY, LH	1	35	159
	8-20397-2145	• TUBE ASSY, LH	1	B	
- 82	AN924-4D	• NUT	2	A	
	MS21994D4	• ELBOW	2	A	
- 83	MS29512-4	• BASKET	2	A	
		• VALVE ASSY, FUEL TRANSFER PILOT SEE FIG. 2.12-34 INDEX 11	RF		
- 84		• TUBE ASSY, LH SEE FIG. 2.12-46 INDEX 135	RF		
- 85		• FITTING, SEE FIG. 2.12-35 INDEX 23	RF		
- 86	8-20397-1637	• TUBE ASSY, LH	1	35	159
	8-20397-2563	• TUBE ASSY, LH	1	B	
- 87	8-20397-1845	• TUBE ASSY, RH	1	35	159
	8-20397-2177	• TUBE ASSY, RH	1	B	
- 88	MS21902D6	• UNION	1	A	
	8-20397-476	• TUBE ASSY, LH	1	35	159
- 89	8-20397-2625	• TUBE ASSY, LH	1	B	
	8-20397-468	• TUBE ASSY, RH	1	35	159
- 90	8-20397-2481	• TUBE ASSY, RH	1	R	
	MS21402D6	• UNION	2	A	
- 91	8-20397-1035	• TUBE ASSY, LH	1	35	159
	8-20397-2527	• TUBE ASSY, LH	1	B	
- 91	8-20397-1823	• TUBE ASSY, RH	1	35	159
	8-20397-2595	• TUBE ASSY, RH	1	B	
- 91	8-20397-1657	• TUBE ASSY, LH	1	35	159
	8-20397-2147	• TUBE ASSY, LH	1	B	
	8-20397-1821	• TUBE ASSY, RH	1	35	159
	8-20397-2593	• TUBE ASSY, RH	1	R	

A AIRPLANES #35 THRU 188, 278 AND ON
 R AIRPLANES #160 THRU 198, 278 AND ON

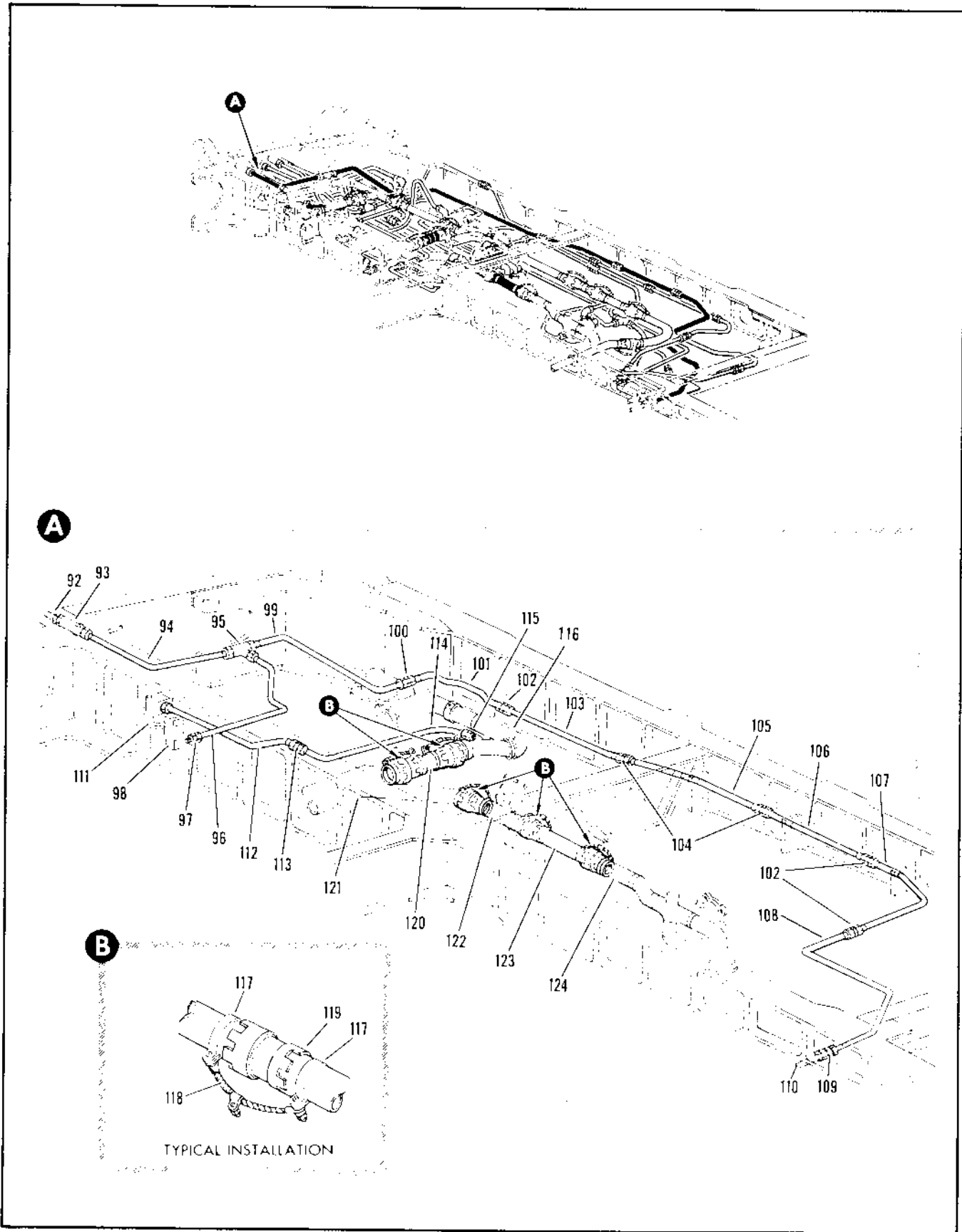

Figure 2.12-21. Wing Transfer Tank Fuel Control Tubing Installation (Sheet 6 of 10)

FIGURE AND INDEX NUMBER	PART NUMBER	DESCRIPTION	UNITS PER ASSY.	USABLE ON CODE	
				FROM	TO
2.12-21- 92		• TUBE ASSEMBLY SEE FIG. 2.12-46 INDEX 145	RF		
- 93		• FITTING, SEE FIG. 2.12-35 INDEX 5	RF		
- 94	8-20397-1651	• TUBE ASSY, TRANSFER TANK AMBIENT SENSING LH	1	35	159
	8-20397-2141	• TUBE ASSY, TRANSFER TANK AMBIENT SENSING LH	1	B	
	8-20397-1849	• TUBE ASSY, TRANSFER TANK AMBIENT SENSING LH	1	35	159
	8-20397-2181	• TUBE ASSY, TRANSFER TANK AMBIENT SENSING RH	1	B	
	MS21905D4	• TUBE ASSY, TRANSFER TANK AMBIENT SENSING RH	1	A	
- 95		• TEE	1	35	159
- 96	8-20397-1649	• TUBE ASSY, LH	1	B	
	8-20397-2575	• TUBE ASSY, LH	1	35	159
	8-20397-1847	• TUBE ASSY, RH	1	B	
	8-20397-2179	• TUBE ASSY, RH	1	A	
- 97	MS21902D4	• UNION	1	A	
	MS29512-4	• GASKET	1	A	
- 98		• VALVE ASSY, SEE FIG. 2.12-1 INDEX 94	RF		
- 99	8-20397-1673	• TUBE ASSY, LH	1	35	159
	8-20397-2157	• TUBE ASSY, LH	1	B	
	8-20397-1833	• TUBE ASSY, RH	1	35	159
	8-20397-2165	• TUBE ASSY, RH	1	B	
-100	MS21902D4	• UNION	1	A	
-101	8-20397-1675	• TUBE ASSEMBLY	1	35	159
	8-20397-2453	• TUBE ASSEMBLY	1	B	
-102	MS21902D4	• UNION	1	A	
-103	8-20397-162	• TUBE ASSY, LH	1	35	159
	8-20397-2219	• TUBE ASSY, LH	1	B	
	8-20397-196	• TUBE ASSY, RH	1	35	159
	8-20397-2469	• TUBE ASSY, RH	1	B	
-104	MS21902D4	• UNION	4	A	
-105	8-20397-249	• TUBE ASSY, LH	1	A	
	8-20397-2471	• TUBE ASSY, LH	1	B	
	8-20397-323	• TUBE ASSY, RH	1	35	159
	8-20397-2473	• TUBE ASSY, LH	1	B	
-106	8-20397-251	• TUBE ASSEMBLY	1	35	159
	8-20397-2195	• TUBE ASSEMBLY	1	B	
-107	8-20397-1669	• TUBE ASSEMBLY	1	35	159
	8-20397-2217	• TUBE ASSEMBLY	1	B	
-108	8-20397-432	• TUBE ASSEMBLY	1	35	159
	8-20397-2197	• TUBE ASSEMBLY	1	B	
-109		• UNION, SPAR #6 BL 142 SEE FIG. 2.12-66	RF		
-110		• TUBE ASSY, SEE FIG 2.12-19 INDEX 11	RF		
-111		• FLANGE, DRAIN SEE FIG. 2.6-37 INDEX 1	RF		
-112	8-20397-654	• TUBE ASSY, LH	1	35	159
	8-20397-2501	• TUBE ASSY, LH	1	9	
	8-20397-648	• TUBE ASSY, RH	1	35	159
	8-20397-2499	• TUBE ASSY, RH	1	B	
-113	MS21902D4	• UNION	1	A	
-114	8-20397-518	• TUBE ASSY, LH	1	35	159
	8-20397-2487	• TUBE ASSY, LH	1	B	
	8-20397-1825	• TUBE ASSY, RH	1	35	159
	8-20397-2597	• TUBE ASSY, RH	1	B	
-115	MS21916D8-4	• REDUCER	1	A	
	MS29512-8	• GASKET	1	A	
-116		• TUBE ASSY, LH SEE FIG. 2.12-30 INDEX 10	RF		
-117	AN735D40	• CLAMP	10	A	
	NAS679A3	• NUT	10	A	
	AN960D10L	• WASHER	10	A	
	AN526-1C32R6	• SCREW	10	A	
-118	MS25183-1884	• JUMPER	5	A	
-119	3605-4GD	• COUPLING, <79326> 92-72500-304	5	A	
	MS29513-333	• PACKING	5	A	
-120	8-20397-204	• TUBE ASSEMBLY	1	35	188
	8-20397-2927	• TUBE ASSEMBLY	1	278	
-121		• TUBE ASSY, LH SEE FIG. 2.12-14 INDEX 73	RF		
-122		• TUBE ASSY, SEE FIG. 2.12-2 INDEX 14	RF		
-123	8-20397-171	• TUBE ASSEMBLY	1	35	188
	8-20397-2923	• TUBE ASSEMBLY	1	278	
-124		• TUBE ASSY, SEE FIG. 2.12-27 INDEX 19	RF		

A AIRPLANES #35 THRU 188, 278 AND ON
 R AIRPLANES #166 THRU 188, 278 AND ON

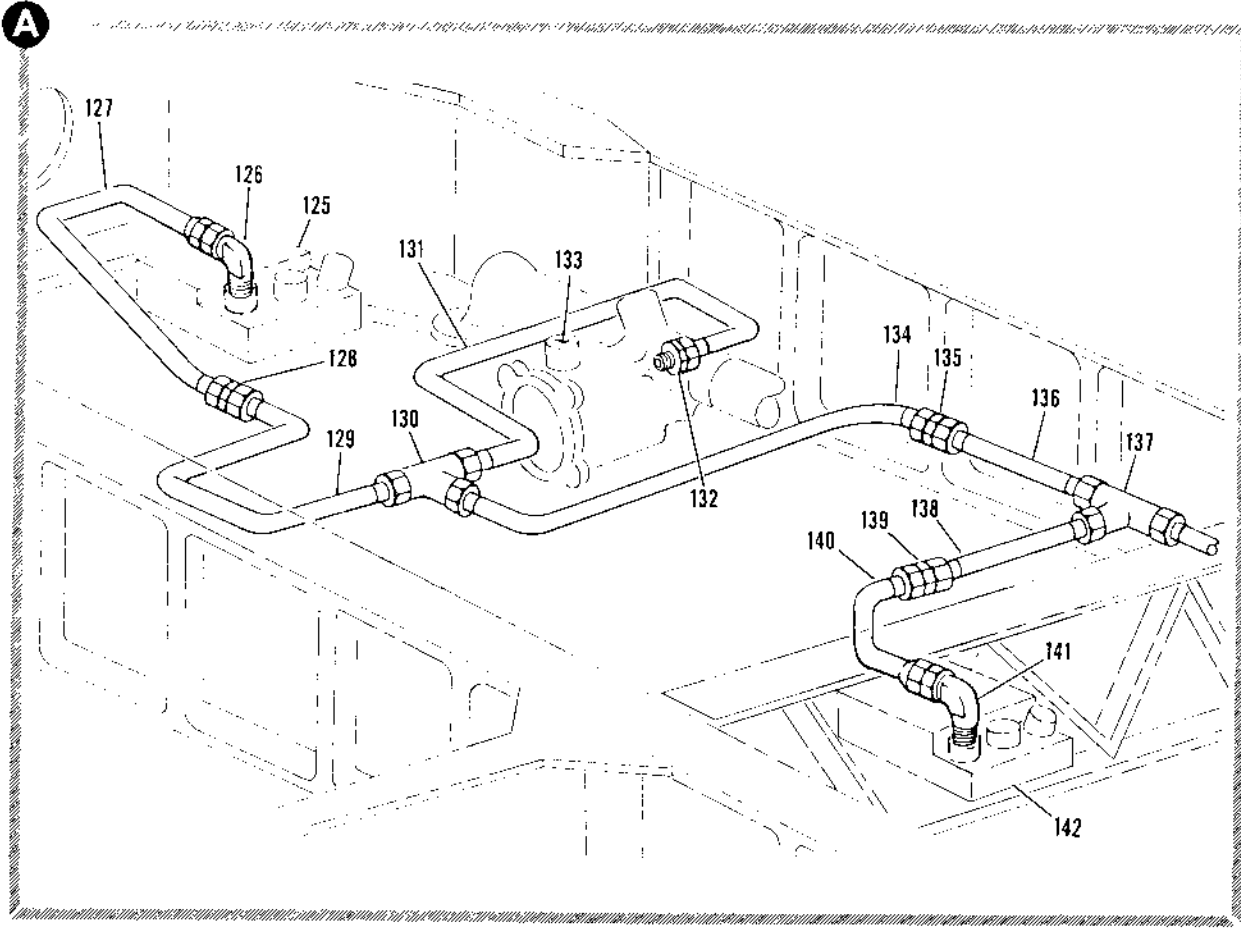
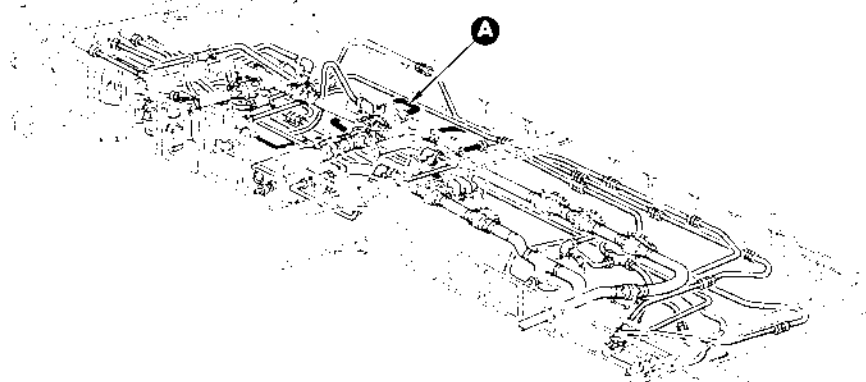

Figure 2.12-21. Wing Transfer Tank Fuel Control Tubing Installation (Sheet 7 of 10)

FIGURE AND INDEX NUMBER	PART NUMBER	DESCRIPTION	UNITS PER ASSY.	USABLE ON CODE	
				FROM	TO
2.12-21-125		• VALVE ASSY, FUEL TRANSFER PILOT SEE FIG. 2.12-29 INDEX 8	RF		
-126	AN924-4D	• NUT	1	A	
	MS21908D4	• ELBOW	1	A	
	MS29512-4	• GASKET	1	A	
-127	8-20397-764	• TUBE ASSY, LH	1	35	159
	8-20397-2511	• TUBE ASSY, LH	1	B	
	8-20397-1431	• TUBE ASSY, RH	1	35	159
	8-20397-2163	• TUBE ASSY, RH	1	B	
-126	MS21916D6-4	• REDUCER	1	A	
-129	8-20397-762	• TUBE ASSY, LH	1	35	159
	8-20397-2513	• TUBE ASSY, LH	1	B	
	8-20397-1835	• TUBE ASSY, RH	1	35	159
	8-20397-2167	• TUBE ASSY, RH	1	B	
-130	MS21905D6	• TEE	1	A	
-131	8-20397-760	• TUBE ASSY, LH	1	35	159
	8-20397-2507	• TUBE ASSY, LH	1	B	
	8-20397-1827	• TUBE ASSY, RH	1	35	159
	8-20397-2599	• TUBE ASSY, RH	1	B	
-132	MS21902D6	• UNION	1	A	
	MS29512-6	• GASKET	1	A	
-133		• VALVE ASSY, TRANSFER TANK INBD SHUTOFF SEE FIG. 2.12-30 INDEX 4	RF		
-134	8-20397-762	• TUBE ASSY, LH	1	35	159
	8-20397-2509	• TUBE ASSY, LH	1	B	
	8-20397-1829	• TUBE ASSY, RH	1	35	159
	8-20397-2161	• TUBE ASSY, RH	1	B	
-135	MS21902D6	• UNION	1	A	
-136	8-20397-766	• TUBE ASSEMBLY	1	35	159
	8-20397-2207	• TUBE ASSEMBLY	1	B	
-137	MS21905D6	• TEE, LH	1	A	
-138	ER824D0E0604	• TEE, RH <92003> 98-90310-038	1	A	
	8-20397-1027	• TUBE ASSY, LH	1	35	159
	8-20397-2525	• TUBE ASSY, LH	1	R	
	8-20397-1437	• TUBE ASSY, RH	1	35	159
	8-20397-2169	• TUBE ASSY, RH	1	B	
-139	MS21916D6-4	• REDUCER, LH	1	A	
-140	8-20397-1653	• TUBE ASSY, LH	1	35	159
	8-20397-2143	• TUBE ASSY, LH	1	B	
	AN924-4D	• NUT, RH	1	A	
	AN924-6	• NUT, LH	1	A	
-141	MS21908D4	• ELBOW, RH	1	A	
	MS21908D6	• ELBOW, LH	1	A	
	MS29512-4	• GASKET, RH	1	A	
	MS29512-6	• GASKET, LH	1	A	
-142		• VALVE ASSY, FUEL TRANSFER PILOT SEE FIG. 2.12-34 INDEX 11	RF		

A AIRPLANES #15 THRU 184, 278 AND ON
B AIRPLANES #160 THRU 182, 278 AND ON

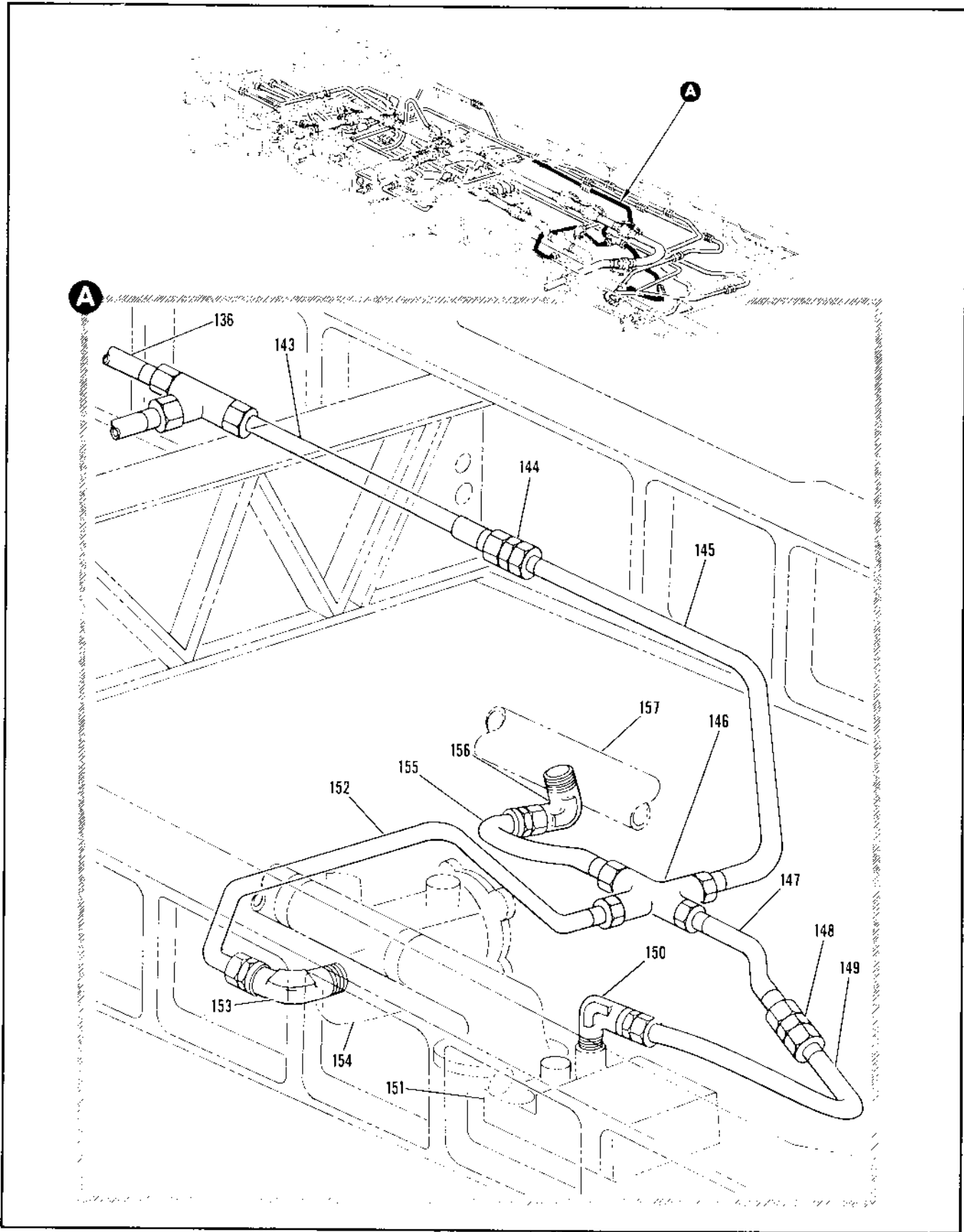

Figure 2.12-21. Wing Transfer Tank Fuel Control Tubing Installation (Sheet 8 of 10)

FIGURE AND INDEX NUMBER	PART NUMBER	DESCRIPTION	UNITS PER ASSY.	USABLE ON CODE	
				FROM	TO
2.12-21-143	8-20397-392	• TUBE ASSY, LH	1	35	159
	8-20397-2475	• TUBE ASSY, LH	1	B	
	8-20397-1815	• TUBE ASSY, RH	1	35	159
	8-20397-2589	• TUBE ASSY, RH	1	B	
-144	MS2190206	• UNION	1	A	
	8-20397-445	• TUBE ASSY, LH	1	35	159
	8-20397-2479	• TUBE ASSY, LH	1	R	
-145	8-20397-1819	• TUBE ASSY, RH	1	35	159
	8-20397-2591	• TUBE ASSY, RH	1	B	
-146	MS2190606	• CROSS	1	A	
	8-20397-1069	• TUBE ASSY, LH	1	35	159
	8-20397-2529	• TUBE ASSY, LH	1	B	
-147	8-20397-1797	• TUBE ASSY, RH	1	35	159
	8-20397-2455	• TUBE ASSY, RH	1	B	
	MS2191606-4	• REDUCER, LH	1	A	
	MS2190206	• UNION, RH	1	A	
-148	8-20397-1075	• TUBE ASSY, LH	1	35	159
	8-20397-2535	• TUBE ASSY, LH	1	B	
	8-20397-1793	• TUBE ASSY, RH	1	35	159
	8-20397-2455	• TUBE ASSY, RH	1	B	
-149	AN924-40	• NUT, LH	1	A	
	MS2190804	• ELBOW, LH	1	A	
	MS29512-4	• GASKET, LH	1	A	
-150	AN924-60	• NUT, RH	1	A	
	MS2190806	• ELBOW, RH	1	A	
	MS29512-6	• GASKET, RH	1	A	
-151		• VALVE ASSY, FUEL TRANSFER PILOT SEE FIG. 2.12-34 INDEX 11	RF		
	8-20397-443	• TUBE ASSY, LH	1	35	159
	8-20397-2477	• TUBE ASSY, LH	1	B	
-152	8-20397-1089	• TUBE ASSY, RH	1	35	159
	8-20397-2543	• TUBE ASSY, RH	1	R	
	AN924-60	• NUT, LH	1	A	
	MS2190806	• ELBOW, LH	1	A	
	MS2190206	• UNION, RH	1	A	
-153	MS29512-6	• GASKET	1	A	
-154		• VALVE ASSY, TRANSFER TANK INRD SHUTOFF SEE FIG. 2.12-30 INDEX 4	RF		
	8-20397-441	• TUBE ASSEMBLY	1	35	159
	8-20397-2199	• TUBE ASSEMBLY	1	B	
	AN924-60	• NUT	1	A	
-155	MS2190806	• ELBOW	1	A	
-156	MS29512-6	• GASKET	1	A	
-157		• TUBE ASSY, VACUUM AND PRESSURE RELIEF LH SEE FIG. 2.12-14 INDEX 30	RF		

A AIRPLANES #35 THRU 188, 276 AND ON
R AIRPLANES #160 THRU 188, 278 AND ON

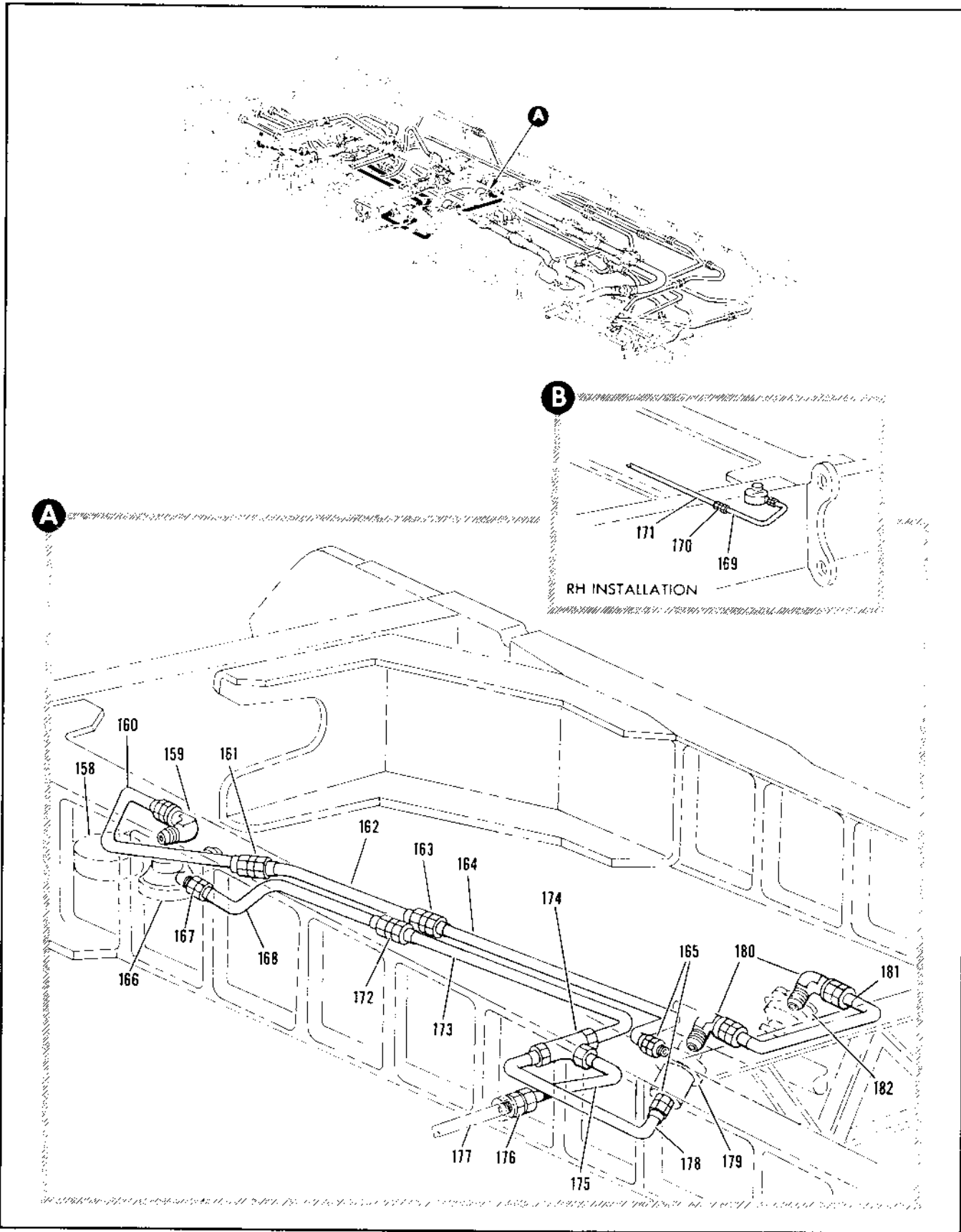

Figure 2.12-21. Wing Transfer Tank Fuel Control Tubing Installation (Sheet 9 of 10)

FIGURE AND INDEX NUMBER	PART NUMBER	DESCRIPTION	UNITS PER ASSY.	USABLE ON CODE	
				FROM	TO
2.12-21-158		• VALVE ASSY, FUEL TANK PILOT FLOAT SEE FIG. 2.12-26 INDEX 6	RF		
	AN924-40	• NUT	1	A	
-159	MS21988D4	• ELBOW	1	A	
	MS29512-4	• GASKET	1	A	
-160	8-20397-1843	• TUBE ASSY, LH	1	35	159
	8-20397-2569	• TUBE ASSY, LH	1	B	
	8-20397-1843	• TUBE ASSY, RH	1	35	159
	8-20397-2175	• TUBE ASSY, RH	1	R	
-161	MS21902D4	• UNION	1	A	
-162	8-20397-1119	• TUBE ASSY, LH	1	35	159
	8-20397-2545	• TUBE ASSY, LH	1	B	
	8-20397-1805	• TUBE ASSY, RH	1	35	159
	8-20397-2581	• TUBE ASSY, RH	1	R	
-163	MS21902D4	• UNION	1	A	
-164	8-20397-1641	• TUBE ASSY, LH	1	35	159
	8-20397-2567	• TUBE ASSY, LH	1	B	
	8-20397-1133	• TUBE ASSY, RH	1	35	159
	8-20397-2547	• TUBE ASSY, RH	1	R	
-165	MS21902D4	• UNION	2	A	
	MS29512-4	• GASKET	2	A	
-166		• VALVE ASSY, FUEL TANK VENT REFUELING SEE FIG. 2.12-26 INDEX 3	RF		
-167	MS21902D4	• UNION	1	A	
	MS29512-4	• GASKET	1	A	
-168	8-20397-1647	• TUBE ASSY, LH	1	35	159
	8-20397-2573	• TUBE ASSY, LH	1	R	
-169	8-20397-1143	• TUBE ASSY, RH	1	35	159
-170	MS21902D4	• UNION, RH	1	35	159
-171	8-20397-1853	• TUBE ASSY, RH	1	35	159
-172	MS21902D4	• UNION	1	A	
-173	8-20397-1645	• TUBE ASSY, LH	1	35	159
	8-20397-2185	• TUBE ASSY, LH	1	R	
	8-20397-1139	• TUBE ASSY, RH	1	35	159
	8-20397-2571	• TUBE ASSY, RH	1	R	
-174	MS21905D4	• TEE	1	A	
-175	8-20397-1101	• TUBE ASSY, RH	1	35	159
	8-20397-2549	• TUBE ASSY, RH	1	R	
-176		• UNION, SPAR #6 BL 60 AND 142 SEE FIG. 2.12-26 INDEX 10	RF		
-177		• TUBE ASSY, LH SEE FIG. 2.12-20 INDEX 43	RF		
-178	8-20397-1103	• TUBE ASSEMBLY	1	35	159
	8-20397-3213	• TUBE ASSEMBLY	1	B	
	8-20397-2215	• TUBE ASSEMBLY	1	R	
-179		• VALVE ASSY, PRESSURE OPERATED PILOT SEE FIG. 2.12-2 INDEX 21	RF		
-180	AN924-40	• NUT	2	A	
	MS21988D4	• ELBOW	2	A	
	MS29512-4	• GASKET	2	A	
-181	8-20397-1639	• TUBE ASSY, LH	1	35	159
	8-20397-2565	• TUBE ASSY, LH	1	B	
	8-20397-1149	• TUBE ASSY, RH	1	35	159
	8-20397-2553	• TUBE ASSY, RH	1	R	
-182		• VALVE ASSY, PILOT OPERATED FUEL SHUTOFF SEE FIG. 2.12-2 INDEX 1	RF		

A AIRPLANES #35 THRU 1PR, 27R AND ON
B AIRPLANES #16L THRU 1PR, 27R AND ON

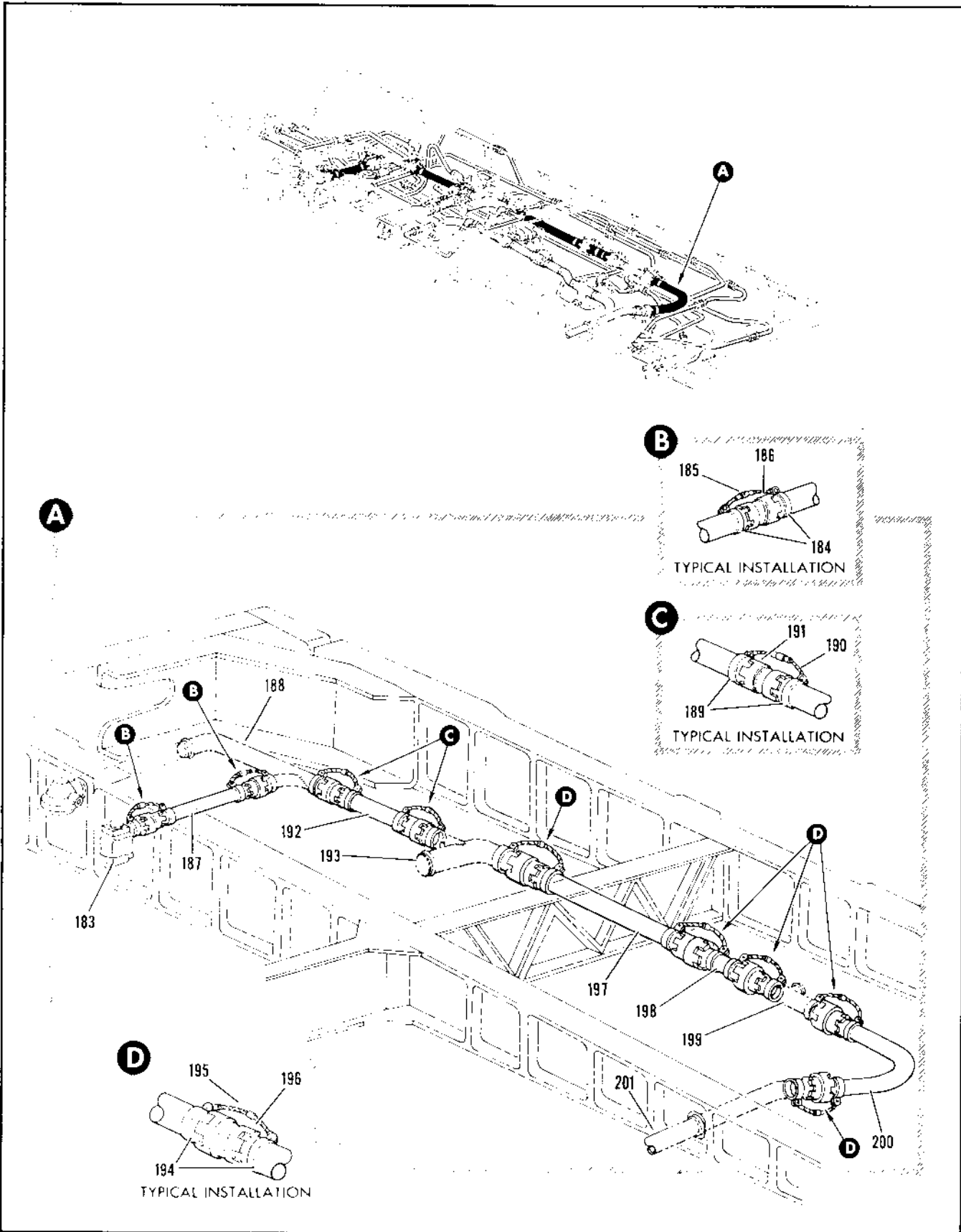

Figure 2.12-21. Wing Transfer Tank Fuel Control Tubing Installation (Sheet 10 of 10)

FIGURE AND INDEX NUMBER	PART NUMBER	DESCRIPTION	UNITS PER ASSY.	USABLE ON CODE	
				FROM	TO
2.12-21-183		1 2 3 4 5 6			
-184	AN735012	• VALVE ASSY, TRANSFER TANK PRESSURE RELIEF SEE FIG. 2.12-1 INDEX 24	RF		
	NAS679A3	• CLAMP	4	A	
	AN960D10L	ATTACHING PARTS	4	A	
	AN526-1032R6	• NUT	4	A	
		• WASHER	4	A	
		• SCREW	4	A	
		-----X----			
-185	MS25083-18B3	• JUMPER	2	A	
-186	3605-120	• COUPLING, <79326> 92-72500-009	2	A	
	MS29513-210	• PACKING	2	A	
-187	8-20397-1121	• TUBE ASSEMBLY	1	A	
-188		• MANIFOLD ASSY, LH SEE FIG. 2.12-25 INDEX 20	RF		
-189	AN735016	• CLAMP	4	A	
		ATTACHING PARTS			
	NAS679A3	• NUT	4	A	
	AN960D10L	• WASHER	4	A	
	AN526-1032R6	• SCREW	4	A	
		-----X----			
-190	MS25083-18B3	• JUMPER	2	A	
-191	3605-160	• COUPLING, <79326> 92-72500-001	2	A	
	MS29513-214	• PACKING	2	A	
-192	8-20397-1123	• TUBE ASSEMBLY	1	A	
-193		• TUBE ASSY, LH SEE FIG. 2.12-25 INDEX 18	RF		
-194	AN735024	• CLAMP	10A		
		ATTACHING PARTS			
	NAS679A3	• NUT	10	A	
	AN960D10L	• WASHER	10	A	
	AN526-1032R6	• SCREW	10	A	
		-----X-----			
-195	MS25083-18B4	• JUMPER	5	A	
-196	3605-240	• COUPLING, <79326> 92-72500-003	5	A	
	MS29513-325	• PACKING	5	A	
-197	8-20397-1665	• TUBE ASSY, LH	1	A	
	8-20397-1807	• TUBE ASSY, RH	1	A	
-198	8-20397-1663	• TUBE ASSEMBLY	1	A	
-199		• TUBE ASSY, VACUUM AND PRESSURE RELIEF LH SEE FIG. 2.12-14 INDEX 30	RF		
-200	8-20397-175	• TUBE ASSEMBLY	1	A	
-201		• TUBE ASSY, TRANSFER TANK VENT SEE FIG. 2.12-4 INDEX 23	RF		
A AIRPLANES #35 THRU 186, 278 AND ON					

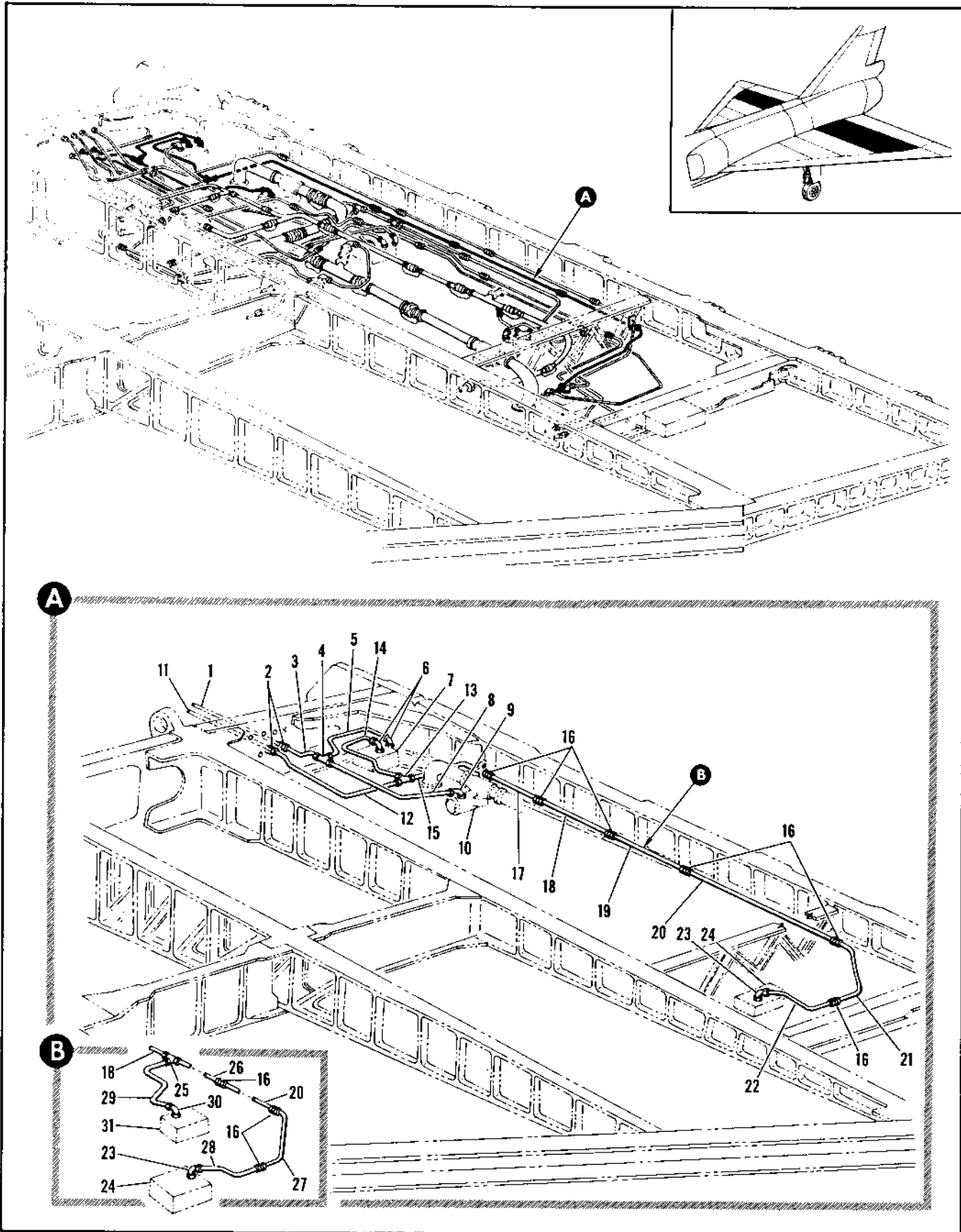

Figure 2.12-22. Wing Transfer Tank Fuel Control Tubing Installation (Sheet 1 of 7)

FIGURE AND INDEX NUMBER	PART NUMBER	DESCRIPTION	UNITS PER ASSY.	USABLE ON CODE	
				FROM	TO
2.12-22	8-20397-865	TUBING INSTALLATION, WING TRANSFER TANK FUEL CONTROL LH FOR NHA SEE FIG. 2.6-32	RF	189	277
	8-20397-867	TUBING INSTALLATION, WING TRANSFER TANK FUEL CONTROL RH FOR NHA SEE FIG. 2.6-32	RF	189	277
- 1		• TUBE ASSY, SEE FIG. 2.12-46 INDEX 16A	RF		
- 2		• FITTING, TRANSFER TANK AMBIENT SENSING SEE FIG. 2.12-35 INDEX 7	RF		
- 3	8-20397-2735	• TUBE ASSY, LH	1	189	277
	8-20397-2799	• TUBE ASSY, RH	1	189	277
- 4	MS2190506	• TEE	1	189	277
- 5	8-20397-2691	• TUBE ASSY, LH	1	189	277
	8-20397-2819	• TUBE ASSY, RH	1	189	277
- 6	MS2190806	• ELBOW	2	189	277
	AN924-6D	• NUT	2	189	277
	MS29512-6	• GASKET	2	189	277
- 7		• VALVE ASSY, FUEL TRANSFER PILOT SEE FIG. 2.12-28 INDEX 6	RF		
- 8	8-20397-2699	• TUBE ASSY, LH	1	189	277
	8-20397-2769	• TUBE ASSY, RH	1	189	277
- 9	MS2190806	• ELBOW	1	189	277
	AN924-6D	• NUT	1	189	277
	MS29512-6	• GASKET	1	189	277
- 10		• VALVE ASSY, TRANSFER TANK INBD SHUTOFF SEE FIG. 2.12-30 INDEX 4	RF		
- 11		• TUBE ASSY, SEE FIG. 2.12-46 INDEX 147	RF		
- 12	8-20397-2669	• TUBE ASSY, LH	1	189	277
	8-20397-2769	• TUBE ASSY, RH	1	189	277
- 13	MS29513-325	• TEE	1	189	277
- 14	8-20397-2693	• TUBE ASSY, LH	1	189	277
	8-20397-2817	• TUBE ASSY, RH	1	189	277
- 15	8-20397-2695	• TUBE ASSY, LH	1	189	277
	8-20397-2833	• TUBE ASSY, RH	1	189	277
- 16	MS2190206	• UNION	6	189	277
- 17	8-20397-2209	• TUBE ASSEMBLY	1	189	277
- 18	8-20397-2191	• TUBE ASSEMBLY	1	189	277
- 19	8-20397-2465	• TUBE ASSY, LH	1	189	277
- 20	8-20397-2193	• TUBE ASSEMBLY	1	189	277
- 21	8-20397-2715	• TUBE ASSY, LH	1	189	277
- 22	8-20397-2537	• TUBE ASSY, LH	1	189	277
- 23	MS2190806	• ELBOW	1	189	277
	AN924-6D	• NUT	1	189	277
	MS29512-6	• GASKET	1	189	277
- 24		• VALVE ASSY, FUEL TANK TRANSFER PILOT RH SEE FIG. 2.12-29 INDEX 8	RF		
- 25	MS2190506	• TEE, RH	1	189	277
- 26	8-20397-2497	• TUBE ASSY, RH	1	189	277
- 27	8-20397-2757	• TUBE ASSY, RH	1	189	277
- 28	8-20397-2461	• TUBE ASSY, RH	1	189	277
- 29	8-20397-2805	• TUBE ASSY, RH	1	189	277
- 30	MS2190806	• ELBOW, RH	1	189	277
	AN924-6D	• NUT, RH	1	189	277
	MS29512-6	• GASKET, RH	1	189	277
- 31		• VALVE ASSY, FUEL TANK TRANSFER PILOT RH SEE FIG. 2.12-34 INDEX 11	RF		

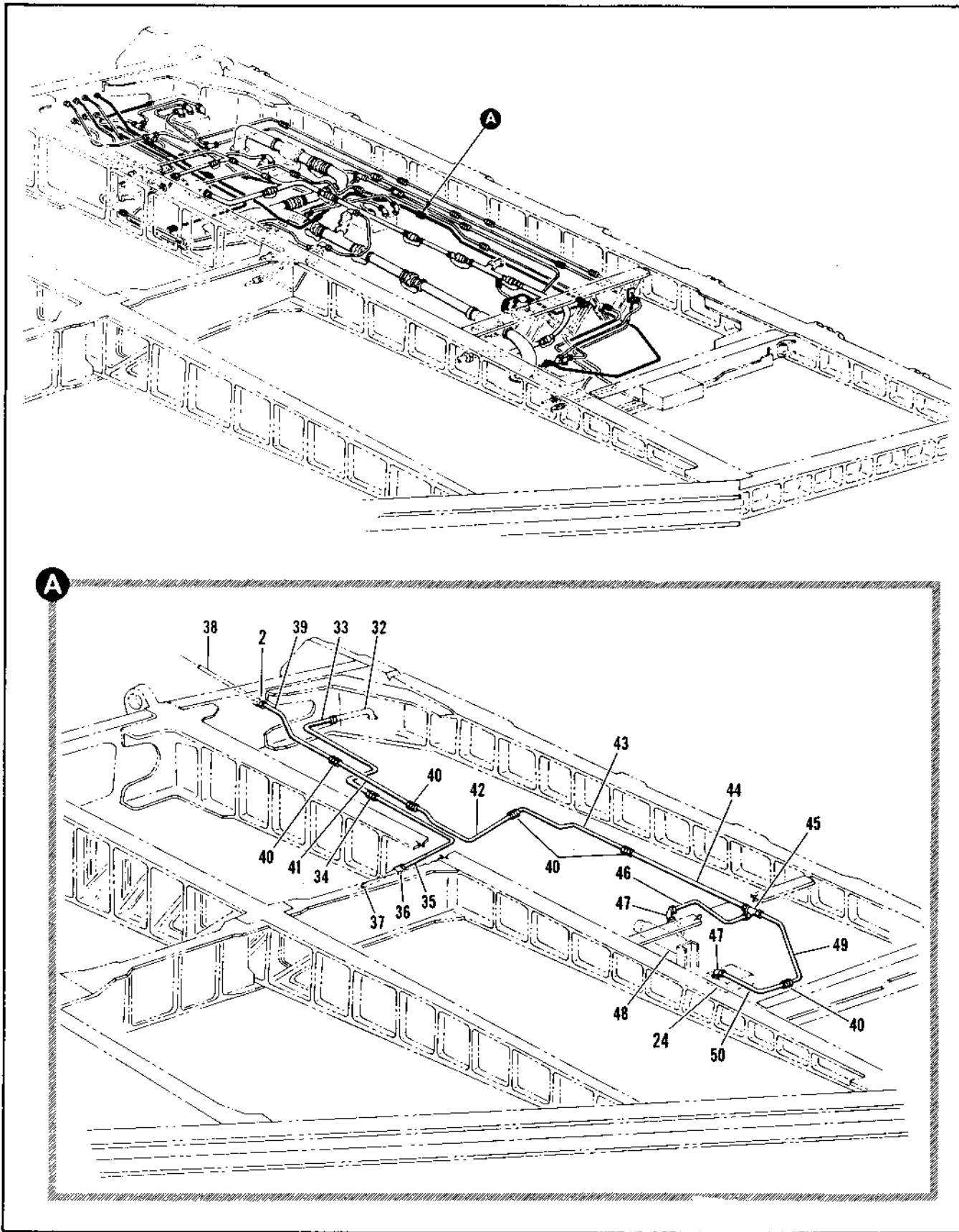

Figure 2.12-22. Wing Transfer Tank Fuel Control Tubing Installation (Sheet 2 of 7)

FIGURE AND INDEX NUMBER	PART NUMBER	DESCRIPTION 1 2 3 4 5 6	UNITS PER ASSY	USABLE ON CODE	
				FROM	TO
2.12-22- 32		• BELLMOUTH ASSY, TRANSFER TANK FUEL SCAVENGE SEE FIG. 2.12-1 INDEX 109	RF		
- 33	8-20397-2673	• TUBE ASSY, LH	1	189	277
	8-20397-2739	• TUBE ASSY, RH	1	189	277
- 34	MS21902D8	• UNION	1	189	277
- 35	8-20397-2671	• TUBE ASSY, LH	1	189	277
	8-20397-2741	• TUBE ASSY, RH	1	189	277
- 36		• UNION, SPAR #6 RL 66 SEE FIG. 2.12-67 INDEX 39	RF		
- 37		• TUBE ASSY, SEE FIG. 2.12-20 INDEX 18	RF		
- 38		• TUBE ASSY, SEE FIG. 2.12-46 INDEX 164	RF		
- 39	8-20397-2667	• TUBE ASSY, LH	1	189	277
	8-20397-2797	• TUBE ASSY, RH	1	189	277
- 40	MS21902D6	• UNION	5	189	277
- 41	8-20397-2205	• TUBE ASSEMBLY	1	189	277
- 42	8-20397-2677	• TUBE ASSY, LH	1	189	277
	8-20397-2783	• TUBE ASSY, RH	1	189	277
- 43	8-20397-2491	• TUBE ASSY, LH	1	189	277
	8-20397-2809	• TUBE ASSY, RH	1	189	277
- 44	8-20397-2489	• TUBE ASSY, LH	1	189	277
	8-20397-2519	• TUBE ASSY, RH	1	189	277
- 45	MS21905D6	• TEE	1	189	277
- 46	8-20397-2659	• TUBE ASSY, LH	1	277	
	8-20397-2759	• TUBE ASSY, RH	1	189	277
- 47	MS21908D6	• FLOW	2	189	277
	AN929-6D	• NUT	2	189	277
	MS24512-6	• GASKET	2	189	277
- 48		• VALVE ASSY, FUEL TRANSFER PILOT SEE FIG. 2.12-28 INDEX 6	PF		
- 49	8-20397-2531	• TUBE ASSY, LH	1	189	277
	8-20397-2837	• TUBE ASSY, RH	1	189	277
- 50	8-20397-2533	• TUBE ASSY, LH	1	189	277
	8-20397-2835	• TUBE ASSY, RH	1	189	277

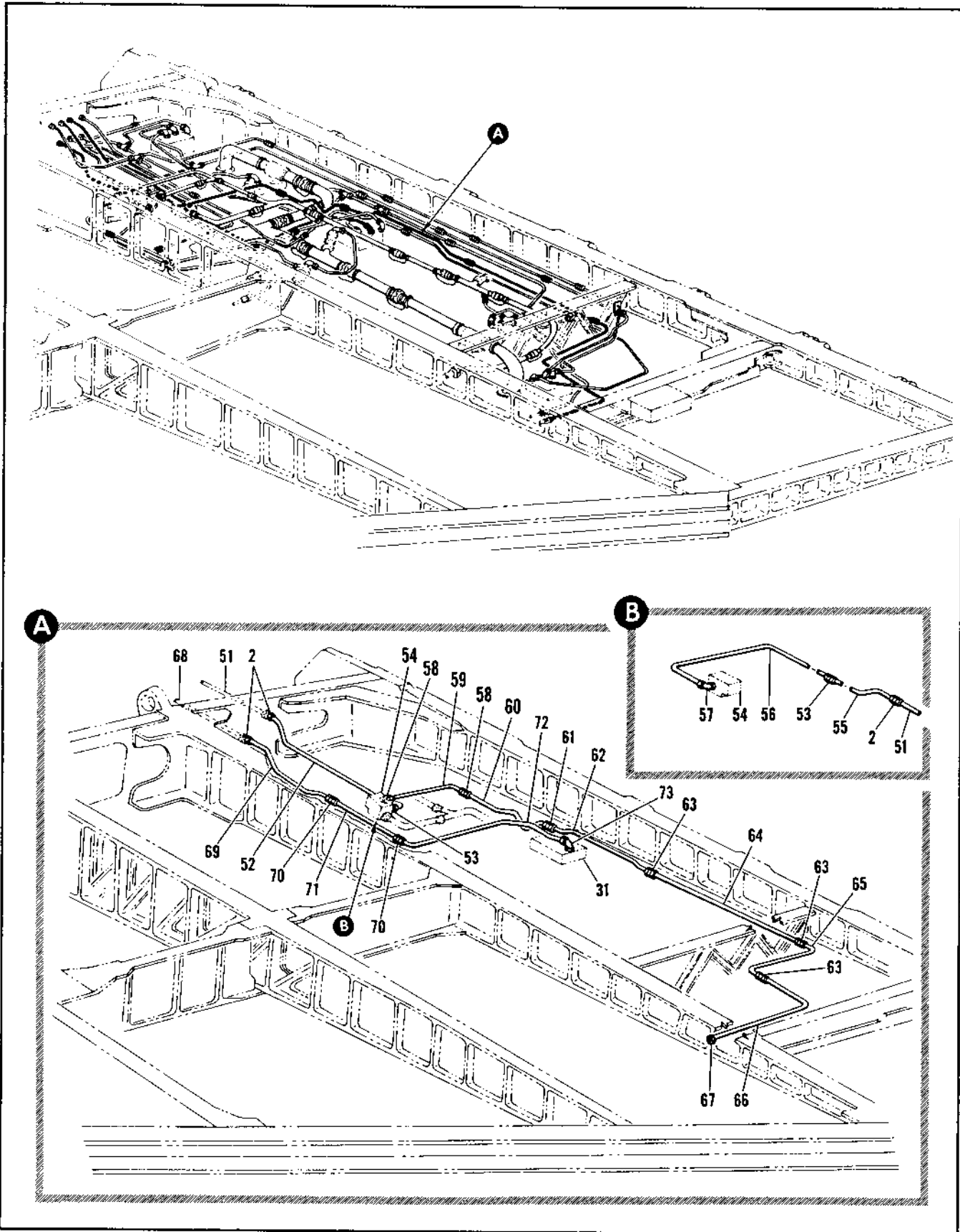

Figure 2.12-22. Wing Transfer Tank Fuel Control Tubing Installation (Sheet 3 of 7)

FIGURE AND INDEX NUMBER	PART NUMBER	DESCRIPTION	UNITS PER ASSY.	USABLE ON CODE	
				FROM	TO
		1 2 3 4 5 6			
2.12-22- 51		• TUBE ASSEMBLY SEE FIG. 2.12-46 INDEX 134	RF		
- 52	8-20397-2679	• TUBE ASSY, LH	1	189	277
- 53	MS2190206	• UNION	2	189	277
	MS29512-6	• GASKET	1	189	277
- 54		• VALVE ASSY, TRANSFER TANK VENT SEE FIG. 2.12-25 INDEX 1	RF		
- 55	8-20397-2781	• TUBE ASSY, RH	1	189	277
- 56	8-20397-2779	• TUBE ASSY, RH	1	189	277
- 57	MS2190806	• ELBOW, RH	1	189	277
	AN924-6D	• NUT, RH	1	189	277
	MS29512-6	• GASKET, RH	1	189	277
- 58	MS2190204	• UNION	2	189	277
	MS29512-4	• GASKET	1	189	277
- 59	8-20397-2713	• TUBE ASSY, LH	1	189	277
	8-20397-2765	• TUBE ASSY, RH	1	189	277
- 60	8-20397-2711	• TUBE ASSY, LH	1	189	277
	8-20397-2767	• TUBE ASSY, RH	1	189	277
- 61	MS2190206	• UNION, LH	1	189	277
	MS2191606-4	• REDUCER, RH	1	189	277
- 62	8-20397-2155	• TUBE ASSY, LH	1	189	277
	8-20397-2785	• TUBE ASSY, RH	1	189	277
- 63	MS2190206	• UNION	3	189	277
- 64	8-20397-2845	• TUBE ASSY, LH	1	189	277
	8-20397-21A9	• TUBE ASSY, RH	1	189	277
- 65	8-20397-2755	• TUBE ASSEMBLY	1	189	277
- 66	8-20397-2763	• TUBE ASSEMBLY	1	189	277
- 67		• UNION, SPAR #6 BL 143 SEE FIG. 2.12-66	RF		
- 68		• TUBE ASSY, SEE FIG. 2.12-46 INDEX 131	RF		
- 69	8-20397-2449	• TUBE ASSY, LH	1	189	277
- 70	MS2190206	• UNION, LH	2	189	277
- 71	8-20397-2505	• TUBE ASSY, LH	1	189	277
- 72	8-20397-2707	• TUBE ASSY, LH	1	189	277
- 73	MS2190806	• ELBOW, LH	1	189	277
	AN924-6D	• NUT, LH	1	189	277
	MS29512-6	• GASKET, LH	1	189	277

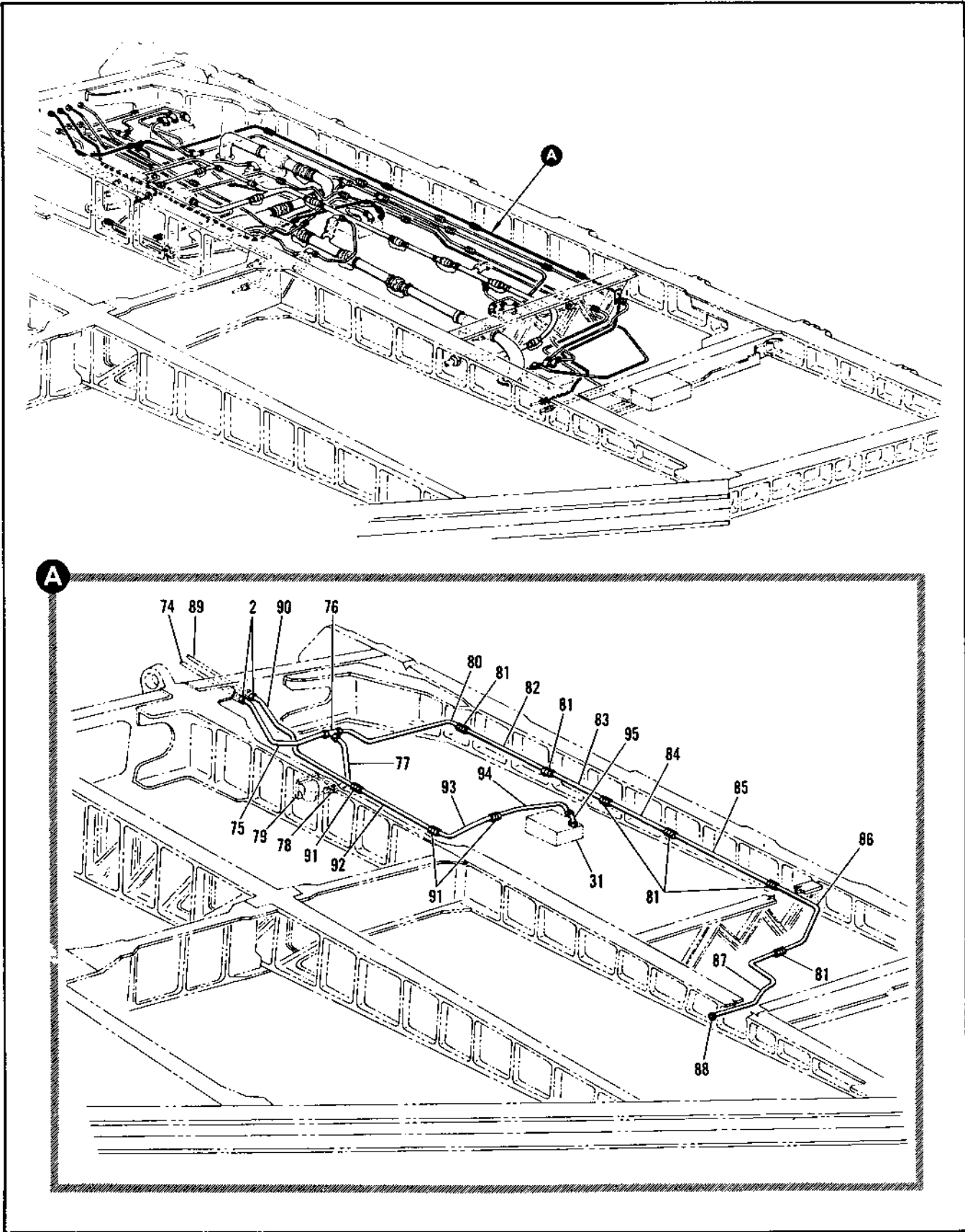

Figure 2.12-22. Wing Transfer Tank Fuel Control Tubing Installation (Sheet 4 of 7)

FIGURE AND INDEX NUMBER	PART NUMBER	DESCRIPTION	UNITS PER ASSY.	USABLE ON CODE	
				FROM	TO
		1 2 3 4 5 6			
2.12-22- 74		• TUBE ASSY, SEE FIG. 2.12-46 INDEX 146	RF		
- 75	8-20397-2141	• TUBE ASSY, LH	1	189	277
	8-20397-2839	• TUBE ASSY, RH	1	189	277
- 76	MS21905D4	• TEE	1	189	277
- 77	8-20397-2575	• TUBE ASSY, LH	1	189	277
	8-20397-2611	• TUBE ASSY, RH	1	189	277
- 78	MS21902D4	• UNION	1	189	277
	MS29512-4	• GASKET	1	189	277
- 79		• VALVE ASSY, TRANSFER TANK PRESSURE RELIEF SEE FIG. 2.12-1 INDEX 94	RF		
- 80	8-20397-2719	• TUBE ASSY, LH	1	189	277
	8-20397-2823	• TUBE ASSY, RH	1	189	277
- 81	MS21902D4	• UNION	6	189	277
- 82	8-20397-2847	• TUBE ASSY, LH	1	189	277
	8-20397-2721	• TUBE ASSY, RH	1	189	277
- 83	8-20397-2657	• TUBE ASSEMBLY	1	189	277
- 84	8-20397-2661	• TUBE ASSY, LH	1	189	277
	8-20397-2793	• TUBE ASSY, RH	1	189	277
- 85	8-20397-2195	• TUBE ASSEMBLY	1	189	277
- 86	8-20397-2717	• TUBE ASSY, LH	1	189	277
	8-20397-2795	• TUBE ASSY, RH	1	189	277
- 87	8-20397-2663	• TUBE ASSY, LH	1	189	277
	8-20397-2803	• TUBE ASSY, RH	1	189	277
- 88		• UNION, SPAR #6 BL RD SEE FIG. 2.12-67	RF		
- 89		• TUBE ASSY, SEE FIG. 2.12-46 INDEX 133	RF		
- 90	8-20397-2681	• TUBE ASSY, LH	1	189	277
	8-20397-2613	• TUBE ASSY, RH	1	189	277
- 91	MS21902D6	• UNION	3	189	277
- 92	8-20397-2685	• TUBE ASSY, LH	1	189	277
	8-20397-2791	• TUBE ASSY, RH	1	189	277
- 93	8-20397-2851	• TUBE ASSY, LH	1	189	277
	8-20397-2747	• TUBE ASSY, RH	1	189	277
- 94	8-20397-2709	• TUBE ASSY, LH	1	189	277
	8-20397-2749	• TUBE ASSY, RH	1	189	277
- 95	MS21908D6	• ELBOW	1	189	277
	AN924-6D	• NUT	1	189	277
	MS29512-6	• GASKET	1	189	277

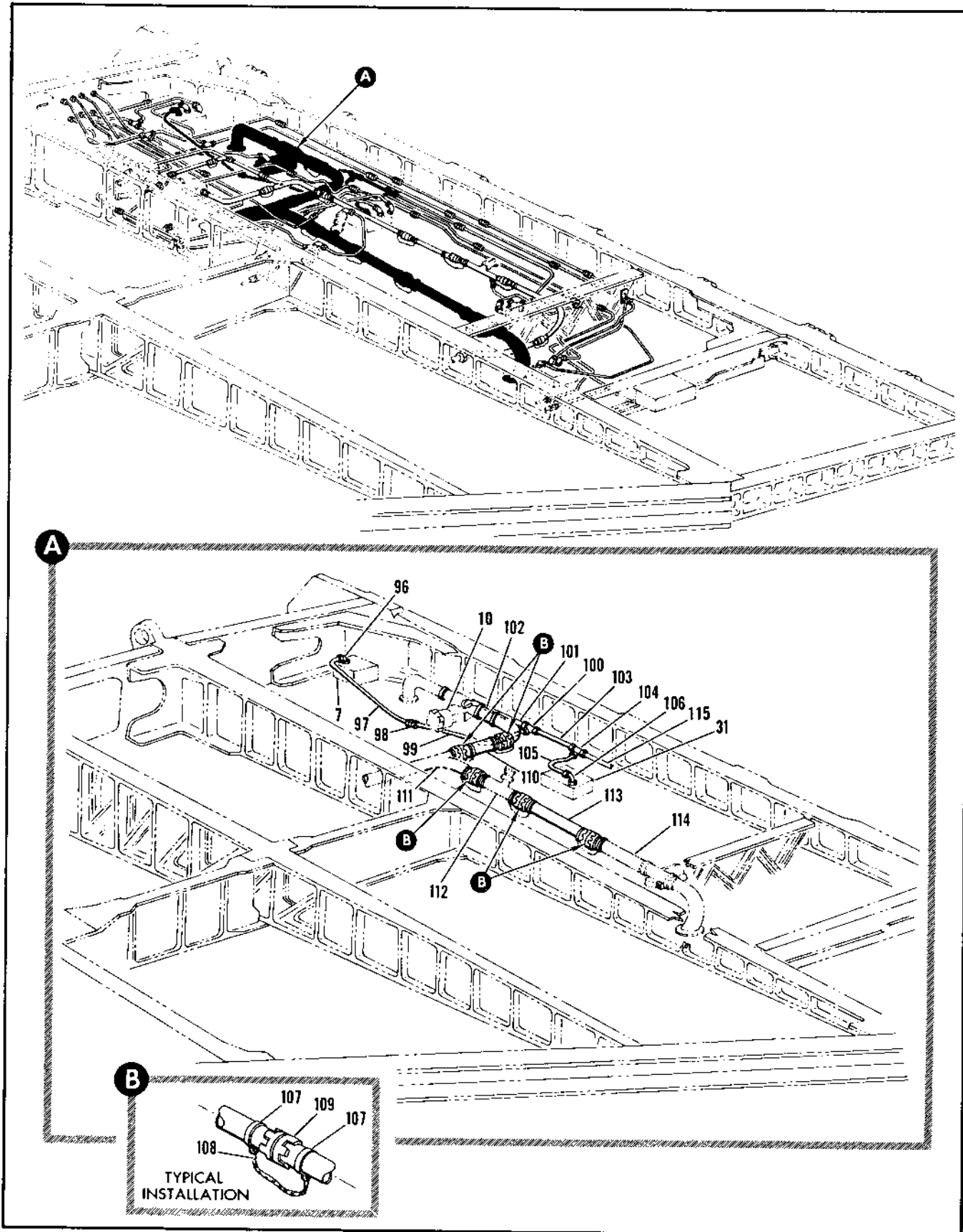

Figure 2.12-22. Wing Transfer Tank Fuel Control Tubing Installation (Sheet 5 of 7)

FIGURE AND INDEX NUMBER	PART NUMBER	DESCRIPTION 1 2 3 4 5 6	UNITS PER ASSY.	USABLE ON CODE	
				FROM	TO
2.12-22- 96	MS2190804	• ELBOW	1	189	277
	AN924-40	• NUT	1	189	277
	MS29512-4	• GASKET	1	189	277
- 97	8-20397-2687	• TUBE ASSY, LH	1	189	277
	8-20397-2825	• TUBE ASSY, RH	1	189	277
- 98	MS2190204	• UNION, LH	1	189	277
- 99	8-20397-2625	• TUBE ASSY, LH	1	189	277
-100	ER8240060604	• TEE, <92003> 98-90319-003	1	189	277
-101	8-20397-2683	• TUBE ASSY, LH	1	189	277
	8-20397-2743	• TUBE ASSY, RH	1	189	277
-102	MS2190806	• ELBOW	1	189	277
	AN924-60	• NUT	1	189	277
	MS29512-6	• GASKET	1	189	277
-103	8-20397-2723	• TUBE ASSEMBLY	1	189	277
-104	ER8240060604	• TEE, <92003> 98-90319-003	1	189	277
-105	8-20397-2705	• TUBE ASSY, LH	1	189	277
	8-20397-2821	• TUBE ASSY, RH	1	189	277
-106	MS2190804	• ELBOW	1	189	277
	AN924-40	• NUT	1	189	277
	MS29512-4	• GASKET	1	189	277
-107	AN735040	• CLAMP	10	189	277
		ATTACHING PARTS			
	NAS679A3	• NUT	10	189	277
	AN960010L	• WASHER	10	189	277
	AN526-1032R6	• SCREW	10	189	277
		----X----			
-108	MS25083-18B4	• JUMPER	5	189	277
-109	8605-400	• COUPLING, <79326> 52-72500-004	5	189	277
	MS29513-333	• PACKING	5	189	277
-110	8-20397-2729	• TUBE ASSEMBLY	1	189	240
	8-20397-2927	• TUBE ASSEMBLY	1	241	277
-111		• TUBE ASSY, SEE FIG. 2.12-14 INDEX 73	RF		
-112		• TUBE ASSY, SEE FIG. 2.12-2 INDEX 14	RF		
-113	8-20397-171	• TUBE ASSEMBLY	1	189	277
-114		• TUBE ASSY, SEE FIG. 2.12-27 INDEX 19	RF		

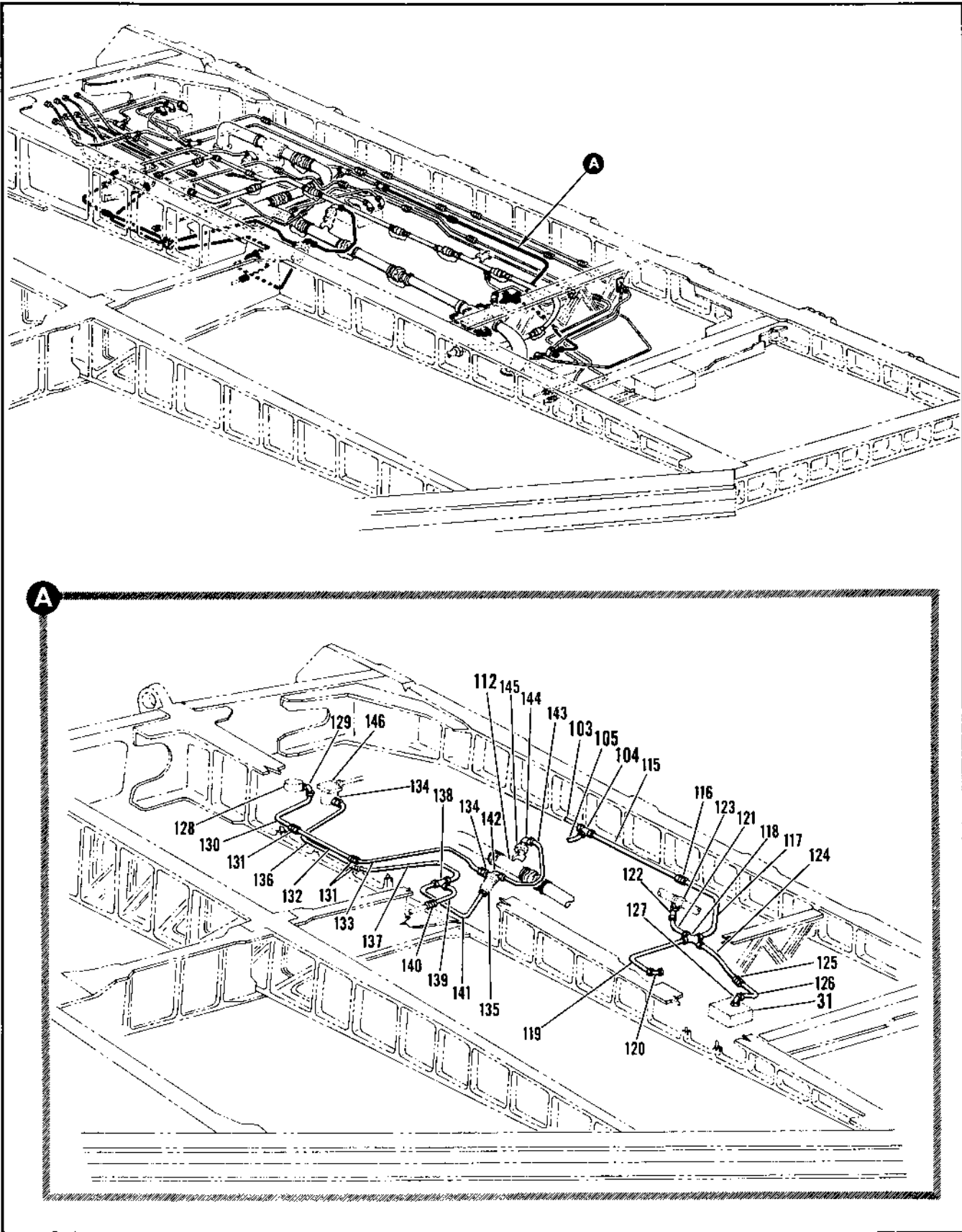

Figure 2.12-22. Wing Transfer Tank Fuel Control Tubing Installation (Sheet 6 of 7)

FIGURE AND INDEX NUMBER	PART NUMBER	DESCRIPTION	UNITS PER ASSY.	USABLE ON CODE	
				FROM	TO
		1 2 3 4 5 6			
2.12-22-115	9-20397-2475	• TUBE ASSY, LH	1	189	277
	8-20397-2753	• TUBE ASSY, RH	1	189	277
-116	MS2190206	• UNION	1	189	277
-117	9-20397-2479	• TUBE ASSY, LH	1	189	215
	8-20397-2939	• TUBE ASSY, LH	1	216	277
	8-20397-2751	• TUBE ASSY, RH	1	189	277
-118	MS2190606	• CROSS	1	189	277
-119	9-20397-2665	• TUBE ASSY, LH	1	189	277
	8-20397-2777	• TUBE ASSY, RH	1	189	277
-120	MS2190806	• ELBOW	1	189	277
	AN924-60	• NUT	1	189	277
	MS29512-6	• GASKET	1	189	277
-121	9-20397-2733	• TUBE ASSY, LH	1	189	277
	8-20397-2801	• TUBE ASSY, RH	1	189	277
-122	MS2190806	• ELBOW	1	189	277
	AN924-60	• NUT	1	189	277
	MS29512-6	• GASKET	1	189	277
-123		• TUBE ASSY, VACUUM AND PRESSURE RELIEF SEE FIG. 2.12-12	RF		
-124	8-20397-2529	• TUBE ASSY, LH	1	189	215
	9-20397-2941	• TUBE ASSY, LH	1	216	215
	8-20397-2829	• TUBE ASSY, RH	1	189	277
-125	MS2191606-4	• REDUCER	1	189	277
-126	8-20397-2535	• TUBE ASSY, LH	1	189	277
	8-20397-2455	• TUBE ASSY	1	189	277
-127	MS2190804	• ELBOW	1	189	277
	AN924-40	• NUT	1	189	277
	MS29512-4	• GASKET	1	189	277
-128		• VALVE ASSY, FUEL TANK PILOT FLOAT SEE FIG. 2.12-1 INDEX 10	RF		
-129	MS2190804	• ELBOW	1	189	277
	AN924-40	• NUT	1	189	277
	MS29512-4	• GASKET	1	189	277
-130	9-20397-2689	• TUBE ASSY, LH	1	189	277
	8-20397-2815	• TUBE ASSY, RH	1	189	277
-131	MS2190204	• UNION	3	189	277
-132	8-20397-2549	• TUBE ASSEMBLY	1	189	277
-133	8-20397-2725	• TUBE ASSY, LH	1	189	277
	8-20397-2761	• TUBE ASSY, RH	1	189	277
-134	MS2190204	• UNION	2	189	277
	MS29512-4	• GASKET	2	189	277
-135		• VALVE ASSY, PRESSURE OPERATED PILOT SEE FIG. 2.12-1 INDEX 25	RF		
-136	8-20397-2773	• TUBE ASSY, LH	1	189	277
	8-20397-2773	• TUBE ASSY, RH	1	189	277
-137	8-20397-2711	• TUBE ASSY, LH	1	189	277
	8-20397-2831	• TUBE ASSY, RH	1	189	277
-138	MS2190504	• TEE	1	189	277
-139	8-20397-2827	• TUBE ASSEMBLY	1	189	277
-140		• UNION, SPAR #6 BL AND 142 SEE FIG. 2.12-66	RF		
-141	8-20397-2697	• TUBE ASSEMBLY	1	189	277
-142	MS2190804	• ELBOW	1	189	277
	AN924-40	• NUT	1	189	277
	MS29512-4	• GASKET	1	189	277
-143	8-20397-2653	• TUBE ASSY, LH	1	189	277
	8-20397-2771	• TUBE ASSY, RH	1	189	277
-144	MS2190204	• ELBOW, LH	1	189	277
	MS2190404	• ELBOW, RH	1	189	277
	AN924-40	• NUT, LH	1	189	277
	MS29512-4	• GASKET	1		
-145		• VALVE ASSY, PILOT OPERATED SHUTOFF SEE FIG. 2.12-1	RF		
-146		• VALVE ASSY, FUEL TANK VENT SEE FIG. 2.12-1 INDEX 16	RF		

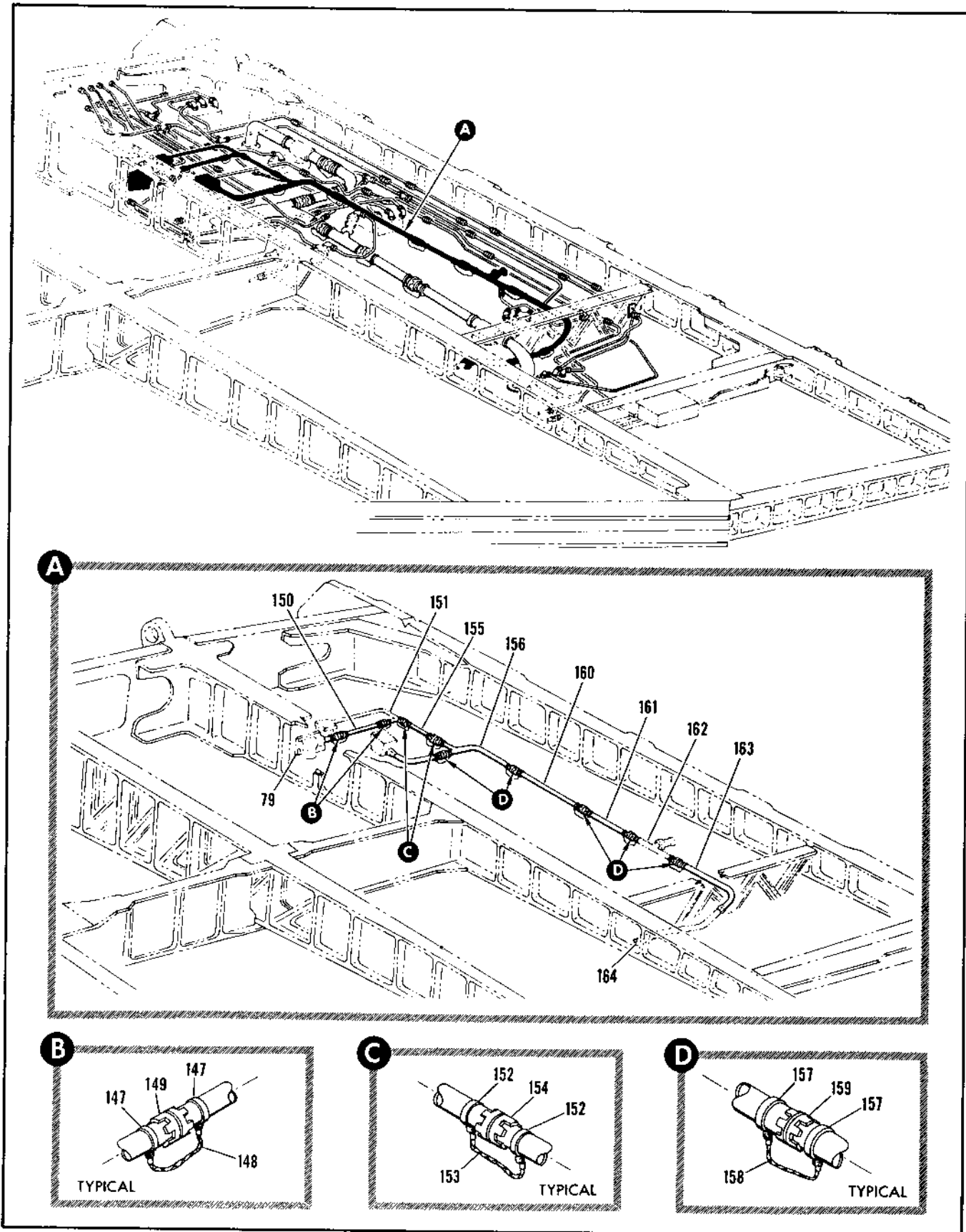

Figure 2.12-22. Wing Transfer Tank Fuel Control Tubing Installation (Sheet 7 of 7)

FIGURE AND INDEX NUMBER	PART NUMBER	DESCRIPTION	UNITS PER ASSY.	USABLE ON CODE	
				FROM	TO
2.12-22-147	AN735012	• CLAMP ATTACHING PARTS	4	189	277
	NAS679A3	• NUT	4	189	277
	AN96010LL	• WASHER	4	189	277
	AN526-1032P6	• SCREW ----X----	4	189	277
-148	MS25043-1R03	• JUMPER	2	189	277
-149	3605-1P0	• COUPLING, <79326> 82-72500-000	2	189	277
	MS29513-211	• PACKING	2	189	277
-150	8-20397-2643	• TUBE ASSEMBLY	1	189	277
-151		• MANIFOLD ASSY, SEE FIG. 2.12-25 INDEX 20	RF		
-152	AN735016	• CLAMP ATTACHING PARTS	4	189	277
	NAS679A3	• NUT	4	189	277
	AN96010LL	• WASHER	4	189	277
	AN526-1032P6	• SCREW ----X----	4	189	277
-153	MS25083-1R03	• JUMPER	2	189	277
-154	3605-16D	• COUPLING, <79326> 82-72500-001	2	189	277
	MS29513-214	• PACKING	2	189	277
-155	8-20397-2737	• TUBE ASSEMBLY	1	189	277
-156		• TUBE ASSY, SEE FIG. 2.12-25 INDEX 18	RF		
-157	AN735024	• CLAMP ATTACHING PARTS	10	189	277
	NAS679A3	• NUT	10	189	277
	AN96010LL	• WASHER	10	189	277
	AN526-1032P6	• SCREW ----X----	10	189	277
-158	MS25083-1R04	• JUMPER	5	189	277
-159	3605-24D	• COUPLING, <79326> 82-72500-103	5	189	277
	MS29513-325	• PACKING	5	189	277
-160	8-20397-1665	• TUBE ASSY, LH	1	189	277
	8-20397-1807	• TUBE ASSY, RH	1	189	277
-151	8-20397-2731	• TUBE ASSY, LH	1	189	277
	8-20397-2841	• TUBE ASSY, RH	1	189	277
-162		• TUBE ASSEMBLY, VACUUM AND PRESSURE RELIEF SEE FIG. 2.12-14 INDEX 30	RF		
-163	8-20397-175	• TUBE ASSEMBLY	1	189	277
-164		• TUBE ASSY, TRANSFER TANK VENT SEE FIG. 2.12-14 INDEX 23	RF		

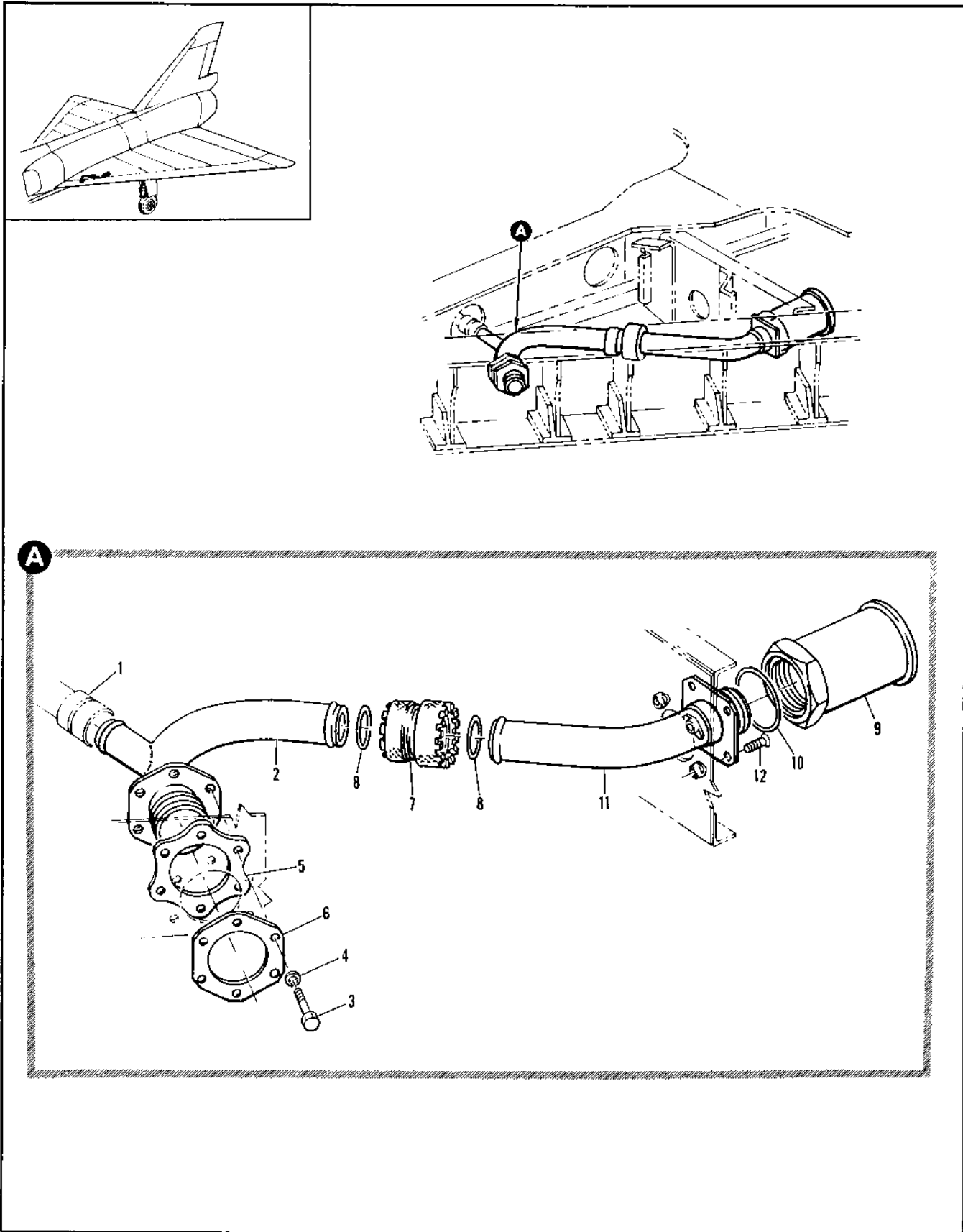

Figure 2.12-23. Tank #1 Suction Relief Valve Installation

FIGURE AND INDEX NUMBER	PART NUMBER	DESCRIPTION 1 2 3 4 5 6	UNITS PER ASSY.	USABLE ON CODE		
				FROM	TO	
2.12-23	8-21294-3	VALVE INSTALLATION, TANK #1 SUCTION RELIEF LH FOR NHA SEE FIG. 2.6-32	RF	A		
	8-21294-1	VALVE INSTALLATION, TANK #1 SUCTION RELIEF LH FOR NHA SEE FIG. 2.6-32	RF	B		
	8-21294-4	VALVE INSTALLATION, TANK #1 SUCTION RELIEF RH FOR NHA SEE FIG. 2.6-32	RF	A		
	8-21294-2	VALVE INSTALLATION, TANK #1 SUCTION RELIEF RH FOR NHA SEE FIG. 2.6-32	RF	B		
	- 1		• TUBE, SEE FIG. 2.12-17 INDEX 28	RF		
	- 2	8-21137	• TUBE ASSY, VENT SUCTION RELIEF WELDED REPLACES NOT INTCHG WITH 8-21295	1	A	
		8-21295	• TUBE ASSY, VENT SUCTION RELIEF WELDED REPLACED BY NOT INTCHG WITH 8-21137 ATTACHING PARTS	1	B	
	- 3	AN4-10A	• BOLT	6	35	
	- 4	AN9K00+16	• WASHER -----X-----	6	35	
	- 5	G75156-4	• GASKET, <83259> SPEC 8-02287-7	1	35	
	- 6	8-21273-13	• PLATE, BACK UP	1	35	
	- 7	3605-200	• COUPLING, <79326> 92-72500-006	1	35	
- 8	MS29513-218	• PACKING, REPLACED BY NAS1593-218	2	35		
	NAS1593-218	• PACKING, REPLACES MS29513-218				
- 9	1111-568371	• VALVE ASSY, FUEL TANK AIR CHECK <92003> SPEC 8-02999 T.O. 6J15-2-105-23	1	35		
	1111-568371M1	• VALVE, VACUUM RELIEF (83259) SPEC 8-02999-5	1	35		
- 10	MS29512-20	• GASKET	1	35		
- 11	8-21136	• TUBE ASSY, WELDED REPLACES NOT INTCHG WITH 8-21297	1	A		
	8-21297	• TUBE ASSY, WELDED REPLACED BY NOT INTCHG WITH 8-21136 ATTACHING PARTS	1	B		
- 12	AN509-10R7	• SCREW -----X-----	4	35		
		A AIRPLANES #35 THRU 277, 287, 292 AND ON				
		B AIRPLANES #278 THRU 286 AND 288 THRU 291				

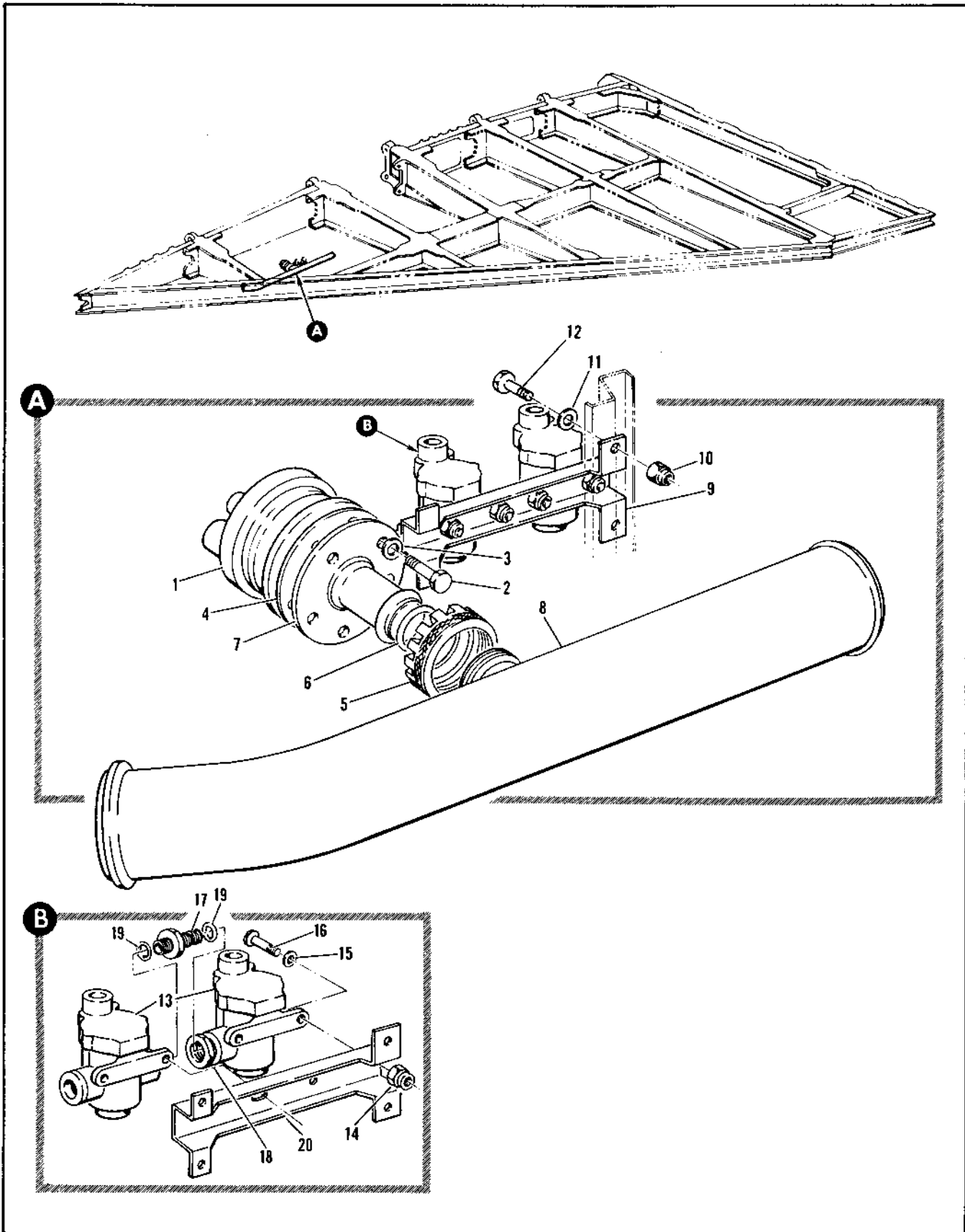

Figure 2.12-24. Tank #1 Refuel Shutoff Valve Installation LH

FIGURE AND INDEX NUMBER	PART NUMBER	DESCRIPTION	UNITS PER ASSY.	USABLE ON CODE	
				FROM	TO
		1 2 3 4 5 6			
2.12-24	R-21194-1	VALVE INSTALLATION, TANK #1 REFUEL SHUTOFF LH FOR NHA SEE FIG. 2.4-32	RF	35	
	R-21194-2	VALVE INSTALLATION, TANK #1 REFUEL SHUTOFF RH FOR NHA SEE FIG. 2.4-32	RF	35	
- 1	15-356-101	• VALVE ASSY, PILOT OPERATED SHUTOFF <92267> SPEC R-22903-1 I.O. 6J15-12-156-13 ATTACHING PARTS	1	35	
- 2	AN4H4A	• BOLT	6	35	
- 3	AN9610416L	• WASHER	6	35	
		-----x-----			
- 4	375156-4	• GASKET, <83269> SPEC R-22237-7	1	35	
- 5	3655-24B	• COUPLING, <79326> R2-72501-05R	1	35	
- 6	MS29513-30B	• PACKING	1	35	
- 7	R-21195	• TUBE ASSY, WELDED	1	35	
- 8	R-21196-1	• TUBE ASSY, FUEL TRANSFER AND REFUELING LH WELDED	1	35	
	R-21196-2	• TUBE ASSY, FUEL TRANSFER AND REFUELING RH WELDED	1	35	
- 9	R-21194-4	• VALVE ASSY, LH	1	35	
	R-21194-10	• VALVE ASSY, RH	1	35	
		ATTACHING PARTS			
- 10	NAS679A3	• NUT	RF	35	
- 11	AN965010L	• WASHER	RF	35	
- 12	AN3-4A	• BOLT	RF	35	
		-----y-----			
- 13	101X1-1	• VALVE ASSY, FULL SHUTOFF <92250> SPEC R-79910-3 I.O. 6J15-10-127-3 ATTACHING PARTS	2	35	
- 14	NAS679A3	• NUT	4	35	
- 15	AN965011L	• WASHER	8	35	
- 16	NAS221-11	• SCREW	4	35	
		-----x-----			
- 17	MS21933-40	• UNION	1	35	
- 18	AN904-4D	• NUT	1	35	
- 19	MS29512-4	• GASKET	2	35	
- 20	R-21194-7	• SUPPORT, LH	1	35	
	R-21194-8	• SUPPORT, RH	1	35	

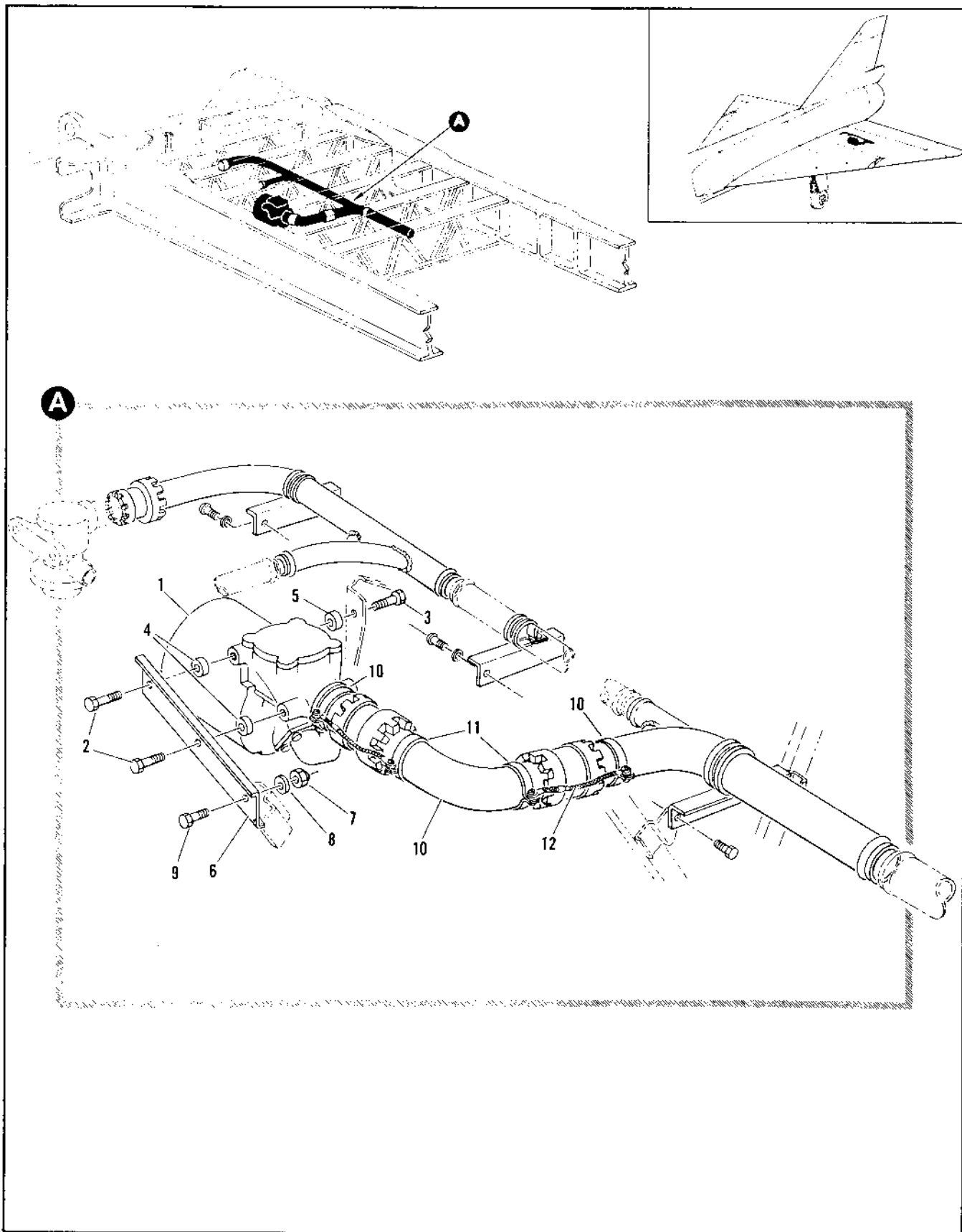

Figure 2.12-25. Transfer Tank Vent Valve Installation (Sheet 1 of 2)

FIGURE AND INDEX NUMBER	PART NUMBER	DESCRIPTION	UNITS PER ASSY.	USABLE ON CODE	
				FROM	TO
		1 2 3 4 5 6			
2.12-20	R-21163-001	VALVE INSTALLATION, TRANSFER TANK VENT LH FOR NHA SEE FIG. 2-4-30	RF	35	188
	R-21163-003	VALVE INSTALLATION, TRANSFER TANK VENT LH FOR NHA SEE FIG. 2-4-30	RF	189	277
	R-21163-005	VALVE INSTALLATION, TRANSFER TANK VENT LH FOR NHA SEE FIG. 2-4-30	RF	278	
	R-21163-002	VALVE INSTALLATION, TRANSFER TANK VENT RH FOR NHA SEE FIG. 2-4-32	RF	35	188
	R-21163-004	VALVE INSTALLATION, TRANSFER TANK VENT RH FOR NHA SEE FIG. 2-4-32	RF	149	277
- 1	R-116455	* VALVE ASSY, TRANSFER TANK VENT (75361) SPEC R-21163-0 T.O. 1015-R-94-3	1	35	
	R-116455	* VALVE ASSY, TRANSFER TANK VENT (75361) SPEC R-21163-0 T.O. 1015-R-94-3 ALT INTCH WITH R-109455 ATTACHING PARTS	RF	35	
- 2	AN4-5A	* BOLT	2	35	
- 3	AN4-5A	* BOLT	1	A	
	AN4-4A	* BOLT	1	189	277
- 4	NAS43004-16	* SPACER	2	A	
	NAS43004-16	* SPACER	2	149	277
- 5	NAS43004-16	* SPACER	1	A	
	NAS43004-20	* SPACER	1	189	277
- 6	R-21164-10	* BRACKET, LH	1	35	
	R-21164-01	* BRACKET, RH	1	35	
		ATTACHING PARTS			
- 7	NAS67943	* NUT, 20-37545-100	1	35	
- 8	AN9612011	* WASHER	1	35	
- 9	AN5-4A	* BOLT	1	35	
		-----X-----			
- 10	R-21162-0	* TUBE	1	A	
	R-21162-21	* TUBE	1	189	277
- 11	AN75016	* CLAMP	4	35	
		ATTACHING PARTS			
	NAS67943	* NUT	4	35	
	AN9612011	* WASHER	4	35	
	AN526-103887	* SCREW	4	35	
		-----X-----			
- 12	MS0143-1887	* JUMPER	2	35	
		* ADDED ON AIRPLANES #75 THRU 240 PER COMVAIR REPORT C554-112			
		A AIRPLANES #75 THRU 184, 275 AND ON			

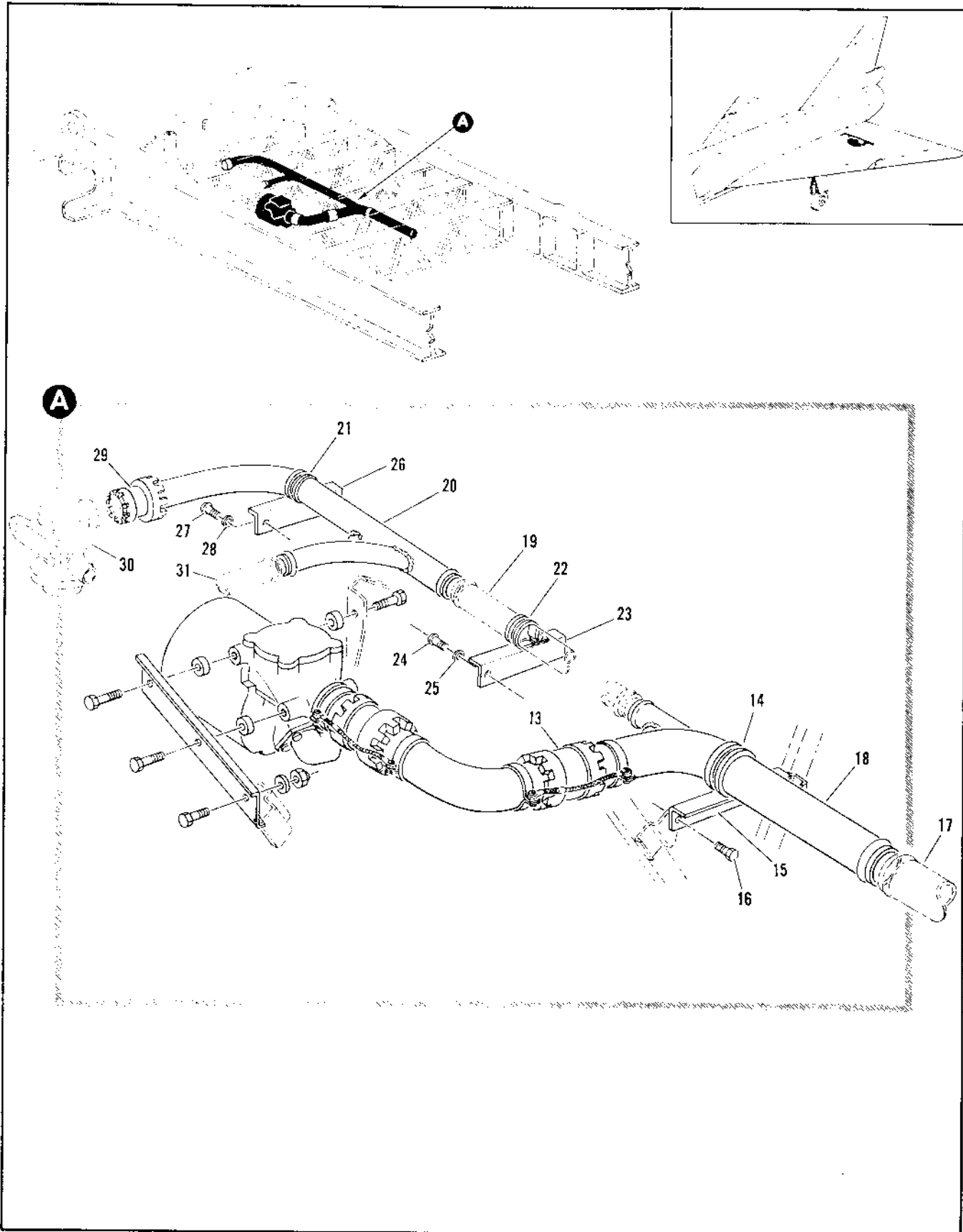

Figure 2.12-25. Transfer Tank Vent Valve Installation (Sheet 2 of 2)

FIGURE AND INDEX NUMBER	PART NUMBER	DESCRIPTION	UNITS PER ASSY.	USABLE ON CODE	
				FROM	TO
		1 2 3 4 5 6			
2.12-25- 13	3605-24D	• COUPLING <79326> 92-72500-013	2		
- 14	MS25913-325	• PACKING	4	35	
	91-98026-023	• CLAMP	1	35	
	VAS679A3	• ATTACHING PARTS	1	35	
	AN520-10RB	• NUT	1	35	
		• SCREW	1	35	
		-----X-----			
- 15	8-21278-41	• SUPPORT, LH	1	35	
	8-21278-42	• SUPPORT, RH	1	35	
		• ATTACHING PARTS			
- 16	AN3-4A	• BOLT	2	35	
		-----X-----			
- 17		• TUBE ASSY, SEE FIG. SEE FIG. 2.12-21 INDEX 197	RF		
- 16	8-21162-11	• TUBE ASSY, LH	1	35	
	8-21162-12	• TUBE ASSY, RH	1	35	
- 19		• TUBE ASSY, LH SEE FIG. 2.12-21 INDEX 192	RF		
- 20	8-21185-1	• MANIFOLD ASSY, LH WELDED	1	A	
	8-21624-1	• MANIFOLD ASSY, LH WELDED	1	189	277
	8-21185-2	• MANIFOLD ASSY, RH WELDED	1	A	
	8-21624-2	• MANIFOLD ASSY, RH WELDED	1	189	277
- 21	91-98026-015	• CLAMP	1	35	
- 22	91-98026-015	• CLAMP	1	A	
		• ATTACHING PARTS			
	NAS221-11	• SCREW	2	A	
	AN960D10L	• WASHER	2	A	
	NAS679A3	• NUT	1	189	277
	AN520-10RB	• SCREW	1	189	277
		-----X-----			
- 23	8-21163-11	• SUPPORT ASSY, LH RIVETED	1	A	
	8-21163-12	• SUPPORT ASSY, RH RIVETED	1	A	
		• ATTACHING PARTS			
- 24	NAS221-8	• SCREW	2	A	
- 25	AN960D10L	• WASHER	2	A	
		-----X-----			
- 25	8-21163-23	• SUPPORT ASSY, LH RIVETED	1	A	
	8-21163-24	• SUPPORT ASSY, RH RIVETED	1	A	
		• ATTACHING PARTS			
- 27	NAS221-8	• SCREW	2	A	
- 28	AN960D10L	• WASHER	2	A	
		-----X-----			
- 29	3605-16D	• COUPLING <79326> 92-72500-017	1	35	
	MS27513-214	• PACKING	1	35	
- 30		• VALVE ASSY, FUEL TANK VENT	RF		
		SEE FIG. 2.12-1 INDEX 32			
- 31		• TUBE ASSY, SEE FIG. 2.12-21 INDEX 187	RF		
A AIRPLANES #35 THRU 190, 276 AND ON					

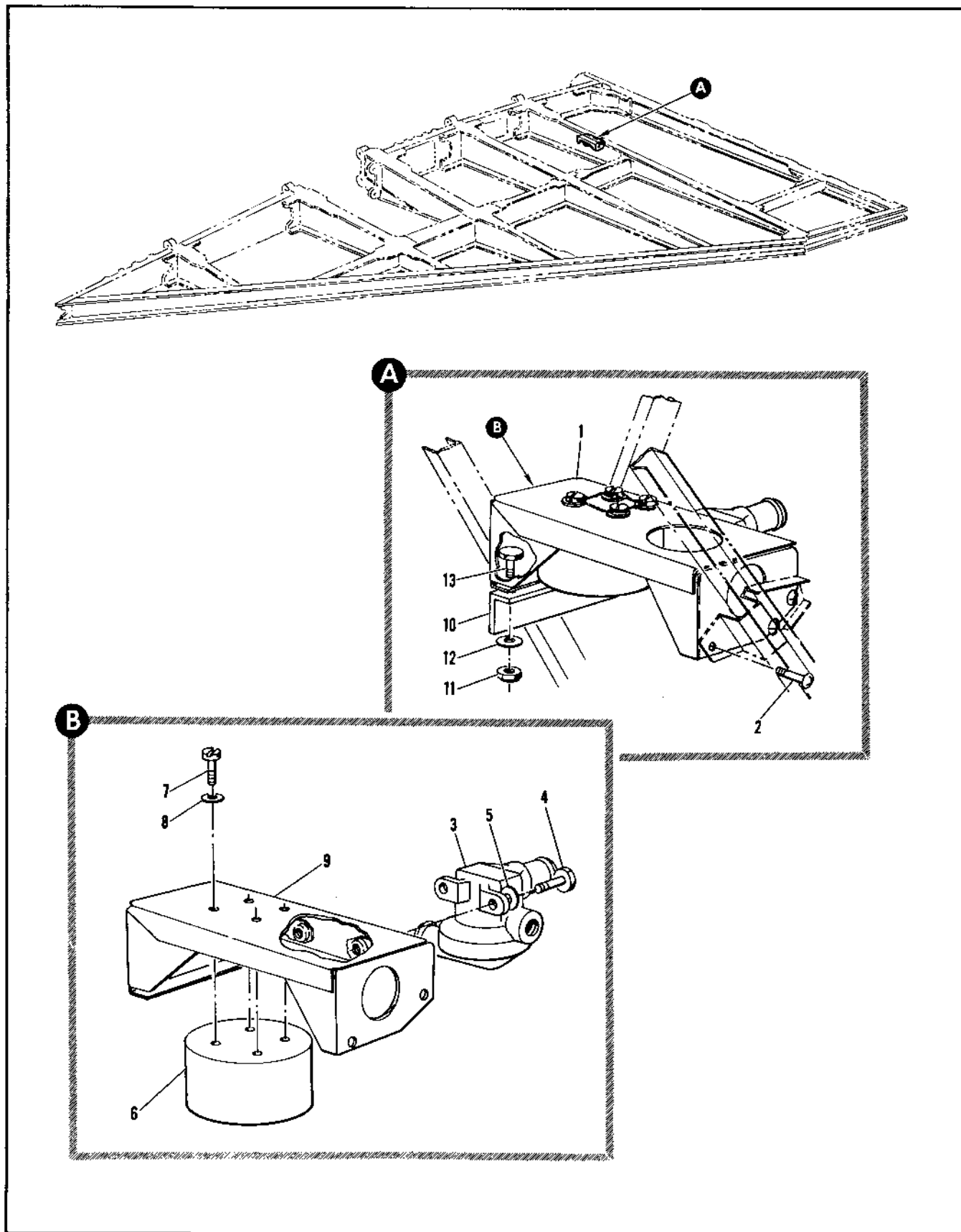

Figure 2.12-26. Transfer Tank Refuel Pilot and Vent Valve Installation LH

FIGURE AND INDEX NUMBER	PART NUMBER	DESCRIPTION	UNITS PER ASSY.	USABLE ON CODE	
				FROM	TO
		1 2 3 4 5 6			
2.12-26	8-21183-1	VALVE INSTALLATION, TRANSFER TANK REFUEL PILOT AND VENT LH FOR NHA SEE FIG. 2.6-32	RF	A	
	8-21183-401	VALVE INSTALLATION, TRANSFER TANK REFUEL PILOT AND VENT LH FOR NHA SEE FIG. 2.6-32	RF	189	277
	8-21183-3	VALVE INSTALLATION, TRANSFER TANK REFUEL PILOT AND VENT RH FOR NHA SEE FIG. 2.6-32	RF	A	
	8-21183-403	VALVE INSTALLATION, TRANSFER TANK REFUEL PILOT AND VENT RH FOR NHA SEE FIG. 2.6-32	RF	189	277
- 1	8-21183-37	• VALVE ASSY, LH	1	35	
	8-21183-38	• VALVE ASSY, RH	1	35	
		ATTACHING PARTS			
- 2	NAS221-5	• SCREW	4	35	
		-----X-----			
- 3	11-5800	• VALVE ASSY, FUEL TANK VENT REFUELING <96736> SPEC 8-00947 T.O. 6J15-8-72-3 REPLACED BY SUITABLE SUB 11-5800-1	1	35	129
	11-5800-1	• VALVE ASSY, FUEL TANK VENT REFUELING <96736> SPEC 8-00947-1 REPLACES SUITABLE SUB FOR 11-5800	1	150	
		ATTACHING PARTS			
- 4	NAS221-9	• SCREW	4	35	
- 5	AN961010L	• WASHER	2	35	
		-----X-----			
- 5	16-356-1	• VALVE ASSY, FUEL TANK PILOT FLOAT (92003) SPEC 8-00904 T.O. 6J15-5-19-3	1	35	
	909555	• VALVE ASSY, FUEL TANK PILOT FLOAT (92003) SPEC 8-00904 T.O. 6J15-3-75-13	1	35	
		ATTACHING PARTS			
- 7	AN502-10-4	• BOLT	4	35	
- 8	AN961010L	• WASHER	4	35	
		-----X-----			
- 9	8-21183-35	• SUPPORT ASSY, LH RIVETED	1	35	
	8-21183-36	• SUPPORT ASSY, RH RIVETED	1	35	
- 10	8-21183-11	• ANGLE, LH	1	A	
	8-21183-43	• ANGLE, LH	1	189	277
	8-21183-12	• ANGLE, RH	1	A	
	8-21183-44	• ANGLE, RH	1	189	277
- 11	702M02	• GUT, <72962> 96-37551-11	2	35	
- 12	AN961010L	• WASHER	2	35	
- 13	AN3-3A	• BOLT	2	35	
A AIRPLANES 435 THRU 189, 276 AND ON					

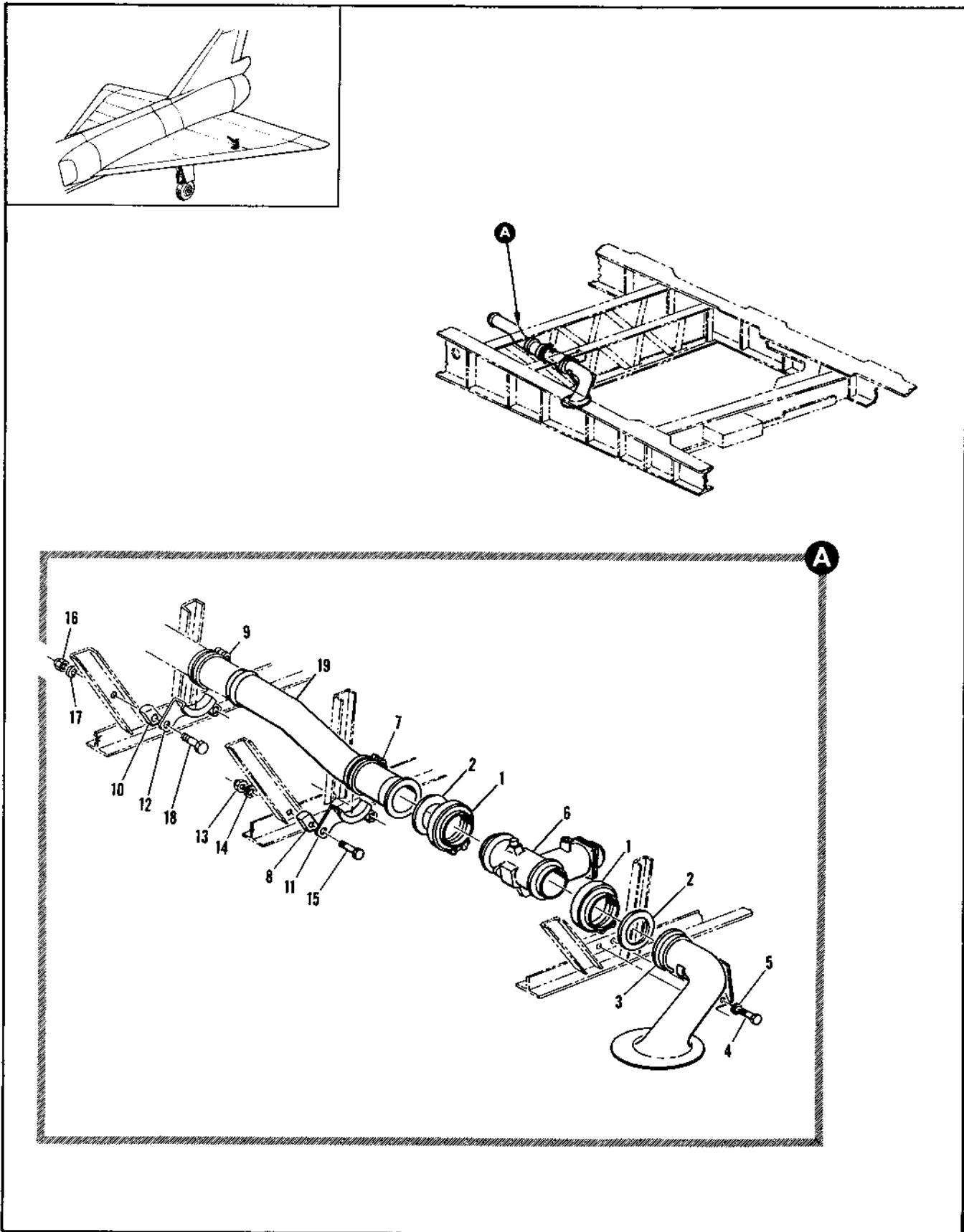

Figure 2.12-27. Transfer Tank Outboard Shutoff Valve Installation

FIGURE AND INDEX NUMBER	PART NUMBER	DESCRIPTION	UNITS PER ASSY.	USABLE ON CODE	
				FROM	TO
		1 2 3 4 5 6			
2.12-27	8-21271-3	VALVE INSTALLATION, TRANSFER TANK OUTRD SHUTOFF LH FOR NHA SEE FIG. 2.6-32	RF	A	
	8-21271-601	VALVE INSTALLATION, TRANSFER TANK OUTRD SHUTOFF LH FOR NHA SEE FIG. 2.6-32	RF	189	277
	8-21271-4	VALVE INSTALLATION, TRANSFER TANK OUTBD SHUTOFF RH FOR NHA SEE FIG. 2.6-32	RF	A	
	8-21271-602	VALVE INSTALLATION, TRANSFER TANK OUTBD SHUTOFF RH FOR NHA SEE FIG. 2.6-32	RF	189	277
- 1	4368-331SH	• COUPLING, <98625> 92-7303-029	2	35	
- 2	374856-1	• GASKET, <93259> SPEC 6-20274-1	2	35	
- 3	8-21588-1	• BELLMOUTH ASSY, LH WELDED REPLACED BY SUITABLE SUB 8-21602-1	1	48	48
	8-21602-1	• BELLMOUTH ASSY, LH WELDED REPLACES SUITABLE SUB FOR 8-21588-1	1	B	
	8-21618-1	• BELLMOUTH ASSY, LH WELDED	1	189	277
	8-21588-2	• BELLMOUTH ASSY, RH WELDED REPLACED BY SUITABLE SUB 8-21602-2	1	48	48
	8-21602-2	• BELLMOUTH ASSY, RH WELDED REPLACES SUITABLE SUB FOR 8-21588-2 REPLACED BY NOT INTCHG WITH 8-21618-2	1	B	
	8-21618-2	• BELLMOUTH ASSY, RH WELDED REPLACES NOT INTCHG WITH 8-21602-2 ATTACHING PARTS	1	89	277
- 4	AN3-4A	• BOLT	2	35	277
	AN3-3A	• BOLT	2	278	
- 5	AN969D10L	• WASHER	2	35	277
	502003	-----X-----			
- 6	503109-9	• VALVE ASSY, TRANSFER TANK OUTRD SHUTOFF <96124> SPEC 9-02274-5 T.O. 6J15-3-71-13	1	35	240
- 7	50230075-258M	• CLAMP, <98625> 91-97602-041	1	35	
- 8	8-28277-7	• CUSHION	1	35	
- 9	50230075-258M	• CLAMP, <98625> 91-97602-041	2	189	277
- 10	8-28277-7	• CUSHION	2	189	277
- 11	8-21118-7	• BRACKET, LH	1	A	
	8-21118-15	• BRACKET, LH	1	189	277
	8-21118-4	• BRACKET, RH	1	A	
	8-21118-16	• BRACKET, RH	1	189	277
- 12	8-21118-19	• BRACKET, LH	1	189	277
	8-21118-20	• BRACKET, RH ATTACHING PARTS	1	189	277
- 13	NAS679A3	• NUT	2	35	
- 14	AN957D10L	• WASHER	2	189	277
- 15	AN3-7A	• BOLT	2	A	
	AN3-4A	• BOLT	2	189	277
- 16	NAS679A3	• NUT	2	189	277
- 17	AN969D10L	• WASHER	2	189	277
- 18	AN3-4A	• BOLT	2	189	277
		-----X-----			
- 19	8-21586	• TUBE ASSY, WELDED REPLACED BY NOT INTCHG WITH 8-21586-1	1	A	
	8-21586-1	• TUBE ASSY, WELDED REPLACES NOT INTCHG WITH 8-21586	1	189	277
		A AIRPLANES #75 THRU 189, 278 AND ON B AIRPLANES #25 THRU 47, 49 THRU 189, 278 AND ON			

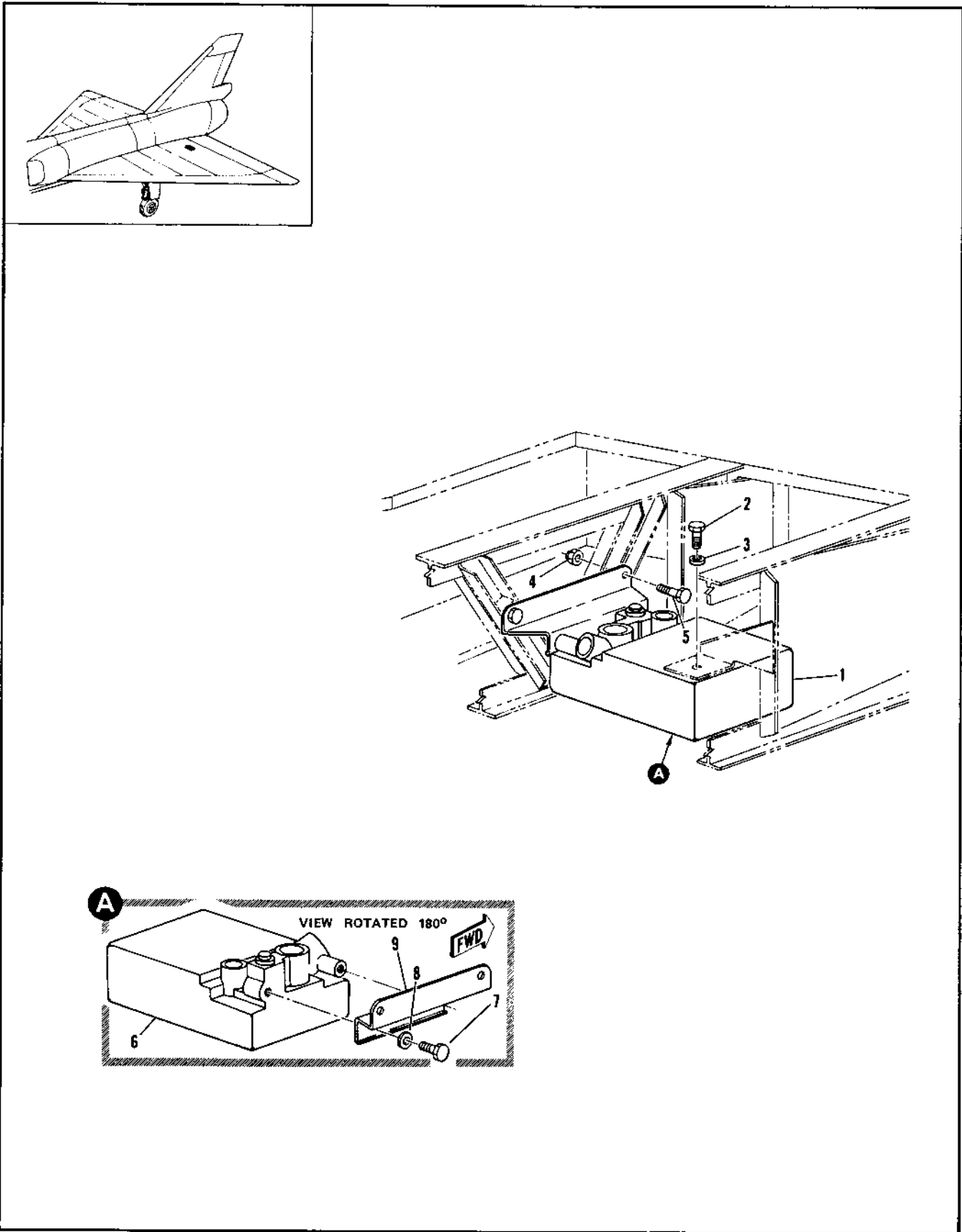

Figure 2.12-28. Transfer Tank Inboard Pilot Valve Installation

FIGURE AND INDEX NUMBER	PART NUMBER	DESCRIPTION	UNITS PER ASSY.	USABLE ON CODE		
				FROM	TO	
2.12-28	3-21179-1	VALVE INSTALLATION, TRANSFER TANK INBD PILOT LH FOR NHA SEE FIG. 2.6-32	RF	35	183	
	4-21179-3	VALVE INSTALLATION, TRANSFER TANK INBD PILOT LH FOR NHA SEE FIG. 2.6-32	RF	189	277	
	8-21179-5	VALVE INSTALLATION, TRANSFER TANK INBD PILOT LH FOR NHA SEE FIG. 2.6-32	RF	278		
	8-21179-2	VALVE INSTALLATION, TRANSFER TANK INBD PILOT RH FOR NHA SEE FIG. 2.6-32	RF	35	188	
	8-21179-4	VALVE INSTALLATION, TRANSFER TANK INBD PILOT RH FOR NHA SEE FIG. 2.6-32	RF	189	277	
	9-21179-6	VALVE INSTALLATION, TRANSFER TANK INBD PILOT RH FOR NHA SEE FIG. 2.6-32	RF	278		
	- 1	3-21179-7	VALVE ASSY, TRANSFER TANK INBD PILOT LH	1	35	129
		8-21179-11	VALVE ASSY, TRANSFER TANK INBD PILOT LH	1	130	188
		3-21179-15	VALVE ASSY, TRANSFER TANK INBD PILOT LH	1	189	240
		8-21179-17	VALVE ASSY, TRANSFER TANK INBD PILOT LH	1	241	277
		8-21179-19	VALVE ASSY, TRANSFER TANK INBD PILOT LH	1	278	
		8-21179-8	VALVE ASSY, TRANSFER TANK INBD PILOT RH	1	35	129
		8-21179-12	VALVE ASSY, TRANSFER TANK INBD PILOT RH	1	130	188
		9-21179-16	VALVE ASSY, TRANSFER TANK INBD PILOT RH	1	189	240
		8-21179-18	VALVE ASSY, TRANSFER TANK INBD PILOT RH	1	241	277
		8-21179-20	VALVE ASSY, TRANSFER TANK INBD PILOT RH ATTACHING PARTS	1	278	
	- 2	AN3H4A	BOLT	1	35	
	- 3	AN960D10L	WASHER	1	35	
	- 4	NAS679A3	NUT	2	35	
	- 5	AN3-7A	BOLT	2	A	
	NAS623-3-1	SCREW	2	189	277	
- 6	762200-7	VALVE ASSY, FUEL TRANSFER PILOT <96124> SPEC 8-72443-7 T.O. 5J15-3-78-3 ATTACHING PARTS	1	35		
- 7	AN3H4A	BOLT	2	35		
- 8	AN960D10L	WASHER	2	35		
- 9	8-21179-9	SUPPORT, LH	1	A		
	8-21179-13	SUPPORT, LH	1	189	277	
	8-21179-10	SUPPORT, RH	1	A		
	8-21179-14	SUPPORT, RH	1	189	277	

A AIRPLANES #35 THRU 188, 278 AND ON

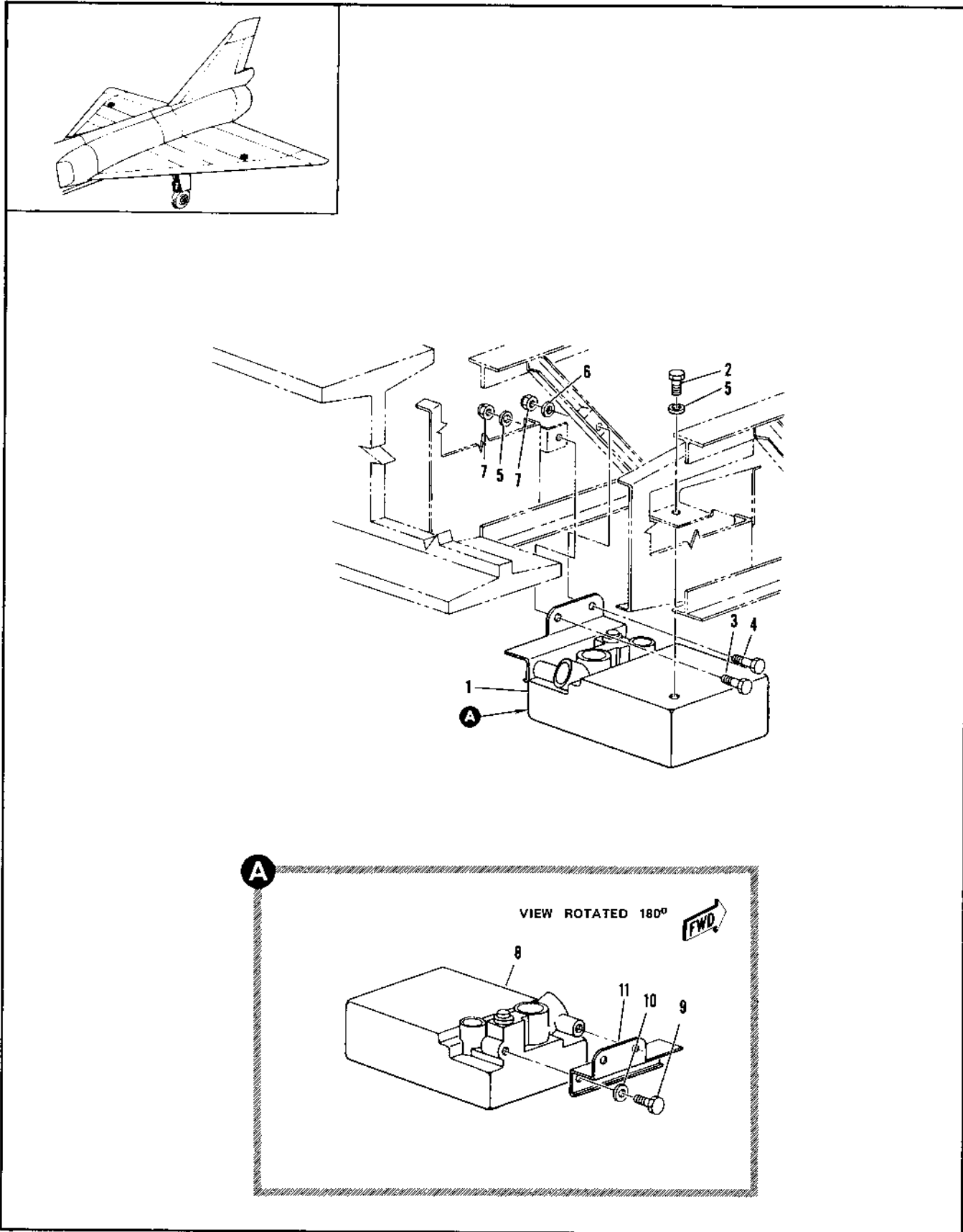

Figure 2.12-29. Transfer Tank Outboard Pilot Valve Installation

FIGURE AND INDEX NUMBER	PART NUMBER	DESCRIPTION	UNITS PER ASSY.	USABLE ON CODE		
				FROM	TO	
2.12-29	8-21180-1	VALVE INSTALLATION, TRANSFER TANK OUTBD PILOT LH FOR NHA SEE FIG. 2.4-32	RF	35	188	
	8-21180-3	VALVE INSTALLATION, TRANSFER TANK OUTBD PILOT LH FOR NHA SEE FIG. 2.4-32	RF	189	277	
	8-21180-5	VALVE INSTALLATION, TRANSFER TANK OUTBD PILOT LH FOR NHA SEE FIG. 2.5-32	RF	278		
	8-21180-2	VALVE INSTALLATION, TRANSFER TANK OUTBD PILOT RH FOR NHA SEE FIG. 2.6-32	RF	35	188	
	8-21180-4	VALVE INSTALLATION, TRANSFER TANK OUTBD PILOT RH FOR NHA SEE FIG. 2.6-32	RF	189	277	
	8-21180-6	VALVE INSTALLATION, TRANSFER TANK OUTBD PILOT RH FOR NHA SEE FIG. 2.6-32	RF	279		
	- 1	2-21180-9	• VALVE ASSY, TRANSFER TANK OUTBD PILOT LH	1	35	129
		8-21180-11	• VALVE ASSY, TRANSFER TANK OUTBD PILOT LH	1	133	188
		8-21180-15	• VALVE ASSY, TRANSFER TANK OUTBD PILOT LH	1	189	277
		8-21180-17	• VALVE ASSY, TRANSFER TANK OUTBD PILOT LH	1	241	277
		8-21180-19	• VALVE ASSY, TRANSFER TANK OUTBD PILOT LH	1	278	
		8-21180-10	• VALVE ASSY, TRANSFER TANK OUTBD PILOT RH	1	35	129
		8-21180-12	• VALVE ASSY, TRANSFER TANK OUTBD PILOT RH	1	133	188
		8-21180-16	• VALVE ASSY, TRANSFER TANK OUTBD PILOT RH	1	189	277
		8-21180-18	• VALVE ASSY, TRANSFER TANK OUTBD PILOT RH	1	241	277
		8-21180-20	• VALVE ASSY, TRANSFER TANK OUTBD PILOT RH	1	279	
		ATTACHING PARTS				
	- 2	AN3H4A	• BOLT	1	35	
	- 3	AN3-4A	• BOLT	1	A	
	- 4	AN3-7A	• BOLT	2	189	277
- 5	AN960D10	• WASHER	2	35		
- 6	AN960D13	• WASHER	1	189	277	
- 7	NAS479A3	• NUT	2	35		
	-----X-----					
- 8	762219-7	• VALVE ASSY, FUEL TRANSFER PILOT <95124> SPEC 8-C2443-7 T.O. 6J19-3-78-3 ATTACHING PARTS	1	35		
- 9	AN3H3A	• BOLT	2	35		
- 10	AN960D13L	• WASHER	2	35		
	-----X-----					
- 11	8-21180-7	• SUPPORT, LH	1	A		
	8-21180-13	• SUPPORT, LH	1	189	277	
	8-21180-8	• SUPPORT, RH	1	A		
	8-21180-14	• SUPPORT, RH	1	189	277	

A AIRPLANES #75 THRU 148, 278 AND ON

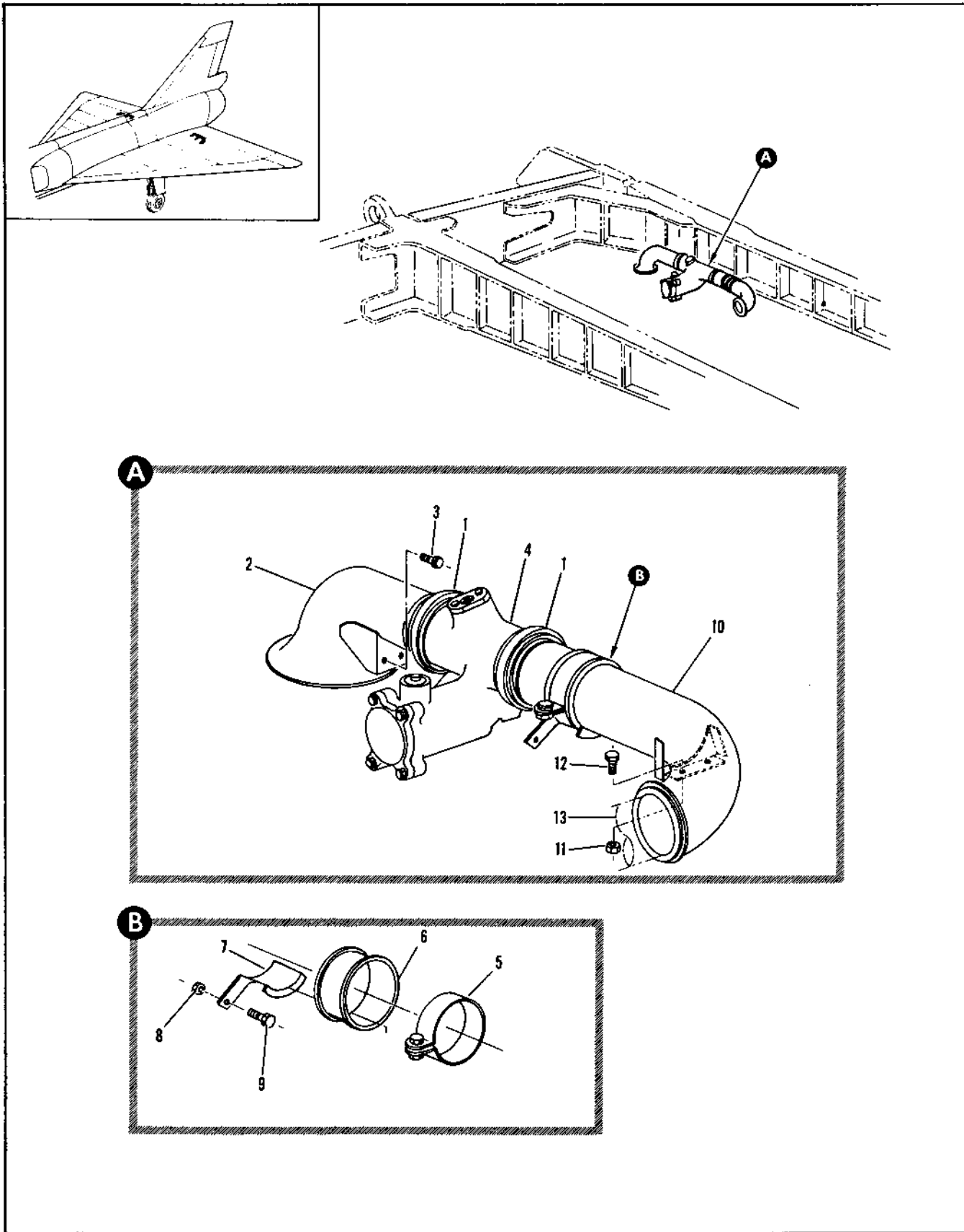

Figure 2.12-30. Transfer Tank Inboard Shutoff Valve Installation

FIGURE AND INDEX NUMBER	PART NUMBER	DESCRIPTION	UNITS PER ASSY.	USABLE ON CODE	
				FROM	TO
2.12-30	8-21525-3	VALVE INSTALLATION, TRANSFER TANK INBOARD SHUTOFF LH MODIFIED BY 8-21837 FOR NMA SEE FIG. 2.6-32	RF	A	
	8-21525-4	VALVE INSTALLATION, TRANSFER TANK INBOARD SHUTOFF RH MODIFIED BY 8-21838 FOR NMA SEE FIG. 2.6-32	RF	A	
- 1	4368-331SH	• COUPLING, <98525> 92-73003-039	2	A	
	274956-1	• GASKET, <83259> SPEC 8-00274-1	2	A	
- 2	8-21537-1	• BELLMOUTH ASSY, LH WELDED REPLACED BY SUITABLE SUB 8-21600-1	1	49	48
	8-21600-1	• BELLMOUTH ASSY, LH WELDED REPLACES SUITABLE SUB FOR 8-21587-1 REPLACED BY NOT INTCHG WITH 8-21617-1	1	A	
	8-21600-2	• BELLMOUTH ASSY, RH WELDED REPLACES SUITABLE SUB FOR 8-21587-2 REPLACED BY NOT INTCHG WITH 8-21617-2	1	A	
- 3	AN3-3A	• ATTACHING PARTS	2	A	
		• BOLT			
		-----Y-----			
- 4	50310-9	• VALVE ASSY, TRANSFER TANK INRD SHUTOFF 95124 SPEC 8-02274-9	1	A	
- 5	5023075-25HM	• CLAMP, <98525> 91-97802-041	1	A	
- 6	8-28077-7	• CUSHION	1	A	
- 7	8-21118-9	• BRACKET, LH REPLACED BY NOT INTCHG WITH 8-21118-21	1	A	
	8-21118-16	• BRACKET, RH REPLACED BY NOT INTCHG WITH 8-21118-22	1	A	
		• ATTACHING PARTS			
- 8	NAS679A3	• NUT	2	A	
- 9	AN3-7A	• BOLT	2	A	
		-----X-----			
- 13	8-21585-5	• TUBE ASSY, LH WELDED	1	A	
	8-21585-6	• TUBE ASSY, RH WELDED	1	A	
		• ATTACHING PARTS			
- 11	NAS679A3	• NUT	2	A	
- 12	AN3-3A	• BOLT	2	A	
		-----X-----			
- 13		• TUBE ASSY, CR SEE FIG. 2.12-21 INDEX 120	RF		
A AIRPLANES R35 THRU 184, 278 AND ON					

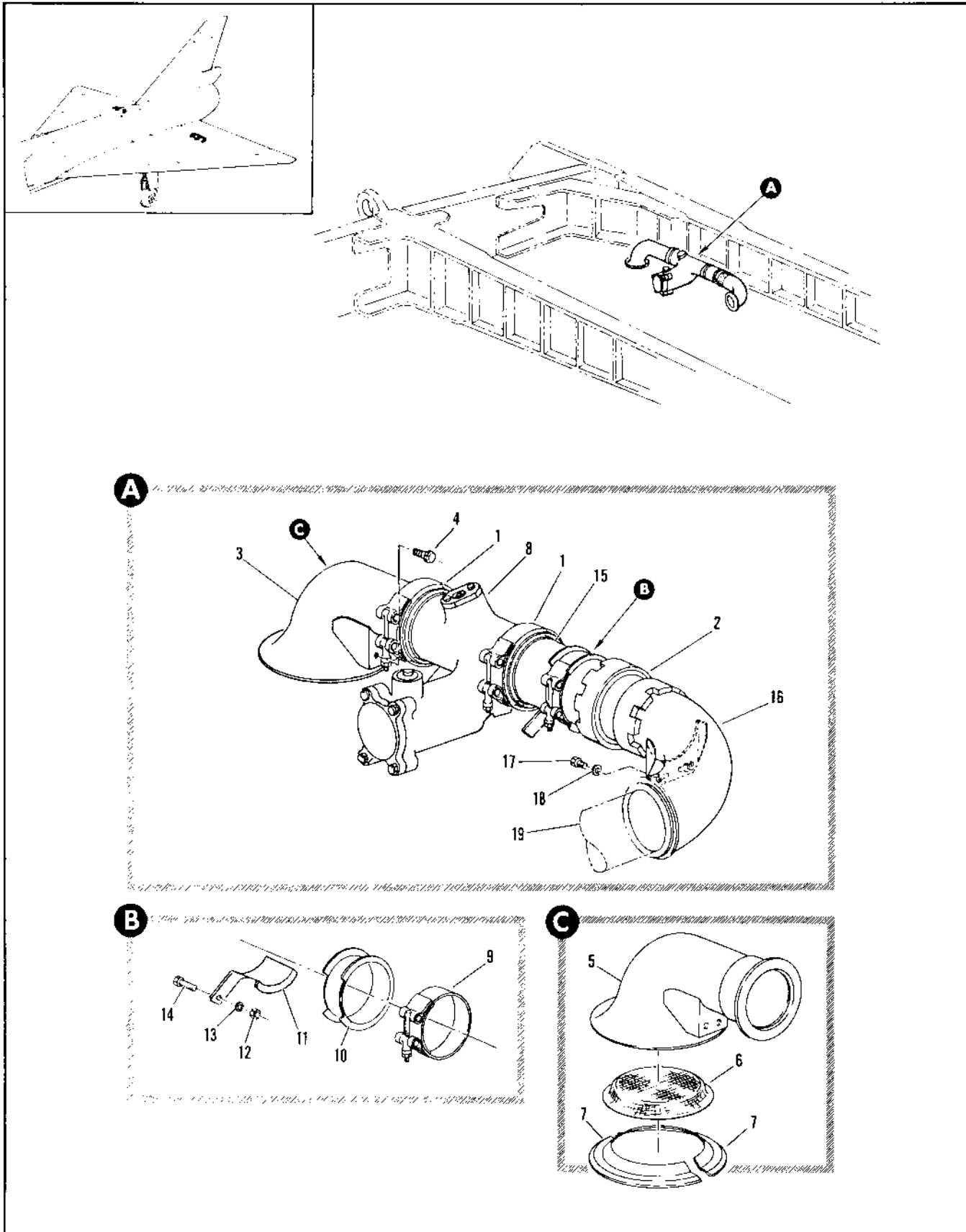

Figure 2.12-31. Transfer Tank Inboard Shutoff Valve Installation

FIGURE AND INDEX NUMBER	PART NUMBER	DESCRIPTION	UNITS PER ASSY.	USABLE ON CODE	
				FROM	TO
		1 2 3 4 5 6			
2.12-31	8-21525-5	VALVE INSTALLATION, TRANSFER TANK INBOARD SHUTOFF LH FOR NHA SEE FIG. 2.6-32	RF	189	277
	8-21525-6	VALVE INSTALLATION, TRANSFER TANK INBOARD SHUTOFF RH FOR NHA SEE FIG. 2.6-32	RF	189	277
- 1	436A-331SH	• COUPLING, <96425> 92-73033-109	2	189	277
	74R56-1	• GASKET, <83259> SPEC 8-10274-1	1	189	277
- 2	3605-40D	• COUPLING, <79326> 92-72510-115	2	189	277
	MS29513-213	• PACKING	1	189	277
- 3	8-21617-1	• BELLMOUTH ASSY, LH	1	189	277
	8-21617-2	• BELLMOUTH ASSY, RH	1	189	277
		ATTACHING PARTS	2	189	277
- 4	AN3-4A	• BOLT			
		-----X-----			
- 5	8-21617-13	• BELLMOUTH ASSY, LH WELDED	1	189	277
	8-21617-14	• BELLMOUTH ASSY, RH WELDED	1	189	277
- 6	8-21600-7	• SCREEN	1	189	277
- 7	8-21600-9	• RETAINER	2	189	277
- 8	593100-9	• VALVE ASSY, TRANSFER TANK INBD SHUTOFF <96124> SPEC 8-02274-9	1	189	277
- 9	59236075-250M	• CLAMP, <96625> 91-97852-041	1	189	277
- 10	8-28277-7	• CUSHION	1	189	277
- 11	8-21118-21	• BRACKET, LH	1	189	277
	8-21118-22	• BRACKET, RH	1	189	277
		ATTACHING PARTS	2	189	277
- 12	NASS79A3	• NUT	2	189	277
- 13	AN960D10	• WASHER	2	189	277
- 14	AN3-10A	• BOLT	2	189	277
		-----X-----			
- 15	8-21623	• TURE ASSY, WELDED	1	189	240
	8-21623-3	• TURE ASSY, WELDED	1	241	277
- 16	8-21623-1	• TURE ASSY, LH WELDED	1	189	240
	8-21623-5	• TURE ASSY, LH WELDED	1	241	277
	8-21623-2	• TURE ASSY, RH WELDED	1	189	240
	8-21623-6	• TURE ASSY, RH WELDED	1	241	277
		ATTACHING PARTS	2	189	277
- 17	AN3-4A	• BOLT	2	189	277
- 18	AN960D10	• WASHER	2	189	277
		-----X-----			
- 19		• TURE ASSY, CG SEE FIG. 2.12-21 INDEX 120	RF		

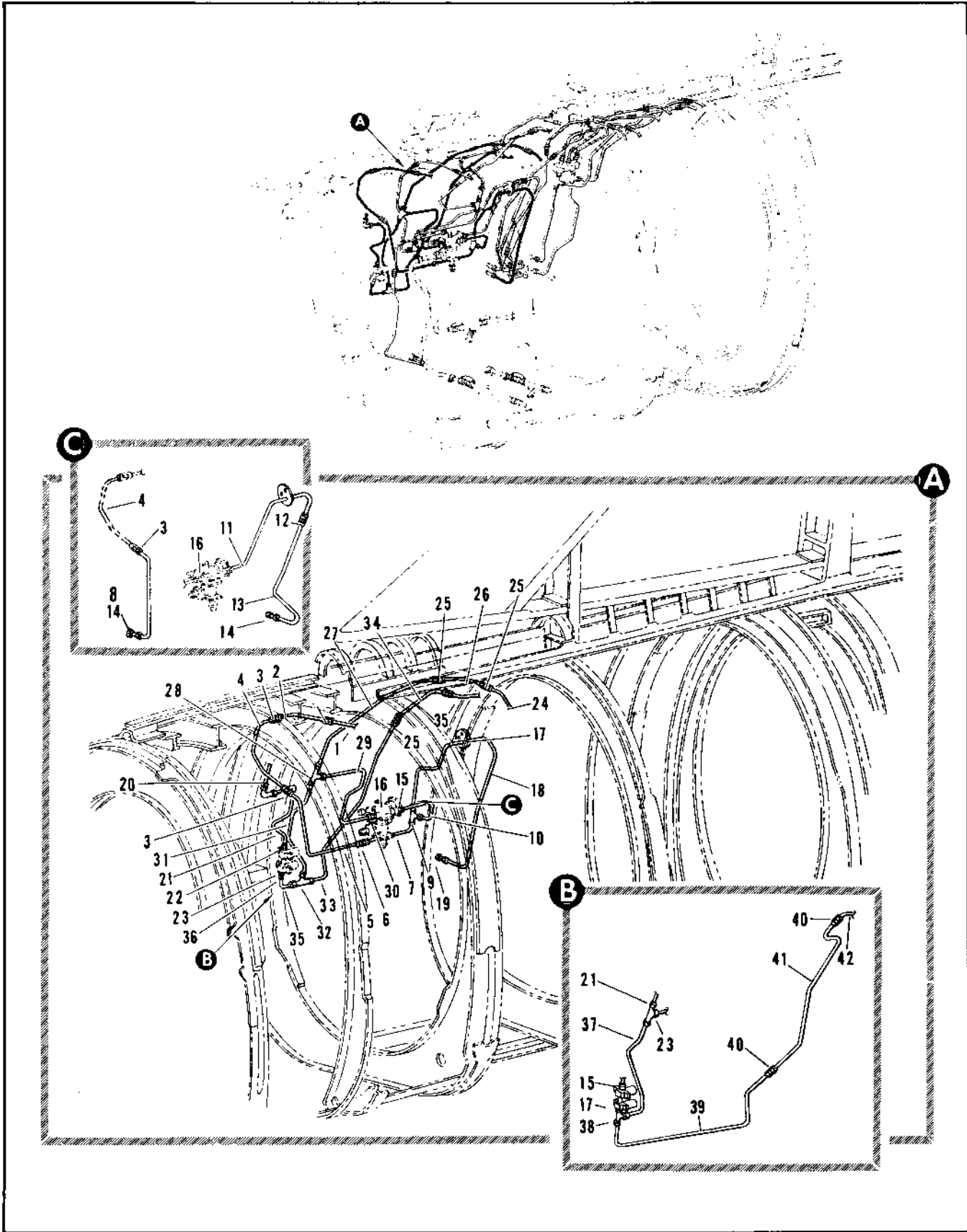

Figure 2.12-32. Fuel Tank Pressure Tubing Installation RH Sta 472 to 577 (Sheet 1 of 4)

FIGURE AND INDEX NUMBER	PART NUMBER	DESCRIPTION	UNITS PER ASSY.	USABLE ON CODE	
				FROM	TO
2.12-32	R-20397-#33	TUBING INSTALLATION, FUEL TANK PRESSURE RN STA 472 TO 577 FOR NHA SEE FIG. 2.3-14	RF 35		
- 1		• TUBE ASSY, SEE FIG. 2.12-46 INDEX 263	RF 1 35		
- 2	8-20397-1437	• TUBE ASSEMBLY	3 35		
- 3	MS2190206	• UNION	1 35		
- 4	R-20397-1439	• TUBE ASSEMBLY	1 35 159		
- 5	R-20397-1441	• TUBE ASSEMBLY	1 35 159		
- 6	MS2190206	• UNION	1 35 159		
- 7	8-20397-1443	• TUBE ASSEMBLY	1 35		
- 8	7144792-01	• TUBE ASSY	1 35 159		
- 9	FR8240061604	• TEE, <20397 9#-20319-01R	1 35 159		
- 10	R-20397-1899	• TUBE ASSEMBLY	1 160 277		
- 11	R-20397-3097	• TUBE ASSEMBLY	1 278		
- 12	4-21834-19	• TUBE ASSEMBLY	1 160		
- 13	MS2191606-4	• REDUCER	1 160		
- 14	R-20397-3095	• TUBE ASSEMBLY	RF		
- 15	MS2190204	• FITTING, TRANSFER TANK AMBIENT SENSING SEE FIG. 2.12 INDEX 4	1 35		
- 16	NAS617-4	• UNION	1 35		
- 17	8-28339-27	• GASKET	RF		
- 18	6-28339-27	• REGULATOR ASSY, AIR PRESSURE TRANSFER TANK SEE FIG. 2.12-38 INDEX 90	2 35 47		
- 19	8-28339-27	• GROMMET	1 48		
- 20	8-28339-1615	• GROMMET	1 35 159		
- 21	H-20397-739	• TUBE ASSEMBLY	RF		
- 22	3-21834-9	• FITTING, TRANSFER TANK AMBIENT SENSING SEE FIG. 2.12-35 INDEX 5	1 35 277		
- 23	MS2190206	• TUBE ASSEMBLY	1 278		
- 24	NAS617-6	• TUBE ASSEMBLY	1 35		
- 25		• UNION	1 35		
- 26	R-20397-1631	• GASKET	RF		
- 27	R-20397-724	• VALVE ASSY, SEE FIG. 2.12-44 INDEX 74	RF		
- 28	MS2190506	• TUBE ASSY, SEE FIG. 2.12-46 INDEX 57	RF		
- 29	3-20397-723	• TUBE ASSY	2 35		
- 30	MS2190206	• UNION	1 35		
- 31	NAS617-6	• GASKET	1 35		
- 32	R-20397-733	• TUBE ASSEMBLY	1 35 47		
- 33	MS2190506	• TEE	2 35 47		
- 34	R-20397-726	• TUBE ASSEMBLY	1 35 47		
- 35	1-20397-741	• TUBE ASSEMBLY	1 35 47		
- 36	R-20397-735	• TUBE ASSEMBLY	1 35 47		
- 37	MS2190206	• UNION	1 35 47		
- 38	NAS617-6	• GASKET	1 35 47		
- 39	R-20397-1537	• TUBE ASSEMBLY	1 48 57		
- 40	R-20397-3007	• TUBE ASSEMBLY	1 4		
- 41	AN924-5F	• NUT	1 48		
- 42	MS2191206	• TEE	1 48		
- 43	NAS617-6	• GASKET	1 48		
- 44	7144792-01	• TUBE ASSY	1 35		
- 45	MS2190206	• UNION	2 48		
- 46	R-20397-658	• TUBE ASSEMBLY	1 48 277		
- 47	R-21034-7	• TUBE ASSEMBLY	1 278		
- 48		• TUBE ASSY, SEE FIG. 2.12-46 INDEX 49	RF		

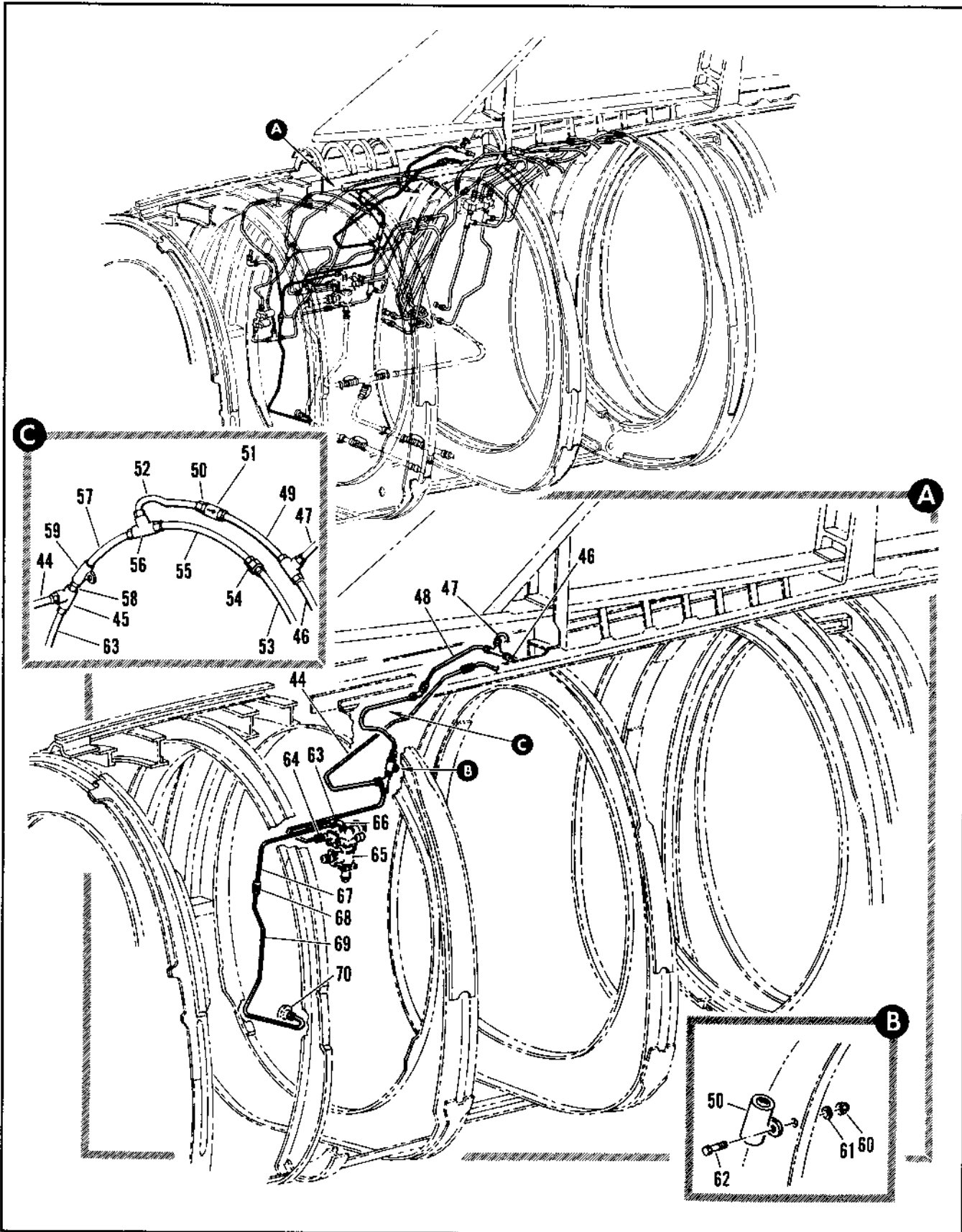

Figure 2.12-32. Fuel Tank Pressure Tubing Installation RH Sta 472 to 577 (Sheet 2 of 4)

FIGURE AND INDEX NUMBER	PART NUMBER	DESCRIPTION 1 2 3 4 5 6	UNITS PER ASSY.	USABLE ON CODE	
				FROM	TO
2.12-32- 43	MS2190204	• UNION	1	35	
- 44	R-20397-2867	• TUBE ASSMPLY	1	35	
- 45	CR8040C61604	• TEE, <92003> 98-90319-034	1	35	
	AN924-6D	• NUT	1	35	
	NAS617-6	• GASKET	RF		
- 46		• TUBE ASSY. SEE FIG. 2.12-44 INDEX 45	RF		
- 47		• TUBE ASSY. SEE FIG. 2.12-45 INDEX 42	1	35	215
- 48	R-20397-717	• TUBE ASSEMBLY	1	35	
- 49	R-20397-2979	• TUBE ASSEMBLY	2	35	
- 50	MS2190206	• UNION	2	35	
	NAS617-6	• GASKET	1	35	
- 51	W535-378F	• VALVE ASSY, AIR CHECK <96138> SPEC R-32998-13 ATTACHING PARTS	1		
	NAS1291-3	• NUT	1	35	
	NAS622A3	• NUT	1	35	
	99-51509-020	• WASHER	1	35	
	AN3-6A	• BOLT			
		----X----	1	35	
- 52	R-20397-2977	• TUBE ASSEMBLY	RF		
- 53		• TUBE ASSY. SEE FIG. 2.12-46 INDEX 55	1	35	
- 54	MS2190206	• UNION	1	35	
- 55	R-20397-2975	• TUBE ASSEMBLY	1	35	
- 56	MS2190906	• TEE	1	35	
	AN924-6D	• NUT	1	35	
	AN9600916	• WASHER	1	35	
- 57	R-20397-2973	• TUBE ASSEMBLY	1	35	
- 58	MS2190206	• UNION	1	35	
	NAS617-6	• GASKET	1	35	
- 59	W535-378F	• VALVE ASSY, AIR CHECK <96138> SPEC R-32998-13 ATTACHING PARTS	1		
- 60	NAS1291-3	• NUT	1	35	
- 61	99-51509-020	• WASHER	1		
- 62	AN520-10F10	• SCREW			
		----X----	1	35	
- 63	R-20397-2971	• TUBE ASSEMBLY	1	35	
- 64	R-28388-9	• UNION, ORIFICE TYPE	1	35	
	NAS617-6	• GASKET	PF		
- 65		• REGULATOR ASSY, AIR PRESSURE TRANSFER TANK SEE FIG. 2.12-38 INDEX 37	1	35	
- 66	MS2190806	• ELBOW	1	35	
	AN924-6D	• NUT	1	35	
	NAS617-6	• GASKET	1	35	
- 67	R-20397-731	• TUBE ASSEMBLY	1	35	
- 68	MS2190206	• UNION	1	35	
- 69	R-20397-761	• TUBE ASSEMBLY	RF		
- 70		• ADAPTER, TRANSFER TANK AIR PRESSURE REGULATOR BLEED DRAIN STA 542 SEE FIG. 2.12-14 INDEX 6			

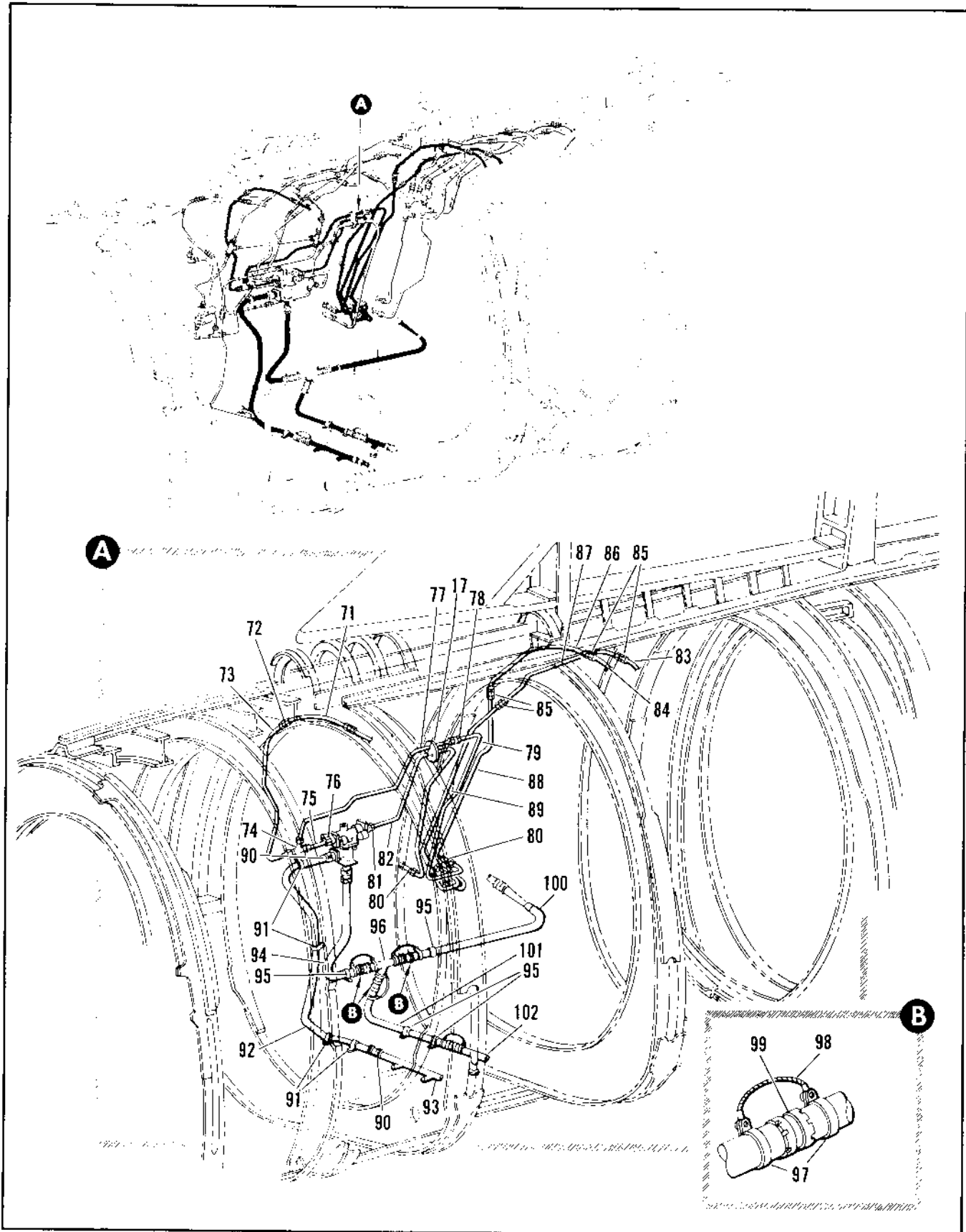

Figure 2.12-32. Fuel Tank Pressure Tubing Installation RH Sta 472 to 577 (Sheet 3 of 4)

FIGURE AND INDEX NUMBER	PART NUMBER	DESCRIPTION	UNITS PER ASSY.	USABLE ON CODE	
				FROM	TO
		1 2 3 4 5 6			
2.12-32- 71		• TUBE ASSY, SEE FIG. 2.12-46 INDEX 110	RF		
- 72	MS21902D6	• UNION	1	35	
- 73	R-20397-1049	• TUBE ASSEMBLY	1	35	
- 74	MS21905D6	• TEE	1	35	
- 75	R-20397-1053	• TUBE ASSEMBLY	1	35	
- 76	MS21902D6	• UNION	1	35	
	NAS617-a	• GASKET	1	35	
- 77	R-20397-1617	• TUBE ASSEMBLY	1	35	
- 78	MS21902D6	• UNION	1	35	
- 79	R-20397-681	• TUBE ASSEMBLY	RF		
- 80		• FITTING, TRANSFER TANK AMBIENT SENSING SEE FIG. 2.12-37 INDEX 5			
		• UNION	1	35	
- 81	MS21902D4	• GASKET	1	33	
	MS29512-4	• TUBE ASSEMBLY	1	35	
- 82	R-20397-1623	• TUBE ASSEMBLY	RF		
- 83		• TUBE ASSY, SEE FIG. 2.12-46 INDEX 124	4	35	
- 84		• TUBE ASSY, SEE FIG. 2.12-46 INDEX 123	1	35	
- 85	MS21902D6	• UNION	1	35	
- 86	R-20397-1575	• TUBE ASSEMBLY	1	35	
- 87	R-20397-1583	• TUBE ASSEMBLY	1	35	
- 88	R-20397-1577	• TUBE ASSEMBLY	2	35	
- 89	R-20397-1585	• TUBE ASSEMBLY	2	35	
- 90	NAS594-20	• FITTING	4	35	
	NAS595-20	• RING	2	35	
- 91	91-98026-019	• CLAMP	1	35	
- 92	R-20397-641	• TUBE ASSEMBLY	RF		
- 93		• TUBE, FUEL TANK PRESSURE SEE FIG. 2.12-58 INDEX 26	1	35	
- 94	R-20397-3035	• TUBE ASSY	4	35	
- 95	91-98026-019	• CLAMP	RF		
- 96		• TEE, FIG. 2.12-58 INDEX 36	6	35	
- 97	AN735D20	• CLAMP			
		ATTACHING PARTS			
	NAS679A3	• NUT	6	35	
	AN960D10L	• WASHER	6	35	
	ANS26-1032R6	• SCREW	6	35	
		----X----	3	35	
- 98	MS25083-1RB3	• JUMPER	3	35	
- 99	3609-200	• COUPLING (79324) 92-72500-306	3	35	
	2-21AS418-6	• PACKING, REPLACED BY NAS1593-21R			
	NAS1593-21R	• PACKING, REPLACES 2-21AS418-6	RF		
-100		• TUBE ASSY, PRESSURE INTAKE TANK SEE FIG. 2.12-58 INDEX 34	1	B	
-101	R-20397-3030	• TUBE ASSY	1	C	
	R-21R34-13	• TUBE ASSEMBLY	RF		
-102		• TUBE ASSY, REGULATOR CROSSOVER DRAIN WELDED SEE FIG. 2.12-58 INDEX 41			
		B AIRPLANES 835 THRU 87, 103 THRU 277			
		C AIRPLANES 848 THRU 102, 278 AND ON			

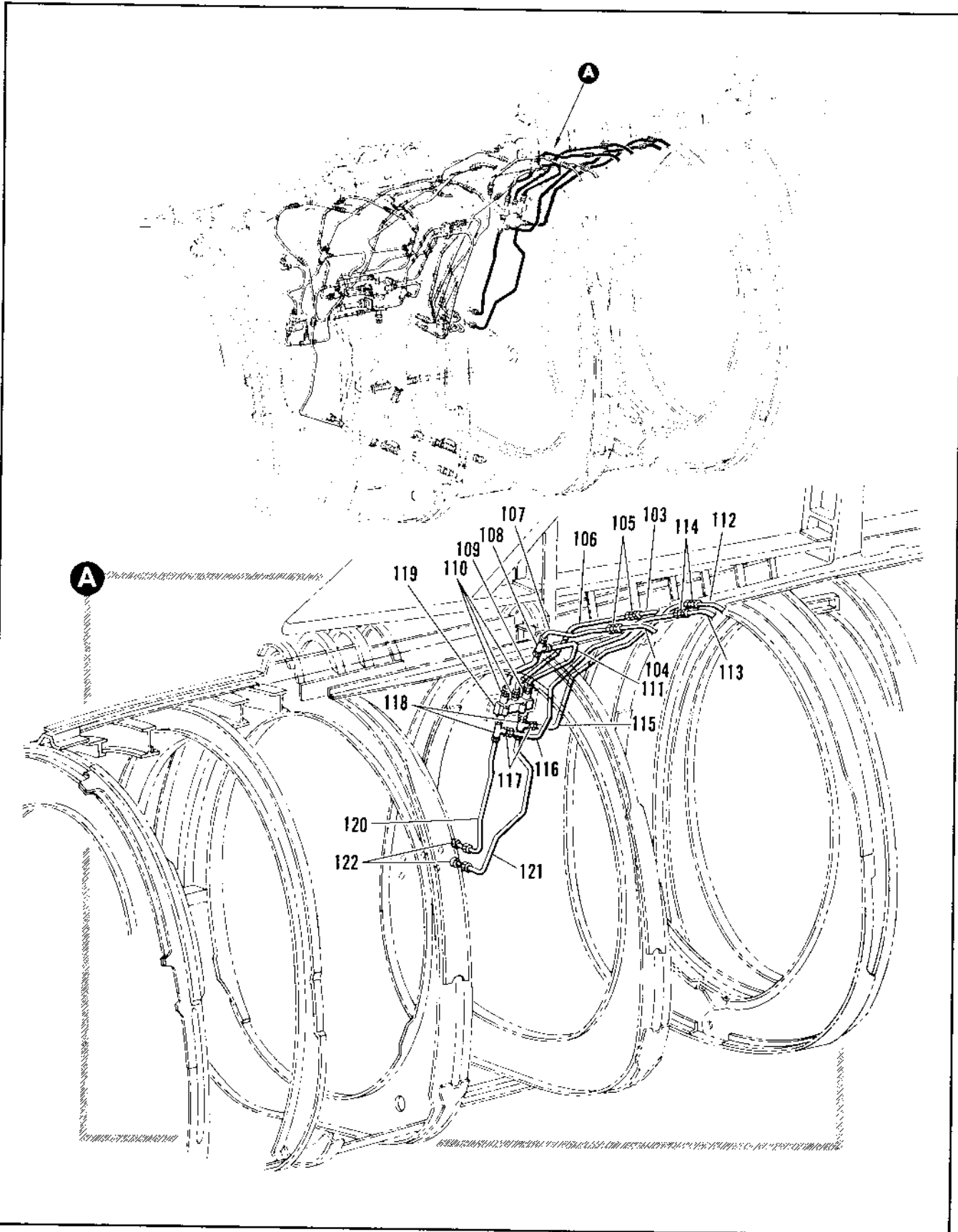

Figure 2.12-32. Fuel Tank Pressure Tubing Installation RH Sta 472 to 577 (Sheet 4 of 4)

FIGURE AND INDEX NUMBER	PART NUMBER	DESCRIPTION 1 2 3 4 5 6	UNITS PER ASSY.	USABLE ON CODE	
				FROM	TO
2.12-32-103		• TUBE ASSY, SEE FIG. 2.12-46 INDEX 152	RF		
-104		• TUBE ASSY, SEE FIG. 2.12-46 INDEX 153	RF		
-105	MS21902D6	• UNION	2	35	
-106	8-20397-663	• TUBE ASSEMBLY	1	35	
-107	8-20397-624	• TUBE ASSEMBLY	1	35	
-108	MS21905D6	• TEE	1	35	
-109	8-20397-522	• TUBE ASSEMBLY	3	35	
-110	MS21902D6	• UNION	3	35	
	NAS617-6	• GASKET	1	35	
-111	8-20397-620	• TUBE ASSEMBLY	RF		
-112		• TUBE ASSY, SEE FIG. 2.12-46 INDEX 176	RF		
-113		• TUBE ASSY, SEE FIG. 2.12-46 INDEX 175	RF		
-114	MS21902D6	• UNION	2	35	
-115	8-20397-1393	• TUBE ASSEMBLY	1	35	
-116	8-20397-1401	• TUBE ASSEMBLY	1	35	
-117	MS21916D6-4	• REDUCER	2	35	
	AN924-6D	• NUT	2	35	
-118	MS21910D6	• TEE	2	35	
	NAS617-6	• GASKET	RF		
-119		• VALVE ASSY, SEE FIG. 2.12-38 INDEX 97	RF		
-120	8-20397-1493	• TUBE ASSEMBLY	1	35	
-121	8-20397-1491	• TUBE ASSEMBLY	1	35	
-122		• FITTING, TRANSFER TANK AMBIENT SENSING SEE FIG. 2.12-35 INDEX 5 AND 6	RF		

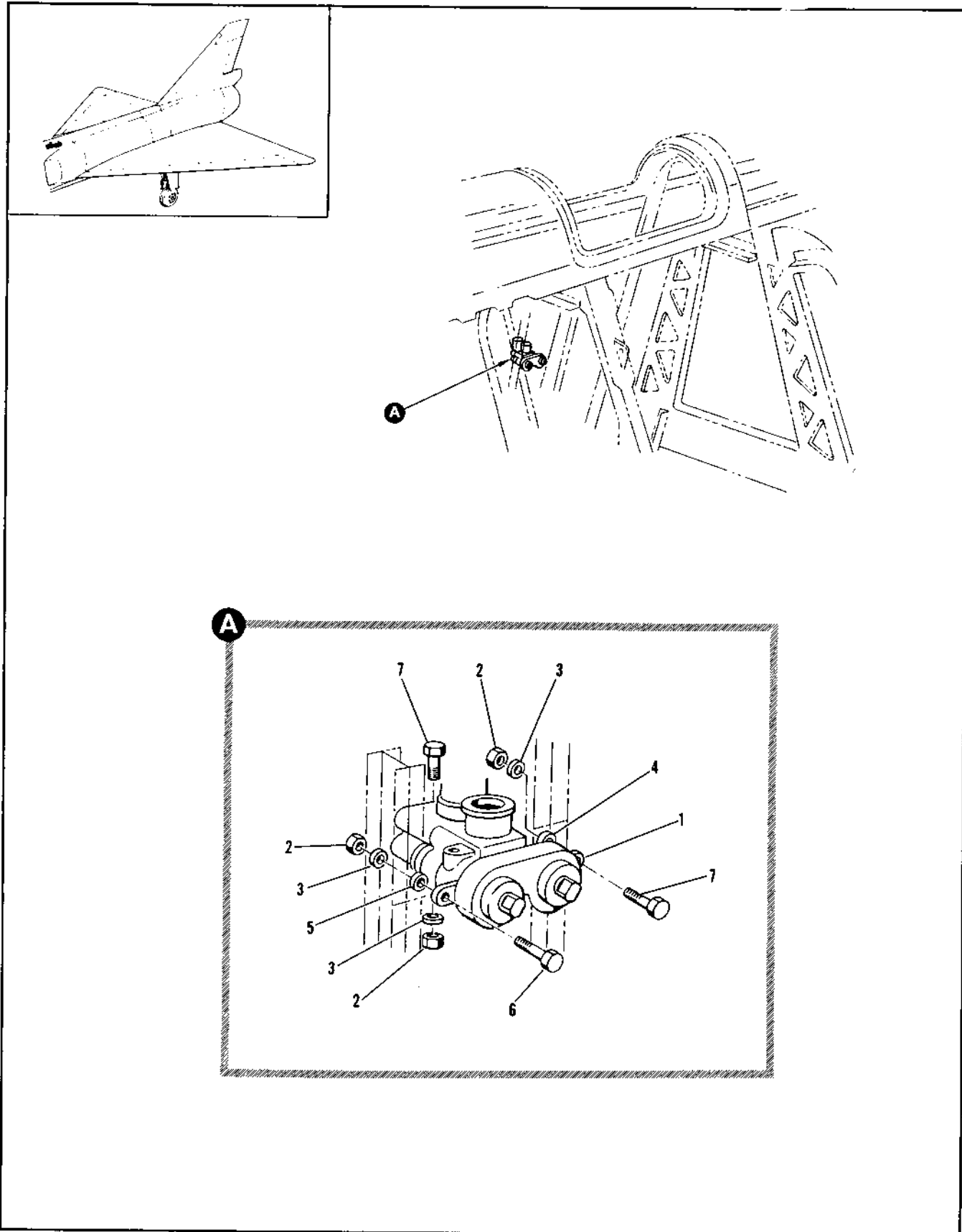

Figure 2.12-33. Emergency Fuel Transfer Valve Installation

FIGURE AND INDEX NUMBER	PART NUMBER	DESCRIPTION 1 2 3 4 5 6	UNITS PER ASSY.	USABLE ON CODE	
				FROM	TO
2.12-31 - 1 - 2 - 3 - 4 - 5 - 6 - 7	6-85029-3	VALVE INSTALLATION, EMERGENCY FUEL TRANSFER FOR NHA SEE FIG. 2.3-11 INDEX 10	RF	35	
	168-101-501	• VALVE ASSY, FUEL TRANSFER REGULATOR AND RELIEF (85029) SPLIC H-00422-5 T.O. 485-1-70-3 ATTACHING PARTS	1	35	
	NAS679A3	• NUT	3	35	
	AN560PD10L	• WASHER	3	35	
	H-85029-15	• SPACER	1	35	
	A-85029-13	• SPACER	1	35	
	AN3-10A	• BOLT	2	35	
AN3-7A	• BOLT -----X-----				

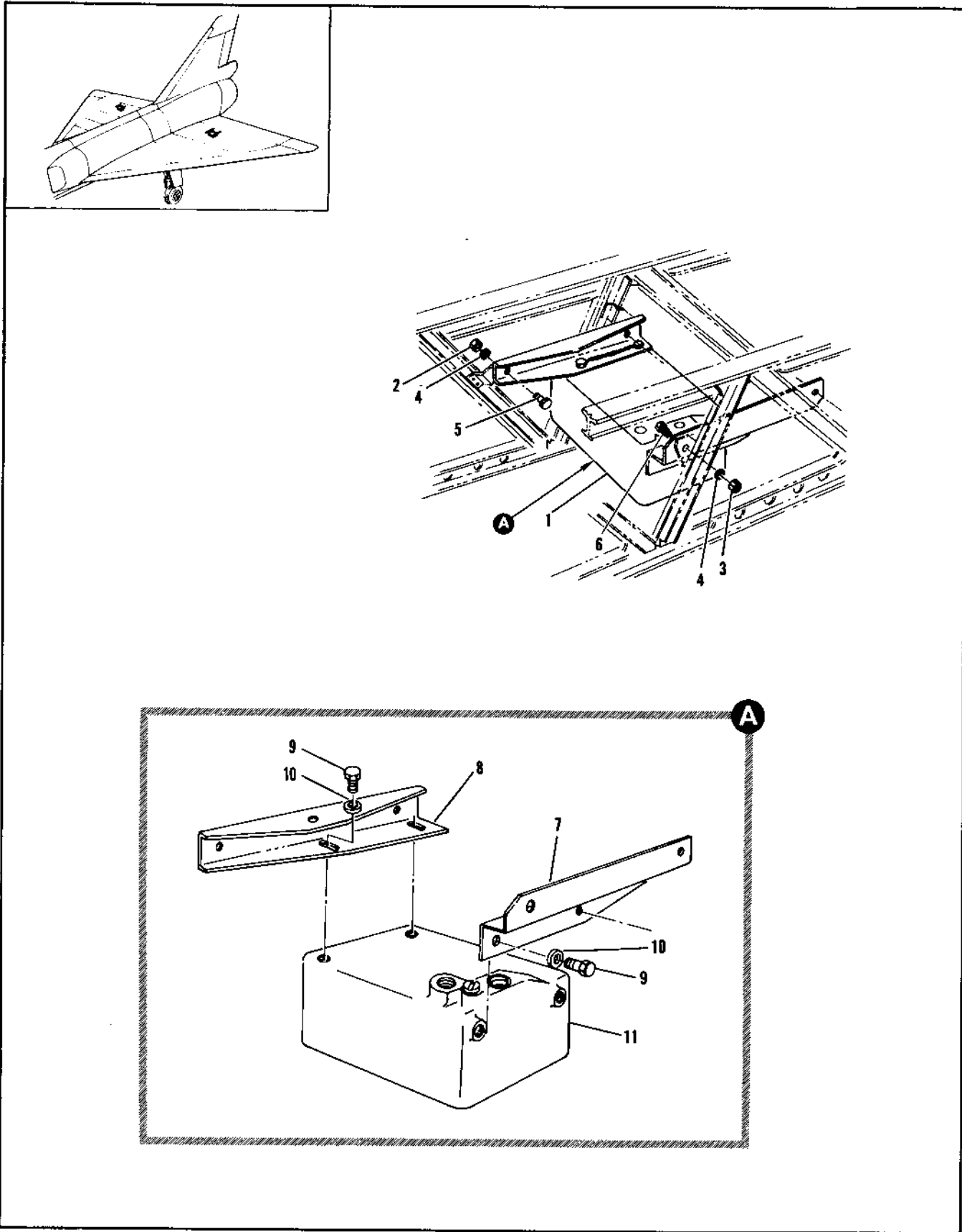

Figure 2.12-34. Transfer Tank Emergency Pilot Valve Installation

FIGURE AND INDEX NUMBER	PART NUMBER	DESCRIPTION	UNITS PER ASSY.	USABLE ON CODE		
				FROM	TO	
2.12-34	R-21168-1	VALVE INSTALLATION, TRANSFER TANK EMERGENCY PILOT LH FOR NHA SEE FIG. 2.6-32	RF	35	188	
	R-21168-3	VALVE INSTALLATION, TRANSFER TANK EMERGENCY PILOT LH FOR NHA SEE FIG. 2.6-32	RF	189	277	
	R-21168-5	VALVE INSTALLATION, TRANSFER TANK EMERGENCY PILOT LH FOR NHA SEE FIG. 2.6-32	RF	278		
	R-21168-2	VALVE INSTALLATION, TRANSFER TANK EMERGENCY PILOT RH FOR NHA SEE FIG. 2.6-32	RF	35	188	
	R-21168-4	VALVE INSTALLATION, TRANSFER TANK EMERGENCY PILOT RH FOR NHA SEE FIG. 2.6-32	RF	189	277	
	R-21168-6	VALVE INSTALLATION, TRANSFER TANK EMERGENCY PILOT RH FOR NHA SEE FIG. 2.6-32	RF	278		
	- 1	R-21168-19	VALVE ASSY, T TANK EMERGENCY PILOT LH	1	35	129
		R-21168-31	VALVE ASSY, T TANK EMERGENCY PILOT LH	1	130	188
		R-21168-37	VALVE ASSY, T TANK EMERGENCY PILOT LH	1	189	240
		R-21168-45	VALVE ASSY, T TANK EMERGENCY PILOT LH	1	241	277
		R-21168-47	VALVE ASSY, T TANK EMERGENCY PILOT RH	1	278	
R-21168-20		VALVE ASSY, T TANK EMERGENCY PILOT RH	1	35	129	
R-21168-32		VALVE ASSY, T TANK EMERGENCY PILOT RH	1	130	188	
R-21168-38		VALVE ASSY, T TANK EMERGENCY PILOT RH	1	189	240	
R-21168-46		VALVE ASSY, T TANK EMERGENCY PILOT LH	1	241	277	
R-21168-48		VALVE ASSY, T TANK EMERGENCY PILOT RH	1	278		
- 2	NAS679A3	NUT	1	35		
	NAS679A3	NUT	3	A		
- 3	NAS687A3	NUTPLATE	3	189	277	
	AN960PD10	WASHER	4	35		
- 4	AN3-4A	BOLT	2	A		
	AN3-6A	BOLT	2	189	277	
- 5	AN3-4A	BOLT	2	A		
	AN3-7A	BOLT	2	189	277	
- 6	R-21168-25	ANGLE ASSY, LH	1	A		
	R-21168-33	ANGLE ASSY, LH RIVETED	1	189	277	
- 7	R-21168-26	ANGLE ASSY, RH	1	A		
	R-21168-34	ANGLE ASSY, RH RIVETED	1	189	277	
- 8	R-21168-17	CHANNEL, LH	1	35	38	
	R-21168-27	CHANNEL, LH	1	B		
- 9	R-21168-35	CHANNEL ASSY, LH RIVETED	1	189	277	
	R-21168-18	CHANNEL, RH	2	35	38	
- 10	R-21168-28	CHANNEL, RH	1	39	60	
	R-21168-29	CHANNEL, RH	1	C		
- 11	R-21168-36	CHANNEL ASSY, RH RIVETED	1	189	277	
	AN960PD10	WASHER	4	35		
	AN3H3A	BOLT	4	35		
	76220-7	VALVE ASSY, FUEL TRANSFER PILOT <96124> SPEC R-12443-7 T.O. 5J15-3-78-3	1	35		

A AIRPLANES #25 THRU 189, 278 AND ON
 B AIRPLANES #29 THRU 189, 278 AND ON
 C AIRPLANES #41 THRU 189, 278 AND ON

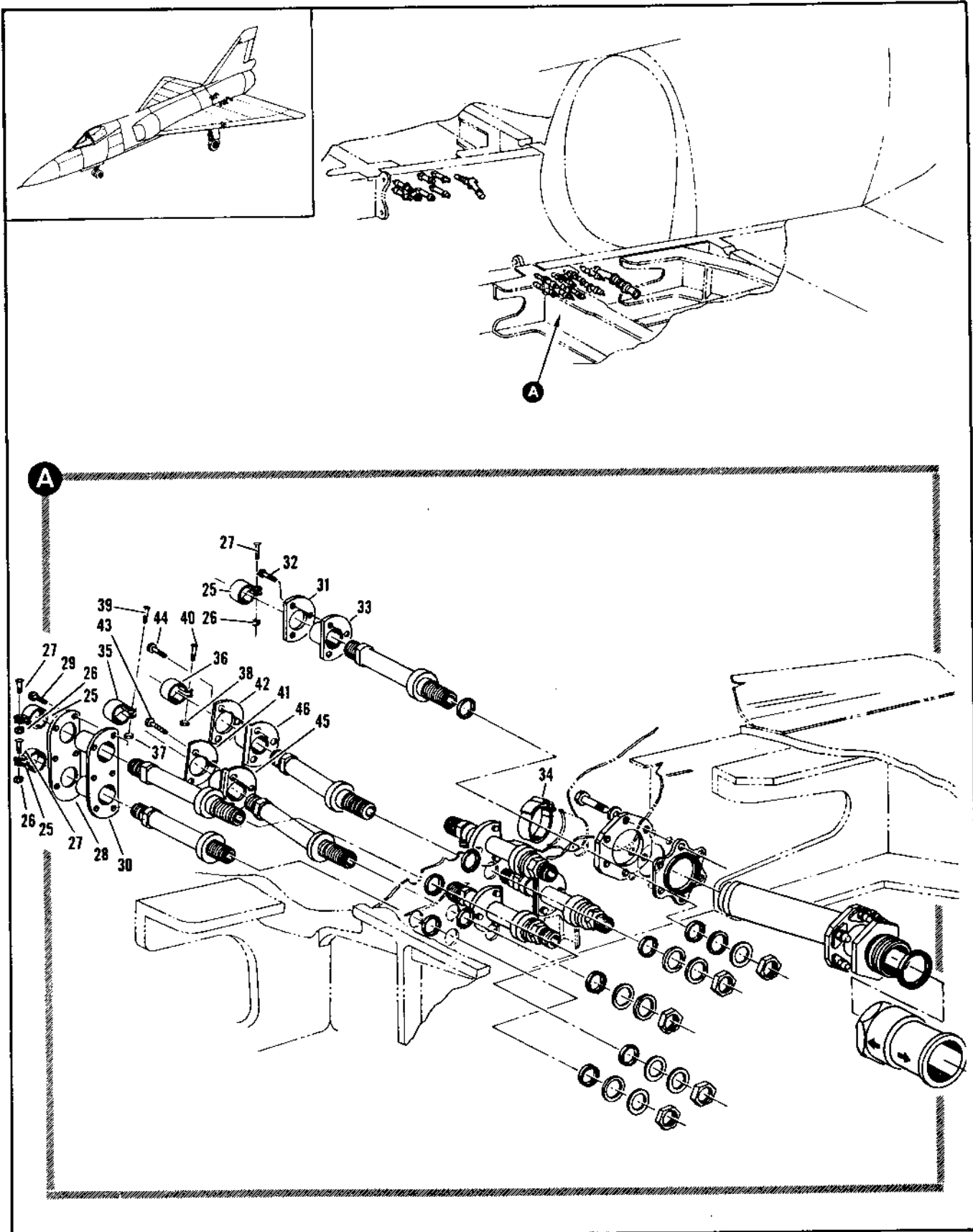

Figure 2.12-35. CG Transfer Tank Pressure Fitting Sta 569 (Sheet 2 of 2)

FIGURE AND INDEX NUMBER	PART NUMBER	DESCRIPTION	UNITS PER ASSY.	USABLE ON CODE	
				FROM	TO
		1 2 3 4 5 6			
2.12-35	8-21236-3	• SEAL INSTL, CG TRANSFER PRESSURE FITTING LH FOR NHA SEE FIG. 2.3-16 INDEX B	RF	B	
	8-21236-1	• SEAL INSTL, CG TRANSFER PRESSURE FITTING LH MODIFIED BY 8-21234 FOR NHA SEE FIG. 2.3-16 INDEX B	RF	278	303
	8-21236-5	• SEAL INSTL, CG TRANSFER PRESSURE FITTING RH FOR NHA SEE FIG. 2.3-16 INDEX B	RF	B	
	8-21236-2	• SEAL INSTL, CG TRANSFER PRESSURE FITTING RH MODIFIED BY 8-21234 FOR NHA SEE FIG. 2.3-16 INDEX B	RF	278	303
- 25	AN735010	• • CLAMP ATTACHING PARTS	6	35	
- 26	NAS479A3	• • NUT	6	35	
- 27	NAS221-8	• • SCREW	6	35	
		-----X-----			
- 28	8-28249-11 8-28249-9	• • RETAINER, SEAL T TANK SENSING LINE • • RETAINER, SEAL T TANK SENSING LINE ATTACHING PARTS	1 1	C 278	 296
- 29	NAS221-9	• • SCREW	6	35	
		-----X-----			
- 30	CP697-1	• • SEAL, <R2430> SPEC 8-12430-1	1	35	
- 31	8-28249-7	• • RETAINER, SEAL T TANK SENSING LINE ATTACHING PARTS	4	35	
- 32	NAS221-8	• • SCREW	12	35	
		-----X-----			
- 33	CR697-5	• • SEAL, <R2430> SPEC 8-12430-5	4	35	
- 34	320-62-1315	• • CLAMP, <R2625> 91-9742-331	1	35	
- 34	AN735010	• • CLAMP	1	35	
- 35	AN735010	• • CLAMP, LH ATTACHING PARTS	1	35	
- 37	NAS479A3	• • NUT	1	35	
- 38	NAS479A3	• • NUT, LH	1	35	
- 39	NAS221-8	• • SCREW	1	35	
- 40	NAS221-8	• • SCREW, LH	1	35	
		-----X-----			
- 41	8-28249-7	• • RETAINER	1	35	
- 42	8-28249-7	• • RETAINER, LH ATTACHING PARTS	1	35	
- 43	NAS221-8	• • SCREW	3	35	
- 44	NAS221-8	• • SCREW, LH	3	35	
		-----X-----			
- 45	CR697-5	• • SEAL, <R2430> SPEC 8-12430-5	1	35	
- 46	CR697-5	• • SEAL, <R2430> SPEC 8-12430-5	1	35	
		P AIRPLANES #35 THRU 277, 374 AND ON C AIRPLANES #35 THRU 277, 297 AND ON			

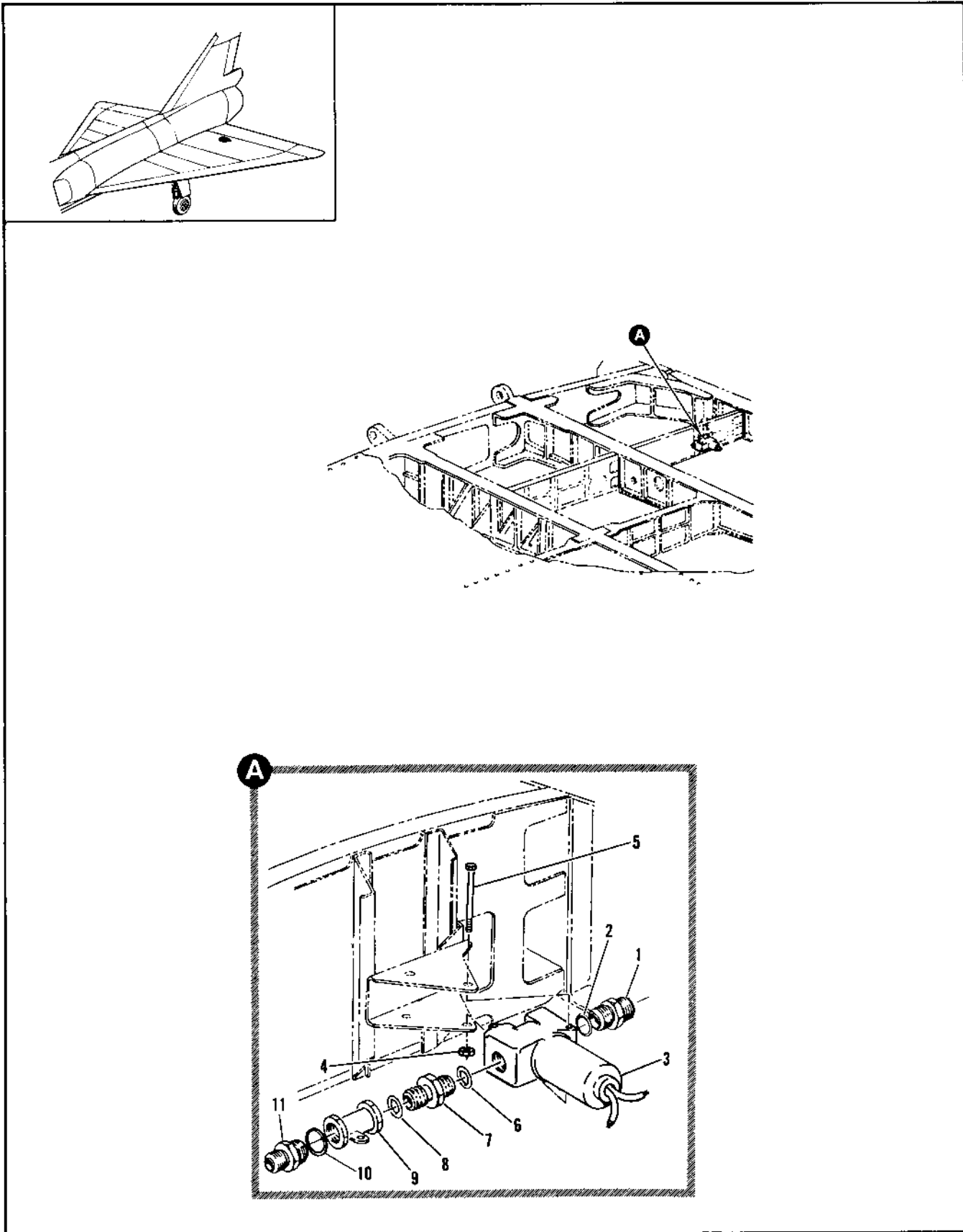

Figure 2.12-36. CG Transfer Line Shutoff Valve Installation

FIGURE AND INDEX NUMBER	PART NUMBER	DESCRIPTION	UNITS PER ASSY.	USABLE ON CODE	
				FROM	TO
2.12-36	R-21537-R11	VALVE INSTALLATION, CG TRANSFER LINE SHUTOFF LH FOR NHA SEE FIG. 2.6-32	RF	35	
	R-21537-R12	VALVE INSTALLATION, CG TRANSFER LINE SHUTOFF RH FOR NHA SEE FIG. 2.6-32	RF	35	
	- 1	MS21902DH	1	35	
	- 2	MS29512-P	1	35	
	- 3	29651	1	35	
	- 4	NAS679A3	2	35	
	- 5	AN3-17A	2	35	
	- 6	MS29512-H	1	35	
	- 7	MS21916DH-6	1	35	
	- 8	MS29512-6	1	35	
	- 9	Q535-378F	1	35	
- 10	MS29512-6	1	35		
- 11	MS21916DH-6	1	35		

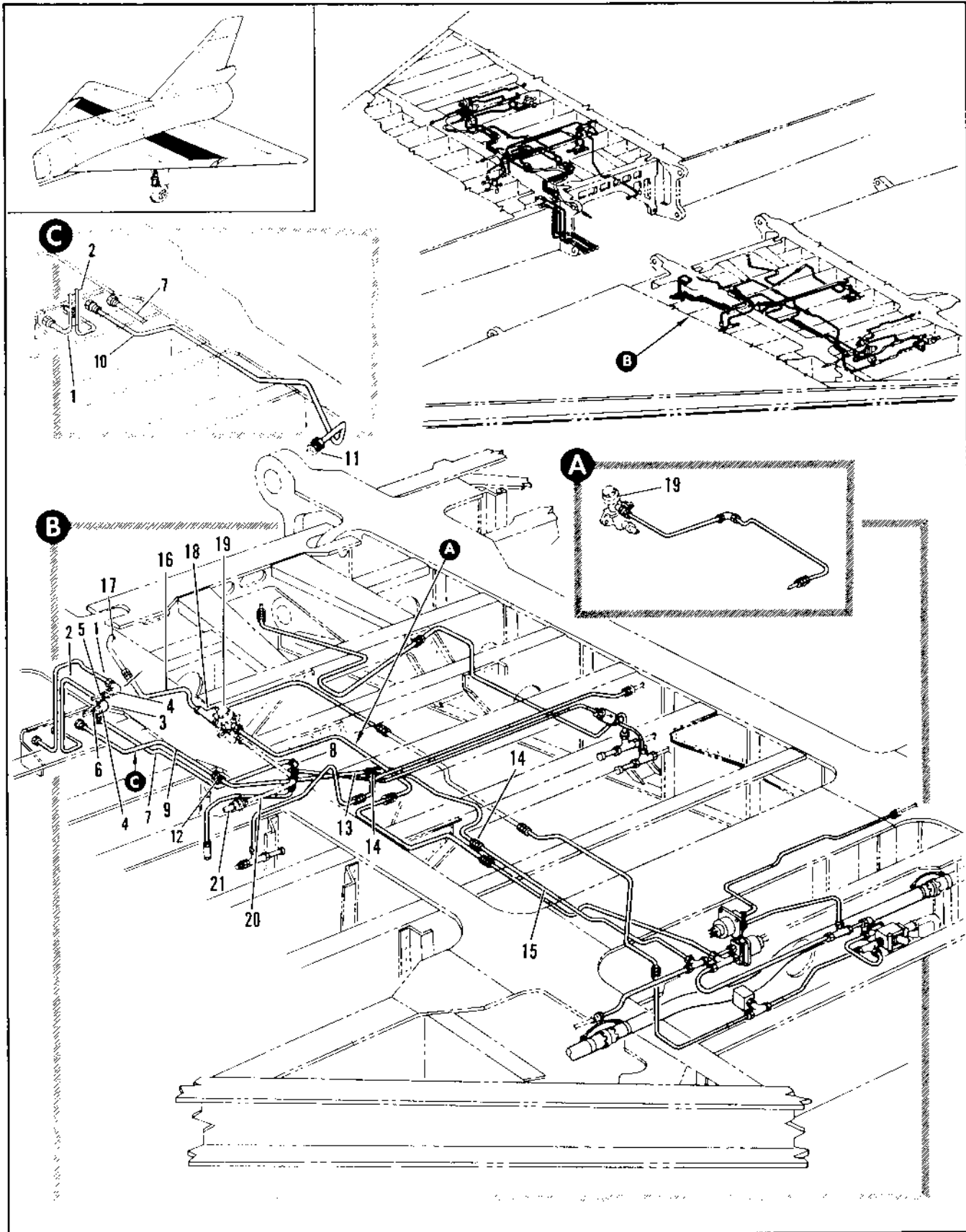

Figure 2.12-37. MLG Wheel Well Fuel Control Tubing Installation (Sheet 1 of 10)

FIGURE AND INDEX NUMBER	PART NUMBER	DESCRIPTION	UNITS PER ASSY.	USABLE ON CODE	
				FROM	TO
		1 2 3 4 5 6			
2.12-37	8-20397-837	TUBING INSTALLATION, MAIN LANDING GEAR WHEEL WELL FUEL CONTROL LH MODIFIED BY 65J34880, 66J40337, AND 66J40340 FOR NHA SEE FIG. 2-6-32	RF		
	8-20397-855	TUBING INSTALLATION, MAIN LANDING GEAR WHEEL WELL FUEL CONTROL LH MODIFIED BY 65J35880, 66J40337, AND 66J40340 FOR NHA SEE FIG. 2-6-32	RF		
	8-20397-865	TUBING INSTALLATION, MAIN LANDING GEAR WHEEL WELL FUEL CONTROL LH MODIFIED BY 65J44880, 66J40337, AND 66J40340 FOR NHA SEE FIG. 2-6-32	RF		
	8-20397-839	TUBING INSTALLATION, MAIN LANDING GEAR WHEEL WELL FUEL CONTROL RH MODIFIED BY 65J34880, 66J40337, AND 66J40340 FOR NHA SEE FIG. 2-6-32	RF		
	8-20397-857	TUBING INSTALLATION, MAIN LANDING GEAR WHEEL WELL FUEL CONTROL RH MODIFIED BY 65J34880, 66J40337, AND 66J40340 FOR NHA SEE FIG. 2-6-32	RF		
	8-20397-867	TUBING INSTALLATION, MAIN LANDING GEAR WHEEL WELL FUEL CONTROL RH MODIFIED BY 65J34880, 66J40337, AND 66J40340 FOR NHA SEE FIG. 2-6-32	RF		
- 1	8-20397-1169	• TUBE ASSY, LH	1	35	
- 2	8-20397-1171	• TUBE ASSY, LH	1	35	
	AN924-40	• NUT, LH	2	35	
	AN939DA	• ELBOW, LH	2	35	
- 3	MS2190204	• UNION, LH	2	35	
	MS29512-4	• GASKET, LH	4	35	
- 4		• UNION, SPAR #3 BL 68 SEE FIG. 2.12-66	RF		
- 5		• TUBE ASSY, LH SEE FIG. 2.12-15 INDEX 206	RF		
- 6	8-20397-839	• TUBE ASSY, LH SEE FIG. 2.12-15 INDEX 198	1	35	
- 7	65A33104-1	• TUBE ASSY, LH	1	35	
- 8	MS2130806	• ELBOW, LH	1	35	
	MS29512-6	• GASKET LH	1		
- 9	65A33106-1	• TUBE ASSY, LH			
- 10	65A33103-1	• TUBE ASSY, LH	RF	160	
- 11		UNION, SPAR 7 BL 58 SEE FIG. 2.12-66	1	35	
- 12	MS2191606-4	• REDUCER, LH	1	35	
- 13	65A33105-1	• TUBE ASSY, LH	2	35	159
- 14	MS2190204	• UNION, LH	1	35	159
- 15	8-20397-1179	• TUBE ASSY, LH	1	35	
- 16	8-20397-319	• TUBE ASSY, LH	1	35	
- 17		• TUBE ASSY, SEE FIG. 2.12-45 INDEX 229	RF		
	MS21916012-7	• REDUCER, LH	1	35	
- 18	MS21916012	• TEE, LH	1	35	
	MS29512-12	• GASKET, LH	1	35	
- 19		• REGULATOR, FUEL TANK PRESSURE SEE FIG. 2.12-1 INDEX 51	RF		
- 20		• TUBE ASSY, FUEL TANK PRESSURE MLG WHEEL WELL LH SEE FIG. 2.12-14 INDEX 89	RF		
- 21		• TUBE ASSY, TANK #1 LH SEE FIG. 2.12-14 INDEX 96	RF		

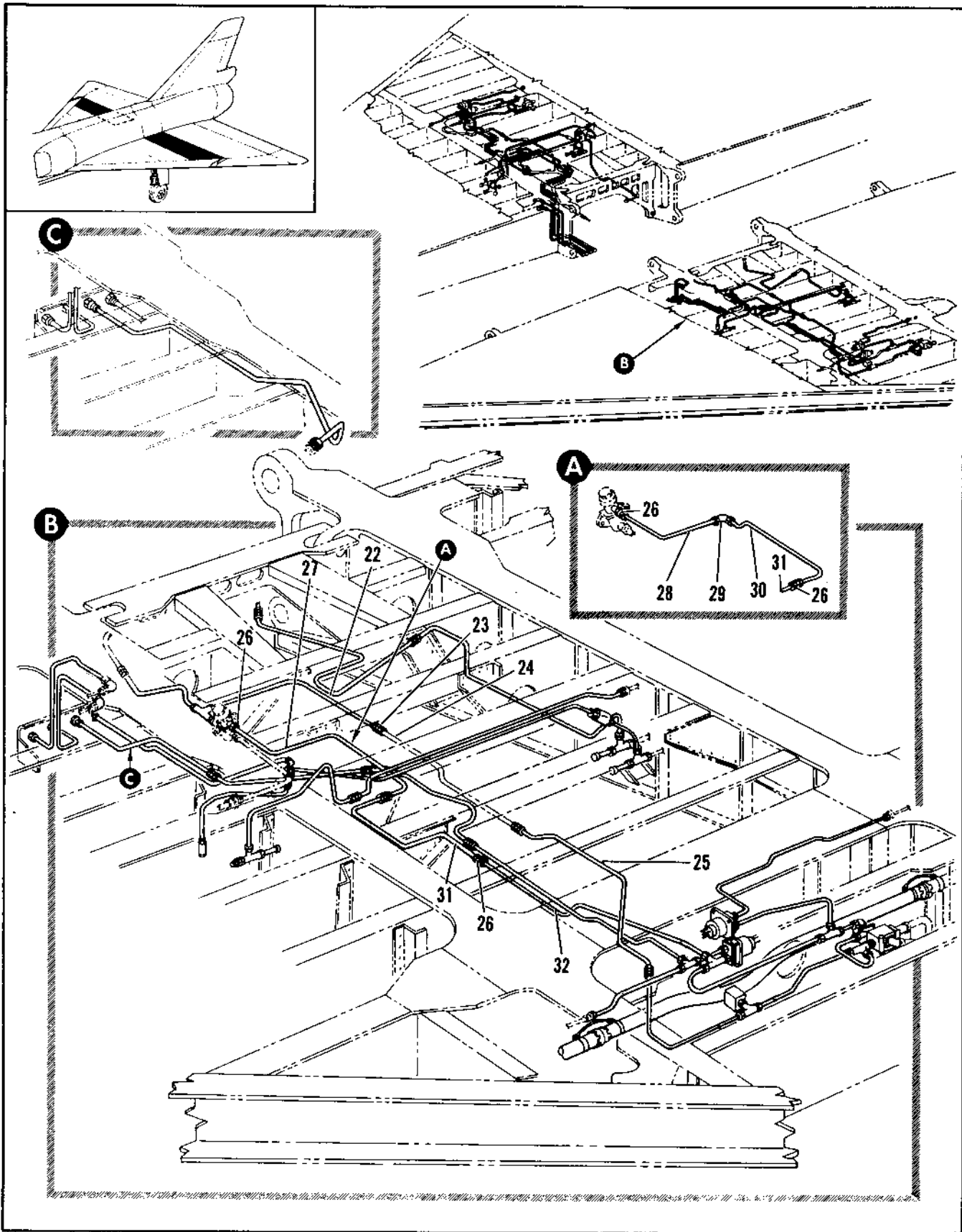

Figure 2.12-37. MLG Wheel Well Fuel Control Tubing Installation (Sheet 2 of 10)

FIGURE AND INDEX NUMBER	PART NUMBER	DESCRIPTION	UNITS PER ASSY.	USABLE ON CODE	
				FROM	TO
2.12-37- - 22 - 23 - 24 - 25 - 26 - 27 - 28 - 29 - 30 - 31 - 32	8-20397-576	• TUBE ASSY, LH	1	35	48
	8-20397-1857	• TUBE ASSY, LH	1	49	129
	8-20397-3031	• TUBE ASSY, LH	1	130	
	MS2190206	• UNION, LH	2	35	
		• TUBE ASSY, LH SEE FIG. 2.12-1 INDEX 72	REF		
		• TUBE ASSY, LH	1	35	129
		• TUBE ASSY, LH	1	130	
		• TUBE ASSY, LH	3	35	
		• UNION, LH	1	36	
		• GASKET, LH	1	35	48
		• TUBE ASSY, LH	1	49	
		• TUBE ASSY, LH	1	49	
		• NUT, LH	1	49	
		• WASHER, LH	1	49	
	• ELBOW, LH	1	49		
	• TUBE ASSY, LH	1	49		
	• TUBE ASSY, LH	1	35		
	• TUBE ASSY, LH	1	35		

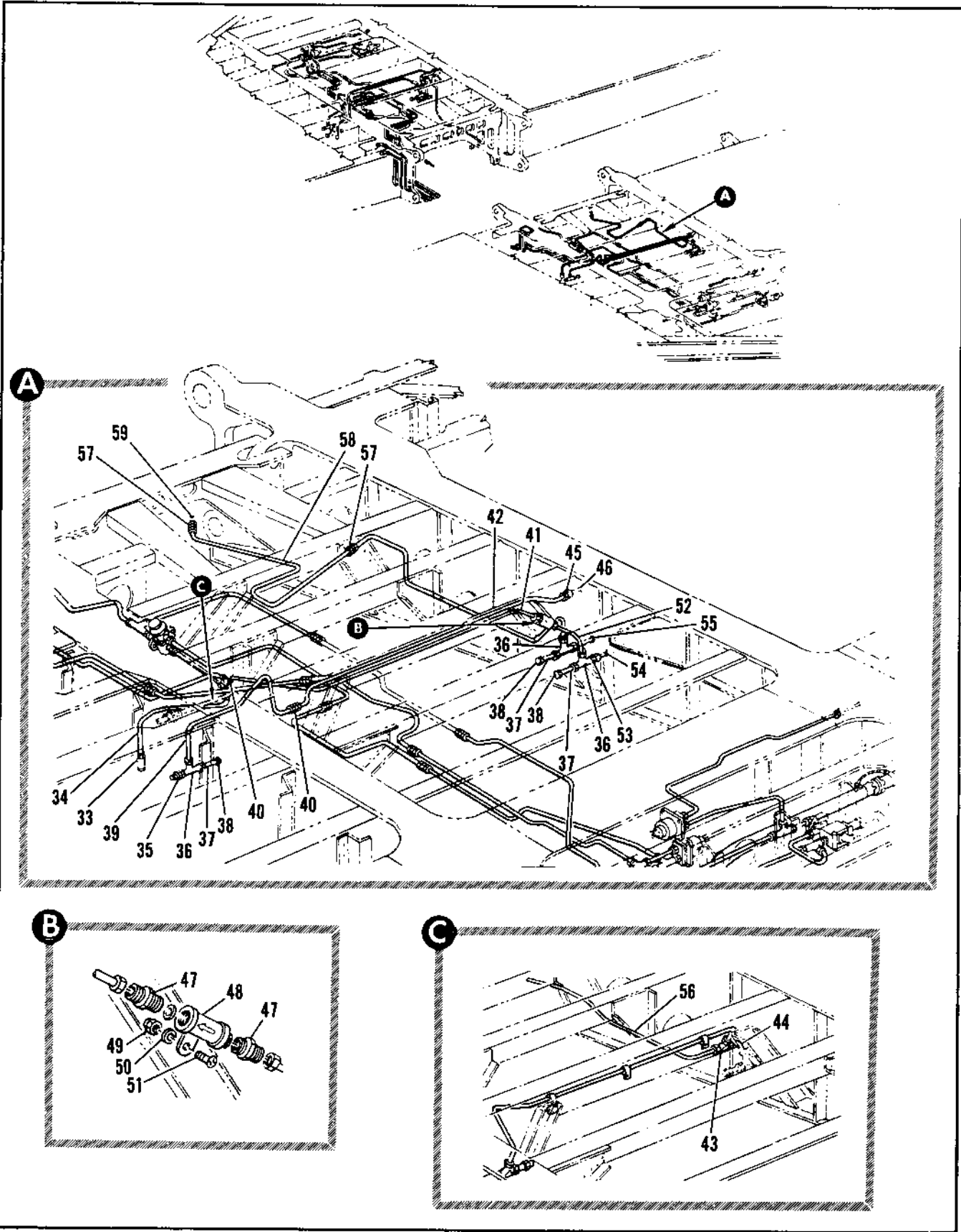

Figure 2.12-37. MLG Wheel Well Fuel Control Tubing Installation (Sheet 3 of 10)

FIGURE AND INDEX NUMBER	PART NUMBER	DESCRIPTION	UNITS PER ASSY.	USABLE ON CODE	
				FROM	TO
2.12-37- 33	3057	• VALVE ASSY, FULL TANK AIR PRESSURE RELIEF LH <92439> SPEC #22399 1.0. SPS-2-35-13	1	35	
- 34	MS29512-10	• GASKET, LH	1	35	
- 35	8-20397-317	• TUBE ASSY, LH	1	35	
- 36	AN924-40	• UNION, SPAR #3 RH SEE FIG. 2.12-66	RF	3	35
- 36	AN934-04	• NUT, LH	3	35	
- 36	MS21902D4	• TFE, LH	3	35	
- 37	MS29512-4	• UNION, LH	9	35	
- 37	8-20335	• GASKET, LH	3	35	
- 38	MS29512-4	• FITTING, VALVE PRESSURE LINE DRAIN TANK #2 LH	3	35	
- 38	1608	• GASKET, LH	3	35	
- 39	8-20397-1289	• VALVE ASSY, PILOT DRAIN LH <91511> 91-12501-001	1	35	
- 40	MS21902D4	• TUBE ASSY, LH	2	35	
- 41	MS29512-4	• UNION, LH	1	35	
- 41	8-20397-1291	• GASKET, LH	1	35	48
- 42	8-20397-1291	• TUBE ASSY, LH	1	49	
- 42	8-20397-1291	• TUBE ASSY, LH	1	35	277
- 42	8-20397-307	• TUBE ASSY, LH	1	278	
- 43	MS21902D4	• TUBE ASSY, LH	1		
- 44	65A35920-1	• TEE, LH	1		
- 45		• TUBE, REFUEL PRESSURE SENSE LH	RF		
- 46		• UNION, SPAR #4 RL 66 SEE FIG. 2.12-66 INDEX 17	RF		
- 46		• TUBE ASSY, SEE FIG. 2.12-20 INDEX 29	2	35	
- 47	MS21916D6-4	• REDUCER, LH	2	35	
- 48	MS29512-6	• GASKET, LH	1	35	
- 48	MS35-37A4	• VALVE ASSY, AIR CHECK LH <9813A> SPEC #22994-13 ATTACHING PARTS	1	35	
- 49	NAS679A3	• NUT	1	35	
- 50	AN952D10L	• WASHER	1	35	
- 51	NAS221-10	• SCREW	1	35	
- 52	8-20397-514	• TUBE ASSY, LH	1	35	
- 53		• UNION, SPAR #4 RL RH SEE FIG. 2.12-67	RF		
- 54		• TUBE ASSY, SEE FIG. 2.12-20 INDEX 32	RF		
- 55		• TUBE ASSY, SEE FIG. 2.12-20 INDEX 47	RF		
- 56	65A35920-1	• TUBE, REFUEL PRESSURE SENSE LH	1		
- 57	MS21902D4	• UNION, LH	2	35	
- 58	8-20397-0949	• TUBE ASSY, LH	1	241	
- 59		• TUBE ASSY, SEE FIG. 2.12-45 INDEX 02	RF		

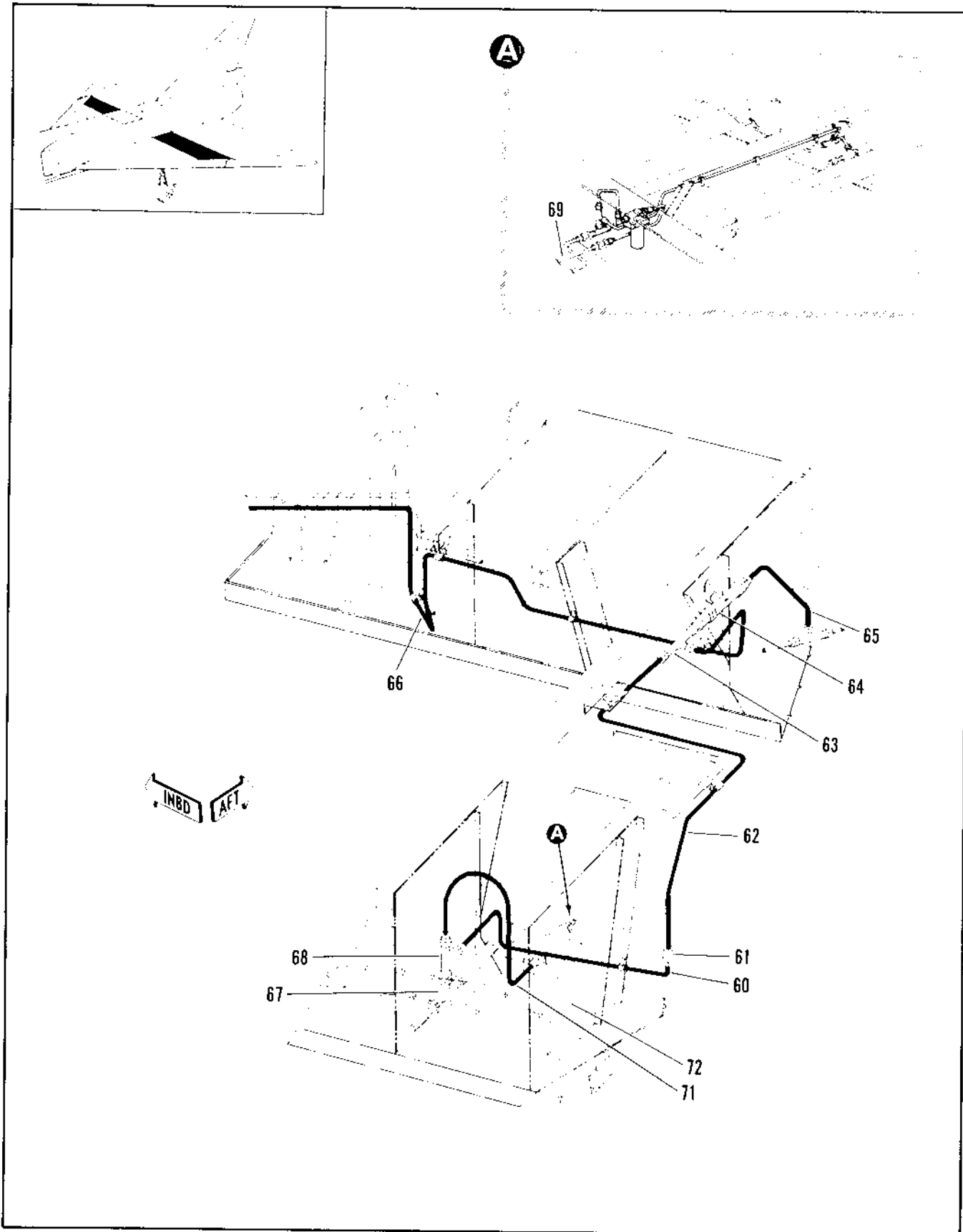

Figure 2.12-37. MLG Wheel Well Fuel Control Tubing Installation (Sheet 4 of 10)

FIGURE AND INDEX NUMBER	PART NUMBER	DESCRIPTION	UNITS PER ASSY.	USABLE ON CODE	
				FROM	TO
		1 2 3 4 5 6			
2.12-37- 60	68A37755-11	• TUBE ASSEMBLY, LH	1		
- 61	MS21912-04	• UNION	1		
- 62	68A37755-13	• TUBE ASSEMBLY			
- 63	MS21912-40	• TEE			
	AN893-20	• RUSHING			
- 64	MS35-1781	• VALVE			
	MS2191606-4	• RUSHING	1		
	MS29512-09	• PACKING	2		
	MS29512-4	• PACKING	1		
	AN303A	• BOLT	2		
	MS679A3XW	• NUT	2		
- 65	68A37755-0	• TUBE ASSEMBLY	1		
- 66	68A37755-48	• TUBE ASSEMBLY	1		
- 67	AN935D4	• TEE	1		
- 68	MS2191104	• TEE	1		
	MS29512-04	• GASKET	1		
	MS2191606-4	• RUSHING	1		
	MS29512-06	• GASKET	1		
	AN924-40	• NUT	1		
- 69		• TUBE ASSY, LH SEE FIG. 2.12-15 INDEX 147	HF		
- 70	R-28335	• FITTING	1		
- 71	66A40310-1	• TUBE ASSY, LH	1		
- 72	66F40496-1	• VALVE INSTALLATION, LH	1		

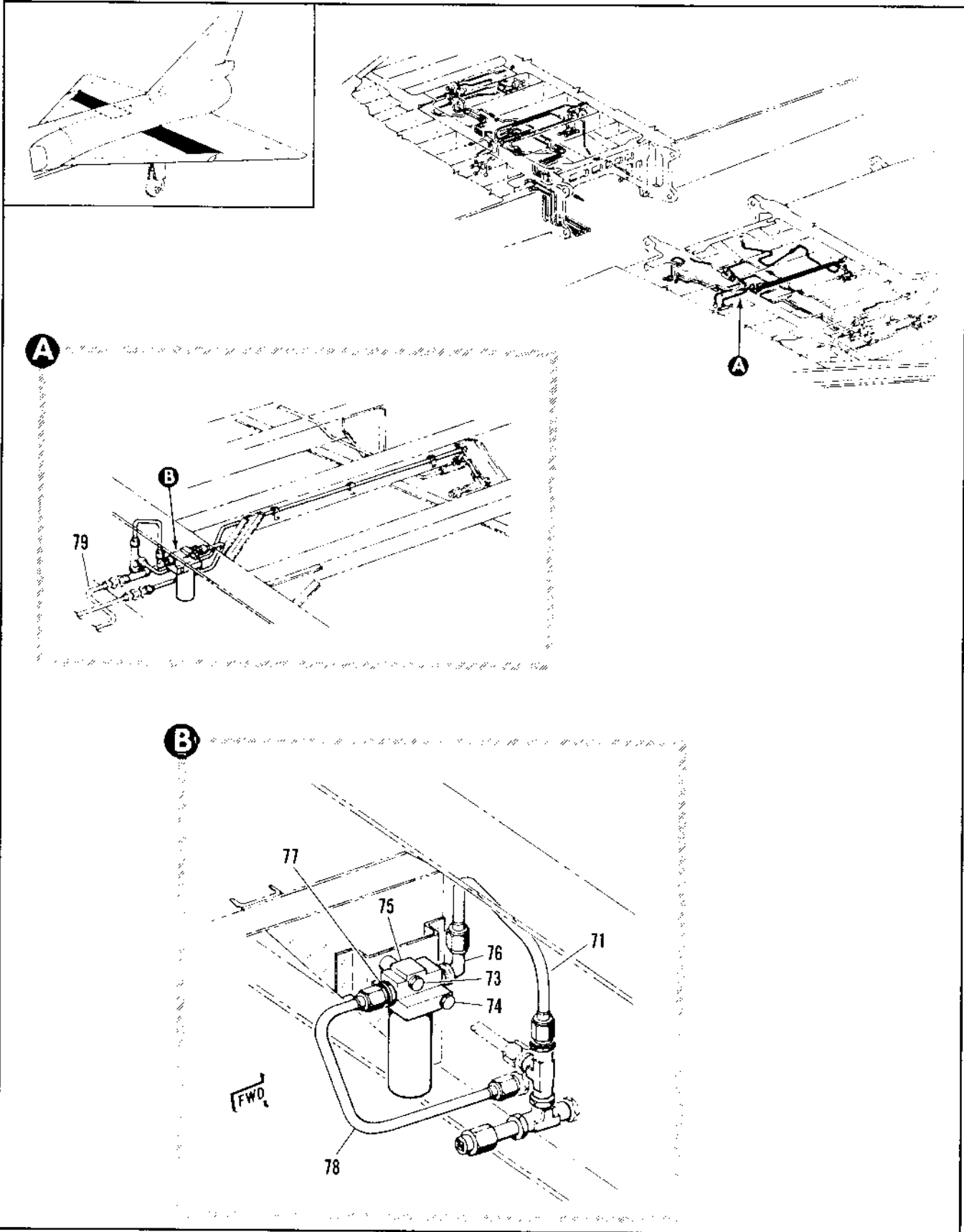

Figure 2.12-37. MLG Wheel Well Fuel Control Tubing Installation (Sheet 5 of 10)

FIGURE AND INDEX NUMBER	PART NUMBER	DESCRIPTION	UNITS PER ASSY.	USABLE ON CODE	
				FROM	TO
		1 2 3 4 5 6			
2.12-37- 73	AN3-16A	ATTACHING PARTS	1		
	AN967010	• BOLT	1		
	NAS43003-30	• WASHER	1		
- 74	AN3-22A	• SPACER	1		
	AN967010	• BOLT	1		
		• WASHER	1		
		-----X-----			
- 75	V21210	• VALVE, SOLENOID OPERATED SHUTOFF	1		
		(96487) SPEC 8-00381-9 T.O. 6J-15-10-107-13			
- 76	MS21909-06	• ELBOW	1		
	AN924-6D	• NUT	1		
	MS29512-6	• PACKING	1		
- 77	MS2191606-4	• REDUCER	1		
	MS29512-6	• PACKING	1		
- 78	66A40314-1	• TUBE ASSEMBLY, LH	1		
- 79		• TUBE ASSEMBLY, LH SEE FIG. 2.12-15 AND 2.12-16 INDEX B1	RF		

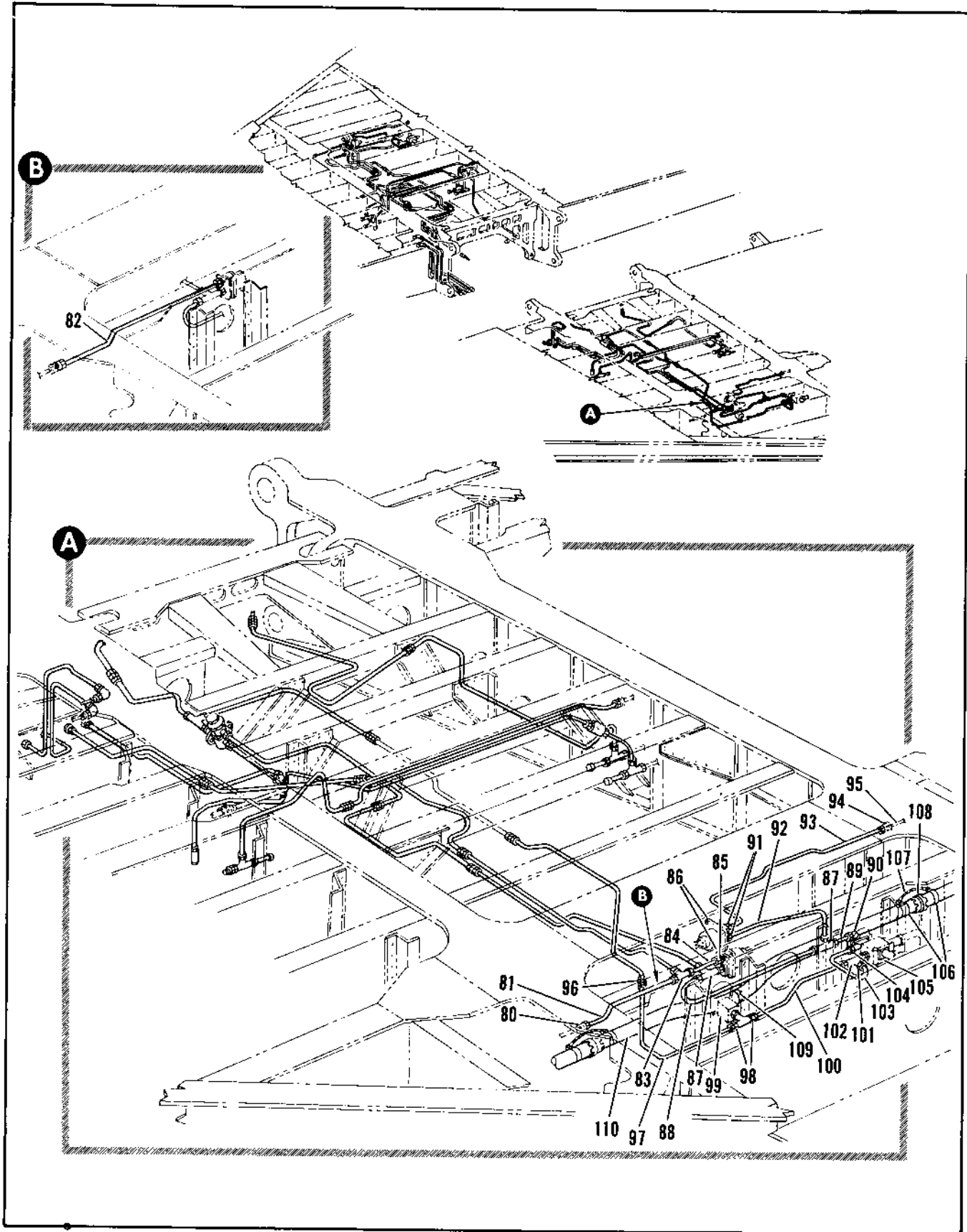

Figure 2.12-37. MLG Wheel Well Fuel Control Tubing Installation (Sheet 6 of 10)

FIGURE AND INDEX NUMBER	PART NUMBER	DESCRIPTION	UNITS PER ASSY.	USABLE ON CODE	
				FROM	TO
		1 2 3 4 5 6			
2.12-17- 80		• UNION, SPARE #3 BL 97 SEE FIG. 2.12-67 INDEX	RF		
- 81	H-21397-1227	• TUBE ASSY, LH	1	35	159
- 82	H-21397-3039	• TUBE ASSY, LH	1	100	
- 83	MS2190304	• TEE, LH	1	35	159
- 84	H-21397-1229	• TUBE ASSY, LH	1	35	67
	H-21397-1967	• TUBE ASSY, LH	1	61	159
- 85	MS2191204	• UNION, LH	1	35	43
	H-29348-11	• UNION, RESTRICTOR LH	1	41	
	MS29512-4	• BASKET, LH	1	35	
- 86		• SWITCH ASSY, TANK PRESSURE SEE FIG. 2.12-1 INDEX 53	RF		
	AN924-40	• NUT, LH	2	35	
	AN9610716	• WASHER, LH	2	35	
- 87	MS2191204	• TEE, LH	2	35	
- 88	H-21397-132	• TUBE ASSY, LH	1	35	
- 89	H-21397-538	• TUBE ASSY, LH	1	35	
	AN924-40	• NUT, LH	1	35	
	AN9610716	• WASHER, LH	1	35	
- 90	MS2190804	• ELBOW, LH	1	35	
- 91	MS2191204	• UNION, LH	2	35	
	MS29512-4	• GASKET, LH	2	35	
- 92	H-21397-140	• TUBE ASSY, LH	1	35	
- 93	H-21397-597	• TUBE ASSY, LH	1	35	
- 94		• UNION, SPARE #4 BL 98 SEE FIG. 2.12-66 INDEX 17	RF		
- 95		• TUBE ASSY, SEE FIG. 2.12-21 INDEX 2	RF		
- 96	MS2191204	• UNION, LH	1	75	
- 97	H-21397-528	• TUBE ASSY, LH	1	35	
- 98	MS21916010-9	• REDUCER, LH	2	35	
- 99	MS29512-17	• GASKET	2	35	
		• VALVE ASSY, SHUTOFF SEE FIG. 2.12-13 INDEX 1	RF		
-100	H-21397-532	• TUBE ASSY, LH	1	35	
	AN924-40	• NUT, LH	1	35	
-101	MS21916010-9	• REDUCER, LH	1	35	
-102	MS2191008	• TEE, LH	2	35	
	MS29512-4	• GASKET, LH	2	35	
-103	H-21397-156	• TUBE ASSY, LH	1	35	
-104	MS2191204	• UNION, LH	1	35	
	MS21912-4	• GASKET, LH	1	35	
-105		• VALVE ASSY, CHECK AND PRESSURE INDICATOR SEE FIG. 2.12-1 INDEX 47	RF		
-106	AN735049	• CLAMP, LH ATTACHING PARTS	2	35	
	NAS67943	• NUT, LH	2	35	
	AN961010L	• WASHER, LH	2	35	
	AN528-1030K6	• SCREW, LH	2	35	

-107	MS25063-1RR6	• JUMPER, LH	1	35	
-108	7675-430	• COUPLING, LH <7932> 92-72503-104	1	35	
	MS29513-333	• PACKING, LH	1	35	
-109	91-27029-139	• CLAMP, LH	1	35	
-110	H-21397-154	• TUBE ASSY, LH	1	35	

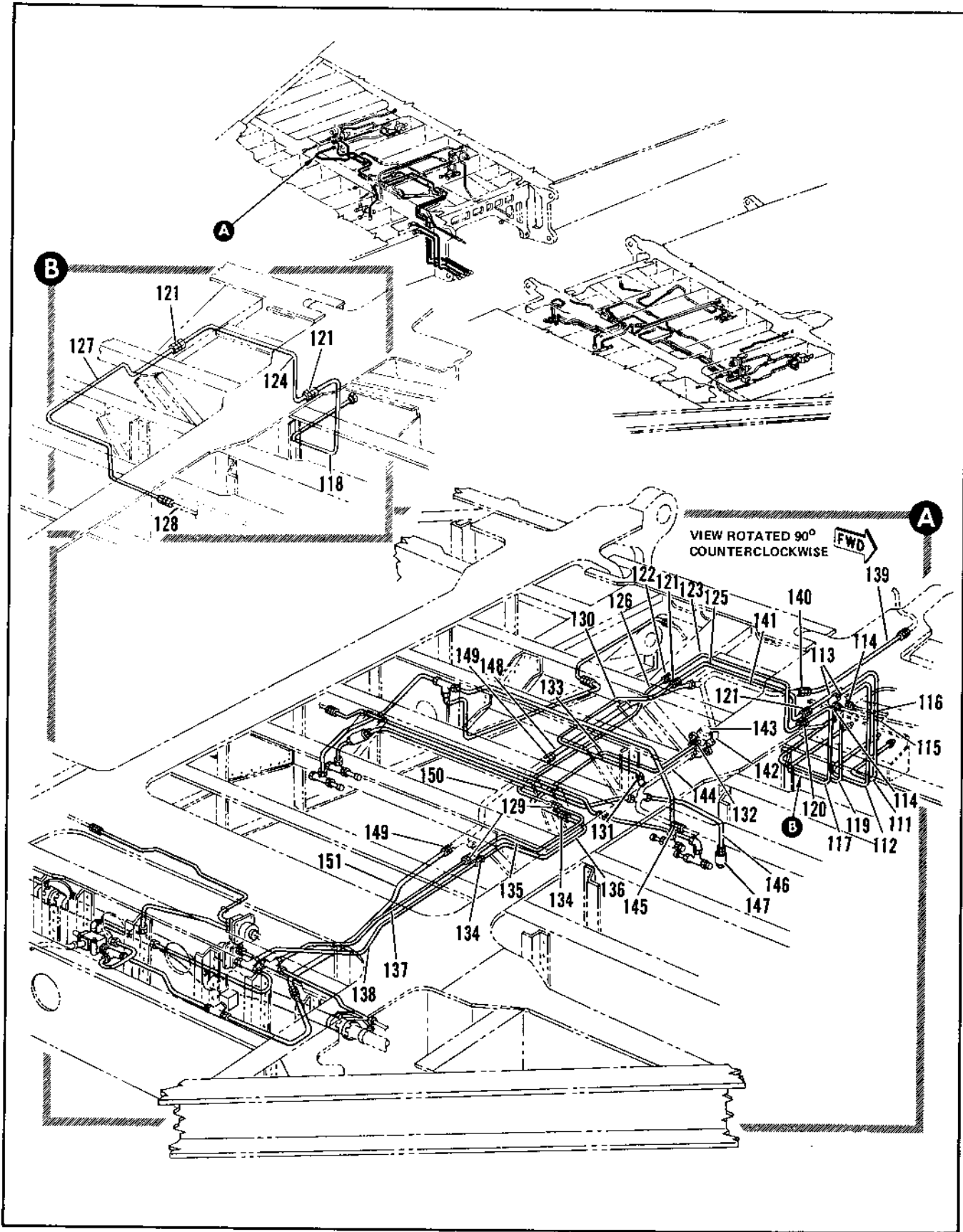

Figure 2.12-37. MLG Wheel Well Fuel Control Tubing Installation (Sheet 7 of 10)

FIGURE AND INDEX NUMBER	PART NUMBER	DESCRIPTION	UNITS PER ASSY.	USABLE ON CODE	
				FROM	TO
2.12-17-111 -112 -113 -114 -115 -116 -117 -118 -119 -120 -121 -122 -123 -124 -125 -126 -127 -128 -129 -130	R-20397-1185	• TUBE ASSY, RH	1	35	
	R-20397-1185	• TUBE ASSY, RH	1	35	
	AN924-40	• NUT, RH	1	35	
	AN939D4	• ELBOW, RH	2	35	
	MS21902D4	• UNION, RH	1	35	
	MS29512-4	• GASKET, RH	2	35	
		• UNION, SPAR #3 BL AS SEE FIG. 2.12-66	RF		
		• TUBE ASSY, RH SEE FIG. 2.12-14 INDEX 105	RF		
		• TUBE ASSY, RH SEE FIG. 2.12-14 INDEX 97	RF		
		• TUBE ASSY, RH	1	35	159
		• TUBE ASSY, RH	1	160	
		• TUBE ASSY, RH	1	35	
		• REDUCER, RH	1	35	159
		• UNION, RH	2	35	
		• UNION, RH	1	35	
	• TUBE ASSY, RH	1	35	159	
	• TUBE ASSY, RH	1	160		
	• TUBE ASSY, RH	1	35		
	• TUBE ASSY, RH	1	35	159	
	• TUBE ASSY, RH	1	160		
	• TUBE ASSY, RH SEE FIG. 2.12-14 INDEX 151	RF			
	• UNION, RH	2	35	159	
	• TUBE ASSY, RH	1	35		
	• NUT, RH	1	35		
	• ELBOW, RH	1	35		
	• GASKET, RH	1	35		
	• UNION, RH	2	35		
	• GASKET, RH	1	35		
	• TUBE ASSY, RH	1	35		
	• UNION, RH	2	35		
	• TUBE ASSY, RH	1	35	159	
	• TUBE ASSY, RH	1	35		
	• TUBE ASSY, RH	1	35	159	
	• TUBE ASSY, RH	1	35		
	• TUBE ASSY, RH	1	35		
	• TUBE ASSY, RH	1	35		
	• UNION, RH	1	35		
	• TUBE ASSY, RH SEE FIG. 2.12-1 INDEX 72	RF			
	• NUT, RH	1	35		
	• ELBOW, RH	1	35		
	• GASKET, RH	1	35		
	• REGULATOR, FUEL TANK PRESSURE RH SEE FIG. 2.12-1 INDEX 71	RF			
	• TUBE ASSY, FUEL TANK PRESSURE M/G WHEEL WELL RH SEE FIG. 2.12-14 INDEX 89	RF			
	• UNION, SPAR #3 BL AS SEE FIG. 2.12-66	RF			
	• TUBE ASSY, RH	1	35		
	• GASKET, RH	1	35		
	• VALVE ASSY, FUEL TANK AIR PRESSURE RELIEF RH (93479) SPEC R-10729	1	35		
	• TUBE ASSY, RH	1	35		
	• UNION, RH	2	35		
	• TUBE ASSY, SEE FIG. 2.12-1 INDEX 72	RF			
	• TUBE ASSY, RH	1	35	60	
	• TUBE ASSY, RH	1	61		
	R-20397-1187	• TUBE ASSY, RH			
	R-20397-2065	• TUBE ASSY, RH			

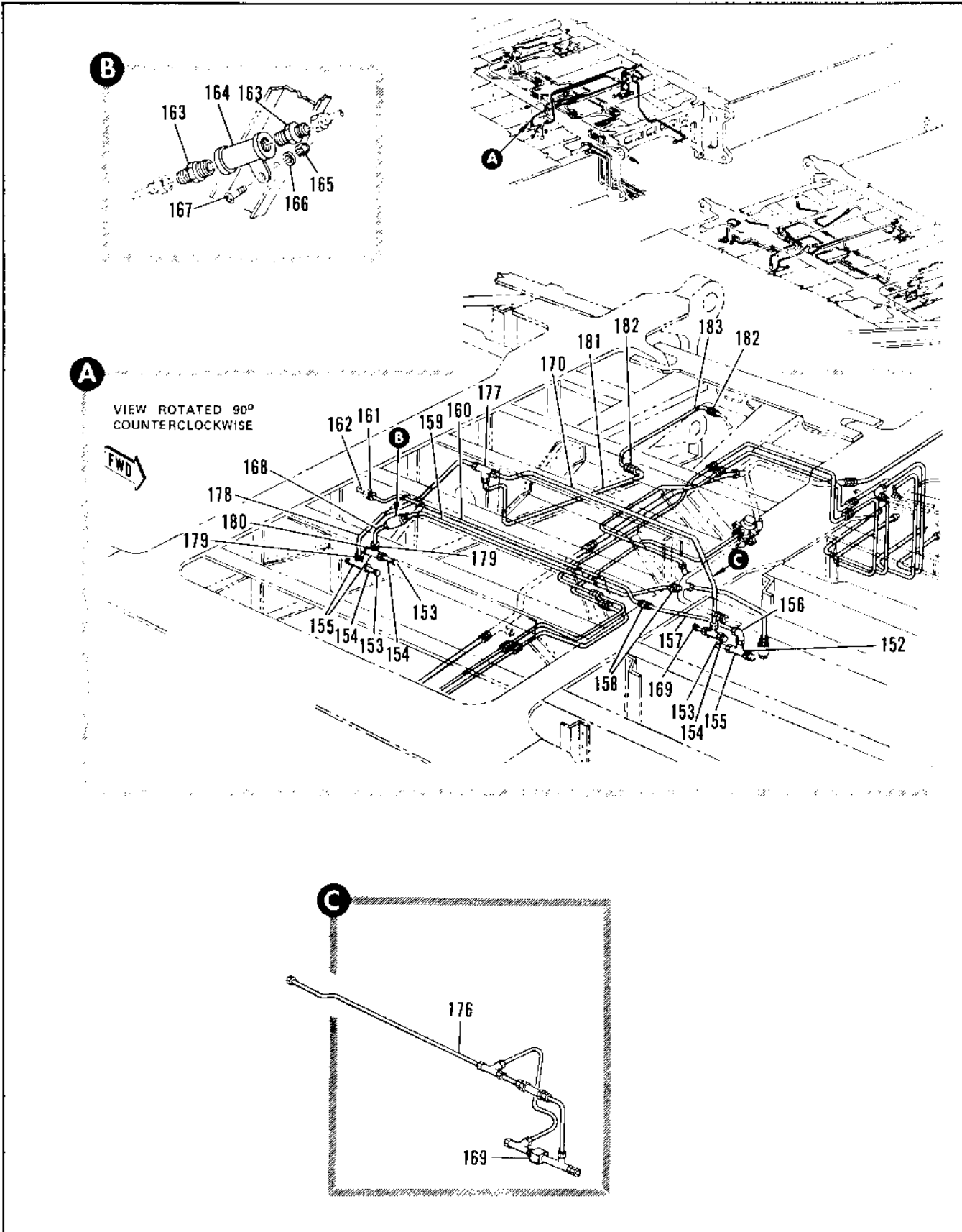

Figure 2.12-37. MLG Wheel Well Fuel Control Tubing Installation (Sheet 8 of 10)

FIGURE AND INDEX NUMBER	PART NUMBER	DESCRIPTION	UNITS PER ASSY.	USABLE ON CODE	
				FROM	TO
2.12-37-152					
-153	MS29512-4 1608	• UNION, SPAR #3 PL 60 SEE FIG. 2.12-66 • GASKET, RH • VALVE ASSY, PILOT DRAIN RH <91511> 92-12501-003	RF 6 3	35	
-154	8-28335	• FITTING, VALVE PRESSURE LINE DRAIN TANK #2 RH	3	35	
-155	AN924-40	• NUT, RH	3	35	
-156	AN93804	• TEE, RH	1	35	
-157	MS2190804	• ELBOW, RH	6	35	
-158	MS29512-4	• GASKET, RH	1	35	
-159	8-20397-1295	• TUBE ASSY, RH	2	35	
-160	MS2190204	• UNION, RH	2	35	
-161	MS29512-4	• GASKET, RH	1	35	48
-162	8-20397-610	• TUBE ASSY, RH	1	49	
-163	8-20397-1871	• TUBE ASSY, RH	1	35	48
-164	8-20397-397 8-20397-1869	• TUBE ASSY, RH • UNION, SPAR #4 PL 66 SEE FIG. 2.12-66 • TUBE ASSY, LH SEE FIG. 2.12-20 INDEX 27	RF 2	35	
-165	MS2191606-4	• REDUCER, RH	2	35	
-166	MS29512-6 MS35-378F	• GASKET, RH • VALVE ASSY, AIR CHECK RH <96136> SPEC 8-22298-13 ATTACHING PARTS	1	35	
-167	NAS679A3	• NUT	1	35	
-168	AN960010L	• WASHER -----X-----	1	35	
-169	NAS221-10	• SCREW	1	35	
-170	8-20397-506	• TUBE ASSY, RH • COCK, PLUG DRAIN SELF LOCKING SEE FIG. 2.12-3 INDEX 17	RF 1	35	49
-171	8-20397-1203	• TUBE ASSY, RH	1	35	
-172	8-20397-2621 1608	• TUBE ASSY, RH • VALVE, RH (91511) 92-12501-003	1	35	
-173	8-28335	• FITTING, RH	1	35	
-174	AN924-40	• NUT, RH	1	35	
-175	AN93804	• TEE, RH	1	35	
-176	8-20397-2621	• TUBE ASSY, RH	1	35	
-177	MS2190504	• TEE, RH	1	35	
-178	8-20397-1205	• TUBE ASSY, RH	2	35	
-179	MS2190204	• UNION, RH	2	35	
-180		• UNION, SPAR #4 PL 66 SEE FIG. 2.12-66	RF		
-181	8-20397-1207	• TUBE ASSY, RH	1	35	
-182	MS2190204	• UNION, RH	2	35	
-183		• TUBE ASSY, RH SEE FIG. 2.12-95 INDEX 225	RF		

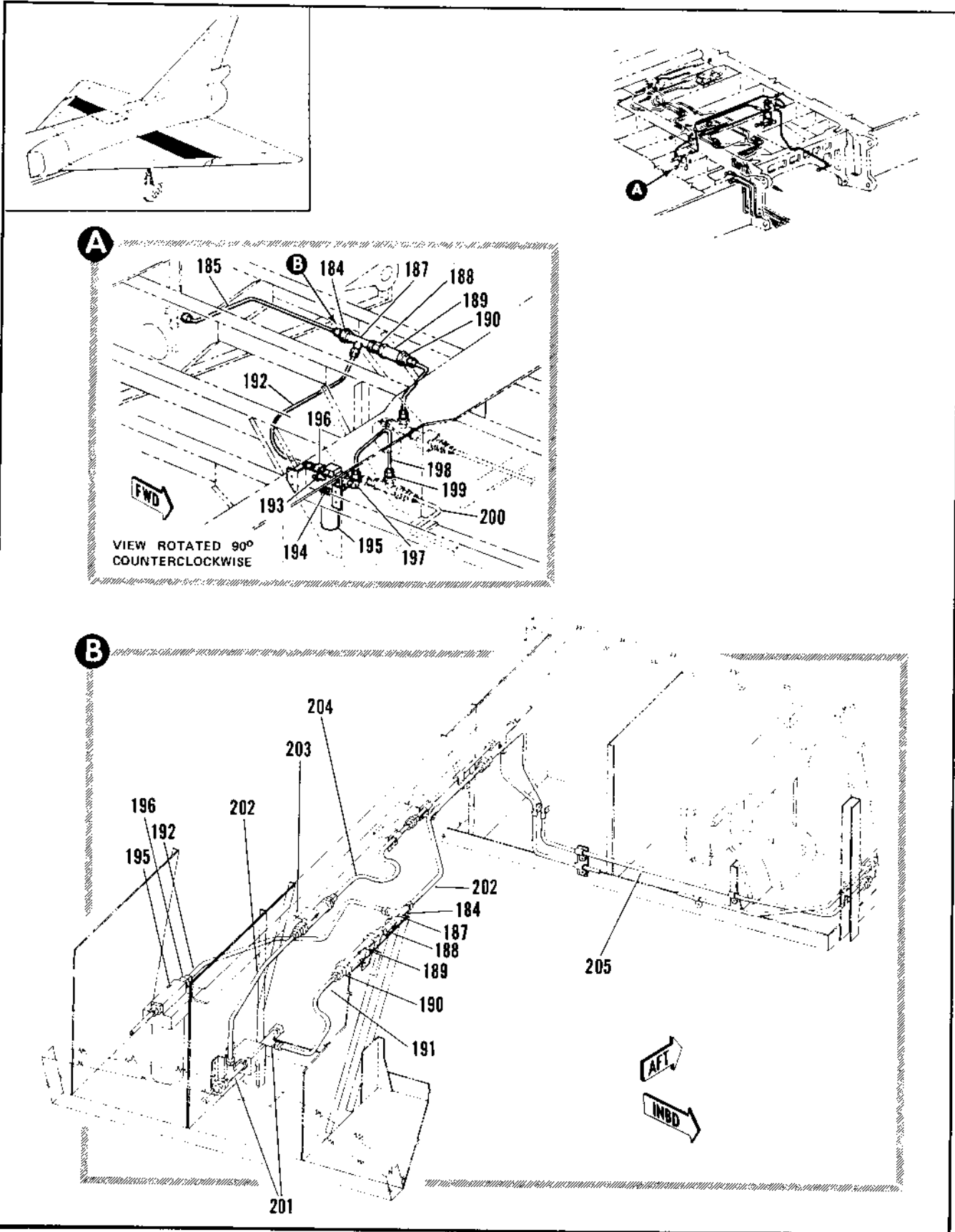

Figure 2.12-37. MLG Wheel Well Fuel Control Tubing Installation (Sheet 9 of 10)

FIGURE AND INDEX NUMBER	PART NUMBER	DESCRIPTION 1 2 3 4 5 6	UNITS PER ASSY.	USABLE ON CODE	
				FROM	TO
2.12-17-151 -185 -186 -187 -188 -189 -190 -191 -192 -193 -194 -195 -196 -197 -198 -199 -200 -201 -202 -203 -204 -205	MS2190204	• UNION	1		
	68A37755-2	• TUBE ASSEMBLY, RH	1	35	
	66A40380-1	• TUBE ASSY, RH	1	35	
	MS2190504	• TEE	1	35	
	AN924-40	• NUT	1	35	
	MS29512-14	• GASKET	1	35	
	AN895-20	• BUSHING	1	35	
	MS29512-16	• GASKET	1	35	
	MS29512-18	• VALVE ASSY, AIR CHECK RH (26159) SPEC R-32098-13	1	35	
	YS2191406-4	• BUSHING	1	35	
	MS29512-16	• GASKET	1	35	
	68A37735-1	• TUBE ASSEMBLY, RH	1	35	
	66A41225-1	• TUBE ASSY, RH	1	35	
	66A41495-2	• VALVE INSTL, AERIAL REFUEL SOLENOID RH ATTACHING PARTS	1	35	
	AN3-16A	• BOLT	1	35	
	AN94-010	• WASHER	1	35	
	NAS43003-3	• SPACER	1	35	
	AN3-22A	• BOLT	1	35	
	AN95-010	• WASHER	1	35	
V21200	• VALVE, SOLENOID OPERATED SHUT-OFF (96487) SPEC R-10311-9 I.O. 15-11-107-13	1	35		
MS21916-4	• REDUCER	1	35		
MS29512-16	• PACKING	1	35		
MS2190406	• ELBOW	1	35		
AN924-40	• NUT	1	35		
MS29512-16	• PACKING	1	35		
66A41500-1	• TUBE ASSY, RH	1	35		
MS21906-4	• BUSHING	1	35		
MS29512-16	• GASKET	1	35		
MS21911-40	• TUBE ASSY, SEE FIG. 2.12-17 AND 2.12-18 INDEX 52.47-1	1	35		
MS29512-4	• TEE	3	35		
MS29512-5	• PACKING	2	35		
AN924-40	• NUT	1	35		
68A37756-1	• TUBE ASSEMBLY	1	35		
W535-378F	• VALVE	1	35		
MS2191204	• BUSHING				
MS29512-4	• PACKING				
AN303A	• BOLT				
NAS679A3X4	• NUT				
68A37756-1	• TUBE ASSEMBLY	1	35		
68A37755-3	• TUBE ASSEMBLY	1	35		
MS2191204	• UNION	1	35		

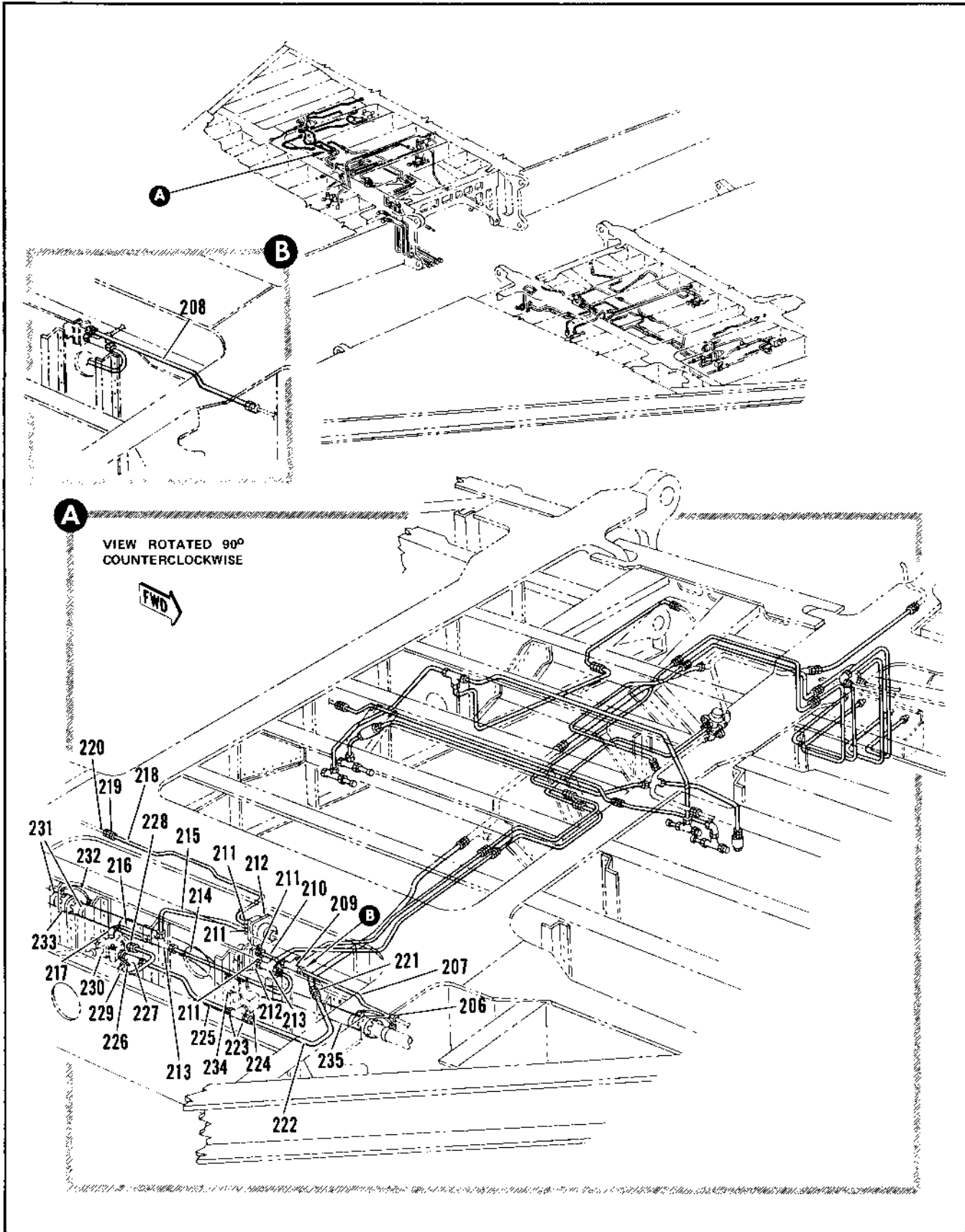

Figure 2.12-37. MLG Wheel Well Fuel Control Tubing Installation (Sheet 10 of 10)

FIGURE AND INDEX NUMBER	PART NUMBER	DESCRIPTION	UNITS PER ASSY.	USABLE ON CODE	
				FROM	TO
2.12-37-206		• UNION, SPAR #3 RL #3 RH SEE FIG. 2.12-66	RF		
-207	8-20397-1293	• TUBE ASSY, RH	1	35	159
-208	8-20397-3103	• TUBE ASSY, RH	1	160	
-209	MS21900D4	• TEE, RH	1	35	159
-210	8-20397-1229	• TUBE ASSY, RH	1	35	60
	8-20397-1965	• TUBE ASSY, RH	1	61	159
-211	MS21902D4	• UNION, RH	4	35	40
	8-28388-11	• UNION, RESTRICTOR RH	1	41	
	MS29512-4	• GASKET, RH	4	35	
-212		• SWITCH ASSY, TANK PRESSURE RH SEE FIG. 2.12-1 INDEX 13	RF		
	AN924-4D	• NUT, RH	2	35	
	AN967D716	• WASHER, RH	2	35	
-213	MS21912D4	• TEE, RH	1	35	
-214	8-20397-132	• TUBE ASSY, RH	1	35	
-215	8-20397-140	• TUBE ASSY, RH	1	35	
-216	8-20397-212	• TUBE ASSY, RH	1	35	
	AN924-4D	• NUT, RH	1	35	
	AN967D716	• WASHER, RH	1	35	
-217	MS21908D4	• FLOW, RH	1	35	
-218	8-20397-599	• TUBE ASSY, RH	RF		
-219		• UNION, SPAR #4 RL #2 RH SEE FIG. 2.12-66	RF		
-220		• TUBE ASSY, RH SEE FIG. 2.12-20 INDEX 2	1	35	
-221	MS21922D4	• UNION, RH	1	35	
-222	8-20397-230	• TUBE ASSY, RH	2	35	
-223	MS21916D10-3	• REDUCER, RH	2	35	
	MS29512-10	• GASKET, RH	RF		
-224		• VALVE ASSY, SHUTOFF SEE FIG. 2.12-13 INDEX 1	1	35	
-225	8-20397-210	• TUBE ASSY, RH	1	35	
	AN924-5D	• NUT, RH	1	35	
-226	MS21917D4-4	• REDUCER, RH	1	35	
-227	MS21911D4	• TEE, RH	1	35	
	MS29512-8	• GASKET, RH	2	35	
-228	MS21902D4	• UNION, RH	1	35	
	MS29512-4	• GASKET, RH	1	35	
-229	8-20397-264	• TUBE ASSY, RH	1	35	
-230		• VALVE ASSY, CHECK AND PRESSURE INDICATOR RH SEE FIG. 2.12-1 INDEX 47	RF		
-231	AN705D4J	• CLAMP, RH ATTACHING PARTS	2	35	
	MS2079A3	• NUT	2	35	
	AN967D10L	• WASHER	2	35	
	AN900-103256	• SCREW	2	35	
		-----X-----	1	35	
-232	MS2079B3-1884	• JUMPER, RH	1	35	
-233	3605-410	• COUPLING, RH 92-72503-004	1	35	
	MS29513-533	• PACKING, RH	1	35	
-234	91-91126-038	• CLAMP, RH	1	35	
-235	8-20397-104	• TUBE ASSY, RH			

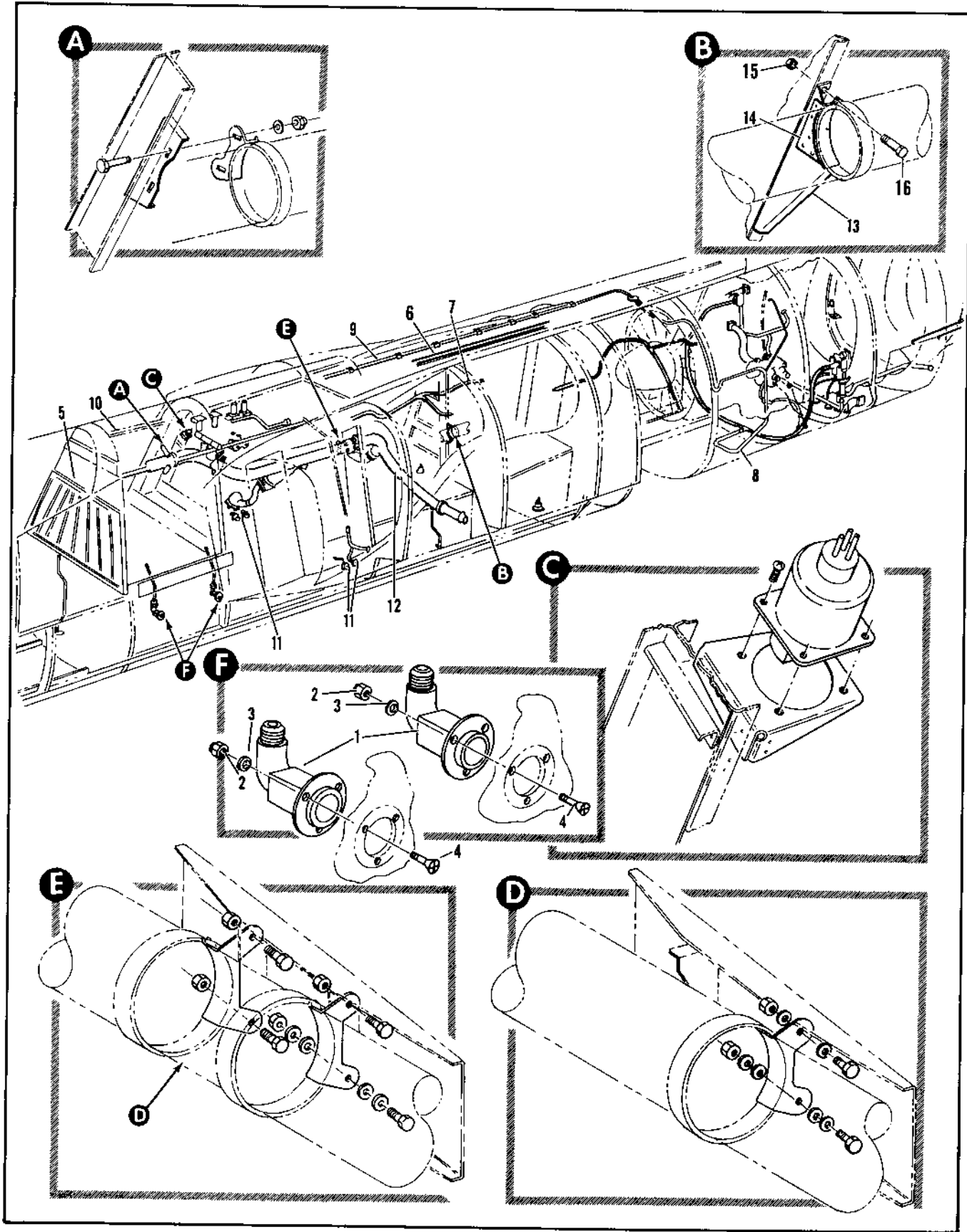

Figure 2.12-38. Fuselage Fuel System (Sheet 1 of 5)

FIGURE AND INDEX NUMBER	PART NUMBER	DESCRIPTION 1 2 3 4 5 6	UNITS PER ASSY.	USABLE ON CODE		
				FROM	TO	
2.12-38		FUSELAGE FUEL SYSTEM				
		• FUSELAGE FUEL ELECTRICAL, SEE FIG. 2.12-39	RF	35		
		• VALVE INSTL, FUSELAGE TANK DRAIN LH STA 225 AND 245 WL 24 FOR NHA SEE FIG. 2.3-4	RF	35		
	- 1	MS20512-4 MS2190206 9308	• GASKET • UNION • VALVE ASSY, DRAIN <91511> 92-13200-002 T.O. QJ15-4-35-3 ATTACHING PARTS	2 2 2	35 35 35	
	- 2	NAS679A3	• NUT	6	35	
	- 3	AN960910	• WASHER	6	35	
	- 4	NAS333P5	• BOLT	6	35	
	- 5		-----X-----			
	- 5		• BARRIER INSTL, FUSELAGE FUEL TANK FUME SEE FIG. 2.12-63	RF		
	- 6		• TUBING INSTL, FUSELAGE FUEL TANK STA 216 TO 253 SEE FIG. 2.12-43	RF		
	- 7		• TUBING INSTL, FUEL TANK PRESSURE STA 253 TO 577 SEE FIG. 2.12-32 AND 2.12-46	RF		
	- 8		• TUBING INSTL, FUEL TANK PRESSURE STA 472 TO 577 SEE FIG. 2.12-32 AND 2.12-46	RF		
	- 9		• FUEL TANK PRESSURE MANIFOLD TUBING SUPPORT SEE FIG. 2.12-57	RF		
	- 10		• TANK ASSY, INTEGRAL FUEL SEE FIG. 2.12-58	RF		
	- 11		• TUBING INSTL, VENT FUSELAGE TANK TO WING SEE FIG. 2.12-47	RF		
	- 12		• TUBING INSTL, FUSELAGE TANK TO WING FUEL TRANSFER SEE FIG. 2.12-48	RF		
		P-28282	• SUPPORT INSTL, CG TRANSFER TUBE STA 316 RH FOR NHA SEE FIG. 2.3-11	RF	35	60
		H-28282-1	• SUPPORT INSTL, CG TRANSFER TUBE STA 316 RH FOR NHA SEE FIG. 2.3-11	RF	61	
	- 13	4-28282-7	• BRACKET	1	35	60
	- 14	4-28282-2 4-28275	• BRACKET	1	61	
	4-28275	• BRACKET, 4.5 DIAMETER TUBE TRANSFER LINE REPLACED BY NOT INCHS WITH 4-28275-7	1	35	60	
	4-28275-7	• BRACKET, 4.5 DIAMETER TUBE TRANSFER LINE REPLACES NOT INCHS WITH 4-28275 ATTACHING PARTS	1	61		
- 15	NAS679A3	• NUT	1	35	60	
	NAS679A3	• NUT	2	61		
	AN960010L	• WASHER	4	61		
- 16	AN3-4A	• BOLT	1	35	60	
	AN3-4A	• BOLT	2	61		
		-----X-----				

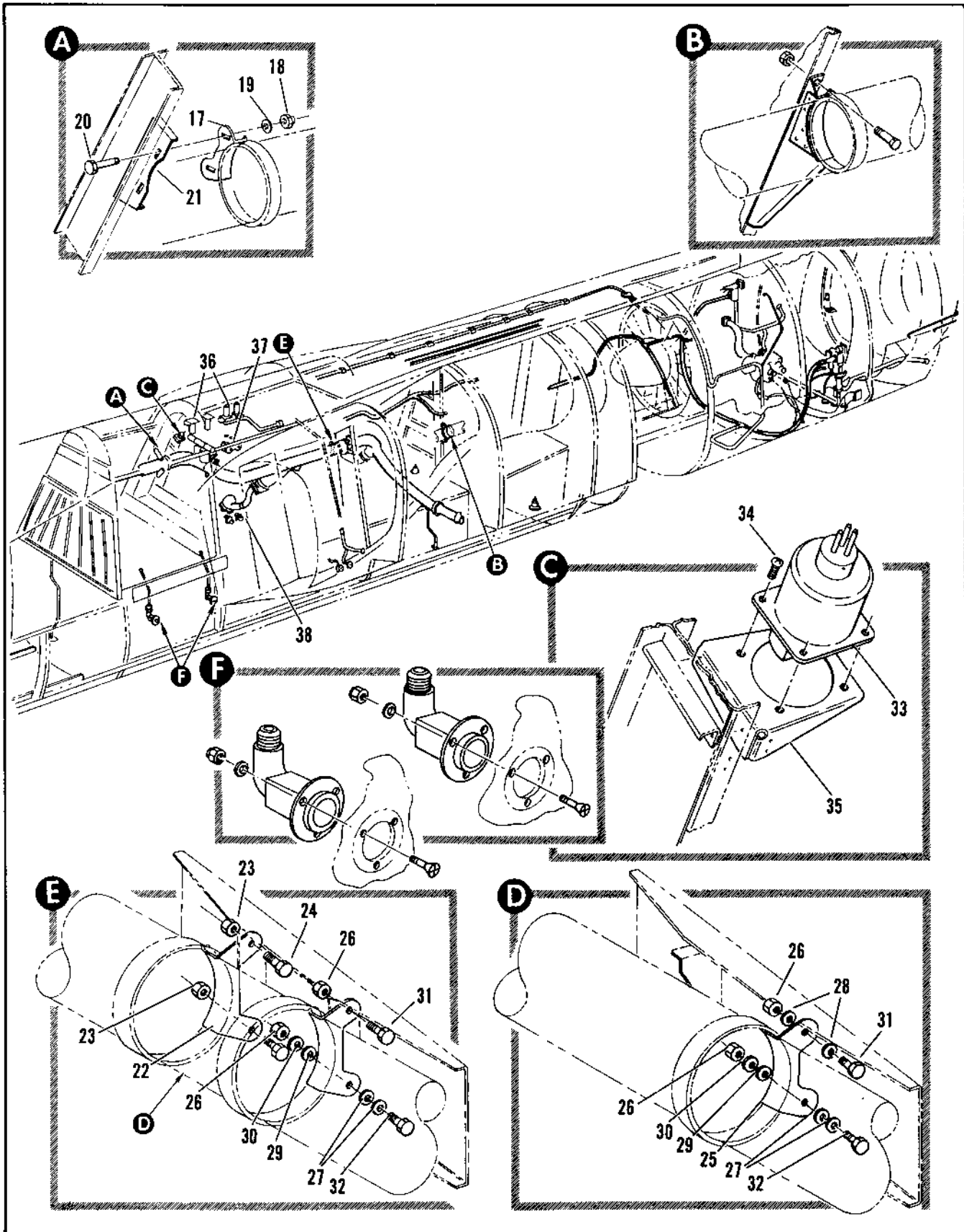

Figure 2.12-38. Fuselage Fuel System (Sheet 2 of 5)

FIGURE AND INDEX NUMBER	PART NUMBER	DESCRIPTION	UNITS PER ASSY.	USABLE ON CODE	
				FROM	TO
		1 2 3 4 5 6			
2.12-38	A-28465	• SUPPORT INSTL, CG TRANSFER TUBE STA 266 FOR NHA SEE FIG. 2.3-11	RF	61	
- 17	A-28468	• • BRACKET ATTACHING PARTS	1	61	
- 18	NAS679A3	• • NUT	2	61	
- 19	AN962D10L	• • WASHER	4	61	
- 20	AN3-4A	• • BOLT	2	61	
		-----X-----			
- 21	A-28463-7 B-28279-1	• • BRACKET • SUPPORT INSTL, CG TRANSFER TUBE STA 324 TO 344 FOR NHA SEE FIG. 2.3-11	1 RF	61	
- 22	B-28468	• • BRACKET, STA 330 REPLACES NOT INTCHG WITH B-28327-9 ATTACHING PARTS	1	61	
- 23	NAS679A3	• • NUT	2	35	
- 24	AN962D10L AN3-4A	• • WASHER • • BOLT	2 2	61 35	
		-----X-----			
- 25	B-28468	• • BRACKET, STA 336 REPLACES NOT INTCHG WITH B-28327-1 ATTACHING PARTS	1	61	
- 26	NAS679A3	• • NUT	2	35	
- 27	AN962D10L	• • WASHER	2	35	
- 28	AN962D10L	• • WASHER	2	61	
- 29	AN962-10L	• • WASHER	1	35	
- 30	AN935-10L	• • WASHER	1	35	
- 31	AN3-4A	• • BOLT	1	35	
- 32	AN3-4A	• • BOLT	1	35	
		-----X-----			
	B-28577	• SWITCH INSTL, EXTERNAL TANK HIGH PRESSURE FOR NHA SEE FIG. 2.3-11 ATTACHING PARTS	RF	35	
- 33	B-22986-11	• • SWITCH ASSY, EXTERNAL FUEL TANK HIGH PRESSURE (K88505) SPEC B-22986-11	1	35	
		-----X-----			
- 34	AN520-1JRF	• • SCREW	4	35	
- 35	B-28377-11	• • BRACKET ASSY, PIVETED	1	35	
- 36		• VALVE INSTL, FUEL PRESS SOLENOID OPERATED SHUTOFF STA 270 SEE FIG. 2.12-54	RF		
- 37		• VALVE INSTL, EMERGENCY FUEL TRANSFER SEE FIG. 2.12-53	RF		
- 38		• VALVE INSTL, PRESSURE REGULATOR REFUELING SEE FIG. 2.12-55	RF		

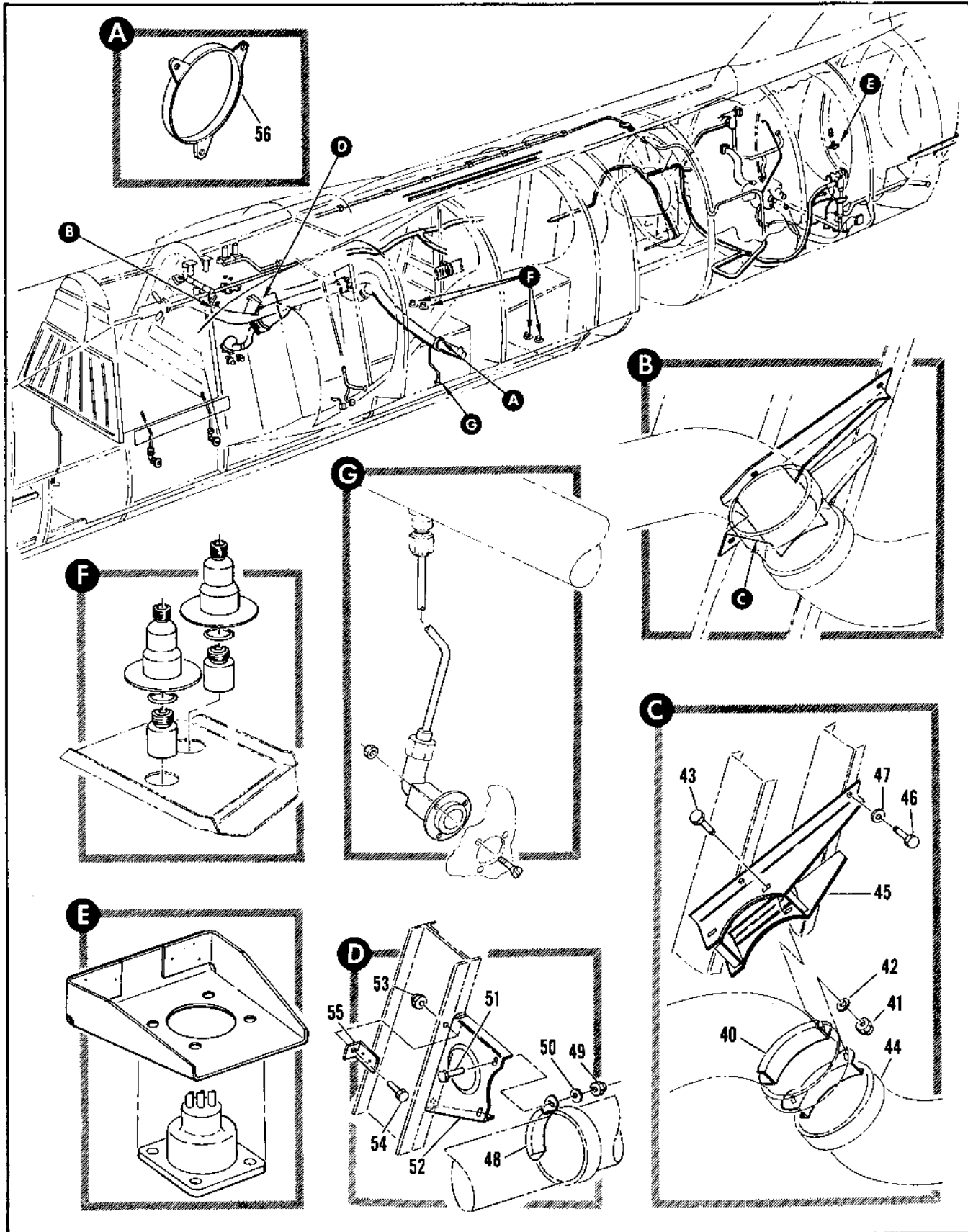

Figure 2.12-38. Fuselage Fuel System (Sheet 3 of 5)

FIGURE AND INDEX NUMBER	PART NUMBER	DESCRIPTION	UNITS PER ASSY.	USABLE ON CODE	
				FROM	TO
2.12-48-39	R-28461	<ul style="list-style-type: none"> • TUBE ASSY. SEE FIG. 2-12-48 INDEX • BRACKET INRTL. FUEL TRANSFER LINE FOR NHA SEE FIG. 2.7-11 	RF		
			RF	61	
- 40	R-28473	<ul style="list-style-type: none"> • TUBE ASSY. SEE FIG. 2.12-48 INDEX 15 • BRACKET, STA 321 • ATTACHING PARTS 	2	61	
- 41	NAS679A3	• NUT	4	61	
- 42	AN95-217L	• WASHER	4	61	
- 43	AN3-4A	• BOLT	4	61	
- 44		-----X-----			
- 45	R-28461-7	<ul style="list-style-type: none"> • TUBE ASSY. SEE FIG. 2.12-48 • BRACKET ASSY. RIVETED • ATTACHING PARTS 	2	61	198
- 46	AN3-4A	• BOLT	4	61	
- 47	AN95-217L	• WASHER	4	61	
		-----X-----			
	R-28462-1	<ul style="list-style-type: none"> • BRACKET INRTL. FUEL TRANSFER LINE FUSELAGE FOR NHA SEE FIG. 2.7-11 	RF	90	
- 48	R-28460	<ul style="list-style-type: none"> • BRACKET, STA 312 • ATTACHING PARTS 	1	90	
- 49	NAS679A3	• NUT	2	90	
- 50	AN95-217L	• WASHER	4	90	
- 51	AN3-4A	• BOLT	2	90	
		-----X-----			
- 52	R-28463-7	<ul style="list-style-type: none"> • BRACKET, STA 312 • ATTACHING PARTS 	1	90	
- 53	NAS679A3	• NUT	3	90	
- 54	AN3-4A	• BOLT	3	90	
		-----X-----			
- 55	R-28462-7	• CLIP	1	90	
	R-28323-5	<ul style="list-style-type: none"> • TUBE INRTL. OF FUEL TRANSFER LH STA 326 FOR NHA SEE FIG. 2.7-11 	RF	35	
	R-28323-4	<ul style="list-style-type: none"> • TUBE INRTL. OF FUEL TRANSFER RH STA 326 FOR NHA SEE FIG. 2.7-11 	RF	35	
	R-28323-15	• TUBE ASSY. WELDED LH	1	35	
	R-28323-16	• TUBE ASSY. WELDED RH	1	35	

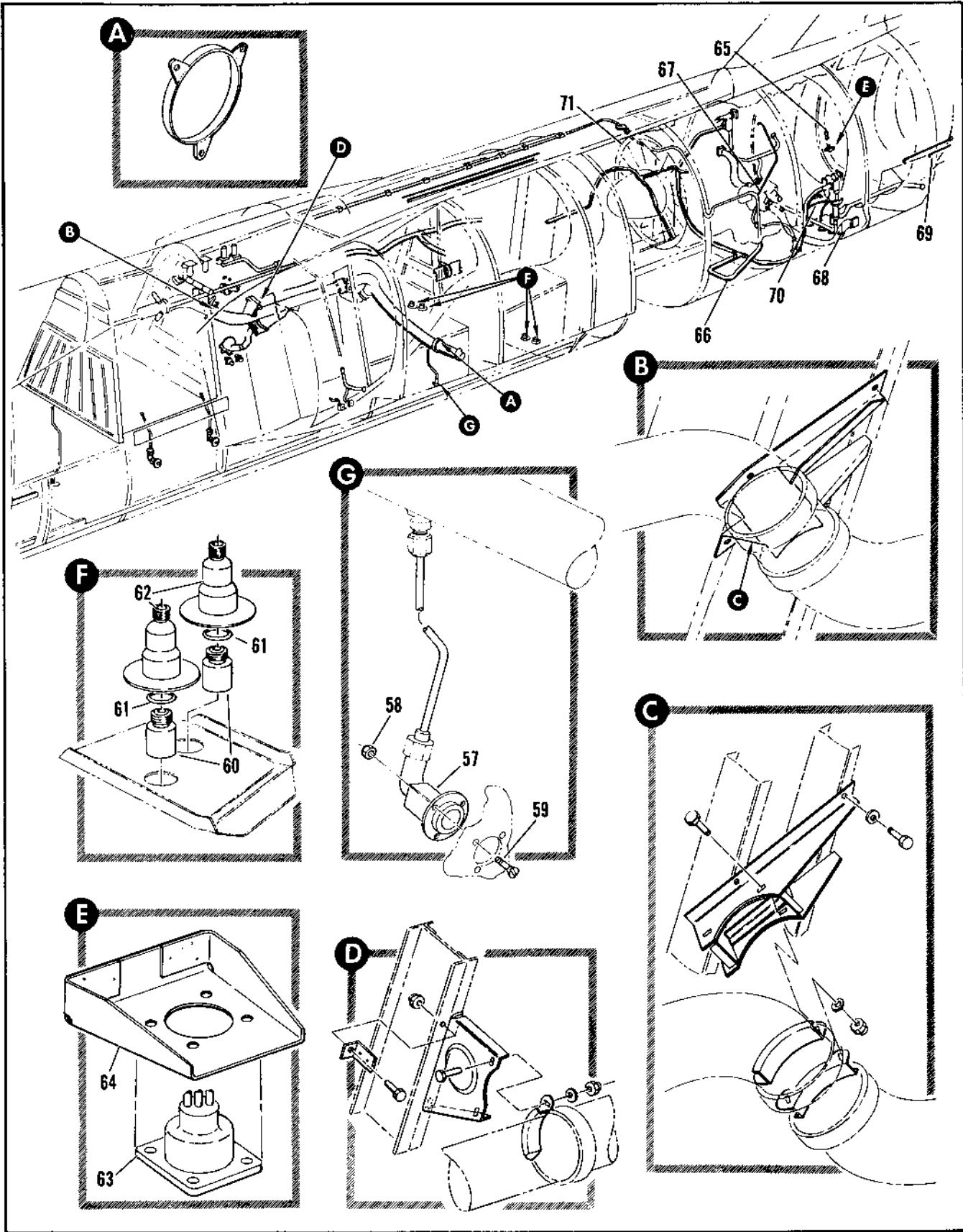

Figure 2.12-38. Fuselage Fuel System (Sheet 4 of 5)

FIGURE AND INDEX NUMBER	PART NUMBER	DESCRIPTION	UNITS PER ASSY.	USABLE ON CODE	
				FROM	TO
		1 2 3 4 5 6			
2.12-38	R-28380	• VALVE INSTL, FUEL TRANSFER DRAIN LH FOR NHA SEE FIG. 2.3-10	RF		
	R-28380-1	• VALVE INSTL, FUEL TRANSFER DRAIN RH FOR NHA SEE FIG. 2.3-10	RF	35	
- 57	8855	• VALVE ASSY, <91511> 92-132.0-001 ATTACHING PARTS	1	35	
- 58	NAS679A3	• NUT, 1/4-27548-002	3	35	
- 59	ANS09-10R10	• SCREW T.O. 6010-4-35-3 -----X-----	3	35	
	R-28419	• VALVE INSTL, REFUEL AND AIR PRESSURE LINES DRAIN STA 778 FOR NHA SEE FIG. 2.3-11	RF		
- 60	150R	• VALVE ASSY, <91511> 92-12501-002	2	35	
- 61	MS29512-6	• GASKET	2	35	
	R-28419-1	• FITTING INSTL, REFUEL AND AIR PRESSURE LINES DRAIN STA 590 LH FOR NHA SEE FIG. 2.3-10	RF	35	
	R-28419-2	• FITTING INSTL, REFUEL AND AIR PRESSURE LINES DRAIN STA 740 RH FOR NHA SEE FIG. 2.3-10	RF	35	
- 62	R-28317	• FITTING, REFUEL PRESSURE LINE DRAIN VALVE	2	35	
	R-28372-1	• SWITCH INSTL, FUSELAGE FUEL TRANSFER EMERGENCY PRESSURE FOR NHA SEE FIG. 2.3-15	RF	35	159
	R-28372-3	• SWITCH INSTL, FUSELAGE FUEL TRANSFER EMERGENCY PRESSURE FOR NHA SEE FIG. 2.3-15	RF	160	
- 63	40064	• SWITCH, EMERGENCY PRESSURE <98505> SPEC R-28294-1 T.O. 450-3-57-73 ATTACHING PARTS	1	35	
	AN345A	• BOLT	4	35	
	AN95010L	• WASHER -----X-----	4	35	
- 64	R-28372-7	• SUPPORT ASSY, RIVETED	1	35	159
	R-28372-13	• SUPPORT ASSY, RIVETED	1	160	
	R-28376	• VALVE INSTL, FUSELAGE TANK SCAVENGE AIR PRESSURE FOR NHA SEE FIG. 2.3-15	4F	35	
- 65	V21100	• VALVE, SOLENOID OPERATED AIR SHUTOFF <954-7> SPEC R-28381-7 ATTACHING PARTS	1	35	
	AN3022A	• BOLT	2	35	
	AN95010L	• WASHER -----X-----	2	35	
- 66	MS21919H26	• CLAMP	1	35	
	NAS679A3	• NUT	1	35	
	NAS221-6	• SCREW	1	35	
- 66		• EQUIPMENT INSTL, FUEL TANK PRESSURE SEE FIG. 2.12-18	RF		
- 67		• EQUALIZER INSTL, FUEL FLOW SEE FIG. 2.12-60	RF		
- 67		• TUBING INSTL, ENGINE FUEL SUPPLY SEE FIG. 2.12-66	RF		
- 67		• HOSE ASSY, AFTER BURNER DRAIN SEE FIG. 2.12-7 INDEX 174	RF		
- 70		• TUBING INSTL, POWER PLANT VENT AND DRAIN SEE FIG. 2.12-13	RF		
- 71		• ENGINE ASSY, SEE FIG. 2.12-7 INDEX 214	RF		

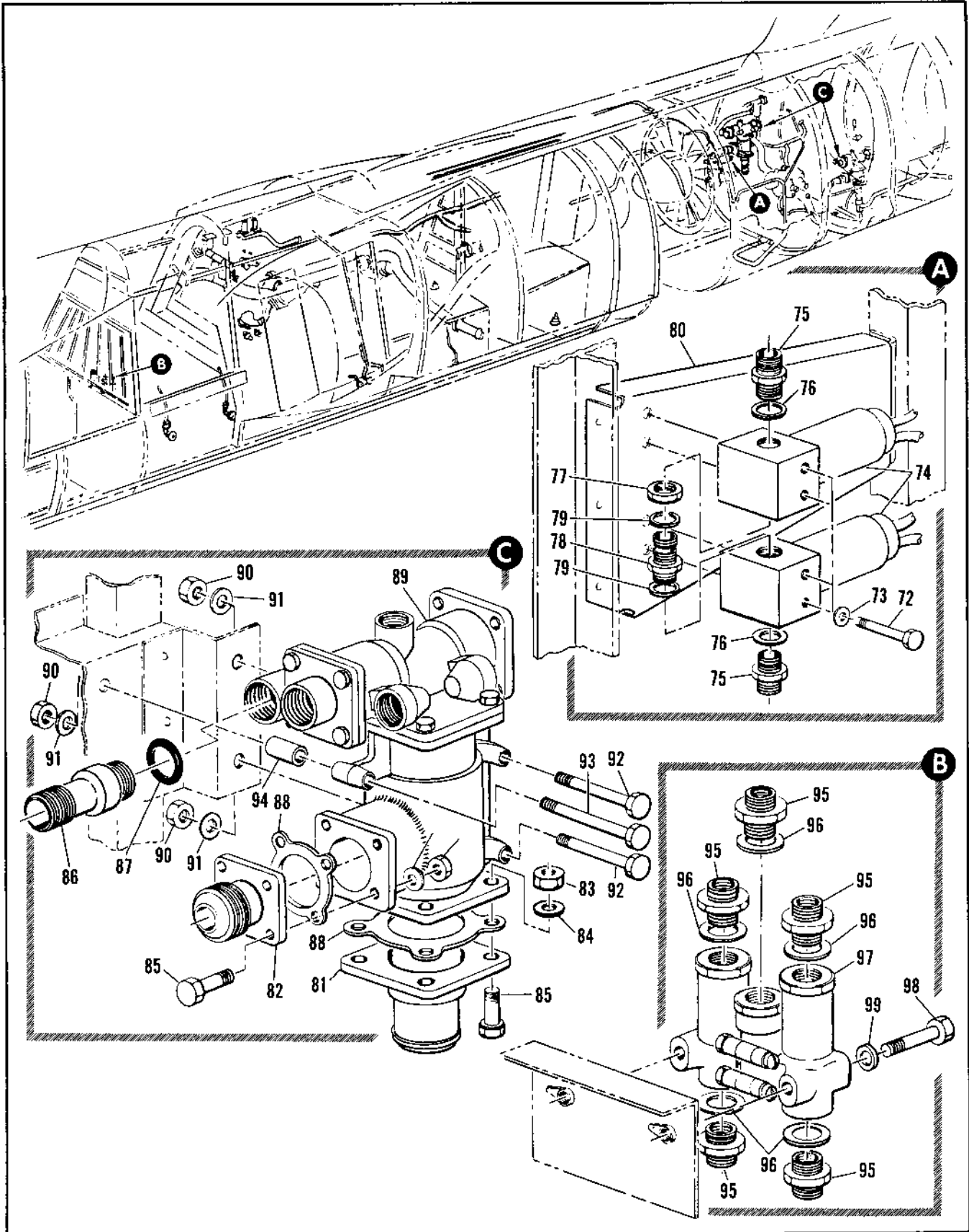

Figure 2.12-38. Fuselage Fuel System (Sheet 5 of 5)

FIGURE AND INDEX NUMBER	PART NUMBER	DESCRIPTION	UNITS PER ASSY.	USABLE ON CODE	
				FROM	TO
2.12-38	8-28256	• VALVE INSTL. SOLENOID AIR SHUTOFF RH FOR NHA SEE FIG. 2.3-15	PF	35	
- 72	AN3-22A	• BOLT	4	35	
- 73	AN960D10L	• WASHER	4	35	
- 74	V21100	• VALVE ASSY. <96487> SPEC R-60381-7 T.O. 6J15-10-107-3	2	35	
- 75	MS2190206	• UNION	2	35	
- 76	NAS617-6	• BASKET	2	35	
- 77	AN924-6D	• NUT	1	35	
- 78	MS2190306	• UNION	1	35	
- 79	NAS617-6	• BASKET	2	35	
- 80	R-28265-7	• BRACKET	1	35	
	R-27380-301	• REGULATOR INSTL. AIR PRESSURE TRANSFER TANK LH FOR NHA SEE FIG. 2.3-15	PF	35	
	R-27380-302	• REGULATOR INSTL. AIR PRESSURE TRANSFER TANK RH FOR NHA SEE FIG. 2.3-15	PF	35	
- 81	AN757D20-24	• CONNECTOR	1	35	
- 82	AN767D20-24	• CONNECTOR	1	35	
		ATTACHING PARTS			
- 83	NAS679A4	• NUT	8	35	
- 84	AN960D416L	• WASHER	8	35	
- 85	AN4-13A	• BOLT	8	35	
		-----X-----			
- 86	R-28388-9	• UNION, ORIFICE TYPE	1	35	
- 87	NAS617-6	• BASKET	1	35	
- 88	460-615-24	• SEAL, R3295 97-93513-003	2	35	
- 89	114100-29	• REGULATOR ASSY. AIR PRESSURE TRANSFER TANK <96124> SPEC R-10377-29 ATTACHING PARTS	1	35	
- 90	NAS679A4	• NUT	3	35	
- 91	AN960D416L	• WASHER	3	35	
- 92	AN4-15A	• BOLT	3	35	
- 93	AN4-22A	• BOLT	1	35	
		-----X-----			
- 94	NAS43DD4-4D	• SPACER	1	35	
	8-28293-1	• VALVE INSTL. FUEL TANK AIR CHECK LH FOR NHA SEE FIG. 2.3-15	PF	35	159
	8-28293-3	• VALVE INSTL. FUEL TANK AIR CHECK LH FOR NHA SEE FIG. 2.3-15	PF	160	
	8-28293-2	• VALVE INSTL. FUEL TANK AIR CHECK RH FOR NHA SEE FIG. 2.3-15	PF	35	
- 95	MS2190206	• UNION	5	35	
- 96	NAS617-6	• BASKET	5	35	
- 97	1111-565531	• VALVE ASSY. <92003> SPEC R-02465-1 T.O. 6J15-2-105-13 ATTACHING PARTS	1	35	
- 98	AN4-22A	• BOLT	2	35	
- 99	AN960D416L	• WASHER	2	35	
		-----X-----			

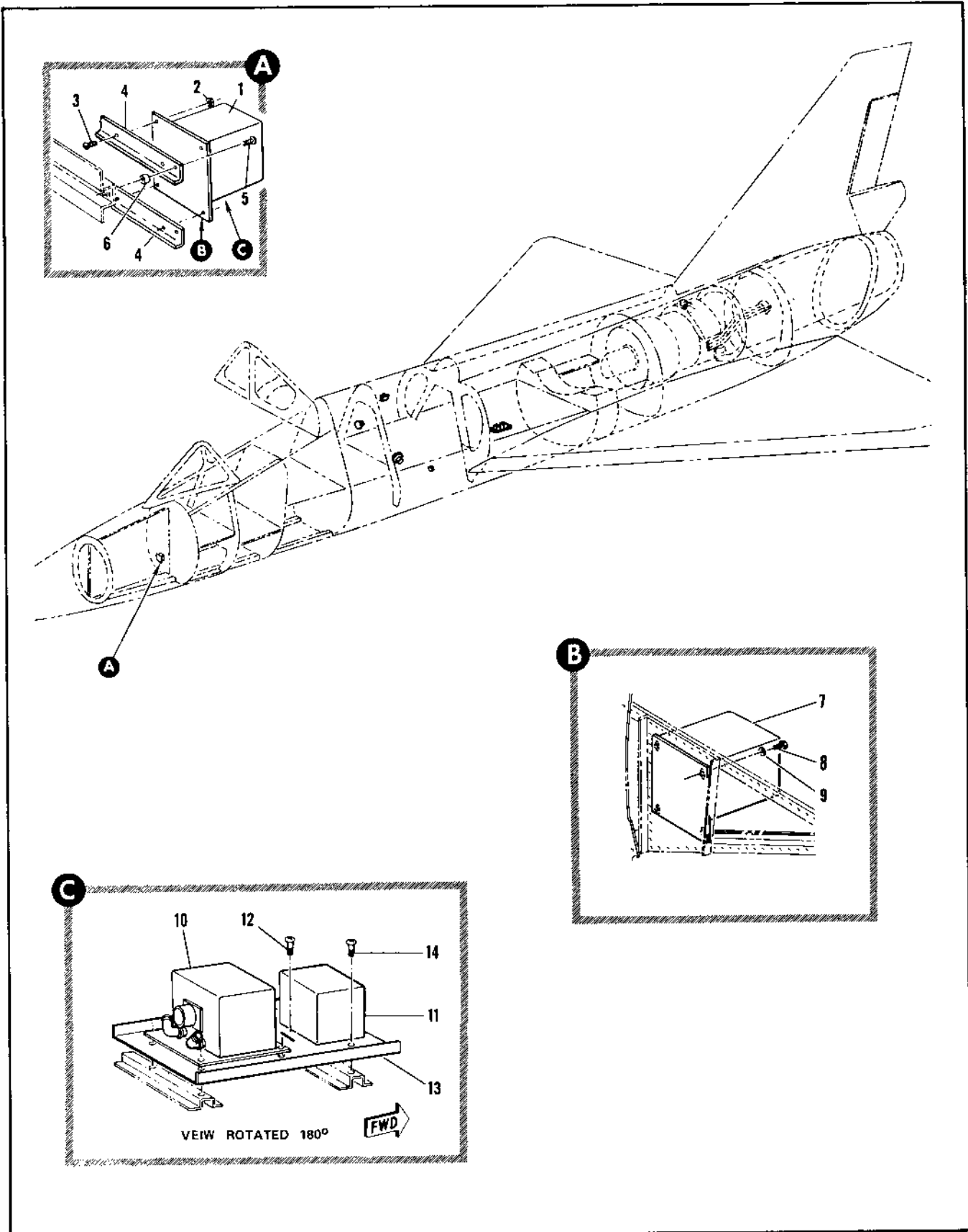

Figure 2.12-39. Fuselage Fuel Electrical (Sheet 1 of 3)

FIGURE AND INDEX NUMBER	PART NUMBER	DESCRIPTION	UNITS PER ASSY.	USABLE ON CODE	
				FROM	TO
		1 2 3 4 5 6			
2.12-39	8-65095-805	FUSELAGE FUEL ELECTRICAL • SWITCH INSTL, ALTITUDE PRESSURE RATIO CG TRANSFER UNIT	RF	A	
	8-65095-807	• SWITCH INSTL, ALTITUDE PRESSURE RATIO CG TRANSFER MODIFIED BY 8-50319	RF	B	
- 1	45529	• • SWITCH, AIR PRESSURE RATIO <72737> SPEC 8-06485-1 T.O. 452-3-106-4	1	A	
	4726A	• • SWITCH, AIR PRESSURE, RATIO (72737) SPEC 8-06485-1 T.O. 452-3-106-4 REPLACES 45529	1		
		ATTACHING PARTS			
- 2	NAS679A08	• • NUT	4	A	
- 3	AN5-5-8R7	• • SCREW	4	A	
		-----X-----			
- 4	8-65095-37	• • SUPPORT, AIR PRESSURE RATIO SWITCH ATTACHING PARTS	2	A	
- 5	AN520-10P10	• • SCREW	4	A	
- 6	NAS43DD3-12	• • SPACER	4	A	
		-----X-----			
- 7	45529	• • SWITCH, AIR PRESSURE RATIO <72737> SPEC 8-06485-1	1	B	
	4726A	• • SWITCH, AIR PRESSURE RATIO (72737) SPEC 8-06485-1 REPLACES 45529	1		
		ATTACHING PARTS			
- 8	AN304A	• • BOLT	4	B	
- 9	AN961PD10L	• • WASHER	4	B	
		-----X-----			
- 10	45529	• • SWITCH, AIR PRESSURE RATIO <81920> SPEC 8-06485-1 T.O. 452-3-106-4	1	B	
	4726A	• • SWITCH, AIR PRESSURE RATIO (81920) SPEC 8-06485-1 T.O. 452-3-106-4 REPLACES 45529	1		
- 11	2059	• • SWITCH, ALTITUDE PRESSURE <81920> SPEC 8-14473-1	1	B	
		ATTACHING PARTS			
- 12	AN520-9R8	• • SCREW	6	B	
		-----X-----			
- 13	8-69651-13	• • PLATE ASSY, SWITCH SUPPORT RIVETED ATTACHING PARTS	1	B	
- 14	AN524-10R7	• • SCREW	4	B	
		-----X-----			
		A AIRPLANES 835 THRU 47 AND 49 THRU 89			
		B AIRPLANES 888, 90 AND ON			

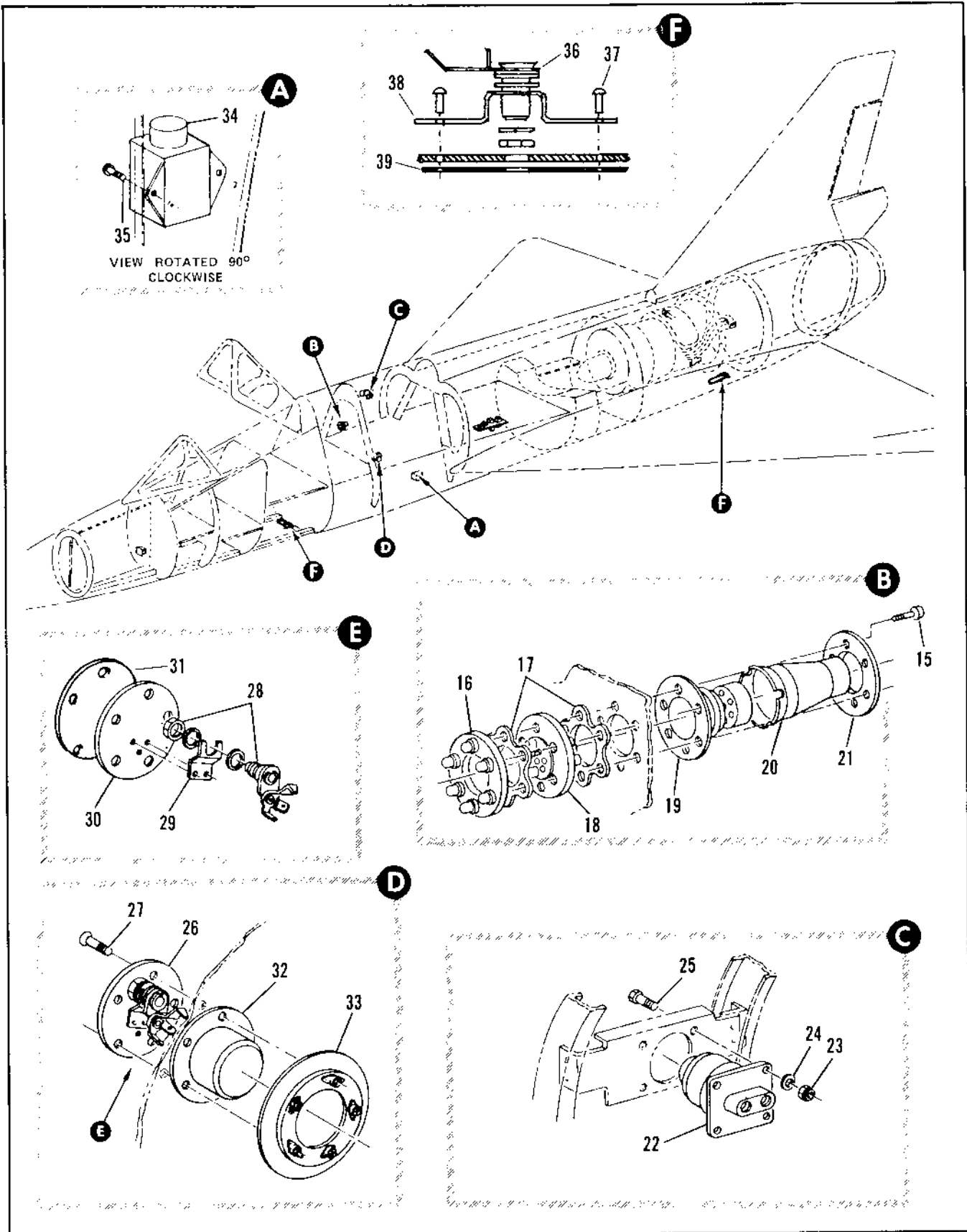

Figure 2.12-39. Fuselage Fuel Electrical (Sheet 2 of 3)

FIGURE AND INDEX NUMBER	PART NUMBER	DESCRIPTION	UNITS PER ASSY.	USABLE ON CODE	
				FROM	TO
2.12-39	P-61135	• RECEPTACLE INSTL, FUSELAGE FUEL TANK STA 253	1	35	
- 15	MS23104-14	• • BOLT	6	35	
- 16	R-21321	• • FLANGE ASSY, RIVETED	1	35	
- 17	100154-1	• • SEAL, FUEL <83259> SPEC P-12396	2	35	
- 18	YHSR42	• • RECEPTACLE, <09922> SPEC R-16315	1	35	
- 19	6719	• • RING, <97822> SPEC P-14242	1	35	
- 20	YHSR28	• • FOOT, <09922> 91-38311-022	1	35	
- 21	8-65273	• • RETAINER, FOOT	1	35	
	8-24367	• SWITCH INSTL, CG TRANSFER EMER PRESSURE FOR MHA SEE FIG. 2.3-3 INDEX 20	PF	35	
- 22	40111	• • SWITCH INSTL, CG TRANSFER EMERGENCY PRESSURE <98505> SPEC R-02986-9 T.O. 152-2-44-65 ATTACHING PARTS	1	35	
- 23	NASE79A3	• • NUT, 95-37545-002	4	35	
- 24	AN956PD10	• • WASHER	4	35	
- 25	AN3-4A	• • BOLT	4	35	
	8-92703	• JACK INSTL, GROUND FUEL LOADING NOZZLE FOR MHA SEE FIG. 2.3-13 INDEX 7	RF	35	
- 26	8-92703-7	• • DOOR ASSY, GROUND FUEL NOZZLE JACK RH ATTACHING PARTS	1	35	
- 27	AN509-1096	• • SCREW	5	35	
- 28	RJ1	• • JACK, <37942> 95-12533-001	1	35	
- 29	8-92703-11	• • CLIP	1	35	
- 30	8-92703-9	• • DOOR	1	35	
- 31	67034662-5	• • DECAL	1	35	
- 32	8-92702	• • BOX ASSY, JACK WELDED	1	35	
- 33	8-92704	• • RETAINER	1	35	
- 34	8-62231-1	• RELAY INSTL, FUEL TRANSFER TEST	RF	35	
	9220-3435	• • RELAY, STA 157 <33344> SPEC R-06289-3 REPLACES INTCHG WITH 9220-3455 ATTACHING PARTS	1	35	
- 35	AN521-10R7	• • SCREW	2	35	
- 36	MS90298-1	• • RECEPTACLE (AN3117-1 ALT) ATTACHING PARTS	1	35	
- 37	AN935-616L	• • WASHER, LOCK	1	35	
- 38	MS20426A05-14	• • PIVET	2	35	
- 39	68037343-7	• • BRACKET	1	35	
- 39	68847874	• • DECAL	1	35	

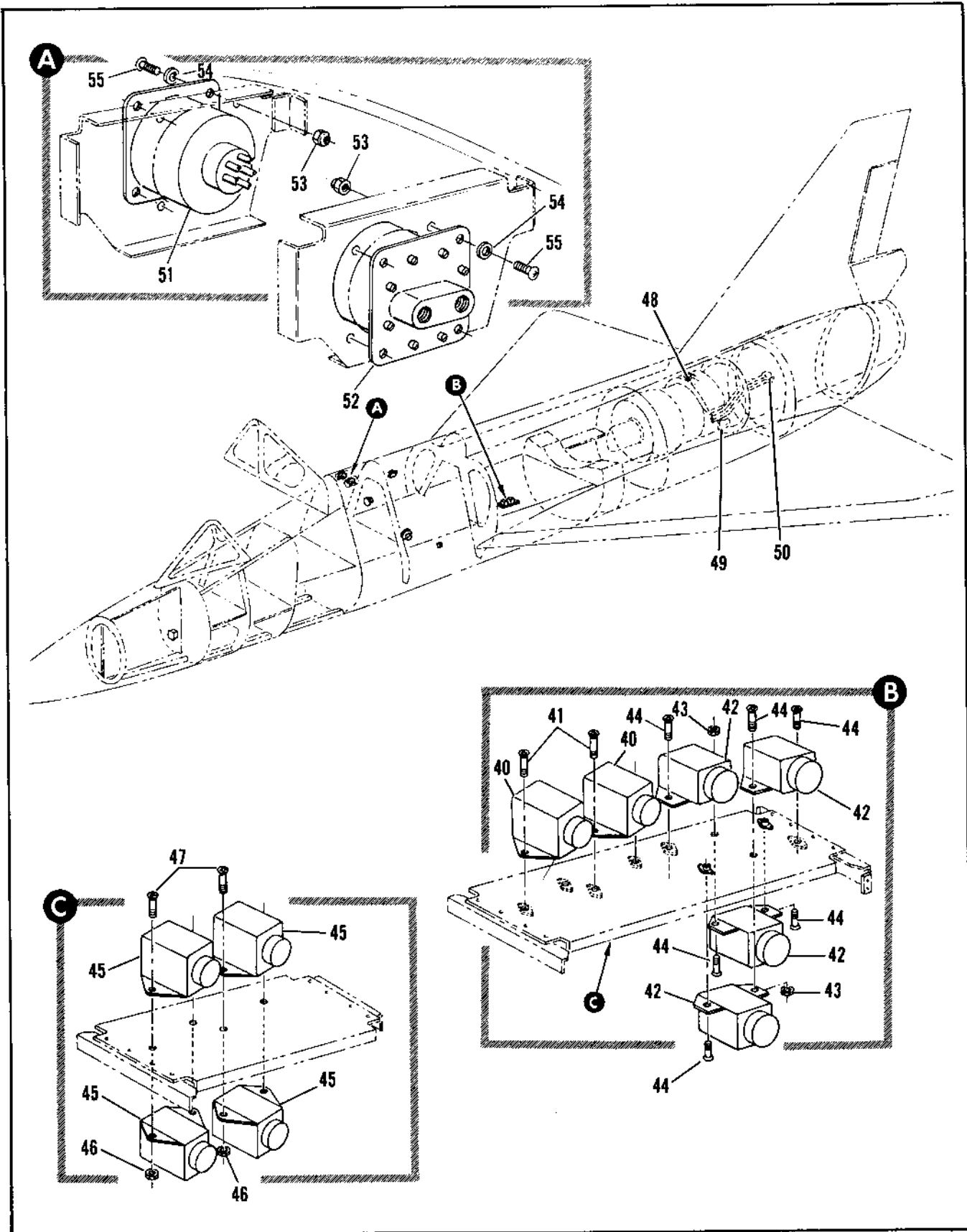

Figure 2.12-39. Fuselage Fuel Electrical (Sheet 3 of 3)

FIGURE AND INDEX NUMBER	PART NUMBER	DESCRIPTION	UNITS PER ASSY.	USABLE ON CODE	
				FROM	TO
2.12-39					
- 40	8-65121-1 9220-3435	• RELAY INSTL. FUEL TRANSFER • RELAY (35344) SPEC 8-76249-3 ATTACHING PARTS	RF 2	35 35	3A 3A
- 41	AN520-10R6	• SCREW	4	35	38
- 42	64-564	-----X----- • RELAY (96261) SPEC 4-76956 ATTACHING PARTS	4	35	3A
- 43	NAS679A3	• NUT	2	35	3A
- 44	AN520-10P6	• SCREW	6	35	3A
		-----X-----			
- 45	8-65121-5 9220-3435	• RELAY INSTL. FUEL TRANSFER • RELAY (35344) SPEC 8-76249-3 ATTACHING PARTS	RF 4	39 39	
- 46	NAS679A3	• NUT	4	39	
- 47	AN520-10R6	• SCREW	4	39	
		-----X-----			
- 48		• SWITCH, ENGINE FUEL PRESSURE SEE FIG. 2.12-65 INDEX 23	RF		
- 49		• TRANSMITTER, RATE OF FUEL FLOW SEE FIG. 2.10-7 INDEX 160	RF		
- 50		• SENSOR, ENGINE FUEL TEMPERATURE ENVELOPE SEE FIG. 2.10-7 INDEX 49	RF		
	8-28414	• SWITCH INSTL. FUSELAGE TANK LOW PRESSURE AND EMERGENCY PRESSURE FOR NHA SEE FIG. 2.5-10	RF	35	
- 51	40364	• SWITCH ASSY, DIFFERENTIAL PRESSURE (98525) SPEC 8-22986-1	1	35	
- 52	40111	• SWITCH ASSY, DIFFERENTIAL PRESSURE (98525) SPEC 8-22986-9 ATTACHING PARTS	1	35	
- 53	NAS679A3	• NUT	8	35	
- 54	AN959010L	• WASHER	8	35	
- 55	NAS221-6	• SCREW	8	35	
		-----X-----			

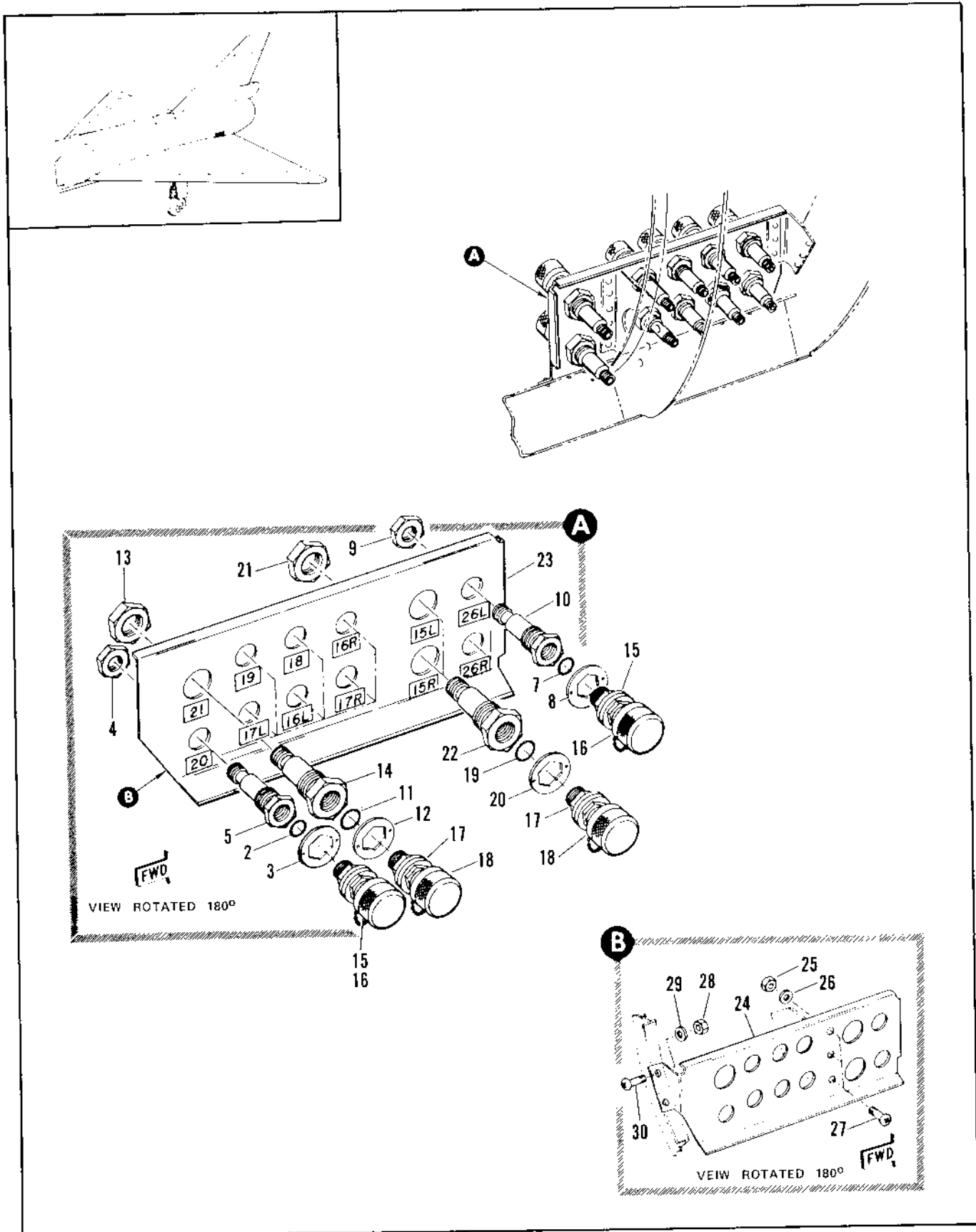

Figure 2.12-40. Fuel System Checkout Panel Aft Installation

FIGURE AND INDEX NUMBER	PART NUMBER	DESCRIPTION	UNITS PER ASSY.	USABLE ON CODE	
				FROM	TO
2.12-10	8-28437	PANEL INSTALLATION, FUEL SYSTEM CHECKOUT AFT FOR NHA SEE FIG. 2.3-15	RF	A	
	8-28409-1	PANEL INSTALLATION, FUEL SYSTEM CHECKOUT AFT FOR NHA SEE FIG. 2.3-15	RF	R	
	6-28409-3	PANEL INSTALLATION, FUEL SYSTEM CHECKOUT AFT FOR NHA SEE FIG. 2.3-15	RF	216	240
	8-28409-5	PANEL INSTALLATION, FUEL SYSTEM CHECKOUT AFT FOR NHA SEE FIG. 2.3-15	RF	241	
- 1	1119-588270	• FITTING, <92003> SPEC R-99922-9	7	35	89
- 2	NAS617-5	• GASKET	7	35	
- 3	8-28522-7	• ADAPTER, FITTING LOCKWIRE	7	35	
- 4	AN924-8D	• NUT	7	35	
- 5	8-28415-7	• ADAPTER	7	35	
- 6	1119-588270	• FITTING, <92003> SPEC R-99922-9	7	35	
- 7	NAS617-5	• GASKET	2	35	
- 8	8-28522-7	• ADAPTER, FITTING LOCKWIRE	2	35	
- 9	AN924-8D	• NUT	2	35	
- 10	8-28415-7	• ADAPTER	2	35	
- 11	NAS617-6	• GASKET	2	35	
- 12	8-28522-7	• ADAPTER, FITTING LOCKWIRE	1	0	
- 13	AN924-10B	• NUT	1	216	
- 14	8-28415-7	• ADAPTER	1	0	
- 15	1119-588270	• FITTING FUEL CHECK OUT <92003> SPEC R-9922-9<APPLICABLE TO TEST POINTS #16, 17, 18, 19, 20, AND 20>	1	0	
- 16	F60F1245	• DUST CAP	6	A	
- 17	1119-588272	• FITTING <92003> SPEC R-99922-13 APPLICABLE TO TEST POINTS #15 AND 21>	5		
- 18	F60F1251	• DUST CAP	2	90	35
- 19	NAS617-6	• GASKET	2		
- 20	8-28522-7	• ADAPTER, FITTING LOCKWIRE	2	35	
- 21	AN924-10B	• NUT	2	216	
- 22	8-28415-7	• ADAPTER	2	35	
- 23	8-28409-19	• PANEL	2	35	
- 24	8-28437-16	• PANEL	1	216	240
- 25	NAS67943	• ATTACHING PARTS	1	241	
- 26	AN901-10L	• NUT	5	241	
- 27	NAS623-3-2	• WASHER	3	241	
- 28	NAS67943	• SCREW	8	241	
- 29	AN961-11L	• NUT	2	241	
- 30	NAS623-3-3	• WASHER	2	241	
		• SCREW	2	241	

		*A ADDED ON AIRPLANES #78 THRU 215 FOR TOTO1-106A-15			
		A AIRPLANES #30 THRU 47 AND 49 THRU 60			
		B AIRPLANES #48 AND 51 THRU 215			
		C AIRPLANES #48, 51 AND 59			

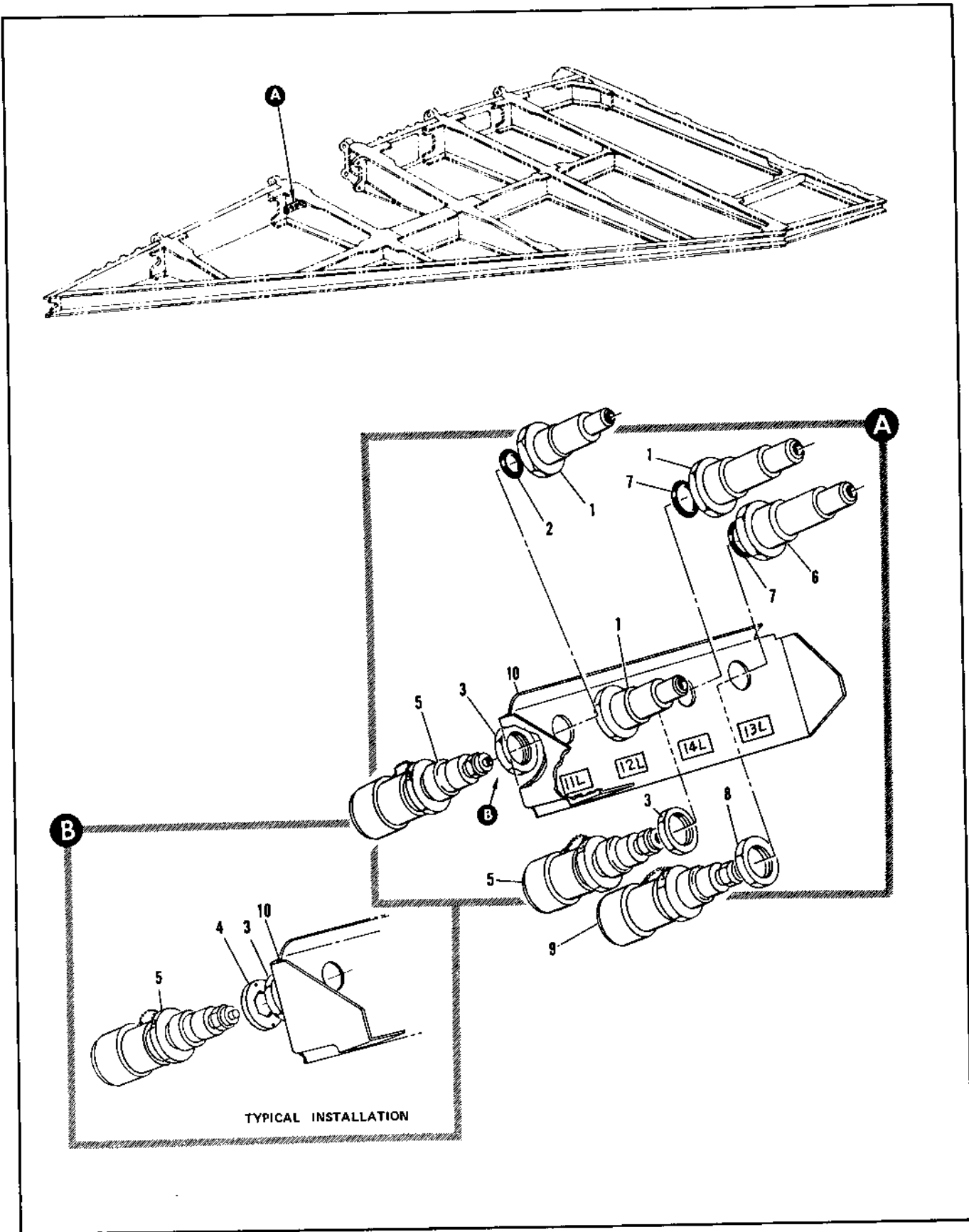

Figure 2.12-41. Fuel System Checkout Intermediate Panel Installation

FIGURE AND INDEX NUMBER	PART NUMBER	DESCRIPTION	UNITS PER ASSY.	USABLE ON CODE	
				FROM	TO
2.12-41	8-28410-1	PANEL INSTALLATION, FUEL SYSTEM CHECK OUT INTERMEDIATE LH FOR NHA SEE FIG. 2-6-32	RF	35	
	8-28410-2	PANEL INSTALLATION, FUEL SYSTEM CHECK OUT INTERMEDIATE RH FOR NHA SEE FIG. 2-6-32	RF	35	
	- 1	8-28415-7	• ADAPTER	2	35
	- 2	NAS617-5	• PACKING	2	35
	- 3	AN924-8D	• NUT	2	35
	- 4	8-28422	• ADAPTER	4	196
	- 5	1119-548273	• FITTING, FUEL CHECK <92003> SPEC 8-09922-9 <APPLICABLE TO TEST POINTS #11, 12, AND 14>	1	
	- 6	8-28415-9	• ADAPTER	2	35
	- 7	NAS617-6	• PACKING	2	35
	- 8	AN924-1CG	• NUT	2	35
- 9	1119-598272	• FITTING, FUEL CHECK <92003> SPEC 8-09922-13 <APPLICABLE TO TEST POINT #13>	2	90	
- 10	8-28410-7	• BRACKET, LH	1	35	
	8-28410-8	• BRACKET, LH	1	35	

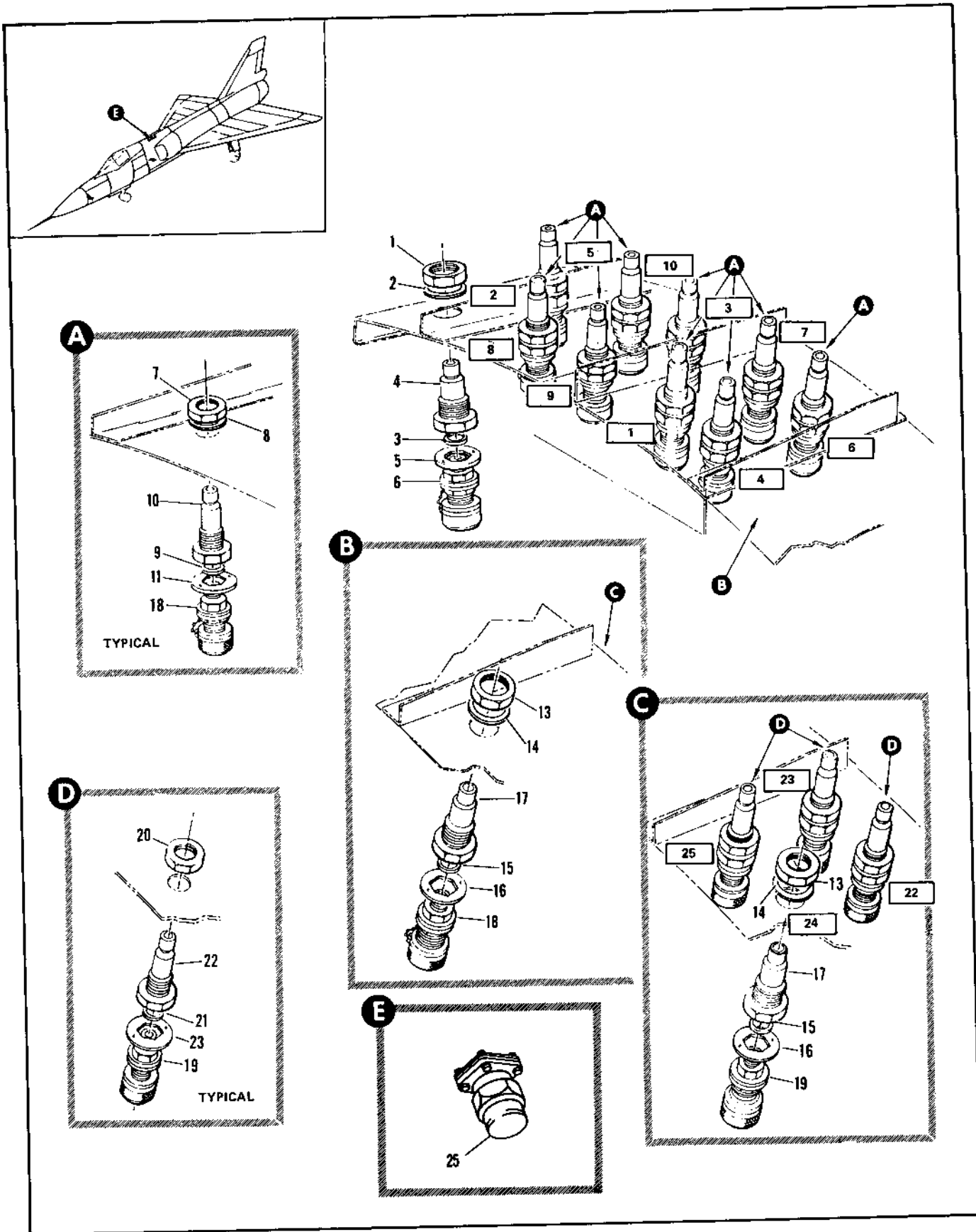

Figure 2.12-42. Fuel System Checkout Adapter Installation Forward

FIGURE AND INDEX NUMBER	PART NUMBER	DESCRIPTION	UNITS PER ASSY.	USABLE ON CODE	
				FROM	TO
2.12-40	8-28411	ADAPTER INSTALLATION, FUEL SYSTEM CHECKOUT FWO FOR NHA SEE FIG. 2.3-11	KF	A	
	8-28411-1	ADAPTER INSTALLATION, FUEL SYSTEM CHECKOUT FWO FOR NHA SEE FIG. 2.7-11	KF	q	
	8-28411-3	ADAPTER INSTALLATION, FUEL SYSTEM CHECKOUT FWO FOR NHA SEE FIG. 2.3-11	PF	216	
- 1	AN924-100	• NUT	1	35	
- 2	AN960D141F	• WASHER	1	35	
- 3	NAS617-6	• GASKET	1	35	
- 4	8-28415-9	• ADAPTER	1	35	
- 5	8-28422-7	• ADAPTER	1	216	
- 5	1119-588272	• FITTING, <92783> SPEC 8-39922-13 APPLICABLE TO TEST POINT #5	1	G	
- 7	AN924-80	• NUT	9	35	
- 8	AN960D121b	• WASHER	9	35	
- 9	NAS617-6	• GASKET	9	35	
- 10	8-28415-7	• ADAPTER	9	35	
- 11	8-28422-7	• ADAPTER	9	35	
- 12	1119-588272	• FITTING, <92783> SPEC 8-39922-13	9	F	
- 13	AN924-100	*B • NUT	1	C	
- 14	AN960D141F	*B • WASHER	1	C	
- 15	NAS617-6	*B • GASKET	1	C	
- 16	8-28422-7	*B • ADAPTER	1	C	
- 17	8-28415-9	*B • ADAPTER	1	C	
- 18	1119-588271	• FITTING, <92803> SPEC 8-39922-13 APPLICABLE TO TEST POINTS #1, 2, 3, 4, 6, 7, 8, 9, AND 10	1	90	216
- 19	1119-588272	*A • FITTING, <92803> SPEC 8-39922-13 APPLICABLE TO TEST POINTS #02, #3, #4 AND #5	1	216	
- 20	AN924-80	• NUT	3	216	
- 21	NAS617-6	• GASKET	3	216	
- 22	8-28415-7	• ADAPTER	3	216	
- 23	8-28422-7	• ADAPTER	3	216	
- 24	1119-588272	• FITTING, <92803> SPEC 8-39922-13	3	216	
- 25	8-28723	• FITTING, DEFUEL AIR PRESSURE LINE, MAKE FROM 8-25723-7 REPLACES NOT INTERCHANGEABLE WITH 8-2723	1	35	
	8-28723-7	• FITTING, ALT INTCHG WITH 8-28723	1	35	
	AN909-14	• FITTING	1		
		*A AIRPLANES #75 THRU 60			
		*B AIRPLANES #13 THRU 61 AND RELOCATED FOR AIRPLANES #41 THRU 215			
		A AIRPLANES #35 THRU 47 AND 49 THRU 60			
		B AIRPLANES #48 AND 51 THRU 215			
		C AIRPLANES #49, 51 AND ON			
		D AIRPLANES #49 AND 51 THRU 73			
		E AIRPLANES #35 THRU 47 AND 49 THRU 89			
		F AIRPLANES #49, 50 AND ON			
		G AIRPLANES #49 AND 51 THRU 60			

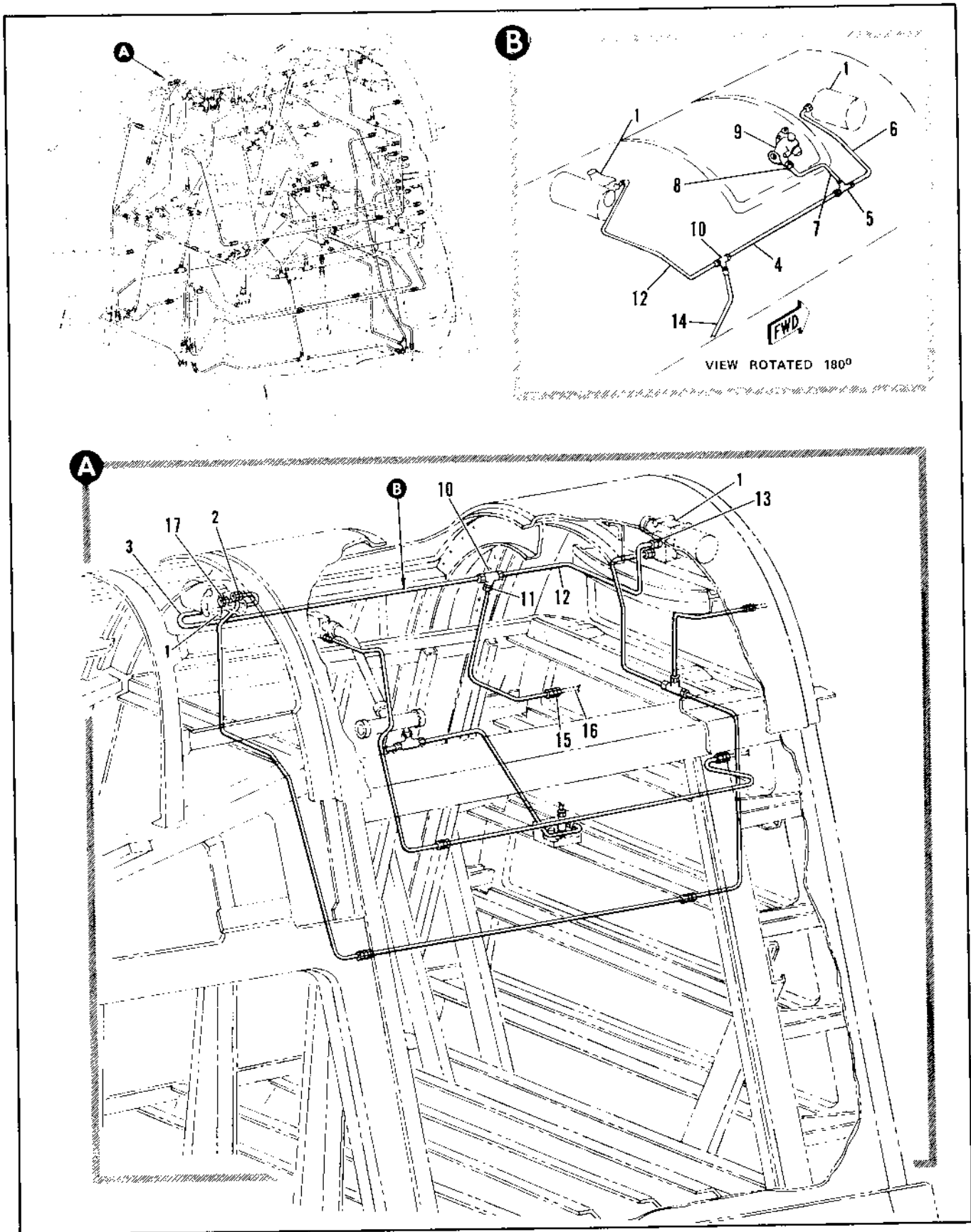

Figure 2.12-43. Fuel Tank Pressure Tubing Installation Sta 217 to 253 (Sheet 1 of 9)

FIGURE AND INDEX NUMBER	PART NUMBER	DESCRIPTION	UNITS PER ASSY.	USABLE ON CODE	
				FROM	TO
		1 2 3 4 5 6			
2.12-43	R-20397-829	TUBING INSTALLATION, FUEL TANK PRESSURE STA 217 TO 253 FOR MHA SEE FIG. 2.3-10	RF	35	159
	8-20397-853	TUBING INSTALLATION, FUEL TANK PRESSURE STA 217 TO 253 FOR MHA SEE FIG. 2.3-10	RF	160	
- 1	MS21902D4	• VALVE ASSY, VENT SEE FIG. 2.12-53 INDEX 12	RF		
- 2	MS29512-4	• UNION	1	35	
		• GASKET	1	35	
- 3	R-20397-798	A • TUBE ASSEMBLY	1	35	159
	8-20397-3175	B • TUBE ASSEMBLY	1	160	
- 4	65A33182-1	C • TUBE ASSY, FUSELAGE TANK AMBIENT SENSE LINE	1		
- 5	MS21905D4	C • TEE	1		
- 6	65A33180-1	C • TUBE ASSY, FUSELAGE TANK AMBIENT SENSE LINE	1		
- 7	65A33194-1	C • TUBE ASSY, FUSELAGE TANK AMBIENT SENSE LINE	1		
- 8	MS21902D4	C • UNION	1		
	MS29512-4	C • GASKET	1		
- 9		• VALVE ASSY, PRESSURE RELIEF SEE FIG. 2.12-51 INDEX 31	RF		
- 10	MS21910D4	• TEE	1	35	
- 11	MS21916D6-4	• REDUCER	1	35	
	MS29512-4	• GASKET	1	35	
- 12	R-20397-1037	• TUBE ASSEMBLY	1	35	159
	8-20397-3177	• TUBE ASSEMBLY	1	160	
- 13	MS21902D4	• UNION	1	35	
	MS29512-4	• GASKET	1	35	
- 14	8-20397-1039	• TUBE ASSEMBLY	1	35	159
	8-20397-3179	• TUBE ASSEMBLY	1	160	
- 15		• UNION, SEE FIG. 2.12-52	RF		
- 16		• TUBE ASSY, SEE FIG. 2.12-45 INDEX 121	RF		
- 17	MS21902D6	• UNION	1	35	
		A REMOVED FROM AIRPLACES 35, 38 THRU 44, 46 THRU 50, 52, 53, 55, 56 THRU 61, 63 THRU 65, 68 THRU 70, 73 THRU 80, 82 THRU 91, 95 THRU 100, 103 THRU 124, 126, 128, THRU 141, 143 THRU 145, 147 THRU 157 AND 159			
		B REMOVED FROM AIRPLANES 160 THRU 167, 169 THRU 173, 175 THRU 179, 181 THRU 198, 200, 201, 203 THRU 215, 217 THRU 226, 228 THRU 235, 237 THRU 241, 244, 245, 247, 248, 251 THRU 252, 254 THRU 267, 269, 270, 272 THRU 279, 281 THRU 286, 288, 290 THRU 294 AND 296 THRU 305			
		C ADDED TO AIRPLANES 15, 34, 38, THRU 44, 46, THRU 50, 52, 53, 55, 56, 58 THRU 61, 63 THRU 64, 68 THRU 70, 73 THRU 80, 82 THRU 91, 95 THRU 100, 103 THRU 124, 126, 128 THRU 141, 143 THRU 145, 147 THRU 157, 159 THRU 167, 169 THRU 173, 175 THRU 178, 180 THRU 188, 200, 201, 203 THRU 215, 217 THRU 228, 228 THRU 235, 237 THRU 241, 244, 245, 247, 248, 251 THRU 252, 254 THRU 257, 259, 270, 272 THRU 279, 281 THRU 286, 288, 291 THRU 294 AND 296 THRU 305 PER T.O. 1F-106A-25			

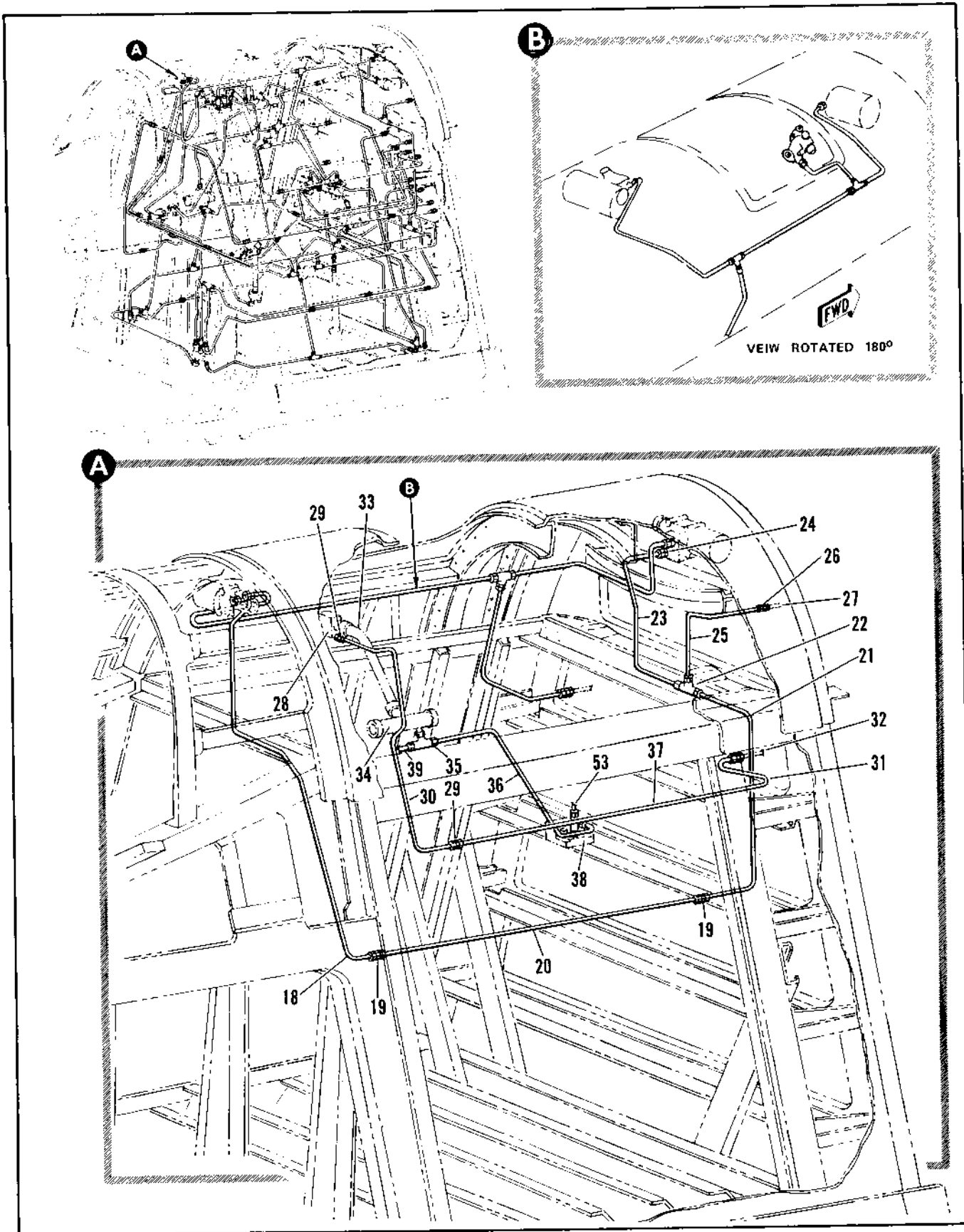

Figure 2.12-43. Fuel Tank Pressure Tubing Installation Sta 217 to 253 (Sheet 2 of 9)

FIGURE AND INDEX NUMBER	PART NUMBER	DESCRIPTION	UNITS PER ASSY.	USABLE ON CODE	
				FROM	TO
				1	2
2.12-43	MS29512-6	• GASKET	1	35	
- 16	8-20397-719	• TUBE ASSEMBLY	1	35	159
	8-20397-3149	• TUBE ASSEMBLY	1	160	
- 19	MS2190206	• UNION	2	35	
- 20	8-20397-894	• TUBE ASSEMBLY	1	35	159
	8-20397-3135	• TUBE ASSEMBLY	1	160	
- 21	8-20397-756	• TUBE ASSEMBLY	1	35	159
	8-20397-3173	• TUBE ASSEMBLY	1	160	
- 22	MS2190506	• TEE	1	35	
- 23	8-20397-752	• TUBE ASSEMBLY	1	35	159
	8-20397-3169	• TUBE ASSEMBLY	1	160	
- 24	MS2190206	• UNION	1	35	
	MS29512-6	• GASKET	1	35	
- 25	8-20397-754	• TUBE ASSEMBLY	1	35	159
	8-20397-3171	• TUBE ASSEMBLY	1	160	
- 26		• UNION, SEE FIG. 2.12-51	RF		
- 27		• TUBE ASSY, SEE FIG. 2.12-44 INDEX 2	RF		
- 28		• VALVE ASSY, PRESSURE RELIEF SEE FIG. 2.12-51 INDEX 21	RF		
- 29	MS2190204	• UNION	2	35	
	MS29512-4	• GASKET	1	35	
- 30	8-20397-1249	• TUBE ASSEMBLY	1	35	159
	8-20397-2131	• TUBE ASSEMBLY	1	160	
- 31	8-20397-696	• TUBE ASSEMBLY	1	35	159
	8-20397-3137	• TUBE ASSEMBLY	1	160	
- 32		• TUBE ASSY, SEE FIG. 2.12-44 INDEX 176	RF		
- 33	8-20397-593	• TUBE ASSEMBLY	1	35	
- 34		• TUBE ASSY, FUEL TANK VENT SEE FIG. 2.12-49 INDEX 16	RF		
- 35	MS2190904	• TEE	1	35	
	AN924-40	• NUT	1	35	
	MS29512-4	• GASKET	1	35	
- 36	8-20397-1247	• TUBE ASSEMBLY	1	35	159
	8-20397-3199	• TUBE ASSEMBLY	1	160	
- 37	MS2191204	• TEE	1	35	
	AN924-40	• NUT	1	35	
	MS29512-4	• GASKET	1	35	
- 38		• VALVE ASSY, SEE FIG. 2.12-52 INDEX 28	RF		

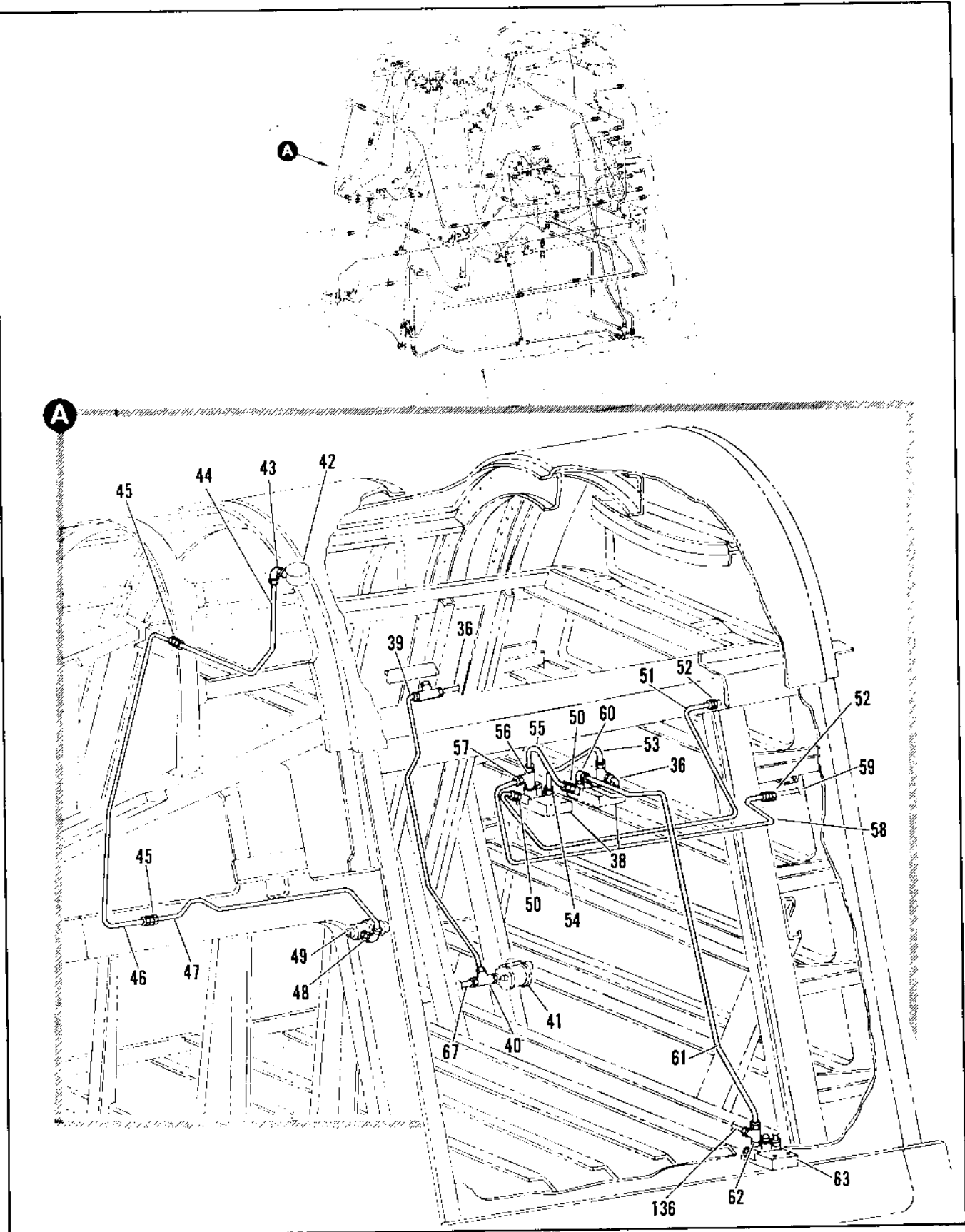

Figure 2.12-43. Fuel Tank Pressure Tubing Installation Sta 217 to 253 (Sheet 3 of 9)

FIGURE AND INDEX NUMBER	PART NUMBER	DESCRIPTION	UNITS PER ASSY.	USABLE ON CODE	
				FROM	TO
2.12-43- 39	B-20397-704	• TUBE ASSEMBLY	1	35	159
- 40	B-20397-3139	• TUBE ASSEMBLY	1	160	
- 41	MS2191204	• TEE	1	35	
- 42		• VALVE ASSY, AIR SHUT-OFF SEE FIG. 2.12-52 INDEX 27	RF		
- 43		• VALVE ASSY, FUSELAGE TANK PILOT SEE FIG. 2.12-52 INDEX 4	RF		
	MS2190804	• ELBOW	1	35	
	AN924-40	• NUT	1	35	
	MS29512-4	• GASKET	1	35	
- 44	B-20397-1255	• TUBE ASSEMBLY	1	35	159
- 45	B-20397-2137	• TUBE ASSEMBLY	1	160	
- 46	MS2190204	• UNION	2	35	
- 46	B-20397-1261	• TUBE ASSEMBLY	1	35	159
- 47	B-20397-2113	• TUBE ASSEMBLY	1	160	
- 47	B-20397-734	• TUBE ASSEMBLY	1	35	159
- 48	B-20397-3161	• TUBE ASSEMBLY	1	160	
	MS2190804	• ELBOW	1	35	
	AN924-40	• NUT	1	35	
	MS29512-4	• GASKET	1	35	
- 49		• VALVE ASSY, PRESSURE OPERATED PILOT SEE FIG. 2.12-52 INDEX 46	RF		
- 50	MS2190206	• UNION	2	35	
	MS29512-6	• GASKET	2	35	
- 51	B-20397-1241	• TUBE ASSEMBLY	1	35	159
- 51	B-20397-3192	• TUBE ASSEMBLY	1	160	
- 52		• UNION, SEE FIG. 2.12-52	RF		
- 53	B-20397-1245	• TUBE ASSEMBLY	1	35	159
- 54	B-20397-3197	• TUBE ASSEMBLY	1	160	
- 54	MS2190204	• UNION	1	35	
- 55	B-20397-1243	• TUBE ASSEMBLY	1	35	159
- 55	B-20397-3195	• TUBE ASSEMBLY	1	160	
- 56	MS2191006	• TEE	1	35	
- 57	MS2191406-4	• REDUCER	1	35	
	AN924-60	• NUT	1	35	
	MS29512-6	• GASKET	1	35	
- 58	B-20397-1285	• TUBE ASSEMBLY	1	35	159
- 59	B-20397-2133	• TUBE ASSEMBLY	1	160	
- 59		• TUBE ASSY, SEE FIG. 2.12-44 INDEX 118	RF		
- 60	MS2190706	• ELBOW	1	35	
	AN924-60	• NUT	1	35	
	MS29512-6	• GASKET	1	35	
- 61	B-20397-1237	• TUBE ASSEMBLY	1	35	159
- 62	B-20397-3189	• TUBE ASSEMBLY	1	160	
- 62	MS2191206	• TEE	1	35	
	AN924-60	• NUT	1	35	
	MS29512-6	• GASKET	1	35	
- 63		• VALVE ASSY, FUEL TRANSFER SEE FIG. 2.12-52 INDEX 11	RF		

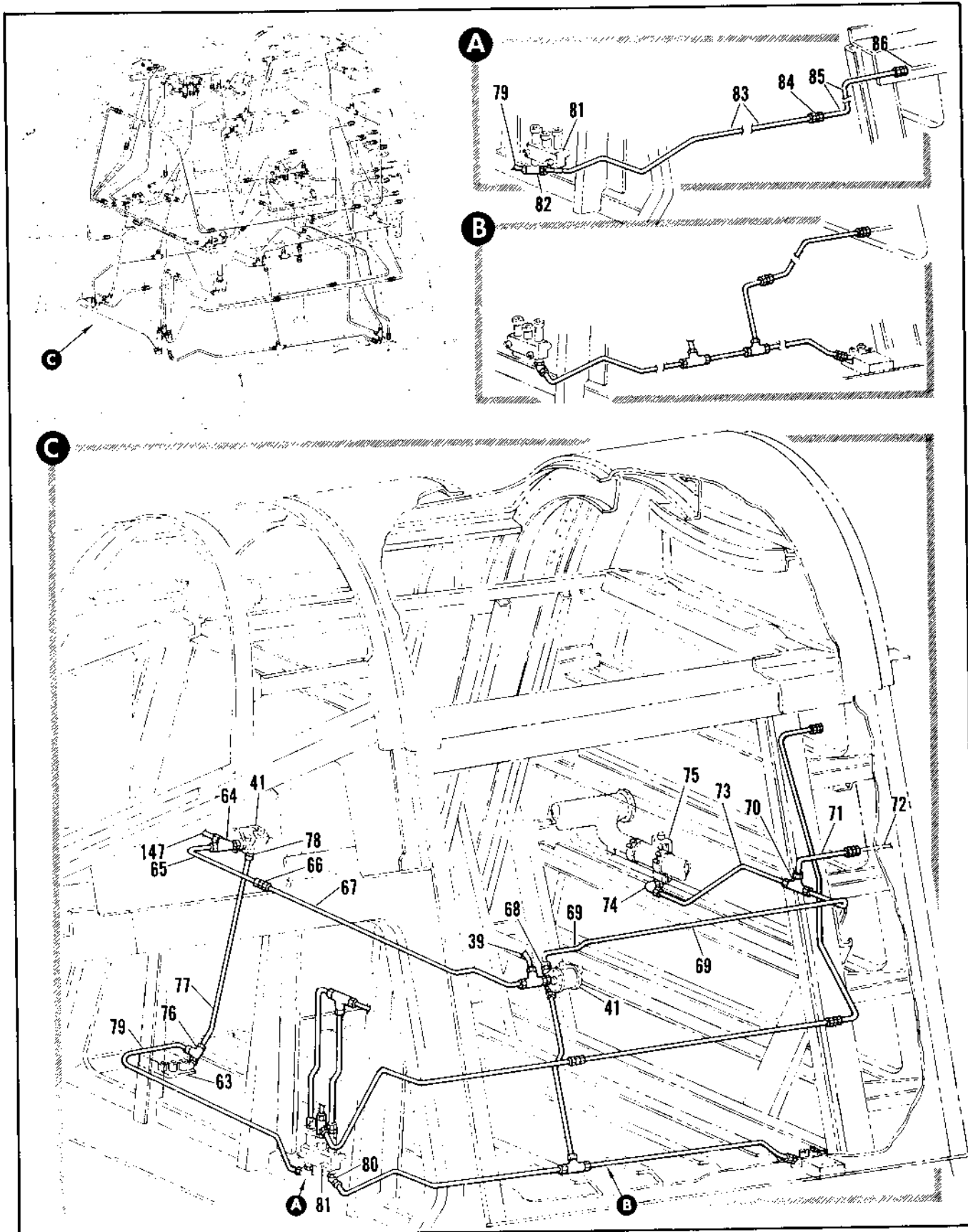

Figure 2.12-43. Fuel Tank Pressure Tubing Installation Sta 217 to 253 (Sheet 4 of 9)

FIGURE AND INDEX NUMBER	PART NUMBER	DESCRIPTION	UNITS PER ASSY.	USABLE ON CODE	
				FROM	TO
		1 2 3 4 5 6			
2.12-44-64	MS2191204	• TEE	1	35	
	AN924-40	• NUT	1	35	
	MS29512-6	• GASKET	1	35	
- 65	R-20397-1267	• TUBE ASSEMBLY	1	35	159
	R-20397-2119	• TUBE ASSEMBLY	1	160	
- 66	MS2190206	• UNION	1	35	
- 67	R-20397-708	• TUBE ASSEMBLY	1	35	159
	R-20397-3141	• TUBE ASSEMBLY	1	160	
- 68	MS2190206	• UNION	1	35	
	MS29512-6	• GASKET	1	35	
- 69	R-20397-1239	• TUBE ASSEMBLY	1	35	159
	R-20397-3191	• TUBE ASSEMBLY	1	160	
- 70	9A-90319-323	• TEE	1	35	
- 71	R-20397-1713	• TUBE ASSEMBLY	1	35	159
	R-20397-2137	• TUBE ASSEMBLY	1	160	
- 72		• TUBE ASSY. SEE FIG. 2.12-44 INDEX 119	RF		
- 73	R-20397-1233	• TUBE ASSEMBLY	1	35	159
	R-20397-3185	• TUBE ASSEMBLY	1	160	215
	R-20397-2935	• TUBE ASSEMBLY	1	216	
- 74	MS2190806	• ELBOW	1	35	
	AN924-60	• NUT	1	35	
	MS29512-6	• GASKET	1	35	
- 75		• VALVE ASSY. FULL TRANSFER SHUT-OFF AFT SEE FIG. 2.10-52 INDEX 86			
- 76	MS2191206	• TEE	1	35	
	AN924-60	• NUT	1	35	
	MS29512-6	• GASKET	1	35	
- 77	R-20397-730	• TUBE ASSEMBLY	1	35	159
	R-20397-3159	• TUBE ASSEMBLY	1	160	
- 78	MS2190206	• UNION	1	35	
	MS29512-6	• GASKET	1	35	
- 79	R-20397-728	• TUBE ASSEMBLY	1	35	159
- 80	MS2190806	• ELBOW	1	35	215
	AN924-60	• NUT	1	35	215
	MS29512-6	• GASKET	1	35	215
- 81		• VALVE ASSY. MANIFOLD AIR CHECK FUEL SEE FIG. 2.12-52 INDEX 17	RF		
- 82	9A-90319-327	• TEE	1	35	
	AN924-60	• NUT	1		
	MS29512-6	• GASKET	1		
- 83	R-20397-2908	• TUBE ASSEMBLY	1	35	
- 84	MS2190206	• UNION	1	35	
- 85	R-20397-2911	• TUBE ASSEMBLY	1	35	
- 86		• TUBE ASSY. RM SEE FIG. 2.12-44 INDEX 113	RF		

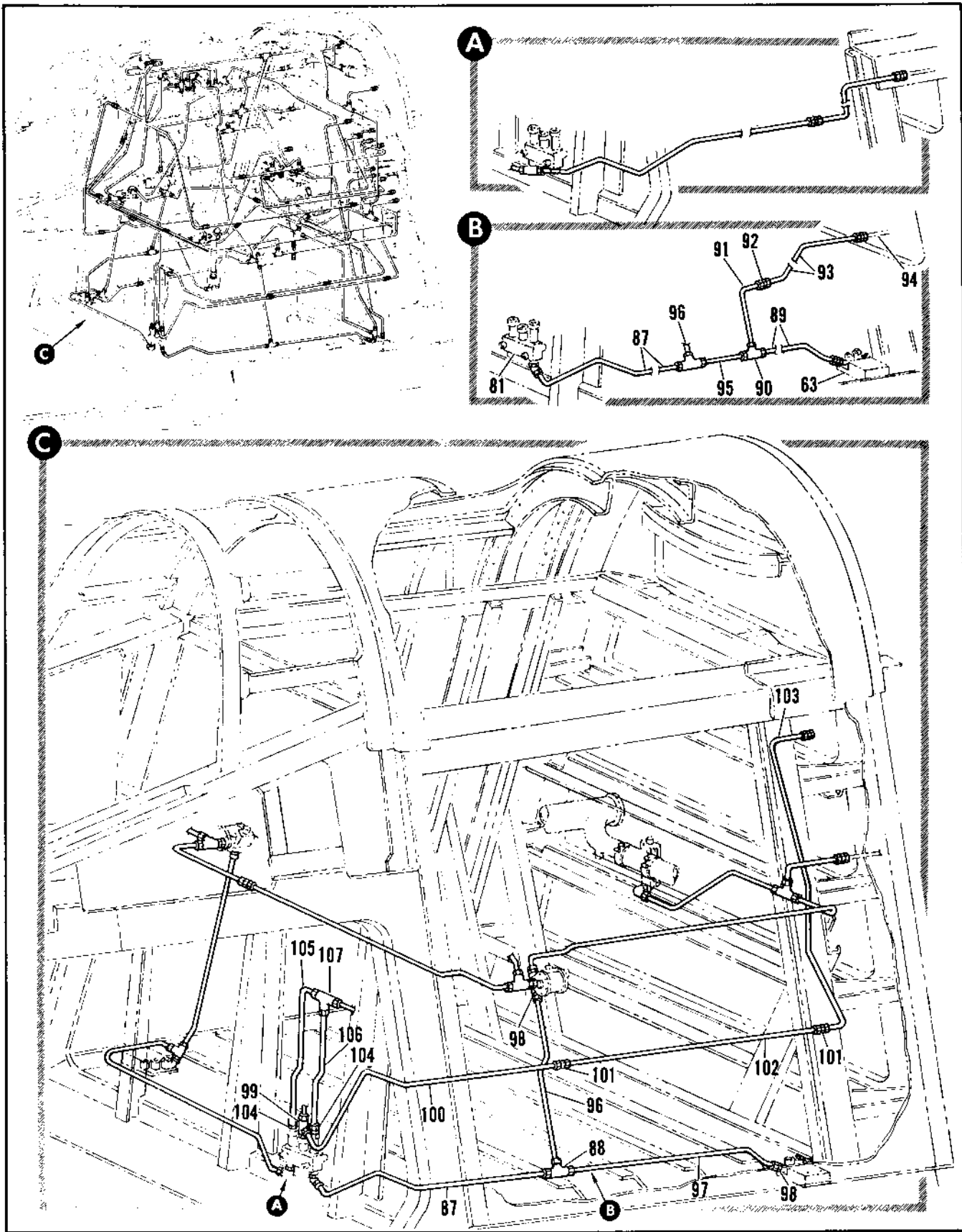

Figure 2.12-43. Fuel Tank Pressure Tubing Installation Sta 217 to 253 (Sheet 5 of 9)

FIGURE AND INDEX NUMBER	PART NUMBER	DESCRIPTION	UNITS PER ASSY.	USABLE ON CODE	
				FROM	TO
2.12-43- 87	R-20397-724	• TUBE ASSEMBLY	1	35	159
	R-20397-3155	• TUBE ASSEMBLY	1	160	215
- 88	MS21905D6	• TEE	1	35	
- 89	R-20397-2915	• TUBE ASSEMBLY	1	35	
- 90	98-71319-008	• TEE	1	35	
- 91	R-20397-2917	• TUBE ASSEMBLY	1	35	
- 92	MS21902D6	• UNION	1	35	
- 93	R-20397-2919	• TUBE ASSEMBLY	1	35	
- 94		• TUBE ASSY, SEE FIG. 2.12-44 INDEX 115	HF		
- 95	R-20397-2913	• TUBE ASSEMBLY	1	216	
- 96	R-20397-712	• TUBE ASSEMBLY	1	35	159
	R-20397-3145	• TUBE ASSEMBLY	1	160	
- 97	R-20397-669	• TUBE ASSEMBLY	1	35	159
	R-20397-3133	• TUBE ASSEMBLY	1	160	215
- 98	MS21902D6	• UNION	1	35	
	MS29512-6	• GASKET	1	35	
- 99	MS21912D6	• TEE	1	35	
	AN924-6D	• NUT	1	35	
	MS29512-6	• GASKET	1	35	
-100	R-20397-1253	• TUBE ASSEMBLY	1	35	159
	R-20397-2105	• TUBE ASSEMBLY	1	160	
-101	MS21902D6	• UNION	2	35	
-102	R-20397-714	• TUBE ASSEMBLY	1	35	159
	R-20397-3147	• TUBE ASSEMBLY	1	160	
-103	R-20397-748	• TUBE ASSEMBLY	1	35	159
	R-20397-3167	• TUBE ASSEMBLY	1	160	
-104	MS21902D6	• UNION	2	35	
	MS29512-6	• GASKET	2	35	
-105	R-20397-722	• TUBE ASSEMBLY	1	35	159
	R-20397-3153	• TUBE ASSEMBLY	1	160	
-106	R-20397-720	• TUBE ASSEMBLY	1	35	159
	R-20397-3151	• TUBE ASSEMBLY	1	160	
-107	MS21905D6	• TEE	1	35	

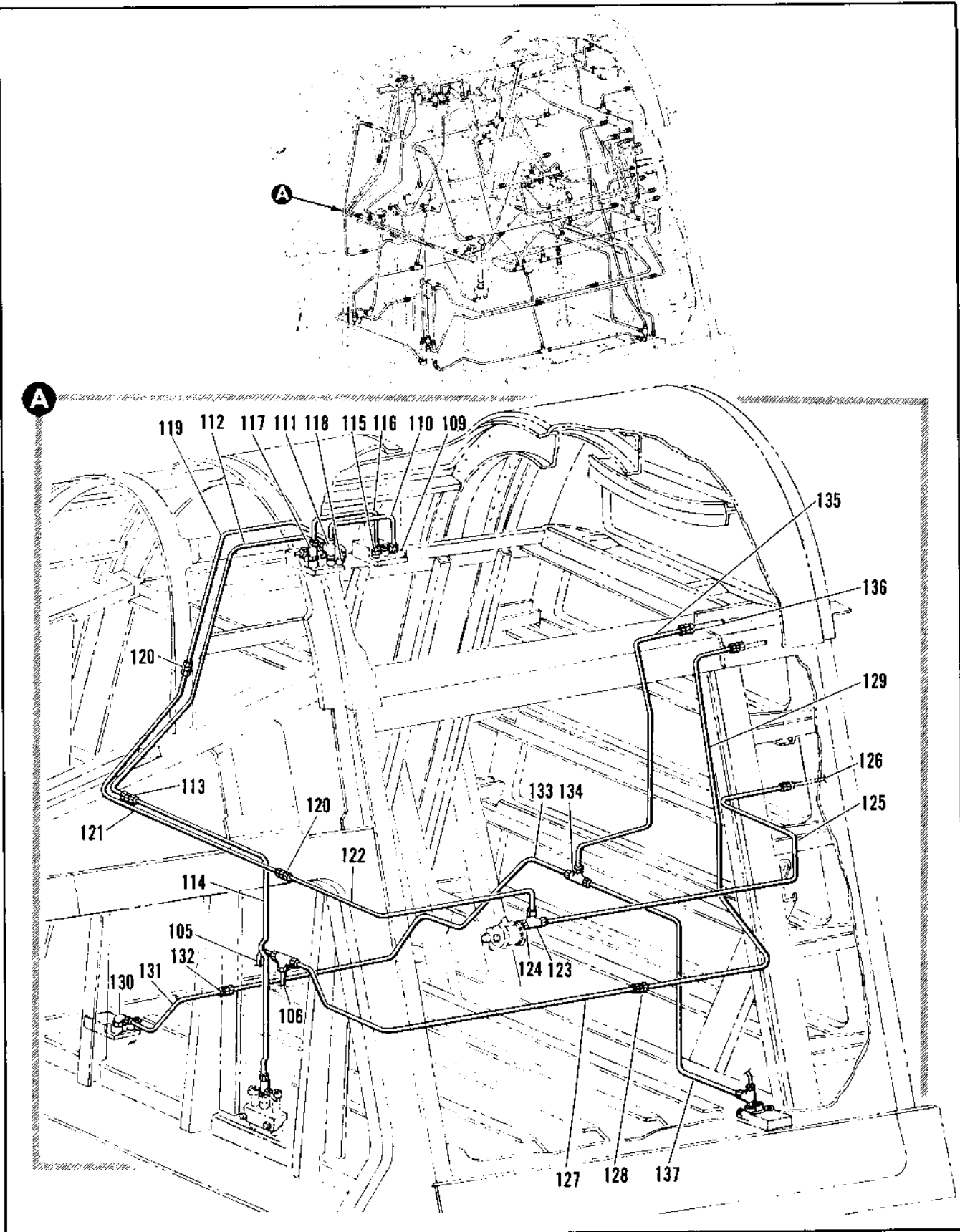

Figure 2.12-43. Fuel Tank Pressure Tubing Installation Sta 217 to 253 (Sheet 6 of 9)

FIGURE AND INDEX NUMBER	PART NUMBER	DESCRIPTION	UNITS PER ASSY.	USABLE ON CODE	
				FROM	TO
				1	2
2.12-43-108		• VALVE ASSY. SEE FIG. 2.12-52 INDEX 42	RF		
-109	MS2190206	• UNION	2	35	
	MS29512-6	• GASKET			
-110	8-20397-1275	• TUBE ASSEMBLY	1	35	159
	8-20397-2125	• TUBE ASSEMBLY	1	160	
-111	MS2191206	• TEE	1	35	
	AN924-60	• NUT	1	35	
	MS29512-6	• GASKET	1	35	
-112	8-20397-1265	• TUBE ASSEMBLY	1	35	159
	8-20397-2115	• TUBE ASSEMBLY	1	160	
-113	MS2190206	• UNION	1	35	
-114	8-20397-1257	• TUBE ASSEMBLY	1	35	159
	8-20397-3166	• TUBE ASSEMBLY	1	160	
-115	MS2190204	• UNION	1	35	
-116	8-20397-1273	• TUBE ASSEMBLY	1	35	159
	8-20397-2123	• TUBE ASSEMBLY	1	160	
-117	MS2191204	• TEE	1	35	
	AN924-40	• NUT	1	35	
	MS29512-4	• GASKET	1	35	
-118	MS2190206	• UNION	1	35	
	MS29512-6	• GASKET	1	35	
-119	8-20397-1267	• TUBE ASSEMBLY	1	35	159
	8-20397-2117	• TUBE ASSEMBLY	1	160	
-120	MS2190206	• UNION	2	35	
-121	8-20397-1259	• TUBE ASSEMBLY	1	35	159
	8-20397-2111	• TUBE ASSEMBLY	1	160	
-122	8-20397-1251	• TUBE ASSEMBLY	1	35	159
	8-20397-2103	• TUBE ASSEMBLY	1	160	
-123	MS2191106	• TEE	1	35	
-124	MS2191606-4	• REDUCER	1	35	
	AN924-60	• NUT	1	35	
	MS29512-6	• GASKET	2	35	
-125	8-20397-1283	• TUBE ASSEMBLY	1	35	159
	8-20397-2131	• TUBE ASSEMBLY	1	160	
-126		• TUBE ASSY. SEE FIG. 2.17-44 INDEX 125	RF		
-127	8-20397-713	• TUBE ASSEMBLY	1	35	159
	8-20397-3143	• TUBE ASSEMBLY	1	160	
-128	MS2190206	• UNION	1	35	
-129	8-20397-1235	• TUBE ASSEMBLY	1	35	159
	8-20397-3187	• TUBE ASSEMBLY	1	160	
-130	MS2190806	• ELBOW	1	35	
	AN924-60	• NUT	1	35	
	MS29512-6	• GASKET	1	35	
-131	8-20397-573	• TUBE ASSEMBLY	1	35	159
	8-20397-3131	• TUBE ASSEMBLY	1	160	
-132	MS2190206	• UNION	1	35	
-133	8-20397-571	• TUBE ASSEMBLY	1	35	159
	8-20397-3129	• TUBE ASSEMBLY	1	160	
-134	MS2190506	• TEE	1	35	
-135	8-20397-1231	• TUBE ASSEMBLY	1	35	159
	8-20397-3183	• TUBE ASSEMBLY	1	160	215
	8-20397-2933	• TUBE ASSEMBLY	1	216	
-136		• TUBE ASSY. SEE FIG. 2.12-45 INDEX 31	RF		
-137	8-20397-567	• TUBE ASSEMBLY	1	35	159
	8-20397-3127	• TUBE ASSEMBLY	1	160	

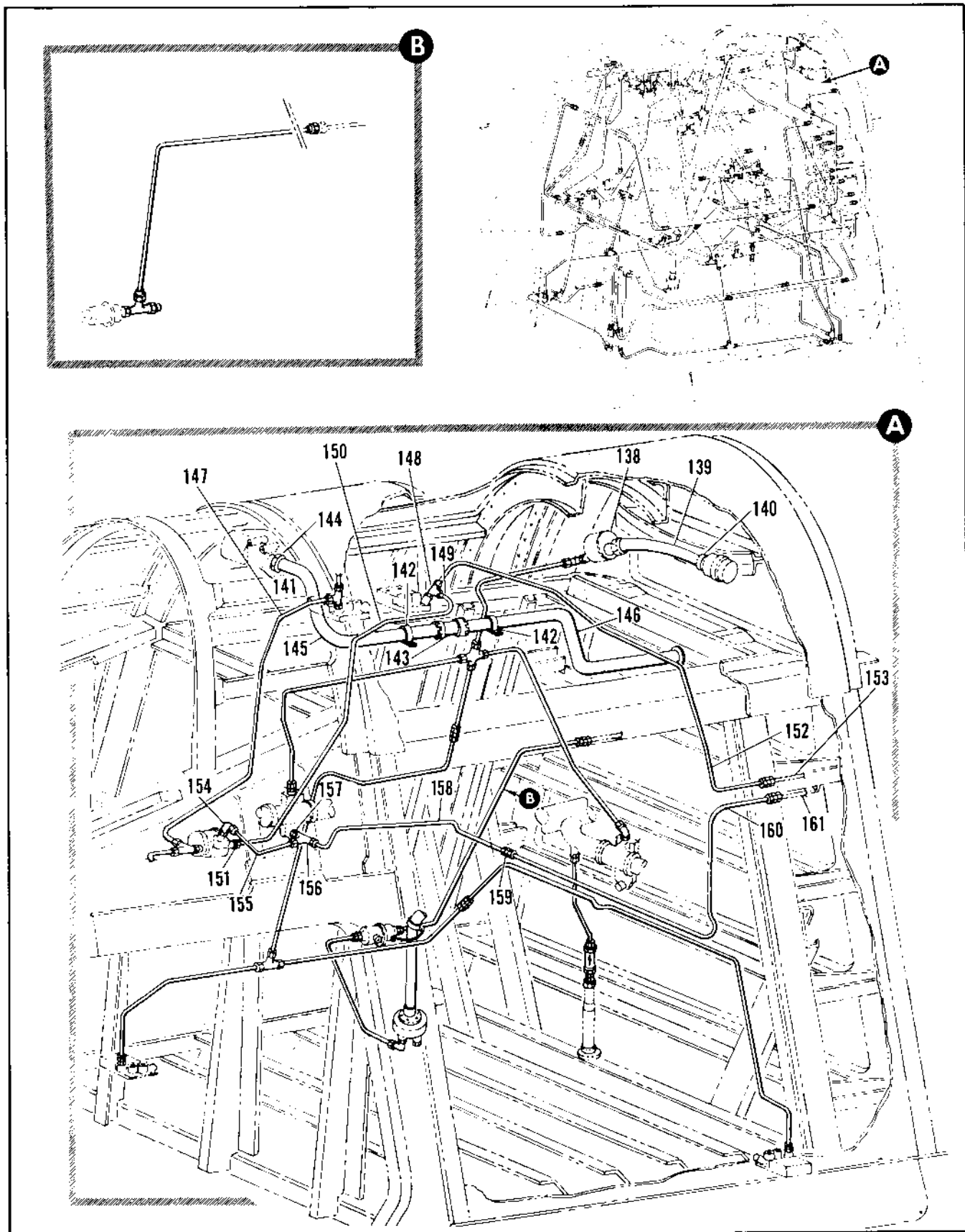

Figure 2.12-43. Fuel Tank Pressure Tubing Installation Sta 217 to 253 (Sheet 7 of 9)

FIGURE AND INDEX NUMBER	PART NUMBER	DESCRIPTION	UNITS PER ASSY.	USABLE ON CODE	
				FROM	TO
		1 2 3 4 5 6			
2.12-43-138		• VALVE ASSY, VACUUM RELIEF SEE FIG. 2.12-49 INDEX 28	RF		
-139	8-20397-790	• TUBE ASSEMBLY	1	35	159
	8-20397-3081	• TUBE ASSEMBLY	1	160	
-140	MS21902D16	• UNION	1	35	
	MS29512-16	• GASKET	1	35	
-141		• VALVE ASSY, AIR CHECK SEE FIG. 2.12-51 INDEX 32	RF		
-142	91-98626-619	• CLAMP	2	189	
-143	3635-200	• COUPLING (79326) 92-72500-106	1	189	
	2-2185418-6	• PACKING, REPLACED BY NAS1593-218	1	189	
	NAS1593-218	• PACKING, REPLACES 2-2185418-6			
-144	AN915-200	• UNION	1	189	
	MS29512-20	• GASKET	1	189	
-145	8-20397-2603	• TUBE ASSEMBLY	1	189	
-146	8-20397-2601	• TUBE ASSEMBLY	1	189	
-147	8-20397-1855	• TUBE ASSEMBLY	1	35	159
	8-20397-2139	• TUBE ASSEMBLY	1	160	
-148	MS21911D6	• TEE	1	35	
-149	MS21916D6-4	• REDUCER	1	35	
	AN924-60	• NUT	1	35	
	MS29512-6	• GASKET	1	35	
-150	8-20397-1271	• TUBE ASSEMBLY	1	35	159
	8-20397-2121	• TUBE ASSEMBLY	1	160	
-151	MS21902D6	• UNION	2	35	
-152	8-20397-1277	• TUBE ASSEMBLY	1	35	159
	8-20397-2121	• TUBE ASSEMBLY	1	160	
-153		• TUBE ASSY, SEE FIG. 2.12-44 INDEX 121	RF		
-154	MS21906D6	• ELBOW	1	35	
	AN924-60	• NUT	1	35	
	MS29512-6	• GASKET	1	35	
-155	8-20397-732	• TUBE ASSEMBLY	1	35	159
	8-20397-2163	• TUBE ASSEMBLY	1	160	
-156	MS21911D6	• TEE	1	35	
	AN924-60	• NUT	1	35	
	MS29512-6	• GASKET	1	35	
-157	MS21916D6-4	• REDUCER	1	35	
	MS29512-4	• GASKET	1	35	
-158	8-20397-1287	• TUBE ASSEMBLY	1	35	159
	8-20397-2135	• TUBE ASSEMBLY	1	160	
-159	MS21902D4	• UNION	1	35	
-160	8-20397-1279	• TUBE ASSEMBLY	1	35	159
	8-20397-2123	• TUBE ASSEMBLY	1	160	215
	8-20397-2543	• TUBE ASSEMBLY	1	216	
-161		• TUBE ASSY, SEE FIG. 2.12-44 INDEX 123	RF		

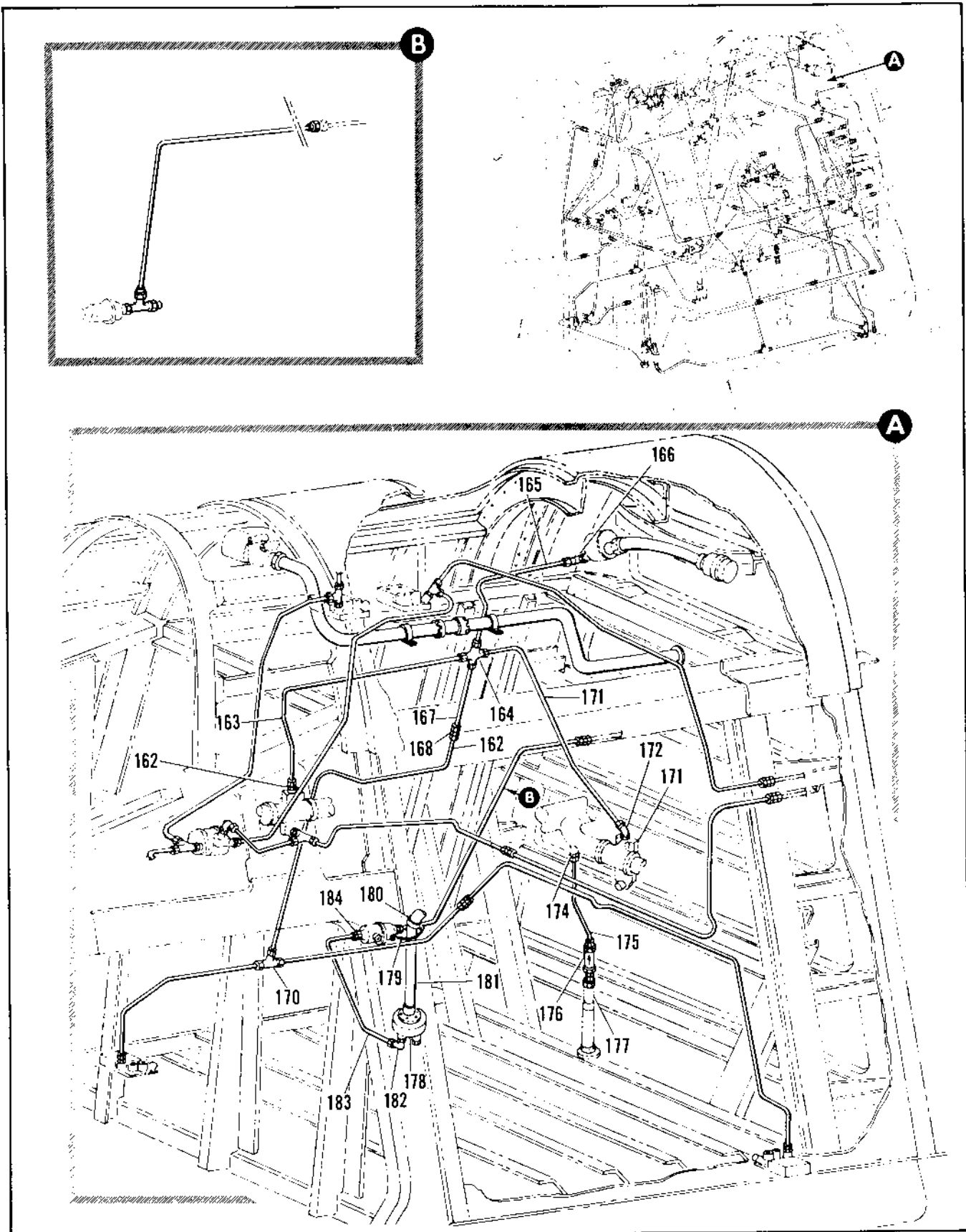

Figure 2.12-43. Fuel Tank Pressure Tubing Installation Sta 217 to 253 (Sheet 8 of 9)

FIGURE AND INDEX NUMBER	PART NUMBER	DESCRIPTION	UNITS PER ASSY.	USABLE ON CODE	
				FROM	TO
2.12-43-162	MS2190206	• UNION	1	35	
	MS29512-6	• GASKET	2	35	
-163	8-20397-543	• TUBE ASSEMBLY	1	35	159
	8-20397-3123	• TUBE ASSEMBLY	1	160	
-164	MS2190606	• CROSS	1	35	
-165	8-20397-545	• TUBE ASSEMBLY	35	159	
	8-20397-3125	• TUBE ASSEMBLY	1	160	
-165	MS2190706	• ELBOW	1	35	
	AN924-60	• NUT	1	35	
	MS29512-6	• GASKET	1	35	
-167	8-20397-521	• TUBE ASSEMBLY	1	35	159
	8-20397-3117	• TUBE ASSEMBLY	1	160	
-168	MS2191606-4	• REDUCER	1	35	
-169	8-20397-519	• TUBE ASSEMBLY	1	35	159
	8-20397-3115	• TUBE ASSEMBLY	1	160	
-170	MS2190504	• TEE	1	35	
-171	8-20397-541	• TUBE ASSEMBLY	1	35	159
	8-20397-3121	• TUBE ASSEMBLY	1	160	215
	8-20397-2929	• TUBE ASSEMBLY	1	216	
-172	MS2190806	• ELBOW	1	35	
	AN924-60	• NUT	1	35	
	MS29512-6	• GASKET	1	35	
-173		• TUBE ASSY, FUEL TRANSFER SEE FIG. 2.12-52 INDEX 115	RF		
-174	MS2190206	• UNION	3	35	
	MS29512-6	• GASKET	3		
-175	8-20397-744	• TUBE ASSEMBLY	1	35	159
	8-20397-3165	• TUBE ASSEMBLY	1	160	215
	8-20397-2931	• TUBE ASSEMBLY	1	216	
-176	W535-37AF	• VALVE, AIR CHECK (46173) SPEC 8-02998-13 ATTACHING PARTS	1	35	
	NAS679A3	• NUT	1	35	
	NAS221-10	• SCREW	1	35	
-177		----X----			
-178		• TURF, FUEL SCAVANGE SEE FIG. 2.12-52 INDEX 100	RF		
-179	MS250R3-10B3	• VALVE ASSY, FUEL CHECK SEE FIG. 2.12-52 INDEX 57			
		• JUMPER ATTACHING PARTS	1	35	
	NAS679A3	• NUT	1	35	
	AN960010L	• WASHER	2	35	
	AN525-1032R5	• SCREW	1	35	
	AN3-5A	• BOLT	1	35	
-180	AN735024	----X----			
-181	8-20397-589	• CLAMP	1	35	
	8-20397-3017	• TUBE ASSEMBLY	1	35	159
-182	MS2190804	• TUBE ASSEMBLY	1	160	
	AN924-40	• ELBOW	1	35	
	MS29512-4	• NUT	1	35	
-183	8-20397-535	• GASKET	1	35	
	8-20397-3119	• TUBE ASSEMBLY	1	35	159
-184	MS2190204	• TUBE ASSEMBLY	1	160	
		• UNION	2	35	

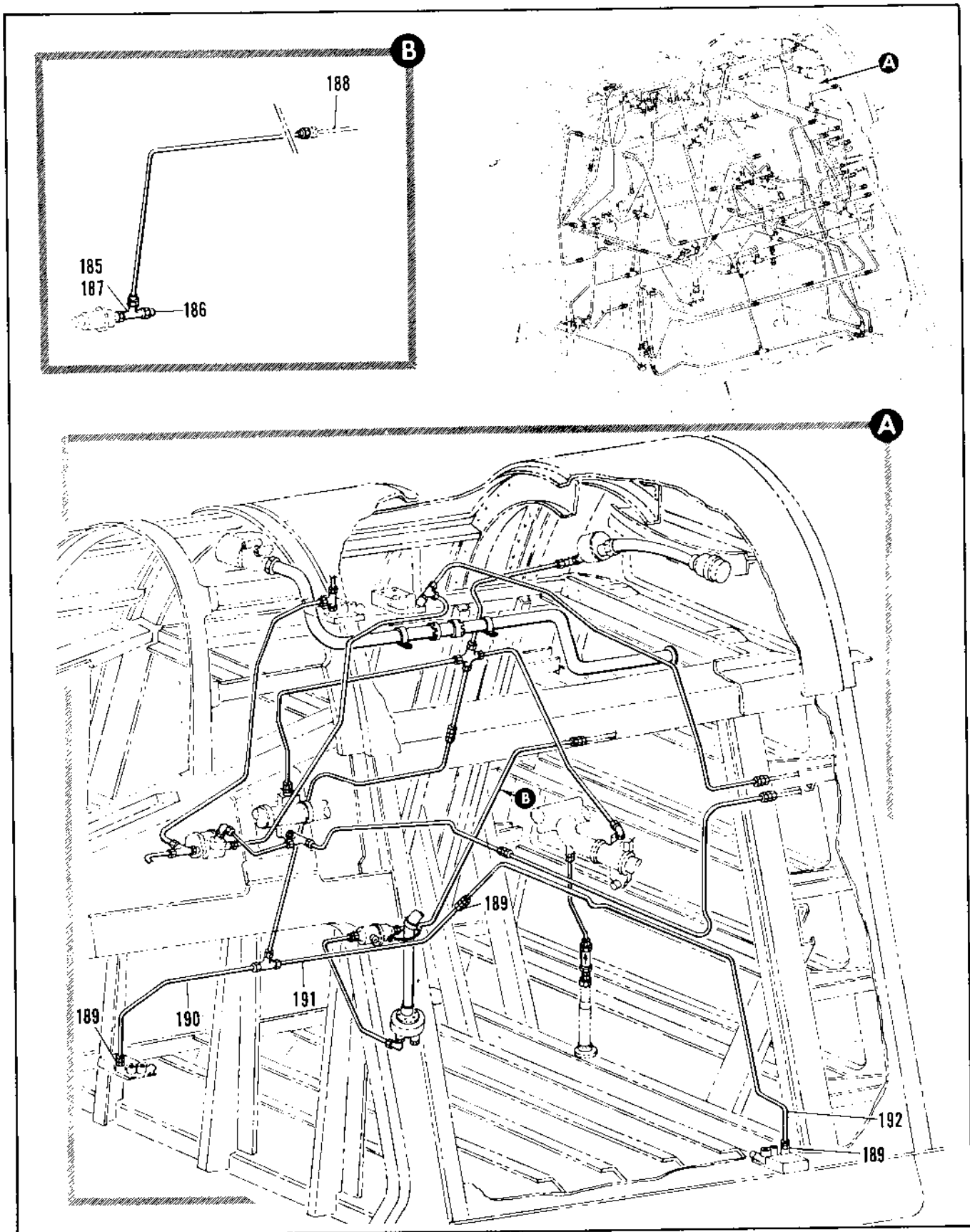

Figure 2.12-43. Fuel Tank Pressure Tubing Installation Sta 217 to 253 (Sheet 9 of 9)

FIGURE AND INDEX NUMBER	PART NUMBER	DESCRIPTION	UNITS PER ASSY	USABLE ON CODE	
				FROM	TO
		1 2 3 4 5 6			
2.12-43-185	MS21912D4	• TEE	1	35	
-186	66B40304-1	• CAP	1	35	
-187	AN924-4	• NUT	1	35	
	MS29512-04	• GASKET	1	35	
-188		• TUBE ASSY. SEE FIG. 2.12-43 INDEX 105	RF		
-189	MS21902C4	• UNION	3	35	
	MS29512-4	• GASKET	3	35	
-190	P-20397-513	• TUBE ASSEMBLY	1	35	159
	8-20397-3109	• TUBE ASSEMBLY	1	160	
-191	8-20397-515	• TUBE ASSEMBLY	1	35	159
	8-20397-3111	• TUBE ASSEMBLY	1	160	
-192	8-20397-517	• TUBE ASSEMBLY	1	35	159
	8-20397-3113	• TUBE ASSEMBLY	1	160	

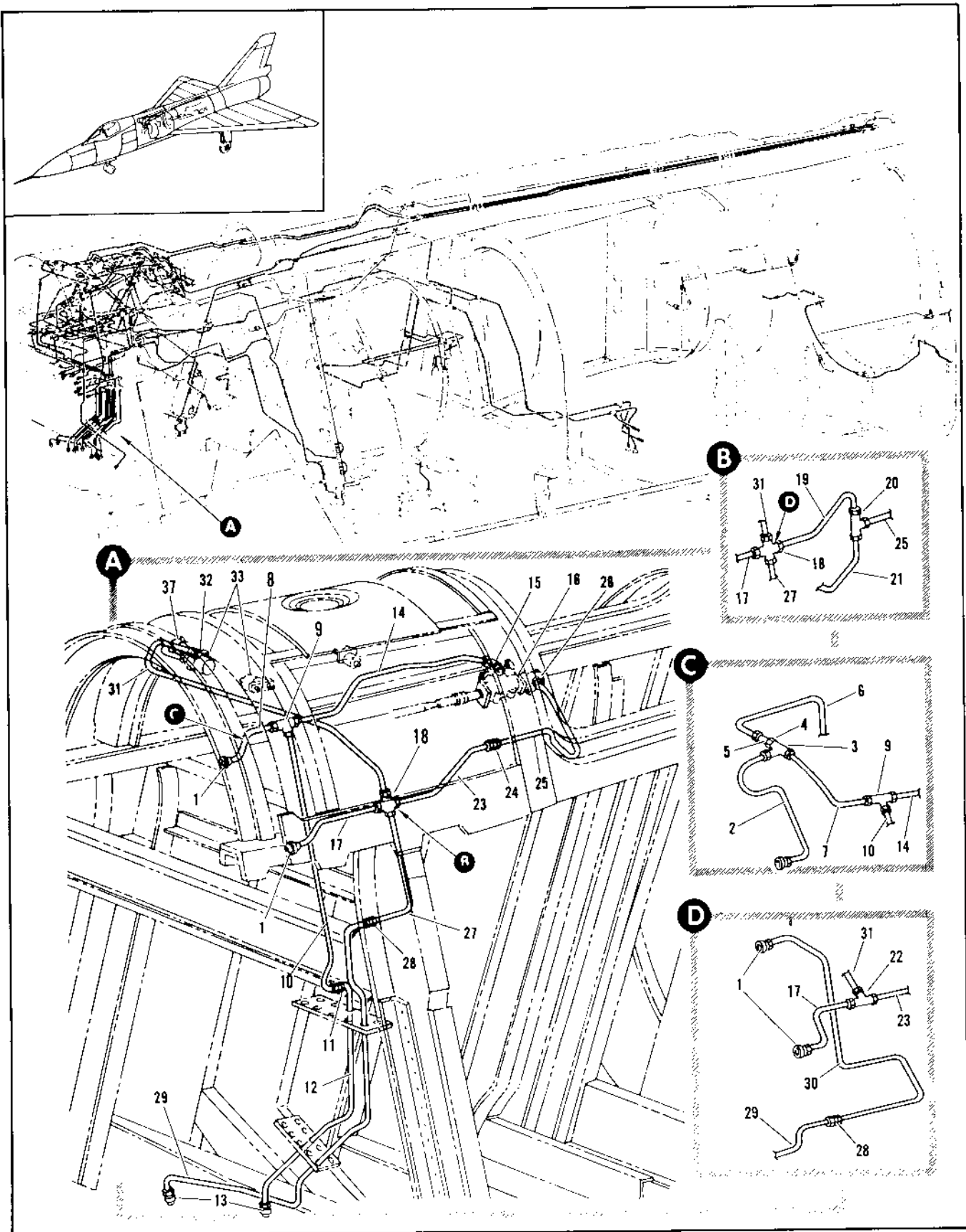

Figure 2.12-44. Fuel Tank Pressure Tubing Installation Sta 253 to 472 LH (Sheet 1 of 7)

FIGURE AND INDEX NUMBER	PART NUMBER	DESCRIPTION	UNITS PER ASSY.	USABLE ON CODE	
				FROM	TO
		1 2 3 4 5 6			
2.12-44	8-20397-831	TUBING INSTALLATION, FUEL TANK PRESSURE	PF		
		REF STA 253 TO 472 LH MODIFIED BY 66J40391 AND 66J40-RR FOR NHA SEE FIG. 2.3-10			
	8-20397-841	TUBING INSTALLATION, FUEL TANK PRESSURE	RF		
		STA 253 TO 472 LH MODIFIED BY LL4J70-0U AND 66J4038-RR FOR NHA SEE FIG. 2.3-10			
- 1		• EQUIPMENT INSTL, FUSELAGE FUEL TRANSFER	RF		
		SEE FIG. 2.12-52			
- 2	8-20397-1979	• TUBE ASSEMBLY	1	35	215
- 3	MS2190206	• TEE	1	35	215
	AN924-60	• NUT	1	35	215
	MS20512-6	• GASKET	1	35	215
- 4	MS2190206	• UNION	1	35	215
	MS20512-6	• GASKET	1	35	215
- 5	4535-37H	• VALVE, AIR CHECK <9613> SPEC 8-02998-13	1	35	215
- 6	8-20397-2001	• TUBE ASSEMBLY	1	35	215
- 7	8-20397-1995	• TUBE ASSEMBLY	1	35	215
- 8	8-20397-1321	• TUBE ASSEMBLY	1	216	
- 9	ERR24006A0604	• TEE, <92003> 98-90319-004	1	35	
- 10	8-20397-1367	• TUBE ASSEMBLY	1	35	
- 11	MS2190206	• UNION	1	35	
- 12	8-20397-1383	• TUBE ASSEMBLY	1	35	
- 13		• ADAPTER, SEE FIG. 2.12-40	PF		
- 14	8-20397-1318	• TUBE ASSEMBLY	1	35	
- 15	MS2190806	• ELPPW	1	35	
	AN924-60	• NUT	1	35	
	MS20512-6	• GASKET	1	35	
- 16		• REGULATOR ASSY, AIR PRESSURE	RF		
		SEE FIG. 2.9-2 INDEX 15			
- 17	8-20397-1324	• TUBE ASSEMBLY	1	35	
- 18	MS2190606	• CROSS	1	35	159
- 19	8-20397-1981	• TUBE ASSEMBLY	1	35	215
- 20	ERR240140604	• TEE, <92003> 98-90319-004	1	35	215
- 21	8-20397-2005	• TUBE ASSEMBLY	1	35	215
- 22	MS2190506	• TEE	1	160	
- 23	8-20397-1327	• TUBE ASSEMBLY	1	216	
- 24	MS2191606-4	• REDUCER	1	216	
- 25	8-20397-480	• TUBE ASSEMBLY	1	35	
- 26	MS2190206	• UNION	1	35	
	MS20512-4	• GASKET	1	35	
- 27	8-20397-1367	• TUBE ASSEMBLY	1	35	159
- 28	MS2190206	• UNION	1	35	
- 29	8-20397-1387	• TUBE ASSEMBLY	1	35	
- 30	8-20397-3083	• TUBE ASSEMBLY	1	160	
- 31	8-20397-1331	• TUBE ASSEMBLY	1	35	
- 32	MS2191606-4	• REDUCER	1	35	
	MS20512-4	• GASKET	1	35	
- 33		• SWITCH ASSY, DIFFERENTIAL PRESSURE	PF		
		SEE FIG. 2.12-39 INDEX 5			

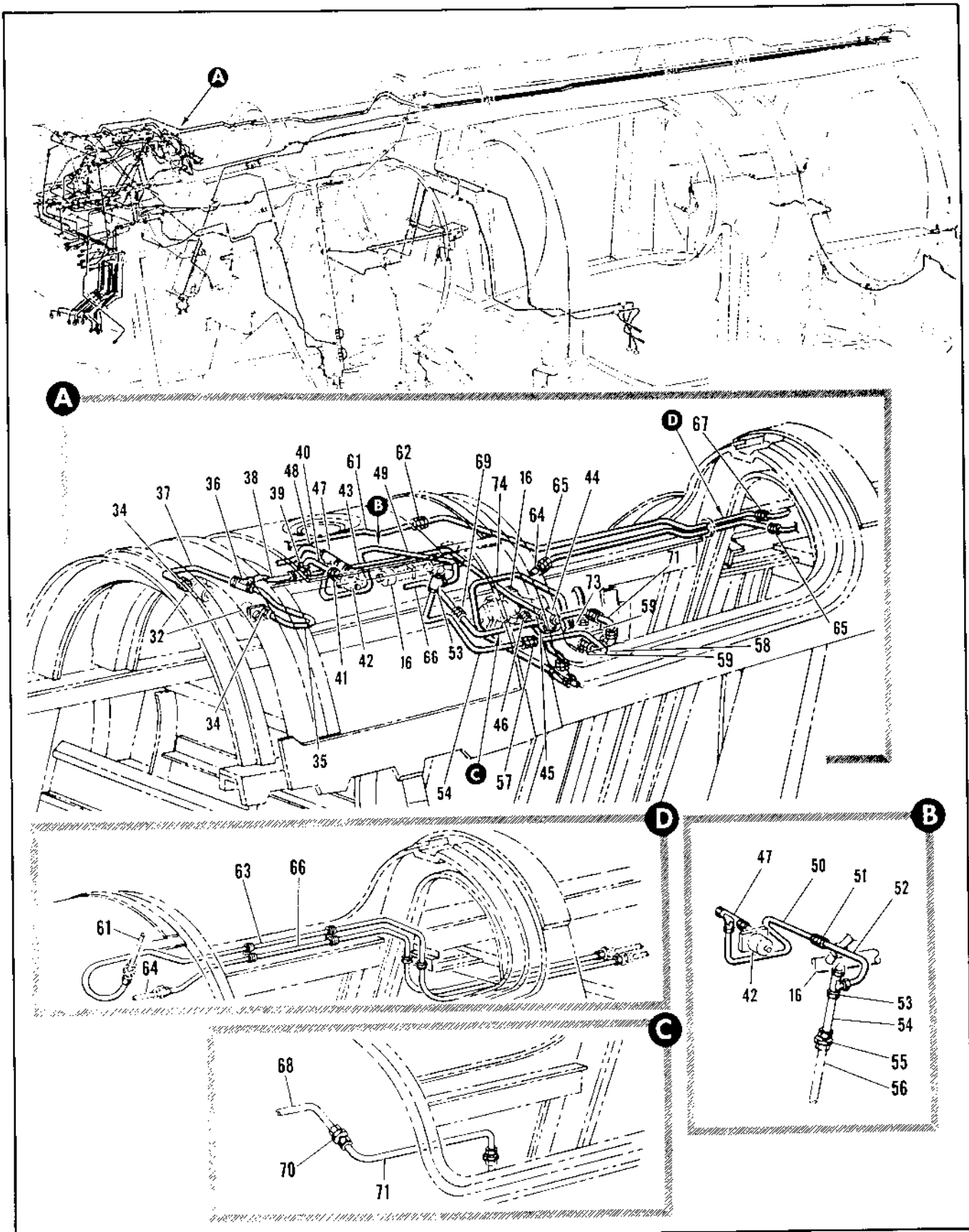

Figure 2.12-44. Fuel Tank Pressure Tubing Installation Sta 253 to 472 LH (Sheet 2 of 7)

FIGURE AND INDEX NUMBER	PART NUMBER	DESCRIPTION	UNITS PER ASSY.	USABLE ON CODE	
				FROM	TO
2.12-44- 34	MS21902D4	• UNION	2	35	
	MS219512-4	• GASKET	2	35	
- 35	8-20397-1303	• TUBE ASSEMBLY	1	35	
- 36	MS21909D4	• TEE	1	35	
	AN924-4D	• NUT	1	35	
	AN961D716	• WASHER	1	35	
- 37	8-20397-1305	• TUBE ASSEMBLY	1	35	
- 38	8-20397-1301	• TUBE ASSEMBLY	1	35	
- 39	MS21905D4	• TEE	1	35	
- 40	8-20397-1299	• TUBE ASSEMBLY	1	35	
- 41	MS21902D4	• UNION	1	35	
	MS29512-4	• GASKET	1	35	
- 42		• SWITCH INSTL. CG TRANSFER SEE FIG. 2.12-39 INDEX 22	RF		
- 43	8-20397-1297	• TUBE ASSEMBLY	1	35	
- 44	MS21905D4	• TEE	1	35	
- 45	8-20397-1159	• TUBE ASSEMBLY	1	35	
- 46	MS21902D4	• UNION	1	35	
	MS29512-4	• GASKET	1	35	
- 47	MS21912D4	• TEE	1	35	
	MS29512-4	• GASKET	1	35	
	AN924-4D	• NUT	1	35	
- 48		• TUBE ASSY. SEE FIG. 2.12-45 INDEX 7	RF		
- 49	8-20397-1307	• TUBE ASSEMBLY	1	35	159
- 50	8-20397-3093	• TUBE ASSEMBLY	1	160	
- 51	MS21902D4	• UNION	1	160	
- 52	63A34496-7	• TUBE ASSEMBLY	1	160	
- 53	MS21912D4	• TEE	1	35	
	AN924-4D	• NUT	1	35	
	MS29512-4	• GASKET	1	35	
- 54	63A34496-9	• TUBE ASSEMBLY	1	35	
- 55	8-20388-15	• UNION	1	35	
- 56	63A34496-11	• TUBE ASSEMBLY	1	35	
- 57	MS21902D4	• UNION	1	35	
- 58	63A34496-17	• TUBE ASSEMBLY	1	35	
- 59	MS21909D4	• TEE	1	35	
	AN924-4D	• NUT	1	35	
	MS29512-4	• GASKET	1	35	
	MS21914-4	• CAP	1	35	
- 60		• VALVE ASSY. FUEL TRANSFER REGULATOR AND RELIEF SEE FIG. 2.12-33 INDEX 1	RF		
- 61		• TUBE ASSY. SEE FIG. 2.12-45 INDEX 39	RF		
- 62	MS21902D6	• UNION	1	35	
- 63	66A41520-1	• TUBE ASSY	1		
- 64		• TUBE ASSY. SEE FIG. 2.12-45 INDEX 72	RF		
- 65	MS21902D6	• UNION	1	35	
- 66	66A41521-1	• TUBE ASSY	1		
- 67	MS21902D6	• UNION	2	35	
- 68		• TUBE ASSY. SEE FIG. 2.12-45 INDEX 22	RF		
- 69	MS21902D6	• UNION	1	35	
- 70	MS21916D6-4	• REDUCER	1	35	

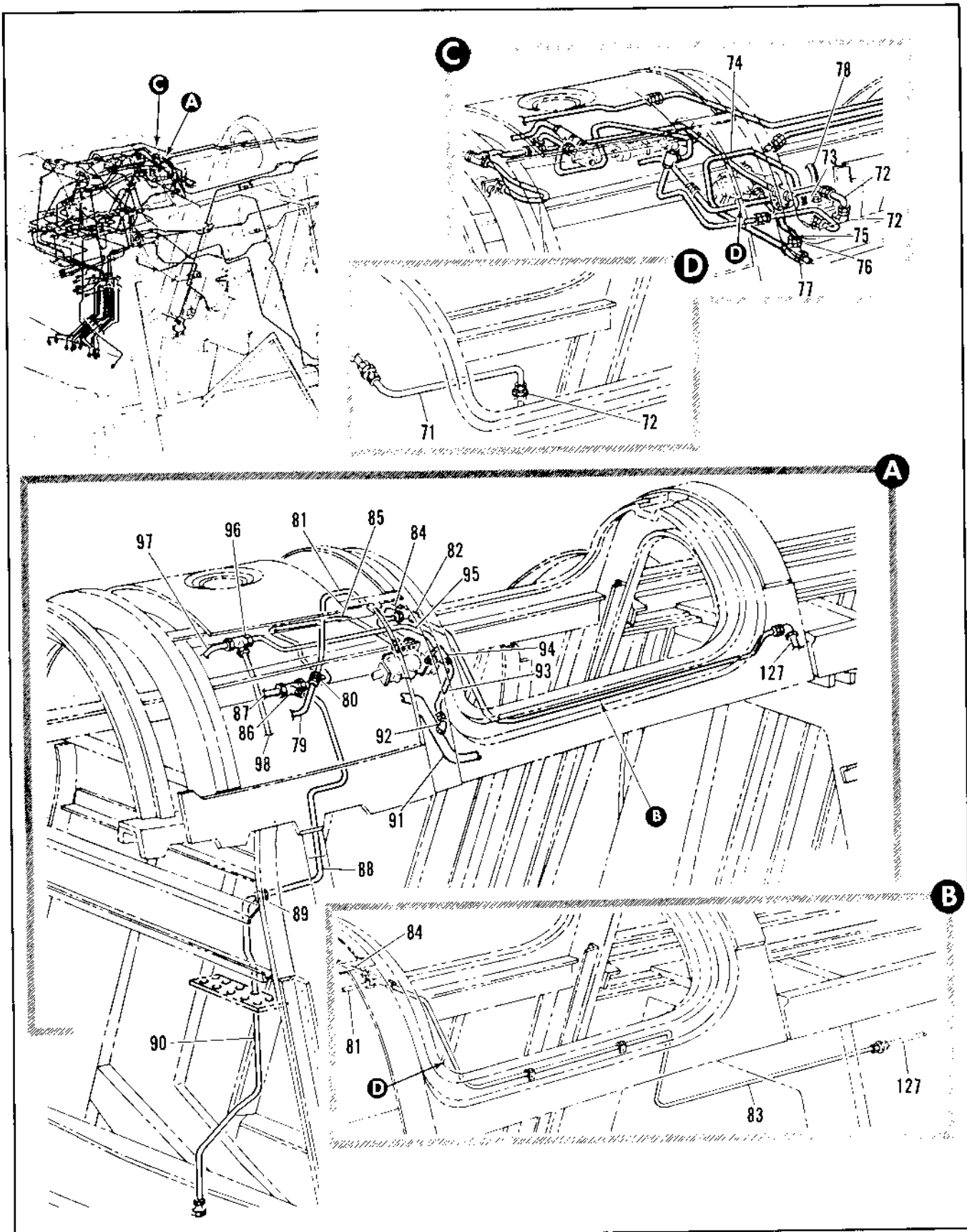

Figure 2.12-44. Fuel Tank Pressure Tubing Installation Sta 253 to 472 LH (Sheet 3 of 7)

FIGURE AND INDEX NUMBER	PART NUMBER	DESCRIPTION	UNITS PER ASSY.	USABLE ON CODE	
				FROM	TO
2.12-44- 71	64A39235-1	• TUBE ASSY, EMERGENCY PRESSURE REGULATOR	1		
- 72	MS21908D4	• ELBOW	1	35	
	AN924-6D	• NUT	1	35	
	MS29512-4	• GASKET	1	35	
- 73	MS21902D6-4	• UNION	1	35	
	MS29512-4	• GASKET	1	35	
- 74	R-23397-1155	• TUBE ASSEMBLY	1	35	
- 75	R-23397-1157	• TUBE ASSEMBLY	1	35	
- 76	MS21916D6-4	• REDUCER	1	35	
	MS29512-6	• GASKET	1	35	
- 77	MS21919D4	• TEE	1	35	
- 78		• HOSE ASSY, AIR PRESSURE FWD SEE FIG. 2.9-2 INDEX 45	RF		
- 79		• TUBE ASSY, SEE FIG. 2.12-45 INDEX 45	RF		
- 80	MS21902D6	• UNION	1	35	
- 81	R-23397-589	• TUBE ASSEMBLY	1	35	
- 82	MS21905D6	• TEE	1	35	
- 83	66A40519-1	• TUBE ASSY	1	35	
- 84	R-23397-1309	• TUBE ASSEMBLY	1	35	
- 85	R-23397-1977	• TUBE ASSEMBLY	1	35	
- 86	ER8240060604	• TEE, <92003> R-90319-01R	1	35	
- 87		• TUBE ASSY, SEE FIG. 2.12-45 INDEX 65	RF		
- 88	R-23397-1365	• TUBE ASSEMBLY	1	35	
- 89	MS21902D4	• UNION	1	35	
- 90	R-23397-1385	• TUBE ASSEMBLY	1	35	
- 91		• TUBING INSTL, FUEL TANK PRESSURE SEE FIG. 2.12-47	RF		
- 92	MS21908D6	• ELBOW	1	35	
	AN924-6D	• NUT	1	35	
	MS29512-6	• GASKET	1	35	
- 93	R-23397-1635	• TUBE ASSEMBLY	1	35	
- 94	MS21909D6	• TEE	1	35	
	AN924-6D	• NUT	1	35	
	MS29512-6	• GASKET	1	35	
- 95	R-23397-1987	• TUBE ASSEMBLY	1	35	
- 96	MS21912D6	• TEE	1	35	
	AN924-6D	• NUT	1	35	
	AN9600916	• WASHER	1	35	
- 97		• TUBE ASSY, SEE FIG. 2.12-45 INDEX 25	RF		
- 98	R-23397-1985	• TUBE ASSEMBLY	1	35	

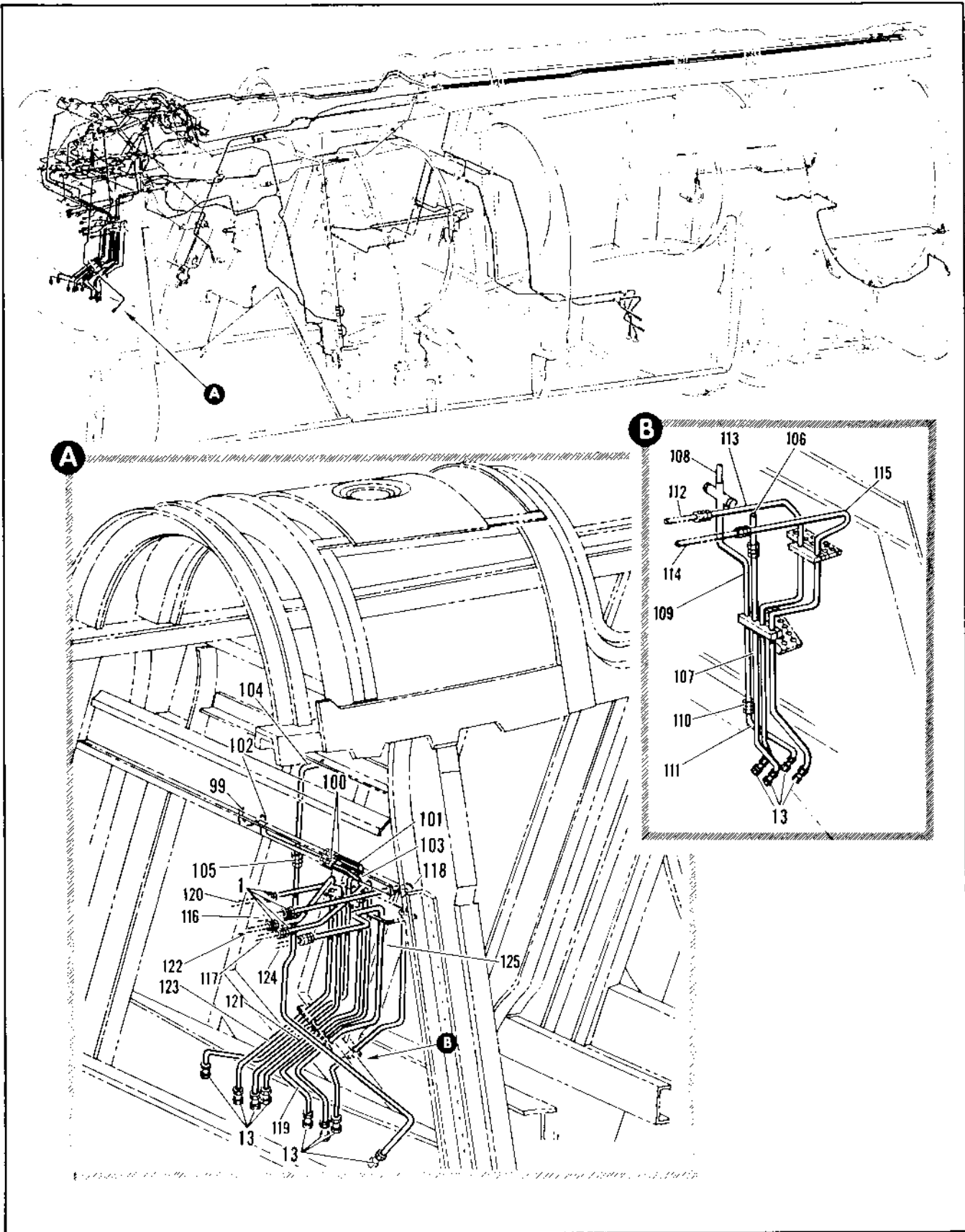

Figure 2.12-44. Fuel Tank Pressure Tubing Installation Sta 253 to 472 LH (Sheet 4 of 7)

FIGURE AND INDEX NUMBER	PART NUMBER	DESCRIPTION	UNITS PER ASSY.	USABLE ON CODE	
				FROM	TO
2.12-44- 99					
-100	MS2190204	• TUBE ASSY, SEE FIG. 2.12-45 INDEX 5	RF		
-101	8-20397-1371	• UNION	2	35	
-102		• TUBE ASSEMBLY	1	35	
-103	8-20397-1381	• TUBE ASSY, SEE FIG. 2.12-45 INDEX 4	RF		
-104		• TUBE ASSEMBLY	1	35	
-105	MS2190206	• TUBE ASSY, SEE FIG. 2.12-45 INDEX 94	RF		
-106		• UNION	1	61	
-107	8-20397-2885	• TUBE ASSY, SEE FIG. 2.12-45 INDEX 91	RF		
-108		• TUBE ASSEMBLY	1	35	
-109	8-20397-2887	• TUBE ASSY, SEE FIG. 2.12-45 INDEX 35	RF		
-110	MS2191606-4	• TUBE ASSEMBLY	1	35	
-111	8-20397-2889	• REDUCER	1	35	
-112		• TUBE ASSEMBLY	1	35	
-113	8-20397-2891	• TUBE ASSY, SEE FIG. 2.12-43 INDEX 92	RF		
-114		• TUBE ASSEMBLY	1	216	
-115	8-20397-2893	• TUBE ASSY, SEE FIG. 2.12-43 INDEX 58	RF		
-116		• TUBE ASSEMBLY	1	216	
-117		• TUBE ASSY, FUSELAGE TANK SEE FIG. 2.12-43 INDEX 53	RF		
-118	8-20397-1377	• TUBE ASSY, FUSELAGE TANK SEE FIG. 2.12-43 INDEX 71	RF		
-119	8-20397-1375	• TUBE ASSEMBLY	1	35	
-120		• TUBE ASSEMBLY	1	35	
-121	8-20397-1373	• TUBE ASSY, FUSELAGE TANK SEE FIG. 2.12-43 INDEX 152	RF		
-122		• TUBE ASSEMBLY	1	35	
-123	8-20397-1369	• TUBE ASSY, FUSELAGE TANK SEE FIG. 2.12-43 INDEX 100	RF		
-124		• TUBE ASSEMBLY	1	35	
-125	8-20397-1374	• TUBE ASSY, FUSELAGE TANK SEE FIG. 2.12-43 INDEX 124	RF		
		• TUBE ASSEMBLY	1	35	

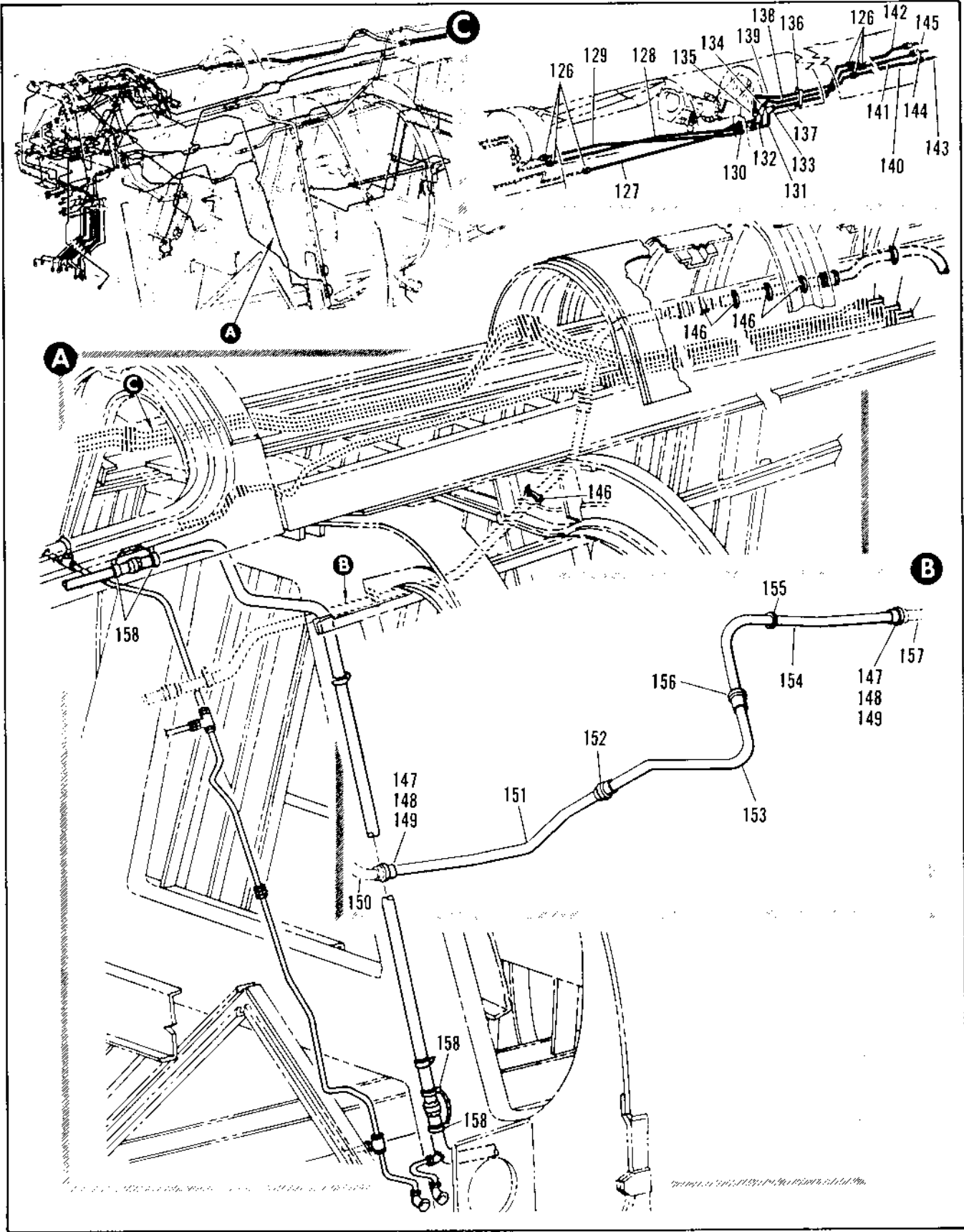

Figure 2.12-44. Fuel Tank Pressure Tubing Installation Sta 253 to 472 LH (Sheet 5 of 7)

FIGURE AND INDEX NUMBER	PART NUMBER	DESCRIPTION	UNITS PER ASSY.	USABLE ON CODE	
				FROM	TO
		1 2 3 4 5 6			
2.12-44-126	MS2190206	• UNION	6	35	
-127	66A47505-1	• TUBE ASSY	1	35	
-128	66A47506-1	• TUBE ASSY	1	35	
-129	66A47507-1	• TUBE ASSY	1	35	
-130	MS2192406	• UNION	3	35	
	AN924-60	• NUT	3	35	
	AN960016L	• WASHER	3	35	
-131	66A47516-1	• TUBE ASSY	1	35	
-132	66A47517-1	• TUBE ASSY	1	35	
-133	MS2190806	• ELBOW, 90 DEGREE	1	35	
	AN924-60	• NUT	1	35	
	AN9600916L	• WASHER	1	35	
-134	MS2190706	• ELBOW, 45 DEGREE	1	35	
	AN924-60	• NUT	1	35	
	AN9600916L	• WASHER	1	35	
-135	MS2192406	• UNION	1	35	
	AN924-60	• NUT	1	35	
	AN9600916L	• WASHER	1	35	
-136	66A47508-1	• CLAMP	1	35	
	MS35207-263	• SCREW	2	35	
	MS21742L3	• NUT	2	35	
	AN960016L	• WASHER	2	35	
-137	66A47522-1	• TUBE ASSY	1	35	
-138	66A47523-1	• TUBE ASSY	1	35	
-139	66A47524-1	• TUBE ASSY	1	35	
-140	66A47544-1	• TUBE ASSY	1	35	
-141	66A47545-1	• TUBE ASSY	1	35	
-142	66A47546-1	• TUBE ASSY	1	35	
-143		• TUBE ASSY, SEE FIG. 2.12-46 INDEX 32	RF	35	
-144		• TUBE ASSY, SEE FIG. 2.12-46 INDEX 31	RF	35	
-145		• TUBE ASSY, SEE FIG. 2.12-46 INDEX 30	RF	35	
-146		• SUPPORT INSTL, FUEL TANK PRESSURE MANIFOLD STA 295 TO 485 SEE FIG. 2.12-51	RF	35	
-147	NAS595-24H	• NUT	2	35	
-148	NAS595-24	• RING	2	35	
-149	NAS594-24	• COUPLING	2	35	
-150		• TUBE ASSY, FUEL TANK PRESSURE SEE FIG. 2.12-2 INDEX 55	RF	35	
-151	67A36511-1	• TUBE ASSY	1	35	
-152	NAS595-24	• RING	1	35	
-153	66041338-1	• TUBE ASSY	1	35	
-154	66041339-1	• TUBE ASSY	1	35	
-155	MS21226-3M	• GROMMET	1	35	
-156	3605-24D	• COUPLING (73326)	1	35	
	MS9060-32S	• PACKING	2	35	
-157		• ELBOW ASSY, FUEL TANK PRESSURE SEE FIG. 2.12-58 INDEX 2	RF	35	
-158	AN735024	• CLAMP	4	35	
		ATTACHING PARTS			
	NAS679A3	• NUT	4	35	
	AN960016L	• WASHER	4	35	

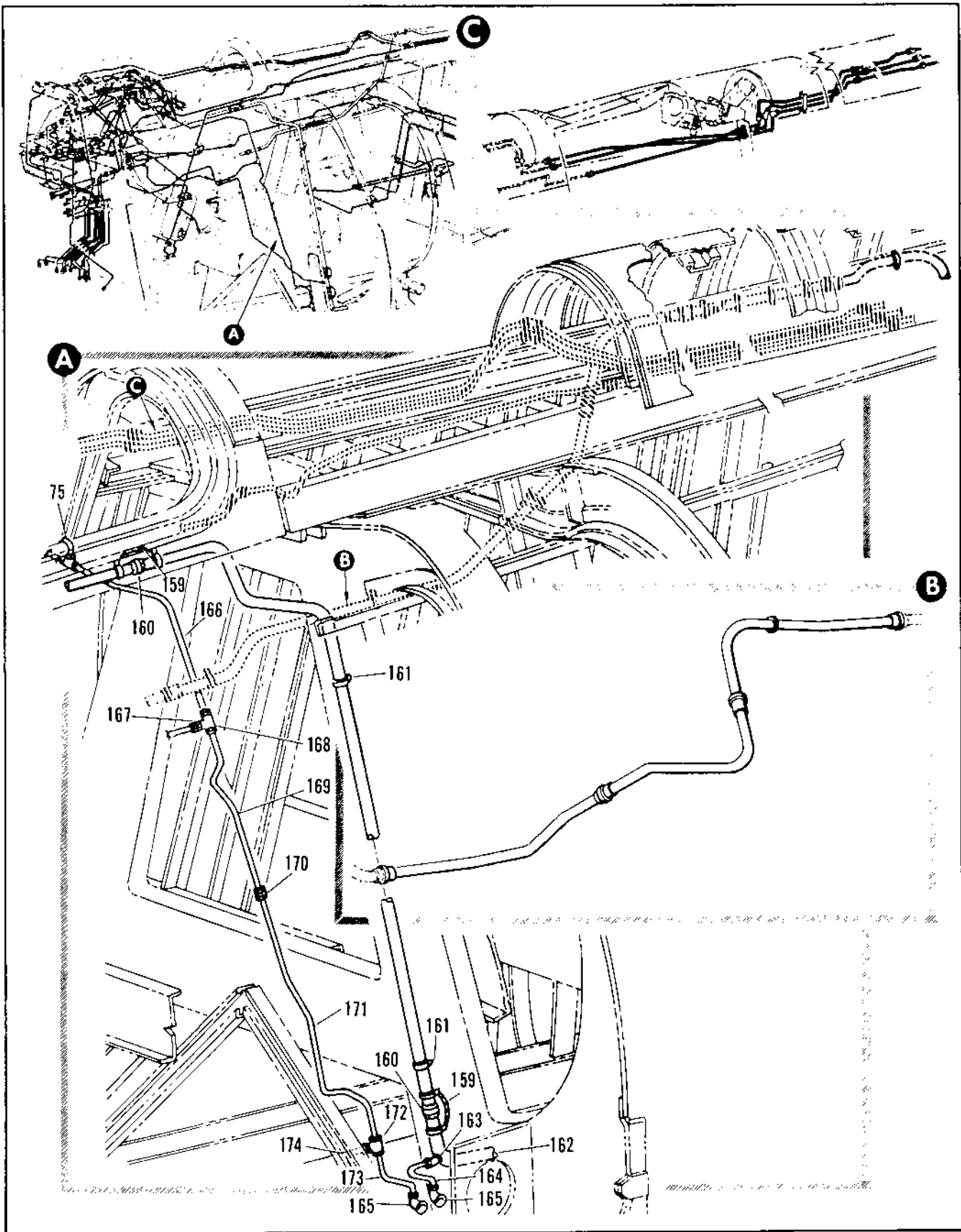

Figure 2.12-44. Fuel Tank Pressure Tubing Installation Sta 253 to 472 LH (Sheet 6 of 7)

FIGURE AND INDEX NUMBER	PART NUMBER	DESCRIPTION	UNITS PER ASSY.	USABLE ON CODE	
				FROM	TO
2.12-44	AN526-1032R6	• SCREW -----X-----	4	35	
-159	MS253R3-1BB4	• JUMPER	2	35	
-160	3605-240	• COUPLING, <79326> 92-72500-303	2	35	
	MS29513-325	• PACKING	2	35	
-161	91-98325-023	• CLAMP	2	35	
-162		• TUBING INSTL, VENT FUSELAGE TANK TO WING SEE FIG. 2.12-47	RF		
-163	MS21908D4	• ELBOW	1	35	
	MS29512-4	• GASKET	1	35	
	AN924-40	• NUT	1	35	
-164	8-20397-482	• TUBE ASSEMBLY	1	35	
-165		• VALVE ASSY, DRAIN SEE FIG. 2.12-47 INDEX 23	RF		
-166	8-20397-1153	• TUBE ASSEMBLY	1	35	
-167	MS21516D6-4	• REDUCER	1	35	
	MS21512-6	• GASKET	1	35	
-168	MS21510D6	• TEE	1	35	
	AN924-60	• NUT	1	35	
	AN9610916	• WASHER	2	35	
-169	8-20397-64	• TUBE ASSEMBLY	1	35	
-170	MS21702D6	• UNION	1	35	
-171	8-20397-124	• TUBE ASSEMBLY	1	35	
-172	MS21913D6	• TEE	1	35	
-173	8-20397-66	• TUBE ASSEMBLY	1	35	
-174		• TUBE ASSY, SEE FIG. 2.12-17 INDEX 32	RF		

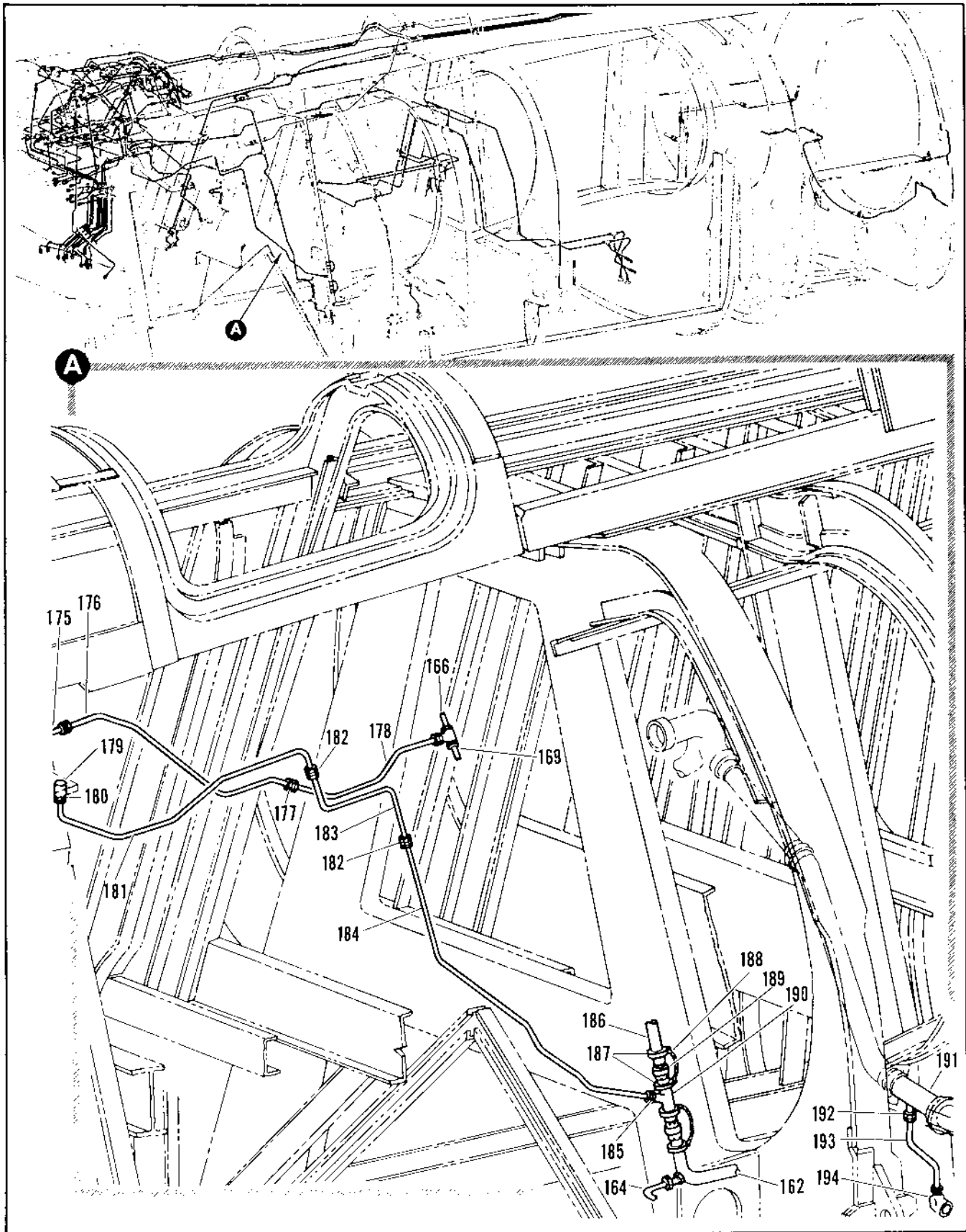

Figure 2.12-44. Fuel Tank Pressure Tubing Installation Sta 253 to 472 LH (Sheet 7 of 7)

FIGURE AND INDEX NUMBER	PART NUMBER	DESCRIPTION	UNITS PER ASSY.	USABLE ON CODE	
				FROM	TO
		1 2 3 4 5 6			
2.12-66-175		• TUBE ASSY. SEE FIG. 2.12-43 INDEX 31	RF		
-175	R-20397-1339	• TUBE ASSEMBLY	1	35	
-177	MS21902D4	• UNION	1	35	
-178	R-20397-67	• TUBE ASSEMBLY	1	35	
-179		• PANEL INSTL. AIR SHUTOFF VALVE AND FILTER SEE FIG. 2.12-64	RF		
-180	R-28498-7	• UNION, RESTRICTOR	1	35	
	MS29512-6	• GASKET	1	35	
-181	R-20397-3071	• TUBE ASSEMBLY	1	35	
-182	MS21922C6	• UNION	2	35	
-183	R-20397-3069	• TUBE ASSEMBLY	1	35	
-184	R-20397-3073	• TUBE ASSEMBLY	1	35	
-185	MS21902D6	• UNION	1	35	
	MS29512-4	• GASKET	1	35	
-186	R-20397-3075	• TUBE ASSEMBLY	1	35	
-187	AN735024	• CLAMP	2	35	
		ATTACHING PARTS			
	NAS679A3	• NUT	2	35	
	AN91031CL	• WASHER	2	35	
	AN528-1532R6	• SCREW	2	35	
		-----X-----			
-184	MS25023-1884	• JUMPER	1	35	
-189	3535-240	• COUPLING, <79326> 92-72510-003	1	35	
	MS29515-325	• PACKING	2	35	
-190	R-28492-1	• TUBE ASSY, VENT	1	35	
-191		• TUBING INSTL. FUSELAGE TANK TO WING TRANSFER SEE FIG. 2.12-49	RF		
-192	MS21922D4	• UNION	1	35	
	MS29512-4	• GASKET	1	35	
-193	R-20397-500	• TUBE ASSEMBLY	1	35	
-194		• VALVE ASSY, DRAIN SEE FIG. 2.12-47 INDEX 23	RF		

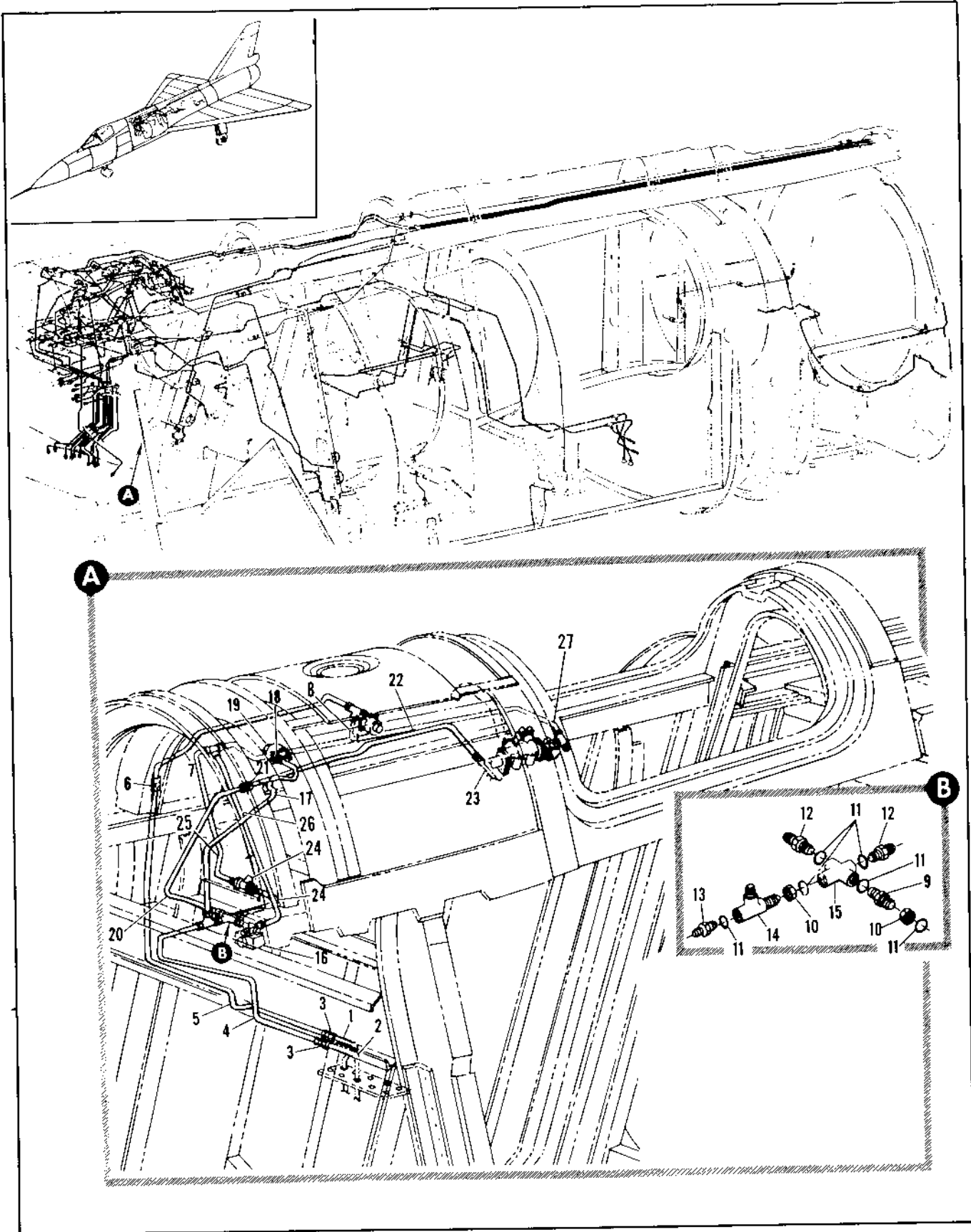

Figure 2.12-45. Fuel Tank Pressure Tubing Installation Sta 253 to 472 RH (Sheet 1 of 11)

FIGURE AND INDEX NUMBER	PART NUMBER	DESCRIPTION	UNITS PER ASSY.	USABLE ON CODE	
				FROM	TO
		1 2 3 4 5 6			
2.12-45	8-20397-831	TUBING INSTALLATION, FUEL TANK PRESSURE STA 253 TO 472 RH FOR NHA SEE FIG. 2.3-11	RF	35	42
	8-20397-831	TUBING INSTALLATION, FUEL TANK PRESSURE STA 253 TO 472 RH MODIFIED BY 66J40337 AND 66J40391 FOR NHA SEE FIG. 2.3-11	RF		
	8-20397-841	TUBING INSTALLATION, FUEL TANK PRESSURE STA 253 TO 472 RH FOR NHA SEE FIG. 2.3-11	RF	43	
	8-20397-841	TUBING INSTALLATION, FUEL TANK PRESSURE STA 253 TO 472 RH MODIFIED BY 66J40337 AND 66J40391 FOR NHA SEE FIG. 2.3-11	RF		
- 1		• TUBE ASSY, SEE FIG. 2.12-44 INDEX 101	RF		
- 2		• TUBE ASSY, SEE FIG. 2.12-44 INDEX 103	RF		
- 3	MS2190204	• UNION	2	35	
- 4	8-20397-1361	• TUBE ASSEMBLY	1	35	
- 5	8-20397-1359	• TUBE ASSEMBLY	1	35	
- 6	MS2190204	• UNION	1	35	
- 7	8-20397-1357	• TUBE ASSEMBLY	1	35	
- 8		• TUBE ASSY, SEE FIG. 2.12-44 INDEX 49	RF		
- 9	MS2190306	• UNION	1	35	
- 10	AN924-6C	• NUT	2	35	
- 11	MS29512-6	• GASKET	6	35	
- 12	MS2190206	• UNION	2	35	
- 13	MS2191606-4	• REDUCER	1	35	
- 14	MS2191106	• TEE	1	35	
- 15	AN937-6D	• CROSS	1	35	
- 16		• VALVE, AIR SHUTOFF SEE FIG. 2.12-64	RF		
- 17	8-20397-1341	• TUBE ASSEMBLY	1	35	129
	8-20397-3043	• TUBE ASSEMBLY	1	139	
- 18	MS2191606-4	• REDUCER	1	35	
	MS29512-4	• GASKET	1	35	
- 19		• SWITCH, FUSELAGE TANK DIFFERENTIAL PRESSURE SEE FIG. 2.12-41 INDEX 51	RF		
- 20	8-20397-1343	• TUBE ASSEMBLY	1	35	
- 21	MS2190206	• UNION	1	35	
- 22	8-20397-1345	• TUBE ASSEMBLY	1	35	
- 23		• TUBE ASSY, SEE FIG. 2.12-44 INDEX 71	RF		
- 24	8-28380-15	• FITTING, EMER CG TRANSFER LINE	1	35	159
	8-28375-9	• FITTING, EMER CG TRANSFER LINE	1	159	
- 25	63A34496-15	• TUBE ASSEMBLY	1	35	
- 26		• TUBE ASSY, SEE FIG. 2.12-44 INDEX 98	RF		
- 27		• TUBE ASSY, SEE FIG. 2.12-44 INDEX 95	RF		

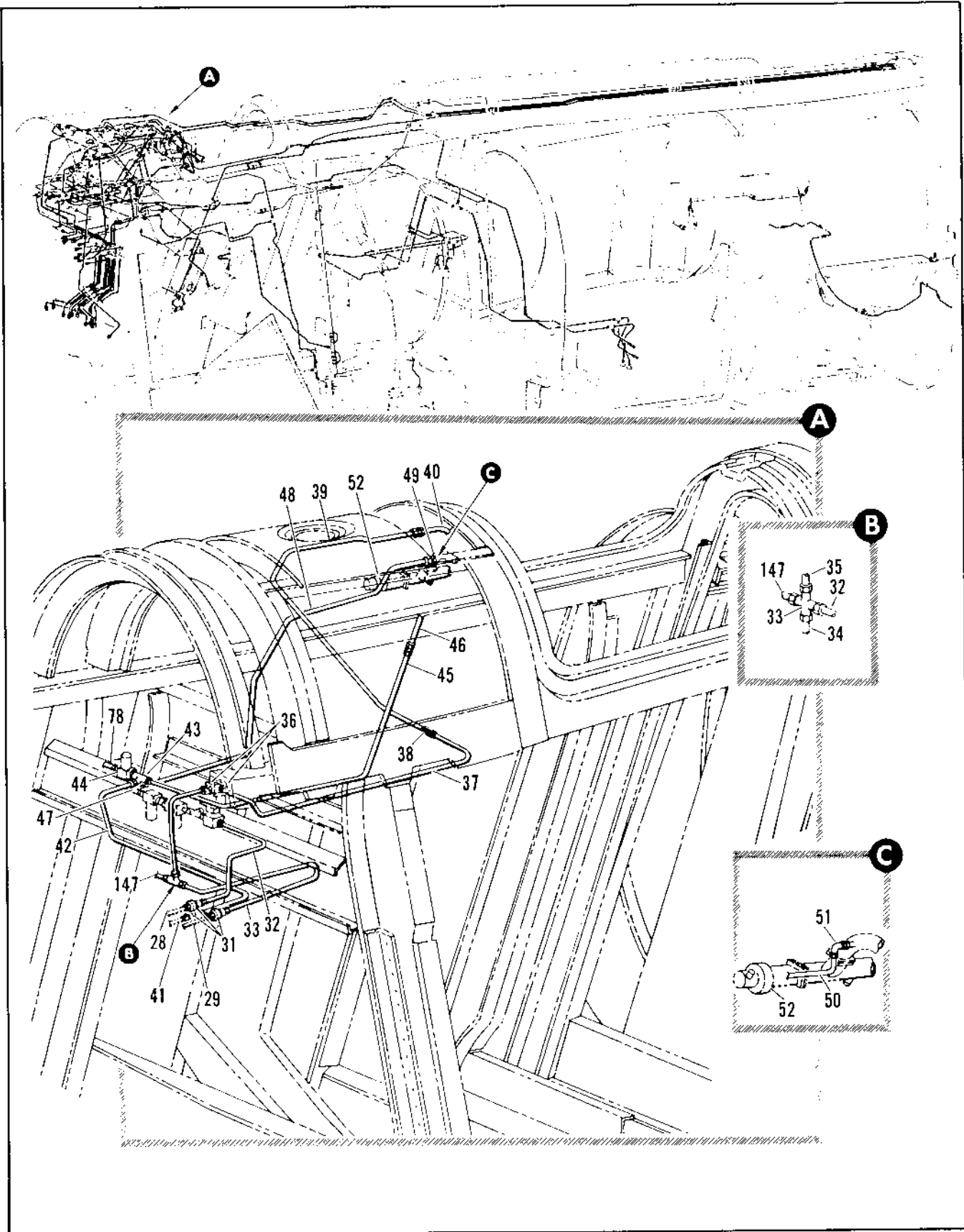

Figure 2.12-45. Fuel Tank Pressure Tubing Installation Sta 253 to 472 RH (Sheet 2 of 11)

FIGURE AND INDEX NUMBER	PART NUMBER	DESCRIPTION	UNITS PER ASSY.	USABLE ON CODE	
				FROM	TO
2.12-45- 28		• TUBE ASSY. SEE FIG. 2.12-43 INDEX 135	RF		
- 29		• TUBE ASSY. SEE FIG. 2.12-43	RF		
- 30		• EQUIPMENT INSTL. FUSELAGE FUEL TANK TRANSFER SEE FIG. 2.12-52	RF		
- 31	R-20397-584	• TUBE ASSEMBLY	1	35	
- 32	R-20397-1337	• TUBE ASSEMBLY	1	35	
- 33	MS190606	• CROSS	1	35	
- 34		• TUBE ASSY. SEE FIG. 2.12-44 INDEX 109	RF		
- 35	R-20397-2881	• TUBE ASSEMBLY	1	35	
- 36	MS2190206	• UNION	2	35	
	MS29512-5	• GASKET	2	35	
- 37	R-20397-1353	• TUBE ASSEMBLY	1	35	
- 38	MS2190206	• UNION	1	35	
- 39	R-20397-1351	• TUBE ASSEMBLY	1	35	
- 40		• TUBE ASSY. SEE FIG. 2.12-44 INDEX 61	RF		
- 41		• TUBE ASSY. SEE FIG. 2.12-43	RF		
- 42	R-20397-582	• TUBE ASSEMBLY	1	35	
- 43	MS2191206	• TEE	1	35	
	MS29512-5	• GASKET	1	35	
	AN924-60	• NUT	1	35	
- 44		• PANEL INSTL. AIR SHUTOFF VALVE AND FILTER SEE FIG. 2.12-54	RF		
- 45	R-20397-586	• TUBE ASSEMBLY	1	35	
- 46		• TUBE ASSY. SEE FIG. 2.12-44 INDEX 81	RF		
- 47	MS2190806	• ELBOW	1	35	
	AN924-60	• NUT	1	35	
	MS29512-6	• GASKET	1	35	
- 48	R-20397-1993	• TUBE ASSEMBLY	1	35	129
- 49	MS2190206	• UNION	1	35	129
	MS29512-5	• GASKET	1	35	129
- 50	R-20397-2221	• TUBE ASSEMBLY	1	130	
- 51	MS2190706	• ELBOW	1	130	
	AN924-60	• NUT	1	130	
	MS29512-6	• GASKET	1	130	
- 52		• REGULATOR ASSY. AIR PRESSURE SEE FIG. 2.9-2 INDEX 16	RF		

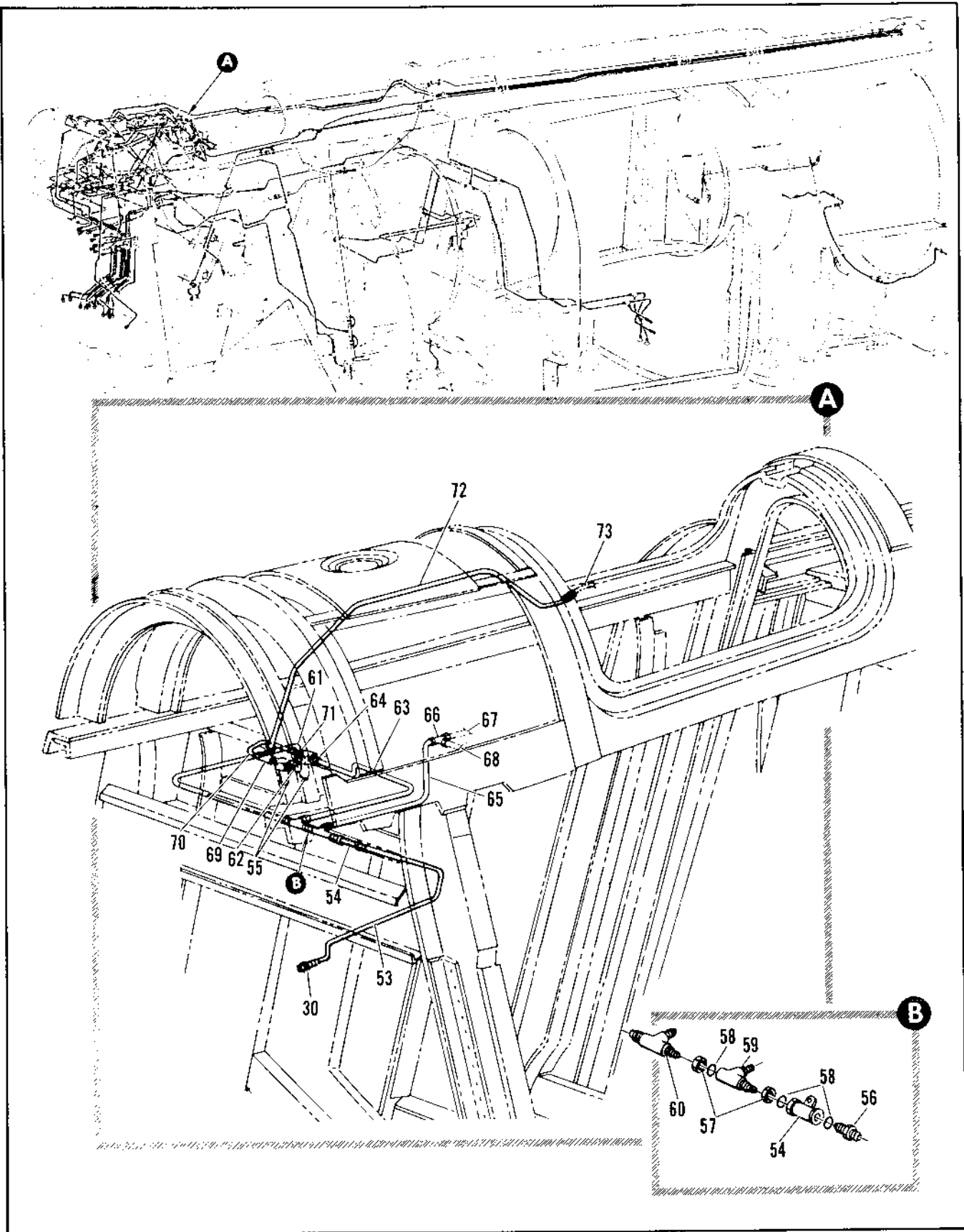

Figure 2.12-45. Fuel Tank Pressure Tubing Installation Sta 253 to 472 RH (Sheet 3 of 11)

FIGURE AND INDEX NUMBER	PART NUMBER	DESCRIPTION	UNITS PER ASSY.	USABLE ON CODE	
				FROM	TO
2.12-45- 53	8-20397-1317	<ul style="list-style-type: none"> • TUBE ASSEMBLY • VALVE, AIR CHECK <98134> SPEC 8-02998-13 • VALVE INSTL, FUEL PRESSURE SHUT-OFF STA 270 SEE FIG. 2.12-54 	1	35	
	MS35-37RF		RF	1	35
- 54					
- 55					
- 56	MS2190206	• UNION	1	35	
- 57	AN924-60	• NUT	2	35	
- 58	MS29512-6	• GASKET	3	35	
- 59	MS2191106	• TEE	1	35	
- 60	MS2191206	• TEE	1	35	
- 61	8-20397-1971	• TUBE ASSEMBLY	1	35	
- 62	MS2190806	• ELBOW	1	35	
	AN924-60	• NUT	1	35	
	MS29512-6	• GASKET	1	35	
- 63	8-20397-1973	• TUBE ASSEMBLY	1	35	
- 64	MS2190206	• UNION	1	35	
	MS29512-6	• GASKET	1	35	
- 65	8-20397-1975	• TUBE ASSEMBLY	1	35	
- 66	ERR240060654	• TEE, <92103> 98-90319-019	1	35	
- 67		• TUBE ASSY, SEE FIG. 2.12-44 INDEX 85	RF		
- 68		• TUBE ASSY, SEE FIG. 2.12-44 INDEX 88	RF		
- 69	MS2191206	• TEE	1	35	
	AN924-60	• NUT	1	35	
	MS29512-6	• GASKET	1	35	
- 70	8-20397-22	• TUBE ASSEMBLY	1	35	
- 71	MS2190206	• UNION	1	35	
	MS29512-6	• GASKET	1	35	
- 72	8-20397-600	• TUBE ASSEMBLY	1	35	
- 73		• TUBE ASSY, SEE FIG. 2.12-44 INDEX 66	RF		

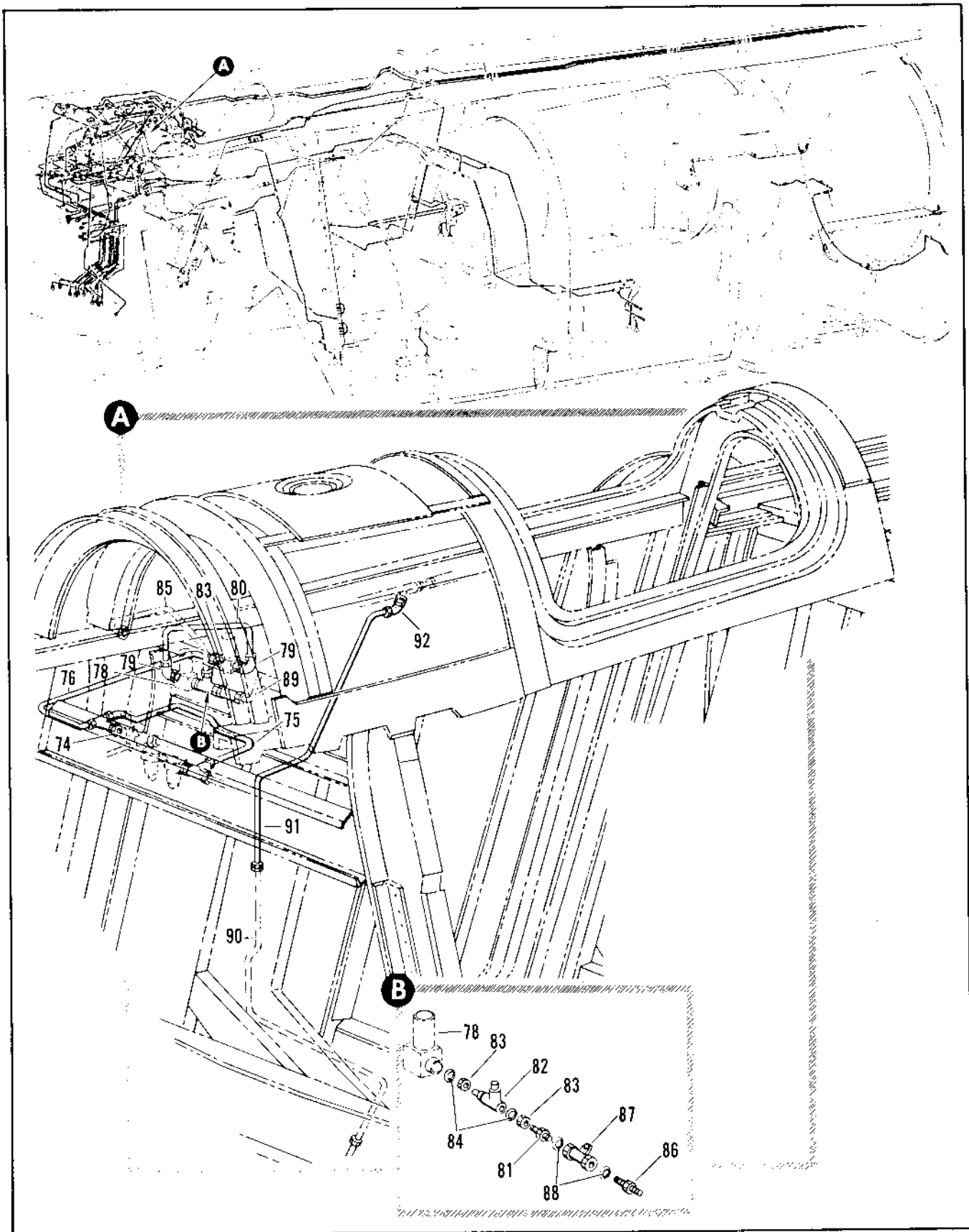

Figure 2.12-45. Fuel Tank Pressure Tubing Installation Sta 253 to 472 RH (Sheet 4 of 11)

FIGURE AND INDEX NUMBER	PART NUMBER	DESCRIPTION	UNITS PER ASSY.	USABLE ON CODE	
				FROM	TO
		1 2 3 4 5 6			
2.12-45- 74	MS21909D6	• TEE	1	35	215
	MS21908D6	• TEE	1	216	
	AN924-6D	• NUT	1	35	
	MS29512-6	• GASKET	1	35	
- 75	8-20397-1989	• TUBE ASSEMBLY	1	35	
- 76	8-20397-1990	• TUBE ASSEMBLY	1	35	215
- 77	MS21902D6	• UNION	1	35	215
	MS29512-6	• GASKET	1	35	215
- 78		• VALVE ASSY, SOLENOID OPERATED SHUTOFF SEE FIG. 2.12-54 INDEX A	RF		
- 79	MS21908D6	• ELBOW	2	35	215
	AN924-6D	• NUT	2	35	215
	MS29512-6	• GASKET	2	35	215
- 80	8-20397-1997	• TUBE ASSEMBLY	1	35	215
- 81	MS21903D6	• UNION	1	35	215
- 82	MS21911D6	• TEE	1	35	215
- 83	AN924-6D	• NUT	2	35	215
- 84	MS29512-6	• GASKET	2	35	215
- 85		• TUBE ASSY, SEE FIG. 2.12-44 INDEX B	RF		
- 86	R-20388-13	• UNION	1	35	
- 87	MS35-378F	• VALVE, AIR CHECK (96138) SPEC 8-02998-13	1	35	
- 88	MS29512-6	• GASKET	2	35	
- 89		• TUBE ASSY, SEE FIG. 2.12-44 INDEX 21	RF		
- 90		• TUBE ASSY, SEE FIG. 2.12-44 INDEX 105	RF		
- 91	8-20397-2083	• TUBE ASSEMBLY	1	35	
- 92	MS21908D6	• ELBOW	1	35	
	AN924-6D	• NUT	1	35	
	MS29512-6	• GASKET	1	35	

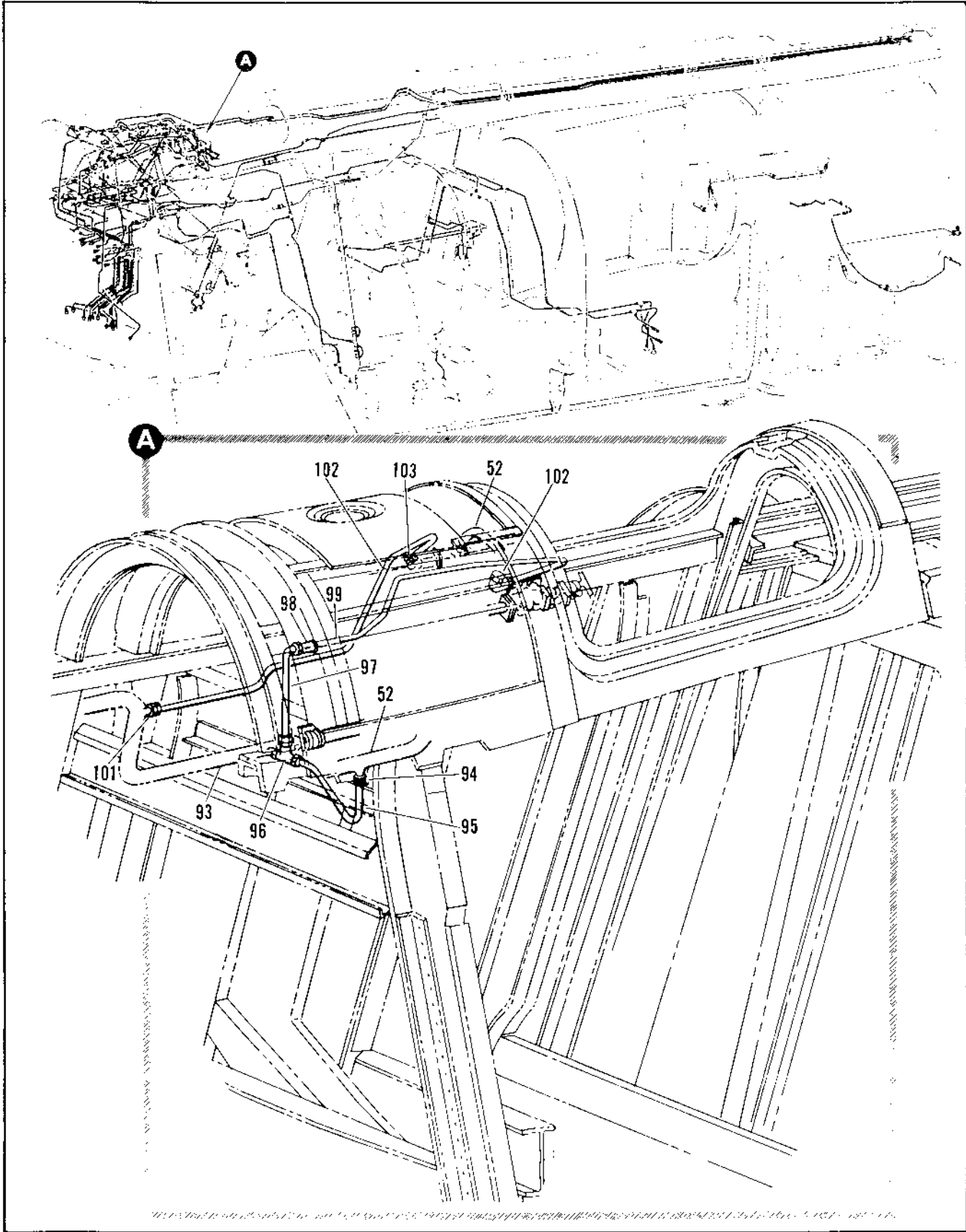

Figure 2.12-45. Fuel Tank Pressure Tubing Installation Sta 253 to 472 RH (Sheet 5 of 11)

FIGURE AND INDEX NUMBER	PART NUMBER	DESCRIPTION	UNITS PER ASSY.	USABLE ON CODE	
				FROM	TO
2.12-45- 93		• TUBING INSTL. VENT FUSELAGE TANK TO WING SEE FIG. 2.12-47	RF		
- 94	MS21902D6	• UNION	1	35	
	MS29512-6	• GASKET	1	35	
- 95	A-20397-780	• TUBE ASSEMBLY	1	35	
- 96	MS21912D6	• TEE	1	35	
	AN924-6D	• NUT	1	35	
- 97	A-20397-782	• TUBE ASSEMBLY	1	35	
- 98	P20-526	• VALVE, DRAIN AUTOMATIC <91R16> SPEC A-C9923-3	1	35	
- 99	8-20397-1991	• TUBE ASSEMBLY	1	35	
-100	MS21902D6	• ELBOW	1	35	
	AN924-6D	• NUT	1	35	
	MS29512-6	• GASKET	1	35	
-101	MS21902D6	• UNION	1	35	
	MS29512-6	• GASKET	1	35	
-102	8-20397-781	• TUBE ASSEMBLY	1	35	
-103	MS21916D6-4	• REDUCER	1	35	
	MS29512-4	• GASKET	1	35	

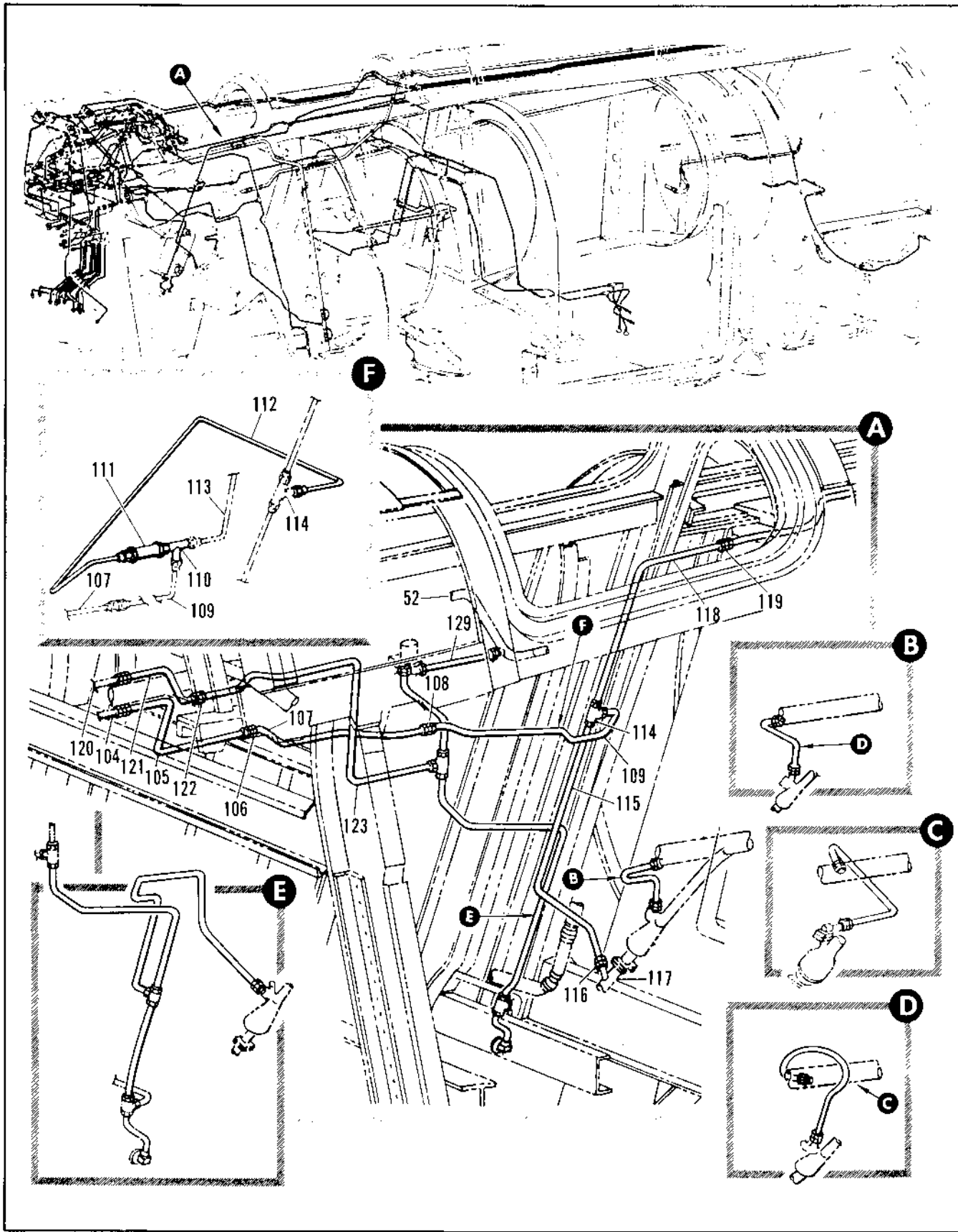

Figure 2.12-45. Fuel Tank Pressure Tubing Installation Sta 253 to 472 RH (Sheet 6 of 11)

FIGURE AND INDEX NUMBER	PART NUMBER	DESCRIPTION	UNITS PER ASSY.	USABLE ON CODE	
				FROM	TO
2.12-45-104					
-105	8-20397-1065	• TUBE ASSY, SEE FIG. 2.12-43 INDEX 185	RF 1	35	
-106	MS21902D4	• TUBE ASSEMBLY	1	35	
-107	8-20397-56	• UNION	1	35	
-108	MS21902D4	• TUBE ASSEMBLY	1	35	
-109	66A40320-1	• UNION	1	35	
-110	MS21912D4	• TUBE ASSY	1	35	
	MS29512-04	• TEE	1		
	MS29512-06	• GASKET	1		
	AN924-4	• GASKET	1		
	AN893-20	• NUT	1		
-111	W535-3/8F	• PUSHING	1		
	MS21916D6-4	• VALVE, AIR CHECK (96134) SPEC 8-02998-13	1		
	MS29512-06	• REDUCER	1		
-112	66A405431-1	• GASKET	1		
-113		• TUBE ASSY	1		
-114	MS21905D4	• TUBE ASSY, SEE FIG. 2.12-67 INDEX 2	RF 1	35	
-115	8-20397-52	• TEE	1	35	89
	8-20397-347	• TUBE ASSEMBLY	1	99	
-116	MS21902D4	• TUBE ASSEMBLY	1	35	
	MS29512-4	• UNION	1	35	
-117		• GASKET	RF 1		
		• TUBE ASSY, REFUELING VALVE			
		SEE FIG. 2.12-55 INDEX 14			
-118	8-20397-272	• TUBE ASSEMBLY	1	35	
-119	MS21902D4	• UNION	1	35	
-120		• TUBE ASSY, SEE FIG. 2.12-43 INDEX 88	RF 1		
-121	8-20397-190	• TUBE ASSEMBLY	1	35	188
	8-20397-2641	• TUBE ASSEMBLY	1	189	
-122	MS21902D6	• UNION	1	35	
-123	8-20397-192	• TUBE ASSEMBLY	1	35	60
	8-20397-2027	• TUBE ASSEMBLY	1	61	188
	8-20397-2643	• TUBE ASSEMBLY	1	189	

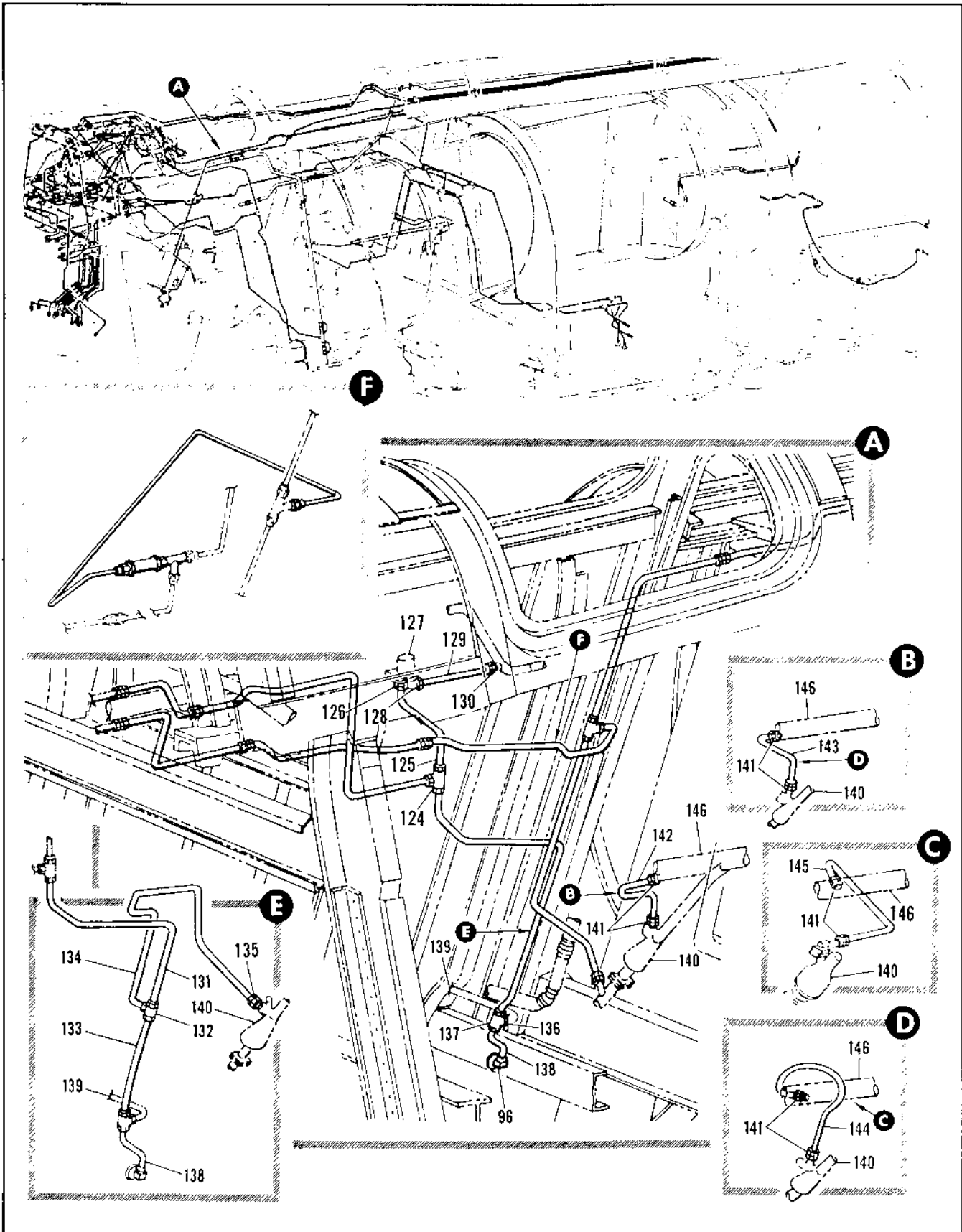

Figure 2.12-45. Fuel Tank Pressure Tubing Installation Sta 253 to 472 RH (Sheet 7 of 11)

FIGURE AND INDEX NUMBER	PART NUMBER	DESCRIPTION	UNITS PER ASSY.	USABLE ON CODE	
				FROM	TO
		1 2 3 4 5 6			
2.12-45-124	MS21905D6	• TEE	1	35	
-125	8-20397-542	• TUBE ASSEMBLY	1	35	
-126	MS21916D6-4	• REDUCER	1	35	
	MS29512-4	• GASKET	1	35	
-127		• SWITCH ASSY, EXTERNAL FUEL TANK HIGH PRESSURE SEE FIG. 2.12-38 INDEX 33	RF		
-128	MS21908D4	• ELBOW	1	35	
	MS29512-4	• GASKET	1	35	
-129	8-20397-544	• TUBE ASSEMBLY	1	35	
-130	MS21902D4	• UNION	1	35	
	MS29512-4	• GASKET	1	35	
-131	8-20397-3021	• TUBE ASSY	1	35	
-132	ER824060604	• TEE (92003) 9A-90319-008	1	35	
-133	8-20397-3019	• TUBE ASSY	1	35	
-134	8-20397-3023	• TUBE ASSY	1	35	
-135	MS21902D4	• UNION	1	35	
-136	MS21916D6-4	• REDUCER	1	35	
	MS29512-6	• GASKET	1	35	
-137	MS21911D6	• TEE	1	35	
-138	8-20397-120	• TUBE ASSEMBLY	1	35	
-139		• TUBE ASSY, SEE FIG. 2.12-15 INDEX 32	RF		
-140		• VALVE ASSY, REFUELING REGULATOR AND CHECK SEE FIG. 2.12-55 INDEX 10	RF		
-141	MS21902D6	• UNION	2	35	
	MS29512-6	• GASKET	2	35	
-142	9-20397-258	• TUBE ASSEMBLY	1	35	60
-143	8-20397-2031	• TUBE ASSEMBLY	1	61	89
-144	8-20397-3009	• TUBE ASSEMBLY	1	90	169
-145	8-20397-2951	• TUBE ASSEMBLY	1	170	
-146		• TUBE ASSY, SEE FIG. 2.12-48	RF		
		A REMOVED FROM AIRPLANES #35 AND 40 B ADDED ON AIRPLANES #35 AND 40			

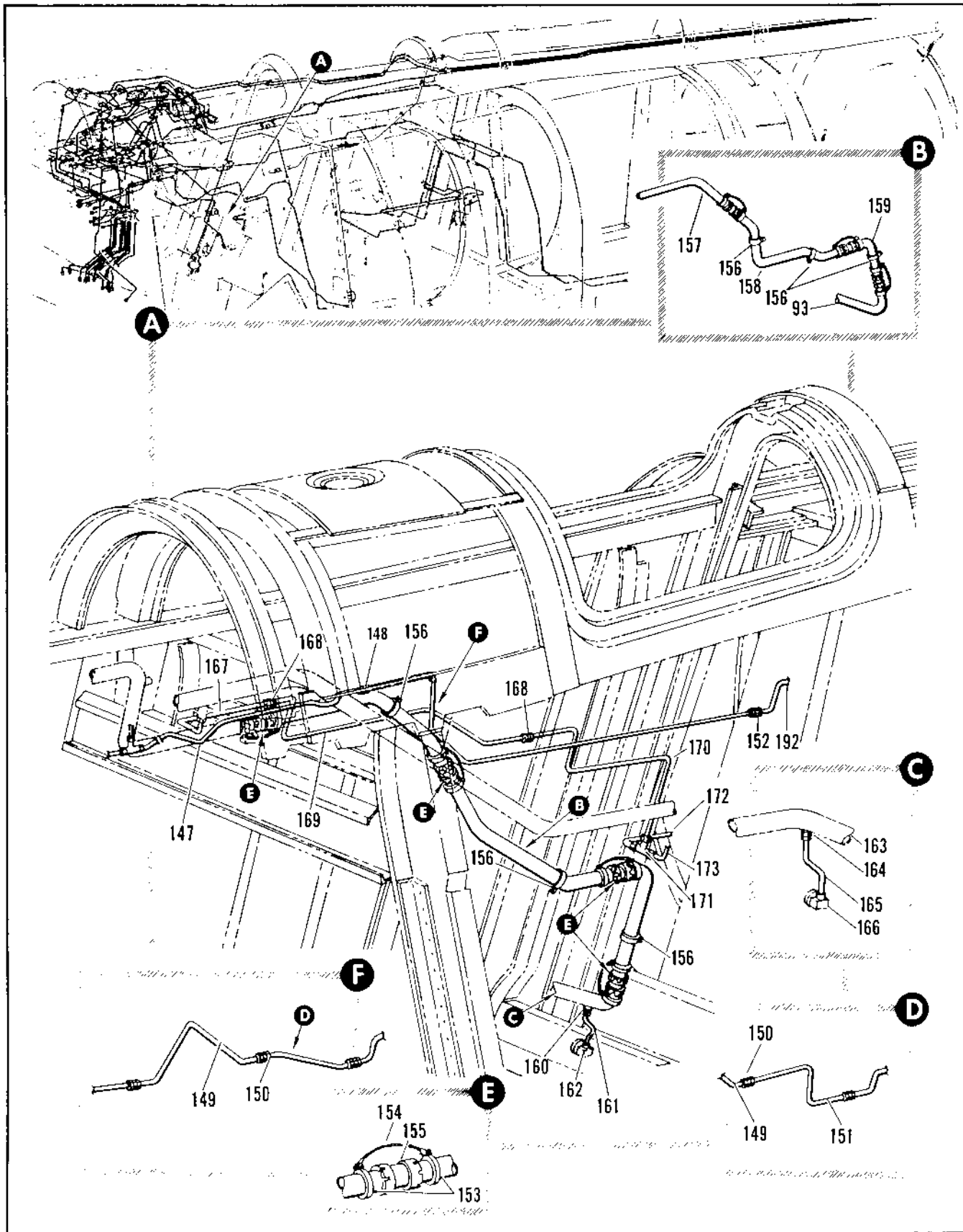

Figure 2.12-45. Fuel Tank Pressure Tubing Installation Sta 253 to 472 RH (Sheet 8 of 11)

FIGURE AND INDEX NUMBER	PART NUMBER	DESCRIPTION	UNITS PER ASSY.	USABLE ON CODE	
				FROM	TO
		1 2 3 4 5 6			
2.12-45-147	R-23397-1389	• TUBE ASSEMBLY	1	35	
-147	MS2190206	• UNION	1	35	
-149	R-23397-2017	• TUBE ASSEMBLY	1	61	
-150	MS2190206	• UNION	1	61	
-151	R-23397-3013	• TUBE ASSEMBLY	1	90	
-152	MS2190204	• UNION	1	35	
-153	AN734024	• CLAMP	8	35	
		ATTACHING PARTS			
	NAS67943	• NUT	8	35	
	AN964D10L	• WASHER	8	35	
	AN526-1038R	• SCREW	8	35	
		-----y-----			
-154	MS25133-1-64	• JUMPER	4	35	
-155	3605-240	• COUPLING, <R326> 92-72900-093	4	35	
	MS29513-325	• PACKING	4	35	
-156	31-33324-010	• CLAMP	3	35	
		WITH R-23397-2023			
-157	R-23397-2017	• TUBE ASSEMBLY	1	90	
-158	R-23397-2021	• TUBE ASSEMBLY	1	90	
-159	R-23397-2023	• TUBE ASSY, REPLACES NOT INTCHG WITH R-23397-252	1	90	
-160	MS2190204	• UNION	1	35	
	MS2512-4	• GASKET	1	35	
-161	R-23397-484	• TUBE ASSEMBLY	1	71	
-162		• VALVE ASSY, DRAIN SEE FIG. 2.12-47 INDEX 23	RF		
-163		• TUBING INSTL, FUSELAGE TANK TO WING TRANSFER SEE FIG. 2.12-44	RF		
-164	MS2190204	• UNION	1	35	
	MS29512-4	• GASKET	1	35	
-165	R-23397-107	• TUBE ASSEMBLY	1	35	
-166		• VALVE ASSY, DRAIN SEE FIG. 2.12-35 INDEX 57	RF		
-167	R-23397-9605	• TUBE ASSEMBLY	1	149	
-168	MS2190204	• UNION	2	149	
-169	R-23397-1671	• TUBE ASSEMBLY	1	149	
-170	R-23397-9627	• TUBE ASSEMBLY	1	149	
-171	MS2190206	• TEE	1	149	
-172	R-23397-9624	• TUBE ASSEMBLY	1	149	
-173	R-23397-9727	• TUBE ASSEMBLY	1	149	

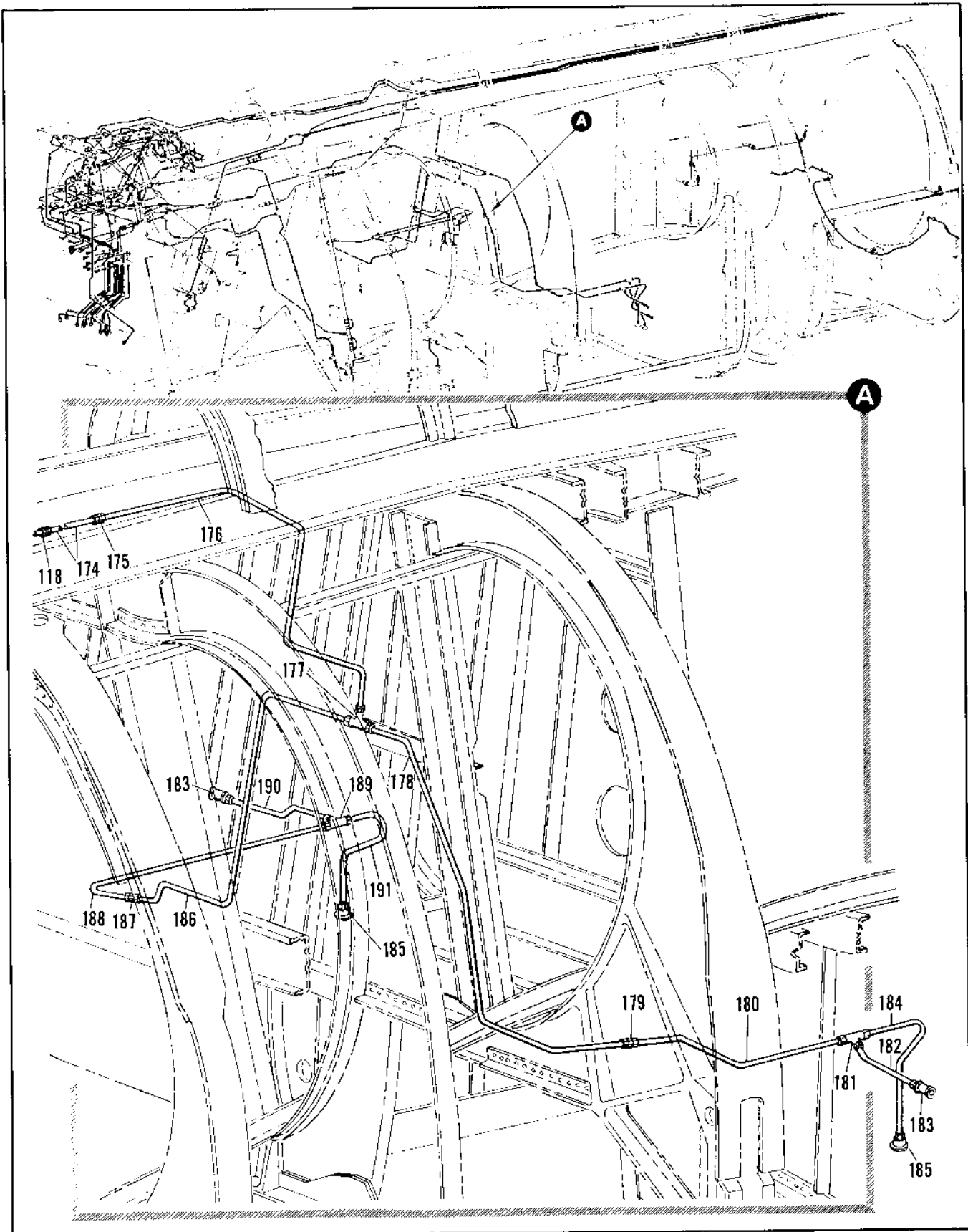

Figure 2.12-45. Fuel Tank Pressure Tubing Installation Sta 253 to 472 RH (Sheet 9 of 11)

FIGURE AND INDEX NUMBER	PART NUMBER	DESCRIPTION	UNITS PER ASSY.	USABLE ON CODE	
				FROM	TO
		1 2 3 4 5 6			
2.12-45-174	8-20397-398	• TUBE ASSEMBLY	1	35	
-175	MS21902D4	• UNION	1	35	
-176	8-20397-1165	• TUBE ASSEMBLY	1	35	42
	8-20397-1703	• TUBE ASSEMBLY	1	43	
-177	MS21905D4	• TEE	1	35	
-178	8-20397-36	• TUBE ASSEMBLY	1	35	42
	8-20397-1707	• TUBE ASSEMBLY	1	43	
-179	MS21902D4	• UNION	1	35	
-180	8-20397-34	• TUBE ASSEMBLY	1	35	
-181	MS21905D4	• TEE	1	35	
-182	8-20397-30	• TUBE ASSEMBLY	1	35	
-183		• FITTING INSTL, WING BULKHEAD FUEL TANK SEE FIG. 2.12-66	RF		
-184	8-20397-1471	• TUBE ASSEMBLY	1	35	
-185		• FITTING, REFUEL PRESSURE LINE DRAIN VALVE SEE FIG. 2.12-40 INDEX 62	RF		
-186	8-20397-38	• TUBE ASSEMBLY	1	35	42
	8-20397-1705	• TUBE ASSEMBLY	1	43	
-187	MS21902D4	• UNION	1	35	
-188	8-20397-1495	• TUBE ASSEMBLY	1	35	
-189	MS21905D4	• TEE	1	35	
-192	8-20397-1497	• TUBE ASSEMBLY	1	35	
-191	8-20397-1499	• TUBE ASSEMBLY	1	35	

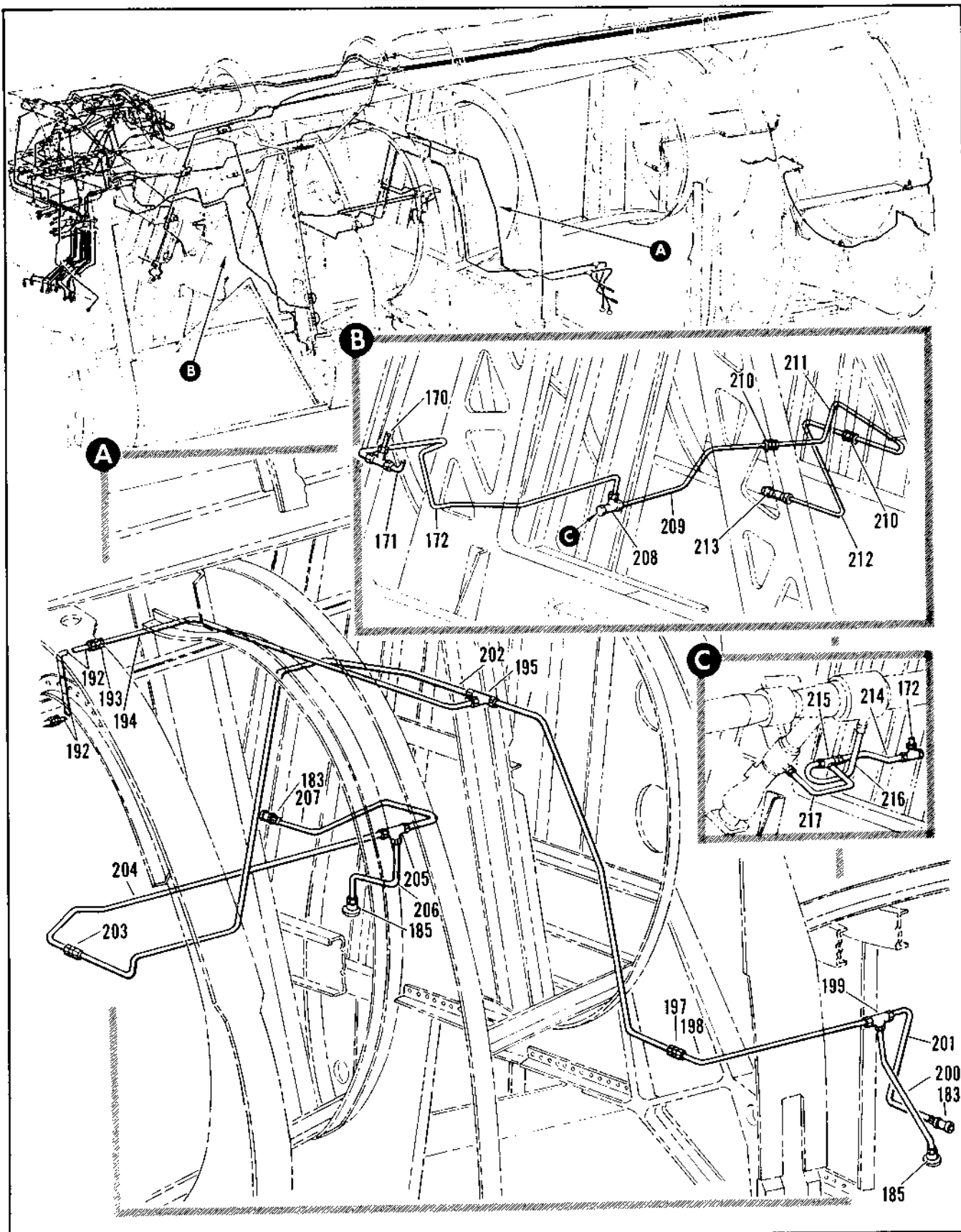

Figure 2.12-45. Fuel Tank Pressure Tubing Installation Sta 253 to 472 RH (Sheet 10 of 11)

FIGURE AND INDEX NUMBER	PART NUMBER	DESCRIPTION	UNITS PER ASSY.	USABLE ON CODE	
				FROM	TO
		1 2 3 4 5 6			
2.12-45-192	8-20397-1457	• TUBE ASSEMBLY	1	35	
-193	MS2190206	• UNION	1	35	
-194	66A4 515-1	• TUBE ASSY	1		
-195	MS2190506	• TEE	1	35	
-196	8-20397-1461	• TUBE ASSEMBLY	1	35	42
	8-20397-1693	• TUBE ASSEMBLY	1	43	
-197	MS2190206	• UNION	1	35	
-198	8-20397-1465	• TUBE ASSEMBLY	1	35	
-199	ER8240160604	• TEE, <9203> 98-90319-108	1	35	
-200	8-20397-1715	• TUBE ASSEMBLY	1	35	
-201	8-20397-1467	• TUBE ASSEMBLY	1	35	
-202	8-20397-1463	• TUBE ASSEMBLY	1	35	42
	8-20397-1701	• TUBE ASSEMBLY	1	43	
-203	MS2190206	• UNION	1	35	
-204	8-20397-1501	• TUBE ASSEMBLY	1	35	42
	8-20397-1709	• TUBE ASSEMBLY	1	43	
-205	ER8240160604	• TEE, <9203> 98-90319-108	1	35	
-206	8-20397-1717	• TUBE ASSEMBLY	1	35	
-207	8-20397-1507	• TUBE ASSEMBLY	1	35	
-208	MS2191206	• TEE	1	189	
	MS2111406	• CAP	1	189	264
	AN924-4D	• NUT	1	189	
	AN95106	• WASHER	1	189	
-209	8-20397-2631	• TUBE ASSEMBLY	1	189	
-210	MS2190206	• UNION	1	189	
-211	8-20397-2633	• TUBE ASSEMBLY	1	189	
-212	8-20397-2635	• TUBE ASSEMBLY	1	189	
-213		• FITTING, STA 354 SEE FIG. 2.12-66 INDEX 3	RF		
-214	8-20397-2957	• TUBE ASSEMBLY	1	265	
-215	MS2191206	• TEE	1	265	
-216	8-20397-2957	• TUBE ASSEMBLY	1	265	
-217	8-20397-2955	• TUBE ASSEMBLY	1	265	

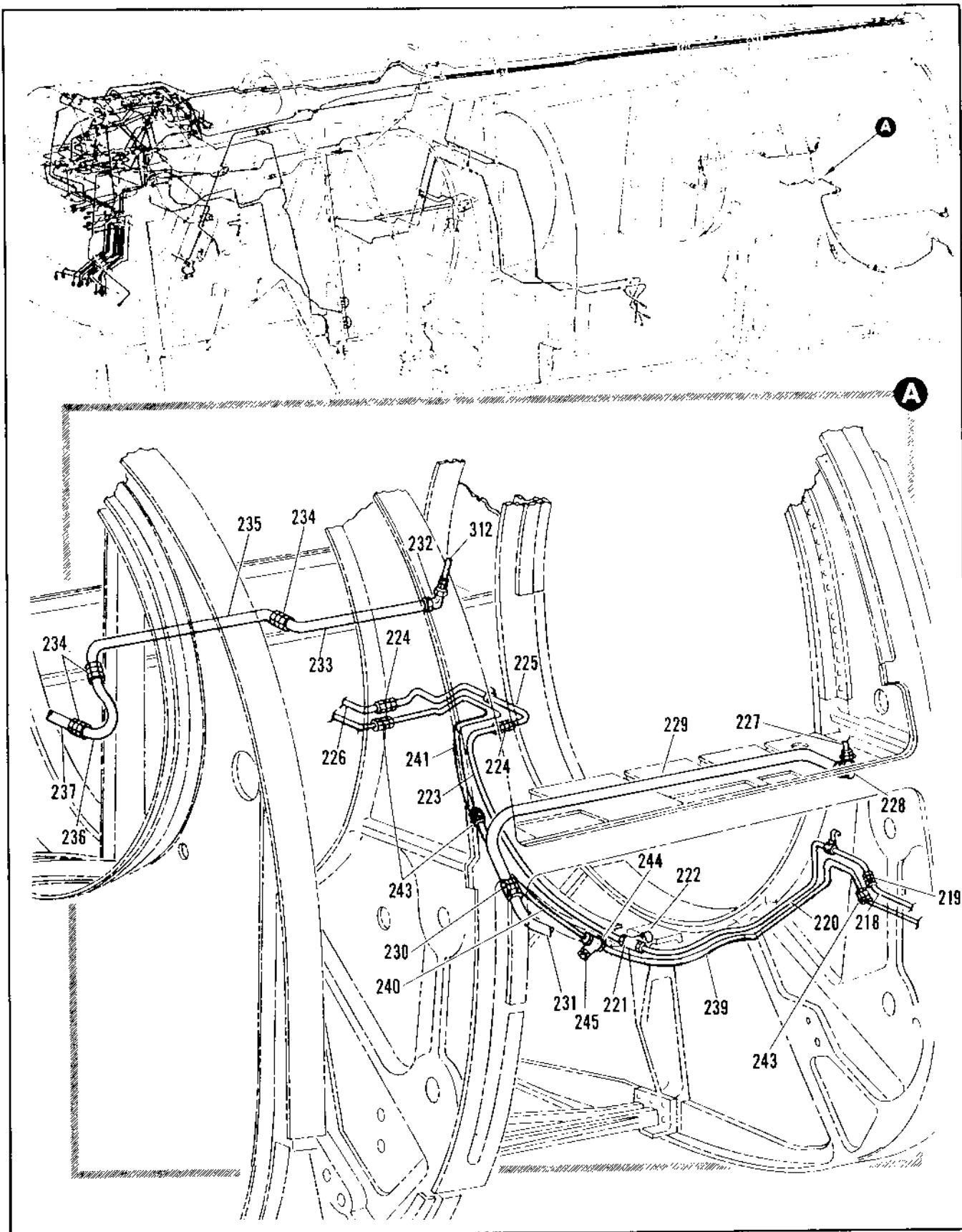

Figure 2-12-45. Fuel Tank Pressure Tubing Installation Sta 253 to 472 RH (Sheet 11 of 11)

FIGURE AND INDEX NUMBER	PART NUMBER	DESCRIPTION 1 2 3 4 5 6	UNITS PER ASSY.	USABLE ON CODE	
				FROM	TO
2.12-45-218		• TUBE ASSY, MWW FUEL CONTROL SEE FIG. 2.12-37 INDEX 5A	RF		
-219	MS2190204	• UNION	1	35	
-221	8-20397-2947	• TUBE ASSEMBLY	1	35	
-221	MS2191004	• TEE	1	35	
	AN924-4D	• NUT	1	35	
	AN9600716	• WASHER	1	35	
	MS29512-4	• GASKET	1	35	
-222	160B	• COCK, DRAIN <91511> 92-12501-063	1	35	
-223	8-21898-21	• TUBE ASSEMBLY	1	35	
-224	MS2190204	• UNION	2	35	
-225	8-21898-19	• TUBE ASSEMBLY	1	35	
-225		• TUBE ASSY, MWW FUEL CONTROL SEE FIG. 2.12-37 INDEX 181	RF		
-227		• TUBE ASSY, FUEL TANK PRESSURE LH SEE FIG. 2.12-46 INDEX 2	RF		
-228	MS21908012	• ELBOW	1	35	
	AN924-12D	• NUT	2	35	
	AN96001716	• WASHER	1	35	
-229	8-20397-321	• TUBE ASSEMBLY	1	35	
-230	MS21902012	• UNION	1	35	
-231		• TUBE ASSY, MWW FUEL SEE FIG. 2.12-37 INDEX 1A	RF		
-232		• TUBE ASSY, FUEL TANK PRESSURE RH SEE FIG. 2.12-46 INDEX 4	RF		
-233	MS21908012	• ELBOW	1	35	
	AN924-12D	• NUT	1	35	
	AN96001716	• WASHER	1	35	
-234	8-20397-236	• TUBE ASSEMBLY	1	35	
-235	MS21902012	• UNION	3	35	
-236	8-20397-274	• TUBE ASSEMBLY	1	35	
-237	8-20397-276	• TUBE ASSEMBLY	1	35	
-238		• TUBE ASSY, MWW FUEL CONTROL RH SEE FIG. 2.12-37 INDEX 139	RF		
-239	68A37755-7	• TUBE ASSEMBLY	1	35	
-240	68A37755-6	• TUBE ASSEMBLY	1	35	
-241	68A37755-5	• TUBE ASSEMBLY	1	35	
-242	68A37755-4	• TUBE ASSEMBLY	1	35	
-243	MS2190204	• UNION	3	35	
-244	MS2191004	• TEE	1	35	
-245	160B	• PLUG	1	35	

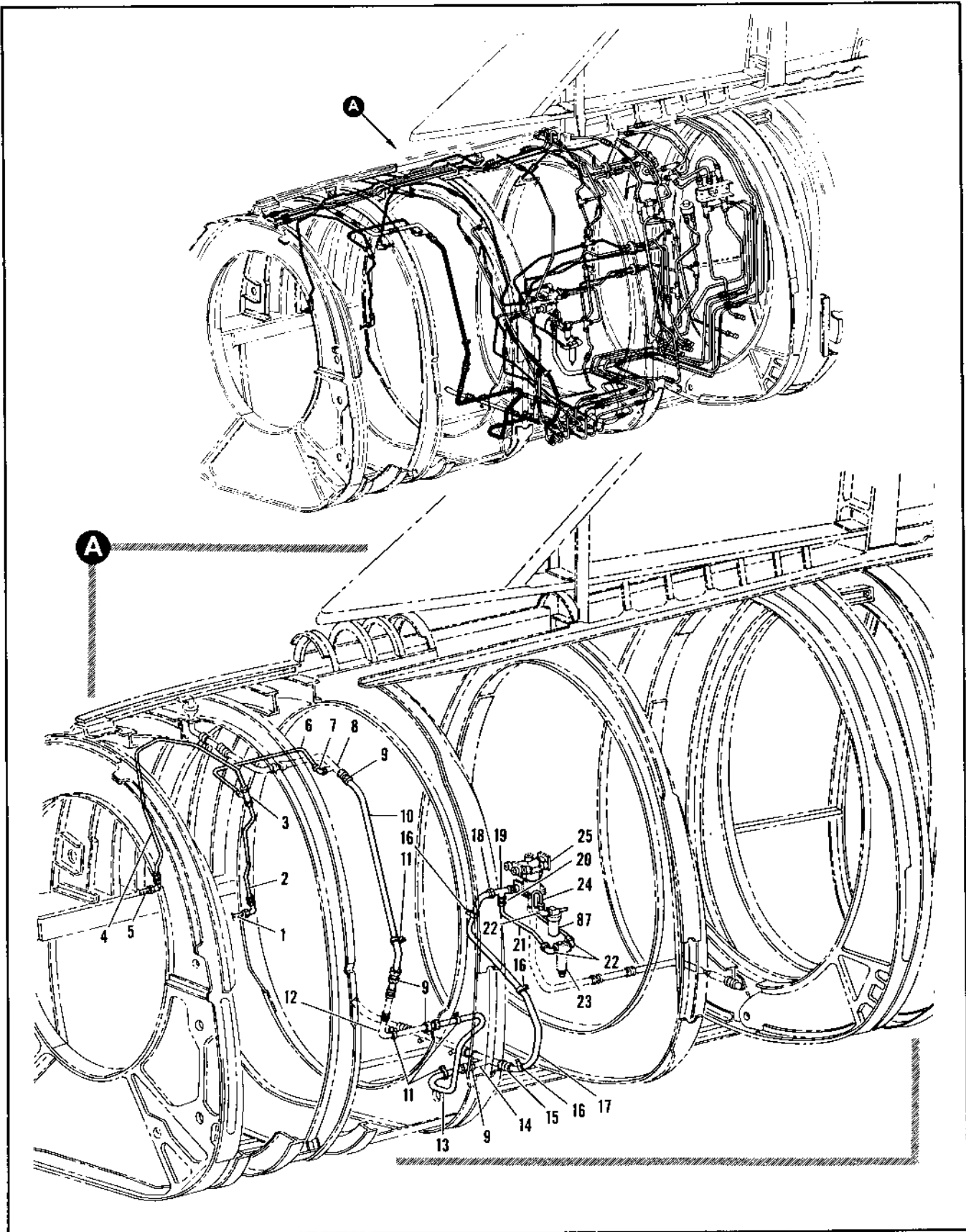

Figure 2.12-46. Fuel Tank Pressure Tubing Installation LH Sta 472 to 577 (Sheet 1 of 8)

FIGURE AND INDEX NUMBER	PART NUMBER	DESCRIPTION	UNITS PER ASSY.	USABLE ON CODE	
				FROM	TO
		1 2 3 4 5 6			
2.12-46	8-20397-833	TUBING INSTALLATION, FUEL TANK PRESSURE LH STA 472 TO 577 FOR AHA SEE FIG. 2.3-14	RF	35	
- 1		• TUBE ASSY, FUEL TANK PRESSURE SEE FIG. 2.12-45 INDEX 229	RF		
- 2	8-20397-270	• TUBE ASSY, FUEL TANK PRESSURE	1	35	
- 3	MS21908D12	• TEE	1	35	
- 4	8-20397-751	• TUBE ASSY, FUEL TANK PRESSURE	1	35	
- 5		• TUBE ASSY, FUEL TANK PRESSURE RH SEE FIG. 2.12-45 INDEX 229	RF		
- 6	8-20397-747	• TUBE ASSY, FUEL TANK PRESSURE	1	35	
- 7	MS21908D12	• ELBOW	1	35	
	AN924-120	• NUT	1	35	
	MS29512-12	• GASKET	1	35	
- 8		• ELBOW ASSY, FUEL TANK PRESSURE SEE FIG. 2.12-58 INDEX 16	RF		
- 9	NAS594-24	• COUPLING	4	35	
	NAS595-24	• RING	4	35	
- 10	8-20397-643	• TUBE ASSY, FUEL TANK PRESSURE	1	35	
- 11	91-98026-023	• CLAMP	4	35	
- 12		• ELBOW ASSY, FUEL TANK PRESSURE SEE FIG. 2.12-58 INDEX 21	RF		
- 13	8-20397-645	• TUBE ASSY, FUEL TANK PRESSURE	1	35	
- 14		• TEE, SEE FIG. 2.12-58 INDEX 23	RF		
- 15	NAS594-20	• COUPLING	1	35	
	NAS595-20	• RING	1	35	
- 16	91-98026-019	• CLAMP	3	35	
- 17	8-20397-639	• TUBE ASSY, FUEL TANK PRESSURE	1	35	
- 18	NAS595-20	• NUT	1	35	
	NAS595-20	• RING	1	35	
- 19		• TUBE ASSY, SEE FIG. 2.12-58 INDEX 30	RF		
- 20	MS21902D6	• UNION	1	35	
	NAS617-6	• GASKET	1	35	
- 21	8-20397-2095	• TUBE ASSY, FUEL TANK PRESSURE	1	35	
- 22	MS21908D6	• ELBOW	3	35	
	AN924-60	• NUT	3	35	
	NAS617-6	• GASKET	3	35	
- 23		• FILTER, HIGH TEMPERATURE AIR SEE FIG. 2.12-59 INDEX 4	RF		
- 24	8-20397-314	• TUBE ASSY, FUEL TANK PRESSURE	1	35	
- 25		• REGULATOR ASSY, AIR PRESSURE TRANSFER TANK SEE FIG. 2.12-36 INDEX 97	RF		

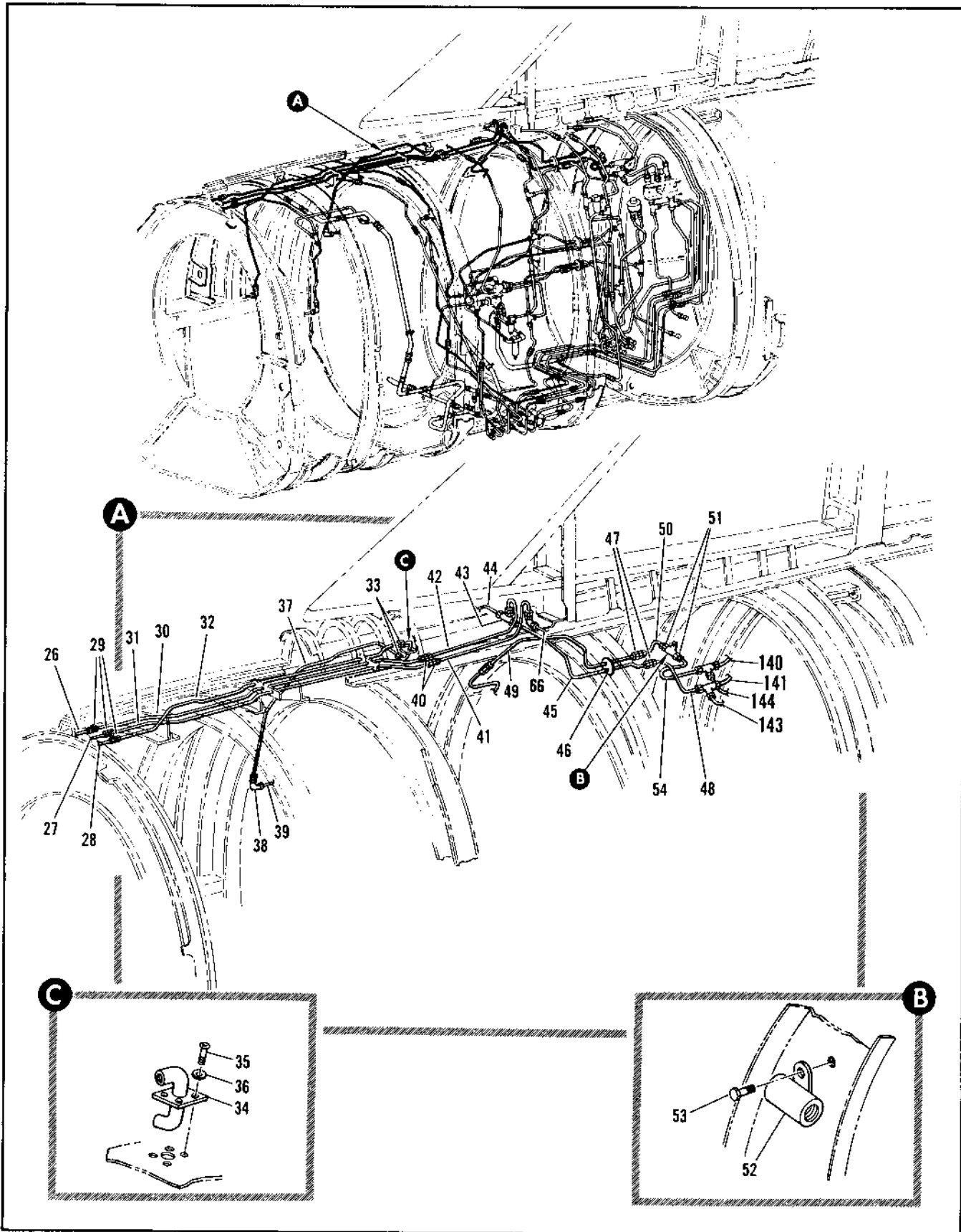

Figure 2.12-46. Fuel Tank Pressure Tubing Installation LH Sta 472 to 577 (Sheet 2 of 8)

FIGURE AND INDEX NUMBER	PART NUMBER	DESCRIPTION	UNITS PER ASSY.	USABLE ON CODE	
				FROM	TO
2.12-46- 26		• TUBE ASSY, FUEL TANK PRESSURE SEE FIG. 2.12-44 INDEX 34	RF		
- 27		• TUBE ASSY, FUEL TANK PRESSURE SEE FIG. 2.12-44 INDEX 33	RF		
- 28		• TUBE ASSY, FUEL TANK PRESSURE SEE FIG. 2.12-44 INDEX 32	RF		
- 29	MS2190206	• UNION	3	35	
- 30	8-20397-102	• TUBE ASSY, UPPER	1	35	
- 31	8-20397-100	• TUBE ASSY, UPPER	1	35	
- 32	8-20397-244	• TUBE ASSY, UPPER	1	35	
- 33	MS2190206	• UNION	2	35	
- 34	8-28243	• FITTING ASSY, FEED THRU WELDED ATTACHING PARTS	1	35	
- 35	NAS221-10	• SCREW	4	35	
- 36	AN961D1CL	• WASHER	4	35	
		-----X-----			
- 37	8-20397-246	• TUBE ASSEMBLY	1	35	
	AN924-6D	• NUT	1	35	
	AN960D916	• WASHER	1	35	
- 38	MS2190806	• ELBOW	1	35	
- 39		• TUBE ASSY, SEE FIG. 2.12-32 INDEX 21	RF		
- 40	MS2190206	• UNION	2	35	
- 41	8-20397-420	• TUBE ASSY, UPPER	1	35	
- 42	8-20397-422	• TUBE ASSY, UPPER	1	35	
	AN924-6D	• NUT	1	35	
	AN960D916	• WASHER	1	35	
- 43	MS2190906	• TEE	1	35	
- 44		• TUBE ASSY, SEE FIG. 2.12-32 INDEX 48	RF		
- 45	8-20397-1839	• TUBE ASSEMBLY	1	35	
- 46	8-28339-19	• GROMMET	2	35	47
	8-28339-19	• GROMMET	1	48	
- 47	MS2190206	• UNION	2	35	
- 48	8-20397-1885	• TUBE ASSEMBLY	1	35	
- 49	8-20397-741	• TUBE ASSEMBLY	1	35	47
	8-20397-662	• TUBE ASSEMBLY	1	48	
- 50	8-20397-1625	• TUBE ASSEMBLY	1	35	
- 51	MS2190206	• UNION	2	35	
	NAS617-6	• PACKING	2	35	
- 52	MS35-3/RF	• VALVE ASSY, CHECK <96134> SPEC 8-02998-13 ATTACHING PARTS	1	35	
- 53	AN3-5A	• BOLT	1	35	
		-----X-----			
- 54	8-20397-1627	• TUBE ASSEMBLY	1	35	

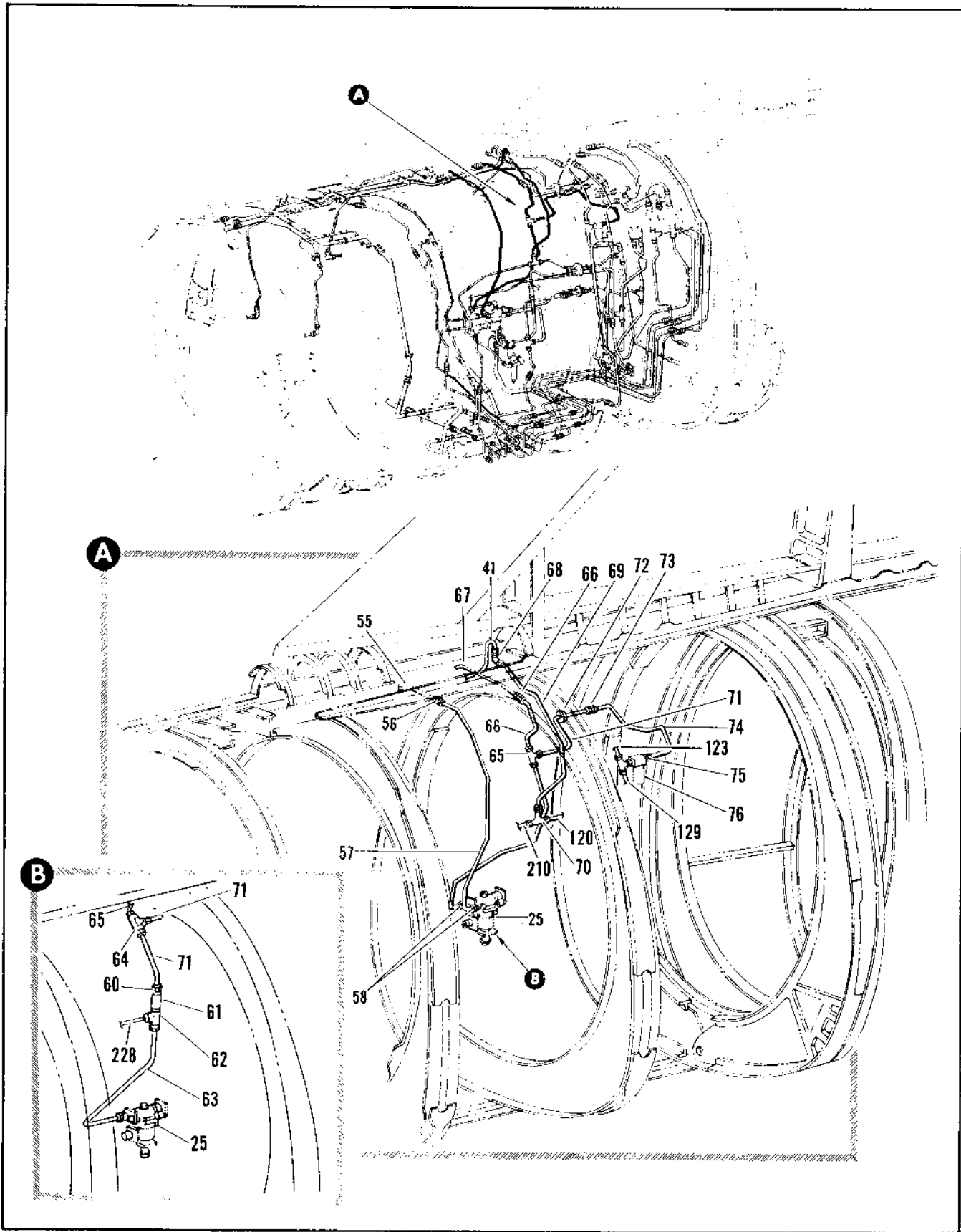

Figure 2.12-46. Fuel Tank Pressure Tubing Installation LH Sta 472 to 577 (Sheet 3 of 8)

FIGURE AND INDEX NUMBER	PART NUMBER	DESCRIPTION	UNITS PER ASSY.	USABLE ON CODE	
				FROM	TO
		1 2 3 4 5 6			
2.12-30-53		• TUBE ASSY. SEE FIG. 2.12-32 INDEX 26	RF		
- 54	MS2181205	• UNION	1	35	
- 54	R-20397-334	• TUBE ASSEMBLY	1	35	
- 58	MS2190276	• UNION	2	35	
	NAS617-6	• GASKET	2	35	
- 59	R-20397-141	• TUBE ASSEMBLY	1	35	
- 60	MS2182207	• UNION	1	35	
	NAS617-6	• GASKET	1	35	
- 61	AS36-178F	• VALVE ASSY. AIR CHECK (K9118) SPEC. R-12884-13	1	35	
- 62	BR040060694	• TEE (K9203) CA-43319-034	1	35	
	AN924-00	• NUT	1	35	
	NAS617-6	• GASKET	1	35	
- 63	R-20397-2455	• TUBE ASSEMBLY	1	216	277
	R-21034-21	• TUBE ASSEMBLY	1	278	
	AN924-00	• NUT	1	35	
	AN9515615	• WASHER	1	35	
- 64	MS2170906	• TEE	1	35	
- 65	R-20397-410	• TUBE ASSEMBLY	1	35	
- 66	MS2182206	• UNION	1	35	
- 67		• TUBE ASSY. SEE FIG. 2.12-32 INDEX 43 AND 55	RF		
	AN924-00	• NUT	1	35	
	AN9515616	• WASHER	1	35	
- 68	MS2170908	• FLOW	1	35	
- 69	R-20397-1057	• TUBE ASSEMBLY	1	35	
	AN924-00	• NUT	1	35	
	AN9515616	• WASHER	1	35	
- 70	MS2181204	• TEE	1	35	
- 71	R-20397-552	• TUBE ASSEMBLY	1	35	47
	R-20397-1567	• TUBE ASSEMBLY	1	48	277
	R-21034-21	• TUBE ASSEMBLY	1	278	
- 72	R-20339-21	• BRONNET	2	35	47
	R-20339-21	• BRONNET	1	48	
- 73	MS2182205	• UNION	1	35	
- 74	R-20397-05	• TUBE ASSEMBLY	1	35	
- 75	MS2182204	• UNION	1	35	
- 76	NAS617-6	• GASKET	1	35	
- 77		• VALVE ASSY. AIR SHUTOFF SEE FIG. 2.12-32 INDEX 54	RF		

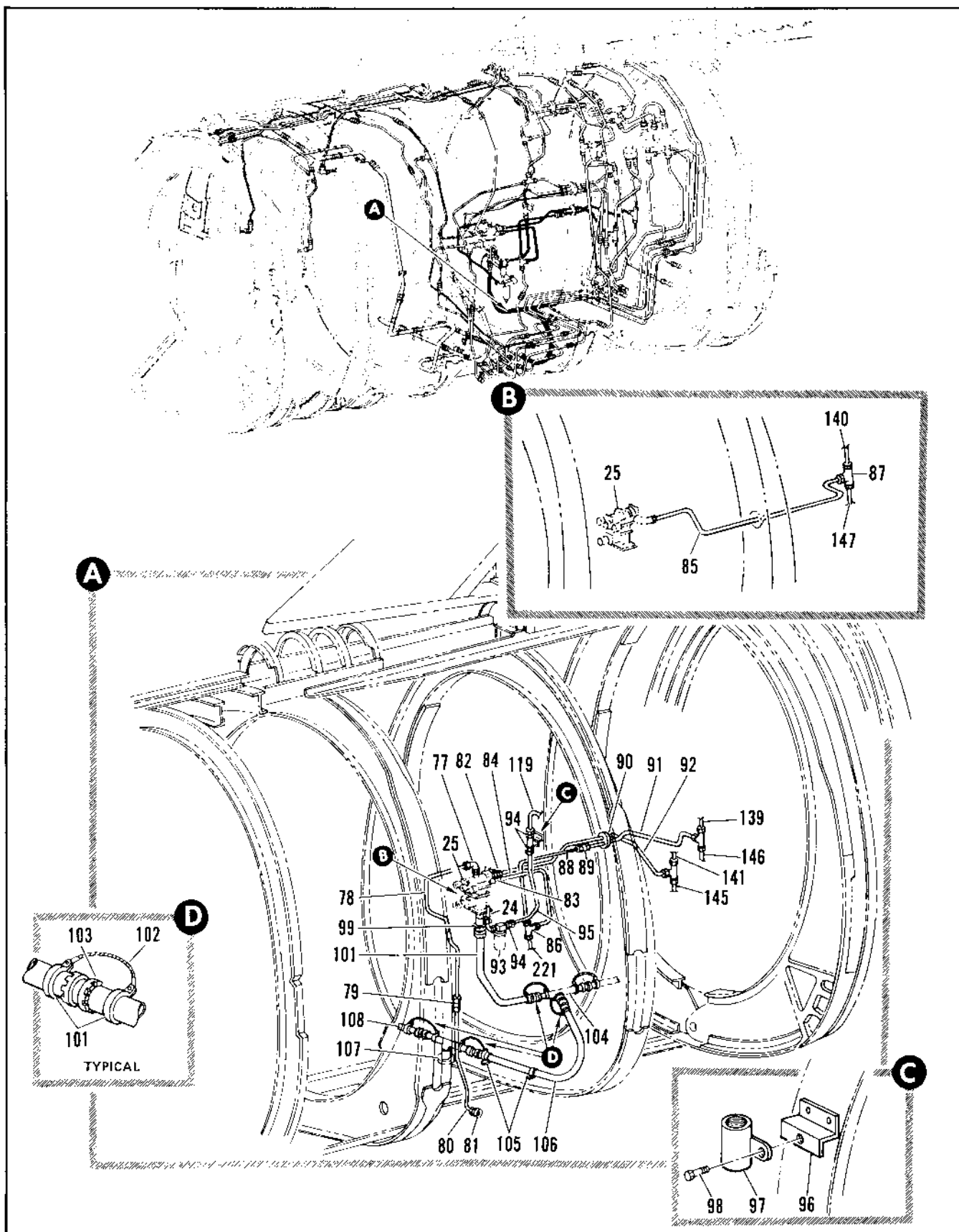

Figure 2.12-46. Fuel Tank Pressure Tubing Installation LH Sta 472 to 577 (Sheet 4 of 8)

FIGURE AND INDEX NUMBER	PART NUMBER	DESCRIPTION	UNITS PER ASSY.	USABLE ON CODE	
				FROM	TO
		1 2 3 4 5 6			
2.12-46- 77	MS2190806	• ELBOW	1	35	
	AN924-6D	• NUT	1	35	
	MS29512-6	• GASKET	1	35	
- 78	8-20397-711	• TUBE ASSEMBLY	1	35	
- 79	MS2190206	• UNION	1	35	
- 80	8-20397-713	• TUBE ASSEMBLY	1	35	
- 81		• ADAPTER, TRANSFER TANK AIR PRESSURE REGULATOR BLEED DRAIN STA 542 SEE FIG. 2.12-16 INDEX 7	RF		
- 82	MS2190204	• UNION	1	35	
	NAS671-4	• GASKET	1	35	
- 83	MS2190204	• UNION	1	35	
	MS29512-4	• GASKET	1	35	
- 84	8-20397-1897	• TUBE ASSEMBLY	1	35	159
- 85	8-20397-3063	• TUBE ASSEMBLY	1	160	
- 86	CR8240063604	• TEE, <92303> 9A-90319-00A	1	35	159
- 87	MS2191006	• TEE	1	160	
	MS2191606-4	• REDUCER	1	160	
	MS29512-6	• GASKET	1	160	
- 88	8-20397-1929	• TUBE ASSEMBLY	1	35	159
- 89	MS2190206	• UNION	1	35	159
- 90	8-28339-25	• GROMMET	2	35	47
	8-28339-25	• GROMMET	1	48	
- 91	8-20397-1931	• TUBE ASSEMBLY	1	35	159
- 92	8-20397-1635	• TUBE ASSEMBLY	1	35	
- 93		• VALVE ASSY, AIR PRESSURE SHUTOFF SEE FIG. 2.12-59 INDEX 9	RF		
- 94	MS2190206	• UNION	3	35	
	NAS617-6	• GASKET	3	35	
- 95	8-20397-316	• TUBE ASSEMBLY	1	35	
- 96	90-93599-103	• BRACKET	1	35	
- 97	MS35-378F	• VALVE ASSY, CHECK <36138> SPEC 8-02998-13 ATTACHING PARTS	1	35	
- 98	AN3-4A	• BOLT	1	35	
- 99	3605-20D	• COUPLING (79326) 92-72503-106	1	35	
	2-2145418-6	• PACKING, REPLACED BY NAS1593-218	1	35	
	NAS1593-218	• PACKING, REPLACES 2-2145418-6			
-100	8-20397-3033	• TUBE ASSEMBLY	1	35	
-101	AN753020	• CLAMP	8	35	
		ATTACHING PARTS			
	NAS579A3	• NUT	8	35	
	AN960019L	• WASHER	8	35	
	AN526-1032R6	• SCREW	8	35	
-102	MS25093-1BB3	• JUMPER	4	35	
-103	2-2145418-6	• PACKING, REPLACED BY NAS1593-218	4	35	
	NAS1593-218	• PACKING, REPLACES 2-2145418-6			
-104		• TEE, SEE FIG. 2.12-59 INDEX 36	RF		
-105	91-95026-019	• CLAMP	2	35	
-106	8-20397-3037	• TUBE ASSEMBLY	1	48	277
	8-21834-11	• TUBE ASSEMBLY	1	A	
-107		• TUBE ASSY, REGULATOR CROSSOVER DRAIN SEE FIG. 2.12-58 INDEX 41	RF		
-108		• TUBE ASSY, SEE FIG. 2.12-32 INDEX 101	RF		
A AIRPLANES #35 THRU 47, 278 AND ON					

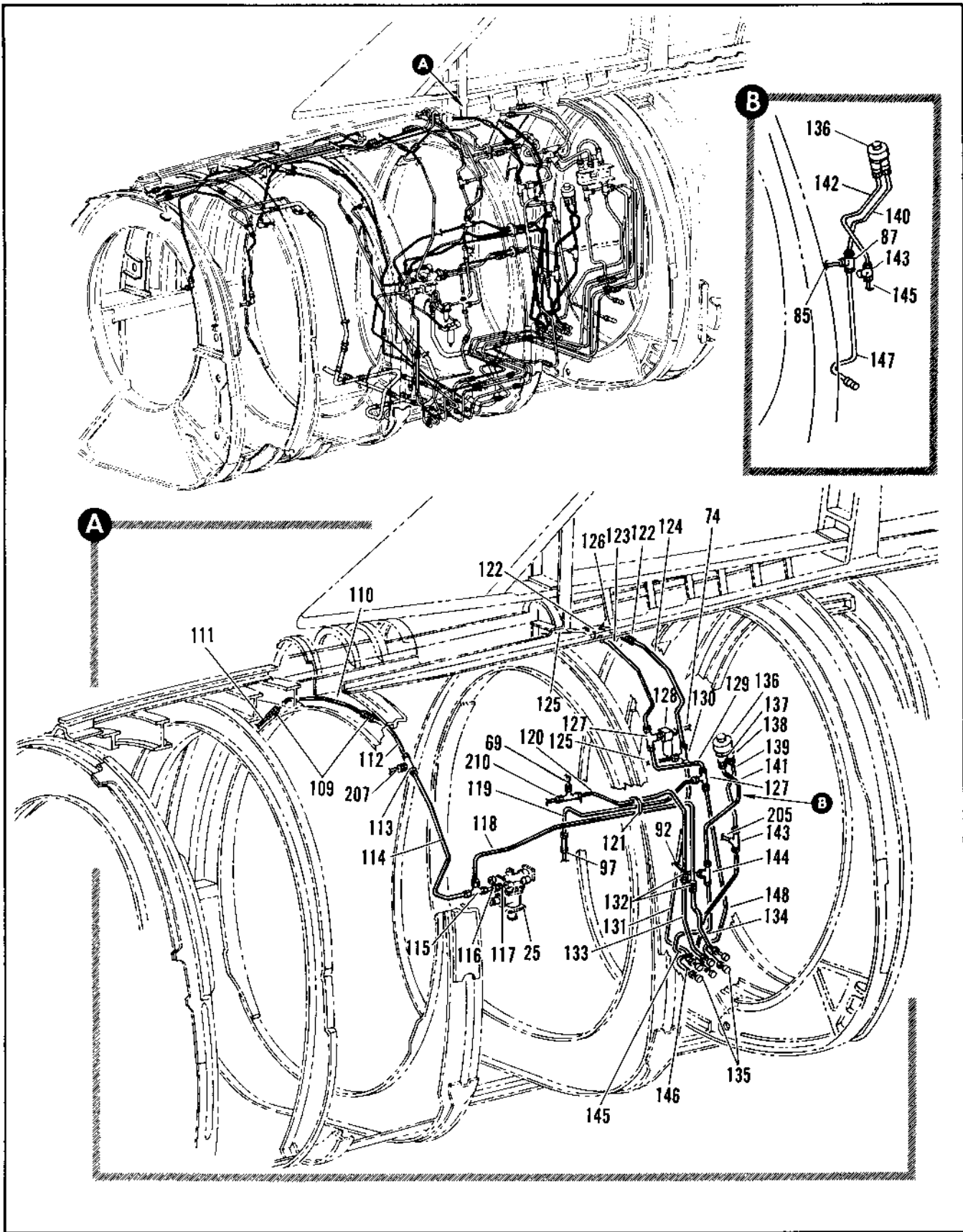

Figure 2.12-46. Fuel Tank Pressure Tubing Installation LH Sta 472 to 577 (Sheet 5 of 8)

FIGURE AND INDEX NUMBER	PART NUMBER	DESCRIPTION	UNITS PER ASSY.	USABLE ON CODE	
				FROM	TO
2.12-46-109	MS2190206	• UNION	2	35	
-110	R-20397-1047	• TUBE ASSEMBLY	1	35	
-111		• TUBE ASSY, SEE FIG. 2.12-32 INDEX 73	RF		
-112	R-20397-1549	• TUBE ASSEMBLY	1	35	
-113	FRR240060604	• TEE, <92003> 98-90319-003	1	35	
-114	R-20397-1597	• TUBE ASSEMBLY	1	35	
-115	MS2190506	• TEE	1	35	
-116	R-20397-1587	• TUBE ASSEMBLY	1	35	
-117	MS2190206	• UNION	1	35	
	NAS617-6	• GASKET	1	35	
-119	R-20397-1593	• TUBE ASSEMBLY	1	35	
-119	R-20397-1063	• TUBE ASSEMBLY	1	35	
-120	R-20397-1597	• TUBE ASSEMBLY	1	35	
-121	R-28339-23	• GROMMET	2	35	47
	R-28339-23	• GROMMET	1	49	277
	R-28339-11	• GROMMET	1	278	
-122	MS2190206	• UNION	2	35	
-123	R-20397-1573	• TUBE ASSEMBLY	1	35	
-124	R-20397-1581	• TUBE ASSEMBLY	1	35	
-125		• TUBE ASSY, SEE FIG. 2.12-32 INDEX 86	RF		
-126		• TUBE ASSY, SEE FIG. 2.12-32 INDEX 97	RF		
	AN924-60	• NUT	2	35	
	AN960D16	• WASHER	2	35	
-127	MS2190906	• TEE	2	35	
-128		• VALVE ASSY, AIR SHUTOFF SEE FIG. 2.12-38 INDEX 69	RF		
-129	R-20397-1571	• TUBE ASSEMBLY	1	35	
-130	FRR240060604	• TEE, <92003> 98-90319-008	1	35	
-131	R-20397-1579	• TUBE ASSEMBLY	1	35	
	AN924-60	• NUT	2	35	
	AN960D916	• WASHER	2	35	
	NAS617-6	• GASKET	1	35	
-132	MS2190206	• UNION	2	35	
-133	R-20397-1599	• TUBE ASSEMBLY	1	35	
-134	R-20397-1595	• TUBE ASSEMBLY	1	35	
-135		• FITTING, TRANSFER TANK AMBIENT SENSING SEE FIG. 2.12-35 INDEX 8	RF		
-135		• SWITCH ASSY, EMERGENCY PRESSURE SEE FIG. 2.12-40 INDEX 53	RF		
-137	MS2190204	• UNION	1	35	
-138	MS2191604	• REDUCER	1	35	159
	MS29512-4	• GASKET	2	35	
-139	R-20397-1693	• TUBE ASSEMBLY	1	35	159
-140	R-20397-3057	• TUBE ASSEMBLY	1	160	
-141	R-20397-308	• TUBE ASSEMBLY	1	35	159
-142	R-20397-3045	• TUBE ASSEMBLY	1	160	
-143	MS2190506	• TEE	1	35	159
-144	MS2190504	• TEE	1	35	
-145	R-20397-1607	• TUBE ASSEMBLY	1	35	
-146	R-20397-1691	• TUBE ASSEMBLY	1	35	159
-147	R-20397-3095	• TUBE ASSEMBLY	1	160	
-148	R-20397-402	• TUBE ASSEMBLY	1	35	

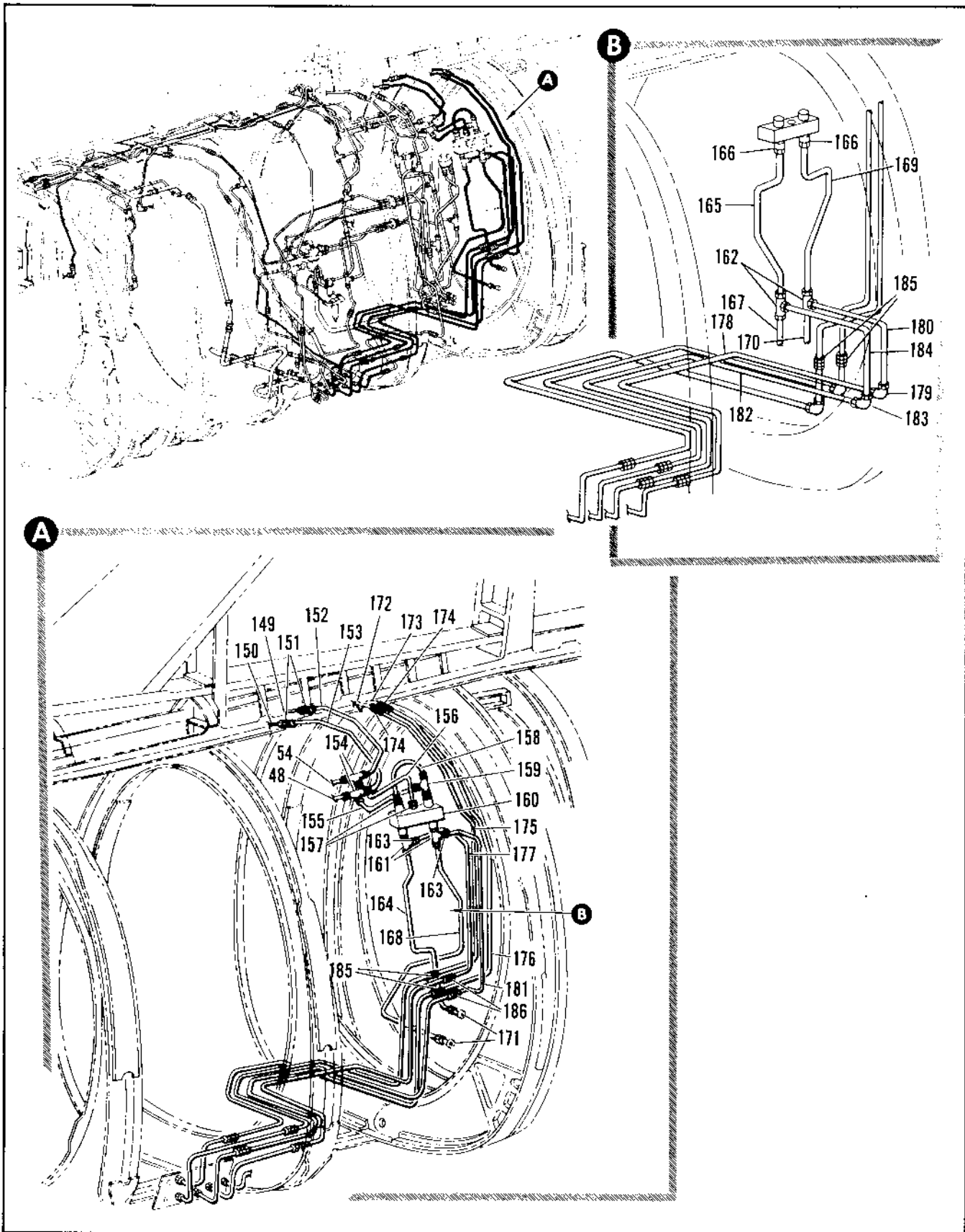

Figure 2.12-46. Fuel Tank Pressure Tubing Installation LH Sta 472 to 577 (Sheet 6 of 8)

FIGURE AND INDEX NUMBER	PART NUMBER	DESCRIPTION	UNITS PER ASSY.	USABLE ON CODE	
				FROM	TO
		1 2 3 4 5 6			
2.12-44-149		• TUBE ASSY, SEE FIG. 2.12-34 INDEX 106	RF		
-150		• TUBE ASSY, SEE FIG. 2.12-34 INDEX 107	RF		
-151	MS2190204	• UNION	2	35	
-152	8-20397-1881	• TUBE ASSEMBLY	1	35	
-153	8-20397-1893	• TUBE ASSEMBLY	1	35	
	AN924-6D	• NUT	2	35	
	AN9500916	• WASHER	2	35	
-154	MS2191206	• TEE	2	35	
-155	8-20397-1881	• TUBE ASSEMBLY	1	35	159
	8-20397-3259	• TUBE ASSEMBLY	1	160	
-156	8-20397-1887	• TUBE ASSEMBLY	1	35	159
	8-20397-3161	• TUBE ASSEMBLY	1	160	
-157	MS2190204	• UNION	2	35	
	MS2191204	• GASKET	2	35	
	AN924-6D	• NUT	1	35	
-158	8-20397-1887	• TUBE ASSEMBLY	1	35	
-159	MS2191206	• TEE	1	35	
	MS2191204	• GASKET	1	35	
-160		• VALVE ASSY, FUEL TANK AIR CHECK SEE FIG. 2.12-48 INDEX 97	RF		
	AN924-6D	• NUT	2	35	159
-161	MS2191004	• TEE	2	35	159
-162	ER2840062-14	• TEE, (3/8" BSPP) 4-20310-10	2	160	
	WAS17-6	• GASKET	4	35	159
-163	MS2191406-4	• REDUCER	2	35	159
-164	8-20397-1487	• TUBE ASSEMBLY	1	35	159
-165	8-20397-1487	• TUBE ASSEMBLY	1	160	
-166	MS2190204	• UNION	2	160	
	MS2191204	• GASKET	2	160	
-167	8-20397-1485	• TUBE ASSEMBLY	1	160	
-168	8-20397-1485	• TUBE ASSEMBLY	1	35	159
-169	8-20397-3761	• TUBE ASSEMBLY	1	160	
-170	8-20397-3761	• TUBE ASSEMBLY	1	160	
-171		• FITTING, TRANSFER TANK AIR/FUEL SENSING SEE FIG. 2.12-46 INDEX 5	RF		
-172		• TUBE ASSY, SEE FIG. 2.12-34 INDEX 116	RF		
-173		• TUBE ASSY, SEE FIG. 2.12-34 INDEX 115	RF		
-174	MS2191004	• UNION	2	35	
-175	8-20397-1483	• TUBE ASSEMBLY	1	35	
-176	8-20397-1485	• TUBE ASSEMBLY	1	35	
-177	8-20397-1418	• TUBE ASSEMBLY	1	35	
-178	8-20397-1483	• TUBE ASSY	1		
-179	MS2191204	• ELBOW	1		
	AN924-6D	• NUT	1		
	AN9500916	• WASHER	1		159
-180	8-20397-1483	• TUBE ASSY	1		
-181	8-20397-1485	• TUBE ASSY	1	35	159
-182	8-20397-1483	• TUBE ASSY	1		
-183	MS2190704	• ELBOW	1		
	AN924-6D	• NUT	1		
	AN9500916	• WASHER	1		
-184	8-20397-1483	• TUBE ASSY	1		
-185	MS2190204	• UNION	2	35	
-186	MS2190204	• UNION	2	35	159

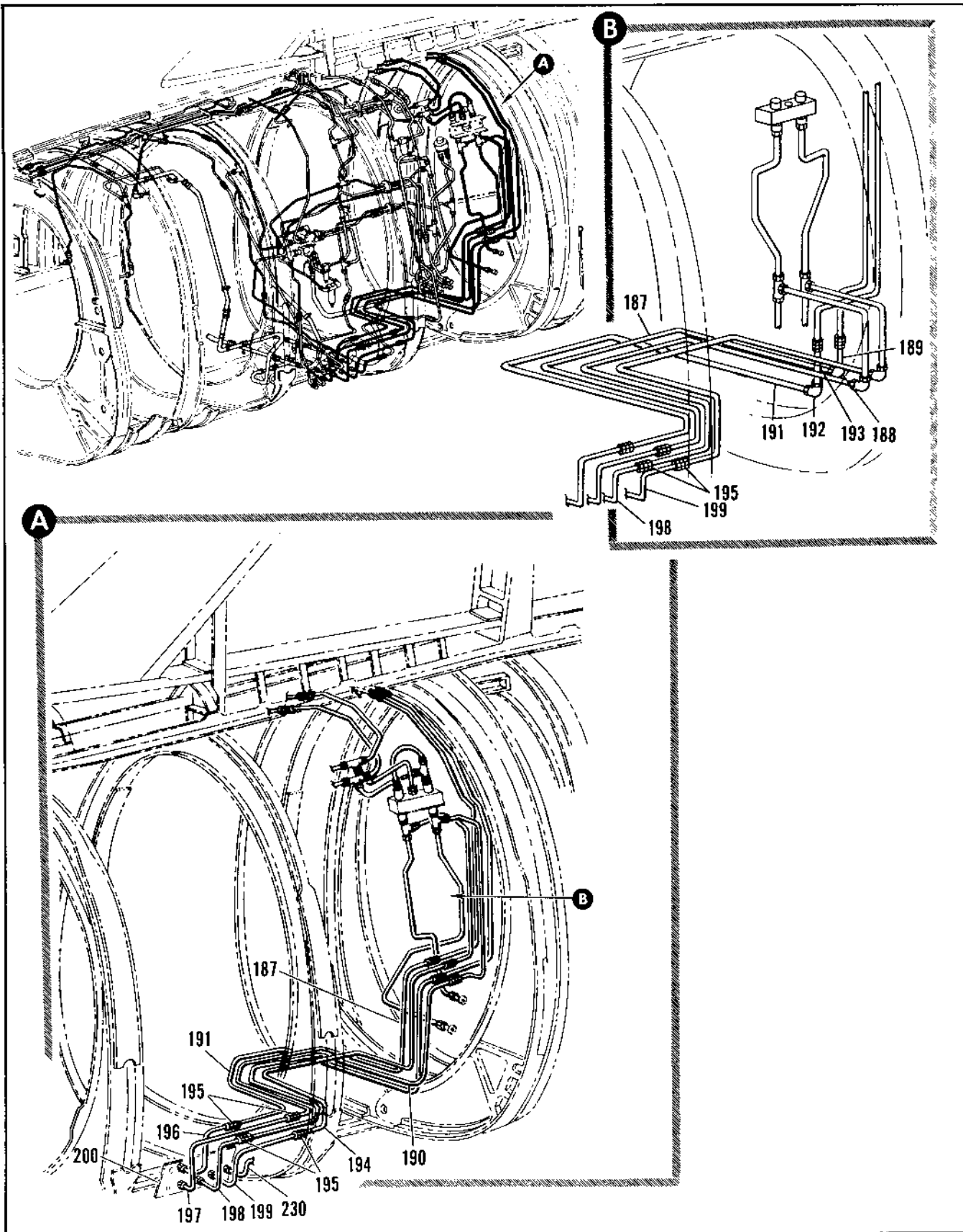

Figure 2.12-46. Fuel Tank Pressure Tubing Installation LH Sta 472 to 577 (Sheet 7 of 8)

FIGURE AND INDEX NUMBER	PART NUMBER	DESCRIPTION	UNITS PER ASSY.	USABLE ON CODE	
				FROM	TO
		1 2 3 4 5 6			
2.12-46-187	8-83304-9	• TUBE ASSY	1		
-188	MS21907D4	• ELBOW	1		
	AN924-40	• NUT	1		
	AN9610716	• WASHER	1		
-189	8-80304-21	• TUBE ASSY	1	35	159
-190	8-80304-67	• TUBE ASSY	1		
-191	8-80304-7	• TUBE ASSY	1		
-192	MS21903D4	• ELBOW	1		
	AN924-40	• NUT	1		
	AN9610716	• WASHER	1		
-193	8-80304-19	• TUBE ASSY	1	35	159
-194	8-80304-69	• TUBE ASSY	1		
-195	MS21902D4	• UNION	4	35	
-196	8-20397-1399	• TUBE ASSEMBLY	1	35	
-197	8-20397-1407	• TUBE ASSEMBLY	1	35	
-198	8-20397-1413	• TUBE ASSEMBLY	1	35	
-199	8-20397-1415	• TUBE ASSEMBLY	1	35	
-200		• PANEL INSTL. FUEL SYSTEM CHECKOUT AFT SEE FIG. 2.12-40	RF		

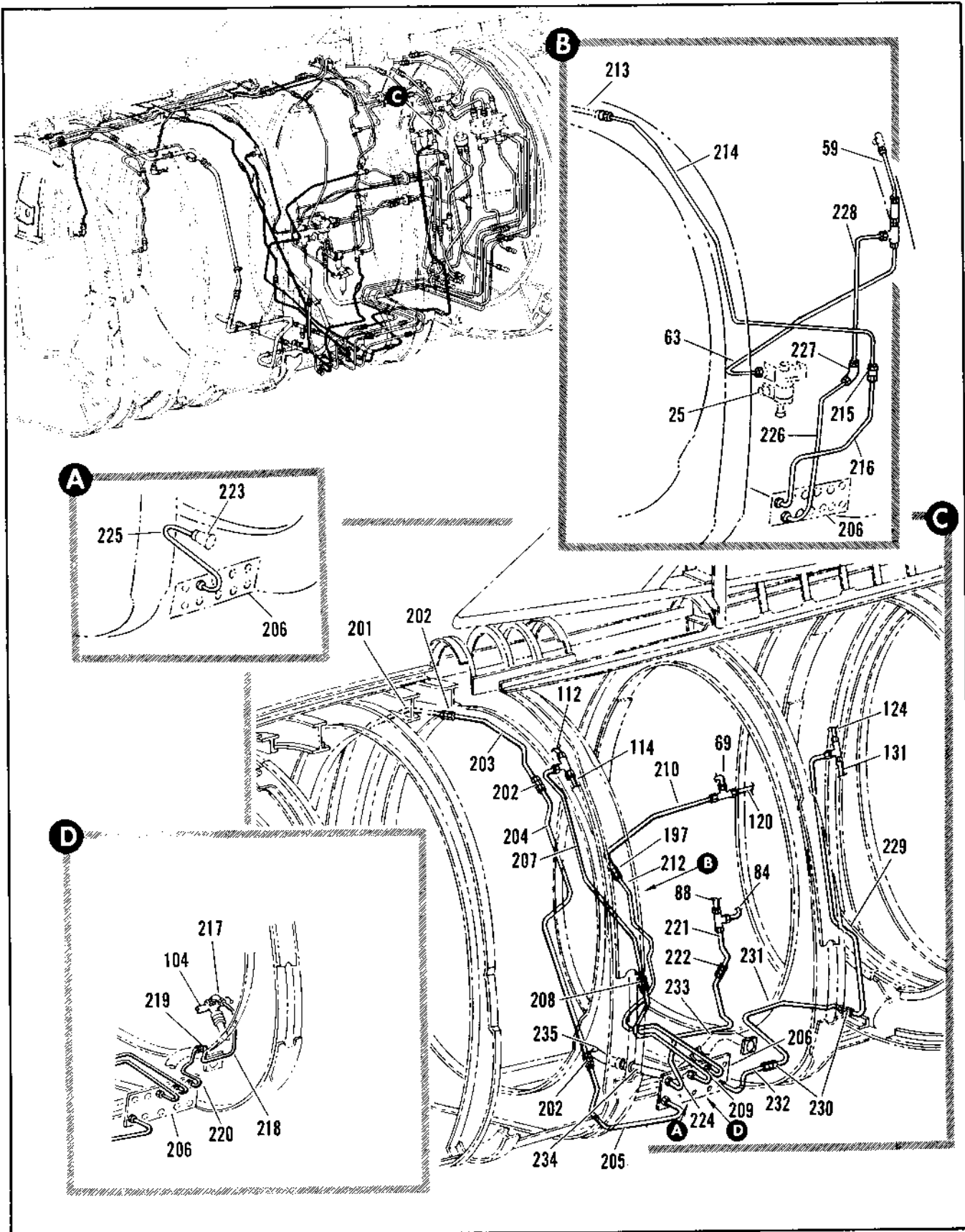

Figure 2.12-46. Fuel Tank Pressure Tubing Installation LH Sta 472 to 577 (Sheet 8 of 8)

FIGURE AND INDEX NUMBER	PART NUMBER	DESCRIPTION 1 2 3 4 5 6	UNITS PER ASSY.	USABLE ON CODE	
				FROM	TO
2.12-46-201		• TUBE ASSY. SEE FIG. 2.12-32 INDEX 2	RF		
-202	MS2190206	• UNION	3	35	
-203	R-23397-1435	• TUBE ASSEMBLY	1	35	
-204	R-23397-3001	• TUBE ASSEMBLY	1	35	
-205	R-23397-2099	• TUBE ASSEMBLY	1	35	
-205		• PANEL INSTL. FUEL SYSTEM CHECKOUT AFT SEE FIG. 2.12-40	RF		
-207	R-23397-3005	• TUBE ASSEMBLY	1	35	
-208	MS2190204	• UNION	1	35	
-209	R-23397-3013	• TUBE ASSEMBLY	1	35	
-210	R-23397-1429	• TUBE ASSEMBLY	1	35	
-211	MS2191606-4	• REDUCER	1	35	
-212	R-23397-2097	• TUBE ASSEMBLY	1	35	
-213		• TUBE ASSY			
-214	R-23397-2069	• TUBE ASSEMBLY	1	35	
-215	MS21903-4	• UNION	1		
	AN924-40	• NUT	1		
	AN950D716	• WASHER	1	35	
	MS2192404	• UNION	1	35	
-216	R-23397-2871	• TUBE ASSEMBLY	1	35	
-217	MS2190304	• ELBOW	1	35	
	AN924-40	• NUT	1	35	
	NAS617-4	• GASKET	1	35	
-218	R-23397-3041	• TUBE ASSY	1	35	
	R-80304-11	• TUBE ASSY	1		
-219	MS2191606-4	• REDUCER	1	35	
-220	R-23397-2013	• TUBE ASSEMBLY	1	35	
-221	R-23397-1451	• TUBE ASSEMBLY	1	35	159
-222	MS2190206	• UNION	1	35	159
-223		• SEAL INSTL. CG TRANSFER PRESSURE FITTING LH SEE FIG. 2.12-35	RF		
-224	R-23397-1449	• TUBE ASSEMBLY	1	35	159
-225	R-23397-3079	• TUBE ASSEMBLY	1	160	215
-226	R-23397-2863	• TUBE ASSEMBLY	1	35	
-227	MS2190304	• ELBOW	1	35	
	AN960D716	• WASHER	1	35	
	AN924-40	• NUT	1	35	
-228	R-23397-2065	• TUBE ASSEMBLY	1	35	
-229	R-23397-1425	• TUBE ASSEMBLY	1	35	
-230	MS2190204	• UNION	2	35	
-231	R-80304-17	• TUBE ASSY	1		
	91-96026-019	• CLAMP	1		
	MS9024-03	• CLAMP	1		
	AN52 -10RB	• SCREW	1		
	NAS1251-7	• NUT	1		
-232	R-23397-2019	• TUBE ASSY	1	35	
-233		• TUBE ASSY, ENGINE FUEL SUPPLY SEE FIG. 2.12-65 INDEX 30	RF		
-234		• TUBE ASSY, ENGINE FUEL SUPPLY SEE FIG. 2.12-65 INDEX 33	RF		
-235		• TUBE ASSY, FUSELAGE ENGINE SUPPLY SEE FIG. 2.12-65 INDEX 9	RF		

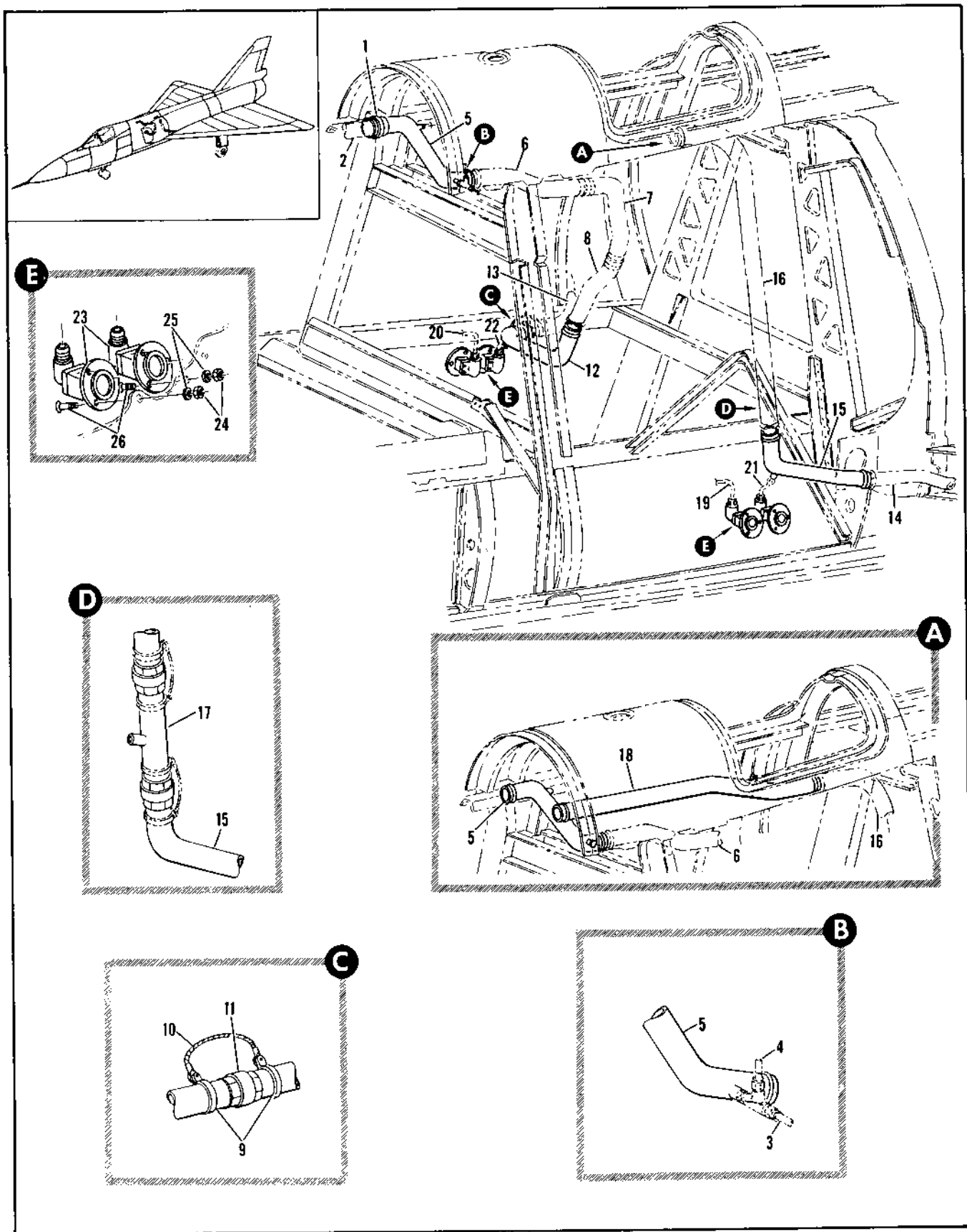

Figure 2.12-47. Vent Fuselage Tank to Wing Tubing Installation

FIGURE AND INDEX NUMBER	PART NUMBER	DESCRIPTION	UNITS PER ASSY.	USABLE ON CODE	
				FROM	TO
2.12-47	8-28219-5	TUBING INSTALLATION, VENT FUSELAGE TANK TO WING FOR NHA SEE FIG. 2.12-3	RF	35	
- 1	3605-240 MS29513-325	• COUPLING, <79326> 92-72500-013	1	35	
- 2		• PACKING	2	35	
- 3		• TUBE ASSY, FUEL TANK VENT RH SEE FIG. 2.12-49 INDEX 33	RF		
- 4		• TUBE ASSY, FUEL SEE FIG. 2.12-45 INDEX 95	RF		
- 5	8-24344	• TUBE ASSY, FUEL SEE FIG. 2.12-45 INDEX 97	RF		
- 6		• TUBE ASSY, RH	1	35	
- 7		• TUBE ASSY, FUEL TANK PRESSURE RH SEE FIG. 2.12-45 INDEX 157	RF		
- 8		• TUBE ASSY, FUEL TANK PRESSURE RH SEE FIG. 2.12-45 INDEX 158	RF		
- 9	AN735024	• TUBE ASSY, FUEL TANK PRESSURE RH SEE FIG. 2.12-45 INDEX 159	RF		
		• CLAMP	2	35	
		ATTACHING PARTS			
	NAS679A3	• NUT	2	35	
	AN963D10L	• WASHER	2	35	
	AN526-1032R6	• SCREW	2	35	
		-----X-----			
- 10	MS29583-1884	• JUMPER	1	35	
- 11	3605-240 MS29513-325	• COUPLING, <79326> 92-72500-013	1	35	
- 12	8-24336-16	• PACKING	2	35	
- 13		• TUBE ASSY, RH WELDED	1	35	
- 14		• TUBE ASSY, RH SEE FIG. 2.12-14 INDEX 7	RF		
- 15	8-24336-15	• TUBE ASSY, LH SEE FIG. 2.12-14 INDEX 7	RF		
- 16		• TUBE ASSY, LH WELDED	1	35	
- 17	8-28492-1	• TUBE ASSY, FUEL TANK PRESSURE	RF		
- 18	8-28355	SEE FIG. 2.12-44 INDEX 184			
- 19		• TUBE ASSY, TANK TO WING VENT LH	1	160	
- 20		• TUBE ASSY, LH STA 255	1	35	
- 21		• TUBE ASSY, FUEL TANK PRESSURE LH SEE FIG. 2.12-44 INDEX 173	RF		
- 22		• TUBE ASSY, FUEL TANK PRESSURE RH SEE FIG. 2.12-44 INDEX 173	RF		
- 23	8858	• TUBE ASSY, FUEL TANK PRESSURE LH SEE FIG. 2.12-44 INDEX 164	RF		
- 24		• TUBE ASSY, FUEL TANK PRESSURE RH SEE FIG. 2.12-44 INDEX 164	RF		
- 25		• VALVE ASSY, DRAIN (01511) 92-13200-001	4	35	
- 26		T.O. 4J15-4-35-3			
		ATTACHING PARTS			
	NAS679A3	• NUT, 96-37545-102	12	35	
	AN961D10L	• WASHER	12	35	
	AN533-10R10	• SCREW	12	35	
		-----Y-----			

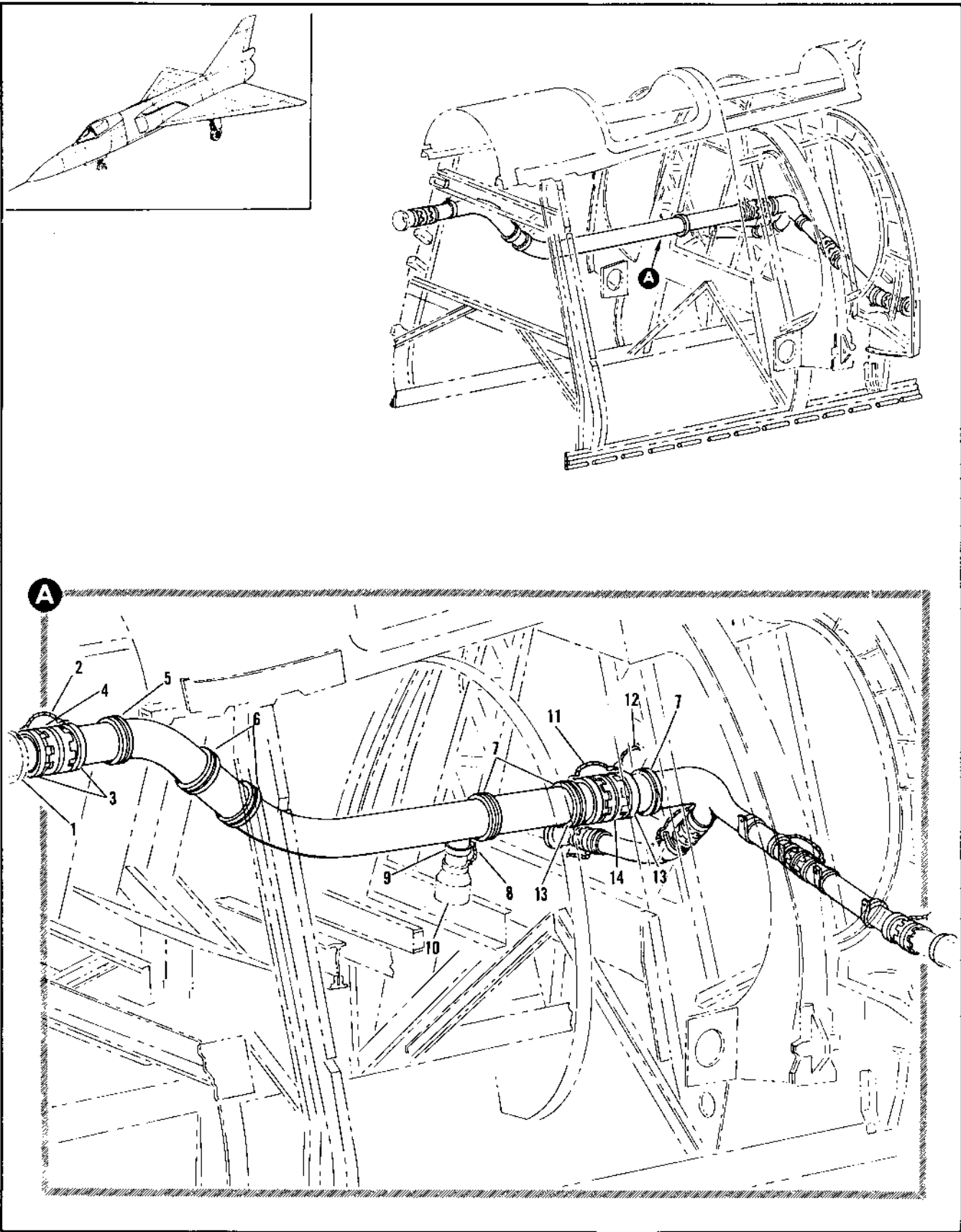

Figure 2.12-48. Fuselage Tank to Wing Fuel Transfer Tubing Installation (Sheet 1 of 3)

FIGURE AND INDEX NUMBER	PART NUMBER	DESCRIPTION	UNITS PER ASSY.	USABLE ON CODE	
				FROM	TO
		1 2 3 4 5 6			
2.12-48	8-27470	TUBING INSTALLATION, FUSELAGE TANK TO WING FUEL TRANSFER FOR NHA SEE FIG. 2.3-3	RF	35	60
	8-27470-3	TUBING INSTALLATION, FUSELAGE TANK TO WING FUEL TRANSFER FOR NHA SEE FIG. 2.3-3	RF	61	188
	8-27470-5	TUBING INSTALLATION, FUSELAGE TANK TO WING FUEL TRANSFER FOR NHA SEE FIG. 2.3-3	RF	189	
- 1		• TUBE ASSY, TRANSFER SEE FIG. 2.12-52 INDEX	RF		
- 2	MS25083-1886	• JUMPER	1	35	188
	NAS679A3	• ATTACHING PARTS			
	AN960D10L	• NUT, GROUND STUD	2	35	188
	AN526-1032R6	• WASHER, GROUND STUD	2	35	188
		• SCREW, GROUND STUD	2	35	188
		-----X-----			
- 3	AN735D64	• CLAMP	2	35	188
- 4	3601-640	• COUPLING, <79326> 72-72500-007	1	35	48
	3605-640	• COUPLING, <79326> 62-72500-020	1	49	188
	MS29513-345	• PACKING	2	35	188
	8-28515-11	• SPACER	1	142	188
- 5	50230C75-458M	• CLAMP, <986255> 91-97802-040	1	35	188
	8-28277-11	• PAD	1	35	188
- 6	50230C75-458M	• CLAMP, <98625> 91-97802-040	2	35	89
	8-28277-13	• PAD	2	35	60
	8-28277-11	• PAD	2	61	89
- 7	50230C75-458M	• CLAMP, <98625> 91-97802-040	3	35	89
	8-28277-11	• PAD	3	35	89
- 8	MS25083-1886	• JUMPER	1	35	264
	MS25193-1888	• JUMPER	1	265	
	NAS679A3	• ATTACHING PARTS			
	AN960D10L	• NUT	2	35	
	AN526-1032R6	• WASHER	2	35	
		• SCREW	2	35	
		-----X-----			
- 9	AN735D32	• CLAMP	1	35	188
- 10		• VALVE ASSY, REFUELING REGULATOR AND CHECK SEE FIG. 2.12-55 INDEX 10	RF		
- 11	MS25183-1886	• JUMPER	1	35	89
- 12	MS25193-1883	• JUMPER	1	35	89
	NAS679A3	• ATTACHING PARTS			
	AN960D10L	• NUT, GROUND STUD	2	35	89
	AN526-1032R6	• WASHER, GROUND STUD	2	35	89
		• SCREW, GROUND STUD	2	35	89
		-----X-----			
- 13	AN735D64	• CLAMP	2	35	89
- 14	3605-720	• COUPLING, <79326>	1	35	89
	MS29513-349	• PACKING	2	35	89
	8-28515-9	• SPACER	2	8	
		B AIRPLANES 436 THRU 39, 41 THRU 47, 49 THRU 89			

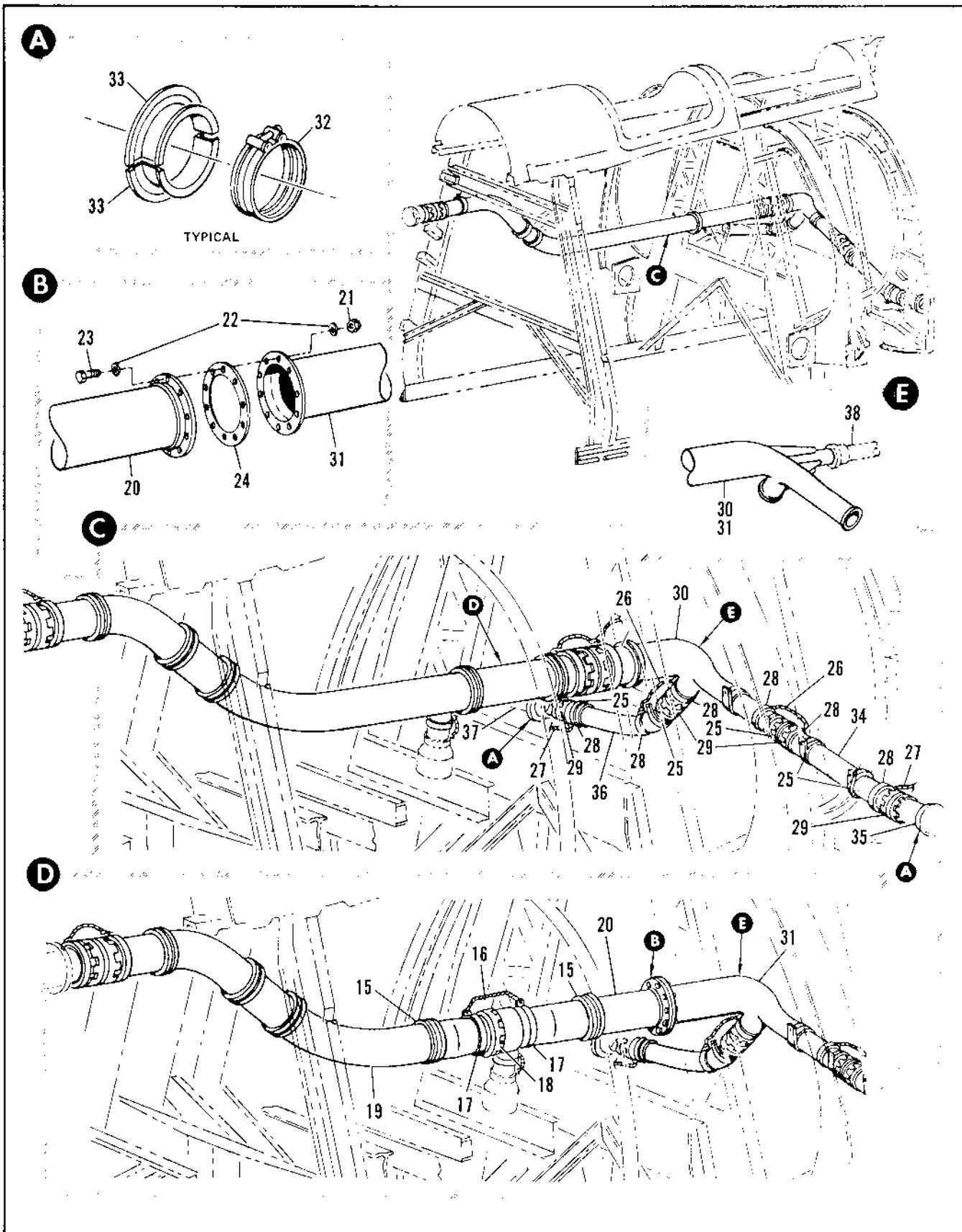

Figure 2.12-48. Fuselage Tank to Wing Fuel Transfer Tubing Installation (Sheet 2 of 3)

FIGURE AND INDEX NUMBER	PART NUMBER	DESCRIPTION	UNITS PER ASSY.	USABLE ON CODE	
				FROM	TO
		1 2 3 4 5 6			
2.12-48 15	50231075-45AM	• CLAMP, <98625> 91-97832-04	2	90	188
	1-28277-11	• PAD	2	90	188
- 16	MS25193-1BBF	• JUMPER	1	90	188
	NAS679A3	ATTACHING PARTS			
	AN967D10L	• NUT, GROUND STUD	2	90	188
	AN526-1032R6	• WASHER, GROUND STUD	2	90	188
		• SCREW, GROUND STUD	2	90	188
		-----X-----			
- 17	AN735064	• CLAMP	2	90	188
- 17	3505-540	• COUPLING, <79326> 92-72510-317	1	90	188
	MS29513-345	• PACKING	1	90	188
	8-28515-7	• SPACER	2	C	
	8-28515-11	• SPACER	2	90	188
- 19	8-28466-1	• TUBE ASSY, WELDED	1	90	152
		REPLACES NOT INTCHG WITH 8-28271-5			
		REPLACED BY SUITABLE SUP 8-28466-3			
	8-28466-3	• TUBE ASSY, WELDED	1	153	188
		REPLACES SUITABLE SUP FOR 8-28466-1			
- 20	8-28491-1	• TUBE ASSY, WELDED REPLACES NOT INTCHG WITH 8-28271-5	1	90	188
		REPLACED BY SUITABLE SUP 8-28491-3			
		ATTACHING PARTS			
- 21	NAS679A4	• NUT	10	90	188
- 22	AN967D0416	• WASHER	20	90	188
- 23	AN4-13A	• BOLT	10	90	188
		-----X-----			
- 24	2891	• GASKET, <98159> SPEC 8-18958-1	1	90	188
- 25	50231075-30AM	• CLAMP, <98625> 91-97832-039	6	35	
	1-28277-9	• PAD	6	35	
- 26	MS25183-1BBF	• JUMPER	2	35	
- 27	MS25183-1BB3	• JUMPER	2	35	
	NAS679A3	ATTACHING PARTS			
	AN907010L	• NUT, GROUND STUD	6	35	
	AN526-1032R6	• WASHER, GROUND STUD	6	35	
		• SCREW, GROUND STUD	6	35	
		-----X-----			
- 28	AN735049	• CLAMP	6	35	
- 29	3635-440	• COUPLING, <79326> 92-72510-316	4	35	
	MS29513-337	• PACKING	8	35	
- 30	66J41344-6	• TEE ASSY, WELDED (ALTERED FROM 8-28272-3)	1	49	89
	66J41344-7	• TEE ASSY, WELDED (ALTERED FROM 8-28272-803)	1	35	48
	66J41344-8	• TEE ASSY, WELDED (ALTERED FROM 8-28272-805)	1	90	188
	66J41344-9		1		
	66J41344-10	• TEE ASSY, WELDED ALTERED FROM 8-28272-11	1		
	66J41344-11	• TEE ASSY, WELDED ALTERED FROM 8-28272-11	1		
- 31	66J41344-6	• TEE ASSY, WELDED ALTERED FROM 8-28272-5	1		
	8-28323	• SEAL INSTL, FUEL	2	35	
- 32	325-62-303M	• CLAMP, <98625> 91-97832-017	1	35	
- 33	1-28523-1	• SEAL	2	35	
- 34	8-28314	• TUBE ASSY, LH WELDED	1	35	188
- 35		• TUBE ASSY, RH FUEL TRANSFER LH	RF		
		SEE FIG. 2.12-14 INDEX 3A			
		C AIRPLAVES 435 AND 40			

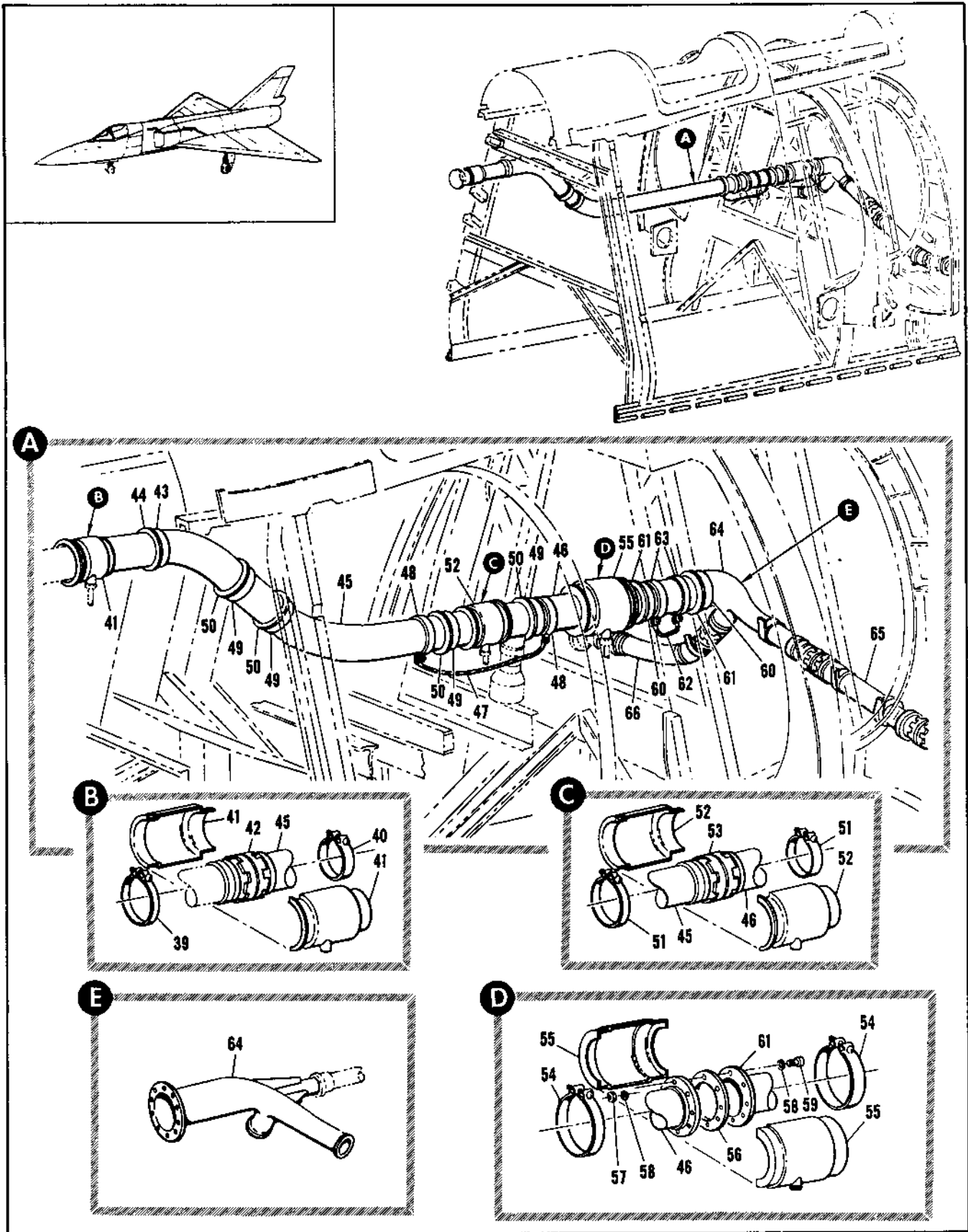

Figure 2.12-48. Fuselage Tank to Wing Fuel Transfer Tubing Installation (Sheet 3 of 3)

FIGURE AND INDEX NUMBER	PART NUMBER	DESCRIPTION	UNITS PER ASSY.	USABLE ON CODE	
				FROM	TO
2.12-48- 36 - 37	9-28313	<ul style="list-style-type: none"> TUBE ASSY, RH WELDED TUBE ASSY, CG FUEL TRANSFER RH SEE FIG. 2.12-14 INDEX 35 	1	35	188
			PF	35	188
- 38			R4		
- 39	91-97815-380	<ul style="list-style-type: none"> TUBE ASSY, SEE FIG. 2.12-68 INDEX 67 	1	189	
- 40	325-52-431M	<ul style="list-style-type: none"> CLAMP 	1	189	
- 41	4508-1	<ul style="list-style-type: none"> CLAMP, <98625> 91-97802-023 	1	189	
- 42	3635-640	<ul style="list-style-type: none"> BOOT, <H4914> SPEC 8-09965-1 	1	189	
- 43	MS29513-345	<ul style="list-style-type: none"> COUPLING, <79325> 22-72500-019 	2	189	
- 44	50230C75-454M	<ul style="list-style-type: none"> PACKING 	3	189	
- 45	8-28277-11	<ul style="list-style-type: none"> CLAMP, <98625> 91-97802-040 	3	189	
- 46	8-28466-3	<ul style="list-style-type: none"> PAD 	1	189	
	8-28491-1	<ul style="list-style-type: none"> TUBE ASSY, WELDED TUBE ASSY, WELDED REPLACED BY SUITABLE SUB 8-28491-3 	1	189	264
	8-28491-3	<ul style="list-style-type: none"> TUBE ASSY, WELDED REPLACES SUITABLE SUB FOR 8-28491-1 ATTACHING PARTS 	1	265	
	NAS679A4	<ul style="list-style-type: none"> NUT 	10	189	
	AN967D10L	<ul style="list-style-type: none"> WASHER 	20	189	
	AN4-13A	<ul style="list-style-type: none"> BOLT 	12	189	
		-----X-----			
- 47	MS25383-1PB2A	<ul style="list-style-type: none"> JUMPER 	1	189	
		ATTACHING PARTS			
	NAS679A3	<ul style="list-style-type: none"> NUT, GROUND STUD 	2	189	
	AN967D10L	<ul style="list-style-type: none"> WASHER, GROUND STUD 	2	189	
	AN526-1032R6	<ul style="list-style-type: none"> SCREW, GROUND STUD 	2	189	
		-----X-----			
- 48	AN735072	<ul style="list-style-type: none"> CLAMP 	2	189	
- 49	50230C75-454M	<ul style="list-style-type: none"> CLAMP, <98625> 91-97802-040 	2	189	
- 50	8-28277-11	<ul style="list-style-type: none"> PAD 	2	189	
- 51	325-52-431M	<ul style="list-style-type: none"> CLAMP, 91-97802-023 	2	189	
- 52	4508-3	<ul style="list-style-type: none"> BOOT, <H4914> SPEC 8-09965-3 	1	189	
- 53	3635-640	<ul style="list-style-type: none"> COUPLING, <79325> 22-72500-019 	1	189	
	MS29513-345	<ul style="list-style-type: none"> PACKING, 91-97802-040 	2	189	
- 54	91-97815-390	<ul style="list-style-type: none"> CLAMP 	2	189	
- 55	4508-7	<ul style="list-style-type: none"> BOOT, <H4914> SPEC 8-09965-7 	1	265	
- 56	2891	<ul style="list-style-type: none"> GASKET, <98159> SPEC 8-19959-1 	1	189	
- 57	NAS679A4	<ul style="list-style-type: none"> NUT 	10	189	
- 58	AN967D10L	<ul style="list-style-type: none"> WASHER 	20	189	
- 59	AN4-13A	<ul style="list-style-type: none"> BOLT 	12	189	
- 60	50230C75-454M	<ul style="list-style-type: none"> CLAMP, <98625> 91-97802-040 	2	189	
- 61	8-28277-11	<ul style="list-style-type: none"> PAD 	2	189	
- 62	MS25383-1PB3	<ul style="list-style-type: none"> JUMPER 	1	189	
		ATTACHING PARTS			
	NAS679A3	<ul style="list-style-type: none"> NUT, GROUND STUD 	2	189	
	AN967D10L	<ul style="list-style-type: none"> WASHER, GROUND STUD 	2	189	
	AN526-1032R6	<ul style="list-style-type: none"> SCREW 	2	189	
		-----X-----			
- 63	AN735072	<ul style="list-style-type: none"> CLAMP 	2	189	
- 64	66J47344-7	<ul style="list-style-type: none"> TEE ASSY, WELDED ALTERED FROM 8-28272-803 	1	189	246
	66J47344-8	<ul style="list-style-type: none"> TEE ASSY, WELDED ALTERED FROM 8-28272-805 	1	247	246
	66J47344-9	<ul style="list-style-type: none"> TEE ASSY, ALTERED FROM 8-28272-807 		189	246
	66J47344-2			247	246
	66J46344-1	<ul style="list-style-type: none"> TEE ASSY, WELDED ALTERED ALTERED FROM 8-28272-809 	1	265	
	66D47343-1	<ul style="list-style-type: none"> TUBE ASSY, SEE FIG. 2.12-67 INDEX 25 	PF	189	
	66D47343-1	<ul style="list-style-type: none"> TUBE ASSY, (SEE FIG. 2.12-67 INDEX 26) 	PF		
- 65	8-28339-1	<ul style="list-style-type: none"> TUBE ASSY, LH WELDED 	1	189	
- 66	8-28313-1	<ul style="list-style-type: none"> TUBE ASSY, RH WELDED 	1	189	

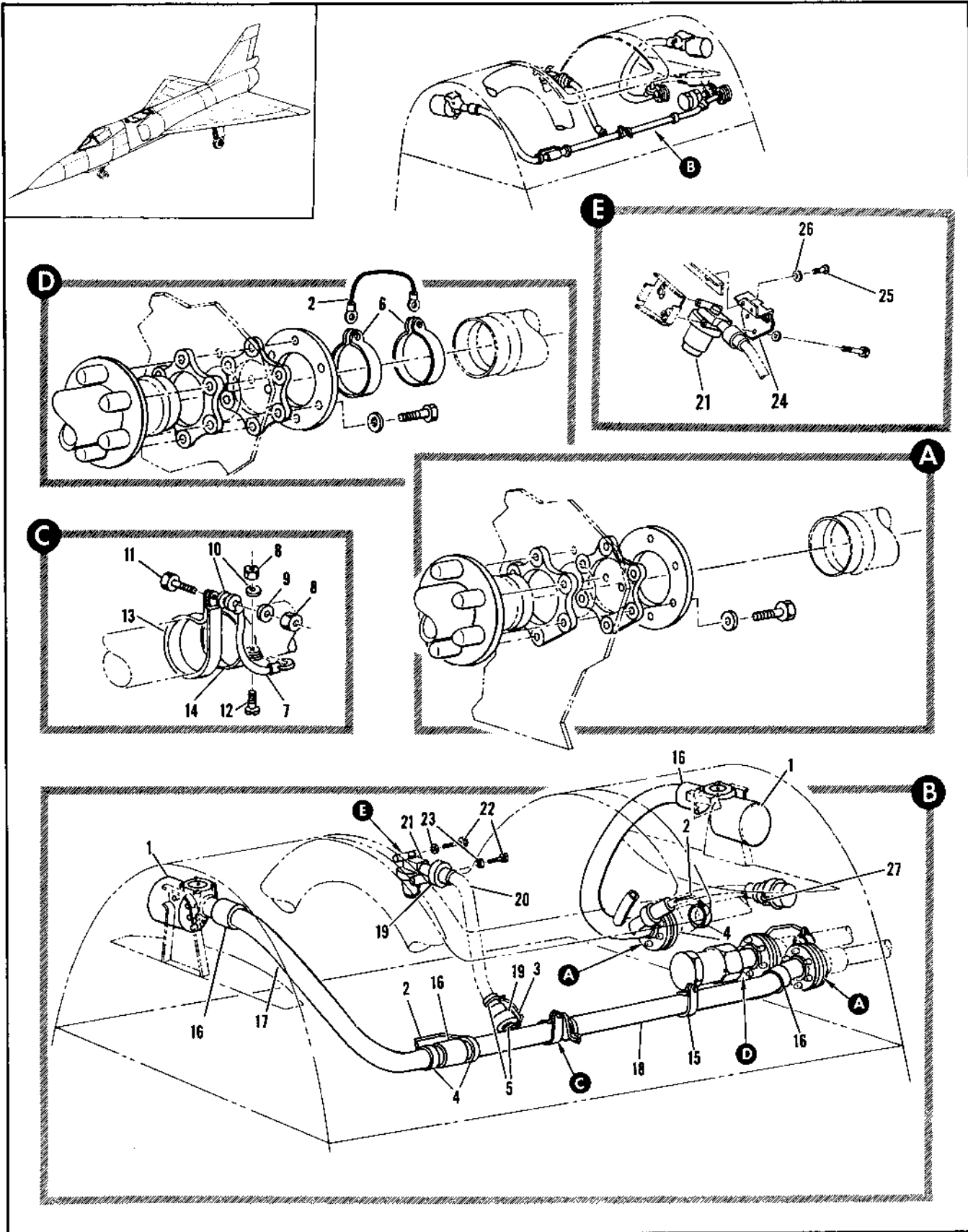

Figure 2.12-49. Fuselage Fuel Tank Vent Tubing Installation (Sheet 1 of 3)

FIGURE AND INDEX NUMBER	PART NUMBER	DESCRIPTION 1 2 3 4 5 6	UNITS PER ASSY.	USABLE ON CODE	
				FROM	TO
2.12-49	8-27447	TUBING INSTALLATION, FUSELAGE FUEL TANK VENT MODIFIED BY 9-21887 FOR NHA SEE FIG. 2.12-50	RF	35	188
	8-27447-1	TUBING INSTALLATION, FUSELAGE FUEL TANK VENT FOR NHA SEE FIG. 2.12-50	RF	189	
- 1	8-28200	• VALVE INSTL, INTEGRAL FUEL TANK VENT FOR BREAKDOWN SEE FIG. 2.12-53	2	35	
- 2	MS25083-1886	• JUMPER	3	35	
- 3	MS25083-1883	• JUMPER	1	35	
	NAS679A3	ATTACHING PARTS	8	35	
	AN967D10L	• NUT	8	35	
	AN526-1032R6	• WASHER	8	35	
		• SCREW			
		-----X-----			
- 4	AN735024	• CLAMP	4	35	
- 5	AN735012	• CLAMP	2	35	
- 6	AN735020	• CLAMP	2	35	
- 7	MS25083-1883	• JUMPER	1	35	
	NAS679A3	ATTACHING PARTS	2	35	
- 9	AN967-10L	• NUT	1	35	
- 10	AN967D10L	• WASHER	2	35	
- 11	AN3-4A	• WASHER	1	35	
- 12	AN526-1032R6	• BOLT	1	35	
		• SCREW			
		-----X-----			
- 13	MS21919DF24	• CLAMP	1	35	
- 14	AN735024	• CLAMP	1	35	
- 15	MS21919DF24	• CLAMP	1	35	
	NAS679A3	• NUT	1	35	
	AN967PD10	• WASHER	2	35	
	AN520-10RH	• SCREW	1	35	
- 15	CF14-150	• COUPLING, <94425> 92-73008-008 REPLACED BY SUITABLE SUB 51500-2-150	4	A	
	51500-2-150	• COUPLING, <94425> 92-73008-014	4	B	
	24548-150	• RETAINER, PACKING USED WITH 5-900-2-150	2		
	52271-150	• STRAP, <98625> 98-54518-001	4	C	
	93888-203	• STRAP, <98625> 98-54518-005	4	208	
- 17	8-28200	• TUBE, FUEL TANK VENT	1	35	
- 18	8-28204-1	• TUBE ASSY, FUEL TANK VENT	1	35	
- 19	3605-120	• COUPLING, <79326> 92-72500-009	2	35	
	MS29513-210	• PACKING	4	35	
- 20		• TUBE ASSY, SEE FIG. 2.12-45 INDEX 33	RF		
- 21	19-356-101	• VALVE ASSY, PRESSURE RELIEF <82267> SPEC 8-1194-17 REPLACES SUITABLE SUB FOR 19-356-61	1	E	
		ATTACHING PARTS			
- 22	AN3H17A	• BOLT	2	35	188
	AN3H29A	• BOLT	2	189	
- 23	AN967PD10L	• WASHER	2	35	
		-----X-----			
- 24	8-27447-9	• BRACKET	1	189	
		ATTACHING PARTS			
- 25	NAS623-3-3	• SCREW	2	189	
- 26	AN967D10L	• WASHER	2	189	
		-----X-----			
- 27	321-62-1875	• CLAMP, <94425> 91-97801-010	1	35	

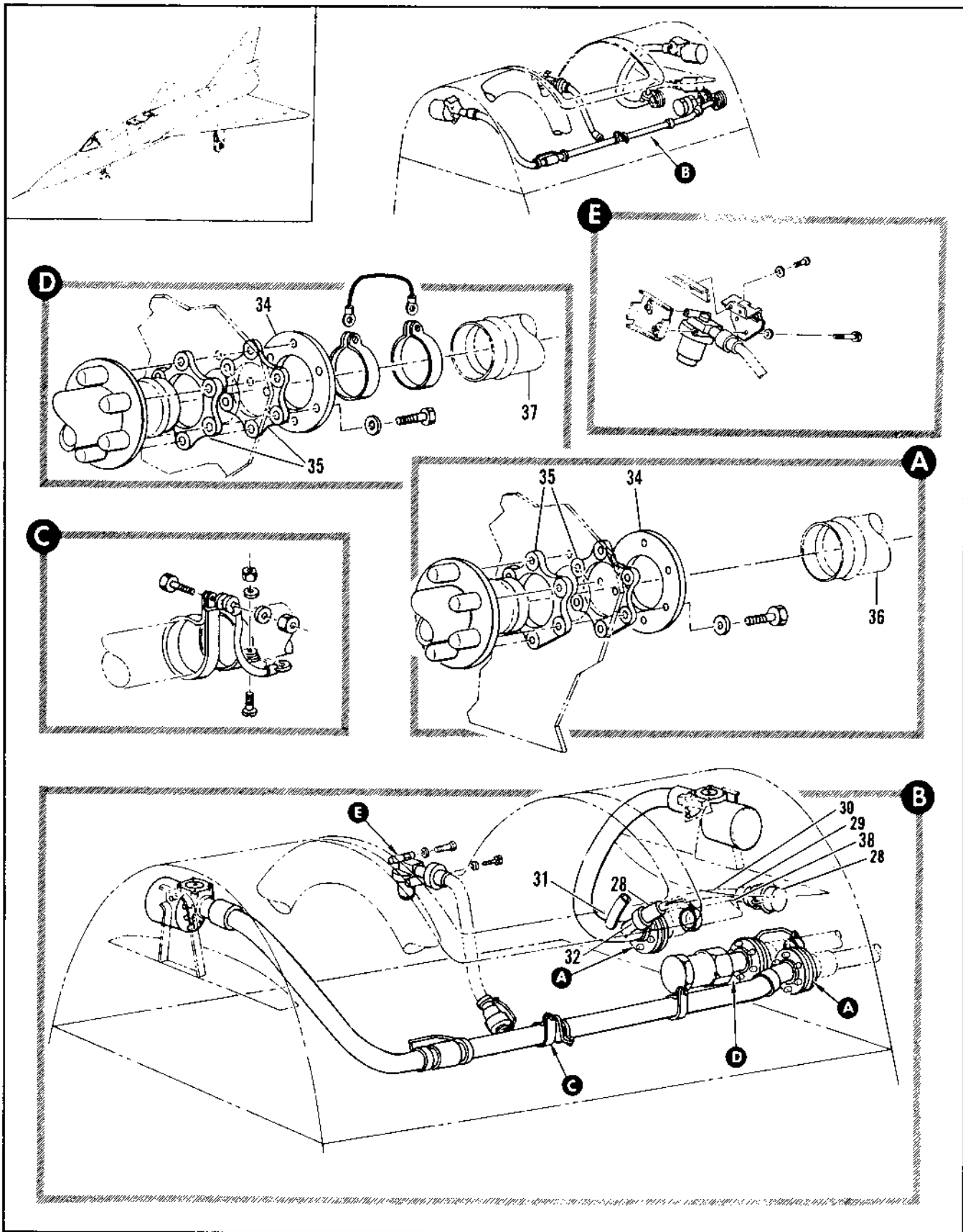

Figure 2.12-49. Fuselage Fuel Tank Vent Tubing Installation (Sheet 2 of 3)

FIGURE AND INDEX NUMBER	PART NUMBER	DESCRIPTION	UNITS PER ASSY.	USABLE ON CODE	
				FROM	TO
2.12-49- 28	312298	• VALVE ASSY, VACUUM RELIEF (R6124) SPEC 6-02997 T.O. 6J15-8-91-3	1	35	
- 29	MS21928D16	• UNION	1	35	
- 30	MS29512-16	• GASKET	1	35	
- 31		• TUBE ASSY, SEE FIG. 2.12-43 INDEX 139	RF		
- 32	3601-160	• TUBE ASSY, SEE FIG. 2.12-45 INDEX 165	RF		
	MS29513-214	• COUPLING, (73326) 92-72500-001	1	35	
- 33	65533174-1	• PACKING	2	35	
		• TUBE ASSY, FUSELAGE TANK VENT PH WELDED REPLACES NOT INTERC. WITH P-27454	1		
- 34	8-28212	• FLANGE	3	35	
- 35	75225	• GASKET, (83759) SPEC 4-02218-1	6	35	
- 36		• TUBE ASSY, LH STA 255 SEE FIG. 2.12-47 INDEX 14	RF		
- 37		• TUBE ASSY, SEE FIG. 2.12-47 INDEX 10	RF		
- 38		• TUBE ASSY, SEE FIG. 2.12-47 INDEX 5	RF		
- 39	MS25183-2PRA	• JUMPER	1		
		ATTACHING PARTS			
	MS21742L7	• NUT	2		
	AN560P0104	• WASHER	2		
	AN525-1348	• SCREW	2		
		-----X-----			
- 40	AN775012	• CLAMP	2		
	3605-120	• COUPLING, (73326)	1		
- 41	MS29513-213	• PACKING	2		
	MS219190F12	• CLAMP	1		
		ATTACHING PARTS			
	MS21742L5	• NUT	1		
	AN521-1091J	• SCREW	1		
	NAS43807-51	• SPACER	1		
- 42	MS214190F12	• CLAMP ATTACHING PARTS	1		
	AN521-1098	• SCREW	1		
		-----X-----			
- 43	65032184-1	• TUBE ASSY, FUSELAGE TANK VENT PH WELDED	1		
		A AIRPLANES 435 THRU 47 AND 49 THRU 61 B AIRPLANES 644, 61 AND 00 C AIRPLANES 648 AND 61 THRU 217 D AIRPLANES 648 THRU 47 AND 49 THRU 69 E AIRPLANES 644, 60 AND 00			

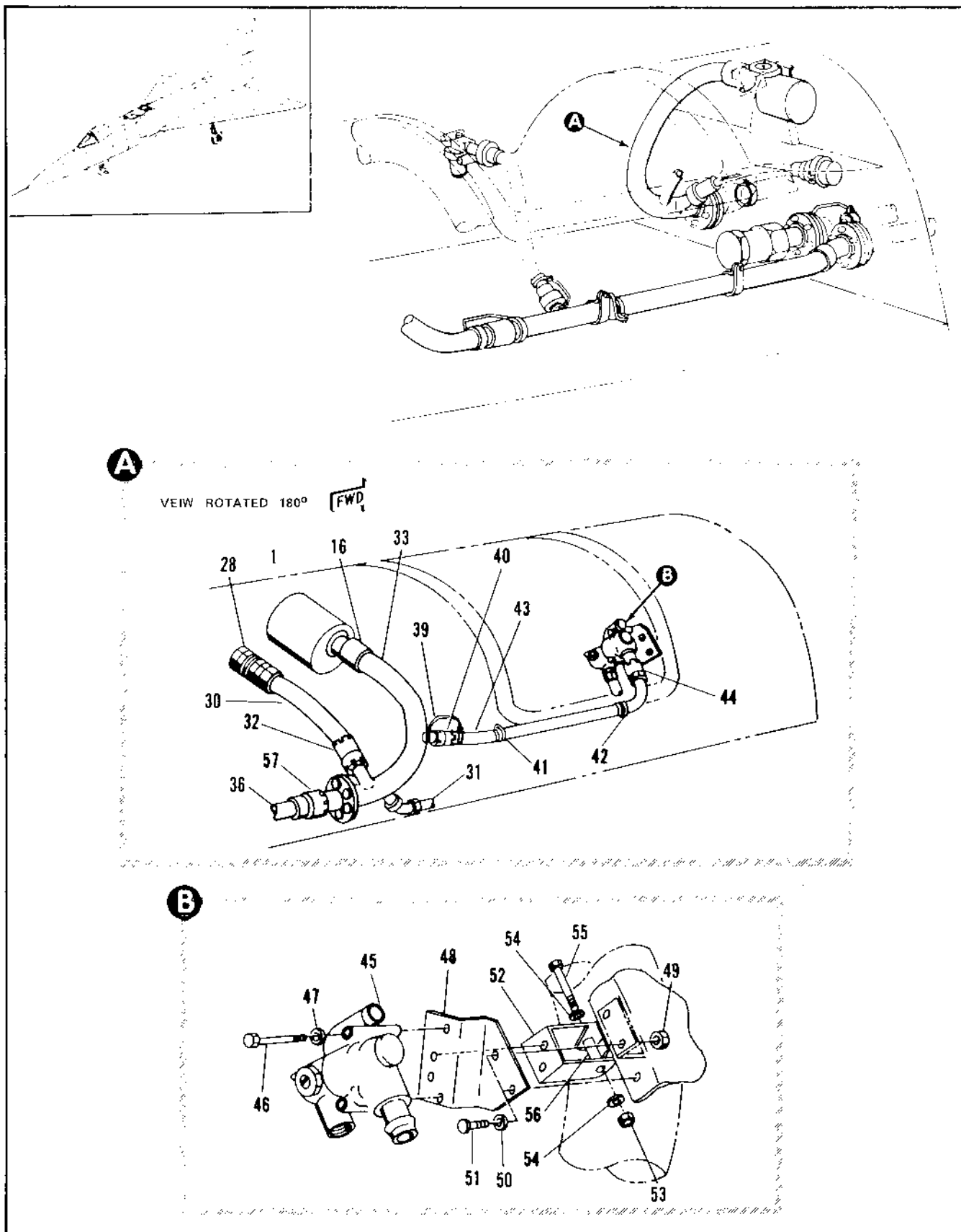

Figure 2.12-49. Fuselage Fuel Tank Vent Tubing Installation (Sheet 3 of 3)

FIGURE AND INDEX NUMBER	PART NUMBER	DESCRIPTION	UNITS PER ASSY.	USABLE ON CODE	
				FROM	TO
		1 2 3 4 5 6			
2.12-49- 44	3655-12D	• COUPLING, (79326)	1		
	MS29513-213	• PACKING	1		
- 45	19-356-101	• VALVE ASSY, PRESSURE RELIEF (82267) T.O. 6J15-2-64-24	1		
- 46	AN3H17A	• BOLT	2		
- 47	AN96CPD10L	• WASHER	2		
		-----X-----			
- 48	65C33174-1	• SUPPORT RELIEF VALVE RIVETED ATTACHING PARTS	1		
- 49	MS21342L3	• NUT	2		
- 50	AN96CPD10L	• WASHER	2		
- 51	AN3-3A	• BOLT	2		
		-----X-----			
- 52	65C33176-1	• BRACKET, PRESSURE RELIEF VALVE ATTACHING PARTS	1		
- 53	MS21342L3	• NUT	1		
- 54	AN96CPD10L	• WASHER	2		
- 55	AN3-13A	• BOLT	1		
- 56	NAS43DD3-58	• SPACER	1		
		-----X-----			
- 57	3605-24D	• COUPLING, (79326)	1	35	
	MS29513-325	• PACKING	2	35	

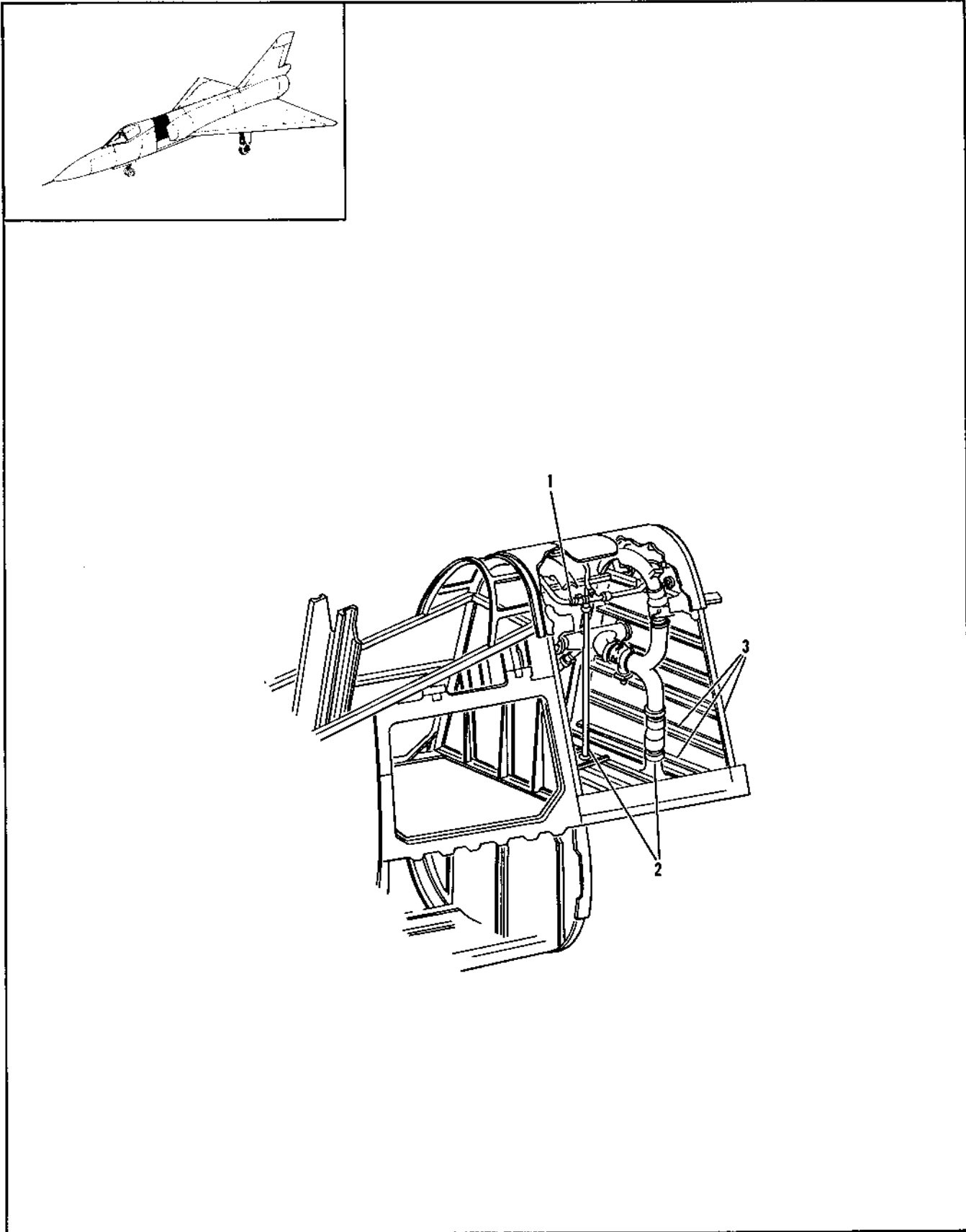

Figure 2.12-50. Fuselage Fuel Tank Assembly

FIGURE AND INDEX NUMBER	PART NUMBER	DESCRIPTION	UNITS PER ASSY.	USABLE ON CODE	
				FROM	TO
		1 2 3 4 5 6			
2.12-50	8-74463	TANK ASSEMBLY, FUSELAGE FULL FOR NHA SEE FIG. 2.3-9	RF	35	
- 1	8-27447	• TUBING INSTL, FUSELAGE FUEL TANK VENT FOR BREAKDOWN SEE FIG. 2.12-49	RF	35	
	8-27447-1	• TUBING INSTL, FUSELAGE FUEL TANK VENT FOR BREAKDOWN SEE FIG. 2.12-49	1	35	198
- 2	8-27451	• EQUIPMENT INSTL, FUSELAGE FUEL TANK TRANSFER FOR BREAKDOWN SEE FIG. 2.12-52	1	189	
	8-27451-3	• EQUIPMENT INSTL, FUSELAGE FUEL TANK TRANSFER FOR BREAKDOWN SEE FIG. 2.12-52	1	35	215
- 3	8-74430	• STRUCTURE ASSY, FUSELAGE FUEL TANK FOR BREAKDOWN SEE FIG. 2.12-51	1	216	
	8-74430-3	• STRUCTURE ASSY, FUSELAGE FUEL TANK FOR BREAKDOWN SEE FIG. 2.12-51	1	35	38
	8-74430-5	• STRUCTURE ASSY, FUSELAGE FUEL TANK FOR BREAKDOWN SEE FIG. 2.12-51	1	39	48
			1	49	

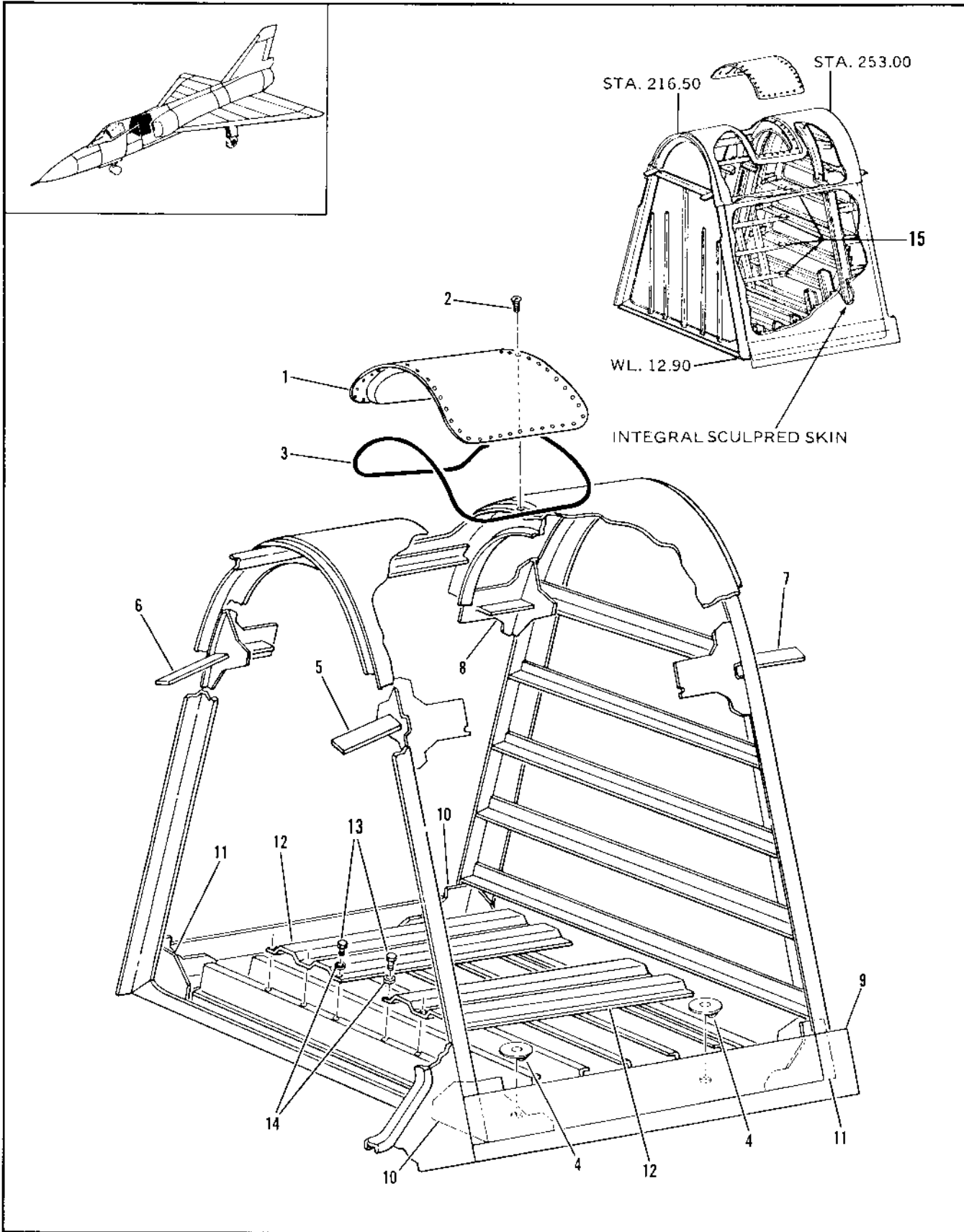

Figure 2.12-51. Fuselage Fuel Tank Structure Assembly

FIGURE AND INDEX NUMBER	PART NUMBER	DESCRIPTION	UNITS PER ASSY.	USABLE ON CODE	
				FROM	TO
		1 2 3 4 5 6			
2.12-31	8-74430	STRUCTURE ASSEMBLY, FUSELAGE FUEL TANK FOR NHA SEE FIG. 2.12-50	RF	35	38
	8-74430-3	STRUCTURE ASSEMBLY, FUSELAGE FUEL TANK FOR NHA SEE FIG. 2.12-50	RF	39	48
	8-74430-5	STRUCTURE ASSEMBLY, FUSELAGE FUEL TANK FOR NHA SEE FIG. 2.12-50	RF	49	
	8-74606	• DOOR INSTL, FUSELAGE FUEL ACCESS	1	35	60
- 1	8-74606-801	• DOOR INSTL, FUSELAGE FUEL ACCESS	1	61	
	8-74606-7	• DOOR, REPLACED BY NOT INTCHG WITH 8-74606-9	1	35	60
	8-74606-9	• DOOR, REPLACES NOT INTCHG WITH 8-74606-7	1	61	151
	8-74606-11	• DOOR, REPLACES NOT INTCHG WITH 8-74606-9	1	152	
- 2	NAS334PA6	• BOLT	RF	35	
		-----X-----			
- 3	8-74905	• SEAL	1	35	
	8-74430-327	• TANK ASSEMBLY	1	39	38
	8-74430-333	• TANK ASSEMBLY	1	39	48
	8-74430-339	• TANK ASSEMBLY	1	49	215
	8-74430-187	• TANK ASSEMBLY	1	216	
- 4	8-28359-7	• BOSS, FUSELAGE TANK DRAIN	2	35	
	8-28371	• BOSS, FUSELAGE TANK DRAIN	2	35	
		ALT INTCHG WITH 8-28359-7			
- 5	8-74707-9	• FITTING, TOP LONGERON FUEL-TIGHT CORNER	1	35	215
	8-74707-15	• FITTING, TOP LONGERON FUEL-TIGHT CORNER	1	216	
	8-74707-7	• FITTING, TOP LONGERON FUEL-TIGHT CORNER	RF	35	
		ALT INTCHG WITH 8-74707-9			
		AND 8-74707-15			
- 6	8-74707-10	• FITTING, TOP LONGERON FUEL-TIGHT CORNER	1	35	215
	8-74707-16	• FITTING, TOP LONGERON FUEL-TIGHT CORNER	1	216	
	8-74707-8	• FITTING, TOP LONGERON FUEL-TIGHT CORNER	RF	35	
		ALT INTCHG WITH 8-74707-10			
		AND 8-74707-16			
- 7	8-74707-11	• FITTING, TOP LONGERON FUEL-TIGHT CORNER	1	35	
	8-74706-11	• FITTING, TOP LONGERON FUEL-TIGHT CORNER	RF	35	
		ALT INTCHG WITH 8-74707-11			
- 8	8-74707-12	• FITTING, TOP LONGERON FUEL-TIGHT CORNER	1	35	
	8-74706-12	• FITTING, TOP LONGERON FUEL-TIGHT CORNER	RF	35	
		ALT INTCHG WITH 8-74707-12			
- 9	8-74709-7	• SUPPORT, LH	1	35	
	8-74709-10	• SUPPORT, RH	1	35	
- 10	8-74709-7	• FITTING, FUSELAGE TANK LOWER CORNER	2	35	
	8-74709-7	• FITTING, FUSELAGE TANK LOWER CORNER	RF	35	
		ALT INTCHG WITH 8-74709-7			
- 11	8-74709-7	• FITTING, FUSELAGE TANK LOWER CORNER	2	35	
	8-74709-8	• FITTING, FUSELAGE TANK LOWER CORNER	RF	35	
		ALT INTCHG WITH 8-74709-8			
- 12	8-74430-81	• FLOOR	2	35	215
	8-74430-387	• FLOOR	1	216	
	8-74430-395	• FLOOR	1	216	
		ATTACHING PARTS			
- 13	AN3-4A	• BOLT	32	35	
- 14	AN960-10	• WASHER	32	35	
		-----X-----			
- 15	8-74430-323	• CHANNEL ASSY	8	35	
		ATTACHING PARTS			
	AN5-6A	• BOLT	2		
	AN960-51B	• WASHER	2		
	NAS606A5	• NUT PLATE	2		
		-----X-----			

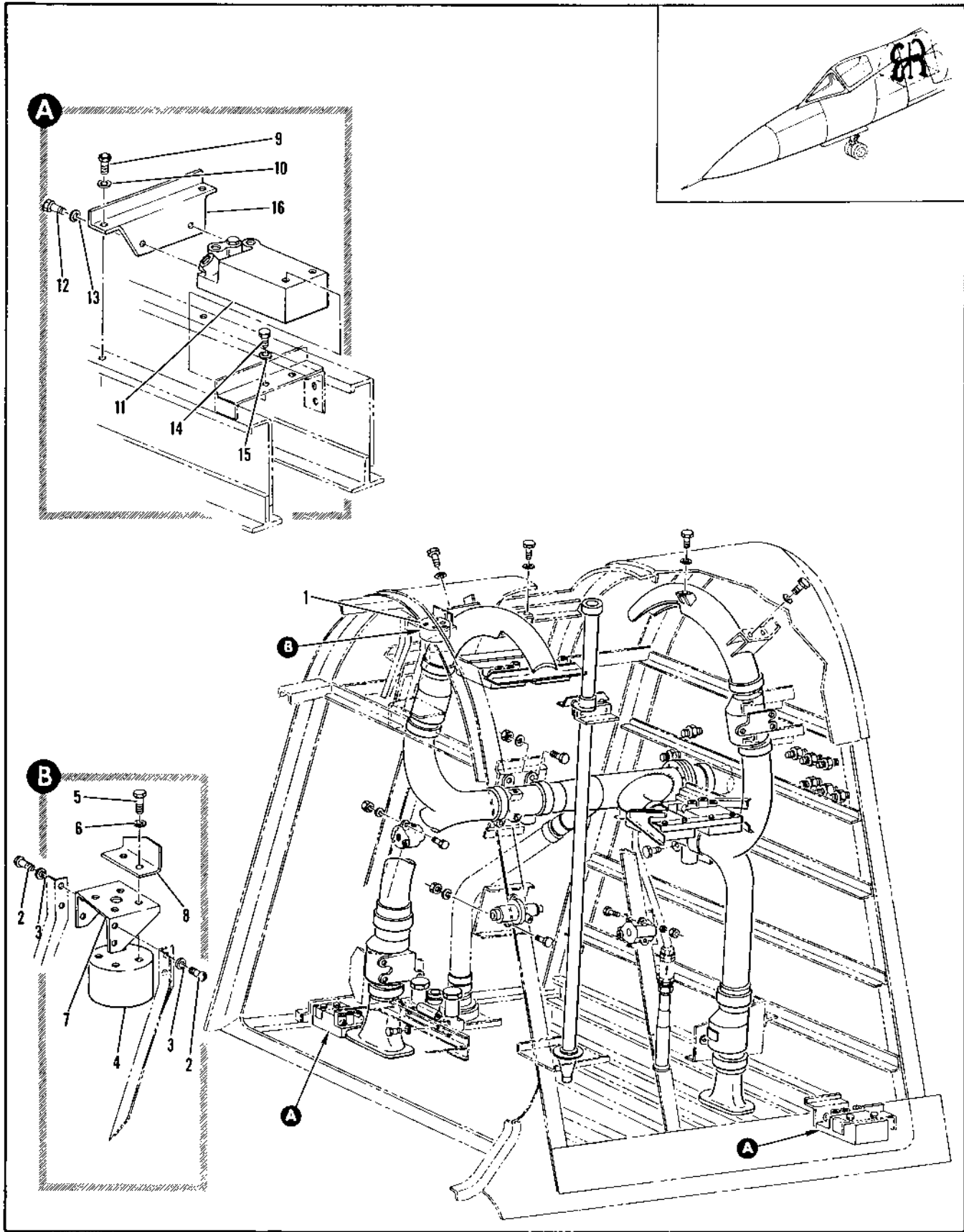

Figure 2.12-52. Fuselage Tank Fuel Transfer Equipment Installation (Sheet 1 of 7)

FIGURE AND INDEX NUMBER	PART NUMBER	DESCRIPTION	UNITS PER ASSY.	USABLE ON CODE	
				FROM	TO
		1 2 3 4 5 6			
2.12-52	8-27451	EQUIPMENT INSTALLATION, FUSELAGE FUEL TANK TRANSFER FOR NHA SEE FIG. 2.12-50	RF	35	215
	8-27451-3	EQUIPMENT INSTALLATION, FUSELAGE FUEL TANK TRANSFER FOR NHA SEE FIG. 2.12-50	RF	216	
	8-28406	• VALVE INSTL, FULL CAPACITY FUSELAGE TANK PILOT	1	35	
- 1	8-28406-19	• • VALVE ASSY, FUSELAGE TANK PILOT ATTACHING PARTS	1	35	
- 2	NAS221-7	• • SCREW	4	35	48
	AN3-3A	• • BOLT	4	49	
- 3	AN968D10	• • WASHER	4	35	
		-----X-----			
- 4	16-346-1	• • • VALVE ASSY, FUSELAGE TANK PILOT (92003) SPEC R-00904 T.O. 6J15-5-19-3	1	35	
	909555	• • • VALVE ASSY, FUSELAGE TANK PILOT (92003) SPEC R-00904 T.O. 6J15-3-75-13 ATTACHING PARTS	1	35	
- 5	AN3H3A	• • • BOLT	4	35	
- 6	AN968D10	• • • WASHER	4	35	
		-----Y-----			
- 7	8-28406-21	• • • BRACKET ASSY, RIVETED	1	35	
- 8	8-28406-17	• • • DEFLECTOR	1	35	
	8-28268-1	• VALVE INSTL, PILOT TANK	1	35	
- 9	AN3-4A	• • BOLT	4	35	
- 10	AN968D10	• • WASHER	4	35	
	8-28268-17	• • VALVE ASSY, LH	1	35	129
	8-28268-27	• • VALVE ASSY, LH	1	130	240
	8-28268-31	• • VALVE ASSY, LH	1	241	
	8-28268-17	• • VALVE ASSY, RH	1	35	48
	8-28268-27	• • VALVE ASSY, RH	1	49	129
	8-28268-25	• • VALVE ASSY, RH	1	130	240
	8-28268-29	• • VALVE ASSY, RH	1	241	
- 11	762200-7	• • • VALVE ASSY, FULL TRANSFER <95124> SPEC R-02443-7 T.O. 6J15-3-78-3 REPLACES SUITABLE SUB FOR 762200-5 ATTACHING PARTS	1	35	
- 12	AN3H3A	• • • BOLT	2	35	
- 13	AN968D10L	• • • WASHER	2	35	
- 14	AN3H4A	• • • BOLT	4	35	
- 15	AN968D10	• • • WASHER	4	35	
		-----Y-----			
- 16	8-29268-7	• • • SUPPORT	1	35	48
	8-28268-21	• • • SUPPORT	1	49	

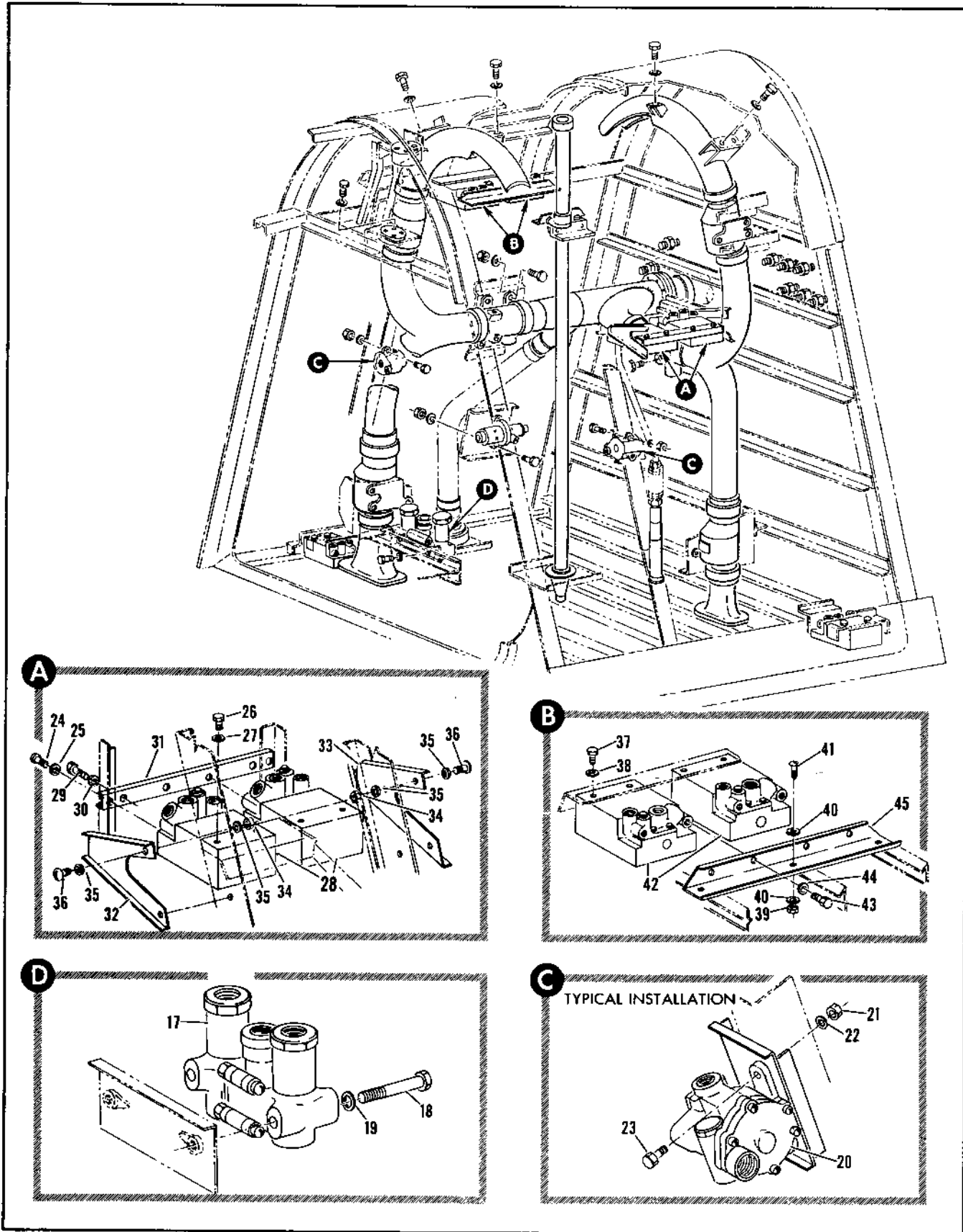

Figure 2.12-52. Fuselage Tank Fuel Transfer Equipment Installation (Sheet 2 of 7)

FIGURE AND INDEX NUMBER	PART NUMBER	DESCRIPTION	UNITS PER ASSY.	USABLE ON CODE	
				FROM	TO
		1 2 3 4 5 6			
2.12-52	8-23336	• VALVE INSTL, MANIFOLD CHECK FUSELAGE TANK	1	35	
- 17	1111-565531	• VALVE ASSY, MANIFOLD AIR CHECK FUEL <92003> SPEC 8-02465-1 T.O. 6J15-2-106-13 ATTACHING PARTS	1	35	
- 18	AN4-22A	• BOLT	2	35	
- 19	AN9670416	• WASHER ----X----	2	35	
	8-28396-3	• VALVE INSTL, AIR SHUTOFF	2	35	
- 20	GV317-110	• VALVE ASSY, <R4997> SPEC 4-00258-3 T.O. RPF-5-74-3 ATTACHING PARTS	2	35	
- 21	NAS679A3	• NUT	4	35	
- 22	AN967010	• WASHER	4	35	
- 23	AN3-6A	• BOLT ----X----	4	35	
	8-28407	• VALVE INSTL, EMERGENCY FUSELAGE TANK PILOT	1	35	
	8-28407-21	• VALVE ASSEMBLY	1	35	129
	8-28407-29	• VALVE ASSEMBLY	1	130	242
	8-28407-31	• VALVE ASSEMBLY ATTACHING PARTS	1	241	
- 24	NAS221-6	• SCREW	2	35	
- 25	AN967010L	• WASHER	2	35	
- 26	AN3H3A	• BOLT	4	35	
- 27	AN967010L	• WASHER ----X----	4	35	
- 28	762230-7	• VALVE ASSY, <96124> SPEC 8-02443-7 T.O. 6J15-3-7R-3 ATTACHING PARTS	2	35	
- 29	AN3H3A	• BOLT	4	35	
- 30	AN967010L	• WASHER ----X----	4	35	
- 31	8-28407-7	• ANGLE	1	35	
- 32	8-28407-25	• BRACKET ASSY, LH RIVETED	1	35	
- 33	8-28407-26	• BRACKET ASSY, RH RIVETED ATTACHING PARTS	1	35	
- 34	NAS679A3	• NUT	4	35	
- 35	AN967010L	• WASHER	8	35	
- 36	NAS221-6	• SCREW ----X----	4	35	
	8-28408	• VALVE INSTL, HIGH LEVEL FUSELAGE TANK PILOT	1	35	
	8-28408-15	• VALVE ASSEMBLY	1	35	129
	8-28408-17	• VALVE ASSEMBLY	1	130	240
	8-28408-19	• VALVE ASSEMBLY ATTACHING PARTS	1	241	
- 37	AN3H3A	• BOLT	4	35	
- 38	AN967010L	• WASHER	4	35	
- 39	NAS679A3	• NUT	3	35	
- 40	AN967010L	• WASHER	6	35	
- 41	NAS221-6	• SCREW ----X----	3	35	
- 42	762290-7	• VALVE ASSY, <96124> SPEC 8-02443-7 T.O. 6J15-3-7R-3 ATTACHING PARTS	2	35	
- 43	AN3H3A	• BOLT	4	35	
- 44	AN967010L	• WASHER ----X----	4	35	
- 45	8-28408-7	• ANGLE	1	35	

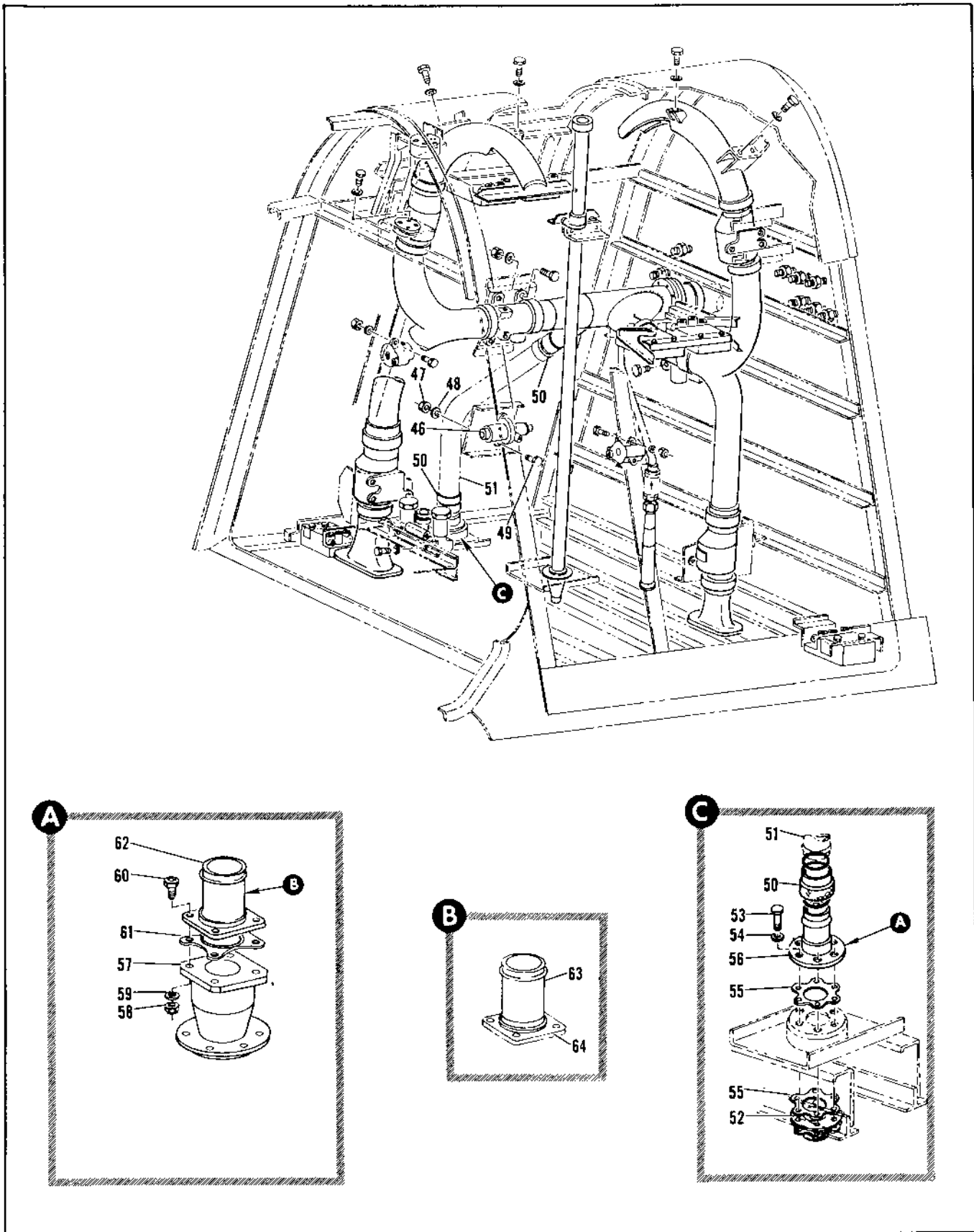

Figure 2.12-52. Fuselage Tank Fuel Transfer Equipment Installation (Sheet 3 of 7)

FIGURE AND INDEX NUMBER	PART NUMBER	DESCRIPTION	UNITS PER ASSY.	USABLE ON CODE	
				FROM	TO
		1 2 3 4 5 6			
2.12-52-46	PV293-110	• VALVE ASSY, PRESSURE OPERATED PILOT (A40R7) SPEC R-22275 T.O. 6J15-3-80-3 REPLACE BY SUITABLE SUB PV293-120	1	35	
	PV293-120	• VALVE ASSY, PRESSURE OPERATED PILOT <57 SPEC R-22275 T.O. 6J15-3-80-3 REPLACE IF SUITABLE SUB FOR PV293-110 ATTACHING PARTS	RF	35	
- 47	NAS679A3	• NUT	2	35	
- 48	AN960D10	• WASHER	2	35	
- 49	AN3-5A	• BOLT	2	35	
		-----X-----			
- 50	3605-240	• COUPLING, <79326> 92-72500-013	2	35	
	MS29513-325	• PACKING	4	35	
- 51		• TUBE ASSY, SEE FIG. 2.12-43 INDEX 181	RF		
- 52	15-356-101	• VALVE ASSY, PILOT OPERATED SHUTOFF FUEL TANK <82247> SPEC R-77.70-11 T.O. 6J15-10-106-3 ATTACHING PARTS	1	35	
- 53	A14-7A	• BOLT	6	35	
- 54	AN961D416L	• WASHER	6	35	
		-----X-----			
- 55	075156-4	• GASKET, <83059> SPEC R-12247-7	2	35	
	MS29513-325	• PACKING	2	130	
- 56	8-28215	• TUBE ASSY, REFUEL LINE WELDED REPLACES NOT INTERCHG WITH R-28488-1	1	35	129
- 57	25-6500	• VALVE ASSY, FUEL CHECK <86736> SPEC R-0 T.O. 6J15-3-111-3 ATTACHING PARTS	1	130	
- 58	NAS679A4	• NUT	4	130	
- 59	AN96 D10L	• WASHER	4	130	
- 60	AN4-11A	• BOLT	4	130	
		-----X-----			
- 61	075356-1	• GASKET, <83059> SPEC R-12247-1	1	130	
- 62	8-28488-1	• TUBE ASSY, FUSELAGE TANK REFUELING LINE REPLACES NOT INTERCHG WITH R-28215	1	130	
- 63	8-28488-7	• TUBE	1	130	
- 64	8-21431	• FLANGE	1	130	

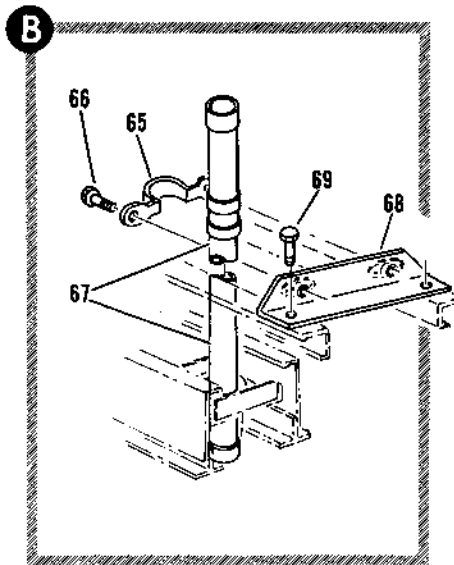
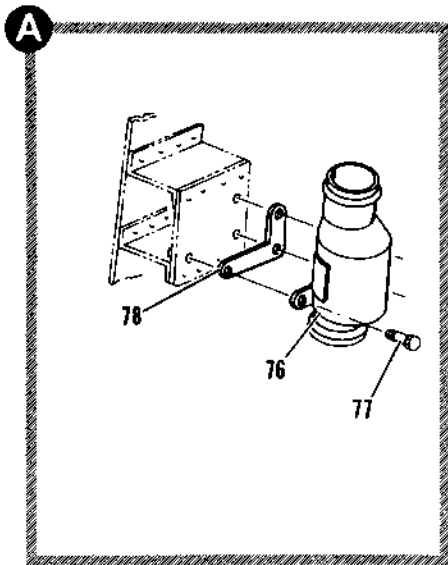
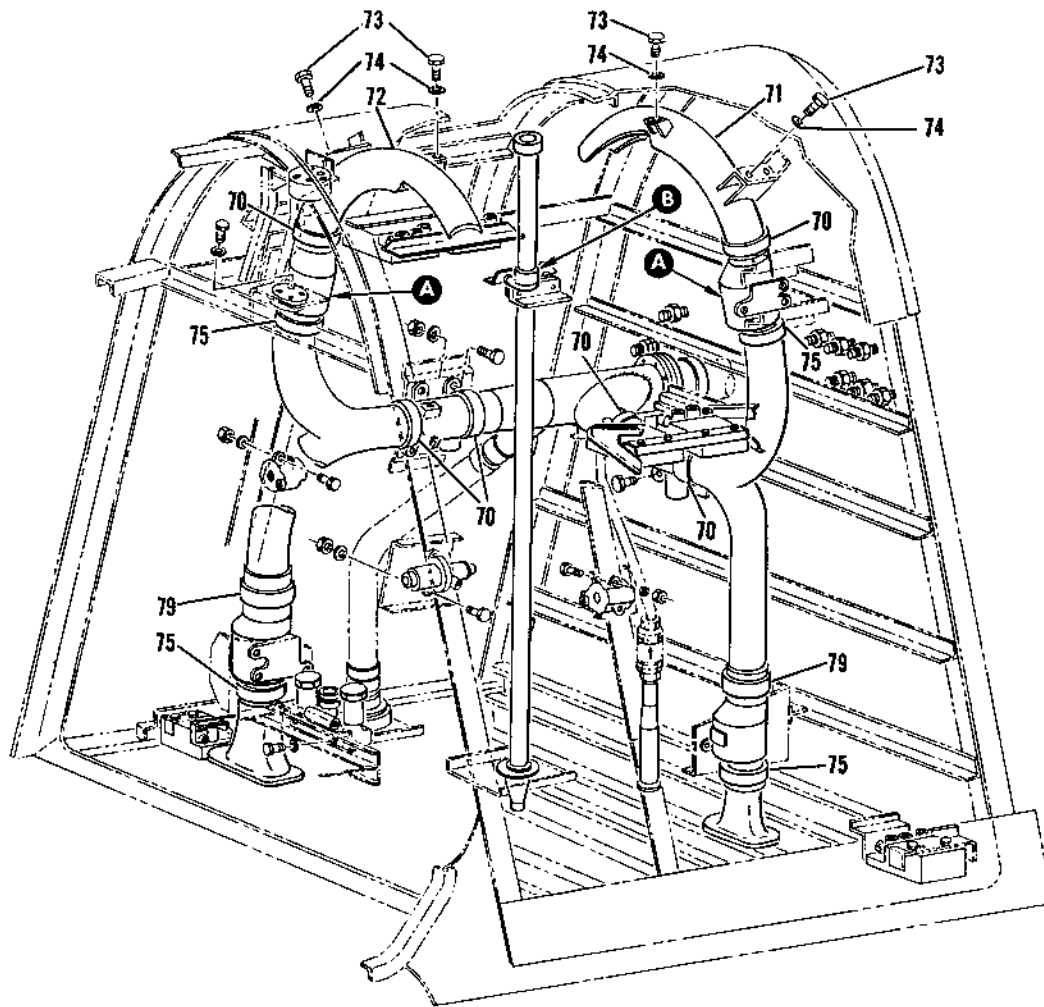

Figure 2.12-52. Fuselage Tank Fuel Transfer Equipment Installation (Sheet 4 of 7)

FIGURE AND INDEX NUMBER	PART NUMBER	DESCRIPTION	UNITS PER ASSY.	USABLE ON CODE	
				FROM	TO
		1 2 3 4 5 6			
2.12-52	8-282A5	• PROBE INSTL, FUSELAGE FUEL TANK	1	35	
- 65	8-21114-7	• • CLAMP	1	35	
- 66	AN520-10R7	• ATTACHING PARTS	2	35	
- 67	FG225A67	• • SCREW	1	35	
- 68	8-282K5-11	• • PROBE, FUEL QUANTITY <400%> SPEC 8-20995-21 T.O. 5L14-3-21-13	1	35	
- 69	AN3-3A	• • PACKET ASSY, RIVETED	2	35	
- 70	CF14-300	• • BOLT	6	35	60
- 71	51500-2-300	• COUPLING, <98625> 92-7308-007 REPLACED BY SUITABLE SUB 51500-2-300	6	61	
- 72	8-27583	• COUPLING, <98625> 92-7308-020 REPLACES SUITABLE SUB FOR CF14-300	1	35	
- 73	8-27582	• TUBE ASSY, LH WELDED	1	35	
- 74	AN4-5A	• TUBE ASSY, RH WELDED	6	35	
- 75	AN9600416	• ATTACHING PARTS	6	35	
- 76	436A-365 SH	• BOLT	4	35	
- 76	074856-2	• WASHER	4	35	
- 76	313700	• COUPLING, <98625> 92-7303-010	2	35	
- 77	AN4-6A	• GASKET, <83259> SPEC 8-10274-3	3	35	
- 78	8-28219	• VALVE ASSY, CHECK AFT <96124> SPEC 8-20997 T.O. 6J15-2-05-23	1	35	
- 79	3605-480	• ATTACHING PARTS	2	35	
- 79	MS25513-337	• BOLT	4	35	
		• SHIM			
		• COUPLING, <79306> 92-72500-016			
		• PACKING			

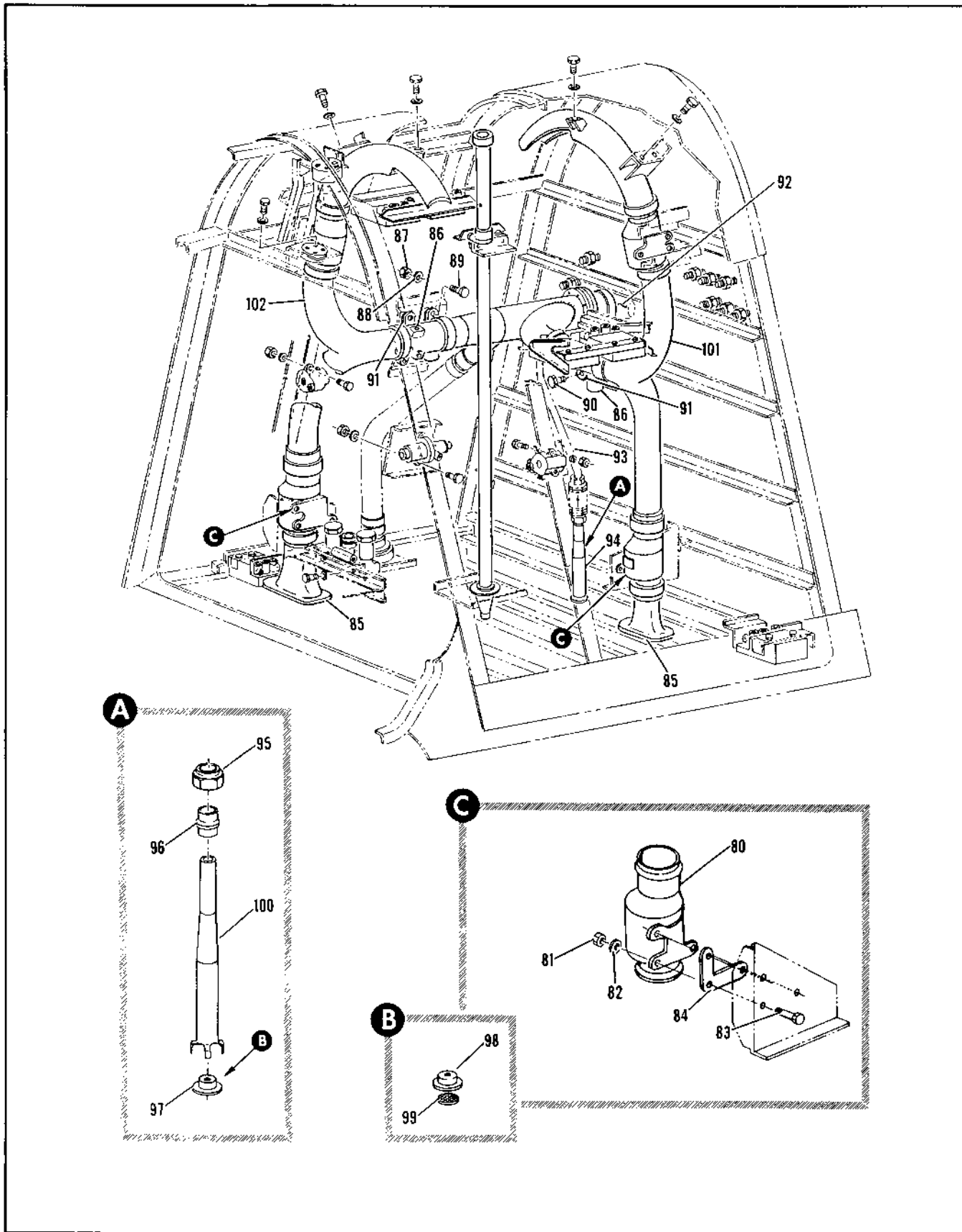

Figure 2.12-52. Fuselage Tank Fuel Transfer Equipment Installation (Sheet 5 of 7)

FIGURE AND INDEX NUMBER	PART NUMBER	DESCRIPTION	UNITS PER ASSY.	USABLE ON CODE	
				FROM	TO
2.12-52- 80	313700	• VALVE ASSY, CHECK FWD <96124> SPEC 8-00897 T.O. 6J1F-2-95-23 ATTACHING PARTS	2	35	
- 81	NAS679A4	• NUT	3	35	
- 82	AN961D416L	• WASHER	3	35	
- 83	AN4-6A	• BOLT	3	35	
		-----X-----			
- 84	8-22219	• SHIM	1	35	
- 85	9-28439	• BELLMOUTH ASSY, RIVETED	2	35	
- 86	503200-7	• VALVE ASSY, FUEL TRANSFER SHUTOFF <9612 SPEC 9-02279-7 ATTACHING PARTS	2	35	
- 87	NAS679A4	• NUT	4	35	
- 88	AN961D416	• WASHER	4	35	
- 89	AN4-7A	• BOLT	4	35	
- 90	AN4-6A	• BOLT	4	35	
		-----Y-----			
- 91	5-28220	• SHIM	2	35	
- 92		• TUBE ASSY, SEE FIG. 2.12-4F	2F		
- 93		• TUBE ASSY, SEE FIG. 2.12-43 INDEX 175	RF		
- 94	8-28381	• TUBE ASSY, FUEL SCAVENGE FUSELAGE TANK	1	35	
- 95	MS21921-6	• NUT	1	35	
- 96	MS21922-6	• SLEEVE	1	35	
- 97	8-28381-13	• SCREEN ASSEMBLY	1	35	
- 98	8-28381-9	• CUP	1	35	
- 99	8-28381-11	• SCREEN	1	35	
-100	9-28381-7	• TUBE, FUEL SCAVENGE	1	35	
-101	8-27580	• TUBE ASSY, FUEL TRANSFER Y LH WELDED	1	35	215
	9-28510	• TUBE ASSY, FUEL TRANSFER Y LH WELDED	1	215	
-102	8-27581	• TUBE ASSY, RH WELDED	1	35	

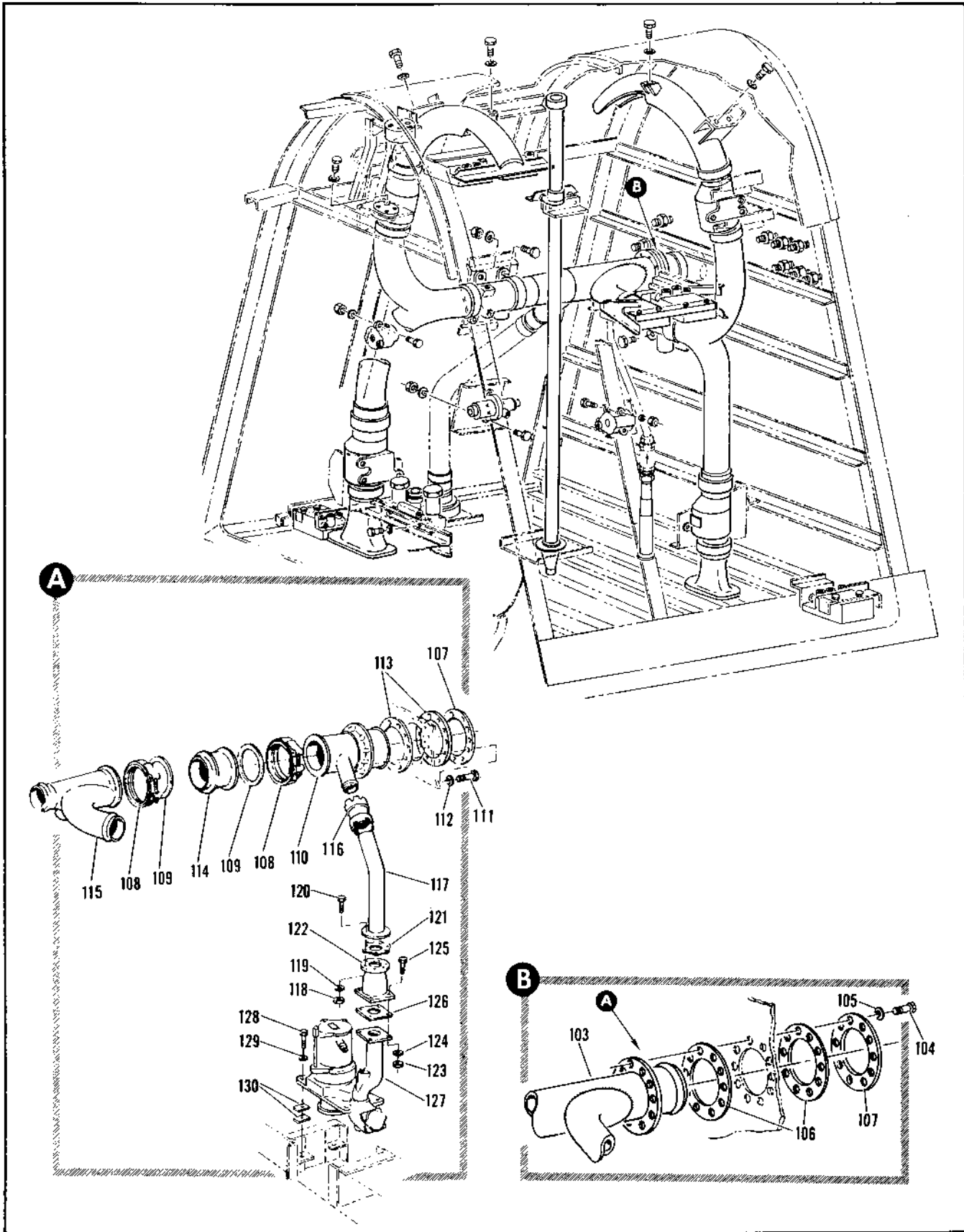

Figure 2.12-52. Fuselage Tank Fuel Transfer Equipment Installation (Sheet 6 of 7)

FIGURE AND INDEX NUMBER	PART NUMBER	DESCRIPTION	UNITS PER ASSY.	USABLE ON CODE	
				FROM	TO
2.12-52-103	8-27452	• TUBE ASSY, TRANSFER WELDED REPLACED BY SUITABLE SUB 8-27452-3	1	35	188
	8-27452-3	• TUBE ASSY, TRANSFER WELDED REPLACES SUITABLE SUB FOR 8-27452 REPLACED BY NOT INTCHG WITH 8-28506-3 AND 8-28508-1 ATTACHING PARTS	1	189	215
-104	AN4-13A	• BOLT	1	35	
-105	AN960D416	• WASHER	1	35	
		-----X-----			
-106	075656	• GASKET, <A3259> SPEC 8-02292-1	2	35	215
-107	8-28213-7	• FLANGE, REPLACES NOT INTCHG WITH 8-2821	1	189	
-108	4404-450M	• COUPLING, <98625> SPEC 92-73003-00R	2	35	
-109	074856-3	• GASKET, <A3259> SPEC 8-00274-7	2	216	
-110	8-28506-3	• TUBE ASSY, FUEL TRANSFER FLANGED REPLACES NOT INTCHG WITH 8-27452-3 ATTACHING PARTS	1	216	
-111	AN4-13A	• BOLT	1	216	
-112	AN960D416	• WASHER	1	216	
		-----X-----			
-113	075656	• GASKET, <A3259> SPEC 8-02292-1	2	216	
-114	8-28521	• TUBE, FUEL TRANSFER	1	216	
-115	8-28508-1	• TUBE ASSY, FUEL TRANSFER WELDED REPLACES NOT INTCHG WITH 8-27452-3	1	216	
-116	3605-24D	• COUPLING, <79326> 92-72500-013	1	216	
	MS29513-325	• PACKING	2	216	
		ATTACHING PARTS			
-117	8-28509-1	• TUBE ASSY, BOOST PUMP	1	216	
-118	NAS679A4	• NUT	6	216	
-119	AN960D416L	• WASHER	5	216	
-120	AN4-7A	• BOLT	6	216	
		-----X-----			
-121	075156-4	• GASKET, <A3259> SPEC 8-02287-7	1	216	
-123	NAS679A4	• NUT	4	216	
-124	AN960D416L	• WASHER	4	216	
-125	AN4-11A	• BOLT	4	216	
		-----X-----			
-126	075356-6	• GASKET, <A3259> SPEC 8-02289-11	1	216	
	8-28502	• PUMP INSTL, FUEL BOOST	1	216	
-127	64-1099-3	• PUMP, FUEL <A2280> SPEC 8-09983-1 T.O. 6J10-3-34-54 ATTACHING PARTS	1	216	
-128	AN4-6A	• BOLT	4	216	
-129	AN960D416	• WASHER	4	216	
		-----X-----			
-130	8-28503	• SHIM	8	216	

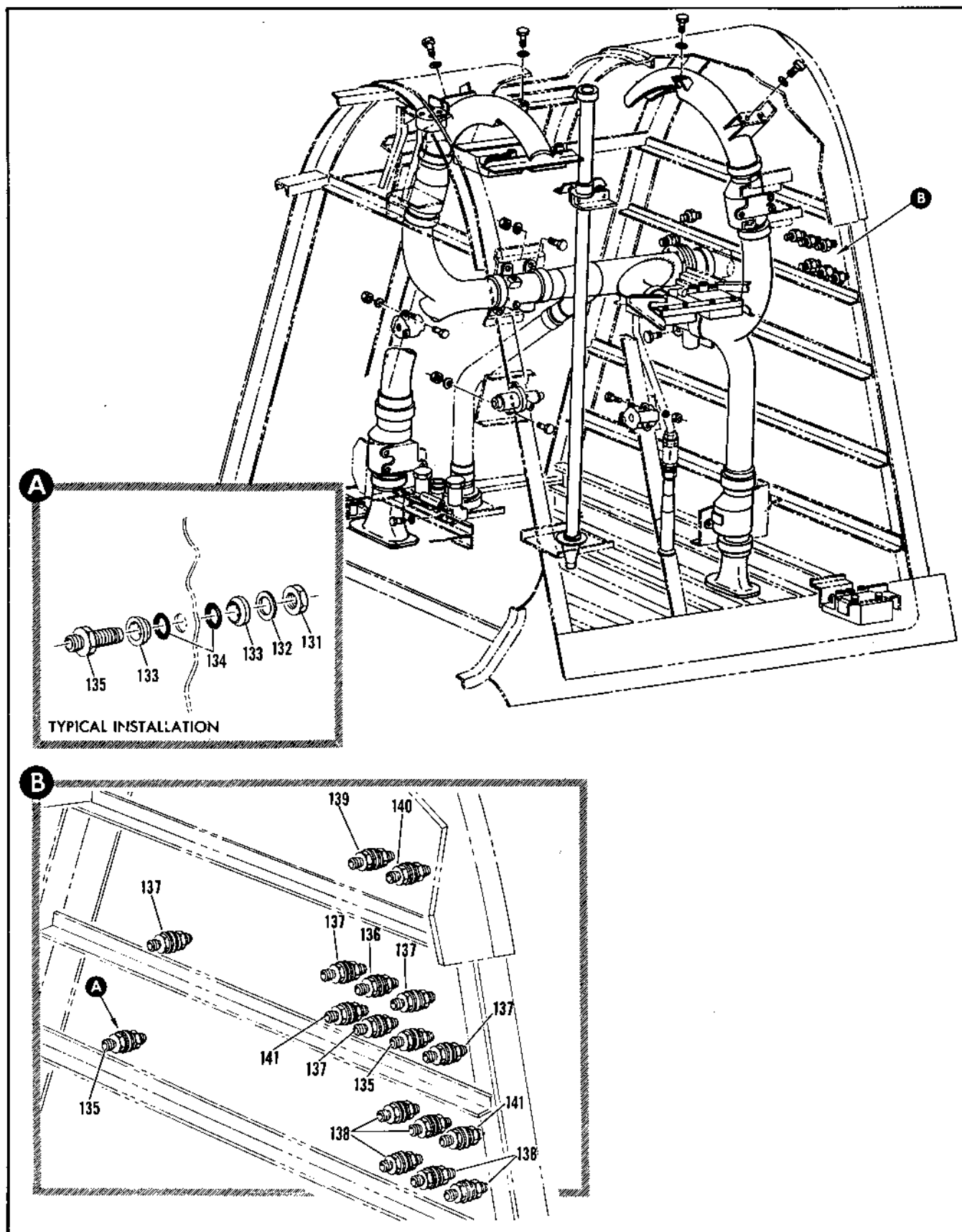

Figure 2.12-52. Fuselage Tank Fuel Transfer Equipment Installation (Sheet 7 of 7)

FIGURE AND INDEX NUMBER	PART NUMBER	DESCRIPTION	UNITS PER ASSY.	USABLE ON CODE	
				FROM	TO
		1 2 3 4 5 6			
2.12-52-131	AN924-4	• NUT	2	35	
-132	AN9610716	• WASHER	2	35	
-133	R-21311-7	• WASHER	4	35	
-134	MS29513-13	• PACKING	4	35	
-135	R-21307-15	• UNION	2	35	
	AN924-6	• NUT	1	35	
	AN9610916	• WASHER	1	35	
	R-21311-19	• WASHER	2	35	
	MS29513-15	• PACKING	2	35	
-136	R-21307-15	• UNION	1	35	
	AN924-6	• NUT	5	35	
	AN9610916	• WASHER	5	35	
	R-21311-19	• WASHER	10	35	
	MS29513-15	• PACKING	10	35	
-137	R-21307-15	• UNION	5	35	
	AN924-4	• NUT	5	35	
	AN9610716	• WASHER	5	35	
	R-21311-7	• WASHER	10	35	
	MS29513-13	• PACKING	10	35	
-137	R-21307-15	• UNION	5	35	
	AN924-6	• NUT	10	35	
	AN9610916	• WASHER	1	35	
	R-21311-19	• WASHER	2	35	
	MS29513-15	• PACKING	2	35	
-138	R-21307-15	• UNION	1	35	
	AN924-6	• NUT	1	160	
	AN9610916	• WASHER	1	160	
	R-21311-19	• WASHER	2	160	
	MS29513-15	• PACKING	2	160	
-140	R-21307-15	• UNION	1	160	
	AN924-4	• NUT	2	216	
	AN924-4	• NUT	2	35	216
	AN9610716	• WASHER	2	216	
	R-21311-7	• WASHER	4	216	
	MS29513-13	• PACKING	4	216	
-141	R-21307-15	• UNION	2	216	

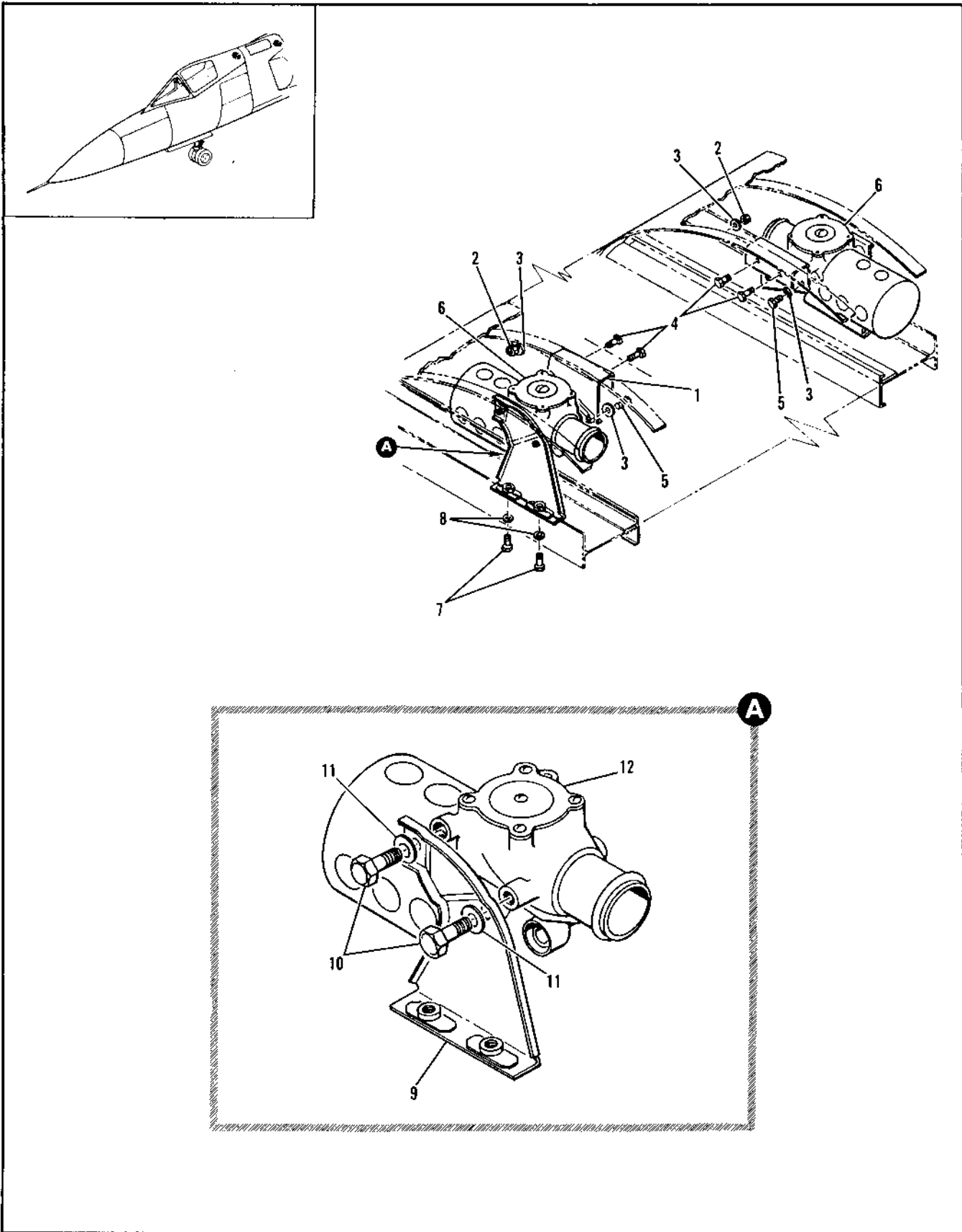

Figure 2.12-53. Fuselage Fuel Tank Vent Valve Installation

FIGURE AND INDEX NUMBER	PART NUMBER	DESCRIPTION	UNITS PER ASSY.	USABLE ON CODE	
				FROM	TO
2.12-53	R-28200	VALVE INSTALLATION, FUSELAGE FUEL TANK VENT FOR NHA SEE FIG. 2.12-49	RF	35	
- 1	R-28200-39	• SUPPORT ASSY, FUSELAGE TANK VENT RIVETS ATTACHING PARTS	2	35	
- 2	NAS679A4	• NUT	4	35	
- 3	AN961PD416	• WASHER	8	35	
- 4	AN4-3A	• BOLT	4	35	
- 5	AN4H5A	• BOLT	4	35	
		-----X-----			
- 6	R-28200-43	• VALVE ASSY, FUSELAGE TANK VENT	2	35	247
	R-28200-47	• VALVE ASSY, FUSELAGE TANK VENT ATTACHING PARTS	2	241	
- 7	NAS4H5A	• BOLT	4	35	
- 8	AN961PD416	• WASHER	4	35	
		-----X-----			
- 9	R-28200-37	• BRACKET ASSY, VENT VALVE RIVETED ATTACHING PARTS	1	35	
- 10	AN4H5A	• BOLT	2	35	
- 11	AN961PD416	• WASHER	2	35	
		-----X-----			
- 12	R-105455	• VALVE ASSY, VENT <7531> SPEC B-00391-9 T.O. 3019-74-3	1	35	
	R-105455	• VALVE ASSY, VENT <75361> SPEC B-00391-9 T.O. 3019-74-3 ALT INTERC. WITH R-105455	RF	35	

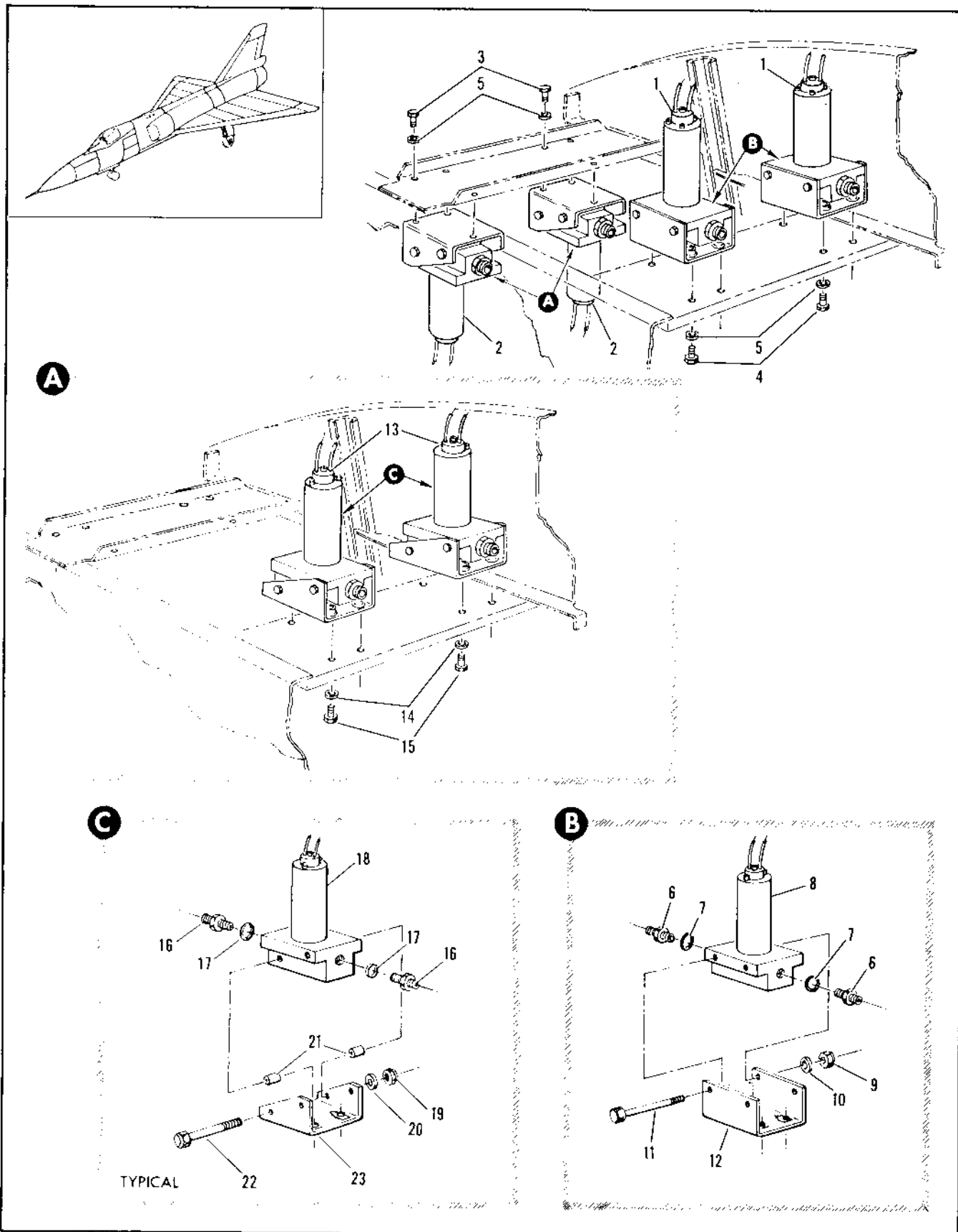

Figure 2.12-54. Fuel Pressure Valve

FIGURE AND INDEX NUMBER	PART NUMBER	DESCRIPTION 1 2 3 4 5 6	UNITS PER ASSY.	USABLE ON CODE	
				FROM	TO
2.12-54	8-28289-3	FUEL PRESSURE VALVE • VALVE INSTL, FUEL PRESSURE SHUTOFF STA 270 FOR NHA SEC FIG. 2.3-11 INDEX 9	RF	35	215
- 1	8-28289-29	• • VALVE ASSY, LH	2	35	215
- 2	8-28289-23	• • VALVE ASSY, RH ATTACHING PARTS	2	35	215
- 3	AN3-4A	• • BOLT	6	35	215
- 4	AN3CH4A	• • BOLT	6	35	215
- 5	AN960D10L	• • WASHER	12	35	215
		-----X-----			
- 6	MS2190206	• • UNION	2	35	215
- 7	NAS617-6	• • PACKING	2	35	215
- 8	V21100	• • VALVE ASSY, SOLENOID OPERATED SHUTOFF LH <96487> SPEC 8-00391-7 T.O. 6J15-10-107-3	1	35	215
	V21200	• • VALVE ASSY, SOLENOID OPERATED SHUTOFF RH <96487> SPEC 8-00391-9 T.O. 6J15-10-107-13	1	35	215
		ATTACHING PARTS			
- 9	NAS679A3	• • NUT	2	35	215
- 10	AN960D10L	• • WASHER	2	35	215
	NAS43003-30	• • SPACER, RH	2	35	215
- 11	AN3-22A	• • BOLT	2	35	215
		-----Y-----			
- 12	8-28289-33	• • BRACKET ASSY, LH RIVETED	1	35	215
	8-28289-11	• • BRACKET ASSY, RH RIVETED	1	35	215
	8-28289-1	• VALVE INSTL, FUEL PRESSURE SHUTOFF STA 270 FOR NHA SEC FIG. 2.3-11	PF	216	
- 13	8-28289-23	• VALVE ASSY, RH ATTACHING PARTS	2	216	
- 14	AN960D10L	• • WASHER	6	216	
- 15	AN3-4A	• • BOLT	6	216	
		-----X-----			
- 16	MS2190206	• • UNION	2	216	
- 17	NAS617-6	• • PACKING	2	216	
- 18	V21200	• • VALVE ASSY, SOLENOID OPERATED SHUTOFF <96487> SPEC 8-00391-9 T.O. 6J15-10-107-13	1	216	
		ATTACHING PARTS			
- 19	NAS679A3	• • NUT	2	216	
- 20	AN960D10L	• • WASHER	2	216	
- 21	NAS43003-30	• • SPACER	2	216	
- 22	AN3-22A	• • BOLT	2	216	
		-----X-----			
- 23	8-28289-11	• • BRACKET ASSY, RIVETED	1	216	

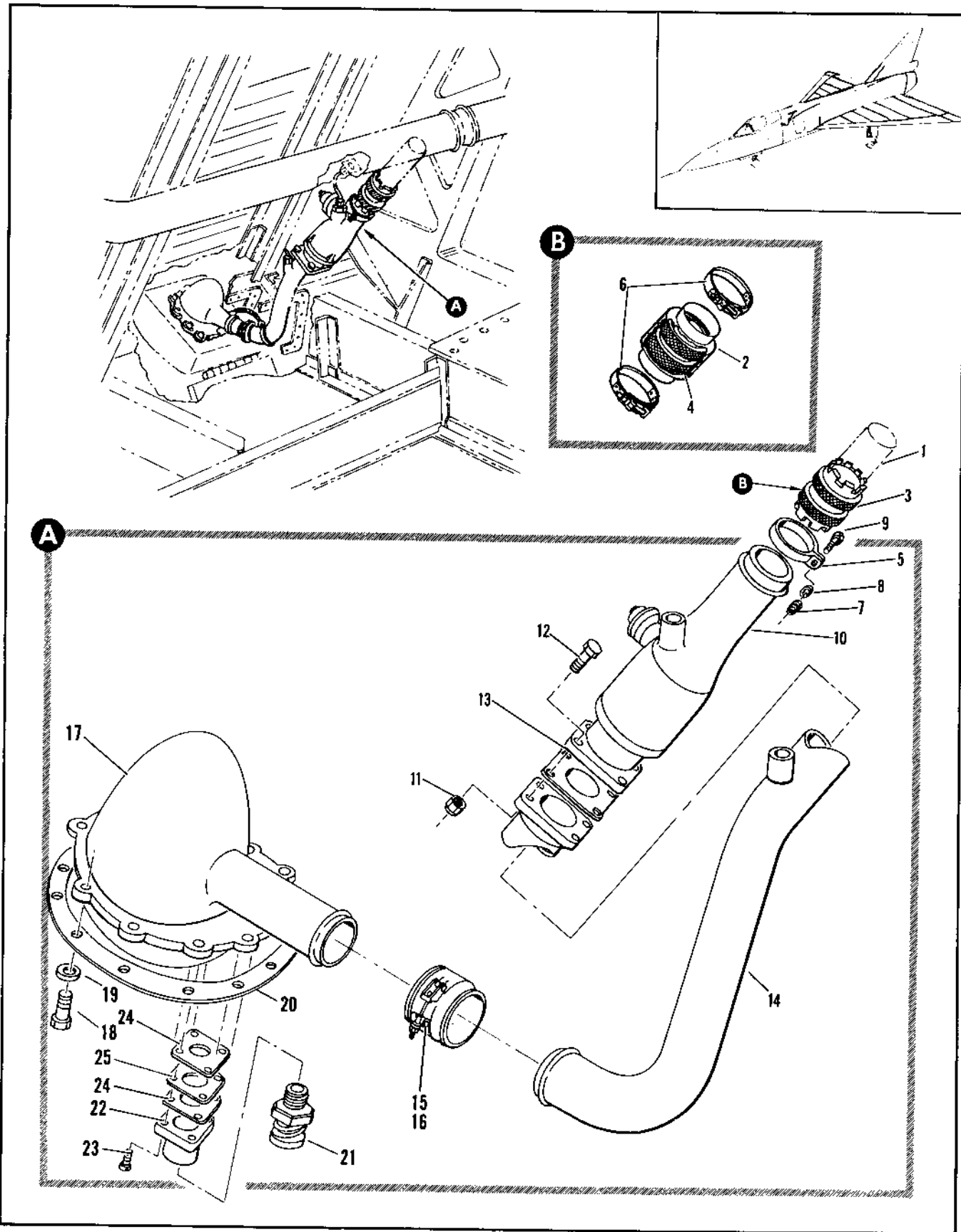

Figure 2.12-55. Pressure Regulator Refueling Valve Installation

FIGURE AND INDEX NUMBER	PART NUMBER	DESCRIPTION	UNITS PER ASSY.	USABLE ON CODE	
				FROM	TO
2.12-55	8-28274	VALVE INSTALLATION, PRESSURE REGULATOR REFUELING FOR NHA SEE FIG. 2.3-3	RF	35	264
	8-28274-1	VALVE INSTALLATION, PRESSURE REGULATOR REFUELING FOR NHA SEE FIG. 2.3-3	RF	265	
- 1		• TUBE ASSY, SEE FIG. 2.12-48	RF		
- 2	450R-9	• BOLT, <84914> SPEC 8-09965-9	1	265	
- 3	3601-32D	• COUPLING, <79326> 92-72500-002	1	35	264
- 4	3605-16D	• COUPLING, <79326> 92-72500-014	1	265	
	MS29513-329	• PACKING	2	35	264
- 5	AN35032	• CLAMP	1	35	264
- 6	329-62-225SH	• CLAMP, <98625> 91-57802-072	2	265	
		ATTACHING PARTS			
- 7	NAS679A3	• NUT	1	35	
- 8	AN960D10L	• WASHER	1	35	
- 9	AN526-1032R6	• SCREW	1	35	
- 10	6133-7	• VALVE ASSY, REFUEL REGULATOR AND CHECK (86090) SPEC 8-02291 T.O. 6J15-7-18-13 REPLACES NOT INTCHG WITH 6133-3 REPLACED BY NOT INTCHG WITH 6133-7	1	35	264
	6133-7	• VALVE ASSY, REFUEL REGULATOR AND CHECK (86090) SPEC 8-02291-1 T.O. 6J15-7-18-13 REPLACED BY NOT INTCHG WITH 6133-9	1	35	215
	6133-9	• VALVE ASSY, REFUEL REGULATOR AND CHECK (86090) SPEC 8-02291-1 T.O. 6J15-7-18-13 REPLACES NOT INTCHG WITH 6133-3 AND 6133-7	1	265	
		ATTACHING PARTS			
- 11	NAS679A5	• NUT	4	35	
- 12	AN5-10A	• BOLT	4	35	
- 13	075356-2	• GASKET, <83259> SPEC 8-02299-3	1	35	
		-----X-----			
- 14	8-28273-1	• TUBE ASSY, WELDED	1	35	
- 15	CF14-200	• COUPLING, <98625> 92-73008-006	1	35	60
	51500-2-200	REPLACED BY SUITABLE SUB 51500-2-200			
		• COUPLING, <98625> 92-73008-016	1	61	
		REPLACES SUITABLE SUB FOR CF14-200			
- 16	24548-200	• RETAINER, PACKING USED WITH 51500-2-200	2		
- 17	701400	• VALVE ASSY, PRESSURE REFUELING <96124> SPEC 8-02969 T.O. 6J15-10-104-3 SEE FIGURE 2.12-27A INDEX 9	RF	35	
		ATTACHING PARTS			
- 18	AN4-6A	• BOLT	11	35	
- 19	AN960D416	• WASHER	11	35	
		-----X-----			
	MS29514-1	• FLANGE, VALVE (96906)	1	35	
	700500	• ADAPTER, PRESSURE FUEL SERVICING (96124)	1	35	
	721400	• CAP, PRESSURE FUEL SERVICING (96124) NOW MS29526-2	1	35	
- 20	8-27575	• GASKET	1	35	
- 21	1108B522-G1	• VALVE ASSY, DRAIN <91511> SPEC 8-0269A-1	1	35	
- 22	8-29363	• ROSS, DRAIN	1	35	
		ATTACHING PARTS			
- 23	AN344A	• BOLT	4	35	
	MS29513-12	• PACKING	1	35	
		-----X-----			
- 24	8-27529	• GASKET	2	35	
- 25	8-28368	• SHIM	1	35	

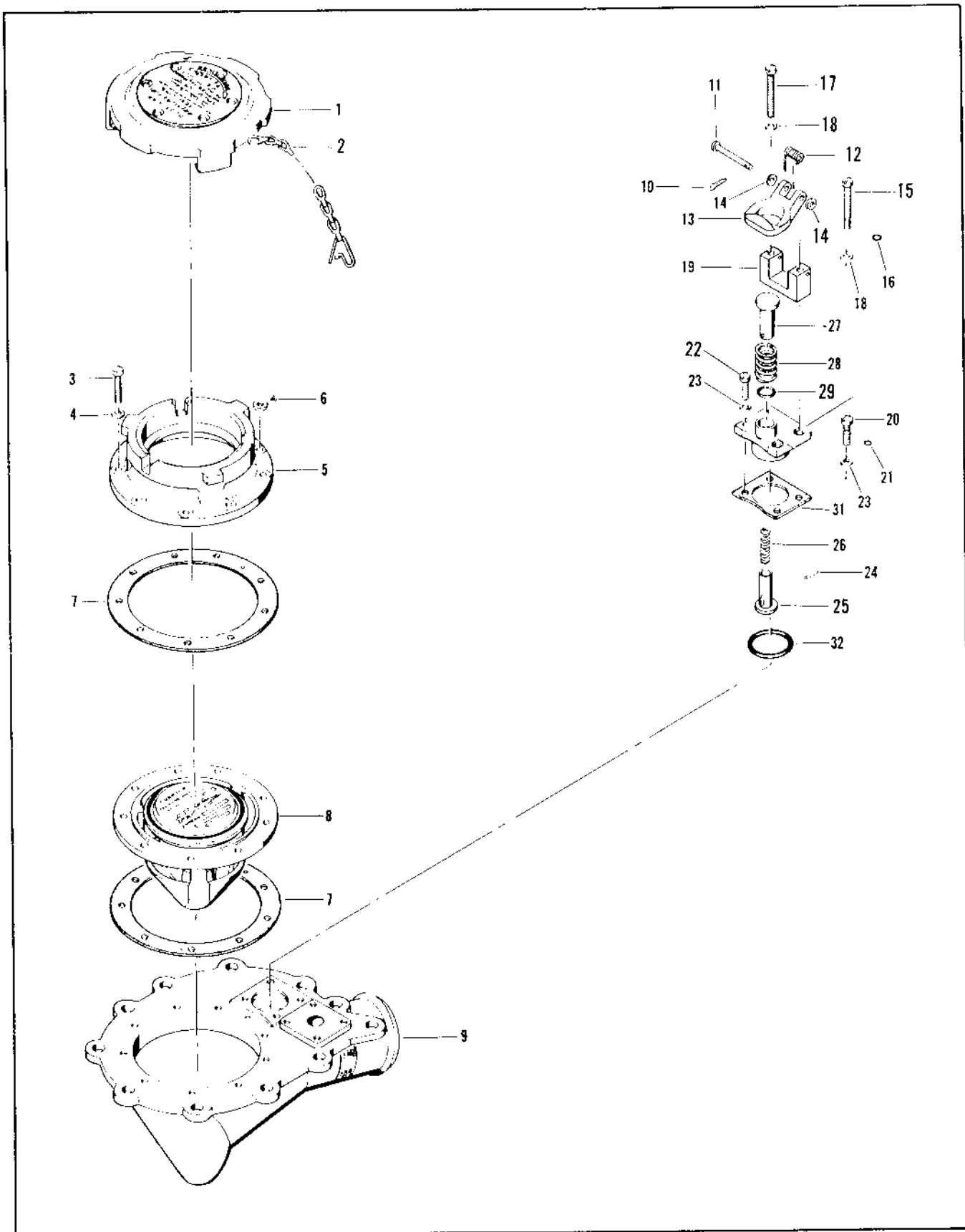

Figure 2.12-56. Pressure Refueling Valve

FIGURE AND INDEX NUMBER	PART NUMBER	DESCRIPTION	UNITS PER ASSY.	USABLE ON CODE	
				FROM	TO
2.12-56	701400	VALVE INSTALLATION, PRESSURE REFUELING FOR NHA SEE FIG. 3-4 T.O. 6J15-10-104-3	RF		
- 1	6986-2	• CAP, PRESSURE FUEL SERVICING (96124) NOW MS29526-2	1	35	
- 2	720017	• • CHAIN, FILLER CAP (96124)	1	35	
- 3	AN500A10-10	• SCREW, MACHINE	9	35	
- 4	AN960-10L	• WASHER, FLAT	9	35	
- 5	MS29514-1	• FLANGE, BAYONET (96906)	1	35	
- 6	700012	• EYE, CHAIN (96124)	1	35	
- 7	700016	• GASKET, (96124)	1	35	
- 8	700500	• ADAPTER, PRESSURE FUEL SERVICING (96124)	1	35	
- 9	701400-2	• HOSE, ASSY (96124)	1	35	
- 10	701402	• BODY, ASSY (96124)	1	35	
- 11	AN381-2-5	*1 • PIN, CUTTER	1	35	
- 12	AN329-49	*1 • PIN, STRAIGHT HEADED	1	35	
- 13	701416	*1 • SPRING, HELICAL, TORSION (96124)	1	35	
- 14	701415	*1 • FOLLOWER, (96124)	1	35	
- 15	AN960-6L	*1 • WASHER, FLAT	2	35	
- 16	701423	*1 • SCREW, MACHINE (96124)	1	35	
- 17	MS29513-005	*1 • PACKING, PREFORMED	1	35	
- 18	AN500A10-24	*1 • SCREW, MACHINE	1	35	
- 19	308717	*1 • WASHER (96124)	4	35	
- 20	701414	*1 • BLOCK, HINGE (96124)	1	35	
- 21	701421	*1 • SCREW, MACHINE (96124)	1	35	
- 22	MS29513-5	*1 • PACKING, PREFORMED	1	35	
- 23	AN500A10-10	*1 • SCREW, MACHINE	1	35	
- 24	308717	*1 • WASHER (96124)	2	35	
- 25	701407	*1 • PIN, STRAIGHT, HEADLESS (96124)	1	35	
- 26	701424	*1 • POPPET, (96124)	1	35	
- 27	701420	*1 • SPRING, HELICAL COMPRESSION (96124)	1	35	
- 28	701408	*1 • STRIKER (96124)	1	35	
- 29	701405	*1 • SPRING, HELICAL COMPRESSION (96124)	1	35	
- 30	MS29513-13	*1 • PACKING, PREFORMED	1	35	
- 31	701422	*1 • BODY VALVE (96124)	1	35	
- 32	701417	*1 • GASKET (96124)	1	35	
	MS29513-22	*1 • PACKING, PREFORMED	1	35	
	701496	• KIT FIELD (96124)	1		
		*1 THESE PARTS CONTAINED IN KIT PART NUMBER 701496			

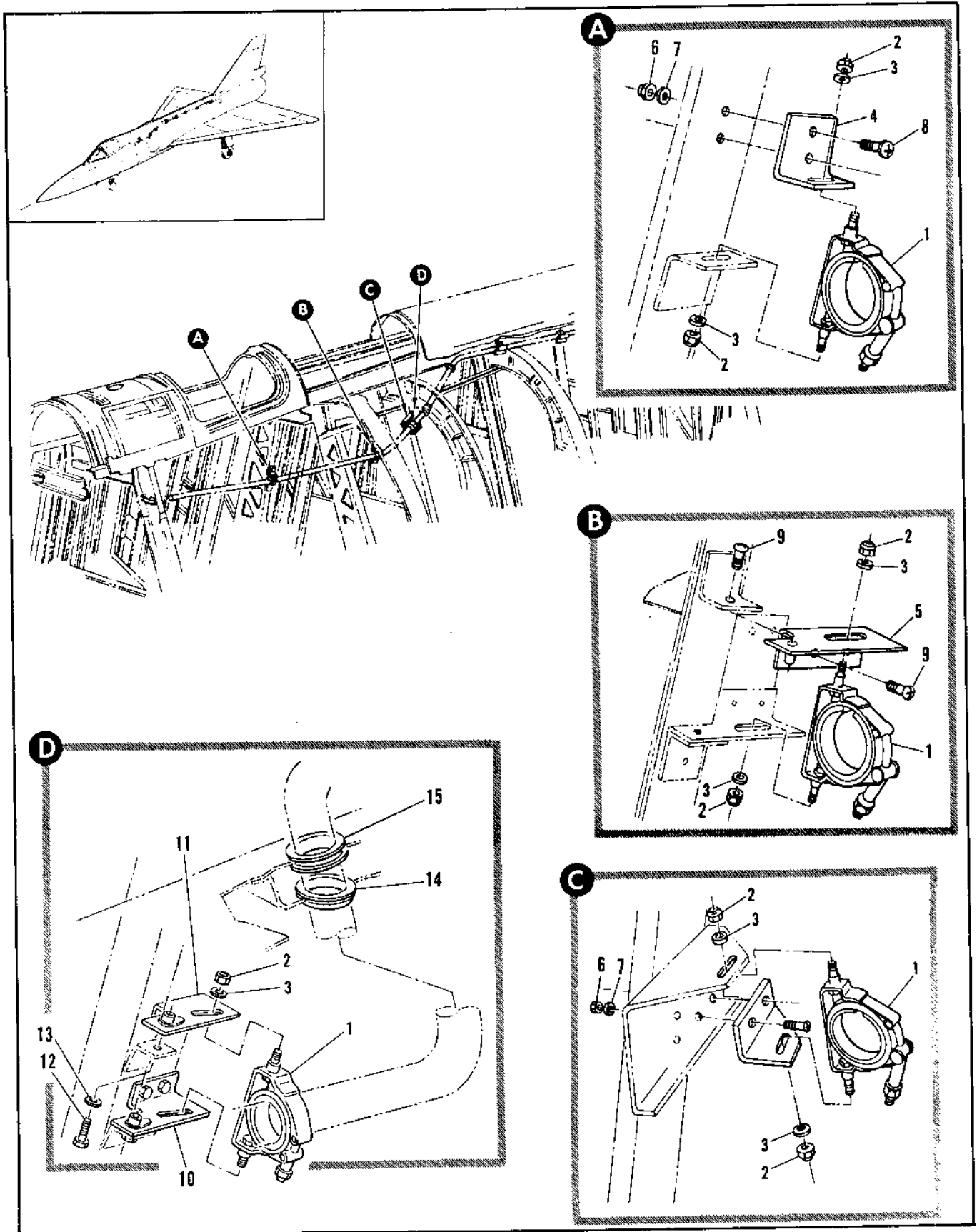

Figure 2.12-57. Fuel Tank Pressure Manifold Tubing Support (Sheet 1 of 2)

FIGURE AND INDEX NUMBER	PART NUMBER	DESCRIPTION 1 2 3 4 5 6	UNITS PER ASSY.	USABLE ON CODE	
				FROM	TO
2.12-57	8-28291	FUEL TANK PRESSURE MANIFOLD TUBING SUPPORT • SUPPORT INSTL, FUEL TANK PRESSURE MANIFOLD STA 295 TO 472 MODIFIED BY 66J4028R	RF	35	
- 1	1606SH	• • CLAMP, <43002> 91-98000-101 ATTACHING PARTS	3	35	
- 2	NAS679A3	• • NUT	6	35	
- 3	AN960C10L	• • WASHER -----X-----	6	35	
- 4	8-28292-29	• • BRACKET, STA 316	1	35	
- 5	3-28292-45	• • BRACKET ASSY, STA 337 RIVETED ATTACHING PARTS	1	35	
- 6	NAS6793A3	• • NUT, STA 316	2	35	
- 7	AN960PD10	• • WASHER, STA 316	2	35	
- 8	NAS221-11	• • SCREW, STA 316	2	35	
- 9	NAS221-5	• • SCREW, STA 337 -----X-----	3	35	
- 10	66040322-1	• • BRACKET	1	35	
- 11	66040323-1	• • BRACKET ATTACHING PARTS	1	35	
- 12	NAS1103-2	• • POLT	6	35	
- 13	AN960PD10L	• • WASHER -----X-----	6	35	
- 14	8-28320-7	• • GROMMET	1	35	
- 15	NMC-AG-T-24	• • GROMMET (13296)	1	35	

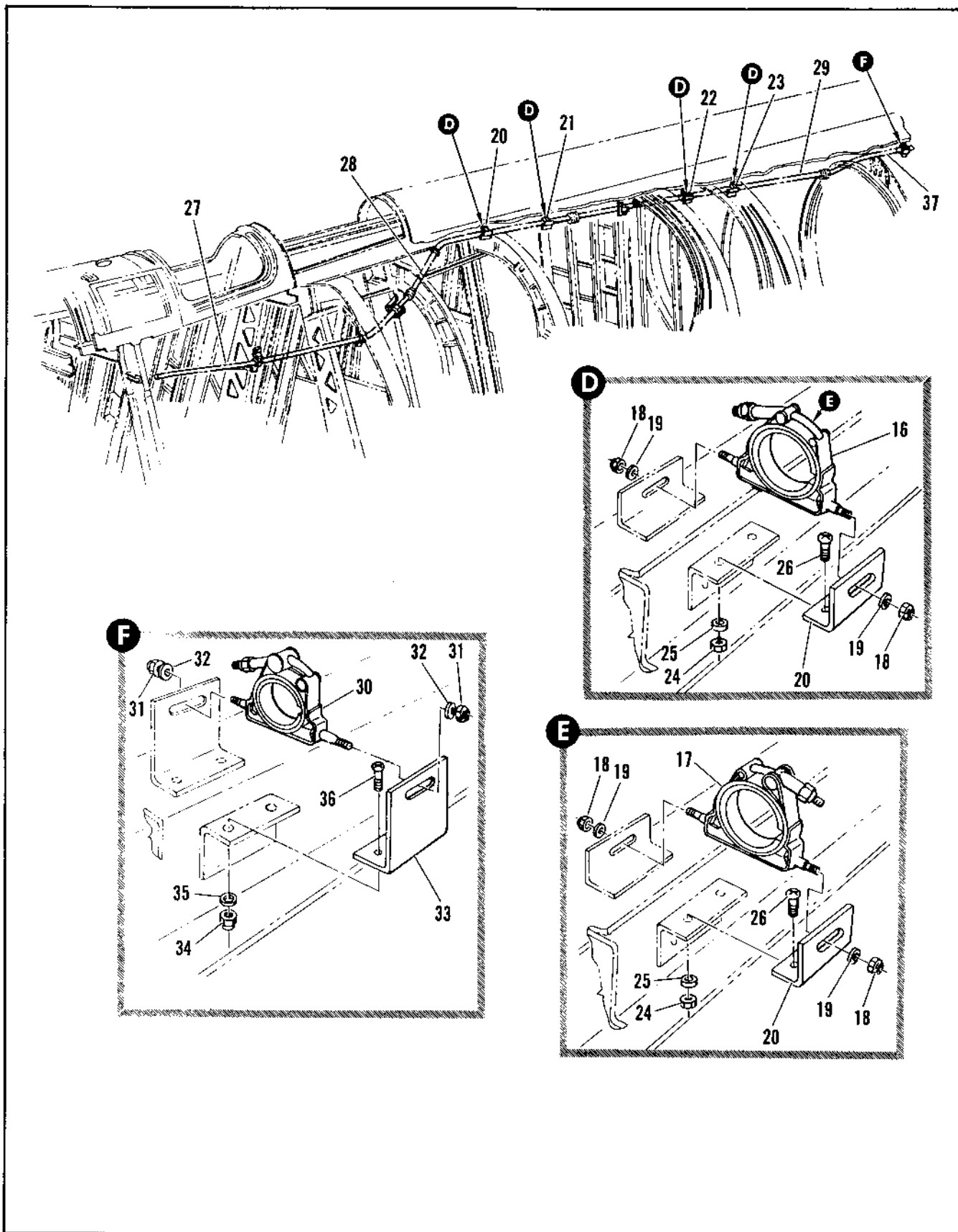

Figure 2.12-57. Fuel Tank Pressure Manifold Tubing Support (Sheet 2 of 2)

FIGURE AND INDEX NUMBER	PART NUMBER	DESCRIPTION	UNITS PER ASSY.	USABLE ON CODE	
				FROM	TO
		1 2 3 4 5 6			
2.12-57- 16	1600SH	• • CLAMP, <43002> 91-98020-601	4	35	60
- 17	1600SH	• • CLAMP, <43002> 91-98020-101	1	35	60
	1600SH	• • CLAMP, <43002> 91-98020-201	5	61	
		ATTACHING PARTS			
- 18	NAS679A3	• • NUT	8	35	
- 19	AN967C10L	• • WASHER	8	35	
		-----X-----			
- 20	8-28292-17	• • BRACKET, STA 377	1	35	
- 21	8-28292-18	• • BRACKET, STA 396	1	35	
- 22	8-28292-17	• • BRACKET, STA 427	1	35	
- 23	8-28292-17	• • BRACKET, STA 447	1	35	
- 24	NAS679A3	• • NUT	8	35	
	NAS679A3	• • NUT	2	35	
- 25	AN967PD10L	• • WASHER	8	35	
	AN967PD10L	• • WASHER	2	35	215
	AN967C10	• • WASHER	2	216	
- 26	AN526-1032R6	• • SCREW	8	35	
	AN526-1032R6	• • SCREW	8	35	
	AN526-1032R6	• • SCREW	2	35	215
	AN526-1032R6	• • SCREW	2	216	
- 27		• • TUBE ASSY, FUEL TANK PRESSURE SEE FIG. 2.12-44	RF		
- 28		• • TUBE ASSY, FUEL TANK PRESSURE SEE FIG. 2.12-44	RF		
- 29		• • TUBE ASSY, FUEL TANK PRESSURE SEE FIG. 2.12-44	RF		
	8-28291-1	• SUPPORT INSTL, FUEL TANK PRESSURE MANIFOLD STA 470 TO 485 FOR NHA SEE FIG. 2.3-14	RF	35	
- 30	1600SH	• • CLAMP, <43002> 91-98020-601	1	35	
		ATTACHING PARTS			
- 31	NAS679A3	• • NUT	2	35	
- 32	AN967C10L	• • WASHER	2	35	
		-----X-----			
- 33	8-28292-49	• • BRACKET, STA 475	1	35	
		ATTACHING PARTS			
- 34	NAS679A3	• • NUT	2	35	
- 35	AN967PD10L	• • WASHER	2	35	
- 36	AN526-1032R6	• • SCREW	2	35	
		-----X-----			
- 37		• • ELROW ASSY, FUEL TANK PRESSURE SEE FIG. 2.10-58 INDEX	RF		

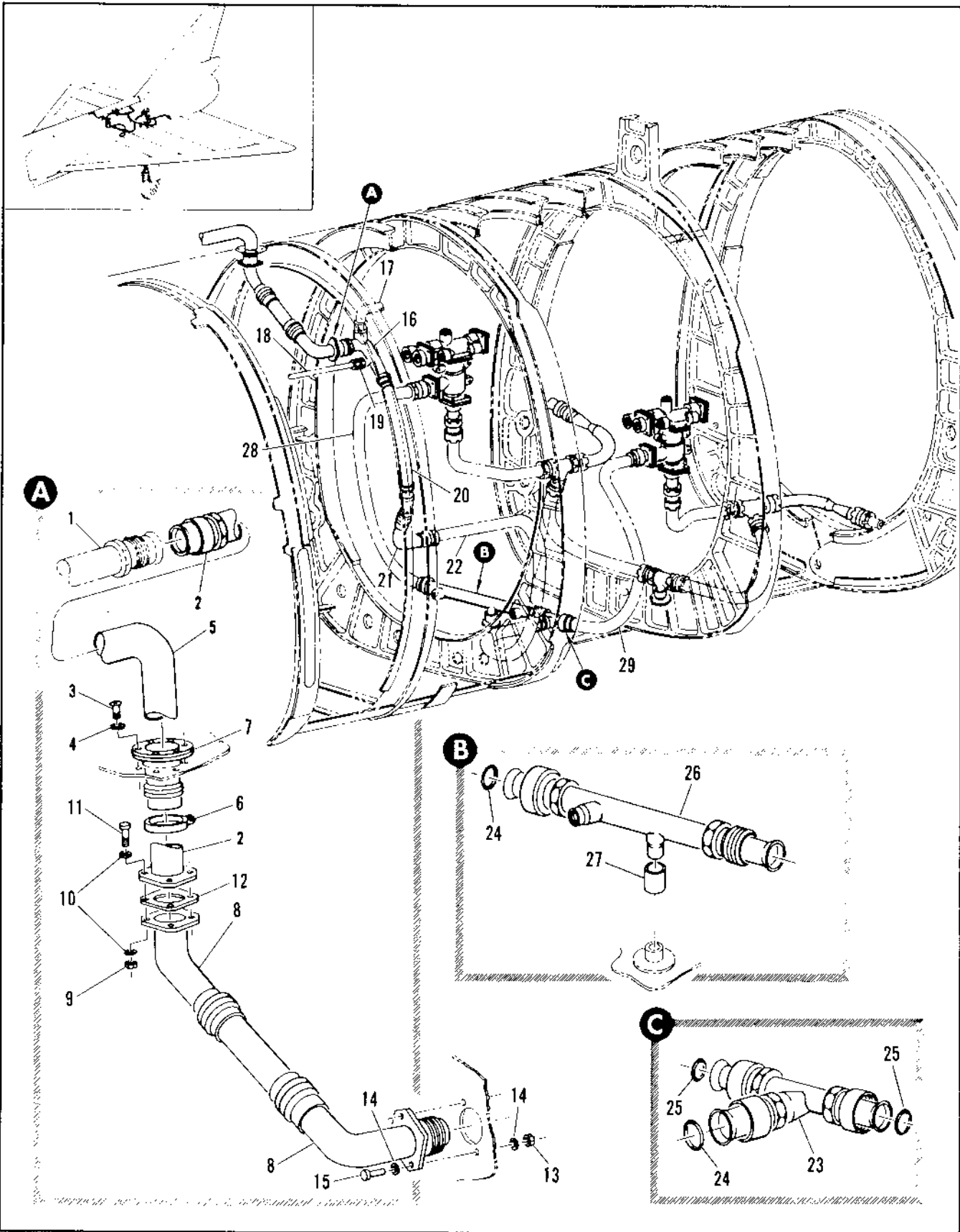

Figure 2.12-58. Fuel Tank Pressure Equipment Installation (Sheet 1 of 2)

FIGURE AND INDEX NUMBER	PART NUMBER	DESCRIPTION	UNITS PER ASSY.	USABLE ON CODE	
				FROM	TO
		1 2 3 4 5 6			
2.12-58	R-27320-1	EQUIPMENT INSTALLATION, FUEL TANK PRESSURE MODIFIED BY R-21234 FOR NHA SEE FIG. 2.1-15	PF	35	
- 1		• TUBE ASSY, FUEL TANK PRESSURE SEE FIG. 2.12-44	PF	35	
- 2	R-27465-5	• ELBOW ASSY, FUEL TANK PRESSURE ATTACHING PARTS	1	35	
- 3	NAS221-10	• SCREW	6	35	
- 4	AN961010L	• WASHER	6	35	
- 5	R-27469-13	• ELBOW, FLANGED TUBE (1A170)	1	35	
- 6	320-62-102M	• CLAMP, <R>2E> 51-57H12-530	1	35	
- 7	L1552	• SEAL, <1174> SPEC R-27469-1	1	35	
- 8	R-27491-1	• ELBOW ASSY, FUEL TANK PRESSURE WELDED	1	35	277
- 8	R-27491-3	• ELBOW ASSY, FUEL TANK PRESSURE WELDED ATTACHING PARTS	1	278	
- 9	NAS679A4	• NUT	4	35	
- 10	AN960-416L	• WASHER	8	35	
- 11	AN4-7A	• ROLET	4	35	
- 12	460-640-24	• GASKET, <0220> 07-08513-0.5	1	35	
- 13	NAS470A7	• NUT	2	35	
- 14	AN960C10L	• WASHER	4	35	
- 15	AN3-6A	• BOLT	2	35	
- 15	R-27464-5	• ELBOW ASSY, FUEL TANK PRESSURE WELDED	1	35	
- 17		• TUBE ASSY, PURGE AIR SEE FIG. 2.10-31 INDEX 5	PF		
- 18	NAS545-24	• PACKING	1	35	
- 18		• TUBE ASSY, FUEL TANK PRESSURE LH SEE FIG. 2.12-44 INDEX 5	PF		
- 19	NAS2102012	• UNION	1	35	
- 2	NAS617-12	• PACKING	1	35	
- 21	R-27493-1	• TUBE ASSY, FUEL TANK PRESSURE LH SEE FIG. 2.12-14 INDEX 1	PF		
- 21	NAS595-24	• ELBOW ASSY, FUEL TANK PRESSURE WELDED	1	35	
- 22		• PACKING	2	35	
- 22		• TUBE ASSY, FUEL TANK PRESSURE LH SEE FIG. 2.12-46 INDEX 17	PF		
- 23	R-28294	• TEE	1	35	
- 24	NAS545-24	• PACKING	1	35	
- 25	NAS545-20	• PACKING	2	35	
- 26	R-28296-3	• TUBE, FUEL TANK PRESSURE RH	1	35	
- 27	R-28319	• SLEEVE	1	35	
- 28		• TUBE ASSY, FUEL TANK PRESSURE RH SEE FIG. 2.12-32 INDEX 22	PF		

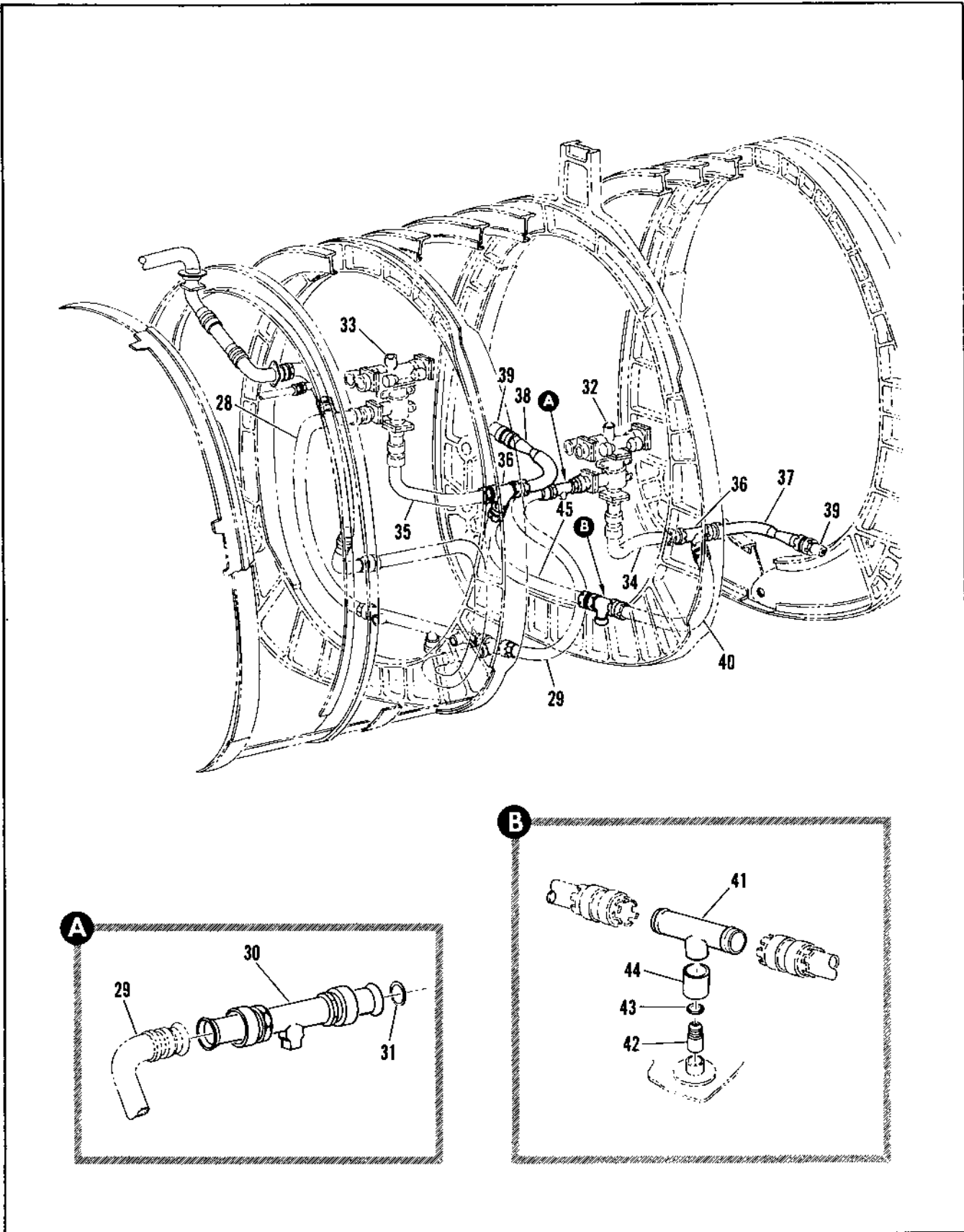

Figure 2.12-58. Fuel Tank Pressure Equipment Installation (Sheet 2 of 2)

FIGURE AND INDEX NUMBER	PART NUMBER	DESCRIPTION	UNITS PER ASSY.	USABLE ON CODE	
				FROM	TO
		1 2 3 4 5 6			
2.12-46-29		• TUBE ASSY, FUEL TANK PRESSURE LH SEE FIG. 2.12-46 INDEX 17	RF		
- 30	8-28298	• TUBE ASSY, LH WELDER	1	35	
- 31	NAS595-20	• PACKING	1	35	
- 32		• REGULATOR ASSY, AIR PRESSURE TRANSFER TANK LH SEE FIG. 2.12-46 INDEX 96	RF		
- 33		• REGULATOR ASSY, AIR PRESSURE TRANSFER TANK RH SEE FIG. 2.12-46 INDEX 95	RF		
- 34		• TUBE ASSY, FUEL TANK PRESSURE LH SEE FIG. 2.12-46 INDEX 1	RF		
- 35		• TUBE ASSY, FUEL TANK PRESSURE RH SEE FIG. 2.12-32 INDEX 94	RF		
- 36	8-27496-5	• TIF, LH REPLACES NOT IN CHG WITH 8-27496-1	1	35	
	8-27496-1	• TIF, RH	1	35	
- 37	8-28559-3	• TUBE ASSY, PRESSURE INTAKE TANK LH	1	35	
- 38	4-28355-4	• TUBE ASSY, PRESSURE INTAKE TANK RH	1	35	
- 39		• TUBE ASSY, SEE FIG. 2.12-75 INDEX 10	RF		
- 40		• TUBE ASSY, FUEL TANK PRESSURE LH SEE FIG. 2.12-46 INDEX 104	RF		
- 41	8-28295-1	• TUBE ASSY, REGULATOR CROSSOVER DRAIN W/LOED	1	35	
- 42	820-206	• VALVE ASSY, DRAIN AUTO	1	35	
- 43	NASA17-4	• PACKING	1	35	
- 44	8-28719	• SLEEVE	1	35	
- 45		• TUBE ASSY, FUEL TANK PRESSURE RH SEE FIG. 2.12-32 INDEX 101	RF		

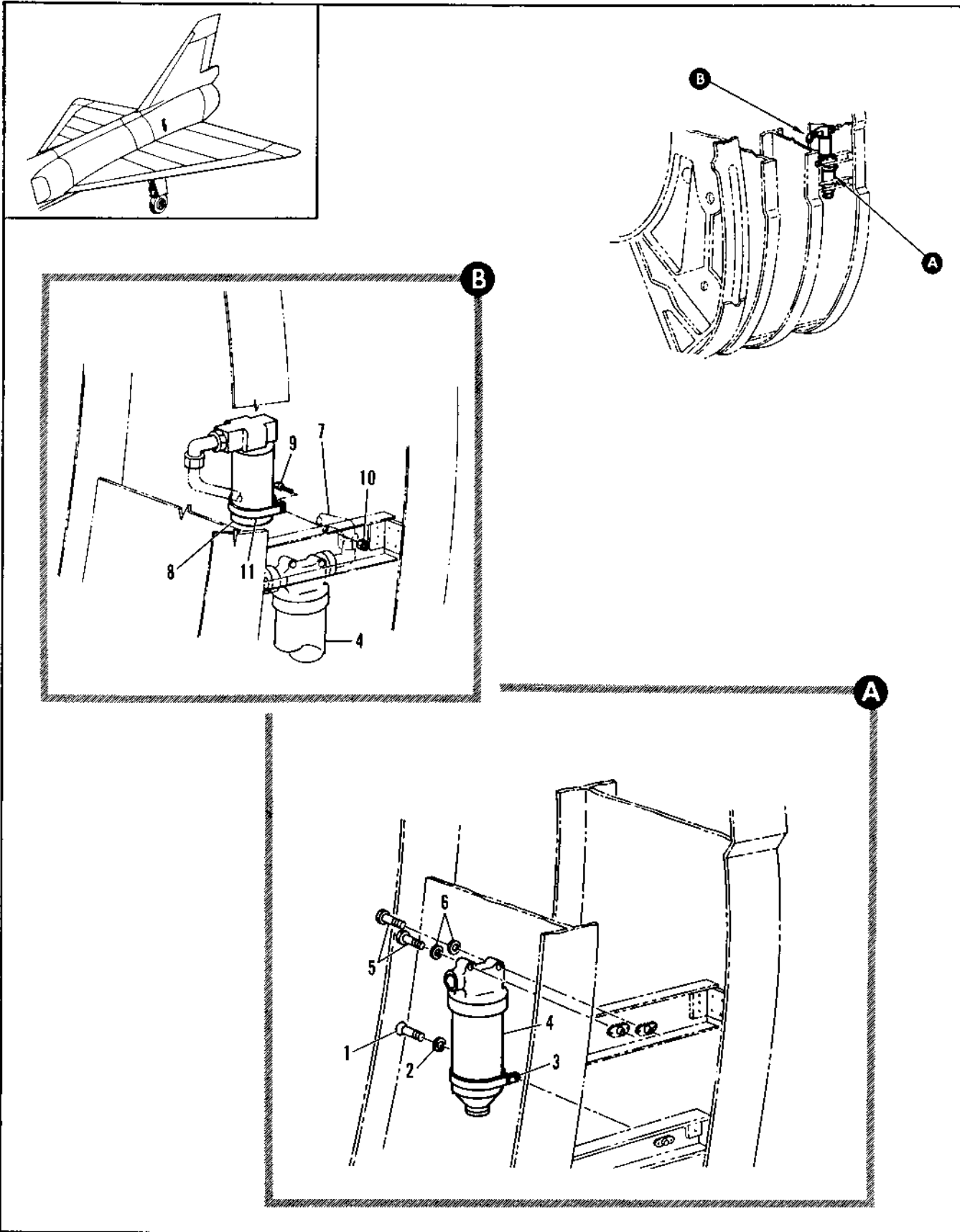

Figure 2.12-59. Fuel Tank Pressurization Air Filter Installation

FIGURE AND INDEX NUMBER	PART NUMBER	DESCRIPTION	UNITS PER ASSY.	USABLE ON CODE	
				FROM	TO
2.12-59	8-28261-3	FILTER INSTALLATION, FUEL TANK PRESSURIZATION AIR MODIFIED BY 8-61368 FOR NHA SEE FIG. 2.3-15	RF	35	
- 1	NAS221-6	• SCREW	1	35	
- 2	AN960D10L	• WASHER	1	35	
- 3	MS21919H36	• CLAMP	1	35	
- 4	902200	• FILTER, HIGH TEMPERATURE AIR <96124> SPEC P-03968-1 T.O. 9P6-2-6-3 ATTACHING PARTS	1	35	
- 5	AN4014A	• BOLT	2	35	
- 6	AN960D416L	• WASHER	2	35	
- 7		-----X----- • TUBE ASSY, FUEL TANK PRESSURE SEE FIG. 2.12-46 INDEX 24	RF		
- 8	C195-01	• VALVE ASSY, AIR PRESSURE SHUTOFF <96138> SPEC 8-02985-1 T.O. 9P5-5-72-3 REPLACES SUITABLE SUP FOR C95-01 ATTACHING PARTS	1	35	
- 9	NAS501-4H12A	• BOLT	2	35	
- 10	NAS221-6	• SCREW	1	35	
- 11	MS21919H32	-----X----- • CLAMP	1	35	

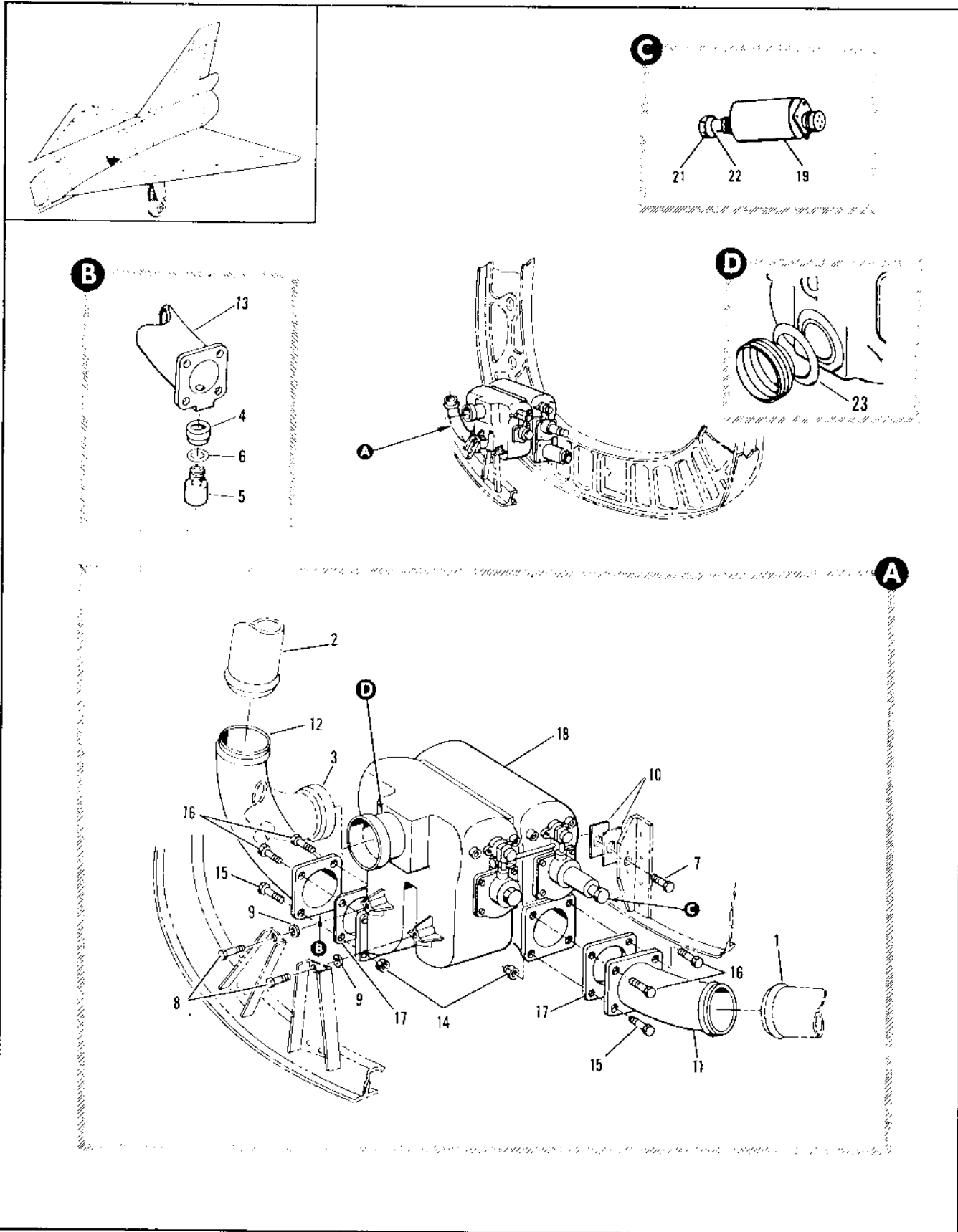

Figure 2.12-60. Fuel Flow Equalizer Installation

FIGURE AND INDEX NUMBER	PART NUMBER	DESCRIPTION	UNITS PER ASSY.	USABLE ON CODE	
				FROM	TO
2.12-60	9-27379-3	EQUALIZER INSTALLATION, FUEL FLOW FOR NHA SEE FIG. 2.3-3	RF	35	
- 1		• TUBE ASSY, SEE FIG. 2.12-65 INDEX 9	RF		
- 2		• TUBE ASSY, FUELLAGE ENGINE SUPPLY SEE FIG. 2.12-18 INDEX 2	RF		
- 3		• TUBE ASSY, FLOW EQUALIZER OUTLET LOWER SEE FIG. 2.12-65 INDEX 12	RF		
- 4	R-26456	• SEAL	1	35	
- 5	160R	• COCK, DRAIN <91511> 92-12531-003	1	35	
- 6	MS29513-12	• PACKING	1	35	247
	R-27379-11	EQUALIZER ASSY, FUEL FLOW	1	35	247
	R-27379-15	• EQUALIZER ASSY, FUEL FLOW ATTACHING PARTS	1	241	
- 7	AN4-6A	• BOLT	1	35	60
	NAS679A4	• NUT	1	61	
	AN960PD41E	• WASHER	1	61	
	AN4-7A	• BOLT	1	61	
- 8	AN4H5A	• BOLT	2	35	
- 9	AN961PD41G	• WASHER	2	35	
- 10	R-27379-13	• SHIM	2	61	
		-----X-----			
- 11	R-27462-1	• TUBE ASSY, LH	1	35	277
	R-21934-27	• TUBE ASSY, LH	1	278	
- 12	R-27463-3	• TUBE ASSY, RH	1	35	60
		REPLACED BY NOT INTERCHG WITH R-27463-5			
- 13	R-27463-5	• TUBE ASSY, RH	1	61	240
		REPLACES NOT INTERCH WITH R-27463-3			
		REPLACED BY SUITABLE SUB R-27463-801			
	R-27463-801	• TUBE ASSY, RH	1	241	
		REPLACES SUITABLE SUB FOR R-27463-5			
		ATTACHING PARTS			
- 14	NAS679A3	• NUT	4	35	
- 15	AN4-6A	• BOLT	4	35	
- 16	AN4H5A	• BOLT	4	35	
		-----X-----			
- 17	175356-4	• GASKET, <AT289> SPEC R-02289-7	2	35	
- 18	93702	• EQUALIZER ASSY, FUEL FLOW <98506> SPEC R-02289 T.O. 6J15-3-14-13	1	35	
- 19	FP25	• SOLENOID, BY-PASS VALVE <98505>	2	35	
	MS29512-5	• PACKING	2	35	
- 20	R9-41	• KIT, FIELD REPAIR, EQUALIZER	RF	35	
- 21	MS29512-5	• PACKING, PREFORMED	2	35	
- 22	FP19	• SEAL, SOLENOID FLANGER (BY-PASS VALVE)	2	35	
- 23	1SFS	• SEAL	2	35	

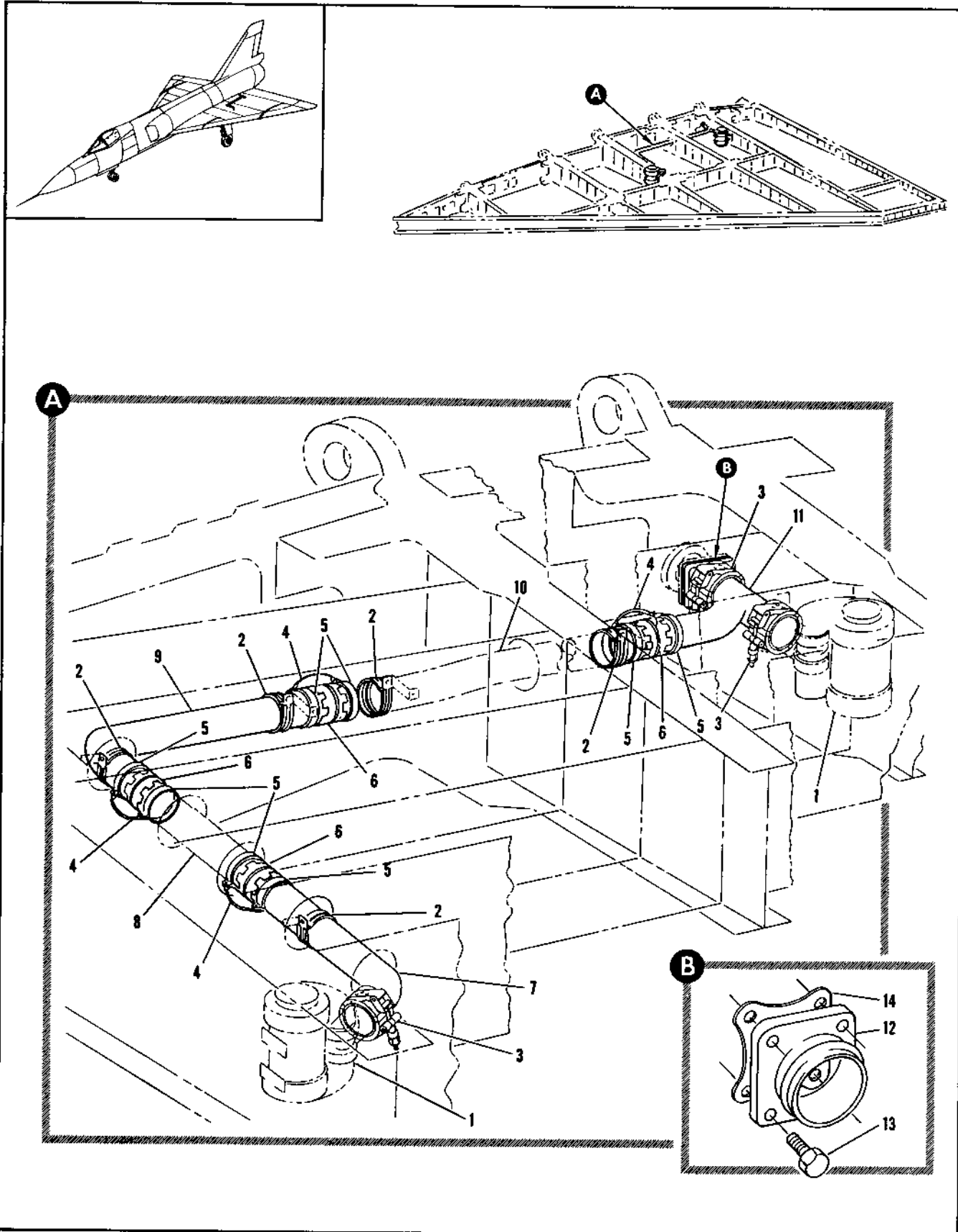

Figure 2.12-61. Engine Fuel Supply Wing Tubing Installation

FIGURE AND INDEX NUMBER	PART NUMBER	DESCRIPTION	UNITS PER ASSY.	USABLE ON CODE	
				FROM	TO
		1 2 3 4 5 6			
2.12-61	H-21540-1	TUBING INSTALLATION, ENGINE FUEL SUPPLY WING LH FOR NHA SEE FIG. 2-6-32	PF	35	
	A-21540-2	TUBING INSTALLATION, ENGINE FUEL SUPPLY WING RH FOR NHA SEE FIG. 2-6-32	RF	35	
- 1		• PUMP ASSY, FUEL BOOST SEE FIG. 2.12-1	RF		
- 2	91-98226-031	• CLAMP ATTACHING PARTS	5	35	
	AN520-10F8	• SCREW	5	35	
- 3	CF14-200	• COUPLING ASSY, <98625> 92-73008-006 REPLACED BY SUITABLE SUP 51500-2-200	3	35	60
	51500-2-200	• COUPLING ASSY, <98625> 92-73008-016 REPLACES SUITABLE SUP FOR CF14-200	3	61	
- 4	MS25083-1BB6	• JUMPER	4	35	277
	MS25083-1BB4	• JUMPER ATTACHING PARTS	4	278	
	NAS679A3	• NUT	8	35	
	AN960010L	• WASHER	8	278	
	AN520-10R8	• SCREW	8	35	277
	AN520-1032R6	• SCREW	8	278	
		-----X-----			
- 5	AN735032	• CLAMP	8	35	
- 6	3605-320	• COUPLING ASSY, <79326> 92-72500-014	4	35	
	MS29513-32P	• PACKING	8	35	
- 7	H-21124-1	• TUBE ASSY, LH WELDED	1	35	
	H-21124-2	• TUBE ASSY, RH WELDED	1	35	
- 8		• TUBE ASSY, LH SEE FIG. 2.12-20 INDEX 9	RF		
- 9	H-21545	• ELBOW	1	35	
- 10		• TUBE ASSY, LH SEE FIG. 2.12-20 INDEX 13	RF		
- 11	H-21120	• TUBE ASSY, WELDED	1	35	
- 12	H-21119	• TUBE ASSY, WELDED ATTACHING PARTS	1	35	
- 13	AN5H6A	• BOLT	4	35	
		-----X-----			
- 14	775356-3	• GASKET, <43259> SPEC H-2249-0	1	35	

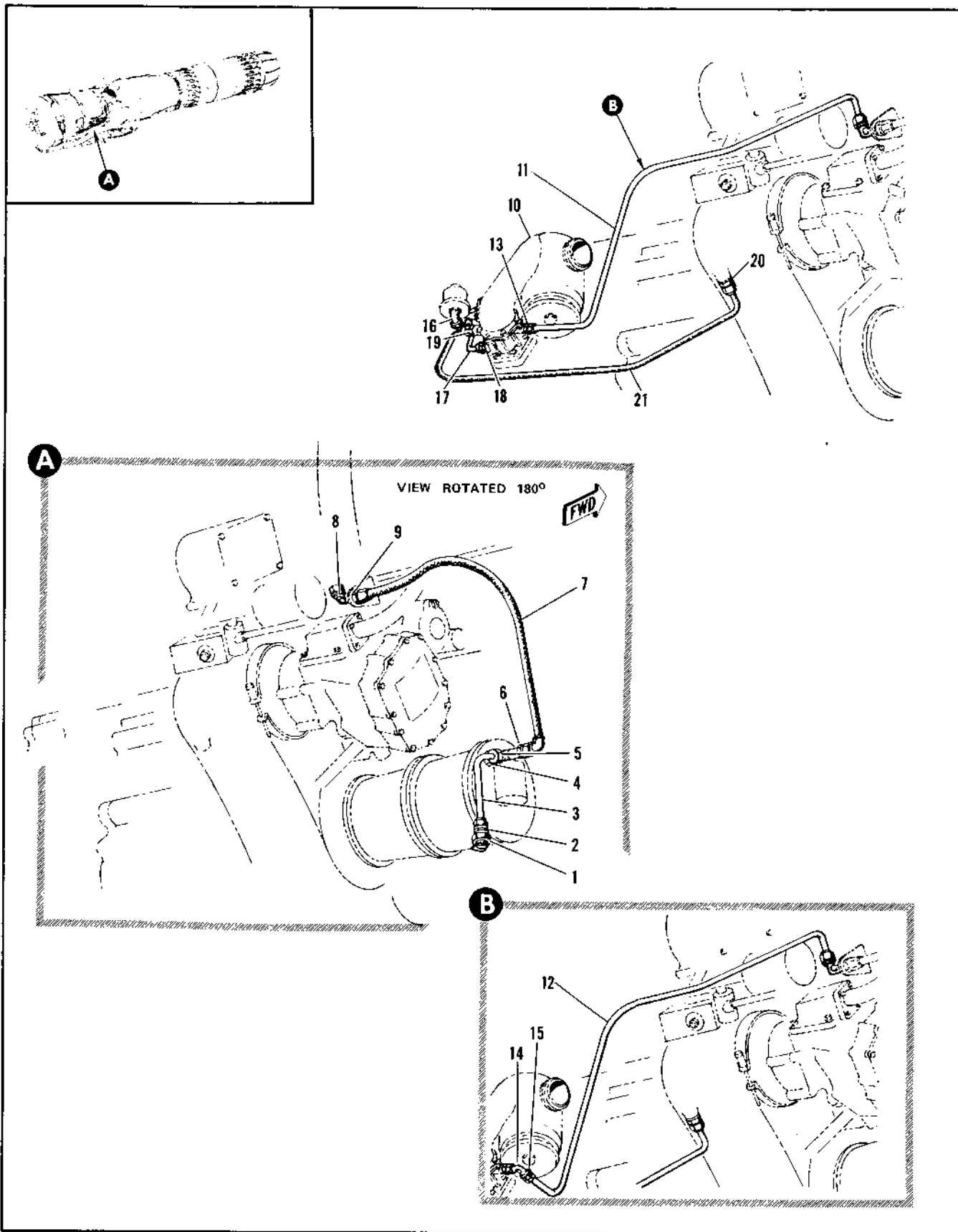

Figure 2.12-62. Engine Fuel Pressure Tubing Installation

FIGURE AND INDEX NUMBER	PART NUMBER	DESCRIPTION	UNITS PER ASSY.	USABLE ON CODE	
				FROM	TO
		1 2 3 4 5 6			
2.12-6.1	H-20397-835	TUBING INSTALLATION, ENGINE FUEL PRESSURE FOR NHA SEE FIG. 2.10-7	RF	35	
- 1	MS21914-4	*1 • CAP	1	35	
- 2	MS21902-4	*1 • UNION	1	35	
- 3	H-20397-1679	*1 • TUBE ASSY, ENGINE FUEL PRESSURE	1	35	
- 4	AN775-4	*1 • BOLT	1	35	
	AN901-4C	*1 • GASKET	2	35	
- 5	FR776-4	*1 • ELBOW, <92003> 93-40013-004	1	35	
- 6	MS21902-4	*1 • UNION	1	35	
	MS29512-4	*1 • GASKET	1	35	
- 7	R992654-0256	*1 • HOSE ASSY, <50599> 94-40510-020	1	35	
- 8	MS21908-4	*1 • ELBOW	1	35	
- 9	AN924-4	*1 • NUT	1	35	
	AN960-716	*1 • WASHER	1	35	
- 10		*1 • STRAINER, FUEL SEE FIG. 2.12-28 INDEX 28	RF		
- 11	H-20397-3015	*1 • TUBE ASSY, ENGINE FUEL PRESSURE	1	103	215
- 12	H-20397-2959	*1 • TUBE ASSY, ENGINE FUEL PRESSURE	1	A	
- 13	MS21902-4	*1 • UNION	1	103	215
	MS29512-4	*1 • GASKET	1	103	215
	AN814-4	*2 • PLUG	1	35	
	S9412-554	*2 • PACKING	1	35	
- 14	MS21907-4	*1 • ELBOW	1	A	
- 15	AN924-4	*1 • NUT	1	A	
	MS29512-4	*1 • GASKET	1	A	
- 16	MS21902-4	*1 • UNION	1	35	
	MS29512-4	*1 • GASKET	1	35	
- 17	R992654-0896	*1 • HOSE ASSY, ENGINE FUEL PRESSURE	1	35	
- 18	H-28358-0	*1 • UNION, ENGINE PRESSURE LINE DRAIN RESTRICTOR	1	35	
- 19	MS2191504-3	*1 • PUSHING	1	35	
	MS29512-4	*1 • GASKET	1	35	
	MS21902-4	*1 • UNION	1	35	
- 20	MS21903-4	*1 • UNION	1	35	
	MS29512-4	*1 • GASKET	1	35	
- 21	R9944004	*1 • HOSE ASSY, <50599>	1	35	
	0260-0				
<p>A AIRPLANES #35 THRU 119, 214 AND ON</p> <p>*1 REMOVED PER TC TO 1F-106-1110 *2 ADDED PER TC TO 1F-106-1110</p>					

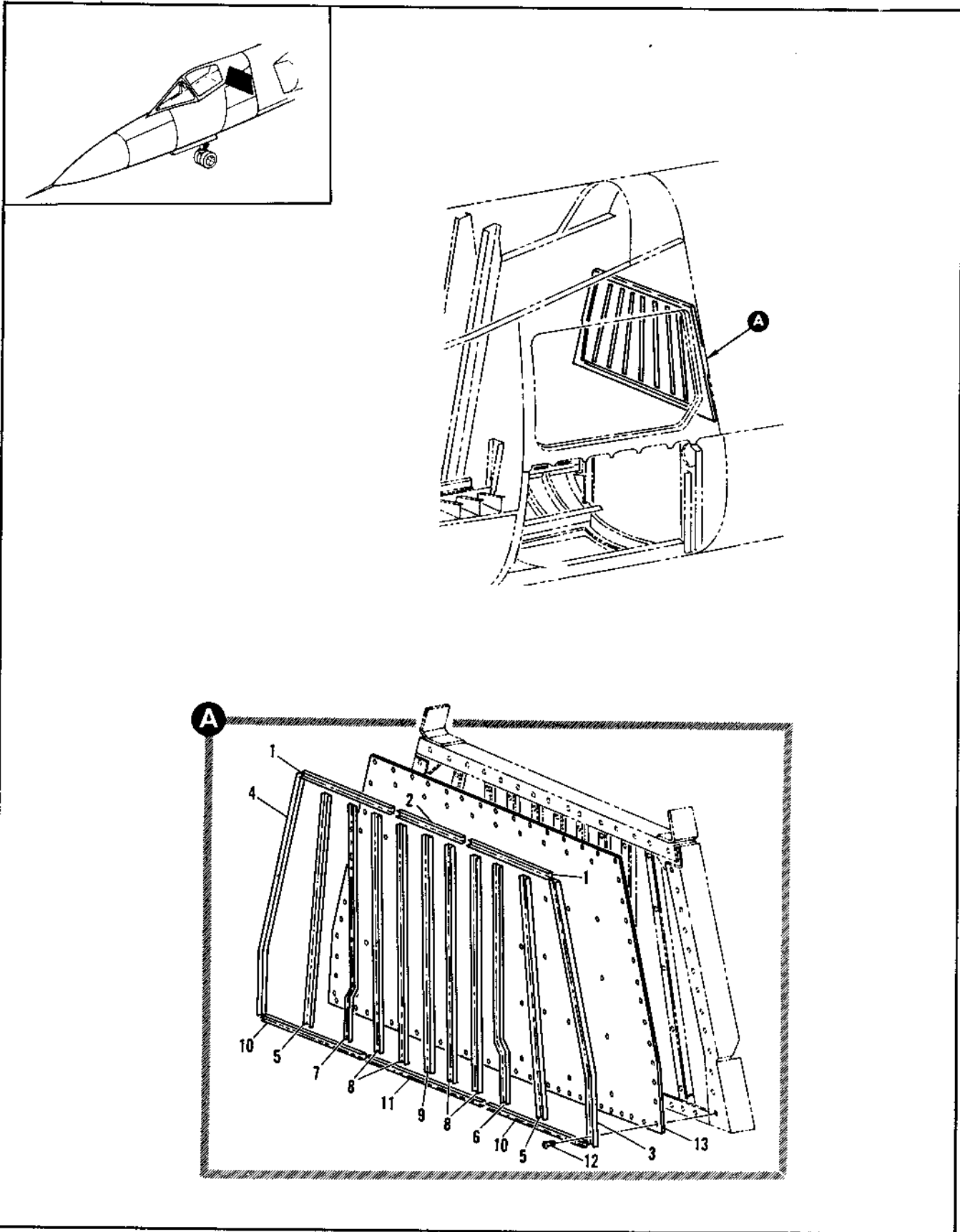

Figure 2.12-63. Fuselage Fuel Tank Fume Barrier Installation

FIGURE AND INDEX NUMBER	PART NUMBER	DESCRIPTION	UNITS PER ASSY.	USABLE ON CODE	
				FROM	TO
2.12-63	8-74907-1	BARRIER INSTALLATION, FUSELAGE FUEL TANK FUME FOR NHA SEE FIG. 2.3-9	RF	35	
- 1	8-74907-107	• RETAINER	2	35	
- 2	8-74907-105	• RETAINER	1	35	
- 3	8-74907-81	• RETAINER, LH	1	35	
- 4	8-74907-52	• RETAINER, RH	1	35	
- 5	8-74907-61	• RETAINER	2	35	
- 6	8-74907-101	• RETAINER, LH	1	35	
- 7	8-74907-102	• RETAINER, RH	1	35	
- 8	8-74907-87	• RETAINER	4	35	
- 9	8-74907-85	• RETAINER	1	35	
- 10	8-74907-83	• RETAINER	2	35	
- 11	8-74907-81	• RETAINER	1	35	
		ATTACHING PARTS			
- 12	AN515-6R5	• SCREW ----X----	AR	35	
- 13	8-74907-7	• SEAL	1	35	

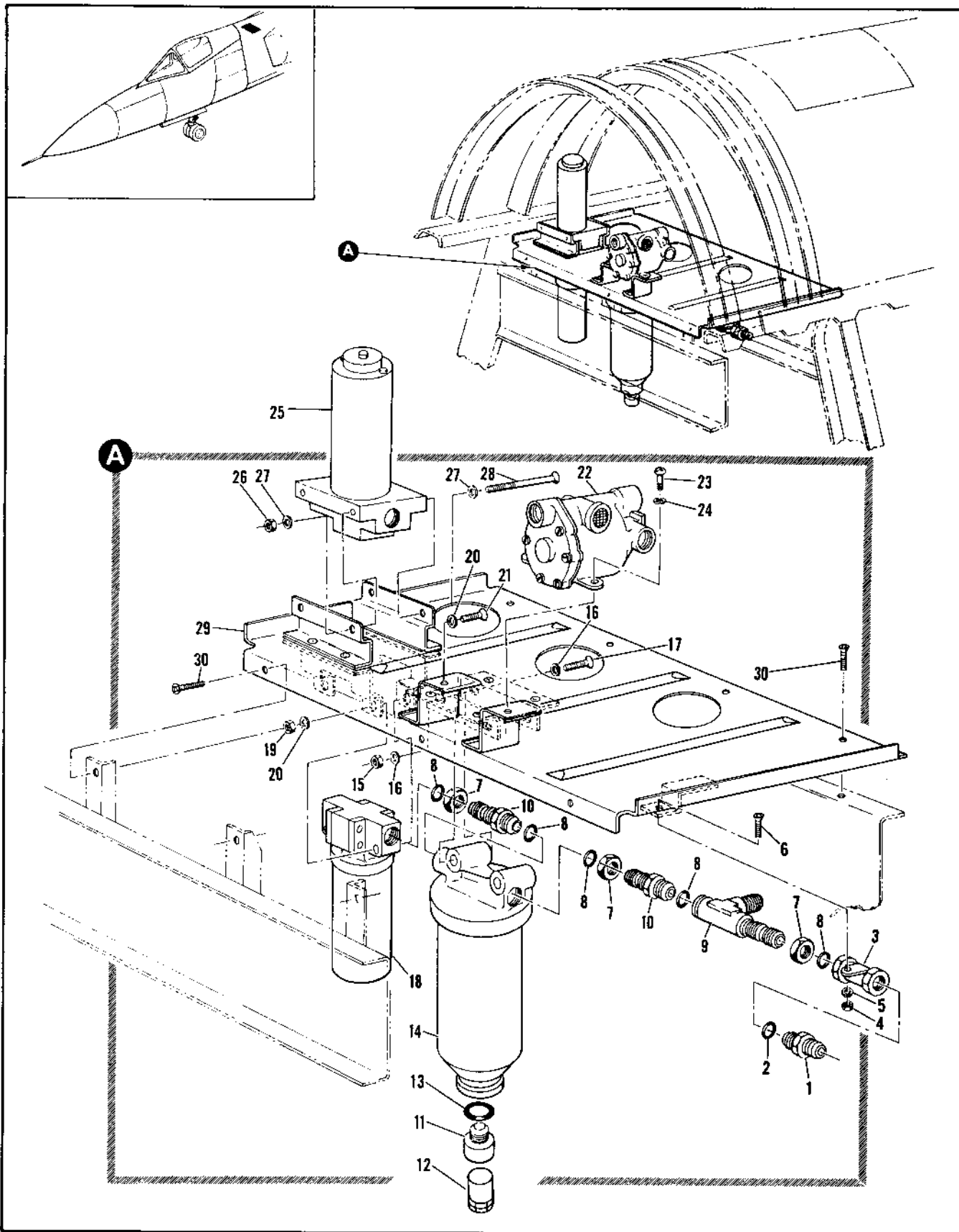

Figure 2.12-64. Air Shutoff Valve and Filter Panel Installation

FIGURE AND INDEX NUMBER	PART NUMBER	DESCRIPTION	UNITS PER ASSY.	USABLE ON CODE	
				FROM	TO
2.12-64	R-28290	PANEL INSTALLATION, AIR SHUTOFF VALVE AND FILTER MODIFIED BY R-01368 FOR NHA SEE FIG. 2.3-10	RF	35	
- 1	MS21902D6	• UNION	1	35	
- 2	NAS617-6	• PACKING	1	35	
- 3	W535-3/RF	• VALVE ASSY, AIR CHECK <9613> SPEC R-02998-9	1	35	
	W535-3/RF	• VALVE ASSY, AIR CHECK <9613> SPEC R-02998-13 ALTERNATE PART FOR W535-3/RF ATTACHING PARTS	RF	35	
- 4	NAS679A3	• NUT	1	35	
- 5	AN960PD10	• WASHER	1	35	
- 6	AN520-10610	• SCREW	1	35	
		-----X-----			
- 7	AN924-60	• NUT	3	35	
- 8	NAS617-6	• PACKING	3	35	
- 9	MS21911D6	• TEE	1	35	
- 10	MS21903D6	• UNION	2	35	
- 11	150R	• VALVE ASSY, DRAIN <91911> 92-12531-002	1	35	159
- 12		• UNION, RESTRICTOR SEE FIG. 2.12-46 INDEX 164	RF	35	
- 13	NAS617-6	• PACKING	1	35	159
- 14	9622FC	• FILTER, AIR <96124> SPEC R-0196R-1 T.O. 996-2-6-3 ATTACHING PARTS	1	35	
- 15	NAS679A4	• NUT	2	35	
- 16	AN960PD416	• WASHER	4	35	
- 17	AN520-416R20	• SCREW	2	35	
		-----X-----			
- 18	C195-01	• VALVE ASSY, AIR PRESSURE SHUTOFF <9613> SPEC R-02995-1 T.O. 908-5-72-3 ATTACHING PARTS	1	35	
- 19	NAS679A4	• NUT	2	35	
- 20	AN960PD416	• WASHER	4	35	
- 21	AN520-416R20	• SCREW	2	35	
		-----Y-----			
- 22	SV310-110	• VALVE ASSY, AIR SHUTOFF <94497> SPEC R-0095R-3 T.O. 105-5-74-3 ATTACHING PARTS	1	35	
- 23	NAS221-6	• SCREW	2	35	
- 24	AN960D101	• WASHER	2	35	
		-----X-----			
- 25	V21100	• VALVE, <96487> SPEC R-01391-7 T.O. 9015-10-187-5 ATTACHING PARTS	1	35	
- 26	NAS679A3	• NUT	2	35	
- 27	AN960PD10	• WASHER	4	35	
- 28	NAS221-37	• SCREW	2	35	
		-----X-----			
- 29	R-28290-33	• PANEL ASSY, AIR SHUTOFF VALVE RIVETED ATTACHING PARTS	1	35	
- 30	AN520-1067	• SCREW	7	35	
		-----X-----			

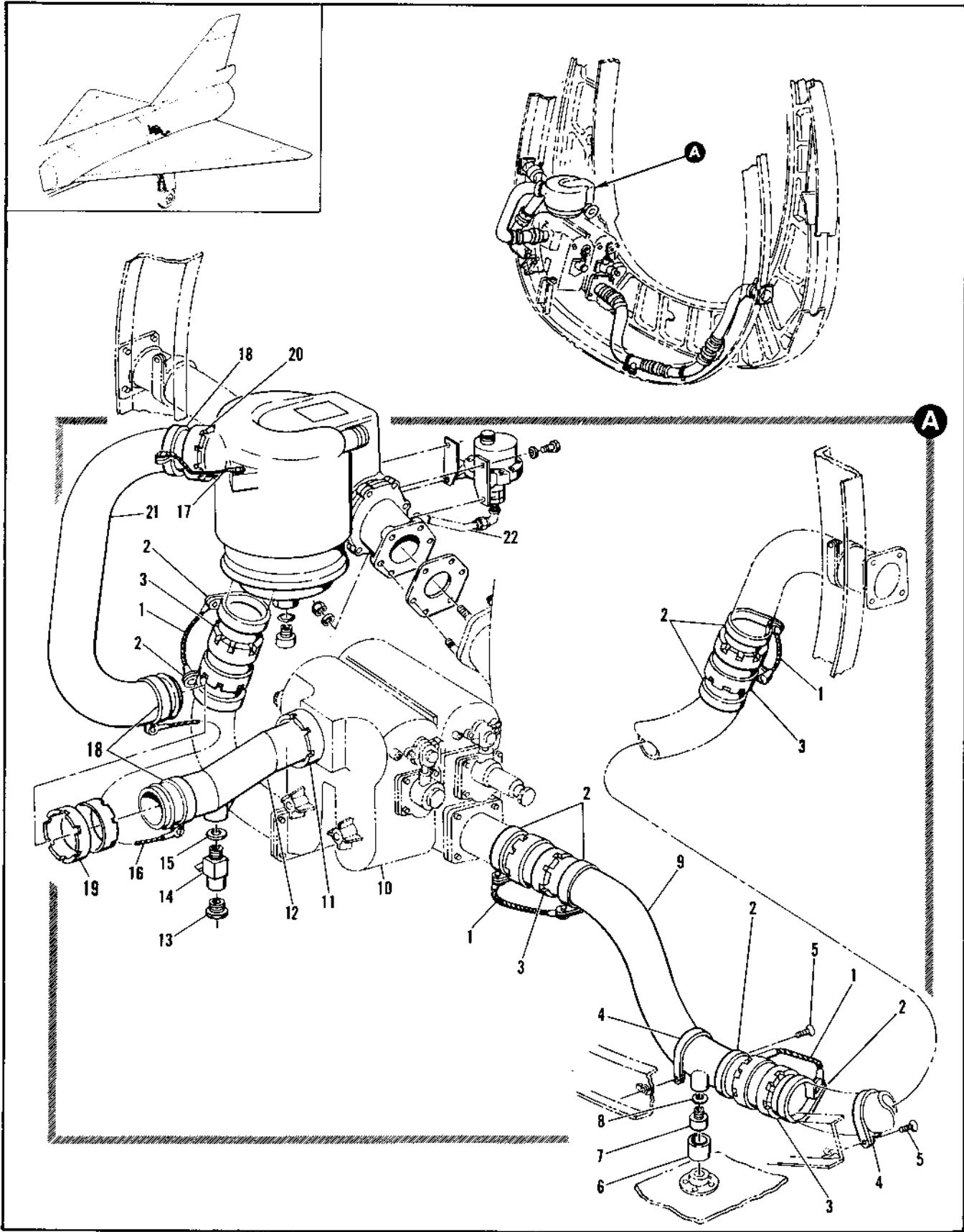

Figure 2.12-65. Engine Fuel Supply Tubing and Strainer (Sheet 1 of 2)

FIGURE AND INDEX NUMBER	PART NUMBER	DESCRIPTION	UNITS PER ASSY	USABLE ON CODE	
				FROM	TO
2.12-65	P-27449-3	ENGINE FUEL SUPPLY TUBING AND STRAINER	RF	39	102
	K-27449-4	TUBING INSTL, ENGINE FUEL SUPPLY FOR NHA SEE FIG. 2.12-15	RF	103	
- 1	MS25083-18R6	• JUMPER	4	35	
	NAS679A3	• NUT	4	35	
	AN520-10RA	• SCREW	4	35	
- 2	AN742D32	• CLAMP	4	35	
- 3	3605-32D	• COUPLING, <79326> 92-7250-010	4	35	
	MS29513-32D	• PACKING	2	35	38
- 4	MS21919DF32	• CLAMP	2	35	
	91-98126-031	• CLAMP	2	35	
- 5	AN520-10RA	• SCREW	1	35	
- 6	P-27449-7	• SLEEVE	1	35	102
- 7	140P	• COCK, DRAIN <91511> 92-12511-003	1	103	
	140R	• COCK, DRAIN <91511> 92-12511-001	1	35	
- 8	MS29513-12	• PACKING	1	35	60
- 9	K-27464-5	• TUBE ASSY, FUSELAGE ENGINE SUPPLY WELDED REPLACED BY SUITABLE SUP P-27464-801	1	61	240
	P-27464-801	• TUBE ASSY, FUSELAGE ENGINE SUPPLY WELDED REPLACED SUITABLE SUP FOR P-27464-8	RF	61	240
	H-27464-403	• TUBE ASSY, FUSELAGE ENGINE SUPPLY WELDED REPLACED BY SUITABLE SUP P-27464-805	RF	61	240
	P-27464-403	• TUBE ASSY, FUSELAGE ENGINE SUPPLY WELDED ALT INTCHG WITH P-27464-801	1	241	
- 10		• TUBE ASSY, FUSELAGE ENGINE SUPPLY WELDED REPLACES SUITABLE SUP FOR P-27464-801	RF		
		• EQUALIZER ASSY, FUEL FLOW SEE FIG. 2.12-12 INDEX 18			
- 11	3655-40D	• COUPLING, <79326> 92-72511-010	1	35	
	MS29513-33Z	• PACKING	1	35	
- 12	K-28459-001	• TUBE ASSY, FLOW EQUALIZER OUTLET LOWER WELDED	1	35	
- 13	AN856016	• PLUG	1	35	
- 14	35251-3	• COCK, DRAIN <81413> 92-13710-003 T.O. 6011-4-21-13	1	35	
- 15	MS29513-217	• PACKING	1	35	
- 16	MS25083-18R6	• JUMPER	1	35	
- 17	MS25083-18R6	• JUMPER	4	35	
	NAS679A7	• NUT	4	35	
	AN520-10RA	• SCREW	3	35	
- 18	AN775D40	• CLAMP	1	35	
- 19	3605-40D	• COUPLING, <79326> 92-7250-010	1	35	
	MS29513-33Z	• PACKING	2	35	
- 20	3655-40D	• COUPLING, 75326 92-72511-010	1	35	
	MS29513-33Z	• PACKING	1	35	
- 21	K-29939-5	• TUBE ASSY, FLOW EQUALIZER OUTLET UPPER SPEC P-29939-8	RF	35	
	K-29939-8	• TUBE ASSY, FLOW EQUALIZER OUTLET UPPER SPEC P-29939-5	RF		
- 22		• TUBE ASSY, SEE FIG. 2.12-12 INDEX 17	RF		

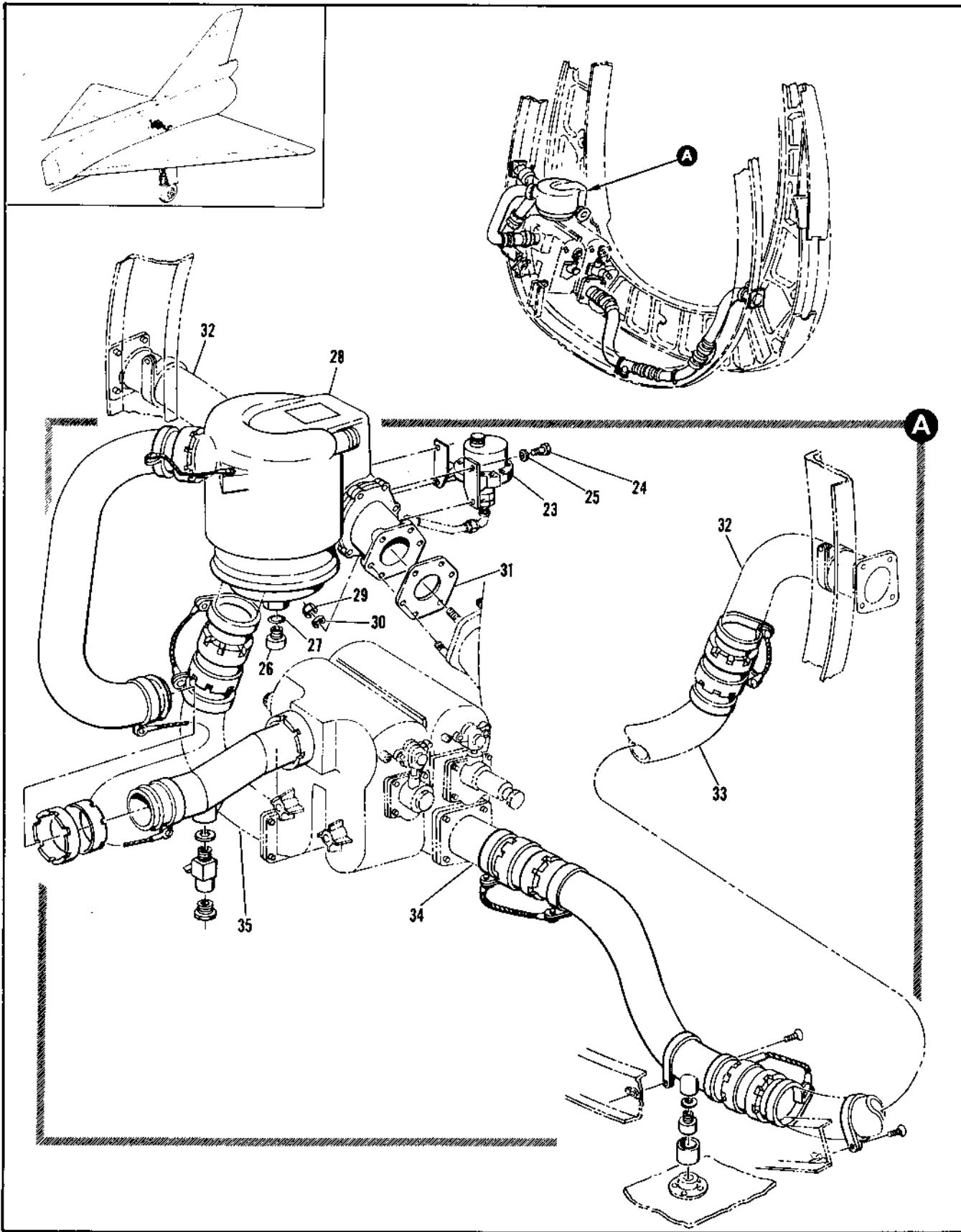

Figure 2.12-65. Engine Fuel Supply Tubing and Strainer (Sheet 2 of 2)

FIGURE AND INDEX NUMBER	PART NUMBER	DESCRIPTION	UNITS PER ASSY	USABLE ON CODE	
				FROM	TO
		1 2 3 4 5 6			
2.12-65	R-27449-P03	• STRAINER INSTL. ENGINE FUEL SUPPLY	RF	35	
- 23	M9395-93-C1	• SWITCH ACTIVATED (91349) SPEC 98-62805 -001, MIL-S-9395-3 ATTACHING PARTS	1	35	
- 24	AN3H4 A	• BOLT	4	35	
- 25	AN960-10L	• WASHER	4	35	
		-----X-----			
- 26	150R	• COCK, DRAIN <91511> 92-12501-002	1	35	
- 27	MS29512-6	• GASKET	1	35	193
- 28	9-1041655	• STRAINER, FUEL <75361> SPEC 8-09941-3 T.O. 6J5-48-4	1	35	193
	R-104175	• STRAINER, FUEL <75361> SPEC 8-09941-3 T.O. 6J5-48-4	1	194	
- 29	NAS679A5	• NUT	6	35	
- 30	AN960-516L	• WASHER	6	35	
- 31	460-C15-40	• SEAL, <R3259> 97-93503-336	1	35	246
- 32	R-27460	• TUBE ASSY, LH WELDED REPLACED BY SUITABLE SUB R-27460-1	1	35	241
	R-27460-1	• TUBE ASSY, LH WELDED REPLACES SUITABLE SUB FOR R-27460	1	241	
	R-27461	• TUBE ASSY, RH WELDED REPLACED BY INTCHG WITH R-28486-1	1	35	60
	R-28486-1	• TUBE ASSY, RH WELDED REPLACES NOT INTCHG WITH R-27461 REPLACED BY SUITABLE SUB R-28486-3	1	61	240
	R-28486-3	• TUBE ASSY, RH WELDED REPLACES SUITABLE SUB FOR R-28486-1	1	241	
- 33	R-28397-256	• TUBE ASSY, ENGINE FUEL SUPPLY	1	35	63
- 34	R-28397-225	• TUBE ASSY, ENGINE FUEL SUPPLY	1	61	240
		• TUBE ASSY, ENGINE FUEL SUPPLY LH SEE FIG. 2.12-60 INDEX 11	RF		
- 35		• TUBE ASSY, ENGINE FUEL SUPPLY RH SEE FIG. 2.12-60 INDEX 12	RF		

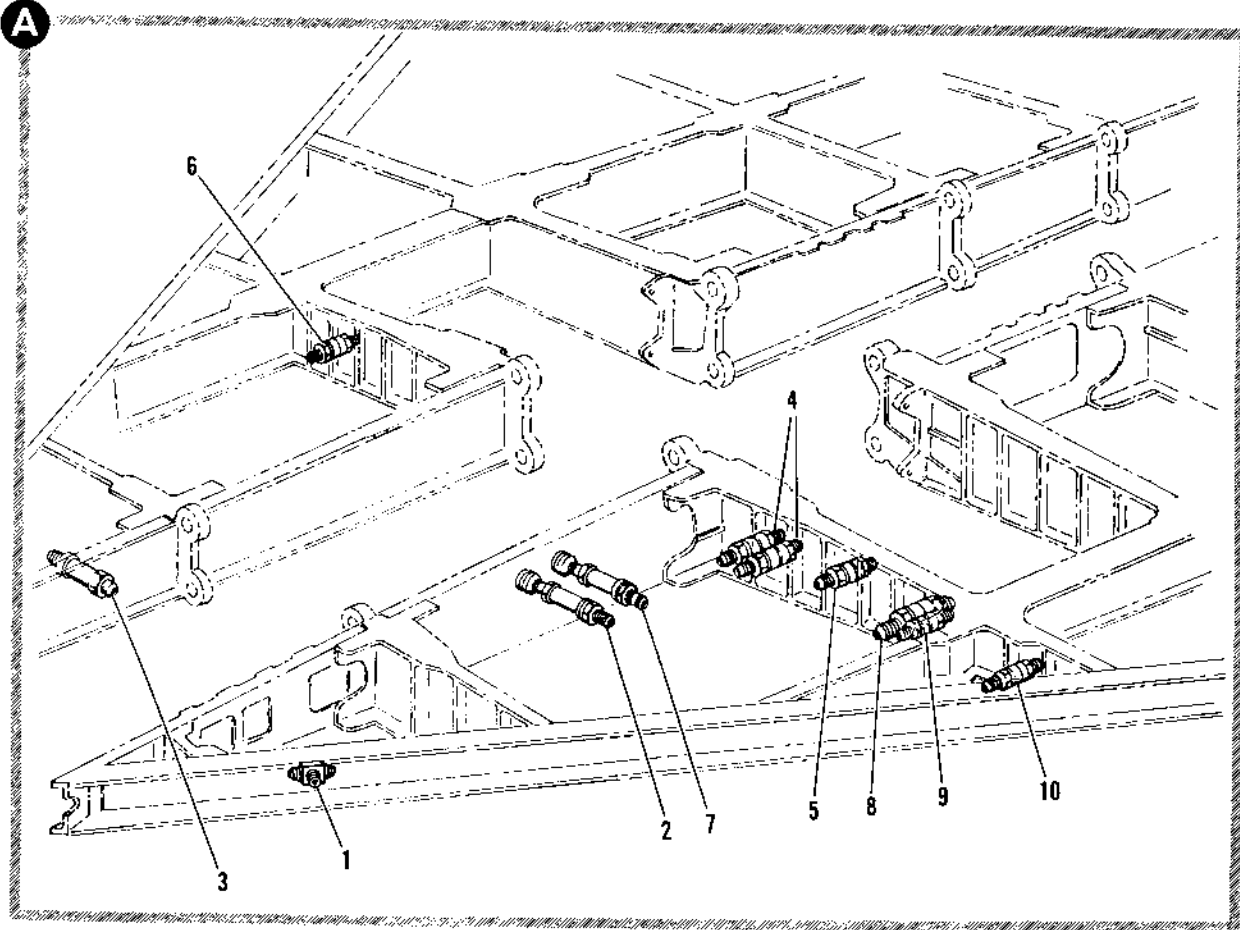
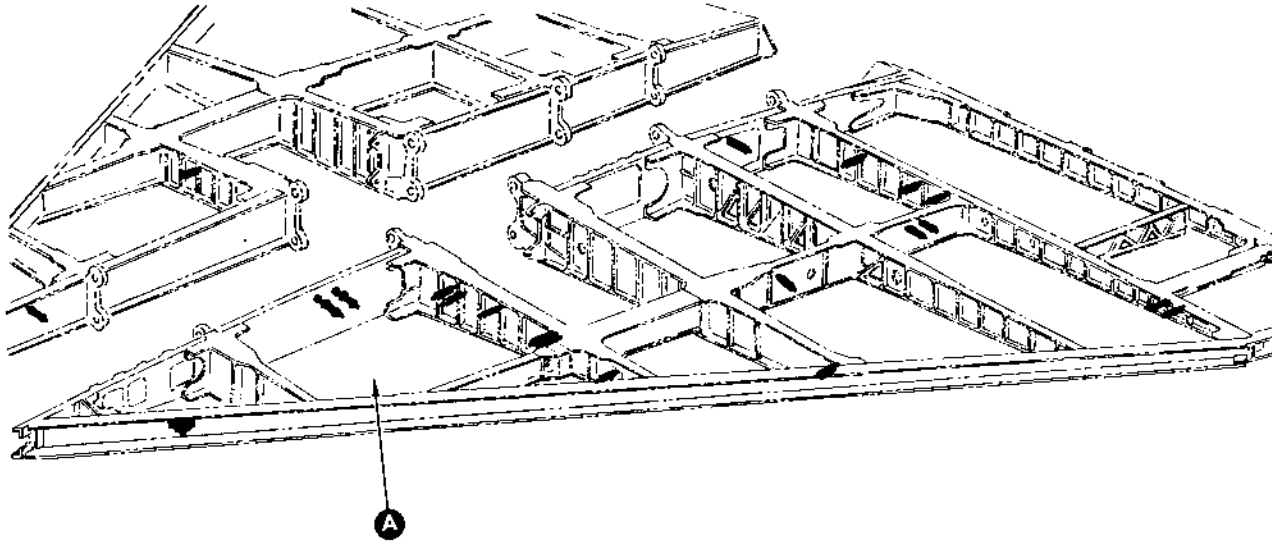

Figure 2.12-66. Wing Fuel Fitting (Sheet 1 of 2)

FIGURE AND INDEX NUMBER	PART NUMBER	DESCRIPTION	UNITS PER ASSY.	USABLE ON CODE	
				FROM	TO
2.12-66	4-21279-5	WING FUEL FITTINGS • FITTING INSTALLATION, WING FUEL TUBING LH FOR NHA SEE FIG. 2.6-32	RF	35	159
	8-21279-811	• FITTING INSTALLATION, WING FUEL TUBING LH FOR NHA SEE FIG. 2.6-32	RF	160	
	8-21279-801	• FITTING INSTALLATION, WING FUEL TUBING RH FOR NHA SEE FIG. 2.6-32	RF	35	159
	8-21279-813	• FITTING INSTALLATION, WING FUEL TUBING RH FOR NHA SEE FIG. 2.6-32	RF	160	188
	8-21279-819	• FITTING INSTALLATION, WING FUEL TUBING RH FOR NHA SEE FIG. 2.6-32	RF	189	
- 1	8-21568	• • CONNECTOR, TANK #1 VENT VALVE STA 138	1	35	
	AN924-40	• • NUT	1	35	
- 2	AN9610716	• • WASHER	1	35	
	8-21311-7	• • WASHER	2	35	
- 3	MS29512-5	• • GASKET	2	35	
	8-21260-7	• • FITTING, STA 340	1	35	
- 4	AN924-60	• • NUT	1	35	
	AN9610916	• • WASHER	1	35	
- 5	8-21311-9	• • WASHER	1	35	
	MS29513-15	• • GASKET	2	35	
- 6	8-21260-9	• • FITTING, STA 354 RH	1	189	
	AN924-60	• • NUT, RH	1	189	
- 7	AN9610916	• • WASHER, RH	1	89	
	8-21311-19	• • WASHER, RH	1	189	
- 8	MS29513-15	• • GASKET, RH	2	189	
	8-21307-7	• • UNION, PL 43 44 AND 50	3	35	
- 9	AN924-40	• • NUT	3	35	
	AN9610716	• • WASHER	3	35	
- 10	8-21311-7	• • WASHER	6	35	
	MS29512-5	• • GASKET	6	35	
- 11	8-20307-15	• • UNION, PL 52	1	160	
	AN924-60	• • NUT	1	160	
- 12	AN9610916	• • WASHER	1	160	
	8-21311-19	• • WASHER	2	160	
- 13	MS29513-15	• • GASKET	2	160	
	8-20307-27	• • UNION, PL 61 RH	1	35	
- 14	AN924-40	• • NUT, RH	1	35	
	AN9610716	• • WASHER, RH	1	35	
- 15	8-21311-7	• • WASHER, RH	2	35	
	MS29512-5	• • GASKET, RH	2	35	
- 16	8-21260-9	• • FITTING, STA 381	1	35	159
	AN924-60	• • NUT	1	35	159
- 17	AN9610916	• • WASHER	1	35	159
	8-21311-19	• • WASHER	1	35	159
- 18	MS29513-15	• • GASKET	2	35	159
	8-20307-13	• • UNION, PL 60	1	35	159
- 19	AN924-160	• • NUT	1	35	
	AN96102116	• • WASHER	1	35	
- 20	8-21311-11	• • WASHER	2	35	
	MS29513-125	• • GASKET	2	35	
- 21	8-20307-27	• • UNION, PL 68	1	35	159
	AN924-40	• • NUT	1	35	159
- 22	AN9610716	• • WASHER	1	35	159
	8-21311-7	• • WASHER	2	35	159
- 23	MS29512-5	• • GASKET	2	35	159

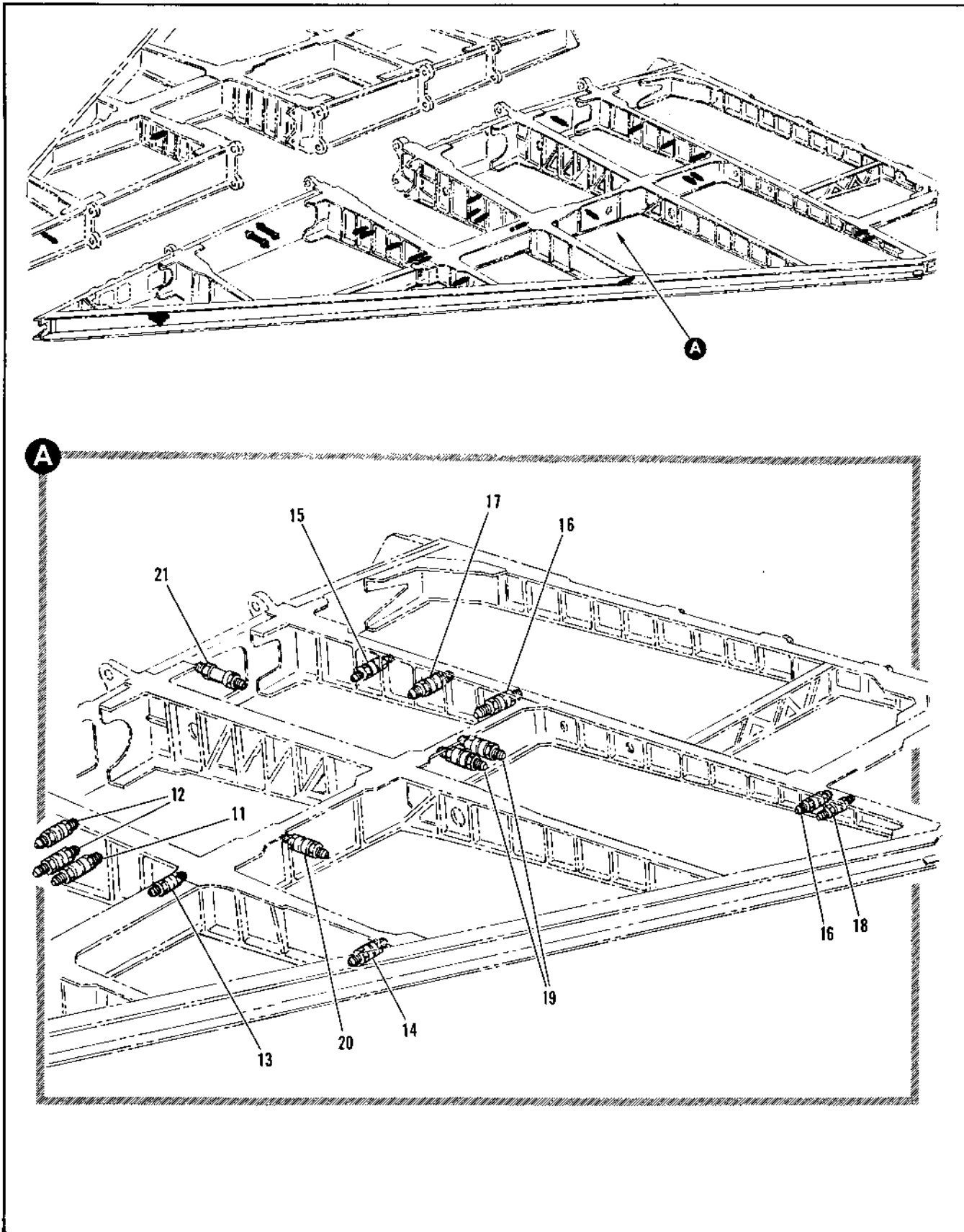

Figure 2.12-66. Wing Fuel Fitting (Sheet 2 of 2)

FIGURE AND INDEX NUMBER	PART NUMBER	DESCRIPTION	UNITS PER ASSY.	USABLE ON CODE	
				FROM	TO
		1 2 3 4 5 6			
2.12-66- 10	R-20307-33	• • UNION, BL 93 REPLACES SUITABLE SUB FOR R-20307-11 REPLACED BY SUITABLE SUP R-20307-37	1	A	
	R-20307-37	• • UNION, PL 93 REPLACES SUITABLE SUB FOR R-20307-33	1	R	
	AN924-40	• • NUT	1	35	159
	AN9600716	• • WASHER	1	35	159
	R-21311-7	• • WASHER	2	35	159
	MS29512-5	• • GASKET	2	35	159
- 11	R-20307-9	• • UNION, BL 6R	1	35	
	AN924-40	• • NUT	1	35	
	AN9600716	• • WASHER	1	35	
	R-21311-7	• • WASHER	2	35	
	MS29512-5	• • GASKET	2	35	
- 12	R-20307-7	• • UNION, BL 66 AND 6R	2	35	
	AN924-40	• • NUT	2	35	
	AN9600716	• • WASHER	2	35	
	R-21311-7	• • WASHER	4	35	
	MS29512-5	• • GASKET	4	35	
- 13	R-20307-19	• • UNION, BL 89 REPLACED BY SUITABLE SUB R-20307-35	1	35	43
	AN924-40	• • NUT	1	35	
	AN9600716	• • WASHER	1	35	
	R-21311-7	• • WASHER	2	35	
	MS29512-5	• • GASKET	2	35	
- 14	R-20307-21	• • UNION, BL 125	1	35	
	AN924-60	• • NUT	1	35	
	AN9600916	• • WASHER	1	35	
	R-21311-19	• • WASHER	2	35	
	MS29513-15	• • GASKET	2	35	
- 15	R-20307-31	• • UNION, BL 49	1	160	
	AN924-60	• • NUT	1	160	
	AN9600916	• • WASHER	1	160	
	R-21311-19	• • WASHER	2	160	
	MS29513-15	• • GASKET	2	160	
- 16	R-20307-25	• • UNION, BL 80 AND 142	2	35	159
	AN924-40	• • NUT	2	35	159
	AN9600716	• • WASHER	2	35	159
	R-21311-7	• • WASHER	4	35	159
	MS29512-5	• • GASKET	4	35	159
- 17	R-20307-29	• • UNION, BL 66	1	35	159
	AN924-60	• • NUT	1	35	159
	AN9601216	• • WASHER	1	35	159
	R-21311-23	• • WASHER	2	35	159
	MS29513-110	• • GASKET	2	35	159
- 18	R-20307-31	• • UNION, PL 143	1	35	159
	AN924-60	• • NUT	1	35	159
	AN9600916	• • WASHER	1	35	159
	R-21311-7	• • WASHER	2	35	159
	MS29513-15	• • GASKET	2	35	159
- 19	R-20307-17	• • UNION, STA 534 AND 540	2	35	159
	AN924-40	• • NUT	2	35	159
	AN9600716	• • WASHER	2	35	159
	R-21311-7	• • WASHER	4	35	159
	MS29512-5	• • GASKET	4	35	159
	AN9600916	• • WASHER	1	160	
	R-21311-19	• • WASHER	1	160	
	MS29513-15	• • GASKET	2	160	
- 20	R-21260-13	• • FITTING, STA 535	1	160	

FIGURE AND INDEX NUMBER	PART NUMBER	DESCRIPTION	UNITS PER ASSY.	USABLE ON CODE	
				FROM	TO
		1 2 3 4 5 6			
2.12-66- 21	8-20307-23	• • UNION, STA 492	1	35	
	AN924-160	• • NUT	1	35	
	8-21311-11	• • WASHER	2	35	
	MS29513-125	• • GASKET	2	35	
	8-21611-1	• FITTING INSTALLATION, LH FOR NHA SEE FIG. 2-6-32	PF	160	
	8-21611-2	• FITTING INSTALLATION, RH FOR NHA SEE FIG. 2-6-32	RF	160	
	AN924-60	• • NUT	1	160	
	AN967D916	• • WASHER	1	160	
	8-21311-19	• • WASHER	1	160	
	MS29513-15	• • GASKET	2	160	
- 22	R-21260-13	• • FITTING, STA 535	1	160	
		A AIRPLANES #44 THRU 47, 49 THRU THRU 60			
		B AIRPLANES #48 61 AND ON			

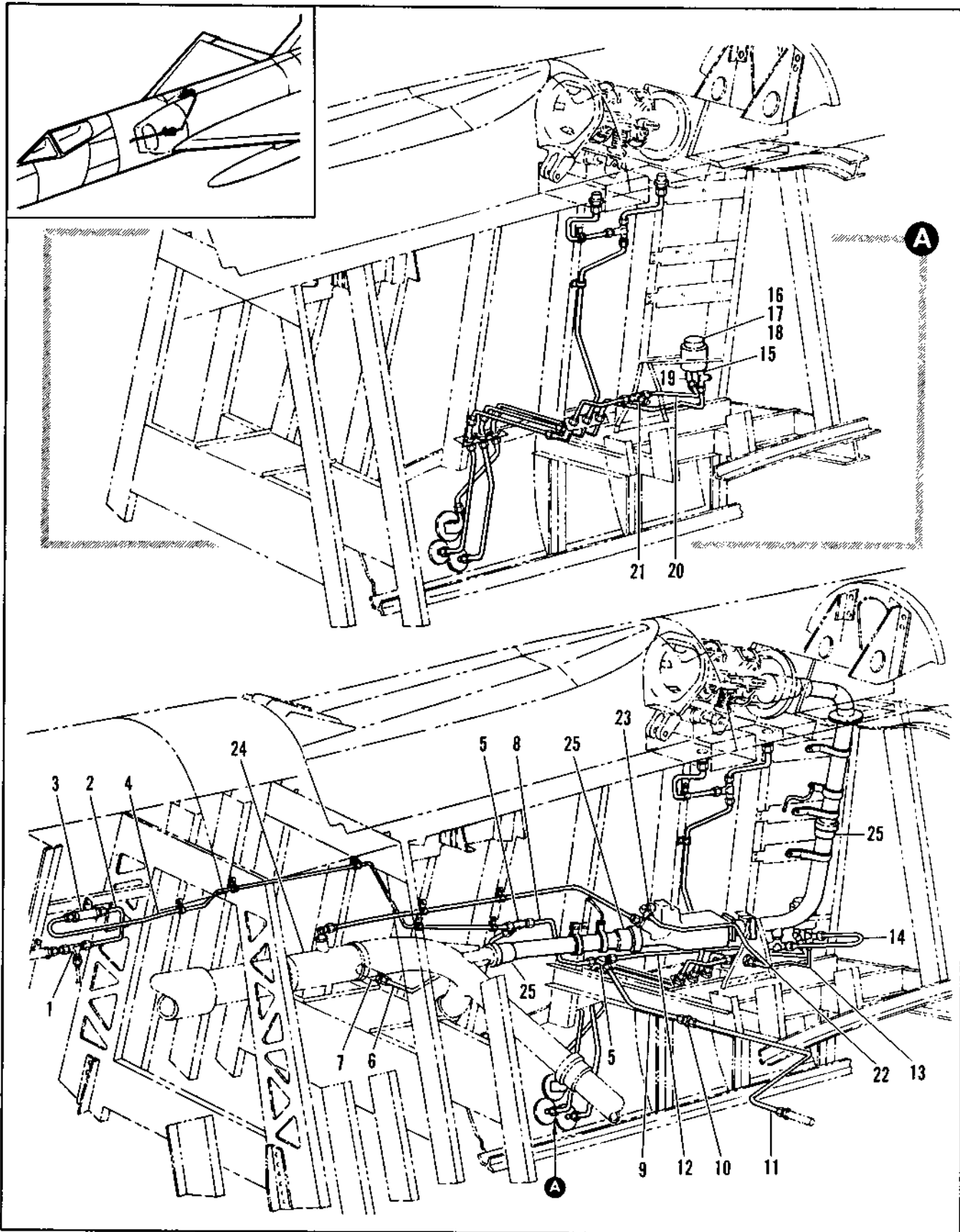

Figure 2.12-67. Aerial Refueling Fuel Tank Pressure Tubing Installation (Sheet 1 of 2)

FIGURE AND INDEX NUMBER	PART NUMBER	DESCRIPTION 1 2 3 4 5 6	UNITS PER ASSY.	USABLE ON CODE	
				FROM	TO
2.12-67		TUBING INSTL, AERIAL REFUELING SYSTEM (66J40337-1 AND 66J40340)	RF	90	
		TUBING INSTL, AERIAL REFUELING SYSTEM (66J40337-1 AND 66J40340)	RF	35	89
- 1		• TFE, SEE FIG. 2.12-49 INDEX 110	RF	35	
- 2	66A40329-1	• TUBE ASSY	1	35	
- 3	MS35-3/RF	• VALVE AIR CHECK (9913P) SPEC R-12998-13	1	35	
	MS29512-6	• GASKET	2	35	
	MS21916D6-4	• REDUCER	2	35	
- 4	66A40331-1	• TUBE ASSY	1	35	
- 5	MS21905D4	• TEE	2	35	
- 6	66A40332-1	• TUBE ASSY	1	35	
- 7		• FITTING, SEE FIG. 2.2-35 AND 2.12-20 INDEX 63.17	RF		
- 8	66A40333-1	• TUBE ASSY	1	35	
- 9	66A40326-1	• TUBE ASSY	1	35	
- 10	MS21902D4	• UNION	1	35	
- 11	66A40335-1	• TUBE ASSY	1	35	
- 12	66A40334-1	• TUBE ASSY	1	35	
- 13	MS21909D4	• TEE	1	35	
	AN924-4	• NUT	1	35	
	MS29512-04	• GASKET	1	35	
- 14	66A40337-1	• TUBE ASSY	1	35	
- 15	MS21912D4	• TEE	1	35	
	AN924-4	• NUT	1	35	
	MS29512-04	• GASKET	1	35	
	66D40336-2	• SWITCH INSTL, AERIAL REFUEL PRESS	1	35	
- 16	420171	• SWITCH PRESSURE (30949) ATTACHING PARTS	1	35	
- 17	AN3-4A	• NUT	4	35	
- 18	AN966D10L	• WASHER	4	35	
		-----X-----			
- 19	MS21907D4	• ELBOW	1	35	
	AN924-4	• NUT	1	35	
	MS29512-04	• GASKET	1	35	
- 20	66A40535-1	• TUBE ASSY	1	35	
- 21	MS21909D4	• TEE	1	35	
	AN924-4	• NUT	1	35	
- 22	66A40535-1	• TUBE ASSY	1	35	
- 23	MS21908D4	• ELBOW	1	35	
	AN924-4	• NUT	1	35	
	MS29512-04	• GASKET	1	35	
- 24		• TEE ASSY, WILDED SEE FIG. 2.12-49 INDEX 30 OR 31	RF	35	
- 25	3605-320	• COUPLING (79326) 92-72510-302	4	35	
	MS29512-320	• PACKING	P	35	

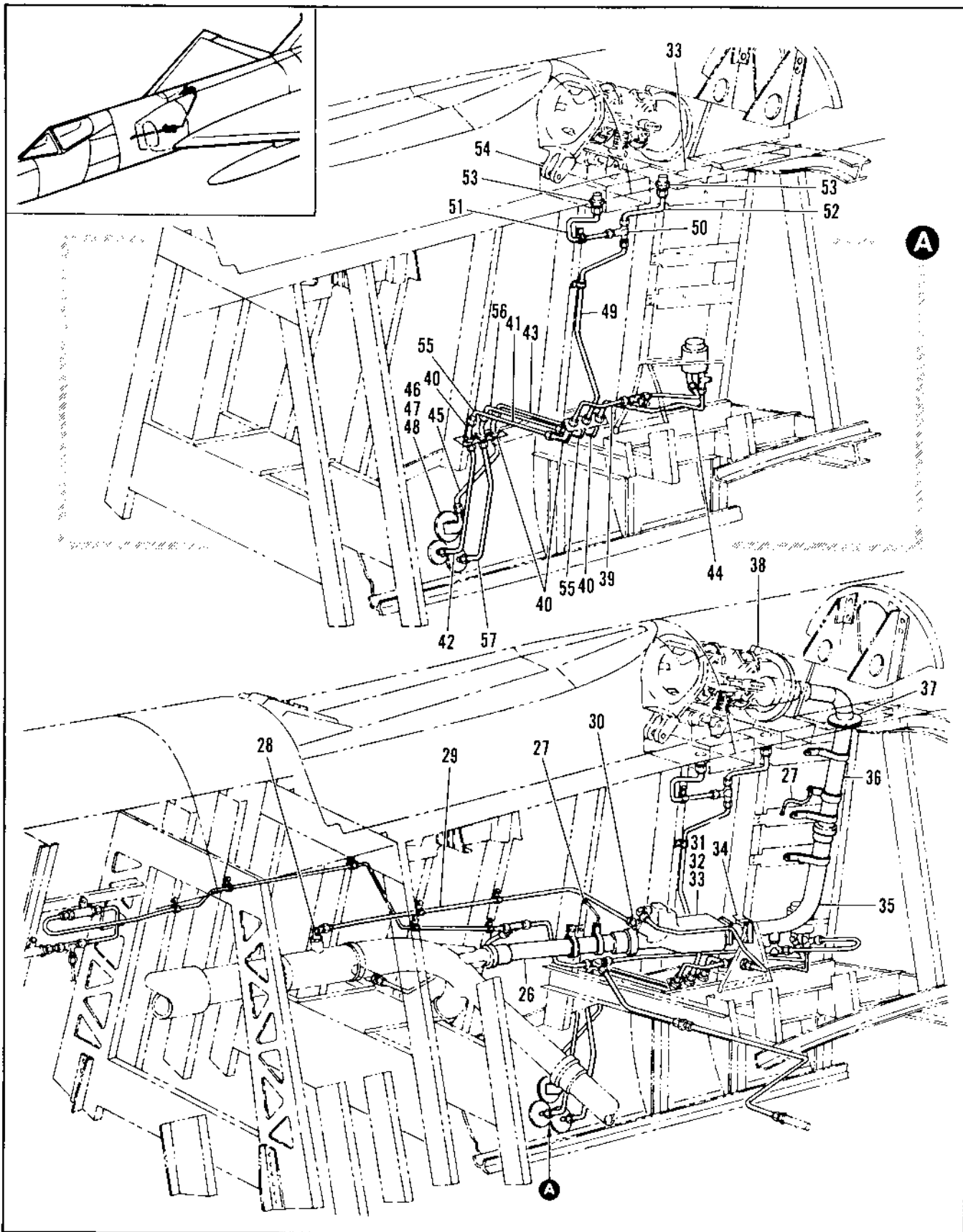

Figure 2.12-67. Aerial Refueling Fuel Tank Pressure Tubing Installation (Sheet 2 of 2)

FIGURE AND INDEX NUMBER	PART NUMBER	DESCRIPTION	UNITS PER ASSY.	USABLE ON CODE	
				FROM	TO
		1 2 3 4 5 6			
1.12-67- 26	66D46343-1	• TUBE, REFUEL FORWARD	1	35	
- 27	MS25043-28P4	• JUMPER	2	35	
- 29	MS21908-60	• ELBOW	1	35	
	AN924-60	• NUT	1	35	
	MS29512-6	• PACKING	1	A	
- 30	MS21901-40	• UNION	1	0	
	MS21908-60	• ELBOW	1	0	
	AN924-60	• NUT	1	0	
	MS29512-6	• PACKING	1	0	
- 31	6133-3	• VALVE ASSY, REFUELING REGULATOR AND CHECK (66190) SPEC R-12291-7 I.O. 6015-7-1R-13	1	C	
	6133-9	• VALVE ASSY, REFUELING REGULATOR AND CHECK (66190) SPEC R-12211-8 I.O. 6017-7-1R-13)	1	0	
		ATTACHING PARTS			
- 32	MS21042L5	• NUT	4	35	
- 33	AN5-10A	• BOLT	4	35	
		-----X-----			
- 34	175356-2	• SEAL (R4299) SPEC R-12299-3	1	35	
- 35	66D46342-1	• TUBE	1	35	
- 36	66D46341-1	• TUBE	1	35	
- 37	MS35489-99	• GROMMET	1	35	
- 38		• SUPPORT ASSY, REFUELING RECEPTACLE	PF	35	
- 39	66A46536-1	• TUBE ASSY	1	35	
- 40	MS2190704	• FLEDM	4	35	
	AN924-4	• NUT	4	35	
- 41	66A46537-1	• TUBE ASSY	1	35	
- 42	66A46538-1	• TUBE ASSY	1	35	
- 43	66A46532-1	• TUBE ASSY	1	35	
- 44	66A46533-1	• TUBE ASSY	1	35	
- 45	66A46534-1	• TUBE ASSY	1	35	
	66J46485-1	• DRAIN AND SENSE TUBE INSTL	1	35	
- 46	6858	• VALVE, DRAIN (9111)	1	35	
		ATTACHING PARTS			
- 47	MS21042L3	• NUT	1	35	
- 48	AN509-10P1	• SCREW	3	35	
		-----X-----			
- 49	66A46504-1	• TUBE ASSY	1	35	
- 50	MS2100506	• YEE	1	35	
- 51	66A46503-1	• TUBE ASSY	1	35	
- 52	66A46512-1	• TUBE ASSY	1	35	
- 53	MS2122205	• UNION	2	35	
	MS29512-6	• PACKING	2	35	
- 54		• FAN ASSEMBLY, SEE FIG 1.13-1	PF	35	
- 55	MS2100706	• ELBOW	1	35	
	AN924-6	• NUT	2	35	
- 56	66A46531-1	• TUBE ASSY	1	35	
- 57	66A46530-1	• TUBE ASSY	1	35	
		A AIRPLANES 875 THRU 894, 131 THRU 148, 147 AND ON			
		B AIRPLANES 891 THRU 130, 159, AND 191 THRU 246			
		C AIRPLANES 8190			
		D AIRPLANES 875 THRU 148, 191 AND ON			

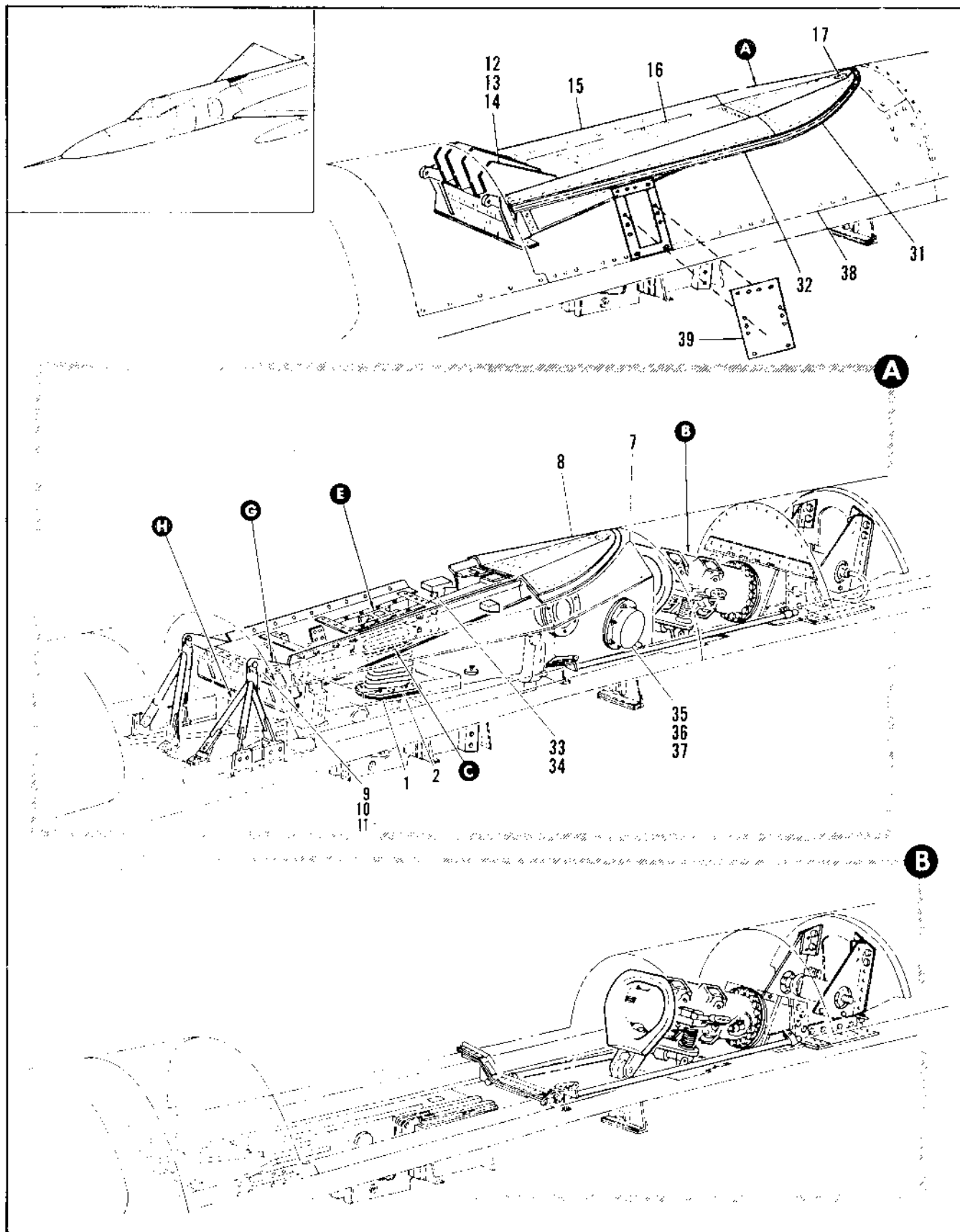

Figure 2.12-68. Aerial Refueling Equipment Dorsal Area (Sheet 1 of 3)

FIGURE AND INDEX NUMBER	PART NUMBER	DESCRIPTION	UNITS PER ASSY.	USABLE ON CODE	
				FROM	TO
2.12-68		AIRIAL REFUELING EQUIPMENT INSTL, DORSAL AREA	RF	35	
- 1	66J40243-1 66J40243-2	• DOOR INSTALLATION, SLIPWAY • RETAINER ATTACHING PARTS	1 1	35 35	
- 2	NAS1103-3	• BOLT -----X-----	14	35	
- 3	66E40424-1 66E40424-2	• SEAL, REPLACED BY NOT INTCHG WITH 66E40424-2 • SEAL REPLACED BY NOT INTCHG WITH 66E40424-1	1 1	35 35	
- 4	66J40243-3	• RETAINER ATTACHING PARTS	1	35	
- 5	NAS1103-7	• BOLT	2	35	
- 6	NAS1103-6	• BOLT -----X-----	6	35	
- 7		• PAN ASSY, SEE FIG. 2-13-1	RF	35	
- 8	66J40259-1	• DOOR ASSY, SLIPWAY ATTACHING PARTS			
- 9	MS24665-153	• PIN, COTTER	1	35	
- 10	AN967C414L	• WASHER	2	35	
- 11	MS20392-3C19	• PIN -----X-----	2	35	
- 12	66D40674-5 66D40674-6	• CHANNEL, DOOR SLIPWAY LH • CHANNEL, DOOR SLIPWAY RH ATTACHING PARTS	1 1	35 35	
- 13	NAS1204-9	• BOLT	2	35	
- 14	NAS1204-10	• BOLT -----X-----	2	35	
- 15	66J40525-1	• FAIRING, DOOR SLIPWAY ATTACHING PARTS	1	35	
- 16	NAS1203-4	• BOLT	56	35	
- 17	NAS1203-3	• BOLT -----X-----	2	35	
- 18	66D40429-1	• ACTUATOR SUPPORT ASSY ATTACHING PARTS	1	35	
- 19	MS21042-4	• NUT	8	35	
- 20	AN960-416	• WASHER	9	35	
- 21	NAS1104-6	• BOLT	4	35	
- 22	NAS1104-5	• BOLT -----X-----	4	35	
- 23	66D40429-2	• SUPPORT	1	35	
- 24	NAS77-6-25	• BUSHING	2	35	
- 25	NAS77-6-014	• BUSHING	1	35	
- 26	66C40675-1 66C40675-2	• PLATE, HINGE LH • PLATE, HINGE RH ATTACHING PARTS	1 1	35 35	
- 27	MS21042-4	• NUT	9	35	
- 28	AN960-416	• WASHER	9	35	
- 29	NAS1104-3	• BOLT	3	35	
- 30	NAS1204-7	• BOLT -----X-----	6	35	
- 31	66J40259-8	• SEAL	1	35	
- 32	66J40259-9	• SEAL	1	35	
- 33	MS21209F8-20	• HELICOIL	1	35	
- 34	NAS428K3-7	• BOLT	1	35	
- 35	66E40986-1 66D40411-1 66D40411-2 MS25309-7512	• LIGHT INSTL, SLIPWAY • LIGHT ASSEMBLY, LH (S1311A) • LIGHT ASSEMBLY, RH (S1311B) • LAMP ATTACHING PARTS	1 1 1 1	35 35 35 35	
- 36	NAS1402-2 AN505-8P7	• SCREW • SCREW -----X-----	6 1	35 35	

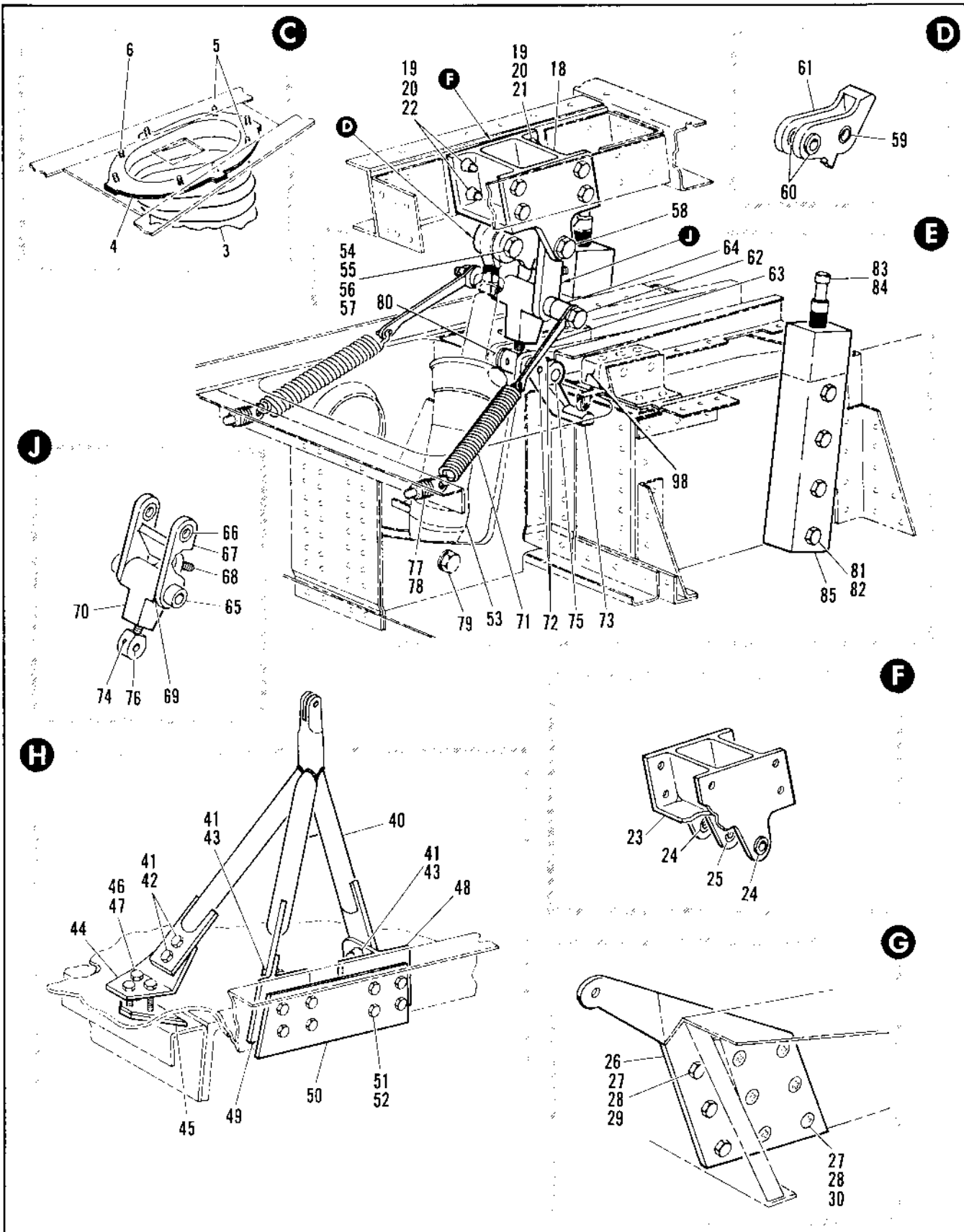

Figure 2.12-68. Aerial Refueling Equipment Dorsal Area (Sheet 2 of 3)

FIGURE AND INDEX NUMBER	PART NUMBER	DESCRIPTION	UNITS PER ASSY.	USABLE ON CODE	
				FROM	TO
2.12-68- 37 - 38	66C40465-1	• • • GASKET • DORSAL INSTL. FOR BREAKDOWN SEE FIG. 2.13-1	2 RF	35	35
	66J40249-1	• SUPPORT INSTL. HINGE STA 320 LH	1	35	
- 39	66J40249-2	• SUPPORT INSTL. HINGE STA 320 RH	1	35	
	68F37910-9	• ACCESS DOOR, LH	1	35	
- 40	68F37910-10	• ACCESS DOOR, RH	1	35	
	66E40242-1	• • SUPPORT ASSY, WELDED LH	1	35	
- 41	66E40242-2	• • SUPPORT ASSY, WELDED RH	1	35	
	MS21042L4	• • ATTACHING PARTS	6	35	
- 42	NAS1104-7	• • NUT	2	35	
- 43	NAS1104-6	• • BOLT	4	35	
- 44	66J40249-3	• • BOLT	1	35	
		----X----	1	35	
- 45	66J40249-4	• • ANGEL, LH	1	35	
	66J40249-6	• • ANGLE, RH	1	35	
- 46	MS21042L4	• • PLATE	1	35	
		ATTACHING PARTS	3	35	
- 47	NAS1104-12	• • NUT	3	35	
- 48	66D40262-1	• • BOLT	1	35	
		----X----	1	35	
- 49	66D40262-2	• • SUPPORT, LH	1	35	
	66D40262-2	• • SUPPORT, RH	1	35	
- 50	66D40255-1	• • SUPPORT, LH	1	35	
	66D40255-2	• • SUPPORT, RH	1	35	
- 51	66J40249-5	• • PLATE	1	35	
		ATTACHING PARTS	8	35	
- 52	MS21042L4	• • NUT	8	35	
- 53	NAS1104-7	• • BOLT	8	35	
		AN96C-416	2	35	
- 54	66E40425-1	• • WASHER	2	35	
		----X----	1	35	
- 55	MS24665-5	• DOOR LINKAGE INST	1	35	
		• ACTUATOR, DOOR FOR NHA	RF	35	
- 56	AN320-6	SEE FIG. 2.8-27 ITEM 1	3	35	
- 57	AN96C-610	• • PIN, COTTER	3	35	
- 58	NAS1106-170	• • NUT	3	35	
- 59	66C40468-1	• • WASHER	3	35	
		• • BOLT	1	35	
- 60	66C40468-2	• • PIN, LINK	1	35	
		LINK, ACTUATOR ASSY	1	35	
- 61	NAS75-6-19P	• • BUSHING	2	35	
- 62	NAS77-6-25	• • BUSHING	2	35	
- 63	66C40468-3	• • LINK	1	35	
- 64	66C40020-3	• • PIN, LINKAGE	1	35	
- 65	66B40510-1	• • LINK, SPRING LH	1	35	
- 66	66B40510-3	• • LINK, SPRING RH	1	35	
		• • SPACER	2	35	
- 67	NAS43004-34	• • LINK ASSY, UPPER	1	35	
- 68	66D40409-1	• • BUSHING	2	35	
- 69	NAS75-6-174	• • BUSHING	2	35	
- 70	NAS75-6-197	• • BUSHING	2	35	
- 71	66C40468-4	• • LINK, UPPER	1	35	
- 72	66D40403-1	• • LINK ASSY, LOWER	1	35	
- 73	NAS1101-4A10L	• • SCREW, SET	1	35	
- 74	NAS75-6-101	• • BUSHING	1	35	
- 75	66D40460-2	• • LINK, LOWER	1	35	

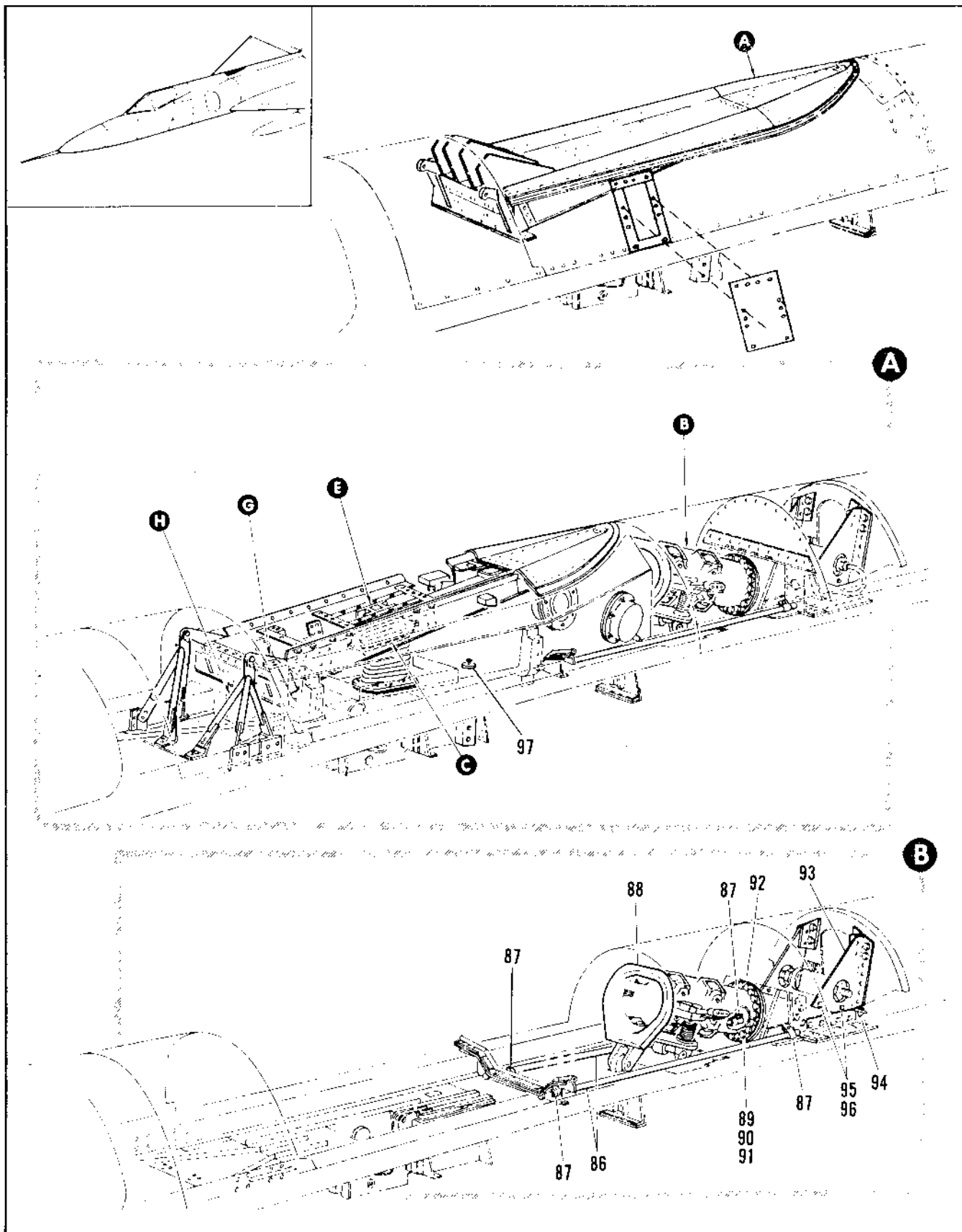

Figure 2.12-68. Aerial Refueling Equipment Dorsal Area (Sheet 3 of 3)

FIGURE AND INDEX NUMBER	PART NUMBER	DESCRIPTION	UNITS PER ASSY.	USABLE ON CODE	
				FROM	TO
		1 2 3 4 5 6			
411-AS- 71	77	• SPRING, LINK (71447)	2		
- 72	NAS1091-393L	• SCREW, SET	2		
- 73	66040221-1	• ARM, ACTUATOR	1		
- 74	NAS1151- 695L	• SCREW, SET	1		
- 75	6604020-1	• PIA, LINK	1		
- 76	6604010-1	• FITTING, LOWER LINK	1		
- 77	6604044-1	• SUPPORT INSTL, DOWN ACTUATOR	1		
- 77	AN421-5A	• BOLT, EYE	1		
- 78	MS214213	• NUT	1		
- 79	NAS77-6-34-1	• BUSHING	2		
- 8	NAS77-8-77	• BUSHING	2		
	66040250-1	• STOP INSTL, SLIPWAY COUR	1		
	66039012-1	• STOP ASSY, VERTICAL ATTACHING PARTS	2		
- 81	MS21 40L7	• NUT	4		
- 82	NAS1113-17	• BOLT	4		
- 83	66039013-1	• BOLT, STOP	1		
- 84	MS2103454-27	• THREAD, INSERT	1		
- 85	66039012-2	• BAR, STOP	1		
- 86	6604069-70	• SEAL INSTL, TORSAL SECTION	1		
- 86	6604069-70	• TOP	2		
- 87	MS21190011	• CLAMP	4		
	MS214213P	• NUT	4		
	MS35206-240	• SCREW	4		
	6604065-1	• AERIAL REFUELLING RECEPTACLE INSTL	1		
- 88	VM66350-1	• RECEPTACLE ASSY (66037) SPEC MIL-R 27021 CLASS 1 T.O. 6A-6-3 ATTACHING PARTS			
- 89	MS21 40-4	• NUT	20		
- 9	AN917-43	• WASHER	20		
- 91	NAS1764-4	• BOLT	20		
- 92	40247	-----			
	66040253	• SEAL ASSY (66109)	1		
- 93		• FLAG, PULLY CONTROL INSTL	1		
		• SUPPORT ASSY, UPPER GIVETEL ATTACHING PARTS	1		
- 94	NAS1107-1	• BOLT	2		
- 95	MS21 42-4	• NUT	4		
- 96	NAS1106-5	• BOLT	4		
- 97	MS21521-1	• SWITCH, OPEN OPEN	1	55	
- 98	DPSS8	• SWITCH, OPEN CLOSED	1	55	

137 12650

AIR-CONDITIONING, PRESSURIZATION, ICE & RAIN PROTECTION SUBSECTION**TABLE OF CONTENTS**

<i>Fig. No.</i>	<i>Title</i>	<i>Page</i>	<i>Fig. No.</i>	<i>Title</i>	<i>Page</i>
2.13-1	Air-Conditioning Pressurization Ice and Rain Protection System	2.13-2	2.13-18	Rain Removal Duct Installation Sta 160 to 217	2.13-80
2.13-2	Ground Test Cockpit Pressure Fitting Installation	2.13-20	2.13-19	Cockpit Air Safety Valve Installation	2.13-84
2.13-3	Ground Test Cockpit Pressure Fitting Installation	2.13-22	2.13-20	Windshield Rain Removal Duct Installation Sta 227 to 295	2.13-86
2.13-4	Cockpit Air Pressure Regulator	2.13-24	2.13-21	Armament Bay Ground Air- Conditioning Duct Installation	2.13-88
2.13-5	Fwd Radar Compartment Cooling Duct Installation Sta 102 to 168	2.13-26	2.13-22	Ground Cooling Duct Installation	2.13-90
2.13-6	Fwd Radar Compartment Cooling Duct Installation Sta 102 to 168	2.13-30	2.13-23	Ground Air-Conditioning Duct Installation	2.13-92
2.13-7	RH NWW Battery Vent Installation	2.13-34	2.13-24	Cockpit Hot Air Bypass Duct Installation Sta 267 to 309	2.13-94
2.13-8	Aft Electronic Compartment Cooling Duct Installation	2.13-36	2.13-25	Engine Bleed Air Duct Installation..	2.13-96
2.13-9	Fwd Radar Compartment and Cockpit Cooling Duct Installation..	2.13-44	2.13-26	Engine Bleed Air to Air Driven Emergency AC Generator Duct Installation.....	2.13-98
2.13-10	Cockpit Air-Conditioning Fwd LH Duct Installation	2.13-52	2.13-27	Engine Bleed Air Duct Installation	2.13-100
2.13-11	HFF Cooling Duct Installation Sta 260 to 628	2.13-54	2.13-28	Leading Edge Duct Anti-Icing Tubing Installation	2.13-104
2.13-12	Cockpit Air-Conditioning Fwd RH Duct Installation	2.13-60	2.13-29	Anti-Icing Air Intake Duct Lip Tubing Installation	2.13-108
2.13-13	Cockpit Air-Conditioning Aft Duct Installation	2.13-62	2.13-30	Refrigeration Unit and Ram Air Inlet Header Installation	2.13-110
2.13-14	Cockpit Air Check Valve Assembly	2.13-68	2.13-31	Refrigeration Unit Assembly	2.13-116
2.13-15	Cockpit Air Duct Installation Sta 171 to 228	2.13-70	2.13-32	Valve Assy, Compressor Inlet Air Tubing Installation	2.13-122
2.13-16	Cockpit Installation Pressure Suit Ventilation	2.13-74	2.13-33	Valve, Canopy Defog-Pressure Regulator	2.13-124
2.13-17	Rain Removal Duct Installation Sta 84 to 160	2.13-76			

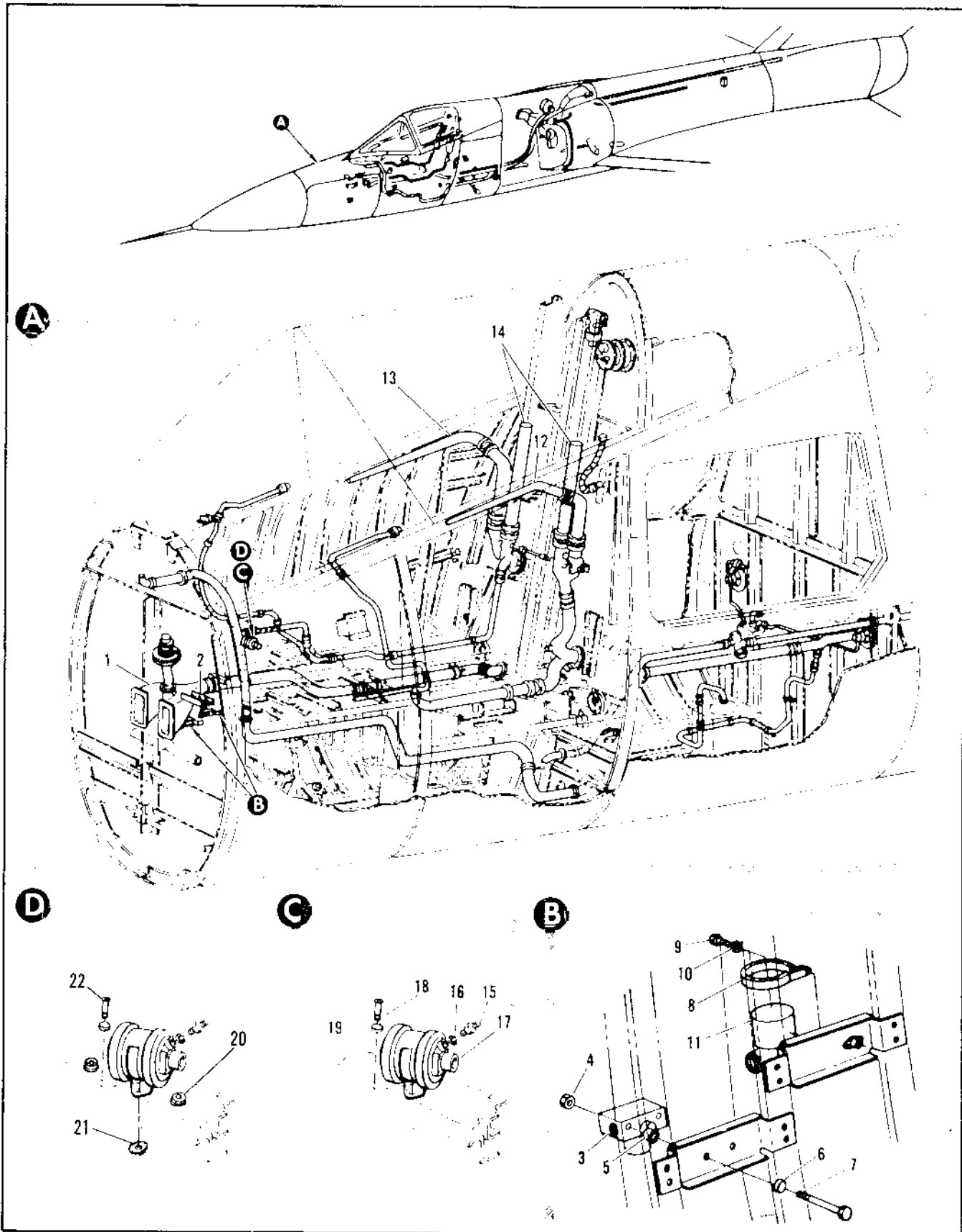

Figure 2.13-1. Air-Conditioning Pressurization Ice and Rain Protection System (Sheet 1 of 9)

FIGURE AND INDEX NUMBER	PART NUMBER	DESCRIPTION	UNITS PER ASSY.	USABLE ON CODE	
				FROM	TO
		1 2 3 4 5 6			
2.13-1		AIR-CONDITIONING PRESSURIZATION ICE AND RAIN PROTECTION SYSTEM			
- 1		• DUCT INSTL, FWD RADAR COMPARTMENT COOLING STA 172 TO 16P SEE FIG. 2.13-5 AND 2.13-6	RF		
- 2		• FITTING INSTL, COCKPIT PRESSURE GROUND TEST SEE FIG. 2.13-2 AND 2.13-3	RF		
	8-23720	• EQUIPMENT INSTL, RADOME ANTI-ICING FOR NHA SEE FIG. 2.3-5 INDEX 36	RF	35	
- 3	MS28720-4	• FILTER, RADOME ANTI-ICING ATTACHING PARTS	1	35	
- 4	NAS679A4	• NUT	2	35	
- 5	NAS43DD4-10	• SPACER	2	35	
- 6	AN96LD416L	• WASHER	2	35	
- 7	AN4-17A	• BOLT	2	35	
		-----X-----			
- 8	91-96026-021	• CLAMP ATTACHING PARTS	1	35	
- 9	AN3-4A	• BOLT	1	35	
- 10	AN96PD10L	• WASHER	1	35	
		-----X-----			
- 11	5152	• VALVE ASSY, RADOME ANTI-ICING <75361> 99-35000-003 T.O. OPS-5-30-3	1	35	
- 12		• DUCT INSTL, COCKPIT AIR-CONDITIONING FWD LH SEE FIG. 2.13-9	RF		
- 13		• DUCT INSTL, COCKPIT AIR-CONDITIONING FWD RH SEE FIG. 2.13-11	RF		
- 14		• DUCT INSTL, COCKPIT AIR-CONDITIONING AFT SEE FIG. 2.13-12	RF		
	8-23730-1	• SWITCH INSTL, COCKPIT LOW PRESSURE WARNING LIGHT FOR NHA SEE FIG. 2.13-1	1	35	
- 15	AN815-4	• UNION	1	35	
- 16	AN6290-4	• GASKET	1	35	
- 17	4151019-56A	ATTACHING PARTS	1	35	
- 18	NAS221-6	• SCREW	2	35	
- 19	AN96PD10L	• WASHER	2	35	
		-----X-----			
		COCKPIT FEED THRU INSTALLATION APX-12			
- 20	69035142-1	• PLUG, FEED THRU	2	35	
- 21	MS21575-3	• NUT	2	35	
- 22	MS35207-216	• SCREW	2	35	

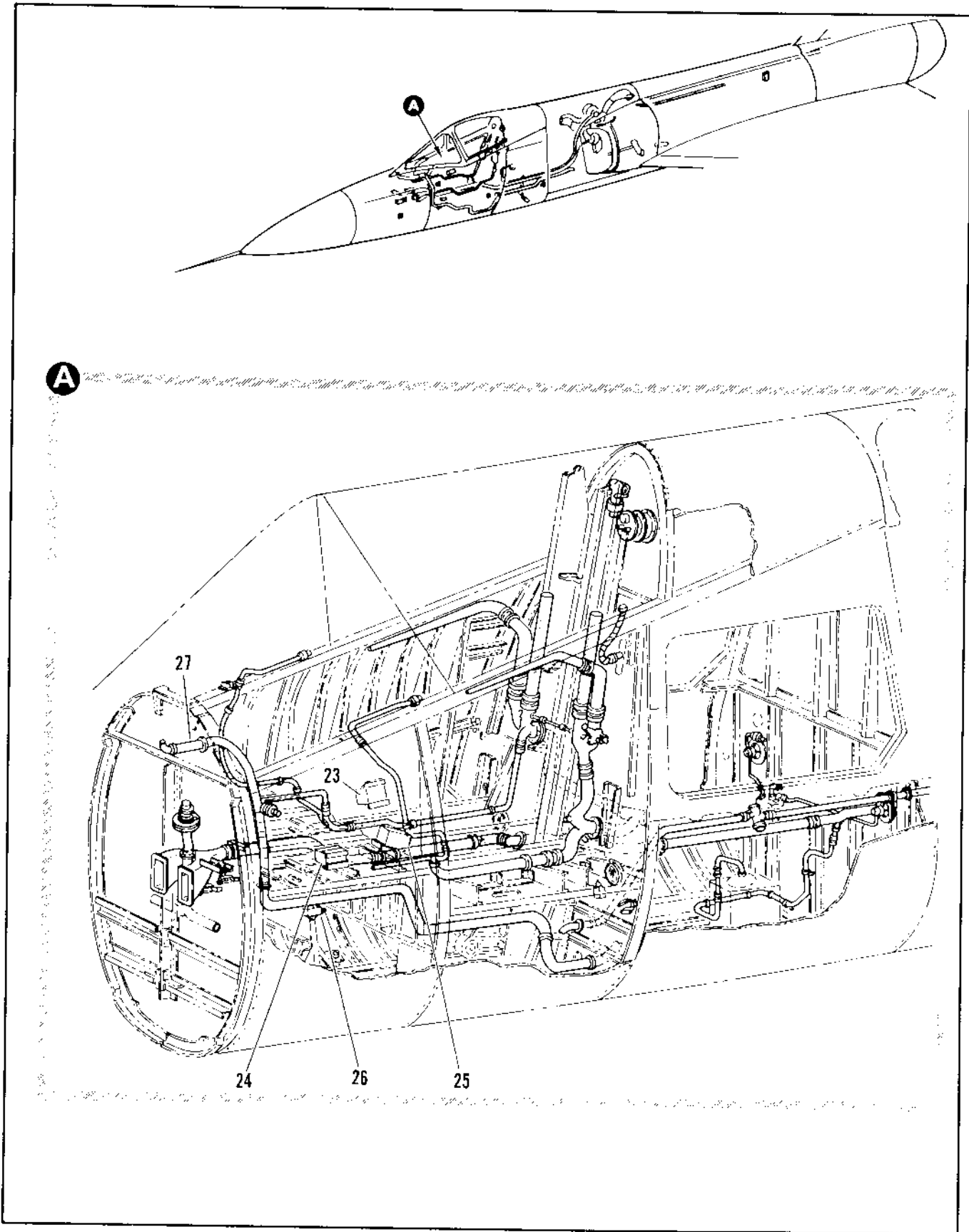

Figure 2.13-1. Air-Conditioning Pressurization Ice and Rain Protection System (Sheet 2 of 9)

FIGURE AND INDEX NUMBER	PART NUMBER	DESCRIPTION	UNITS PER ASSY.	USABLE ON CODE	
				FROM	TO
		1 2 3 4 5 6			
2.13-1 - 23	8-62203-993 848-1	<ul style="list-style-type: none"> • CONTROL INSTL, WINDSHIELD ANTI-ICING LH • CONTROL ASSY, ELECTRICALLY HEATED WINDSHIELD <97896> SPEC 8-61277-1 I.O. 1513-2-46-1 ATTACHING PARTS 	1 1	35 35	
	AN520-10FH AN3-4A	<ul style="list-style-type: none"> • SCREW • BOLT -----X----- 	3 1	35 35	
- 24	8-62232 848-1	<ul style="list-style-type: none"> • CONTROL INSTL, WINDSHIELD ANTI-ICING RH • CONTROL ASSY, ELECTRICALLY HEATED WINDSHIELD <97896> SPEC 8-61277-1 I.O. 1513-2-46-1 ATTACHING PARTS 	1 1	R R	
	AN520-10FH	<ul style="list-style-type: none"> • SCREW -----Y----- 	4	R	
- 25	8-95692-1 848-1	<ul style="list-style-type: none"> • CONTROL INSTL, WINDSHIELD ANTI-ICING RH FOR NMA SEE FIG. 2.7-5 • CONTROL ASSY, ELECTRICALLY HEATED WINDSHIELD <97896> SPEC 8-61277-1 I.O. 1513-2-46-1 ATTACHING PARTS 	PF 1	A A	
	NAS679A7 AN967010L NAS221-P	<ul style="list-style-type: none"> • NUT • WASHER • SCREW -----X----- 	4 4 4	A A A	
- 26	8-69792 9220-3434	<ul style="list-style-type: none"> • RELAY INSTL, PITOT HEAT • RELAY, <75344> SPEC 8-65878-1 ATTACHING PARTS 	1 1	35 35	
	NAS679A3 NAS221-P	<ul style="list-style-type: none"> • NUT • SCREW -----X----- 	2 2	35 35	
- 27		<ul style="list-style-type: none"> • DUCT INSTL, RAIN REMOVAL STA 64 TO 160 SEE FIG. 2.10-17 	PF		
		<p>A AIRPLANES 341, 40 AND 3A B AIRPLANES 335 THRU 47 AND 41 THRU 49</p>			

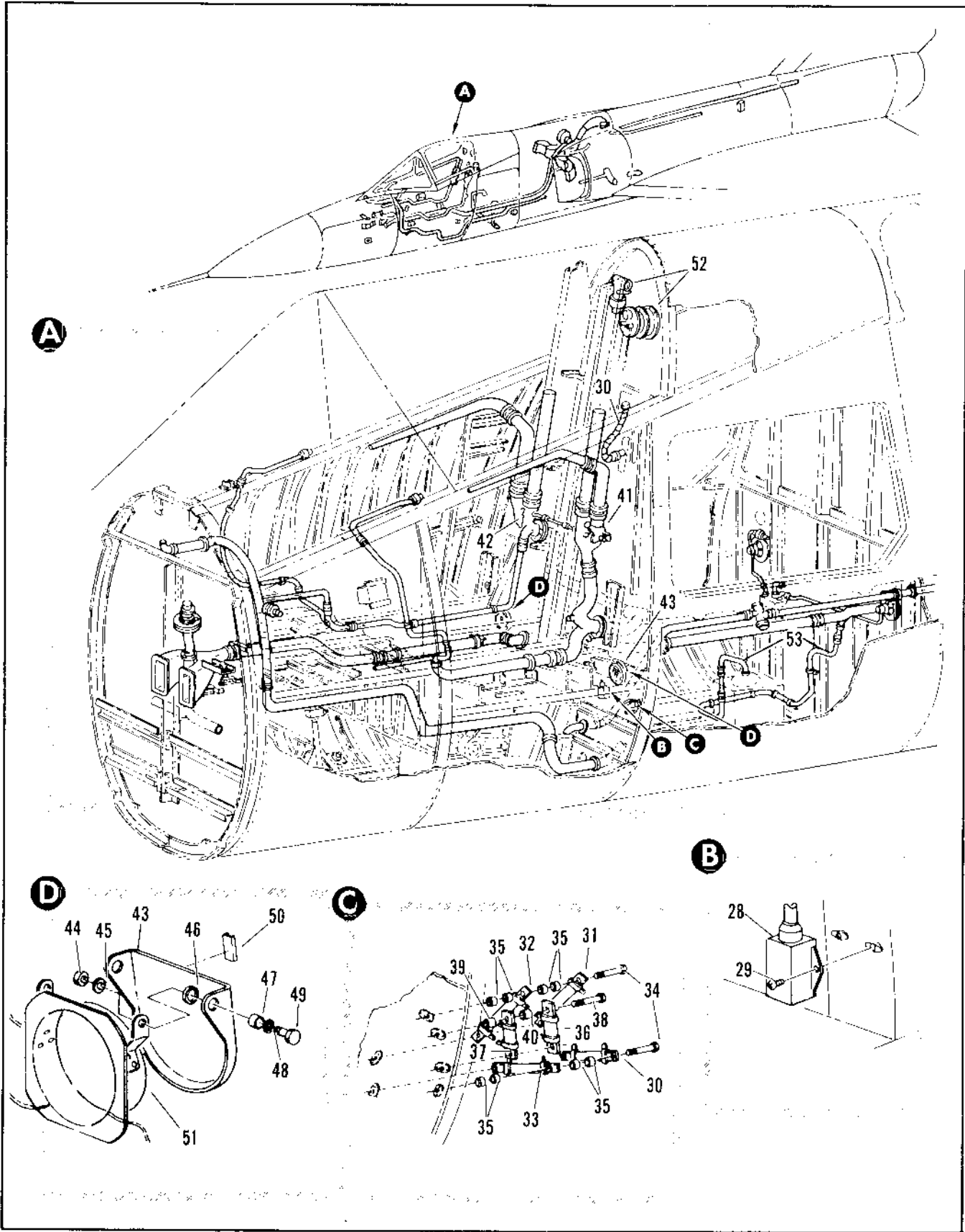

Figure 2.13-1. Air-Conditioning Pressurization Ice and Rain Protection System (Sheet 3 of 9)

FIGURE AND INDEX NUMBER	PART NUMBER	DESCRIPTION	UNITS PER ASSY	USABLE ON CODE	
				FROM	TO
		1 2 3 4 5 6			
2.13-1	8-62226-5	• RELAY INSTL, WINDSHIELD ANTI-ICING SHUT-DOWN	1	35	
- 28	9220-3435	• • RELAY, <35744> SPEC 4-16209-3	1	35	
- 29	AN520-10R7	• • SCREW	2	35	
	8-94472	• HOSE INSTL, PILOT SUIT VENTILATING STA 172 FOR NHA SEE FIG. 2.1-1 INDEX 65	RF	35	188
	8-94187	• HOSE INSTL, PILOT SUIT VENTILATING STA 172 FOR NHA SEE FIG. 2.1-1 INDEX 65	RF	189	
- 30	MS22055H24	• • HOSE, PILOT SUIT VENTILATING	1	35	
	AN6105T24A	• • HOSE, PILOT SUIT VENTILATING SUITABLE SUR	1	35	
	8-62228-1	• RESISTOR INSTL, MASK DE-FOG	1	35	
- 31	RW22V1R0	• • RESISTOR, 97-47104-001	1	35	
- 32	RW22V2R0	• • RESISTOR, 97-47104-010	2	35	
- 33	RW22V5R0	• • RESISTOR, 97-47104-017	1	35	
		ATTACHING PARTS			
- 34	AN3020A	• • BOLT	4	35	
- 35	NAS43003-24	• • SPACER	8	35	
		-----X-----			
- 36	RW22V1R0	• • RESISTOR, 97-47104-004	1	35	
- 37	RW22V2R0	• • RESISTOR, 97-47104-006 REPLACES NOT INTICG WITH RW22V2R0	1	35	
		ATTACHING PARTS			
- 38	AN3020A	• • BOLT	2	35	
- 39	NAS43003-14	• • SPACER	2	35	
- 40	NAS43003-32	• • SPACER	2	35	
		-----X-----			
- 41		• VALVE ASSY, COCKPIT AIR DIVERTER LH SEE FIG. 2.13-13 INDEX 34	RF		
- 42		• VALVE ASSY, COCKPIT AIR DIVERTER RH SEE FIG. 2.13-13 INDEX 45	RF		
	8-23630	• VALVE INSTL, PURGE AIR CHECK FOR NHA SEE FIG. 2.3-4 INDEX 43	RF	35	
	8-23633	• • VALVE ASSY, PURGE AIR CHECK	2	35	
	8-23633-701	• • VALVE ASSY, PURGE AIR CHECK LH	1	130	
	8-23633-702	• • VALVE ASSY, PURGE AIR CHECK RH	1	130	215
	8-23633-1	• • VALVE ASSY, PURGE AIR CHECK RH	1	216	
- 43	8-23602	• • FLAPPER, CHECK VALVE	1	35	
		ATTACHING PARTS			
- 44	AN310-3	• • • NUT	2	35	
- 45	AN961010	• • • WASHER	2	35	129
	AN960010L	• • • WASHER	2	130	
- 46	AN94000510L	• • • WASHER	2	35	
- 47	NAS43HT3-2	• • • SPACER	2	35	
- 48	99-51504-024	• • • WASHER	2	130	
- 49	AN3-5	• • • BOLT	2	35	
		-----Y-----			
- 50	8-23603-713	• • • STOP	1	130	
- 51	8-23634	• • • DUCT ASSY, CHECK VALVE RIVETED	1	35	
- 52		• VALVE INSTL, COCKPIT AIR SAFETY SEE FIG. 2.13-19	RF		
- 53		• DUCT INSTL, ANT ELECTRONIC COMPARTMENT COOLING STA 148 TO 216 SEE FIG. 2.13-5	RF		

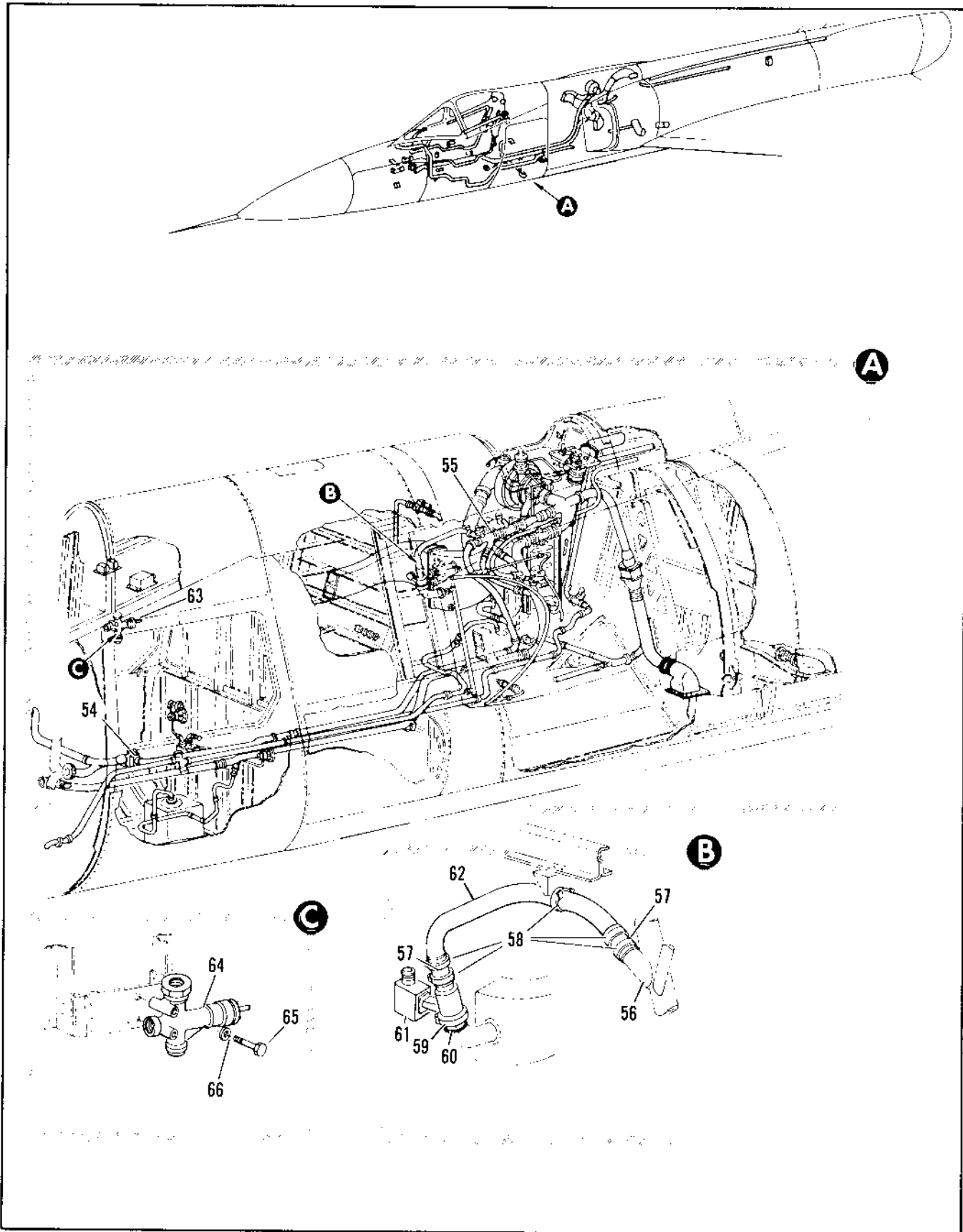

Figure 2.13-1. Air-Conditioning Pressurization Ice and Rain Protection System (Sheet 4 of 9)

FIGURE AND INDEX NUMBER	PART NUMBER	DESCRIPTION 1 2 3 4 5 6	UNITS PER ASSY.	USABLE ON CODE	
				FROM	TO
2.13-1- 54		• VALVE ASSY, COCKPIT AIR CHECK SEE FIG. 2.13-14	RF		
- 55		• DUCT INSTL, FWD RADAR COMPARTMENT AND COCKPIT COOLING SEE FIG. 2.13-9	RF		
	8-23595	• DUCT INSTL, EMERGENCY ELECTRONIC RAM AIR FOR NHA SEE FIG. 2.3-12	RF	35	
- 56		• DUCT ASSY, ELECTRONIC COOLING SEE FIG. 2.13-8 INDEX 29	RF		
- 57	AD390-3	• COUPLING, <92799> SPEC 8-00939-3	2	35	
- 58	326-62-312S	• CLAMP, <98625> 91-97801-004	5	35	
- 59	4480-369S	• COUPLING, <98625> 92-73003-015	1	35	
- 60	7-2253-1	• GASKET, <90307> 94-16002-004	1	35	
- 61	40D690	• VALVE ASSY, RAM AIR <97990> SPEC 8-02277-1 T.O. 15A2-2-62-3	1	35	
- 62	8-23594-7	• DUCT, EMERGENCY ELECTRONIC RAM AIR	RF	35	
	8-23594-1	• DUCT ASSY, EMERGENCY ELECTRONIC RAM AIR ALT INTCHG WITH 8-23594-7	RF	35	
- 63	8-85045-1	• VALVE INSTL, EMERGENCY COCKPIT PRESSURIZATION FOR NHA SEE FIG. 2.3-3	RF	35	
- 64	11140	• VALVE ASSY, <99643> SPEC 8-00494-1 T.O. 15H5-2-27-23 ATTACHING PARTS	1	35	
- 65	AN3-15A	• BOLT	2	35	
- 66	AN960PD10	• WASHER -----X-----	2	35	
		A AIRPLANES #48, 90 AND ON B AIRPLANES #35 THRU 47 AND 49 THRU 89			

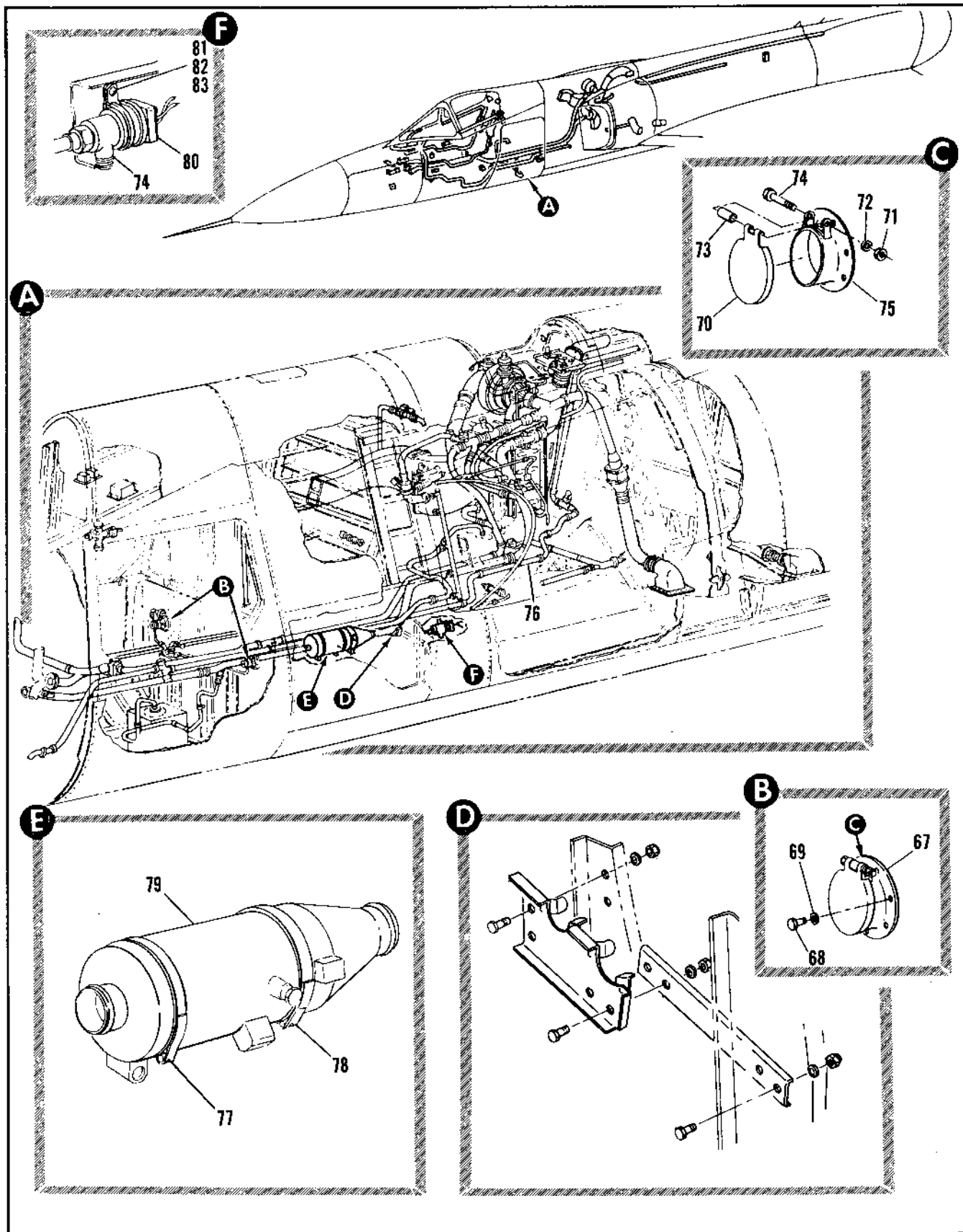

Figure 2.13-1. Air-Conditioning Pressurization Ice and Rain Protection System (Sheet 5 of 9)

FIGURE AND INDEX NUMBER	PART NUMBER	DESCRIPTION 1 2 3 4 5 6	UNITS PER ASSY.	USABLE ON CODE	
				FROM	TO
2.13-1	8-23097	• VALVE INSTL, ELECTRONIC COMPARTMENT CHECK FOR NHA SEE FIG. 2.13-3	PF	35	
- 67	8-23093	• VALVE ASSY, SWING CHECK LH	1	35	
	8-23093-1	• VALVE ASSY, SWING CHECK RH	1	35	
		ATTACHING PARTS			
- 68	AN3-4A	• BOLT	12	35	
- 69	AN960D10L	• WASHER	12	35	
		-----X-----			
- 70	8-23095	• FLAPPER, HINGED CHECK VALVE	1	35	
		ATTACHING PARTS			
- 71	NAS67943	• NUT	1	35	
- 72	AN960D10	• WASHER	1	35	
- 73	NAS430D3-94	• SPACER	1	35	
- 74	AN3-25A	• BOLT	1	35	
		-----X-----			
- 75	8-25094	• BODY, CHECK VALVE LH	1	35	
	8-23094-1	• BODY, CHECK VALVE RH	1	35	
- 76		• DUCT INSTL, WINDSHIELD RAIN REMOVAL STA 227 TO 225 SEE FIG. 2.13-20	RF		
	8-23525	• BRACKET INSTL, COCKPIT COOLING DUCT FOR NHA SEE FIG. 2.13-4	PF	35	
- 77	320-42-4125	• CLAMP, (98025) 91-07801-014	1		
- 78	64J34050-40	• CLAMP ASSY, RIVETED	1		
- 79	595350-1	• SEPARATOR, MOISTURE AIRCRAFT AIR CONDITIONING SYSTEM (73037) SPEC 44834861-1, T.O. 983-2-13-2	1		
- 80	MS21919H14	• CLAMP	1		
		ATTACHING PARTS			
- 81	MS21942L3	• NUT	1		
- 82	AN960D10L	• WASHER	1		
- 83	AN520-13FP	• SCREW	1		
		-----X-----			
- 84	27900	• VALVE ASSY, MOISTURE SEPARATOR SERVO BYPASS (89643)	1		

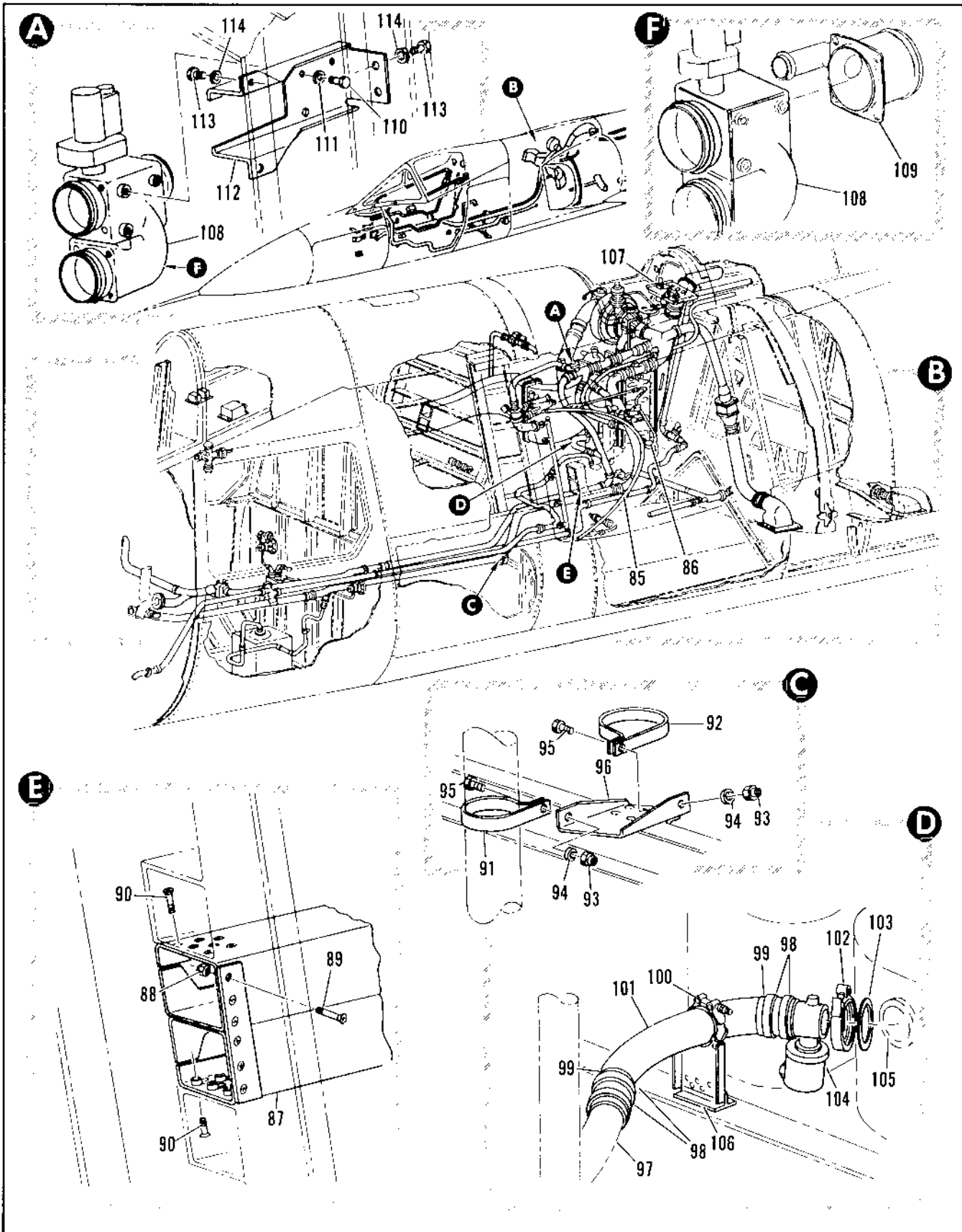

Figure 2.13-1. Air-Conditioning Pressurization Ice and Rain Protection System (Sheet 6 of 9)

FIGURE AND INDEX NUMBER	PART NUMBER	DESCRIPTION	UNITS PER ASSY.	USABLE ON CODE	
				FROM	TO
2.13-1- 85		• TUBING INSTL. LEADING EDGE DUCT ANTI-ICING SEE FIG. 2.13-28	RF		
- 86		• TUBING INSTL. ANTI-ICING AIR INTAKE DUCT SEE FIG. 2.13-29	RF		
	8-74572-1	• DUCT INSTL. BOUNDARY BLEED FWD LH FOR NHA SEE FIG. 2.3-13	RF	35	
	8-74572-2	• DUCT INSTL. BOUNDARY BLEED FWD RH FOR NHA SEE FIG. 2.3-13	RF	35	
- 87	8-74572-41 8-74572-42	• • DUCT ASSY. BOUNDARY BLEED FWD LH RIVETED • • DUCT ASSY. BOUNDARY BLEED FWD RH RIVETED ATTACHING PARTS	1 1	35 35	
- 88	AN310-3	• • NUT	6	35	
- 89	NAS333PA	• • BOLT	6	35	
- 90	NAS333PA	• • BOLT	14	35	
	8-23524	• SUPPORT INSTL. COCKPIT AND ELECTRONIC COOLING DUCT STA 254 FOR NHA SEE FIG. 2.3-13	RF	35	
- 91	AN742D32	• • CLAMP	1	35	240
- 92	AN742D48 AN742-48	• • CLAMP • • CLAMP	1 1	35 241	
		ATTACHING PARTS			
- 93	NAS679A3	• • NUT	2	35	
- 94	AN96 PD10L	• • WASHER	2	35	
- 95	AN3-5A	• • BOLT	2	35	
		-----X-----			
- 96	8-23524-7 8-23390	• • SUPPORT • DUCT INSTL. RAM AIR STA 256 TO 276 FOR NHA SEE FIG. 2.3-13	1 RF	35 35	
- 97		• • DUCT ASSY. COCKPIT COOLING SEE FIG. 2.13-9	RF		
- 98	AN737W74	• • CLAMP	4	35	
- 99	AD297-7	• COUPLING, <98779> SPEC 8-1257-7	2	35	
-100	321-52-2155	• • CLAMP, <14625> 91-37491-8L	1	35	
-101	8-23391	• • DUCT	1	35	
-102	446402R1M	• • COUPLING, <98625> 52-73066-002	1	35	
-103	7-2153-1	• • GASKET, <10387> 94-1032-105	1	35	
-104	400705	• • VALVE ASSY. RAM AIR DUCT <97390> SPEC 8-12277 T.O. 1542-3-35-3	1	35	
	58TC160-7	• • VALVE ASSY. <98880> SPEC 8-12277 T.O. 1542-2-55-3 ALT INTCHG WITH 400705	RF	35	
-105		• • HEADER ASSY. HEAT EXCHANGER INLET SEE FIG. 2.13-30 INDEX 60	RF		
-106	8-23390-11	• • SUPPORT ASSY. RIVETED	1	5	
-107		• PANEL INSTL. AIR SHUTOFF VALVE AND FILTER SEE FIG. 2.12-60	RF		
	8-23360	• VALVE INSTL. COCKPIT DIVERTER AND SHUTOFF FOR NHA SEE FIG. 2.3-10	RF	35	
-108	64J34050-5	• • VALVE ASSY. COCKPIT DIVERTER AND SHUTOFF ALTERED FROM 120215	1		
-109	54034071-1	• • DUCT ASSY. PRESSURE SUIT SUPPLY WELDED ATTACHING PARTS	1		
-110	AN3H3A	• • BOLT	3	35	
-111	AN96 PD10L	• • WASHER	3	35	
		-----X-----			

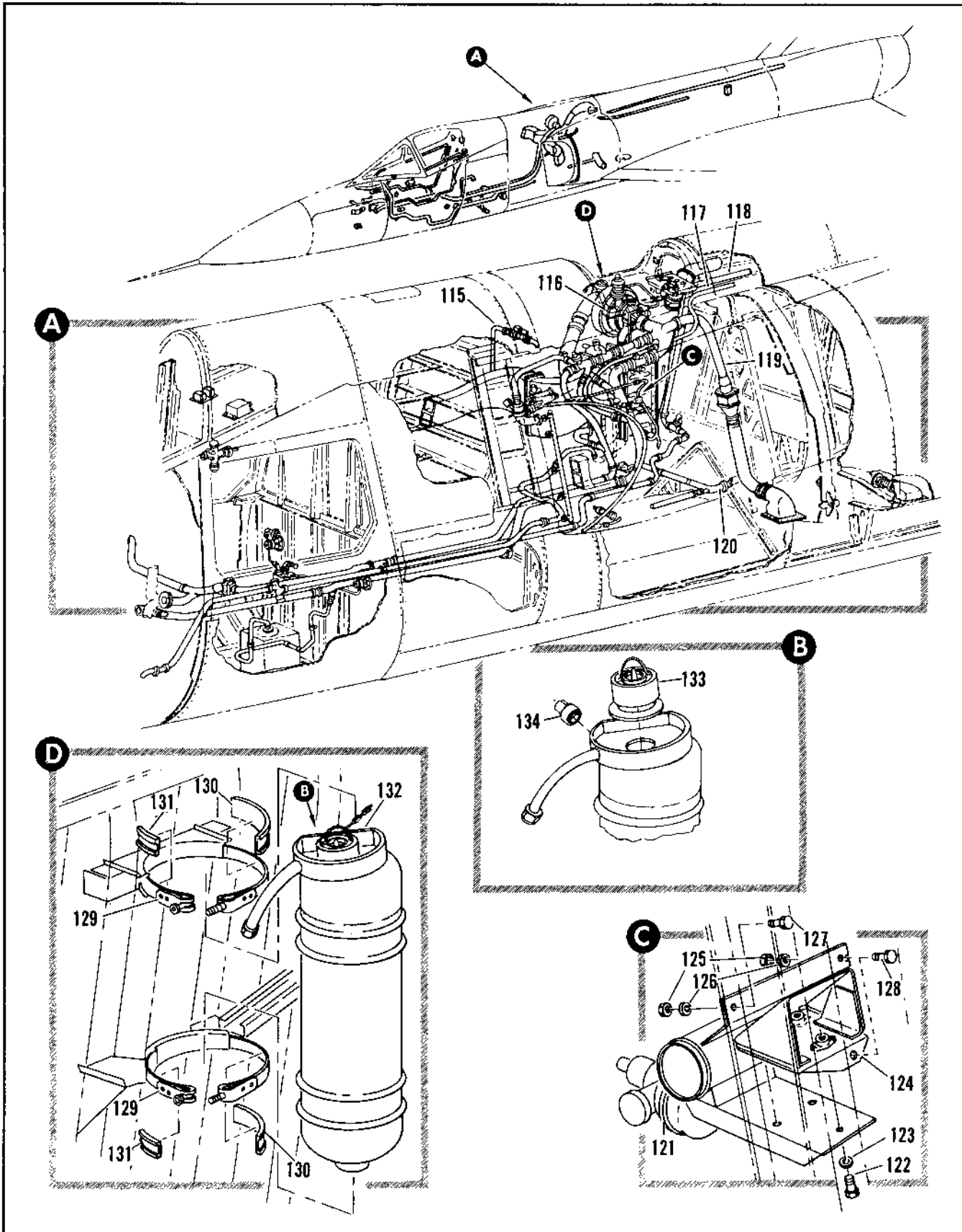

Figure 2.13-1. Air-Conditioning Pressurization Ice and Rain Protection System (Sheet 7 of 9)

FIGURE AND INDEX NUMBER	PART NUMBER	DESCRIPTION	UNITS PER ASSY.	USABLE ON CODE	
				FROM	TO
2.13-1-112	W-23356-7	• • BRACKET, VALVE SUPPORT ATTACHING PARTS	1	35	
-113	AN3-4A	• • BOLT	4	35	
-114	AN96 PD11L	• • WASHER	4	35	
-115		-----X-----			
-115		• DUCT INSTL, COCKPIT HOT AIR BYPASS STA 24 TO 309 SEE FIG. 2.13-24	PF		
-116		• REFRIGERATION UNIT INSTL, SEE FIG. 2.13-26	PF		
-117		• DUCT INSTL, IFF COOLING STA 267 TO 628 SEE FIG. 2.13-11			
-118		• DUCT INSTL, ENGINE BLEED AIR SEE FIG. 2.13-25	PF		
-119		• DUCT INSTL, GROUND COOLING SEE FIG. 2.13-22	PF		
-120		• DUCT INSTL, GROUND AIR-CONDITIONING SEE FIG. 2.13-23	PF		
	W-23522	• VALVE INSTL, ELECTRONIC COMPARTMENT COOLING FOR NHA SEE FIG. 2.3-10			
-121	106470	• • VALVE ASSY, FLOW DIVIDER <79210> SPEC R-10270-2 T.O. 15A2-3-R-63 ATTACHING PARTS	1	35	
-122	AN3-4A	• • BOLT	3	35	
-123	AN96 PD11L	• • WASHER	3	35	
-124	W-23501	• • BRACKET ASSY, RIVETED ATTACHING PARTS	1	75	
-125	NAS575A3	• • NUT	3	35	
-126	AN96 PD11L	• • WASHER	3	35	
-127	AN3-4A	• • BOLT	1	35	
-128	AN3-4A	• • BOLT	2	35	
		-----X-----			
	W-23710	• TANK INSTL, GLYCOL TANK, ANTI-ICING FOR NHA SEE FIG. 2.3-10	PF	35	
-129	326-75-6759	• • CLAMP, <49625> 91-87601-017	2	35	
-130	AN4011-6-071	• • PAD	2	35	
-131	AN131-6-023	• • PAD	2	35	
-132	W-23747-1	• • TANK ASSY, GLYCOL TANK, ANTI-ICING	1	35	
	W-23707-27	• • CAP ASSY, GLYCOL TANK, ANTI-ICING	1	35	
-133	4376	• • • CAP ASSY, GLYCOL TANK, ANTI-ICING <43431> 93-74500-001	1	35	
-134	W-23703-7	• • • PASSY, GLYCOL TANK INLET	1	35	

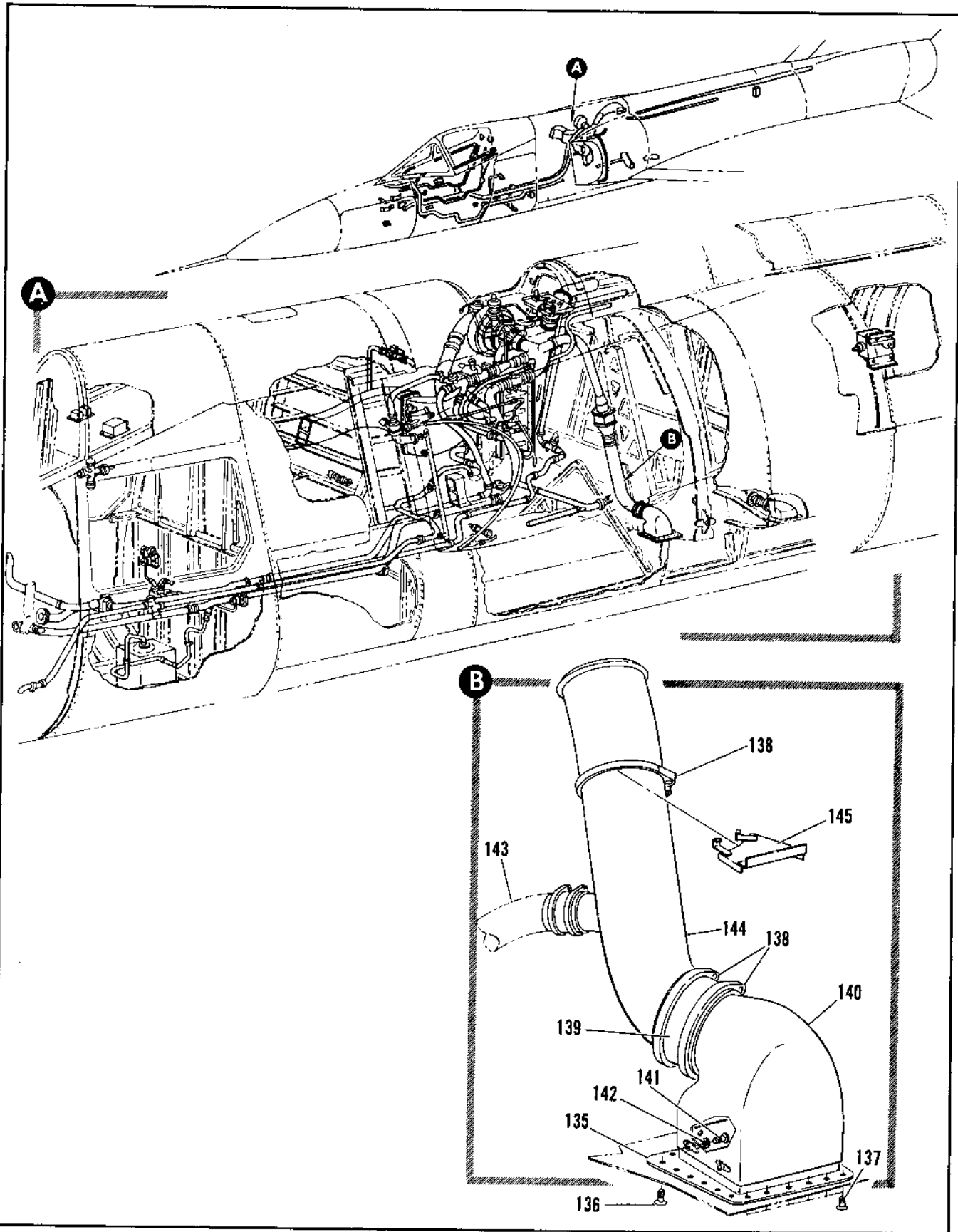

Figure 2.13-1. Air-Conditioning Pressurization Ice and Rain Protection System (Sheet 8 of 9)

FIGURE AND INDEX NUMBER	PART NUMBER	DESCRIPTION					
		1	2	3	4	5	6
2.13-1	B-23510-1	• DUCT INSTL. ELECTRONIC COMPARTMENT FOR NHA SEE FIG. 2.3-11					
-135	B-23527-1	• DOOR ASSY. ELECTRONIC COMPARTMENT GROUND CONNECTION ACCESS FOR BREAKDOWN SEE FIG. 2.2-P ATTACHING PARTS					
-136	NAS333PA4-5	• SCREW					
-137	NAS333PA5-5	• SCREW -----X-----					
-138	321-62-42ES	• CLAMP, <4425> 91-97401-020					
-139	NAS21-32-12	• COUPLING					
-140	B-23569-1	• DUCT ASSY. TRANSITION GROUND CONNECTOR ATTACHING PARTS					
-141	AN526-1032R6	• SCREW					
-142	AN963PD10L	• WASHER -----X-----					
-143		• DUCT ASSY. GROUND AIR DISTRIBUTION SEE FIG. 2.13-23 INDEX 10					
-144	B-23549-1	• DUCT ASSY. GROUND CONNECTOR ELECTRONIC COMPARTMENT WELDED					
-145	B-23566	• BRACKET ASSY. RIVETED					

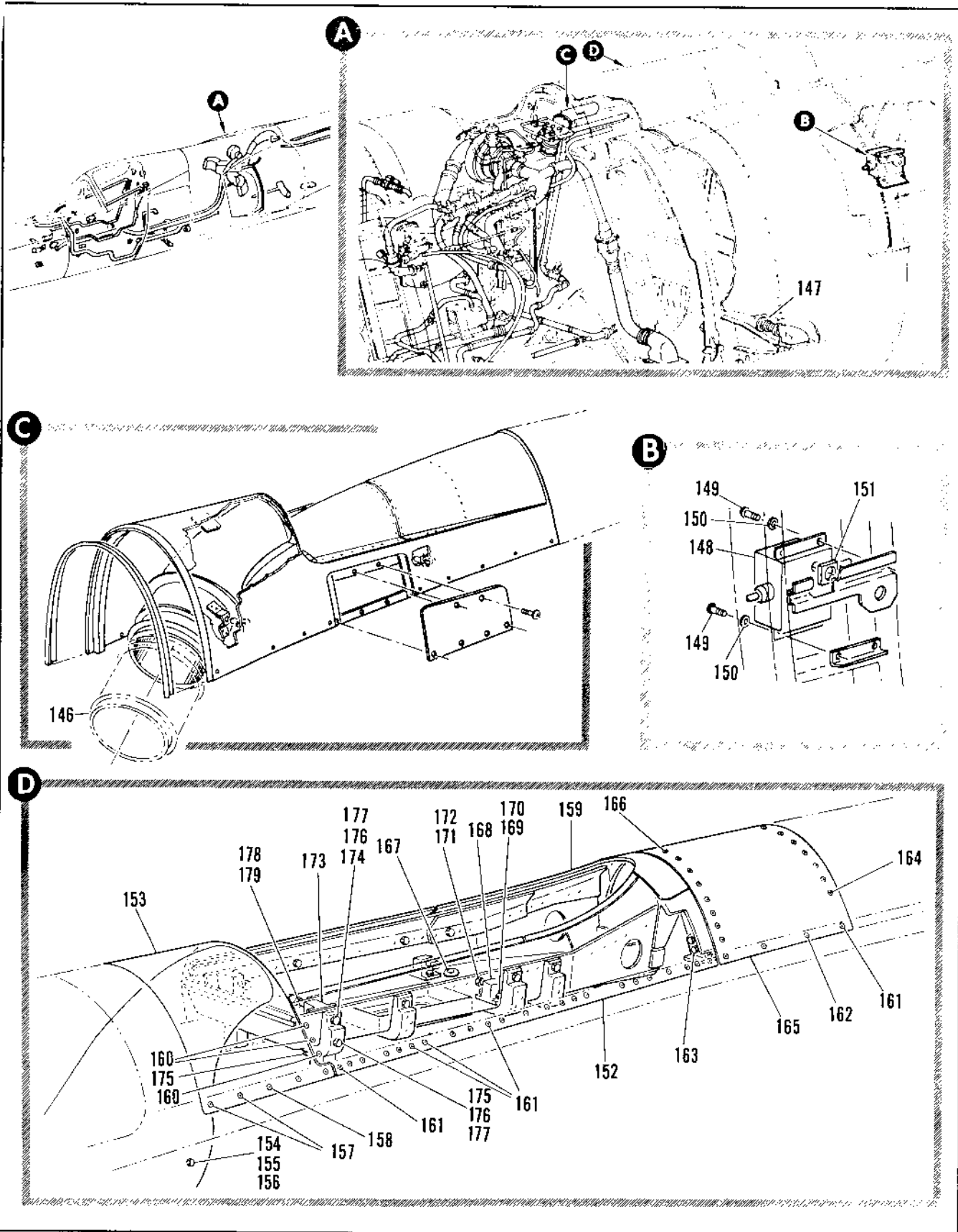

Figure 2.13-1. Air-Conditioning Pressurization Ice and Rain Protection System (Sheet 9 of 9)

FIGURE AND INDEX NUMBER	PART NUMBER	DESCRIPTION 1 2 3 4 5 6	UNITS PER ASSY.	USABLE ON CODE	
				FROM	TO
2.13-1-146		. . . DUCT ASSY. HEAT EXCHANGER EXHAUST SEE FIG. 2.13-30 INDEX 1	1	35	
-147		. DUCT INSTL. ARMAMENT PAY GROUND AIR-CONDITIONING CONNECTOR STA 340 SEE FIG. 2.13-19	RF		
-148	8-65059-1 666-2016	. DETECTOR INSTL. ICE . . DETECTOR ASSY. ICE <716AR> SPEC 8-06423 T.O. 15E3-2-36-3 ATTACHING PARTS	RF 1	35 35	
-149	AN520-10R7	. . SCREW	4	35	
-150	AN960-18L	. . WASHER	AR	35	
-151	8-65058-11	. . GASKET	1	35	
-152	66J4246-1	. DORSAL INSTL. STA 308.5 TO 370.7	1		
-153	66J42690-1	. . DORSAL ASSY. RIVETED STA 308.5 TO STA 322.0 ATTACHING PARTS	1		
-154	AN4-4A	. . BOLT	2		
-155	99-51509-316	. . WASHER	4		
-156	AN960-416L	. . WASHER	2		
-157	AN509-10P17	. . SCREW	4		
-158	AN509-10P11	. . SCREW	6		
-159	66J39840-1	. . DORSAL ASSY. STA 308.5 TO STA 370.7 ATTACHING PARTS	1		
-160	NAS1203-2	. . BOLT	6		
-161	AN509-10P11	. . SCREW	16		
-162	AN509-10P13	. . SCREW	34		
-163	NAS1304-5	. . BOLT	4		
-164	NAS1203-7	. . BOLT	15		
-165	66E39841-1	. . . SKIN ASSY. DORSAL RIVETED ATTACHING PARTS	1		
-166	NAS1203-5	. . . BOLT	17		
-167	66J40246-1	. . . PAN ASSY. FUEL TIGHT	1		
-168	MS35489-14	. . . GROMMET	2		
-169	66D39810-1	. . . STOP ASSY. AFT LH	1		
-170	66D39810-2	. . . STOP ASSY. AFT RH ATTACHING PARTS	1		
-171	MS2142L4 NUT	2		
-172	NAS1104-14 BOLT	2		
-173	NAS428-5-12 BOLT, STOP	1		
-174	AN314-5P NUT	1		
-175	MS21209F5-21 THREAD INSERT	1		
-176	66E39811-1	. . . STOP ASSY. FWD LH	1		
-177	66E39811-2	. . . STOP ASSY. FWD RH ATTACHING PARTS	1		
-178	NAS1105-13	. . . BOLT	1		
-179	NAS1105-17	. . . BOLT	2		
-180	NAS577-5A	. . . BARREL NUT	3		
-181	NAS578-5A	. . . RETAINER	3		
-182	NAS428-5-12 BOLT, STOP	1		
-183	AN314-5P NUT	1		
-184	MS21209F5-21 THREAD INSERT	1		

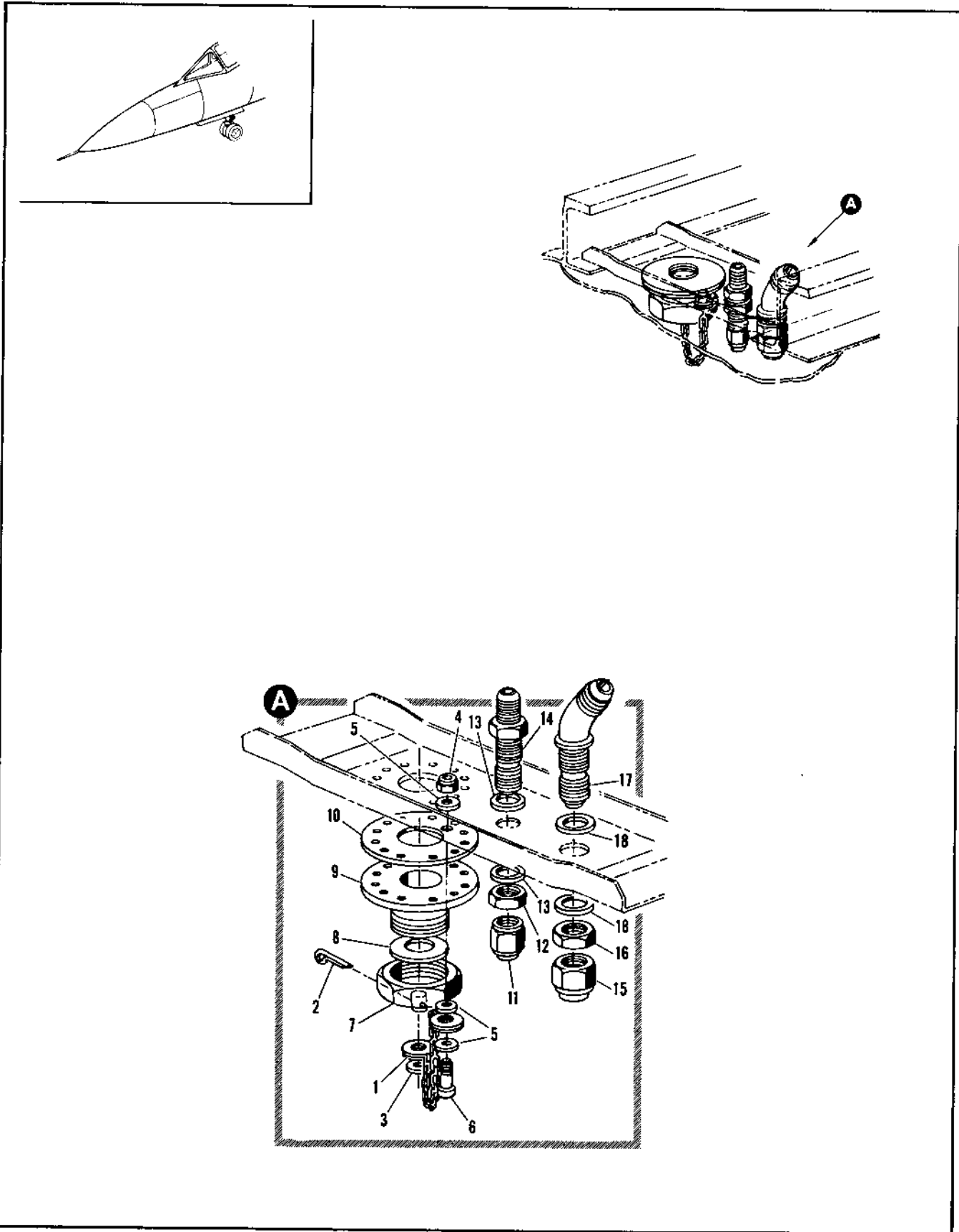

Figure 2.13-2. Ground Test Cockpit Pressure Fitting Installation

FIGURE AND INDEX NUMBER	PART NUMBER	DESCRIPTION 1 2 3 4 5 6	UNITS PER ASSY.	USABLE ON CODE	
				FROM	TO
2.13-2	K-23340-1	FITTING INSTALLATION, COCKPIT PRESSURE GROUND TEST FOR NHA SEE FIG. 2.3-4	RF	A	
- 1	NAF1088-1A5	• CHAIN, COCKPIT TEST FITTING ATTACHING PARTS	1	A	
- 2	AN3PC-1-1	• PIN, COTTER	1	A	
- 3	AN96006	• WASHER	1	A	
- 4	NAS679A06	• NUT	1	A	
- 5	AN96006	• WASHER	1	A	
- 6	AN560A6-P	• SCREW	1	A	
		-----X-----			
- 7	8-87460	• CAP, COCKPIT PRESSURE TEST FITTING	1	A	
- 8	99-53900-002	• WASHER	1	A	
- 9	8-87461	• FITTING, COCKPIT PRESSURE GROUND TEST	1	A	
- 10	8-87462	• SEAL, COCKPIT PRESSURE TEST FITTING	1	A	
- 11	AN929-3	• CAP	1	A	
- 12	AN924-3	• NUT	1	A	
- 13	AN9600616	• WASHER	2	A	
- 14	AN832-3	• UNION	1	A	
- 15	MS21914-4	• CAP	1	A	
- 16	AN924-4D	• NUT	1	A	
- 17	MS21907D4	• ELBOW	1	A	
- 18	AN9600716	• WASHER	2	A	
		A AIRPLANES 435 THRU 47 AND 49 THRU 89			

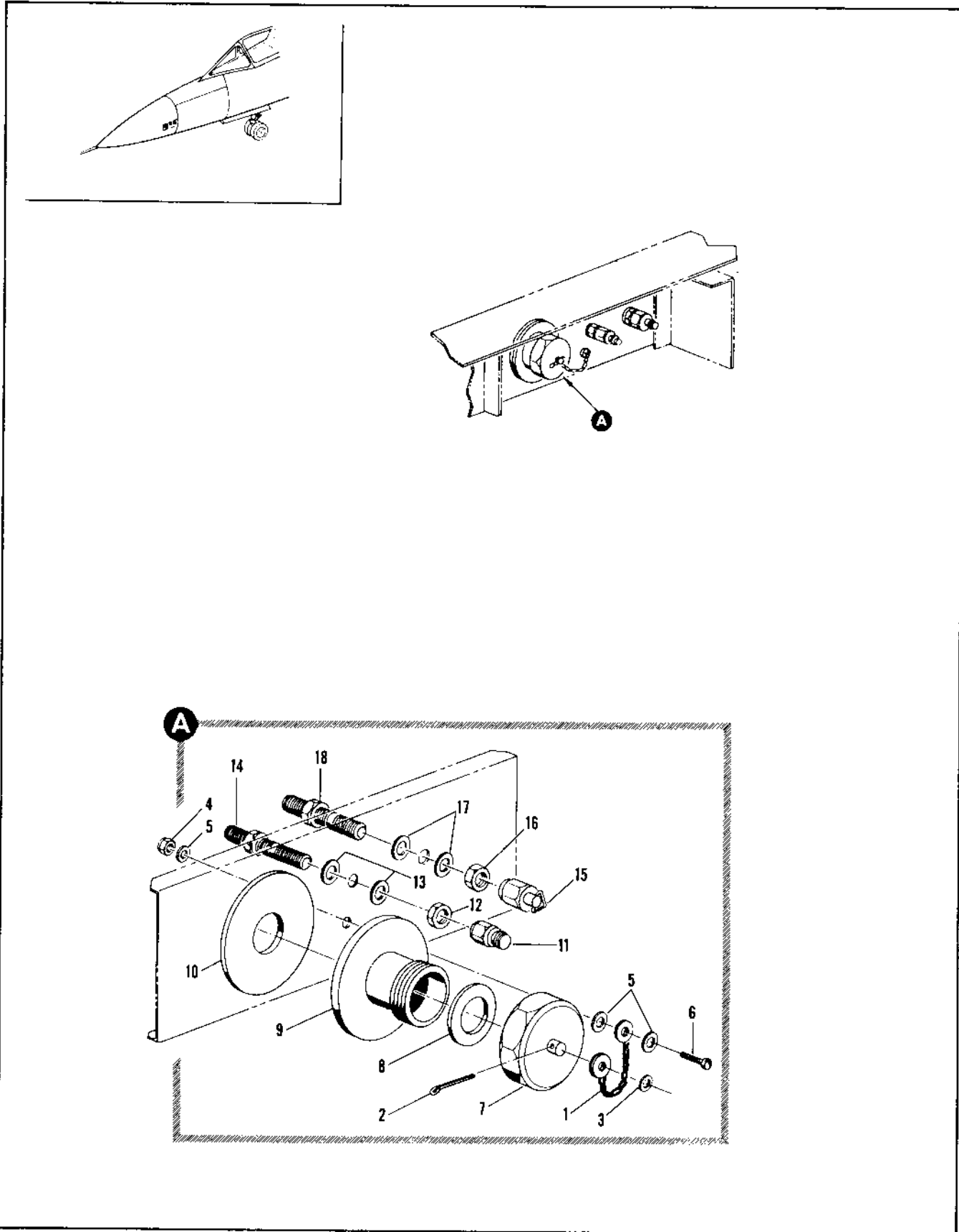

Figure 2.13-3. Ground Test Cockpit Pressure Fitting Installation

FIGURE AND INDEX NUMBER	PART NUMBER	DESCRIPTION	UNITS PER ASSY.	USABLE ON CODE	
				FROM	TO
		1 2 3 4 5 6			
2.15-1	P-21968	FITTING INSTALLATION, COCKPIT PRESSURE	9F		A
- 1	MS1088-1A5	GROUND TEST FOR MHA SEE FIG. 2.3-4	1		A
- 2	AN380-1-1	• CHAIN, COCKPIT TEST FITTING	1		A
- 3	AN96006	ATTACHING PARTS	1		A
- 4	MS679A06	• PIN, COTTER	1		A
- 5	AN96006	• WASHER	1		A
- 6	AN96006	• NUT	3		A
- 6	AN500A6-A	• WASHER	1		A
- 7	P-87860	• SCREW	1		A
- 7	P-87860	-----X-----	1		A
- 8	P9-55004-002	• CAP, COCKPIT PRESSURE TEST FITTING	1		A
- 9	P-87861	• WASHER	1		A
- 10	P-87862	• FITTING, COCKPIT PRESSURE GROUND TEST	1		A
- 11	AN929-3	• SEAL, COCKPIT PRESSURE TEST FITTING	1		A
- 12	AN924-3	• CAP	1		A
- 12	AN924-3	• NUT	2		A
- 13	AN9600616	• WASHER	2		A
- 14	AN930-3	• UNION	1		A
- 15	MS21914-4	• CAP	1		A
- 15	AN929-4D	• NUT	1		A
- 17	AN9600710	• WASHER	2		A
- 18	MS21924D4	• UNION	1		A
		A AIRPLANES #48, 98 AND ON			

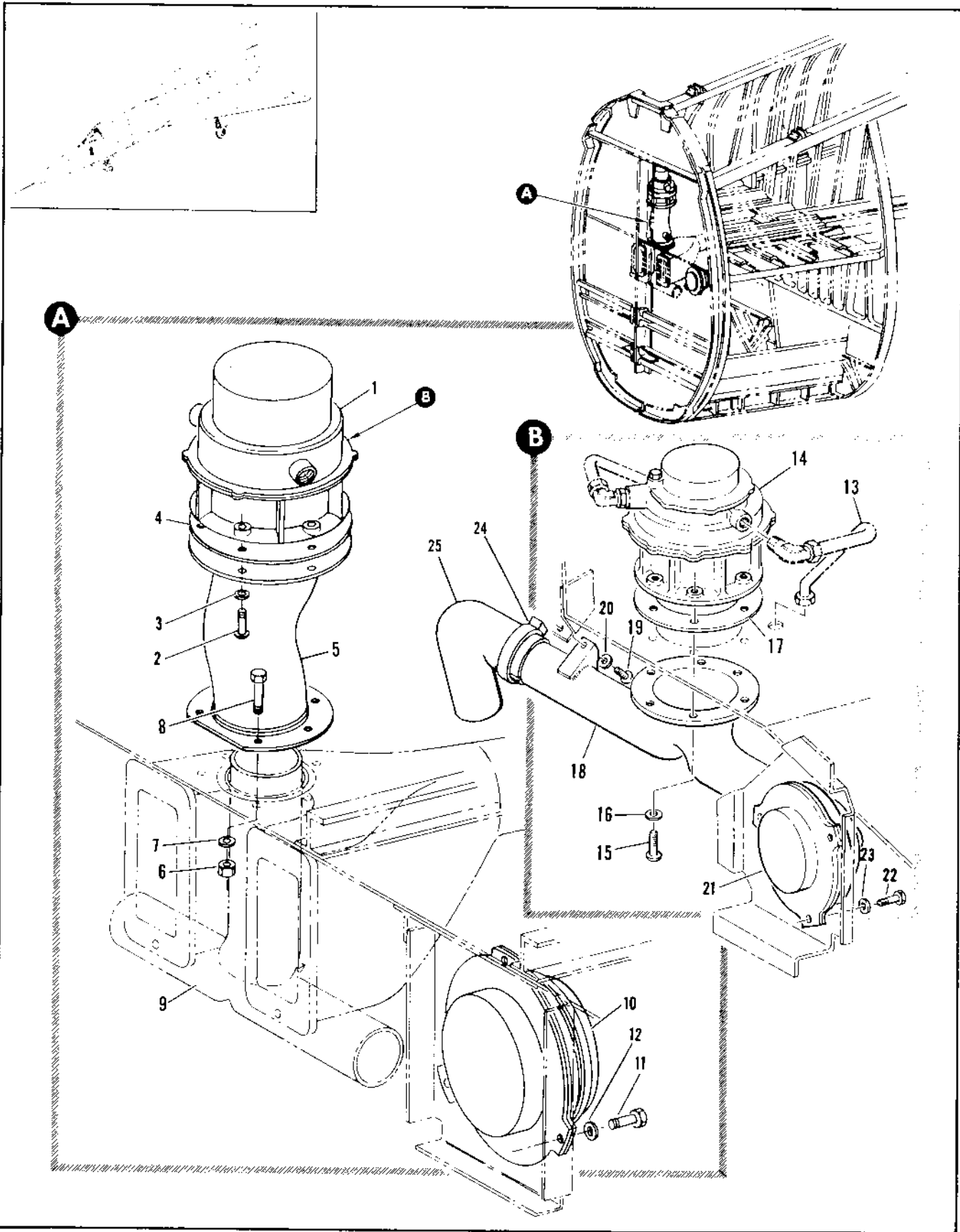

Figure 2.13-4. Cockpit Air Pressure Regulator

FIGURE AND INDEX NUMBER	PART NUMBER	DESCRIPTION	UNITS PER ASSY.	USABLE ON CODE	
				FROM	TO
		1 2 3 4 5 6			
2.13-4		COCKPIT AIR PRESSURE REGULATOR			
	4-23320-3	REGULATOR INSTL, COCKPIT AIR PRESSURE FOR MHA SEE FIG. 2.3-4	RF	A	
- 1	102204-2	VALVE ASSY, OUTFLOW COCKPIT AIR <72210> SPEC 8-12257-3 T.O. 15A2-3-14-23 REPLACED BY SUITABLE SUB 102204-4 ATTACHING PARTS	1	A	
- 2	AN526-1032R12	SCREW	6	A	
- 3	AN961-10L	WASHER	6	A	
		-----X-----			
- 4	8-23361	GASKET, REPLACED BY NOT INTCHG WITH 8-87272	1	A	
- 5	4-23301-9	SUPPORT ATTACHING PARTS	1	A	
- 6	NAS679A3	NUT	5	A	
- 7	AN963-10L	WASHER	5	A	
- 8	AN3-5A	BOLT	5	A	
		-----X-----			
- 9		DUCT ASSY, ELECTRONIC COOLING TEE STA 105 SEE FIG. 2.13-5	RF		
	8-23320-5	CONTROL INSTL, COCKPIT AIR PRESSURE REGULATOR FOR MHA SEE FIG. 2.3-4	RF	A	
- 10	102200-60	CONTROL, COCKPIT AIR PRESSURE REGULATOR <72210> SPEC 4-82257-5 T.O. 15A1-2-12-123 ATTACHING PARTS	1	A	
- 11	AN3-4A	BOLT	3	A	
- 12	AN960-10L	WASHER	3	A	
		-----X-----			
	8-23865	REGULATOR INSTL, COCKPIT AIR PRESSURE FOR MHA SEE FIG. 2.3-4	RF	A	
- 13		TUBING INSTL, LOW PRESSURE PNEUMATIC SEE FIG. 2.9-4	RF		
- 14	102204-4	VALVE ASSY, AIR OUTFLOW <72210> SPEC 8-82257-7 T.O. 15A2-3-14-37 REPLACES SUITABLE SUB FOR 102204-2 ATTACHING PARTS	1	B	
- 15	AN526-1032R12	SCREW	6	B	
- 16	AN960-10L	WASHER	6	R	
		-----X-----			
- 17	8-87272	GASKET, REPLACES NOT INTCHG WITH 8-23361	1	R	
- 18	8-23862	DUCT ASSY, COCKPIT DISCHARGE WELDED ATTACHING PARTS	1	R	
- 19	AN526-1032R10	SCREW	32	R	
- 20	AN960-10L	WASHER	32	R	
		-----X-----			
- 21	102200-60	CONTROL, COCKPIT AIR PRESSURE REGULATOR <72210> SPEC 4-82257-5 T.O. 15A1-2-12-123 ATTACHING PARTS	1	B	
- 22	AN3-4A	BOLT	3	R	
- 23	AN963-10L	WASHER	3	B	
		-----X-----			
	7242463-10	DUCT INSTL, BATTERY CHARGER EXTENDER	1	B	
- 24	AN737TW62	CLAMP	1	R	
- 25	7242442-11	DUCT	1	R	
		A AIRPLANES #35 THRU 47 AND 49 THRU 89 B AIRPLANES #48, 90 AND 89			

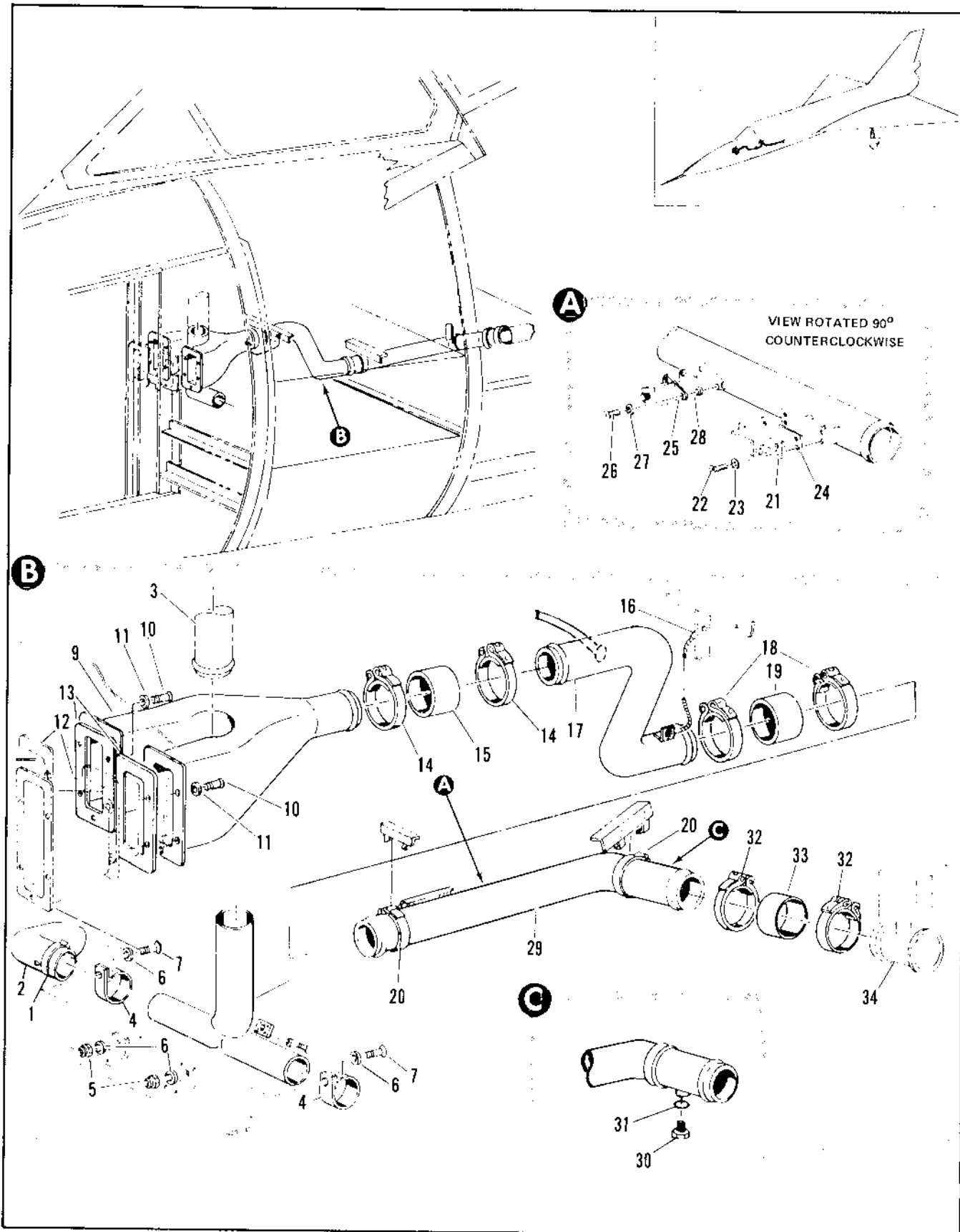

Figure 2.13-5. Forward Radar Compartment Cooling Duct Installation Sta 102 to 168 (Sheet 1 of 2)

FIGURE AND INDEX NUMBER	PART NUMBER	DESCRIPTION	UNITS PER ASSY.	USABLE ON CODE	
				FROM	TO
		1 2 3 4 5 6			
2.13-5	7242862-10	DUCT INSTL, BATTERY CHARGER EXTENDER	1	B	
- 1	AN737WR2	• CLAMP	1	B	
- 2	7242941-01	• DUCT	1	B	
- 3		• SUPPORT, SEE FIG. 2.13-5 INDEX 7	RF		
- 4	91-98017-034	• CLAMP, 0936DL36 ATTACHING PARTS	2	B	
- 5	NAS679A3	• NUT	2	B	
- 6	AN960C10L	• WASHER	4	B	
- 7	AN526C10R12	• SCREW	2	B	
- 8	8-23506-1	• DUCT ASSY, ELECTRONIC COOLING TEE STA 135 WELDED	1	B	
- 9	8-20R05-7	• DUCT ASSY, FWD RADAR COMPARTMENT COOLING OUTLET WELDED	1	B	
	8-21893-23	• DUCT ASSY, FWD RADAR COMPARTMENT COOLING OUTLET WELDED	1	B	
	7242870-10	PIPE INSTL, NOSE WHEEL WELL FOR NHA SEE FIG. 2.3-4	RF	B	
	64D34199-1	• DUCT ASSY, FWD RADAR COMPARTMENT COOLING INLET, WELDED REPLACED BY SUITABLE SUB 64D34199-3	1		
	64D34199-3	• DUCT ASSY, FWD RADAR COMPARTMENT COOLING INLET, WELDED, REPLACES SUITABLE SUB FOR 64D34199-1 ATTACHING PARTS	1		
- 10	AN526-8R6	• SCREW	10	B	
- 11	AN960CRL	• WASHER	10	B	
- 12	651009-1	• DUCT ASSY, FLEX RUBBER <82577> FURNISHED WITH <82577> 464073 LH AND 464273 SERIES MR-1 RADAR RACKS	RF	B	
- 13	8-23507	• GASKET, ELECTRONIC COOLING STA 102	2	B	
- 14	326-62-325S	• CLAMP, <98625> 91-97801-025	2	B	
- 15	A0297-3	• COUPLING, <92799> SPEC 8-00297-3	1	B	
- 16	MS25063-2886	• JUMPER, STA 133 ATTACHING PARTS	1	9	
	AN345C10	• NUT, GROUND STUD	4	B	
	AN935-10L	• WASHER, GROUND STUD	4	B	
	AN960D10L	• WASHER, GROUND STUD	4	B	
	AN960C10L	• WASHER, GROUND STUD	4	B	
	AN526C1032-12	• SCREW, GROUND STUD	2	B	
- 17	8-23501	• DUCT ASSY, WELDED	1	B	
	778814-10	• DUCT ASSY, ALTERED FROM 8-23501	1	B	
- 18	326-62-325S	• CLAMP, <98625> 91-97801-025	2	B	
- 19	A0297-3	• COUPLING, <92799> SPEC 8-00297-3	1	B	
- 20	326-62-312S	• CLAMP, <98625> 91-97801-004	2	B	
- 21	67D36655-1	• DETECTOR, AIR COOLING (98750) MODIFICATION OF 25830021 (80234)	1		
	67B36656-1	• PLATE IDENTIFICATION ATTACHING PARTS	1		
- 22	NAS623-3-A	• SCREW	4		
- 23	AN960PD10L	• WASHER	4		
		----X----			
		A AIRPLANES #35 THRU 47 AND 49 THRU 60			
		B AIRPLANES #35 THRU 47 AND 49 THRU 89			

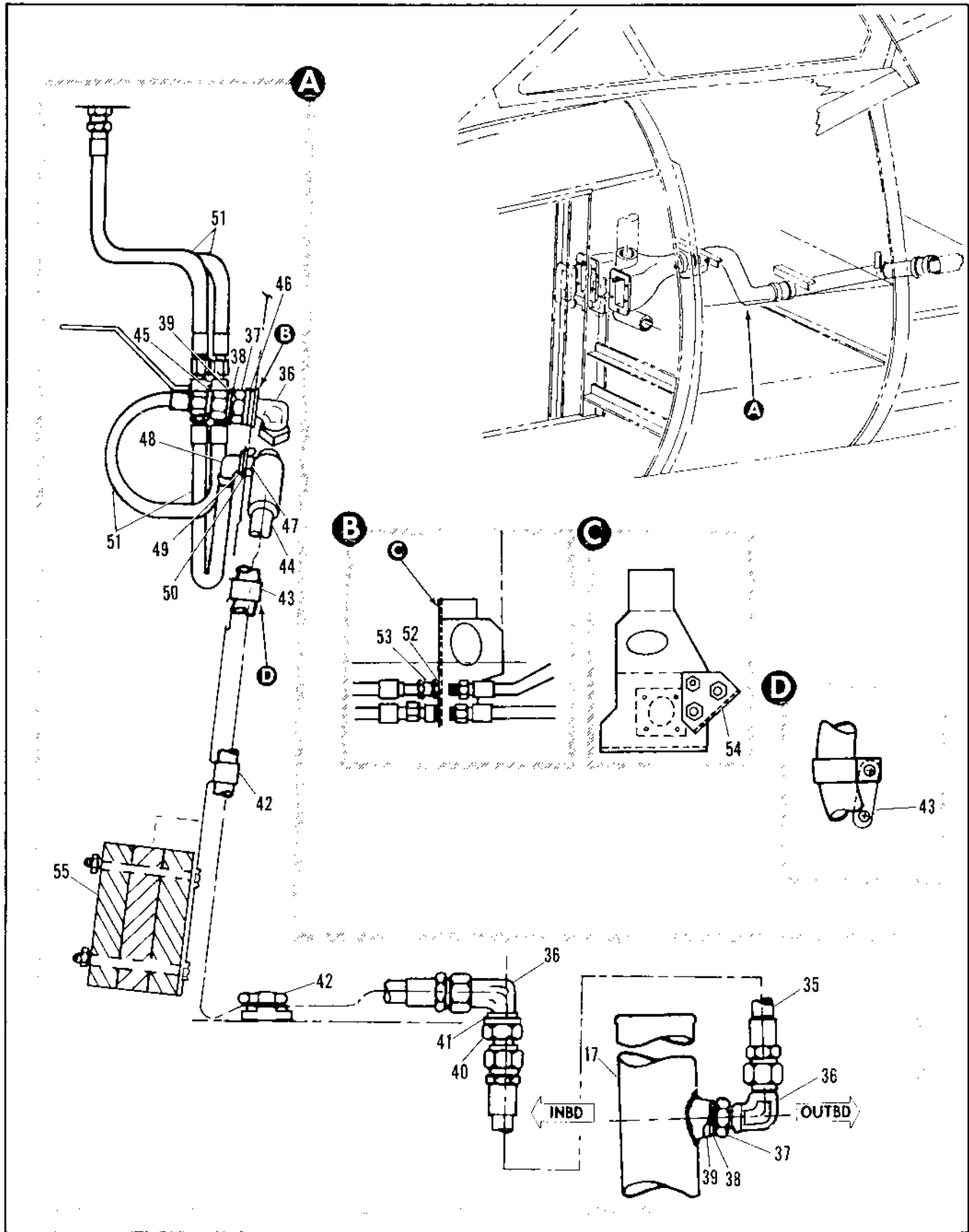

Figure 2.13-5. Forward Radar Compartment Cooling Duct Installation Sta 102 to 168 (Sheet 2 of 2)

FIGURE AND INDEX NUMBER	PART NUMBER	DESCRIPTION	UNITS PER ASSY.	USABLE ON CODE	
				FROM	TO
		1 2 3 4 5 6			
2.13-5- 24	3-23965-1	• GASKET	1	B	
- 25	25821031	• SENSOR, HIGH TEMPERATURE <90234> SPEC A-02946-3 ATTACHING PARTS	1		
- 26	NAS623-2-4	• SCREW	3		
- 27	AN966PDL	• WASHER	3		
- 28	3-23965-3	• GASKET	1	B	
- 29	64E34297-1	• DUCT ASSY	1	B	
- 30	AN814-CP	• PLUG	1	B	
- 31	MS2877A-6	• GASKET	1	B	
- 32	326-62-3259	• CLAMP, <92625> 91-97A01-025	2	B	
- 33	AD297-3	• COUPLING, <92749> SPEC R-02297-3	1	B	
- 34		• VALVE, RAM AIR COOLING SEE FIG. 2.13-R INDEX 3	RF		
	774R469	49 HOSE INSTALLATION I.R. COOLING SYSTEM		B	
- 35	AN6270-4D-150	• HOSE ASSEMBLY	1	B	
- 36	AN833-4D	• ELBOW	1	B	
- 37	AN62870-4	• NUT	1	4	
- 38	MS28777-4	• WASHER	1	B	
- 39	MS28778-4	• PACKING	1	B	
- 40	AN924-4D	• NUT	1	B	
- 41	AN961PD1216	• WASHER	2	B	
- 42	MS21104912	• CLAMP	1	B	
	JAS1435-3-4	ATTACHING PARTS			
	AN96 C11L	SCREW	1	B	
	NAS1041-03	WASHER	1	B	
		NUT	2	B	
- 43	774R469-01	49 • CLIP ATTACHING PARTS	1	B	
	MS21104012	CLAMP	1	B	
	JAS1435-3-4	SCREW	2	B	
	NAS1291-07	NUT	2	B	
- 44	774R409-10	• HOSE ASSEMBLY	1	B	
- 45	AN8940R-4	• BUSHING	1	B	
- 46	AN961PD1216	• WASHER	1	B	
- 47	AN924-4D	• NUT	3	B	
- 48	774R412-10	• ELBOW, ALTERED FROM AN673-4D	1	B	
- 49	AN961PD916	• WASHER	2	B	
- 50	AN961PD716L	• WASHER	2	B	
- 51	AN627-4D-1120	• HOSE ASSEMBLY	1	4	
- 52	AN924-4D	NUT	2	B	
- 53	AN833-4D	UNION	2	B	
- 54	774R419-01	CLIP	1	B	
		ATTACHING PARTS			
	MS51050-13	SCREW	1	B	
	NAS1070-416	SCREW	1	B	
	MS21742-3	NUT	1	B	
- 55	774R417-01	49 • BALLAST ASSEMBLY ATTACHING PARTS	1	B	
	AN4H35A	BOLT	4	B	
	AN970-4	WASHER	4	B	
	NAS1070-416	SCREW	4	B	
	MS21742-4	NUT	4	B	
		ATTACHING PARTS			

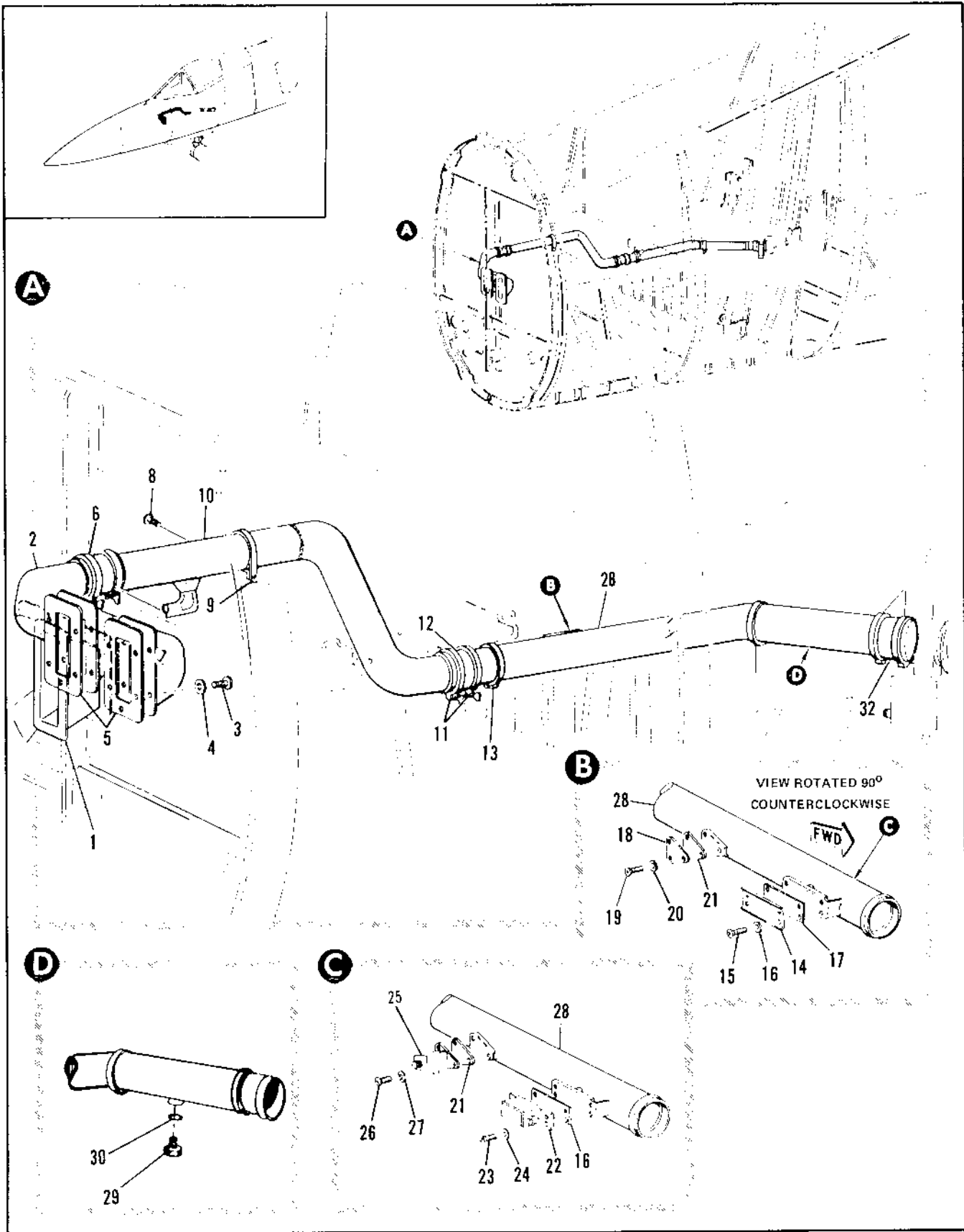

Figure 2.13-6. Forward Radar Compartment Cooling Duct Installation Sta 102 to 168 (Sheet 1 of 2)

FIGURE AND INDEX NUMBER	PART NUMBER	DESCRIPTION	UNITS PER ASSY.	USABLE ON CODE	
				FROM	TO
2.13-6	R-23500-007	DUCT INSTL, FWD RADAR COMPT COOLING STA 102 TO 16R MODIFIED BY 6-21892, S-20160 AND 07D36613 FOR NHA SEE FIG 2.3-4	RF	B	
	7242469-10	*1 PIPE INSTL, FWP ELECTRONIC COMPARTMENT FOR NHA SEE FIG. 2.3-4	RF	B	
- 1	6S1009-1	• DUCT ASSY, FLEX RUBBER <R2477> FURNISHED WITH <R2777> 464073 LH AND 414273 RH SERIES MP-1 FORWARD RADAR RACKS	RF	B	
- 2	64034286-1	• DUCT ASSY, MANIFOLD INLET, FWD ELECTRONICS COMPARTMENT, WELDED REPLACED BY SUITABLE SUB 64034286-3	1		
	7242922-01	• PIPE ATTACHING PARTS	1	B	
- 3	AN520-86R	• SCREW	10	B	
- 4	AN960CPL	• WASHER	10	B	
		-----X-----			
- 5	R-23507	• GASKET	2	B	
- 6	AN737TW51	• CLAMP	2	B	
- 7	NAS521-20-12	• COUPLING	1	R	
- 8	AN520-10R	• SCREW	1	R	
- 9	R-23500-45	• CLAMP	1	B	
- 10	R-23860	• DUCT ASSY, WELDED	1	B	
	7748611-10	• DUCT ASSY, WELDED, ALTERED FROM R-23860	1	B	
- 11	AN737TW50	• CLAMP	2	B	
	326-62-325A	• CLAMP, <R6625> 91-97011-125 ALT INCHG WITH AN737TW50	PF	B	
- 12	A0297-3	• COUPLING, <R2799> SPEC 4-0 297-3	1	R	
- 13	326-62-2125	• CLAMP, <R6625> 91-97011-125	2	B	
- 14	R-23564-7	• CAP	1	C	
		• CAP			
- 15	NAS623-3-2	• SCREW	4	C	
- 16	AN960PD11L	• WASHER	4	C	
		-----Y-----			
- 17	R-23565-1	• GASKET	1	R	
- 18	R-23564-9	• CAP ATTACHING PARTS	1	C	
- 19	NAS623-3-2	• SCREW	3	C	
- 20	AN960PD11L	• WASHER	3	C	
		-----Y-----			
- 21	R-23965-3	• GASKET	1	R	
- 22		• DETECTOR, DEFICIENT COOLING (BC224) MOD BY 67516655-1 ATTACHING PARTS	1	B	
- 23	NAS623-3-4	• SCREW	4	130	
- 24	AN960PD11L	• WASHER	4	130	
		-----X-----			

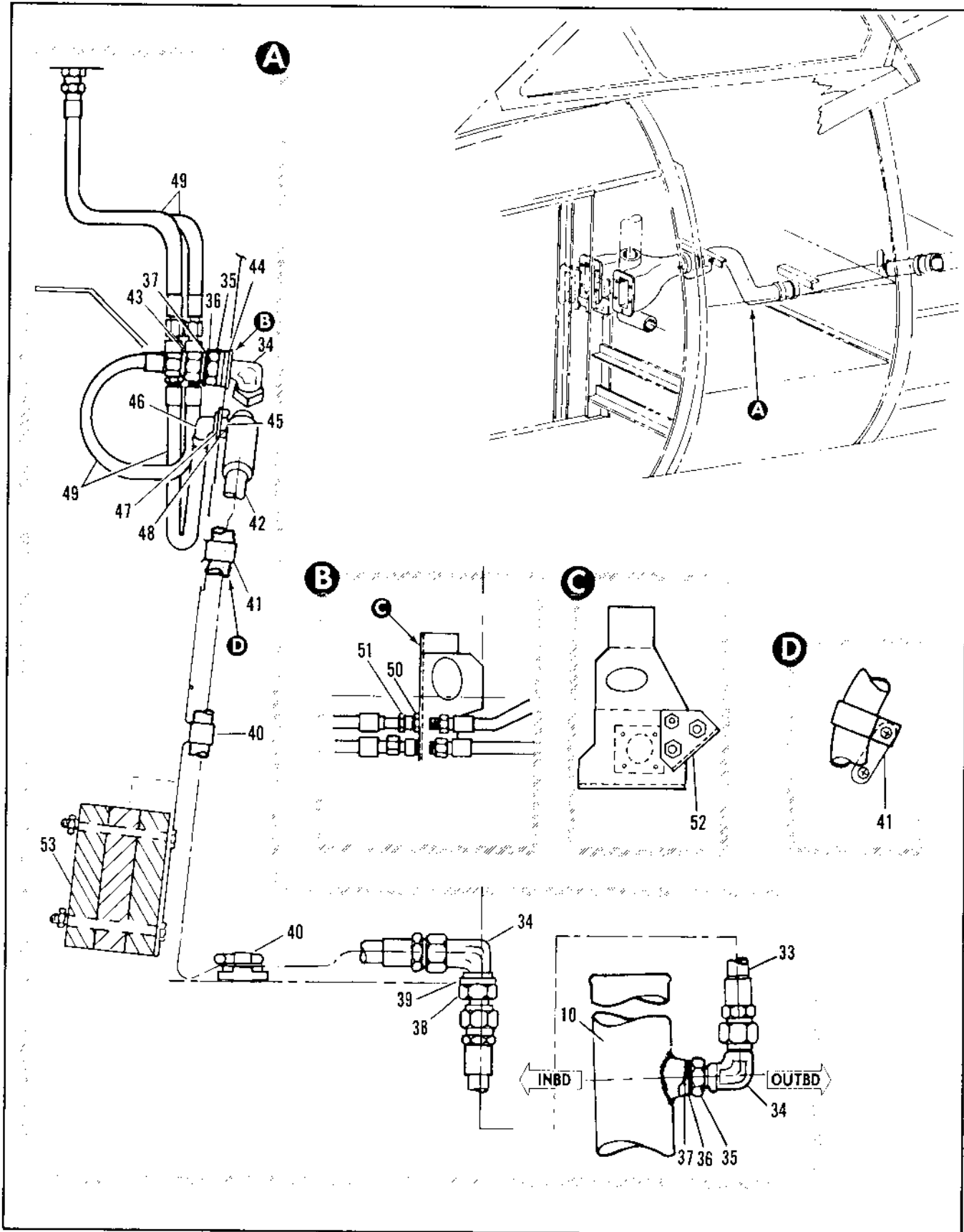

Figure 2.13-6. Forward Radar Compartment Cooling Duct Installation Sta 102 to 168 (Sheet 2 of 2)

FIGURE AND INDEX NUMBER	PART NUMBER	DESCRIPTION	UNITS PER ASSY.	USABLE ON CODE	
				FROM	TO
2.13-6- 25	25820031	• SENSOR, HIGH TEMPERATURE (P1234) SPEC 8-02948-3 T.O. 9A5-1-3-3 ATTACHING PARTS	1	130	
- 26	NAS623-2-4	• SCREW	3	130	
- 27	AN960PDL	• WASHER	3	130	
- 28	64E34297-1	• DUCT ASSY	1	B	
- 29	AN814-EDL	• • PLUG	1	B	
- 30	MS28778-6	• • GASKET	1	B	
- 31	326-62-325S	• CLAMP, (98625) 91-97P01-325	2	B	
- 32	AN297-3	• COUPLING (92799) SPEC 8-02997-3	1	B	
- 33	AN6270-PC-120	• HOSE ASSEMBLY	1	B	
- 34	AN813-PC	• ELBOW	1	B	
- 35	AN62890-8	• NUT	1	B	
- 36	MS28777-8	• WASHER	1	B	
- 37	MS28778-8	• PACKING	1	B	
- 38	AN924-40	• NUT	1	B	
- 39	AN960P01216	• WASHER	2	B	
- 40	MS21104-012	• CLAMP	1	B	
		ATTACHING PARTS			
	NAS1635-3-6	SCREW	1	B	
	AN960C16L	WASHER	1	B	
	NAS1291-C3	NUT	2	B	
		-----X-----			
- 41	7748608-01	• CLIP	1	B	
		ATTACHING PARTS			
	MS21104012	CLAMP	1	B	
	NAS1635-3-6	SCREW	2	B	
	NAS1291-C3	NUT	2	B	
- 42	7748604-10	• HOSE ASSEMBLY	1	B	
- 43	AN8940R-4	• PUSHING	1	B	
- 44	AN960P01216	• WASHER	1	B	
- 45	AN924-40	• NUT	3	B	
- 46	7748612-10	• ELBOW, ALTERED FROM AN833-40	1	B	
- 47	AN960P0916	• WASHER	2	B	
- 48	AN960P0716L	• WASHER	2	B	
- 49	AN6270-40-0120	• HOSE ASSEMBLY	1	B	
- 50	AN924-40	NUT	2	B	
- 51	AN832-40	UNION	2	B	
- 52	7748619-11	CLIP	1	B	
		ATTACHING PARTS			
	MS5195A-63	SCREW	1	B	
	NAS1070-416	WASHER	1	B	
	MS21042-3	NUT	1	B	
		-----X-----			
- 53	7748617-01	BALLAST ASSEMBLY	1	B	
		ATTACHING PARTS			
	AN4H35A	BOLT	4	B	
	AN970-4	WASHER	4	B	
	NAS1070-416	WASHER	4	B	
	MS21042-4	NUT	4	B	
		ATTACHING PARTS			
		B 4R, 90 AND ON			

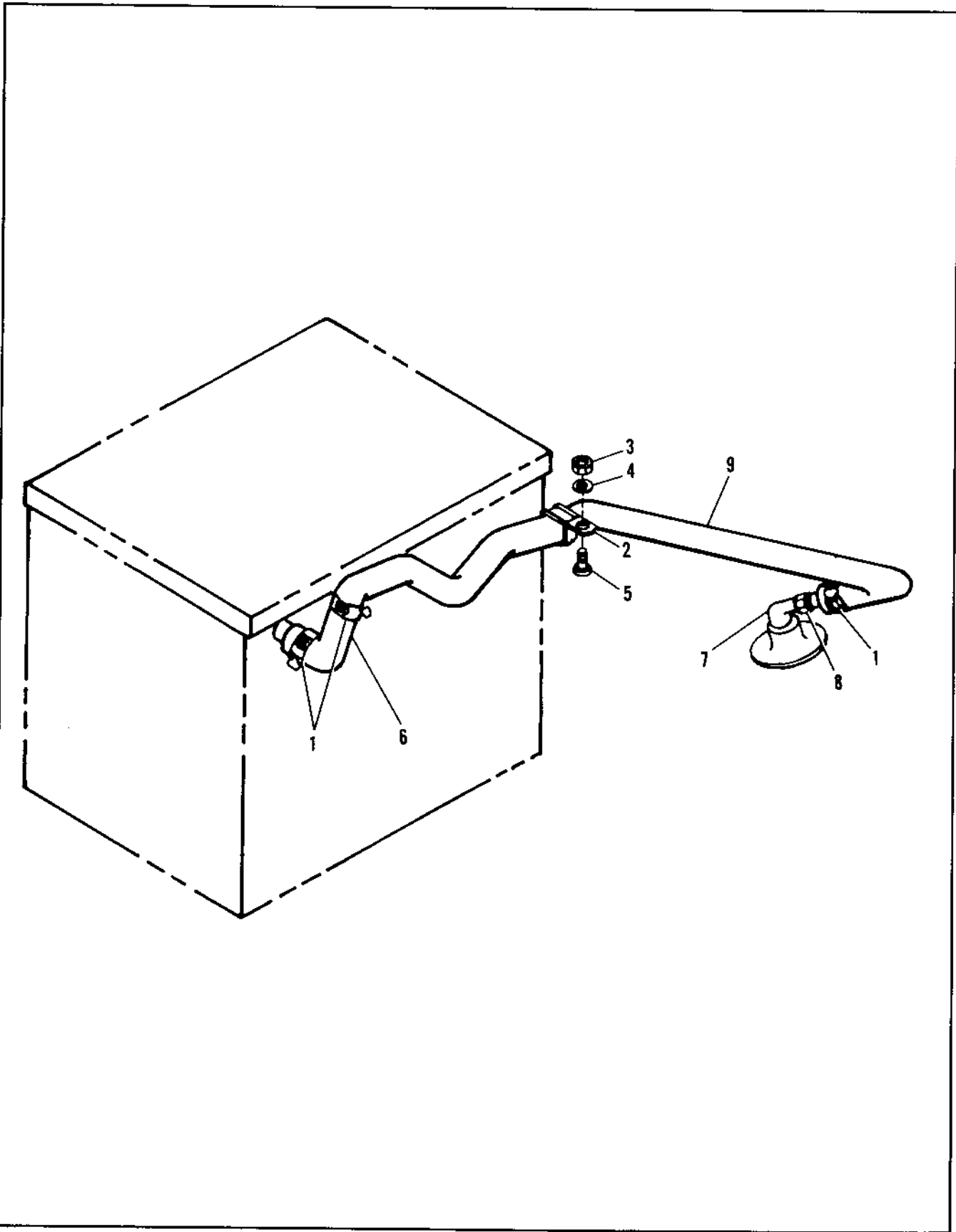

Figure 2.13-7. RH NWW Battery Vent Installation

FIGURE AND INDEX NUMBER	PART NUMBER	DESCRIPTION	UNITS PER ASSY.	USABLE ON CODE	
				FROM	TO
		1 2 3 4 5 6			
2.13-7	7242864-10	VENT INSTL, RH N/W BATTERY	1	35	
- 1	AN737TW30	• CLAMP	3	35	
- 2	MS21919WDF11	• CLAMP	1	35	
		ATTACHING PARTS			
- 3	MS21842-0R	• NUT	1	35	
- 4	AN960PDR	• WASHER	2	35	
- 5	MS35266-242	• SCREW	1	35	
		----X----			
- 6	9555A	• ELBOW, RUBBER (74144)	1	35	
- 7	MS25822-8J	• ELBOW	1	35	
- 8	7242865-10	• TUBE ASSY	1	35	
- 9	7242874-10	• HOSE	1	35	

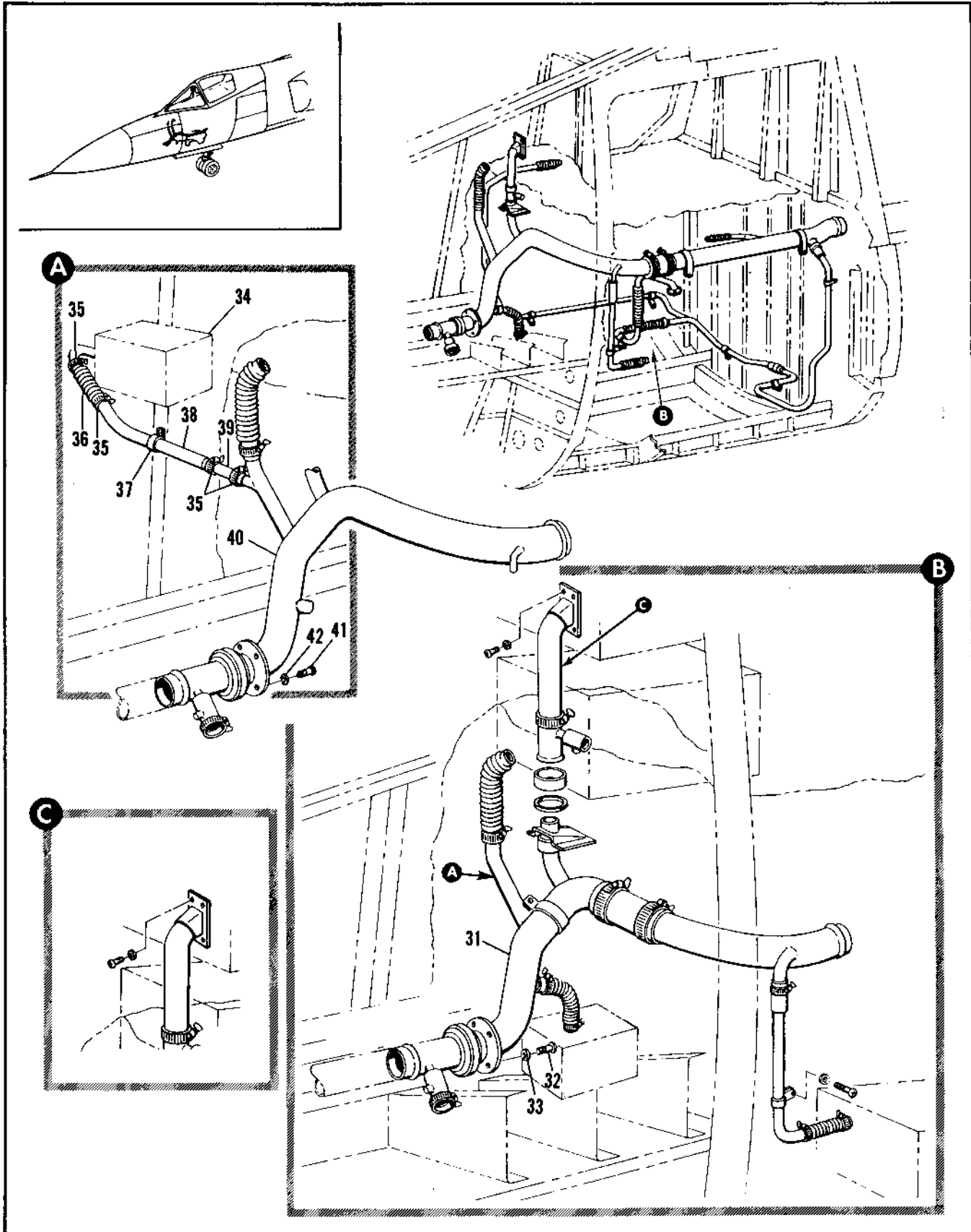

Figure 2.13-8. Aft Electronic Compartment Cooling Duct Installation (Sheet 2 of 4)

FIGURE AND INDEX NUMBER	PART NUMBER	DESCRIPTION 1 2 3 4 5 6	UNITS PER ASSY.	USABLE ON CODE	
				FROM	TO
2.13-39	64D34279-1	• DUCT ASSY, ELECTRONIC COOLING WELDED ALTERED FROM R-2139A-7 ATTACHING PARTS	1		
- 32	AN521010RB	• SCREW	4	35	129
- 33	AN967010L	• WASHER	4	35	129
- 34	464220-150	• CONVERTER, DATA LINK TYPE CV702/ARR61 REFNO-1-7122 GFAL SEE FIG. 2.18-20 INDEX 43	PF	160	
- 35	AN757TW46	• CLAMP	4	160	
- 36	3-1604-P-23-6	• DUCT, FLEX (7082K) R-2139A-13	1	160	
- 37	AN742016	• CLAMP ATTACHING PARTS	1	160	
	AN521-1097	• SCREW -----X-----	1	160	
- 38	64D34273-1	• TUBE ASSY, DATA LINK CONVERTER COOLING INLET WELDED ALTERED FROM 3-23-71	1	35	
- 39	NAS521-P-12	• COUPLING	1	35	
- 40	64D34276-1	• DUCT ASSY, ELECTRONIC COOLING WELDED ALTERED FROM R-255A1-2 ATTACHING PARTS	1	130	
- 41	AN521010RB	• SCREW	4	130	
- 42	AN967010L	• WASHER -----X-----	4	130	

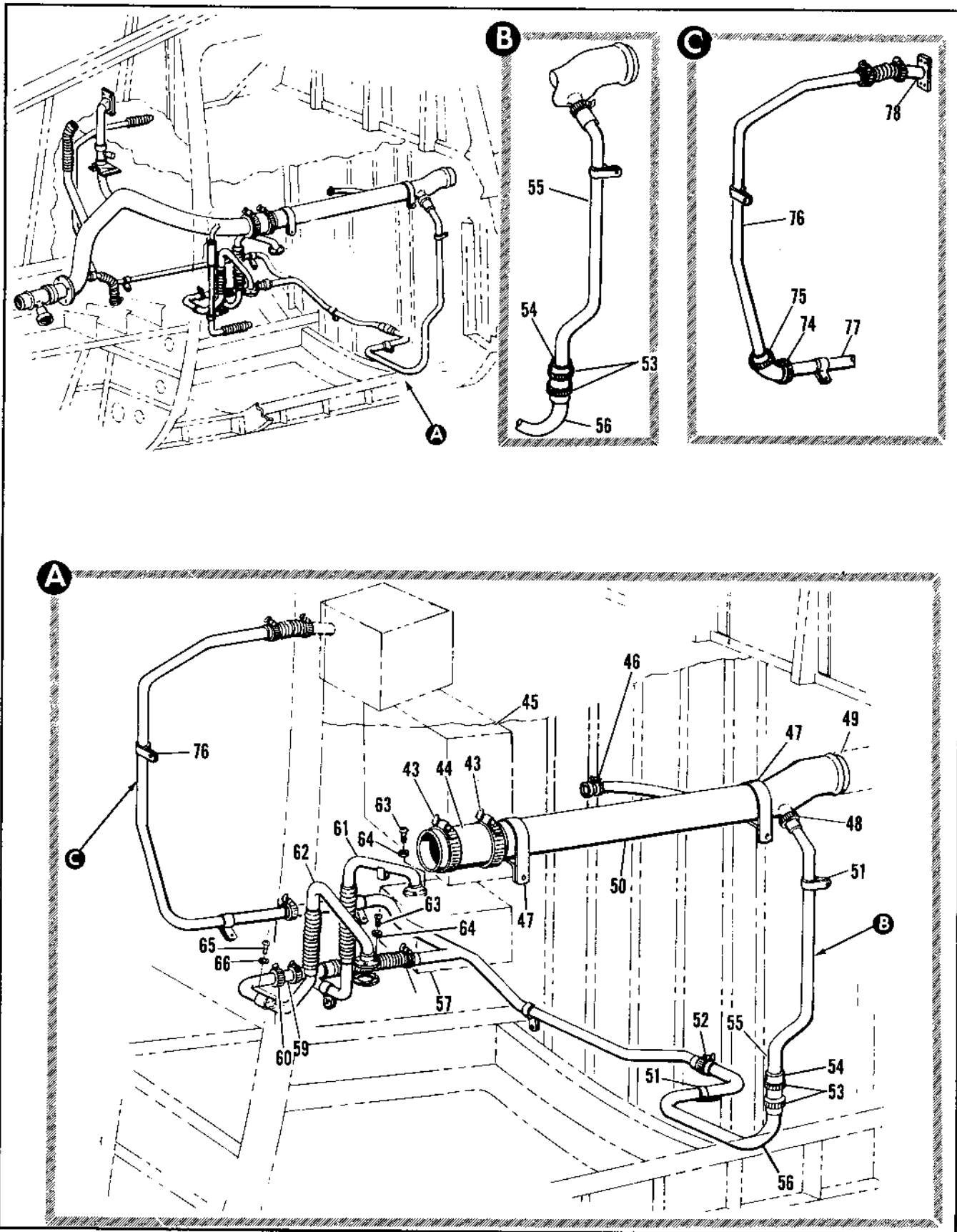

Figure 2.13-8. Aft Electronic Compartment Cooling Duct Installation (Sheet 3 of 4)

FIGURE AND INDEX NUMBER	PART NUMBER	DESCRIPTION	UNITS PER ASSY.	USABLE ON CODE	
				FROM	TO
2.13-8- 43	AN737TW127	• CLAMP	2	35	
	AC297-3	• COUPLING, (CR779) SPEC 1-00297-3	1	35	
- 44		• CODER-DECODER, IFF TRANSPONDER	RF		
- 45	AN737TW3A	• CLAMP	2	35	
- 46	AN742D4B	• CLAMP	2	35	
- 47		ATTACHING PARTS			
	AN526-1032R	• SCREW	2	35	
	AN960PD1CL	• WASHER	2	35	
		-----X-----			
- 48	AN737TW5F	• CLAMP	1	35	
- 49		• DUCT ASSY, ELECTRONIC COOLING SEE FIG. 2.13-9	RF		
- 50	7242933-10	• DUCT ASSY, WELDED	1	35	
- 51	AN742D24	• CLAMP	1	35	
		ATTACHING PARTS			
	NAS679A3	• NUT	1	35	
	AN960PD1CL	• WASHER	2	35	
	NAS42DD3-20	• SPACER	1	35	
	AN526-1032R12	• SCREW	1	35	
	AN526-1032R	• SCREW	1	35	
		-----X-----			
- 52	AN737TW5A	• CLAMP	1	35	
- 53	AN737TW5F	• CLAMP	2	35	
- 54	NAS521-12-12	• COUPLING	1	35	
- 55	7242930-10	• TUBE ASSY	1	35	
- 56	7243031-10	• TUBE ASSY	1	35	
- 57		• RECEIVER-TRANSMITTER, IFF RADIO	RF		
- 58	AN737TW3B	• CLAMP	2	A	
- 59	H-23840-47	• SLEEVE	1	A	
- 60	640342P1-1	• TUBE ASSY, IFF RADIO RECEIVER COOLING INLET WELDED ALTERNATED FROM CR735-803 (22630) SPEC 1-02922-803	1		
- 61	3010-1	• DUCT ASSY, FLEX (971) SPEC 1-02922-1 REPLACED BY SUITABLE SUP CR735-801	1	49	215
	640342B0-1	• TUBE ASSY, IFF RADIO RECEIVER COOLING WELDED ALTERNATED FROM CR735-801 (22630) SPEC 1-02922-801	1	35	
- 62	3010-5	• DUCT ASSY, FLEX (971) SPEC 1-02922-5	1		
	640342B1-1	• TUBE ASSY, IFF RADIO RECEIVER COOLING INLET WELDED ALTERNATED FROM CR735-803 (22630) SPEC 1-02922-803	1	35	
		ATTACHING PARTS			
- 63	AN510D6RF	• SCREW	R	49	
- 64	AN961P0PL	• WASHER	R	49	
	AN510D6RF	• SCREW	P	35	47
	AN961P06L	• WASHER	P	35	47
- 65	NAS221-6	• SCREW	1	35	47
- 66	AN935-10	WASHER, LOCK	1	35	47
		-----X-----			

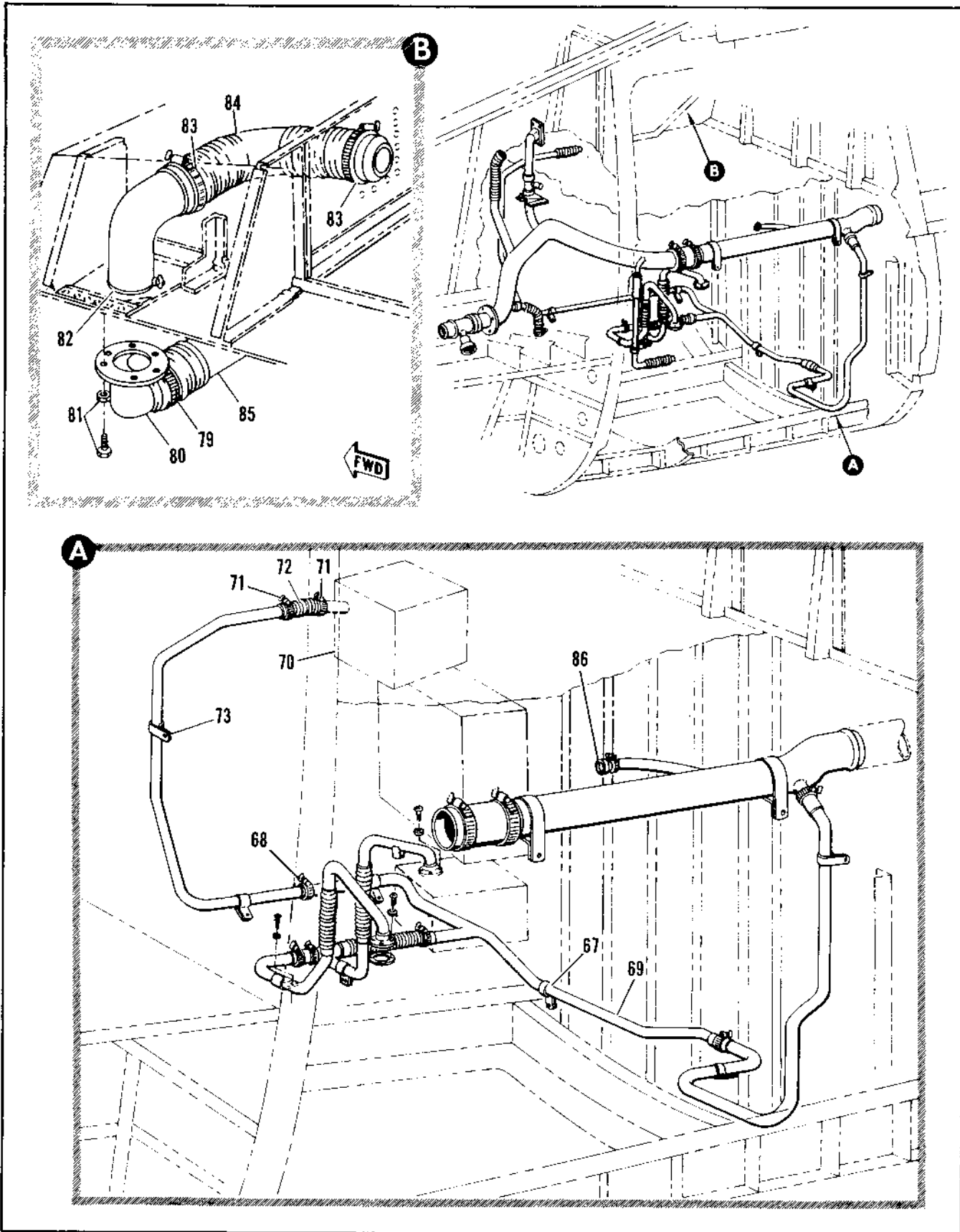

Figure 2.13-8. Aft Electronic Compartment Cooling Duct Installation (Sheet 4 of 4)

FIGURE AND INDEX NUMBER	PART NUMBER	DESCRIPTION	UNITS PER ASSY.	USABLE ON CODE	
				FROM	TO
		1 2 3 4 5 6			
2.13-8- 67	AN742024	• CLAMP ATTACHING PARTS	2	35	
	AN526-1032RR	• SCREW	2	35	
	AN960PD10L	• WASHER ----X----	2	35	
- 68	AN737TW3R	• CLAMP	1	35	
- 69	7242931-10	• TUBE ASSY	1	35	
- 70		• AMPLIFIER, NAVIGATION AND LANDING APPROACH COMPUTER	RF		
- 71	AN737TW5R	• CLAMP	2	35	
- 72	NAS1376ACE50914	• DUCT, FLEX	1	35	
- 73	AN742024	• CLAMP ATTACHING PARTS	1	35	
	AN526-1032RR	• SCREW	2	35	
	AN960PD10L	• WASHER ----X----	2	35	
- 74	AN742024	• CLAMP ATTACHING PARTS	2	35	
	MS21045L3	• NUT	1	35	
	AN960PD10L	• WASHER	2	35	
	AN526-1032RR	• SCREW ----X----	2	35	
- 75	AN737TW3R	• CLAMP	2	35	
- 76	7242932-10	• TUBE ASSY	1	35	
- 77	7243037-10	• TUBE ASSY	1	35	
- 7A	7242884-10	• CONNECTION STRAIGHT, FLANGED HOSE ATTACHING PARTS	1	35	
	AN4-6A	• BOLT	4	35	
	AN960D4-10	• WASHER	4	35	
	7242890-03	• GASKET ----X----	4	35	
- 79	402-267	• CLAMP (38425)	1		
- 80	67E3E567-1	• PIPE, AIR CONDITIONING • HEATING DROUND COOLING AIR ATTACHING PARTS	1		
- 81	MS35207-264	• SCREW	6		
	AN960PD-10	• WASHER ----X----	6		
- 82	66E40085-1	• DUCT, OUTLET BROUND AIR	1		
- 83	AN737TW9R	• CLAMP	2		
- 84	NAS1374A11S048	• DUCT	1		
- 85		• RACK, ELECTRONIC EQUIPMENT (42577) SPEC SEE FIG. 2.18-21 INDEX 6	RF		
- 86	NAS521-R-10	• SLEEVE	2	35	

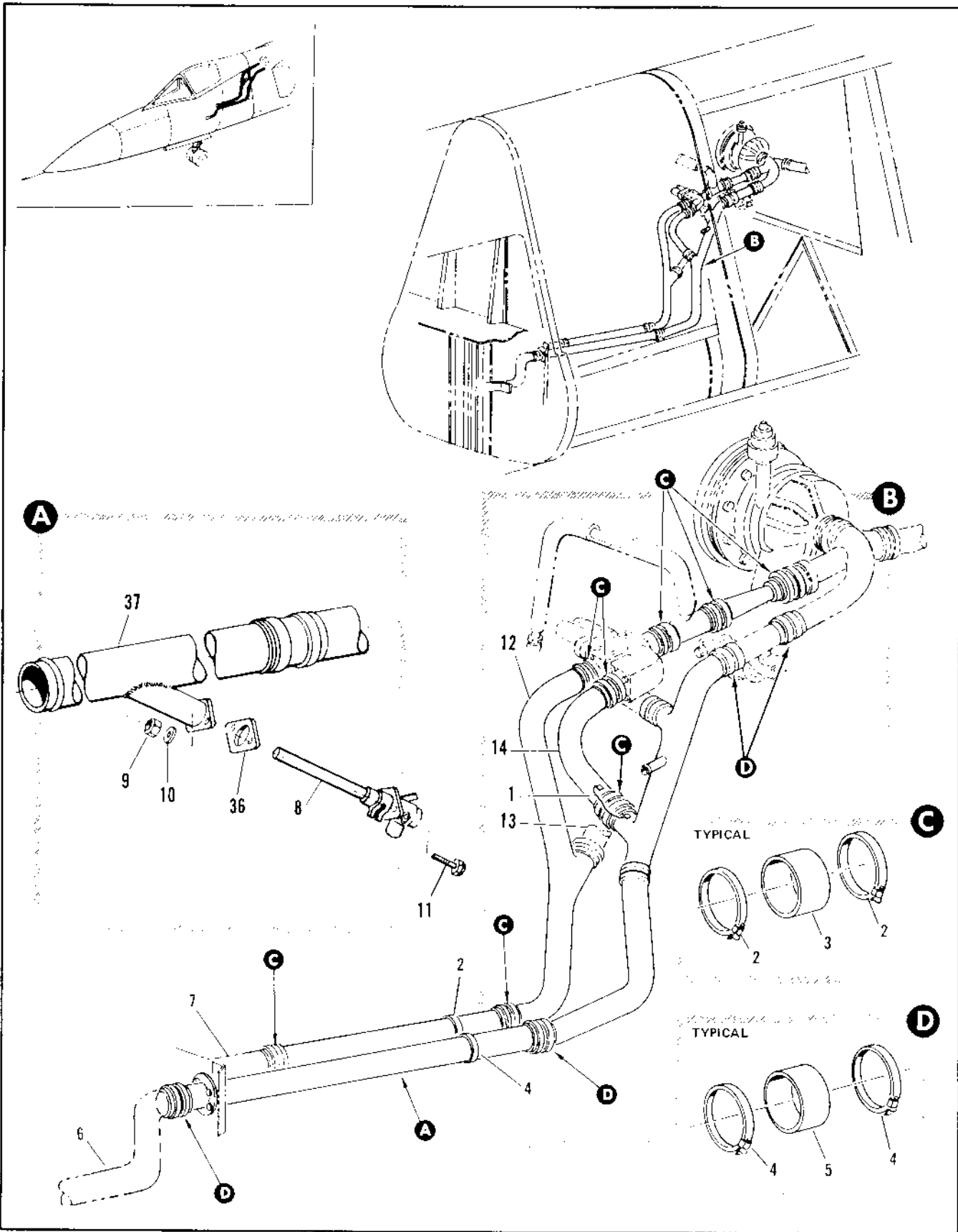

Figure 2.13-9. Forward Radar Compartment and Cockpit Cooling Duct Installation (Sheet 1 of 4)

FIGURE AND INDEX NUMBER	PART NUMBER	DESCRIPTION	UNITS PER ASSY.	USABLE ON CODE	
				FROM	TO
		1 2 3 4 5 6			
2.13-9	4-23520-801	DUCT INSTALLATION, FWD RADAR COMPARTMENT AND COCKPIT COOLING FOR NHA SEE FIG. 2.3-9	PF	35	
- 1	MS25083-2PB6	• JUMPER, STA 263	1	35	R9
	MS25083-3SR	• JUMPER, STA 263	1	90	
	MS25083-4FB3	• JUMPER, STA 263	1	90	
	AN345-10	ATTACHING PARTS	2	35	
	AN935-10L	• NUT, GROUND STUD	4	35	
	AN960-10L	• WASHER, GROUND STUD	4	35	
	AN960D10L	• WASHER, GROUND STUD	4	35	
	AN526-1032R12	• WASHER, GROUND STUD	2	35	
		-----X-----			
- 2	AN737TW74	• CLAMP	17	35	
- 3	AD297-7	• COUPLING, <42799> SPEC 4-04297-7	9	35	
- 4	AN737TW107	• CLAMP	9	35	
- 5	AD297-3	• COUPLING, <42799> SPEC 4-04297-3	4	35	
- 6		• DUCT ASSY, FWD ELECTRONIC STA 16R TO 203 SEE FIG. 2.13-8	PF		
- 7		• DUCT, SEE FIG. 2.13-15	RF		
	AN3-3A	• BOLT	5	35	240
	AN960D10L	• WASHER	5	35	240
		-----X-----			
- 8	107890-1	• THERMOSTAT ASSY, MOISTURE SEPARATOR OUTLET HOT AIR BYPASS (99193) SPEC 4-09989-1	1	241	
- 9	NAS679A3	• NUT	2	241	
- 10	AN960D10L	• WASHER	2	241	
- 11	NAS1103-5	• BOLT	2	241	
		-----X-----			
- 12	R-23351-1	• DUCT ASSY, COCKPIT COOLING WELDED	1		
- 13		• DUCT INSTL, RAM AIR SEE FIG. 2.13-1	RF		
- 14	R-23352	• DUCT ASSY, DIVERTER ELBOW WELDED	1	35	39
	R-23352-1	• DUCT ASSY, ALT INTNG WITH R-23352 REPLACED BY SUITABLE SUP R-23352-5	RF	35	38
	R-23352-3	• DUCT ASSY, DIVERTER ELBOW WELDED	1	39	
	R-23352-5	• DUCT ASSY, ALT INTNG WITH R-23352-3 REPLACES SUITABLE SUP FOR R-23352-1	PF	39	

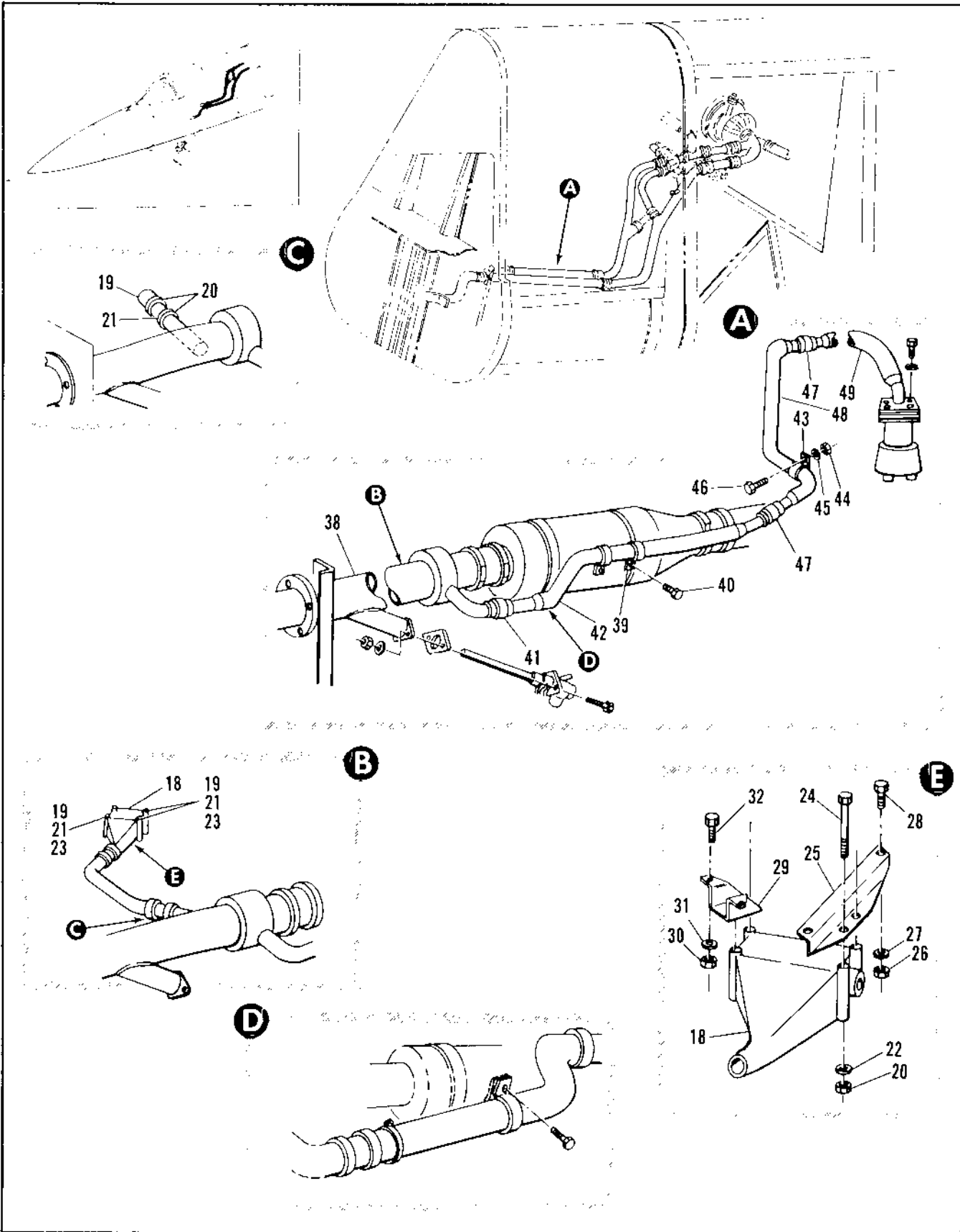

Figure 2.13-9. Forward Radar Compartment and Cockpit Cooling Duct Installation (Sheet 2 of 4)

FIGURE AND INDEX NUMBER	PART NUMBER	DESCRIPTION	UNITS PER ASSY.	USABLE ON CODE	
				FROM	TO
		1 2 3 4 5 6			
2.13-9- 15	AN737RM34	• CLAMP	4		
	AN737TW34	• CLAMP	4		
- 16	NAS521-6-10	• COUPLING	2		
- 17	64C340E6-1	• TUBE, COOLING FLUID TUNE MAGNETRON	1		
- 18	9534130	• COOLER, AIR-OIL (27462) SPEC B-28689-1 ATTACHING PARTS	1		
- 19	MS21042L3	• NUT	3		
- 20	MS21042L3	• NUT	4		
- 21	AN960C10	• WASHER	3		
- 22	AN960C10	• WASHER	4		
- 23	AN3-23A	• BOLT	3		
- 24	AN3-23A	• BOLT	4		
		-----X-----			
- 25	A-23864-11	• ANGLE ATTACHING PARTS	1		
- 26	MS21042L3	• NUT	2		
- 27	AN960C10	• WASHER	2		
- 28	AN3-3A	• BOLT	2		
		-----X-----			
- 29	B-23864-13	• HAT ATTACHING PARTS	1		
- 30	MS21042L3	• NUT	2		
- 31	AN960C10	• WASHER	2		
- 32	AN3-3A	• BOLT	2		
		-----X-----			
- 33	64C34295-1	• CAP	1		
- 34	AN737TW34	• CLAMP	2		
- 35	NAS521-6-10	• COUPLING	1		
- 36	A-238779-6	• GASKET	1	241	
- 37	B-23813-1	• DUCT ASSY, ELECTRONIC COOLING WELDED REPLACES NUT INTCHG WITH A-23813 ATTACHING PARTS	1	241	
	AN3-3A	• BOLT	5	241	
	AN960D10L	• WASHER	5	241	
		-----X-----			
- 38	64E34054-1	• DUCT ASSY, MOISTURE SEPARATOR WELDED	1		
- 39	MS21019H20	• CLAMP ATTACHING PARTS	1		
- 40	AN3-3A	• BOLT	1		
		-----X-----			
- 41	NAS595-1E	• RING	1		
- 42	B3E35690-1	• DUCT ASSY, ELECTRONIC HOT AIR BYPASS WELDED	1		
- 43	MS21019H20	• CLAMP ATTACHING PARTS	1		
- 44	MS21042L3	• NUT	1		
- 45	AN960PP10L	• WASHER	1		
- 46	AN3-3A	• BOLT	1		
		-----X-----			
- 47	4185-12	• RING (95100)	2		
- 48	B3E35692-1	• DUCT ASSY, ELECTRONIC HOT AIR BYPASS WELDED	1		
- 49	B3E35694-1	• DUCT ASSY, ELECTRONIC HOT AIR BYPASS WELDED	1		

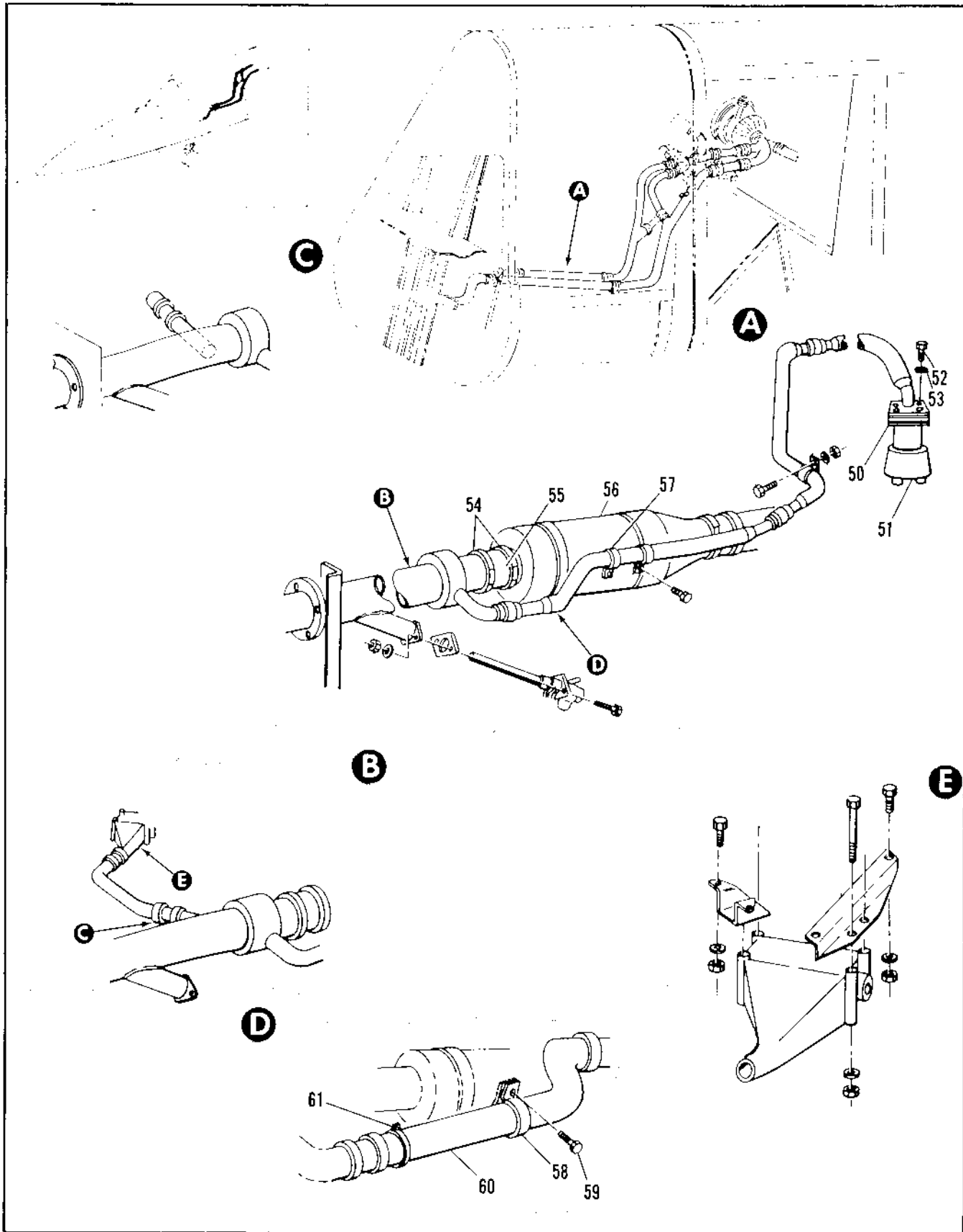

Figure 2.13-9. Forward Radar Compartment and Cockpit Cooling Duct Installation (Sheet 3 of 4)

FIGURE AND INDEX NUMBER	PART NUMBER	DESCRIPTION 1 2 3 4 5 6	UNITS PER ASSY.	USABLE ON CODE	
				FROM	TO
2.13-9- 50	8-23879-7	• GASKET, <MADE FROM P/N 60-1-16X36X33>	2		
- 51	106760-1	• VALVE ASSY, MOISTURE SEPARATOR OUTLET HOT AIR BYPASS (R9183) SPEC A-99988-1 ATTACHING PARTS	1		
- 52	AN3-6A	• BOLT	4		
- 53	AN960C10L	• WASHER	4		
- 54	AN737TW107	• CLAMP	2		
- 55	AD297-3	• COUPLING (R2799) SPEC A-10297-3	1		
- 56	HS598350-1	• SEPARATOR, MOISTURE AIRCRAFT AIR CONDITIONING SYSTEM SEE FIG. 2.13-1 INDEX 78-1	RF		
- 57	WS21919H19	• CLAMP	1		
	AN520-10R6	• ATTACHING PARTS	1		
	AN960-10	• SCREW	1		
	NAS679A3	• WASHER	1		
- 58	WS21919DG32	• NUT	1		
		• CLAMP	1		
		• ATTACHING PARTS	1		
- 59	AN3-3A	• BOLT	1		
- 60	64E34064-1	• DUCT ASSY, CABIN COOLING WELDED	1		
- 61	AN735D32	• CLAMP	1		

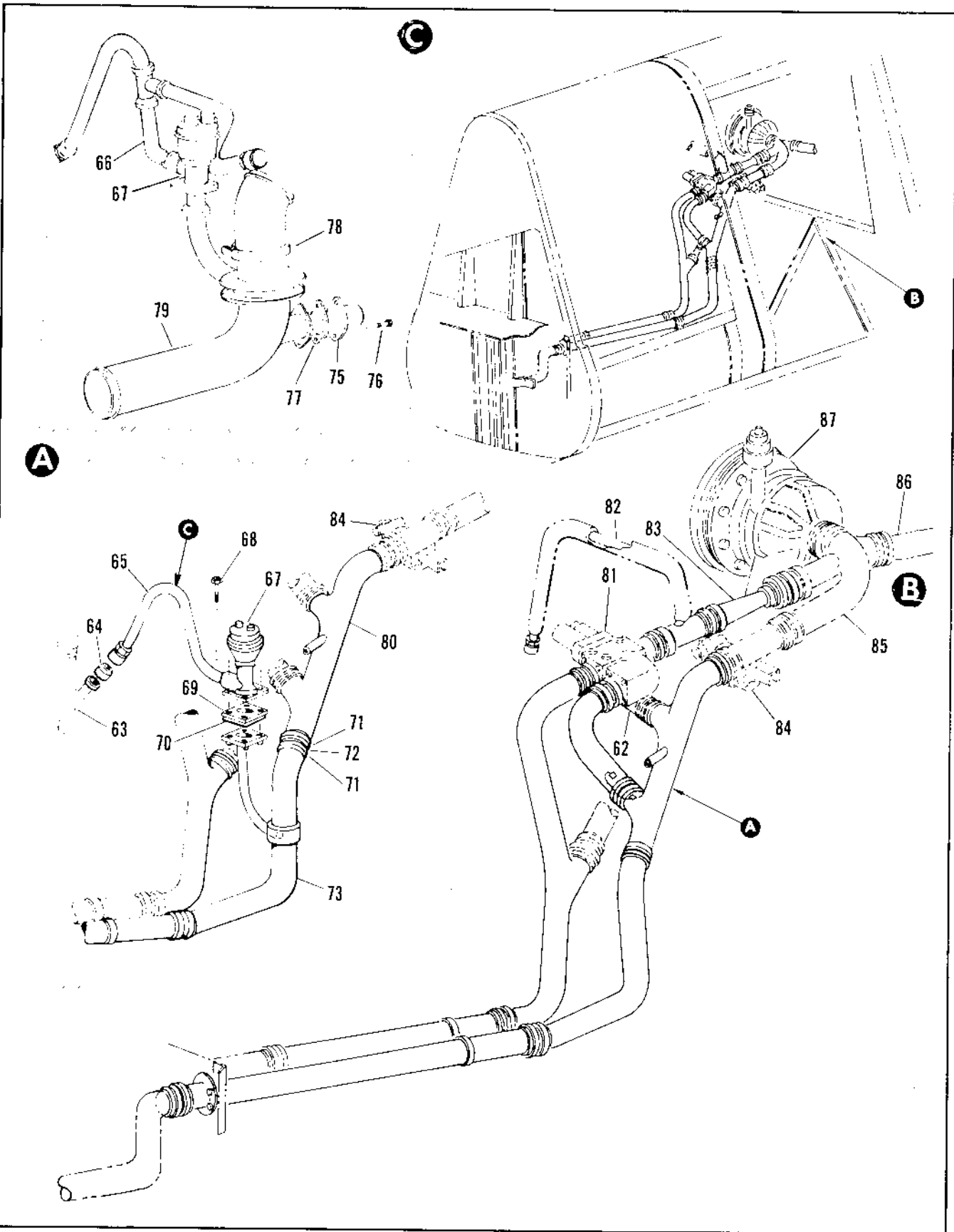

Figure 2.13-9. Forward Radar Compartment and Cockpit Cooling Duct Installation (Sheet 4 of 4)

FIGURE AND INDEX NUMBER	PART NUMBER	DESCRIPTION 1 2 3 4 5 6	UNITS PER ASSY.	USABLE ON CODE	
				FROM	TO
2.13-4- 62		• DUCT INSTL, EMERGENCY ELECTRONIC RAM AIR SEE FIG. 2.13-1	RF		
- 63		• DUCT INSTL, COCKPIT HOT AIR BYPASS SEE FIG. 2.13-24	RF		
- 64	2894	• PIN, RITE 57-6002-100	1	241	
- 65	R-23801-1	• DUCT ASSY, ELECTRONIC HOT AIR BYPASS WELDED	1	241	
- 66	63E35696-1	• DUCT ASSY, ELECTRONIC HOT AIR BYPASS WELDED	1		
- 67	106780-1	• VALVE ASSY, MOISTURE SEPARATOR INLET HOT AIR BYPASS (99193) SPEC 8-19586-1 ATTACHING PARTS	1	241	
- 68	NAS1103-1	• BOLT -----X-----	4	241	
- 69	R-23879-7	• GASKET	1	241	
- 70	R-23879-7	• GASKET	1		
- 71	AN737TW107	• CLAMP	2	241	
- 72	AD297-3	• COUPLING, (92199) SPEC 8-00297-3	1	241	
- 73	R-23514-501	• DUCT ASSY, ELECTRONIC COOLING WELDED REPLACES NOT INTCHG WITH R-23514-5	1	241	
- 74	R-23514-511	• DUCT ASSY, ELECTRONIC COOLING WELDED REPLACES NOT INTCHG WITH R-23514-5	1	241	
- 75	107890-6	• THERMOSTAT ASSY, MOISTURE SEPARATOR INLET HOT AIR BYPASS (99193) ATTACHING PARTS	1		
- 76	NAS1103-5	• BOLT -----X-----	2		
- 77	R-23879-9	• GASKET, (MADE FROM P/N 60-1-16X36X33)	1		
- 78	AN740-4R	• CLAMP	1		
- 79	64E340F3-1	• FLUID ASSY, MOISTURE SEPARATOR INLET WELDED	1		
- 80	R-23514-503	• DUCT ASSY, ELECTRONIC COOLING WELDED REPLACES NOT INTCHG WITH R-23514-5	1	241	
- 81		• VALVE INSTL, COCKPIT DIVERSE FLOW SHUTOFF SEE FIG. 2.13-1	RF		
- 82		• DUCT INSTL, COCKPIT HOT AIR BYPASS STA 267 TO 318 SEE FIG. 2.13-22	RF		
- 83	106472	• CONTROL, FUEL FLOW (71013) SPEC 8-12270-1	1	25	
- 84		• VALVE INSTL, ELECTRONIC COMPARTMENT COOLING SEE FIG. 2.13-1	RF		
- 85		• DUCT ASSY, REFRIGERATION TURBINE OUTLET SEE FIG. 2.13-31 INDEX 8	RF		
- 86		• DUCT INSTL, DROUND COOLING SEE FIG. 2.13-21	RF		
- 87		• TURBINE AND COMPRESSOR ASSY, REFRIGERATION SEE FIG. 2.13-31 INDEX 14	RF		

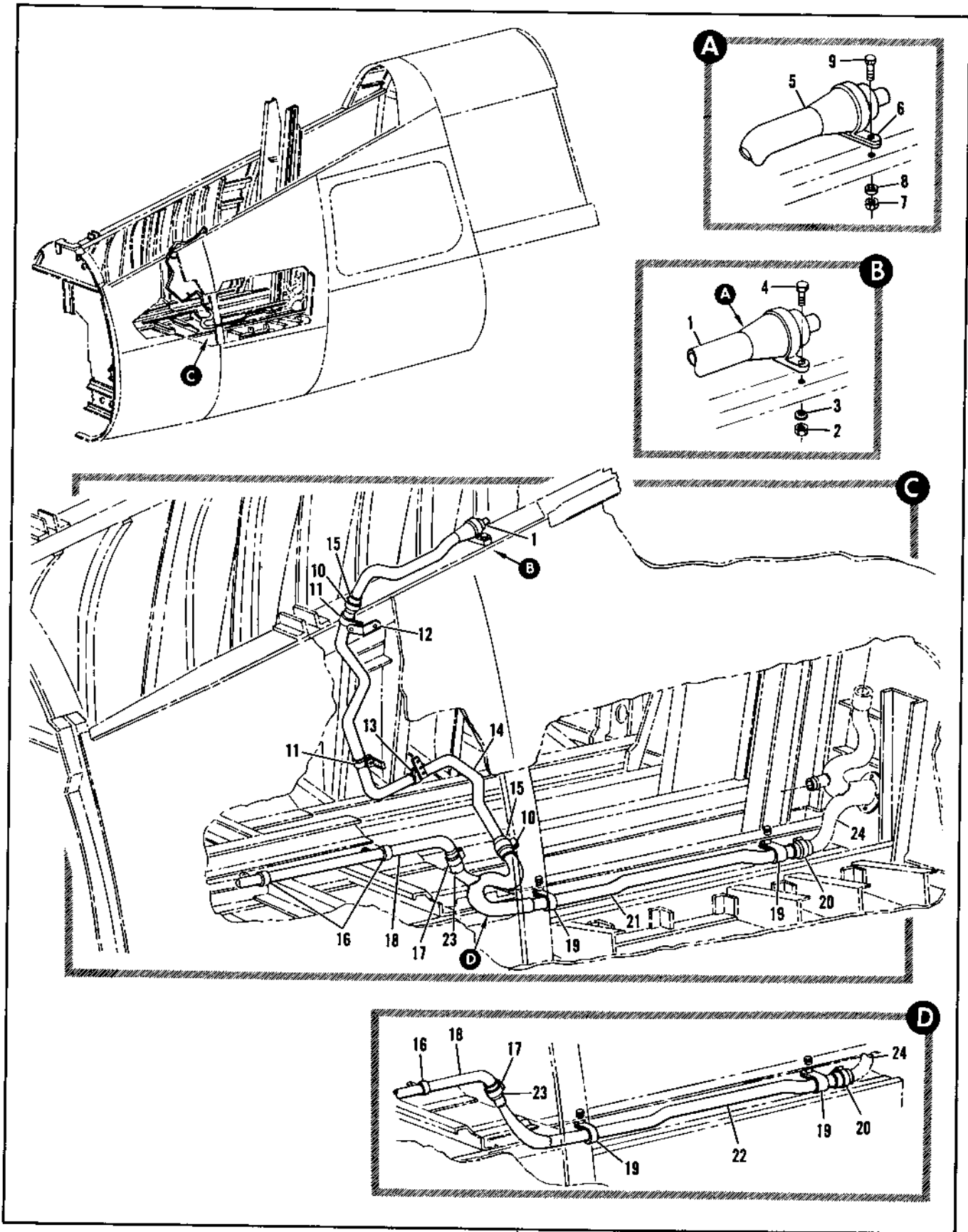

Figure 2.13-10. Cockpit Air-Conditioning Forward LH Duct Installation

FIGURE AND INDEX NUMBER	PART NUMBER	DESCRIPTION 1 2 3 4 5 6	UNITS PER ASSY.	USABLE ON CODE	
				FROM	TO
2.13-10	H-23300-003	DUCT INSTALLATION, COCKPIT AIR-CONDITIONING FWD LH FOR MHA SEE FIG. 2-1-4	RF	A	
	H-23300-011	DUCT INSTALLATION, COCKPIT AIR CONDITIONING FWD LH FOR MHA SEE FIG. 2-1-4	RF	B	
- 1	2112-3	• VENTILATOR, PILOT <#1896> SPEC P-00484-3 REPLACED BY SUITABLE SUB 2112-5 ATTACHING PARTS	1	35	38
- 2	NAS679A3	• NUT	1	35	38
- 3	AN960D10L	• WASHER	1	35	38
- 4	AN3-4A	• BOLT	1	35	38
- 5	2112-5	• VENTILATOR, PILOT <#1896> SPEC P-00484-5 REPLACES SUITABLE SUB FOR 2112-3	1	C	
- 6	AN742D21	• CLAMP ATTACHING PARTS	1	C	
- 7	NAS679A3	• NUT	1	C	
- 8	AN960D10L	• WASHER	1	C	
- 9	AN3-4A	• BOLT	1	C	
- 10	AN737TW30	• CLAMP	2	A	
- 11	AN742D10	• CLAMP ATTACHING PARTS	2	A	
	NAS679A3	• NUT	2	A	
	AN960D10L	• WASHER	2	A	
	AN526-1032R	• SCREW	1	A	
	AN520C108F	• SCREW	1	A	
- 12	AN743-12	• BRACKET ATTACHING PARTS	1	A	
	NAS679A3	• NUT	1	A	
	AN960D10L	• WASHER	1	A	
	AN3-1A	• BOLT	1	A	
- 13	MS219190611	• CLAMP ATTACHING PARTS	1	A	
	NAS679A3	• NUT	1	A	
	AN960D10L	• WASHER	2	A	
	AN520C108F	• SCREW	1	A	
- 14	H-23300	• TUBE ASSY, COCKPIT AIR VENT	1	A	
- 15	NAS521-0-0	• COUPLING	2	A	
- 16	AN742D12	• CLAMP ATTACHING PARTS	2	35	
	NAS679A3	• NUT	2	35	
	AN960D10L	• WASHER	4	35	
	AN3-5A	• BOLT	2	35	
- 17	AN737TW34	• CLAMP	1	35	
- 18	H-23305	• PICCOLO ASSY, WELDED	1	35	
- 19	H-23321	• CLAMP ATTACHING PARTS	2	35	
	NAS679A3	• NUT	2	35	
	AN960D10L	• WASHER	4	35	
	NAS43003-12	• SPACER	2	35	
	AN3-6A	• BOLT	2	35	

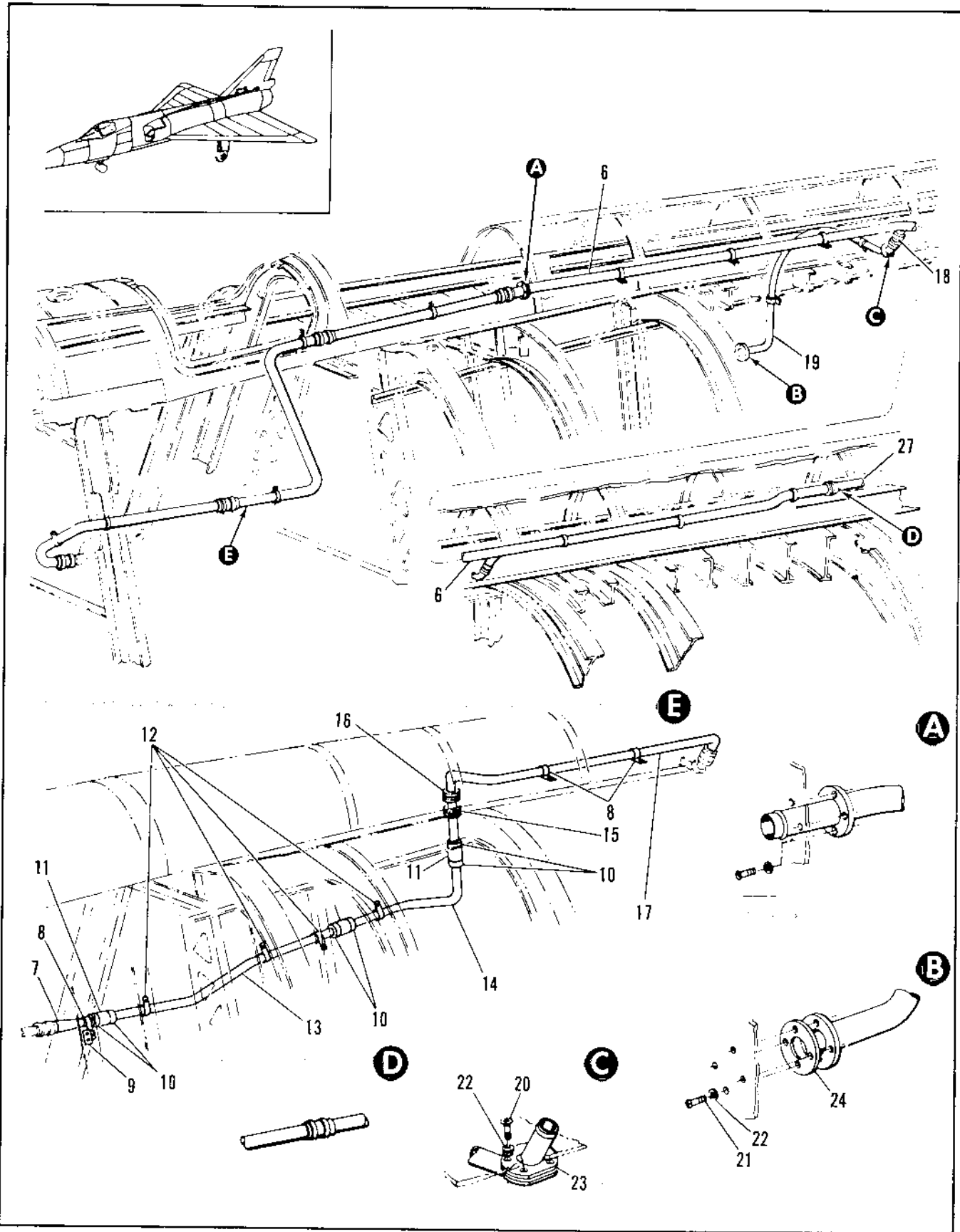

Figure 2.13-11. IFF Cooling Duct Installation Sta 260 to 628 (Sheet 1 of 3)

FIGURE AND INDEX NUMBER	PART NUMBER	DESCRIPTION	UNITS PER ASSY.	USABLE ON CODE	
				FROM	TO
		1 2 3 4 5 6			
2.13-11	R-23851-3	DUCT INSTL, IFF COOLING STA 260 TO 428 MODIFIED BY 66J40464 FOR NHA SEE FIG. 2.13-3			
	R-23851-5	DUCT INSTL, IFF COOLING STA 260 TO 428 MODIFIED BY 66J40464 FOR NHA SEE FIG. 2.13-3			
	R-23851-7-1	DUCT INSTL, IFF COOLING STA 260 TO 492 MODIFIED BY 66J40464 FOR NHA SEE FIG. 2.13-3			
	R-82309	DUCT INSTL, IFF COOLING STA 492 TO 428 MODIFIED BY 66J40464 FOR NHA SEE FIG. 2.13-3	RF		
- 1		• DUCT INSTL, FWD RADAR COMPARTMENT AND COCKPIT COOLING SEE FIG. 2.13-9	RF		
- 2	AN742024	• CLAMP	2	35	
		ATTACHING PARTS			
	NAS679A3	• NUT	1	35	
	NAS679A3	• NUT	1	35	89
	AN961010L	• WASHER	6	35	
	AN961010L	• WASHER	2	35	
	AN528-1041	• SCREW	2	35	
		-----X-----			
- 3	AN737TW5	• CLAMP	4	35	
- 4	NAS520-6-12	• COUPLING	2	35	
- 5	R-23854-1	• DUCT ASSY, WELDED STA 260 TO 297	1	35	
	R-23854-3	• DUCT ASSY, WELDED STA 260 TO 297 ALT INTCHS WITH R-23854-1	RF	35	
- 6	R-23851-3	• DUCT ASSY, STA 342 TO 492 REPLACES NPT INTCHS WITH R-23851-1	1	44	
- 7	66C40474-1	• DUCT, TRANSITION	1		
- 8	AN742012	• CLAMP	3		
		ATTACHING PARTS			
	MS35207-240	• SCREW	1		
	AN961010L	• WASHER	1		
		-----X-----			
- 9	66C40475-1	• BRACKET	1		
		ATTACHING PARTS			
	MS2142L3	• NUT	2		
	AN961010L	• WASHER	2		
	MS35207-240	• SCREW	2		
		-----X-----			
- 10	AN737TW30	• CLAMP	6		
- 11	NAS520-6-12	• COUPLING	4		
- 12	AN742012	• CLAMP	4		
		ATTACHING PARTS			
	MS2142L3	• NUT	1		
	AN961010L	• WASHER	1		
	MS35207-240	• SCREW	1		
		-----Y-----			
- 13	66A40476-1	• TUBE	1		
- 14	66A40477-1	• TUBE	1		
- 15	MS35409-70	• PROMMET	1		
- 16	MS35409-70	• PROMMET	1		
- 17	67A30428-1	• TUBE	1		

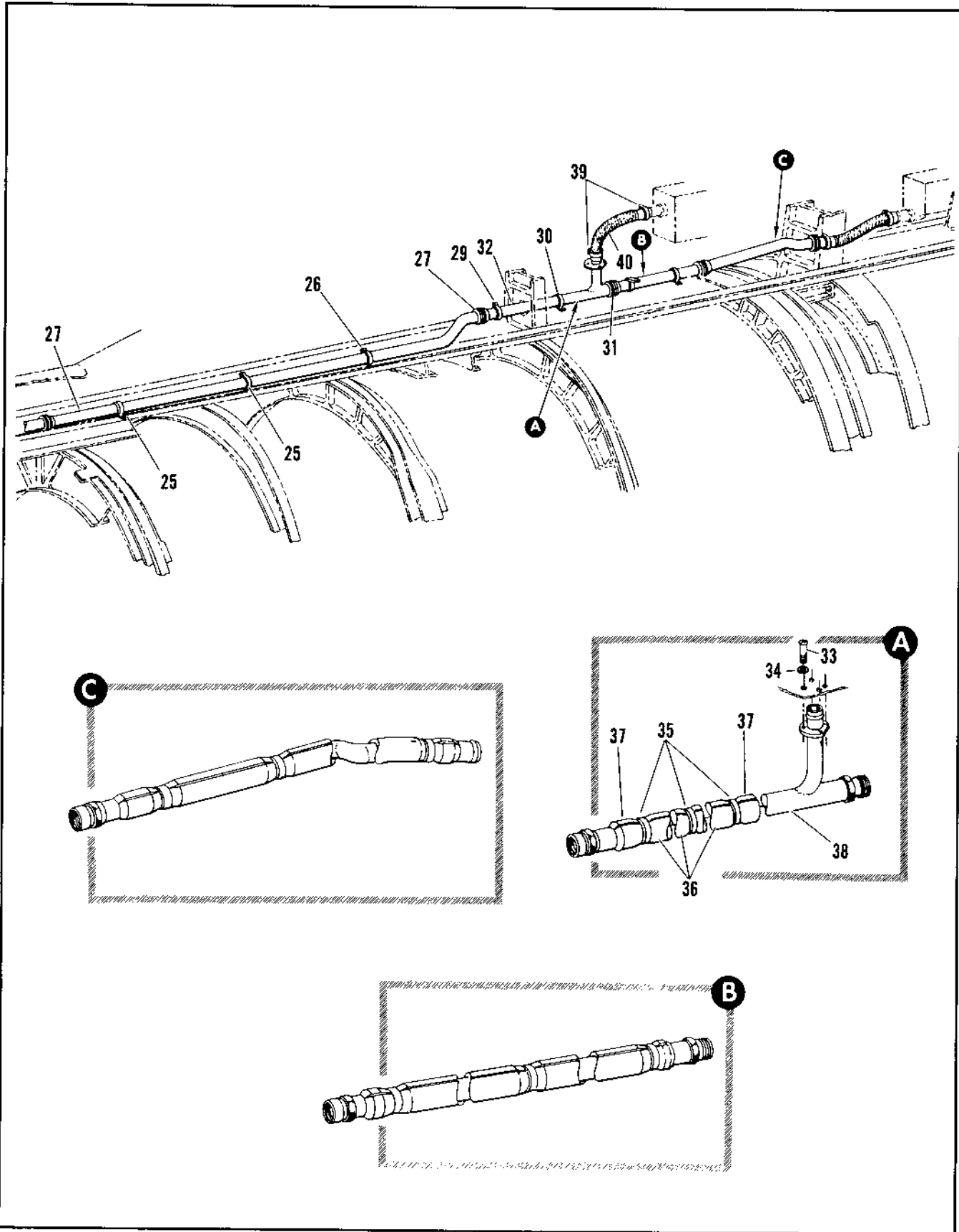

Figure 2.13-11. IFF Cooling Duct Installation Sta 260 to 628 (Sheet 2 of 3)

FIGURE AND INDEX NUMBER	PART NUMBER	DESCRIPTION	UNITS PER ASSY.	USABLE ON CODE	
				FROM	TO
2.13-11- 18	NAS500-6-10	• COUPLING	1	35	
	64J54090	• DUCT ASSY, WELDED ATTACHING PARTS	1		
- 2	AN520-10P7	• SCREW	4	35	
- 21	AN520-10P6	• SCREW	4	35	
- 22	AN961P011L	• WASHER	4	35	
		-----X-----			
- 23	8-23457-1	• BASKET	1	35	
- 24	8-23156	• BASKET	1	35	
- 25	AN74902E	• CLAMP	2	35	
		ATTACHING PARTS			
	AN520-10P7	• SCREW	2	35	
	AN961P011L	• WASHER	2	35	
	NAS479A2	• NUT	2	278	
		-----X-----			
- 26	AN749022	• CLAMP	1	45	
		ATTACHING PARTS			
	AN520-10P7	• SCREW	1	35	
	AN961P011L	• WASHER	1	35	
	NAS479A3	• NUT	1	279	
		-----X-----			
- 27	NAS502-16	• RING	1	35	
- 28	8-23526-3	• DUCT ASSY, STA 482 TO 553 REPLACES BY NOT INTCHG WITH 8-23526-5	1	35	45
	8-23526-5	• DUCT ASSY, STA 482 TO 553 REPLACES NOT INTCHG WITH 8-23526-3	1	44	
- 29	AN74901E	• CLAMP	1	35	
		ATTACHING PARTS			
	AN520-10P7	• SCREW	1	35	
	AN961P011L	• WASHER	1	35	
	NAS479A3	• NUT	1	278	
		-----X-----			
- 30	AN749022	• CLAMP	1	35	
		ATTACHING PARTS			
	AN520-10P7	• SCREW	1	35	
	AN961P011L	• WASHER	1	35	
		-----X-----			
- 31	NAS502-17	• RING	1	35	
- 32	8-23534-1	• TUBE ASSY, STA 150 TO 177	1	35	
	8-23541-11	• TUBE ASSY, STA 153 TO 177 ALT INTCHG WITH 8-23539-1 ALTERED FROM 8-23534	PF	35	
	8-23534	• TUBE ASSEMBLY	PF		
		ATTACHING PARTS			
- 33	AN520-10P7	• SCREW	4	35	
- 34	AN961P011L	• WASHER	4	35	
		-----X-----			
- 35	PC420	• CLAMP, <14011> SPEC 8-12434-1	3	35	
- 36	18-22209-1	• INSULATION, <18741> SPEC 8-12451-1	1	35	
- 37	18-22209-2	• INSULATION, <18741> SPEC 8-12451-2	1	35	
- 38	8-23534-17	• TUBE ASSY, WELDED	1	35	
	8-23534-17	• TUBE ASSY, WELDED WITH 8-23541-11	PF	35	
- 39	AN74901E	• CLAMP	2	35	
- 40	7-1694-1-41-1	• HOSE, FLEX <71612> 84--1120--01	1	35	

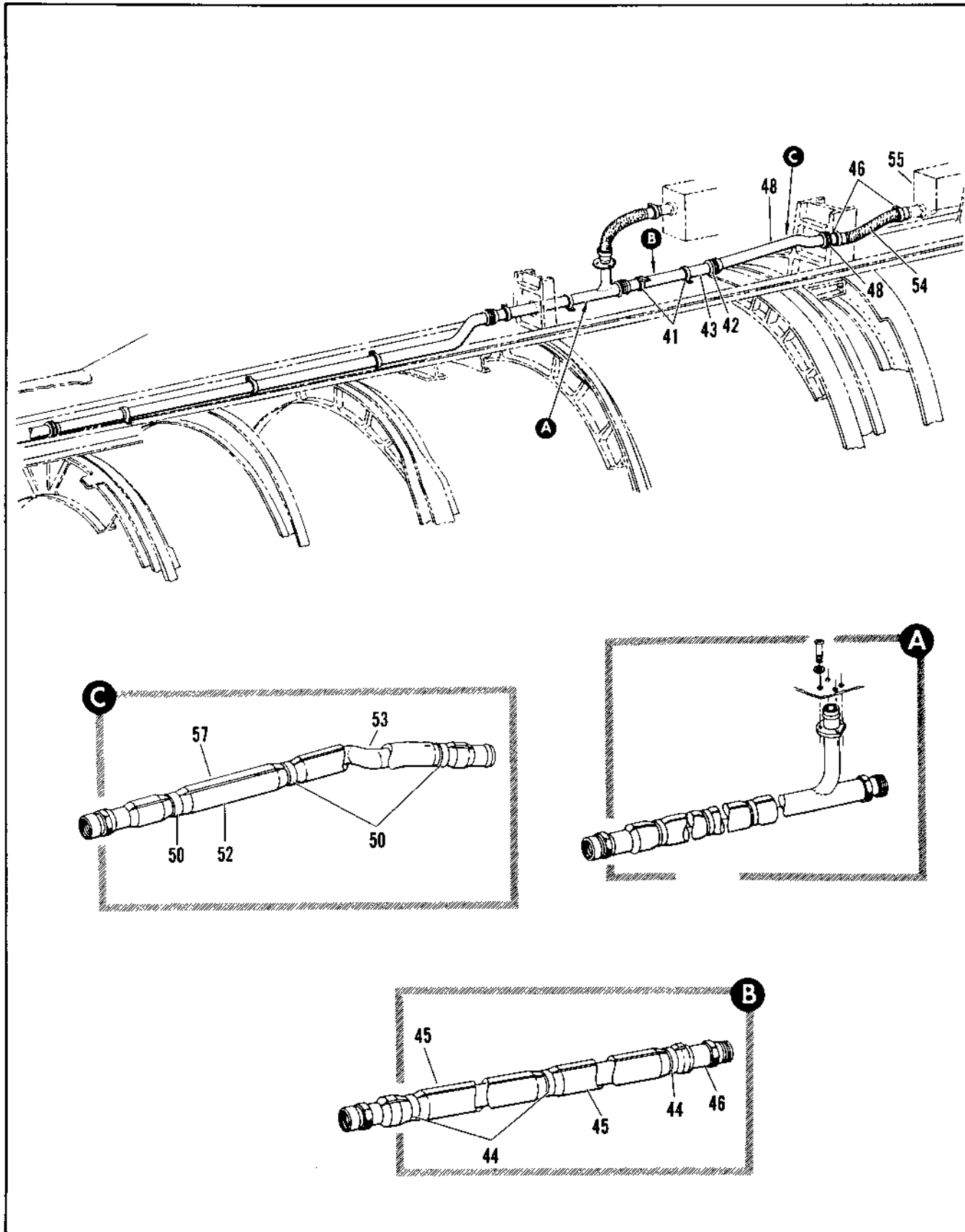

Figure 2.13-11. IFF Cooling Duct Installation Sta 260 to 628 (Sheet 3 of 3)

FIGURE AND INDEX NUMBER	PART NUMBER	DESCRIPTION	UNITS PER ASSY.	USABLE ON CODE	
				FROM	TO
		1 2 3 4 5 6			
2.13-11- 41	AN742D22	• CLAMP ATTACHING PARTS	2	35	
	AN520-10R7	• SCREW	2	35	
	AN963PD19L	• WASHER	2	35	
- 42	NASS92-16	• RING	1	35	
- 43	8-23535	• TUBE ASSY, STA 577 TO 594	1	35	
- 44	PC425	• • CLAMP, <04811> SPEC R-02434-1	3	35	
- 45	18-22230-1	• • BLANKET, INSULATION, TMH SPEC 8-02452-1	2	35	
- 46	8-23535-9	• • TUBE ASSY, WELDED	1	35	
- 47	AN737TW3F	• CLAMP	2	35	
- 48	AN931C14S20	• GROMMET	1	35	69
	AN931C16S22	• GROMMET	1	70	
- 49	8-23536-1	• TUBE ASSY, STA 598 TO 617	1	35	
- 50	PC425	• • CLAMP, <04811> SPEC R-02434-1	3	35	
- 51	18-22227-3	• • BLANKET, INSULATION <78741> SPEC 8-02446-3	1	35	
- 52	18-22227-1	• • BLANKET, INSULATION <78741> SPEC 8-02446-1	1	35	
- 53	8-23536-19	• • TUBE ASSY, WELDED	1	35	
- 54	3-1664-R-54-6	• HOSE, FLEX <70628> 84-R0085-002	1	35	
- 55		• EQUIPMENT INSTL, IFF 46/APX-27 AFT SEE FIG. 2.18-4	RF		

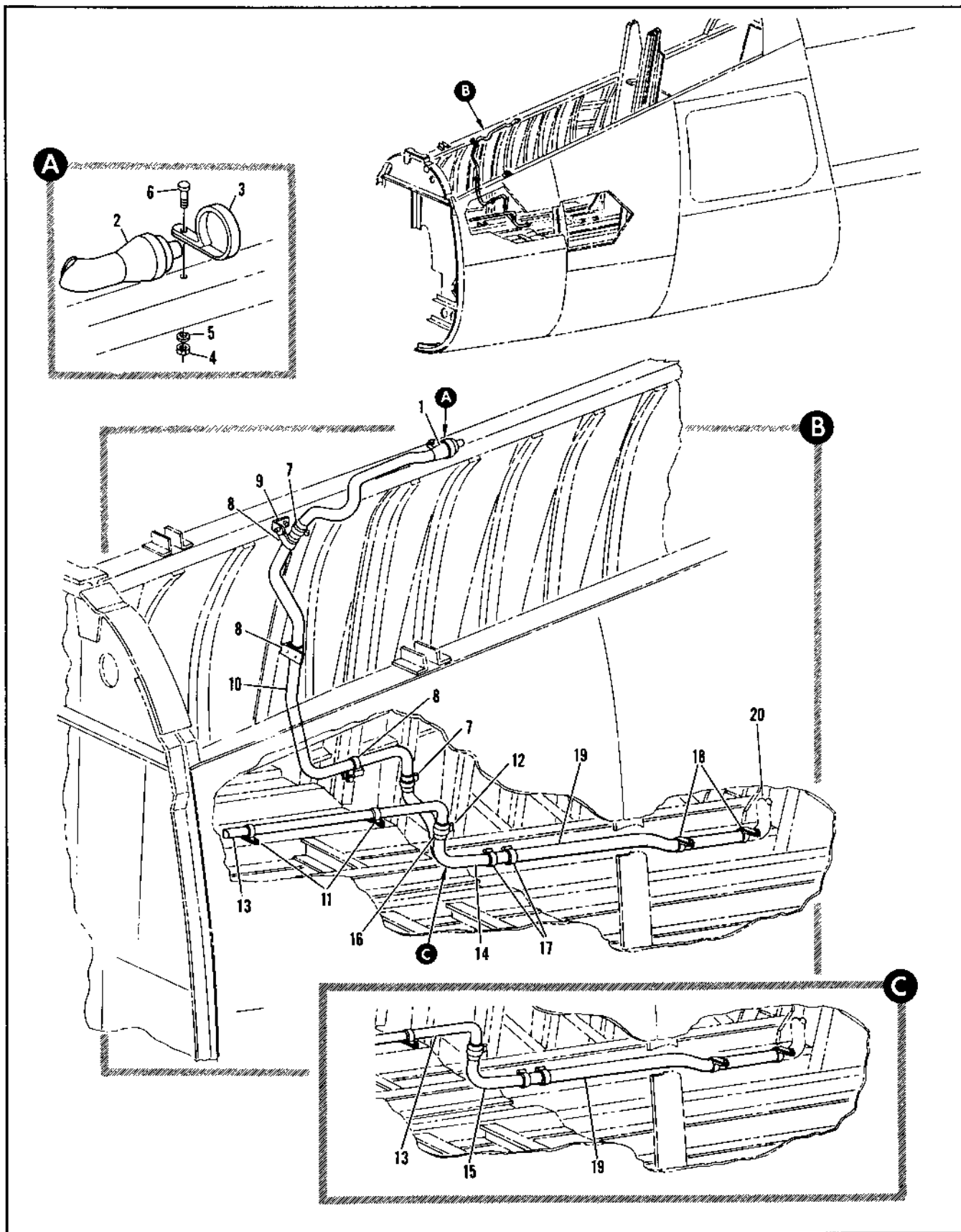

Figure 2.13-12. Cockpit Air-Conditioning Forward RH Duct Installation

FIGURE AND INDEX NUMBER	PART NUMBER	DESCRIPTION	UNITS PER ASSY.	USABLE ON CODE	
				FROM	TO
		1 2 3 4 5 6			
2.13-12	8-23300-665	DUCT INSTALLATION, COCKPIT AIR-CONDITIONING FWD RH FOR NHA SEE FIG. 2.13-4	RF	A	
	8-23300-813	DUCT INSTALLATION, COCKPIT AIR-CONDITIONING FWD RH FOR NHA SEE FIG. 2.13-4	RF	B	
- 1	2111-2	• VENTILATOR, PILOT (P1896) SPEC R-00369-1 REPLACED BY SUITABLE SUB 2111-3 ATTACHING PARTS	1	35	3A
	NAS679A3	• NUT	1	35	3A
	AN960D10L	• WASHER	1	35	3A
	AN3-4A	• BOLT	1	35	3A
		-----X-----			
- 2	2111-3	• VENTILATOR, (P1896) SPEC R-0369-3 REPLACES SUITABLE SUB FOR 2111-2	1	C	
- 3	AN742D21	• CLAMP ATTACHING PARTS	1	C	
- 4	NAS679A3	• NUT	1	C	
- 5	AN960D10L	• WASHER	1	C	
- 6	AN3-4A	• BOLT	1	C	
		-----X-----			
- 7	AN737TW30	• CLAMP	2	A	
- 8	AN742D10	• CLAMP ATTACHING PARTS	3	A	
	NAS679A3	• NUT	2	A	
	AN960D10L	• WASHER	5	A	
	NAS43DD3-11	• SPACER	1	A	
	AN520C10R13	• SCREW	1	A	
	AN520C10R7	• SCREW	2	A	
		-----X-----			
- 9	8-23300-15	• CLIP ATTACHING PARTS	1	A	
	NAS679A3	• NUT	1	A	
	AN960D10L	• WASHER	2	A	
	AN520C10RH	• SCREW	1	A	
		-----X-----			
- 10	8-23373-1	• TUBE ASSY, CABIN AIR VENT BONDED	1	A	
- 11	AN742D12	• CLAMP ATTACHING PARTS	2	35	
	NAS679A3	• NUT	2	35	
	AN960D10L	• WASHER	4	35	
	AN3-5A	• BOLT	2	35	
		-----X-----			
- 12	AN737TW34	• CLAMP	1	35	
- 13	8-23324	• PICCOLO ASSY, WELDED	1	35	
- 14	8-23366-1	• DUCT ASSY, AIR-CONDITIONING WELDED	1	A	
	8-23323-17	• DUCT ASSY, COCKPIT AIR-CONDITIONING WELDED	1	A	
- 15	8-23452	• COUPLING	1	B	
- 16	NAS521-6-9	• CLAMP	1	35	
- 17	AN737TW56	• CLAMP	2	35	
- 18	AN742D20	• CLAMP ATTACHING PARTS	2	35	
	NAS679A3	• NUT	2	35	
	AN960D10L	• WASHER	4	35	
	AN3-6A	• BOLT	2	35	
		-----X-----			
- 19	8-23389	• DUCT ASSY, COCKPIT AIR RH	1	35	
- 20		• DUCT ASSY, SEE FIG. 2.13-13 INDEX 59	RF		

A AIRPLANES #35 THRU 47 AND 49 THRU 89
 B AIRPLANES #48, 90 AND 00
 C AIRPLANES #39 THRU 47 AND 49 THRU 89

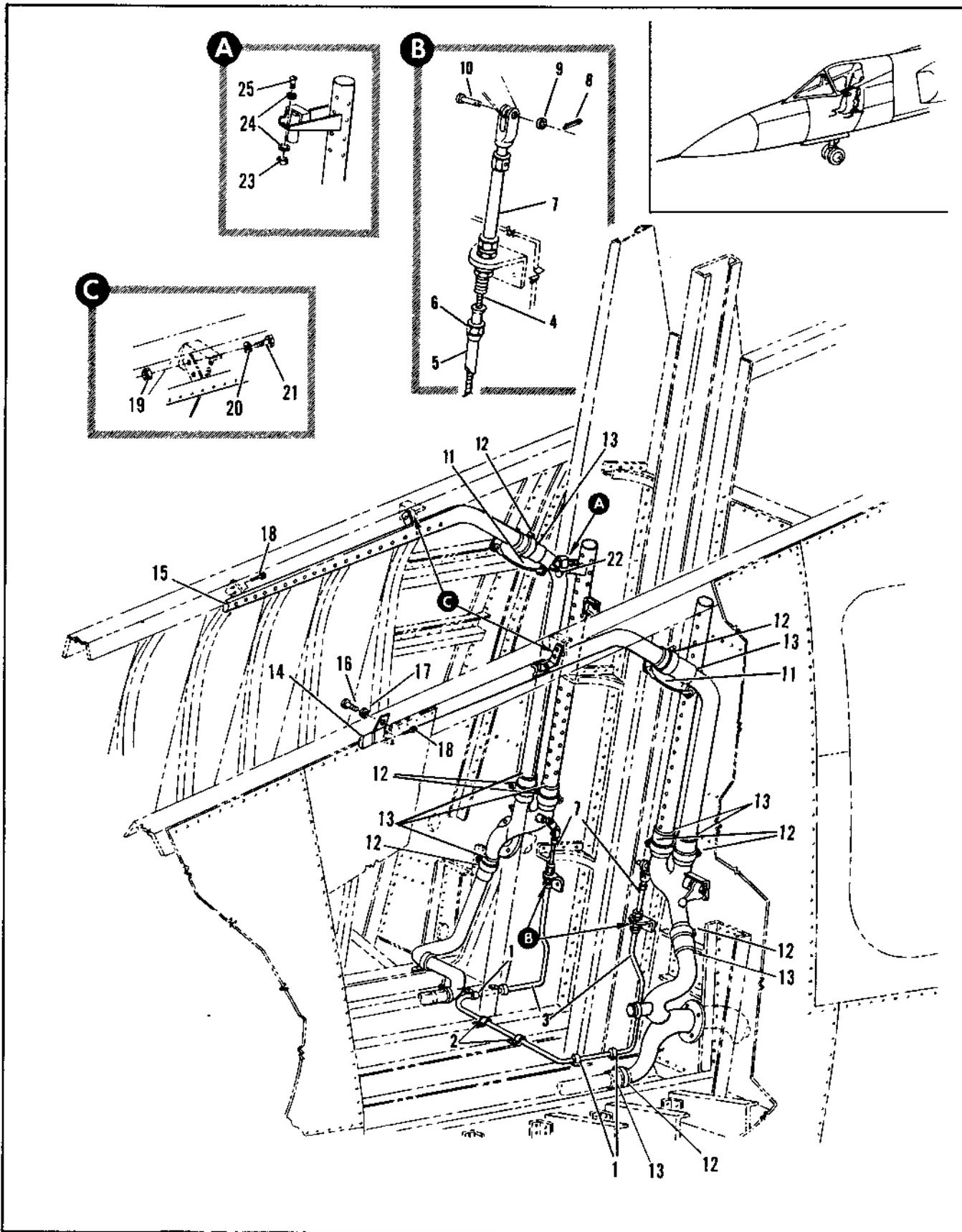

Figure 2.13-13. Cockpit Air-Conditioning Aft Duct Installation (Sheet 1 of 3)

FIGURE AND INDEX NUMBER	PART NUMBER	DESCRIPTION	UNITS PER ASSY.	USABLE ON CODE	
				FROM	TO
		1 2 3 4 5 6			
2.13-13	R-23300-P07	DUCT INSTALLATION, COCKPIT AIR-CONDITIONING AFT FOR NHA SEE FIG. 2.3-4	RF	A	
	R-23300-609	DUCT INSTALLATION, COCKPIT AIR-CONDITIONING AFT FOR NHA SEE FIG. 2.3-4	RF	B	
- 1	A5506	• SUPPORT, CONDUIT <78710> 98-59800-001 • ATTACHING PARTS	4	35	
	NAS679A3	• NUT	4	35	
	AN960D10L	• WASHER	8	35	
	AN520-10R10	• SCREW, LH	2	35	
	AN520-10R12	• SCREW, RH	2	35	
		----X----			
- 2	A5506	• SUPPORT, CONDUIT <78711> 98-59800-001 • ATTACHING PARTS	2	61	
	NAS679A3	• NUT	2	61	
	AN960D10L	• WASHER	4	61	
	AN520-10R12	• SCREW	2	61	
		----X----			
- 3	R-23300-29	• TELEFLY ASSEMBLY	1	35	
- 4	R-23300-23	• CABLE	1	35	
- 5	R-23300-27	• TUBE	1	35	
- 6	A6338	• NUT, <78710> 96-36503-101	2	35	
- 7	C7745-8	• TELESCOPIC UNIT, <78711> 92-65800-012 T.O. 1601-4-7-3 • ATTACHING PARTS	2	35	
- 8	AN381-2-12	• PIN, CUTTER	2	35	
- 9	AN960PD10	• WASHER	2	35	
- 10	AN393-17	• PIN	2	35	
		----X----			
- 11	MS25083-2B85	• JUMPER • ATTACHING PARTS	2	35	
	AN345C10	• NUT	8	35	
	AN960C10L	• WASHER	8	35	
	AN935-10L	• WASHER	8	35	
	AN960D10L	• WASHER	8	35	
	AN520C10R12-12	• SCREW	4	35	
		----X----			
- 12	AN737TW66	• CLAMP	7	35	
- 13	NAS521-12-9	• COUPLING	2	35	
- 14	R-23315-P05	• PICCOLO ASSY, COCKPIT AIR LH WELDED	1	35	
- 15	R-23315-P07	• PICCOLO ASSY, COCKPIT AIR RH WELDED REPLACES BY NOT INTCHG WITH R-23315-P06	1	35	60
	R-23315-806	• PICCOLO ASSY, COCKPIT AIR RH WELDED REPLACES NOT INTCHG WITH R-23315-P07 • ATTACHING PARTS	1	61	
- 16	AN520-10R8	• SCREW, LH	1	35	
	AN520-10FA	• SCREW, RH	1	61	
- 17	AN960D10L	• WASHER, LH	1	35	
	AN960D10L	• WASHER, RH	1	61	
- 18	NAS464P4A6	• BOLT	4	35	
- 19	NAS679A3	• NUT	4	35	
- 20	AN960D10L	• WASHER	4	35	
- 21	AN3-4A	• BOLT	4	35	
		----X----			
- 22	AYLF5725	• SENSOR, <65149> SPEC 6-18475-2	1	35	240
- 23	NAS679A5B	• NUT	4	35	240
- 24	AN960PD8L	• WASHER	8	35	240
- 25	AN515-3R7	• SCREW	4	35	240
		A AIRPLANES #75 THRU 47 AND 49 THRU 89 B AIRPLANES #44, 95 AND ON			

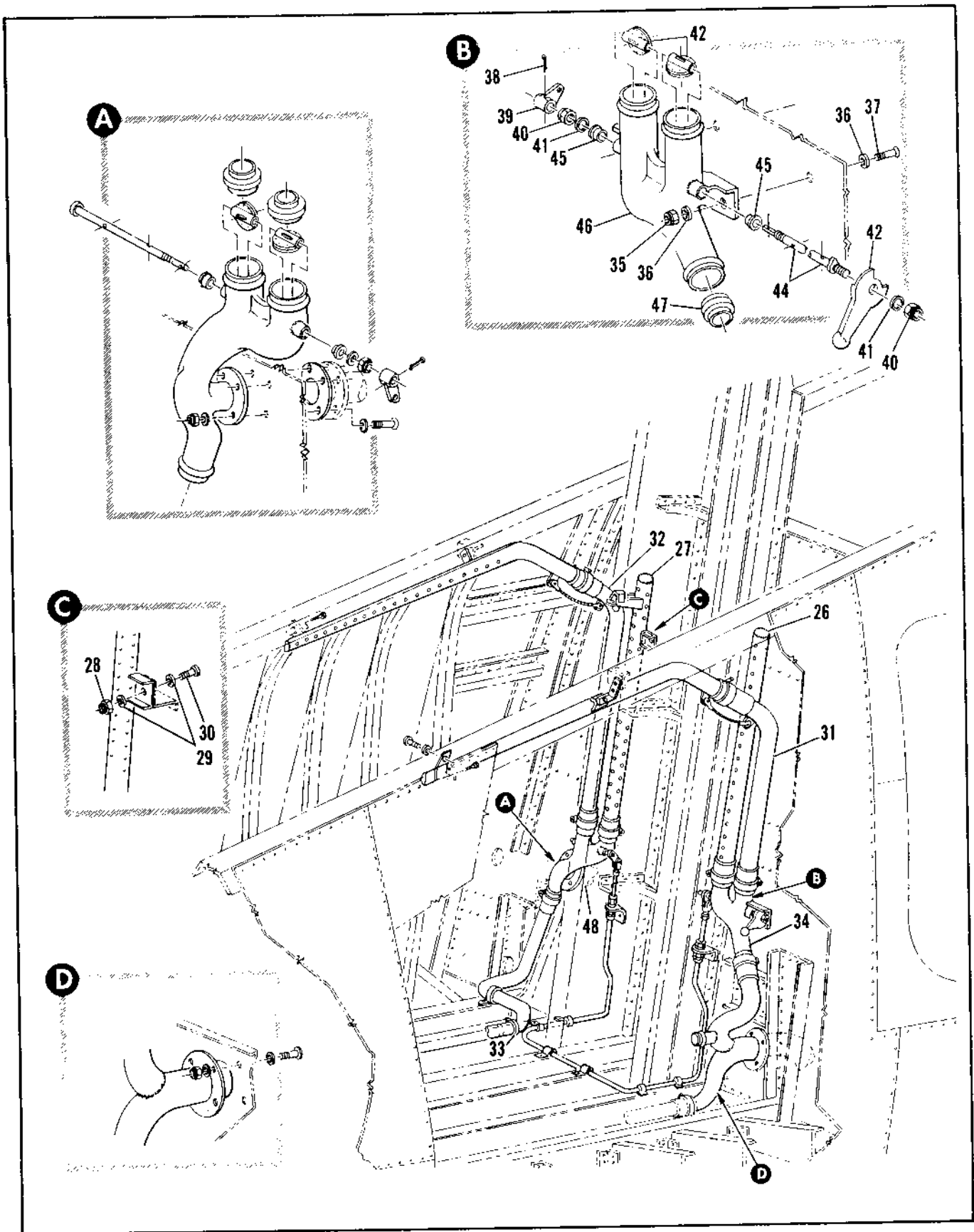

Figure 2.13-13. Cockpit Air-Conditioning Aft Duct Installation (Sheet 2 of 3)

FIGURE AND INDEX NUMBER	PART NUMBER	DESCRIPTION	UNITS PER ASSY.	USABLE ON CODE	
				FROM	TO
2.13-13- 26 - 27	9-23384-2	• PICCOLO ASSY, COCKPIT AIR BYPASS LH WELDED	1	A	
	9-23384-4	• PICCOLO ASSY, COCKPIT AIR BYPASS LH WELDED	1	B	
	9-23384-3	• PICCOLO ASSY, COCKPIT AIR BYPASS RH WELDED	1	A	
	9-23384-5	• PICCOLO ASSY, COCKPIT AIR BYPASS RH WELDED	1	C	
	9-23384-801	• PICCOLO ASSY, COCKPIT AIR BYPASS RH WELDED ATTACHING PARTS	1	241	
- 28	NAS679A3	• NUT	4	35	
- 29	AN960D10L	• WASHER	8	35	
- 30	AN521-10RP	• SCREW	4	35	
		-----X-----			
- 31	9-23392	• ELBOW ASSY, LH WELDED	1	A	
	9-23392-1	• ELBOW ASSY, LH WELDED	1	B	
- 32	9-23392-2	• ELBOW ASSY, RH WELDED	1	35	
- 33	AN737TW6L	• CLAMP	1	35	
- 34	9-23398-1	• VALVE ASSY, COCKPIT AIR DIVERTER LH REPLACED BY SUITABLE SUB 9-23398-5	1	35	47
	9-23398-5	• VALVE ASSY, COCKPIT AIR DIVERTER LH REPLACES SUITABLE SUB FOR 9-23398-1	1	49	48
	9-23398-805	• VALVE ASSY, COCKPIT AIR DIVERTER LH REPLACED BY NOT INTERCHG WITH 9-23398-805	1	49	89
	9-23398-806	• VALVE ASSY, COCKPIT AIR DIVERTER LH REPLACED BY NOT INTERCHG WITH 9-23398-805	1	90	129
	9-23398-803	• VALVE ASSY, COCKPIT AIR DIVERTER LH REPLACES NOT INTERCHG WITH 9-23398-5 AND 9-23398-801	1	139	
	9-23398-805	• VALVE ASSY, COCKPIT AIR DIVERTER LH REPLACES NOT INTERCHG WITH 9-23398-805 ATTACHING PARTS	1	139	
- 35	NAS679A3	• NUT	2	35	
- 36	AN960D10L	• WASHER	4	35	
- 37	AN521-10P13	• SCREW	2	35	
		-----X-----			
- 38	AN395H70-7	• PIN, COTTER	1	35	89
- 39	9-23395-7	• ARM, ACTUATOR REPLACED BY NOT INTERCHG WITH 9-23395-9	1	35	89
	9-23395-9	• ARM, ACTUATOR REPLACES NOT INTERCHG WITH 9-23395-7	1	90	
- 40	NAS679A4	• NUT	2	35	
- 41	AN960-41LL	• WASHER	2	35	
- 42	9-23319-9	• LEVER, REPLACED BY SUITABLE SUB 9-23319-11	1	A	
	9-23319-11	• LEVER, REPLACES SUITABLE SUB FOR 9-23319-9	1	B	
- 43	9-23316	• PUTTY-FLY	2	35	
- 44	9-23379	• SHAFT, REPLACED BY SUITABLE SUB 9-23379-7	1	35	124
	9-23379-7	• SHAFT, REPLACES SUITABLE SUB FOR 9-23379	1	132	
- 45	9-23363	• RUSHING	2	35	
- 46	9-23391-7	• VALVE, BODY	1	A	
	9-23391-8	• VALVE, BODY	1	B	
- 47	9-23377-1	• ORIFICE, LH	1	35	
- 48		• DUCT ASSY, COCKPIT AIR SEE FIG. 2.13-17 INDEX 5	RF		

A AIRPLANES #75 THRU 47 AND 49 THRU 89
 B AIRPLANES #48, NO ADD ON
 C AIRPLANES #49 AND 91 THRU 147

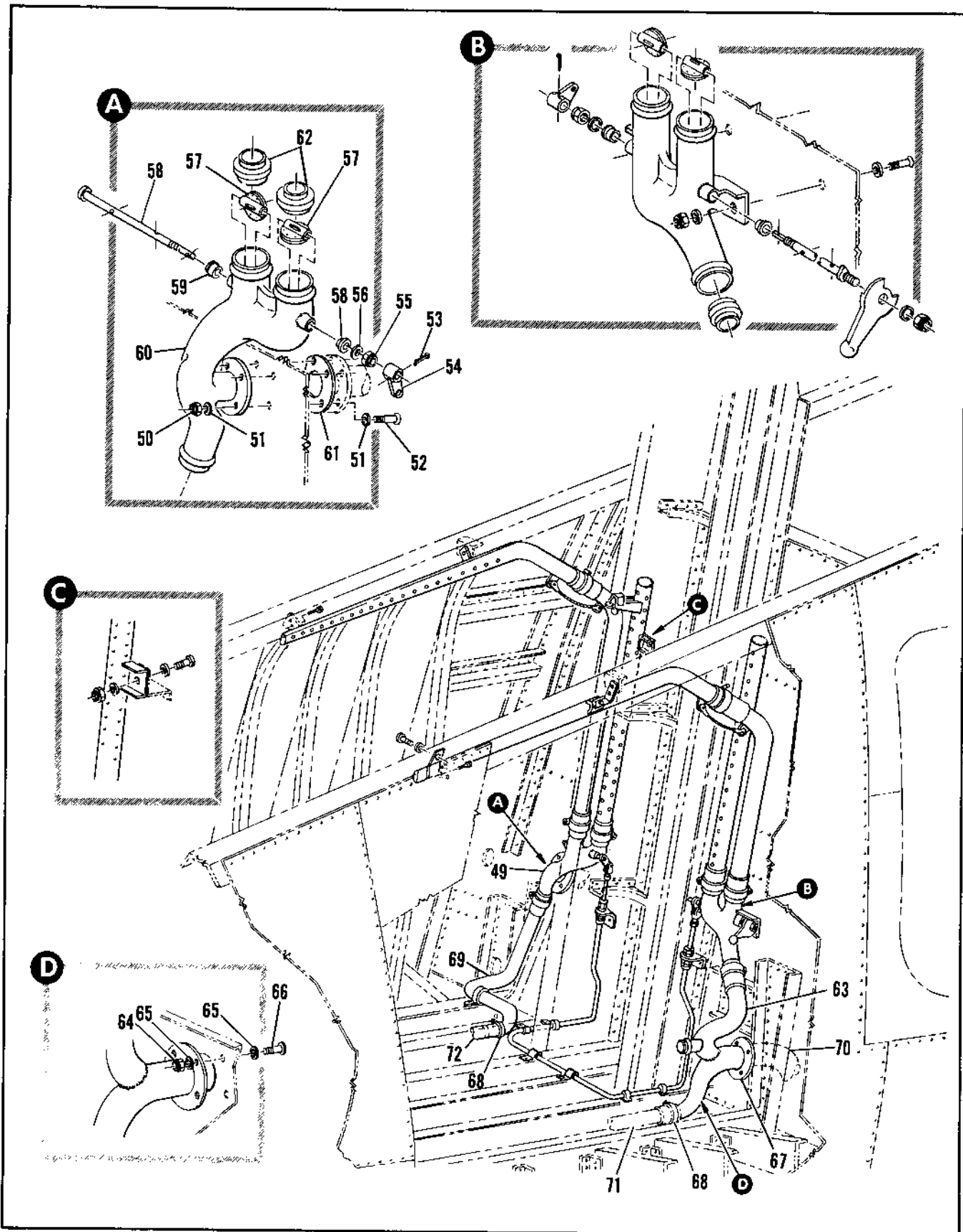

Figure 2.13-13. Cockpit Air-Conditioning Aft Duct Installation (Sheet 3 of 3)

FIGURE AND INDEX NUMBER	PART NUMBER	DESCRIPTION	UNITS PER ASSY.	USABLE ON CODE	
				FROM	TO
2.13-13- 49	R-23389-1	• VALVE ASSY, COCKPIT AIR DIVERTER RH REPLACED BY SUITABLE SUB R-23389-5	1	35	47
	R-23389-5	• VALVE ASSY, COCKPIT AIR DIVERTER RH REPLACES SUITABLE SUB FOR R-23389-1	1	48	48
- 50	R-23389-801	• VALVE ASSY, COCKPIT AIR DIVERTER RH	1	49	89
	R-23389-803	• VALVE ASSY, COCKPIT AIR DIVERTER RH	1	90	129
	R-23389-805	• VALVE ASSY, COCKPIT AIR DIVERTER RH ATTACHING PARTS	1	130	
	NAS679A3	• NUT	4	35	
	AN963D10L	• WASHER	8	35	
- 51	AN520-10RH	• SCREW	4	A	
	AN3-5A	• BOLT	4	B	
- 52		-----X-----			
- 53	AN384H70-7	• PIN, COTTER	1	35	89
- 54	6-23395-7	• ARM, ACTUATOR	1	35	89
	6-23395-9	• ARM, ACTUATOR	1	90	
- 55	NAS679A4	• NUT	1	35	
- 56	AN960C416L	• WASHER	1	35	
- 57	R-23316	• BUTTERFLY	2	35	
- 58	R-23370	• SHAFT	1	35	
- 59	R-23383	• PUSHING	2	35	
- 60	R-23392-9	• VALVE, BODY	1	A	
	R-23392-11	• VALVE, BODY	1	B	
- 61	R-23385-9	• GASKET	1	35	
- 62	R-23377-1	• ORIFICE, LH	2	35	
- 63	R-23394-1	• DUCT ASSY, COCKPIT AIR CONDITIONING LH WELDED REPLACED BY SUITABLE SUB R-23394-3	1	A	
	R-23394-3	• DUCT ASSY, COCKPIT AIR CONDITIONING LH WELDED REPLACES SUITABLE SUB FOR R-23394-1 ATTACHING PARTS	1	B	
- 64	NAS679A3	• NUT	4	35	
- 65	AN960D10L	• WASHER	8	35	
- 66	AN520-10RH	• SCREW	4	A	
	AN3-5A	• BOLT	4	B	
- 67	R-23395-7	• GASKET	1	35	
- 68	AN737TW56	• CLAMP	2	35	
- 69	R-23386	• DUCT ASSY, COCKPIT AIR RH BONDED	1	35	
- 70		• DUCT ASSY, COCKPIT AIR WELDED SEE FIG. 2.13-15 INDEX 5	RF		
- 71		• DUCT ASSY, AIR-CONDITIONING SEE FIG. 2.13-11	RF		
- 72		• DUCT ASSY, AIR-CONDITIONING SEE FIG. 2.13-12 P AIRPLANES 848, 93 AND ON	RF		

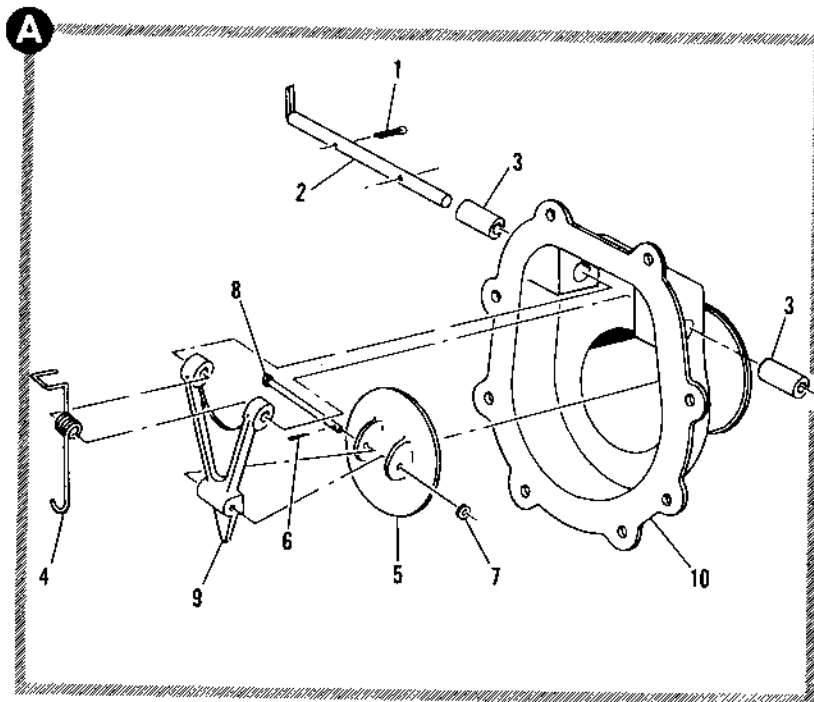
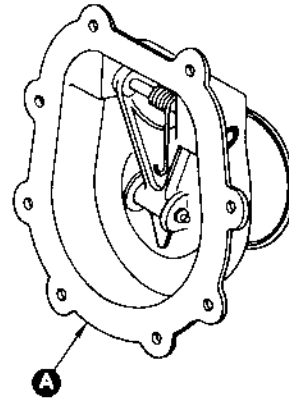
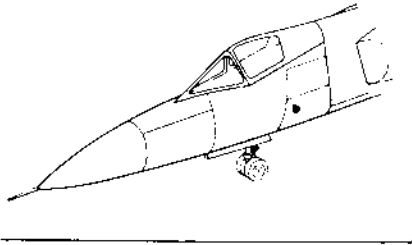

Figure 2.13-14. Cockpit Air Check Valve Assembly

FIGURE AND INDEX NUMBER	PART NUMBER	DESCRIPTION 1 2 3 4 5 6	UNITS PER ASSY.	USABLE ON CODE	
				FROM	TO
2.13-14	R-23330	VALVE ASSEMBLY, COCKPIT AIR CHECK FOR NHA SEE FIG. 2.13-15 INDEX 11	RF	35	
- 1	AN381-1-3	• PIN, COTTER	2	35	
- 2	R-23339-1	• SHAFT ASSY, WELDED	1	35	
- 3	R-23338	• RUSHING	2	35	
- 4	R-23337	• SPRING	1	35	
- 5	R-23376	• FLAPPER	1	35	
		ATTACHING PARTS			
- 6	AN390-2-1	• PIN, COTTER	1	35	
- 7	AN960-4L	• WASHER	1	35	
- 8	AN392-25	• PIN	1	35	
		-----X-----			
- 9	R-23335-7	• ARM	1	35	
- 10	R-23334-9	• BODY, VALVE	1	35	

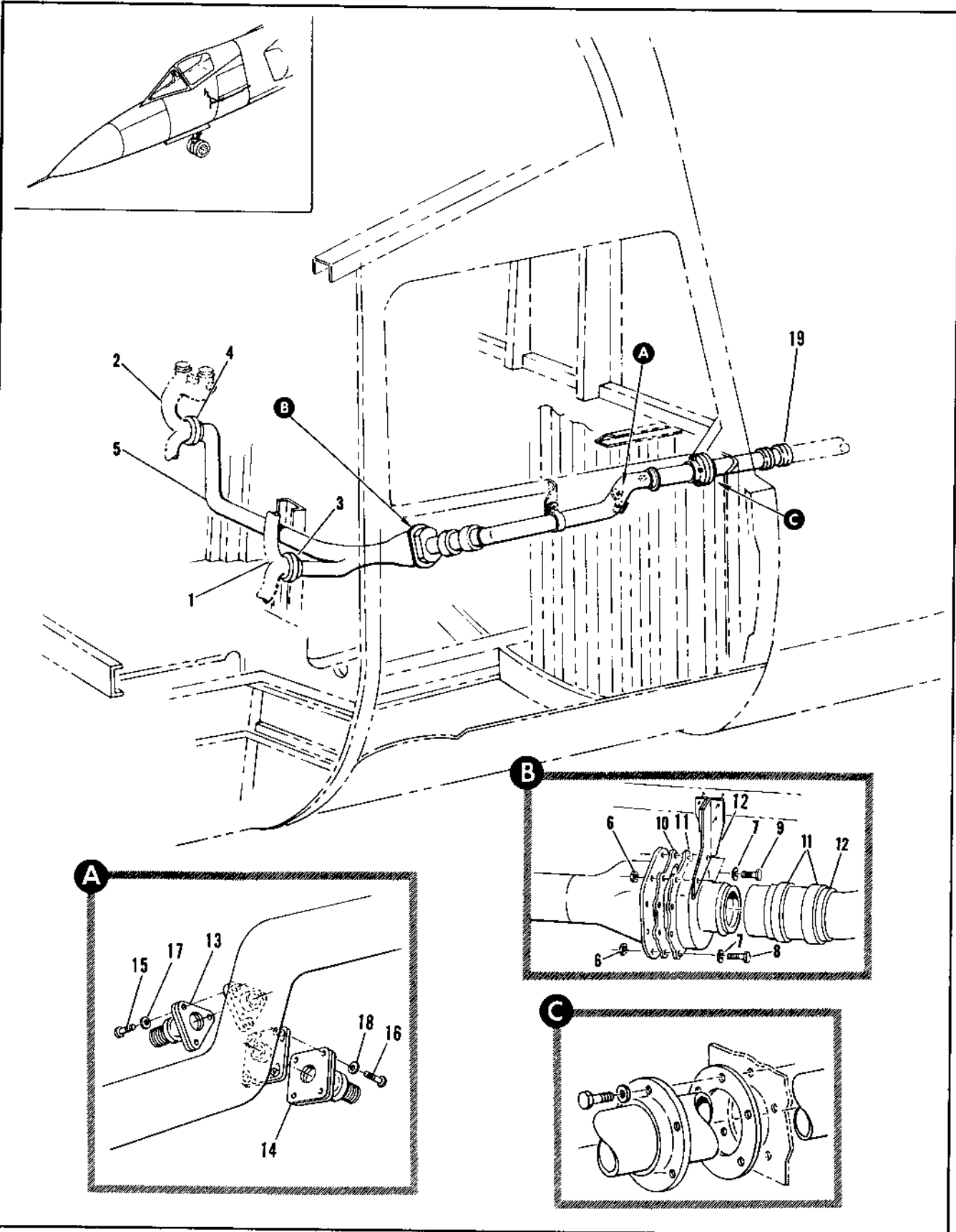

Figure 2.13-15. Cockpit Air Duct Installation Sta 171 to 228 (Sheet 1 of 2)

FIGURE AND INDEX NUMBER	PART NUMBER	DESCRIPTION	UNITS PER ASSY.	USABLE ON CODE	
				FROM	TO
		1 2 3 4 5 6			
2.13-15	R-23900-803	DUCT INSTALLATION, COCKPIT AIR STA 171 TO TO 228 FOR NHA SEE FIG. 2.13-3	RF	35	
- 1		• DUCT ASSY, SEE FIG. 2.13-13	RF		
- 2		• VALVE ASSY, COCKPIT AIR DIVERTER RH SEE FIG. 2.13-13	RF		
- 3	R-23385-7	• GASKET	1	35	
- 4	R-23385-9	• GASKET	1	35	
- 5	R-23399	• DUCT ASSY, COCKPIT AIR WELDED ATTACHING PARTS	1	35	
- 6	NAS678A3	• NUT	2	35	
- 7	AN961C10	• WASHER	2	35	
- 8	AN526-1032R9	• SCREW	6	35	
- 9	AN526-1032R12	• SCREW	2	35	
		-----X-----			
- 10	R-23344	• GASKET	1	35	
- 11	R-23380	• VALVE ASSY, COCKPIT AIR CHECK FOR BREAKDOWN SEE FIG. 2.13-14	1	35	
- 12	R-23900-15	• BRACKET ASSY, RIVETED	1	35	
- 13	AYLFB24-1	• ELEMENT, DUCT TEMPERATURE HIGH LIMIT <65149> SPEC R-12495-7	1	35	
- 14	AYLFB25-1A	• ELEMENT, DUCT TEMPERATURE SENSOR <65149> SPEC R-12495-5 NO REPLACEMENT ATTACHING PARTS	1	35	240
- 15	AN520C10RB	• SCREW	3	35	
- 16	AN520C10R6	• SCREW	4	35	240
- 17	AN960C10L	• WASHER	3	35	
- 18	AN960C10L	• WASHER	4	35	240
		-----X-----			
- 19		• DUCT, COCKPIT COOLING SEE FIG. 2.13-9 INDEX 15 AND 15.3	RF		

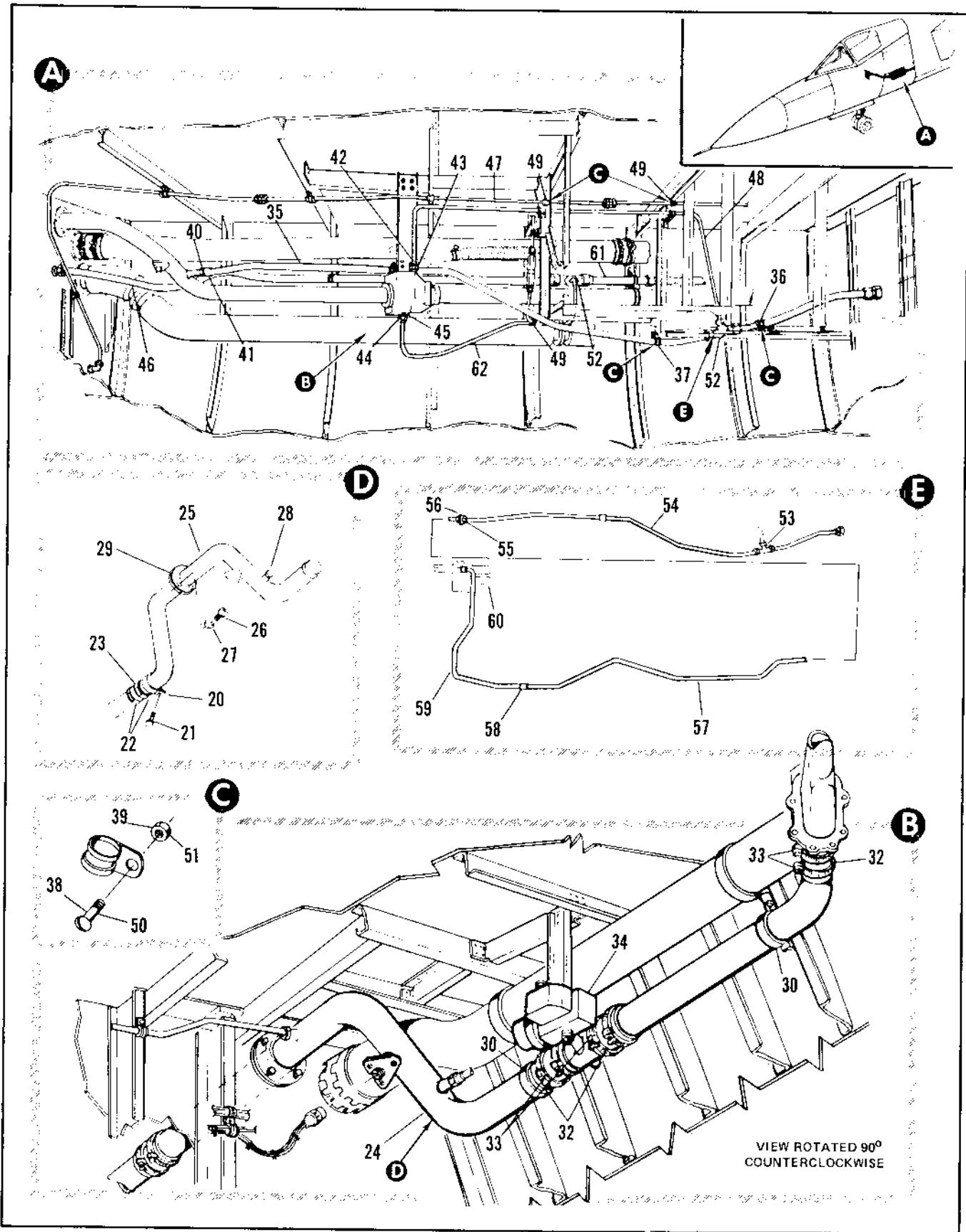

Figure 2.13-15. Cockpit Air Duct Installation Sta 171 to 228 (Sheet 2 of 2)

FIGURE AND INDEX NUMBER	PART NUMBER	DESCRIPTION	UNITS PER ASSY.	USABLE ON CODE	
				FROM	TO
		1 2 3 4 5 6			
2.13-15- 20	MS21919039	• CLAMP ATTACHING PARTS	1		
- 21	AN3-3A	• BOLT -----X-----	1		
- 22	AN737TW74	• CLAMP	2		
- 23	AD297-7	• COUPLING	1		
- 24	62J34007-3	• DUCT ASSY	1		
	62J34007-5	• DUCT ASSY	1		
- 25	64J34008-1	• DUCT ASSY, CAPIN AIR CONDIT- TIONING ATTACHING PARTS	1		
- 26	AN526-1032R	• SCREW	3		
- 27	AN94010	• WASHER -----X-----	5		
- 28	64J34008-10	• CAP	1		
- 29	8-23345	• BASKET	1		
- 30	AN742032	• CLAMP	2		
- 31	62J34007-1	• DUCT ASSY	1		
- 32	AD297-7	• COUPLING	3		
- 33	AN737TW74	• CLAMP	2		
- 34	26041030	• REGULATOR	1		
- 35	62A35027-1	• TUBE ASSY ATTACHING PARTS	1		
- 36	91-94026-011M	• CLAMP	1		
- 37	91-94026-011M	• CLAMP	1		
- 38	AN527-10R	• SCREW	4		
- 39	NAS1091-7	• NUT -----X-----	1		
- 40	NAS501-6-9	• COUPLING	1		
- 41	AN737TW30	• CLAMP	2		
- 42	MS2190204	• UNION	1		
- 43	MS28778-4	• G-FINE	1		
- 44	MS2191605-4	• REDUCER	1		
- 45	MS28778-5	• G-FINE	1		
- 46	62A35023-1	• TUBE ASSY	1		
- 47	62A35029-1	• TUBE ASSY	1		
- 48	62A35025-1	• TUBE ASSY ATTACHING PARTS	1		
- 49	91-94026-003	• CLAMP	4		
- 50	AN527-10R	• SCREW	4		
- 51	NAS1091-7	• NUT -----X-----	3		
- 52	FR8240121204	• TEE	1		
- 53	FR8240121204	• TEE	1		
- 54	64A34220-1	• TUBE ASSY, LOW PRESSURE PNEUMATIC	1		
- 55	AN924-12F	• NUT	1		
- 56	MS21924012	• UNION	1		
- 57	64A34221-1	• TUBE ASSY, AIR CONDITIONING	1		
- 58	MS2192012	• UNION	1		
- 59	64A34222-1	• TUBE ASSY, AIR CONDITIONING	1		
- 60	64J34000-1	• VALVE ASSY, CAPIN AIR DIVERTER AND SHUTOFF SEE FIG. 2.13-1 INDEX 100	1		
- 61	62A35024-14	• TUBE ASSY	1		
- 62	62A35026-1	• TUBE ASSY	1		

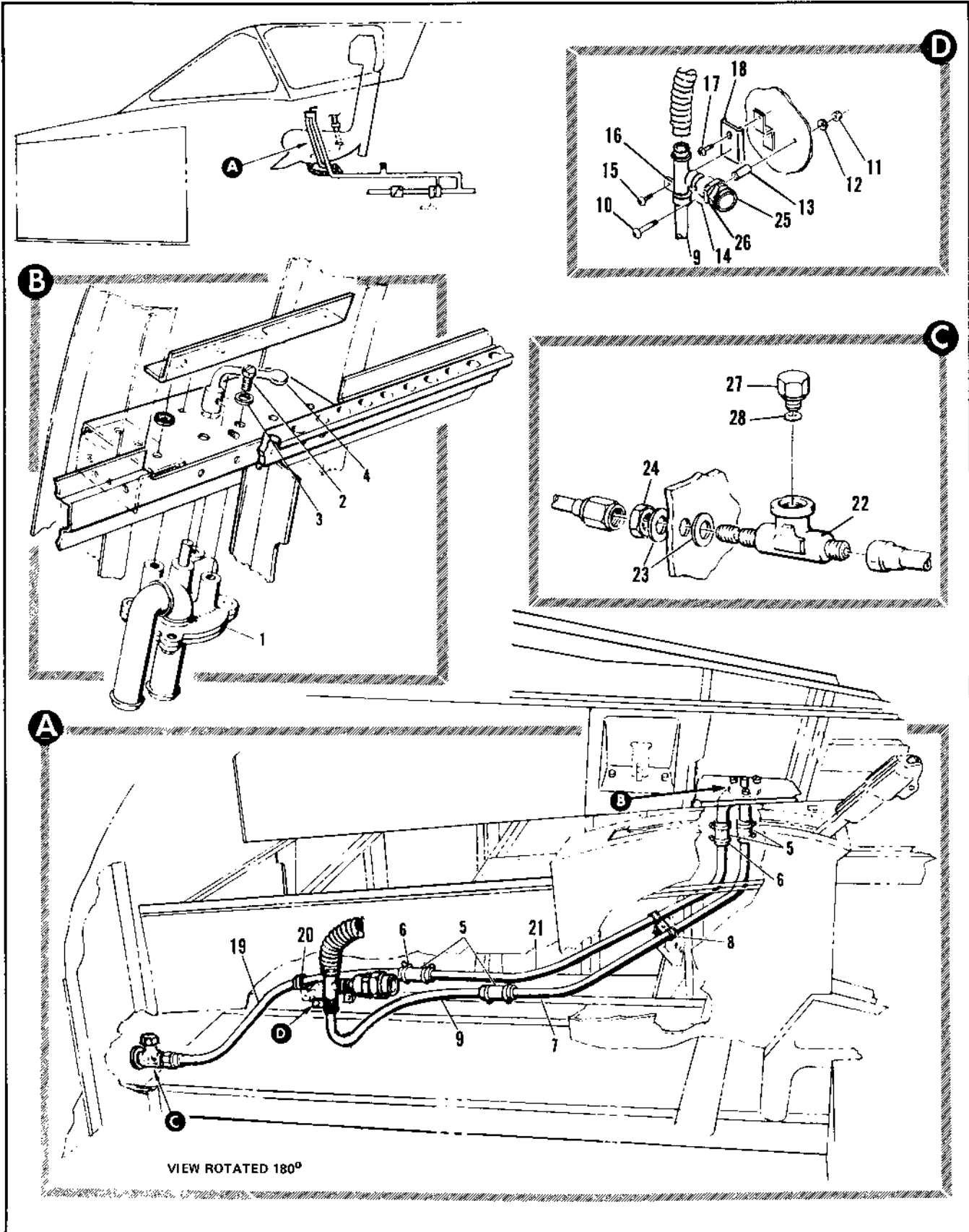

Figure 2.13-16. Cockpit Installation Pressure Suit Ventilation

FIGURE AND INDEX NUMBER	PART NUMBER	DESCRIPTION	UNITS PER ASSY.	USABLE ON CODE	
				FROM	TO
2.13-16		1 2 3 4 5 6			
-	61034801	COCKPIT INSTALLATION PRESSURE SUIT VENTILATION			
- 1	41C435	• VALVE INST. PRESSURE SUIT MANUAL CONTROL <979917> 62035003-1	1		
- 2	AN502-10-R	• VALVE, PRESSURE SUIT MANUAL CONTROL <97991> 62035003-1	1		
- 3	AN960PD10	ATTACHING PARTS	3		
- 4	61034805-1	• SCREW	3		
- 5	WAS521-6-9	• WASHER	3		
- 6	AN7371W30	-----X-----			
- 7	62A35032-1	• HANDLE	1		
- 8	91-98026-011	• COUPLING	4		
- 9	65035937-1	• CLAMP	8		
- 10	MS35207-264	• TUBE ASSEMBLY	1		
- 11	MS21042L3	ATTACHING PARTS	1		
- 12	AN961PD10L	• CLAMP	1		
- 13	NAS43003-44	-----X-----			
- 14	MS219190-14	• TUBE ASSEMBLY, WELDED	1		
- 15	MS35207-263	ATTACHING PARTS	1		
- 16	91-98026-011	• SCREW	1		
- 17	AN521-10R7	• CLAMP	1		
- 18	65035947-1	• SCREW	1		
- 19	62A350-1	• BRACKET	1		
- 20	91-98026-011	-----X-----			
- 21	62A35031-1	• TUBE ASSEMBLY	1		
- 22	MS21910R10	ATTACHING PARTS	1		
- 23	AN96 01716	• CLAMP	2		
- 24	AN924012	• CLAMP	1		
- 25	62E5006-1	-----X-----			
- 26	MS28778-16	• TUBE ASSEMBLY	1		
- 27	MS21913017	• TEE	1		
- 28	MS28775-12	ATTACHING PARTS	1		
		• WASHER	2		
		• NUT	1		
		-----X-----			
		• VALVE	1		
		• O-RING	1		
		• PLUG	1		
		• O-RING	1		

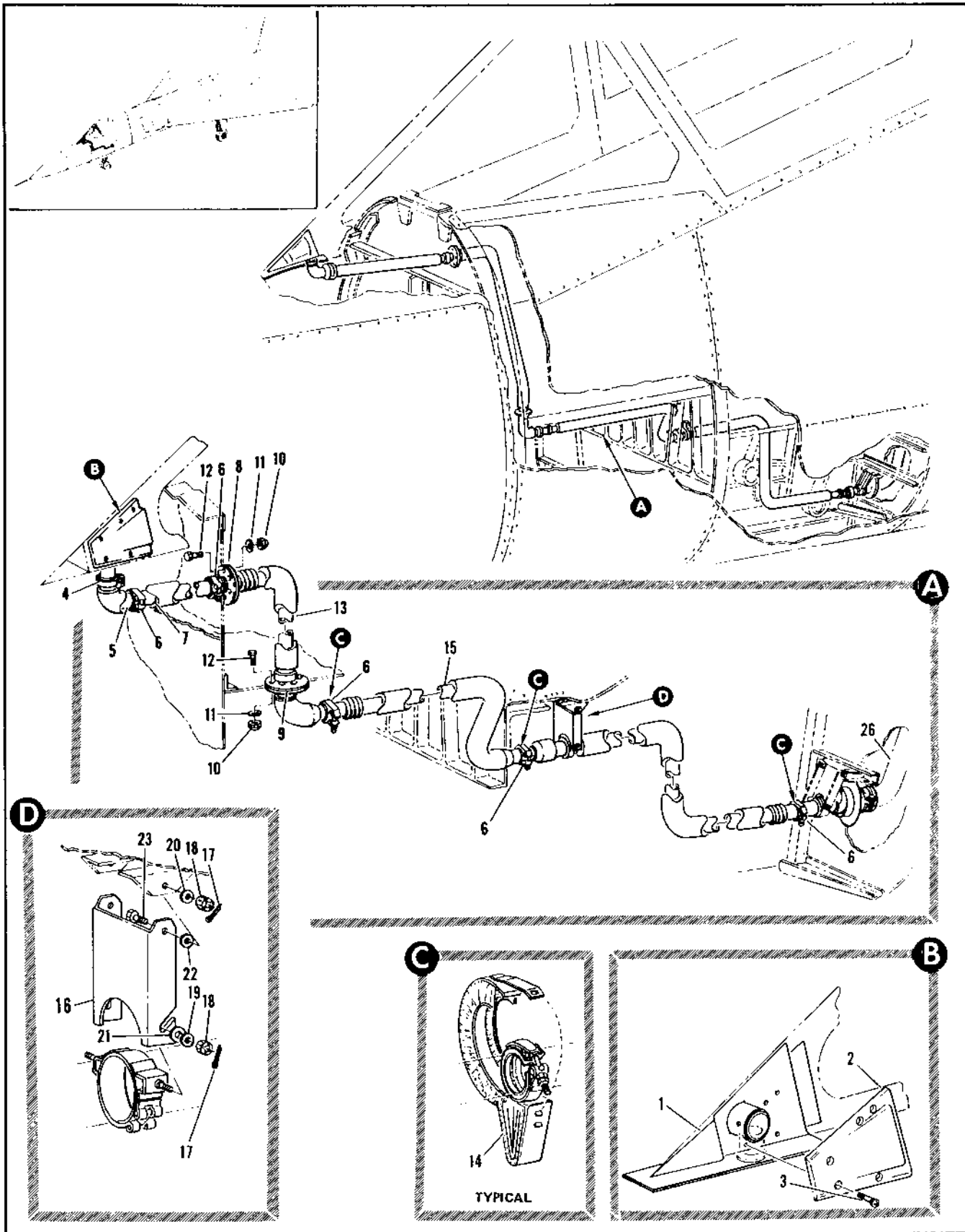

Figure 2.13-17. Rain Removal Duct Installation Sta 84 to 160 (Sheet 1 of 2)

FIGURE AND INDEX NUMBER	PART NUMBER	DESCRIPTION	UNITS PER ASSY.	USABLE ON CODE	
				FROM	TO
		1 2 3 4 5 6			
2.13-17	8-23400-5	DUCT INSTL, RAIN REMOVAL STA 14 TO 180 MODIFIED BY 86J51471 FOR NHA SEE FIG. 2.7-4	PF		
	8-23400-703	DUCT INSTL, RAIN REMOVAL STA 14 TO 180 MODIFIED BY 86J51471 FOR NHA SEE FIG. 2.7-4	PF		
- 1		• MATRINS ASSY, WINDSHIELD FWD SEE FIG. 2.4-2	PF		
- 2	8-23401-1	• NOZZLE, RAIN REMOVAL ATTACHING PARTS	1	35	
- 3	MS24494C96	• SCREW	5	75	
- 4	4369-231M	• COUPLING, <K8825> 64-75 12-115	1	35	129
	24502-15L	• COUPLING, <K8825> 64-75 12-208	1	130	
	7-2553-4	• BASKET, <K0107> 54-16 012-011	1	35	
	21205-04H	• NUT	1		
- 5	8-23402	• DUCT ASSY, RAIN REMOVAL WELDED REPLACED BY SUITABLE SUB 8-23402-1	1	35	159
	8-23402-1	• DUCT ASSY, RAIN REMOVAL WELDED REPLACES SUITABLE SUB FOR 8-23402	1	160	
- 6	24502-175	• COUPLING, <K8825> 64-75 12-115	5	35	
	17185-1750	• BASKET, <K8825> 54-16 012-005	5	35	
- 7	8-23403-1	• DUCT ASSY, RAIN REMOVAL WELDED REPLACED BY SUITABLE SUB 8-23403-3	1	35	159
	8-23403-3	• DUCT ASSY, RAIN REMOVAL WELDED REPLACES SUITABLE SUB FOR 8-23403-1	1	160	
- 8	8-23409	• INSULATOR	1	35	
- 9	8-23411	• INSULATOR	1	75	
		• ATTACHING PARTS			
- 10	NAS679A3	• NUT	12	35	
- 11	AN961-15	• WASHER	12	35	
- 12	AN345A	• BOLT	12	35	
- 13	8-23404-1	• DUCT ASSY, RAIN REMOVAL WELDED REPLACED BY SUITABLE SUB 8-23404-3	1	35	159
	8-23404-3	• DUCT ASSY, RAIN REMOVAL WELDED REPLACES SUITABLE SUB FOR 8-23404-1	1	160	
- 14	534-1	• COVER, <K8791> SPEC 8-10457-1	1	35	
- 15	8-23405-1	• DUCT ASSY, RAIN REMOVAL WELDED	1	A	
	8-23405-5	• DUCT ASSY, RAIN REMOVAL WELDED REPLACED BY SUITABLE SUB 8-23405-601	1	C	
	8-23405-601	• DUCT ASSY, RAIN REMOVAL WELDED REPLACES SUITABLE SUB FOR 8-23405-5	1	160	
- 16	8-23413	• SUPPORT ASSY, WELDED ATTACHING PARTS	1	35	
- 17	AN321-2-5	• PIN, COTTER	4	35	
- 18	AN310-3	• NUT	4	75	
- 19	AN561-12L	• WASHER	2	35	
- 20	AN961-15	• WASHER	2	35	
- 21	AN9600410	• WASHER	2	A	
- 22	28-29803-17L	• SPACER	2	35	
- 23	AN345	• BOLT	2	75	

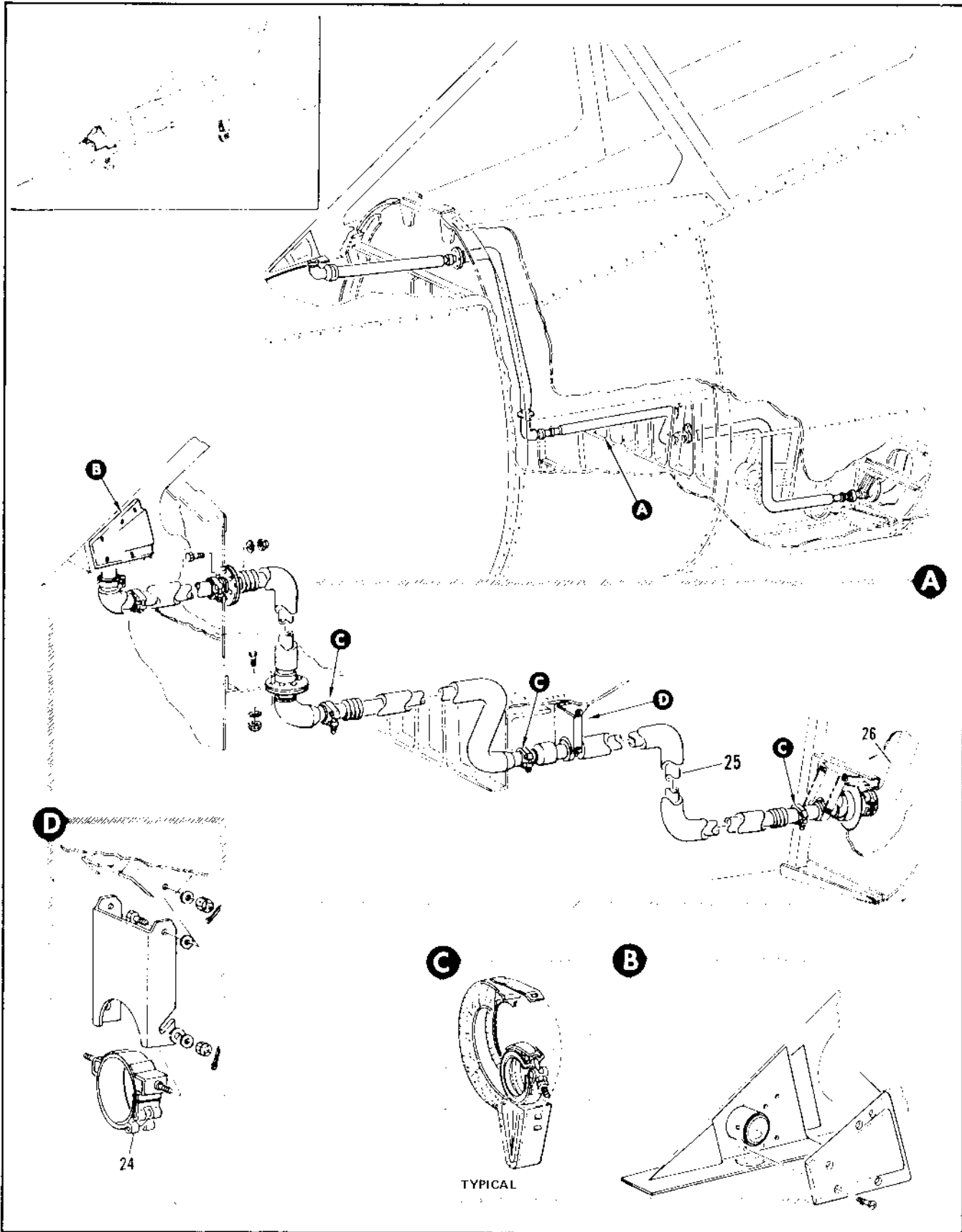

Figure 2.13-17. Rain Removal Duct Installation Sta 84 to 160 (Sheet 2 of 2)

FIGURE AND INDEX NUMBER	PART NUMBER	DESCRIPTION	UNITS PER ASSY.	USABLE ON CODE	
				FROM	TO
2.13-17- 24 - 25 - 26	50240-200 66J3P400-1	<p>1 2 3 4 5 6</p> <ul style="list-style-type: none"> * SUPPORT, CLAMP <9R625> 98-60000-011 DUCT ASSY, RAIN RAIN REMOVAL WELDED * DUCT ASSY, RAIN REMOVAL WELDED SEE FIG. 2.13-18 INDEX 14 <p>A AIRPLANES #35 THRU 47 AND 49 THRU 89 B AIRPLANES #48, 90 AND ON C AIRPLANES #44 AND 90 THRU 159</p>	1 1 RF	35	

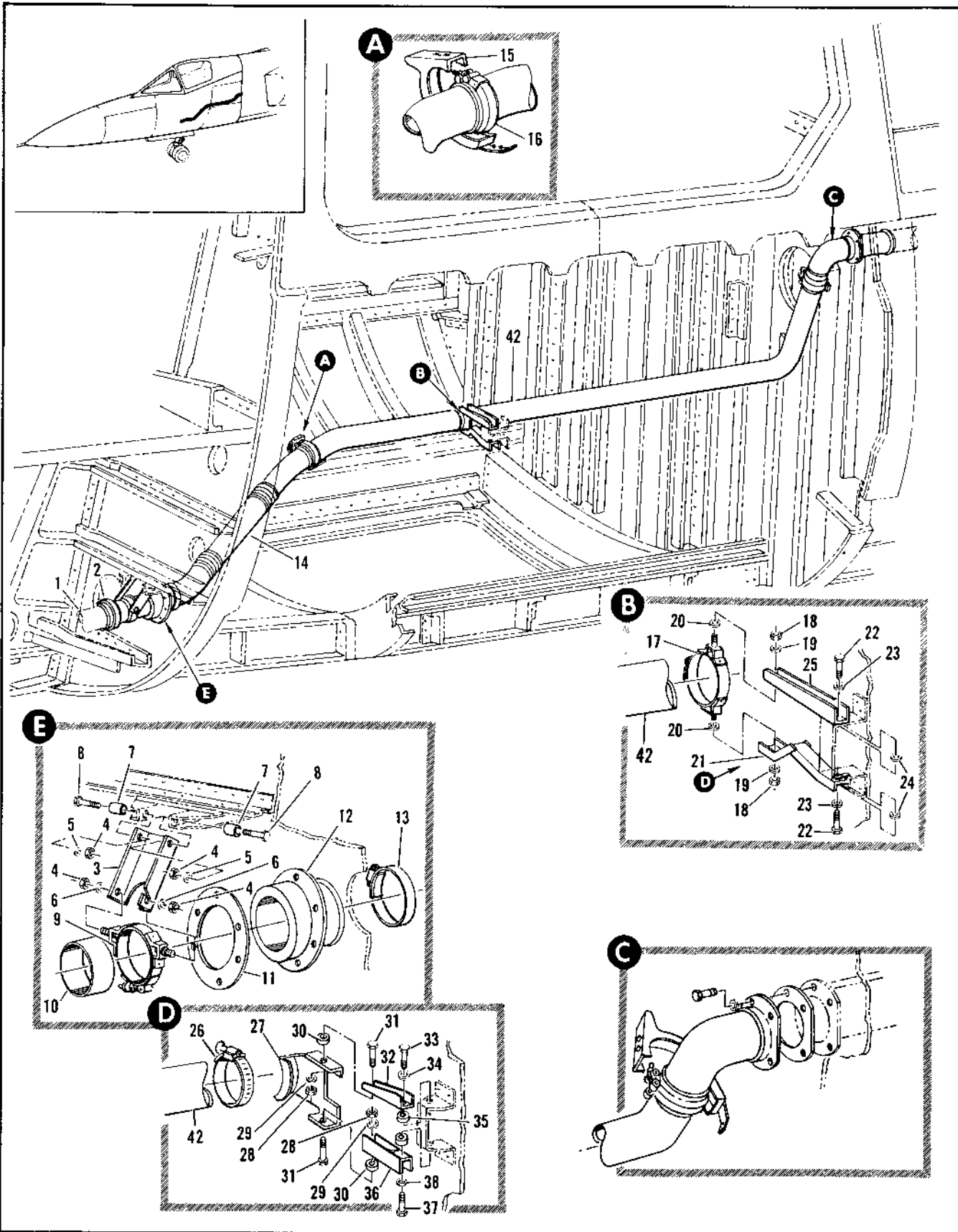

Figure 2.13-18. Rain Removal Duct Installation Sta 160 to 217 (Sheet 1 of 2)

FIGURE AND INDEX NUMBER	PART NUMBER	DESCRIPTION	UNITS PER ASSY.	USABLE ON CODE	
				FROM	TO
2.13-18	R-23400-011	DUCT INSTALLATION, RAIN REMOVAL STA 189 TO 217 FOR NHA SEE FIG. 2.13-3	R#	35	
- 1		• DUCT ASSY, RAIN REMOVAL SEE FIG. 2.13-17	R#	1	35
- 2	24502-175 17189-175C	• COUPLING, <98625> 94-16009-006	1	35	
- 3	R-23414-3	• GASKET, <98625> 94-16009-002	1	35	
- 4	AN310-3	• SUPPORT ASSY, WELDED	4	35	
- 5	AN960-10	ATTACHING PARTS	2	35	
- 6	AN960-10L AN96004L	• NUT	2	35	
- 7	98-29503-012	• WASHER	2	35	
- 8	AN3-5	• WASHER	2	35	
- 9	90240-2-000	• WASHER	2	35	
- 10	R-23410-11	• SPACER	2	35	
- 11	R-23421	• BOLT	1	35	
- 12	D1805	-----X-----	1	35	
- 13	AN737TW2	• SUPPORT, CLAMP <98625> 94-16000-011	1	35	150
- 14	R-23407	• INSULATOR	1	35	
- 15	R-23407-1	• RETAINER	1	35	
- 16	634-1	• SEAL, <75345> SPEC R-10286-1	1	35	
- 17	24502-175 17189-175C	• CLAMP	1	35	159
- 18	90240-2-000	• DUCT ASSY, RAIN REMOVAL WELDED	1	160	
- 19		• DUCT ASSY, RAIN REMOVAL WELDED	1	35	
- 20		• COVER, <98741> SPEC R-10457-1	1	35	
- 21		• COUPLING, <98625> 94-16009-006	1	35	
- 22		• GASKET, <98625> 94-16009-002	1	35	
- 23		• SUPPORT, <98625> 94-16005-011	1	35	170
- 24		ATTACHING PARTS	2	35	100
- 25		• NUT	2	35	100
- 26		• WASHER	2	35	100
- 27		• WASHER	2	35	100
- 28		-----X-----	1	35	170
- 29		• SUPPORT ASSY, WELDED	1	35	170
- 30		ATTACHING PARTS	2	35	100
- 31		• BOLT	2	35	100
- 32		• WASHER	2	35	100
- 33		• WASHER	2	35	100
- 34		-----Y-----	1	35	100
- 35		• SUPPORT	1	103	
- 36		• CLAMP	1	103	
- 37		• SUPPORT	1	103	
- 38		ATTACHING PARTS	2	103	
- 39		• NUT	2	103	
- 40		• WASHER	2	103	
- 41		• WASHER	2	103	
- 42		• BOLT	2	103	
- 43		-----X-----	1	103	
- 44		• CHANNEL	1	103	
- 45		ATTACHING PARTS	1	103	
- 46		• BOLT	1	103	
- 47		• WASHER	1	103	
- 48		• WASHER	1	103	
- 49		-----X-----	1	103	
- 50		• SUPPORT ASSY, WELDED	1	103	
- 51		ATTACHING PARTS	1	103	
- 52		• BOLT	1	103	
- 53		• WASHER	1	103	

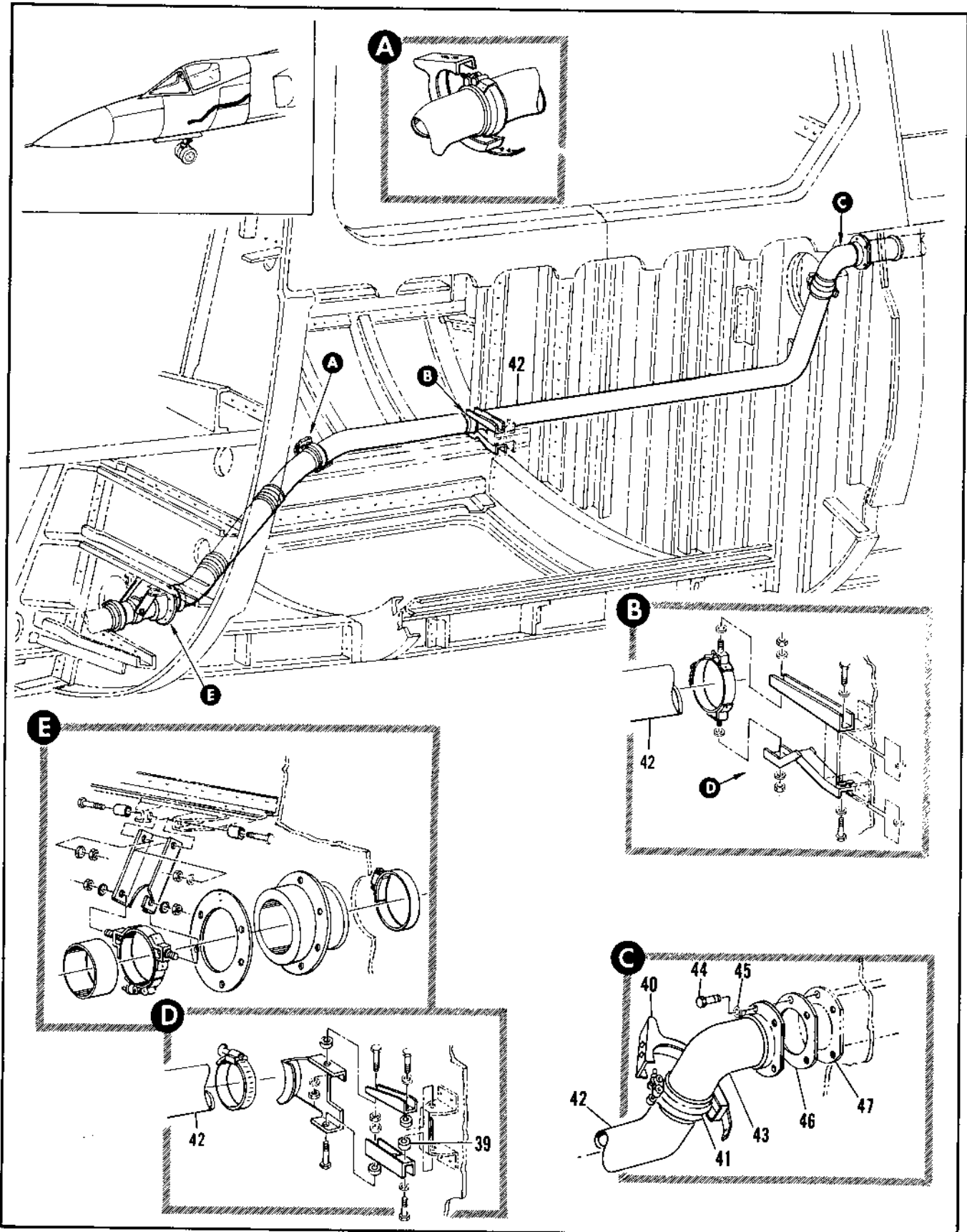

Figure 2.13-18. Rain Removal Duct Installation Sta 160 to 217 (Sheet 2 of 2)

FIGURE AND INDEX NUMBER	PART NUMBER	DESCRIPTION	UNITS PER ASSY.	USABLE ON CODE	
				FROM	TO
2.13-18- 39	79-53000-129	• WASHER -----X-----	1	103	
- 40	634-1	• COVER, <98741> SPEC 8-00452-1	1	35	
- 41	24502-175	• COUPLING, <98625> 82-73102-006	1	35	
	17189-175C	• GASKET, <98625> 84-16009-002	1	35	
- 42	8-23441	• DUCT ASSY, RAIN REMOVAL REPLACED BY SUITABLE SUB 8-23441-1	1	35	159
	8-23441-1	• DUCT ASSY, RAIN REMOVAL REPLACES SUITABLE SUB FOR 8-23441	1	160	
- 43	8-23425-1	• DUCT ASSY, RAIN REMOVAL REPLACED BY SUITABLE SUB 8-23425-3	1	35	159
	8-23425-3	• DUCT ASSY, RAIN REMOVAL REPLACES SUITABLE SUB FOR 8-23425-1	1	160	
		ATTACHING PARTS			
- 44	AN3-5A	• BOLT	4	35	
- 45	AN96C-10	• WASHER	4	35	
		-----X-----			
- 46	8-23433	• INSULATOR	1	35	
- 47		• DUCT ASSY, SEE FIG. 2.13-21	RF		

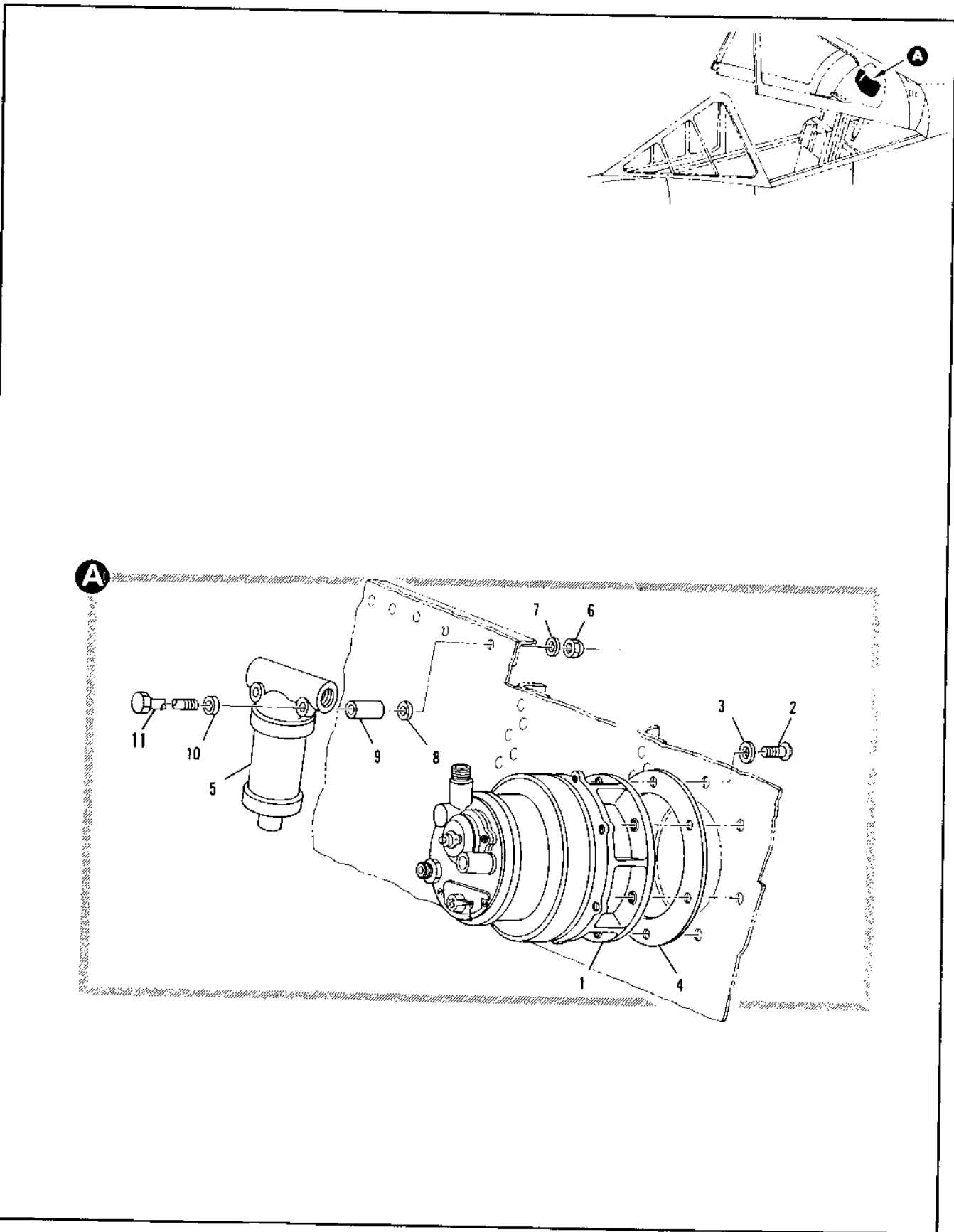

Figure 2.13-19. Cockpit Air Safety Valve Installation

FIGURE AND INDEX NUMBER	PART NUMBER	DESCRIPTION 1 2 3 4 5 6	UNITS PER ASSY.	USABLE ON CODE	
				FROM	TO
2.13-19	R-23330	VALVE INSTALLATION, COCKPIT AIR SAFETY FOR NHA SEE FIG. 2.3-3	RF		35
- 1	103680-40	• VALVE ASSY. <70210> SPEC R-12285-3 T.O. 15A2-4-4-93 ATTACHING PARTS	1		35
- 2	AN526-1032R12	• SCREW	6		35
- 3	AN960-10	• WASHER -----X-----	6		35
- 4	9-87272	• GASKET	1		35
- 5	AV181376	• VALVE ASSY. SOLENOID <73761> 99-35000-101 T.O. 4J15-10-1-54 ATTACHING PARTS	1		35
- 6	NAS679A3	• NUT	2		35
- 7	AN960D10	• WASHER	2		35
- 8	99-51509-006	• WASHER	2		35
- 9	NAS43003-32	• SPACER	2		35
- 10	NAS43003-12	• SPACER	2		35
- 11	AN3-20A	• BOLT -----X-----	2		35

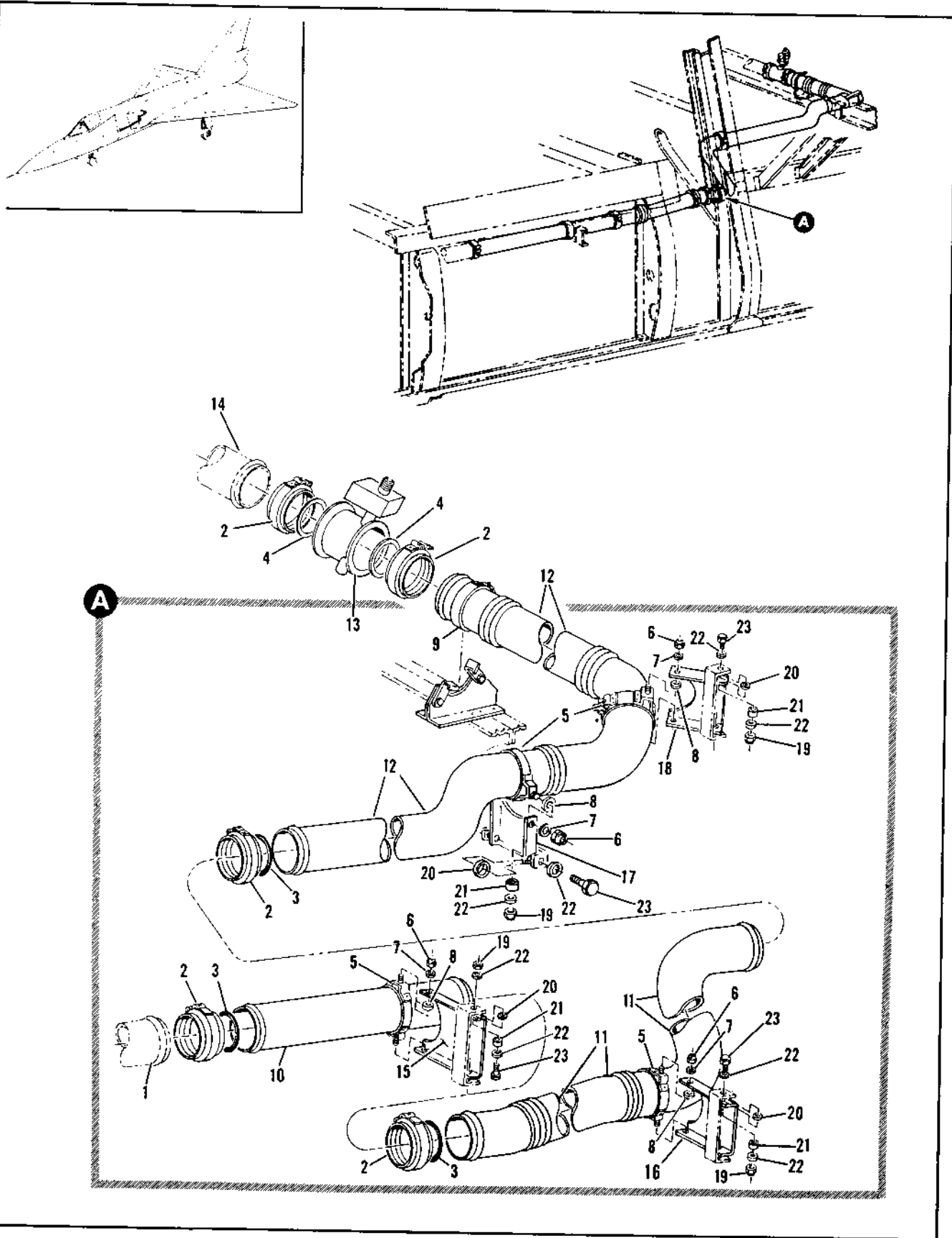

Figure 2.13-20. Windshield Rain Removal Duct Installation Sta 227 to 295

FIGURE AND INDEX NUMBER	PART NUMBER	DESCRIPTION	UNITS PER ASSY.	USABLE ON CODE	
				FROM	TO
		1 2 3 4 5 6			
2.13-20	R-23450-1	DUCT INSTALLATION, WINDSHIELD RAIN REMOVAL STA 227 TO 205 FOR JHA SEE FIG. 2.3-3	RF	35	
- 1		• DUCT INSTL, RAIN REMOVAL SEE FIG. 2.3-15	RF	5	35
- 2	24502-175	• COUPLING, <98625> 92-73002-006	5	35	
- 3	17189-175C	• GASKET, <98625> 94-16009-002	3	35	
- 4	24096-175C	• GASKET, <98625> 94-16005-003	2	35	
- 5	50248-2.080	• SUPPORT, CLAMP <98625> 98-50000-011	4	35	
		ATTACHING PARTS			
- 6	NAS679A3	• NUT	8	35	
- 7	AN960-10	• WASHER	8	35	
- 8	AN960-416L	• WASHER	8	35	
		-----X-----			
- 9	320-62-225M	• CLAMP, <98625> 91-97902-329	1	35	
- 10	B-23427	• DUCT ASSY, WELDED REPLACED BY SUITABLE SUB B-23427-1	1	35	159
	A-23427-1	• DUCT ASSY, WELDED REPLACES SUITABLE SUB FOR B-23427	1	160	
- 11	A-23439	• DUCT ASSY, WELDED REPLACED BY SUITABLE SUB B-23439-1	1	35	159
	B-23439-1	• DUCT ASSY, WELDED REPLACES SUITABLE SUB FOR B-23439	1	160	
- 12	B-23432-1	• DUCT ASSY, WELDED REPLACED BY SUITABLE SUB B-23432-3	1	35	159
	B-23432-3	• DUCT ASSY, WELDED REPLACES SUITABLE SUB FOR B-23432-1	1	160	
- 13	105946	• VALVE, SOLENOID <7210> SPEC B-02974-1 T.O. 1502-516-3	1	35	
- 14		• DUCT INSTL, ENGINE BLEED AIR SEE FIG. 2.13-25	RF		
- 15	B-23435	• SUPPORT ASSY, WELDED	1	35	
- 16	A-23435-1	• SUPPORT ASSY, WELDED	1	35	
- 17	B-23435-3	• SUPPORT ASSY, WELDED	1	35	
- 18	A-23437	• SUPPORT ASSY, WELDED	1	35	
		ATTACHING PARTS			
- 19	NAS679A3	• NUT	8	35	
- 20	NAS43HT6-0	• SPACER	8	35	
- 21	NAS43HT3-10	• SPACER	8	35	
- 22	AN960-10L	• WASHER	16	35	
- 23	AN3-5A	• BOLT	6	35	
		-----X-----			

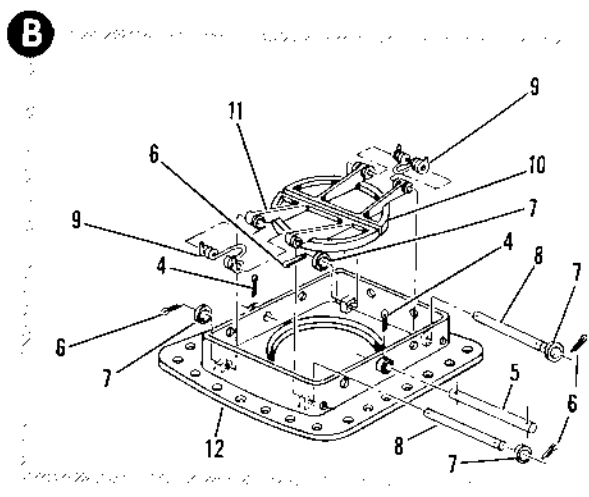
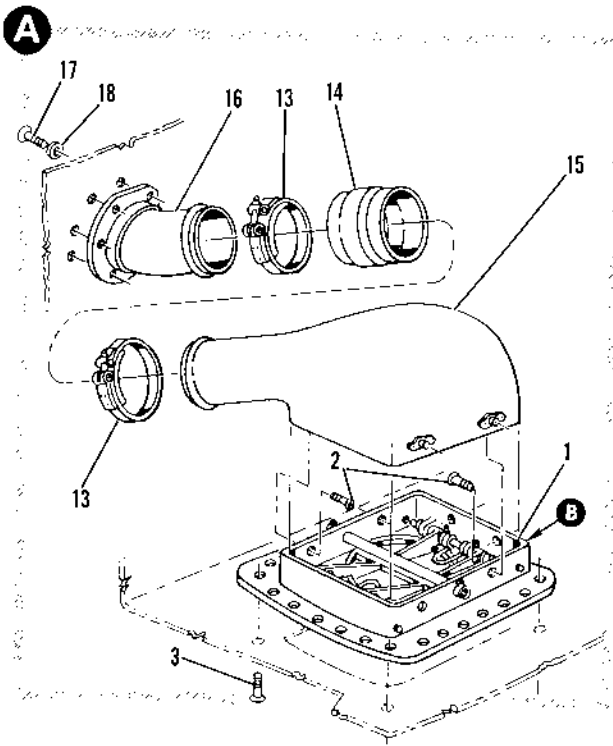
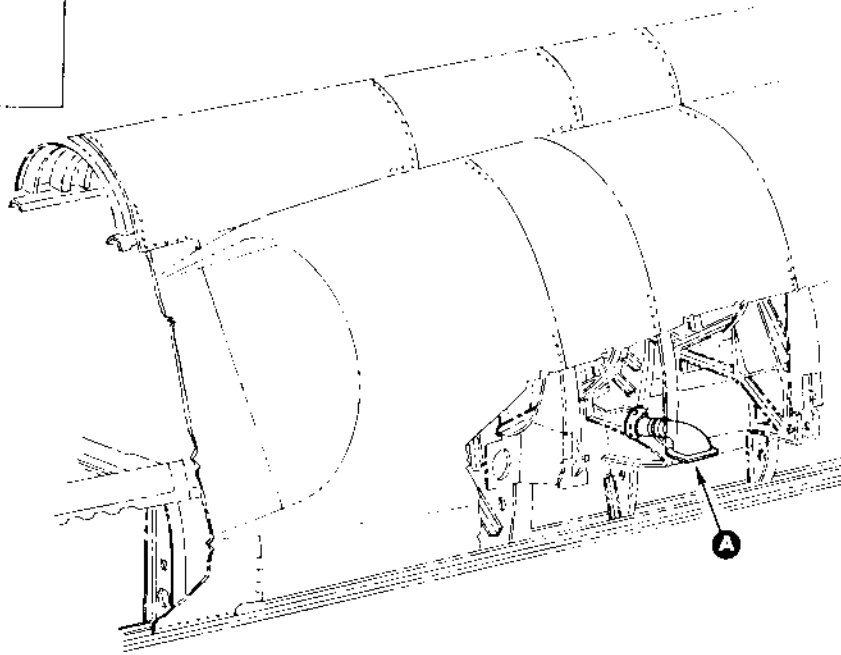
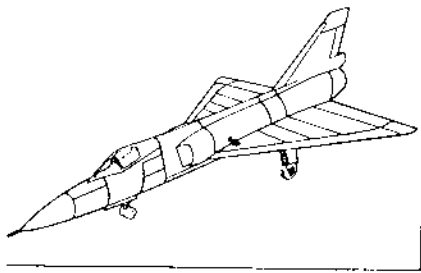

Figure 2.13-21. Armament Bay Ground Air-Conditioning Duct Installation

FIGURE AND INDEX NUMBER	PART NUMBER	DESCRIPTION 1 2 3 4 5 6	UNITS PER ASSY.	USABLE ON CODE	
				FROM	TO
2.13-21	R-23550	DUCT INSTL, ARMAMENT BAY GROUND AIR-CONDITIONING CONNECTOR STA 340 FOR NHA SEE FIG. 2.3-11	RF	35	
- 1	R-23504	• DOOR ASSY, ARMAMENT BAY GROUND AIR-CONDITIONING ACCESS ATTACHING PARTS	1	35	
- 2	AN524-1032R6	• SCREW	6	35	
- 3	NAS333PA4-5	• SCREW	26	35	
- 4	AN360-2-2	• PIN, COTTER	2	35	
- 5	R-23548	• SHAFT	1	35	
- 6	AN380-2-1	• PIN	4	35	
- 7	AN960C13	• WASHER	4	35	
- 8	R-23528	• PIN	2	35	
- 9	R-90538-1	• SPRING	2	35	
- 10	R-23547-19	• DOOR	1	35	
- 11	R-23547-21	• DOOR	1	35	
- 12	R-777P5-11	• FRAME	1	35	
- 13	321-26-423S	• CLAMP	2	35	
- 14	AD297-1	• COUPLING, FLEXIBLE LOOP <78MM> SPEC 2-17297-1	1	35	
- 15	R-23681	• DUCT ASSY, GROUND HEATING TRANSITION RIVETED	1	35	
- 16	R-23682	• DUCT ASSY, ARMAMENT BAY HEATING WELDED ATTACHING PARTS	1	35	
- 17	AN524-1032R6	• SCREW	6	35	
- 18	AN960P010L	• WASHER	6	35	
		-----X-----			

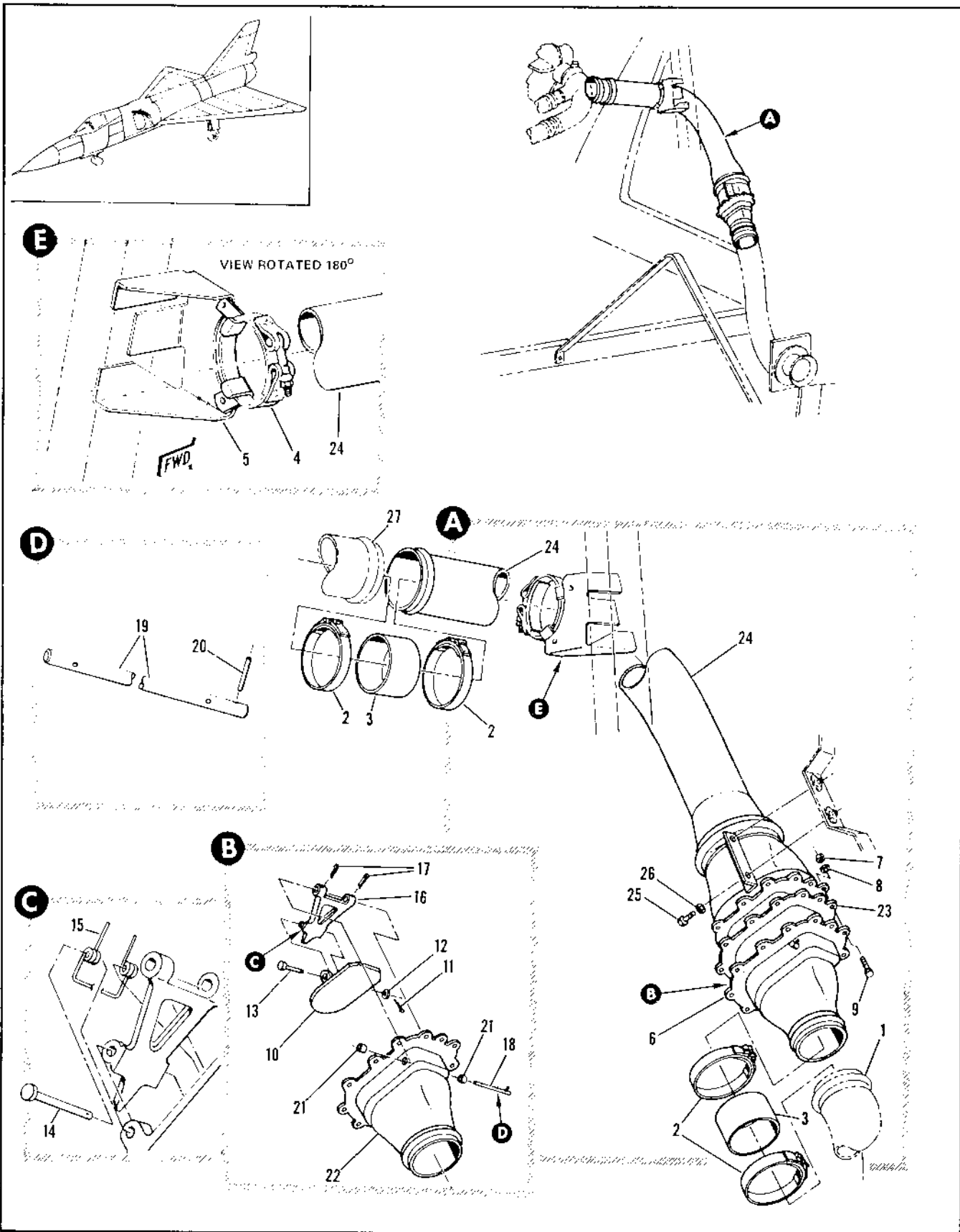

Figure 2.13-22. Ground Cooling Duct Installation

FIGURE AND INDEX NUMBER	PART NUMBER	DESCRIPTION	UNITS PER ASSY.	USABLE ON CODE	
				FROM	TO
		1 2 3 4 5 6			
2.13-22	a-23580	DUCT INSTALLATION, GROUND COOLING FOR NHA SEE FIG. 2.13-17	RF	35	
- 1		• DUCT ASSY, SEE FIG. 2.13-1 INDEX 144	RF		
- 2	361-62-4205	• CLAMP, <98605> 91-97401-02	4	35	
- 3	AD297-1	COUPLING, FLEXIBLE <92798> SPEC 9-00297-1	2	35	
- 4	326-52-400M	• CLAMP, <98625> 91-97401-006	1	35	
- 5	R-23578-1	• SUPPORT ASSY, RIVETED	1	160	
- 6	R-23649-1	• VALVE ASSY, GROUND COOLING REPLACES SUITABLE SUB R-23640-1	1	35	89
	R-23640-3	• VALVE ASSY, GROUND COOLING REPLACES SUITABLE SUB FOR R-23640-1 ATTACHING PARTS	1	160	
- 7	NASA79A3	• NUT	11	35	
- 8	AN961C10	• WASHER	11	35	
- 9	AN3H4A	• BOLT	11	35	
		-----X-----			
- 10	R-23553-2	• FLAPPER ATTACHING PARTS	1	35	
- 11	AN380-2-1	• PIN, COTTER	1	35	
- 12	AN960-4L	• WASHER	1	35	69
- 13	AN392-57	• PIN	1	35	
- 14	MS20392-1-63	• PIN	1	35	
		-----X-----			
- 15	R-23641	• SPRING	1	35	
- 16	S-23552-7	• ARM	1	35	
- 17	AN391-1-5	• PIN, COTTER	2	35	
- 18	R-23559-1	• SHAFT ASSEMBLY	1	35	
- 19	R-23559-2	• SHAFT	1	35	
- 20	79-112-662-1-25	• PIN, <70462> 90-70462-1-1.5	1	35	
- 21	R-23564	• PUSHING	2	35	
- 22	R-23551-7	• BODY	1	35	
- 23	R-23556	• BASKET	1	35	
- 24	S-23563-1	• DUCT ASSY, TRANSITION WELDED REPLACES SUITABLE SUB FOR R-23563 ATTACHING PARTS	1	160	
- 25	AN3-3A	• BOLT	2	35	
- 26	AN960C10	• WASHER	2	35	
		-----X-----			
- 27		• DUCT ASSY, REFRIGERATION TURBINE OUTLET SEE FIG. 2.13-31 INDEX 9	RF		

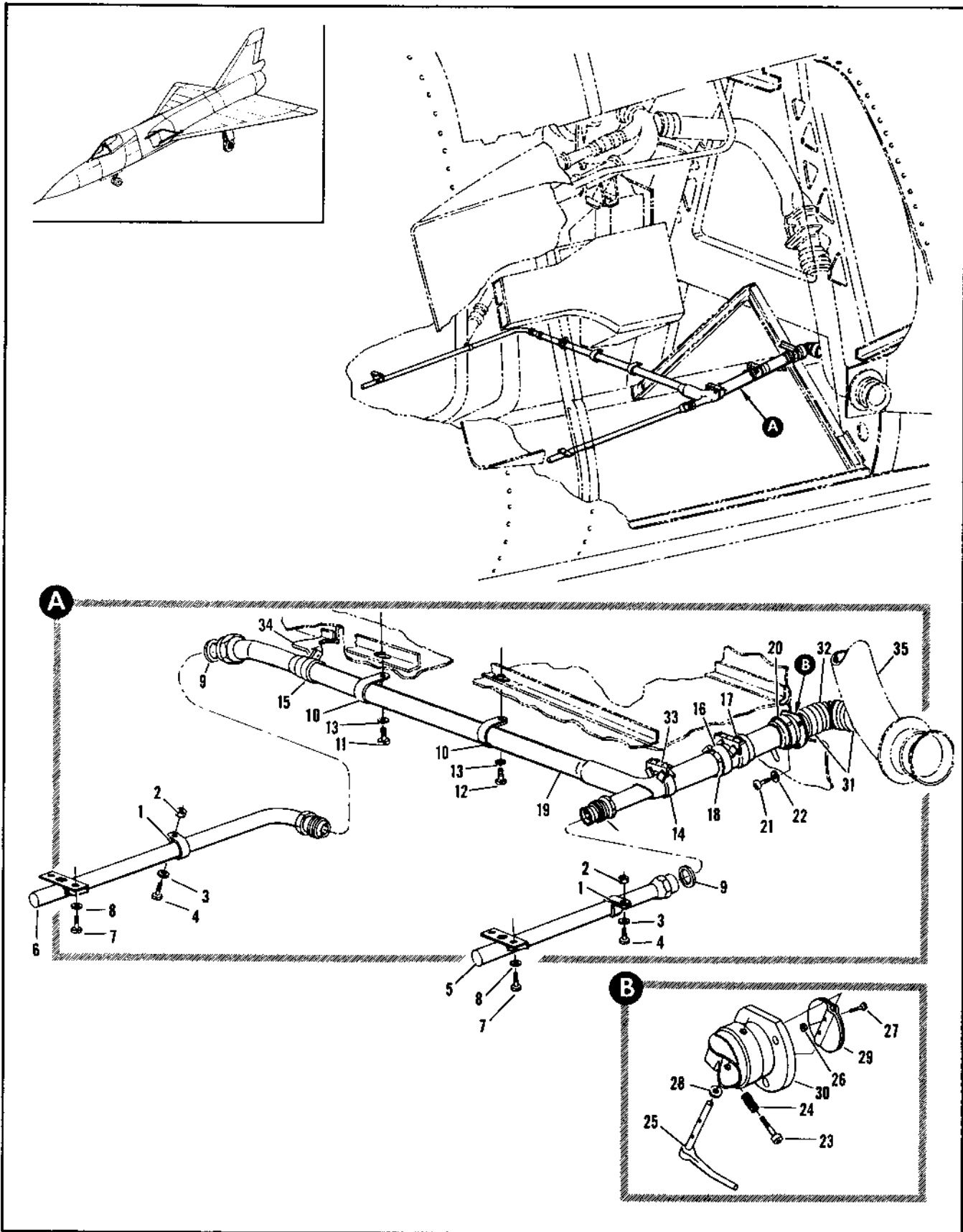

Figure 2.13-23. Ground Air-Conditioning Duct Installation

FIGURE AND INDEX NUMBER	PART NUMBER	DESCRIPTION	UNITS PER ASSY.	USABLE ON CODE	
				FROM	TO
2.13-23	8-23990-1	DUCT INSTALLATION, GROUND AIR-CONDITIONING FOR NHA SEE FIG. 2.3-13	RF	35	
- 1	AN735-20	• CLAMP	2	35	
		ATTACHING PARTS			
- 2	NAS679A3	• NUT	2	35	
- 3	AN960PD10L	• WASHER	2	35	
- 4	NAS221-9	• SCREW	2	35	
		-----X-----			
- 5	8-23994-1	• DUCT ASSY, GROUND AIR DELIVERY LH WELDED REPLACED BY SUITABLE SUB 8-23994-3	1	35	129
	8-23994-3	• DUCT ASSY, GROUND AIR DELIVERY LH WELDED REPLACES SUITABLE SUB FOR 8-23994-1	1	130	
- 6	8-23993-1	• DUCT ASSY, GROUND AIR DELIVERY RH WELDED REPLACED BY SUITABLE SUB 8-23993-3	1	35	129
	8-23993-3	• DUCT ASSY, GROUND AIR DELIVERY RH WELDED REPLACES SUITABLE SUB FOR 8-23993-1	1	130	
		ATTACHING PARTS			
- 7	NAS221-9	• SCREW	4	35	
- 8	AN960PD10L	• WASHER	4	35	
		-----X-----			
- 9	NAS592-20	• RING	2	35	
- 10	MS21919D628	• CLAMP	2	35	
		ATTACHING PARTS			
- 11	NAS221-9	• SCREW	1	35	
- 12	AN4-5A	• BOLT	1	35	
- 13	AN960PD10L	• WASHER	2	35	
		-----X-----			
- 14	AN737W74	• CLAMP	1	35	
- 15	AN737TW66	• CLAMP	1	35	
- 16	AN737TW82	• CLAMP	1	35	188
	AN737TW74	• CLAMP	1	189	
- 17	AN737TW74	• CLAMP	1	35	
- 18	NAS521-16-12	• COUPLING	1	35	
- 19	8-23992-5	• DUCT ASSY, GROUND AIR DISTRIBUTION WELDED REPLACED BY SUITABLE SUB 8-23992-801	1	35	188
	8-23992-801	• DUCT ASSY, GROUND AIR DISTRIBUTION WELDED REPLACES SUITABLE SUB FOR 8-23992-5	1	189	
- 20	8-23607	• VALVE ASSY, BUTTERFLY	1	35	
		ATTACHING PARTS			
- 21	NAS221-9	• SCREW	3	35	
- 22	AN960PD10L	• WASHER	3	35	
		-----X-----			
- 23	8-23614	• PIN, VALVE BUTTERFLY MANUAL	1	35	
- 24	8-02932-1	• SPRING	1	35	
- 25	8-23607-13	• ARM ASSY, WELDED	1	35	
		ATTACHING PARTS			
- 26	NAS679A04	• NUT	2	35	
- 27	AN515C488	• SCREW	2	35	
		-----X-----			
- 28	AN960-416L	• WASHER	1	35	
- 29	8-23609	• BUTTERFLY ASSY, WELDED	1	35	
- 30	8-23607-15	• BODY ASSY, WELDED	1	35	
- 31	AN737TW74	• CLAMP	2	35	
- 32	13-116B	• DUCT, GROUND AIR CONDITIONING FLEXIBLE SPEC 8-00490-1	1	35	
- 33	8-23996	• BRACKET	1	35	
- 34	8-23995	• BRACKET	1	35	
- 35		• DUCT ASSY, SEE FIG. 2.13-1 INDEX 144	RF		

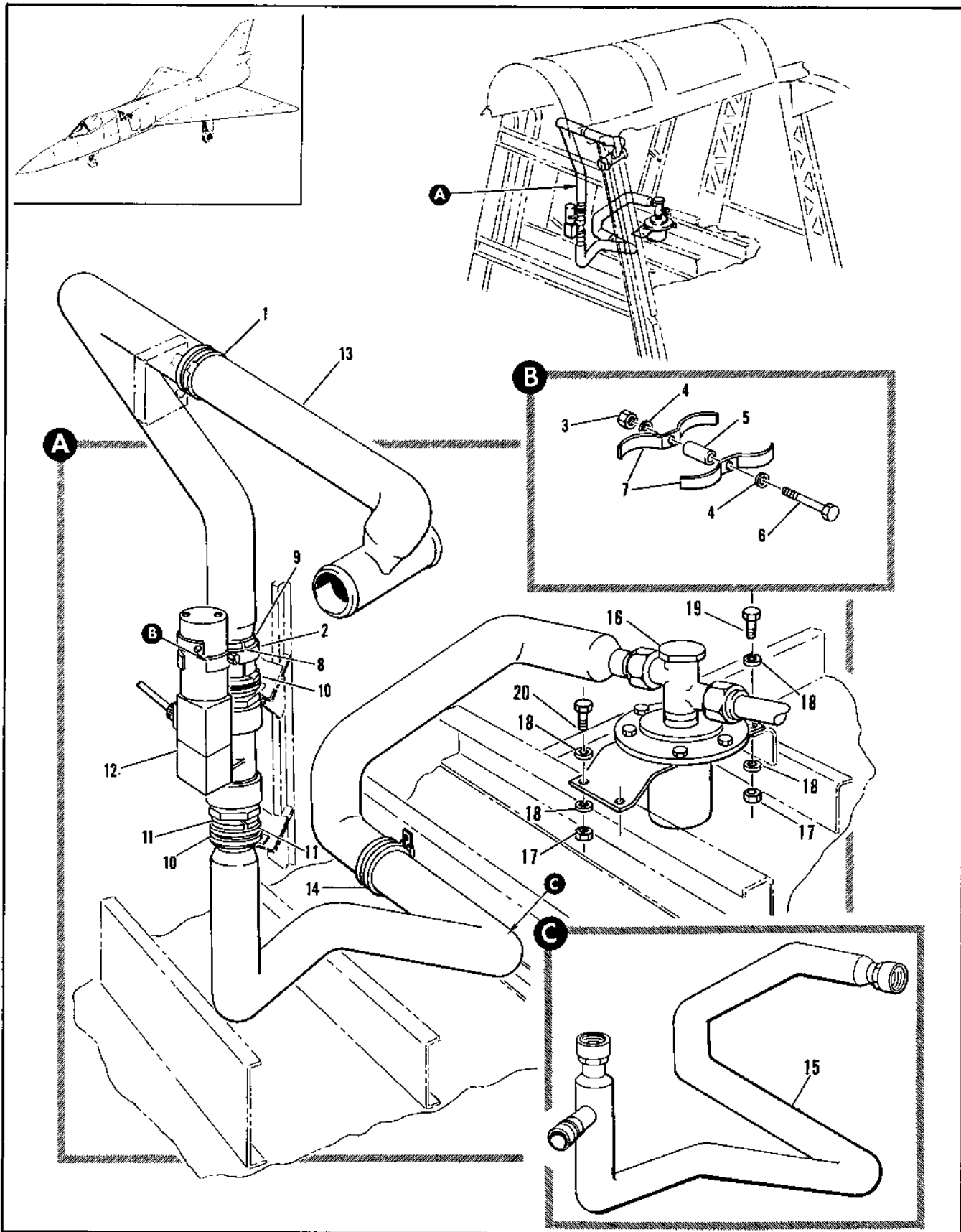

Figure 2.13-24. Cockpit Hot Air Bypass Duct Installation Sta 267 to 309

FIGURE AND INDEX NUMBER	PART NUMBER	DESCRIPTION	UNITS PER ASSY.	USABLE ON CODE	
				FROM	TO
		1 2 3 4 5 6			
2.13-24	8-23575-1	DUCT INSTALLATION, COCKPIT HOT AIR BYPASS STA 267 TO 309 FOR NHA SEE FIG. 2.3-12	RF	35	
- 1	320-62-225M	• CLAMP, <98625> 91-97802-029	1	35	
- 2	8-23540-17	• CLAMP ASSY, COCKPIT HOT AIR BYPASS	1	35	
- 3	NAS679C3	• NUT	1	35	
- 4	99-51539-006	• WASHER	2	35	
- 5	NAS43HT3-66	• SPACER	1	35	
- 6	AN3C15A	• BOLT	1	35	
- 7	8-23540-25	• BRACKET	2	35	
- 8	8-23542-13	• INSULATOR, HALF	1	35	
- 9	8-23542-15	• INSULATOR, HALF	1	35	
- 10	320C62-1R1SH	• CLAMP, <98625> 91-97802-026	2	35	
- 11	8-23542-11	• INSULATOR, HALF	2	35	
- 12	DYL25791	• VALVE ASSY, COCKPIT TEMPERATURE CONTROL <65149> SPEC R-02958-3 T.O. 1FA2-2-14-63	1	35	
- 13	8-23842	• TUBE ASSY, COCKPIT HOT AIR BYPASS WELDED REPLACED BY SUITABLE SUB 8-23842-3	1	35	159
	8-23842-3	• TUBE ASSY, COCKPIT HOT AIR BYPASS WELDED REPLACES SUITABLE SUB FOR 8-23842	1	160	
- 14	320C62-206SH	• CLAMP, <98625> 91-97802-024	1	35	
- 15	8-23576-803	• DUCT ASSY, COCKPIT HOT AIR BYPASS WELDED REPLACES NOT INTCHG WITH 8-23576-5	1	241	
- 16	108390-6	• VALVE ASSY, REGULATOR AND SHUTOFF HOT AIR PRESSURE <70212> SPEC R-62977-13 T.O. 15E2-4-6-114 REPLACES SUITABLE SUB FOR 108390 ATTACHING PARTS	1	241	
- 17	NAS679C3	• NUT	4	35	
- 18	AN960PD10L	• WASHER	9	35	
- 19	AN3C4A	• BOLT	4	35	
		-----X-----			

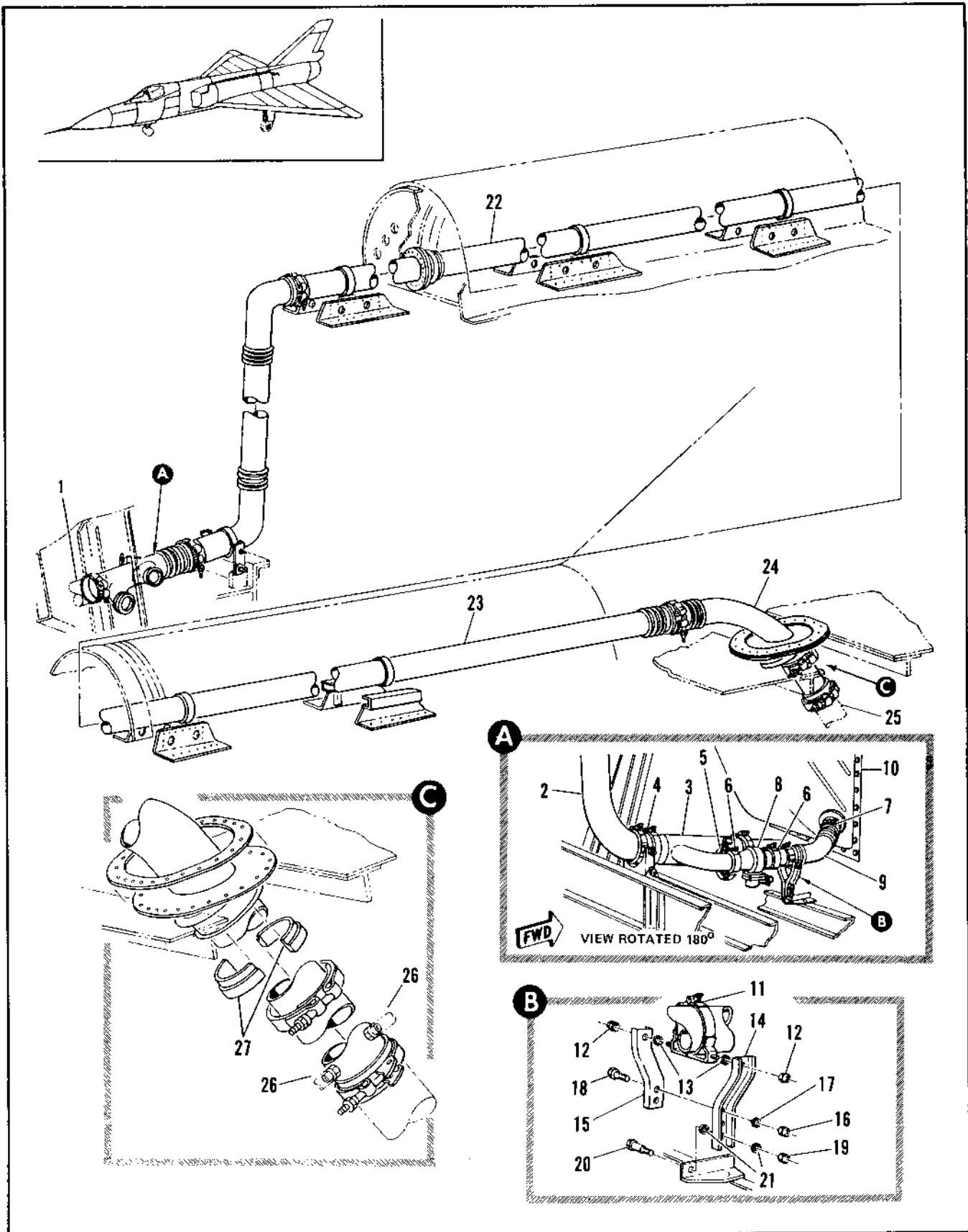

Figure 2.13-25. Engine Bleed Air Duct Installation

FIGURE AND INDEX NUMBER	PART NUMBER	DESCRIPTION	UNITS PER ASSY.	USABLE ON CODE	
				FROM	TO
2.13-25- 1		• HEAT EXCHANGER ASSY, REFRIGERATION UNIT SEE FIG. 2.13-31	RF		
- 2	8-23246-RC3	• DUCT ASSY, BLEED AIR EJECTOR	1	278	303
	8-23246-RC1	• DUCT ASSY, BLEED AIR EJECTOR	1	304	
- 3	8-23246-5	• DUCT ASSY, BLEED AIR EJECTOR	1	278	
- 4	24503-300	• CLAMP V BAND CRES	1	35	
- 5	634-1	• INSULATION ASSY, CLAMP COVER SPEC 8-00452-1	1	278	
	17189-300C	• GASKET, <98625> 94-16009-005	1	278	
- 6	24502-175	• COUPLING, <98625> 92-73012-011	2	278	
	24096-175C	• GASKET, <98625> 94-16005-003	2	278	
- 7	24502-175	• COUPLING, <98625> 92-73012-011	1	278	
	17189-175C	• GASKET, <98625> 94-16009-002	1	278	
- 8	21013	• VALVE, JET PUMP BLEED AIR EJECTOR SYSTEM SPEC 8-09995-1 I.O. 15A2-2-91-3	1	278	
- 9	8-23245-1	• DUCT ASSY, BLEED AIR EJECTOR ELBOW	1	278	
- 10		• HEADER AND EJECTOR ASSY, SEE FIG. 2.13-31	RF		
- 11	54077-175	• SUPPORT, <98625> 9R-60000-062 ATTACHING PARTS	1	278	
- 12	NAS1291-3	• NUT	2	278	
- 13	99-53000-125	• WASHER ----X----	2	278	
- 14	6-23244-15	• SUPPORT	1	278	
- 15	8-23244-17	• SUPPORT ATTACHING PARTS	1	278	
- 16	NAS679C3	• NUT	2	278	
- 17	AN960C16L	• WASHER	2	278	
- 18	AN3C4A	• BOLT	2	278	
- 19	NAS679A3	• NUT	1	278	
- 20	AN960C416L	• WASHER	2	278	
- 21	NAS1297-3-2	• BOLT ----X----	1	278	
- 22	68E37334-1	• DUCT, ENGINE BLEED AIR, WELDED, MODI- FIED FROM 8-23225-1	1	35	
- 23	68E37334-3	• DUCT, ENGINE BLEED AIR, WELDED, MODI- FIED FROM 8-23225-1	1	35	
- 24	8-23224-803	• DUCT ASSY, SEE FIG. 2.13-26	RF		
- 25		• DUCT ASSY, ENGINE BLEED AIR MANIFOLD SEE FIG. 2.10-7 INDEX 42	RF		
- 26		• HOSE ASSY, FLEX	RF		
- 27	8-23201	• INSULATOR	1	35	

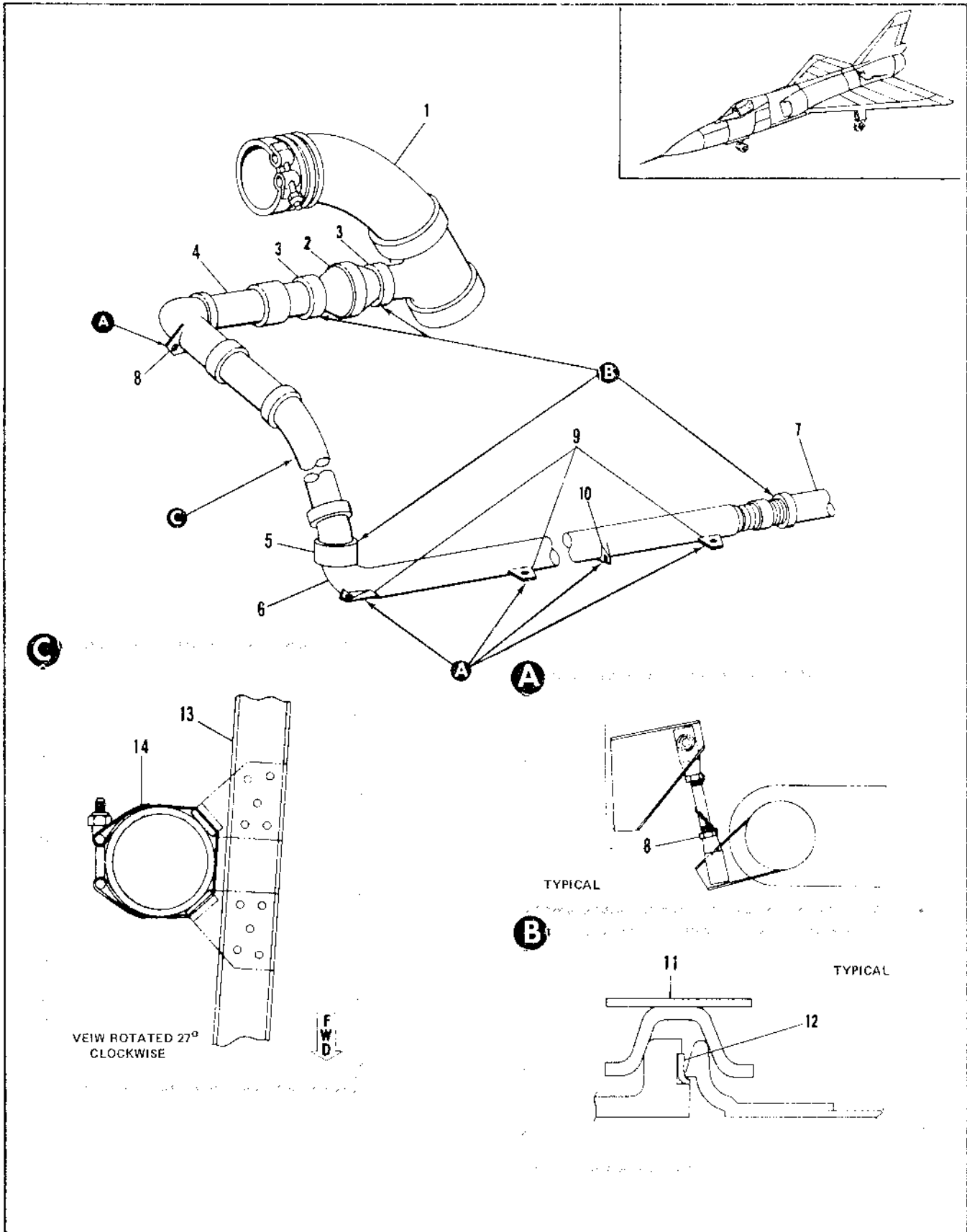

Figure 2.13-26. Engine Bleed Air to Air Driven Emergency AC Generator Duct Installation

FIGURE AND INDEX NUMBER	PART NUMBER	DESCRIPTION	UNITS PER ASSY.	USABLE ON CODE	
				FROM	TO
		1 2 3 4 5 6			
2.13-26	8-80303	DUCT INSTALLATION, ENGINE BLEED AIR TO AIR DRIVEN EMERGENCY AC GENERATOR	RF		
- 1	8-23224-F03	• DUCT ASSY	1		
- 2	21013	• VALVE, SHUTOFF	1		
- 3	24502-175	• CLAMP	2		
	24096-175-C	• GASKET	2		
- 4	8-80305-1	• DUCT ASSY	1		
- 5	634-1	• INSULATION ASSY	1		
	24505-175	• CLAMP	1		
	17189-175-C-1	• GASKET	1		
- 6	8-80306-1	• DUCT ASSY	J		
	8-80306-3	• DUCT ASSY, ALT INTCHG	RF		
- 7		• GENERATOR INSTALLATION, SEE FIG. 2.17-# INDEX 57	RF		
- 8	90-45201-001	• JOINT ASSY	2		
	NAS354-4-240	• ROD	1		
	NAS509-4	• NUT	2		
	AN960-416L	• WASHER	4		
	NAS1291-4	• NUT	2		
- 9	90-45201-001	• JOINT ASSY	6		
	NAS354-4-300	• ROD	3		
	NAS509-4	• NUT	6		
	AN960-416L	• WASHER	12		
	NAS1291-4	• NUT	6		
- 10	90-45201-001	• JOINT ASSY	2		
	NAS354-4-310	• ROD	1		
	NAS509-4	• NUT	2		
	AN960-416L	• WASHER	4		
	NAS1291-4	• NUT	2		
- 11	24502-175	• CLAMP	1		
- 12	24096-175-C	• GASKET	1		
- 13	8-80303-37	• CHANNEL	RF		
- 14	41-97815-013	• CLAMP	1		

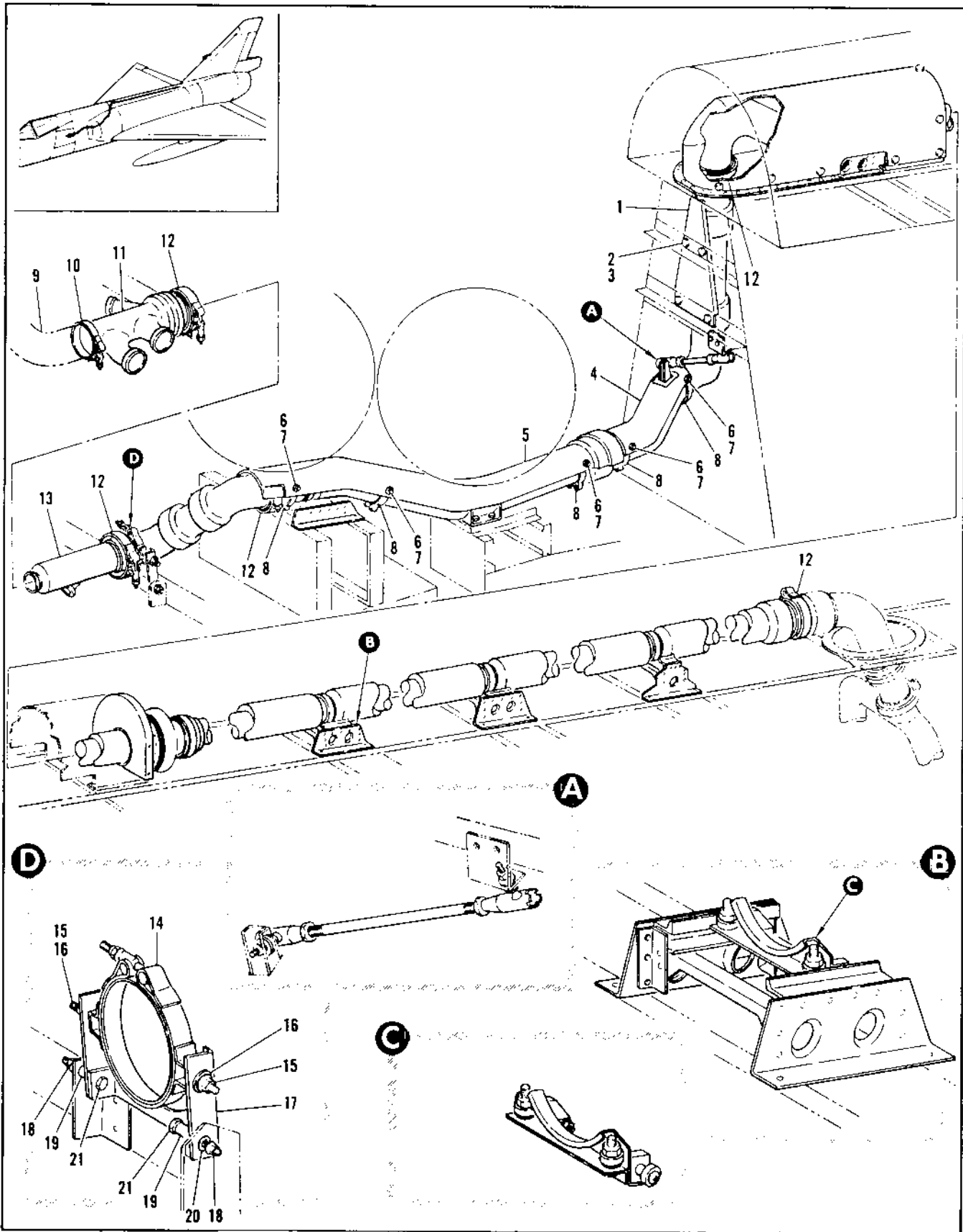

Figure 2.13-27. Engine Bleed Air Duct Installation (Sheet 1 of 2)

FIGURE AND INDEX NUMBER	PART NUMBER	DESCRIPTION	UNITS PER ASSY.	USABLE ON CODE	
				FROM	TO
		1 2 3 4 5 6			
2.13-27	8-23200	DUCT INSTL, ENGINE BLEED AIR MODIFIED BY 66J4022R FOR NHA SEE FIG. 2.3-3	RF		
	8-23200-3	DUCT INSTL, ENGINE BLEED AIR MODIFIED BY 66J4022R FOR NHA SEE FIG. 2.3-3	RF		
	8-23200-5	DUCT INSTL, ENGINE BLEED AIR MODIFIED BY 66J4022R FOR NHA SEE FIG. 2.3-3	RF		
- 1	66J40462-1 66D40513-1	• SHROUD INSTL, BLEED AIR DUCT • Baffle ASSY, RIVETED ATTACHING PARTS	1 1		
- 2	AN3-4A	• BOLT	4		
- 3	AN960D10L	• WASHER	4		
		-----X-----			
- 4	66E40603-1	• SHROUD, AFT	1		
- 5	66J40512-1	• SHROUD, FWD ATTACHING PARTS	1		
- 6	MS21042L3	• NUT	10		
- 7	AN960D10L	• WASHER	10		
- 8	900-400-2-3A	• CLAMP (98625)	5		
		-----X-----			
- 9		• HEAT EXCHANGER ASSY, REFRIGERATION UNIT SEE FIG. 2.13-31 INDEX 53	RF		
- 10	24502-250	• COUPLING (98625) 92-73002-001	1		
	17189-250C	• GASKET (98625) 94-16009-004	1		
- 11	8-23208-5	• DUCT ASSY, BLEED AIR WELDED REPLACED BY SUITABLE SUBSTITUTE 8-23208-605	1		
	8-23208-805	• DUCT ASSY, BLEED AIR WELDED REPLACES SUITABLE SUBSTITUTE FOR 8-23208-5	1		
- 12	24503-300	• CLAMP, V BAND CRES (98625)	5		
	17189-300C	• GASKET (98625) 94-16009-005	5		
- 13	8-23246-5	• DUCT ASSY, BLEED AIR EJECTOR	1		
- 14	80240-325	• SUPPORT (98625) ATTACHING PARTS	1		
- 15	MS21042L4	• NUT	2		
- 16	AN960-416L	• WASHER	2		
		-----X-----			
- 17	66C40446-1	• BRACKET ASSY, WELDED ATTACHING PARTS	1		
- 18	MS21042L3	• NUT	2		
- 19	MS43HT3-2R	• SPACER	2		
- 20	AN960-516L	• WASHER	1		
- 21	AN3-7A	• BOLT	2		
		-----X-----			

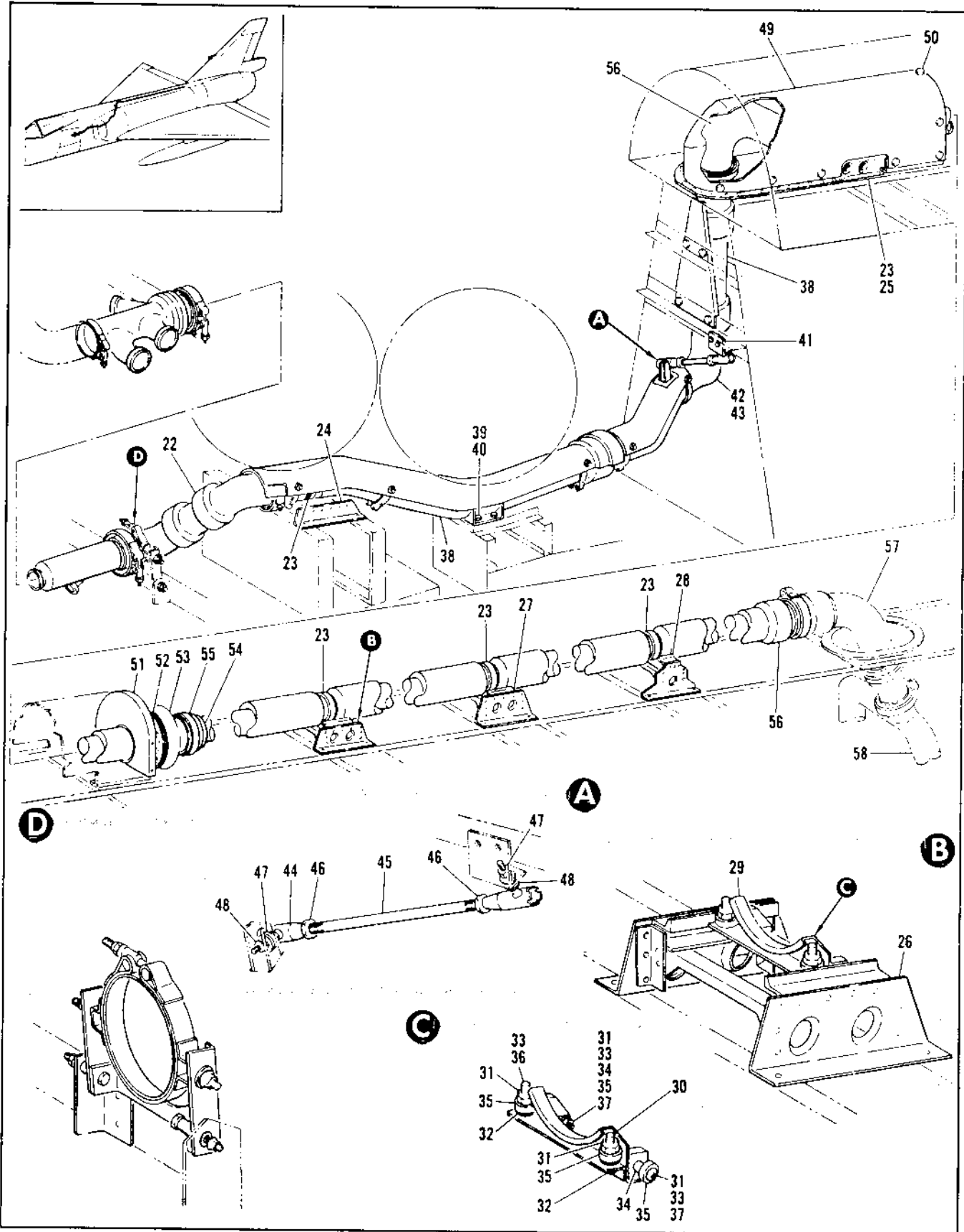

Figure 2.13-27. Engine Bleed Air Duct Installation (Sheet 2 of 2)

FIGURE AND INDEX NUMBER	PART NUMBER	DESCRIPTION	UNITS PER ASSY.	USABLE ON CODE	
				FROM	TO
		1 2 3 4 5 6			
2.13-27- 22	66J40229-6	• DUCT ASSY, WELDED (98750)	1		
- 23	325-62-325M	• CLAMP (98625) 91-97802-010	5		
- 24	8-23220-801	• SUPPORT ASSY, MODIFIED BY 66J40228 (98750)	1		
	8-23220-805	• SUPPORT ASSY, MODIFIED BY 66J40228 (98750)	1		
- 25	8-23220	• SUPPORT ASSY, MODIFIED BY 66J40228 (98750)	1		
- 26	8-23220-3	• SUPPORT ASSY, STA 412 TO 418.5	1		
- 27	8-23220-1	• SUPPORT ASSY, STA 451.9 TO 458.3	1		
	8-23220-809	• SUPPORT ASSY, STA 451.9 TO 458.3	1		
- 28	8-23220-803	• SUPPORT ASSY, STA 495.8 TO 502.9	1		
- 29	8-23210	• ROLLER ASSY, ENGINE BLEED AIR	1		
- 30	8-23210-15	• . . . BLOCK ASSY, RIVETED	1		
- 31	NAS679A3	• . . . NUT (80205)	4		
- 32	AN960-10	• . . . WASHER (88044)	4		
- 33	AN960-10L	• . . . WASHER (88044)	4		
- 34	NAS43HT3-16	• . . . SPACER (80205)	2		
- 35	MS27641-3	• . . . BEARING (96906)	4		
- 36	NAS221-14	• . . . SCREW (80205)	2		
- 37	NAS221-30	• . . . SCREW (80205)	2		
- 38	66J40230-16	• DUCT ASSY, WELDED (98750)	1		
- 39	AN304	• BOLT (88044)	4		
- 40	66C40449-1	• WASHER (98750)	4		
- 41	66C40233-1	• DUCT SUPPORT (98750)	1		
		ATTACHING PARTS			
- 42	MS21042L3	• NUT (96906)	2		
- 43	AN3-4	• BOLT (88044)	2		
		-----X-----			
- 44	AN276-6	• JOINT ASSY (88044)	2		
- 45	NAS354-4-210	• ROD (80205)	1		
- 46	NAS509-4	• NUT (80205)	2		
- 47	MS21042L4	• NUT (96906)	2		
- 48	AN960-416L	• WASHER (88044)	2		
- 49	66J40461-1	• COVER ASSY (98750)	1		
		ATTACHING PARTS			
- 50	NAS1103-1	• BOLT (80205)	13		
		-----X-----			
- 51	66E40453-1	• FLANGE ASSY, RIVETED (98750)	1		
- 52	8-23219-1	• RETAINER	1		
- 53	4591	• SEAL (98135) SPEC 8-02299-1	1		
- 54	8-23222	• INSULATOR	1		
- 55	325-62-431M	• CLAMP (98625) 91-97802-023	1		
- 56	66J40231-7	• DUCT ASSY, BLEED AIR (98750)	1		
- 57		• DUCT ASSY, SEE FIG. 2.13-25 INDEX 24	RF		
- 58		• DUCT ASSY, ENGINE BLEED AIR MANIFOLD SEE FIG. 2.10-7 INDEX 42	RF		

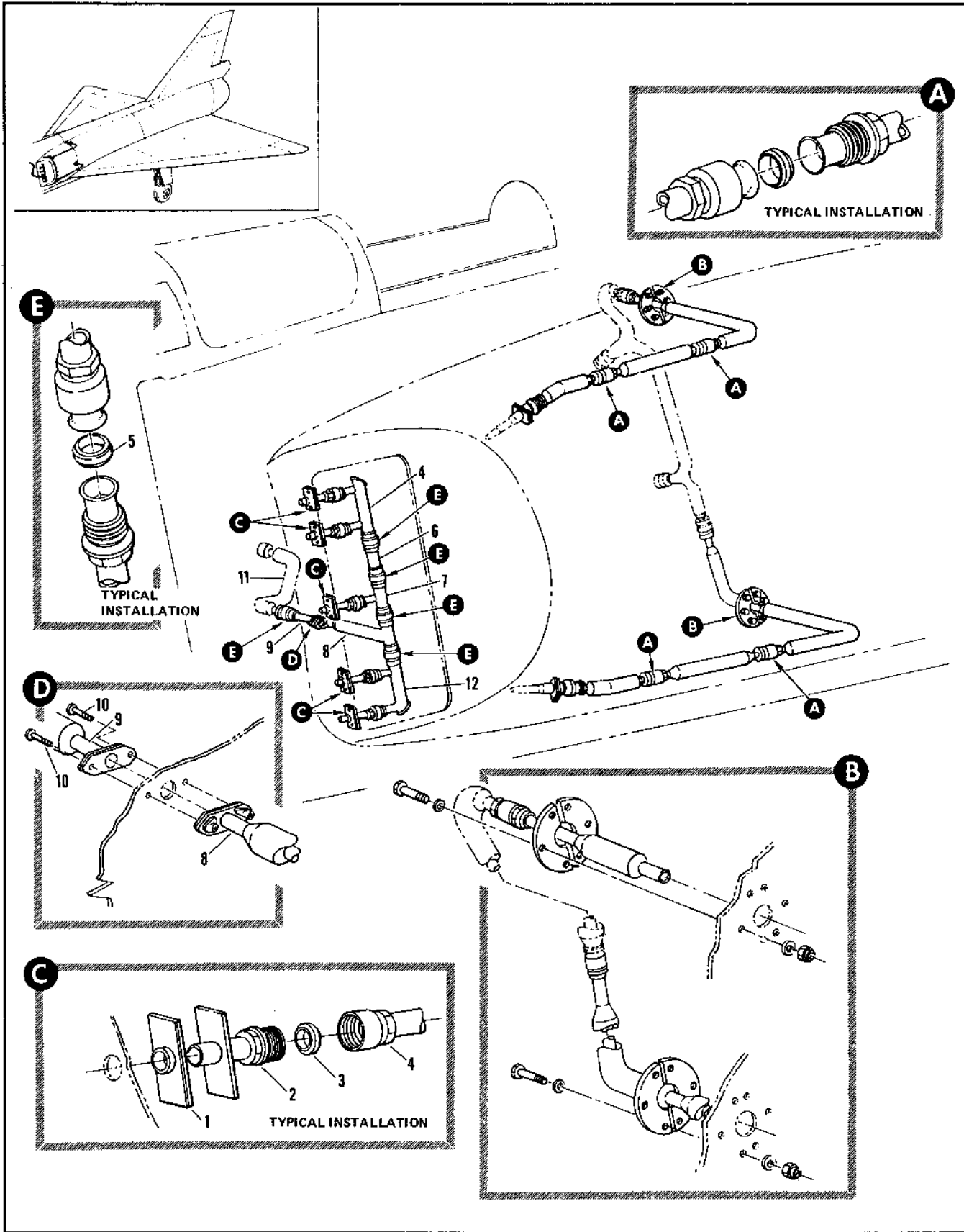

Figure 2.13-28. Leading Edge Duct Anti-Icing Tubing Installation (Sheet 1 of 2)

FIGURE AND INDEX NUMBER	PART NUMBER	DESCRIPTION	UNITS PER ASSY.	USABLE ON CODE	
				FROM	TO
		1 2 3 4 5 6			
2.13-28	R-77584-1	TUBING INSTALLATION, LEADING EDGE DUCT ANTI-ICING LH FOR WMA SEE FIG. 2.11-3	RF	35	
	R-77584-2	TUBING INSTALLATION, LEADING EDGE DUCT ANTI-ICING RH FOR WMA SEE FIG. 2.11-3	RF	35	
- 1	R-74040	• SLEEVE	5	35	
- 2	R-77511-21	• TUBE ASSEMBLY	5	35	
- 3	4185-6	• RING, <98159> 97-60002-001	5	35	
- 4	R-77511-25	• TUBE ASSY, WELDED REPLACED BY SUITABLE SUB R-77511-225	1	35	159
	R-77511-225	• TUBE ASSY, WELDED REPLACES SUITABLE SUB FOR R-77511-25	1	160	
	4184-6	• • COUPLING, <98159> 92-74004-001	2	35	
- 5	4185-10	• RING, <98159> 97-60002-102	5	35	129
	2838	• RING, <98159> 97-60002-105	5	160	
- 6	R-77511-29	• TUBE ASSEMBLY	1	35	
	4184-10	• • COUPLING, <98159> 92-74004-012	2	35	
- 7	R-77511-33	• TUBE ASSY, WELDED REPLACED BY SUITABLE SUB R-77511-227	1	35	159
	R-77511-227	• TUBE ASSY, WELDED REPLACES SUITABLE SUB FOR R-77511-33	1	160	
	4184-6	• • COUPLING, <98159> 92-74004-001	1	35	
- 8	R-77511-37	• TUBE ASSY, LH	1	35	
	R-77511-39	• TUBE ASSY, RH	1	35	
- 9	R-77511-127	• TUBE ASSY, WELDED REPLACED BY SUITABLE SUB R-77511-233	1	35	159
	R-77511-233	• TUBE ASSY, WELDED REPLACES SUITABLE SUB FOR R-77511-127	1	160	
		ATTACHING PARTS			
- 10	NAS221-10	• SCREW	2	35	
- 11		----- • TUBING INSTL, ANTI-ICING AIR INTAKE DUCT LIP SEE FIG. 2.13-28	RF		
- 12	R-77511-41	• TUBE ASSY, WELDED REPLACED BY SUITABLE SUB R-77511-229	1	35	159
	R-77511-229	• TUBE ASSY, WELDED REPLACES SUITABLE SUB FOR R-77511-41	1	160	
	4184-6	• • COUPLING, <98159> 92-74004-001	2	35	

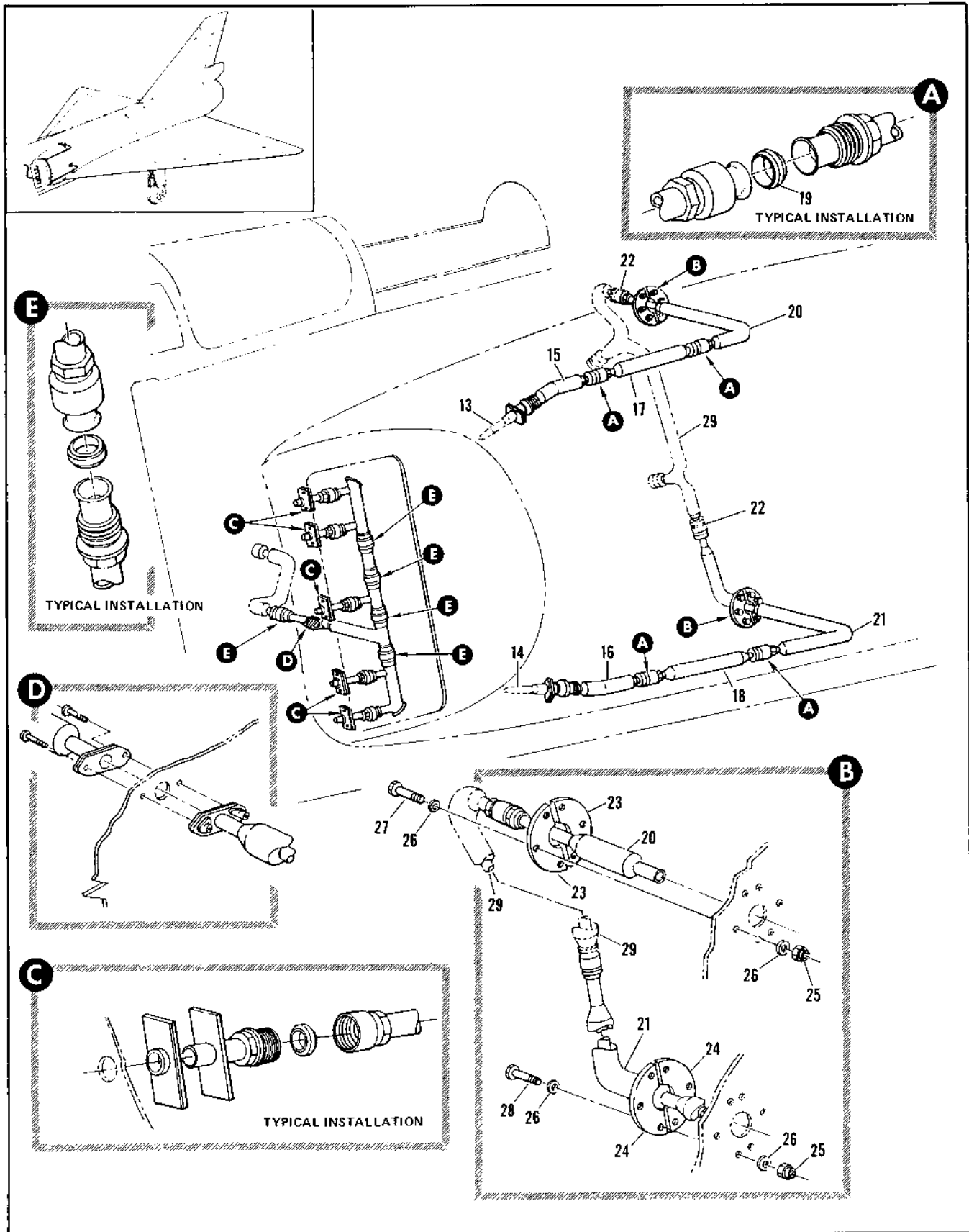

Figure 2.13-28. Leading Edge Duct Anti-Icing Tubing Installation (Sheet 2 of 2)

FIGURE AND INDEX NUMBER	PART NUMBER	DESCRIPTION	UNITS PER ASSY.	USABLE ON CODE	
				FROM	TO
		1 2 3 4 5 6			
2.13-28- 13		• TUBE ASSY, UPPER LH SEE FIG. 2.11-3	RF		
- 14		• TUBE ASSY, LOWER LH SEE FIG. 2.11-3	1	35	
- 15	8-77584-61	• TUBE ASSY, UPPER LH WELDED	1	35	
	8-77584-62	• TUBE ASSY, UPPER RH WELDED	1	35	
- 16	8-77584-65	• TUBE ASSY, LOWER LH WELDED	1	35	
	8-77584-66	• TUBE ASSY, LOWER RH WELDED	1	35	
	2506-10	• COUPLING, <98159> 92-74004-004	1	35	
- 17	8-77584-69	• TUBE ASSY, UPPER	1	35	
- 18	8-77584-71	• TUBE ASSY, LOWER	1	35	
	2506-10	• COUPLING, <98159> 92-74004-004	1	35	
- 19	4185-10	• RING, RITE 97-60502-002	4	35	
- 20	8-77584-51	• TUBE ASSY, UPPER LH REPLACED BY NOT INTCHG WITH 8-77584-129	1	35	159
	8-77584-129	• TUBE ASSY, UPPER LH REPLACES NOT INTCHG WITH 8-77584-51	1	160	
	8-77584-52	• TUBE ASSY, UPPER RH REPLACED BY NOT INTCHG WITH 8-77584-130	1	35	159
	8-77584-130	• TUBE ASSY, UPPER RH REPLACES NOT INTCHG WITH 8-77584-52	1	160	
- 21	8-77584-55	• TUBE ASSY, LOWER LH REPLACED BY NOT INTCHG WITH 8-77584-139	1	35	159
	8-77584-139	• TUBE ASSY, LOWER LH REPLACES NOT INTCHG WITH 8-77584-55	1	160	
	8-77584-56	• TUBE ASSY, LOWER RH REPLACED BY NOT INTCHG WITH 8-77584-140	1	35	159
	8-77584-140	• TUBE ASSY, LOWER RH REPLACES NOT INTCHG WITH 8-77584-56	1	160	
	4184-10	• COUPLING, <98159> 92-74004-002	1	35	60
	2506-10	• COUPLING, <98155> 92-74004-004	1	61	
- 22	4185-10	• RING, <98159> 97-60502-002	2	35	159
	2838	• RING, <98159> 97-60502-005	2	160	
- 23	8-77511-221	• SEAL	2	35	
- 24	8-77511-223	• SEAL	2	35	
		ATTACHING PARTS			
- 25	AN314-3	• NUT	12	35	
- 26	AN960C10L	• WASHER	24	35	
- 27	AN3C5	• BOLT	6	35	
- 28	AN3C4	• BOLT	6	35	
		-----X-----			
- 29		• DUCT ASSY, ANTI-ICING LH WELDED SEE FIG. 2.13-29 INDEX 1	RF		

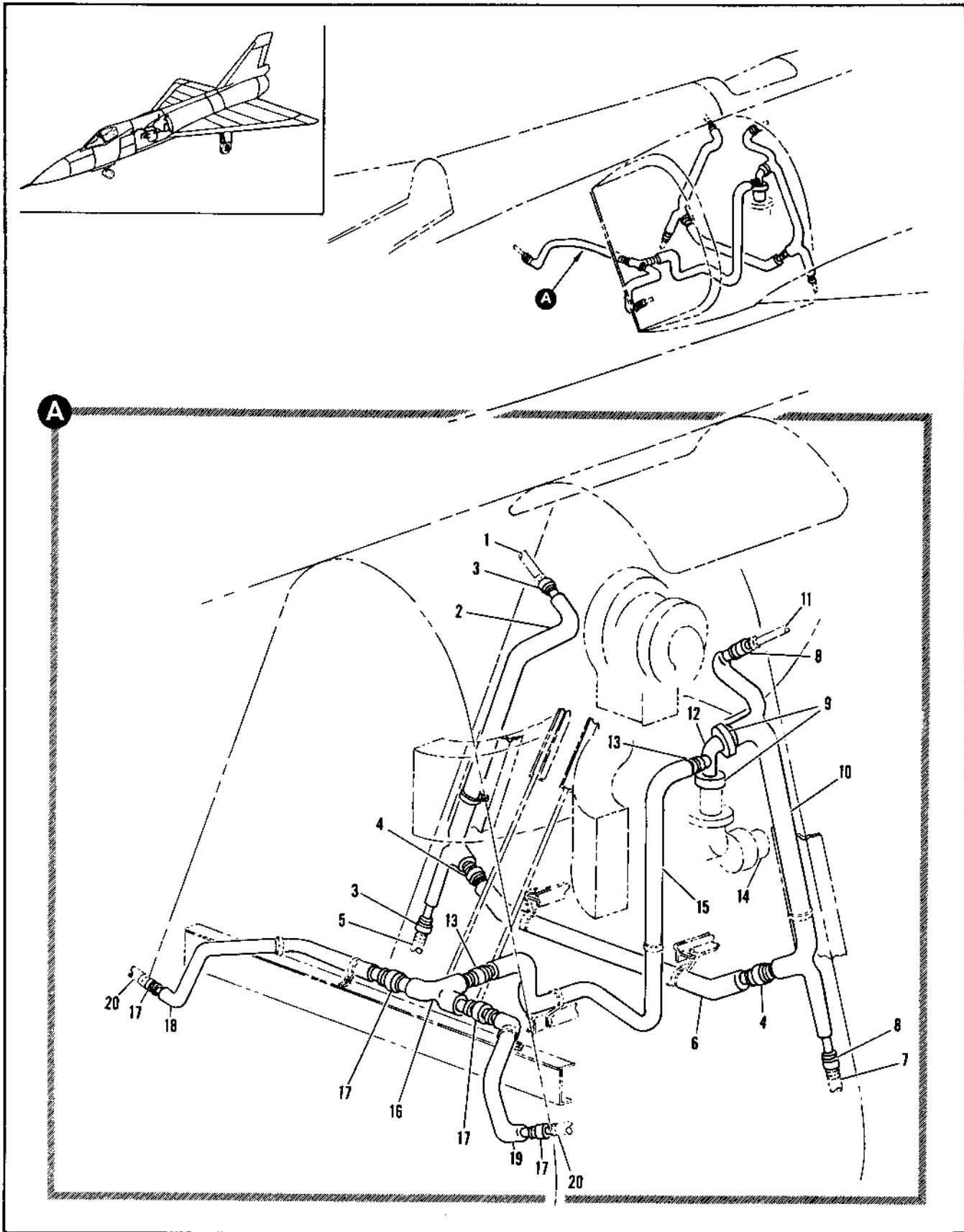

Figure 2.13-29. Anti-Icing Air Intake Duct Lip Tubing Installation

FIGURE AND INDEX NUMBER	PART NUMBER	DESCRIPTION	UNITS PER ASSY.	USABLE ON CODE	
				FROM	TO
		1 2 3 4 5 6			
2.13-29	8-23800	TUBING INSTALLATION, ANTI-ICING AIR INTAKE DUCT LIP FOR NHA SEE FIG. 2.13-10	RF	35	
- 1		• TUBE ASSY, UPPER RH SEE FIG. 2.13-28	RF		
- 2	8-23804-1	• DUCT ASSY, ANTI-ICING RH WELDED REPLACED BY NOT INTCHG WITH 8-23804-5	1	35	159
	8-23804-5	• DUCT ASSY, ANTI-ICING RH WELDED REPLACES NOT INTCHG WITH 8-23804-1	1	160	
- 3	4185-10 2838	• RING, <98159> 97-60502-002	2	35	159
- 4	NAS595-16 2894	• RING, <98159> 97-60502-005	2	160	
		• RING	2	35	159
- 5		• RING, <98159> 97-60502-006	2	160	
		• TUBE ASSY, LOWER RH SEE FIG. 2.13-28	RF		
- 6	8-23807	• TUBE ASSY, AFT CONNECTING REPLACED BY NOT INTCHG WITH 8-23807-3	1	35	159
	8-23807-3	• TUBE ASSY, AFT CONNECTING REPLACES NOT INTCHG WITH 8-23807	1	160	
- 7		• TUBE ASSY, LOWER LH SEE FIG. 2.13-28 INDEX 21	RF		
- 8	4185-10 2838	• RING, <98159> 97-60502-002	2	35	159
- 9	4464C206M 7-2053-3	• RING, <98159> 97-60502-005	2	160	
		• COUPLING, (98625) 92-73005-016	2	35	
- 10	8-23803-1	• GASKET, <00307> 94-16002-014	2	35	159
		• DUCT ASSY, ANTI-ICING LH WELDED REPLACED BY SUITABLE SUB 8-23803-5	1	35	159
	8-23803-5	• DUCT ASSY, ANTI-ICING LH WELDED REPLACES SUITABLE SUB FOR 8-23803-1	1	160	
- 11		• TUBE ASSY, UPPER LH SEE FIG. 2.13-28 INDEX 23	RF		
- 12	8-23805	• ELBOW ASSY, WELDED REPLACED BY NOT INTCHG WITH 8-23805-1	1	35	159
	8-23805-1	• ELBOW ASSY, WELDED REPLACES NOT INTCHG WITH 8-23805	1	160	
- 13	NAS595-16 2894	• RING	2	35	159
		• RING, <98159> 97-60502-006	2	160	
- 14		• VALVE ASSY, AIR REGULATOR AND SHUTOFF	RF		
- 15	8-23801	• TUBE ASSY, FWD TAKE-OFF REPLACED BY SUITABLE SUB 8-23801-3	1	35	159
	8-23801-3	• TUBE ASSY, FWD TAKE-OFF REPLACES SUITABLE SUB FOR 8-23801	1	160	
- 16	8-23802-1	• TEE ASSY, FWD WELDED REPLACED BY SUITABLE SUB 8-23802-3	1	35	159
	8-23802-3	• TEE ASSY, FWD WELDED REPLACES SUITABLE SUB FOR 8-23802-1	1	160	
- 17	4185-10 2838	• RING, <98159> 97-60502-002	4	35	159
		• RING, <98159> 97-60502-005	4	160	
- 18	8-23806-1	• TUBE ASSY, FWD RH REPLACED BY NOT INTCHG WITH 8-23806-5	1	35	159
	8-23806-5	• TUBE ASSY, FWD RH REPLACES NOT INTCHG WITH 8-23806-1	1	160	
- 19	8-23808-1	• TUBE ASSY, FWD LH REPLACED BY NOT INTCHG WITH 8-23808-5	1	35	159
	8-23808-5	• TUBE ASSY, FWD LH REPLACES NOT INTCHG WITH 8-23808-1	1	160	
- 20		• TUBE ASSY, SEE FIG. 2.13-28 INDEX 2	RF		

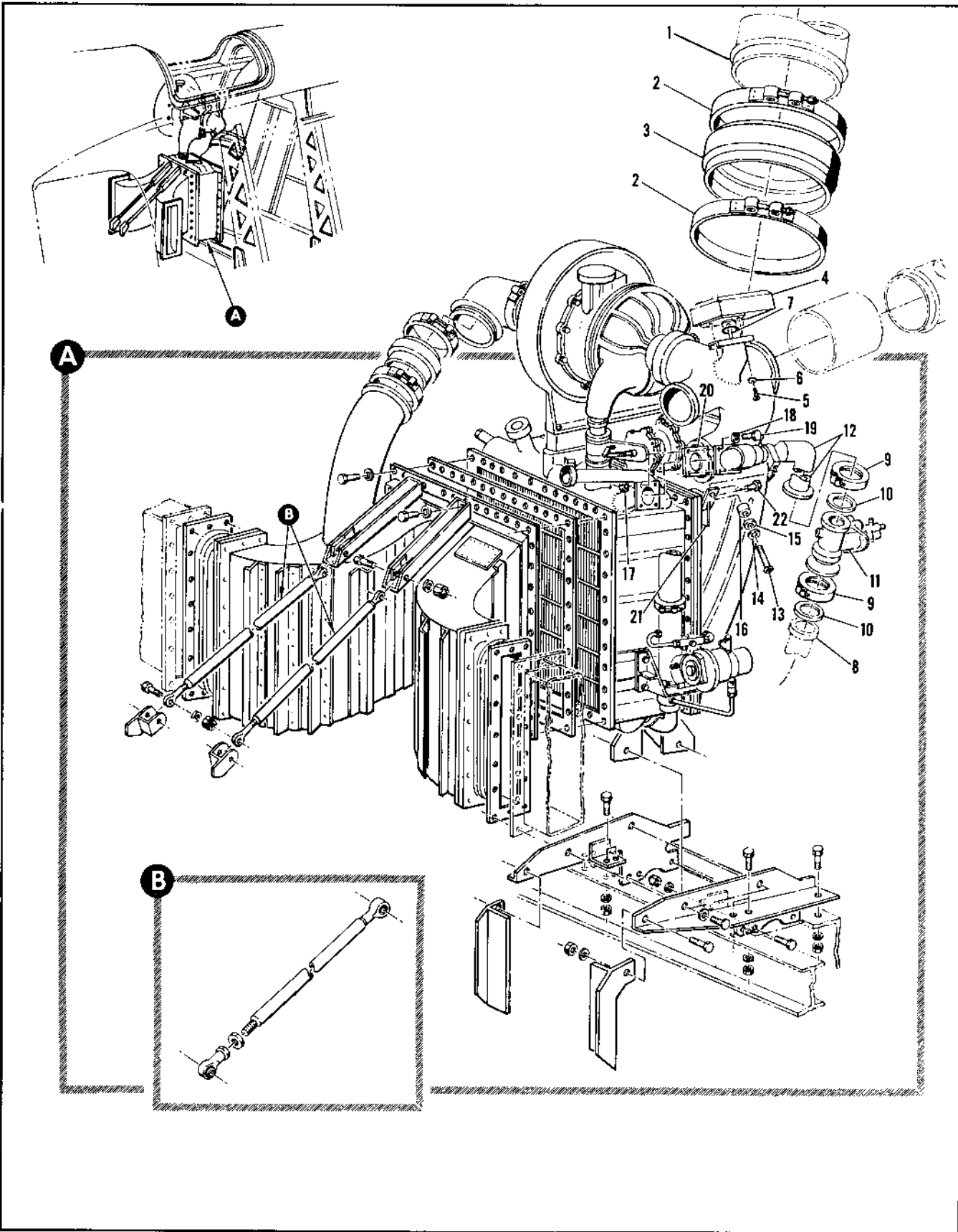

Figure 2.13-30. Refrigeration Unit and Ram Air Inlet Header Installation (Sheet 1 of 3)

FIGURE AND INDEX NUMBER	PART NUMBER	DESCRIPTION	UNITS PER ASSY.	USABLE ON CODE	
				FROM	TO
2.13-30	A-23130	• COUPLING INSTL, HEAT EXCHANGER EXHAUST EXIT DUCT FOR NHA SEE FIG. 2.1-1	PF	35	
-	R-23100-405	REFRIGERATION UNIT AND RAM AIR INLET HEADER INSTALLATION, MODIFIED BY R-80310 FOR NHA SEE FIG. 2.3-B	PF	35	
	R-23100-901	HEADER INSTALLATION, RAM AIR INLET FOR NHA SEE FIG. 2.3-B	PF	35	43
	R-23101-409	HEADER INSTALLATION, RAM AIR INLET FOR NHA SEE FIG. 2.3-B	RF	44	
- 1		• DUCT ASSY, HEAT EXCHANGER SEE FIG. 2.13-1	RF		
- 2	365-62-862M	• CLAMP, <98625> 91-97/23-227	2	35	
- 3	N120-62-862M	• CLAMP	2	535	
- 4	NAS220-6A-12	• COUPLING	1	35	
- 4	197826-8-1	• THERMOSTAT, LOW TEMPERATURE LIMITING (70213)	1		
		ATTACHING PARTS			
- 5	NAS221-12	• SCREW	3	35	
- 6	AN960PD10	• WASHER	3	35	
		----X----			
- 7	MS28775-21P	• PACKING	1	35	
- 8		• DUCT ASSY, BLEED AIR SEE FIG. 2.13-23 INDEX 4	PF		
- 9	24502-200	• COUPLING, <98625> 92-72/12-009	2	35	
- 10	24096-200C	• GASKET, <98625> 94-16005-012	2	35	
- 11	106638-3	• VALVE ASSY, BYPASS <70210> SPEC R-19912-1 T.O. 15A2-2-20-183	1	35	
- 12	A-23597	• DUCT ASSY, EXCHANGER BYPASS WELDED	1	35	159
- 13	NAS221-11	• BOLT	1	35	
- 14	AN960C10	• WASHER	1	35	
- 15	AN960C516L	• WASHER	1	35	
- 16	NAS43HT3-14	• SPACER	1	35	
- 17	NAS679A4	• NUT	4	35	
- 18	AN963C416L	• WASHER	4	35	
- 19	AN4C7A	• BOLT	4	35	
		----X----			
- 20	A2375C	• GASKET, <97968> 94-16013-042	1	35	
- 21	R-23942	• BRACKET	1	35	
	R-23969	• BRACKET, ALT INCHS WITH R-23942	RF	35	
		ATTACHING PARTS			
- 22	AN3-5A	• BOLT	2	35	
		----X----			

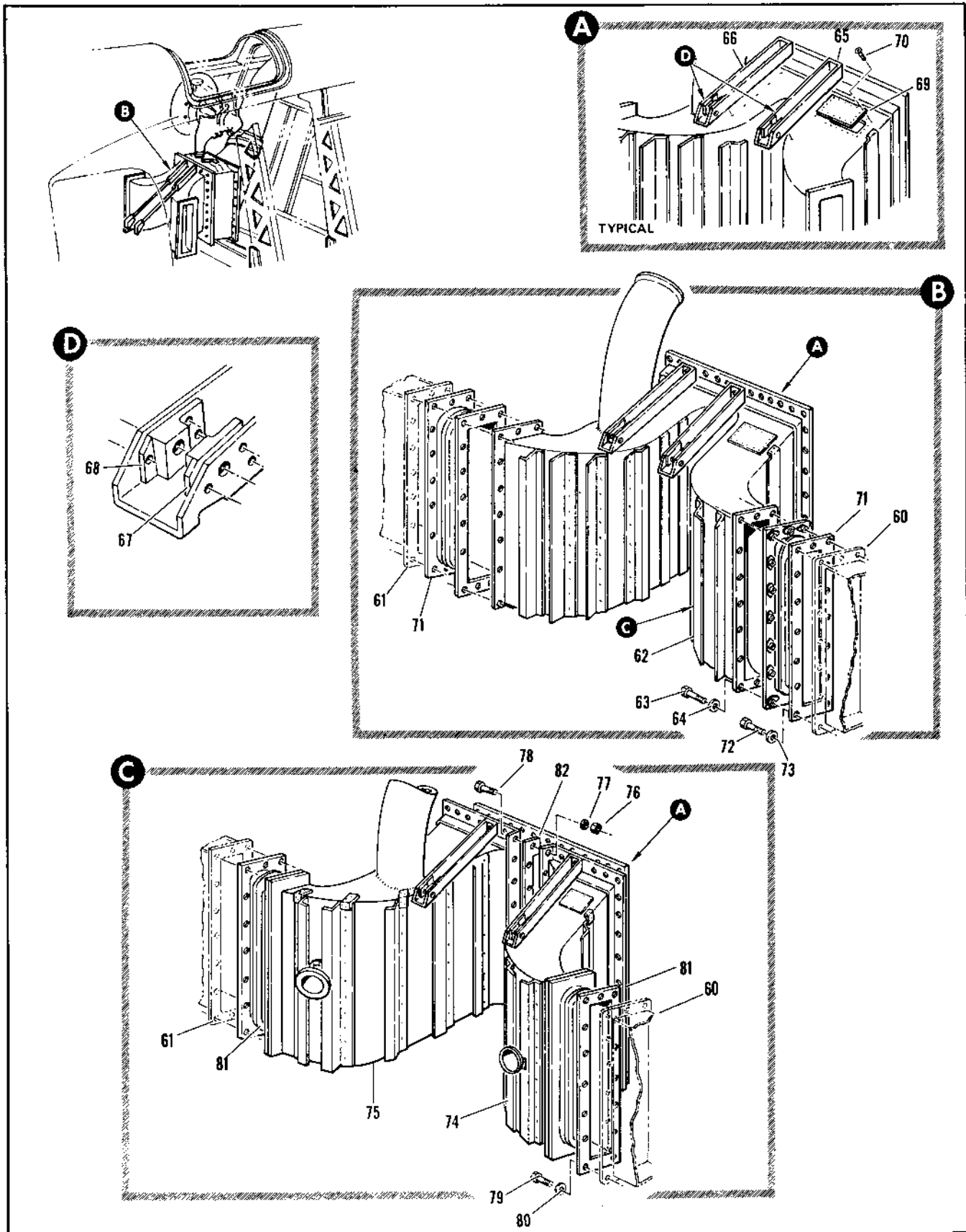

Figure 2.13-30. Refrigeration Unit and Ram Air Inlet Header Installation (Sheet 2 of 3)

FIGURE AND INDEX NUMBER	PART NUMBER	DESCRIPTION	UNITS PER ASSY.	USABLE ON CODE	
				FROM	TO
		1 2 3 4 5 6			
2.13-30- 23	321-62-431M	• CLAMP, <98625> 91-97852-123	2	35	
- 24	AD297-1	• COUPLING, <42799> SPEC R-60297-1	1	35	
- 25		• COUPLING, SEE FIG. 2.13-22 INDEX 3	RF		
- 26		• DUCT ASSY, TRANSITION SEE FIG. 2.13-22 INDEX 24	RF		
- 27	R-23150-3	• REFRIGERATION UNIT ASSY, FOR BREAKDOWN SEE FIG. 2.13-31	1	35	240
	R-23150-R05	• REFRIGERATION UNIT ASSY, FOR BREAKDOWN SEE FIG. 2.13-31 ATTACHING PARTS	1	241	
- 28	AN3-6A	• BOLT	2	35	
- 29	AN3-4A	• BOLT	47	35	43
	AN3-4A	• BOLT	46	44	
- 30	AN960010L	• WASHER	49	35	43
	AN960010L	• WASHER	48	44	
- 31	AN174A6	• BOLT	4	35	
- 32	AN9600416L	• WASHER	4	35	
		-----X-----			
- 33	R-23121	• GASKET	1	35	
- 34	6-23112	• STRUT ASSY, HEAT EXCHANGER STABILIZER ATTACHING PARTS	2	35	
- 35	NAS679A3	• NUT	4	35	
- 36	AN960010L	• WASHER	4	35	
- 37	NAS464P3A17	• BOLT	2	35	
- 38	NAS464P3A10	• BOLT	2	35	
		-----X-----			
- 39	HRBM3	• BEARING, ROD END <97613> 95-60013-002	1	35	
- 40	AN316-4R	• NUT	1	35	
- 41	R-23112-9	• TUBE ASSY, RIVETED	1	35	
- 42	R-23113	• FITTING, STABILIZER LH	1	35	
- 43	R-23114	• FITTING, STABILIZER RH	1	35	
- 44	R-23100-11	• CLIP ATTACHING PARTS	2	35	
- 45	NAS679A3	• NUT	4	35	
- 46	99-51509-006	• WASHER	4	35	
- 47	NAS464P3A3	• BOLT	4	35	
		-----X-----			
- 48	R-23100-7	• TEE, LH	1	35	
- 49	R-23100-8	• TEE, RH ATTACHING PARTS	1	35	
- 50	NAS679A3	• NUT	2	35	
- 51	AN960010L	• WASHER	2	35	
- 52	NAS464P3A3	• BOLT	2	35	
		-----X-----			
- 53	R-23100-9	• SUPPORT, LH	1	35	
- 54	R-23100-10	• SUPPORT, RH ATTACHING PARTS	1	35	
- 55	NAS679A3	• NUT	12	35	
- 56	AN960010L	• WASHER	6	35	
- 57	99-51509-006	• WASHER	4	35	
- 58	NAS464P3A3	• BOLT	10	35	
- 59	NAS464P3A15	• BOLT	2	35	
		-----X-----			

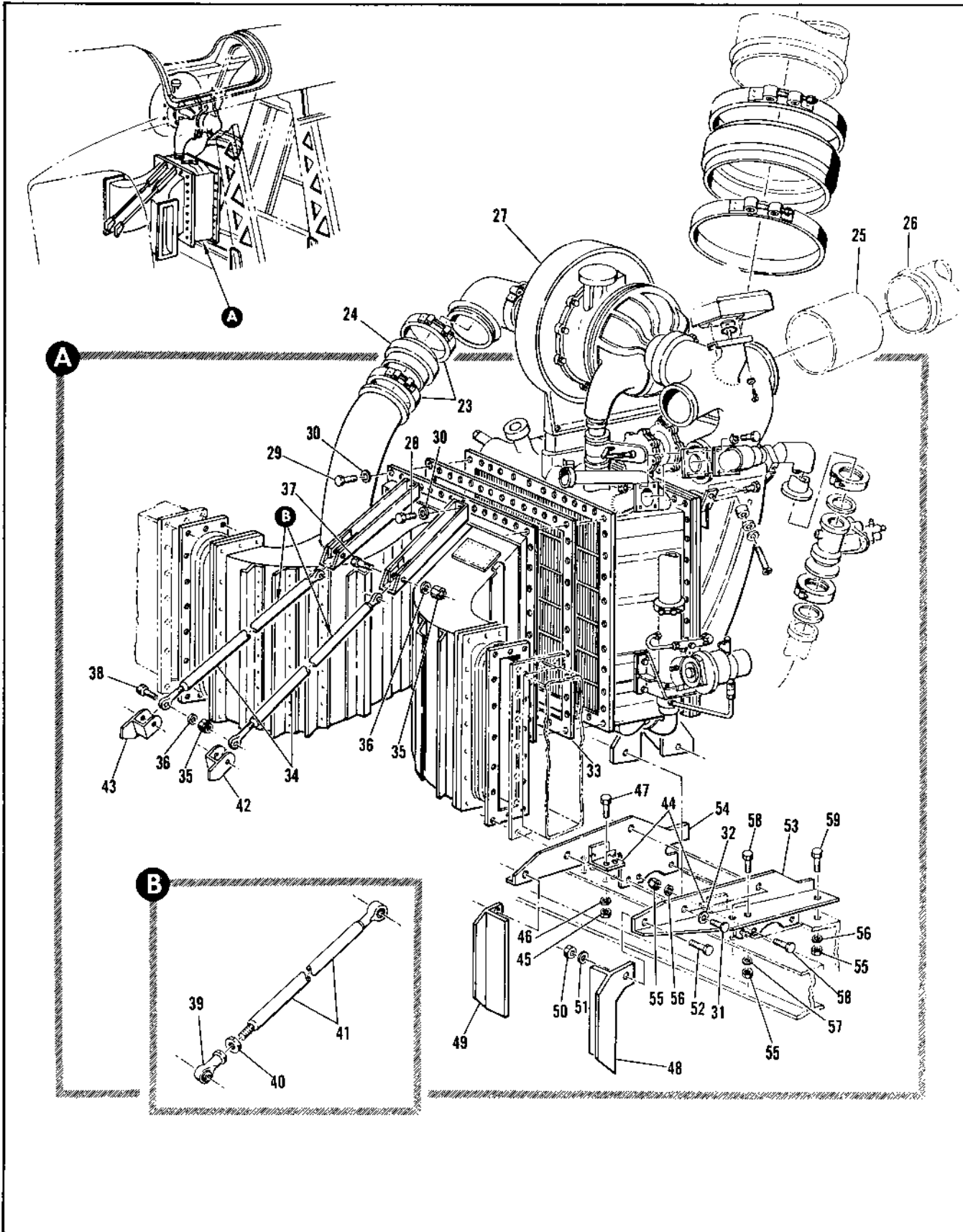

Figure 2.13-30. Refrigeration Unit and Ram Air Inlet Header Installation (Sheet 3 of 3)

FIGURE AND INDEX NUMBER	PART NUMBER	DESCRIPTION	UNITS PER ASSY.	USABLE ON CODE	
				FROM	TO
2.13-80- 60			RF		
- 61		• DUCT ASSY, BOUNDARY BLEED FWD LH SEE FIG. 2.13-1 INDEX 97	RF		
- 62	R-23101-3	• DUCT ASSY, BOUNDARY BLEED FWD RH SEE FIG. 2.13-1 INDEX 97	1	35	43
- 63	AN3-3A	• HEADER ASSY, HEAT EXCHANGER INLET ATTACHING PARTS	36	35	43
- 64	AN967010L	• BOLT	36	35	43
		• WASHER			
		-----X-----			
- 65	R-23108	• CHANNEL ASSY, LH	1	35	43
- 66	R-23108-1	• CHANNEL ASSY, RH	1	35	43
- 67	R-23107-7	• FITTING	1	35	43
- 68	R-23107-8	• FITTING	1	35	43
- 69	R-23101-119	• DOOR, ACCESS ATTACHING PARTS	1	35	43
- 70	NAS221-R	• SCREW	20	35	43
		-----X-----			
- 71	R-23100-17	• DUCT ASSY, HEAT EXCHANGER TO BOUNDARY BLEED MIXED ATTACHING PARTS	2	35	43
- 72	AN3-4A	• BOLT	32	35	43
- 73	AN960010L	• WASHER	32	35	43
		-----X-----			
- 74	R-23101-801	• HEADER ASSY, HEAT EXCHANGER INLET LH	1	44	
- 75	R-23101-803	• HEADER ASSY, HEAT EXCHANGER INLET RH ATTACHING PARTS	1	44	
- 76	NAS679A3	• NUT	11	44	
- 77	AN960010L	• WASHER	11	44	
- 78	AN304A	• BOLT	11	44	
- 79	AN3-6A	• BOLT	32	44	
- 80	AN960010L	• WASHER	32	44	
		-----X-----			
	R-23108	• CHANNEL ASSY, LH	1	44	
	R-23108-1	• CHANNEL ASSY, RH	1	44	
	R-23107-7	• FITTING	1	44	
	R-23107-8	• FITTING	1	44	
	R-23101-119	• DOOR, LH ATTACHING PARTS	1	44	
	NAS221-R	• SCREW, LH	20	44	
		-----X-----			
- 81	3-4360	• DUCT, FLEX (7062R) SPEC R-F2453-1	1	44	
	R-23100-17	• DUCT ASSY, ALT INTCG WITH 3-4360 FOR REPLACEMENT USE 3-4360	RF	A	
- 82	R-23124	• GASKET	1	44	
		A. AIRPLANES 275, 277, 301 AND GA			

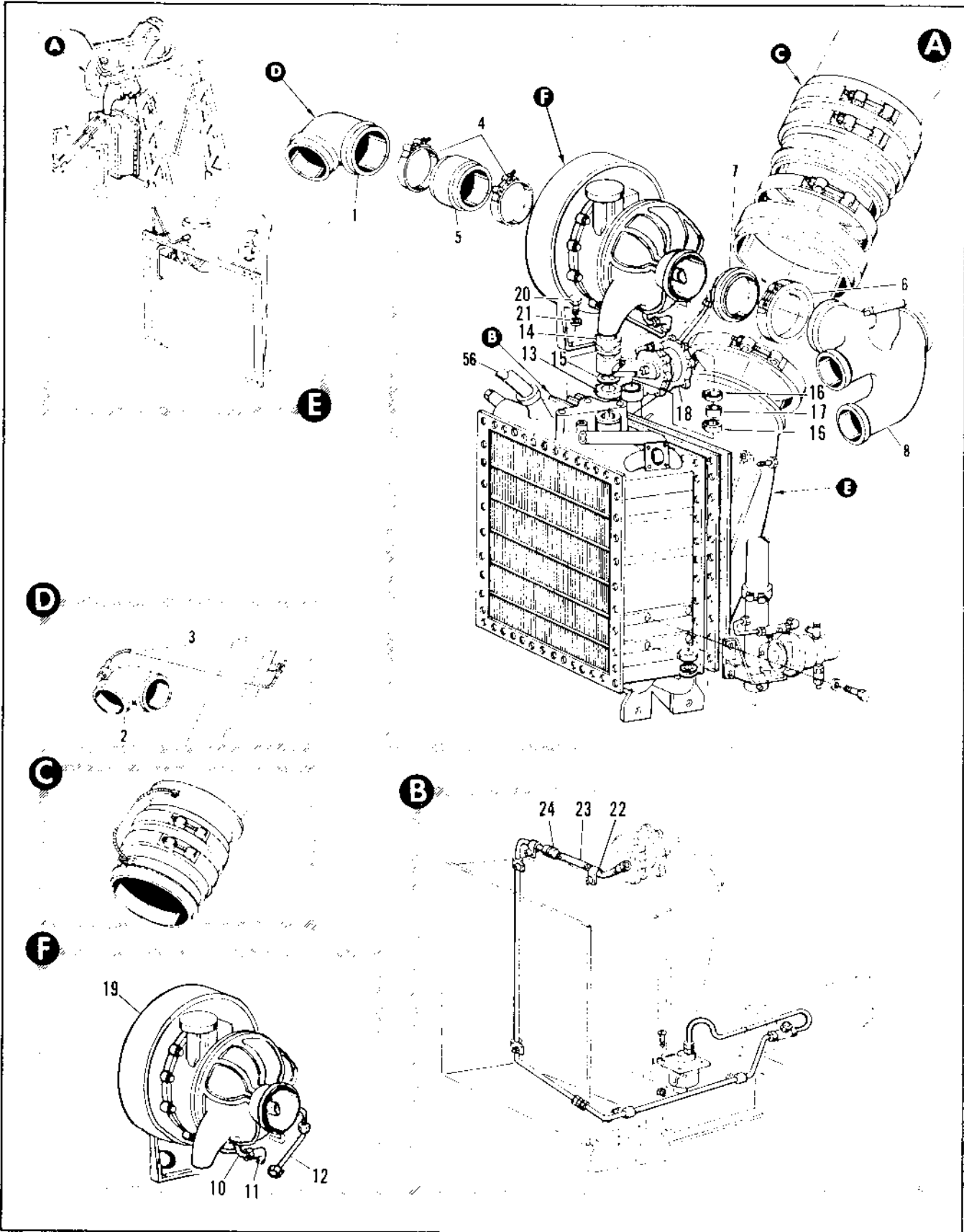

Figure 2.13-31. Refrigeration Unit Assembly (Sheet 1 of 3)

FIGURE AND INDEX NUMBER	PART NUMBER	DESCRIPTION	UNITS PER ASSY.	USABLE ON CODE	
				FROM	TO
		1 2 3 4 5 6			
2.13-31	R-23150-3	REFRIGERATION UNIT ASSEMBLY, FOR NHA SEE FIG. 2.13-30	RF	35	240
	R-23150-805	REFRIGERATION UNIT ASSEMBLY MODIFIED BY R-21892 FOR NHA SEE FIG. 2.13-30	RF	241	
- 1	R-23120	• DUCT ASSY, COMPRESSION INLET WELDED REPLACED BY SUITABLE SUB R-23120-1	1	35	38
- 2	R-23120-1	• DUCT ASSY, COMPRESSION INLET WELDED REPLACES SUITABLE SUB FOR R-23120	1	39	
- 3	MS25083-2RR5	• JUMPER ATTACHING PARTS	1	39	
	AN345C10	• NUT	1	39	
	AN960C10L	• WASHER	1	39	
	AN935-10L	• WASHER	1	39	
	AN960D10L	• WASHER	1	39	
	AN526-1032R12	• SCREW	1	39	
	AN3-3A	• BOLT	1	39	
		----X----			
- 4	50230075-45PM	• CLAMP, <98625> 91-97802-040	2	35	
- 5	AD297-5	• COUPLING, <92799> SPEC R-00297-5	1	35	
- 6	15355-4.310 18275-350	• COUPLING, <92799> SPEC R-00297-5 • COUPLING, <92759> REPLACES SUITABLE SUB FOR 15355-4.310	1	35	
- 7	7-2253-4	• GASKET, <90307> 94-16002-002	1	35	
- 8	R-23106-R01	• DUCT ASSY, REFRIGERATION TURBINE OUTLET WELDED	1	160	
- 9	197097	• TUBE ASSEMBLY REFRIGERATION UNIT (96193)	1	35	
- 10	107096	• TUBE ASSEMBLY REFRIGERATION UNIT OIL PRESSURIZATION LINE (96193)	1	35	
- 11	AN837-4D	• ELBOW (88044)	1	35	
- 12	R-23150-13	• TUBE ASSEMBLY	1	35	
- 13	15095-2.810	• COUPLING, <98625> 92-73003-014	1	35	
- 14	15095-3.060	• COUPLING, <98625> 92-73003-013	1	35	
- 15	SS38.5A26	• PACKING, <96193> 96-58515-001	2	35	
- 16	50230075-308M	• CLAMP, <98625> 91-97802-039	2	35	
- 17	AD390-3	• COUPLING, <92799> SPEC R-00939-3	1	35	
- 18	104584-2	• VALVE ASSY, PRESSURE REGULATOR AND SHUTOFF, MODEL CV2560-3 (96193) ALTERED FROM 102119, T.O. 15A2-7-6-4	1	35	
- 19	107037-1	• TURBINE AND COMPRESSOR ASSEMBLY (96913) REPLACES SUITABLE SUB FOR 26003 ATTACHING PARTS	1	35	
- 20	AN4H5A	• BOLT	3	35	
- 21	AN960C416L	• WASHER	3	35	
		----X----			
- 22	MS21919D65	• CLAMP ATTACHING PARTS	1	278	
	NAS43-3-H	• SPACER	1	278	
		----X----			
- 23	R3800-4-0120	• HOSE ASSY, TETRAFLUORETHYLENE <50599> 94-80505-030	1	278	
- 24	ANR15-4	• UNION	1	278	
		*1 USED WITH TURBINE, PART NO. 107037			

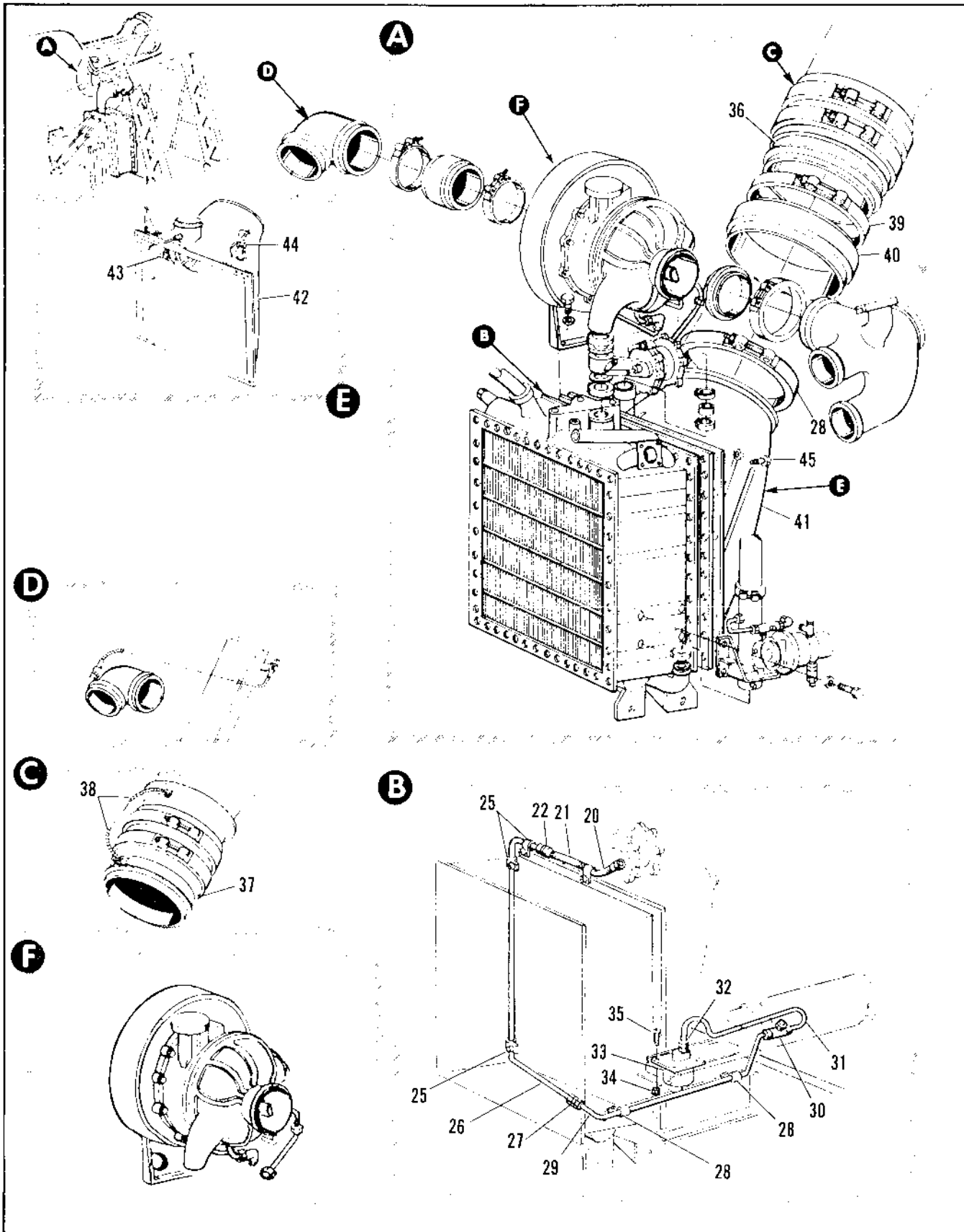

Figure 2.13-31. Refrigeration Unit Assembly (Sheet 2 of 3)

FIGURE AND INDEX NUMBER	PART NUMBER	DESCRIPTION	UNITS PER ASSY.	USABLE ON CODE	
				FROM	TO
		1 2 3 4 5 6			
2.13-31- 25	MS21912004	• CLAMP ATTACHING PARTS	3	278	
	AN3-7A	• BOLT	3	278	
	NAS43-3-24	• SPACER	3	278	
		-----X-----			
- 26	W-21892-05	• TUBE ASSEMBLY	1	278	
- 27	MS21902-4	• UNION	1	278	
- 28	MS21919064	• CLAMP ATTACHING PARTS	2	278	
	NAS1291-3	• NUT	2	278	
	NAS221-6	• SCREW -----X-----	2	278	
- 29	W-21892-11	• TUBE ASSEMBLY	1	278	
- 30	MS21909-4	• TEE	1	278	
	AN924-4	• NUT	1	278	
	AN6245-4	• GASKET	1	278	
- 31	W-21892-7	• TUBE ASSEMBLY	1	278	
- 32	MS21902-4	• UNION	1	278	
	AN6245-4	• GASKET	1	278	
- 33	4-1365	• SWITCH, PRESSURE SENSING BLEED AIR EJECTOR SYSTEM CONTROL SPEC W-02586-5 ATTACHING PARTS	1	278	
- 34	NAS1291-3	• NUT	4	278	
- 35	NAS221-6	• SCREW -----Y-----	4	278	
- 36	W-23142	• DUCT ASSY, HEAT EXCHANGER EXHAUST WELDED	1	35	38
- 37	W-23102-3	• DUCT ASSY, HEAT EXCHANGER EXHAUST WELDED	1	39	
- 38	MS25083-2607	• JUMPER ATTACHING PARTS	1	39	
	AN390010	• NUT	2	39	
	AN960010L	• WASHER	2	39	
	AN930-10L	• WASHER	2	39	
	AN960010L	• WASHER	2	39	
	AN526-1030010	• SCREW -----X-----	2	39	
- 39	165-62-862M	• CLAMP, (48607) 91-97807-007	20	35	
	N120-62-852M	• CLAMP	20	35	
- 40	NAS129-64-12	• COUPLING	1	35	
- 41	W-23241-1	• AIR EJECTOR ASSY, ALTERED FROM 24022-3	1	278	373
	104586	AIR EJECTOR ASSY, MODEL EJ2-1 ALTERED FROM W- 23241-1 IDENTIFIED AS 6403475-3 T.O. 15A11-0-1	1		
	104591	• AIR EJECTOR ASSY, MODEL EJ2-2 ALTERED FROM W- 23241-3 IDENTIFIED AS 6403475-1 T.O. 15A11-2-3	1		
- 42	105426	• AIR EJECTOR (96191)	1		
- 43	104610	• ACTUATOR ASSEMBLY, EJECTOR VALVE (96193)	1	35	
- 44	104618	• VALVE ASSEMBLY, AIR EJECTOR 10720 (96192) ATTACHING PARTS	1	35	
- 45	AN3-4A	• BOLT	49	35	277
	AN3-4A	• BOLT	45	278	

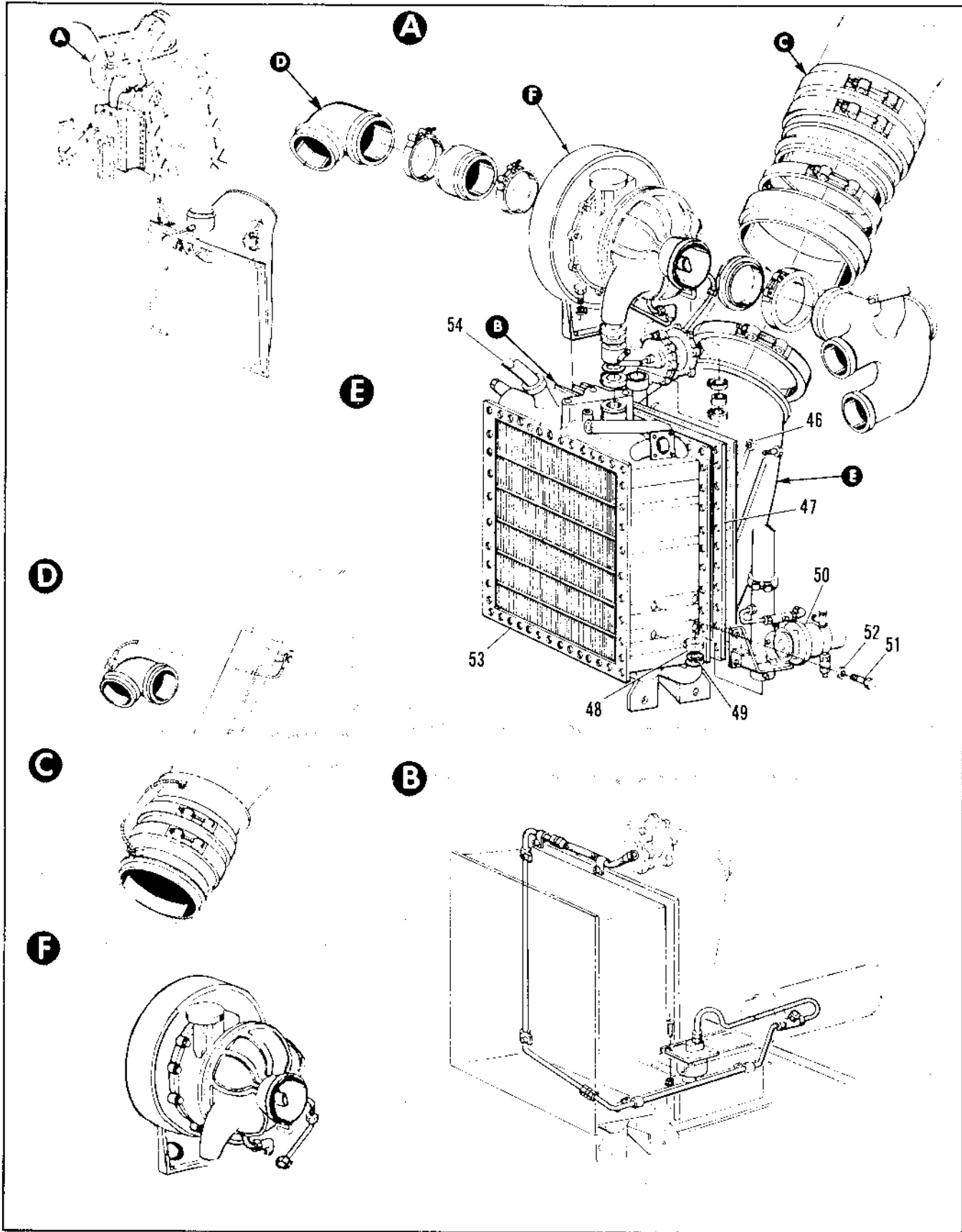

Figure 2.13-31. Refrigeration Unit Assembly (Sheet 3 of 3)

FIGURE AND INDEX NUMBER	PART NUMBER	DESCRIPTION	UNITS PER ASSY.	USABLE ON CODE	
				FROM	TO
2.13-31- 50	AN960D10L	<ul style="list-style-type: none"> • WASHER • WASHER • GASKET • COUPLING, (98625) 92-7305-016 • GASKET, (00307) 54-16002-014 • REGULATOR ASSY, DUCT LIP ANTI-ICING AIR PRESSURE SHUTOFF AND DIFFERENTIAL (7021) SPEC 8-0245-3 T.O. 1502-4-6-33 ATTACHING PARTS • BOLT • WASHER -----X----- • HEAT EXCHANGER ASSY, AIR-TO AIR (96193) • HOSE ASSY, HEAT EXCHANGER OUTLET SEE FIG. 2.2-7 INDEX 75 	49	35	277
- 47	AN960D10L		45	277	
- 48	P-23121		1	35	
- 49	4464-206M		1	35	
- 51	7-2053-3		1	35	
- 52	108322-265-1-3		1	35	
- 53	AN3-4A		4	35	
- 54	AN960D10L		4	35	
	109717		1	35	
			RF		

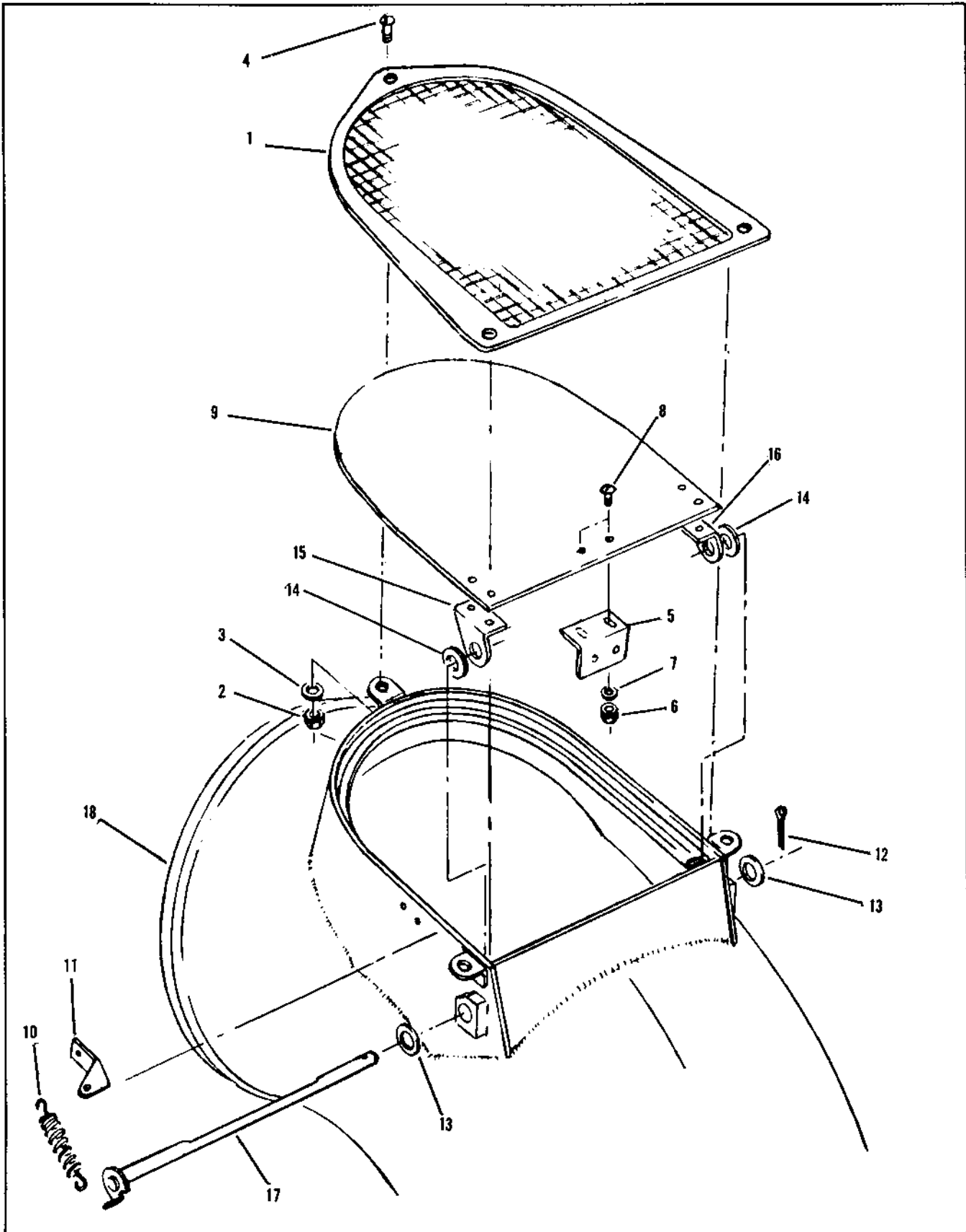

Figure 2.13-32. Valve Assembly Compressor Inlet Air Diverter

FIGURE AND INDEX NUMBER	PART NUMBER	DESCRIPTION	UNITS PER ASSY.	USABLE ON CODE	
				FROM	TO
2.13-32	63E35687-1	VALVE ASSY, COMPRESSOR INLET AIR DIVERter FOR VHA SEE FIG. 2.13-31 INDEX 2	PF		
- 1	63C35685-1	• SCREEN ASSY	1		
- 2	MS21042L3	ATTACHING PARTS • NUT	3		
- 3	AN960D10	• WASHER	3		
- 4	AN520-1CRB	• SCREW	3		
- 5	63C35678-1	• BRACKET ATTACHING PARTS	1		
- 6	MS21042L3	• NUT	2		
- 7	AN960D10	• WASHER	2		
- 8	AN520-1CRB	• SCREW	2		
- 9	63C35682-1	• PLATE	1		
- 10	MS24586C62	• SPRING	1		
- 11	63C35689-1	• BRACKET	1		
- 12	MS24665-299	• PIN, COTTER	1		
- 13	AN960C516	• WASHER	1		
- 14	41-26003-005	• BUSHING	1		
- 15	63C35679-1	BRACKET	1		
- 16	63C35679-2	• BRACKET	1		
- 17	63C35681-1	• SHAFT ASSY, WELDED	1		
- 18	63E35675-1	• HOUSING ASSY, WELDED	1		

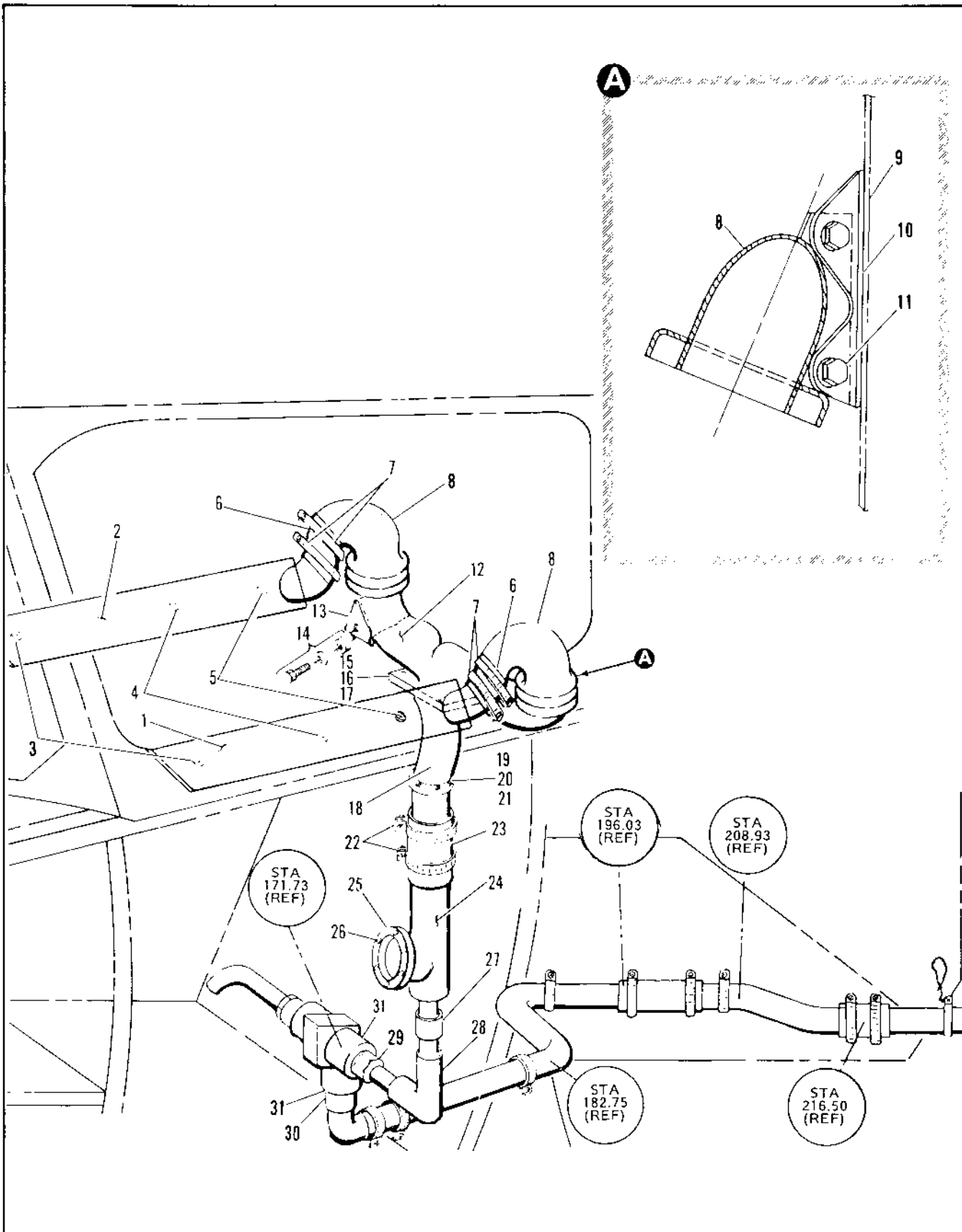

Figure 2.13-33. Valve, Canopy Defog-Pressure Regulator (Sheet 1 of 4)

FIGURE AND INDEX NUMBER	PART NUMBER	DESCRIPTION	UNITS PER ASSY.	USABLE ON CODE	
				FROM	TO
		1 2 3 4 5 6			
2.13-33	7037267-10	CANOPY HOT AIR DEFOG SYSTEM INSTALLATION STATION 126.39 TO 287.50 (98750)	REF	35	
	7037407-10	. CANOPY DUCT INSTALLATION L/H STA 126.38 TO 175.12 (98750)	REF	35	
	7037407-20	. CANOPY DUCT INSTALLATION. R/H STA 126.38 TO 175.12 (98750)	REF	35	
- 1	7036860-10	. . DUCT ASSY L/H (98750)	1		
- 2	7036862-20	. . DUCT ASSY R/H (98750)	1		
- 3	MS24694-60	. . SCREW (96906)	2		
	99-51507-003	. . WASHER (14170)	2		
- 4	MS24694-57	. . SCREW (96906)	2		
	99-51507-003	. . WASHER (14170)	2		
- 5	AN509-10R16	. . SCREW (88044)	2		
	99-51507-003	. . WASHER (14170)	2		
- 6	NAS520-14-12	. . COUPLING (80205)	2		
- 7	AN737TW66	. . CLAMP (88044)	4		
- 8	7037352-10	. . DUCT ASSY L/H (98750)	1		
	7037052-20	. . DUCT ASSY R/H (98750)	1		
- 9	8-74801-11	. . PANEL, CANOPY (14170)	REF		
- 10	7140017-01	. . CLIP L/H (98750)	1		
	7140017-02	. . CLIP R/H (98750)	1		
		ATTACHING PARTS			
- 11	AN3-4A	. . BOLT (88044)	4		
	AN960-10L	. . WASHER (88044)	4		
	MS2104AN3	. . NUT (96906)	4		
		-----X-----			
- 12	7036878-10	. MANIFOLD (98750)	1		
- 13	7036876-10	. BRACKET ASSY (98750)	2		
		ATTACHING PARTS			
- 14	AN3-3A	. BOLT (88044)	4		
	AN960-10L	. WASHER (88044)	4		
	MS2104AN3	. NUT (96906)	4		
		-----X-----			
- 15	7036881-01	. FILLER (98750)	1		
- 16	7036880-01	. DOUBLER (98750)	1		
- 17	AN3-4A	. BOLT (88044)	4		
	AN960-10L	. WASHER (88044)	4		
- 18	703600-10	. DUCT ASSY (98750)	1		
- 19	7037016-01	. DOUBLER (98750)	1		
- 20	7036918-01	. SEAL (98750)	1		
- 21	7036918-03	. SEAL (98750)	1		
- 22	AN737TW74	. CLAMP (88044)	1		
- 23	NAS720-16-12	. COUPLING (80205)	2		
- 24	8-23938	. DUCT ASSY (14170)	1		
- 25	7036874-01	. FILLER (98750)	1		
- 26	7036950-10	. SCREW (98750)	1		
	AN3-4A	. BOLT (88044)	6		
	AN960-10L	. WASHER (88044)	6		
- 27	NAS595-12E	. RING (80205)	2		
- 28	70369668-10	. TUBE ASSY (98750)	1		
- 29	7037160-01	. GASKET (98750)	1		
- 30	7037153-01	. DOUBLER (98750)	1	35	
- 31	7037154-01	. FILLER (98750)	1		

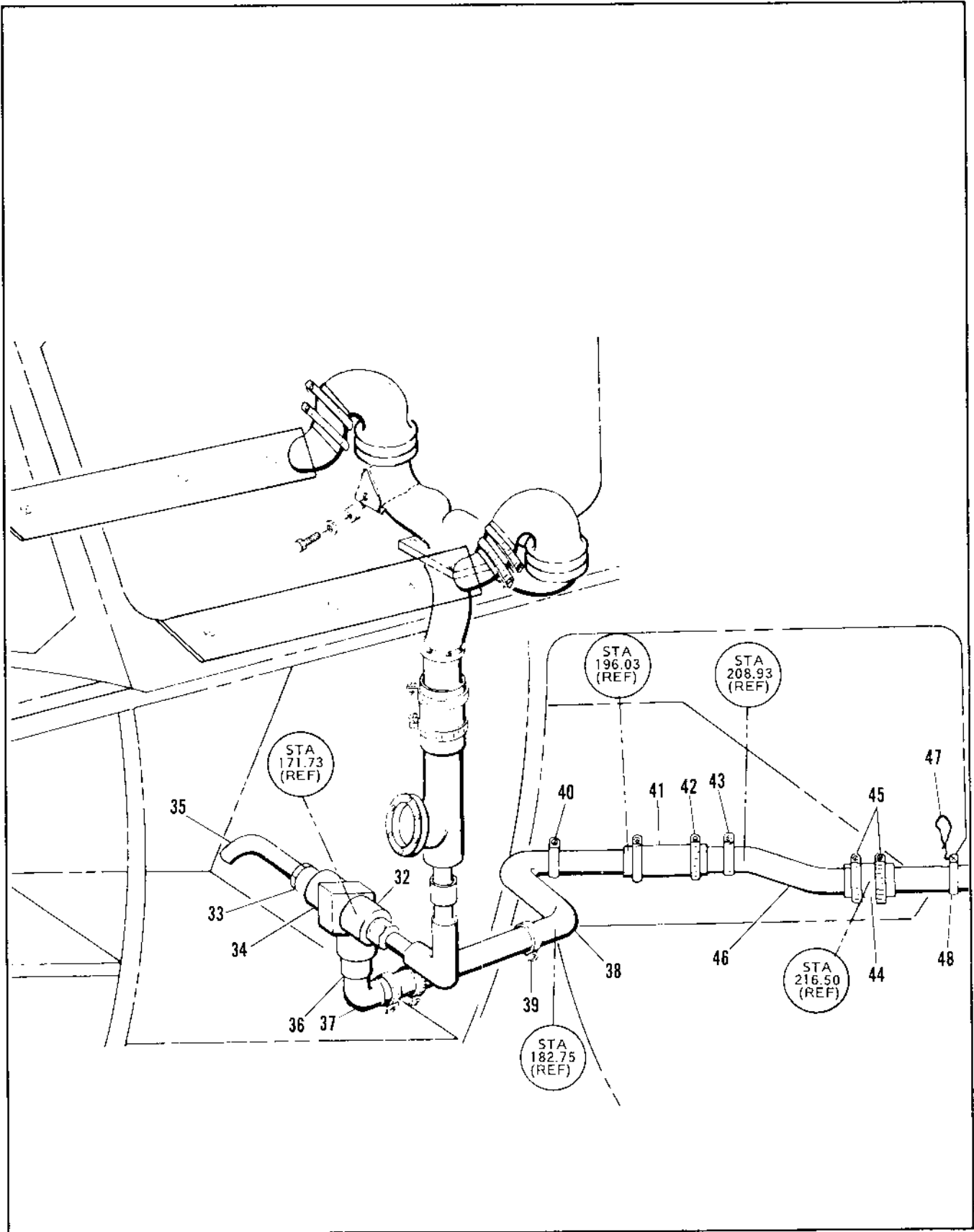

Figure 2.13-33. Valve, Canopy Defog-Pressure Regulator (Sheet 2 of 4)

FIGURE AND INDEX NUMBER	PART NUMBER	DESCRIPTION	UNITS PER ASSY.	USABLE ON CODE	
				FROM	TO
2.13-33- 32	5055	• REGULATOR ATTACHING PARTS	1		
	AN4-5A	• BOLT	2		
	AN960-416L	• WASHER	2		
	NAS67904M	• NUT -----X-----	2		
- 33	7037032-10	• TUBE ASSY	1		
- 34	MS21906-40	• UNION	1		
	MS28774-4	• PACKING	1		
- 35	MS21908-40	• ELBOW	1		
	AN924-4D	• NUT	1		
	AN960PD716	• WASHER	1		
- 36	AN924-12S	• NUT	1		
	MS29512-12	• PACKING	1		
- 37	MS24374-12S	• ELBOW	1		
- 38	7036967-10	• TUBE ASSEMBLY	1		
- 39	MS21919H20	• CLAMP ATTACHING PARTS	1		
	AN3-3A	• BOLT	1		
	AN960-10L	• WASHER	1		
	MS21044N3	• NUT -----X-----	1		
- 40	MS21919H20	• CLAMP ATTACHING PARTS	1		
	AN3-4A	• BOLT -----X-----	1		
- 41	NAS545-12E	• PIN	1		
- 42	7037257-01	• COVER ATTACHING PARTS	1		
	AN737TW44	• CLAMP -----X-----	2		
- 43	MS21919H24	• CLAMP ATTACHING PARTS	1		
	AN3-4A	• BOLT	1		
	AN960-10L	• WASHER	1		
	MS21044N3	• NUT -----X-----	1		
- 44	7037257-01	• COVER ATTACHING PARTS	2		

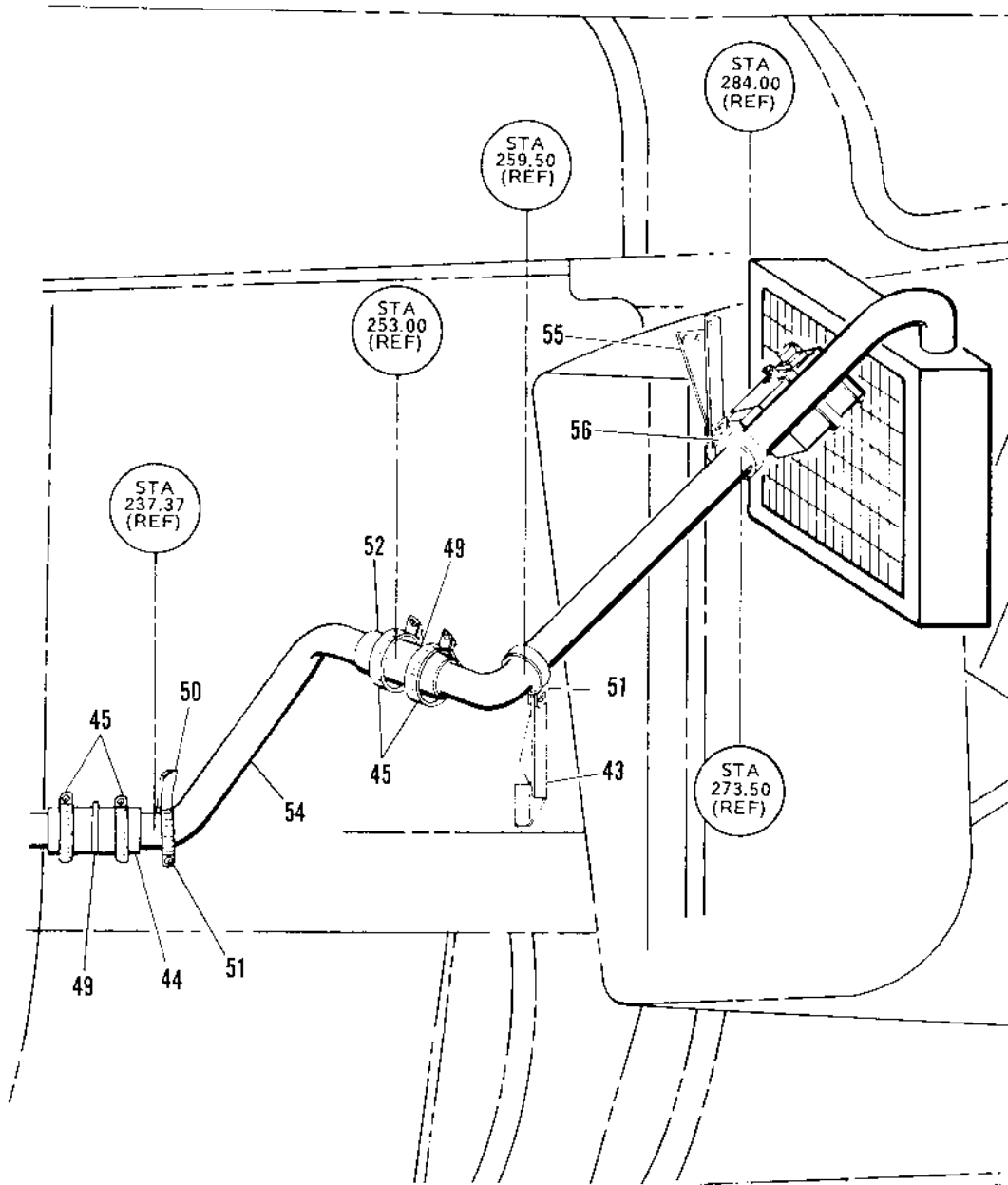

Figure 2.13-33. Valve, Canopy Defog-Pressure Regulator (Sheet 3 of 4)

FIGURE AND INDEX NUMBER	PART NUMBER	DESCRIPTION	UNITS PER ASSY.	USABLE ON CODE	
				FROM	TO
		1 2 3 4 5 6			
2.13-33- 40	AN737TW5F	• CLAMP -----X-----	6		
- 46	7036966-10	• TUBE ASSY	1		
- 47	7140247-10	• CLIP ASSY	1		
- 48	MS21919H24	• CLAMP ATTACHING PARTS	1		
	AN3-4A AN960-10L	• BOLT • WASHER -----X-----	1 1		
- 49	NAS595-16C	• RING	2		
- 50	7037002-10	• BRACKET ATTACHING PARTS	1		
	AN3-3A AN960-10L MS21044N3	• BOLT • WASHER • NUT -----X-----	4 4 4		
- 51	MS21919H24	• CLAMP ATTACHING PARTS	2		
	MS35207-262 AN960-10L	• SCREW • WASHER -----X-----	2 2		
- 52	7037257D3	COVER			
- 53	7037004-10	• BRACKET ATTACHING PARTS	1		
	MS35207-263 AN960-10L	• SCREW • WASHER -----X-----	2 2		
- 54	7036964-10	• TUBE ASSY	1		
- 55	7037003-01	• BRACKET ATTACHING PARTS	1		
	AN3-5A AN960-10L NAS679C3	• BOLT • WASHER • NUT -----X-----	2 4 2		

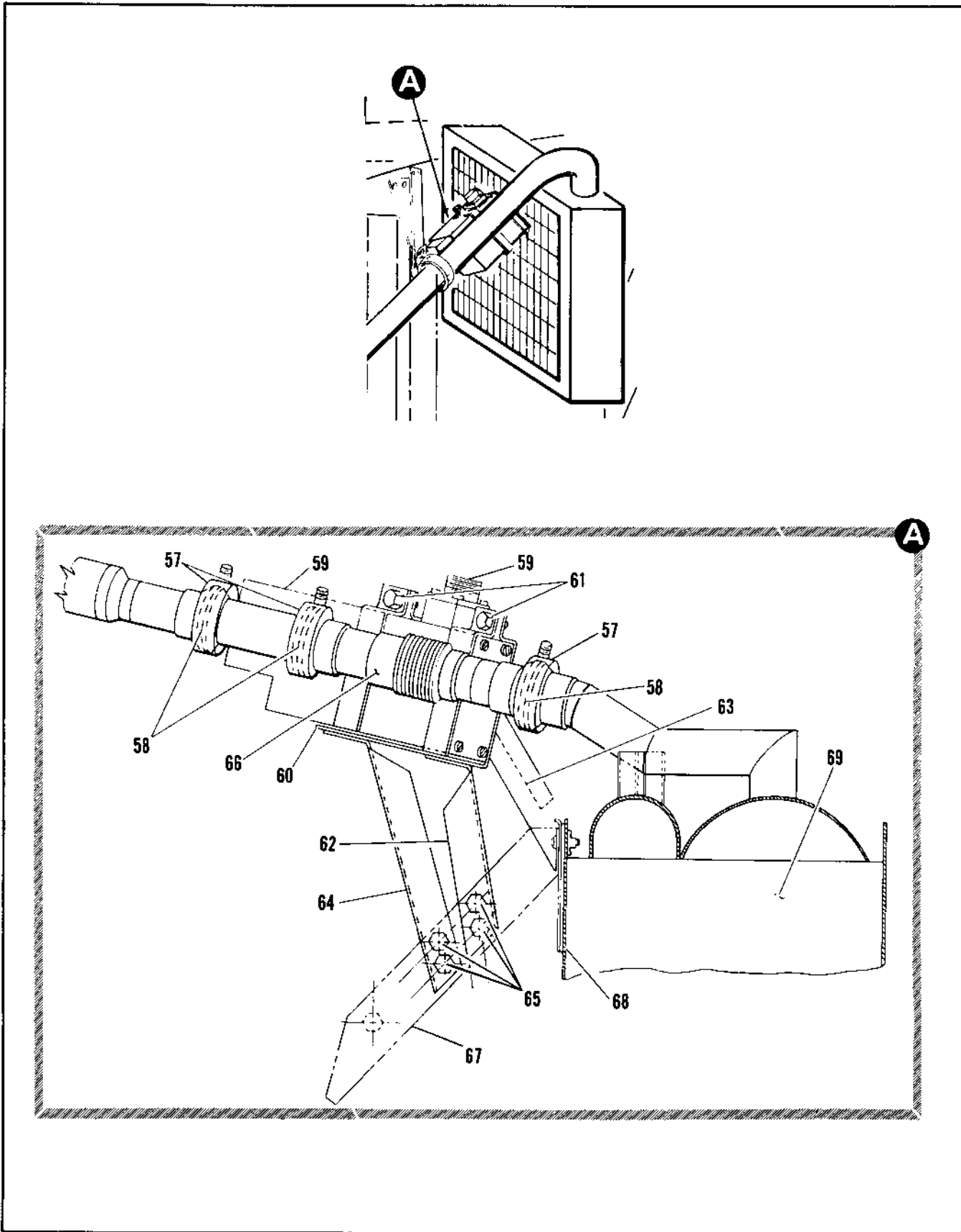

Figure 2.13-33. Valve, Canopy Defog-Pressure Regulator (Sheet 4 of 4)

FIGURE AND INDEX NUMBER	PART NUMBER	DESCRIPTION	UNITS PER ASSY	USABLE ON CODE	
				FROM	TO
		1 2 3 4 5 6			
2.13-33- 56	MS21919H24	• CLAMP ATTACHING PARTS	1		
	AN3-3A	• BOLT	1		
	AN969-10L	• WASHER	1		
	NAS679C3	• NUT	1		
		-----X-----			
- 57	4261C170-M	• VALVE INSTALLATION, SHUTOFF	1		
- 58	12067-100S	• CLAMP	3		
- 59	35-121A	• GASKET	3		
- 60	7036900-01	• VALVE	1		
- 61	7036887-10	• BRACKET, VALVE SUPPORT	1		
- 62	7036897-01	• CLAMP ASSY	2		
- 63	7036859-01	• BRACKET	1		
- 64	7036856-01	• BRACKET	1		
		ATTACHING PARTS			
- 65	AN3-4A	• BOLT	4		
	AN969-10L	• WASHER	4		
	MS21044N3	• NUT	4		
		-----X-----			
- 66	7036990-10	• TUBE ASSY	1		
- 67	9-23108	• CHANNEL ASSY L/H SEE FIG. 2.13-30 INDEX 65	REF		
- 68	9-23101	• HEATER ASSY L/H SEE FIG. 2.13-30 INDEX 75	REF		
- 69		• HEAT EXCHANGER SEE FIG. 2.13-27 INDEX 53	REF		

FLIGHT CONTROLS SUBSECTION

TABLE OF CONTENTS

<i>Fig. No.</i>	<i>Title</i>	<i>Page</i>	<i>Fig. No.</i>	<i>Title</i>	<i>Page</i>
2.14-1	Flight Controls.....	2.14-2	2.14-26	Rudder and Brake Pedal Installation	2.14-120
2.14-2	Aileron Control Potentiometer Installation Sta 136	2.14-6	2.14-27	Rudder and Brake Pedal Installation	2.14-122
2.14-3	Airspeed Tubing Installation Sta -44 to 41.....	2.14-8	2.14-28	Rudder and Brake Pedal Hanger Tube Assembly.....	2.14-124
2.14-4	Airspeed Tubing Installation Sta 41 to 216.....	2.14-10	2.14-29	Rudder and Brake Pedal Hanger Tube Assembly	2.14-126
2.14-5	Airspeed Tubing Water Trap Installation	2.14-22	2.14-30	Rudder Cable and Linkage Installation	2.14-128
2.14-6	Electrical Flight Controls	2.14-24	2.14-31	Rudder Cable Fair-Lead Installation	2.14-132
2.14-7	Pitch G Limiter Assembly	2.14-30	2.14-32	Rudder Control Installation Sta 108.....	2.14-134
2.14-8	Electrical Pitch G Limiter Chassis Assembly	2.14-32	2.14-33	Rudder Control Installation Sta 108.....	2.14-136
2.14-9	Flight Control Stick Installation.....	2.14-40	2.14-34	Rudder Cable Pulley Installation Sta 284 to 324	2.14-138
2.14-10	Flight Control Stick Assembly.....	2.14-48	2.14-35	Elevator and Rudder Airfeel Tubing Installation Sta 472 to Vertical Stabilizer	2.14-140
2.14-11	Elevon Flight Controls.....	2.14-54	2.14-36	Elevator and Aileron Control Idler Installation Sta 216.....	2.14-144
2.14-12	Aileron Control Bell Crank Installation Sta 142	2.14-60	2.14-37	Elevator and Rudder Airfeel Tubing Installation Sta 472 to Vertical Stabilizer	2.14-146
2.14-13	Elevator and Aileron Control Idler Installation Sta 170.....	2.14-62	2.14-38	Elevator and Rudder Airfeel Intake Installation	2.14-150
2.14-14	Elevon Control Tube Support Installation Sta 216 to 431	2.14-64	2.14-39	Vertical Stabilizer Elevator and Rudder Airfeel Tubing Installation	2.14-152
2.14-15	Elevon Control Linkage Installation	2.14-68	2.14-40	Elevon Control Idler Installation Sta 524.....	2.14-154
2.14-16	Aileron RH Bell Crank Installation Sta 353	2.14-78	2.14-41	Rudder Trim and Feel Control Installation	2.14-156
2.14-17	Elevator and Aileron Control Tube Seal Installation	2.14-80	2.14-42	Rudder Trim and Feel Control Assembly	2.14-160
2.14-18	Elevator and Aileron Bell Crank Installation Sta 472	2.14-82	2.14-43	Servo Valve Rudder Actuator Installation	2.14-162
2.14-19	Elevator LH Bell Crank Installation Sta 426	2.14-88	2.14-44	Control Stick Counterbalance Installation Sta 145	2.14-164
2.14-20	Elevon Control Tube Installation Sta 477.....	2.14-90			
2.14-21	Elevator Airfeel Regulator Installation Sta 481 to 488	2.14-96			
2.14-22	Elevon Control Installation Sta 472 to 507.....	2.14-98			
2.14-23	Elevon Control Assembly Sta 472 to 507.....	2.14-100			
2.14-24	Elevator Feel Cylinder Assembly.....	2.14-116			
2.14-25	Elevon Followup Crank Installation	2.14-118			

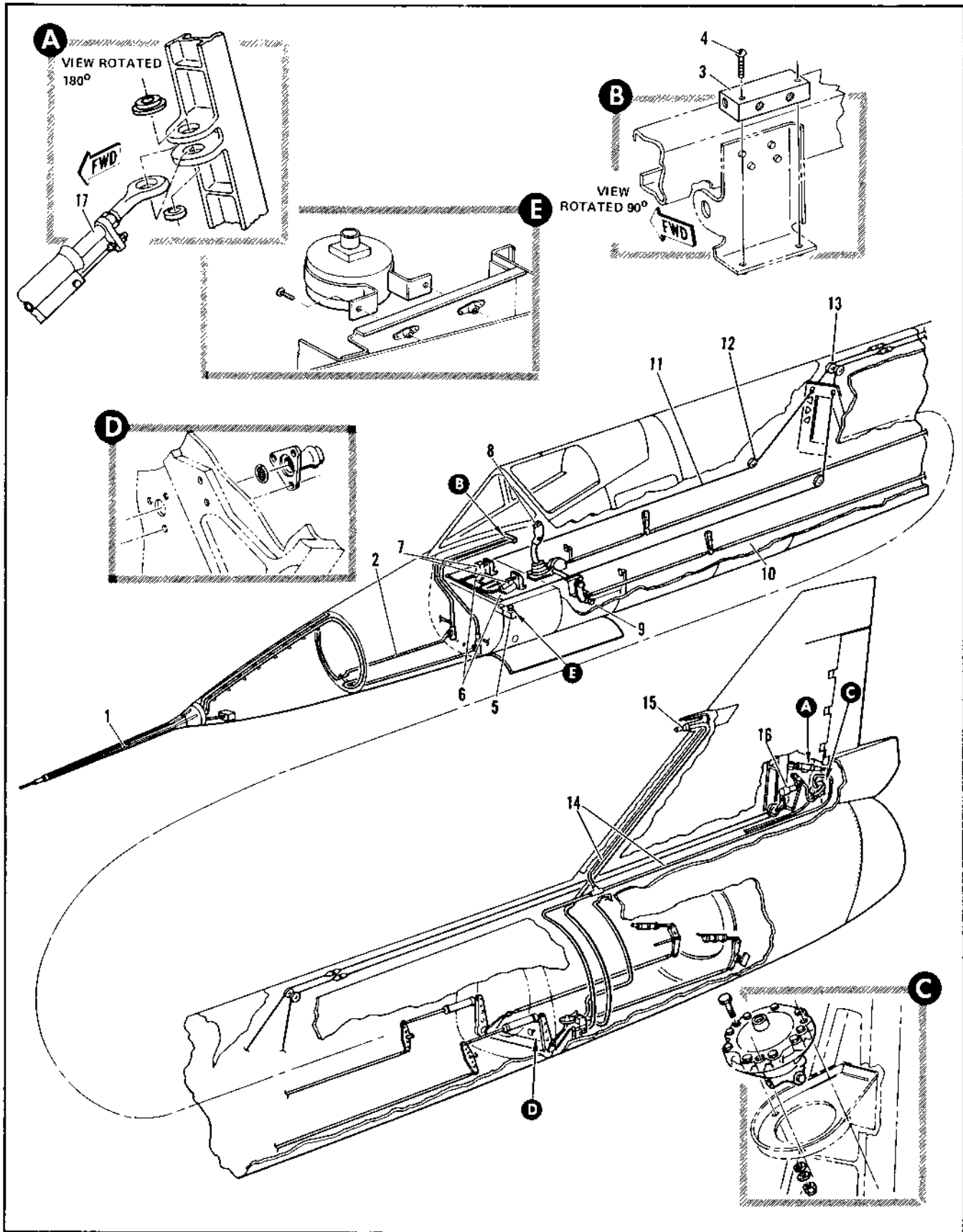

Figure 2.14-1. Flight Controls (Sheet 1 of 2)

FIGURE AND INDEX NUMBER	PART NUMBER	DESCRIPTION 1 2 3 4 5 6	UNITS PER ASSY.	USABLE ON CODE	
				FROM	TO
2.14-1		FLIGHT CONTROLS			
- 1		• HOHM ASSY, NOSE SEE FIG. 2.3-1 INDEX 17	RF		
- 2		• TUNING INSTL, AIRSPEED STA 41 TO 216 SEE FIG. 2.14-4	RF		
- 3	P-35379	• HARIFIELD, INSTRUMENT PANEL STATIC LINE CMA IS 8-40033-819 AND 8-40033-831 AND P-90033-833	1	35	39
- 4	AN515-9R20	• ATTACHING PARTS • SCREW	9	35	39
- 5		-----X-----			
- 6		• ELECTRICAL FLIGHT CONTROLS SEE FIG. 2.14-6	RF		
- 7		• CONTROL INSTL, RUDDER STA 118 SEE FIG. 2.14-32	RF		
- 8		• PEDAL INSTL, RUDDER AND BRAKE SEE FIG. 2.14-26	RF		
- 9		• STICK INSTL, FLIGHT CONTROL SEE FIG. 2.14-9	RF		
- 10		• COUNTERBALANCE INSTL, CONTROL STICK STA 145 SEE FIG. 2.14-44	RF		
- 11		• ELEVON FLIGHT CONTROLS SEE FIG. 2.14-11	RF		
- 12		• CABLE AND LINKAGE INSTL, RUDDER SEE FIG. 2.14-30	RF		
- 13		• PULLEY INSTL, RUDDER CABLE LH STA 284 SEE FIG. 2.14-34	RF		
- 14		• PULLEY INSTL, RUDDER CABLE STA 324 SEE FIG. 2.14-34	RF		
- 15		• TUNING INSTL, ELEVATOR AND RUDDER AIRFEEL SEE FIG. 2.14-35	RF		
- 16		• INTAKE INSTL, ELEVATOR AND RUDDER AIRFEEL SEE FIG. 2.14-38	RF		
- 17		• CONTROL INSTL, RUDDER TRIM AND FEEL SEE FIG. 2.14-41	RF		
- 18		• ACTUATOR INSTL, RUDDER SEE FIG. 2-14-43	RF		

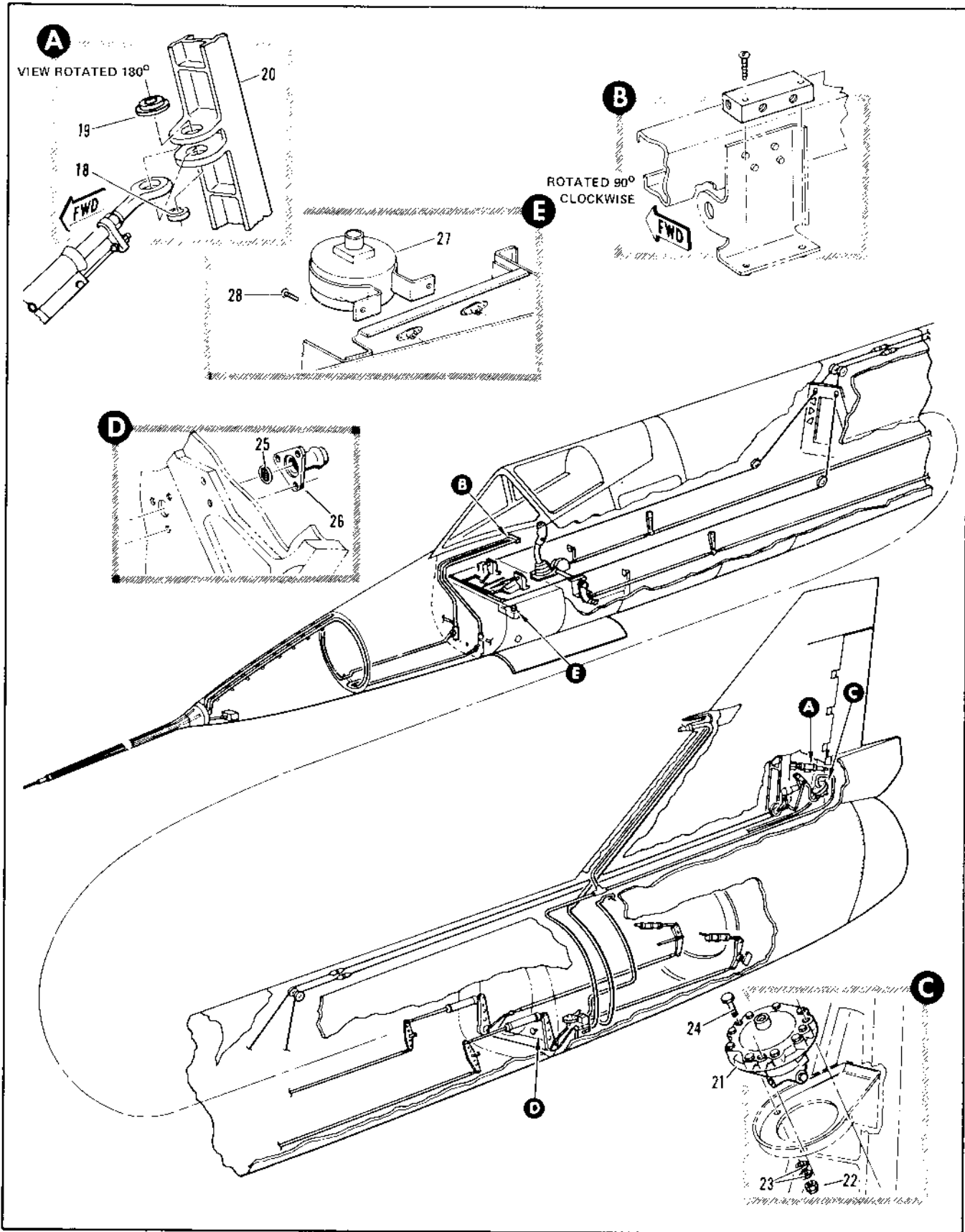

Figure 2.14-1. Flight Controls (Sheet 2 of 2)

FIGURE AND INDEX NUMBER	PART NUMBER	DESCRIPTION	UNITS PER ASSY.	USABLE ON CODE	
				FROM	TO
		1 2 3 4 5 6			
2.14-1	8-14035-25	• SPAR ASSY, #4 FOR NHA SEE FIG. 2.7-8	RF	A	
	8-14035-7	• SPAR ASSY, #4 FOR NHA SEE FIG. 2.7-8	RF	278	304
- 18	8-15403	• • PUSHING	1	35	
- 19	8-15402-9	• • PUSHING	1	35	
- 20	8-14764	• • SPAR	1	A	
	8-14764-1	• • SPAR	1	278	304
	8-85310-3	• REGULATOR INSTL. VARIABLE AIR PRESSURE FOR NHA SEE FIG. 2.7-6	RF	35	
- 21	107700-11	• • REGULATOR, VARIABLE AIR PRESSURE <96124> SPEC 8-10423-5 T.O. 8PS-3-60-3 REPLACES SUITABLE SUB FOR 107700-1	1	B	
	1607700-1	• • REGULATOR, VARIABLE AIR PRESSURE <96124> SPEC 8-10423-3 REPLACED BY SUITABLE SUB 107700-11 ATTACHING PARTS	1	C	
- 22	NAS679A3	• • NUT	3	35	
- 23	AN960PD10L	• • WASHEN	6	35	
- 24	AN3-10A	• • BOLT	3	35	
	8-42347	• CONNECTOR INSTL. STATIC AIR STA 472 FOR NHA SEE FIG. 2.3-11	RF	35	
- 25	8-42349	• • SCREW, REPLACED BY NOT INTCHG WITH 8-42349-7	1	D	
	8-42349-7	• • SCREW, REPLACES NOT INTCHG WITH 8-42349	1	90	277
- 26	8-42348	• • CONNECTOR, REPLACED BY NOT INTCHG WITH 8-42348-7	1	D	
	8-42348-7	• • CONNECTOR, REPLACES NOT INTCHG WITH 8-42348	1	90	277
	8-93403	• SWITCH INSTL. PRESSURE INDICATED AIRSPEED FOR NHA SEE FIG. 2.3-4	RF	189	
- 27	42D13	• • SWITCH, PRESSURE INDICATED AIRSPEED <891490 SPEC 8-16425-3> ATTACHING PARTS	1	189	
- 28	AN520-10R7	• • SCREW	2	139	
		-----X-----			
		A AIRPLANES #59 THRU 277 AND 305			
		B AIRPLANES #25 THRU 277, 281, 287 AND ON			
		C AIRPLANES #278 THRU 280 AND 282 THRU 286			
		D AIRPLANES #35 THRU 49, 274 AND ON			

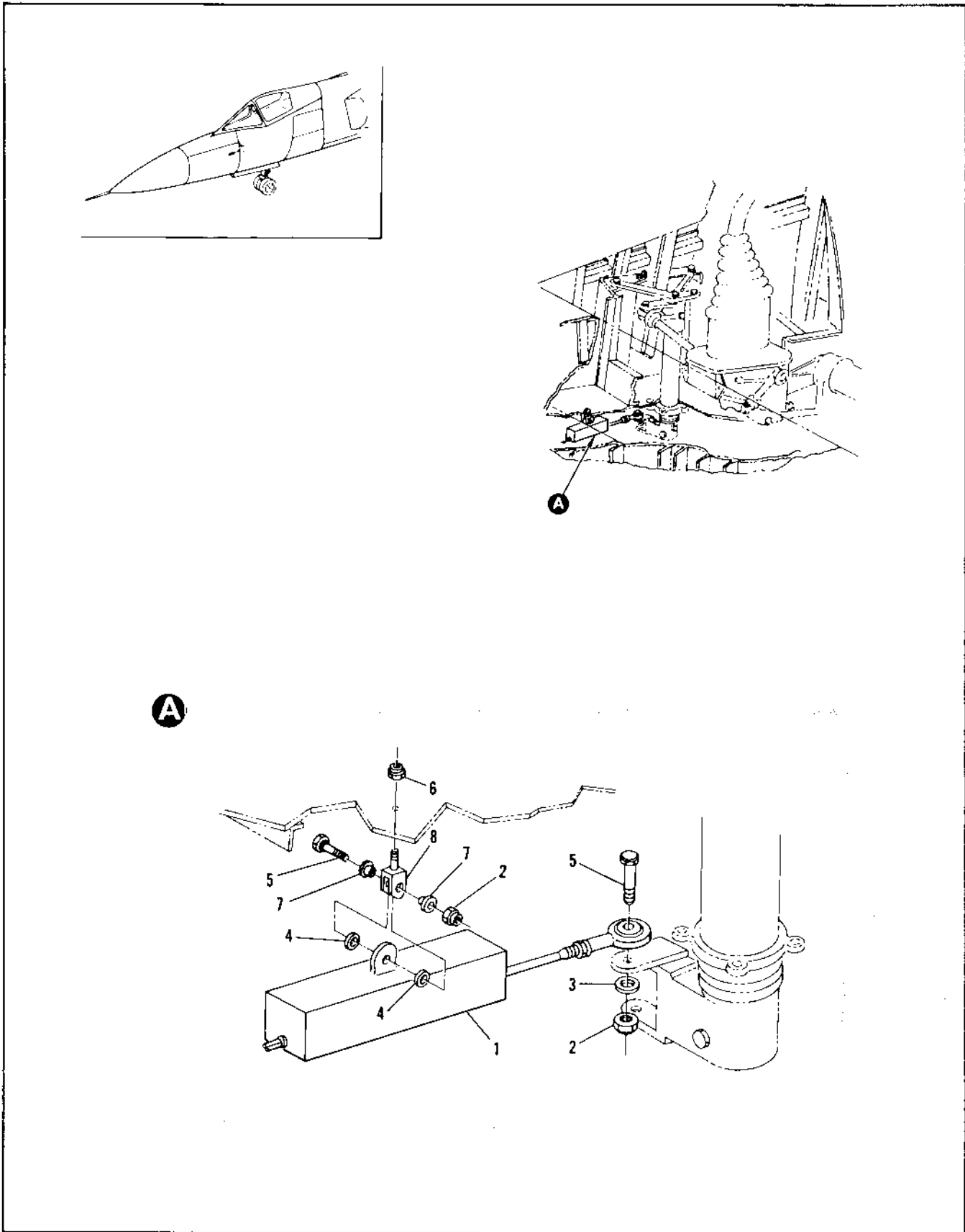

Figure 2.14-2. Aileron Control Potentiometer Installation Sta 136

FIGURE AND INDEX NUMBER	PART NUMBER	DESCRIPTION	UNITS PER ASSY.	USABLE ON CODE	
				FROM	TO
		1 2 3 4 5 6			
2.14-2	8-42417-1	POTENTIOMETER INSTALLATION, AILERON CONTROL STA 136 FOR NHA SEE FIG. 2.3-4	PF	35	
- 1	C3026	• POTENTIOMETER, AILERON POSITION K2914S SPEC P-367E1 ATTACHING PARTS	1	35	
- 2	MS21043-3	• NUT	2	35	
- 3	99-51009-023	• WASHER	1	35	
- 4	8-42452	• WASHER	2	35	
- 5	NAS454-3411	• BOLT	2	35	
	8-12418	-----X----- • CLEVIS ASSY, POTENTIOMETER ATTACHING PARTS	1	35	
- 6	MS21043-4	• NUT	1	35	
- 7	NAS77-3-16	-----X----- • • BRUSHING	2	35	
- 8	8-42418-7	• • CLEVIS	1	35	

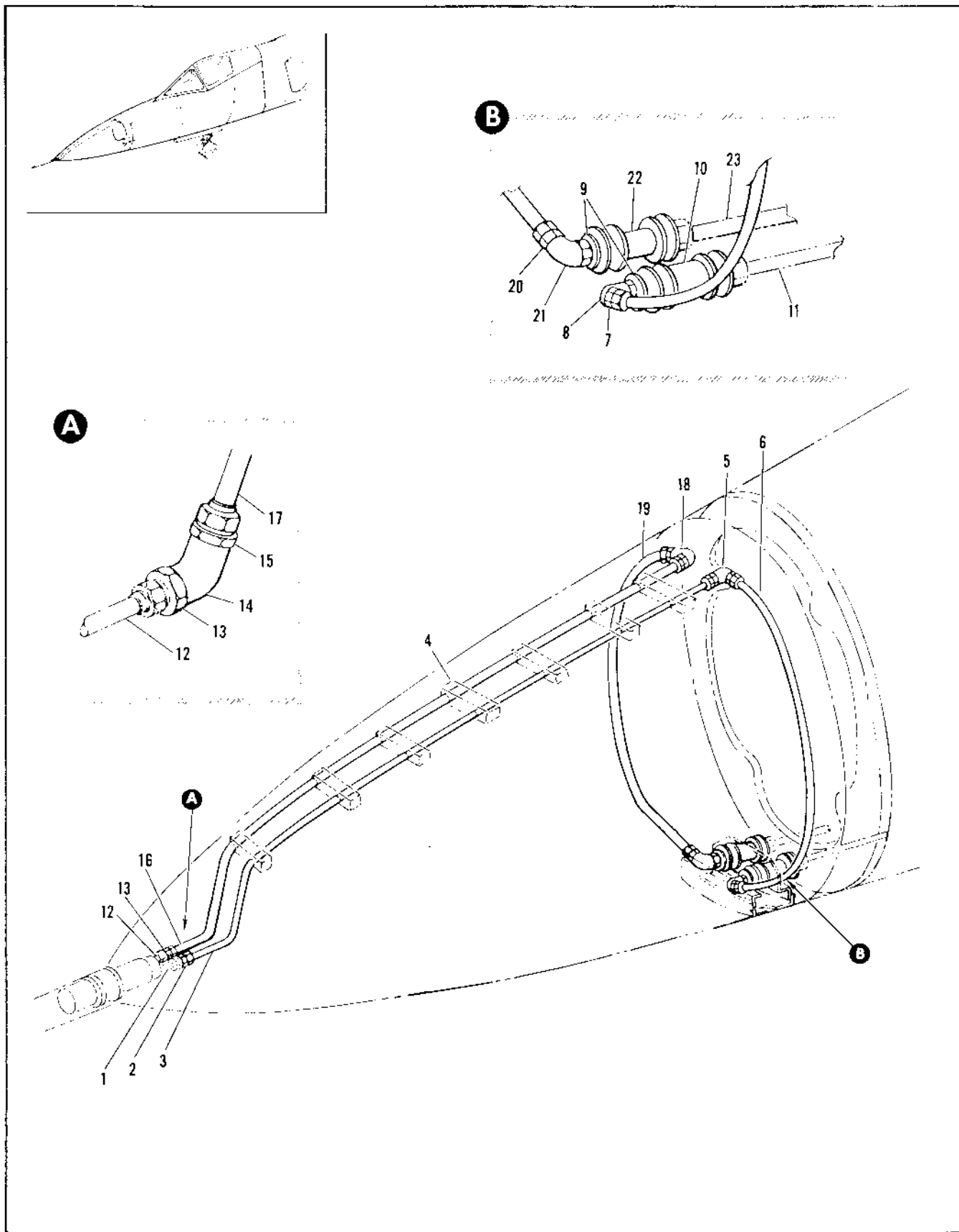

Figure 2.14-3. Airspeed Tubing Installation Sta - 44 to 41

FIGURE AND INDEX NUMBER	PART NUMBER	DESCRIPTION	UNITS PER ASSY.	USABLE ON CODE	
				FROM	TO
		1 2 3 4 5 6			
2.14-4	R-36192-1	TUNING INSTALLATION, AIR SPEED STA -44 TO 41	9F	35	
- 1		• TUBE ASSY, SEE FIG. 2.14-1 INDEX 24 FOR NHA SEE FIG. 2.3-1	4F		
- 2	MS2190204	• UNION	1	35	
- 3	R-36192-121	• TUBE ASSY, AIRSPEED	1	A	
	R-28192-31	• TUBE ASSY, AIRSPEED	1	48	48
- 4		• BLOCK, AIRSPEED TUBE SEE FIG. 2.3-2 INDEX 4	1F		
- 5	MS2190104	• ELBOW	1	35	
	AN924-40	• NUT	1	35	
	AN9007104	• WASHER	1	35	
- 6	R-36192-123	• TUBE ASSY, AIRSPEED	1	A	
	R-28192-33	• TUBE ASSY, AIRSPEED	1	35	
- 7	MS2190204	• UNION	1	35	
- 8	AN924-40	• ELBOW	2	35	
	AN6290-4	• GASKET	2	35	
- 9	R-28192-1	• WASHER	1	35	
- 10	100491-4	• COUPLING, <10624> SPLIC #2272-3	1F		
- 11		• TUBE ASSY, AIR SPEED SEE FIG. 2.14-4 INDEX 2	4F		
- 12		• TUBE ASSY, SEE FIG. 2.3-1 INDEX 23	1	35	
- 13	MS219176-4	• REDUCER	1	48	48
- 14	AN94104	• ELBOW	1	48	48
- 15	MS2190204	• UNION	1	35	
	AN6290-4	• GASKET	1	A	
- 16	R-36192-119	• TUBE ASSY, AIRSPEED	1	48	48
- 17	R-36192-40	• TUBE ASSY, AIRSPEED	1	35	
- 18	MS2190104	• ELBOW	1	35	
	AN924-40	• NUT	1	35	
	AN9010910	• WASHER	1	A	
- 19	R-36192-117	• TUBE ASSY, AIRSPEED	1	35	
	R-36192-47	• TUBE ASSY, AIRSPEED	1	35	
- 20	MS2190204	• UNION	1	35	
- 21	AN93906	• ELBOW	1	35	
	AN6290-6	• GASKET	2	35	
- 22	100491-6	• COUPLING, <10624> SPLIC #2274-201	1	35	
- 23		• TUBE ASSY, AIRSPEED SEE FIG. 2.14-4 INDEX 2	4F		

4 AIRPLANE #35 THRU 47, 49 AND 6V

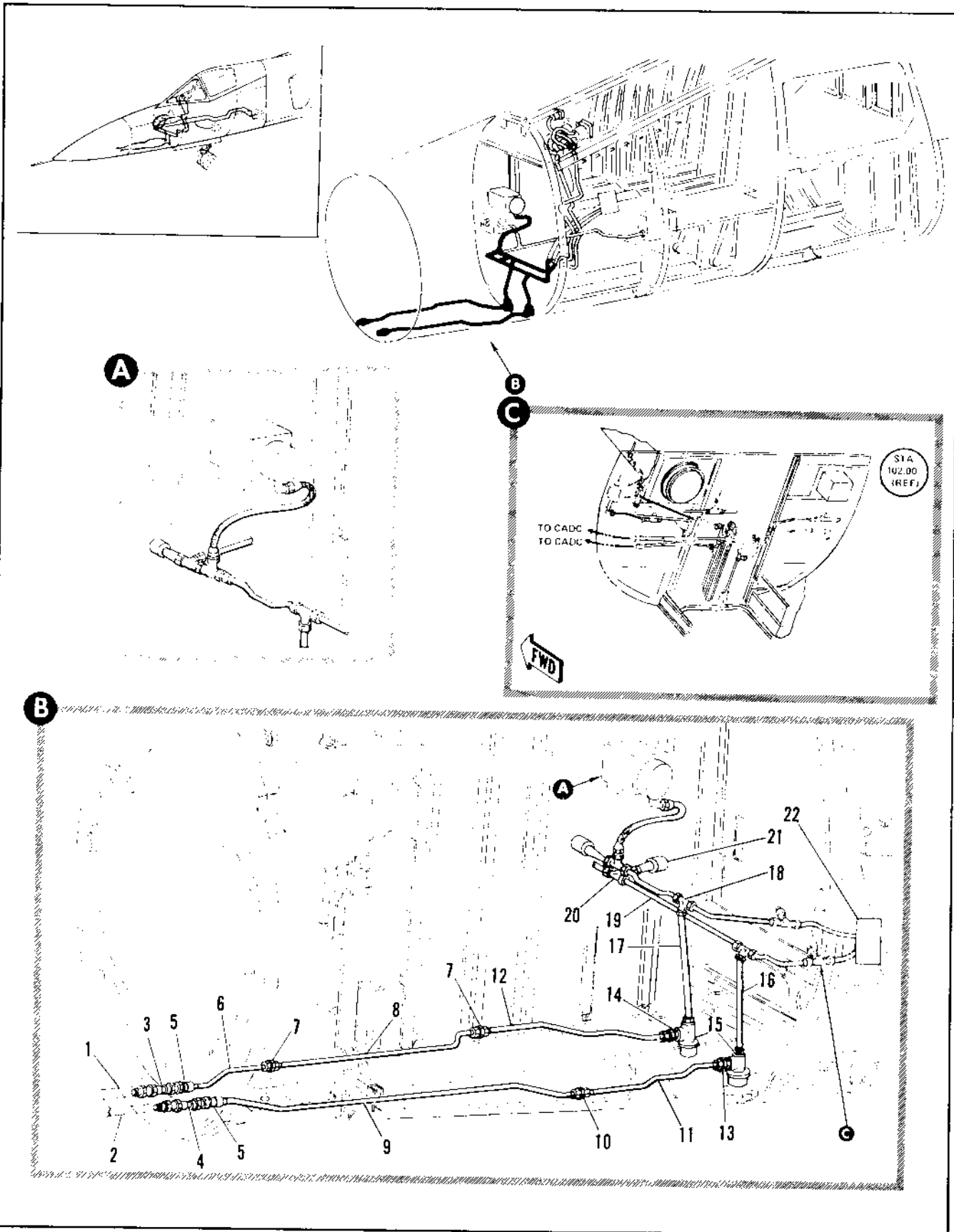

Figure 2.14-4. Airspeed Tubing Installation Sta 41 to 216 (Sheet 1 of 6)

FIGURE AND INDEX NUMBER	PART NUMBER	DESCRIPTION	UNITS PER ASSY.	USABLE ON CODE	
				FROM	TO
		1 2 3 4 5 6			
2.14-4	8-38192-5	TUBING INSTALLATION, AIRSPEED STA 41 TO 216 MODIFIED BY 8-31983 FOR MHA SEE FIG. 2.3-4	RF	35	
- 1		• TUBE ASSY, AIRSPEED SEE FIG. 2.14-3 INDEX 19	RF		
- 2		• TUBE ASSY, AIRSPEED SEE FIG. 2.14-3 INDEX 6	RF		
- 3	100452-6	• COUPLING, <0624> SPEC R-32279-5 T.O. 9P8-3-1	1	35	
- 4	100452-4	• COUPLING, <0624> SPEC R-32279-1 T.O. 9P8-3-3	1	35	
- 5	8-38101	• WASHER	8	35	
- 6	8-38192-25	• TUBE ASSY, AIRSPEED	1	35	
- 7	MS2191206	• UNION	2	35	
- 8	8-38192-27	• TUBE ASSY, AIRSPEED	1	35	
- 9	8-38192-31	• TUBE ASSY, AIRSPEED	1	35	
- 10	MS2190204	• UNION	1	35	
+ 11	8-38192-33	• TUBE ASSY, AIRSPEED	1	35	129
- 11	8-38192-125	• TUBE ASSY, AIRSPEED	1	35	129
- 12	8-38192-29	• TUBE ASSY, AIRSPEED	1	35	
- 13	MS2190304	• UNION	1	35	
	AN9600716	• WASHER	1	35	
	AN924-40	• NUT	1	35	
- 14	MS2190306	• UNION	1	35	
	AN9600916	• WASHER	1	35	
	AN924-60	• NUT	1	35	
- 15		• TRAP INSTL, AIRSPEED TUBING WATER SEE FIG. 2.14-5	RF		
- 16	7140265-10	• TUBE ASSY, AIRSPEED	1	35	
	MS2190206	• UNION	1	35	
	AN924-60	• NUT	1	35	
	AN6290-6	• GASKET	1	35	
- 17	7140201-10	• TUBE ASSY, INFRARED SEEKER	1	35	
- 18	MS2190504	• TEE	1	35	
- 19	7140210-10	• TUBE ASSY, INFRARED SEEKER	1	35	
- 20	MS2191204	• TEE	2	35	
	AN9600716	• WASHER	1	35	
	AN924-40	• NUT	1	35	
+ 21	MS21914-40	• CAP	1	D	
- 22		• COMPUTER CENTRAL AIR DATA (CADC) SEE FIG. 2.14-31 INDEX 1	RF		
		D AIRPLANES 875 AND 8N, AND AIRPLANES 56-0453, 57-0845, 09-0024, AND 59-0074 WHEN MODIFIED BY T.O. 1F-106-1114.			

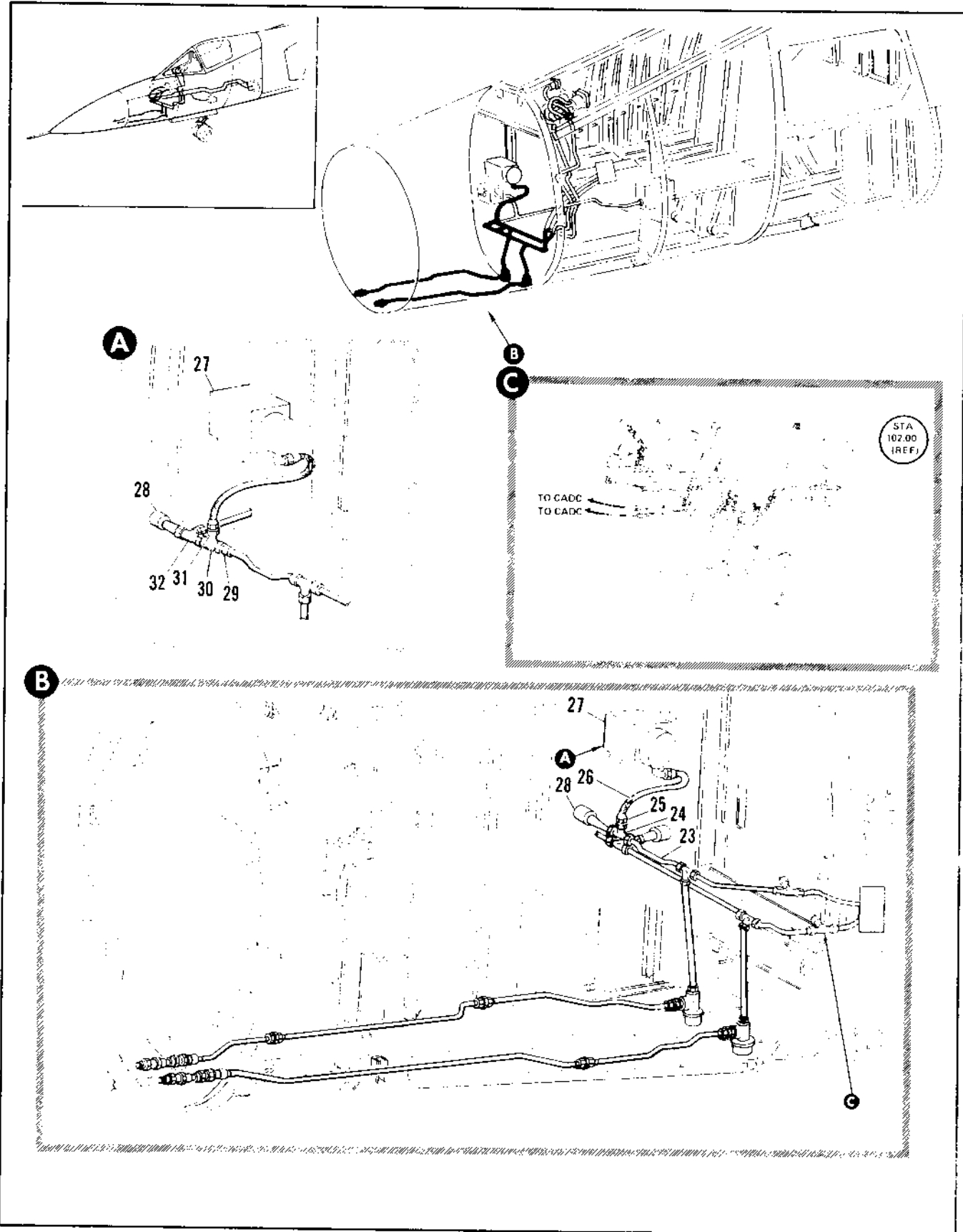

Figure 2.14-4. Airspeed Tubing Installation Sta 41 to 216 (Sheet 2 of 6)

FIGURE AND INDEX NUMBER	PART NUMBER	DESCRIPTION	UNITS PER ASSY.	USABLE ON CODE	
				FROM	TO
		1 2 3 4 5 6			
2.14-4- 23	7140202-10	• TUBE ASSY, AIRSPEED	1	35	
- 24	MS21910D6	• TEE	1	35	159
	AN924-60	• NUT	1	35	159
	AN6290-6	• GASKET	1	35	159
	AN9600916	• WASHER	1	35	159
- 25	MS2191606-4	• REDUCER	1	35	159
- 26	616046-4-0074	• HOSE, <00624> 94-80517-056	1	35	
- 27		• SWITCH, AIR PRESSURE RATIO SEE FIG. 2.12-41 INDEX 11	RF		
- 28	MS21914-60		1	D	
- 29	MS2190306	• UNION	1	160	
	AN924-60	• NUT	1	160	
	AN9600916	• WASHER	1	160	
- 30	AN93806	• TEE	1	160	
	AN6290-6	• GASKET	1	160	
- 31	MS2191206-4	• REDUCER	1	160	
	AN6290-6	• GASKET	1	160	
- 32	MS2191206	• TEE	1	160	
		D AIRPLANES 35 AND ON AND AIRPLANES 56-0453, 57-0245, 58-0024, AND 59-0074 WHEN MODIFIED BY T.O. 1F-106-1114.			

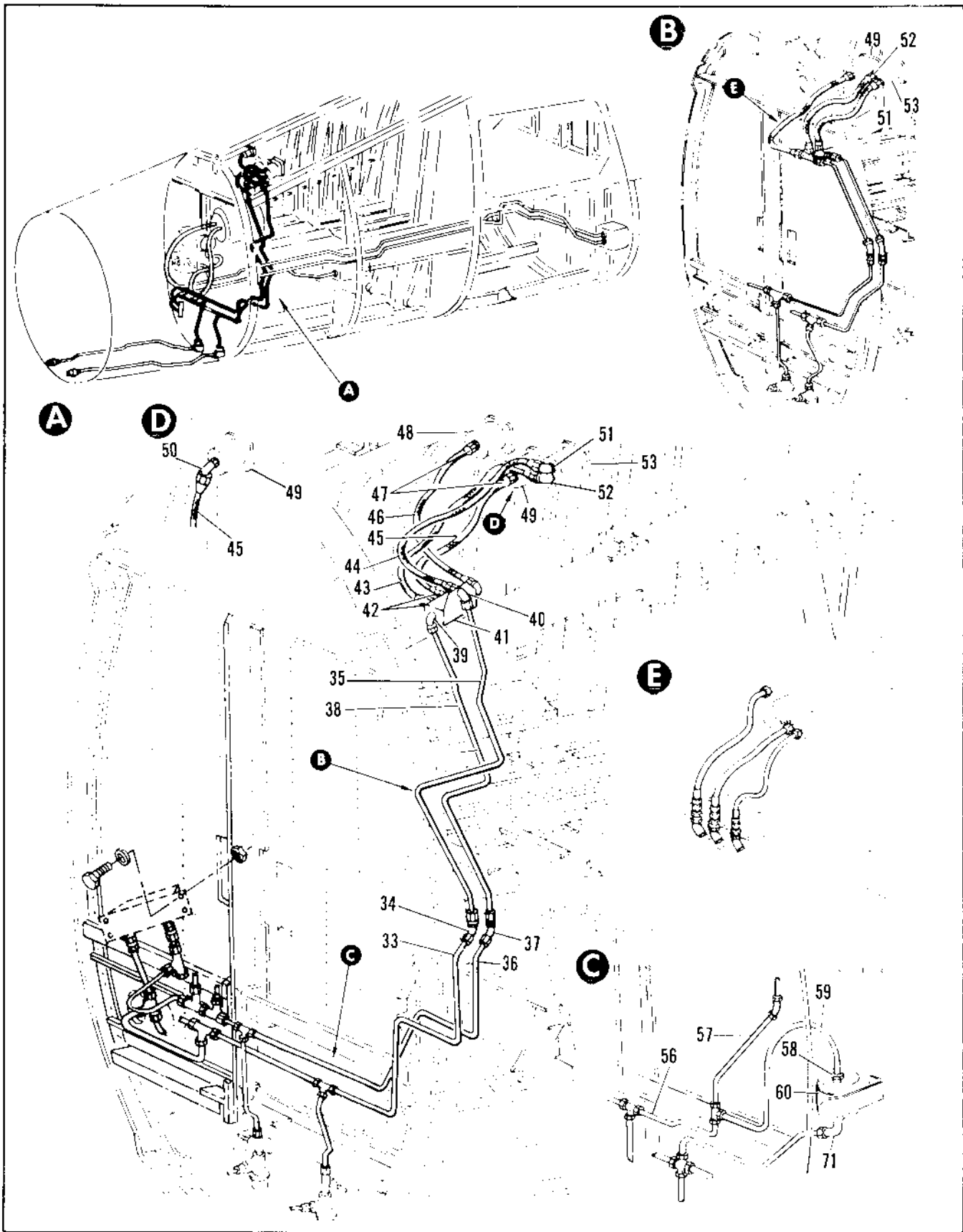

Figure 2.14-4. Airspeed Tubing Installation Sta 41 to 216 (Sheet 3 of 6)

FIGURE AND INDEX NUMBER	PART NUMBER	DESCRIPTION	UNITS PER ASSY.	USABLE ON CODE	
				FROM	TO
		1 2 3 4 5 6			
2.14-4- 33	8-38092-77	• TUBE ASSY, AIRSPEED	1	A	
- 34	MS2190704	• ELBOW PER TCT01FP106-569	1	A	
	AN9600716	• WASHER	1	A	
	AN924-4D	• NUT	1	A	
- 35	8-38092-41	• TUBE ASSY, AIRSPEED	1	A	
- 36	8-38092-11	• TUBE ASSY, AIRSPEED	1	A	
- 37	MS2190706	• ELBOW	1	A	
	AN9600916	• WASHER	1	A	
	AN924-6D	• NUT	1	A	
- 38	8-38092-39	• TUBE ASSY, AIRSPEED	1	A	
- 39	ER82200602	• ELBOW, <92003> 93-39753-002	2	A	
- 40	MS2190704	• ELBOW	1	A	
	AN924-4D	• NUT	1	A	
	AN9600716L	• WASHER	1	A	
- 41		• MANIFOLD, INSTRUMENT PANEL STATIC LINE SEE FIG. 2.14-1	RF		
- 42	ER81600602	• ADAPTER, <92003> 90-0429-004	2	A	
- 43	616044-6-00127	• HOSE, <00624> 94-80517-037	1	A	
- 44	616044-4-0140	• HOSE, <00624> 94-80517-036	1	A	
- 45	616044-6-0207	• HOSE, <00624> 94-80517-034	1	35	
- 46	616044-6-0240	• HOSE, <00624> 94-80514-035	1	B	
- 47	ER81606-2	• ADAPTER, <92003> 90-04929-004	2	B	
- 48		• INDICATOR, RATE OF CLIMB SEE FIG. 2.16-1 INDEX 83	RF		
- 49		• ALTIMETER, PRESSURE SEE FIG. 2.16-1 INDEX 77	RF		
- 50	ER937-0406	• ELBOW, <92003> 93-40020-001	1	A	
	AN6290-4	• GASKET	1	A	
	AN924-4D	• NUT	1	A	
- 51	ER816-4	• ADAPTER, PIPE TO TUBE <92003> 90-04929-006	1		
- 52	ER81606-2	• ADAPTER, PIPE TO TUBE <92003> 90-04929-007	1		
	AN6290-4	• GASKET	2	35	
- 53		• INDICATOR, AIRSPEED SEE FIG. 2.16-1 INDEX 50	RF		
- 54	7140206-10	• TUBE ASSY, AIRSPEED	1	B	
- 55	8-38092-103	• TUBE ASSY, AIRSPEED	1	B	
- 56	7146203-10	• TUBE ASSY, INFRARED SPEAKER	1	35	
- 57	8-38092-161	• TUBE ASSY, AIRSPEED	1	35	
- 58	MS2190204	• UNION	1	35	
	AN6290-4	• GASKET	1	35	
- 59	8-38092-165	• TUBE ASSY, AIRSPEED	1	35	
- 60		• SWITCH, PRESSURE INDICATED AIR SPEED SEE FIG. 2.14-1 INDEX 27	PF		
- 61	MS2190804	• ELBOW	1	35	
	AN6290-4	• GASKET	1	35	
	AN924-4D	• NUT	1	35	
A AIRPLANES #35 THRU 47 AND 49 THRU 69					
B AIRPLANES #48, 90 AND ON					

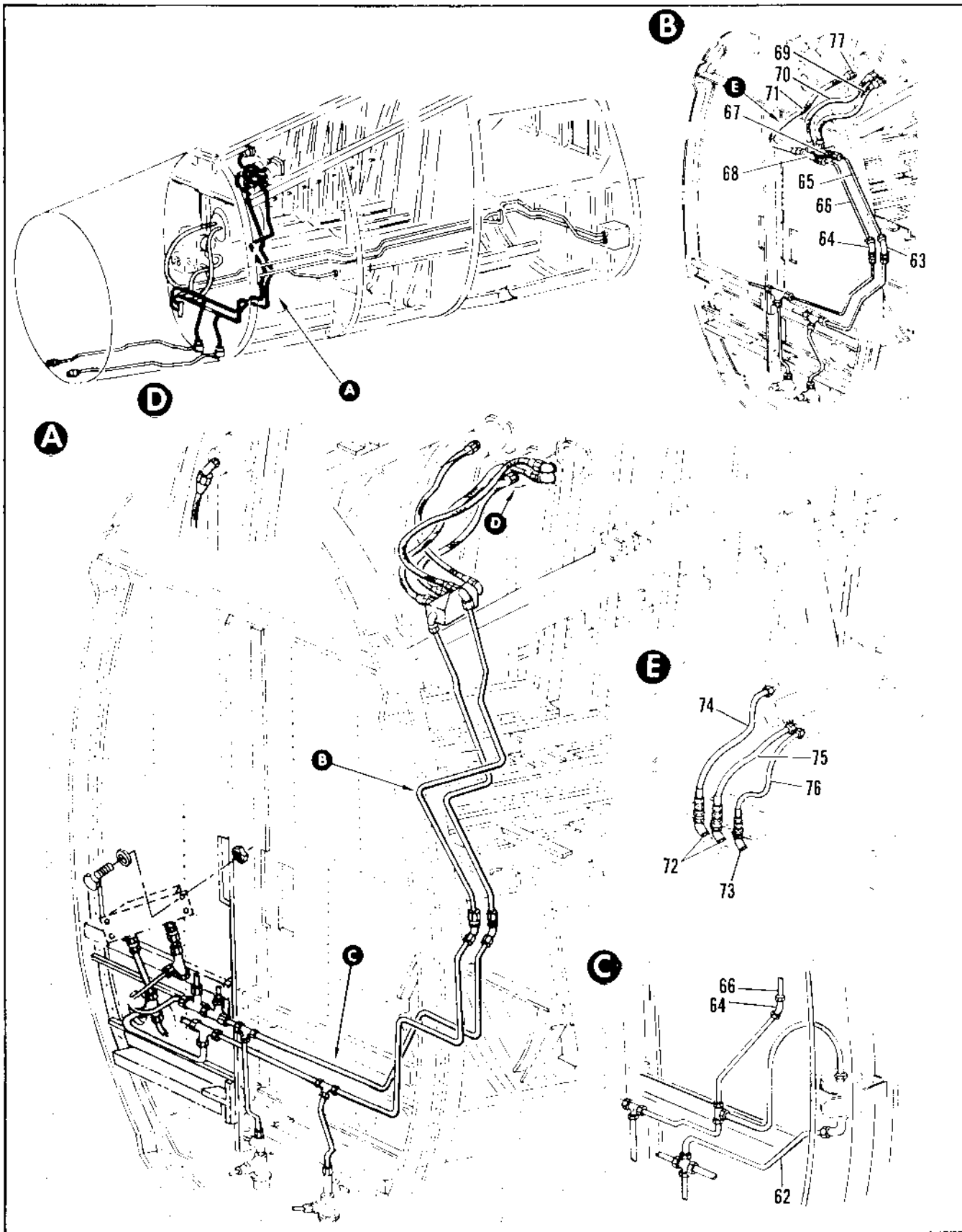

Figure 2.14-4. Airspeed Tubing Installation Sta 41 to 216 (Sheet 4 of 6)

FIGURE AND INDEX NUMBER	PART NUMBER	DESCRIPTION	UNITS PER ASSY.	USABLE ON CODE	
				FROM	TO
		1 2 3 4 5 6			
2.14-4- 62	31983-23	• TUBE ASSY, AIRSPEED	1	35	
- 63	MS2190704	• ELBOW	1	B	
	AN9600716	• WASHER	1	B	
	AN924-40	• NUT	1	B	
- 64	MS2190706	• ELBOW	1	B	
	AN9600916	• WASHER	1	B	
	AN924-60	• NUT	1	B	
- 65	8-38092-113	• TUBE ASSY, AIRSPEED	1	B	
- 66	8-38092-109	• TUBE ASSY, AIRSPEED	1	C	
- 67	MS2190804	• ELBOW	1	130	
	MS2190304	• UNION	1	B	
	AN9600716	• WASHER	1		
	AN924-40	• NUT	1	B	
- 68	MS2191206	• TEE	1		
	AN9600916	• WASHER	1		
	AN924-60	• NUT	1	B	
- 69	616046-4-0274	• HOSE ASSY, <00624> 94-80517-042	1	B	
- 70	616043-6-0274	• HOSE ASSY, <00624> 94-80517-041	1	B	
- 71	616046-6-0300	• HOSE, <00624> 94-80517-043	2	B	
- 72	MS2190706	• ELBOW	4	B	
	AN9600916	• WASHER	2	B	
	AN924-60	• NUT	2	B	
- 73	MS2190704	• ELBOW	1	B	
	AN9600716	• WASHER	2	B	
	AN924-40	• NUT	1	B	
- 74	616048-6-0092	• HOSE (00624)	1	B	
- 75	616048-6-0074	• HOSE (00624)	1	B	
- 76	616046-4-0076	• HOSE (00624)	1	B	
- 77	MS2191606-4	• REDUCER	1	B	
	AN6290-4	• GASKET	1	B	
		B AIRPLANES #48, 90 AND ON			
		C AIRPLANES #48 AND 90 THRU 129			

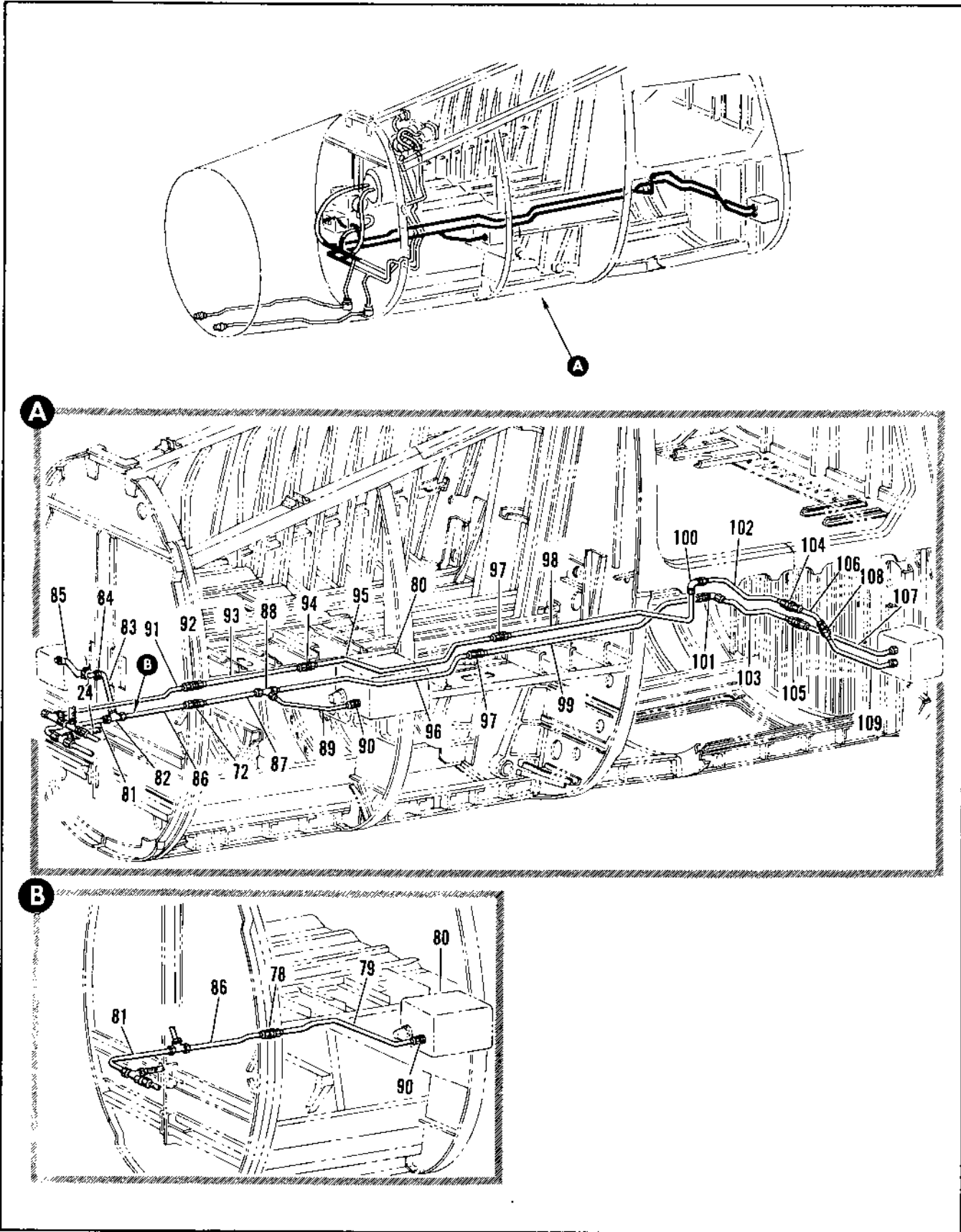

Figure 2.14-4. Airspeed Tubing Installation Sta 41 to 216 (Sheet 5 of 6)

FIGURE AND INDEX NUMBER	PART NUMBER	DESCRIPTION	UNITS PER ASSY.	USABLE ON CODE	
				FROM	TO
		1 2 3 4 5 6			
2.14-4- 78	MS2190704	• UNION	1	35	
	AN924-40	• WASHER	1	35	188
	AN924-40	• NUT	1	35	
- 79	8-38092-23	• TUBE ASSY, AIRSPEED	1	35	188
- 80		• TRANSMITTER, PRESSURE RATIO SEE FIG. 2.17-11 INDEX 1	RF		
- 81	8-38092-83	• TUBE ASSY, AIRSPEED	1	35	
- 82	MS2190504	• TEE	1	35	
- 83	8-38092-125	• TUBE ASSY, AIRSPEED	1	48	
- 84	MS2190704	• NUT	1	35	
	AN924-40	• ELBOW	1	35	
- 85	616044-4-0124	• HOSE, <90624> 94-40517-205	1	35	
- 86	8-38092-87	• TUBE ASSY, AIRSPEED	1	189	
- 87	8-38092-131	• TUBE ASSY, AIRSPEED	1	189	
- 88	MS2190504	• TEE	1	189	
- 89	8-38092-133	• TUBE ASSY, AIRSPEED	1	35	
- 90	MS2190204	• UNION	1	35	
	AN6290-4	• CASKET	1	189	
- 91	8-38092-137	• TUBE ASSY, AIRSPEED	1	189	
- 92	MS2190306	• UNION	1	189	
	AN924-60	• NUT	1	189	
- 93	8-38092-139	• TUBE ASSY, AIRSPEED	2	189	
- 94	MS2190204	• UNION	1	189	
- 95	8-38092-141	• TUBE ASSY, AIRSPEED	1	189	
- 96	8-38092-135	• TUBE ASSY, AIRSPEED	2	189	
- 97	MS2190204	• UNION	1	189	
- 98	8-38092-145	• TUBE ASSY, AIRSPEED	1	189	
- 99	8-38092-141	• TUBE ASSY, AIRSPEED	1	189	
-100	MS2190806	• ELBOW	1	189	
-101	MS2190704	• ELBOW	1	189	
	AN9600914	• WASHER	1	189	
	AN9600716	• WASHER	1	189	
	AN924-60	• NUT	1	189	
	AN924-40	• NUT	1	189	
-102	8-38092-151	• TUBE ASSY, AIRSPEED	1	189	
-103	8-38092-147	• TUBE ASSY, AIRSPEED	1	189	
-104	MS2190306	• UNION	1	189	
-105	MS2190304	• UNION	1	189	
	AN924-60	• NUT	1	189	
	AN924-40	• NUT	1	189	
-106	8-38092-157	• TUBE ASSY, AIRSPEED	1	189	
-107	8-84749-9	• TUBE ASSY, AIRSPEED	1	189	
-108	MS2191606-4	• REDUCER	1	189	
-109	8-84753-9	• TUBE ASSY, AIRSPEED	1	189	

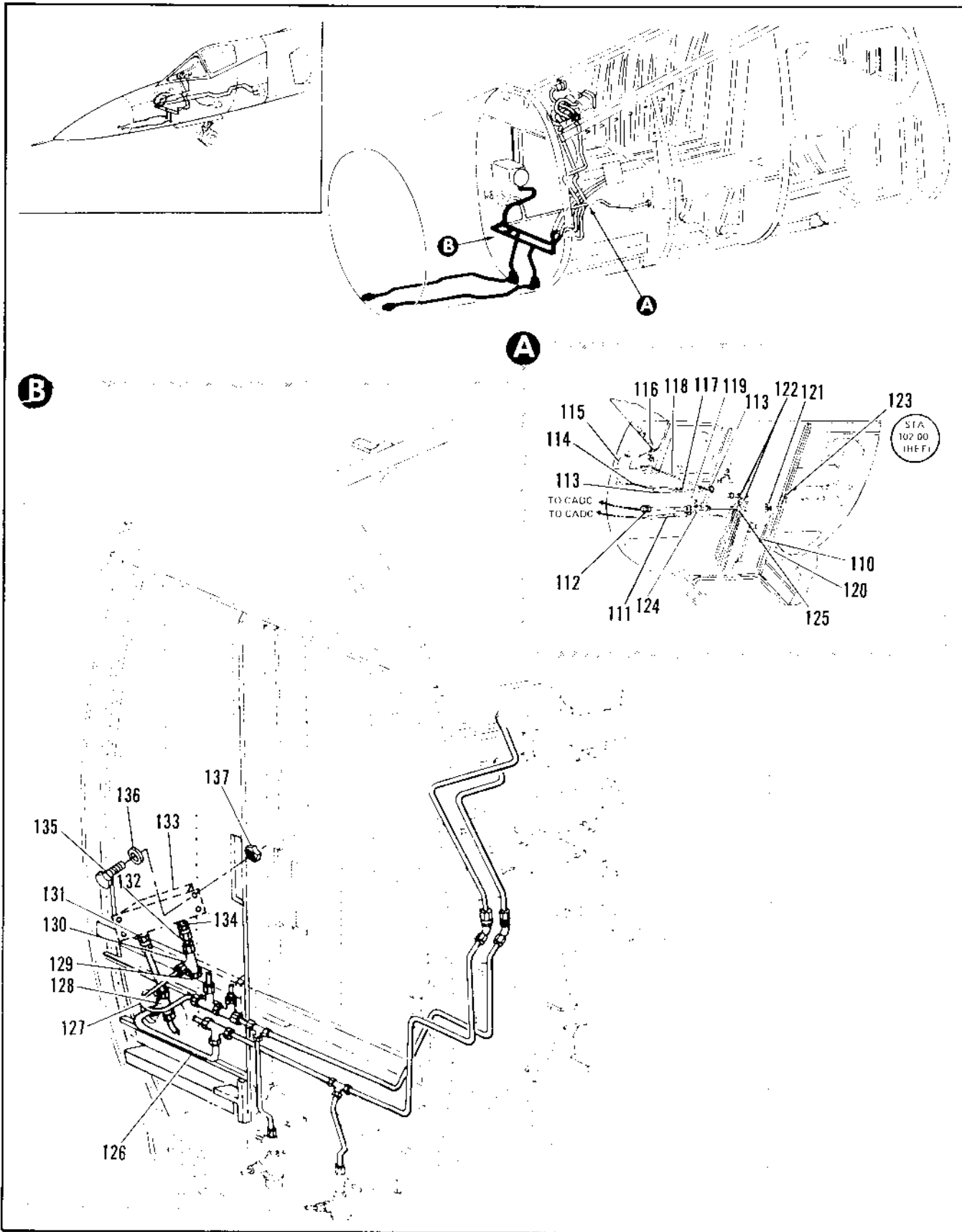

Figure 2.14-4. Airspeed Tubing Installation Sta 41 to 216 (Sheet 6 of 6)

FIGURE AND INDEX NUMBER	PART NUMBER	DESCRIPTION	UNITS PER ASSY.	USABLE ON CODE	
				FROM	TO
		1 2 3 4 5 6			
2.14-3-110	7140212-10	• (SEE FIGURE 2.9-20) FOR BREAKDOWN	1	35	
-111	MS80016006A	• HOSE	1	35	
-112	MS80016006A	• HOSE	1	35	
-113	MS21919004	• CLAMP	1	35	
	NAS43003-04	• • SPACER	1	35	
	MS35207-260	• • SCREW	1	35	
-114	7140208-10	• TUBE	1	8	
	7140242-10	• TUBE	1	V	
-115	H-36425	• SWITCH AIRSPEED (REF)	1	35	
-116	7140209-10	• TUBE	1	8	
	7140243-10	• TUBE	1	V	
-117	7140209-10	• TUBE	1	35	
-118	7140211-10	• TUBE	1	8	
	7140244-10	• TUBE	1	V	
-119	7140207-10	• TUBE	1	8	
	7140245-10	• TUBE	1	V	
-121	MS21919004	• CLAMP	1	35	
	NAS43003-24	• • SPACER	1	35	
	MS35207-265	• • SCREW	1	35	
	MS2142L3	• • NUT	1	35	
-121	MS21919004	• CLAMP	2	35	
	MS35207-265	• • SCREW	1	35	
	AN960-10	• • WASHER	1	35	
	MS2143-3	• • SPACER	1	35	
-122	MS21919004	• CLAMP	1	35	
	MS35207-265	• • SCREW	1	35	
	AN960-10	• • WASHER	1	35	
-123	MS21919004	• CLAMP	1	35	
	NAS43003-27	• • SPACER	1	35	
	MS35207-265	• • SCREW	1	35	
	AN960-10	• • WASHER	1	35	
	MS2143-3	• • NUT	1	35	
-124	7140209-10	• SUPPORT	1	35	
-125	MS21919004	• CLAMP	1	35	
-126	7240227-10	• TUBE ASSY, AIRSPEED	1		
-127	7240209-1	• TUBE ASSY, AIRSPEED	1		
-128	MS21919004	• TEE	1	F	
-129	7240228-10	• TUBE ASSY, AIRSPEED	1	F	
-130	MS21919004	• TEE	1	F	
-131	MS21919004	• UNION	1	F	
	MS26777-4	• • PACKING	1	F	
-132	7240229-10	• TUBE ASSY, AIRSPEED	1	F	
-133	7909525	• TRANSDUCER, ALTITUDE-AIRSPEED	1	F	
-134	MS21919004	• UNION	1	F	
	MS26777-4	• • PACKING	1	F	
-135	MS35207	• SCREW	4	F	
-136	AN960-10L	• WASHER	4	F	
-137	MS2144N3	• NUT	4	F	

E AIRPLANES 16-1403, 17-1404,
 39-1024 AND 39-0074 WING
 MODIFIED BY T.O. 1F-1 8-1114
 W WOUND INSTRUMENTED AIRCRAFT
 V VERTICAL INSTRUMENTED AIRCRAFT

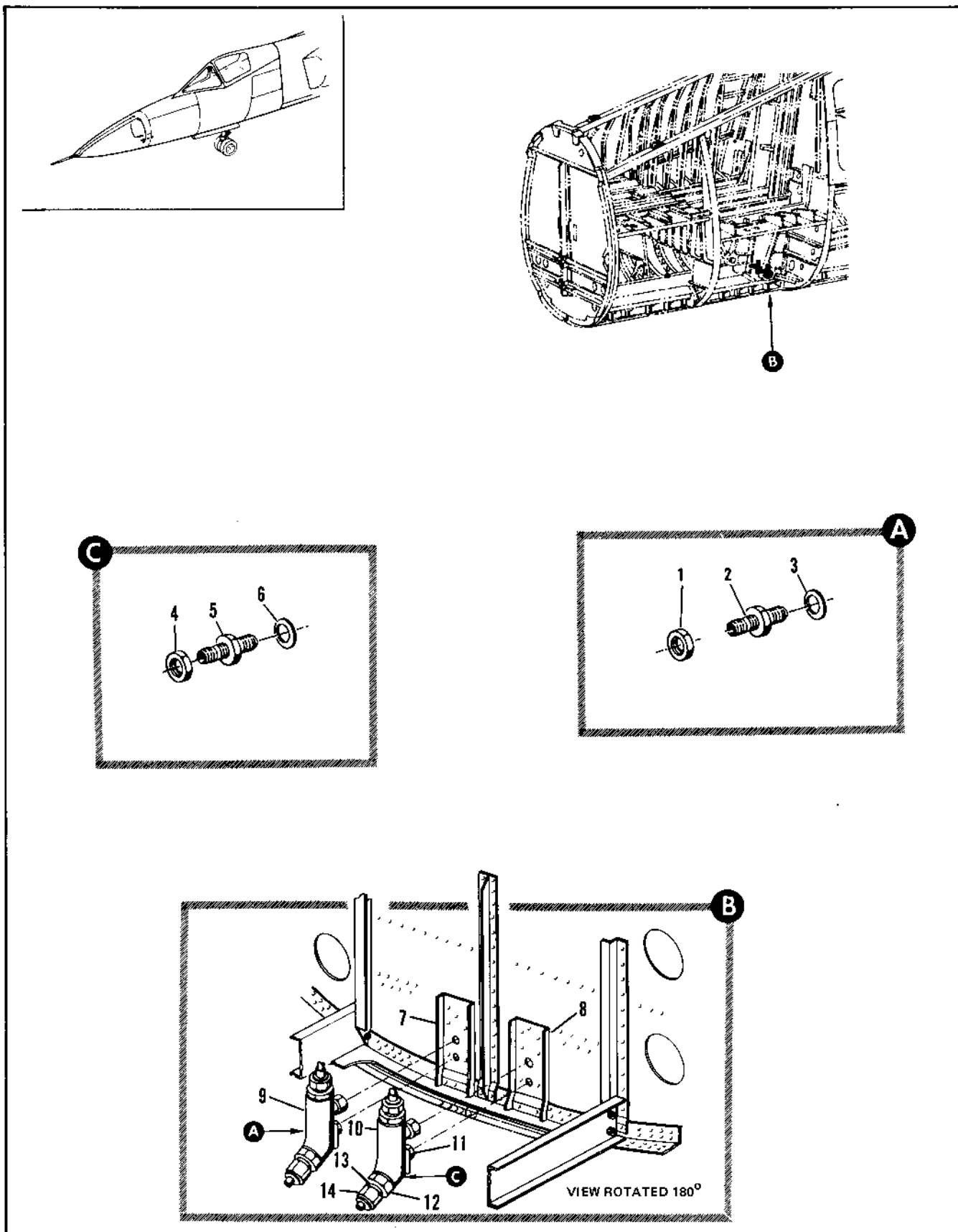

Figure 2.14-5. Airspeed Tubing Water Trap Installation

FIGURE AND INDEX NUMBER	PART NUMBER	DESCRIPTION	UNITS PER ASSY.	USABLE ON CODE	
				FROM	TO
		1 2 3 4 5 6			
2.14-5	8-38631-1	TRAP INSTALLATION, AIRSPEED TUBING WATER FOR NHA SEE FIG. 2.3-4	RF	35	
- 1	AN924-40	• NUT	1	35	
- 2	MS2190304	• FITTING, BULKHEAD	1	35	
- 3	AN6290-4	• GASKET	1	35	
- 4	AN924-60	• NUT	1	35	
- 5	MS2198306	• FITTING, BULKHEAD	1	35	
- 6	AN6290-6	• GASKET	1	35	
- 7	8-74220-257	• DOUBLER	1	35	
- 8	8-74220-259	• DOUBLER	1	35	
- 9	62034109-1	• BODY, WATER TRAP	1	35	
- 10	62034109-2	• BODY, WATER TRAP	1	35	
- 11	AN4CH4A6	• BOLT	1	35	
- 12	AN9610416	• WASHER	1	35	
- 13	MS28778-4	• PACKING	1	35	
- 14	AN815-40	• UNION	1	35	
	AN929-4	• CAP	1	35	

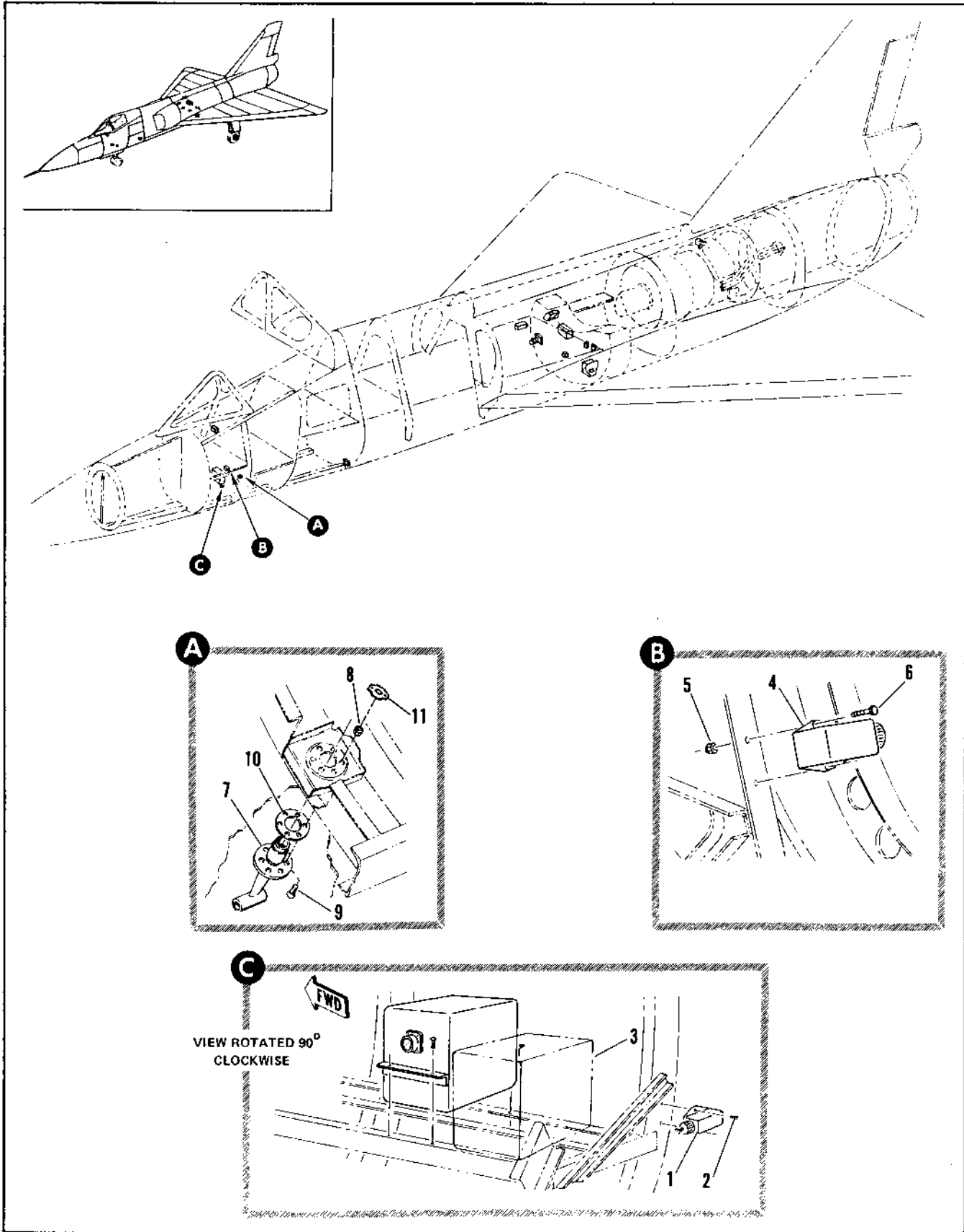

Figure 2.14-6. Electrical Flight Controls (Sheet 1 of 3)

FIGURE AND INDEX NUMBER	PART NUMBER	DESCRIPTION 1 2 3 4 5 6	UNITS PER ASSY.	USABLE ON CODE	
				FROM	TO
2.14-6		ELECTRICAL FLIGHT CONTROLS			
- 1	8-65018-5 9230-3434	• CONTROL INSTL, ELEVON TRIM AND FEEL SERVO • RELAY, <35344> SPEC N-36259-1 ATTACHING PARTS	1	35	60
- 2	AN520-10K6	• SCREW -----X-----	2	35	60
- 3		• CONTROL BOX ASSY, NLG STEERING AND DAMPING SEE FIG. 2.17-11 INDEX 9	RF		
- 4	8-65106 9230-3465	• RELAY INSTL, TRIM SERVO EMERGENCY DISCONNECT • RELAY, <35344> SPEC N-36289-5 ATTACHING PARTS	1 1	35 35	129 129
- 5	NAS679A3	• NUT	2	35	129
- 6	NAS221-8	• BOLT -----X-----	3	35	129
	8-38070-1	• PROBE INSTL, TOTAL TEMPERATURE STA 151 FOR NHA SEE FIG. 2.1-1	RF	35	47
	8-38070-3	• PROBE INSTL, TOTAL TEMPERATURE STA 151 FOR NHA SEE FIG. 2.1-1	RF	48	
- 7	117CV 3225-1A	• PROBE, TOTAL TEMPERATURE <04274> SPEC B-33255-1 GF AE • PROBE, TOTAL TEMPERATURE <19315> AERN060-1602 TYPE NA-1 GF AE ATTACHING PARTS	1 1	35 48	47
- 8	NAS679A3	• NUT	6	35	47
- 9	32FT832 ANS09-10RA ANS19-BR3	• NUT, <56878> 96-37525-001 • SCREW • SCREW	6 6 6	48 35 48	47
- 10	8-38070-11	• GASKET -----X-----	1	35	
- 11	MS21075-3	• NUTPLATE	6	35	

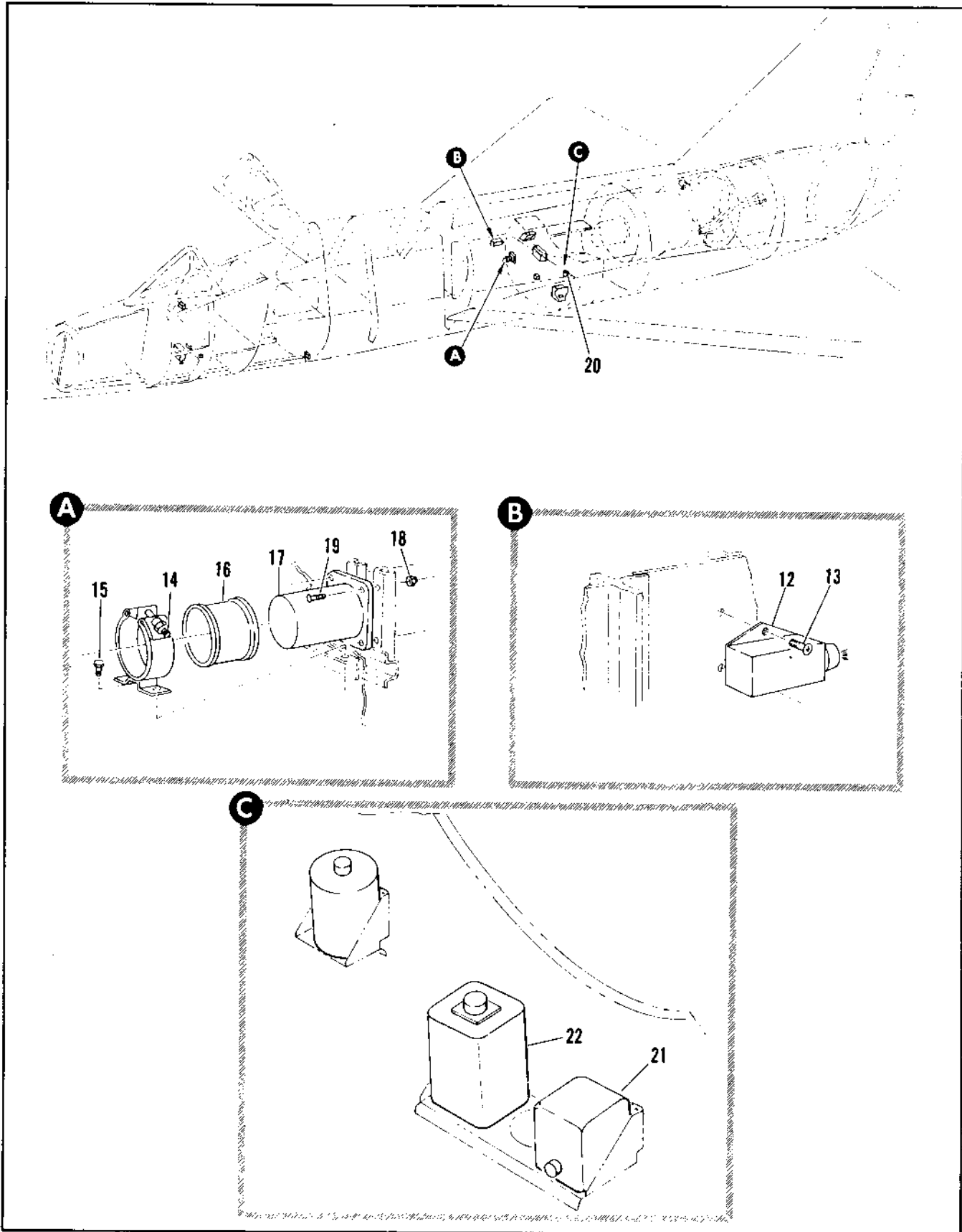

Figure 2.14-6. Electrical Flight Controls (Sheet 2 of 3)

FIGURE AND INDEX NUMBER	PART NUMBER	DESCRIPTION	UNITS PER ASSY.	USABLE ON CODE	
				FROM	TO
		1 2 3 4 5 6			
2.14-6	8-65131-1	• RELAY INSTALLATION, G ACCELEROMETER TRIM	1	35	
- 12	9230-3669	• • RELAY,	1	35	
	9227-3853	• • RELAY, ALT	RF	35	
- 13	NAS221-9	ATTACHING PARTS			
		• • SCREW	2	35	277
		----X----			
	8-65127-1	• ACCELEROMETER INSTL, NORMAL	RF	B	
- 14	8-65127-801	• ACCELEROMETER INSTL, NORMAL	RF	D	
	916-3375	• • SUPPORT, <98625> 98-60002-002	1	B	
	91-97815-035	• • CLAMP	1	D	
- 15	ANA-3A	ATTACHING PARTS			
- 16	8-36573-19	• • BOLT	2	B	
- 17	24522E	• • BOOT, HARNESS BULKHEAD FEED-THRU	1	35	
		• • ACCELEROMETER, NORMAL <72737>	1	35	89
		SPEC 8-06406-1 T.O.5F2-10-14			
		REPLACED BY SUITABLE SUB 24522J			
	24522J	• • ACCELEROMETER, NORMAL <72737>	1	90	
		SPEC 8-06406-3 REPLACES SUITABLE SUB			
		FOR 24522E			
	24522K	• • ACCELEROMETER, PITCH G LIMITER	1		
		T.O.5F2-10-14			
		ATTACHING PARTS			
- 18	NAS679A3	• • NUT	4	35	
- 19	AN520-10R12	• • SCREW	4	35	
		----X----			
	8-36301-1	• ACCELEROMETER INSTL, STA 431	1	G	
- 20	8-36301-805	• ACCELEROMETER INSTL, STA 431	1	61	89
	464061-150	• • ACCELEROMETER, AIRCRAFT-NORMAL	1	H	
		<82577> AERN052-8933 GFAE			
		ATTACHING PARTS			
	NAS679A3	• • NUT	4	H	
	AN520-10R10	• • SCREW	4	G	
	AN520-10R12	• • SCREW	2	61	89
	AN3-12A	• • BOLT	2	61	89
		----X----			
- 21	8-36409-1	• ACCELEROMETER INSTL, STA 431	1	F	
	WCLC1-1-41	• • TRANSMITTER, ACCELEROMETER LINEAR	1	F	
		AERON060-6300 TYPE TRU 3&A GFAE			
		ATTACHING PARTS			
	MS21043-3	• • NUT	4	F	
	AN520-10R8	• • SCREW	2	F	
	NAS1103-10	• • BOLT	2	F	
		----X----			
- 22	8-36409-3	• ACCELEROMETER INSTL, STA 431	1	F	
	464061-150	• • ACCELEROMETER, AIRCRAFT-NORMAL	1	F	
		<82577> AERN052-8933 GFAE			
	NAS679A3	• • NUT	4	F	
	AN520-10R10	• • SCREW	2	F	
	NAS1103-4	• • BOLT	2	F	
		B AIRPLANES #35 THRU 154, AND 157 THRU 162			
		D AIRPLANES #155, 156, 163 AND ON			
		F AIRPLANES #48, 90 AND ON			
		G AIRPLANES #35 THRU 47 AND 49 THRU 60			
		H AIRPLANES #35 THRU 47 AND 49 THRU 89			

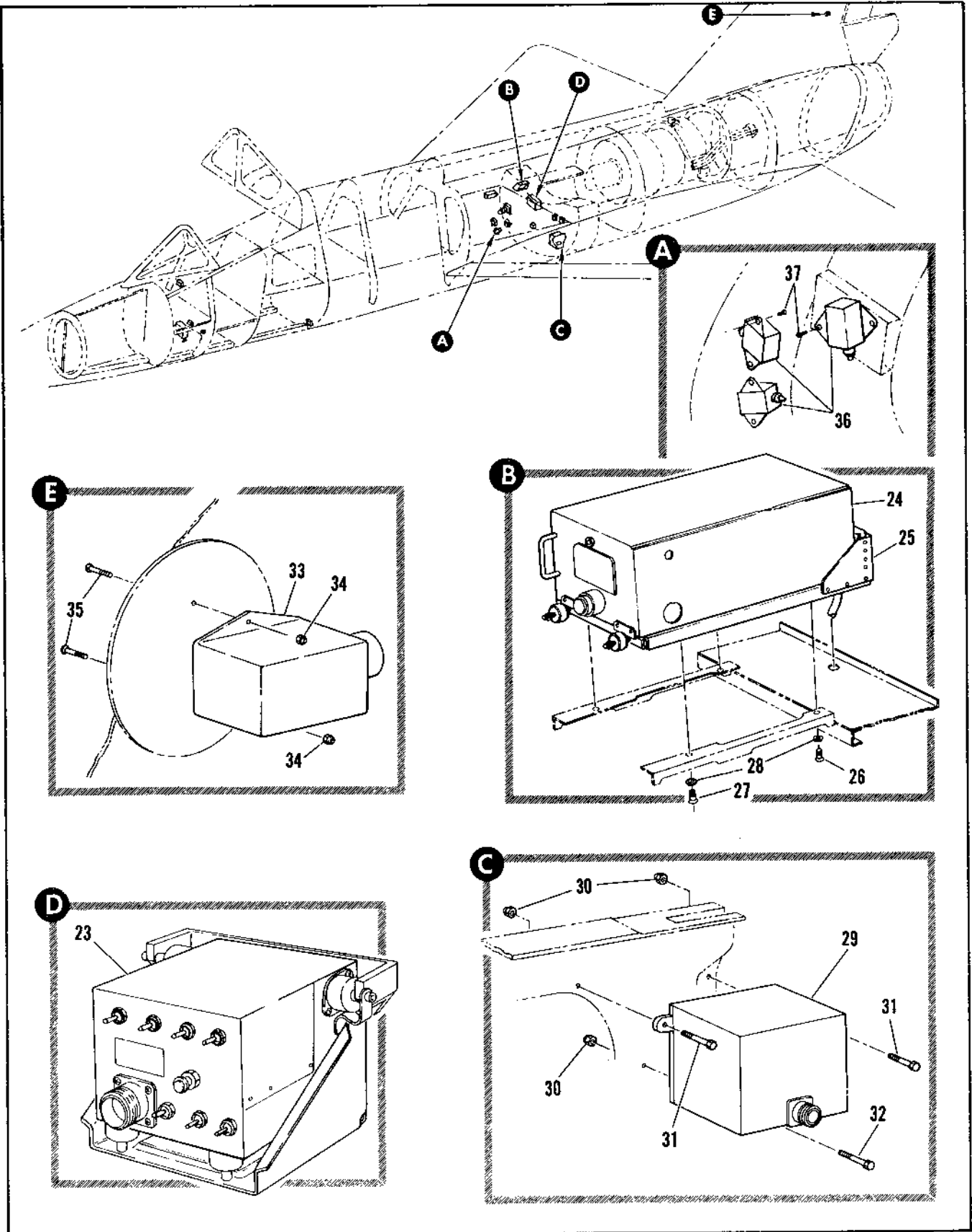

Figure 2.14-6. Electrical Flight Controls (Sheet 3 of 3)

FIGURE AND INDEX NUMBER	PART NUMBER	DESCRIPTION	UNITS PER ASSY.	USABLE ON CODE	
				FROM	TO
2.14-6 - 23	8-65045	. LIMITER INSTL, PITCH G	RF	35	
	8-61100-803	. . LIMITER ASSY, PITCH G T.O.5A17-4-3-4 ATTACHING PARTS	1	35	
	AN4C26A	. . BOLT	1	35	
	AN4C17A	. . BOLT	1	35	
	AN4C26A	. . BOLT	1	35	
	NAS43004-R	. . SPACER	1	35	
		-----X-----			
- 24	8-65288-1	. AMPLIFIER INSTL, PITCH AND YAW DAMPER	1	35	
	1131-31101	. . AMPLIFIER, <00543> SPEC 8-06991-3 T.O.5A3-39-4 REPLACED BY SUITABLE SUB 1131-36001	1	35	89
	1131-34601	. . AMPLIFIER, <00543> SPEC 8-06991-3	RF	35	89
	1131-35001	. . AMPLIFIER, <00543> SPEC 8-06991-5 REPLACES SUITABLE SUB FOR 1131-31101 REPLACED BY SUITABLE SUB 1131-36001	1	A	
	1131-37001	. . AMPLIFIER, <00543> SPEC 8-06991-803	1	C	
	1131-36001	. . AMPLIFIER, <00543> SPEC 8-06991-801 REPLACES SUITABLE SUB FOR 1131-35001	1	216	
	1131-36501	. . AMPLIFIER, <00543> SPEC 8-06991-801 ALT INTCHG WITH 1131-36001 REPLACED BY SUITABLE SUB 1131-39101	RF	216	
	1131-34001	. . AMPLIFIER, <00543> SPEC 8-06991-801	RF	216	
	1131-39101	. . AMPLIFIER, <00543> SPEC 8-06991-807 REPLACES SUITABLE SUB FOR 1131-36501	1		
- 25	1131-32101	. . RACK, <00543> SPEC 8-06991-1 T.O.5A3-35-4 ATTACHING PARTS	1	35	
- 26	AN520-10R12	. . SCREW	3	35	
- 27	AN520-10R12	. . SCREW	1	35	
	AN520-10R14	. . SCREW	1	35	
- 28	AN960-10L	. . WASHER	4	35	
		-----Y-----			
- 29	8-65044	. TRANSMITTER INSTL, TURN RATE	RF	35	
	10234G1	. . TRANSMITTER ASSY, TURN RATE <86452> SPEC 8-06287 T.O.5A18-8-4	1	35	
	28593	. . TRANSMITTER, <40531> SPEC 8-06287 T.O.5A18-9-4 ALT INTCHG WITH 10234G1	RF		
	11671G1	. . TRANSMITTER <88932> SPEC 8-06287 T.O.5A18-8-4 ALT INTCHG WITH 10234G1 AND 28593 ATTACHING PARTS	RF		9
- 30	MS21043-4	. . NUT	3	35	
- 31	AN4-23A	. . BOLT	2	35	
- 32	AN4-17A	. . BOLT	1	35	
		-----X-----			
- 33	8-61042-1	. RELAY INSTL, RUDDER INTERLOCK	1	35	
	9230-3669	. . RELAY, <35344> SPEC 8-06289-5	1	35	
	9227-3853	. . RELAY, SPEC 8-106289-5 (ALT FOR 9230-3669) ATTACHING PARTS	RF		
- 34	MS21043-3	. . NUT	2	35	
- 35	AN509-10R10	. . SCREW	2	35	
		-----X-----			
- 36	8-6503-813	. RELAY INSTL, STA 405	1	35	
	9230-3434	. . RELAY, PITCH G LIMITER INTERLOCK ELEVATOR AND AILERON CHANNEL <35344> SPEC 8-06289-1 ATTACHING PARTS	3	35	
- 37	NAS221-9	. . SCREW	6	35	
		-----X-----			
		A AIRPLANES #90 THRU 129, 143 THRU 175 AND 204 THRU 215			
		C AIRPLANES #130 THRU 142 AND 176 THRU 203			

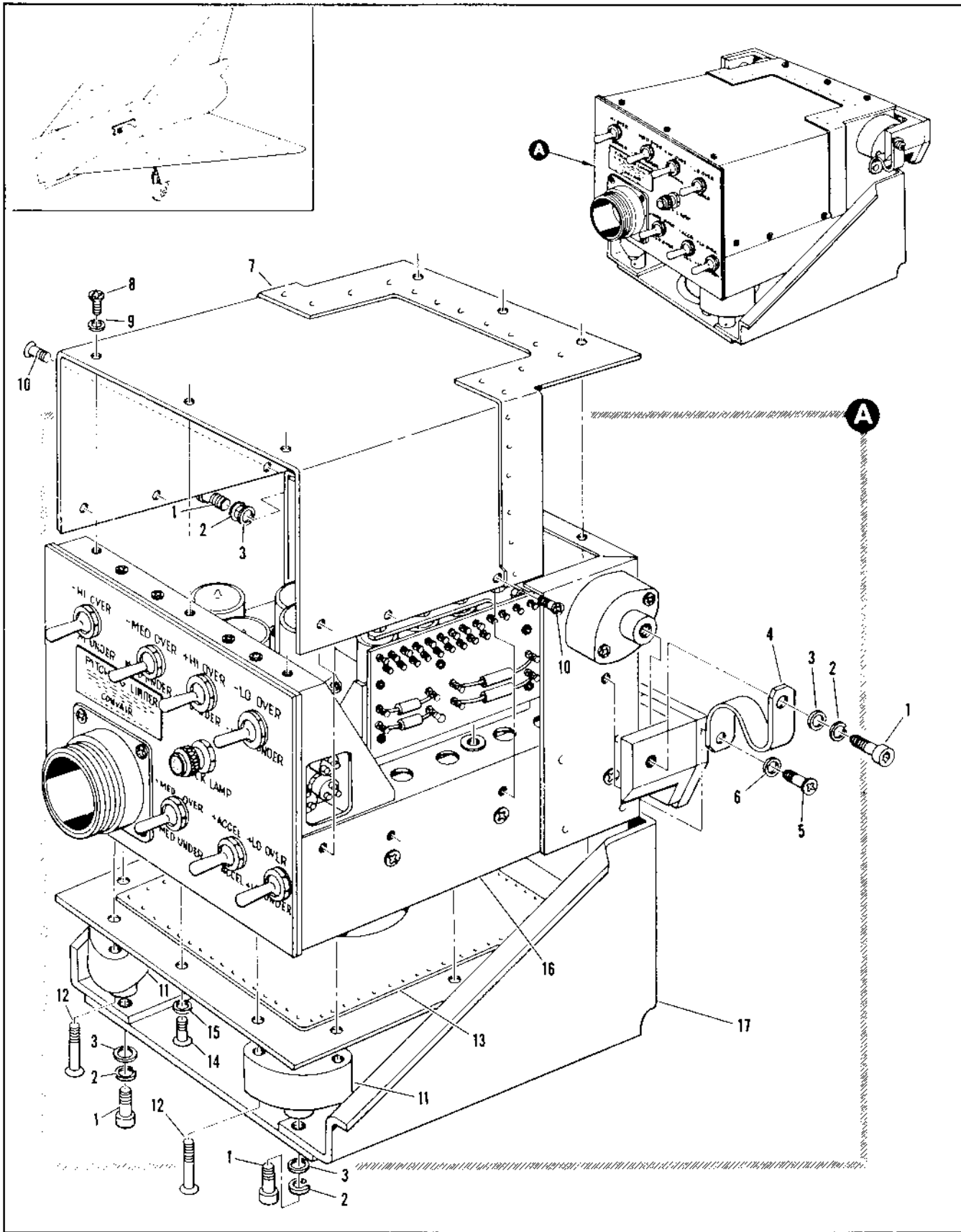

Figure 2.14-7. Pitch G Limiter Assembly

FIGURE AND INDEX NUMBER	PART NUMBER	DESCRIPTION	UNITS PER ASSY.	USABLE ON CODE	
				FROM	TO
		1 2 3 4 5 6			
2.14-7	8-61100-801	LIMITER ASSEMBLY, PITCH G FOR NHA SEE FIG. 2.14-6	RF	35	
- 1	NAS678C832H8	• SCREW	4	35	
- 2	AN935-8L	• WASHER	4	35	
- 3	AN960-8L	• WASHER	4	35	
- 4	8-61127	• STRAP, PITCH G LIMITER BONDING ATTACHING PARTS	1	35	
- 5	AN515-6R6	• SCREW	1	35	
- 6	AN960-6L	• WASHER	1	35	
		-----X-----			
- 7	8-61112-3	• COVER ASSY, PITCH G LIMITER WELDED ATTACHING PARTS	1	35	
- 8	AN515-6R6	• SCREW	10	35	
- 9	AN960-6L	• WASHER	10	35	
- 10	AN507-632R5	• SCREW	2	35	
		-----X-----			
- 11	HTG-7	• MOUNT, PITCH G LIMITER SHOCK <76005> SPEC P-36469-1 ATTACHING PARTS	2	35	
- 12	AN509-8R18	• SCREW	4	35	
		-----X-----			
- 13	8-61113-1	• PLATE ASSY, PITCH G LIMITER BONDED ATTACHING PARTS	1	35	
- 14	AN515-6R7	• SCREW	6	35	
- 15	AN960-6L	• WASHER	6	35	
		-----X-----			
- 16	8-61102-3	• CHASSIS ASSY, ELECTRICAL PITCH G LIMITER FOR BREAKDOWN SEE FIG. 2.14-B	1	35	
- 17	8-61115-1	• BRACKET ASSY, PITCH G LIMITER MOUNTING RIVETED	1	35	

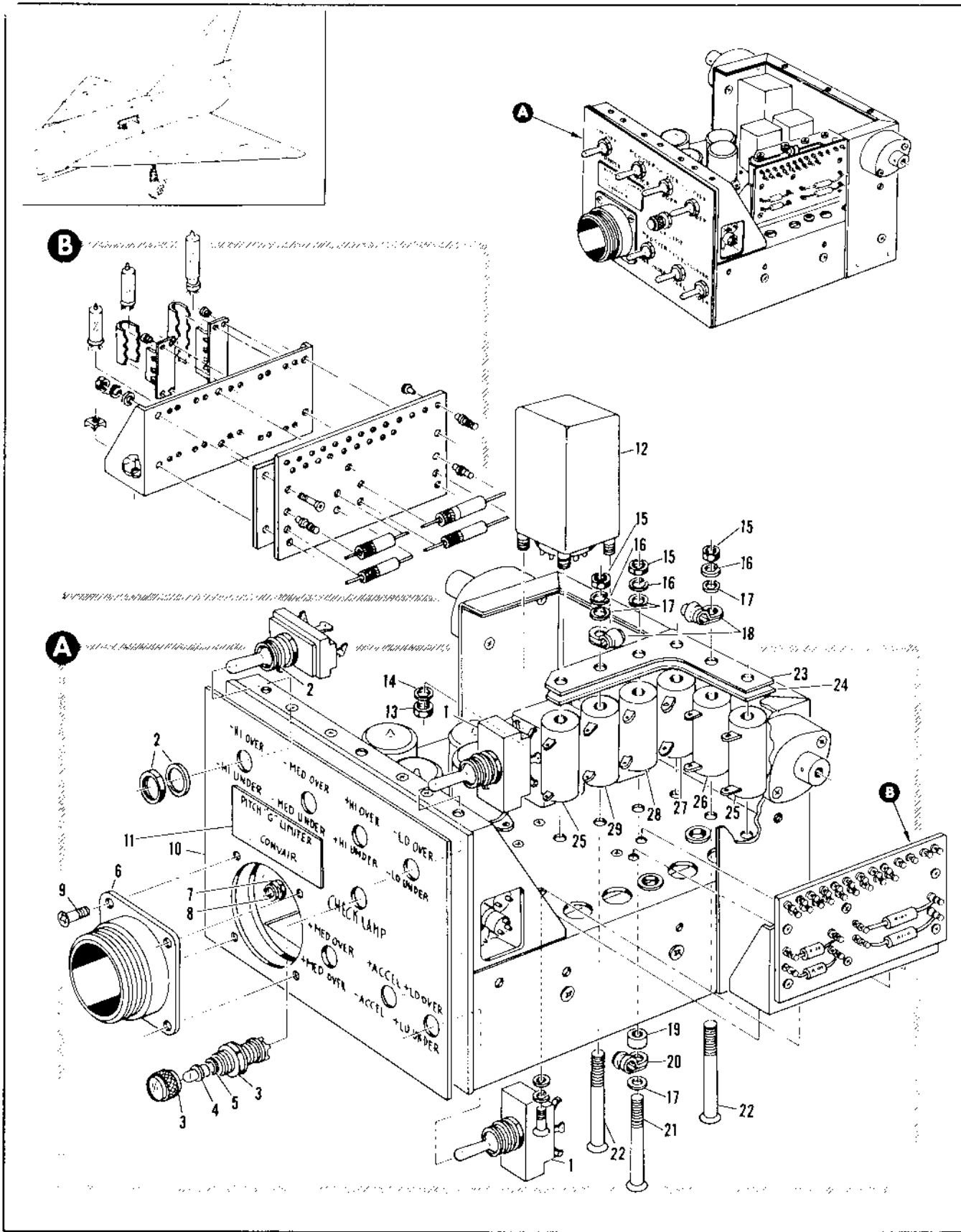

Figure 2.14-8. Electrical Pitch G Limiter Chassis Assembly (Sheet 1 of 4)

FIGURE AND INDEX NUMBER	PART NUMBER	DESCRIPTION	UNITS PER ASSY.	USABLE ON CODE	
				FROM	TO
		1 2 3 4 5 6			
2.14-B	8-61102-3	CHASSIS ASSEMBLY, ELECTRICAL PITCH G LIMITER FOR MA SEE FIG. 2.14-7	RF	35	
- 1	MS35059-12	• SWITCH, 98-45900-067	2	35	
- 2	7673K	• SWITCH, <15405> 98-69037-0.1	5	35	
- 3	VM911M7WT7	• LIGHT, INDICATOR <47074> 95-65123-007	1	35	
- 4	AN3140-327	• LAMP	1	35	
- 5	AN935A716S	• WASHER	1	35	
- 6	SSE2-2H-12P112	• CONNECTOR, <71468> 92-50140-003 ATTACHING PARTS	1	35	
- 7	MS21743-6	• NUT	4	35	
- 8	AN960-41	• WASHER	4	35	
- 9	AN500A6-3	• SCREW	4	35	
- 10	8-61121-11	• NAMEPLATE, PITCH G LIMITER SWITCH IDENTIFICATION	1	35	
- 11	8-61124	• NAMEPLATE, PITCH G LIMITER ATTACHING PARTS	1	35	
	AN353-00-0	• SCREW	4	35	
- 12	PA2343	• TRANSFORMER, PITCH G LIMITER <12223> SPEC 8-1744P ATTACHING PARTS	1	35	
- 13	MS21743-6	• NUT	4	35	
- 14	AN960-41	• WASHER	4	35	
- 15	MS21743-6	• NUT	6	35	
- 16	AN935-6	• WASHER	6	35	
- 17	AN960-6L	• WASHER	7	35	
- 18	3/16-4	• CLAMP, <45937> 91-48100-150	2	35	
- 19	NAS45001-10	• SPACER	1	35	
- 20	3/16-4	• CLAMP, <45937> 91-48100-150	1	35	
- 21	AN510-5K46	• SCREW	1	35	
- 22	AN510-5K44	• SCREW	1	35	
- 23	8-61124	• PLATE, MOUNTING CAPACITOR G LIMITER	2	35	
- 24	8-61131	• INSULATOR	1	35	
- 25	RB194E20.00F	• RESISTOR, 97-47078-001	2	35	
- 26	RB194E75.00F	• RESISTOR, 97-47079-001	1	35	
- 27	RB194E50.00F	• RESISTOR, 97-47079-010	1	35	
- 28	RB194E20.00F	• RESISTOR, 97-47079-009	1	35	
- 29	RB194E43.00F	• RESISTOR, 97-47079-009	1	35	

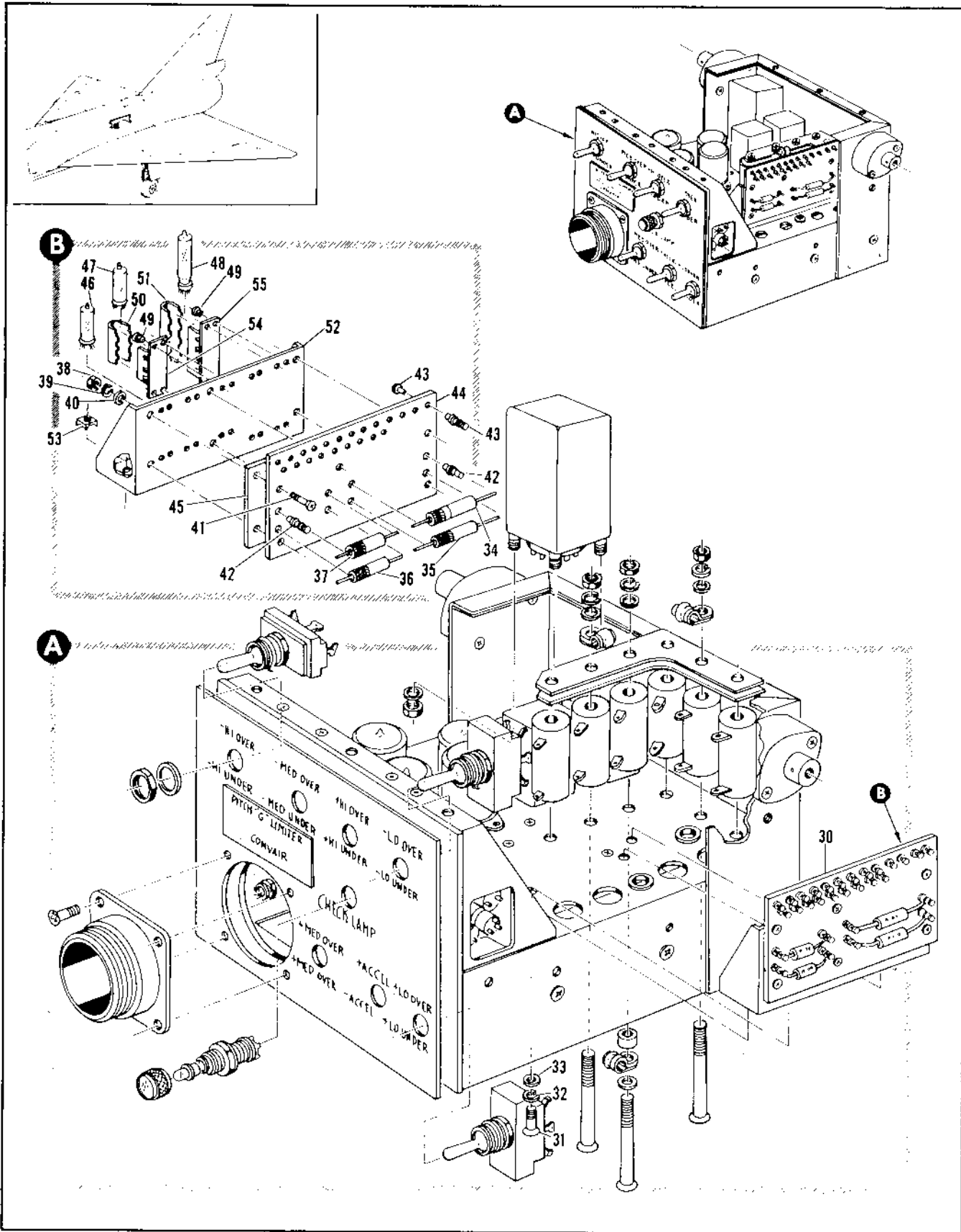

Figure 2.14-8. Electrical Pitch G Limiter Chassis Assembly (Sheet 2 of 4)

FIGURE AND INDEX NUMBER	PART NUMBER	DESCRIPTION	UNITS PER ASSY.	USABLE ON CODE	
				FROM	TO
2.14-8- 30	0-61102-9	• EQUIPMENT ASSY, PITCH G LIMITER ELECTRICAL ATTACHING PARTS	1	35	
- 31	AN515-6R5	• SCREW	4	35	
- 32	AN935-6	• WASHER	4	35	
- 33	AN960-6L	• WASHER	4	35	
		-----X-----			
- 34	RC426F104J	• RESISTOR, 97-40002-049	1	35	
- 35	RC426F225J	• RESISTOR, 97-40002-065	1	35	
- 36	RC426F105J	• RESISTOR, 97-40002-061	1	35	
- 37	RC426F474J 0-61119	• RESISTOR, 97-40002-057 • TERMINAL BOARD ASSY, PITCH G LIMITER ATTACHING PARTS	1	35	
- 38	MS21043-4	• NUT	5	35	
- 39	NAS620-4L	• WASHER	5	35	
- 40	AN935-4	• WASHER	5	35	
- 41	AN515-4R6	• SCREW	5	35	
		-----X-----			
- 42	12500	• TERMINAL, <88245> 98-91005-003	8	35	
- 43	25100	• TERMINAL, <88245> 98-91000-012	22	35	
- 44	0-61119-7	• BOARD, TERMINAL	1	35	
- 45	0-61132	• INSULATOR, TERMINAL BOARD	1	35	
- 46	JAN6111	• TUBE, 93-45300-005	1	35	
- 46	JAN6112	• TUBE, 93-45400-005	2	35	
- 47	JAN5787WA	• TUBE, 93-46000-004	2	35	
- 48	0-61120 0-61120-9	• SUPPORT ASSY, TERMINAL BOARD • BRACKET ASSEMBLY	1	35	
- 49	A1280	• EYELET, <57771> 93-59000-025	20	35	
- 50	T3-491	• SHIELD, <98978> 98-04000-004	3	35	
- 51	T3-401	• SHIELD, <98978> 98-04200-005	2	35	
- 52	0-61120-7	• BRACKET	1	35	
- 53	0W2285	• NUT, <72400> 96-36501-001	4	35	
- 54	T3-361	• RETAINER, <98978> 97-56000-001	3	35	
- 55	T3-381	• RETAINER, <98978> 97-56000-002	2	35	

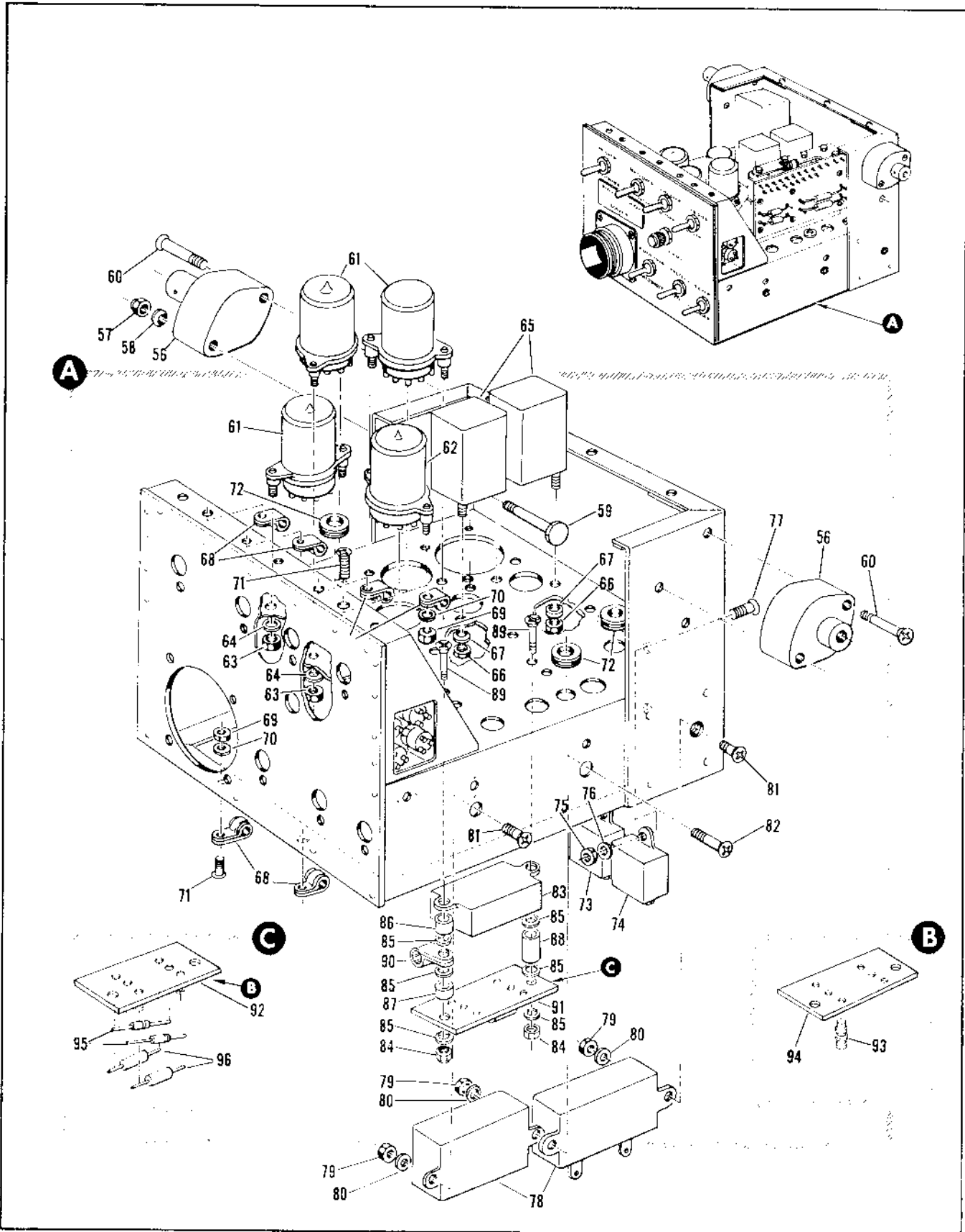

Figure 2.14-8. Electrical Pitch G Limiter Chassis Assembly (Sheet 3 of 4)

FIGURE AND INDEX NUMBER	PART NUMBER	DESCRIPTION	UNITS PER ASSY.	USABLE ON CODE	
				FROM	TO
		1 2 3 4 5 6			
2.14-8- 56	HT0-7	• MOUNT, PITCH G LIMITER SHOCK <76005> SPEC R-06469-1 ATTACHING PARTS	2	35	
- 57	NAS679A0R	• NUT	1	35	
- 58	M-61109-7	• WASHER	1	35	
- 59	S-61110-9	• SCREW	1	35	
- 60	AN507-8R16	• SCREW	3	35	
		-----X-----			
- 61	UN312586	• RELAY, <61775> 97-37015-002	3	35	
- 62	UN334609	• RELAY, <61775> 97-37015-016 ATTACHING PARTS	1		
- 63	NAS679A06	• NUT	8	35	
- 64	AN960-6L	• WASHER	6	35	
		-----X-----			
- 65	PA3107	• CHOKE, PITCH G LIMITER <80223> SPEC 8-06470 ATTACHING PARTS	2	35	
- 66	NAS679A06	• NUT	4	35	
- 67	AN960-6L	• WASHER	4	35	
		-----X-----			
- 68	174-6	• CLAMP, <95947> 91-90005-010 ATTACHING PARTS	6	35	
- 69	NAS679A04	• NUT	6	35	
- 70	AN960-4L	• WASHER	6	35	
- 71	AN507-44CR5	• SCREW	6	35	
		-----X-----			
- 72	R152-15FA5-2	• BRONNET, <94903> 94-35006-062	3	35	
- 73	MY05-1-100E	• CAPACITOR, <92217> 91-57021-006	1	35	
- 74	MY25-1-200E	• CAPACITOR, <92217> 91-57021-017 ATTACHING PARTS	1	35	
- 75	NAS679A04	• NUT	4	35	
- 76	AN960-4L	• WASHER	4	35	
- 77	AN507-44CR5	• SCREW	4	35	
		-----X-----			
- 78	CP53R1EF205K	• CAPACITOR, 91-57007-017 ATTACHING PARTS	2	35	
- 79	NAS679A0R	• NUT	3	35	
- 80	AN960-4L	• WASHER	3	35	
- 81	AN507-832R6	• SCREW	2	35	
- 82	AN507-832R7	• SCREW	1	35	
		-----X-----			
- 83	MY2-1-200E	• CAPACITOR, <92217> 91-57021-005 ATTACHING PARTS	1	35	
- 84	NAS679A0R	• NUT	2	35	
- 85	AN960-6L	• WASHER	6	35	
- 86	NAS43003-64	• SPACER	1	35	
- 87	NAS43003-25	• SPACER	1	35	
- 88	NAS43003-96	• SPACER	1	35	
- 89	AN515-8R32	• SCREW	2	35	
		-----X-----			
- 9	3716-4	• CLAMP, <95947> 91-90005-010	1	35	
- 91	M-61113	• TERMINAL BOARD ASSY, PITCH G LIMITER NO 2	1	35	
- 92	S-61110-9	• . . . TERMINAL BOARD ASSEMBLY	1	35	
- 93	12800	• . . . TERMINAL, <88245> 98-91110-003	6	35	
- 94	M-61113-7	• . . . BOARD, TERMINAL	1	35	
- 95	JANIN454	• . . . DIODE, 97-95502-011	2	35	
- 96	MS35043-147	• . . . RESISTOR	2	35	

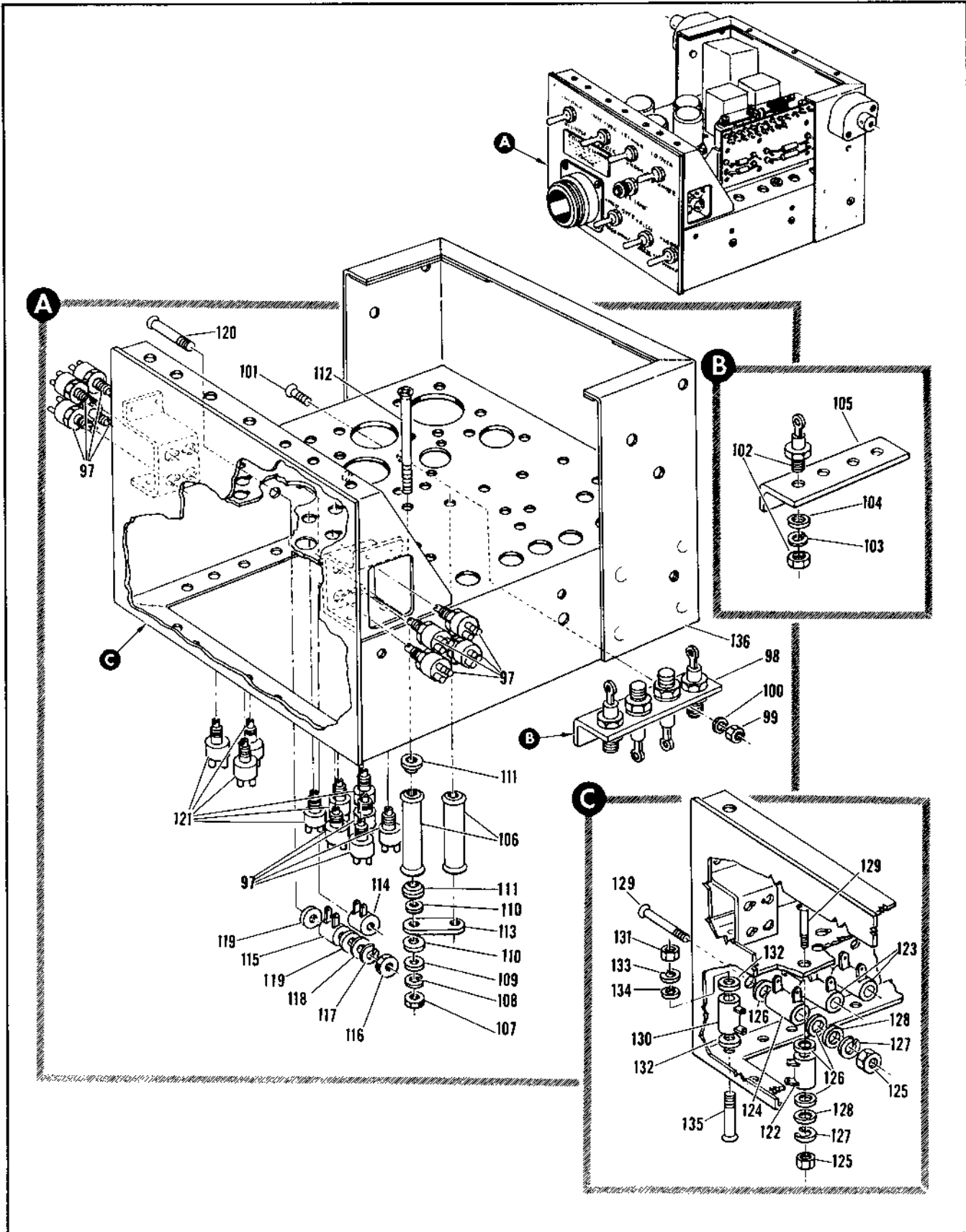

Figure 2.14-8. Electrical Pitch G Limiter Chassis Assembly (Sheet 4 of 4)

FIGURE AND INDEX NUMBER	PART NUMBER	DESCRIPTION	UNITS PER ASSY.	USABLE ON CODE	
				FROM	TO
2.14-R- 97	T5AS3S200YY503	<ul style="list-style-type: none"> • RESISTOR, <02297> 47-54003-012 • BRACKET ASSY, DIODE MOUNTING ATTACHING PARTS 	12		
	8-61105-1		1	35	
- 98					
- 99	NAS679A06	• NUT	2	35	
-100	AN960-4L	• WASHER	2	35	
-101	AN507-632R7	• SCREW	2	35	
		-----X-----			
	8-61105-7	• DIODE ASSY, PITCH G LIMITER	4	35	
-102	92-93407-003	• DIODE	1	35	
-103	AN935-10L	• WASHER	4	35	
-104	AN960-10L	• WASHER	4	35	
-105	8-61122-9	• BRACKET	1	35	
-106	9-6110352	• RESISTOR, 97-47000-043 ATTACHING PARTS	2	35	
-107	MS21-43-3	• NUT	2	35	
-108	AN935-10	• WASHER	2	35	
-109	AN960-10	• WASHER	2	35	
-110	8-61123-11	• WASHER	4	35	
-111	8-61126	• WASHER	4	35	
-112	AN507-17R36	• SCREW	2	35	
		-----X-----			
-113	8-61125	• LINK, RESISTOR	1	35	
-114	RB09AE5000CF	• RESISTOR, 47-47006-024	1	35	
-115	RB09AL2200CF	• RESISTOR, 47-47007-005 ATTACHING PARTS	1	35	
-116					
-117	NAS679A04	• NUT	2	35	
-117	AN935-9	• WASHER	2	35	
-118	AN960-4L	• WASHER	2	35	
-118	8-61123-7	• WASHER	6	35	
-121	AN507-440R14	• SCREW	2	35	
		-----X-----			
-121	APH5AS3S200Y2Y	• RESISTOR, 112 <02297> 47-54003-013	6	35	
-122	RB17AE22001F	• RESISTOR, 47-47001-008	1	35	
-123	RB17AE64001F	• RESISTOR, 47-47001-002	2	35	
-124	RB17AE18001F	• RESISTOR, 47-47001-001 ATTACHING PARTS	1	35	
-125	NAS679A06	• NUT	4	35	
-126	8-61123-9	• WASHER	8	35	
-127	AN935-6	• WASHER	4	35	
-128	AN960-6L	• WASHER	4	35	
-129	AN507-632R04	• SCREW	4	35	
		-----X-----			
-131	RB09AE2700CF	• RESISTOR, 47-47007-007 ATTACHING PARTS	1	35	
-131	NAS679A04	• NUT	1	35	
-132	8-61123-7	• WASHER	2	35	
-133	AN935-4	• WASHER	1	35	
-134	AN960-4L	• WASHER	1	35	
-135	AN507-440R14	• SCREW	1	35	
		-----X-----			
-136	8-61103-1	• CHASSIS ASSY, PITCH G LIMITER RIVETED	1	35	

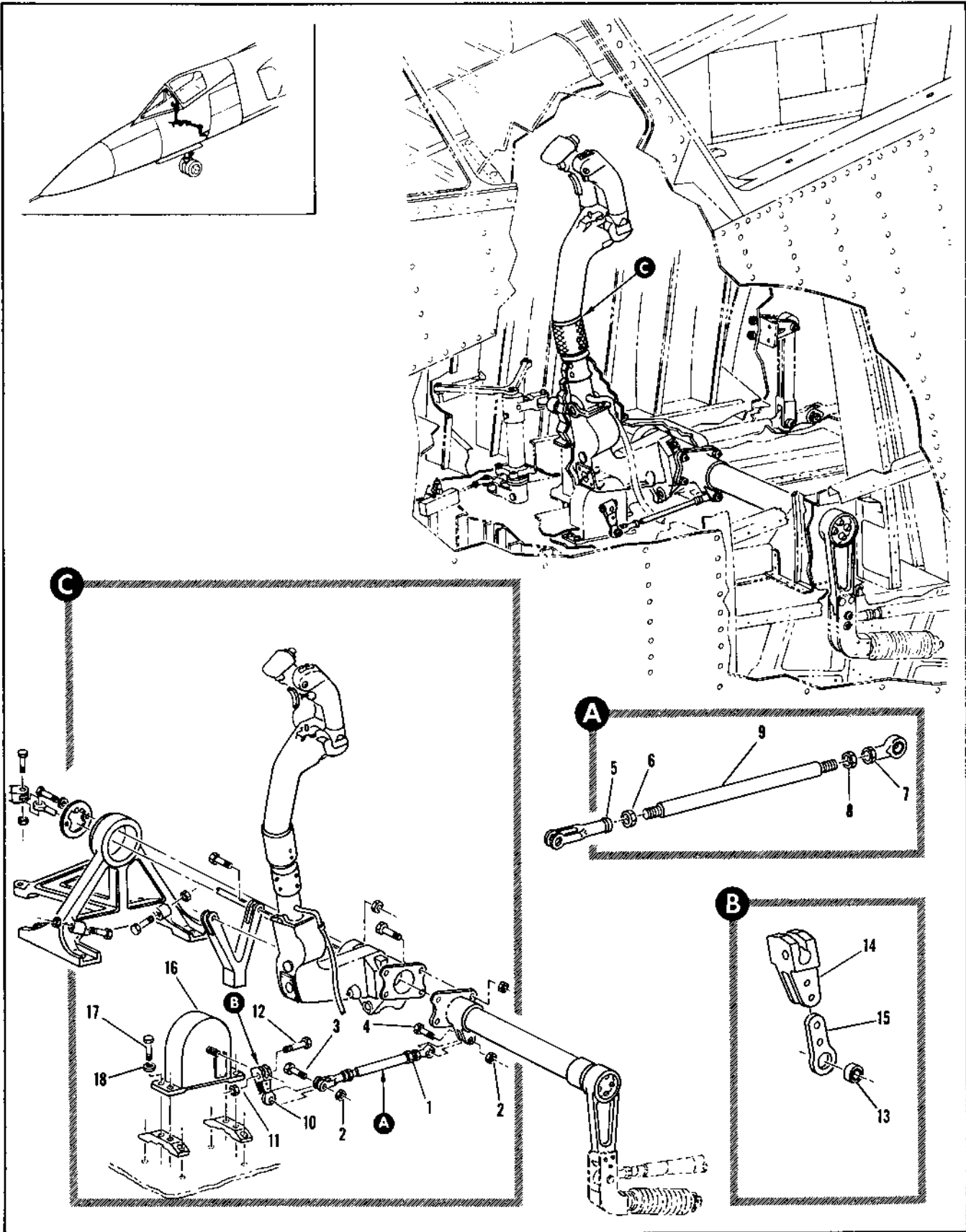

Figure 2.14-9. Flight Control Stick Installation (Sheet 1 of 4)

FIGURE AND INDEX NUMBER	PART NUMBER	DESCRIPTION	UNITS PER ASSY.	USABLE ON CODE		
				FROM	TO	
2.14-9	8-42574-1	STICK INSTALLATION, FLIGHT CONTROL MODIFIED BY 8-21820 AND 8-42595 FOR NHA SEE FIG. 2.3-4	RF	A		
	8-42574-5	STICK INSTALLATION, FLIGHT CONTROL FOR NHA SEE FIG. 2.3-4	RF	B		
	- 1	8-42585	• ROD ASSY, DAMPER CONTROL STICK	1	A	
		8-42585-1	• ROD ASSY, DAMPER CONTROL STICK	1	C	
		8-42585-3	• ROD ASSY, DAMPER CONTROL STICK ATTACHING PARTS	1	133	
	- 2	MS21043-4	• NUT	2	35	
	- 3	NAS464-P4A9	• BOLT	1	35	
	- 4	NAS464-4A18	• BOLT	1	35	
			-----X-----			
	- 5	AN486-1	• • CLEVIS	1	35	
	- 6	AN316C4R	• • NUT	1	35	
	- 7	RE4F5E6540	• • BEARING, <21335> 90-60102-002 REPLACED BY SUITABLE SUB RE4F5	1	35	4A
		RE4F5	• • BEARING, <21335> 90-60102-001 REPLACES SUITABLE SUB FOR RE4F5E6540	1	39	129
		RE4F5E7414	• • BEARING, <21335> 90-60102-009	1	130	
	- 8	AN316C5R	• • NUT	1	35	
	- 9	8-42585-7	• • ROD	1	A	
		8-42585-9	• • ROD	1	B	
	- 10	8-42584	• BELL CRANK ASSY, DAMPER CONTROL STICK REPLACED BY SUITABLE SUB 8-42584-1	1	35	129
	8-42584-1	• BELL CRANK ASSY, DAMPER CONTROL STICK REPLACES SUITABLE SUB FOR 8-42584 ATTACHING PARTS	1	130		
- 11	MS21043-4	• NUT	1	35		
- 12	AN174-12A	• BOLT	1	35		
		-----X-----				
- 13	KS4A	• • BEARING, <21335> 90-54001-002 REPLACED BY SUITABLE SUB KS4AE7414	1	35	129	
	KS4AE7414	• • BEARING, <21335> 90-54001-017 REPLACES SUITABLE SUB FOR KS4A	1	130		
- 14	8-42948-7	• • FORK	1	35		
	8-42568	• • FORK, ALT INCHG WITH 8-42948-7	RF	35		
- 15	8-42567	• • ARM	1	35		
- 16	1042	• DAMPER, CONTROL STICK <81982> SPEC 8-04948-1 T.O. 9H13-2-3 ATTACHING PARTS	1	35		
- 17	AN174-6A	• BOLT	4	35		
- 18	AN961C415	• WASHER	4	35		
		-----X-----				
		A AIRPLANES #35 THRU 47 AND 49 THRU 89				
		B AIRPLANES #48, 90 AND ON				
		C AIRPLANES #44 AND 93 THRU 129				

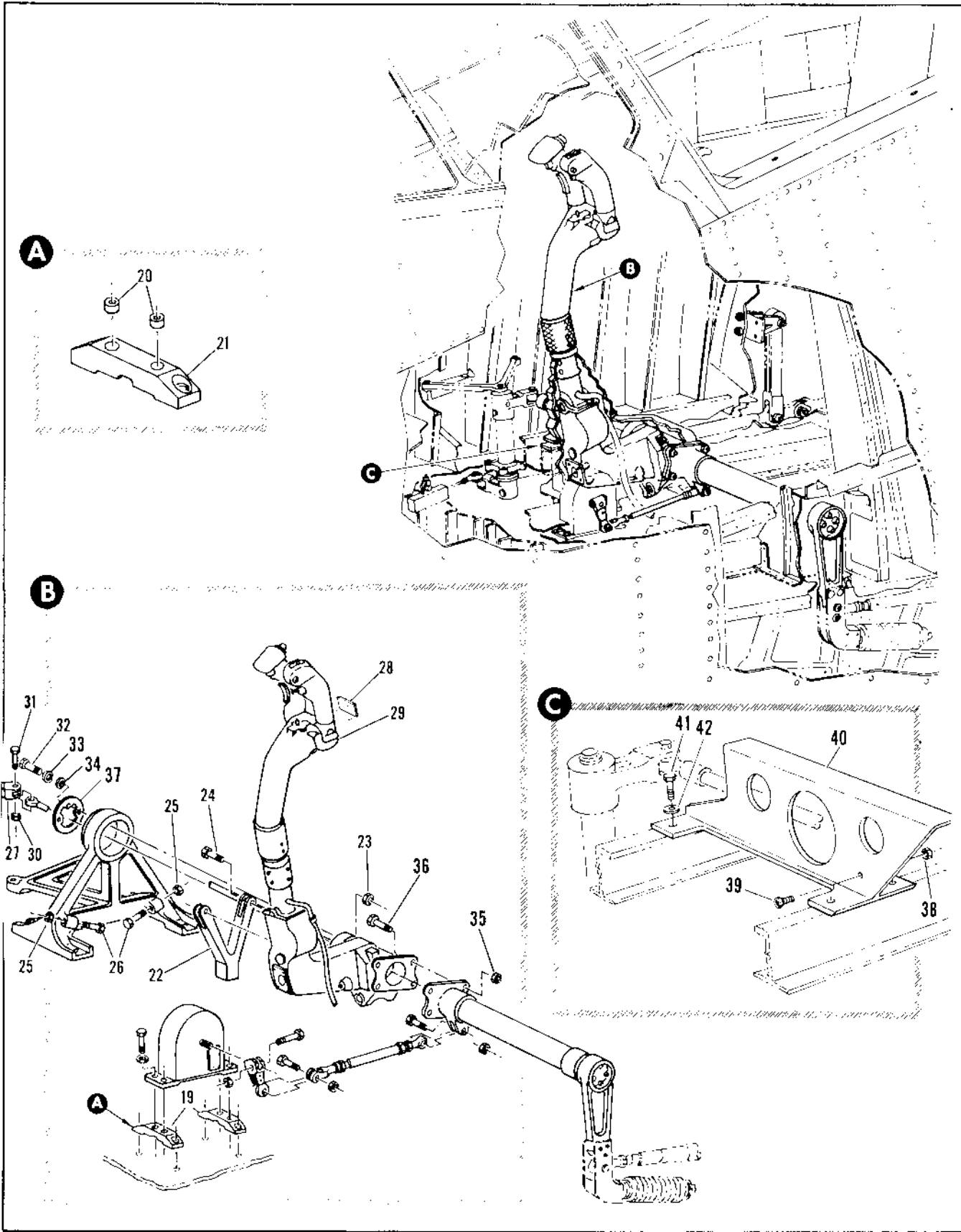

Figure 2.14-9. Flight Control Stick Installation (Sheet 2 of 4)

FIGURE AND INDEX NUMBER	PART NUMBER	DESCRIPTION	UNITS PER ASSY.	USABLE ON CODE	
				FROM	TO
		1 2 3 4 5 6			
2.14-9- 19	R-42186	• SUPPORT ASSY, DAMPER REPLACED BY NOT INTCHG WITH R-42599	2	A	
	R-42599	• SUPPORT ASSY, DAMPER REPLACES NOT INTCHG WITH R-42599	2	B	
- 2	3591-40X38-	• INSERT, <51767> 51-15303-107	2	35	
- 21	R-42599-7	• SUPPORT	1	A	
	R-42599-7	• SUPPORT	1	B	
- 22	R-42572	• STOP	1	35	
		ATTACHING PARTS			
- 23	MS2143-4	• NUT	2	35	
- 24	NAS464-4417	• BOLT	2	35	
		-----X-----			
- 25	AN310C4F	• NUT	2	35	
- 26	NAS464K4-16	• BOLT	2	35	
- 27		• WELL CRANK ASSY, UPPER AIRCRAFT CONTROL SEE FIG. 2.14-12 INDEX 11	RF		
- 28	61R34349	• DECAL, -THIS AIRCRAFT EQUIPPED WITH POSITIVE NWS-	1		
- 29	R-42575-1	• STICK ASSY, FLIGHT CONTROL FOR BREAKDOWN SEE FIG. 2.14-10	1	35	4F
	R-42575-3	• STICK ASSY, FLIGHT CONTROL FOR BREAKDOWN SEE FIG. 2.14-10	1	49	129
	R-42575-5	• STICK ASSY, FLIGHT CONTROL FOR BREAKDOWN SEE FIG. 2.14-10	1	130	
		ATTACHING PARTS			
- 30	MS2143-4	• NUT	1	35	
- 31	NAS464-4417	• BOLT	1	35	
- 32	NAS221-9	• BOLT	3	35	
- 33	AN930-16L	• WASHER, LOCK	3	35	
- 34	AN950-110L	• WASHER	2	35	
- 35	MS2143-4	• NUT	4	35	
- 36	NAS464-4422	• BOLT	4	35	
		-----X-----			
- 37	R-42574-13	• RETAINER	1	35	
	R-95-93-1	• GUARD INSTL, AIRCRAFT CONTROL TUBE FOR NWA SEE FIG. 2.14-9	1	161	
- 38	AN363-1032	• NUT	1	143	
- 39	AN227-1041	• STUD	1	183	
- 40	S-95993-12	• COVER	1	187	21A
	S-95993-15	• COVER	1	217	
		ATTACHING PARTS			
- 41	AN500FA	• BOLT	4	143	18A
- 42	AN56-P10	• WASHER	4	177	18A
	AN363-1032	• NUT	2	183	
	AN37-FA	• BOLT	3	189	
	AN950-110	• WASHER	5	143	
		2. AIRPLACES 84F THRU 47 AND 47 THRU 49			
		3. AIRPLACES 84G, 90 AND 91			

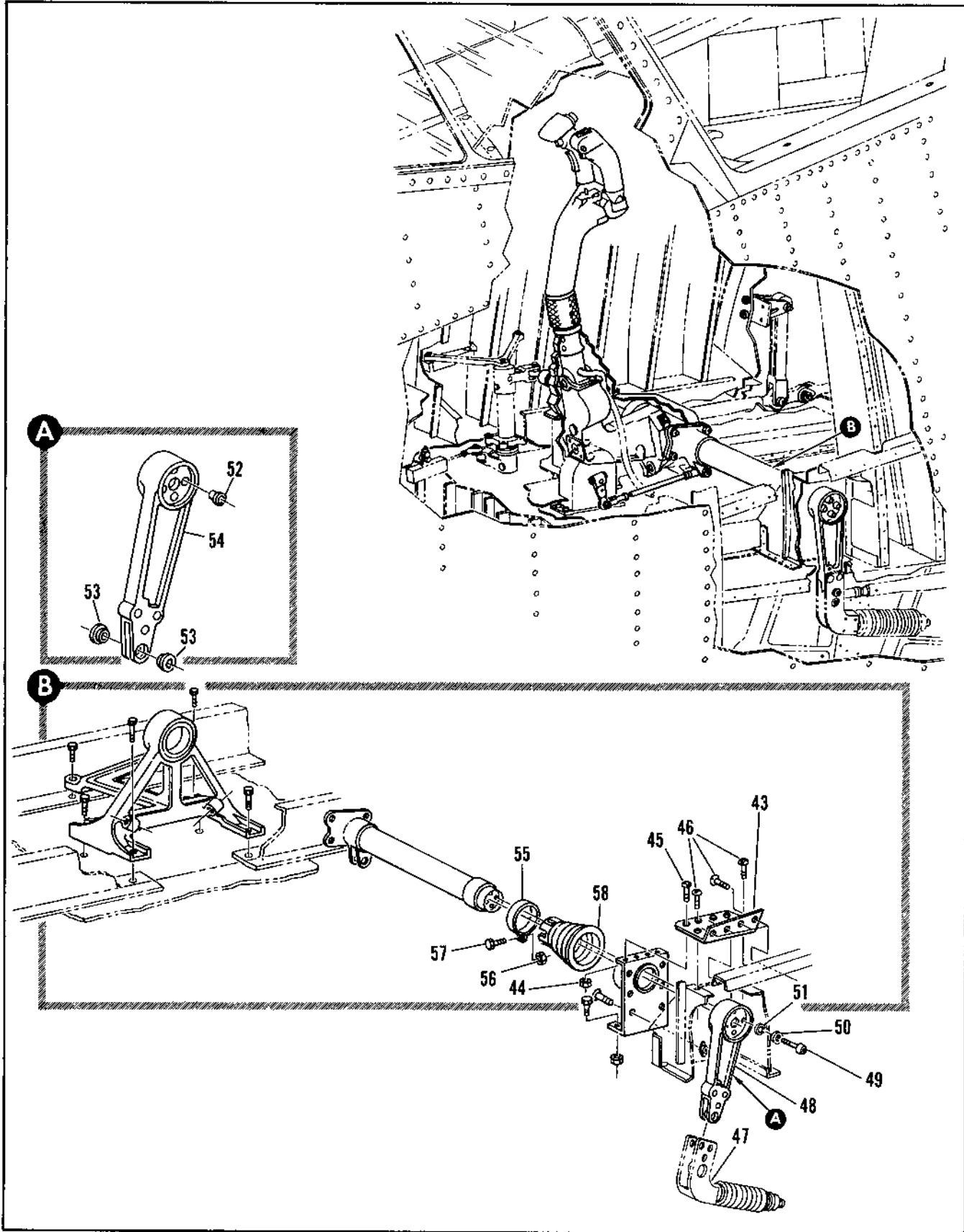

Figure 2.14-9. Flight Control Stick Installation (Sheet 3 of 4)

FIGURE AND INDEX NUMBER	PART NUMBER	DESCRIPTION	UNITS PER ASSY.	USABLE ON CODE	
				FROM	TO
		1 2 3 4 5 6			
2.14-9- 43	8-42574-17	• COVER ATTACHING PARTS	1	35	
- 44	MS21043-3	• NUT	4	35	
- 45	AN23-9A	• BOLT	4	35	
- 46	AN23-8A	• BOLT	6	35	
- 47		-----X----- • COUNTERBLANCE ASSY, CONTROL STICK SEE FIG. 2.14-44 INDEX 3	RF		
- 48	8-42944-9	• BELL CRANK ASSY, CONTROL STICK SHAFT ATTACHING PARTS	1	35	
- 49	MS20004-12	• BOLT	4	35	
- 50	MS20002C4	• WASHER	4	35	
- 51	AN935-12L	• WASHER, LOCK	4	35	
- 52	8-42371-7	• BUSHING, REPLACED BY SUITABLE SUB 8-42371-9	4	35	3A
	P-42371-9	• BUSHING, REPLACES SUITABLE SUB FOR 8-42371-7	4	39	
- 53	NAS77-4-23	• BUSHING	2	35	
- 54	8-42944-11	• BELL CRANK	1	35	
- 55	8-02-212	• CLAMP, <9862E> 91-97805-081 ATTACHING PARTS	1	35	
- 56	MS21043-3	• NUT	1	35	
- 57	AN526-1032R16	• SCREW	1	35	
- 58	1601000	-----X----- • SEAL, <98769> SPEC 8-04350	1	35	

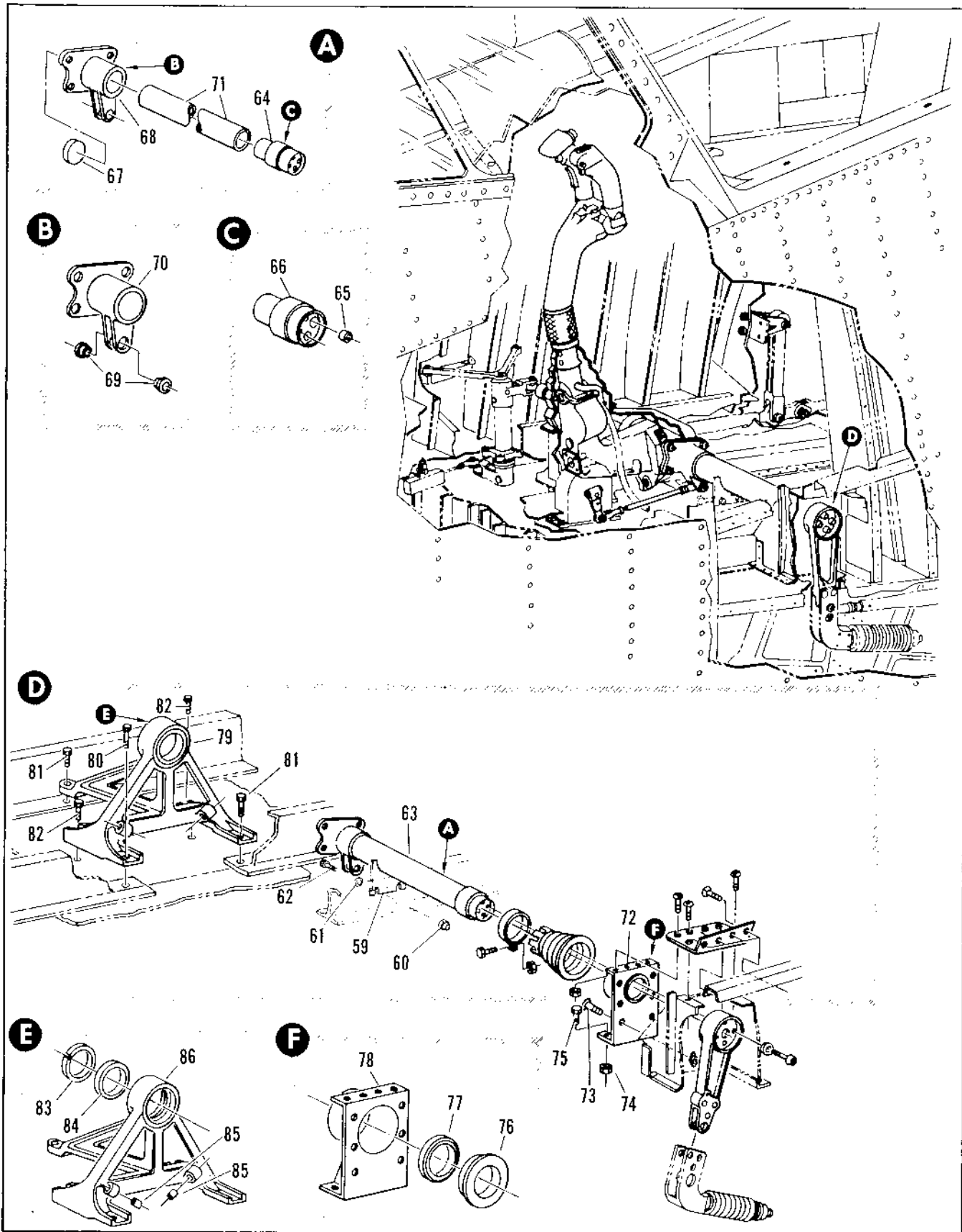

Figure 2.14-9. Flight Control Stick Installation (Sheet 4 of 4)

FIGURE AND INDEX NUMBER	PART NUMBER	DESCRIPTION	UNITS PER ASSY.	USABLE ON CODE	
				FROM	TO
2.14-9	R-95437-1	• SUPPORT INSTL, ELEVATOR TORQUE TUBE FOR NHA SEE FIG. 2.7-4	1	216	
- 59	R-95437-3	• • SUPPORT ATTACHING PARTS	1	216	
- 60	MS21143-3	• • NUT	2	216	
- 61	AN951C16L	• • WASHER	2	216	
- 62	NAS1133-4	• • BOLT	2	216	
- 63	R-42365	• TUBE ASSY, ELEVATOR TORQUE	1	35	
- 64	R-42367	• • PLUG ASSY, TUBE	1	35	
- 65	MS21209F4-20	• • • INSERT, <91767> 95-13033-007	1	63	
- 66	R-42367-7	• • • PLUG	1	35	
- 67	R-42370	• • CUP	1	35	
- 68	R-42946-1	• • FLANGE ASSY, TUBE	1	35	
- 69	NAS77-4-23	• • • BUSHING	2	35	
- 70	R-42946-7	• • • FLANGE	1	35	
- 71	R-42366	• • TUBE	1	35	129
- 72	R-42944-1	• SUPPORT ASSY, LH	1	35	
	R-42944-3	• SUPPORT ASSY, LH ATTACHING PARTS	1	130	
- 73	AN23-9A	• BOLT	6	35	
- 74	MS21143-3	• NUT	4	35	
- 75	AN173-6A	• BOLT	4	35	
- 76	R-42329-7	• • RETAINER	1	35	
- 77	B54500	• • BEARING, <21335> 95-54003-007 REPLACED BY SUITABLE SUB B54500E7414	1	35	129
	B54500E7414	• • BEARING, <21335> 95-54003-021 REPLACES SUITABLE SUB FOR B54500	1	130	
- 78	R-42944-7	• • SUPPORT	1	35	
- 79	R-42943-5	• SUPPORT ASSY, CENTER REPLACED BY SUITABLE SUB R-42943-801	1	35	129
	R-42943-801	• SUPPORT ASSY, CENTER REPLACES SUITABLE SUB FOR R-42943-5	1	130	
- 80	AN174-10A	• BOLT	1	35	
- 81	AN174-7A	• BOLT	2	35	
- 82	AN174-6A	• BOLT	2	35	
- 83	R-42924	• • RETAINER	1	35	
- 84	B54500	• • BEARING, <21335> 95-54003-007 REPLACED BY SUITABLE SUB B54500E7414	1	35	129
	B54500E7414	• • BEARING, <21335> 95-54003-021 REPLACES SUITABLE SUB FOR B54500	1	130	
- 85	1191-40NX182	• • INSERT, <91767> 95-13033-011	2	35	
- 86	R-42943-13	• • SUPPORT	1	35	

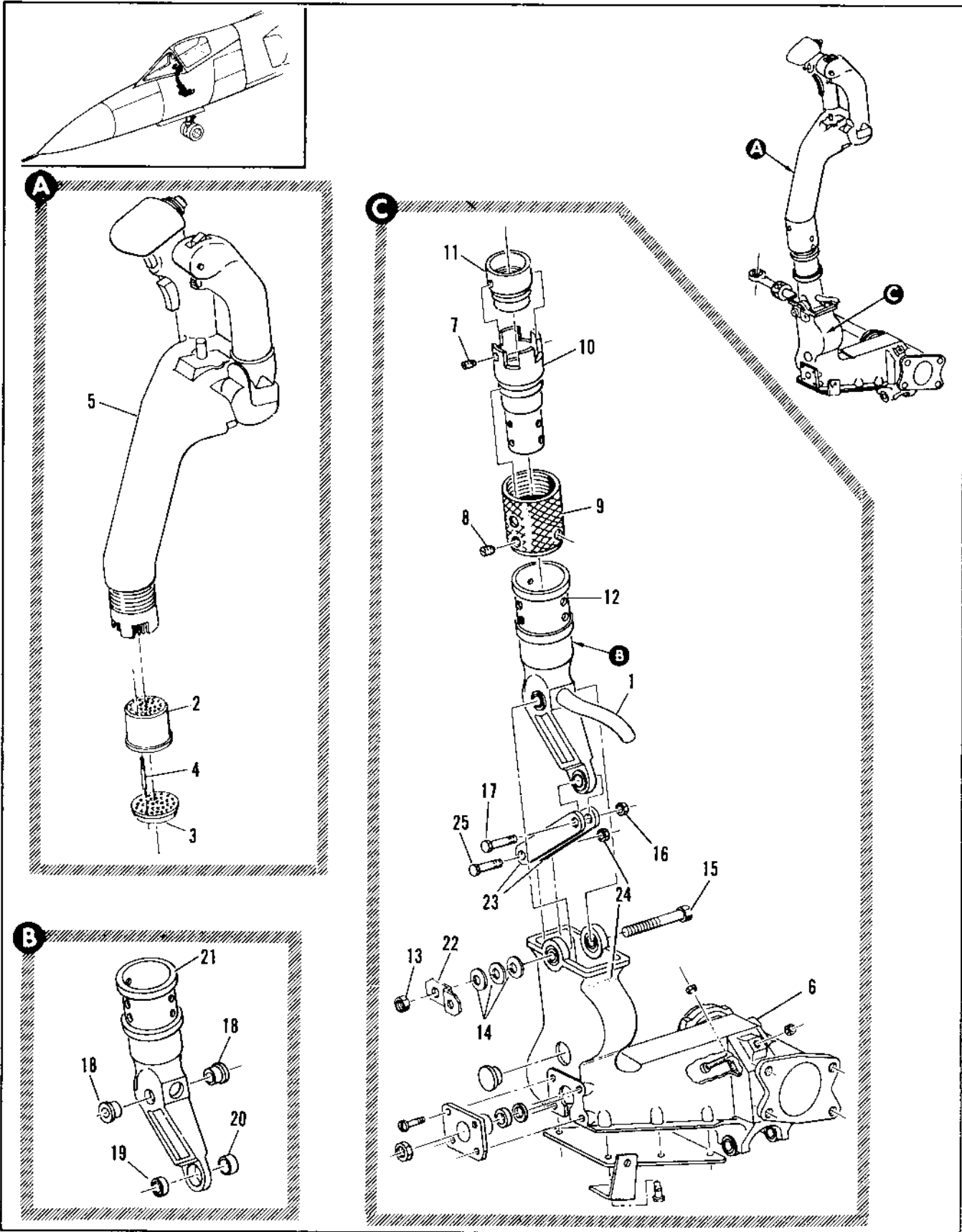

Figure 2.14-10. Flight Control Stick Assembly (Sheet 1 of 3)

FIGURE AND INDEX NUMBER	PART NUMBER	DESCRIPTION 1 2 3 4 5 6	UNITS PER ASSY.	USABLE ON CODE	
				FROM	TO
2.14-10	8-42575-1	STICK ASSEMBLY, FLIGHT CONTROL FOR NHA SEE FIG. 2.14-9	RF	35	48
	8-42575-3	STICK ASSEMBLY, FLIGHT CONTROL FOR NHA SEE FIG. 2.14-9	RF	49	129
	8-42575-5	STICK ASSEMBLY, FLIGHT CONTROL FOR NHA SEE FIG. 2.14-9	RF	130	
- 1	8-64649-803	• HARNESS ASSY, CENTER STICK	1	35	48
	8-64649-807	• HARNESS ASSY, CENTER STICK	1	49	
- 2	105-039-00	• • INSULATOR, ELECTRICAL CONNECTOR (71468) 95-07102-001	1		
- 3	105-040-00	• • INSULATOR, ELECTRICAL CONNECTOR (71468) 95-07-102-002	1		
- 4	031-064-00	• • CONTACT, ELECTRICAL CONNECTOR (71468) 92-63901-007	37		
- 5	464083-180MD3	• CONTROL, AIRCRAFT AND RADAR MANUAL (82577) SFAE ALT 464083-180MDX3	1	35	
- 6	8-425-19	• BASE ASSY, CONTROL STICK	1	35	48
	8-42575-21	• BASE ASSY, CONTROL STICK REPLACED BY SUITABLE SUB 8-42575-23	1	49	129
	8-42575-23	• BASE ASSY, CONTROL STICK REPLACES SUITABLE SUB FOR 8-42575-21	1	130	
- 7	AN565EC4H3	• • SCREW, 97-98004-001	2	35	
- 8	MS51963-34	• • SCREW	2	35	
- 9	8-47516	• • NUT, CONTROL GRIP TO STICK ADAPTER	1	35	
- 10	8-47519-7	• • ADAPTER	1	35	
- 11	8-47518	• • RETAINER, CONTROL STICK CONTACT PLUG	1	35	
- 12	8-42949-1	• • BELL CRANK ASSY, CONTROL STICK REPLACED BY SUITABLE SUB 8-42949-3	1	35	129
	8-42949-3	• • BELL CRANK ASSY, CONTROL STICK REPLACES SUITABLE SUB FOR 8-42949-1 ATTACHING PARTS	1	130	
- 13	MS21043-6	• • NUT	1	35	
- 14	AN9600616	• • WASHER	3	35	
- 15	NAS464P6L36	• • BOLT	1	35	
- 16	NAS679A4	• • NUT	1	35	
- 17	NAS454-4A77	• • BOLT	1	35	
		----X----			
- 18	NAS77-6-50	• • • BUSHING	2	35	
- 19	KS4A	• • • BEARING, <21335> 90-58001-002 REPLACED BY SUITABLE SUB KS4AE	1	35	129
	KS4AE7414	• • • BEARING, <21335> 90-58001-017 REPLACES SUITABLE SUB FOR KS4A	1	130	
	KS4A	• • • BEARING, ALT INTCHG WITH KS4AE7414	RF	130	
- 20	98-14000-009	• • • SLEEVE	1	35	
- 21	8-42949-7	• • • BELL CRANK	1	35	
- 22	8-42467	• • • BRACKET	1	35	
- 23	8-42431	• • • LINK ATTACHING PARTS	2	35	
- 24	MS21043-4	• • NUT	1	35	
- 25	NAS464-4A7	• • BOLT ----X----	1	35	

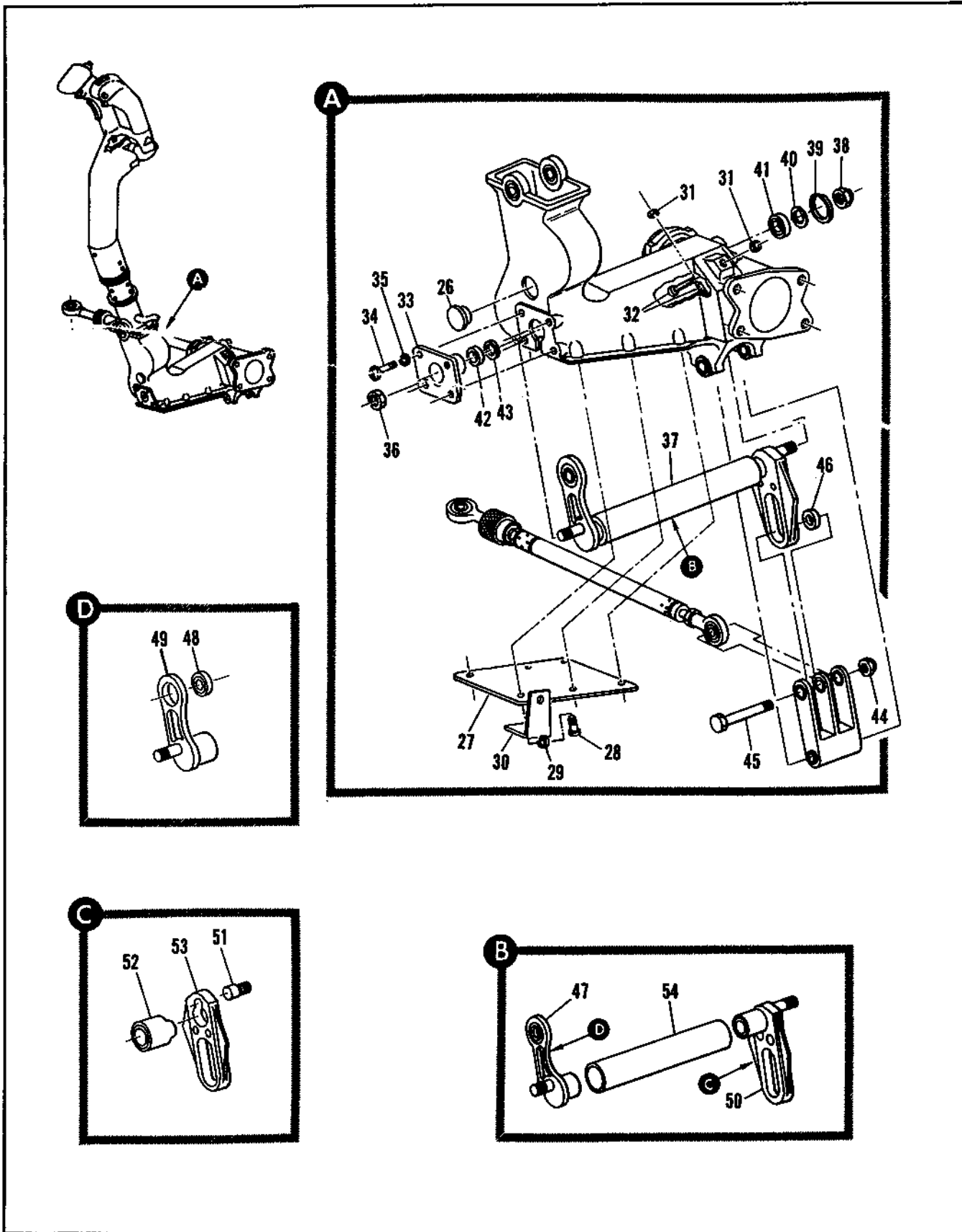

Figure 2.14-10. Flight Control Stick Assembly (Sheet 2 of 3)

FIGURE AND INDEX NUMBER	PART NUMBER	DESCRIPTION	UNITS PER ASSY.	USABLE ON CODE	
				FROM	TO
2.14-10- 26	SS51334	. . BUTTON, <61864> 91-3300-014 REPLACED BY NOT INTCHG WITH HS51026	1	35	48
	HS51026	. . BUTTON, <61864> 91-3300-013 REPLACES NOT INTCHG WITH SS51334	1	49	
- 27	8-42575-17	. . COVER ATTACHING PARTS	1	35	
- 28	NAS221-8	. . SCREW (80205)	6	35	
- 29	AN935-10L	. . WASHER, LOCK (88044) -----X-----	6	35	
- 30	8-42468	. . BRACKET	1	35	
- 31	AN316-4R	. . NUT (88044)	2	35	
- 32	NAS42BK4-10	. . BOLT (80205)	2	35	
- 33	8-42438	. . SUPPORT, AILERON TORQUE TUBE ATTACHING PARTS	1	35	
- 34	NAS221-9	. . SCREW (80205)	4	35	
- 35	AN935-10L	. . WASHER, LOCK (88044) -----X-----	4	35	
- 36	RE4F5E7414	. . . BEARING, <21335> 90-60002-009	1	130	
- 37	8-42432	. . TUBE ASSY, AILERON TORQUE REPLACED BY SUITABLE SUB 8-42432-1	1	35	129
	8-42432-1	. . TUBE ASSY, AILERON TORQUE REPLACES SUITABLE SUB FOR 8-42432 ATTACHING PARTS	1	130	
- 38	MS21043-4	. . NUT (96906)	1	35	
- 39	8-42415-11	. . RETAINER, SPRING (88044)	1	35	
- 40	MS16625-1075	. . RING, (96906) 97-61500-007	1	35	
- 41	MS27641-4	. . BEARING (96906)	1	35	129
	KP4AE7414	. . BEARING, <21335> 90-58009-017	1	130	
- 42	AN201KP4A	. . BEARING (88044)	1	35	129
	KP4AE7414	. . BEARING, <21335> 90-58009-017	1	130	
- 43	MS20002C4	. . WASHER (96906)	1	35	
- 44	MS21043-4	. . NUT (96906)	1	35	
- 45	NAS464-4A28	. . BOLT (80205)	1	35	
- 46	AN201KP4A	. . BEARING (88044)	1	35	129
	AKP4AE7414	. . BEARING, <21335> 90-58009-027 -----X-----	1	130	
- 47	8-42952-1	. . . BELL CRANK ASSY, TUBE REPLACED BY SUITABLE SUB 8-42952-3	1	35	129
	8-42433	. . . BELL CRANK ASSY, TUBE ALT INTCHG WITH 8-42952-1	RF	35	129
	8-42952-3	. . . BELL CRANK ASSY, TUBE REPLACES SUITABLE SUB FOR 8-42952-1	1	130	
	8-42933-1	. . . BELL CRANK ASSY, TUBE ALT INTCHG WITH 8-42952-3	RF	130	
- 48	KS4A BEARING, <21335> 90-58001-002	1	35	129
	KP4AE7414 BEARING, <21335> 90-58009-017	1	130	
- 49	8-42952-7 BELL CRANK	1	35	
	8-42433-7 BELL CRANK, ALT INTCHG WITH 8-42952-7	RF	35	
- 50	8-42435 CAM ASSY, TUBE	1	35	
- 51	8-42447 PIN	1	35	
- 52	8-42448 ROD	1	35	
- 53	8-42442 PLATE	1	35	
- 54	8-42434 TUBE	1	35	

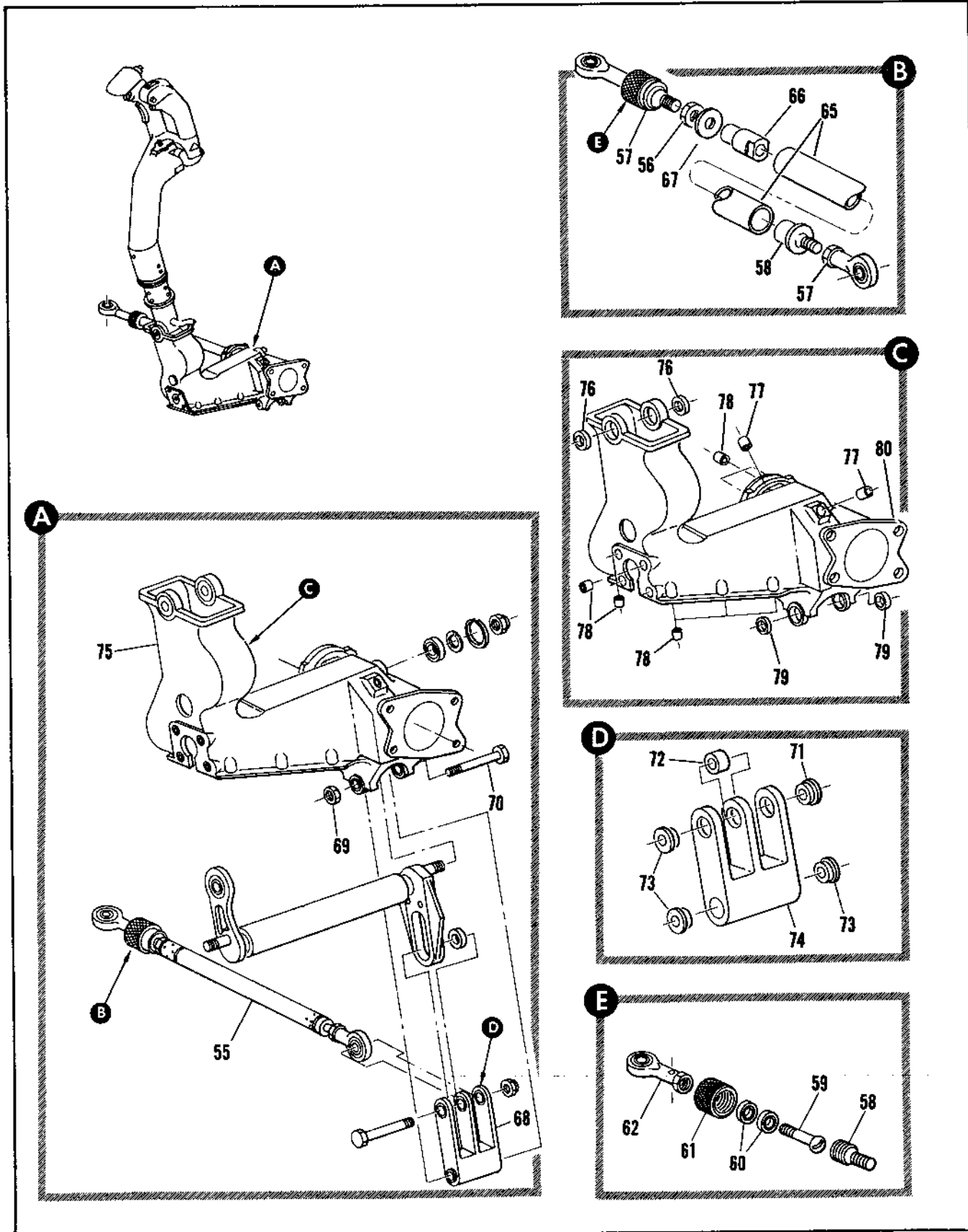

Figure 2.14-10. Flight Control Stick Assembly (Sheet 3 of 3)

FIGURE AND INDEX NUMBER	PART NUMBER	DESCRIPTION	UNITS PER ASSY.	USABLE ON CODE	
				FROM	TO
		1 2 3 4 5 6			
2.14-10- 55	64A33161-3	• • TUBE ASSY, AILERON CONTROL STICK REPLACED BY SUITABLE SUB 64A33161-E	1	35	129
	64A33161-5	• • TUBE ASSY, AILERON CONTROL STICK REPLACES SUITABLE SUB FOR 64A33161-3	1	130	
- 56	AN316-6R	• • • NUT	1	35	129
- 57	R-42410-9	• • • SWIVEL ASSY, REPLACED BY SUITABLE SUB R-42410-11	1	130	
	R-42410-11	• • • SWIVEL ASSY, REPLACES SUITABLE SUB FOR R-42410-9	1	35	
- 58	R-42412	• • • ADAPTER	1	35	
- 59	NAS223-16	• • • SCREW	2	35	129
- 60	AN201KP5A	• • • BEARING, 90-58000-102	2	130	
	KP5AL7414	• • • BEARING, <21335> 93-58000-019	1	35	
- 61	R-42414	• • • NUT	1	35	129
- 62	RE4F5	• • • BEARING, <21335> 93-58002-001	1	130	
	RE4F5E7414	• • • BEARING, <21335> 93-58002-009	1	35	
- 64	E4F33114-11	• • • CONNECTOR	1	35	
- 65	R-42411-11	• • • TUBE	1	35	
- 66	R-42440	• • • FITTING	1	35	
- 67	NAS460-616	• • • WASHER	1	35	
- 68	R-42436	• • • PULL CRANK ASSY, CONTROL TUBE ATTACHING PARTS	75		
- 69	MS21043-4	• • NUT	1	35	
- 70	NAS464-4A36	• • BOLT	1	35	
		-----X-----	1	35	
- 71	NAS77-4-2E	• • • BUSHING	1	35	
- 72	NAS75-4-11C	• • • BUSHING	3	35	
- 73	NAS77-4-25	• • • BUSHING	1	35	
- 74	R-42436-7	• • • PULL CRANK	1	35	49
- 75	R-42445-1	• • • BASE ASSY, FLIGHT CONTROL STICK REPLACED BY SUITABLE SUB R-42945 OR R/42945/5	1	49	129
	R-42945-3	• • • BASE ASSY, FLIGHT CONTROL STICK REPLACES SUITABLE SUB FOR R-42945-1	1	130	
	R-42945-5	• • • BASE ASSY, FLIGHT CONTROL STICK REPLACES SUITABLE SUB FOR R-42945-1 OR R/42945/3	1	130	
- 76	AN201KP6A	• • • BEARING, 93-58000-103	2	35	129
	KP6AE7414	• • • BEARING, <21335> 93-58000-021	2	130	
- 77	3591-40NX38M	• • • INSERT, <91767> 95-13003-007	13	35	129
- 78	3591-30NX28E	• • • INSERT, <91767> 95-13003-005	2	35	129
- 79	AN201KP4A	• • • BEARING, 93-58000-101	2	130	
	MS27541-5	• • • BEARING, <21335> 93-58000-017	1	35	49
- 80	R-42945-7	• • • BASE	1	49	
	R-42945-9	• • • BASE	1	49	

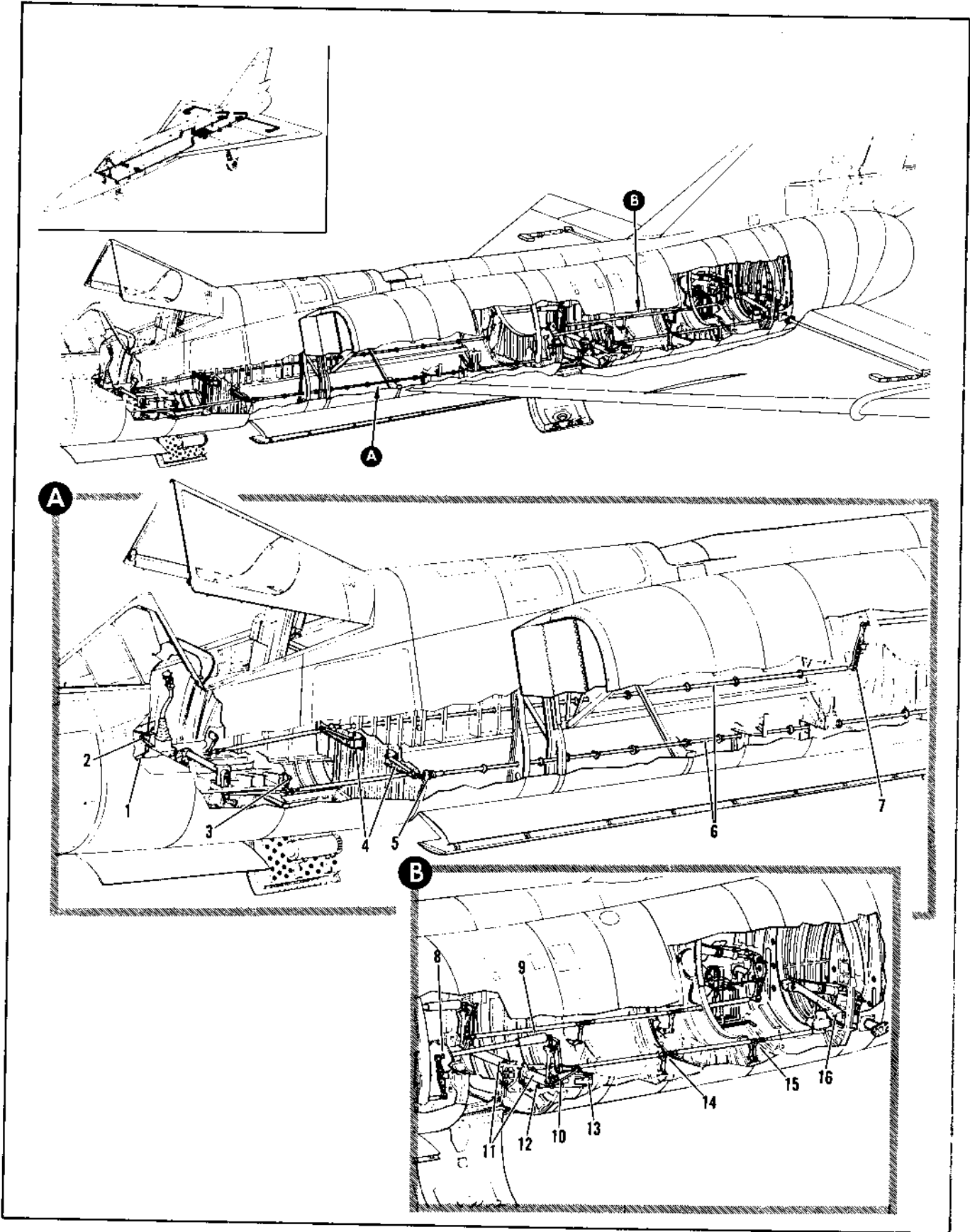

Figure 2.14-11. Elevon Flight Controls (Sheet 1 of 3)

FIGURE AND INDEX NUMBER	PART NUMBER	DESCRIPTION	UNITS PER ASSY.	USABLE ON CODE	
				FROM	TO
		1 2 3 4 5 6			
2.14-11		ELEVON FLIGHT CONTROLS			
- 1		• POTENTIOMETER INSTL, AILERON CONTROL • STA 136 SEE FIG. 2.14-2	RF RF		
- 2		SEE FIG. 2.14-12			
- 3		• IDLER INSTL, ELEVATOR AND AILERON CONTROL STA 170 SEE FIG. 2.14-13	RF		
- 4		• IDLER INSTL, ELEVATOR AND AILERON CONTROL STA 216 SEE FIG. 2.14-36	RF		
- 5		• SUPPORT INSTL, ELEVON CONTROL TUBE LH STA 216 TO 431 SEE FIG. 2.14-14	RF		
- 6		• LINKAGE INSTL, ELEVON CONTROL SEE FIG. 2.14-15	RF		
- 7		• BELL CRANK INSTL, AILERON RH STA 353 SEE FIG. 2.14-16	RF		
- 8		• BELL CRANK INSTL, ELEVATOR LH STA 426 SEE FIG. 2.14-19	RF		
- 9		• SEAL INSTL, ELEVATOR AND AILERON CONTROL TUBE LH SEE FIG. 2.14-17	RF RF		
- 10		• BELL CRANK INSTL, ELEVATOR AND AILERON STA 472 SEE FIG. 2.14-18 SEE FIG. 2.14-20	RF RF		
- 11		• REGULATOR INSTL, ELEVATOR AIRFEEL STA 481 TO 498 SEE FIG. 2.14-21	RF		
- 12		• CONTROL INSTL, ELEVON STA 472 TO 507 SEE FIG. 2.14-22	RF		
- 13		• IDLER INSTL, ELEVON CONTROL STA 524 SEE FIG. 2.14-40	RF		
- 14		• IDLER INSTL, ELEVON CONTROL STA 561 SEE FIG. 2.14-40	RF		
- 15		• CRANK INSTL, ELEVON FOLLOWUP LH SEE FIG. 2.14-25	RF		

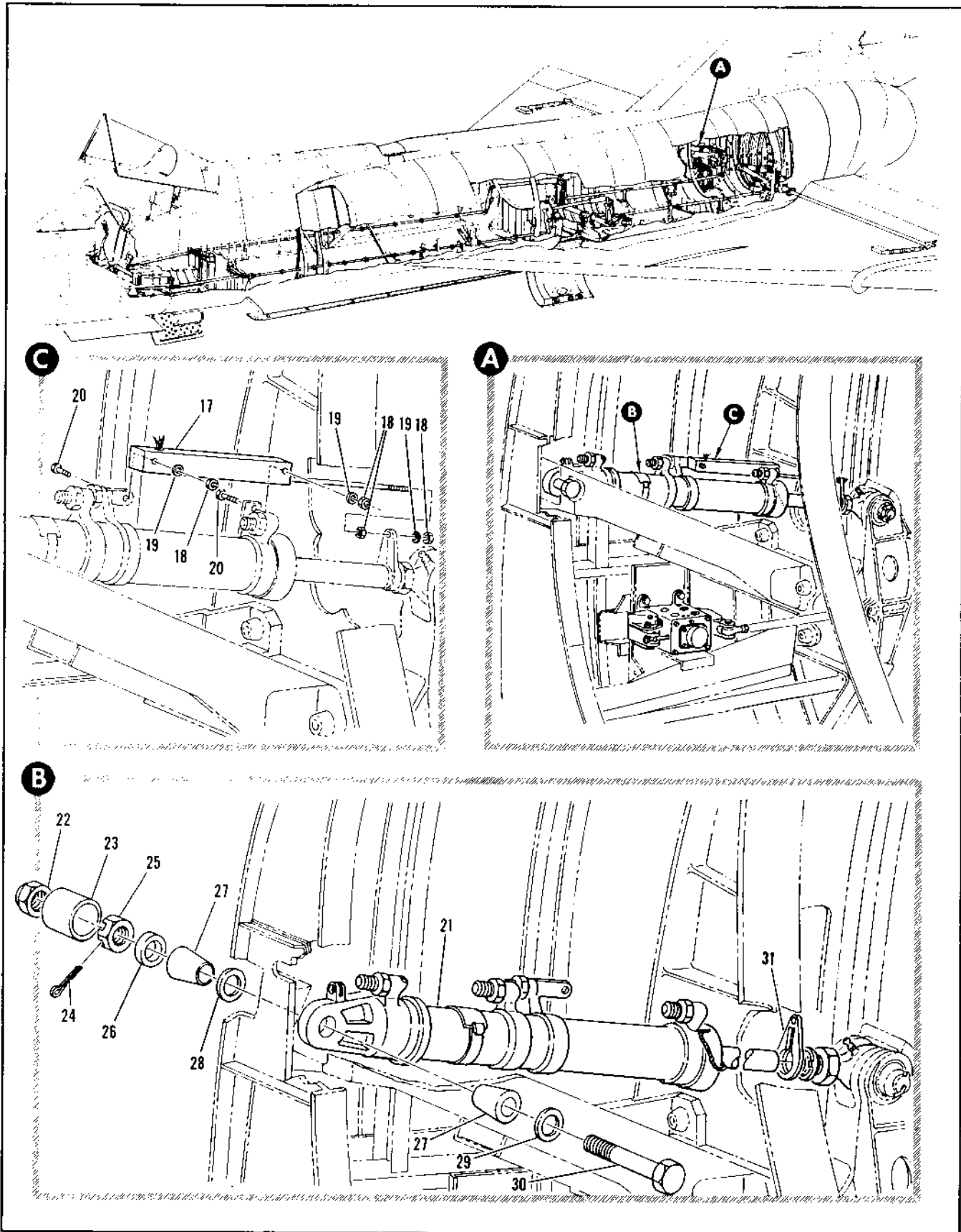

Figure 2.14-11. Elevon Flight Controls (Sheet 2 of 3)

FIGURE AND INDEX NUMBER	PART NUMBER	DESCRIPTION 1 2 3 4 5 6	UNITS PER ASSY.	USABLE ON CODE	
				FROM	TO
2.14-11	8-81312	• POTENTIOMETER INSTL, ELEVON INRD ACTUATING CYLINDER FOR NHA SEE FIG. 2.3-3	RF	35	
- 17	C3025	• • POTENTIOMETER, ELEVON POSITION <02918> SPEC 8-04952 ATTACHING PARTS	1	35	
- 18	MS21243-3	• • NUT	4	35	
- 19	AN960-10L	• • WASHER	3	35	
- 20	AN3-13A	• • BOLT	2	35	
		----X----			
	8-81053-1	• ACTUATOR INSTL, INRD ELEVON LH STA 571 TO 597 FOR NHA SEE FIG. 2.3-3	RF	35	41
	8-81053-3	• ACTUATOR INSTL, INRD ELEVON LH STA 571 TO 579 FOR NHA SEE FIG. 2.3-3	RF	42	
	8-81053-2	• ACTUATOR INSTL, INRD ELEVON RH STA 571 TO 597 FOR NHA SEE FIG. 2.3-3	RF	35	41
	8-81053-4	• ACTUATOR INSTL, INRD ELEVON RH STA 571 TO 597 FOR NHA SEE FIG. 2.3-3	RF	42	
- 21	10907-31	• • ACTUATOR ASSY, ELEVON <97395> SPEC 8-09480-5 T.O. 9H2-4-78-3 REPLACED BY SUITABLE SUB 10907-51	1	35	63
	10907-51	• • ACTUATOR ASSY, ELEVON <97395> SPEC 8-09480-9 T.O. 9H2-4-78-3 REPLACES SUITABLE SUB FOR 10907-31 ATTACHING PARTS	1	61	
- 22	32FT1216	• • NUT, <5687> 96-37525-110	1	35	41
- 23	8-81242	• • COLLAR	1	35	41
- 24	96-79730-043	• • PIN	1	35	41
	AN381-4-28	• • PIN, CUTTER	1	42	
- 25	AN310-12	• • NUT	1	35	
- 25	8-81241	• • SPACER	1	35	
- 27	8-8-239	• • BUSHING	2	35	
- 28	8-81240	• • WASHER	1	35	
- 29	AN960C1216L	• • WASHER	1	35	
- 30	8-80206-7	• • BOLT, REPLACED BY NOT INTCHG WITH 8-80206-11	1	35	
	8-80206-11	• • BOLT, REPLACES NOT INTCHG WITH 8-80206-7	1	42	
		----X----			
- 31	8-81235-9	• • HORN, ELEVON POTENTIOMETER DRIVE	1	35	

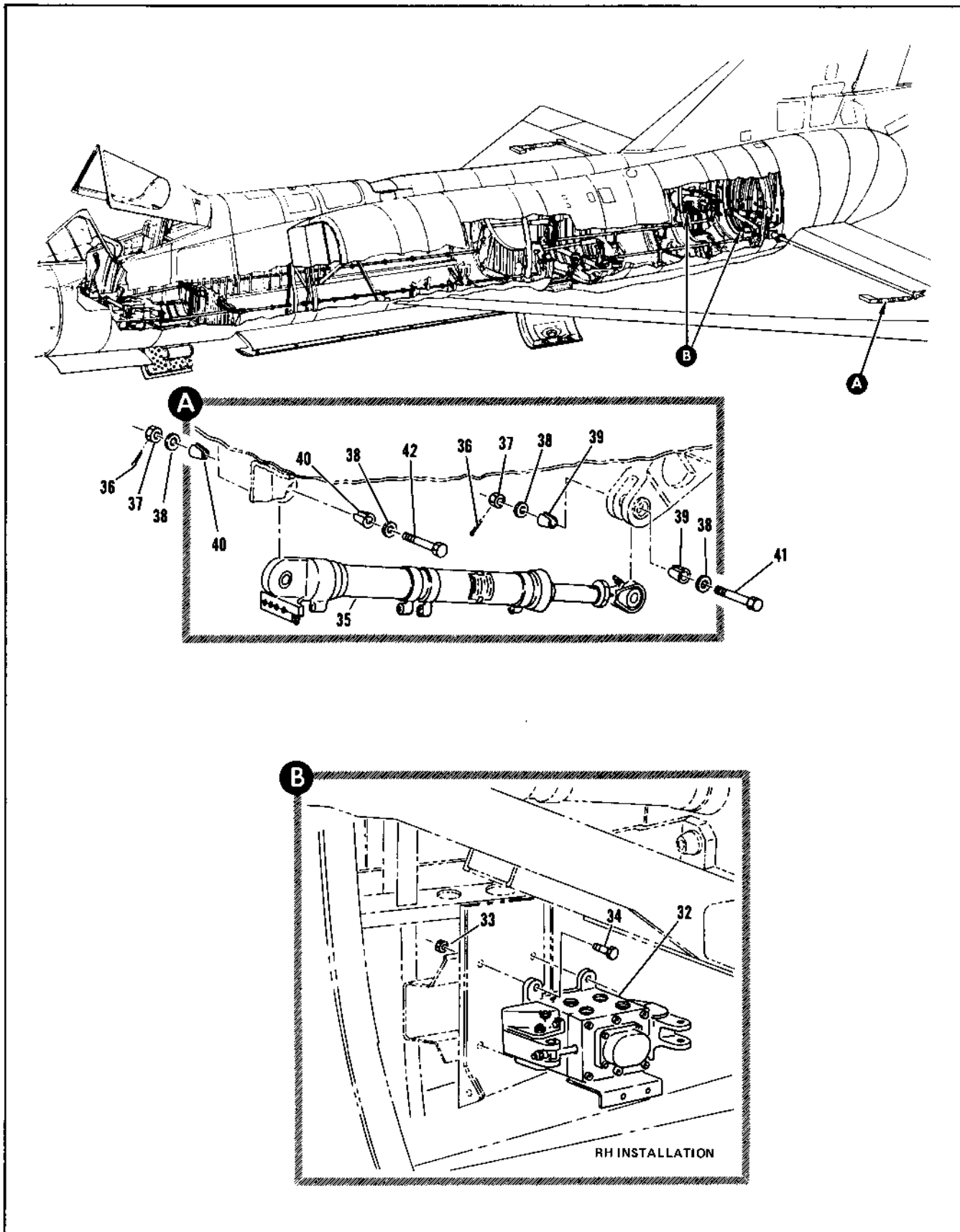

Figure 2.14-11. Elevon Flight Controls (Sheet 3 of 3)

FIGURE AND INDEX NUMBER	PART NUMBER	DESCRIPTION 1 2 3 4 5 6	UNITS PER ASSY.	USABLE ON CODE	
				FROM	TO
2.14-11	8-1005-5	• VALVE INSTL, ELEVON CONTROL FOR NHA SEE FIG. 2.3-15	RF	35	
- 32	1001C	• VALVE ASSY, ELEVON CONTROL <94697> SPEC 8-08479-5 T.O. 9H8-3-76-14 ALT INTCHG WITH 1C-102A AND 100900	1	35	89
	100900	• VALVE ASSY, ELEVON CONTROL <81873> SPEC 8-08479-9 T.O. 9H8-3-68-4 ALT INTCHG WITH 1001C AND 1C-102A	RF		
	10-102A	• VALVE ASSY, ELEVON CONTROL <94697> SPEC 8-08479-9 T.O. 9H8-3-89-4 ALT INTCHG WITH 1001C AND 100900 ATTACHING PARTS	RF		
- 33	MS21043-4	• NUT	4	35	
	MS21047-4	• NUT PLATE, SUITABLE SUB FOR MS21043-4	RF		
	MS21047-4	• NUT PLATE, SUITABLE SUB FOR MS21043-4	RF		
- 34	MS21078-4	• NUT PLATE, SUITABLE SUB FOR MS21043-4	RF		
	AN4-10A	• BOLT	4	35	
	8-82010-1	• ACTUATOR INSTL, ELEVON OUTRD LH MODIFIED BY 8-80133 FOR NHA SEE FIG. 2.6-2	RF	35	
	8-82010-2	• ACTUATOR INSTL, ELEVON OUTRD RH MODIFIED BY 8-80133 FOR NHA SEE FIG. 2.6-1 AND 2.6-2	RF	35	
- 35	10907-51	• ACTUATOR ASSY, ELEVON OUTBOARD <82918> SPEC 8-08480-9 T.O. 9H2-4-7H-3 REPLACES SUITABLE SUB FOR 10907-31 ATTACHING PARTS	1	35	
- 36	AN380-4-6	• PIN, COTTER	2	35	
- 37	AN320-12	• NUT	2	35	
- 38	AN960C1216L	• WASHER	4	35	
- 39	4-13755	• BUSHING	2	35	
- 40	8-18769	• PUSHING	2	35	
- 41	8-80206	• BOLT	1	35	
- 42	8-80206-9	• BOLT	1	35	
		----X----			

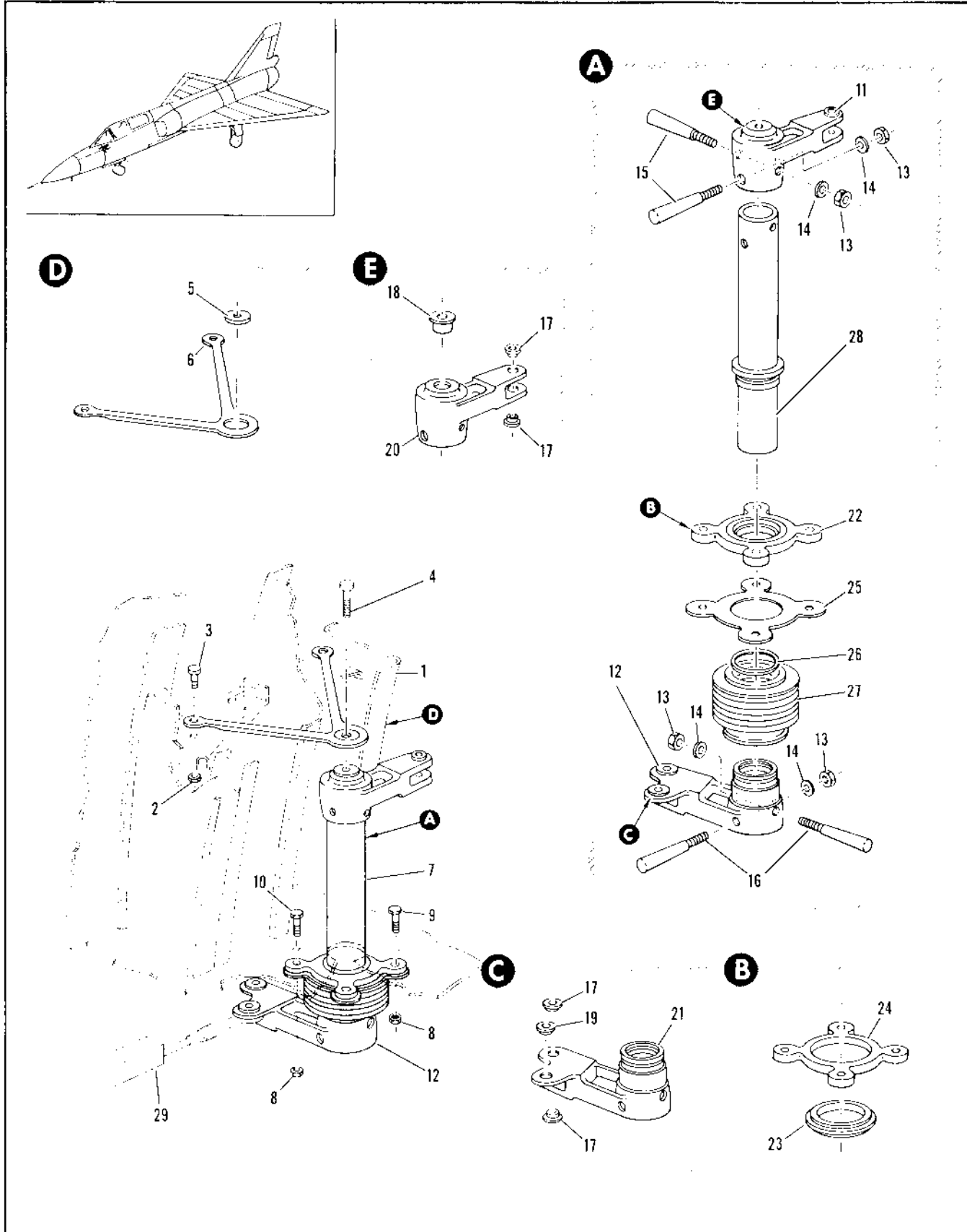

Figure 2.14-12. Aileron Control Bell Crank Installation Sta 142

FIGURE AND INDEX NUMBER	PART NUMBER	DESCRIPTION	UNITS PER ASSY.	USABLE ON CODE	
				FROM	TO
2.14-12	W-42401-F	BELL CRANK INSTALLATION, AILERON CONTROL STA 142 FOR NHA SEE FIG. 2.14-4	RF	35	
- 1	W-42453 W-42453-1	• SUPPORT ASSY, AILERON CONTROL • SUPPORT ASSY, AILERON CONTROL ATTACHING PARTS	1 1	35 130	129
- 2	MS21043-4	• NUT	2	35	
- 3	NAS464-4A8	• BOLT	1	35	159
- 4	NAS464-4A8 NAS464-4A10	• BOLT	1	160	
- 5	KS4A KS4AF7414	• BEARING, <21335> 90-58001-002 REPLACED BY SUITABLE SUP KS4AF7414 • BEARING, <21335> 90-58001-017 REPLACES SUITABLE SUP FOR KS4A	1 1	35 130	159
- 6	R-42443-7	• SUPPORT, AILERON STA 142	1	35	
- 7	R-42444 R-42444-1	• TUBE ASSY, AILERON TORQUE STA 142 REPLACED BY SUITABLE SUP R-42444-1 • TUBE ASSY, AILERON TORQUE STA 142 REPLACES SUITABLE SUP FOR R-42444 ATTACHING PARTS	1	130	129
- 8	MS21043-3	• NUT	4	35	
- 9	AN173-7A	• BOLT	2	35	
- 10	AN173-6A	• BOLT	2	35	
- 11	W-42450-1	• BELL CRANK ASSY, UPPER AILERON CONTROL	1	35	
- 12	W-42451-1	• BELL CRANK ASSY, LOWER AILERON CONTROL ATTACHING PARTS	1	35	
- 13	MS21043-3	• NUT	4	35	
- 14	AN970-1	• WASHER	4	35	
- 15	AN380-1-194	• PIN, UPPER BELL CRANK	2	35	
- 16	AN380-1-134	• PIN, LOWER BELL CRANK	2	35	
- 17	NAS77-4-21	• BUSHING	2	35	
- 18	NAS77-4-22	• BUSHING, UPPER	1	35	
- 19	NAS77-311	• BUSHING, LOWER	1	35	
- 20	R-42950-7	• BELL CRANK, UPPER	1	35	
- 21	R-42951-7	• BELL CRANK, LOWER	1	35	129
- 22	R-42662-1 R-2662-3	• HOUSING ASSY, AILERON TORQUE TUBE REPLACED BY SUITABLE SUP R-42662-1 • HOUSING ASSY, AILERON TORQUE TUBE REPLACES SUITABLE SUP FOR R-42662-1	1	130	
- 23	B542DD B542DDX7414	• BEARING <21335> 90-58003-016 REPLACED BY SUITABLE SUP B542DDX7414 • BEARING <21335> 90-58003-017 REPLACES SUITABLE SUP FOR B542DD	113	130	129
- 24	R-42662-F	• HOUSING	1	35	
- 25	R-42407-5	• RETAINER	1	35	
- 26	R-42443	• WASHER	1	35	
- 27	1601100	• SEAL, <KORZEB> SPEC R-4370	1	35	
- 28	R-42445	• TUBE	1	35	
- 29		• POTENTIOMETER, AILERON POSITION SEE FIG. 2.14-2	RF		

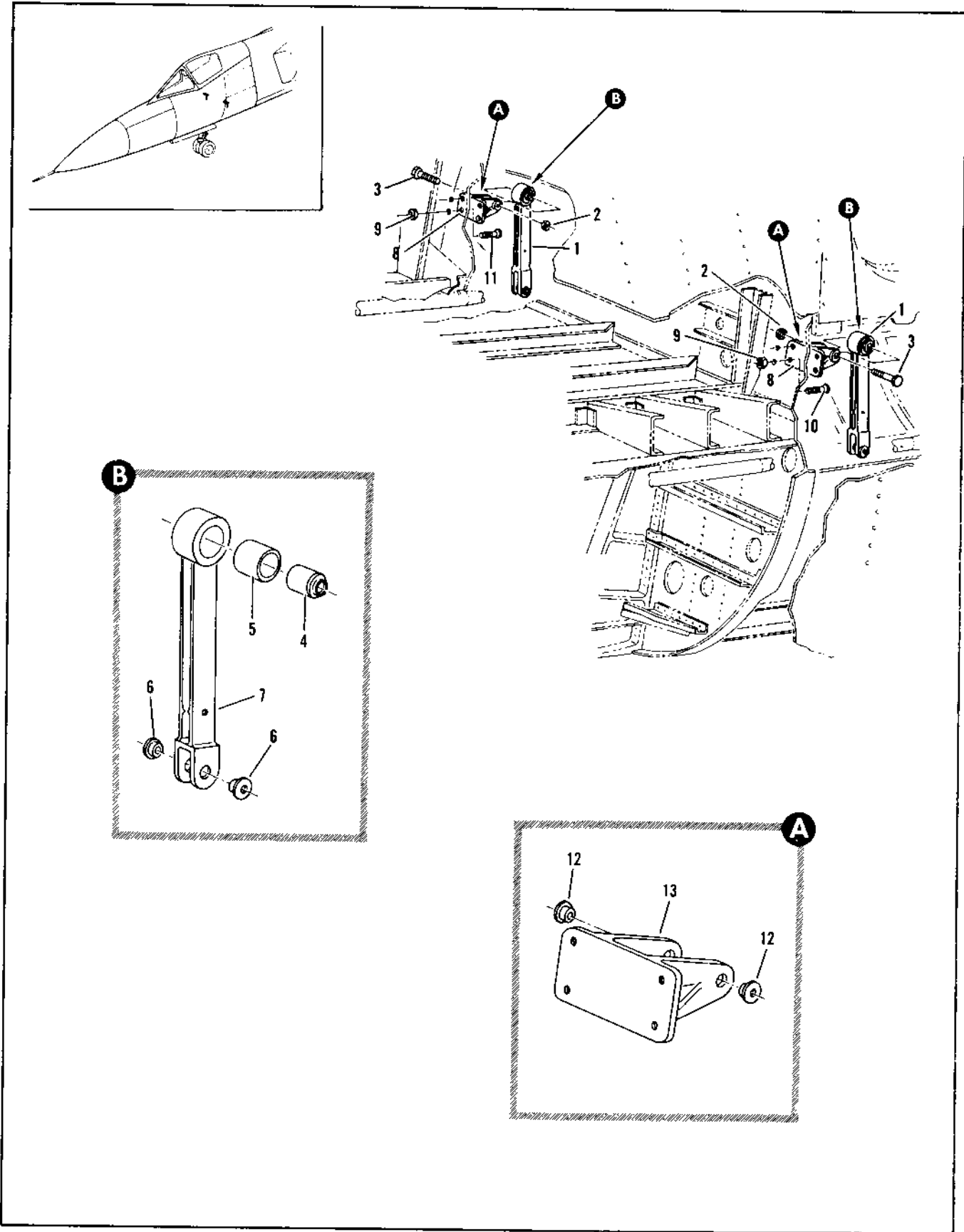

Figure 2.14-13. Elevator and Aileron Control Idler Installation Sta 170

FIGURE AND INDEX NUMBER	PART NUMBER	DESCRIPTION	UNITS PER ASSY.	USABLE ON CODE	
				FROM	TO
		1 2 3 4 5 6			
2.14-13	8-42302	IDLER INSTALLATION, ELEVATOR AND AILERON CONTROL STA 170 FOR NHA SEE FIG. 2.3-4	RF 35		
- 1	8-42630-3	• IDLER ASSY, ELEVATOR AND AILERON CONTROL REPLACED BY INTCHG WITH 8-42630-5 REPLACED BY SUITABLE SUB 8-42630-801	2 35	48	
	8-42553-1	• IDLER ASSY, ELEVATOR AND AILERON CONTROL ALT INTCHG WITH 8-42630-3	RF 35	48	
	8-42630-5	• IDLER ASSY, ELEVATOR AND AILERON CONTROL REPLACES INTCHG WITH 8-42630-3 REPLACED BY SUITABLE SUB 8-42630-801	2 49	129	
	8-42630-801	• IDLER ASSY, ELEVATOR AND AILERON CONTROL REPLACES SUITABLE SUB FOR 8-42630-3 AND 8-42630-5	2 130		
		ATTACHING PARTS			
- 2	MS21043-4	• NUT	2 35		
- 3	NAS464-4A21	• BOLT	2 35		
		----X----			
- 4	DW4KE6549	• BEARING, <21335> 90-58002-012	1 35	48	
	DW4KE6536	• BEARING, <21335> 90-58002-006 USE WITH 8-42553-1	RF 35	48	
	DW4K	• BEARING, <21335> 90-58002-001 REPLACED BY SUITABLE SUB DW4KE7414	1 49	129	
	DW4KE7414	• BEARING, <21335> 90-58002-013 REPLACES SUITABLE SUB FOR DW4K	1 130		
- 5	98-14000-037	• SLEEVE	1 35		
- 6	NAS77-4-21	• BUSHING	2 35		
- 7	8-42630-11	• IDLER	1 35		
	8-42630-9	• IDLER	RF 35	48	
	8-42553-7	• IDLER, USE WITH 8-42553-1	RF 35		
- 8	8-42639-1	• SUPPORT ASSY, ELEVATOR AND AILERON CONTROL ATTACHING PARTS	2 35		
		ATTACHING PARTS			
- 9	MS21043-7	• NUT	8 35		
- 10	AN23-11A	• BOLT, CLEVIS LH	4 35		
- 11	AN23-10A	• BOLT, CLEVIS RH	4 35		
		----X----			
- 12	NAS77-4-21	• BUSHING	2 35		
- 13	8-42639-7	• SUPPORT	1 35		

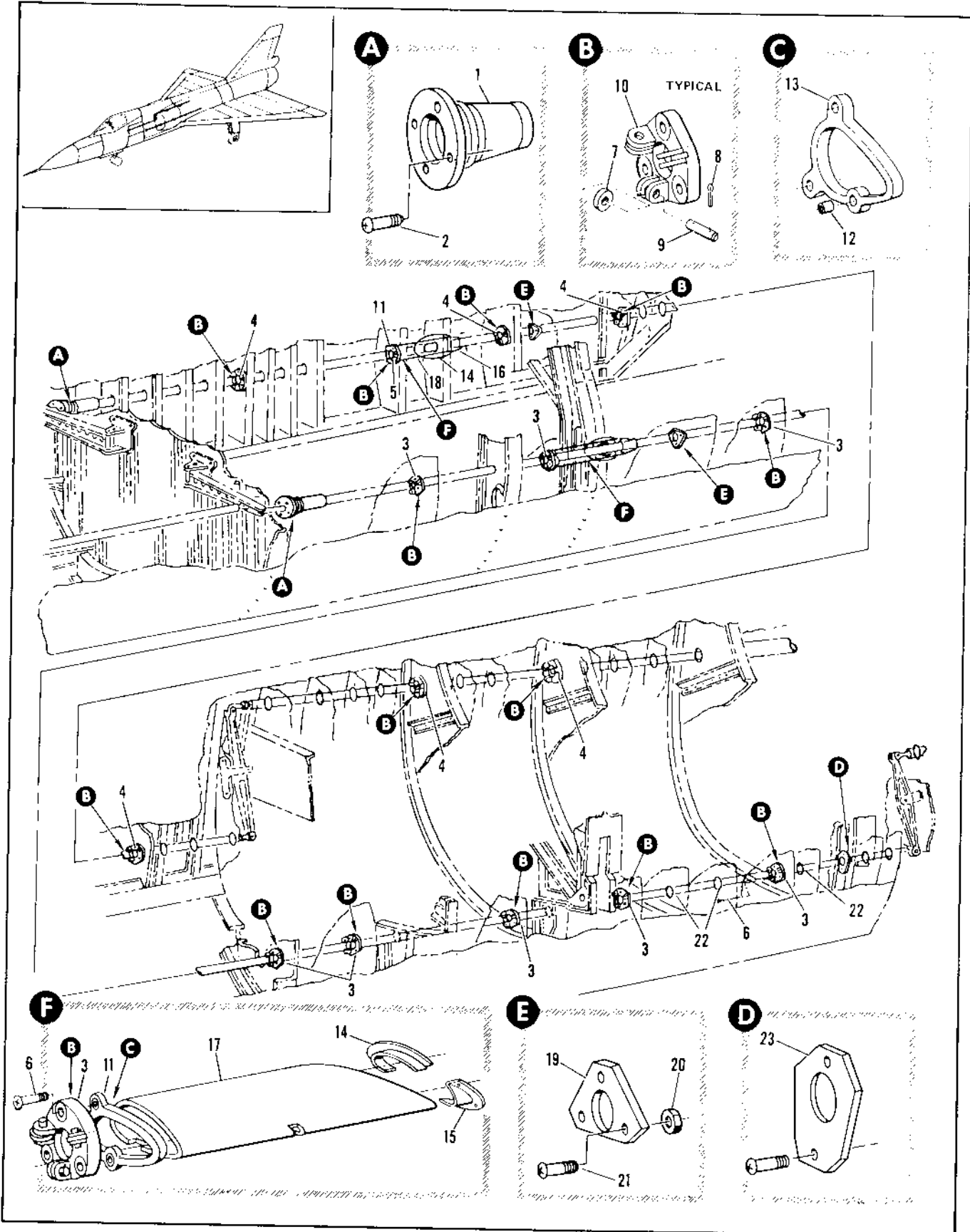

Figure 2.14-14. Elevation Control Tube Support Installation Sta 216 to 431 (Sheet 1 of 2)

FIGURE AND INDEX NUMBER	PART NUMBER	DESCRIPTION	UNITS PER ASSY.	USABLE ON CODE		
				FROM	TO	
2.14-14	R-42557-1	SUPPORT INSTALLATION, ELEVON CONTROL TUBE LH STA 216 TO 431 FOR NHA SEE FIG. 2.3-11	RF	35	129	
	R-42557-5	SUPPORT INSTALLATION, ELEVON CONTROL TUBE LH STA 216 TO 431 FOR NHA SEE FIG. 2.3-11	RF	130		
	R-42557-3	SUPPORT INSTALLATION, ELEVON CONTROL TUBE RH STA 216 TO 431 FOR NHA SEE FIG. 2.3-11	RF	35	129	
	R-42557-801	SUPPORT INSTALLATION, ELEVON CONTROL TUBE RH STA 216 TO 431 FOR NHA SEE FIG. 2.3-11	RF	130		
	- 1	1601096-3	• BELLOWS, <98769> SPEC 8-4393-1	1	35	
	- 2	NAS221-7	• ATTACHING PARTS • SCREW ----X----	4	35	
	- 3	R-42511-1	• SUPPORT ASSY, LH	8	35	
	- 4	R-42511-1	• SUPPORT ASSY, RH	6	35	
	- 5	R-42511-1	• SUPPORT ASSY, RH REPLACED BY NOT INTCHG WITH R-42511-3	1	35	215
		R-42511-3	• SUPPORT ASSY, RH REPLACES NOT INTCHG WITH R-42511-1	1	216	
			• ATTACHING PARTS			
	- 6	NAS221-12	• SCREW, LH	24	35	
		NAS221-12	• SCREW, RH	18	35	
		NAS221-12	• SCREW, RH	3	35	215
		NAS221-13	• SCREW, RH	3	216	
		AN963C10	• WASHER	3	216	
	- 7	R-42510	• ROLLER • ATTACHING PARTS	3	35	
	- 8	AN380-2-1	• PIN	3	35	
	- 9	R-42512	• PIN	3	35	
			----X----			
	- 10	R-42568-11	• SUPPORT	1	35	
		R-42568-11	• SUPPORT, RH	1	35	215
		R-42568-15	• SUPPORT, RH	1	216	
	- 11	R-42569-1	• RETAINER ASSY, SHROUD	1	35	129
- 12	3591-3CNX	• INSERT, <91767> 93-0303-006	3	35	129	
- 13	R-42553-7	• RETAINER	1	35	125	
	R-42553-7	• RETAINER, ALT INTCHG WITH R-42569-7	RF	35	129	
- 14	R-42556	• COLLAR ASSY, SHROUD WELDED	1	35	129	
- 15	R-42568-7	• CLAMP, LH	1	35	129	
- 16	R-42568-8	• CLAMP, RH	1	35	129	
- 17	R-42569-7	• SHROUD, LH REPLACED BY NOT INTCHG WITH R-42597	1	35	129	
- 18	R-42569-8	• SHROUD, RH REPLACED BY NOT INTCHG WITH R-42597	1	35	129	
	R-42597	• SHROUD, REPLACES NOT INTCHG WITH R-42569-7 AND R-42569-8	2	130		
- 19	R-42564	• SUPPORT, ELEVON TUBE • ATTACHING PARTS	1	35		
- 20	MS21043-3	• NUT	3	35		
- 21	NAS221-10	• SCREW ----X----	3	35		
- 22	R-42561-7	• FAIR-LEAD, LH	3	35		
- 23	R-42563	• FAIR-LEAD, LH	1	35		
- 24	NAS221-11	• SCREW ----X----	2	35		

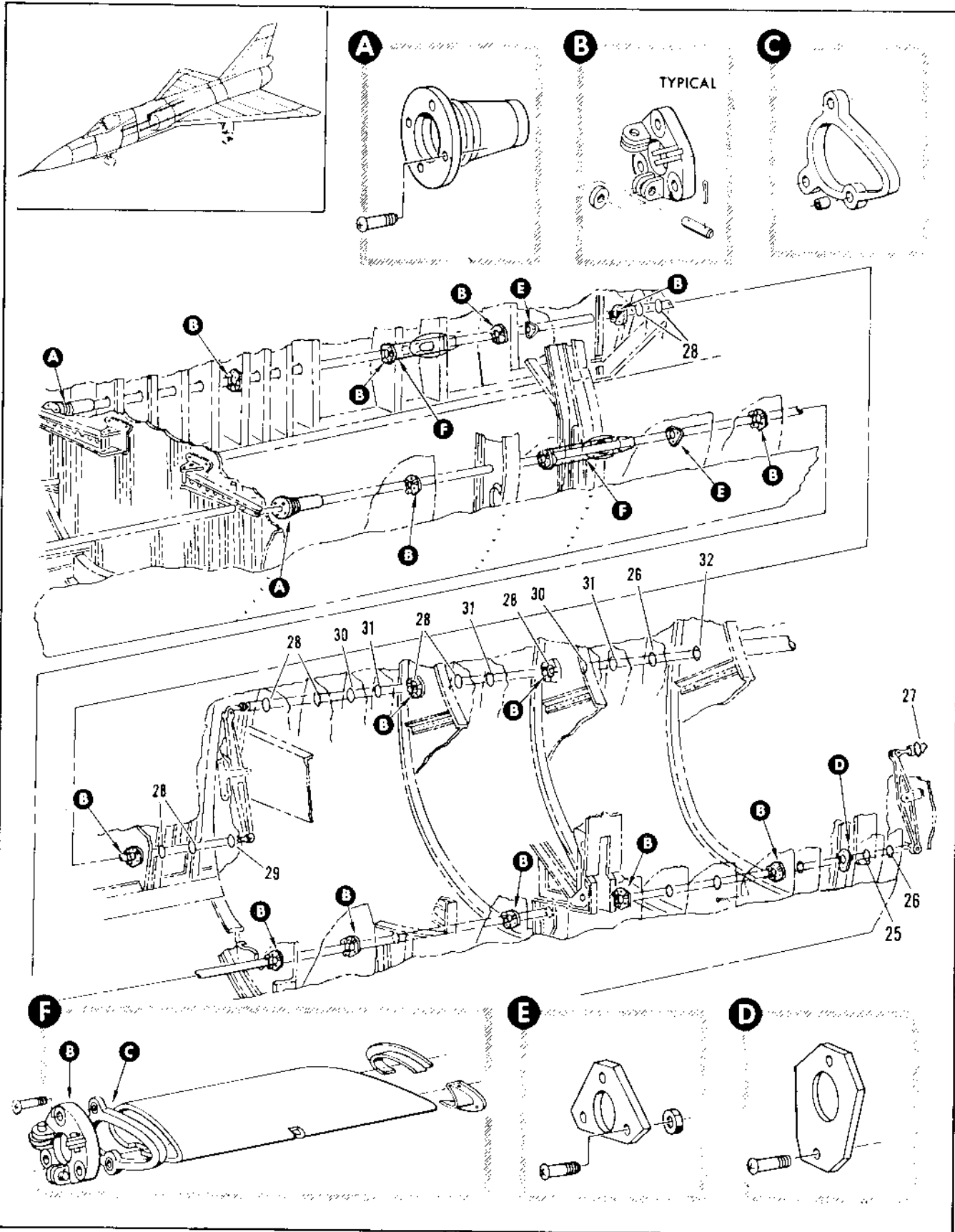

Figure 2.14-14. Elevon Control Tube Support Installation Sta 216 to 431 (Sheet 2 of 2)

FIGURE AND INDEX NUMBER	PART NUMBER	DESCRIPTION	UNITS PER ASSY.	USABLE ON CODE	
				FROM	TO
		1 2 3 4 5 6			
2.14-14- 25	6-42561-17	• FAIR-LEAD, LH	1	35	
- 26	6-42561-15	• FAIR-LEAD	1	35	
- 27	6-42561-25	• FAIR-LEAD, LY	1	35	
- 28	6-42561-7	• FAIR-LEAD, RB	9	35	
- 29	6-42561-13	• FAIR-LEAD, RH	1	35	
- 30	6-42561-11	• FAIR-LEAD, RH	2	35	
- 31	6-42561-19	• FAIR-LEAD, RB REPLACED BY NOT INTCHS WITH 6-42561-17	2	35	99
	6-42561-27	• FAIR-LEAD, RB REPLACES NOT INTCHS WITH 6-42561-19	2	90	
- 32	6-42561-18	• FAIR-LEAD, RB	1	35	

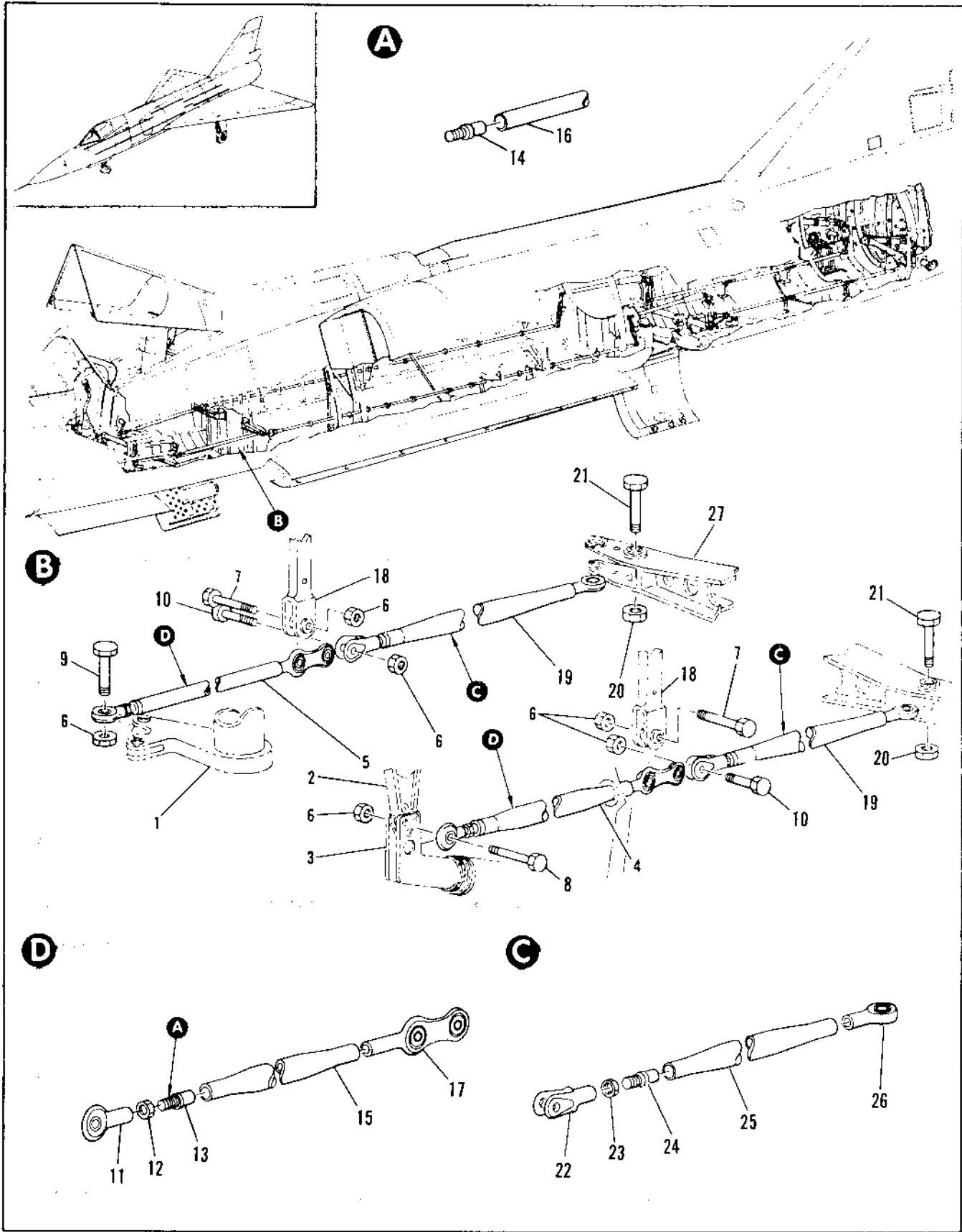

Figure 2.14-15. Elevon Control Linkage Installation (Sheet 1 of 5)

FIGURE AND INDEX NUMBER	PART NUMBER	DESCRIPTION	UNITS PER ASSY.	USABLE ON CODE	
				FROM	TO
		1 2 3 4 5 6			
2.14-15	n-40534	LINKAGE INSTALLATION, ELEVON CONTROL STA 472 FWD FOR NHA SEE FIG. 2.3-3	RF	35	277
	87405047801	LINKAGE INSTALLATION, ELEVON CONTROL STA 472 FWD FOR NHA SEE FIG. 2.3-3	RF	278	
	8-41101	LINKAGE INSTALLATION, ELEVON CONTROL STA 472 AFT FOR NHA SEE FIG. 2.3-3	RF	278	
- 1		• BELL CRANK ASSY, LOWER AILERON CONTROL SEE FIG. 2.14-12 INDEX 12	RF		
- 2		• BELL CRANK ASSY, CONTROL STICK SHAFT SEE FIG. 2.14-9 INDEX 42	RF		
- 3		• COUNTERBALANCE ASSY, CONTROL STICK SEE FIG. 2.14-44	RF		
- 4	64A33155-863	• ROD ASSY, CONTROL LINKAGE REPLACED BY SUITABLE SUB 64A33155-873	1	35	48
	64A33155-873	• ROD ASSY, CONTROL LINKAGE LH REPLACES SUITABLE SUB FOR 64A33155-863 REPLACED BY SUITABLE SUB 64A33155-623	1	49	129
	64A33155-623	• ROD ASSY, CONTROL LINKAGE LH REPLACES SUITABLE SUB FOR 64A33155-873	1	130	
- 5	64A33155-861	• ROD ASSY, CONTROL LINKAGE RH REPLACED BY SUITABLE SUB 64A33155-871	1	35	48
	64A33155-871	• ROD ASSY, CONTROL LINKAGE RH REPLACES SUITABLE SUB FOR 64A33155-861 REPLACED BY SUITABLE SUB 64A33155-621	1	49	129
	64A33155-621	• ROD ASSY, CONTROL LINKAGE RH REPLACES SUITABLE SUB FOR 64A33155-871 ATTACHING PARTS	1	130	
- 6	MS21244-4	• • NUT	6	35	
- 7	MS27576-4-18	• • BOLT	2	35	
- 8	MS27576-4-19	• • BOLT	1	35	
- 9	MS27576-4-18	• • BOLT	1	35	
- 10	MS27576-4-13	• • BOLT	2	35	
		-----X-----			
- 11	RE4F5	• • BEARING, <21335> 90-60002-001	1	35	129
	RE4F5E7414	• • BEARING, <21335> 90-60002-009	1	130	
- 12	AN316-5R	• • NUT	1	35	
- 13	64F33114-13	• • CONNECTOR	1	35	
- 14	64F33114-19	• • CONNECTOR	1	35	
- 15	R-42100-69	• • TUBE, LH	1	35	
- 16	R-42100-67	• • TUBE, RH	1	35	
- 17	A45547	• • BEARING, ROD END (77869) SPEC 8-04371-801	1	35	48
	A45547	• • BEARING, ROD END (77896) SPEC 8-04371-803	1	49	
- 18		• IDLER ASSY, ELEVATOR AND AILERON CONTROL SEE FIG. 2.14-13 INDEX 1	RF		
- 19	64A33155-809	• ROD ASSY, ELEVATOR AND AILERON CONTROL REPLACED BY SUITABLE SUB 64A33155-887	2	35	129
	64A33155-887	• ROD ASSY, ELEVATOR AND AILERON CONTROL REPLACES SUITABLE SUB FOR 64A33155-809 ATTACHING PARTS	2	130	
- 20	MS21244-4	• • NUT	2	35	
- 21	MS27576-4-20	• • BOLT	2	35	
		-----X-----			
- 22	6-42521	• • CLEVIS	1	35	
- 23	AN316-5R	• • NUT	1	35	
- 24	64F33114-13	• • CONNECTOR	1	35	
- 25	R-42100-23	• • TUBE	1	35	
- 26	RE4H8	• • BEARING, <21335> 90-60006-003 REPLACED BY SUITABLE SUB RE4H8E7414	1	35	129
	RE4H8E7414	• • BEARING, <21335> 90-60006-005 REPLACES SUITABLE SUB FOR RE4H8	1	130	
- 27		• IDLER ASSY, ELEVATOR AND AILERON CONTROL STA 216 SEE FIG. 2.14-36 INDEX 2	RF		

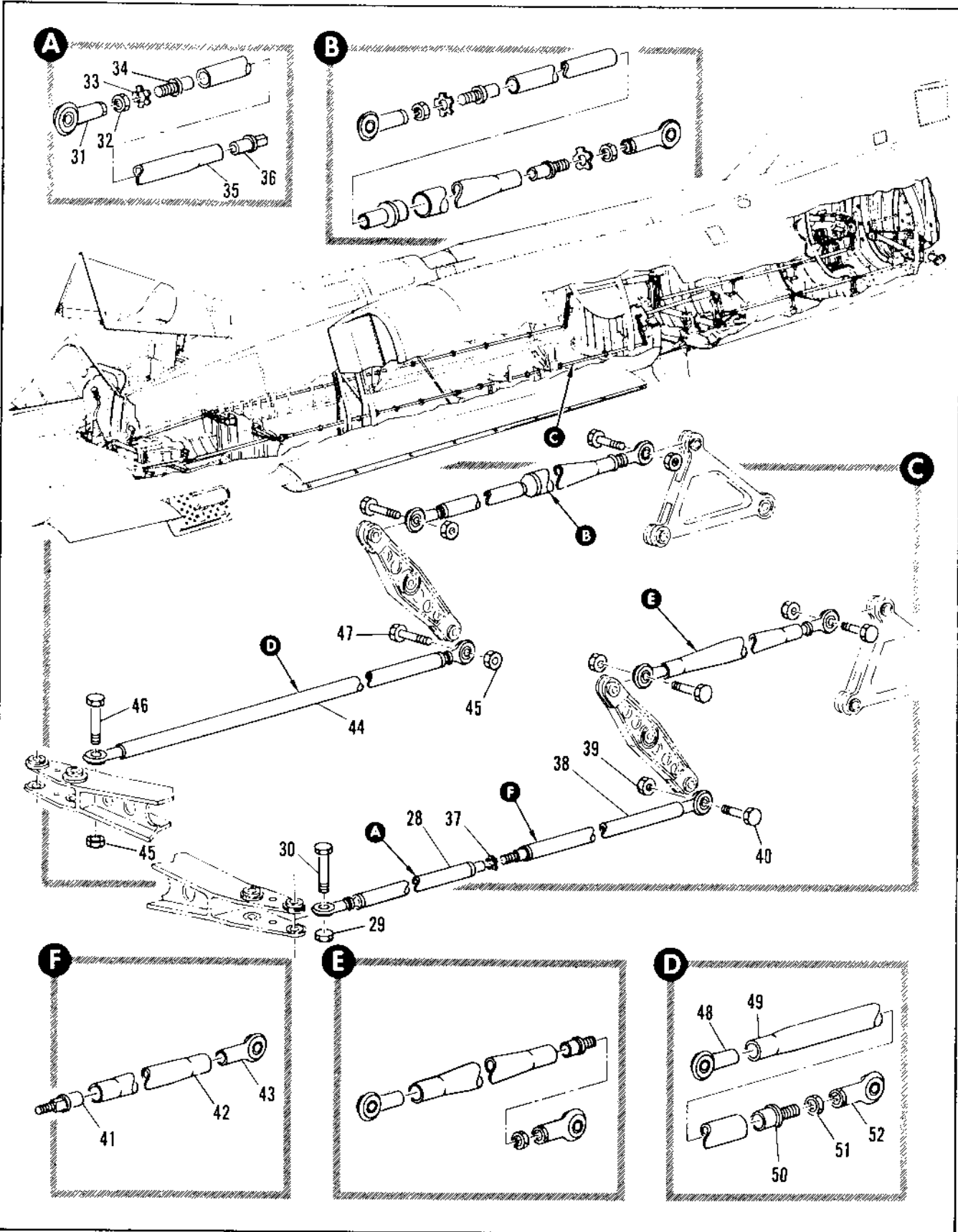

Figure 2.14-15. Elevation Control Linkage Installation (Sheet 2 of 5)

FIGURE AND INDEX NUMBER	PART NUMBER	DESCRIPTION	UNITS PER ASSY.	USABLE ON CODE	
				FROM	TO
2.14-15- 28	44A33155-017	• ROD ASSY, CONTROL LINKAGE REPLACED BY SUITABLE SUP 64A33155-017	1	35	129
	44A33155-017	• ROD ASSY, CONTROL LINKAGE REPLACES SUITABLE SUP FOR 44A33155-017 ATTACHING PARTS	1	133	
- 29	MS21044-4	• NUT	1	35	
- 30	MS27176-4-01	• BOLT	1	35	
		-----X-----			
- 31	RE4FR	• BEARING, (21335) 90-40002-001	1	35	129
	RE4FR-L7414	• BEARING, (21335) 90-40002-001	1	133	
- 32	AN316-5R	• NUT	1	35	
- 33	MS27111-1	• WASHER	1	35	
- 34	64F33114-17	• CONNECTOR	1	35	
- 35	A-42100-21	• TUBE	1	35	
- 36	64F33114-17	• CONNECTOR	1	35	
- 37	WASHER-1H	• WASHER, LH	1	35	
- 38	44A33155-017	• ROD ASSY, CONTROL LINKAGE LOWER REPLACED BY SUITABLE SUP 44A33155-015	1	35	129
	44A33155-015	• ROD ASSY, CONTROL LINKAGE LOWER REPLACES SUITABLE SUP FOR 44A33155-017 ATTACHING PARTS	1	133	
- 39	MS21044-4	• NUT	1	35	
- 40	MS27176-4-11	• BOLT	1	35	
		-----X-----			
- 41	64F33114-17	• CONNECTOR	1	35	
- 42	A-42100-21	• TUBE	1	35	
- 43	RE4FR	• BEARING, (21335) 90-40002-003 REPLACED BY SUITABLE SUP RE4HRL7414	1	35	129
- 44	44A33155-015	• ROD ASSY, CONTROL LINKAGE REPLACED BY SUITABLE SUP 64A33155-017	1	35	129
	64A33155-017	• ROD ASSY, CONTROL LINKAGE REPLACES SUITABLE SUP FOR 44A33155-015 ATTACHING PARTS	1	133	
- 45	MS21044-4	• NUT	1	35	
- 46	MS27176-4-01	• BOLT	1	35	
- 47	MS29373-4-11	• BOLT	1	35	
		-----X-----			
- 48	RE4FR	• BEARING, (21335) 90-40002-003 REPLACED BY SUITABLE SUP RE4HRL7414	1	35	129
	RE4FR-L7414	• BEARING, (21335) 90-40002-003 REPLACES SUITABLE SUP FOR RE4FR	1	133	
- 49	A-42100-21	• TUBE	1	35	
- 50	64F33114-17	• CONNECTOR	1	35	
- 51	AN316-5R	• NUT	1	35	
- 52	RE4FR	• BEARING, (21335) 90-40002-001	1	35	129
	RE4FR-L7414	• BEARING, (21335) 90-40002-001	1	133	

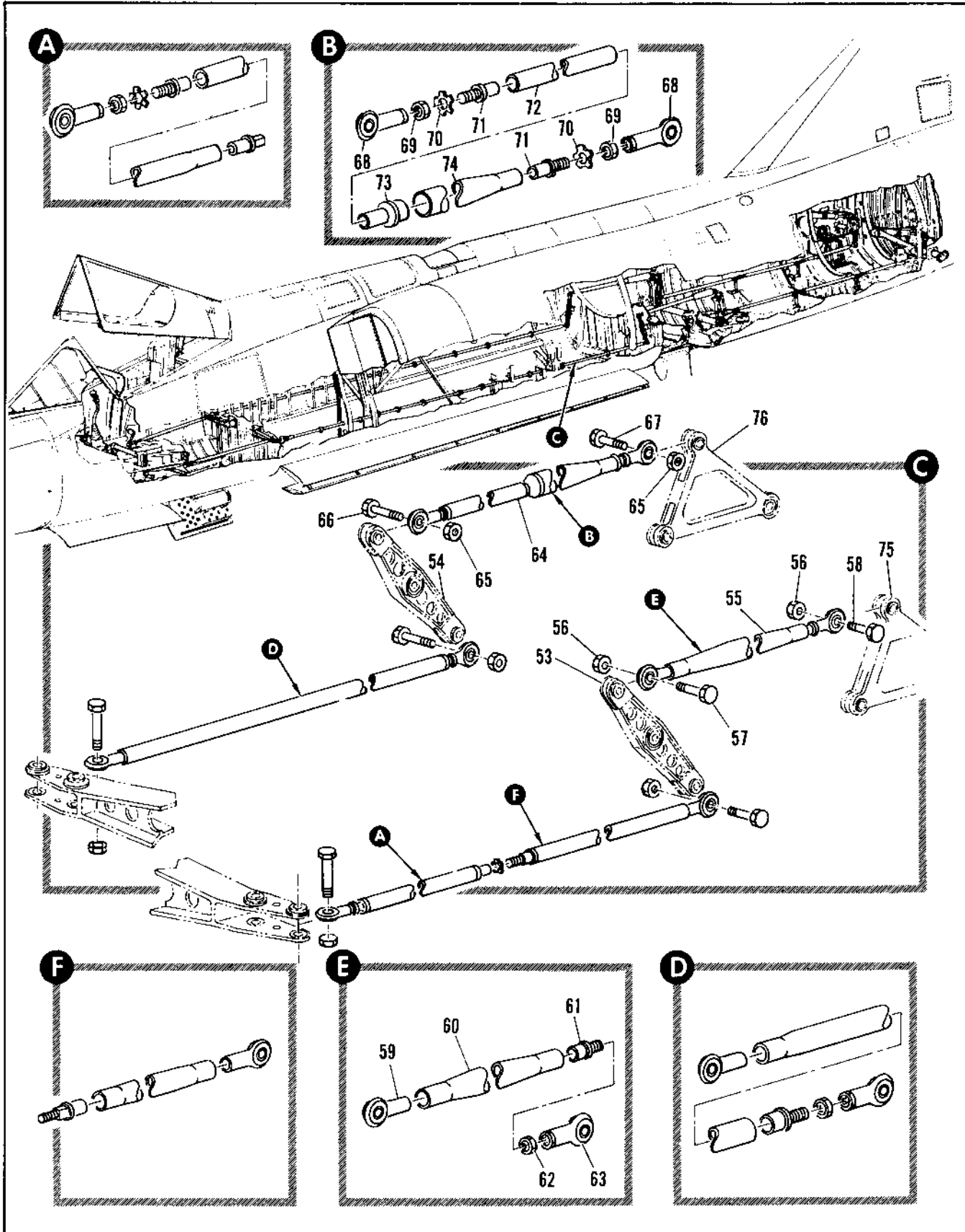

Figure 2.14-15. Elevon Control Linkage Installation (Sheet 3 of 5)

FIGURE AND INDEX NUMBER	PART NUMBER	DESCRIPTION	UNITS PER ASSY.	USABLE ON CODE	
				FROM	TO
2.14-15- 53		• BELL CRANK ASSY, ELEVATOR SEE FIG. 2.14-19	RF		
- 54		• BELL CRANK ASSY, AILERON FIG. 2.14-16	RF		
- 55	64A33155-647	• ROD ASSY, CONTROL LINKAGE UPPER REPLACED BY SUITABLE SUB 64A33155-613	1	35	129
	64A33155-613	• ROD ASSY, CONTROL LINKAGE UPPER REPLACES SUITABLE SUB FOR 64A33155-647 ATTACHING PARTS	1	130	
- 56	MS21244-4	• • NUT	2	35	
- 57	MS27576-4-19	• • BOLT	1	35	
- 58	MS27576-4-17	• • BOLT	1	35	
		-----X-----			
- 59	RE4HB	• • BEARING, <21335> 90-60006-003 REPLACED BY SUITABLE SUB RE4HBE7414	1	35	129
	RE4HBE7414	• • BEARING, <21335> 90-60006-005 REPLACES SUITABLE SUB FOR RE4HB	1	130	
- 60	A-42110-61	• • TUBE	1	35	
- 61	64F33114-13	• • CONNECTOR	1	35	
- 62	AN316-5R	• • NUT	1	35	
- 63	RE4FB	• • BEARING, <21335> 90-60002-001	1	35	129
	RE4FBE7414	• • BEARING, <21335> 90-60002-009	1	130	
- 64	64A33155-641	• ROD ASSY, CONTROL LINKAGE REPLACED BY SUITABLE SUB 64A33155-607	1	35	129
	64A33155-607	• ROD ASSY, CONTROL LINKAGE REPLACES SUITABLE SUB FOR 64A33155-641 ATTACHING PARTS	1	130	
- 65	MS21244-4	• • NUT	2	35	
- 66	MS27576-4-19	• • BOLT	1	35	
- 67	MS27576-4-17	• • BOLT	1	35	
		-----X-----			
- 68	RE4FB	• • BEARING, <21335> 90-60002-001	2	35	129
	RE4FBE7414	• • BEARING, <21335> 90-60002-009	2	130	
- 69	AN316-5R	• • NUT	2	35	
- 70	NAS460-516	• • WASHER	2	35	
- 71	64F33114-17	• • CONNECTOR	2	35	
- 72	A-42100-49	• • TUBE	1	35	
- 73	A-42427	• • ADAPTER	1	35	
- 74	A-42100-51	• • TUBE	1	35	
- 75		• BELL CRANK ASSY, ELEVATOR SEE FIG. 392-64 SEE FIG. 2.14-18 INDEX 65	RF		
- 76		• BELL CRANK ASSY, AILERON STA 475 SEE FIG. 2.14-18 INDEX 26	RF		

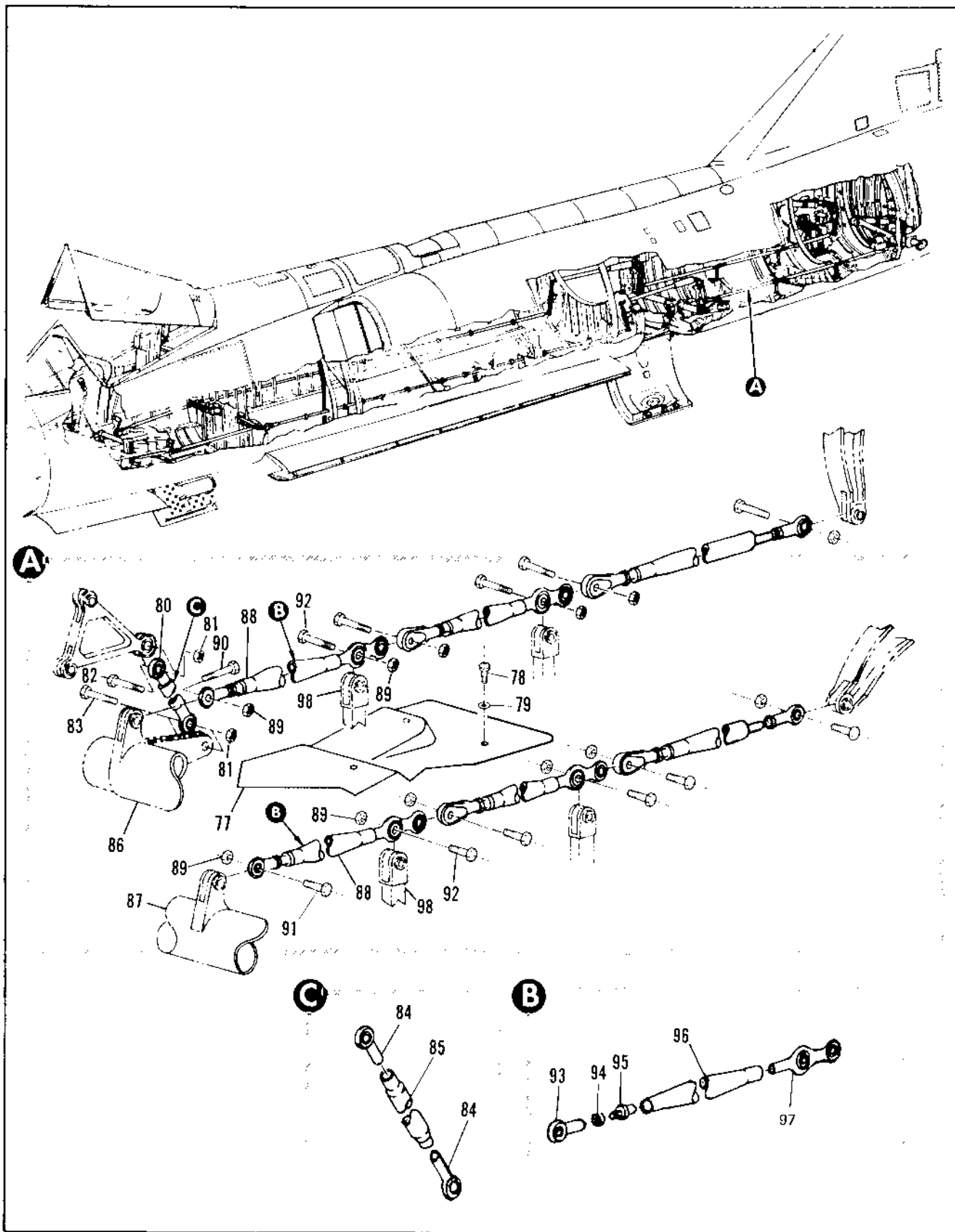

Figure 2.14-15. Elevation Control Linkage Installation (Sheet 4 of 5)

FIGURE AND INDEX NUMBER	PART NUMBER	DESCRIPTION	UNITS PER ASSY.	USABLE ON CODE	
				FROM	TO
2.14-15- 77	63J36860-3	• COVER ASSY, RIVETED ATTACHING PARTS	1	35	89
- 78	AN502-10-8	• SCREW	3	35	
- 79	99-51509-029	• WASHER	3	35	
		-----X-----			
- 80	8-42100-843	• ROD ASSY, CONTROL LINKAGE REPLACED BY SUITABLE SUB 8-42100-609	1	35	129
	8-42100-609	• ROD ASSY, CONTROL LINKAGE REPLACES SUITABLE SUB FOR 8-42100-843 ATTACHING PARTS	1	130	
- 81	MS21244-4	• NUT	2	35	
- 82	MS27576-4-17	• BOLT	1	35	
- 83	MS27576-4-18	• BOLT	1	35	
		-----X-----			
- 84	RE4HB	• BEARING, <21335> 90-60006-003 REPLACED SUITABLE SUB RE4HBE7414	2	35	129
	RE4HBE7414	• BEARING, <21335> 90-60006-005 REPLACES SUITABLE SUB FOR RE4HB	2	130	
- 85	8-42100-55	• TUBE	1	35	
- 86		• TUBE ASSY, ELEVON RH SEE FIG. 2.14-20 INDEX 74	RF		
- 87		• TUBE ASSY, ELEVON LH SEE FIG. 2.14-20 INDEX 31	RF		
- 88	EA433155-891	• ROD ASSY, CONTROL LINKAGE, (STEEL) ATTACHING PARTS	1	35	
- 89	MS21244-4	• NUT	4	35	
- 90	MS27576-4-17	• BOLT	1	35	
- 91	MS27576-4-18	• BOLT	1	35	
- 92	MS27576-4-18	• BOLT	2	35	
		-----X-----			
- 93	RE4F5	• BEARING, <21335> 90-60002-001	1	35	129
	RE4F5E7414	• BEARING, <21335> 90-60002-009	1	130	
- 94	AN314-5R	• NUT	1	35	
- 95	94F33114-17	• CONNECTOR	1	35	
- 96	8-42100-65	• TUBE	1	35	
- 97	A45547	• BEARING, ROD END <77896> SPEC 8-03471-801	1	35	48
	A45547	• BEARING, ROD END <77896> SPEC 8-04371-803	1	49	
- 98		• IDLER INSTL, ELEVON CONTROL STA 524 SEE FIG. 2.14-40	RF		

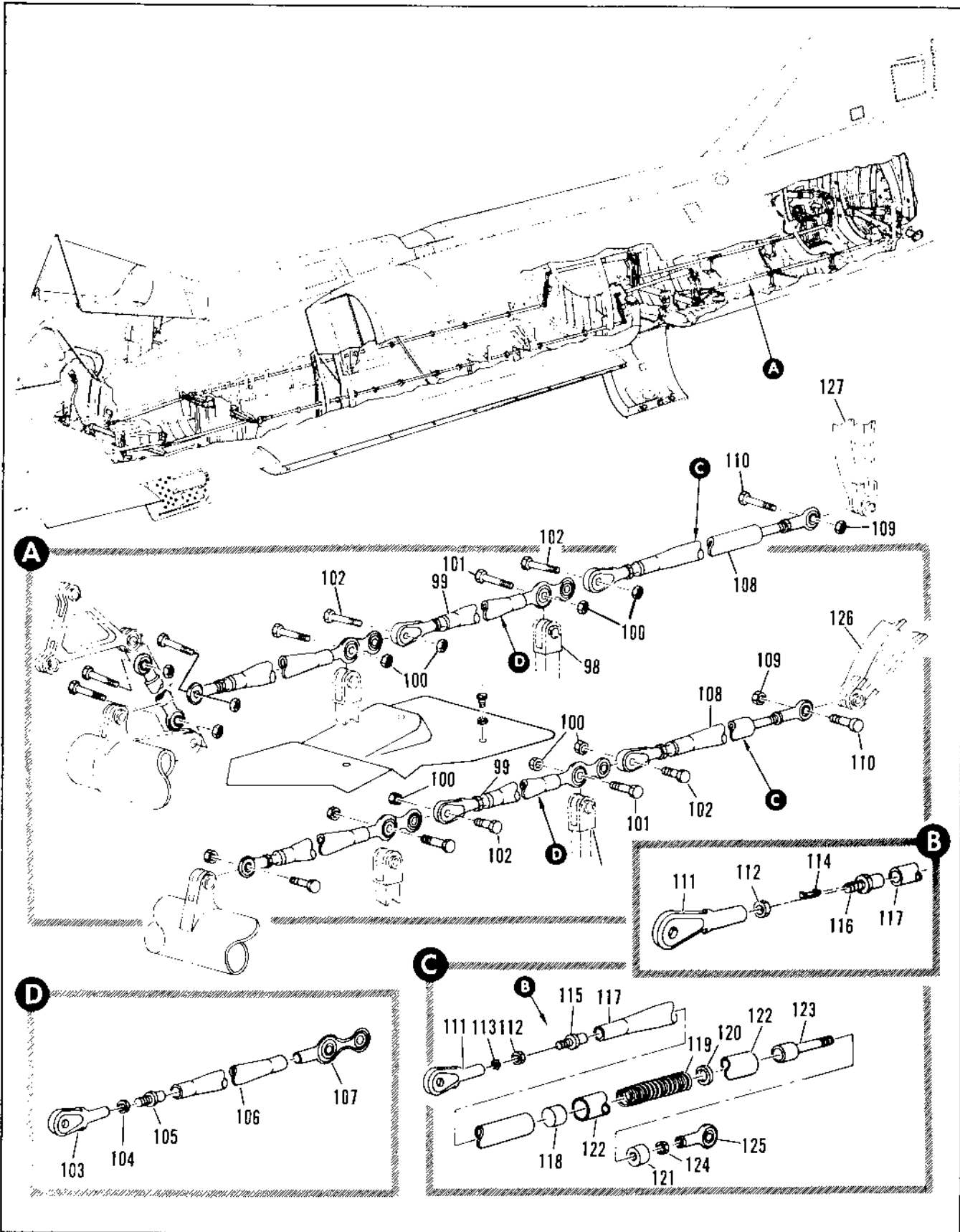

Figure 2.14-15. Elevon Control Linkage Installation (Sheet 5 of 5)

FIGURE AND INDEX NUMBER	PART NUMBER	DESCRIPTION	UNITS PER ASSY.	USABLE ON CODE	
				FROM	TO
2.14-15- 99	64A33155-857	• ROD ASSY, CONTROL LINKAGE REPLACED BY SUITABLE SUB 64A33155-867	2	35	48
	64A33155-867	• ROD ASSY, CONTROL LINKAGE REPLACES SUITABLE SUB FOR 64A33155-857 ATTACHING PARTS	2	49	
-100	MS21244-4	• • NUT	6	35	
-101	MS27576-4-18	• • BOLT	2	35	
-102	MS27576-4-13	• • BOLT	4	35	
		-----X-----			
-103	8-42521	• • CLEVIS, ELEVON CONTROL ROD	1	35	
-104	AN316-5R	• • NUT	1	35	
-105	64F33114-13	• • CONNECTOR	1	35	
-106	8-42100-63	• • TUBE	1	35	48
-107	A45547	• • BEARING, ROD END <77896> SPEC 8-04371-801	1	49	
	A45547	• • BEARING, ROD END <77896> SPEC 8-04371-803	2	35	89
-108	64A33162-3	• ROD ASSY, LOAD RELIEF	2	90	129
	64A33162-5	• ROD ASSY, LOAD RELIEF	2	130	198
	64A33162-801	• ROD ASSY, LOAD RELIEF	2	199	
	64A33162-823	• ROD ASSY, LOAD RELIEF ATTACHING PARTS	2	35	
-109	MS27244-4	• • NUT	2	35	
-110	MS27576-4-13	• • BOLT			
		-----X-----			
-111	8-42521	• • CLEVIS, ELEVON CONTROL	1	35	198
	8-42521-7	• • CLEVIS, ELEVON CONTROL	1	199	
-112	NAS559-5	• • NUT	1	35	
-113	NAS463-516	• • WASHER	1	35	198
-114	NAS559-1	• • LOCK	1	199	
-115	64F33114-7	• • CONNECTOR	1	35	198
-116	64F33114-9	• • CONNECTOR	1	199	
-117	8-42547-7	• • TUBE	1	35	
-118	8-42551	• • SLEEVE	1	35	
-119	8-42550	• • SPRING	1	35	
-120	MS20002-9	• • WASHER	1	35	
-121	8-42552	• • RETAINER	1	35	
	8-42548	• • TUBE ASSY, LOAD RELIEF	1	35	
-122	8-42548-7	• • • TUBE	1	35	
-123	8-42549	• • • ADAPTER	1	35	
-124	AN316-5R	• • NUT	1	35	129
-125	RE4F5E7164	• • BEARING, <21335> 90-60002-308	1	35	
	RE4F5E7416	• • BEARING, <21335> 90-60002-316	1	130	
-126		• CRANK ASSY, ELEVON FOLLOWUP LH SEE FIG. 2.14-25	RF		
-127		• CRANK ASSY, ELEVON FOLLOWUP RH SEE FIG. 2.14-25	RF		

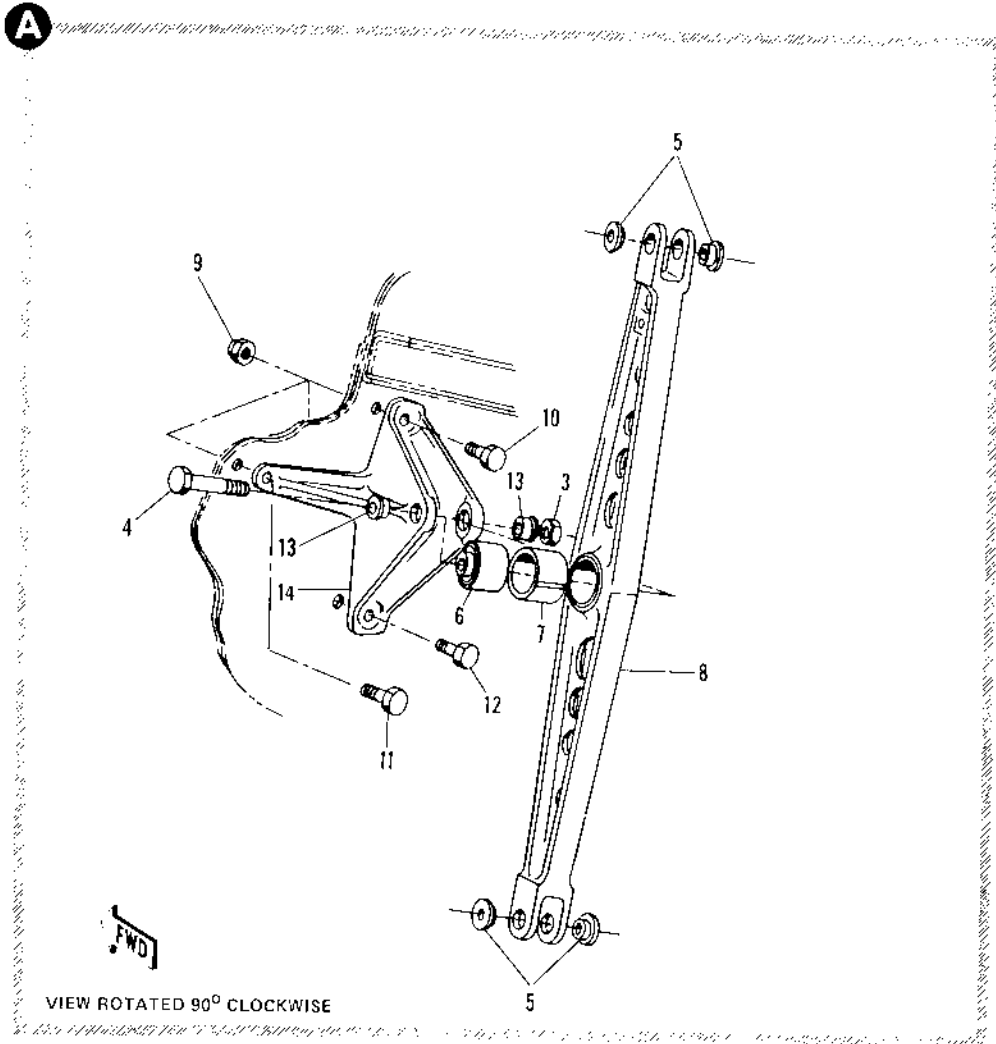
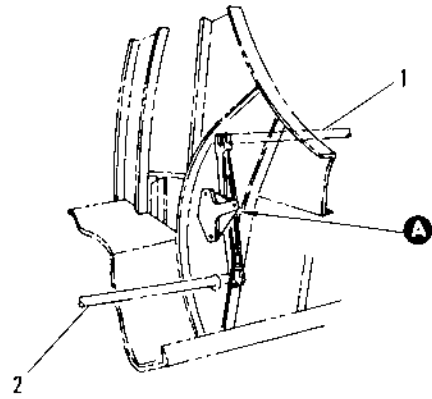
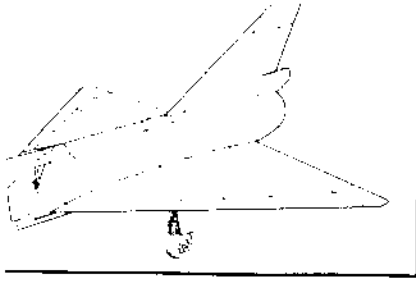

Figure 2.14-16. Aileron RH Bell Crank Installation Sta 353

FIGURE AND INDEX NUMBER	PART NUMBER	DESCRIPTION 1 2 3 4 5 6	UNITS PER ASSY.	USABLE ON CODE	
				FROM	TO
2.14-16	B-42425-1	BELL CRANK INSTALLATION, AILERON PH STA 353 FOR NHA SEE FIG. 2.3-11	RF	35	
- 1		• ROD ASSY, CONTROL LINKAGE SEE FIG. 2.14-55 INDEX 55	RF		
- 2		• ROD ASSY, CONTROL LINKAGE SEE FIG. 2.14-15 INDEX 34	RF		
	B-42685-3	• BELL CRANK ASSY, AILERON STA 353 REPLACED BY SUITABLE SUB B-42685-5	1	35	129
	B-42685-5	• BELL CRANK ASSY, AILERON STA 353 REPLACES SUITABLE SUP FOR B-42685-3 ATTACHING PARTS	1	130	
- 3	MS21043-5	• NUT	1	35	
- 4	NAS44-5A26	• BOLT	1	35	
		-----X-----			
- 5	NAS77-4-22	• • BUSHING	4	35	
- 6	DW5	• • BEARING, <21335> 90-50102-003 REPLACED BY SUITABLE SUB DW5E7414	1	35	129
	DW5E7414	• • BEARING, <21335> 90-50102-015 REPLACES SUITABLE SUB FOR DW5	1	130	
- 7	B-14000-35	• • SLEEVE	1	35	
- 8	B-42685-11	• • BELL CRANK	1	35	
	B-42685-1	• SUPPORT ASSY, AILERON ATTACHING PARTS	1	35	
- 9	MS21043-4	• NUT	3	35	
- 10	AN4-7A	• BOLT	1	35	
- 11	AN4-6A	• BOLT	1	35	
- 12	AN4-5A	• BOLT	1	35	
		-----X-----			
- 13	NAS77-5-31	• • BUSHING	2	35	
- 14	B-42685-7	• • SUPPORT	1	35	

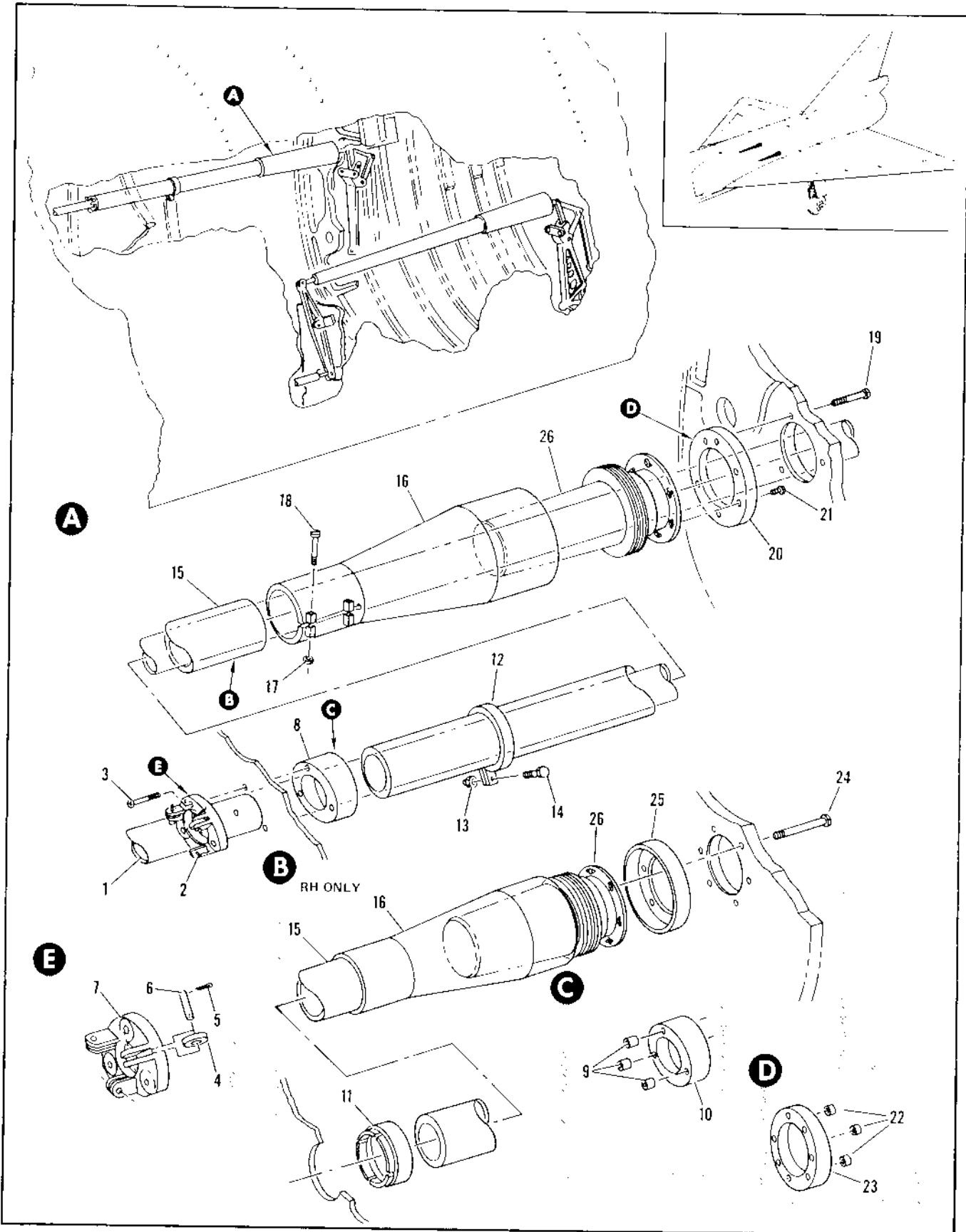

Figure 2.14-17. Elevator and Aileron Control Tube Seal Installation

FIGURE AND INDEX NUMBER	PART NUMBER	DESCRIPTION	UNITS PER ASSY.	USABLE ON CODE	
				FROM	TO
2.14-17	8-42560-1	SEAL INSTALLATION, ELEVATOR AND AILERON CONTROL TUBE LH FOR NHA SEE FIG. 2.3-11	RF	35	
	8-42560-3	SEAL INSTALLATION, ELEVATOR AND AILERON CONTROL TUBE RH FOR NHA SEE FIG. 2.3-11	RF	35	
- 1		• ROD ASSY, CONTROL LINKAGE SEE FIG. 2.14-15 INDEX RH	RF		
- 2	8-42511-1	• SUPPORT ASSY, RH REPLACED BY NOT INTCHG WITH 8-42511-3	1	35	215
	8-42511-3	• SUPPORT ASSY, RH REPLACES NOT INTCHG WITH 8-42511-1 ATTACHING PARTS	1	216	
- 3	NAS221-16	• SCREW, RH	3	35	215
	NAS221-17	• SCREW, RH	3	216	
	AN950C10	• WASHER, RH	3	216	
- 4	8-42510	• ROLLER, RH ATTACHING PARTS	3	35	
- 5	AN381-2-1	• PIN, COTTER RH	3	35	
- 6	8-42512	• PIN, RH -----X-----	3	35	
- 7	8-42568-11	• SUPPORT, RH	1	35	215
	8-42568-15	• SUPPORT, RH	1	216	
- 8	8-42513-1	• SUPPORT ASSY, AILERON CONTROL TUBE SEAL RH	1	35	
- 9	3591-30M7387	• INSERT, RH <91767> 95-03003-006	3	35	
- 10	8-42563	• SUPPORT, RH	1	35	
- 11	8-42514	• INSERT, LH	1	35	
- 12	MS21919D036	• CLAMPL ATTACHING PARTS	1	35	
- 13	MS21043-3	• NUT	1	35	
- 14	AN3-4A	• BOLT -----X-----	1	35	
- 15	8-42517	• TUBE, ELEVATOR AND AILERON CONTROL SEAL	1	35	
- 16	8-42516	• COVER ASSY, WELDED	1	35	
	8-42516-7.1	• COVER ASSY, WELDED ALT INTCHG WITH 8-42516 ATTACHING PARTS	RF	35	
- 17	MS21043-3	• NUT	2	35	
- 18	AN3-15A	• BOLT -----X-----	2	35	
- 19	NAS221-10	• SCREW, RH	3	35	
- 20	8-42571-1	• SUPPORT ASSY, RH ATTACHING PARTS	1	35	
- 21	NAS221-10	• SCREW, RH -----X-----	6	35	
- 22	3591-30M7387	• INSERT, RH <91767> 95-03003-006	3	35	
- 23	8-42571-7	• SUPPORT, RH	1	35	
- 24	NAS221-21	• SCREW, LH	6	35	
- 25	8-42515	• RING, LH	1	35	
- 26	10260	• SEAL, <7362> SPEC 8-04395	1	35	

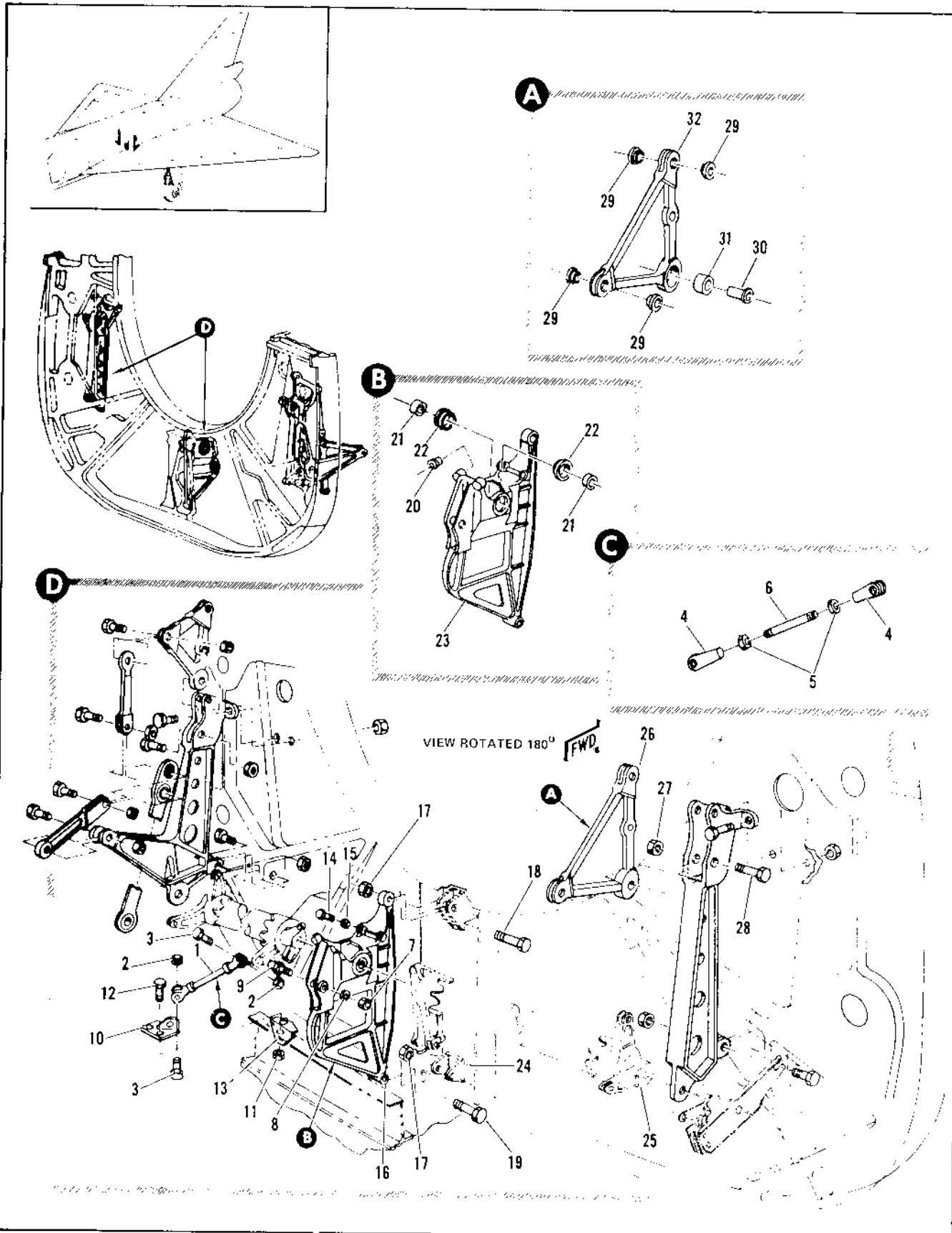

Figure 2.14-18. Elevator and Aileron Bell Crank Installation Sta 472 (Sheet 1 of 3)

FIGURE AND INDEX NUMBER	PART NUMBER	DESCRIPTION	UNITS PER ASSY.	USABLE ON CODE	
				FROM	TO
		1 2 3 4 5 6			
2.11-18	4-4252F	BELL CRANK INSTALLATION, ELEVATOR AND AILERON STA 472 MODIFIED BY 4-41111 FOR NHA SEE FIG. 2.3-3	6F	35	
- 1	4-42540	• BRACE ASSY, STA 487 ATTACHING PARTS	1	35	
- 2	MS21433-4	• NUT	2	35	
- 3	AN4-17A	• BOLT	2	35	
		-----X-----			
- 4	AN665-34P	• TERMINAL	2	35	
- 5	AN316-44	• NUT	2	35	
- 6	4-42540-7	• FOR	1	35	
- 7	MS21433-5	• NUT	1	35	
- 8	AN9510516	• WASHER	1	35	
- 9	4-4253E	• BOLT, FIF	1	35	
- 10	4-4253F	• FITTING, SUPPORT STA 487 ATTACHING PARTS	1	35	
- 11	MS21433-3	• NUT	3	35	
- 12	AN23-6A	• BOLT	4	35	
		-----X-----			
- 13	4-42525-4	• BRACKET	1	35	
- 14	NAS424-4-17	• BOLT	4	35	
- 15	AN315-4R	• NUT	2	35	
- 16	4-42660-1	• SUPPORT ASSY, TORQUE TUBE STA 476 REPLACES BY SUITABLE SUB 4-42660-3	1	35	127
	4-42660-3	• SUPPORT ASSY, TORQUE TUBE STA 476 REPLACES SUITABLE SUB FOR 4-42660-1 ATTACHING PARTS	1	130	
- 17	MS21433-5	• NUT	2	35	
- 18	NAS464-5A12	• BOLT	1	35	
- 19	NAS464-5A20	• BOLT	1	35	
		-----X-----			
- 20	1191-40X-162	• INSERT, <91767> 95-1300-011	4	35	
- 21	KS6A	• BEARING, <21335> 95-13001-011 REPLACES BY SUITABLE SUB KS6AE7414	2	35	129
	KS6AE7414	• BEARING, <21335> 95-13001-019 REPLACES SUITABLE SUB FOR KS6AE7414	2	130	
- 22	4-42542	• SLEEVE	2	35	
- 23	4-42660-7	• SUPPORT	1	35	
- 24		• SUPPORT, SEE FIG. 2.14-34	6F		
- 25		• BELL CRANK ASSY, OUTBOARD SEE FIG. 2.14-20 INDEX 64	6F		
- 26	4-42635-1	• BELL CRANK ASSY, AILERON STA 475 REPLACES BY SUITABLE SUB 4-42635-3	1	35	127
	4-42635-3	• BELL CRANK ASSY, AILERON STA 475 REPLACES SUITABLE SUB FOR 4-42635-1 ATTACHING PARTS	1	130	
- 27	MS21433-4	• NUT	1	35	
- 28	NAS4-4-4424	• BOLT	1	35	
		-----X-----			
- 29	NAS77-4-1A	• PUSHING	4	35	
- 30	3R-14000-037	• SLEEVE	4	35	
- 31	DW4K	• BEARING, <21335> 95-13002-001 REPLACES BY SUITABLE SUB DW4KE7414	1	35	129
	DW4KE7414	• BEARING, <21335> 95-13002-013 REPLACES SUITABLE SUB FOR DW4K	1	130	
- 32	4-42635-7	• BELL CRANK, STA 475			

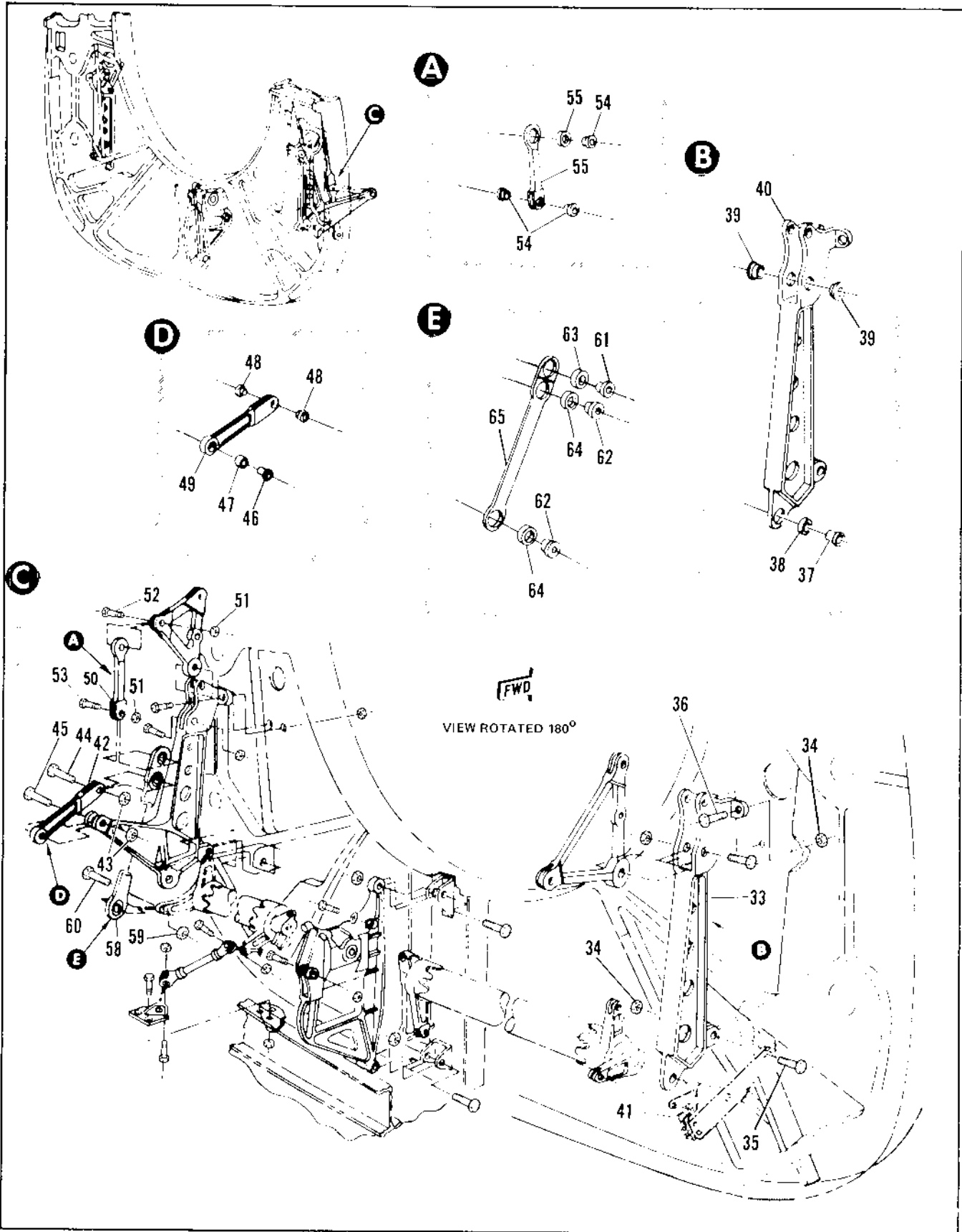

Figure 2.14-18. Elevator and Aileron Bell Crank Installation Sta 472 (Sheet 2 of 3)

FIGURE AND INDEX NUMBER	PART NUMBER	DESCRIPTION	UNITS PER ASSY.	USABLE ON CODE	
				FROM	TO
2.10.38- 33	8-42634-3	• SUPPORT ASSY, AILERON STA 476 REPLACED BY INTCHG WITH 8-42634-5	1	35	129
	8-42634-5	• SUPPORT ASSY, AILERON STA 476 REPLACES INTCHG WITH 8-42634-3 ATTACHING PARTS	1	130	
- 34	MS21243-4	• NUT	3	35	
- 35	NAS646-9A12	• BOLT	1	35	
- 35	AN174-15A	• BOLT	2	35	
- 37	98-14900-011	• SLEEVE	1	35	
- 38	KS6A	• BEARING, <21335> 90-58001-001 REPLACED BY SUITABLE SUB KS6ME7414	1	35	129
	KS6AE7414	• BEARING, <21335> 90-58001-019 REPLACES SUITABLE SUB FOR KS6A	1	130	
- 37	NAS77-4-27	• PUSHING	2	35	
- 40	8-42634-11	• SUPPORT	1	35	
- 41		• SWITCH INSTL, AILERON LIMIT	RF		
- 42	8-42636-1	• TOLLER ASSY, ELEVATOR STA 475 REPLACED BY SUITABLE SUB 8-42636-3	1	35	129
	8-42637-3	• TOLLER ASSY, ELEVATOR STA 475 REPLACES SUITABLE SUB FOR 8-42636-1 ATTACHING PARTS	1	130	
- 43	MS21244-4	• NUT	2	35	
- 44	MS27576-4-15	• BOLT	1	35	
- 45	MS27576-4-25	• BOLT	1	35	
- 46	98/14900/037	• SLEEVE	1	35	
- 47	QW4K	• BEARING, <21335> 90-58002-001 REPLACED BY SUITABLE SUB QW4KE7414	1	35	129
	QW4KE7414	• BEARING, <21335> 90-58002-019 REPLACES SUITABLE SUB FOR QW4K	1	130	
- 48	NAS77-4-21	• PUSHING	2	35	
- 49	8-42638-7	• TOLLER	1	35	
- 50	8-42318	• ROD ASSY, ELEVATOR STA 475 REPLACED BY SUITABLE SUB 8-42318-1	1	35	129
	8-42318-1	• ROD ASSY, ELEVATOR STA 475 REPLACES SUITABLE SUB FOR 8-42318 ATTACHING PARTS	1	130	
- 51	MS21244-4	• NUT	2	35	
- 52	MS27576-4-15	• BOLT	1	35	
- 53	MS27576-4-25	• BOLT	1	35	
- 54	98-14900-004	• SLEEVE	1	35	
- 55	AN2-18P44	• BEARING	1	35	129
	KP44-7414	• BEARING, <21335> 90-58009-017	1	130	
- 56	NAS77-4-21	• PUSHING	2	35	
- 57	8-42319-7	• LINK	1	35	
- 58	8-42319	• LINK ASSY, ELEVATOR STA 475 REPLACED BY SUITABLE SUB 8-42319-1	1	35	129
	8-42319-1	• LINK ASSY, ELEVATOR STA 475 REPLACES SUITABLE SUB FOR 8-42319 ATTACHING PARTS	1	130	
- 59	MS21244-4	• NUT	1	35	
- 60	MS27576-4-25	• BOLT	1	35	

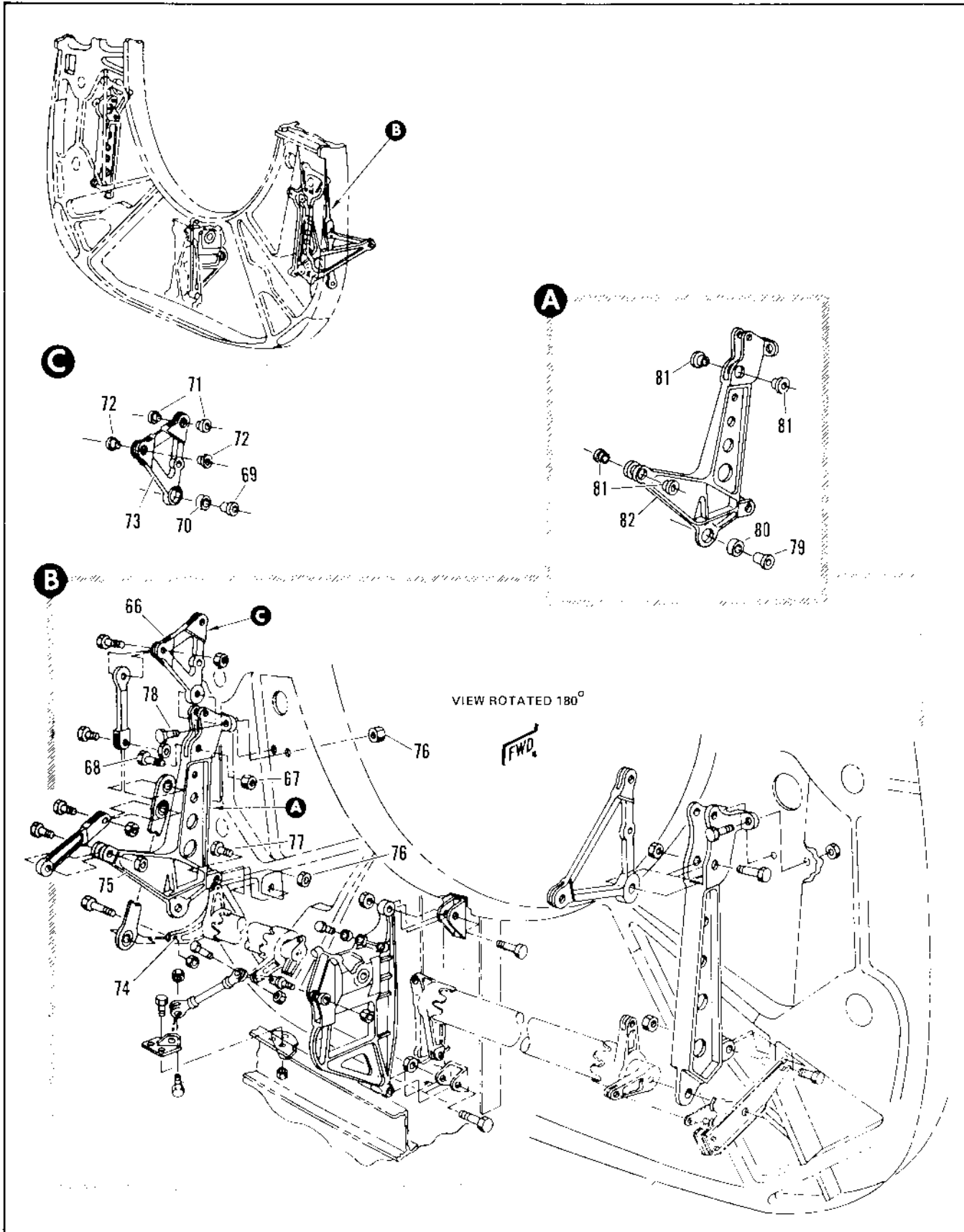

Figure 2.14-18. Elevator and Aileron Bell Crank Installation Sta 472 (Sheet 3 of 3)

FIGURE AND INDEX NUMBER	PART NUMBER	DESCRIPTION 1 2 3 4 5 6	UNITS PER ASSY.	USABLE ON CODE	
				FROM	TO
2.14-18- 61	98/14000/009	• SLEEVE	1	35	
- 62	98-14000-003	• SLEEVE	2	35	
- 63	AN201KP4A	• BEARING	1	35	129
	KP4AE7414	• BEARING, <21335> 90-58009-017	1	130	
- 64	AN200KS4	• BEARING	2	35	129
	KS4E7414	• BEARING, <21335> 90-58009-015	2	130	
- 65	8-42637-7	• LINK	1	35	
- 66	8-42637-1	• BELL CRANK ASSY, ELEVATOR	1	35	129
	6-42637-3	REPLACED BY SUITABLE SUB 8-42637-3	1	130	
		• BELL CRANK ASSY, ELEVATOR			
		REPLACES SUITABLE FOR 8-42637-1			
		ATTACHING PARTS			
- 67	MS21043-4	• NUT	1	35	
- 68	NAS464-442R	• BOLT	1	35	
		-----X-----			
- 69	98/14000/037	• SLEEVE	1	35	
- 70	QW4K	• BEARING, <21335> 90-58002-001	1	35	129
	QW4KE7414	REPLACED BY SUITABLE SUB QW4KE7414			
		• BEARING, <21335> 90-58002-013	1	130	
		REPLACES SUITABLE SUB FOR QW4K			
- 71	NAS77-4-1B	• BUSHING	2	35	55
- 72	NAS77-4-23	• BUSHING	2	35	
- 73	8-42637-7	• BELL CRANK, LH	1	35	
- 74		• BELL CRANK ASSY, OUTBOARD LH	RF		
		SEE FIG. 2.14-23 INDEX 22			
- 75	8-42638-1	• SUPPORT ASSY, ELEVATOR STA 476	1	35	129
	8-42638-3	REPLACED BY SUITABLE SUB 8-42638-3	1	130	
		• SUPPORT ASSY, ELEVATOR STA 476			
		REPLACES SUITABLE SUB FOR 8-42638-1			
		ATTACHING PARTS			
- 76	MS21043-4	• NUT	3	35	
- 77	NAS464-441R	• BOLT	1	35	
- 78	AN174-19L	• BOLT	2	35	
		-----X-----			
- 79	98/14000/011	• SLEEVE	1	35	
- 80	KS6A	• BEARING, <21335> 90-58001-011	1	35	129
	KS6AE7414	REPLACED BY SUITABLE SUB KS6AE7414			
		• BEARING, <21335> 90-58001-019	1	130	
		REPLACES SUITABLE SUB FOR KS6A			
- 81	NAS77-4-32	• BUSHING	4	35	
- 82	8-42638-7	• SUPPORT	1	35	

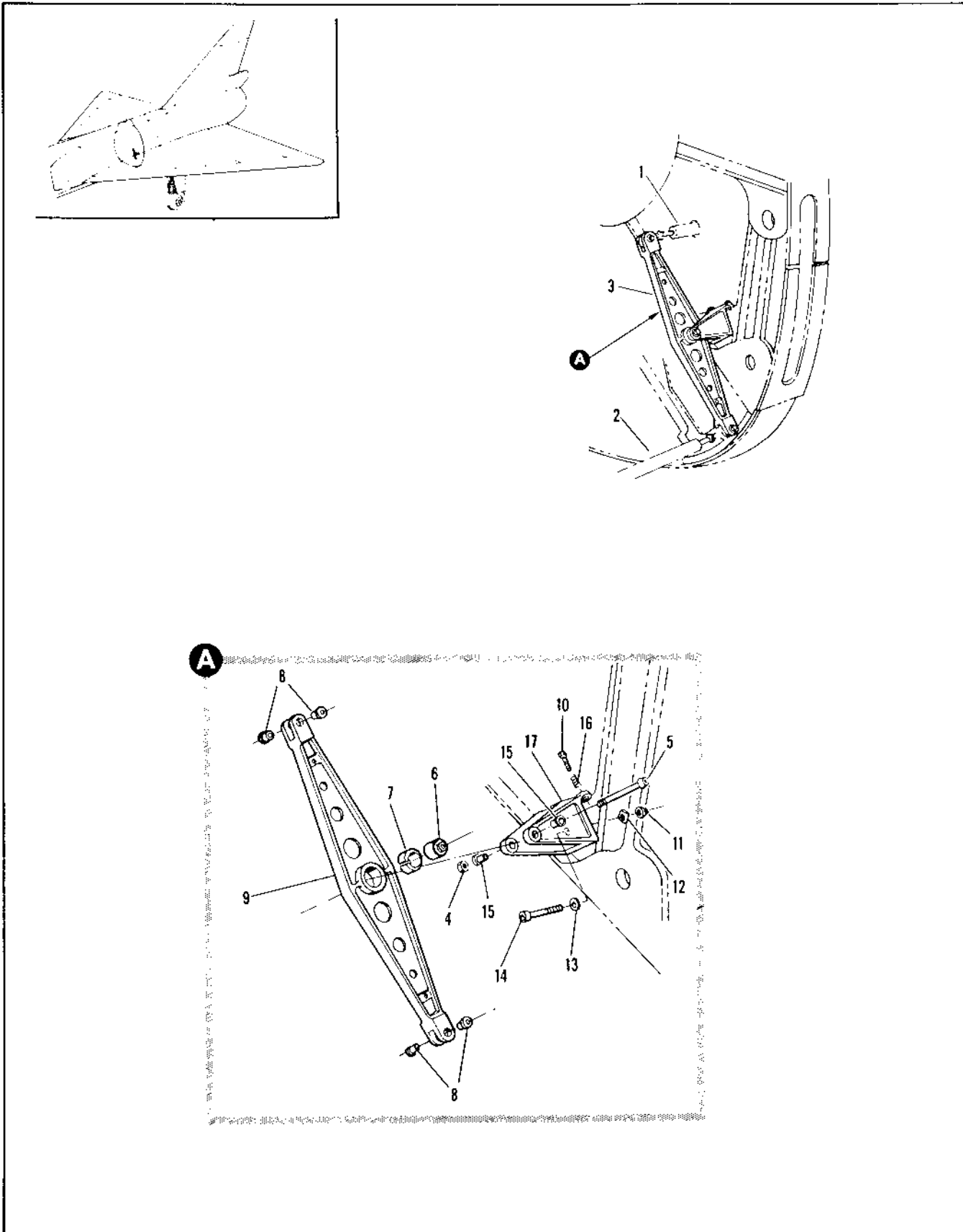

Figure 2.14-19. Elevator LH Bell Crank Installation Sta 426

FIGURE AND INDEX NUMBER	PART NUMBER	DESCRIPTION 1 2 3 4 5 6	UNITS PER ASSY.	USABLE ON CODE	
				FROM	TO
2.14-19	8-42352	BELL CRANK INSTALLATION, ELEVATOR LH STA 426 FOR NHA SEE FIG. 2.3-11	RF	35	
- 1		• ROD ASSY, CONTROL UPPER SEE FIG. 2.14-15 INDEX 55	RF		
- 2		• ROD ASSY, CONTROL LOWER SEE FIG. 2.14-15 INDEX 38	RF		
- 3	8-42683-1	• BELL CRANK ASSY, ELEVATOR REPLACED BY SUITABLE SUB 8-42683-3	1	35	129
	8-42683-3	• BELL CRANK ASSY, ELEVATOR REPLACES SUITABLE SUB FOR 8-42683-1 ATTACHING PARTS	1	35	
- 4	MS21043-6	• NUT	1	35	
- 5	NAS464-6A31	• BOLT	1	35	
- 6		----X----			
	DW6	REPLACED BY SUITABLE SUB DW6E7414 • BEARING, <21335> 92-58922-004 REPLACES SUITABLE SUB FOR DW6	1	35	129
- 7	98-14000-039	• SLEEVE	1	35	
- 8	NAS77-4-22	• BUSHING	4	35	
- 9	8-42683-7	• BELL CRANK	1	35	
- 10	AN502-10-10	• SCREW, ADJUSTMENT	2	35	
	8-42684-1	• SUPPORT ASSY, ELEVATOR BELL CRANK ATTACHING PARTS	1	35	
- 11	45FW524	• NUT, <56876> 96-37510-102	1	35	
- 12	8-42174	• BLOCK	1	35	60
	AN9680516	• WASHER	3	35	
- 13	MS2000205	• WASHER	1	35	
- 14	MS20005-30	• BOLT	1	35	
		----X----			
- 15	NAS77-6-31	• BUSHING	2	35	
- 16	1191-3CNX.285	• INSERT, <91767> 95-P3060-012	2	35	
- 17	8-42684-7	• SUPPORT	1	35	

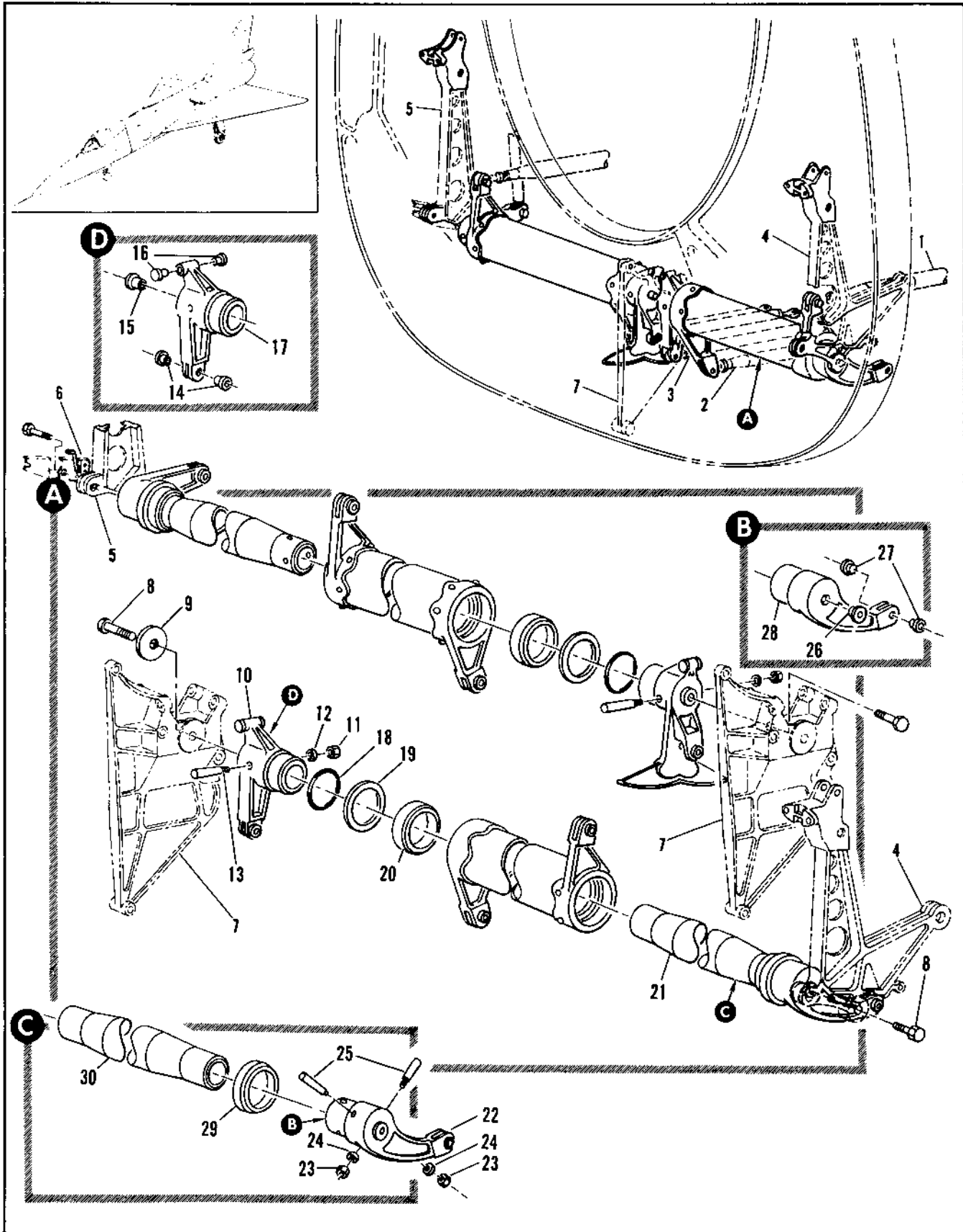

Figure 2.14-20. Elevation Control Tube Installation Sta 477 (Sheet 1 of 3)

FIGURE AND INDEX NUMBER	PART NUMBER	DESCRIPTION	UNITS PER ASSY.	USABLE ON CODE	
				FROM	TO
2.14-20	8-42520-5	TUBE INSTALLATION, ELEVON CONTROL STA 477 FOR NHA SEE FIG. 2.14-10	RF	35	
- 1		• ROD ASSY, CONTROL LINKAGE SEE FIG. 2.14-15	RF		
- 2		• ROD ASSY, CONTROL LINKAGE SEE FIG. 2.14-23	RF		
- 3		• ROD ASSY, CONTROL LINKAGE SEE FIG. 2.14-23	RF		
- 4		• SUPPORT ASSY, ELEVATOR STA 476 SEE FIG. 2.14-18 INDEX 75	R4		
- 5		• SUPPORT ASSY, AILERON STA 476 SEE FIG. 2.14-18 INDEX 33	RF		
- 6		• SWITCH INSTALLATION, AILERON LIMIT	RF		
- 7		• SUPPORT ASSY, TORQUE TUBE STA 476 SEE FIG. 2.14-18 INDEX 16	RF		
	8-42520-11	• TUBE ASSY, LH	1	35	129
	8-42520-21	• TUBE ASSY, LH ATTACHING PARTS	1	35	129
- 8	AN175-12A	• BOLT	2	35	
- 9	AN967C61-L	• WASHER ----X----	AR		
- 10	8-42656-3	• BELL CRANK ASSY, INRD LH ATTACHING PARTS	1	35	
- 11	MS21043-3	• NUT	2	35	
- 12	AN975-3	• WASHER	2	35	
- 13	AN385-1-16A	• PIN ----X----	2	35	
- 14	NAS77-4-29	• BUSHING	2	35	
- 15	NAS77-6-33	• BUSHING	1	35	
- 16	8-49789	• PAD	2	35	
- 17	8-42656-9	• BELL CRANK	1	35	
- 18	NAS617-21	• CASKET	1	35	
- 19	8-42565	• WASHER	1	35	
- 20	KP29BK	• BEARING, <21335> 90-58005-005 REPLACED BY SUITABLE SUB KP29BKE7414	1	35	129
	KP29BKE7414	• BEARING, <21335> 90-58005-008 REPLACES SUITABLE SUB FOR KP29BK	1	130	
- 21	8-42331-1	• TUBE ASSY, ELEVATOR LH REPLACED BY SUITABLE SUB 8-42331-3	1	35	129
	8-42331-3	• TUBE ASSY, ELEVATOR LH REPLACES SUITABLE SUB FOR 8-42331-1	1	130	
- 22	8-42657-3	• BELL CRANK ASSY, OUTBOARD LH ATTACHING PARTS	1	35	
- 23	MS21043-3	• NUT	2	35	
- 24	AN975-3	• WASHER	2	35	
- 25	AN385-1-16A	• PIN ----X----	2	35	
- 26	NAS77-6-34	• BUSHING	1	35	
- 27	NAS77-4-30	• BUSHING	2	35	
- 28	8-42657-9	• BELL CRANK	1	35	
- 29	KP29BK	• BEARING, <21335> 90-58005-005 REPLACED BY SUITABLE SUB KP29BKE7414	1	35	129
	KP29BKE7414	• BEARING, <21335> 90-58005-008 REPLACES SUITABLE SUB FOR KP29BK	1	130	
- 30	8-42530-9	• TUBE, AILERON AND ELEVATOR TORQUE	1	35	

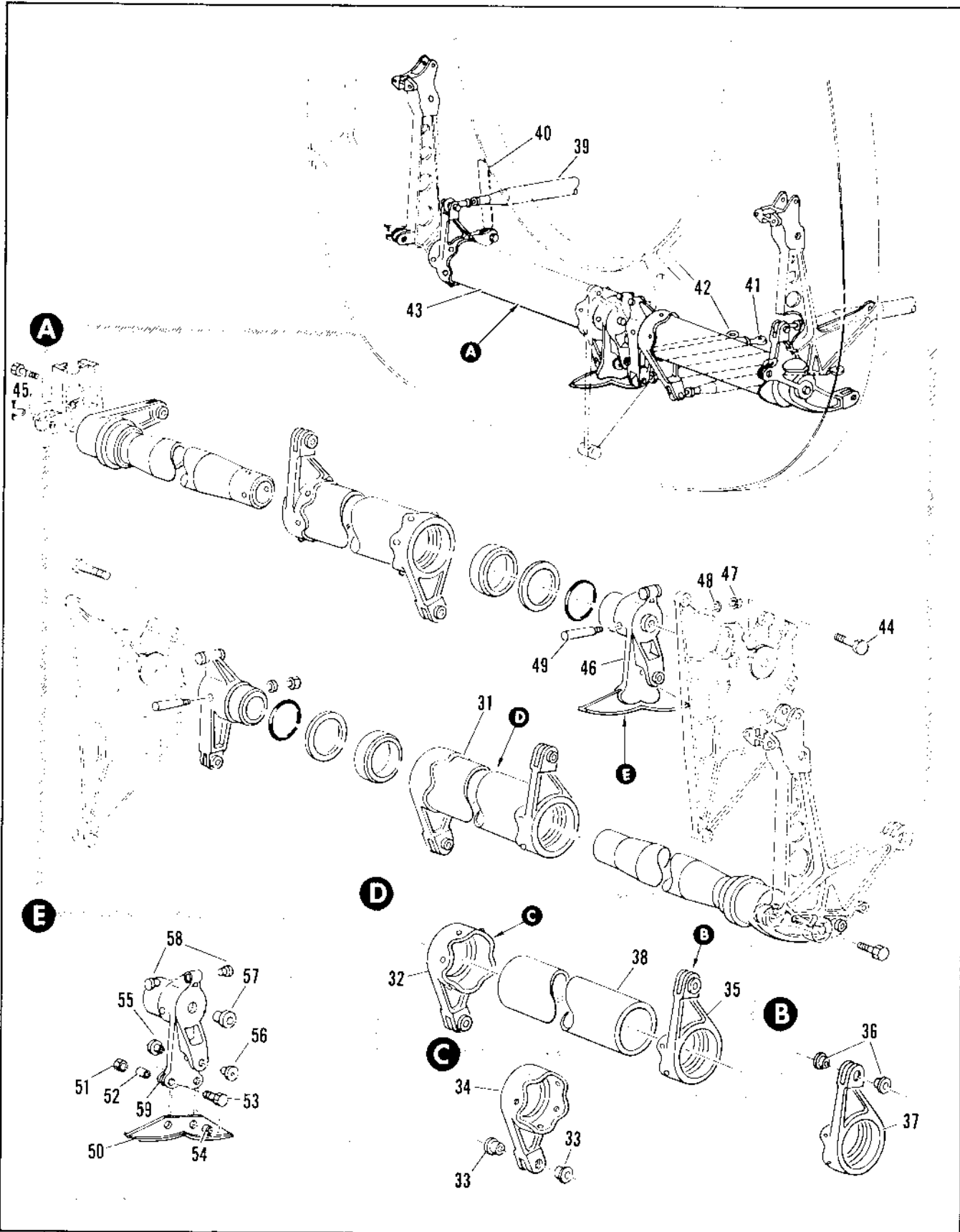

Figure 2.14-20. Elevon Control Tube Installation Sta 477 (Sheet 2 of 3)

FIGURE AND INDEX NUMBER	PART NUMBER	DESCRIPTION	UNITS PER ASSY.	USABLE ON CODE	
				FROM	TO
		1 2 3 4 5 6			
2.14-20- 31	B-42524-1	• • TUBE ASSY, ELVON LH	2	35	
- 32	1-42659-3	• • • BELL CRANK ASSY, INRD LH	1	35	
- 33	NAS77-4-19	• • • • BUSHING	2	35	
- 34	B-42658-11	• • • • BELL CRANK	1	35	
- 35	B-42658-3	• • • BELL CRANK ASSY, INRD LH	1	35	
- 36	NAS77-4-20	• • • • BUSHING	2	35	
- 37	B-42658-9	• • • • BELL CRANK	1	35	
- 38	B-42522-9	• • TUBE	1	35	
- 39		• ROD ASSY, CONTROL LINKAGE SEE FIG. 2.14-15 INDEX RA	RF		
- 40		• ROD ASSY, CONTROL LINKAGE SEE FIG. 2.14-15 INDEX RA	RF		
- 41		• ROD ASSY, CONTROL LINKAGE RH SEE FIG. 2.14-23 INDEX 1	RF		
- 42		• ROD ASSY, CONTROL LINKAGE SEE FIG. 2.14-23 INDEX 1	RF		
- 43	B-42520-19	• TUBE ASSY, RH	1	35	129
	B-42520-23	• TUBE ASSY, RH	1	35	
		ATTACHING PARTS			
- 44	AN175-12A	• BOLT	1	35	
- 45	AN175-12A	• BOLT	1	35	
		-----X-----			
- 46	B-42654-P03	• • BELL CRANK ASSY, INRD RH ATTACHING PARTS	1	35	
- 47	MS21043-3	• • NUT	2	35	35
- 48	AN975-3	• • WASHER	2	35	
- 49	AN385-1-16A	• • PIN	2	35	
		-----X-----			
- 50	B-42450-7	• • • CAM ATTACHING PARTS	1	35	
- 51	MS21043-3	• • • NUT	1	35	
- 52	NAS75-3-003	• • • BUSHING	1	35	
- 53	B-42465	• • • BOLT	1	35	
- 54	B-42466	• • • SPACER	1	35	
		-----X-----			
- 55	B-42654-17	• • • BELL CRANK ASSY, RH	1	35	
- 56	NAS77-4-36	• • • • BUSHING	1	35	
- 57	NAS77-4-17	• • • • BUSHING	1	35	
- 58	NAS77-6-33	• • • • BUSHING	2	35	
- 59	B-49789	• • • • PAD	2	35	
- 59	B-42654-15	• • • • BELL CRANK	1	35	

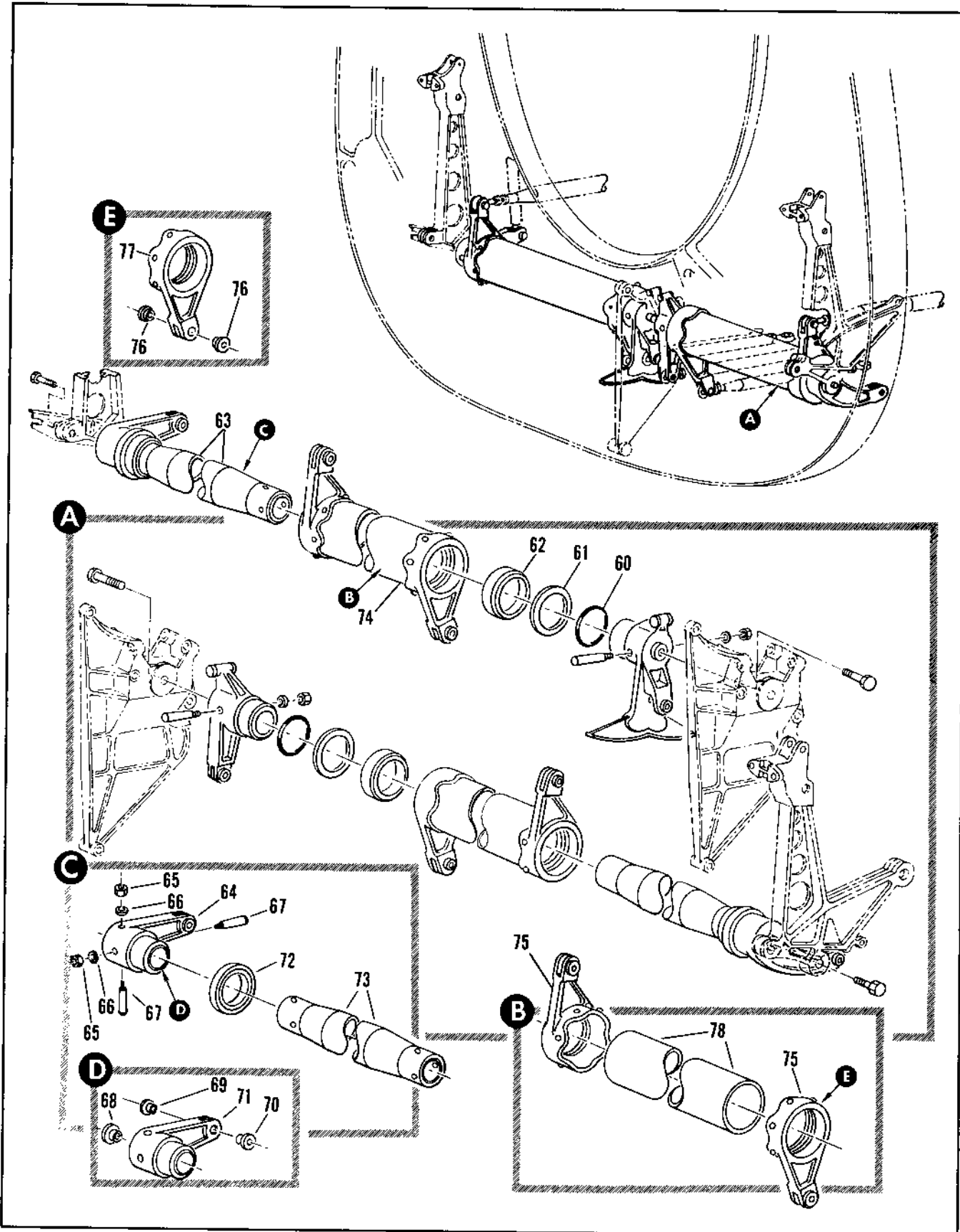

Figure 2.14-20. Elevon Control Tube Installation Sta 477 (Sheet 3 of 3)

FIGURE AND INDEX NUMBER	PART NUMBER	DESCRIPTION	UNITS PER ASSY.	USABLE ON CODE	
				FROM	TO
		1 2 3 4 5 6			
2.14-20- 60	NAS617-20	. . GASKET (80205)	1	35	
- 61	8-42565	. . WASHER	1	35	
- 62	KP29BK	. . BEARING, <21335> 90-58005-005 REPLACED BY SUITABLE SUB KP29BKE7414	1	35	129
	KP29BKE7414	. . BEARING, <21355> 90-58005-008 REPLACES SUITABLE SUB FOR KP29BK	1	130	
- 63	8-42416-1	. . TUBE ASSY, AILERON RH	1	35	129
	8-42416-3	. . TUBE ASSY, AILERON RH (SUITABLE SUB 8-42416-1)	1	130	
- 64	8-42655-3	. . BELL CRANK ASSY, OUTBD RH	1	35	
		ATTACHING PARTS			
- 65	MS21043-3	. . NUT (96906)	2	35	
- 66	AN975-3	. . WASHER (88044)	2	35	
- 67	AN386-1-16A	. . PIN (88044)	2	35	
		-----X-----			
- 68	NAS77-6-33	. . . BUSHING (80205)	1	35	
- 69	NAS77-4-17	. . . BUSHING (80205)	1	35	
- 70	NAS77-4-19	. . . BUSHING (80205)	1	35	
- 71	8-42655-9	. . . BELL CRANK	1	35	
- 72	KP29BK	. . BEARING, <21335> 90-58005-005 REPLACED BY SUITABLE SUB KP29BKE7414	1	35	129
	KP29BKE7414	. . BEARING, <21335> 90-58005-008 REPLACES SUITABLE SUB FOR KP29BK	1	130	
- 73	8-42530-7	. . . TUBE	1	35	
- 74	8-42527-1	. . TUBE ASSY, ELEVON RH	1	35	
- 75	8-42658-4	. . BELL CRANK ASSY, RH	2	35	
- 76	NAS77-4-20	. . . BUSHING (80205)	2	35	
- 77	8-42558-10	. . . BELL CRANK	1	35	
- 78	8-42529-7	. . . TUBE	1	35	

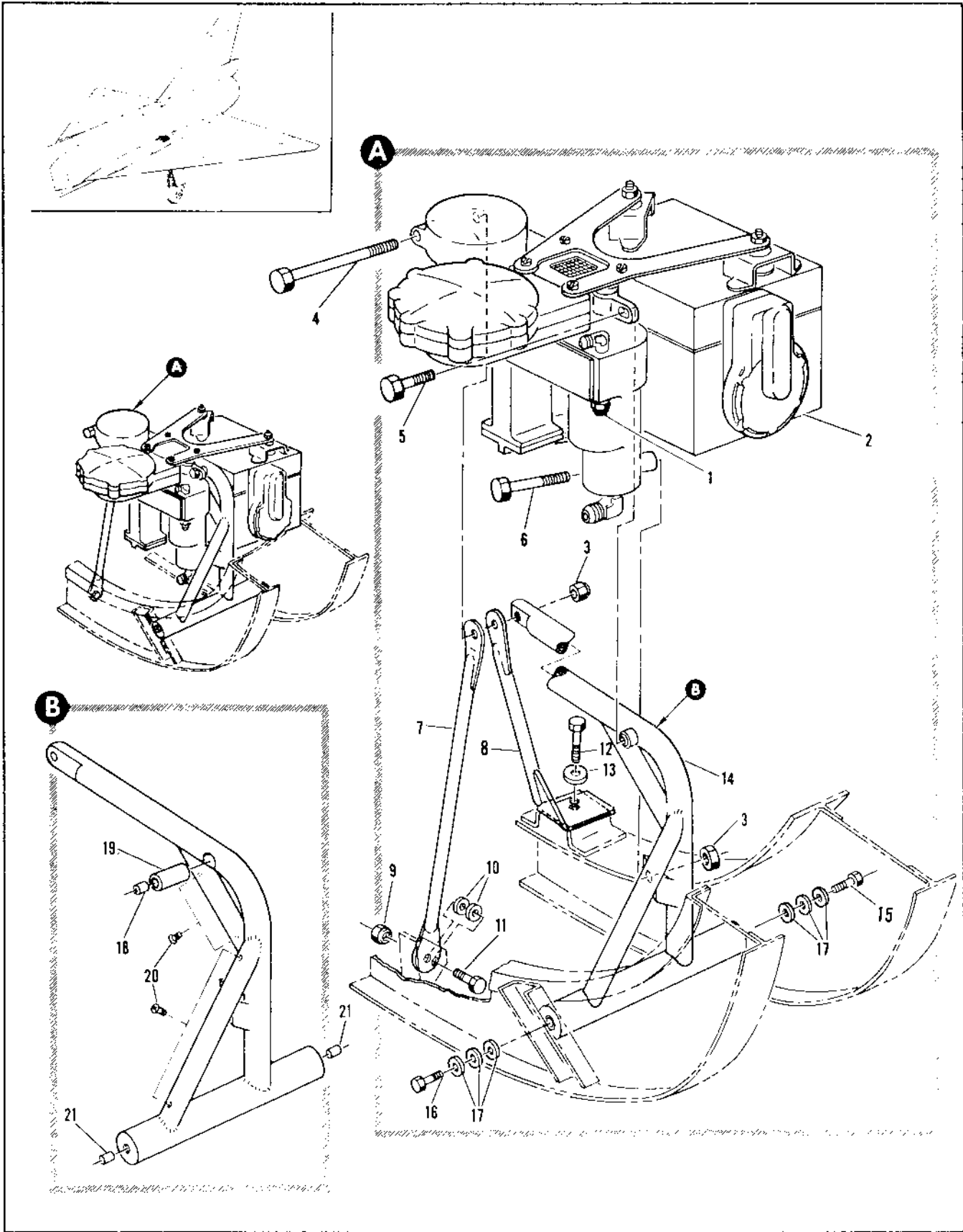

Figure 2.14-21. Elevator Airfeel Regulator Installation Sta 481 to 488

FIGURE AND INDEX NUMBER	PART NUMBER	DESCRIPTION	UNITS PER ASSY.	USABLE ON CODE	
				FROM	TO
2.14-21	8-42330-1	REGULATOR INSTALLATION, ELEVATOR AIRFEEL STA 481 TO 488 MODIFIED BY 8-41114 FOR NHA SEE FIG. 2.3-14	RF	35	
- 1	AN929-3D	• CAP	1	241	
- 2	S733	• REGULATOR, ELEVATOR CONTROL FEEL SYSTEM <00303> SPEC 8-04394-1 T.O. 9P10-2-3-4 REPLACED BY SUITABLE SUB S741	1	35	60
	S741		1	61	
	S741	• REGULATOR, ELEVATOR CONTROL FEEL SYSTEM <00303> SPEC 8-04394-3 T.O. 9P10-2-3-4 REPLACES SUITABLE SUB FOR S733 ATTACHING PARTS	1	61	
- 3	NAS1291-5	• NUT	2	35	
- 4	NAS464-5A45	• BOLT	1	35	
- 5	AN5-5A	• BOLT	1	35	
- 6	NAS464-5A27	• BOLT	1	35	
		-----X-----	1	35	
- 7	8-42350-5	• SUPPORT ASSY, FWD WELDED	1	35	
- 8	8-42350-801	• SUPPORT ASSY, AFT WELDED ATTACHING PARTS	1	35	
		• NUT	2	35	
- 9	MS21343-4	• WASHER	1	35	
- 10	AN960-416	• BOLT	1	35	
- 11	AN4-6A	• BOLT	1	35	
- 12	NAS464-4A12	• WASHER	1	35	
- 13	AN960-416	-----X-----	1	35	
- 14	8-42351-1	• MOUNT ASSY, REGULATOR ATTACHING PARTS	1	35	
- 15	AN4-7A	• BOLT	1	A	
- 16	AN4-7A	• BOLT	1	278	304
	AN4-6A	• BOLT	6	35	
- 17	AN960-416L	• WASHER	1	35	
		-----X-----	1	35	
- 18	NAS1222-5E	• INSERT	1	35	
- 19	8-42351-39	• PIN, MOUNT ASSEMBLY	4	35	
- 20	AN504-6R4	• SCREW	2	35	
- 21	NAS1222-4E	• INSERT			
A AIRPLANES #35 THRU 277 AND 305					

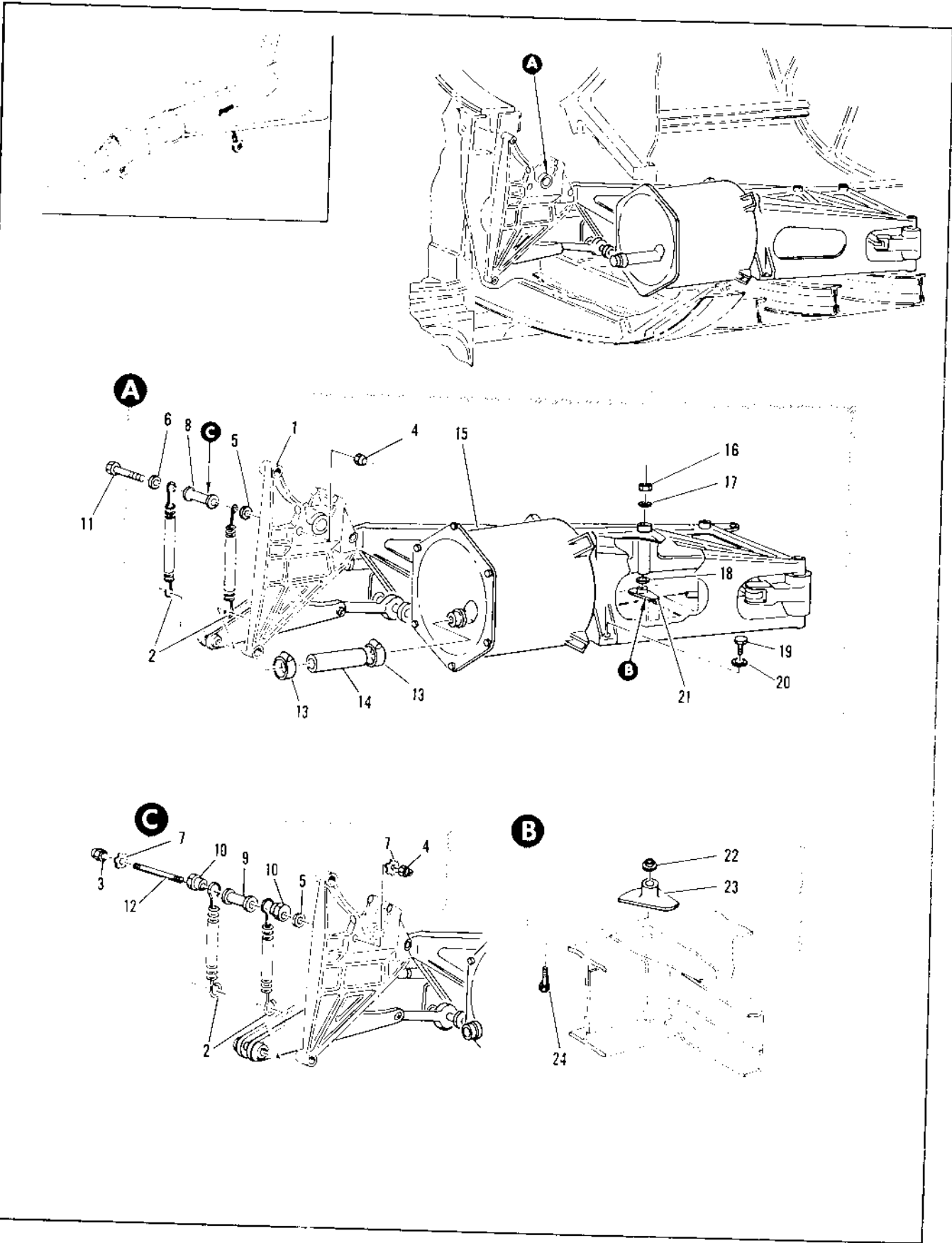

Figure 2.14-22. Elevon Control Installation Sta 472 to 507

FIGURE AND INDEX NUMBER	PART NUMBER	DESCRIPTION 1 2 3 4 5 6	UNITS PER ASSY.	USABLE ON CODE	
				FROM	TO
2.14-22	R-42508-R03	CONTROL INSTALLATION, ELEVON STA 472 TO 507 MODIFIED BY R-41112 FOR NHA SEE FIG. 2.3-3	RF	B	
	R-42508-5	CONTROL INSTALLATION, ELEVON STA 472 TO 507 MODIFIED BY F-41112 FOR NHA SEE FIG. 2.3-3	RF	A	
- 1	R-42560-3	SUPPORT ASSY, TORQUE TUBE STA 476 SEE FIG. 2.14-1B INDEX 15	1	35	
- 2	R-42423-7	* SPIRNG ATTACHING PARTS	2	35	
- 3	MS21043-4	* NUT	1	9	
- 4	MS21043-3	* NUT	1	35	
- 5	AN960-416	* WASHER	1	35	
- 6	AN960-416L	* WASHER	1	A	
- 7	AN936A10	* WASHER	2	B	
- 8	R-42534-11	* SPACER	1	A	
- 9	NAS43003-60	* SPACER	1	R	
- 10	H-42456	* SLEEVE	2	B	
- 11	NAS464-4A53	* BOLT	1	A	
- 12	R-42455	* ROD -----X-----	1	B	
- 13	AN737TW46	* CLAMP	2	35	
- 14	CR704	* HOSE, 2-2A30> 94-R0006-001	1	35	
- 15	S-42508-29	* CONTROL ASSY, ELEVON STA 472 TO 507 FOR BREAKDOWN SEE FIG. 2.14-23 ATTACHING PARTS	1	35	
- 16	MS21043-5	* NUT	1	35	
- 17	AN960-516	* WASHER	1	35	
- 18	99-51509-010	* WASHER	1	35	
- 19	NAS464-4A9	* BOLT	1	35	
- 20	AN960-416	* WASHER -----X-----	RF	35	
- 21	R-42554-1	* FITTING INSTL, ELEVON CONTROL SUPPORT FOR NHA SEE FIG 2.3-3	1	35	
- 22	R-42555	* FITTING ASSEMBLY	1	35	
- 23	R-42559-7	* BUSHING	1	35	
- 24	R-42555-7	* FITTING	1	35	
- 24	NAS464-5A14	* BOLT			
		A AIRPLANES #279, 2-1 AND 246 THRU 303 B AIRPLANES #15 THRU 274, 240, 282 THRU 285, 304, AND 305			

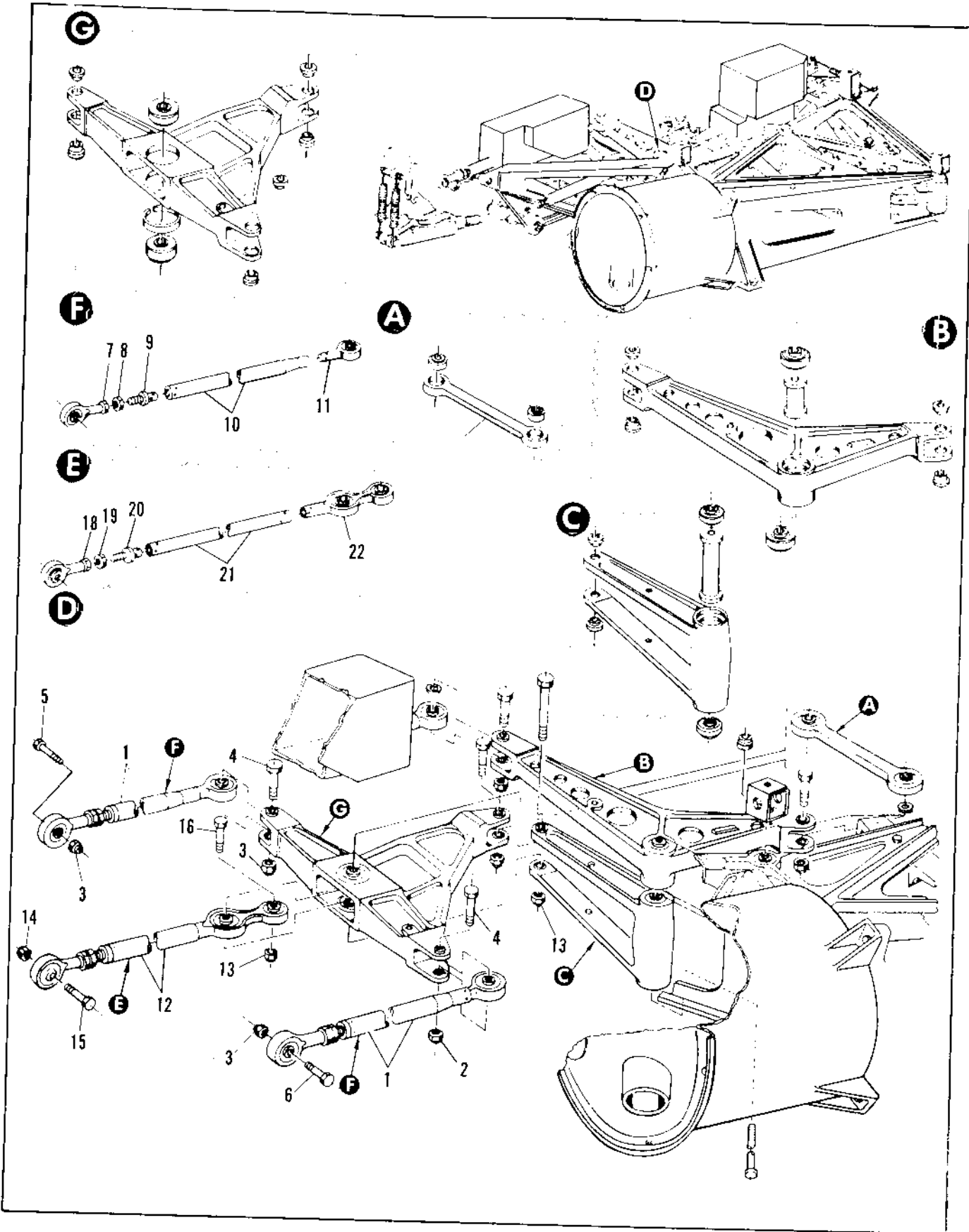

Figure 2.14-23. Elevon Control Assembly Sta 472 to 507 (Sheet 1 of 8)

FIGURE AND INDEX NUMBER	PART NUMBER	DESCRIPTION 1 2 3 4 5 6	UNITS PER ASSY.	USABLE ON CODE	
				FROM	TO
2.14-23	R-42508-29	CONTROL ASSEMBLY, ELEVON STA 472 TO 507 MODIFIED BY P-41112 FOR NHA SEE FIG. 2.14-22	RF	35	
- 1	64A33155-8P1	* ROD ASSY, CONTROL LINKAGE REPLACES SUITABLE SUB FOR 64A33155-817	2	35	
- 2	MS21043-4	* NUT	2	35	
- 3	MS21244-4	* NUT	2	35	
- 4	NAS454-4A17	* BOLT	2	35	
- 5	MS27576-4-1R	* BOLT	1	35	
- 6	MS27576-4-1R	* BOLT	1	35	
- 7	RE4F5E7414	-----X----- * BEARING, <21335> 90-60006-009	1	35	
- 8	AN316-5R	* NUT	1	35	
- 9	64F33114-13	* CONNECTOR	1	35	
- 10	B-42100-31	* TUBE	1	35	
- 11	RE4H8E7414	* BEARING, <21335> 90-60006-005 REPLACES	1	35	
- 12	64A33155-625	* ROD ASSY, CONTROL LINKAGE ATTACHING PARTS	1	35	
- 13	MS21043-4	* NUT	2	35	
- 14	MS21244-4	* NUT	1	35	
- 14	MS27576-4-21	* BOLT	1	35	
- 16	NAS454-4A13	* BOLT	1	35	
- 17	NAS464-4A31	* BOLT	1	35	
- 18	RE4F5E7414	-----X----- * BEARING <21335> 90-60002-009	1	35	
- 19	AN316-5R	* NUT	1	35	
- 20	64F33114-19	* CONNECTOR	1	35	
- 21	R-42100-71	* TUBE	2	35	
- 22	A45547	* BEARING, <77696> SPEC 8-24371-803	1	35	

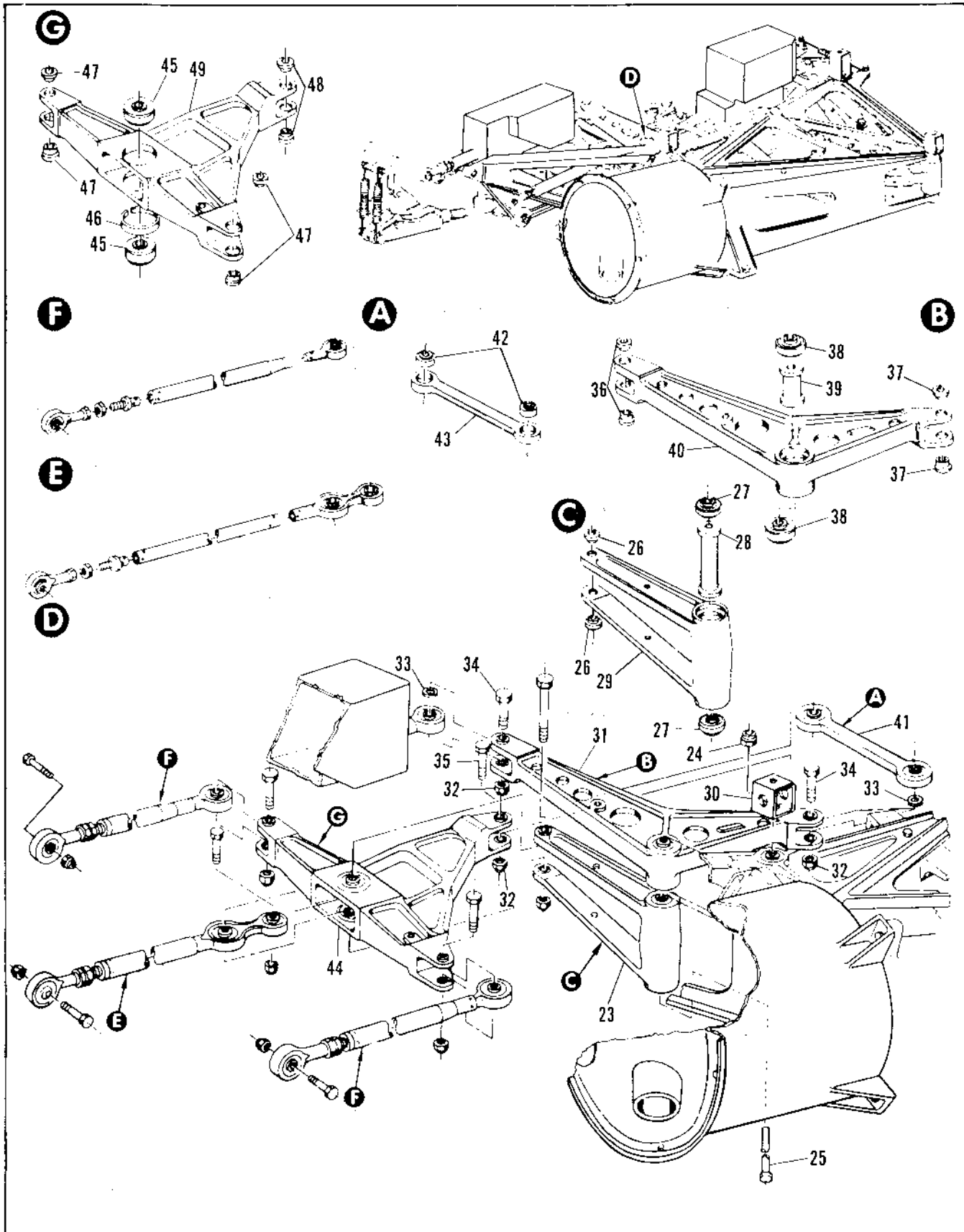

Figure 2.14-23. Elevon Control Assembly Sta 472 to 507 (Sheet 2 of 8)

FIGURE AND INDEX NUMBER	PART NUMBER	DESCRIPTION	UNITS PER ASSY.	USABLE ON CODE	
				FROM	TO
		1 2 3 4 5 6			
2.14-23- 23	8-42621-3	• IDLER ASSY, ELEVON CONTROL ATTACHING PARTS	1	35	
- 24	22FT624	• NUT, <56478> 96-37525-105	1	35	
- 25	8-42535 AN6C-64	• BOLT • BOLT, ALT INTCHG WITH 8-42535 -----X-----	1 RF	35	
- 26	NAS77-4-34	• PUSHING	2	35	
- 27	KP6AE7414	• • BEARING, <21335> 90-54000-021	2	35	
- 28	8-42181-25	• • SPOOL	1	35	
- 29	8-42621-7	• • IDLER	1	35	
- 30	8-42737-1	• PRACKET ASSY, RIVETED	1	35	
- 31	8-42623-5	• BELL CRANK ASSY, AILERON CONTROL ATTACHING PARTS	1	35	
- 32	MS21243-4	• NUT	3	35	
- 33	8-40106-7	• WASHER	1	35	
- 34	NAS464-4A17	• BOLT	2	35	
- 35	NAS464-4A16	• BOLT -----X-----	1	35	
- 36	NAS77-4-29	• • BUSHING	2	35	
- 37	NAS77-4-21	• • BUSHING	2	35	
- 38	KP6AE7414	• • BEARING, <21335> 90-54000-021	2	35	
- 39	8-42181-23	• • SPOOL	1	35	
- 40	8-42623-7	• • BELL CRANK	1	35	
- 41	8-42509-1	• LINK ASSY, ELEVON MIXER	1	35	
- 42	KS4F7414	• • BEARING, <21335> 90-54000-015	2	35	
- 43	8-42509-7	• • LINK	1	35	
- 44	8-42622-5	• BELL CRANK ASSY, ELEVON CONTROL MIXER	1	35	
- 45	KP4AF7414	• • BEARING, <21335> 90-54000-017	2	35	
- 46	98-14600-009	• • SLEEVE	1	35	
- 47	NAS77-4-19	• • PUSHING	4	35	
- 48	NAS77-4-21	• • PUSHING	2	35	
- 49	8-42622-9	• • BELL CRANK	1	35	

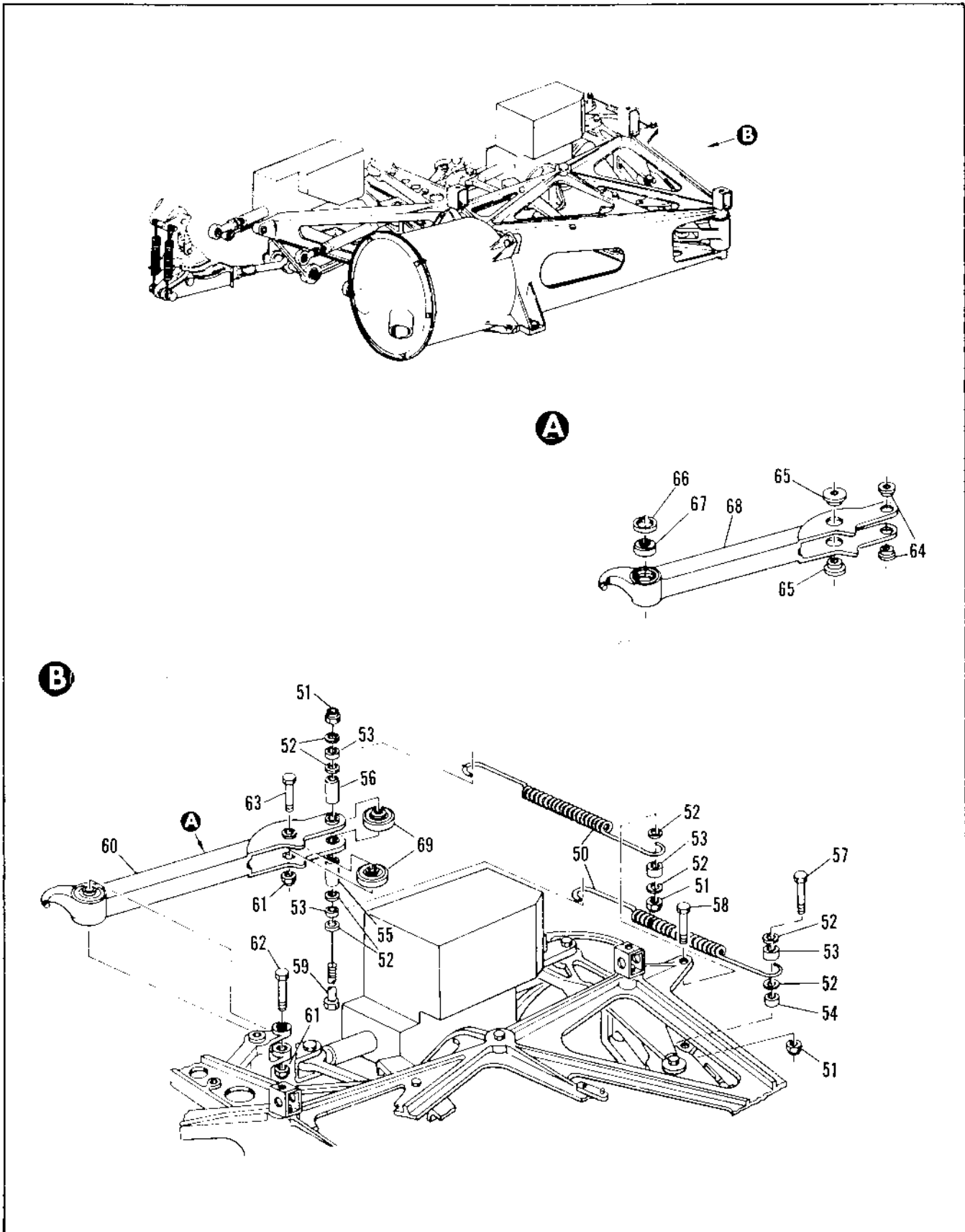

Figure 2.14-23. Elevon Control Assembly Sta 472 to 507 (Sheet 3 of 8)

FIGURE AND INDEX NUMBER	PART NUMBER	DESCRIPTION 1 2 3 4 5 6	UNITS PER ASSY.	USABLE ON CODE	
				FROM	TO
2.14-23- 50	8-42307	• SPRING ATTACHING PARTS	2	35	
- 51	MS21043-4	• NUT	3	35	
- 52	MS20162-4	• WASHER	8	35	
- 53	NAS43HT4-4	• SPACER	4	35	
- 54	NAS75-4-905	• BUSHING	1	35	
- 55	NAS75-4-024	• BUSHING	1	35	
- 56	NAS75-4-016	• BUSHING	1	35	
- 57	NAS464-4A9	• BOLT	1	35	
- 58	NAS464-4A7	• BOLT	1	35	
- 59	NAS464-4A41	• BOLT	1	35	
- 60	8-42626-901	• ARM ASSY, ELEVATOR CENTERING ATTACHING PARTS	1	35	
- 61	MS21043-4	• NUT	2	35	
- 62	NAS464-4A26	• BOLT	1	35	
- 63	NAS464-4A17	• BOLT	1	35	
- 64	NAS77-4-21	• BUSHING	2	35	
- 65	NAS77-4-27	• BUSHING	2	35	
- 66	98-14500-017	• SLF EVE	1	35	
- 67	DW9KE7414	• BEARING, <21335> 90-54002-013	1	35	
- 68	8-42626-13	• ARM	1	35	
- 69	AKP4816-PE7414	• BEARING, <21335> 90-54011-008	2	35	

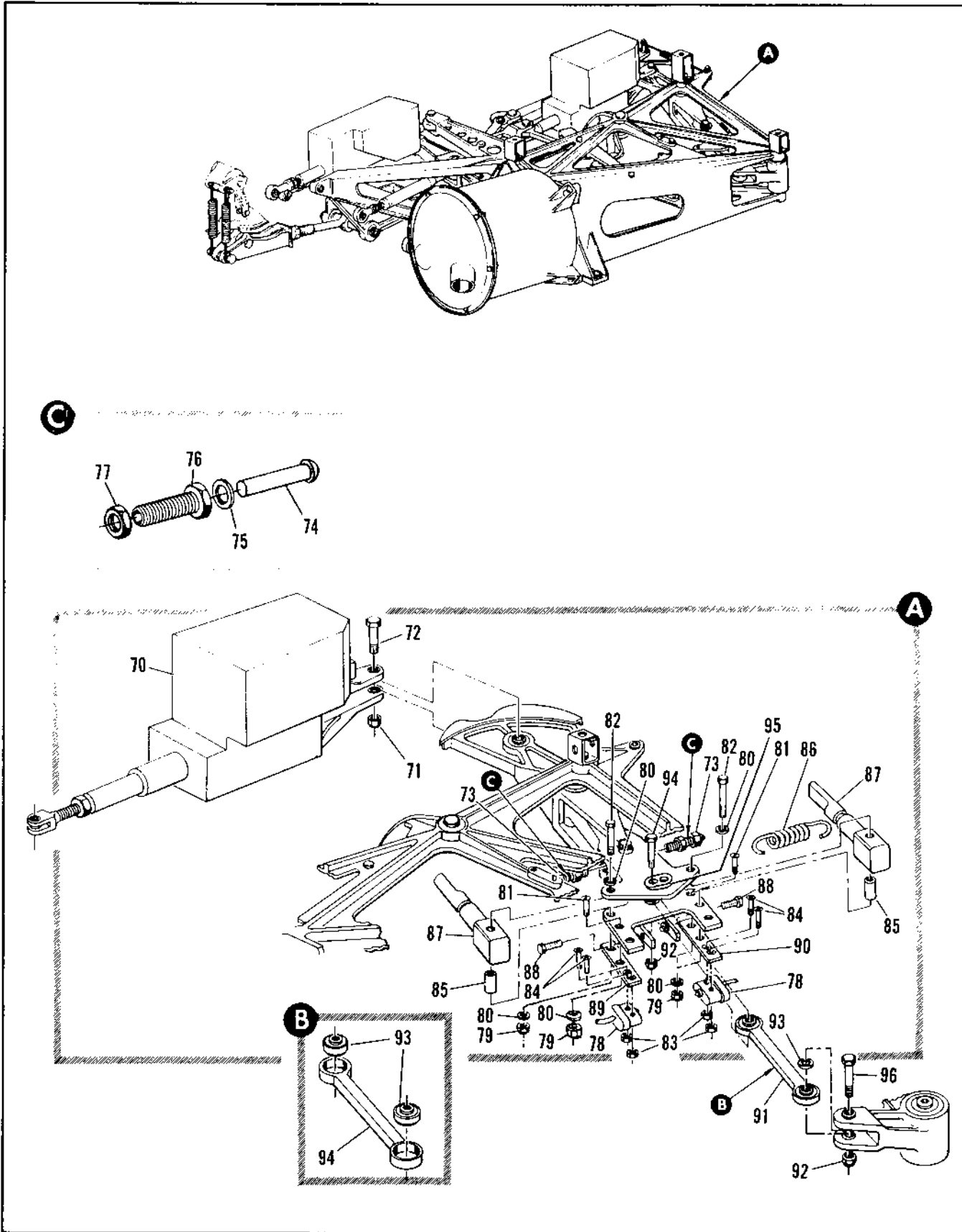

Figure 2.14-23. Elevon Control Assembly Sta 472 to 507 (Sheet 4 of 8)

FIGURE AND INDEX NUMBER	PART NUMBER	DESCRIPTION	UNITS PER ASSY.	USABLE ON CODE	
				FROM	TO
		1 2 3 4 5 6			
1.15-23- 70	SYLC6963	• ACTUATOR ASSY, ELEVATOR TRIM <65149> SPEC R-34461-805 ATTACHING PARTS	1	35	
- 71	MS21043-4	• NUT	1	35	
- 72	NAS464-4A16	• BOLT	1	35	
- 73	B-42008-25	-----X-----	2	35	
- 74	R-42330-7	• CONTROL ASSY, ELEVATOR TRIM SWITCH	1	35	
- 75	R-42374	• PIN, REPLACES SUITABLE SUB FOR R-42330	1	35	
- 76	B-42330	• WASHER	1	35	
- 77	AN316-5R	• BOLT	1	35	
- 78	G1181	• NUT	2	35	
	61383	• SWITCH, ELEVATOR TRIM FOLLOWUP <C9795> SPEC B-06464-1	RF	35	
- 79	MS21042-06	• SWITCH, ELEVATOR TRIM FOLLOWUP <02105> SPEC J-16464-1 ALT INCHES WITH S1181	4	35	
- 80	AN960-6L	• NUT, <75237> 96-37545-006	4	35	
- 81	AN507-032R10	• WASHER	2	35	
		ATTACHING PARTS			
- 82	AN515-0R22	• SCREW	2	35	
- 83	22NM26	• NUT, <72962> 96-37512-107	4	35	
- 84	AN515-2R9	• SCREW	4	35	
		-----X-----			
- 85	B-42346	• BUSHING	2	35	
- 86	R-42340-1	• SPRING	1	35	
- 87	B-42337	• LEVER	2	35	
- 88	NAS42R-3-7	• BOLT	2	35	
- 89	R-42373-1	• MOUNT, ELEVATOR TRIM SWITCH	1	35	
- 90	R-42373-3	• MOUNT, ELEVATOR TRIM SWITCH	1	35	
- 91	R-42379-1	• LINK ASSY, ELEVON MIXER	2	35	
		ATTACHING PARTS			
- 92	MS21043-4	• NUT	2	35	
- 93	B-40115-7	• WASHER	1	35	
- 94	NAS464-4A17	• BOLT	1	35	
- 95	R-65012-209	• CLIP	1	35	
- 96	NAS464-4A16	• BOLT	1	35	
		-----X-----			
- 97	KS467414	• BEARING, <21335> 91-44001-015	2	35	
- 98	R-42519-7	• LINK	1	35	

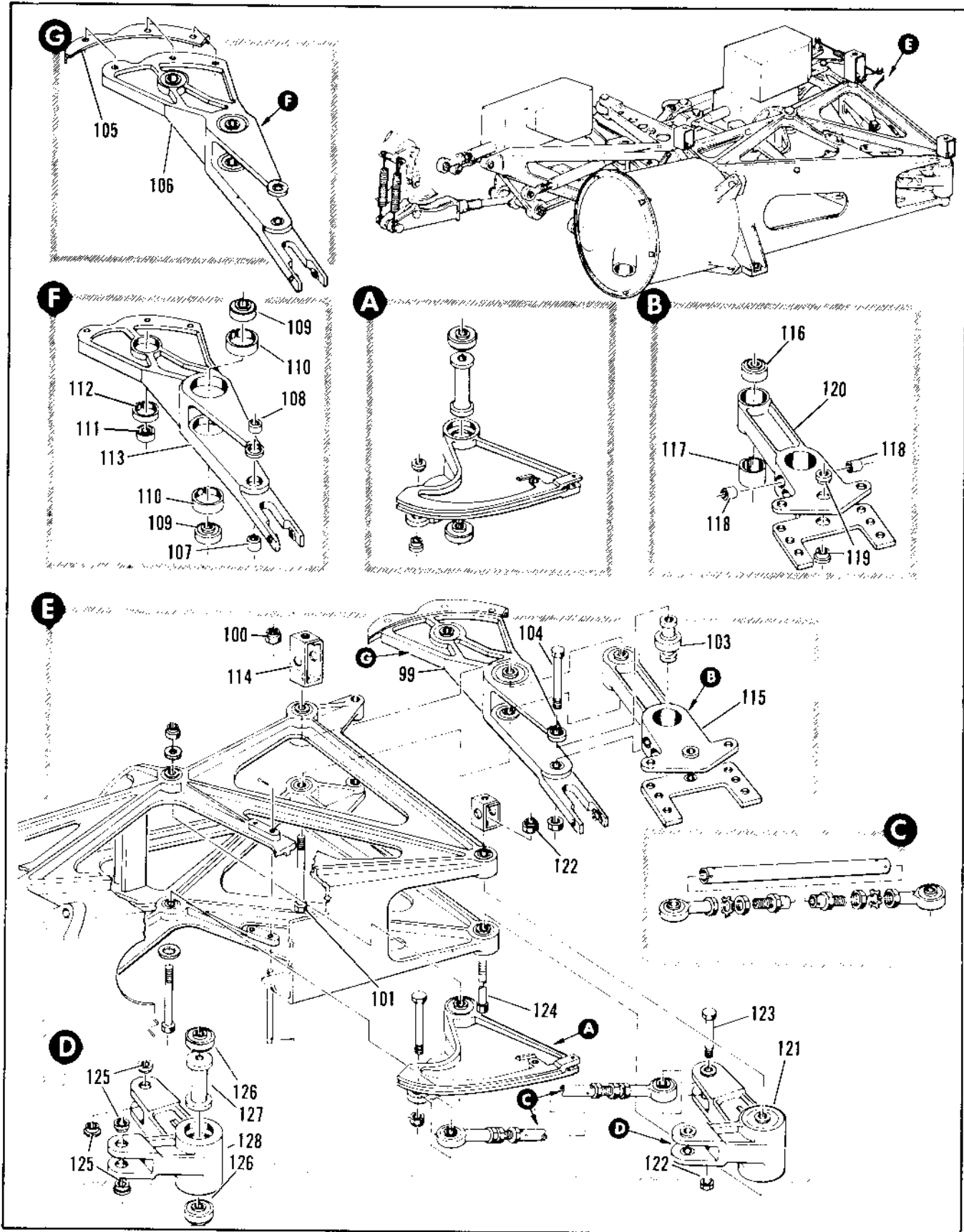

Figure 2.14-23. Elevon Control Assembly Sta 472 to 507 (Sheet 5 of 8)

FIGURE AND INDEX NUMBER	PART NUMBER	DESCRIPTION	UNITS PER ASSY.	USABLE ON CODE	
				FROM	TO
2.14-23- 99	8-42628-5	• BELL CRANK ASSY, ELEVATOR FEEL ATTACHING PARTS	1	35	
-100	MS21043-5	• NUT	1	35	
-101	NAS464-5A61	• BOLT	1	35	
-102	MS21043-4	• NUT	1	35	
-103	8-42339	• SPACER	1	35	
-104	NAS464-4A25	• BOLT	1	35	
		-----X-----			
-105	8-42308-9	• • CAM	1	35	
-106	8-42628-17	• • BELL CRANK ASSEMBLY	1	35	
-107	NAS75-4-312	• • • RUSHING	1	35	
-108	NAS75-4-036	• • • RUSHING	1	35	
-109	KP5AE7414	• • • BEARING, <21335> 90-58009-019	2	35	
-110	98-14000-310	• • • SLEEVE	2	35	
-111	KP4E7414	• • • BEARING, <21335> 90-58008-083	1	35	
-112	98-14000-503	• • • SLEEVE	1	35	
-113	8-42628-13	• • • BELL CRANK	1	35	
-114	8-42737-3	• BRACKET ASSY, RIVETED	1	35	
-115	8-42665-3	• YOKE ASSY, ELEVATOR FEEL	1	35	
-116	DW5E7414	• • BEARING <21335> 90-58002-015	1	35	
-117	98-14000-038	• • SLEEVE	1	35	
-118	1191-50X15032	• • INSERT, <91767> 95-63000-026	2	35	
-119	NAS77-4-19	• • RUSHING	2	35	
-120	8-42665-7	• YOKE	1	35	
-121	8-42624-5	• BELL CRANK ASSY, ELEVATOR FEEL ATTACHING PARTS	1	35	
-122	MS21043-4	• NUT	2	35	
-123	NAS464-4A21	• BOLT	1	35	
-124	NAS464-4A63	• BOLT	1	35	
		-----X-----			
-125	NAS77-4-29	• • RUSHING	4	35	
-126	KP4AE7414	• • BEARING, <21335> 90-58009-017	2	35	
-127	8-42101-27	• • SPOOL	1	35	
-128	8-42624-11	• • BELL CRANK	1	35	

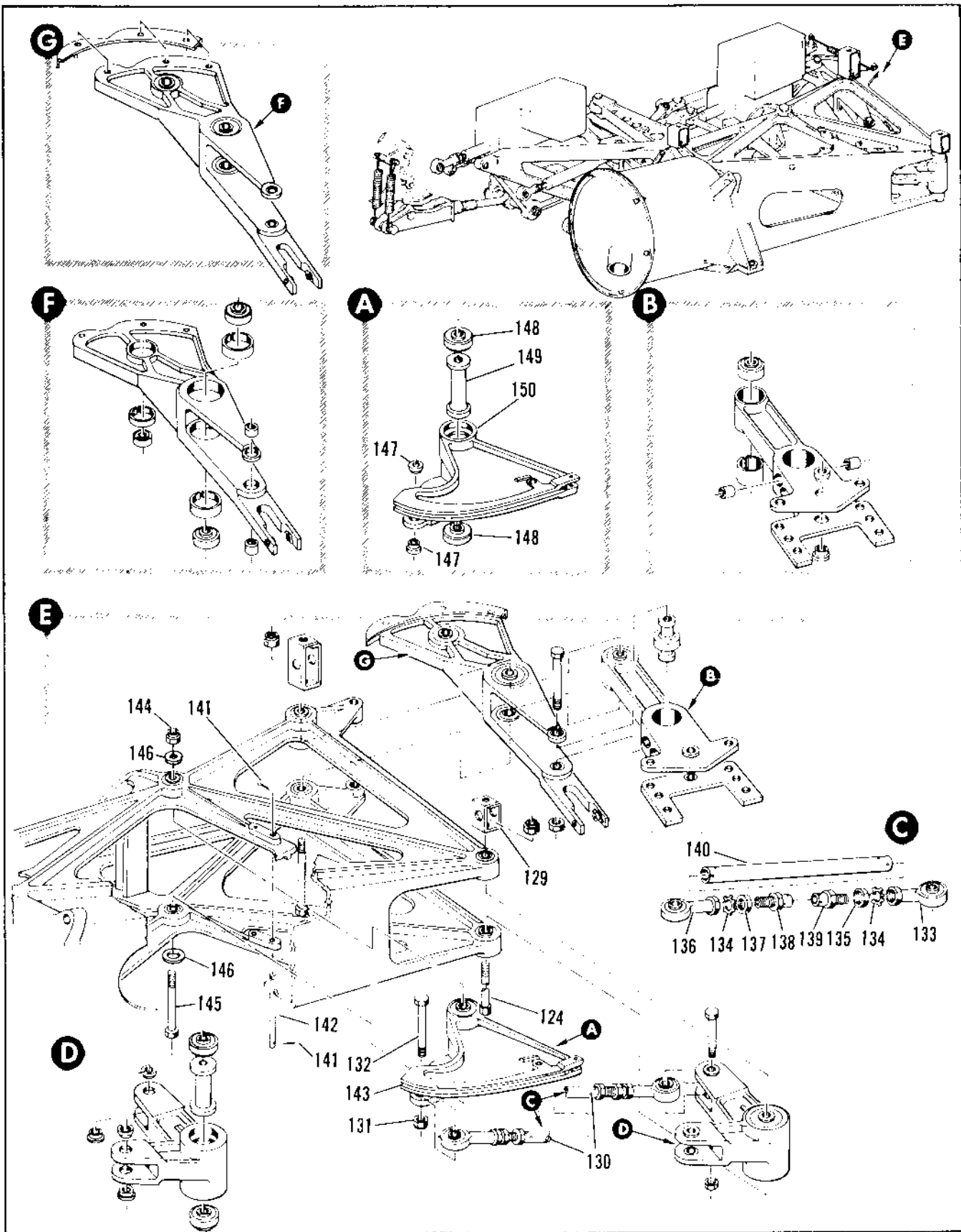

Figure 2.14-23. Elevon Control Assembly Sta 472 to 507 (Sheet 6 of 8)

FIGURE AND INDEX NUMBER	PART NUMBER	DESCRIPTION 1 2 3 4 5 6	UNITS PER ASSY.	USABLE ON CODE	
				FROM	TO
111-13-129	8-42757	• BRACKET ASSY, COVER ELEVON CONTROL	1	35	
-130	8-42315-1	• ROD ASSY, ELEVATOR FEEL ATTACHING PARTS	1	35	
-131	MS21443-4	• NUT	1	35	
-132	NAS44-4421	• BOLT	1	35	
		-----X-----			
-133	RF4FL7414	• BEARING, <21335> 50-60002-C09	2	35	
-134	NAS40-516	• WASHER	2	35	
-135	AN314-5R	• NUT	1	35	
-136	RF4FL7414	• BEARING, <21335> 50-60002-C11	2	35	
-137	AN314-3L	• NUT	1	35	
	8-2303-9	• TUBE ASSY, MIVTED	1	35	
-138	8-42341-7	• ROD END	1	35	
-139	8-42341-9	• ROD END	1	35	
-140	8-42313-7	• TUBE	2	35	
-141	AN541-2-2	• PIN, COTTER	1	35	
-142	NAS40776	• PIN	1	35	
-143	8-42389-3	• QUADRANT ASSY, ELEVATOR FEEL ATTACHING PARTS	1	35	
-144	MS21343-9	• NUT	1	35	
-145	AN179-53	• BOLT	1	35	
-146	AN567-416	• WASHER	2	35	
		-----X-----			
-147	NAS77-4-05	• WASHING	2	35	
-148	XP4417414	• BEARING, <21335> 50-50004-117	2	35	
-149	8-42101-79	• SPOOL	1	35	
-150	8-42349-7	• QUADRANT	1	35	

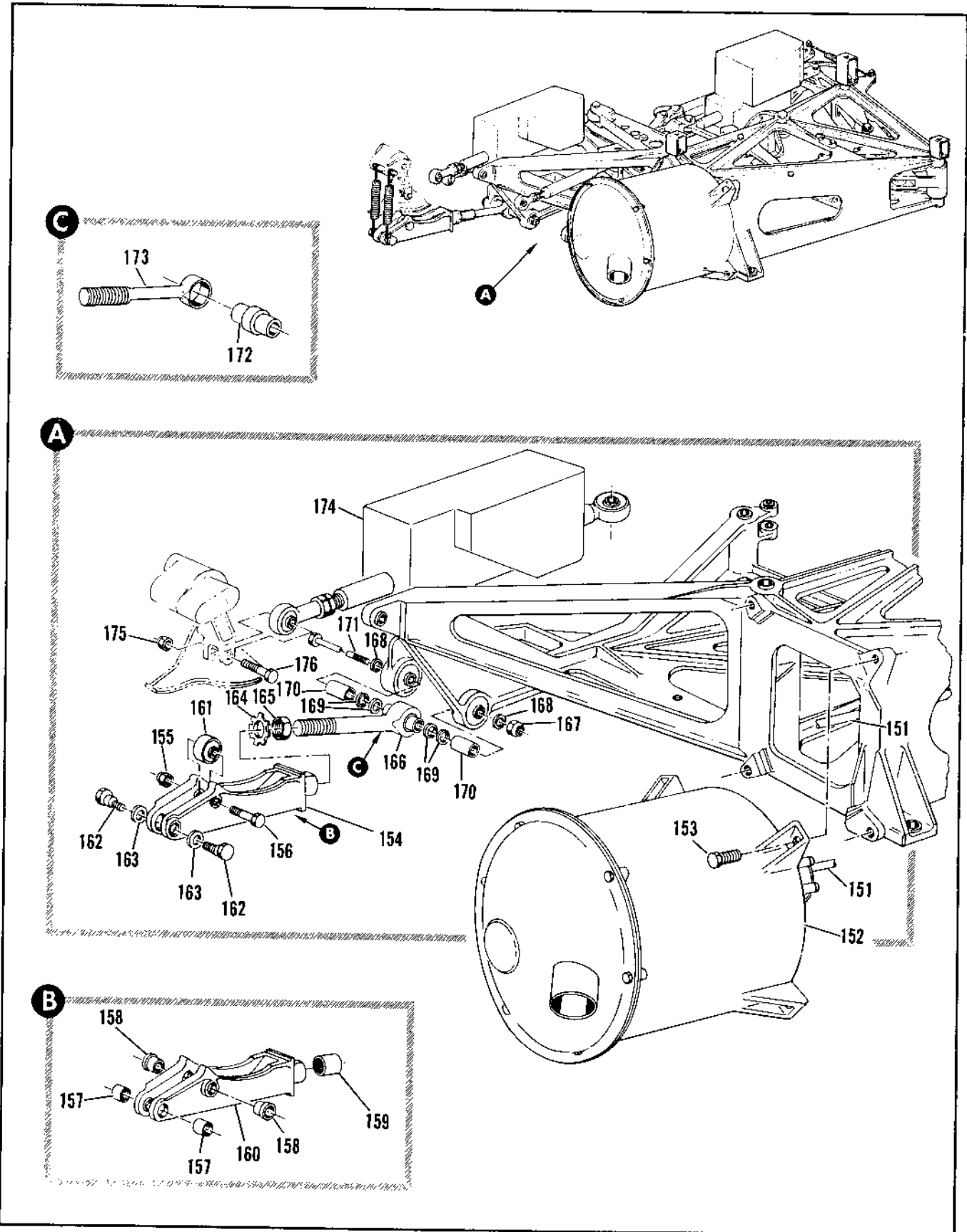

Figure 2.14-23. Elevon Control Assembly Sta 472 to 507 (Sheet 7 of 8)

FIGURE AND INDEX NUMBER	PART NUMBER	DESCRIPTION	UNITS PER ASSY.	USABLE ON CODE	
				FROM	TO
2.14-23-151			RF		
-152	8-42325-1	• CABLE ASSY, ELEVATOR FEEL SEE FIG. 2.14-24 INDEX 6	1	35	
-153	AN174-5A	• CYLINDER ASSY, ELEVATOR FEEL FOR BREAKDOWN SEE FIG. 2.14-24 ATTACHING PARTS	4	35	
-154	8-42682-1	• BOLT -----X-----	1	35	
-155	MS21043-4	• FORK ASSY, AILERON RIM ACTUATOR ATTACHING PARTS	1	35	
-156	NAS464-4A21	• NUT	1	35	
-157	1191-8CNX-3PC	• BOLT	2	35	
-158	NAS77-4-41	• INSERT, <91767> 95-03003-008	2	35	
-159	1191-8CNX3&4	• RUSHING	1	35	
-160	8-42682-1	• INSERT, <91767> 95-03100-028	1	35	
-161	AKP4R16-2E7414	• FORK	1	35	
-162	8-42733	• BEARING, <21335> 90-58011-008 REPLACES	2	35	
-163	99-51507-312	• SCREW, ECCENTRIC SPRING ADJUSTMENT	2	35	
-164	MS27111-5	• WASHER	1	35	
-165	AN316-8P	• WASHER	1	35	
-166	8-42699-3	• NUT	1	35	
-167	MS21043-4	• LINK ASSY, IDLER ATTACHING PARTS	1	35	
-168	AN9670416L	• NUT	RF	35	
-169	AN960C416L	• WASHER	5	35	
-170	NAS43DD4-45	• WASHER	2	35	
-171	NAS464-4A49	• SPACER	1	35	
-172	8-42454-1	• BOLT	1	35	
-173	8-42699-7	• PLUG -----X-----	1	35	
-174	RS145M11-1	• LINK	1	35	
-175	MS21244-4	• ACTUATOR, AILERON TRIM <81039> SPEC 4-04424-5 ATTACHING PARTS	1	35	
-176	MS27576-4-20	• NUT	1	35	
		• BOLT -----X-----	1	35	

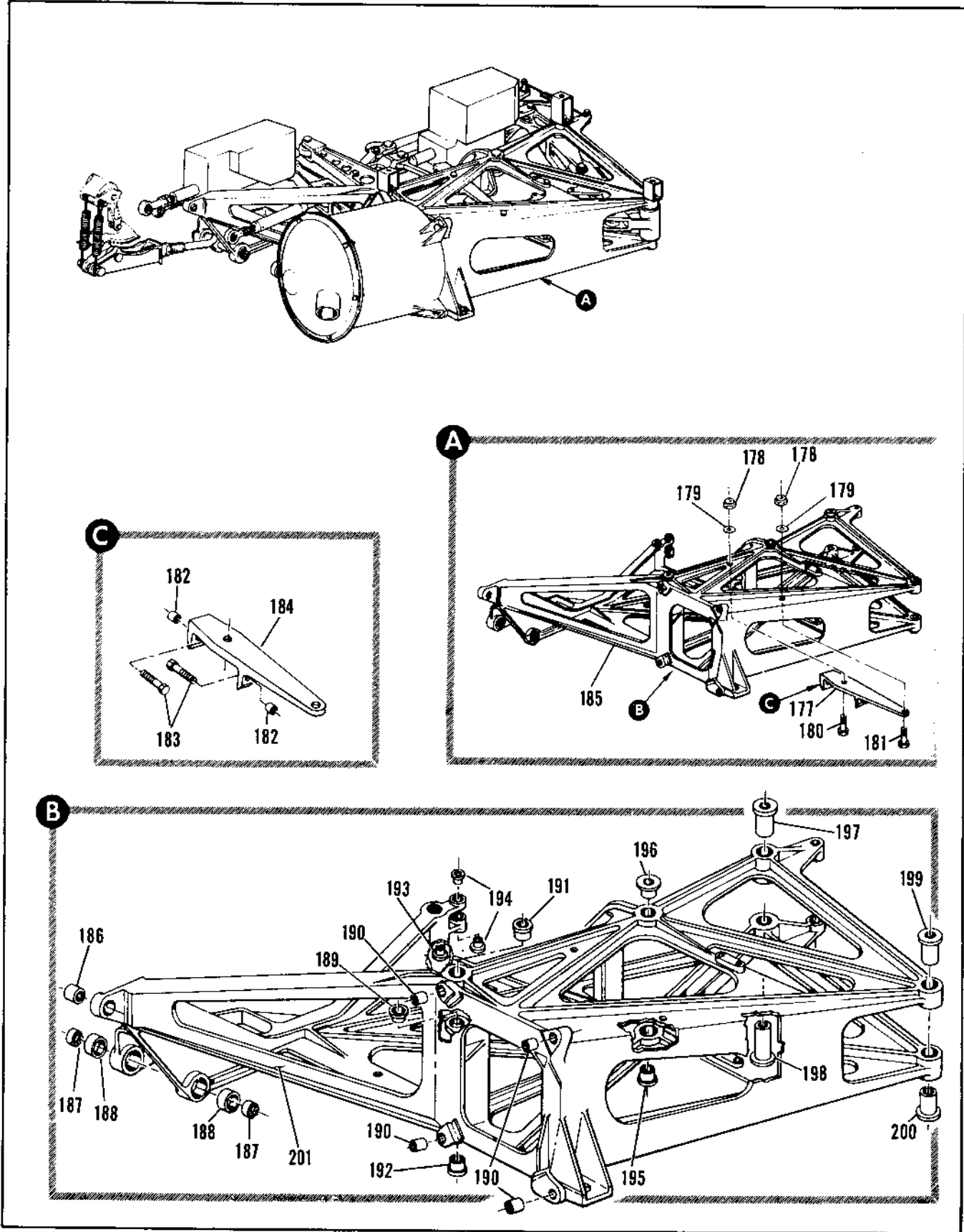

Figure 2.14-23. Elevon Control Assembly Sta 472 to 507 (Sheet 8 of 8)

FIGURE AND INDEX NUMBER	PART NUMBER	DESCRIPTION	UNITS PER ASSY.	USABLE ON CODE	
				FROM	TO
2.14-23-177	S-42454-3	• STOP ASSY, ELEVON STA 472 ATTACHING PARTS	1	35	
-178	MS21043-4	• NUT	2	35	
-179	AN960-416	• WASHER	2	35	
-180	AN4-7A	• BOLT	1	35	
-181	AN4-7A	• BOLT	1	35	
-182	3591-30NX.295	• • INSERT, <91767> 91-13003-005	2	35	
-183	NAS42AK3	• POLT	2	35	
-184	8-42454-7	• • STOP	1	35	
-185	S-42620-8	• SUPPORT ASSY, ELEVON CONTROL	1	35	
-186	NAS75-5-116	• • RUSHING	1	35	
-187	KP4AE7414	• • BEARING, <21335> 90-5P109-017	2	35	
-188	98-14000-009	• • SLEEVE	2	35	
-189	NAS75-6012	• • RUSHING	1	35	
-190	1191-6CNX.330	• • INSERT, <91767> 95-03013-008	4	35	
-191	NAS77-6-64	• • RUSHING	1	35	
-192	NAS77-6-28	• • RUSHING	1	35	
-193	8-42559-7	• • RUSHING	1	35	
-194	NAS77-4-32	• • RUSHING	2	35	
-195	NAS77-4-65	• • RUSHING	1	35	
-196	NAS77-4-97	• • RUSHING	1	35	
-197	NAS77-5-97	• • RUSHING	1	35	
-198	NAS77-5-12	• • RUSHING	1	35	
-200	NAS77-4-77	• • RUSHING	1	35	
-201	8-42620-9	• • SUPPORT	1	35	

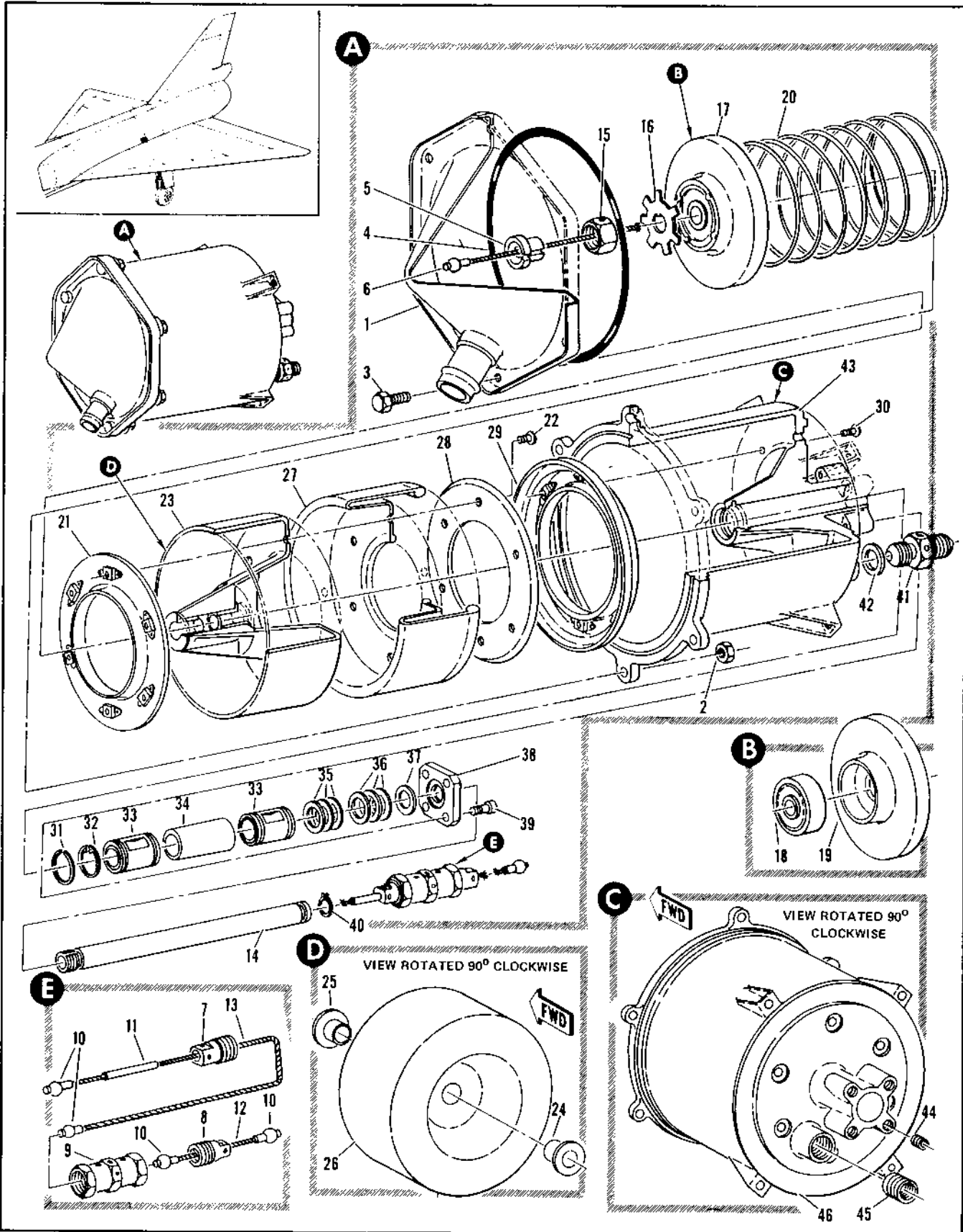

Figure 2.14-24. Elevator Feel Cylinder Assembly

FIGURE AND INDEX NUMBER	PART NUMBER	DESCRIPTION	UNITS PER ASSY.	USABLE ON CODE	
				FROM	TO
2.14-24	0-42325-1	CYLINDER ASSY, ELEVATOR FEEL FOR NHA SFL FIG. 2.14-23	REF		35
- 1	0-42315	* COVER ASSY, ELEVATOR FEEL CYLINDER WELDED ATTACHING PARTS	1		35
- 2	MS21043-3	* NUT	6		35
- 3	AN3-5A	* BOLT	6		35
- 4	AN6230-41	-----X----- * PACKING	1		35
- 5	0-42333	* RETAINER	1		35
- 6	0-42337	* CABLE ASSY, ELEVATOR FEEL	1		35
- 7	0-42359-7	* NUT, LH	1		35
- 8	0-42359	* NUT	1		35
- 9	0-42359	* BARREL	1		35
- 10	AN66404	* TERMINAL	4		35
- 11	0-42309-11	* SLEEVE, CABLE SEAL	1		35
- 12	0-42309-7	* CABLE	1		35
- 13	0-42309-9	* CABLE	1		35
- 14	0-42311	* SHAFT, ELEVATOR FEEL ATTACHING PARTS	1		35
- 15	0-42334	* NUT	1		35
- 16	NAS901-R16	* WASHER	1		35
- 17	0-42650-1	-----X----- * RETAINER ASSY, SPRING	1		35
- 18	AN201KP8A	* BEARING, 90-5A000-104	1		35
- 19	0-42650-7	* RETAINER	1		35
- 20	0-42313	* SPRING	1		35
- 21	0-42312	* RETAINER ASSY, SPRING RIVETED ATTACHING PARTS	1		35
- 22	AN521-1032-R	* SCREW	6		35
- 23	0-42627-1	-----X----- * PISTON ASSY, CYLINDER ELEVATOR FEEL	1		35
- 24	NAS77AB-30	* PUSHING	1		35
- 25	0-42317	* PUSHING	1		35
- 26	0-42627-7	* PISTON	1		35
- 27	08126	* SEAL, <1170> SPEC 0-44387-1	1		35
- 28	0-42314	* RETAINER, SEAL	1		35
- 29	0-42316	* RETAINER ASSY, SEAL RIVETED ATTACHING PARTS	1		35
- 30	AN521-1032-R	* SCREW	6		35
- 31	0-42415-5	-----X----- * RETAINER	1		35
- 32	NAS50-A7	* RING	1		35
- 33	AP1421	* BEARING, BALL <96881> 90-5A1007-001	2		35
- 34	0-42306	* SPACER	1		35
- 35	49-51509-003	* WASHER	AN		35
- 36	49-51519-005	* WASHER	AN		35
- 37	0-42318	* WASHER	1		35
- 38	0-42314	* PLATE	1		35
- 39	AN522-10-6	ATTACHING PARTS * SCREW	4		35
- 40	NAS51-90	-----X----- * RING	1		35
- 41	0-42329-7	* UNION, MAKE FROM AN815-40	1		35
- 42	99-51604-109	* WASHER	1		35
- 43	0-42664-1	* CYLINDER ASSY, ELEVATOR FEEL	1		35
- 44	1191-30N>.3-0	* INSERT, <51767> 95-33000-006	4		35
- 45	1191-12CNX>28	* INSERT, <51767> 95-33000-014	1		35
- 46	0-42664-7	* CYLINDER	1		35

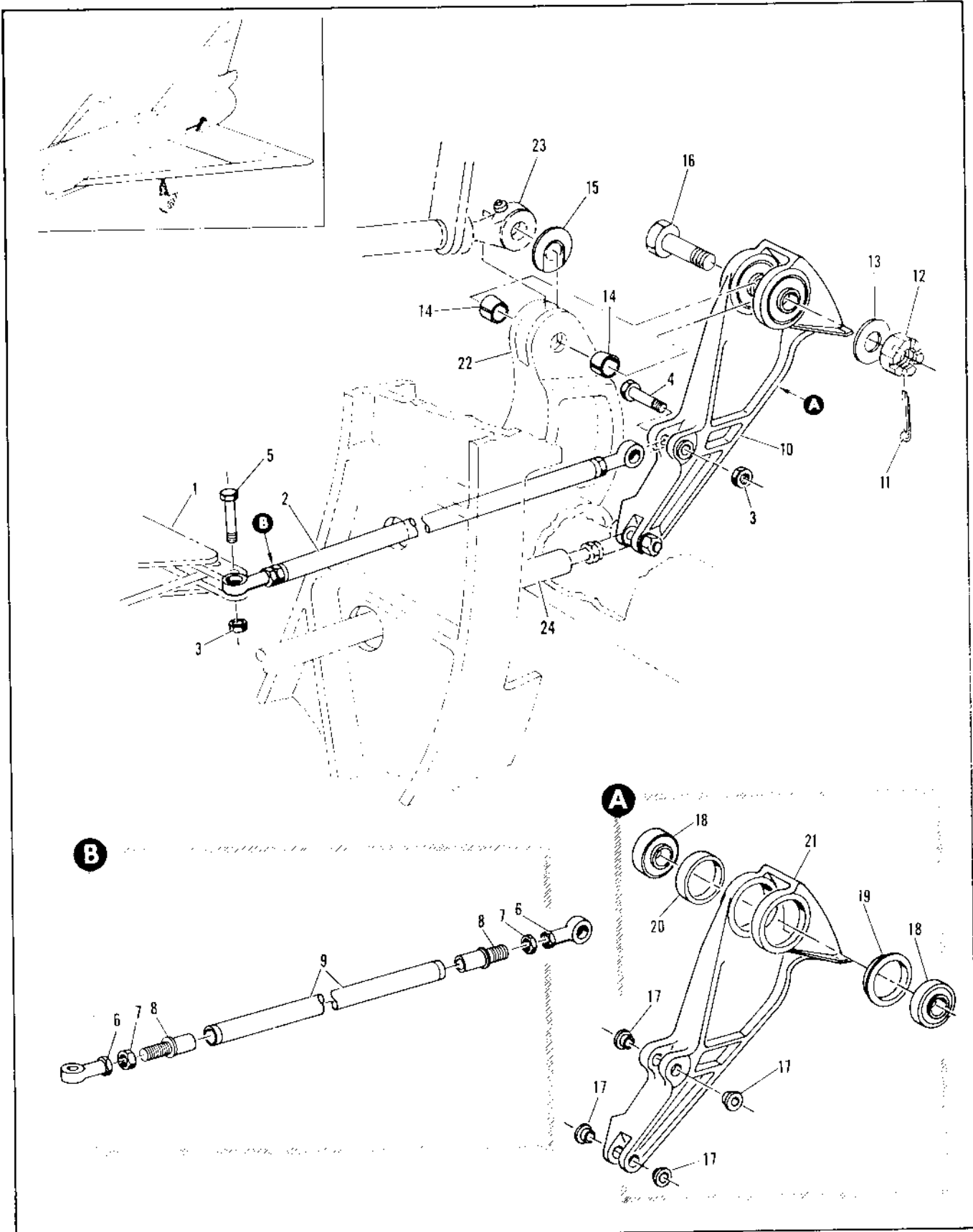

Figure 2.14-25. Elevation Followup Crank Installation

FIGURE AND INDEX NUMBER	PART NUMBER	DESCRIPTION	UNITS PER ASSY.	USABLE ON CODE	
				FROM	TO
		1 2 3 4 5 6			
2.14-25	8-42652-8	CRANK INSTALLATION, ELEVON FOLLOWUP LH MODIFIED BY 8-41111 FOR NHA SEE FIG. 2.3-3	RF	35	
	8-42652-7	CRANK INSTALLATION, ELEVON FOLLOWUP RH MODIFIED BY 8-41111 FOR NHA SEE FIG. 2.3-3	RF	35	
- 1		• VALVE ASSY, ELEVON CONTROL SEE FIG. 2.14-11 INDEX 30	RF		
- 2	64A33155-874	• ROD ASSY, CONTROL LINKAGE REPLACED BY SUITABLE SUB 64A33155-627	1	35	124
	64A33155-627	• ROD ASSY, CONTROL LINKAGE REPLACES SUITABLE SUB FOR 64A33155-874 ATTACHING PARTS	1	139	
- 3	MS21044-4	• NUT	2	35	
- 4	MS27576-4-10	• BOLT	1	35	
- 5	MS27576-4-10	• BOLT, USE WITH 10-1010 AND 10090	1	35	
	MS27576-4-23	• BOLT, USE WITH 10-102A	1	35	
		-----X-----			
- 6	RE4F5E7164	• BEARING, <21335> 70-60002-001	2	35	124
	RE4F5E7416	• BEARING, <21335> 90-60002-010	2	139	
- 7	AN316-5R	• NUT	2	35	
- 8	64F33114-14	• CONNECTOR	2	35	
- 9	8-42610-20	• TUBE	1	35	
- 10	8-42654-3	• CRANK ASSY, ELEVON FOLLOWUP LH	1	35	124
	8-42654-7	• CRANK ASSY, ELEVON FOLLOWUP LH	1	139	
	8-42654-4	• CRANK ASSY, ELEVON FOLLOWUP RH	1	35	124
	8-42654-8	• CRANK ASSY, ELEVON FOLLOWUP RH ATTACHING PARTS	1	139	
- 11	AN320-4-8	• PIN, COTTER	1	35	
- 12	AN320-12	• NUT	1	35	
- 13	AN960-1216	• WASHER	1	35	
- 14	8-15718	• PUSHING	2	35	
- 15	8-81240	• WASHER	1	35	
- 16	8-83216	• BOLT	1	35	
		-----X-----			
- 17	7AS77-4-22	• PUSHING	4	35	
- 18	KP12AF7164	• BEARING, <21335> 80-50000-110	2	35	124
	KP12AF7416	• BEARING, <21335> 90-50000-124	2	139	
- 19	8-42613	• SLEEVE	1	35	
- 20	9H-14000-014	• SLEEVE	1	35	
- 21	8-42654-8	• CRANK, LH	1	35	
	8-42654-10	• CRANK, RH	1	35	
- 22		• FITTING ASSY, ELEVON NOVA INBD LH SEE FIG. 2.6-17 INDEX 11	RF		
- 23		• ACTUATOR ASSY, ELEVON OUTBD SEE FIG. 2.14-11 INDEX 35	RF		
- 24		• ROD ASSY, LOAD RELIEF SEE FIG. SEE FIG. 2.14-15 INDEX 108	RF		

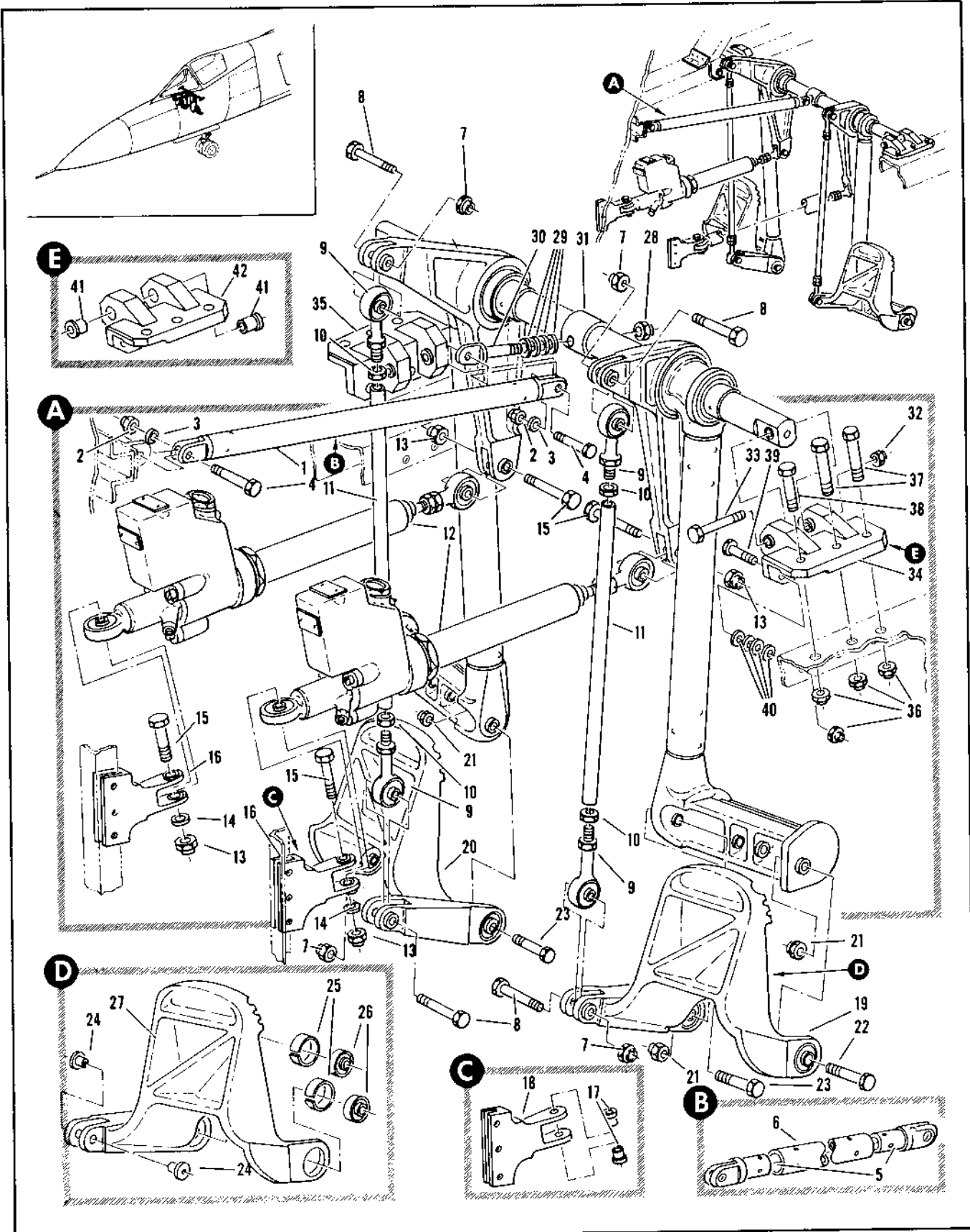

Figure 2.14-26. Rudder and Brake Pedal Installation

FIGURE AND INDEX NUMBER	PART NUMBER	DESCRIPTION	UNITS PER ASSY.	USABLE ON CODE	
				FROM	TO
2.14-26	8-42245	PEDAL INSTALLATION, RUDDER AND BRAKE FOR NMA SEE FIG. 2.3-4	RF		A
- 1	8-42100-853	• ROD ASSY, SUPPORT ATTACHING PARTS	1		A
- 2	MS21043-4	• NUT	2		A
- 3	AN960PD416	• WASHER	2		A
- 4	NAS464-4A7	• BOLT	2		A
		-----X-----			
- 5	8-42261	• CLEVIS	2		A
- 6	8-42100-77	• TUBE	1		A
- 7	MS21043-4	• NUT	4		A
- 8	NAS464-4A19	• BOLT	4		A
- 9	AN951RL4F5	• BEARING, 90-58026-006	4		A
- 10	AN315-5R	• NUT	4		A
- 11	NAS354-5-13EG	• ROD	4		A
- 12	16260-1	• CYLINDER, MASTER BRAKE <79004> SPEC 8-00489-5 T.O. JRA1-35-4 REPLACED BY NOT INTCHG WITH 17780 ATTACHING PARTS	2		A
- 13	MS21043-4	• NUT	4		A
- 14	8-40106	• WASHER	4		A
- 15	NAS464-4A17	• BOLT	4		A
		-----X-----			
- 16	8-42939-1	• FITTING ASSY, SUPPORT BRAKE CYLINDER	2		A
- 17	NAS77-4-24	• PUSHING	2		A
- 18	8-4239-7	• FITTING	1		A
- 19	8-42933-1	• PEDAL ASSY, BRAKE LH REPLACED BY NOT INTCHG WITH 8-42955-1	1		A
- 20	8-42933-2	• PEDAL ASSY, BRAKE RH REPLACED BY NOT INTCHG WITH 8-42955-2 ATTACHING PARTS	1		A
- 21	MS21043-4	• NUT	4		A
- 22	NAS464-4A5	• BOLT	2		A
- 23	NAS464-4A12	• BOLT	2		A
		-----X-----			
- 24	NAS77-4-24	• PUSHING	2		A
- 25	AN201KPA4	• SLEEVE, 90-14000-309	2		A
- 26	KS4A	• BEARING, <21535> 90-58001-002	2		A
- 27	8-42933-9	• PEDAL, LH	1		A
	8-42933-10	• PEDAL, RH	1		A
- 28	MS21043-5	• NUT	1		A
- 29	AN960PD516L	• WASHER	4		A
- 30	AN44-15	• BOLT, EYE	1		A
- 31	8-42245-7	• TUBE ASSY, RUDDER AND BRAKE PEDAL HANGER FOR BREAKDOWN SEE FIG. 2.14-26 ATTACHING PARTS	1		A
- 32	MS21043-5	• NUT	2		A
- 33	NAS464-5A35	• BOLT	2		A
		-----X-----			
- 34	8-42255-1	• FITTING ASSY, HANGER CLEVIS LH REPLACED BY NOT INTCHG WITH 8-42268-1	1		A
- 35	8-42255-2	• FITTING ASSY, HANGER CLEVIS RH REPLACED BY NOT INTCHG WITH 8-42268-2 ATTACHING PARTS	1		A
- 36	MS21043-4	• NUT	10		A
- 37	NAS464-4A10	• BOLT	4		A
- 38	NAS464-4A8	• BOLT	2		A
- 39	NAS464-4A6	• BOLT	4		A
- 40	8-42249	• SHIM			
		-----X-----			
- 41	NAS77A5-56	• PUSHING	4		A
- 42	8-42255-9	• FITTING, LH REPLACED BY NOT INTCHG WITH 8-42268-7	1		A
	8-42255-10	• FITTING, RH REPLACED BY NOT INTCHG WITH 8-42268-8	1		A

A AIRPLANES #35 THRU 47 AND 49 THRU 89

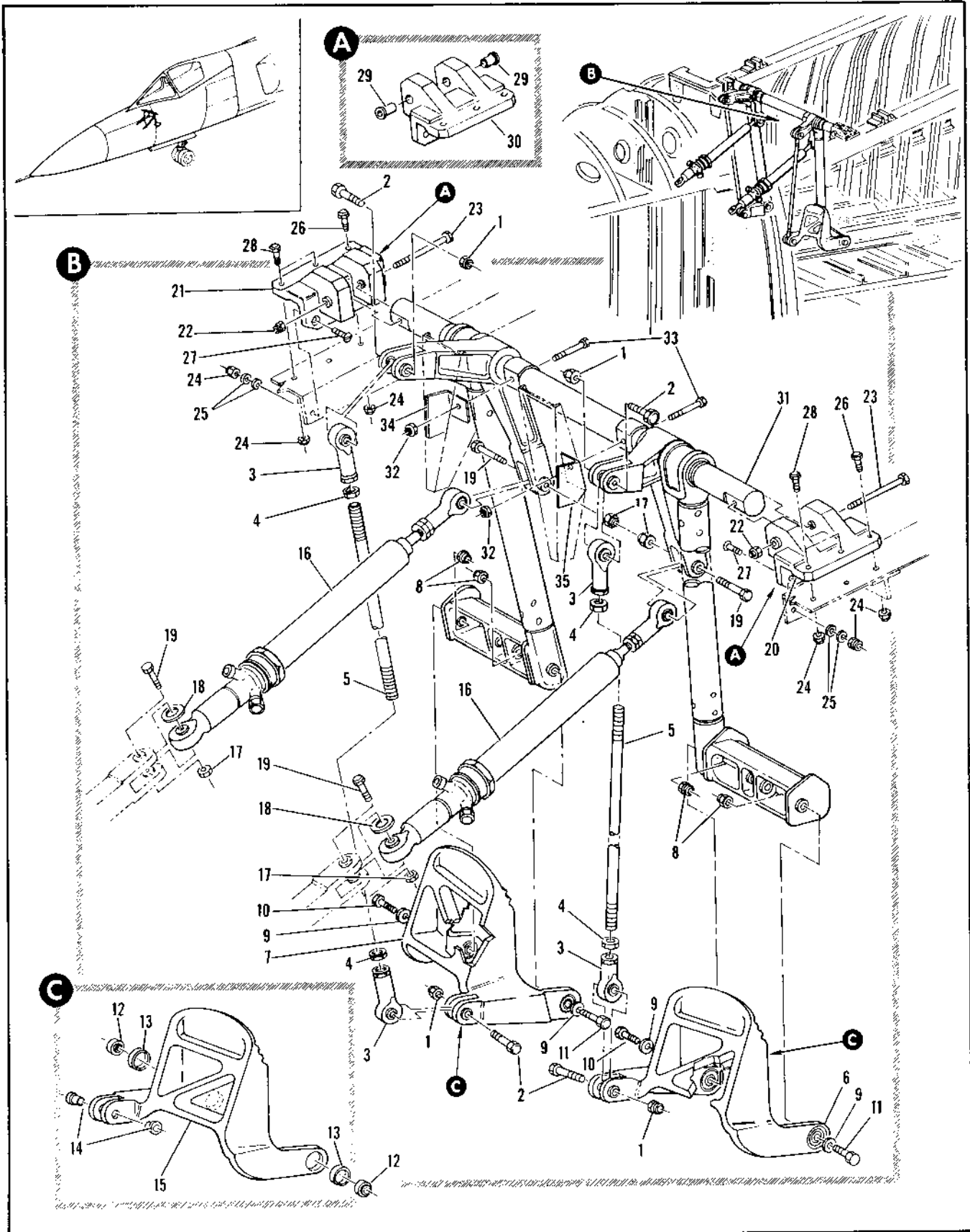

Figure 2.14-27. Rudder and Brake Pedal Installation

FIGURE AND INDEX NUMBER	PART NUMBER	DESCRIPTION	UNITS PER ASSY.	USABLE ON CODE	
				FROM	TO
2.14-27	8-42245-1	PEDAL INSTALLATION, RUDDER AND BRAKE FOR NHA SEE FIG. 2.3-4	RF		A
- 1	MS21043-4	• NUT	4	A	A
- 2	NAS464-4A19	• BOLT	4	A	A
- 3	RE4F5	• BEARING, <21335> 90-60002-001	4	A	A
- 4	AN316-5R	• NUT	4	A	A
- 5	NAS354-5-1312	• ROD	2	A	A
- 6	8-42955-1	• PEDAL ASSY, BRAKE LH REPLCES NOT INTCHG WITH 8-42933-1	1	A	A
- 7	8-42955-2	• PEDAL ASSY, BRAKE RH REPLACES NOT INTCHG WITH 8-42933-2 ATTACHING PARTS	1	A	A
- 8	MS21043-4	• NUT	4	A	A
- 9	AN960PD416L	• WASHER	4	A	A
- 10	NAS464-4A12	• BOLT	2	A	A
- 11	NAS464-4A10	• BOLT	2	A	A
- 12	KS4A	• BEARING, <21335> 90-52001-002	2	A	A
- 13	98-14000-009	• SLEEVE	2	A	A
- 14	NAS77-4-24	• BUSHING	2	A	A
- 15	8-42955-9	• PEDAL, LH	1	A	A
- 15	8-42955-10	• PEDAL, RH	1	A	A
- 15	17780	• CYLINDER, MASTER BRAKE <79294> SPEC 8-00489-7 T.O. 48A1-38-3 REPLACES NOT INTCHG WITH 16260-1 ATTACHING PARTS	2	A	A
- 17	MS21043-4	• NUT	4	A	A
- 18	8-40156	• WASHER	2	A	A
- 19	NAS464-4A17	• BOLT	4	A	A
- 20	8-42268-1	• FITTING ASSY, LH REPLACES NOT INTCHG WITH 8-42255-1	1	A	A
- 21	8-42268-2	• FITTING ASSY, RH REPLACES NOT INTCHG WITH 8-42255-2 ATTACHING PARTS	1	A	A
- 22	MS21043-5	• NUT	2	A	A
- 23	NAS464-5A35	• BOLT	2	A	A
- 24	MS21043-4	• NUT	8	A	A
- 25	8-42249	• SHIM, LAMINATED WASHER	8	A	A
- 26	NAS464-4A12	• BOLT	2	A	A
- 27	AN569-416R14	• SCREW	4	A	A
- 28	NAS464-4A14	• BOLT	4	A	A
- 29	NAS77A5-56	• BUSHING	2	A	A
- 30	8-42255-7	• FITTING, LH REPLCES NOT INTCHG WITH 8-42255-9	1	A	A
- 30	8-42268-8	• FITTING, RH REPLCES NOT INTCHG WITH 8-42255-10	1	A	A
- 31	8-42245-17	• TUBE ASSY, RUDDER AND BRAKE PEDAL HANGER FOR BREAKDOWN SEE FIG. 2.14-29 ATTACHING PARTS	1	A	A
- 32	MS21043-4	• NUT	2	A	A
- 33	AN4-15A	• BOLT	2	A	A
- 34	8-42245-13	• BRACKET	1	A	A
- 35	8-42245-14	• BRACKET	1	A	A

A AIRPLANES #48, 90 AND ON

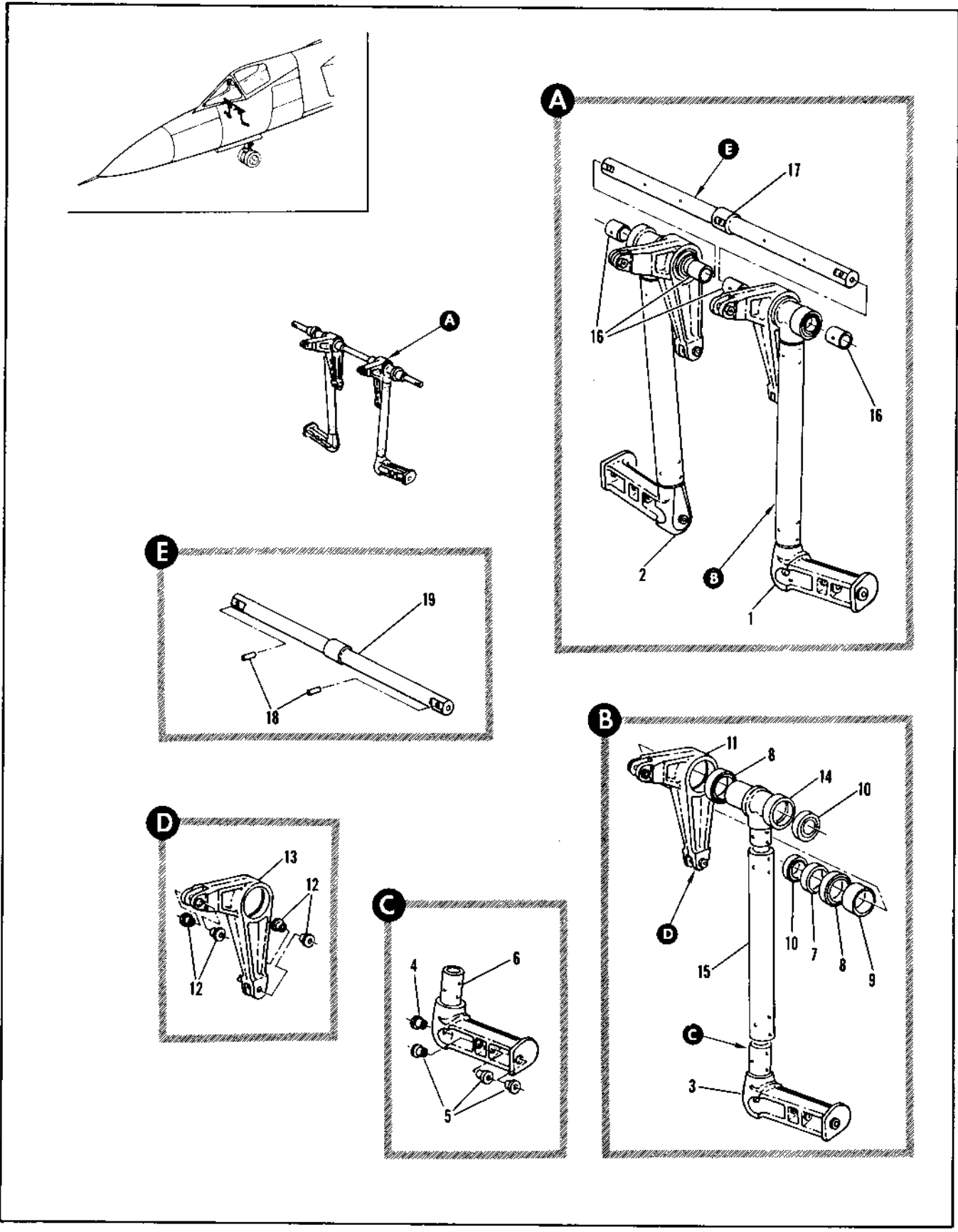

Figure 2.14-28. Rudder and Brake Pedal Hanger Tube Assembly

FIGURE AND INDEX NUMBER	PART NUMBER	DESCRIPTION	UNITS PER ASSY.	USABLE ON CODE	
				FROM	TO
		1 2 3 4 5 6			
2.14-28	8-42245-7	TUBE ASSEMBLY, RUDDER AND BRAKE PEDAL HANGER FOR NHA SEE FIG. 2.14-26	RF	A	
- 1	8-42248-1	• HANGER ASSY, RUDDER PEDAL BAR LH REPLACED BY NOT INTCHG WITH 8-42270-1	1	A	
- 2	8-42248-2	• HANGER ASSY, RUDDER PEDAL BAR RH REPLACED BY NOT INTCHG WITH 8-42270-2	1	A	
- 3	8-42934-1	• • BAR ASSY, RUDDER PEDAL LH	1	A	
	8-42934-2	• • BAR ASSY, RUDDER PEDAL RH	1	A	
- 4	NAS77-4-41	• • • BUSHING	1	A	
- 5	NAS77-4-24	• • • BUSHING	3	A	
- 6	8-42934-9	• • • BAR, PEDAL LH	1	A	
	8-42934-10	• • • BAR, PEDAL RH	1	A	
- 7	8-42260-7	• RETAINER, BEARING	1	A	
- 8	8544DD	• BEARING, <21335> 90-58303-008	2	A	
- 9	8-42260-9	• RETAINER, BEARING	1	A	
- 10	8541DD	• BEARING, <21335> 90-58303-010	2	A	
- 11	8-42936-1	• BELL CRANK ASSY, BRAKE LH REPLACED BY NOT INTCHG WITH 8-42956-1	1	A	
	8-42936-2	• BELL CRANK ASSY, BRAKE RH REPLACED BY NOT INTCHG WITH 8-42956-2	1	A	
- 12	NAS77-4-24	• • • BUSHING	4	A	
- 13	8-42936-9	• • • BELL CRANK, LH	1	A	
	8-42936-10	• • • BELL CRANK, RH	1	A	
- 14	8-42937-7	• FITTING, TUBE UPPER REPLACED BY NOT INTCHG WITH 8-42957-7	1	A	
- 15	8-42254	• TUBE, PEDAL HANGER	1	A	
- 16	8-42265	• SPACER, HANGER SUPPORT TUBE REPLACED BY NOT INTCHG WITH 8-42272	4	A	
- 17	8-42246-1	• TUBE ASSY, HANGER SUPPORT REPLACED BY NOT INTCHG WITH 8-42269-1	1	A	
	8-42266	• TUBE, SUPPORT PEDAL HANGER ALT INTCHG WITH 8-42246-1	RF	A	
- 18	NAS76A5-330	• • BUSHING	2	A	
- 19	8-42246-7	• • TUBE	1	A	
A AIRPLANES #35 THRU 47 AND THRU 89					

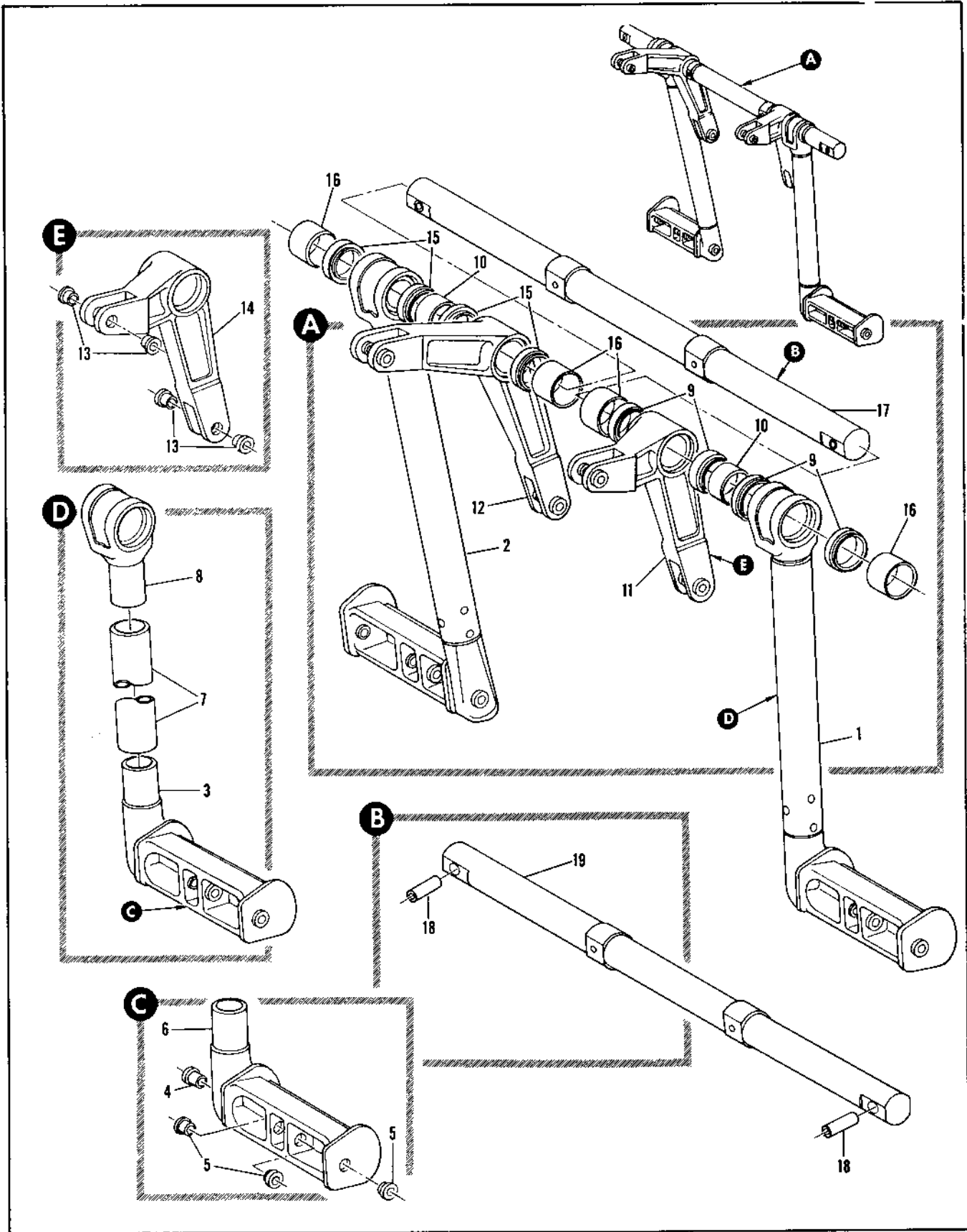

Figure 2.14-29. Rudder and Brake Pedal Hanger Tube Assembly

FIGURE AND INDEX NUMBER	PART NUMBER	DESCRIPTION	UNITS PER ASSY.	USABLE ON CODE	
				FROM	TO
		1 2 3 4 5 6			
2.14-29	R-42245-17	TUBE ASSEMBLY, RUDDER AND BRAKE PEDAL HANGER FOR NHA SEE FIG. 2.14-27	RF	A	
- 1	R-42270-1	• HANGER ASSY, RUDDER PEDAL BAR LH REPLACES NOT INTCHG WITH R-42248-1	1	A	
- 2	R-42270-2	• HANGER ASSY, RUDDER PEDAL BAR RH REPLACES NOT INTCHG WITH R-42248-2	1	A	
- 3	R-42934-1	• • BAR ASSY, RUDDER PEDAL LH	1	A	
	R-42934-2	• • BAR ASSY, RUDDER PEDAL RH	1	A	
- 4	NAS77-4-41	• • • BUSHING	1	A	
- 5	NAS77-4-24	• • • BUSHING	3	A	
- 6	R-42934-9	• • • BAR, PEDAL LH	1	A	
	R-42934-10	• • • BAR, PEDAL RH	1	A	
- 7	R-42273	• • TUBE	1	A	
- 8	R-42957-7	• • FITTING	1	A	
- 9	954100	• BEARING, <21335> 90-5803-11	4	A	
- 10	R-42272-7	• SPACER	2	A	
- 11	R-42956-1	• BELL CRANK ASSY, BRAKE CONTROL LH REPLACES NOT INTCHG WITH R-42936-1	1	A	
- 12	R-42956-2	• BELL CRANK ASSY, BRAKE CONTROL RH REPLACES NOT INTCHG WITH R-42936-2	1	A	
- 13	NAS77-4-24	• • BUSHING	4	A	
	R-42956-3	• • BELL CRANK, LH	1	A	
- 14	R-42956-10	• • BELL CRANK, RH	1	A	
- 15	954100	• BEARING, <21335> 90-5803-010	4	A	
- 16	R-42272	• SPACER, REPLACES NOT INTCHG WITH R-42265	4	A	
- 17	R-42269-1	• TUBE ASSY, RUDDER BAR SUPPORT REPLACES NOT INTCHG WITH R-42246-1	1	A	
- 18	NAS78A5-33	• • BUSHING	2	A	
- 19	R-42267-7	• • TUBE	1	A	
		A AIRPLANES N48, 90 AND 04			

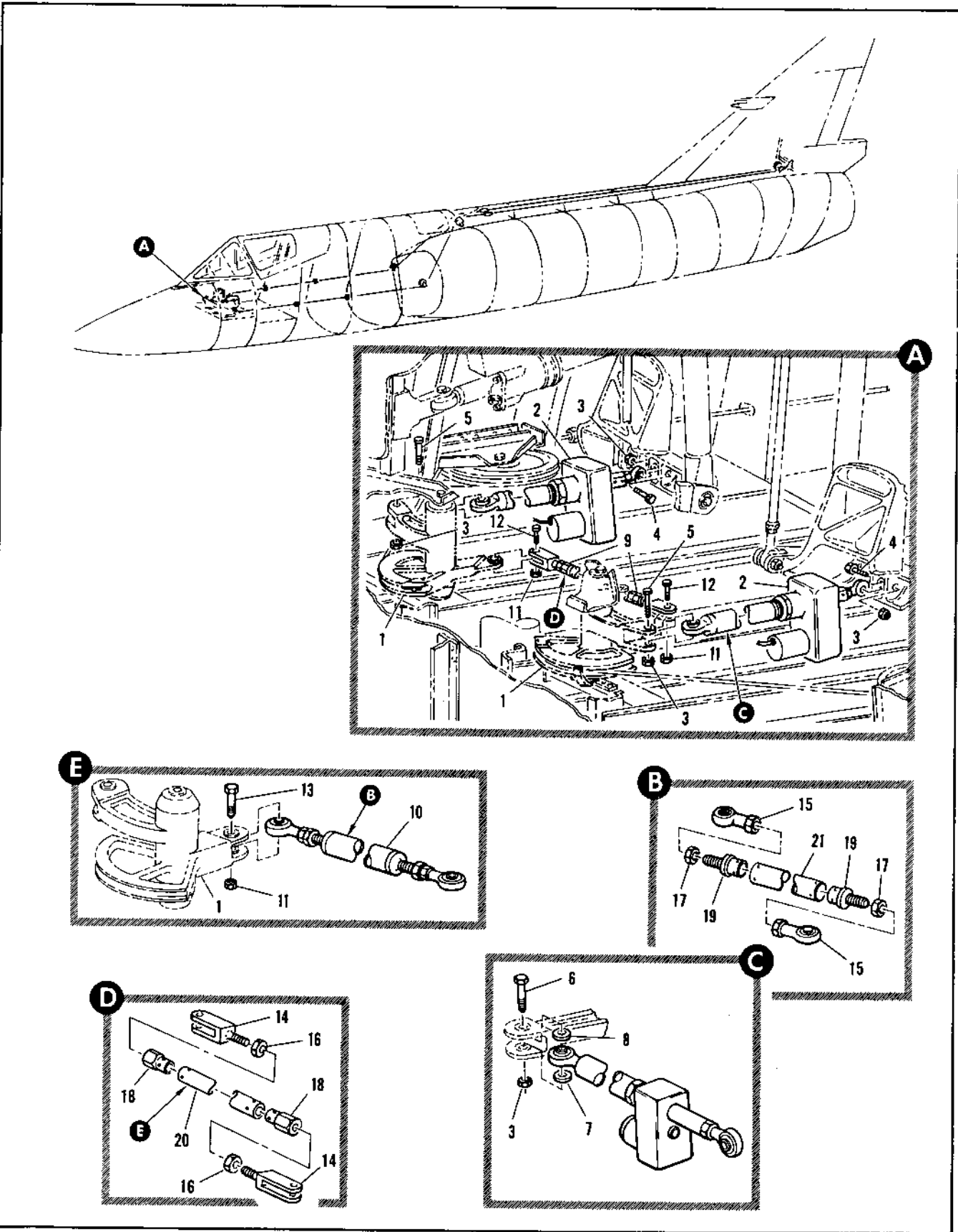

Figure 2.14-30. Rudder Cable and Linkage Installation (Sheet 1 of 2)

FIGURE AND INDEX NUMBER	PART NUMBER	DESCRIPTION	UNITS PER ASSY.	USABLE ON CODE	
				FROM	TO
		1 2 3 4 5 6			
2.14-30	8-40204-3	CABLE AND LINKAGE INSTL, RUDDER MODIFIED BY 66J40963 FOR NHA SEE FIG. 2.3-3	RF		
	8-40204-801	CABLE AND LINKAGE INSTL, RUDDER MODIFIED BY 66J40963 FOR NHA SEE FIG. 2.3-3	RF		
	8-40204-805	CABLE AND LINKAGE INSTL, RUDDER, MODIFIED BY 66J40963 FOR NHA SEE FIG. 2.3-3	RF		
- 1		• BELL CRANK ASSY, RH SEE FIG. 2.14-32	RF		
- 2	1501101-1	• LINK, RUDDER PEDAL ADJUST <45402> SPEC 8-04959-5 T.O. 803-16-3-4 REPLACED BY SUITABLE SUB 1501101-2	2	35	129
	1501101-2	• LINK, RUDDER PEDAL ADJUST <45402> SPEC 8-04959-801 T.O. 803-16-3-4 REPLACES SUITABLE SUB FOR 1501101-1 ATTACHING PARTS	2	130	
- 3	MS21043-4	• NUT	4	35	
- 4	NAS464-4A17	• BOLT	2	35	
- 5	NAS464-4A18	• BOLT	2	A	
- 6	NAS464-4A19	• BOLT	2	D	
- 7	8-40106-13	• WASHER	1	D	
- 8	8-40103-9	• WASHER	1	B	
	8-43106-13	• WASHER	1	278	
		-----X-----			
- 9	8-42100-855	• ROD ASSY, RUDDER CONTROL REPLACED BY NOT INTCHG WITH 64A33155-879	1	A	
- 10	64A33155-879	• ROD ASSY, RUDDER CONTROL REPLACES NOT INTCHG WITH 8-42100-855 REPLACED BY SUITABLE SUB 64A33155-629	1	C	
	64A33155-629	• ROD ASSY, RUDDER CONTROL REPLACES SUITABLE SUB FOR 64A33155-879 ATTACHING PARTS	1	130	
- 11	MS21043-4	• NUT	2	35	
- 12	AN174-7A	• BOLT	2	A	
- 13	NAS464-4A21	• BOLT	2	D	
		-----X-----			
- 14	8-42243	• CLEVIS, RUDDER CONTROL	2	A	
- 15	RE4F5E7164	• BEARING, <21335> 90-60002-50R	2	C	
	RE4F5E7416	• BEARING, <21335> 90-60002-21C	2	130	
- 16	AN316-4R	• NUT	2	A	
- 17	AN316-5R	• NUT	2	D	
- 18	8-42244	• FITTING	2	A	
- 19	64F33114-15	• CONNECTOR	2	D	
- 20	8-42103-79	• TUBE	1	A	
- 21	8-42100-81	• TUBE	1	D	
		A AIRPLANES #35 THRU 47 AND 49 THRU 89			
		E AIRPLANES #48 AND 90 THRU 277			
		C AIRPLANES #48 AND 90 THRU 129			
		D AIRPLANES #48, 90 AND ON			

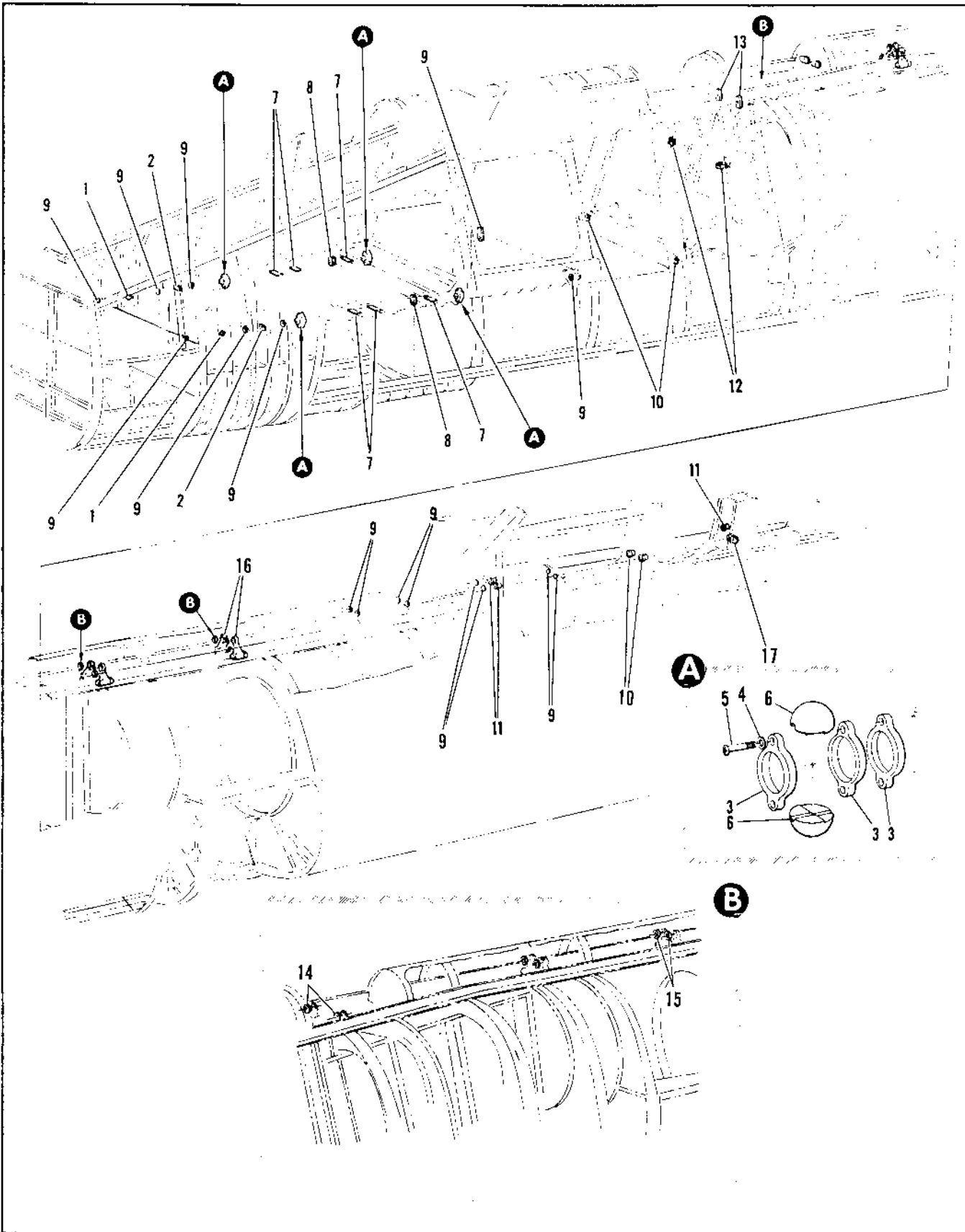

Figure 2.14-31. Rudder Cable Fair-Lead Installation

FIGURE AND INDEX NUMBER	PART NUMBER	DESCRIPTION	UNITS PER ASSY.	USABLE ON CODE	
				FROM	TO
2.14-31	8-42229	FAIR-LEAD INSTL, RUDDER CABLE MODIFIED BY 66J40963 FOR NHA SEE FIG. 2.3-4	RF		
- 1	8-42228	• FAIR-LEAD, STA 138	2	35	
- 2	8-42228-13	• FAIR-LEAD, STA 152	2	35	
- 3	8-42615	• RETAINER, CONTROL CABLE SEAL STA 168 AND 216	12	35	
		ATTACHING PARTS			
- 4	AN960PD10L	• WASHER	4	35	
- 5	NAS221-18	• SCREW	4	35	
		-----X-----			
- 6	8-42227-7	• SEAL, CABLE CONTROL PRESSURE	8	35	
- 7	8-42228-17	• FAIR-LEAD	6	35	
- 8	8-42228-15	• FAIR-LEAD, STA 196	2	35	
- 9	8-49115	• FAIR-LEAD	16	35	
- 10	8-49110-13	• FAIR-LEAD	5	35	
- 11	8-49110-11	• FAIR-LEAD	2	35	
- 12	8-42228-23	• FAIR-LEAD, STA 294	4	35	
- 13	8-42228-21	• FAIR-LEAD, STA 316	2	35	
- 14	8-49115	• FAIR-LEAD, STA 337	2		
		ATTACHING PARTS			
	AN960PD10L	• WASHER	4	35	
	NAS221-13	• SCREW	4	35	
		-----X-----			
- 15	8-42228-9	• FAIR-LEAD, STA 470	2	35	129
	8-42228-27	• FAIR-LEAD, STA 470	2	130	
- 16	8-42615-7	• SUPPORT, FAIR-LEAD STA 470	2	35	
		ATTACHING PARTS			
	AN960PD10L	• WASHER	4	35	
	NAS221-13	• SCREW	4	35	
		-----X-----			
- 17	8-42228/25	• FAIR-LEAD	1	35	
		ATTACHING PARTS			
	NAS679AC	• NUT	2	35	
	AN509-FR11	• SCREW	2	35	
		-----X-----			

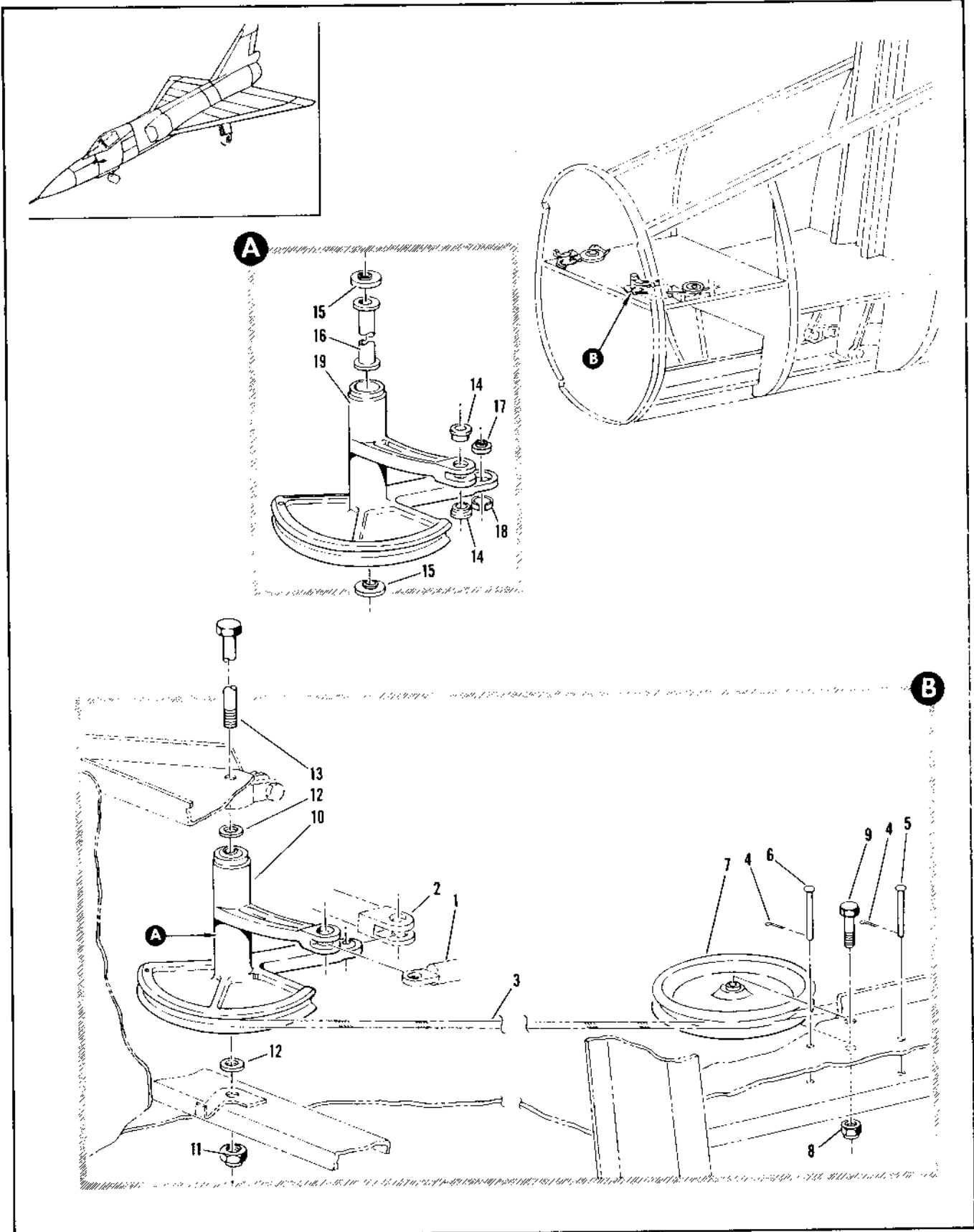

Figure 2.14-32. Rudder Control Installation Sta 108

FIGURE AND INDEX NUMBER	PART NUMBER	DESCRIPTION	UNITS PER ASSY.	USABLE ON CODE	
				FROM	TO
		1 2 3 4 5 6			
2.14-17	8-42242-1	CONTROL INSTALLATION, RUDDER LH STA 108 FOR NHA SEE FIG. 2.3-5	RF	A	
	8-42242-2	CONTROL INSTALLATION, RUDDER RH STA 108 FOR NHA SEE FIG. 2.3-5	RF	A	
- 1		• LINK RUDDER PEDAL ADJUST SEE FIG. 2.14-30 INDEX 2	RF		
- 2		• ROD ASSY, RUDDER CONTROL SEE FIG. 2.14-30 INDEX 9	RF		
- 3		• CABLE ASSY, RUDDER CONTROL SEE FIG. 2.14-30 INDEX 22	RF		
- 4	AN385-2-1	• PIN, COTTER	2	A	
- 5	NAS427W13	• PIN	1	A	
- 6	NAS427W12	• PIN	1	A	
- 7	54655-3	• PULLEY, <71503> 97-07500-004 ATTACHING PARTS	1	A	xxx
- 8	MS21243-4	• NUT	1	A	
- 9	AN5-11A	• BOLT	1	A	
		-----X-----			
- 10	8-42930-1	• BELL CRANK ASSY, LH REPLACED BY NOT INTCHG WITH 8-42959	1	A	
	8-42930-2	• BELL CRANK ASSY, RH REPLACED BY NOT INTCHG WITH 8-42959-1 ATTACHING PARTS	1	A	
- 11	MS21243-4	• NUT	1	A	
- 12	AN961P0410	• WASHER	2	A	
- 13	AN174-93A	• BOLT	1	A	
		-----X-----			
- 14	NAS77-4-40	• BUSHING	2	A	
- 15	AN201KP4A	• BEARING	1	A	
- 16	8-42214	• SPACER	1	B	
	8-42214-2	• SPACER	1	61	84
- 17	MS4A	• BEARING, <21335> 40-00011-002	1	A	
- 18	88-14800-009	• RELIEF	1	A	
- 19	8-42930-9	• BELL CRANK, LH ALTERED FROM 8-42930-7	1	A	
	8-42930-7	• BELL CRANK, LH	RF		
	8-42930-1	• BELL CRANK, RH ALTERED FROM 8-42930-9	1	A	
	8-42930-3	• BELL CRANK, RH	RF		
		A AIRPLANES #75 THRU #7 AND #9 THRU #9			
		B AIRPLANES #35 THRU #7 AND #9 THRU #9			

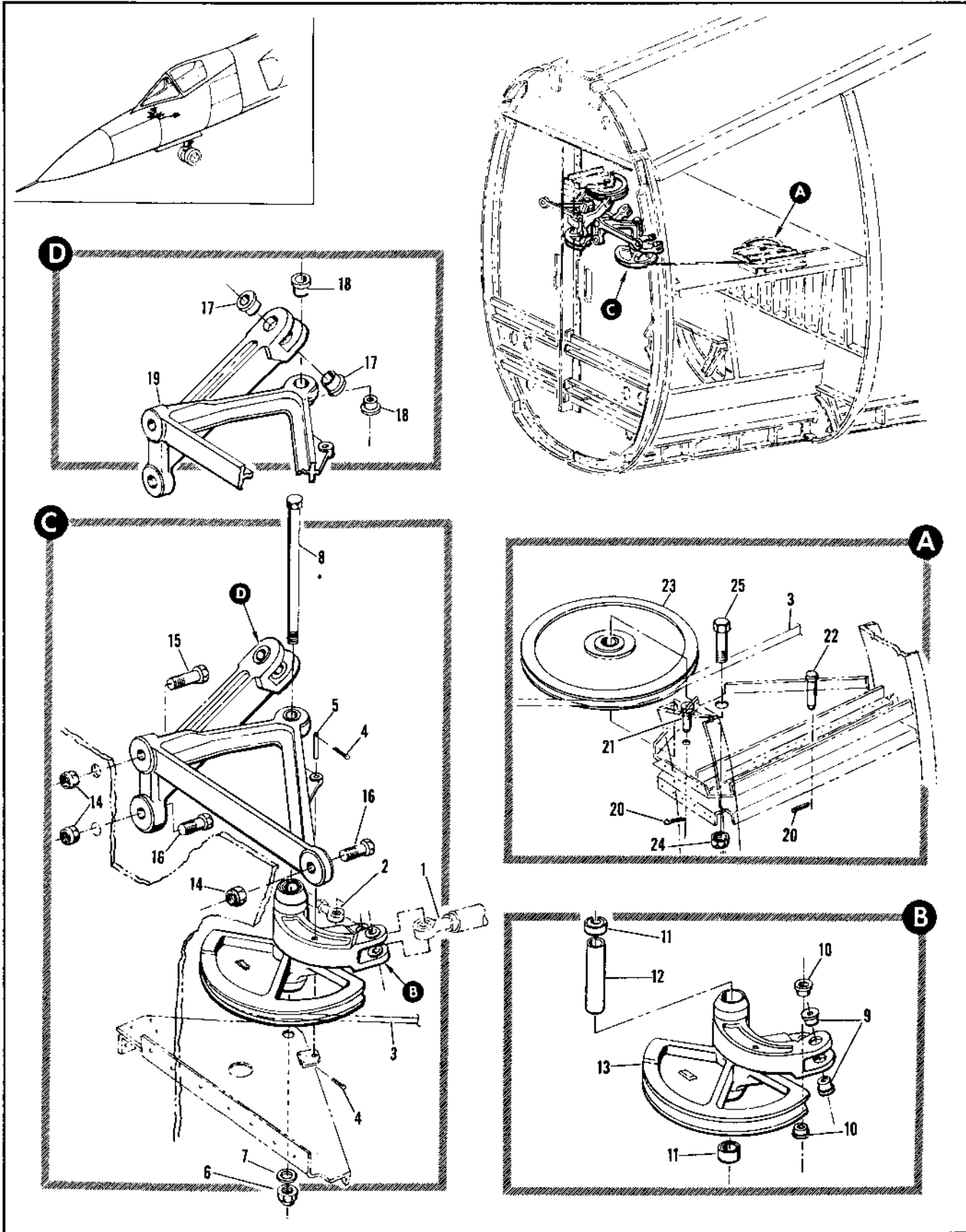

Figure 2.14-33. Rudder Control Installation Sta 108

FIGURE AND INDEX NUMBER	PART NUMBER	DESCRIPTION	UNITS PER ASSY.	USABLE ON CODE	
				FROM	TO
2.14-33	8-42242-801	CONTROL INSTALLATION, RUDDER LH STA 108 FOR NHA SEE FIG. 2.3-5	RF	A	
	8-42242-802	CONTROL INSTALLATION, RUDDER RH STA 108 FOR NHA SEE FIG. 2.3-5	RF	A	
- 1		• LINK, RUDDER PEDAL ADJUST SEE FIG. 2.14-30 INDEX 2	RF		
- 2		• ROD ASSY, RUDDER CONTROL SEE FIG. 2.14-30 INDEX 10	RF		
- 3		• CABLE ASSY, RUDDER CONTROL SEE FIG. 2.14-30 INDEX 22	RF		
- 4	AN380-2-1	• PIN, COTTER	2	A	
- 5	NAS427W12	• PIN	1	A	
	8-42959	• BELL CRANK ASSY, RUDDER CONTROL LH REPLACES NOT INTCHG WITH 8-42930-1 REPLACED BY SUITABLE SUB 8-42959-3	1	B	
	8-42959-3	• BELL CRANK ASSY, RUDDER CONTROL LH REPLACES SUITABLE SUB FOR 8-42959	1	130	
	8-42959-1	• BELL CRANK ASSY, RUDDER CONTROL RH REPLACES NOT INTCHG WITH 8-42930-2 REPLACED BY SUITABLE SUB 8-42959-5	1	B	
	8-42959-5	• BELL CRANK ASSY, RUDDER CONTROL RH REPLACES SUITABLE SUB FOR 8-42959-1 ATTACHING PARTS	1	130	
- 6	MS21043-4	• NUT	1	A	XXX
- 7	AN960PD415	• WASHER	1	A	
- 8	NAS464-4A43	• BOLT, LH	1	A	
	NAS464-4A41	• BOLT, RH	1	A	
		-----X-----			
- 9	NAS77-4-41	• BUSHING	2	A	
- 10	NAS77-4-29	• BUSHING	2	B	
- 11	AN201KP4A	• BEARING	2	B	
	KP4A17414	• BEARING, <21335> 90-50059-017	2	130	
- 12	8-42274	• SPACER	1	B	
	8-42101-19	• SPOOL	1	130	
- 13	8-42959-9	• BELL CRANK, LH	1	A	
	8-42959-13	• BELL CRANK, RH	1	A	
	8-42959-1	• SUPPORT ASSY, LH RUDDER CONTROL BELL CRANK	1	A	
	8-42959-3	• SUPPORT ASSY, RH RUDDER CONTROL BELL CRANK ATTACHING PARTS	1	A	
- 14	MS21043-4	• NUT	3	A	
- 15	NAS1184-5	• BOLT	1	A	
- 16	NAS1184-6	• BOLT	2	A	
		-----X-----			
- 17	NAS77-4-24	• BUSHING	2	A	
- 18	NAS77-4-36	• BUSHING	2	A	
- 19	8-42959-4	• SUPPORT, LH	1	A	
	8-42959-10	• SUPPORT, RH	1	A	
- 20	AN380-2-1	• PIN, COTTER	2	A	
- 21	NAS427W12	• PIN	1	A	
- 22	NAS427W13	• PIN	1	A	
- 23	122644M2124Tf	• PULLEY, <71505> 97-07501-004 ATTACHING PARTS	1	A	
- 24	MS21043-4	• NUT	1	A	
- 25	NAS464-5A12	• BOLT	1	A	
		-----X-----			

A AIRPLANES #48, 90 AND ON
B AIRPLANES #48 AND 90 THRU 129

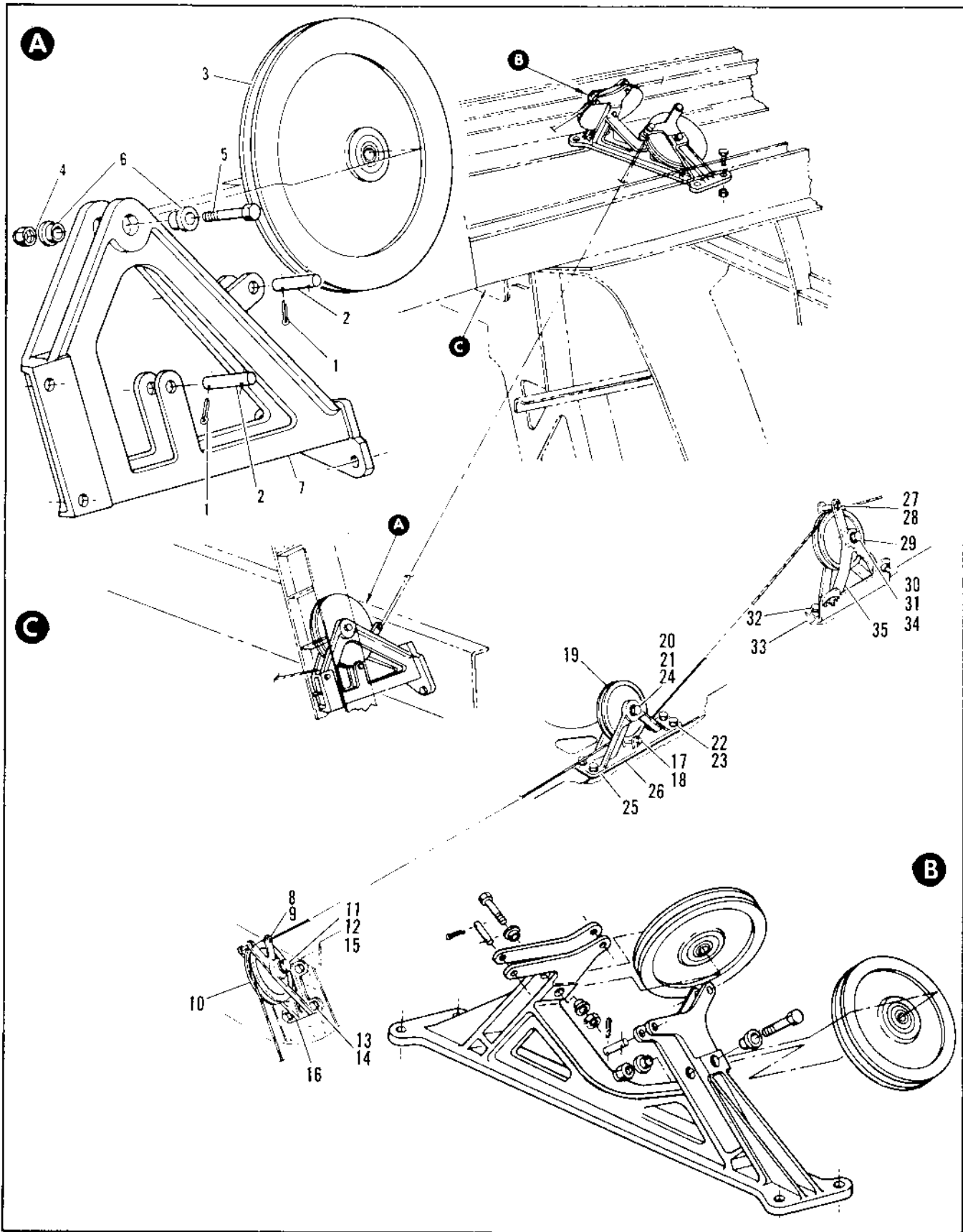

Figure 2.14-34. Rudder Cable Pulley Installation Sta 284 to 324

FIGURE AND INDEX NUMBER	PART NUMBER	DESCRIPTION	UNITS PER ASSY.	USABLE ON CODE		
				FROM	TO	
2.14-14	8-42233-1	PULLEY INSTALLATION, RUDDER CABLE LH STA 284 FOR NHA SEE FIG. 2.3-11	RF	35		
	8-42233-2	PULLEY INSTALLATION, RUDDER CABLE RH STA 284 FOR NHA SEE FIG. 2.3-11	RF	35		
	8-42233-3	PULLEY INSTL. RUBBER CABLE, MODIFIED BY 66J40963 FOR NHA SEE FIG. 2.3-11	RF			
	- 1	MS24665-86	• PIN, COTTER STA 284	4		
	- 2	NAS427W17	• PIN, STA 284	1	35	
	- 3	94665-3	• PULLEY, <71504> 97-07500-004 STA 284	RF	35	
		1223A4H2024T6	• PULLEY, <71503> 97-07500-002 STA 284 ALT INTCHG WITH 97665/3 ATTACHING PARTS			
	- 4	22FT524	• NUT, <5687R> 96-37525-004	1	35	
	- 5	NAS414-5A24	• BOLT	1	35	
			-----X-----			
		8-42687-1	• SUPPORT ASSY, STA 284 LH	1	35	
		8-42687-2	• SUPPORT ASSY, STA 284 RH	1	35	
	- 6	NAS77-5-39	• BUSHING	2	35	
	- 7	8-42687-9	• SUPPORT, LH	1	35	
		8-42687-10	• SUPPORT, RH	1	35	
	- 8	MS24665-86	• PIN, COTTER STA 320	8		
	- 9	NAS427W20	• PIN, STA 320	4		
	- 10	MS20220A3	• PULLEY	2	XX	
			ATTACHING PARTS			
	- 11	MS2142L5	• NUT	2		
	- 12	NAS1105-24	• BOLT	2		
			-----X-----			
		66E41964-1	• SUPPORT ASSY, STA 323 ATTACHING PARTS	2		
	- 13	NAS1104-F	• BOLT	8		
	- 14	AN950PP416	• WASHER	6		
			-----Y-----			
	- 15	NAS77-5-39	• BUSHING	2		
	- 16	66E41964-3	• SUPPORT	1		
	- 17	MS24665-86	• PIN, COTTER STA 377	4		
	- 18	NAS427W18	• PIN, STA 377	2		
	- 19	MS20220A3	• PULLEY	2		
			ATTACHING PARTS			
	- 20	MS2142L5	• NUT	2		
- 21	NAS1105-24	• BOLT	2			
		-----X-----				
	66E41968-1	• SUPPORT ASSY, STA 377 ATTACHING PARTS	2			
- 22	NAS1104-12	• BOLT	4			
- 23	AN950PP416	• WASHER	6			
		-----X-----				
- 24	NAS77-5-39	• BUSHING	2			
- 25	66E41968-3	• SUPPORT	1			
- 26	66E41968-1	• FILLER PLATE	4			
- 27	MS24665-86	• PIN, COTTER STA 416	4			
- 28	NAS427W16	• PIN, STA 416	2			
- 29	MS20220A3	• PULLEY	2			
		ATTACHING PARTS				
- 30	MS2142L5	• NUT	2			
- 31	NAS1105-24	• BOLT	2			
		-----X-----				
	66E41969-1	• SUPPORT ASSY, STA 416 ATTACHING PARTS	2			
- 32	AN950PP416	• WASHER	6			
		-----X-----				
- 33	NAS77-5-39	• BUSHING	2			
- 34	66E41969-3	• SUPPORT	2			

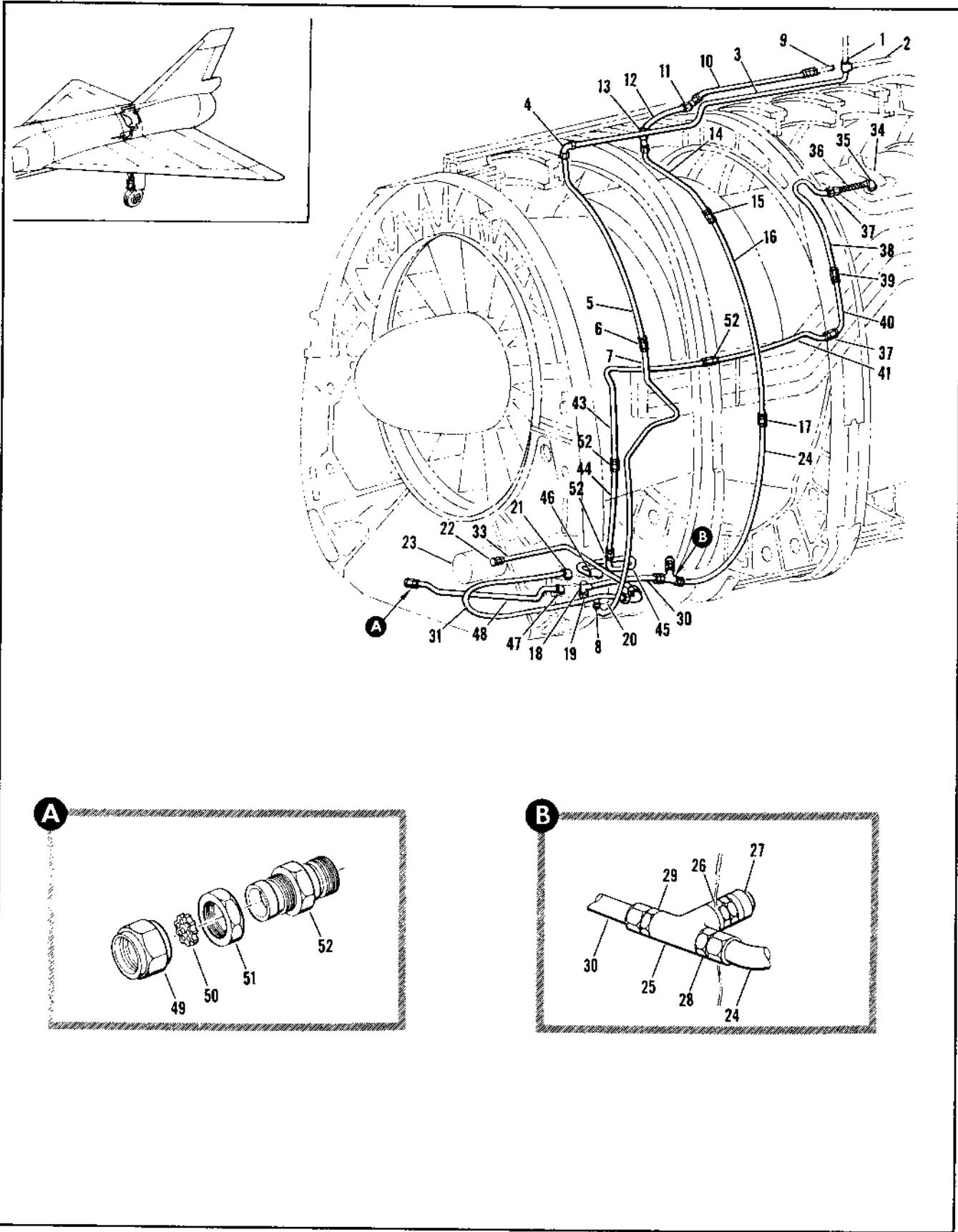

Figure 2.14-35. Elevator and Rudder Airfeel Tubing Installation Sta 472 to Vertical Stabilizer

FIGURE AND INDEX NUMBER	PART NUMBER	DESCRIPTION	UNITS PER ASSY.	USABLE ON CODE	
				FROM	TO
2.14-35	8-42103-5	TUBING INSTALLATION, ELEVATOR AND RUDDER AIRFEEL STA 472 TO VERTICAL STABILIZER MODIFIED BY 8-41109 FOR NHA SEE FIG. 2.3-15	PF	35	43
- 1		• TUBE ASSY, ELEVATOR AND RUDDER AIRFEEL SEE FIG. 2.14-39 INDEX 2	RF		
- 2		• TUBE ASSY, ELEVATOR AND RUDDER AIRFEEL SEE FIG. 2.14-39 INDEX 5	RF		
- 3	8-42103-67	• TUBE ASSY, ELEVATOR AND RUDDER AIRFEEL	1	35	43
- 4	MS21908D4	• ELBOW	1	35	43
	AN924-4D	• NUT	1	35	43
	AN960D716	• WASHER	1	35	43
- 5	58-42103-35	• TUBE ASSY, AIRFEEL	1	35	43
- 6	MS21902D4	• UNION	1	35	43
- 7	8-42103-37	• TUBE ASSY, AIRFEEL	1	35	43
- 8	AN816-4D	• NIPPLE	RF		
- 9		• HOSE, AIRFEEL SEE FIG. 2.14-38	1	35	43
- 10	8-42103-59	• TUBE ASSY, AIRFEEL	1	35	43
- 11	MS21907D10	• ELBOW	1	35	43
	AN924-10D	• NUT	3	35	43
	AN960D1416	• WASHER	1	35	43
- 12	8-42103-61	• TUBE ASSY, AIRFEEL	1	35	43
- 13	MS21907D10	• ELBOW	1	35	43
	AN924-13D	• NUT	1	35	43
	AN960D1416	• WASHER	1	35	43
- 14	8-42103-65	• TUBE ASSY, AIRFEEL	1	35	43
- 15	MS21916012-10	• REDUCER	1	35	43
- 16	8-42103-63	• TUBE ASSY, AIRFEEL	1	35	43
- 17	MS21902D12	• UNION	1	35	43
- 18	AN826-13D	• TEE	1	35	43
- 19	AN929-10	• CAP	PF		
- 20		• REGULATOR, ELEVATOR CONTROL FEEL SYSTEM SEE FIG. 2.14-21	1	35	43
- 21	AN822-8D	• ELBOW	1	35	43
- 22	AN815-8D	• UNION	1	35	43
	AN6290-8	• GASKET	RF		
- 23		• CYLINDER ASSY, ELEVATOR FEEL SEE FIG. 2.14-24	1	35	43
- 24	8-42103-81	• TUBE ASSY, AIRFEEL	1	35	43
- 25	AN930D10	• TEE	1	35	43
- 26	AN919-13D	• REDUCER	1	35	43
- 27	AN924-4	• CAP	1	35	43
	AN960D1416	• WASHER	1	35	43
- 28	MS21916012-10	• REDUCER	1	35	43
- 29	MS21903D10	• UNION	3	35	43
	AN6290-15	• GASKET	1	35	43
	AN924-10D	• NUT	1	35	43
- 30	8-42103-65	• TUBE ASSY, AIRFEEL	1	35	43
- 31	8-42103-75	• TUBE ASSY, AIRFEEL	1	35	43
- 32	AN821-8D	• ELBOW	1	35	43
- 33	8-42103-85	• TUBE ASSY, AIRFEEL	RF		
- 34		• DUCT ASSY, ENGINE BLEED AIR SEE FIG. 2.13-23 INDEX 45	1	35	43
- 35	4190-578015	• ELBOW, <92033> 93-40114-002	1	35	43
- 36	CP111	• HOSE ASSY, FLEX <61481> SPEC 8-00453-140	2	35	43
- 37	MS21903D4	• UNION			

FIGURE AND INDEX NUMBER	PART NUMBER	DESCRIPTION	UNITS PER ASSY.	USABLE ON CODE	
				FROM	TO
		1 2 3 4 5 6			
2.14-15	AN924-40	• NUT	2	35	43
	AN9600716L	• WASHER	2	35	43
- 38	8-89304-41	• TUBE ASSY	1		
- 39	MS21916D4-2	• REDUCER	1	35	43
- 40	8-42103-75	• TUBE ASSY, AIRFEEL	1	35	43
- 41	8-42103-87	• TUBE ASSY, AIRFEEL	1	35	43
- 42	MS21902D2	• UNION	3	35	43
- 43	8-42103-25	• TUBE ASSY, AIRFEEL	1	35	43
- 44	8-42103-45	• TUBE ASSY, AIRFEEL	1	35	43
- 45	8-42103-21	• TUBE ASSY, AIRFEEL	1	35	43
- 46	AN822-20	• ELBOW	1	35	43
- 47	AN822-40	• ELBOW	1	35	43
- 48	8-42103-43	• TUBE ASSY, AIRFEEL	1	35	43
	8-42356	• INLET INSTL, STATIC AIR REGULATOR AIRFEEL FOR NHA SEE FIG. 2.3-12	RF	35	43
- 49	AN818-4	• • NUT	1	35	43
- 50	8-42357	• • SCREEN	1	35	43
- 51	AN924-4	• • NUT	1	35	43
- 52	MS21903-4	• • UNION	1	35	43

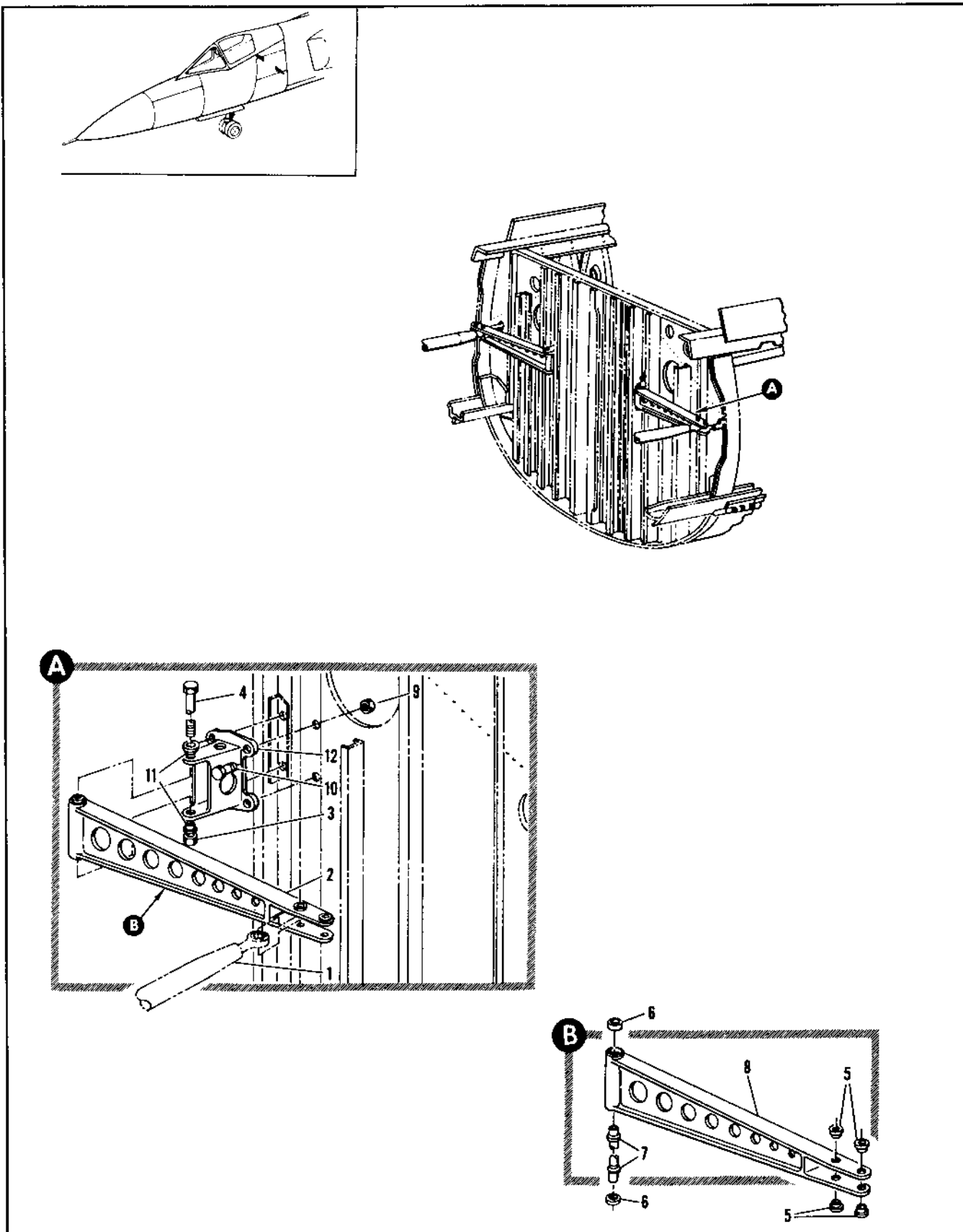

Figure 2.14-36. Elevator and Aileron Control Idler Installation Sta 216

FIGURE AND INDEX NUMBER	PART NUMBER	DESCRIPTION	UNITS PER ASSY.	USABLE ON CODE	
				FROM	TO
				1 2 3 4 5 6	
2.14-36	8-42537	IDLER INSTALLATION, ELEVATOR AND AILERON CONTROL STA 216 FOR NHA SEE FIG. 2.3-4	RF	35	
- 1		• ROD ASSY, ELEVATOR AND AILERON CONTROL SEE FIG. 2.14-15	RF		
- 2	8-42641-1	• IDLER ASSY, ELEVATOR AND AILERON CONTROL STA 216	2	35	129
	8-42641-3	• IDLER ASSY, ELEVATOR AND AILERON CONTROL STA 216 ATTACHING PARTS	2	130	
- 3	MS21243-4	• NUT	2	35	
- 4	AN174-42A	• BOLT	2	35	
		-----X-----			
- 5	NAS77-4-25	• • RUSHING	4	35	
- 6	AN281KP4A	• • BEARING, 90-58000-101	2	35	129
	KP4AF7414	• • BEARING, <21335> 90-58000-017	2	130	
- 7	8-42101-9	• • SPOOL, BEARING SPACER REPLACED SUITABLE SUB 8-42101-21	1	35	129
	8-42101-21	• • SPOOL, BEARING SPACER REPLACES SUITABLE SUB FOR 8-42101-9	1	130	129
- 8	8-42641-7	• • IDLER	1	35	
	8-42653-1	• BRACKET ASSY, ELEVATOR AND AILERON STA 216 ATTACHING PARTS	2	35	
- 9	MS21243-4	• NUT	8	35	
- 10	AN4-7A	• BOLT	8	35	
		-----X-----			
- 11	NAS77-4-34	• • RUSHING	2	35	
- 12	8-42653-7	• • BRACKET	1	35	

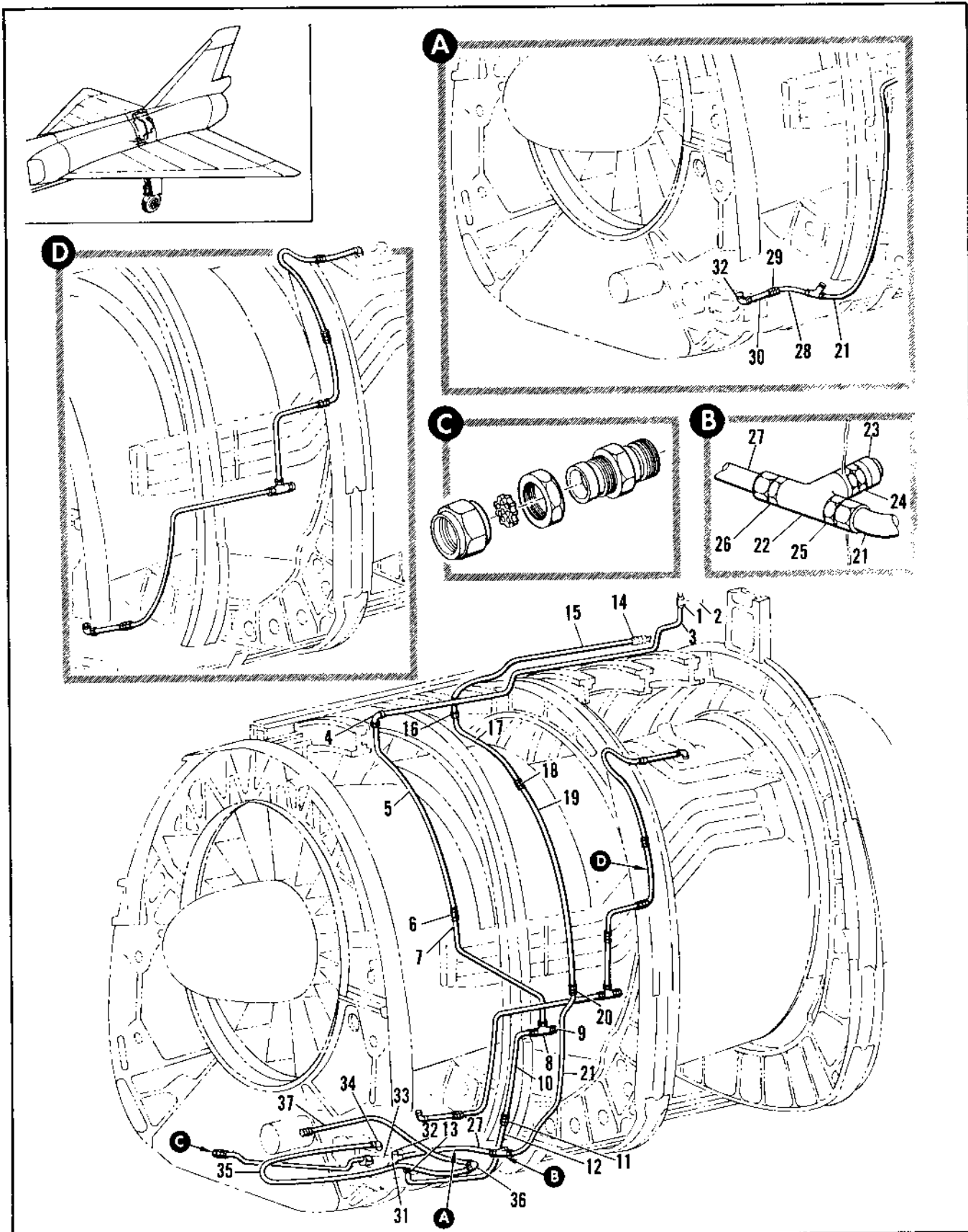

Figure 2.14-37. Elevator and Rudder Airfeel Tubing Installation Sta 472 to Vertical Stabilizer (Sheet 1 of 2)

FIGURE AND INDEX NUMBER	PART NUMBER	DESCRIPTION	UNITS PER ASSY.	USABLE ON CODE	
				FROM	TO
		1 2 3 4 5 6			
2.14-17	4-42103-701	TUBING INSTALLATION, ELEVATOR AND RUDDER AIRFEEL STA 472 TO VERTICAL STABILIZER MODIFIED BY 4-41109 FOR NHA SEE FIG. 2.3-15	RF	44	47
	6-42103-103	TUBING INSTALLATION, ELEVATOR AND RUDDER AIRFEEL STA 472 TO VERTICAL STABILIZER MODIFIED BY 4-41109 FOR NHA SEE FIG. 2.3-15	RF	48	
- 1		• TUBE ASSY, ELEVATOR AND RUDDER AIRFEEL SEE FIG. 2-14-39 INDEX 2	RF		
- 2		• TUBE ASSY, ELEVATOR AND RUDDER AIRFEEL SEE FIG. 2.14-39 INDEX 5	RF		
- 3	4-42103-67	• TUBE ASSY, AIRFEEL	1	44	
- 4	MS2190604	• FLOW	1	44	
	AN924-40	• NUT	1	44	
	AN9600716	• WASHER	1	44	
- 5	4-42103-103	• TUBE ASSY, AIRFEEL	1	44	
- 6	MS2190204	• UNION	1	44	
- 7	4-42103-105	• TUBE ASSY, AIRFEEL	1	44	
- 8	MS2191204	• TEE	1	44	
- 9	MS21914-4	• CAP	1	44	
	AN924-40	• NUT	1	44	
	AN9600716	• WASHER	1	44	
- 10	4-42103-49	• TUBE ASSY, AIRFEEL	1	44	
- 11	MS2190204	• UNION	1	44	
- 12	4-42103-47	• TUBE ASSY, AIRFEEL	1	44	
- 13	AN810-40	• NIPPLE	1	44	
- 14		• HOSE AIRFEEL SEE FIG. 2.14-38 INDEX 5	RF		
- 15	4-42103-57	• TUBE ASSY, AIRFEEL	1	44	
- 16	MS21907016	• FLOW	1	44	
	AN924-100	• NUT	1	44	
	AN9600716	• WASHER	1	44	
- 17	4-42103-05	• TUBE ASSY, AIRFEEL	1	44	
- 18	MS21916010	• REDUCER	1	44	
- 19	4-42103-03	• TUBE ASSY, AIRFEEL	1	44	
- 20	MS21902012	• UNION	1	44	
- 21	4-42103-81	• TUBE ASSY, AIRFEEL	1	44	
- 22	AN918010	• TEE	1	44	
- 23	MS21914-4	• CAP	1	44	
- 24	MS21903010	• UNION	1	44	
- 25	MS21916010	• REDUCER	1	44	
	AN6230-10	• GASKET	1	44	
	AN924-100	• NUT	1	44	XXX
	AN9600716	• WASHER	1	44	XXX
- 26	MS21916010	• REDUCER	1	44	XXX
- 27	4-42103-03	• TUBE ASSY, AIRFEEL	1	44	61
- 28	4-42103-121	• TUBE ASSY, AIRFEEL	1	61	XXX
- 29	MS21902010	• UNION	1	61	XXX
- 30	4-42103-125	• TUBE ASSY, AIRFEEL	1	61	
- 31	AN526-100	• TEE	1	44	XXX
- 32	AN924-10	• CAP	1	44	XXX
- 33		• REGULATOR, ELEVATOR CONTROL FEEL SYSTEM SEE FIG. 2.14-21 INDEX 2	RF		
- 34	AN822-60	• FLOW	1	44	
- 35	4-42103-79	• TUBE ASSY, AIRFEEL	1	44	
- 36	AN921-40	• FLOW	1	44	
- 37	4-42103-05	• TUBE ASSY, AIRFEEL	1	44	

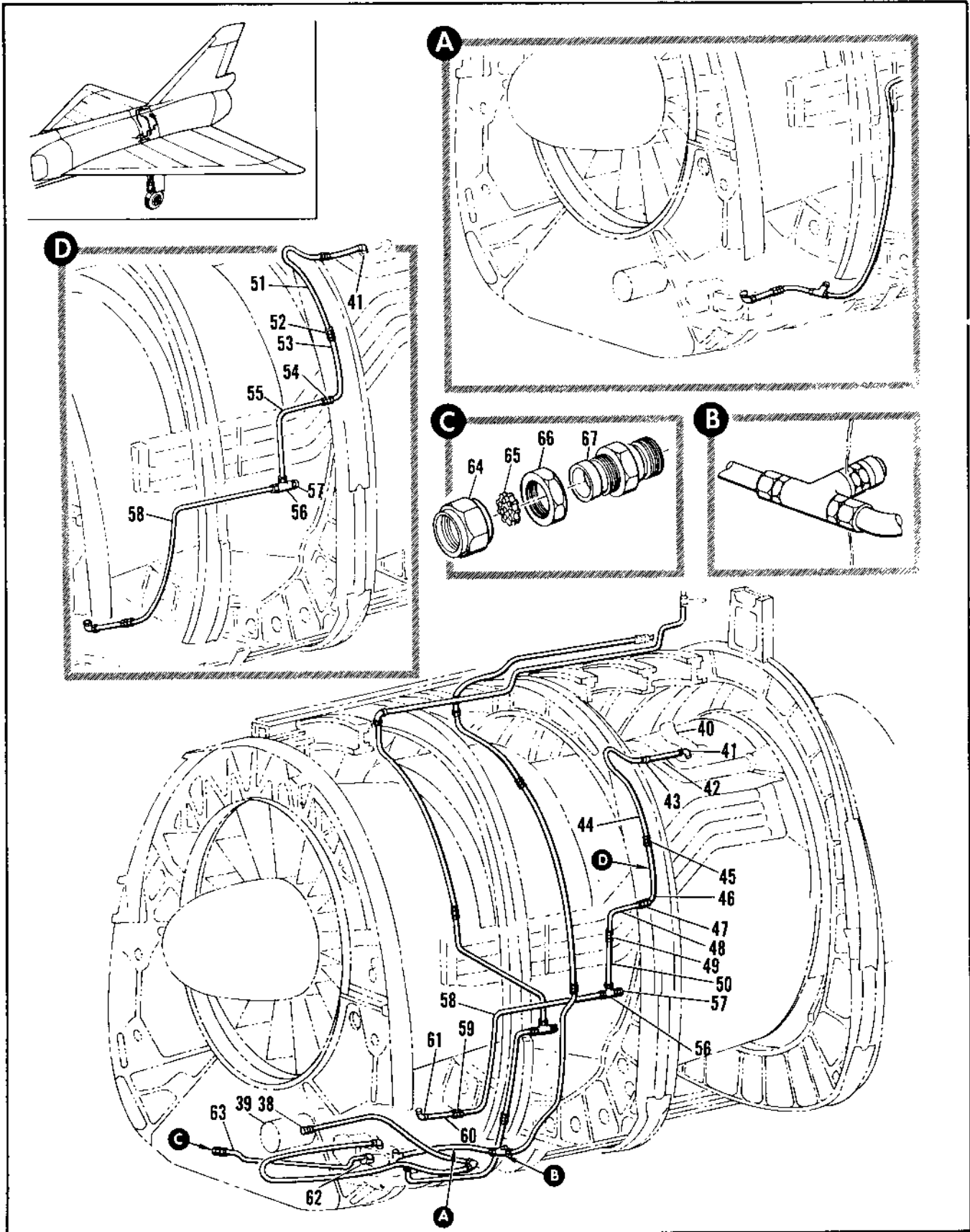

Figure 2.14-37. Elevator and Rudder Airfeel Tubing Installation Sta 472 to Vertical Stabilizer (Sheet 2 of 2)

FIGURE AND INDEX NUMBER	PART NUMBER	DESCRIPTION	UNITS PER ASSY.	USABLE ON CODE	
				FROM	TO
2.14-37- 38	AN815-8D	• UNION	1	44	
	AN6290-8	• GASKET	1	44	
- 39		• CYLINDER ASSY, ELEVATOR FEEL SEE FIG. 2.14-24 INDEX 43	RF		
- 40		• DUCT ASSY, BLEED AIR SEE FIG. 2.13-23 INDEX 45	1	44	
- 41	4190-57R13	• ELBOW, <92°CS> 93-40013-001	1	44	
- 42	C9111	• HOSE, <14P1> SPEC R-00483-1+0	1	44	
- 43	MS2190304	• UNION	1	44	
	AN924-4D	• NUT	1	44	
	AN9690716L	• WASHER	1	A	
- 44	R-80384-91	• TUBE ASSY	1	A	
- 45	MS2191604-2	• REDUCER	1	44	47
- 46	R-42103-74	• TUBE ASSY, AIRFEEL	1	44	47
- 47	MS2190304	• UNION	1	44	47
- 48	R-42103-93	• TUBE ASSY, AIRFEEL	1	44	47
- 49	MS2190202	• UNION	1		
- 50	R-42103-92	• TUBE ASSY, AIRFEEL	1	48	277
- 51	R-80384-97	• TUBE ASSY	1	48	277
- 52	MS2191604-2	• REDUCER	1	48	
- 53	R-42103-107	• TUBE ASSY, AIRFEEL	1	48	
- 54	MS2190202	• UNION	1	44	
- 55	R-42103-109	• TUBE ASSY, AIRFEEL	1	44	
- 56	MS21912-20	• TEE	1	44	
- 57	MS21914-2	• CAP	1	44	
	AN924-2D	• NUT	1	44	
	AN9690516	• WASHER	1	44	
- 58	R-42103-91	• TUBE ASSY, AIRFEEL	1	44	67
- 59	MS2190202	• UNION	1	44	
- 60	R-42103-89	• TUBE ASSY, AIRFEEL	1	61	
	R-42103-121	• TUBE ASSY, AIRFEEL	1	44	
- 61	AN822-2D	• ELBOW	1	44	
- 62	AN822-4D	• ELBOW	1	44	
- 63	R-42103-45	• TUBE ASSY, AIRFEEL	RF	44	
	R-42356	• INLET INSTL, STATIC AIR REGULATOR AIRFEEL FOR NMA SEE FIG. 2.3-1c	1	44	
- 64	AN818-4	• NUT	1	44	
- 65	R-42357	• SCREW	1	44	
- 66	AN924-4	• NUT	1	44	
- 67	MS21903-4	• UNION	1	44	

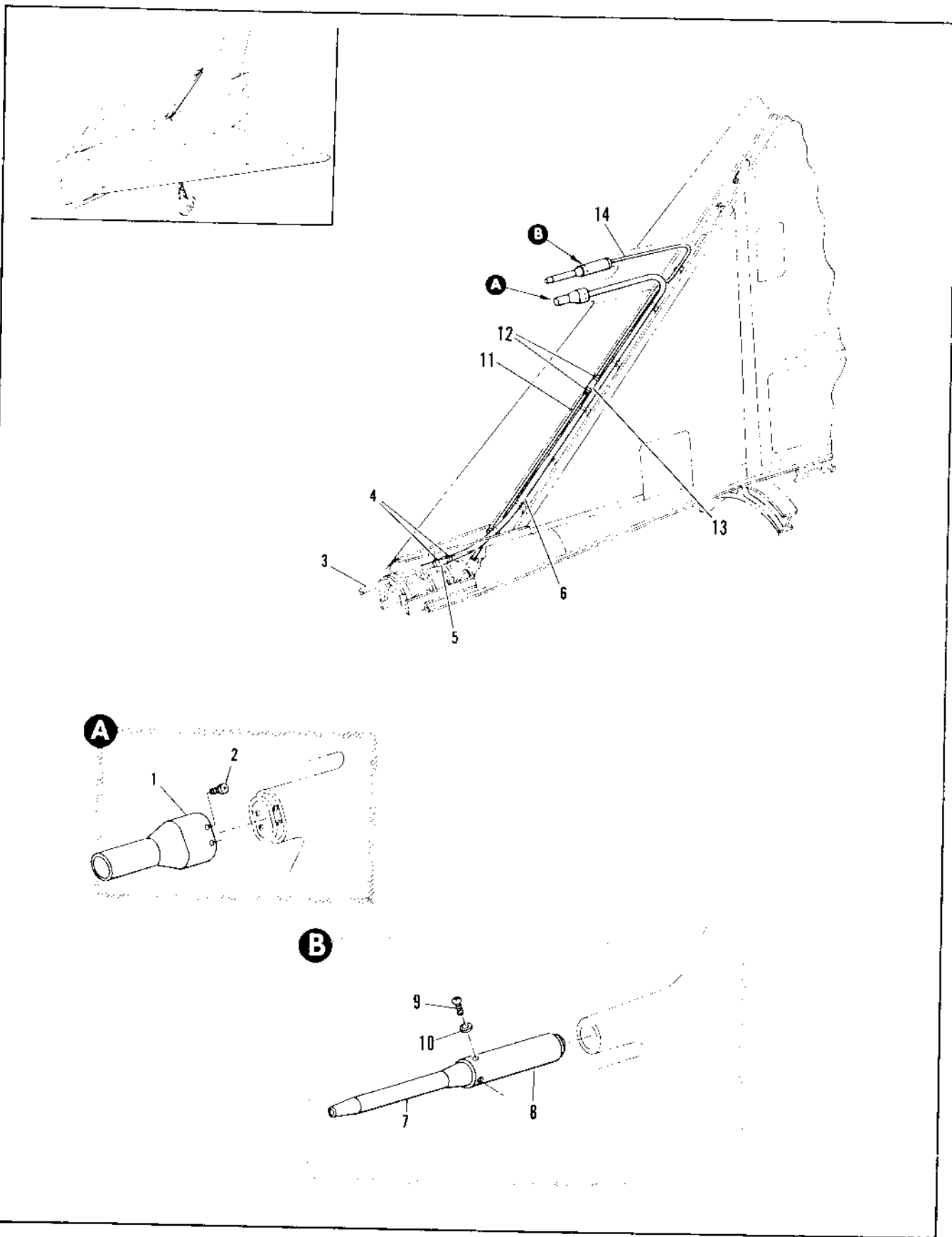

Figure 2.14-38. Elevator and Rudder Airfeel Intake Installation

FIGURE AND INDEX NUMBER	PART NUMBER	DESCRIPTION 1 2 3 4 5 6	UNITS PER ASSY.	USABLE ON CODE	
				FROM	TO
2.14-18	8-42332-1	INTAKE INSTALLATION, ELEVATOR AND RUDDER AIRFEEL MODIFIED BY 8-4110" FOR NHA SEE FIG. 2.7-6	RF	30	
- 1	8-42335 11480	• INTAKE, AIRFEEL ALTERED FROM 11480 • INTAKE, AIRFEEL WITH HEATING ELEMENT <97926> SPEC 8-04273 ATTACHING PARTS	1 RF	35	
- 2	AN525-832R5	• SCREW -----X-----	4	35	
- 3		• TUBE ASSY, AIRFEEL SEE 2.14-35 INDEX 10	RF		
- 4	AN737TW34	• CLAMP, HOSE	2	35	
- 5	8-42332-13	• HOSE, AIRFEEL	1	35	
- 6	8-42332-21	• TUBE, AIRFEEL	1	35	
- 7	AN5813-1	• TUBE, PITOT	1	35	
- 8	42413410	• SLEEVE ASSY, PITOT STATIC ATTACHING PARTS	1		
- 9	AN521-6R4	• SCREW	4	35	
- 10	AN933-6	• WASHER -----X-----	4	35	
- 11		• TUBE ASSY, ELEVATOR AND RUDDER AIRFEEL SEE FIG. 2.14-39 INDEX 2	RF		
- 12	AN737TW22	• CLAMP, HOSE	2	35	
- 13	8-42332-11	• HOSE, ELEVATOR AND RUDDER AIRFEEL INTAKE	1	35	
- 14	8-42332-23	• TUBE, PITOT AIRFEEL	1	35	

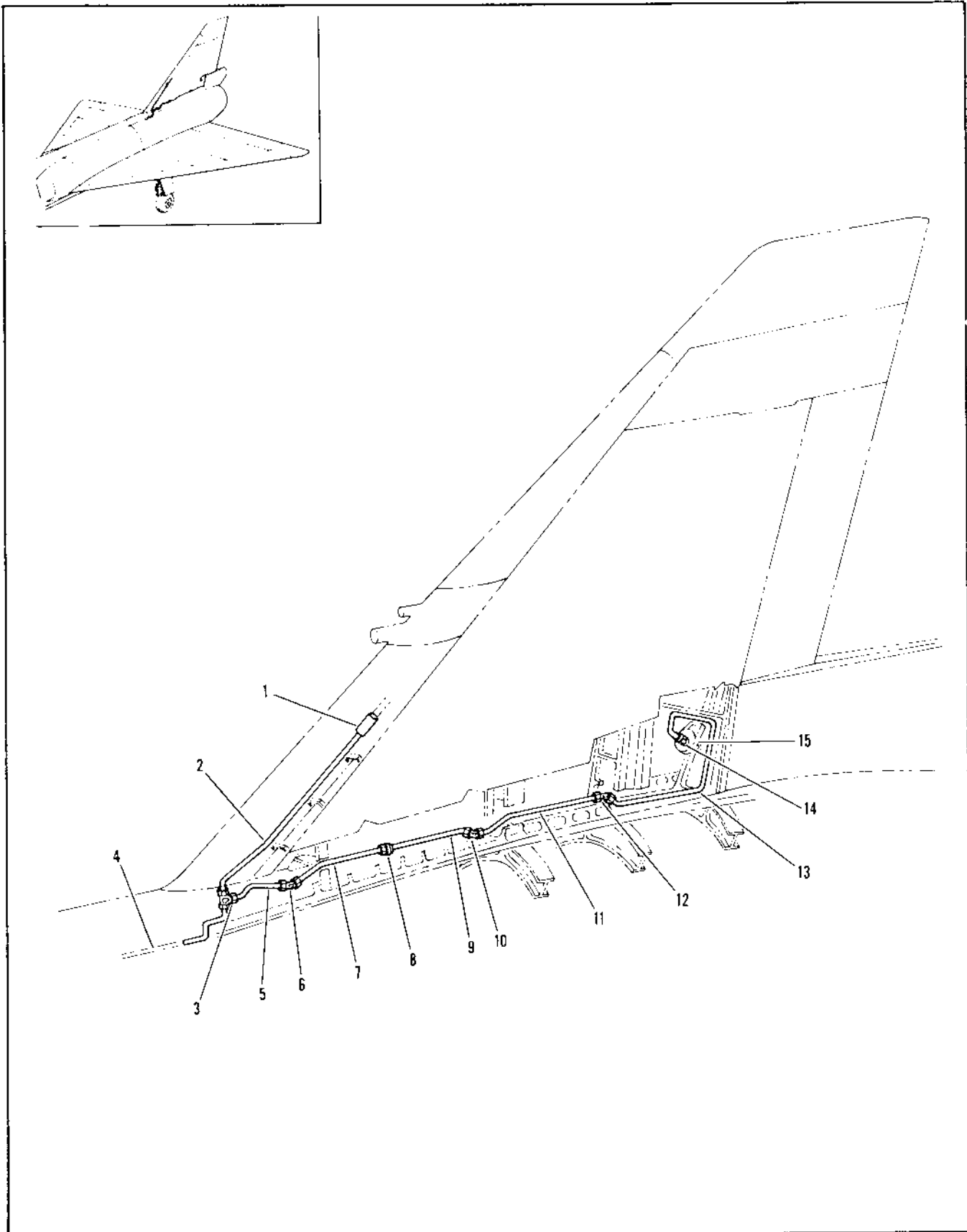

Figure 2.14-39. Vertical Stabilizer Elevator and Rudder Airfeel Tubing Installation

FIGURE AND INDEX NUMBER	PART NUMBER	DESCRIPTION	UNITS PER ASSY.	USABLE ON CODE	
				FROM	TO
		1 2 3 4 5 6			
2.14-39	8-42103-1	TUBING INSTALLATION, ELEVATOR AND RUDDER AIRFEEL VERTICAL STABILIZER MODIFIED BY B-41109 FOR NHA SEE FIG. 2.3-15	RF	35	
- 1		• HOSE, AIRFEEL INTAKE ELEVATOR AND RUDDER SEE FIG. 2.14-38	RF		
- 2	8-42103-7	• TUBE ASSY, AIRFEEL ELEVATOR AND RUDDER	1	35	
- 3	MS21912D4	• TEE	1	35	
	AN924-40	• NUT	1	35	
	AN963D716L	• WASHER	1	35	
- 4		• TUBE ASSY, AIRFEEL ELEVATOR AND RUDDER SEE FIG. 2.14-35 INDEX 3	RF		
- 5	8-42103-9	• TUBE ASSY, AIRFEEL ELEVATOR AND RUDDER	1	35	
- 6	MS21907D4	• ELBOW	1	35	
	AN924-40	• NUT	1	35	
- 7	8-42103-11	• TUBE ASSY, AIRFEEL ELEVATOR AND RUDDER	1	35	
- 8	MS21902D4	• UNION	1	35	
- 9	8-42103-13	• TUBE ASSY, AIRFEEL ELEVATOR AND RUDDER	1	35	
- 10	MS21907D4	• ELBOW	1	35	
	AN924-40	• NUT	1	35	
- 11	8-42103-15	• TUBE ASSY, AIRFEEL ELEVATOR AND RUDDER	1	35	
- 12	MS21907D4	• ELBOW	1	35	
	AN924-40	• NUT	1	35	
- 13	8-42103-17	• TUBE ASSY, AIRFEEL ELEVATOR AND RUDDER	1	35	
- 14	MS21902D4	• UNION	1	35	
	AN924-4	• GASKET	1	35	
- 15		• REGULATOR ASSY, VARIABLE AIR PRESSURE SEE FIG. 2.14-1 INDEX 21	RF		

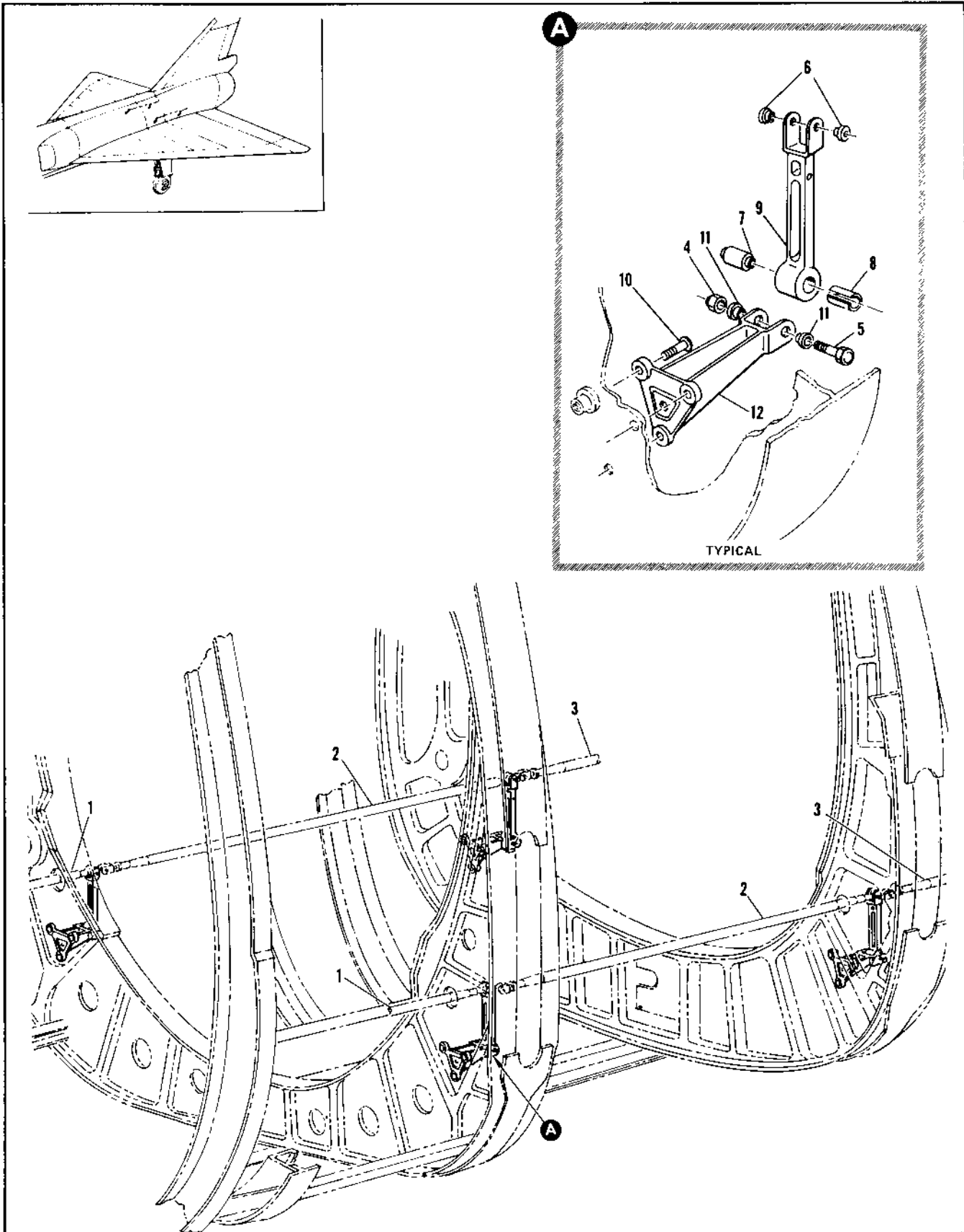

Figure 2.14-40. Elevon Control Idler Installation Sta 524

FIGURE AND INDEX NUMBER	PART NUMBER	DESCRIPTION	UNITS PER ASSY.	USABLE ON CODE	
				FROM	TO
		1 2 3 4 5 6			
2.14-40	8-42554	IDLER INSTALLATION, ELEVON CONTROL STA 524 MODIFIED BY 8-41111 FOR NHA SEE FIG. 2.3-16	RF	35	
	8-42563	IDLER INSTALLATION, ELEVON CONTROL STA 561 MODIFIED BY 8-41111 FOR NHA SEE FIG. 2.3-16	RF	35	
- 1		• ROD ASSY, CONTROL LINKAGE SEE FIG. 2.14-15 INDEX 86	RF		
- 2		• ROD ASSY, CONTROL LINKAGE SEE FIG. 2.14-15 INDEX 96	RF		
- 3		• ROD ASSY, LOAD RELIEF SEE FIG. 2.14-15 INDEX 105	RF		
	8-42630-3	• IDLER ASSY, ELEVON CONTROL REPLACED BY INTCHG WITH 8-42630-5	2	35	48
	8-42553-1	• IDLER ASSY, ELEVON CONTROL ALT INTCHG WITH 8-42630-3	RF	35	48
	8-42630-5	• IDLER ASSY, ELEVON CONTROL REPLACES INTCHG WITH 8-42630-3 REPLACED BY SUITABLE SUB 8-42630-801	2	49	129
	8-42630-801	• IDLER ASSY, ELEVON CONTROL REPLACES SUITABLE SUB FOR 8-42630-5 ATTACHING PARTS	2	130	
- 4	MS21043-4	• NUT	2	35	
- 5	NAS464-4422	• BOLT -----X-----	2	35	
- 6	NAS77-4-21	• • BUSHING	2	35	
- 7	98-14030-537	• • SLEEVE	1	35	
- 8	DW4KE6549	• • BEARING, <21335> 90-54002-012	1	35	48
	DW4KF6536	• • BEARING, <21335> 90-54002-006 USE WITH 8-42553-1 REPLACED BY SUITABLE SUB DW4KE7414	4F	35	48
	DW4K	• • BEARING, <21335> 90-54002-001 REPLACED BY SUITABLE SUB DW4KE7414	1	49	129
	DW4KF7414	• • BEARING, <21335> 90-54002-013 REPLACES SUITABLE SUB DW4KE6536 OR DW4K	1	130	
- 9	8-42630-11	• • IDLER	1	35	
	8-42553-7	• • IDLER, USE WITH 8-42553-1	RF	35	48
	8-42631-1	• SUPPORT ASSY, ELEVON CONTROL ATTACHING PARTS	2	35	
- 10	NAS221-13	SCREW REPLACED BY INTCHG, WITH BOLT AN3H7A	6	35	47
	AN3H7A	BOLT, REPLACES INTCHG WITH SCREW NAS221-13	6	48	
	NAS688-43	• NUT	6	48	
	NAS221-14	SCREW REPLACED BY INTCHG WITH BOLT AN3H7A	6	48	
	AN3H7A	BOLT, REPLACES INTCHG WITH SCREW NAS221-14 -----X-----	2	35	
- 11	NAS77-4-21	• • BUSHING	1	35	
- 12	8-42631-7	• • SUPPORT	1	35	

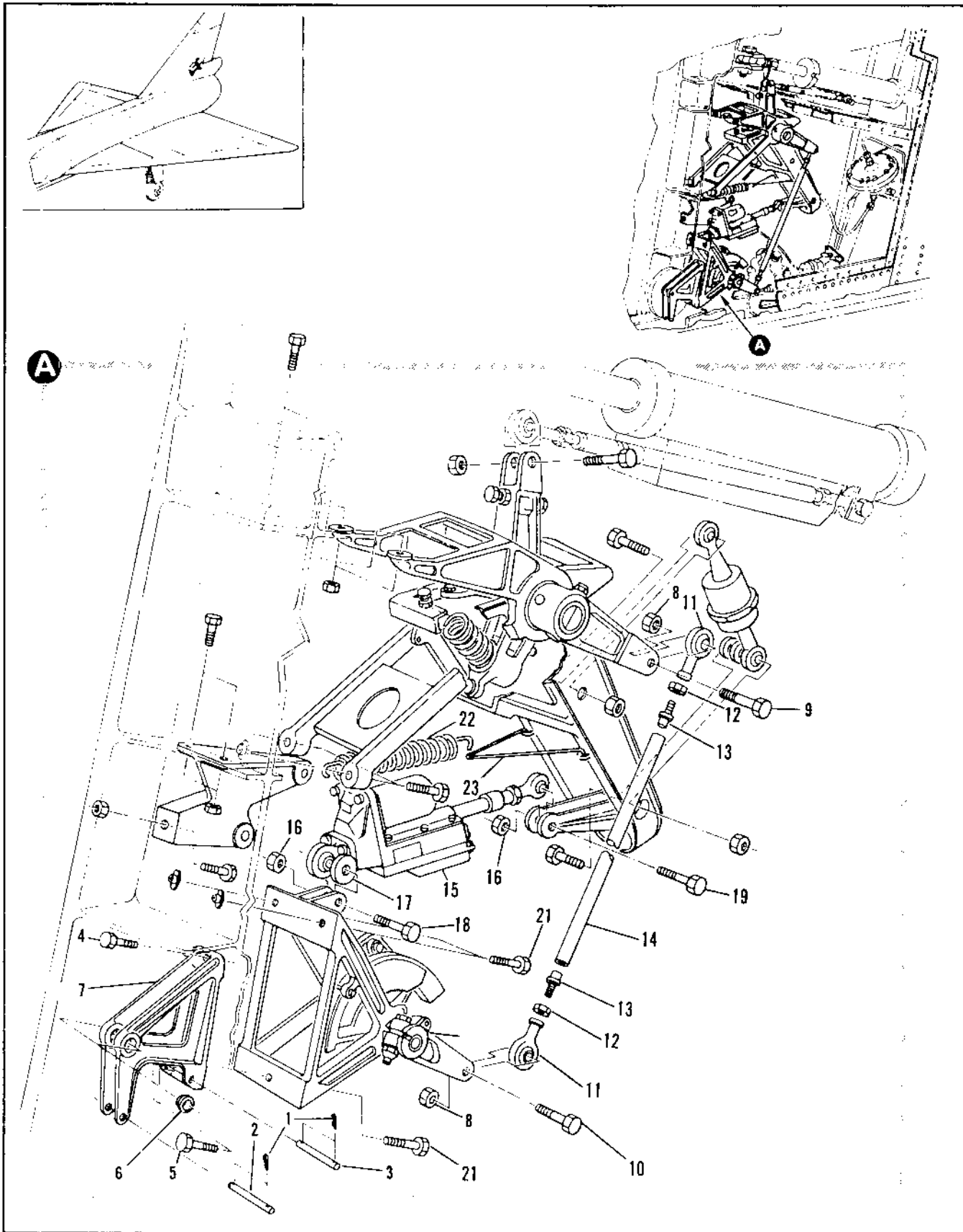

Figure 2.14-41. Rudder Trim and Feel Control Installation (Sheet 1 of 2)

FIGURE AND INDEX NUMBER	PART NUMBER	DESCRIPTION	UNITS PER ASSY.	USABLE ON CODE	
				FROM	TO
		1 2 3 4 5 6			
2.14-41	8-42209-3	CONTROL INSTALLATION, RUDDER TRIM AND FEEL	RF	35	
- 1	AN380-2-1	• PIN, COTTER (88044)	4	35	
- 2	NAS427W19	• PIN (80205)	1	35	
- 3	NAS427W38	• PIN (80205)	1	35	
	8-42661-1	• SUPPORT ASSY, RUDDER PULLEY ATTACHING PARTS	1	35	
- 4	AN4-6A	• BOLT (88044)	1	35	
- 5	AN4-10A	• BOLT (88044)	2	35	
		-----X-----			
- 6	NAS77-5-32	• BUSHING (80205)	2	35	
- 7	8-42661-7	• SUPPORT	1	35	
	64A33155-827	• ROD ASSY, TRIM AND FEEL RUDDER CONTROL LINKAGE (98750)	1	35	129
	64A33155-601	• ROD ASSY, TRIM AND FEEL RUDDER CONTROL LINKAGE (98750) ATTACHING PARTS	1	130	
- 8	MS21244-4	• NUT (96906)	2	35	
- 9	MS27576-4-17	• BOLT (96906)	1	35	
- 10	MS27576-4-19	• BOLT (96906)	1	35	
		-----X-----			
- 11	RE4F5	• BEARING, <21335> 90-60002-001	2	35	129
	RE4F5E7414	• BEARING, <21335> 90-60002-009	2	130	
	RE4F5	• BEARING, <21335> 90-60002-001 ALT INTCHG WITH RE4F5E7414	RF	130	
- 12	AN316-5R	• NUT (88044)	2	35	
- 13	64F33114-11	• CONNECTOR (98750)	2	35	
- 14	8-42100-41	• TUBE	1	35	
- 15	31381	• ACTUATOR ASSY, RUDDER TRIM <35351> SPEC 8-04267-801 ATTACHING PARTS	1	35	
- 16	MS21043-4	• NUT (96906)	2	35	
- 17	8-48106-11	• WASHER	1	35	
- 18	NAS464P4A14	• BOLT (80205)	1	35	
- 19	NAS464P4A17	• BOLT (80205)	1	35	
		-----X-----			
- 20	R75-10002-30-1A	• REGULATOR ASSY, RUDDER CABLE TENSION (45402) SPEC 8-04247-1 T.O.16R1-2-3-33 REPLACED BY SUITABLE SUB R75-10002-30-2A	1	35	129
	R75-10002-30-2A	• REGULATOR, ASSY RUDDER CABLE TENSION <45402> SPEC 8-04247-3 T.O.16R1-2-3-33 REPLACES SUITABLE SUB FOR R75-10002-30-1A ATTACHING PARTS	1	130	
- 21	AN4-6A	• BOLT (88044)	3	35	
		-----X-----			
- 22	8-42225	• SPRING, RUDDER TRIM ACTUATOR	1	35	
- 23	8-42230	• CONNECTOR, RUDDER TRIM ACTUATOR	1	35	

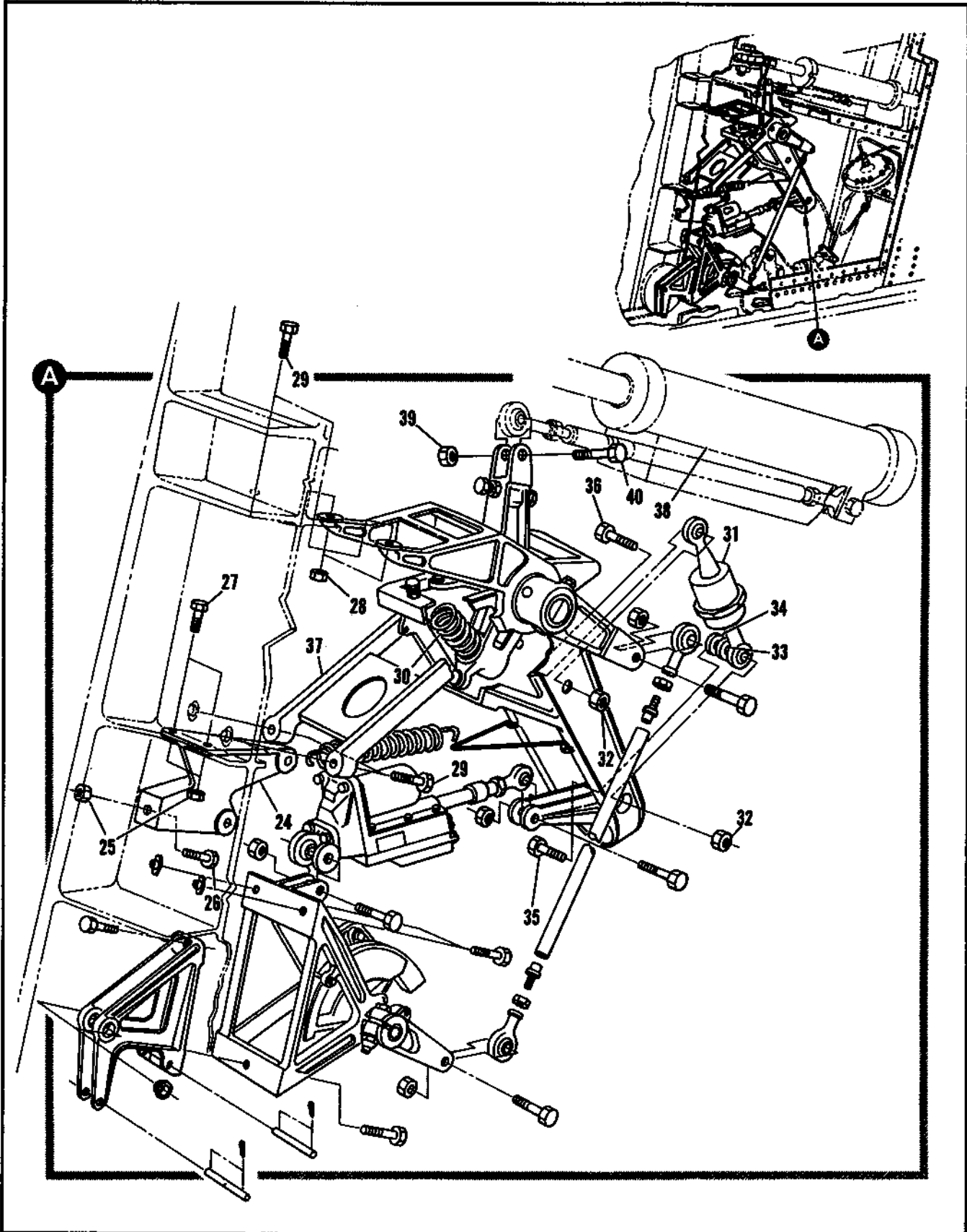

Figure 2.14-41. Rudder Trim and Feel Control Installation (Sheet 2 of 2)

FIGURE AND INDEX NUMBER	PART NUMBER	DESCRIPTION	UNITS PER ASSY.	USABLE ON CODE	
				FROM	TO
2.14-41- 24	6-42688-11 8-42239-1	• SUPPORT, POTENTIOMETER • SUPPORT, POTENTIOMETER ALT INTERG WITH 6-42688-11 ATTACHING PARTS	1 RF	35 35	188 188
- 25	MS21043-3	• NUT	3	35	188
- 26	AN3-5A	• BOLT	1	35	188
- 27	AN3-5A	• BOLT	2	35	188
	8-42209-11 8-42209-1B	• CONTROL ASSY, TRIM AND FEEL • CONTROL ASSY, TRIM AND FEEL ATTACHING PARTS	1 1	35 130	129
- 28	MS21043-4	• NUT	2	35	
- 29	AN4-5A	• BOLT	4	35	
- 30	8-42219	• SPRING, CENTERING	1	35	129
- 31	60027-1	• CYLINDER ASSY, RUDDER FEEL <96215> SPEC 8-10421-3 T.O. 02-3-17-33 REPLACED BY SUITABLE SUP 60027-2	1	130	
	60027-2	• CYLINDER ASSY, RUDDER FEEL <96215> SPEC 8-10421-9 T.O. 02-3-17-33 REPLACES SUITABLE SUP FOR 60027-1 ATTACHING PARTS	2	35	
- 32	MS21043-4	• NUT	1	35	
- 33	R-40106	• WASHER	1	35	
- 34	R-40106-11	• WASHER	1	35	
- 35	NAS464P4A20	• BOLT	1	35	
- 36	NAS464P4A17	• BOLT	1	35	129
- 37	8-42209-15	• CONTROL ASSY, RUDDER TRIM AND FEEL FOR BREAKDOWN SEE FIG. 2.14-42	1	150	
	6-42239-17	• CONTROL ASSY, RUDDER TRIM AND FEEL FOR BREAKDOWN SEE FIG. 2.14-42	RF		
- 38		• ACTUATOR ASSY, SERVO VALVE CONTROL RUDDER SEE FIG. 2.14-43 INDEX 2	1	35	
- 39	MS21244-4	• NUT	1	35	
- 40	MS27576-4-17	• BOLT			

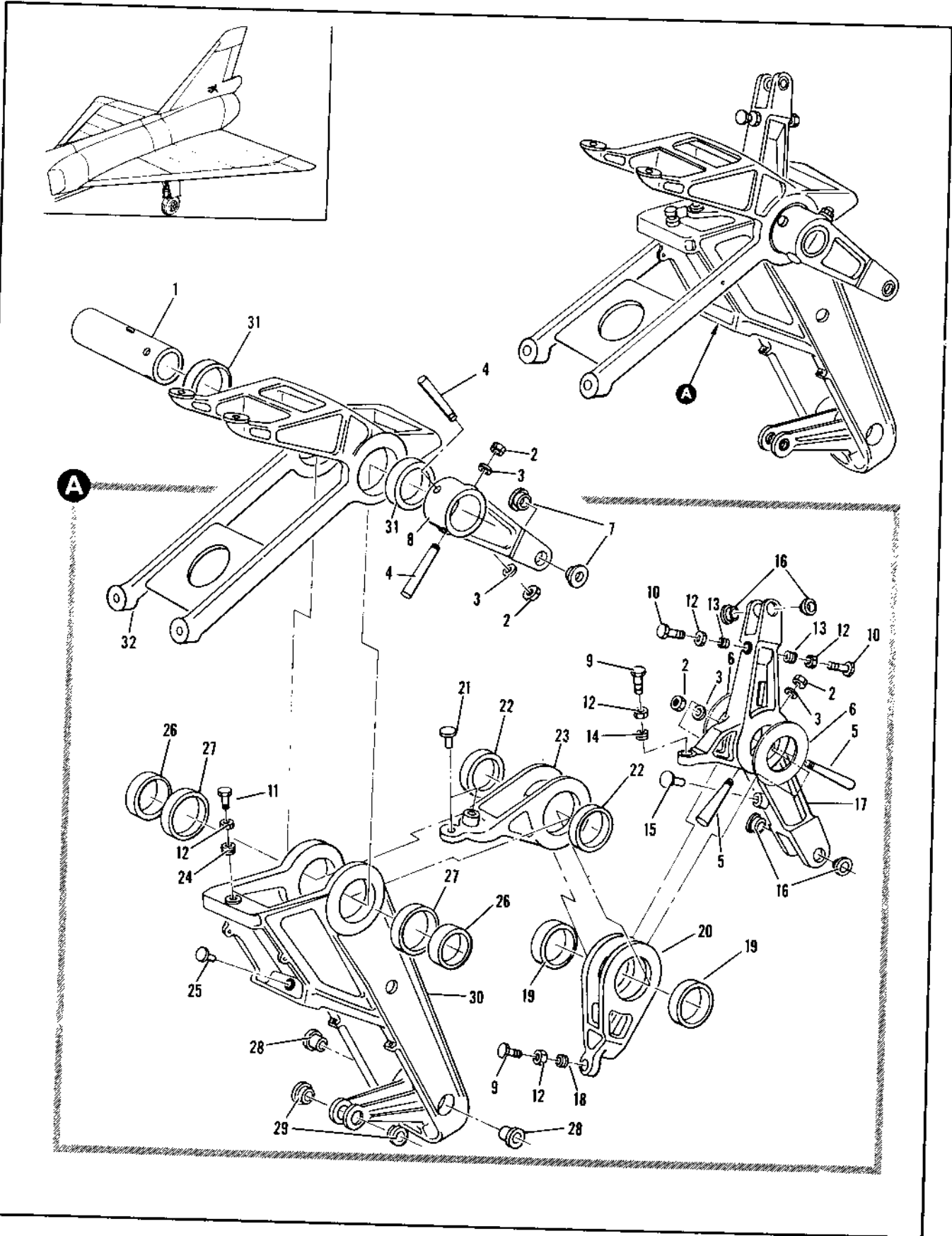

Figure 2.14-42. Rudder Trim and Feet Control Assembly

FIGURE AND INDEX NUMBER	PART NUMBER	DESCRIPTION	UNITS PER ASSY.	USABLE ON CODE	
				FROM	TO
2.14-42	R-42209-13	CONTROL ASSEMBLY, RUDDER TRIM AND FEEL MODIFIED BY 6-4-1111	RF	35	129
	R-42209-17	FOR NHA SEE FIG. 2.14-41 CONTROL ASSEMBLY, RUDDER TRIM AND FEEL FOR NHA SEE FIG. 2.14-41	RF	130	
	- 1 R-42211	* SHAFT, RUDDER TRIM AND FEEL ATTACHING PARTS	1	35	
	- 2 MS21543-3	* NUT	4	35	
	- 3 AN975-3	* WASHER	4	35	
	- 4 AN386-1-15A	* PIN	2	35	
	- 5 AN386-1-15A	* PIN	2	35	
	- 6 R-42238	-----X----- * WASHER, RUDDER TRIM	2	35	
	6-42607-1	* BELL CRANK ASSY, RUDDER STA 657	1	35	
	- 7 NAS77-4-18	* BUSHING	2	35	
	- 8 6-42607-7	* BELL CRANK	1	35	
	- 9 NAS42R-4-10	* BOLT	2	35	
	- 10 NAS42R-4-7	* BOLT	2	35	
	- 11 NAS42E-4-13	* BOLT	1	35	
	- 12 AN316-4R	* NUT	5	35	
	R-42608-3	* BELL CRANK ASSY, RUDDER CONTROL TRIM AND FEEL STA 657	1	35	
	- 13 1191-4CNX1/2	* INSERT (91767) 95-33000-011	2	35	
	- 14 1191-4CNX1/4	* INSERT (91767) 95-03000-010	1	35	
	- 15 R-49789	* PAD, THROTTLE CRANK STOP	1	35	
	- 16 NAS77-4-18	* BUSHING	4	35	
	- 17 R-42608-9	* BELL CRANK	1	35	129
	R-42604-1	* SUPPORT ASSY, CENTERING SPRING LOWER REPLACED BY SUITABLE SUB R-42604-3	1	35	129
	R-42604-3	* SUPPORT ASSY, CENTERING SPRING LOWER REPLACES SUITABLE SUB FOR R-42604-1	1	130	
	- 18 1191-4CNX1/4	* INSERT, (91767) 95-33000-010	2	35	129
	- 19 B542DD	* BEARING, (21335) 90-58003-006	2	130	
	B542DDE7414	* BEARING, (21335) 90-59003-017	RF	130	
	B542DD	* BEARING, (21335) 90-58003-006 ALT INTCHG WITH B542DDE7414	1	35	
	- 20 R-42604-7	* SUPPORT	1	35	129
	R-42604-61	* SUPPORT ASSY, CENTERING SPRING UPPER REPLACED BY SUITABLE SUB R-42605-3	1	130	
	R-42605-3	* SUPPORT ASSY, CENTERING SPRING UPPER REPLACES SUITABLE SUB FOR R-42605	1	130	
	- 21 R-49789	* PAD, THROTTLE CRANK STOP	2	35	129
	- 22 B542DD	* BEARING, (21335) 90-58003-006	2	130	
B542DDE7414	* BEARING, (21335) 90-59003-017	RF	130		
B542DD	* BEARING, (21335) 90-58003-006 ALT INTCHG WITH B542DDE7414	1	35		
- 23 R-42605-7	* SUPPORT	1	35	129	
R-42611-1	* SUPPORT ASSY, RUDDER TRIM AND FEEL REPLACED BY SUITABLE SUB R-42611-3	1	130		
R-42611-3	* SUPPORT ASSY, RUDDER TRIM AND FEEL REPLACES SUITABLE SUB FOR R-42611-1	1	130		
- 24 1191-4CNX3/8	* INSERT, (91767) 95-03000-004	1	35		
- 25 R-49789	* PAD, THROTTLE CRANK STOP	1	35	129	
- 26 AN202KP21B	* BEARING, 90-58003-006	2	130		
KP21BE7414	* BEARING, (21335) 90-58005-006	RF	130		
AN202KP21B	* BEARING, ALT INTCHG WITH KP21BE7414	2	35		
98-14000-017	* SLEEVE	2	35		
- 27 NAS77-4-50	* BUSHING	2	35		
- 28 NAS77-4-18	* BUSHING	2	35		
- 29 R-42611-7	* SUPPORT	1	35		
- 30 R-42609-3	* SUPPORT ASSY, RUDDER TRIM AND FEEL REPLACED BY SUITABLE SUB R-42609-5	1	35	129	
R-42609-5	* SUPPORT ASSY, RUDDER TRIM AND FEEL REPLACES SUITABLE SUB FOR R-42609-3	1	130		
- 31 AN202KP21B	* BEARING, 90-58003-006	2	35	129	
KP21BE7414	* BEARING, (21335) 90-58005-006	2	130		
AN202KP21B	* BEARING, ALT INTCHG WITH KP21BE7414	RF	130		
- 32 R-42609-11	* SUPPORT	1	35		

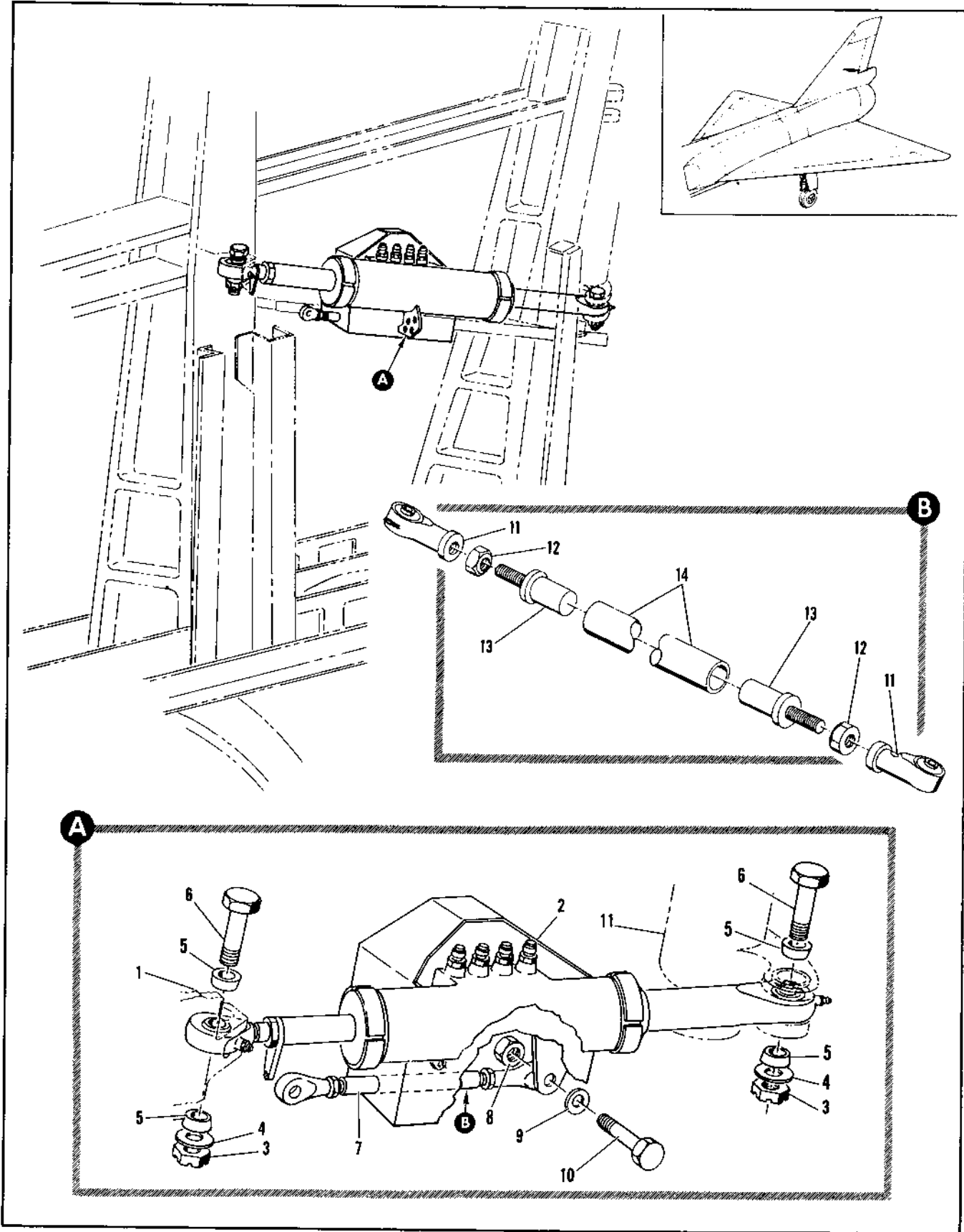

Figure 2.14-43. Servo Valve Rudder Actuator Installation

FIGURE AND INDEX NUMBER	PART NUMBER	DESCRIPTION 1 2 3 4 5 6	UNITS PER ASSY.	USABLE ON CODE	
				FROM	TO
2.14-43	R-82007	ACTUATOR INSTALLATION, SERVO VALVE RUDDER MODIFIED BY 9-69686 AND 9-80131 FOR NHA SEE FIG. 2.7-6	RF	35	
- 1		• SPAR, SEE FIG. 364-28	RF		
- 2	100700-7	• ACTUATOR ASSY, SERVO VALVE CONTROL RUDDER <81873> SPEC 8-08481-807 T.O.9H8-14-51-104 REPLACED BY SUITABLE SUB 100700-11	1	35	129
	100700-9	• ACTUATOR ASSY, SERVO VALVE CONTROL RUDDER <81873> SPEC 8-08481-807 T.O.9H8-14-51-104 ALT INTCHG WITH 100700-7	RF	35	129
	100700-11	• ACTUATOR RUDDER (81873) SPEC 8-08481-809 T.O.9H8-14-51-104	1	35	
	100700-13	• ACTUATOR, RUDDER (81873) SPEC 8-08481-809 T.O.9H8-14-51-104 ALT INTCHG WITH 100700-11 ATTACHING PARTS	RF	35	
- 3	AN320-14	• NUT	2	35	
- 4	AN960C1416L	• WASHER	2	35	
- 5	R-15R04	• BUSHING	4	35	
- 6	R-82209	• BOLT	2	35	
		-----X-----			
- 7	64A33155-245	• ROD ASSY, RUDDER TRIM AND FEEL CONTROL LINKAGE FURNISHED WITH (81873) 100700-7 REPLACED BY SUITABLE SUB 64A33155-611 AND 100700-9	1	35	129
	64A33155-611	• ROD ASSY, RUDDER TRIM AND FEEL CONTROL UNKAGE FURNISHED WITH (81873) 100700-11 AND 100700-13 REPLACES SUITABLE SUB FOR 64A33155-845 ATTACHING PARTS	RF	130	
- 8	AN320-4	• NUT	RF	35	
- 9	AN960D416	• WASHER	AR	35	
- 10	NAS454P4-18	• BOLT	RF	35	
		-----X-----			
- 11	RF4F5	• BEARING	2	35	
- 12	AN316-5R	• NUT	2	35	
- 13	64F33114-11	• CONNECTOR	2	35	
- 14		• TUBE	RF	35	
- 15		• HORN ASSY, RUDDER ACTUATOR SEE FIG. 2.7-5	RF		

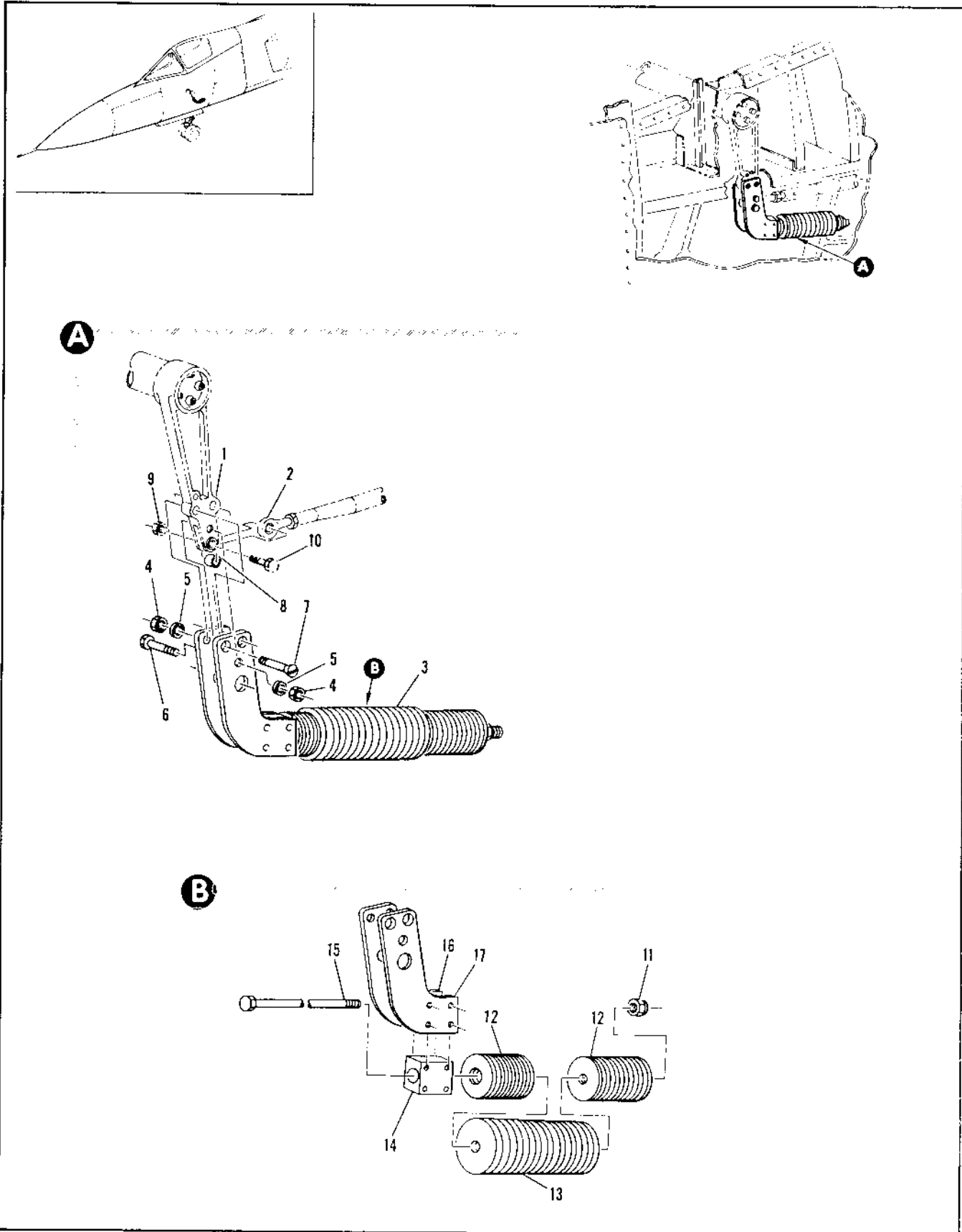

Figure 2.14-44. Control Stick Counterbalance Installation Sta 145

FIGURE AND INDEX NUMBER	PART NUMBER	DESCRIPTION	UNITS PER ASSY.	USABLE ON CODE	
				FROM	TO
		1 2 3 4 5 6			
2.14-44	8-42368	COUNTERBALANCE INSTALLATION, CONTROL STICK STA 145 FOR NHA SEE FIG. 2.3-4	RF	35	
- 1		• BELL CRANK ASSY, CONTROL STICK SHAFT SEE FIG. 2.14-9 INDEX 48	RF		
- 2		• ROD ASSY, CONTROL LINKAGE LH SEE FIG. 2.14-15	RF		
- 3	8-42368-7 8-42368-9	• COUNTERBALANCE ASSEMBLY, CONTROL STICK • COUNTERBALANCE ASSEMBLY, CONTROL STICK ATTACHING PARTS	1 1	35 130	129
- 4	MS21043-4	• NUT	3	35	
- 5	AN9600416L	• WASHER	3	35	
- 6	AN4-16A	• BOLT	1	35	
- 7	NAS334PA16	• BOLT	2	35	
- 8	NAS430D4-45	• SPACER	1	35	
- 9		• NUT, SEE FIG. 2.14-15 INDEX 6	RF		
- 10		• BOLT, SEE FIG. 2.14-15 INDEX 7 -----X-----	RF		
- 11	MS21043-6	• • NUT	1	35	
- 12	8-42323-11	• • WASHER, COUNTERBALANCE STICK	18	35	129
	8-42323-11	• • WASHER, COUNTERBLANACE STICK	28	130	
- 13	8-42323-13	• • WASHER, COUNTERBALANCE STICK	15	35	129
	8-42323-13	• • WASHER, COUNTERBALANCE STICK	13	130	
- 14	8-42322-7	• • BODY, COUNTERBALANCE STICK	1	35	
- 15	8-42324-7	• • BOLT	1	35	
- 16	8-42369-7	• • ARM	1	35	
- 17	8-42369-9	• • ARM	1	35	

LANDING GEAR SUBSECTION

TABLE OF CONTENTS

<i>Fig. No.</i>	<i>Title</i>	<i>Page</i>	<i>Fig. No.</i>	<i>Title</i>	<i>Page</i>
2.15-1	Landing Gear	2.15-2	2.15-21	Main Landing Gear Wing Fairing Assembly	2.15-66
2.15-2	Nose Landing Gear Up and Down Switch Installation	2.15-10	2.15-22	Main Landing Gear Door Actuator Installation	2.15-68
2.15-3	Nose Landing Gear Door Close Switch Installation	2.15-12	2.15-23	Main Landing Gear Door Actuator Installation	2.15-76
2.15-4	Main Landing Gear Up Switch Installation	2.15-14	2.15-24	Main Landing Gear Door Fwd Stop Assembly	2.15-82
2.15-5	Landing Light Installation	2.15-16	2.15-25	Main Landing Gear Installation	2.15-86
2.15-6	Taxi Light Installation	2.15-20	2.15-26	Main Landing Gear Hydraulic Actuator Tubing Installation	2.15-94
2.15-7	Landing Gear Emergency Release Control Installation	2.15-22	2.15-27	Main Landing Gear Door Assembly	2.15-98
2.15-8	Nose Landing Gear Command Transmitter Installation	2.15-24	2.15-28	Main Landing Gear Fitting Installation BL 38	2.15-102
2.15-9	Nose Landing Gear Command Synchro Transmitter Installation..	2.15-28	2.15-29	Main Landing Gear Fitting Assembly BL 38	2.15-104
2.15-10	Landing Gear Electrical	2.15-32	2.15-30	Lower Longeron Installation Sta 412 to 472	2.15-106
2.15-11	Nose Landing Gear Command Synchro Transmitter Installation..	2.15-34	2.15-31	Main Landing Gear Door Hinge and Longeron	2.15-108
2.15-12	Taxi and Landing Light G Suit and No Fog Switch Installation	2.15-38	2.15-32	Main Landing Gear Door Open Switch Installation	2.15-112
2.15-13	Nose Landing Gear Door Mechanism Installation	2.15-40	2.15-33	Main Landing Gear Door Installation	2.15-114
2.15-14	Nose Landing Gear Door Installation	2.15-42	2.15-34	Main Landing Gear Door Assembly Spares	2.15-116
2.15-15	Nose Landing Gear Door Seal Frame	2.15-46	2.15-35	Main Landing Gear Door Assembly Spares	2.15-118
2.15-16	Nose Landing Gear Installation	2.15-48	2.15-36	Nose Landing Gear Drag Strut Fitting Assembly	2.15-122
2.15-17	Nose Landing Gear Steering Damper Assembly	2.15-54	2.15-37	Emergency Arresting System	2.15-124
2.15-18	Landing Gear Control Box Installation	2.15-58	2.15-38	Emergency Arresting Hook Installation	2.15-126
2.15-19	Main Landing Gear Wing Fairing Installation	2.15-60			
2.15-20	Main Landing Gear Wing Fairing Link Assembly	2.15-64			

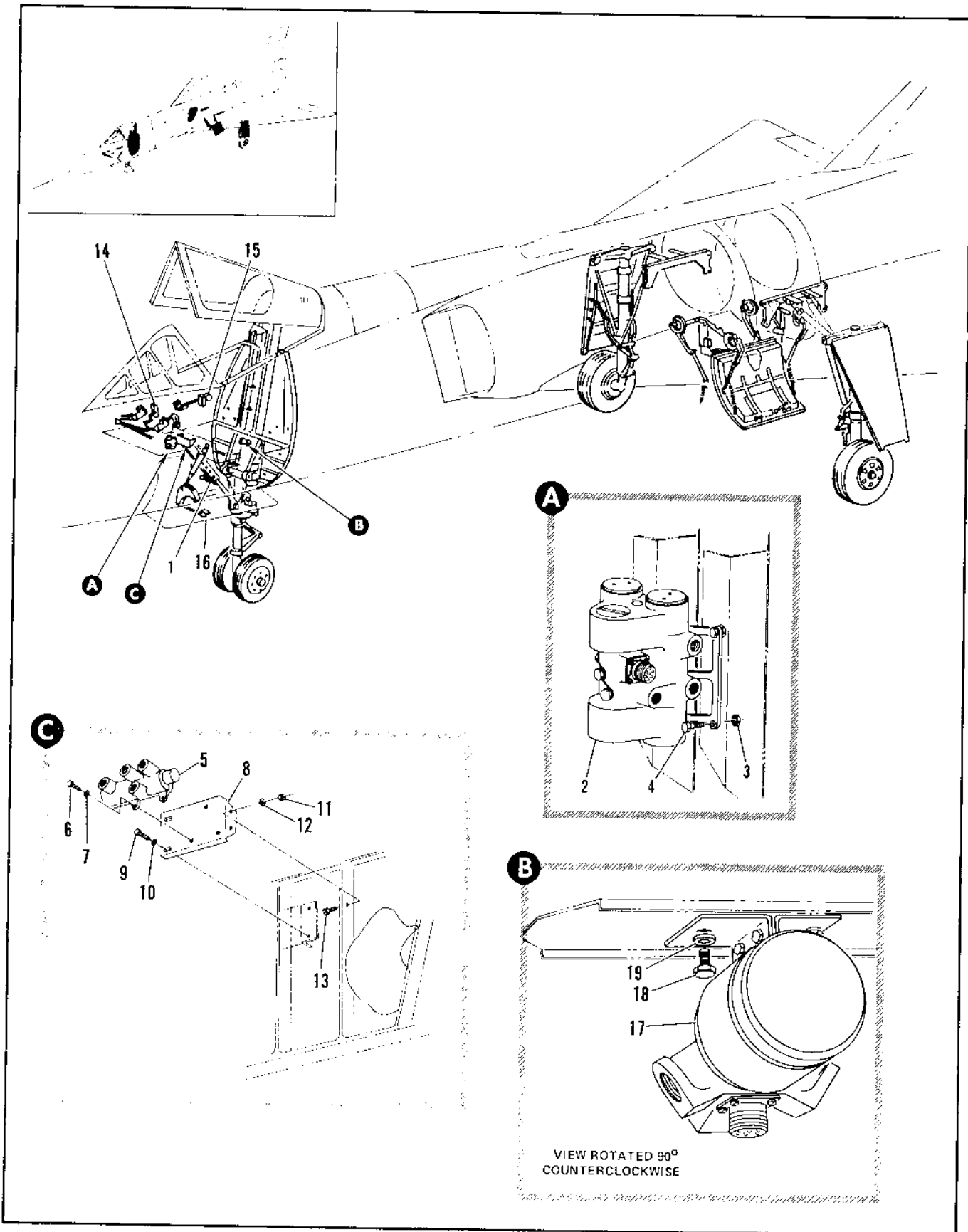

Figure 2.15-1. Landing Gear (Sheet 1 of 4)

FIGURE AND INDEX NUMBER	PART NUMBER	DESCRIPTION	UNITS PER ASSY.	USABLE ON CODE	
				FROM	TO
2.15-1		LANDING GEAR			
- 1	8-81054-1	• LANDING GEAR ELECTRICAL SEE FIG. 2.15-10	RF		
	R-84008	• VALVE INSTL. NLG HYDRAULIC SELECTOR FOR NHA SEE FIG. 2.3-4	RF	A	
- 2	1371-579106	• VALVE INSTL. NLG HYDRAULIC SELECTOR FOR NHA SEE FIG. 2.3-4	1	35	
	HP465100-5	• VALVE ASSY. NLG HYDRAULIC CONTROL <9203> SPEC 8-38475-5 T.O. 9HR-14-212-3	RF	A	
	1371-579106	• VALVE ASSY. NLG HYDRAULIC CONTROL <84685> SPEC 8-38475-5 ALT INTCHG WITH 1371-579106 T.O. 9HR-14-190-3	1	B	
		• VALVE ASSY. NLG HYDRAULIC CONTROL <9203> SPEC 8-38475-5			
		ATTACHING PARTS			
- 3	NAS679A3	• NUT	4	35	
- 4	AN3-5A	• BOLT	4	A	
	NAS1133-4	• BOLT	4	B	
		-----X-----			
	64034322-9	• VALVE INSTALLATION, NLG BYPASS	1		
	64034322-3	• VALVE INSTALLATION, NLG BYPASS	1		
- 5	64034403-1	• VALVE, EMERGENCY BYPASS SPEC 64034322	1		
	AV11E1121	• VALVE, EMERGENCY BYPASS SPEC 64034322			
		ATTACHING PARTS			
- 6	AN3-5A	• BOLT	3		
- 7	AN563D10L	• WASHER	3		
		-----X-----			
- 8	64034491-1	• BRACKET ASSY, VALVE MOUNTING RIVETED	1		
	64034492-1	• BRACKET ASSY, VALVE MOUNTING RIVETED	1		
		ATTACHING PARTS			
- 9	AN3-4A	• BOLT	2		
- 10	AN961D10L	• WASHER	2		
- 11	MS21042L3	• NUT	2		
- 12	AN963D10L	• WASHER	2		
- 13	AN3-4A	• BOLT	2		
	AN3-5A	• BOLT	2		
- 14		• PEDAL INSTL. RUDDER AND BRAKE SEE FIG. 2.14-26	RF		
- 15		• CONTROL INSTL. LANDING GEAR EMERGENCY RELEASE SEE FIG. 2.15-7	RF		
- 16		• MECHANISM INSTL. NLG DOOR SEE FIG. 2.15-13	RF		
	R-84006	• VALVE INSTL. HYDRAULIC NOSE WHEEL STEERING FOR NHA SEE FIG. 2.3-4	RF	35	
- 17	52367	• VALVE ASSY. HYDRAULIC CONTROL NOSE WHEEL STEERING <00585> SPEC 8-38366 T.O. 9HR-14-99-43	1	35	
		ATTACHING PARTS			
- 19	AN963D10	• WASHER	2	35	
		-----X-----			
		A AIRPLANES #35 THRU 47 AND 49 THRU 59			
		B AIRPLANES #46, 90 AND 94			

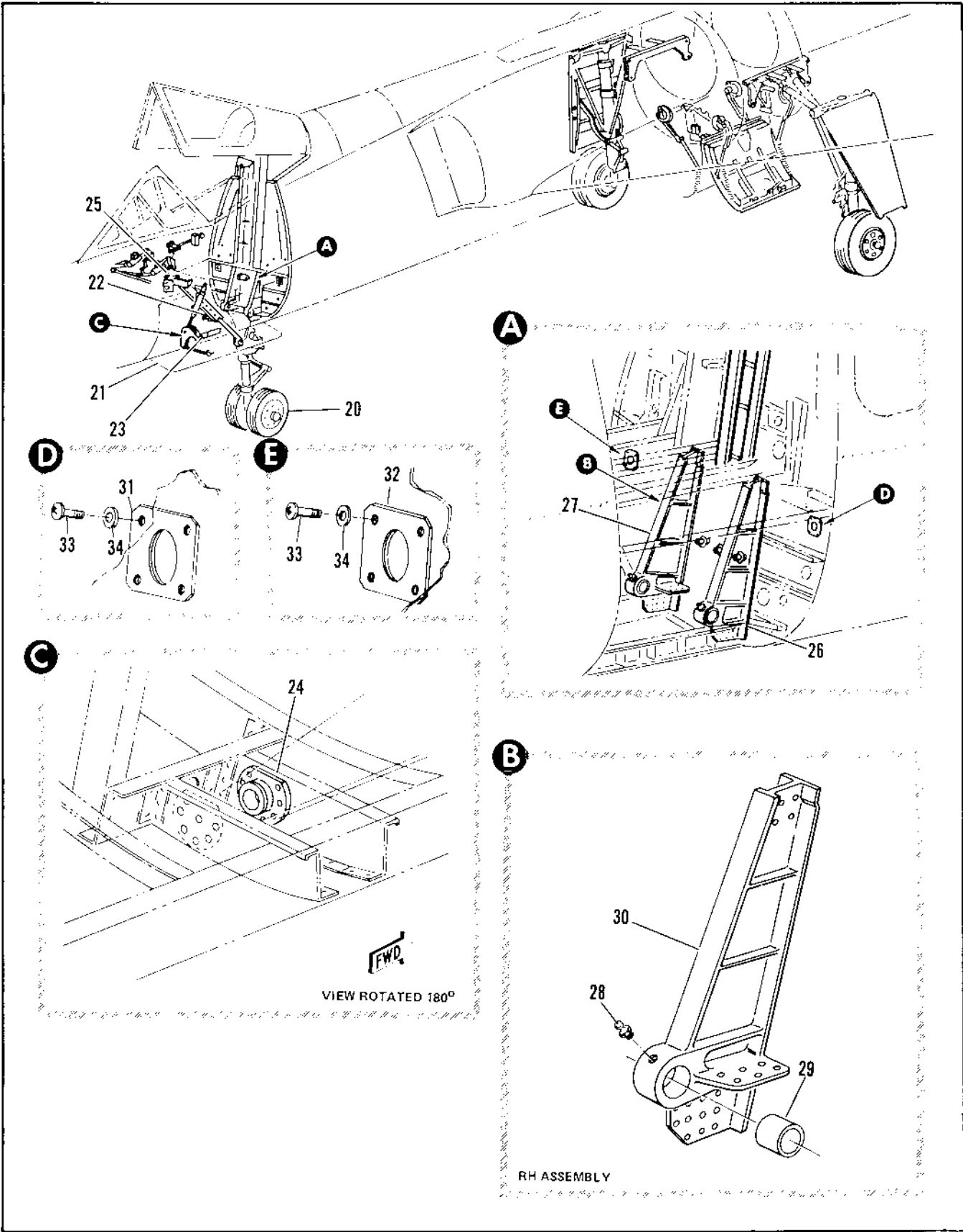

Figure 2.15-1. Landing Gear (Sheet 2 of 4)

FIGURE AND INDEX NUMBER	PART NUMBER	DESCRIPTION	UNITS PER ASSY.	USABLE ON CODE	
				FROM	TO
		1 2 3 4 5 6			
A.15-1- 20		• GEAR INSTL, NOSE LANDING SEE FIG. 2.15-16	RF		
- 21		• DOOR INSTL, NLE SEE FIG. 2.15-14	RF		
- 22		• STOP, NLG DOOR RH SEE FIG. 2.3-8 INDEX 18	RF		
	8-74233	• SUPPORT INSTL, NLG DOOR MECHANISM FOR NHA SEE FIG. 2.7-7	RF	35	
- 23	8-74235-49	• SUPPORT ASSY, NLG DOOR	1	35	
- 24	8-74738	• . . . ADAPTER, NLG DOOR PIVOT ARM SUPPORT	2	35	
- 25		• FITTING ASSY, NLG DRAG STRUT SEE FIG. 2.15-36	RF		
	8-77240	• BULKHEAD INSTL, FUSELAGE CAPTED STA 172 MODIFIED BY 66J40275 FOR NHA SEE FIG. 2.3-4			
- 26	8-77230-R01	• FITTING ASSY, NLG LH	1		
	8-77230-1	• FITTING ASSY, NLG LH REPLACES SUITABLE SUB FOR 8-74327-1	1	278	
- 27	8-77230-R 2	• FITTING ASSY, NLG RH REPLACES SUITABLE SUB FOR 8-74327-2	1		
	8-77230-2	• FITTING ASSY, NLG RH	1	278	
- 28	MS15021-1	• . . . FITTING	1	35	
- 29	8-74591	• . . . BUSHING	1	35	
	8-77230-11	• . . . FITTING, LH	1		
	8-77230-7	• . . . FITTING, LH	1	278	
- 30	8-77230-12	• . . . FITTING, RH	1		
	8-77230-8	• . . . FITTING, RH	1	278	
- 31	8-4255-5	• SEAL INSTL, ELEVATOR AND WINGRON STA 171	1	35	
- 32	8-42426	• SEAL, WINGRON ROD	1	35	
	8-42353-7	• SEAL, ELEVATOR ROD ATTACHING PARTS	1	35	
- 33	NAS201-11	• . . . SCREW	4	35	
- 34	AN969C10	• . . . WASHER	4	35	
		-----X-----			

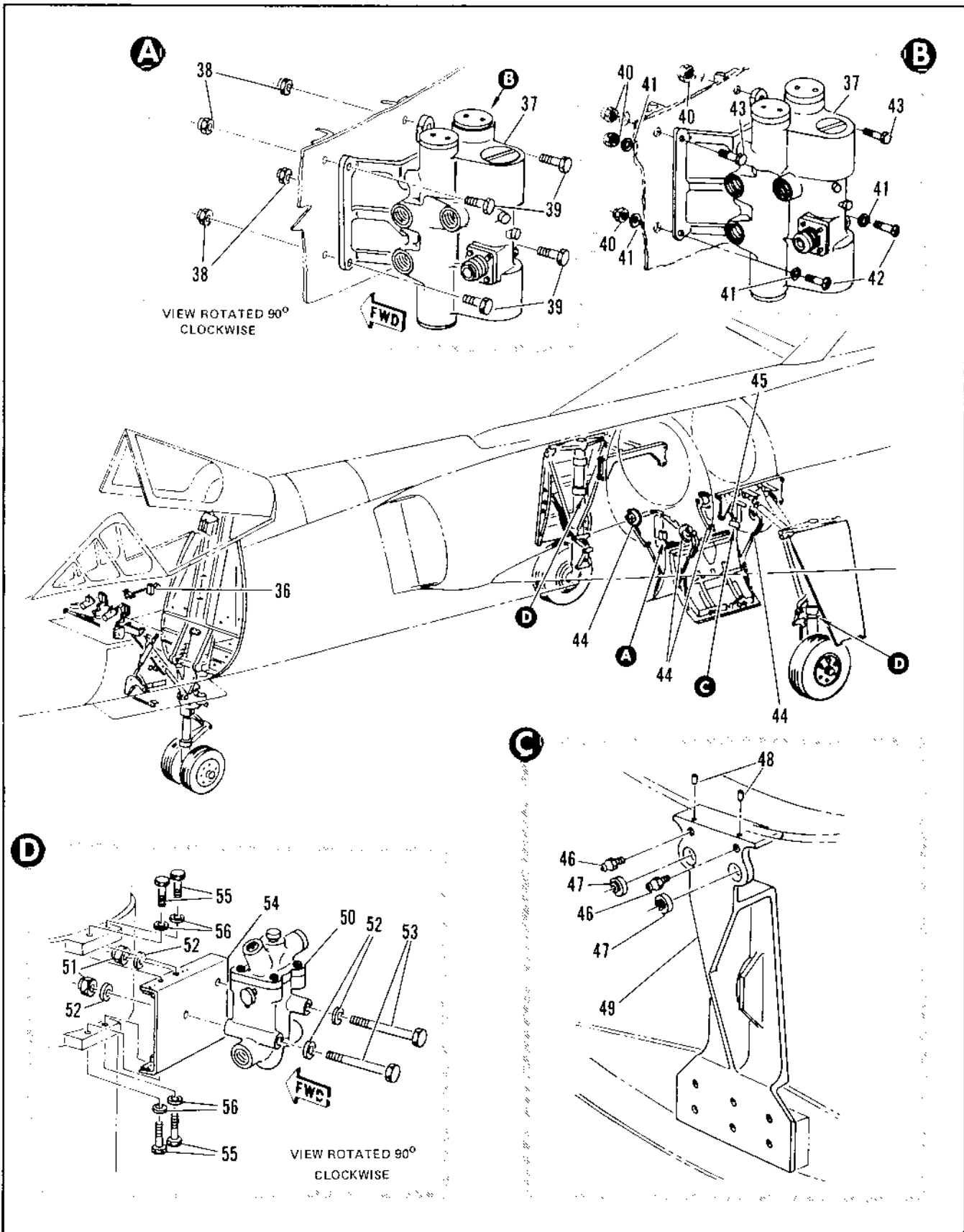

Figure 2.15-1. Landing Gear (Sheet 3 of 4)

FIGURE AND INDEX NUMBER	PART NUMBER	DESCRIPTION	UNITS PER ASSY.	USABLE ON CODE	
				FROM	TO
2.15-1- 36		• CONTROL PDK INSTL, LANDING GEAR SEE FIG. 2.15-1R	RF		
	R-81033	• VALVE INSTL, MLG SELECTOR FOR NHA SEE FIG. 2.3-11	RF	35	60
	R-81033-1	• VALVE INSTL, MLG SELECTOR FOR NHA SEE FIG. 2.3-11	RF	61	
- 37	1371-579106	• VALVE ASSY, MLG HYDRAULIC CONTROL (02003) SPEC R-00470-5, I.O. 9H4-14-212-3	1	35	
- 38	NAS67943	• NUT	4	35	60
- 39	AN3-5A	• BOLT	4	35	60
- 40	NAS67943	• NUT	4	61	
- 41	AN960D10	• WASHER	4	61	
- 42	NAS221-11	• SCREW	2	61	
- 43	NAS454-3410	• BOLT	2	61	
- 44		• ACTUATOR INSTL, MLG ODR SEE FIG. 2.15-23	RF		
- 45	R-77115	• ADAPTER ASSY, ACTUATING CYLINDER LONGERON STA 472 REPLACED BY NOT INTCHG WITH R-74751-1 FOR NHA SEE FIG. 2.3-10	RF	35	60
	R-74751-1	• ADAPTER ASSY, MLG DOOR ACTUATOR AFT REPLACES NOT INTCHG WITH R-77115 FOR NHA SEE FIG. 2.3-11	RF	61	
- 46	MS15001-1	• LUBRICATOR	2	35	
- 47	HSB6555A HSB655A	• BEARING, <97413> R-80001-161 • BEARING, <97413> R-80001-174 ALT INTCHG WITH HSB6555A	2 RF	35 35	
- 48	R-77115-9	• PLUG	2	35	60
- 49	R-77115-7 R-74751-7 R-85544-3	• ADAPTER • ADAPTER • VALVE INSTL, BRAKE RELAY LH FOR NHA SEE FIG. 2.6-1 AND 2.6-2	1 1 RF	35 61 35	
	R-86304-4	• VALVE INSTL, BRAKE RELAY RH FOR NHA SEE FIG. 2.6-1 AND 2.6-2	RF	35	
- 50	18050	• VALVE ASSY, BRAKE RELAY <79294> SPEC R-00417-11 I.O. 48A5-19-3 REPLACES SUITABLE SUB FOR 16400-1	1	H	
	17720	• VALVE ASSY, BRAKE RELAY <79294> SPEC R-00417-9 I.O. 48A5-20-3 ATTACHING PARTS	1	61	89
- 51	NAS679A4	• NUT	2	35	
- 52	AN960-416	• WASHER	4	35	
- 53	AN4-22A	• BOLT	2	35	
- 54	R-86304-13 R-86304-14	• BRACKET ASSY, LH RIVETED • BRACKET ASSY, RH RIVETED ATTACHING PARTS	1 1	35 35	
- 55	AN3-5A	• BOLT	4	35	
- 55	AN960-10L	• WASHER -----X-----	4	35	

R AIRPLANES #48, 90 AND ON
C AIRPLANES #35 THRU 47 AND 49 THRU 60

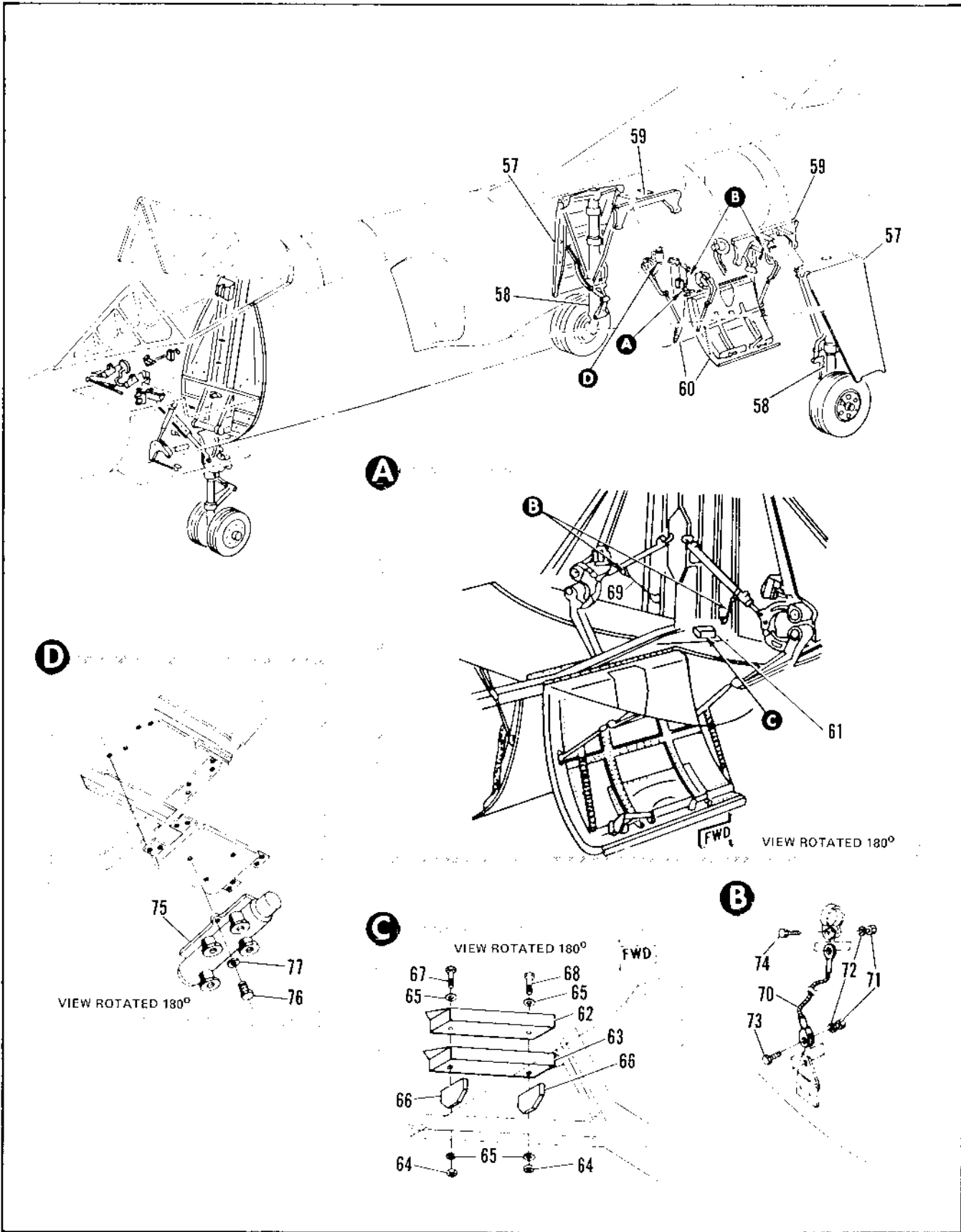

Figure 2.15-1. Landing Gear (Sheet 4 of 4)

FIGURE AND INDEX NUMBER	PART NUMBER	DESCRIPTION	UNITS PER ASSY.	USABLE ON CODE	
				FROM	TO
		1 2 3 4 5 6			
2.15-1-57		• FAIRING INSTL, MLG WING LH SEE FIG. 2.15-19	RF		
- 58		• GEAR INSTL, MAIN LANDING LH SEE FIG. 2.15-25	RF		
- 59		• FITTING INSTL, MLG BL 3R LH SEE FIG. 2.15-28	RF		
- 60		• DOOR INSTL, MLG SEE FIG. 2.15-33	RF		
		• DOOR ASSY, MLG LH SPARES SEE FIG. 2.15-34	RF		
- 61	63C34487-1	• CONTAINER INSTL, GROUND SAFETY PINS	1	35	
- 62	63E34488-1	• CONTAINER ASSY, SAFETY PINS	1	35	
- 63	63E34489-1	• . . . FRAME	1	35	
	63E34489-3	• . . . HAG	1		
	63E34488-13	• . . . COVER ASSY, CONTAINER	1		
		----X----			
- 64	NAS679A3	• . . . NUT	2		
- 65	AN961-10L	• . . . WASHER	4		
- 66	H-92943-7	• . . . SPACER	2		
- 67	AN173-22A	• . . . BOLT	1		
- 68	AN173-34A	• . . . BOLT	1		
		----X----			
	67H344-111	• . . . SAFETY PIN, MLG	2	35	
	536590	• . . . SAFETY PIN, MLG	1	35	
	H-95514	• . . . SAFETY PIN, TAIL HOOK	1	35	
	65C3295-1	• . . . SAFETY PIN, EXTERNAL FUEL TANK EJECTION	2	35	
	63C52550-1	• . . . TEE HANDLE ASSY, RAM AIR TURBINE DOOR	1		
	H-96155	• . . . PIN ASSY, MANUAL DOOR CONTROL VALVE LOCK	1		
	HL-PP3-1-100	• . . . PIN, NON LOCKING QUICK RELEASE (64256) 96-72809-003	1		
- 69	H-83001-1	• CABLE INSTL, MLG DOOR CYLINDER RESTRAINER LH STA 431 FOR NHA SEE FIG. 2.3-3	RF	189	
	H-83001-2	• CABLE INSTL, MLG DOOR CYLINDER RESTRAINER RH STA 431 FOR NHA SEE FIG. 2.3-3	RF	189	
	H-83001-3	• CABLE INSTL, MLG DOOR CYLINDER RESTRAINER LH STA 472 FOR NHA SEE FIG. 2.3-3	RF	189	
	H-83001-4	• CABLE INSTL, MLG DOOR CYLINDER RESTRAINER RH STA 472 FOR NHA SEE FIG. 2.3-3	RF	189	
- 70	H-82402-7	• . . . CABLE ASSY, SWAGED LH STA 431	1		
	H-83001-7	• . . . CABLE ASSY, SWAGED LH STA 431	1	189	
	H-82402-7	• . . . CABLE ASSY, SWAGED RH STA 431	1		
	H-83001-7	• . . . CABLE ASSY, SWAGED RH STA 431	1	189	
	H-82402-7	• . . . CABLE ASSY, SWAGED LH STA 472	1		
	H-83001-9	• . . . CABLE ASSY, SWAGED LH STA 472	1	189	
	H-82402-7	• . . . CABLE ASSY, SWAGED RH STA 472	1		
	H-83001-10	• . . . CABLE ASSY, SWAGED RH STA 472 ATTACHING PARTS	1	189	
- 71	NAS679A3	• . . . NUT	2	189	
- 72	AN961-10L	• . . . WASHER	2	189	
- 73	AN308A	• . . . BOLT, UPPER	1	189	
- 74	NAS1103-1	• . . . BOLT, LOWER	1		
	AN108A	• . . . BOLT, LOWER	1	189	
	68D37869-1	• . . . CLAMP	1	35	
		----X----			
- 75	64E34321-1	• VALVE INSTALLATION, MLG BYPASS	1		
	64D34320-1	• . . . VALVE, EMERGENCY BYPASS SPEC 64D34320	1		
	6V11-1121	• . . . VALVE, EMERGENCY BYPASS SPEC 64D3432	1		
		ATTACHING PARTS			
- 76	AN3-8A	• . . . BOLT	3		
- 77	AN510111	• . . . WASHER	3		
		----X----			

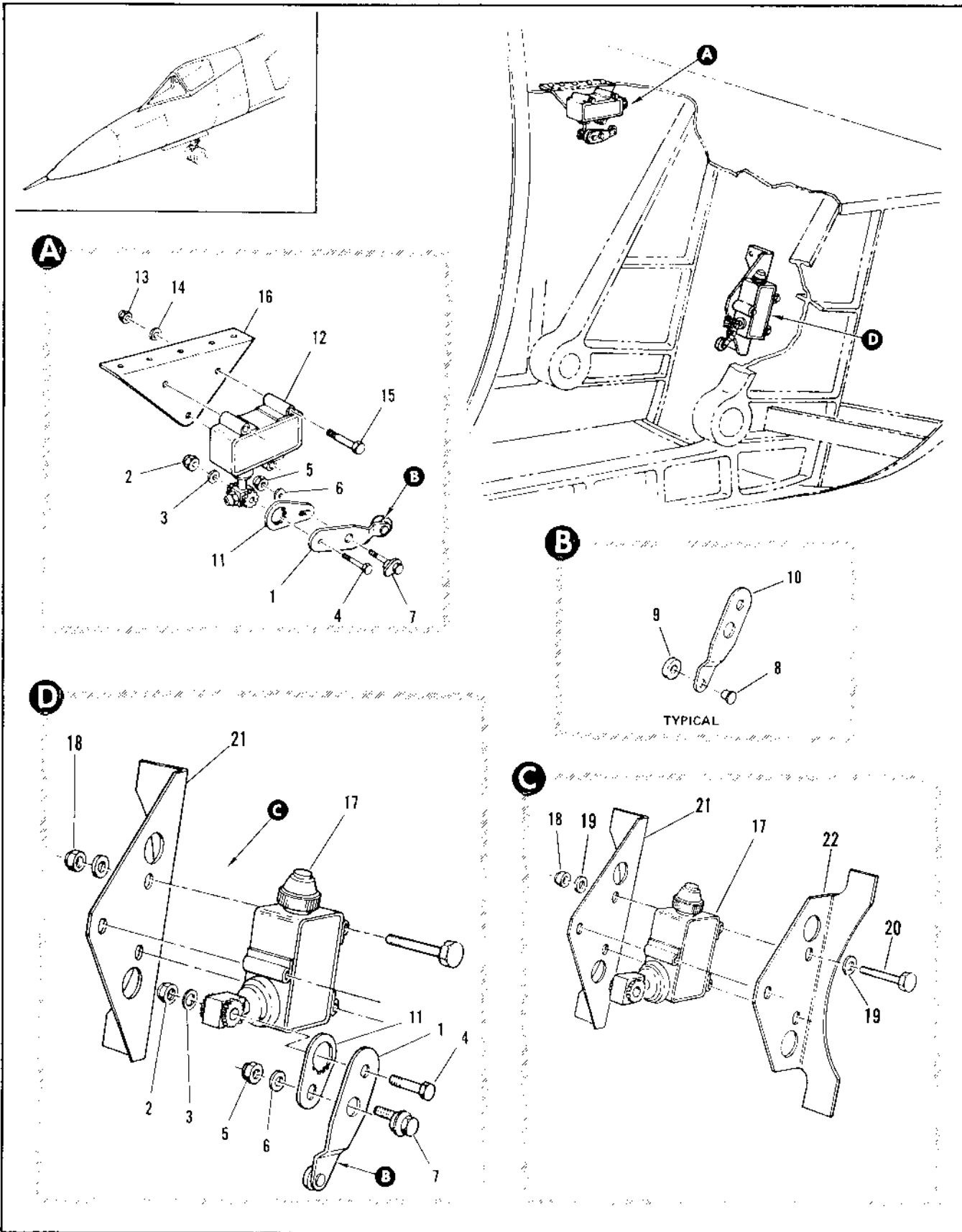

Figure 2.15-2. Nose Landing Gear Up and Down Switch Installation

FIGURE AND INDEX NUMBER	PART NUMBER	DESCRIPTION	UNITS PER ASSY.	USABLE ON CODE	
				FROM	TO
2.15-2	8-52109-1	SWITCH INSTALLATION, NOSE LANDING GEAR UP AND DOWN FOR NHA SEE FIG. 2.3-4	RF	35	264
	8-52109-3	SWITCH INSTALLATION, NOSE LANDING GEAR UP AND DOWN FOR NHA SEE FIG. 2.3-4	RF	265	
- 1	8-68043-1	• ARM ASSY, NLG UP AND DOWN SWITCH ATTACHING PARTS	2	35	
- 2	NAS679A3	• NUT	2	35	
- 3	AN935-10	• WASHER	2	35	
- 4	AN3-10A	• RCLT	2	35	
- 5	NAS679A08	• NUT	2	35	
- 6	AN935-8	• WASHER	2	35	
- 7	8-68038-7	• BOLT	2	35	
		-----X-----			
- 8	8-68051-7	• • STUD	1	35	
- 9	8-68052-7	• • ROLLER	1	35	
- 10	8-68043-7	• • ARM	1	35	
- 11	612742	• FLATE, ADJUST <97198> SPEC 8-06986-7	2	35	
- 12	69C37529-1	• SWITCH ASSY, NLG UP <97198> SPEC 8-06983-803 (REPLACED BY PART NO. H12-1011, FSCM 97198) NOT INTERCHANGEABLE WITH 69C37529-1	1	35	
- 13	NAS679A3	• NUT	3	35	
- 14	AN960-10L	• WASHER	3	35	
- 15	AN3-15A	• BOLT	3	35	
		-----X-----			
- 16	8-52110	• BRACKET, NLG UP SWITCH	1	35	
- 17	69C37529-1	• SWITCH ASSY, NLG DOWN <97198> SPEC 8-06983-803 (REPLACED BY PART NO. H12-1011, FSCM 97198) NOT INTERCHANGEABLE WITH 69C37529-1	1	35	
- 18	NAS679A3	• NUT	3	35	
- 19	AN960D10	• WASHER	6	265	
- 20	AN3-16A	• BOLT	3	265	
		-----X-----			
- 21	8-52111-7	• BRACKET, NLG DOWN SWITCH RH	1	35	
- 22	8-52111-9	• BRACKET, NLG DOWN SWITCH LH	1	265	

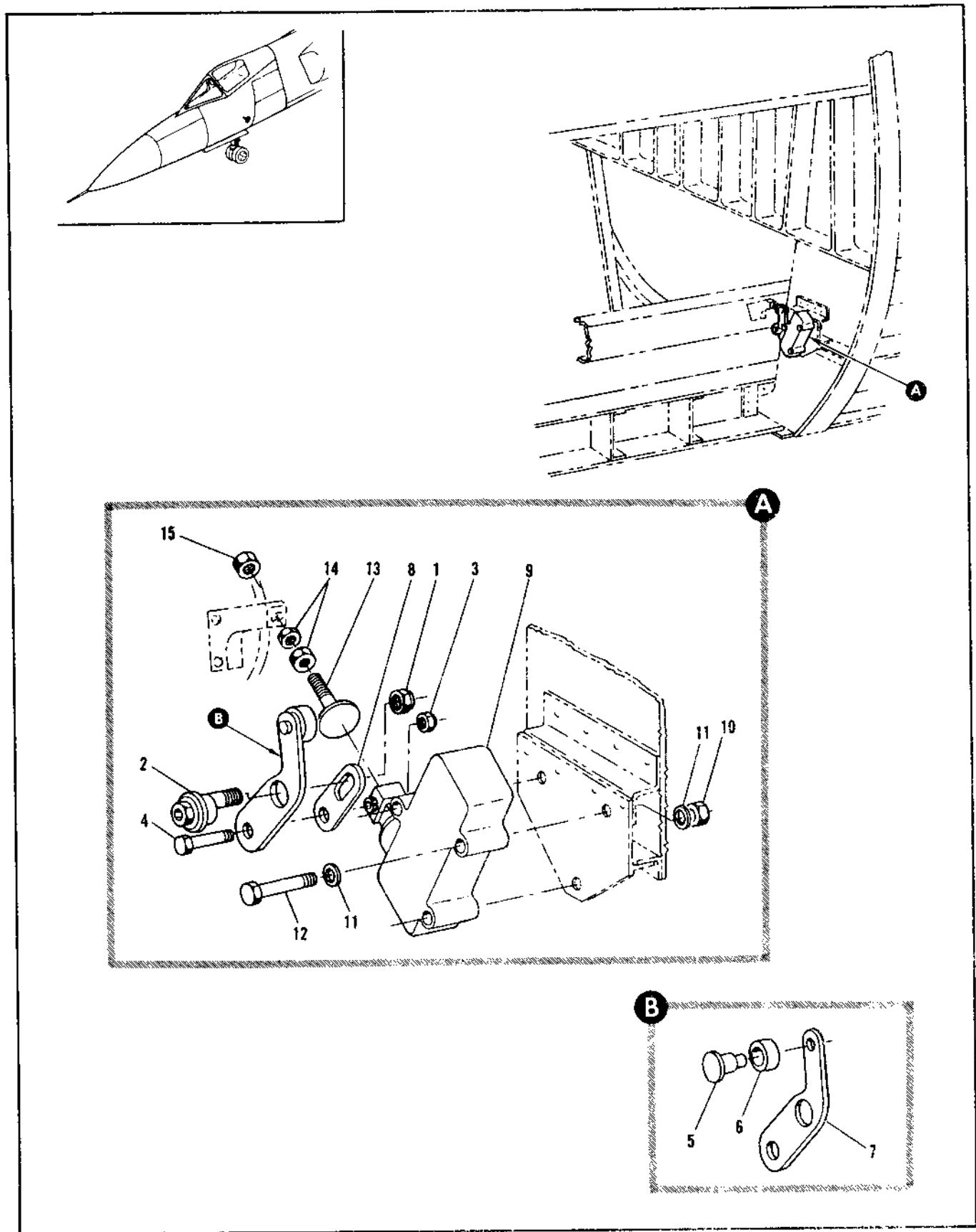

Figure 2.15-3. Nose Landing Gear Door Close Switch Installation

FIGURE AND INDEX NUMBER	PART NUMBER	DESCRIPTION 1 2 3 4 5 6	UNITS PER ASSY.	USABLE ON CODE	
				FROM	TO
2.15-3	8-57117-5	SWITCH INSTALLATION, NOSE LANDING GEAR DOOR CLOSE FOR NHA SEE FIG. 2.3-3	PF	35	
- 1	NAS679A08	• NUT	1	35	
- 2	8-68038-7 8-57003-1	• BOLT, LIMIT SWITCH ADJUST • ARM ASSY, NLG DOOR CLOSE LIMIT SWITCH ATTACHING PARTS	1 1	35 35	
- 3	NAS679A3	• NUT	1	35	
- 4	AN3-10A	• BOLT	1	35	
		-----X-----			
- 5	8-68051-11	• STUD, ACTUATOR ARM ROLLER	1	35	
- 6	8-68052-11	• ROLLER, ACTUATOR ARM	1	35	
- 7	8-57003-7	• ARM, ACTUATOR	1	35	
- 8	312742	• PLATE, LIMIT SWITCH ADJUST <97198> SPEC 8-06986-7	1	35	
- 9	69C37529-1	• SWITCH ASSY, NLG DOOR CLOSE <97198> SPEC 8-06983-803 (REPLACED BY PART NO. H12-1011, FSCM 97198) NOT INTERCHANGEABLE WITH 69C37529-1	1	35	
- 10	NAS679A3	• NUT	3	35	
- 11	AN960-10L	• WASHER	6	35	
- 12	AN3-16A	• BOLT	3	35	
		-----X-----			
- 13	8-56607	• BOLT, NLG DOOR CLOSE SWITCH	1	35	
- 14	AN316-4R	• NUT	2	35	
- 15	NAS679A4	• NUT	1	35	

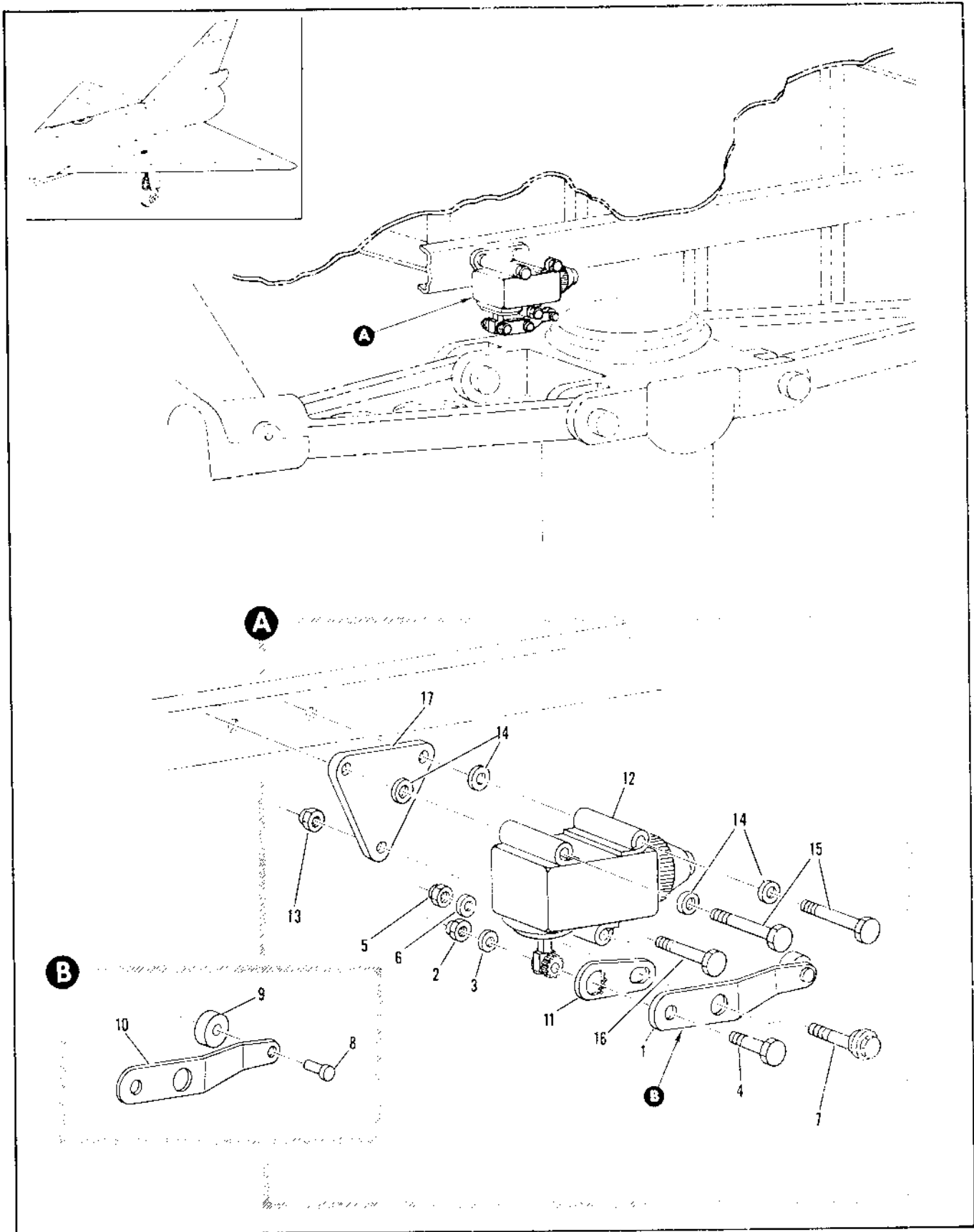

Figure 2.15-4. Main Landing Gear Up Switch Installation

FIGURE AND INDEX NUMBER	PART NUMBER	DESCRIPTION	UNITS PER ASSY.	USABLE ON CODE	
				FROM	TO
		1 2 3 4 5 6			
2.15-4	8-51016-3	SWITCH INSTALLATION, MAIN LANDING GEAR UP LH MODIFIED BY 8-44801-3 FOR NHA SEE FIG. 2.6-32	RF	A	
	8-51016-5	SWITCH INSTALLATION, MAIN LANDING GEAR UP LH FOR NHA SEE FIG. 2.6-32	RF	49	277
	8-51016-1	SWITCH INSTALLATION, MAIN LANDING GEAR UP LH MODIFIED BY 8-44801-1 FOR NHA SEE FIG. 2.6-32	RF	278	287
	8-51016-4	SWITCH INSTALLATION, MAIN LANDING GEAR UP RH MODIFIED BY 8-44801-4 FOR NHA SEE FIG. 2.6-32	RF	A	
	8-51016-6	SWITCH INSTALLATION, MAIN LANDING GEAR UP RH FOR NHA SEE FIG. 2.6-32	RF	49	277
	8-51016-2	SWITCH INSTALLATION, MAIN LANDING GEAR UP RH MODIFIED BY 8-44801-2 FOR NHA SEE FIG. 2.6-32	RF	278	287
- 1	8-68048-1	• ARM ASSY, MLG ACTUATOR LIMIT SWITCH	1	A	
	8-68048-3	• ARM ASSY, MLG ACTUATOR LIMIT SWITCH LH	1	49	287
	8-68048-4	• ARM ASSY, MLG ACTUATOR LIMIT SWITCH RH	1	49	287
		ATTACHING PARTS			
- 2	NAS679A08	• NUT, 96-37545-001	1	35	
- 3	AN960D8	• WASHER (88044)	1	35	
- 4	AN3-10A	• BOLT (88044)	1	35	
- 5	NAS679A3	• NUT, 96-37545-002	1	35	
- 6	AN960PD10	• WASHER (88044)	1	35	
- 7	8-68038-7	• BOLT, ADJUST LIMIT SWITCH	1	35	
		----X----			
- 8	8-68051-9	• • STUD	1	35	
- 9	8-68052-9	• • ROLLER	1	35	
- 10	8-68048-7	• • ARM	1	A	
	8-68048-9	• • ARM, LH (MAKE FROM 8-68048-7)	1	49	287
	8-68048-10	• • ARM, RH (MAKE FROM 8-68048-7)	1	49	287
- 11	012742	• PLATE, ADJUST ACTUATOR ARM <97198> SPEC 8-06986-7	1	35	
- 12	69C37529-1	• SWITCH ASSY, MLG LIMIT <97198> SPEC 8-06983-803	1	35	
		ATTACHING PARTS			
- 13	NAS679A3	• NUT, 96-37545-002	1	35	
- 14	AN960PD10L	• WASHER (88044)	4	35	
- 15	AN3-16A	• BOLT (88044)	2	35	
- 16	AN3-15A	• BOLT (88044)	1	35	
		----X----			
- 17	8-51156	• PLATE, UP SWITCH	1	35	
		A AIRPLANES #35 THRU 48, 288 AND ON			

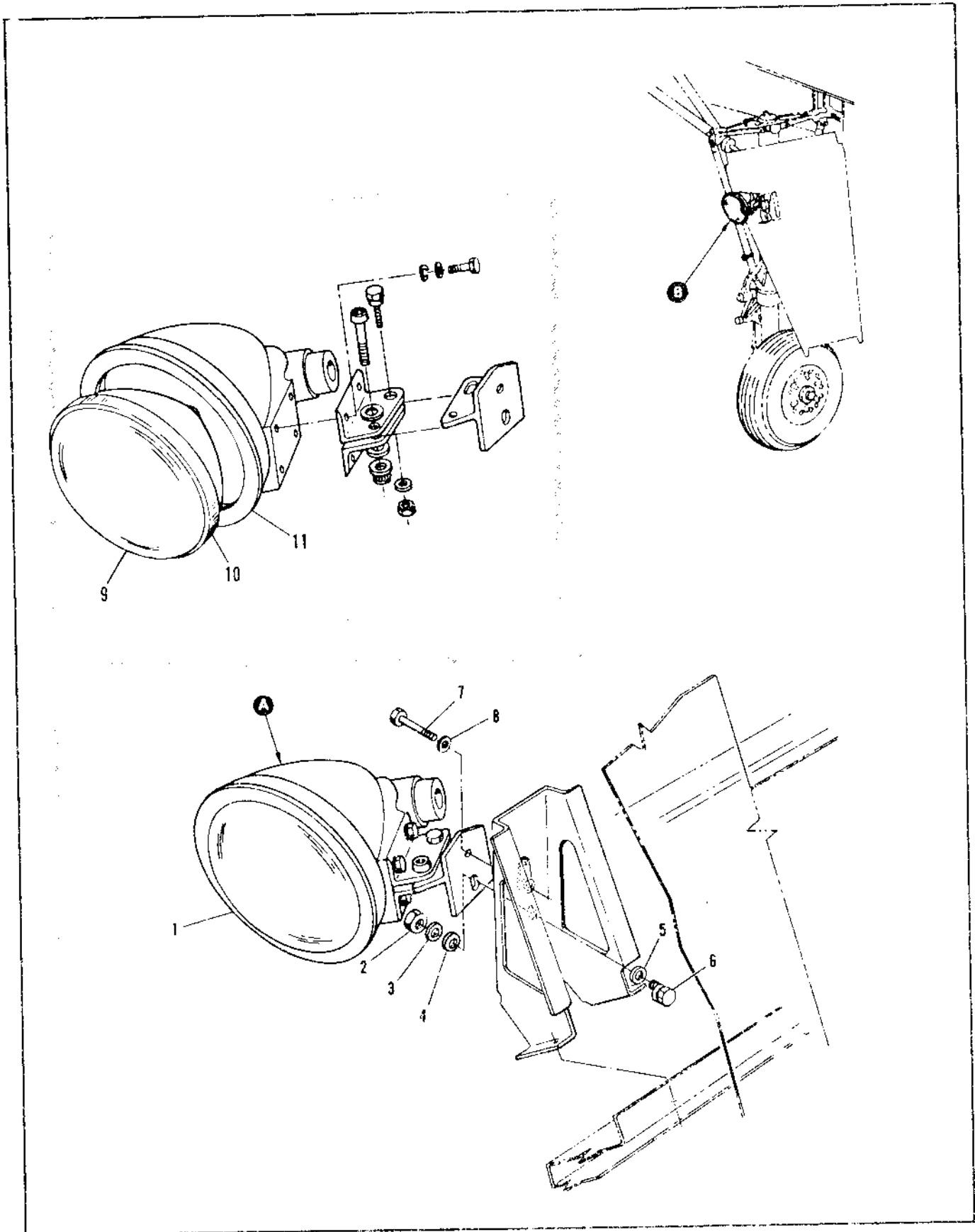

Figure 2.15-5. Landing Light Installation (Sheet 1 of 2)

FIGURE AND INDEX NUMBER	PART NUMBER	DESCRIPTION 1 2 3 4 5 6	UNITS PER ASSY.	USABLE ON CODE		
				FROM	TO	
2.15-8	8-90706-1	LIGHT INSTALLATION, LANDING LH FOR NHA SEE FIG. 2.4-1 AND 2.6-2	RF	35		
	8-90706-2	LIGHT INSTALLATION, LANDING RH FOR NHA SEE FIG. 2.4-1 AND 2.6-2	RF	35		
	- 1	8-90706-19	• LIGHT ASSY, LANDING LH	1	A	
		8-90706-27	• LIGHT ASSY, LANDING LH	1	130	277
		8-90706-20	• LIGHT ASSY, LANDING RH	1	A	
		8-90706-28	• LIGHT ASSY, LANDING RH	1	130	277
			ATTACHING PARTS			
	- 2	NA5679A4	• NUT	1	35	
	- 3	99-51509-004	• WASHER	1	35	
	- 4	99-51509-007	• WASHER	1	35	
	- 5	AN960-416L	• WASHER	1	35	
- 6	8-65252	• BOLT, LANDING LIGHT ADJUSTING	1	35		
- 7	AN4-9A	• BOLT	1	35		
- 8	AN960D13L	• WASHER	1	35		
		-----X-----				
- 9	8553	• LAMP, <72914> FURNISHED WITH B5325-1-24 AND B5325A1-24	RF	A		
	4580	• LAMP UNIT, AIRCRAFT HEADLIGHT <72914> 95-47800-006	1	130	277	
	4581	• LAMP UNIT, AIRCRAFT HEADLIGHT ALTERNATE, INTERCHANGEABLE WITH 4580				
- 10	A-3108	• BAND, RETAINER LAMP <72914>	1	35		
- 11	B5325-1-24	• LIGHT, AIRCRAFT LANDING LH <72914> 95-47800-002 REPLACED BY SUITABLE SUB B5325A1	1	278	278	
	8-90706-21	• LIGHT, AIRCRAFT LANDING LH REPLACES AND ALTERED FROM B5325-1-24 REPLACED BY SUITABLE SUB 8-90706-23	1	B		
	8-90706-22	• LIGHT, AIRCRAFT LANDING LH ALTERED FROM B5325A1-24 REPLACES SUITABLE SUB FOR 8-90706-21	1	49	129	
	B5325A1-24	• LIGHT, AIRCRAFT LANDING <72914> 95-43100-002 REPLACED BY SUITABLE SUB B5325A1	RF			
	8-90706-25	• LIGHT, AIRCRAFT LANDING LH ALTERED FROM B5325A1	1	130	277	
	B5325A1	• LIGHT, AIRCRAFT LANDING <72914> 95-43100-003 REPLACES SUITABLE SUB FOR B5325A1-24 AND B5325-1-24	RF			
	B5325-1-24	• LIGHT, AIRCRAFT LANDING RH <72914> 95-47800-002 REPLACED BY SUITABLE SUB B5325A1	1	278	278	
	8-90706-26	• LIGHT, AIRCRAFT LANDING RH REPLACES AND ALTERED FROM B5325-1-24 REPLACED BY SUITABLE SUB 8-90706-28	1	R		
	8-90706-24	• LIGHT, AIRCRAFT LANDING RH ALTERED FROM B5325A1-24 REPLACES SUITABLE SUB FOR 8-90706-26	1	49	129	
	B5325A1-24	• LIGHT, AIRCRAFT LANDING <72914> 95-43100-002 REPLACED BY SUITABLE SUB B5325A1	RF			
	8-90706-28	• LIGHT, AIRCRAFT LANDING RH ALTERED FROM B5325A1	1	130	277	
	B5325A1	• LIGHT, AIRCRAFT LANDING <72914>	RF			

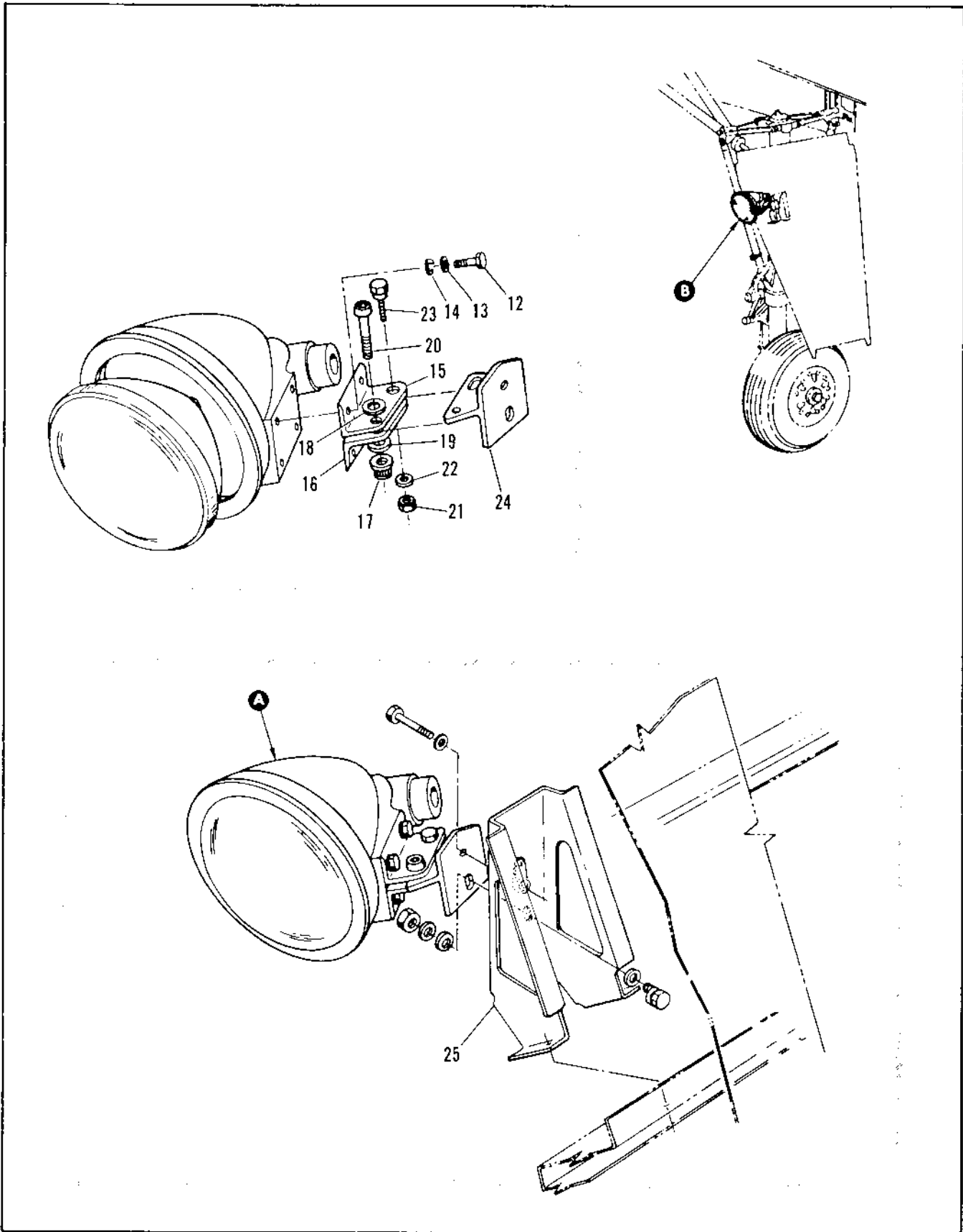

Figure 2.15-5. Landing Light Installation (Sheet 2 of 2)

FIGURE AND INDEX NUMBER	PART NUMBER	DESCRIPTION	UNITS PER ASSY.	USABLE ON CODE	
				FROM	TO
2.15-5		95-33100-033 REPLACES SUITABLE SUB FOR B5329A1-24 AND B5329-1-24 ATTACHING PARTS			
- 12	AN3-4A	• • BOLT	4	35	
- 13	AN960010L	• • WASHER	4	35	
- 14	AN935-10L	• • WASHER	4	35	
		----X----			
- 16	H-65258-6	• • BRACKET	1	35	
- 16	H-65258-7	• • BRACKET	1	35	
		ATTACHING PARTS			
- 17	FB049	• • NUT, <72962> 96-3751 -050	1	35	
- 18	MS2000204	• • WASHER	1	35	
- 19	MS20002-4	• • WASHER	1	35	
- 20	MS20004-4	• • BOLT	1	35	
- 21	NAS679A4	• • NUT	1	35	
- 22	99-51505-007	• • WASHER	1	35	
- 23	H-65252-9	• • BOLT, LANDING LIGHT ADJUSTING	1	35	
		----X----			
- 24	H-65260-10	• • BRACKET, LANDING LIGHT INBD ADJUSTMENT LH REPLACED BY SUITABLE SUB H-65260-16	1	278	333
	H-65260-16	• • BRACKET, LANDING LIGHT INBD ADJUSTMENT LH REPLACES SUITABLE SUB FOR H-65260-10	1	C	
	H-65260-9	• • BRACKET, LANDING LIGHT INBD ADJUSTMENT RH REPLACED BY SUITABLE SUB H-65260-16	127	H3	3
	H-65260-15	• • BRACKET, LANDING LIGHT INBD ADJUSTMENT RH REPLACES SUITABLE SUB FOR H-65260-9	1	C	
- 24	H-92706-15	• SUPPORT ASSY, LH RIVETED	1	35	
	H-92706-16	• SUPPORT ASSY, RH RIVETED	1	35	
		A AIRPLANES #35 THRU 129, 278 AND ON			
		B AIRPLANES #35 THRU 48, 279 AND ON			
		C AIRPLANES #35 THRU 277, 304 AND ON			

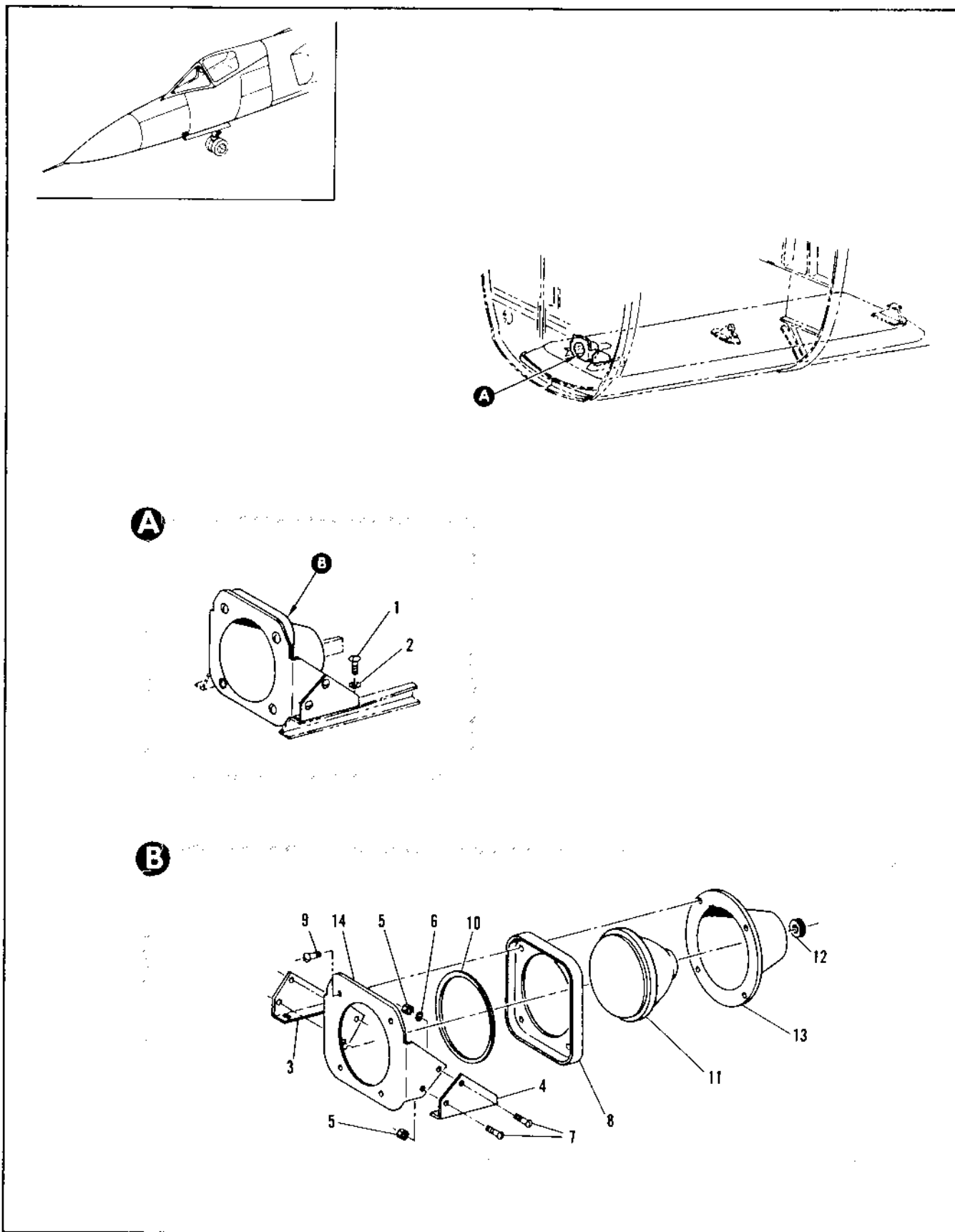

Figure 2.15-6. Taxi Light Installation

FIGURE AND INDEX NUMBER	PART NUMBER	DESCRIPTION	UNITS PER ASSY.	USABLE ON CODE	
				FROM	TO
2.15-6	R-90705	LIGHT INSTALLATION, TAXI FOR MHA SEE FIG. 2.3-3	PF	35	
	R-90705-7	• LIGHT ASSY, TAXI	1	35	
- 1	AN520-1CR4	ATTACHING PARTS	4	35	
- 2	AN960D1GL	• SCREW	4	35	
		• WASHER			
		-----X-----			
- 3	R-67263-4	• BRACKET, TAXI LIGHT MOUNT RH	1	35	
- 4	R-67263-7	• BRACKET, TAXI LIGHT MOUNT LH	1	35	
		ATTACHING PARTS			
- 5	NAS679A?	• NUT	4	35	
- 6	AN960D1GL	• WASHER	2	35	
- 7	AN520-1CR7	• SCREW	4	35	
		-----X-----			
- 8	R-67263-7	• RETAINER, TAXI LIGHT	1	35	
		ATTACHING PARTS			
- 9	AN520-1CR18	• SCREW	4	35	
		-----X-----			
- 10	R-67264	• RING, TAXI LIGHT CUSHION (MAKE FROM AMS320B)	1	35	
- 11	WL0892 TRADE 4570	• LAMP, <24455> 95-47800-001	1	35	
- 12	R15001ER-1	• GROMMET, <94903> 94-35001-002	1	35	
- 13	R-67265-403	• GUARD ASSY, TAXI LIGHT RIVETED	1	35	
- 14	R-67264-1	• SUPPORT, TAXI LIGHT	2	35	

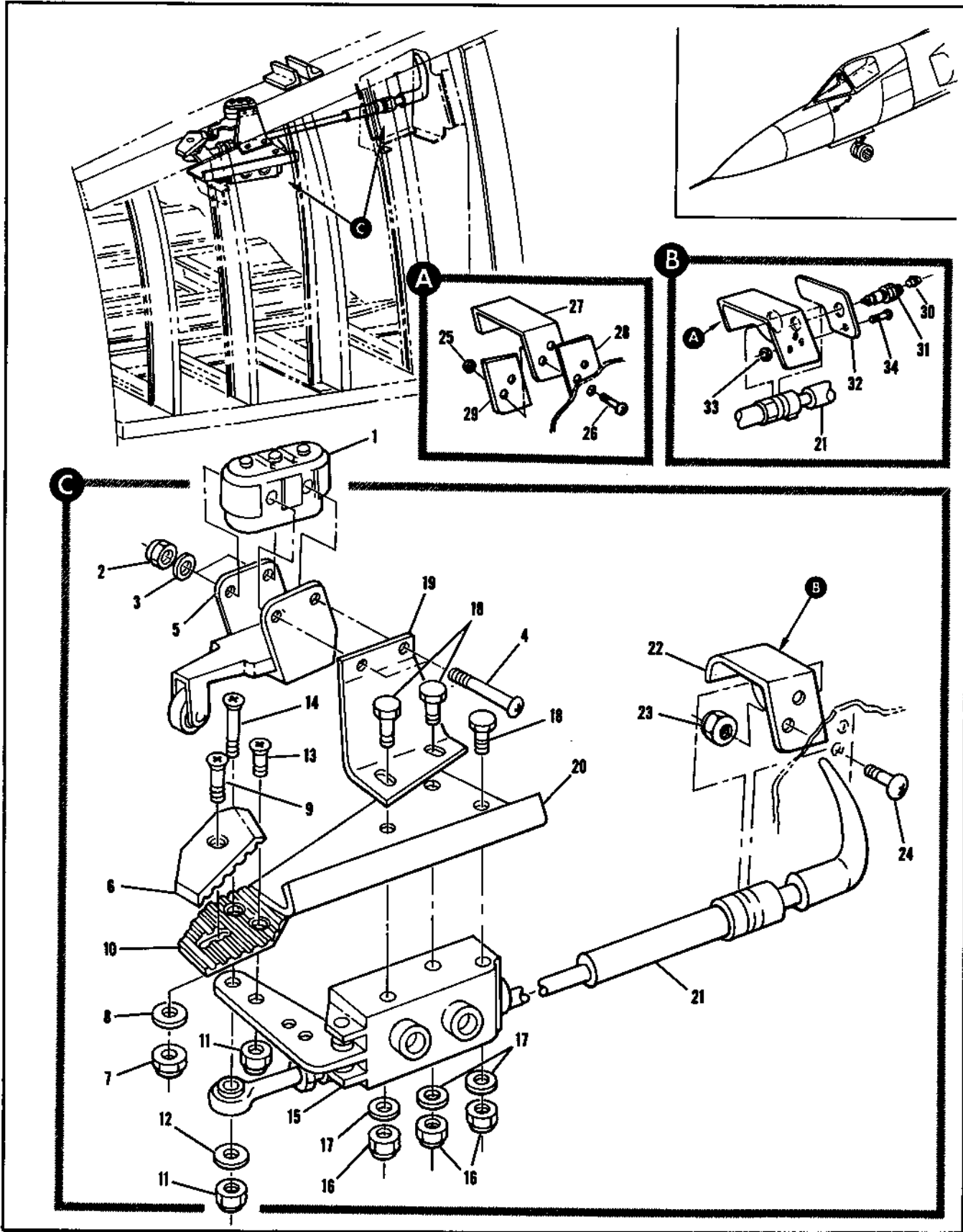

Figure 2.15-7. Landing Gear Emergency Release Control Installation

FIGURE AND INDEX NUMBER	PART NUMBER	DESCRIPTION	UNITS PER ASSY.	USABLE ON CODE		
				FROM	TO	
2.15-7	R-94462-1	CONTROL INSTALLATION, LANDING BEAR EMERGENCY RELEASE FOR NHA SEE 2.7-5	RF	35	159	
	R-94462-1	CONTROL INSTALLATION LANDING BEAR EMERGENCY RELEASE FOR NHA SEE FIG. 2.7-5	RF	167		
	- 1	101HS1	1	35		
	- 2	AN347-6	• NUT, FURNISHED WITH AN3169-1	RF	35	
	- 3	AN937A6	• WASHER, FURNISHED WITH AN3169-1	RF	35	
	- 4	AN519-6-16	• SCREW, FURNISHED WITH AN3169-1			
			-----X-----			
	- 5	AN3169-1	• ACTUATOR	1	35	
	- 6	R-94415-7	• CAM, EMERGENCY LANDING RELEASE REPLACED BY NOT INTCHG WITH R-94415-11	1	35	159
		R-94415-11	• CAM, EMERGENCY LANDING RELEASE REPLACES NOT INTCHG WITH R-94415-7	1	160	
			ATTACHING PARTS			
	- 7	NAS679A3	• NUT	1	35	
	- 8	AN960-10L	• WASHER	1	35	
	- 9	AN509-10R19	• SCREW	1	35	
			-----X-----			
	- 10	R-94415-7	• PLATE, EMERGENCY LANDING RELEASE ATTACHING PARTS	1	35	
	- 11	NAS679A3	• NUT	1	35	
	- 12	AN960-10L	• WASHER	1	35	
	- 13	AN509-10R11	• SCREW	1	35	
	- 14	AN509-10R19	• SCREW	1	35	
			-----X-----			
	- 15	471K21	• VALVE ASSY, <33525> SPEC R-30401-3 T.O. 095-1-9-13	1	35	
			ATTACHING PARTS			
	- 16	NAS679A3	• NUT	3	35	
	- 17	AN960-10L	• WASHER	3	35	
	- 18	AN3-14A	• BOLT	3	35	
			-----X-----			
	- 19	R-94462-7	• ANGLE	1	35	
	- 20	R-94462-8	• ANGLE	1	35	159
		R-94462-17	• ANGLE	1	160	
		R-94462-19	• ANGLE	1	160	
	- 21	11533-2	• CONTROL ASSY, LG EMERGENCY RELEASE <78710> SPEC R-19735-3 T.O. 995-F-73-1 REPLACED BY SUITABLE SUB 11533-3	1	35	159
		11533-3	• CONTROL ASSY, LG EMERGENCY RELEASE <78710> SPEC R-39335-5 T.O. 995-F-73-3 REPLACES SUITABLE SUB FOR 11533-2	1	160	
	- 22	R-94422-11	• SUPPORT ATTACHING PARTS	1	35	159
- 23	NAS679A3	• NUT	2	35	159	
- 24	AN509-10R19	• SCREW	2	35	159	
		-----X-----				
	R-94462-25	• SUPPORT ASSY ATTACHING PARTS	1	160		
- 25	NAS679A3	• NUT	1	160		
- 26	AN519-10R12	• SCREW	2	160		
		-----X-----				
- 27	R-94422-11	• SUPPORT	1	160		
- 28	R-94462-21	• SPACER	1	160		
- 29	R-94462-27	• FILLER	1	160		
	R-94711-177	• LAMP INSTL, EMERGENCY LG CONTROL	1	35		
- 30	AN3140-327	• LAMP	1	35		
- 31	20715-307	• LIGHT ASSY, <72914> SPEC R-19441-1 REPLACED BY INTCHG WITH M225016-4A	1	35	159	
	M225016-4A	• LIGHT ASSY, REPLACES INTCHG WITH 20715-307	1	160		
- 32	R-94421-7	• PLATE ATTACHING PARTS	1	35		
- 33	NAS679A3	• NUT	1	35		
- 34	AN519-6R10	• SCREW	1	35		
		-----X-----				

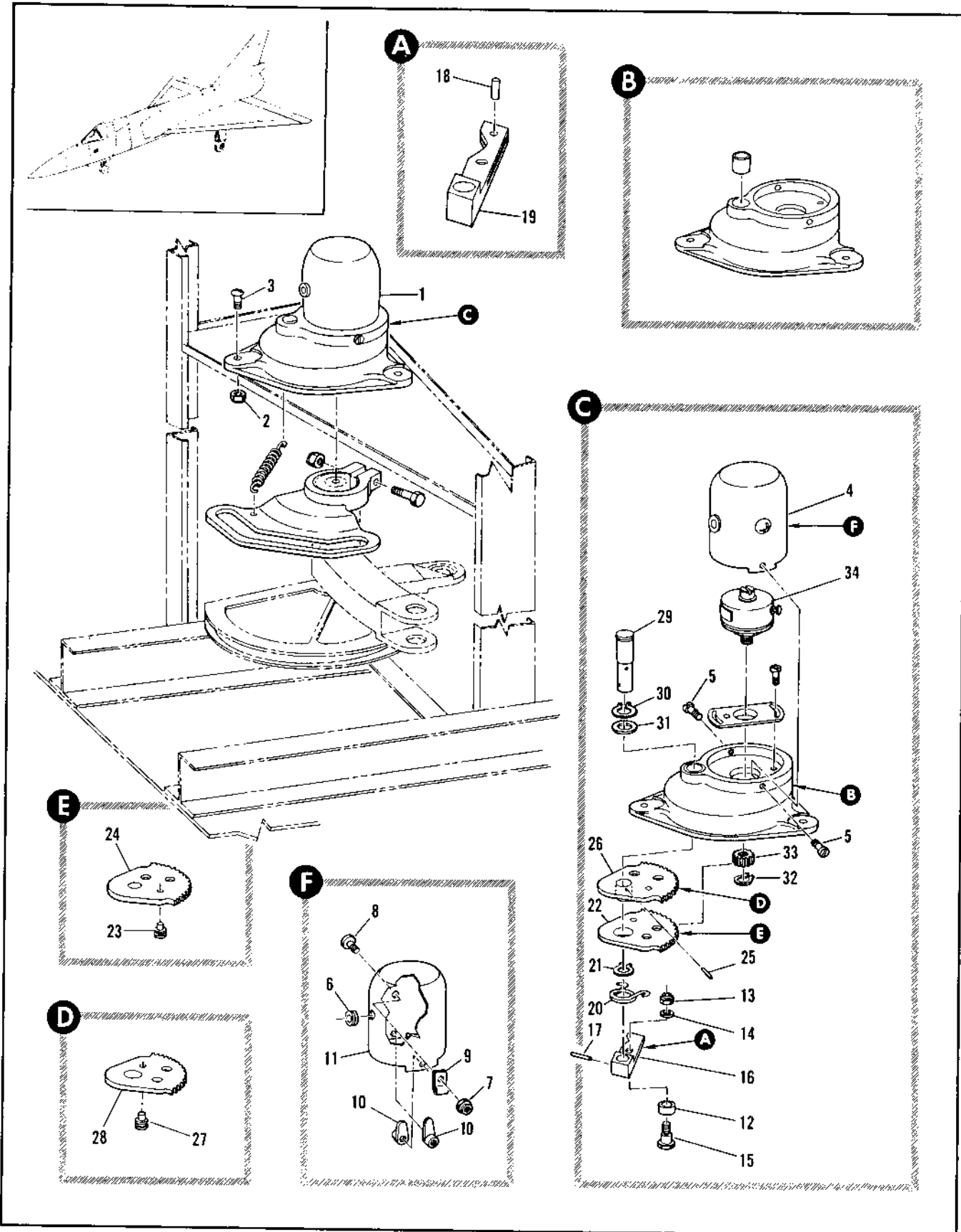

Figure 2.15-8. Nose Landing Gear Command Transmitter Installation (Sheet 1 of 2)

FIGURE AND INDEX NUMBER	PART NUMBER	DESCRIPTION	UNITS PER ASSY.	USABLE ON CODE	
				FROM	TO
2.15-R	6-52158	TRANSMITTER INSTALLATION, NOSE LANDING GEAR COMMAND FOR NHA SEE FIG. 2.3-4	RF	35	38
- 1	8-52137	• GEAR BOX ASSY, POTENTIOMETER NOSE WHEEL REPLACED BY NOT INTCHG WITH 8-52162-9 ATTACHING PARTS	1	35	34
- 2	NAS679A3	• NUT	2	35	38
- 3	AN527-10322F	• SCREW	2	35	38
- 4	8-52159	• COVER ASSY, NOSE WHEEL STEERING GEAR BOX ATTACHING PARTS	1	35	34
- 5	AN500A4-F	• SCREW	2	35	38
- 6	ANR31-3-F	• GROMMET	1	35	38
- 7	NAS679A3	• NUT	1	35	38
- 8	AN527-10322F	• SCREW	1	35	38
- 9	NS21919063	• CLAMP	1	35	38
- 10	AK2118-32	• NUTPLATE	2	35	38
- 11	6-52150-7	• COVER	1	35	34
- 12	8-52147	• ROLLER ATTACHING PARTS	1	35	38
- 13	NAS679A3	• NUT	1	35	38
- 14	AN96306L	• WASHER	1	35	38
- 15	8-52146	• STUD	1	35	38
- 16	8-52145	• LEVER ASSY, REPLACED BY NOT INTCHG WITH 8-52145-1 ATTACHING PARTS	1	35	34
- 17	96-79736-039	• FIN ----X----	1	35	34
- 18	96-79737-037	• PIN ----X----	1	35	38
- 19	8-52148-7	• LEVER	1	35	38
- 20	8-52144	• SPRING	1	35	34
- 21	NAS51-39	• RETAINER	1	35	38
- 22	8-52149	• GEAR ASSY, LOWER	2	35	35
- 23	6-52143-7	• STUD	1	35	34
- 24	8-52148-7	• GEAR, ALTERED FROM 6144 6144	1	35	38
- 25	96-79730-039	• PIN	RF	35	34
- 26	8-52141	• GEAR ASSY, UPPER	1	35	34
- 27	8-52140-9	• STUD	1	35	34
- 28	8-52141-7	• GEAR, ALTERED FROM 6144 6144	1	35	35
- 29	8-52140	• SHAFT, REPLACED BY NOT INTCHG WITH 8-52140-7 ATTACHING PARTS	RF	35	34
- 30	NAS51-31	• RETAINER	1	35	38
- 31	AN96306L	• WASHER ----Y----	1	35	38
- 32	NAS51-25	• RETAINER	1	35	38
- 33	8-52143	• GEAR	1	35	38
- 34	8309-1-1	• POTENTIOMETER, <73136> 97-04112-105	1	35	38
- 35	8309-1	• POTENTIOMETER, <73136> 97-04112-004 ALT INTCHG WITH 8312-1-1	RF	35	38
- 36	8-52139	• ADAPTER ATTACHING PARTS	1	35	38

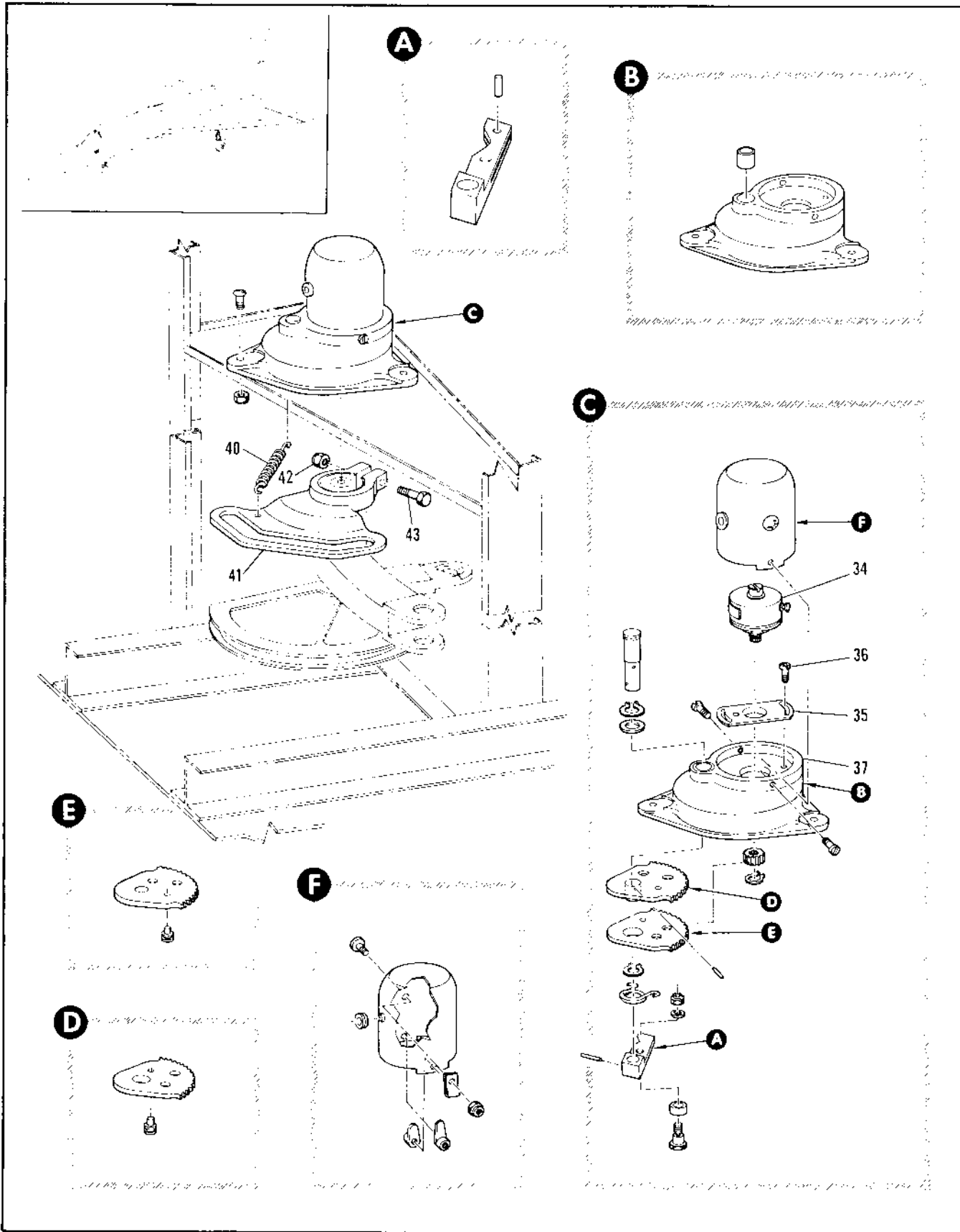

Figure 2.15-8. Nose Landing Gear Command Transmitter Installation (Sheet 2 of 2)

FIGURE AND INDEX NUMBER	PART NUMBER	DESCRIPTION	UNITS PER ASSY.	USABLE ON CODE	
				FROM	TO
		1 2 3 4 5 6			
2.15-8- 36	AN500A4-4	• • SCREW -----X-----	2	35	38
- 37	8-52138-1	• • GEAR CASE ASSEMBLY	1	35	3A
- 38	8-52154	• • GEAR CASE ASSY, ALT INTCHG WITH 8-52138-1	RF	35	3A
- 39	GB59	• • BEARING, (E0380) 90-50507-001	1	35	3A
- 40	8-52138-7	• • GEAR CASE	1	35	3A
- 41	8-52154-7	• • GEAR CASE, ALT INTCHG WITH 8-52138-7	PF	35	3A
- 42	8-52151	• SPRING	1	35	3A
- 43	8-52148-7	• CAM, REPLACED BY NOT INTCHG WITH 8-52148-9	1	35	3A
- 44	8-52153	• CAM, ALT INTCHG WITH 8-52148-7	RF	35	3A
- 45	NAS679A3	ATTACHING PARTS	1	35	3A
- 46	AN3-1CA	• NUT	1	35	3A
- 47		• BOLT -----X-----	1	35	3A

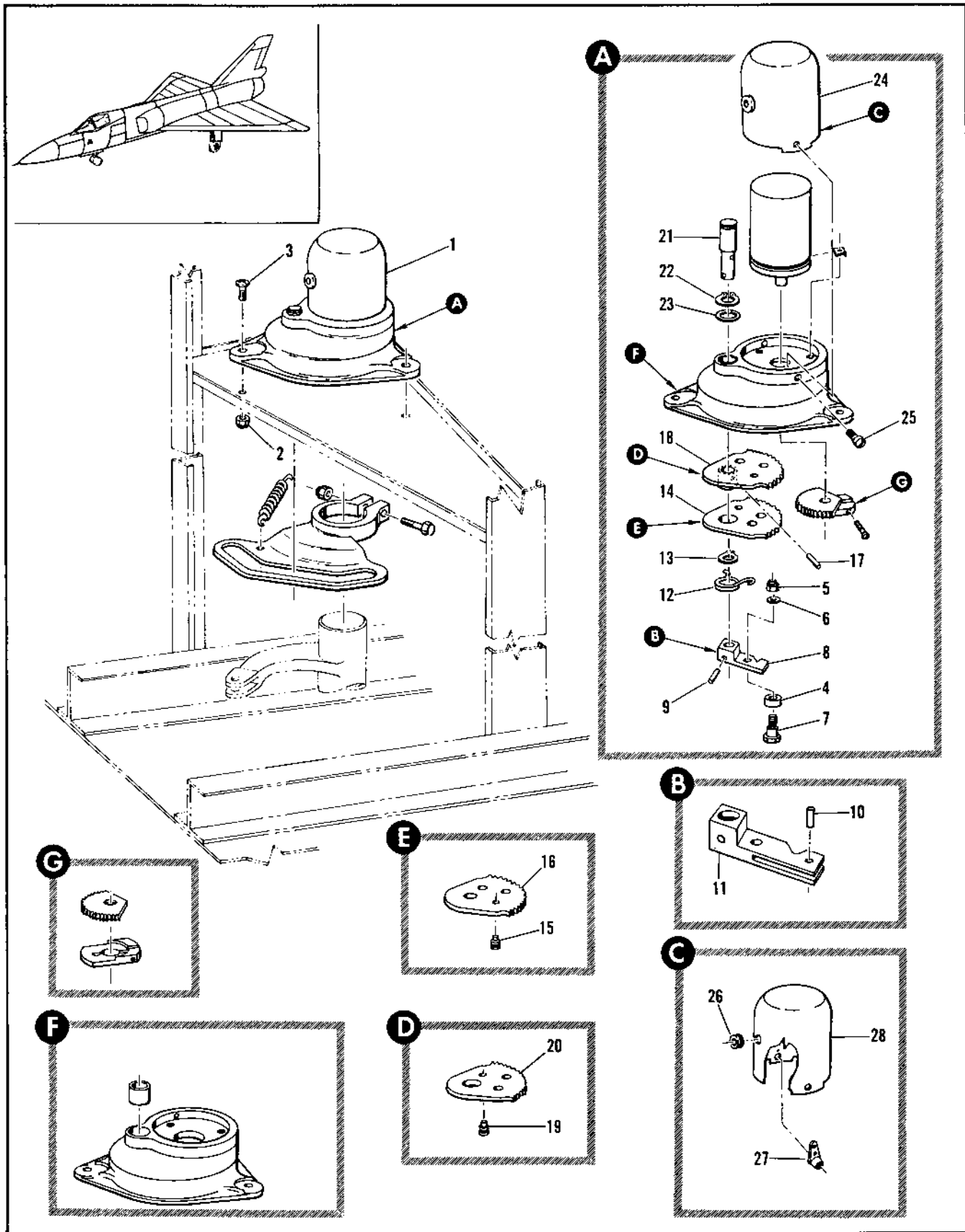

Figure 2.15-9. Nose Landing Gear Command Synchro Transmitter Installation (Sheet 1 of 2)

FIGURE AND INDEX NUMBER	PART NUMBER	DESCRIPTION	UNITS PER ASSY.	USABLE ON CODE	
				FROM	TO
2.15-9	8-52161	TRANSMITTER INSTALLATION, NOSE LANDING GEAR COMMAND SYNCHRO FOR NHA SEE FIG. 2-3-4	RF		A
- 1	8-52162-1	• TRANSMITTER ASSY, NOSE WHEEL STEERING COMMAND SYNCHRO REPLACED BY NOT INTCHG WITH 8-52162-3	1		A
- 2	NAS679A3	• NUT	2		A
- 3	AN526-1032RR	• SCREW	2		A
- 4	8-52147	• ROLLER, CAM FOLLOWER NOSE WHEEL STEERING	1		A
- 5	NAS679A06	• NUT	1		A
- 6	AN96006L	• WASHER	1		A
- 7	8-52146	• STUD, CAM ROLLER NOSE WHEEL STEERING	1		A
- 8	8-52145	• LEVER ASSY, CAM FOLLOWER NOSE WHEEL STEERING REPLACED BY NOT INTCHG WITH 8-52145-1	1		A
- 9	96-79700-039	• PIN	2		A
- 10	96-79700-037	• PIN	1		A
- 11	8-52145-7	• LEVER	1		A
- 12	8-52144	• SPRING, TORSION SECTOR GEAR NOSE WHEEL STEERING	1		A
- 13	NAS51-39	• RETAINER	1		A
- 14	8-52193	• GEAR ASSY, LWR QUADRANT NOSE WHEEL STEERING	1		A
- 15	8-52149-7	• STUD	1		A
- 16	8-52193-7	• GEAR, LWR ALTERED FROM G146	1		A
- 17	G146	• GEAR, <71041> 94-20004-005	PF		A
- 18	96-79700-039	• PIN	1		A
- 19	8-52192	• GEAR ASSY, UPPER QUADRANT NOSE WHEEL STEERING	1		A
- 20	8-52149-9	• STUD	1		A
- 21	8-52192-7	• GEAR, UPPER ALTERED FROM G148	1		A
- 22	G148	• GEAR, <71041> 94-20004-007	RF		A
- 23	8-52140	• SHAFT, CAM FOLLOWER NOSE WHEEL STEERING REPLACED BY NOT INTCHG WITH 8-52140-7	1		A
- 24	NAS51-31	• RETAINER	1		A
- 25	AN960-516	• WASHER	1		A
- 26	8-52150-1	• COVER ASSY, GEAR BOX NOSE WHEEL STEERING ATTACHING PARTS	1		A
- 27	ANSJJAR-C	• SCREW	2		A
- 28	AN931-5-4	• GROMMET	1		A
- 29	MK2000-832	• NUTPLATE, <75237> 96-37575-005	2		A
- 30	8-52150-5	• COVER	1		A
A AIRPLANES #39 THRU 47 AND 49 THRU 89					

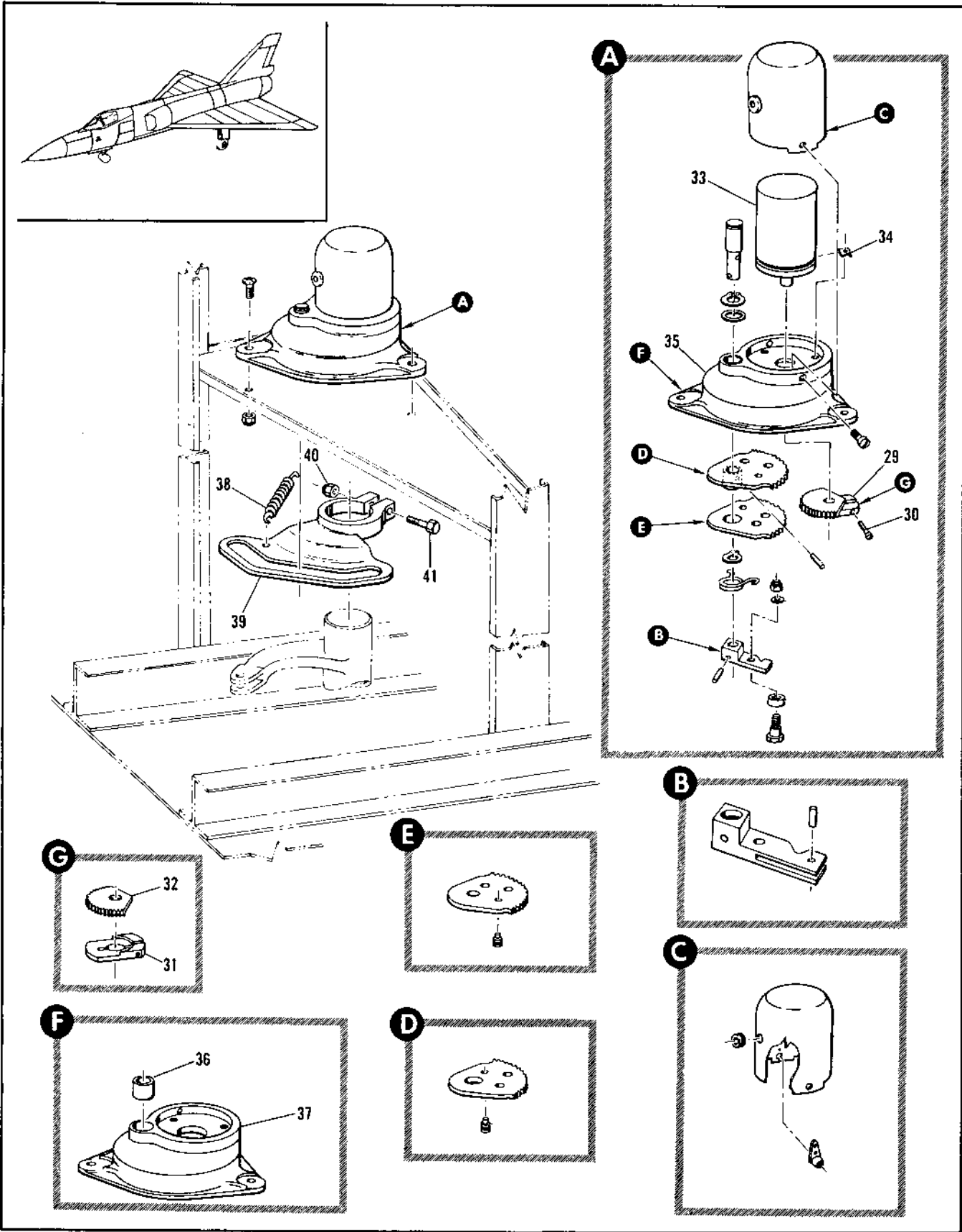

Figure 2.15-9. Nose Landing Gear Command Synchro Transmitter Installation (Sheet 2 of 2)

FIGURE AND INDEX NUMBER	PART NUMBER	DESCRIPTION 1 2 3 4 5 6	UNITS PER ASSY.	USABLE ON CODE	
				FROM	TO
2.15-9- 29	R-52162-9	• • GEAR ASSY, SYNCHRO DRIVE SECTOR NOSE WHEEL STEERING ATTACHING PARTS	1	A	
- 30	AN501A4-10	• • SCREW ----X----	1	A	
- 31	R-52222	• • • CLAMP, GEAR RETAINER NOSE WHEEL STEERING	1	A	
- 32	R-52190	• • • GEAR, SYNCHRO DRIVE SECTOR NOSE WHEEL STEERING ALTERED FROM 6143	1	A	
	6143	• • • GEAR, <71041> 94-20004-002	RF		
- 33	913-002	• • TRANSMITTER, SYNCHRO <98810> SPEC R-05341-1	1	A	
- 34	643019	• • CLAMP, <95542> 91-98301-001	3	A	
- 35	R-52138-3	• • GEAR CASE ASSY, POTENTIOMETER NOSE WHEEL STEERING	1	A	
	R-52154-1	• • GEAR CASE ASSY, POTENTIOMETER NOSE WHEEL STEERING ALT INTCHG WITH R-52138-3	RF	A	
- 36	6859	• • • BEARING, <60360> 92-60507-001	1	A	
- 37	R-52138-9	• • • GEAR CASE	1	A	
	R-52154-9	• • • GEAR CASE, USE WITH R-52154	RF	A	
- 38	R-52151	• SPRING, CAM FOLLOWER NOSE WHEEL STEERING	1	A	
- 39	R-52148-7	• CAM, STEERING COMMAND NOSE WHEEL REPLACED BY NOT INTCHG WITH R-52148-9	1	A	
	R-52153	• CAM, STEERING COMMAND NOSE WHEEL ALT INTCHG WITH R-52148-7 ATTACHING PARTS	RF	A	
- 40	NAS675A3	• NUT	1	A	
- 41	AN3-1A	• PLT ----X----	1	A	
A AIRPLAINS #39 THRU 47 AND 49 THRU 89					

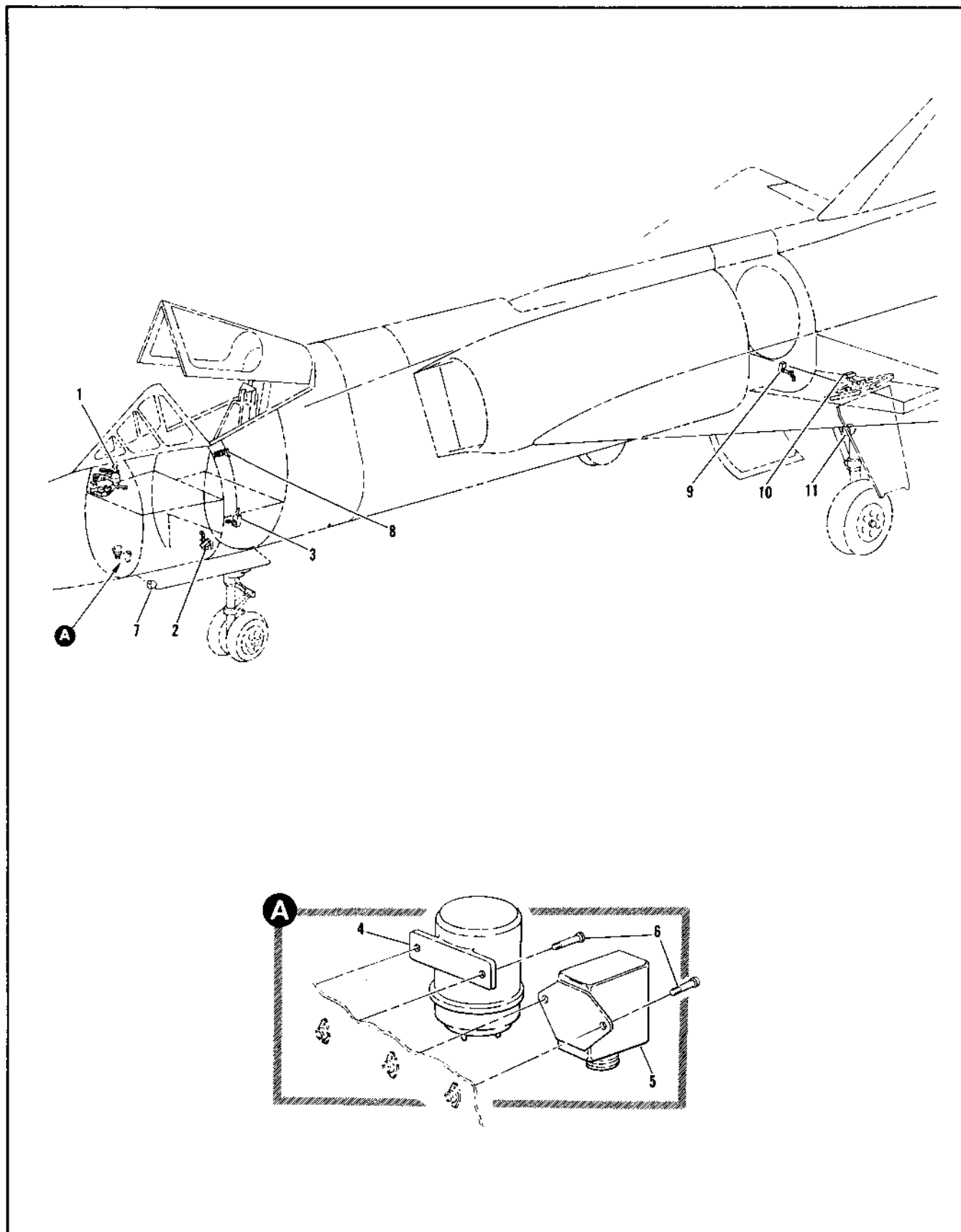

Figure 2.15-10. Landing Gear Electrical

FIGURE AND INDEX NUMBER	PART NUMBER	DESCRIPTION	UNITS PER ASSY.	USABLE ON CODE	
				FROM	TO
		1 2 3 4 5 6			
2.15-10		LANDING GEAR ELECTRICAL			
- 1		• BELL CRANK ASSY, RH SEE FIG. 2-14-33	RF		
- 2		• SWITCH INSTL, MLG DOOR CLOSE SEE FIG. 2.15-3	RF		
- 3		• SWITCH INSTL, MLG UP AND DOWN SEE FIG. 2.15-2	RF		
- 4	8-65028-1	• RELAY INSTL, TAXI LIGHT	1	35	
- 5	64-564	• RELAY, <96041> SPEC R-36756	1	35	
	9220-3435	• RELAY, <35344> SPEC R-26289-3	1	35	
	9220-3433	• RELAY, <35744> SPEC R-36249 ALT INTCHG WITH 9220-3435 ATTACHING PARTS	RF	35	
- 6	NAS221-9	• SCREW ----X----	4	35	
- 7		• LIGHT INSTL, TAXI SEE FIG. 2.15-6	RF		
- 8		• SWITCH INSTL, TAXI AND LANDING LIGHT G SUIT AND NO FOG SEE FIG. 2.15-12	RF		
- 9		• SWITCH INSTL, MLG DOOR OPEN SEE FIG. 2.15-32	RF		
- 10		• SWITCH INSTL, MLG UP SEE FIG. 2.15-4	RF		
- 11		• LIGHT INSTL, LANDING SEE FIG. 2.15-4	RF		

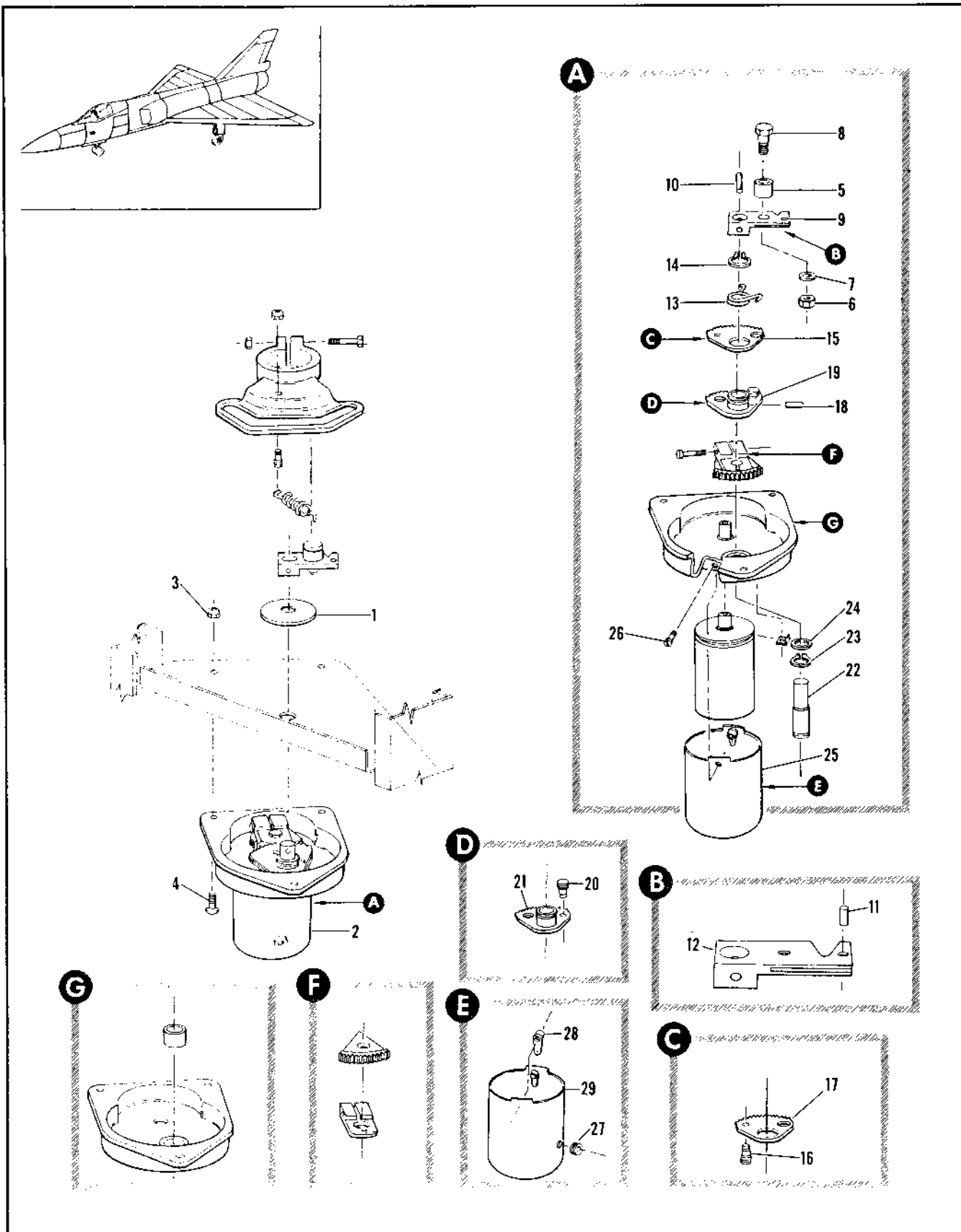

Figure 2.15-11. Nose Landing Gear Command Synchro Transmitter Installation (Sheet 1 of 2)

FIGURE AND INDEX NUMBER	PART NUMBER	DESCRIPTION	UNITS PER ASSY.	USABLE ON CODE	
				FROM	TO
2.15-11	8-52161-1	TRANSMITTER INSTALLATION, NOSE LANDING GEAR COMMAND SYNCHRO FOR NHA SEE FIG. 2.3-4	RF		A
- 1	8-52161-7	• SEAL, COMMAND SYNCHRO TRANSMITTER	1		B
- 2	8-52162-3	• TRANSMITTER ASSY, NOSE WHEEL STEERING COMMAND SYNCHRO REPLACES NOT INTCHG WITH 8-52162-1 T.O. 1F-106A-3 ATTACHING PARTS	1		A
- 3	NAS679A3	• NUT	2		A
- 4	AN525-1032R9	• SCREW	2		A
- 5	8-52147	• ROLLER, CAM FOLLOWER NOSE WHEEL STEERING ATTACHING PARTS	1		A
- 6	NAS679A06	• NUT	1		A
- 7	AN940D6L	• WASHER	1		A
- 8	8-52146	• STUD, CAM FOLLOWER NOSE WHEEL STEERING ATTACHING PARTS	1		A
- 9	8-52145-1	• LEVER ASSY, CAM FOLLOWER NOSE WHEEL STEERING REPLACES NOT INTCHG WITH 8-52145 ATTACHING PARTS	1		A
- 10	96-79700-039	• PIN	2		A
- 11	96-79700-037	• PIN	1		A
- 12	8-52145-K	• LEVER	1		A
- 13	8-52144	• SPRING, TORSION SECTOR GEAR NOSE WHEEL STEERING	1		A
- 14	NAS51-39	• RETAINER	1		A
- 15	8-52193	• GEAR ASSY, LWR QUADRANT NOSE WHEEL STEERING	1		A
- 16	8-52142-7	• STUD	1		A
- 17	8-52193-7	• GEAR, LWR ALTERED FROM 8144	1		A
- 18	96-79700-034	• GEAR, <71241> 94-20094-105	RF		A
- 19	8-52142	• PIN	1		A
- 20	8-52142	• GEAR ASSY, UPPER QUADRANT NOSE WHEEL STEERING	1		A
- 21	8-52149-9	• STUD	1		A
- 22	8-52192-7	• GEAR, UPPER ALTERED FROM 8148	1		A
- 23	96-79700-037	• GEAR, <71241> 94-20094-107	RF		A
- 24	8-52142-7	• SHAFT, CAM FOLLOWER NOSE WHEEL STEERING REPLACES NOT INTCHG WITH 8-52142 ATTACHING PARTS	1		A
- 25	NAS51-31	• RETAINER	1		A
- 26	AN940D51F	• WASHER	1		A
- 27	8-52150-1	• COVER ASSY, GEAR BOX NOSE WHEEL STEERING ATTACHING PARTS	1		A
- 28	AN500AP-6	• SCREW	2		A
- 29	AN931-8-9	• CRUMMET	1		A
- 30	96-79700-032	• MULTIPLE, <75237> 96-30075-105	2		A
- 31	8-52150-9	• COVER	1		A

A AIRPLANES #49, 90 AND ON
B AIRPLANES #90 THRU 121 AND 160 AND ON

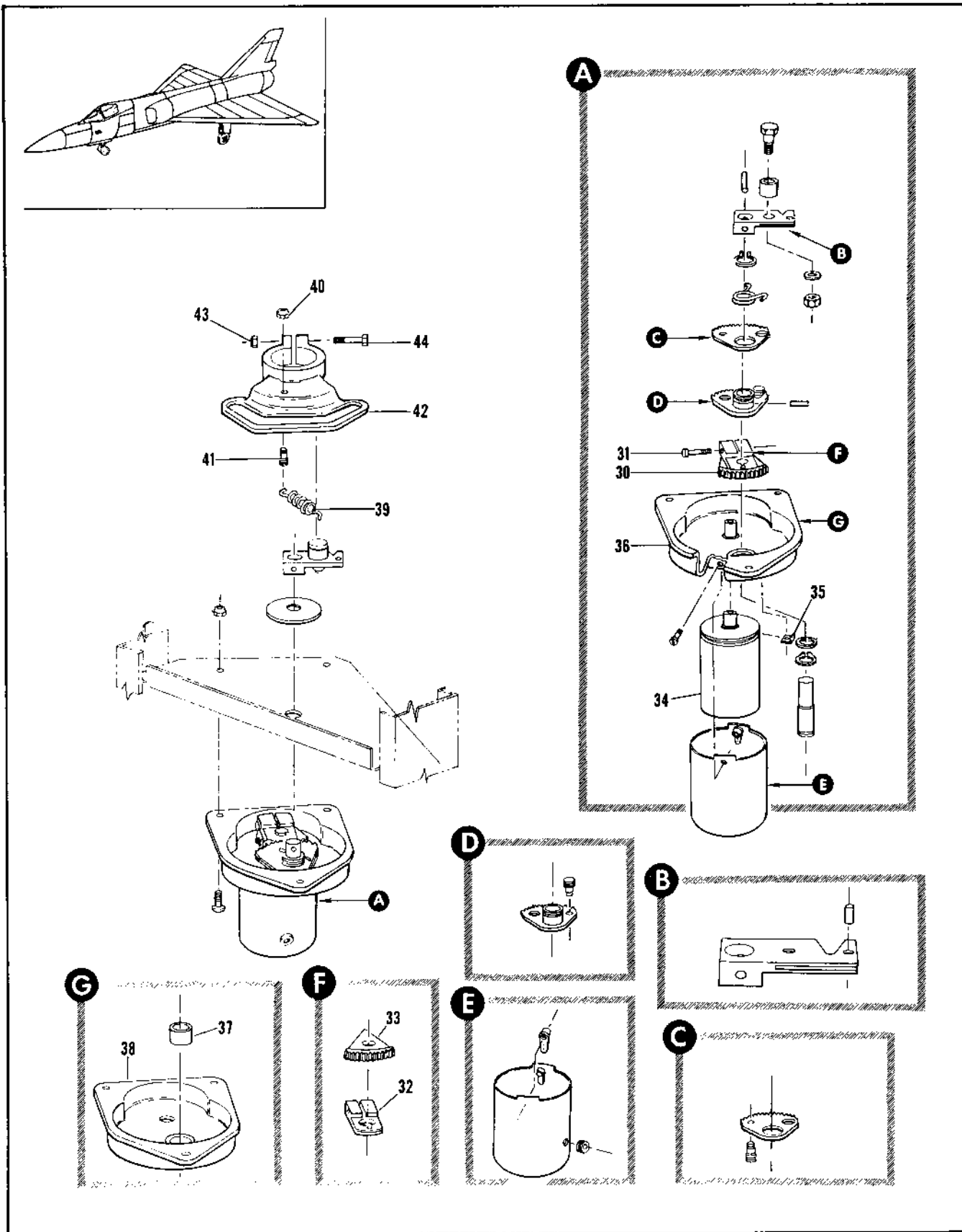

Figure 2.15-11. Nose Landing Gear Command Synchro Transmitter Installation (Sheet 2 of 2)

FIGURE AND INDEX NUMBER	PART NUMBER	DESCRIPTION	UNITS PER ASSY.	USABLE ON CODE	
				FROM	TO
				1	2
2.15-11- 40	R-52152-5	• • GEAR ASSY, SYNCHRO DRIVE SECTOR NOSE WHEEL STEERING REPLACES NOT INTCHG WITH R-52137	1		A
- 31	AN513A4-10	• • SCREW	1		A
- 32	R-52222	• • • CLAMP, GEAR RETAINER NOSE WHEEL STEERING	1		A
- 33	R-52175	• • • GEAR, SYNCHRO DRIVE SECTOR NOSE WHEEL STEERING ALTERNATE FROM G142	1		A
- 34	R-143	• • • GEAR, <71241> R4-23754-102	RF		
- 35	9915-102	• • TRANSMITTER, SYNCHRO <R-410> SPEC R-35341-1	1		A
- 36	643019	• • CLAMP, <R5542> 91-98321- 01	3		A
- 37	R-52138-3	• • GEAR CASE ASSY, POTENTIOMETER NOSE WHEEL STEERING	1		A
- 38	R-52154-1	• • GEAR CASE ASSY, POTENTIOMETER NOSE WHEEL STEERING ALT INTCHG WITH R-52138-3	RF		A
- 39	3B59	• • • BEARING, <R33PC> 91-60537-101	1		A
- 40	R-52139-1	• • • GEAR CASE	1		A
- 41	R-52154-6	• • • GEAR CASE, USE WITH R-52154	RF		A
- 42	R-52151	• SPRING, CAM FOLLOWER NOSE WHEEL STEERING	1		A
- 43	NAS679A3	• NUT	1		A
- 44	R-52224	• STUD, CAM SPRING	1		A
- 45	R-52146-6	• CAM, STEERING COMMAND NOSE WHEEL REPLACES NOT INTCHG WITH R-52148-7	1		A
- 46	R-52153-7	• CAM, STEERING COMMAND NOSE WHEEL ALT INTCHG WITH R-52146-6	RF		A
- 47	NAS679A3	• NUT	1		A
- 48	AN3-16A	• BOLT	1		A
		-----X-----			
		A AIRPLANES R4B, 90 AND ON			

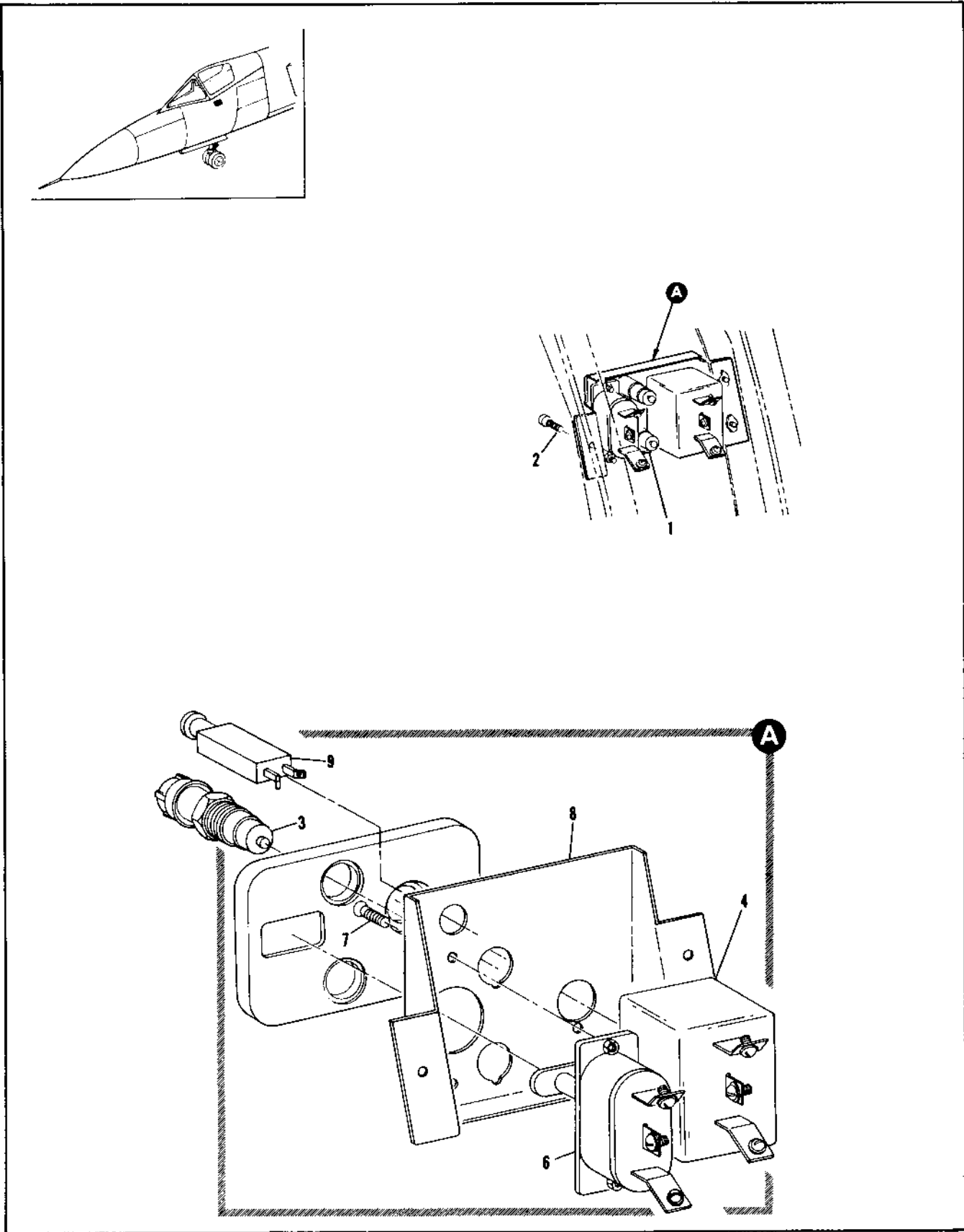

Figure 2.15-12. Taxi and Landing Light G Suit and No Fog Switch Installation

FIGURE AND INDEX NUMBER	PART NUMBER	DESCRIPTION	UNITS PER ASSY.	USABLE ON CODE	
				FROM	TO
		1 2 3 4 5 6			
2.15-12	H-95593	SWITCH INSTALLATION, TAXI AND LANDING LIGHT G SUIT AND NO FOG FOR NHA SEE FIG. 2.3-6	RF	35	
- 1	H-95593-19	• SWITCH ASSY, TAXI AND LANDING LIGHT G SUIT AND NO FOG	1	35	43
	H-95593-13	• SWITCH ASSY, TAXI AND LANDING LIGHT G SUIT AND NO FOG	1	44	240
	H-95593-15	• SWITCH ASSY, TAXI AND LANDING LIGHT G SUIT AND NO FOG	1	241	
- 2	AN525-103PR7	• SCREW -----X-----	3	35	
	H-94711-19 ⁴	• LAMP INSTALLATION	2	35	
	AN3140-327	• LAMP, WHITE	1	35	
- 3	1950	• LIGHT, PANEL <P3564> SPEC 8-04441-1	2	35	39
	MS25010-44	• LIGHT, PANEL ALT INTCHG WITH 1950	2	50	
- 4	51-33101	• SWITCH, COCKPIT NO FOG AND VENT SUIT <35323> SPEC 8-069K2-1 REPLACED BY NOT INTCHG WITH 8906K728	1	35	43
	8906K728	• SWITCH, COCKPIT NO FOG AND VENT SUIT <15415> SPEC 8-06999-1 REPLACES NOT INTCHG WITH 51-33101	1	44	240
	8906K706	• SWITCH, COCKPIT NO FOG AND VENT SUIT <15415> SPEC 8-06999-1 REPLACES NOT INTCHG WITH 51-33101	1	241	
- 5	H-95113	• PLATE, TAXI LIGHT AND LANDING LIGHT AND COCKPIT NO FOG	1	35	
- 6	AN3022-118	• SWITCH, TAXI LIGHT AND LANDING LIGHT ATTACHING PARTS	1	35	
- 7	AN507-632R4	• SCREW -----X-----	2	35	
- 8	65F33930-11	• BRACKET	1	35	
- 9	MD1503A-C	BREAKER, CIRCUIT, AIM-26 ARM/DISARM/ MONITOR PW	1		

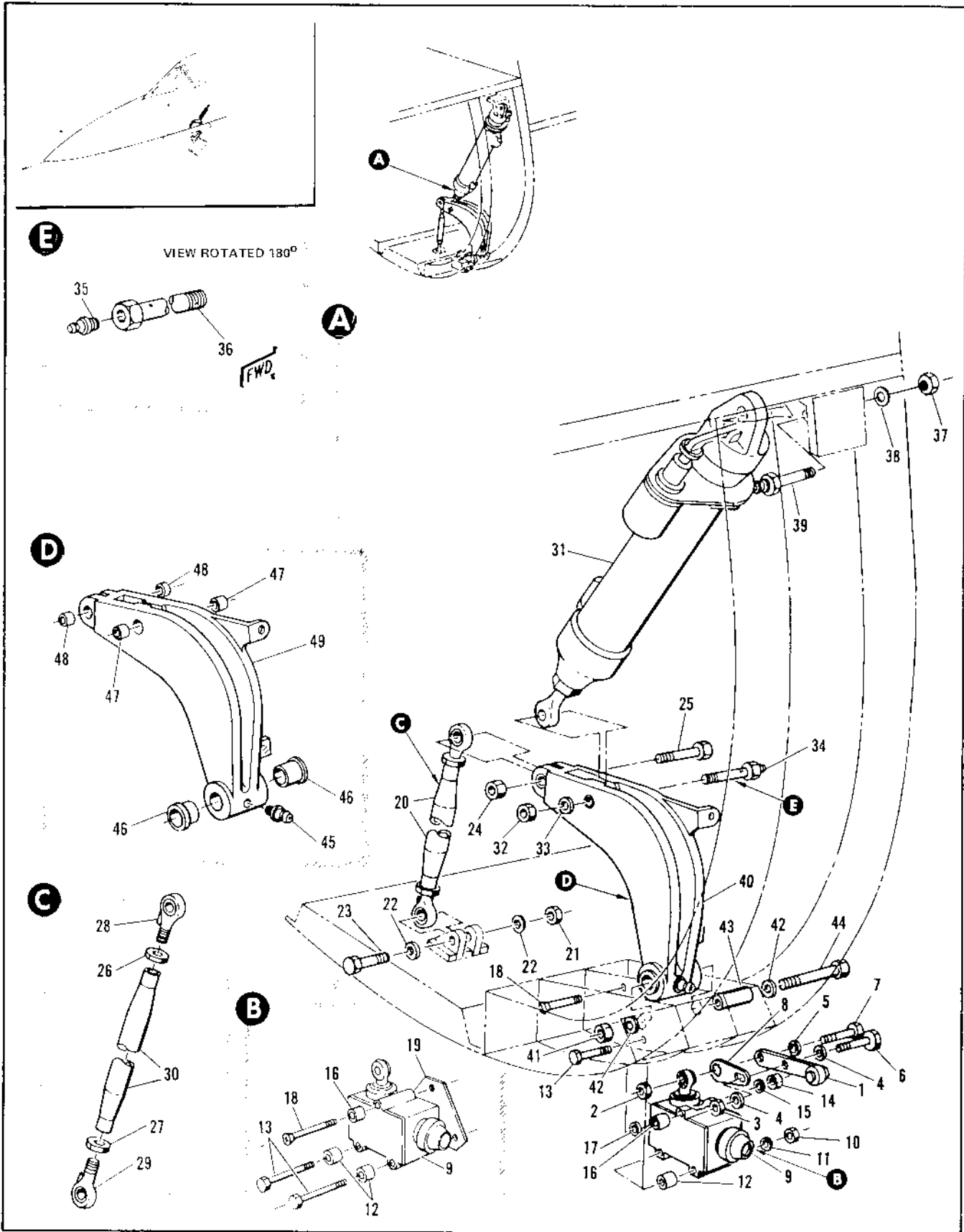

Figure 2.15-13. Nose Landing Gear Door Mechanism Installation

FIGURE AND INDEX NUMBER	PART NUMBER	DESCRIPTION	UNITS PER ASSY.	USABLE ON CODE	
				FROM	TO
2.15 13	R-45010-1	MECHANISM INSTALLATION, NOSE LANDING GEAR DOOR FOR NHA SEE FIG. 2.3-3	RF	35	
- 1	R-65743-1	• ARM ASSY, RIVETED	1	35	
- 2	NAS679A3	• NUT	1	35	
- 3	NAS679A3	• NUT	1	35	
- 4	AN960010L	• WASHER	2	35	
- 5	AN96009	• WASHER	1	35	
- 6	R-68138-7	• BOLT	1	35	
- 7	AN3-7A	• BOLT	1	35	
- 8	112742	• PLATE, <97199> SPEC R-1698F-7	1	35	
- 9	69C37529-1	• SWITCH, LIMIT <97199> SPEC B-06943-873	1	35	
- 10	NAS579A3	• NUT	2	35	60
- 11	AN960010L	• WASHER	2	35	60
- 12	NAS42006-50	• SPACER	2	35	
- 13	AN3-21A	• BOLT	2	35	
- 14	NAS679A3	• NUT	1	35	60
- 15	AN960010L	• WASHER	1	35	60
- 16	NAS42006-26	• SPACER	1	35	
- 17	69-53302-001	• WASHER	1	35	
- 18	MS24694S775	• SCREW	1	35	
- 19	R-45010-7	• PLATE ASSY, NLG DOOR MECHANISM	1	61	
- 20	R-45010-7	• TUBE ASSY, NLG DOOR MECHANISM ATTACHING PARTS	1	35	
- 21	AN320-5	• NUT	1	35	
- 22	AN9600616	• WASHER	2	35	
- 23	NAS464-5-16	• BOLT	1	35	
- 24	AN320-5	• NUT	1	35	
- 25	NAS464-5-20	• BOLT	1	35	
		-----X-----			
- 26	AN316-6R	• NUT	1	35	
- 27	AN316-6L	• NUT	1	35	
- 28	HE5-4	• BEARING, ROD END <97413> SPEC B-74317-1	1	35	
- 29	HE5-4	• BEARING, ROD END <97413> SPEC B-74317-2	1	35	
- 30	R-45109-7	• TUBE	1	35	
- 31	364FA4	• ACTUATOR ASSY, NLG DOOR (79062), SPEC R-06489, I.O. 9H2-5-141-3, INTCHG WITH 5-1037	1	35	
	5-1037	• ACTUATOR ASSY, NLG DOOR (04423), SPEC R-06489, I.O. 9H2-5-130-3, ALT INTCHG WITH 364FA4	RF	35	
- 32	AN320-6	• NUT	1	35	
- 33	AN9600616	• WASHER	1	35	
- 34	R-84209	• BOLT ASSY, NLG DOOR ACTUATOR LOWER	1	35	
- 35	MS10001-1	• FITTING	1	35	
- 36	R-84209-7	• BOLT	1	35	188
- 37	AN316-6	• NUT	1	189	
	AN320-6	• NUT	1	35	188
- 38	AN9600616	• WASHER	1	189	
	AN9600616	• WASHER	1	189	
- 39	R-80217-9	• BOLT, NLG DOOR ACTUATOR UPPER	1	35	
- 40	R-45018-1	• ARM ASSY, NLG DOOR MECHANISM	1	35	
	R-45008-3	• ARM ASSY, NLG DOOR MECHANISM ALT INTCHG WITH R-45018-1 ATTACHING PARTS	RF	35	
- 41	AN320-4	• NUT	1	35	
- 42	AN9600416L	• WASHER	1	35	
- 43	NAS72-4-112	• BUSHING	1	35	
- 44	NAS464-4-36	• BOLT	1	35	
		-----X-----			
- 45	MS10001-1	• FITTING	1	35	
- 46	NAS77A7-50	• PUSHING	2	35	
- 47	NAS76A6-121	• PUSHING	2	35	
- 48	NAS76A6-113	• BUSHING	2	35	
- 49	R-45017-7	• ARM	1	35	
	R-45008-3	• ARM, ALT INTCHG WITH R-45017-7	RF	35	

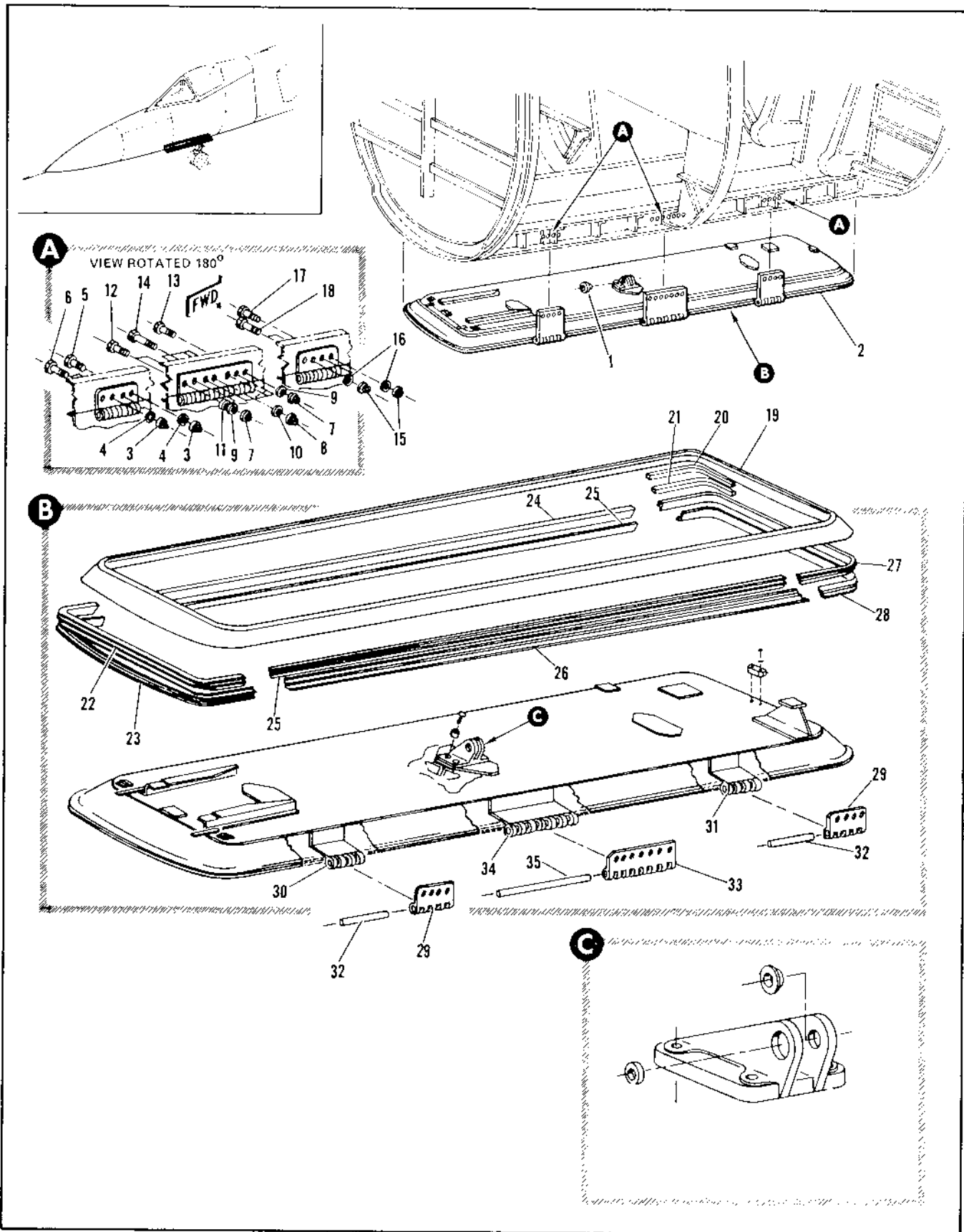

Figure 2.15-14. Nose Landing Gear Door Installation (Sheet 1 of 2)

FIGURE AND INDEX NUMBER	PART NUMBER	DESCRIPTION	UNITS PER ASSY	USABLE ON CODE	
				FROM	TO
2.15-14	8-74626	DOOR INSTALLATION, NOSE LANDING GEAR FOR NHA SEE FIG. 2.3-3	RF	35	
- 1	8-77755	• BUSHING, ADAPTER NLG DOOR	1	35	
- 2	8-74626-175	• DOOR ASSY, NLG REPLACES NOT INTERCHG WITH 8-74626-187	1	35	36
	8-74626-187	• DOOR ASSY, NLG REPLACED BY NOT INTERCHG WITH 8-74626-175	1	37	
		ATTACHING PARTS			
- 3	NAS679A3	• NUT, AFT 96-37545-002	4	35	
- 4	AN960-10L	• WASHER, AFT	4	35	
- 5	AN3-5A	• BOLT, AFT	2	35	
- 6	AN3-6A	• BOLT, AFT	2	35	
- 7	NAS679A2	• NUT, CENTER 96-37545-002	3	35	
- 8	NAS679A4	• NUT, 96-37545-003	4	35	
- 9	AN960-10L	• WASHER	2	35	
- 10	AN960-416L	• WASHER	4	35	
- 11	AN960-10	• WASHER	1	35	
- 12	NAS464-3A8	• BOLT	2	35	
- 13	NAS464-3A5	• BOLT	1	35	
- 14	NAS464-4A5	• BOLT	4	35	
- 15	NAS679A3	• NUT, FWD 96-37545-002	4	35	
- 16	AN960-10L	• WASHER, FWD	4	35	
- 17	AN3-5A	• BOLT, FWD	2	35	
- 18	AN3-5A	• BOLT, FWD	2	35	
		-----X-----			
- 19	8-74937-15	• SEAL, REPLACED BY SUITABLE SUB 8-74937-19	1	35	49
	8-74937-19	• SEAL, REPLACES SUITABLE SUB FOR 8-74937-15	1	90	
	8-78738	• SEAL, ALT INTCHG WITH 8-74937-15 AND 8-74937-19			
- 20	8-74626-87	• INSERT, MAKE FROM 340-8210303-9	1	35	
- 21	8-74626-49	• INSERT, MAKE FROM 340-8210303-9	1	35	
	340-8210303-9	• INSERT	RF		
- 22	8-74626-71	• RETAINER, NOSE WHEEL DOOR	1	35	
- 23	8-74626-69	• RETAINER, NOSE WHEEL DOOR	1	35	
- 24	8-74626-77	• RETAINER, NOSE WHEEL DOOR	1	35	
- 25	8-74626-67	• RETAINER, NOSE WHEEL DOOR	2	35	
- 26	8-74626-65	• RETAINER, NOSE WHEEL DOOR	1	35	
- 27	8-74626-73	• RETAINER, NOSE WHEEL DOOR	1	35	
- 28	8-74626-75	• RETAINER, NOSE WHEEL DOOR	1	35	
- 29	8-77707-9	• HINGE, OUTBD	2	35	
	8-74543-9	• HINGE, OUTBD ALT INTCHG WITH 8-77707-9	RF	35	
- 30	8-74508-11	• HINGE, FWD INBD	1	35	
	8-74332-9	• HINGE, FWD INBD ALT INTCHG WITH 8-74508-11	RF	3	
- 31	8-74500-9	• HINGE, AFT INBD	1	35	
	8-74932-7	• HINGE, AFT INBD ALT INTCHG WITH 8-74500-9	RF	3	
		ATTACHING PARTS			
- 32	8-74626-110	• PIN	2	35	
		-----Y-----			
- 33	8-74643-7	• HINGE, CENTER OUTBD	1	35	
- 34	8-74933	• HINGE, CENTER INBD	1	35	
		ATTACHING PARTS			
- 35	8-74626-110	• PIN	1	35	
		-----X-----			

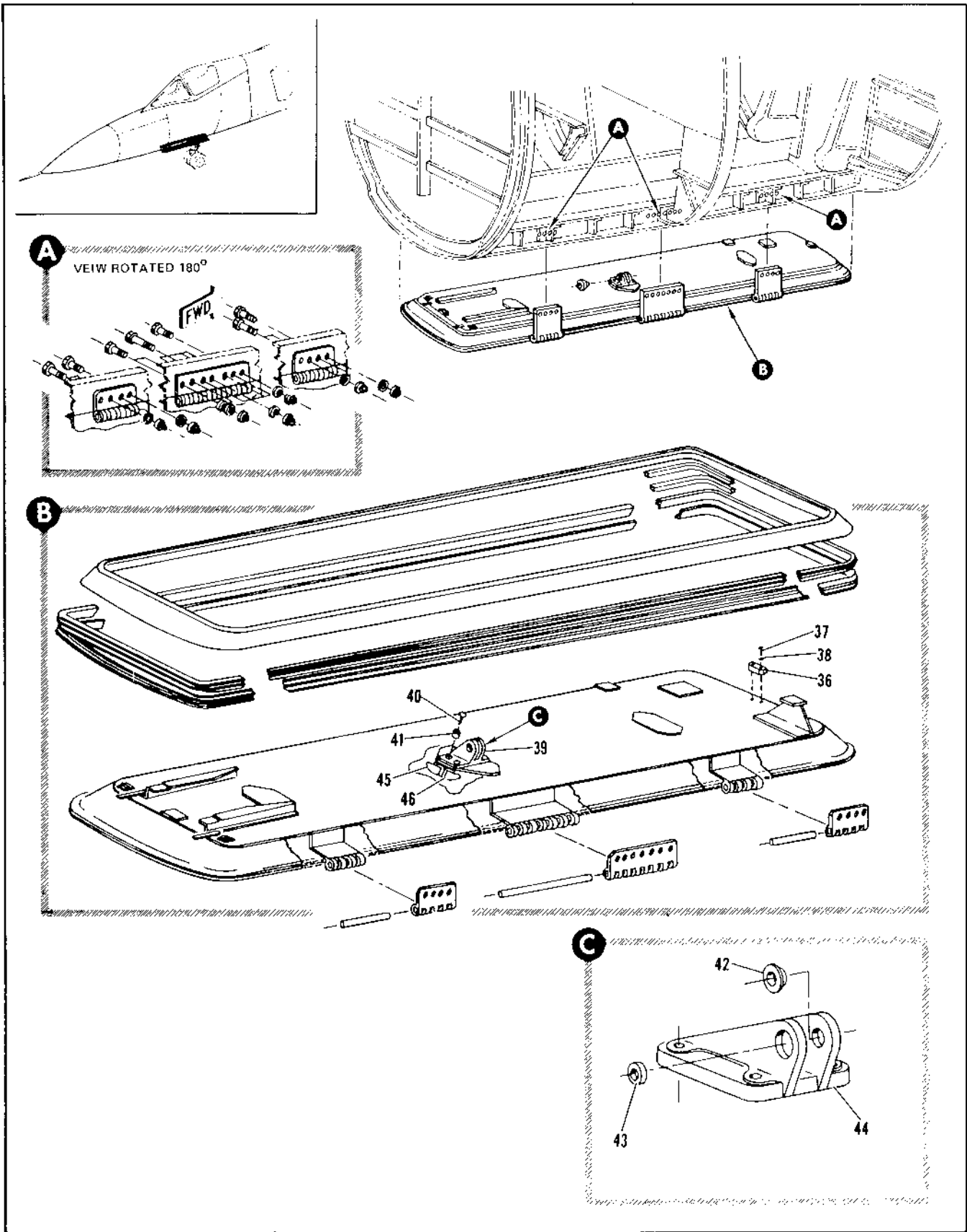

Figure 2.15-14. Nose Landing Gear Door Installation (Sheet 2 of 2)

FIGURE AND INDEX NUMBER	PART NUMBER	DESCRIPTION	UNITS PER ASSY.	USABLE ON CODE	
				FROM	TO
		1 2 3 4 5 6			
2.15-10-36	8-74936	• • STOP, NLG DOOR ATTACHING PARTS	1	35	
- 37	NAS221-19	• • SCREW	2	35	
- 38	AN960-10L	• • WASHER	2	35	
		-----X-----			
- 39	8-74934-3	• • ADAPTER ASSY, NLG DOOR ACTUATOR UPPER ATTACHING PARTS	1	35	
- 40	ALSF-15-9	• • PIN, <29666> 9E-79002-309	4	35	
- 41	LC-06	• • COLLAR, <29666> 92-17000-001	4	35	
		-----X-----			
- 42	NAS77-5-19	• • BUSHING	1	35	
- 43	NAS75-7-005	• • BUSHING	1	35	
- 44	8-74934-9	• • ADAPTER	1	35	
- 45	8-74935-9	• • ADAPTER	1	35	
- 46	8-74935-9	• • ADAPTER, LESS TWO 0.125 DIA HOLES	1	35	89
	8-74935-11	• • ADAPTER	1	90	

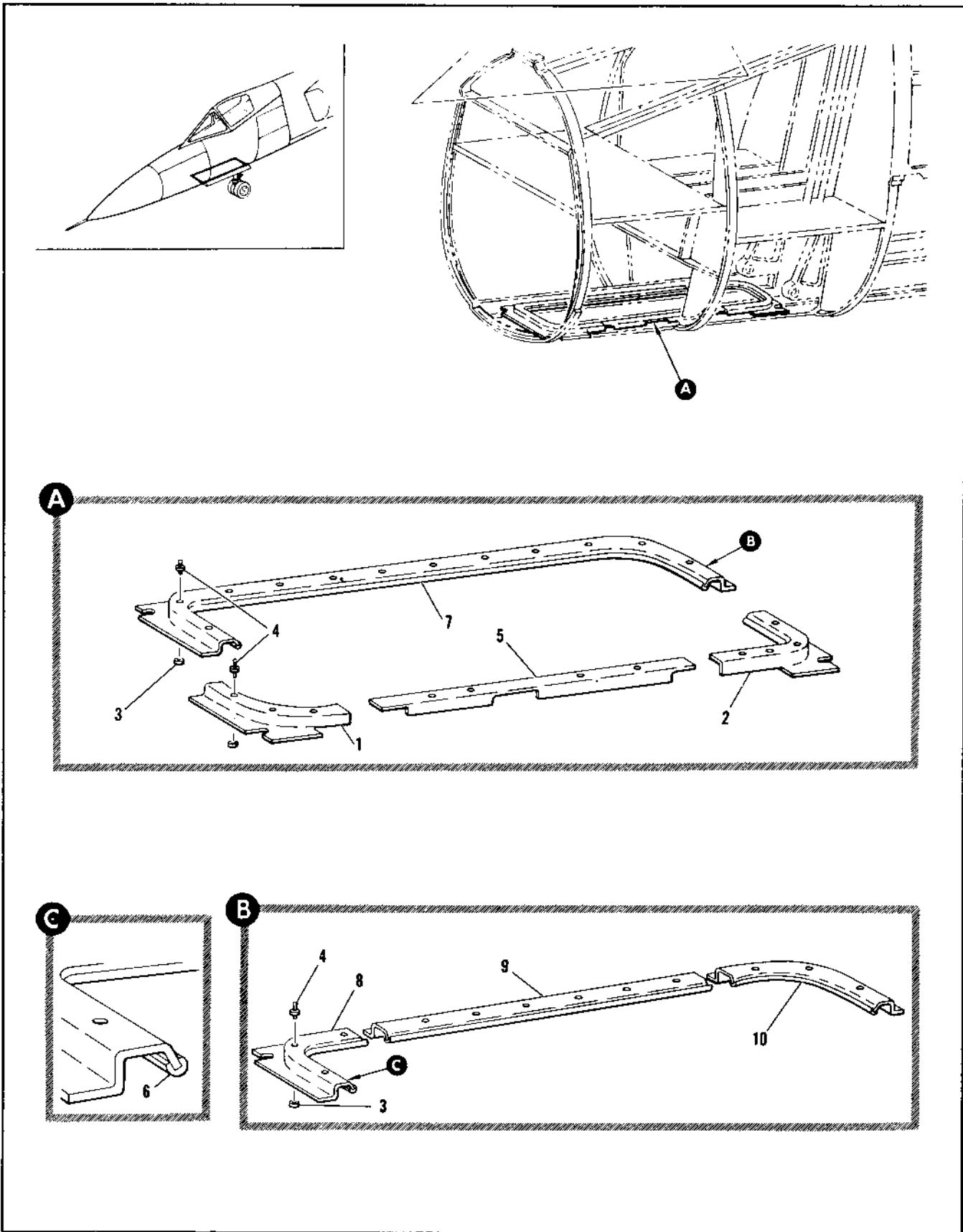

Figure 2.15-15. Nose Landing Gear Door Seal Frame

FIGURE AND INDEX NUMBER	PART NUMBER	DESCRIPTION	UNITS PER ASSY.	USABLE ON CODE	
				FROM	TO
		1 2 3 4 5 6			
2.15-15	R-74642-1	NOSE LANDING GEAR DOOR SEAL FRAME • FRAME INSTL, NOSE LANDING GEAR DOOR SEAL LH FOR NHA SEE FIG. 2.3-7	4F	35	
- 1	R-74642-21	• PAN	1	35	
- 2	R-74642-23	• PAN	1	35	
- 3	AN227-3	• WASHER	11	35	
- 4	AN227-5	• STUD	11	35	
	R-74642-4	• FRAME INSTL, NOSE LANDING GEAR DOOR SEAL LH FOR NHA SEE FIG. 2.3-4	4F	35	
- 5	R-74642-25	• PAN	1	35	
	AN227-3	• WASHER	11	35	
	AN227-5	• STUD	11	35	
- 6	S-74642-17	• CHANNEL, MAKE FROM R-74638	1	35	
	R-74658	• NYLON EXTRUSION	RF		
	R-74642-3	• FRAME INSTL, NOSE LANDING GEAR DOOR SEAL RH FOR NHA SEE FIG. 2.3-8	RF	35	60
	R-74642-01	• FRAME INSTL, NOSE LANDING GEAR DOOR SEAL RH FOR NHA SEE FIG. 2.3-8	RF	61	
- 7	R-74642-7	• PAN, REPLACED BY NOT INTCHG WITH R-74642-27 S-74642-29 S-74642-31	1	35	60
- 8	R-74642-27	• PAN, REPLACES NOT INTCHG WITH R-74642-7	1	61	
- 9	R-74642-29	• PAN, REPLACES NOT INTCHG WITH R-74642-7	1	61	
- 10	R-74642-31	• PAN, REPLACES NOT INTCHG WITH R-74642-7	1	61	
	AN227-3	• WASHER	12	35	
	AN227-5	• STUD	12	35	

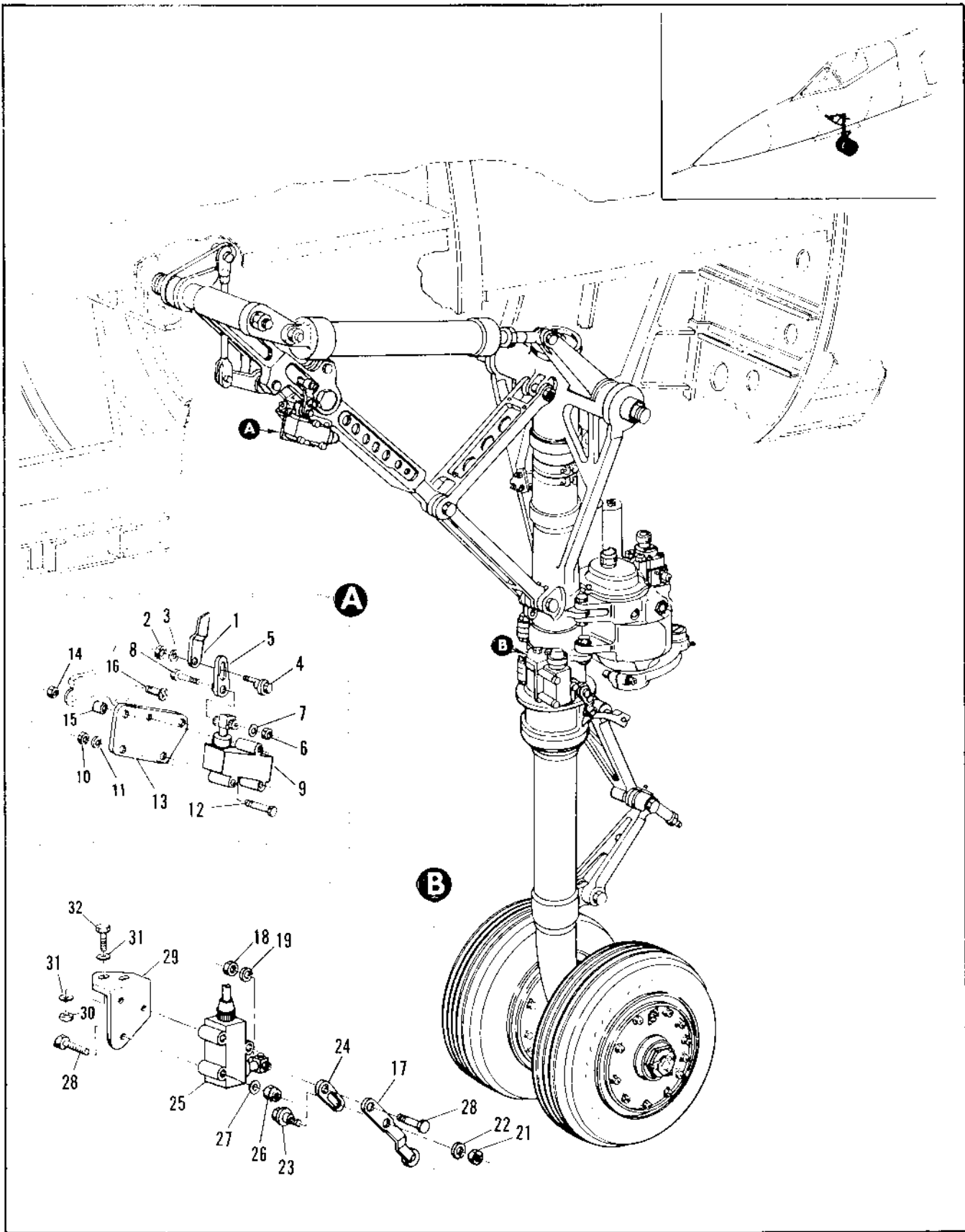

Figure 2.15-16. Nose Landing Gear Installation (Sheet 1 of 3)

FIGURE AND INDEX NUMBER	PART NUMBER	DESCRIPTION	UNITS PER ASSY.	USABLE ON CODE	
				FROM	TO
		1 2 3 4 5 6			
2.15-16	8-52003-801	GEAR INSTALLATION, NOSE LANDING MODIFIED BY R-71135 FOR NHA SEE FIG. 2.3-3	RF	35	35
	8-52003-803	GEAR INSTALLATION, NOSE LANDING FOR NHA SEE FIG. 2.3-3	RF	39	217
	8-52003-805	GEAR INSTALLATION, NOSE LANDING FOR NHA SEE FIG. 2.3-3	RF	218	240
	8-52003-811	GEAR INSTALLATION, NOSE LANDING FOR NHA SEE FIG. 2.3-3	RF	241	254
	8-52003-807	GEAR INSTALLATION, NOSE LANDING FOR NHA SEE FIG. 2.3-3	RF	265	
- 1	8-68047-7	• ARM, UP POSITION INDICATOR SWITCH	1	35	
- 2	NAS679A3	• NUT	1	35	
- 3	AN935-3	• WASHER	1	35	
- 4	8-68038-7	• BOLT	1	35	
- 5	012742	• PLATE, <9719A> SPEC R-416A-7	1	35	
- 6	NAS679A3	• NUT	1	35	
- 7	AN935-10	• WASHER	1	35	
- 8	AN3-10A	• BOLT	1	35	
- 9	69037529-1	• SWITCH, UP POSITION INDICATOR <9719A> SPEC R-06983-803 ATTACHING PARTS	1	35	
- 10	NAS679A3	• NUT	3	35	
- 11	AN960-10L	• WASHER	3	35	
- 12	AN3-15A	• BOLT	2	35	
		-----X-----			
- 13	8-52115	• PLATE	1	35	254
	8-52003-7	• PLATE ASSY, PIVOTED ATTACHING PARTS	1	265	
- 14	NAS679A3	• NUT	2	35	
- 15	NAS43903-16	• SPACER	1	35	
- 16	AN505-10R14	• SCREW	2	35	
		-----X-----			
- 17	8-68143-1	• ARM ASSY, NOSE WHEEL STEERING LIMIT SWITCH ATTACHING PARTS	1	35	
- 18	NAS679A3	• NUT	1	35	
- 19	AN935-10	• WASHER	1	35	
- 20	AN3-10A	• BOLT	1	35	
- 21	NAS679A3	• NUT	1	35	
- 22	AN935-6	• WASHER	1	35	
- 23	8-68138-7	• BOLT	1	35	
		-----X-----			
- 24	012742	• PLATE<9719->			
- 25	012-27	• SWITCH, NOSE WHEEL STEERING LIMIT <9719A> SPEC R-06983-803 ATTACHING PARTS	1	35	
- 26	NAS679A3	• NUT	3	35	
- 27	AN960-10L	• WASHER	3	35	
- 28	AN3-15A	• BOLT	1	35	
		-----X-----			
- 29	8-52114	• BRACKET ATTACHING PARTS	1	35	
- 30	NAS679A3	• NUT	2	35	
- 31	AN960-416L	• WASHER	4	35	
- 32	AN4-10A	• BOLT	2	35	
		-----X-----			

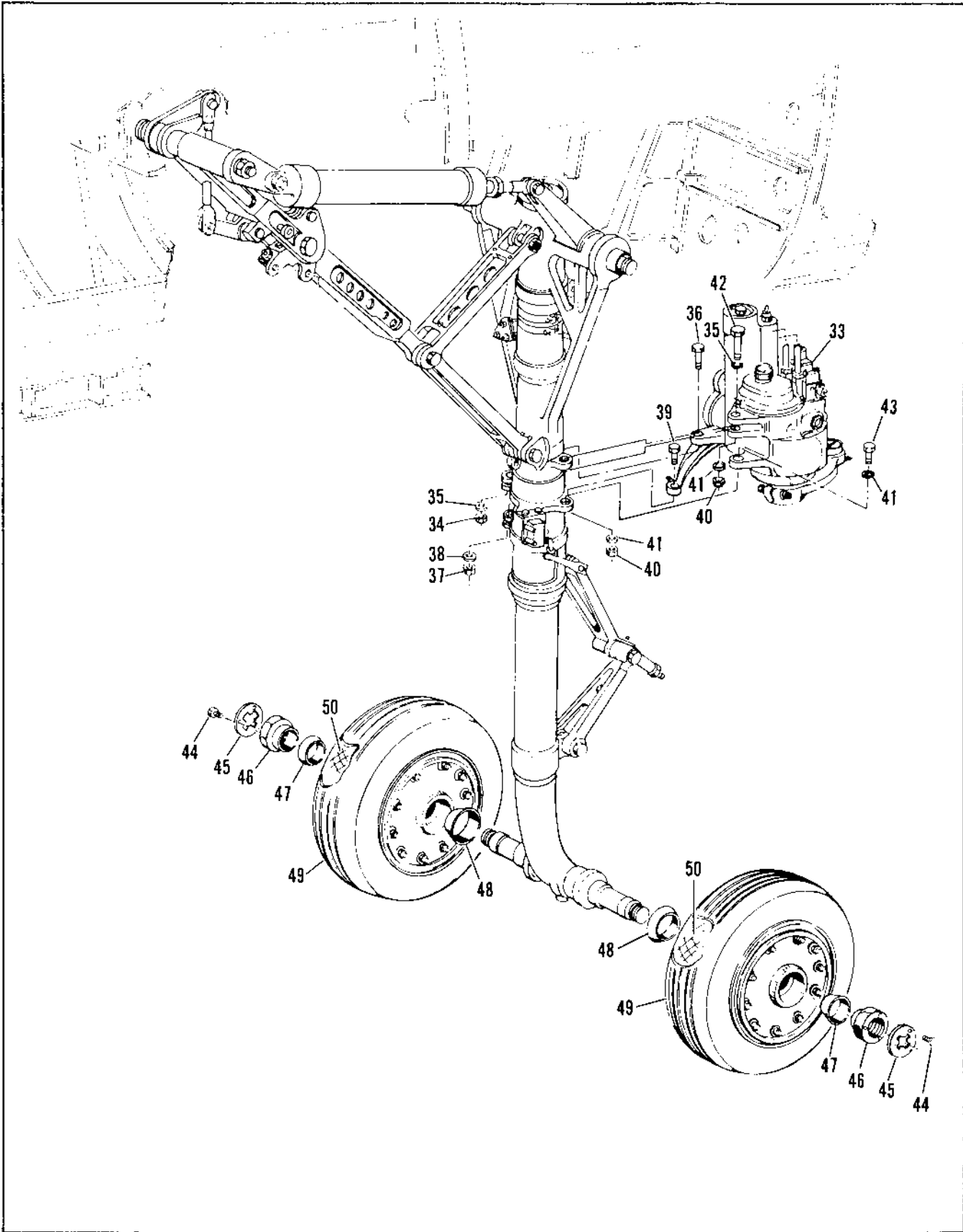

Figure 2.15-16. Nose Landing Gear Installation (Sheet 2 of 3)

FIGURE AND INDEX NUMBER	PART NUMBER	DESCRIPTION	UNITS PER ASSY.	USABLE ON CODE	
				FROM	TO
2.15-16- 33	8-52136-3	• DAMPER ASSY, NLG STEERING FOR BREAKDOWN SEE FIG. 2.15-17	1	35	38
	8-52136-5	• DAMPER ASSY, NLG STEERING FOR BREAKDOWN SEE FIG. 2.15-17	1	39	60
	8-52136-801	• DAMPER ASSY, NLG STEERING FOR BREAKDOWN SEE FIG. 2.15-17	1	A	
	8-52136-803	• DAMPER ASSY, NLG STEERING FOR BREAKDOWN SEE FIG. 2.15-17	1	B	
	8-52136-805	• DAMPER ASSY, NLG STEERING FOR BREAKDOWN SEE FIG. 2.15-17 ATTACHING PARTS	1	41	
- 34	AN320-9	*1 • NUT	RF	35	
- 35	AN960-916	*1 • WASHER	RF	35	
- 36	578668	*1 • BOLT	RF	35	
- 37	AN320-8	*1 • NUT	RF	35	
- 38	AN960-816	*1 • WASHER	RF	35	
- 39	578669	*1 • BOLT	RF	35	
- 40	AN320-9	*1 • NUT	2	35	
- 41	AN960-916	*1 • WASHER	4	35	
- 42	NAS464-9-27	*1 • BOLT	1	35	
- 43	NAS464-9-19	*1 • BOLT	1	35	
		-----X-----			
- 44	AN3H3A	*1 • BOLT	RF	35	
- 45	578630-1	*1 • PLATE, AXLE LOCK	RF	35	
- 46	634609-101	*1 • NUT ASSY, AXLE	RF	35	
- 47	578617-1	*1 • SPACER, OUTER BEARING	RF	35	
- 48	578619-1	*1 • SPACER, INNER BEARING	RF	35	
- 49	580514	*1 • TIRE, (61463)	2	35	
- 50	5201236	*1 • TUBE, (61463)	2	35	
- 51	3-1080	*1 • WHEEL (97153) ALT INTCHG	2	35	
		*1 FURNISHED WITH SHOCK STRUT PART NO. 578600-801			
		A AIRPLANES #61 THRU 119, 112 THRU 121, AND 123			
		B AIRPLANES #111, 122, AND 124 THRU 240			

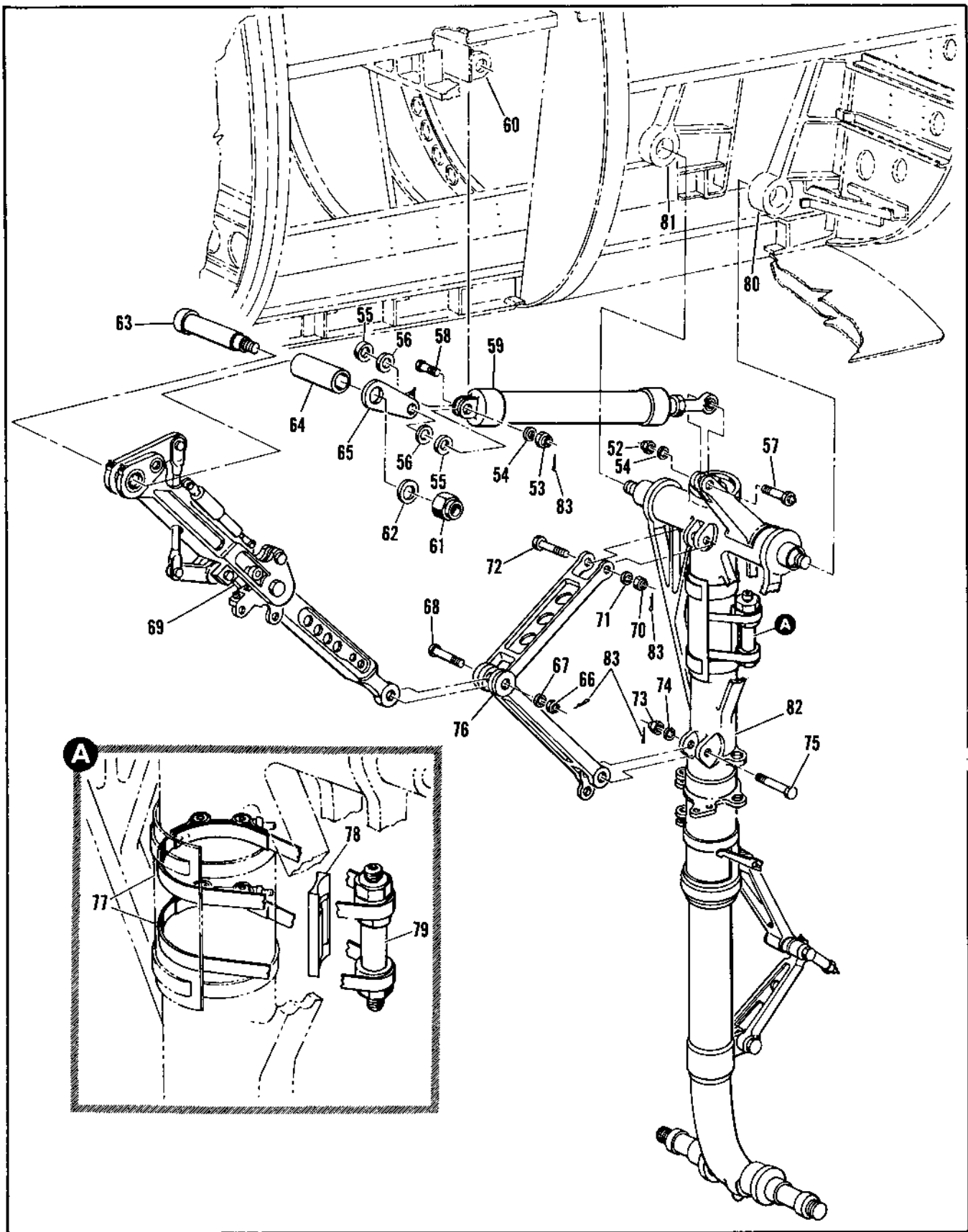

Figure 2.15-16. Nose Landing Gear Installation (Sheet 3 of 3)

FIGURE AND INDEX NUMBER	PART NUMBER		DESCRIPTION	UNITS PER ASSY.	USABLE ON CODE	
					FROM	TO
2.15-16- 52	NAS679A7	*1	. NUT (80205)	RF	35	
- 53	AN320-7	*2	. NUT (88044)	RF	35	
- 54	AN960-716	*3	. WASHER (88044)	RF	35	
- 55	8-52227-7		. WASHER	2	60	
- 56	8-52227-9		. WASHER	2	60	
- 57	578629-1	*1	. BOLT	RF	35	
- 58	NAS464-7-16	*2	. BOLT (80205)	RF	35	
- 59	339EA1	*5	. ACTUATOR ASSY, NLG <78062> SPEC 8-08488-1 T.O. 9M2-3-32-3	1	35	
- 60			. FITTING ASSY, NLG DRAG STRUT SEE FIG. 2.15-37	RF		
- 61	AN7502-15	*2	. NUT (88044)	RF	35	
- 62	538840	*2	. WASHER	RF	35	
- 63	538835	*2	. SHAFT	RF	35	
- 64	538834	*2	. SPACER	RF	35	
- 65	578804-101	*2	. LEVER ASSEMBLY	RF	35	
- 66	AN320D12	*4	. NUT (88044)	RF	35	
- 67	AN960-1216L	*4	. WASHER (88044)	RF	35	
- 68	538838	*4	. BOLT	RF	35	
- 69	578800-501		. DRAG STRUT, NLG <39661> SPEC 8-05308-9 T.O. 4S2-40-14	1	35	
- 70	AN320C7	*1	. NUT (88044)	RF	35	
- 71	AN960-716L	*1	. WASHER (88044)	RF	35	
- 72	NAS464-7-48	*1	. BOLT (80205)	RF	35	
- 73	AN320C8	*1	. NUT (88044)	RF	35	
- 74	AN960-816	*1	. WASHER (88044)	RF	35	
- 75	578657-1	*1	. BOLT	RF	35	
- 76	578850-101		. A-FRAME, <39661> SPEC 8-05308-11 T.O. 4SA6-8-3	1	35	
- 77	8-84011		. RESTRICTOR INSTL, HYDRAULIC DUAL RATE	1	241	
- 78	325-62-475M		. CLAMP, <98625> 91-97802-077	2		
- 79	8-84216		. SPACER	1	241	
- 80	8-84010-1		. RESTRICTOR	1	241	
- 81			. FITTING, NLG LH SEE FIG. 2.15-1 INDEX 17	RF		
- 82	578600-501		. FITTING, NLG RH SEE FIG. 2.15-1 INDEX 18	RF		
			. SHOCK STRUT, NLG <39661> T.O. 4S2-40-4, INTCHG WITH 634600-503	1	35	
	634600-503		. SHOCK STRUT, NLG <39661> T.O. 4S2-50-41, ALT INTCHG WITH 578600-501	RF	35	
- 83	MS24665-283		. PIN, COTTER (96906)	RF	35	
		*1	FURNISHED WITH SHOCK STRUT PART NO. 578600-501			
		*2	FURNISHED WITH DRAG STRUT PART NO. 578800-501			
		*3	FURNISHED WITH SHOCK STRUT PART NO. 578600-501 AND DRAG STRUT PART NO. 578800-501			
		*4	FURNISHED WITH A-FRAME PART NO. 578850-101			
		*5	SPARES FOR FUTURE PROCUREMENT			

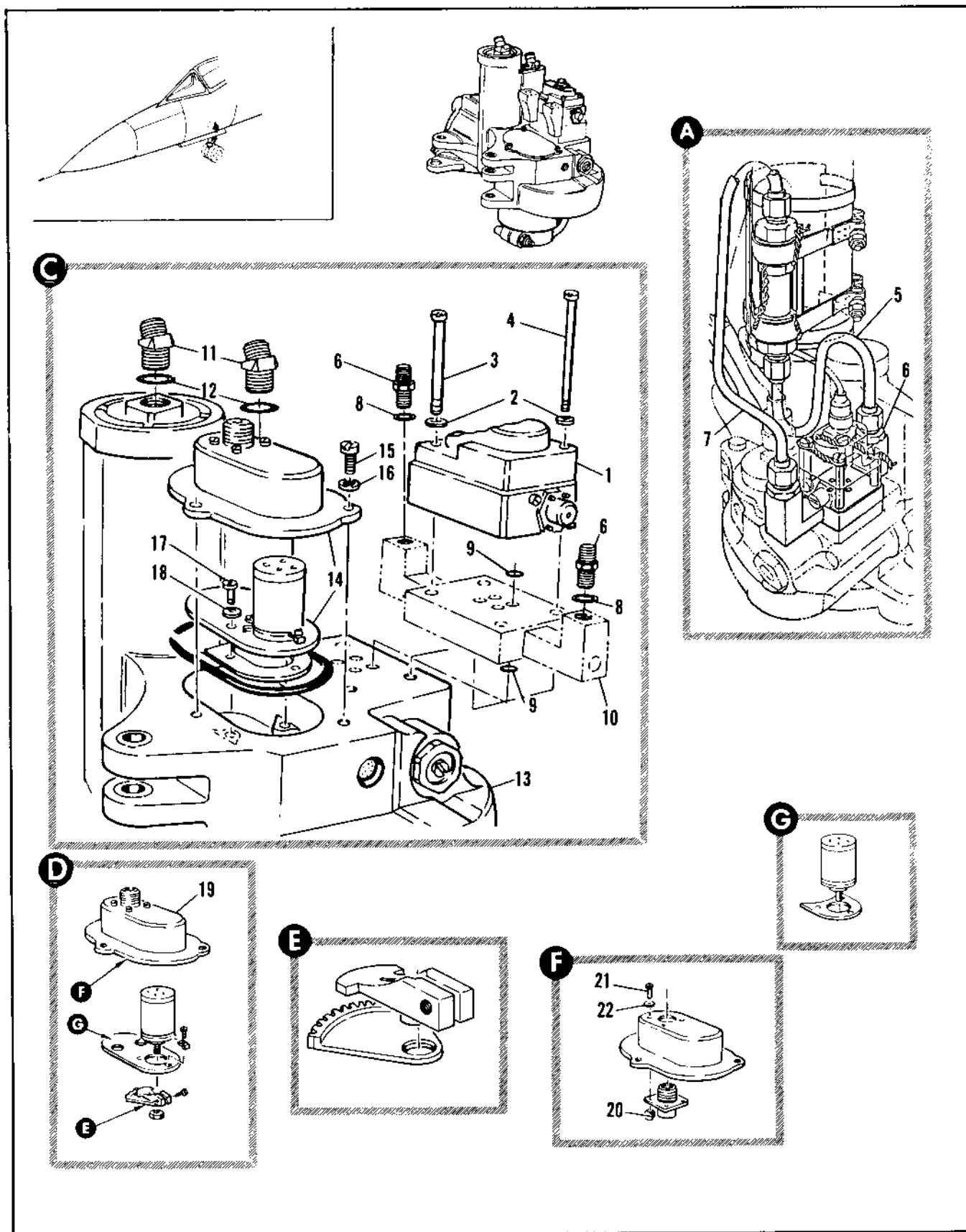

Figure 2.15-17. Nose Landing Gear Steering Damper Assembly (Sheet 1 of 2)

FIGURE AND INDEX NUMBER	PART NUMBER	DESCRIPTION	UNITS PER ASSY.	USABLE ON CODE	
				FROM	TO
		1 2 3 4 5 6			
2.15-17	8-52136-1	DAMPER ASSEMBLY, NOSE LANDING GEAR STEERING FOR NHA SEE FIG. 2.15-14	RF	35	38
	8-52136-5	DAMPER ASSEMBLY, NOSE LANDING GEAR STEERING FOR NHA SEE FIG. 2.15-14	RF	39	60
	8-52136-401	DAMPER ASSEMBLY, NOSE LANDING GEAR STEERING FOR NHA SEE FIG. 2.15-14	RF	8	
	8-52136-40A	DAMPER ASSEMBLY, NOSE LANDING GEAR STEERING FOR NHA SEE FIG. 2.15-14	RF	0	
	8-52136-405	DAMPER ASSY, NOSE LANDING GEAR STEERING FOR NHA SEE FIG. 2.15-14	RF	241	
- 1	M4347	• VALVE, STEERING CONTROL (94497) SPEC 8-05339-1 T.O. 9H-14-210-3 ATTACHING PARTS	1	35	
- 2	NAS620-10L	• WASHER	4	35	
- 3	8-52215-7	• SCREW	2	35	
- 4	8-52215-9	• SCREW	2	35	
		-----X----			
	8-52228	• VALVE INSTL, NOSE WHEEL STEERING RESTRICTOR	1	8	
	8-52228-1	• VALVE INSTL, NOSE WHEEL STEERING RESTRICTOR	1	241	
- 5	8-80132-241	• • TUBE ASSEMBLY	1	35	
- 6	MS21916-6-40	• • REDUCER	2	35	
- 7	8-80132-243	• • TUBE ASSEMBLY T.O. 9H8-B-20-3	1	35	
- 8	MS28778-4	• • BASKET	2	35	
- 9	MS28778-010	• • PACKING	4	35	
- 10	8-52212	• • ADAPTER ASSY, WELDED	1	35	
- 11	8-52215	• ELBOW, SPECIAL FLARELESS TUBE	2	35	
- 12	AN6227-6	• PACKING	2	35	
- 13	8163-2	• STEER-CAMP UNIT ASSY, (75667) SPEC 8-05314-17 T.O. 4SA2-34-14	1	35	38
- 14	8294	• POTENTIOMETER, TRANSMITTER NOSE WHEEL STEERING FOLLOWUP CONTROL T.O. 4SA2-34-14	1	35	38
	8-52185-1	• SYNCHRO TRANSMITTER ASSY, NOSE WHEEL STEERING FOLLOWUP CONTROL T.O. 12A1-43	1	39	129
	8-52185-5	• SYNCHRO TRANSMITTER ASSY, NOSE WHEEL STEERING FOLLOWUP CONTROL	1	130	189
	8-52185-401	• SYNCHRO TRANSMITTER ASSY, NOSE WHEEL STEERING FOLLOWUP CONTROL ATTACHING PARTS	1	189	
- 15	AN591AC10-A	• SCREW	3	35	
- 16	AN960-10L	• WASHER	3	35	
- 17	AN500AC6-7	• SCREW	2	35	
- 18	AN960E6	• WASHER	2	35	
		-----X----			
- 19	8-52185-9	• • COVER ASSY, REPLACED BY SUITABLE SUB 8-52185-13	1	39	12
	8-52185-13	• • COVER ASSY, REPLACES SUITABLE SUB FOR 8-52185-9 REPLACED BY SUITABLE SUB 8-52185-15	1	130	188
	8-52185-15	• • COVER ASSY, REPLACES SUITABLE SUB FOR 8-52185-13	1	189	
- 20	NAS679A04	• • • NUT	4	39	
- 21	AN505A4-6	• • • SCREW	4	39	
- 22	AN960-4L	• • • WASHER	4	39	

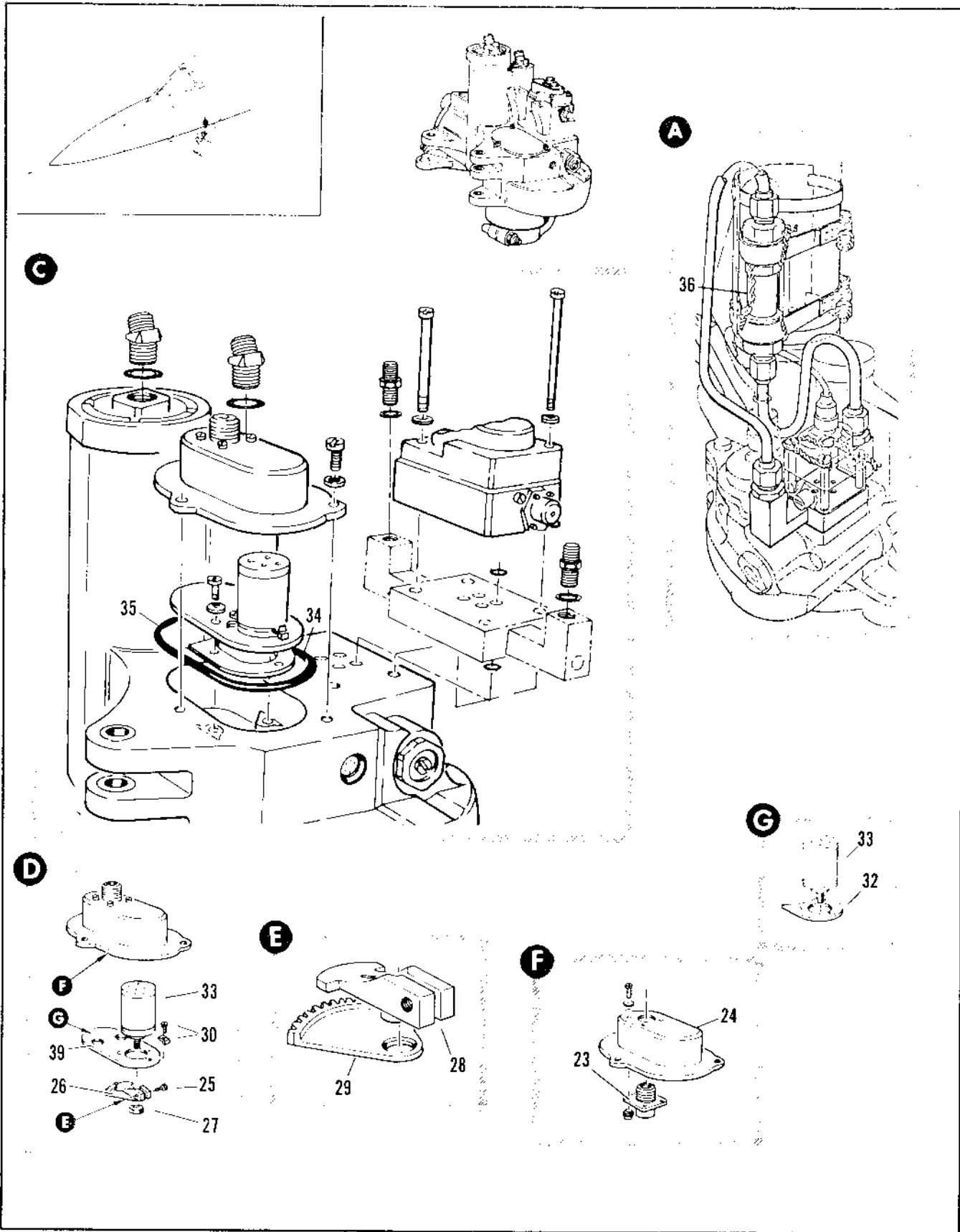

Figure 2.15-17. Nose Landing Gear Steering Damper Assembly (Sheet 2 of 2)

FIGURE AND INDEX NUMBER	PART NUMBER	DESCRIPTION	UNITS PER ASSY.	USABLE ON CODE	
				FROM	TO
		1 2 3 4 5 6			
2.15-17- 13	GS02-14SEP111	• • • RECEPTACLE, <71468> 32-51182-001	1	39	
- 24	8-52189-7	• • • COVER	1	39	
- 25	AN53, AH4-7	• • SCREW	1	39	
- 26	8-52195-11	• • GEAR ASSEMBLY ATTACHING PARTS	1	39	
- 27	844584	• • NUT, FURNISHED WITH SYNCHRO TRANSMITTER -----X-----	PF	39	
- 28	8-52186-7	• • • ARM	1	39	
- 29	8-52187	• • • GEAR	3	39	
- 30	6U080443-19	• • CLIP ASSY, <95542> 91-9A701-001	1	39	129
- 31	8-52198	• • PLATE, REPLACED BY NOT INTCHG WITH 8-52188-7 AND 8-52188-9	1	39	
- 32	8-52188-7	• • PLATE, REPLACES NOT INTCHG WITH 8-52188	1	39	
- 33	8913-152	• • SYNCHRO TRANSMITTER, <48418> SPEC 8-15341-1	1	39	
- 34	8-52188-9	• SNIM, REPLACES NOT INTCHG WITH 8-52188	1	39	
- 35	AN623-13	• PACKING	1	39	
- 37	8-45-13	• RESTRICTOR, HYDRAULIC DUAL RATE SEE FIG. 2.15-17	REF		
		A AIRPLANES #75 THRU 81, 111, 122, 124 AND ON			
		B AIRPLANES #61 THRU 11, 111 THRU 121, AND 123			

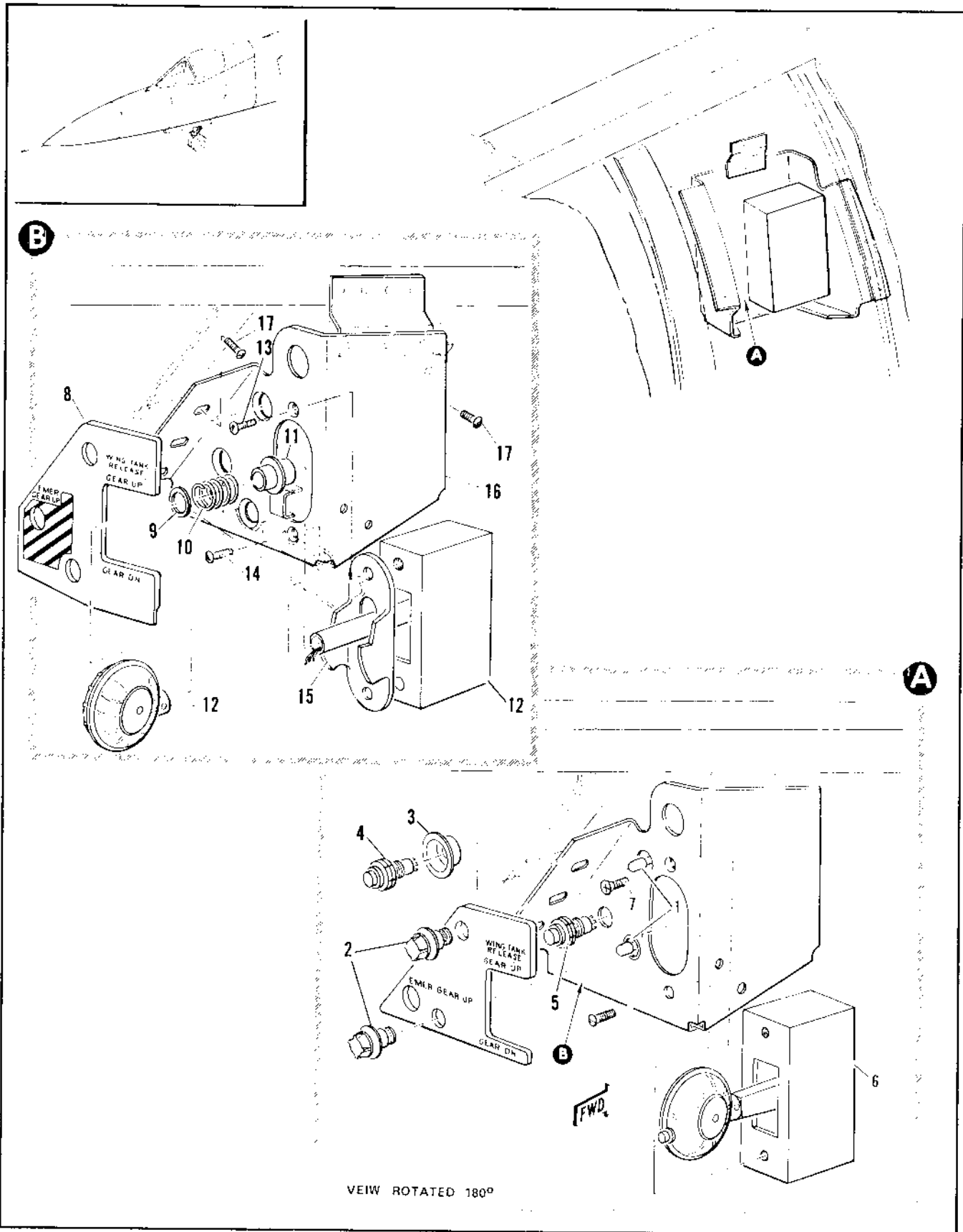

Figure 2.15-18. Landing Gear Control Box Installation

FIGURE AND INDEX NUMBER	PART NUMBER	DESCRIPTION 1 2 3 4 5 6	UNITS PER ASSY.	USABLE ON CODE	
				FROM	TO
2.15-18	8-94680-3	CONTROL BOX INSTALLATION, LANDING GEAR FOR NHA SEE FIG. 2.3-5	RF	35	
	8-94680-5	CONTROL BOX INSTALLATION, LANDING GEAR FOR NHA SEE FIG. 2.3-6	RF	160	
- 1	8-94711-69	• LIGHT INSTL, LG CONTROL BOX	1	35	
- 2	AN3140-327	• • LAMP	2	35	
	MS25010-4A	• LIGHT	2	35	
	1950	• LIGHT, PANEL PLASTIC PLATE LIGHTING <83564> SPEC 8-09441-1 ALT INTCHG WITH MS25010-4A	RF	35	
- 3	8-94569	• SHIELD, PUSH BUTTON SWITCH	1	35	
- 4	MS25089-36	• SWITCH, PUSH BUTTON EXTERNAL TANK JETTISON	1	35	
- 5	MS25089-36R	• SWITCH, PUSHBUTTON, EMERGENCY LANDING GEAR RETRACT	1	35	
- 6	11862	• BOX, CONTROL <81839> SPEC 8-06922-3 T.O. 856-5-2-13 ATTACHING PARTS	1	35	159
- 7	AN509-10R99	• SCREW			
		-----X-----			
- 8	8-94693-15	• PLATE, REPLACES NOT INTCHG WITH 8-94693-11	1	160	
- 9	99-51505-053	• WASHER, Q8H1012-2	1	160	
- 10	8-99592	• SPRING	1	160	
- 11	8-48805-77	• LATCH ASSY, CONTROL BOX WELDED	1	160	
	8-48805-75	• • GRIP	1	160	
	8-48805-73	• • KEY	1	A	
	8-99590	• • SLIDE			
- 12	11862	• BOX, CONTROL <81839> SPEC 8-06922-3 T.O. 856-5-2-13 ATTACHING PARTS	1	160	
- 13	AN520-10R9	• SCREW	1		
- 14	AN509-10R10	• SCREW	1	160	
		-----X-----			
- 15	8-99593	• LATCH			
- 16	8-94680-19	• SUPPORT	6	35	
		ATTACHING PARTS			
- 17	AN520-10R6	• SCREW			
		-----X-----			
A AIRPLANES #35 THRU #9 AND 160 AND ON					

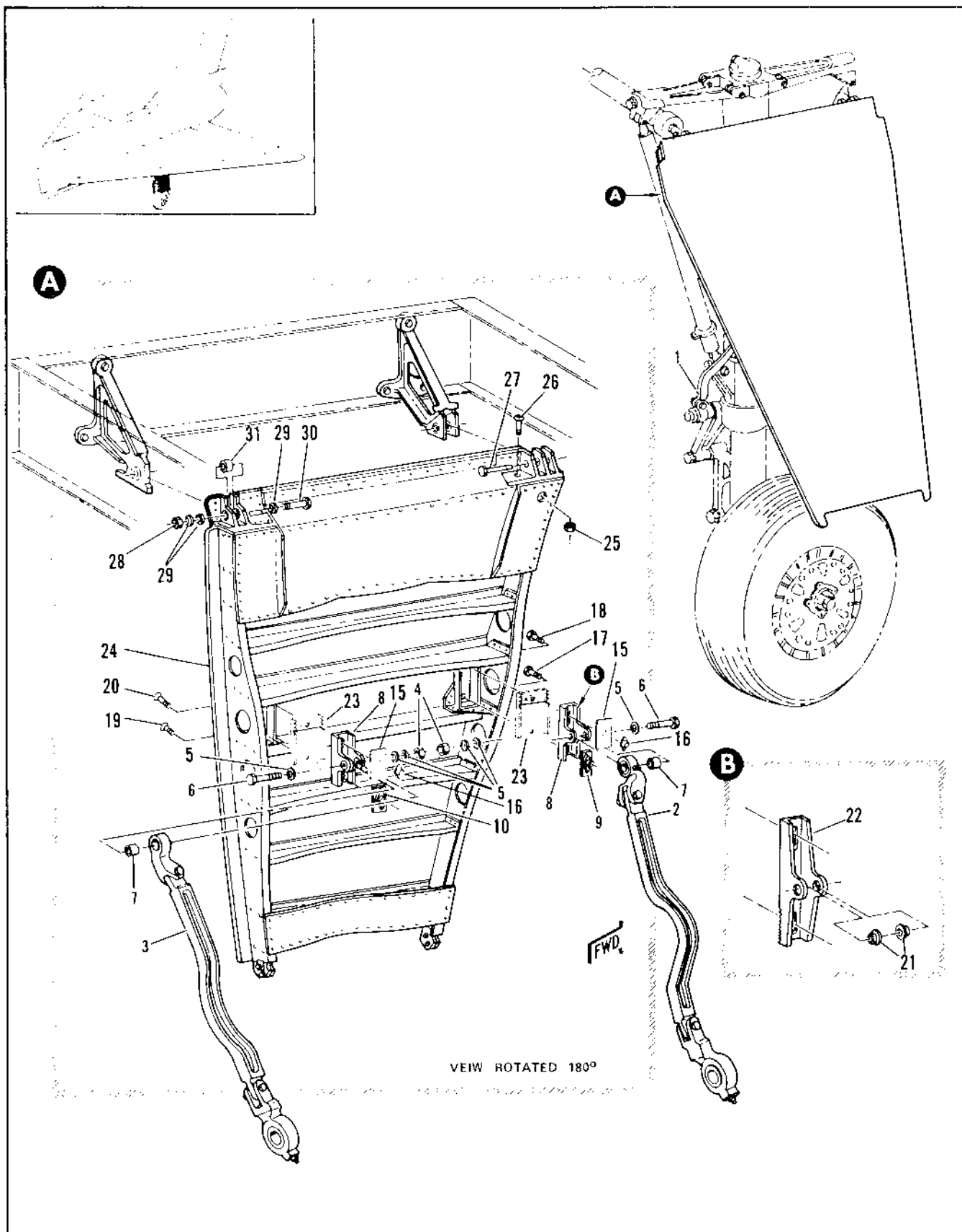

Figure 2.15-19. Main Landing Gear Wing Fairing Installation (Sheet 1 of 2)

FIGURE AND INDEX NUMBER	PART NUMBER	DESCRIPTION	UNITS PER ASSY.	USABLE ON CODE	
				FROM	TO
		1 2 3 4 5 6			
	R-17630-1	FAIRING INSTALLATION, MAIN LANDING GEAR WING LH FOR VHA SEE FIG. 2.6-1 AND 2.6-2	1	RF	35
	R-17630-25	FAIRING ASSEMBLY, MAIN LANDING GEAR WING LH SPARES FOR R-17630-1 WITH ATTACHING PARTS BAC AND TIED TO R-17630-31 ASSY WITH 0.250 EXCESS MATERIAL ON PERIMETER	RF		35
	R-17630-2	FAIRING INSTALLATION, MAIN LANDING GEAR WING RH FOR VHA SEE FIG. 2.6-1 AND 2.6-2	RF		35
	R-17630-26	FAIRING ASSEMBLY, M/LG WING RH SPARES FOR R-17630-2 WITH ATTACHING PARTS BAC AND TIED TO R-17630-32 ASSY WITH 0.250 EXCESS MATERIAL ON PERIMETER	RF		35
- 3	R-17659-1	• CHECK STRUT, M/L - SEE FIG. 2.15-25	RF		35
- 3	R-17659-2	• LINK ASSY, M/LG FAIRING FWD FOR BREAKDOWN SEE FIG. 2.15-20	1		35
- 3	R-17659-3	• LINK ASSY, M/LG FAIRING AFT FOR BREAKDOWN SEE FIG. 2.15-20	1		35
- 4	AN311-5	• NUT	2		35
- 5	AN961P0516	• WASHER	5		35
- 6	H-445A9-1	• BOLT	2		35
- 7	NAS72-5-018	• BUSHING	2		35
		-----X-----			
	R-85200-4	• LOCAL, LH	1		35
- 8	R-17665	• YOKE ASSY, M/LG FAIRING ATTACHING PARTS	2		35
- 9	R-17666	• NUT ASSY, FWD RIVETER	2		35
- 10	R-17667-1	• NUT ASSY, AFT RIVETER	2		35
- 11	NAS334PA1-5	• SCREW, FWD	1		35
- 12	NAS334PA1-6	• SCREW, FWD	1		35
- 13	NAS334PA1-7	• SCREW, AFT	1		35
- 14	NAS334PA1-8	• SCREW, AFT	1		35
- 15	R-17668-1	• PLATE	2		35
- 16	MS21444-5	• NUT	2		35
- 17	NAS334CPA1-5	• SCREW, FWD, INRD, ALT NAS334PA1-5	1		35
- 18	NAS335CPA1-5	• SCREW, FWD, OUTRD, ALT NAS334PA1-5	1		35
- 19	NAS334CPA1-9	• SCREW, AFT, INRD, ALT NAS334PA1-7	1		35
- 20	NAS335CPA1-7	• SCREW, AFT, OUTRD, ALT NAS334PA1-7	1		35
		-----X-----			
- 21	R-17669-11	• BUSHING, HINGE SUPPORT WING FAIRING MAKE FROM R-17667-17	2		35
		• BUSHING	RF		
- 22	R-17669-7	• YOKE	1		35
- 23	R-17669-9	• PLATE	2		35
- 24	R-17630-31	• FAIRING ASSY, M/LG LH FOR BREAKDOWN SEE FIG. 2.15-21	1		35
	R-17630-32	• FAIRING ASSY, M/LG RH FOR BREAKDOWN SEE FIG. 2.15-21	1		35
		ATTACHING PARTS			
- 25	MS21420-4	• NUT, FWD	1		35
- 26	AN533-418P-17669	• SCREW, FWD	1		35
- 27		• P15, HINGE FWD REPLACES SUITABLE SUP R-17669-1	1		A
	R-17669-1	• P15, HINGE FWD REPLACES SUITABLE SUP FOR R-17669	1		39 277
- 28	AN311-5	• NUT, AFT	1		35
- 29	AN961P0516	• WASHER, AFT	3		35
- 30	H-445A9-1	• BOLT, AFT	1		35
- 31	NAS72-5-009	• BUSHING, AFT	1		35
		-----X-----			
		• AIRPLANE'S 45 THRU 54, 278 AND ON			

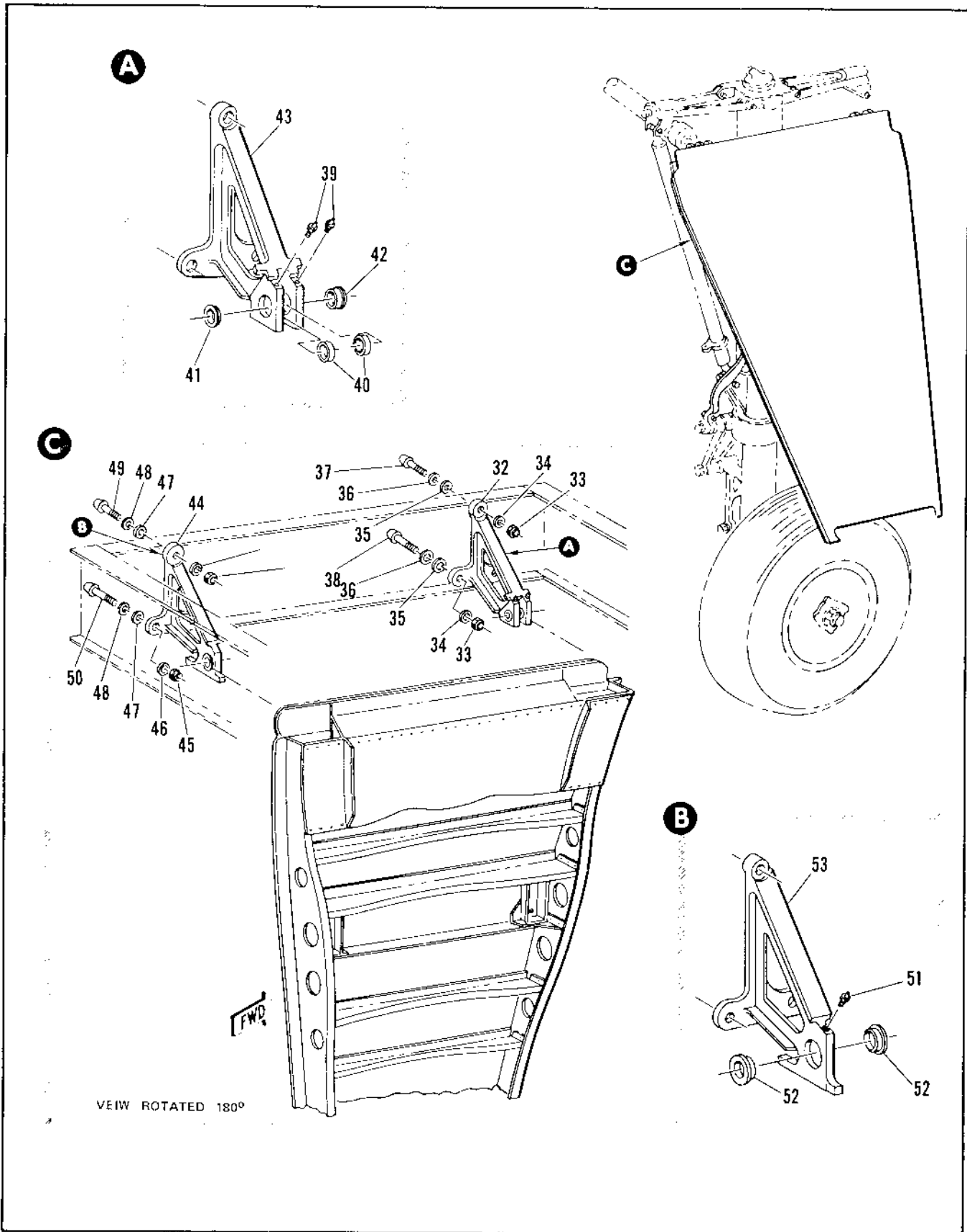
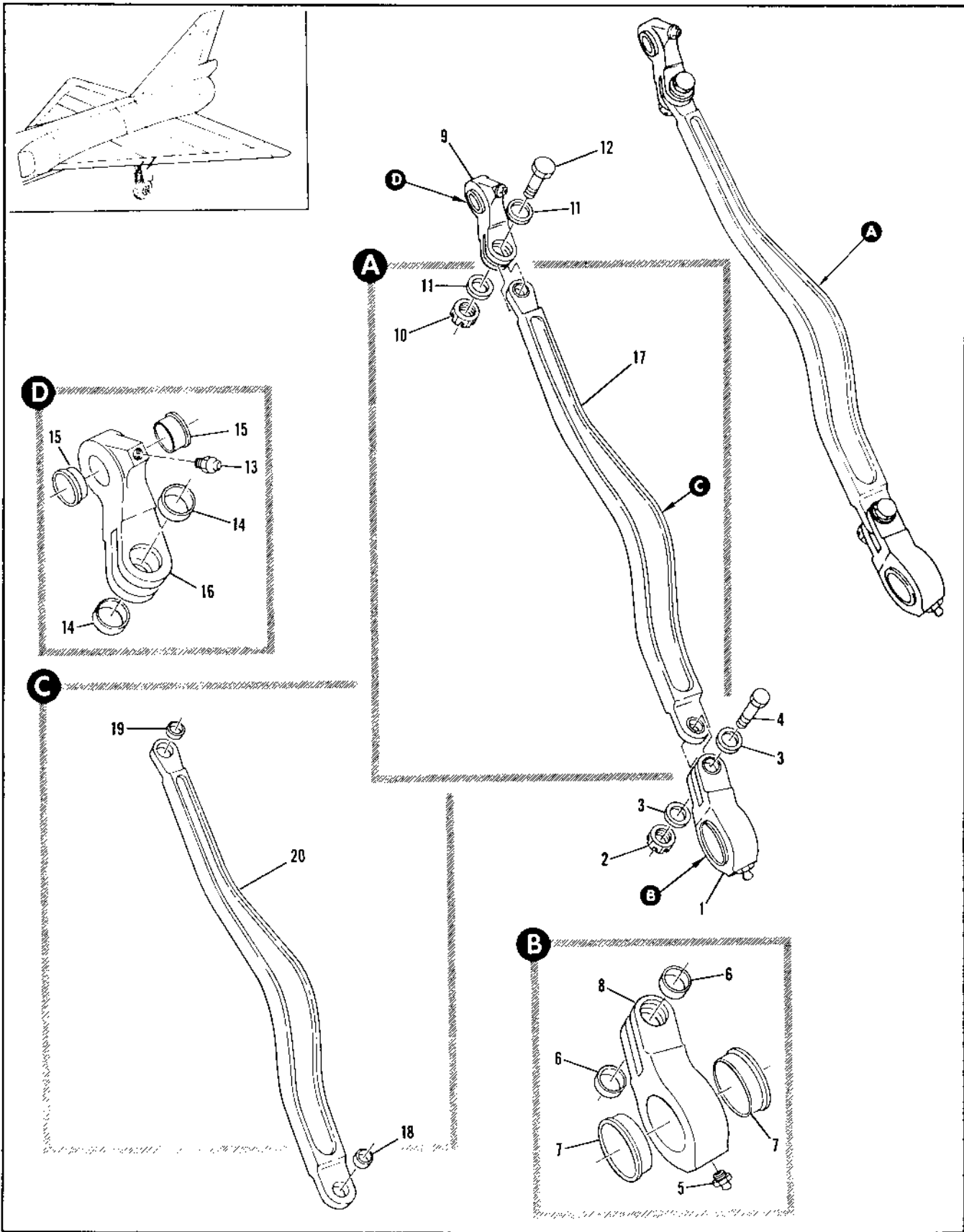

Figure 2.15-19. Main Landing Gear Wing Fairing Installation (Sheet 2 of 2)

FIGURE AND INDEX NUMBER	PART NUMBER	DESCRIPTION	UNITS PER ASSY.	USABLE ON CODE	
				FROM	TO
2.15-19-32	R-17671-3	• SUPPORT ASSY, FWD HINGE LH	1	35	
	R-17681-3	• SUPPORT ASSY, FWD HINGE LH ALT INTCHG WITH R-17671-3	RF	35	
	R-17671-4	• SUPPORT ASSY, FWD HINGE RH	1	35	
	R-17681-4	• SUPPORT ASSY, FWD HINGE RH ALT INTCHG WITH R-17671-4 ATTACHING PARTS	RF	35	
- 33	NAS679A5	• NUT	3	35	
- 34	AN961P0510	• WASHER	AK3	35	
- 35	R-17695	• WASHER	3	35	
- 36	MS2000209	• WASHER	3	35	
- 37	MS20005-18	• BOLT	1	35	
- 38	MS20005-22	• BOLT	2	35	
		-----X-----			
- 39	MS10011-1	• FITTING	2	35	
- 40	R-17696-7	• BUSHING	2	35	
- 41	R-17671-9	• BUSHING, HINGE SUPPORT WING FAIRING MAKE FROM R-17697-11	1	35	
	R-176-1-9	• BUSHING, HINGE SUPPORT WING FAIRING MAKE FROM R-17697-11 USE WITH R-176-1-7 AND R-17681-4	RF	35	
- 42	R-17671-11	• BUSHING, HINGE SUPPORT WING FAIRING MAKE FROM R-17697-11	1	35	
	R-17697-11	• BUSHING	RF		
	R-17691-11	• BUSHING, HINGE SUPPORT WING FAIRING MAKE FROM R-17697-11 USE WITH R-17681-3 AND R-17681-4	RF	35	
- 43	R-17671-12	• SUPPORT, LH MAKE FROM R-17671-13	1	35	
	R-17681-13	• SUPPORT, LH USE WITH R-17671-3	RF	35	
	R-17671-16	• SUPPORT, RH MAKE FROM R-17671-13	1	35	
	R-17671-13	• SUPPORT	RF		
	R-17681-14	• SUPPORT, RH USE WITH R-17681-4	RF	3	
- 44	R-17672-1	• SUPPORT ASSY, AFT HINGE	1	35	
	R-17682-1	• SUPPORT ASSY, AFT HINGE LH ALT INTCHG WITH R-17672-1	RF	35	
	R-17682-2	• SUPPORT ASSY, AFT HINGE RH ALT INTCHG WITH R-17672-1 ATTACHING PARTS	RF	35	
- 45	NAS679A5	• NUT	3	35	
- 46	AN961P0510	• WASHER	AK	35	
- 47	R-17695	• WASHER	3	35	
- 48	MS2000209	• WASHER	3	35	
- 49	MS20005-18	• BOLT	1	35	
- 50	MS20005-22	• BOLT	2	35	
		-----X-----			
- 51	MS10011-1	• FITTING	1	35	
- 52	R-17672-3	• BUSHING, HINGE SUPPORT WING FAIRING MAKE FROM R-17697-19	2	35	
	R-17682-4	• BUSHING, HINGE SUPPORT WING FAIRING MAKE FROM R-17697-19 USE WITH R-17682-1 AND R-17682-2	RF	35	
	R-17682-11	• BUSHING, HINGE SUPPORT WING FAIRING MAKE FROM R-17697-19 USE WITH R-17682-1 AND R-17682-2	RF	35	
	R-17697-19	• BUSHING	RF		
- 53	R-17672-7	• SUPPORT	1	35	
	R-17682-7	• SUPPORT, LH USE WITH R-17672-1	RF	35	
	R-17682-8	• SUPPORT, RH USE WITH R-17672-1	RF	35	



2.15-20. Main Landing Gear Wing Fairing Link Assembly

FIGURE AND INDEX NUMBER	PART NUMBER	DESCRIPTION	UNITS PER ASSY.	USABLE ON CODE	
				FROM	TO
		1 2 3 4 5 6			
2.15-20	R-17699-1	LINK ASSEMBLY, MAIN LANDING GEAR FAIRING WING FWD FOR NHA SEE FIG. 2.15-19	RF	35	
	8-17699-2	LINK ASSEMBLY, MAIN LANDING GEAR FAIRING WING AFT FOR NHA SEE FIG. 2.15-19	RF	35	
- 1	R-17695-1	• FORK ASSY, MLG LINK WING FAIRING INBD	1	35	
	8-17691	• FORK ASSY, MLG LINK WING FAIRING INBD ALT INTCHG WITH 8-17685-1	RF	35	
		ATTACHING PARTS			
- 2	AN320-5	• NUT	1	35	
- 3	AN960P0516	• WASHER	2	35	
- 4	NAS454-5-13	• BOLT	1	35	
		-----X-----			
- 5	MS15001-1	• • FITTING	1	35	
- 6	NAS75-5-006	• • BUSHING	2	35	
- 7	8-17529	• • BUSHING	2	35	
- 8	8-17685-7	• • FORK	1	35	
	8-17690-7	• • FORK, ALT INTCHG WITH 8-17685-7	RF	35	
- 9	8-17698-1	• FORK ASSY, MLG LINK WING FAIRING OUTBD LH	1	35	
	8-17691-1	• FORK ASSY, MLG LINK WING FAIRING OUTBD LH ALT INTCHG WITH 8-17698-1	RF	35	
	8-17698-2	• FORK ASSY, MLG LINK WING FAIRING OUTBD RH	1	35	
	8-17691-2	• FORK ASSY, MLG LINK WING FAIRING OUTBD RH ALT INTCHG WITH 8-17698-2	RF	35	
		ATTACHING PARTS			
- 10	AN320-5	• NUT	1	35	
- 11	AN960P0516	• WASHER	2	35	
- 12	NAS464-P5-12	• BOLT	1	35	
		-----X-----			
- 13	MS15001-1	• • FITTING	1	35	
- 14	NAS75-5-006	• • BUSHING	2	35	
- 15	8-17698-9	• • BUSHING, MAKE FROM NAS77AH-21	2	35	
	8-17691-9	• • BUSHING, MAKE FROM NAS77AH-21 ALT INTCHG WITH 8-17698-9	RF	35	
- 16	8-17698-7	• • FORK, LH	1	35	
	8-17691-7	• • FORK, LH ALT INTCHG WITH 8-17691-7	RF	35	
	8-17698-8	• • FORK, RH	1	35	
	8-17691-8	• • FORK, RH ALT INTCHG WITH 8-17691-8	RF	35	
- 17	8-17675-1	• LINK ASSY, MLG FAIRING	1	35	
	8-17676	• LINK ASSY, MLG FAIRING ALT INTCHG WITH 8-17675-1	RF	35	
- 18	NAS75-5-009	• • BUSHING	1	35	
- 19	NAS75-5-007	• • BUSHING	1	35	
- 20	8-17675-7	• • LINK	1	35	
	8-17676-1	• • LINK, ALT INTCHG WITH 8-17675-7	RF	35	

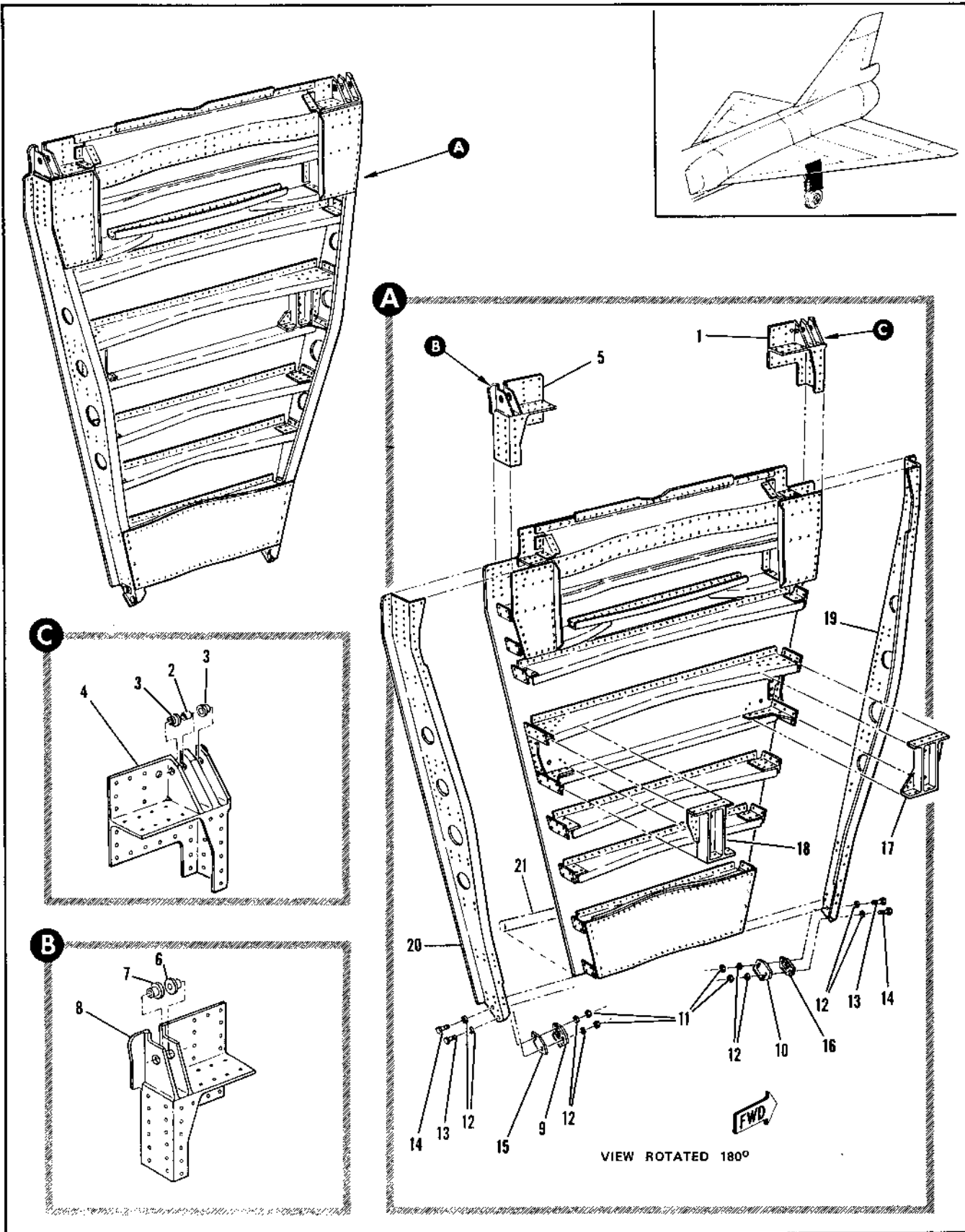

Figure 2.15-21. Main Landing Gear Wing Fairing Assembly

FIGURE AND INDEX NUMBER	PART NUMBER	DESCRIPTION	UNITS PER ASSY.	USABLE ON CODE	
				FROM	TO
		1 2 3 4 5 6			
2.15-21	R-17630-P1	FAIRING ASSEMBLY, MAIN LANDING GEAR WING LH FOR NHA, SEE FIG. 2.15-1P	RF	35	
	8-17630-82	FAIRING ASSEMBLY, MAIN LANDING GEAR WING RH FOR NHA, SEE FIG. 2.15-1P	RF	35	
- 1	8-17683-1	. HINGE ASSY, MLG FWD LH	1	35	
	8-17683-2	. HINGE ASSY, MLG FWD RH	1	35	
- 2	8-17696-9	. . PUSHING	1	35	
- 3	8-17683-9	. . PUSHING, ALTERED FROM 8-17697-13	2	35	
	8-17697-13	. . BUSHING	RF		
- 4	8-17683-7	. . HINGE, LH	1	35	
	8-17683-8	. . HINGE, RH	1	35	
- 5	8-17684-1	. HINGE ASSY, MLG AFT LH	1	35	
	8-17684-2	. HINGE ASSY, MLG AFT RH	1	35	
- 6	8-17684-9	. . PUSHING, ALTERED FROM 8-17697-15	1	35	
- 7	8-17684-11	. . PUSHING, ALTERED FROM 8-17697-15	1	35	
	8-17697-15	. . BUSHING	RF		
- 8	8-17684-7	. . HINGE, LH	1	35	
	8-17684-8	. . HINGE, RH	1	35	
- 9	8-17677-7	. PLATE, MLG STRIKER AFT	1	35	
- 10	8-17677-9	. PLATE, MLG STRIKER FWD ATTACHING PARTS	1	35	
- 11	NAS679A5	. NUT	4	35	
- 12	AN961PD516L	. WASHER	8	35	
- 13	NAS484P5A4	. BOLT	2	35	
- 14	NAS484P5A6	. BOLT	2	35	
		----X----			
- 15	8-18683-7	. PLATE, MLG STRIKER FWD	1	35	
- 16	8-18683-8	. PLATE, MLG STRIKER AFT	1	35	
- 17	8-17630-7	. BRACKET, YOKE ATTACH LINK WING FAIRING LH	1	35	
	8-17630-8	. BRACKET, YOKE ATTACH LINK WING FAIRING RH	1	35	
- 18	8-17630-17	. BRACKET, YOKE ATTACH LINK WING FAIRING LH	1	35	
	8-17630-9	. BRACKET, YOKE ATTACH LINK WING FAIRING RH	1	35	
	8-17630-13	. FAIRING ASSY, LH WELDED	1	35	
	8-17630-14	. FAIRING ASSY, RH WELDED	1	35	
	8-17630-77	. . BEAM ASSY, FWD LH	1	35	
	8-17630-88	. . BEAM ASSY, FWD RH	1	35	
- 19	8-17630-13	. . . BEAM, FWD LH WITH EXCESS 0.25 INCH MATERIAL ON OUTSIDE AND EACH END OF BOTTOM OF FLANGE FOR TRIM	1	35	
	8-17630-14	. . . BEAM, FWD RH WITH EXCESS 0.25 INCH MATERIAL ON OUTSIDE AND EACH END OF BOTTOM OF FLANGE FOR TRIM	1	35	
	8-17630-89	. . BEAM ASSY, FWD LH	1	35	
	8-17630-90	. . BEAM ASSY, FWD RH	1	35	
- 20	8-17630-15	. . . BEAM, ALT LH WITH EXCESS 0.25 INCH MATERIAL ON OUTSIDE AND EACH END OF BOTTOM OF FLANGE FOR TRIM	1	35	
	8-17630-16	. . . BEAM, AFT RH WITH EXCESS 0.25 INCH MATERIAL ON OUTSIDE AND EACH END OF BOTTOM OF FLANGE FOR TRIM	1	35	
- 21		. STRIP, SEE FIG. 2.15-33 INDEX 16	RF		

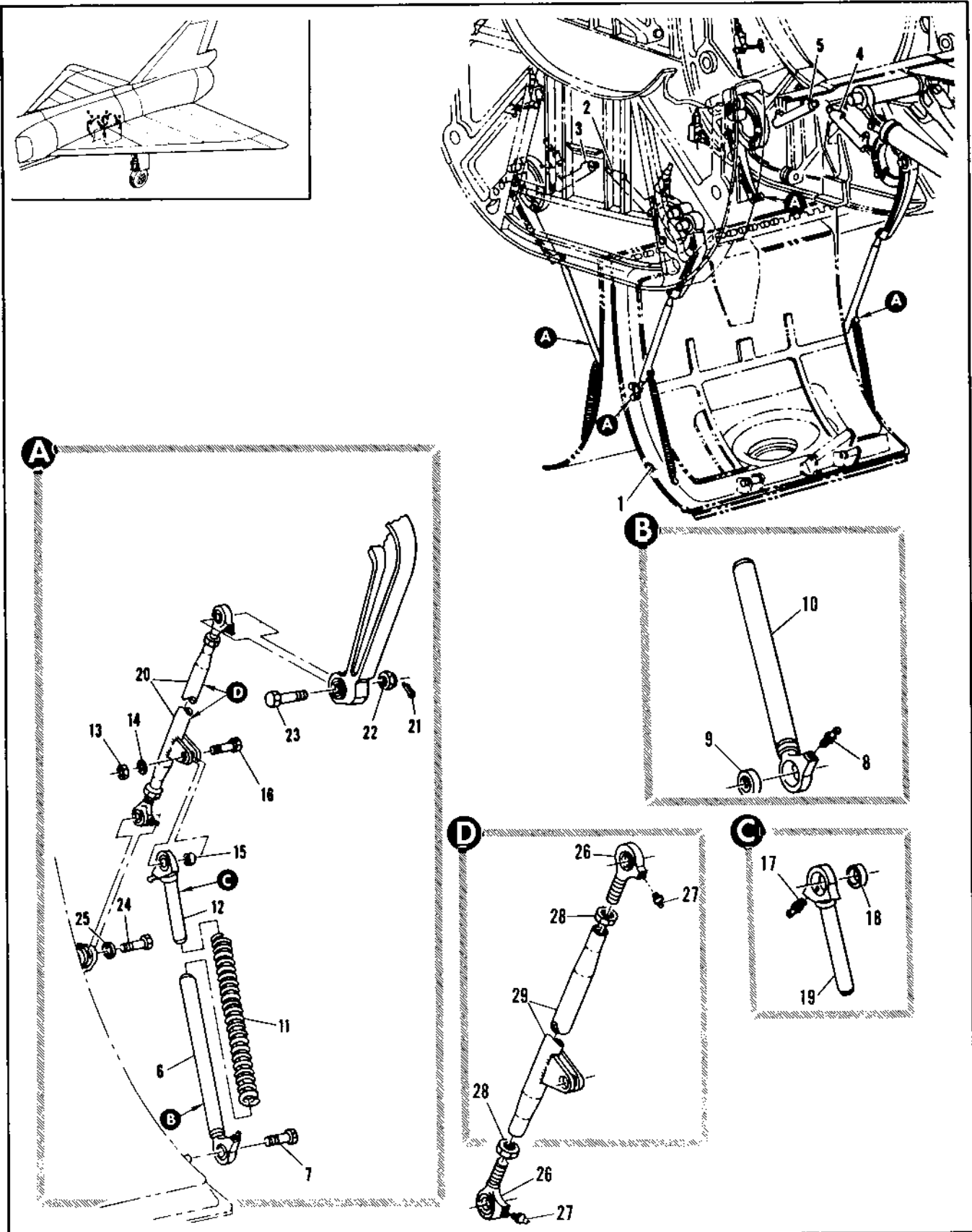

Figure 2.15-22. Main Landing Gear Door Actuator Installation (Sheet 1 of 4)

FIGURE AND INDEX NUMBER	PART NUMBER	DESCRIPTION 1 2 3 4 5 6	UNITS PER ASSY.	USABLE ON CODE	
				FROM	TO
2.15-22	8-44546-3	ACTUATOR INSTALLATION, MAIN LANDING GEAR DOOR MODIFIED BY 8-80620 FOR NHA SEE FIG. 2.3-3	RF	35	215
- 1		• DOOR INSTL, MLG SEE FIG. 2.15-33	RF		
- 2	8-44546-11	• ACTUATOR ASSY, MLG DOOR FWD LH	1	35	215
- 3	8-44546-12	• ACTUATOR ASSY, MLG DOOR FWD RH	1	35	215
- 4	8-44546-13	• ACTUATOR ASSY, MLG DOOR AFT LH	1	35	215
- 5	8-44546-14	• ACTUATOR ASSY, MLG DOOR AFT RH	1	35	215
- 6	8-44572-1	• • TUBE ASSY, MLG DOOR MECHANISM SPRING ATTACHING PARTS	1	35	215
- 7	NAS464P4A13	• . BOLT (80205) -----X-----	1	35	215
- 8	MS15001-1	• . . FITTING (96906)	1	35	215
- 9	HSBG4S	• . . BEARING, <02758>90-60000-151	1	35	215
- 10	8-44572-9	• . . TUBE	1	35	215
- 11	8-04291	• . SPRING, COMPRESSION	1	35	215
- 12	8-44571	• • TUBE ASSY, MLG DOOR MECHANISM SPRING ATTACHING PARTS	1	35	215
- 13	NAS679A3	• . NUT (80205)	1	35	215
- 14	AN960-10	• . WASHER (88044)	1	35	215
- 15	NAS73-3-006	• . BUSHING (80205)	1	35	215
- 16	NAS1103-8	• . BOLT (80205) -----X-----	1	35	215
- 17	MS15001-1	• . . FITTING (96906)	1	35	215
- 18	NAS75-6-004	• . . BUSHING (80205)	1	35	215
- 19	8-44571-9	• . . TUBE	1	35	215
- 20	8-44569	• • TUBE ASSY, MLG DOOR MECHANISM ATTACHING PARTS	1	35	215
- 21	AN380-3-3	• . PIN, COTTER (88044)	1	35	215
- 22	AN320-6	• . NUT (88044)	1	35	215
- 23	NAS454P6-16	• . BOLT (80205)	1	35	215
- 24	8-44589-7	• • BOLT, MLG DOOR MECHANISM	1	35	215
- 25	AN9600616	• . WASHER (88044) -----X-----	1	35	215
- 26	HE6-2F	• . . BEARING, <97613> 98-60005-004	2	35	215
- 27	3017	• . . FITTING (95879)	1	35	215
- 28	AN316-7R	• . . NUT (88044)	2	35	215
- 29	8-44569-15	• . . ROD ASSY, WELDED	1	35	215

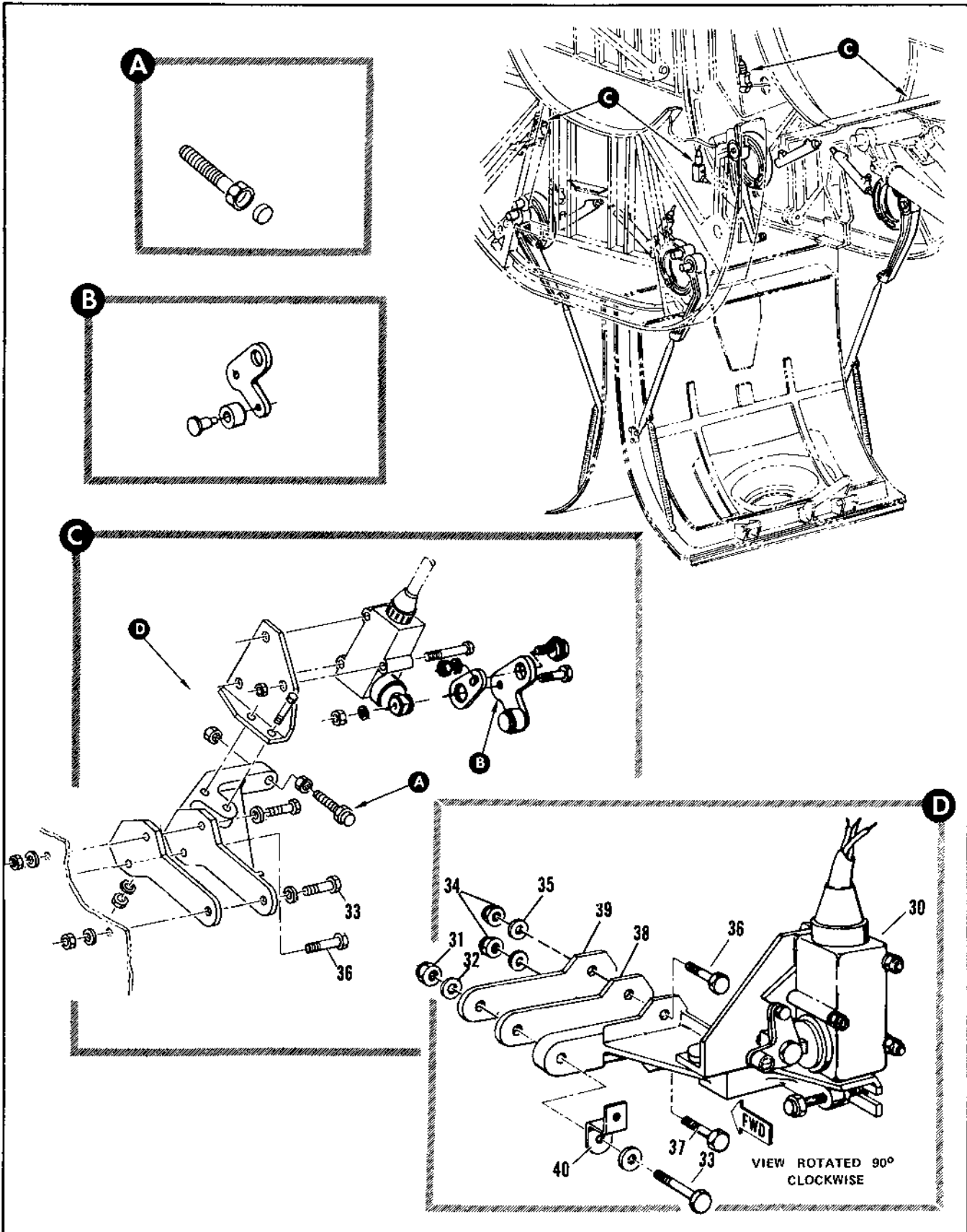

Figure 2.15-22. Main Landing Gear Door Actuator Installation (Sheet 2 of 4)

FIGURE AND INDEX NUMBER	PART NUMBER	DESCRIPTION 1 2 3 4 5 6	UNITS PER ASSY.	USABLE ON CODE	
				FROM	TO
2.15-22- 30	8-44625-1	• • STOP ASSY, MLG DOOR LH FWD FOR BREAKDOWN SEE FIG. 2.15-24	1		
	8-44625-2	• • STOP ASSY, MLG DOOR RH FWD FOR BREAKDOWN SEE FIG. 2.15-24	1		
	8-44625-3	• • STOP ASSY, MLG DOOR LH AFT FOR BREAKDOWN SEE FIG. 2.15-24	1		
	8-44625-4	• • STOP ASSY, MLG DOOR RH AFT FOR BREAKDOWN SEE FIG. 2.15-24 ATTACHING PARTS	1		
- 31	NAS679A5	• • NUT	1	35	215
- 32	AN9600516	• • WASHER	1	35	215
- 33	AN5-12A	• • BOLT, FWD	1	35	215
	AN5-14A	• • BOLT, AFT	1	35	215
- 34	NAS679A3	• • NUT, FWD	2	35	215
	NAS679A4	• • NUT, AFT	2	35	215
- 35	AN960010	• • WASHER, FWD	2	35	215
	AN9600416	• • WASHER, AFT	2	35	215
- 36	AN3-10A	• • BOLT, FWD	1	35	215
	AN4-15A	• • BOLT, AFT	1	35	215
- 37	AN3-10A	• • BOLT, FWD	1	35	215
	AN4-13A	• • BOLT, AFT	1	35	215
		-----X-----			
- 38	8-71282-9	• • FILLER, TAPERED LH AFT	1		
	8-71282-10	• • FILLER, TAPERED RH AFT	1		
- 39	7140192	• • SHIM	AR	35	215
- 40	8-80073-51	• • BRACKET, 2 AFT LH AND RH AND 1 FWD LH	3		

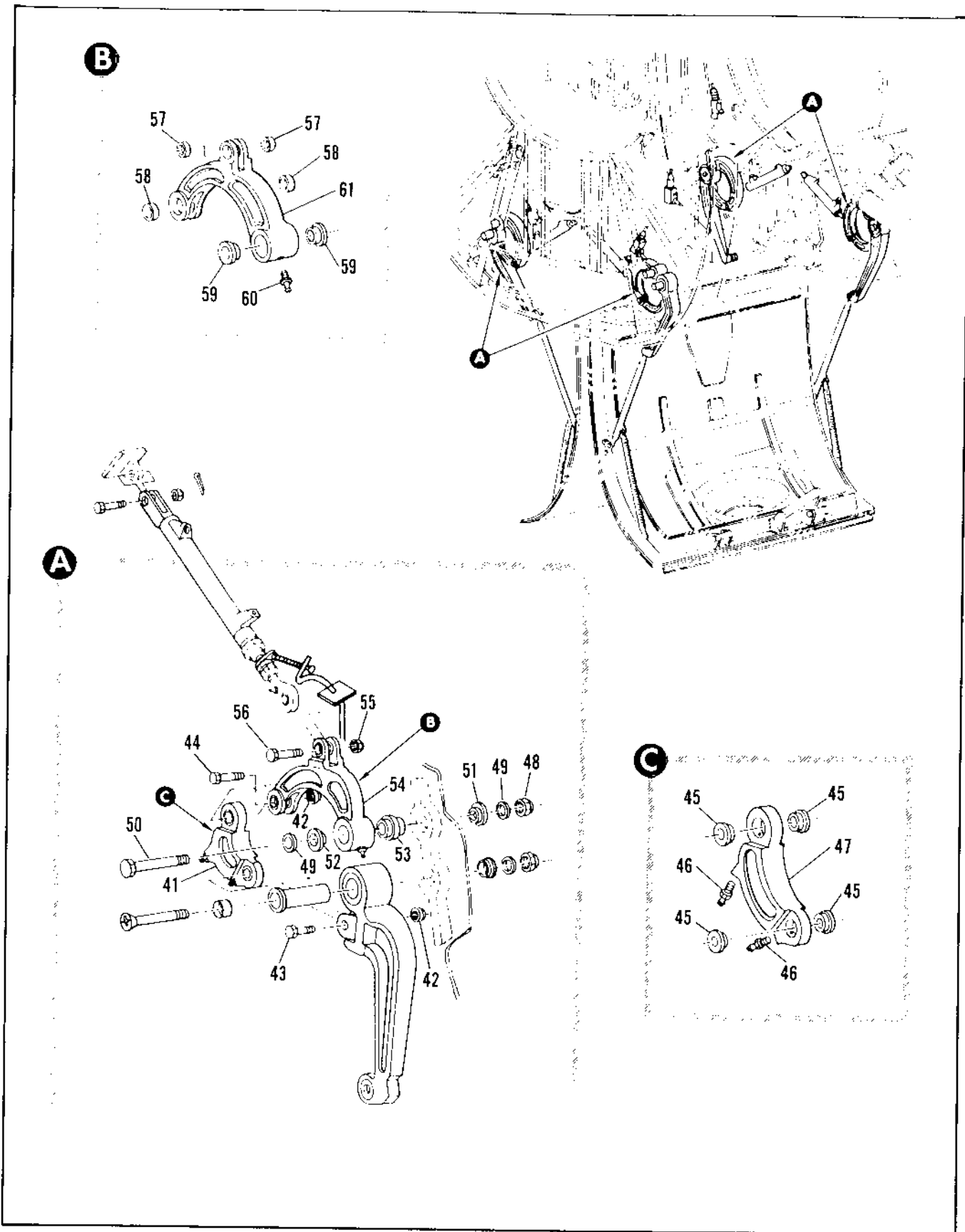

Figure 2.15-22. Main Landing Gear Door Actuator Installation (Sheet 3 of 4)

FIGURE AND INDEX NUMBER	PART NUMBER	DESCRIPTION 1 2 3 4 5 6	UNITS PER ASSY.	USABLE ON CODE	
				FROM	TO
2.15-30- 41	B-4456A-1	• • LINK ASSEMBLY	1	35	215
	B-4457A	• • LINK ASSY, ALT INTCHG WITH B-4456A-1 ATTACHING PARTS	PF	35	215
- 42	AN321-A	• • NUT	2	35	215
- 43	NAS444P6-16	• • BOLT	1	35	215
- 44	NAS444P6-16	• • BOLT	1	35	215
		-----X-----			
- 45	NAS77A8-16	• • • PUSHING	4	35	215
- 46	MS16031-1	• • • FITTING	2	35	215
- 47	B-44569-7	• • • LINK	1	35	215
		• • • LINK, ALT INTCHG WITH B-44569-7	PF	35	215
- 48	NAS779A4	• • NUT	1	35	215
- 49	AN911041F	• • WASHER	2	35	215
- 50	AN4-42A	• • BOLT	1	35	215
- 51	B-44562	• • CAP, MCG DOOR MECHANISM SHAFT	1	35	215
- 52	B-44564	• • CAP, MCG DOOR MECHANISM IDLER SHAFT	1	35	215
- 53	B-44561	• • SHAFT, MCG DOOR MECHANISM IDLER	1	35	215
- 54	B-44564-1	• • IDLER ASSY, FWD LH AFT RH	1	35	215
		• • IDLER ASSY, FWD LH AFT RH ALT INTCHG WITH B-44569-1	PF	35	215
	B-44564-2	• • IDLER ASSY, FWD RH AFT LH	1	35	215
	B-44567-3	• • IDLER ASSY, FWD RH AFT LH ALT INTCHG WITH B-44564-2 ATTACHING PARTS	PF	35	215
- 55	AN321-A	• • NUT	PF	35	215
- 56	NAS444P5-16	• • BOLT	1	35	215
		-----X-----			
- 57	NAS77A5-10R	• • • BUSHING	2	35	215
- 58	NAS77A6-10R	• • • BUSHING	2	35	215
- 59	NAS77A8U-44	• • • BUSHING	2	35	215
- 60	MS16031-1	• • • FITTING	1	35	215
- 61	B-44564-7	• • • IDLER, FWD LH AFT RH MAKE FROM B-44564	1	35	215
	B-44567-7	• • • IDLER, FWD LH AFT RH ALT INTCHG WITH B-44564-7	PF	35	215
	B-44564-8	• • • IDLER, FWD RH AFT LH MAKE FROM B-44564	1	35	215
	B-44567-8	• • • IDLER, FWD RH AFT LH ALT INTCHG WITH B-44564-8	PF	35	215
	B-44569	• • • IDLER			

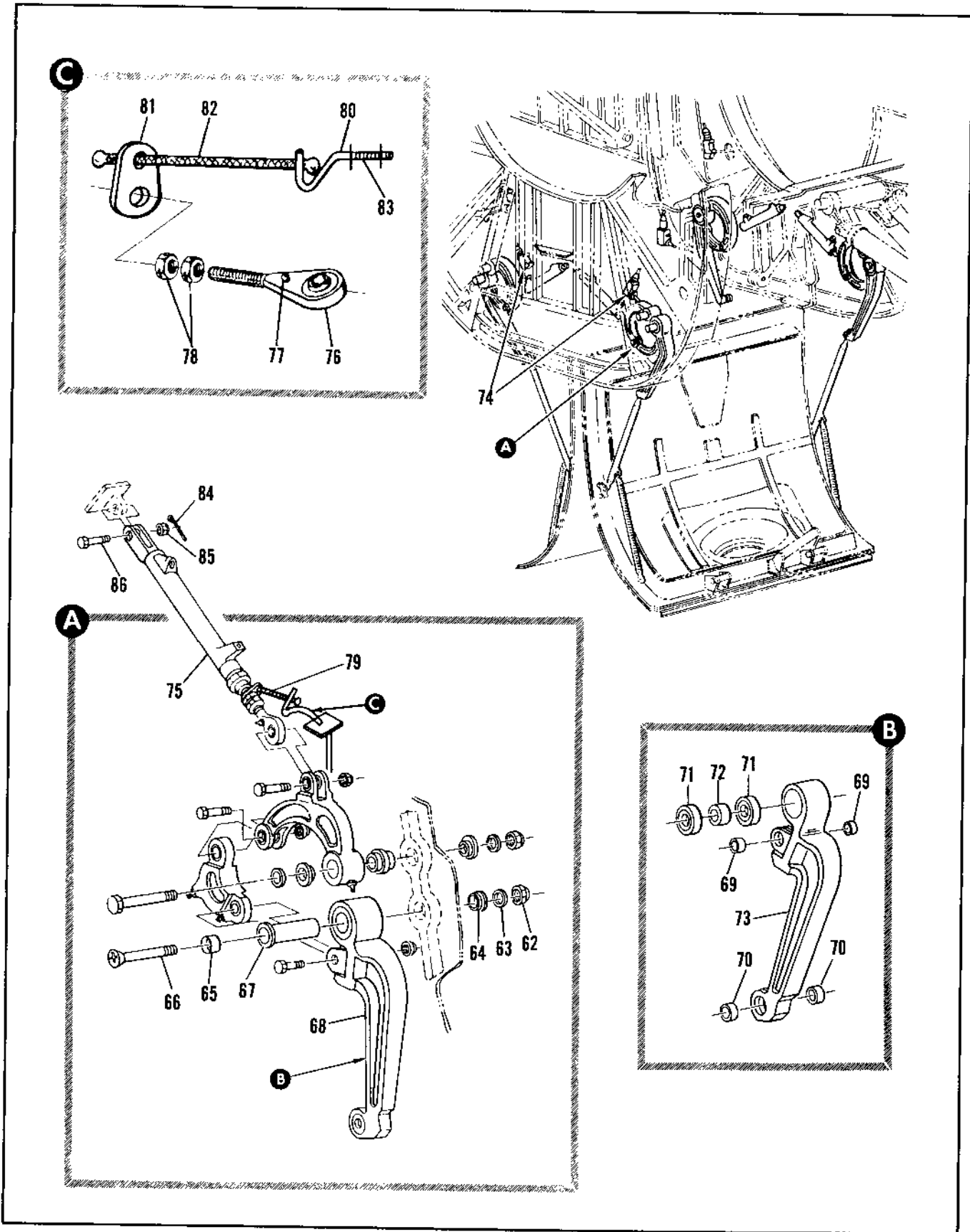

Figure 2.15-22. Main Landing Gear Door Actuator Installation (Sheet 4 of 4)

FIGURE AND INDEX NUMBER	PART NUMBER	DESCRIPTION	UNITS PER ASSY.	USABLE ON CODE	
				FROM	TO
		1 2 3 4 5 6			
2.15-22- 62	NAS679A4	• • NUT	1	35	215
- 63	AN961D416	• • WASHER	1	35	215
- 64	8-44582	• • CAP	1	35	215
- 65	8-44585	• • CAP	1	35	215
- 66	NAS334PA37	• • BOLT	1	35	215
- 67	8-44583	• • SHAFT, MLG DOOR MECHANISM ARM	1	35	215
- 68	8-44565-3	• • ARM ASSY, FWD LH AFT RH REPLACES SUITABLE SUB FOR 8-44565-1	1	35	215
	8-44566-1	• • ARM ASSY, FWD LH AFT RH ALT INTCHG WITH 8-44565-3	RF	35	215
	8-44565-4	• • ARM ASSY, FWD RH AFT LH	1	35	215
	8-44566-2	• • ARM ASSY, FWD RH AFT LH ALT INTCHG WITH 8-44565-4	RF	35	215
- 69		• • • BUSHING	2	35	215
- 70	NAS75-6-008	• • • BUSHING	2	35	215
- 71	AN211KP20A	• • • BEARING	2	35	215
- 72	91-27004-029	• • • SPACER	1	35	215
- 73	8-44565-11	• • • ARM, FWD LH AFT RH	1	35	215
	8-44566-7	• • • ARM, FWD LH AFT ALT INTCHG WITH 8-44565-11	RF	35	215
	8-44565-12	• • • ARM, FWD RH AFT LH	1	35	215
	8-44566-8	• • • ARM, FWD RH AFT LH ALT INTCHG WITH 8-44565-12	RF	35	215
- 74		• • SWITCH ASSY, MLG DOOR OPEN LIMIT SEE FIG. 2.15-32	RF		
- 75	60029-2	• • CYLINDER, MLG DOOR (96215) SPEC 8-08487 T.O. 942-2-43-2 REPLACES 60029 AND 60029-1			
- 76	71534	• • • ROD END	1	35	215
- 77	MS15081-1	• • • • FITTING, LUBE	1	35	215
- 78	NAS19-5	• • • NUT	2	35	215
- 79	7037734-10	• • WIRE-ROPE ASSY	1	35	215
- 80	7037732-01	• • • BRACKET	1	35	215
- 81	7037733-01	• • • PLATE	1	35	215
- 82	7037734-01	• • • WIRE ROPE	1	35	215
- 83	NAS43HT5-6	• • SPACER	1	35	215
- 84	AN383-3-2	• • PIN, COTTER	1	35	215
- 85	AN320-5	• • NUT	1	35	215
- 85	NAS454P5-14	• • BOLT	1	35	215
		-----X-----			

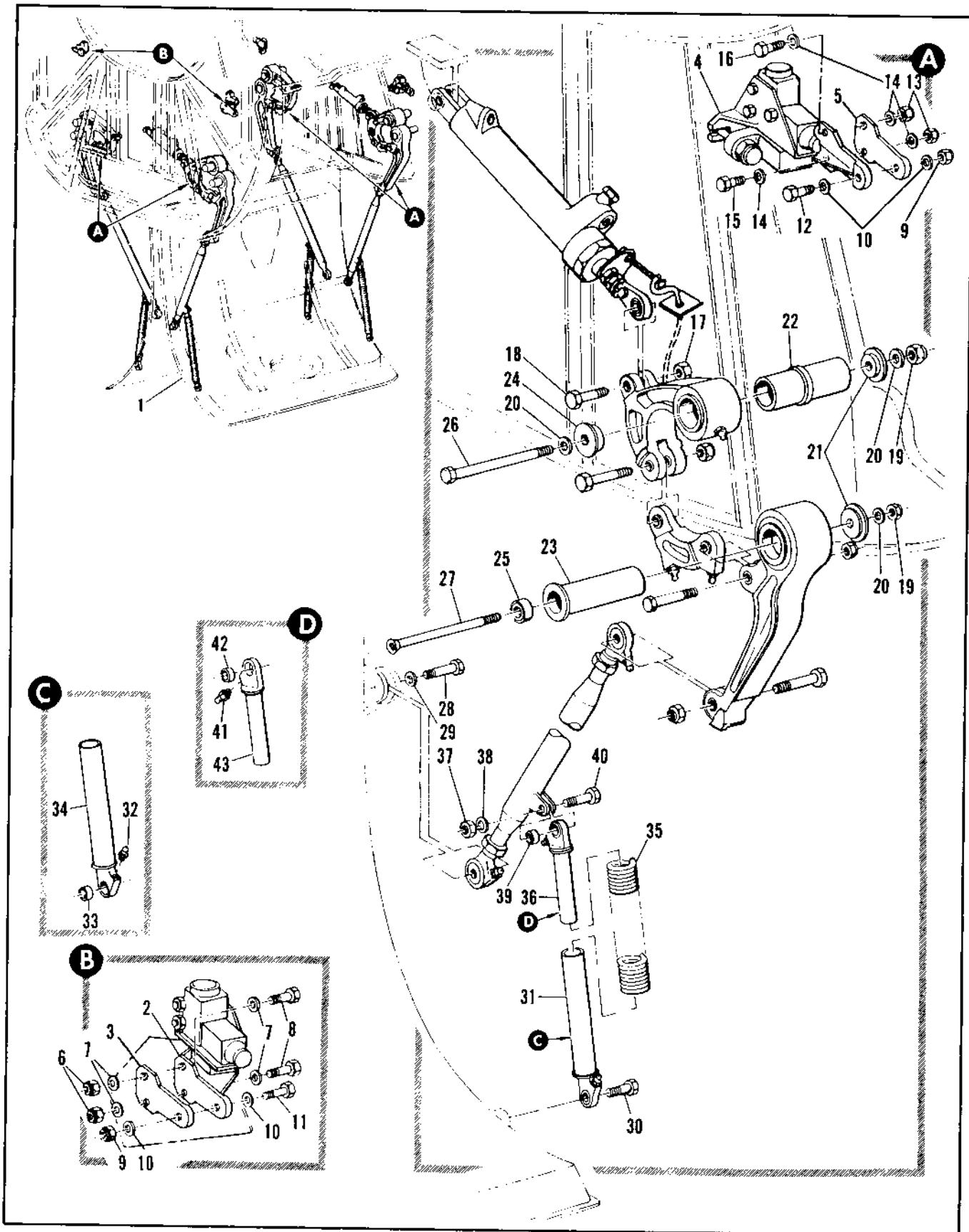

Figure 2.15-23. Main Landing Gear Door Actuator Installation (Sheet 1 of 3)

FIGURE AND INDEX NUMBER	PART NUMBER	DESCRIPTION	UNITS PER ASSY.	USABLE ON CODE	
				FROM	TO
		1 2 3 4 5 6			
2.15-23		SPEC 8-38487 TO 9H2-2-43-2 REPLACES 60029 AND 60029-1			
-	8-44546-5	ACTUATOR INSTALLATION, MAIN LANDING GEAR DOOR FOR NHA SEE FIG. 2-3-3	RF	216	
- 1		• DOOR INSTL. MLG SEE FIG. 2-15-23	RF		
- 2	8-44625-1	• STOP ASSY, MAIN LANDING GEAR DOOR FWD LH FOR BREAKDOWN SEE FIG. 2-15-24	12	316	
	8-44525-2	• STOP ASSY, MAIN LANDING GEAR DOOR FWD RH FOR BREAKDOWN SEE FIG. 2-15-24	1	216	
- 3	7140192	• SHIM	AR	216	
- 4	8-44625-3	• STOP ASSY, MAIN LANDING GEAR DOOR AFT LH FOR BREAKDOWN SEE FIG. 2-15-24	1	216	
	8-44625-4	• STOP ASSY, MAIN LANDING GEAR DOOR AFT RH FOR BREAKDOWN SEE FIG. 2-15-24	1	216	
- 5	7140192	• SHIM	AR	216	
		ATTACHING PARTS			
- 6	NAS679A3	• NUT, FWD	4	216	
- 7	AN960D10	• WASHER, FWD	8	216	
- 8	AN3-10A	• BOLT, FWD	4	216	
- 9	NAS679A5	• NUT	4	216	
- 10	AN960D516	• WASHER	8	216	
- 11	AN5-12A	• BOLT, FWD	2	216	
- 12	AN5-14A	• BOLT, AFT	2	216	
- 13	NAS679A4	• NUT, AFT	4	216	
- 14	AN960D416	• WASHER, AFT	8	216	
- 15	AN4-13A	• BOLT, AFT	2	216	
- 16	AN4-16A	• BOLT, AFT	2	216	
		-----X-----			
- 17	AN380-2-3	• PIN, COTTER	4	216	
- 18	AN320-5	• NUT	4	216	
- 19	NAS464P5-16	• BOLT	1	216	
- 19	NAS679A4	• NUT	4	216	
- 20	AN960D416	• WASHER	16	216	
- 21	8-44582	• CAP	8	216	
- 22	8-44581	• SHAFT	4	216	
- 23	8-44580	• SHAFT	4	216	
- 24	8-44584	• CAP	4	216	
- 25	8-44585	• CAP	4	216	
- 26	AN4-42A	• BOLT	4	216	
- 27	NAS334PA37	• BOLT	4	216	
- 28	8-44589-7	• BOLT, MAIN LANDING GEAR DOOR	4	216	
- 29	AN960D616	• WASHER	4	216	
- 30	NAS464P4A13	• BOLT	4	216	
	8-44546-15	• ACTUATOR ASSY, MAIN LANDING GEAR DOOR FWD LH	1	216	
	8-44546-16	• ACTUATOR ASSY, MAIN LANDING GEAR DOOR FWD RH	1	216	
	8-44546-17	• ACTUATOR ASSY, MAIN LANDING GEAR DOOR AFT LH	1	216	
	8-44546-18	• ACTUATOR ASSY, MAIN LANDING GEAR DOOR AFT RH	1	216	
- 31	8-44572-1	• TUBE ASSY, SPRING	1	216	
- 32	MS15001-1	• FITTING	1	216	
- 33	MSBG45	• BEARING, <02758> 90-60000-151	1	216	
- 34	8-44572-9	• TUBE	1	216	
- 35	8-04291	• SPRING, HELICAL COMPRESSION	1	216	
- 36	8-44571	• ROD ASSY, MAIN LANDING GEAR DOOR	1	216	
		ATTACHING PARTS			
- 37	NAS679A3	• NUT	1	216	
- 38	AN960-10	• WASHER	1	216	
- 39	NAS73-3-006	• BUSHING	1	216	
- 40	NAS1103-R	• BOLT	1	216	
		-----X-----			
- 41	MS15001-1	• FITTING	1	216	
- 42	NAS75-5-004	• BUSHING	2	216	
- 43	8-44571-9	• ROD	1	216	

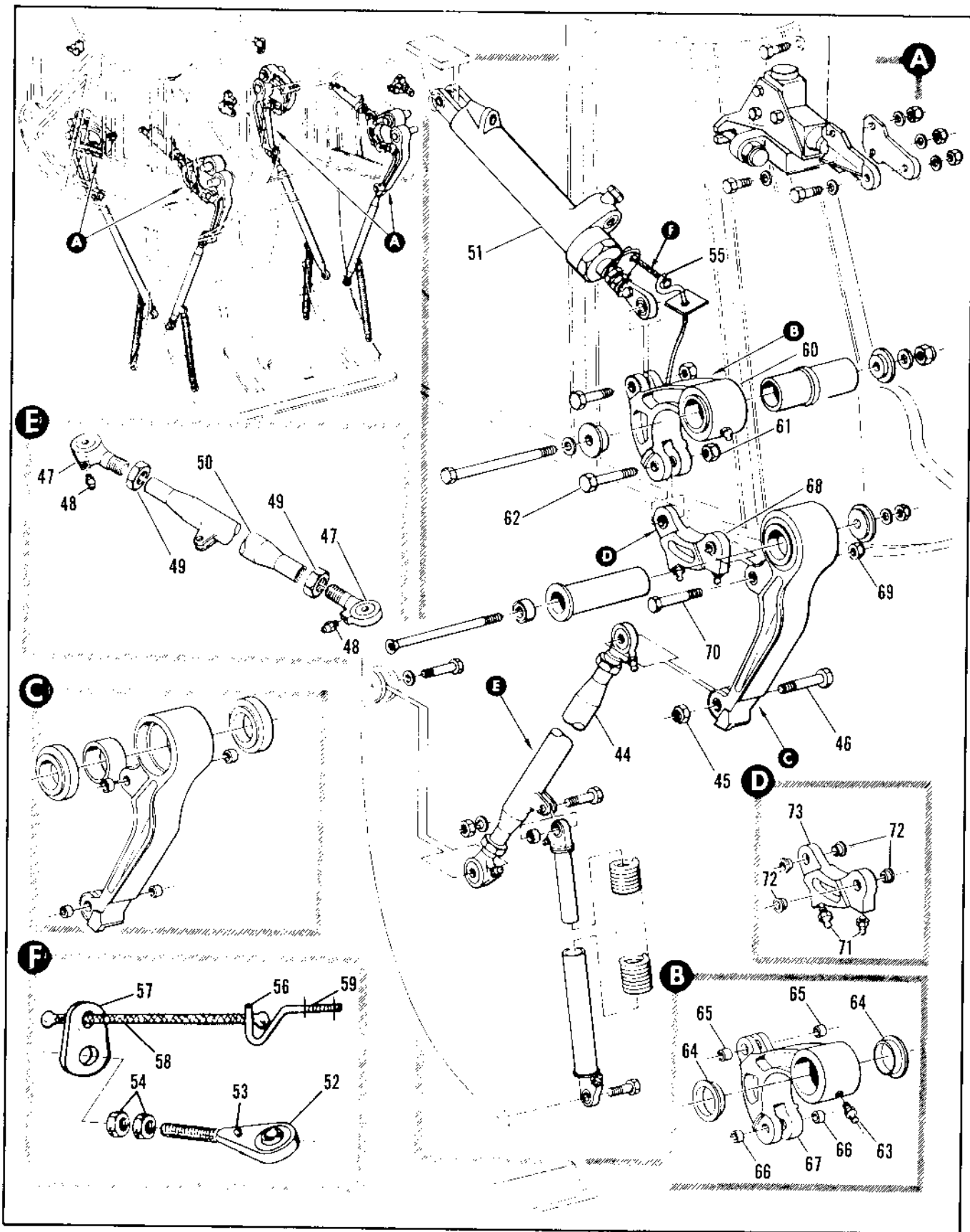
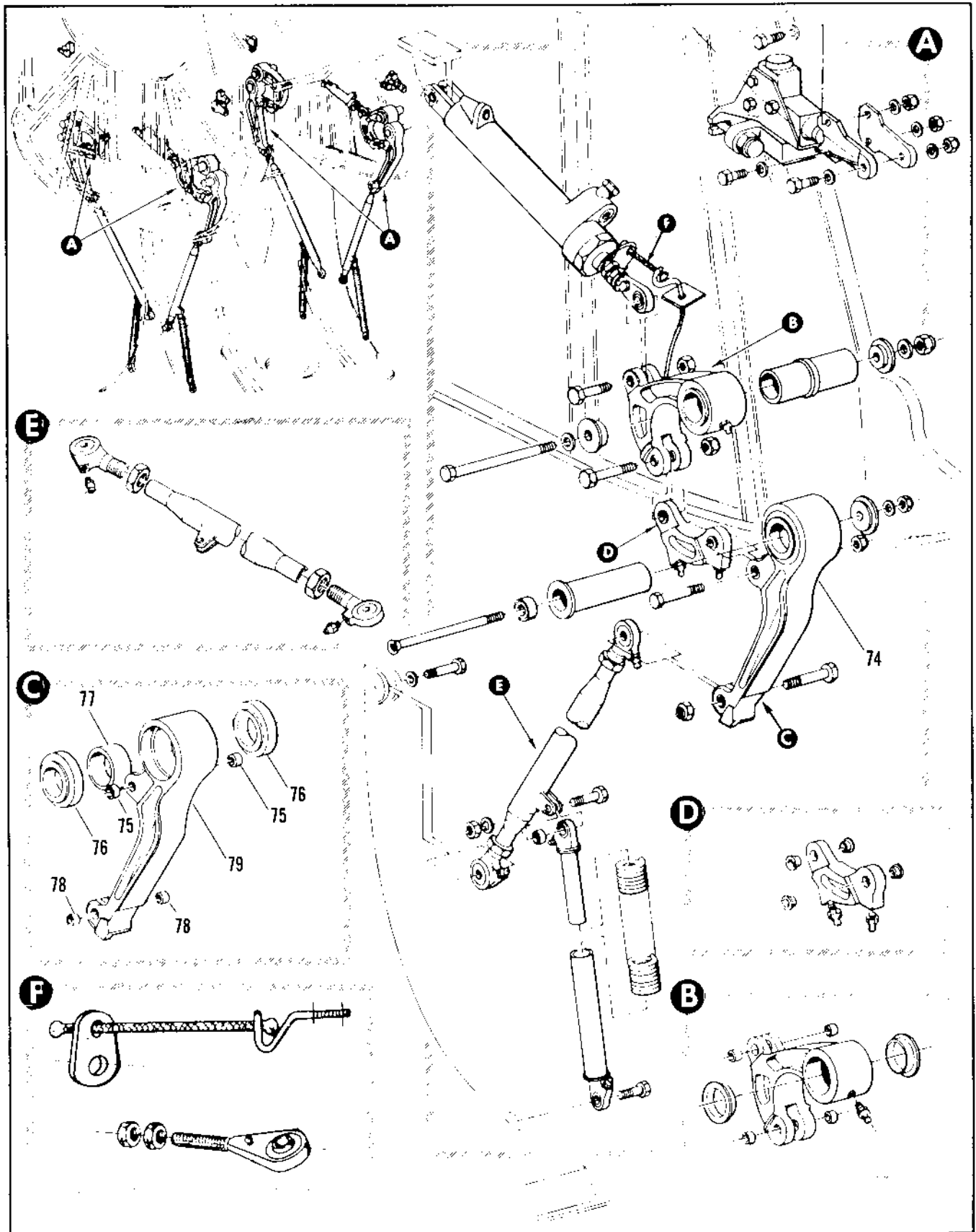

Figure 2.15-23. Main Landing Gear Door Actuator Installation (Sheet 2 of 3)

FIGURE AND INDEX NUMBER	PART NUMBER	DESCRIPTION	UNITS PER ASSY.	USABLE ON CODE	
				FROM	TO
2.15-23- 44	8-44569	• • TUBE ASSY, MAIN LANDING GEAR DOOR ATTACHING PARTS	1	216	
	AN380-3-3	. . PIN, COTTER (88044)	1	216	
- 45	AN320-6	. . NUT (88044)	1	216	
- 46	NAS464P6-16	. . BOLT (80205)	1	216	
		----X----			
- 47	HE6-2F	• • • BEARING, <97613> 90-60305-004	2	216	
- 48	3017	. . . FITTING (95879)	1	216	
- 49	AN316-7R	. . . NUT (88044)	2	216	
- 50	8-44569-15	• • • TUBE ASSY, MAIN LANDING GEAR WELDED	1	216	
- 51	60029-2	• • CYLINDER, MLG DOOR (96215)			
- 52	71534	• • • ROD END	1	216	
- 53	MS15001-1	. . . FITTING, LUBE (96906)	1	216	
- 54	NAS509-5	. . . NUT (80205)	2	216	
- 55	7037734-10	• • WIRE-ROPE ASSY	1	216	
- 56	7037732-01	• • • BRACKET	1	216	
- 57	7037733-01	• • • PLATE	1	216	
- 58	7037734-01	• • WIRE ROPE	1	216	
- 59	NAS43HT5-6	. . SPACER (80205)	1	216	
- 60	8-44564-1	• • IDLER ASSY, MAIN LANDING GEAR DOOR FWD LH AFT RH	1	216	
	8-44567-1	• • IDLER ASSY, MAIN LANDING GEAR DOOR FWD LH AFT RH ALT INTCHG WITH 8-44564-1	RF	216	
	8-44564-2	• • IDLER ASSY, MAIN LANDING GEAR DOOR AFT FWD RH AFT LH	1	216	
	8-44567-2	• • IDLER ASSY, MAIN LANDING GEAR DOOR FWD RH AFT LH ALT INTCHG WITH 8-44564-2	RF	216	
	AN380-3-3	. . PIN, COTTER (88044)	1	216	
- 61	AN320-6	. . NUT (88044)	1	216	
- 62	NAS464P6-18	. . BOLT (80205)	1	216	
		----X----			
- 63	MS15001-4	. . . FITTING (96906)	1	216	
- 64	NAS77A20-44	. . . BUSHING (80205)	2	216	
- 65	NAS76A5-008	. . . BUSHING (80205)	2	216	
- 66	NAS76A6-009	. . . BUSHING (80205)	2	216	
- 67	8-44564-7	• • • IDLER, FWD LH AFT RH MAKE FROM 8-44564	1	216	
	8-44567-7	• • • IDLER, FWD LH AFT RH ALT INTCHG WITH 8-44564-7	RF	216	
	8-44564-8	• • • IDLER, FWD RH AFT LH MAKE FROM 8-44564	1	216	
	8-44567-8	• • • IDLER, FWD RH AFT LH ALT INTCHG WITH 8-44564-8	RF	216	
	8-44564	• • • IDLER	RF		
- 68	8-44568-1	• • LINK ASSY, MAIN LANDING GEAR DOOR	1	216	
	8-44574-1	• • LINK ASSY, MAIN LANDING GEAR DOOR ALT INTCHG WITH 8-44568-1	RF	216	
		ATTACHING PARTS			
- 69	AN320-6	. . NUT (88044)	1	216	
- 70	NAS464P6-16	. . BOLT (80205)	1	216	
		----X----			
- 71	MS15001-1	. . . FITTING (96906)	2	216	
- 72	NAS77A6-16	. . . BUSHING (80205)	4	216	
- 73	8-44568-7	• • • LINK, MAKE FROM 8-44568	1	216	



2.15-23. Main Landing Gear Door Actuator Installation (Sheet 3 of 3)

FIGURE AND INDEX NUMBER	PART NUMBER	DESCRIPTION	UNITS PER ASSY.	USABLE ON CODE	
				FROM	TO
2.15-23 - 74 - 75 - 76 - 77 - 78 - 79	8-44564-7	• • • LINK, ALT INTCHG WITH 8-44568-7	RF	216	
	8-44565-3	• • • LINK • • ARM ASSY, MAIN LANDING GEAR DOOR FWD LH AFT RH REPLACES SUITABLE SUB FOR 8-44565-1	RF 1	216	
	8-44566-1	• • ARM ASSY, MAIN LANDING GEAR DOOR FWD LH AFT RH ALT INTCHG WITH 8-44565-3	RF	216	
	8-44565-4	• • ARM ASSY, MAIN LANDING GEAR DOOR FWD RH AFT LH	1	216	
	8-44566-2	• • ARM ASSY, MAIN LANDING GEAR DOOR FWD RH AFT LH ALT INTCHG WITH 8-44565-4	RF	216	
	NAS75-6-007	• • • BUSHING	2	216	
	AN271KP2CA	• • • BEARING	2	216	
	91-27004-029	• • • SPACER	1	216	
	NAS75-6-108	• • • PUSHING	2	216	
	8-44565-11	• • • ARM, FWD LH AFT RH MAKE FROM 8-44565-9	1	216	
	8-44565-7	• • • ARM, FWD LH AFT RH ALT INTCHG WITH 8-44565-11	RF	216	
	8-44565-9	• • • ARM	RF		
	8-44565-12	• • • ARM, FWD RH AFT LH MAKE FROM 8-44565-10	1	216	
	8-44565-10	• • • ARM, FWD RH AFT LH ALT INTCHG WITH 8-44565-12	RF	216	
	8-44565-10	• • • ARM	RF		

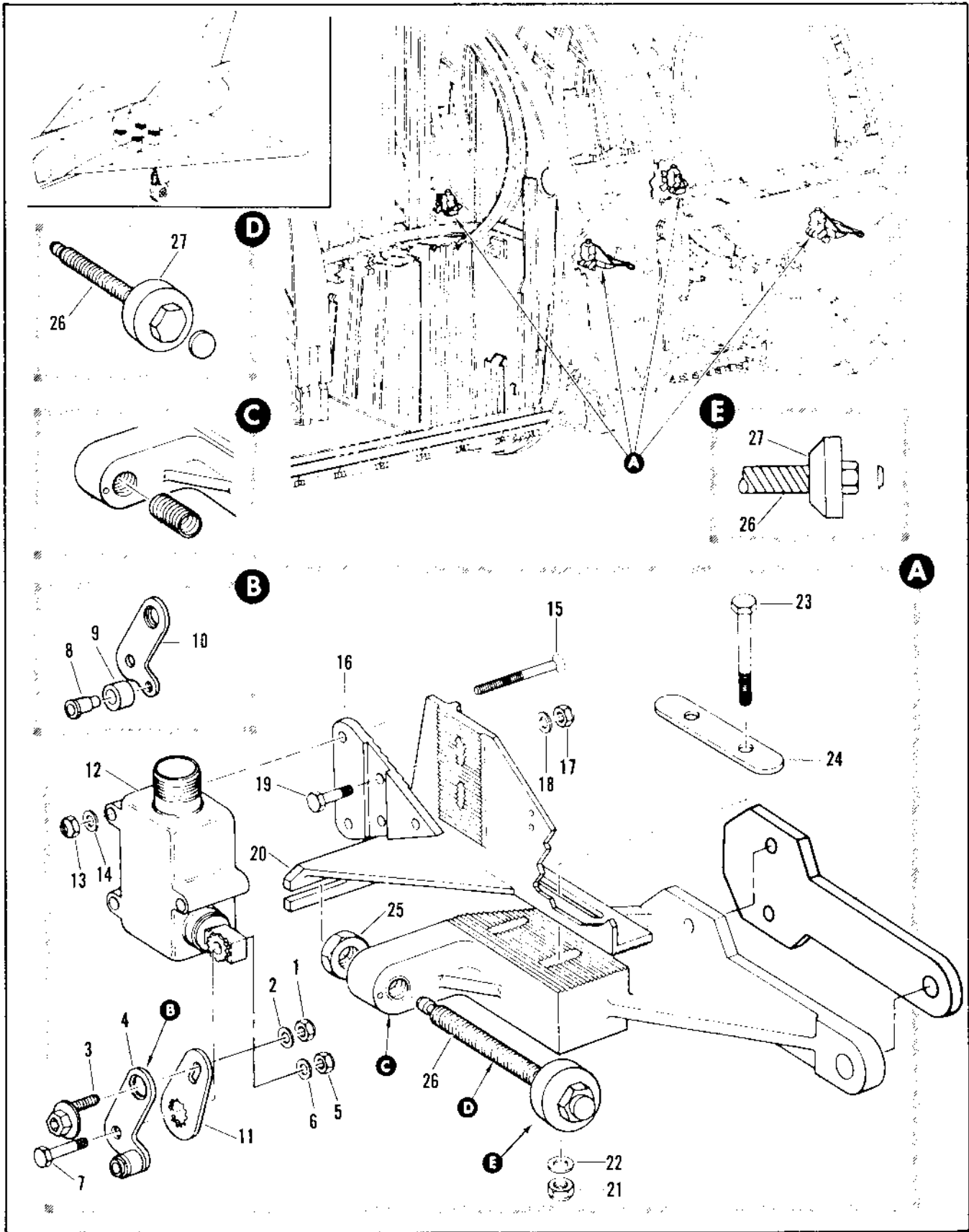

Figure 2.15-24. Main Landing Gear Door Fwd Stop Assembly (Sheet 1 of 2)

FIGURE AND INDEX NUMBER	PART NUMBER	DESCRIPTION	UNITS PER ASSY.	USABLE ON CODE	
				FROM	TO
		1 2 3 4 5 6			
2.15-24	8-44625-1	STOP ASSY, MAIN LANDING GEAR DOOR FWD LH FOR NHA SEE FIG. 2.15-22 AND 2.15-23	RF	216	
	8-44625-2	STOP ASSY, MAIN LANDING GEAR DOOR FWD RH FOR NHA SEE FIG. 2.15-22 AND 2.15-23	RF	216	
	8-44625-3	STOP ASSY, MAIN LANDING GEAR DOOR AFT LH FOR NHA SEE FIG. 2.15-22 AND 2.15-23	RF	216	
	8-44625-4	STOP ASSY, MAIN LANDING GEAR DOOR AFT RH FOR NHA SEE FIG. 2.15-22 AND 2.15-23	RF	216	
- 1	NAS679A08	• NUT	1	216	
- 2	AN935-8	• WASHER	1	216	
	AN960-8	• WASHER	1	216	
- 3	8-68038-7	• BOLT	1	216	
- 4	8-65098-3	• ARM ASSY, ACTUATOR LIMIT SWITCH FWD RH AFT LH REPLACES SUITABLE SUB FOR 8-65098-1	1	216	
	8-65098-4	• ARM ASSY, ACTUATOR LIMIT SWITCH FWD LH AFT RH REPLACES SUITABLE SUB FOR 8-65098-2	1	216	
		ATTACHING PARTS			
- 5	NAS1291-3	• NUT	1	216	
- 6	AN960-10	• WASHER	1	216	
- 7	NAS1103-11	• BOLT	1	216	
	NAS1103-10	• BOLT	1	216	
		-----X-----			
- 8	8-68051-11	• STUD	1	216	
- 9	8-68052-11	• ROLLER	1	216	
- 10	8-65098-7	• ARM	1	216	
- 11	112742	• PLATE, <97198> SPEC 8-06986-7	1	216	
- 12	H12-27	• SWITCH, LIMIT <97198> SPEC 8-06983-803	1	216	
		ATTACHING PARTS			
- 13	NAS679A3	• NUT	3	216	
- 14	AN960-10L	• WASHER	3	216	
- 15	AN509-10R29	• BOLT	3	216	
		-----X-----			
- 16	8-44622-7	• PLATE	1	216	
		ATTACHING PARTS			
- 17	NAS679A3	• NUT	2	216	
- 18	AN960D10	• WASHER	2	216	
- 19	AN3-5A	• BOLT	2	216	
		-----X-----			
- 20	8-44621-7	• BRACKET, SWITCH MAIN LANDING GEAR DOOR FWD LH AFT RH REPLACES NOT INTCHG WITH 8-44573-9	1	216	
	8-44621-8	• BRACKET, SWITCH MAIN LANDING GEAR DOOR FWD RH AFT LH REPLACES NOT INTCHG WITH 8-44573-10	1	216	
		ATTACHING PARTS			
- 21	NAS679A3	• NUT	2	216	
- 22	AN960D10	• WASHER	2	216	
- 23	AN3-14A	• BOLT	2	216	
		-----X-----			
- 24	8-44620	• PLATE	1	216	
- 25	NAS679-6	• NUT	1	216	
- 26	7747445-10	• BOLT ASSY, STOP DOOR	1	35	
- 27	7747444-01	• NUT	1	35	

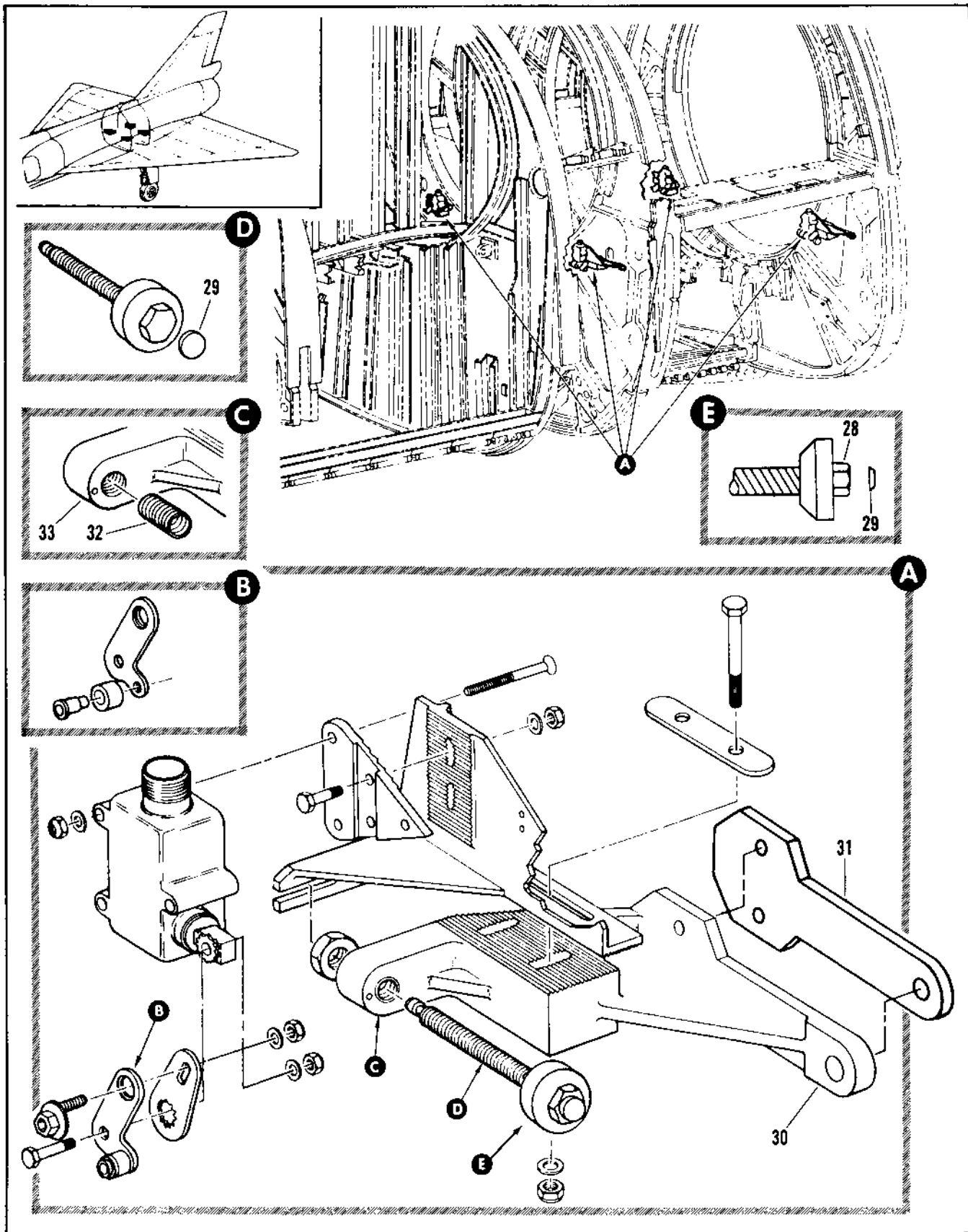

Figure 2.15-24. Main Landing Gear Door Fwd Stop Assembly (Sheet 2 of 2)

FIGURE AND INDEX NUMBER	PART NUMBER	DESCRIPTION	UNITS PER ASSY.	USABLE ON CODE	
				FROM	TO
		1 2 3 4 5 6			
2.15-24- 28	8-44623-9	. . BOLT ASSY	1	35	
- 25	240-3140311-8	. . . BUMPER (MAKE FROM AMS 3209)	1	35	
	8-44623-7	. . . BOLT	1	35	
- 30	8-44624-13	. STOP ASSY, MAIN LANDING GEAR DOOR AFT LH	1	216	
	8-44624-14	. STOP ASSY, MAIN LANDING GEAR DOOR AFT RH	1	216	
	8-44624-11	. STOP ASSY, MAIN LANDING GEAR DOOR FWD LH	1	216	
	8-44624-12	. STOP ASSY, MAIN LANDING GEAR DOOR FWD RH	1	216	
- 31	7141920-01	. SHIM	1	35	
	7141920-03	. SHIM	1	35	
	7141920-05	. SHIM	1	35	
- 32	1191-60NX9/16	. . INSERT, AFT 55-03000-015	1	216	
- 33	8-44624-7	. . STOP, FWD LH	1	216	
	8-44624-8	. . STOP, FWD RH	1	216	
	8-44624-9	. . STOP, AFT LH	1	216	
	8-44624-10	. . STOP, AFT RH	1	216	

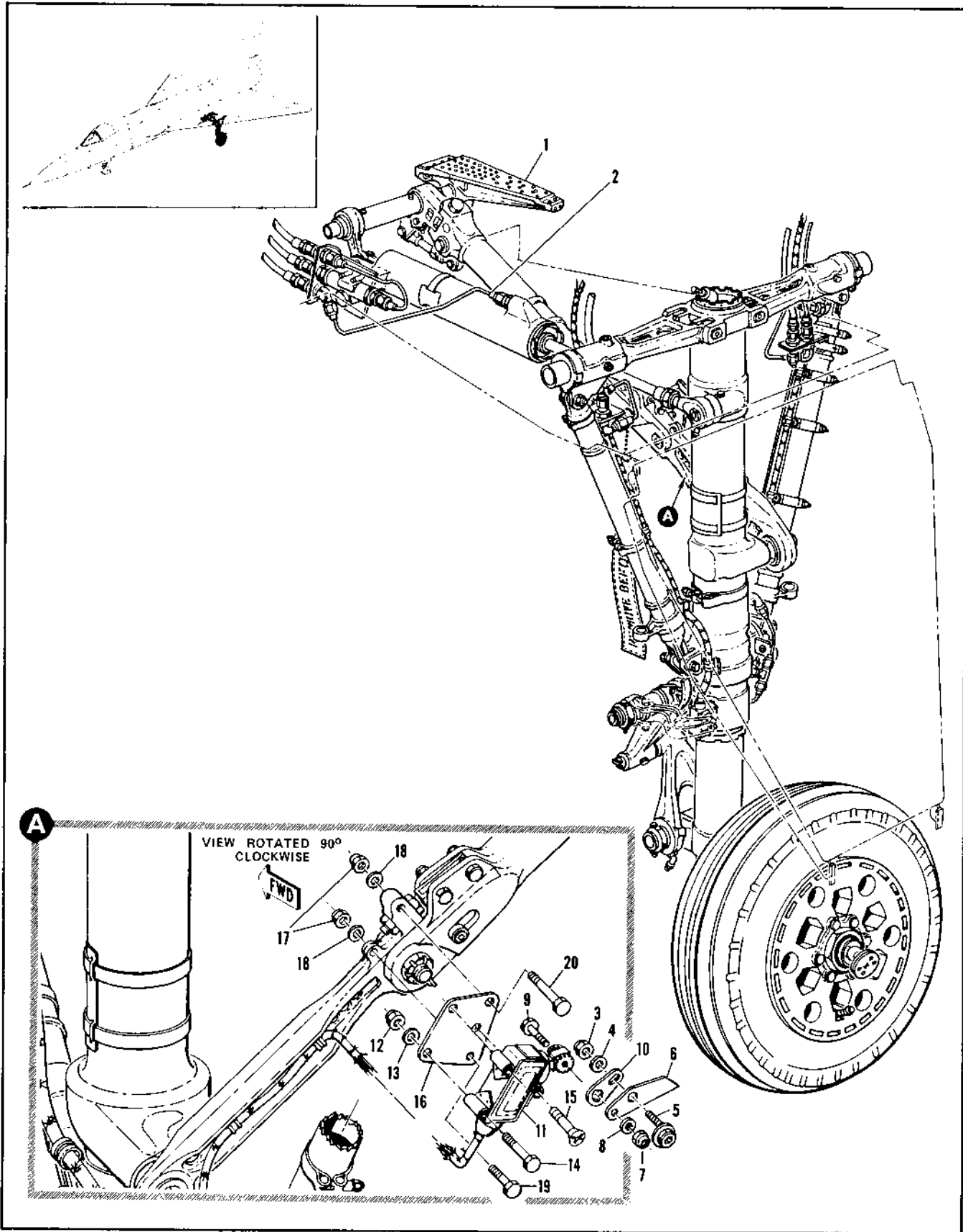

Figure 2.15-25. Main Landing Gear Installation (Sheet 1 of 4)

FIGURE AND INDEX NUMBER	PART NUMBER	DESCRIPTION	UNITS PER ASSY.	USABLE ON CODE	
				FROM	TO
		1 2 3 4 5 6			
2.15-25	8-51013-3	GEAR INSTALLATION, MAIN LANDING LH MODIFIED BY 8-51017-1,-3,-5, 8-51018 AND 8-51303-1,-3	RF	A	
	8-51013	FOR NHA SEE FIG. 2.6-1 AND 2.6-2 GEAR INSTALLATION, MAIN LANDING LH MODIFIED BY 8-51017-1,-3,-5, 8-51018, AND 8-51303-1,-3	RF	278	287
	8-51013-5	FOR NHA SEE FIG. 2.6-1 AND 2.6-2 GEAR INSTALLATION, MAIN LANDING RH MODIFIED BY 8-51017-1,-3,-5, 8-51018, AND 8-51303-1,-3	RF	A	
	8-51013-1	FOR NHA SEE FIG. 2.6-1 AND 2.6-2 GEAR INSTALLATION, MAIN LANDING RH MODIFIED BY 8-51017-1,-3,-5, 8-51018, AND 8-51303-1,-3	RF	278	287
- 1		FOR NHA SEE FIG. 2.6-1 AND 2.6-2 • SUPPORT, MLG SIDE BRACE AFT LH SEE FIG. 2.15-29	RF		
- 2	8-80031-1	• TUBING INSTL, MLG ACTUATOR HYDRAULIC LH FOR BREAKDOWN SEE FIG. 2.15-26	1	B	
	8-80031-3	• TUBING INSTL, MLG ACTUATOR HYDRAULIC RH FOR BREAKDOWN SEE FIG. 2.15-26	1	B	
- 3	NAS679A08	• NUT, 96-37545-101	1	35	
- 4	AN960D8	• WASHER	1	35	
- 5	8-68036-7	• BOLT	1	35	
- 6	8-65263	• ARM	1	35	
		ATTACHING PARTS			
- 7	NAS679A3	• NUT, 96-37545-902	1	35	
- 8	AN960PD10L	• WASHER	1	35	
- 9	AN3-7A	• BOLT	1	35	
		-----X-----			
- 10	U12742	• PLATE, <97198> SPEC 8-56986-7	1	35	
- 11	H12-27	• SWITCH, LIMIT <97198> SPEC 8-06983-803	1	35	
		ATTACHING PARTS			
- 12	NAS679A3	• NUT	3	35	
- 13	AN960PD10L	• WASHER	3	35	
- 14	AN3-15A	• BOLT	2	35	
- 15	ANS09-10R27	• SCREW	1	35	
		-----X-----			
- 16	8-51154-9	• PLATE	1	35	
		ATTACHING PARTS			
- 17	NAS679A3	• NUT	2	35	
- 18	AN960PD10L	• WASHER	2	35	
- 19	AN3-15A	• BOLT	1	35	
- 20	AN3-15A	• BOLT	1	35	
		-----X-----			
		A AIRPLANES #35 THRU 277, 288 AND ON			
		B AIRPLANES #35 THRU 48, 288 AND ON			

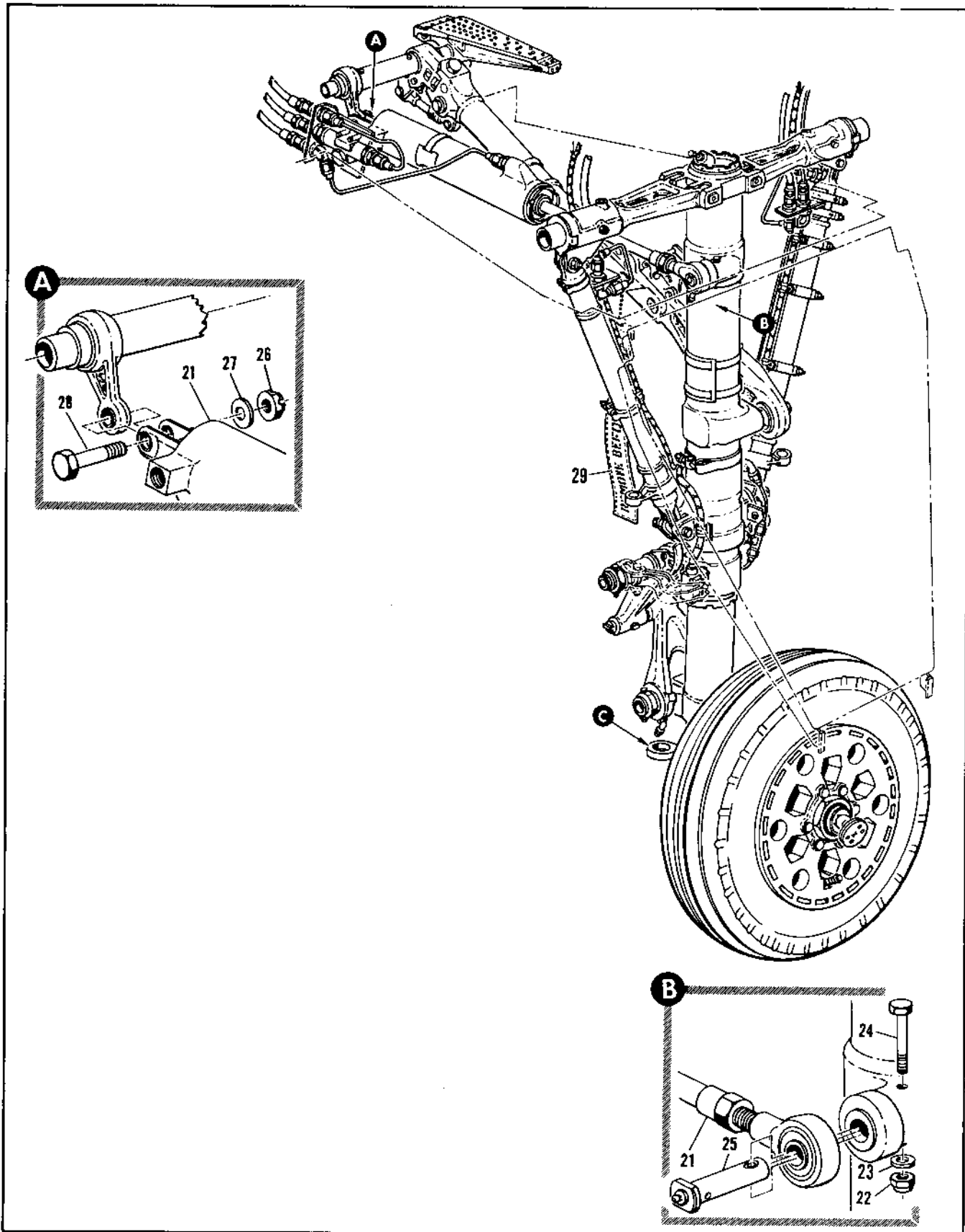

Figure 2.15-25. Main Landing Gear Installation (Sheet 2 of 4)

FIGURE AND INDEX NUMBER	PART NUMBER	DESCRIPTION	UNITS PER ASSY.	USABLE ON CODE	
				FROM	TO
		1 2 3 4 5 6			
2.15-25- 21	7855-9	• ACTUATOR ASSY, MLG (75662) SPEC 9-08486-7 T.O. 9H2-2-44-3 REPLACED BY SUITABLE SUB 7855-11	1	35	
	7855-11	• ACTUATOR ASSY, MLG (75662) SPEC 8-08486-7 T.O. 9H2-244-3 REPLACES SUITABLE SUB 7855-9	1	35	
		ATTACHING PARTS			
- 22	MS21083D4	*1 • NUT	RF	35	
- 23	AN960PD416	*1 • WASHER	RF	35	
- 24	AN4-22A	*1 • BOLT	RF	35	
- 25	538010	*1 • PIN	RF	35	
- 26	AN325-10	*2 • NUT	RF	35	
- 27	AN960-1016	*2 • WASHER	RF	35	
- 28	NAS464P10-20	*2 • BOLT (USED WITH ACTUATORS 7855-7 AND 7855-9)	RF	35	
	NAS454P10-29	• BOLT (USED WITH ACTUATOR 7855-11) -----X-----	1	35	
- 29	SE-0A52-3604	• STREAMER ASSY, WARNING TYPE A	1	35	
		*1 FURNISHED WITH SHOCK STRUT PART NO. 578100-505			
		*2 FURNISHED WITH (39661) SIDE STRUT			

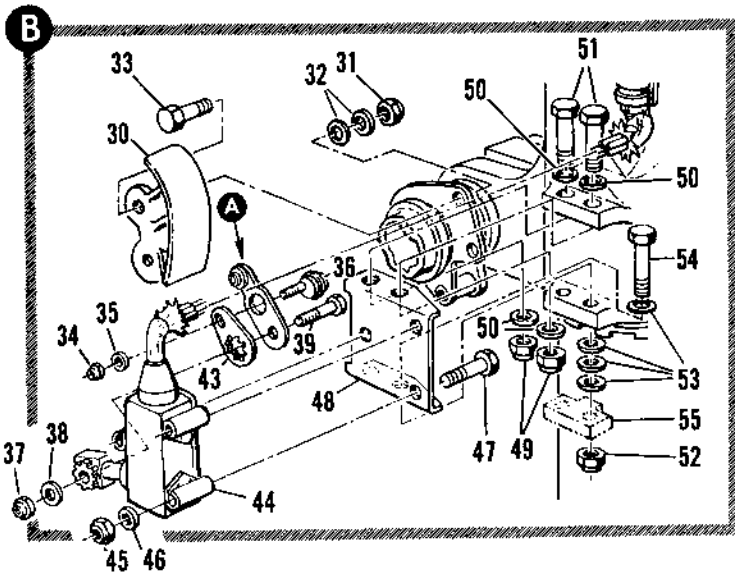
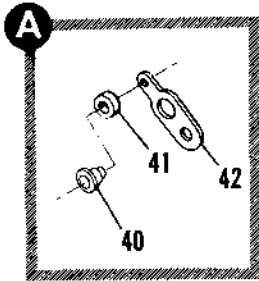
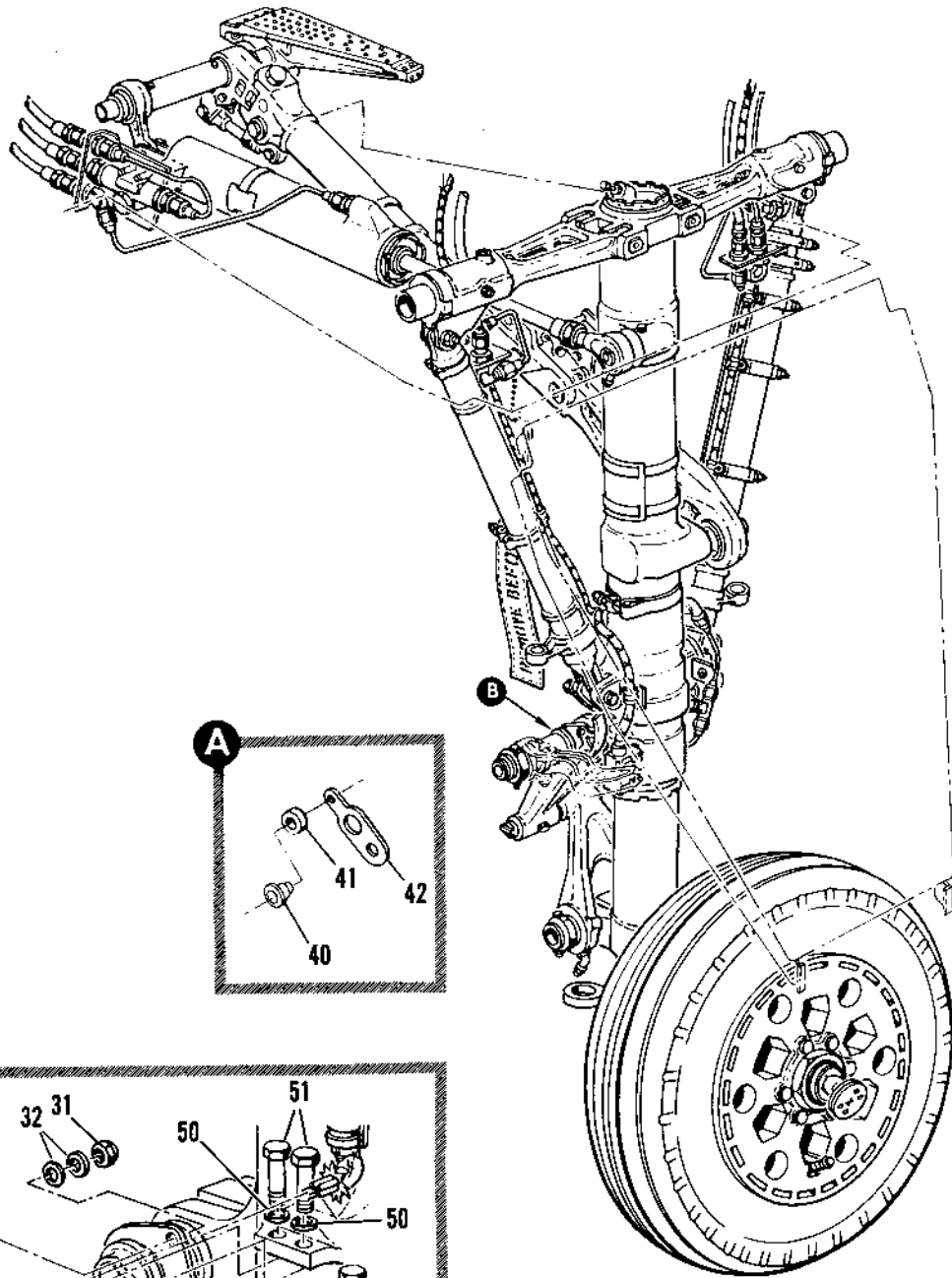

Figure 2.15-25. Main Landing Gear Installation (Sheet 3 of 4)

FIGURE AND INDEX NUMBER	PART NUMBER	DESCRIPTION	UNITS PER ASSY.	USABLE ON CODE	
				FROM	TO
		1 2 3 4 5 6			
2.15-25- 30	8-51152-7 8-51155-7	• CAM, SAFETY SWITCH LH • CAM, SAFETY SWITCH LH ALT INTCHG WITH 8-51152-7	1 RF	35 35	
	8-51152-R 8-51155-R	• CAM, SAFETY SWITCH RH • CAM, SAFETY SWITCH RH ALT INTCHG WITH 8-51152-R	1 RF	35 35	
- 31	NAS679A3	• NUT	2	35	
- 32	AN960PD10L	• WASHER	4	35	
- 33	AN3-5A	• BOLT	2	35	
		-----X-----			
- 34	NAS679A08	• NUT, 96-37545-001	1	35	
- 35	AN960D8	• WASHER	1	35	
- 36	8-68032-7 8-65262	• BOLT • ARM ASSY, SAFETY SWITCH ATTACHING PARTS	1 1	35 35	
- 37	NAS679A3	• NUT, 96-37545-002	1	35	
- 38	AN960PD10L	• WASHER	1	35	
- 39	AN3-7A	• BOLT	1	35	
		-----Y-----			
- 40	8-68751-7	• STUD	1	35	
- 41	8-68852-7	• ROLLER	1	35	
- 42	8-65262-7	• ARM	1	35	
- 43	812742	• PLATE, <97198> SPEC 8-06989-7	1	35	
- 44	69C37529-1	• SWITCH, SAFETY <97198> SPEC 8-06983-80*	1	35	
		ATTACHING PARTS			
- 45	NAS679A3	• NUT	3	35	
- 46	AN960PD10L	• WASHER	3	35	
- 47	AN3-15A	• BOLT	3	35	
		-----X-----			
- 48	8-51153-9	• BRACKET ATTACHING PARTS	1	35	
- 49	NAS679A3	• NUT	2	35	
- 50	AN960PD10L	• WASHER	4	35	
- 51	AN3-5A	• BOLT	2	35	
- 52	NAS679A3	• NUT	RF	35	
- 53	AN960PD10L	• WASHER	RF	35	
- 54	AN3-11A	• BOLT	RF	35	
		-----X-----			
- 55	5391-2	• LOCK	RF	35	
		1 FURNISHED WITH SHOCK STRUT PART NO. 578102-50			

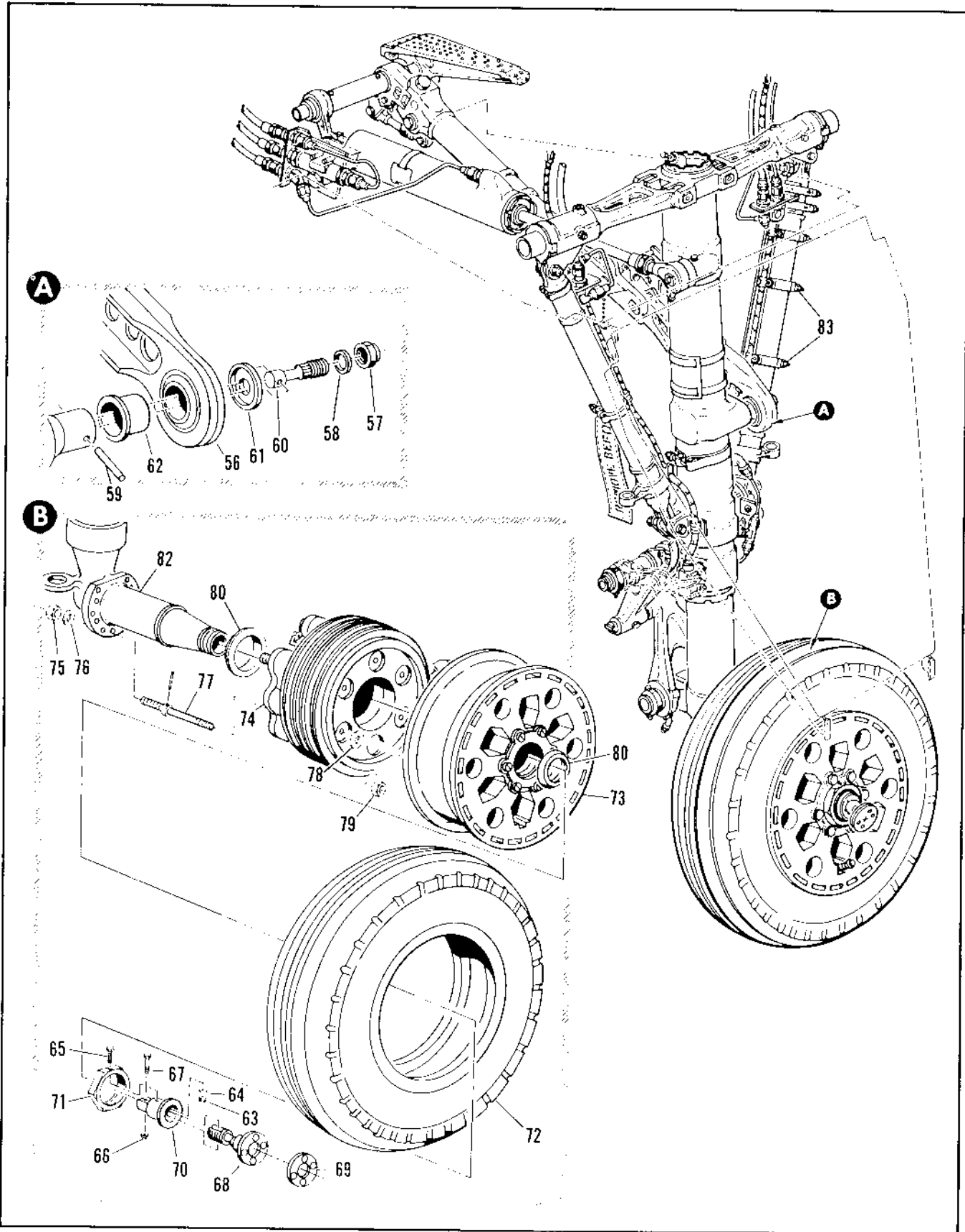

Figure 2.15-25. Main Landing Gear Installation (Sheet 4 of 4)

FIGURE AND INDEX NUMBER	PART NUMBER	DESCRIPTION	UNITS PER ASSY.	USABLE ON CODE	
				FROM	TO
2.15-25- 56	578350-501	• SIDE STRUT, MLG <39661> SPEC 8-05312-19 T.O. 4S1-32-14 ATTACHING PARTS	1	35	
- 57	AN364-918C	*1 • NUT	RF	35	
- 58	AN960-916	*1 • WASHER	RF	35	
- 59	578153-1	*1 • PIN	RF	35	
- 60	578152-1	*1 • STUD	RF	35	
- 61	578155-1	*1 • RETAINER	RF	35	
- 62	578154-1	*1 • BUSHING	RF	35	
		-----X-----			
	8-44548	• BUMPER INSTL, MLG	1	35	
- 63	NAS679A4	• • NUT	1	35	
- 64	AN960D416	• • WASHER	1	35	
- 65	AN4-11A	• • BOLT	1	35	
- 66	NAS679A3	• • NUT	1	35	
- 67	AN3-16A	• • BOLT	1	35	
- 68	8-44549	• • BUMPER ASSY, MLG SWAGED	1	35	
- 69	8-44551	• • PLATE	1	35	
- 70	8-44553	• • FITTING	1	35	
- 71	578179-1	*1 • NUT	RF	35	
- 72	60090767	• TIRE, MLG	1	35	
- 73	63J32425-5	• WHEEL, MLG (98747) T.O. 4W1-7-1173 GFAE	1	35	
- 74	151806-1	• BRAKE, MLG T.O. 4B1-4-223 ATTACHING PARTS	1	35	
- 75	MS21045-7	*3 • NUT, SELF-LOCKING, HEX	RF	35	
- 76	AN960-716	*3 • WASHER, FLAT	RF	35	
- 77	150467	*3 • BOLT AND PIN ASSY	8	35	
- 78	NAS42HY12-8	*3 • WASHER	RF	35	
- 79	22FT624	*3 • NUT, SELF-LOCKING, HEX	RF	35	
		-----X-----			
- 80	578180-1	*1 • SPACER	RF	35	
- 81	578181-1	*1 • SPACER	RF	35	
- 82	578100-505	• SHOCK STRUT, MLG (39661) SPEC 8-05312-15 T.O. 4S1-32-24	1	35	
- 83	21675-2150-2	• CLAMP	6	35	
		*1 FURNISHED WITH SHOCK STRUT PART NO. 578100-505			
		*3 FURNISHED WITH BRAKE ASSY.			

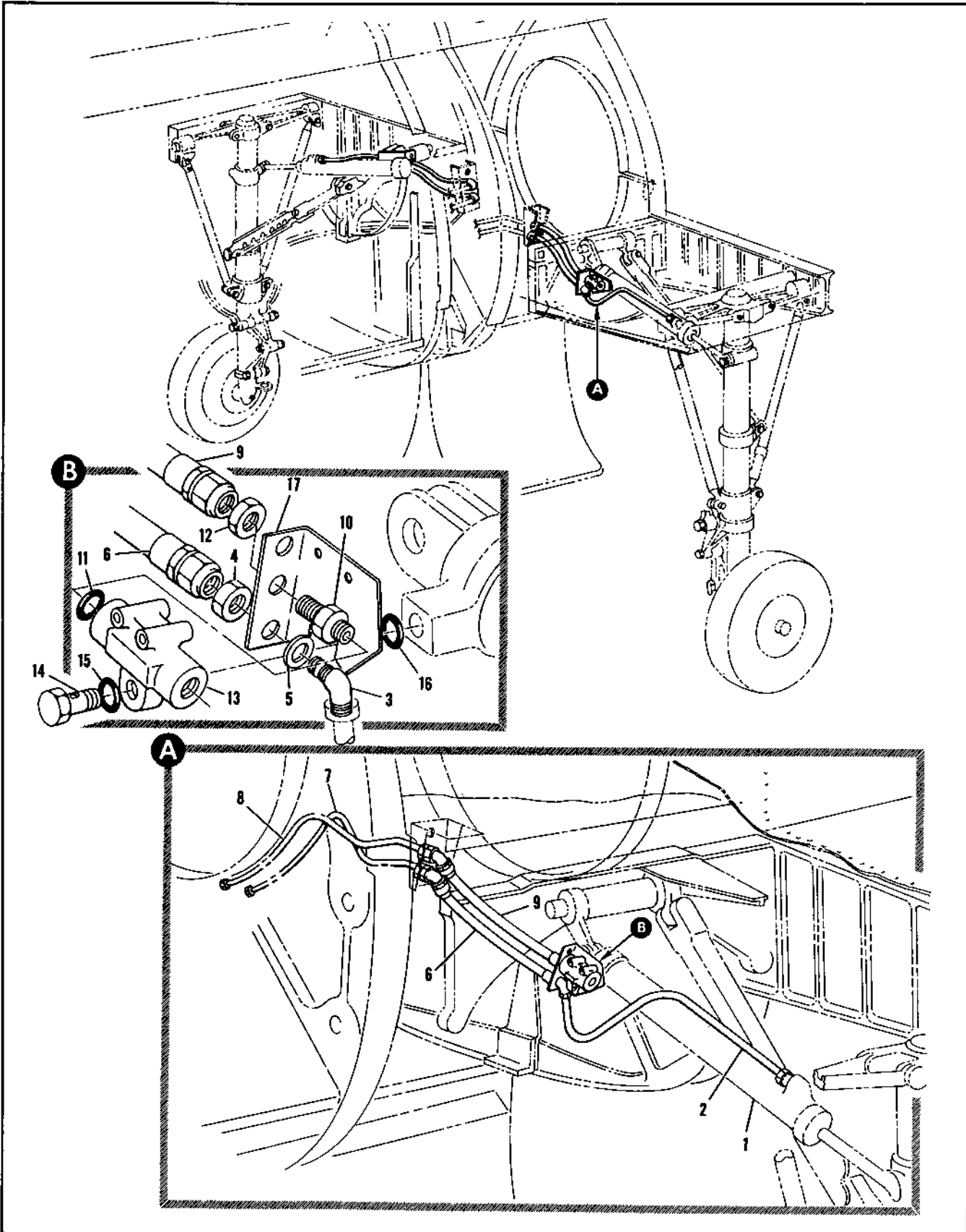

Figure 2.15-26. Main Landing Gear Hydraulic Actuator Tubing Installation (Sheet 1 of 2)

FIGURE AND INDEX NUMBER	PART NUMBER	DESCRIPTION	UNITS PER ASSY.	USABLE ON CODE	
				FROM	TO
		1 2 3 4 5 6			
2.15-26	R-80031-1	TUBING INSTALLATION, MAIN LANDING GEAR ACTUATOR HYDRAULIC LH MODIFIED BY R-80133 FOR NHA SEE FIG. 2.15-25	RF	A	
	R-80031-2	TUBING INSTALLATION, MAIN LANDING GEAR ACTUATOR HYDRAULIC LH FOR NHA SEE FIG. 2.6-32	RF	49	77
	R-80031-3	TUBING INSTALLATION, MAIN LANDING GEAR ACTUATOR HYDRAULIC RH MODIFIED BY R-80133 FOR NHA SEE FIG. 2.15-25	RF	A	
	R-80031-817	TUBING INSTALLATION, MAIN LANDING GEAR ACTUATOR HYDRAULIC RH FOR NHA SEE FIG. 2.6-32	RF	49	77
- 1		• ACTUATOR ASSY, MLG SEE FIG. 2.15-25 INDEX 21	RF		
- 2	R-80031-197	• TUBE ASSY, LH	1	35	48
	R-80031-199	• TUBE ASSY, RH	1	35	48
	R-80031-399	• TUBE ASSEMBLY	1	39	48
- 3	MS21967D6	• ELBOW	1	35	48
- 4	AN924-6D	• NUT	1	35	48
- 5	AN960D916L	• WASHER	1	35	48
- 6	CR295800CC6-0142	• HOSE ASSY, <50599> SPEC R-10090-141	1	35	48
- 7		• TUBE ASSY, SEE FIG. 2.6-16 INDEX 15	RF		
- 8		• TUBE ASSY, SEE FIG. 2.6-16 INDEX 7	RF		
- 9	CR295800CC6-0142	• HOSE ASSY, <50599> SPEC R-10090-141	1	35	48
- 10	MS21903D6	• UNION	1	35	48
- 11	MS28778-6	• GASKET	1	35	48
- 12	AN924-6D	• NUT	1	35	48
- 13	52676	• VALVE ASSY, SHUTTLE <00512> SPEC R-00363 T.O. 9HR-5-50-13 ATTACHING PARTS	1	35	48
- 14	R-84207-7	• BOLT	1	35	48
	R-84207-8	• BOLT -----X-----	RF		
- 15	MS28775-110	• PACKING	1	35	48
- 16	MS28778-6	• GASKET	1	35	48
	MS28775-111	• GASKET	RF		
- 17	R-80031-857	• BRACKET	1	35	48
	R-80031-859	• BRACKET	1	39	48
A AIRPLANES #35 THRU 48, 27- AND ON					
*1 USE IN CYLINDER MODIFIED WITH HELICOIL INSERT IN DOWN PORT.					

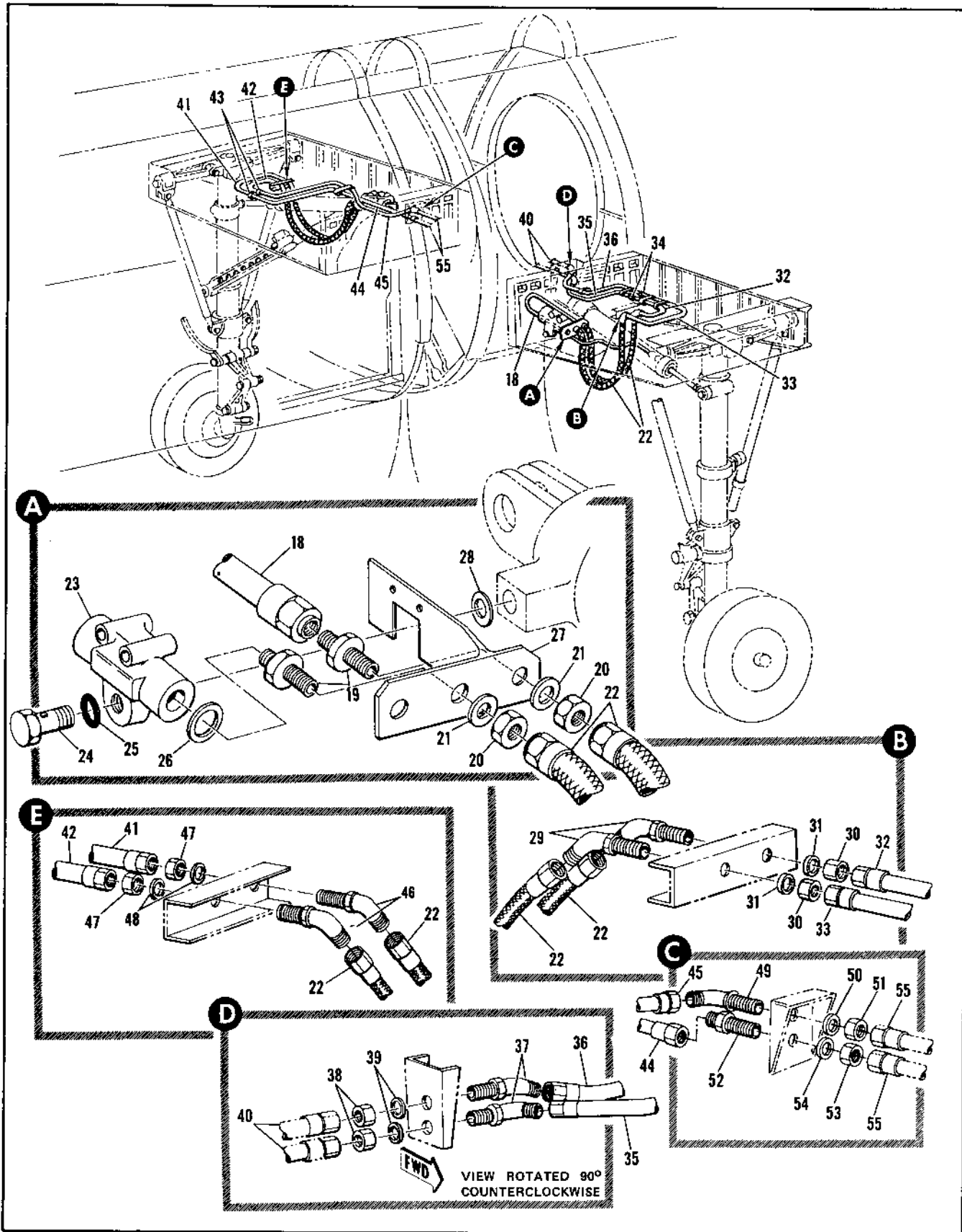

Figure 2.15-26. Main Landing Gear Hydraulic Actuator Tubing Installation (Sheet 2 of 2)

FIGURE AND INDEX NUMBER	PART NUMBER	DESCRIPTION	UNITS PER ASSY.	USABLE ON CODE	
				FROM	TO
		1 2 3 4 5 6			
2.15-06- 18	R-80031-409	• TUBE ASSEMBLY	1	49	
- 19	MS2190306	• UNION	2	49	
- 20	AN924-60	• NUT	2	49	
- 21	AN9610916	• WASHER	2	49	
- 22	CR295840006-0142	• HOSE ASSY, <0599> SPEC 8-19599-141	2	49	
- 23	52676	• VALVE ASSY, SHUTTLE <0512> SPEC 8-00103 T.O. RHB-5-50-13 ATTACHING PARTS	1	49	
- 24	R-84207-7	• BOLT	1	49	
	R-84207-8 *1	• BOLT	RF		
		-----X-----			
- 25	MS28775-4115	• PACKING	1	49	
- 26	MS28776-6	• GASKET	1	49	
- 27	B-69113-241	• BRACKET	1	49	
- 28	MS28778-4	• GASKET	1	49	
	MS28775-111 *1	• GASKET	RF		
- 29	MS2190706	• ELBOW, LH	2	49	
- 30	AN924-60	• NUT, LH	2		
- 31	AN9600916	• WASHER, LH	2	49	
- 32	R-80031-415	• TUBE ASSY, LH	1	49	129
	R-85031-595	• TUBE ASSY, LH	1	130	
- 33	R-80031-411	• TUBE ASSY, LH	1	49	129
	S-81151-593	• TUBE ASSY, LH	1	130	
- 34	MS2190306	• UNION, LH	2	49	
- 35	R-80031-409	• TUBE ASSY, LH	1	49	
- 36	R-80031-413	• TUBE ASSY, LH	1	49	
- 37	MS2190706	• ELBOW, LH	2	49	
- 38	AN924-60	• NUT, LH	2	49	
- 39	AN9600916	• WASHER, LH	2	49	
- 40		• TUBE ASSY, SEE FIG. 2.4-15 INDEX 7 AND 2.8-16 INDEX 15	RF		
- 41	R-80031-569	• TUBE ASSY, RH	1	49	
- 42	R-80031-565	• TUBE ASSY, RH	1	49	
- 43	MS2190206	• UNION, RH	2	49	
- 44	R-80031-567	• TUBE ASSY, RH	1	49	
- 45	R-80031-563	• TUBE ASSY, RH	1	49	
- 46	MS2190706	• ELBOW, RH	2	49	
- 47	AN924-60	• NUT, RH	2	49	
- 48	AN9600916	• WASHER, RH	2	49	
- 49	MS2190706	• ELBOW, RH	1	49	
- 50	AN924-60	• NUT, RH	1	49	
- 51	AN9610916	• WASHER, RH	1	49	
- 52	MS2190306	• UNION, RH	1	49	
- 53	AN924-60	• NUT, RH	1	49	
- 54	AN9600916	• WASHER, RH	1	49	
- 55		• TUBE ASSY, SEE FIG. 2.4-15 INDEX 4A AND 2.8-16 INDEX 55	RF		
		*1 USE IN CYLINDER MODIFIED WITH HELICOIL INSERT IN DOWN PORT			

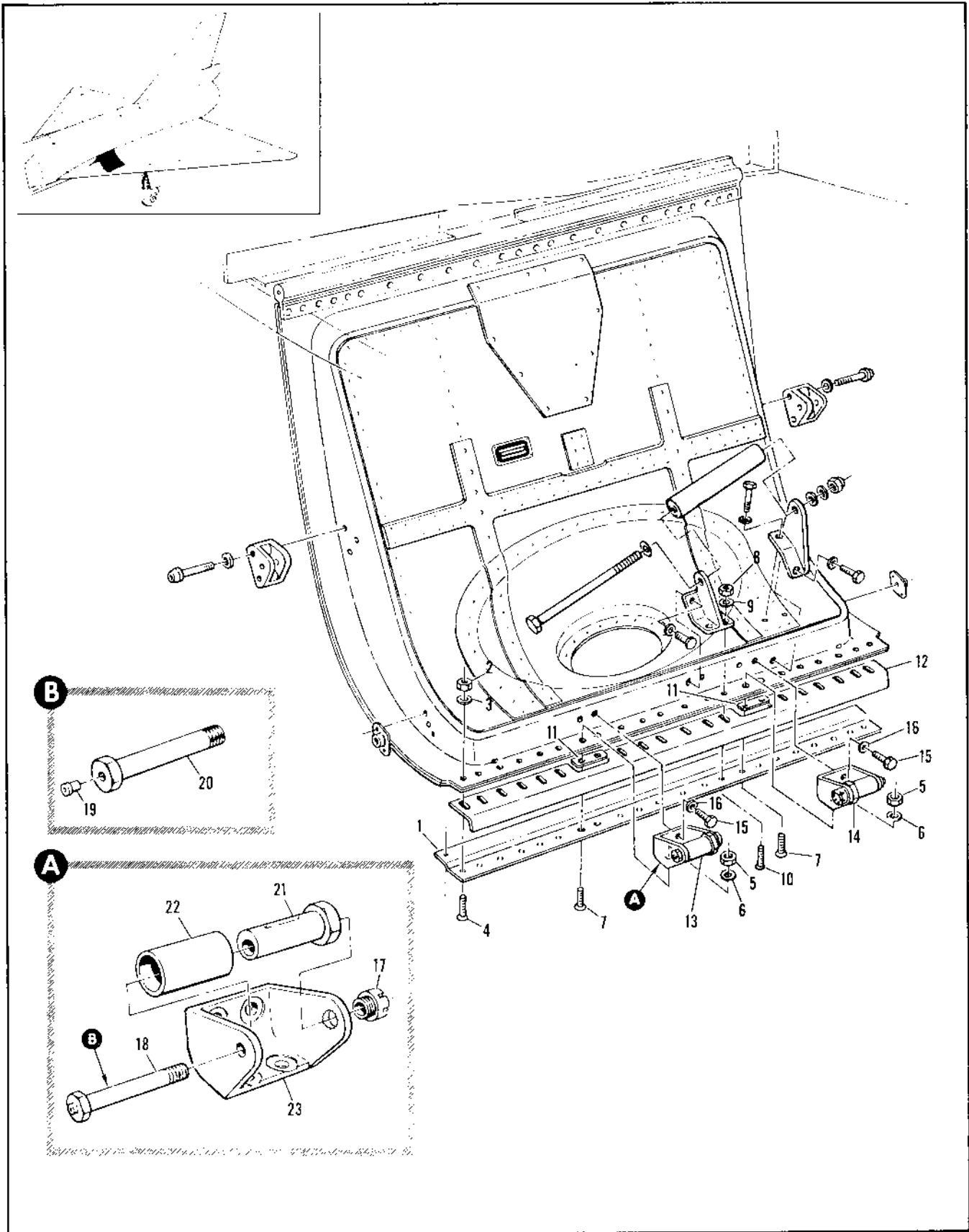

Figure 2.15-27. Main Landing Gear Door Assembly (Sheet 1 of 2)

FIGURE AND INDEX NUMBER	PART NUMBER	DESCRIPTION	UNITS PER ASSY.	USABLE ON CODE		
				FROM	TO	
2.15-27	8-44545-155	DOOR ASSEMBLY, MAIN LANDING GEAR LH FOR NHA SEE FIG. 2.15-33	WF	35		
	8-44545-156	DOOR ASSEMBLY, MAIN LANDING GEAR RH FOR NHA SEE FIG. 2.15-33	WF	35		
	- 1	8-44545-153 8-44545-154	• STRIP, LH • STRIP, RH ATTACHING PARTS	1 1	35 35	
	- 2	NAS479A3	• NUT	16	35	
	- 3	AN960D10L	• WASHER	18	35	
	- 4	AN509-10R10	• SCREW	18	35	
	- 5	NAS479A4	• NUT	4	35	
	- 6	AN960D416L	• WASHER	4	35	
	- 7	AN509-416R12	• SCREW	4	35	
	- 8	NAS479A3	• NUT	2	35	
	- 9	AN960D10L	• WASHER	2	35	
	- 10	AN509-10R12	• SCREW	2	35	
			-----X-----			
	- 11	8-44545-149	• SPACER	2	35	
	- 12	8-44545-151 8-44545-167 8-44545-152 8-44545-168	• ANGLE, LH • ANGLE, LH • ANGLE, RH • ANGLE, RH	1 1 1 1	35 35 35 35	89 89
	- 13	8-44556-4	• SUPPORT ASSY, FAIRING STA 443	1	35	
	- 14	8-44556-3	• SUPPORT ASSY, FAIRING STA 459 ATTACHING PARTS	1	35	
	- 15	AN4-6A	• BOLT	4	35	
	- 16	AN960D416L	• WASHER	4	35	
			-----X-----			
	- 17	8-44532	• NUT	1	35	
	- 18	8-44523	• BOLT ASSEMBLY	1	35	
	- 19	NAS516-1	• FITTING	1	35	
- 20	8-44523-7	• BOLT	1	35		
- 21	8-44522	• BUSHING	1	35		
- 22	8-44525	• ROLLER	1	35		
- 23	8-44563-14 8-44575-10	• SUPPORT, STA 443 FAIRING • SUPPORT, STA 443 FAIRING ALT INTERG WITH 8-44563-14	1 1	35 35		
	8-44563-13 8-44575-9	• SUPPORT, STA 459 FAIRING • SUPPORT, STA 459 FAIRING ALT INTERG WITH 8-44563-13	1 1	35 35		

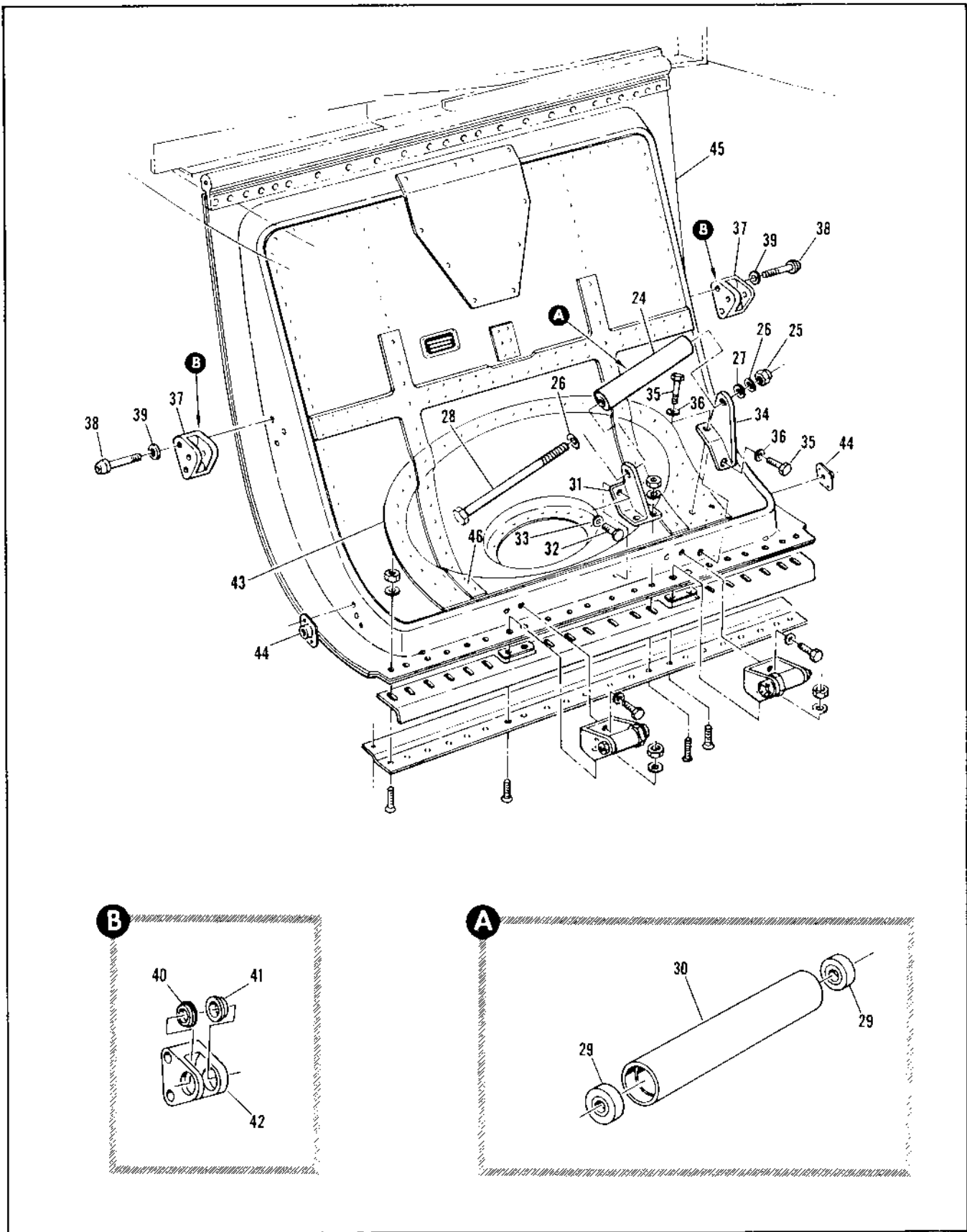

Figure 2.15-27. Main Landing Gear Door Assembly (Sheet 2 of 2)

FIGURE AND INDEX NUMBER	PART NUMBER	DESCRIPTION	UNITS PER ASSY.	USABLE ON CODE	
				FROM	TO
		1 2 3 4 5 6			
2.15-27- 24	R-44554	• ROLLER ASSEMBLY ATTACHING PARTS	1	35	
- 25	AN318-4	• NUT	1	35	
- 26	AN961041FL	• WASHER	2	35	
- 27	AN961041G	• WASHER	1	35	
- 28	AN4-75	• BOLT	1	35	
		-----X-----			
- 29	AN200KP4	• BEARING	2	35	
- 30	R-44558-7	• TUBE	1	35	
- 31	R-44561-5	• SUPPORT, FWD ROLLER M/G DOOR LH	1	35	
	R-44577-7	• SUPPORT, FWD ROLLER M/G DOOR LH ALT INTCHG WITH R-44561-5	RF	35	
	R-44561-10	• SUPPORT, FWD ROLLER M/G DOOR RH	1	35	
	R-44577-8	• SUPPORT, FWD ROLLER M/G DOOR RH ALT INTCHG WITH R-44561-10	RF	35	
		ATTACHING PARTS			
- 32	AN3-5A	• BOLT	2	35	
- 33	AN961010L	• WASHER	2	35	
		-----X-----			
- 34	R-44562-7	• SUPPORT, AFT ROLLER M/G DOOR LH	1	35	
	R-44576-7	• SUPPORT, AFT ROLLER M/G DOOR LH ALT INTCHG WITH R-44562-7	RF	35	
	R-44562-10	• SUPPORT, AFT ROLLER M/G DOOR RH	1	35	
	R-44576-8	• SUPPORT, AFT ROLLER M/G DOOR RH ALT INTCHG WITH R-44562-10	RF	35	
		ATTACHING PARTS			
- 35	AN3-5A	• BOLT	3	35	
- 36	AN960010L	• WASHER	3	35	
		-----X-----			
- 37	R-44554-1	• SUPPORT ASSY, M/G DOOR MECHANISM	2	35	
	R-44579	• SUPPORT ASSY, M/G DOOR MECHANISM ALT INTCHG WITH R-44554-1	RF	35	
		ATTACHING PARTS			
- 38	MS20024-22	• BOLT	4	35	
- 39	MS2002024	• WASHER	4	35	
		-----X-----			
- 40	R-44554-9	• BUSHING, ALTERED FROM NAS77-6-14	1	35	
- 41	R-44554-11	• BUSHING, ALTERED FROM NAS77-6-27	1	35	
- 42	R-44554-7	• SUPPORT	1	35	
- 43	R-44545-101	• PAN, LH	1	35	
	R-44545-102	• PAN, RH	1	35	
- 44	R-44578	• SUPPORT	2	35	
- 45	R-44545-56	• DOOR ASSY, M/G LH RIVETED	1	35	
	R-44545-56	• DOOR ASSY, M/G RH RIVETED	1	35	
- 46	R-44545-55	• PLATE, LH	1	35	
	R-44545-11	• PLATE, RH	1	35	

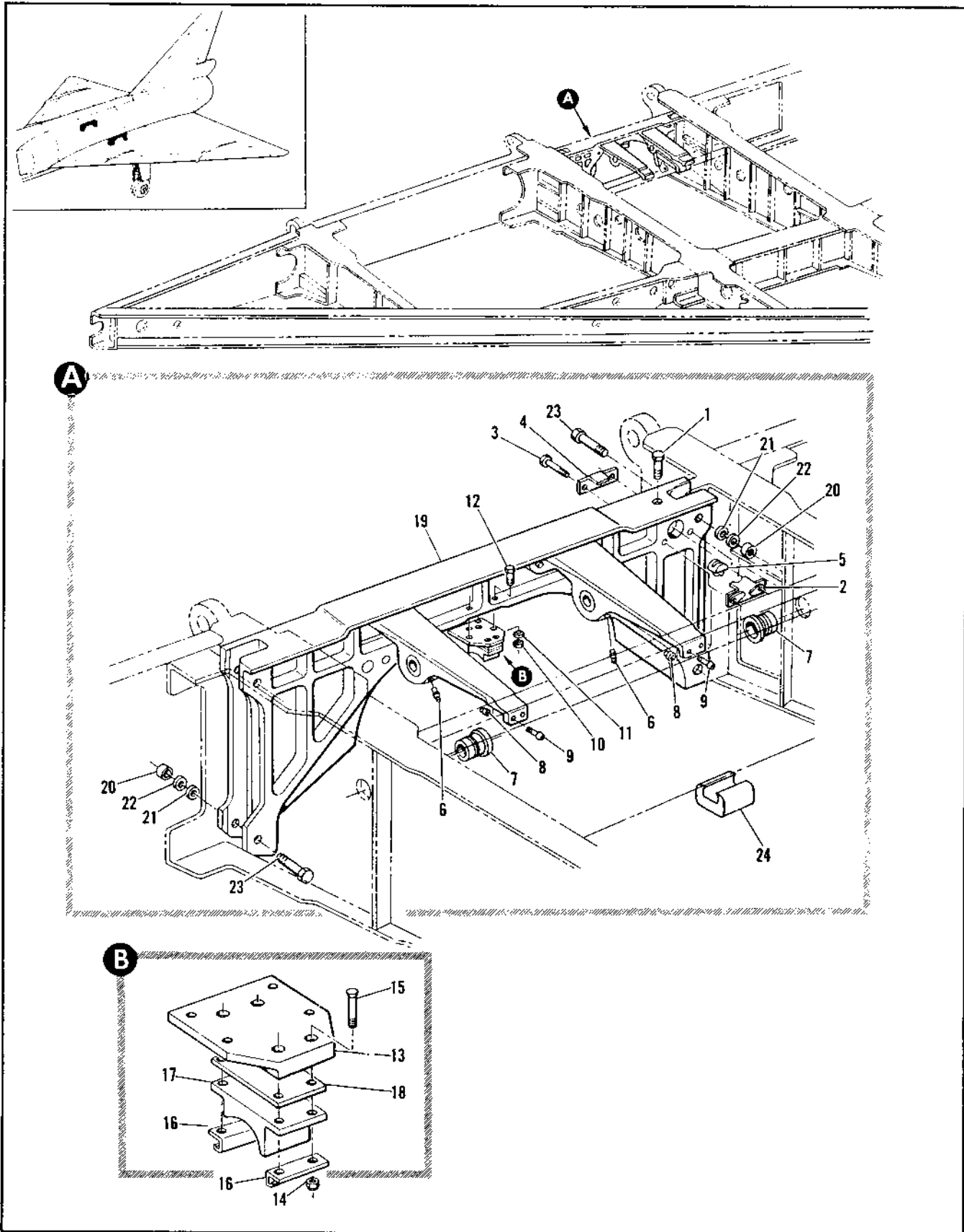

Figure 2.15-28. Main Landing Gear Fitting Installation BL 38

FIGURE AND INDEX NUMBER	PART NUMBER	DESCRIPTION 1 2 3 4 5 6	UNITS PER ASSY.	USABLE ON CODE	
				FROM	TO
2.15-28	8-18320-1	FITTING INSTALLATION, MAIN LANDING GEAR PL 39 LH FOR NHA SEE FIG. 2.6-39	RF	35	
	8-18320-2	FITTING INSTALLATION, MAIN LANDING GEAR BL 38 RH FOR NHA SEE FIG. 2.6-39	RF	35	
- 1	8-18935	• BOLT, AFT ACFT HOIST <PLUG>	1	35	
- 2	8-18320-11	• BRACKET ASSY, HOIST BOLT RETAINER RIVETED ATTACHING PARTS	1	35	
- 3	NAS221-9	• SCREW -----X-----	2	35	
- 4	8-18320-13	• BRACKET	1	35	
- 5	2452-126	• NUT, <72962> 96-37509-178	1	35	
- 6	MS15001-1	• FITTING	2	35	
- 7	8-16512-7	• BUSHING, REPLACED BY INTCHO WITH 8-16512-9	2	35	159
	8-16512-9	• BUSHING, REPLACES INTCHO WITH 8-16512-7	2	169	
- 8	LC-06	• COLLAR, <29666> 92-17000-001	4	35	
- 9	ALPHH-16-7	• LOCKBOLT, <29666> 96-79002-606	4	35	
	8-51114	• STOP INSTL, MAIN LANDING GEAR BUMPER	1	35	
- 10	NAS679A3	• NUT	4	35	
- 11	AN961-10L	• WASHER	4	35	
- 12	AN3-5A	• BOLT	4	35	
- 13	8-51139	• PLATE ATTACHING PARTS	1	35	
- 14	NAS679A3	• NUT	4	35	
- 15	AN509-10R16	• SCREW -----Y-----	4	35	
- 16	8-51143	• CLIP	2	35	
- 17	8-51138-7	• PAD, BUMPER, SHOCK STRUT	1	35	
- 18	8-51140	• SHIM	AR	35	
- 19	8-18320-7	• FITTING ASSY, MAIN LANDING GEAR BL 38 LH FOR BREAKDOWN SEE FIG. 2.15-29	1	35	
	8-18320-9	• FITTING ASSY, MAIN LANDING GEAR BL 38 RH FOR BREAKDOWN SEE FIG. 2.15-29 ATTACHING PARTS	1	35	
- 20	AN320-10	• NUT	4	35	
- 21	AN961-101F	• WASHER	4	35	
- 22	AN961-1010L	• WASHER	AR	35	
- 23	NAS494-10-73	• BOLT	4	35	
- 24	8-51134	• BUMPER, MLG SIDE BRACE -----X-----	1	35	

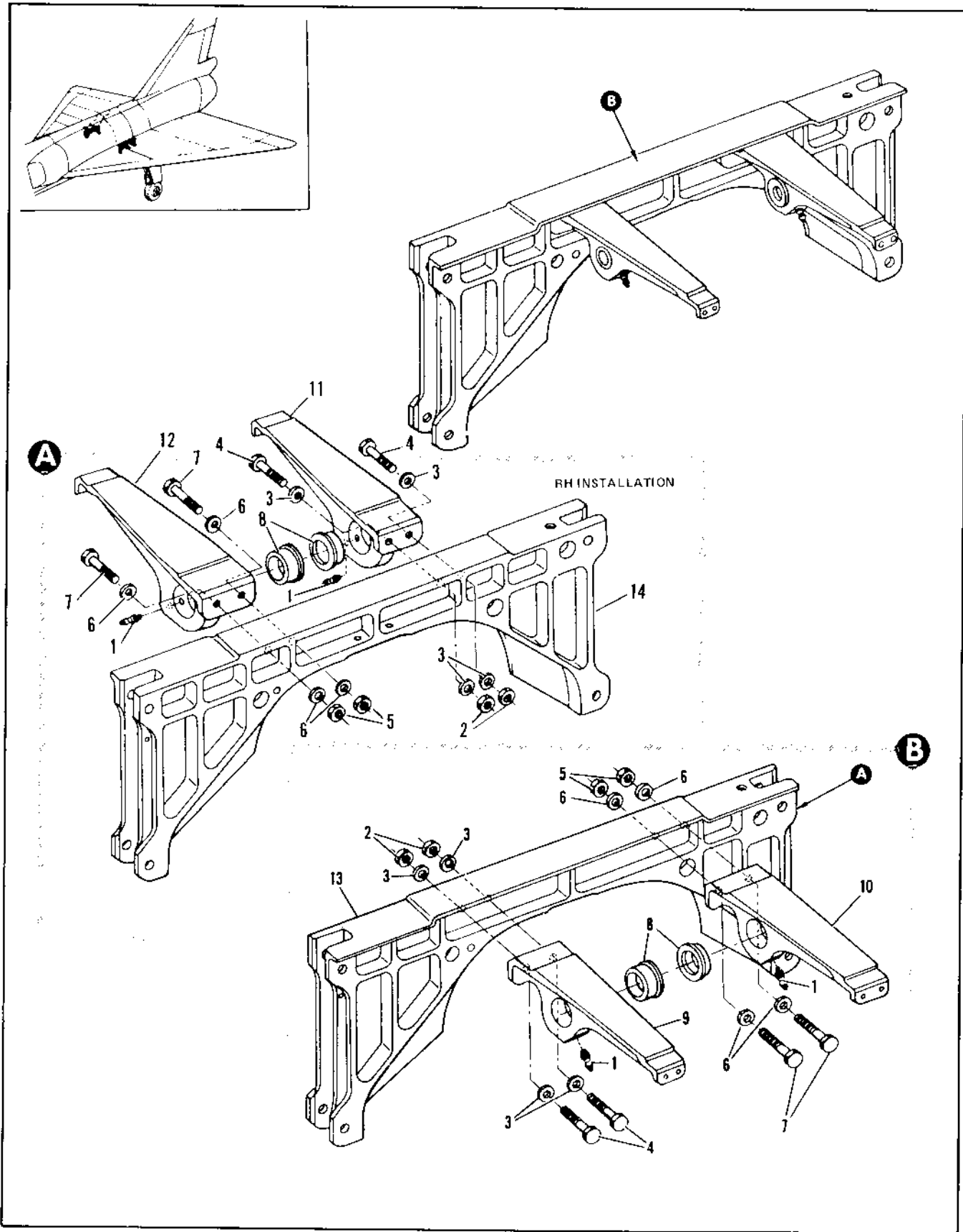

Figure 2.15-29. Main Landing Gear Fitting Assembly BL 38

FIGURE AND INDEX NUMBER	PART NUMBER	DESCRIPTION	UNITS PER ASSY.	USABLE ON CODE		
				FROM	TO	
2.15-29	8-18320-7	FITTING ASSEMBLY, MLG BL 38 LH FOR NHA SEE FIG. 2.15-28	RF	35		
	8-18320-9	FITTING ASSEMBLY, MLG BL 38 RH FOR NHA SEE FIG. 2.15-28	RF	35		
	- 1	MS15001-1	• LUBRICATOR	2	35	
		8-18814-1	• SUPPORT ASSY, MLG SIDE BRACE FWD LH	1	35	
		8-18724-1	• SUPPORT ASSY, MLG SIDE BRACE FWD LH ALT INTCHG WITH AND REPLACES 8-18814-1	RF	35	
		8-18815-1	• SUPPORT ASSY, MLG SIDE BRACE AFT LH	1	35	
		8-18724	• SUPPORT ASSY, MLG SIDE BRACE AFT LH ALT INTCHG WITH AND REPLACES 8-18815-1	RF	35	
		8-18814-3	• SUPPORT ASSY, MLG SIDE BRACE AFT RH	1	35	
		8-18724-3	• SUPPORT ASSY, MLG SIDE BRACE AFT RH ALT INTCHG WITH AND REPLACES 8-18814-3	RF	35	
		8-18815-3	• SUPPORT ASSY, MLG SIDE BRACE FWD RH	1	35	
		8-18724-5	• SUPPORT ASSY, MLG SIDE BRACE FWD RH ALT INTCHG WITH AND REPLACES 8-18815-3	RF	35	
			ATTACHING PARTS			
	- 2	NAS679A7	• NUT	2	35	
	- 3	AN960-716L	• WASHER	4	35	
- 4	NAS464-7A10	• BOLT	2	35		
	NAS464-7A12	• BOLT, FOR USE WITH SUPPORT ASSY, P/NS 8-18724-1 AND -3	2	35		
- 5	NAS1022A8	• NUT	2	35		
- 6	AN960-816L	• WASHER	4	35		
- 7	NAS464-8A10	• BOLT	2	35		
	NAS464-8A12	• BOLT, FOR USE WITH SUPPORT ASSY, P/NS 8-18724 AND -5	2	35		
		-----X-----				
- 8	8-16511	• BUSHING	1	35		
- 9	8-18814-11	• SUPPORT, FWD LH	1	35		
	8-18724-11	• SUPPORT, FWD LH	RF	35		
	8-18724-19	• SUPPORT, FWD LH ALT INTCHG AND REPLACES 8-18724-11 AND 8-18814-11	RF	35		
- 10	8-18815-11	• SUPPORT, AFT LH	1	35		
	8-18724-15	• SUPPORT, AFT LH	RF	35		
	8-18724-23	• SUPPORT, AFT LH ALT INTCHG AND REPLACES 8-18724-15 AND 8-18815-11	RF	35		
- 11	8-18814-13	• SUPPORT, AFT RH	1	35		
	8-18724-13	• SUPPORT, AFT RH	RF	35		
	8-18724-21	• SUPPORT, AFT RH ALT INTCHG AND REPLACES 8-18724-13 AND 8-18814-13	RF	35		
- 12	8-18815-13	• SUPPORT, FWD RH	1	35		
	8-18724-17	• SUPPORT, FWD RH	RF	35		
	8-19724-25	• SUPPORT, FWD RH ALT INTCHG AND REPLACES 8-18724-17 AND 8-18815-13	RF	35		
- 13	8-18811-11	• FITTING, MLG BRIDGE LH	1	35		
	8-18711-7	• FITTING, MLG BRIDGE LH ALT INTCHG WITH 8-18811-11	RF	35		
- 14	8-18811-12	• FITTING, MLG BRIDGE RH	1	35		
	8-18711-8	• FITTING, MLG BRIDGE RH ALT INTCHG WITH 8-18811-12	RF	35		

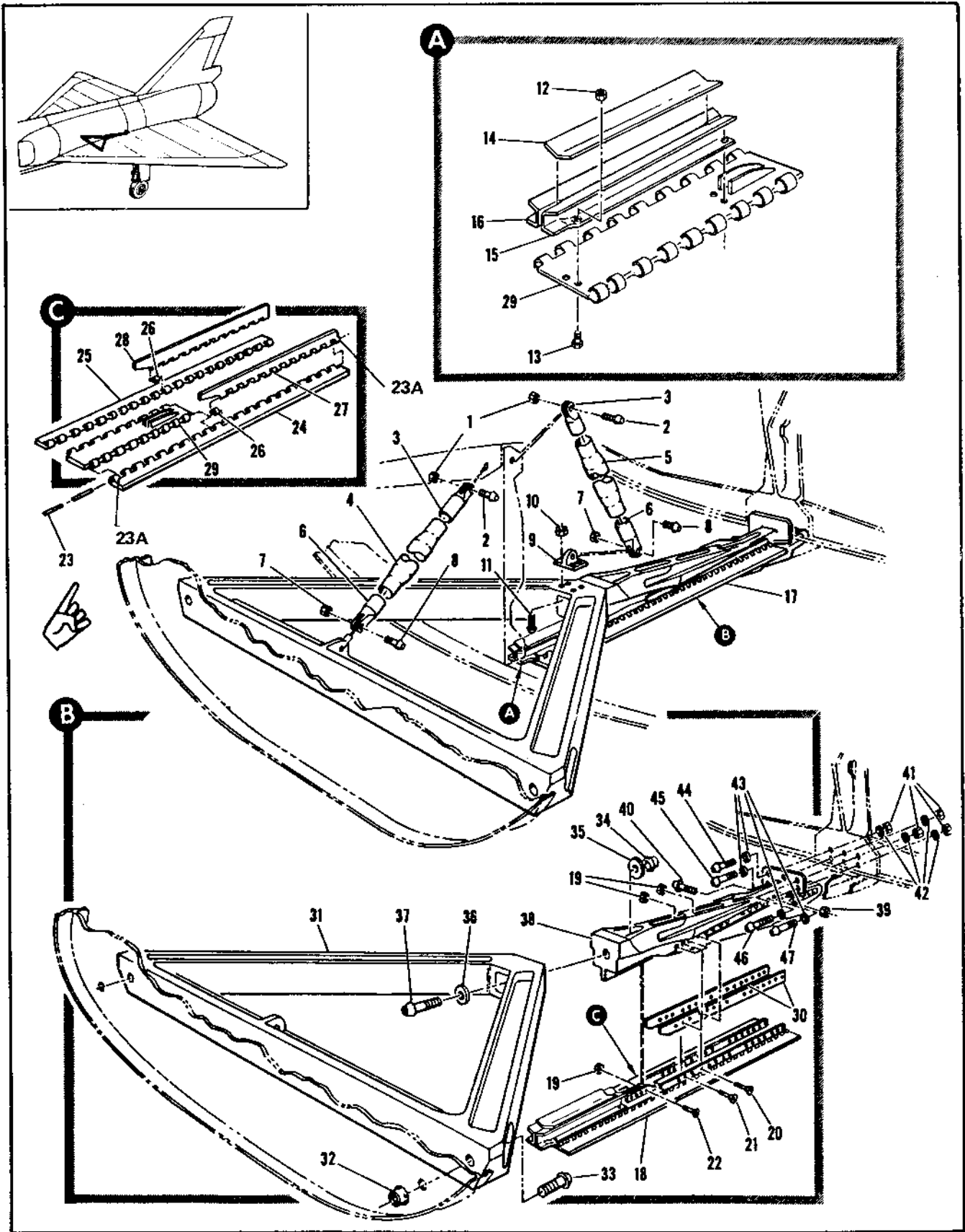

Figure 2.15-30. Lower Longeron Installation Sta 412 to 472

FIGURE AND INDEX NUMBER	PART NUMBER	DESCRIPTION	UNITS PER ASSY.	USABLE ON CODE	
				FROM	TO
		1 2 3 4 5 6			
2.15-30	8-74191-1	LONGERON INSTALLATION, LOWER STA 412 TO 472 FOR NHA SEE FIG. 2.3-10	RF	35	60
	8-74155-3	• BRACE ASSY, FWD	1	35	60
	8-74155-1	• BRACE ASSY, AFT	1	35	60
		ATTACHING PARTS			
- 1	FN22M524	• NUT, <75237> 96-37612-002	2	35	60
- 2	MS20005-12	• BOLT	2	35	60
		----X----			
- 3	8-74187	• CLEVIS	1	35	60
- 4	8-74188-9	• BRACE, FWD	1	35	60
- 5	8-74188-7	• BRACE, AFT	1	35	60
- 6	8-74187	• CLEVIS	2	35	60
		ATTACHING PARTS			
- 7	FN22M524	• NUT, <75237> 96-37612-002	2	35	60
- 8	MS20005-14	• BOLT	2	35	60
		----X----			
- 9	8-77526	• SUPPORT	1	35	60
		ATTACHING PARTS			
- 10	FN22M428	• NUT, <75237> 96-37612-001	4	35	60
- 11	MS20004-12	• BOLT	4	35	60
		----X----			
- 12	NAS679A3	• NUT	24	35	60
- 13	NAS333PA5	• SCREW	24	35	60
	8-42541-7	• SUPPORT, LOWER LONGERON STA 472	1	35	60
- 14	8-74191-11	• PLATE	1	35	60
- 15	8-74191-9	• CHANNEL, LOWER LONGERON STA 412 TO 472 LH	1	35	60
- 16	8-74191-10	• CHANNEL, LOWER LONGERON STA 412 TO 472 RH	1	35	60
- 17	8-74191-21	• LONGERON ASSY, LOWER	1	35	60
- 18	8-74793-1	• HINGE ASSY, MLG DOOR	1	35	60
		ATTACHING PARTS			
- 19	NAS679A3	• NUT	03	403	506 3
- 20	NAS333PA7	• SCREW	24	35	60
- 21	NAS333PA7-5	• SCREW	6	35	60
- 22	NAS464-3A8	• SCREW	4	35	60
		----X----			
- 23	AN253-4-3713	• PIN	2	35	60
- 23A	MS20426AD3-8	• HINGE, PIN LOCK	2	35	60
- 24	8-74793-45	• HINGE, HALF LH	1	35	60
- 25	8-74793-46	• HINGE, HALF RH	1	35	60
- 26	8-74793-13	• SPACER	2	35	60
- 27	8-74793-27	• PLATE, HINGE LH REPLACED BY NOT INTCHG WITH 8-74793-31	1	35	60
- 28	8-74793-28	• PLATE, HINGE RH REPLACED BY NOT INTCHG WITH 8-74793-32	1	35	60
- 29	8-74793-21	• PLATE, HINGE REPLACED BY NOT INTCHG WITH 8-74793-33, 8-74793-34, 8-74793-39 AND 8-74793-40	1	35	60
- 30	8-77531-7	• SHIM, REPLACED BY NOT INTCHG WITH 8-77191-9	2	35	60
- 31	8-74190	• LONGERON, STA 412 TO 443	1	35	60
		ATTACHING PARTS			
- 32	42FW1018	• NUT, <56878> 96-37510-008	2	35	60
- 33	MS20012-26	• BOLT	2	35	60
- 34	42FW1614	• NUT, <56878> 96-37510-010	1	35	60
- 35	MS20002C16	• WASHER	1	35	60
- 36	MS20002-16	• WASHER	1	35	60
- 37	MS20016-34	• BOLT	1	35	60
		----X----			
- 38	8-74111-9	• LONGERON, STA 443 TO 472	1	35	60
		REPLACED BY NOT INTCHG WITH 8-74132-13			
		ATTACHING PARTS			
- 39	AN320-8	• NUT	7	35	60
- 40	8-74742	• BOLT (MAKE FROM NAS464PBA22)	7	35	60
- 41	FN22M624	• NUT, <75237> 96-37612-003	6	35	60
- 42	MS20002-6	• WASHER	6	35	60
- 43	MS20002C6	• WASHER	6	35	60
- 44	MS20006-24	• BOLT	2	35	60
- 45	MS20006-24	• BOLT	2	35	60
- 46	MS20006-28	• BOLT	1	35	60
- 47	MS20006-28	• BOLT	1	35	60
		----X----			

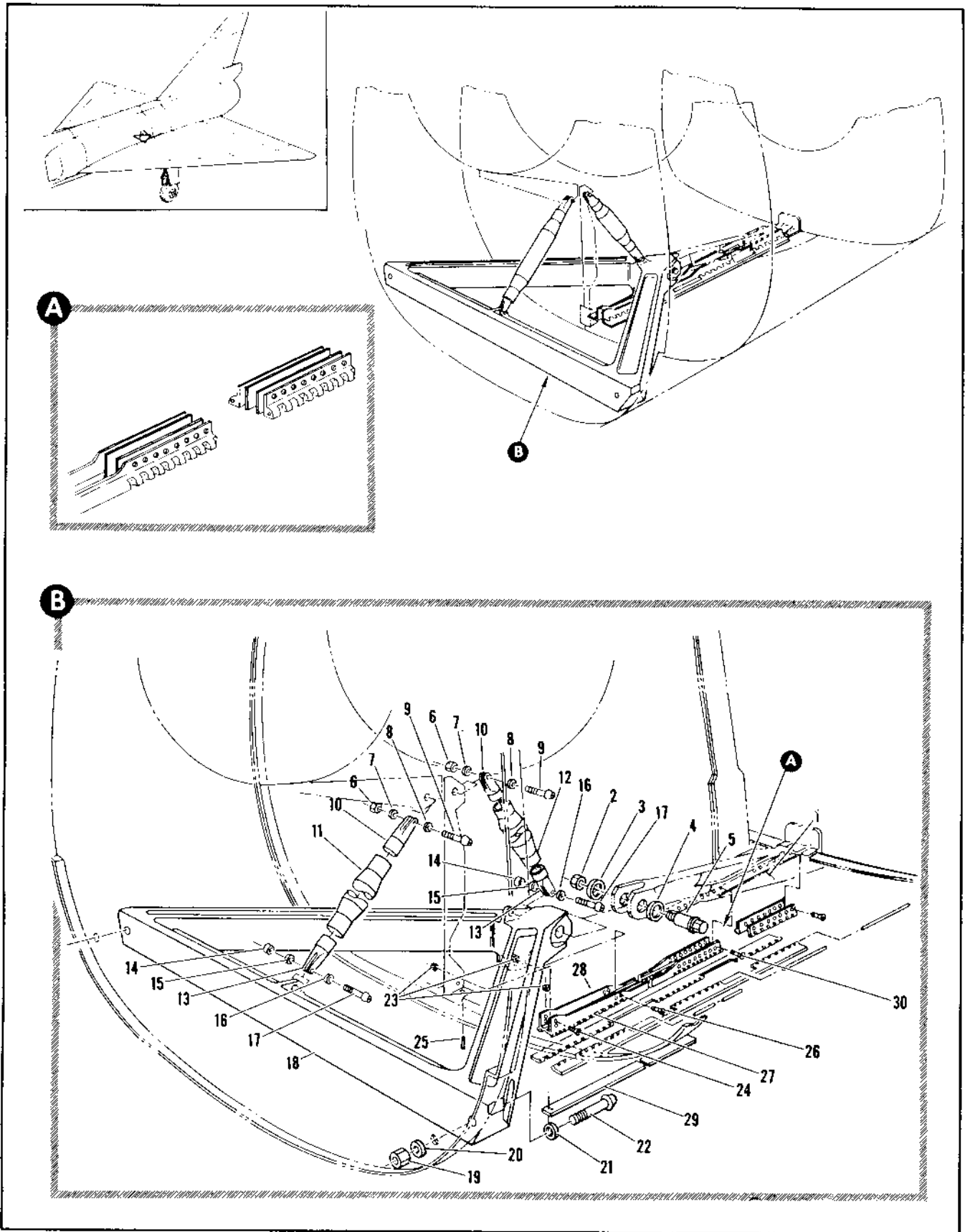

Figure 2.15-31. Main Landing Gear Door Hinge and Longeron (Sheet 1 of 2)

FIGURE AND INDEX NUMBER	PART NUMBER	DESCRIPTION	UNITS PER ASSY.	USABLE ON CODE	
				FROM	TO
2.15-31					
- 1		MAIN LANDING GEAR DOOR HINGE AND LONGERON • LONGERON, LWR FUSELAGE STA 444 TO 607 SEE FIG. 2.3-3 INDEX 03	RF		
	8-77191	• ATTACHMENT INSTL, LONGERON LOWER STA 445 FOR NHA SEE FIG. 2.3-3	RF	61	
- 2	AN325-16	• • NUT	1	61	
- 3	8-77788-9	• • WASHER	1	61	
- 4	8-77788-7	• • WASHER	1	61	
- 5	8-74777-7	• • BOLT	1	61	
	8-77191-1	• LONGERON INSTL, LOWER STA 412 TO 472 FOR NHA SEE FIG. 2.3-10	RF	61	
	8-74155-3	• • BRACE ASSY, LONGERON FWD	1	61	
	8-74155-1	• • BRACE ASSY, LONGERON AFT ATTACHING PARTS	1	61	
- 6	42FW524	• • NUT, <56878> 96-37510-002	2	61	
- 7	MS20002-5	• • WASHER	2	61	
- 8	MS20002C5	• • WASHER	2	61	
- 9	MS20002-14	• • BOLT	2	61	
		-----X-----			
- 10	8-74187	• • • CLEVIS	1	61	
- 11	8-74188-9	• • • BRACE, FWD	1	61	
- 12	8-74188-7	• • • BRACE, AFT	1	61	
- 13	8-74187-701	• • CLEVIS ATTACHING PARTS	2	61	
- 14	42FW524	• • NUT, <56878> 96-37510-002	2	61	
- 15	MS20002-5	• • WASHER	2	61	
- 16	MS20002C5	• • WASHER	2	61	
- 17	MS20002-14	• • BOLT	2	61	
		-----X-----			
- 18	8-74130-713	• • LONGERON, LOWER ATTACHING PARTS	1	61	
- 19	42FW1216	• • NUT, <56878> 96-37510-008	1	61	
- 20	MS20002-12	• • WASHER	1	61	
- 21	MS20002C12	• • WASHER	1	61	
- 22	MS20012-28	• • BOLT	1	61	
		-----X-----			
	8-77191-5	• HINGE INSTL, LONGERON LOWER STA 412 TO 472 FOR NHA SEE FIG. 2.3-10	RF	61	
	8-74793-801	• • HINGE ASSEMBLY ATTACHING PARTS	1	61	
- 23	NAS679A3	• • NUT	10	61	
- 24	AN3-6A	• • BOLT	4	61	
- 25	NAS333PA6	• • SCREW	4	61	
- 26	NAS333PA6-5	• • SCREW	2	61	
		-----X-----			
- 27	8-74793-33	• • • HINGE PLATE, LH REPLACES NOT INTCHG WITH 8-74793-21	1	61	
- 28	8-74793-34	• • • HINGE PLATE, RH REPLACES NOT INTCHG WITH 8-74793-21	1	61	
- 29	8-74793-35	• • • PLATE	1	61	
	8-77191-501	• HINGE INSTL, LONGERON LOWER STA 412 TO 472 FOR NHA SEE FIG. 2.3-3	RF	61	
	8-74793-5	• • HINGE ASSEMBLY ATTACHING PARTS	1	61	
- 30	NAS333PA-5	• • SCREW	16	61	
		-----X-----			

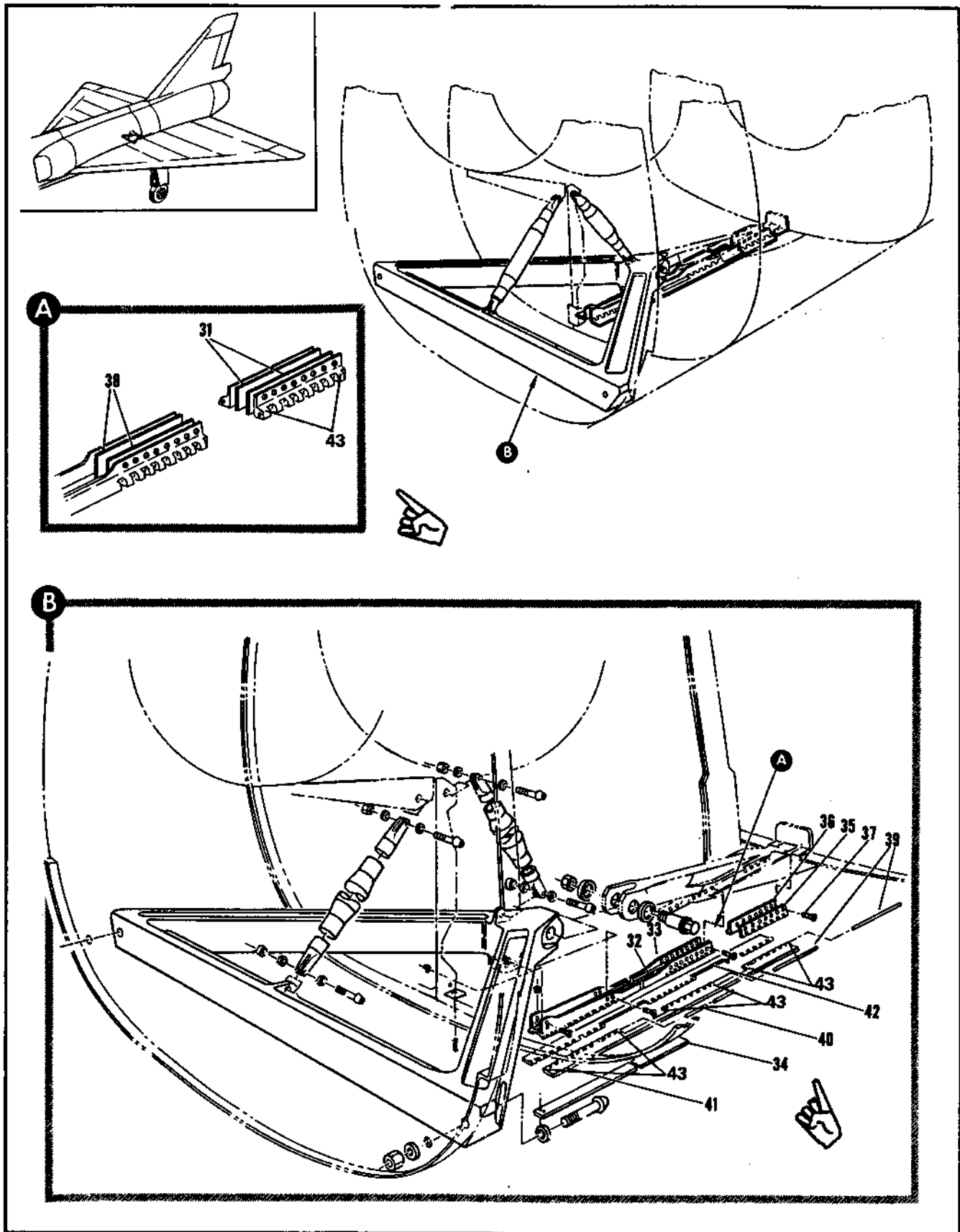

Figure 2.15-31. Main Landing Gear Door Hinge and Longeron (Sheet 2 of 2)

FIGURE AND INDEX NUMBER	PART NUMBER	DESCRIPTION	UNITS PER ASSY.	USABLE ON CODE	
				FROM	TO
2.15-31	31	8-77191-9	. . . SHIM, REPLACES NOT INTCHG WITH 8-77531-7	2	61
-	32	8-74793-39	. . . HINGE, LH REPLACES NOT INTCHG WITH 8-74793-21	1	61
-	33	8-74793-40	. . . HINGE, RH REPLACES NOT INTCHG WITH 8-74793-21	1	61
-	34	8-74793-37 8-77191-3	. . . PLATE . HINGE INSTL, LONGERON FUSELAGE LOWER STA 412 TO 472 LH FOR NHA SEE FIG. 2.3-14	1 RF	61 61
		8-77191-4	. HINGE INSTL, LONGERON FUSELAGE LOWER STA 412 TO 472 RH FOR NHA SEE FIG. 2.3-14	RF	61
-	35	8-74793-31	. . HINGE, LH REPLACES NOT INTCHG WITH 8-74793-27	1	61
-	36	8-74793-32	. . HINGE, RH REPLACES NOT INTCHG WITH 8-74793-28	1	61
-	37	NAS333PA4-5	. . SCREW ----- X -----	8	61
-	38	8-77191-9 8-77191-803 8-77191-804	. . SHIM, REPLACES NOT INTCHG WITH 8-77531-7 . HINGE INSTL, LONGERON LOWER STA 412 TO 472 LH FOR NHA SEE FIG. 2.3-3 . HINGE INSTL, LONGERON LOWER STA 412 TO 472 RH FOR NHA SEE FIG. 2.3-3	1 RF RF	61 61 61
		8-74793-3	. . HINGE ASSY, LH	1	61
		8-74793-4	. . HINGE ASSY, RH	1	61
-	39	AN253-4-800 PIN	2	61
-	40	AN253-4-850 PIN	1	61
-	41	8-74793-29 HINGE, HALF LH	1	61
-	42	8-74793-30 HINGE, HALF RH	1	61
-	43	MS20426AD3-8 HINGE, PIN LOCK	12	61

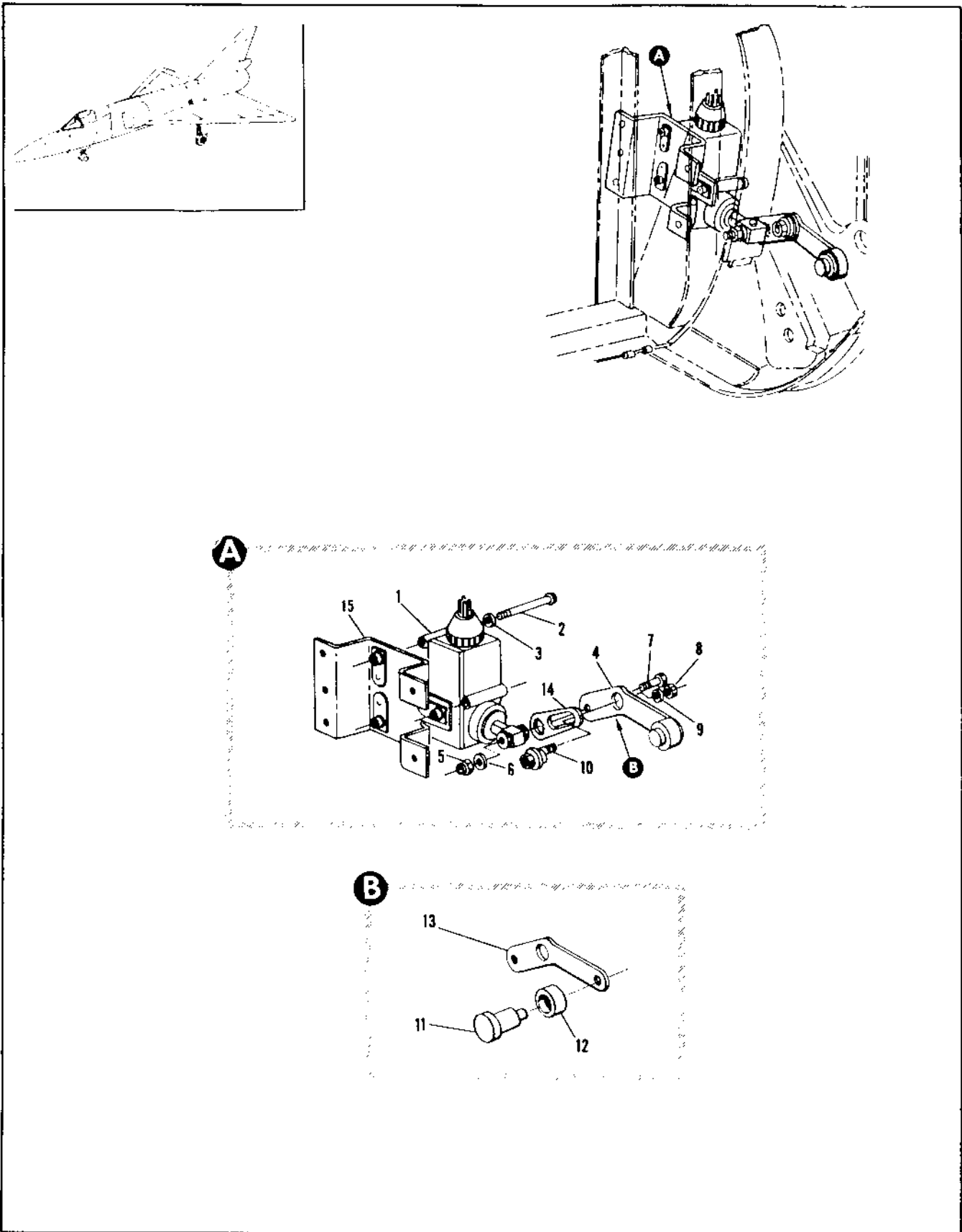

Figure 2.15-32. Main Landing Gear Door Open Switch Installation

FIGURE AND INDEX NUMBER	PART NUMBER	DESCRIPTION	UNITS PER ASSY.	USABLE ON CODE		
				FROM	TO	
2.15-32	8-44592-1	SWITCH INSTALLATION, MAIN LANDING GEAR DOOR OPEN LH FOR NHA SEE FIG. 2.3-3	RF	35	60	
	8-44592-5	SWITCH INSTALLATION, MAIN LANDING GEAR DOOR OPEN LH FOR NHA SEE FIG. 2.3-3	RF	61		
	8-44592-2	SWITCH INSTALLATION, MAIN LANDING GEAR DOOR OPEN RH FOR NHA SEE FIG. 2.3-3	RF	35	60	
	8-44592-6	SWITCH INSTALLATION, MAIN LANDING GEAR DOOR OPEN RH FOR NHA SEE FIG. 2.3-3	RF	61		
	- 1	812-27	• SWITCH ASSY, MLG DOOR LIMIT <97198> SPEC 8-65983-833 ATTACHING PARTS	1	35	
	- 2	AN521-1CR26	• SCREW	3	35	
	- 3	AN967-10L	• WASHER	3	35	
			----X----			
	- 4	8-65099-1	• ARM ASSY, ACTUATOR LIMIT SWITCH LH	1	35	
		8-65099-2	• ARM ASSY, ACTUATOR LIMIT SWITCH RH ATTACHING PARTS	1	35	
	- 5	NAS67943	• NUT	1	35	
	- 6	AN935-10	• WASHER	1	35	
	- 7	AN3-10A	• BOLT	1	35	
	- 8	NAS67940A	• NUT	1	35	
	- 9	AN935-8	• WASHER	1	35	
- 10	8-68038-7	• BOLT	1	35		
		----X----				
- 11	8-68051-9	• STUD	1	35		
- 12	8-68052-9	• ROLLER	1	35		
- 13	8-65099-7	• ARM	1	35		
- 14	1107-509	• PLATE, <97198> SPEC 8-66986-7	1	35		
- 15	8-44593-2	• BRACKET ASSY, DOOR OPEN SWITCH MLG RIVETED	1	35	60	
	8-44543-3	• BRACKET ASSY, DOOR OPEN SWITCH MLG LH RIVETED	1	61		
	8-44543-4	• BRACKET ASSY, DOOR OPEN SWITCH MLG RH RIVETED	1	61		

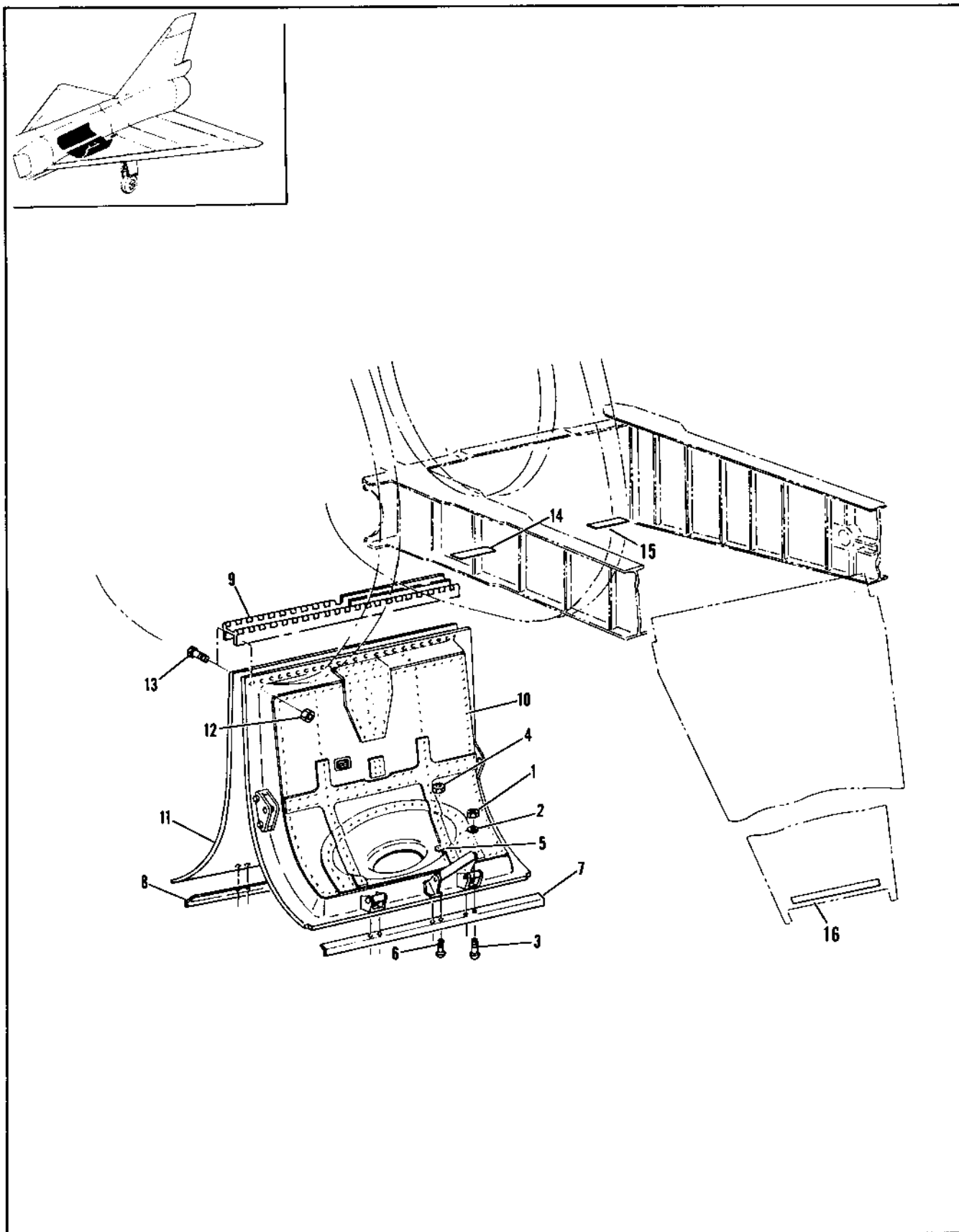

Figure 2.15-33. Main Landing Gear Door Installation

FIGURE AND INDEX NUMBER	PART NUMBER	DESCRIPTION	UNITS PER ASSY.	USABLE ON CODE	
				FROM	TO
		1 2 3 4 5 6			
2.15-33	P-44545-5	DOOR INSTALLATION, MAIN LANDING GEAR FOR NHA SEE FIG. 2.3-3	RF	35	
	8-44545-529	• DOOR ASSY, MAIN LANDING GEAR LH SPARES FOR BREAKDOWN SEE FIG. 2.15-34	RF	35	
	8-44545-530	• DOOR ASSY, MAIN LANDING GEAR RH SPARES FOR BREAKDOWN SEE FIG. 2.15-34	RF	35	
- 1	NAS679A4	• NUT	8	35	
- 2	AN963D417L	• WASHER	8	35	
- 3	AN509-41R12	• SCREW	8	35	
- 4	NAS679A3	• NUT	4	35	
- 5	AN963D13L	• WASHER	4	35	
- 6	AN509-10R12	• SCREW	4	35	
- 7	8-44545-103	• ANGLE, LH	1	35	
- 8	8-44545-104	ANGLE, RH	1	35	
- 9		• HINGE ASSY, MAIN LANDING GEAR DOOR SEE FIG. 2.15-30 INDEX 18	RF		
- 10	8-44545-155	• DOOR ASSY, MAIN LANDING GEAR LH FOR BREAKDOWN SEE FIG. 2.15-27	1	35	
- 11	8-44545-156	• DOOR ASSY, MAIN LANDING GEAR RH FOR BREAKDOWN SEE FIG. 2.15-27 ATTACHING PARTS	1	35	
- 12	NAS679A3	• NUT	50	35	
- 13	AN509-10R11	• SCREW	50	35	
- 14	8-44545-59	• STRIP, <MADE FROM MIL-P-15035 TYPE FBM>	2	35	
- 15	8-44545-63	• STRIP, <MADE FROM MIL-P-15035 TYPE FBM>	2	35	
- 16	8-44545-61	• STRIP, <MADE FROM MIL-P-15035 TYPE FBM>	2	35	

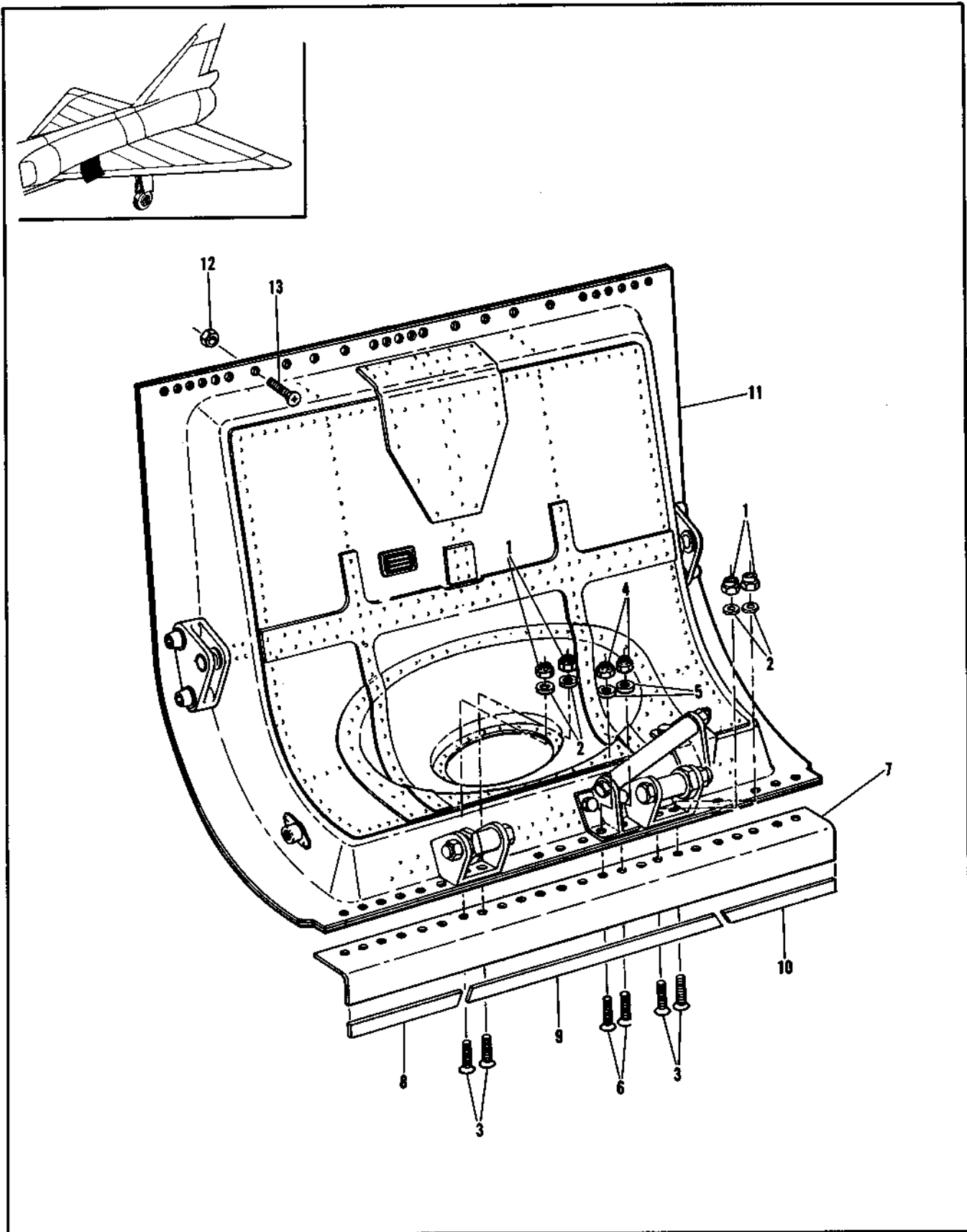

Figure 2.15-34. Main Landing Gear Door Assembly Spares

FIGURE AND INDEX NUMBER	PART NUMBER	DESCRIPTION	UNITS PER ASSY.	USABLE ON CODE		
				FROM	TO	
2.15-34	R-44545-529	DOOR ASSEMBLY, MAIN LANDING GEAR LH SPARES WITH R-44545-59, -61, -69, AND ATTACHING HARDWARE BAG AND TIED SEE FIG. 2.15-33	RF	35		
	R-44545-530	DOOR ASSEMBLY, MAIN LANDING GEAR RH SPARES WITH R-44545-59, -61, -69, AND ATTACHING HARDWARE BAG AND TIED SEE FIG. 2.15-33	RF	35		
	- 1	NAS679A4	• NUT	4	35	
	- 2	AN9610416L	• WASHER	4	35	
	- 3	AN509-416K12	• SCREW	4	35	
	- 4	NAS679A3	• NUT	2	35	
	- 5	AN9610416L	• WASHER	2	35	
	- 6	AN509-10912	• SCREW	2	35	
	- 7	R-44545-103	• ANGLE, LH	1	35	
		R-44545-104	• ANGLE, RH	1	35	
	- 8	R-44545-59	• STRIP	1	35	
	- 9	R-44545-61	• STRIP	1	35	
	- 10	R-44545-63	• STRIP	1	35	
- 11	R-44545-155	• DOOR ASSY, MLG LH SPARES FOR BREAKDOWN SEE FIG. 2.15-35	1	35		
	R-44545-156	• DOOR ASSY, MLG RH SPARES FOR BREAKDOWN SEE FIG. 2.15-35 ATTACHING PARTS	1	35		
- 12	NAS679A3	• NUT	25	35		
- 13	AN509-10911	• SCREW	25	35		
		-----X-----				

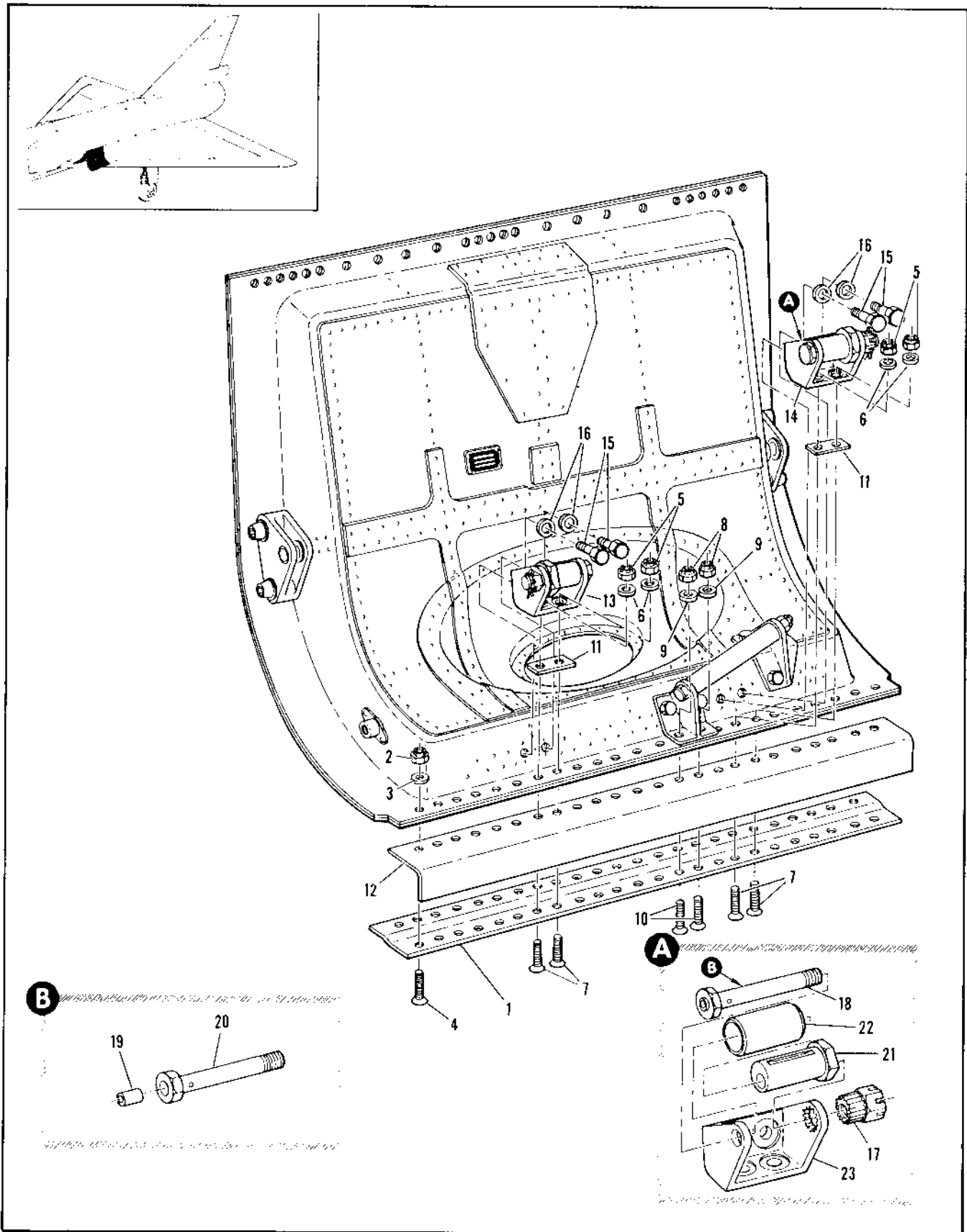

Figure 2.15-35. Main Landing Gear Door Assembly Spares (Sheet 1 of 2)

FIGURE AND INDEX NUMBER	PART NUMBER	DESCRIPTION	UNITS PER ASSY.	USABLE ON CODE	
				FROM	TO
		1 2 3 4 5 6			
2.15-35	R-44545-155	DOOR ASSEMBLY, MAIN LANDING GEAR LH SPARE	RF	35	
	R-44545-156	DOOR ASSEMBLY, MAIN LANDING GEAR RH SPARE	RF	35	
- 1	R-44545-153	• STRIP, LH	1	35	
	R-44545-154	• STRIP, RH	1	35	
		ATTACHING PARTS			
- 2	NAS679A3	• NUT	18	35	
- 3	AN960D10L	• WASHER	18	35	
- 4	AN509-10R10	• SCREW	18	35	
- 5	NAS679A4	• NUT	4	35	
- 6	AN960D416L	• WASHER	4	35	
- 7	AN509-416R12	• SCREW	4	35	
- 8	NAS679A3	• NUT	2	35	
- 9	AN960D10L	• WASHER	2	35	
- 10	AN509-10R12	• SCREW	2	35	
		-----X-----			
- 11	R-44545-149	• SPACER	2	35	
- 12	R-44545-151	• ANGLE, LH	1	35	99
	R-44545-167	• ANGLE, LH	1	90	
	R-44545-152	• ANGLE, RH	1	35	99
	R-44545-168	• ANGLE, RH	1	90	
- 13	R-44556-4	• SUPPORT ASSY, FAIRING STA 443	1	35	
- 14	R-44556-3	• SUPPORT ASSY, FAIRING STA 459	1	35	
		ATTACHING PARTS			
- 15	AN4-6A	• BOLT	4	35	
- 16	AN960D416L	• WASHER	4	35	
		-----X-----			
- 17	R-44552	• NUT	1	35	
- 18	R-44523	• BOLT ASSEMBLY	1	35	
- 19	NAS515-1	• FITTING	1	35	
- 20	R-44523-7	• BOLT	1	35	
- 21	R-44522	• BUSHING	1	35	
- 22	R-44525	• ROLLER	1	35	
	R-44563-14	• SUPPORT, STA 443	1	35	
	R-44575-10	• SUPPORT, STA 443	RF	35	
		ALT INTCHG WITH R-44563-14			
- 23	R-44563-11	• SUPPORT, STA 459	1	35	
	R-44575-9	• SUPPORT, STA 459	RF	35	
		ALT INTCHG WITH R-44563-13			

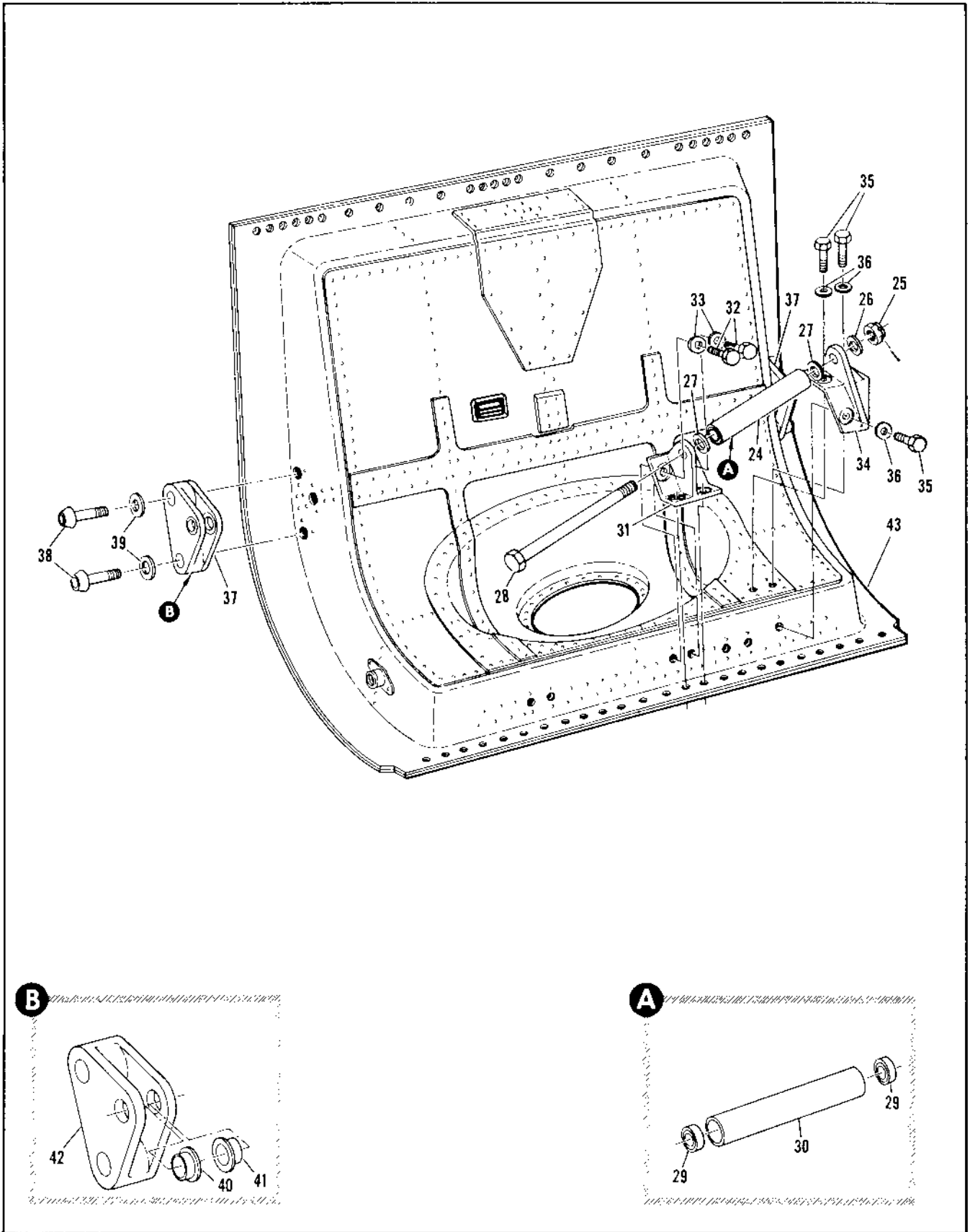

Figure 2.15-35. Main Landing Gear Door Assembly Spares (Sheet 2 of 2)

FIGURE AND INDEX NUMBER	PART NUMBER	DESCRIPTION 1 2 3 4 5 6	UNITS PER ASSY.	USABLE ON CODE	
				FROM	TO
2.15-35- 24	A-4455R	• ROLLER ASSEMBLY ATTACHING PARTS	1	35	
- 25	AN310-4	• NUT	1	35	
- 26	AN960016	• WASHER	1	35	
- 27	AN960016L	• WASHER	2	35	
- 28	AN447E	• BOLT	1	35	
		-----X-----			
- 29	AN209KP4	• BEARING	2	35	
- 30	B-4455R-7	• TUBE	1	35	
- 31	B-44551-9	• SUPPORT, FWD ROLLER LH	1	35	
	B-44577-7	• SUPPORT, FWD ROLLER LH ALT INTCHG WITH B-44551-9	RF	35	
	B-44551-10	• SUPPORT, FWD ROLLER RH	1	35	
	B-44577-8	• SUPPORT, FWD ROLLER RH ALT INTCHG WITH B-44551-10 ATTACHING PARTS	RF	35	
- 32	AN3-5A	• BOLT	2	35	
- 33	AN960010L	• WASHER	2	35	
		-----X-----			
- 34	B-44562-9	• SUPPORT, AFT ROLLER LH	1	35	
	B-44576-7	• SUPPORT, AFT ROLLER LH ALT INTCHG WITH B-44562-9	RF	35	
	B-44562-10	• SUPPORT, AFT ROLLER RH	1	35	
	B-44576-8	• SUPPORT, AFT ROLLER RH ALT INTCHG WITH B-44562-10 ATTACHING PARTS	RF	35	
- 35	AN3-5A	• BOLT	3	35	
- 36	AN960010L	• WASHER	3	35	
		-----X-----			
- 37	B-44554-1	• SUPPORT ASSY, MLC DOOR MECHANISM ATTACHING PARTS	2	35	
- 38	MS20504-22	• BOLT	4	35	
- 39	MS2050204	• WASHER	4	35	
		-----X-----			
- 40	B-44554-6	• BUSHING, ALTERED FROM NAS77-6-14	1	35	
- 41	B-44554-11	• BUSHING, ALTERED FROM NAS77-6-27	1	35	
- 42	B-44554-7	• SUPPORT	1	35	
	B-44579	• SUPPORT ASSY, MLC DOOR MECHANISM ALT INTCHG WITH B-44554-1	RF	35	
	B-44579-9	• BUSHING, ALTERED FROM NAS77-6-14	1	35	
	B-44579-11	• BUSHING, ALTERED FROM NAS77-6-27	1	35	
	B-44579-7	• SUPPORT	1	35	
- 43	B-44545-95	• DOOR ASSY, RIVETED LH	1	35	
	B-44545-96	• DOOR ASSY, RIVETED RH	1	35	
	B-44545-101	• PAN, LH	1	35	
	B-44545-102	• PAN, RH	1	35	

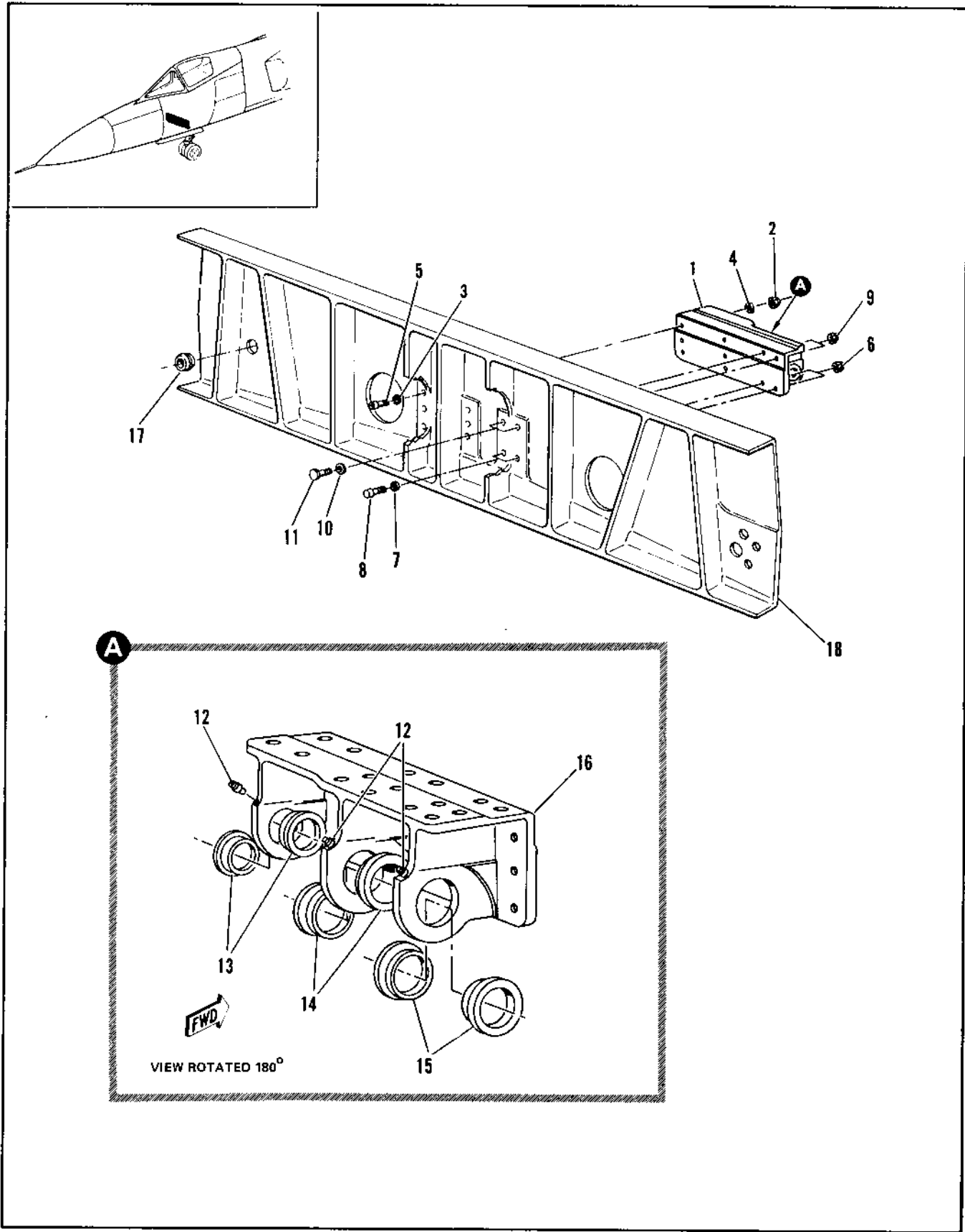

Figure 2.15-36. Nose Landing Gear Drag Strut Fitting Assembly

FIGURE AND INDEX NUMBER	PART NUMBER	DESCRIPTION 1 2 3 4 5 6	UNITS PER ASSY.	USABLE ON CODE		
				FROM	TO	
2.15-36	8-74141-1	FITTING ASSEMBLY, NLC DRAG STRUT FOR NHA SEE FIG. 2.3-4	RF	A		
	A-78725	FITTING ASSEMBLY, NLC DRAG STRUT FOR NHA SEE FIG. 2.3-4	RF	B		
	8-78725-1	FITTING ASSEMBLY, NLC DRAG STRUT FOR NHA SEE FIG. 2.3-4	RF	189		
	- 1	8-74736-1	• FITTING ASSY, NLC DRAG STRUT REPLACED BY NOT INTCHG WITH 8-74736-3	1	A	
		8-74719-3	• FITTING ASSY, NLC DRAG STRUT ALT INTCHG WITH 8-74736-1	RF	A	
		8-74736-3	• FITTING ASSY, NLC DRAG STRUT REPLACES NOT INTCHG WITH 8-74736-1	1	C	
			ATTACHING PARTS			
	- 2	NAS679A5	• NUT	6	35	
	- 3	MS20002C5	• WASHER	6	35	
	- 4	MS20002-5	• WASHER	6	35	
	- 5	MS20005-8	• BOLT	6	35	
	- 6	NAS679A4	• NUT	2	35	
	- 7	MS20002C4	• WASHER	2	35	
	- 8	MS20004-2	• BOLT	2	35	
	- 9	NAS679A3	• NUT	2	A	
		NAS679A4	• NUT	2	C	
	- 10	MS20002C4	• WASHER	2	C	
	- 11	NAS464P3A7	• BOLT	2	A	
	MS20004-8	• BOLT	2	C		
		-----X-----				
- 12	MS15001-1	• LUBRICATOR	3	35		
- 13	8-72774-7	• BUSHING	2	35		
- 14	8-72774-9	• BUSHING	2	35		
- 15	8-72774-11	• BUSHING	2	35		
- 16	8-74736-7	• FITTING	1	A		
	8-74719-13	• FITTING, ALT INTCHG WITH 8-74736-7	RF	A		
	8-74736-8	• FITTING	1	C		
- 17	S11154-8BY	• GROMMET, <97820> 94-35015-016	1	A		
	S11154-8DY	• GROMMET, <97820> 94-35015-040	1	C		
- 18	8-74122-27	• BEAM, CROSS STA 132	1	A		
		A AIRPLANES #35 THRU 47 AND 49 THRU 89				
		B AIRPLANES #48 AND 90 THRU 188				
		C AIRPLANES #48, 90 AND CN				

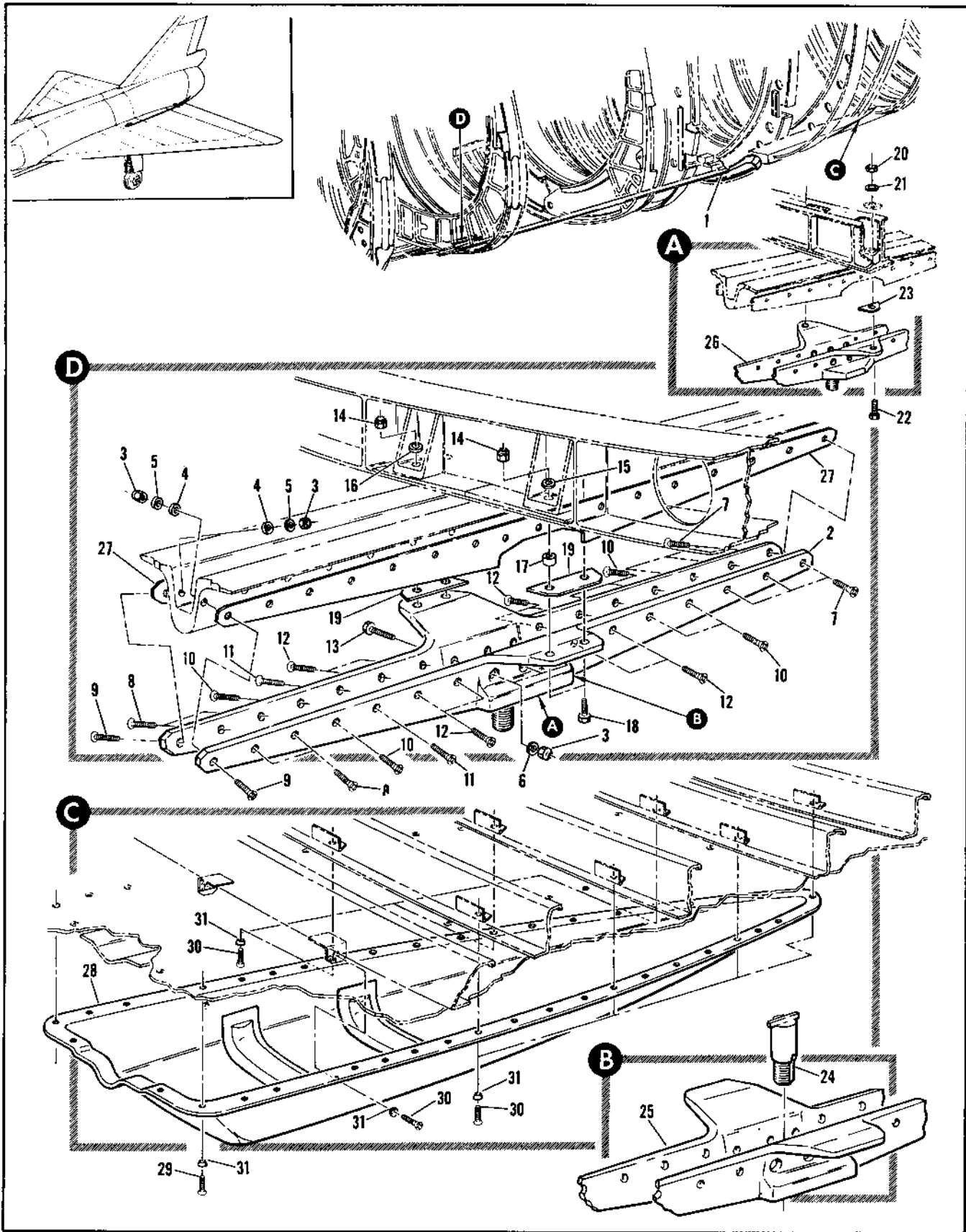

Figure 2.15-37. Emergency Arresting System

FIGURE AND INDEX NUMBER	PART NUMBER	DESCRIPTION	UNITS PER ASSY.	USABLE ON CODE	
				FROM	TO
		1 2 3 4 5 6			
2.15-37 - 1	8-78734	EMERGENCY ARRESTING SYSTEM • HOOK INSTL, EMERGENCY ARRESTING SEE FIG. 2.15-38	RF		
- 2	8-78733-3 8-78733-5	• FITTING INSTL, TAIL HOOK FOR NHA SEE FIG. 2.3-14 • FITTING ASSY, TAIL HOOK • FITTING ASSY, TAIL HOOK ATTACHING PARTS	RF 1 1	130	277 A A
- 3	NAS1291-4	• NUT	31	130	277
- 4	NAS679A4	• NUT	31		C
- 5	AN9600416	• WASHER	AR		C
- 6	AN9600416L	• WASHER	AR		C
- 7	AN960-416	• WASHER	AR		C
+ 7	NAS1204-7	• BOLT	6	130	277
- 8	NAS1204-8	• BOLT	4		C
- 9	NAS1204-7	• BOLT	4		E
- 10	NAS1204-7	• BOLT	2	130	277
- 11	NAS1204-8	• BOLT	2		C
- 12	NAS1204-8	• BOLT	6		C
- 13	NAS1204-9	• BOLT	2	130	277
- 14	NAS1204-9	• BOLT	2		C
- 15	NAS1204-9	• BOLT	2		E
- 16	NAS1304-18	• BOLT	1	130	277
- 17	NAS1304-28	• BOLT	3		C
- 18	NAS1291-5	• NUT	4		A
- 19	AN9600516L	• WASHER	2	49	60
- 20	AN960-516L	• WASHER	2	49	60
- 21	NAS75-5-10	• PUSHING	4	49	60
- 22	NAS1305-13	• BOLT	4		A
- 23	8-78734-7	• SPACER	2		A
- 24	EWN22-6	• NUT, <56878> 96-3758 -003	2		B
- 25	MS2008206	• WASHER	2		D
- 26	EWN22-6-20	• BOLT, <56878> 95-52024-0A5	2		R
- 27	8-71191-11	• FILLER	2		6
- 28	8-78737-7	• PIN, TAIL HOOK	1		A
- 29	8-78737	• PIN, TAIL HOOK	1		A
- 30	8-78733-23	• FITTING ASSY, WELDED	1	130	215
- 31	8-78733-21	• FITTING ASSY, WELDED	RF		
- 32	8-78733-43	• FITTING ASSY, WELDED	1		D
- 33	8-78733-33	• FITTING ASSY, WELDED	1		B
- 34	8-78733-31	• FITTING ASSY, WELDED	RF		
- 35	8-78734-9	• SHIM	AR		F
- 36	8-78736-1	• FAIRING INSTL, TAIL HOOK FOR NHA SEE FIG. 2.1-1	RF	130	
- 37	8-78736-17	• FAIRING ASSY, BONDED ATTACHING PARTS	1		F
- 38	NAS1203-2	• SCREW	54		F
- 39	NAS1203-3	• SCREW	6		F
- 40	99-51400-002	• WASHER	47		F
		-----X-----			
		A AIRPLANES 449 THRU 60 AND 130 THRU 277			
		B AIRPLANES 435 AND 39 THRU 43			
		C AIRPLANES 875, 38 THRU 47 AND 49 THRU 60			
		D AIRPLANES 849 THRU 60 AND 216 THRU 277			
		E AIRPLANES 834, 38 THRU 47, 49 THRU 60 AND 130 THRU 277			
		F AIRPLANES 815, 38 THRU 43, 49 THRU 60 AND 130 AND ON			

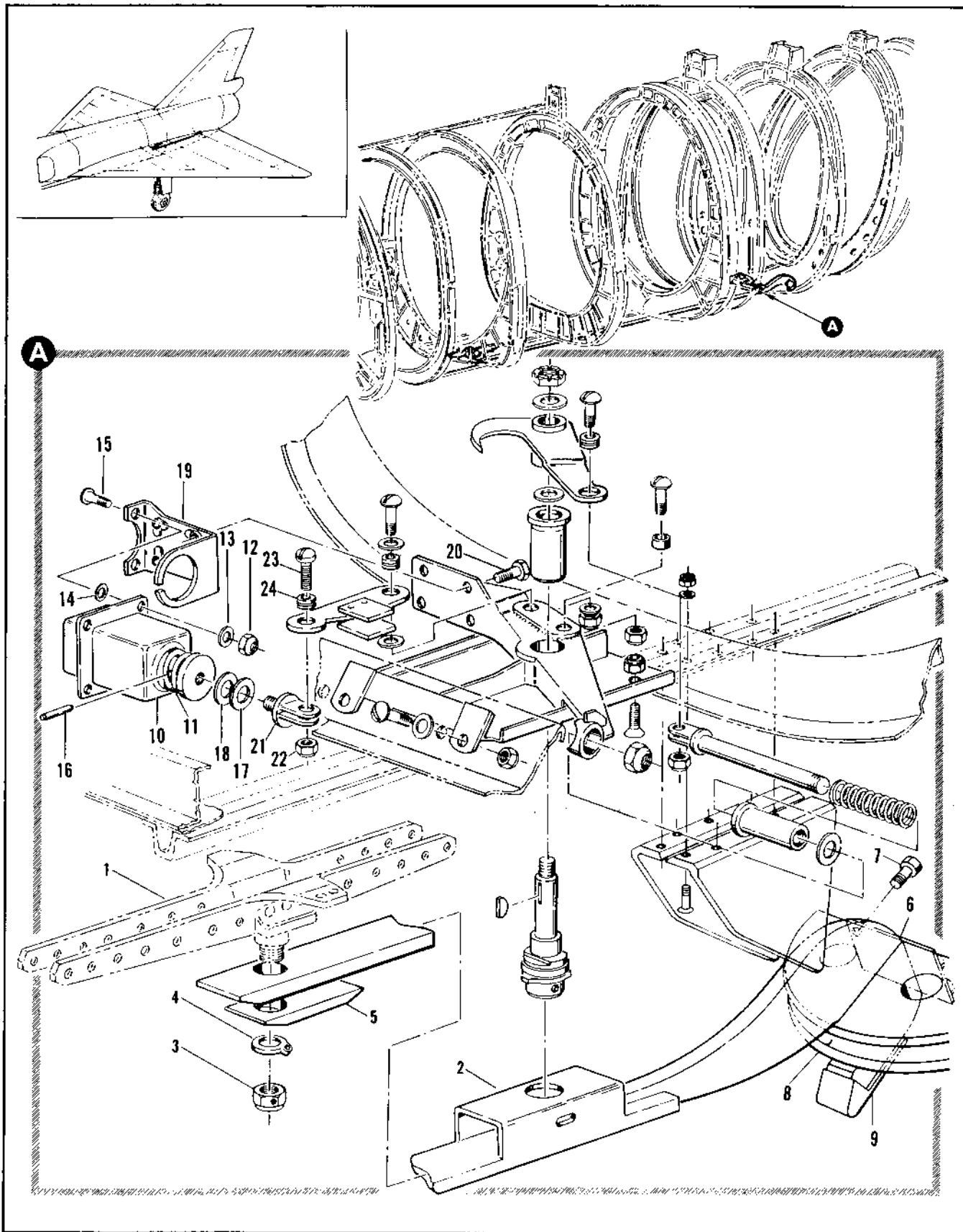

Figure 2.15-38. Emergency Arresting Hook Installation (Sheet 1 of 3)

FIGURE AND INDEX NUMBER	PART NUMBER	DESCRIPTION 1 2 3 4 5 6	UNITS PER ASSY.	USABLE ON CODE	
				FROM	TO
2.15-38	R-51050	HOOK INSTALLATION, EMERGENCY ARRESTING FOR NHA SEE FIG. 2.3-3	RF		
	R-51050-1	HOOK INSTALLATION, EMERGENCY ARRESTING	RF		
- 1		• FITTING ASSY, TAIL HOOK SEE FIG. 2.15-37	RF		
- 2	67848A2	• HOOK ASSY, TAIL <96157> SPEC R-05359-3 ATTACHING PARTS	1	35	
- 3	NAS509-16	• NUT	1	35	
- 4	R-51054	• WASHER -----X-----	1	35	
- 5	67839	• • DOUBLER	1	35	
	67828A3	• • SHOE ASSY, <96157>	1	35	
- 6	67824	• • • PLATE, <96157> HOOK SHOE ATTACHING PARTS	1	35	
- 7	MS20074-J3-04	• • • BOLT -----X-----	4	35	
- 8	67828A3	• • SHOE ASSY <96157>	1	35	
	67833	• • • SHOE, <96157>	1	35	
- 9	67844A1	• • • PLATE, WEAR	1	35	
- 10	13304-11	• SOLENOID, <71468> 98-28301-304	1	35	
- 11	61834397	• SPRING ATTACHING PARTS	1	35	
- 12	NAS1291-3	• NUT, 96-37525-002	2	35	
- 13	AN960010	• WASHER	2	35	
- 14	AN960010L	• WASHER	2	35	
- 15	AN3-7A	• BOLT	2	35	
- 16	96-79700-094	• PIN -----X-----	1	35	
- 17	AN9600416	• WASHER	1	35	
- 18	AN9600416L	• WASHER	1	35	
- 19	R-51052	• BRACKET, ASSY, RIVETED ATTACHING PARTS	1	35	
- 20	AN3-4A	• BOLT -----X-----	4	35	
- 21	R-51065	• CLEVIS ATTACHING PARTS	1	35	
- 22	NAS1291-3	• NUT, 96-37525-002	1	35	
- 23	NAS623-3-5	• SCREW -----X-----	1	35	
- 24	NAS72-3-002	• BUSHING	1	35	

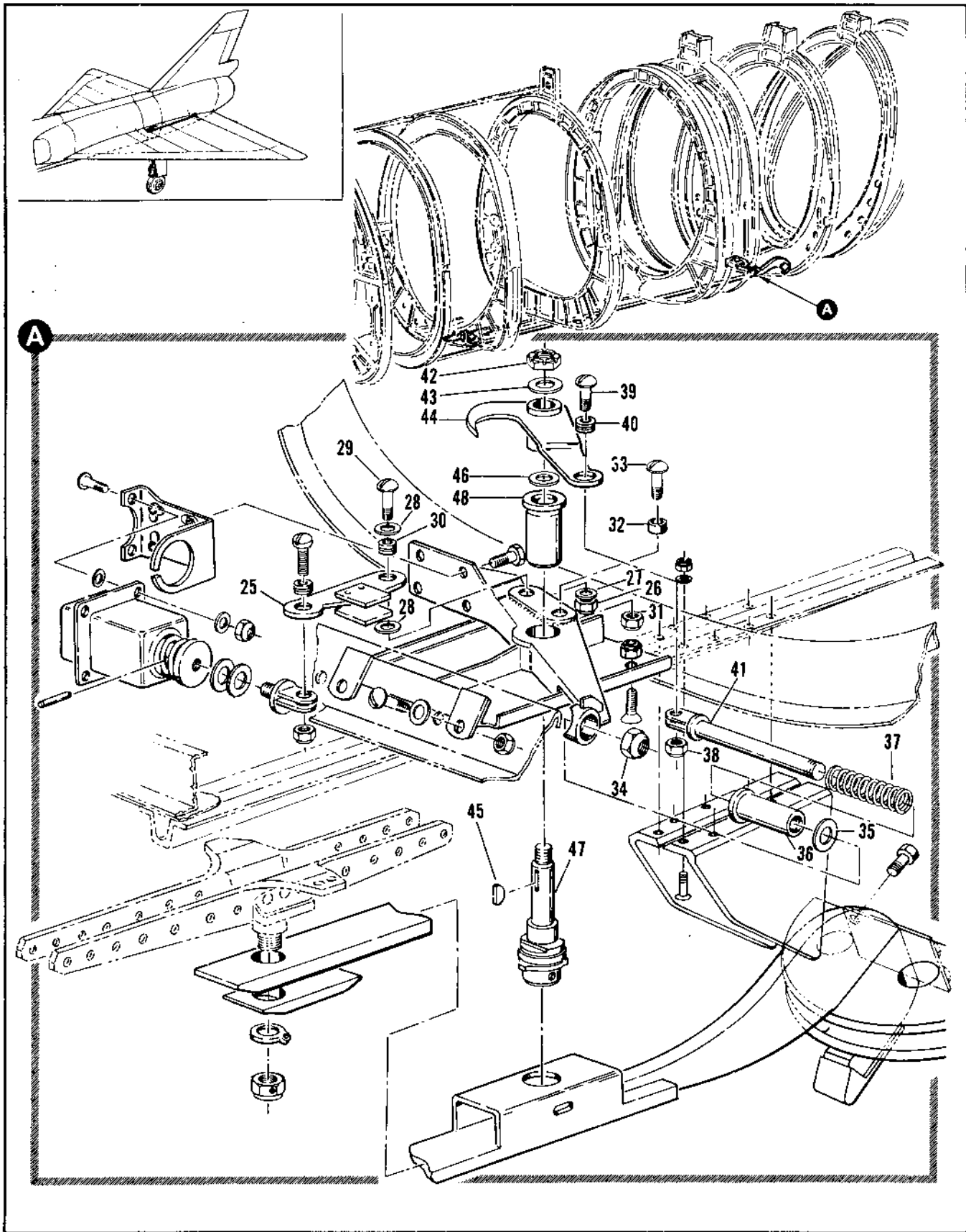

Figure 2.15-38. Emergency Arresting Hook Installation (Sheet 2 of 3)

FIGURE AND INDEX NUMBER	PART NUMBER	DESCRIPTION	UNITS PER ASSY.	USABLE ON CODE	
				FROM	TO
		1 2 3 4 5 6			
2.15-38-01	61R343R2	• TRIGGER ASSY ATTACHING PARTS	1	35	
- 25	NAS1291-3	• NUT, 96-37525-002	1		
- 27	AN961D10L	• WASHER	1		
- 28	99-51507-032	• WASHER	2		
- 29	NAS623-3-7	• SCREW	1		
		-----X-----			
- 31	NAS72-3-002	• PUSHING	1		
- 31	NAS1291-3	• NUT, 96-37525-002	1		
- 32	NAS42006-19	• SPACER	1		
- 33	NAS621-3-7	• SCREW	1		
- 34	22FFR20	• NUT, <E6978> 96-37525-007	1		
- 35	R-51157	• WASHER	1		
- 36	R-51055	• CAP	1		
- 37	R-51053	• SPRING	1		
- 38	NAS1291-3	• NUT, 96-37525-002	1		
- 39	NAS623-3-5	• SCREW	1		
- 40	NAS72-3-002	• PUSHING	1		
- 41	R-51051	• PLUNGER	1		
	AN962-816	• WASHER	AR	35	
- 42	AN323-5	• NUT	1		
- 43	AN960-516	• WASHER	1		
- 44	R-51061	• LEVER	1		
- 45	AN280H304	• KEY	1		
- 46	99-51507-044	• WASHER	1		
- 47	R-51060	• SHAFT	1		
- 48	R-51064	• PUSHING	1	75	

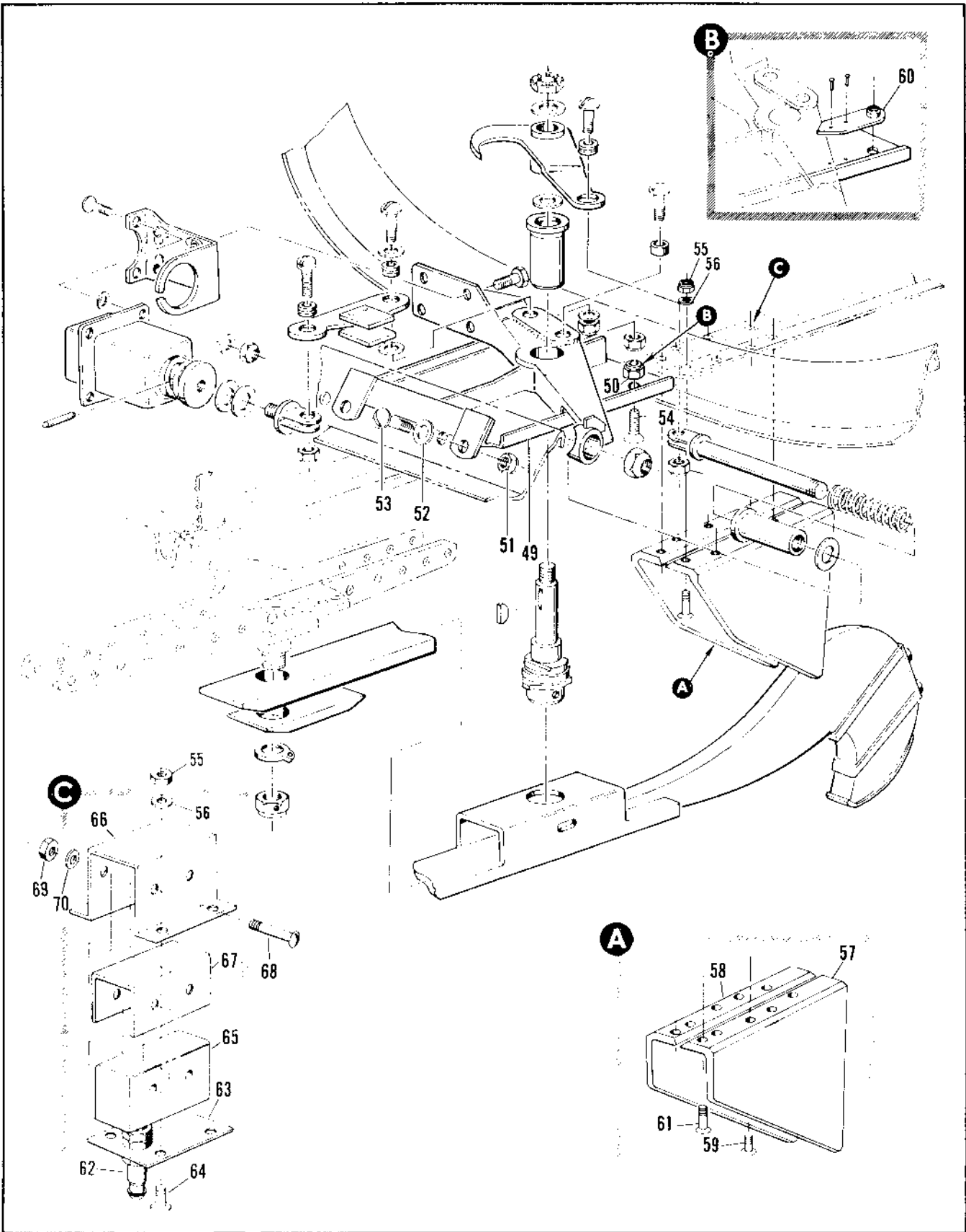

Figure 2.15-38. Emergency Arresting Hook Installation (Sheet 3 of 3)

FIGURE AND INDEX NUMBER	PART NUMBER	DESCRIPTION	UNITS PER ASSY.	USABLE ON CODE	
				FROM	TO
2.15-38- 49	2-51066-7	• BRACKET, TAIL HOOK LATCH			
- 50	NAS679A3	• NUT	2	35	
- 51	NAS679A3	• NUT	2	35	
- 52	AN660010	• WASHER	2	35	
- 53	NAS1153-6	• BOLT	2	35	
- 54	AN500-10R14	• SCREW	2	35	
- 55	NAS679A4	• NUT	2	35	
- 56	AN960-416	• WASHER	2	35	
- 57	62C34529-1	• REFLECTOR, LH	1	35	
- 58	62C34529-2	• REFLECTOR, RH	1	35	
- 59	AN500-416R14	• SCREW	6	35	
- 60	NAS679A3	• NUT PLATE	2	35	
- 61	AN500-10R17	• SCREW	2	35	
- 62	AN3167-1	• ACTUATOR ASSY, BARRIER HOOK INDICATOR LIGHT <40931>	1	35	
- 63	62R34032	• PLATE	1	35	
- 64	AN500-416R16	• SCREW	2	35	
- 65	MS253R3	• SWITCH ASSY, BARRIER HOOK INDICATOR LIGHT <40931>	1	35	
- 66	62R34031	• GUARD	1	35	
- 67	5PA3	• COVER <40931>	1	35	
- 68	AN510-6H24	• SCREW	2	35	
- 69	AN340-6	• NUT	2	35	
- 70	AN934A6	• WASHER	2	35	

INSTRUMENTS SUBSECTION

TABLE OF CONTENTS

<i>Fig. No.</i>	<i>Title</i>	<i>Page</i>	<i>Fig. No.</i>	<i>Title</i>	<i>Page</i>
2.16-1	Pilot Instrument Panel Installation	2.16-2	2.16-14	Fuel Control LH Console Panel Assembly	2.16-66
2.16-2	Pilot Instrument Panel Installation	2.16-18	2.16-15 A	Aerial Refuel Control, LH Console Switch (Rotary) Altitude	2.16-68
2.16-3	Pilot Instrument Panel Rack Installation	2.16-30	2.16-16	Band Selector	2.16-70
2.16-4	Pilot Instrument Panel Rack Assembly	2.16-34	2.16-17	RH Console Panel and Control Box Master Warning Lamp Installation	2.16-72
2.16-5	Pilot Instrument Panel Assembly	2.16-38	2.16-18	Hydraulic Indicator Generator Refrigeration and Cockpit Air Switch RH Console Panel Assembly	2.16-74
2.16-6	Instrument Panel Upper Support Installation	2.16-42	2.16-19	MA-1 Anti-Ice De-Fog and Rain Removal Switch Panel	2.16-76
2.16-7	Instrument Panel Lower Support Installation	2.16-44	2.16-20	Nose Landing Gear Steering and Canopy Switch RH Console Panel Assembly	2.16-78
2.16-8	Pilot Console Equipment Installation	2.16-46	2.16-21	Lighting Control RH Console Panel Assembly	2.16-80
2.16-9	Master Electrical Power and Audio Warning Cut Off LH Console Panel Assembly	2.16-52	2.16-22	Lighting Control RH Console Panel Assembly	2.16-82
2.16-10	Miscellaneous Switch RH Console Panel Assembly	2.16-56	2.16-23	Pilot Standby Compass	2.16-84
2.16-11	Armament Control LH Console Panel Assembly	2.16-58	2.16-24	Exhaust Gas Temperature Recorder Installation	2.16-86
2.16-12	LH Console Switch Panel Assembly	2.16-62	2.16-25	Exhaust Gas Temperature Equipment Installation	2.16-88
2.16-13	Anti-G Suit and Mask De-Fog Equipment	2.16-64			

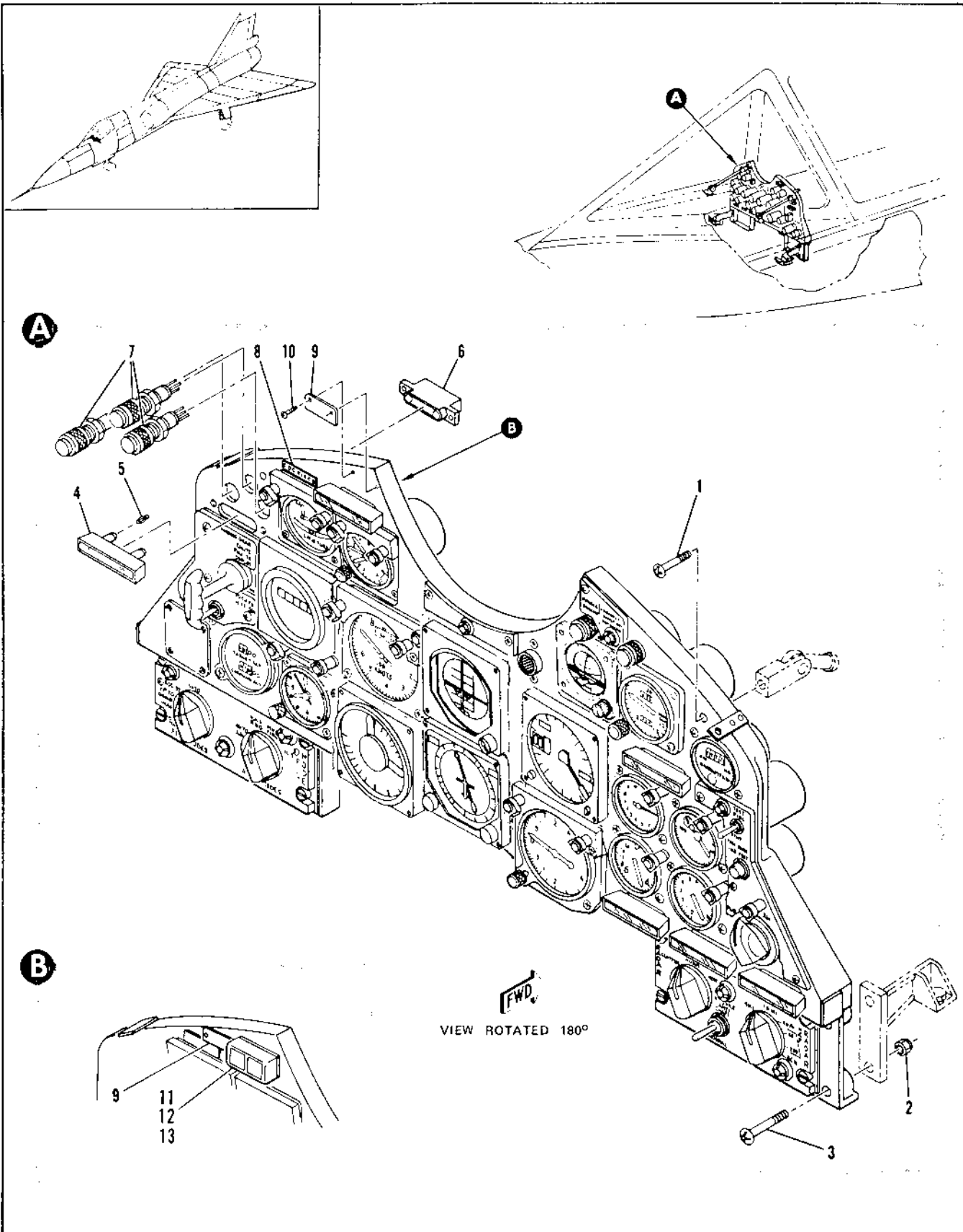

Figure 2.16-1. Pilot Instrument Panel Installation (Sheet 1 of 8)

FIGURE AND INDEX NUMBER	PART NUMBER	DESCRIPTION 1 2 3 4 5 6	UNITS PER ASSY.	USABLE ON CODE	
				FROM	TO
2.16-1	R-36056--17	PANEL INSTALLATION, PILOT INSTRUMENT FOR NHA SEE FIG. 2.1-1	RF	A	
	R-36147-125	• EQUIPMENT ASSY, PILOT INSTRUMENT PANEL MODIFIED BY 64E35433 ATTACHING PARTS	1	A	
- 1	NK521-11812	• • SCREW, <02415> 97-91001-002	2	A	
- 2	NAS679A4	• • NUT, 96-37545-323	4	A	
- 3	AN520-416R20	• • SCREW	4	A	
		-----X-----			
- 4	R-94711-229	• • CAP INSTL, GEAR UNSAFE INDICATOR	1	A	
	M2V1-I	• • • CAP, <01590> SPEC 7-09469-21	1	A	
- 5	AN3121-313	• • • LAMP	2	A	
- 6	285-10	• • CASE, GEAR UNSAFE INDICATOR <01590> SPEC 8-09469-19	1	A	
- 7	VM911M199	• • LIGHT ASSY, PRESS TO TEST INDICATOR <07134> SPEC 9-06016-23	3	A	
- 8	R-38605-23	• • NAMEPLATE, DC ELECTRIC	1	A	
- 9	R-38497	• • NAMEPLATE, RADIO CALL	1	A	
- 10	MS21316-22	• • SCREW	2		
		-----X-----			
- 11	526-1573-004	• • CAP, <01590> TANK EMPTY INDICATOR	1		
- 12	042-1573-004	• • BASE <01590>	1		
- 13	MS25231-1819	• • LAMP	2		
		A AIRPLANES #35 THRU 47 AND 49 THRU 89			

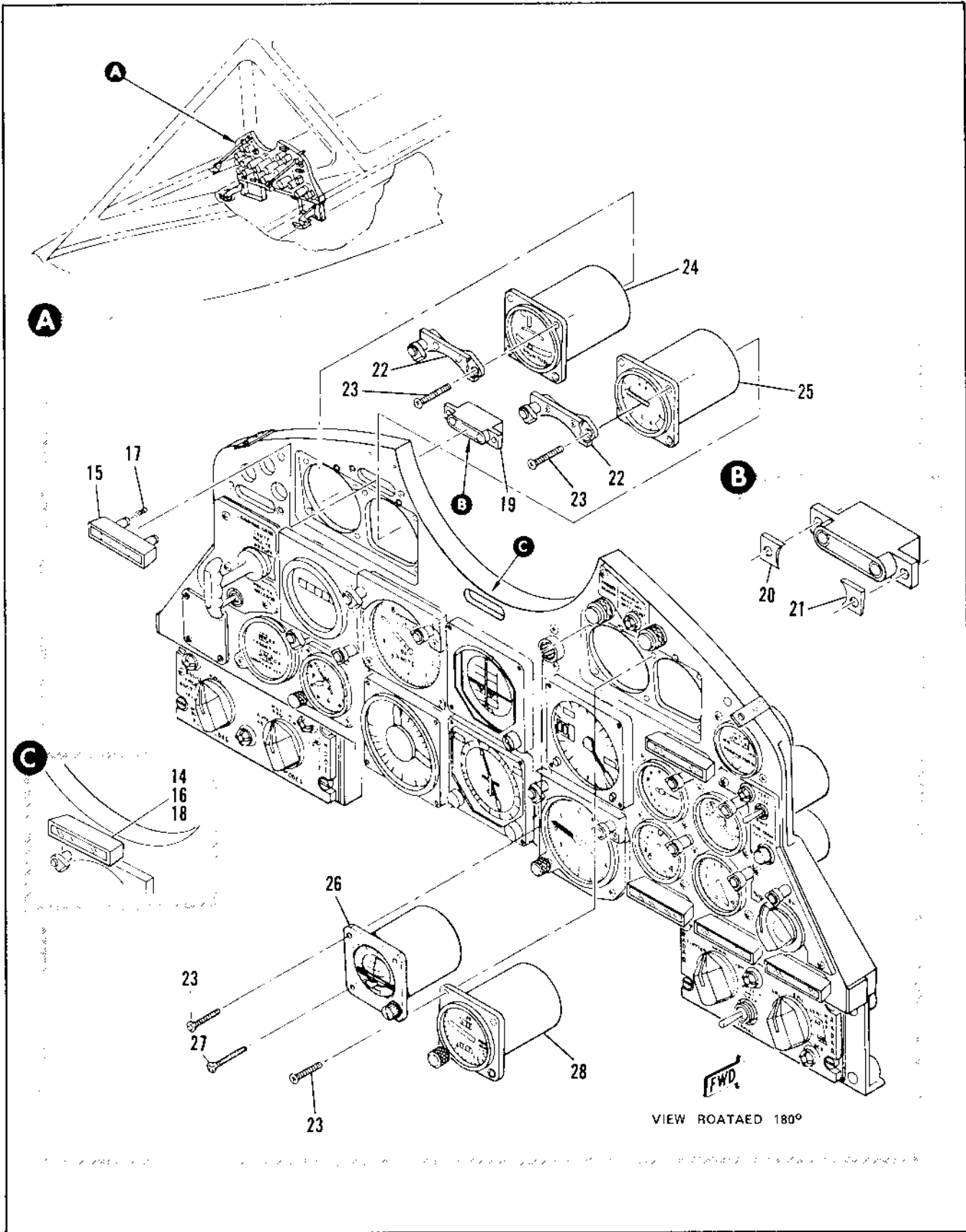

Figure 2.16-1. Pilot Instrument Panel Installation (Sheet 2 of 8)

FIGURE AND INDEX NUMBER	PART NUMBER	DESCRIPTION	UNITS PER ASSY.	USABLE ON CODE	
				FROM	TO
		1 2 3 4 5 6			
2.16-1	A-94711-223	• • CAP INSTL, MAXIMUM MANEUVER LIMIT INDICATOR	1	A	
- 14	N2V2-1	• • • CAP, <P1590> SPEC A-09469-5	1	A	
- 15	R26-1573-004	CAP (#1590) TANK EMPTY INDICATOR	1		
- 16	AN3121-313	• • • LAMP	2	A	
- 17	MS25231-1819	LAMP	2		
- 18	240-1A	• • BASE, MAXIMUM MANEUVER LIMIT INDICATOR <81590> SPEC 8-09469-7	1	A	
- 19	242-1573-004	BASE (#1590)	1		
- 20	B-95686-0	• • SHIM	1	A	
- 21	B-95686-7	• • SHIM	1	A	
- 22	B8745-2	• • LIGHT ASSY, <72914> SPEC A-0273-1 ATTACHING PARTS	4	A	
- 23	AN567-632R16	• • SCREW -----X-----	8	A	
- 24	MS28241-1	• • INDICATOR, TURN AND SLIP 4 MINUTE TURN WITH A1050	RF	A	
- 25	AC106-1P	• • INDICATOR, CABIN AIR PRESSURE <75485> WITH AC106	RF	A	
- 26	ARC42A/2	• • INDICATOR, STDBY ATTITUDE	1		
- 27	MS35206-323	• • SCREW	1		
- 28	R807-16	• • INDICATOR, PRESSURE RATIO <70212>	1	A	
A AIRPLANES #35 THRU 47 AND 49 THRU 89					

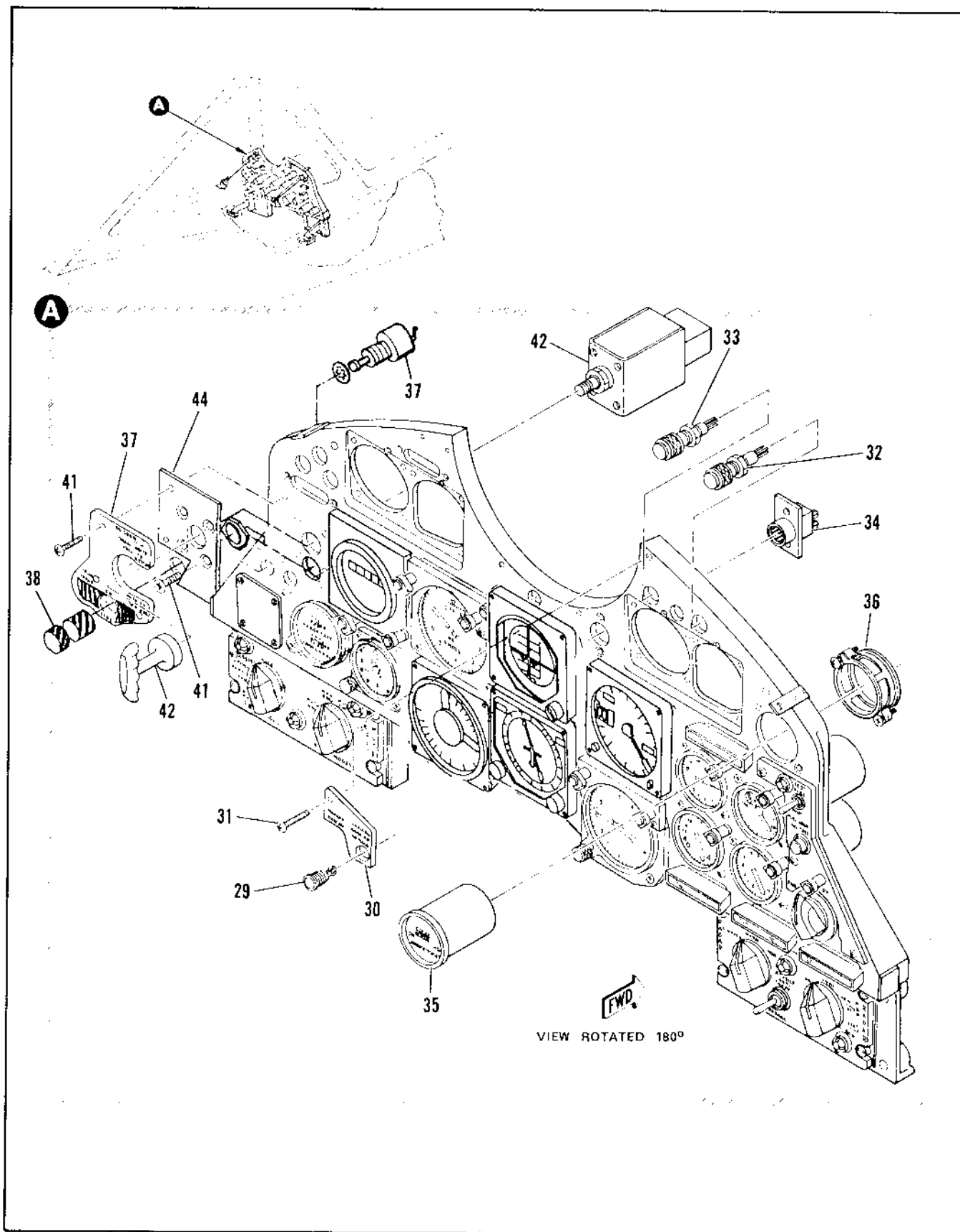

Figure 2.16-1. Pilot Instrument Panel Installation (Sheet 3 of 8)

FIGURE AND INDEX NUMBER	PART NUMBER	DESCRIPTION	UNITS PER ASSY.	USABLE ON CODE	
				FROM	TO
		1 2 3 4 5 6			
2.16-1- 29	107A	• • RECEPTACLE, <04211> SPEC P-09394-23	1	A	
- 30	18-1024-27	• • NAMEPLATE, MARKER BEACON VARIABLE RAMP RETRACTED <07109> SPEC P-09394-27 ATTACHING PARTS	1	A	
- 31	AN515-6R8	• • SCREW -----X-----	1	A	
- 32	VM911M208	• • LIGHT INDICATOR VARIABLE RAMP NOT RETRACTED (87034) SPEC 8-06916-25 INCH6 WITH PART NO. MS25041-8	1	A	
- 33	MS25041-3	• • LIGHT INDICATOR, MARKER BEACON 96906	1	A	
- 34	464334-150	• • ANNUNCIATOR, COMPUTER MODE <02577>	1	A	
- 35	464259-150	• • CONTROL, ANALOG SIGNAL BAROMETER SETTING <02577> T.O. 11F13-24-2-14	1	A	
- 36	18117	• • CLAMP, <94625> 91-07103-057 SPEC 8-13391-13	1	A	
- 37	A314AMS3B	• • SWITCH, BARRIER HOOK RELEASE WARNING LIGHT	1	A	
- 38	6603A551-7	• • EXTENSION SWITCH GUARD	1	A	
- 39	107A	• • RECEPTACLE, <04211> SPEC P-09394-23	1	C	
- 40	0-61392	• • NAMEPLATE, DRAG CHUTE AND BARRIER HOOK DOWN ATTACHING PARTS	1	C	
- 41	AN51568R12	• • SCREW -----X-----	3	C	
- 42	11-2161-001	• • CONTROL ASSY, DRAG CHUTE RELEASE REPLACES SUITABLE SUB FOR 12375, P-09388-1 ATTACHING PARTS	1 XXX	35 XXX	XXX
- 43	MS24694S48	• • SCREW -----X-----	4	A	
- 44	0-38627-11	• • DOUBLER	1	A	
<p>A AIRPLANES #35 THRU 47 AND 49 THRU 89 B AIRPLANES #36 THRU 47 AND 49 THRU 89 C AIRPLANES #35 THRU 47 AND 49 THRU 60 D AIRPLANES #44 THRU 47 AND 49 THRU 89</p>					

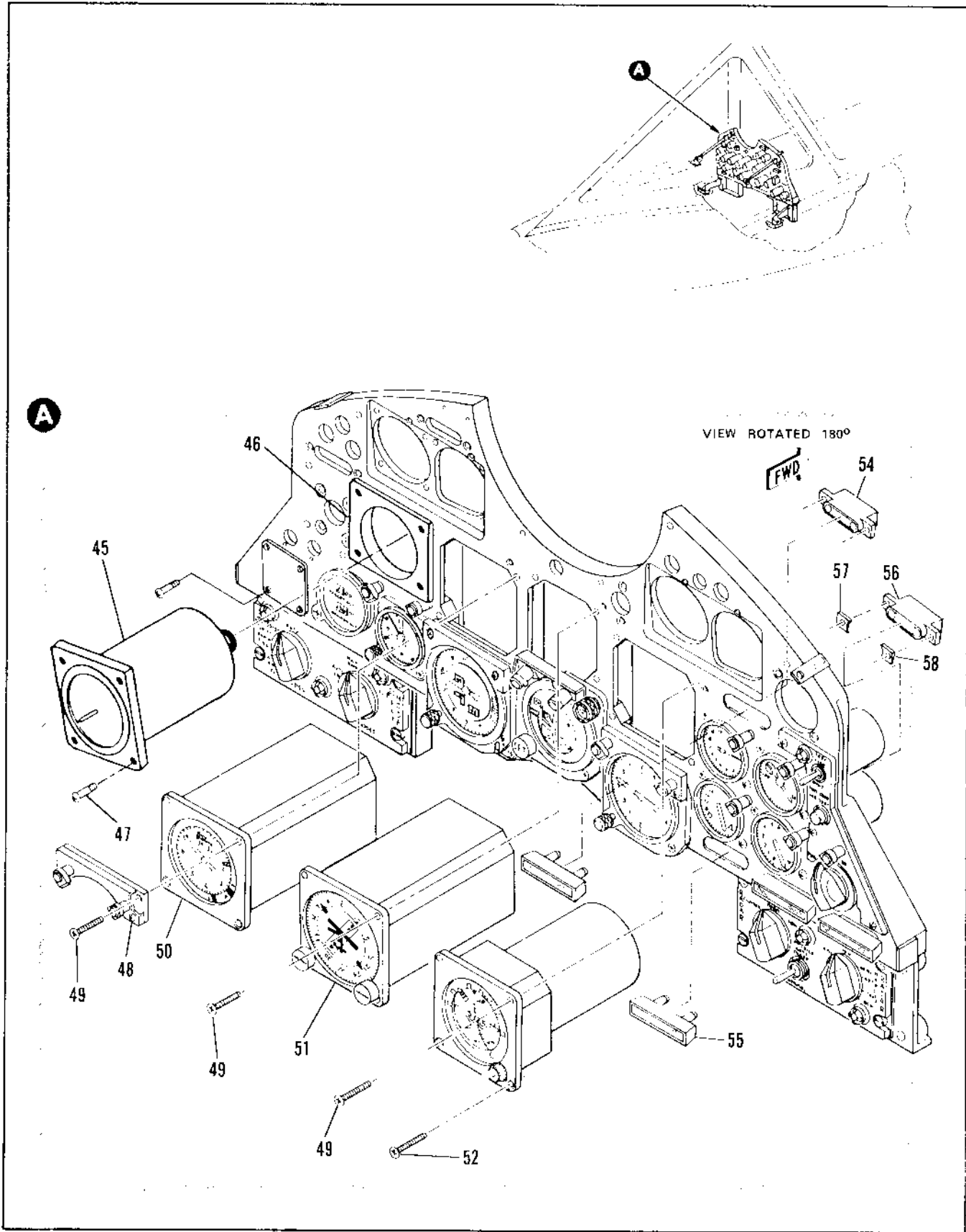

Figure 2.16-1. Pilot Instrument Panel Installation (Sheet 4 of 8)

FIGURE AND INDEX NUMBER	PART NUMBER	DESCRIPTION	UNITS PER ASSY.	USABLE ON CODE	
				FROM	TO
		1 2 3 4 5 6			
- 42	1D-1961	• • INDICATOR, UHF CHANNEL (87690)	1		
- 43	2R419-1P	• • ADAPTER, UHF CHANNEL	1		
- 44	MS35024-232	• • SCREW	9		
- 45	R5611	• • LIGHT ASSY, INDICATOR (K77014) 93-2301-213 ATTACHED PARTS	1	A	
- 46	AN517-63811	• • SCREW -----X-----	1	A	
- 51	A29381-04-106	• • INDICATOR, AIRSPEED (K09944) SPEC # 4252-3 I.D., 5F4-2-26-4 REPLACES SUITABLE SUB FOR A793-1-04-001	1		
- 51	7728-010-2	• • INDICATOR, ATTITUDE DIFECTOR (86197)	4	A	
- 52	AN517-63811	• • SCREW	4	A	
- 53	N2V1-2	• • CAP, (K1590) SPEC # 29469-25 REPLACES NOT INTCHG WITH N2V2-1	1	A	
- 54	AN3121-313 285-1F	• • LAMP • • BASE, FIRE WARNING INDICATOR (81590) SPEC # 29469-27 REPLACES NOT INTCHG WITH 281-1C	2 1	A A	
- 55	N2V1-1	• • CAP, (K1590) SPEC # 29469-25 REPLACES NOT INTCHG WITH N2V2-2	1	A	
- 56	AN3121-313 285-1F	• • LAMP • • BASE, CANOPY UNLOCK INDICATOR (81590) SPEC # 29469-27 REPLACES NOT INTCHG WITH 281-1C	2 1	A A	RP
- 57	R-95486-8	• • SWITCH	1	B	
- 58	R-95486-7	• • SWITCH	1	B	
- 59	AAU-107A	• • ALTIMETER	1	A	
- 61	MS35214-31	• • SCREW	4	A	
		A AIRPLANES #35 THRU 47 AND 49 THRU 89			
		B AIRPLANES #36 THRU 47 AND 49 THRU 89			
		C AIRPLANES #38 THRU 47 AND 49 THRU 89			

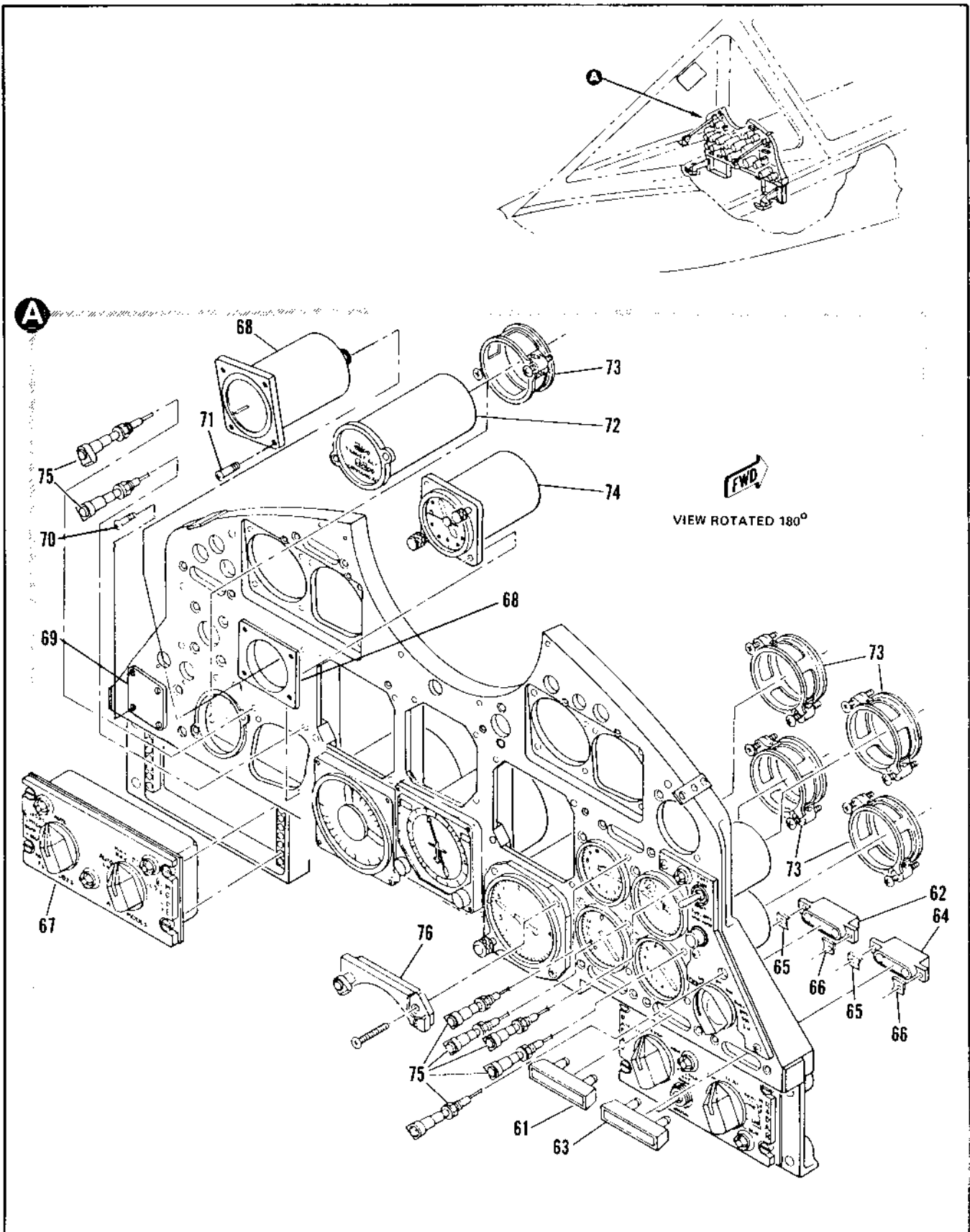

Figure 2.16-1. Pilot Instrument Panel Installation (Sheet 5 of 8)

FIGURE AND INDEX NUMBER	PART NUMBER	DESCRIPTION	UNITS PER ASSY.	USABLE ON CODE	
				FROM	TO
		1 2 3 4 5 6			
2.16-1	8-94711-235	• • CAP INSTL, MASTER WARNING INDICATOR	1	A	
- 61	N2V1-4	• • • CAP, <R1590> SPEC 8-09469-33	1	R	
	AN3121-313	• • • LAMP	2	A	
- 62	2R5-1G	• • BASE, MASTER WARNING INDICATOR <R1590> SPEC 8-09469-31	1	A	
	8-94711-237	• • CAP INSTL, HYDRAULIC FAILURE INDICATOR	1	A	
- 63	N2V1-5	• • • CAP, <R1590> SPEC 8-09469-37	1	A	
	AN3121-313	• • • LAMP	2	A	
- 64	2R5-1H	• • BASE, HYDRAULIC FAILURE INDICATOR <R1590> SPEC 8-09469-35	1	A	
- 65	8-95686-8	• • SHIM	2	A	
- 66	8-95686-7	• • SHIM	2	A	
- 67	464163	• • CONTROL, AFCS MODE <R2577>	1	A	
- 68	10-1961	• • INDICATOR, UHF CHANNEL <37695>	1		
- 69	7841459	• • ADAPTER, UHF CHANNEL INDICATOR			
- 70		• • COVER, PLATE	1		
- 71		• • SCREW	4		
	MS35205-232	• • SCREW 4			
- 72	464943	• • INDICATOR ASSY, COMMAND TARGET ALTITUDE <R2577>	1	A	
- 73	18110-1	• • CLAMP, <98625> 91-97100-301 SPEC 8-03381-7	5	A	
- 74	22322S-ET12	• • CLOCK, <79330> TYPE A-13A	1	A	
- 75	AR120	• • LIGHT, POST <72914> 93-82000-006	7	A	
- 76	R6610	• • LIGHT ASSY, INDICATOR <72914> 93-R2001-001	1	A	
		A AIRPLANES #35 THRU 47 AND 49 THRU 89			
		B AIRPLANES #36 THRU 47 AND 49 THRU 89			
		F AIRPLANES #36 THRU 47 AND 57 THRU 99			

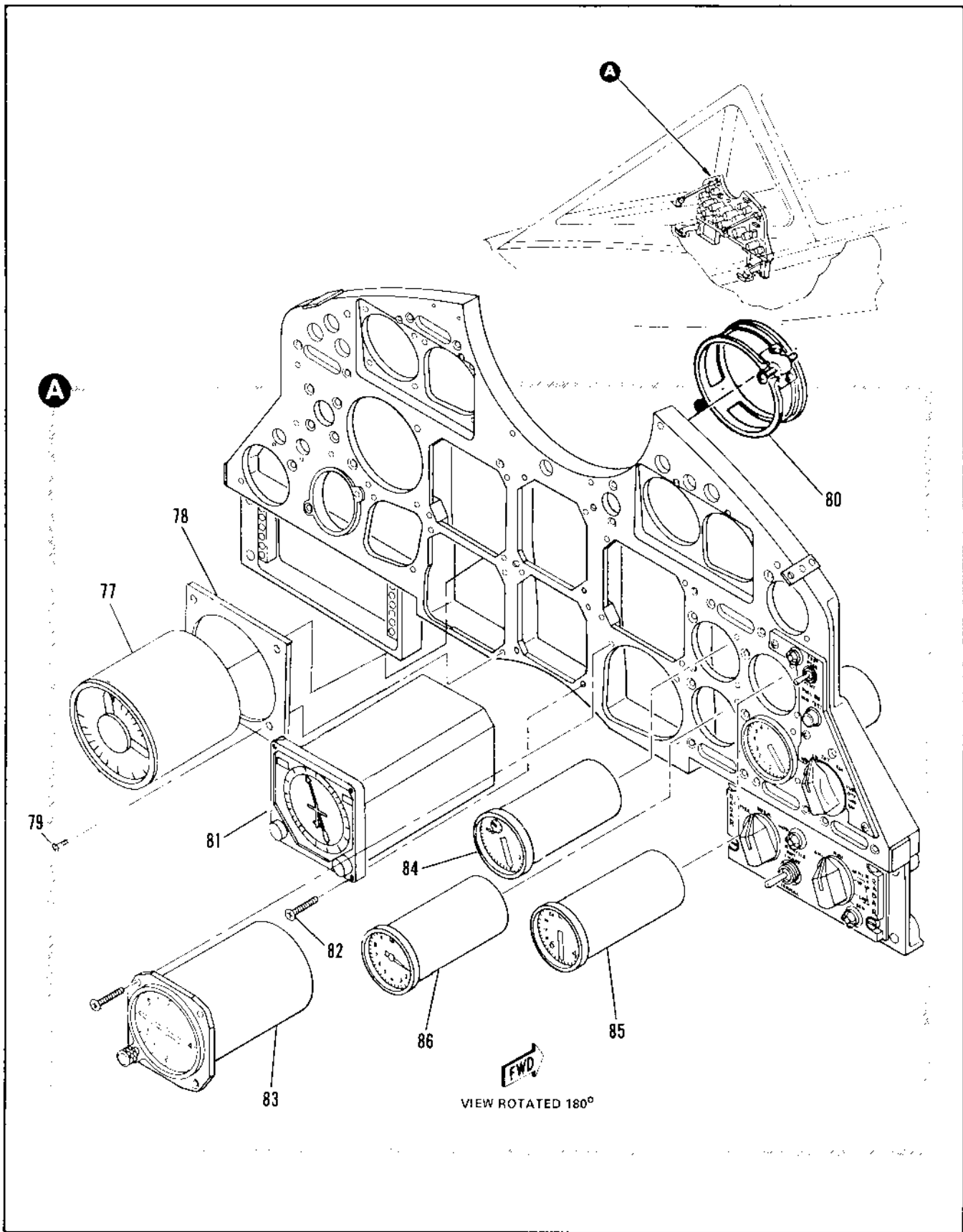

Figure 2.16-1. Pilot Instrument Panel Installation (Sheet 6 of 8)

FIGURE AND INDEX NUMBER	PART NUMBER	DESCRIPTION	UNITS PER ASSY.	USABLE ON CODE	
				FROM	TO
		1 2 3 4 5 6			
2.16-1- 77	464880	• • INDICATOR, MACH NUMBER (82577)	1		
- 78	7841459	• • ADAPTER, INSTRUMENT MACH NO.			
- 79	AN51985R16	• • SCREW	1	35	35
- 80	19114	• • CLAMP, (93625) 41-97100-303			
- 81	77001000-2	• • INDICATOR, HORIZONTAL SITUATION (86197) ATTACHING PARTS	4	A	
- 82	AN507-632R16	• • SCREW -----X-----	1	A	
- 83	MS28349-1	• • INDICATOR, RATE OF CLIMB ALT INTCHG WITH 715RKP-236	1	A	
- 84	8DJR1CAA1	• • INDICATOR, ELECTRICAL TACHOMETER (99427) TYPE MU-1	1	A	
- 85	25101B21C1B3	• • INDICATOR, FUEL FLOW RATE (19315) INTCHG WITH 25101B21B1B1	1		
- 86	0H1R5R51	• • INDICATOR, PROGRAMMER (99869)	1		
		A AIRPLANES #35 THRU 47 AND 49 THRU 89			

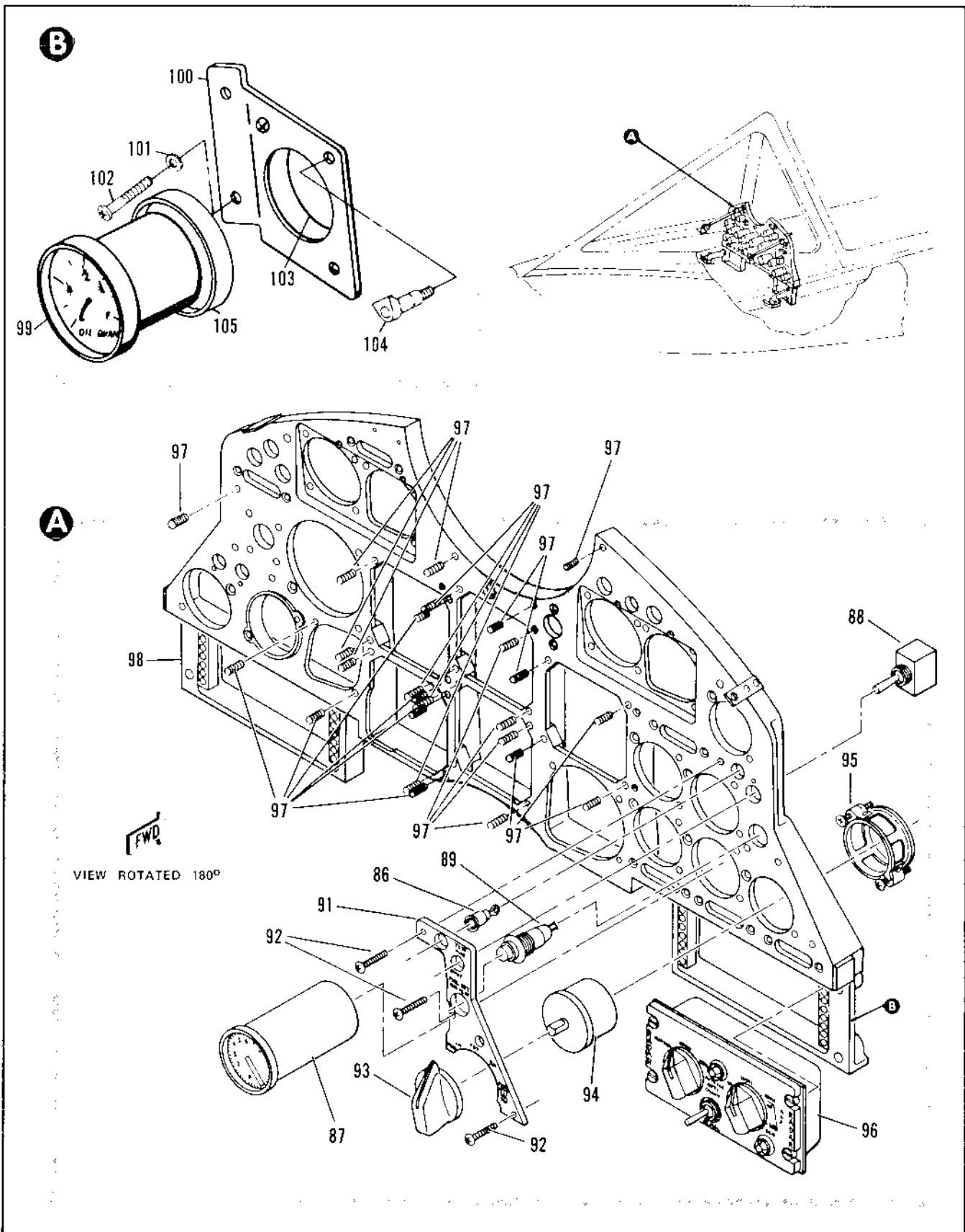

Figure 2.16-1. Pilot Instrument Panel Installation (Sheet 7 of 8)

FIGURE AND INDEX NUMBER	PART NUMBER	DESCRIPTION	UNITS PER ASSY.	USABLE ON CODE	
				FROM	TO
		1 2 3 4 5 6			
2.16-1- 87	JG402A16	• • INDICATOR ASSY, FUEL QUANTITY SELECTOR <40931> SPEC 8-03246-13 T.O.15L6-3-20-63	1	A	
- 88	R906K702	• • SWITCH, TEST FIRE OVERHEAT <15605> SPEC 8-06907-11	1	A	
- 89	MS25089-3C	• • SWITCH, FUEL QUANTITY TEST (81640) REPLACED BY NOT INTCHG WITH W103UB6CP	1	A	
- 90	105	• • RECEPTACLE, <04211> SPEC 8-C9394-21	1	A	
- 91	18-1005	• • NAMEPLATE, FUEL QUANTITY <07199> SPEC 8-C9394-19 REPLACED BY NOT INTCHG WITH 18-1027-37	1	35	47
	18-1005-31A	• • NAMEPLATE, FUEL QUANTITY <071E6> SPEC 8-C9394-31 ATTACHING PARTS	1	49	89
- 92	AN514-FR3	• • SCREW -----X-----	3	A	
- 93	PPM9341-1	• • KNOB, FUEL QUANTITY SELECTOR <01575> SPEC 8-09341-1 REPLACED BY PPM9341-5	1	A	
- 94	R655R10	• • SWITCH, FUEL QUANTITY SELECTOR (40931) ALT INTCHG WITH 8-61459-3 ATTACHING PARTS			
- 95	19719	• • CLAMP, <99625> 91-97100-006 SPEC 8-03381-15 -----X-----	1	A	
- 96	464375	• • CONTROL, RADAR SET (A2577)	1		
	8-38612-H01	• • PANEL ASSY, PILOT INSTRUMENT	1	35	47
	8-38612-A02	• • PANEL ASSY, PILOT INSTRUMENT	1	49	89
- 97	3585-06CNX1276	• • • INSERT, <91757> 85-03303-002	16	A	
- 98	62E35433-5	• • PANEL ALTERED FROM 8-38612-41 OR -43	1	A	
		A AIRPLANES #35 THRU 47 AND 49 THRU 89 B AIRPLANES #36 THRU 47 AND 49 THRU 89			

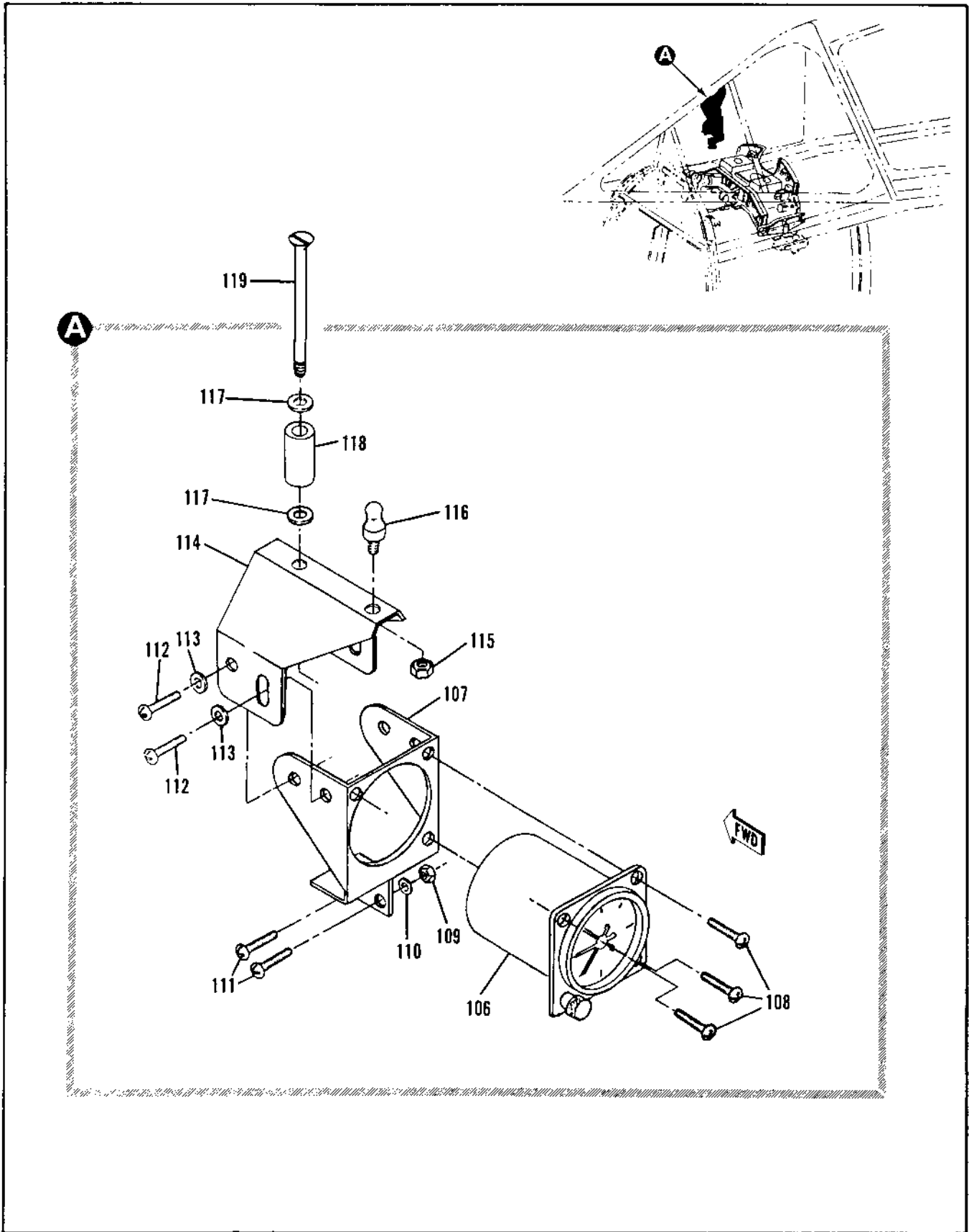

Figure 2.16-1. Pilot Instrument Panel Installation (Sheet 8 of 8)

FIGURE AND INDEX NUMBER	PART NUMBER	DESCRIPTION	UNITS PER ASSY.	USABLE ON CODE	
				FROM	TO
		1 2 3 4 5 6			
2.16-1- 99	1707-08-100-1	• • INDICATOR, OIL QUANTITY (24494)	1		
-100	1307-00-610-1	• • BRACKET (24494)	1		
		ATTACHING PARTS			
-101	NAS620-416L	• • WASHER	2		
		-----X-----			
-102	AN520-416R30	• • SCREW	2		
-103	MS28042-1	• • CLAMP	1		
-104	MS25499-1-327	• • POST LIGHT	1		
-105	63C35553-1	• SPACER	1		
-106	MS28325-1	• ACCELEROMETER	1		
-107	6RF37667-1	• MOUNT	1		
		ATTACHING PARTS			
-108	MS35206-231	• • SCREW	3		
-109	MS21083N06	• • NUT	2		
-110	AN960PD6L	• • WASHER	2		
-111	MS35206-229	• • SCREW	2		
-112	MS35206-245	• • SCREW	4		
-113	A4950P0R	• • WASHER	4		
-114	6RF37666-1	• • BRACKET	1		
-115	AN364-632	• • NUT	1		
-116	P116-421-6-3	• • STUD	1		
-117	AN950PD10	• • WASHER	2		
-118	NAS43003-72	• • SPACER	1		
-119	NAS533PA27	• • SCREW	1		

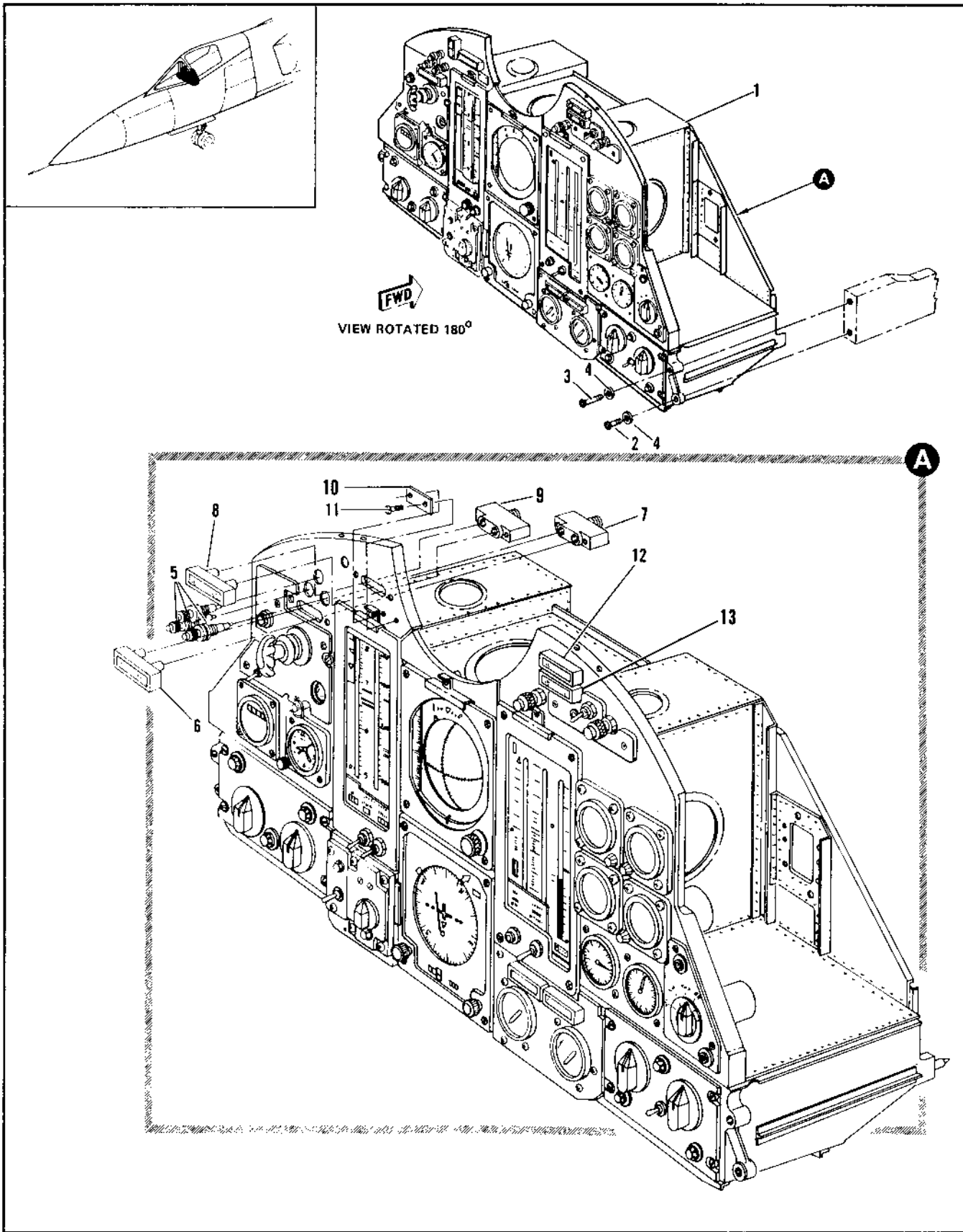

Figure 2.16-2. Pilot Instrument Panel Installation (Sheet 1 of 6)

FIGURE AND INDEX NUMBER	PART NUMBER	DESCRIPTION	UNITS PER ASSY.	USABLE ON CODE	
				FROM	TO
2.16-2-1	--3F102-809	• • EQUIPMENT ASSY, PILOT INSTRUMENT MODIFIED BY 62J15439 ATTACHING PARTS	1	A	
- 2	NAS464P3A4	• SCREW	2	A	
- 3	NAS464P3A14	• SCREW	2	A	
- 4	AN946-17	• WASHER	4	A	
		-----X-----			
	H-94711-257	• • LAMP INSTL, AIRPLANE LIGHTING	1	A	
	MS25237-327	• • • LAMP	3	A	
- 5	VM211M199	• • LIGHT, INDICATOR <R7734> SPEC 8-06916-23	3	A	
	H-94711-225	• • CAP INSTL, GEAR UNSAFE INDICATOR	1	A	
	AN3121-313	• • • LAMP	2	A	
- 6	N2V1-1	• • • CAP, GEAR UNSAFE INDICATOR <R1590> SPEC 8-09469-21	1	A	
- 7	285-10	• • BASE, GEAR UNSAFE INDICATOR <R1590> SPEC 8-09469-13	1	A	
	H-94711-223	• • CAP INSTL, MAXIMUM MANEUVER LIMIT	1	A	
	AN3121-313	• • • LAMP	2	A	
- 8	N2V2-1	• • • CAP, MAXIMUM MANEUVER LIMIT <R1590> SPEC 8-09469-5	1	A	
- 9	280-1A	• • BASE, MAXIMUM MANEUVER LIMIT <R1590> SPEC 8-09469-7	1	A	
- 10	H-39497	• • NAMEPLATE, RADIO CALL ATTACHING PARTS	1	A	
- 11	AN530-464	• • SCREW	2	A	
		-----X-----			
- 12	N2V1-2	• • • CAP, FIRE WARNING INDICATOR (R1590) SPEC 8-09469-25	1	A	
- 13	285-1F	• • BASE, FIRE WARNING INDICATOR (R1590) SPEC 8-09469-23	1	A	
	H-94711-235	• • CAP INSTL, MASTER WARNING INDICATOR	1	A	
	AN3121-313	• • • LAMP	2	A	
	N2V1-4	• • • CAP, MASTER WARNING INDICATOR (R1590) SPEC 8-09469-33	1	A	
	285-10	• • BASE, MASTER WARNING INDICATOR (R1590) SPEC 8-09469-31	1	A	
		A AIRPLANES BAR, 90 AND ON			

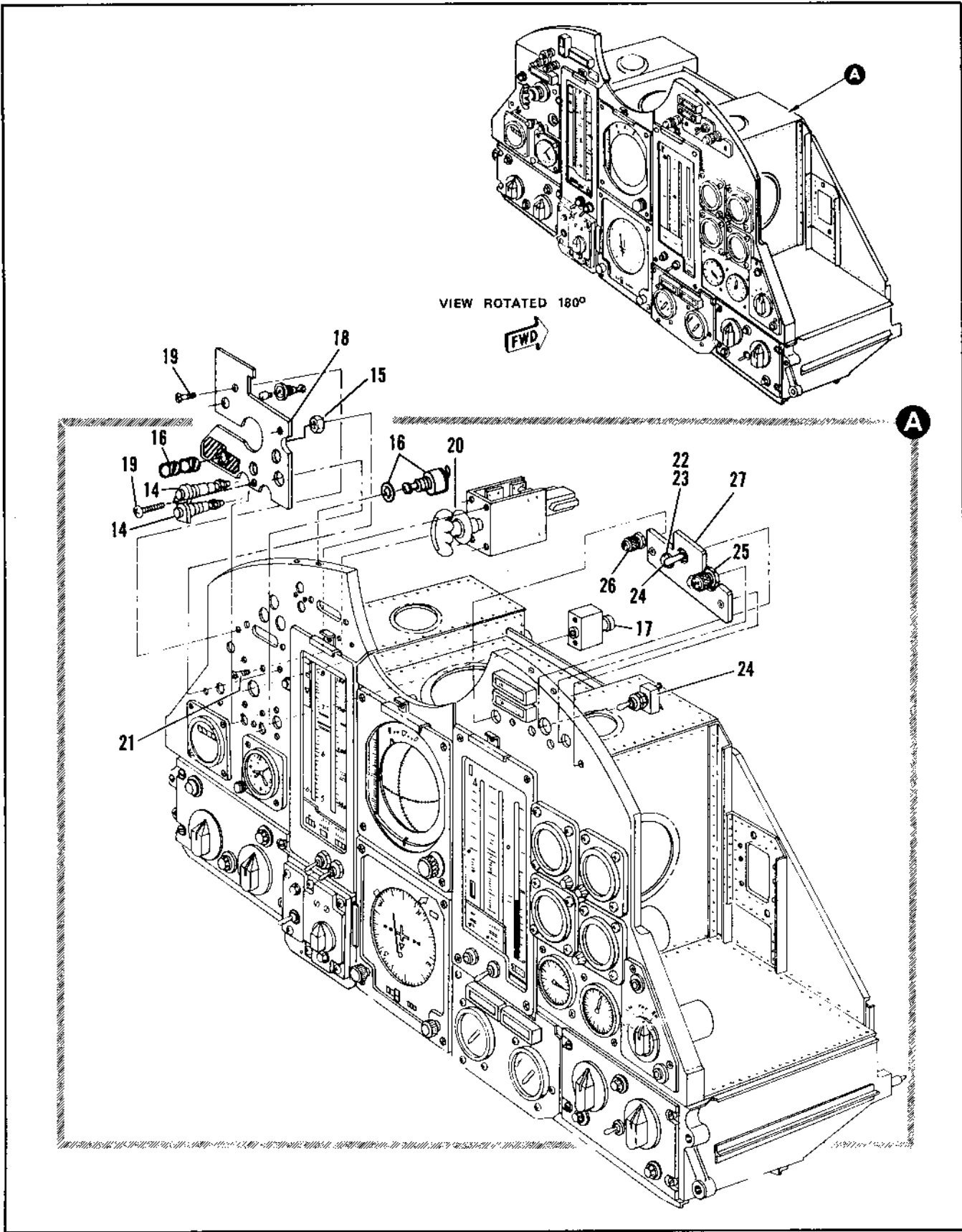

Figure 2.16-2. Pilot Instrument Panel Installation (Sheet 2 of 6)

FIGURE AND INDEX NUMBER	PART NUMBER	DESCRIPTION	UNITS PER ASSY.	USABLE ON CODE	
				FROM	TO
		1 2 3 4 5 6			
2.16-2	8-94711-255	• • LAMP INSTL, AIRPLANE LIGHTING	1	A	
	MS25237-327	• • • LAMP	2	A	
- 14	11160	• • LIGHT, INDICATOR POST <72914> SPEC 8-09439-3	2	A	
- 15	A314AMS3B	• • SWITCH, BARRIER HOOK RELEASE WARNING LIGHT	1	A	
- 16	66C38551-7	• • • EXTENSION SWITCH GUARD	1	A	
- 17	464034	• • ANNUNCIATOR, COMPUTER MODE <82577>	1	A	
- 18	18-1027-47	• • NAMEPLATE, DRAG CHUTE AND TAIL HOOK DOWN <87199> SPEC 8-09394-47 ATTACHING PARTS	1	A	
- 19	MS24694S3	• • SCREW	3		
- 20	11-2161-001	• • CONTROL ASSY, DRAG CHUTE RELEASE SWITCH <78710> SPEC 8-09389-3 T.O.2JAB-12-3 REPLACES SUITABLE SUB FOR 12375 ATTACHING PARTS	1	A	
			XXX	XXX	XXX
- 21	MS24694S3	• • SCREW	4	A	
		-----X-----			
- 22	8-94711-249	• • LAMP INSTL, AIRPLANE LIGHTING	1	A	
- 23	MS25237-327	• • • LAMP	2	A	
	107A	• • RECEPTACLE, PLASTIC PANEL LIGHTING (04211)	1	A	
- 24	8906K702	• • SWITCH, FIRE DETECTION TEST (15605) SPEC 8-06907-11	1	A	
- 25	42280	• • LIGHT, INDICATOR MARKER BEACON (72914) SPEC 8-09494-1 REPLACED BY INTCHG WITH 8-32891-1	1	A	
- 26	VM911M208	• • LIGHT VARIABLE RAMP NOT RETRACTED (87034) SPEC 8-06916-25 INTCHG WITH PART NO. MS25041-8	1		
- 27	63035514-3	• • PANEL ASSY, FIRE DETECTOR TEST	1	A	
		A AIRPLANES #48, 90 AND ON			

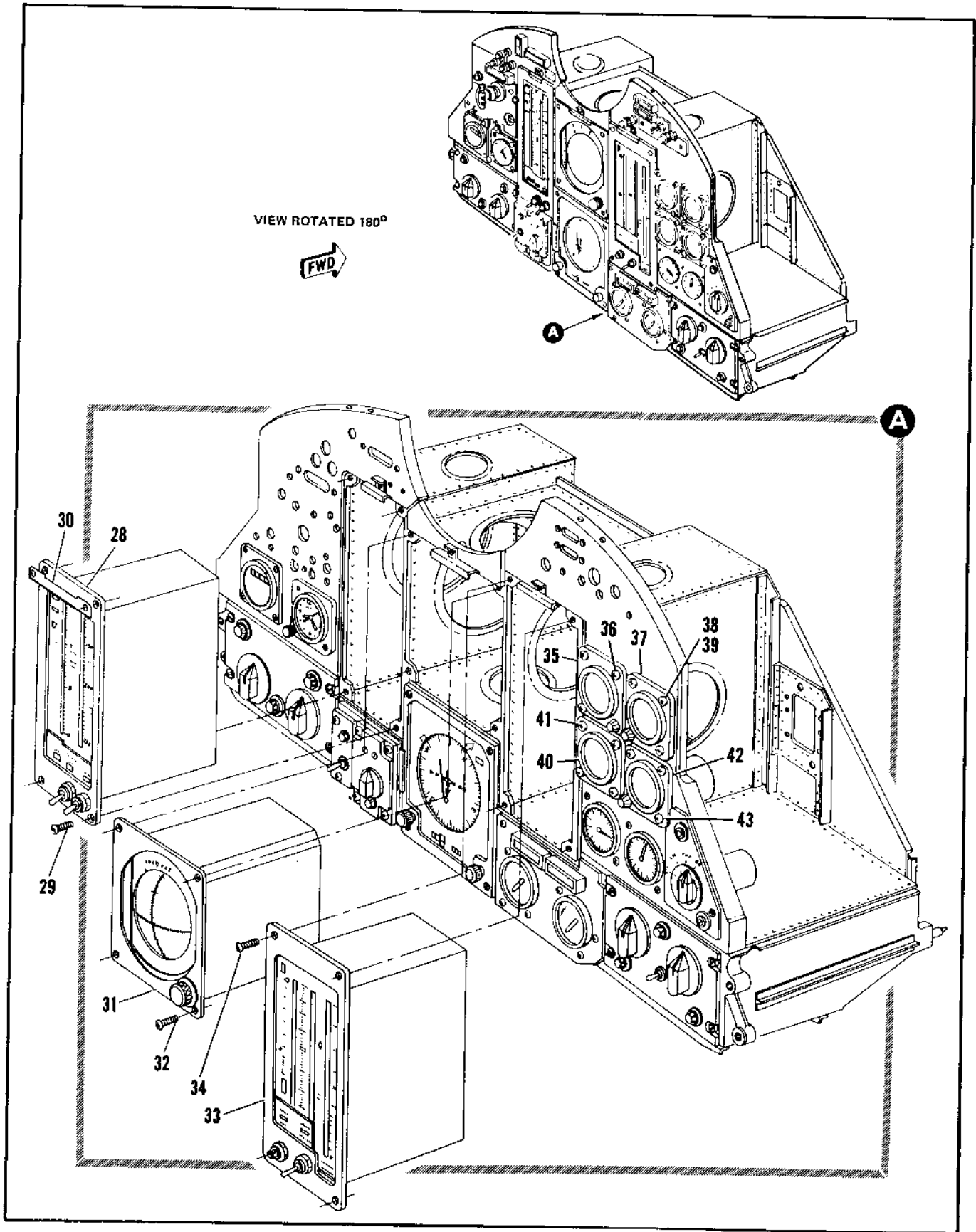

Figure 2.16-2. Pilot Instrument Panel Installation (Sheet 3 of 6)

FIGURE AND INDEX NUMBER	PART NUMBER	DESCRIPTION	UNITS PER ASSY.	USABLE ON CODE	
				FROM	TO
2.16-2- 28	MILA27329	• • INDICATOR, INDICATED AIRSPEED <19315> ATTACHING PARTS	1	A	
- 29	AN515-8R12	• • SCREW -----X-----	4	A	
- 30	8-95864-9	• • NAMEPLATE	1	A	
- 31	ARU-2R/A	• • INDICATOR, ATTITUDE DIRECTOR ATTACHING PARTS	1	A	
- 32	AN520-10R12	• • SCREW -----X-----	4	A	
- 33	18001-2A5B1	• • INDICATOR, ALTITUDE VERTICAL SPEED <19315> ATTACHING PARTS	1	A	
- 34	AN515-8R12	• • SCREW -----X-----	4	A	
- 35	ARU42/A-2	• • INDICATOR, STDBY ATTITUDE ATTACHING PARTS	1		
- 36	MS35206-232	• • SCREW -----X-----	3		
- 37	1587-9A1A1	• • INDICATOR, STDBY ALTIMETER ATTACHING PARTS	1		
- 38	MS35206-250	• • SCREW -----X-----	3		
- 39	NAS43003-16	• • SPACER	3		
- 40	1458-64A-A1	• • INDICATOR, STDBY AIRSPEED <19315> ATTACHING PARTS	3		
- 41	AN515-8R12	• • SCREW -----X-----	4		
- 42	9807-16	• • INDICATOR, THRUST (77045) ATTACHING PARTS	1		
- 43	AN515-6R12	• • SCREW -----X-----	3		
		A AIRPLANES #48, 90 AND ON			

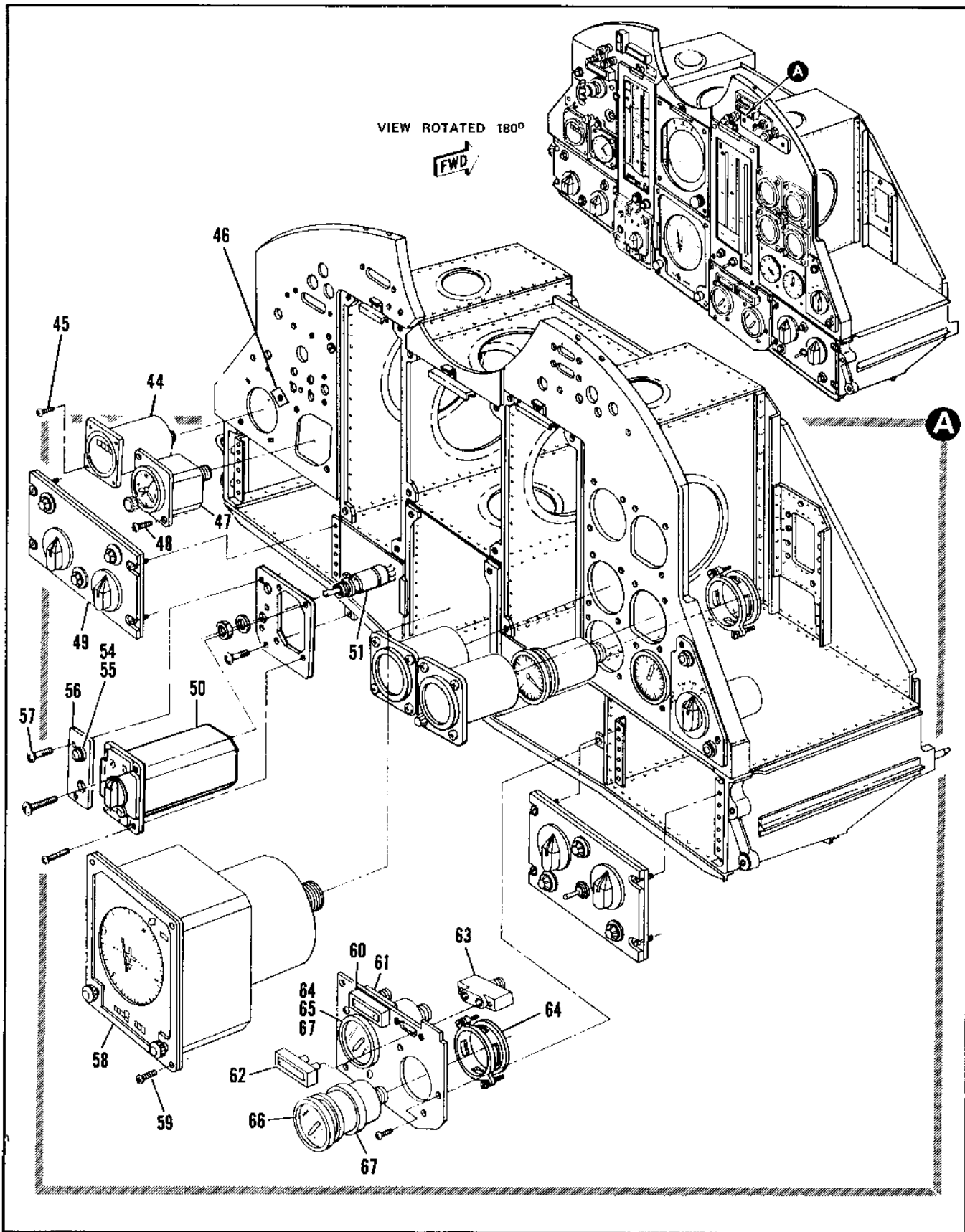

Figure 2.16-2. Pilot Instrument Panel Installation (Sheet 4 of 6)

FIGURE AND INDEX NUMBER	PART NUMBER	DESCRIPTION	UNITS PER ASSY.	USABLE ON CODE	
				FROM	TO
		1 2 3 4 5 6			
2.16-2- 44	1D-1961	• • INDICATOR, UHF CHANNEL (37695)	1		
- 45	MS35236-232	• • SCREW	4		
- 46	NAS447-16	• • NUT	4		
- 47	223225-ET12	• • CLOCK, EIGHT DAY AIRCRAFT MECHANICAL <79300> ATTACHING PARTS			
- 48	AN515-6R12	• • SCREW -----X-----	2	A	
- 49	464163-165	• • CONTROL, FLIGHT MODE AFCS <82577>	1	A	
- 50	464463	• • CONTROL, CONVERTER BEARING SELECTOR (82577) T.O.11F13-19-6-4 ATTACHING PARTS	1	A	
- 51	AN515-9R12	• • SCREW	2	A	
- 52	AN515-6R12	• • SCREW -----X-----	2	A	
- 53	8-06963-3	• • • SWITCH, HEADING SELECTOR (83008)	1		
- 54	MS25237-327	• • • LAMP	1	A	
- 55	107A	• • RECEPTACLE, PLASTIC PANEL LIGHTING (04211) SPEC 8-09394-23			
- 56	62035463-1	• • PANEL ASSY, PLASTIC HEADING SELECT ATTACHING PARTS	1	A	
- 57	AN515-6R8	• • SCREW -----X-----	2	A	
- 58	522-1393-003	• • INDICATOR, HORIZONTAL SITUATION <95105> REPLACED BY SUITABLE SUP 522-2411-003 ATTACHING PARTS	1	A	
- 59	AN520-10R12	• • SCREW -----X-----	4	A	
- 60	N2V1-3	• • • CAP, CANOPY UNLOCK INDICATOR (91590) SPEC 8-109469-27	1		
- 61	285-1F	• • BASE, CANOPY UNLOCK INDICATOR (91190) SPEC 8-09469-27	1		
	8-94711-237	• • CAP INSTL, HYDRAULIC FAILURE INDICATOR	1		
	AN3121-313	• • • LAMP	2		
- 62	N2V1-5	• • • CAP, HYDRAULIC FAILURE INDICATOR (91590) SPEC 8-09469-27	1		
- 63	285-1H	• • BASE, HYDRAULIC FAILURE INDICATOR (91590) SPEC 8-09469-27	1		
- 64	1811-1	• • CLAMP, INSTRUMENT PANEL MOUNTING (98425) SPEC 8-03391-7	2		
- 65	UG413A10	• • INDICATOR, FUEL QUANTITY (40931) SPEC 8-03392-3	1		
- 66	9837-4	• • INDICATOR, RATE OF FUEL FLOW (77145)	1		
- 67	63035553-1	• • SPACER	2		

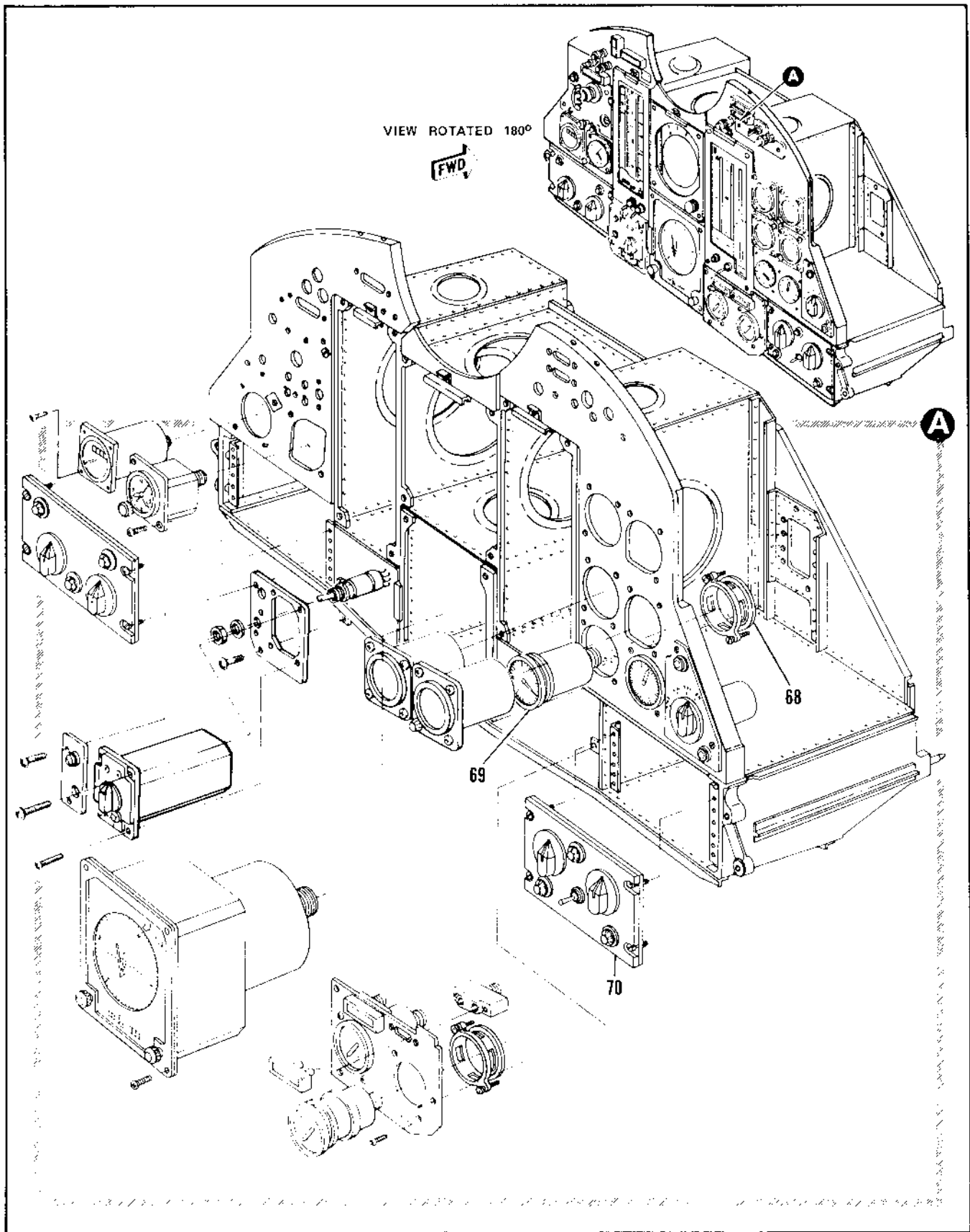

Figure 2.16-2. Pilot Instrument Panel Installation (Sheet 5 of 6)

FIGURE AND INDEX NUMBER	PART NUMBER	DESCRIPTION	UNITS PER ASSY.	USABLE ON CODE	
				FROM	TO
2.16-2- 68	18113-1	1 2 3 4 5 6 • • CLAMP, INSTRUMENT PANEL MOUNTING (98625) SPEC • • INDICATOR, PROGRAMMER (98869) • • CONTROL, RADAR SFT (42577)	1 2 1 1	A A A	
- 69	BH1R5R51				
- 70	454305	A AIRPLANES #43, 99 AND ON			

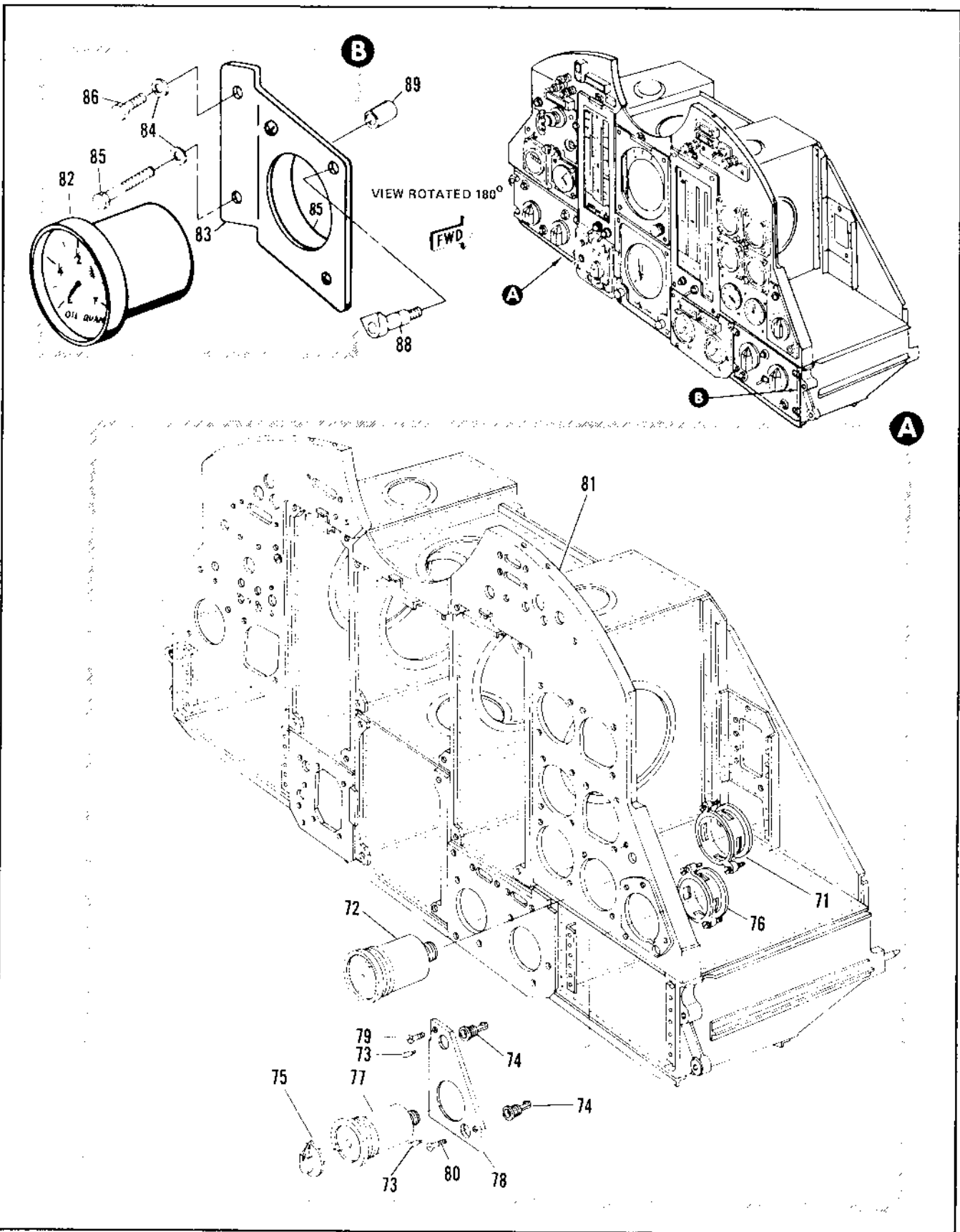

Figure 2.16-2. Pilot Instrument Panel Installation (Sheet 6 of 6)

FIGURE AND INDEX NUMBER	PART NUMBER	DESCRIPTION	UNITS PER ASSY.	USABLE ON CODE	
				FROM	TO
2.16-2- 71	1R110-1	• • CLAMP, INSTRUMENT PANEL MOUNTING <99425> SPEC R-073-1-7	1		A
- 72	PDJPLAA1	• • INDICATOR, ELECTRICAL TACHOMETER (24446)	1		A
- 73	MS25237-327	• • • LAMP	2		A
- 74	107A	• • RECEPTACLE, PLASTIC PANEL LIGHTING <14211> <19394-23	1		A
- 75	PPMR341-1	• • KNOB, FUEL QUANTITY SELECTOR <01515> SPEC R-09341-1	1		A
- 76	19719	• • CLAMP, INSTRUMENT PANEL MOUNTING <99425> SPEC R-033-1-15	1		A
- 77	RC55R10	• • SWITCH, FUEL QUANTITY SELECTOR (40931)			
- 78	6203-465-1	• • PANEL ASSY, PLASTIC FUEL QUANTITY SELECT ATTACHING PARTS	1		
- 79	AN515-6RH	• • SCREW	1		A
- 80	AN515-6R12	• • SCREW	1		A
- 81	66E4-408-12	• • PANEL ASSY, PILOT INSTRUMENT ALTERED FROM R-13543 FOR BREAKDOWN SEE FIG. 2.16-5	1		C
- 82	1007-00-100-1	• • INDICATOR, OIL QUANTITY (24494)	1		
- 83	1007-00-604-1	• • BRACKET ATTACHING PARTS	1		
- 84	AN960-10	• • WASHER	2		
- 85	AN3-12A	• • BOLT	1		
- 86	AN3-7A	• • BOLT	1		
- 87	MS20042-1	• • CLAMP	1		
- 88	MS25449-1-329	• • POST LIGHT	1		
- 89	1007-00-606-1	• • SPACER	1		
- 90	6303553-1	• SPACER	1		
-----X----- A AIRPLANES #42, 93 AND 94 C AIRPLANES #44 AND 90 THRU 129					

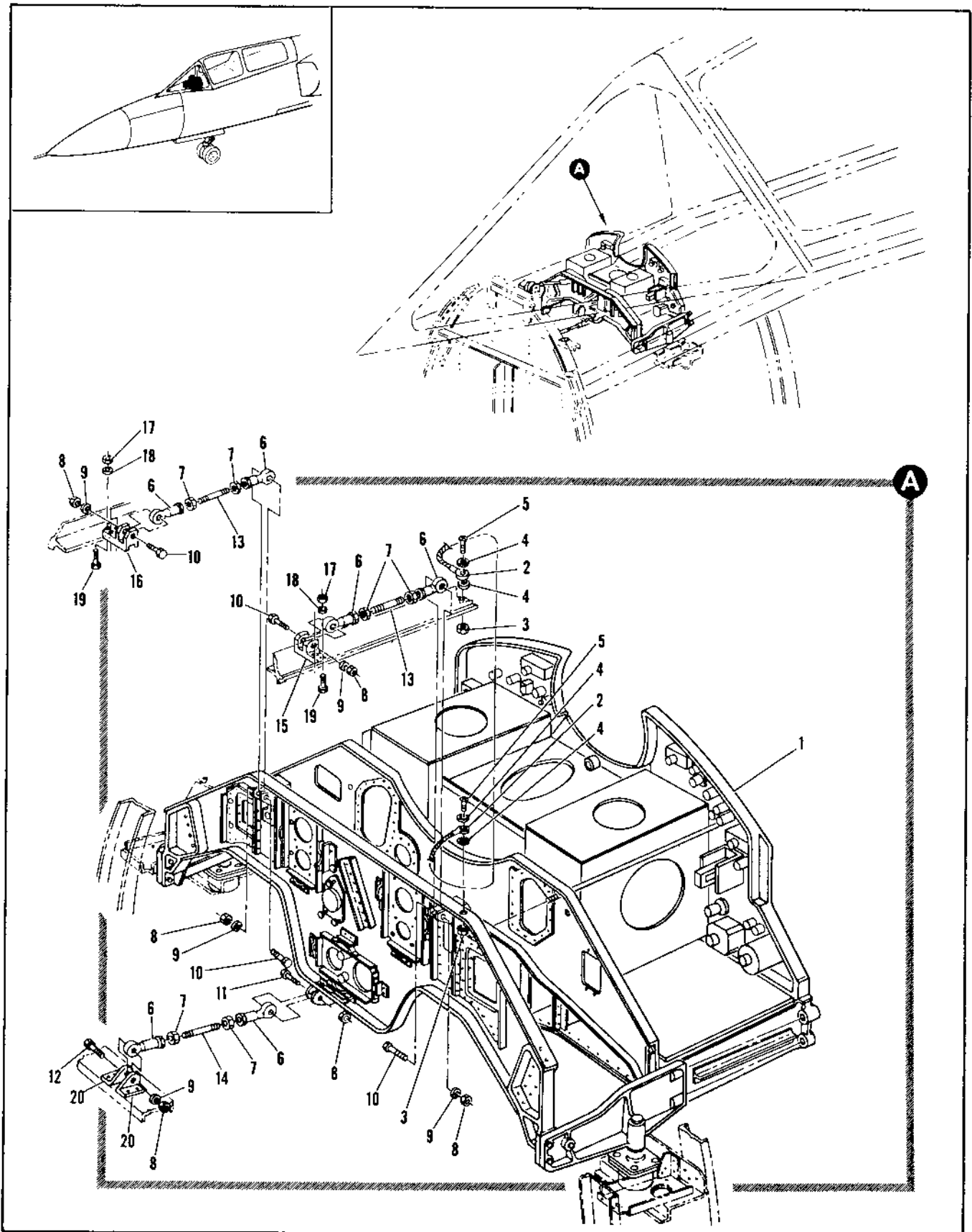

Figure 2-16-3. Pilot Instrument Panel Rack Installation (Sheet 1 of 2)

FIGURE AND INDEX NUMBER	PART NUMBER	DESCRIPTION	UNITS PER ASSY.	USABLE ON CODE	
				FROM	TO
2.16-3	R-95653	PACK INSTALLATION, PILOT INSTRUMENT PANEL FOR NHA SEE FIG. 2.13-4	RF		A
- 1		• EQUIPMENT ASSY, PILOT INSTRUMENT PANEL SEE FIG. 2.16-2	RF		
- 2	MS25083-1AA3	• JUMPER	1		A
- 3	H10-06	ATTACHING PARTS			
- 4	AN96006L	• NUT, GROUND STUD <75237> 96-37545-006	2		A
- 5	AN5260632-5	• WASHER, GROUND STUD	4		A
- 6	JB77-2-4	• BOLT, ROUND STUD	2		A
- 7	NAS679A3	-----X-----			
- 8	AN316-4	• MOUNT, ROD END <76105> 96-07508-001	6		A
- 9	AN960-10L	• NUT	6		A
- 10	AN23-16A	• NUT	6		A
- 11	AN23-14A	• WASHER	5		A
- 12	AN23-13A	• SCREW	4		A
- 13	NAS354-4-210	• SCREW	1		A
- 14	NAS354-4-250	• SCREW	1		A
- 15	R-95674-7	• ROD	2		A
- 16	R-95674-5	• ROD	1		A
- 17	NAS679A3	• FITTING, ROD SUPPORT LH	1		A
- 18	AN960-10L	• FITTING, ROD SUPPORT RH	1		A
- 19	AN23-10A	ATTACHING PARTS			
- 20	R-95653-15	• NUT	5		A
		• WASHER	6		A
		• SCREW	4		A
		-----X-----			
		• ANGLE	2		A
		A AIRPLANES #48, 50 AND ON			

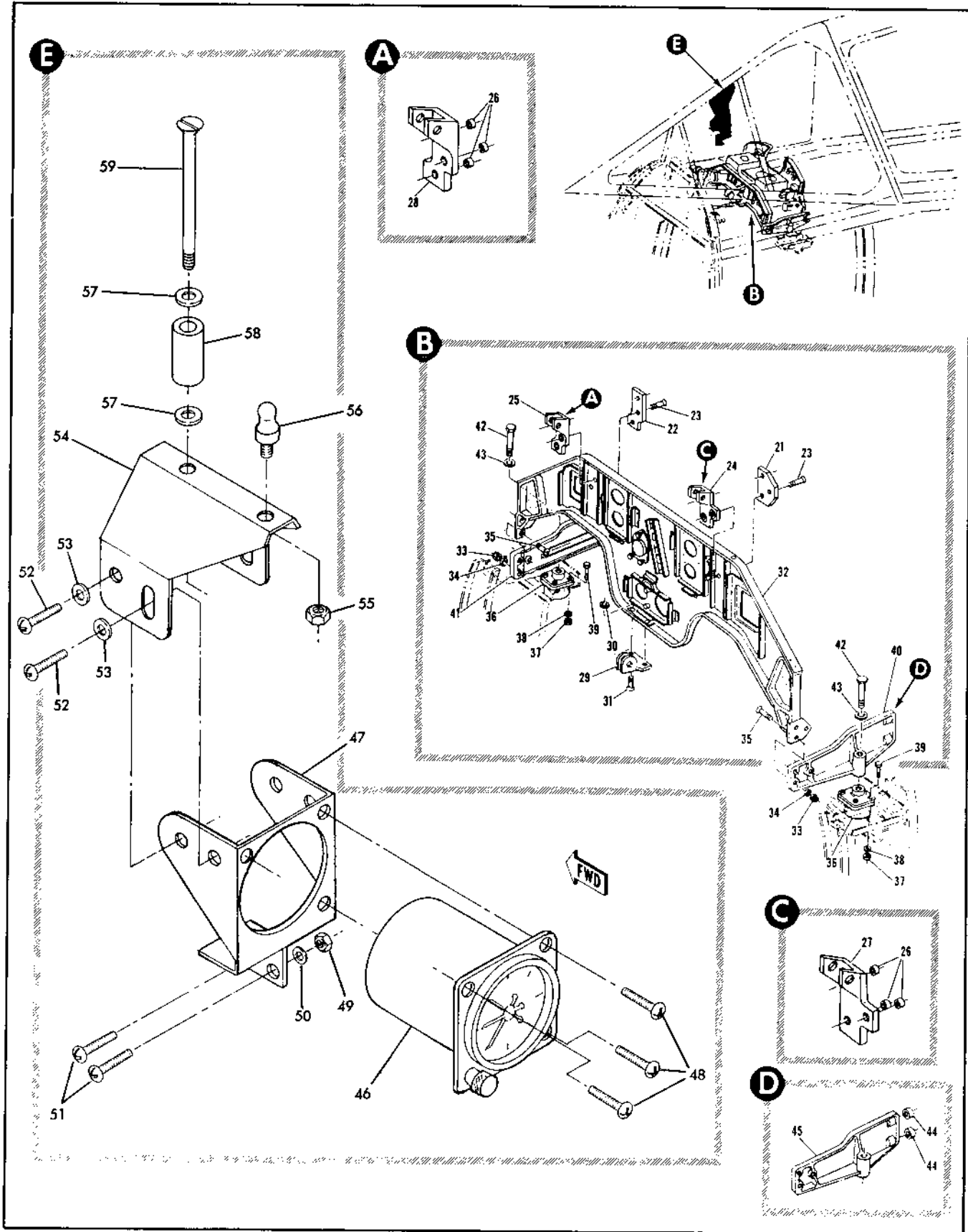

Figure 2.16-3. Pilot Instrument Panel Rack Installation (Sheet 2 of 2)

FIGURE AND INDEX NUMBER	PART NUMBER	DESCRIPTION	UNITS PER ASSY.	USABLE ON CODE	
				FROM	TO
		1 2 3 4 5 6			
2.16-3- 21	8-95675-7	• SPACER, LH	1	A	
- 22	8-95675-9	• SPACER, RH	1	A	
		ATTACHING PARTS			
- 23	AN521-10F10	• SCREW	6	A	
	62035438-1	• SPACER	1		
	62033464-1	• LOCK, ATTACHING	1		
		ATTACHING PARTS			
	MS35217-266	• SCREW	2		
		-----X-----			
- 24	8-95674-3	• FITTING ASSY, ROD SUPPORT LH	1	A	
- 25	8-95674-1	• FITTING ASSY, ROD SUPPORT RH	1	A	
- 26	3591-3CNX.380	• INSERT, <91767> 95-03033-380	3	A	
- 27	8-95674-13	• FITTING, LH	1	A	
- 28	8-95674-11	• FITTING, RH	1	A	
- 29	8-95674	• FITTING, ROD SUPPORT	1	A	
		ATTACHING PARTS			
- 30	NAS679A08	• NUT	2	A	
- 31	AN513-AR6	• SCREW	2	A	
		-----X-----			
- 32	62J35439-19	• PACK ASSY, PILOT INSTRUMENT PANEL ALTERED FROM 8-95633-7 FOR BREAKDOWN SEE FIG. 2.14-4	1	A	
		ATTACHING PARTS			
- 33	NAS679A3	• NUT	6	A	
- 34	AN955-10L	• WASHER	6	A	
- 35	NAS333-7	• SCREW	6	A	
		-----X-----			
- 36	UT2-80	• MOUNT, SHOCK <76005> 96-J7505-007 REPLACES NOT INCHT WITH K500-4	2	A	
		ATTACHING PARTS			
- 37	NAS679A7	• NUT	8	A	
- 38	AN950010L	• WASHER	8	A	
- 39	NAS221-13	• SCREW	8	A	
		-----X-----			
- 40	8-95654-1	• SUPPORT ASSY, INSTRUMENT PANEL PACK LH	1	A	
- 41	8-95654-2	• SUPPORT ASSY, INSTRUMENT PANEL PACK RH	1	A	
		ATTACHING PARTS			
- 42	AN176H13	• BOLT	2	A	
- 43	AN9600616	• WASHER	2	A	
		-----X-----			
- 44	3591-3CNX.380	• INSERT, <91767> 95-03033-380	2	A	
- 45	8-95654-8	• SUPPORT, LH MAKE FROM 8-95654-7	1	A	
	8-95654-7	• SUPPORT, LH	RF		
	8-95654-10	• SUPPORT, RH MAKE FROM 8-95654-8	1	A	
	8-95654-9	• SUPPORT, RH	RF		
- 46	MS20125-1	• ACCELEROMETER	1	A	
- 47	68F37567-1	• MOUNT	1	A	
		ATTACHING PARTS			
- 48	MS35216-231	• SCREW	3	A	
- 49	MS21183M08	• NUT	2	A	
- 50	AN960000L	• WASHER	2	A	
- 51	MS35216-220	• SCREW	2	A	
- 52	MS35216-245	• SCREW	4	A	
- 53	AN961008	• WASHER	4	A	
- 54	68F37566-1	• BRACKET	1	A	
- 55	AN364-632	• NUT	1	A	
- 56	P116-421-6-7	• STUD	1	A	
- 57	AN9600010	• WASHER	2	A	
- 58	NAS43003-72	• SPACER	1	A	
- 59	NAS333PA77	• SCREW	1	A	
		-----X-----			
		A AIRPLANES 848, 90 AND 6N			

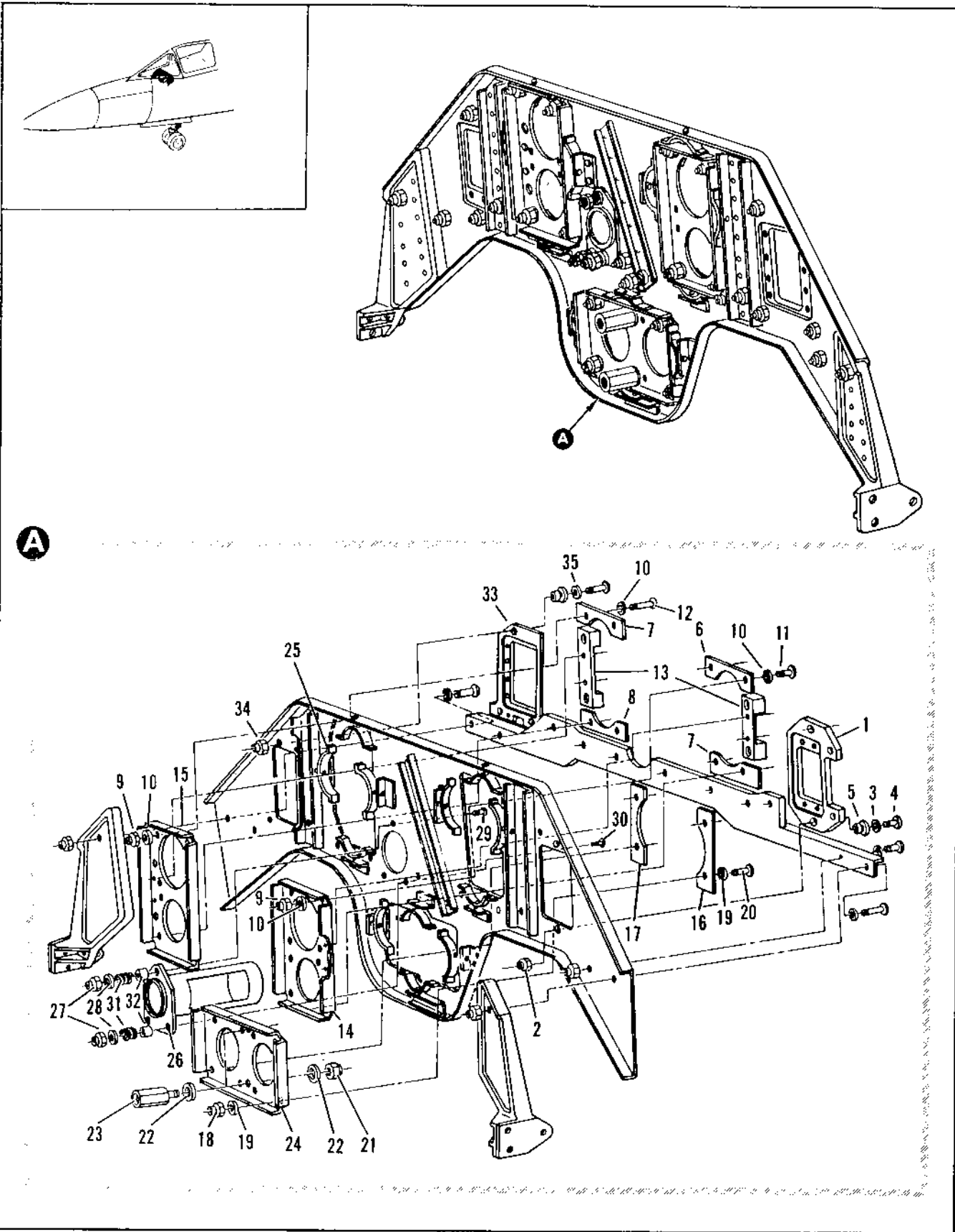

Figure 2.16-4. Pilot Instrument Panel Rack Assembly (Sheet 1 of 2)

FIGURE AND INDEX NUMBER	PART NUMBER	DESCRIPTION	UNITS PER ASSY.	USABLE ON CODE	
				FROM	TO
2.16-4	62J35439-19	RACK ASSEMBLY, PILOT INSTRUMENT PANEL ALTERED FROM 8-95653-7 FOR NHA SEE FIG. 2.15-3	RF	A	
- 1	8-95672-7	• PLATE, ADAPTER • ATTACHING PARTS	1	A	
- 2	NAS679A08	• NUT	2	A	
- 3	AN960-8L	• WASHER	2	A	
- 4	NAS221-9	• SCREW	2	A	
- 5	8-95673-7	• SPACER	2	A	
		-----X-----			
	8-95653-65	• PLATE ASSY, INSTRUMENT PANEL RACK LH	1	A	
	8-95653-67	• PLATE ASSY, INSTRUMENT PANEL RACK RH	1	A	
- 6	8-95653-57	• PLATE, MOUNTING LH	1	A	
- 7	8-95653-59	• PLATE, MOUNTING	1	A	
- 8	8-95653-61	• PLATE, MOUNTING RH • ATTACHING PARTS	1	A	
- 9	NAS679A04	• NUT	8	A	
- 10	AN960-4	• WASHER	16	48	48
	99-51509-053	• SPACER	8	90	
	AN960-4L	• WASHER, ALT INTCHG WITH 99-51509-053	RF	90	
- 11	NAS600-4	• SCREW, LH	4	A	
- 12	NAS610-6	• SCREW, RH	4	A	
		-----X-----			
- 13	8-95665-49	• GUIDE	2	A	
- 14	8-95653-51	• MOUNT, PLUG LH	1	A	
- 15	8-95653-53	• MOUNT, PLUG RH	1	A	
	8-95653-63	• PLATE ASSY, INSTRUMENT PANEL RACK	1	A	
- 16	8-95653-56	• PLATE, MOUNTING LH	1	A	
- 17	8-95653-57	• PLATE, MOUNTING RH • ATTACHING PARTS	1	A	
- 18	NAS679A08	• NUT	4	A	
- 19	AN960-4	• WASHER	8	48	48
	99-51509-053	• SPACER	4	90	
	AN960-4L	• WASHER, ALT INTCHG WITH 99-51509-053	RF	90	
- 20	NAS600-4	• SCREW	4	A	
		-----X-----			
- 21	NAS679A08	• NUT	2	A	
- 22	AN960-8L	• WASHER	4	A	
- 23	8-95653-49	• GUIDE	2	A	
- 24	8-95653-55	• MOUNT, PLUG	1	A	
- 25	8-95667	• SPRING	12	A	
- 26	8-95666	• CONNECTOR ASSY, ATTITUDE IND INSTR RACK • ATTACHING PARTS	1	A	
- 27	NAS679A08	• NUT	3	A	
- 28	AN960-8L	• WASHER	3	A	
- 29	NAS610-11	• SCREW	1	A	
- 30	MS24674S14	• SCREW	2	48	48
	MS24674S11	• SCREW	1	90	
		-----X-----			
- 31	8-95672-1	• SPRING, INSTRUMENT RACK	3	A	
- 32	8-95666-7	• SPACER	3	A	
- 33	8-95671-7	• PLATE, ADAPTER • ATTACHING PARTS	1	A	
- 34	NAS679A08	• NUT	4	A	
- 35	AN960-8L	• WASHER	4	A	

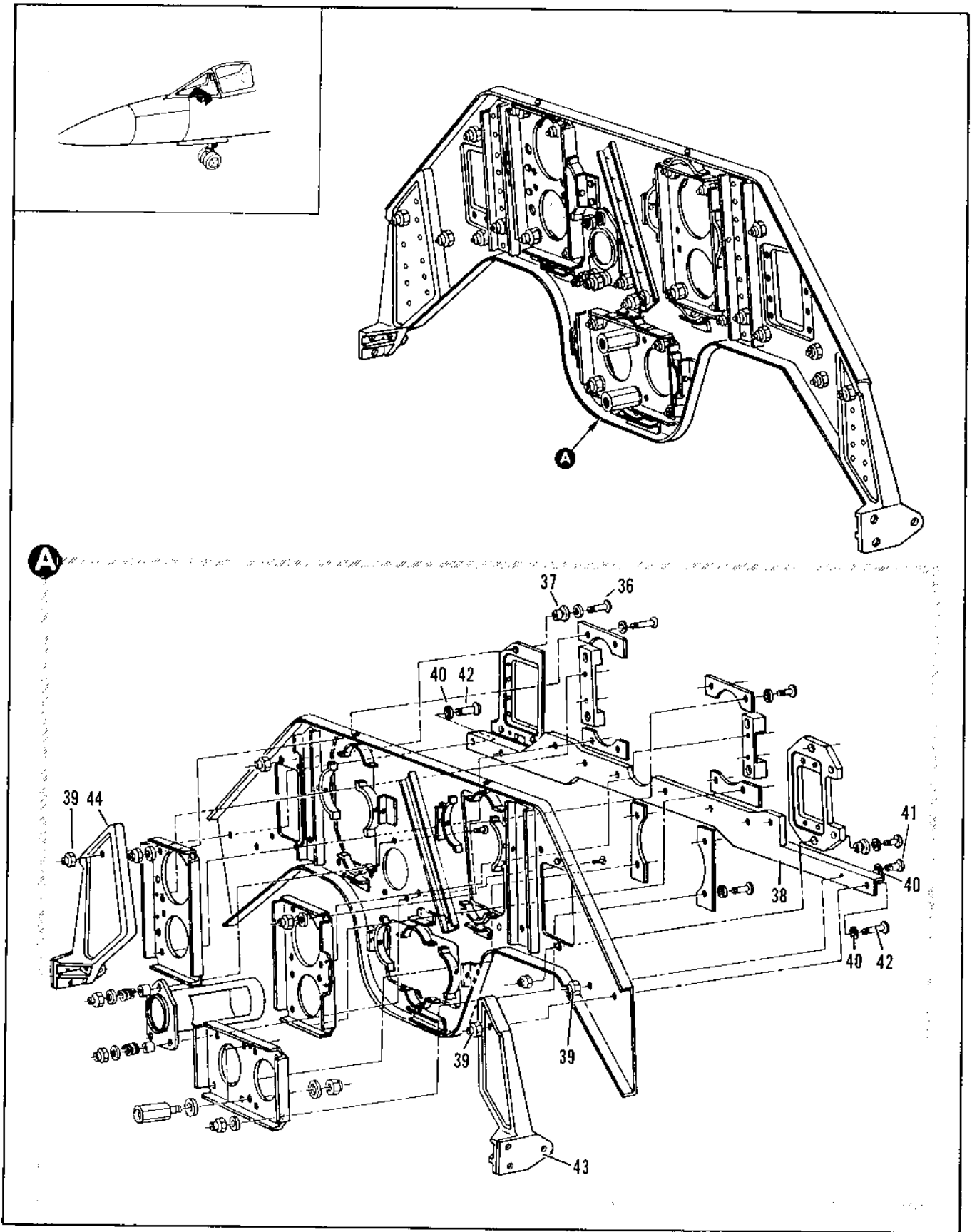

Figure 2.16-4. Pilot Instrument Panel Rack Assembly (Sheet 2 of 2)

FIGURE AND INDEX NUMBER	PART NUMBER	DESCRIPTION	UNITS PER ASSY.	USABLE ON CODE	
				FROM	TO
		1 2 3 4 5 6			
2.16-4- 36	NAS229-9	• SCREW	4		A
- 37	8-95673-7	• SPACER	4		A
	64J35439-19	-----X----- RACK ASSEMBLY, PILOT INSTRUMENT PANEL ALTERED FROM 8-95653-7 FOR NHA SEE FIG. 2-15-3	RF		A
- 38	62035497-1	• STIFFENER, INSTRUMENT RACK ALTERED FROM 8-5924 ATTACHING PARTS	1		A
- 39	NAS679A3	• NUT	13		A
- 40	AN950D13L	• WASHER	13		A
- 41	NAS221-7	• SCREW	11		A
- 42	NAS221-8	• SCREW	2		A
		-----X-----			
- 43	8-95655-9	• SUPPORT, INSTRUMENT PANEL LH	1		A
- 44	8-95655-10	• SUPPORT, INSTRUMENT PANEL RH	1		A
- 45	64J35439-17	• RACK ALTERED FROM 8-95662-7	1		
		A AIRPLANES #48, 90 AND ON			

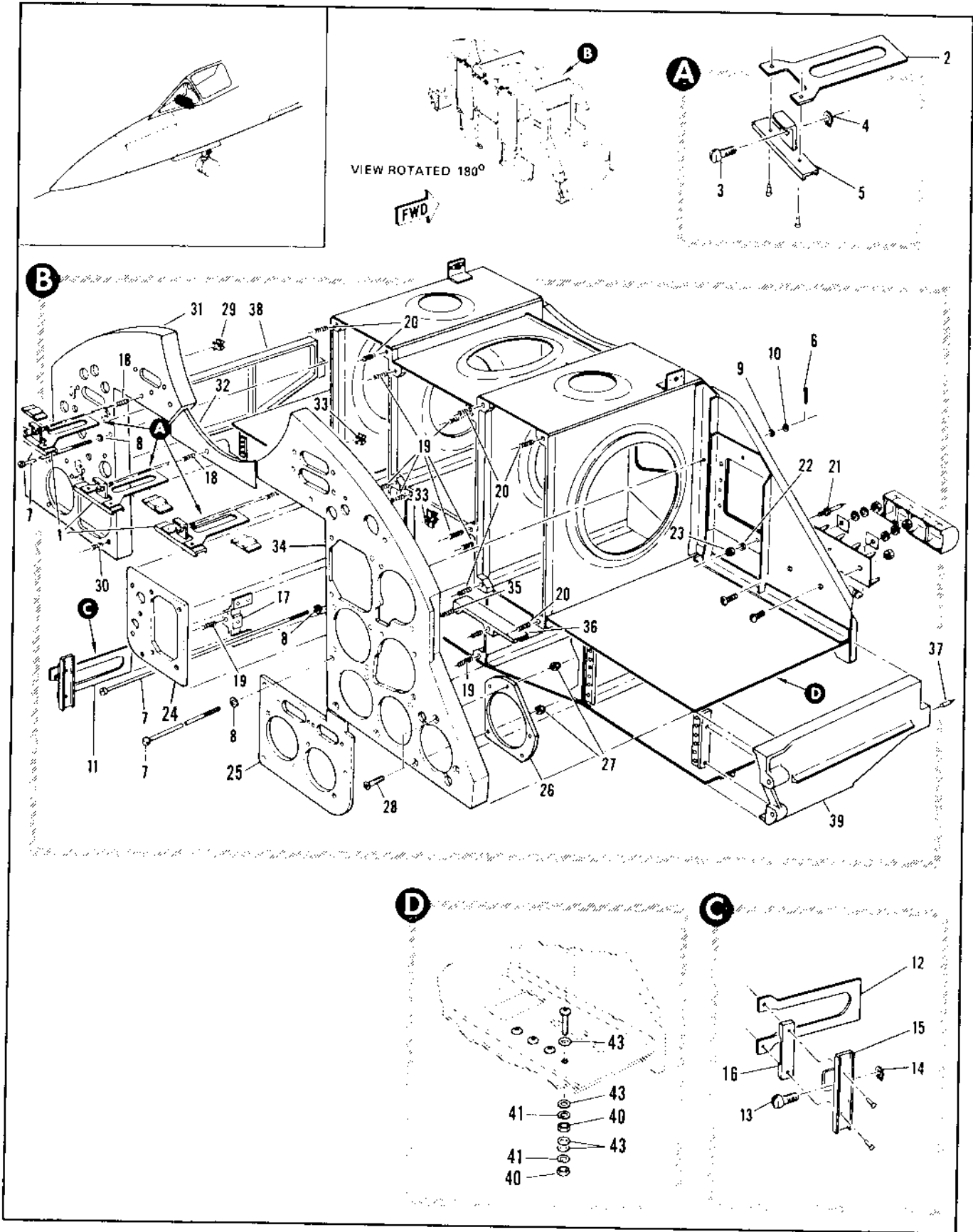

Figure 2.16-5. Pilot Instrument Panel Assembly (Sheet 1 of 2)

FIGURE AND INDEX NUMBER	PART NUMBER	DESCRIPTION	UNITS PER ASSY.	USABLE ON CODE	
				FROM	TO
2.16-5	8-38643-815	PANEL ASSEMBLY, PILOT INSTRUMENT MODIFIED BY 62J35439	1		A
- 1	8-38644	• EXTRACTOR ASSY, INSTRUMENT PANEL	3		B
- 2	8-38640-7	• • GUIDE	1		B
- 3	8-38645	• • SCREW	1		B
- 4	NAS670-18	• • SNAP RING	1		B
- 5	R-38665-7	• • GRIP	1		B
- 6	AN381-2-6	• PIN	2		C
- 7	R-38651-7	• BOLT, EXTRACTOR	2		C
- 8	AN96010L	• WASHER	2		C
- 9	99-53000-093	• WASHER	2		C
- 10	NAS620-10	• WASHER	2		C
- 11	8-38644-1	• EXTRACTOR ASSY, INSTRUMENT PANEL	1		B
- 12	8-38640-9	• • GUIDE	1		B
- 13	8-38645	• • SCREW	1		B
- 14	NAS670-18	• • SNAP RING	1		B
- 15	8-38646-9	• • GRIP	1		B
- 16	8-38647-9	• • SPACER	1		B
- 17	8-38641	• RETAINER	1		C
- 18	NAS1222-3E	• INSERT	2		C
- 19	NAS1222-3E	• INSERT	9		C
- 20	NAS1222-08E	• INSERT	8		C
- 21	R-38649-7	• PIN, GUID	3		C
- 22	AN96010L	• WASHER	3		C
- 23	NAS679A3	• NUT	3		C
- 24	62D35472-1	• PLATE	1		C
- 25	62D35471-1	• PLATE	1		C
- 26	8-38648	• SPACER	1		C
- 27	NAS679A06	• NUT	2		C
- 28	AN507-632P2	• SCREW	2		A
	8-38638-1	• PANEL ASSY, INSTRUMENT LH	1		A
	8-38638-3	• PANEL ASSY, INSTRUMENT LH	1	130	C
- 29	NAS487-16	• • NUT	5		C
- 30	NAS1222-06E	• • INSERT, 95-03003-002	1		C
- 31	7747297-19	• • PANEL, LH	1		A
- 32	8-38650-7	• PANEL, CENTER	1		C
- 33	MS33737-11	• • NUT	3		C
	67E35467-7	• PANEL ASSY, INSTRUMENT RH ALT INTCHG WITH 67E36659-2	1		C
- 34	62E35467-9	• • PANEL, RH ALT INTCHG WITH 67E36659-4	1		C
- 35	NAS1222-06E	• • INSERT, 95-03003-002	1		C
- 36	8-38637-15	• • SUPPORT	1		C
	8-38642-1	• SUPPORT ASSY, LH	1		C
	8-38642-2	• SUPPORT ASSY, RH	1		C
- 37	R-38649-9	• • PIN, GUIDE	1		C
- 38	R-38642-9	• • SUPPORT, LH	1		C
- 39	8-38642-10	• • SUPPORT, RH	1		C
- 40	MS20341-10S	• NUT, GROUND STUD	8		C
- 41	MS35338-43	• WASHER, GROUND STUD	8		C
- 42	AN960-10L	• WASHER, GROUND STUD	8		C
- 43	AN96010L	• WASHER, GROUND STUD	8		C

A AIRPLANES #46 AND 90 THRU 129
R AIRPLANES #48 AND 93 THRU 246
C AIRPLANES #46, 90 AND 94

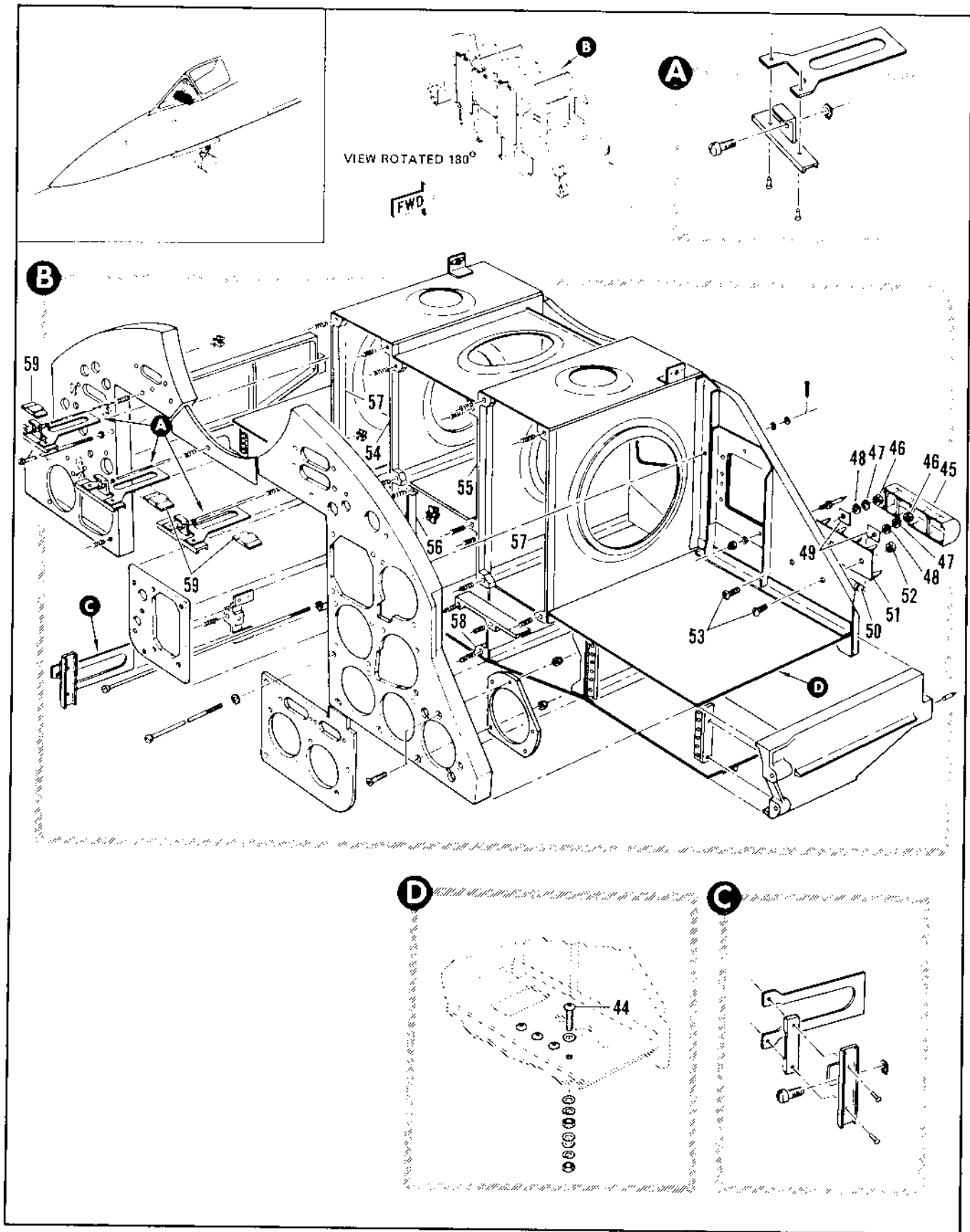

Figure 2.16-5. Pilot Instrument Panel Assembly (Sheet 2 of 2)

FIGURE AND INDEX NUMBER	PART NUMBER	DESCRIPTION	UNITS PER ASSY.	USABLE ON CODE	
				FROM	TO
		1 2 3 4 5 6			
2.14-01-44	MS35207-265	• SCREW, GROUND STUD	4		
- 45	197-2	• TERMINAL COVER, <74212> 91-50002-90P	1	C	
- 46	MS347-4	• NUT	2	C	
- 47	AN937-4L	• WASHER	2	C	
- 48	AN937-4	• WASHER	2	C	
- 49	MS25027-1	• INSULATOR	2	C	
- 50	RC206F470U	• RESISTOR, 97-40000-009	1	C	
- 51	MS25123-11-2	• TERMINAL STRIP ATTACHING PARTS	1	C	
- 52	MS1591-14	• NUT	2	C	
- 53	AN51404B5	• SCREW -----X-----	2	C	
- 54	9-38637-7	• SUPPORT	1	C	
- 55	9-38637-8	• SUPPORT	1	C	
- 56	9-38637-9	• SUPPORT	1	C	
- 57	9-38637-11	• SUPPORT	2	C	
- 58	9-38637-17	• SUPPORT	1	C	
- 59	9-38647-7	• SPACER	1	C	

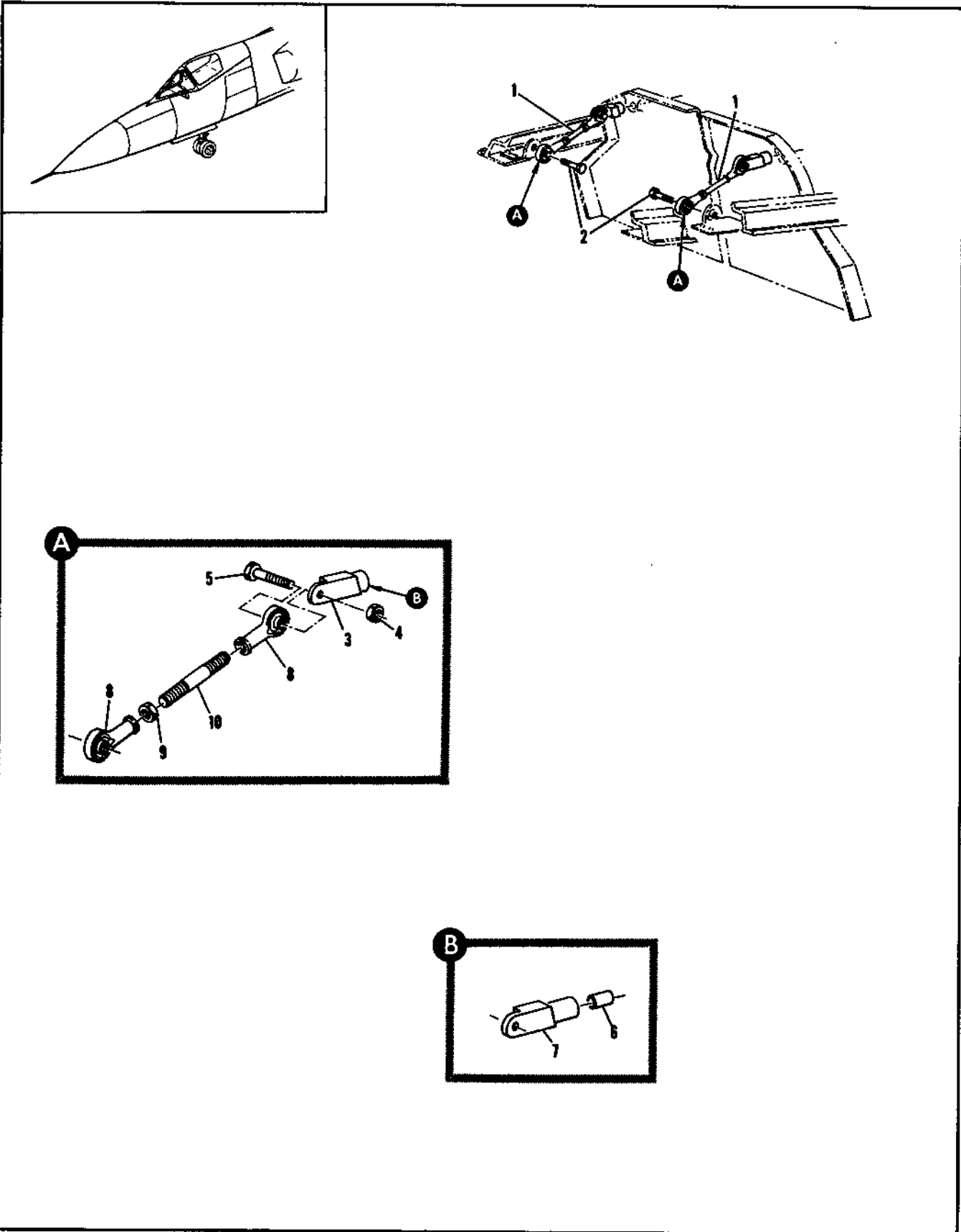

Figure 2.16-6. Instrument Panel Upper Support Installation

FIGURE AND INDEX NUMBER	PART NUMBER	DESCRIPTION 1 2 3 4 5 6	UNITS PER ASSY.	USABLE ON CODE	
				FROM	TO
2.16-6	8-38358-001	SUPPORT INSTALLATION, INSTRUMENT PANEL UPPER FOR NHA SEE FIG. 2.16-9	1	A	
- 1	4-34156-7	• SUPPORT ASSY, INSTRUMENT PANEL UPPER ATTACHING PARTS	2	A	
- 2	AN3-7A	• BOLT -----X-----	2	A	
- 3	8-38611-1	• • SUPPORT ASSY, UPPER ATTACHING PARTS	1	A	
- 4	NAS679A3	• • NUT	1	A	
- 6	AN3-7A	• • BOLT -----X-----	1	A	
- 4	2100-3	• • • INSERT, <K8831> 95-13002-001	1	A	
- 7	8-38615-9	• • • SUPPORT	1	A	
- 8	AN881HEB2N	• • BEARING	2	A	
- 9	AN316-4P	• • NUT	1	A	
- 11	8-38617-9	• • ROD	1	A	
		A AIRPLANES #35 THRU 47 AND 49 THRU 89			

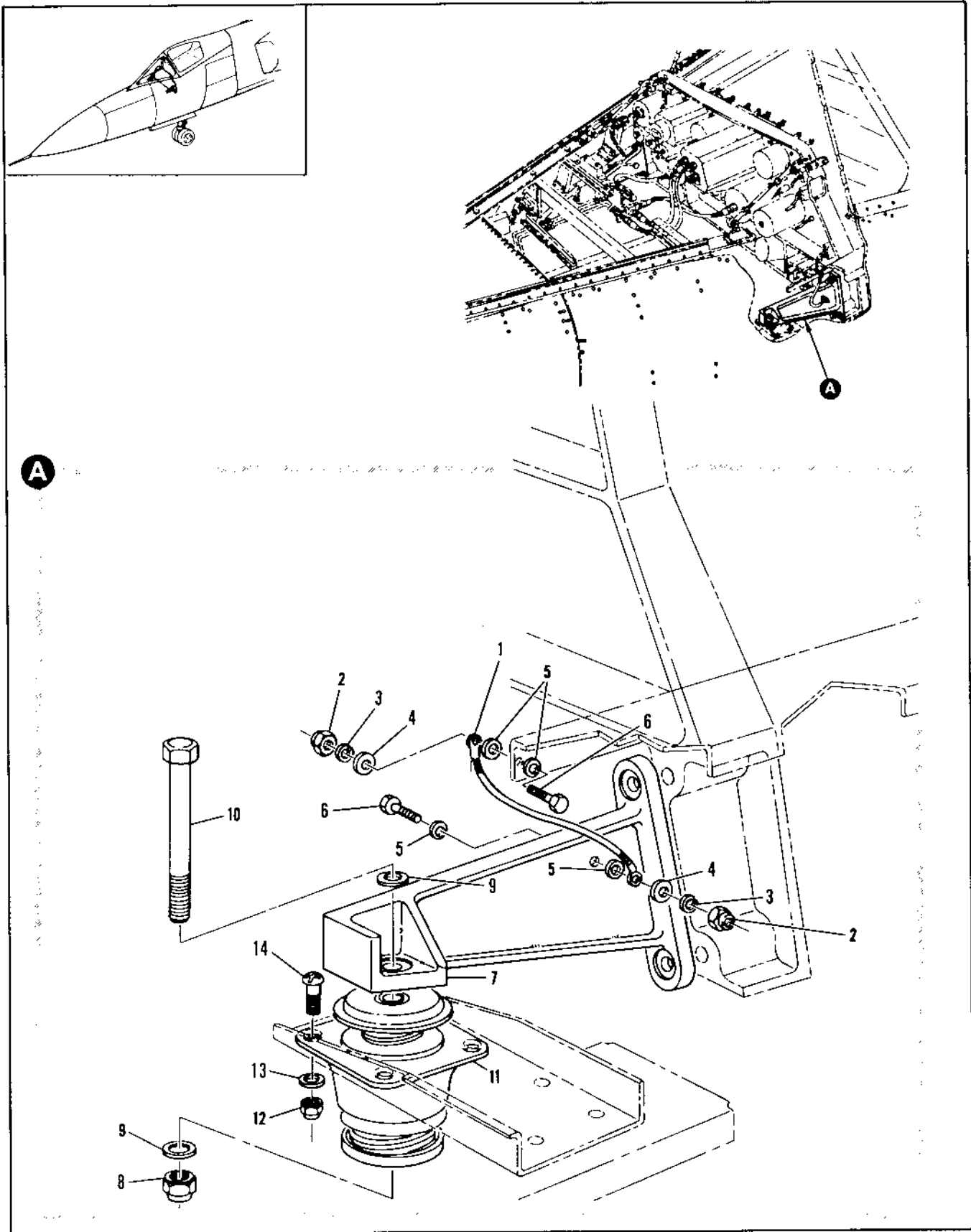

Figure 2.16-7. Instrument Panel Lower Support Installation

FIGURE AND INDEX NUMBER	PART NUMBER	DESCRIPTION	UNITS PER ASSY.	USABLE ON CODE	
				FROM	TO
		1 2 3 4 5 6			
2.16-7	B-38554-5	SUPPORT INSTALLATION, INSTRUMENT PANEL LOWER LH FOR SHA SEE FIG. 2.3-6	PF	A	
	Y-38554-7	SUPPORT INSTALLATION, INSTRUMENT PANEL LOWER RH FOR SHA SEE FIG. 2.3-6	PF	A	
- 1	MS25023-1083	• BUMPER, LH ATTACHING PARTS	1	A	
- 2	NAS679A3	• NUT, GROUND STUD LH	2	A	
- 3	AN935-10	• WASHER, GROUND STUD LH	2	A	
- 4	AN960-10L	• WASHER, GROUND STUD LH	2	A	
- 5	AN960-10L	• WASHER, GROUND STUD LH	4	A	
- 6	NAS424-3-5	• BOLT, GROUND STUD LH ----X----	2	A	
- 7	B-38635-9 B-38635-11	• SUPPORT, LOWER LH • SUPPORT, LOWER RH ATTACHING PARTS	1 1	A A	
- 8	NAS679A4	• NUT	1	A	
- 9	AN9610416	• WASHER	2	A	
- 10	AN4-25A	• BOLT ----X----	1	A	
- 11	K5A-4	• MOUNT, SHOCK (S1114) SPEC N-09295-1 REPLACED BY MGT INCH) WITH UT2-50 ATTACHING PARTS	2	A	
- 12	NAS679A3	• NUT	4	A	
- 13	AN96010L	• WASHER	4	A	
- 14	ANS2-1086	• SCREW ----X----	4	A	
		4 AIRPLANES #35 THRU 47 AND 49 THRU 89			

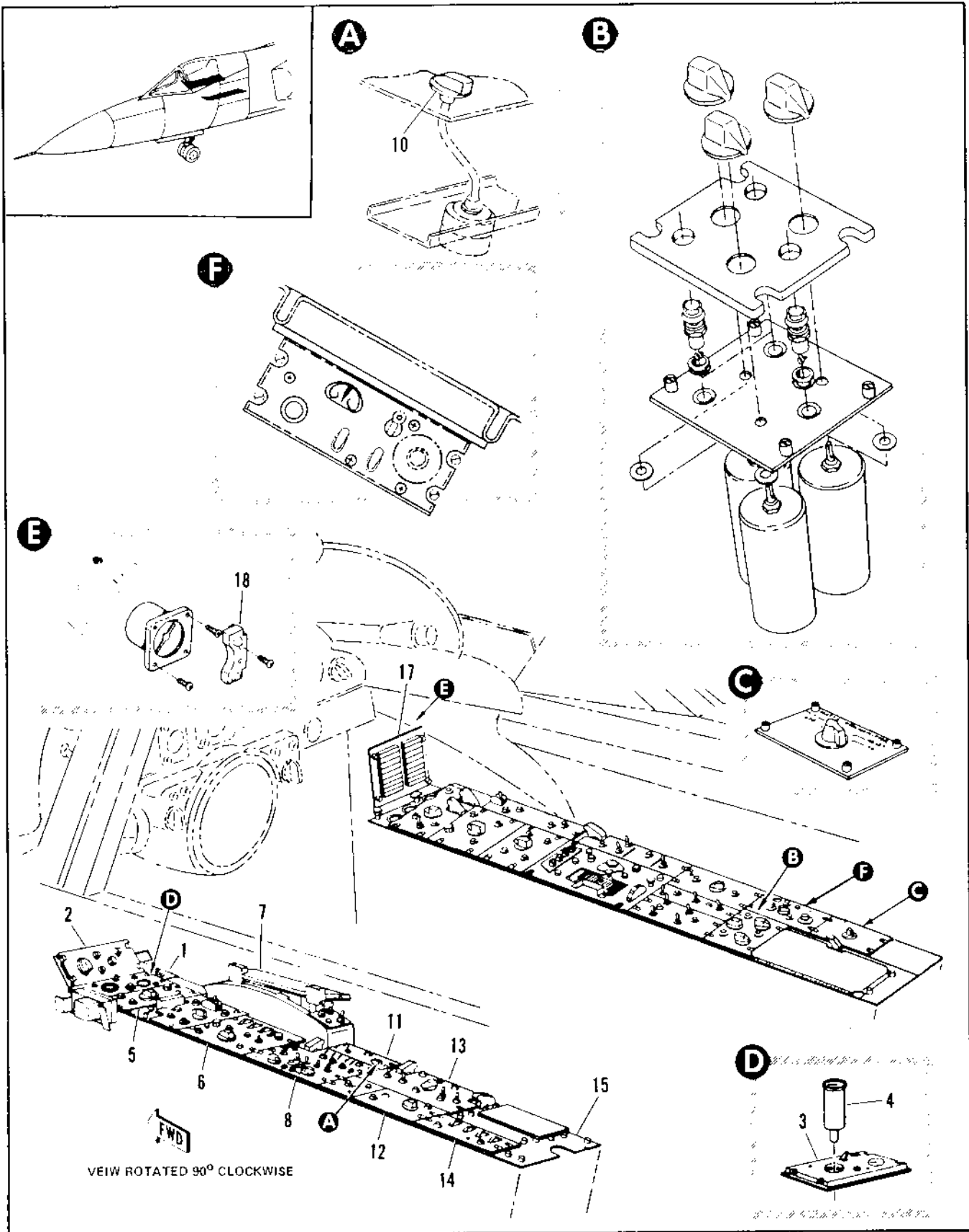

Figure 2.16-8. Pilot Console Equipment Installation (Sheet 1 of 3)

FIGURE AND INDEX NUMBER	PART NUMBER	DESCRIPTION	UNITS PER ASSY.	USABLE ON CODE	
				FROM	TO
2.16-8	8-94666-835	EQUIPMENT INSTL, PILOT CONSOLE MODIFIED BY 66D40467 AND 66D40094 FOR NHA SEE FIG. 2.3-5	1	35	
- 1	8-95607-1	• PANEL ASSY, MASTER ELECTRICAL POWER AND AUDIO WARNING CUTOFF LH CONSOLE FOR BREAKDOWN SEE FIG. 2.16-9	1	35	47
	8-95683-3	• PANEL ASSY, MASTER ELECTRICAL POWER AND AUDIO WARNING CUTOFF LH CONSOLE FOR BREAKDOWN SEE FIG. 2.16-9	1	48	
- 2	464855	• CONTROL, RADAR SET-AZIMUTH SCAN AND HORIZON (82577)	1		
- 3	F1065002-5	• PANEL ASSY, LIQUID OXYGEN CONTROL (97413) SPEC 8-09275-3 T.O. 15X10-5-3	1	35	
- 4	JG180A14	• INDICATOR (38315)	1		
- 5	464755	• PANEL ASSY, RECEIVER ILAS LH CONSOLE (82577)	1	35	
- 6	705908-801	• CONTROL ASSY, FREQUENCY SELECTOR COMMUNICATION LH CONSOLE, C-9533, REF 12R4-2ARC164-4 (37695)	1		
	MX10061	• ADAPTER, CONTROL	1	RF	
- 7		• PLATE ASSY, PILOT CHECK LIST MOUNTING SEE FIG. 2.5-4 INDEX 8	1		
- 8	C-6280(P)APY	• CONTROL TRANSPONDER, IDENTIFICATION LH CONSOLE	1	35	
- 9	8-62215-1	• PANEL ASSY, SWITCH LH CONSOLE FOR BREAKDOWN SEE FIG. 2.16-12	1	D	
	8-62215-3	• PANEL ASSY, SWITCH LH CONSOLE FOR BREAKDOWN SEE FIG. 2.16-12	1	E	
- 10		• KNOB, COCKPIT CONTROL PANEL SEE FIG. 2.16-13 INDEX 1	1	RF	
- 11	8-95598	• PANEL ASSY, ANTI-G SUIT AND MASK DE-FOG LH CONSOLE FOR BREAKDOWN SEE FIG. 2.16-13	1	35	129
	8-95598-1	• PANEL ASSY, ANTI-G SUIT AND MASK DE-FOG LH CONSOLE FOR BREAKDOWN SEE FIG. 2.16-13	1	130	
- 12	464905	• CONTROL, POWER SYSTEM (82577) GFAF	1		
- 13	62D34835-1	• PANEL ASSY, FUEL CONTROL LH CONSOLE FOR BREAKDOWN SEE FIG. 2.16-14	1		
	62D34835-3	• PANEL ASSY, FUEL CONTROL LH CONSOLE FOR BREAKDOWN SEE FIG. 2.16-14	1	M	
- 14	464655	• CONTROL ASSY, CODER DECODER LH CONSOLE (82577) AERNO 52-9038 GFAE T.O. 11F-13-2S-2-4	1	35	
- 15	464796	• PANEL, SET TEST LH CONSOLE (82577)	1		
	67836506-1	• PANEL ASSY, BLANK LH CONSOLE ALTERED FROM 8-94691-825	1		
- 16	66D40987-2	• PANEL ASSY, AERIAL REFUELING CONTROL FOR BREAKDOWN SEE FIG. 2.16-15	1		
- 17	F280-1F	• PANEL ASSY, MASTER WARNING CONTROL RH CONSOLE (97896) SPEC 8-06275-7 T.O. 8010-7-2-13	1	35	
	8-94711-269	• LAMP INSTL, RH CONSOLE MASTER WARNING FOR BREAKDOWN SEE FIG. 2.16-17	1	188	
- 18	B8785-2	• LIGHT ASSY (72914) SPEC 8-09273-1	1		
		D AIRPLANES #35 THRU 37, 43 AND ON E AIRPLANES #38 THRU 42, 49 AND ON			

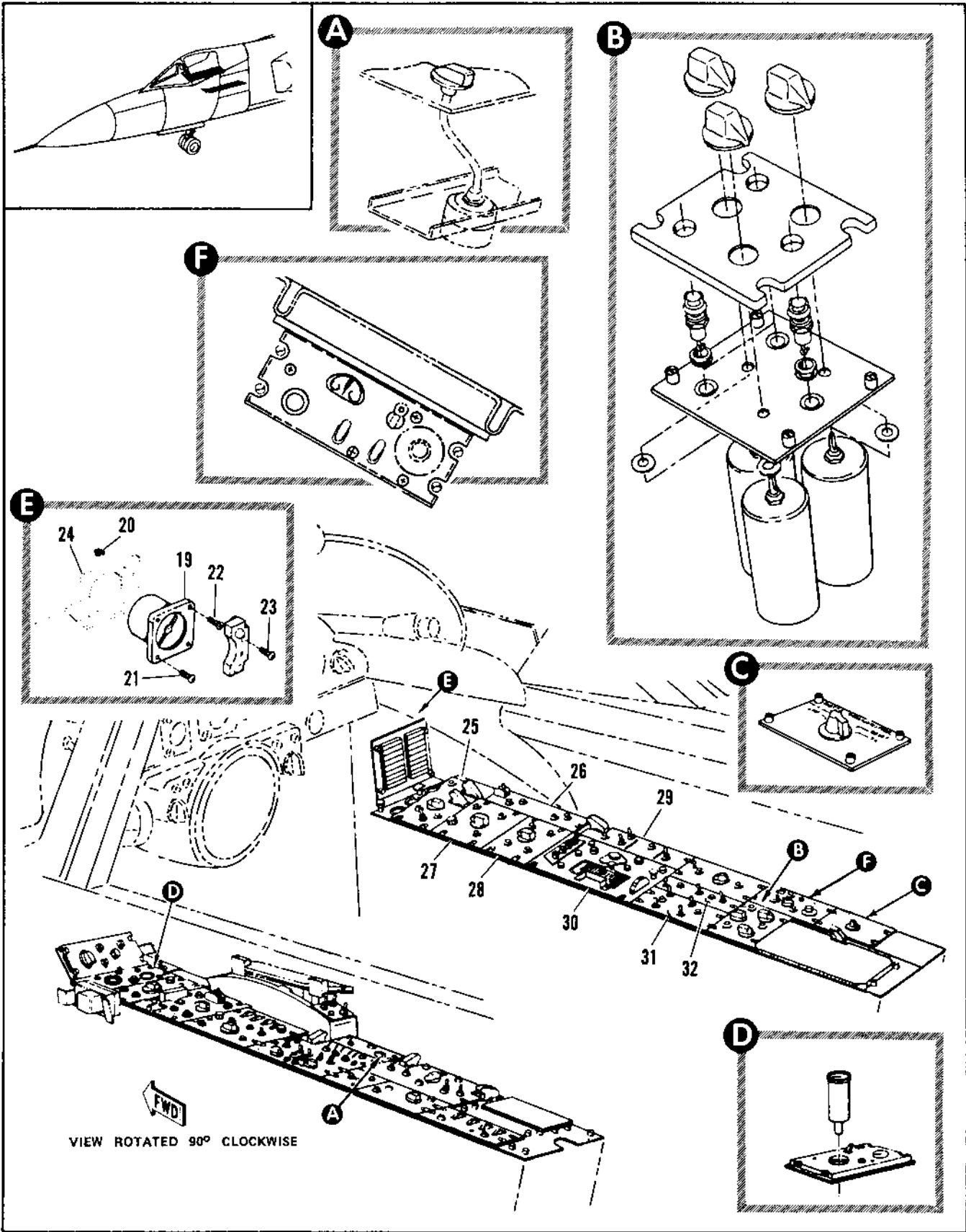

Figure 2.16-8. Pilot Console Equipment Installation (Sheet 2 of 3)

FIGURE AND INDEX NUMBER	PART NUMBER	DESCRIPTION	UNITS PER ASSY.	USABLE ON CODE	
				FROM	TO
		1 2 3 4 5 6			
2.16-8- 19	AC105-16	• INDICATOR, CABIN AIR PRESSURE (75485) ALT INTCHG WITH AC104 ATTACHING PARTS			
- 27	MS33737-9	• NUT	4		
- 21	MS35206-232	• SCREW	2		
- 22	MS35206-232	• SCREW	2		
- 23	MS35206-232	• SCREW	2		
		-----X-----			
- 24	62016435-1	• BRACKET	1		
- 25	7242456-70	• EQUIPMENT INSTALLATION, COCKPIT CONSOLE FOR BREAKDOWN SEE FIG. 2.16-18	1	A	
	7242456-90	• EQUIPMENT INSTALLATION, COCKPIT CONSOLE FOR BREAKDOWN SEE FIG. 2.16-18	1	48	48
	7242456-130	• EQUIPMENT INSTALLATION, COCKPIT CONSOLE FOR BREAKDOWN SEE FIG. 2.16-18	1	61	89
	7242456-110	• EQUIPMENT INSTALLATION, COCKPIT CONSOLE FOR BREAKDOWN SEE FIG. 2.16-18	1	90	159
	7242456-150	• EQUIPMENT INSTALLATION, COCKPIT CONSOLE FOR BREAKDOWN SEE FIG. 2.16-18	1	160	
- 26	64H33377-3	• PANEL ASSY, DATA LINK ANTENNA, CANOPY SWITCH AND WARN LIGHT TEST RH CONSOLE FOR BREAKDOWN SEE FIG. 2.16-20	1	35	
- 27	464915	• CONTROL ASSY, TACAN CHANNEL SELECTOR (R2577) DEAE	1		
- 28	464955	• CONTROL ASSY, AUTO NAVIGATION (R2577)	1	35	
- 29	8-95587-1	• PANEL ASSY, MA-1 ANTI-ICE DE-FOG AND RAIN REMOVAL SWITCH RH CONSOLE FOR BREAKDOWN SEE FIG. 2.16-19	1	9	
	8-95587-3	• PANEL ASSY, MA-1 ANTI-ICE DE-FOG AND RAIN REMOVAL SWITCH RH CONSOLE FOR BREAKDOWN SEE FIG. 2.16-19	1	48	48
	8-95599-101	• PANEL ASSY, MA-1 ANTI-ICE DE-FOG AND RAIN REMOVAL SWITCH RH CONSOLE FOR BREAKDOWN SEE FIG. 2.16-19	1	90	
- 30	464319	• CONTROL, TIME DIVISION DATA LINK, TYPE C-2558ZARR	1	35	
- 31	8-62224	• PANEL ASSY, LIGHTING CONTROL RH CONSOLE FOR BREAKDOWN SEE FIG. 2.16-21	1	9	
	8-63671-5	• PANEL ASSY, LIGHTING CONTROL RH CONSOLE FOR BREAKDOWN SEE FIG. 2.16-22	1	90	215
	8-63671-AC5	• PANEL ASSY, LIGHTING CONTROL RH CONSOLE FOR BREAKDOWN SEE FIG. 2.16-22	1	F	
	8-94798-9	• PLATE	1	C	
- 32	8-62212	• PANEL ASSY, MISCELLANEOUS SWITCH RH CONSOLE FOR BREAKDOWN SEE FIG. 2.16-16	1	35	49
	8-62212-3	• PANEL ASSY, MISCELLANEOUS SWITCH RH CONSOLE FOR BREAKDOWN SEE FIG. 2.16-16	1	90	

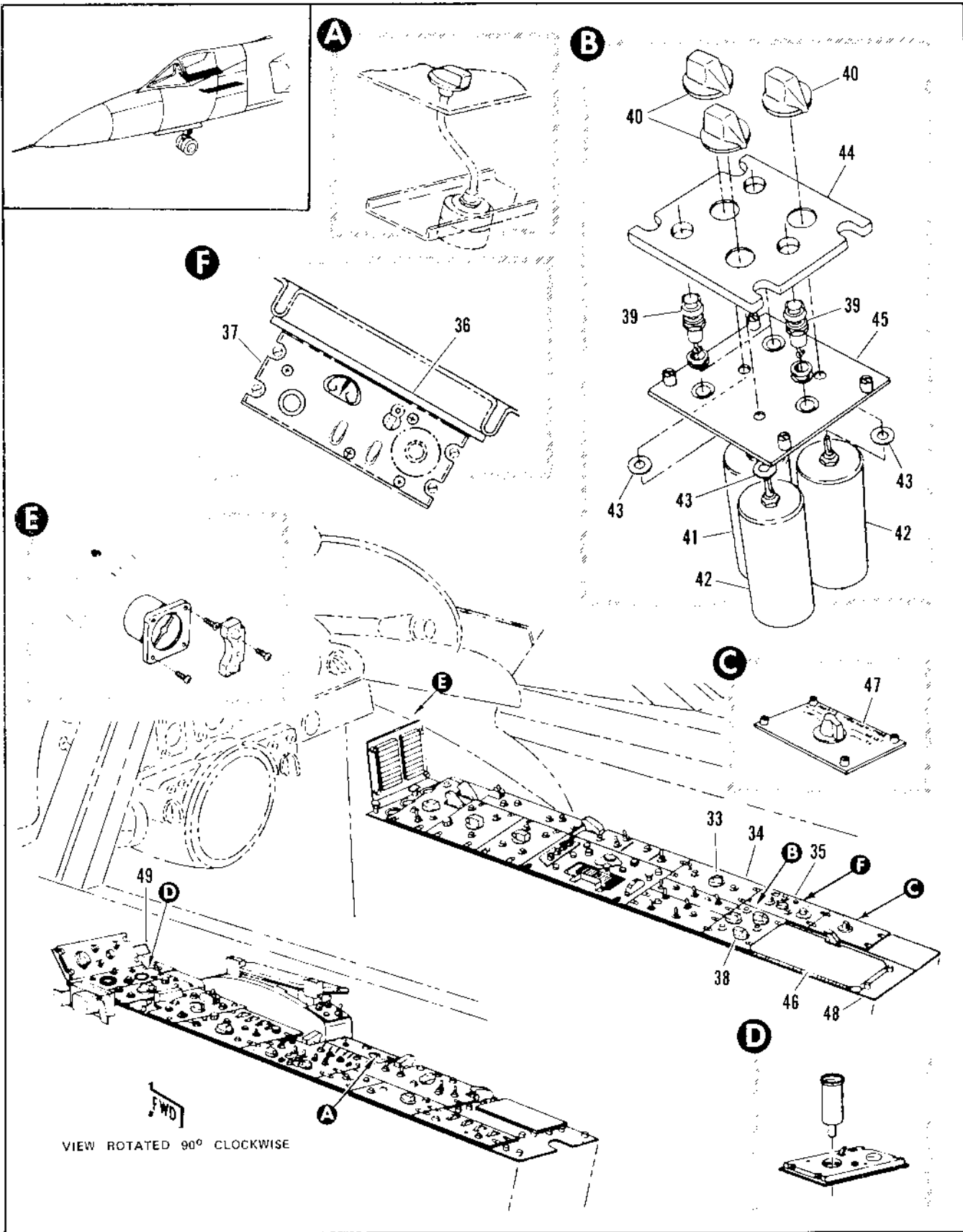

Figure 2.16-8. Pilot Console Equipment Installation (Sheet 3 of 3)

FIGURE AND INDEX NUMBER	PART NUMBER	DESCRIPTION	UNITS PER ASSY.	USABLE ON CODE	
				FROM	TO
		1 2 3 4 5 6			
2.16-8- 33	PPM9341-12	• KNOB, COCKPIT CONTROL PANEL RH CONSOLE <01515> SPEC 8-09341-9 REPLACES NOT INTCHG WITH PPM9341-3	1	35	
- 34	TYLZ6889	• CONTROL ASSY, COCKPIT TEMPERATURE <65149> SPEC 8-98495-15 T.O.15A8-5-17-3 REPLACES SUITABLE SUB FOR CYL25638-3	1	35	
- 35	6263-423050-2	• PANEL ASSY, CONTROL GYRO COMPASS RH CONSOLE <88818>	1	B	
	131312-01	• PANEL ASSY, CONTROL GYRO COMPASS RH CONSOLE <35351>	1	C	
	7839946-10	• FILLER INSTL, CONSOLE, RH, ATTITUDE HEADING REFERENCE SYSTEM	1		
- 36	7839947-01	• FILLER <96750>	1		
- 37	156561-01-01	• CONTROLLER <35351> GFAE	1		
- 38	8-62227	• PANEL ASSY, LIGHTING CONTROL POWERSTATS RH CONSOLE	1	8	
	8-62227-1	• PANEL ASSY, LIGHTING CONTROL POWERSTATS RH CONSOLE	1	48	48
	8-62227-3	• PANEL ASSY, LIGHTING CONTROL POWERSTATS RH CONSOLE	1	90	
	8-94711-191	• LAMP INSTL, AIRPLANE LIGHTING	1	35	
	MS25237-327	• LAMP	3	35	
- 39	1950	• LIGHT ASSY, PLASTIC PLATE LIGHTING PANEL <83564> SPEC 8-09441-1	3	35	
	MS25010-4A	• LIGHT	3	90	
	A7076	• GROMMET, INSTRUMENT LIGHT	3	90	
- 40	PPM9341-5	• KNOB, COCKPIT CONTROL PANEL <01515> SPEC 8-09341-5 REPLACES SUITABLE SUB FOR PPM9341-1	3	35	
- 41	6455	• POWER STAT, LIGHTING CONTROL <95266> SPEC 8-06475-1 REPLACES NOT INTCHG WITH 8-1001	1	B	
- 42	6451	• POWERSTAT, LIGHTING CONTROL <95266> SPEC 8-06475-3 REPLACES NOT INTCHG WITH 5-1002	2	B	
- 43	AN9600616	• WASHER	3	B	
- 44	8-62226-7	• PLATE, DESIGNATION LIGHTING CONTROL POWERSTATS	1	35	
- 45	8-62225-1	• PANEL ASSY, MOUNTING LIGHTING CONTROL POWERSTATS	1	B	
	PF3-1/2-38	• STUD, FASTENER <72794> 98-56501-001	4	35	
	PS2-1/2	• SPRING, FASTENER <72794> 98-37000-003	4	35	
	PC3-1/2	• RETAINER, FASTENER <72794> 97-58300-001	4	35	
	8-62225-7	• PLATE	1	B	
	8-62225-9	• PLATE	1	C	
- 46		• CASE ASSY, MAP AND FLIGHT REPORT SEE FIG. 2.5-7	RF		
- 47	60B74063	• PANEL ASSY, MATTS SWITCH	1	35	
	60B74057	• SWITCH	1		
	45292F2	• SWITCH (76854) ALT INTCHG WITH 60B74057	1		
	MS25166-1	• KNOB	1		
	60B74064	• PANEL	1		
	PF3-1/2-38	• STUD, FASTENER (72794) 98-56501-001	4		
	PS3-1/2	• SPRING, FASTENER (72794) 98-37000-003	4		
	PC3-1/2	• RETAINER, FASTENER	4		
- 48	8-94681-833	• PANEL ASSY, BLANK RH CONSOLE	1	35	
	PF3-1/2-38	• STUD, FASTENER <72794> 98-56501-001	4	35	
	PS3-1/2	• SPRING, FASTENER <72794> 98-37000-003	4	35	
	PCS-1/2	• RETAINER, FASTENER	4	35	
	8-94681-47	• PANEL	1	35	
- 49	7239065	• SWITCH, ALTITUDE BAND SELECTOR, ASSY FOR BREAKDOWN SEE FIG. 2.16-16	1		
		B AIRPLANES #35 THRU 47 AND 49 THRU 89			
		C AIRPLANES #48, 90 AND ON			
		F AIRPLANES #48, 216 AND ON			
		M AIRPLANES #35 THRU 47, 49 THRU 215			

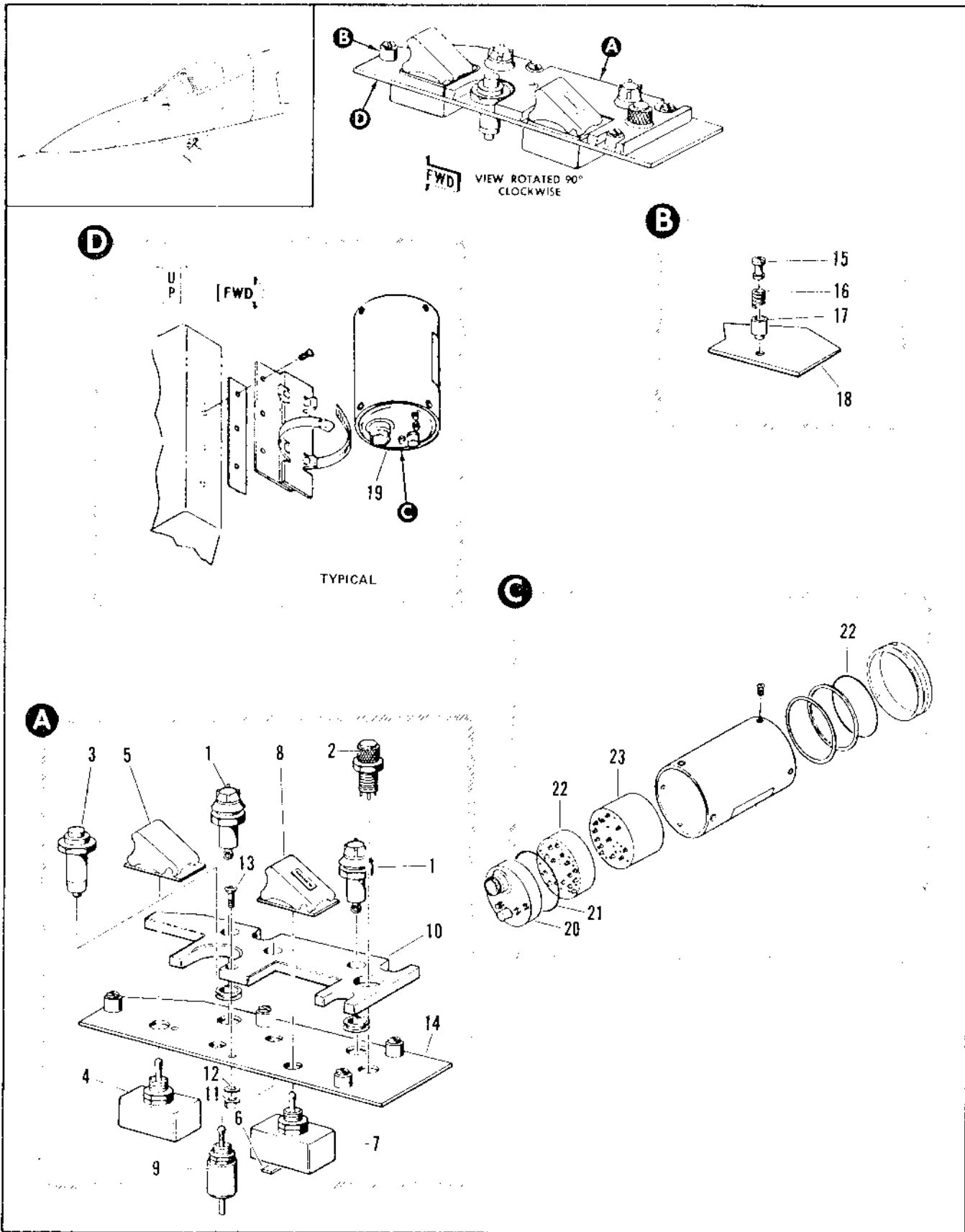

Figure 2.16-9. Master Electrical Power and Audio Warning Cut Off LH Console Panel Assembly (Sheet 1 of 2)

FIGURE AND INDEX NUMBER	PART NUMBER	DESCRIPTION	UNITS PER ASSY.	USABLE ON CODE	
				FROM	TO
		1 2 3 4 5 6			
2.16-9	8-95683	PANEL ASSMPLY, MASTER ELECTRICAL POWER AND AUDIO WARNING CUTOFF LH CONSOLE FOR NHA SEE FIG. 2.16-9	RF	B	
	8-95607	PANEL ASSMPLY, MASTER ELECTRICAL POWER AND AUDIO WARNING CUTOFF LH CONSOLE MODIFIED BY 8-61368 FOR NHA SEE FIG. 2.16-9	RF	39	43
	8-95607-1	PANEL ASSMPLY, MASTER ELECTRICAL POWER AND AUDIO WARNING CUTOFF LH CONSOLE MODIFIED BY 8-61368 FOR NHA SEE FIG. 2.16-9	RF	44	47
	8-95683-2	PANEL ASSMPLY, MASTER ELECTRICAL POWER AND AUDIO WARNING CUTOFF LH CONSOLE FOR NHA SEE FIG. 2.16-9	RF		
- 1	8-94711-197 AN3140-327 MS25311-94	• LAMP INSTL, AIRPLANE LIGHTING • LAMP • LIGHT ASSY, PLASTIC PLATE LIGHTING PANEL <R3564> SPEC 8-09441-1 ALT INTCHG WITH 1950	1 1 2	35	35
- 2	MS25237-727 A7076 VM911428	• LAMP • GROMMET, INSTRUMENT LIGHT • LIGHT ASSY, INDICATOR PRESS TO TEST <P7034> SPEC 8-06915-25	2 2 1	35	35
- 3	MS25189-30	• SWITCH, PUSH BUTTON LANDING GEAR AUDIO WARNING CUTOFF (81640) REPLACED BY NOT INTCHG WITH MS25289-30	1	35	
- 4	8936K728	• SWITCH, TORQUE 4 POLE <15605> SPEC 8-06999-1 REPLACES NOT INTCHG WITH 51-33101	1	35	44
- 5	MS25224-3	• GUARD	1		
- 6	85-07103-012	• INSULATOR	1	9	XXX
- 7	8936K708	• SWITCH, TOGGLE 2 POLE <15605> SPEC 8-06915-9	1		
- 8	MS25224-3	• GUARD	1		
- 9	MS35054-24	• SWITCH, ISLE THRUST - SUITABLE SUB SOR WC 1398, SPEC 8-16975	1		A
- 10	8-95682-7	• PLATE, DESIGNATION MASTER ELECTRICAL POWER AND AUDIO WARNING CUTOFF ATTACHING PARTS	1		A
- 11	NAS679A06	• NUT	1	35	
- 12	AN96106	• WASHER	1	35	
- 13	AN515-6R10	• SCREW	1	35	
- 14	8-95620-5	• PANEL ASSY, MOUNTING MASTER ELECTRICAL POWER AND AUDIO WARNING CUTOFF	1		A
- 15	RF3-172-39	• STUD, FASTENER <72794> 99-56561-001	4	35	
- 16	RS3-172	• SPRING, FASTENER <72794> 99-37000-007	4	35	
- 17	RF3-172	• RETAINER, FASTENER <72794> 97-58300-001	4	35	
- 18	8-95620-9 8-95620-11 8-95620-13	• PANEL • PANEL • PANEL	1 1 1	35	38 89
- 19	1007-10-000-1	• SIGNAL PROCESSOR ASSY (24494)	1	35	
- 20	1001-02-000-1	• SWITCH MODULE ASSY	1	35	
- 21	2-31	• O-RING (63259)	2	35	
- 22	1001-02-000-1	• RATE METER ASSY	1	35	
- 23	1001-10-000-1	• POWER SUPPLY ASSY	1	35	
		A AIRPLANES 438 THRU 47, 90 AND ON B AIRPLANES 438 THRU 39, 48 THRU 89			

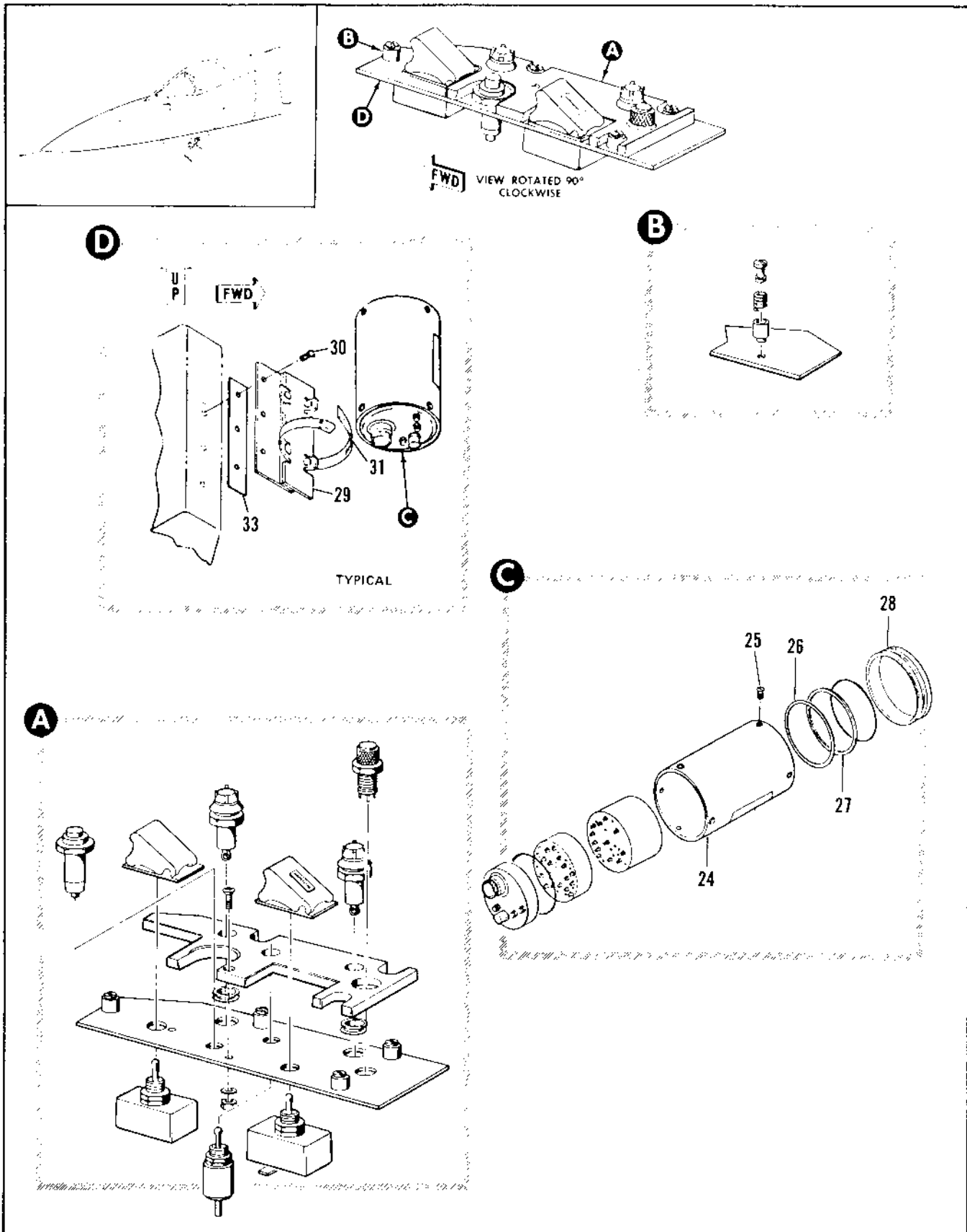

Figure 2.16-9. Master Electrical Power and Audio Warning Cut Off LH Console Panel Assembly (Sheet 2 of 2)

FIGURE AND INDEX NUMBER	PART NUMBER	DESCRIPTION 1 2 3 4 5 6	UNITS PER ASSY.	USABLE ON CODE	
				FROM	TO
2.16-4- 24	1001-00-147-1	• • HOUSING	1	35	
- 25	M551359-1	• • SCREW, MACHINE	1	35	
- 26	1003-00-144-5	• • SHIM, INSULATOR	1	35	
- 27	1001-00-144-1	• • SHIM, INSULATOR	1	35	
- 28	1007-00-011-1	• • CAP	1	35	
- 29	1007-00-012-1	• • PACKET ASSY. (24494) ATTACHING PARTS	1	35	
- 30	AN527-17E10	• • SCREW, MACHINE ----- -----y-----	2	35	
- 31	1007-00-012-13	• • SPACER	1	35	
- 32	AN737TW66	• • CLAMP	2	35	
- 33	1007-00-012-13	• • SPACER	1	35	

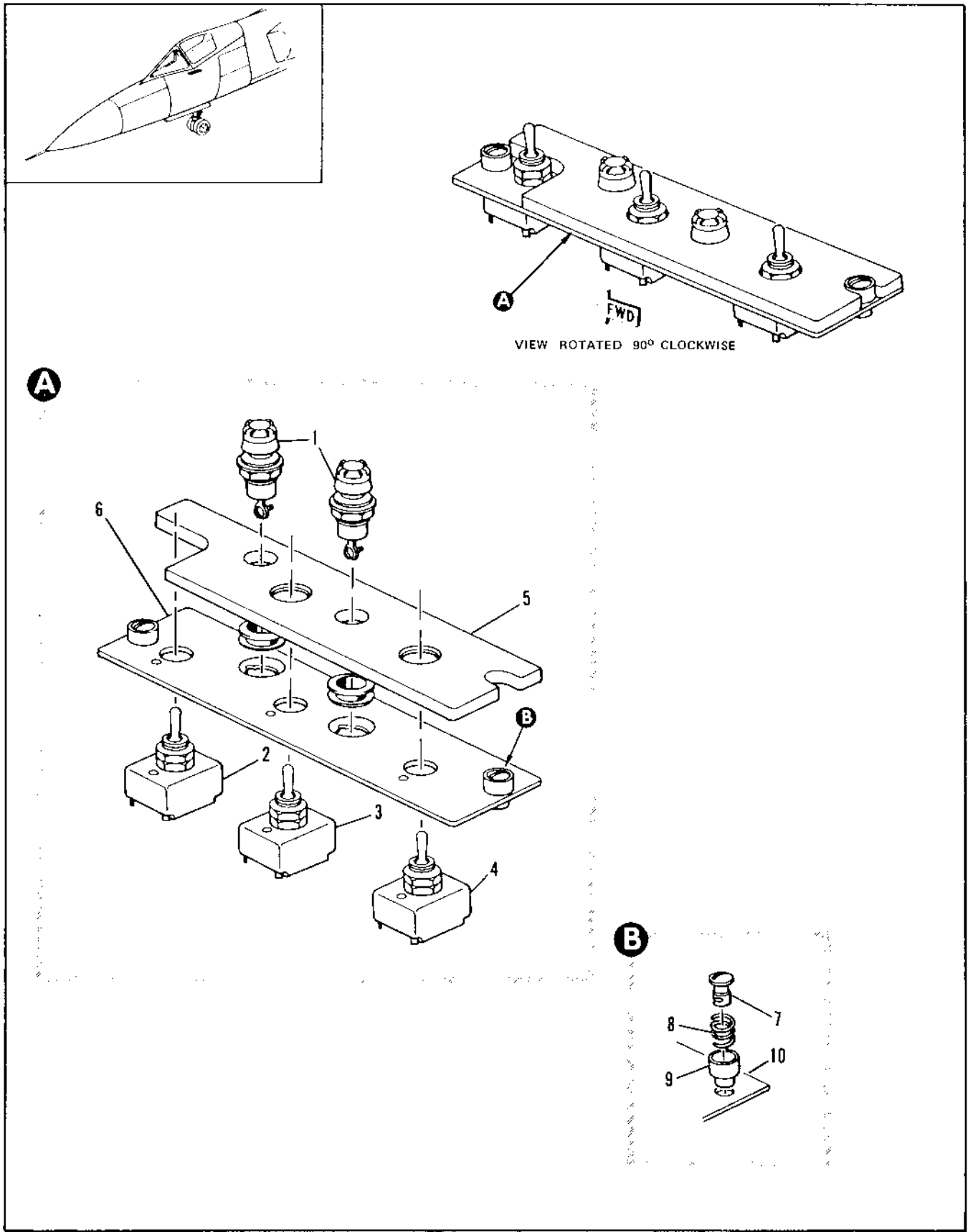

Figure 2.16-10. Miscellaneous Switch RH Console Panel Assembly

FIGURE AND INDEX NUMBER	PART NUMBER	DESCRIPTION	UNITS PER ASSY.	USABLE ON CODE	
				FROM	TO
2.16-10	R-62212	PANEL ASSEMBLY, MISCELLANEOUS SWITCH RH CONSOLE FOR NHA SEE FIG. 2.16-8	RF	35	89
	R-62212-3	PANEL ASSEMBLY, MISCELLANEOUS SWITCH RH CONSOLE FOR NHA SEE FIG. 2.16-8	RF	90	
	R-94711-183	• LAMP INSTL, AIRPLAIRPLANE LIGHTING	1	35	
	MS25237-327	• LAMP	2	35	
	1950	• LIGHT ASSY, PLASTIC PLATE LIGHTING PANEL <43563> SPEC R-30441-1	2	35	89
	MS25010-4A	• LIGHT ASSEMBLY	2	90	
	A7074	• GRMMFT, INSTRUMENT LIGHT	2	90	
	9906K698	• SWITCH, TOGGLE ONE HOLE MOUNTING (15605) SPEC R-06927-3, REPLACED BY MS25064-21	1	35	
	MS24523-33	• SWITCH, TOGGLE, ON-OFF-ON SINGLE POLE SINGLE THROW (96926)	1	35	
	9906K996	• SWITCH, TOGGLE 4 POLE ONE HOLE MOUNTING <15275> SPEC R-06999-3	1	35	
R-62211-7	• PLATE, DESIGNATION SWITCH PANEL	1	35		
R-62210-1	• PANEL ASSY, MOUNTING MISCELLANEOUS SWITCH	1	35		
PF3-1/2-38	• SING, FASTENER <72724> 99-56501-001	2	35		
PS3-1/2	• SPRING, FASTENER <72724> 99-37400-003	2	35		
PC3-1/2	• RETAINER, FASTENER <72724> 97-58300-001	2	35		
R-62210-9	• PANEL	1	35		

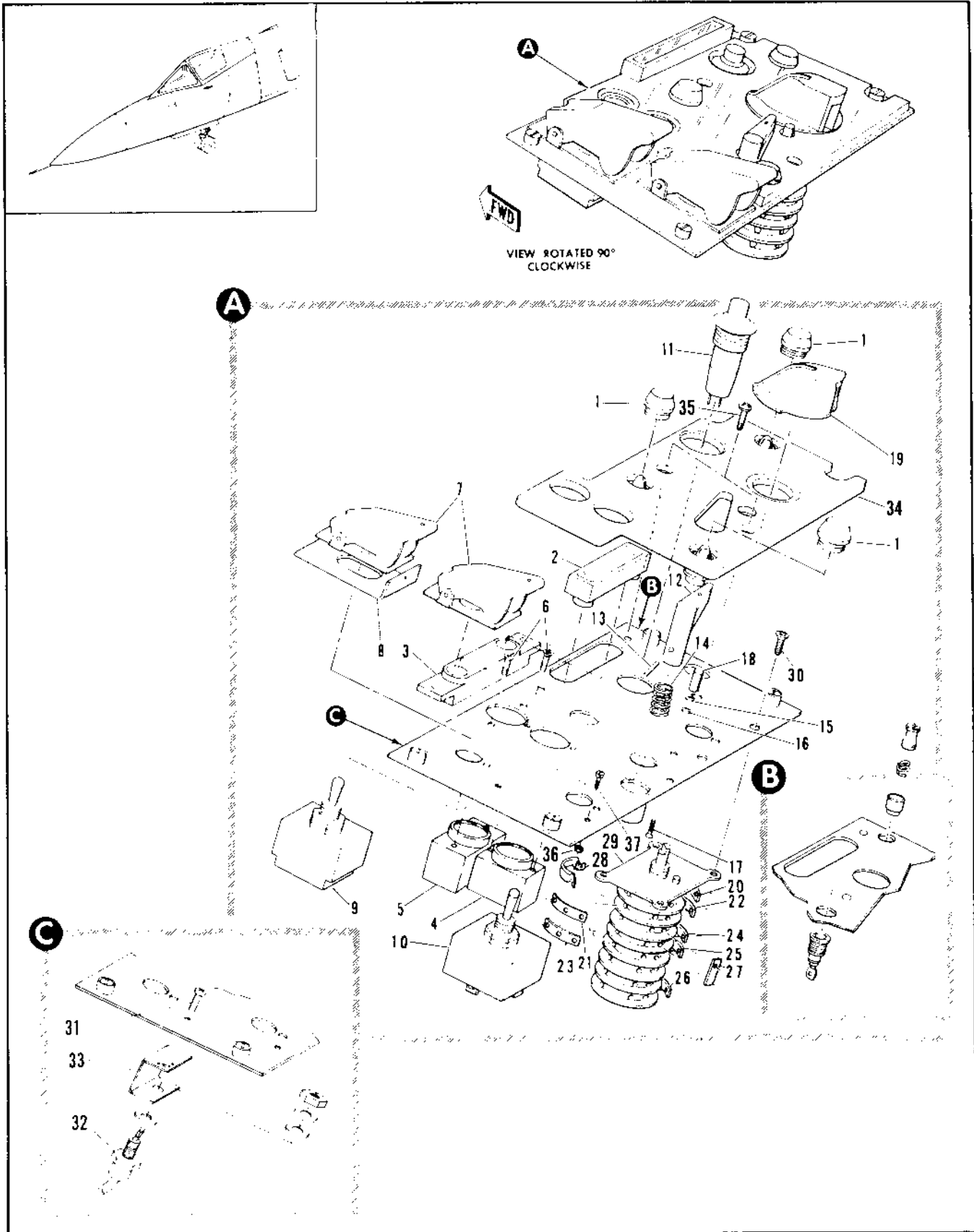

Figure 2.16-11. Armament Control LH Console Panel Assembly (Sheet 1 of 2)

FIGURE AND INDEX NUMBER	PART NUMBER	DESCRIPTION	UNITS PER ASSY.	USABLE ON CODE	
				FROM	TO
2.16-11	7144638-10	PANEL ASSY, ARMAMENT CONTROL LH CONSOLE FOR NHA SEE FIG. 2.16-2	RF	35	
- 1	8-94711-271 10695 MS25237-327	• LAMP INSTL, AIRPLANE LIGHTING • CAP, <72914> 91-50004-004 • LAMP	1 3 3	35 35 35	
- 2	TV1-25	• CAP, INDICATOR <81590> SPEC 8-09337-25	1	35	
- 3	757E9	• BASE, INDICATOR <81590> SPEC 8-09337-23	1	35	
- 4	SA803-133L	• INDICATOR, ARMAMENT <03034> SPEC 8-06901-1	1	35	
- 5	SAB03-279LH	• INDICATOR, LOCK AND UNLOCK SPEC 8-06901-7 REPLACES SUITABLE SUB FOR SA803-262LH	1	35	
- 6	AN507-632R3	• SCREW	4		
- 7	MS25224-1	• GUARD	2	35	
- 8	8-65315	• ADAPTER, ARMAMENT CONTROL	1	35	
- 9	8906K706	• SWITCH, TOGGLE DOUBLE POLE ONE HOLE MOUNTING <15605> SPEC 8-06915-5	1	35	
- 10	8906K728	• SWITCH, TOGGLE FOUR POLE ONE HOLE MOUNTING <15605> SPEC 9-06999-1 REPLACES NOT INTCHG WITH 51-33101	1	35	
- 11	MS25089-30	• SWITCH, PUSHBUTTON, ARMAMENT BAY DOOR CLOSE SUITABLE SUB FOR MS25189-30	1	130	
- 12	8-62399	• GUARD ASSY, ARMAMENT CONTROL WELDED	1	35	
- 13	8-65305-7	• PIN, ARMAMENT CONTROL	1	35	
- 14	1	• SPRING, HELICAL COMPRESSION <71447> 98-36008-008	1	35	
- 15	AN935-4L	• WASHER	1	35	
- 16	AN960-4L	• WASHER	1	35	
- 17	MS24693-S5	• SCREW	1	35	
- 18	8-62398-7	• STOP, ARMAMENT CONTROL	1	35	
- 19	63A25390	• KNOB, ARMAMENT CONTROL <01515> SPEC 9-09341-7	1	35	
- 20	8-65029-31	• BUSBAR, TERMINAL POST #15 16 AND 17	1	35	
- 21	8-65029-31	• BUSBAR, TERMINAL POST #21 AND 23	1	35	
- 22	8-65029-31	• BUSBAR, TERMINAL POST #25 26 AND 27	1	35	
- 23	8-65029-31	• BUSBAR, TERMINAL POST #41 AND 43	1	35	
- 24	8-65029-31	• BUSBAR, TERMINAL POST #45 46 AND 47	1	35	
- 25	8-65029-31	• BUSBAR, TERMINAL POST #55 56 AND 57	1	35	
- 26	8-65029-31	• BUSBAR, TERMINAL POST #85 86 AND 87	1	35	
- 27	8-62269-9	• BUSBAR, TERMINAL POST #C3 AND C4	1	35	
- 28	8-62269-803 8-62269-15	• BUSEAR ASSY, TERMINAL POST #53 AND 55 • BUSEAR	1	35	
- 29	8-63662-5	• SWITCH, SELECTOR (WAFER C9 UNUSED) ATTACHING PARTS	1	35	
- 30	MS24694S48	• SCREW -----X-----	4	35	
- 31	7144637-10 MS51957-45B	• BRACKET ASSY, ARMAMENT CONTROL PANEL ATTACHING PARTS • SCREW -----X-----	1 1	A A	
- 32	IN3673A	• SEMICONDUCTOR	1	A	
- 33	7144664-10	• BRACKET ASSY	1	A	
- 34	7144639-61 18-1029	• PANEL, ARMAMENT CONTROL PLASTIC • PANEL, ARMAMENT CONTROL PLASTIC ATTACHING PARTS	1 1	A B	
- 35	ANS1506R8	• SCREW	2	35	
- 36	MS21040-06	• NUT	1	35	
- 37	ANS00AC6-6	• SCREW	1	35	

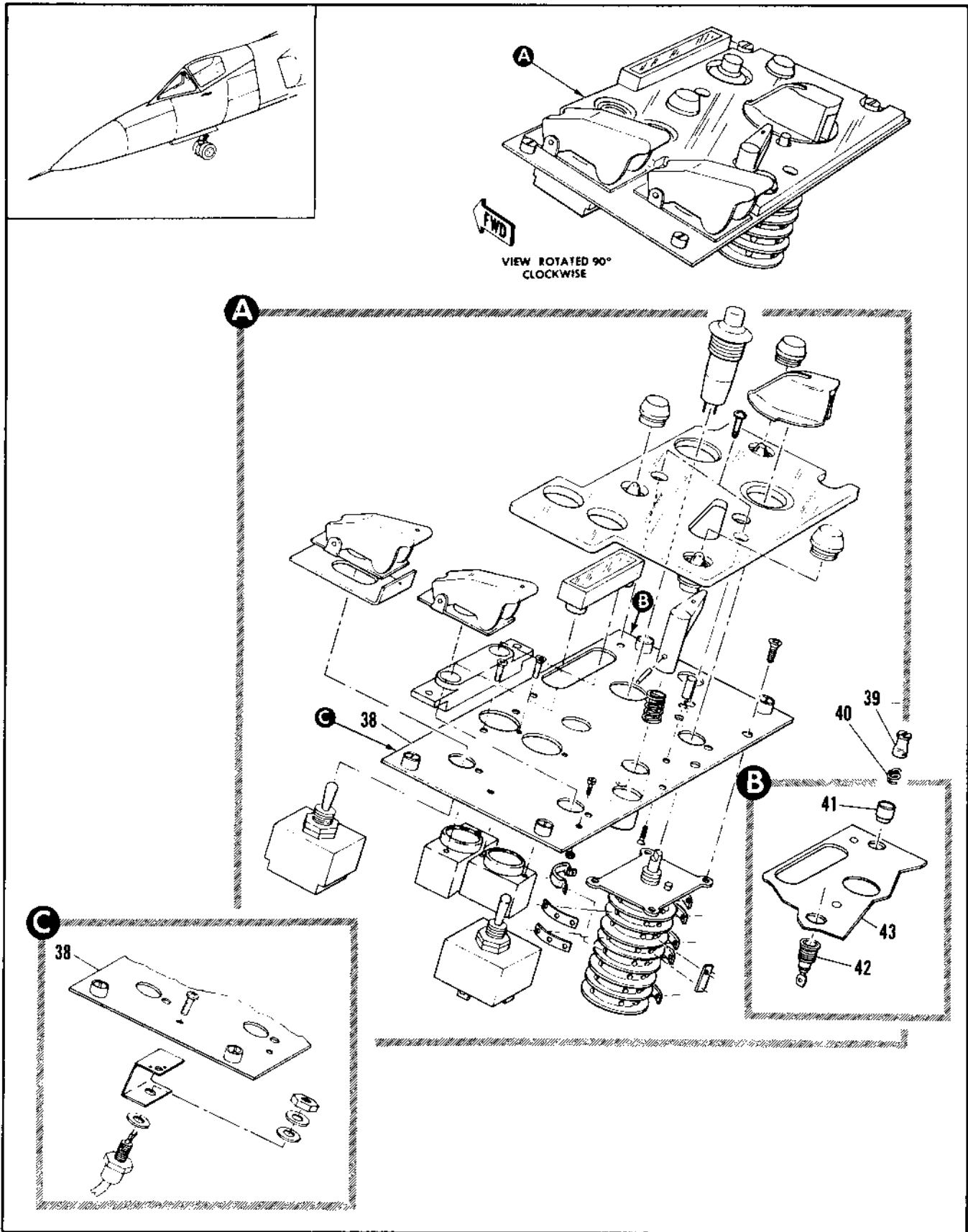

Figure 2.16-11. Armament Control LH Console Panel Assembly (Sheet 2 of 2)

FIGURE AND INDEX NUMBER	PART NUMBER	DESCRIPTION	UNITS PER ASSY.	USABLE ON CODE	
				FROM	TO
		1 2 3 4 5 6			
2.16-11- 38	8-62219-5	<p>-----X-----</p> <ul style="list-style-type: none"> • PANEL ASSY, MOUNTING ARMAMENT CONTROL • • STUD, FASTENER <72794> 98-56501-001 • • SPRING, FASTENER <72794> 98-37080-003 • • RETAINER, FASTENER <72794> 97-58300-001 • • RETAINER, FASTENER <72794> 97-58300-001 • • TERMINAL, SOCKET <04211> • • PLATE ASSY, WELDED 	1 4 4 4	35 35 35 35	
- 39	PF3-1/2-38				
- 40	PS3-1/2				
- 41	PC3-1/2				
- 42	107A		1	35	
- 43	8-62219-15		1	35	
		<p>A - AIRPLANES #46, 47, 56, 91 AND ON.</p> <p>B - AIRPLANES #35 THRU 46, 49 THRU 53, AND 59 THRU 89.</p>			

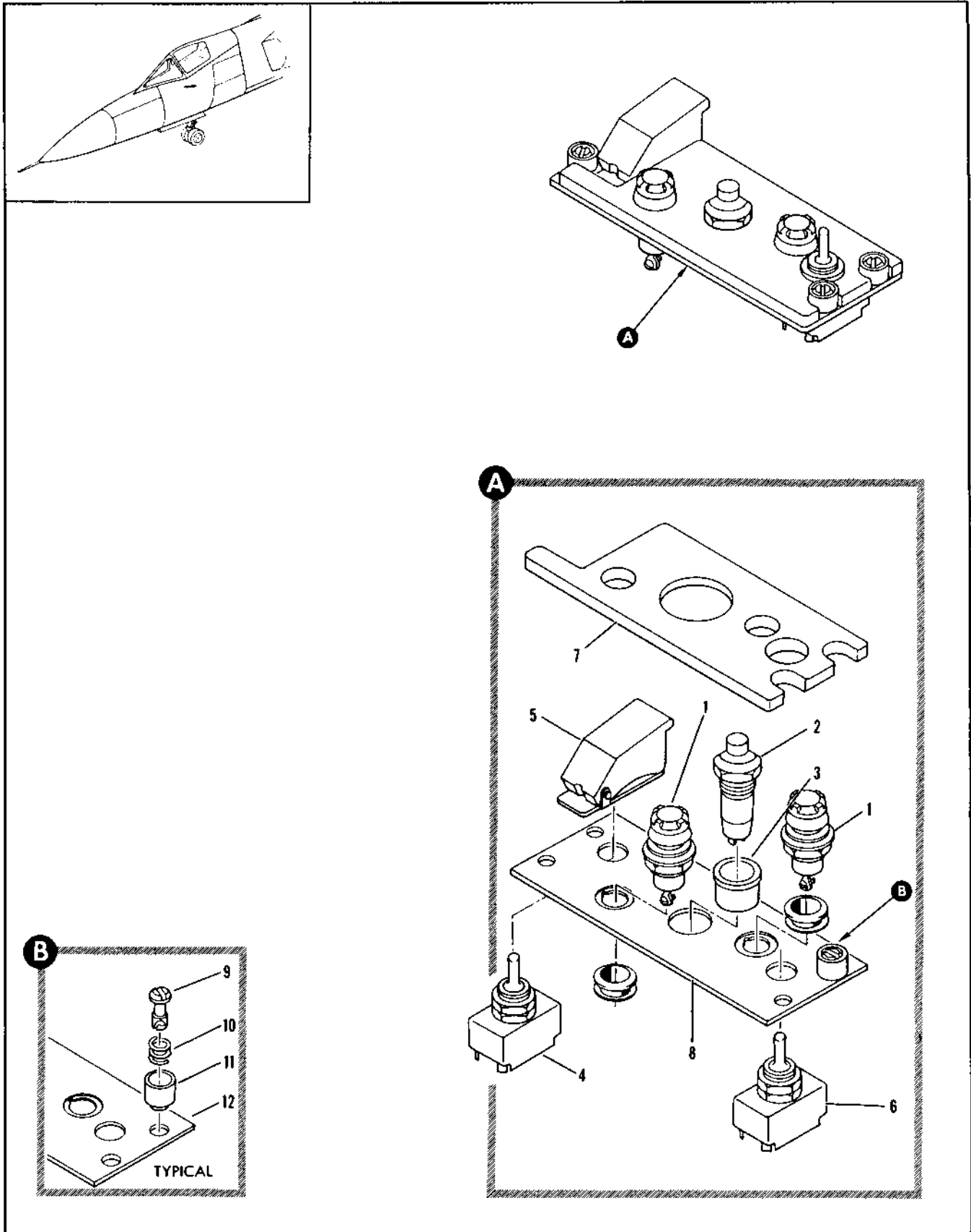

Figure 2.16-12. LH Console Switch Panel Assembly

FIGURE AND INDEX NUMBER	PART NUMBER	DESCRIPTION	UNITS PER ASSY.	USABLE ON CODE	
				FROM	TO
		1 2 3 4 5 6			
2.16-12	R-62215-1	PANEL ASSEMBLY, SWITCH LH CONSOLE FOR NHA SEE FIG. 2.16-1	2F	A	
	R-62215-3	PANEL ASSEMBLY, SWITCH LH CONSOLE FOR NHA SEE FIG. 2.16-1	2F	B	
	R-94711-1P	• LAMP INSTL, AIRPLANE LIGHTING	1	35	
	MS25237-327	• LAMP	2	35	
- 1	MS25215-4A	• LIGHT ASSY, PANEL PLASTIC PLATE LIGHTING (M3564) SPEC R-05441-13 ALT INTENS WITH IPR	2	A	
	A7076	• DROMMET, INSTRUMENT LIGHT	2	35	
- 2	MS25069-30	• SWITCH, PUSH BUTTON ARMAMENT RECYCLE SUITABLE SUB FOR MS25049-30	1	A	
- 3	R-94509	• SHIELD, PUSH BUTTON SWITCH	1	A	
- 4	R906K706	• SWITCH, TORQUE DOUBLE HOLE ONE HOLE MOUNTING (15605) SPEC R-14915-5	1	A	
- 5	MS25224-3	• GUARD	1	A	
- 6	R906K709	• SWITCH, TORQUE DOUBLE HOLE ONE HOLE MOUNTING (15605) SPEC R-14915-11	1	A	
- 7	R-62214-7	• PLATE, DESIGNATION SWITCH PANEL	1	A	
- 8	R-62213-1	• PANEL ASSY, MOUNTING SWITCH	1	A	
- 9	PF3-172-3H	• STUD, FASTENER (72794) 98-58501-001	4	A	
- 10	PS3-172	• SPRING, FASTENER (72794) 98-37000-003	4	A	
- 11	PC3-172	• RETAINER, FASTENER (72794) 97-58300-001	4	A	
- 12	R-62213-9	• PANEL	1	A	
		A AIRPLANES #35 THRU 37, 43 AND ON			
		B AIRPLANES #38 THRU 40, 48 AND ON			

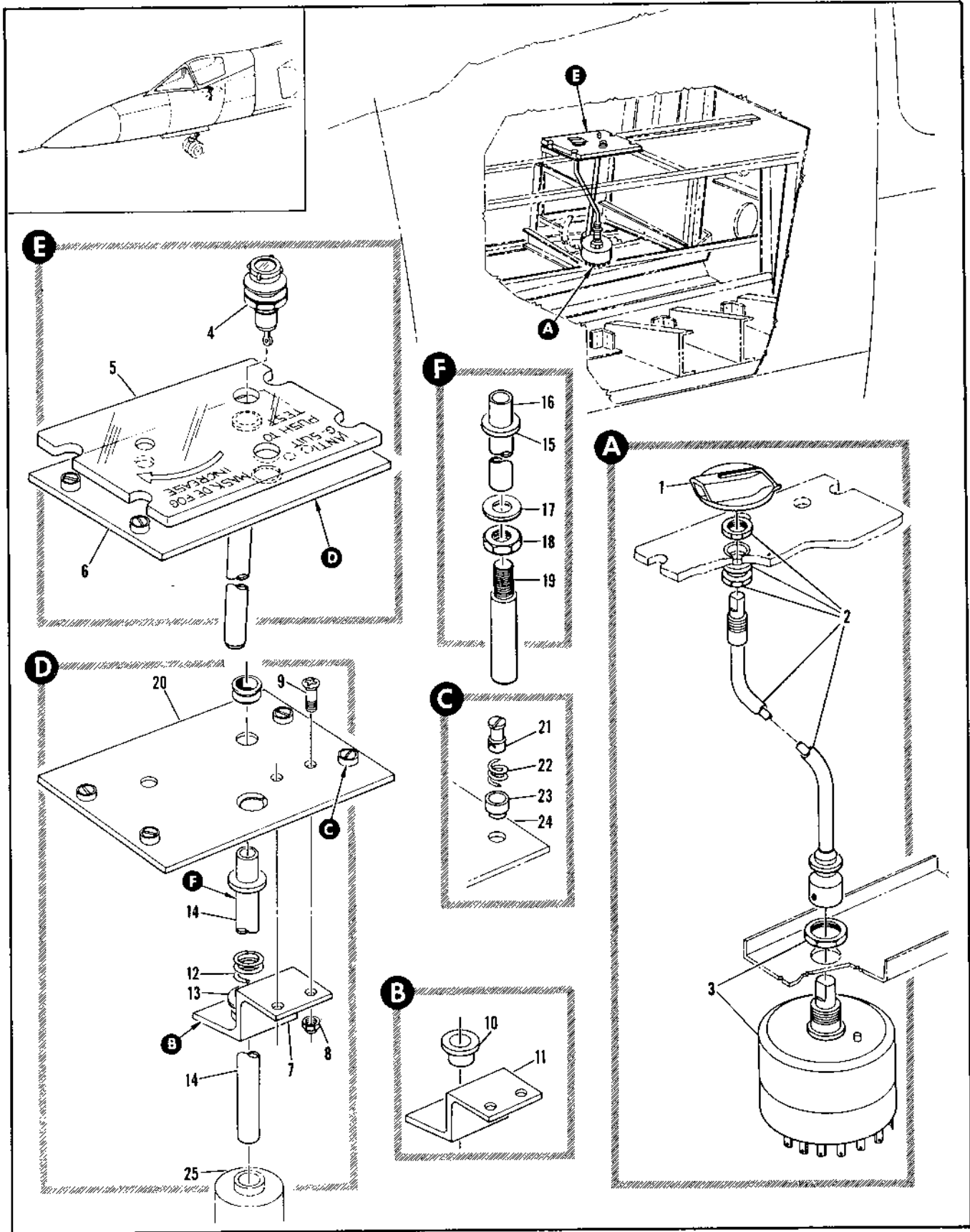

Figure 2.16-13. Anti-G Suit and Mask De-Fog Equipment

FIGURE AND INDEX NUMBER	PART NUMBER	DESCRIPTION	UNITS PER ASSY.	USABLE ON CODE	
				FROM	TO
		1 2 3 4 5 6			
2.16-13		ANTI-G SUIT AND MASK DE-FOG EQUIPMENT			
	8-95424	• SWITCH INSTL, MASK DE-FOG FOR MHA SEE FIG. 2.3-B	AF	35	
- 1	PPM9341-1	• • KNOR, COCKPIT CONTROL PANEL <J1010> SPEC 8-79341-1	1	35	
- 2	L42540-H.75	• • CONTROL, MASK DE-FOG SWITCH <2725> SPEC 8-79293-3 REPLACES SUITABLE SUB FOR L42449-H.75	1	160	
- 3	1307-3	• • SWITCH ASSY, ROTARY - POSITION SPEC 8-76462-3	1	160	
	8-95594	• PANEL ASSY, ANTI-G SUIT AND MASK DE-FOG FOR MHA SEE FIG. 2.16-B	9F	35	129
	8-95594-1	• PANEL ASSY, ANTI-G SUIT AND MASK DE-FOG FOR MHA SEE FIG. 2.16-B	9F	130	
	8-94711-1R1	• • LAMP INSTL, PANEL	1	35	
	AN3140-427	• • LAMP	1	35	
- 4	MS25710-4A	• • LIGHT, PANEL <83564> SPEC 8-0944-1 ALT INCHG WITH 1960	1	35	
	A7376	• • GROMMET, INSTRUMENT LIGHT	1	35	
- 5	8-95596	• • PANEL, PLASTIC	1	35	
- 6	8-95597	• • PANEL ASSY, MOUNTING REPLACED BY SUITABLE SUB 8-95597-1	1	35	129
	8-95597-1	• • PANEL ASSY, MOUNTING REPLACES SUITABLE SUB FOR 8-95597	1	130	
- 7	8-95597-17	• • CLIP ASSEMBLY	1	35	60
	8-95597-21	• • CLIP ASSEMBLY ATTACHING PARTS	1	61	
- 8	NAS679A-4	• • NUT	2	35	
- 9	AN537-3284	• • SCREW	2	35	

- 10	01-21711-111	• • RUSHING, FLANGED	1	35	
- 11	8-95597-15	• • CLIP	1	35	60
	8-95597-19	• • CLIP	1	61	
- 12	8-05071	• • SPRING	1	35	129
- 13	AN98100616	• • WASHER	1	35	129
- 14	8-95597	• • TUBE ASSY, WELDED	1	35	129
	8-95597-1	• • TUBE ASSEMBLY	1	130	
- 15	AN98100616	• • WASHER	1	130	
- 16	8-95597-11	• • RTG	1	130	
- 17	AN0610414L	• • WASHER	1	130	
- 18	AN316-4	• • NUT	1	130	
- 19	8-95597-13	• • STUD	1	130	
- 20	8-95597-11	• • PLATE ASSY, MOUNTING	1	35	
- 21	PF3-1/2-70	• • STUD, FASTENER <7734> SH-56501-001	4	35	
- 22	PS3-1/2	• • SPRING, FASTENER <7722> SH-37001-003	4	35	
- 23	PC3-1/2	• • RETAINER, FASTENER <7724> 97-EP100-101	4	35	
- 24	8-95597-7	• • PLATE	1	35	
- 25		• VALVE INSTL, ANTI-G SUIT SEE FIG. 2.0-1	AF		

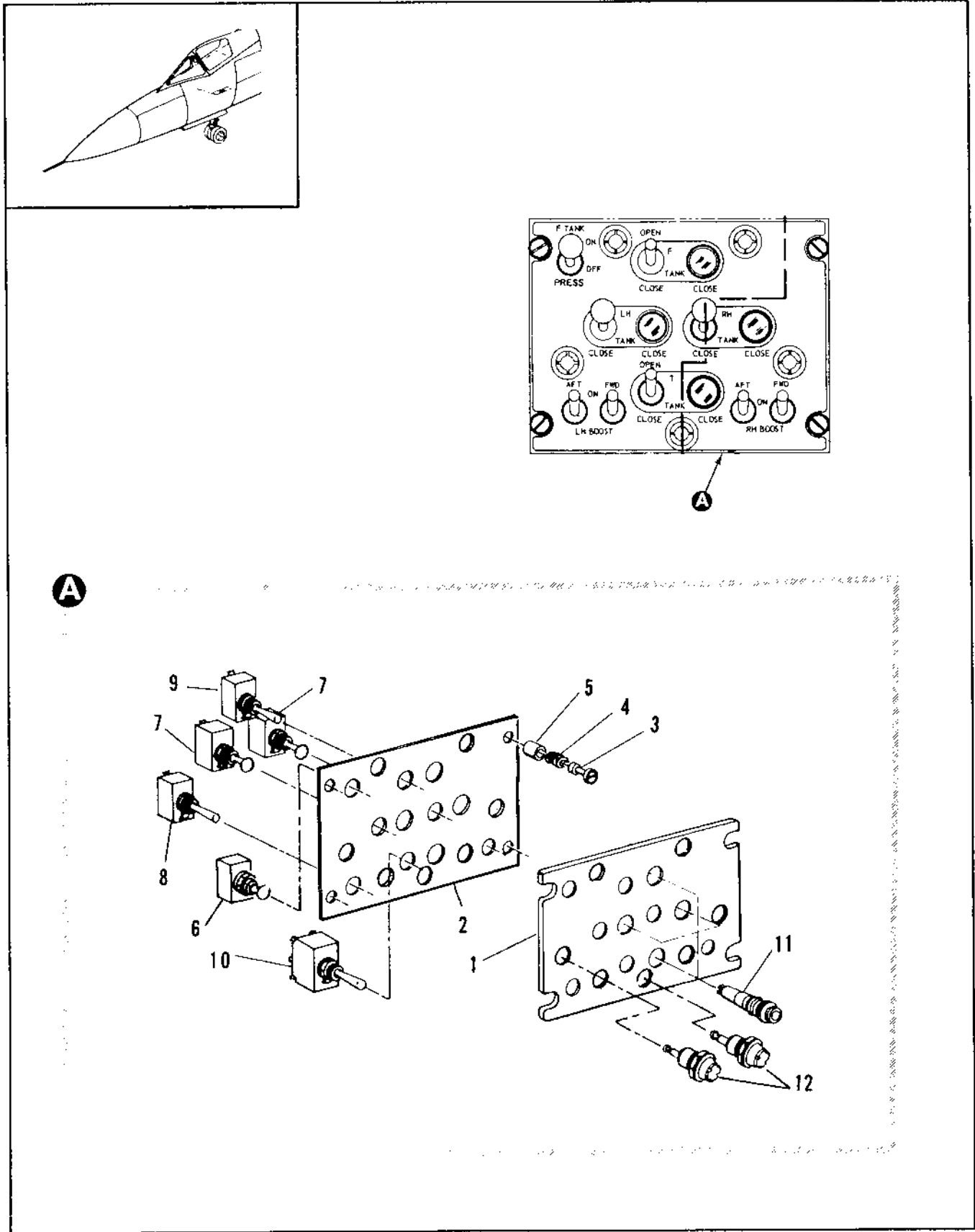

Figure 2.16-14. Fuel Control LH Console Panel Assembly

FIGURE AND INDEX NUMBER	PART NUMBER	DESCRIPTION	UNITS PER ASSY.	USABLE ON CODE	
				FROM	TO
		1 2 3 4 5 6			
2.16-14	62034835-1	PANEL ASSY, FUEL CONTROL LH CONSOLE FOR NHA SEE FIG. 2.16-R	RF		A
	62034835-3	PANEL ASSY, FUEL CONTROL FOR NHA SEE FIG. 2.16-R	RF		B
- 1	7747432-01	• PLATE ASSY, PLASTIC-FUEL CONTROL (BOOST)	1		A
	7747432-03	• PLATE ASSY, PLASTIC-FUEL CONTROL (PRESSURE)	1		B
- 2	62034835-1	• PLATE MOUNTING-FUEL CONTROL	1		35
- 3	PF3-1/2-38	• STUC, FASTENER (72794) 98-56501-001	4		35
- 4	FF3-1/2	• SPRING, FASTENER (72794) 99-37050-003	4		35
- 5	PC3-1/2	• RETAINER, FASTENER (72794) 97-59300-051	4		35
	MF1800-06	• NUT PLATE (75237) 97-3753A-708	2		35
- 6	MS24658-22D	• SWITCH, F TANK EMER BOOST TOGGLE SINGLE POLE LEVERLOCK ONE HOLE MOUNTING	1		A
	MS24659-22D	• SWITCH, F TANK EMER PRESSURE TOGGLE SINGLE POLE LEVERLOCK ONE HOLE MOUNTING	1		B
- 7	MS24658-23F	• SWITCH, FUEL SHUTOFF VALVE, TOGGLE SINGLE POLE LEVERLOCK ONE HOLE MOUNTING	2		35
- 8	MS35758-24	• SWITCH, FUEL TANK BOOSTER PUMP TOGGLE SINGLE POLE, ONE HOLE MOUNTING REPLACES 8906K699	4		35
- 9	8906K699	• SWITCH, F TANK, TOGGLE SINGLE POLE ONE HOLE MOUNTING (15405) SPEC 8-15907-5	1		35
- 10	8906K776	• SWITCH, T TANK, TOGGLE DOUBLE POLE ONE HOLE MOUNTING (15405) SPEC 8-06915-5	1		35
- 11	MS25241-4	• LIGHT ASSY, INDICATOR PRESS TO TEST SUITABLE SUB FOR VM911420A	4		35
	MS25237-327	• LAMP	4		35
- 12	MS25010H11A37	• LIGHT ASSY, PANEL ILLUMINATION	5		35
	AN3149-327	• LAMP	5		35
	AN776	• BROMMET	5		35
- 13	MS24659-22D	• SWITCH, FUEL CONTROL, SINGLE POLE, EXT. TANK EMER.	1		35
		A AIRPLANES #49, 217 AND ON (EMER F TANK BOOST)			
		B AIRPLANES #35 THRU 47, 49 THRU 215 (EMER F TANK PRESSURE)			

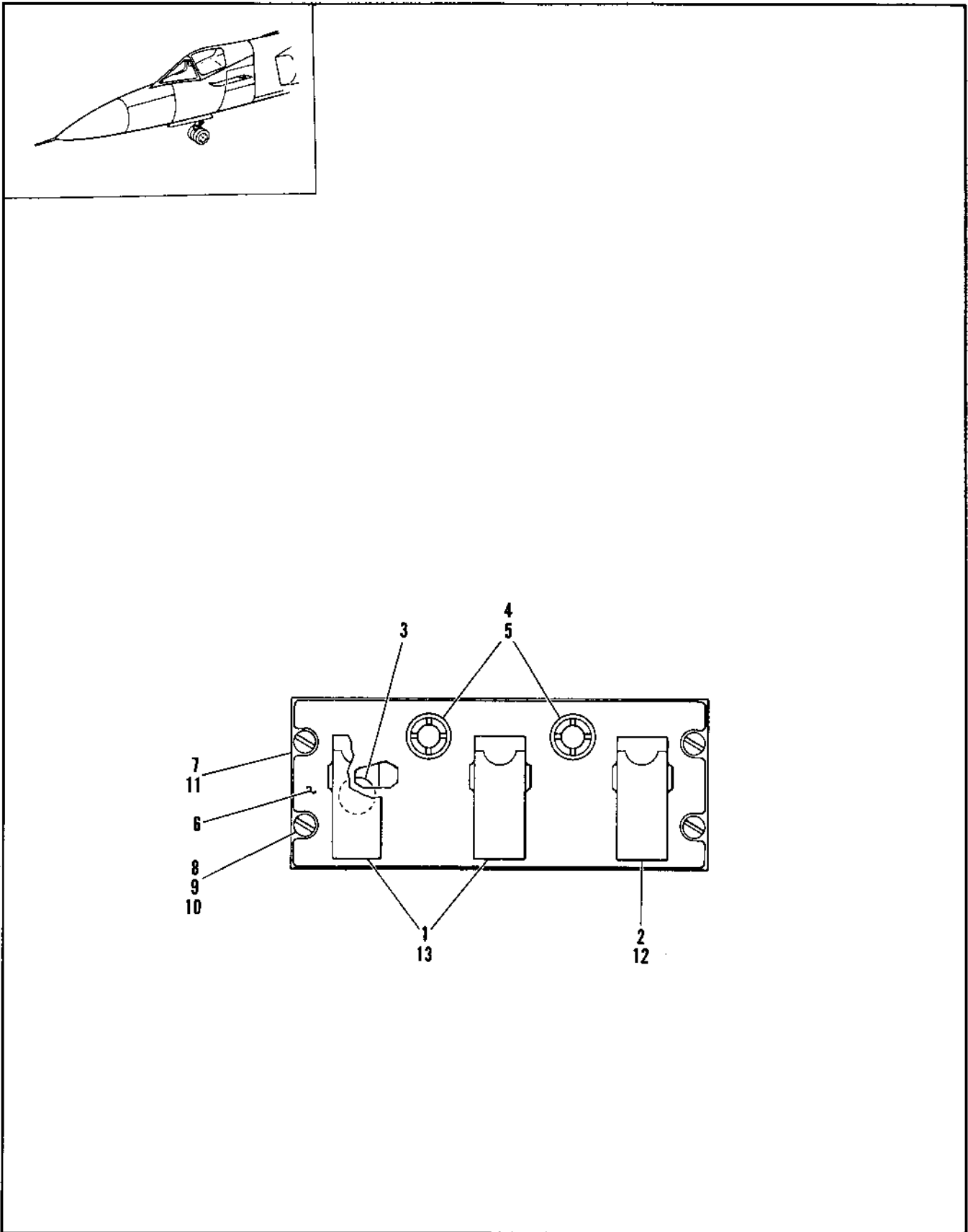

Figure 2.16-15. Aerial Refuel Control, LH Console

FIGURE AND INDEX NUMBER	PART NUMBER	DESCRIPTION	UNITS PER ASSY.	USABLE ON CODE	
				FROM	TO
		1 2 3 4 5 6			
2.16-15	6604987-2	PANFL ASSY, AERIAL REFUELING CONTROL FOR NHA SEE FIG. 2.16-A	RF	35	4B
	6604 987-1	PANFL ASSY, AERIAL REFUELING CONTROL FOR NHA SEE FIG. 2.16-A	RF	49	
- 1	MS24523-23	• SWITCH	2	35	
- 2	MS24524-23	• SWITCH	1	35	
- 3	AN961-R10L	• WASHER	3	35	
- 4	MS25110P11A	• LIGHT ASSY	2	35	
- 5	MS25237-307	• LAMP	2	35	
- 6	66049413-1	• PLATE, PLASTIC AERIAL REFUELING	1	35	
- 7	66049417-1	• PANEL ASSY, AERIAL REFUELING	1	35	4B
	66049414-1	• PANFL ASSY, AERIAL REFUELING ALTERED FROM 8-94681-5	2	49	
- 8	PF3-172-76	• STUD, FASTENER (72794) 98-56501-001	4	35	
- 9	PS3-172	• SPRING, FASTENER (72794) 98-37000-003	4	35	
- 10	PC3-172	• RETAINER, FASTENER (72794) 97-58300-001	4	35	
- 11	66049417-2	• PANEL	1	35	4B
	8-94681-13	• PANEL, ALTERED BY 66049414	1	49	
- 12	MS25224-3	• GUARD	1	35	
- 13	MS25224-1	• GUARD	2	35	

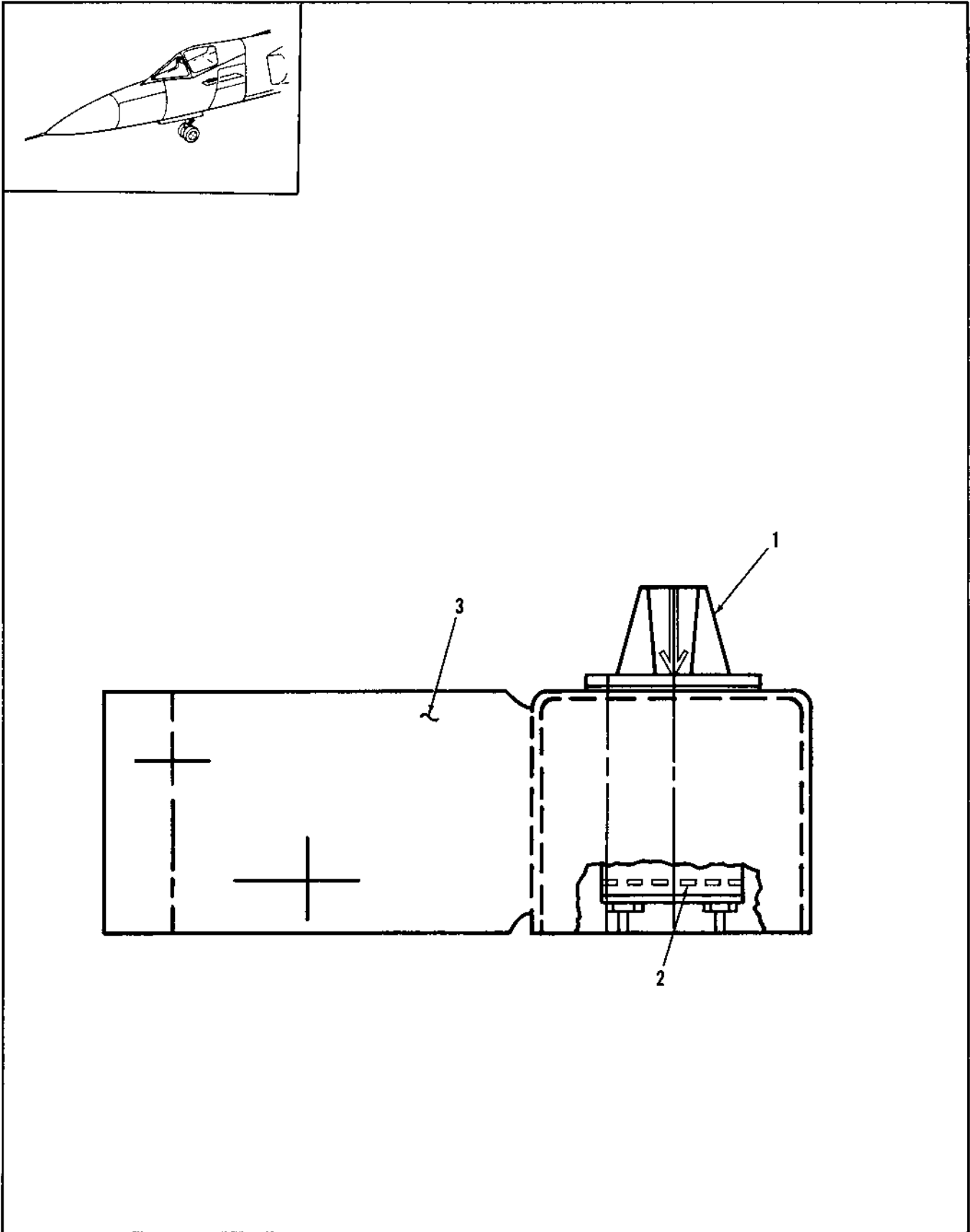

Figure 2.16-16. Switch (Rotary) Altitude Band Selector

FIGURE AND INDEX NUMBER	PART NUMBER	DESCRIPTION 1 2 3 4 5 6	UNITS PER ASSY.	USABLE ON CODE	
				FROM	TO
2.16-16	7239065	• SWITCH ASSEMBLY (INSTALLED THROUGH TCTO 1F-106-1090 - RIVETED TO PANEL 8-95577			
- 1	M3746-4-3353	• SWITCH	1		
- 2	MS91528-144R	• KNOB	1		
- 3	7239064-01	• BRACKET, ALTITUDE BAND SELECTOR SWITCH	1		

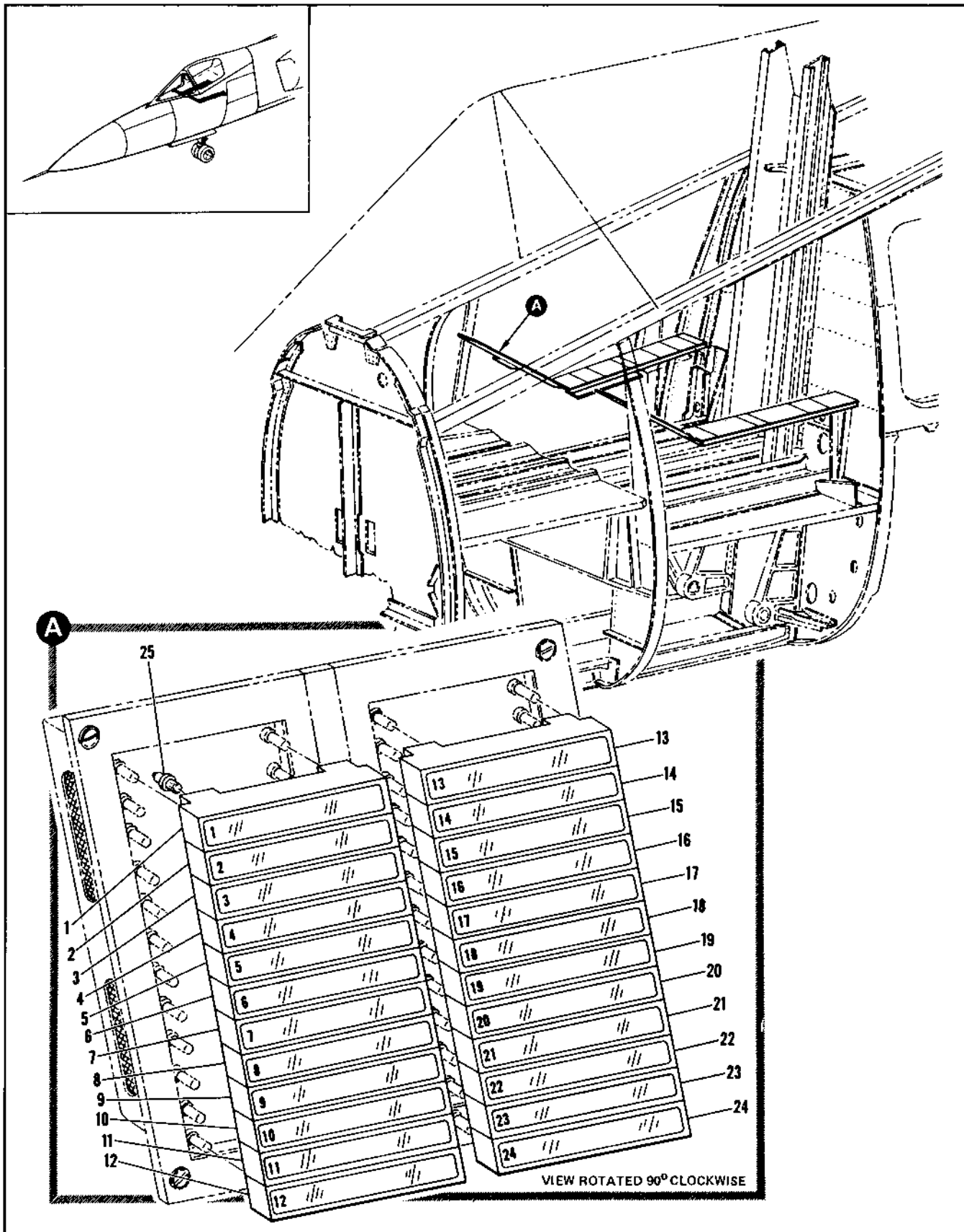

Figure 2.16-17. RH Console Panel and Control Box Master Warning Lamp Installation

FIGURE AND INDEX NUMBER	PART NUMBER	DESCRIPTION	UNITS PER ASSY.	USABLE ON CODE	
				FROM	TO
2.16-17	8-94711-217	LAMP INSTALLATION, RH CONSOLE PANEL AND CONTROL BOX MASTER WARNING PANEL FOR NHA SEE FIG. 2.16-8	RF	35	188
	8-94711-269	LAMP INSTALLATION, RH CONSOLE PANEL AND FOR NHA SEE FIG. 2.16-8	RF	189	
- 1	F377-1A	• CAPSULE, AC POWER FAIL <97896> SPEC 8-06275-857	1	35	
- 2	F377-1A1	• CAPSULE, DC POWER FAIL <97896> SPEC 8-06275-859	1	35	
- 3	F377-1A2	• CAPSULE, EMERGENCY FUEL ON <97896> SPEC 8-06275-861	1	35	
- 4	F377-1A3	• CAPSULE, FUEL LOW L <97896> SPEC 8-06275-863	1	35	
- 5	F377-1A4	• CAPSULE, FUEL LOW R <97896> SPEC 8-06275-865	1	35	
- 6	F377-1A5	• CAPSULE, FUEL TANK PRESSURE L <97896> SPEC 8-06275-867	1	35	
- 7	F377-1A6	• CAPSULE, FUEL TANK PRESSURE R <97896> SPEC 8-06275-869	1	35	
- 8	F377-1A7	• CAPSULE, FUEL BOOST PRESSURE L <97896> SPEC 8-06275-871	1	35	
- 9	F377-1A8	• CAPSULE, FUEL BOOST PRESSURE R <97896> SPEC 8-06275-873	1	35	
- 10	F377-1A9	• CAPSULE, ENGINE ANTI-ICE <97896> SPEC 8-06275-875	1	35	
- 11	F377-1A35	• CAPSULE, HYD OIL HOT <97896> SPEC 8-06275-113	1	35	89
- 12	F377-1A18	• CAPSULE, CABIN PRESSURE LOW <97896> SPEC 8-06275-889	1	35	
- 13	F377-1A10	• CAPSULE, MISFIRE <97896> SPEC 8-06275-877	1	35	
- 14	F377-1A11	• CAPSULE, DOOR OPEN <97896> SPEC 8-06275-879	1	35	
- 15	F377-1A12	• CAPSULE, OIL PRESSURE <97896> SPEC 8-06275-881	1	35	
- 16	F377-1A13	• CAPSULE, PNEUMATIC PRESSURE (97896) SPEC 8-06275-883	1	35	
- 17	F377-1A14	• CAPSULE, ENGINE COMPARTMENT OVER PRESSURE <97896> SPEC 8-06275-885	1	35	
- 18	F377-1A37	• CAPSULE OIL QTY LOW	1	35	
- 19	F377-1A27	• CAPSULE, ELECTRONIC COOLING <97896> SPEC 8-06275-897	1	35	
- 20	F377-1A21	• CAPSULE, N-U OVER SPEED <97896> SPEC 8-06275-849	1	35	48
	F377-1A28	• CAPSULE, FUEL VALVE CLOSED <97896> SPEC 8-06275-899	1	49	
- 21	F377-1A22	• CAPSULE, OXYGEN LOW LEVEL	1	35	
- 22	F377-1A23	• CAPSULE, OXYGEN LOW LEVEL (97896) SPEC 8-06275-851	1	35	
- 23	F377-1A24	• CAPSULE, FLIGHT MODE FAIL <97896> SPEC 8-06275-855	1	35	
- 24	F377-1A39	• CAPSLE CADC FAIL (97896) SPEC 8-06275	1	35	
- 25	AN3140-327	• LAMP	48	35	

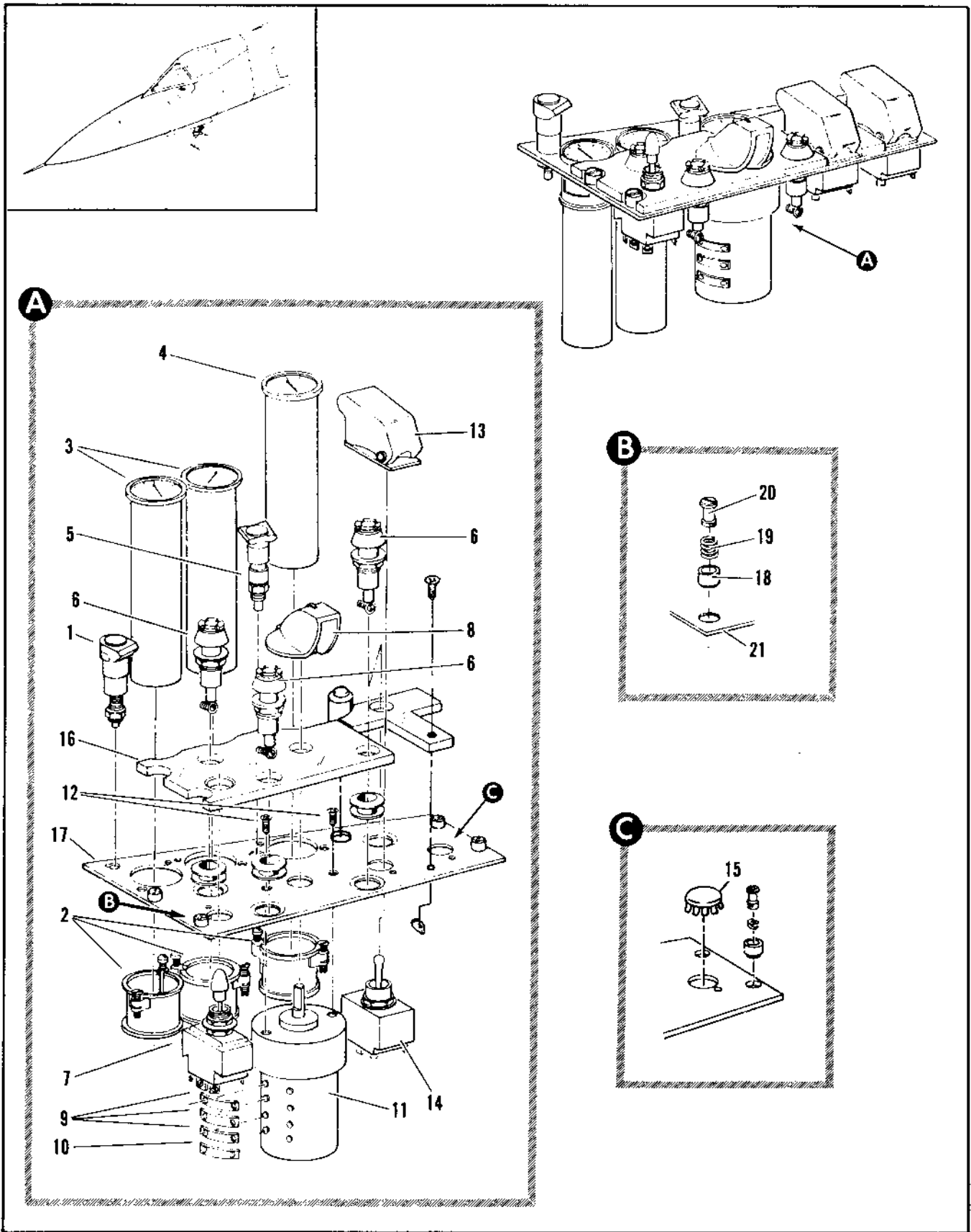

Figure 2.16-18. Hydraulic Indicator Generator Refrigeration and Cockpit Air Switch RH Console Panel Assembly

FIGURE AND INDEX NUMBER	PART NUMBER	DESCRIPTION	UNITS PER ASSY.	USABLE ON CODE	
				FROM	TO
		1 2 3 4 5 6			
2.16-18	7242856-70 7242856-110	EQUIPMENT INSTALLATION, COCKPIT EQUIPMENT INSTALLATION, COCKPIT CONSOLE MOD OF FOR NHA SEE FIG. 2.16-8	RF RF	A 91	159
	7242856-90	EQUIPMENT INSTALLATION, COCKPIT CONSOLE MOD OF FOR NHA SEE FIG. 2.16-8	RF	48	48
	7243856-130	EQUIPMENT INSTALLATION, COCKPIT CONSOLE MOD OF FOR NHA SEE FIG. 2.16-8	RF	61	89
	7242856-110	EQUIPMENT INSTALLATION, COCKPIT CONSOLE MOD OF FOR NHA SEE FIG. 2.16-8	RF	60	8
	7242856-150	EQUIPMENT INSTALLATION, COCKPIT CONSOLE MOD OF FOR NHA SEE FIG. 2.16-8	RF	169	
- 1	11160	• LIGHT, <72914> SPEC 8-09439-3	1	B	
- 2	19137 19137-9	• CLAMP, <98625> 91-97100-109 • CLAMP, <98625> SPEC 8-03381-17	3 3	35	35
- 3	26801A3793A1 AGUI-AU	• INDICATOR, HYDRAULIC PRESSURE <77064>	2	B	
- 4	ESU17A	• INDICATOR	2		
- 5	11155	• LIGHT, <72914> SPEC 8-09439-1	1	35	
	8-94711-153	• LAMP INSTALLATION	1	B	
	AN3411-327	• LAMP	1	35	
- 6	MS25718-4A	• LAMP	6	35	
	A7076	• LIGHT, <83564> SPEC 8-09441-1 ALT INTCHG WITH 1950	3	35	
- 7	MS25126-C3	• BROWNET, INSTRUMENT LIGHT	1	35	60
	MS25127-4	• SWITCH, 2 POLE, REFRIGERATION (15605) SPEC 8-09440-3	1	35	60
- 8	PPM9341-1	• SWITCH, 4 POLE, REFRIGERATION	1	61	N
	PPM9341-3	• KNOB, <11515> SPEC 8-09341-1 REPLACED BY SUITABLE SUB PPM9341-5	1	35	50
	PPM9341-3	• KNOB, <11515> SPEC 8-09341-3 REPLACED BY NOT INTCHG WITH PPM9341-12	1	160	
- 9	8-65029-43	• BUSBAR	3	35	60
- 10	8-65029-43	• BUSBAR	1	61	
- 11	1262	• SWITCH, COCKPIT AIR <81812> SPEC 8-06972-1 ATTACHING PARTS	1	35	
- 12	AN507-632R5	• SCREW	2	35	
- 13	MS25224-3	• GUARD	3	35	
- 14	MS27907-5	• SWITCH	1	35	
- 15	7243028-C1	• PLUS BUTTON			
- 16	8-95610-1	• PANEL	1	35	50
	8-95610-3	• PANEL	1	61	
- 17	67036501-4	• PANEL ASSY	1	49	48
	67036501-5	• PANEL ASSY	1	61	89
	97036501-7	• PANEL ASSY	1	90	
	67036501-5				
- 18	PF3-1/2-38	• STUD, FASTENER <72794> 92-56501-001	4	35	
- 19	PS3-1/2	• SPRING, FASTENER <72794> 92-37001-102	4	35	
- 20	PC3-1/2	• RETAINER, FASTENER <72794> 92-58101-101	4	35	
- 21	8-95609-7	• PLATE	1	A	
	8-95609-9	• PLATE	1	48	48
	8-95609-13	• PLATE	1	61	89
	8-95609-11	• PLATE	1	90	
- 22	VM911M4	• LIGHT INDICATOR	1	35	
- 23	MS35214-26	• SCREW	1	35	
- 24	MS25237-327	• LAMP	1	35	
- 25	A6B48076-1	• PLATE, IDENTIFICATION	1	35	
- 26	MS21075-26	• PLATE, NUT	1	35	

A AIRPLANES 475 THRU 47 AND 49 THRU 60
B AIRPLANES 435 THRU 47 AND 49 THRU 89

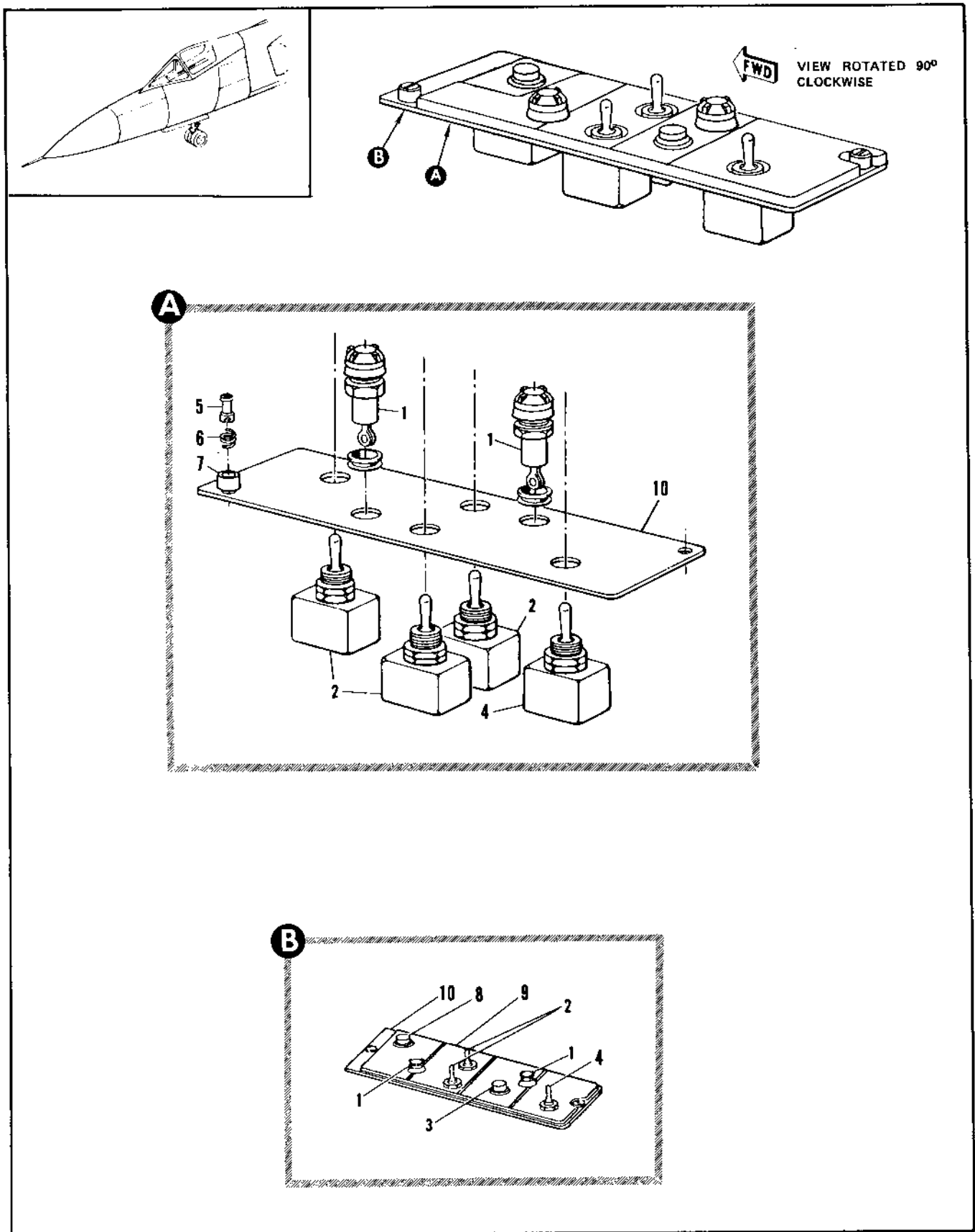

Figure 2.16-19. MA-1 Anti-Ice De-Fog and Rain Removal Switch Panel

FIGURE AND INDEX NUMBER	PART NUMBER	DESCRIPTION	UNITS PER ASSY.	USABLE ON CODE	
				FROM	TO
		1 2 3 4 5 6			
2.16-19		MA-1 ANTI-ICE DE-FOG AND RAIN REMOVAL SWITCH PANEL			
	R-95587-1	• PANEL ASSY, MA-1 ANTI-ICE DE-FOG AND RAIN REMOVAL SWITCH RH CONSOLE FOR NHA SEE FIGURE 2.16-9	RF	A	
	R-94711-021	• • LAMP INSTL, AIRPLANE LIGHTING	1	A	
	AN314G-327	• • LAMP	2	A	
- 1	1959	• • LIGHT ASSY, PANEL PLASTIC PLATE LIGHTING <83564> SPEC 8-39441-1	2	A	
- 2	MS25168-21	• • SWITCH, TOGGLE ONE POLE MOUNTING (15A05) SPEC 8-06907-3, INTCHG WITH 8936K698	2	A	
- 3	MS25089-30	• • SWITCH, PUSH BUTTON, ENGINE ANTI-ICE TEST REPLACES NOT INTCHG WITH WC1395	1	A	
- 4	2TL1-16	• • SWITCH, TOGGLE DOUBLE POLE 3 POSITION CENTER ON <91929> SPEC 8-26471-1	1	A	
- 5	PF3-1/2-3S	• • STUD, FASTENER <72794> 98-56501-001	2	A	
- 6	PS3-1/2	• • SPRING, FASTENER <72794> 98-37000-003	2	A	
- 7	PC3-1/2	• • RETAINER, FASTENER <72794> 97-58300-001	2	A	
- 8	3PR11	• • SWITCH, EST SPREAD (1929)	1		
- 9	64034468-1	• • PANEL, PLASTIC	1		
- 10	R-51374-9	• • PANEL ASSY, MOUNTING MA-1 ANTI-ICE DE-FOG AND RAIN REMOVAL SWITCH	1	A	
		A AIRPLANES #35 THRU 47 AND 49 THRU 89			

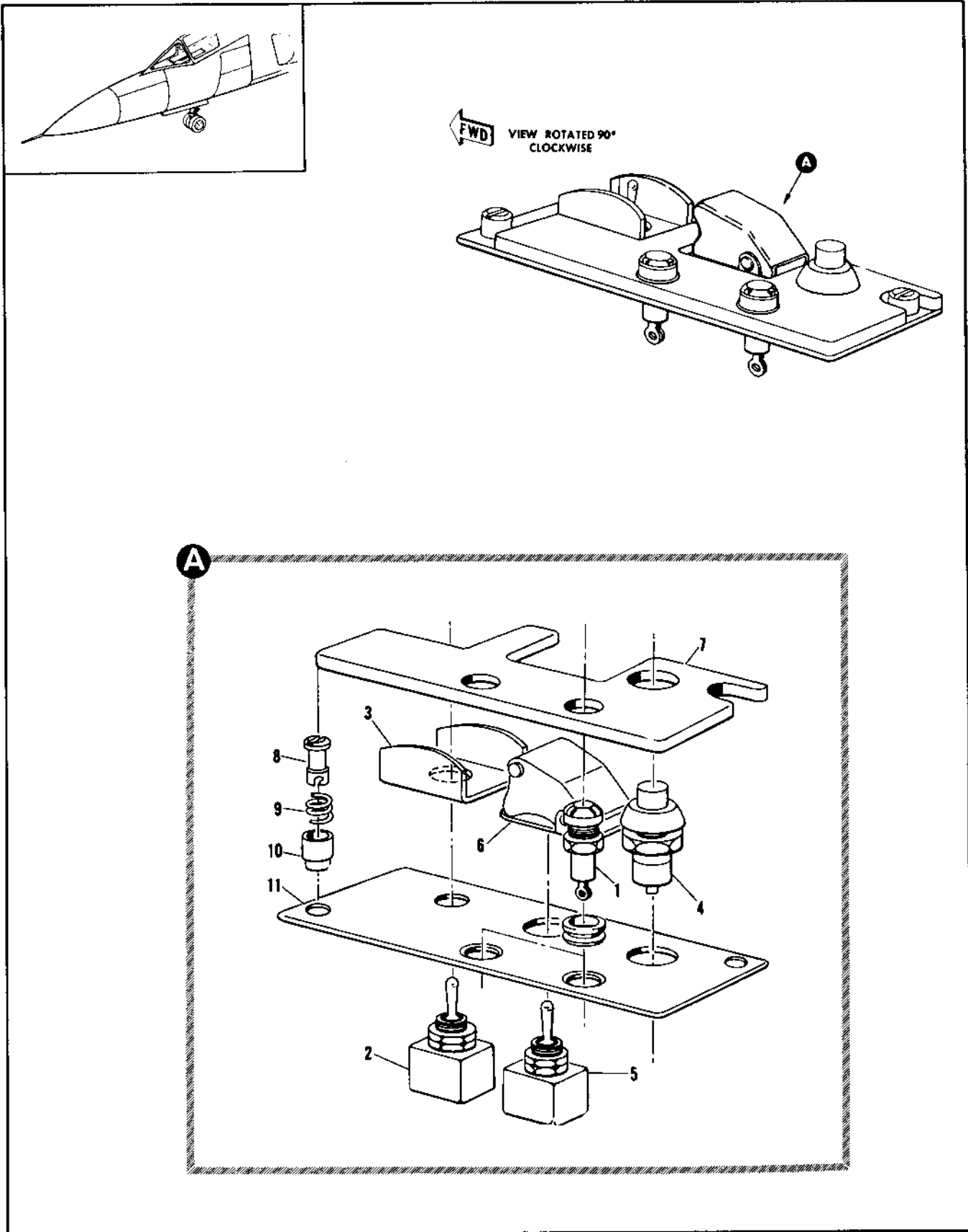

Figure 2.16-20. Nose Landing Gear Steering and Canopy Switch RH Console Panel Assembly

FIGURE AND INDEX NUMBER	PART NUMBER	DESCRIPTION	UNITS PER ASSY.	USABLE ON CODE	
				FROM	TO
2.16-20	44H33377-3	PANEL ASSY, DATA LINK CANOPY SWITCH AND WARNING LIGHT TEST FOR NHA SEE FIG. 2-16-R	RF	35	
	A-94711-211	• LAMP INSTL, AIRPLANE LIGHTING	2	35	
	AN3140-327	• LAMP	2	35	
- 1	MS2517-4A	• LIGHT ASSEMBLY	2	35	
	A7270	• GROMMET, INSTRUMENT LIGHT	2	35	
- 2	6906K705	• SWITCH, TOGGLE DOUBLE HOLE ONE HOLE MOUNTING <15605> SPEC 4-16915-11	1	35	
- 3	F-52014-7	• GUARD, CHANNEL	10	35	
- 4	MS20189-30	• SWITCH, PUSHBUTTON, WARNING LIGHTS TEST	1	35	
- 5	6906K705	• SWITCH, TOGGLE DOUBLE HOLE ONE HOLE MOUNTING <15605> SPEC 4-16915-3	1	35	215
	6906K705	• SWITCH, MOUNTING <15605> SPEC 4-16915-5	1	215	
- 6	MS20225-1	• GUARD	1	35	215
	MS20224-1	• GUARD	1	215	
- 7	62034514-7	• PLATE, PLASTIC	1	35	
- 8	PF3-172-50	• STUD, FASTENER <72794> 97-56501-001	2	35	
- 9	FS3-172	• SPRING, FASTENER <72794> 97-37030-303	2	35	
- 10	PC3-172	• RETAINER, FASTENER <72794> 97-56502-01	2	35	
- 11	62034512-3	• PANEL	1	35	

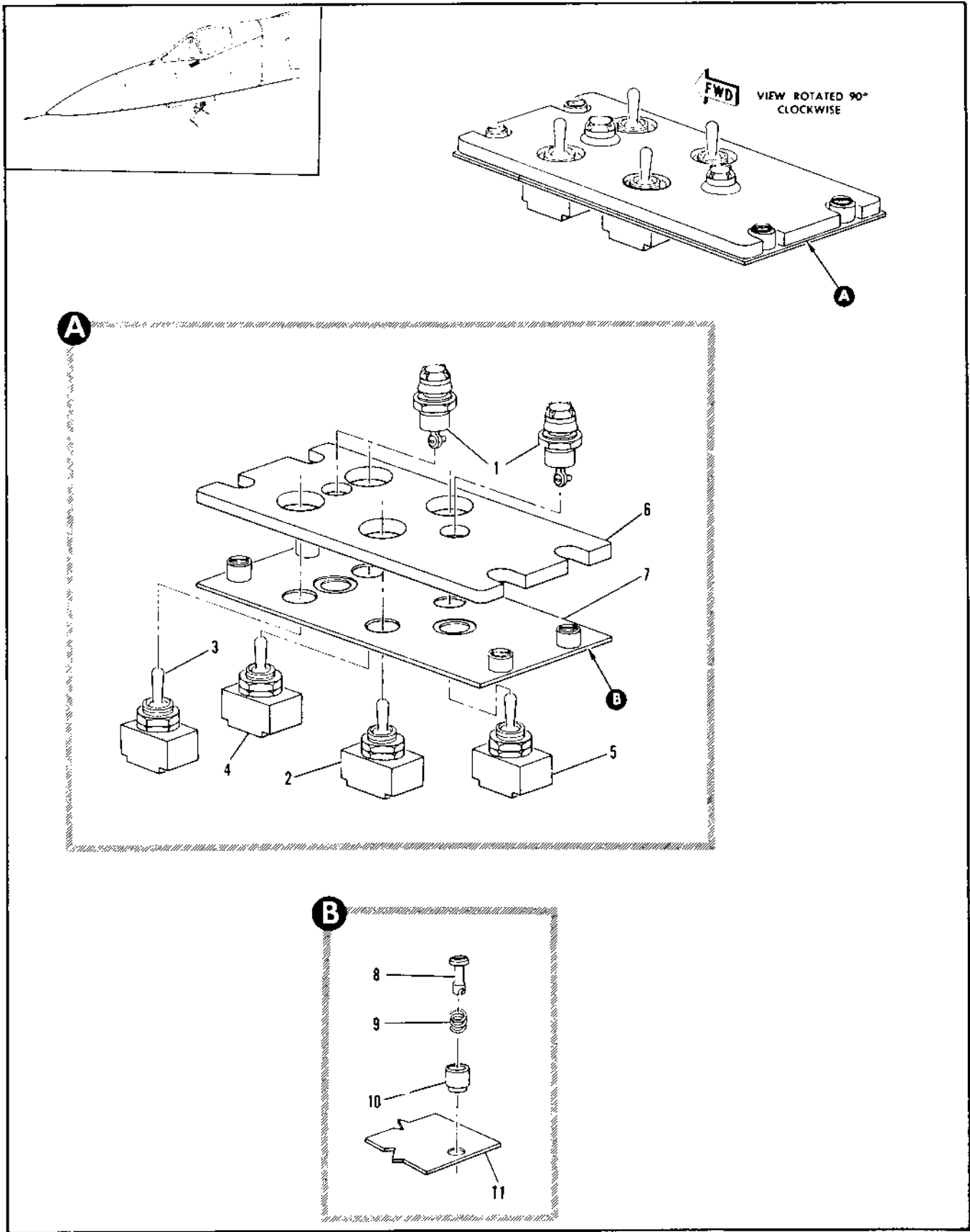

Figure 2.16-21. Lighting Control RH Console Panel Assembly

FIGURE AND INDEX NUMBER	PART NUMBER	DESCRIPTION	UNITS PER ASSY.	USABLE ON CODE	
				FROM	TO
2.16-21	R-62224	PANEL ASSEMBLY, LIGHTING CONTROL RH CONSOLE FOR WHA SEE FIG. 2.16-A	1	A	
	R-94711-139	• LAMP INSTL, AIRPLANE LIGHTING	1	A	
	MS25237-327	• LAMP	2	A	
- 1	MS25110-4A	• LIGHT ASSY, PLASTIC PLATE LIGHTING PANEL <P7564> SPEC R-09441-1, ALT INTCHG WITH 1950	2	A	
- 2	R906K699	• SWITCH, TOGGLE SINGLE POLE ONE HOLE MOUNTING <15605> SPEC R-06907-5	1	A	
- 3	R906K710	• SWITCH, TOGGLE DOUBLE POLE DOUBLE THROW <15675> SPEC R-06903-1	1	A	
- 4	R906K706	• SWITCH, TOGGLE DOUBLE POLE ONE HOLE MOUNTING <15605> SPEC R-06915-5	1	A	
- 5	R906K704	• SWITCH, TOGGLE DOUBLE POLE ONE HOLE MOUNTING <15605> SPEC R-06915-1 REPLACED BY SUJIAABLE SUB MS24524-21	1	A	
- 6	R-62223	• PLATE, DESIGNATION LIGHTING CONTROL	1	A	
- 7	R-62222	• PANEL ASSY, MOUNTING LIGHTING CONTROL	1	A	
- 8	PF3-1/2-38	• STUD, FASTENER <72774> 98-56501-001	4	A	
- 9	PS3-1/2	• SPRING, FASTENER <72774> 98-37000-003	4	A	
- 10	PC3-1/2	• RETAINER, FASTENER <72774> 97-58300-001	4	A	
- 11	R-62222-7	• PANEL	1	A	
A AIRPLANES #35 THRU 47 AND 49 THRU 89					

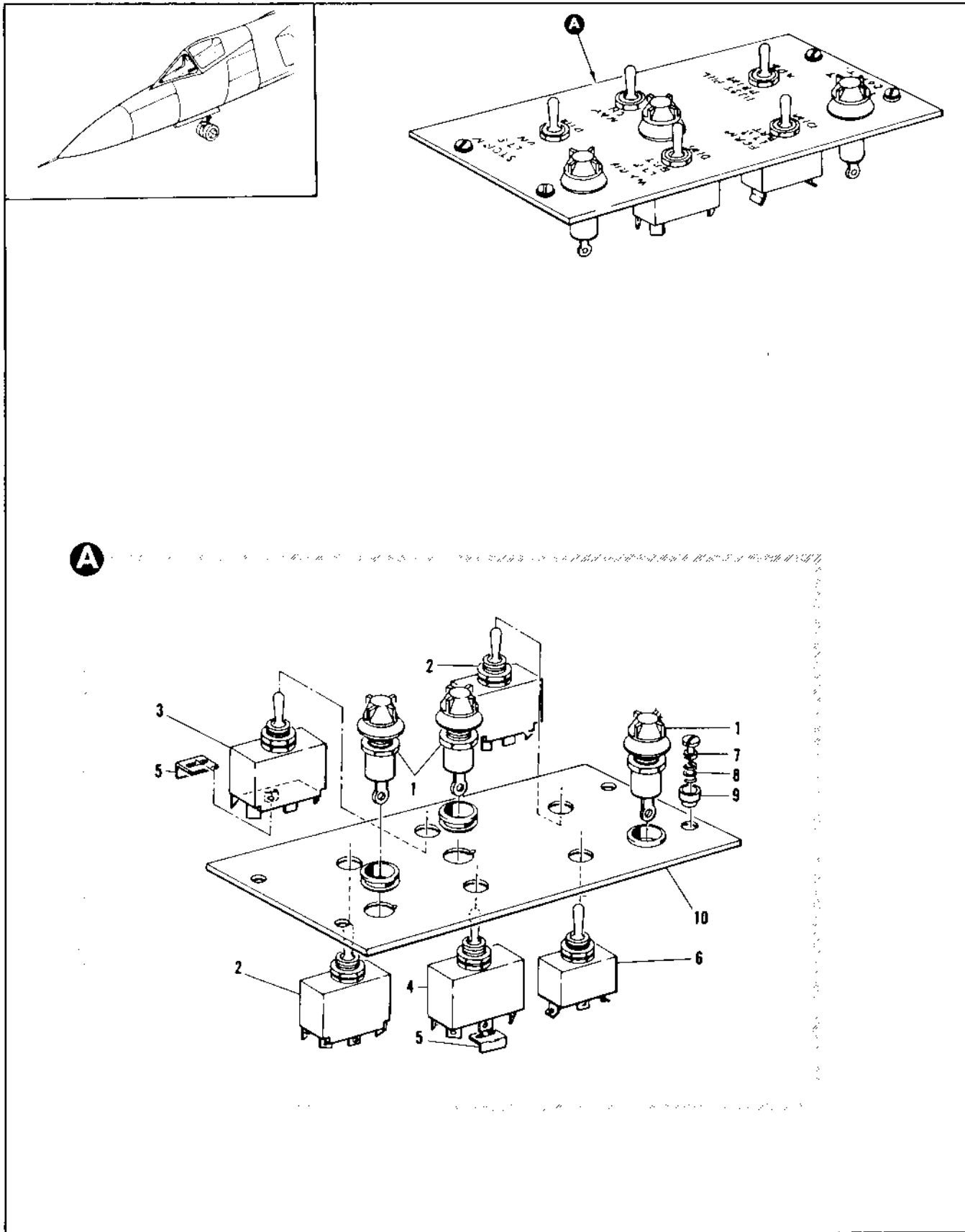

Figure 2.16-22. Lighting Control RH Console Panel Assembly

FIGURE AND INDEX NUMBER	PART NUMBER	DESCRIPTION	UNITS PER ASSY.	USABLE ON CODE	
				FROM	TO
2.16-22	R-63671-805	PANEL ASSEMBLY, LIGHTING CONTROL RH CONSOLE FOR NHA SEE FIG. 2.16-A	RF	A	
	8-63671-5	PANEL ASSEMBLY, LIGHTING CONTROL RH CONSOLE MODIFIED BY R-32825 FOR NHA SEE FIG. 2.16-B	RF	93	215
	8-99711-147	• LAMP INSTL, AIRPLANE LIGHTING	1	R	
	MS20237-327	• LAMP	3	B	
	MS25310-4A	• LIGHT	3	R	
	47076	• GROMMET, INSTRUMENT LIGHT	3	R	
	8906K706	• SWITCH, TOGGLE DOUBLE POLE ONE HOLE MOUNTING <15605> SPEC R-76915-5	2	B	
	8906K704	• SWITCH, TOGGLE DOUBLE POLE ONE HOLE MOUNTING <15605> SPEC R-76915-1 REPLACED BY SUITABLE SUB MS24524-21	1	A	
	MS24524-21	• SWITCH, REPLACES SUITABLE SUB FOR 8906K704	1	A	
	8906K710	• SWITCH, TOGGLE DOUBLE POLE DOUBLE THROW <15605> SPEC R-15607-1	1	B	
	35-07103-002	• INSULATOR	2	C	
	8906K699	• SWITCH, TOGGLE SINGLE POLE ONE HOLE MOUNTING <15604> SPEC R-76907-5	1	R	
	R-63670-1	• PANEL ASSY, SWITCH LIGHTING CONTROL	1	B	
	PF3-1/2-3A	• STOP, FASTENER <72794> 98-37000-003	4	R	
	PS3-1/2	• SPRING, FASTENER <72794> 98-37000-003	4	R	
PC3-1/2	• RETAINER, FASTENER <72794> 97-58500-001	4	R		
8-63670-5	• PLATE	1	R		
		A AIRPLANES #44, 215 AND ON			
		B AIRPLANES #44, 93 AND ON			
		C AIRPLANES #44, 135 AND ON			

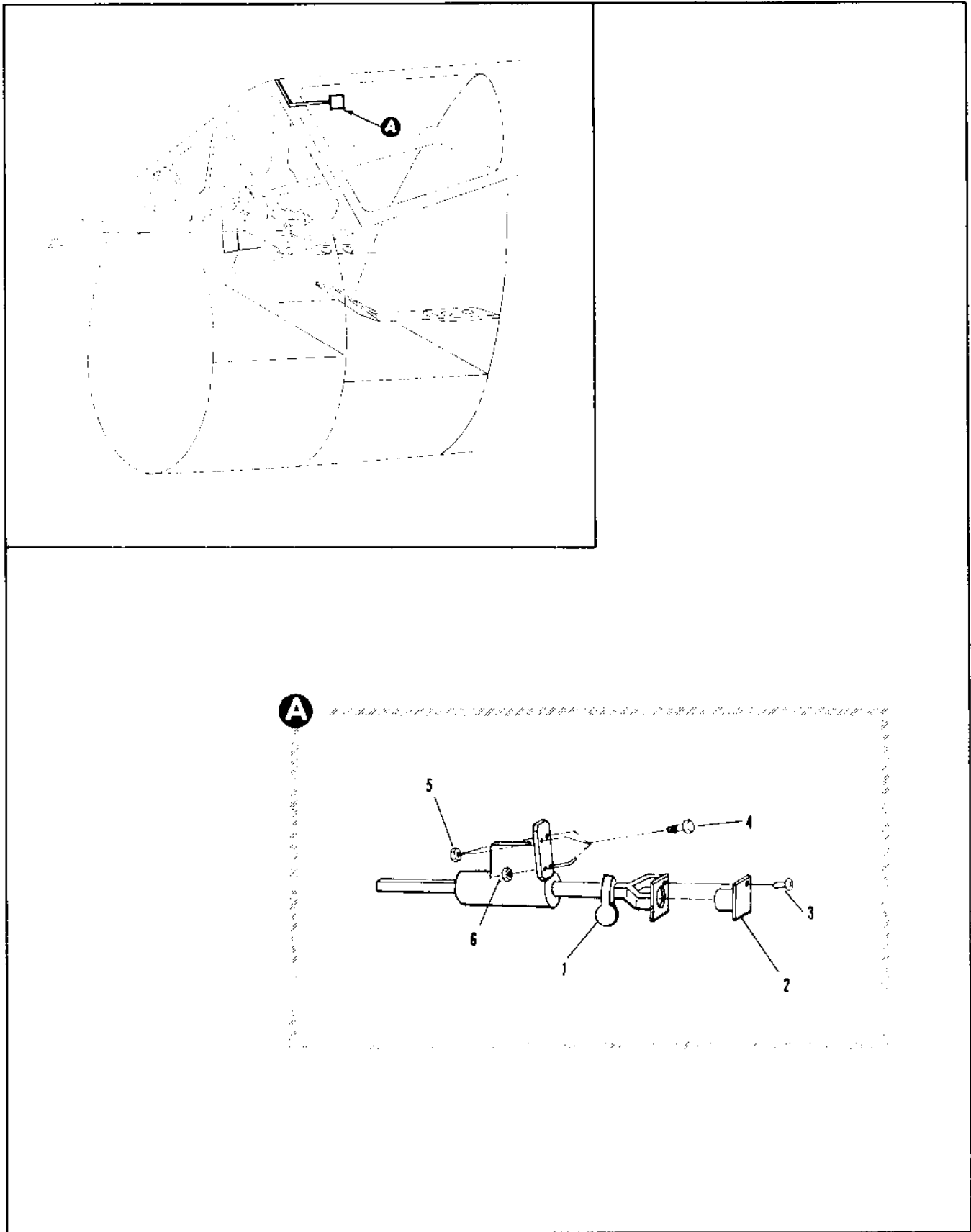

Figure 2.16-23. Pilot Standby Compass

FIGURE AND INDEX NUMBER	PART NUMBER	DESCRIPTION	UNITS PER ASSY.	USABLE ON CODE	
				FROM	TO
		1 2 3 4 5 6			
2.16-23		PILOT STANDRY COMPASS INSTL	RF		35
- 1	7445983-10	• • BRACKET ASSY	1		35
- 2	MS17983-2	• • COMPASS, MAGNETIC	1		35
- 3	MS35219-29	• • SCREW	4		35
- 4	NAS1303-9	• • BOLT	4		35
- 5	MS21042-3	• • NUT	2		35
- 6	MS21043-7	• • NUT	2		35

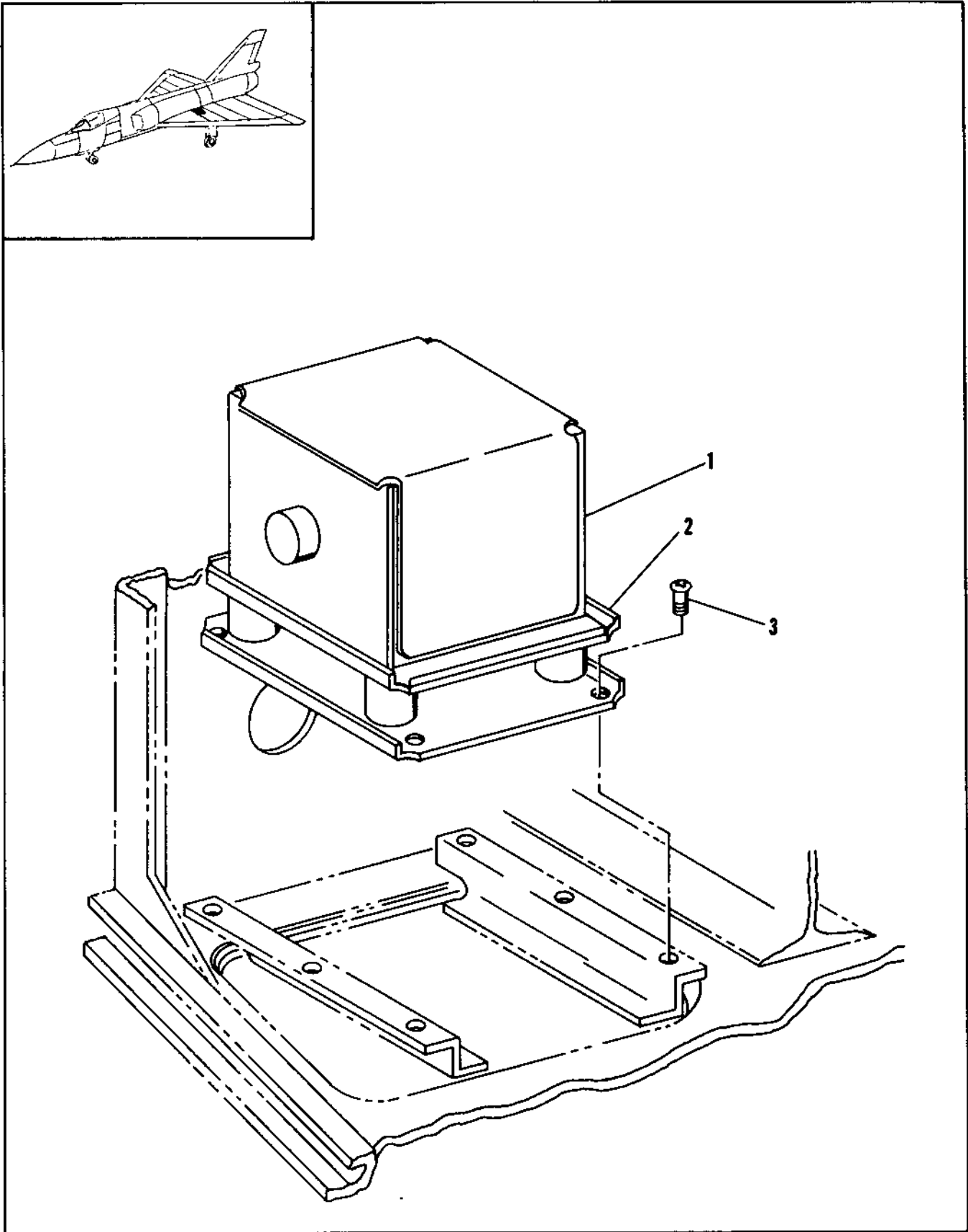

Figure 2.16-24. Exhaust Gas Temperature Recorder Installation

FIGURE AND INDEX NUMBER	PART NUMBER	DESCRIPTION	UNITS PER ASSY.	USABLE ON CODE	
				FROM	TO
2.16-24	4F34490-1	RECORDER INSTALLATION, EXHAUST GAS TEMPERATURE	1	35	
- 1	H15601	• RECORDER, EXHAUST GAS TEMPERATURE (98869)	1	35	
- 2	RH7221	• SHOCKMOUNT ASSY. (98869) ATTACHING PARTS	1	35	
- 3	AN515-8R7	• SCREW -----X-----	6	35	

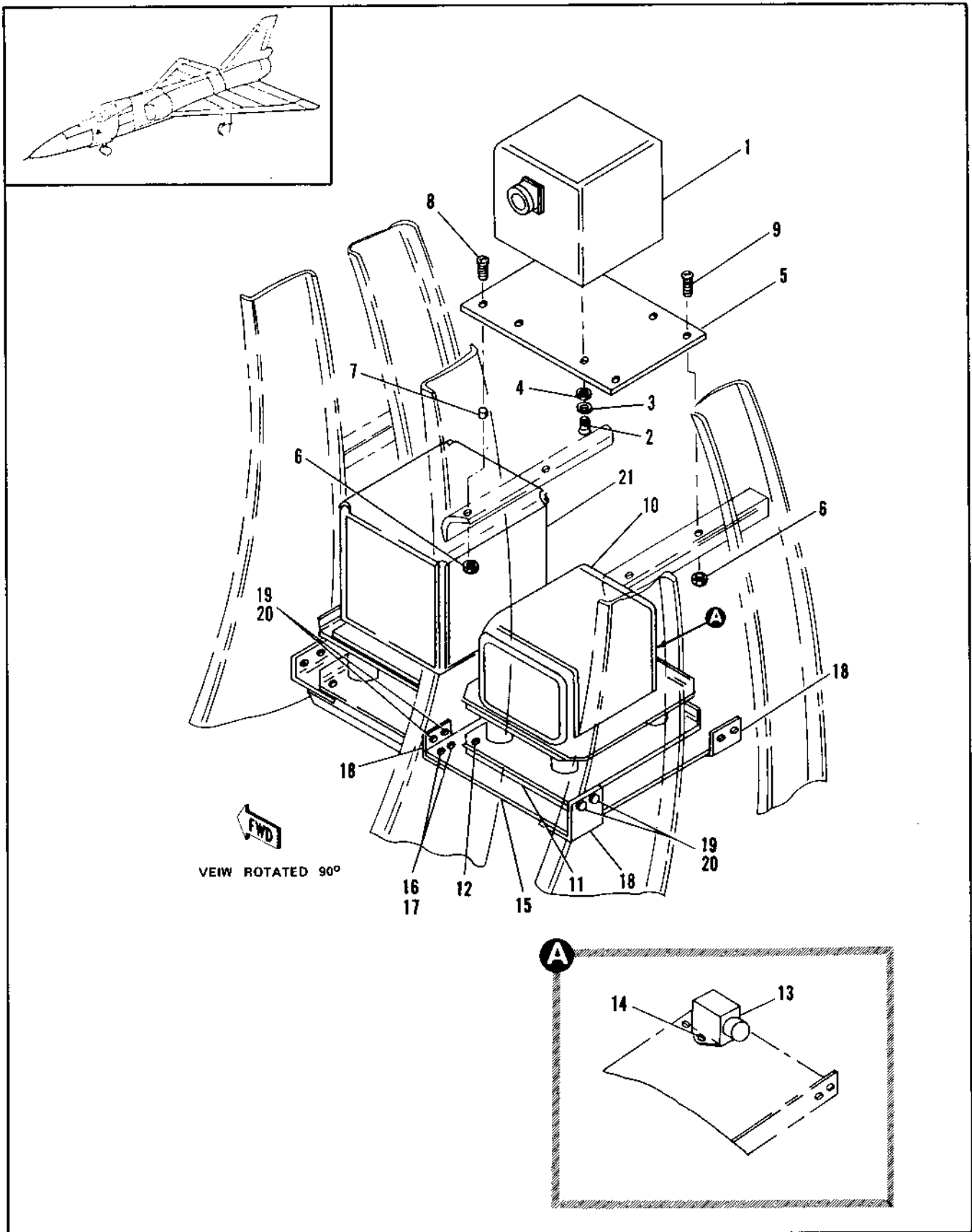

Figure 2.16-25. Exhaust Gas Temperature Equipment Installation (Sheet 1 of 2)

FIGURE AND INDEX NUMBER	PART NUMBER	DESCRIPTION 1 2 3 4 5 6	UNITS PER ASSY.	USABLE ON CODE	
				FROM	TO
2.16A-15	64F34464-1	EQUIPMENT INSTALLATION, EXHAUST GAS TEMPERATURE	1	35	
- 1	MS27060	• INVERTER, GFAE ATTACHING PARTS	1	35	
- 2	AN521-10K7	• SCREW	4	35	
- 3	AN939-10L	• LOCKWASHER	4	35	
- 4	AN967D11	• WASHER -----X-----	4	35	
- 5	64F34467-1	• PLATE, EXHAUST GAS TEMPERATURE INVERTER ATTACHING PARTS	1	35	
- 6	MS21742LOR	• NUT	4	35	
- 7	MS43083-14	• SPACER	2	35	
- 8	AN515-PR10	• SCREW	2	35	
- 9	AN517-PR6	• SCREW -----X-----	2	35	
- 10	H15501	• COMPUTER, FACTOR (98869) GFAE	1	35	
- 11	BH7222	• SHOCKMOUNT ASSY, (98869) ATTACHING PARTS	1	35	
- 12	AN515-PR6	• SCREW -----X-----	4	35	
- 13	R-96889-3	• RELAY (75344) ATTACHING PARTS	1	35	
- 14	AN521-10K8	• SCREW -----X-----	2	35	
- 15	64D74478-1	• PLATE ASSY, EXHAUST GAS TEMPERATURE FACTOR COMPUTER (RIVETED) ATTACHING PARTS	1	35	
- 16	MS21742LOR	• NUT	8	35	
- 17	AN515-PR6	• SCREW -----X-----	8	35	
- 18	64R34479-1	• BRACKET, EGT FACTOR COMPUTER ATTACHING PARTS	4	35	
- 19	MS21742LOR	• NUT	8	35	
- 20	AN515-PR6	• SCREW -----X-----	8	35	

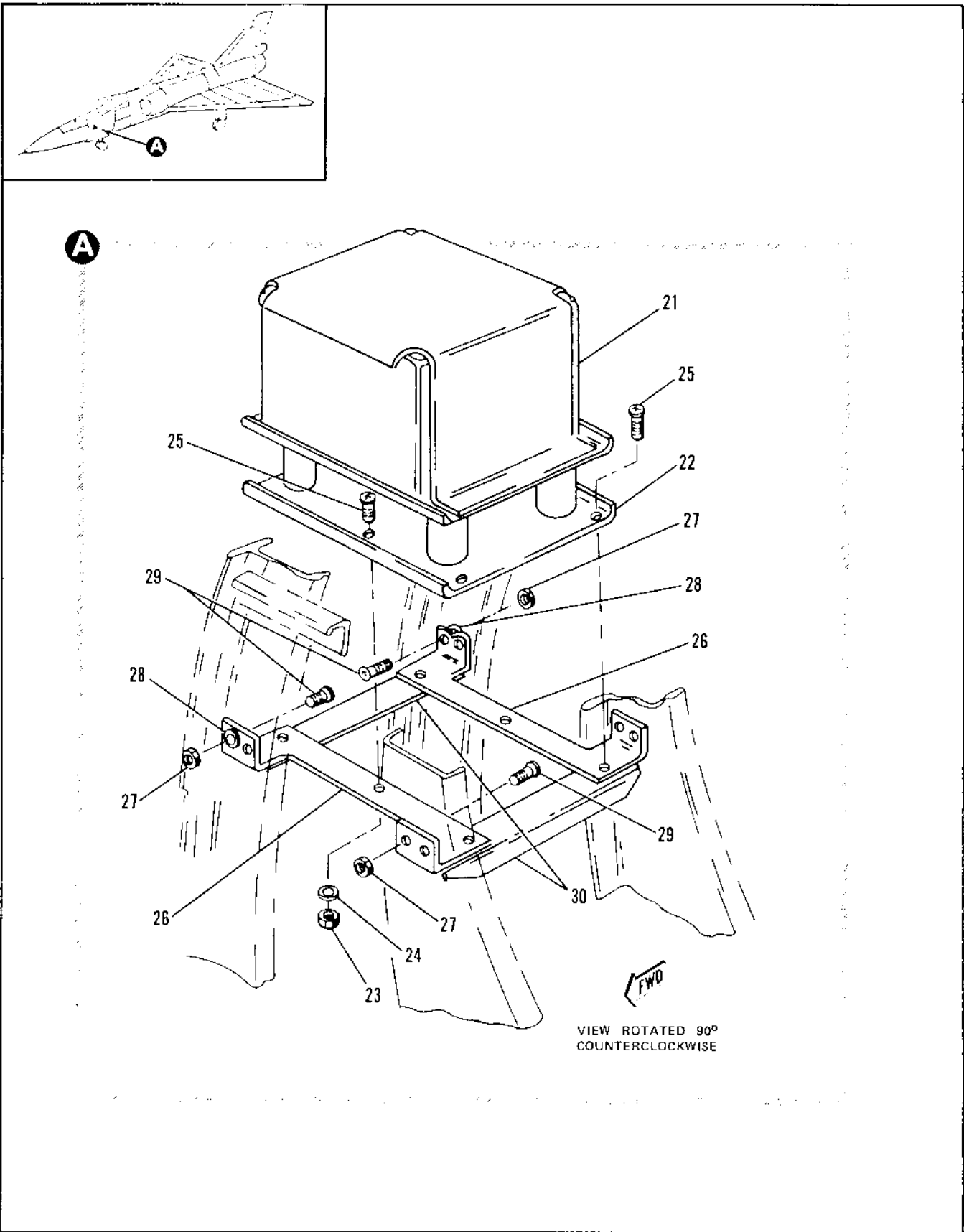

Figure 2.16-25. Exhaust Gas Temperature Equipment Installation (Sheet 2 of 2)

FIGURE AND INDEX NUMBER	PART NUMBER	DESCRIPTION	UNITS PER ASSY.	USABLE ON CODE	
				FROM	TO
		1 2 3 4 5 6			
2.16-25- 21	H154C	• COMPUTER, SPREAD (98869)	1	35	
- 22	RH7222	• SHOCKMOUNT SSY, (98869) ATTACHING PARTS	1	35	
- 23	MS21042L3	• NUT	2	35	
- 24	AN940D10	• WASHER	2	35	
- 25	AN520-10R8	• SCREW	6	35	
- 26	64C34461-1	-----X----- • BRACKET, SPREAD COMPUTER ATTACHING PARTS	2	35	
- 27	MS21042L08	• NUT	6	35	
- 28	AN940D9L	• WASHER	2	35	
- 29	AN515-8R6	• SCREW	6	35	
- 30	64C34463-1	-----X----- • STIFFENER ASSY, SPREAD COMPUTER RIVETED	2	35	

ELECTRICAL SUBSECTION

TABLE OF CONTENTS

<i>Fig. No.</i>	<i>Title</i>	<i>Page</i>	<i>Fig. No.</i>	<i>Title</i>	<i>Page</i>
2.17-1	Airplane Lighting	2.17-2	2.17-24	Panel Instl Nose Wheel Well Circuit Breaker	2.17-90
2.17-2	AC Distribution Splice Installation Sta 169	2.17-8	2.17-25	Panel Instl Nose Wheel Well Circuit Breaker	2.17-92
2.17-3	Instrument Panel Ambient Light Installation	2.17-10	2.17-26	Cockpit Circuit Breaker Panel Assembly LH	2.17-94
2.17-4	Cockpit Flood and Thunderstorm Lighting	2.17-12	2.17-27	Cockpit Circuit Breaker Panel Assembly LH	2.17-98
2.17-5	Airplane Lighting, LH Forward Electronics Compartment	2.17-14	2.17-28	Cockpit Circuit Breaker Panel Assembly LH	2.17-102
2.17-6	Airplane Lighting, RH Forward Electronics Compartment	2.17-16	2.17-29	Cockpit Circuit Breaker Panel Assembly RH	2.17-106
2.17-7	Airplane Lighting, Radome Compartment	2.17-18	2.17-30	Circuit Breaker Lighting Panel Assembly	2.17-112
2.17-8	AC-DC Power Source Equipment	2.17-20	2.17-31	Cockpit Circuit Breaker Panel Assembly RH	2.17-114
2.17-9	Tacan Power Source Switch Panel	2.17-32	2.17-32	Main Wheel Well Circuit Breaker Panel Installation	2.17-118
2.17-10	DC Emergency Power Supply Battery Installation Sta 120	2.17-34	2.17-33	Main Wheel Well Circuit Breaker Panel Assembly	2.17-120
2.17-11	Electrical Power Distribution Equipment	2.17-36	2.17-34	Main Wheel Well Fuse Panel Cover Assembly	2.17-126
2.17-12	Gyro Cut-off Relay Sta 216.50	2.17-56	2.17-35	Main Wheel Well Circuit Breaker Panel Assembly	2.17-128
2.17-13	Fire and Overheat Control Detector Installation	2.17-58	2.17-36	Barrier Hook Indicator Light Relay Installation	2.17-134
2.17-14	Warning Light Dimming Box Installation	2.17-60	2.17-37	Rapid Tune Magnetron Main Wheel Well Electrical Equipment	2.17
2.17-15	Relay Installation Sta 371 to 391	2.17-62	2.17-38	Main Wheel Well Auxiliary Circuit Breaker Panel	2.17-138
2.17-16	Relay Installation 370.70 to 377.50	2.17-64	2.17-39	LH Aft Console Aerial Refueling Equipment Installation	2.17-140
2.17-17	Fuel Boost Pump and Miscel- laneous Relay Installation	2.17-66	2.17-40	Missile Bay Aerial Refueling Electrical Equipment Installation	2.17-142
2.17-18	Relay Installation RH NWW Sta 113.76 to 126.72	2.17-70	2.17-41	Normal Accelerometer Terminal Board	2.17-144
2.17-19	Nose Wheel Well Fuse Box Installation	2.17-72	2.17-42	TRT and Gyro Cut off Switch and Relay	2.17-146
2.17-20	Equipment Installation RH Upper NWW	2.17-74	2.17-43	RH Main Wheel Well G1C3 Interphone Connector	2.17-148
2.17-21	Nose Wheel Well Circuit Breaker Panel Assembly	2.17-76			
2.17-22	Warning Light Dimming Relay Installation RH	2.17-82			
2.17-23	Nose Wheel Well Circuit Breaker Panel Assembly	2.17-84			

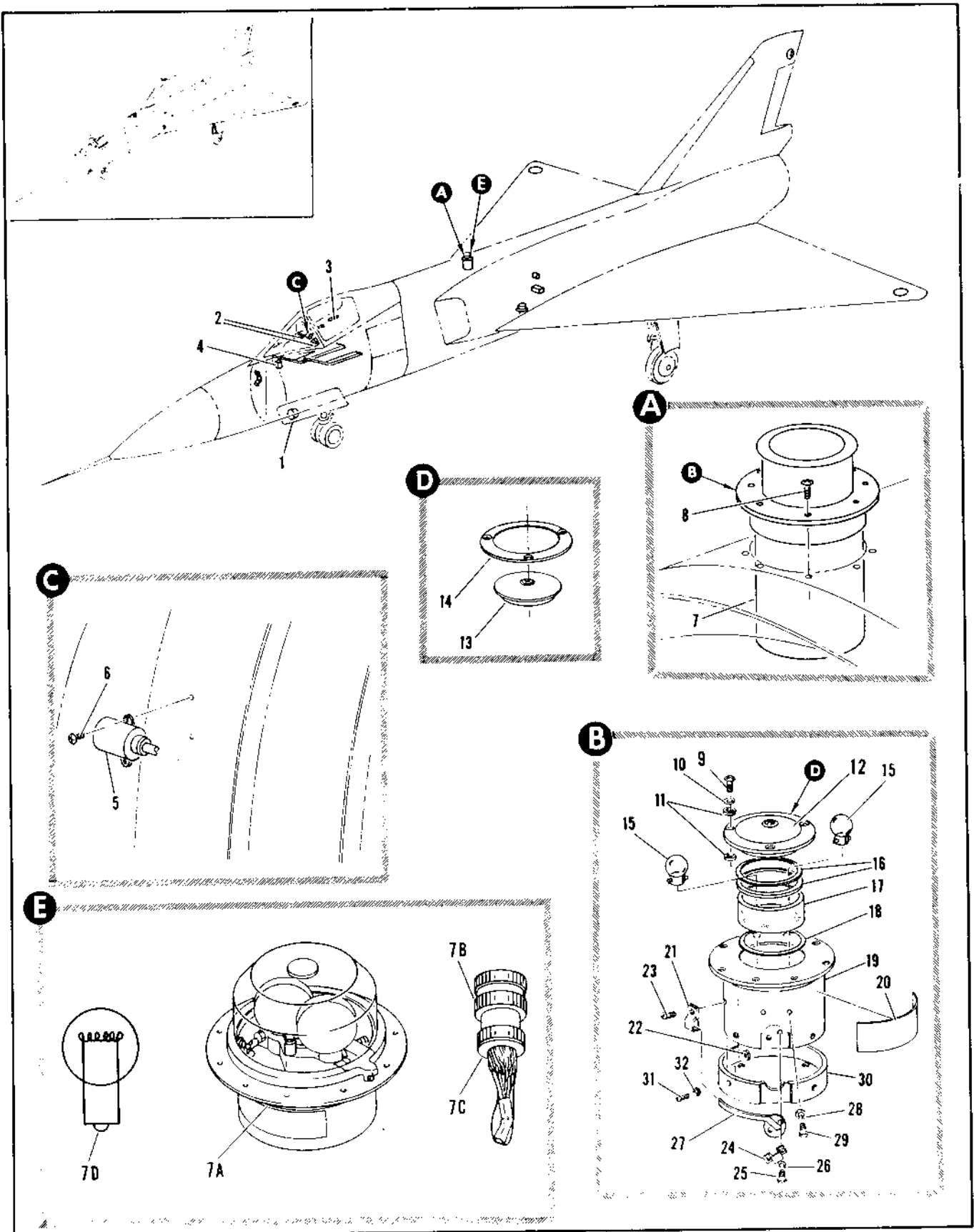

Figure 2.17-1. Airplane Lighting (Sheet 1 of 3)

FIGURE AND INDEX NUMBER	PART NUMBER	DESCRIPTION	UNITS PER ASSY.	USABLE ON CODE	
				FROM	TO
2.17-1		AIRPLANE LIGHTING			
- 1		• LIGHT INSTL, TAXI SEE FIG. 2.15-6	RF		
- 2		• LIGHT INSTL, COCKPIT FLOOD AND INSTRUMENT ILLUMINATION SEE FIG. 2.17-4	RF		
- 3		• LIGHT INSTL, COCKPIT FLOOD AND INSTRUMENT ILLUMINATION RH SEE FIG. 2.17-4	RF		
- 4		• PART ASSY, FUSE LIGHTING SEE FIG. 2.17-30	RF		
	8-62334-3	• RELAY INSTL, FLOOD LIGHT TRANSFER	1		A
	8-62334-5	• RELAY INSTL, FLOOD LIGHT TRANSFER	1		B
- 5	9227-402A	• RELAY, <25244> SPEC 8-36448-1	1		35
		ATTACHING PARTS			
- 6	AN520-10R7	• SCREW	2		35
		----X----			
- 7	8-65031	• LIGHT INSTL, BEACON AND FUSELAGE UPPER	1		35
	68455-1	• LIGHT ASSY, NAVIGATION BEACON AND FUSELAGE UPPER <72914> SPEC 8-06924-1 T.O. 8D10-6-12-3 (WHEN EXHAUSTED USE 40-0110-17)	1		35
- 7A	40-0110-17	• LIGHT ASSY, NAVIGATION BEACON AND FUSELAGE UPPER <72914> T.O. 8D3-8-17-13	1		35
- 7B	M83723-23R1103N	• CANNON PLUG	1		35
- 7C	M83723-35A10R	• BACKSHELL	1		35
- 7D	1939	• LAMP <52656>	2		35
		ATTACHING PARTS			
- 8	AN509-8R7	• SCREW	8		35
		----X----			
- 9	COML	• SCREW, 8-32X2 LG CTSK HD STL MACH	3		35
- 10	COML	• LOCKWASHER, 1508 EXTERNAL	3		35
- 11	A8298-1	• GROMMET	6		35
- 12	B9285-5	• COVER ASSEMBLY	1		35
- 13	A8456-1	• LENS	1		35
- 14	B8308-5	• COVER	1		35
- 15	A8289-24	• LAMP	2		35
- 16	A9289-1	• GASKET	2		35
- 17	A8454-1	• FILTER, AVIATION RED	1		35
- 18	A9288-1	• GASKET	1		35
- 19	D8453-1	• COVER	1		35
- 20	A8921-1	• NAMEPLATE	1		35
- 21	A5207	• CLIP	1		35
		ATTACHING PARTS			
- 22	COML	• STOP NUT, <20955> 22M40	1		35
- 23	COML	• SCREW, 4-40X1/4 LG PAN HD STL MACH	1		35
		----X----			
- 24	A6297-1	• CLAMP	1		35
		ATTACHING PARTS			
- 25	COML	• SCREW, 4-40X1/8 LG RD HD BRASS CAD PL	2		35
- 26	COML	• LOCKWASHER, #4 SPLIT	2		35
		----X----			
- 27	COML	• PIGTAILS, 24 LG 20 GA WIRE 726-W8777	A		35
- 28	COML	• LOCKWASHER, #4 INTERNAL	>		35
- 29	COML	• SCREW, 4-40X1/4 LG PAN HD STL MACH	9		35
- 30	B8452-1	• COVER	1		35
		ATTACHING PARTS			
- 31	COML	• SCREW, 4-40X1/4 LG PAN HD STL MACH	4		35
- 32	COML	• LOCKWASHER, #4 INTERNAL	4		35
		----X----			
		A AIRPLANES #35 THRU 47 AND 49 THRU 89			
		B AIRPLANES #48, 93 AND ON			

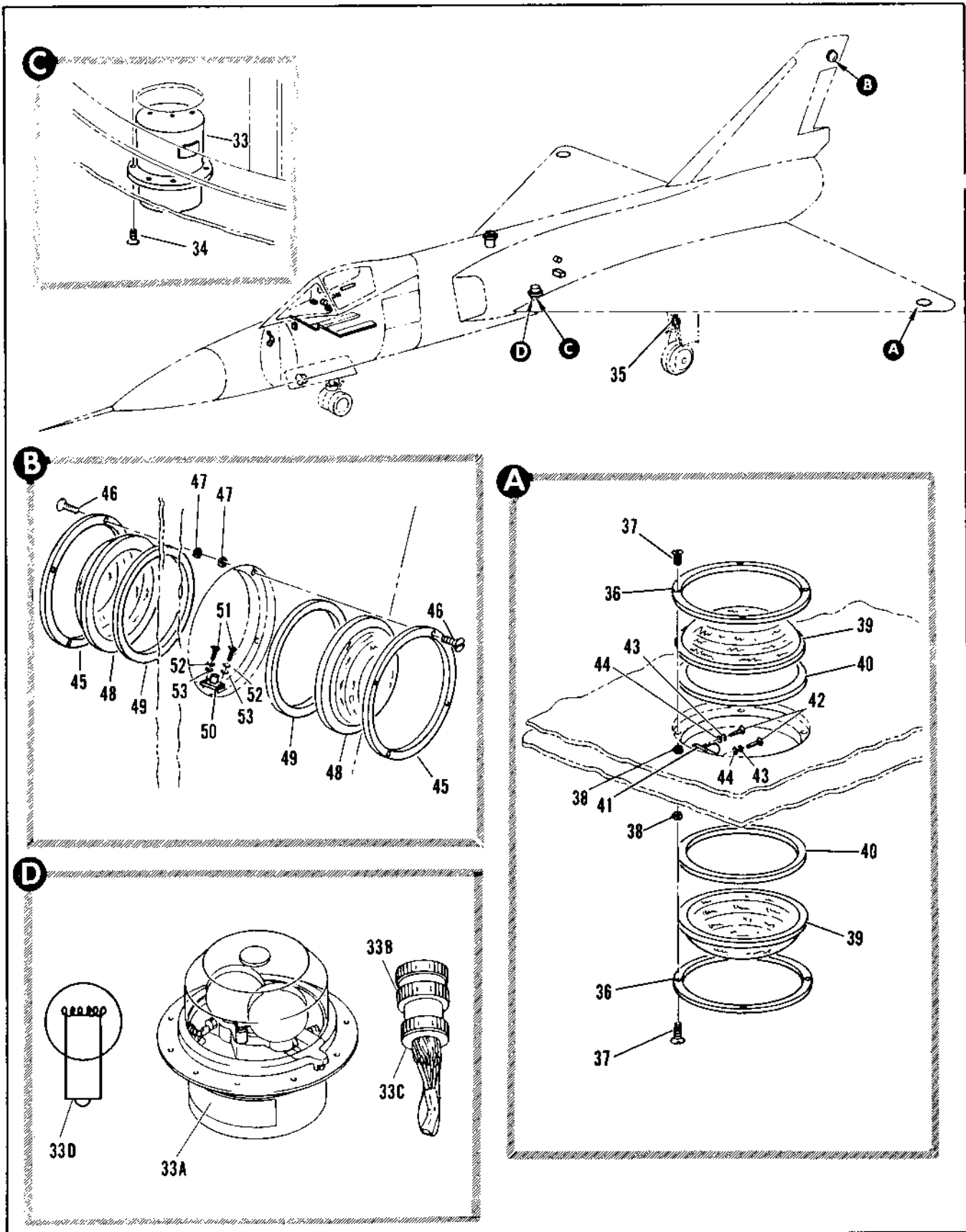

Figure 2.17-1. Airplane Lighting (Sheet 2 of 3)

FIGURE AND INDEX NUMBER	PART NUMBER	DESCRIPTION	UNITS PER ASSY.	USABLE ON CODE	
				FROM	TO
		1 2 3 4 5 8			
2.17-1	8-65034	• LIGHT INSTL, BEACON AND FUSELAGE LWR STA 442	1	35	
- 33	68450-1	• • LIGHT, <72914> SPEC 8-06924-3 T.O. 8D10-6-12-3 (WHEN EXHAUSTED USE 5 OF 3-3)			
	B9285-4	• • • LENSE ASSY	1	35	
	A8451-1	• • • LENS	1	35	
- 33A	M58085-3	• LIGHT ASSY NAVIGATION BEACON <78366> T.O. 8D10-11-6-3	1	35	
- 33B	M83723-23R1103N	• CANNON PLOG	1	35	
- 33C	M83723-35A10R	• BACKSHELL	1	35	
- 33D	1939	• LAMP <52656>	2	35	
		ATTACHING PARTS			
- 34	AN509-8R7	• • SCREW	8	35	
		-----X-----			
- 35		• LIGHT INSTL, LANDING LH SEE FIG. 2.15-5	RF		
		• LIGHT INSTL, LANDING RH SEE FIG. 2.15-5	RF		
	8-61036-1	• LIGHT INSTL, POSITION WING TIP LH	1	35	
	8-61036-2	• LIGHT INSTL, POSITION WING TIP RH	1	35	
- 36	A7463	• • RETAINER, LENS WING AND TAIL LIGHT ASSY <72914> 97-57501-001	2	35	
		ATTACHING PARTS			
- 37	AN507-632R8	• • SCREW	8	35	
- 38	68-C4-62	• • NUT	8	35	
		-----X-----			
- 39	A8087-1	• • LENS, POSITION LIGHT AVIATION RED LH <72914> 95-56000-001	2	35	
- 40	A5621	• • GASKET, LENS TAIL LIGHT ASSEMBLY <72914> 94-16006-001	2	35	
	A8087-2	• • LENS, POSITION LIGHT AVIATION GREEN RH <72914> 95-56000-002	2	35	
	8-94711-29	• • LAMP INSTL, WING TIP LIGHTS MODIFIED BY 8-61598	1	35	
		• • • LAMP, INCANDESCENT <24455> 95-47013-006	1	278	
- 41	8-61253	• • SOCKET, LIGHT WING TIP ALTERED FROM A6305 <72914>	1	35	
		ATTACHING PARTS			
- 42	AN515-6R6	• • SCREW	2	35	43
	AN515-6R7	• • SCREW	2	44	
- 43	AN935-6L	• • WASHER	2	44	
- 44	AN960-6L	• • WASHER	2	44	
		-----X-----			
- 45	8-65079	• LIGHT INSTL, POSITION VERTICAL FIN	RF	35	
	A7463	• • RETAINER, <72914> 97-57501-001	2	35	
		ATTACHING PARTS			
- 46	AN507-632R8	• • SCREW	8	35	
- 47	68-C4-62	• • NUT	8	35	
		-----X-----			
- 48	A5626A1	• • LENS, CLEAR LOWER RECOGNITION LIGHT <72914> 95-56000-003	2	35	
- 49	A5621	• • GASKET, <72914> 94-16006-001	2	35	
	8-94711-51	• • LAMP INSTL, POSITION MODIFIED BY 8-61598	1	35	
	1725	• • LAMP, INCANDESCENT <24455> 95-47013-006	1	278	
- 50	8-61253	• • SOCKET, LIGHT ALTERED FROM A6305 <72914>	1	35	
	A6305	• • SOCKET, LIGHT <72914>	RF		
		ATTACHING PARTS			
- 51	AN515-6R6	• • SCREW	2	35	43
	AN515-6R7	• • SCREW	2	44	
- 52	AN935-6L	• • WASHER	2	44	
- 53	AN960-6L	• • WASHER	2	44	
		-----X-----			

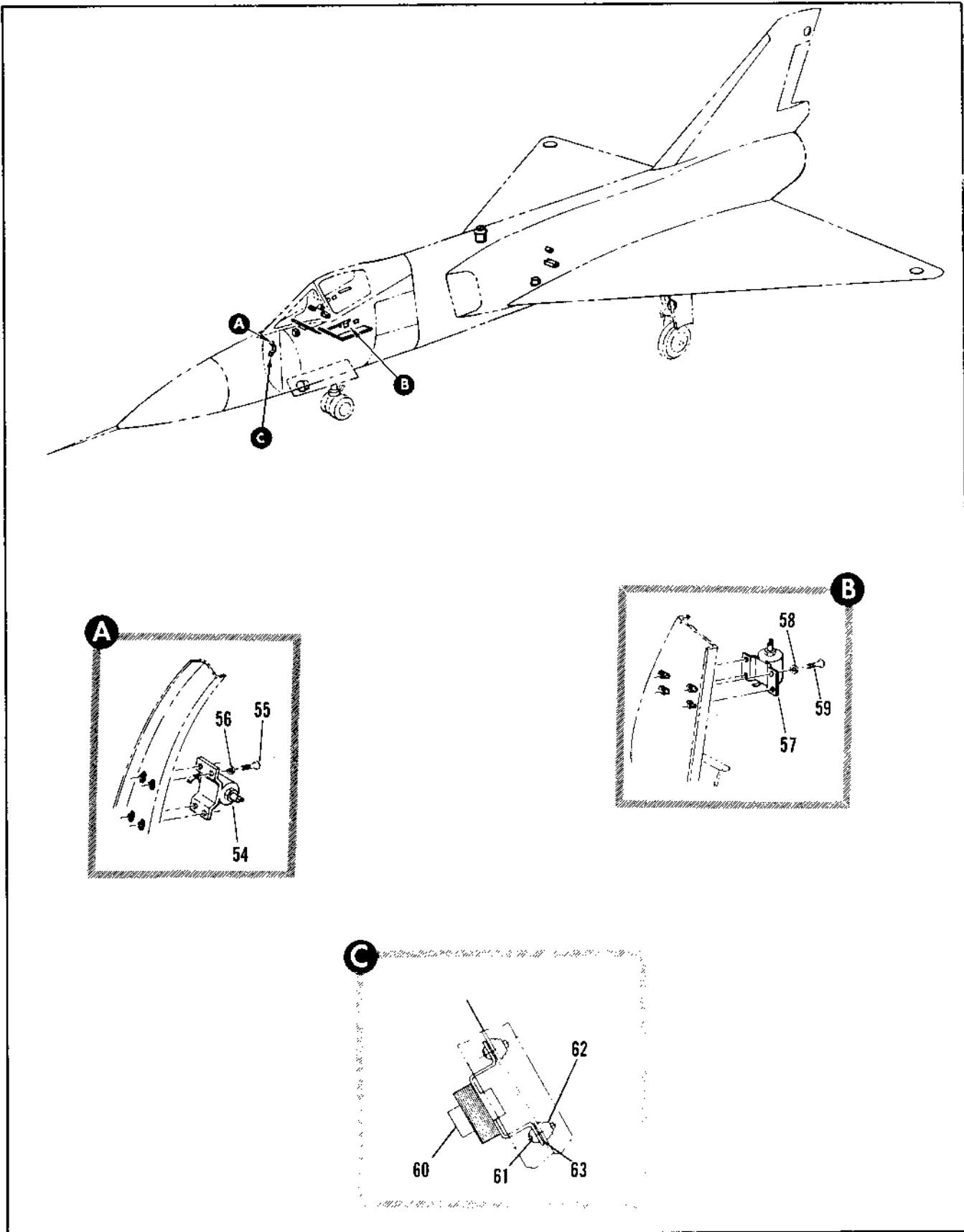

Figure 2.17-1. Airplane Lighting (Sheet 3 of 3)

FIGURE AND INDEX NUMBER	PART NUMBER	DESCRIPTION 1 2 3 4 5 6	UNITS PER ASSY.	USABLE ON CODE	
				FROM	TO
2.17-1	8-62236	• TRANSFORMER INSTL, LIGHTING INSTRUMENT PANEL	1	R	
- 54	7224	• • TRANSFORMER, LIGHTING INSTRUMENT PANEL <95266> SPEC 8-06475-5 ATTACHING PARTS	1	B	
- 55	NAS623-3-2	• • SCREW	4	B	
- 56	AN963-10L	• • WASHER ----X----	4	B	
	8262233	• TRANSFORMER INSTL, LIGHTING CONSOLE	1	B	
- 57	7225	• • TRANSFORMER, LIGHTING CONSOLE <95266> SPEC 8-06475-871 ATTACHING PARTS	1	B	
- 58	AN960-10L	• • WASHER	4	B	
- 59	NAS62332	• • SCREW ----X----	4	B	
- 60	7224	• TRANSFORMER, LIGHTING, AAU-19/A ALTIMETER (95266) SPEC 8-06475-5 ATTACHING PARTS	1	R	
- 61	MS35207-262	• • SCREW	4	R	
- 62	MS21942-3	• • NUT	4	R	
- 63	AN963-10L	• • WASHER ----X----	4	R	
		B AIRPLANES #48, 90 AND ON R ROUND INSTRUMENTED AIRCRAFT			

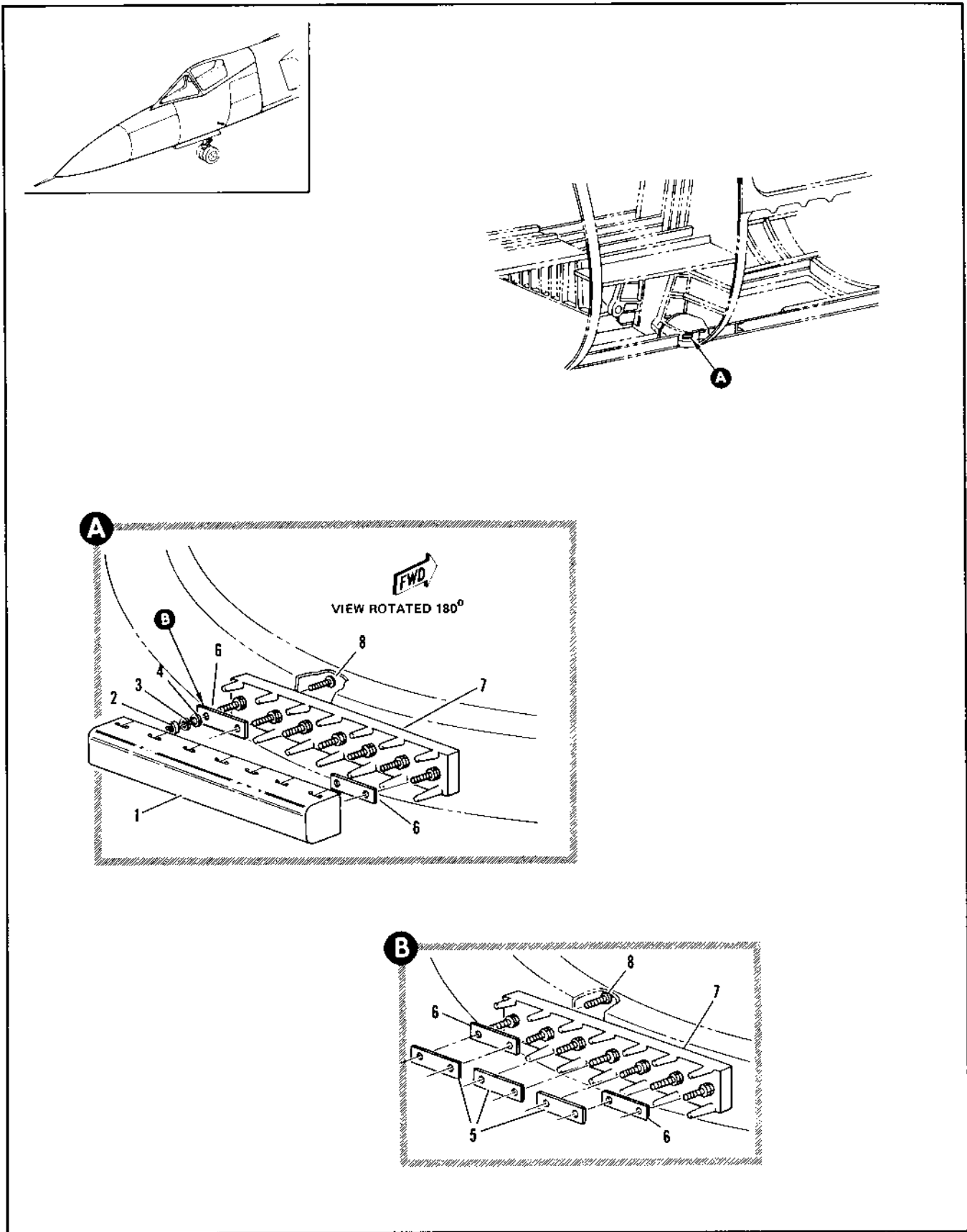

Figure 2.17-2. AC Distribution Splice Installation Sta 169

FIGURE AND INDEX NUMBER	PART NUMBER	DESCRIPTION	UNITS PER ASSY.	USABLE ON CODE	
				FROM	TO
		1 2 3 4 5 6			
2.17-8	B-65127-5	SPLICE INSTALLATION, AC DISTRIBUTION STA 169	1	35	
- 1	MS18129-12S-16	• COVER, (36906)	1	35	
- 2	AN345-10	• NUT	7	35	
- 3	AN935-10L	• WASHER	7	35	
- 4	AN961-10L	• WASHER	7	35	
- 5	AN3433-4-2	• BUSBAR	3	35	
- 6	AN3434-4	• INSULATOR	2	35	
- 7	AN3436-4-7	• TERMINAL BLOCK	1	35	
		ATTACHING PARTS			
- 8	ANS154R6	• SCREW	2	35	
		-----Y-----			

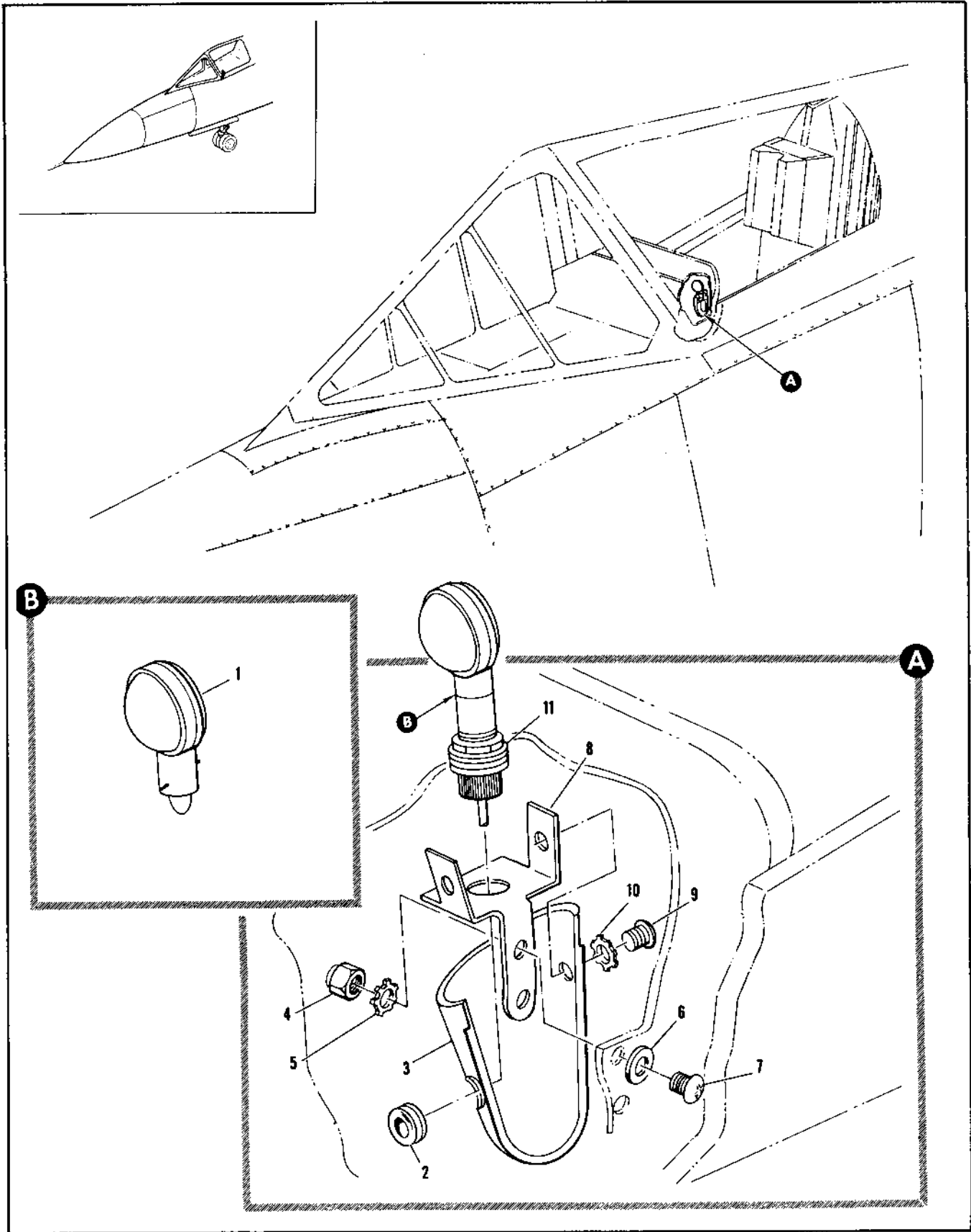

Figure 2.17-3. Instrument Panel Ambient Light Installation

FIGURE AND INDEX NUMBER	PART NUMBER	DESCRIPTION	UNITS PER ASSY.	USABLE ON CODE	
				FROM	TO
2.17-3	8-95989-1	LIGHT INSTALLATION, INSTRUMENT PANEL AMBIENT LH FOR NHA SEE FIG. 2.1-1	RF		A
	8-95989-2	LIGHT INSTALLATION, INSTRUMENT PANEL AMBIENT RH FOR NHA SEE FIG. 2.1-1	RF		A
	8-99711-149	• LAMP INSTALLATION	1		A
- 1	A7079A24	• LAMP, <72914> 95-47011-002	1		A
- 2	S11154-3AY	• GROMMET, <97820> 94-35006-001	1		A
	8-95989-9	• HOOD, LH REPLACED BY SUITABLE SUP 8-95988-13	1		R
- 3	8-95988-13	• HOOD, LH REPLACES SUITABLE SUB FOR 8-95988-9	1		93
	8-95988-10	• HOOD, RH REPLACED BY SUITABLE SUB 8-95988-14	1		R
	8-95988-14	• HOOD, RH REPLACES SUITABLE SUB FOR 8-95988-10	1		93
		ATTACHING PARTS			
- 4	NAS679A3	• NUT	2		A
- 5	AN936B10	• WASHER	2		A
- 6	AN960010L	• WASHER	2		A
- 7	AN5200D10R5	• SCREW	2		A
		-----X-----			
- 8	8-95989-7	• BRACKET ASSY, RIVETED ATTACHING PARTS	1		A
- 9	AN515008R6	• SCREW	2		A
- 10	AN936BB	• WASHER	2		A
		-----X-----			
- 11	23750	• SOCKET ASSY, AMBIENT LIGHT <72914> SPEC 28-09403-1	1		A
		A AIRPLANES #48, 90 AND ON			
		R AIRPLANES #48 AND 90 THRU 92			

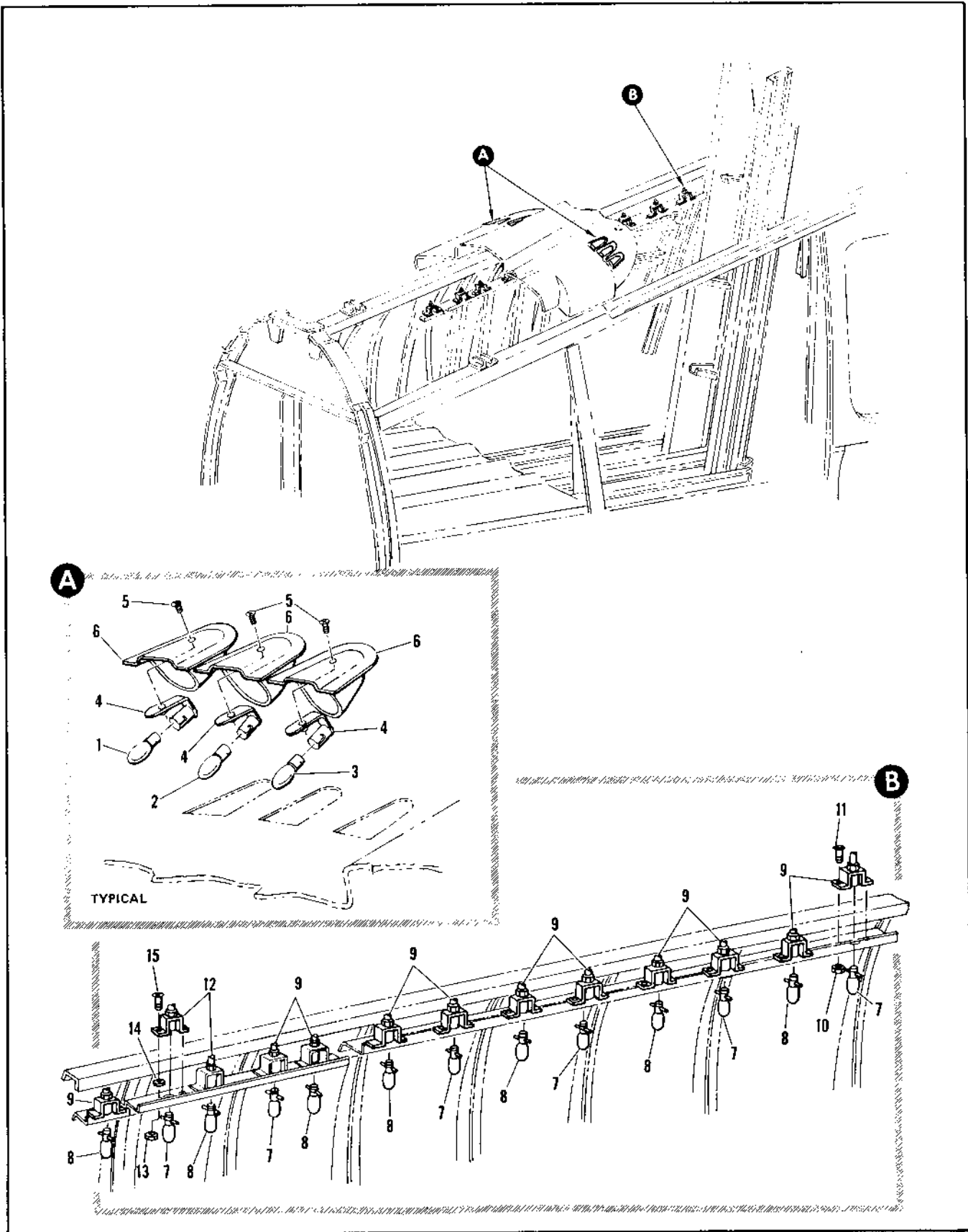

Figure 2.17-4. Cockpit Flood and Thunderstorm Lighting

FIGURE AND INDEX NUMBER	PART NUMBER	DESCRIPTION 1 2 3 4 5 6	UNITS PER ASSY.	USABLE ON CODE	
				FROM	TO
2.17-4	8-94976-805	COCKPIT FLOOD AND THUNDERSTORM LIGHTING • LIGHTING INSTL, COCKPIT FLOOD AND THUNDERSTORM STA 140 FOR NHA SEE FIG. 2.1-1	RF	35	
- 1	8-94711-75	• • LAMP INSTL, FLOODLIGHT	1	35	
	MS25231R313	• • • LAMP, RED	2	35	
- 2	8-94711-71	• • LAMP INSTL, THUNDERSTORM	1	35	
	1495	• • • LAMP, WHITE <24455> 95-47001-005	2	35	
- 3	8-94711-73	• • LAMP INSTL, FLOODLIGHT	1	35	
	1495R	• • • LAMP, RED <24455> 95-47001-004	2	35	
- 4	A9663-1	• • LAMPHOLDER, MINIATURE BAYONET BRACKET MOUNTING <72914> SPEC 9-09242-1 ATTACHING PARTS	6	35	
- 5	AN526-832R5	• • SCREW -----X-----	6	35	
- 6	8-94572	• • REFLECTOR, LIGHT FLOOD AND THUNDERSTORM	6	35	
	8-94976-807	• LIGHTING INSTL, COCKPIT FLOOD AND THUNDERSTORM LH FOR NHA SEE FIG. 2.3-7	RF	35	
	8-94976-811	• LIGHTING INSTL, COCKPIT FLOOD AND THUNDERSTORM RH FOR NHA SEE FIG. 2.3-8	RF	35	
- 7	8-94711-151	• • LAMP INSTL, THUNDERSTORM	1	35	
	MS25231-313	• • • LAMP, WHITE	6	35	
- 8	8-94711-149	• • LAMP INSTL, FLOOD	1	35	
	MS25231R313	• • • LAMP, RED	7	35	
- 9	A3162-1	• • SOCKET, LAMP <72914> SPEC 8-09345 ATTACHING PARTS	11	35	
- 10	NAS679A06	• • NUT	22	35	
- 11	AN515-6R4	• • SCREW -----X-----	22	35	
- 12	A8162-1	• • SOCKET, LAMP <72914> SPEC 8-09345 ATTACHING PARTS	2	35	
- 13	NAS679A06	• • NUT, LH	4	35	
	NAS679A0P	• • NUT, RH	4	35	
- 14	AN950PD6	• • WASHER	8	35	
	AN515-6R4	• • SCREW, LH	4	35	
- 15	AN515-6R6	• • SCREW, RH -----X-----	4	35	

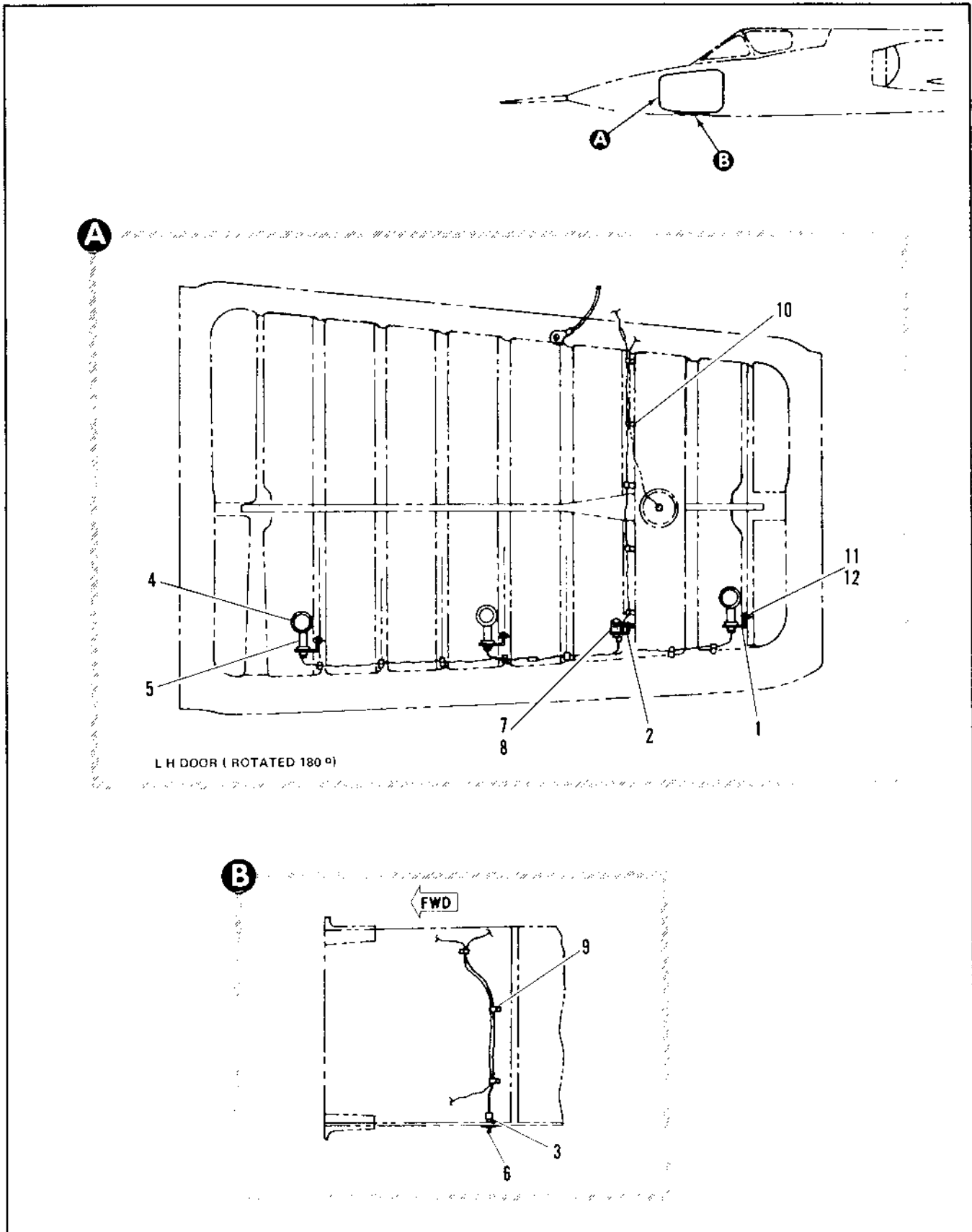

Figure 2.17-5. Airplane Lighting, LH Forward Electronics Compartment

FIGURE AND INDEX NUMBER	PART NUMBER	DESCRIPTION	UNITS PER ASSY.	USABLE ON CODE	
				FROM	TO
2.17-5		AIRPLANE LIGHTING, LH FORWARD ELECTRONICS COMPARTMENT			
- 1	64033005-7	• SOCKET BRACKET	3		
- 2	64033006-7	• SWITCH BRACKET	1		
- 3	MS25005-1	• SWITCH	1		
- 4	47512-24	• LAMP	3		
- 5	23750	• SOCKET ASSEMBLY	3		
- 6	MCD7711	• ACTUATOR	1		
- 7	MS24523-23	• SWITCH	1		
- 8	MS25225-1	• GUARD	1		
- 9	MS21919005	• CLAMP	3		
- 10	MS21919002	• CLAMP	8		
- 11	AN520-10R5	• SCREW	16		
- 12	MS21042-3	• NUT	16		

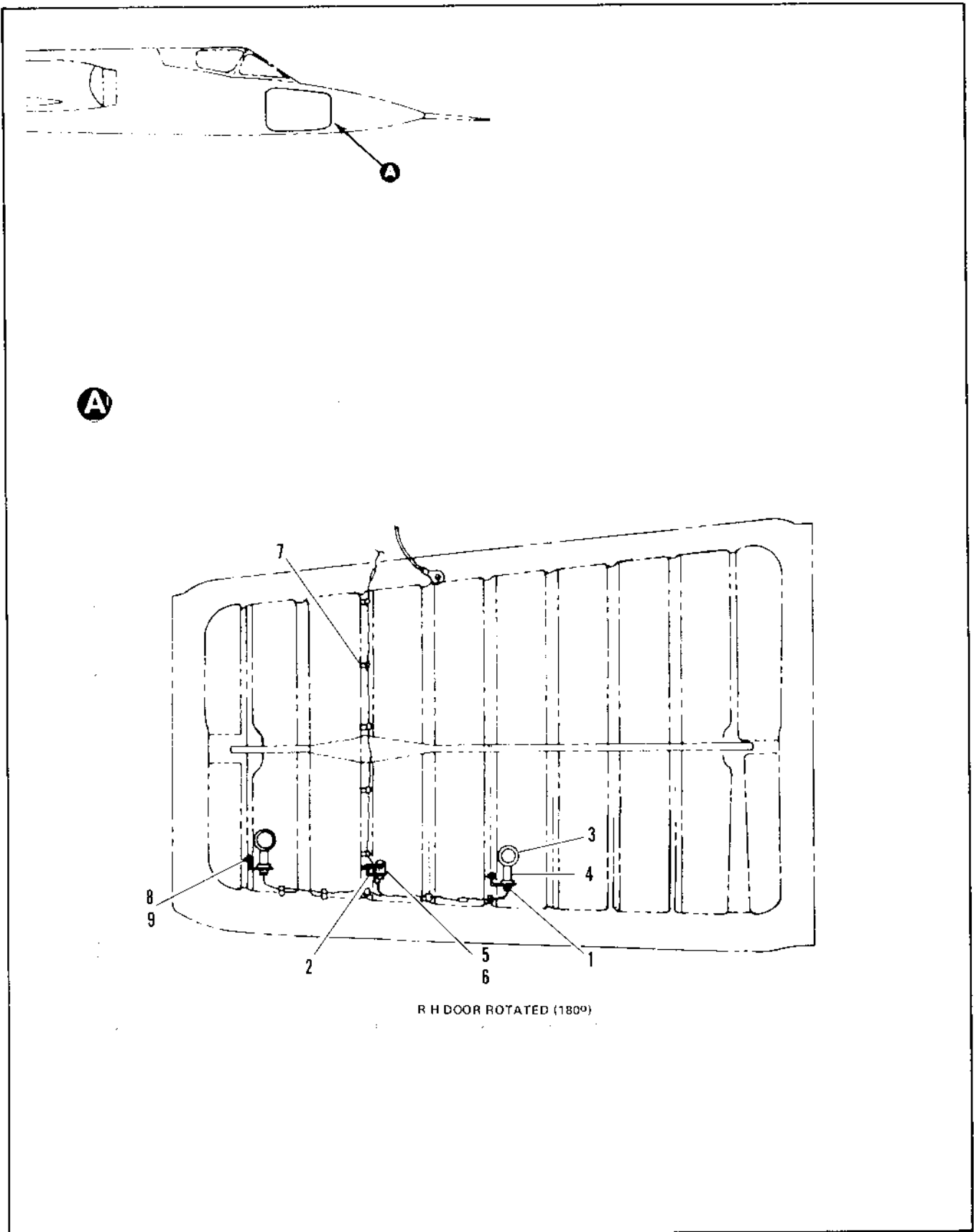

Figure 2.17-6. Airplane Lighting, RH Forward Electronics Compartment

FIGURE AND INDEX NUMBER	PART NUMBER	DESCRIPTION	UNITS PER ASSY.	USABLE ON CODE	
				FROM	TO
		1 2 3 4 5 6			
2.17-6		AIRPLANE LIGHTING, RH FORWARD ELECTRONICS COMPARTMENT			
- 1	64033005-7	• SOCKET BRACKET	2		
- 2	64033006-8	• SWITCH BRACKET	1		
- 3	A7512-24	• LAMP	2		
- 4	23750	• SOCKET ASSEMBLY	2		
- 5	MS24523-23	• SWITCH	1		
- 6	MS25225-1	• GUARD	1		
- 7	MS21919062	• CLAMP	8		
- 8	ANS20-1085	• SCREW	14		
- 9	MS21042-3	• NUT	14		

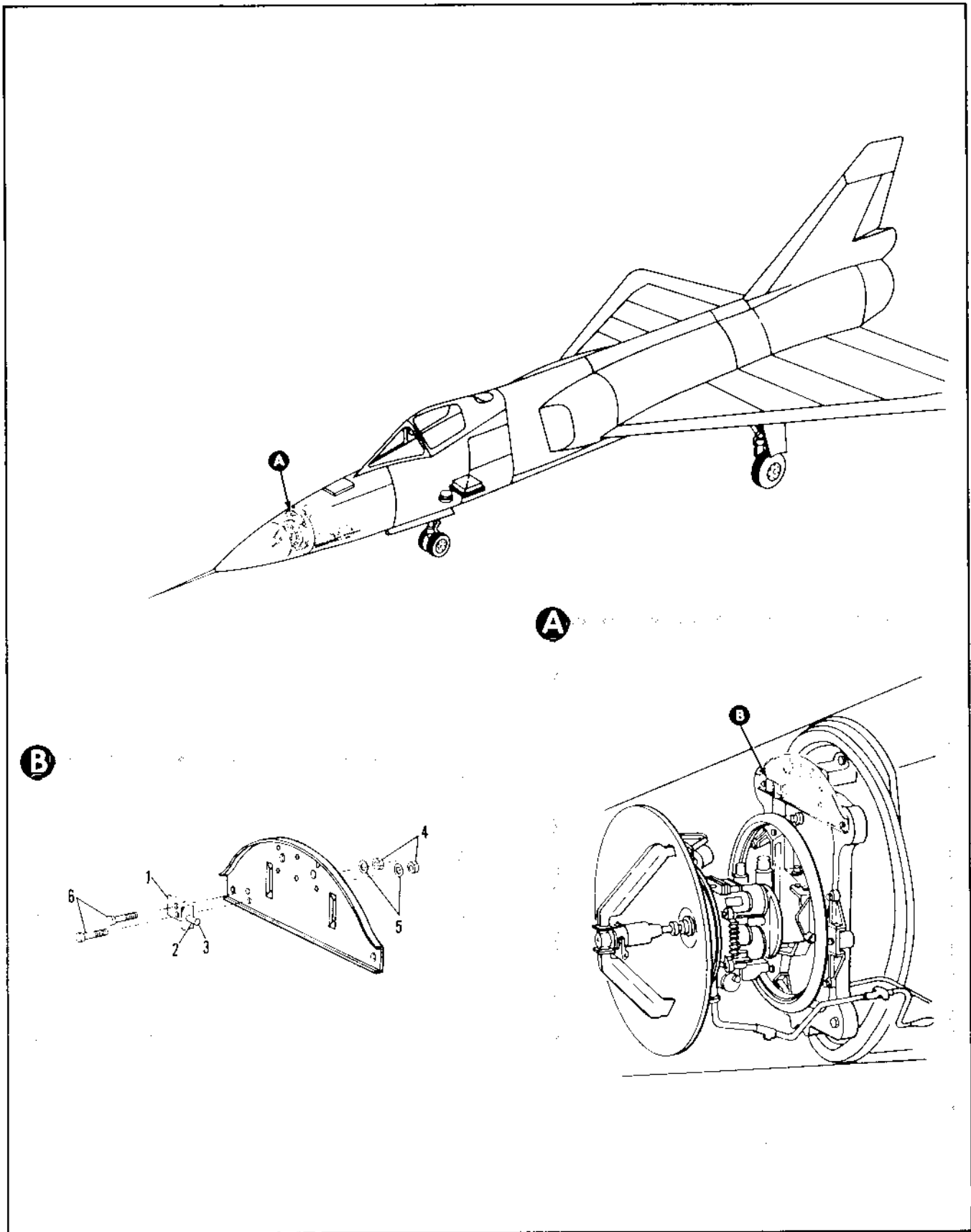

Figure 2.17-7. Airplane Lighting, Radome Compartment

FIGURE AND INDEX NUMBER	PART NUMBER	DESCRIPTION	UNITS PER ASSY.	USABLE ON CODE	
				FROM	TO
		1 2 3 4 5 6			
2.17-		AIRPLANE LIGHTING, RADOME COMPARTMENT			
- 1	69C34932	• BRACKET, LAMP SOCKET ASSY, AF	1		
- 2	23750	• SOCKET ASSY, AF DWG X69C34932	1		
- 3	MS2533H-7079	• LAMP	1		
- 4	MS21044N05	• NUT	2		
- 5	AN969L08	• WASHER	2		
- 6	MS27039-0808	• SCREW	2		

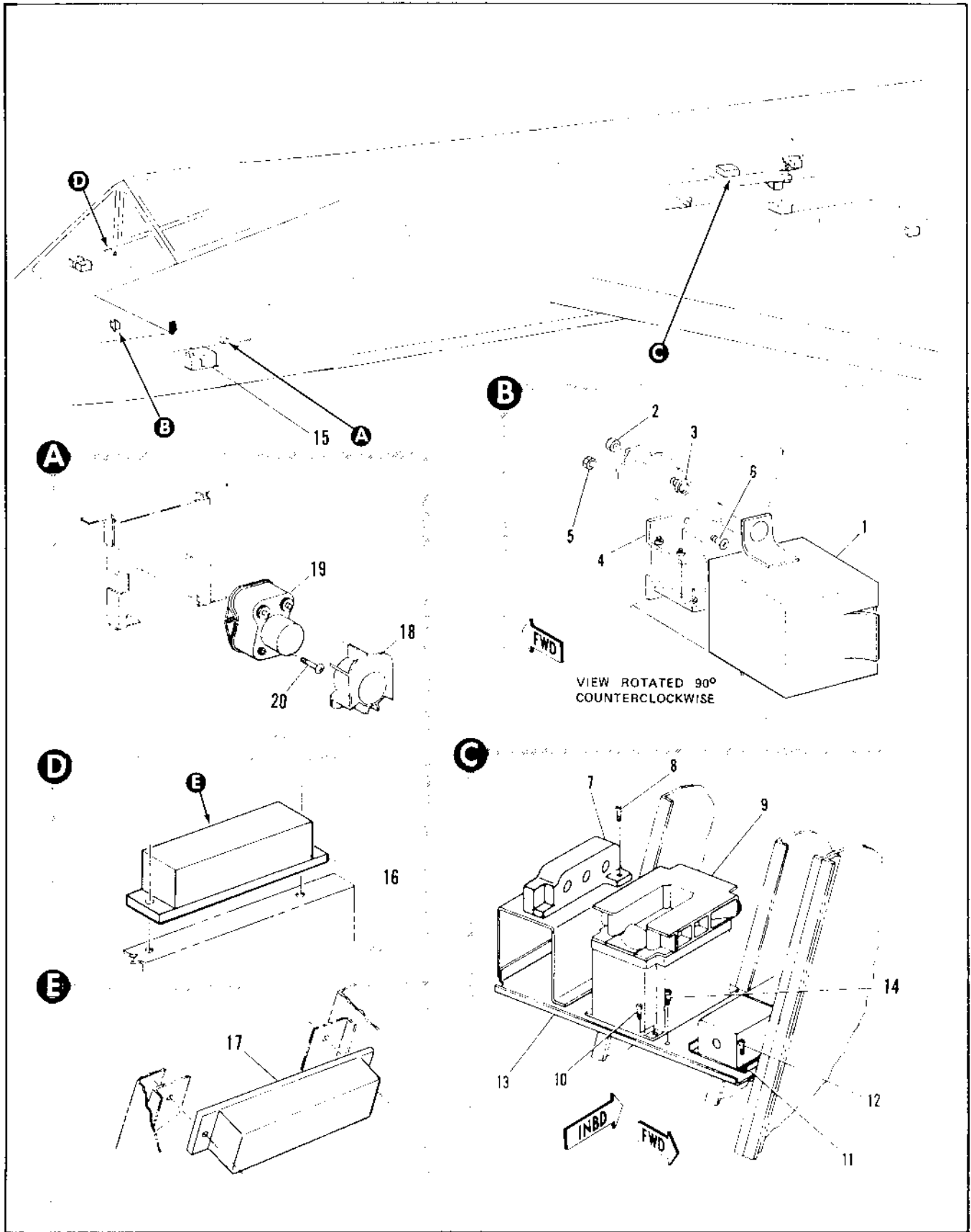

Figure 2.17-8. AC-DC Power Source Equipment (Sheet 1 of 6)

FIGURE AND INDEX NUMBER	PART NUMBER	DESCRIPTION	UNITS PER ASSY.	USABLE ON CODE	
				FROM	TO
		1 2 3 4 5 6			
12.17-8		AC-DC POWER SOURCE EQUIPMENT			
	8-65007-1	• TRANSFORMER INSTL, 26 VOLT AC INSTRUMENT	1	A	
	8-65007-3	• TRANSFORMER INSTL, 26 VOLT AC INSTRUMENT	1	B	
- 1	8-65199	• COVER ASSY, 26 VOLT INSTRUMENT TRANSFORMER STITCHED ATTACHING PARTS	1	35	
- 2	NAS679A3	• • NUT	2	35	
- 3	AN227-10810	• • STUD	2	35	
		-----X-----			
- 4	9T39Y2058	• • TRANSFORMER, <88422> 99-03005-003	1	35	
	9T392963	• • TRANSFORMER, <88422> ATTACHING PARTS			
	NAS679A3	• NUT (88422)	2	35	
	NAS221-8	• SCREW (88422)	2	A	
	NAS221-9	• SCREW	2	B	
		-----X-----			
	8140591-10	• TRANSFORMER INSTALLATION, 26 VAC INSTRUMENT	1	91	
	8140592-10	• TRANSFORMER INSTALLATION, 26 VAC INSTRUMENT	1	35	89
- 5	8140590-10	• BRACKET ASSEMBLY	1	91	
- 6	6551	• TRANSFORMER (95266) ATTACHING PARTS	1	35	
	MS21042-3	• • • NUT	2	91	
		• • • NUT	4	35	89
	AN960-10	• • • WASHER	2	91	
		• • • WASHER	4	35	89
	AN3-3A	• • • BOLT	6	91	
		• • • BOLT	4	35	89
		-----X-----			
	7242880-10	• EQUIPMENT INSTL. AC POWER	1	35	
- 7	909C453-1	• • TRANSFORMER (83843) GFAE AF INSTALLED ATTACHING PARTS	1	35	
		• • SCREW	3	35	
- 8	MS270391C1-13	• • SCREW	3	35	
		-----X-----			
- 9	BH-124AC	• CONTACTOR AC POWER 3PDT 225 AMP (74063) 7242889-30 ATTACHING PARTS	1	35	
- 10	MS27039C1-09	• • SCREW	4	35	
		-----X-----			

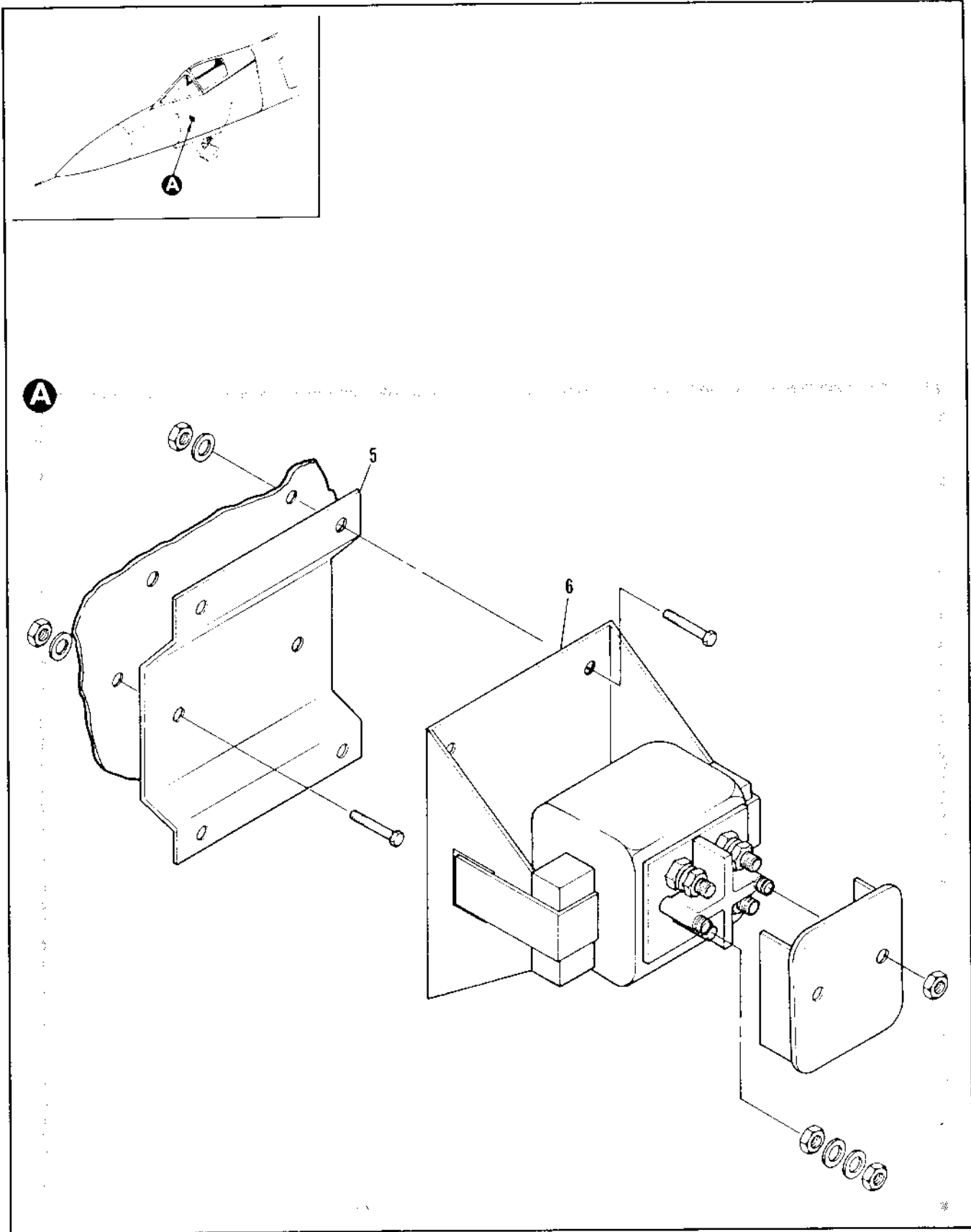

Figure 2.17-8. AC-DC Power Source Equipment (Sheet 1A of 6)

FIGURE AND INDEX NUMBER	PART NUMBER	DESCRIPTION	UNITS PER ASSY.	USABLE ON CODE		
				FROM	TO	
				1	2	3
2.17-8-11	DC10786-5	• POWER MONITOR (07148) ATTACHING PARTS	1		35	
- 12	MS27039C0808	• SCREW ----X----	4		35	
- 13	7242904-10	• BASE ASSY ATTACHING PARTS	1		35	
- 14	MS27039C1-12	• SCREW ----X----	4		35	
- 15		• BATTERY INSTL, DC EMERGENCY POWER SUPPLY STA 120 SEE FIG. 2.17-10	RF			
	8-62204-803	• RESISTOR INSTL, ENGINE EXHAUST TEMPERATURE CALIBRATING STA 113 TO 120	1		A	
- 16	AN5534-2	• RESISTOR ATTACHING PARTS	1		A	
	AN515-8R10	• SCREW ----X----	2		A	
	8-62204-807	• RESISTOR INSTL, ENGINE EXHAUST TEMPERATURE CALIBRATING STA 126 TO 132	1		B	
- 17	AN5534-2	• RESISTOR ATTACHING PARTS	1		B	
	AN520-8R10	• SCREW ----X----	2		B	
- 18	8-65020-8C1	• RELAY INSTL, DC BUS TIE NONESSENTIAL FWD	1		35	
- 19	49-2667-2	• COVER, <15605> 92-7440G-001	1		35	
	MS24140D2	• RELAY ATTACHING PARTS	1		35	
- 20	NAS221-10	• SCREW ----X----	2		35	
		A AIRPLANES #35 THRU 47 AND 49 THRU 89 B AIRPLANES #48, 90 AND ON C AIRPLANES #57 THRU 89, 130 AND ON				

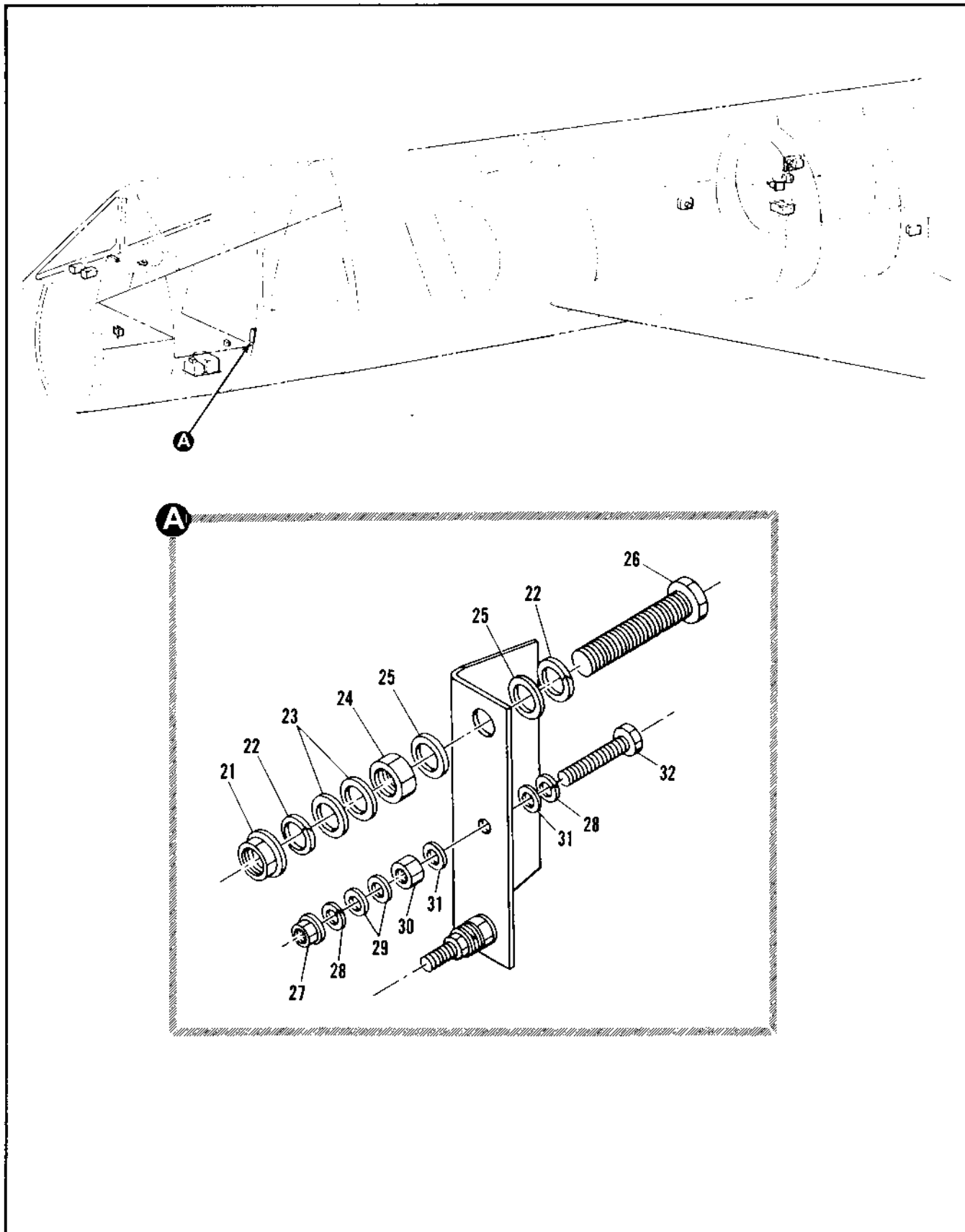

Figure 2.17-8. AC-DC Power Source Equipment (Sheet 2 of 6)

FIGURE AND INDEX NUMBER	PART NUMBER	DESCRIPTION	UNITS PER ASSY.	USABLE ON CODE	
				FROM	TO
		1 2 3 4 5 6			
2.17-8	7243039-1	• BRACKET INSTL, GROUND STUD	1	35	
	7242989-10	• • BRACKET ASSY	1	35	
- 21	MS21042-6	• • • NUT	1	35	
- 22	MS35339-46	• • • WASHER	2	35	
- 23	AN967-616L	• • • WASHER	2	35	
- 24	AN316-6P	• • • NUT	1	35	
- 25	AN967-616L	• • • WASHER	2	35	
- 26	NAS428-6-16	• • • BOLT	1	35	
- 27	MS21042-3	• • • NUT	2	35	
- 28	MS35339-40	• • • WASHER	4	35	
- 29	AN967-10L	• • • WASHER	4	35	
- 30	MS35650-302	• • • NUT	2	35	
- 31	AN967-106	• • • WASHER	4	35	
- 32	NAS428-3-7	• • • BOLT	2	35	

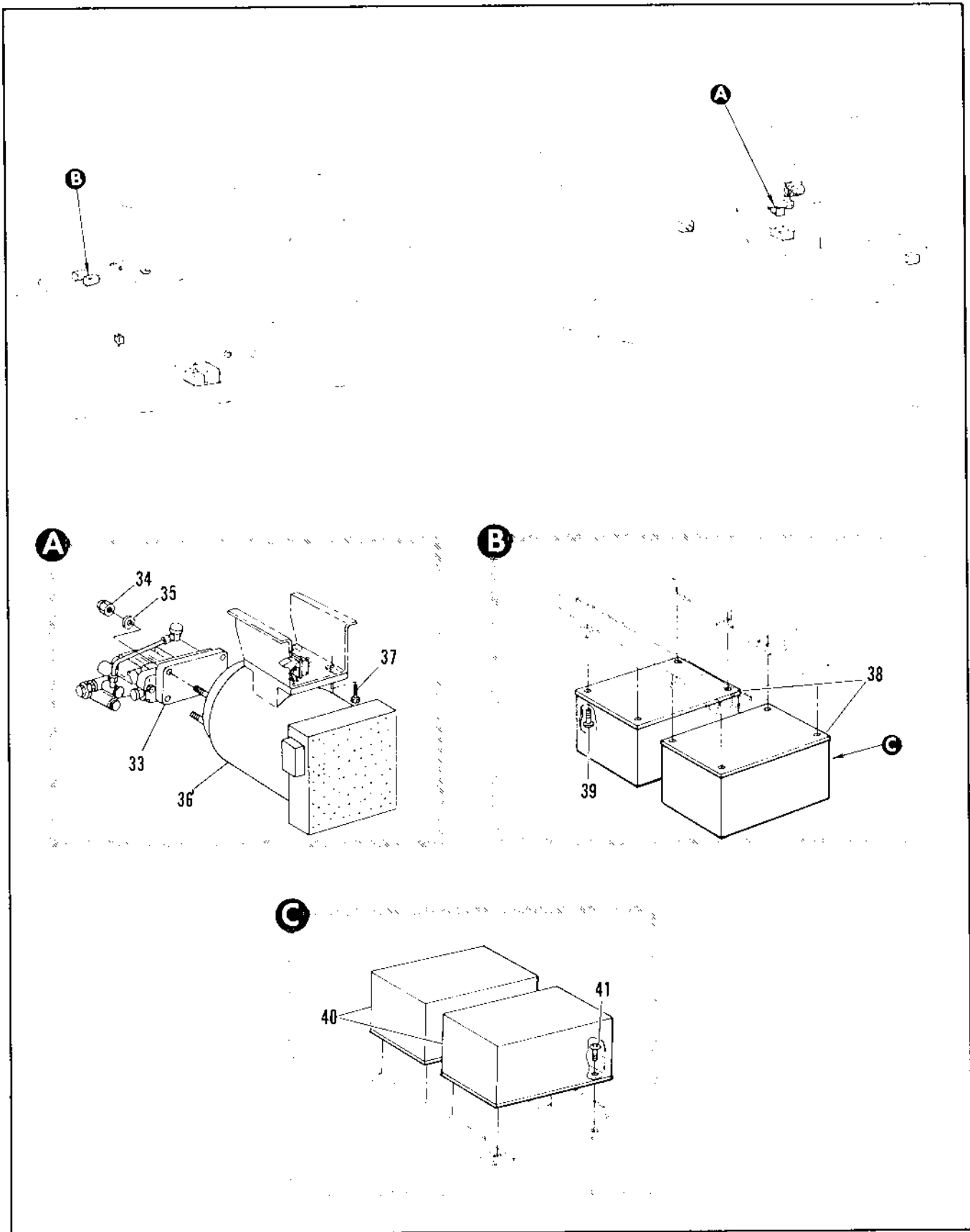

Figure 2.17-8. AC-DC Power Source Equipment (Sheet 3 of 6)

FIGURE AND INDEX NUMBER	PART NUMBER	DESCRIPTION 1 2 3 4 5 6	UNITS PER ASSY.	USABLE ON CODE	
				FROM	TO
2.17-8- 33	EA50040-2	• DRIVE ASSY, EMERGENCY HYD ALTERNATOR <88748> SPEC 8-08496-3 T.O. 9H6-3-1R-4 REPLACED BY NOT INCHG WITH EA50040-2A	1	35	240
	EA50040-2A	• DRIVE ASSY, EMERGENCY HYDRAULIC ALTERNATOR <80048> SPEC 8-08496-5 T.O. 9H6-3-1R-4 REPLACES SUITABLE SUR FOR EA50040-2	1	241	
	EA50040-2AB	• DRIVE ASSY, EMERGENCY HYDRAULIC ALTERNATOR SPEC 8-08496-5 T.O. 9H6-3-1R-4 REPLACES AND SUITABLE SUR FOR EA50040-2 AND EA50043-2A ATTACHING PARTS	RF	35	
- 34	NAS679A5	• NUT	4	35	
- 35	AN961-516	• WASHER -----X-----	4	35	
- 36	AGE53-2	• GENERATOR ASSY, EMERGENCY AC <07679> SPEC 8-06240-1 T.O. 6A6-3-7-4	1	130	
- 37	AN4-10A	• BOLT	4	35	
	8-62299-R01	• TRANSFORMER INSTL, WINDSHIELD ANTI-ICE	1	A	
	8-62299-R03	• TRANSFORMER INSTL, WINDSHIELD ANTI-ICE	1	A	
- 38	6934	• TRANSFORMER, <95266> SPEC 8-06454-1 ATTACHING PARTS	2	A	
- 39	AN520-1087	• SCREW -----X-----	8	A	
- 40	6934	• TRANSFORMER, <95266> SPEC 8-06454-1 ATTACHING PARTS	2	B	
- 41	NAS221-P	• SCREW -----X-----	8	B	

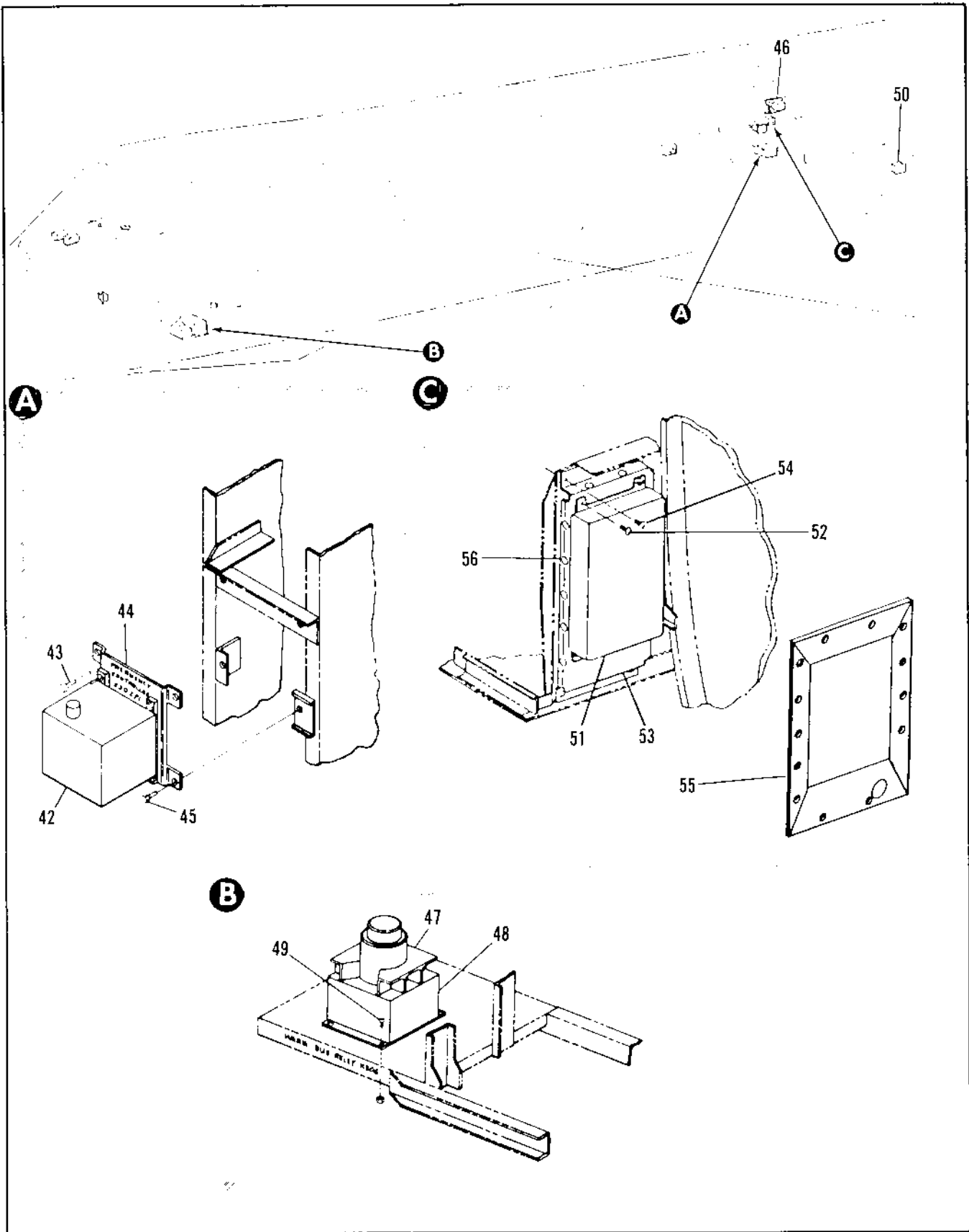

Figure 2.17-8. AC-DC Power Source Equipment (Sheet 4 of 6)

FIGURE AND INDEX NUMBER	PART NUMBER	DESCRIPTION	UNITS PER ASSY.	USABLE ON CODE	
				FROM	TO
		1 2 3 4 5 6			
2.17-8	7242879-10	• CONTROLLER INSTALLATION, FREQUENCY	1	35	
- 42	708415	• • FREQUENCY CONTROLLER (P9167) ATTACHING PARTS	1	35	
- 43	AN3-4A	• • BOLT -----X-----	4	35	
- 44	7242859-10	• • BRACKET ASSY, RIVETED ATTACHING PARTS	1	35	
- 45	AN3-4A	• • BOLT -----X-----	4	35	
	8-65048	• CONTROLLER INSTL, AC GENERATOR DRIVE FREQUENCY	9F	35	
- 46	686305	• • CONTROLLER, FREQUENCY AND LOAD (58417) AERNO42-P545 GFAC	1	130	
	7242874-10	• RELAY INSTL, WARM BUS	1	35	
- 47	MS27243-4	• • COVER, TERMINAL	1	35	
- 48	MS24168D2	• • RELAY, GFAC AF INSTALLED ATTACHING PARTS	1	35	
- 49	MS27039-1-071	• • SCREW	03	403	5
	8-65140-5	• RELAY INSTL, AC EMERGENCY POWER DISCONNECT	1	35	
- 50	P-6447A3	• • RELAY, (25244) SPEC 8-06447-3 ATTACHING PARTS	1	35	
	AN520-10RE	• • SCREW -----X-----	4	35	
	7242884-10	• CONTROL INSTL, AC GENERATOR	1	35	
- 51	976J474-2	• • GENERATOR CONTROL, AC, GFAC AF INSTALLED ATTACHING PARTS	1	35	
- 52	MS27039-1-07	• • SCREW -----X-----	4	35	
- 53	7242858-10	• • PLATE ASSY ATTACHING PARTS	1	35	
- 54	MS27039-4-08	• • SCREW -----X-----	4	35	
- 55	7B39254-10	• • COVER, AC GENERATOR CONTROL	1	35	
	MS27981-3N	• • CAP, SNAP	13	35	
	MS27981-3N	• • SOCKET, SNAP	13	35	
	MIL-C-43006	• • CLOTH, VINYL (TYPE I OR II, GFAY)	AR		
- 56	MS27981-4N	• • STUD, SNAP	13	35	

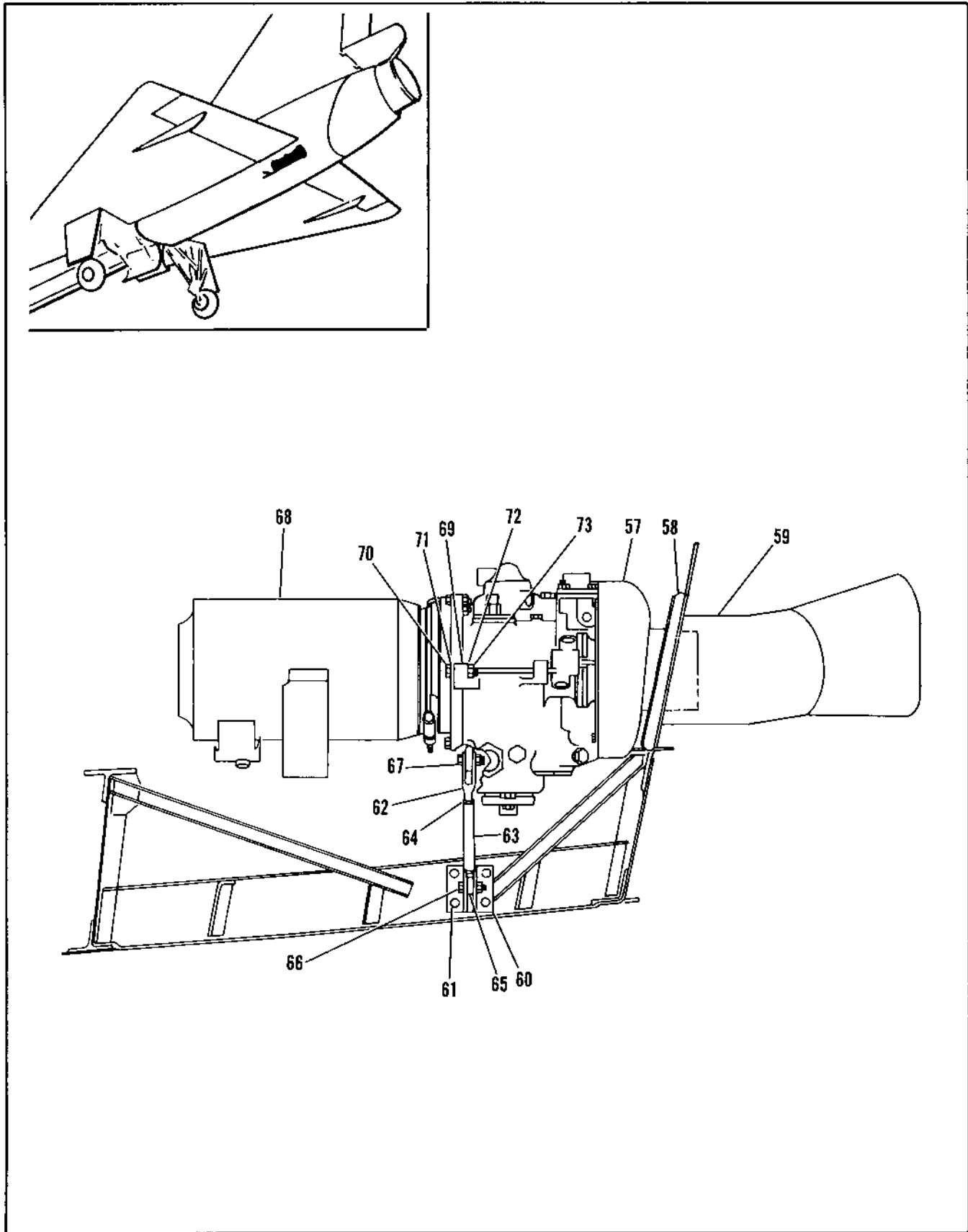

Figure 2.17-8. AC-DC Power Source Equipment (Sheet 5 of 6)

FIGURE AND INDEX NUMBER	PART NUMBER	DESCRIPTION	UNITS PER ASSY.	USABLE ON CODE	
				FROM	TO
2.17-8	9-80301	• GENERATOR INSTALLATION, AIR TURBINE DRIVEN EMERGENCY AC	RF		
- 57	103001	• • MOTOR, AIR TURBINE	1		
- 58	663-01	• • SEAL	1		
- 59	3-80307-1	• • DUCT ASSY	1		
- 60	9-77143-7	• • FITTING	1		
		ATTACHING PARTS			
- 61	NAS1103-2	• • BOLT	4		
	NAS1291-3	• • NUT	4		
	AN960PD10L	• • WASHER	4		
		-----X-----			
- 62	R-80312-7	• • FORK	1		
- 63	R-0313-7	• • BARREL	1		
- 64	NAS559-5	• • NUT	1		
- 65	28REMLH-4A	• • BEARING (F1376)	1		
	KEL4-5	• • BEARING, ALT INTCHG	RF		
- 66	AN174-11	• • BOLT	1		
	AN310-4	• • NUT	1		
	AN960PD416	• • WASHER	2		
	MS24565-132	• • PIN	1		
- 67	AN174-17	• • BOLT	1		
	AN317-4	• • NUT	1		
	AN960PD416	• • WASHER	1		
	MS24565-132	• • PIN	1		
- 68	201434	• • GENERATOR, AIR TURBINE DRIVEN EMERGENCY AC	1		
- 69	R-77142-9	• • FITTING	1		
		ATTACHING PARTS			
	NAS1104-4	• • BOLT	4		
	NAS1291-4	• • NUT	4		
	AN960-414L	• • WASHER	4		
		-----X-----			
- 70	R-80314-8	• • BOLT	1		
- 71	AN960PD516L	• • WASHER	1		
- 72	AN960PD516	• • WASHER	1		
- 73	AN363-524	• • NUT	1		

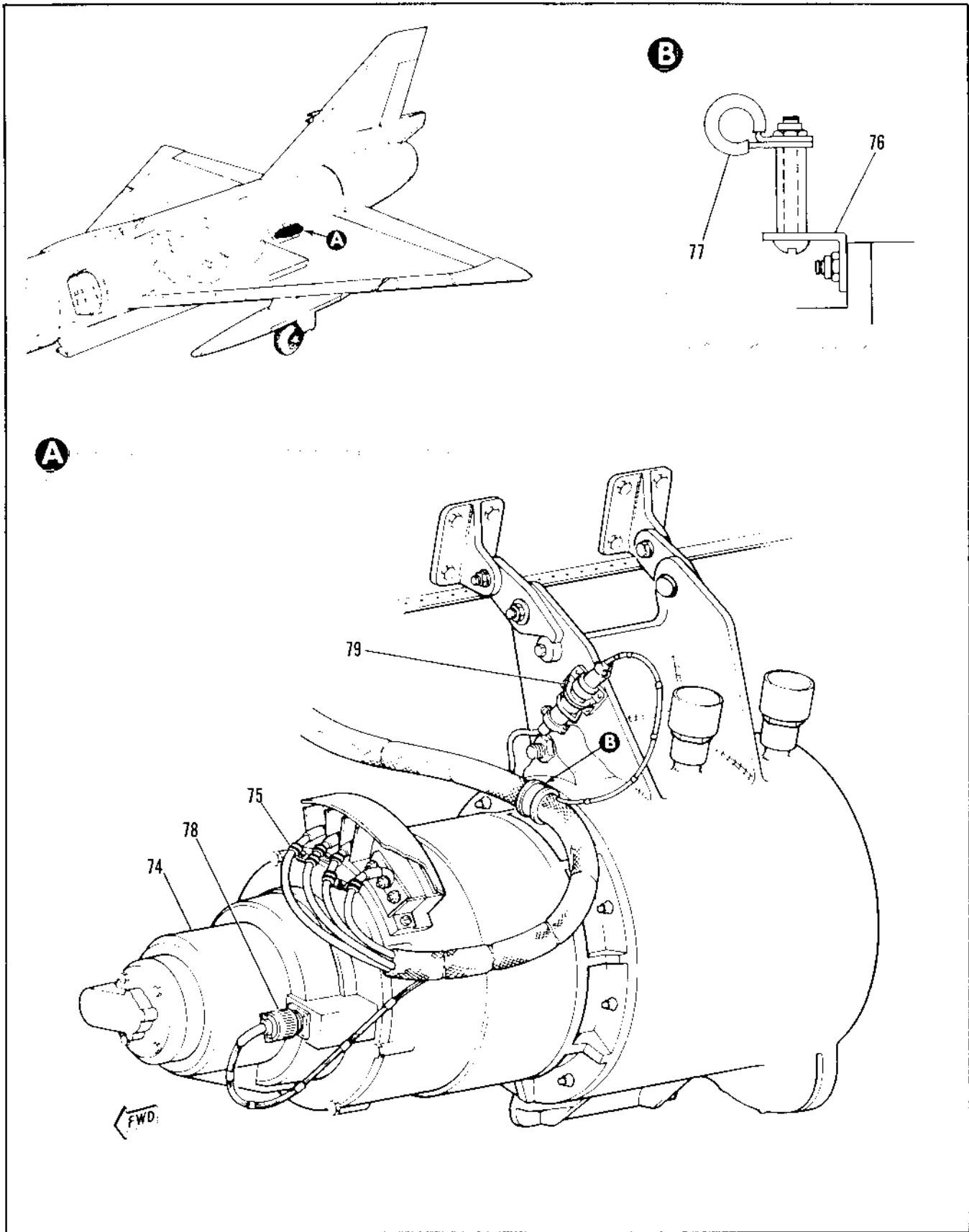

Figure 2.17-8. AC-DC Power Source Equipment (Sheet 6 of 6)

FIGURE AND INDEX NUMBER	PART NUMBER	DESCRIPTION	UNITS PER ASSY.	USABLE ON CODE	
				FROM	TO
		1 2 3 4 5 6			
2.17-8- 74	976J404-1	• • GENERATOR, MAIN AC (A3943) SEE T.O. 8A6-10-4-4 FOR BREAKDOWN	1	35	
- 75	MS21919WDF7	• • CLAMP ATTACHING PARTS	6		
	MS35207-264	• • BOLT	3		
	MS21043-3	• • NUT	3		
		-----X-----			
- 76	7243009-03	• • BRACKET (9R750)	1		
- 77	MS21919DF13	• • CLAMP ATTACHING PARTS	1		
	NAS43DD3-40	• • SPACER	1		
	NAS603-20P	• • BOLT	1		
	MS21043-3	• • NUT	1		
		-----X-----			
- 78	M93723-75R147N	• • CONNECTOR (P15004)	1		
	M93723-15S14F	• • BACKSHELL	1		
- 79	M93723-23R15R2N	• • CONNECTOR (P15007)	1		
	M93723-35N15F	• • BACKSHELL	1		

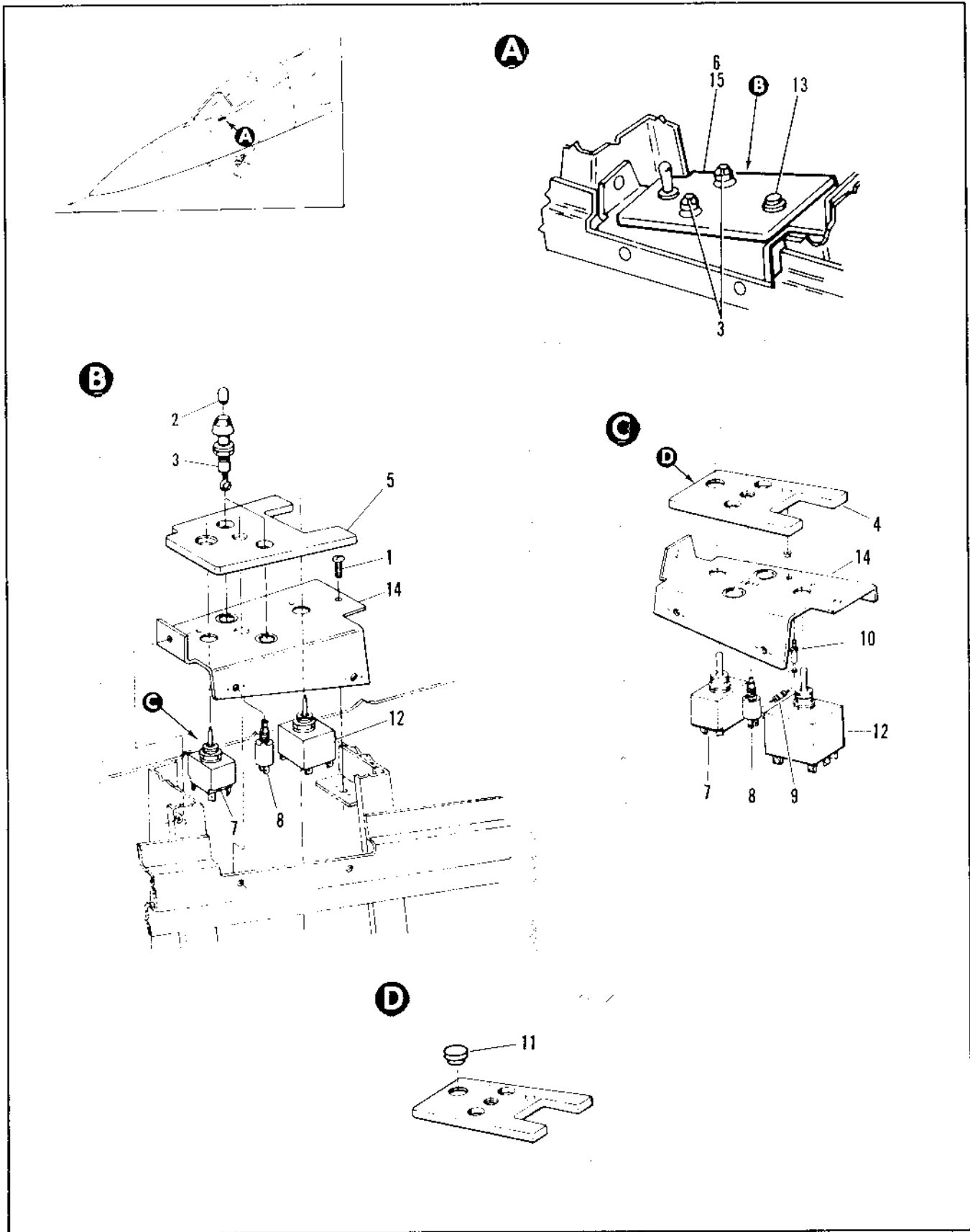

Figure 2.17-9. Tacan Power Source Switch Panel

FIGURE AND INDEX NUMBER	PART NUMBER	DESCRIPTION	UNITS PER ASSY.	USABLE ON CODE	
				FROM	TO
		1 2 3 4 5 6			
2.17-9	R-32455-1	TACAN POWER SOURCE SWITCH PANEL • PANEL ASSY, TACAN POWER SOURCE SWITCH MODIFIED BY 63E35552 FOR NHA SEE FIG. 2.1-1	RF PF		
	R-32455-1	• PANEL ASSY, TACAN POWER SOURCE SWITCH MODIFIED BY 63E35552 FOR NHA SEE FIG. 2.1-1	PF		
	R-32455-1	• PANEL ASSY, TACAN POWER SOURCE SWITCH MODIFIED BY 63E35552 AND 64D39959 FOR NHA SEE FIG. 2.1-1	RF		
- 1	AN520-10FA	• SCREW -----X-----	4		
- 2	AN3140-327	• • LAMP	2		
- 3	MS25010-4A	• • LIGHT ASSEMBLY	2		
- 4	63D35551-1 7841520	• • PANEL, PLASTIC • • • DECAL, PLASTIC EMER GEN START AND TACAN RANGE MOD OF	1 1		
- 5	63D35550-1	• • PANEL, PLASTIC	1		
- 6	64D34467-1I1	• • PANEL, PLASTIC EMERGENCY GENERATOR START AND EGT SPREAD	1		
- 7	MS35059-28	• • SWITCH	1		
- 8	RV6L-AYSA255B RV6WAYSL252A	• • RESISTOR, VARIABLE 97-49005-013	1		
- 9	RC320F562J	• • RESISTOR, VARIABLE	1		
- 10	8831136-2	• • RESISTOR	1		
- 11	HS49152	• • INSULATOR, STANDOFF	2		
- 12	R906K72A	• • PLUG, PLASTIC (93056)	1		
- 13	3PB11	• • SWITCH, (17605) SPEC 4-36491	1		
- 14	R-32455-10 R-32455-3	• • SWITCH, EGT SPREAD (91020) • • BRACKET ASSY, RIVETED	1 1		
- 15	64D34467-1	• PANEL ASSY, TACAN POWER SOURCE SWITCH FOR NHA SEE FIG. 2.1-1 • PANEL, PLASTIC EMERGENCY GENERATOR START AND EGT SPREAD	RF 1		

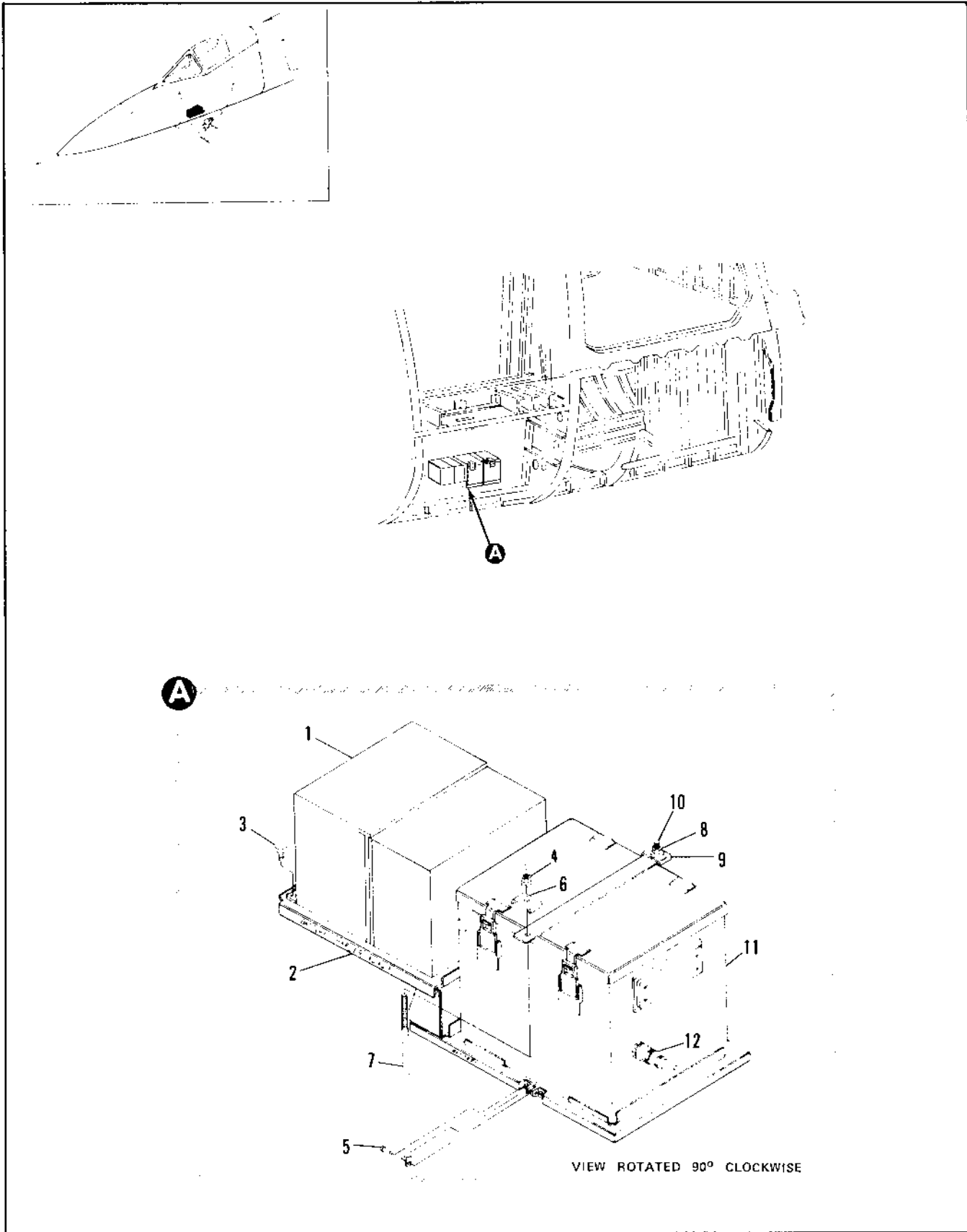

Figure 2.17-10. DC Emergency Power Supply Battery Installation Sta 120

FIGURE AND INDEX NUMBER	PART NUMBER	DESCRIPTION	UNITS PER ASSY.	USABLE ON CODE	
				FROM	TO
		1 2 3 4 5 6			
2.10-10		AC-DC POWER SOURCE EQUIPMENT			
- 1	464691-150 7242465-17	• BATTERY CHARGER (S2577) • EQUIPMENT INSTL, NWW	1	35	
		LOWER MODIFICATION	1	35	
- 2	7242440-11	• SHELF, BATTERY CHARGER (28750) ATTACHING PARTS	1	35	
- 3	AN3-NA	• BOLT			

- 4	MS21143-8	• NUT	1	35	
- 5	MS20382-1-15	• PIN	1	35	
- 6	WRN4200-88	• RETAINER (28524)	1	35	
- 7	7242366-01	• RETAINER	1	35	
- 8	MS21143-8	• NUT	2	35	
- 9	WRN4200-88	• RETAINER (28524)	1	35	
- 10	7242473-11	• RETAINER	1	35	
- 11	7242098-10 7243197	• BATTERY, GBE AF INSTALLED • SENSCH, BATTERY (KIT) (28750)	1	35	
- 12	44034036561	• TEMPERATURE SENSOR ASSEMBLY BATTERY (1221)	1	35	

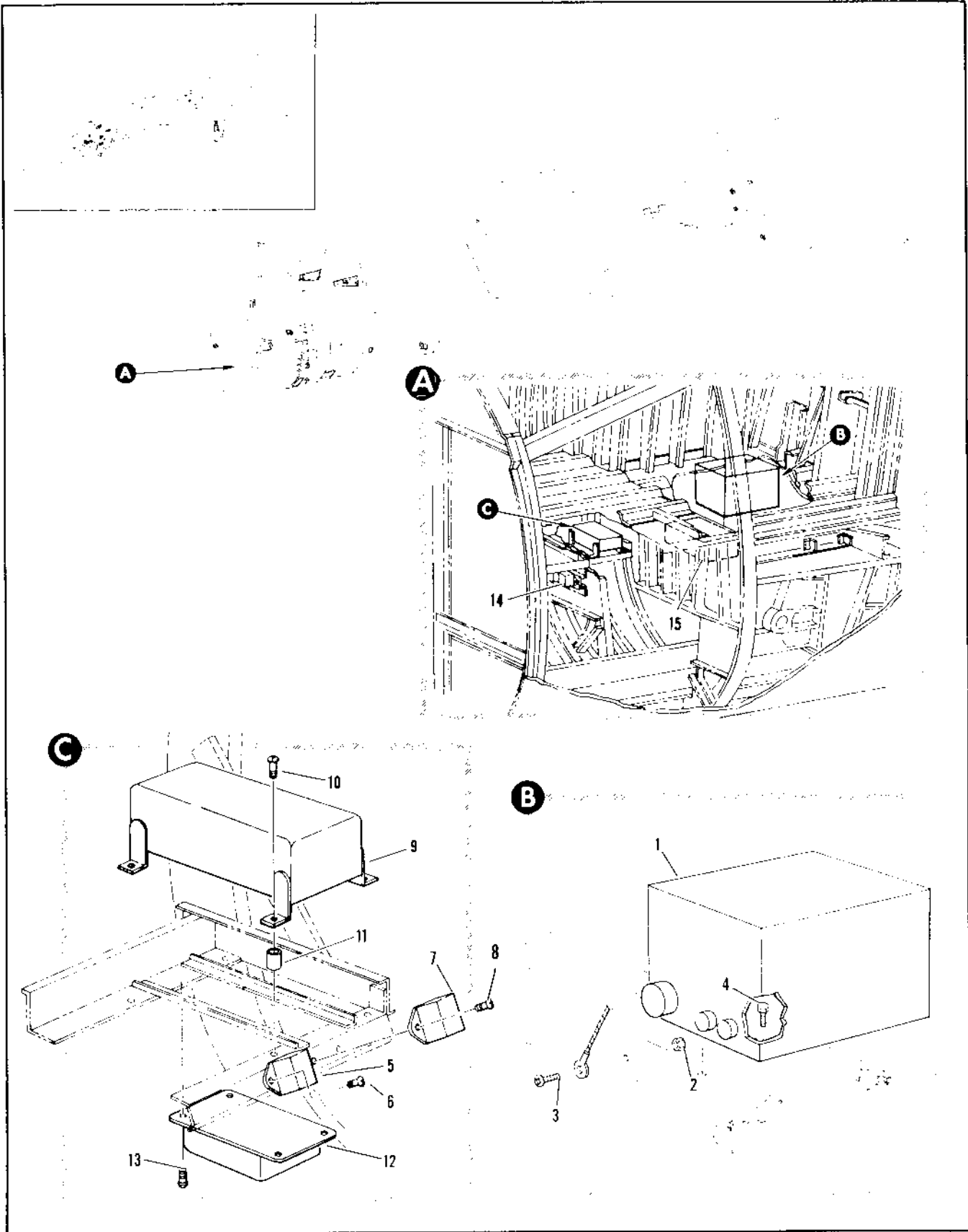

Figure 2.17-11. Electrical Power Distribution Equipment (Sheet 1 of 10)

FIGURE AND INDEX NUMBER	PART NUMBER	DESCRIPTION	UNITS PER ASSY.	USABLE ON CODE	
				FROM	TO
		1 2 3 4 5 6			
2.17-11		ELECTRICAL POWER DISTRIBUTION EQUIPMENT			
	R-38197-3	• TRANSMITTER INSTL, ENGINE PRESSURE RATIO FOR NHA SEE FIG. 2.17-9	RF	35	
- 1	24124-4	• • TRANSMITTER, PRESSURE RATIO <7J210> AFR1061-2444 TYPE MKP GFAB ATTACHING PARTS	1	35	
- 2	NASA79A2	• • NUT	1	35	
	LC27RT3	• • LENS	1	35	
	W-L9111141	• • LAMP	1	35	
- 3	AN526-1032R6	• • SCREW	1	35	
- 4	AN3-4A	• • FOLT	4	35	
		-----X-----			
	R-6501R-3	• CONTROL INSTL, NLG STEERING DAMPER	1	35	38
	R-6501R-403	• CONTROL INSTL, NLG STEERING DAMPER	1	39	40
	R-650R-815	• CONTROL INSTL, NLG STEERING DAMPER	1	61	
- 5	9221-3433	• • RELAY, WARNING LIGHT TEST <35344> SPEC W-06289	1	35	
		ATTACHING PARTS			
- 6	AN521-10R6	• • SCREW	2	35	
		-----X-----			
- 7	9221-3435	• • RELAY, ICE DETECTOR <35344> SPEC W-06289-3	1	35	
	9221-34-33	• • RELAY, ICE DETECTOR <35344> SPEC W-06289 ALT INTCHG WITH 9221-3435 ATTACHING PARTS	RF	35	
- 8	AN521-10R6	• • SCREW	2	35	
		-----X-----			
- 9	1007	• • CONTROL BOX ASSY, NLG STEERING AND DAMPING <74072> SPEC R-75314-15 T.O. 842-14-2-3 REPLACED BY NOT INTCHG WITH 1067	1	35	38
	1067	• • CONTROL BOX ASSY, NLG STEERING AND DAMPING <74072> SPEC R-75314-23 T.O. 843-14-2-14 REPLACES NOT INTCHG WITH 1007 ATTACHING PARTS	1	39	
- 10	AN521-10R2	• • SCREW	4	35	38
- 11	NASA1003-41	• • SPACER	4		
	AN521-10R7	• • SCREW	4	39	
		-----X-----			
- 12	25430134-11	• • REGULATOR, ATU SENSOR VOLTAGE <7234> SPEC W-0948-F T.O. 011-2-17 ATTACHING PARTS	1	61	
- 13	AN521-10R2	• • SCREW	6		
	AN515-10R4	• • SCREW	4	61	
		-----Y-----			
- 14		• RELAY INSTL, WARNING LIGHT DIMMING RH SEE FIG. 2.17-22	RF		
- 15		• BOX INSTL, WARNING LIGHT DIMMING SEE FIG. 2.17-13	RF		
		A AIRPLANES 840 THRU 47 AND 48 THRU 49 B AIRPLANES 842, 87 AND 88			

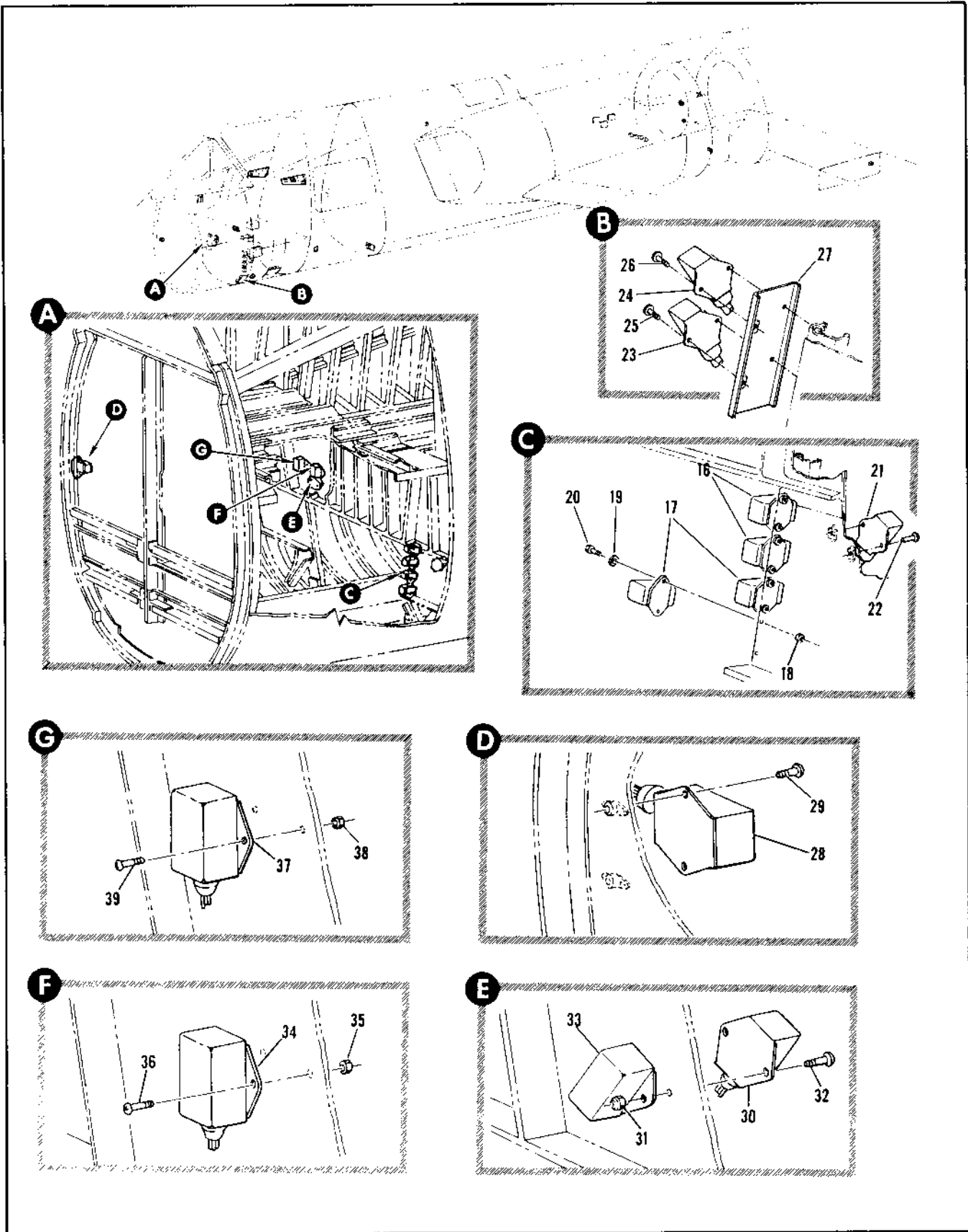

Figure 2.17-11. Electrical Power Distribution Equipment (Sheet 2 of 10)

FIGURE AND INDEX NUMBER	PART NUMBER	DESCRIPTION	UNITS PER ASSY.	USABLE ON CODE	
				FROM	TO
2.17-11	8-65209	• RELAY INSTL, LH STA 133	1	A	
	9220-3433	• RELAY, SPEED BRAKE AND EMERGENCY RETRACT <35344> SPEC A-36289	2	A	
- 16	9220-3435	• RELAY, EMERGENCY EXTEND AND CONTROL <35344> SPEC A-36289-3	2	A	
- 17	9220-3433	• RELAY, EMERGENCY EXTEND AND CONTROL <35344> SPEC A-36289 ALT INTCHS WITH 9220-3435 ATTACHING PARTS	RF	A	
- 18	NAS679A3	• NUT	8	A	
- 19	AN521-10L	• WASHER	8	A	
- 20	NAS221-F	• SCREW	8	A	
		-----X-----			
- 21	8-65293	• RELAY INSTL, CHUTE JETTISON INTERLOCK	1	49	89
	9220-3435	• RELAY, <35344> SPEC A-36289 ATTACHING PARTS	1	49	99
- 22	NAS221-G	• SCREW	2	49	89
		-----X-----			
	8-65298-1	• RELAY INSTL, STA 132, LH SIDE	1	48	48
	8-65298	• RELAY INSTL, STA 132, LH SIDE	1	92	
- 23	9220-3433	• RELAY, LANDING GEAR CONTROL <35344> SPEC A-36289	1	R	
- 24	9220-3435	• RELAY, CHUTE JETTISON INTERLOCK <35344> SPEC A-36289-3 ATTACHING PARTS	1	50	
- 25	AN521-10F6	• SCREW	2	B	
- 26	AN521-10F6	• SCREW	2	92	
		-----X-----			
- 27	8-65298-B	• PANEL ASSY, RIVETED	1	B	
	8-65182-1	• RELAY INSTL, VARIABLE AIR RAMP POSITION WARNING LIGHT	1	35	
- 28	9220-3435	• RELAY, <35344> SPEC A-36289-3 ATTACHING PARTS	1	35	
- 29	AN521-10H7	• SCREW	2	35	
		-----X-----			
	8-65276	• RELAY INSTL, FIRE DETECTOR INDICATOR LOOP	1	49	89
	8-65276-1	• RELAY INSTL, FIRE DETECTOR INDICATOR LOOP	1	92	
- 30	9220-3435	• RELAY, <35344> SPEC A-36289-3 ATTACHING PARTS	1	49	
- 31	NAS679A3	• NUT	2	49	XXX
- 32	AN521-10H10	• SCREW	2	49	
		-----X-----			
- 33	9220-3435	• RELAY, NOSE WHEEL STEERING CONTROL <35344> SPEC A-36289-3	1		
	8-65181	• RELAY INSTL, AUXILIARY DIMMING OVERHEAT	1	49	89
	8-65181-1	• RELAY INSTL, AUXILIARY DIMMING OVERHEAT	1	92	
- 34	9220-3435	• RELAY, <35344> SPEC A-36289-3 ATTACHING PARTS	1	49	
- 35	NAS679A3	• NUT	2	49	
- 36	AN521-10H10	• SCREW	2	49	
		-----X-----			
	8-65194	• RELAY INSTL, WARN LIGHT TEST RELAY #2	1	A	
	8-65194-1	• RELAY INSTL, WARN LIGHT TEST RELAY #2	1	92	
- 37	9220-3433	• RELAY, <35344> SPEC A-36289 ATTACHING PARTS	1	35	
- 38	NAS679A3	• NUT	2	35	
- 39	AN521-10H10	• SCREW	2	35	
	NAS221-11	• SCREW	2	35	
		-----X-----			

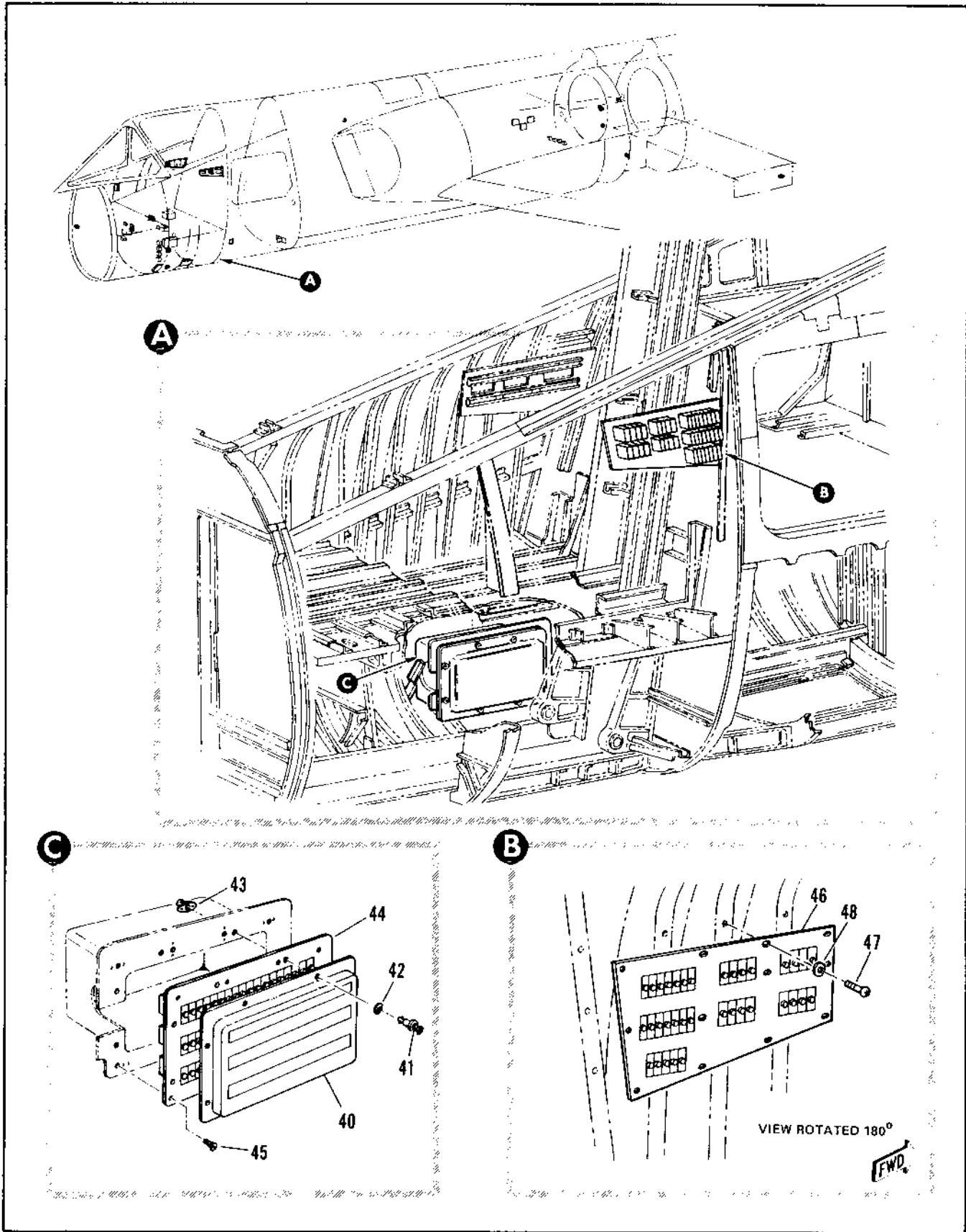

Figure 2.17-11. Electrical Power Distribution Equipment (Sheet 3 of 10)

FIGURE AND INDEX NUMBER	PART NUMBER	DESCRIPTION	UNITS PER ASSY.	USABLE ON CODE	
				FROM	TO
2.17-11	H-65921-407	• PANEL INSTL, NOSE WHEEL WELL FUSE	1	35	
	H-65922-408	• COVER ASSY, NOSE WHEEL WELL FUSE PANEL RIVETED	1	35	
		ATTACHING PARTS			
- 41	2600-12	• STUD, FASTENER <71294> 99-52001-012	8	35	
- 42	2600SW	• WASHER, FASTENER <71294> 99-53600-002	8	35	
- 43	212-12	• RECEPTACLE, FASTENER <71294> 97-31002-001	8	35	
		-----X-----			
- 44	7242466-10	• PANEL INSTL, NOSE WHEEL WELL FOR BREAKDOWN SEE FIG. 2.17-24	1	35	39
	7242466-30	• PANEL INSTL, NOSE WHEEL WELL FOR BREAKDOWN SEE FIG. 2.17-24	1	39	47
	7242466-40	• PANEL INSTL, NOSE WHEEL WELL FOR BREAKDOWN SEE FIG. 2.17-24	1	42	48
	7242466-50	• PANEL INSTL, NOSE WHEEL WELL FOR BREAKDOWN SEE FIG. 2.17-24	1	43	49
	7242466-60	• PANEL INSTL, NOSE WHEEL WELL FOR BREAKDOWN SEE FIG. 2.17-24	1	49	60
	7242466-70	• PANEL INSTL, NOSE WHEEL WELL FOR BREAKDOWN SEE FIG. 2.17-24	1	61	89
	7242466-110	• PANEL INSTL, NOSE WHEEL WELL FOR BREAKDOWN SEE FIG. 2.17-24	1	91	128
	7242466-130	• PANEL INSTL, NOSE WHEEL WELL FOR BREAKDOWN SEE FIG. 2.17-24	1	131	159
	7242466-150	• PANEL INSTL, NOSE WHEEL WELL FOR BREAKDOWN SEE FIG. 2.17-24	1	68	188
	7242466-170	• PANEL INSTL, NOSE WHEEL WELL FOR BREAKDOWN SEE FIG. 2.17-24	1	189	239
	7242466-190	• PANEL INSTL, NOSE WHEEL WELL FOR BREAKDOWN SEE FIG. 2.17-24	1	244	
		ATTACHING PARTS			
- 45	AN509-10R13	• SCREW	9	35	
		-----X-----			
- 46	H-94658-801	• PANEL INSTL, COCKPIT C, B LH MODIFIED BY R-1348 FOR NPA SEE FIG. 2.3-6	8F	35	
	H-62375-1	• PANEL ASSY, COCKPIT C, B LH FOR BREAKDOWN SEE FIG. 2.17-26	1	35	89
	H-62375-601	• PANEL ASSY, COCKPIT C, B LH FOR BREAKDOWN SEE FIG. 2.17-27	1	91	129
	H-62375-607	• PANEL ASSY, COCKPIT C, B LH FOR BREAKDOWN SEE FIG. 2.17-27	1	130	159
	H-62375-405	• PANEL ASSY, COCKPIT C, B LH FOR BREAKDOWN SEE FIG. 2.17-27	1	160	215
	H-62375-607	• PANEL ASSY, COCKPIT C, B LH FOR BREAKDOWN SEE FIG. 2.17-27	1	219	
		ATTACHING PARTS			
- 47	AN500-10P7	• SCREW	12	35	
- 48	AN967-1LL	• WASHER	12	35	
		-----X-----			

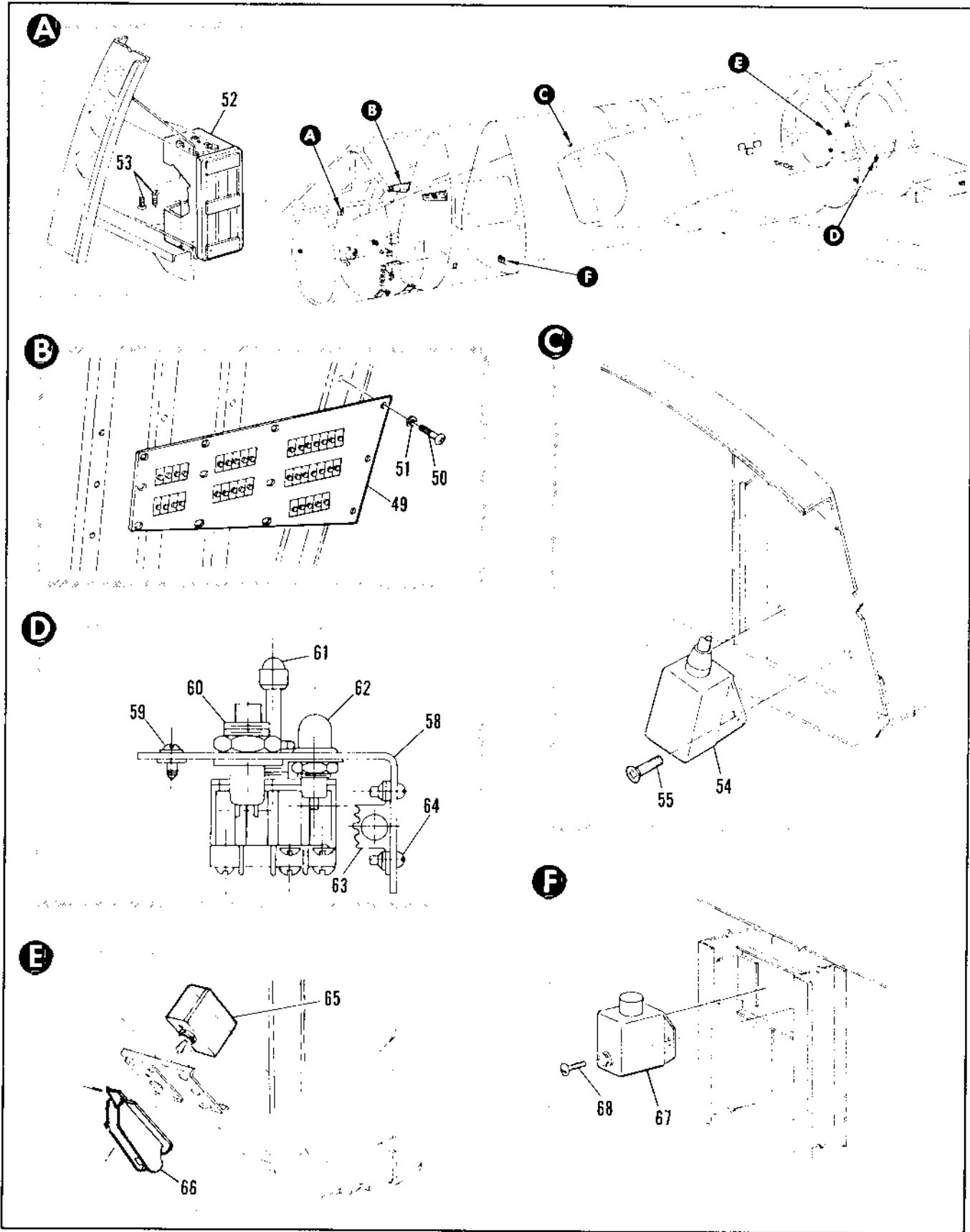

Figure 2.17-11. Electrical Power Distribution Equipment (Sheet 4 of 10)

FIGURE AND INDEX NUMBER	PART NUMBER	DESCRIPTION	UNITS PER ASSY.	USABLE ON CODE	
				FROM	TO
2.17-11	R-74457-5	• PANEL INSTL, COCKPIT FUSE RH FOR NHA SEE FIG. 2.3-4	RF	25	
- 49	R-62376-1	• • PANEL ASSY, COCKPIT FUSE RH FOR BREAKDOWN SEE FIG. 2.17-29	1	C	
	R-62376-803	• • PANEL ASSY, COCKPIT C, B RH FOR BREAKDOWN SEE FIG. 2.17-31	1	48	48
	R-62376-807	• • PANEL ASSY, COCKPIT C, B RH FOR BREAKDOWN SEE FIG. 2.17-29	1	61	89
	R-62376-805	• • PANEL ASSY, COCKPIT C, B RH FOR BREAKDOWN SEE FIG. 2.17-31	1	93	129
	R-62376-809	• • PANEL ASSY, COCKPIT C, B RH FOR BREAKDOWN SEE FIG. 2.17-31	1	130	159
	R-62376-811	• • PANEL ASSY, COCKPIT C, B RH FOR BREAKDOWN SEE FIG. 2.17-31	1	166	215
	R-62376-813	• • PANEL ASSY, COCKPIT C, B RH FOR BREAKDOWN SEE FIG. 2.17-31 ATTACHING PARTS	1	216	
- 51	AN521-10K7	• • SCREW	12	35	
- 51	AN960-10L	• • WASHER	12	35	
	R-95649	• PANEL INSTL, C, B LIGHTING FOR NHA SEE FIG. 2.3-4	RF	B	
- 52	R-62235	• • PANEL ASSY, C, B LIGHTING ATTACHING PARTS	1	R	
- 53	NAS623-3-4	• • SCREW	8	48	89
	NAS623-3-2	• • SCREW	8	90	
	R-65170-807	• RELAY INSTL, STA 246	1	35	
- 54	923L-3660	• • RELAY, BEACON LIGHT <35344> SPEC R-06289-5 ATTACHING PARTS	1	35	
- 55	AN520-10R7	• • SCREW	2	35	
		-----X-----			
- 56	MS25224-3	*1 • SWITCH INSTL, STARTER IGNITION DISARMING	1		
- 57	MS35058-22	*1 • GUARD	1		
		*1 • SWITCH	1		
		*1 • SWITCH INSTL, STARTER CARTRIDGE/PNEUMATIC SELECT MODE	1		
- 58	7947102-10	*2 • BRACKET ASSY	1		
- 59	MS35016-2FA	*2 • • SCREW	3	35	
	AN960-01L	*2 • • WASHER	3	35	
	MS21469-4	*2 • • NUT	3	35	
- 60	MS2549-1FA	*2 • SWITCH, PUSH TO TEST	1	35	
- 61	MS27422-1A	*2 • SWITCH, STARTER SELECT MODE	1	35	
- 62	101-3830-0971-201	*2 • LAMP ASSY, EXCLUDING LAMP	1	35	
- 63	PER7769310	*2 • RESISTOR (21349)	1	35	
- 64	MS51757-6	*2 • SCREW	2	35	
	MS51498-43	*2 • • WASHER	2	35	
	MS3549-224	*2 • • NUT	2	35	
	R61043-1	• SWITCH INSTL, ENSIVE IGNITION DISARMING	1	35	
- 65	9304629	• SWITCH, (15005) SPEC R-06507-5	1	35	
- 66	MS25224-3	• • GUARD	1		
	R-65329	• TIMING ELEMENT INSTL, VARI-RAMP STA 216	1	189	
- 67	11891	• • TIMING ELEMENT, ELECTRICAL (20349) SPEC R-10430-1 ATTACHING PARTS	1	189	
- 68	AN520-10R6	• • SCREW	2	189	
		-----Y-----			
		*1 REMOVED PER TCID 1F-106-1110			
		*2 REMOVED PER TCID 1F-106-1110			

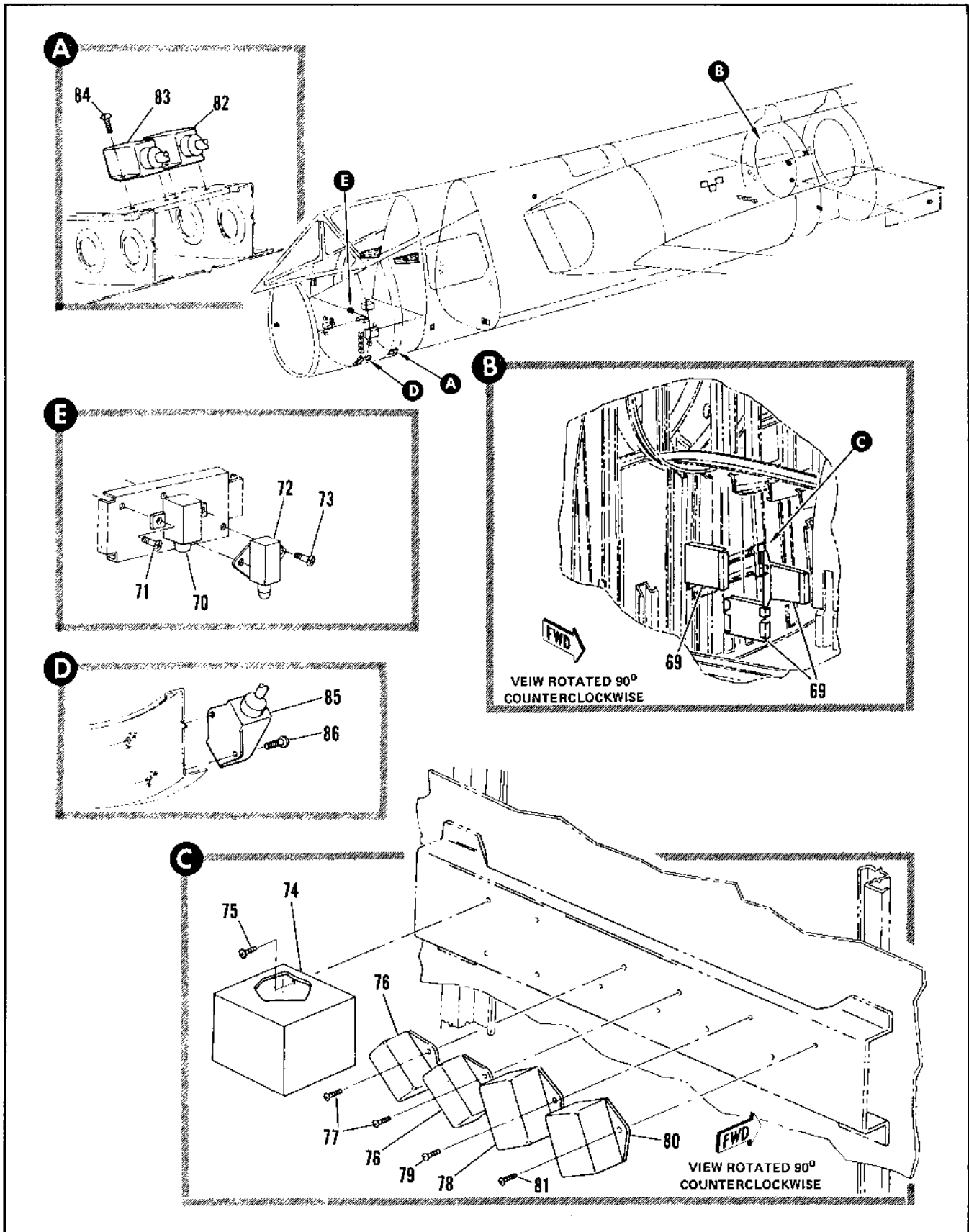

Figure 2.17-11. Electrical Power Distribution Equipment (Sheet 5 of 10)

FIGURE AND INDEX NUMBER	PART NUMBER	DESCRIPTION 1 2 3 4 5 6	UNITS PER ASSY.	USABLE ON CODE	
				FROM	TO
2.17-11- 69	8-65332-1	• RELAY INSTALLATION STA 371 TO 391 SEE FIG. 2.17-10	1	90	
- 70	1129A	• RELAY INSTL, SURFACE AND ENGINE ANTI-ICE STA 147.90	1	90	
- 71	AN520-10RE AN520-10RR	• RELAY, ENGINE ANTI-ICE TIME DELAY <01972> SPEC 8-06481-1 ATTACHING PARTS	2 2	90	
- 72	9226-4766	• RELAY, ENGINE ANTI-ICE LATCH <35344> 97-38022-011 ATTACHING PARTS	1	90	
- 73	AN520-10RE AN520-10RR	• SCREW • SCREW -----X-----	2 2	90	
- 74	8-65107-3 0E00555	• RELAY INSTL, STA 412 MODIFIED BY 8-61598 • TRANSFORMER, POSITION LIGHT <95266> SPEC 8-06499-1 ATTACHING PARTS	1 1	35	277
- 75	AN520-10R7	• SCREW -----X-----	4	35	
- 76	9220-3433	• RELAY, HYDRAULIC LOW PRESSURE WARNING <35344> SPEC 8-06289 ATTACHING PARTS	2 2	35	188 188
- 77	AN520-10R7	• SCREW -----X-----	4	35	
- 78	9230-3434	• RELAY, LOWER BEACON LIGHT <35344> SPEC 8-06099-1 ATTACHING PARTS	1	35	
- 79	AN520-10R7	• SCREW -----X-----	2	35	
- 80	9230-3669 9227-3853	• RELAY, ELEVON INTERLOCK <35344> SPEC 8-06289-5 • RELAY, ELEVON INTERLOCK ALT FOR 9230- 3669 ATTACHING PARTS	1 RF	35	
- 81	AN520-10R7	• SCREW -----X-----	2	35	
- 82	8-65299	• RELAY INSTL, EMERGENCY EXTEND AND RETRACT	1	R	
- 83	9220-3435 9220-3433	• RELAY, EXTEND <35344> SPEC 8-06289-3 • RELAY RETRACT <35344> SPEC 8-06289 ATTACHING PARTS	1 1	R	
- 84	AN520-10R6	• SCREW -----X-----	4	R	
- 85	8-65297 9220-3433	• RELAY INSTL, LANDING GEAR CONTROL • RELAY, <35344> SPEC 8-06289 ATTACHING PARTS	1 2	R 3	
- 86	AN520-10R6	• SCREW -----X-----	2	R	
B AIRPLANES 848, 90 AND ON					

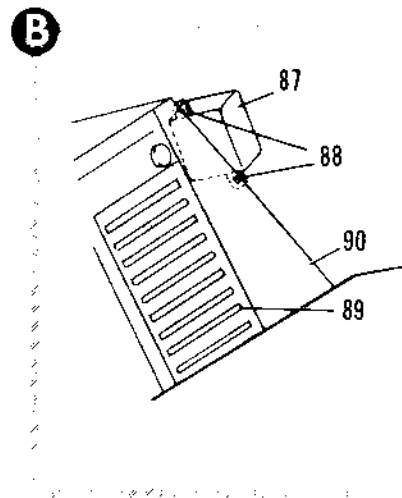
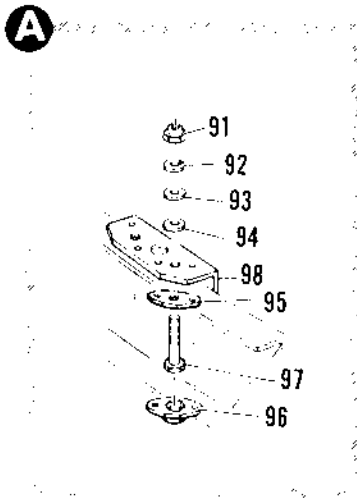
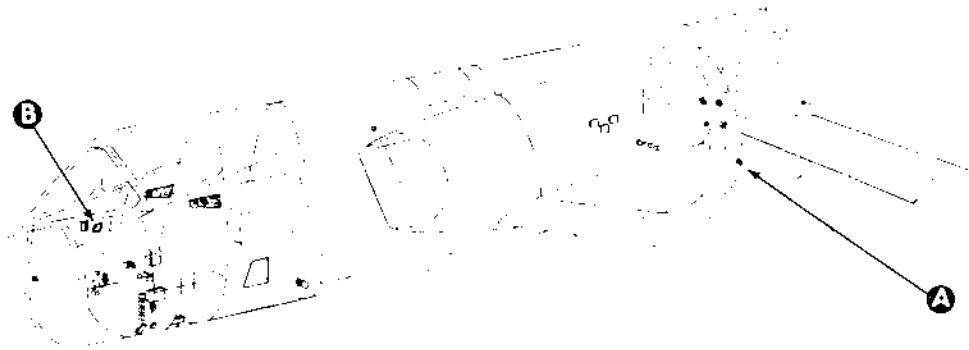

Figure 2.17-11. Electrical Power Distribution Equipment (Sheet 6 of 10)

FIGURE AND INDEX NUMBER	PART NUMBER	DESCRIPTION	UNITS PER ASSY.	USABLE ON CODE	
				FROM	TO
2.17-11	8-65197	• STUD INSTL, ENGINE ACCESSORY GROUND	1	35	
	8-65177-7	• • STUD ASSY, GROUND	1	35	
	7037135	• RELAY INSTL INTERVAL TIMER CANOPY ACTUATING CIRCUIT			
	- 87 TD-1087REVF	• • RELAY INTERVAL TIMER (35344)	1	35	
	- 88 MS35286-262	• • • SCREW	2		
	MS35138-43	• • • WASHER (LOCK)	2		
	AN960-10L	• • • WASHER (FLAT)	2		
	- 89 F289-1F	• PANEL ASSY, MASTER WARNING RH CONSOLE	REF		
	- 90 8-95595-1	• SUPPORT PANEL ASSY, MASTER WARNING	REF		
	- 91 NAS679A6	• • • NUT, GROUND STUD	2	35	
	- 92 AN935-616L	• • • WASHER, GROUND STUD	2	35	
	- 93 AN960-616L	• • • WASHER, GROUND STUD	2	35	
	- 94 AN9610616L	• • • WASHER, GROUND STUD	2	35	
	- 95 NAS463WCD616	• • • SHIM	2	35	
	- 96 6800-354	• • • RETAINER, BOLT (80534) 97-58002-004	2	35	
	- 97 NAS428-6-12	• • • BOLT, GROUND STUD	2	35	
	- 98 3-68177-9	• • • CLIP	1	35	
		----X----			

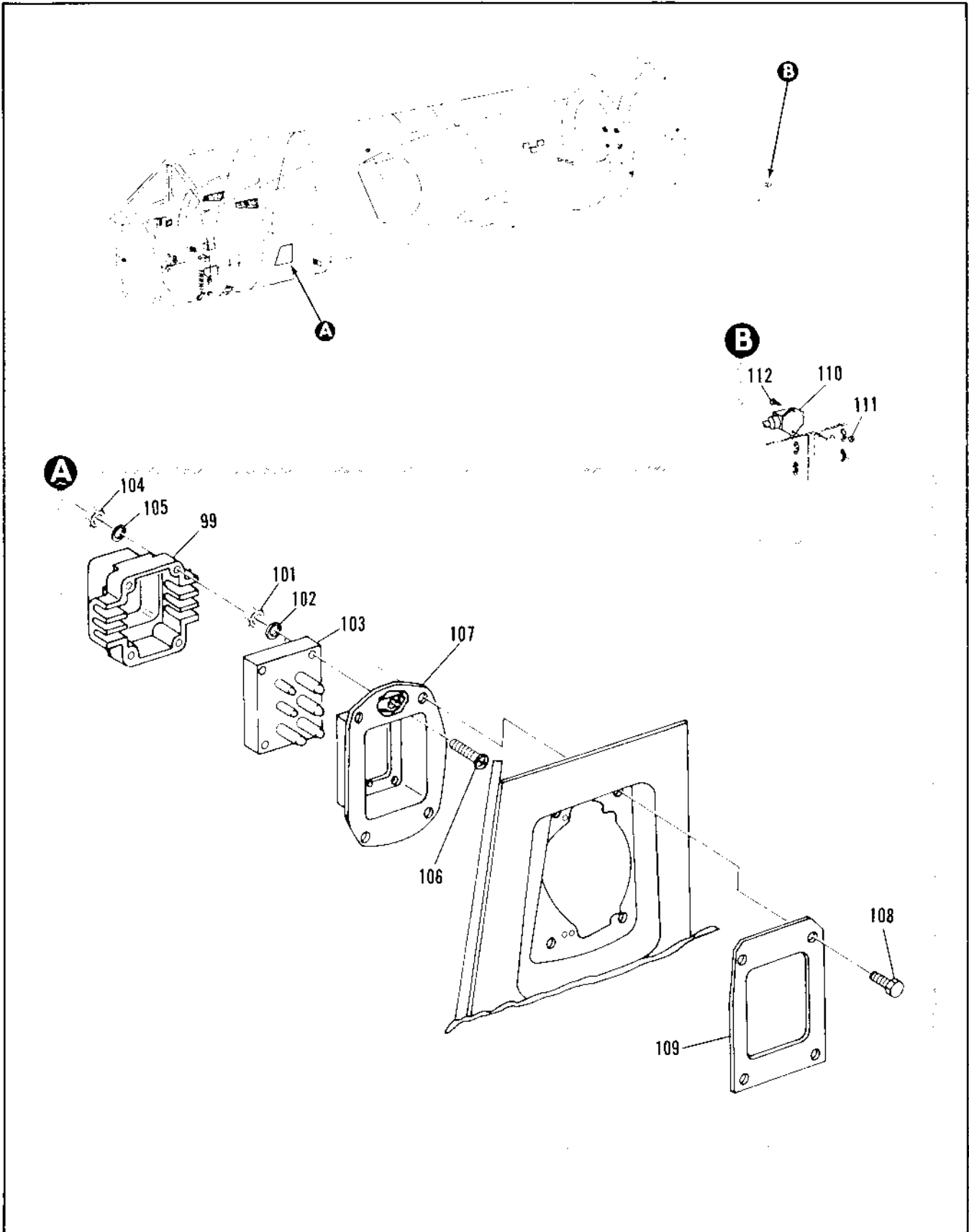

Figure 2.17-11. Electrical Power Distribution Equipment (Sheet 7 of 10)

FIGURE AND INDEX NUMBER	PART NUMBER	DESCRIPTION 1 2 3 4 5 6	UNITS PER ASSY.	USABLE ON CODE	
				FROM	TO
2.17-11- 99	7243025-10	• RECEPTACLE INSTL, EXTERNAL POWER	1	35	
-100	MS90362-2	• SHIELD, GF AE AF INSTALLED ATTACHING PARTS	1	35	
-101	MS21045L3	• NUT	4	35	
-102	AN960-10L	• WASHER	4	35	
		----X----			
-103	MS90362-1	• RECEPTACLE, GF AE AF INSTALLED ATTACHING PARTS	1	35	
-104	MS21045L3	• NUT	4	35	
-105	AN960-10L	• WASHER	4	35	
-106	MS35267-270	• SCREW	4	35	
		----X----			
-107	7243027-10	• HOUSING ASSY ATTACHING PARTS	1	35	
-108	AN405A	• BOLT	4	35	
		----X----			
-109	7243026-01	• PLATE	1	35	
	8-61041-3	• RELAY INSTL, EXTERNAL FUEL VALVE CONTROL LH	20	103	5
	8-61041-4	• RELAY INSTL, EXTERNAL FUEL VALVE CONTROL RH	1	35	
	66040274-1	• RELAY INSTL, FUEL INDICATOR LIGHT LH	1		
	66040274-2	• RELAY INSTL, FUEL INDICATOR LIGHT RH	1		
-110	9220-3435	• RELAY (35344) SPEC 8-10299-3 ATTACHING PARTS	1		
-111	MS21042L3	• NUT	2		
-112	MS35267-264	• SCREW	2		
		----X----			

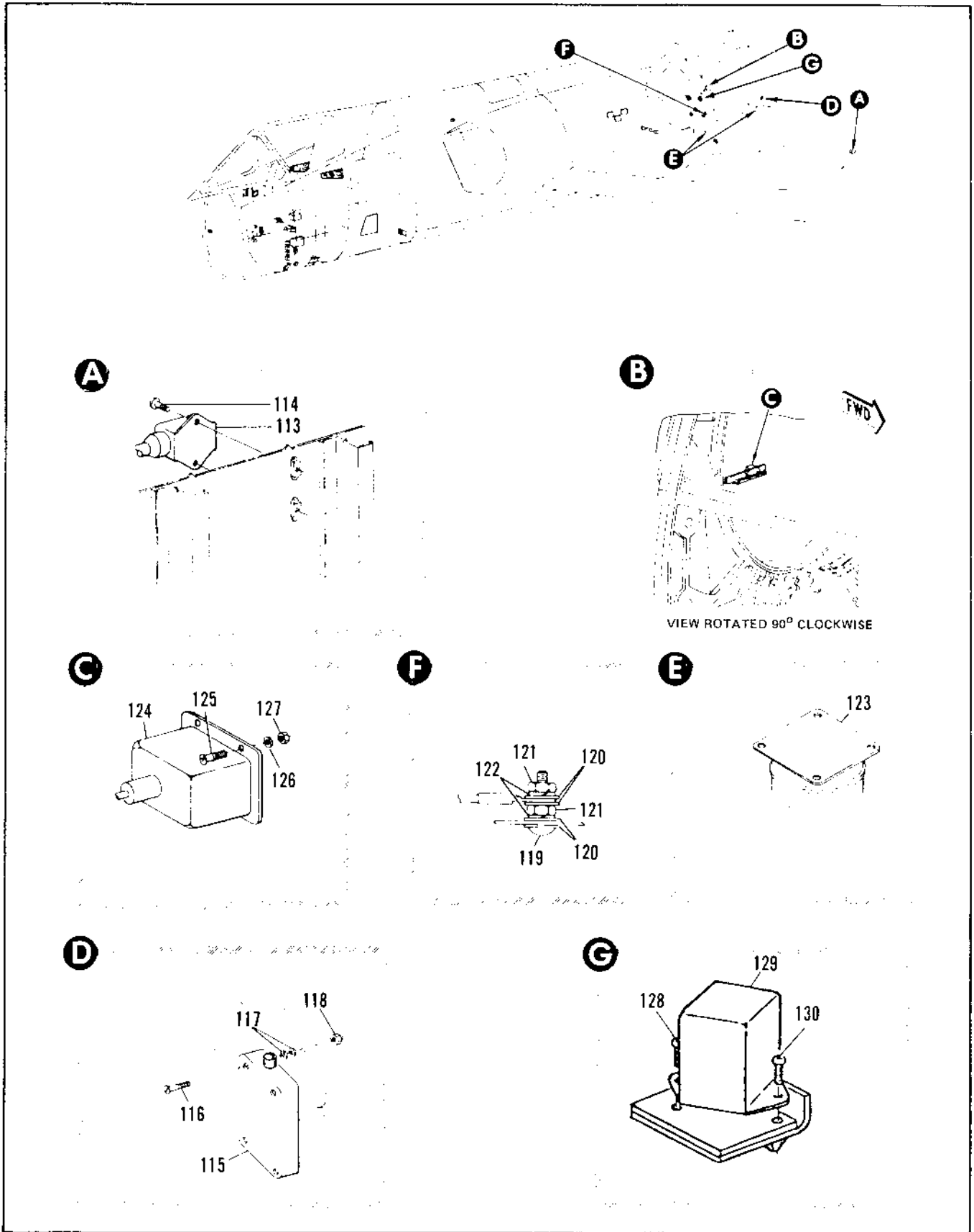

Figure 2.17-11. Electrical Power Distribution Equipment (Sheet 8 of 10)

FIGURE AND INDEX NUMBER	PART NUMBER	DESCRIPTION 1 2 3 4 5 6	UNITS PER ASSY.	USABLE ON CODE	
				FROM	TO
2.17-11-113	9220-3435	• • RELAY, <35344> SPEC 8-06289-3 ATTACHING PARTS	1	35	
-114	NAS221-10	• • SCREW ----X----	2	35	
-115	201435	• REGULATOR, VOLTAGE 8-01243-5 ATTACHING PARTS	1		
-116	AN526-1032R10	• SCREW	4		
-117	AN960010	• WASHER	4		
-118	AN365-1032	• NUT ----X----	4		
-119	AN526-1032R12	• SCREW	2		
-120	AN960010L	• WASHER	8		
-121	AN345-10	• NUT	4		
-122	AN935-10	• WASHER	4		
-123	MS24567-D2 BH-138AKH	• CONTACTOR • CONTACTOR (74063) ALT PART FOR MS24567-D2 ATTACHING PARTS	35 1		
	AN520-10R10	• SCREW ----X----	4		
-124	9346-4322 CL-236	• RELAY, 8-06447-3 • RELAY, ALT INTCHG ATTACHING PARTS	1 RF		
-125	AN520-10R8	• SCREW	4		
-126	AN960010L	• WASHER	4		
-127	AN365-1032	• NUT	4		
-128	806289-5	• RELAY, AIS POWER (14170) ATTACHING PARTS	1		
-129	MS35207-260	• SCREW	1		
-130	MS35207-261	• SCREW ----X----	1		

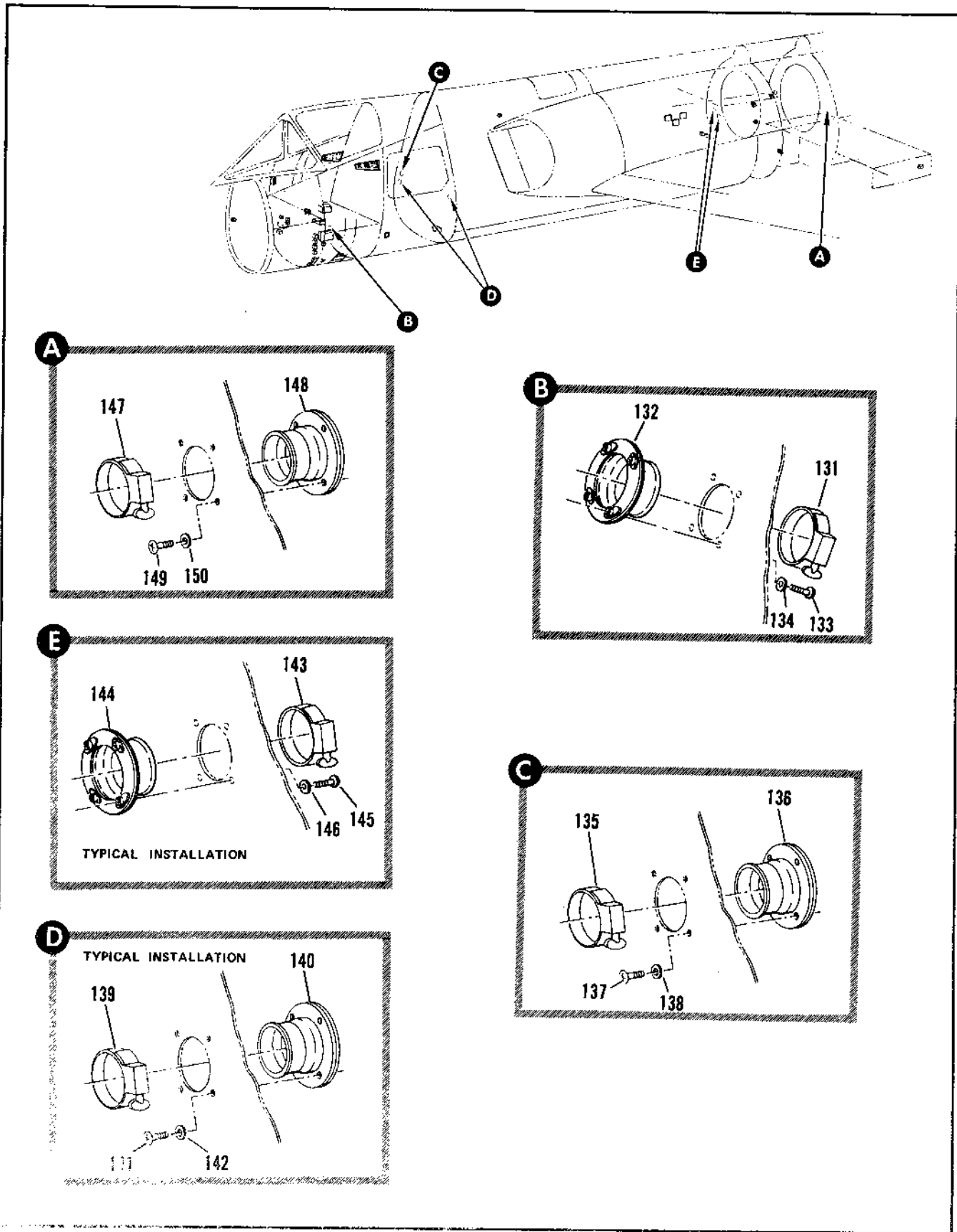

Figure 2.17-11. Electrical Power Distribution Equipment (Sheet 9 of 10)

FIGURE AND INDEX NUMBER	PART NUMBER	DESCRIPTION	UNITS PER ASSY.	USABLE ON CODE	
				FROM	TO
		1 2 3 4 5 6			
2.17-11	B-65035-812	• ROOT INSTL, HARNESS FEED THRU STA 171.50 WL 32.43 PL 18.81 RH	1	35	
-131	AN737TW59	• • CLAMP	1	35	
-132	R2959	• • ROOT ASSY, <75345> SPEC R-06933-5 ATTACHING PARTS	1	35	
-133	NAS221-6	• • SCREW	4	35	
-134	AN967010L	• • WASHER	4	35	
	B-65035-815	• ROOT INSTL, HARNESS FEED THRU STA 217 WL 16.30 PL 20.43	1	35	
-135	AN737TW59	• • CLAMP	1	35	
-136	R2949	• • ROOT ASSY, <75345> SPEC R-06933-10 ATTACHING PARTS	1	35	
-137	NAS221-7	• • SCREW	4	35	
-138	AN967010L	• • WASHER	4	35	
	B-65035-817	• ROOT INSTL, HARNESS FEED THRU STA 216.50 WL 16.30 PL 16.13	1	35	
	B-65035-820	• ROOT INSTL, HARNESS FEED THRU STA 216.50 WL 21.45 PL 23.91	1	35	
-139	AN737TW74	• • CLAMP	1	35	
-140	R2959	• • ROOT ASSY, <75345> SPEC R-06933-3 ATTACHING PARTS	1	35	
-141	NAS221-7	• • SCREW	4	35	
-142	AN967010L	• • WASHER	4	35	
	B-65035-811	• ROOT INSTL, HARNESS FEED THRU STA 431 WL 2.60 PL 26.50	1	35	89
	B-65035-813	• ROOT INSTL, HARNESS FEED THRU STA 431 WL 2.60 PL 26.50	1	90	
	B-65035-817	• ROOT INSTL, HARNESS FEED THRU STA 431 WL 2.60 PL 30.70	1	35	99
	B-65035-821	• ROOT INSTL, HARNESS FEED THRU STA 431 WL 2.60 PL 30.70	1	90	
-143	AN737TW59	• • CLAMP	1	35	
-144	R2949	• • ROOT ASSY, <75345> SPEC R-06933-1	1	35	90
	R2959	• • ROOT ASSY, <75345> SPEC R-06933-3 ATTACHING PARTS	1	90	
-145	NAS221-12	• • SCREW	4	35	
-146	AN967010L	• • WASHER	4	35	
	B-65035-814	• ROOT INSTL, HARNESS FEED THRU STA 472.00 WL 2.60 PL 25.37	1	35	
-147	AN737TW59	• • CLAMP	1	35	
-148	R2949	• • ROOT ASSY, <75345> SPEC R-06933-1 ATTACHING PARTS	1	35	
-149	NAS221-8	• • SCREW	4	35	
-150	AN967010L	• • WASHER	4	35	

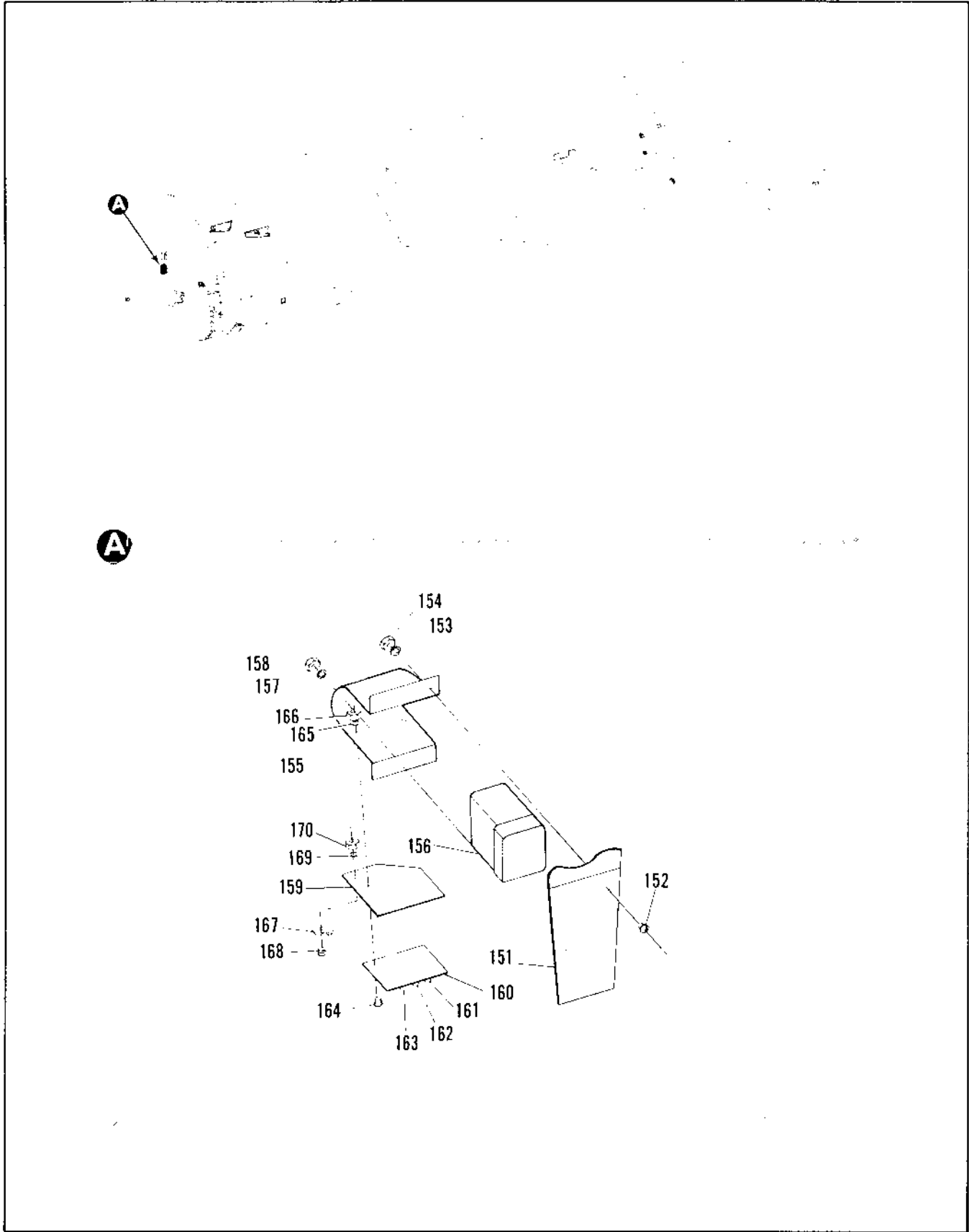

Figure 2.17-11. Electrical Power Distribution Equipment (Sheet 10 of 10)

FIGURE AND INDEX NUMBER	PART NUMBER	DESCRIPTION	UNITS PER ASSY.	USABLE ON CODE	
				FROM	TO
		1 2 3 4 5 6			
2.17-11	7841466-10	• BRACKET INSTALLATION, STATION 129 ATTACHING PARTS	1		
-151	R-95095-39	• FAIRING (14170)	1		
-152	MS27030-0206	• SCREW	4		
-153	AN967-4	• WASHER	4		
-154	MS21742-08	• NUT	4		
	7841466-30	• SUBASSEMBLY, BRACKET ATTACHING PARTS	1		
-155	7841471	• BRACKET (98750)	1		
-156	MS2591492	• RELAY	1		
-157	MS3533-137	• WASHER	3		
-158	NAS671-4	• NUT	3		
-159	7841467	• SPACER (98750)	1		
-160	7841468-10	• RESISTOR BOARD ASSY (98750)	1		
-161	RCR4201510S	• RESISTOR, 15K, 2W, MIL-R-11	1		
-162	RCR4201020S	• RESISTOR, 1K, 2W, MIL-R-11	1		
-163	RCR4200110S	• RESISTOR, 510, 2W, MIL-R-11	1		
-164	MS35206-216	• SCREW	4		
-165	MS3533-137	• WASHER	4		
-166	NAS671-4	• NUT	4		
-167	MS21919W06	• CLAMP, CUSHIONED	1		
-168	MS27739-1-15	• SCREW	1		
-169	AN967-10	• WASHER	1		
-170	MS21744-N3	• NUT	1		

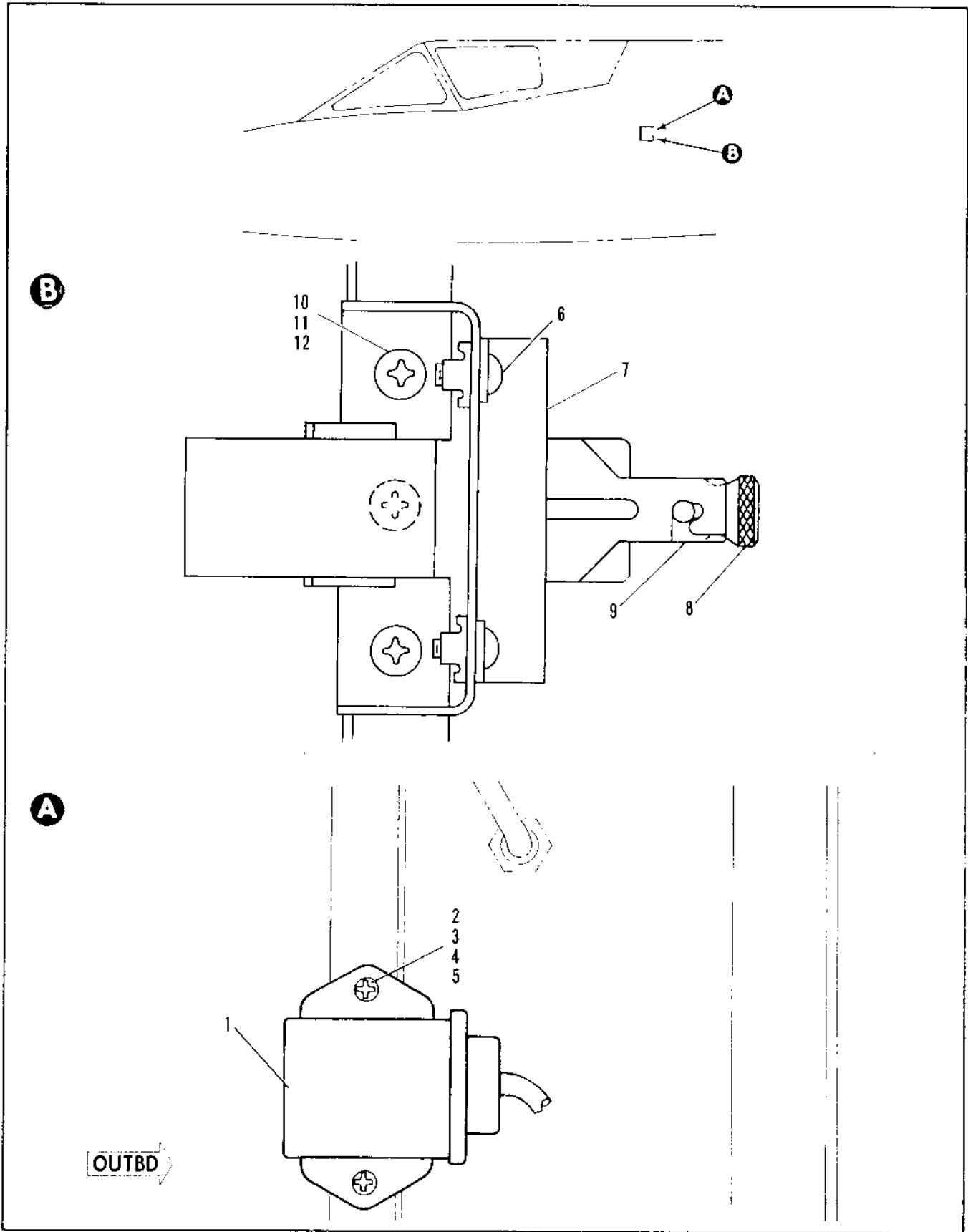

Figure 2.17-12. Gyro Cut-off Relay Sta 216.50

FIGURE AND INDEX NUMBER	PART NUMBER	DESCRIPTION 1 2 3 4 5 6	UNITS PER ASSY.	USABLE ON CODE	
				FROM	TO
2.17-12		RELAY INSTL. GYRO CUT OFF	1		
- 1	FP135-104V	• RELAY, GYRO CUT OFF	1	R	
- 2	MS35207-267	• • SCREW	2	R	
- 3	MS3533F-43	• • WASHER, LOCK	2	R	
- 4	AN960-10L	• • WASHER, FLAT	2	R	
- 5	MS20500-1032	• • NUT, HEX	2	V	
	7445609	• INSTL Dwg, GYRO CUT-OFF RELAY			
	7445599-10	• • BRACKET	1	V	
- 6	MS36207-262	• • SCREW	2	V	
- 7	M6106/3-001	• • TRACK	1	V	
- 8	M6106/2-001	• • RELAY	1	V	
- 9	M6106/5-001	• • BRACKET AND SOCKET	1	V	
- 10	MS35207-264	• • SCREW	3	V	
- 12	MS21044N3	• • • NUT	3	V	
		R ROUND INSTRUMENT			
		V VERTICAL INSTRUMENT			

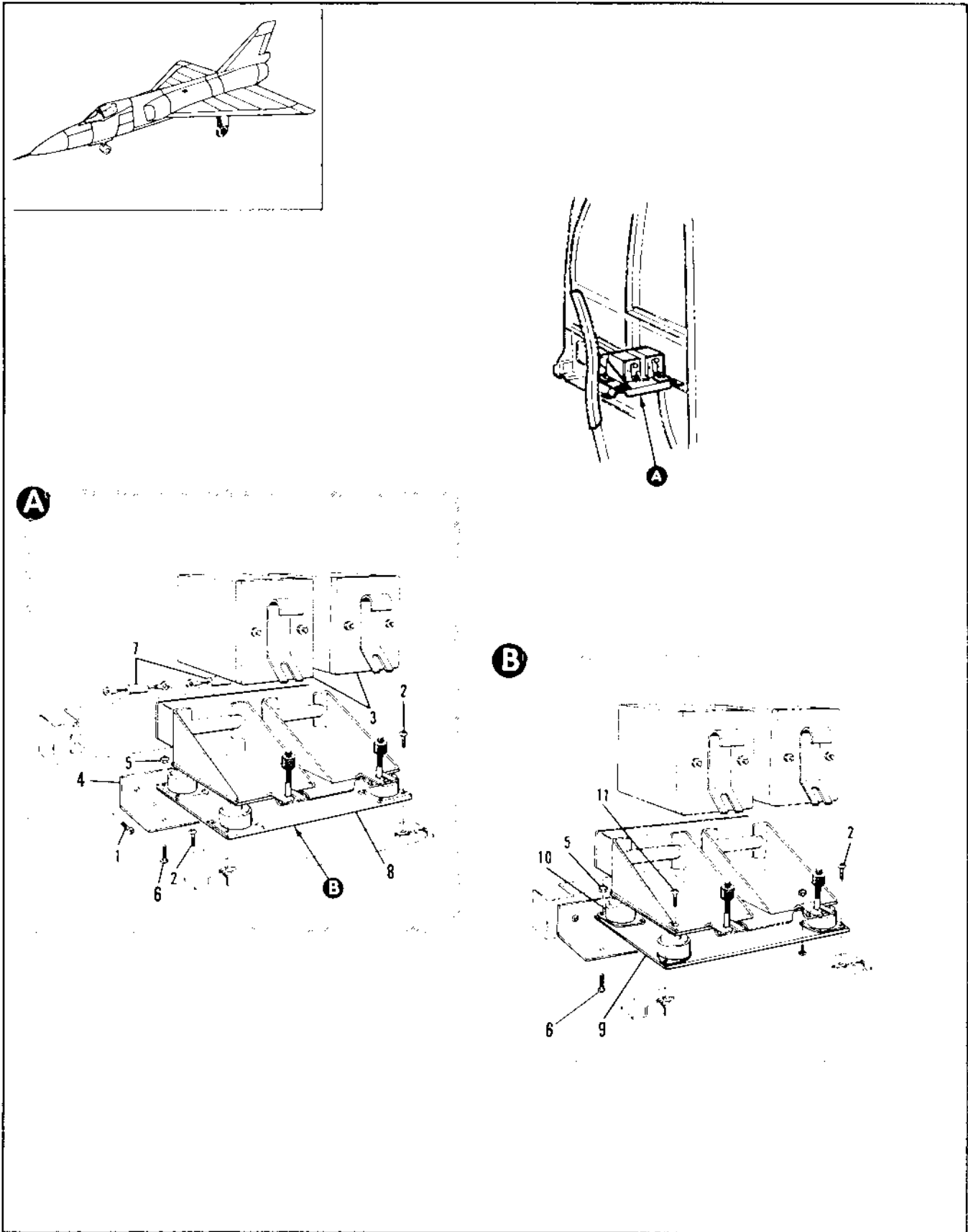

Figure 2.17-13. Fire and Overheat Control Detector Installation

FIGURE AND INDEX NUMBER	PART NUMBER	DESCRIPTION	UNITS PER ASSY.	USABLE ON CODE	
				FROM	TO
2.17-13	4-65286-1	DETECTOR INSTALLATION, FIRE AND OVERHEAT CONTROL MOD BY 7144647-10	RF		35
	4-65286-17	• DETECTOR ASSEMBLY ATTACHING PARTS	1		35
	- 1 AN515-1096	• SCREW	2		35
	- 2 AN515-686	• SCREW	2		35
		-----X-----			
	- 3 227-28-2	• • DETECTOR, <19500> 92-64232-001	1		35
	- 3 227-28-5	• • DETECTOR, <19500> 92-64232-001 ALT INTCHG WITH 227-28-2	RF		35
		• • DETECTOR ALT INTCHG WITH 227-28-5			
	- 4 227-28-5A	• • ANGLE	RF		35
	- 4 8-65286-11	• ATTACHING PARTS	1		35
	- 5 WAS979436	• • NUT, 36-37545-006	2		35
- 6 AN515-1096	• • SCREW	4		35	
	-----X-----				
- 7 41250-100	• • RESISTOR, <80099> 97-47070-001	2		35	
- 8 41262-2	• • PACK, <19500> 97-19702-002	1		35	
- 8 41484-1	• • PACK, <19500> 97-19702-02 ALT NOT INTCHG WITH 41262-2. NOTE: DETECTOR 227-28-5A REQUIRED FOR USE WITH 41484-2	1		35	
- 9 7144755-10	• • PACK, REWORK OF 41484-2	1			
- 10 7224P1	• • ISOLATOR, (13636) ATTACHING PARTS	4			
- 11 MS51957-45E	• • SCREW	4			
	MS35138-137	• • WASHER, LOCK	4		
		-----X-----			
		1 REMOVE PER TOTO 1F-106A-59 FROM AIRPLANES #98, 90 AND ON			
		2 ADDED PER TOTO 1F-106A-58 ON AIRPLANES #98, 90 AND ON			

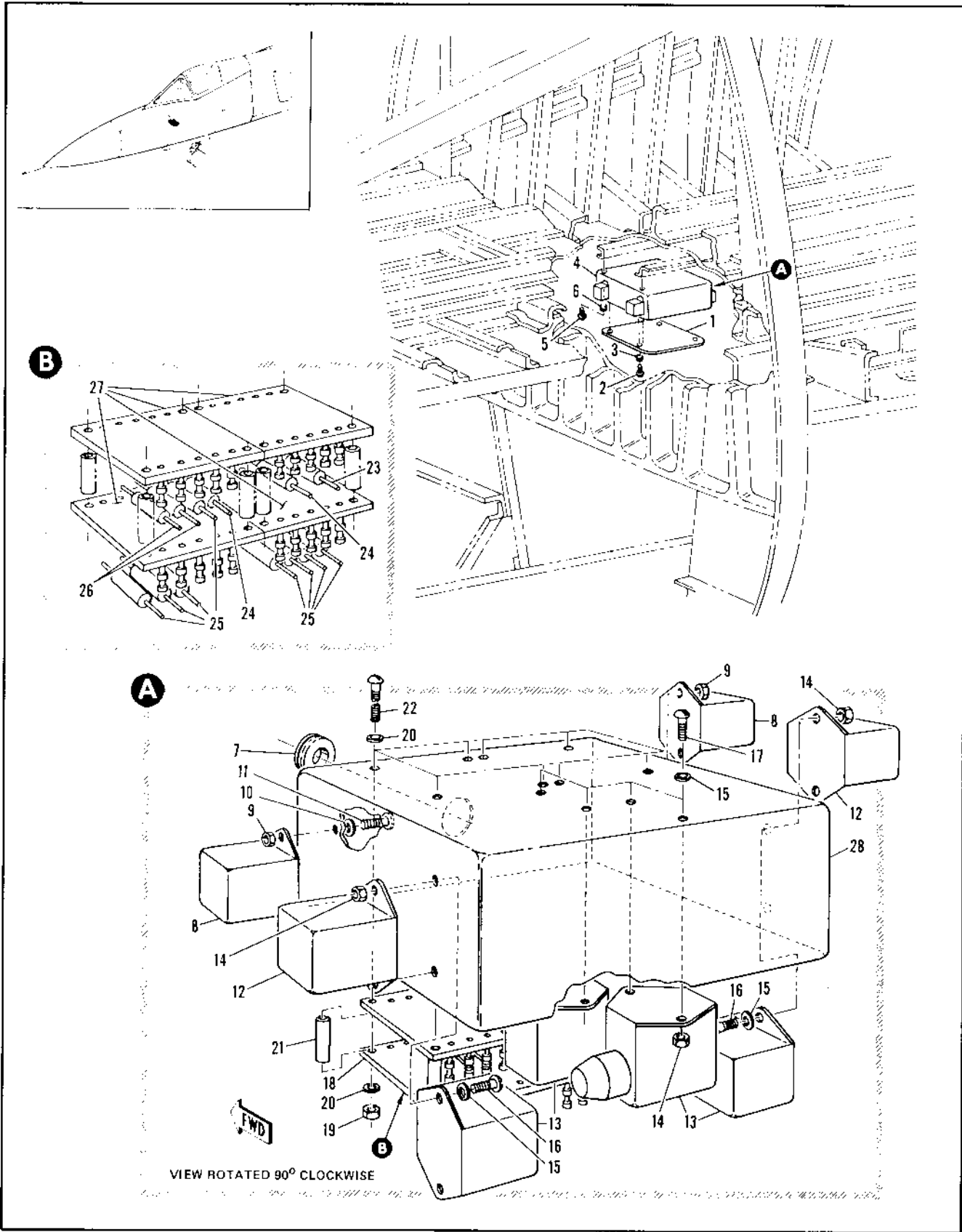

Figure 2.17-14. Warning Light Dimming Box Installation

FIGURE AND INDEX NUMBER	PART NUMBER	DESCRIPTION	UNITS PER ASSY.	USABLE ON CODE	
				FROM	TO
2.17-14	R-65063-3	BOX INSTALLATION, WARNING LIGHT DIMMING MODIFIED BY R-6135*	1	35	
- 1	R-65061-19	• COVER, MOUNTING BOX REPLACES NOT INTCHG WITH R-65061-9 ATTACHING PARTS	1	35	
- 2	AN520-10P7	• SCREW	4	35	
- 3	AN960010L	• WASHER	4	35	
- 4	R-65062-203 R-65062-205	• BOX ASSY, WARNING LIGHT DIMMING • BOX ASSY, WARNING LIGHT DIMMING ATTACHING PARTS	1 1	35 90	89
- 5	AN521-10P7	• SCREW	4	35	
- 6	AN960010L	• WASHER	4	35	
- 7	S11154-10BY	• GROMMET, <97820> 84-35006-017	1	35	
- 8	9220-3435	• RELAY, <35344> SPEC R-06289-3 ATTACHING PARTS	2	35	
- 9	NAS679A3	• NUT	4	35	
- 10	AN960010L	• WASHER	4	35	
- 11	AN521-10P7	• SCREW	4	35	
- 12	9220-3435	• RELAY, <35344> SPEC R-06289-3	2	35	
- 13	9220-3435	• RELAY, <35344> SPEC R-06289-3 ATTACHING PARTS	4	35	
- 14	NAS679A3	• NUT	8	35	
- 15	AN960010L	• WASHER	4	35	
- 16	AN521-10P7	• SCREW	4	35	
- 17	AN520-10P7	• SCREW	4	35	
- 18	R-65062-27 R-65062-21	• RESISTOR ASSEMBLY • RESISTOR ASSEMBLY ATTACHING PARTS	1	90	
- 19	NAS679A06	• NUT, 96-37545-006	8	35	
- 20	AN960010L	• WASHER	16	35	
- 21	9A-20806-018	• SPACER	8	35	
- 22	AN51-06424	• SCREW	8	35	
- 23	RW550291	• RESISTOR, 97-47065-002	1	35	
- 24	RW550131	• RESISTOR, 97-47046-005	2	35	
- 25	RW550131	• RESISTOR, REPLACES RW550131	PF	35	
- 26	RW550561	• L RESISTOR, 97-47065-001	8	35	
- 26	RW550561	• RESISTOR, 97-47065-001	2	35	
- 27	R-65062-25 Y140103732	• TERMINAL BOARD, MAKE FROM X140103732 • TERMINAL BOARD, <71079> 98-91711-002	4	35	
- 28	R-65061-1	• BOX ASSY, MOUNTING RIVETED REPLACES NOT INTCHG WITH R-65061	1	35	
- 29	R-65061-17	• BOX, REPLACES NOT INTCHG WITH R-65061-7	1	35	

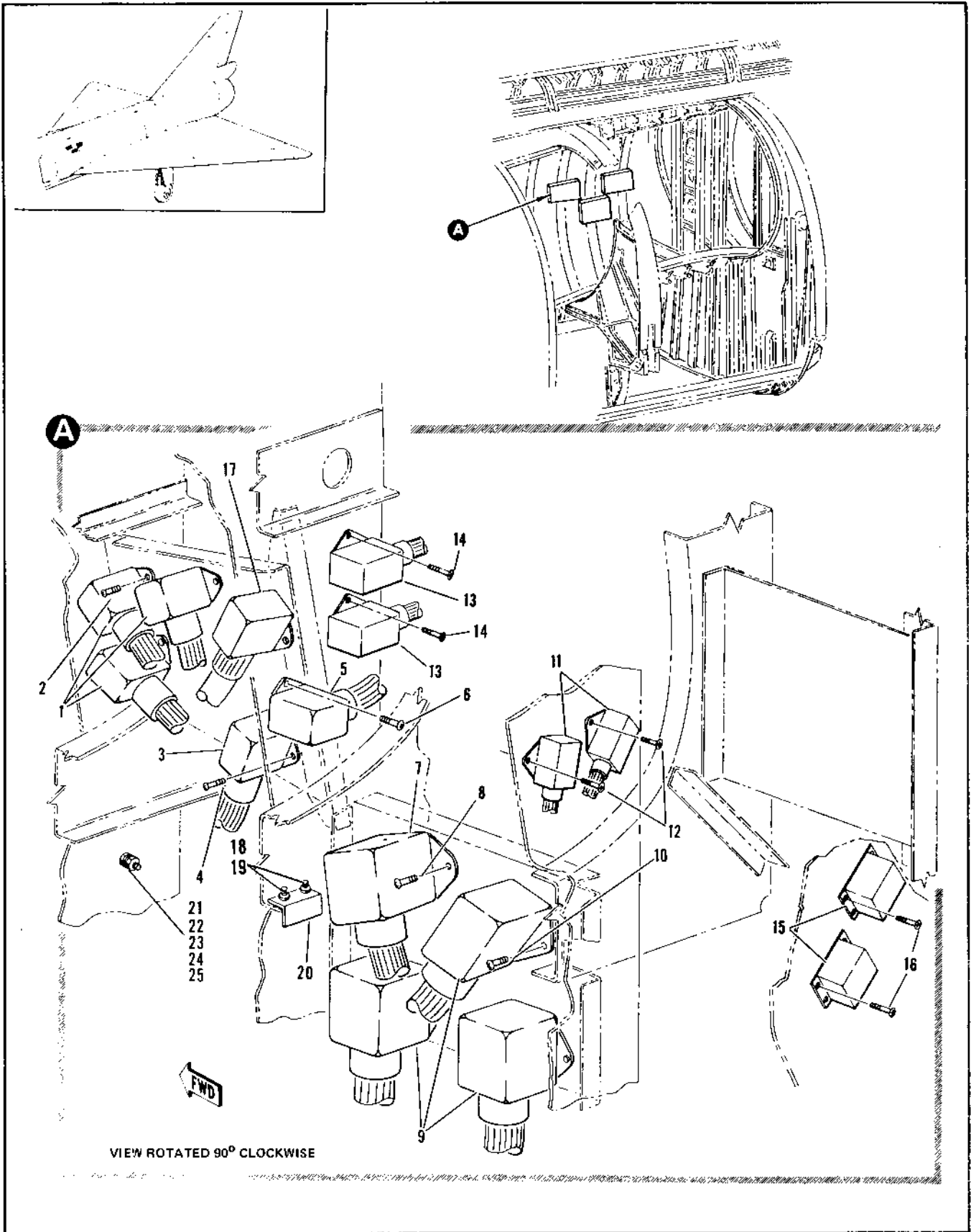

Figure 2.17-15. Relay Installation Sta 371 to 391

FIGURE AND INDEX NUMBER	PART NUMBER	DESCRIPTION	UNITS PER ASSY.	USABLE ON CODE	
				FROM	TO
1.17-15	8-65175	RELAY INSTALLATION, STA 371 TO 351 MODIFIED BY 48075-53	1	35	
- 1	7242451-10 8220-3433	RELAY INSTL, STA 370.70 TO STA 377.50 • RELAY, AC EXTERNAL POWER INTERLOCK AC EMERGENCY CONTROL AND DC EXTERNAL POWER INTERLOCK < > SPEC 8-14289 ATTACHING PARTS	3	35	
- 2	AN521-1097	• SCREW -----X-----	6	35	
- 3	8220-3433	• RELAY, MAIN WHEEL WELL DOOR CLOSE <35344> SPEC 8-26289-3 ATTACHING PARTS	1	35	
- 4	AN521-1097	• SCREW -----X-----	2	35	
- 5	4220-3433	• RELAY, AC EMERGENCY POWER DISCONNECT <35344> SPEC 8-26289-3 ATTACHING PARTS	1	35	
- 6	AN521-1097	• SCREW -----X-----	2	35	
- 7	9230-3434	• RELAY, EXTERNAL FULL TASK EJECTION <35344> SPEC 8-26289-1 ATTACHING PARTS	1	35	
- 8	AN521-1097	• SCREW -----X-----	2	35	
- 9	8230-3434	• RELAY, IGNITION ARMING ANTI-ICE CONTROL AND IGNITION <35344> SPEC 8-26289-1 ATTACHING PARTS	3	75	
- 10	AN521-1097	• SCREW -----X-----	6	35	
- 11	4220-3433	• RELAY, FIRE AND OVERHEAT DETECTOR TEST <35344> SPEC 8-26289-3 ATTACHING PARTS	2	35	
- 12	AN521-1097	• SCREW -----X-----	4	35	
- 13	8220-3433	• RELAY, MAIN WHEEL WELL DOOR CLOSE AND HYDRAULIC FLASHER RESET <35344> SPEC 8-26289-3 ATTACHING PARTS	2	35	
- 14	AN521-1097	• SCREW -----X-----	4	35	
- 15	4113-1R	• FLASHER, FIRE DETECTOR AND OVERHEAT AND HYDRAULIC PRESSURE WARNING <37994> SPEC 1-74517-0 T.O. 101-1-19-3	2	35	
- 16	1198-01	• FLASHER, WARNING (72110) ALTERNATE WITH 4113-1R ATTACHING PARTS	1	35	
- 17	AN521-1097	• SCREW -----X-----	6	35	
- 18	8220-3433	• RELAY <35344> ATTACHING PARTS	1		
- 19	AN521-1097	• SCREW -----X-----	1		
- 20	141391 AN971-410 H303-503-1	• RECTIFIER • WASHER • BRACKET ASSY PIVOTED ATTACHING PARTS	2 2 1		
- 21	AN521-1097	• SCREW -----X-----	2		
- 22	AN741-1F	• NUT, GROUND STUD	2		
- 23	AN931-10	• WASHER, GROUND STUD	2		
- 24	AN961-13L	• WASHER, GROUND STUD	2		
- 25	AN967-0101	• WASHER, GROUND STUD	2		
- 26	AN521-1097	• SCREW, GROUND STUD	1		

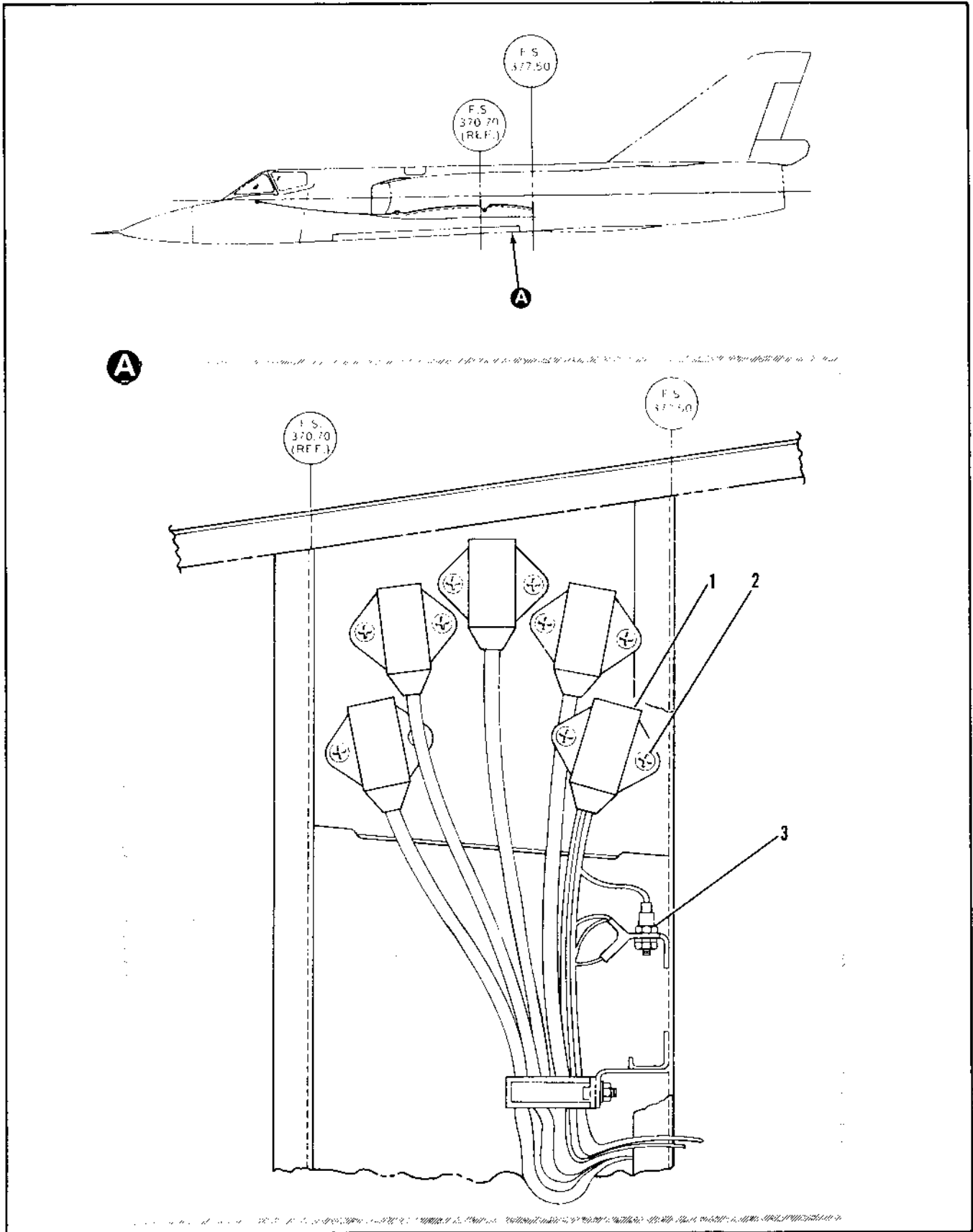

Figure 2.17-16. Relay Installation 370.70 to 377.50

FIGURE AND INDEX NUMBER	PART NUMBER	DESCRIPTION	UNITS PER ASSY.	USABLE ON CODE	
				FROM	TO
2.17-16	7R39379-10	RELAY INSTL STA 370.7 TO 377.5			
- 1	R-06289-3	• RELAY, RAILS NOT UP AND LOCKED	1	A	
- 2	MS35207-262	• • SCREW	2	A	
- 3	1N1614R	• DIODE ASSEMBLY	2	A	

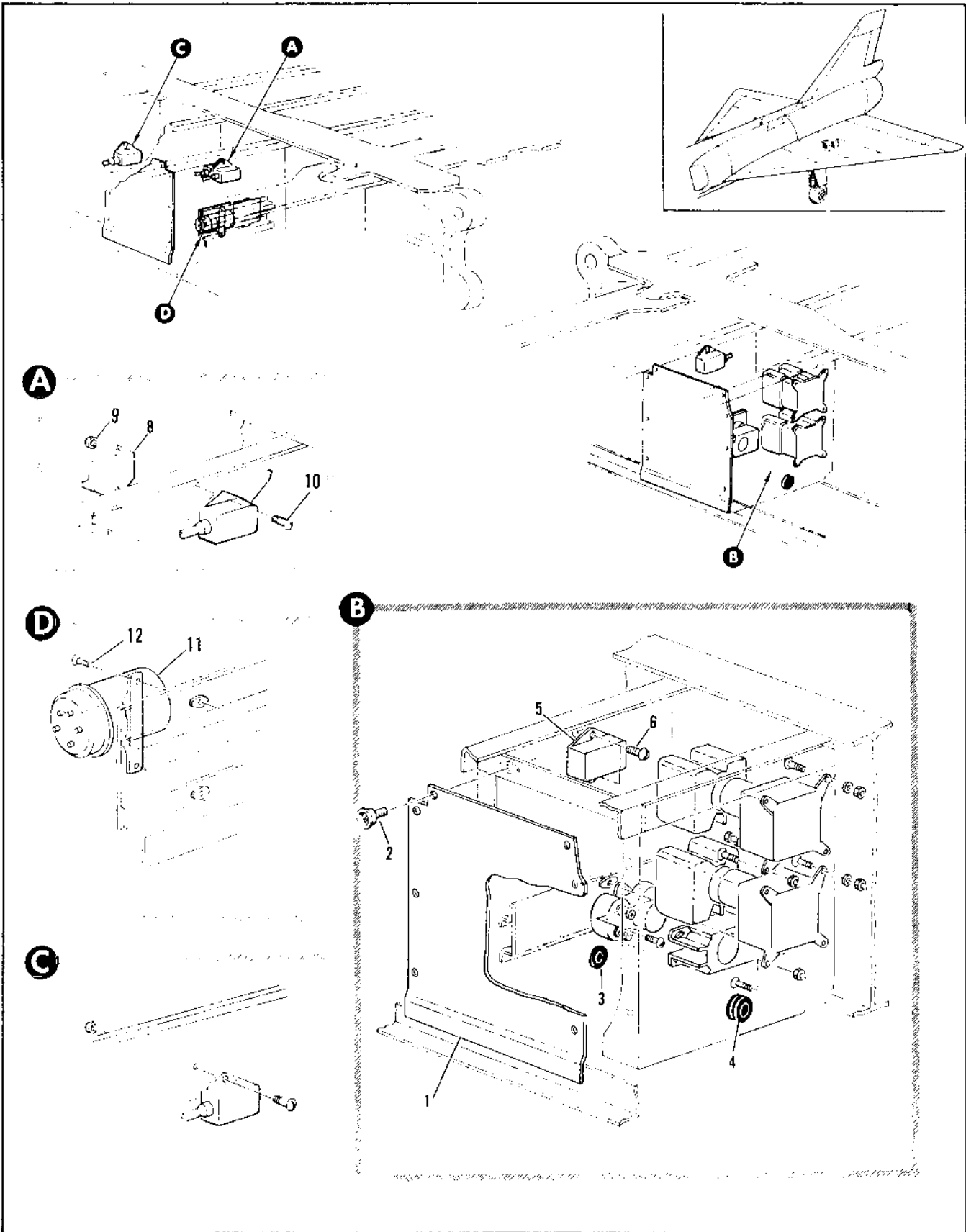

Figure 2.17-17. Fuel Boost Pump and Miscellaneous Relay Installation (Sheet 1 of 2)

FIGURE AND INDEX NUMBER	PART NUMBER	DESCRIPTION	UNITS PER ASSY.	USABLE ON CODE		
				FROM	TO	
2.17-17	B-65147-R17	RELAY INSTALLATION, FUEL BOOST PUMP AND MISCELLANEOUS LH MODIFIED BY 8-61405	PF	A		
	B-65147-R25	RELAY INSTALLATION, FUEL BOOST PUMP AND MISCELLANEOUS LH	RF	44	129	
	B-65147-R27	RELAY INSTALLATION, FUEL BOOST PUMP AND MISCELLANEOUS LH	RF	130	277	
	B-65147-R05	RELAY INSTALLATION, FUEL BOOST PUMP AND MISCELLANEOUS LH MODIFIED BY 8-61405	RF	278	303	
	B-65147-R18	RELAY INSTALLATION, FUEL BOOST PUMP AND MISCELLANEOUS RH MODIFIED BY 8-61405	RF	A		
	B-65147-R26	RELAY INSTALLATION, FUEL BOOST PUMP AND MISCELLANEOUS RH	RF	44	277	
	B-65047-R07	RELAY INSTALLATION, FUEL BOOST PUMP AND MISCELLANEOUS RH MODIFIED BY 8-61405	RF	278	303	
	B-65147-R29	RELAY INSTALLATION, FUEL BOOST PUMP AND MISCELLANEOUS RH	PF	197	277	
	- 1	B-65257-1	• COVER, LH REPLACES NOT INTCHG WITH 3-65291-1	1	35	43
		B-65291-1	• COVER, LH REPLACES NOT INTCHG WITH 3-65257-1	1	44	
		B-65257-2	• COVER, RH REPLACES BY NOT INTCHG WITH 3-65291-2	1	35	43
		B-65291-2	• COVER, RH REPLACES NOT INTCHG WITH 3-65257-2	1	44	
- 2	AN227-1096 AN227-1096	• STUD • STUD	8 6	35 44	43	
- 3	R1501E18-1	• GROMMET, <94903> 94-35001-002	1	35		
- 4	R1501E10-1	• GROMMET, <94903> 94-35001-000	1	44		
- 5	9203-3435	• RELAY, FUEL SCAVENGE LH <35344> SPEC 3-35289-3	1	35		
- 6	AN520-1096	• SCREW, LH	2	35		
- 7	9233-3434	• RELAY, FUEL SCAVENGE INHD RH <35344> SPEC 3-35289-1	1	35		
- 8	9233-3434	• RELAY, FUEL SCAVENGE OUTHD RH <35344> SPEC 3-35289-2	1	35		
- 9	NAS675A3	• NUT, RH	2	35		
- 10	AN520-1096	• SCREW, RH	2	35		
- 11	64-549	• RELAY, AFTERBURNER CONT RH <34261> SPEC 3-63756	1	35		
- 12	AN520-1096	• SCREW, RH	2	35		

A AIRPLANES 170 THRU 43, 574, AND 305
 B AIRPLANES 435 THRU 43, 074 AND ON

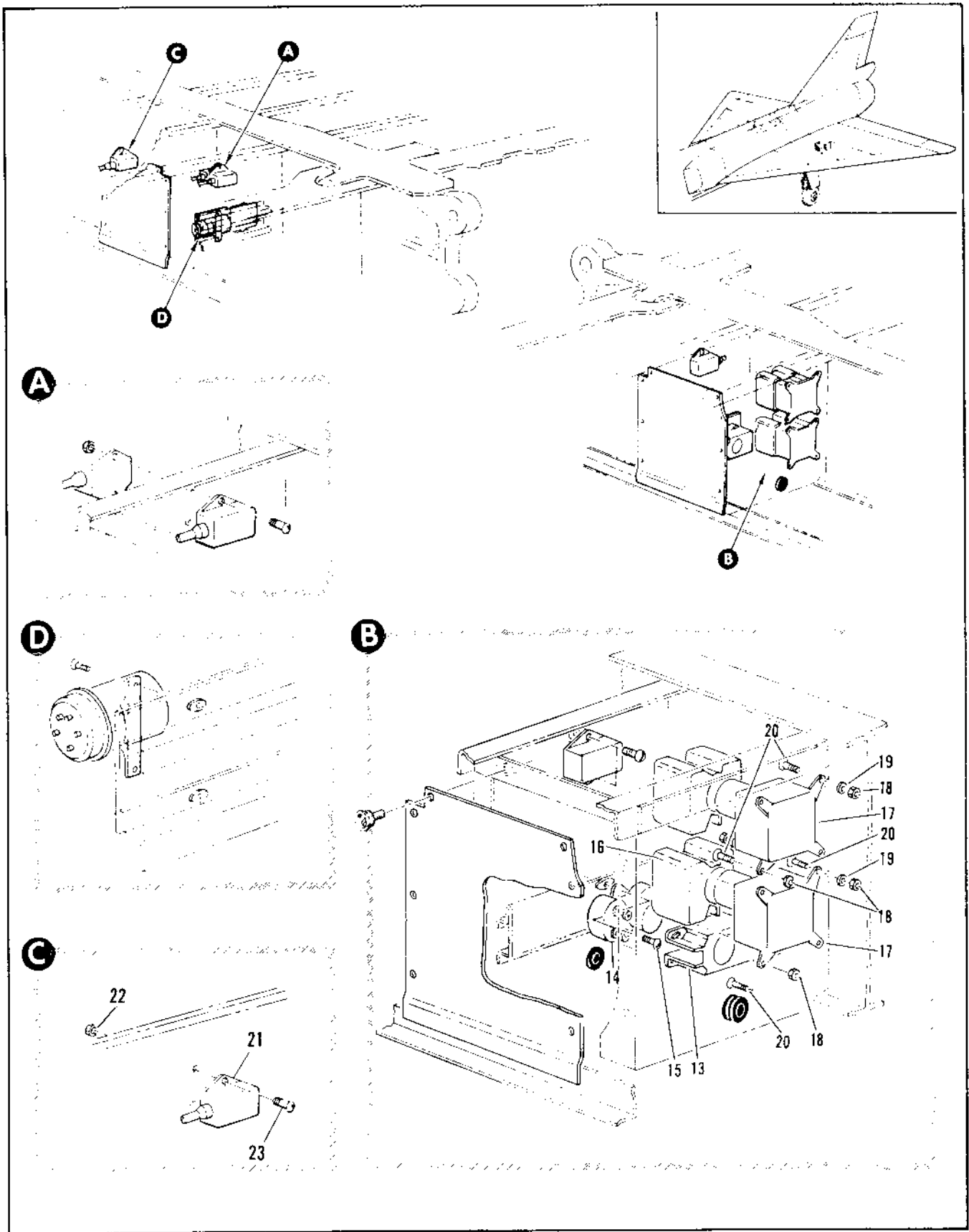

Figure 2.17-17. Fuel Boost Pump and Miscellaneous Relay Installation (Sheet 2 of 2)

FIGURE AND INDEX NUMBER	PART NUMBER	DESCRIPTION	UNITS PER ASSY.	USABLE ON CODE	
				FROM	TO
		1 2 3 4 5 6			
2.17-17- 13	49-2457-0	• COVER, TERMINAL <15605> 92-74400-001	1	35	
- 14	MS2414302	• RELAY, LANDING LIGHT ATTACHING PARTS	1	35	
- 15	AN521-14RB	• SCREW -----X-----	2	35	
- 16	49-2461-2	• COVER, TERMINAL <15605> 92-74400-002	2	35	
- 17	MS24143-1	• RELAY, FUEL BOOST PUMP ATTACHING PARTS	2	35	
- 18	NAS679A3	• NUT	8	35	
- 19	AN9510P10	• WASHER	4	35	
- 20	AN520-17P10	• SCREW -----X-----	8	35	
- 21	9220-3433	• RELAY, <35244> SPEC R-06289 ATTACHING PARTS	1	197	277
- 22	AN363-1032	• NUT	2	197	277
- 23	AN520-10R6	• SCREW -----X-----	2	197	277

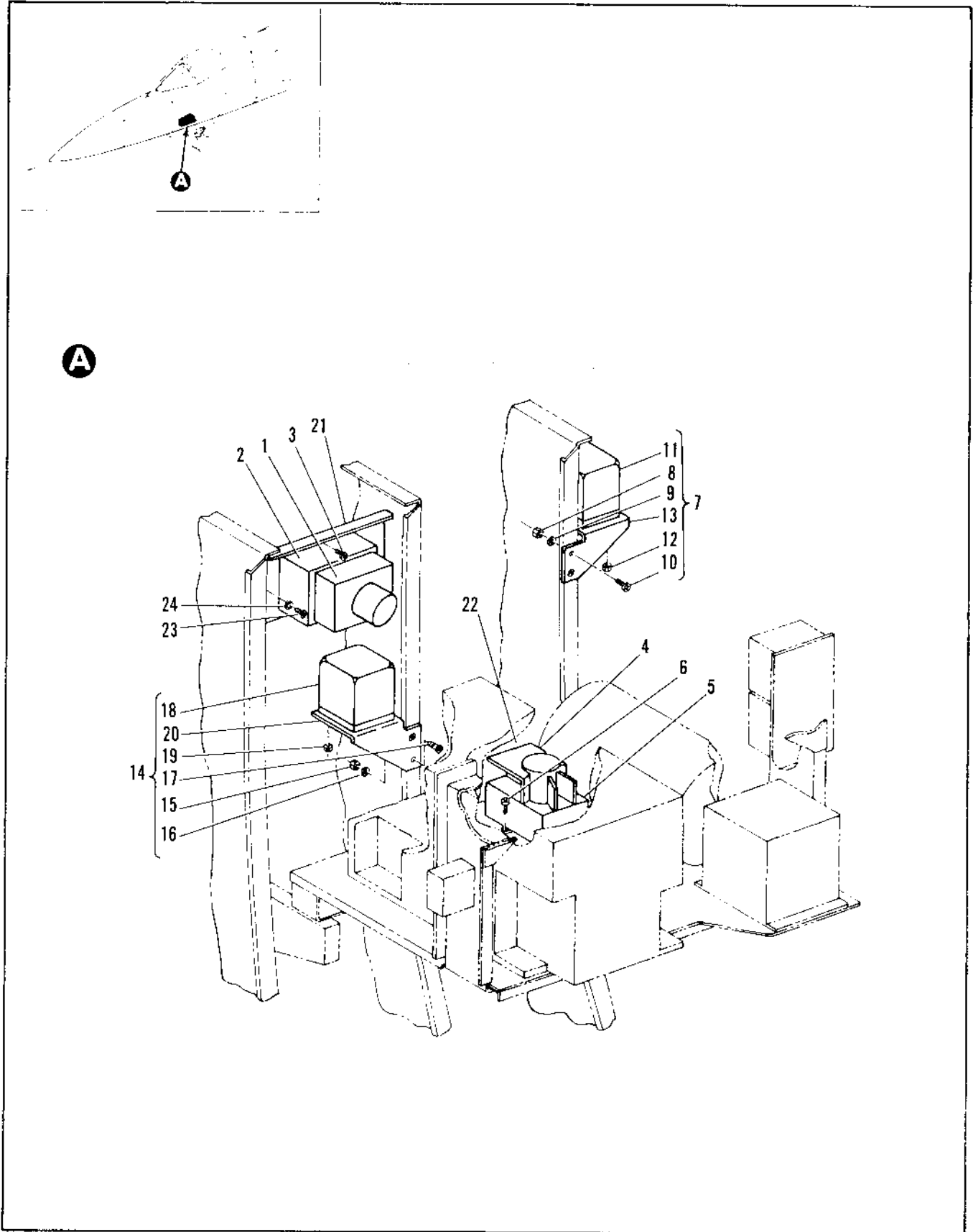

Figure 2.17-18. Relay Installation RH NWW Sta 113.76 to 126.72

FIGURE AND INDEX NUMBER	PART NUMBER	DESCRIPTION	UNITS PER ASSY.	USABLE ON CODE	
				FROM	TO
		1 2 3 4 5 6			
2.17-18	7243022-10	RELAY INSTL. 9R MWV STA 113.74 TO STA 126.72	1	A	
	7242491-10	RELAY INSTL. 9R MWV STA 113.74 TO STA 126.72	1	A	
	F-65256	RELAY INSTL. DC BUSS TIE NON ESSENTIAL	1	35	
- 1	49-2667-2	COVER (49-25) 92-74400-011	1	35	
		GFAC AF INSTALLED			
- 2	MS2414002	RELAY GFAC AF INSTALLED	1	35	
		ATTACHING PARTS			
- 3	MS35207-264	SCREW	2	35	
		-----X-----			
- 4	MS27043-3	COVER	1	35	
- 4	MS2414001	RELAY	1	35	
		ATTACHING PARTS			
- 5	MS35207-264	SCREW	2	35	
		-----X-----			
- 7	7243123-10	RELAY ASSY	1	A	
		ATTACHING PARTS			
- 8	MS21042-08	NUT	2	A	
- 9	AN960-81	WASHER	2	A	
- 10	MS27039-0600	SCREW	2	A	
		-----X-----			
- 11	4230-3502	RELAY (35344) GFAC AF INSTALLED	1	A	
		ATTACHING PARTS			
- 12	MS21043-16	NUT	4	A	
		-----X-----			
- 13	7243024-01	BRACKET	1	A	
- 14	7243017-10	RELAY ASSY	1	B	
		ATTACHING PARTS			
- 15	MS21042-08	NUT	2	B	
- 16	AN960-81	WASHER	2	B	
- 17	MS27039-0600	SCREW	2	B	
		-----X-----			
- 18	4230-3502	RELAY (35344) GFAC AF INSTALLED	1	B	
		ATTACHING PARTS			
- 19	MS21043-16	NUT	4	B	
		-----X-----			
- 20	7242492-10	BRACKET	1	B	
- 21	7242494-10	BRACKET ASSY, RELAY MTG STA 113.74 - STA 120.84	1	35	
- 22	7242495-10	BRACKET ASSY, RELAY MTG STA 120.84 - STA 126.72	1	35	
		ATTACHING PARTS			
- 23	MS35207-262	SCREW	3	35	
- 24	AN960-10L	WASHER	3	35	
		-----X-----			
		A AIRPLANES #19 THRU 47 AND 49 THRU 89			
		B AIRPLANES #48 AND 51 AND ON			

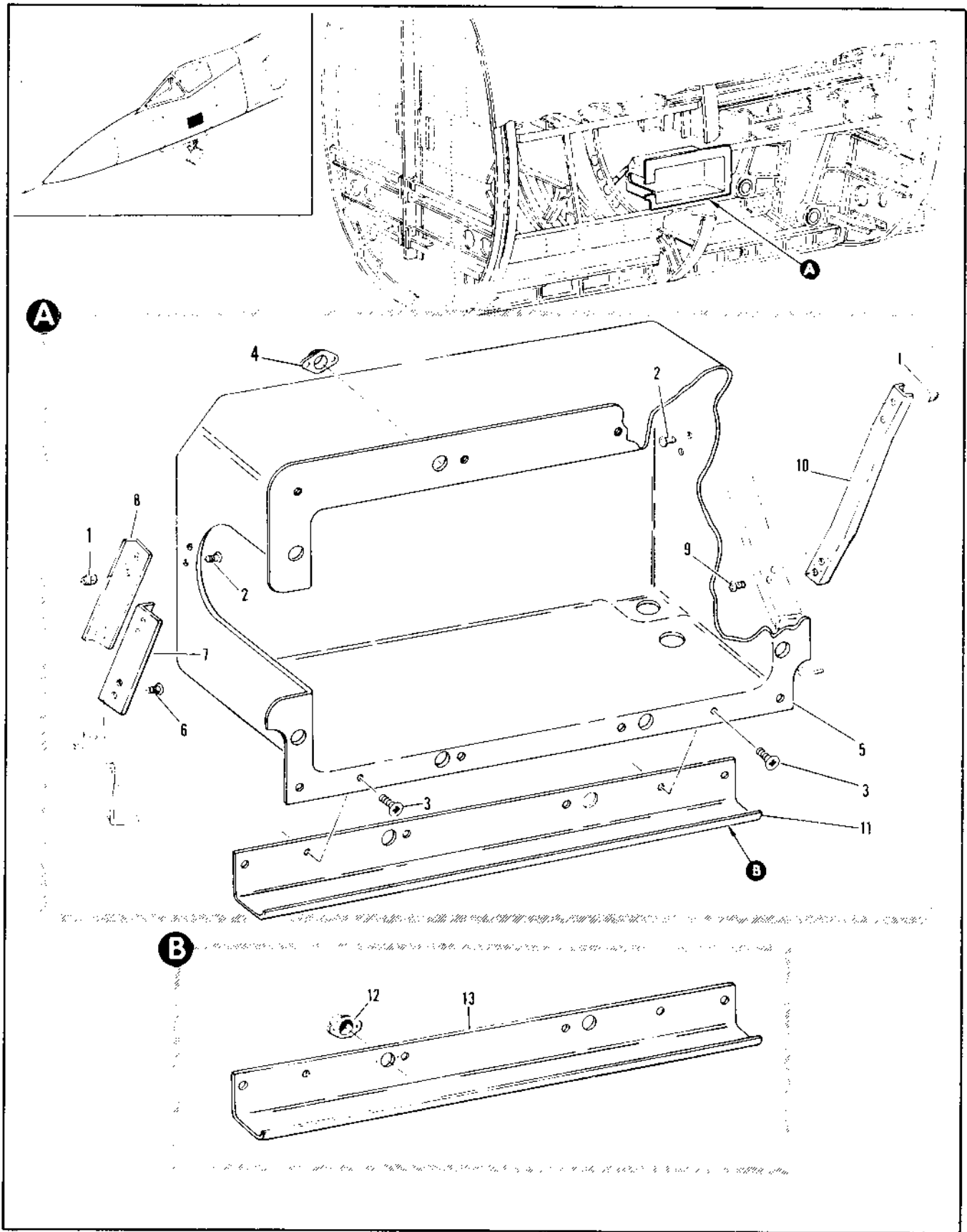

Figure 2.17-19. Nose Wheel Well Fuse Box Installation

FIGURE AND INDEX NUMBER	PART NUMBER	DESCRIPTION	UNITS PER ASSY.	USABLE ON CODE		
				FROM	TO	
2.17-19	8-65021-01	BOX INSTALLATION, NOS1 WHEEL WELL FUSE	1	35		
	8-65022-01	• BOX ASSY, FUSE PANEL	1	35		
		ATTACHING PARTS				
	- 1	NAS579A*	• NUT	4	35	
	- 2	AN503-10R6	• SCREW	4	35	
	- 3	AN507-10R7	• SCREW	2	35	
		-----X-----				
	- 4	212-12	• FASTENER, RECEPTACLE <71281> 97-31002-001	6	35	
	- 5	8-65022-25	• BOX	1	35	
		8-65021-27	• SUPPORT ASSY, BOX FWD	1	35	
			ATTACHING PARTS			
	- 6	AN520-10R6	• SCREW	2	35	
		-----X-----				
	- 7	8-65021-29	• SUPPORT	1	35	
	- 8	8-65021-31	• SUPPORT	1	35	
	8-65021-03	• SUPPORT ASSY, BOX AFT	1	35		
		ATTACHING PARTS				
- 9	AN520-10R6	• SCREW	2	35		
	-----X-----					
- 10	8-65021-25	• SUPPORT	1	35		
- 11	8-65021-13	• SUPPORT ASSY, FUSE PANEL	1	35		
- 12	212-12	• FASTENER, RECEPTACLE <71281> 97-31002-001	2	35		
- 13	8-65021-7	• ANGLE	1	35		

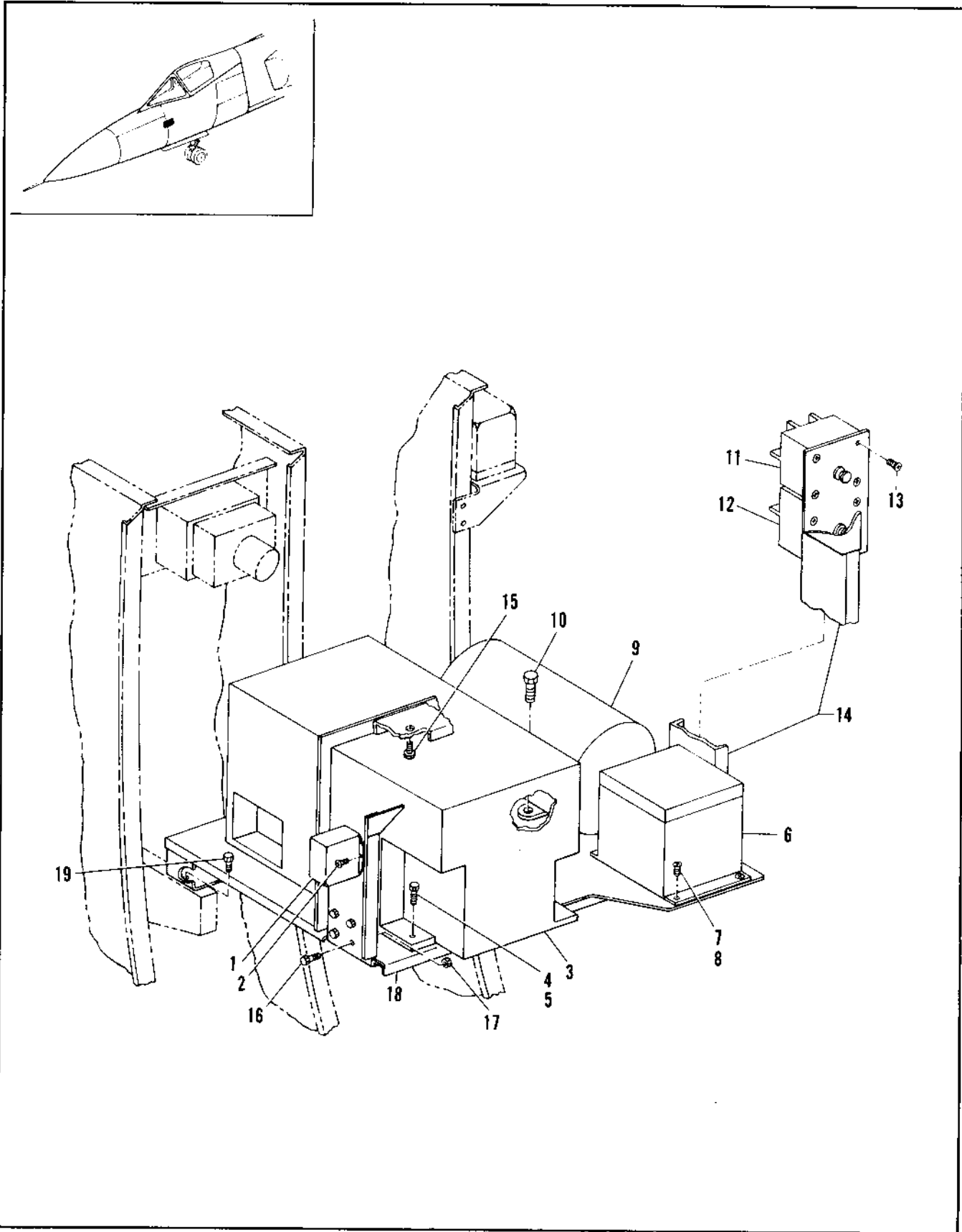

Figure 2.17-20. Equipment Installation RH Upper NWW

FIGURE AND INDEX NUMBER	PART NUMBER	DESCRIPTION 1 2 3 4 5 6	UNITS PER ASSY.	USABLE ON CODE	
				FROM	TO
2.17-20	7243034-1B	EQUIPMENT INSTL. RH UPPER NOSE WHEEL WELL	1	35	
	- 1 9220-3435	• RELAY (35344) SPEC 8-05289-3 GFAE AF INSTALLED	1	35	
	- 2 MS35207-262	ATTACHING PARTS • SCREW	2	35	
	- 3 MS28132-2	• CONVERTER, 200A XFMR-RECT	1	35	
	- 4 AN4-7A	ATTACHING PARTS • BOLT	3	35	
	- 5 AN4-10A	• BOLT	1	35	
	- 6 MS2722101	• CONTRACTOR, BATTERY GFAE AF INSTALLED	1	35	
	- 7 MS35207-262	ATTACHING PARTS • SCREW	3	35	
	- 8 MS35207-264	• SCREW	1	35	
	- 9 MS18103-1	• CONVERTER, 50A EMER XFMR-RECT GFAE AF INSTALLED	1		35
	- 10 AN3-4A	ATTACHING PARTS • BOLT	4	35	
	- 11 MS21984-5	• CIRCUIT BREAKER	1	35	
	- 12 MS21984-25	• CIRCUIT BREAKER	1	35	
	- 13 MS35206-22H	ATTACHING PARTS • SCREW	8	35	
	- 14 7243035-1G	• SUPPORT ASSY, UPPER SHFLF	1	35	
	- 15 AN4-11A	ATTACHING PARTS • BOLT	2	35	
	- 16 AN3-4A	• BOLT	8	35	
	- 17 MS21043-3	• NUT	4	35	
	- 18 7243036-1C	• SHELF ASSY	1	35	
- 19 AN3-4A	ATTACHING PARTS • BOLT	3	35		

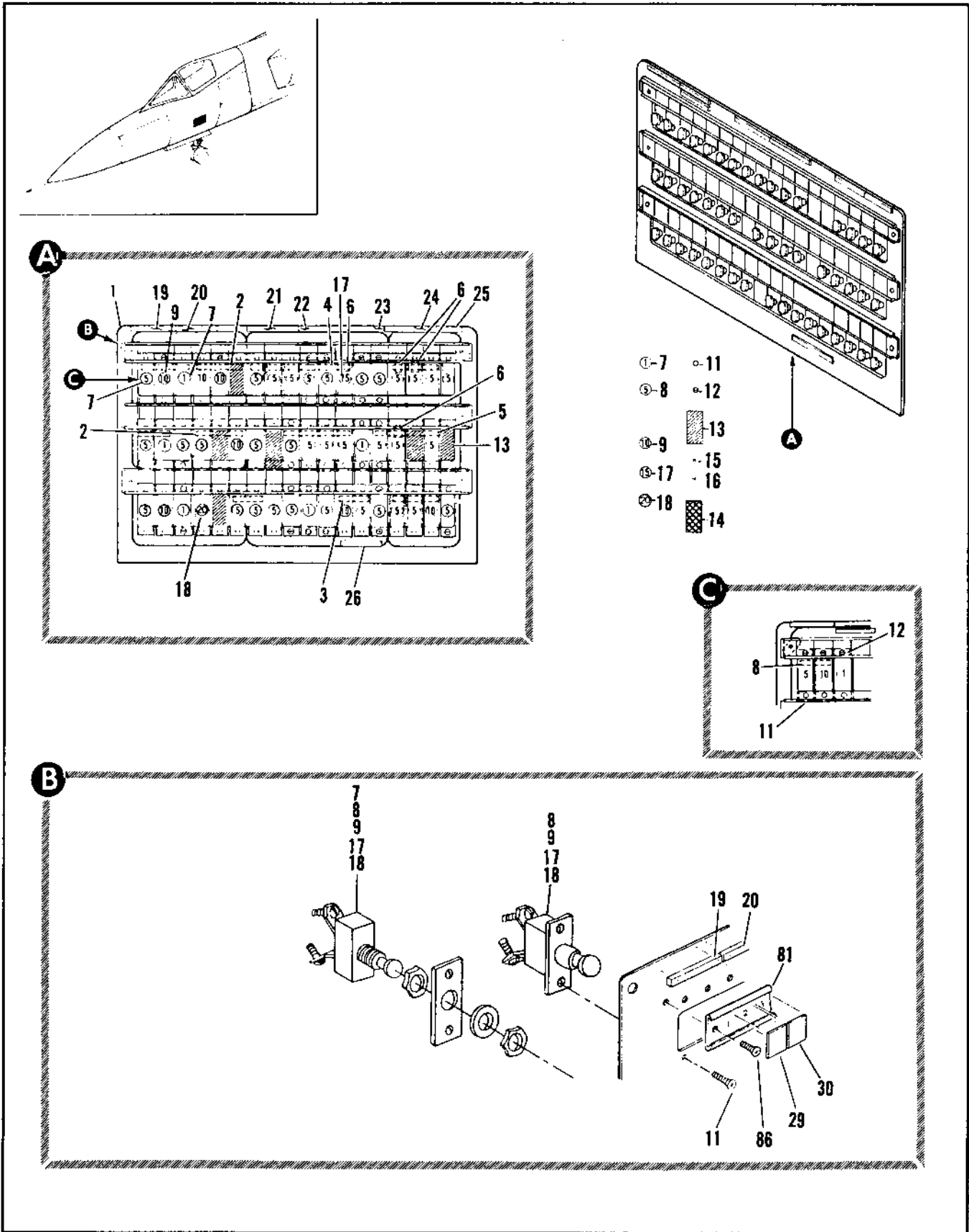
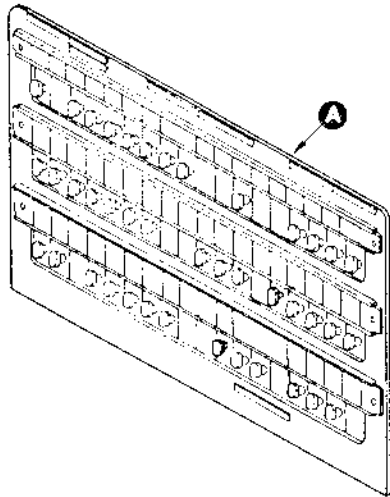

Figure 2.17-21. Nose Wheel Well Circuit Breaker Panel Assembly (Sheet 1 of 3)

FIGURE AND INDEX NUMBER	PART NUMBER	DESCRIPTION	UNITS PER ASSY	USABLE ON CODE		
				FROM	TO	
2.17-21- 1	7242866-10	PANEL ASSEMBLY, NOSE-WHEEL WELL CIRCUIT BREAKER		35	3	
	7242866-30	PANEL ASSEMBLY, NOSE-WHEEL WELL CIRCUIT BREAKER		39	47	
	7242866-50	PANEL ASSEMBLY, NOSE-WHEEL WELL CIRCUIT BREAKER		49	61	
	7242866-70	PANEL ASSEMBLY, NOSE-WHEEL WELL CIRCUIT BREAKER		61	89	
- 2	8-65029-9	• BUSBAR	2	A		
- 3	865029-7	• BUSBAR		A		
- 4	8-65029-13	• BUSBAR		A		
- 5	8-65029-11	• BUSBAR	3	A		
- 6	8-62375-11	• BUSBAR ASSEMBLY	4	A		
	NAS679A08	• NUT	1	A		
	AN960-8L	• WASHER	1	A		
	AN936B8	• WASHER	1	A		
	AN935-8L	• WASHER	1	A		
	AN515-8R8	• SCREW	1	A		
	8-65029-41	• BUSHBAR	1	A		
	4001-001-1	• CIRCUIT BREAKER	4	A		
	7747307	• PLATE, MOUNTING	4	A		
	- 8	D7271-3-5	• CIRCUIT BREAKER (82647)	34	A	
		7271-8-5	• CIRCUIT BREAKER, ALT. INTERCHG WITH 7271-3-5			
		7747307	• PLATE, MOUNTING	34		
	- 9	D7271-3-10	• CIRCUIT BREAKER (82647)	14		
		7271-8-10	• CIRCUIT BREAKER ALT INTCHG WITH D7271-3-10 (82647)			
	7747307	• PLATE, MOUNTING	14			
- 10	DELETED					
- 11	MS35206-230	• SCREW	68	A		
- 12	MS35206-230	• SCREW	32	A		
	AN960-6L	• WASHER	68	A		
	AN960-6L	• WASHER	32	A		
- 13	8-62300	• PLATE ASSY, FILLER RIVETED	2	A		
	8-62300	• PLATE ASSY, FILLER RIVETED	1	A		
- 14	8-62300-401	• PLATE ASSY, FILLER RIVETED ATTACHING PARTS	1	A		
- 15	MS35206-230	• SCREW	3	A		
- 16	MS35206-230	• SCREW	1	A		
	AN960-6L	• WASHER	3	A		
- 17	D7271-3-15	• CIRCUIT BREAKER	1	A		
	7271-8-15	• CIRCUIT BREAKER, ALT. INTCHG WITH 7271-3-15				
	7747307	• PLATE, MOUNTING FUSE	1			
- 18	D7271-3-20	• CIRCUIT BREAKER (82647)	1	A		
	7271-8-20	• CIRCUIT BREAKER, ALT. INTCHG WITH D7271-3-20 (82647)				
	7747307	• PLATE, MOUNTING	1			
- 19	8-65149-85	• NAMEPLATE, COLOR CODE	1	A		
- 20	8-65149-89	• NAMEPLATE, 115/200V AC ESS	1	A		
- 21	8-65149-127	• NAMEPLATE, BAT TERM PWR	1	A		
- 22	8-65149-81	• NAMEPLATE, 115/200V AC NON-ESS	1	A		
- 23	8-65149-87	• NAMEPLATE, 28V DC NON-ESS	1	A		
- 24	8-65149-169	• NAMEPLATE, 28V AC ESS REPLACED BY NOT INTCHG WITH 8-65149-169	1	A		
- 25	8-65149-91	• NAMEPLATE, 28V DC ESS	1	A		
- 26	8-65149-105	• NAMEPLATE, 28V DC CANOPY	1	A		

A AIRPLANES #35 THRU 47 AND 49 THRU 89



A

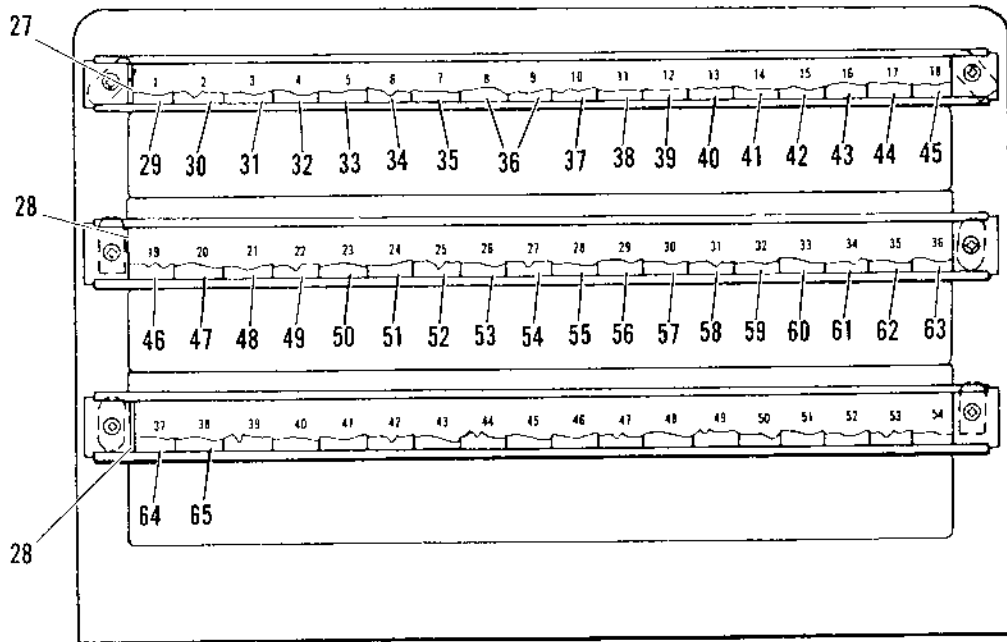
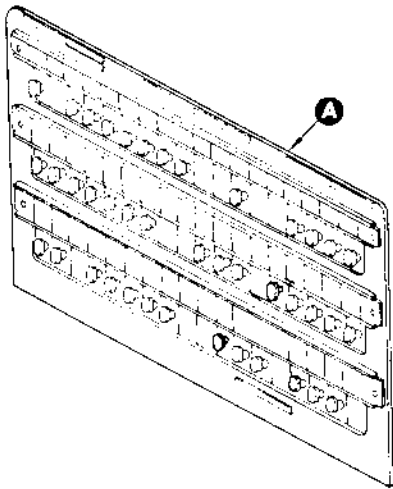

Figure 2.17-21. Nose Wheel Well Circuit Breaker Panel Assembly (Sheet 2 of 3)

FIGURE AND INDEX NUMBER	PART NUMBER	DESCRIPTION	UNITS PER ASSY.	USABLE ON CODE	
				FROM	TO
		1 2 3 4 5 6			
2.17-21- 27	8-65151-19	• PLATE, PROTECTOR	1	A	
- 28	8-65151-19	• PLATE, PROTECTOR	2	A	
- 29	63035505-1	• PLATE, DESIGNATION EMERG AC GEN START 5 AMP	1	A	
- 30	7242963-01	• PLATE, DESIGNATION MA-1 PWR/A 10A 28L	1	A	
- 31	1007-10-116-3	• NAMEPLATE, OIL QTY IND LAMP	1	A	
- 32	8-65149-185	• NAMEPLATE, AIR DATA COMPUTER 10 AMP	1	A	
- 33	7242963-03	• PLATE, DESIGNATION MA-1 PWR/C 10A 28L	1	A	
- 34	8-62364-7	• NAMEPLATE, BLANK	1	A	
- 35	8-65149-18	• NAMEPLATE, LOG GEAR POS 5 AMP	1	A	
- 36	8-65149-175	• NAMEPLATE, FUEL LOW WARN LH 5 AMP RH 5 AMP	1	A	
- 37	7839892-23	• NAMEPLATE, BLANK	1	A	
- 38	7839892-23	• NAMEPLATE, BLANK	1	A	
- 39	7839892-23	• NAMEPLATE, BLANK	1	R	
- 40	8-65149-23	• NAMEPLATE, MA-1 PWR 10 AMP	1	A	
- 41	8-65149-157	• NAMEPLATE, ELECTRONIC RTU SENSOR 5 AMP	1	A	
- 42	8-65149-170	• NAMEPLATE, ANTI-ICE WARN 5 AMP	1	A	
- 43	8-65149-28	• NAMEPLATE, FLT CONT DAMPER 5 AMP	1	A	
- 44	8-65149-21	• NAMEPLATE, TAXI LT 5 AMP	1	A	
- 45	8-65149-121	• NAMEPLATE, MA-1 NON-ECS 5 AMP	1	A	
- 46	8-65149-35	• NAMEPLATE, NOSE WHEEL STEER 5 AMP	1	A	
- 47	8-65149-37	• NAMEPLATE, FUEL QTY 5 AMP	1	A	
- 48	8-65149-39	• NAMEPLATE, TVST TRANS 1 AMP	1	A	
- 49	8-65149-41	• NAMEPLATE, PRESS RATIO IND 5 AMP	1	A	
- 50	8-65149-43	• NAMEPLATE, PITOT HT 5 AMP	1	A	
- 51	8-62364-7	• NAMEPLATE, BLANK	1	A	
- 52	7242963-01	• PLATE, DESIGNATION MA-1 PWR/B 10A 24BL	1	A	
- 53	8-65149-49	• NAMEPLATE, CANOPY UNLOCK 5 AMP	1	A	
- 54	8-65149-13	• NAMEPLATE, TAIL HOOK RELEASE 5A	1	A	
- 55	8-65149-127	• NAMEPLATE, MACH SWITCH CONT 5 AMP	1	A	
- 56	8-65149-57	• NAMEPLATE, RAM AIR CONT 5 AMP	1	A	
- 57	8-65149-116	• NAMEPLATE, MAX MAN WARN 5 AMP	1	A	
- 58	8-65149-57	• NAMEPLATE, SPEED BRAKE 5 AMP	1	A	
- 59	1007-10-116-1	• NAMEPLATE, OIL QTY WARN LAMP	1	A	
- 60	8-65149-161	• NAMEPLATE, CANOPY CLUTCH RELEASE 5 AMP	1	A	
- 61	8-65149-65	• NAMEPLATE, UPPER REACON LT 5 AMP	1	A	
- 62	8-62364-7	• NAMEPLATE, BLANK	1	A	
- 63	8-65149-46	• NAMEPLATE, FITCH G LIMIT 5 AMP	1	A	
- 64	8-31883-7	• NAMEPLATE, EGT CND COOL 5A	1	A	
- 65	8-65149-46	• NAMEPLATE, INLET CONT 5 AMP	1	A	
- 65	8-65149-71	• NAMEPLATE, MA-1 TEST PWR 1. AMP	1	A	

A AIRPLANES 655 THRU 47 AND 49 THROUGH 89
 F FOUNDED INSTRUMENT AIRPLANES



A

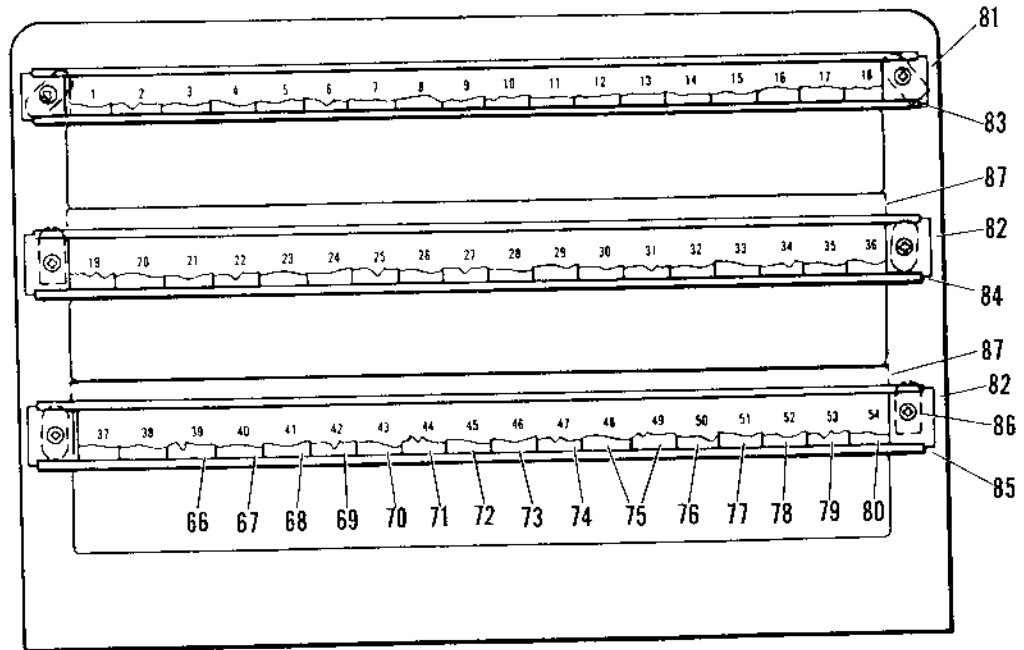

Figure 2.17-21. Nose Wheel Well Circuit Breaker Panel Assembly (Sheet 3 of 3)

FIGURE AND INDEX NUMBER	PART NUMBER	DESCRIPTION	UNITS PER ASSY.	USABLE ON CODE	
				FROM	TO
2.17-21- 66	7833692-25 *3	• NAMEPLATE, BLANK	1	R	
- 67	7242963-17 *2	• PLATE, DESIGNATION BAT CHARGER PHASE 20A ACY	1	35	47
- 68	7242963-11	• PLATE, DESIGNATION 41Y	1	35	47
- 69	7545360-01	• NAMEPLATE, UHF COMM 54	1	35	47
	7242963-13	• PLATE, DESIGNATION 42Y	1	35	47
- 70	8-65149-125	• NAMEPLATE, CAB VENT AND PRESS WARN 5 AMP	1	35	47
- 71	8-65149-107	• NAMEPLATE, ANGLE OF ATTACK 5 AMP REPLACED BY NOT INTCHG WITH 8-65149-177	1	35	38
	8-65149-177	• NAMEPLATE, ANGLE OF ATTACK 5 AMP REPLACES NOT INTCHG WITH 8-65149-107	1	39	47
- 72	8-62364-7	• NAMEPLATE, BLANK	1	35	38
	8-65149-113	• NAMEPLATE, NOSE WHEEL STEER 5 AMP	1	39	47
- 73	8-65149-147	• NAMEPLATE, FLT DIR SYSTEM 1 AMP	1	35	47
- 74	8-65149-129	• NAMEPLATE, EMER CHUTE DEPLOY 5 AMP	1	35	47
- 75	8-65149-173	• NAMEPLATE, CANOPY ACT PWR 5 AMP CONT 10 AMP	1	35	47
- 76	8-31883-9	• NAMEPLATE, ECI GND COOL 5 AMP	1	35	47
- 77	8-65149-77	• NAMEPLATE, SEACON LTS CONT 5 AMP	1	35	47
- 78	8-65149-79	• NAMEPLATE, INLET CONT 5 AMP	1	35	47
- 79	8-65149-146	• NAMEPLATE, CANOPY SEC PWR 15 AMP	1	35	47
- 80	8-65149-149	• NAMEPLATE, FLT DIR SYSTEM 5 AMP	1	35	47
- 81	8-62364-37	• STOP, NAMEPLATE	2	35	47
- 82	8-62364-9	• STOP, NAMEPLATE	4	35	47
- 83	8-62362-19	• HOLDER, NAMEPLATE	1	35	47
- 84	8-62362-21	• HOLDER, NAMEPLATE	1	35	47
- 85	8-62362-23	• HOLDER, NAMEPLATE ATTACHING PARTS	1	35	47
- 86	AN526-1032P6	• SCREW -----X-----	6	35	47
- 87	8-65022-21	• HAT	2	35	47
	8-65024-15	• PANEL	1	35	47

R POUND INSTRUMENT AIRPLANES

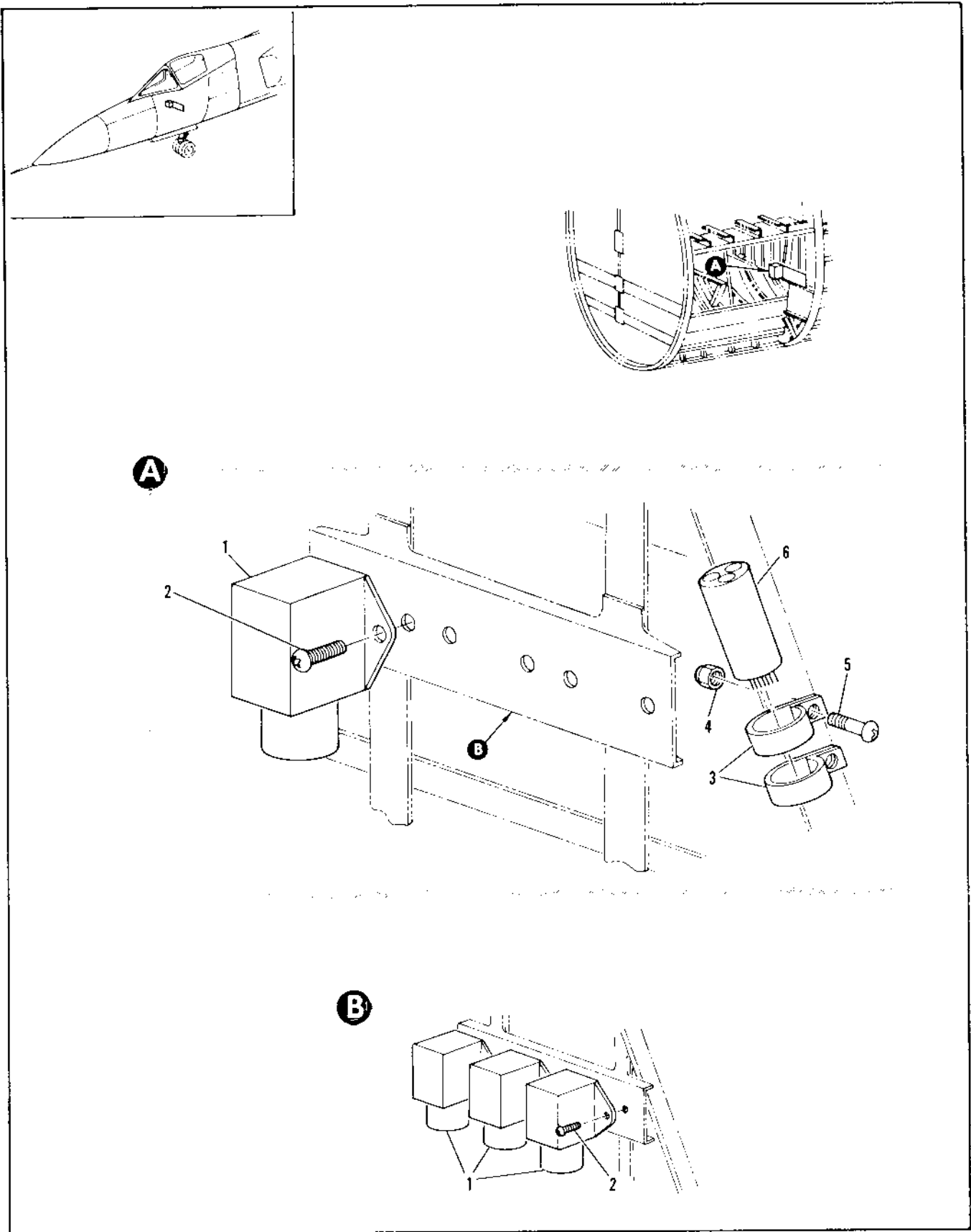

Figure 2.17-22. Warning Light Dimming Relay Installation RH

FIGURE AND INDEX NUMBER	PART NUMBER	DESCRIPTION	UNITS PER ASSY.	USABLE ON CODE	
				FROM	TO
		1 2 3 4 5 6			
2.17-22	8-65159-3	RELAY INSTALLATION, WARNING LIGHT DIMMING RH	1	35	
- 1	9220-3435	• RELAY, CANOPY UNLOCKED FIRE AND GEAR UNSAFE <35344> SPEC 9-C6289-3 ATTACHING PARTS	3	49	
- 2	AN520-10P10	• SCREW ----X----	6	35	
- 3	1-1/2-611435	• CLAMP, <95987> 91-98002-025 ATTACHING PARTS	2	35	
- 4	NAS679A3	• NUT	2	35	
- 5	NAS221-10	• SCREW ----X----	2	35	
- 6	8-65164-1	• RESISTOR ASSY, WARNING LIGHT DIMMING BONDED	1	35	
	RW55G131	• RESISTOR, 97-47046-005	3	35	
	RW55V131	• RESISTOR, REPLACES RW55G131	3	35	

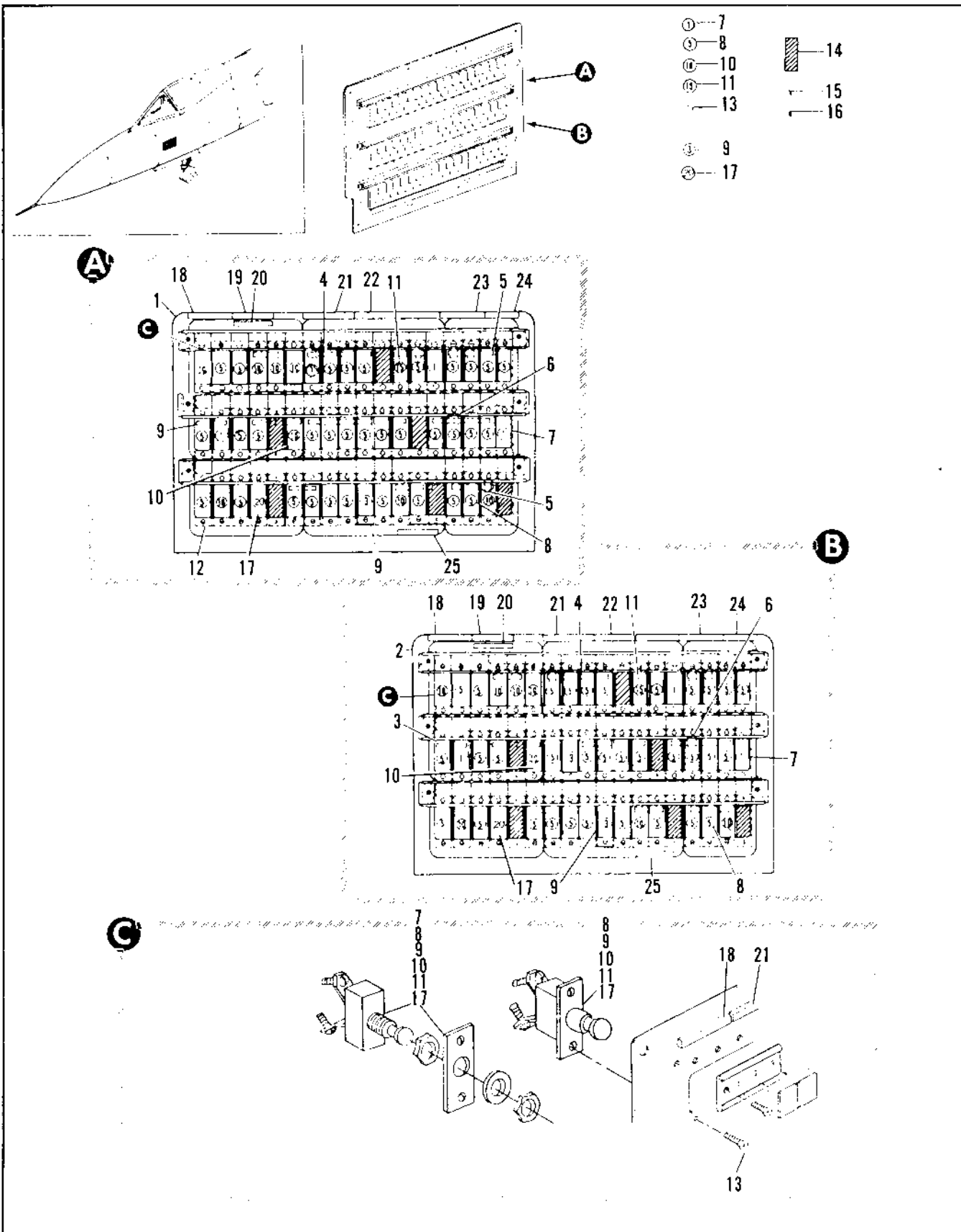

Figure 2.17-23. Nose Wheel Well Circuit Breaker Panel Assembly (Sheet 1 of 2)

FIGURE AND INDEX NUMBER	PART NUMBER	DESCRIPTION	UNITS PER ASSY.	USABLE ON CODE	
				FROM	TO
		1 2 3 4 5 6			
2.17-23- 1	7242866-90	PANEL ASSEMBLY, NOSE WHEEL WELL CIRCUIT BREAKER		98	48
	7242866-110	PANEL ASSEMBLY, NOSE WHEEL WELL CIRCUIT BREAKER	RF	91	128
- 2	7242866-130	PANEL ASSEMBLY, NOSE WHEEL WELL CIRCUIT BREAKER	RF	131	159
	7242866-150	PANEL ASSEMBLY, NOSE WHEEL WELL CIRCUIT BREAKER	RF	160	188
	7242866-170	PANEL ASSEMBLY, NOSE WHEEL WELL CIRCUIT BREAKER	RF	189	239
	7242866-190	PANEL ASSEMBLY, NOSE WHEEL WELL CIRCUIT BREAKER		244	
- 3	8-05029-7	• BUSBAR	2	A	
- 4	8-65029-11	• BUSBAR	2	A	
- 5	8-65029-9	• BUSBAR	2	A	
- 6	8-62375-11	• BUSBAR ASSEMBLY	6	91	159
	NAS679A08	• • NUT	1	91	159
	AN960-8L	• • WASHER	1	91	159
	AN936B8	• • WASHER	1	91	159
	AN935-8L	• • WASHER	1	91	159
	AN515-8R8	• • SCREW	1	91	159
	8-65029-41	• • BUSBAR	1	91	159
- 7	4001-001-1	• • CIRCUIT BREAKER	2	A	
	7747307	• • PLATE, MOUNTING	2		
- 8	07271-3-5	• CIRCUIT BREAKER (82647)	34	A	
	7271-8-5	• CIRCUIT BREAKER, ALT. INTCHG WITH 7271-3-5 (82647)	34		
	7747307	• • PLATE MOUNTING	34		
- 9	07271-3-3	• CIRCUIT BREAKER (82647)	1	A	
	4001-001-3	• CIRCUIT BREAKER, ALT. INTCHG WITH 7271-3-3 (82647)	1		
	7747307	• • PLATE, MOUNTING	1		
- 10	D7271-3-10	• CIRCUIT BREAKER (82647)	8	A	
	7271-8-10	• CIRCUIT BREAKER, ALT. INTCHG WITH D7271-3-10 (82647)	8		
	7747307	• • PLATE, MOUNTING	8		
- 11	D7271-3-15	• CIRCUIT BREAKER (82647)	1	A	
	7271-8-15	• CIRCUIT BREAKER, ALT. INTCHG WITH 7271-3-15 (82647)	1		
	7747307	• • PLATE, MOUNTING	1		
- 12	DELETED				
- 13	MS35206-230	ATTACHING PARTS			
	AN960-6L	• SCREW	43	A	
		• WASHER	43	A	
		-----X-----			
- 14	8-62300	• PLATE ASSY, FILLER RIVETED		A	
- 15	MS35206-230	• SCREW	1		
- 16	AN960-6L	• WASHER	1	A	
- 17	D7271-3-20	• CIRCUIT BREAKER (82647)	1		
	7271-8-20	• CIRCUIT BREAKER, ALT INTCHG WITH D7271-3-20 (82647)	1	A	
	7747307	• • PLATE, MOUNTING	1		
- 18	8-65149-85	• NAMEPLATE, COLOR CODE	1	A	
- 19	8-65149-89	• NAMEPLATE, 115/200V AC ESS	1	A	
- 20	8-65149-127	• NAMEPLATE, BAT TERM PWR	1	A	
- 21	8-65149-81	• NAMEPLATE, 115/200V AC NON-ESS	1	A	
- 22	8-65149-87	• NAMEPLATE, 28V DC NON ESS	1	A	
- 23	8-65149-169	• NAMEPLATE, 28V AC ESS	1	A	
- 24	8-65149-91	• NAMEPLATE, 28V DC ESS	1	A	
- 25	8-65149-105	• NAMEPLATE, 28V DC CANOPY	1		
		A AIRPLANES #48, 91 AND ON			

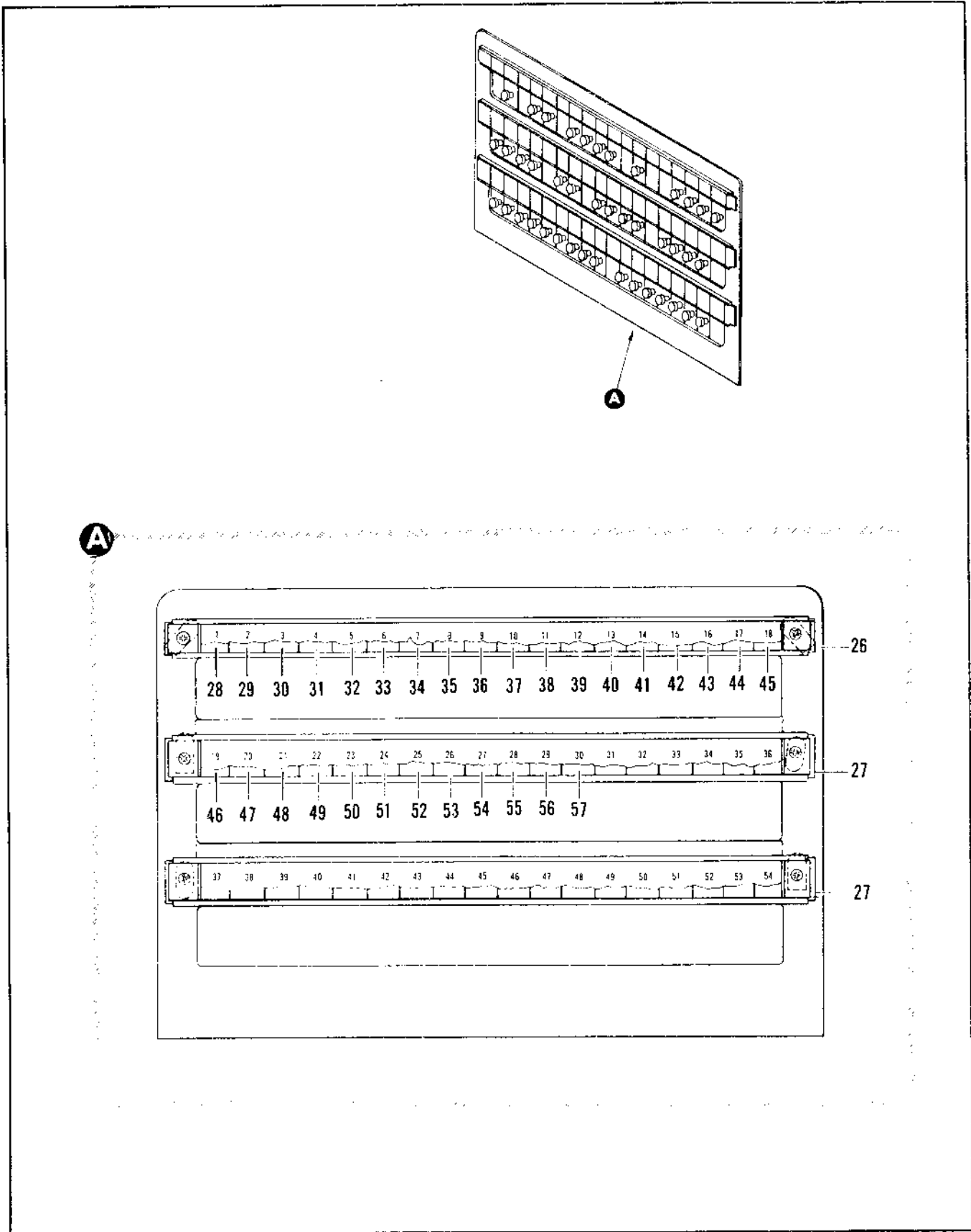
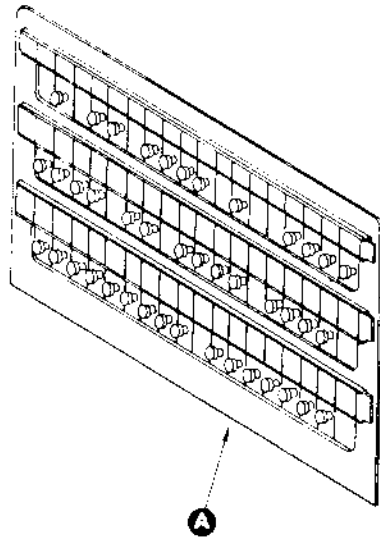

Figure 2.17-23. Nose Wheel Well Circuit Breaker Panel Assembly (Sheet 2 of 2)

FIGURE AND INDEX NUMBER	PART NUMBER	DESCRIPTION	UNITS PER ASSY.	USABLE ON CODE	
				FROM	TO
		1 2 3 4 5 6			
2.17-33- 26	8-65151-10	• PROTECTOR, NAMEPLATE	1		A
- 27	8-65151-15	• PROTECTOR, NAMEPLATE	2		A
- 28	8-65149-189	• NAMEPLATE, MISSILE GYRO PHASE A 10A	1		A
- 29	7242963-01	• PLATE, DESIGNATION MA-1 PWR PHASE A 10A 28L	1		A
- 30	8-65149-191	• NAMEPLATE, MISSILE GYRO PHASE B 5A	1		A
- 31	8-65149-185	• NAMEPLATE, AIR DATA COMPUTER 12A	1		A
- 32	7242963-03	• PLATE, DESIGNATION MA-1 PWR PHASE C 10A 58L	1		A
- 33	8-65149-193	• NAMEPLATE, MISSILE GYRO PHASE C 10A	1		A
- 34	8-65149-19	• NAMEPLATE, LGS GEAR POS 5A	1		A
- 35	8-65149-175	• NAMEPLATE, FUEL LOW WARN LH 5A	1		A
- 36	8-65149-175	• NAMEPLATE, FUEL LOW WARN RH 5A	1		A
- 37	8-65149-179	• NAMEPLATE, ANTI-ICE WARN 5A	1		A
- 38	8-62364-7	• NAMEPLATE, BLANK	1		A
- 39	8-65149-23	• NAMEPLATE, MA-1 PWR 15A	1		A
- 40	8-65149-154	• NAMEPLATE, ELECTRONIC RTU SENSOR 5A	1		A
- 41		• NAMEPLATE, OIL QTY WARN 1A	1		A
- 42	8-45149-29	• NAMEPLATE, FLT CONT DAMPER 5A	1		A
- 43	8-65149-31	• NAMEPLATE, TAXI LT 5A	1		A
- 44	8-65149-121	• NAMEPLATE, MA-U NON ESS 5A	1		A
- 45	8-65149-35	• NAMEPLATE, NOSE WHEEL STEER 5A	1		A
- 46	8-65149-37	• NAMEPLATE, FUEL QTY 5A	1		A
- 47	8-65149-163	• NAMEPLATE, 1ST TRANS PRIMARY 5A	1		A
- 48	8-65149-41	• NAMEPLATE, PRESS RATIO IND 5A	1		A
- 49	8-65149-43	• NAMEPLATE, PITOT HT 5A	1		A
- 50	61035505-3	• PLATE, DESIGNATION EMERG AC GEN START 5 AMP	1		A
- 51	7242963-05	• PLATE, DESIGNATION MA-1 PWR PHASE B 10A 248L	1		A
- 52	8-65149-40	• NAMEPLATE, CANOPY UNLOCK 5A	1		A
- 53	8-61391-13	• NAMEPLATE, TAIL HOOK RELEASE 5A	1		B
	8-62364-7	• NAMEPLATE, BLANK	1		C
- 54	8-65149-127	• NAMEPLATE, MACH SWITCH CONT 5A REPLACES NOT INTCMC WITH 8-62364-7	1		A
- 55	8-65149-83	• NAMEPLATE, RAM AIR CONT 5A	1		A
- 56	8-65149-109	• NAMEPLATE, MAX MAN WARN 5A	1		A
- 57	8-65149-87	• NAMEPLATE, SPEED BRAKE 5A	1		A
		A AIRPLANES #44, 91 AND SUBSEQUENT			
		B AIRPLANES #48, 91 THRU 128			
		C AIRPLANES #1 THRU 34, 131, AND SUBSEQUENT			



A

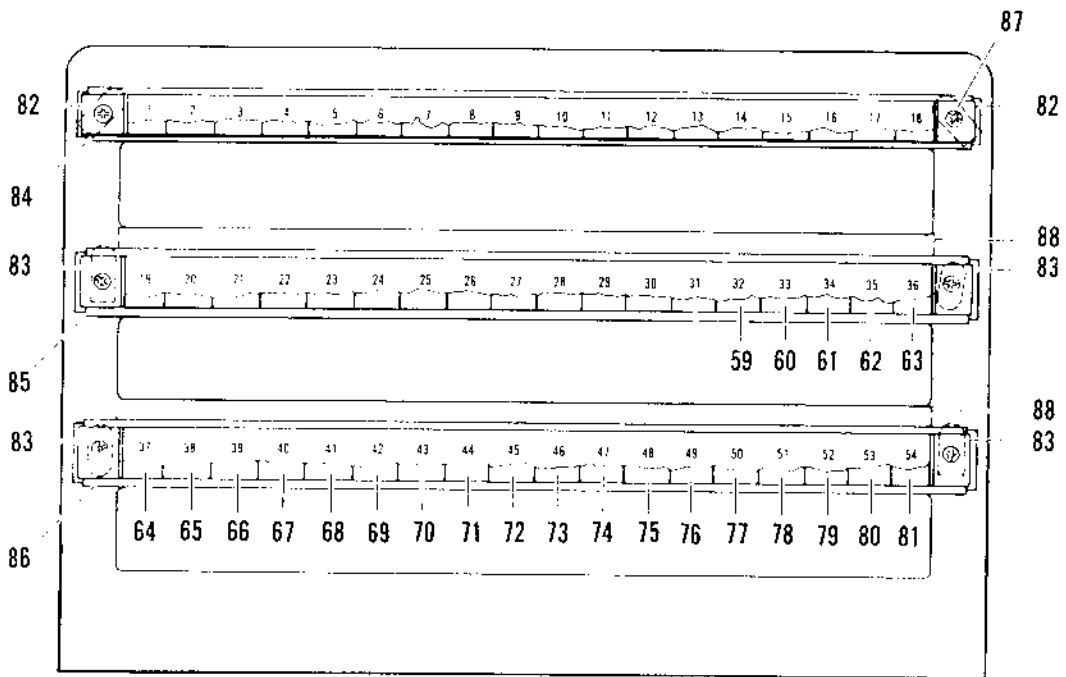

Figure 2.17-23. Nose Wheel Well Circuit Breaker Panel Assembly (Sheet 3 of 3)

FIGURE AND INDEX NUMBER	PART NUMBER	DESCRIPTION	UNITS PER ASSY.	USABLE ON CODE	
				FROM	TO
		1 2 3 4 5 6			
2.17-23- 58	3-62354-7	• NAMEPLATE, FLANK	1	A	
- 59	8-65149-16	• NAMEPLATE, CANOPY CLUTCH RELEASE 5A	1	A	
- 60	8-65149-63	• NAMEPLATE, 4DR BAY 3 UPPER PEACON LTS-5A	1	A	
- 61	7242763-11	• PLATE, DESIGNATION 349	1	A	
- 62	8-65149-53	• NAMEPLATE, PITCH G LIMIT 5A	1	A	
- 63		• NAMEPLATE, MIL QTY INT. 14	1		
- 64	8-65149-49	• NAMEPLATE, INLET CONT 5A	1	A	
- 65	8-65149-71	• NAMEPLATE, MA-1 TEST PWR 10A	1	A	
- 66	8-65149-165	• NAMEPLATE, INST TRANS SECONDARY 5A	1	B	
	8-65149-297	• NAMEPLATE, TAIL HOOK RELEASE 5A	1	C	
- 67	7242963-07	• PLATE, DESIGNATION 9AT CHARGER PHASE A 2CA 4CY	1	A	
- 68	7242963-11	• PLATE, DESIGNATION 41Y	1	A	
- 69	7545363-01	• NAMEPLATE, UHF COMM 5A	1	A	
- 70	8-65149-125	• NAMEPLATE, CAB VENT AND PRESS WARN 5A	1	A	
- 71	8-65149-177	• NAMEPLATE, ANGLE OF ATTACK 5A	1	A	
- 72	8-65149-113	• NAMEPLATE, NOSE WHEEL STEER 5A	1	A	
- 73	62035441-5	• NAMEPLATE, SCRY VSI PWR 3A PHASE C	1	A	
- 74	8-65149-129	• NAMEPLATE, EMER CHUTE DEPLOY 5A	1	A	
- 75	8-65149-161	• NAMEPLATE, CANOPY ACTUATOR PWR 10A CONT 5A	1	A	
- 76	8-65149-181	• NAMEPLATE, CANOPY ACT. PWR CONT 5A	1	A	
- 77	3-62354-7	• NAMEPLATE, BLANK	1	A	
- 78	8-65149-77	• NAMEPLATE, CMPTR BAY LTS & PEACON CONT-5A	1	A	
- 79	8-65149-79	• NAMEPLATE, INLET CONT 5A	1	A	
- 80	8-65149-166	• NAMEPLATE, CANOPY SEC PWR 10A	1	A	
- 81	8-62364-7	• NAMEPLATE, BLANK	1	A	
- 82	8-62364-37	• STOP, NAMEPLATE	2		
- 83	3-62354-45	• STOP, NAMEPLATE	4		
- 84	8-62362-19	• HOLDER, NAMEPLATE	1		
- 85	8-62362-21	• HOLDER, NAMEPLATE	1		
- 86	8-62362-23	• HOLDER, NAMEPLATE	1		
		ATTACHING PARTS			
- 87	AN526-1032R6	• SCREW	6		
		-----X-----			
- 88	8-65022-01	• MAT	2		
	8-65124-15	• PANEL	1		
		A AIRPLANES #48, 91 AND SUBSEQUENT			
		B AIRPLANES #48, 91 THRU 124			
		C AIRPLANES #1 THRU 39, 131 AND SUBSEQUENT			

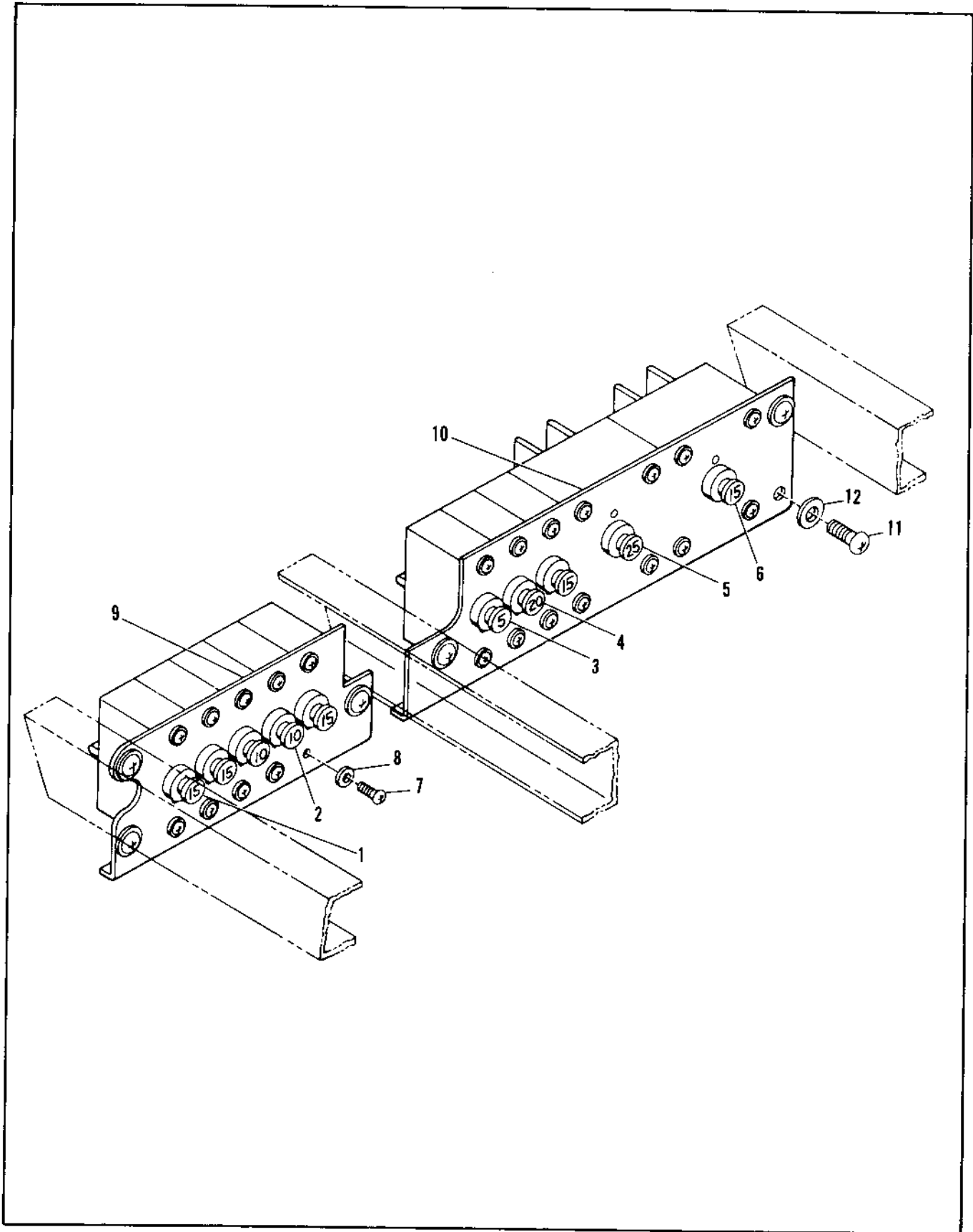

Figure 2.17-24. Panel Instl. Nose Wheel Well Circuit Breaker

FIGURE AND INDEX NUMBER	PART NUMBER	DESCRIPTION 1 2 3 4 5 6	UNITS PER ASSY.	USABLE ON CODE	
				FROM	TO
2.17-91	7242968-10	PANEL INSTL, ROSE WHEEL WELL CIRCUIT BREAKER	1		
- 1	MS25017-15 MS25005-15	• CIRCUIT BREAKER, GFAC AF INSTALLED • CIRCUIT BREAKER ALT INTCHG WITH MS25017-15 GFAC AF INSTALLED	4 4 2		
- 2	MS25017-10 MS25052-10	• CIRCUIT BREAKER, GFAC AF INSTALLED • CIRCUIT BREAKER, ALT INTCHG WITH MS25017-10 GFAC AF INSTALLED	2 2 2		
- 3	MS25017-5 MS25005-5	• CIRCUIT BREAKER, GFAC AF INSTALLED • CIRCUIT BREAKER, ALT INTCHG WITH MS25017-5 GFAC AF INSTALLED	1 1 1		
- 4	MS25017-20 MS25005-20	• CIRCUIT BREAKER, GFAC AF INSTALLED • CIRCUIT BREAKER, ALT INTCHG WITH MS25017-20 GFAC AF INSTALLED	1 1 1		
- 6	MS21984-15	• CIRCUIT BREAKER ATTACHING PARTS	1		
- 7	MS35206-22A	• SCREW	24		
- 8	AN96006L	• WASHER -----X-----	24		
- 9	7243001-01	• PANEL, AFT	1		
- 10	7243002-01	• PANEL, FWD ATTACHING PARTS	1		
- 11	MS35207-26A	• SCREW	6		
- 12	AN960010L	• WASHER -----X-----	6		

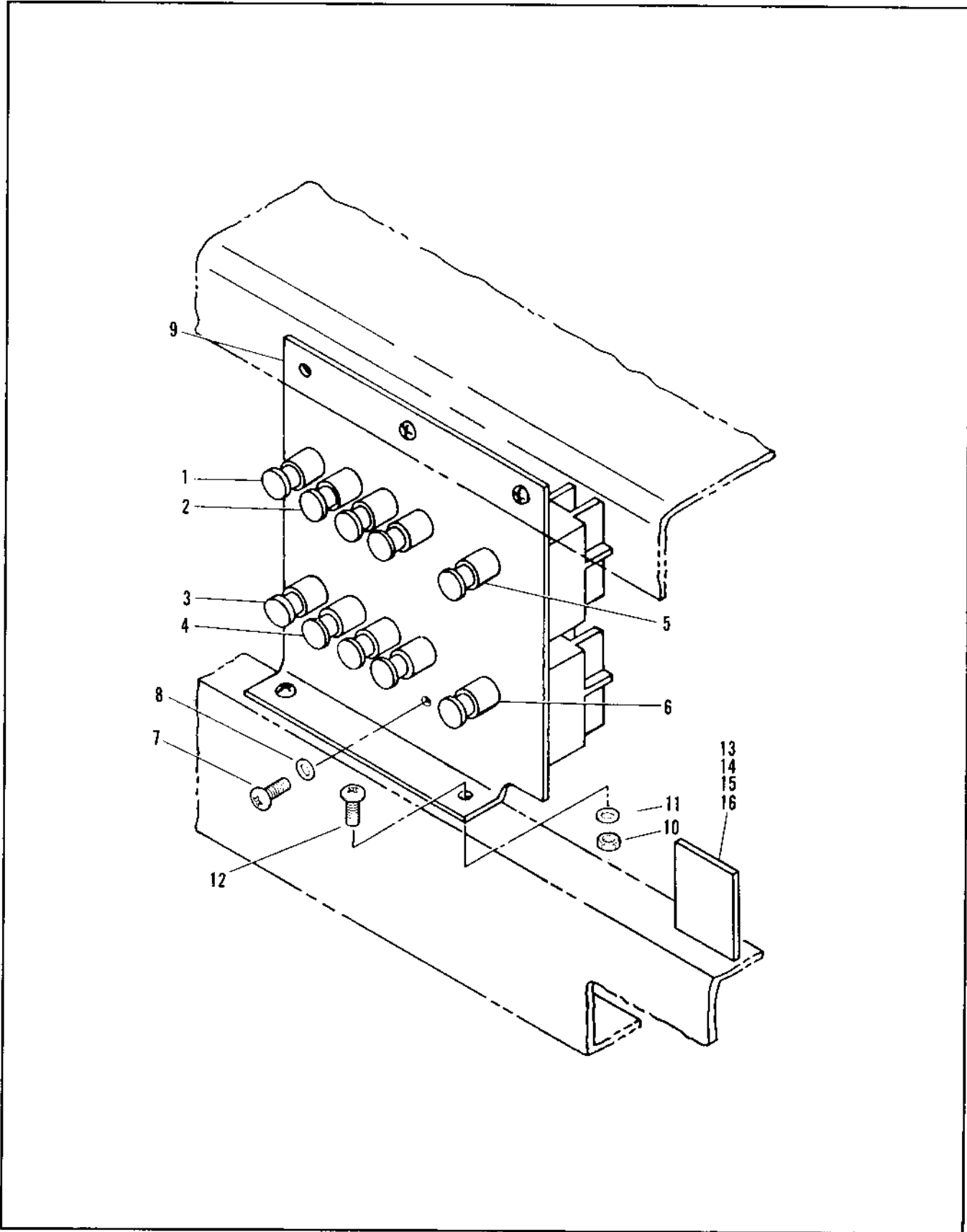

Figure 2.17-25. Panel Instl. Nose Wheel Well Circuit Breaker

FIGURE AND INDEX NUMBER	PART NUMBER	DESCRIPTION 1 2 3 4 5 6	UNITS PER ASSY.	USABLE ON CODE	
				FROM	TO
2.17-25	7242973-10	PANEL INSTL, LH MWV CIRCUIT BREAKER	1		
- 1	MS25017-15	• CIRCUIT BREAKER, GFAE AF INSTALLED	4		
	MS25005-15	• CIRCUIT BREAKER, ALT INTCHG WITH MS25017-15 GFAE AF INSTALLED	4		
- 2	MS25017-10	• CIRCUIT BREAKER, GFAE AF INSTALLED	2		
	MS25005-10	• CIRCUIT BREAKER, ALT INTCHG WITH MS25017-10 GFAE AF INSTALLED	2		
- 3	MS25017-5	• CIRCUIT BREAKER, GFAE AF INSTALLED	1		
	MS25005-5	• CIRCUIT BREAKER, ALT INTCHG WITH MS25017-5 GFAE AF INSTALLED	1		
- 4	MS25017-20	• CIRCUIT BREAKER, GFAE AF INSTALLED	1		
	MS25005-20	• CIRCUIT BREAKER, ALT INTCHG WITH MS25017-20 GFAE AF INSTALLED	1		
- 5	MS21984-25	• CIRCUIT BREAKER	1		
- 6	MS21984-15	• CIRCUIT BREAKER	1		
- 7	MS35206-22R	ATTACHING PARTS	24		
- 8	AN960C6L	• SCREW	24		
		• WASHER			
		-----X-----			
- 9	7243000-10	• PANEL ASSY, CIRCUIT BREAKER RIVETED	1		
		ATTACHING PARTS			
- 10	MS21043-3	• NUT	2		
- 11	AN960C60L	• WASHER	5		
- 12	MS35207-262	• SCREW	5		
		-----X-----			
- 13	MS21R1-22C	• CAP	1		
		ATTACHING PARTS			
- 14	MS21044N38	• NUT	1		
- 15	AN960-R	• WASHER	1		
- 16	MS35206-245	• SCREW	1		
		-----X-----			

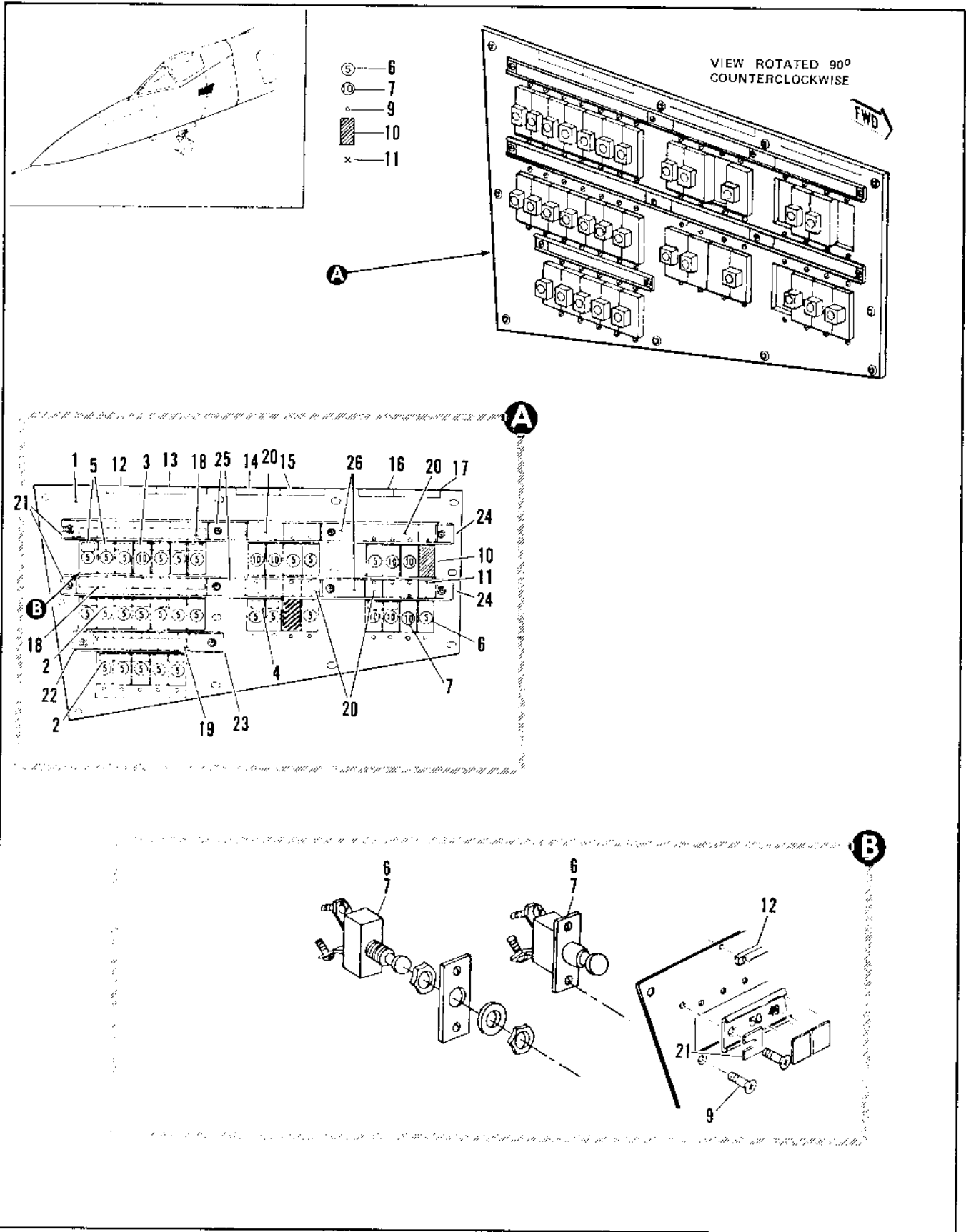
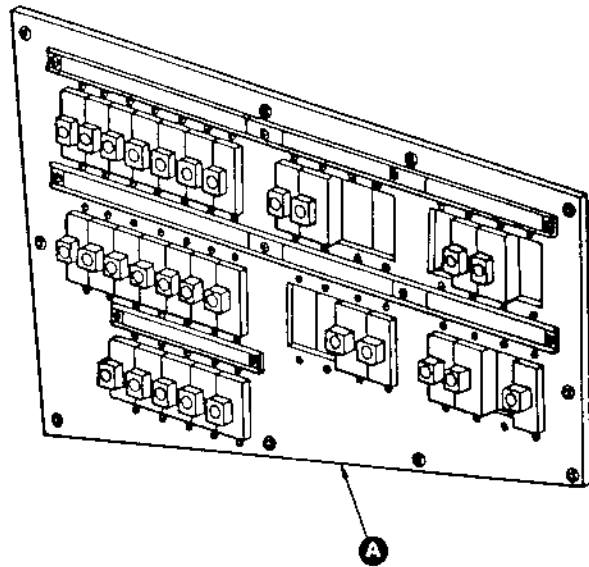

Figure 2.17-26. Cockpit Circuit Breaker Panel Assembly LH (Sheet 1 of 2)

FIGURE AND INDEX NUMBER	PART NUMBER	DESCRIPTION	UNITS PER ASSY.	USABLE ON CODE		
				FROM	TO	
2.17-26-	1	8-62375-1	PANEL ASSEMBLY, COCKPIT FUSE LH MODIFIED BY 8-61972 AND 8-6136R FOR NHA SEE FIG. 2-17-11	RF	35	89
-	2	8-65029-25	• BUSBAR	1	35	89
-	3	8-65029-13	• BUSBAR	2	35	89
-	4	8-65029-7	• BUSBAR	1	35	89
-	5	8-62375-11	• BUSBAR ASSEMBLY	2	35	89
		NAS679A08	• • NUT	1	35	89
		AN960-8L	• • WASHER	1	35	89
		AN936B0	• • WASHER	1	35	89
		AN935-8L	• • WASHER	1	35	89
		AN515-8R	• • SCREW	1	35	89
		8-65029-41	• • BUSBAR	1	35	89
-	6	07271-3-5	• CIRCUIT BREAKER (82647)	25	35	89
		7271-8-5	• CIRCUIT BREAKER, ALT INTCHG WITH 07271-3-5 (82647)	25	35	89
		7747307	• • PLATE MOUNTING	25	35	89
-	7	07271-3-10	• CIRCUIT BREAKER (82647)	8	35	39
		7271-8-10	• CIRCUIT BREAKER, ALT INTCHG WITH 07271-3-10 (82647)	8	35	39
		7747307	• • PLATE, MOUNTING	8	35	89
-	8	DELETED.				
-	9	MS35206-230	ATTACHING PARTS • SCREW	66	35	89
-	10	8-62300	----X---- • NAMEPLATE ASSY, BLANK ATTACHING PARTS	1	35	89
-	11	MS35206-230	• SCREW ----X----	2	35	89
-	12	8-65149-81	• NAMEPLATE, 115/200 AC NON-ESS	1	35	89
-	13	8-65149-83	• NAMEPLATE, 14-28V AC NON-ESS	1	35	89
-	14	8-65149-87	• NAMEPLATE, 28V DC NON-ESS	1	35	89
-	15	8-65149-89	• NAMEPLATE, 115/200V AC ESS	1	35	89
-	16	8-65149-91	• NAMEPLATE, 28V DC ESS	1	35	89
-	17	8-65149-85	• NAMEPLATE, COLOR CODE	1	35	89
-	18	8-65151-23	• PROTECTOR, NAMEPLATE	2	35	89
-	19	8-65151-27	• PROTECTOR, NAMEPLATE	1	35	89
-	20	8-65151-25	• PROTECTOR, NAMEPLATE	4	35	89
-	21	8-62364-35	• STOP	2	35	89
-	22	8262364-39	• STOP	1	35	89
-	23	8-62364-41	• STOP	1	35	89
-	24	8-62364-37	• STOP	2	35	89
-	25	8-62364-31	• SPACER	2	35	89
-	26	8-62364-33	• SPACER	2	35	89



A

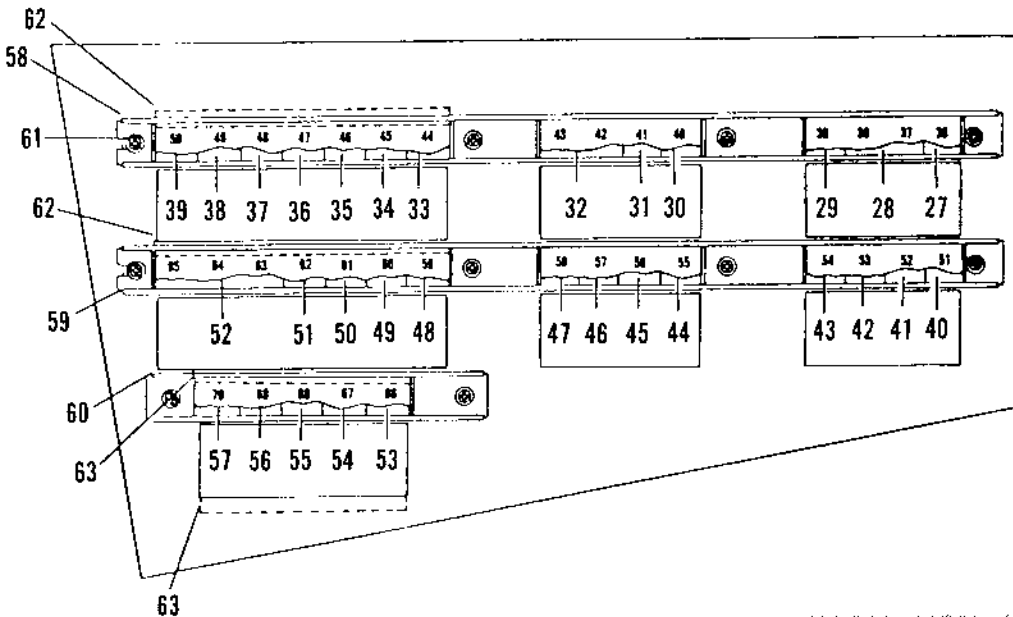
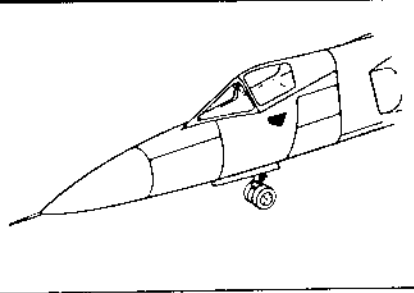

Figure 2.17-26. Cockpit Circuit Breaker Panel Assembly LH (Sheet 2 of 2)

FIGURE AND INDEX NUMBER	PART NUMBER	DESCRIPTION	UNITS PER ASSY.	USABLE ON CODE	
				FROM	TO
		1 2 3 4 5 6			
2.17-26- 27	8-62364-15	• NAMEPLATE, BLANK	1	35	89
- 28	8-62379-75	• NAMEPLATE, WINDSHIELD ANTI-FOG ANTI-ICE LH 10A	1	35	89
- 29	8-61371-7	• NAMEPLATE, IDLE THRUST CONT 5A	1		
- 30	8-62379-71	• NAMEPLATE, FUEL VALVE WARN 5A	1	35	89
- 31	8-62379-85	• NAMEPLATE, SPL WPN RELEASE LOCK 5A	1		
- 32	8-62379-77	• NAMEPLATE, WINDSHIELD ANTI-FOG ANTI-ICE RH 10A	1	35	89
- 33	8-62379-9	• NAMEPLATE, ANTI-ICE CONT 5A	1	35	89
- 34	8-62379-11	• NAMEPLATE, RAIN REMOVAL 5A	1	35	89
- 35	8-62379-13	• NAMEPLATE, CABIN PRESS CONT 5A	1	35	89
- 36	8-62379-15	• NAMEPLATE, MASK DE-FOG 10A	1	35	89
- 37	8-62379-17	• NAMEPLATE, PITOT HEAD 5A	1	35	89
- 38	8-62379-19	• NAMEPLATE, TANK EJECT CONT 5A	1	35	89
- 39	8-62379-51	• NAMEPLATE, FUEL TRANS CONT 5A	1	35	89
- 40	8-62379-23	• NAMEPLATE, STORM LTS 5A REPLACED BY NOT INTCHG WITH 8-62379-89	1	A	
	8-62379-89	• NAMEPLATE, STORM LTS 5A REPLACES NOT INTCHG WITH 8-62379-23	1	48	48
- 41	8-62379-79	• NAMEPLATE, EMERG FUEL TANK PRESS 10A	1	35	89
- 42	8-62379-35	• NAMEPLATE, RUDDER PEDAL ADJ 10A	1	35	89
- 43	8-62379-29	• NAMEPLATE, SEAT ADJ 10A	1	35	89
- 44	8-62379-31	• NAMEPLATE, CANOPY ANTI-FOG 5A	1	35	89
- 45	8-62300	• NAMEPLATE, BLANK	1	35	89
- 46	8-62379-67	• NAMEPLATE, BOOST PUMP CONT AFT 5A	1	35	89
- 47	8-62379-69	• NAMEPLATE, BOOST PUMP CONT FWD 5A	1		89
- 48	8-62379-57	• NAMEPLATE, IGN CONTS A	1	35	89
- 49	8-62379-53	• NAMEPLATE, TAXI AND LDG LT CONT 5A	1	35	89
- 50	8-62379-39	• NAMEPLATE, VAR INLET OVERRIDE 5A	1	35	89
- 51	8-62379-41	• NAMEPLATE, LDG GEAR CONT 5A	1	35	89
- 52	8-62379-44	• NAMEPLATE, FUEL VALVE SHUT-OFF 5A	1	35	89
- 53	8-62379-73	• NAMEPLATE, EMERG FUEL TRANSFER 5A	1	35	89
- 54	8-62379-59	• NAMEPLATE, RUDDER TRIM 5A	1	35	89
- 55	8-62379-61	• NAMEPLATE, TAKE OFF TRIM 5A	1	35	89
- 56	8-62379-63	• NAMEPLATE, AFTER BURNER CONTS A	1	35	89
- 57	8-62379-65	• NAMEPLATE, EMERG FUEL CONT 5A	1	35	89
- 58	8-62362-33	• HOLDER, NAMEPLATE	1	35	89
- 59	8-62362-35	• HOLDER, NAMEPLATE	1	35	89
- 60	8-62362-41	• HOLDER, NAMEPLATE ATTACHING PARTS	1	35	89
- 61	AN520-10R6	• SCREW	10	35	89
	AN960-10L	• WASHER -----X-----	10	35	89
- 62	8-62375-9	• STIFFENER	2	35	89
- 63	8-62375-7	• STIFFENER	2	35	89
	8-62377-7	• PANEL	1	35	89

VIEW ROTATED 90°
COUNTERCLOCKWISE



A

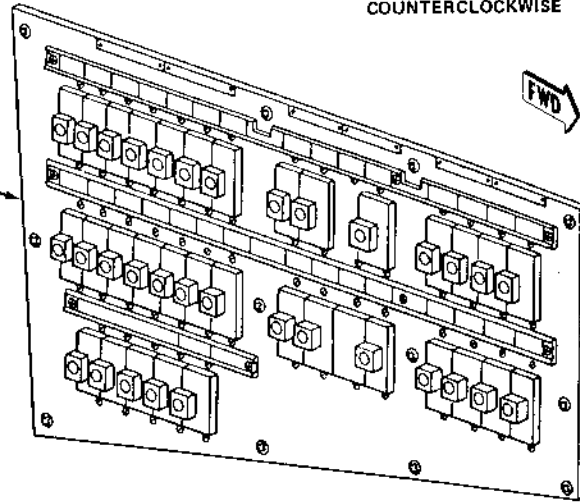

- ⑤ — 6
- ⑩ — 7
- — 9
- — 11

A

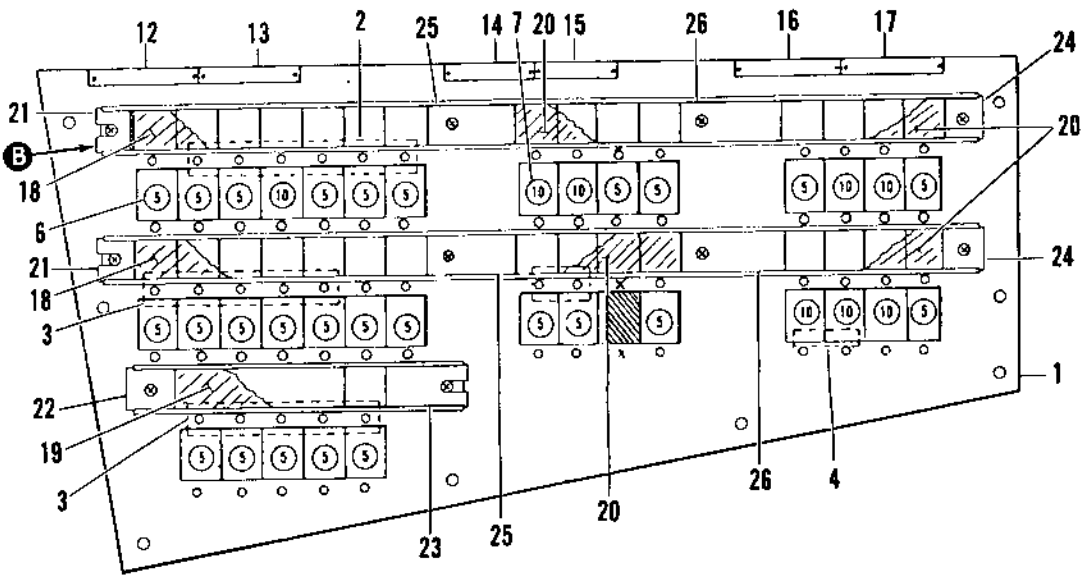

B

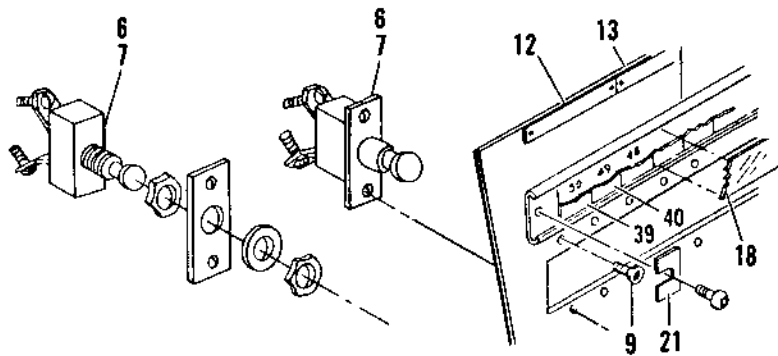

TYPICAL INSTALLATION

Figure 2.17-27. Cockpit Circuit Breaker Panel Assembly LH (Sheet 1 of 2)

FIGURE AND INDEX NUMBER	PART NUMBER	DESCRIPTION 1 2 3 4 5 6	UNITS PER ASSY.	USABLE ON CODE	
				FROM	TO
2.17-27- 1	8-62375-801	PANEL ASSEMBLY, COCKPIT CIRCUIT BREAKER LH FOR NHA SEE FIG. 2.17-11	RF	90	129
	8-62375-803	PANEL ASSEMBLY, COCKPIT CIRCUIT BREAKER LH FOR NHA SEE FIG. 2.17-11	RF	130	159
	8-62375-805	PANEL ASSEMBLY, COCKPIT CIRCUIT BREAKER LH		160	215
- 2	8-65029-13	• BUSBAR	1	90	215
- 3	8-65029-25	• BUSBAR	2	90	215
- 4	8-65029-7	• BUSBAR	1	90	215
- 5	8-65029-7	• BUSBAR	1	90	215
- 6	AN520-10R6	• SCREW	10	90	215
	7271-8-5	• CIRCUIT BREAKER, ALT INTCHG WITH D7271-3-5 (82647)	26	35	89
	7747307	• PLATE MOUNTING	26	35	89
- 7	D7271-3-10	• CIRCUIT BREAKER (82647)	8	35	39
	7271-8-10	• CIRCUIT BREAKER, ALT INTCHG WITH D7271-3-10 (82647)	8	35	39
	7747307	• PLATE MOUNTING	8	35	89
- 8	DELETED				
- 9	MS35206-230	ATTACHING PARTS • SCREW	68		
- 10	DELETED	-----X-----			
- 11	MS35206-230	ATTACHING PARTS • SCREW	2		
- 12	8-65149-81	• NAMEPLATE, 115/200V AC NON-ESS	1	90	215
- 13	8-65149-83	• NAMEPLATE, 14-28V AC NON-ESS	1	90	215
- 14	8-65149-87	• NAMEPLATE, 28V DC NON-ESS	1	90	215
- 15	8-65149-89	• NAMEPLATE, 115/200V AC ESS	1	90	215
- 16	8-65149-91	• NAMEPLATE, 28V DC ESS	1	90	215
- 17	8-65149-85	• NAMEPLATE, COLOR CODE	1	90	215
- 18	8-65151-23	• PROTECTOR, NAMEPLATE	2	90	215
- 19	8-65151-27	• PROTECTOR, NAMEPLATE	1	90	215
- 20	8-65151-25	• PROTECTOR, NAMEPLATE	4	90	215
- 21	8-62364-35	• STOP	2	90	215
- 22	8-62364-39	• STOP	1	90	215
- 23	8-62364-41	• STOP	1	90	215
- 24	8-62364-37	• STOP	2	90	215
- 25	8-62364-31	• SPACER	2	90	215
- 26	8-62364-33	• SPACER	2	90	215

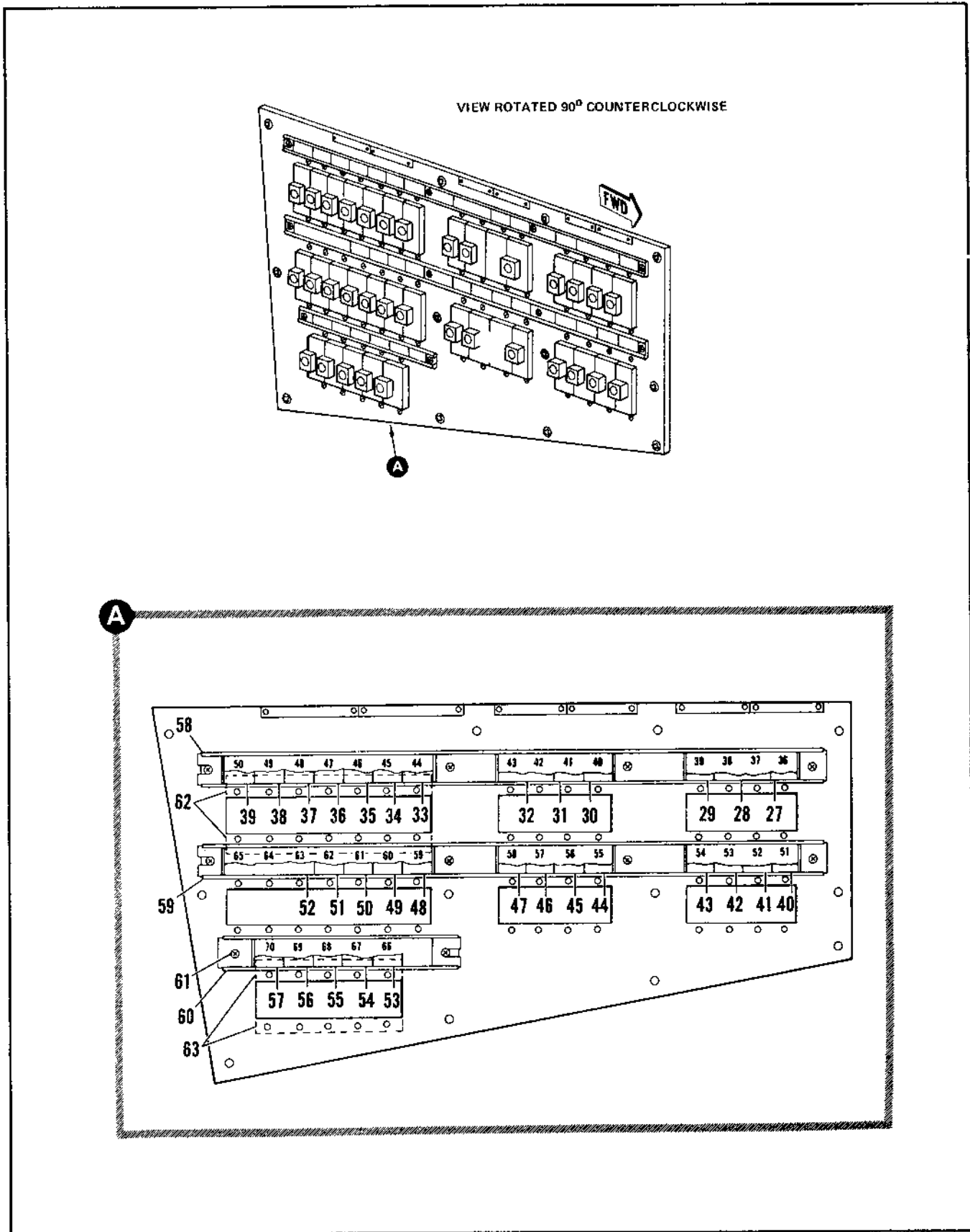

Figure 2.17-27. Cockpit Circuit Breaker Panel Assembly LH (Sheet 2 of 2)

FIGURE AND INDEX NUMBER	PART NUMBER	DESCRIPTION	UNITS PER ASSY.	USABLE ON CODE	
				FROM	TO
		1 2 3 4 5 6			
2.17-27- 27	8-62379-87	• NAMEPLATE, AFCS CONT MOD 5A	1	90	215
- 28	8-62379-75	• NAMEPLATE, WINDSHIELD ANTI-FOG ANTI-ICE LH 10A	1	90	215
- 29	8-62379-83	• NAMEPLATE, ENGINE IDLE THRUST 5A	1	90	215
- 30	8-62379-71	• NAMEPLATE, FUEL VALVE WARN 5A	1	90	215
- 31	8-62379-85	• NAMEPLATE, SPL WPN RELEASE LOCK 5A	1	90	215
- 32	8-62379-77	• NAMEPLATE, WINDSHIELD ANTI-FOG ANTI-ICE RH 10 AMP	1	90	215
- 33	8-62379-9	• NAMEPLATE, ANTI-ICE CONT 5 AMP	1	90	215
- 34	8-62379-11	• NAMEPLATE, RAIN REMOVAL 5A	1	90	215
- 35	8-62379-13	• NAMEPLATE, CABIN PRESS CONT 5A	1	90	215
- 36	8-62379-15	• NAMEPLATE, MASK DE-FOG 10A	1	90	215
- 37	8-62379-17	• NAMEPLATE, PITOT HEAT 5A	1	90	215
- 38	8-62379-19	• NAMEPLATE, TANK EJECT CONT 5A	1	90	215
- 39	8-62379-51	• NAMEPLATE, FUEL TRANSFER CONT 5A	1	90	215
- 40	8-62379-89	• NAMEPLATE, STORM LTS 5A REPLACES NOT INTCHG WITH 8-62379-23	1	90	215
- 41	8-62379-79	• NAMEPLATE, EMERG FUEL TANK PRESS 10 AMP	1	90	215
- 42	8-62379-35	• NAMEPLATE, RUDDER PEDAL ADJ 10 AMP	1	90	215
- 43	8-62379-29	• NAMEPLATE, SEAT ADJ 10 AMP	1	90	215
- 44	8-62379-31	• NAMEPLATE, CANOPY ANTI-FOG 5 AMP	1	90	215
- 45	8-62330	• NAMEPLATE, BLANK	1	90	215
- 46	8-62379-67	• NAMEPLATE, BOOST PUMP CONT AFT 5 AMP	1	90	215
- 47	8-62379-69	• NAMEPLATE, BOOST PUMP CONT FWD 5 AMP	1	90	215
- 48	8-62379-57	• NAMEPLATE, IGN CONT 5 AMP	1	90	215
- 49	8-62379-53	• NAMEPLATE, TAXI AND LDG LT CONT 5A	1	90	215
- 50	8-62379-39	• NAMEPLATE, VAR INLET OVERRIDE 5A	1	90	215
- 51	8-62379-41	• NAMEPLATE, LDG GEAR CONT 5A	1	130	215
- 52	8-62379-43	• NAMEPLATE, FUEL VALVE SHUT-OFF FWD 5A	1	90	215
- 53	8-62379-73	• NAMEPLATE, EMERG FUEL TRANSFER 5 AMP	1	90	215
- 54	8-62379-59	• NAMEPLATE, RUDDER TRIM 5 AMP	1	90	215
- 55	8-62379-61	• NAMEPLATE, TAKE OFF TRIM 5 AMP	1	90	215
- 56	8-62379-63	• NAMEPLATE, AFTER BURNER CONT 5 AMP	1	90	215
- 57	8-62379-65	• NAMEPLATE, EMERG FUEL CONT 5 AMP	1	90	215
- 58	8-62362-33	• HOLDER, NAMEPLATE	1	90	215
- 59	8-62362-35	• HOLDER, NAMEPLATE	1	90	215
- 60	8-62362-41	• HOLDER, NAMEPLATE	1	90	215
		ATTACHING PARTS			
- 61	8-62375-9	• STIFFENER	2	90	215
	AN960-10L	• WASHER	10	90	215
		-----X-----			
- 62	8-62375-9	• STIFFENER	2	90	215
- 63	8-62375-7	• STIFFENER	2	90	215
	8-62377-7	• PANEL	1	90	215

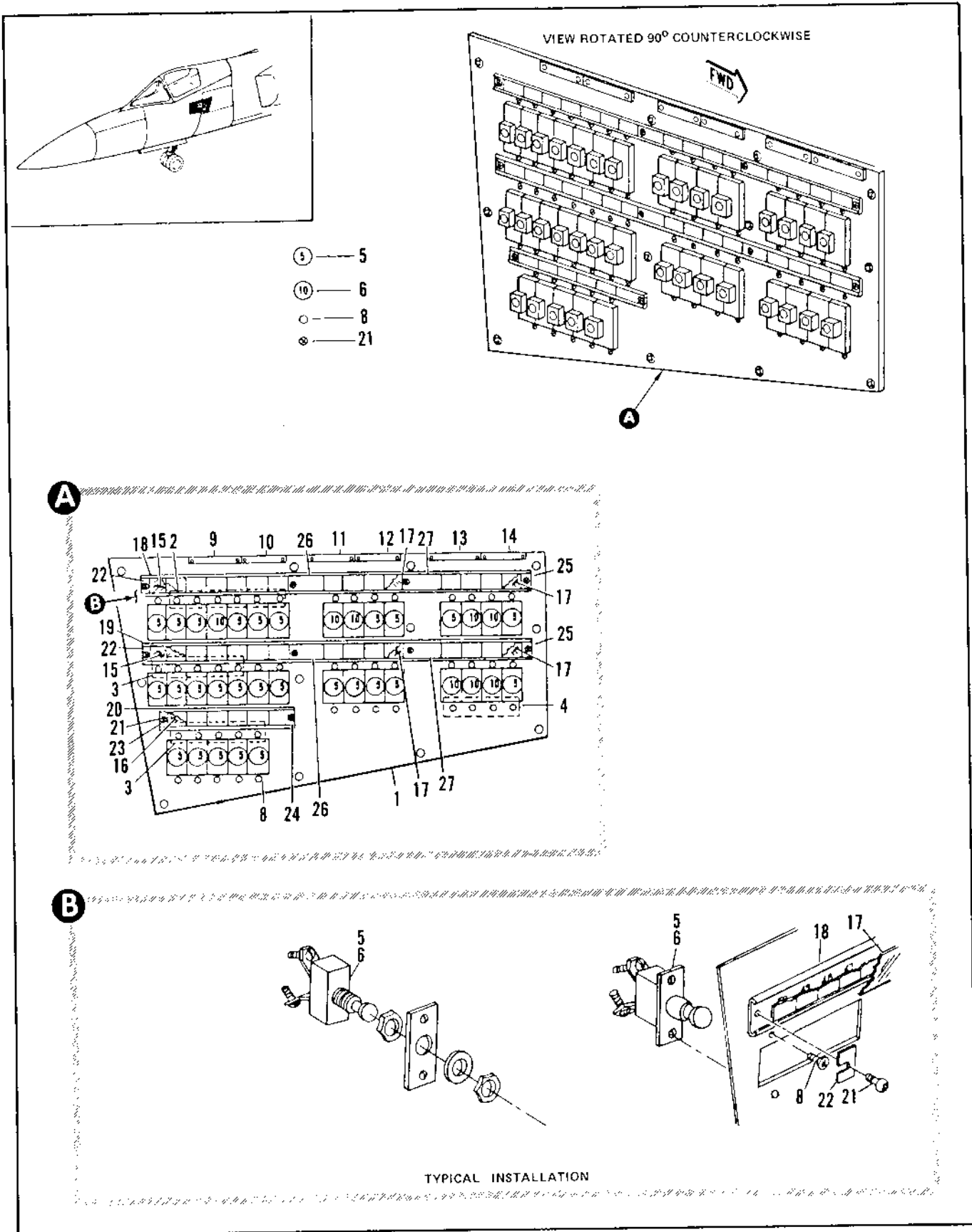
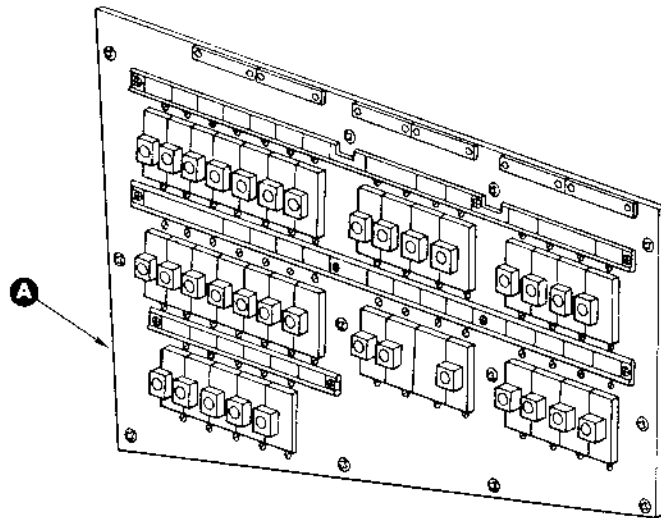

Figure 2.17-28. Cockpit Circuit Breaker Panel Assembly LH (Sheet 1 of 2)

FIGURE AND INDEX NUMBER	PART NUMBER	DESCRIPTION	UNITS PER ASSY.	USABLE ON CODE	
				FROM	TO
				1	2
2.17-28- 1	8-62375-807	PANEL ASSEMBLY, COCKPIT FUSE LH FOR NHA SEE FIG. 2.17-11	RF	219	
- 2	8-65029-13	• BUSBAR	1	219	
- 3	8-65029-25	• BUSBAR	2	219	
- 4	8-65029-11	• BUSBAR	1	219	
- 5	D7271-3-5 7271-8-5	• CIRCUIT BREAKER (82647) • CIRCUIT BREAKER, ALT INTCHG WITH D7271-3-5 (82647)	26 26	219 35	89
	7747307	• PLATE MOUNTING			
- 6	D7271-3-10 7271-8-10	• CIRCUIT BREAKER (82647) • CIRCUIT BREAKER, ALT INTCHG WITH D7271-3-10 (82647)	8 8 8	35 35 35	39 39 89
	7747307	• PLATE MOUNTING			
- 7	DELETED				
- 8	MS35206-230	ATTACHING PARTS • SCREW	68	219	
		-----X-----			
- 9	8-65149-81	• NAMEPLATE, 115/200V AC NON-FSS	1	219	
- 10	8-65149-205	• NAMEPLATE, 14-28V AC ESS	1	219	
- 11	8-65149-87	• NAMEPLATE, 28V DC NON-ESS	1	219	
- 12	8-65149-89	• NAMEPLATE, 115/200V AC ESS	1	219	
- 13	8-65149-91	• NAMEPLATE, 28V DC ESS	1	219	
- 14	8-65149-85	• NAMEPLATE, COLOR CODE	1	219	
- 15	8-65151-23	• PROTECTOR, NAMEPLATE	2	219	
- 16	8-65151-27	• PROTECTOR, NAMEPLATE	1	219	
- 17	8-65151-25	• PROTECTOR, NAMEPLATE	4	219	
- 18	8-62362-33	• HOLDER, NAMEPLATE	1	219	
- 19	8-62362-35	• HOLDER, NAMEPLATE	1	219	
- 20	8-62362-41	• HOLDER, NAMEPLATE	1	219	
		ATTACHING PARTS			
- 21	AN520-10R6	• SCREW	10	219	
		-----X-----			
	AN960-10L	• WASHER	10	219	
- 22	8-62364-35	• STOP	2	219	
- 23	8-62364-39	• STOP	1	219	
- 24	8-62364-41	• STOP	1	219	
- 25	8-62364-37	• STOP	2	219	
- 26	8-62364-31	• SPACER	2	219	
- 27	8-62364-33	• SPACER	2	219	



A

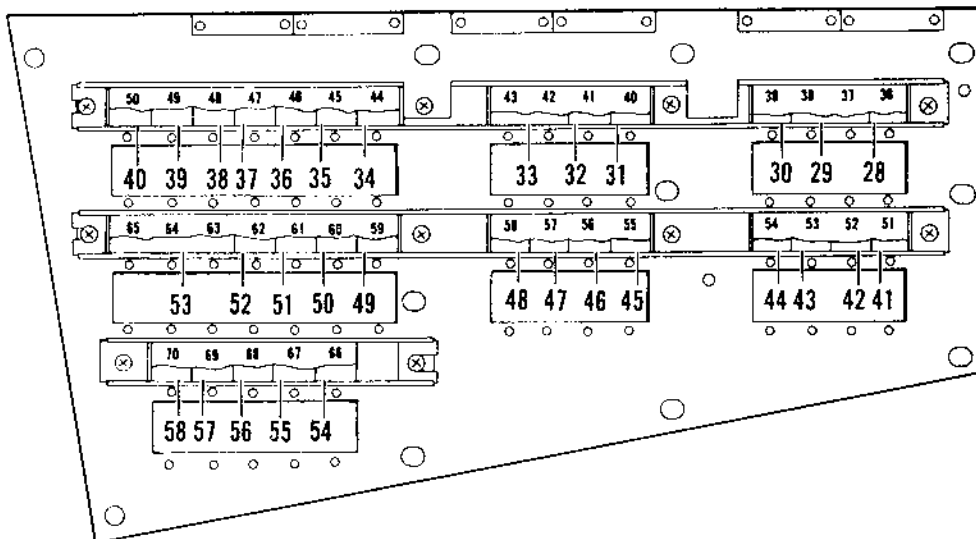

Figure 2.17-28. Cockpit Circuit Breaker Panel Assembly LH (Sheet 2 of 2)

FIGURE AND INDEX NUMBER	PART NUMBER	DESCRIPTION	UNITS PER ASSY.	USABLE ON CODE	
				FROM	TO
2.17-28- - 28 - 29 - 30 - 31 - 32 - 33 - 34 - 35 - 36 - 37 - 38 - 39 - 40 - 41 - 42 - 43 - 44 - 45 - 46 - 47 - 48 - 49 - 50 - 51 - 52 - 53 - 54 - 55 - 56 - 57 - 58 - 59 - 60	8-62379-87	• NAMEPLATE, AFCS CONT MOD 5 AMP	1	219	
	8-62379-75	• NAMEPLATE, WINDSHIELD ANTI-FOG ANTI-ICE LH 10 AMP	1	219	
	8-62379-83	• NAMEPLATE, ENGINE IDLE THRUST 5 AMP	1	219	
	8-62379-71	• NAMEPLATE, FUEL VALVE WARN 5 AMP	1	219	
	9-62379-95	• NAMEPLATE, SPL WPN RELEASE LOCK 5 AMP	1	219	
	9-62379-77	• NAMEPLATE, WINDSHIELD ANTI-FOG ANTI-ICE RH 10 AMP	1	219	
	8-62379-9	• NAMEPLATE, ANTI-ICE CONT 5 AMP	1	219	
	8-62379-11	• NAMEPLATE, RAIN REMOVAL	1	219	
	8-62379-13	• NAMEPLATE, CABIN PRESS CONT 5 AMP	1	219	
	8-62379-15	• NAMEPLATE, MASK DE-FOG 10 AMP	1	219	
	8-62379-17	• NAMEPLATE, PITOT HEAT 5 AMP	1	219	
	8-62379-19	• NAMEPLATE, TANK EJECT CONT 5 AMP	1	219	
	8-62379-51	• NAMEPLATE, FUEL TRANS CONT 5 AMP	1	219	
	8-62379-89	• NAMEPLATE, STORM LTS 5 AMP	1	219	
	8-62379-93	• NAMEPLATE, EMERG FUEL TANK BOOST CONT 5 AMP	1	219	
	8-62379-35	• NAMEPLATE, RUDDER PEDAL ADJ 10 AMP	1	219	
	8-62379-29	• NAMEPLATE, SEAT ADJ 10 AMP	1	219	
	8-62379-31	• NAMEPLATE, CANOPY ANTI-FOG 5 AMP	1	219	
	8-63200	• NAMEPLATE, BLANK	1	219	
	8-62379-67	• NAMEPLATE, BOOST PUMP CONT AFT 5 AMP	1	219	
	8-62379-69	• NAMEPLATE, BOOST PUMP CONT FWD 5 AMP	1	219	
	8-62379-57	• NAMEPLATE, IGN CONT 5 AMP	1	219	
	8-62379-53	• NAMEPLATE, TAXI AND LDG GEAR CONT 5 AMP	1	219	
	8-62379-39	• NAMEPLATE, VAR INLET OVERRIDE 5 AMP	1	219	
	8-62379-41	• NAMEPLATE, LDG GEAR CONT 5 AMP	1	219	
	8-62379-43	• NAMEPLATE, FUEL VALVE SHUT-OFF FWD 5 AMP	1	219	
	8-62379-73	• NAMEPLATE, EMERG FUEL TRANSFER 5 AMP	1	219	
	8-62379-59	• NAMEPLATE, RUDDER TRIM 5 AMP	1	219	
	8-62379-61	• NAMEPLATE, TAKEOFF TRIM 5 AMP	1	219	
	8-62379-63	• NAMEPLATE, AFTER BURNER CONT 5 AMP	1	219	
	8-62379-65	• NAMEPLATE, EMERG FUEL CONT 5 AMP	2	219	
	8-62375-9	• STIFFENER	2	219	
	8-62375-7	• STIFFENER	1	219	
	8-62377-7	• PANEL	1	219	

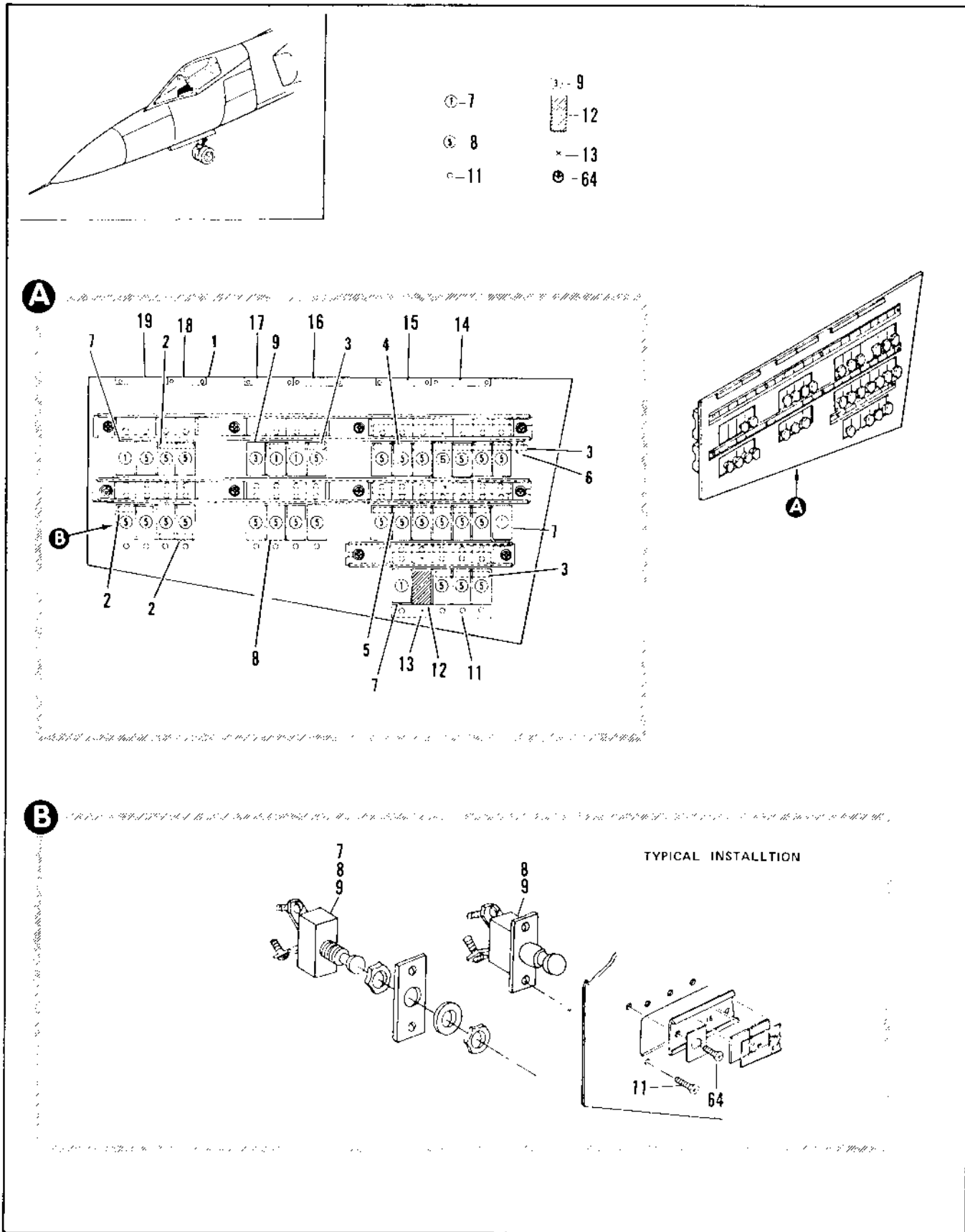
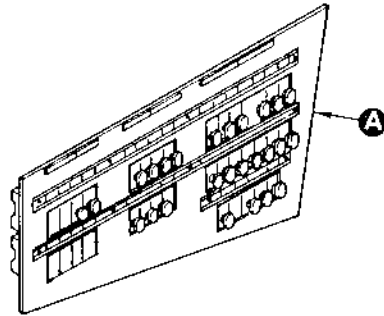

Figure 2.17-29. Cockpit Circuit Breaker Panel Assembly RH (Sheet 1 of 3)

FIGURE AND INDEX NUMBER	PART NUMBER	DESCRIPTION	UNITS PER ASSY.	USABLE ON CODE	
				FROM	TO
		1 2 3 4 5 6			
2.17-29- 1	8-62376-1	PANEL ASSEMBLY, COCKPIT FUSE RH FOR NHA SEE FIG. 2.17-11	RF	B	
- 2	8-62379-807	PANEL ASSEMBLY, CIRCUIT BREAKER RH		61	89
- 3	8-65029-7	• BUSBAR	3	A	
- 4	8-65029-9	• BUSBAR	3	A	
- 5	8-65029-15	• BUSBAR	1	A	
- 6	8-65029-13	• BUSBAR	1	A	
	8-62375-11	• BUSBAR ASSEMBLY	1	A	
	NAS679A08	• • NUT	1	A	
	AN960-8L	• • WASHER	1	A	
	AN936B8	• • WASHER	1	A	
	AN935-8L	• • WASHER	1	A	
	AN515-8R	• • SCREW	1	A	
	8-65029-41	• • BUSBAR	1	A	
- 7	4001-001-1	• CIRCUIT BREAKER	5	A	
	7747307	• • PLATE, MOUNTING	5	A	
- 8	D7271-3-5	• CIRCUIT BREAKER (82647)	28	A	
	7271-8-5	• CIRCUIT BREAKER, ALT INTCHG WITH D7271-3-5 (82647)	28	A	
	7747307	• • PLATE MOUNTING	28	A	
- 9	D7271-3-3	• CIRCUIT BREAKER (82647)	1	A	
	4001-001-3	• CIRCUIT BREAKER, ALT INTCHG WITH D7271-3-3 (82647)	1	A	
	7747307	• • PLATE MOUNTING	1	A	
- 10	DELETED				
- 11	MS35206-230	• ATTACHING PARTS • SCREW	66	A	
- 12	8-62300	• PLATE ASSY, FILLER RIVETED	2	A	
- 13	MS35206-230	• SCREW	2	A	
- 14	8-65149-85	• NAMEPLATE, COLOR CODE	1	A	
- 15	8-65149-91	• NAMEPLATE, 28V DC ESS	1	A	
- 16	8-65149-89	• NAMEPLATE, 115/200V AC ESS	1	A	
- 17	8-65149-87	• NAMEPLATE, 28V DC NON-ESS	1	A	
- 18	8-65149-83	• NAMEPLATE, 14-28V AC NON-ESS	1	A	
- 19	8-65149-81	• NAMEPLATE, 115/200V AC NON-ESS	1	A	
		B AIRPLANES #35 THRU 47 THRU 60			



A

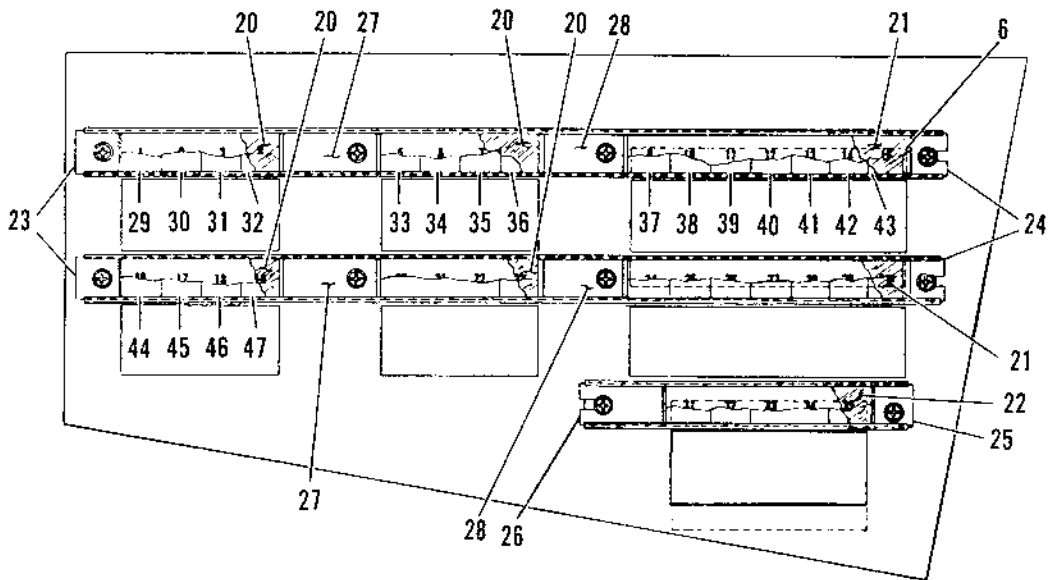

Figure 2.17-29. Cockpit Circuit Breaker Panel Assembly RH (Sheet 2 of 3)

FIGURE AND INDEX NUMBER	PART NUMBER	DESCRIPTION	UNITS PER ASSY.	USABLE ON CODE	
				FROM	TO
		1 2 3 4 5 6			
2.17-29- 20	8-65151-25	• PROTECTOR, NAMEPLATE	4	A	
- 21	8-65151-239	• PROTECTOR, NAMEPLATE	2	A	
- 22	8-65151-27	• PROTECTOR, NAMEPLATE	1	A	
- 23	8-62364-37	• STOP	2	A	
- 24	8-62364-35	• STOP	2	A	
- 25	8-62364-39	• STOP	1	A	
- 26	8-62364-41	• STOP	1	A	
- 27	8-62364-33	• SPACER	2	A	
- 28	8-62364-31	• SPACER	2	A	
- 29	61834187	• LABEL, FUSE MATTS	1	A, B	
- 30	8-62378-9	• NAMEPLATE, MISSILE GYRO PHASE C 5 AMP	1	A	
- 31	8-62378-7	• NAMEPLATE, OXYGEN QTY 5 AMP	1	A	
- 32	8-62378-5	• NAMEPLATE, COCKPIT HEAT CONT 5 AMP	1	A	
- 33	8-61598-13	• NAMEPLATE, FORM LTS 3 AMP	1	A, B	
- 34	8-62378-13	• NAMEPLATE, CONSOLE LTS 1 AMP REPLACED BY NOT INTCHG WITH 8-62378-R1	1	A	
- 35	8-62378-15	• NAMEPLATE, INST PNL LTS 1 AMP REPLACED BY NOT INTCHG WITH 8-62378-R3	1	A	
- 36	8-62378-17	• NAMEPLATE, EMER CKPT LTS 5 AMP	1	A	
- 37	8-62378-19	• NAMEPLATE, WARN LTS 5 AMP	1	A	
- 38	8-62378-21	• NAMEPLATE, WARN LTS DIM 5 AMP	1	A	
- 39	8-62378-23	• NAMEPLATE, MA WARN CONT 5 AMP	1	A	
- 40	7839892-35	• NAMEPLATE, STANDBY ATTITUDE INDICATOR, 5A	1	A	
- 41	64C34482-1	• NAMEPLATE, EGT 5A REF	1	A	
		• NAMEPLATE, BLANK	1	A	
- 42	8-62378-29	• NAMEPLATE, FIRE OVHT TEST 5 AMP	1	A	
- 43	8-62378-31	• NAMEPLATE, MAP READING LT 5 AMP	1	A	
- 44	7839892-01	• NAMEPLATE, BLANK	1	R	
- 45	7839892-01	• NAMEPLATE, BLANK	1	R	
- 46	7839892-01	• NAMEPLATE, BLANK	1	R	
- 47	7839892-01	• NAMEPLATE, BLANK	1	R	

A AIRPLANES #35 THRU 47 AND 49. THROUGH 89

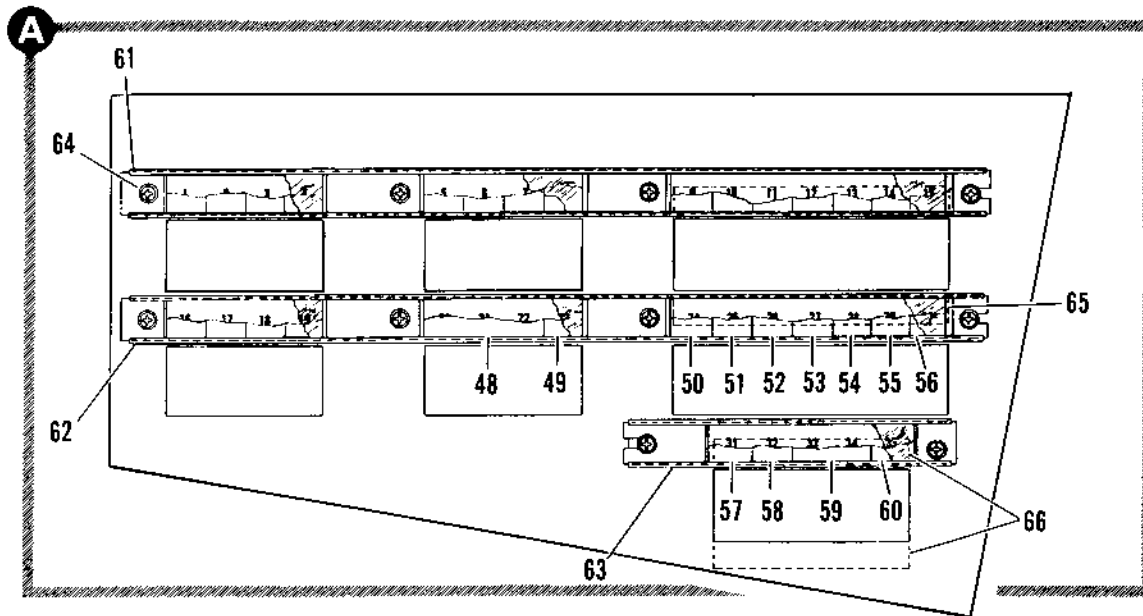
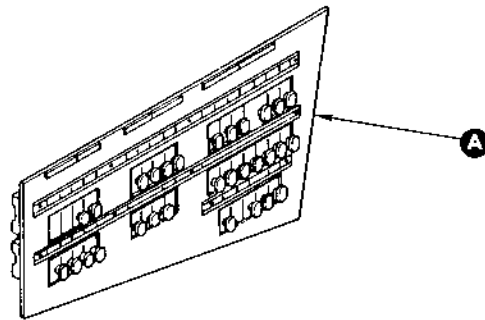

Figure 2.17-29. Cockpit Circuit Breaker Panel Assembly RH (Sheet 3 of 3)

FIGURE AND INDEX NUMBER	PART NUMBER	DESCRIPTION	UNITS PER ASSY.	USABLE ON CODE	
				FROM	TO
2.17-29- 48	7839892-33	• NAMEPLATE, ECA & SCC POWER PHASE A, PHASE B, PHASE C 5 AMP	1		R
- 49	8-32827-7	• NAMEPLATE, MISSILE GYRO CHASE A 5 AMP	1		A
- 50	8-62378-43	• NAMEPLATE, HYD PRESS WARN 5 AMP	1		A
- 51	8-62378-45	• NAMEPLATE, OXYGEN LOW WARN 5 AMP	1		A
- 52	8-62378-47	• NAMEPLATE, EMER CKPT LTG 5 AMP	1		A
- 53	8-62378-49	• NAMEPLATE, CABIN HEAT VALVE	1		A
- 54	8-62378-51	• NAMEPLATE, TURN SLIP 5 AMP	1		A
- 55	7839892-05	• NAMEPLATE, GLIDE SLOPE POINTER BIAS	1		R
- 56	64C34482-3	• NAMEPLATE, EGT 1A BLUE	1		A
- 57	8-65149-115	• NAMEPLATE, CKPT FLOOD LTS 1 AMP	1		A
- 58	8-62364-15	• NAMEPLATE, BLANK	1		A
- 59	8-62378-71	• NAMEPLATE, VAR INLET PITOT HT 5 AMP	1		A
- 60	8-32827-11	• NAMEPLATE, MISSILE GYRO PHASE B 5 AMP	1		A
- 61	8-62362-37	• HOLDER, NAMEPLATE	1		A
- 62	8-62362-39	• HOLDER, NAMEPLATE	1		A
- 63	8-62362-43	• HOLDER, NAMEPLATE ATTACHING PARTS	1		A
- 64	AN520-10R6 AN960-10L	• SCREW • WASHER -----X-----	1		A
- 65	8-62375-9	• STIFFENER	2		A
- 66	8-62375-7 8-62377-P	• STIFFENER • PANEL	2 1		A A

A AIRPLANES #35 THRU 47 AND 49 THRU 89
R ROUND INSTRUMENT AIRPLANES

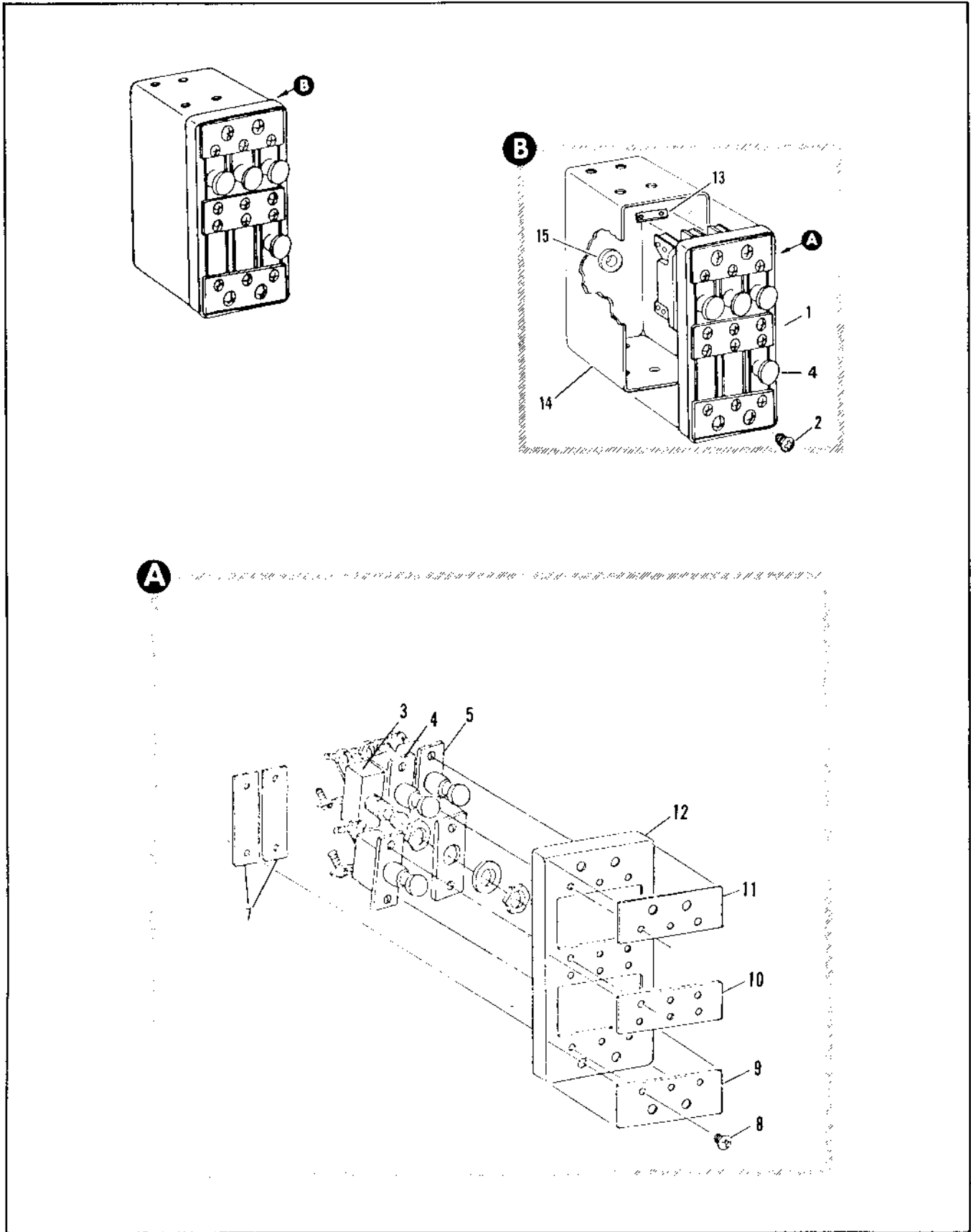

Figure 2.17-30. Circuit Breaker Lighting Panel Assembly

FIGURE AND INDEX NUMBER	PART NUMBER	DESCRIPTION	UNITS PER ASSY.	USABLE ON CODE	
				FROM	TO
				1 2 3 4 5 6	
2.17-30	8-62235	PANEL ASSEMBLY, FUSE LIGHTING FOR NHA SEE FIG. 2.17-11	RF		A
- 1	8-62235-9	• COVER ASSMBLY	1		A
- 2	AN520-10R6	• ATTACHING PARTS • SCREW	4		A
- 3	4001-001-1 7747307	• CIRCUIT BREAKER • PLATE, MOUNTING	1 1		A A
- 4	D7271-3-5	• CIRCUIT BREAKER	2		A
- 5	D7271-3-10	• CIRCUIT BREAKER	1		A
- 6	DELETED				
- 7	8-62300	• PLATE, FILLER • ATTACHING PARTS	2		A
- 8	MS35206-230	• SCREW	12		A
- 9	8-65089-177	• NAMEPLATE, CONS ENG LTS 5 VOLT	1		A
- 10	8-65089-179	• NAMEPLATE, AC ESS LIGHTING	1		A
- 11	8-65089-181	• NAMEPLATE, HSI MODE 4 VOLT ENG INST 5 VOLT FLT INST 5 VOLT	1		A
- 12	8-62235-17	• COVER	1		A
- 13	8-65029-7	• BUSBAR, FUSE	1		A
- 14	8-62235-7	• ROX ASSY, RIVETED	1		A
- 15	3-1194-PA4	• GROMMET, <97820> 94-35006-004	1		A
		A AIRPLANES #48, 90 AND ON			

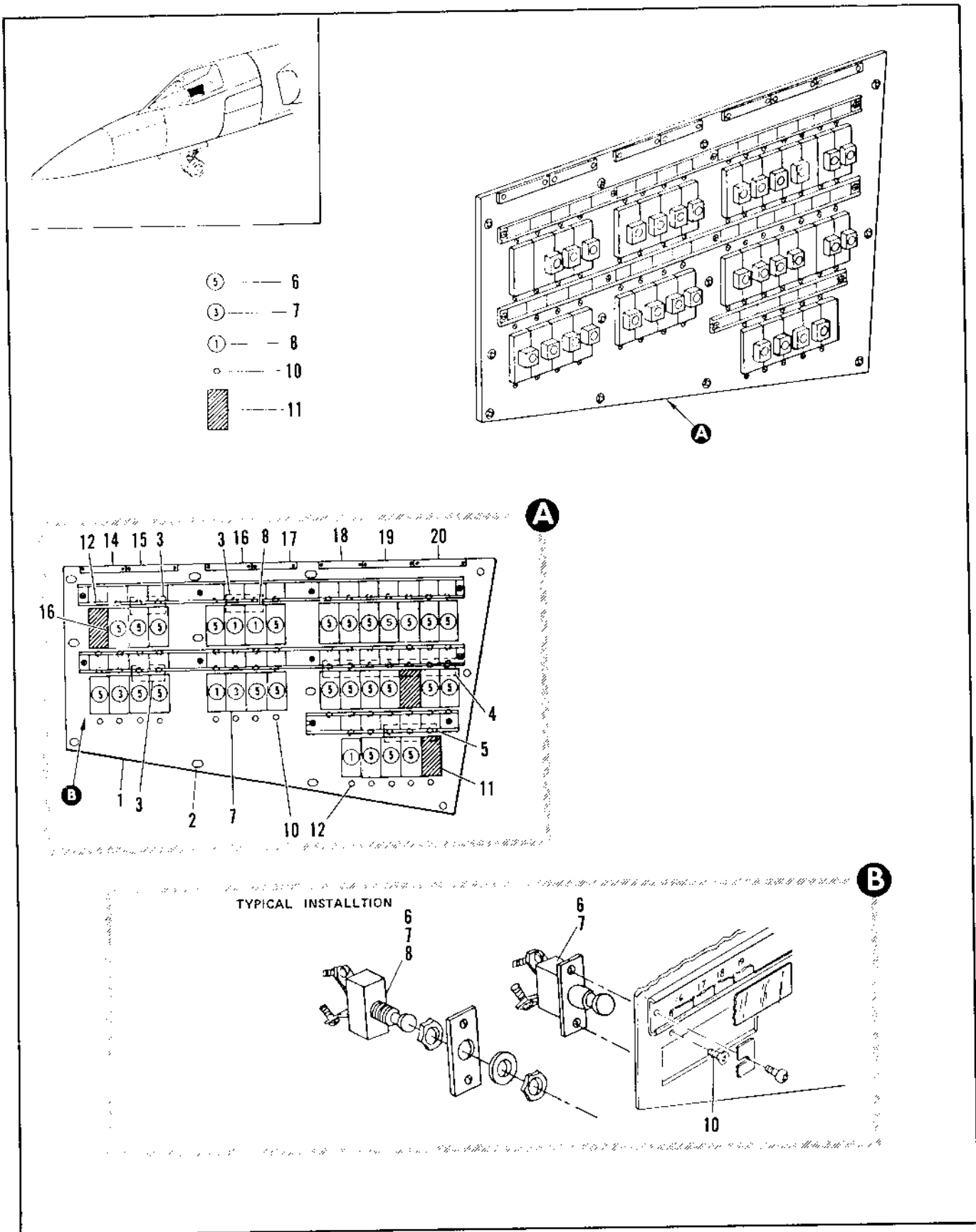

Figure 2.17-31. Cockpit Circuit Breaker Panel Assembly RH (Sheet 1 of 2)

FIGURE AND INDEX NUMBER	PART NUMBER	DESCRIPTION	UNITS PER ASSY.	USABLE ON CODE	
				FROM	TO
		1 2 3 4 5 6			
2.17-31- 1	8-62376-809	PANEL ASSEMBLY, COCKPIT FUSE RH FOR NHA SEE FIG. 2.17-11	RF	130	159
	8-62376-811	PANEL ASSEMBLY, COCKPIT FUSE RH FOR NHA SEE FIG. 2.17-11	RF	160	215
	8-62376-805	PANEL ASSEMBLY, COCKPIT FUSE RH FOR NHA SEE FIG. 2.17-11		90	129
	8-62376-803	PANEL ASSEMBLY, COCKPIT FUSE RH FOR NHA SEE FIG. 2.17-11		48	48
- 2	8-62376-813	PANEL ASSEMBLY, COCKPIT FUSE RH MODIFIED BY 8-32844, 8-61598 AND 66C49096		219	
- 3	8-65029-7	• BUSBAR	3	130	
- 4	8-65029-15	• BUSBAR	1	130	
- 5	8-65029-9	• BUSBAR	1	130	
- 6	D7271-3-5	• CIRCUIT BREAKER (82647)	26	A	
	7271-8-5	• CIRCUIT BREAKER, ALT INTCHG WITH D7271-3-5 (82647)	26	A	
	7747307	• PLATE, MOUNTING	26	A	
- 7	D7271-3-3	• CIRCUIT BREAKER (82647)	2	A	
	4001-001-3	• CIRCUIT BREAKER ALT INTCHG WITH D7271-3-3 (82647)	2	A	
	7747307	• PLATE, MOUNTING	2	A	
- 8	4001-001-1	• CIRCUIT BREAKER	4	A	
	77407307	• PLATE, MOUNTING	4	A	
- 9	DELETED				
- 10	MS35206-230	ATTACHING PARTS • SCREW	64	A	
- 11	8-62300	• PLATE ASSY, FILLER RIVETED ATTACHING PARTS	3	A	
- 12	MS35206-230	• SCREW	6	A	
- 13	DELETED				
- 14	8-65149-85	• NAMEPLATE, COLOR CODE	1	A	
- 15	8-65149-91	• NAMEPLATE, 28V DC ESS	1	A	
- 16	8-65149-89	• NAMEPLATE, 115/200V AC ESS	1	A	
- 17	8-65149-171	• NAMEPLATE, 4V AC ESS	1	A	
- 18	8-65149-169	• NAMEPLATE, 28V AC ESS	1	A	
- 19	8-65149-81	• NAMEPLATE, 115/200V AC NON-ESS	1	A	
- 20	8-65149-205	• NAMEPLATE, 14-28V AC ESS	1	A	
		A AIRPLANES #48, 90 AND ON			

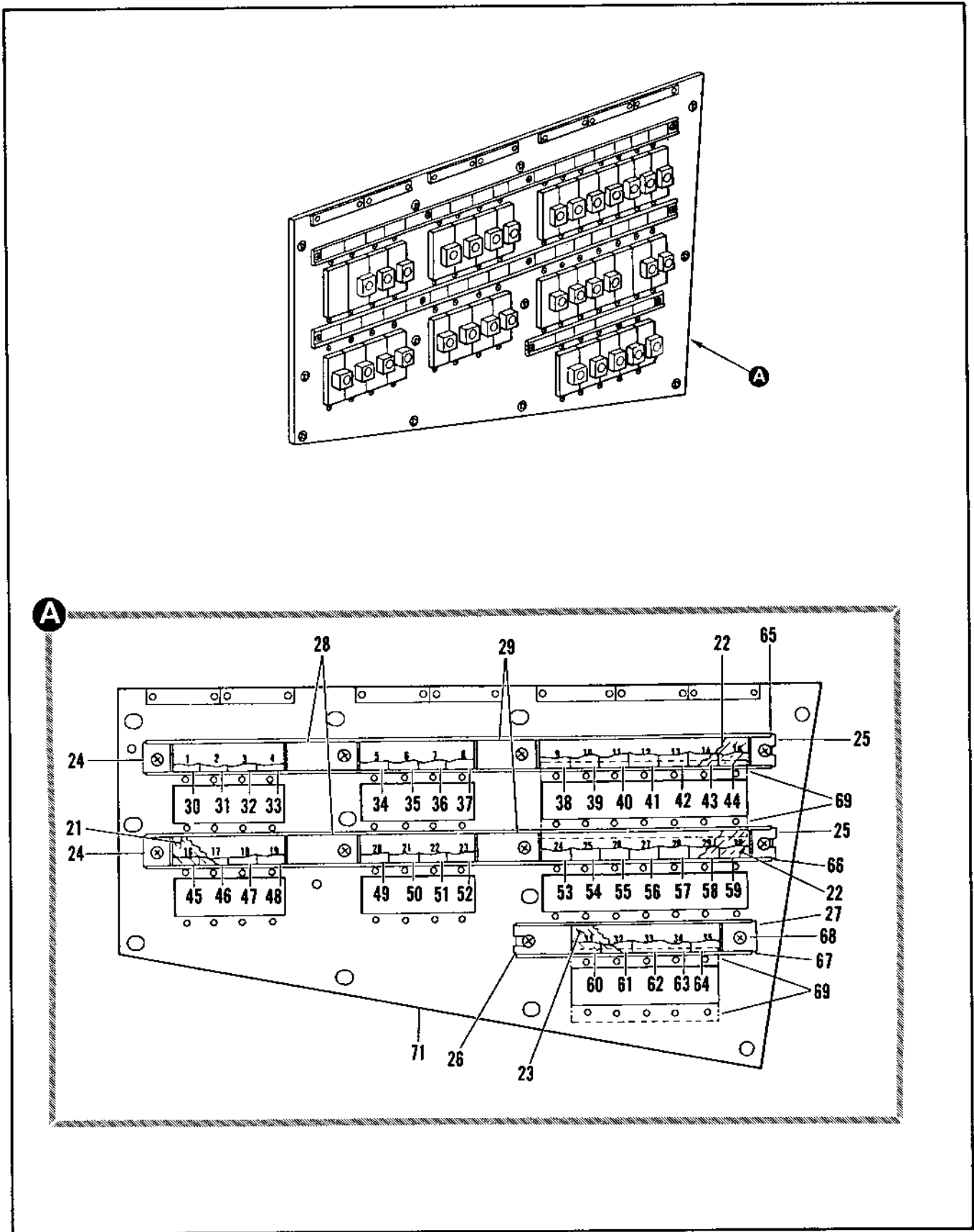

Figure 2.17-31. Cockpit Circuit Breaker Panel Assembly RH (Sheet 2 of 2)

FIGURE AND INDEX NUMBER	PART NUMBER	DESCRIPTION	UNITS PER ASSY.	USABLE ON CODE	
				FROM	TO
		1 2 3 4 5 6			
2.17-31- 21	A-65151-25	• PROTECTOR, NAMEPLATE	4	A	
- 22	8-65151-23	• PROTECTOR, NAMEPLATE	2	A	
- 23	8-65151-27	• PROTECTOR, NAMEPLATE	1	A	
- 24	8-62364-37	• STOP	?	A	
- 25	8-62364-35	• STOP	2	A	
- 26	8-62364-41	• STOP	1	A	
- 27	8-62364-39	• STOP	1	A	
- 28	8-62364-33	• SPACER	2	A	
- 29	8-62364-31	• SPACER	2	A	
- 30	8-62364-15	• NAMEPLATE, BLANK	1	A	
- 31	618340A7	• LABEL, FUSE MATTS	1	A	
- 32	8-62378-7	• NAMEPLATE, OXYGEN QTY 5 AMP	1	A	
- 33	8-62378-9	• NAMEPLATE, CABIN HEAT CONT 5 AMP	1	A	
- 34	8-61598-13	• NAMEPLATE, FORM LTS 3 AMP	1	A	
- 35	8-62378-109	• NAMEPLATE, CONSOLE LIGHTS PRIMARY 1 AMP	1	A	
- 36	8-62378-119	• NAMEPLATE, INST PNL LTS PRIMARY 3 AMP	1	A	
- 37	8-62378-17	• NAMEPLATE, EMER CKPT LTG 5 AMP	1	A	
- 38	8-62378-19	• NAMEPLATE, WARN LTS 5 AMP	1	A	
- 39	8-62378-21	• NAMEPLATE, WARN LTS DIM 5 AMP	1	A	
- 40	8-62378-23	• NAMEPLATE, MA WARN CONT 5 AMP	1	A	
- 41	7839892-35	• NAMEPLATE, STANDBY ATTITUDE INDICATOR, 5A	1	A	
- 42	64C34482-1	• NAMEPLATE, EGT 5 AMP	1	A	
- 43	8-62378-29	• NAMEPLATE, FIRE OVHT TEST 5 AMP	1	A	
- 44	8-62378-31	• NAMEPLATE, MAP READING LT 5 AMP	1	A	
- 45	8-62378-85	• NAMEPLATE, CONSOLE LIGHTS SEC 5 AMP	1	A	
- 46	8-62378-117	• NAMEPLATE, INST PNL LIGHTS SEC 5 AMP	1	A	
- 47	8-62378-89	• NAMEPLATE, ATTITUDE DIRECTOR IND 5 AMP	1	A	
- 48	8-62378-91	• NAMEPLATE, HOP SITUATION IND 5 AMP	1	A	
- 49	8-62378-97	• NAMEPLATE, HST MODE LIGHTS 1 AMP	1	A	
- 50	8-62378-121	• NAMEPLATE, RED CKPT FLOOD LTS PRIMARY 3 AMP	1	A	
- 51	8-62378-95	• NAMEPLATE, RED CKPT FLOOD LTS SEC 5 AMP	1	A	
- 52	8-62378-107	• NAMEPLATE, INST TRANS SEC 5 AMP	1	A	
- 53	8-62378-43	• NAMEPLATE, HYD PRESS WARN 5 AMP	1	A	
- 54	8-62378-45	• NAMEPLATE, OXYGEN LOW WARN 5 AMP	1	A	
- 55	8-62378-47	• NAMEPLATE, EMER CKPT LTS 5 AMP	1	A	
- 56	8-62378-49	• NAMEPLATE, CABIN HEAT VALVE 5 AMP	1	A	
- 57	8-62364-15	• NAMEPLATE, BLANK	1	A	
- 58	8-62378-99	• NAMEPLATE, HEADING SELECTOR SWITCH 5 AMP	1	A	
- 59	8-62378-103	• NAMEPLATE, BEARING SELECTOR SWITCH 5 AMP	1	A	
- 60	64C34482-3	• NAMEPLATE, FGT 1A BLUE	1	A	
- 61	8-62378-103	• NAMEPLATE, ALT AND VERT SPD-MACH AMPLS 5 AMP	1	A	
- 62	8-62378-71	• NAMEPLATE, VAR INLET PITOT HT 5 AMP	1	A	
- 63		• NAMEPLATE, VAR INLET PITOT HT LH 5 AMP	1	A	
- 64	8-62364-15	• NAMEPLATE, BLANK	1	A	
- 65	8-62362-37	• HOLDER, NAMEPLATE	1	A	
- 66	8-62362-39	• HOLDER, NAMEPLATE	1	A	
- 67	8-62362-43	• HOLDER, NAMEPLATE	1	A	
		ATTACHING PARTS			
- 68	AN523-10R6	• SCREW	10	A	
	AN967-10L	• WASHER	10	A	
		-----X-----			
- 69	8-62375-9	• STIFFENER	2	A	
- 70	8-62375-7	• STIFFENER	2	A	
- 71	8-62377-8	• PANEL	1	A	

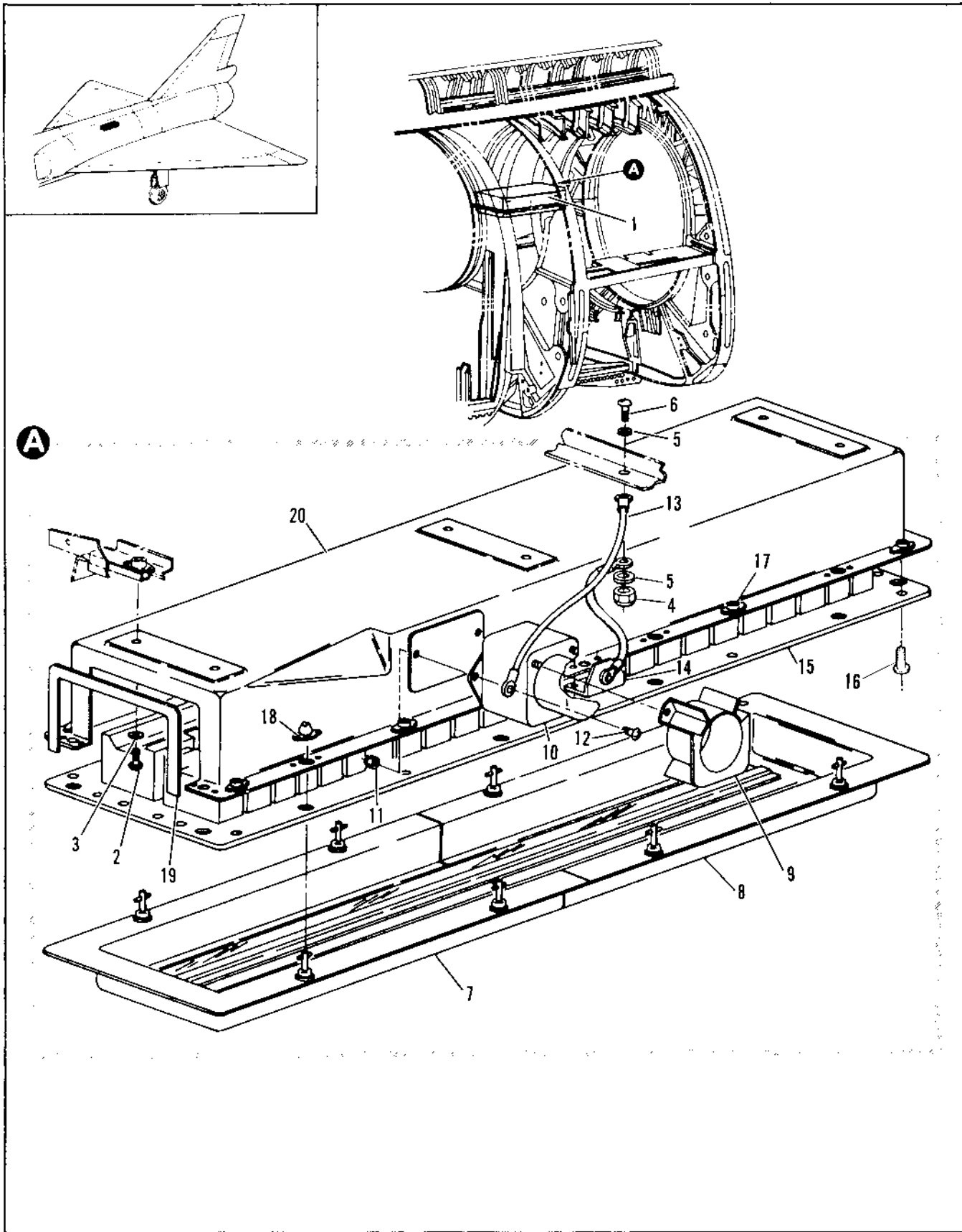

Figure 2.17-32. Main Wheel Well Circuit Breaker Panel Installation

FIGURE AND INDEX NUMBER	PART NUMBER	DESCRIPTION	UNITS PER ASSY.	USABLE ON CODE	
				FROM	TO
		1 2 3 4 5 8			
2.17-32	8-65043-809	PANEL INSTALLATION, MAIN WHEEL WELL	1	35	
- 1	8-65068-833	• PANEL ASSY, MAIN WHEEL WELL	1	35	47
	8-65068-835	• PANEL ASSY, MAIN WHEEL WELL	1	48	48
	8-65068-829	• PANEL ASSY, MAIN WHEEL WELL	1	49	89
	8-65068-831	• PANEL ASSY, MAIN WHEEL WELL	1	91	128
	8-65068-837	• PANEL ASSY, MAIN WHEEL WELL	1	131	159
	8-65068-839	• PANEL ASSY, MAIN WHEEL WELL	1	160	188
	8-65068-845	• PANEL ASSY, MAIN WHEEL WELL	1	189	215
	8-65068-843	• PANEL ASSY, MAIN WHEEL WELL	1	219	
		ATTACHING PARTS			
- 2	AN520-10R8	• SCREW	6	35	
- 3	99-51505-012	• WASHER	6	35	
- 4	NAS679A3	• NUT	1	35	
- 5	AN960D10L	• WASHER	2	35	
- 6	AN526-10-7	• SCREW	1	35	
		-----X-----			
- 7	8-65071-809	• • COVER ASSY, MAIN WHEEL WELL C.B. PANEL FWD FOR BREAKDOWN SEE FIG. 2.17-34	1	35	48
	8-65071-815	• • COVER ASSY, MAIN WHEEL WELL C.B. PANEL FWD FOR BREAKDOWN SEE FIG. 2.17-34	1	49	
- 8	8-65071-812	• • COVER ASSY, MAIN WHEEL WELL C.B. PANEL AFT FOR BREAKDOWN SEE FIG. 2.17-34	1	35	48
	8-65071-816	• • COVER ASSY, MAIN WHEEL WELL C.B. PANEL AFT FOR BREAKDOWN SEE FIG. 2.17-34	1	49	
- 9	49-2667-2	• • COVER, <15605> 92-74400-001	1	35	
- 10	MS24140D2	• • RELAY	1	35	
		ATTACHING PARTS			
- 11	NAS679A3	• • NUT	2	35	
- 12	AN520-10R10	• • SCREW	2	35	
		-----X-----			
- 13	MS25083-2R84	• • JUMPER	1	35	89
- 14	8-65071-65	• • JUMPER ASSEMBLY	1	35	
- 15	8-65070-827	• • PANEL ASSY, MAIN WHEEL WELL C.B. FOR BREAKDOWN SEE FIG. 2.17-33	1	A	
	7242886-10	• • PANEL INSTL, MAIN WHEEL WELL FOR BREAKDOWN SEE FIG 2.17-33	1	35	47
	7242886-30	• • PANEL INSTL, MAIN WHEEL WELL FUSE FOR BREAKDOWN SEE FIG. 2.17-33	1	49	89
	7242886-50	• • PANEL INSTL, MAIN WHEEL WELL C.B. FOR BREAKDOWN SEE FIG. 2.17-35	1	48	48
	7242886-70	• • PANEL INSTL, MAIN WHEEL WELL C.B. FOR BREAKDOWN SEE FIG. 2.17-35	1	91	128
	7242886-90	• • PANEL INSTL, MAIN WHEEL WELL FOR BREAKDOWN SEE FIG. 2.17-35	1	131	159
	7242886-113	• • PANEL INSTL, MAIN WHEEL WELL C.B. FOR BREAKDOWN SEE FIG. 2.17-35	1	160	188
	7242886-130	• • PANEL INSTL, MAIN WHEEL WELL C.B. FOR BREAKDOWN SEE FIG. 2.17-35	1	189	215
	7242886-150	• • PANEL INSTL, MAIN WHEEL WELL C.B. FOR BREAKDOWN SEE FIG. 2.17-35	1	219	
- 16	AN509-10R6	• • SCREW	10	35	
		-----X-----			
	8-65071-813	• • BOX ASSY, MAIN WHEEL WELL CB PANEL REPLACED BY NOT INTCHG WITH 8-65071-817	1	35	48
	8-65071-817	• • BOX ASSY, MAIN WHEEL WELL CB PANEL REPLACES NOT INTCHG WITH 8-65071-813	1	49	
- 17	212-12N	• • • RECEPTACLE, FASTENER <71286> 97-31002-002	7	35	
- 18	5R2-1	• • RECEPTACLE, FASTENER<71286> 97-31014-001	1	35	48
	212-12N	• • • RECEPTACLE, FASTENER <71286> 97-31002-002	1	49	
- 19	8-65071-49	• • • DOUBLFF	01	35	
- 20	8-65071-47	• • • BOX	1	35	

A AIRPLANES #35 THRU 47 AND 49 THRU 89

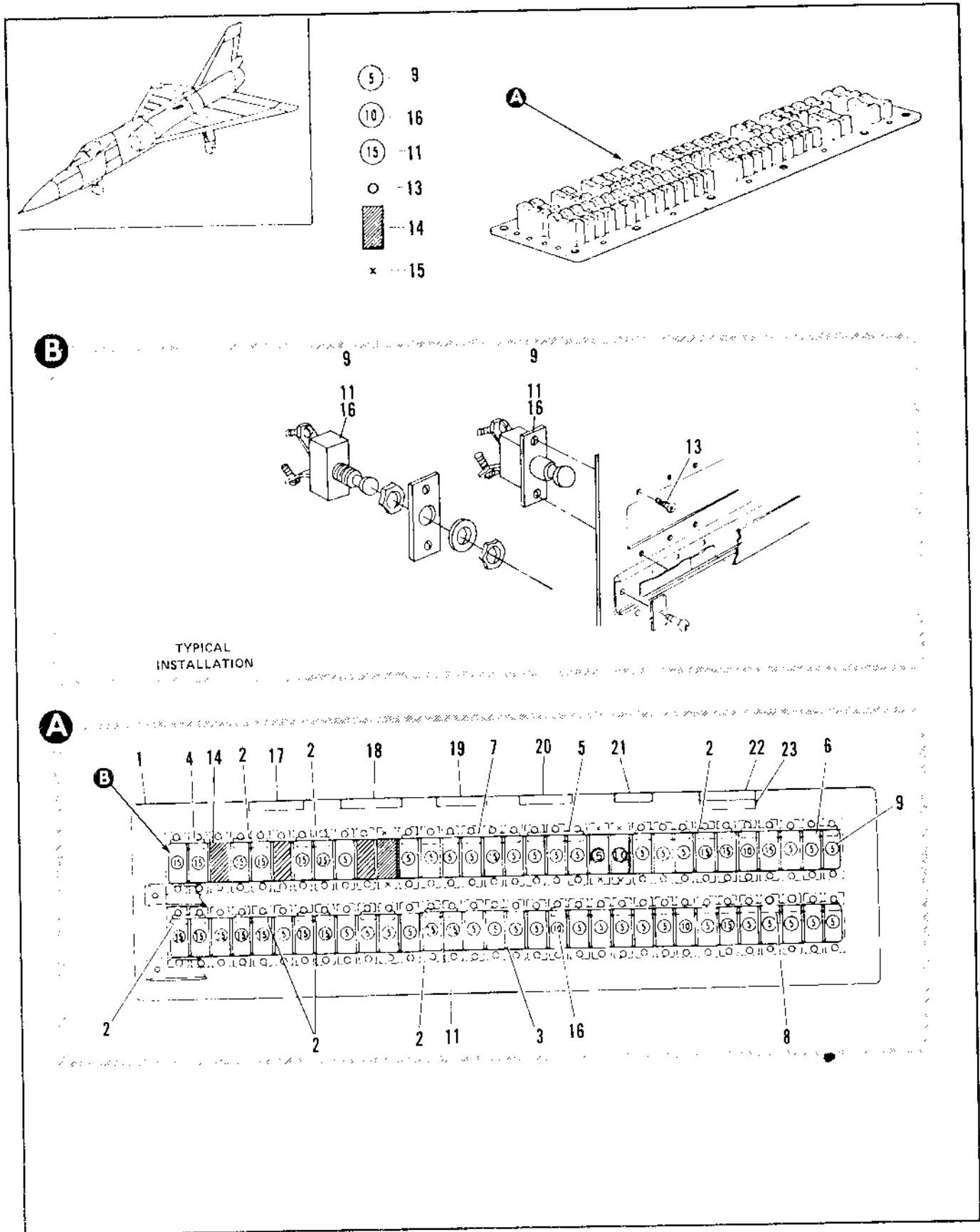

Figure 2.17-33. Main Wheel Well Circuit Breaker Panel Assembly (Sheet 1 of 2)

FIGURE AND INDEX NUMBER	PART NUMBER	DESCRIPTION	UNITS PER ASSY.	USABLE ON CODE	
				FROM	TO
2.17-33- 1	7242886-10	PANEL INSTL, MAIN WHEEL WELL FUSE FOR NHA SEE FIG. 2.17-32	RF	35	47
	7242886-30	• PANEL INSTL, MAIN WHEEL WELL FUSE FOR NHA SEE FIG. 2.17-32	RF	49	89
- 2	8-65029-7	• BUSBAR	8	A	
- 3	8-65029-7	• BUSBAR	1	A	
- 4	8-65029-7	• BUSBAR	2	A	
- 5	8-65029-9	• BUSBAR	2	A	
- 6	8-65029-25	• BUSBAR	1	A	
- 7	8-65029-13	• BUSBAR	1	A	
- 8	8-65029-37	• BUSBAR	1	A	
- 9	D7271-3-5	• CIRCUIT BREAKER (82647)	36	A	
	7271-R-5	• CIRCUIT BREAKER, ALT INTERCHG WITH 07271-3-5	36	A	
	7747307	• PLATE, MOUNTING	36	A	
- 10	DELETED				
- 11	D7271-3-15	• CIRCUIT BREAKER (82647)	20	A	
	7271-R-15	• CIRCUIT BREAKER, ALT, INTERCHG WITH 07271-3-15	20	A	
	7747307	• PLATE, MOUNTING (82647)	20	A	
- 12	DELETED				
- 13	MS35206-230	ATTACHING PARTS • SCREW	118	A	
- 14	9-62300	• PLATE ASSY, FILLER RIVETED ATTACHING PARTS	3	A	
- 15	MS35206-230	• SCREW	6	A	
- 16	D7271-3-10	• CIRCUIT BREAKER	3	A	
	7271-R-10	• CIRCUIT BREAKER ALT, INTERCHG WITH 7271-3-10 (82647)	3	A	
	7747307	• PLATE, MOUNTING	3	A	
- 17	8-65149-85	• NAMEPLATE, COLOR CODE	1	A	
- 18	8-65149-81	• NAMEPLATE, 115/200V AC NON-ESS	1	A	
- 19	8-65149-89	• NAMEPLATE, 115/200 AC ESS	1	A	
- 20	8-65149-87	• NAMEPLATE, 28V DC NON-ESS	1	A	
- 21	8-65149-91	• NAMEPLATE, 28V DC ESS	1	A	
- 22	8-65149-83	• NAMEPLATE, 14-28V AC NON-ESS	1	A	
- 23	8-61598-21	• NAMEPLATE, 6-28V AC NON-ESS	1	A	

A AIRPLANES #35 THRU 47 AND 49 THRU 89

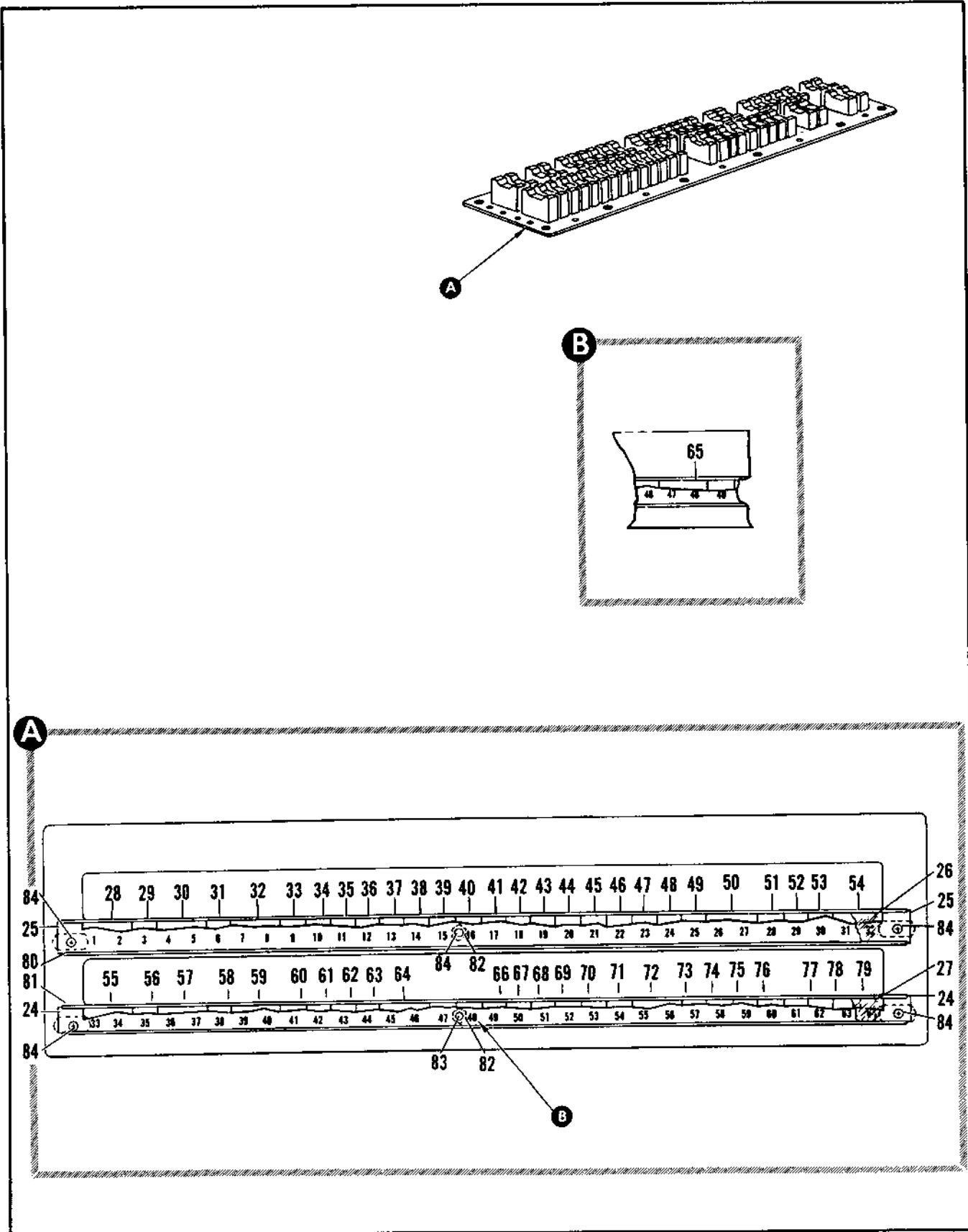

Figure 2.17-33. Main Wheel Well Circuit Breaker Panel Assembly (Sheet 2 of 2)

FIGURE AND INDEX NUMBER	PART NUMBER	DESCRIPTION	UNITS PER ASSY.	USABLE ON CODE	
				FROM	TO
		1 2 3 4 5 6			
2.17-33- 24	8-62364-11	• STOP, NAMEPLATE	2	A	
- 25	8-62364-13	• STOP, NAMEPLATE	1	A	
- 26	8-65151-17	• PROTECTOR, NAMEPLATE	1	A	
- 27	8-65151-21	• PROTECTOR, NAMEPLATE	1	A	
- 28	8-65150-7	• NAMEPLATE, BSTR PUMP 15 AMP C	1	A	
- 29	8-62364-7	• PLATE, BLANK	1	A	
- 30	8-65150-9	• NAMEPLATE, BSTR PUMP 15 AMP B	1	A	
- 31	8-62364-7	• PLATE, BLANK	1	A	
- 32	8-65150-11	• NAMEPLATE, BSTR PUMP 15 AMP A	1	A	
- 33	8-65150-93	• NAMEPLATE, PITCH G LIMIT 5 AMP	1	A	
- 34	8-62364-7	• PLATE, BLANK	1	A	
- 35	8-62364-7	• NAMEPLATE, BLANK	1	A	
- 36	8-65150-15	• NAMEPLATE, EXT FUEL SHUTOFF 5 AMP	1	A	
- 37	8-65150-131	• NAMEPLATE, VARI RAMP TIME DELAY	1	A	
- 38	8-65150-17	• NAMEPLATE, UPPER INTAKE HEATER 5 AMP	1	A	
- 39	8-65150-19	• NAMEPLATE, LOWER INTAKE HEATER 5 AMP	1	A	
- 40	8-65150-21	• NAMEPLATE, ICE DET INT 15 AMP	1	A	
- 41	8-65150-23	• NAMEPLATE, LOWER REACON LT 5 AMP	1	A	
- 42	8-65150-25	• NAMEPLATE, TANK PRESS LOW 5 AMP	1	A	
- 43	8-65150-27	• NAMEPLATE, OIL PRESS LOW 5 AMP	1	A	
- 44	8-65150-29	• NAMEPLATE, PNEU PRESS LOW 5 AMP	1	A	
- 45	7545365-17	• NAMEPLATE, A.I.S. POD 5 AMP	1	A	
- 46	7545365-21	• NAMEPLATE, A.I.S. POD 10 AMP PHASE C	1	A	
- 47	66C4356R-1	• NAMEPLATE, BLANK	1	A	
- 48	8-61411-7	• NAMEPLATE, TACAN ILS EMERG			
- 49	8-65150-35	• NAMEPLATE, START CONT 5 AMP	1	A	
- 50	8-65150-99	• NAMEPLATE, FUEL TRANS PWR 15 AMP	1	A	
- 51	8-65150-39	• NAMEPLATE, START PWR 10 AMP	1	A	
- 52	8-65150-41	• NAMEPLATE, ENG IGN 15 AMP	1	A	
- 53	8-61432-9	• NAMEPLATE, JET PUMP VALVE	1	A	
- 54	8-65150-43	• NAMEPLATE, FUEL SCAV SOL LH 5 AMP RH 5 AMP	1	A	
- 55	8-65150-45	• NAMEPLATE, BSTR PUMP 15 AMP C	1	A	
- 56	8-65150-47	• NAMEPLATE, TURN RATE XMTR 5 AMP C	1	A	
- 57	8-65150-49	• NAMEPLATE, BSTR PUMP 15 AMP B	1	A	
- 58	8-65150-51	• NAMEPLATE, TURN RATE XMTR 5 AMP B	1	A	
- 59	8-65150-53	• NAMEPLATE, BSTR PUMP 15 AMP A	1	A	
- 60	8-65150-55	• NAMEPLATE, TURN RATE XMTR 5 AMP A	1	A	
- 61	8-61598-7	• NAMEPLATE, FIN LT 5A	1		
- 62	8-65150-59	• NAMEPLATE, FUS LTS 5 AMP	1	A	
- 63	8-65150-61	• NAMEPLATE, ELEVON TRIM 5 AMP INTCHG WITH 8-65150-111	1	A	
- 64	8-65150-101	• NAMEPLATE, LOS LTS 15 AMP	1		
- 65	8-61598-9	• NAMEPLATE, WING LTS LH 5 AMP RH 5 AMP	1		
- 66	8-65150-65	• NAMEPLATE, AC EMER PWR CONT 5 AMP	1	A	
- 67	8-65150-67	• NAMEPLATE, RADOME ANTI-ICE 5 AMP	1	A	
- 68	8-65150-69	• NAMEPLATE, ANTI-ICE PWR 10 AMP	1	A	
- 69	8-65150-71	• NAMEPLATE, FIRE OVHT WARN 5 AMP	1	A	
- 70	8-65150-73	• NAMEPLATE, COMPT PRESS VARV 5 AMP	1	A	
- 71	8-65150-75	• NAMEPLATE, BSTR PRESS LOW 5 AMP	1	A	
- 72	8-65150-77	• NAMEPLATE, PWR FAIL WARN 5 AMP	1	A	
- 73	8-65150-79	• NAMEPLATE, TANK EJECT PWR 10 AMP	1	A	
- 74	8-65150-113	• NAMEPLATE, HYD SYS OVER TEMP WARN 5 AMP	1		

FIGURE AND INDEX NUMBER	PART NUMBER	DESCRIPTION	UNITS PER ASSY.	USABLE ON CODE	
				FROM	TO
		1 2 3 4 5 6			
2.17-33- 75	8-65150-81	• NAMEPLATE, AB PWR 15 AMP	1	A	
- 76	8-65150-83	• NAMEPLATE, OIL COOL CONT 5 AMP	1	A	
- 77	8-65150-95	• NAMEPLATE, TANK SCAV SOL 5 AMP	1	A	
- 78	8-65150-85	• NAMEPLATE, FUEL FLOW BY-PASS 5 AMP	1	A	
- 79	8-65150-87	• NAMEPLATE, ENG AND COOL 5 AMP	1	A	
- 80	8-62362-25	• HOLDER, NAMEPLATE	1	A	
- 81	8-62362-27	• HOLDER, NAMEPLATE	1	A	
		ATTACHING PARTS			
- 82	NAS679A3	• NUT	2	A	
- 83	AN509-10R4	• SCREW	2	A	
- 84	AN525-1032R6	• SCREW	4	A	
		----X----			
	8-65069-19	• PANEL	1	A	
		A AIRPLANES #35 THRU 47 AND 49 THRU 89			

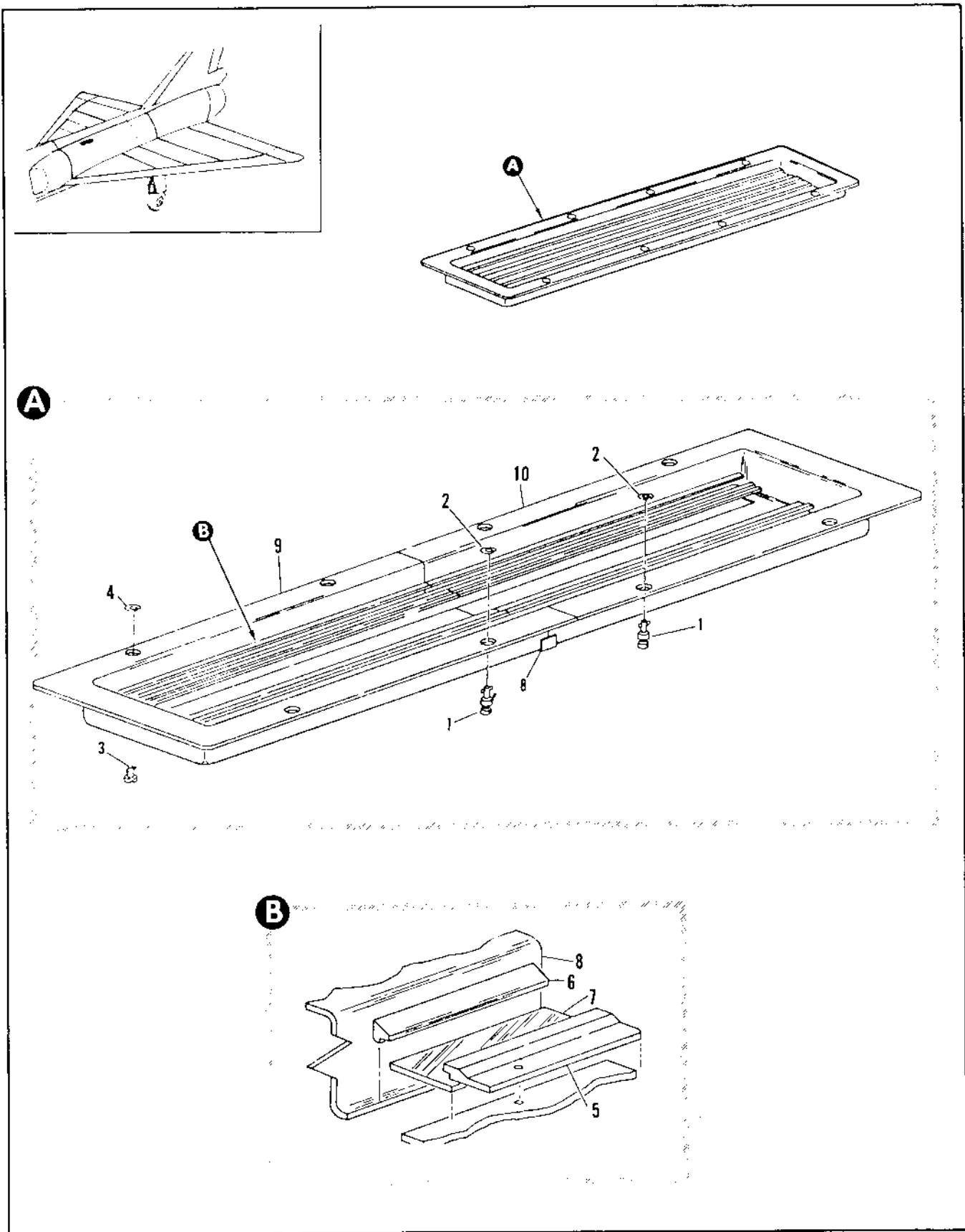

Figure 2.17-34. Main Wheel Well Fuse Panel Cover Assembly

FIGURE AND INDEX NUMBER	PART NUMBER	DESCRIPTION	UNITS PER ASSY.	USABLE ON CODE	
				FROM	TO
		1 2 3 4 5 6			
2.17-34	8-65071-809	COVER ASSEMBLY, MAIN WHEEL WELL C.B. PANEL FWD REPLACED BY NOT INTCHG WITH 8-65071-815 FOR NHA SEE FIG. 2.17-32	RF	35	48
	8-65071-815	COVER ASSEMBLY, MAIN WHEEL WELL C.B. PANEL FWD REPLACES NOT INTCHG WITH 8-65071-809 FOR NHA SEE FIG. 2.17-32	RF	49	
	8-65071-812	COVER ASSEMBLY, MAIN WHEEL WELL C.B. PANEL AFT REPLACED BY SUITABLE SUB 8-65071-816 FOR NHA SEE FIG. 2.17-32	RF	35	48
	8-65071-816	COVER ASSEMBLY, MAIN WHEEL WELL C.B. PANEL AFT REPLACES SUITABLE SUB FOR 8-65071-812 FOR NHA SEE FIG. 2.17-32	RF	49	
- 1	2600-12	• STUD, FASTENER FWD <71286> 98-58001-012	3	35	
	2600-12	• STUD, FASTENER AFT <71286> 98-58001-012	4	35	
- 2	2600SW	• WASHER, FASTENER FWD <71286> 99-53600-002	3	35	
	2600SW	• WASHER, FASTENER AFT <71286> 99-53600-002	4	35	
- 3	5S5-18	• STUD, FASTENER FWD <71286> 98-56506-006	1	35	
- 4	5S3-1	• WASHER, FASTENER FWD <71286> 99-53600-003	1	35	
- 5	8-65071-59	• RETAINER	1	35	
	8-65071-50	• RETAINER	1	35	
- 6	8-65071-61	• BEZEL	2	35	
- 7	8-65071-57	• WINDOW	2	35	
- 8	8-65071-62	• STRIP	1	49	
- 9	8-65071-63	• COVER, FWD	1	35	
- 10	8-65071-64	• COVER, AFT	1	35	

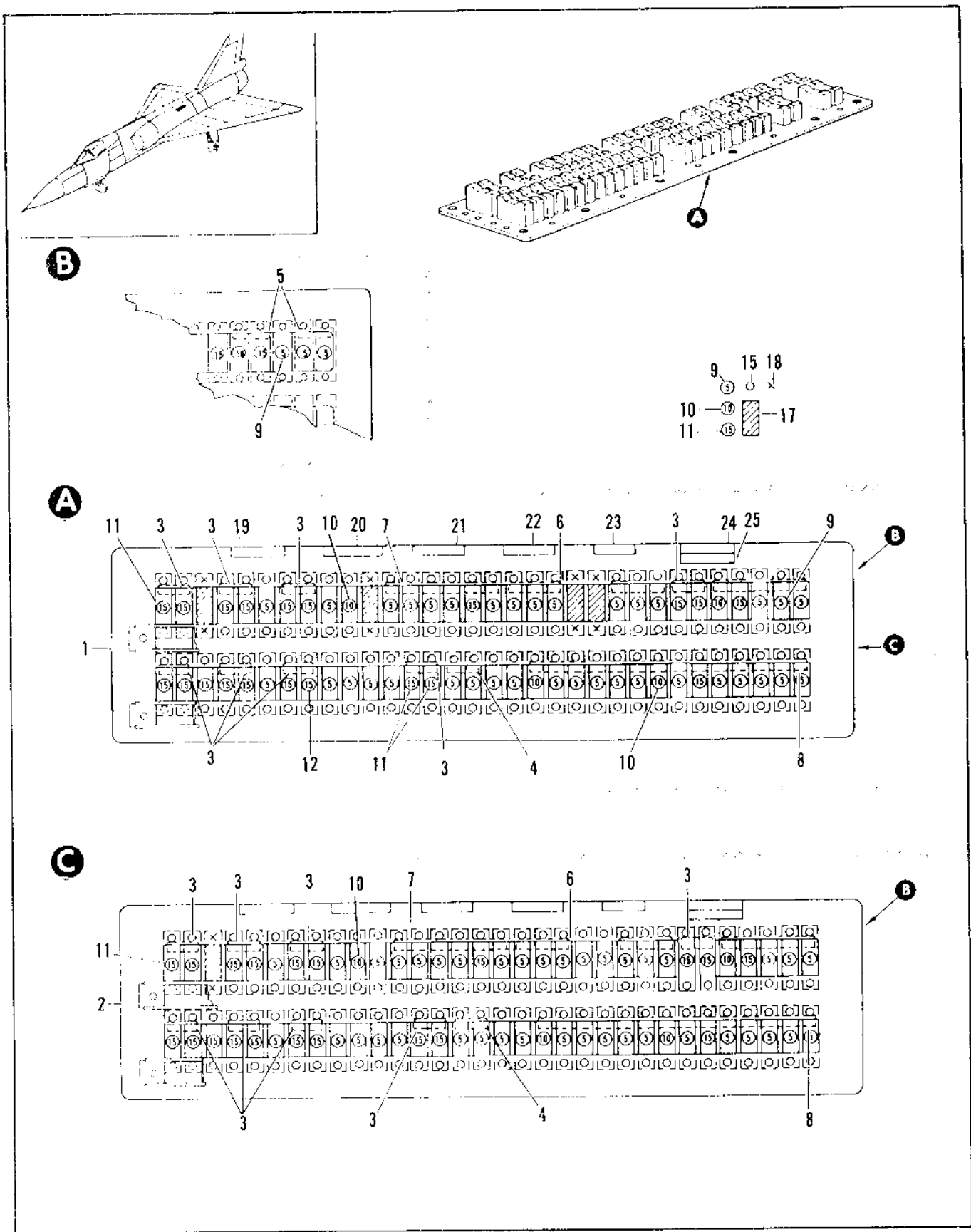

Figure 2.17-35. Main Wheel Well Circuit Breaker Panel Assembly (Sheet 1 of 2)

FIGURE AND INDEX NUMBER	PART NUMBER	DESCRIPTION	UNITS PER ASSY.	USABLE ON CODE	
				FROM	TO
		1 2 3 4 5 6			
2.17-35- 1	7242886-50	PANEL ASSEMBLY, MAIN WHEEL WELL FUSE FOR NHA SEE FIG. 2.17-32	RF	48	48
	7242886-70	PANEL ASSEMBLY, MAIN WHEEL WELL FUSE FOR NHA SEE FIG. 2.17-32		91	128
	7242886-90	PANEL ASSEMBLY, MAIN WHEEL WELL FUSE FOR NHA SEE FIG. 2.17-32		131	159
	7242886-110	PANEL ASSEMBLY, MAIN WHEEL WELL FUSE FOR NHA SEE FIG. 2.17-32		160	188
	7242886-130	PANEL ASSEMBLY, MAIN WHEEL WELL FUSE FOR NHA SEE FIG. 2.17-32		189	215
- 2	7242866-150	• PANEL ASSEMBLY, MAIN WHEEL WELL FUSE FOR NHA SEE FIG. 2.17-32	RF	A	
- 3	8-65029-7	• BUSBAR	8	B	
- 4	8-65029-7	• BUSBAR			
- 5	8-65029-7	• BUSBAR	1		
- 6	8-65029-9	• BUSBAR	1	B	
- 7	8-65029-13	• BUSBAR	1	B	
- 8	8-65029-37	• BUSBAR	1	B	
- 9	D7271-3-5	• CIRCUIT BREAKER (82647)	36	B	
	7271-8-5	• CIRCUIT BREAKER, ALT INTCHG WITH D7271-3-5 (82647)	36	B	
	7747309	• • PLATE MOUNTING	36	B	
- 10	07271-3-10	• CIRCUIT BREAKER (82647)	4	B	
	7271-A-10	• CIRCUIT BREAKER, ALT INTCHG WITH 07271-3-10 (82647)	4	B	
	7747307	• • PLATE MOUNTING	4	B	
- 11	7271-3-15	• CIRCUIT BREAKER (82647)	19	B	
- 12	7172-8-15	• CIRCUIT BREAKER, ALT INTCHG WITH 7271-3-15 (82647)	19	B	
	7747307	• • PLATE MOUNTING	19	B	
- 13	DELETED				
- 14	DELETED				
- 15	MS35206-230	• SCREW	1178	B	
- 16					
- 17	8-62300	• PLATE ASSY, FILLER RIVETED ATTACHING PARTS	4	B	
- 18	MS35206-230	• SCREW	8	B	
- 19	8-65149-85	• NAMEPLATE, COLOR CODE	1	B	
- 20	8-65149-81	• NAMEPLATE, 115/200V AC NON-ESS	1	B	
- 21	8-65149-89	• NAMEPLATE, 115/200V AC ESS	1	B	
- 22	8-65149-87	• NAMEPLATE, 28V DC NON-ESS	1	B	
- 23	8-65149-61	• NAMEPLATE, 28V DC ESS	1	B	
- 24	8-65149-83	• NAMEPLATE, 14-28V AC NON-ESS	1	B	
- 25	8-61598-21	• NAMEPLATE, 6-28V AC NON-ESS	1	B	

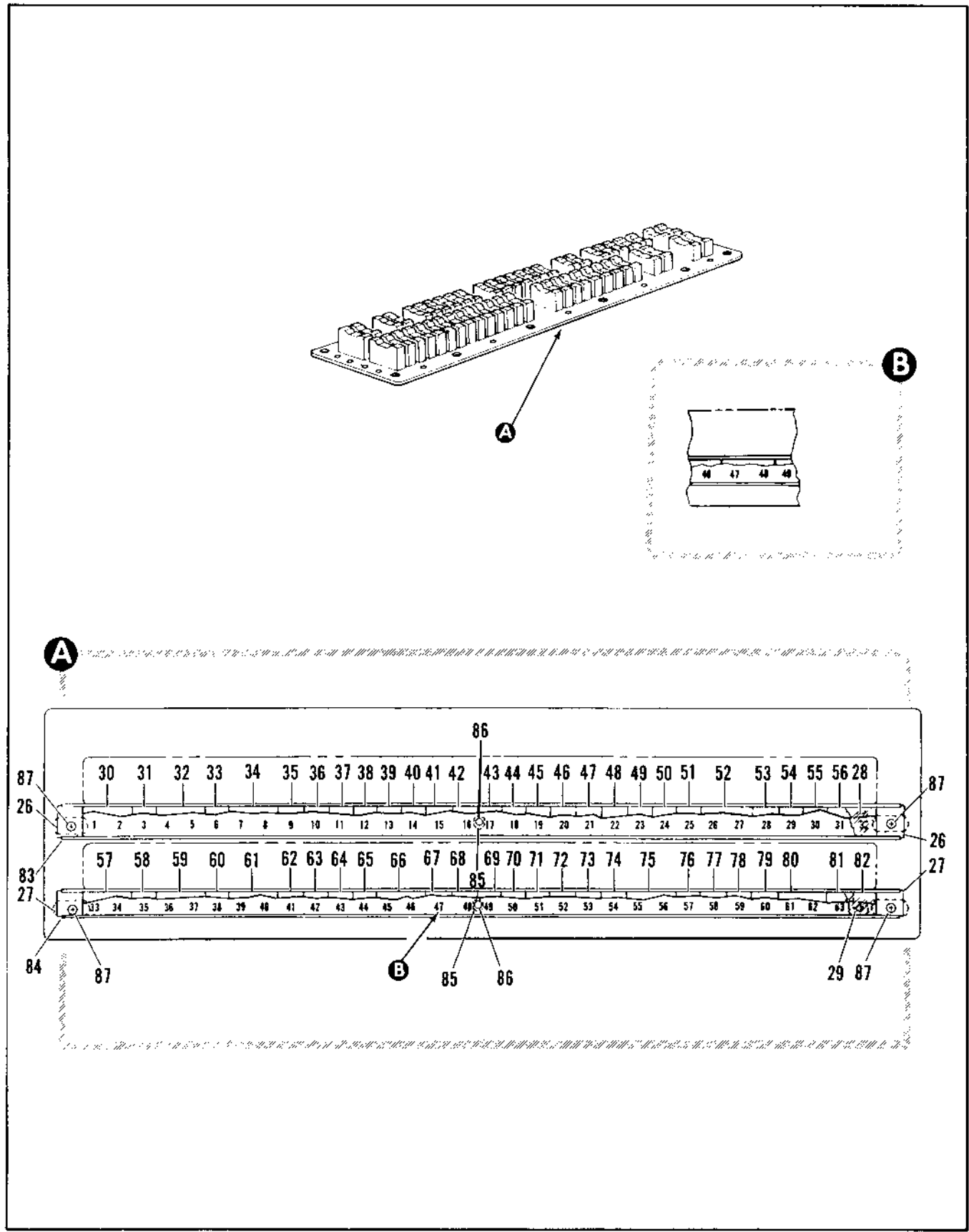

Figure 2.17-35. Main Wheel Well Circuit Breaker Panel Assembly (Sheet 2 of 2)

FIGURE AND INDEX NUMBER	PART NUMBER	DESCRIPTION	UNITS PER ASSY.	USABLE ON CODE	
				FROM	TO
		1 2 3 4 5 6			
2.17-13- 26	A-62354-47	• STOP, NAMEPLATE	2	R	
- 27	A-62354-45	• STOP, NAMEPLATE	2	R	
- 28	P-65151-17	• PROTECTOR, NAMEPLATE	1	R	
- 29	P-65151-21	• PROTECTOR, NAMEPLATE	1	3	
- 30	A-65150-7	• NAMEPLATE, BSTR PUMP 10 AMP PHASE C	1	R	
- 31	7242997-31	• PLATE, DESIGNATION 5	1	R	
- 32	A-65150-9	• NAMEPLATE, BSTR PUMP 10 AMP PHASE B	1	3	
+ 33	7545360-13	• NAMEPLATE, A.I.S. POD 5 AMP PHASE C	1	R	
- 34	A-65150-11	• NAMEPLATE, BSTR PUMP 10 AMP PHASE A	1	B	
- 35	A-65150-03	• NAMEPLATE, PITCH G LIMIT 5 AMP	1	R	
- 36	7545360-15	• NAMEPLATE, A.I.S. POD 10 AMP	1	R	
- 37	A-62357-7	• NAMEPLATE, BLANK			
- 38	A-65150-15	• NAMEPLATE, F TANK BOOST POWER 5A PHASE A	1	A	
- 39	A-65150-131	• NAMEPLATE, EXT FUEL SHUTOFF 5 AMP	1	R	
- 40	A-65150-17	• NAMEPLATE, VARI RAMP TIME DELAY	1	B	
- 41	A-65150-19	• NAMEPLATE, UPPER INTAKE HEATER 5 AMP	1	B	
- 42	A-65150-21	• NAMEPLATE, LOWER INTAKE HEATER 5 AMP	1	B	
- 43	A-65150-23	• NAMEPLATE, ICE DET INT 10 AMP	1	P	
- 44	A-65150-25	• NAMEPLATE, LOWER BEACON LT 5 AMP	1	R	
- 45	A-65150-27	• NAMEPLATE, TANK PRESS LOW 5 AMP	1	R	
- 46	A-65150-29	• NAMEPLATE, OIL PRESS LOW 5 AMP	1	R	
- 47	A-62357-7	• NAMEPLATE, BLANK			
- 48	A-62357-7	• NAMEPLATE, F TANK BOOST POWER 5A PHASE B	1	C	
- 49	86C4 56H-1	• NAMEPLATE, BLANK	1	A	
- 50	P-61411-7	• NAMEPLATE, EXTERNAL TANK EMPTY IND 5 AMP	1		
- 51	A-65150-25	• NAMEPLATE, FACAV ILS EMERG	1	R	
- 52	A-65150-59	• NAMEPLATE, START CONT 5 AMP	1	B	
- 53	A-65150-39	• NAMEPLATE, FUEL TRANS PUR 10 AMP	1	R	
- 54	A-65150-41	• NAMEPLATE, START, PWR 10 AMP	1	R	
- 55	A-61432-5	• NAMEPLATE, ENG IC 15 AMP	1	B	
- 56	A-65150-43	• NAMEPLATE, JET PUMP VALVE	1	R	
- 57	A-65150-45	• NAMEPLATE, FUEL SCAV SOL 5 AMP	1	R	
- 58	A-65150-47	• NAMEPLATE, BSTR PUMP 10 AMP PHASE C	1	R	
- 59	A-65150-49	• NAMEPLATE, TURN RATE XMTR 5 AMP PHASE C	1	R	
- 60	A-65150-51	• NAMEPLATE, BSTR PUMP 10 AMP PHASE B	1	R	
- 61	A-65150-53	• NAMEPLATE, TURN RATE XMTR 5 AMP PHASE B	1	R	
- 62	A-65150-55	• NAMEPLATE, BSTR PUMP 10 AMP PHASE A	1	3	
- 63	A-65150-57	• NAMEPLATE, TURN RATE XMTR 5 AMP PHASE A	1	H	
- 64	A-65150-59	• NAMEPLATE, FIM LT 5 AMP	1	R	
- 65	A-65150-61	• NAMEPLATE, FUS LTS 5 AMP	1	R	
- 66	A-65150-101	• NAMEPLATE, ELEVON TRIM 5 AMP	1	R	
- 67	A-65150-103	• NAMEPLATE, LOG LTS 15 AMP	1	R	
- 68	A-65150-105	• NAMEPLATE, LOG LTS LH 15 AMP RH 15 AMP	1	P	
- 69	A-61548-3	• REPLACES NOT IN CHG WITH A-65150-101			
- 70	A-61548-5	• NAMEPLATE, WING LTC LH 5 AMP			
- 71	A-61548-7	• NAMEPLATE, WING LTC RH 5 AMP			
- 72	A-65150-65	• NAMEPLATE, AC EMER FUR CONT 5 AMP	1	B	
- 73	A-65150-67	• NAMEPLATE, PADOME ANTI-ICE 5 AMP	1	B	
- 74	A-65150-69	• NAMEPLATE, ANTI-ICE PUR 10 AMP	1	S	
- 75	A-65150-71	• NAMEPLATE, PIPE OVHT WARN 5 AMP	1	R	
- 76	A-65150-73	• NAMEPLATE, COMET PRESS VARI 5 AMP	1	R	
- 77	A-65150-75	• NAMEPLATE, BSTR PRESS LOW 5 AMP	1	R	

FIGURE AND INDEX NUMBER	PART NUMBER	DESCRIPTION 1 2 3 4 5 6	UNITS PER ASSY.	USABLE ON CODE	
				FROM	TO
2.17-35-	R-65150-77	• NAMEPLATE, PWR FAIL WARN 5 AMP	1		B
- 76	R-65150-79	• NAMEPLATE, TANK EJECT PWR 10 AMP	1		R
- 77	R-65150-117	• NAMEPLATE, HYD SYS OVER TEMP WARN 5 AMP	1		B
- 78	R-65150-81	• NAMEPLATE, HP PWR 15 AMP	1		B
- 79	R-65150-83	• NAMEPLATE, OIL COOL CONT 5 AMP	1		B
- 80	R-65150-95	• NAMEPLATE, TANK SCAV SOL 5 AMP	1		B
- 81	R-65150-85	• NAMEPLATE, FUEL FLOW BY-PASS 5 AMP	1		B
- 82	R-65151-97	• NAMEPLATE, ENG AND COOL 5 AMP	1		B
- 83	R-62362-25	• HOLDER, NAMEPLATE	1		B
- 84	R-62362-27	• HOLDER, NAMEPLATE	1		B
- 85	NAS679A3	• NUT	2		B
- 86	ANS29-10R4	• SCREW	2		B
- 87	ANS26-1032R6	• SCREW	4		B
		-----X-----			
	R-65069-19	• PANEL	1		B
<p>A AIRPLANES #1 THRU 34, 219 AND ON B ALL VERTICAL INSTRUMENTED AIRPLANES C FOR SOME VERTICAL INSTRUMENTED AIRPLANES</p>					

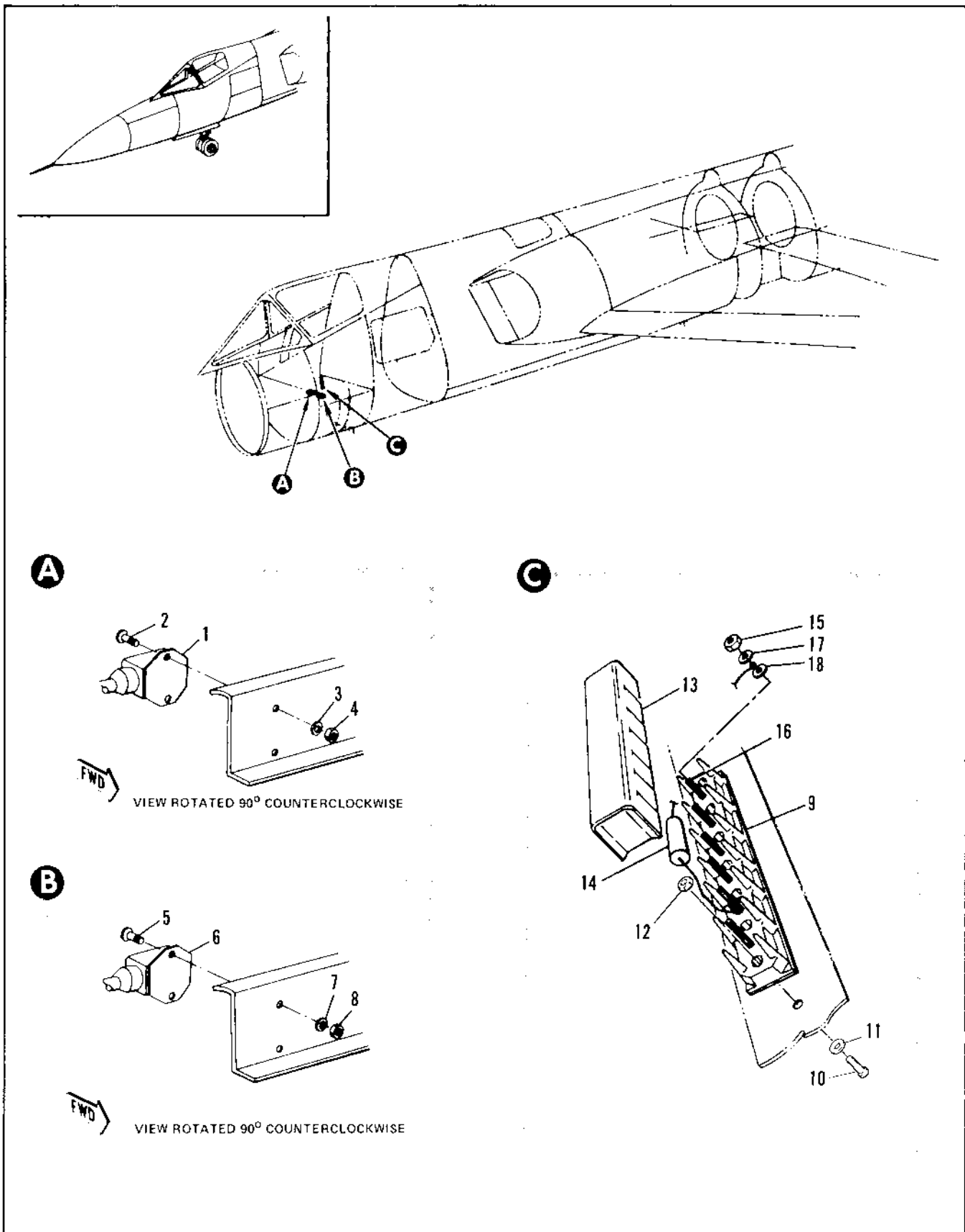

Figure 2.17-36. Barrier Hook Indicator Light Relay Installation

FIGURE AND INDEX NUMBER	PART NUMBER	DESCRIPTION 1 2 3 4 5 6	UNITS PER ASSY.	USABLE ON CODE	
				FROM	TO
2.17 36	62034040	RELAY INSTL, BARRIER HOOK INDICATOR LIGHT	REF		
- 1	P222-3473	• RELAY, BARRIER HOOK INDICATOR LIGHT TEST STA 147-90 <35344> ATTACHING PARTS	1		
- 2	AN520010R5	• SCREW	2		
- 3	AN961010L	• WASHER	2		
- 4	MS2236401032	• NUT	2		
		-----X-----			
- 5	9224-3452	• RELAY, BARRIER HOOK INDICATOR LIGHT DIMMING STA 152.90 <35344> ATTACHING PARTS	1		
- 6	AN520010R5	• SCREW	2		
- 7	AN961010L	• WASHER	2		
- 8	MS2236401032	• NUT	2		
		-----X-----			
- 9	AN3436-1-6	• TERMINAL BLOCK ASSY, REPLACED BY SUITABLE SUR MS25123-1-20	1		
	MS25123-1-6	• TERMINAL BLOCK ASSY, REPLACED SUITABLE SUR FOR AN3436-1-6 ATTACHING PARTS	REF		
- 10	AN510004R7	• SCREW	2		
- 11	AN96 04	• WASHER	2		
- 12	MS21.47-04	• NUT	2		
		-----X-----			
- 13	197-A	• COVER, TERMINAL BLOCK <49641> REPLACED BY SUITABLE SUR 412A-2	1		
	412B-6-20	• COVER, TERMINAL BLOCK, REPLACES SUITABLE SUR 337-A	REF		
		RESISTOR INSTALLATION, DIMMING AFK-72			
- 14	RW55V131	• RESISTOR	1	35	
- 15	MS20341-64	• NUT	2	35	
- 16	MS25116-2	• TERMINAL LUG	2	35	
- 17	AN961-6L	• WASHER	2	35	
- 18	AN963-6L	• WASHER	2	35	

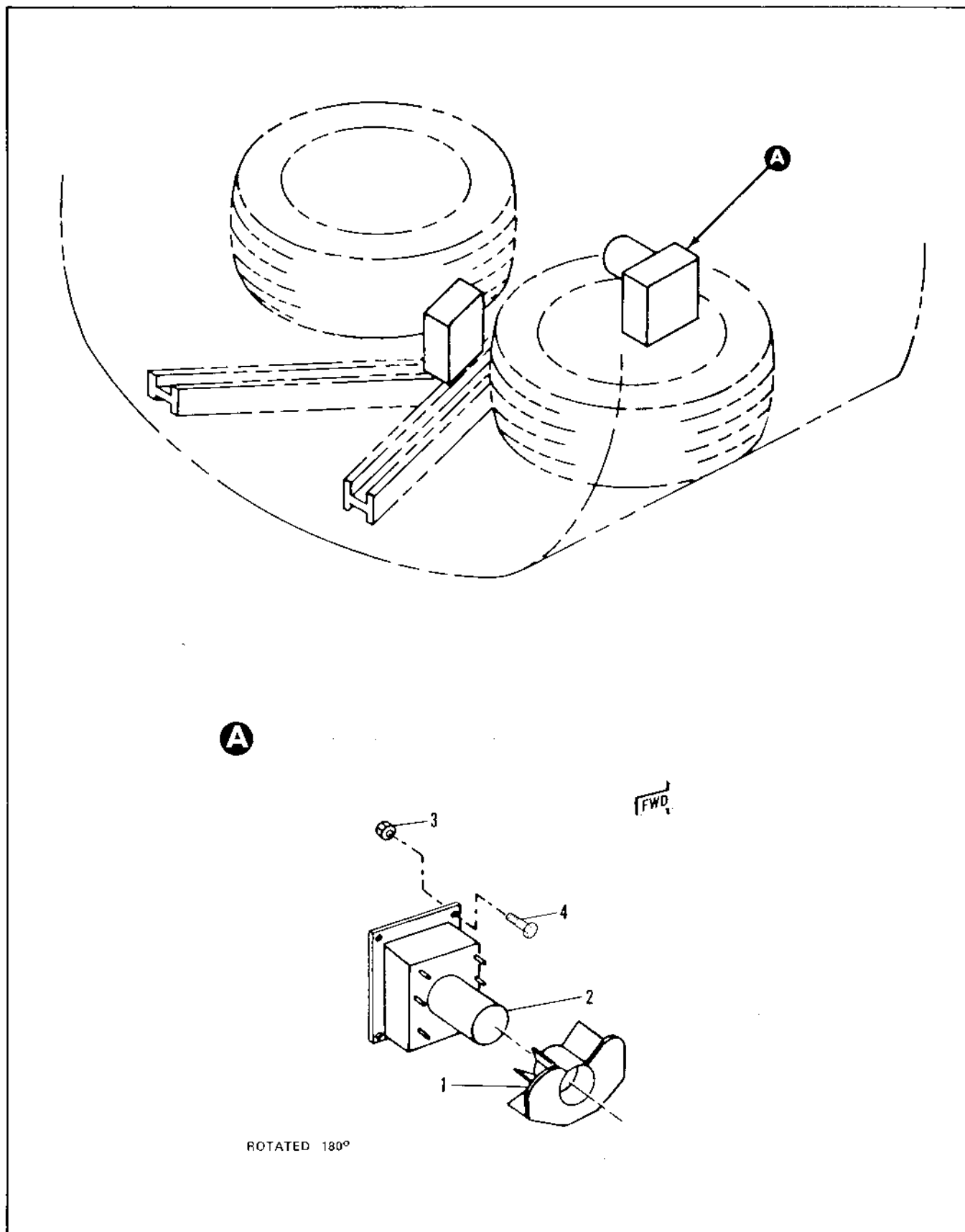

Figure 2.17-37. Rapid Tune Magnetron Main Wheel Well Electrical Equipment

FIGURE AND INDEX NUMBER	PART NUMBER	DESCRIPTION	UNITS PER ASSY.	USABLE ON CODE	
				FROM	TO
2.17-37		1 2 3 4 5 6 RAPID TUNE MAGNETRON MAIN WHEEL WELL ELECTRICAL EQUIPMENT	RF		
	A-32932-3	• RELAY INSTL. RAPID TUNE MAGNETRON GROUND POWER	1		
- 1	49-2561-2	• • COVER, RELAY SWITCH TERMINAL (15535) 92-74400-002	1		
- 2	MS2714301	• • RELAY ATTACHING PARTS	1		
- 3	MS21042L3	• • NUT	4		
- 4	AN520-1CR7	• • SCREW	4		
		----X----			

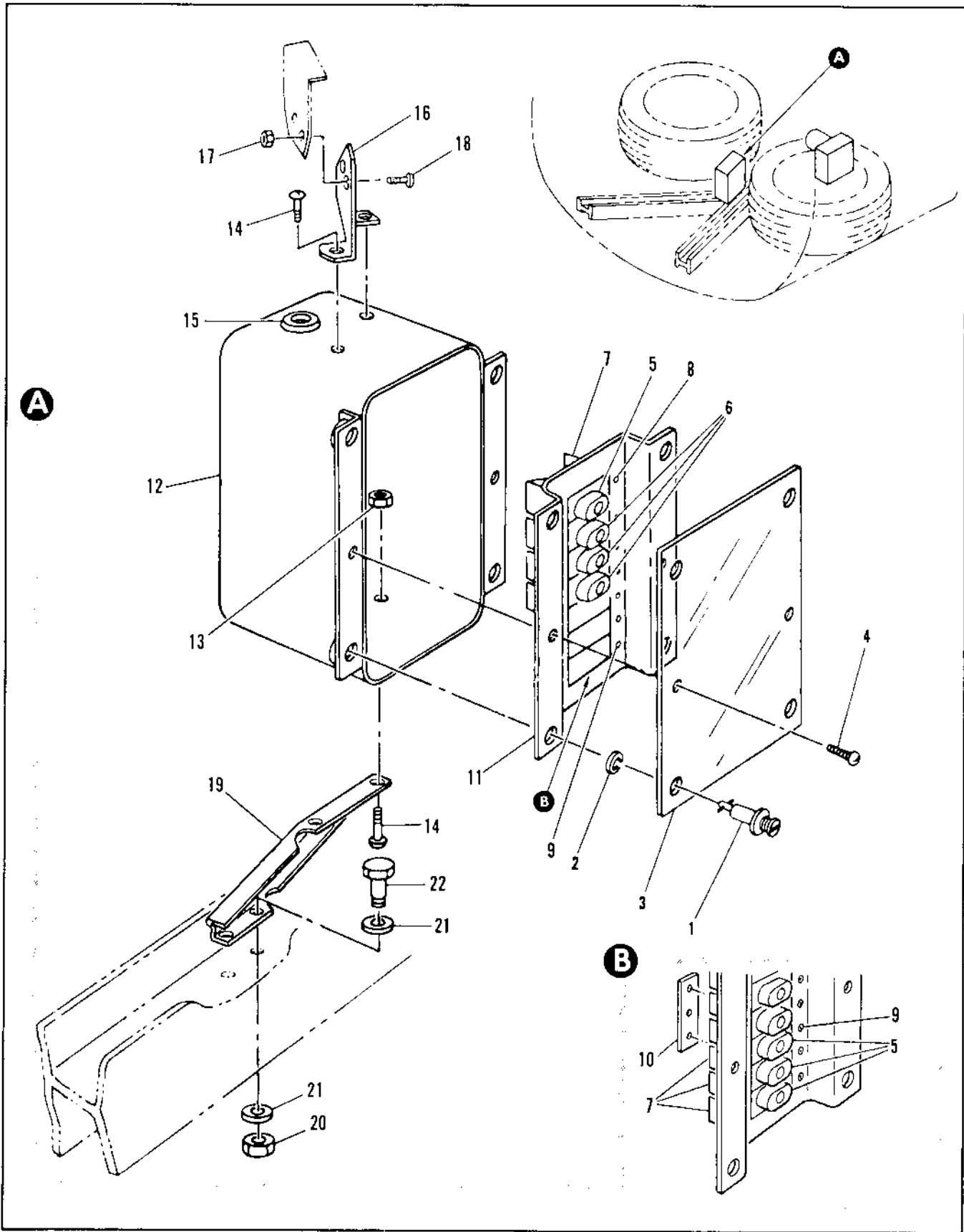

Figure 2.17-38. Main Wheel Well Auxiliary Circuit Breaker Panel

FIGURE AND INDEX NUMBER	PART NUMBER	DESCRIPTION	UNITS PER ASSY.	USABLE ON CODE	
				FROM	TO
2.17-38	8-32930-1	PANEL INSTL. AUXILIARY MAIN WHEEL WELL FUSE	1	A	
- 1	8-32934-5 2600-5	• COVER ASSY. AUXILIARY FUSE PANEL • STUD ASSY. TURNLOCK FASTENER (71286) 88-54001-003	1 4	A A	
- 2	2600SW	• WASHER, TURNLOCK FASTENER (71286) 89-53613-012	4	A	
- 3	8-32934-13 8-32934-803	• COVER • PANEL ASSY. AUXILIARY FUSE MODIFIED BY 68040279	1 1	A A	
- 4	AN526-10R7	ATTACHING PARTS • SCREW	2	A	
- 5	D7271-3-8 7277-R-5	• CIRCUIT BREAKER (82647) • CIRCUIT BREAKER ALT INTCHG WITH D7271-3-5 (82647)	4 4		
	7747317 FIL15T5	• PLATE, MOUNTING • FUSE, REPLACED BY, D7271-3-5 OR 7271-R-5	4 4		
- 6	D7271-3-15 7271-R-15	• CIRCUIT BREAKER (82647) • CIRCUIT BREAKER, ALT INTCHG WITH D7271-3-15 (82647)	3 3		
	7747317 FIL15T5	• PLATE, MOUNTING • FUSE, REPLACED BY D7271-3-15 OR D7271-3-15 OR 7271-R-15	3 3		
- 7	FIL61T5	• FUSE HOLDER, PANEL MOUNTING (09922) 94-12002-001	7	A	
- 8	AN526-632R6	ATTACHING PARTS • SCREW	8	A	
- 9	AN526-632R6	• SCREW	6	A	
- 10	8-65029-9	• RUSHAP	1		
- 11	8-32934-801	• PANEL ASSY. RIVETED	1	A	
- 12	8-32933-3	• PCB ASSY. AUXILIARY FUSE RIVETED ATTACHING PARTS	1	A	
- 13	MS21042L3	• NUT	4	A	
- 14	AN526-1032R6	• SCREW	4	A	
- 15	MS35489-17A	• GROMMET	1	A	
- 16	8-32933-21	• BRACKET ATTACHING PARTS	1	A	
- 17	MS21042L3	• NUT	2	A	
- 18	AN421-1732R6	• SCREW	2	A	
- 19	8-32933-17	• BRACKET ATTACHING PARTS	1	A	
- 20	MS21042L3	• NUT	2	A	
- 21	AN963-17L	• WASHER	4	A	
- 22	AN173-7A	• BOLT	2	A	

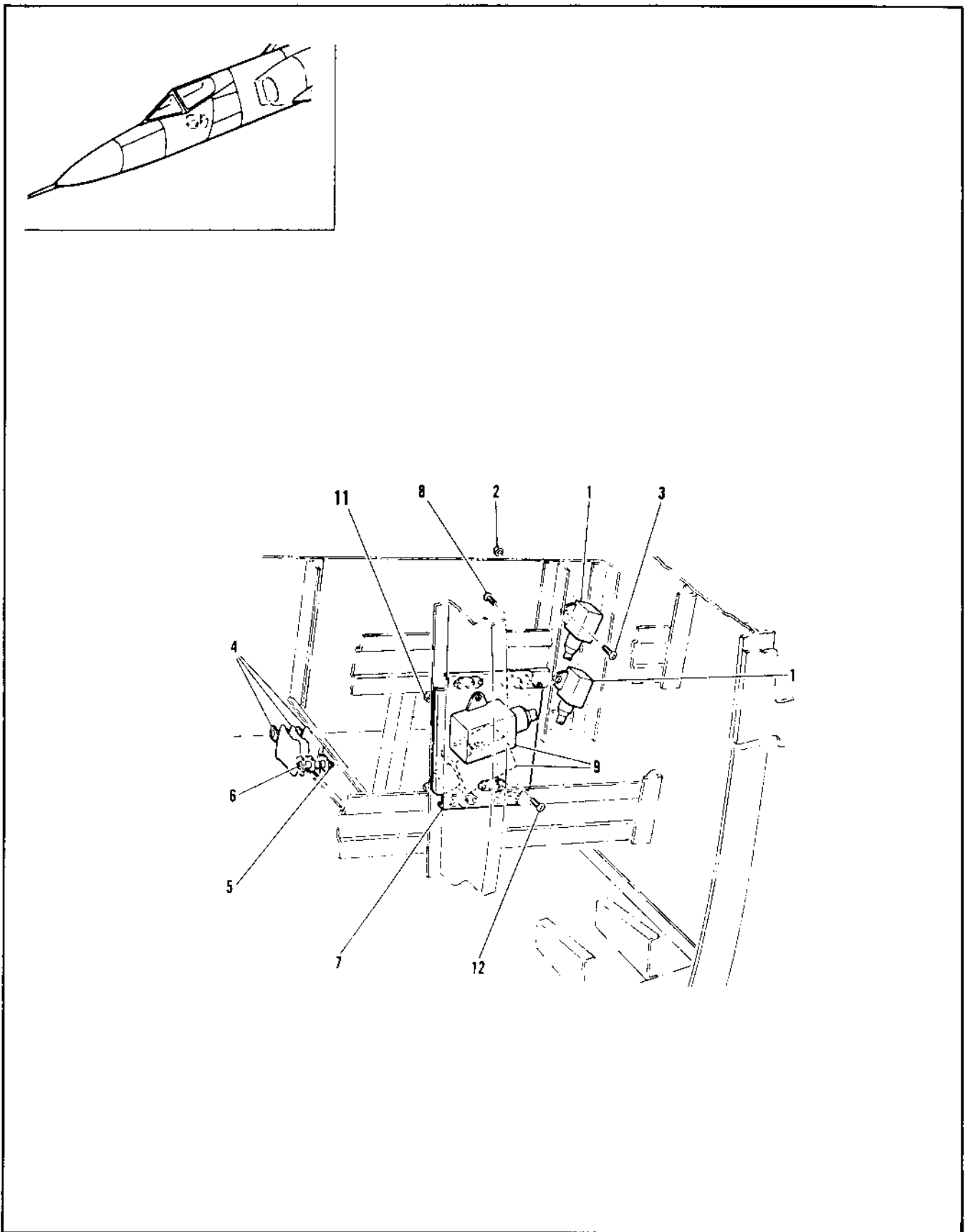

Figure 2.17-39. LH Aft Console Aerial Refueling Equipment Installation

FIGURE AND INDEX NUMBER	PART NUMBER	DESCRIPTION	UNITS PER ASSY.	USABLE ON CODE	
				FROM	TO
		1 2 3 4 5 6			
2.17-39	66E41275-1	EQUIPMENT INSTL, ELECTRICAL COCKPIT	RF		
- 1	9224-3434	• RELAY (35344) SPEC 4-26249-3 ATTACHING PARTS	2	35	
- 2	MS21942L3	• NUT	4		
- 3	MS35277-263	• SCREW	4		
		-----X-----			
- 4	RW295131	• RESISTOR (44655) ATTACHING PARTS	7	35	
- 5	MS21942L3	• NUT	2		
- 6	AN527-10R26	• SCREW	2		
		-----X-----			
- 7	66E7027-2	• PLATE ATTACHING PARTS	1	35	
- 8	MS35204-243	• SCREW	4		
		-----X-----			
- 9	9234-3434	• RELAY (35344) SPEC 8-26249-1 ATTACHING PARTS	2	35	
- 10	MS21942L3	• SCREW	2		
- 11	MS21942L3	• NUT	1		
- 12	MS35277-263	• SCREW	1		
		-----X-----			

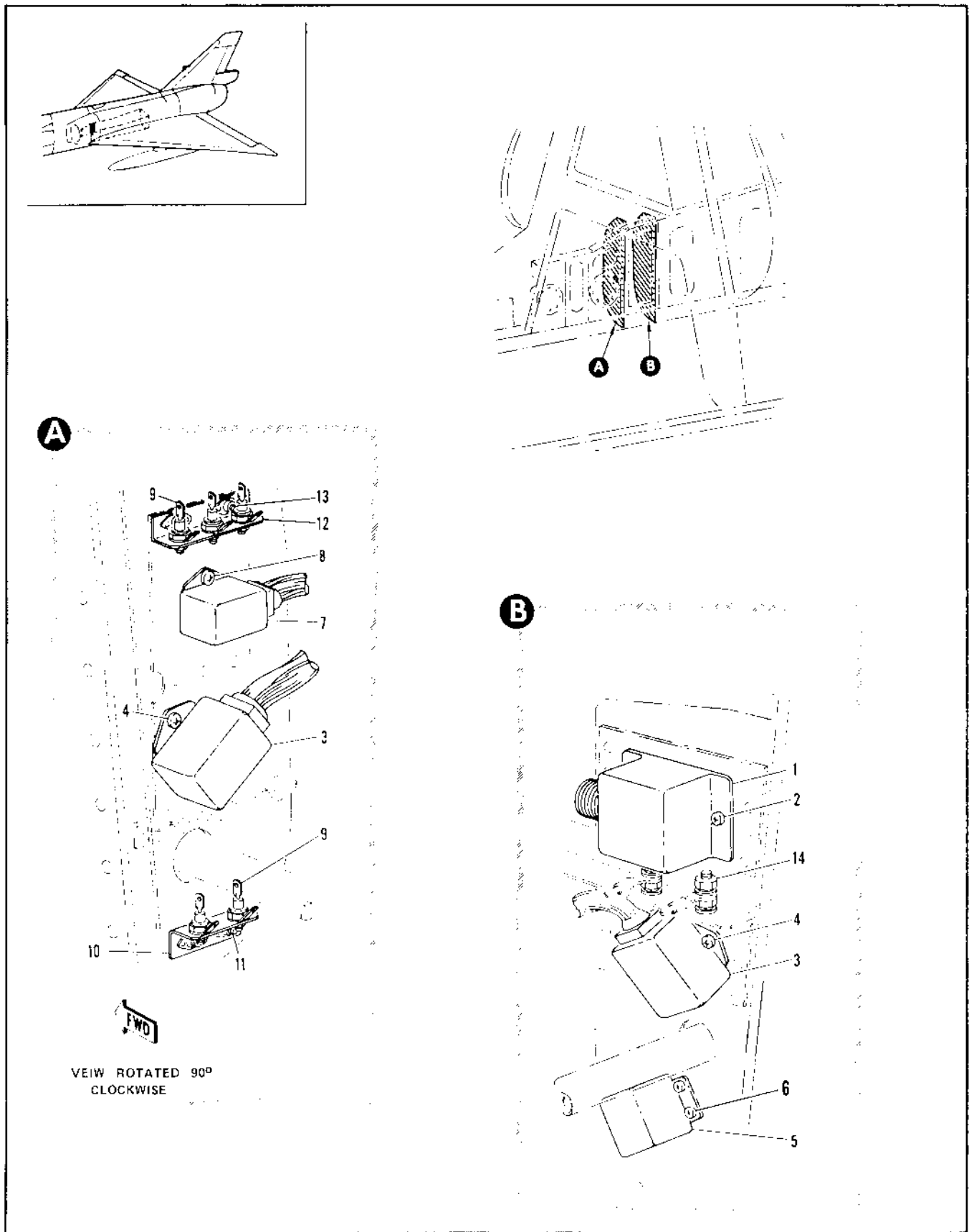

Figure 2.17-40. Missile Bay Aerial Refueling Electrical Equipment Installation

FIGURE AND INDEX NUMBER	PART NUMBER	DESCRIPTION	UNITS PER ASSY.	USABLE ON CODE	
				FROM	TO
		1 2 3 4 5 6			
2.17-40	66E40276-1	EQUIP INSTL, ELECTRICAL MISSILE BAY	001035		
- 1	2105-3	• AMPLIFIER <53750> ATTACHING PARTS			
- 2	MS35206-245	• SCREW -----X-----	3		
- 3	9230-3434	• RELAY <35344> SPEC 8-06289-1 ATTACHING PARTS	2	35	
- 4	MS35207-263	• SCREW -----X-----			
- 5	2705AB34C005	• RELAY <98403>		10	35
- 6	MS35206-229	• SCREW -----X-----	4		
- 7	9220-3435	• RELAY <35344> SPEC 8-06289-3 ATTACHING PARTS	1	35	
- 8	MS35207-263	• SCREW -----X-----	2		
- 9	JAN1N1202A	• RECTIFIER, DIODE (93539) ATTACHING PARTS	5	35	
	DF3D	• INSULATOR, TEFLON (02735)	1		
	DF6C	• INSULATOR, MICA (02735)	2		
	NR59B	• TERMINAL LUG (95303)	1		
	NR109A	• WASHER, LOCK (95303)	1		
	NA38C	• NUT, SPECIAL (02735)	1		
- 10	63C35503-1	• BRACKET ATTACHING PARTS	1		
- 11	MS35207-263	• SCREW -----X-----	2		
- 12	66C40569-1	• BRACKET ATTACHING PARTS	1	25	
- 13	MS35206-245	• SCREW -----X-----	2		
- 14	MS20341-105	• NUT	4		
	MS35338-43	• WASHER	4		
	AN960-10L	• WASHER	4		
	AN960010L	• WASHER	4		
	MS35207-263	• SCREW	2		

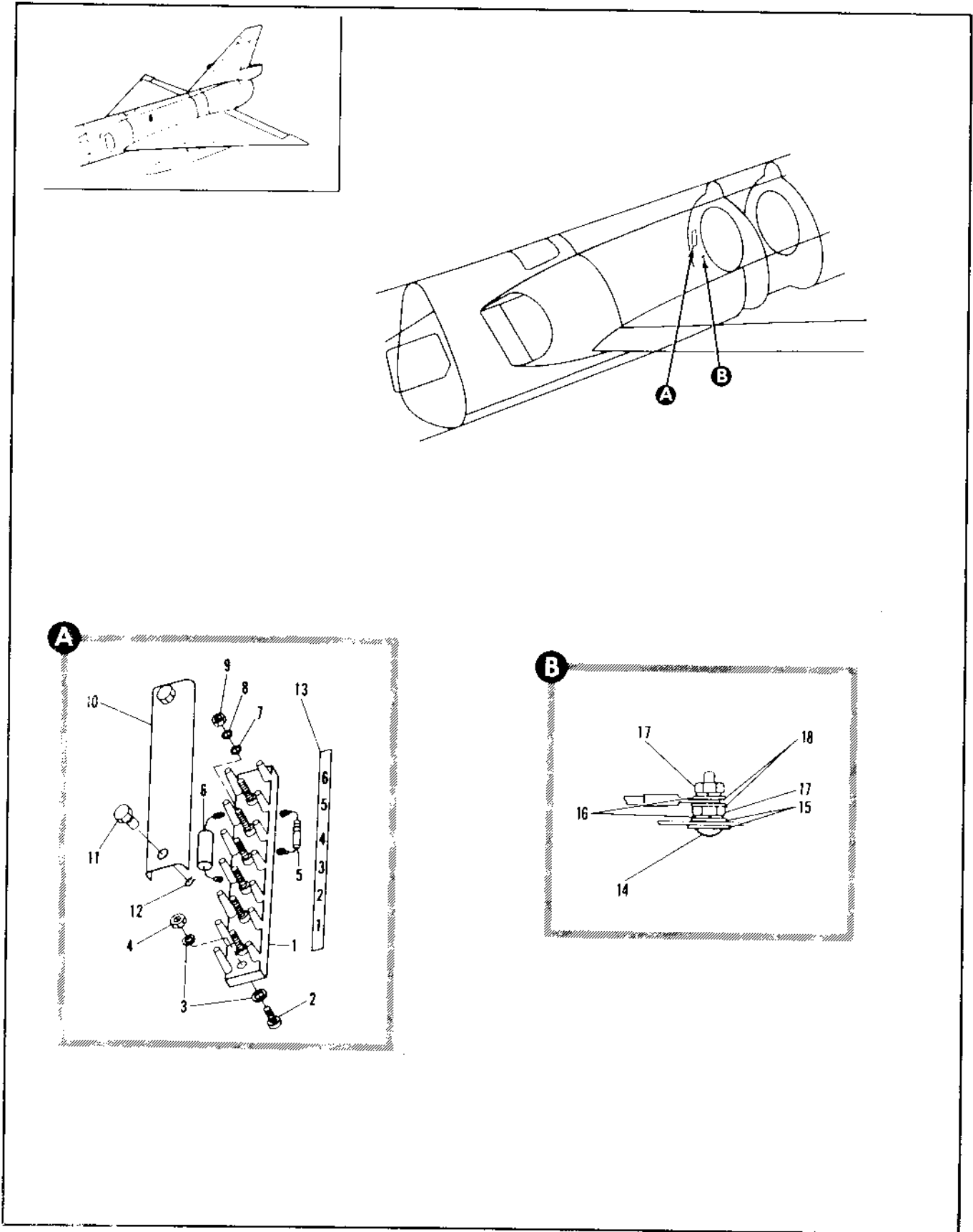

Figure 2.17-41. Normal Accelerometer Terminal Board

FIGURE AND INDEX NUMBER	PART NUMBER	DESCRIPTION	UNITS PER ASSY.	USABLE ON CODE	
				FROM	TO
		1 2 3 4 5 6			
2.17-41	7140358	TERMINAL BOARD INSTL, NORMAL ACCELEROMETER	1	35	
- 1	MS27212-1-6	• TERMINAL BOARD ASSY (ORDER MS 27215-1-20)	1	35	
		ATTACHING PARTS			
- 2	MS35206-218	• SCREW	2	35	
- 3	MS27183-4	• WASHER	10	35	
- 4	MS21744ND4	• NUT	2	35	
- 5	RN6504993F	• RESISTOR	2	35	
- 6	CH39A1NC125K	• CAPACITOR	1	35	
- 7	AN96106L	• WASHER	4	35	
- 8	MS35338-136	• WASHER	4	35	
- 9	MS35649-262	• NUT	4	35	
- 10	MS18629-11S-6	• COVER (ORDER MS18029-28)	1	35	
- 11	MS18029-21	• NUT	2	35	
- 12	MS16624-1040	• RING, RETAINING	2	35	
- 13	56C74130	• DECAL	1	35	
		-----X-----			
- 14	MS35217-265	• SCREW	1	35	
- 15	AN960PD10L	• WASHER	2	35	
- 16	MS35338-43	• WASHER, LOCK	2	35	
- 17	MS35650-302	• NUT	2	35	
- 18	AN960-10L	• WASHER	2	35	

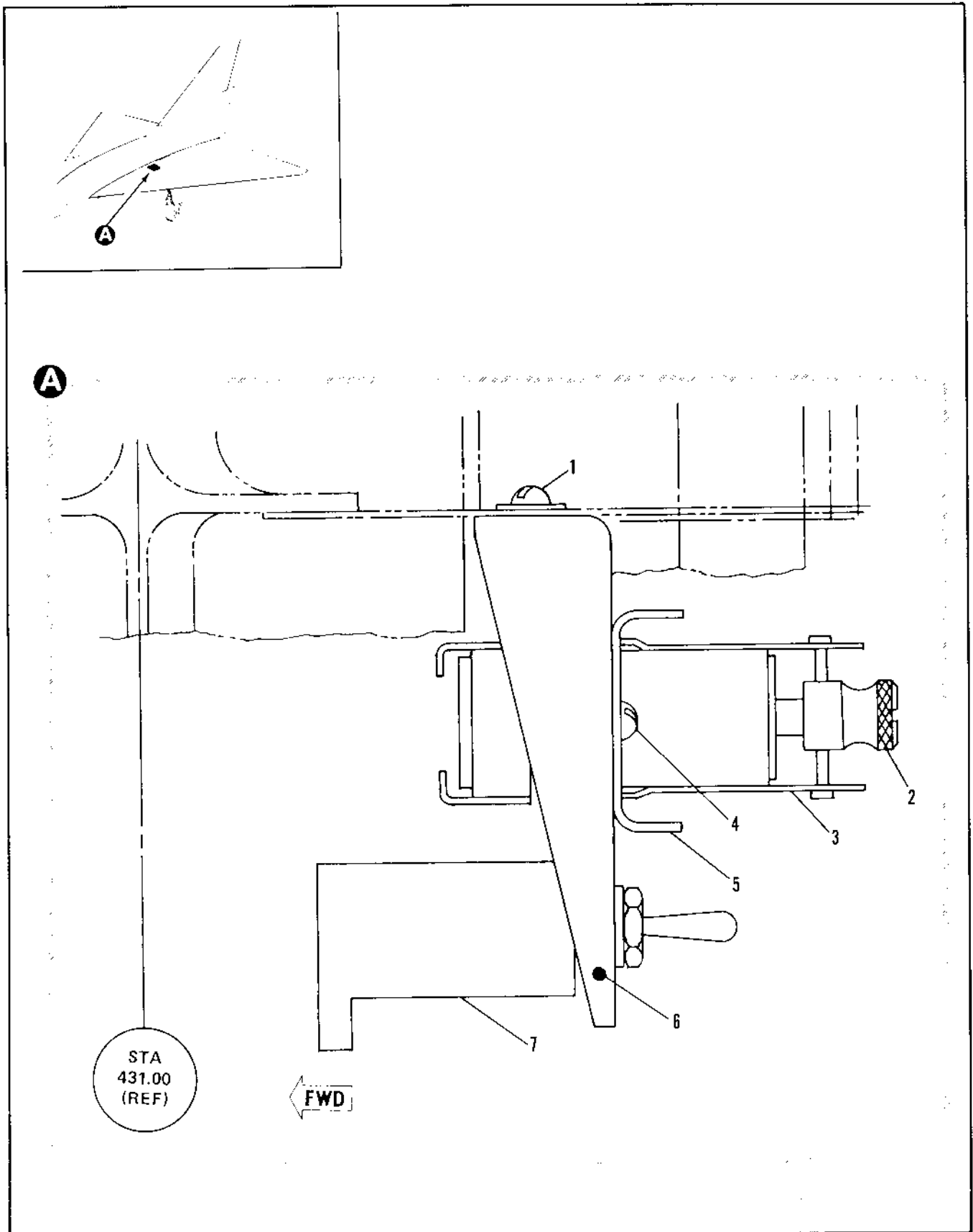

Figure 2.17-42. TRT and Gyro Cut Off Switch and Relay

FIGURE AND INDEX NUMBER	PART NUMBER	DESCRIPTION	UNITS PER ASSY.	USABLE ON CODE	
				FROM	TO
		1 2 3 4 5 6			
2.17-11	7445449	• • INSTL D4C FOR TRT RELAY AND TRT/ CYR9 CUT-OFF SWITCH		ALL	
- 1	MS35207-263	• • SCREW	3		
- 2	AN260-1 P1	• • WASHER	3		
- 3	M610672-001	• • RELAY	1		
- 4	M610675-001	• • BRACKET AND SOCKET	1		
- 5	MS35207-262	• • SCREW	2		
- 6	M610673-001	• • TRACK	1		
- 7	7745008-10	• • BRACKET	1		
- 7	5ET1-6	• • SWITCH	1		

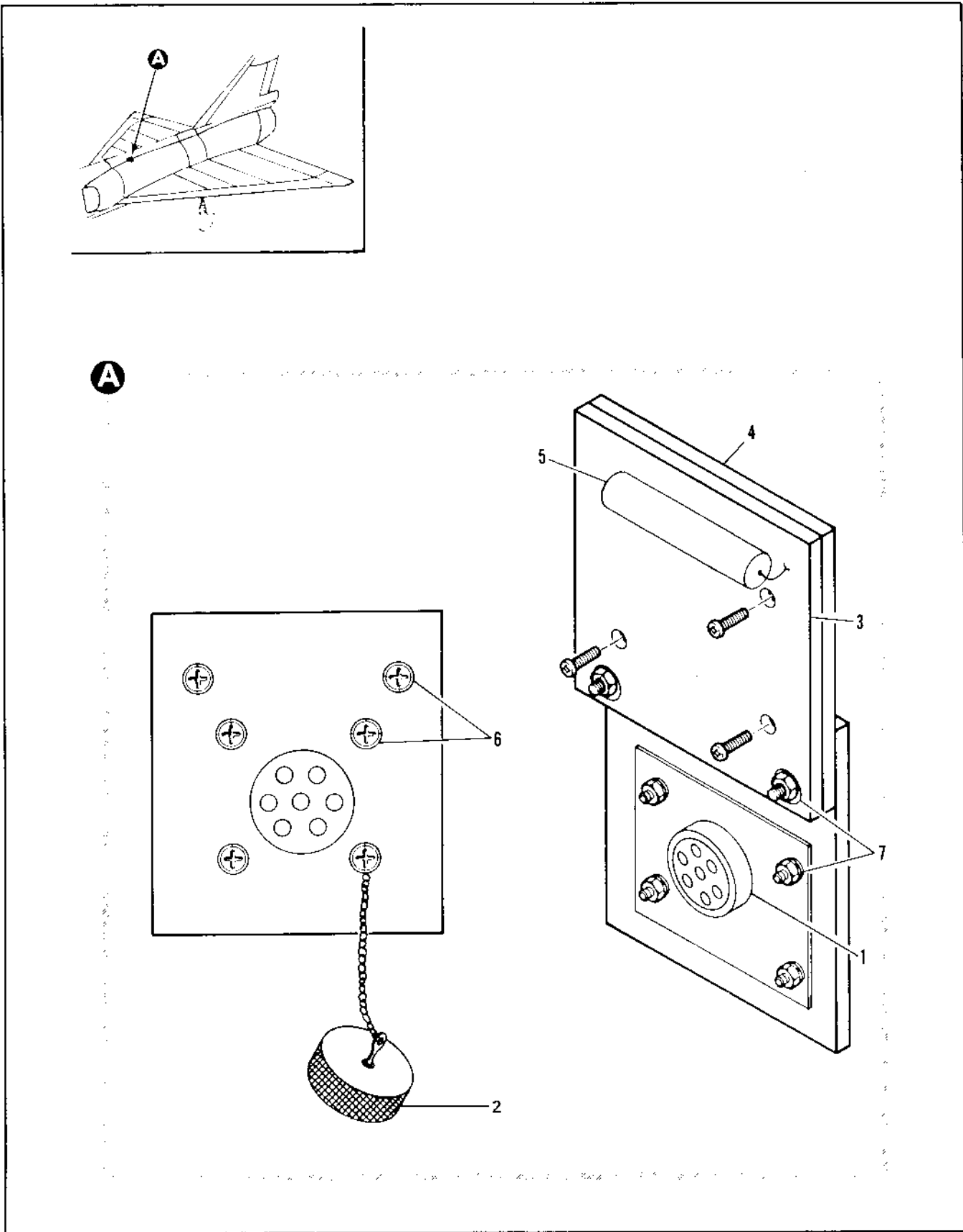

Figure 2.17-43. RH Main Wheel Well G1C3 Interphone Connector

FIGURE AND INDEX NUMBER	PART NUMBER	DESCRIPTION	UNITS PER ASSY.	USABLE ON CODE	
				FROM	TO
		1 2 3 4 5 6			
2.17-43-	CA3100ER-16S-1S	• CONNECTOR INTERPHONE -G2C3	1		
- 2	2229-6	• DUST COVER	1		
- 3	S-35404-9S	• RESISTOR BOARD	1		
- 4	B-36404-11	• INSULATOR	1		
- 5	RW67V1R1	• RESISTOR	1		
- 6	AN513-61R7	• SCREW	6		
- 7	WAS679466	• NUT	6		

GT PAGES

ELECTRONIC SUBSECTION**TABLE OF CONTENTS**

<i>Fig. No.</i>	<i>Title</i>	<i>Page</i>	<i>Fig. No.</i>	<i>Title</i>	<i>Page</i>
2.18-1	Flight Director Computer Equipment and AIMS Switch	2.18-2	2.18-19	Amplifier Equipment Sta 113 to 153	2.18-48
2.18-2	Fin Tip Installation Upper	2.18-6	2.18-20	Electrical Equipment Installation Sta 168 to 216	2.18-50
2.18-3	Fin Tip Installation Lower	2.18-8	2.18-21	Upper Aft LH Electronic Compartment Equipment Installation	2.18-54
2.18-4	Deleted		2.18-22	Lower Aft RH Electronic Compartment AFCS Equipment Installation	2.18-56
2.18-5	Electronic Circuit Breaker Panel Installation	2.18-12	2.18-23	Upper Aft RH Electronic Compartment Equipment Installation	2.18-58
2.18-6	Electronic Antennas	2.18-14	2.18-24	Signal Conditioner and Buffer Unit	2.18-62
2.18-7	ILAS Localizer Antenna Installation	2.18-20	2.18-25	Attitude Heading Reference System.....	2.18-64
2.18-8	Radar Antenna Support Installation Sta 41	2.18-22	2.18-26	Central Air Data Computer (CADC)....	2.18-70
2.18-9	Automatic Direction Finder Antenna	2.18-24	2.18-27	J-4 Compass Auxiliary Reference Group	2.18-72
2.18-10	Radar	2.18-26	2.18-28	Automatic Flight Control System	2.18-74
2.18-11	MMST Radar Scope Installation	2.18-28	2.18-29	Steering Computer and Gyroscope Control	2.18-76
2.18-12	Tactical Situation Display	2.18-30	2.18-30	Marker Beacon Equipment	2.18-78
2.18-13	Tactical Situation Display Installation	2.18-32	2.18-31	Angle of Attack Transmitter Installation	2.18-80
2.18-14	Pressurization Group	2.18-34	2.18-32	Deleted	
2.18-15	Radar Pressurization Tubing Installation	2.18-36	2.18-33	Power Distribution	2.18-84
2.18-16	Transmitter-Receiver Equipment Installation	2.18-40	2.18-34	Data Link Antenna and Network Installation	2.18-86
2.18-17	Fwd LH Electronic Compartment Electrical Equipment Installation	2.18-42	2.18-35	Counters and Timers Installation	2.18-88
2.18-18	Fwd RH Electronic Compartment Electrical Equipment Installation	2.18-46	2.18-36	Beta Vane Installation	2.18-92
			2.18-37	Attitude Warning System Installation..	2.18-94
			2.18-38	Flight Loads Recorder System	2.18-96

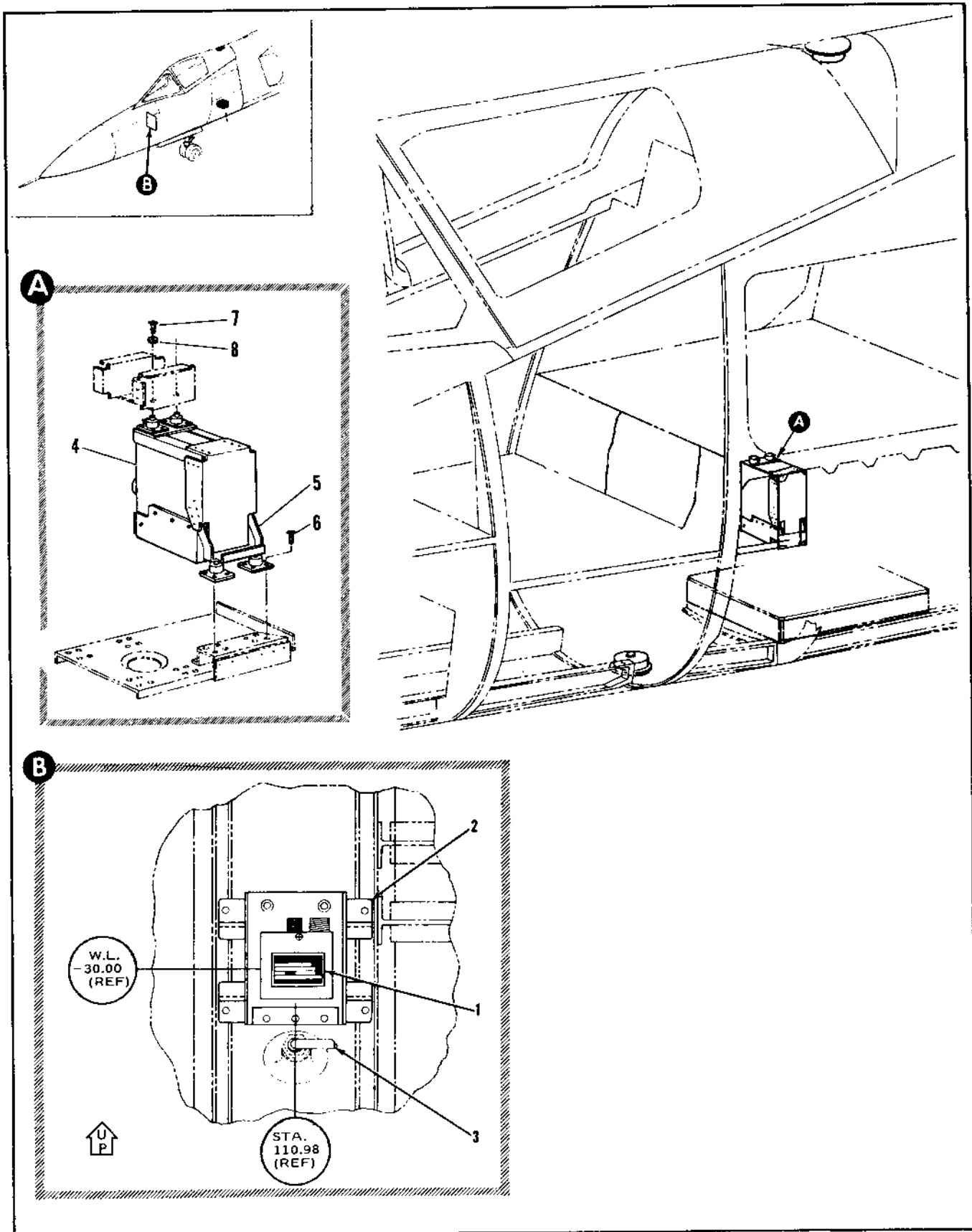

Figure 2.18-1. Flight Director Computer Equipment and Aims Switch (Sheet 1 of 2)

FIGURE AND INDEX NUMBER	PART NUMBER	DESCRIPTION	UNITS PER ASSY.	USABLE ON CODE	
				FROM	TO
		1 2 3 4 5 6			
2.18-1	7037237	INSTL DWG, AIMS SWITCH	1	35	
- 1	SA-14747A	• SWITCHING UNIT, ANTENNA	2	35	
- 2	7037199-10	• BRACKET			
- 3	P-5761	• TUBING INST (REF)	1	A	
- 4	464720-151	• CONVERTER, FLIGHT DIRECTOR SIGNAL DATA	1	A	
- 5	464911-100	• RACK FLIGHT DIRECTOR ELOC EQUIPMENT (REF 77) ATTACHING PARTS			
- 6	NAS221-7	• SCREW	4	A	
- 7	NAS220-8	• SCREW	2	A	
- 8	AN962-8	• WASHER	2	A	
		A AIRPLANES 35 THRU 47 AND 49 THRU 49			

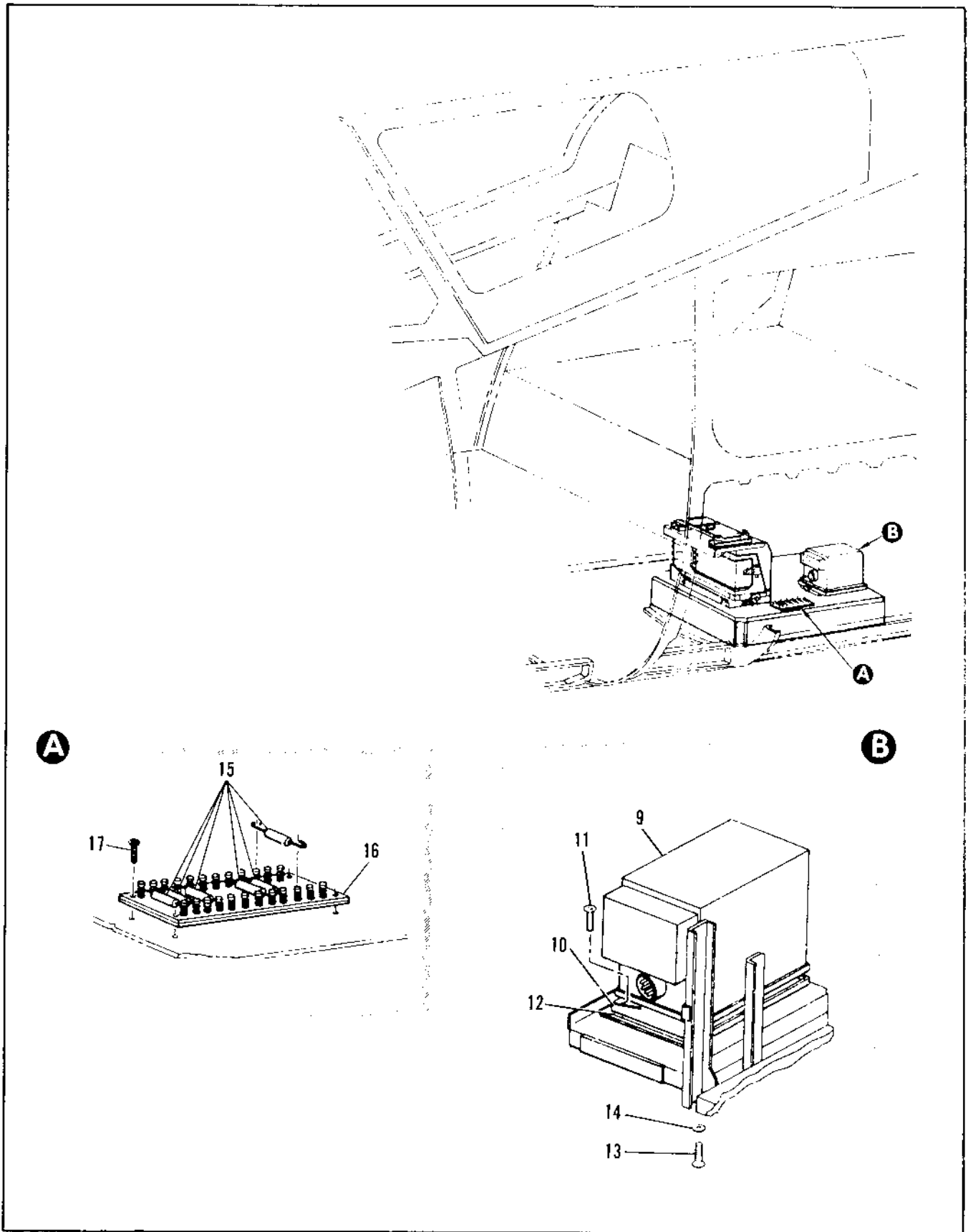
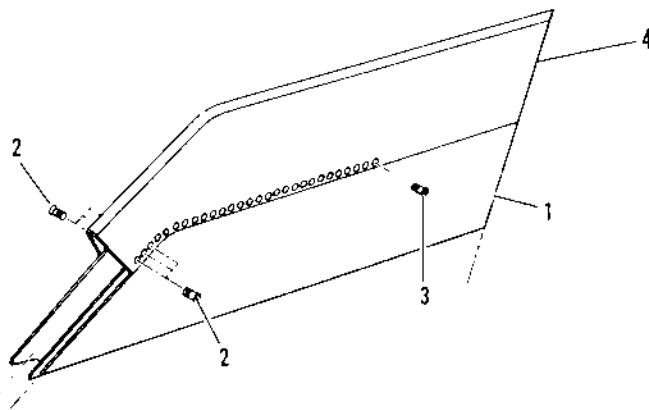
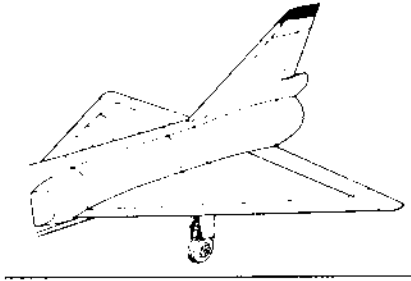

Figure 2.18-1. Flight Director Computer Equipment and Aims Switch (Sheet 2 of 2)

FIGURE AND INDEX NUMBER	PART NUMBER	DESCRIPTION	UNITS PER ASSY.	USABLE ON CODE	
				FROM	TO
		1 2 3 4 5 6			
2.18-1	7243013-11	*1 . COMPUTER INCL, FLIGHT DIRECTOR	1		B
- 1	CPU47A	*1 . . COMPUTER, FLIGHT DIRECTOR (42577) AEP0349-6300 GFAC AF INSTALLED	1		B
- 10	8-36767	*1 . . RAIL, MOUNTING ATTACHING PARTS	2		B
- 11	MS24564S54	*1 . . SCREW -----X-----	8		B
- 12	7243016-11	*1 . . SHIM	2		B
	8-33476	*1 . . RESISTOR BOARD ASSEMBLY, GFAC AF INSTALLED ATTACHING PARTS	1		B
- 13	MS35206-230	*1 . . SCREW	4		B
- 14	AN9504	*1 . . WASHER -----X-----	4		B
- 15	RC206F102J	*1 . . RESISTOR, 97-40000-02F	6		B
- 16	8-33476-11	*1 . . TERMINAL BOARD ASSEMBLY	1		B
- 17	AN513-6R5	*1 . . SCREW	4		B
		*1 ADDED PER TOTO 1F-106-13-1 B AIRPLANES #48, 90 AND ON			



2.18-2. Fin Tip Installation Upper

FIGURE AND INDEX NUMBER	PART NUMBER	DESCRIPTION	UNITS PER ASSY.	USABLE ON CODE	
				FROM	TO
2.18-2	R-14521-1	TIP INSTALLATION, FIN UPPER FOR NHA SEE FIG. 2.3-4	#F	35	
- 1	R-14521-3	• TIP ASSY, FIN UPPER REPLACES NOT INTCHG WITH R-14521-3	1	A	
	R-14521-1	• TIP ASSY, FIN UPPER REPLACED BY NOT INTCHG WITH R-14521-3	1	278	286
	R-14521-3	• TIP ASSY, FIN UPPER REPLACES NOT INTCHG WITH R-14521-1 REPLACED BY NOT INTCHG WITH R-14521-3	1	287	300
- 2	NAS333PA5-B	• SCREW	6	35	
- 3	NAS333PA6	• SCREW	74	B	XXX
	NAS333PA7-C	• SCREW	74	C	
		-----X-----			
- 4	R-14521-17	• • TIP ASSY, FIN	1	D	
	R-14521-11	• • TIP ASSY, FIN	1	278	286
		A AIRPLANES #25 THRU 277, 301 AND ON			
		B AIRPLANES #278 THRU 280 AND 282 THRU 285			
		C AIRPLANES #30 THRU 277, 281 AND 286 AND ON			
		D AIRPLANES #15 THRU 277, 297 AND ON			

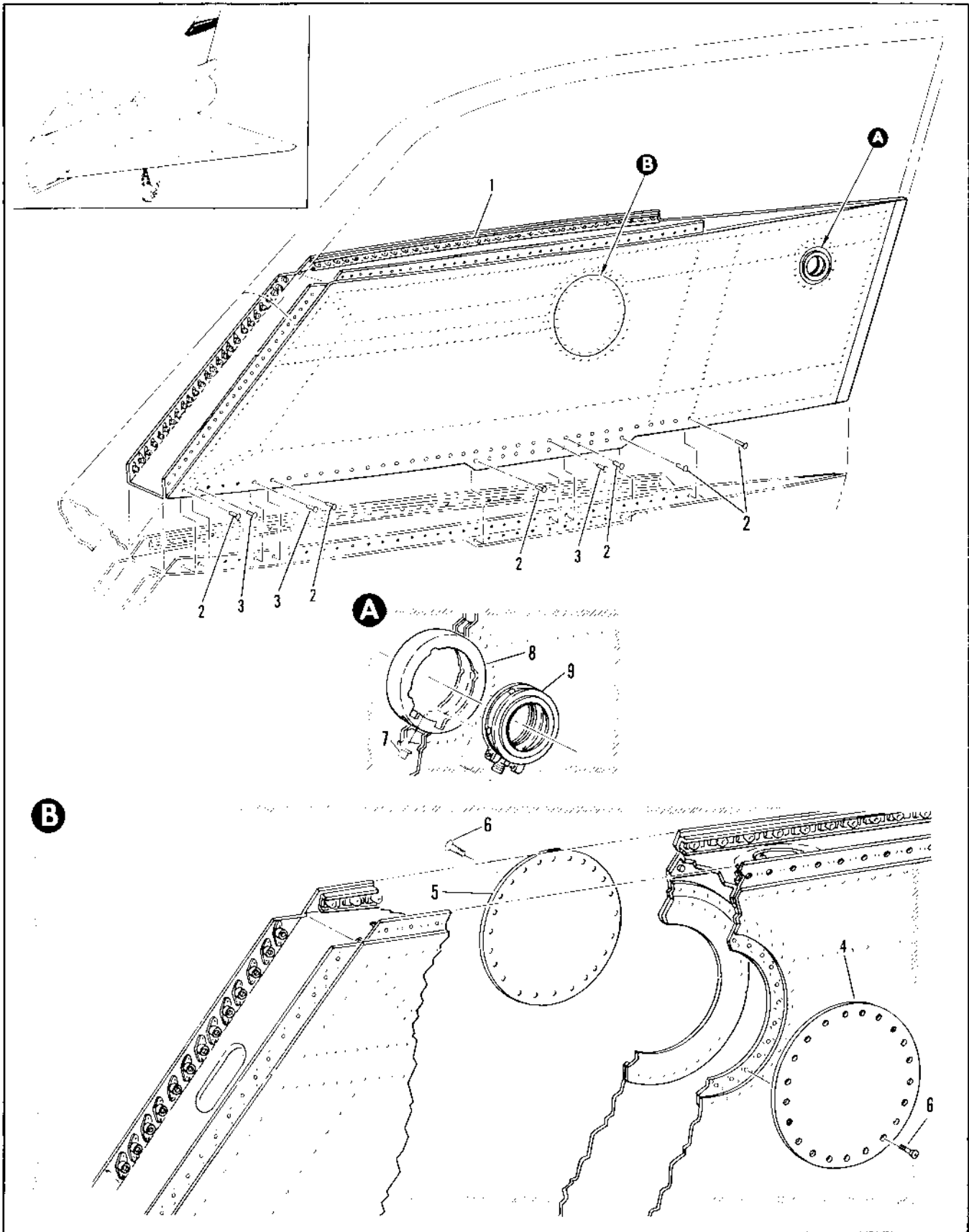

Figure 2.18-3. Fin Tip Installation Lower

FIGURE AND INDEX NUMBER	PART NUMBER	DESCRIPTION	UNITS PER ASSY.	USABLE ON CODE	
				FROM	TO
		1 2 3 4 5 6			
2.18-3	R-14518	TIP INSTALLATION, FIN LOWER	1	3-	
- 1	R-14518-1	FOR NHA SEE FIG. 2.7-2 INDEX 31	1	A	
	R-14518	• TIP ASSY, FIN LOWER REPLACES NOT INTCHD WITH R-14518	1	27-	300
- 2	F267-7	• TIP ASSY, FIN LOWER	1		
- 3	F267-8	REPLACED BY NOT INTCHD WITH R-14518-1 ATTACHING PARTS	1		
		• JO-BOLT, (K94524) 97-63014-109	1	35	
		• JO-BOLT, (K94524) 97-63014-109	1	35	
		-----X-----			
- 4	65C33712	• DOOR, ACCESS FIN TIP LH	1		
- 5	65C33712	• DOOR, ACCESS FIN TIP RH REPLACES NOT INTCHD WITH R-14923-9	1		
		ATTACHING PARTS			
- 6	NAS333PA4-F	• SCREW, LH, PH	42	35	
		-----X-----			
- 7	R-14735	• FITTING, FIN TIP TUBE	1	35	
- 8	R-14734	• RING, FIN TIP LIGHT	1	35	
- 9	R5277-1	• RETAINER, LENS FIN TIP LIGHT (70514) 97-57501-001	2	35	
		• AIRPLANES 215 THRU 277, 311 AND ON			
		*3 ADDED PER TC TO 1F-106A-243			

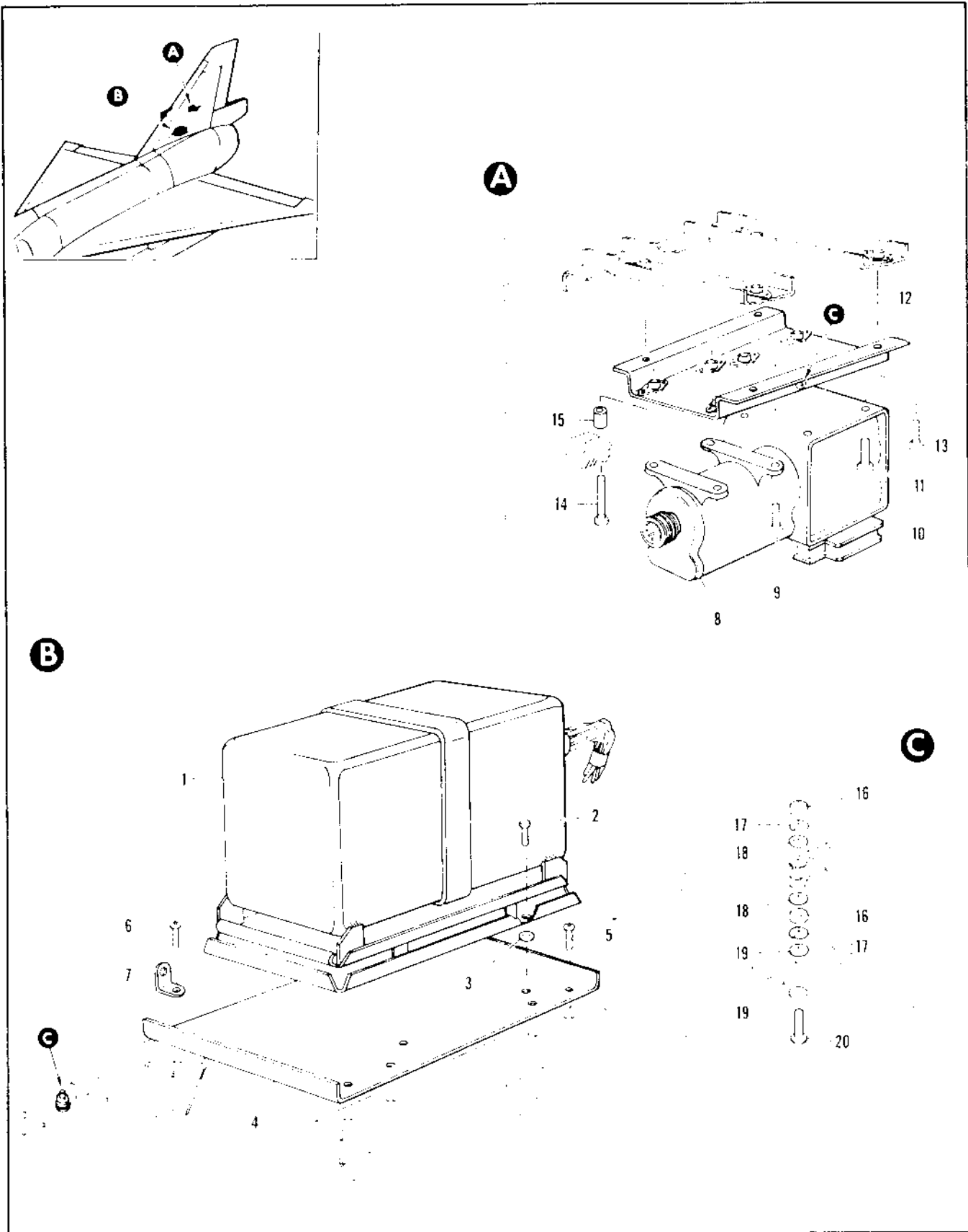

Figure 2.18-4. Standby Attitude Indicator Equipment Installation

FIGURE AND INDEX NUMBER	PART NUMBER	DESCRIPTION	UNITS PER ASSY.	USABLE ON CODE	
				FROM	TO
		1 2 3 4 5 6			
2.18-4		EQUIPMENT INSTALLATION, STANDBY ATTITUDE INDICATOR			
- 1	124015-01-14	• GYROSCOPE, DISPLACEMENT, ROLL AND PITCH (MS2811) TYPE MC-1 ATTACHING PARTS	1		
- 2	AN4-52	• BOLT	4		
- 3	AN96100414	• WASHER	AR		
		-----X-----			
- 4	A2035427-1	• SUPPORT ASSY, RIVETED ATTACHING PARTS	1		
- 5	MS36217-265	• SCREW	6		
- 6	MS35217-267	• SCREW	2		
		-----X-----			
- 7	AN743-12	• BRACKET	2		
- 8	76500	• GYROSCOPE, RATE SWITCHING (MS2811) TYPE MC-1 ATTACHING PARTS	1		
		-----X-----			
- 9	MS36217-267	• SCREW	4		
		-----X-----			
- 10	A277	• TRANSFORMER (950266) GRID A-5000-1 ATTACHING PARTS	1		
		-----X-----			
- 11	AN3-34	• BOLT	4		
		-----X-----			
- 12	A2035427-1	• SUPPORT ASSY, RIVETED ATTACHING PARTS	1		
- 13	MS36217-267	• SCREW	3		
- 14	MS36217-267	• SCREW	1		
		-----X-----			
- 15	MS43003-64	• SCREW	1		
- 16	MS27441-135	• NUT, GROUND STUD	4		
- 17	MS35319-43	• WASHER, GROUND STUD	4		
- 18	AN961111L	• WASHER, GROUND STUD	4		
- 19	AN961111L	• WASHER, GROUND STUD	4		
- 20	MS35217-265	• SCREW, GROUND STUD	2		

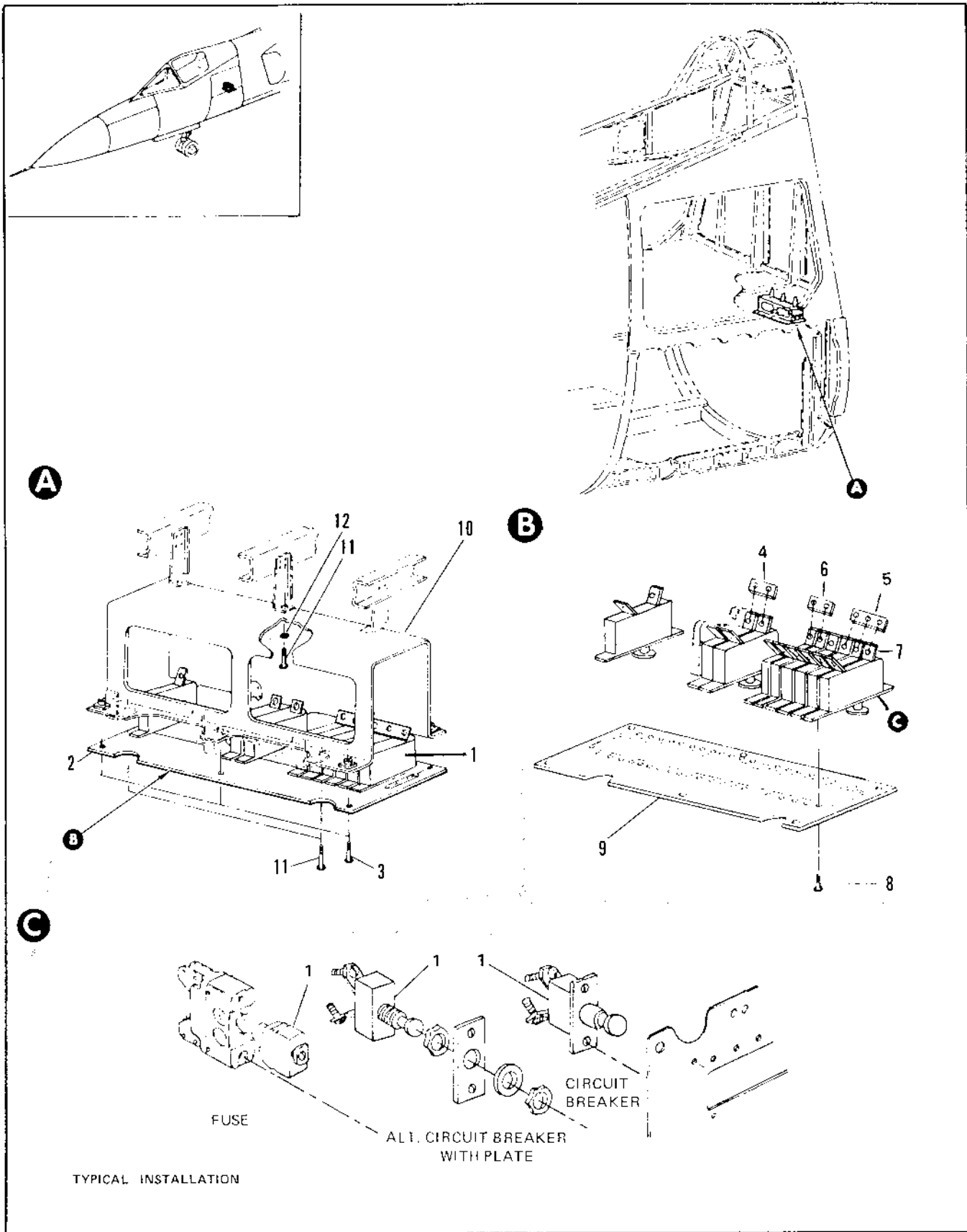

Figure 2.18-5. Electronic Circuit Breaker Panel Installation

FIGURE AND INDEX NUMBER	PART NUMBER	DESCRIPTION	UNITS PER ASSY.	USABLE ON CODE	
				FROM	TO
2.18-5	8-36421	PANEL INSTALLATION, ELECTRONIC FUSE MODIFIED BY 8-31885	1		A
- 1	7172-3-5	• CIRCUIT BREAKER	10		A
	7171-8-5	• CIRCUIT BREAKER, ALT INTCNG WITH 7172-3-5	1		A
	7747307	• PLATE, MOUNTING	10		A
	FIL05T5	• FUSE, REPLACED BY 7272-3-5 OR 7172-8-5	10		A
- 2	8-36421-35	• PANEL ASSY, CIRCUIT BREAKER	1		B
	8-36421-37	• PANEL ASSY, CIRCUIT BREAKER ATTACHING PARTS	1	130	
- 3	AN520-10R8	• SCREW -----X-----	6		A
- 4	8-65029-7	• BUSBAR	1		A
- 5	8-65029-9	• BUSBAR	1		A
- 6	8-65029-7	• BUSBAR	1	XXX	
- 7	F1H60T5	• FUSE HOLDER, <09922> 94-12002-001 ATTACHING PARTS	10		A
- 8	AN515-6R8	• SCREW -----X-----	20		A
- >	8-36421-31	• PANEL	1		B
	8-36421-29	• PANEL	1	130	
- 10	8-36420	• GUARD ASSY, RIVETED ATTACHING PARTS	1		A
- 11	AN520-10R8	• SCREW	5		A
- 12	AN960-10L	• WASHER -----X-----	3		A

A AIRPLANES #48, 90 AND ON
B AIRPLANES #48, 90 THRU 129

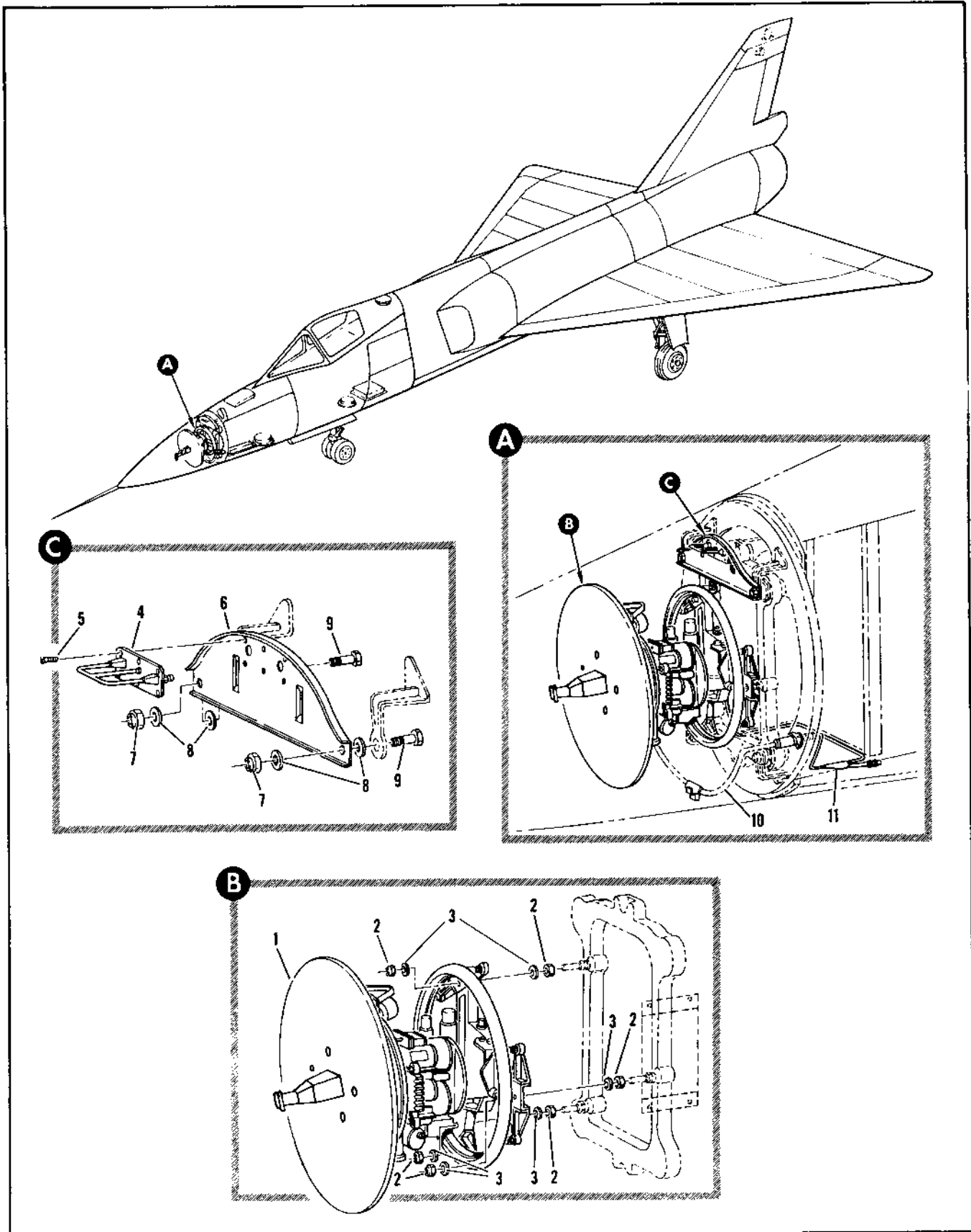

Figure 2.18-6. Electronic Antennas (Sheet 1 of 3)

FIGURE AND INDEX NUMBER	PART NUMBER	DESCRIPTION	UNITS PER ASSY.	USABLE ON CODE	
				FROM	TO
2.18-6		ELECTRONIC ANTENNAS			
- 1	8-36285 464017	. ANTENNA INSTL, MA-1 RADAR . ANTENNA, MA-1 RADAR <82577> GFAE	1 1	35	
- 2	MS21083NR	ATTACHING PARTS . NUT, <82577> GFAE	6	35	
- 3	435-17-0870	. WASHER, <82577> GFAE ----X----	6	35	
- 4	8-36222 57PA	. ANTENNA INSTL, ILAS GLIDE SLOPE . ANTENNA, ILAS GLIDE SLOPE CHROME <95105> 90-17406-001	1 1	35 35	
- 5	AN509-10R10	ATTACHING PARTS . SCREW ----X----	6	35	
- 6	8-36591	. MOUNT ASSY, GLIDE SLOPE ANTENNA RIVETED ATTACHING PARTS	1	35	
- 7	AN365-820	. NUT	2	35	
- 8	AN960-816	. WASHER	4	35	
- 9	AN8-7A	. BOLT ----X----	2	35	
- 10		. ANTENNA ASSY, ILAS LOCALIZER SEE FIG. 2.18-7 INDEX 3	RF		
- 11	7151	. CABLE ASSY, LOCALIZER ANTENNA LEAD IN <97244> SPEC 8-03359-1	1	35	

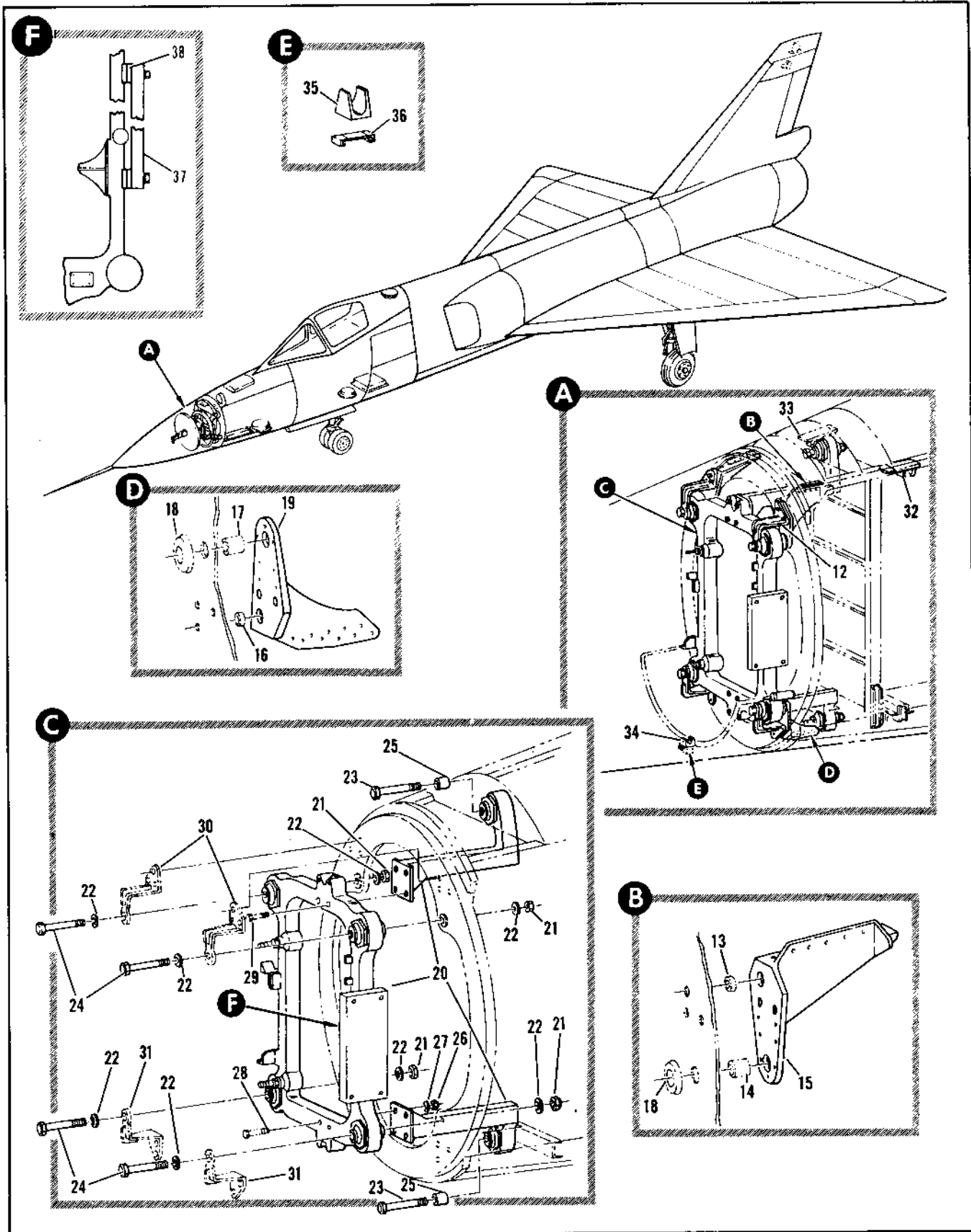

Figure 2.18-6. Electronic Antennas (Sheet 2 of 3)

FIGURE AND INDEX NUMBER	PART NUMBER	DESCRIPTION 1 2 3 4 5 6	UNITS PER ASSY.	USABLE ON CODE	
				FROM	TO
2.18-6- 12		• SUPPORT INSTL, RADAR ANTENNA STA 41 SEE FIG. 2.18-8	RF		
	A-74735-1	• SUPPORT INSTL, GLIDE SLOPE ANTENNA FOR NHA SEE FIG. 2.3-5	RF	35	
- 13		• BUSHING, SEE FIG. 2.18-8 INDEX 10	RF		
- 14		• BUSHING, SEE FIG. 2.18-8 INDEX 11	RF		
- 15	A-74126-9	• FITTING, UPPER RADAR SUPPORT LH	1	35	
	B-74126-10	• FITTING, UPPER RADAR SUPPORT RH	1	35	
	A-74735-3	• SUPPORT INSTL, LOCALIZER ANTENNA FOR NHA SEE FIG. 2.3-6	RF	35	
- 16		• BUSHING, SEE FIG. 2.18-8 INDEX 10	RF		
- 17		• BUSHING, SEE FIG. 2.18-8 INDEX 11	RF		
- 18		• FILLER, SEE FIG. 2.18-8 INDEX 7	RF		
- 19	B-74127-9	• FITTING, LOWER RADAR SUPPORT LH	1	35	
	K-74127-10	• FITTING, LOWER RADAR SUPPORT RH	1	35	
	A-36284	• RACK INSTL, ANTENNA TRANSMITTER-RECEIVER GROUP	RF	35	
- 20	464173	• RACK, ELECTRONIC EQUIPMENT ANTENNA TRANSFER GROUP (82577) GFAC ATTACHING PARTS	1		
- 21	AN355-420	• NUT	4	35	
- 22	AN960-815	• WASHER	8	35	
- 23	AN179-44A	• BOLT	2	35	
- 24	AN179-45A	• BOLT	4	35	
- 25	A-74918	• BUSHING, SLIP RADAR SUPPORT	2	35	
- 26	NAS679A4	• NUT, FURNISHED WITH (82577) 464173 GFAC	RF	35	
- 27	AN960-416L	• WASHER, FURNISHED WITH (82577) 464173 GFAC	RF	35	
- 28	AN4-10A	• BOLT, FURNISHED WITH (82577) 464173 GFAC	RF	35	
- 29	AN4-15A	• BOLT, FURNISHED WITH (82577) 464173 GFAC -----X-----	RF		
- 30		• FITTING, UPPER SEE FIG. 2.18-8 INDEX 8	RF		
- 31		• FITTING, LOWER SEE FIG. 2.18-8 INDEX 9	RF		
- 32		• SUPPORT ASSY, RADAR RACK STA 63 UPPER LH SEE FIG. 2.3-5 INDEX 8	RF		
- 33		• SUPPORT ASSY, RADAR RACK STA 63 UPPER RH SEE FIG. 2.3-5 INDEX 10	RF		
- 34	A-36714	• SUPPORT ASSY, LOCALIZER ANTENNA FOR NHA SEE FIG. 2.3-2	RF	35	
- 35	A-36713	• FLOCK	1	35	
- 36	B-37475	• RETAINER	1	35	
- 37	5008206	• BALLAST (82577) ATTACHING PARTS	1		
	AN3-16A	• BOLT	4		
	MS21042-3	• NUT	4		
	AN960C10L	• WASHER	8		
- 38	5008207	• SPACER (82577) -----X-----	2		

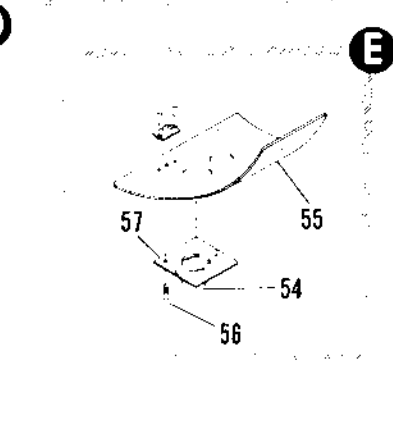
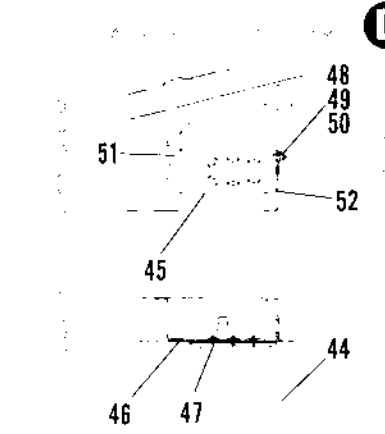
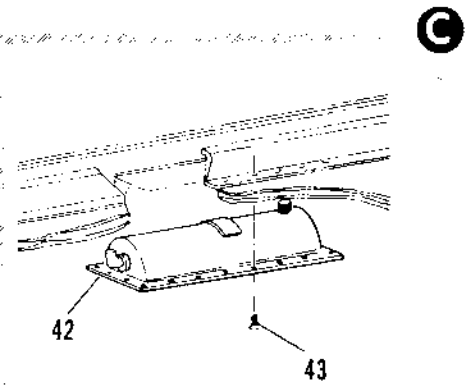
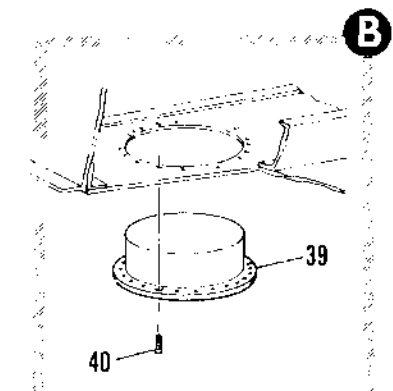
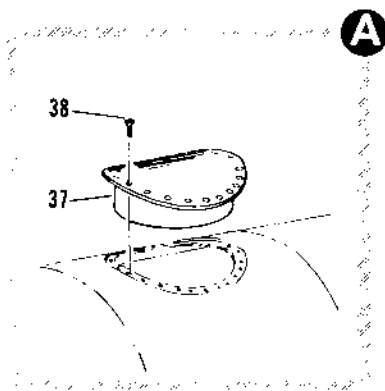
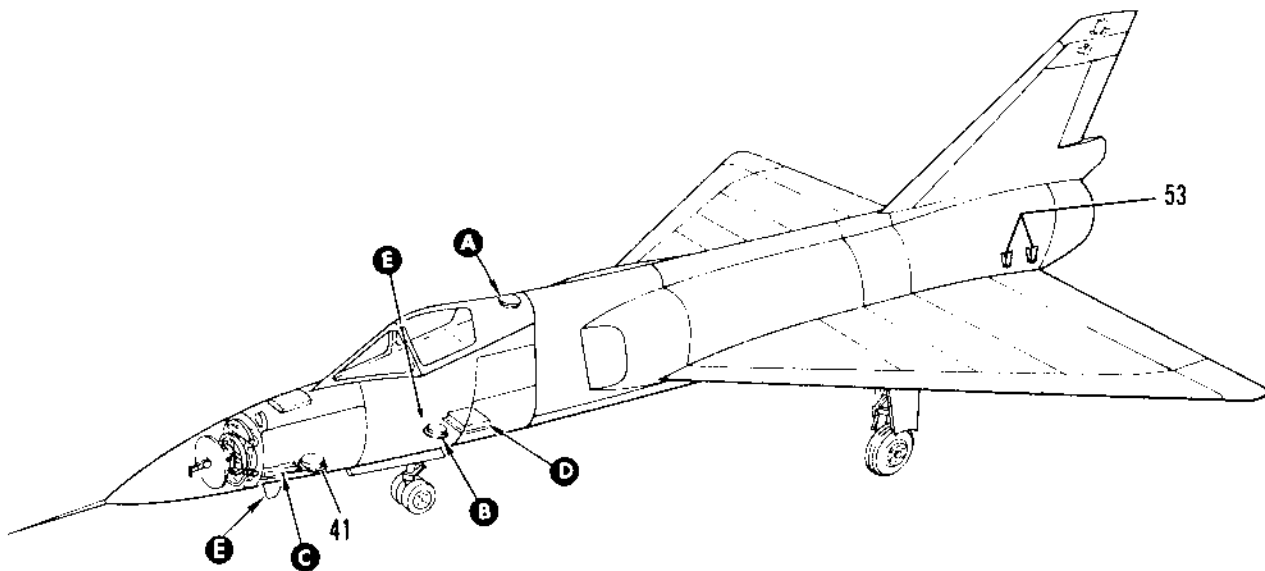

Figure 2.18-6. Electronic Antennas (Sheet 3 of 3)

FIGURE AND INDEX NUMBER	PART NUMBER	DESCRIPTION	UNITS PER ASSY.	USABLE ON CODE	
				FROM	TO
		1 2 3 4 5 6			
2.18-B	--76227	• ANTENNA INSTL. IFF HIFER	1	35	
- 37	2248	• ANTENNA, IFF (40150) SPEC --413344 ATTACHING PARTS	1	35	
- 38	AN503-499	• SCREW -----Y-----	24	35	
- 39	w-30224	• ANTENNA INSTL. IFF ANNULAR SLOT	1	35	
- 40	2247	• ANTENNA, IFF (42197) SPEC --42197 ATTACHING PARTS	1	35	
- 41	AN503-499	• SCREW -----X-----	24	35	
- 42		• AUTOMATIC DIRECTION FINDER ANTENNA SEE FIG. 2.12-9	PF		
- 43		• ANTENNA INSTL. ILLUM MARKER BEACON SEE FIG. 2.12-9	PF		
- 44	227A-1	• ANTENNA, MARKER BEACON (40112) 90-17410-1 ATTACHING PARTS	1	35	
- 45	AN503-499	• SCREW -----X-----	24	35	
- 46	7347118-10	*2 • ANTENNA INSTL. UHF	1	35	
- 47	ATHALZARC	*2 • ANTENNA, UHF	2	35	
- 48	7347117-10	*2 • BRACKET	1	35	
- 49	7347127-01	*2 • GASKET	1	35	
- 50	MS24594-054	*2 • SCREW	6	35	
- 51	AN3-44	*2 • BOLT	1	35	
- 52	AN610610L	*2 • WASHER	1	35	
- 53	MS2142-2	*2 • NUT	1	35	
- 54	MS27426405-B	*1 • RIVET	3	35	
- 55	MS27470405-B	*1 • RIVET	1	35	
- 56	AT-741A	*4 • ANTENNA NETWORK ASSY. INSTL. DATA LINK SEE FIG. 2.18-24 FOR BREAKDOWN	1	35	
- 57	E9034848-1	*8 • ANTENNA, TACAN (40140) DOUBLER ASSY. ATTACHING PARTS	1		
	E9034848-7	*8 • PLATE	1		
	MS2175174	*8 • NUT PLATE	6		
	MS20426403-	*8 • RIVET	16		
- 58	MS24-03-27	*1 • SCREW	6		
- 59	E6039125-7	*7 • GASKET	1		
		*2 ADDED BY TOTO DF-104-1121 REPLACE WITH ASSEMBLY LOCALLY MANUFACTURED IN ACCORDANCE WITH SA-ALC DWS 75450-4, 754-44 AND 754-650.			
		*4 AFTER TOTO DF-104-1121			
		*7 ADDED ON E-11.6A VERT 1 INST ADFI 40, 91 AND 92			

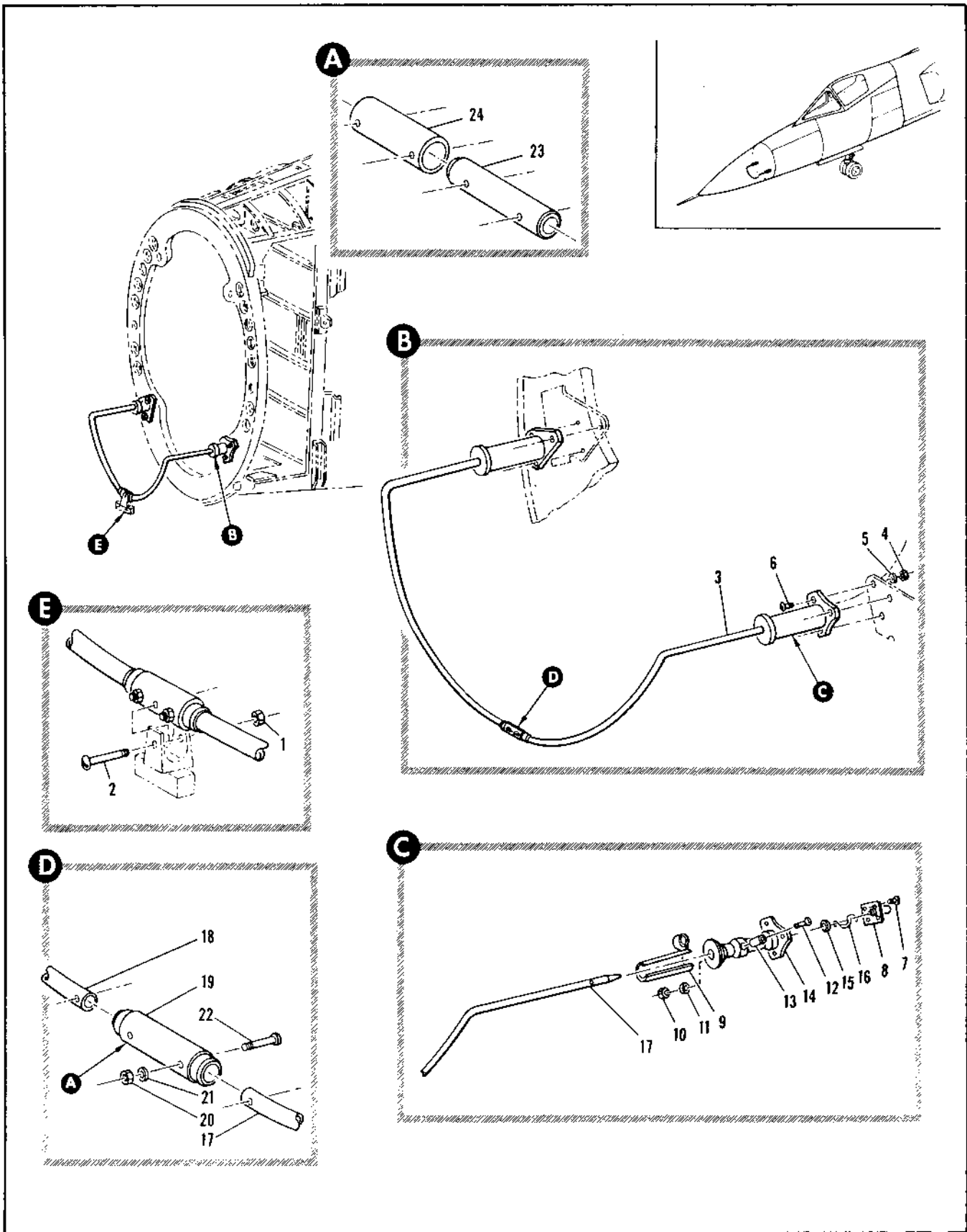

Figure 2.18-7. ILAS Localizer Antenna Installation

FIGURE AND INDEX NUMBER	PART NUMBER	DESCRIPTION	UNITS PER ASSY.	USABLE ON CODE	
				FROM	TO
2.18-7	8-36224	ANTENNA INSTALLATION, ILAS LOCALIZER MODIFIED BY A-77782 FOR NHA SEE FIG. 2.3-1	28	75	
- 1	N632X	• NUT, <95987> 97-49 14-107	1	35	
- 2	N632-1	• SCREW, <95987> 97-49 14-107	1	35	
- 3	8-36220-1	• ANTENNA ASSY, ILAS LOCALIZER MODIFICATION MAKE FROM 8-36217-1 ATTACHING PARTS	1		
- 4	NAS679A3	• NUT	6	35	
- 5	AN939-10L	• WASHER	6	35	
- 6	AN939-10R6	• SCREW	6	35	
- 7	AN517-3P4	• SCREW	8	35	
- 8	UG290A/U	• • RECEPTACLE	2	35	
- 9	8-36711-3	• • SHIELD ASSY, LH WELDED	1	35	
- 10	8-36711-4	• • SHIELD ASSY, RH WELDED ATTACHING PARTS	1	35	
- 11	N632X	• NUT, <95987> 97-49 14-107	2	35	
- 12	AN939-10R6	• WASHER	2	35	
- 13	M932-11/2	• SCREW, <95987> 97-49 14-107	2	35	
- 14	8-36217-9	• • TUBE	2	35	
- 15	8-36686-3	• • SUPPORT, LOCALIZER ANTENNA	2	35	
- 16	99-51506-005	• • WASHER	2	35	
- 17	8-36217-7	• • JUMPER	2	35	
- 18	8-36697-5	• • TUBE ASSY, LH WELDED	1	35	
- 19	8-36697-4	• • TUBE ASSY, RH WELDED	1	35	
- 20	8-36712	• • SLEEVE ASSEMBLY ATTACHING PARTS	1		
- 21	N632X	• NUT, <95987> 97-49 14-107	2	35	
- 22	AN939-10R6	• WASHER	2	35	
- 23	N632-1	• SCREW, <95987> 97-49 14-107	2	35	
- 24	8-36659-1	• • SLEEVE	1	35	
- 25	8-36711	• • TUBE	1	35	

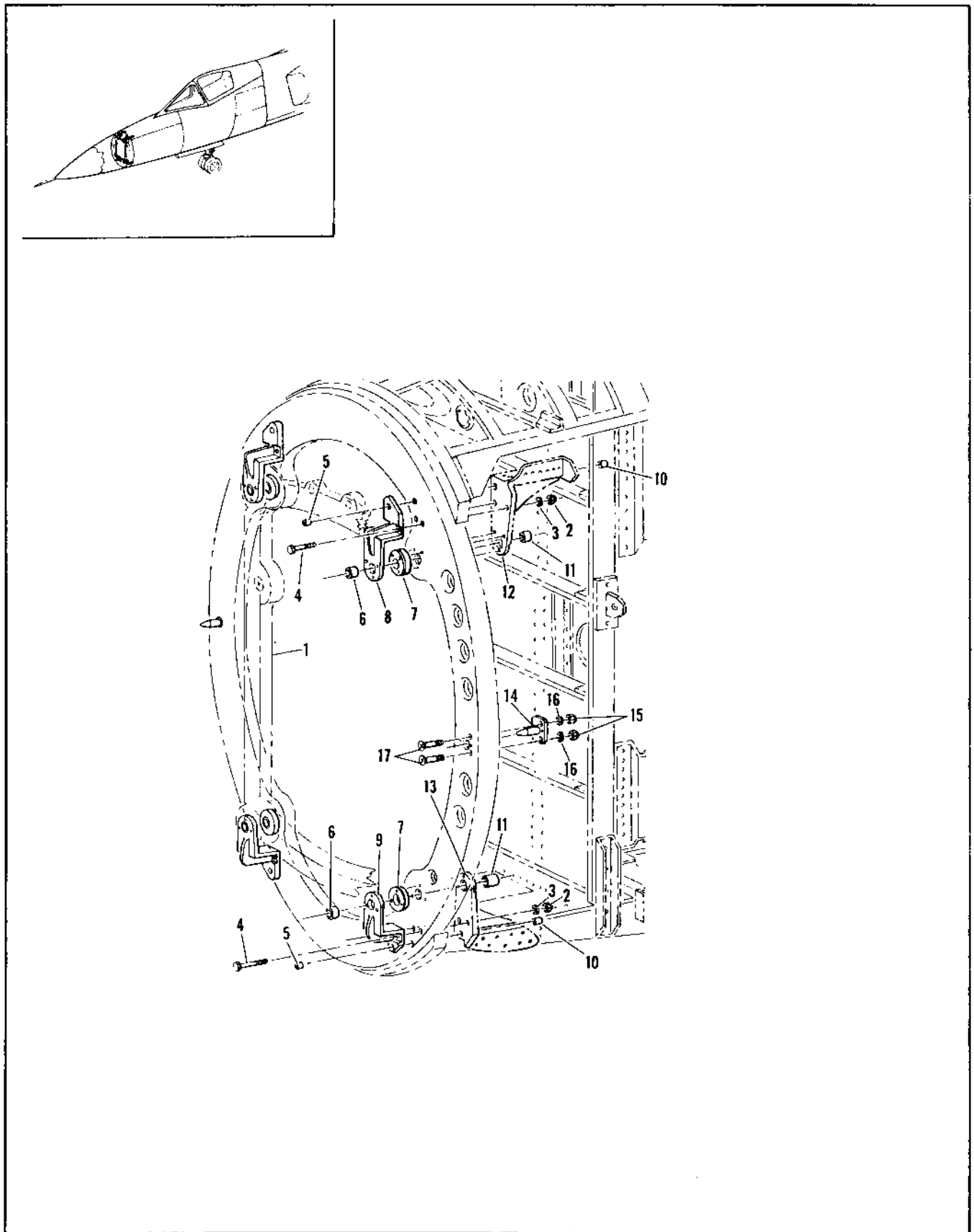

Figure 2.18-8. Radar Antenna Support Installation Sta 41

FIGURE AND INDEX NUMBER	PART NUMBER	DESCRIPTION 1 2 3 4 5 6	UNITS PER ASSY.	USABLE ON CODE	
				FROM	TO
2.1F 8	6-74735	SUPPORT INSTALLATION, RADAR ANTENNA STA 41 FOR IMA SEE FIG. 2.3-5	RF	75	
- 1		• RACK, ANTENNA TRANSMITTER-RECEIVER GROUP ELECTRICAL EQUIPMENT SEE FIG. 2.18-7 INDEX 20	RF		
- 2	NAS679A9	• NUT	4	35	
- 3	AN957-414	• WASHER	8	35	
- 4	AN4-17A	• BOLT	2	35	
- 5	91-27134-014	• BUSHING	4	35	
- 6	91-27134-028	• BUSHING	4	35	
- 7	6-74735-7	• FILLER	4	35	
- 8	6-74792-7	• FITTING, UPPER LH MAKE FROM 6-74792	1	35	
	6-74792-8	• FITTING, UPPER RH MAKE FROM 6-74792	1	35	
	6-74792	• FITTING	RF		
- 9	6-74792-9	• FITTING, LOWER LH	1	35	
	6-74792-10	• FITTING, LOWER RH	1	35	
- 10	91-27134-012	• BUSHING	4	35	
- 11	91-27134-009	• BUSHING	4	35	
- 12		• FITTING, UPPER RADAR SUPPORT SEE FIG. 2.18-7 INDEX 15	RF		
- 13		• FITTING, LOWER RADAR SUPPORT SEE FIG. 2.18-7 INDEX 17	RF		
- 14	6-74753	• PIN, RADOME SHEAR ATTACHING PARTS	2	35	
- 15	NAS679A3	• NUT	4	35	
- 16	AN960-10	• WASHER	4	35	
- 17	AN519-17311	• SCREW	4	35	
		-----X-----			

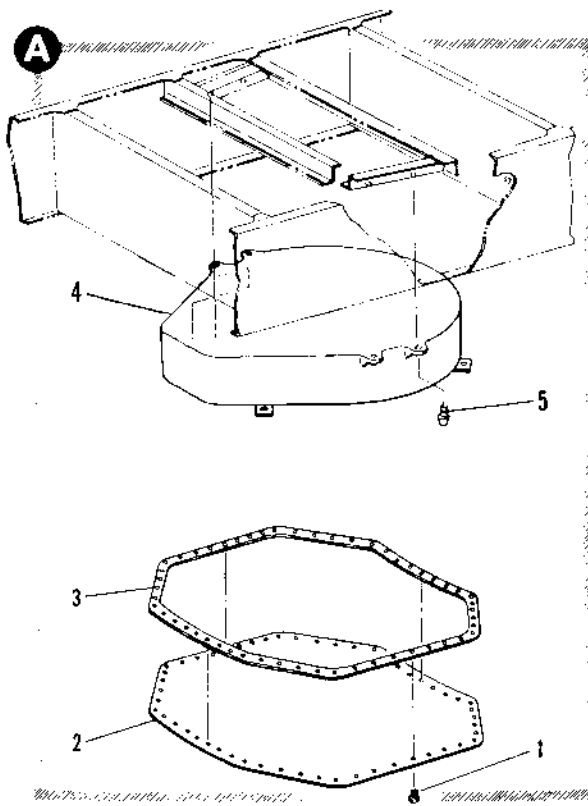
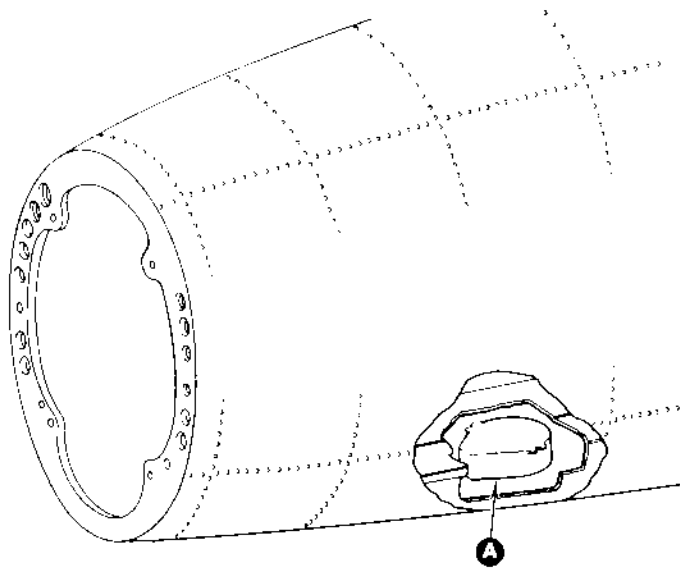

Figure 2.18-9. Automatic Direction Finder Antenna

FIGURE AND INDEX NUMBER	PART NUMBER	DESCRIPTION 1 2 3 4 5 6	UNITS PER ASSY.	USABLE ON CODE	
				FROM	TO
2.18-9	5-36211	AUTOMATIC DIRECTION FINDER ANTENNA	1	35	
	6-36575	• COVER INSTL, ADF AN/ARA-25 ANTENNA	1	35	
	- 1	• • COVER ASSY, ADF AN/ARA-25 ANTENNA ATTACHING PARTS	12	35	
	- 2	• • SCREW ----X----	1	35	
	- 3	• • • COVER • • • GASKET	1	35	
- 4	8-36211-B 464117	• ANTENNA INSTL, ADF AN/ARA-25 • ANTENNA, ADF (A2577) APRN052-5127 GFAE ATTACHING PARTS	1	35	
- 5	MS20504-B	• BOLT ----X----	4	35	

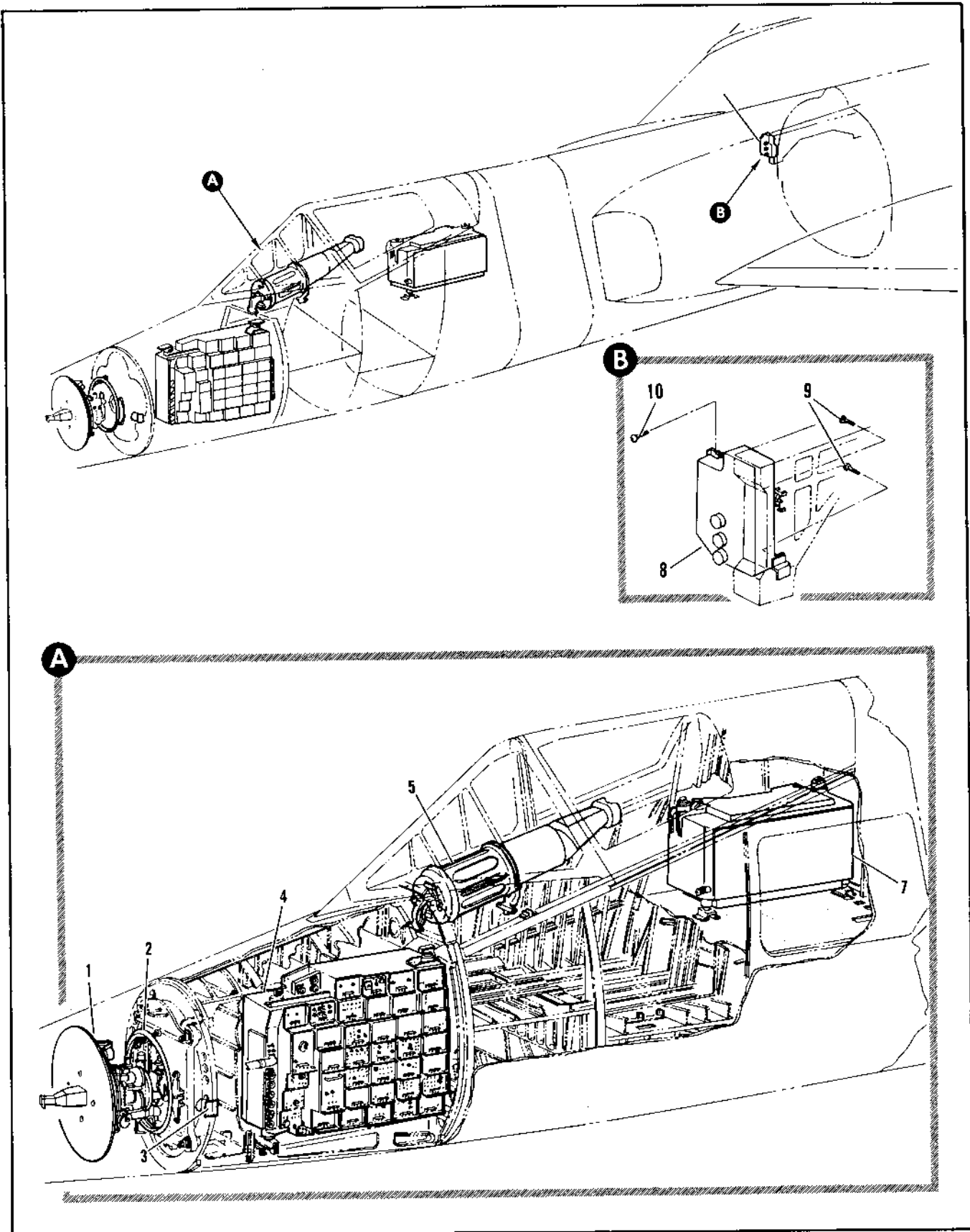

Figure 2.18-10. Radar

FIGURE AND INDEX NUMBER	PART NUMBER	DESCRIPTION 1 2 3 4 5 6	UNITS PER ASSY.	USABLE ON CODE	
				FROM	TO
2.18-10		RADAR			
- 1		• ANTENNA INSTL, MA-1 RADAR SEE FIG. 2.18-6	RF		
- 2		• EQUIPMENT INSTL, TRANSMITTER-RECEIVER SEE FIG. 2.18-16	RF		
- 3		• TRANSMITTER INSTL, ANGLE OF ATTACK SEE FIG. 2.18-31	RF		
- 4		• EQUIPMENT INSTL, FWD LH ELECTRONIC COMPARTMENT ELECTRICAL SEE FIG. 2.18-21	RF		
- 5		• RADARSCOPE INSTL, SEE FIG. 2.18-11	RF		
- 6		• EQUIPMENT INSTL, UPPER AFT RH ELECTRONIC COMPARTMENT SEE FIG. 2.18-23	RF		
- 7	A-36357-1	• PANEL INSTL, ARMAMENT ELECTRICAL TEST STA 439	1	35	
- 8	464596	• • PANEL, ARMAMENT ELECTRICAL TEST <82577> GFAC ATTACHING PARTS	1	35	
- 9	AN520-10R6	• • SCREW	2	35	
	AN305	• • SCREW, ALT INTCHG WITH AN520-10R6	2	35	
- 10	AN520-10R8	• • SCREW -----X-----	2	35	

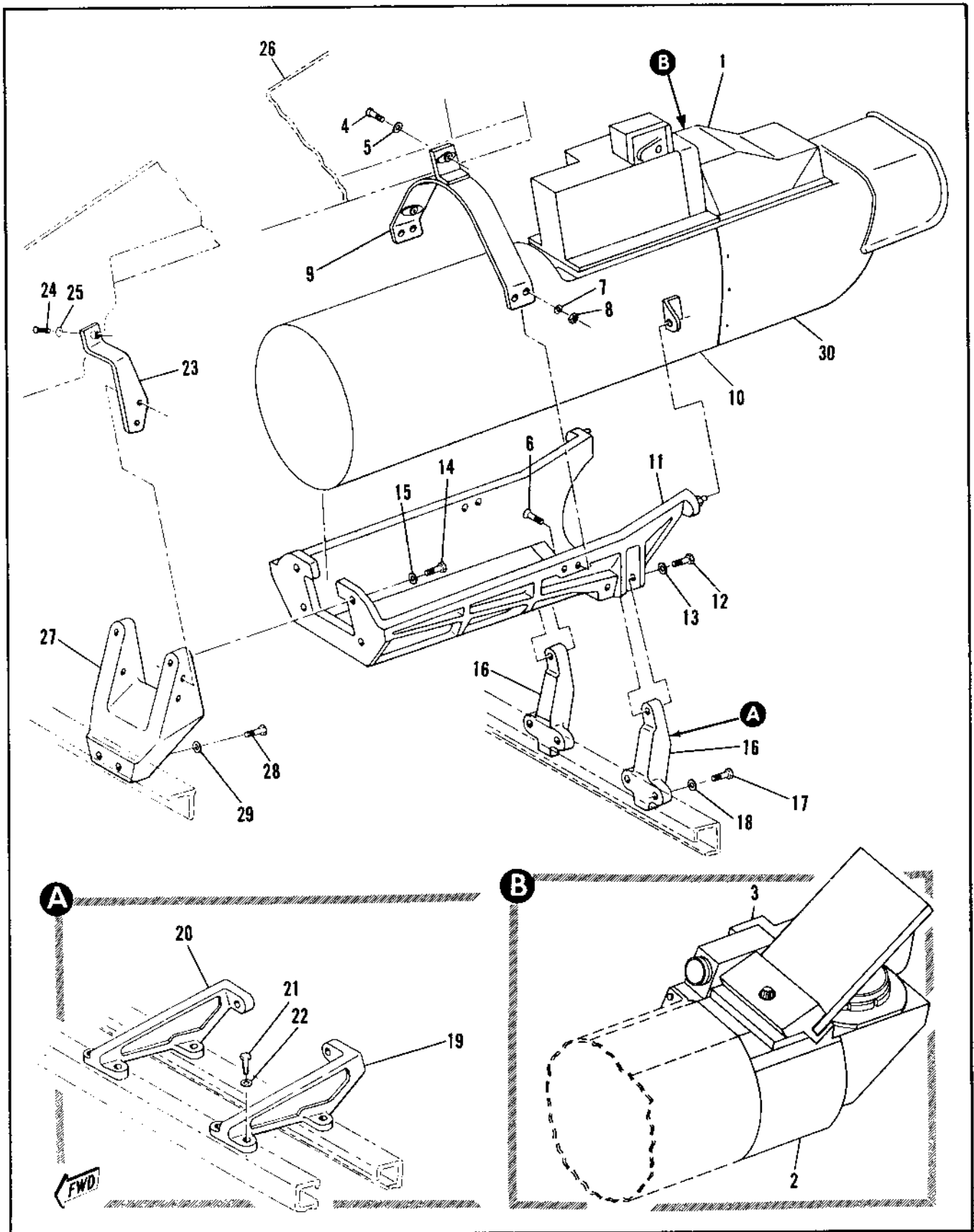

Figure 2.18-11. MMST Radar Scope Installation

FIGURE AND INDEX NUMBER	PART NUMBER	DESCRIPTION	UNITS PER ASSY.	USABLE ON CODE		
				FROM	TO	
2.18-11	66J41924-1	MMST RADAR SCOPE INSTALLATION FOR MHA SEE FIG. 2-3-4	PF		A	
	66J41924-2	MMST RADAR SCOPE INSTALLATION FOR MHA SEE FIG. 2-3-4	PF		B	
	- 1	464149-142 *2	• RECORDER, PHOTO (92577) GFAC	1		A
	- 2	52A30 *2	• ODU ASSEMBLY (93757) GFAC	1		B
	- 3	52300 *2	• CAMERA ASSEMBLY (33755) GFAC	1		B
	- 4	MS35207-264	• SCREW	1		
	- 5	AN961-17	• WASHER	1		
	- 6	AN520-3R16	• SCREW	4		
	- 7	AN967-21	• WASHER	4		
	- 8	MS21942L14	• NUT	4		
	- 9	66D41921-1	• SUPPORT, AFT Baffle	1		
	- 10	464080 *2	• INDICATOR, FLIGHT COMMAND (92577) GFAC	1		
	- 11	464002 *2	• RACK (92577) GFAC	1		
			ATTACHING PARTS			
	- 12	AN4-27A	• BOLT	2		
	- 13	AN967-41B	• WASHER	2		A
		AN967-41FL	• WASHER	2		B
	- 14	AN3-7A	• BOLT	4		
	- 15	AN961-17L	• WASHER	4		
			-----X-----			
	- 16	66D41922-1	• SUPPORT, AFT	2		A
			ATTACHING PARTS			
	- 17	AN3-7A	• BOLT	2		A
	- 18	AN967-10L	• WASHER	2		A
			-----Y-----			
	- 19	66D40933-7	*2	• SUPPORT AFT, LH	1	R
	- 20	66D40933-8	*2	• SUPPORT AFT, RH	1	R
			ATTACHING PARTS			
	- 21	AN3-7A	• BOLT	4		B
	- 22	AN967-10L	• WASHER	4		B
			-----X-----			
	- 23	66D40934-1	• SUPPORT	1		A
		7747263-10	*2	• SUPPORT	1	R
		ATTACHING PARTS				
- 24	MS5207-264	• SCREW	3			
- 25	AN967-10	• WASHER	3			
		-----Y-----				
- 26	66E40961-1	• Baffle (ALTERED FROM 8-32873-15 OR 8-32873-17) FOR BREAKDOWN SEE FIG. 2-3-3	PF		A	
	7747267-10	*2	• Baffle ASSY	1	K	
- 27	66D41926-1	• SUPPORT, FORWARD	1		A	
	7747212-10	*2	• SUPPORT, FWD	1	K	
		ATTACHING PARTS				
- 28	AN3-7A	• BOLT	2			
- 29	AN967-10L	• WASHER	2			
		-----X-----				
- 30	3032860	*2	• FILTER AND CONTROL ASSY	1		

A 35 THRU 47 AND 49 THRU 49
 B 49, 51 AND 51
 *2 AFTER T.O. 1F-106-1173

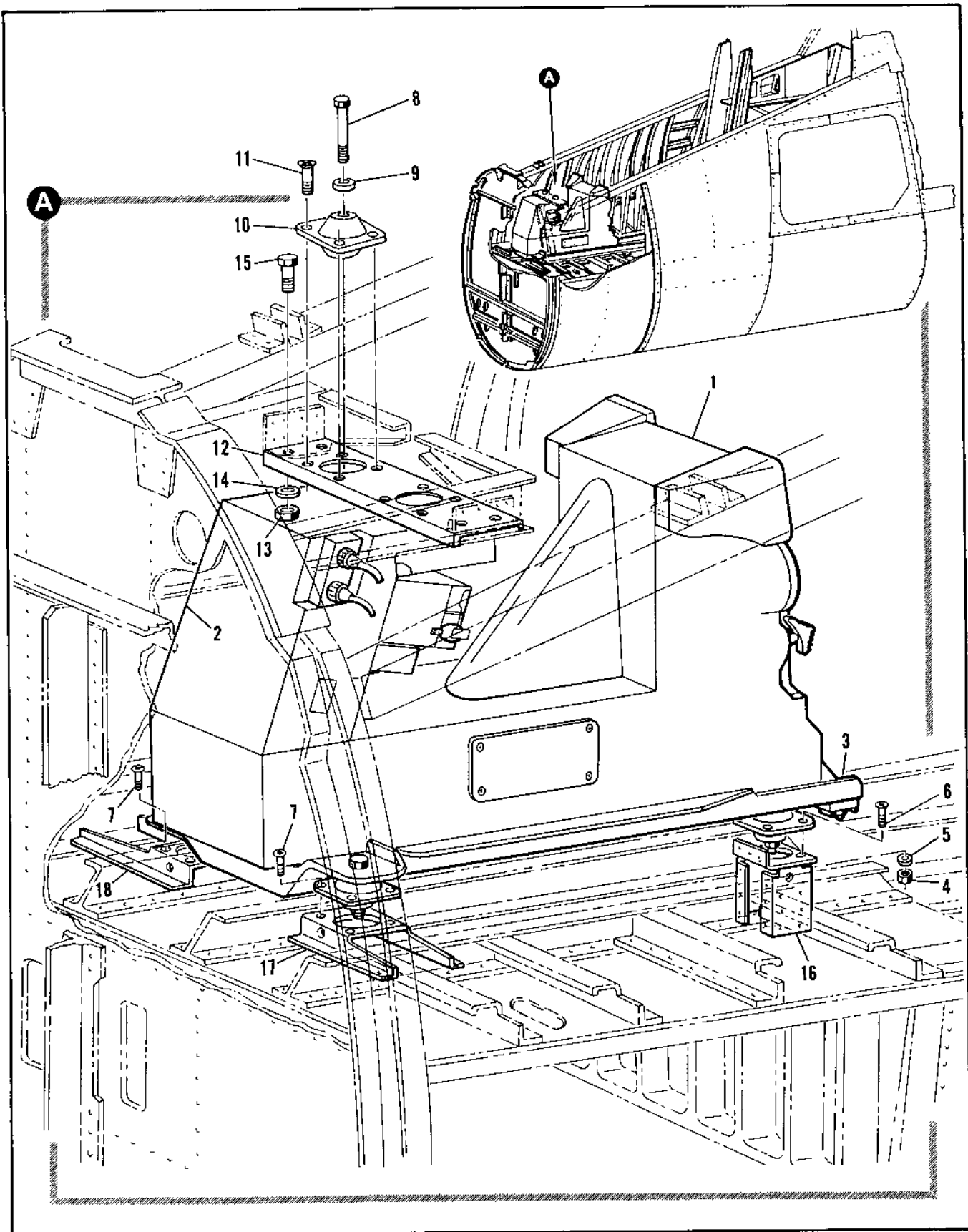

Figure 2.18-12. Tactical Situation Display

FIGURE AND INDEX NUMBER	PART NUMBER	DESCRIPTION	UNITS PER ASSY.	USABLE ON CODE	
				FROM	TO
		1 2 3 4 5 6			
2.18-12	8-95146-3	TACTICAL SITUATION DISPLAY • DISPLAY INSTL. TACTICAL SITUATION FOR MHA SEE FIG. 2.1-1	RF	A	
- 1	464121	• INDICATOR, TACTICAL SITUATION (81577) DFAL	1	A	
- 2	464922	• CONVERTER SIGNAL DATA	1	A	
- 3	464112	• PACK, TACTICAL SITUATION INDICATOR ELECTRICAL EQUIPMENT (42577) AERN052-9060 6FAC ATTACHING PARTS	1	A	
- 4	NAS679A3	• NUT	4	A	
- 5	AN961011L	• WASHER	4	A	
- 6	NAS221-11	• SCREW	4	P	
	AN3-4A	• BOLT	4	E 2	89
- 7	NAS221-11	• SCREW	8	P	
	AN3-4A	• BOLT	8	K 3	89
- 8	AN4-11A	• BOLT	2	E	
- 9	AN961011L	• WASHER	2	A	
		-----X-----			
	8-95546-110	• SUPPORT INSTL. TACTICAL SITUATION INDICATOR FOR MHA SEE FIG. 2.3-4	RF	35	89
	8-95546-117	• SUPPORT INSTL. TACTICAL SITUATION INDICATOR FOR MHA SEE FIG. 2.3-4	RF	75	89
- 10	K306-14	• MOUNT, SHOCK (82577) DFAL ATTACHING PARTS	2	35	89
- 11	NAS221-11	• SCREW	8	35	89
		-----Y-----			
- 12	8-95546-117	• SUPPORT ASSY. UPPER RIVETED ATTACHING PARTS	1	35	89
- 13	NAS679A3	• NUT	4	35	89
- 14	AN961011L	• WASHER	4	35	89
- 15	NAS464-303	• BOLT	4	35	89
		-----X-----			
- 16	8-95546-115	• SUPPORT ASSY. AFT RIVETED	1	A	
- 17	8-95546-113	• SUPPORT ASSY. LH FWD RIVETED	1	35	89
- 18	8-95546-117	• SUPPORT ASSY. RH FWD RIVETED	1	35	89
		A AIRPLANES 475 THRU 47 AND 49 THRU 89			
		B AIRPLANES 435 THRU 47 AND 49 THRU 88			

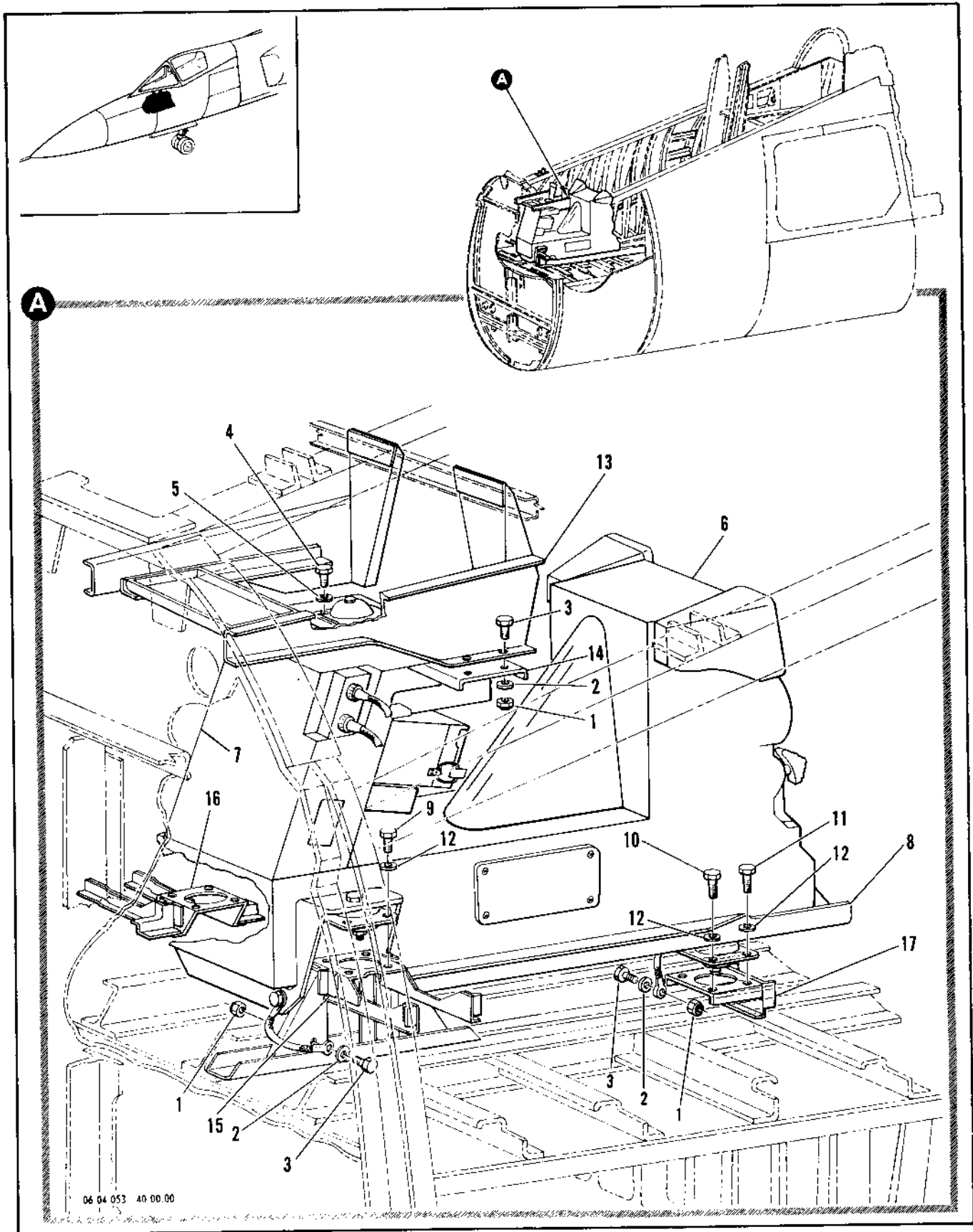

Figure 2.18-13. Tactical Situation Display Installation

FIGURE AND INDEX NUMBER	PART NUMBER	DESCRIPTION	UNITS PER ASSY.	USABLE ON CODE		
				FROM	TO	
2.18-13	R-95481-1	DISPLAY INSTALLATION, TACTICAL SITUATION FOR MHA SEE FIG. 2.3-4	RF	48	48	
	R-95481	DISPLAY INSTALLATION, TACTICAL SITUATION FOR MHA SEE FIG. 2.3-4	PF	90		
	- 1	WASHER	6	A		
	- 2	AN966-10L	6	A		
	- 3	AN3-4A	6	A		
	- 4	AN3-5A	8	A		
	- 5	AN966-10L	8	A		
	- 6	464141	1	A		
	- 7	464928	1	A		
	- 8	464112	1	A		
	- 9	AN3-5A	8	A		
	- 10	AN3-4A	2	A		
	- 11	AN3-7A	2	A		
	- 12	AN966-10L	12	A		
	- 13	R-95581-79	• SUPPORT ASSEMBLY	1	A	
	- 14	R-95581-73	• CHANNEL ASSY, RIVETED	1	A	
	- 15	R-95581-40	• SUPPORT ASSY, RIVETED	1	48	48
- 16	R-95581-45	• SUPPORT ASSY, RIVETED	1	90	90	
- 17	R-95581-43	• SUPPORT ASSY, RIVETED	1	A		
	R-95581-41	• SUPPORT ASSY, RIVETED	1	A		
		A AIRPLANES #48, 90 AND ON				

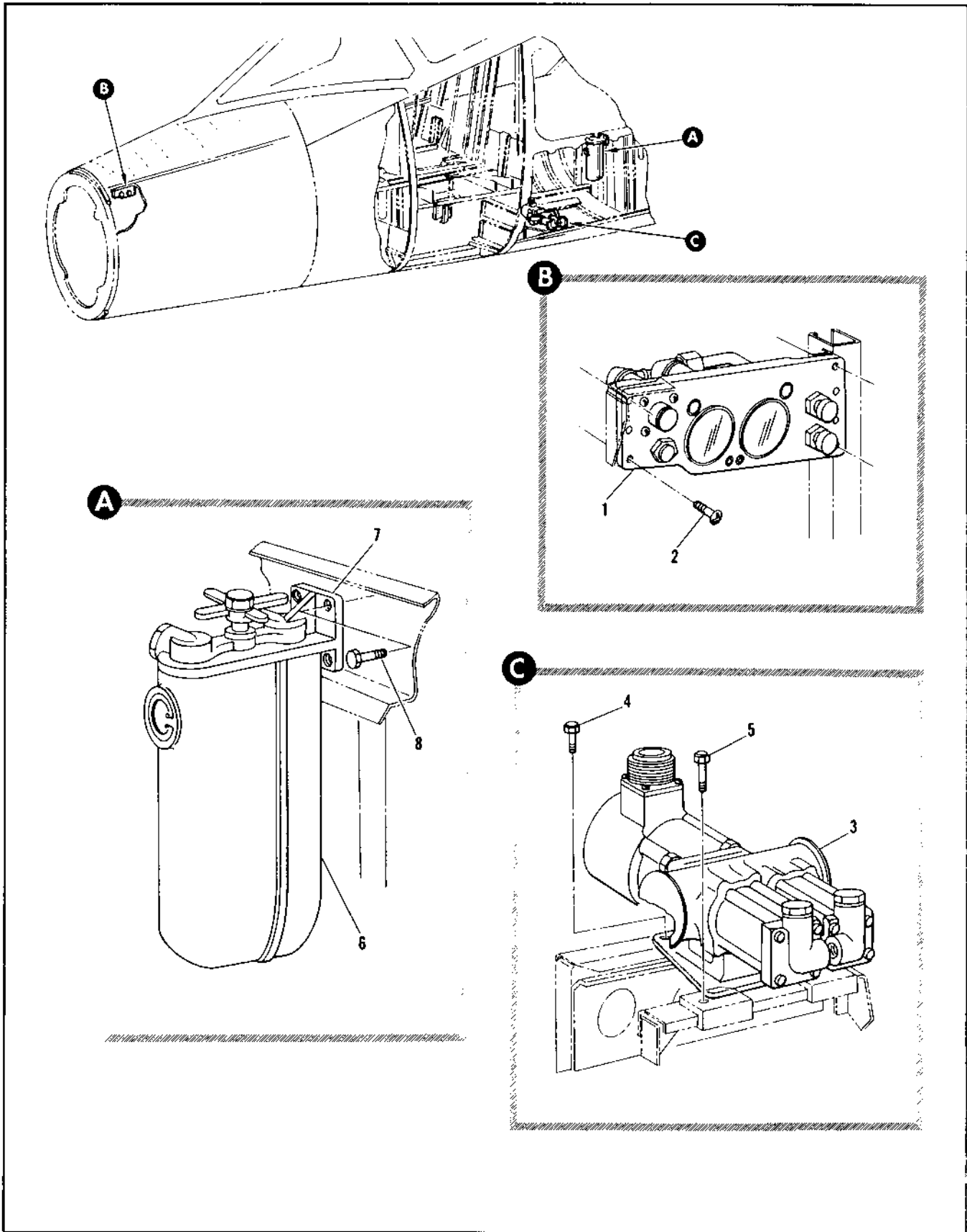

Figure 2.18-14. Pressurization Group

FIGURE AND INDEX NUMBER	PART NUMBER	DESCRIPTION 1 2 3 4 5 6	UNITS PER ASSY.	USABLE ON CODE		
				FROM	TO	
2.18-14	8-76292-1 464004-13	• PRESSURIZATION GROUP	1	35		
		• INDICATOR, INSTL, RADAR PRESSURIZATION	1	35		
	- 2	NAS221-11	• • INDICATOR, RADAR PRESSURE (K82577) AERNO52-8919 GFAB ATTACHING PARTS	4	35	
			• • SCREW -----X-----			
	- 3	8-35384-1 46445	• COMPRESSOR, INSTL, AFT ELECTRONIC COMPARTMENT RECIPROCATING POWER DRIVEN AIR STA 185	1	35	
			• • COMPRESSOR, (K82577) AERNO52-8927 GFAB TO 11F11-4-4 INCH WITH 463040 BY USE OF ATTACHING PARTS	1	35	
	- 4	67C45432 MS51058-03	• • BRACKET, MOUNTING, COMPRESSOR	1		
			• • SCREW ATTACHING PARTS	4		
	- 5	AN4-5A AN4-7A	• • BOLT	2	35	
			• • BOLT -----X-----	2	35	
	- 6	8-39378-1	• DEHYDRATOR, INSTL, AFT ELECTRONIC COMPARTMENT RADAR AIR PRESSURE STA 217 LH	1	35	
			• DEHYDRATOR, INSTL, AFT ELECTRONIC COMPARTMENT RADAR AIR PRESSURE STA 217 RH	1	35	
	- 7	463097-100MD1 464574	• • DEHYDRATOR, (K82577) GFAB	1	35	
			• • RACK, DEHYDRATOR (K82577) AERNO52-8928 GFAB LH	1	35	
	- 8	464774	• • RACK, DEHYDRATOR (K82577) AERNO52-8907 GFAB RH ATTACHING PARTS	1	35	
• • SCREW, LH			4	35		
	NAS221-11 AN3-1 A	• • BOLT, RH -----X-----	4	35		

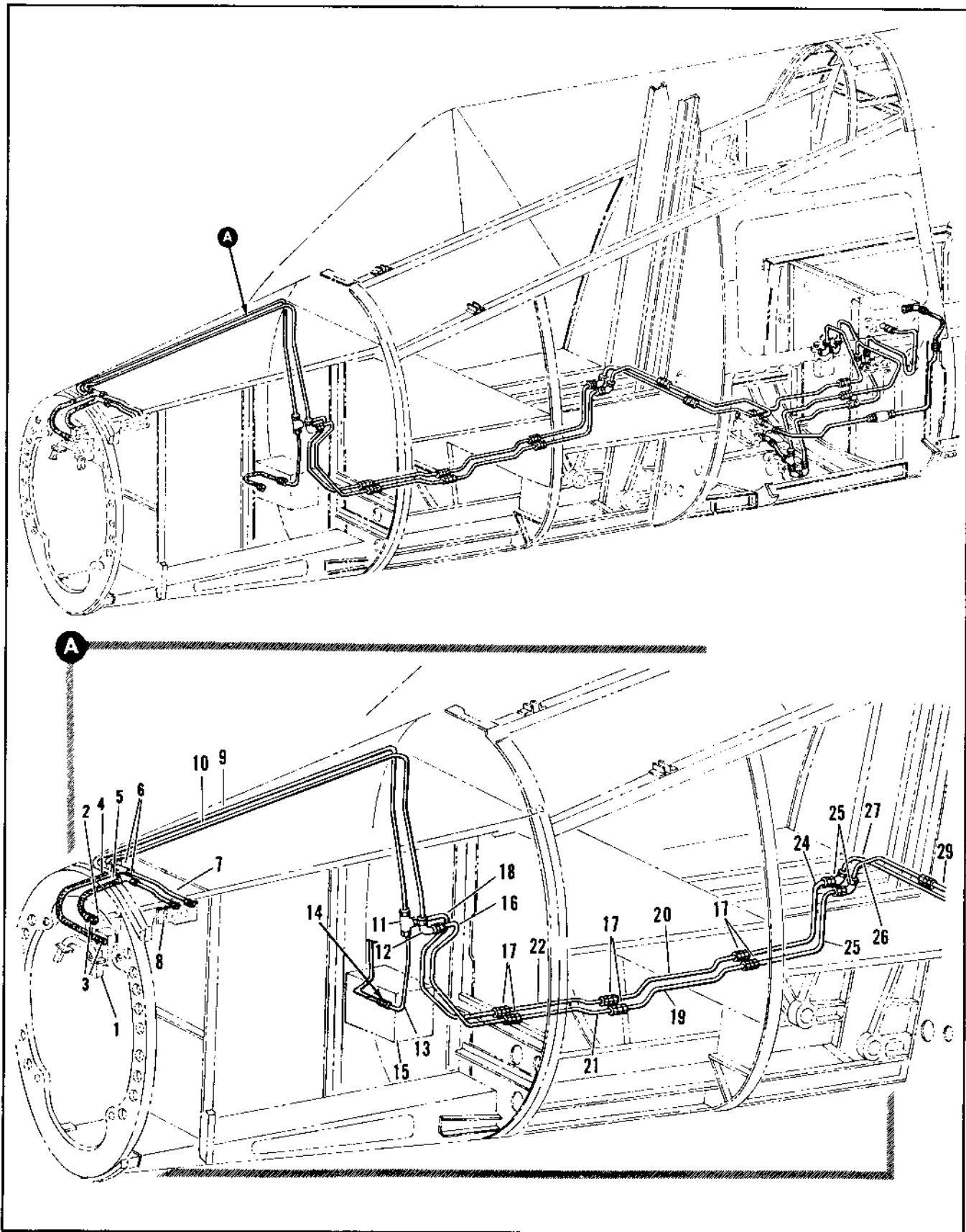

Figure 2.18-15. Radar Pressurization Tubing Installation (Sheet 1 of 2)

FIGURE AND INDEX NUMBER	PART NUMBER	DESCRIPTION	UNITS PER ASSY.	USABLE ON CODE	
				FROM	TO
2.18-15	R-36204-1	TUBING INSTALLATION, RADAR PRESSURIZATION FOR VHA SEE FIG. 2.3-4	RF	A	
	R-36204-1	TUBING INSTALLATION, RADAR PRESSURIZATION FOR VHA SEE FIG. 2.3-4	RF	B	
- 1		• GAGE UNDE ASSY, RADAR SEE FIG. 2.18-16 INDEX 14	RF		
- 2		• RECEIVER-TRANSMITTER, RADAR SEE FIG. 2.18-16 INDEX 22	RF		
- 3	MS21903D4	• UNION	2	35	
	AN924-40	• NUT	2	35	
- 4	416246-4-1247	HOSE ASSY, <1624> R4-R0517-17 USE WITH R-36204-1	1	35	
	R-36204-101	• HOSE ASSY, RADAR PRESSURIZATION USE WITH R-36204-5	RF	35	
	616244-4-154	• HOSE ASSY, <1624> R4-R0517-136	1	35	
- 5	616248-4-1130	• HOSE ASSY, <1624> R4-R0517-116	1	35	
- 6	MS21912D4	• TEE	2	35	
	AN924-40	• NUT	2	35	
	AN9610714	• WASHER	2	35	
- 7	R-44-09-9F	• TUBE ASSY	2		
	MS21414D4	• ELBOW	2		
	AN924-40	• NUT	2		
	MS26773-4	• PACKING	2		
- 8		• INDICATOR, RADAR PRESSURE SEE FIG. 2.18-14 INDEX 1	RF		
- 9	R-36204-11	• TUBE ASSY, RADAR PRESSURIZATION	1	A	
	R-36204-102	• TUBE ASSY, RADAR PRESSURIZATION	1	B	
- 10	R-36204-13	• TUBE ASSY, RADAR PRESSURIZATION	1	C	
	R-36204-127	• TUBE ASSY, RADAR PRESSURIZATION	1	D	
- 11	MS21903D4	• TEE	1	35	
	AN924-40	• NUT	1	35	
	AN9610714	• WASHER	1	35	
- 12	MS2140-D4	• ELBOW	1	35	
	AN924-40	• NUT	1	35	
	AN9610714	• WASHER	1	35	
- 13	R-36204-12	• TUBE ASSY, RADAR PRESSURIZATION	1	A	
	R-36204-147	• TUBE ASSY, RADAR PRESSURIZATION	1	B	
- 14	MS21114D4	• CAP	RF		
- 15		• MAGNETIC DRUM, DATA STORAGE SEE FIG. 2.18-18 INDEX 6	RF		
- 16	R-36204-1	• TUBE ASSY, RADAR PRESSURIZATION	1	A	
	R-36204-154	• TUBE ASSY, RADAR PRESSURIZATION	1	4A	4B
	R-36204-171	• TUBE ASSY, RADAR PRESSURIZATION	1	5A	
- 17	MS21902D4	• UNION	6	35	
- 18	R-36204-17	• TUBE ASSY, RADAR PRESSURIZATION	1	A	
	R-36204-156	• TUBE ASSY, RADAR PRESSURIZATION	1	4A	4B
	R-36204-177	• TUBE ASSY, RADAR PRESSURIZATION	1	5A	
- 19	R-36204-17	• TUBE ASSY, RADAR PRESSURIZATION	1	A	
	R-36204-157	• TUBE ASSY, RADAR PRESSURIZATION	1	B	
- 20	R-36204-161	• TUBE ASSY, RADAR PRESSURIZATION	1	A	
	R-36204-158	• TUBE ASSY, RADAR PRESSURIZATION	1	B	
- 21	R-36204-15	• TUBE ASSY, RADAR PRESSURIZATION	1	A	
	R-36204-161	• TUBE ASSY, RADAR PRESSURIZATION	1	B	
- 22	R-36204-161	• TUBE ASSY, RADAR PRESSURIZATION	1	A	
	R-36204-167	• TUBE ASSY, RADAR PRESSURIZATION	1	B	
- 23	R-36204-157	• TUBE ASSY, RADAR PRESSURIZATION	1	35	
- 24	R-36204-17	• TUBE ASSY, RADAR PRESSURIZATION	1	35	
- 25	MS21403D4	• ELBOW	2	35	
	AN924-40	• NUT	2	35	
	AN9610714	• WASHER	2	35	
- 26	R-36204-17	• TUBE ASSY, RADAR PRESSURIZATION	1	35	
- 27	R-36204-111	• TUBE ASSY, RADAR PRESSURIZATION	1	35	

3 AIRPLANES #75 THRU #7 AND #9 THRU #9
 6 AIRPLANES #49, 50 AND 50

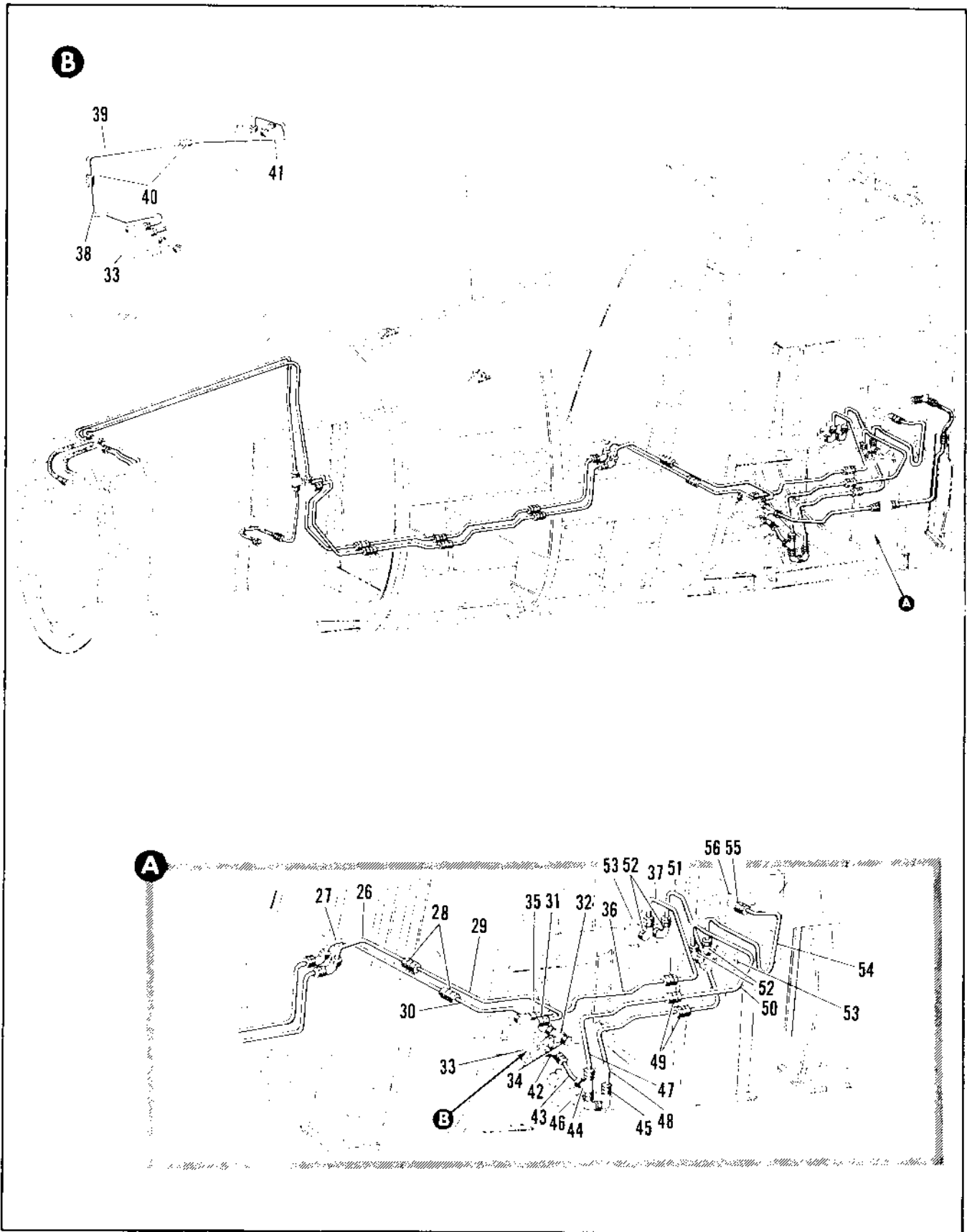

Figure 2.18-15. Radar Pressurization Tubing Installation (Sheet 2 of 2)

FIGURE AND INDEX NUMBER	PART NUMBER	DESCRIPTION	UNITS PER ASSY.	USABLE ON CODE	
				FROM	TO
		1 2 3 4 5 6			
2.18-15- 28	MS21902D4	• UNION	2	35	
- 29	8-36206-97	• TUBE ASSY, RADAR PRESSURIZATION	1	A	
	8-36206-135	• TUBE ASSY, RADAR PRESSURIZATION	1	B	
- 30	8-36206-95	• TUBE ASSY, RADAR PRESSURIZATION	1	A	
	8-36206-133	• TUBE ASSY, RADAR PRESSURIZATION	1	B	
- 31	MS21902D4	• UNION	1	35	
	AN6290-4	• GASKET	1	35	
- 32	MS21909D4	• TEE	1	35	
	AN924-4D	• NUT	1	35	
	AN6290-4	• GASKET	1	35	
- 33		• VALVE ASSY, AUTOMATIC REGULATING PRESSURE SEE FIG. 2.18-20 INDEX 5	RF		
- 34	MS21914-4D	• CAP, PRESSURE SEAL	1		
- 35	MS21902-6	• UNION	2	35	
	AN6290-6	• GASKET	2	35	
- 36	8-36206-103	• TUBE ASSY, DEHYDRATOR RH	1	A	
	8-36206-137	• TUBE ASSY, DEHYDRATOR RH	1	C	
	8-36206-171	• TUBE ASSY, DEHYDRATOR RH	1	130	
- 37	8-36206-105	• TUBE ASSY, DEHYDRATOR RH	1	A	
	8-36206-139	• TUBE ASSY, DEHYDRATOR RH	1	48	48
- 38	8-36206-179	• TUBE ASSY, DEHYDRATOR RH	1	90	
- 39	8-36206-181	• TUBE ASSY, DEHYDRATOR RH	1	90	
- 40	MS21902D6	• UNION	2	90	
- 41	8-36206-177	• TUBE ASSY, DEHYDRATOR RH	1	90	129
	8-36206-185	• TUBE ASSY, DEHYDRATOR RH	1	130	
- 42	MS21909D6	• ELBOW	1	35	
	AN924-6D	• NUT	1	35	
	AN6290-6	• GASKET	1	35	
- 43	8-36206-111	• TUBE ASSY, COMPRESSOR	1	A	
	8-36206-145	• TUBE ASSY, COMPRESSOR	1	B	
- 44	MS21912D6	• TEE	1	35	
	AN924-6D	• NUT	1	35	
	AN6290-6	• GASKET	1	35	
- 45	MS21902D6	• UNION	1	35	
- 46		• COMPRESSOR, SEE FIG. 2.18-14 INDEX 3	RF		
- 47	8-36206-113	• TUBE ASSY, DEHYDRATOR LH	1	A	
	8-36206-147	• TUBE ASSY, DEHYDRATOR LH	1	B	
- 48	8-36206-169	• TUBE ASSY, DEHYDRATOR RH	1	A	
	8-36206-143	• TUBE ASSY, DEHYDRATOR RH	1	B	
- 49	MS21902D6	• UNION	2	35	
- 50	8-36206-115	• TUBE ASSY, DEHYDRATOR LH	1	A	
	8-36206-149	• TUBE ASSY, DEHYDRATOR LH	1	B	
- 51	8-36206-107	• TUBE ASSY, DEHYDRATOR RH	1	A	
	8-36206-141	• TUBE ASSY, DEHYDRATOR RH	1	C	
	8-36206-183	• TUBE ASSY, DEHYDRATOR RH	1	130	
- 52	MS21909D6	• ELBOW	4	35	
	AN924-6D	• NUT	4	35	
	AN6290-6	• GASKET	4	35	
- 53		• DEHYDRATOR, SEE FIG. 2.18-14 INDEX 6	RF		
- 54	8-36206-117	• TUBE ASSY, DEHYDRATOR LH	1	A	
	8-36206-151	• TUBE ASSY, DEHYDRATOR LH	1	B	
- 55	MS21902D6	• UNION	1	35	
	AN6290-6	• GASKET	1	35	
- 56		• MANIFOLD ASSEMBLY	RF		

A AIRPLANES #35 THRU 47 AND 49 THRU 89
 B AIRPLANES #48, 90 AND ON
 C AIRPLANES #48 AND 90 THRU 129

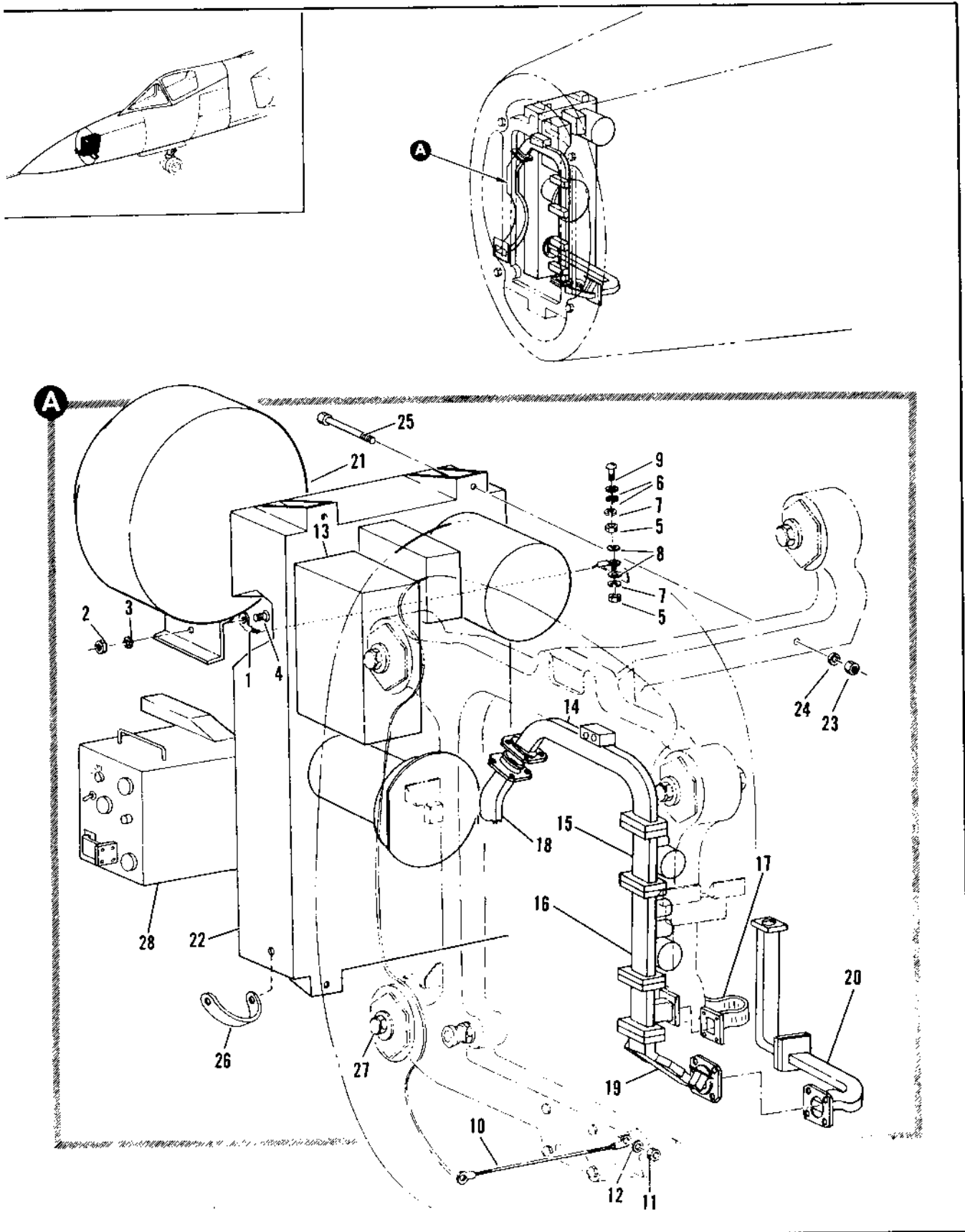

Figure 2.18-16. Transmitter-Receiver Equipment Installation

FIGURE AND INDEX NUMBER	PART NUMBER	DESCRIPTION	UNITS PER ASSY.	USABLE ON CODE	
				FROM	TO
2.18-16		EQUIPMENT INSTALLATION, (TRANSMITTER-RECEIVER ALT INTCHG WITH 9-16244-1	RF	75	
- 1	MS25017-18W12	• JUMPER, GFAE	1	35	
		ATTACHING PARTS			
- 2	MS21033N9	• NUT, <82577> GFAE	1	35	
- 3	AN951-10L	• WASHER, GFAE	1	35	
- 4	366349-879	• SCREW, <82577> GFAE	1	35	
- 5	AN345-10	• NUT	2	35	
- 6	AN951-10L	• WASHER, GFAE	2	35	
- 7	AN951-10	• WASHER	2	35	
- 8	AN951-10L	• WASHER	2	35	
- 9	AN521-10R6	• SCREW	1	35	
		-----X-----			
- 10	MS25013-18P10	• JUMPER, GFAE	1	35	
		ATTACHING PARTS			
- 11	943925-79	• NUT, <82577> GFAE	1	35	
- 12	AN951-10L	• WASHER, GFAE	1	35	
		-----X-----			
- 13	464541	• PROGRAMMER, (82577) GFAE	1		
- 14	464216	• WAVEGUIDE ASSY, RADAR (82577) GFAE	1		
- 15	464984	• COUPLER-DIRECTIONAL, TEST (82577) GFAE	1		
- 16	464452	• DUPLEXER, CIRCULATOR (82577) GFAE	1		
- 17	464516-160	• WAVEGUIDE ASSY, RECEIVER (82577) GFAE			
		-----X-----			
- 18	464149	• WAVEGUIDE ASSY			
- 19	464384	• COUPLER, RADAR DIRECTIONAL (82577) GFAE	1		
- 20	464014	• WAVEGUIDE ASSY, RADAR (82577) GFAE	1		
	455573A	• WAVEGUIDE	1		
	455223	• WAVEGUIDE, FLEXIBLE			
- 21	464139	• DUCT ASSY, MODULATOR COOLING <82577> 46RN052-371 GFAE	1	35	
- 22	464565	• TRANSMITTER, RADAR (82577) GFAE	1		
		ATTACHING PARTS			
- 23	943925-R0	NUT, <82577> GFAE	4	35	
- 24	AN951-616L	• WASHER, GFAE	4	35	
- 25	AN6-39A	• BOLT, GFAE	4	35	
		-----X-----			
- 26	4231-8	• GROUND STRAP, <82577> GFAE	1	35	
- 27		• PACK INSTL, ANTENNA TRANSMITTER-RECEIVER GROUP SEE FIG. 2.18-6	RF		
- 28	464465	• RECEIVER, RADAR (82577) GFAE	1		

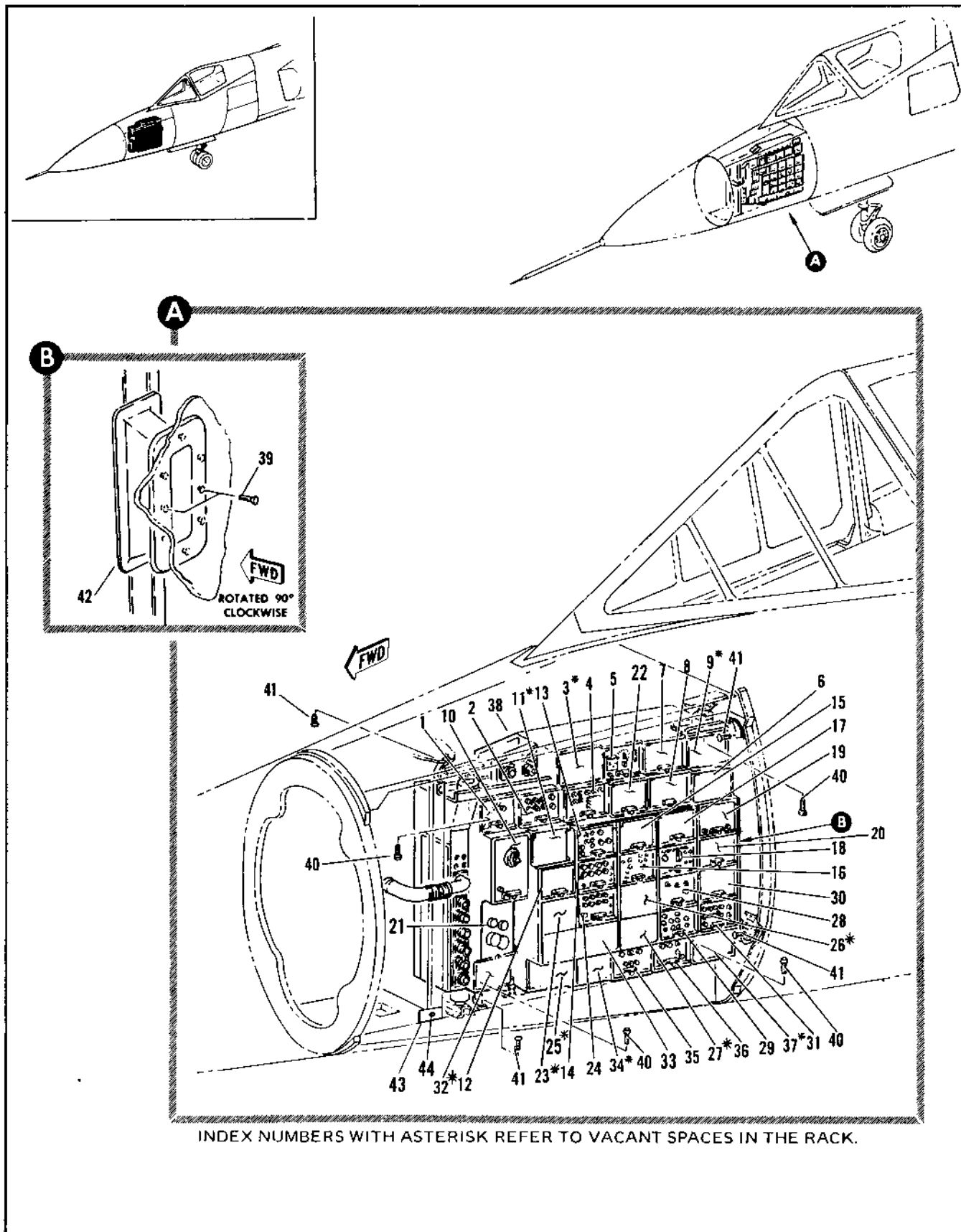

Figure 2.18-17. Fwd LH Electronic Compartment Electrical Equipment Installation

FIGURE AND INDEX NUMBER	PART NUMBER		DESCRIPTION	UNITS PER ASSY.	USABLE ON CODE	
					FROM	TO
			1 2 3 4 5 6			
2.18-17	7242855-10	*2	RACK INSTL, FWD LH COMPARTMENT	1	A	
	7242855-30	*2	RACK INSTL, FWD LH COMPARTMENT	1	B	
- 1	464741		• POWER SUPPLY, LOW VOLTAGE (82577) GFAE	1	35	
- 2	464196		• SWITCH, RADAR SELF TEST RELAY (82577) GFAE	1	35	
- 3	VACANT					
- 4	464346		• COMPUTER, STEERING SIGNAL (82557) GFAE	1	35	
- 5	464096		• METER, RADAR SELF TEST (82577) GFAE	1	35	
- 6	52450	*3	• SUPPORT ELECTRONIC (98750) GFAE	1	35	
	52630	*3	• JUMPER CONNECTOR (98750) GFAE	1	35	
- 7	464040		• CONVERTER, SIGNAL DATA INFRARED (82577) GFAE	1	35	
- 8	464063		• SWITCH BOX, RADAR RELAY (82577) GFAE	1	35	
- 9	VACANT					
- 10	464856		• AMPLIFIER, TRANSMITTER TUNING ELECTRONIC CONTROL (82577) AERN052-9047 GFAE	1	35	
- 11	VACANT			1	35	
- 12	464041		• AMPLIFIER, RATE GYRO TORQUE GENERATOR (82577) AERN052-8925 GFAE	1	35	
- 13	464241		• AMPLIFIER, ANTENNA CONTROL COMPUTER (82577) GFAE	1	35	
- 14	464206		• AMPLIFIER, ANTENNA SERVO ELECTRICAL CONTROL (82577) AERN052-9222 GFAE	1	35	
- 15	464506		• AMPLIFIER, ELEVATION DRIVE ELECTRICAL CONTROL (82577) AERN052-9029 GFAE	1	35	
- 16	464106		• AMPLIFIER, AZIMUTH DRIVE ELECTRICAL CONTROL (82577) GFAE	1	35	
- 17	464141		• AMPLIFIER, MD1X3, MDX3 ANTENNA TRACKING ELECTRONIC CONTROL (82577) GFAE	1	35	
- 18	464523		• CONVERTER, SIGNAL DATA TIME SHARING (82577) GFAE	1	35	
- 19	464663		• RELAY SWITCH INFRARED (82577) GFAE	1	35	
- 20	464223		• CONVERTER, ATTACK DISPLAY SIGNAL DATA (82577) GFAE	1	35	
- 21	464641		• AMPLIFIER, ELECTRONIC CONTROL AFC (82577) GFAE	1	35	
- 22	464841		• AMPLIFIER ELECTRONIC CONTROL HYDRAULIC DRIVE (82577) GFAE	1	35	
- 23	VACANT					
- 24	464020		• CONVERTER, AGC AND ANGLE TRACK WAVE FORM (82577) GFAE	1	35	
- 25	VACANT					
- 26	464082		• GATE, ELECTRONIC CLUTTER (82577) GFAE	1	35	
- 27	VACANT					
- 28	VACANT					
- 29	464103		• SYNCHRONIZER, RANGE TRACKING ELECTRICAL (82577) GFAE	1	35	
- 30	464395		• AMPLIFIER, ATTACK DISPLAY (82577) GFAE	1	35	
- 31	464195		• AMPLIFIER, VIDEO AND AZIMUTH SWEEP GENERATOR INDICATOR (82577) GFAE	1	35	
- 32	VACANT					
- 33	464926	*2	• POWER SUPPLY, MULTI-DC (82577)	1	35	
- 34	VACANT					
- 35	464095		• AMPLIFIER, PREAMPLIFIER VIDEO TRACKING (82577) GFAE	1	35	
- 36	464389		• GENERATOR, SWEEP INDICATOR (82577) GFAE	1	35	
- 37	VACANT	*2				
- 38	464073-138		• RACK, ELECTRICAL EQUIPMENT LH FWD COMPARTMENT (82577) GFAE, AF INSTALLED	1	A	
	464673-139	*2	• RACK, ELECTRICAL EQUIPMENT LH FWD COMPARTMENT (82577) GFAE, AF INSTALLED ATTACHING PARTS	1	B	
- 39	AN509-8R8		• SCREW	2	35	
- 40	NAS608-5-20		• SCREW	4	35	

FIGURE AND INDEX NUMBER	PART NUMBER	DESCRIPTION	UNITS PER ASSY.	USABLE ON CODE	
				FROM	TO
2.18-17- 41	46520-1186	• SCREW -----X-----	4		35
- 42	651139-1	• DUCT ASSY, FLEX RUBBER (R2577) FURNISHED WITH (R2577) 4-4173 SERIES MR-1 RADAR RACKS	RF		35
- 43	7748121-07	• PATCH			
- 44	839124711-1	• TEST JACK			
		*2 ADDED PER TCTO 1F-106-1081			
		*3 ADDED PER TCTO 1F-106-1122			
		A AIRPLANES #35 THRU 47 AND 49 THRU 89			
		B AIRPLANES #48, 81 AND ON			

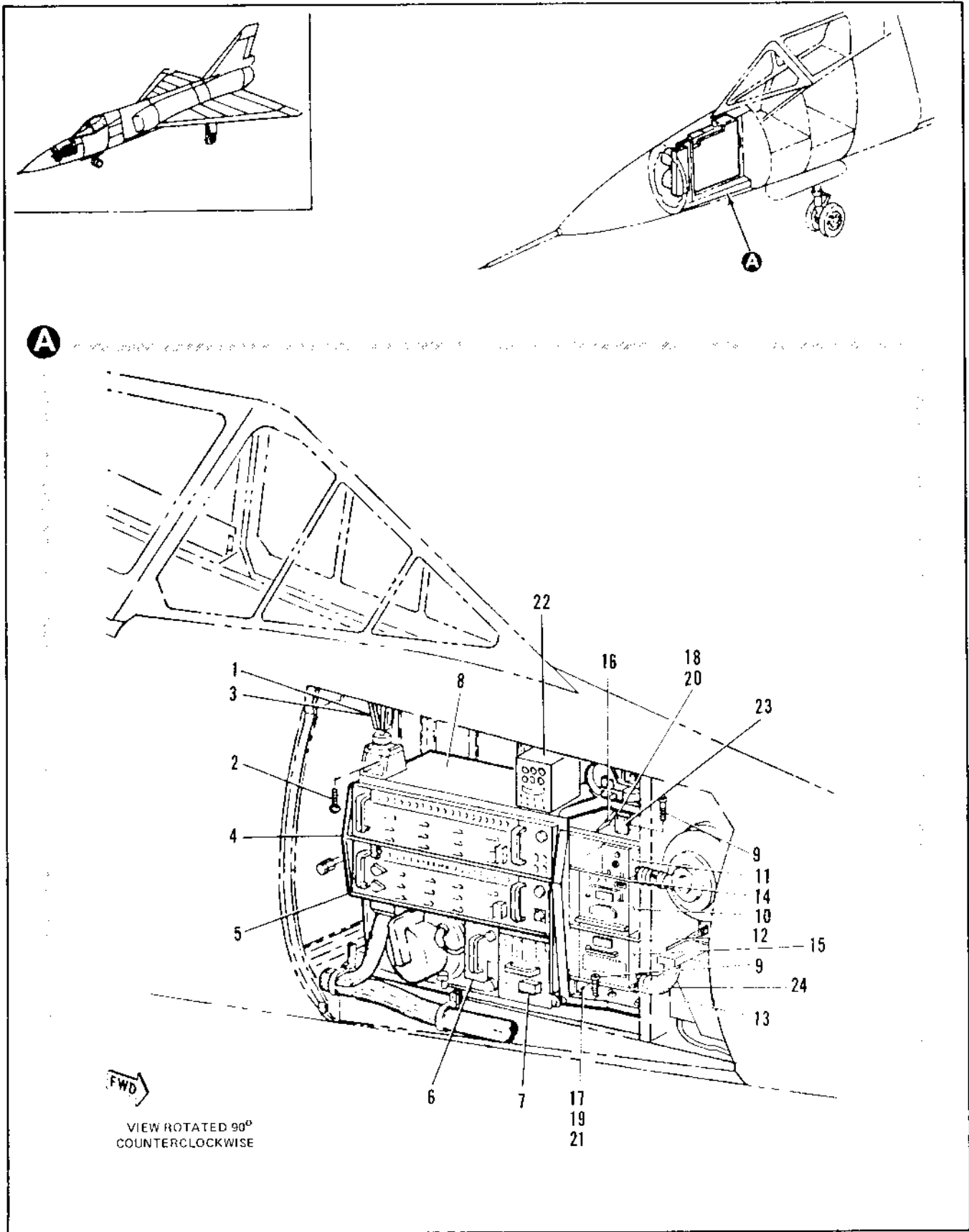

Figure 2.18-18. Fwd RH Electronic Compartment Electrical Equipment Installation

FIGURE AND INDEX NUMBER	PART NUMBER	DESCRIPTION	UNITS PER ASSY.	USABLE ON CODE	
				FROM	TO
		1 2 3 4 5 6			
2.18-18- 1	66040720-1	• SUPPORT ASSY, RACK UPPER RH RIVETED	1		
- 2	NAS1351-5+32	• SCREW	1		
- 3	MS27039-1-20	• SCREW	4		
		----X----			
- 4	464846-150	• COMPUTER (82577)	1		
- 5	464140-164	• CONVERTER (82577)	1		
- 6	464857-150	• MAGNETIC DRUM, DATA STORAGE (82577)	1		
- 7	464526-151	• COMPUTER, POWER SUPPLY (82577)	1		
- 8	464273-185	• RACK, ELECTRONIC EQUIPMENT (82577)	1		
		ATTACHING PARTS			
- 9	NAS1351-5-20	• SCREW	3		
		----X----			
- 10	RT859A/APX-72	• IFF EQUIPMENT INSTALLATION	1	35	
- 11	TS1843A	• • RECEIVER TRANSMITTER, IFF/APX-72	1	35	
- 12	MT3809	• • TEST SET-AN/APX-72	1	35	
- 13	MT4579/U*	• • MOUNT/RT 859	1	35	
	ON089560-15*	• • MOUNT/TRANSPONDER KIT-1A	1	35	
- 14	MT3513	• • CONNECTOR/MT4759/U	1	35	
- 15	KIT-1A	• • MOUNT/TS 1843	1	35	
- 16	69F34828-1	• • TRANSPONDER, IFF	1	35	
- 17	HS21042-3	• • RACK, IFF EQUIPMENT INSTALLATION	1	35	
- 18	AN960-10L	• NUT	4	35	
- 19	AN960-10	• • WASHER	16	35	
- 20	MS35204-267	• • WASHER	4	35	
- 21	AN3-5A	• • SCREW	4	35	
- 22	464A21	• • BOLT	4	35	
- 23	67D34273	• • INTERFACE AMPLIFIER	1	35	
- 24	NAS1375A06CA032	• • IFF RELAY MODULE	1	35	
		• DUCT	1		

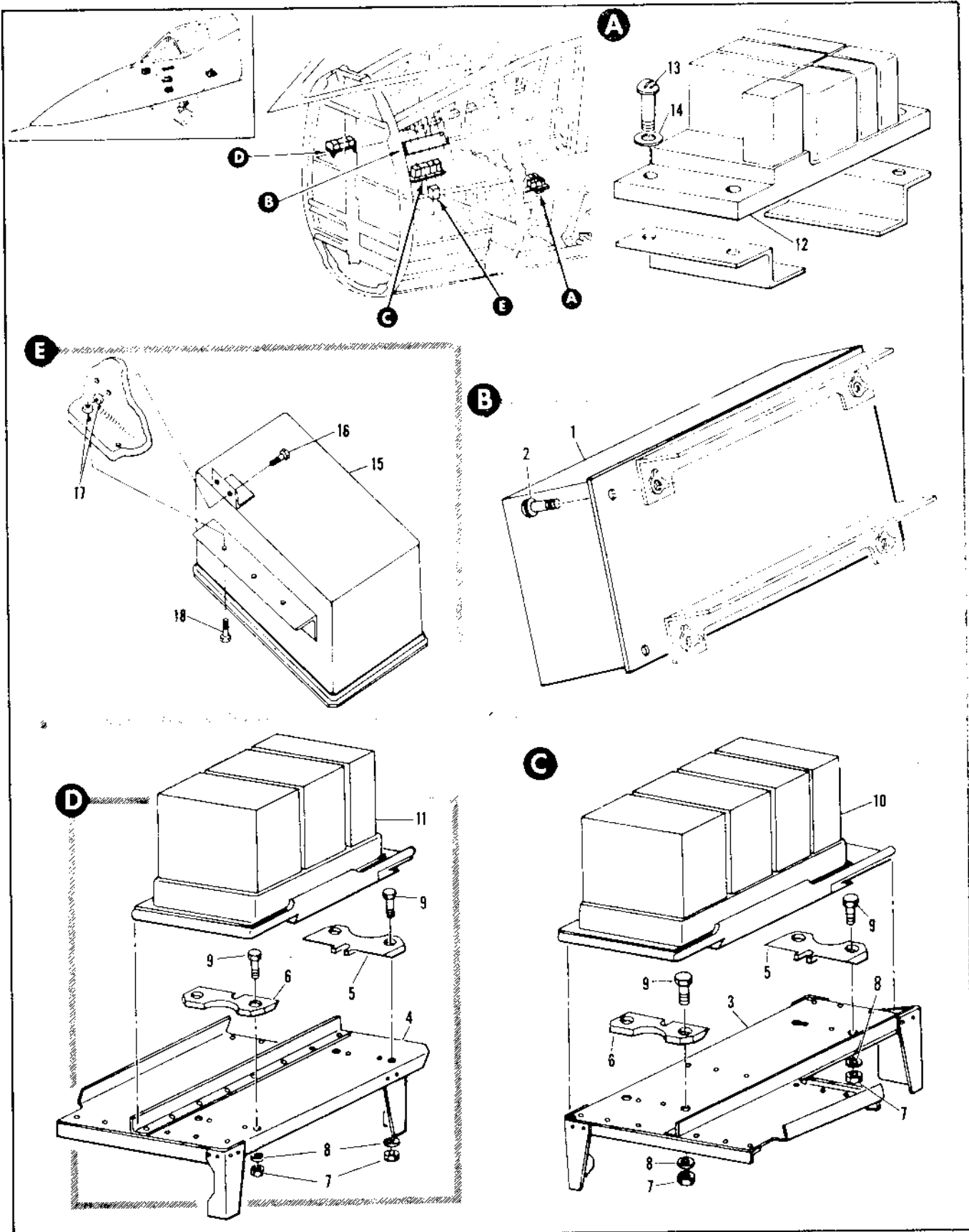

Figure 2.18-19. Amplifier Equipment Sta 113 to 153

FIGURE AND INDEX NUMBER	PART NUMBER	DESCRIPTION	UNITS PER ASSY.	USABLE ON CODE	
				FROM	TO
2.18-19		1 2 3 4 5 6			
	8-94541-1	AMPLIFIER EQUIPMENT, STA 113 TO 113	FF		A
- 1	464326	• AMPLIFIER INSTL, MAGNETIC FOR NHA SEE FIG. 2.3-4	1		A
- 2	AN526-1032P	• • AMPLIFIER ASSY, VERTICAL SITUATION (R2507) GEAR ATTACHING PARTS	4		A
	4-95484-5	• • SCREW -----X-----	RF		F
	8-95658-701	• AMPLIFIER INSTL, VERTICAL SPEED AND ALTITUDE LH FOR NHA SEE FIG. 2.3-4	RF		H
- 3	8-95658-01	• • SHELF ASSY, RIVETED LH	1		B
- 4	8-95658-03	• • SHELF ASSY, RIVETED RH	1		B
- 5	8-95696	• • WEDGE, AMPLIFIER RETAINING AFT	1		B
- 6	8-95697	• • WEDGE, AMPLIFIER RETAINING FWD ATTACHING PARTS	1		B
- 7	NAS679A3	• • • NUT	4		B
- 8	AN960-10L	• • • WASHER	4		B
- 9	AN3-5A	• • • BOLT -----X-----	4		B
- 10	15462-1A1	• • AMPLIFIER, INDICATED AIR SPEED MACH NO. <15315> AERN060-6321 LH	1		B
- 11	15461-1A1	• • AMPLIFIER, INDICATED AIR SPEED MACH NO. <15315> AERN060-6322 GEAR RH	1		B
	8-95244	• AMPLIFIER INSTL, HORIZONTAL SITUATION INDICATOR	1		B
- 12	522-1394-330	• • AMPLIFIER, HORIZONTAL SITUATION DISPLAY <32125> AERN060-6315 GEAR	1		B
- 13	AN526-832R10	• • SCREW	4		B
- 14	AN960-10L	• • WASHER -----X-----	4		B
- 15	8339-340P92	• SIGNAL CONDITIONER BUFFER UNIT CN-1180/MPM-841V			1
- 16	AN3-4A	• • BOLT	2		
- 17	MS21744-03	• • NUT, SELF-LOCKING	2		
- 18	AN3-7A	• • BOLT	3		
		A AIRPLANES #25 THRU 47 AND 48 THRU 99			
		B AIRPLANES #48, 93 AND ON			

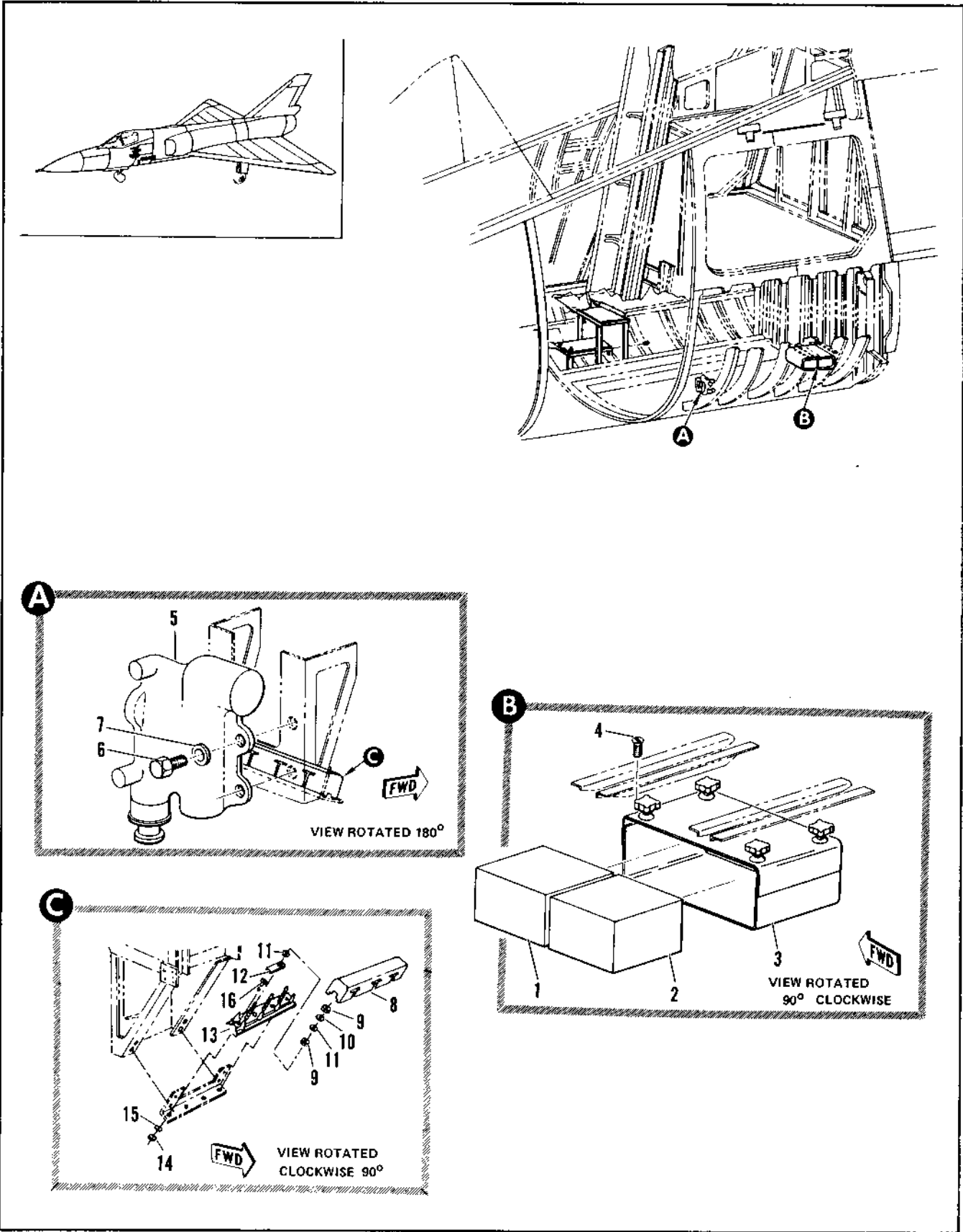

Figure 2.18-20. Electrical Equipment Installation Sta 168 to 216 (Sheet 1 of 2)

FIGURE AND INDEX NUMBER	PART NUMBER	DESCRIPTION 1 2 3 4 5 6	UNITS PER ASSY.	USABLE ON CODE	
				FROM	TO
2.18-20		ELECTRICAL EQUIPMENT INSTALLATION, STA 148 TO 215			
- 1	464520	• • CONVERTER, SIGNAL DATA (#2577) GFAC	1		
- 2	464520	• • CONVERTER, SIGNAL DATA (#2577) GFAC AFRN052-P102 GFAC	1	A	
- 3	4646-2-15VMDX2	• • RACK, COCKPIT DISPLAY (#2577) AFRN052-P102 GFAC ATTACHING PARTS	1	A	
- 4	AN50P-10R23	• • SCREW -----X-----	16	A	
	8-36408-1	• VALVE INSTL, REGULATING PRESSURE	1	A	
	3-363P2-1	• VALVE INSTL, REGULATING PRESSURE	1	J	
- 5	444157	• • VALVE ASSY, AUTOMATIC REGULATING PRESSURE (#2577) AERN052-P953 GFAC ATTACHING PARTS	1	35	
- 6	AN4-22A	• • BOLT	3	35	129
	AN4-20A	• • BOLT	3	130	
- 7	AN96-10416L	• • WASHER	3	35	
		-----X-----			
- 8	199-3	• COVER, TERMINAL BOARD (#74212) 51-50002-039	1		
- 9	AN341-416	• NUT	6		
- 10	AN335A416F	• LOCKWASHER	3		
- 11	AN961-416	• WASHER	6		
- 12	MS25227-1	• INSULATING STRIP	2		
- 13	MS25123-7-3	• TERMINAL BOARD ASSEMBLY	1		
- 14	NAS1291-01	• NUT	2		
- 15	AN96-106L	• WASHER	2		
- 16	AN511-5817	• SCREW	2		
		A AIRPLANES #45, 90 AND 98 B AIRPLANES #75 THRU 47 AND 49 THRU 89			

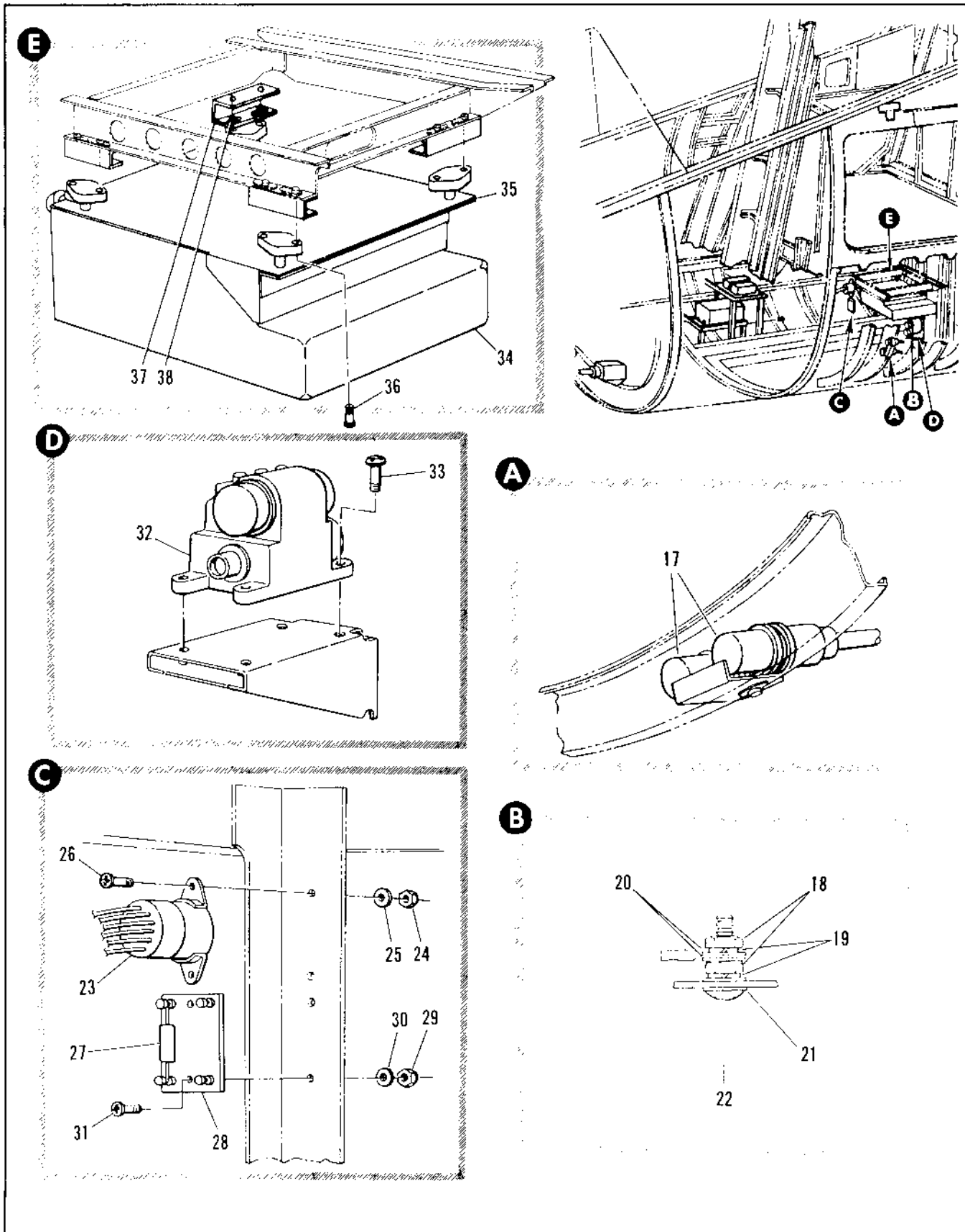

Figure 2.18-20. Electrical Equipment Installation Sta 168 to 216 (Sheet 2 of 2)

FIGURE AND INDEX NUMBER	PART NUMBER		DESCRIPTION	UNITS PER ASSY.	USABLE ON CODE	
					FROM	TO
2.18-20 + 17 - 18 - 19 - 20 - 21 - 22 - 23 - 24 - 25 - 26 - 27 - 28 - 29 - 30 - 31 - 32 - 33 - 34 - 35 - 36 - 37 - 38	8-34863	*1	• HARNESS ASSY, LOCALIZER DAMPING CAPACITOR	1	A	
	S21605	*1	• • CAPACITOR, FIXED ELECTROLYTIC <55289> 91-57061-004	2	A	
	AN345-10	*2	• • NUT, GROUND STUD	2		
	AN935-10	*2	• • WASHER, GROUND STUD	2		
	AN967-10L		• • WASHER, GROUND STUD	2		
	AN967D1CL	*2	• • WASHER, GROUND STUD	2		
	AN526-1032R12	*2	• • SCREW, GROUND STUD	1		
	8-32852-1		• RELAY AND RESISTOR INSTL, ILS FLAG INTERLOCK	1	B	
	8-31898-1		• • HARNESS ASSY, ILS FLAG RELAY	1	B	
	265J18		• • • RELAY, <99699> ATTACHING PARTS	1	B	
	NAS679A06		• • • NUT	2	B	
	AN960D6L		• • • WASHER	2	B	
	AN526-632RH		• • • SCREW	2	B	
			-----X-----			
	8-32852-7		• • RESISTOR BOARD ASSEMBLY	1	B	
	RC206F114J		• • • RESISTOR, 97-40000-125	1	B	
	8-32852-11		• • • TERMINAL BOARD, MAKE FROM X1401B3/32	1	B	
	X1401B3/32		• • • TERMINAL BOARD, <71279> 98-91711-004 ATTACHING PARTS	RF	B	
	NAS679A06		• • • NUT	2	B	
	AN967D6L		• • • WASHER	2	B	
	AN526-632R6		• • • SCREW	2	B	
			-----X-----			
	8-36392-1		• TRANSMITTER INSTL, RATE GYRO	1	A	
	131311-01		• • TRANSMITTER, RATE GYRO <3531> AERN068-6311 GFAC	1	C	
	A2460		• • TRANSMITTER, RATE GYRO <01278> TYPE TRU-2A7A AERN068-6613 GFAC ATTACHING PARTS	1	160	
	NAS221-8		• • SCREW	4	C	
	NAS221-11		• • SCREW	4	160	
			-----X-----			
	8-36431-3	*3	• CONVERTER INSTL, DATA LINK NHA IS 8-30024	1	160	
	464220-150	*3	• • CONVERTER, DATA LINK TYPE CV 703/ARR61 AERNO 81-9222 GFAC SEE FIG. 8-18-24 INDEX 42	1	160	
	464811-150	*3	• • RACK, TIME DIVISION DATA LINK CONVERTER ATTACHING PARTS	1	160	
	AN509-8R26	*3	• • SCREW	8	160	
			-----X-----			
7037266-10	*4	• SPACER ASSY	4	35		
AN3-3A	*4	• BOLT	8	35		
		*1 ADDED ON AIRPLANES #35 THRU 47 AND 49 THRU 89 PER TCTO 1F-106-596				
		*2 ADDED ON AIRPLANES 90 THRU 159 PER TCTO 1F-106-626				
		*3 ADDED ON AIRPLANES #35 THRU 159 PER INTENT OF T.O. 11F-MA1-529				
		*4 ADDED ON AIRPLANES #35 AND ON PER T.O. 1F-106-1072				
		A AIRPLANES #48, 90 AND ON				
		B AIRPLANES #35 THRU 47 AND 49 THRU 89				
		C AIRPLANES #43 AND 90 THRU 162				

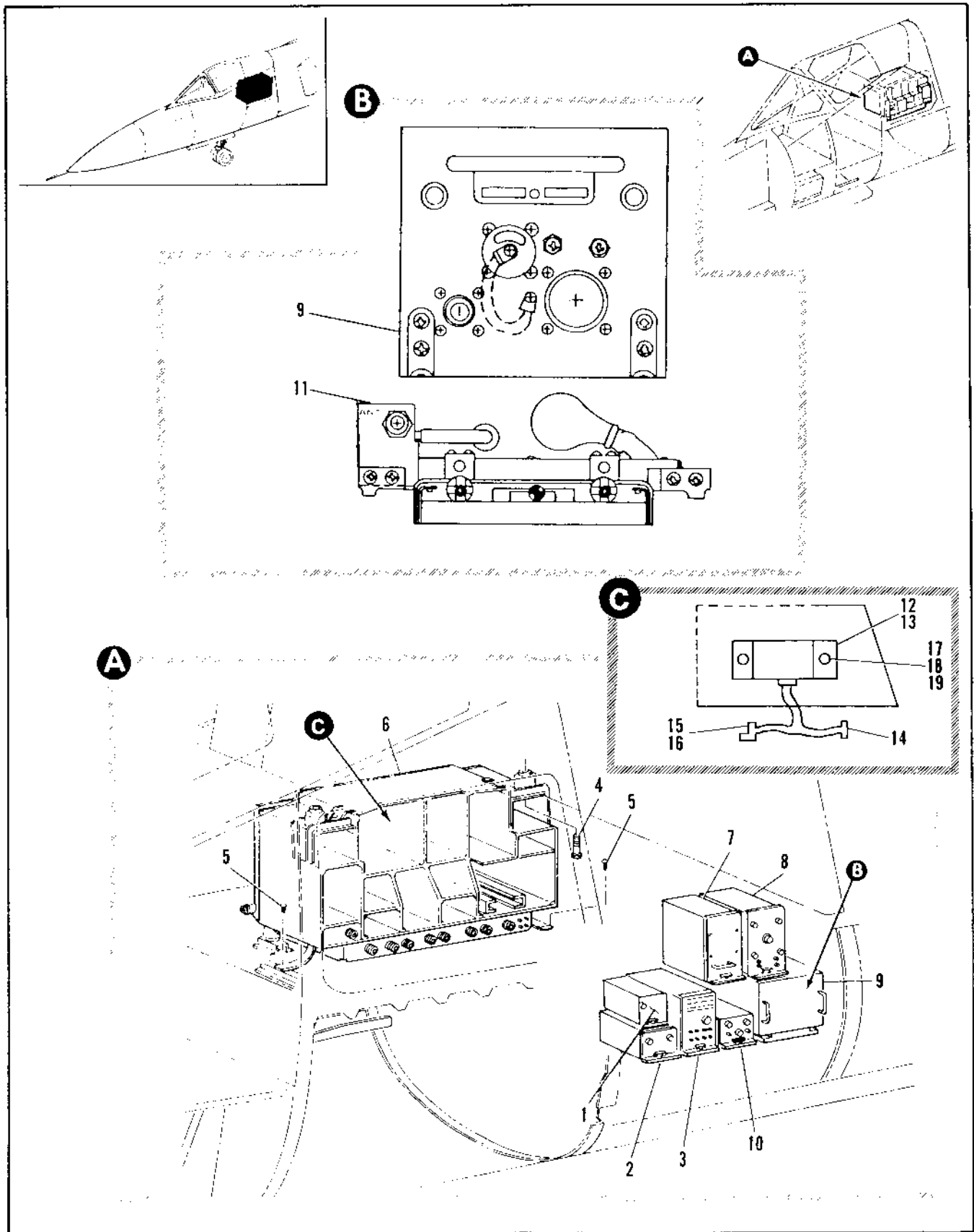

Figure 2.18-21. Upper Aft LH Electronic Compartment Equipment Installation

FIGURE AND INDEX NUMBER	PART NUMBER	DESCRIPTION	UNITS PER ASSY.	USABLE ON CODE	
				FROM	TO
2.18-21	8-36247	EQUIPMENT INSTALLATION, UPPER AFT LH ELECTRONIC COMPARTMENT	1	35	
- 1	464367	• RECEIVER, ILAS LOCALIZER RADIO R772/ARN51 <R2577> GFAE	1	35	
- 2	464257	• RECEIVER, ILAS GLIDE SLOPE AND MARKER BEACON RADIO R771/ARN51 <R2577> GFAE	1	35	
- 3	464657-150MD8	• RECEIVER, DATA LINK AERN081-8222 TYPE R884/ARRE1 GFAE	1	35	
- 4	NAS608-5-20	ATTACHING PARTS	4	35	
- 5	AN520-10R8	• SCREW	2	35	
- 6	464074	• SCREW -----X-----	1		
- 7	464529	• RACK ELECTRONIC EQUIPMENT (R2577) GFAE	1		
- 8	464629	• RECEIVER, TRANSMITTER (R2577) GFAE	1		
- 9	705907-801	• CONVERTER, SIGNAL DATA (R2577) GFAE	1		
- 10	464646	• RECEIVER, TRANSMITTER UHF (37645) RT1145/ARC-164	1		
- 11	MT-4737	• AMPLIFIER, ELECTRONIC CONTROL (R2577) GFAE	1		
- 12	8140631-10*	• MOUNT RECEIVER TRANSMITTER UHF (37695) GFAE -----X-----	1		A
- 13	MC14050BAL*	• AMPLIFIER ASSY (98750) TACAN	3		A
- 14	RTK07-16-61S-059*	• IC, AMP (04713)	1		A
- 15	RTK06-16-61P*	• CONNECTOR W/BK SHELL (11139)	1		A
- 16	32700-2-07*	• CONNECTOR (11139)	1		A
- 17	AN4-5A*	• BACKSHELL (11139)	1		A
- 18	AN960-416*	ATTACHING PARTS	2		A
- 19	MS21042-N4*	• BOLT	2		A
		• WASHER	2		A
		• NUT	2		A
		-----X-----			
		A CODE - ROUND MODEL ONLY			
		* AFTER TCTO 1F-106-1224			

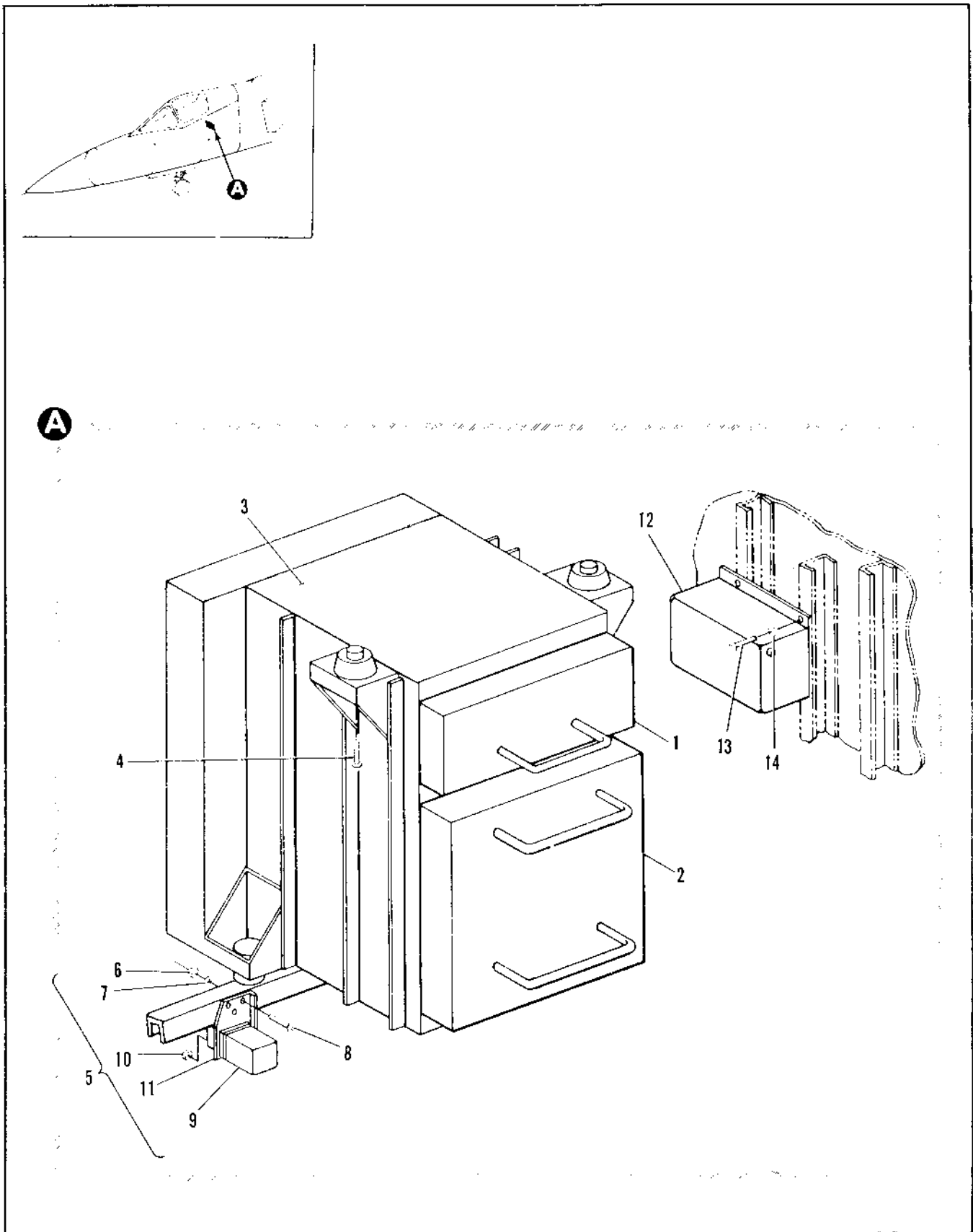

Figure 2.18-22. Lower Aft RH Electronic Compartment AFCS Equipment Installation

FIGURE AND INDEX NUMBER	PART NUMBER	DESCRIPTION	UNITS PER ASSY.	USABLE ON CODE	
				FROM	TO
		1 2 3 4 5 6			
2.18-22		EQUIPMENT INSTL. ELECTRONIC			
		LT. PR. AFT. ELECTRONIC COMPARTMENT			
		BACK INSTL. 404-73	1	35	
- 1	7243171-10	*2			
	464518	*2	1	35	
- 2	464319	*2	1	35	
- 3	464323	*2	1	35	
		• BACK APCS ELECTRONIC EQUIPMENT (2577) SHAL BE INSTALLED			
		ATTACHING PARTS			
- 4	AN4-320	*2	4	35	
		• BOLT			
		-----X-----			
	7243148-10	*2	1	35	
- 5	7243143-10	*2	1	35	
		• RELAY ASSY			
		ATTACHING PARTS			
- 6	MS21142-1	*2	3	55	
		• NUT			
- 7	AN361-8L	*2	3	35	
		• WASHER			
- 8	MS2739-1A10	*2	3	35	
		• SCREW			
		-----X-----			
- 9	3231-3542	*2	1	35	
		• RELAY (15877) BEF. BE INSTALLED			
		ATTACHING PARTS			
- 10	MS21143-11	*2	4	35	
		• NUT			
		-----X-----			
- 11	7243144-01	*2	1	35	
		• BRACKET			
	7243144-11	*2			
- 12	CF52444	*2	1	35	
		FILTER INSTL. 1600 HZ BAND PASS			
		• FILTER (27294) 7243144-11			
		ATTACHING PARTS			
- 13	MS2739-1-11	*2	4	35	
		• SCREW			
- 14	ANPE-C16	*2	4	35	
		• WASHER			
		-----X-----			
		*2 ADDED FOR ICID 14-11-10-1			

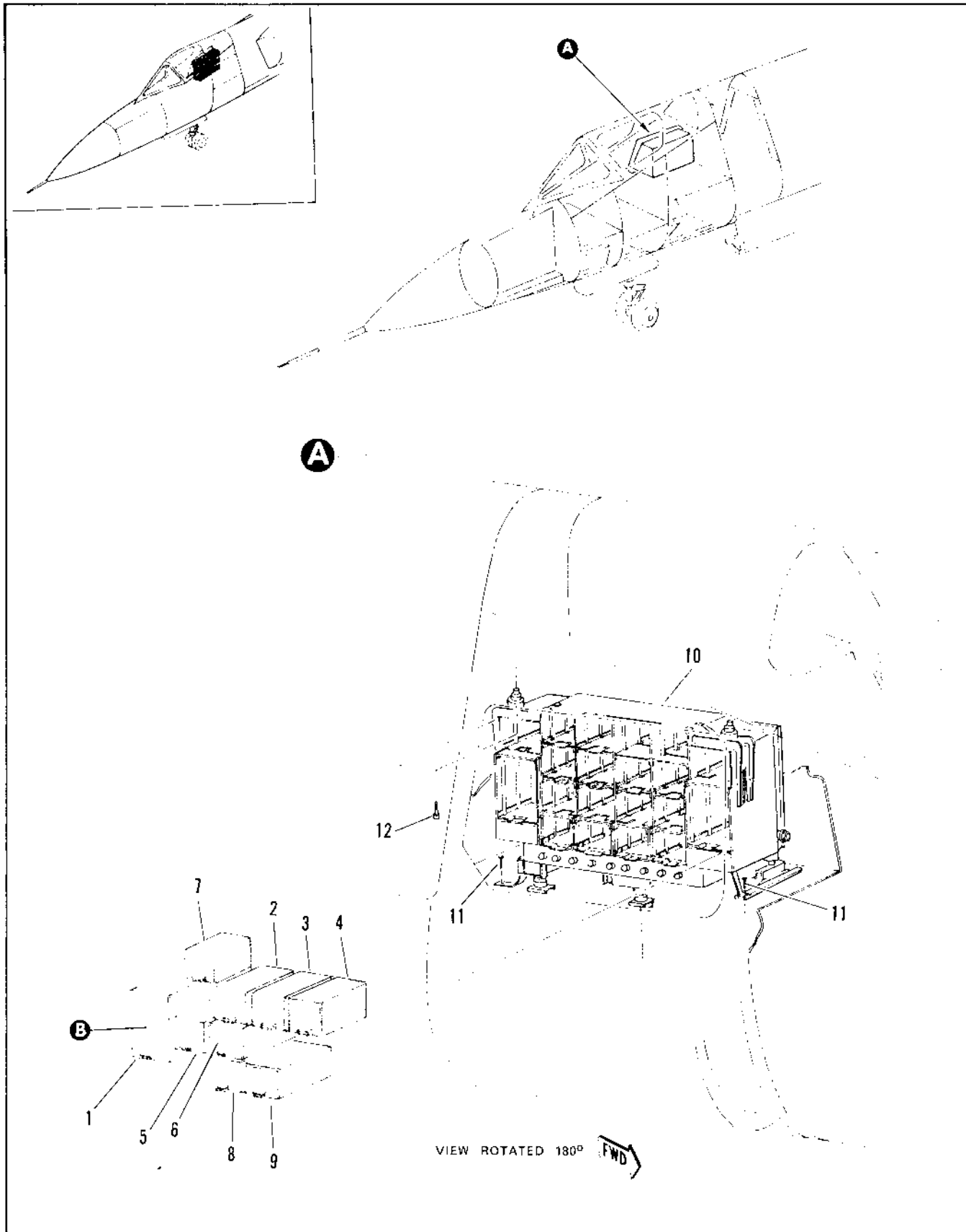

Figure 2.18-23. Upper Aft RH Electronic Compartment Equipment Installation (Sheet 1 of 2)

FIGURE AND INDEX NUMBER	PART NUMBER	DESCRIPTION	UNITS PER ASSY.	USABLE ON CODE	
				FROM	TO
		1 2 3 4 5 6			
2.18-2	4-36248	EQUIPMENT INSTALLATION, UPPER LEFT RH ELECTRONIC COMPARTMENT	1	35	
- 1	7747000-1	*2 • RELAY	1		
- 2	464454	• RELAY, MODE SELECTION (K2577) GFAE	1	35	
- 3	464456	• RELAY, ARMAMENT TEST (K2577) GFAE	1	35	
- 4	464458	• POWER SUPPLY, MAIN MODE (K2577) ASRNO2-4911 GFAE	1	35	
- 5	464453	• SELECTOR, MISSILE AFO CHANNEL (K2577) ASRNO2-4911 GFAE	1	35	
- 6	464459	• RELAY, ARMAMENT SELECTION (K2577) ASRNO2-4919 GFAE	1	35	
- 7	464454	• RELAY, PARAMETER SETTING (K2577) ASRNO2-4919 GFAE	1	35	
- 8	46441	• AMPLIFIER, PASSIVE DETECTION SYNCHRO SIGNAL (K2577) GFAE	1	35	
- 9	464307-152	• POWER SUPPLY, ARMAMENT CONTROL (K2577) ASRNO2-4919 GFAE	1	35	
- 10	464174-174	• RACK, ELECTRICAL EQUIPMENT (K2577) GFAE ATTACHMENT PARTS	1		
- 11	AN521-10RF	• SCREW	2	35	
- 12	WASCOA-5-21	• SCREW	4	35	
		-----X-----			
		*2 AFTER T.O. 1F-106A-1174			

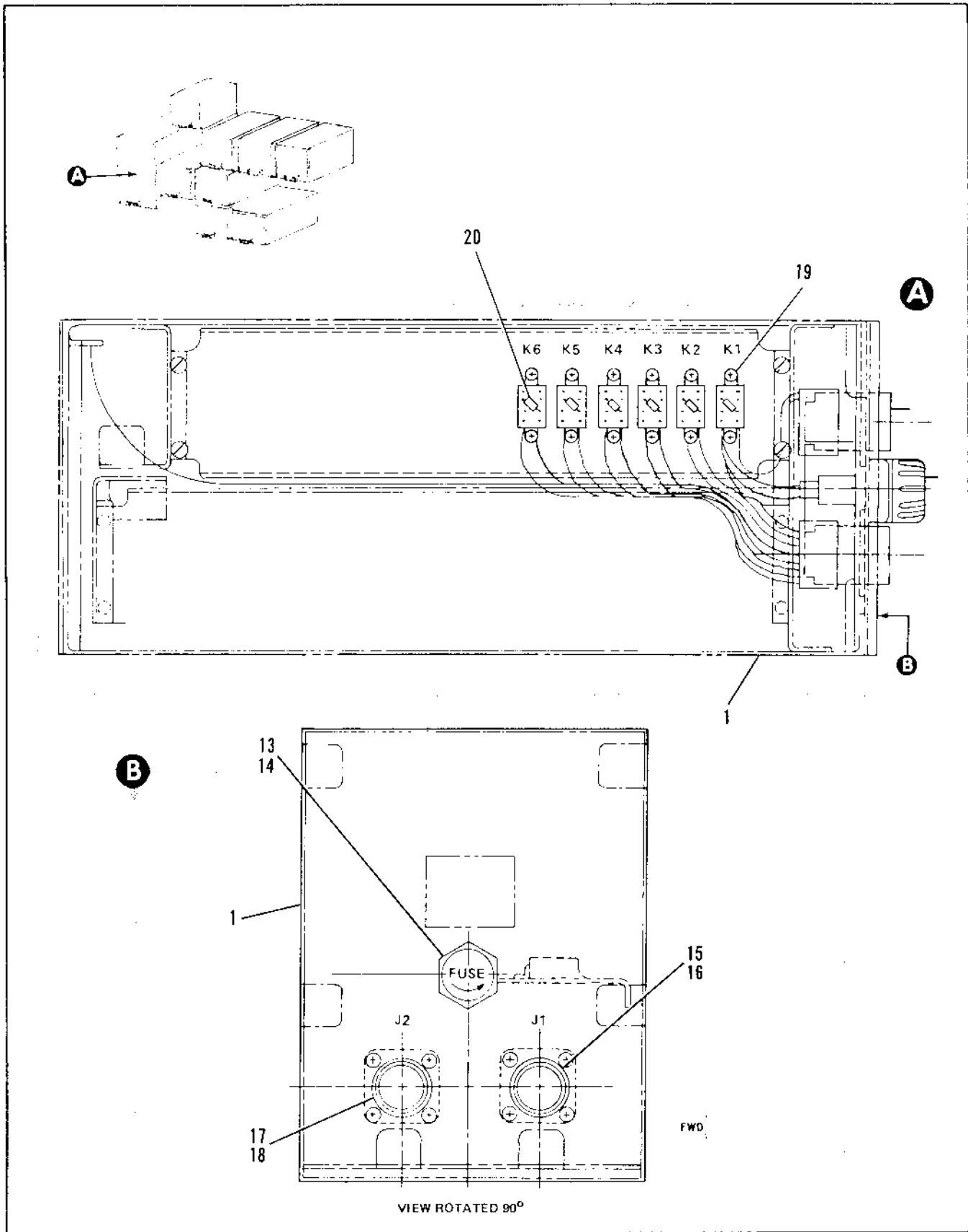

Figure 2.18-23. Upper Aft RH Electronic Compartment Equipment Installation (Sheet 2 of 2)

FIGURE AND INDEX NUMBER	PART NUMBER	DESCRIPTION	UNITS PER ASSY.	USABLE ON CODE	
				FROM	TO
		1 2 3 4 5 6			
2.18-23-	F32A2501	• FUSE	1		
- 14	FHN254	• FUSE HOLDER	1		
- 15	M83723-01R1623N	• CONNECTOR	1		
- 16	M83723-15N15	• BACK SHELL	1		
- 17	M83723-02R1623N	• CONNECTOR	3		
- 18	M83723-15N16	• BACK SHELL	1		
- 19	EX2038	• RELAY	6		
- 20	IN645	• DIODE	6		

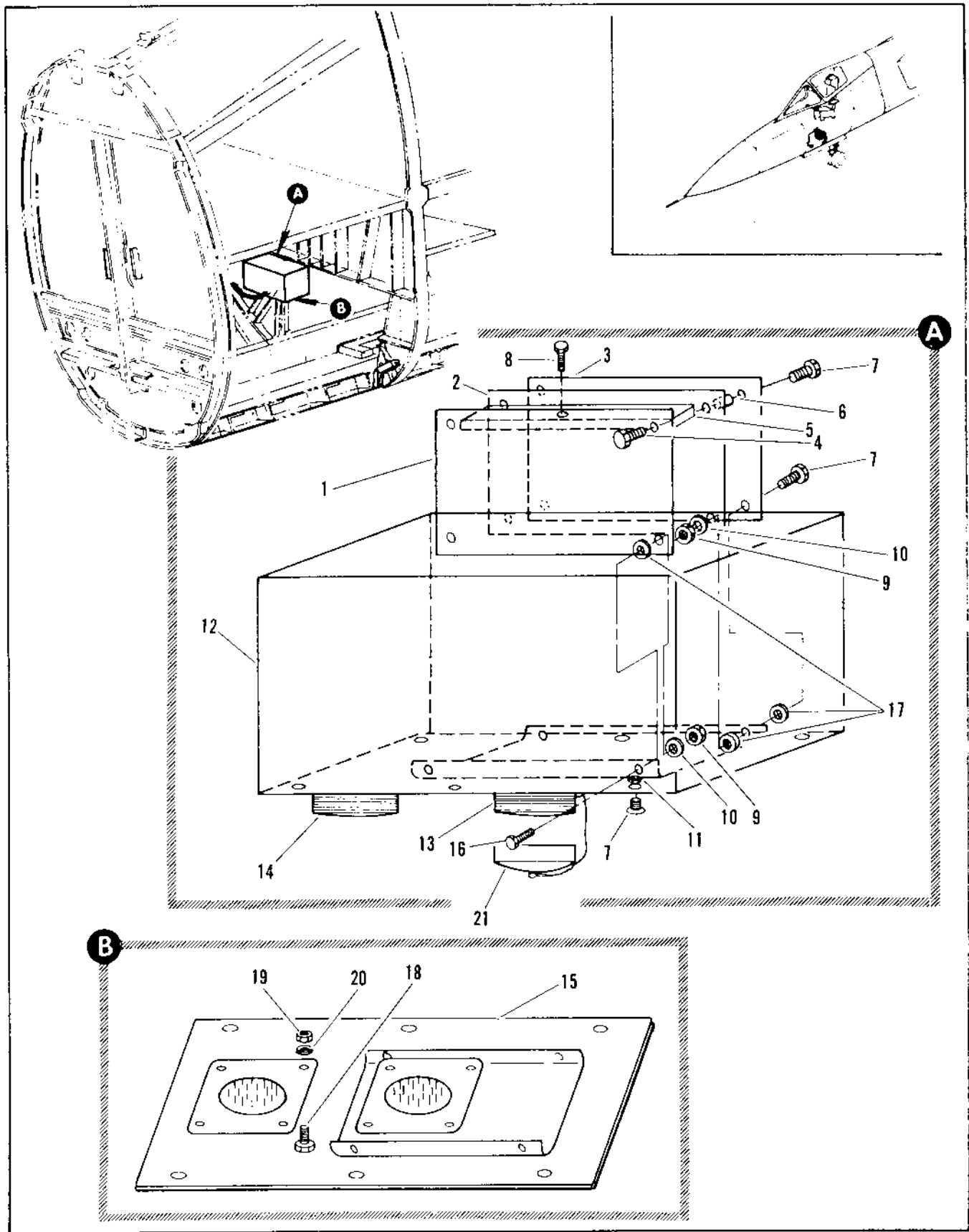

Figure 2.18-24. Signal Conditioner and Buffer Unit

FIGURE AND INDEX NUMBER	PART NUMBER	DESCRIPTION	UNITS PER ASSY.	USABLE ON CODE	
				FROM	TO
		1 2 3 4 5 6			
2.18-24	5339-040682	SIGNAL CONDITIONER AND BUFFER UNIT	1		
- 1	5339-040682	• • CIRCUIT CARD	1		
- 2	5339-040683	• • CIRCUIT CARD	1		
- 3	5339-040684	• • CIRCUIT CARD	1		
- 4	MS1957-06	• • SCREW	2		
- 5	5339-040791	• • SUPPORT	1		
- 6	-502	• • SPACER	2		
- 7	MS1957-32	• • SCREW	10		
- 8	MS1957-26	• • SCREW	1		
- 9	MS5649-64	• • NUT	4		
- 10	MS3533A-135	• • WASHER	4		
- 11	MS1598-06Y	• • WASHER	6		
- 12	5339-040685	• • ENCLOSURE	1		
- 13	MS3122022-55S	• • CONNECTOR	1		
- 14	MS3122022-55P	• • CONNECTOR	1		
- 15	5339-040686	• • COVER	1		
- 16	MS1957-31	• • SCREW	2		
- 17	2563	• • WASHER (2 REQUIRED EACH LOCATION)	12		
- 18	MS1957-17	• • SCREW	8		
- 19	MS5649-44	• • NUT	8		
- 20	MS3533A-135	• • WASHER	8		
- 21	10-101960-223	• • CAP	1		

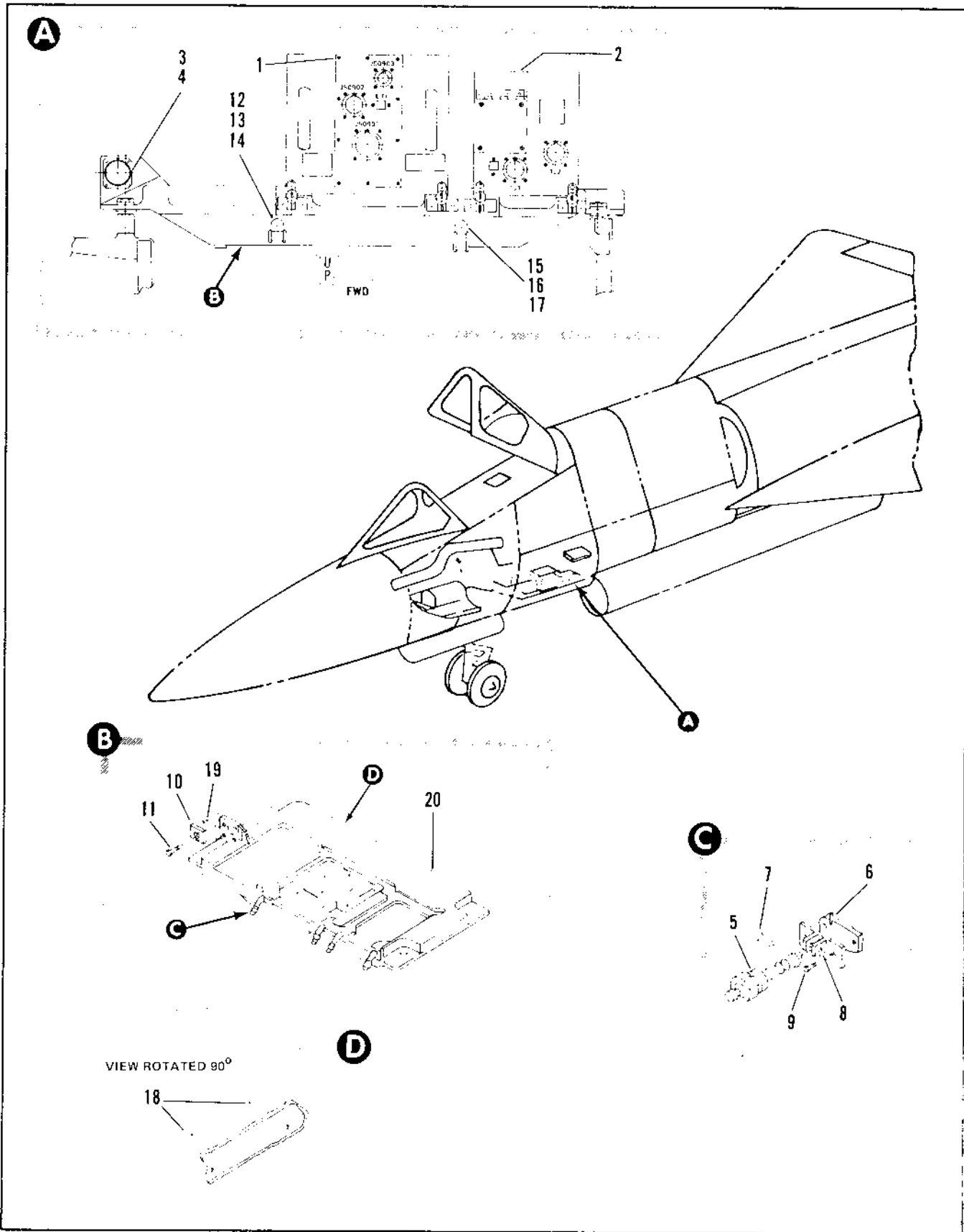

Figure 2.18-25. Attitude Heading Reference System (Sheet 1 of 3)

FIGURE AND INDEX NUMBER	PART NUMBER		DESCRIPTION	UNITS PER ASSY.	USABLE ON CODE	
					FROM	TO
		1 2 3 4 5 6				
2.18-25	7839900-10	*1	ATTITUDE HEADING REFERENCE SYSTEM <98750>	1	B	
	7839900-30	*1	ATTITUDE HEADING REFERENCE SYSTEM <98750>	1	A	
	7839904-10	*1	* RACK INSTL, ELECTRICAL EQUIPMENT, LHAF <98750>	1		
- 1	464509-150	*1	* . . CONVERTER, STABLE COORD <92577> GFAE	1		
- 2	15655A-01-01	*1	* . . AMPLIFIER, ELECTRICAL CONTROL <35351> GFAE	1		
	7839890-10	*1	* . . RACK ASSY, ELECTRICAL EQUIPMENT LHAF <98750> ATTACHING PARTS	1		
- 3	AN4-5A	*1	* . . BOLT	4		
- 4	AN960-416	*1	* . . WASHER -----X-----	4		
- 5	MS14108-5	*1	* . . FASTENER	4		
- 6	MS24665-146	*1	* . . PIN	4		
- 7	MS20392-1015	*1	* . . . PIN	4		
- 8	NAS573-9	*1	* . . . HINGE ATTACHING PARTS	4		
- 9	NAS1100E3-8	*1	* . . . SCREW -----Y-----	8		
- 10	7839925-10	*1	* . . . CONNECTOR ASSY <98750> ATTACHING PARTS	1		
- 11	NAS1100E06-7	*1	* . . . SCREW -----X-----	4		
- 12	MS21919WDG11	*1	* . . . CLAMP ATTACHING PARTS	1		
- 13	MS35207-264	*1	* . . . SCREW	1		
- 14	AN960-10	*1	* . . . WASHER	1		
	AN960C10	*1	* . . . WASHER (SUBSTITUTE FOR AN960-10) -----X-----	1		
- 15	MS21919WDG16	*1	* . . . CLAMP ATTACHING PARTS	1		
- 16	MS35207-264	*1	* . . . SCREW	1		
- 17	AN960-10	*1	* . . . WASHER	1		
	AN960C10	*1	* . . . WASHER (SUBSTITUTE FOR AN960-10) -----X-----	1		
	7839891-10	*1	* . . . RACK SUBASSY <98750>	1		
- 18	MS21207F1-16	*1	* INSERT	10		
- 19	MS21209C1615	*1	* INSERT	1		
- 20	7839891-01	*1	* CASTING	1		

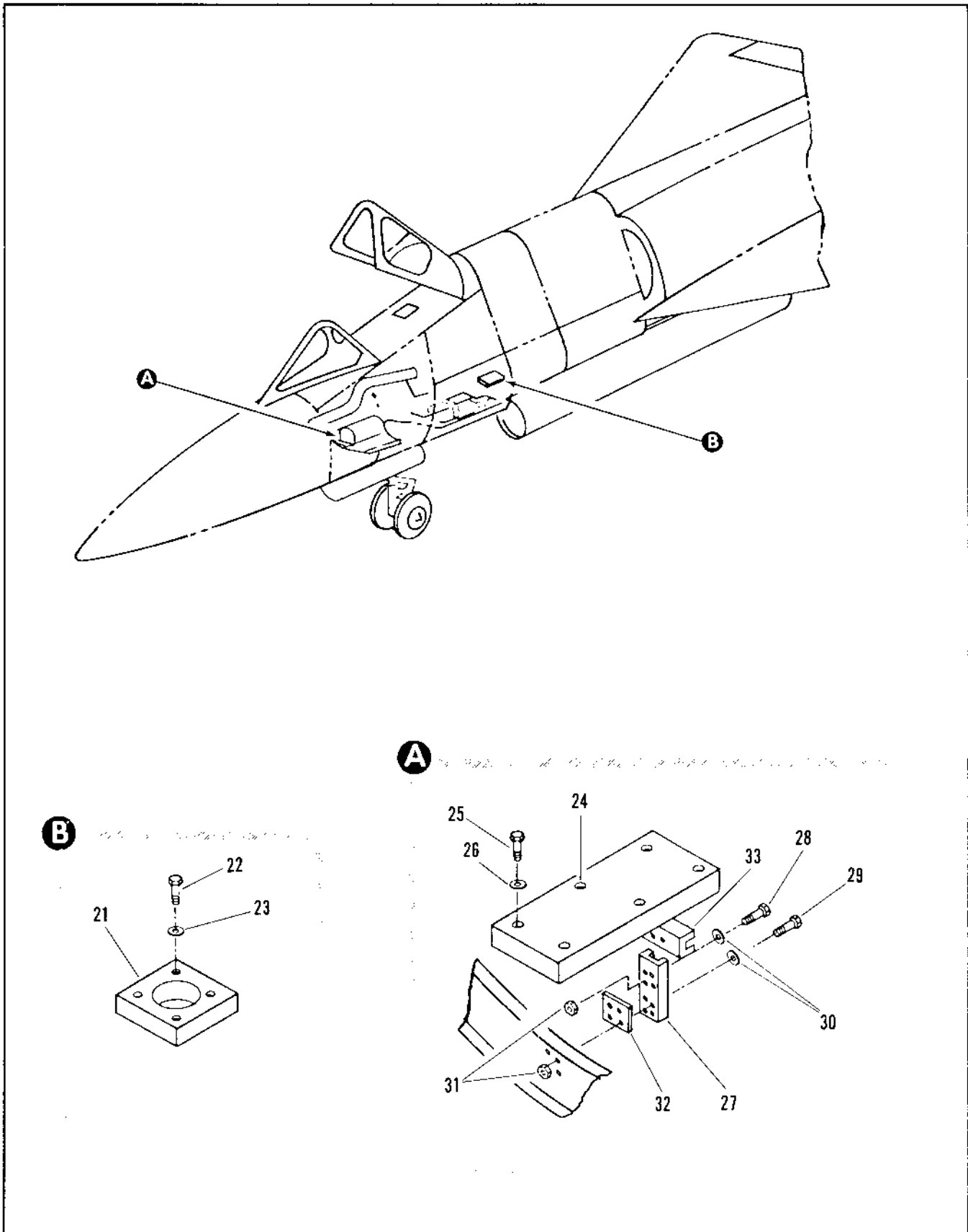

Figure 2.18-25. Attitude Heading Reference System (Sheet 2 of 3)

FIGURE AND INDEX NUMBER	PART NUMBER		DESCRIPTION	UNITS PER ASSY.	USABLE ON CODE	
					FROM	TO
		1 2 3 4 5 6				
2.18-25	7839949	+1	• BALLAST INSTL STA 201.5 <98750>	1	A	
- 21	7839933-01	+1	• • BALLAST <98750> ATTACHING PARTS	1	A	
- 22	AN3-15A	+1	• • BOLT	4	A	
- 23	AN977-3	+1	• • WASHER -----X-----	4	A	
	7839929	+1	• BALLAST INSTL STA 177 <98750>	1	B	
- 24	7839941-01	+1	• • BALLAST ATTACHING PARTS	1	B	
- 25	AN3-15A	+1	• • BOLT	6	B	
- 26	AN977-3	+1	• • WASHER -----X-----	6	B	
- 27	7839929-01	+1	• • BRACE ATTACHING PARTS	1	B	
- 28	MS27039-0610	+1	• • SCREW	3	B	
- 29	MS27039-1809	+1	• • SCREW	4	B	
- 30	AN967-8	+1	• • WASHER	7	B	
- 31	MS21744NJP	+1	• • NUT -----X-----	7	B	
- 32	7839935-01	+1	• • SHM <98750>	1	B	
- 33	7839926-10	+1	• • SUPPORT ASSY	1	B	

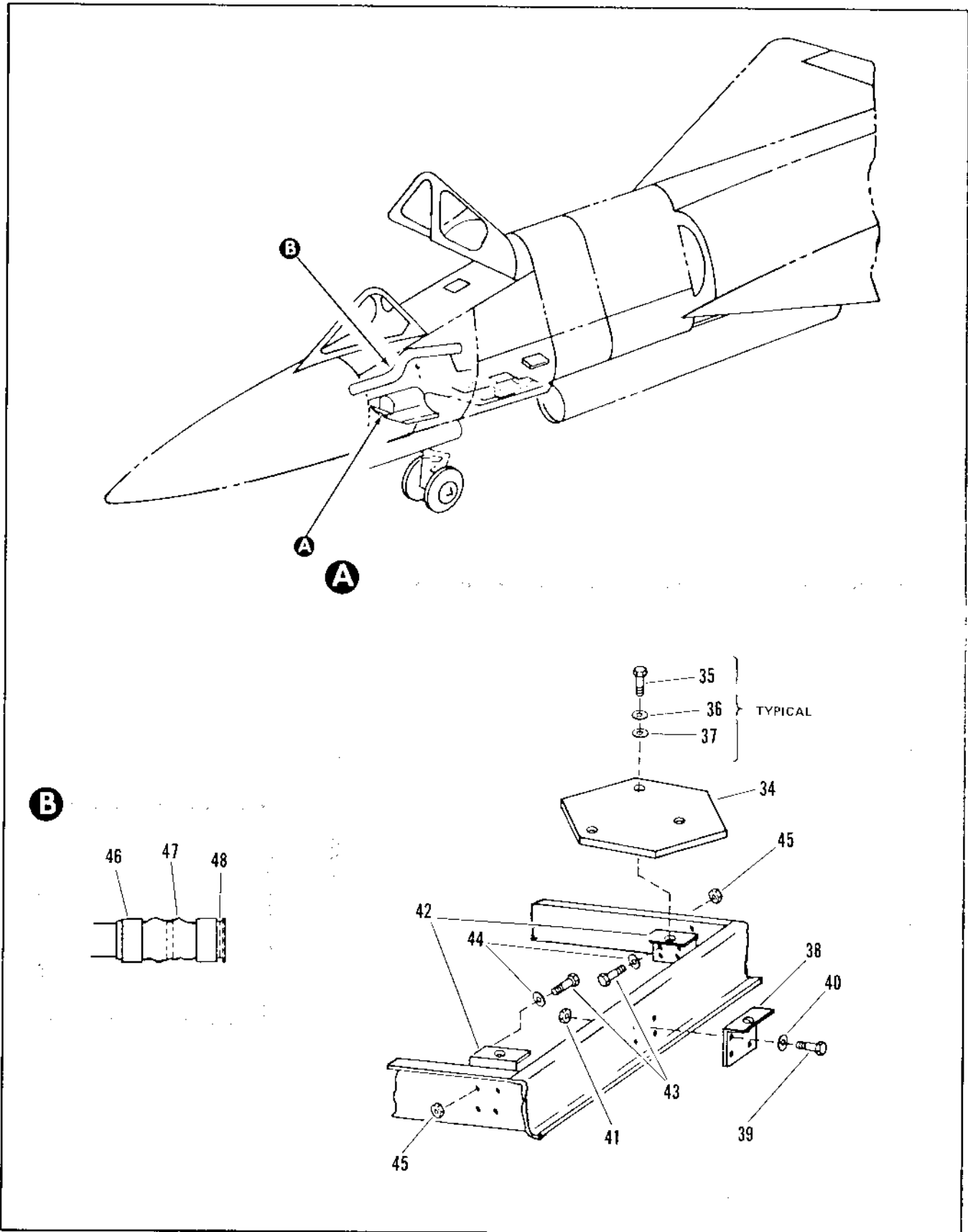

Figure 2.18-25. Attitude Heading Reference System (Sheet 3 of 3)

FIGURE AND INDEX NUMBER	PART NUMBER	1	2	3	4	5	6	UNITS PER ASSY.	USABLE ON CODE	
									FROM	TO
2.18-25	7839932-10	*1	BALLAST INSTL STA 1744 (98750)					1		
- 34	7839931-10	*1	BALLAST 98750 ATTACHING PARTS					1		
- 35	AN4-17A	*1	BOLT					3		
- 36	AN960-416	*1	WASHER					3		
- 37	AN970-4	*1	WASHER					7		
- 38	7839937-10	*1	CLIP ASSY (98750) ATTACHING PARTS					1		
- 39	MS27039-0809	*1	SCREW					4		
- 40	AN960-3	*1	WASHER					4		
- 41	MS21044-N08	*1	NUT					4		
- 42	7839936-01	*1	SUPPORT (98750) ATTACHING PARTS					2		
- 43	MS27039-0809	*1	SCREW					6		
- 44	AN960-8	*1	WASHER					8		
- 45	MS21044-N08	*1	NUT					8		
	7839912-10	*1	CAP INSTL, COOLING DUCT, AFT ELECTRIC COMPARTMENT					1		
- 46	AN737TW3F	*1	CLAMP					2		
- 47	NA8521-8-12	*1	COUPLING					2		
- 48	7839914-10	*1	CAP ASSY					2		
<p>A ROUND INSTRUMENT AIRPLANES B VERTICAL INSTRUMENT AIRPLANES</p> <p>*1 ADDED PER TC TO 1F-106-1181</p>										

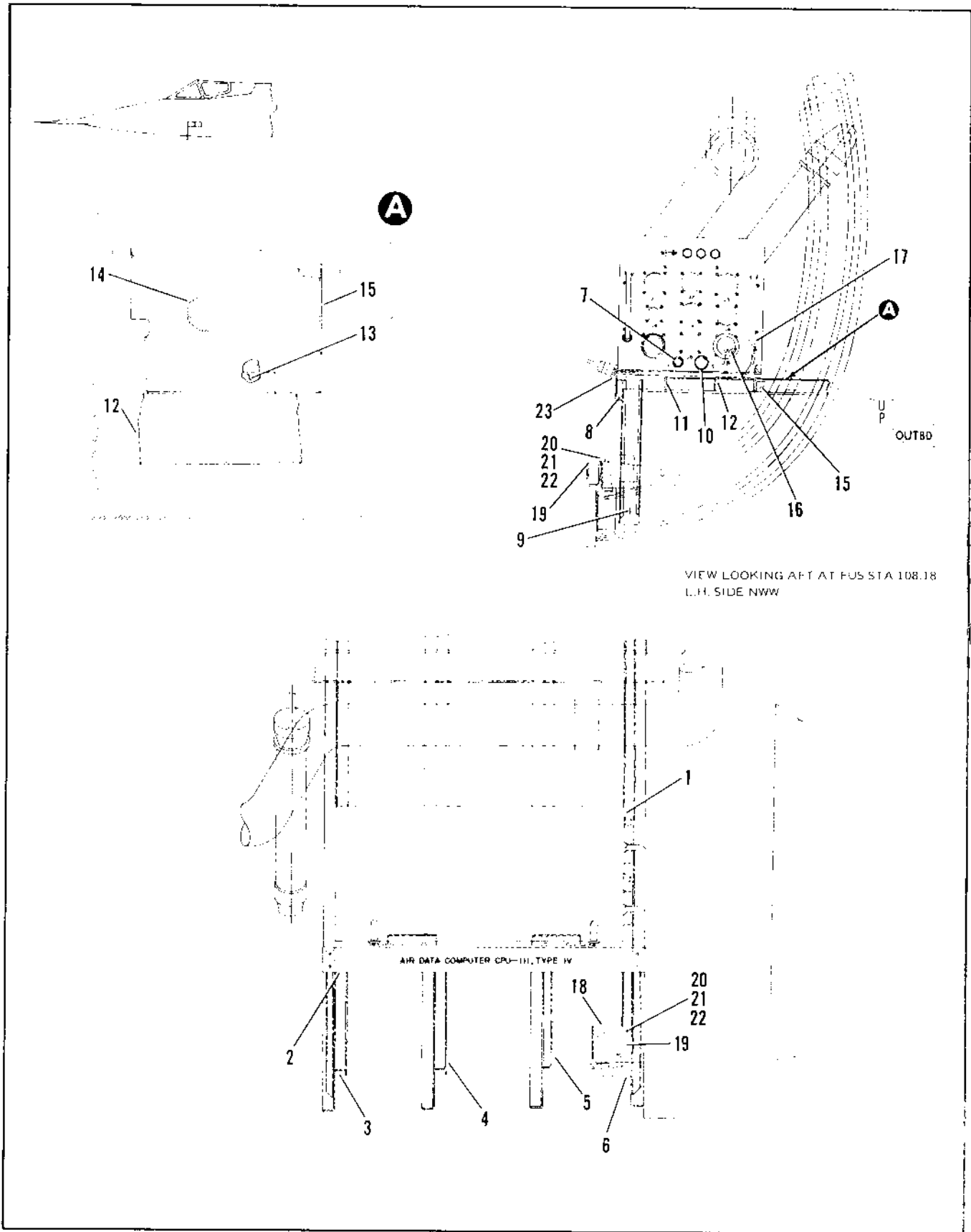

Figure 2.18-26. Central Air Data Computer (CADC)

FIGURE AND INDEX NUMBER	PART NUMBER	DESCRIPTION	UNITS PER ASSY.	USABLE ON CODE	
				FROM	TO
		1 2 3 4 5 6			
2.18-26	7037189	COMPUTER INSTC, CPU111, TYPE IV			
- 1	1964703-1	• COMPUTER CENTRAL AIR DATA (CACD)	1	35	
	TYPE IV				
- 2	7037214-1C	• MOUNT ASSY	1	35	
- 3	8-74224	• FRAME (REF)	1	35	
- 4	8-74223	• FRAME (REF)	1	35	
- 5	8-74222	• FRAME (REF)	1	35	
- 6	8-74221	• FRAME (REF)	1	35	
- 7	MS21902D4	• UNION	1	35	
	MS29512-04	• • PACKING	1		
- 8	7037220-01	• SPACER	2	35	
- 9	8-35152-17	• SUPPORT (REF)	1		
	8-36283-17	• SUPPORT (REF)	1		
- 10	MS21902D6	• UNION	1	35	
	MS29512-06	• • PACKING	1	35	
- 11	7037214-01	• SUPPORT	1	35	
- 12	7037214-03	• SUPPORT	1	35	
- 13	7037196-01	• CLIP	1	35	
- 14	MS21266-1N	• GROMMET	1	V	
- 15	8-35152-21	• SUPPORT, INTERCOSTAL (REF)	1		
	8-36283-21	• SUPPORT, INTERCOSTAL (REF)	1		
- 16	MS3181-20C	• CAP	1	V	
- 17	MS21919WH5	• CLAMP	1	V	
	MS35206-243	• SCREW	1	V	
	AN960-8	• • WASHER	1	V	
	MS21044N08	• • NUT	1	V	
- 18	7037233-01	• BRACKET	1	35	
- 19	MS3181-22C	• CAP	1	35	
		ATTACHING PARTS			
- 20	MS35206-245	• • SCREW	1	35	
- 21	AN960-8	• • WASHER	1	35	
- 22	MS21044N08	• • NUT	1	35	
- 23	1982859-1	• MOUNTING BASE, ELECT	1	35	
		*1 REMOVED AND RELOCATED FROM AIRPLANES #35 THRU 47 AND 49 THRU 89 PER TCDO 1F-106-1081			
		R ROUND INSTRUMENTED AIRCRAFT			
		V VERTICAL INSTRUMENTED AIRCRAFT			

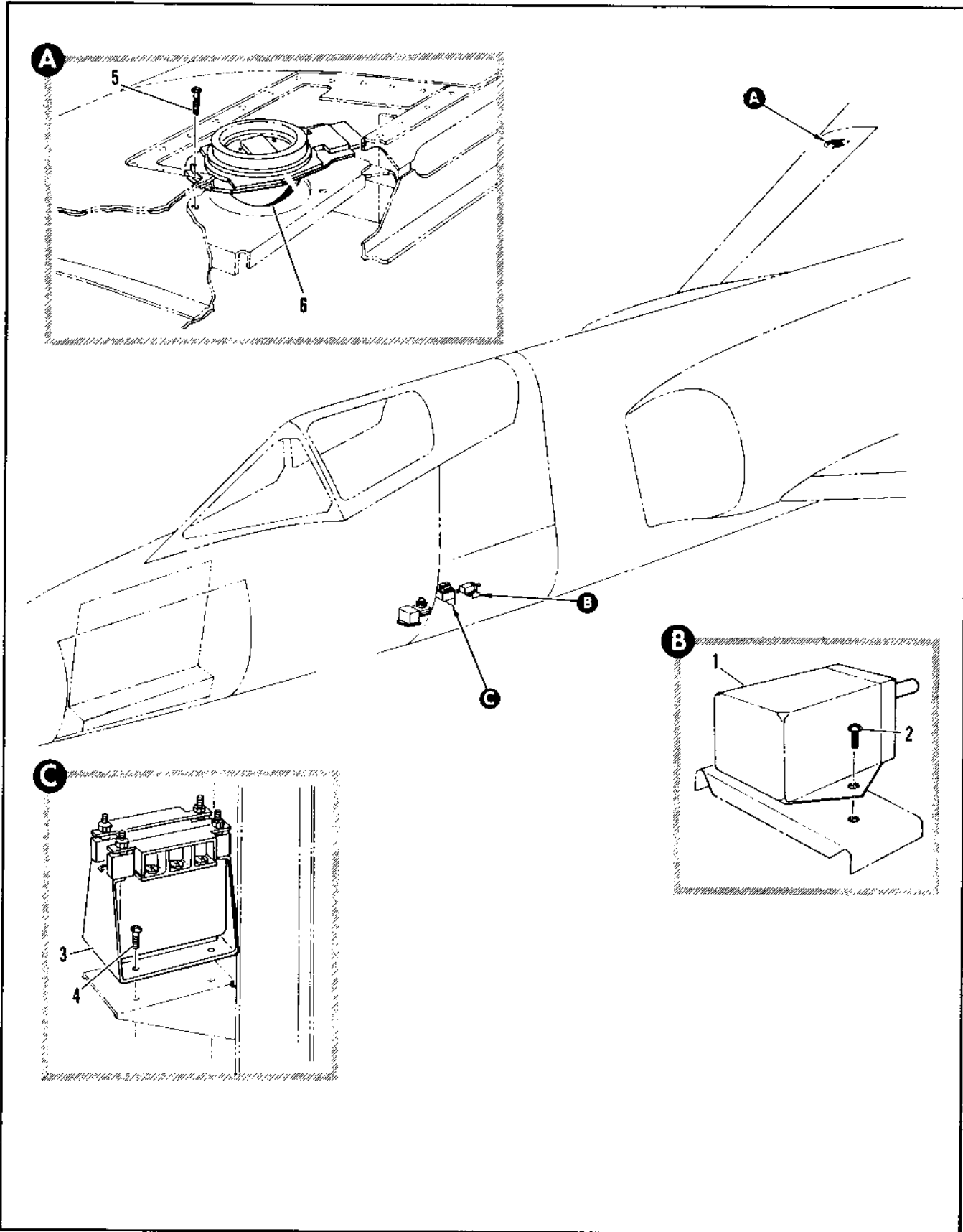

Figure 2.18-27. J-4 Compass Auxiliary Reference Group

FIGURE AND INDEX NUMBER	PART NUMBER	DESCRIPTION	UNITS PER ASSY.	USABLE ON CODE	
				FROM	TO
		1 2 3 4 5 6			
2.18-20	4-36298-1	• RELAY INSTL, J-4 INTERLOCK	1	40	
- 1	12-37-1647	• • RELAY, C35244> SPEC R-36298-1 ATTACHING PARTS	1	40	
- 2	AN31-1148	• • SCREW	2	40	
		-----X-----			
	0-36247-1	• TRANSFORMER INSTL, J-4 FLIGHT POWER SENSING STA 211	9F	4	
- 3	4027	• • TRANSFORMER, FLIGHT POWER SENSING 211/211FM C95266> SPEC R-36247-1 ATTACHING PARTS	1	4	
- 4	AN3-3A	• • SCUT	4	4	
		-----X-----			
	1-31150	• TRANSMITTER INSTL, J-4 COMPASS REMOTE STA 179	1	30	
- 5	AN5106911	• • SCREW	3	30	
- 6	02-309	• • DETECTOR, MAGNETIC AZIMUTH C96230> AERN067-1417 TYPE DT-1757AUN LFAE	1	30	
		Δ AIRPLANES #75 THRU 47 AND 48 THRU 49			

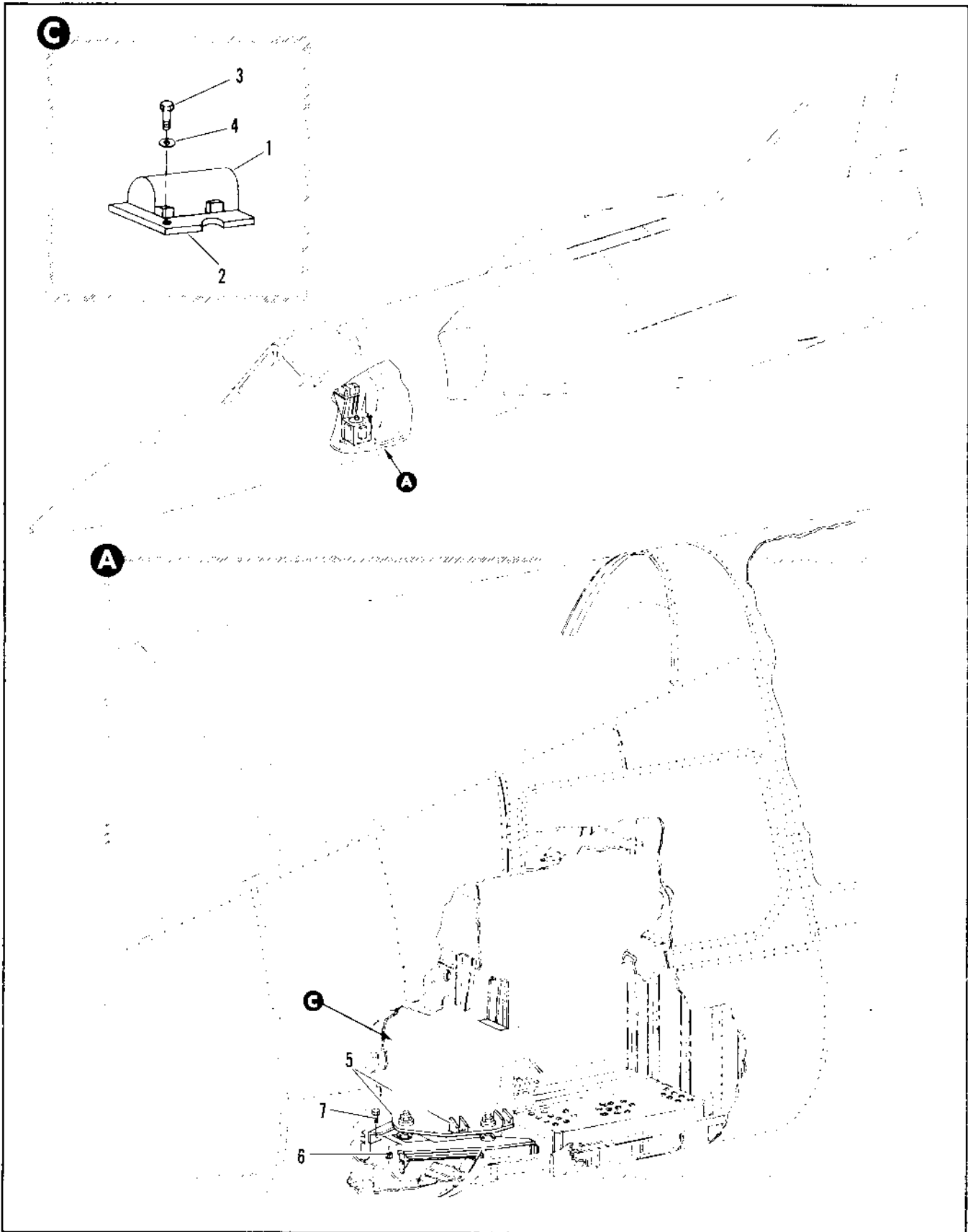

Figure 2.18-28. Automatic Flight Control System

FIGURE AND INDEX NUMBER	PART NUMBER	DESCRIPTION	UNITS PER ASSY.	USABLE ON CODE	
				FROM	TO
		1 2 3 4 5 6			
2.18-28		AUTOMATIC FLIGHT CONTROL SYSTEM			
- 1	156555-31-02 *2	• GYROSCOPE, DISPLACEMENT 35351, AFCS, STA 170	1		
- 2	163292-31 *2	• BASE, MOUNTING 35351 GEAR ATTACHING PARTS	1		
- 3	AN5-7A *2	• • BOLT	4		
- 4	AN96-516L *2	• • WASHER -----X-----	4		
- 5	464474	• • PACK, STABLE PLATFORM ATTACHING PARTS	1	35	
- 6	NAS679A4	• • NUT	6	35	
- 7	AN4-5A	• • BOLT -----X-----	8	35	
		*2 ADDED PER TC TO 1F-106-1141			

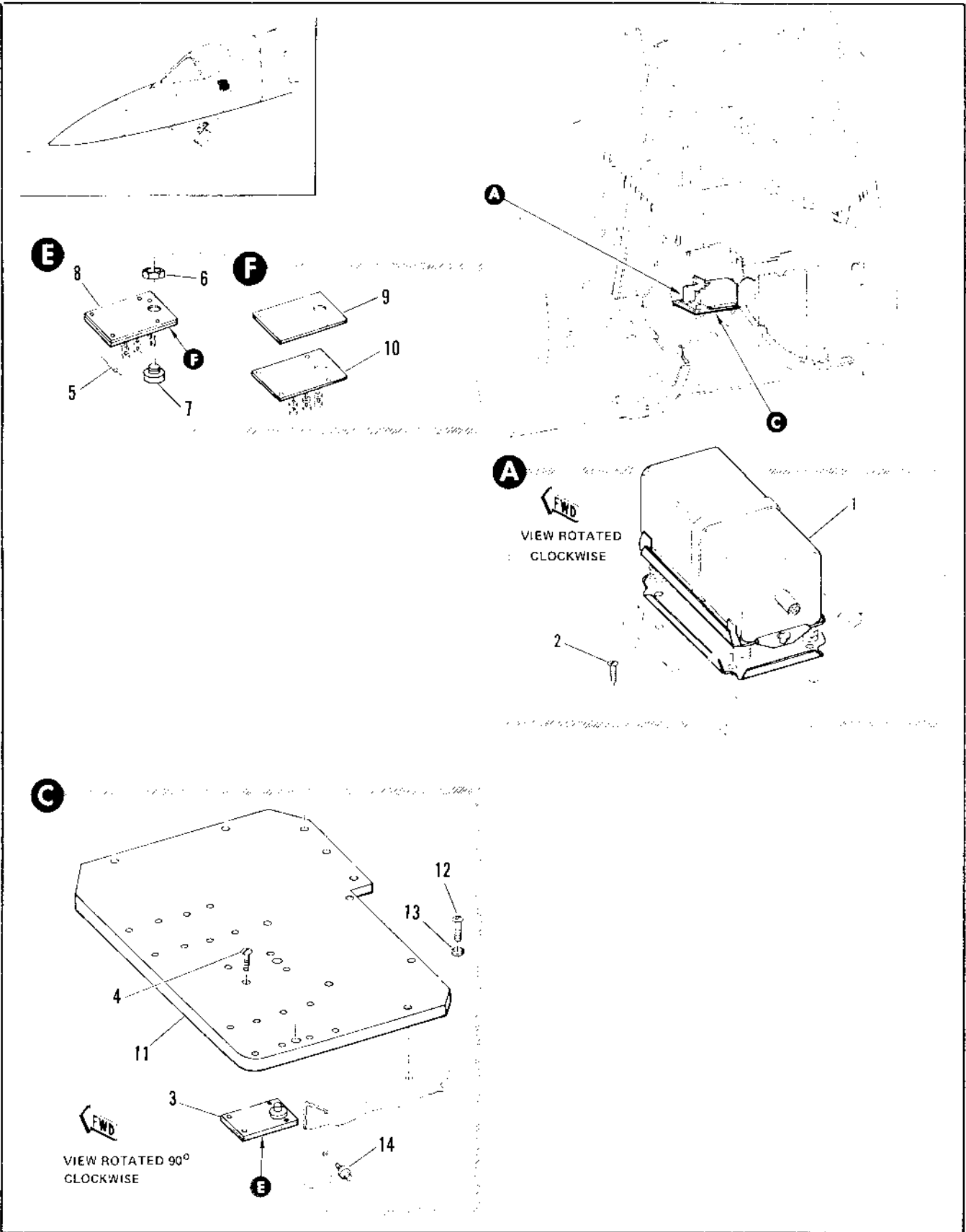

Figure 2.18-29. Steering Computer and Gyroscope Control

FIGURE AND INDEX NUMBER	PART NUMBER	DESCRIPTION	UNITS PER ASSY.	USABLE ON CODE	
				FROM	TO
		1 2 3 4 5 6			
2.18-29		STEERING COMPUTER AND GYROSCOPE CONTROL			
- 1	P-36384-1 7902C	• CONTROL INSTL. GYROSCOPE • CONTROL, GYROSCOPE (35351) AERN041-5937 GFAE	1 1	A	A
- 2	AN521-10R4	• SCREW	4	A	
	P-36384	• EQUIPMENT ASSY, STEERING COMPUTER AND GYROSCOPE CONTROL	1	A	
- 3	A-36763	• RESISTOR BOARD ASSY, STEERING COMPUTER	1	A	
- 4	AN515-6R6	• SCREW	4	A	
- 5	RC206F102J	• RESISTOR, FIXED 57-910.J-025	3	A	
- 6	B6-36521-007	• NUT	1	A	
- 7	RVAL4YSA253A	• RESISTOR, VARIABLE 47-45011-004	1	A	
- 8	B-36763-11	• TERMINAL BOARD ASSEMBLY	1	A	
- 9	P-36763-7	• INSULATOR	1	A	
- 10	B-36763-15	• TERMINAL BOARD	1	A	
- 11	A-36762	• PLATE, MOUNTING	1	A	
- 12	AN521-10R12	• SCREW	7	A	
- 13	AN361-1C	• WASHER	7	A	
- 14	55-14002-001	• JACK, TEST	1	A	
		A LIPPLAYS 435 THRU 47 AND 49 THRU 99			

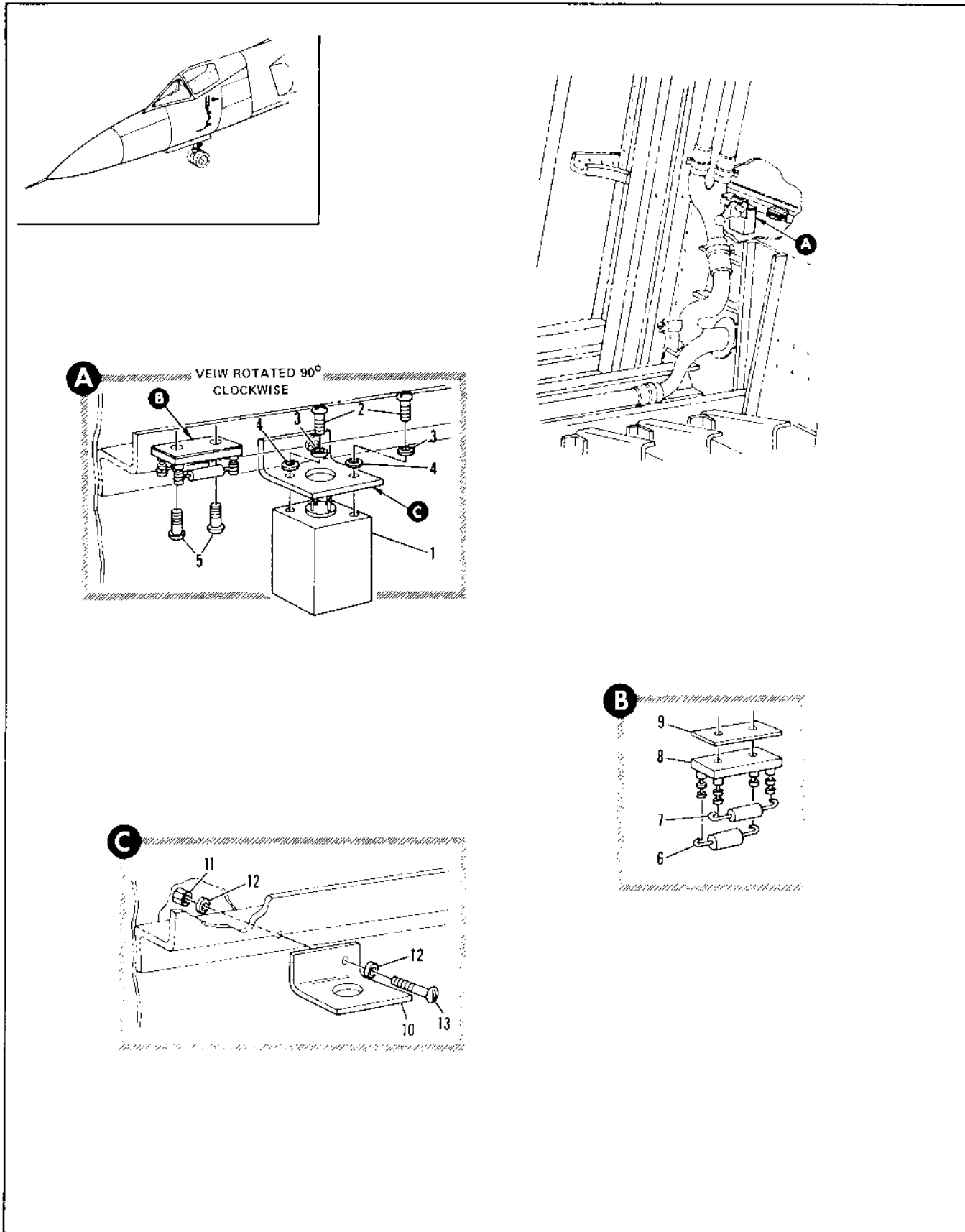

Figure 2.18-30. Marker Beacon Equipment

FIGURE AND INDEX NUMBER	PART NUMBER	DESCRIPTION 1 2 3 4 5 6	UNITS PER ASSY.	USABLE ON CODE	
				FROM	TO
2.18-30		MARKER BEACON EQUIPMENT			
- 1	R-36404-1 T8860	• TRANSFORMER INSTL, MARKER BEACON • TRANSFORMER, <B10-5> 95-1101-304	1 1	75 75	
		ATTACHING PARTS			
- 2	AN513-685	• SCREW	2	35	
- 3	AN935-6	• WASHER	2	35	
- 4	AN961-6	• WASHER	2	35	
		-----x-----			
	R-36404-7	• RESISTOR INSTL, MARKER BEACON	1	35	
		ATTACHING PARTS			
- 5	AN527-10280	• SCREW	2	35	
		-----x-----			
- 6	RC320F621J	• RESISTOR, 57-41001-03P	1	35	
- 7	RC420F121J	• RESISTOR, 57-40002-01A	1	35	
- 8	R-36404-3	• TERMINAL BOARD	1	35	
- 9	R-36404-11	• INSULATOR	1	75	
	R-36404	• BRACKET INSTL, MARKER BEACON TRANSFORMER	1	35	
- 10	R-36404-13	• BRACKET	1	35	
		ATTACHING PARTS			
- 11	NAS479A3	• NUT	1	35	
- 12	AN961-010L	• WASHER	2	35	
- 13	AN527-10410	• SCREW	1	35	
		-----x-----			

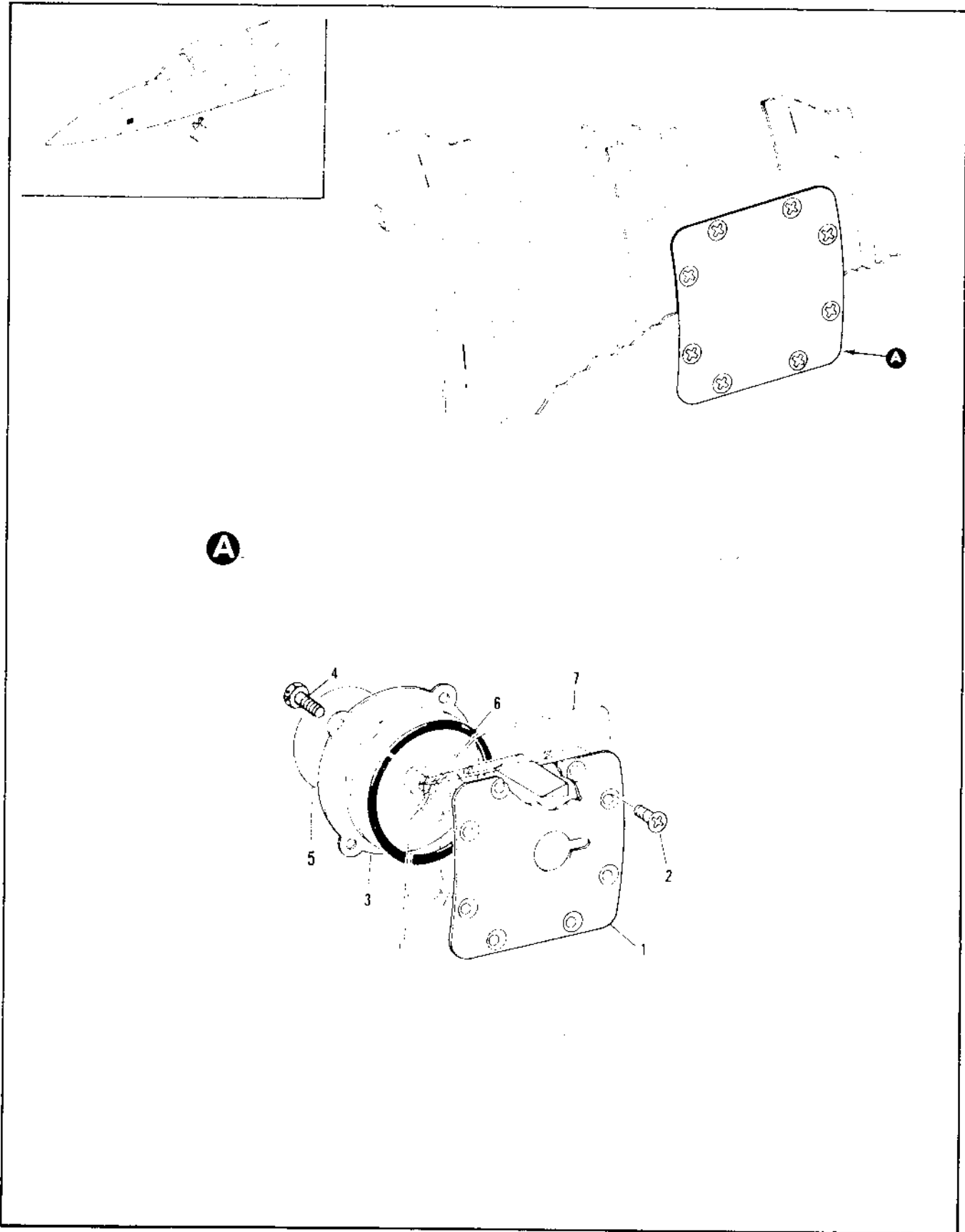

Figure 2.18-31. Angle of Attack Transmitter Installation

FIGURE AND INDEX NUMBER	PART NUMBER	DESCRIPTION	UNITS PER ASSY.	USABLE ON CODE	
				FROM	TO
		1 2 3 4 5 6			
2.18-11	6-30757-1	TRANSMITTER INSTALLATION, ANGLE OF ATTACK FOR NHA SEE FIG. 2.18-4	RF	35	
- 1	4-30758-7	• COVER	1	35	
- 2	AN519-414R17	• ATTACHING PARTS • SCREW	R	35	
- 3	6-30759-13	• RETAINER	1	35	
- 4	AN11380F	• ATTACHING PARTS • BOLT	4	35	
- 5	MS24172-1	• TRANSMITTER, ANGLE OF ATTACK ACRNO60-1403 DEAF	1	35	
	4922-1A	• TRANSMITTER, ANGLE OF ATTACK <10315> ACRNO60-1403 DEAF ALTERNATE	RF	35	
	2552A3	• TRANSMITTER, ANGLE OF ATTACK <70737> ACRNO60-1403 DEAF ALTERNATE	RF	35	
	604741	• TRANSMITTER, ANGLE OF ATTACK <94571> ALTERNATE	RF	35	
	6169F2	• TRANSMITTER, ANGLE OF ATTACK <94571> ALTERNATE	RF	35	
	914674	• TRANSMITTER, ANGLE OF ATTACK <94571> ALTERNATE	RF	35	
	256045	• TRANSMITTER, ANGLE OF ATTACK <72737> ALTERNATE	RF	35	
	16137-3	• TRANSMITTER, ANGLE OF ATTACK <97926> ALTERNATE	RF	35	
	14235-4	• TRANSMITTER, ANGLE OF ATTACK <94571> ALTERNATE	RF	35	
	2562415	• TRANSMITTER, ANGLE OF ATTACK <72737> ALTERNATE	RF	35	
- 6	MS24113-040	• BASKET	1	35	
- 7		• SUPPORT ASSY, ANGLE OF ATTACK TRANSMITTER LN SEE FIG. 2.18-11	RF		

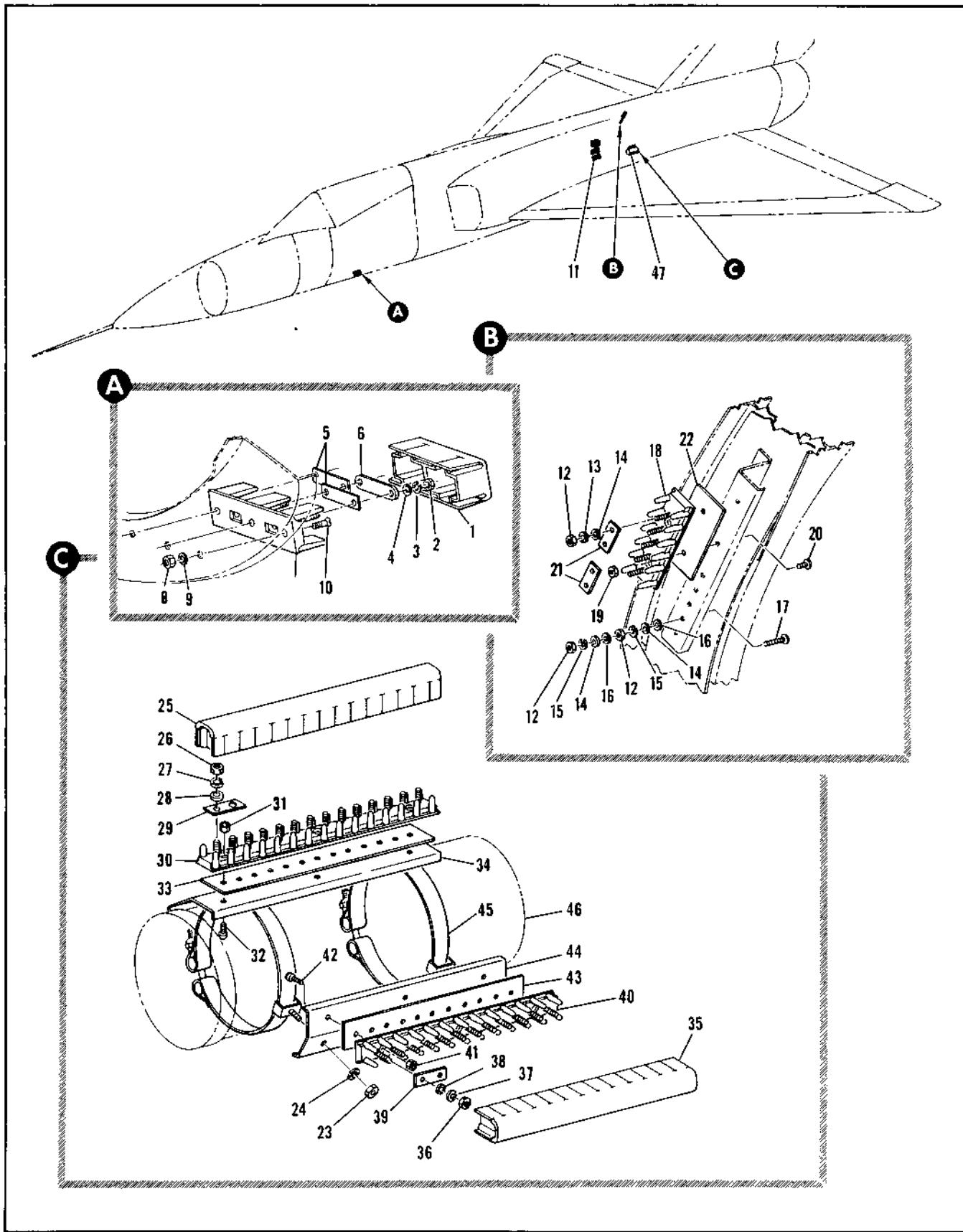

Figure 2.18-32. Generator Group

FIGURE AND INDEX NUMBER	PART NUMBER	DESCRIPTION	UNITS PER ASSY.	USABLE ON CODE	
				FROM	TO
2.18-32		GENERATOR GROUP			
	2-36373-1	• SPLICE INSTL, GROUND POWER STA 168	1	35	38
	2-36373-5	• SPLICE INSTL, GROUND POWER STA 168	1	H	
- 1	38940	• COVER, <74212> 91-50003-01A	2	C	
- 2	AN341-41R	• NUT	2	C	
- 3	AN935A916H	• WASHER	2	C	
- 4	AN361-41R	• WASHER	2	C	
- 5	MS25227-5	• STRIP, INSULATING	2	C	
- 6	MS25226-4-2	• PUSHBAR	1	P	
- 7	AN3436-4-2	• TERMINAL PLUG, ATTACHING PARTS	1	C	
- 8	NAS679A06	• NUT	3	C	
- 9	AN95106	• WASHER	3	C	
- 10	AN115-4R	• SCREW	3	C	
		-----X-----			
- 11	2-36363	• SPLICE INSTL, GENERATOR STA 480	RF	35	
	2-36363-7	• SPLICE ASSEMBLY	1	35	
- 12	AN341-10	• NUT	15	35	
- 13	AN935-10L	• WASHER	15	35	
- 14	AN961-10L	• WASHER	15	35	
- 15	AN935-10	• WASHER	10	35	
- 16	AN961-10L	• WASHER	10	35	
- 17	AN52-1012PA	• SCREW	5	35	
- 18	AN3416-3-5	• TERMINAL STRIP	1	35	
- 19	NAS679A04	• NUT	2	35	
- 20	AN515-494	• SCREW	2	35	
- 21	NAS1067-4	• INSULATOR	2	35	
- 22	96-86000-004	• PLATE, DESIGNATION	1	35	
	R-36744	• SPLICE INSTL, DC GENERATOR STA 495	1	A	
	R-36746-11	• SPLICE ASSY, UPPER	1	A	
	R-36746-1A	• SPLICE ASSY, LOWER	1	A	
		ATTACHING PARTS			
- 23	AN341-10	• NUT	4	A	
- 24	AN935-10L	• WASHER	4	A	
		-----X-----			
- 25	38940	• COVER, UPPER <74212> 92-74501-001	1	A	
- 26	AN341-4	• NUT, UPPER	14	A	
- 27	AN935-4L	• WASHER, UPPER	14	A	
- 28	AN961-4L	• WASHER, UPPER	14	A	
- 29	MS25227-2	• STRIP	3	A	
- 30	AN3436-2-14	• TERMINAL BLOCK ASSY, UPPER	1	A	
- 31	NAS679A04	• NUT, <74237> 95-37545-005	3	A	
- 32	NAS610-6	• SCREW	7	A	
- 33	96-86000-412	• NAMEPLATE	1	A	
- 34	R-36746-7	• BRACKET	1	A	
- 35	38940	• COVER, LOWER <74212> 92-74501-002	1	A	
- 36	AN341-4	• NUT, LOWER	12	A	
- 37	AN935-4L	• WASHER, LOWER	12	A	
- 38	AN961-4L	• WASHER, LOWER	12	A	
- 39	MS25227-2	• STRIP	3	A	
- 40	AN3436-2-10	• TERMINAL BLOCK ASSY, LOWER	1	A	
- 41	NAS679A04	• NUT	3	A	
- 42	NAS610-6	• SCREW	7	A	
- 43	96-86000-41	• NAMEPLATE, LOWER	1	A	
- 44	R-36746-9	• BRACKET	1	A	
- 45	951-551-3-2A	• CLAMP, T-BOLT <96605> 98-50000-024	2	A	
- 46		• GENERATOR, DC PAD C	RF		
		SEE FIG. 2.18-25 INDEX 19			
- 47		• GENERATOR, 10 PAD C	RF		
		SEE FIG. 2.17-25 INDEX 25			
		A AIRPLANES 475 THRU 47 AND 48 THRU 56			
		B AIRPLANES 475 THRU 47 AND 48 THRU 59			
		C AIRPLANES 475 THRU 47 AND 48 THRU 59			

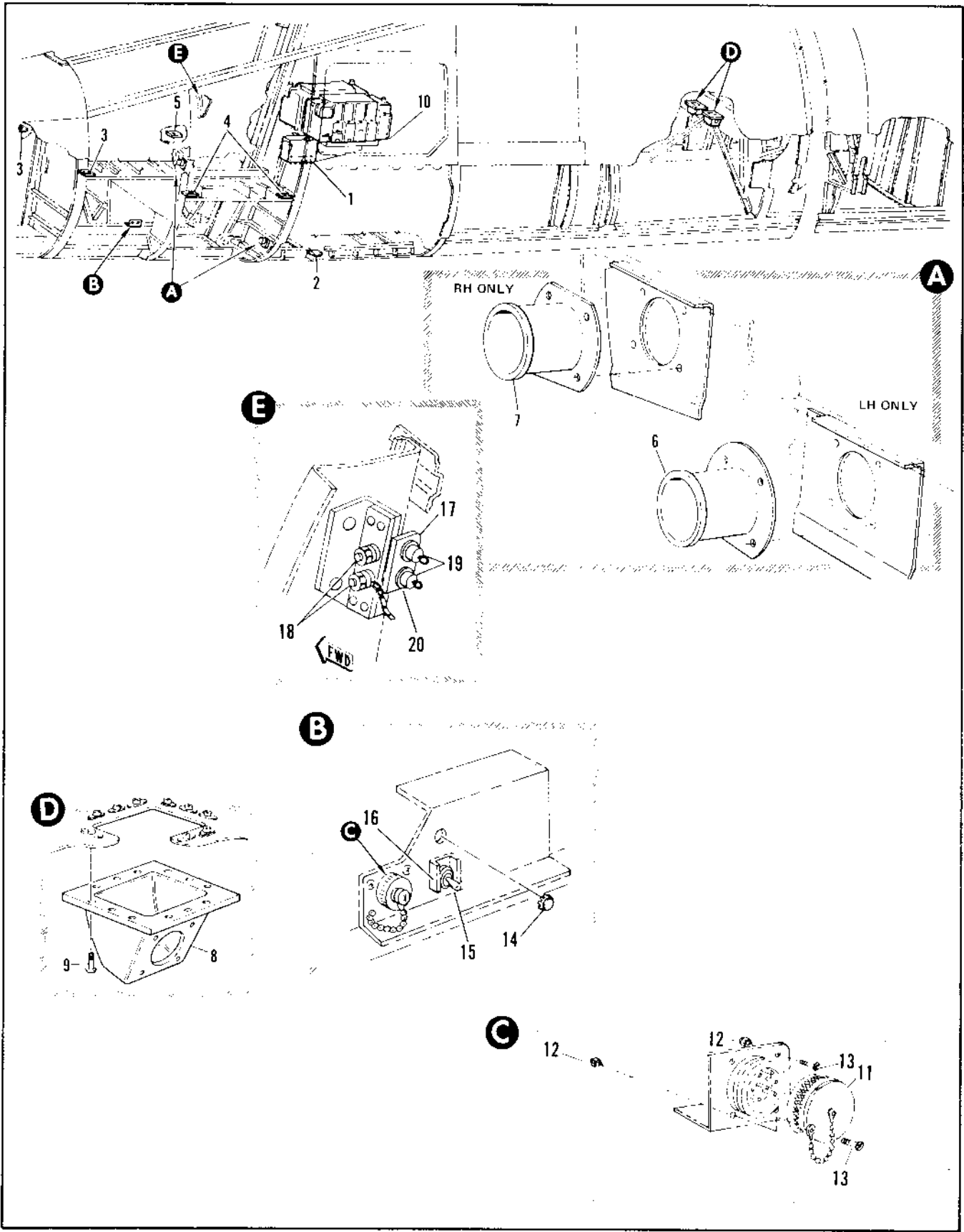

Figure 2.18-33. Power Distribution

FIGURE AND INDEX NUMBER	PART NUMBER	DESCRIPTION	UNITS PER ASSY.	USABLE ON CODE	
				FROM	TO
		1 2 3 4 5 6			
2.18-33		POWER DISTRIBUTION			
- 1		• PRESSURIZATION GROUP, SEE FIG. 2.18-14	RF		
- 2		• GENERATOR GROUP, SEE FIG. 2.18-32	RF		
	8-36741	• PLATE INSTL, COCKPIT FLOOR FEED THRU STA 110 LH RH 136 LH 155 LH AND 160 LH	1	A	
	8-36741-1	• PLATE INSTL, COCKPIT FLOOR FEED THRU STA 136 LH 155 RH AND 160 LH	1	B	
- 3	8-68298	• PLATE, FEED THRU ATTACHING PARTS	2	35	
	AN515-8R8	• SCREW	8	35	
		-----X-----			
- 4	8-68298	• PLATE, FEED THRU ATTACHING PARTS	2	A	
	AN515-8R8	• SCREW	8	A	
		-----X-----			
- 5	8-68298	• PLATE, FEED THRU	1	A	
	8-68298-7	• PLATE, FEED THRU ATTACHING PARTS	1	B	
	AN515-8R8	• SCREW	4	35	
		-----X-----			
	8-36743-1	• FEED THRU INSTL, FWD LAUNCHER HARNESS STA 171	1	35	
	8-36739-1	• PLATE ASSY, FEED THRU LH	1	35	
	8-36740-1	• PLATE ASSY, FEED THRU RH	1	35	
- 6	4333-3	• BOOT, LH <94914> SPEC 8-00486-3	1	35	
- 7	4333-1	• BOOT, RH <94914> SPEC 8-00486-1	1	35	
	8-36770	• BOX INSTL, ELECTRICAL CONNECTOR STA 308	1	35	
- 8	8-36768-11	• BOX, MOUNTING ELECTRICAL CONNECTOR LH	1	35	
	8-36768-12	• BOX, MOUNTING ELECTRICAL CONNECTOR RH ATTACHING PARTS	1	35	
- 9	AN520-10R10	• SCREW	24	35	
		-----X-----			
- 10		• EQUIPMENT INSTL, UPPER AFT RH ELECTRONICS COMPARTMENT SEE FIG. 2.18-23	RF		
	8-36249-3	• COVER INSTL, NOSE WHEEL WELL AIC-10 RECEPTACLE STA 138 MODIFIED BY 8-31884 AND 8-61974	1	C	
	8-36249-5	• COVER INSTL, NOSE WHEEL WELL AIC-10 RECEPTACLE STA 138 MODIFIED BY 8-31884 AND 8-61974	1	D	
	8-36249-801	• COVER INSTL, NOSE WHEEL WELL AIC-10 RECEPTACLE STA 138	1	130	188
	8-36249-803	• COVER INSTL, NOSE WHEEL AIC-10 RECEPTACLE STA 138	1	189	
- 11	2209-6	• COVER, <71468> 92-74202-003	1	35	
- 12	NAS679A06	• NUT	1		
- 13	AN515-6R7	• SCREW	1		
- 14	HS-51163	• PLUG, BUTTON <90763>	1		
- 15	8906K868	• SWITCH, TOGGLE <15605> SPEC 8-06915-13 REPLACES NOT INTCHG WITH 8906K700	1	E	
- 16	8-62216-7	• GUARD, CHANNEL	1	E	
	67036585-1	• DIODE INSTL, POWER SUPPLY	1		
- 17	8-32013-13	• SUPPORT ATTACHING PARTS	1		
- 18	MS21042L3	• NUT	2		
	AN960-10L	• WASHER	4		
	MS35207-263	• SCREW	2		
		-----X-----			
- 19	IN1200	• DIODE, SPEC MIL-F-1/1108	2		
- 20	MS21042L3	• NUT	2		
		B AIRPLANES #48, 90 AND ON			
		C AIRPLANES #35 THRU 47 AND 49 THRU 60			
		D AIRPLANES #48 AND 61 THRU 129			
		E AIRPLANES #48, 61 AND ON			

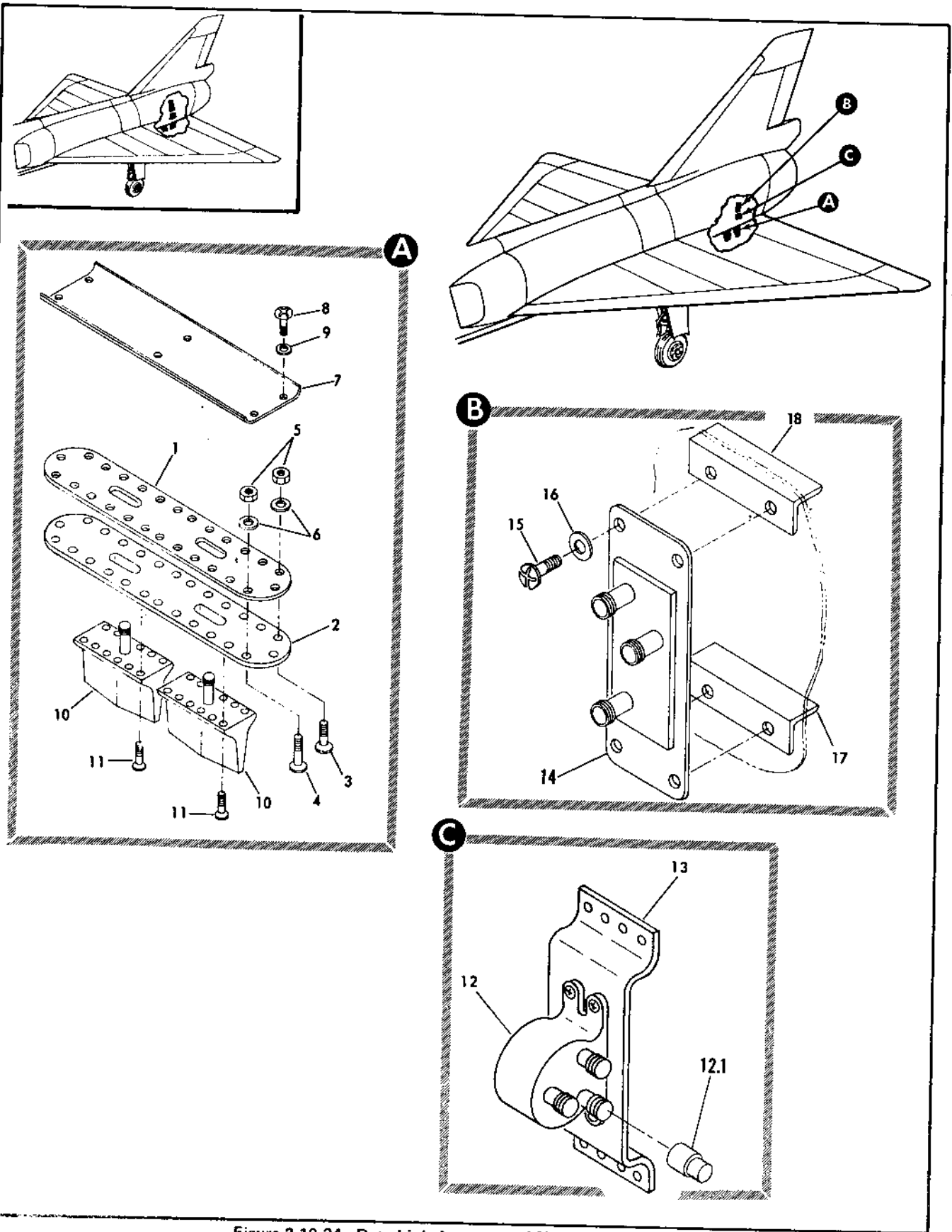

Figure 2.18-34. Data Link Antenna and Network Installation

FIGURE AND INDEX NUMBER	PART NUMBER	DESCRIPTION	UNITS PER ASSY.	USABLE ON CODE	
				FROM	TO
		1 2 3 4 5 6			
2.18-34	64H33373	ANTENNA AND NETWORK INSTL. DATA LINK	RF		35
	64H33373-1	ADAPTER INSTALLATION	RF		35
- 1	63D34179-7	• GASKET	1		35
- 2	63034179-30	• ADAPTER	1		35
		ATTACHING PARTS			
- 3	AN509-10R10	• SCREW	12		35
- 4	AN509-10R11	• SCREW	14		35
- 5	MS21042-3	• NUT	26		35
- 6	AN960-10	• WASHER	26		35
		-----X-----			
- 7	62C34824-7	• GUARD	1		35
		ATTACHING PARTS			
- 8	AN520-10R6	• SCREW	6		35
- 9	AN960-10	• WASHER	6		35
		-----X-----			
	64H33377-1	ANTENNA INSTALLATION	RF		35
- 10	AT-879/ARC	ANTENNA	2		35
		ATTACHING PARTS			
- 11	AN509-8R8	• SCREW	8		35
		-----X-----			
	64H33373-3	SWITCH INSTALLATION	RF		35
- 12	SA-521/AA	• SWITCH, RF TRANSMISSION	1		35
- 12.1	29500	• LOAD	1		35
- 13	64D33372-1	• MOUNT, SWITCH (RIVETED)	1		35
	64D33373-5I	NETWORK INSTALLATION	RF		35
- 14	MX-3479/ARR	• NETWORK	1		35
		ATTACHING PARTS			
- 15	AN3-11A	• BOLT	4		35
- 16	AN960-10	• WASHER	4		35
- 17	62C34498-1	• STIFFNER	1		35
- 18	62C34499-1	• STIFFNER	1		35
		-----X-----			

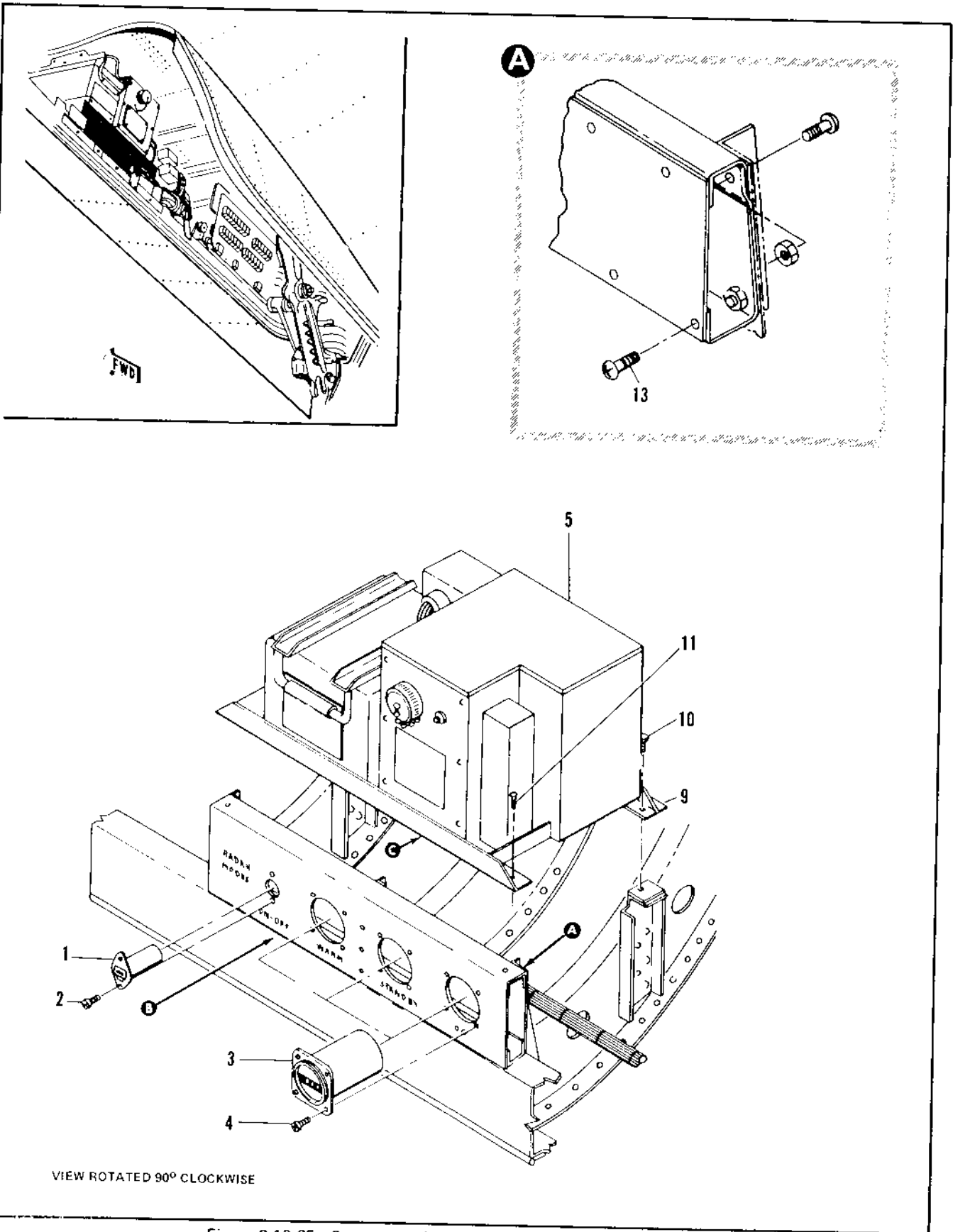

Figure 2.18-35. Counters and Timers Installation (Sheet 1 of 2)

FIGURE AND INDEX NUMBER	PART NUMBER	DESCRIPTION	UNITS PER ASSY.	USABLE ON CODE	
				FROM	TO
		1 2 3 4 5 6			
2.18-35	7242-57-10 *2	EQUIPMENT INSTALLATION, NEW LOWER MODIFICATION	1	35	
- 1	K1901204A	• INDICATOR, LEVELS (CP 15)	1	35	
		ATTACHING PARTS			
- 2	AN5104P7	• • SCREW	2	35	
		-----X-----			
- 3	MS2453-3	• METER, TIME TOTALIZING, DIGITAL, ALTERNATE AND INTERCHANGEABLE WITH MS2453-5)	3	35	
		ATTACHING PARTS			
- 4	AN5106P7	• • SCREW	12	15	
		-----X-----			
- 5		• BATTERY INSTALLATION, DC EMERGENCY POWER SUPPLY STA 112	9F	35	
- 6	724558-1 *2	• HINGE, HOUSING ATTACHING PARTS	2	35	
- 7	MS21743-7 *2	• NUT	2	35	
- 8	MS2759C1-15 *2	• SCREW	2	35	
		-----X-----			
- 9	7242431-10 *2	• SHELF ASSY, LOWER ATTACHING PARTS	1	35	
- 10	AN4-106 *2	• BELT	3	35	
- 11	MS24-694C1-4 *2	• SCREW	3	35	
		-----X-----			

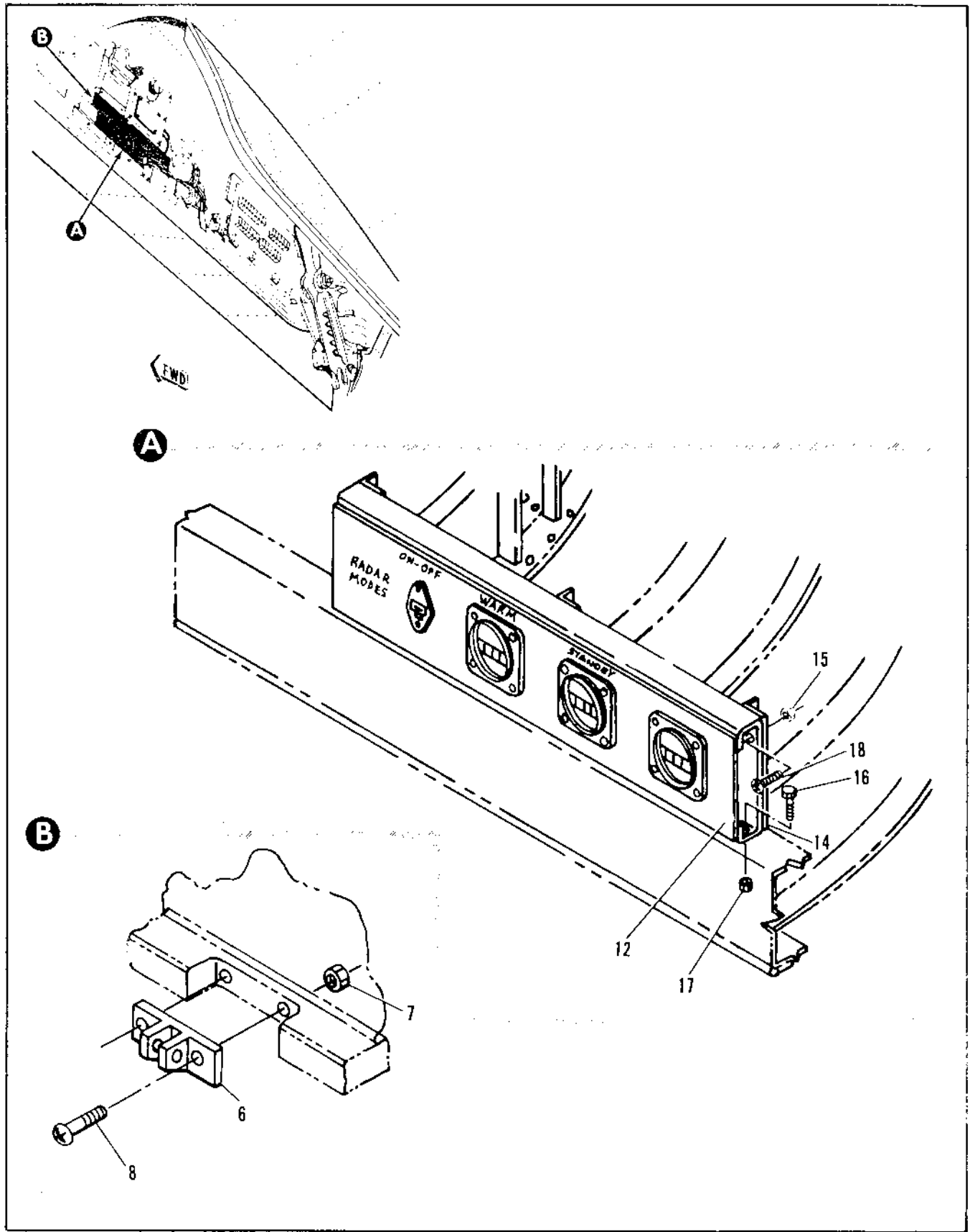

Figure 2.18-35. Counters and Timers Installation (Sheet 2 of 2)

FIGURE AND INDEX NUMBER	PART NUMBER	DESCRIPTION	UNITS PER ASSY.	USABLE ON CODE	
				FROM	TO
		1 2 3 4 5 6			
2.18-15-10	7243033-1	*2 • COVER BRACKET ATTACHING PARTS	1	35	
- 13	MS2733903-16	*2 • SCREW -----X-----	12	35	
- 14	7243032-10	*2 • BRACKET ASSY ATTACHING PARTS	1	35	
- 15	MS27339101-07	*2 • SCREW	6	35	
- 16	AN3-4A	*2 • BOLT	1	35	
- 17	MS21042L3	*2 • NUT	1	35	
- 18	MS21043-7	*2 • NUT -----X-----	6	35	
		*2 ADDED PER TOTO 1F-107-10R1			

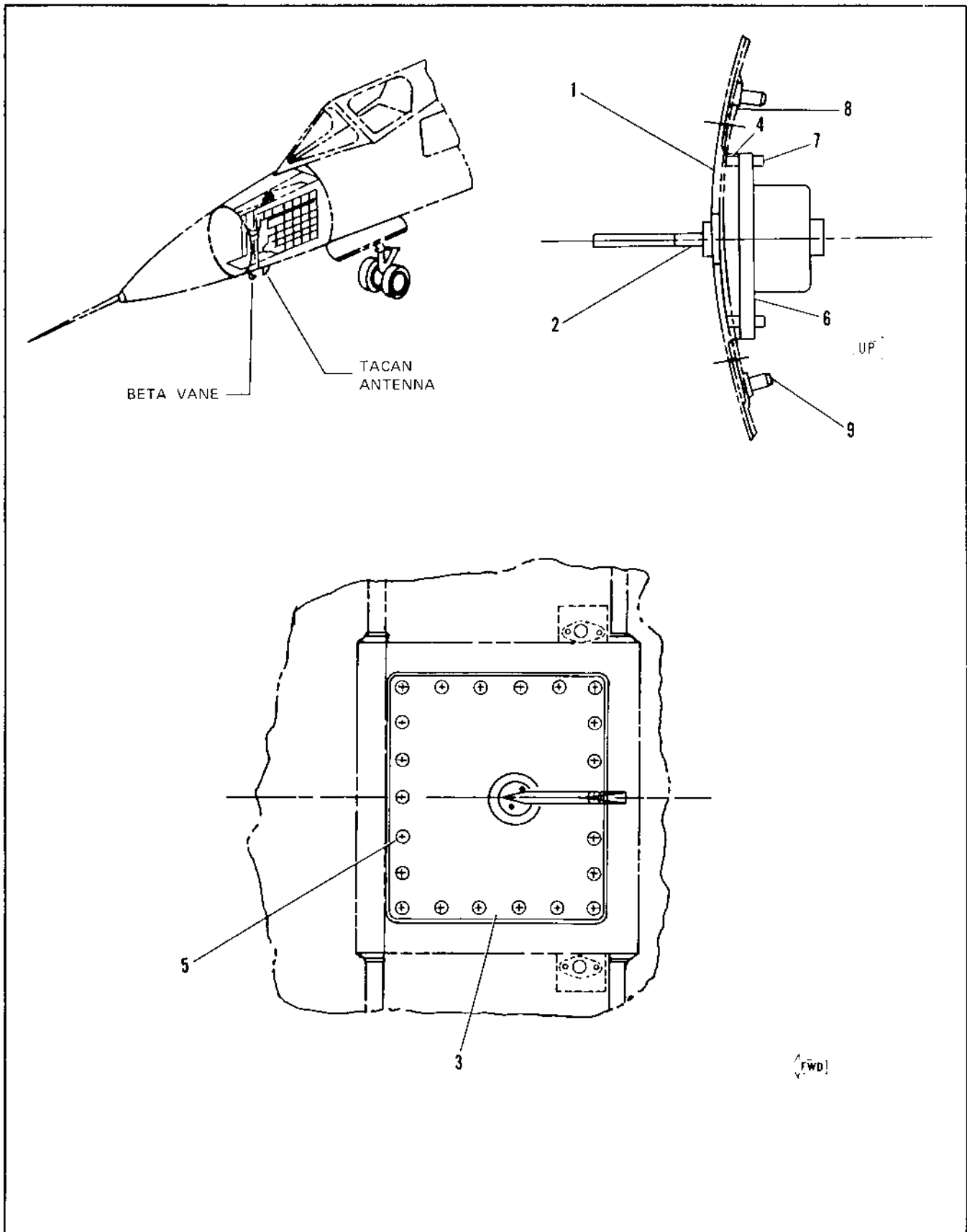

Figure 2.18-36. Beta Vane Installation

FIGURE AND INDEX NUMBER	PART NUMBER	DESCRIPTION	UNITS PER ASSY.	USABLE ON CODE	
				FROM	TO
2-18-36	7346840-10	*1 BETA VANE INSTALLATION	REF	A	
- 1	52130	*1 . BETA VANE ASSY	1	A	
- 2	2562A 3	*1 . TRANSMITTER SYCHRO (MS24378-3)	1	A	
- 3	52131-1	*1 . MOUNTING PLATE ATTACHING PARTS	1	A	
- 4	MS21209	*1 . . INSERT, HELICOIL LOCKS	4	A	
- 5	MS24693-C274	*1 . . SCREWS -----X-----	22	A	
- 6	52133	*1 . . RING ATTACHING PARTS	1	A	
- 7	MS16996-12	*1 . . SCREWS -----X-----	4	A	
- 8	7346840-01	*1 . DOUBLER	2	A	
- 9	A4A1B 1-080	*1 . RECEPTACLE (84256)	2	A	
		* ADDED PER TOTO 1F-106-1122			
		A. AIRPLANES 48, 90 AND ON			

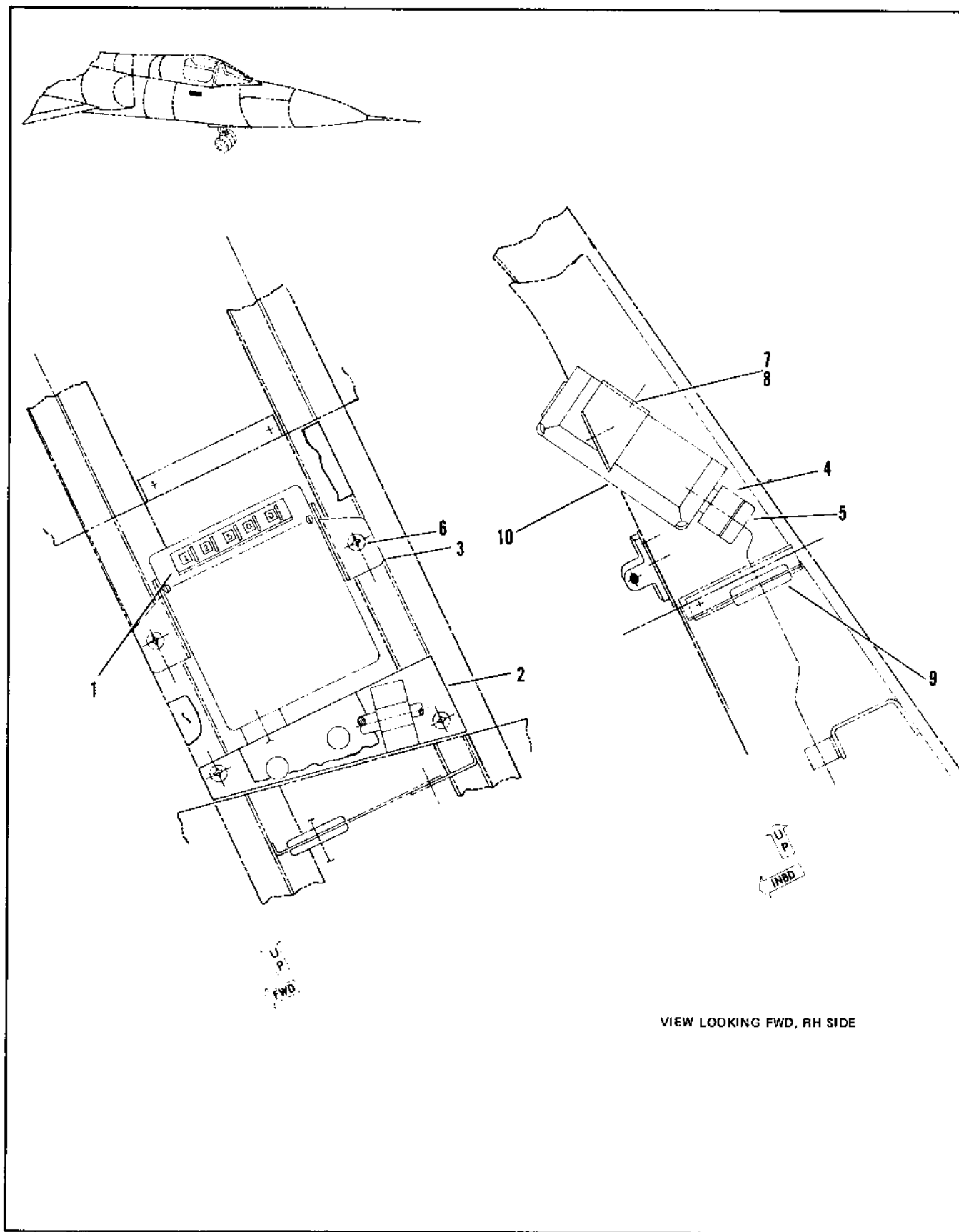

Figure 2.18-37. Altitude Warning System Installation

FIGURE AND INDEX NUMBER	PART NUMBER	DESCRIPTION	UNITS PER ASSY.	USABLE ON CODE	
				FROM	TO
2.18-17	7747300	ALTITUDE WARNING SYSTEM SWITCH INSTALLATION	1	V, R	
- 1	4074-1117	SWITCH, ALTITUDE WARNING (07120)	1	V, R	
- 2	7747205-10	ATTACHING PARTS	1	V, R	
- 3	7747202-1	• PLATE ASSEMBLY	1	V, R	
- 4	483723722P1006N	• BACKL	1	V, R	
- 5	MS372371511P	• RECEPTACLE CONNECTOR	1	V, R	
- 6	AN524-1032R6	• NUT	4	V, R	
- 7	MS35206-244	• SCREW	2	V, R	
- 8	AN561-H	• SCREW	2	V, R	
- 9	MS35944-20	• WASHER	1	V, R	
- 10	7640116-10	• Pommel	1	V, R	
		• BOX ASSEMBLY	1	V, R	
		V AIRPLANES 57-435 THRU 57-2464, 57-2467, 57-2468 AND ON			
		R AIRPLANES 57-246 THRU 57-2469, 57-2464 THRU 57-2465			

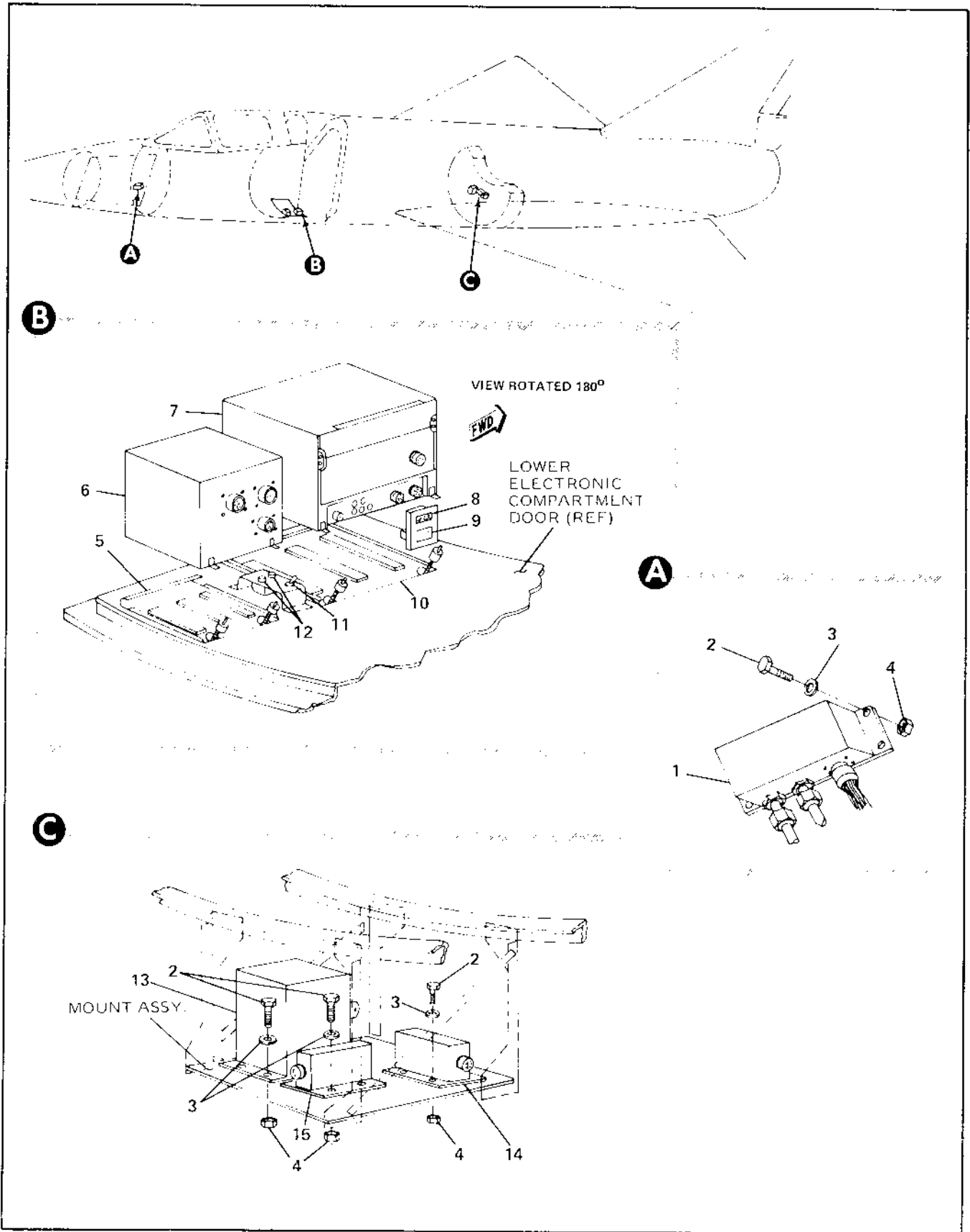

Figure 2.18-38. Flight Loads Recorder System

FIGURE AND INDEX NUMBER	PART NUMBER	DESCRIPTION	UNITS PER ASSY.	USABLE ON CODE	
				FROM	TO
		1 2 3 4 5 6			
2.18-38	MXU-553 SYS	FLIGHT LOADS RECORDER INSTALLATION	1		A
- 1	7902975	• TRANSDUCER, ALTITUDE-AIRSPED	1		A
- 2	MS35217-265	• SCREW	15		A
- 3	AN967-1PL	• WASHER	15		A
- 4	MS21744N3	• NUT	15		A
- 5	7346426-10	• TRAY ASSY, MULTIPLEXER	1		A
- 6	7951789	• CONVERTER-MULTIPLEXER	1		A
- 7	7952128-001	• RECORDER, MXU-553/A	1		A
- 8	MS25376-02	• RELAY, TANKS EMPTY, K2	1		A
- 9	MS25372-01	• RELAY, ON-OFF, K1	1		A
- 10	7345920-10	• TRAY ASSY, RECORDER	1		A
- 11	MS35159-23	• SWITCH, TEST	1		A
- 12	F70-A-821	• FUSE, DC F1, AC F2	2		A
- 13	7902976	• RATE-GYRO 93322	1		A
- 14	7902477-3	• ACCELEROMETER, LATERAL 93322	1		A
- 15	7902977-2	• ACCELEROMETER, NORMAL 93322	1		A
		A AIRPLANES 52-04530, 57-02450 54-0074, 57-0074 WHEN MODIFIED BY T.O. 1F-106-1114.			

OXYGEN SUBSECTION

TABLE OF CONTENTS

<i>Fig. No.</i>	<i>Title</i>	<i>Page</i>	<i>Fig. No.</i>	<i>Title</i>	<i>Page</i>
2.19-1	Liquid Oxygen System	2.19-2	2.19-4	Liquid Oxygen Tubing Installation	2.19-10
2.19-2	Liquid Oxygen Equipment Installation	2.19-4	2.19-5	Liquid Oxygen Tubing Installation	2.19-14
2.19-3	Liquid Oxygen Tubing Installation	2.19-6			

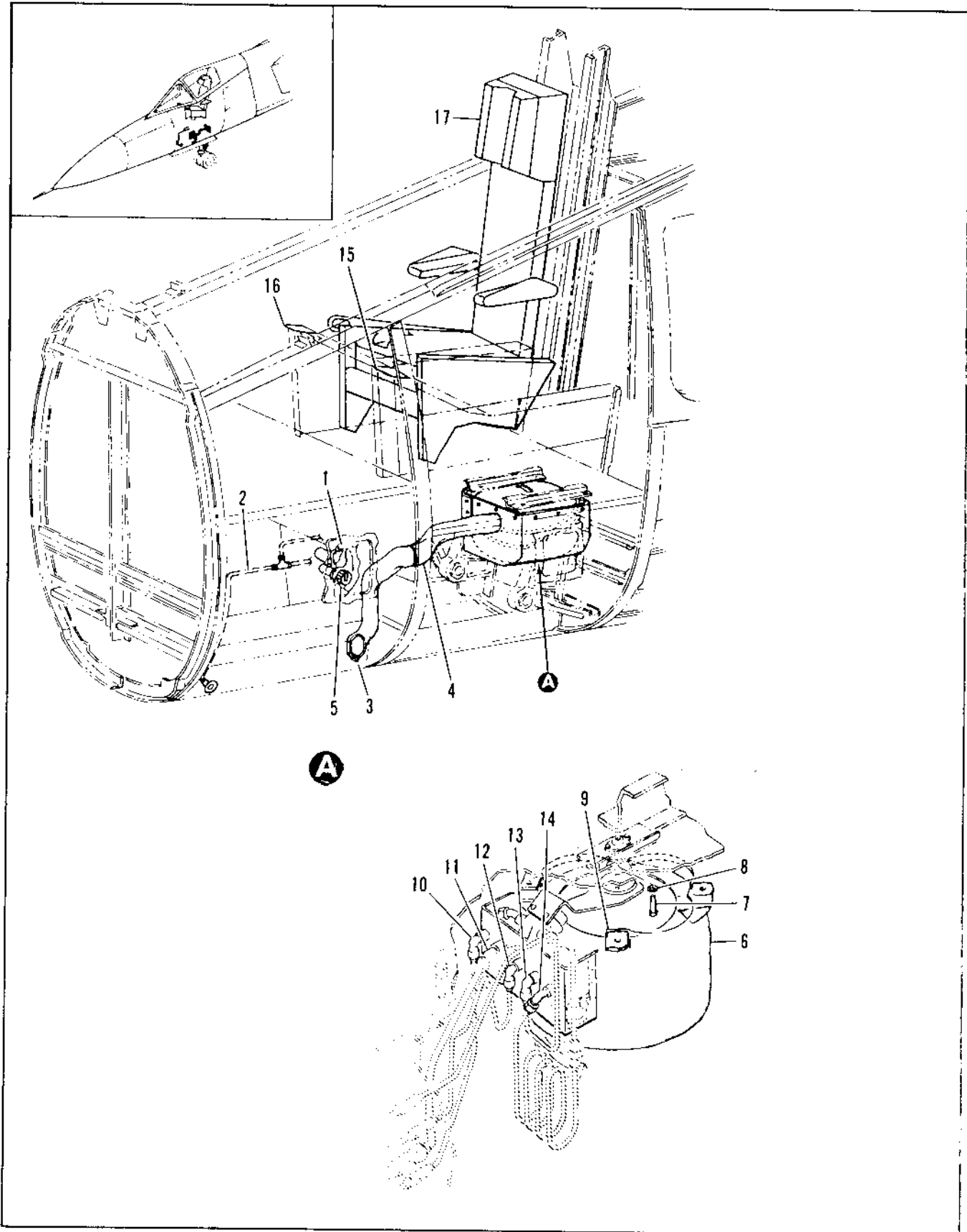

Figure 2.19-1. Liquid Oxygen System

FIGURE AND INDEX NUMBER	PART NUMBER	DESCRIPTION	UNITS PER ASSY.	USABLE ON CODE	
				FROM	TO
		1 2 3 4 5 6			
2.19-1		LIQUID OXYGEN SYSTEM			
- 1		• COVER ASSY, LIQUID OXYGEN ACCESS SEE FIG. 2.19-1 INDEX 1)	RF		
- 2		• TUBING INSTL, LIQUID OXYGEN SEE FIG. 2.19-3	RF		
- 3	8-92497 8-92496-1	• SHROUD INSTL, LIQUID OXYGEN TUBING • SHROUD ASSY, LIQUID OXYGEN TUBING EPT STITCHED	1 1	35	
- 4	8-92496-1	• SHROUD ASSY, LIQUID OXYGEN TUBING AFT STITCHED REPLACED BY NOT INTCHG WITH 8-92496-5	1	35	89
	8-92496-5	• SHROUD ASSY, LIQUID OXYGEN TUBING AFT STITCHED REPLACES NOT INTCHG WITH 8-92496-1	1	80	
- 5		• EQUIPMENT INSTL, LIQUID OXYGEN SEE FIG. 2.19-2	RF		
	8-92490-405	• CONVERTER INSTL, LIQUID OXYGEN MODIFIED BY 8603-401 FOR MHA SEE FIG. 2.1-1			
- 6	29031-1-12	• CONVERTER ASSY, LIQUID TO GASEOUS OXYGEN (25001) 8-92490-3 T.O. 15X2-6-4-4 ATTACHING PARTS	1		
- 7	AN9-104	• BOLT	4		
- 8	AN96-0415	• WASHER	4		
- 9	8-99466	• HANDLE	1		
- 10	MS20622-40	• ELBOW	1		
- 11	MS20622-40	• ELBOW	1		
- 12	MS20622-F-40	• ELBOW	1		
- 13	MS20622-17	• ELBOW	1		
- 14	MS20623-50	• ELBOW	1		
- 15		• INDICATOR, LIQUID OXYGEN QUANTITY SEE FIG. 2.1-3	RF		
- 16		• REGULATOR ASSY, DILUTE DEMAND OXYGEN LM CONSOLE SEE FIG. 2.16-8	RF		
- 17		• STAT ASSY, FUNCTION	RF		

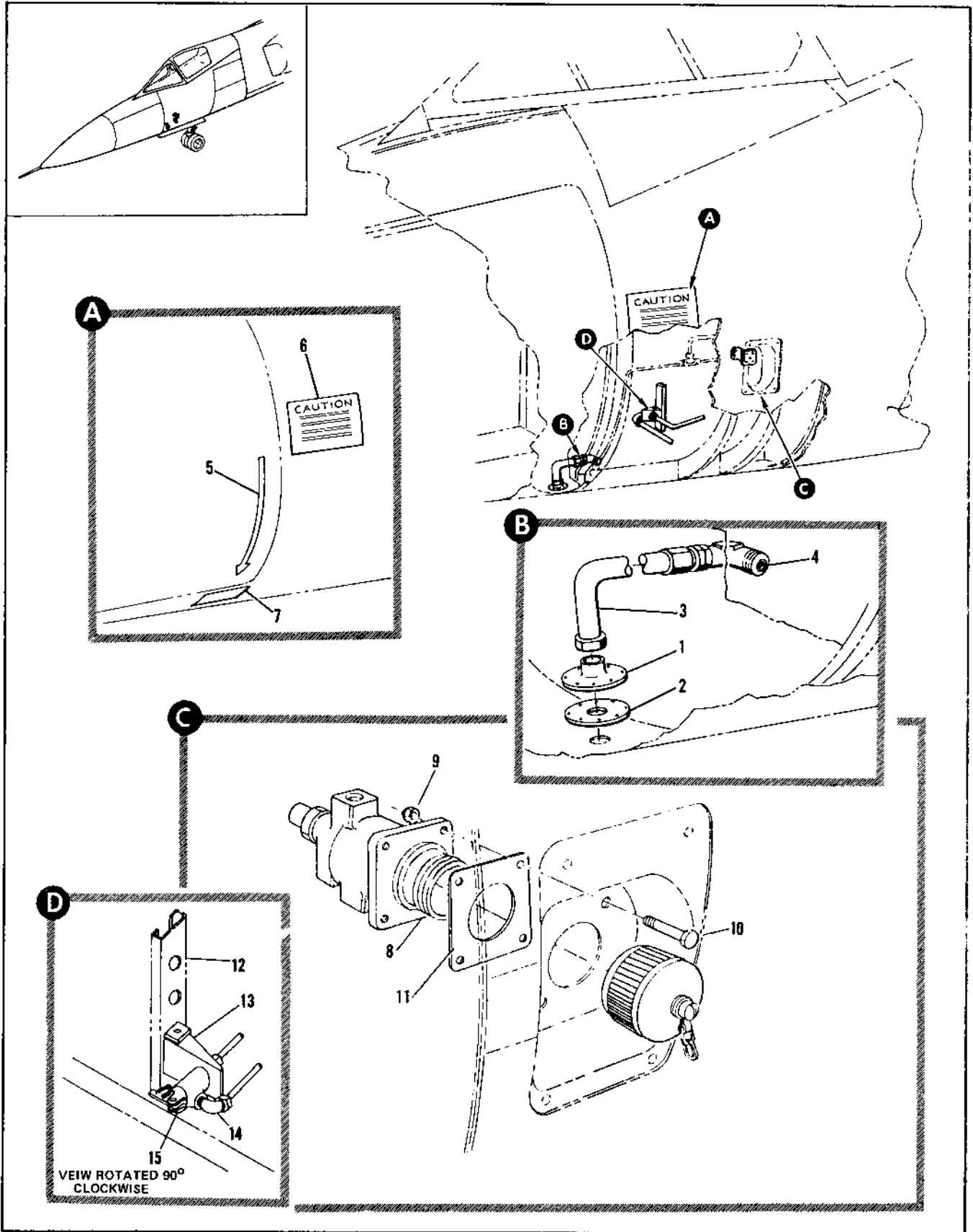

Figure 2.19-2. Liquid Oxygen Equipment Installation

FIGURE AND INDEX NUMBER	PART NUMBER	DESCRIPTION	UNITS PER ASSY.	USABLE ON CODE	
				FROM	TO
2.19-2	8-92452-804	EQUIPMENT INSTALLATION, LIQUID OXYGEN FOR WHA SEE FIG. 2.3-6	1		35
- 1	8-92492	• FITTING, LIQUID OXYGEN OVERBOARD VENT	1		35
- 2	8-92455-7	• SEAL, PORT LIQUID OXYGEN OVERBOARD VENT	1		35
- 3	8-92493	• TUBE ASSY, LIQUID OXYGEN OVERBOARD VENT	1		35
- 4	AN937-20	• FLOW	1		35
	AN924-10	• NUT	1		35
	AN967PD1216	• WASHER	1		35
- 5	3-95567-9	• DECAL, MARKING AND STENCILING	1		35
- 6	3-95567-11	• DECAL, MARKING AND STENCILING	1		35
- 7	3-95567-17	• DECAL, MARKING AND STENCILING	1		35
- 8	8050	• VALVE ASSY, LIQUID OXYGEN PRESSURE BUILDUP AND VENT (81547) SPEC 8-09278-1 T.O. 15XR-8-6-3	1		35
	439000-3	• VALVE ASSY, LIQUID OXYGEN PRESSURE BUILD UP AND VENT, REPLACES 8050 ATTACHING PARTS	1		35
- 9	NAS674A3	• NUT	4		35
- 10	AN3-5A	• BOLT	4		35
		-----X-----			
- 11	8-92491	• SEAL, VALVE FILLER BUILDUP AND VENT	1		35
- 12	8-35152	• SUPPORT	PF		
- 13	64C33605-1	• BRACKET	1		
- 14	MS20922-6-20	• ELBOW	1		
- 15	20C-1071-11	• VALVE, DRAIN, MIL-V-25962	1		

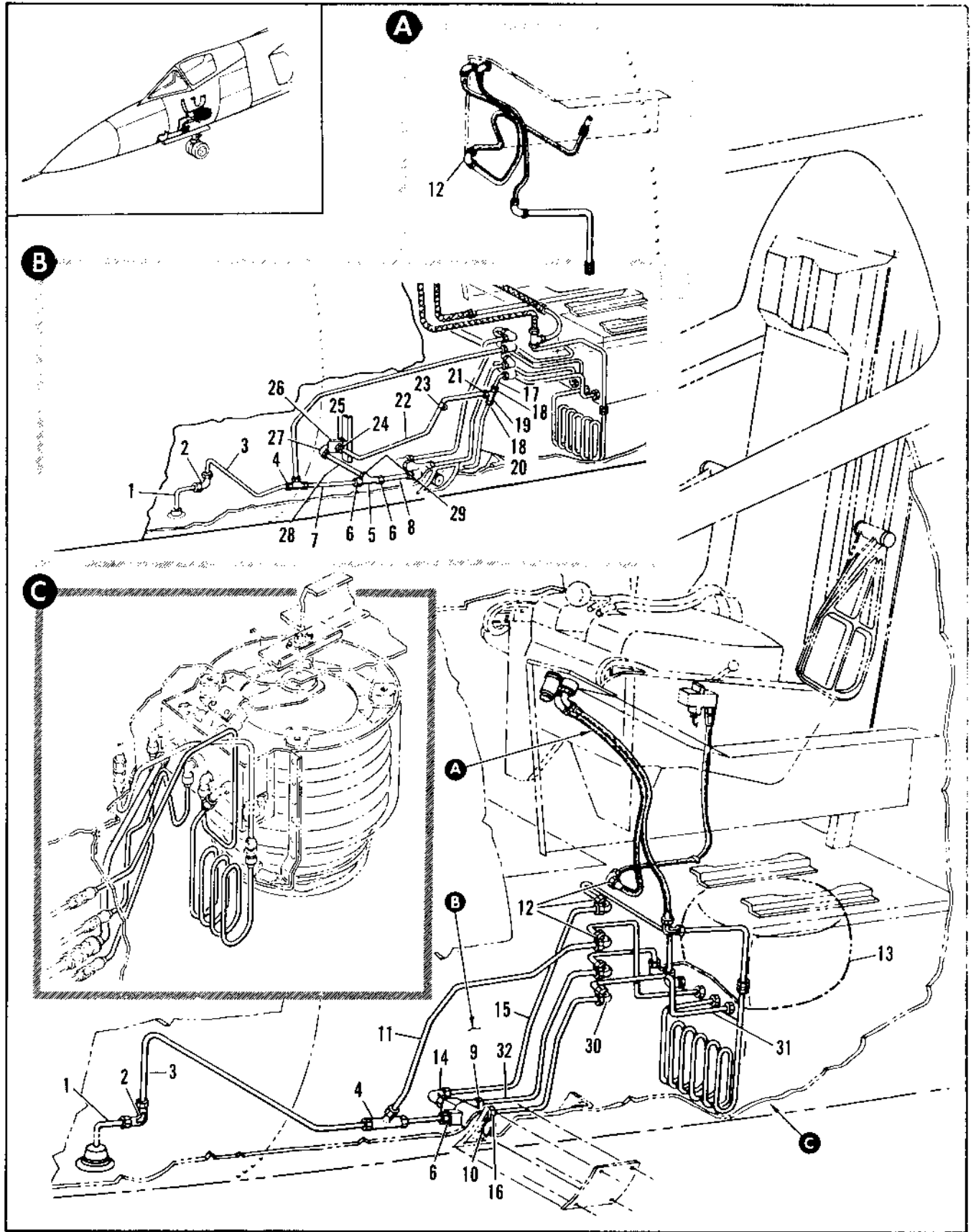

Figure 2.19-3. Liquid Oxygen Tubing Installation (Sheet 1 of 2)

FIGURE AND INDEX NUMBER	PART NUMBER	DESCRIPTION	UNITS PER ASSY.	USABLE ON CODE	
				FROM	TO
2.19-3	W-92450	TUBING INSTLL. LIQUID OXYGEN MODIFIED BY W-93471 FOR 200 SEE FIG. 2.19-1	RF		
- 1		• TUBE ASSY. LIQUID OXYGEN OVERBOARD VENT SEE FIG. 2.19-2 INDEX 3	RF		
- 2	AN937-20	• ELBOW	1	35	60
- 3	AN924-40	• NUT	1	35	60
- 4	AN941012-1-	• WASHER	1	35	60
- 5	W-92471	• TUBE ASSEMBLY	1	35	60
- 6	AN934-40	• TEE, ALUMINUM FROM AN934-40	1	35	60
- 7	AN310-17	• TEE	1		
- 8	MS29778-6	• UNION	2		
- 9	65A33075-2	• PACKING	2		
- 10	65A33075-1	• TUBE ASSY. VMC VENT	1		
- 11	AN416-20	• TUBE ASSY. VMC VENT	1		
- 12	W-92490-25	• NIPPLE	2	35	60
- 13	AN837-30	• VALVE ASSY. LIQUID OXYGEN PRESSURE BUILDUP AND VENT SEE FIG. 2.19-3 INDEX 4	RF		
- 14	AN924-50	• TUBE ASSEMBLY	1	35	60
- 15	AN924-50	• ELBOW	3	35	60
- 16	AN924-50	• NUT	3	35	60
- 17	AN924-50	• WASHER	3	35	60
- 18	AN924-50	• CONVERTER ASSY. LIQUID TO GASEOUS OXYGEN SEE FIG. 2.19-1 INDEX 5	RF		
- 19	AN826-30	• ELBOW	1	35	60
- 20	W-92490-17	• TUBE ASSEMBLY	1	35	60
- 21	AN821-10	• NIPPLE	1	35	60
- 22	65A33075-2	• TUBE ASSY. FILLER	1		
- 23	AN821-10	• UNION	2		
- 24	MS29778-6	• PACKING	2		
- 25	AN934-40	• TEE	1		
- 26	65A33075-1	• TUBE ASSY. FILLER	1		
- 27	AN919-70	• REDUCER	1		
- 28	MS29778-6	• PACKING	1		
- 29	65A33075-2	• TUBE ASSY. DRAIN	1		
- 30	MS21-1100A	• CLAMP	1		
	MS35127-26X	ATTACHING PARTS			
	MS491003-44	• SCREW	1		
	MS21-42L3	• SPACER	1		
		• NUT	1		
		-----X-----			
- 31	MS2440305	• NUT	1		
- 32	W-92490-11	• PACKET	1		
- 33	210-111-11	• VALVE, DRAIN, SEE FIG. 2.19-2, INDEX 15	RF		
- 34	MS29778-6	• ELBOW	1		
- 35	65A33075-1	• TUBE ASSY. DRAIN	1		
- 36	AN919-120	• REDUCER	1		
- 37	MS29778-6	• PACKING	1		
- 38	AN831-40	• ELBOW	1	35	60
- 39	AN924-50	• NUT	1	35	60
- 40	AN924-50	• WASHER	1	35	60
- 41	W-92490-23	• TUBE ASSY	1	35	60
- 42	W-92490-17	• TUBE ASSY	1	35	60

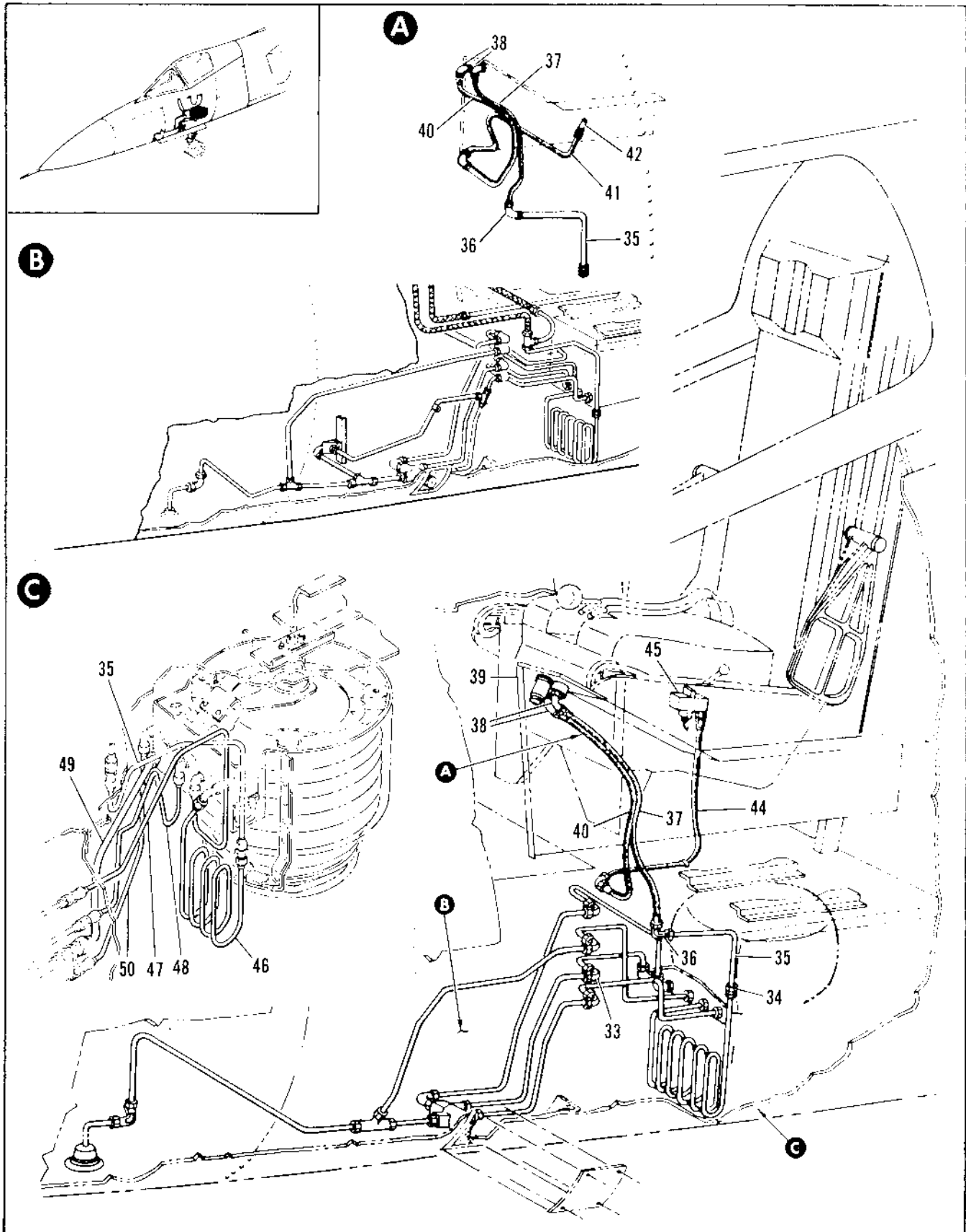

Figure 2.19-3. Liquid Oxygen Tubing Installation (Sheet 2 of 2)

FIGURE AND INDEX NUMBER	PART NUMBER	DESCRIPTION	UNITS PER ASSY.	USABLE ON CODE	
				FROM	TO
				1	2
2.19-3- 33	AN833-8D	• ELBOW	1	35	60
	AN924-8D	• NUT	1	35	60
	AN9601216	• WASHER	1	35	60
- 34	AN915-5D	• UNION	1	35	60
- 35	R-92490-31	• TUBE ASSEMBLY	1	35	60
- 36	AN833-5D	• ELBOW	1	35	60
	AN924-5D	• NUT	2	35	60
	AN9600816	• WASHER	2	35	60
- 37	AN6339-5-24	• HOSE ASSEMBLY	1	35	60
- 38	AN923-5D	• ELBOW	2	35	60
- 39		• PANEL ASSY, LIQUID OXYGEN CONTROL	RF		
- 40	AN6339-5-32	• HOSE ASSEMBLY	1	35	60
- 41	AN6337-5-32	• HOSE ASSY	1		
- 42		• DISCONNECT, G AND VENT SUIT	RF		
- 43	AN742-2C	• CLAMP	1		
		ATTACHING PARTS			
	MS20364-1032	• NUT	1		
	AN961-102	• WASHER	1		
	NAS221-10	• SCREW	1		
		-----X-----			
- 44	MS24548-5-40	• HOSE ASSEMBLY	1	35	
- 45		• DISCONNECT, SURVIVAL KIT CONTAINER TO AIRPLANE SEE FIG. 2.4-11 INDEX 2	RF		
			RF		
- 46	66A38397-1	• TUBE ASSY, SUPPLY	1		
- 47	66A38396-1	• TUBE ASSY, BUILDUP	1		
- 48	66A38399-1	• TUBE ASSY, PRESSURE RELIEF	1		
- 49	66A38398-1	• TUBE ASSY, VENT	1		
- 50	66A38395-1	• TUBE ASSY, FILLER	1		

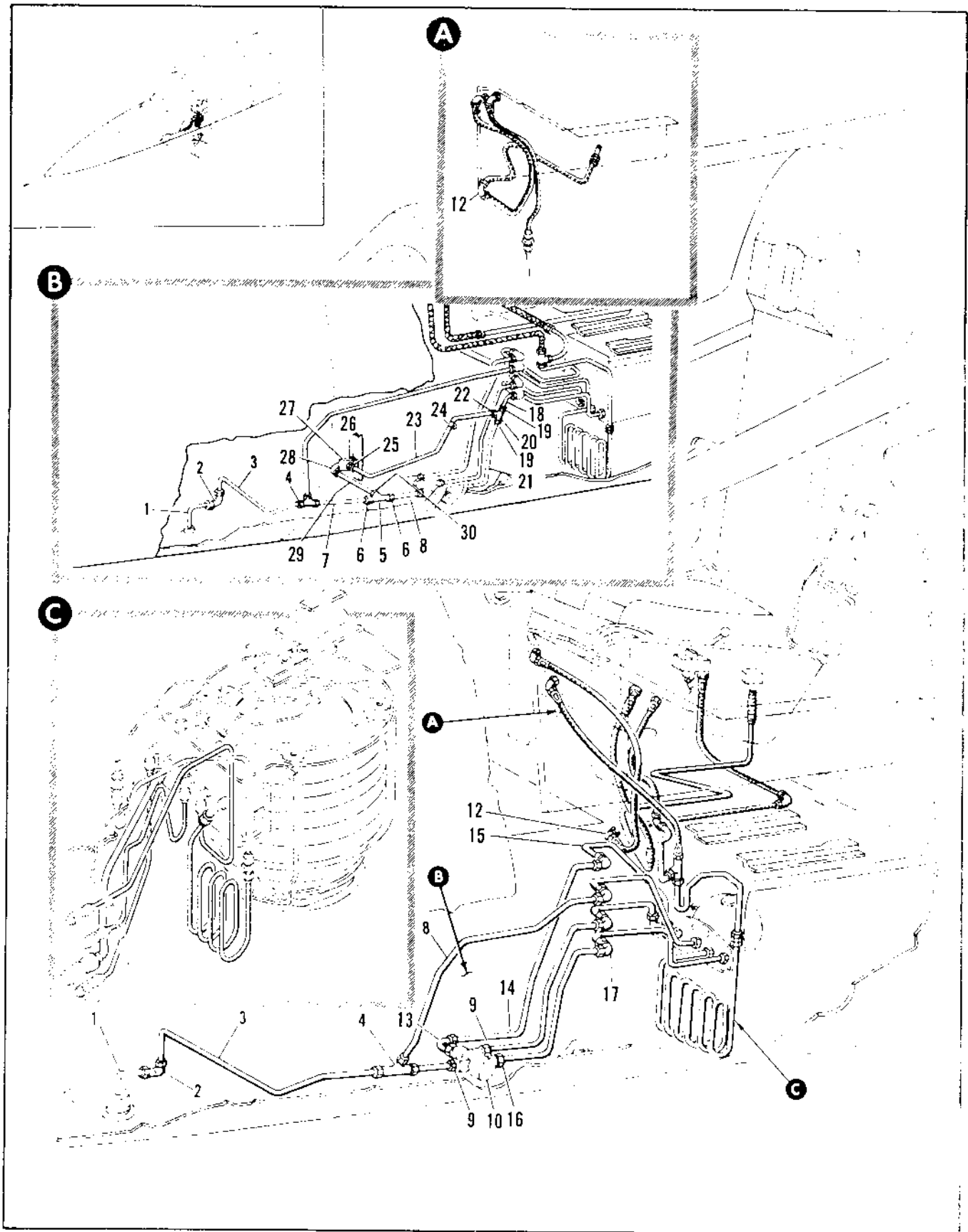

Figure 2.19-4. Liquid Oxygen Tubing Installation (Sheet 1 of 2)

FIGURE AND INDEX NUMBER	PART NUMBER	DESCRIPTION	UNITS PER ASSY.	USABLE ON CODE	
				FROM	TO
2.19-0	R-92490-1	TUBING INSTL. LIQUID OXYGEN MODIFIED BY 6403-401 FOR QHA SEE FIG. 2.3-4	9F		
- 1		• TUBE ASSY. LIQUID OXYGEN OVERBOARD VENT SEE FIG. 2.19-3 INDEX 3	9F		
- 2	AN937-8D	• FLOW	1	61	89
	AN924-8D	• NUT	1	61	89
	AN95701216	• WASHER	1	61	89
- 3	B-92490-70	• TUBE ASSEMBLY	1	61	89
- 4	R-92470	• TFE, ALTERED FROM AN934-8D	1	61	89
- 5	AN93308	• TFC	1		
- 6	AN814-8D	• UNION	2		
	MS29774-8	• PACKING	2		
- 7	65A33608-2	• TUBE ASSY. OVRD VENT	1		
- 8	65A33408-1	• TUBE ASSY. OVRD VENT	1		
- 9	AN815-8D	• NIPPLE	2	61	89
- 10		• VALVE ASSY. LIQUID OXYGEN PRESSURE BUILDUP AND VENT SEE FIG. 2.19-2 INDEX 8	9F		
- 11	R-92490-25	• TUBE ASSEMBLY	1	61	89
- 12	AN937-8D	• FLOW	4	61	89
	AN924-8D	• NUT	4	61	89
	AN9400814	• WASHER	4	61	89
- 13	AN822-8D	• FLOW	1	61	89
- 14	R-92490-17	• TUBE ASSEMBLY	1	61	89
- 15	R-92490-19	• TUBE ASSEMBLY	1	61	89
- 16	AN814-8-8D	• NIPPLE	1	61	89
- 17	AN933-8D	• FLOW	1		
	AN904-8D	• NUT	1		
	AN96 01216	• WASHER	1		
- 18	65A33708-2	• TUBE ASSY. FILLER	1		
- 19	AN815-8D	• UNION	2		
	MS29774-6	• PACKING	2		
- 20	AN933-06	• TFC	1		
- 21	65A33408-1	• TUBE ASSY. FILLER	1		
- 22	AN910-70	• REDUCER	1		
	MS29778-6	• PACKING	1		
- 23	65A33-17-2	• TUBE ASSY. TRIN	1		
- 24	MS21215004	• CLAMP	1		
		ATTACHING PARTS			
	MS35127-24	• NUT	1		
	NAG470NT-44	• SPACER	1		
	MS21245L1	• NUT	1		
- 25	MS2441004	• NUT	1		
- 26	64035605-1	• BRACKET	1		
- 27	2304111-11	• VALVE, DRAIN, SEE FIG. 2.19-2, INDEX 14	9F		
- 28	MS2122-8D	• FLOW	1		
- 29	65A33408-1	• TUBE ASSY. DRAIN	1		
- 30	AN910-100	• REDUCER	1		
	MS29778-8	• PACKING	1		

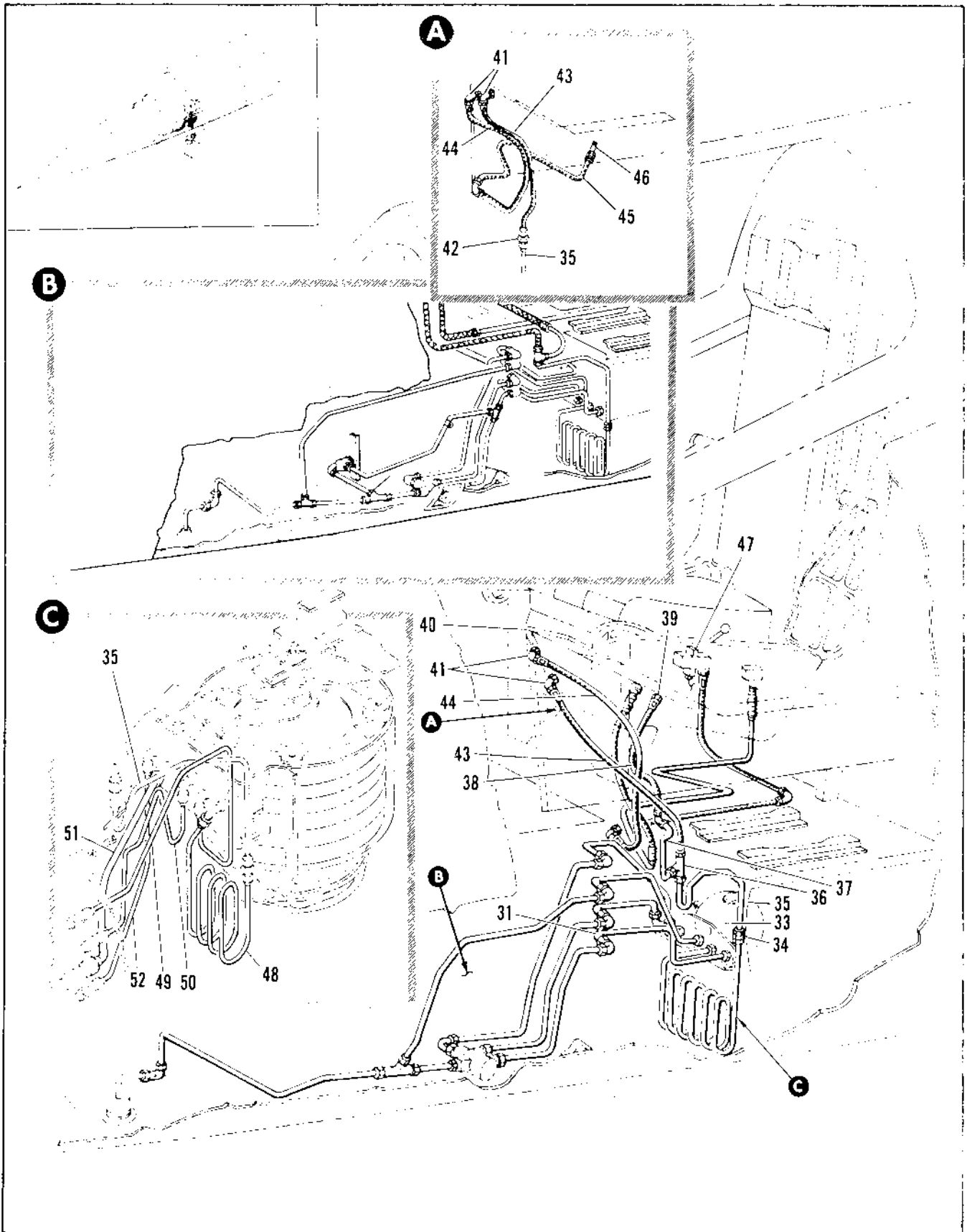

Figure 2.19-4. Liquid Oxygen Tubing Installation (Sheet 2 of 2)

FIGURE AND INDEX NUMBER	PART NUMBER	DESCRIPTION	UNITS PER ASSY.	USABLE ON CODE	
				FROM	TO
2.19-4-31	1-92490-13	• TUBE ASSEMBLY	1	61	88
	AN833-8U	• ELBOW	1	61	88
- 32	AN924-4U	• NUT	1	61	88
- 33	AN924-4U	• WASHER	1	61	88
- 34	AN810-50	• UNION	2	61	89
- 35	1-92491-87	• TUBE ASSEMBLY	1	61	89
- 36	AN834U5	• TUBE	1	61	89
- 37	AN924-50	• NUT	1	61	89
- 38	AN924-50	• WASHER	1	61	89
- 39	1-92493-85	• TUBE ASSEMBLY	1	61	89
- 40	AN635-45-14	• HOSE ASSEMBLY	1	61	89
- 41	AN610-50	• NIPPLE	1	61	89
- 42	AN627-80	• PANEL ASSY. LIQUID OXYGEN CONTROL SEE FIG. 2.14-8 INDEX 3	RF		
- 43	AN830-80	• ELBOW	2	61	89
- 44	AN924-50	• UNION	1		
- 45	AN924-50	• NUT	1		
- 46	AN924-81U	• WASHER	1		
- 47	AN635-45-24	• HOSE ASSEMBLY	1	61	89
- 48	AN635-45-12	• HOSE ASSEMBLY	1	61	89
- 49	AN635-45-25	• HOSE ASSEMBLY	1		
- 50		• DISCONNECT, G AND VENT SUIT SEE FIG. 2.4-12 INDEX 1	RF		
- 51		• DISCONNECT, SURVIVAL KIT CONTAINER TO AIRPLANE SEE FIG. 2.4-12 INDEX 2	RF		
- 52	66A35397-1	• TUBE ASSY. SUPPLY	1		
- 53	66A35398-1	• TUBE ASSY. BUILDUP	1		
- 54	66A35399-1	• TUBE ASSY. PRESSURE RELIEF	1		
- 55	66A35398-1	• TUBE ASSY. VENT	1		
- 56	66A35395-1	• TUBE ASSY. FILLER	1		

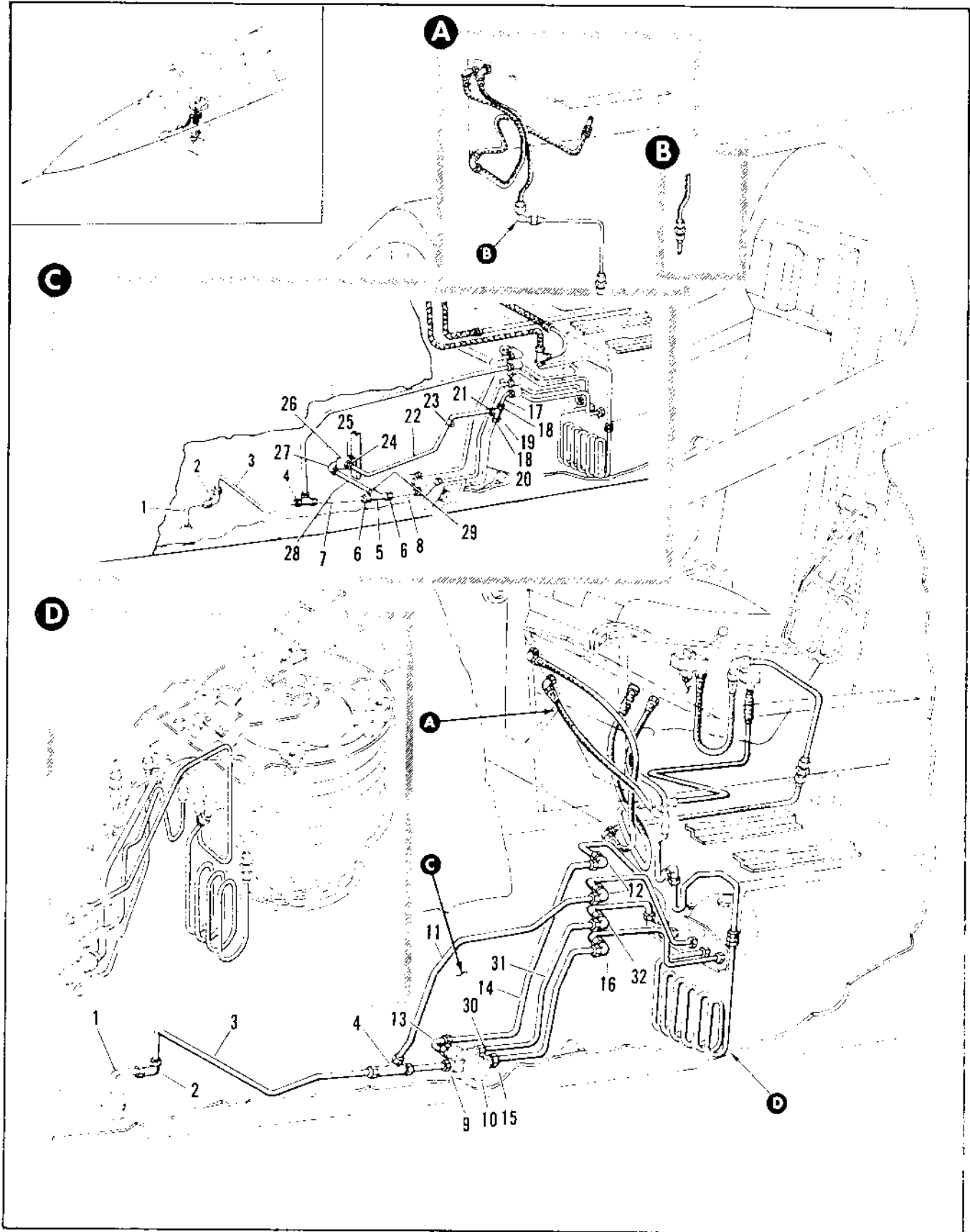

Figure 2.19-5. Liquid Oxygen Tubing Installation (Sheet 1 of 2)

FIGURE AND INDEX NUMBER	PART NUMBER	DESCRIPTION	UNITS PER ASSY.	USABLE ON CODE	
				FROM	TO
2.19-5	8-92490-3	TUBING INSTL. LIQUID OXYGEN MODIFIED BY 66J38421 FOR NHA SEE FIG. 2.3-4	RF	90	
- 1		• TUBE ASSY. LIQUID OXYGEN OVERBOARD VENT SEE FIG. 2.19-2 INDEX 3	RF		
- 2	AN837-8D	• ELBOW	1	90	
	AN924-8D	• NUT	1	90	
	AN96001216	• WASHER	1	90	
- 3	8-92490-3	• TUBE ASSEMBLY	1	90	
- 4	8-92470	• TEE, ALTERED FROM AN824-9D	1	90	
- 5	AN938D8	• TEE	1		
- 6	AN915-8D	• UNION	2		
	MS28778-2	• PACKING	2		
- 7	65A33805-2	• TUBE ASSY. OVRD VENT	1		
- 8	65A33805-1	• TUBE ASSY. OVRD VENT	1		
- 9	AN816-8D	• NIPPLE	1	90	
- 10		• VALVE ASSY. LIQUID OXYGEN PRESSURE BUILDUP AND VENT SEE FIG. 2.19-2 INDEX 3	RF		
- 11	8-92470-25	• TUBE ASSEMBLY	1	90	
- 12	AN837-8D	• ELBOW	2	90	
	AN924-8D	• NUT	2	90	
	AN96001216	• WASHER	2	90	
- 13	AN822-8D	• ELBOW	1	90	
- 14	8-92490-17	• TUBE ASSEMBLY	1	90	
- 15	AN816-8D	• NIPPLE	1	90	
- 16	AN833-8D	• ELBOW	1		
	AN924-8D	• NUT	1		
	AN96001216	• WASHER	1		
- 17	65A33806-2	• TUBE ASSY. FILLER	2		
- 18	AN815-8D	• UNION	2		
	MS28778-6	• PACKING	2		
- 19	AN938D6	• TEE	1		
- 20	65A33806-1	• TUBE ASSY. FILLER	1		
- 21	AN919-7D	• REDUCER	1		
	MS28778-2	• PACKING	1		
- 22	65A33807-2	• TUBE ASSY. DRAIN	1		
- 23	MS21919055	• CLAMP	1		
		ATTACHING PARTS			
	MS35027-26-	• NUT	1		
	NAS43003-44	• SPACER	1		
	MS21042L3	• NUT	1		
		-----X-----			
- 24	MS2443305	• NUT	1		
- 25	64C33605-1	• BRACKET	1		
- 26	20C-1301-111	• VALVE, DRAIN. SEE FIG. 2.19-2. INDEX 15	RF		
- 27	MS28922-6D	• ELBOW	1		
- 28	65A33807-1	• TUBE ASSY. DRAIN	1		
- 29	AN919-12D	• REDUCER	1		
	MS28778-2	• PACKING	1		
- 30	AN816-8D	• NIPPLE	1	90	
- 31	8-92490-13	• TUBE ASSEMBLY	1	90	
- 32	AN833-8D	• ELBOW	1	90	
	AN924-8D	• NUT	1	90	
	AN96001216	• WASHER	1	90	

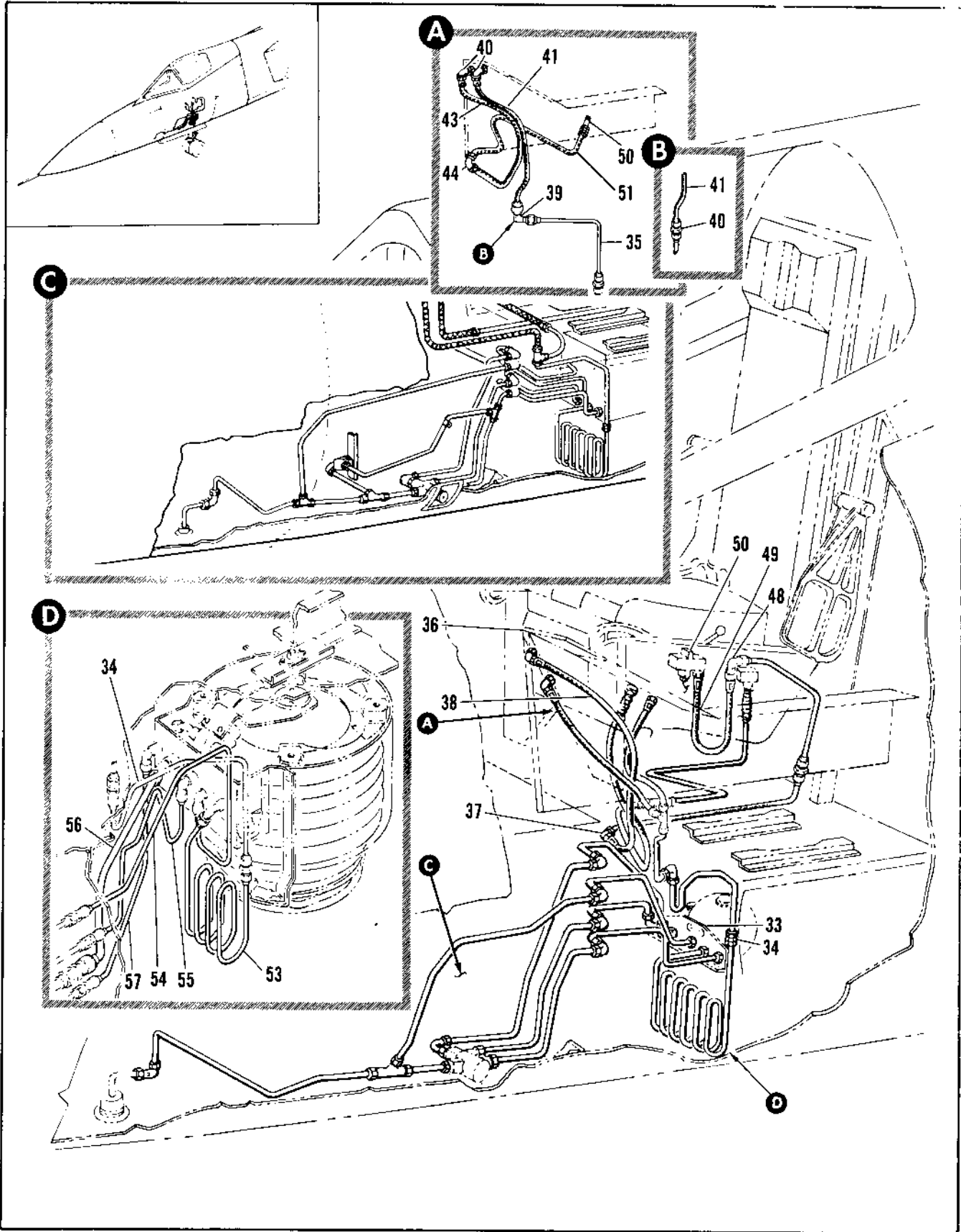

Figure 2.19-5. Liquid Oxygen Tubing Installation (Sheet 2 of 2)

FIGURE AND INDEX NUMBER	PART NUMBER	DESCRIPTION 1 2 3 4 5 6	UNITS PER ASSY.	USABLE ON CODE	
				FROM	TO
2.19-5- 33		• CONVERTER ASSY, LIQUID TO GASEOUS OXYGEN SEE FIG. 2.4-1 INDEX 10	RF		
- 34	AN813-50	• UNION	1	90	
- 35	4-92490-31	• TUBE ASSEMBLY	1		
- 36		• PANEL ASSY, LIQUID OXYGEN CONTROL	RF		
- 37	AN823-50	• ELBOW	2	90	129
- 38	AN6139-5-32	• HOSE ASSEMBLY	1	90	129
- 39	AN813-50	• ELBOW	1	130	149
- 40	AN832-50	• UNION	1	189	
	AN924-50	• NUT	2	130	
	AN9610816	• WASHER	2	130	
- 41	AN6039-5-24	• HOSE ASSEMBLY	1	130	
- 42	AN823-50	• ELBOW	2	130	
- 43	AN6039-5-32	• HOSE ASSEMBLY	1	130	
- 44	AN837-50	• ELBOW	1	90	240
	AN833-50	• ELBOW	1	241	
	AN924-50	• NUT	1	90	
	AN9610816	• WASHER	1	90	
- 45	4-92490-37	• TUBE ASSEMBLY	1	90	169
- 46	AN813-50	• UNION	1	90	188
- 47	3-92490-41	• TUBE ASSEMBLY	1	90	188
- 48	AN833-50	• ELBOW	1	90	188
	AN924-50	• NUT	1	90	188
	AN9610816	• WASHER	1	90	188
- 49	AN6039-5-24	• HOSE ASSEMBLY	1	90	188
- 50		• DISCONNECT, SURVIVAL KIT CONTAINER TO AIRPLANE SEE FIG. 2.4-11 INDEX 2	RF		
- 51	AN6039-5-32	• HOSE ASSEMBLY	1	189	
- 52		• DISCONNECT, G AND VENT SUIT	RF		
- 53	66A34337-1	• TUBE ASSY, SUPPLY	1		
- 54	66A34396-1	• TUBE ASSY, BUILDUP	1		
- 55	66A34399-1	• TUBE ASSY, PRESSURE RELIEF	1		
- 56	66A34398-1	• TUBE ASSY, VENT	1		
- 57	66A34395-1	• TUBE ASSY, FILLER	1		

ARMAMENT SUBSECTION**TABLE OF CONTENTS**

<i>Fig. No.</i>	<i>Title</i>	<i>Page</i>	<i>Fig. No.</i>	<i>Title</i>	<i>Page</i>
2.20-1	Armament	2.20-2	2.20-24	Fwd Displacement Gear Lower Drag Arm Assembly	2.20-82D
2.20-2	Armament Electrical	2.20-6	2.20-25	Fwd Displacement Gear Lower Drag Arm Assembly Alternate	2.20-84
2.20-3	Armament Manual Control	2.20-10	2.20-26	Fwd Displacement Gear Upper Drag Arm Assembly	2.20-86
2.20-4	Armament Launcher Fwd Upper Switch Installation	2.20-16	2.20-27	Fwd Displacement Gear Upper Drag Arm Assembly Alternate	2.20-90
2.20-5	Armament Bay Door Open and Closed Switch	2.20-18	2.20-28	Armament Upper and Lower Drag Arm Support Installation	2.20-92
2.20-6	Fwd Armament Bay Launcher Down Switch Installation	2.20-20	2.20-29	Fwd Displacement Gear Upper Drag Arm Assembly	2.20-96
2.20-7	Fwd Armament Harness Clamp Installation	2.20-22	2.20-30	Shock Cross Bridge Web Installation	2.20-98
2.20-8	Fwd Armament Harness Clamp Installation	2.20-24	2.20-31	Aft LH Armament Installation	2.20-100
2.20-9	Armament Bay Door Master Pneumatic Selector Valve Installation	2.20-28	2.20-32	Aft Displacement Gear Lower Drag Arm Assembly	2.20-112
2.20-10	Armament Bay Door Center Selector Valve	2.20-30	2.20-33	Aft Displacement Gear Up-Latch Assembly	2.20-114
2.20-11	Armament Bay Door Actuator Installation	2.20-32	2.20-34	MB-1 Armament Installation	2.20-118
2.20-12	Armament Bay Door Center Actuator Support Installation	2.20-40	2.20-35	MB-1 Ejector Support	2.20-122
2.20-13	Armament Bay Door Aft Actuator Support Installation	2.20-42	2.20-36	Fwd Umbilical Plug Retainer Assembly	2.20-124
2.20-14	Armament Bay Door Hinge Lower Longeron	2.20-44	2.20-37	M61A1 Gun Installation	2.20-126
2.20-15	Armament Bay Door Installation Sta 216 to 412	2.20-46	2.20-38	M61A1 Gun Air Induction Installation	2.20-128
2.20-16	Armament Bay Inbd Door Assembly	2.20-50	2.20-39	M61A1 Missile Bay Door Fairing Installation	2.20-130
2.20-17	Armament Bay Inbd Aft Door Assy ..	2.20-54	2.20-40	M61A1 Gun System Assembly	2.20-134
2.20-18	Armament Bay Inbd Fwd Door Assy .	2.20-58	2.20-41	M61A1 Gun Muzzle Fairing Assembly	2.20-136
2.20-19	Armament Bay Outbd Door Assembly	2.20-62	2.20-42	M61A1 Gun Fwd Access Fairing	2.20-138
2.20-20	Armament Bay Door Rod Assembly	2.20-70	2.20-43	Fairing Fwd Adapter Assembly	2.20-140
2.20-21	MB-1 Nose Deflector Installation ..	2.20-72	2.20-44	M61A1 Gun Enclosure Assembly	2.20-142
2.20-22	MB-1 Nose Deflector Installation ..	2.20-74	2.20-45	M61A1 Gun Enclosure Assembly	2.20-146
2.20-23	Fwd Armament Installation	2.20-76	2.20-46	Air Inlet Gun Enclosure Adapter Assembly	2.20-148
2.20-23A	Launcher Cable Connector Installation FWD Armament Bay (After Compliance with TCTO 1F-106-1159)	2.20-82	2.20-47	Armament Cross Bridge Fwd Support Assembly	2.20-150
2.20-23B	Launcher Cable Connector Installation AFT Armament Bay (After Compliance with TCTO 1F-106-1159)	2.20-82B	2.20-48	Infrared Seeker Installation	2.20-154
			2.20-49	Decal Installation, Armament System	2.20-162
			2.20-50	AIS Pod Installation	2.20-164

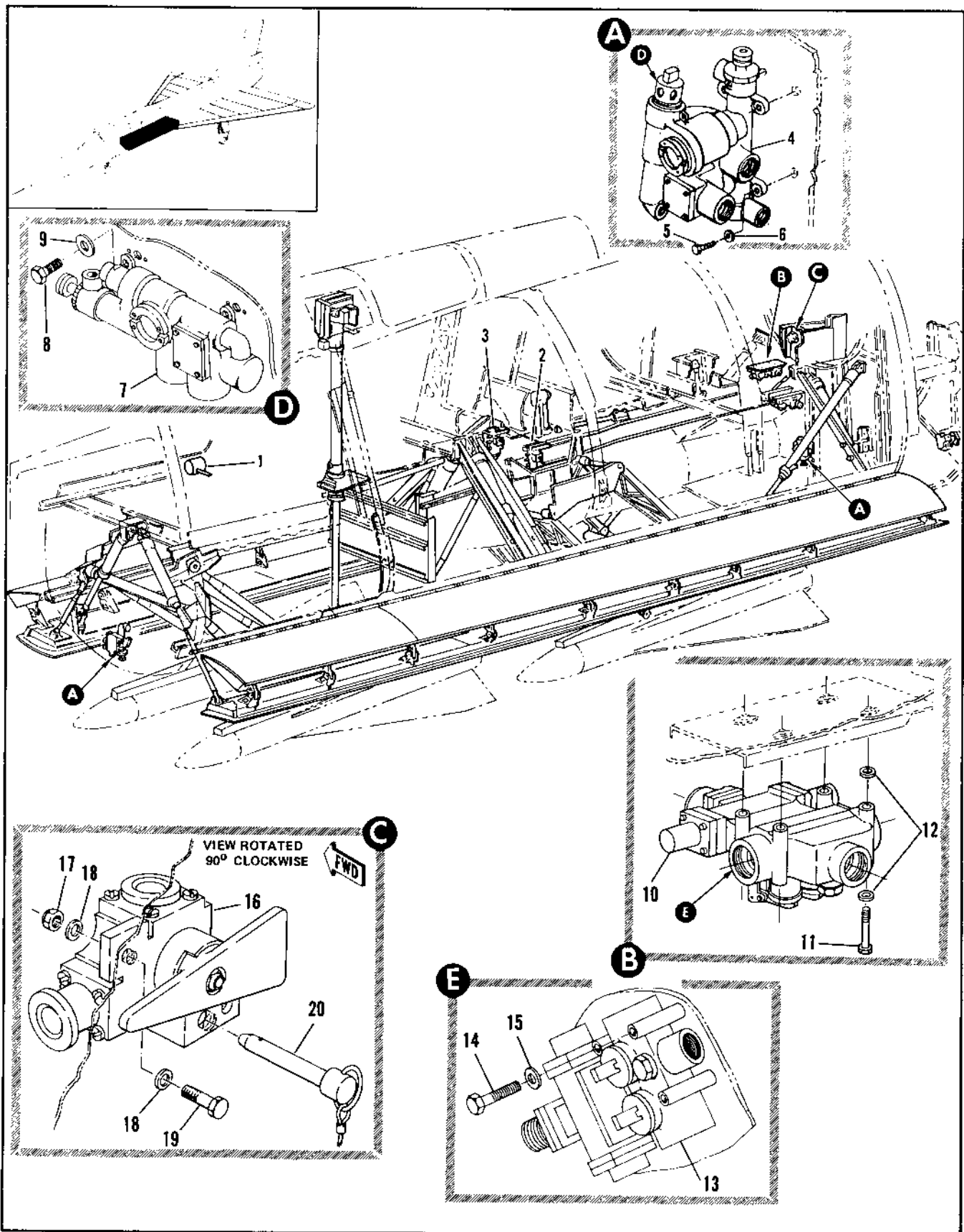

Figure 2.20-1. Armament (Sheet 1 of 2)

FIGURE AND INDEX NUMBER	PART NUMBER	DESCRIPTION	UNITS PER ASSY.	USABLE ON CODE	
				FROM	TO
		1 2 3 4 5 6			
2.20-1		ARMAMENT			
- 1		• ARMAMENT ELECTRICAL, SEE FIG. 2.20-2	RF		
- 2		• VALVE INSTL, ARMAMENT BY DOOR MASTER PNEUMATIC SELECTOR SEE FIG. 2.20-9	RF		
- 3		• VALVE INSTL, ARMAMENT BY DOOR CENTER PNEUMATIC SELECTOR SEE FIG. 2.20-10	RF		
	8-85022-1	• VALVE INSTL, ARMAMENT BY DOOR PNEUMATIC SELECTOR FOR NHA SEE FIG. 2.3-4	RF	35	
	8-85053-1	• VALVE INSTL, ARMAMENT BY DOOR AFT PNEUMATIC SELECTOR MOD BY 7144624-30 FOR NHA SEE FIG. 2.3-11	RF	35	
- 4	11510-1	• VALVE ASSY, SELECTOR FWD <40643> SPEC R-18549-1 T.O. 1F-106A-4	1	35	
	11510-5	• VALVE ASSY, SELECTOR AFT <40643> SPEC R-18549-5 T.O. 1F-106A-4	1	A	
- 5	AN3-5A	• BOLT (88044)	4	A	
- 6	AN960-10L	• WASHER (88044)	4	A	
		-----X-----			
- 7	11510-5	• VALVE ASSY, SELECTOR AFT <40643> SPEC R-18549-5 T.O. 1F-106A-4	1	B	
		ATTACHING PARTS			
- 8	AN3-5A	• BOLT (88044)	4	B	
- 9	AN960-10L	• WASHER (88044)	4	B	
		-----X-----			
	8-85022-1	• VALVE INSTL, ARMAMENT SELECTOR AFT (98750) FOR NHA SEE FIG. 2.3-11 MOD BY 7144623-30	RF	35	
- 10	202034	• VALVE ASSY, SOLENOID OPERATED SELECTOR <94241> SPEC R-10544-5	1	A	
	54414-1	• VALVE ASSY, SOLENOID OPERATED SELECTOR <90902> SPEC R-10544-5 T.O. 1F-106A-4 ALT INTCHG WITH 202034	RF	A	
		ATTACHING PARTS			
- 11	AN3-17A	• BOLT (88044)	4	A	
- 12	AN960-10L	• WASHER (88044)	4	A	
		-----X-----			
- 13	202034	• VALVE ASSY, SOLENOID OPERATED SELECTOR, (94641) SPEC R-10444-5	1	B	
	54414-1	• VALVE ASSY, SOLENOID OPERATED SELECTOR, (90902) SPEC R-10444-5 T.O. 1F-106A-4 ALT INTCHG WITH 202034	RF	B	
		ATTACHING PARTS			
- 14	AN3-17A	• BOLT (88044)	4	B	
- 15	AN960-10L	• WASHER (88044)	4	B	
		-----X-----			
	8-85053-1	• VALVE INSTL, ARMAMENT GEAR LOCK MANUAL FOR NHA SEE FIG. 2.3-11	RF	35	
- 16	214A2	• VALVE, MANUAL <8214> SPEC R-10444-5	1	35	
		ATTACHING PARTS			
- 17	NAS675A3	• NUT (88205)	2	35	
- 18	AN960-10L	• WASHER (88044)	4	35	
- 19	AN3-7A	• BOLT (88044)	2	35	
		-----X-----			
	8-95011	• PIN INSTL, ARMAMENT GEAR SAFETY VALVE LOCK	1	35	
- 2	RL-P01-1.625	• PIN, <84254> 06-70200-107	1	35	

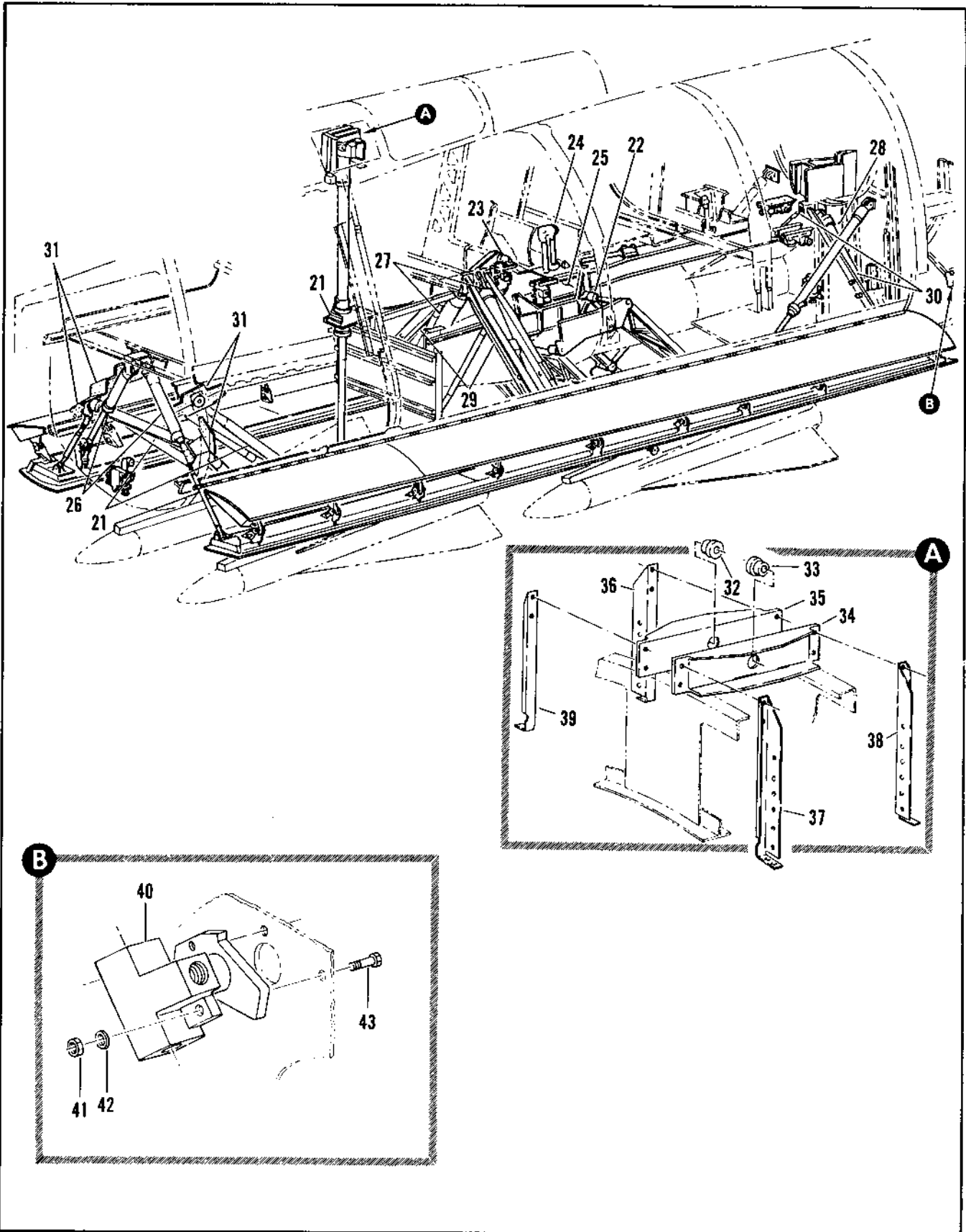

Figure 2.20-1. Armament (Sheet 2 of 2)

FIGURE AND INDEX NUMBER	PART NUMBER	DESCRIPTION	UNITS PER ASSY.	USABLE ON CODE	
				FROM	TO
		1 2 3 4 5 6			
2.20-1- 21		• ARMAMENT INSTL, FWD SEE FIG. 2.20-23	RF		
- 22		• ARMAMENT INSTL, AFT LH SEE FIG. 2.20-31	RF		
- 23		• ARMAMENT INSTL, AFT RH SEE FIG. 2.20-31	RF		
- 24		• ARMAMENT INSTL, MB-1 SEE FIG. 2.20-34	RF		
- 25		• MB-1 EJECTOR SUPPORT SEE FIG. 2.20-35	RF		
- 26		• ACTUATOR INSTL, ARMAMENT BAY DOOR FWD SEE FIG. 2.20-12	RF		
- 27		• ACTUATOR INSTL, ARMAMENT BAY DOOR CENTER SEE FIG. 2.20-12	RF		
- 28		• ACTUATOR INSTL, ARMAMENT BAY DOOR AFT SEE FIG. 2.20-12	RF		
- 29		• SUPPORT INSTL, ARMAMENT BAY DOOR CENTER ACTUATOR SEE FIG. 2.20-12	RF		
- 30		• SUPPORT INSTL, ARMAMENT BAY DOOR AFT ACTUATOR SEE FIG. 2.20-12	RF		
- 31		• SUPPORT INSTL, ARMAMENT UPPER AND LOWER DRAG ARM SEE FIG. 2.20-28	RF		
	8-77953	• SUPPORT INSTL, ARMAMENT EXTENSION ACTUATOR FOR NHA SEE FIG. 2.3-11	RF	35	
- 32	NAS77-9-11	• BUSHING (80209)	1	35	
- 33	NAS77-9-22	• BUSHING (80209)	1	35	
- 34	8-77954-7	• SUPPORT, FWD	1	35	
- 35	8-77954-8	• SUPPORT, AFT	1	35	
- 36	8-77953-09	• ANGLE	1	35	
- 37	8-77953-12	• ANGLE	1	35	
- 38	8-77953-10	• ANGLE, LH	1	35	
- 39	8-77953-11	• ANGLE, RH	1	35	
	8-85146-1	• VALVE INSTL, ARMAMENT BAY DOOR MANUAL SAFETY STA 431 FOR NHA SEE FIG. 2.3-11 ATTACHING PARTS	RF	35	
- 40	3017A2	• VALVE, MANUAL SAFETY (85014) SPEC 8-06485-1 T.O. 1F-106A-3	1	35	
- 41	NAS79A3	• NUT (80209)	2	35	
- 42	AN86-L-10	• WASHER (80209)	2	35	
- 43	AN3-7A	• BOLT (80209)	2	35	
- 44		• DOOR INSTL, ARMAMENT BAY STA 210 TO 412 SEE FIG. 2.20-13	RF		
- 45		• LONGERON INSTL, ARMAMENT BAY DOOR HINGE LOWER LH STA 165 TO 253 SEE FIG. 2.20-12	RF		
- 46		• LONGERON INSTL, ARMAMENT BAY DOOR HINGE LOWER RH STA 253 TO 412 SEE FIG. 2.20-12	RF		
- 47		• DEFLECTOR INSTL, MB-1 SEE FIG. 2.20-22	RF		
		A REMOVED AND RELOCATED PER TCTC 1F-106A-55 ON AIRPLANES 848, 90 AND ON			
		B ADDED AND RELOCATED PER TCTC 1F-106A-55 ON AIRPLANES 848, 90 AND ON			

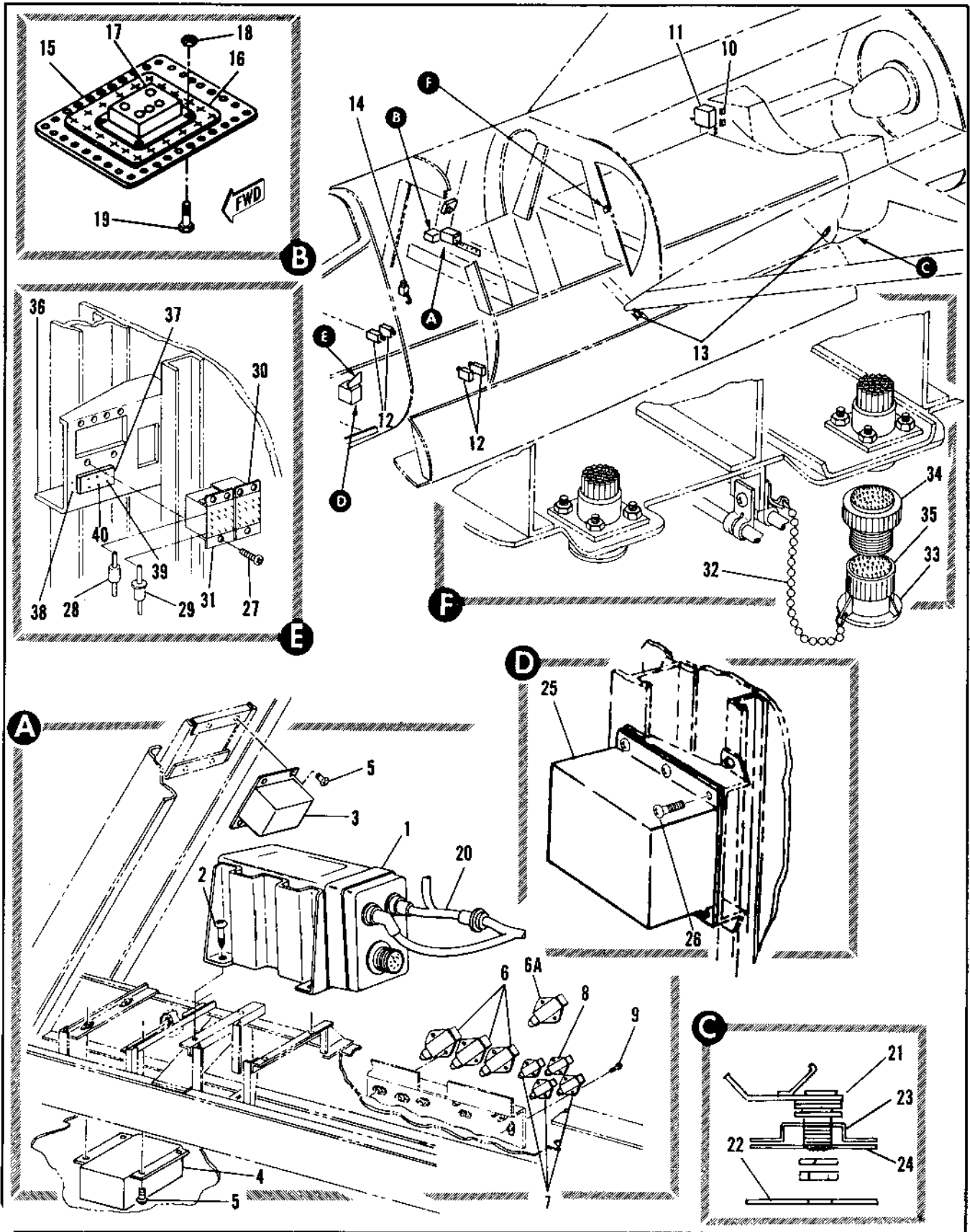

Figure 2.20-2. Armament Electrical

FIGURE AND INDEX NUMBER	PART NUMBER	DESCRIPTION	UNITS PER ASSY.	USABLE ON CODE	
				FROM	TO
2.20-2		ARMAMENT ELECTRICAL			
	8-65032-5	• EQUIPMENT INSTL, ARMAMENT CONTROL	1	35	129
	8-65032-803	• EQUIPMENT INSTL, ARMAMENT CONTROL	1	130	
- 1	11393-3	• • INTERVALOMETER, ARMAMENT <00048> SPEC 8-06299-3 T.O.11F13-11-13-4 REPLACES NOT INTCHG WITH 11393-1 ATTACHING PARTS	1	35	
- 2	MS51958-62	• • SCREW (96906) ----X----	4	35	
- 3	T228A	• • TIMER, CABIN AIR CONTROL MISSILE LAUNCHING <72152> SPEC 8-06299 T.O.8D3-6-4-3	1	35	
- 4	RY437A	• • RELAY, <72152> SPEC P-06295 T.O.11F8-2-5-3 ATTACHING PARTS	1	35	
- 5	MS51958-61	• • SCREW (96906) ----X----	8	35	
- 6	8-06900A	• • RELAY, FWD, AFT AND SPECIAL WEAPON MISFIRE (35344) SPEC 8-06900	3	35	
- 6A	MS27401-21	• • RELAY, AUXILIARY FWD MISFIRE ATTACHING PARTS	1	ALL	
	NAS1635-06-6	• • SCREW	2	ALL	
	NAS620C6	• • WASHER ----X----	2	ALL	
- 7	8-06289A3	• • RELAY, AUXILIARY DOOR OPEN, AUXILIARY AFT MISFIRE AND IGNITER SAFE (35344) SPEC 8-06289-3	3	35	
- 8	8-06289-1 REV 6	• • RELAY, DOOR POSITION (35344) SPEC 8-06289 ATTACHING PARTS	1	35	
- 9	MS51958-61	• • SCREW (96906) ----X----	14	35	
- 10		• RELAY INSTL, ARMAMENT MANUAL CONTROL PANEL. SEE FIG. 2-20-3		RF	
- 11		• PANEL INSTL, ARMAMENT MANUAL CONTROL. SEE FIG. 2-20-3		RF	
- 12		• SWITCH INSTL, ARMAMENT BAY DOOR LIMIT LH. SEE FIG. 2-20-5		RF	
- 13		• SWITCH INSTL, ARMAMENT BAY DOOR OPEN AND CLOSED. SEE FIG. 2-20-5		RF	
- 14		• SWITCH INSTL, ARMAMENT LAUNCHER FWD UPPER. SEE FIG. 2-20-4		RF	
- 15	8-74481-12102189	• DOOR, INTERVALOMETER ACCESS (MODIFIED BY TCTO 1F-106-1093 (98750))			
- 16	7140977-01	• • DOUBLER (INSTALLED BY TCTO 1F-106-1093 (98750))			
- 17	TD-1179	• • RELAY, TIME DELAY (LEACH)			
- 18	MS21044N3	• • • NUT (96906)			
- 19	MS35207-259	• • • SCREW (96906)	4		
- 20	7140400-10	• • • HARNESS, TIME DELAY, FWD LAUNCHER (98750)	1		
- 21	MS90298-2	• RECEPTACLE (96906)	1	ALL	
- 22	68842894	• DECAL, "GROUND HERE" (98750)	1	ALL	
- 23	7239607-10	• BRACKET (98750)	1	ALL	
- 24	7239733-10	• FILLER (98750)	1	ALL	
	7144640-30	• CONTROL INSTL, GUN FIRING (98750)	1	A	
- 25	188F683	• • CONTROL, GUN FIRING GFAE	1	A	
- 26	MS35207-264	• • SCREW (96906)	6	A	
- 27	NAS1100-06-5	• • SCREW (80205)	6	A	
	MS35338-41	• • WASHER, LOCK (96906) ----X----	6	A	
- 28	1N3613	• • • RECTIFIER	1	A	
- 29	1N972B	• • • DIODE	1	A	

FIGURE AND INDEX NUMBER	PART NUMBER	DESCRIPTION	UNITS PER ASSY.	USABLE ON CODE	
				FROM	TO
		1 2 3 4 5 6			
2.20-2- 30	MS3726-4-013	RELAY, K2A GUN FIRE	1	X	
- 31	MS27400-1	RELAY, K1A GUN READY	1	X	
	7144759-10	• CONNECTOR INSTL, BAY DOOR CONTROL (98750)	1	A	
	7144648-10	• • CONNECTOR ASSY, BAY DOOR CONTROL (98750)	1	A	
- 32	NAS1201B10A18S	• • • CHAIN (80205)	1	A	
- 33	7144648-01	• • • PLATE, ID (98750)	1	A	
- 34	M83723-23F2815N	• • • CONNECTOR, PLUG, ELECT	1	A	
- 35	M83723-35N28F	• • • BACKSHELL	1	A	
- 36	M83726-4-106 **	• RELAY, K3A TIME DELAY	1		
		• CAMERA			
- 37	SO-1048-8308 **	• SOCKET	1		
- 38	MS24693-C52 **	• SCREW	3		
- 39	MS2748816	• SEALING PLUG	9		
- 40	001-5490-001 **	• CONTACT	5		
		A ADDED ON AIRPLANES #44, 90 AND ON PER TCTO 1F-106A-558			
		** ADDED ON AIRPLANES PER TCTO 1F-106A-1122			

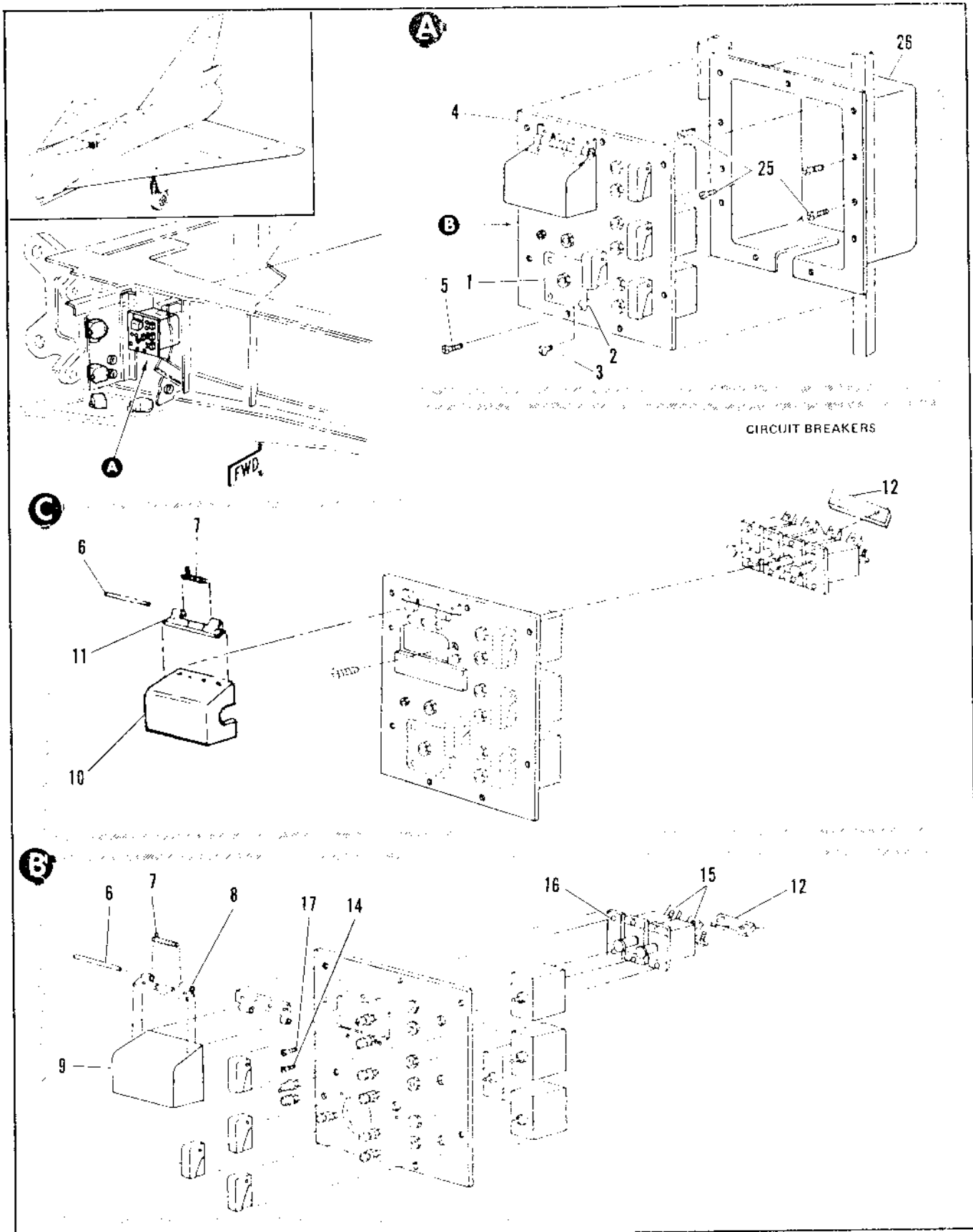

Figure 2.20-3. Armament Manual Control (Sheet 1 of 3)

FIGURE AND INDEX NUMBER	PART NUMBER	DESCRIPTION	UNITS PER ASSY.	USABLE ON CODE	
				FROM	TO
		1 2 3 4 5 6			
2.20-3	8-65010-5	ARMAMENT MANUAL CONTROL • PANEL INSTL. ARMAMENT MANUAL CONTROL MOD BY 7144636-10	RF	A	
- 1	8044031-01	• • PLATF (IF REQUIRED) ATTACHING PARTS	1	B	
- 2	MS21042-06	• • NUT (IF REQUIRED)	4	B	
- 3	MS35206-227	• • SCREW (IF REQUIRED) ----X----	4	B	
- 4	7144730-10	• • PANEL ASSY. ARMAMENT MANUAL CONTROL ATTACHING PARTS	1	C	
- 5	MS51558-63	• • SCREW (96906) ----X----	7	B	
- 6	MS20253-2-248	• • • PIN, HINGE (96906)	1	B	
- 7	8-67493-7	• • • SPRING	1	B	
	8-65053-1	• • • BOX ASSY, FUSE PANEL	1	B	
- 8	8-65053-11	• • • HINGE, HALF	1	B	
- 9	8-65053-9	• • • BOX	1	B	
- 10	7144729-01	• • • COVER, PANEL, CONTROL MISSILE BAY DOOR REMARK OF 8-65053-1 (98750)	1	B	
- 11	8-65053-11	• • • HINGE, HALF	1	B	
- 12	8-65029-7	• • • BUSBAR	1	B	
- 13	DELETED				
- 14	MS35206-230	ATTACHING PARTS • • • SCREW	4	B	
- 15	7271-3-J	• • • CIRCUIT BREAKER (82647)	2		
- 16	8-62300	• • • NAMEPLATE ASSY, BLANK RIVETED ATTACHING PARTS	1	B	
- 17	MS35206-230	• • • SCREW ----X----	2	B	
		A AIRPLANES #35 THRU 277 B AIRPLANES #35 THRU 47 AND 49 THRU 89 C AIRPLANES #48, 90 AND ON			

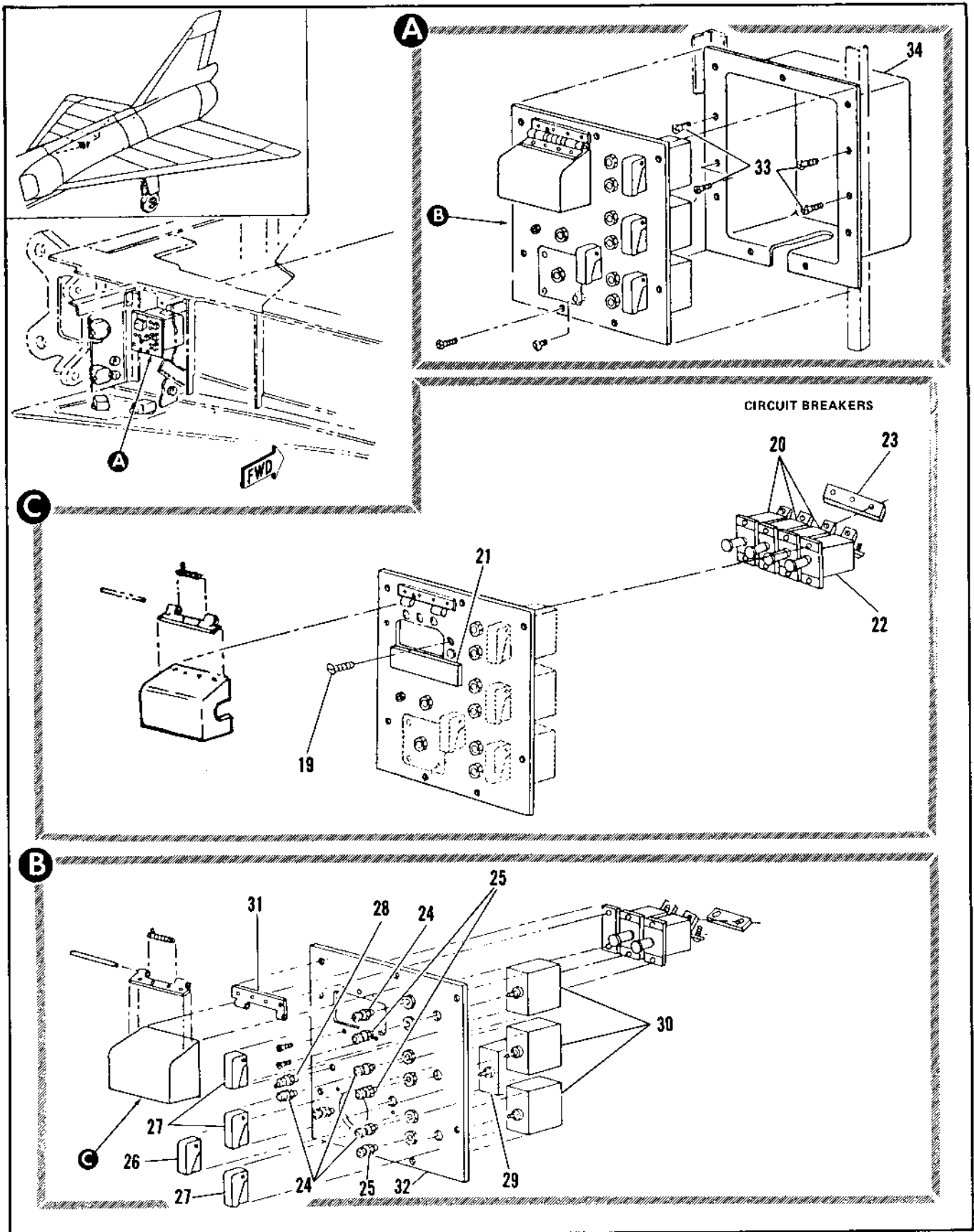

Figure 2.20-3. Armament Manual Control (Sheet 2 of 3)

FIGURE AND INDEX NUMBER	PART NUMBER	DESCRIPTION	UNITS PER ASSY.	USABLE ON CODE	
				FROM	TO
2.20-3- 18	DELETED				
- 19	MS35206-230	ATTACHING PARTS • • • SCREW	2		C
- 20	7271-3-5	• • • CIRCUIT BREAKER (82647)	3		C
- 21	7144658-10	• • • PLATE, DESIGNATOR (98750)	1		C
- 22	MS25244-30	• • • CIRCUIT BREAKER (96906)-	1		C
- 23	3V7-12-48-2	• • • BUS, (91812)	1		C
- 24	VM911M199	• • • LIGHT ASSY, INDICATOR <87034> SPEC 8-06916-23	5		A
	10855M57	• • • CAP ASSY, FURNISHED WITH VM911M199 <87034> SPEC 8-06916-13	1		A
	MS25237-327	• • • LAMP	1		A
- 25	VM911M198	• • • LIGHT ASSY, INDICATOR <87034> SPEC 8-06916-21 REPLACES SUITABLE SUB FOR VM911M111	3		A
	10855M56	• • • CAP ASSY, FURNISHED WITH VM911M198 <87034> SPEC 8-06916-3 REPLACED BY SUITABLE SUB VM 911M198	1		A
- 26	MS25224-1	• • • GUARD, SWITCH	1		A
- 27	MS25223-2	• • • GUARD, SWITCH	3		A
	AN3333-2	• • • GUARD, SWITCH ALT INTCHG WITH MS25223-2	RF		A
- 28	8906K703	• • • SWITCH, INTERVALOMETER RESET <15605> SPEC 8-06907-13	1		A
- 29	8906K706	• • • SWITCH, ARMAMENT TEST <15605> SPEC 8-06915-5	1		A
- 30	8906K710	• • • SWITCH, ARMAMENT DOOR AND LAUNCHER <15605> SPEC 8-06903-1	3		A
	8-65011-5	• • • PANEL ASSY, ARMAMENT MANUAL CONTROL MOUNTING	1		A
- 31	8-65011-9	• • • HINGE, HALF	1		A
- 32	8-65011-27	• • • PANEL	1		A
	8-65053-5	• • COVER ASSY, ARMAMENT MANUAL CONTROL PANEL RIVETED ATTACHING PARTS	1		A
- 33	MS24694-50	• • SCREW -----X----	4		A
- 34	8-65053-17	• • • BOX	1		A

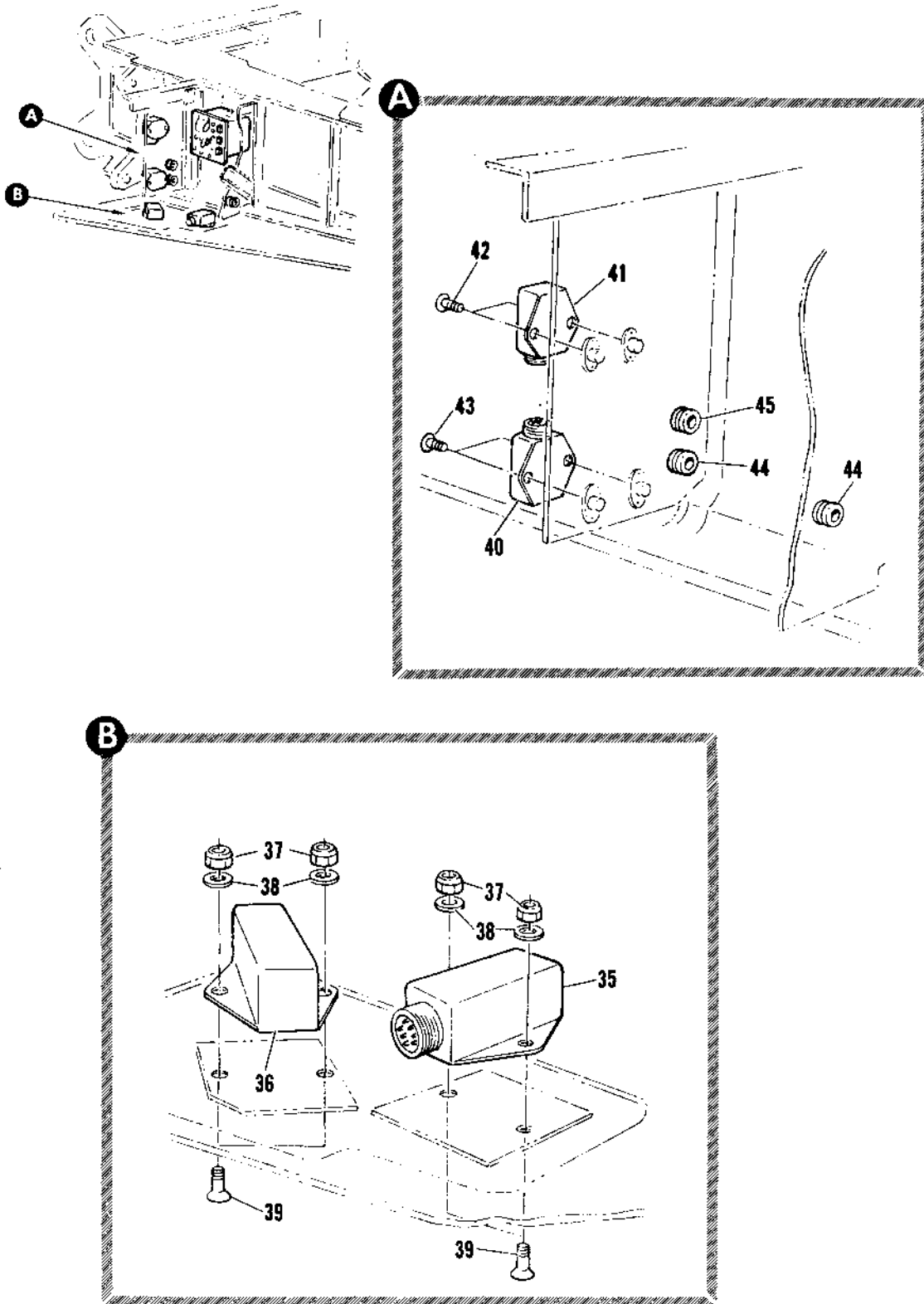

Figure 2.20-3. Armament Manual Control (Sheet 3 of 3)

FIGURE AND INDEX NUMBER	PART NUMBER	DESCRIPTION	UNITS PER ASSY.	USABLE ON CODE	
				FROM	TO
2.20-3	8-65010-3	• RELAY INSTL, ARMAMENT MANUAL CONTROL PANEL	1	35	
- 35	8-06289A	• • RELAY, LAUNCHER REMOTE CONTROL UPPER <35344> SPEC 8-06289-3	1	F	
- 36	8-06289A3	• • RELAY, ARMAMENT DOOR REMOTE CONTROL LWR <35344> SPEC 8-06289 ATTACHING PARTS	1	E	
- 37	NAS679A3	• • NUT	4	E	
- 38	AN960-10L	• • SCREW	4	E	
- 39	AN557C1032R8	• • SCREW -----X-----	4	E	
- 40	8-06289A3	• • RELAY, LAUNCHER REMOTE CONTROL UPPER <35344> SPEC 8-06289-3	1	278	281
- 41	8-06289A	• • RELAY, LAUNCHER REMOTE CONTROL LOWER <35344> SPEC 8-06289 ATTACHING PARTS	1	278	281
- 42	MS35207-261	• • SCREW	2	278	281
- 43	MS35207-263	• • SCREW -----X-----	2	278	281
- 44	R15001E10-1	• • GROMMET, <94503> 94-35001-001	2	35	
- 45	R15001E16-1	• • GROMMET, <94903> 94-35001-011	1	F	
	R15001E10-1	• • GROMMET, <94903> 94-35001-001	1	278	285
		E AIRPLANES #35 THRU 277, 281 AND ON			
		F AIRPLANES #35 THRU 277, 287 AND ON			

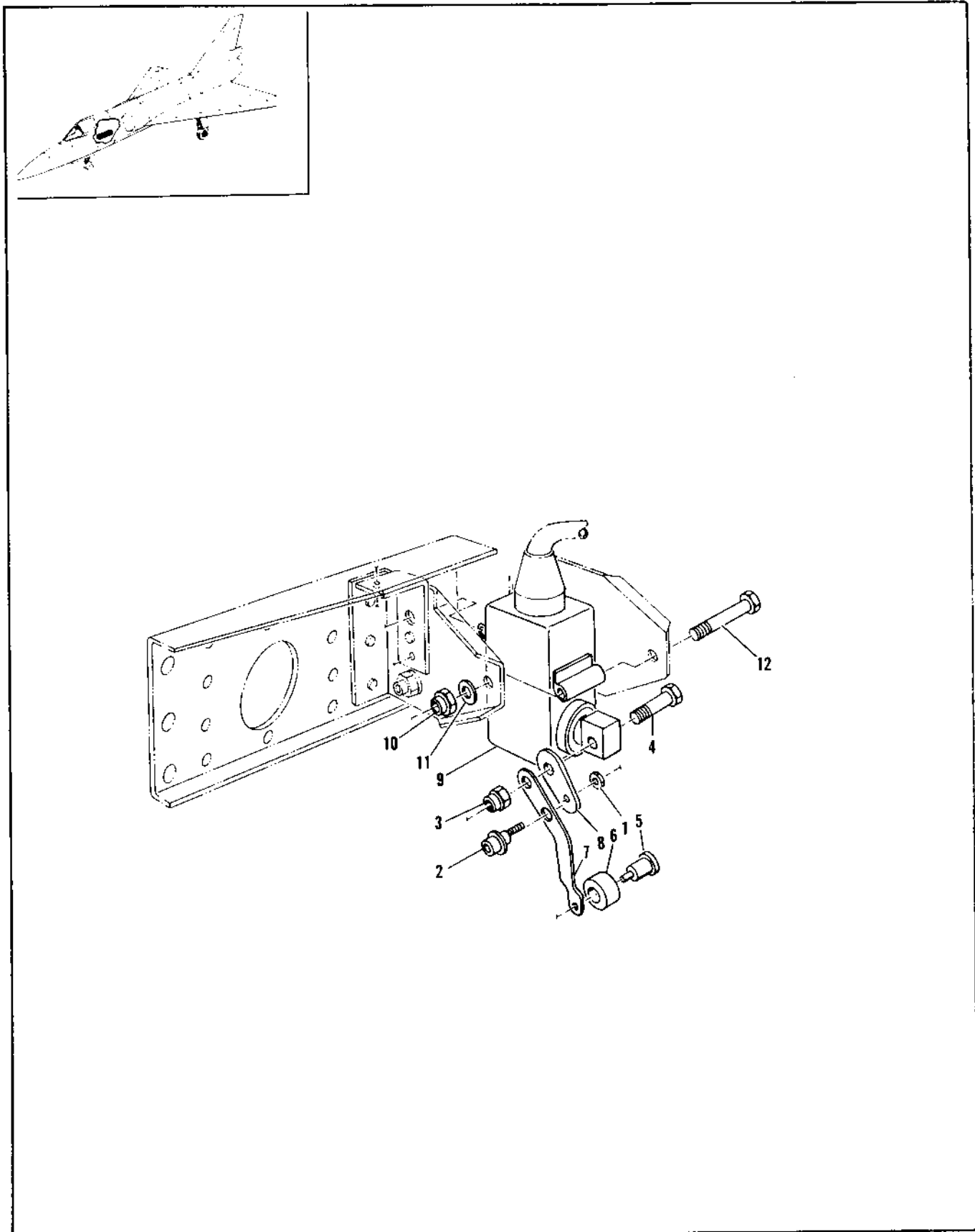

Figure 2.20-4. Armament Launcher Fwd Upper Switch Installation

FIGURE AND INDEX NUMBER	PART NUMBER	DESCRIPTION	UNITS PER ASSY.	USABLE ON CODE	
				FROM	TO
		1 2 3 4 5 6			
2.20-4	8-57039-1	SWITCH INSTALLATION, ARMAMENT LAUNCHER FWD UPPER	RF	35	
	8-57940-1	• ARM ASSY, LIMIT SWITCH FOR NHA SEE FIG. 2.3-4	1	35	
- 1	NAS679C08	• NUT	1	35	
- 2	8-68038-7	• BOLT	1	35	
- 3	NAS679C3	• NUT	1	35	
- 4	AN3C10A	• BOLT	1	35	
		----X----			
- 5	8-68051-9	• • STUD, ROLLER	1	35	
- 6	8-68052-9	• • ROLLER	1	35	
- 7	8-57340-7	• • ARM	1	35	
- 8	1107-509	• PLATE, <97498> SPEC 8-06986-7	1	35	
- 9	69C37529-2	• SWITCH ASSY, (REPLACED BY PART NO. H12-1011, FSCM 97198) NOT INTERCHANGEABLE WITH 69C37529-2	1	35	
- 10	NAS679A3	• NUT	3	35	
- 11	AN960-10L	• WASHER	3	35	
- 12	AN3-16A	• BOLT	3	35	
		----X----			

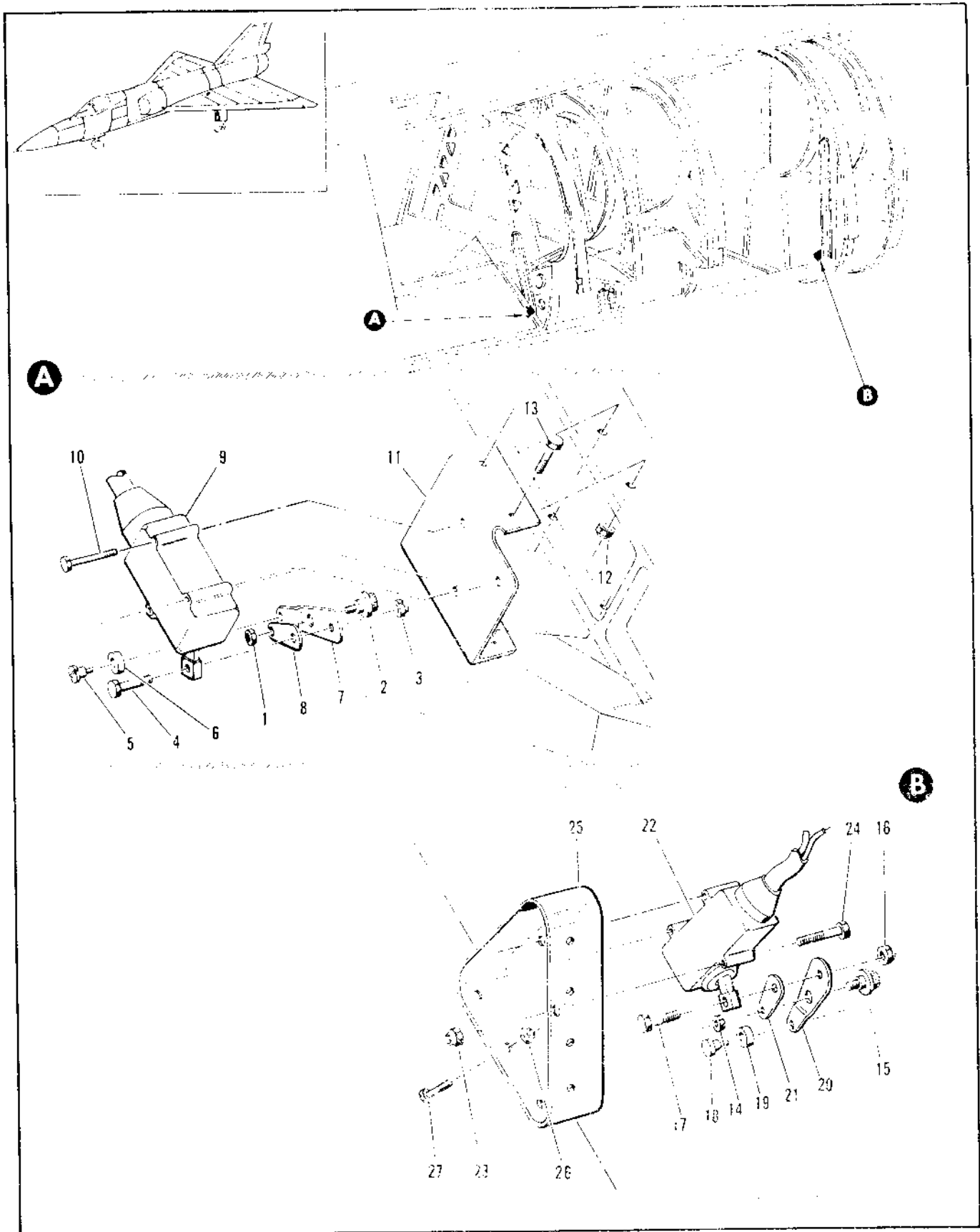

Figure 2.20-5. Armament Bay Door Open and Closed Switch

FIGURE AND INDEX NUMBER	PART NUMBER	DESCRIPTION	UNITS PER ASSY.	USABLE ON CODE	
				FROM	TO
2.20-5		1 2 3 4 5 6			
	8-65589-1	ARMAMENT BAY DOOR OPEN AND CLOSED SWITCH • SWITCH INSTL, ARMAMENT BAY DOOR CLOSED LH FOR NHA SEE FIG. 2.3-10	RF	35	
	8-65589-2	• SWITCH INSTL, ARMAMENT BAY DOOR CLOSED RH FOR NHA SEE FIG. 2.3-10	RF	35	
- 1	NAS679C08	• • NUT	1	35	
- 2	8-68038-7	• • BOLT, LIMIT SWITCH ADJUST	1	35	
	8-68046-1	• • ARM ASSY, LIMIT SWITCH ACTUATOR ATTACHING PARTS	1	35	
- 3	NAS679C3	• • NUT	1	35	
- 4	AN3C7A	• • BOLT	1	35	
		-----X-----			
- 5	8-68051-9	• • • STUD, ROLLER	1	35	
- 6	8-68052-9	• • • ROLLER	1	35	
- 7	8-68046-7	• • • ARM	1	35	
- 8	1107-509	• • PLATE, ACTUATOR ARM ADJUST <97198> SPEC 8-66986-7	1	35	
- 9	69C37529-2	• SWITCH ASSY, (REPLACED BY PART NO. H12-1011, (97151) FSCM 97198) NOT INTERCHANGEABLE WITH 69C37529-2	1	35	
- 10	AN3-14	• • BOLT	3	35	
		-----X-----			
- 11	8-65589-9	• • BRACKET ASSY, LH RIVETED	1	35	
	8-65589-10	• • BRACKET ASSY, RH RIVETED ATTACHING PARTS	1	35	
- 12	NAS679A3	• • NUT	4	35	
- 13	AN3-4	• • BOLT	4	35	
		-----X-----			
	8-65588-3	• SWITCH INSTL, ARMAMENT BAY DOOR OPEN LH FOR NHA SEE FIG. 2.3-10	RF	35	
	8-65588-4	• SWITCH INSTL, ARMAMENT BAY DOOR OPEN RH FOR NHA SEE FIG. 2.3-10	RF	35	
- 14	NAS679C08	• • NUT	1	35	
- 15	8-68038-7	• • BOLT, LIMIT SWITCH ADJUST	1	35	
- 16	NAS679C3	• • NUT	1	35	
	8-68046-1	• • ARM ASSY, LIMIT SWITCH ACTUATOR ATTACHING PARTS	1	35	
- 17	AN3C7A	• • BOLT	1	35	
		-----X-----			
- 18	8-68051-9	• • • STUD, ROLLER	1	35	
- 19	8-68052-9	• • • ROLLER	1	35	
- 20	8-68046-7	• • • ARM	1	35	
- 21	1107-509	• • PLATE, ACTUATOR ARM ADJUST <97198> SPEC 8-66986-7	1	35	
- 22	69C37529-2	• SWITCH ASSY, (REPLACED BY PART NO. H12-1011, FSCM 97198) NOT INTERCHANGEABLE WITH 69C37529-2	1	35	
- 23	NAS679A3	• • NUT	3	35	
- 24	AN3-14	• • BOLT	3	35	
		-----X-----			
- 25	8-65588-9	• • PAN, LH	1	35	
	8-65588-10	• • PAN, RH ATTACHING PARTS	1	35	
- 26	NAS679A3	• • NUT	3	35	
- 27	MS35207-262	• • SCREW	3	35	
		-----X-----			

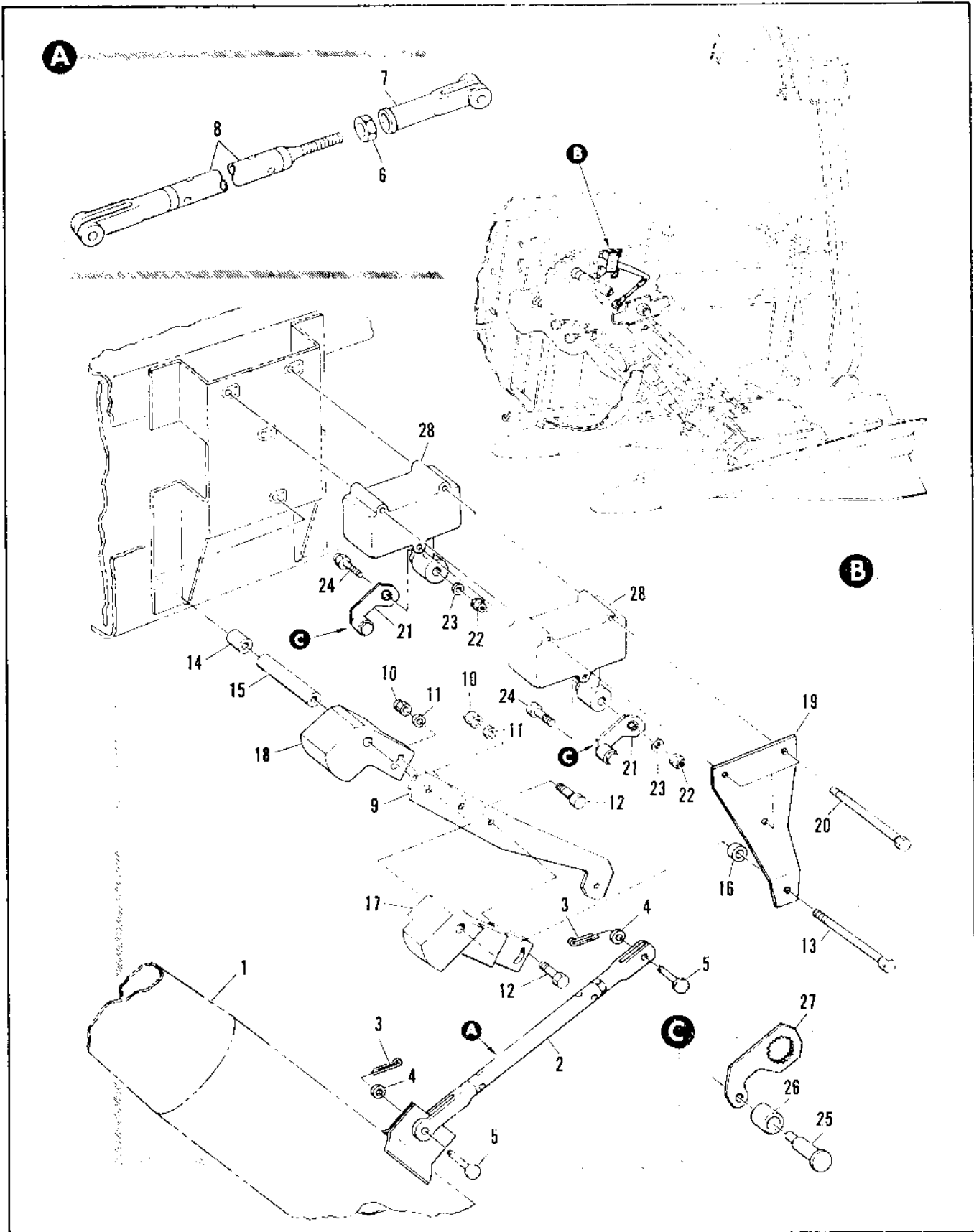

Figure 2.20-6. Fwd Armament Bay Launcher Down Switch Installation

FIGURE AND INDEX NUMBER	PART NUMBER	DESCRIPTION	UNITS PER ASSY.	USABLE ON CODE	
				FROM	TO
2.20-6	8-57987	SWITCH INSTALLATION, FWD ARMENT BAY LAUNCHER DOWN FOR NHA SEE FIG. 2.3-4	RF	35	
- 1		• ARM ASSY, FWD DISPLACEMENT GEAR UPPER DRAG SEE FIG. 2.20-29	RF		
- 2	8-57987-17	• ROD ASSY, LAUNCHER DOWN SWITCH ATTACHING PARTS	1	35	
- 3	MS24665-132	• PIN, COTTER <96906>	2	35	
- 4	AN960-10L	• WASHER <88044>	2	35	
- 5	MS20392-2C19	• PIN <96906>	2	35	
- 6	AN316-4R	-----X-----			
- 7	MS27975-3	• NUT <88044>	1	35	
- 8	NAS356-63-695	• CLEVIS <96906>	1	35	
- 9	8-57963-7	• ROD <80205>	1	35	
		• LINK	1	35	
- 10	MS21042L3	ATTACHING PARTS			
- 11	AN960-10	• NUT <96906>	2	35	
- 12	AN3-6A	• WASHER <88044>	2	35	
	AN3-33A	• BOLT <88044>	2	35	
	AN3-34A	• BOLT <88044>	1	35	
- 13	NAS43DD6-19	• BOLT <88044>	1	35	
- 14	NAS72-3C214	• SPACER <80205>	1	35	
- 15	NAS43DD6-7	• RUSHING <80205>	1	35	
		• SPACER <80205>	1	35	
		-----X-----			
- 17	8-57964-7	• CAM	1	35	
- 18	8-57988-7	• CAM, LAUNCHER DOWN SWITCH	1	35	
- 19	8-57987-13	• PLATE, LAUNCHER DOWN SWITCH ATTACHING PARTS	1	35	
- 20	AN3-30A	• BOLT <88044>	3	35	
	AN3-27A	• BOLT <88044>	3		
		-----X-----			
- 21	8-57990-1	• ARM ASSY, LAUNCHER DOWN SWITCH ATTACHING PARTS	2	35	
- 22	NAS679A3	• NUT <80205>	2	35	
- 23	99-51509-029	• WASHER	2	35	
- 24	AN3-7A	• BOLT <88044>	2	35	
		-----X-----			
- 25	8-68051-9	• STUD, ROLLER	1	35	
- 26	8-68052-9	• ROLLER	1	35	
- 27	8-57990-7	• ARM	1	35	
- 28	69C37529-2	• SWITCH ASSY, (REPLACED BY PART NO. H12-1011, FSCM 97198) NOT INTERCHANGEABLE WITH 69C37529-2	2	35	
	8-57987-19		RF	35	

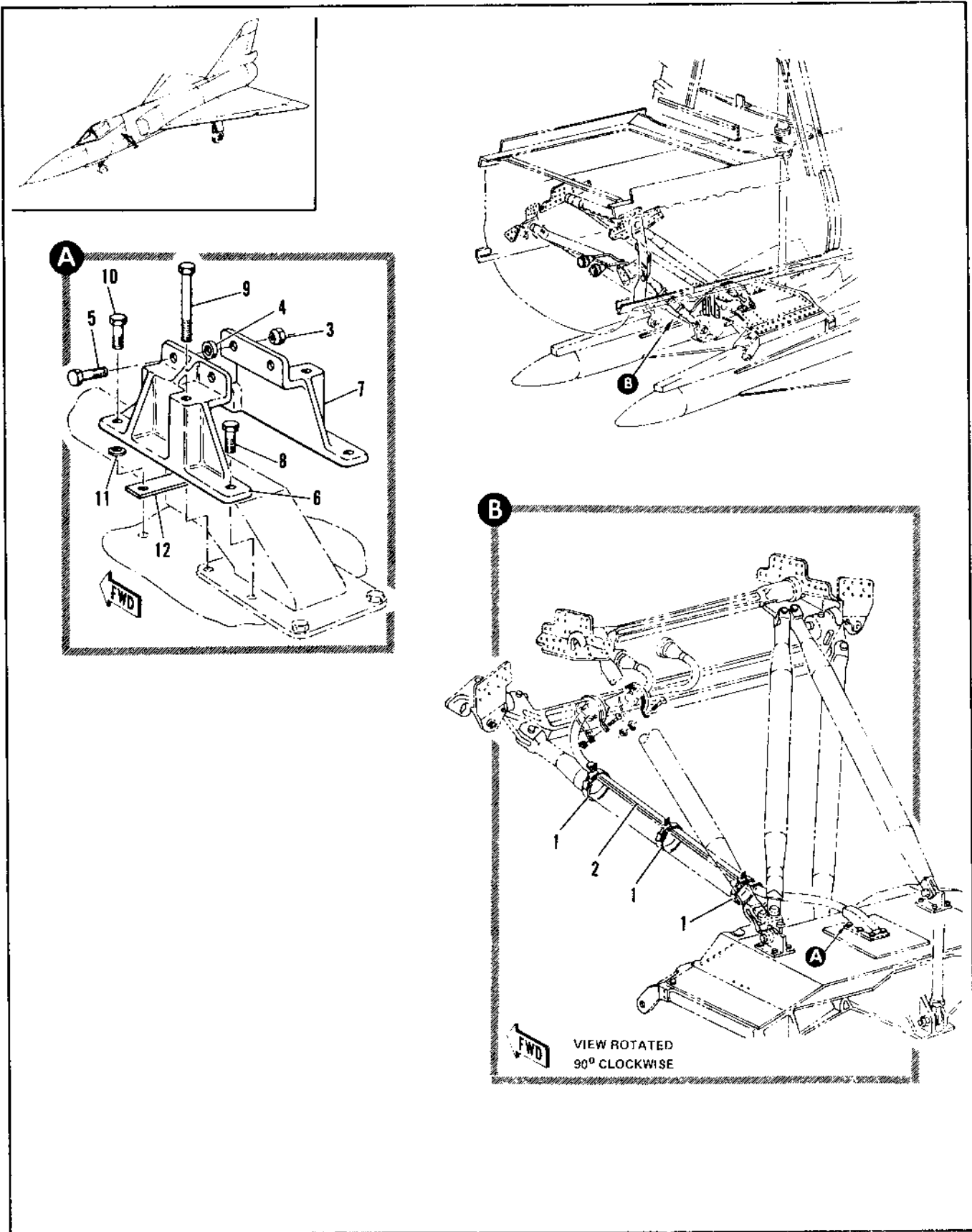

Figure 2.20-7. Fwd Armament Harness Clamp Installation

FIGURE AND INDEX NUMBER	PART NUMBER	DESCRIPTION 1 2 3 4 5 6	UNITS PER ASSY.	USABLE ON CODE	
				FROM	TO
2.20-7	R-57926-R11	CLAMP INSTALLATION, FWD APPARENT HARNESS FOR MHA SEE FIG. 2.20-23	FF	35	124
- 1	325-62-32EM	• CLAMP, <9862F> 91-97802-11	3	35	124
- 2	6-57984-7	• SHIELD	1	35	124
- 3	NAS679AS	• NUT	2	35	124
- 4	NAS1291-3	• BOLT	2		
- 5	AN960-10	• WASHER	4	35	124
- 6	AN3-6A	• BOLT	2	35	124
- 6	NAS1103-6	• BOLT	2		
- 6	R-57496-9	• BRACKET, HARNESS REPLACES NOT INCHG WITH R-57492	1	35	124
- 7	R-57497-7	• BRACKET, ALT INCHG WITH R-57498-9	FF	35	124
- 7	R-57498-10	• BRACKET, HARNESS REPLACES NOT INCHG WITH R-57492	1	35	124
- 7	R-57497-8	• BRACKET, ALT INCHG WITH R-57496-10 ATTACHING PARTS	FF	35	124
- 8	AN3-6A	• BOLT	2	35	124
- 9	NAS1103-6	• BOLT	2		
- 9	AN3-30A	• BOLT	2	35	124
- 10	NAS1103-42	• BOLT	2		
- 10	AN3-7A	• BOLT	2	35	124
- 11	NAS1103-P	• BOLT	2		
- 11	AN960PD10	• WASHER	1	35	124
- 12	R-57926-67	• SHIM -----X-----	1	35	124

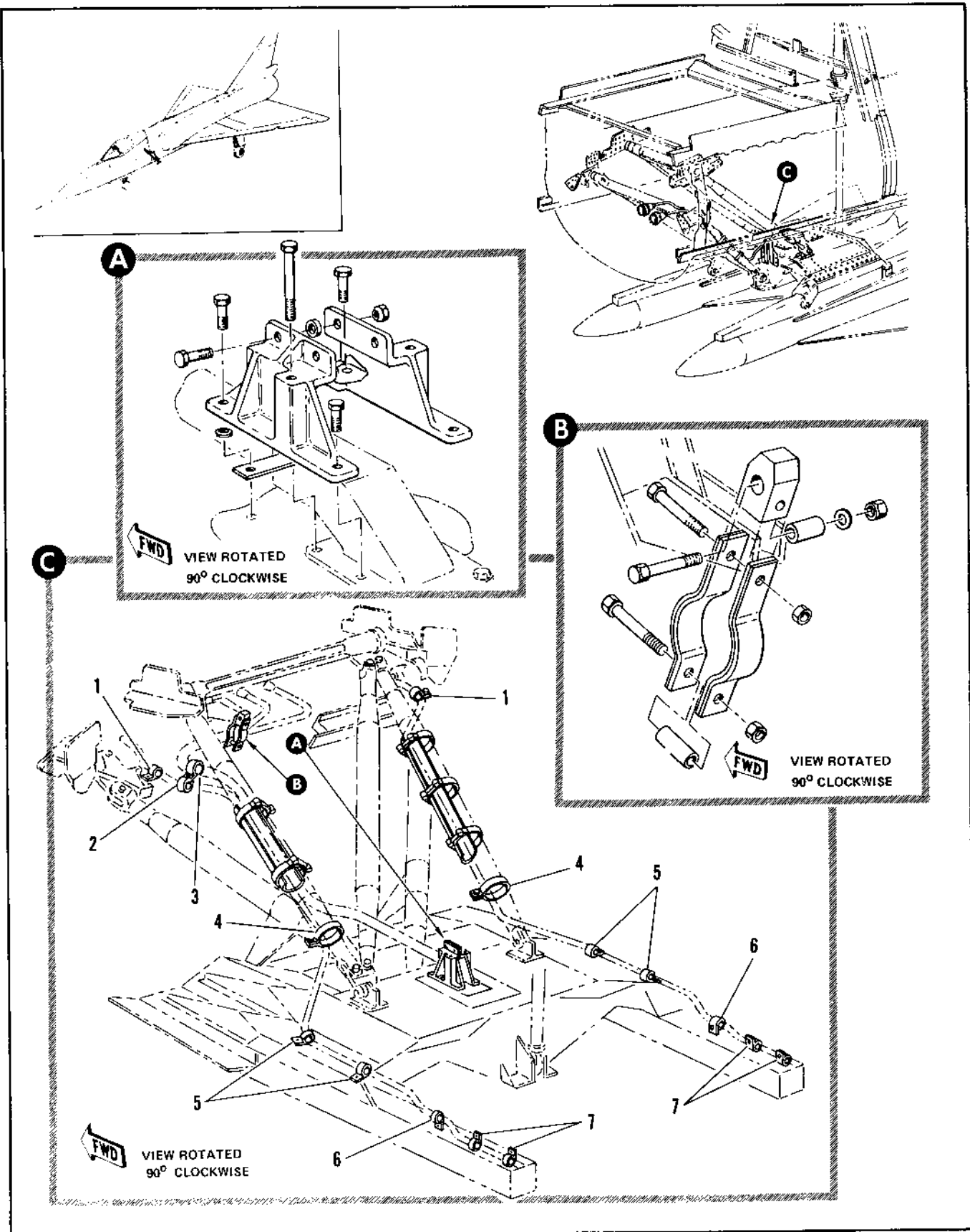

Figure 2.20-8. Fwd Armament Harness Clamp Installation (Sheet 1 of 2)

FIGURE AND INDEX NUMBER	PART NUMBER	DESCRIPTION	UNITS PER ASSY.	USABLE ON CODE	
				FROM	TO
2.20-8	8-57316	CLAMP INSTALLATION, FWD ARMAMENT HARNESS FOR NHA SEE FIG. 2.20-23	RF	35	
- 1	MS21919D613	• CLAMP	2	35	
	NAS679A3	ATTACHING PARTS			
	AN960-10L	• NUT	2	35	
	NAS1103-4	• WASHER	2	35	
		• BOLT	2	35	
		-----X-----			
- 2	MS21919D613	• CLAMP	1	35	
- 3	MS21919D616	• CLAMP	1	35	
	MS21919D621	• CLAMP	1		
		ATTACHING PARTS			
	NAS679A3	• NUT	1	35	
	NAS1103-4	• BOLT	1	35	
		-----X-----			
- 4	MS21919D628	• CLAMP	2	35	
	MS21919D634	• CLAMP	1		
		ATTACHING PARTS			
	NAS679A3	• NUT	2	35	
	NAS1103-4	• BOLT	2	35	
		-----X-----			
- 5	MS21919D613	• CLAMP	4	35	
		ATTACHING PARTS			
	AN173-5A	• BOLT	4	35	
		-----X-----			
- 6	MS21919D613	• CLAMP	2	35	
		ATTACHING PARTS			
	AN3H6A	• BOLT	2	35	
	AN960-10L	• WASHER	2	35	
	NAS130D3-24	• SPACER	2	35	
		-----X-----			
- 7	MS21919D613	• CLAMP	4	35	
		ATTACHING PARTS			
	AN3H6A	• BOLT	4	35	
	AN960-10L	• WASHER	4	35	
	NAS130D3-24	• SPACER	4	35	
		-----X-----			

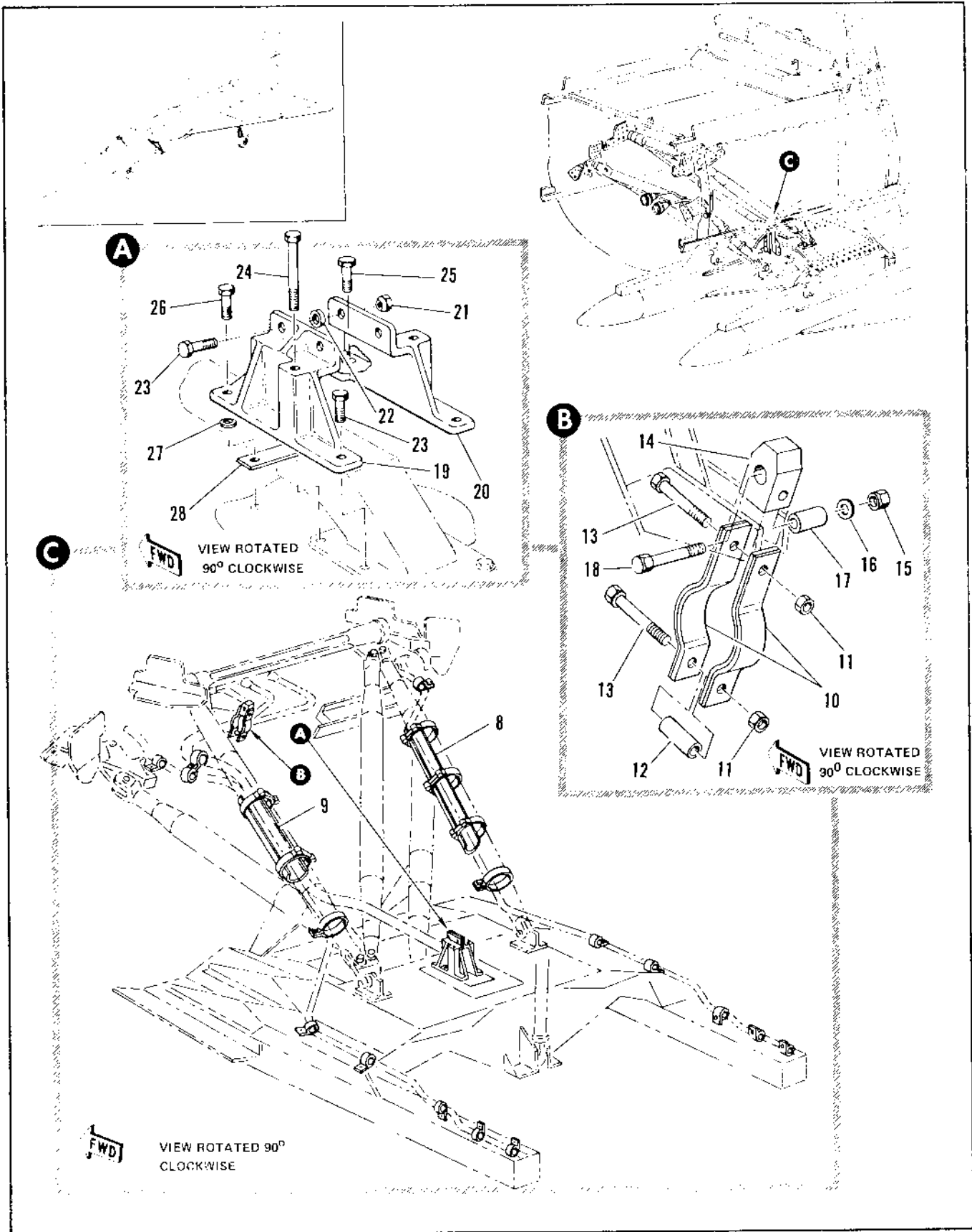

Figure 2.20-8. Fwd Armament Harness Clamp Installation (Sheet 2 of 2)

FIGURE AND INDEX NUMBER	PART NUMBER	DESCRIPTION	UNITS PER ASSY.	USABLE ON CODE	
				FROM	TO
		1 2 3 4 5 6			
2.20-8- 8	4-57318	• SHIELD ASSY, HARNESS RIVETED	1	35	
- 9	8-57319	• SHIELD ASSY, HARNESS RIVETED	1	35	
- 10	8-57315	• CLAMP, HARNESS SUPPORT ATTACHING PARTS	2	131	
- 11	NAS679A3	• NUT	2	131	
- 12	NAS43003-80	• SPACER	1	131	
- 13	NAS1103-22	• BOLT -----X-----	2	131	
- 14	8-57314	• BLOCK, HARNESS SUPPORT ATTACHING PARTS	1	131	
- 15	NAS679A4	• NUT	1	130	
- 16	AN961C416L	• WASHER	1	130	
- 17	NAS72-4E102	• RUSHING	1	130	
- 18	NAS1104-23	• BOLT -----X-----	1	130	
- 19	8-57498-9	• BRACKET, HARNESS REPLACES NOT INTCHG WITH 8-57499	1	130	
- 20	8-57498-10	• BRACKET, HARNESS REPLACES NOT INTCHG WITH 8-57499 ATTACHING PARTS	1	130	
- 21	NAS679A3	• NUT	2	130	
- 22	AN961-10	• WASHER	2	130	
- 23	NAS1103-6	• BOLT	4	130	
- 24	NAS1103-42	• BOLT	2	130	
- 25	NAS1103-8	• BOLT	1	130	186
- 26	AN3-5A	• BOLT	1	130	
- 26	AN3-7A	• BOLT	1	130	
- 27	AN961PD11	• WASHER -----X-----	1	130	
- 28	8-57426-67	• SHIM	1	130	

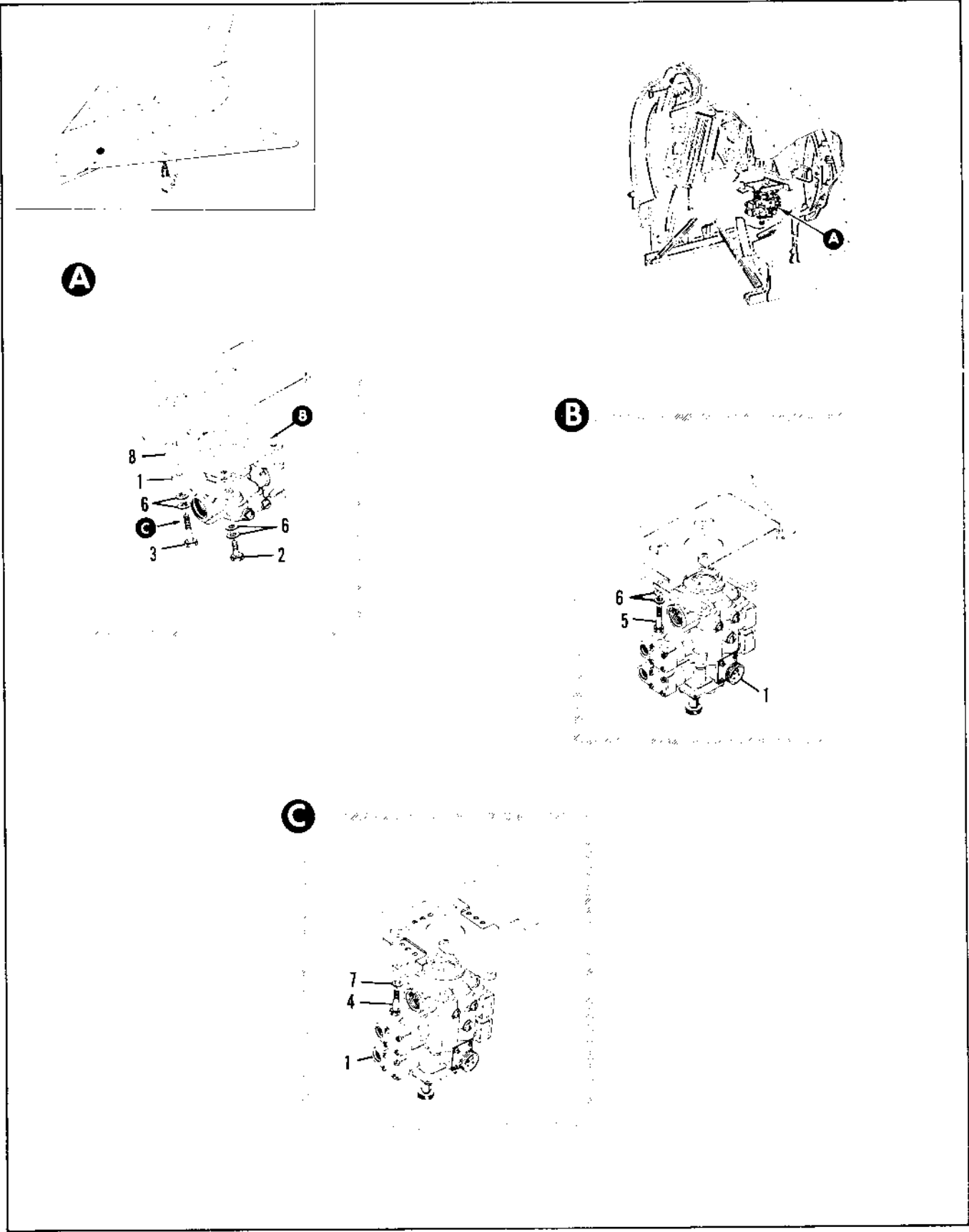

Figure 2.20-9. Armament Bay Door Master Pneumatic Selector Valve Installation

FIGURE AND INDEX NUMBER	PART NUMBER	DESCRIPTION	UNITS PER ASSY.	USABLE ON CODE	
				FROM	TO
		1 2 3 4 5 6			
2.20-9	A-85049-1	VALVE INSTALLATION, ARMAMENT BAY DOOR MASTER PNEUMATIC SELECTOR MOD BY 7144760-30 FOR NHA SEE FIG. 2.3-11	RF	35	40
	B-85023-1	VALVE INSTALLATION, ARMAMENT BAY DOOR MASTER PNEUMATIC SELECTOR MOD BY 7144760-10 FOR NHA SEE FIG. 2.3-11	RF	43	
- 1	11001-3	• VALVE ASSY, SELECTOR <9642> SPEC R-10986-3 T.O. 311-9-26-3 ATTACHING PARTS	1	35	
- 2	AN3-7A	• BOLT	2	35	40
- 3	AN3-14A	• BOLT	2	35	40
- 4	AN3-5A	• BOLT	4	35	
- 5	AN3-5A	• BOLT	4	43	
- 6	AN960-10L	• WASHER	1	4	
- 7	AN960-10L	• WASHER	1	5	
		-----X-----			
- 8	B-85049-17	• ADAPTER	1	35	40
		A REMOVED PER TCTO 1F-106A-558 FROM AIRPLANES #48, 90 AND ON			
		B ADDED PER TCTO 1F-106A-559 ON AIRPLANES #48, 90 AND ON			

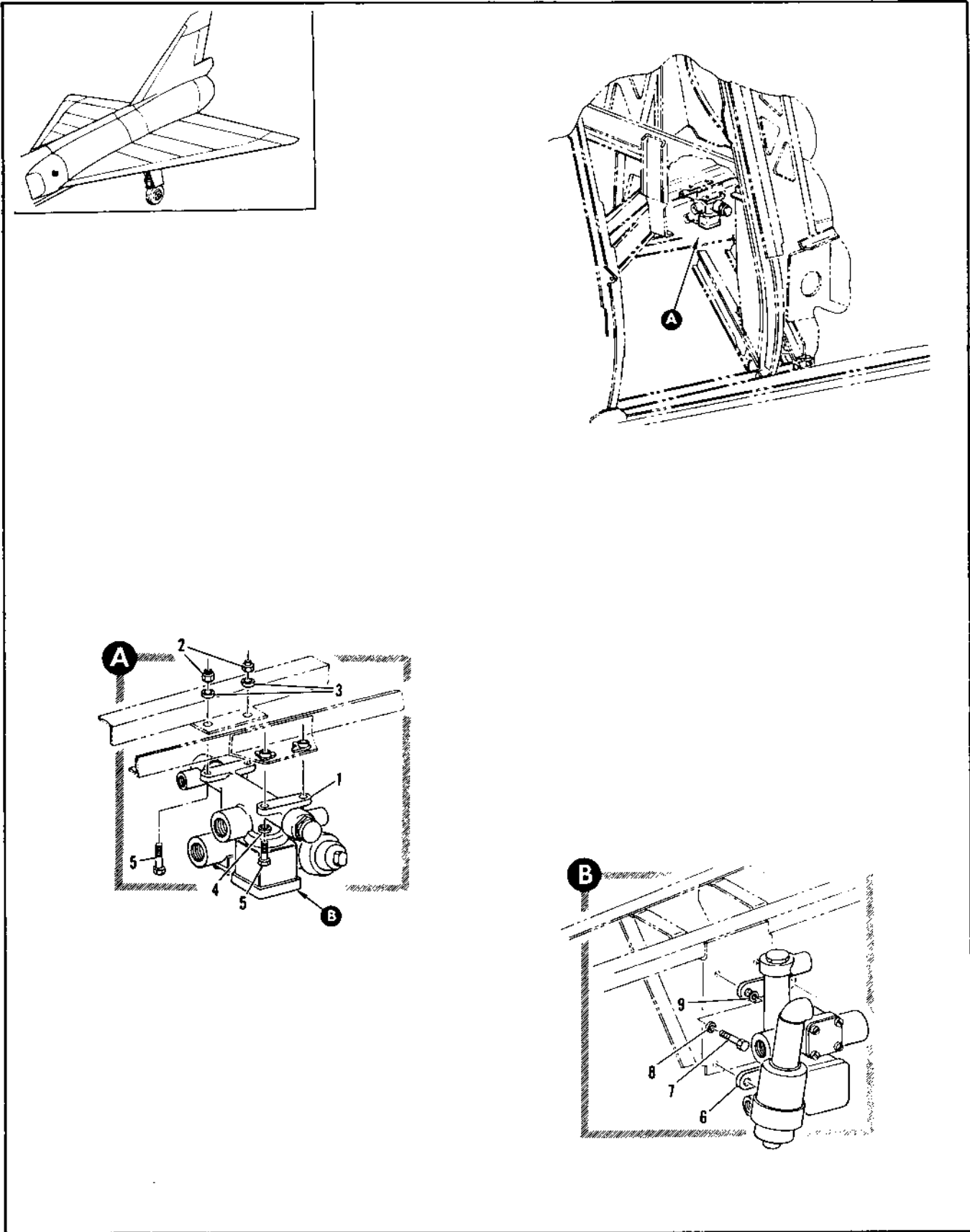

Figure 2.20-10. Armament Bay Door Center Selector Valve

FIGURE AND INDEX NUMBER	PART NUMBER	DESCRIPTION 1 2 3 4 5 6	UNITS PER ASSY.	USABLE ON CODE	
				FROM	TO
2.20-10	8-85059-1	ARMAMENT BAY DOOR CENTER SELECTOR VALVE • VALVE INSTL. ARMAMENT BAY DOOR CENTER PNEUMATIC SELECTOR FOR NHA SEE FIG. 2.3-11	PF	35	41
- 1	11510-3	• VALVE ASSY. PRESSURE OPERATED SELECTOR <99643> SPEC 8-10565-3 T.O.OPS-9-24-13 ATTACHING PARTS	1	35	41
- 2	NAS679A3	• NUT	2	35	42
- 3	AN960-10L	• WASHER	4	35	42
- 4	AN960C10L	• WASHER	2	35	42
- 5	NAS1103-6	• BOLT	4	35	42
		-----X-----			
	8-85051-1	• VALVE INSTL. ARMAMENT BAY DOOR CENTER PNEUMATIC SELECTOR FOR NHA SEE FIG. 2.3-11	PF	43	
- 6	11510-3	• VALVE ASSY. PRESSURE OPERATED SELECTOR <99643> SPEC 8-10565-3 T.O.OPS-9-24-13 ATTACHING PARTS	1	43	
- 7	AN3-6A	• BOLT	4	43	
- 8	AN960-10L	• WASHER	4	43	
- 9	AN960-10	• WASHER	4	43	
		-----X-----			

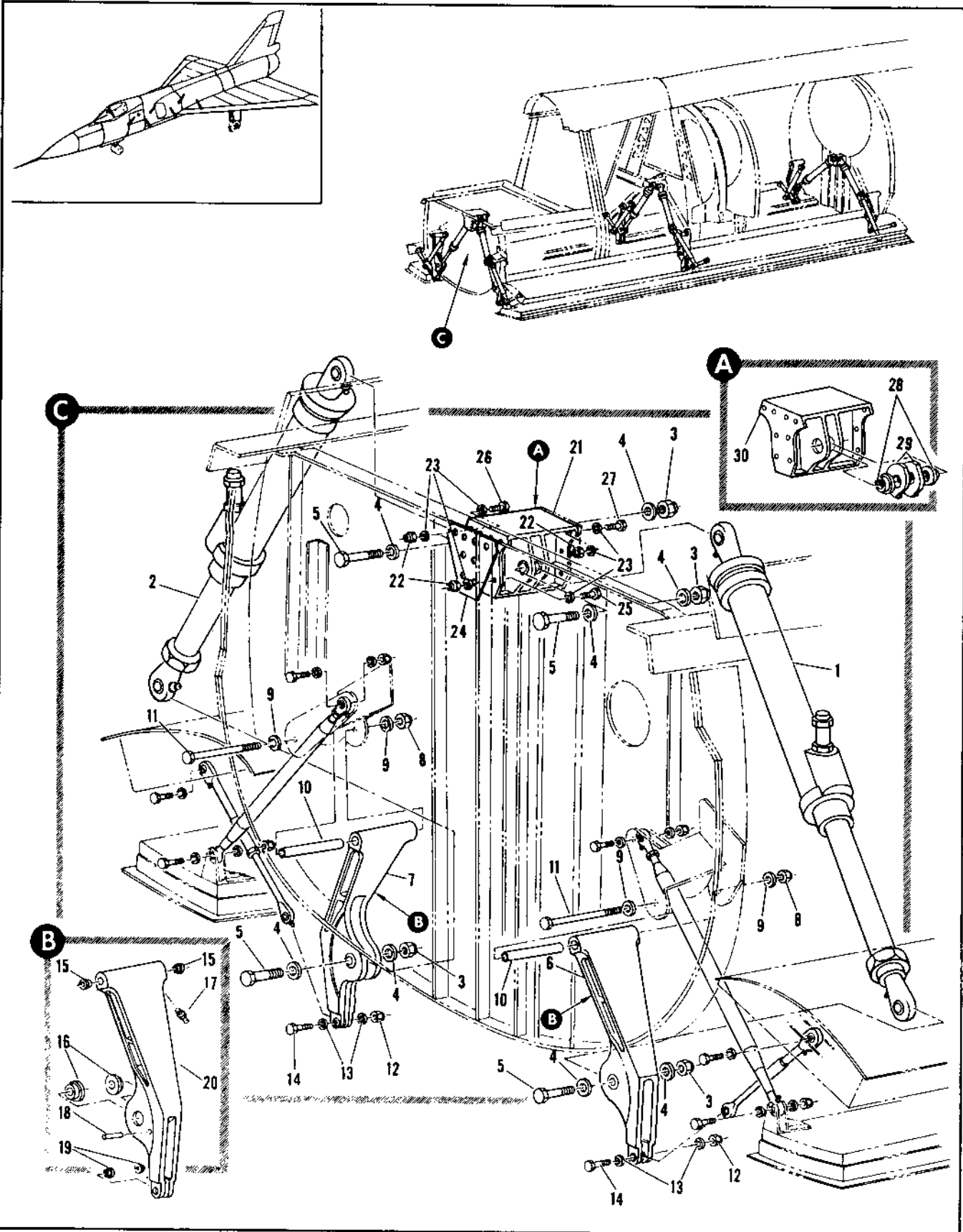

Figure 2.20-11. Armament Bay Door Actuator Installation (Sheet 1 of 4)

FIGURE AND INDEX NUMBER	PART NUMBER	DESCRIPTION	UNITS PER ASSY.	USABLE ON CODE	
				FROM	TO
		1 2 3 4 5 6			
2.20-11	8-45512-1	ACTUATOR INSTALLATION, ARMAMENT BAY DOOR FWD FOR NHA SEE FIG. 2.3-3	PF	35	
	8-45512-3	ACTUATOR INSTALLATION, ARMAMENT BAY DOOR CENTER FOR NHA SEE FIG. 2.3-3	PF	35	
	8-45512-5	ACTUATOR INSTALLATION, ARMAMENT BAY DOOR AFT FOR NHA SEE FIG. 2.3-3	PF	35	
- 1	10950-7	• ACTUATOR ASSY, ARMAMENT BAY DOOR FWD LH (97395) SPEC 8-10932-3 T.O. 9P2-3-29-52	1	35	
- 2	10950-8	• ACTUATOR ASSY, ARMAMENT BAY DOOR FWD RH (97395) SPEC 8-10932-4 T.O. 9P2-3-29-52	1	35	
		ATTACHING PARTS			
- 3	AN320-8	• NUT, FWD	4	35	
- 4	AN9600816	• WASHER, FWD	8	35	
- 5	NAS464-8-20	• BOLT, FWD	4	35	
		-----X-----			
- 6	8-45862-3	• IDLER ASSY, ARMAMENT BAY DOOR FWD LH	1	35	
	8-45863-3	• IDLER ASSY, ARMAMENT BAY DOOR FWD LH ALT INTCHG WITH 8-45862-3	PF	35	
- 7	8-45862-4	• IDLER ASSY, ARMAMENT BAY DOOR FWD RH	1	35	
	8-45863-4	• IDLER ASSY, ARMAMENT BAY DOOR FWD RH ALT INTCHG WITH 8-45862-4	PF	35	
		ATTACHING PARTS			
- 8	AN310-12	• NUT, FWD	2	35	
- 9	AN96001216	• WASHER, FWD	4	35	
- 10	8-45869-9	• BUSHING, FWD	2	35	
- 11	8-45852-11	• BOLT, FWD	2	35	
- 12	AN320-7	• NUT, FWD	2	35	
- 13	AN9600716	• WASHER, FWD	4	35	
- 14	NAS464P7-18	• BOLT, FWD	2	35	
		-----X-----			
- 15	8-45881-9	• BUSHING	2	35	
- 16	8-45878-7	• BUSHING, FWD	2	35	
- 17	MS15001-1	• FITTING	1	35	
- 18	8-45894	• PIN	1	35	
- 19	8-45877	• BUSHING, FWD	2	35	
- 20	8-45862-9	• IDLER, FWD LH	1	35	
	8-45860-3	• IDLER, FWD LH ALT INTCHG WITH 8-45862-9	PF	35	
	8-45862-10	• IDLER, FWD RH	1	35	
	8-45863-8	• IDLER, FWD RH ALT INTCHG WITH 8-45862-10	PF	35	
- 21	8-45847-3	• SUPPORT ASSY, ARMAMENT BAY DOOR FWD	1	35	
	8-45848-1	• SUPPORT ASSY, ARMAMENT BAY DOOR FWD ALT INTCHG WITH 8-45847-3	PF	35	
		ATTACHING PARTS			
- 22	NAS579A3	• NUT	16	35	
- 23	AN961010	• WASHER	32	35	
- 24	8-45812-4	• SHIM, FWD	1	35	
- 25	NAS464-3A7	• BOLT, FWD	6	35	
- 26	NAS464-3A6	• BOLT, FWD	2	35	
- 27	NAS464-3A5	• BOLT, AFT	8	35	
		-----X-----			
- 28	8-45874-9	• BUSHING	4	35	
- 29	8-45847-9	• WASHER	4	35	
- 30	8-45847-7	• SUPPORT	1	35	
	8-45848-7	• SUPPORT, ALT INTCHG WITH 8-45847-7	PF	35	

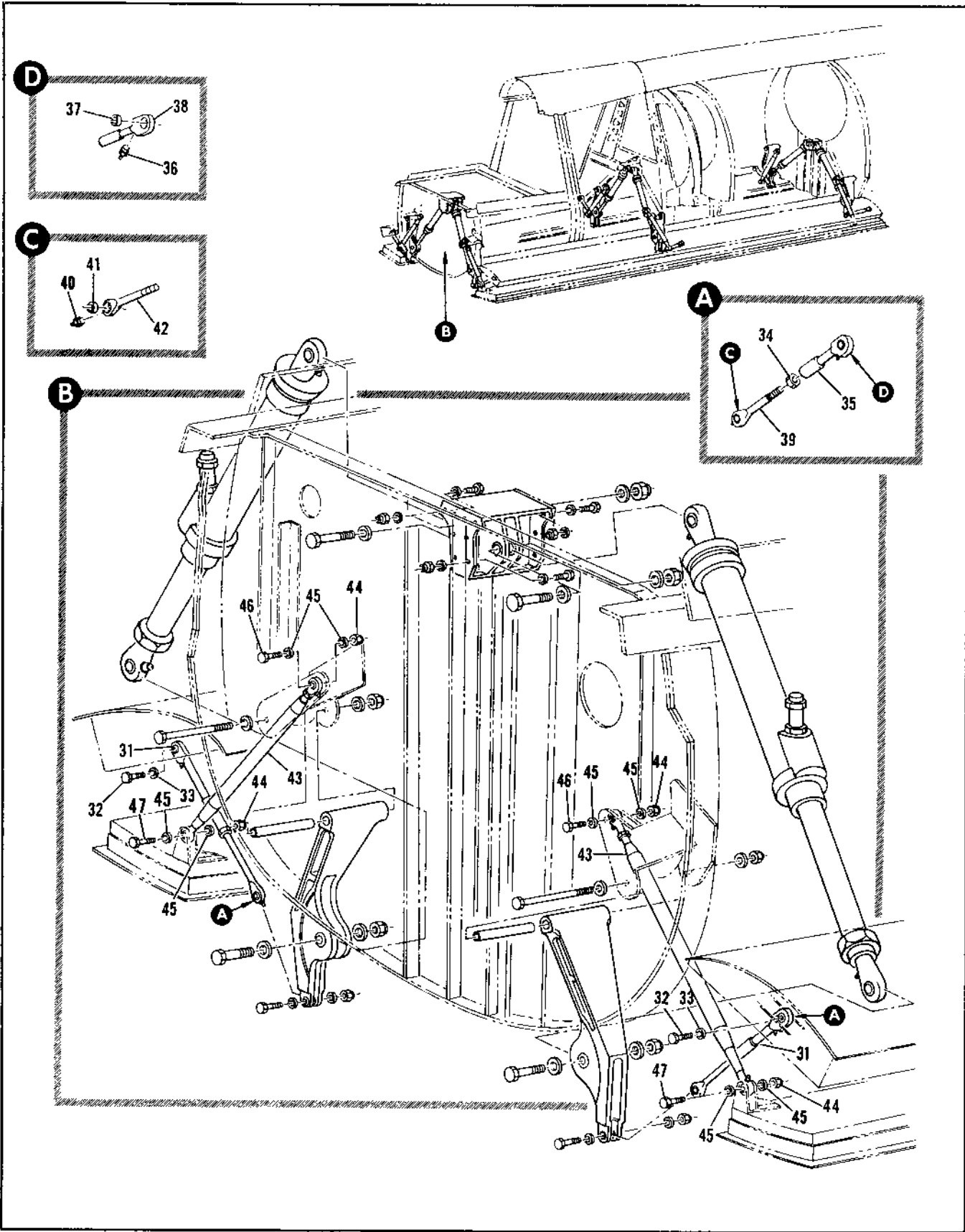

Figure 2.20-11. Armament Bay Door Actuator Installation (Sheet 2 of 4)

FIGURE AND INDEX NUMBER	PART NUMBER	DESCRIPTION	UNITS PER ASSY.	USABLE ON CODE	
				FROM	TO
2.20-11- 31	B-45883	• LINK ASSY, ARMAMENT BAY DOOR FWD ATTACHING PARTS	2		35
- 32	B-45886-9	• BOLT, FWD	2		35
- 33	NAS509-R	• WASHER, FWD -----X-----	1		35
	B-45889-1	• ROD END ASSY, FWD	1		35
- 34	NAS509-8	• NUT, FWD	1		35
- 35	B-45890	• ROD END ASSY, FWD ALT INTCHG WITH B-45889-1	AF		35
- 36	MS15001-1	• • • FITTING	1		35
- 37	KSBY7-1	• • • BEARING, <97613> 57-50111-116	1		35
- 38	B-45891-7	• • • HOUSING	1		35
- 39	B-45891-1	• • • HOUSING, ALT INTCHG WITH B-45891-7	AF		35
	B-45892	• ROD END ASSY, FWD	1		35
		• ROD END ASSY, FWD ALT INTCHG WITH B-45891-1, B-45872-1 B-45837	AF		35
- 40	MS15001-1	• • • FITTING	1		35
- 41	KWB7-5	• • • BEARING, <97613> 97-50115-005	1		35
- 42	B-45891-7	• • • HOUSING	1		35
	B-45892-7	• • • HOUSING, ALT INTCHG WITH B-45891-7	1		35
- 43	B-45893-3	• ROD ASSY, ARMAMENT BAY DOOR FWD FOR BREAKDOWN SEE FIG. 2.20-15 ATTACHING PARTS	2		35
- 44	AN320-4	• NUT, FWD	4		35
- 45	AN560D414	• WASHER, FWD	6		35
- 46	NAS464-4-11	• BOLT, FWD	2		35
- 47	NAS464-4-16	• BOLT, FWD -----X-----	2		35

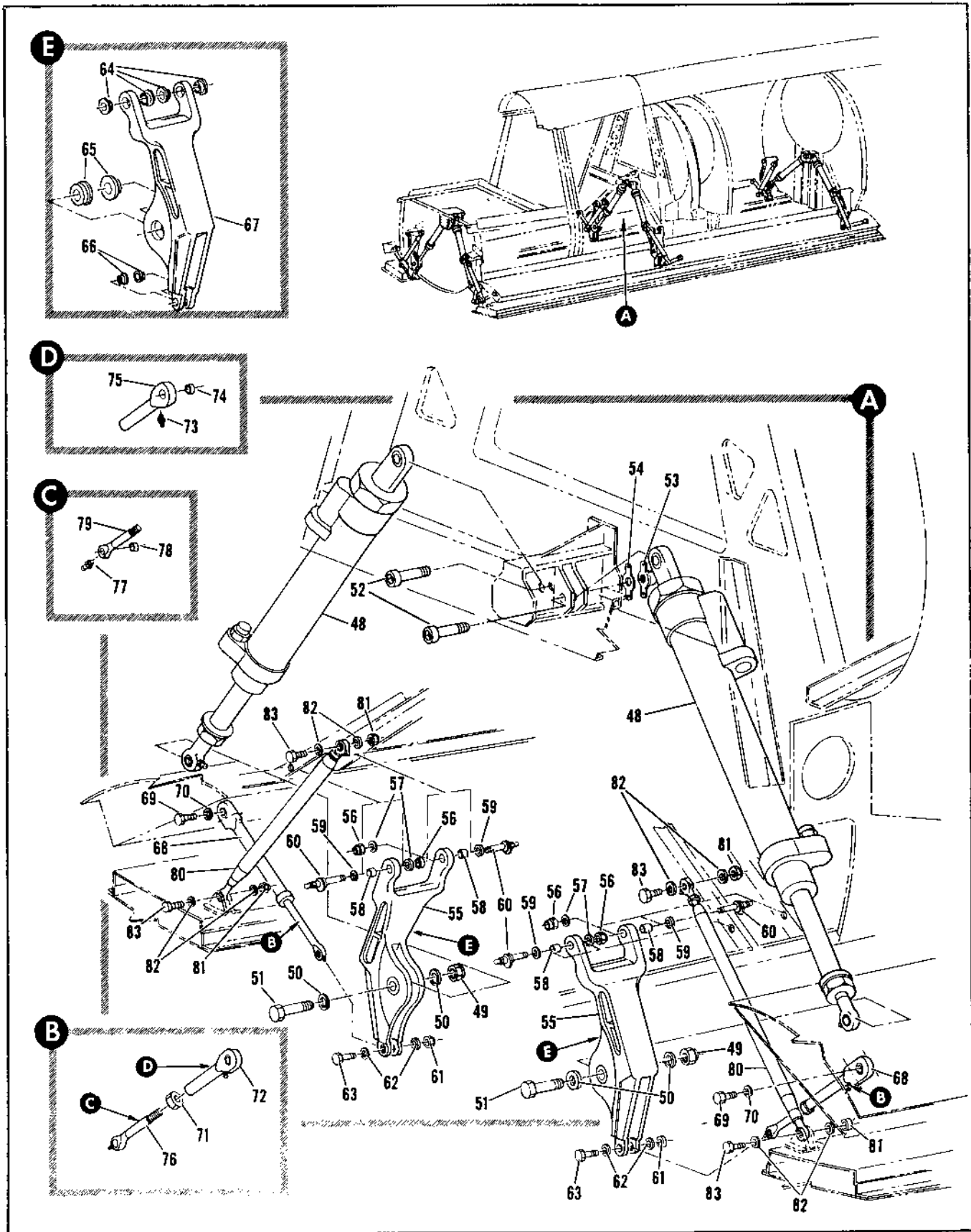

Figure 2.20-11. Armament Bay Door Actuator Installation (Sheet 3 of 4)

FIGURE AND INDEX NUMBER	PART NUMBER	DESCRIPTION	UNITS PER ASSY.	USABLE ON CODE	
				FROM	TO
2.20-11- 48	10951-21	• ACTUATOR ASSY, ARMAMENT BAY DOOR CENTER <97395> SPEC P-00133-1 T.O. 3P2-3-24-23 ATTACHING PARTS	2	35	
- 49	AN321-10	• NUT, CENTER	2	35	
- 50	AN96101014	• WASHER, CENTER	4	35	
- 51	NAS464-10-23	• BOLT, CENTER	2	35	
- 52	P-45874	• BOLT, CENTER	2	35	
- 53	P6-17504-003	• NUTPLATE	2	35	
- 54	P-17928-4	• SPACER	2	35	
		-----X-----			
- 55	R-45864-1	• IDLER ASSY, ARMAMENT BAY DOOR CENTER	2	35	
	R-45865	• EULER ASSY, ARMAMENT BAY DOOR CENTER ALT INTCHG WITH R-45864-1 ATTACHING PARTS	4	35	
- 56	AN321-10	• NUT, CENTER	4	35	
- 57	AN96101014	• WASHER, CENTER	4	35	
- 58	P-45874	• BUSHING, CENTER	4	35	
- 59	P9-01509-014	• WASHER, CENTER	4	35	
- 60	R-45863-1	• BOLT ASSY, CENTER	4	35	
- 61	AN321-9	• NUT, CENTER	2	35	
- 62	AN96101014	• WASHER, CENTER	4	35	
- 63	NAS464-9-21	• BOLT, CENTER	2	35	
		-----X-----			
- 64	R-45861-7	• BUSHING, CENTER	4	35	
- 65	R-45862	• BUSHING, CENTER	2	35	
- 66	R-45879	• BUSHING, CENTER	2	35	
- 67	R-45864-7	• IDLER, CENTER	2	35	
- 68	R-45865-7	• IDLER, CENTER ALT INTCHG WITH R-45864-7	RF	35	
- 69	R-45832	• LINK ASSY, ARMAMENT BAY DOOR CENTER ATTACHING PARTS	2	35	
- 69	R-45877-7	• BOLT, CENTER	2	35	
- 70	AN96101014	• WASHER, CENTER	2	35	
		-----X-----			
- 71	NAS539-8	• NUT, CENTER	1	35	
- 72	R-45871-1	• ROD END ASSY, CENTER	1	35	
	R-45836	• ROD END ASSY, CENTER ALT INTCHG WITH R-45871-1	RF	35	
	R-45836-1	• ROD END ASSY, CENTER ALT INTCHG WITH R-45871-1	RF	35	
- 73	MS15011-1	• FITTING	1	35	
- 74	MSHY100RA	• BEARING, <97613> 90-50711-007	1	35	
- 75	R-45871-7	• HOUSING	1	35	
	R-45835-7	• HOUSING, ALT INTCHG WITH R-45871-7	RF	35	
	R-45835-7	• HOUSING, ALT INTCHG WITH R-45871-7	RF	35	
- 76	R-45870-1	• ROD END ASSY, CENTER	1	35	
	R-45835	• ROD END ASSY, CENTER ALT INTCHG WITH R-45870-1	RF	35	
	R-45835-1	• ROD END ASSY, CENTER ALT INTCHG WITH R-45870-1	RF	35	
- 77	MS15011-1	• FITTING	1	35	
- 78	KWB9-F	• BEARING, <97613> 90-600012-006	1	35	
- 79	R-45870-7	• HOUSING	1	35	
	R-45835-7	• HOUSING, ALT INTCHG WITH R-45870-7	1	35	
	R-45835-9	• HOUSING, ALT INTCHG WITH R-45870-7	1	35	
- 80	R-45840-1	• ROD ASSY, ARMAMENT BAY DOOR CENTER FOR SRELDOWN SPEC 415, 2.20-27 ATTACHING PARTS	2	35	
- 81	AN321-9	• NUT, CENTER	4	35	
- 82	AN96101014	• WASHER, CENTER	4	35	
- 83	NAS464-10-15	• BOLT, CENTER	4	35	
		-----X-----			

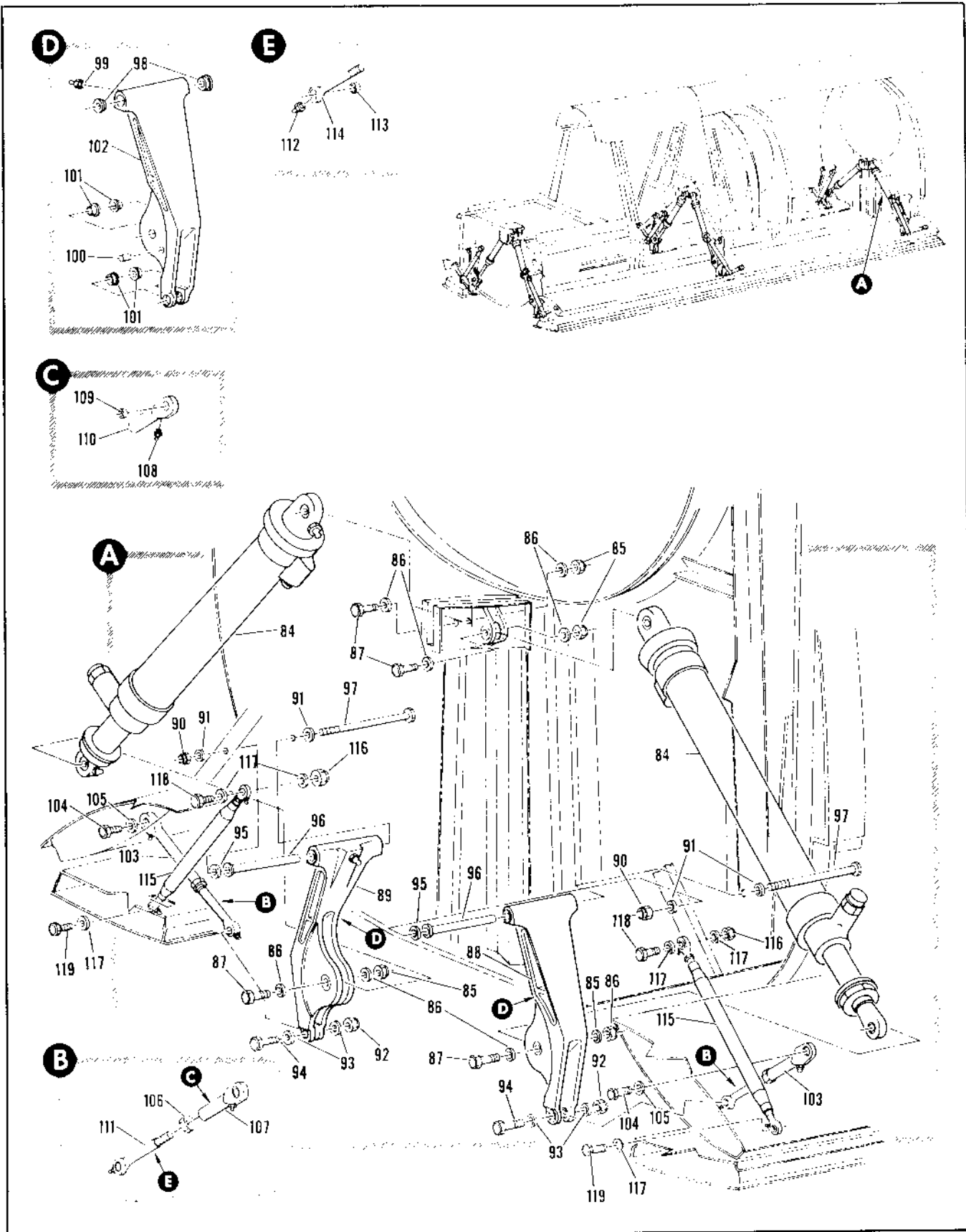

Figure 2.20-11. Armament Bay Door Actuator Installation (Sheet 4 of 4)

FIGURE AND INDEX NUMBER	PART NUMBER	DESCRIPTION	UNITS PER ASSY.	USABLE ON CODE	
				FROM	TO
2.20-11-84	10950-11	• ACTUATOR ASSY, ARMAMENT BAY DOOR AFT <97395> SPEC R-00934-1 T.O. 9P2-3-29-33 ATTACHING PARTS	2	35	
- 85	AN320-7	• NUT, AFT	4	35	
- 86	AN960D716	• WASHER, AFT	6	35	
- 87	NAS464-P7-1R	• BOLT, AFT	4	35	
		-----X-----			
- 88	8-45866-3 8-45867-7	• IDLER ASSY, ARMAMENT BAY DOOR AFT LH • IDLER ASSY, ARMAMENT BAY DOOR AFT LH ALT INTCHG WITH 8-45866-3	1 RF	35 35	
- 89	8-45866-4 8-45867-4	• IDLER ASSY, ARMAMENT BAY DOOR AFT RH • IDLER ASSY, ARMAMENT BAY DOOR AFT RH ALT INTCHG WITH 8-45866-4	1 RF	35 35	
		ATTACHING PARTS			
- 90	AN310-12	• NUT, AFT	4	35	
- 91	AN960D1216	• WASHER, AFT	6	35	
- 92	AN320-7	• NUT, AFT	4	35	
- 93	AN960D716	• WASHER, AFT	6	35	
- 94	NAS464-7-1R	• BOLT, AFT	4	35	
- 95	8-45866	• SHIM, AFT	2	35	
- 96	8-45867-7	• BUSHING, AFT	2	35	
- 97	8-45862-13	• BOLT, AFT	2	35	
		-----X-----			
- 98	8-45881-9	• BUSHING	2	35	
- 99	MS15001-1	• FITTING	1	35	
-100	8-45894	• PIN	1	35	
-101	8-45877	• BUSHING, AFT	4	35	
-102	8-45866-7 8-45867-7 8-45866-8 8-45867-8	• IDLER, AFT LH • IDLER, AFT LH ALT INTCHG WITH 8-45866-7 • IDLER, AFT RH • IDLER, AFT RH ALT INTCHG WITH 8-45866-8	1 RF 1 RF	35 35 35 35	
-103	8-45833	• LINK ASSY, ARMAMENT BAY DOOR AFT	2	35	
		ATTACHING PARTS			
-104	8-45886-7	• BOLT, AFT	2	35	
-105	AN960D716	• WASHER, AFT	2	35	
		-----X-----			
-106	NAS609-R	• NUT, AFT	1	35	
-107	8-45873-1 8-45838	• ROD END ASSY, AFT • ROD END ASSY, AFT ALT INTCHG WITH 8-45873-1	1 5F	35 35	
-108	MS15001-1	• FITTING	1	35	
-109	K8B7-1	• BEARING, <97613> 91-6011-006	1	35	
-110	8-45873-7 8-45836-7	• HOUSING • HOUSING, ALT INTCHG WITH 8-45873-7	1 RF	35 35	
-111	8-45872-1 8-45837	• ROD END ASSY, AFT • ROD END ASSY, AFT ALT INTCHG WITH 8-45872-1	1 RF	35 35	
-112	MS15001-1	• FITTING	1	35	
-113	K8B7-5	• BEARING, <97617> 91-60115-005	1	35	
-114	8-45872-7 8-45837-7	• HOUSING • HOUSING, ALT INTCHG WITH 8-45837-7	1 RF	35 35	
-115	8-45841-1	• ROD ASSY, ARMAMENT BAY DOOR AFT FOR BREAKDOWN SEE FIG. 2.20-20	2	35	
		ATTACHING PARTS			
-116	AN320-4	• NUT, AFT	2	35	
-117	AN960D416	• WASHER, AFT	6	35	
-118	NAS464-4-1R	• BOLT, AFT	2	35	
-119	8-45888	• BOLT, AFT	2	35	
		-----X-----			

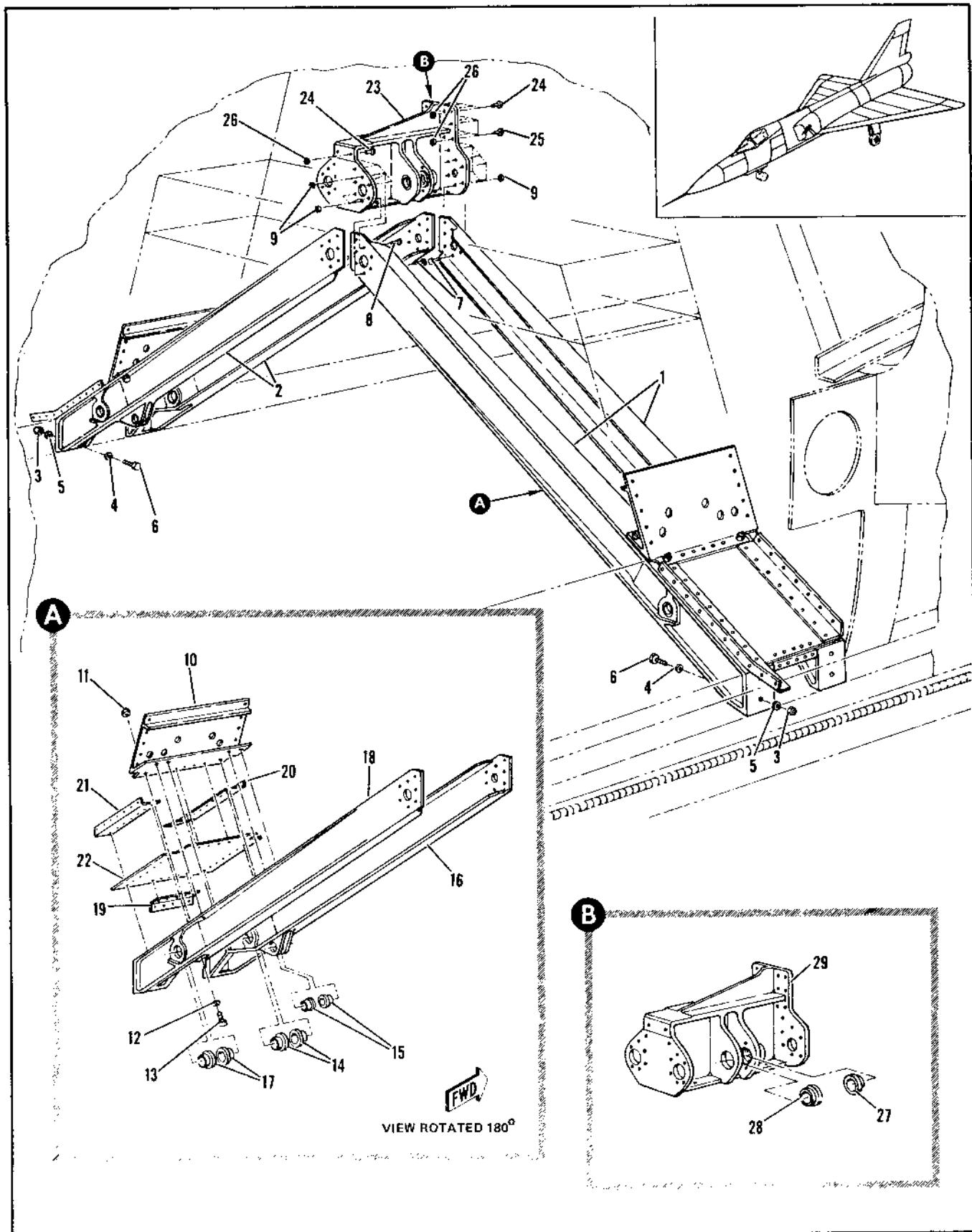

Figure 2.20-12. Armament Bay Door Center Actuator Support Installation

FIGURE AND INDEX NUMBER	PART NUMBER	DESCRIPTION	UNITS PER ASSY.	USABLE ON CODE	
				FROM	TO
2.20-12	8-77962	SUPPORT INSTALLATION, ARMAMENT BAY DOOR CENTER ACTUATOR CLR NHA SEE FIG. 2-3-11	1	35	
- 1	8-77962-23	• STRUT ASSY, LH	1	35	
- 2	8-77962-24	• STRUT ASSY, RH	1	35	
		ATTACHING PARTS			
- 3	42FW42B	• NUT, <56876> 96-3751-111	4	35	
- 4	MS20002C4	• WASHER	4	35	
- 5	AN900-4161	• WASHER	4	35	
- 6	MS20004-10	• BOLT	4	35	
- 7	SALP-T6-4	• BOLT, <29666> 96-7400-038	20	35	
- 8	SALP-T6-7	• BOLT, <29666> 96-7400-037	8	35	
- 9	CLC-C4	• COLLAR, <29666> 92-17100-005	24	35	
		----X----			
- 10	8-77962-7	• PLATE, LH	1	35	
	8-77962-8	• PLATE, RH	1	35	
		ATTACHING PARTS			
- 11	SN22442B	• NUT, <56876> 96-37612-001	4	35	
	MS20002C4	• NUT	4	35	
- 12	MS20002C4	• WASHER	4	35	
- 13	MS20004-5	• BOLT	4	35	
	MS20004-6	• BOLT	4	35	
		----X----			
	8-77930-3	• STRUT ASSY, DOOR MECHANISM SUPPORT FWD LH	1	35	
	8-77930-4	• STRUT ASSY, DOOR MECHANISM SUPPORT FWD RH	1	35	
- 14	8-77751-23	• BUSHING	2	35	
- 15	8-77751-21	• BUSHING	1	35	
- 16	8-77930-11	• STRUT, FWD LH	1	35	
	8-77930-12	• STRUT, FWD RH	1	35	
	8-77931-1	• STRUT ASSY, DOOR MECHANISM SUPPORT AFT LH	1	35	
	8-77931-2	• STRUT ASSY, DOOR MECHANISM SUPPORT AFT RH	1	35	
- 17	8-77751-23	• BUSHING	2	35	
- 18	8-77931-7	• STRUT AFT LH	1	35	
	8-77931-8	• STRUT, AFT RH	1	35	
- 19	8-77962-15	• ANGLE, LH	1	35	
	8-77962-16	• ANGLE, RH	1	35	
- 20	8-77962-11	• ANGLE, LH	1	35	
	8-77962-12	• ANGLE, RH	1	35	
- 21	8-77962-13	• ANGLE, LH	1	35	
	8-77962-14	• ANGLE, RH	1	35	
- 22	8-77962-9	• SKIN	1	35	
- 23	8-77909-5	• SUPPORT ASSEMBLY	1	35	
	8-77928-1	• SUPPORT ASSY, ALT INTERC WITH 8-77909-3	1	35	
		ATTACHING PARTS			
- 24	SALP-T6-4	• BOLT, <29666> 96-7400-038	8	35	
- 25	SALP-T6-7	• BOLT, <29666> 96-7400-037	8	35	
- 26	CLC-C4	• COLLAR, <29666> 92-17100-005	24	35	
		----X----			
- 27	8-77751-17	• BUSHING	2	35	
- 28	8-77751-19	• BUSHING	2	35	
- 29	8-77909-7	• SUPPORT	1	35	
	8-77928-7	• SUPPORT, ALT INTERC WITH 8-77909-7	1	35	

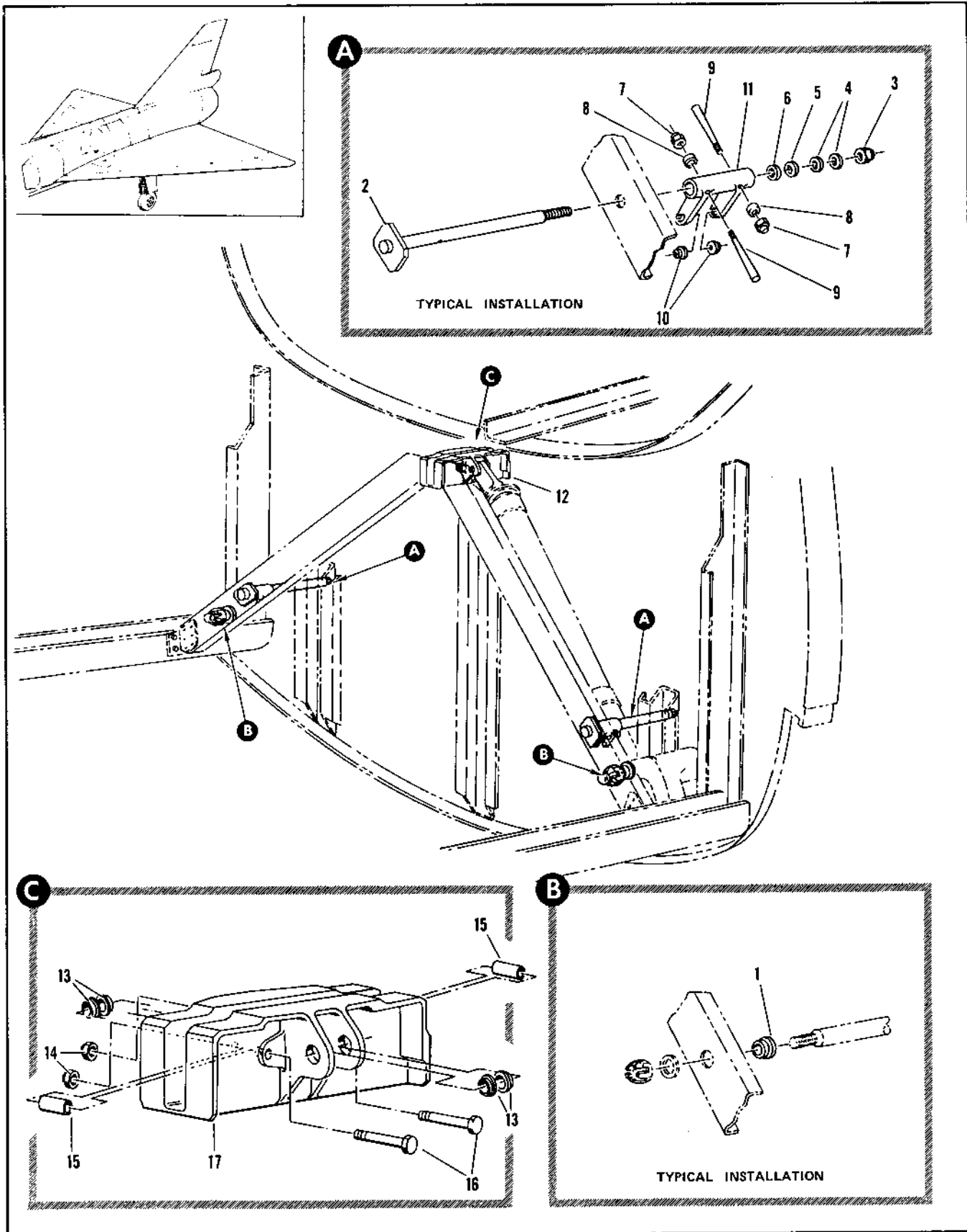

Figure 2.20-13. Armament Bay Door Aft Actuator Support Installation

FIGURE AND INDEX NUMBER	PART NUMBER	DESCRIPTION	UNITS PER ASSY.	USABLE ON CODE	
				FROM	TO
2.20-13	8-74931	SUPPORT INSTALLATION, ARMAMENT BAY DOOR AFT ACTUATOR FOR NHA SEE FIG. 2.3-10	RF	35	
- 1	8-77761-13	• BUSHING	2	35	
- 2	8-77918	• TUBE ASSY, AFT ACTUATOR SUPPORT ATTACHING PARTS	2	35	
- 3	NAS679A5	• NUT, 96-37545-004	2	35	
- 4	AN9610516	• WASHER	4	35	
- 5	8-74931-17	• SHIM	2	35	
- 6	MS20032C5	• WASHER	2	35	
		-----X-----			
- 7	NAS679A3	• NUT, 96-37545-002	4	35	
- 8	AN975-2	• WASHER	4	35	
- 9	AN386-1-8A	• PIN	4	35	
	8-77939-1	• ADAPTER ASSY, AFT ACTUATOR SUPPORT	2	35	
	8-77753	• ADAPTER ASSY, AFT ACTUATOR SUPPORT ALT INTCHG WITH 8-77939-1	RF	35	
- 10	8-77761-7	• BUSHING	2	35	
- 11	8-77939-7	• ADAPTER	1	35	35
	8-77939-11	• ADAPTER	1	35	
	8-77753-7	• ADAPTER, ALT INTCHG WITH 8-77939-7 AND 8-77939-11	1	35	
- 12	8-77752	• ADAPTER ASSY, AFT ACTUATOR SUPPORT	1	35	
- 13	8-77761-9	• BUSHING	4	35	
- 14	NAS679A4	• NUT, 96-37545-003	2	35	
- 15	NAS43003-4-40	• SPACER	2	35	
- 16	AN4-14A	• BOLT	2	35	
- 17	8-77752-7	• ADAPTER	1	35	

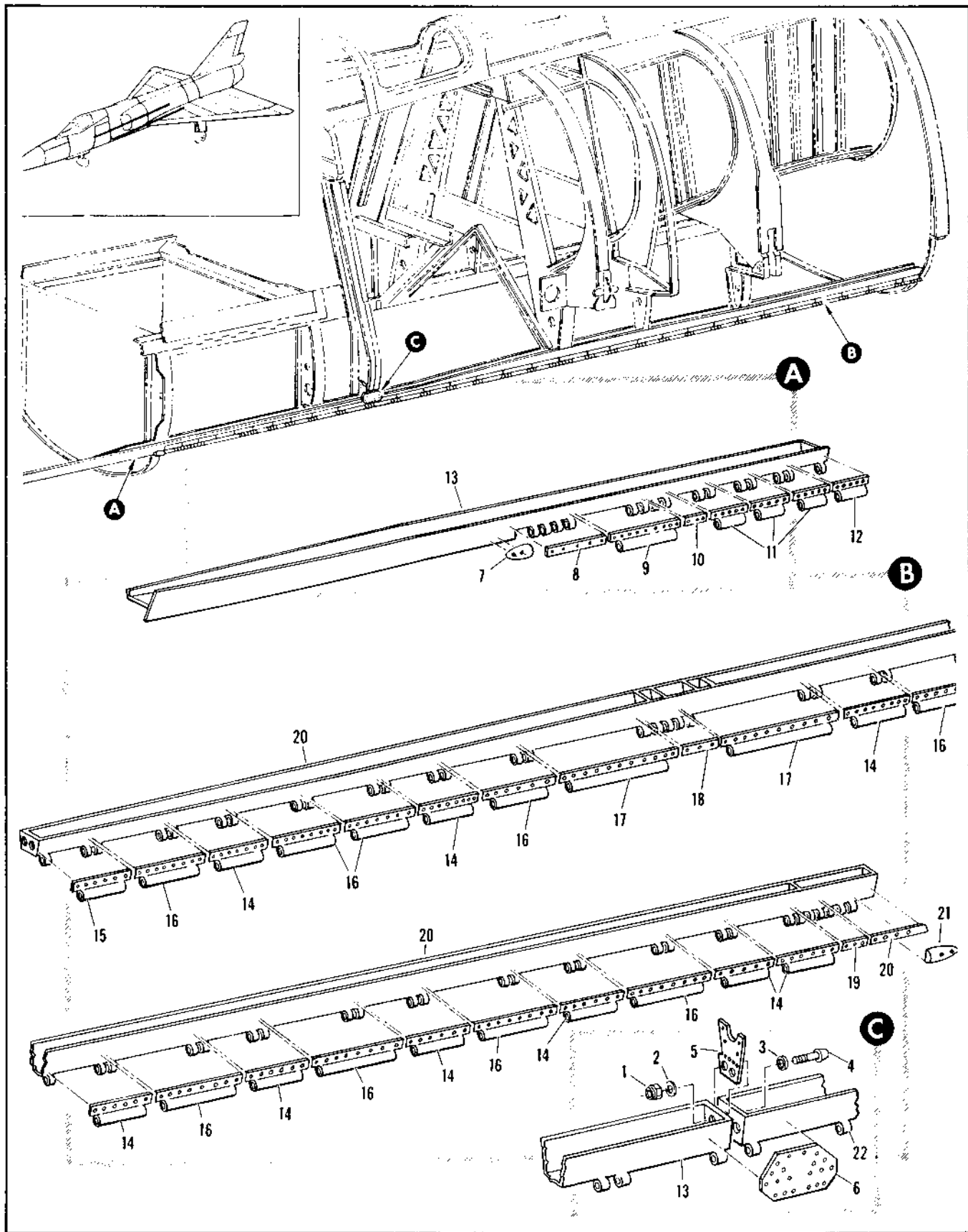

Figure 2.20-14. Armament Bay Door Hinge Lower Longeron

FIGURE AND INDEX NUMBER	PART NUMBER	DESCRIPTION	UNITS PER ASSY.	USABLE ON CODE	
				FROM	TO
2.20-14	8-74163-801	ARMAMENT BAY DOOR HINGE LOWER LONGERON	RF	35	
	8-74163-PC2	ATTACHMENT INSTL, ARMAMENT BAY DOOR LONGERON LH FOR NHA SEE FIG. 2.3-3	RF	35	
- 1	FN22M-720	ATTACHMENT INSTL, ARMAMENT BAY DOOR LONGERON RH FOR NHA SEE FIG. 2.3-3			
- 2	MS20002C8	NUT, <75237> 96-37510-304	2	35	
- 3	MS20002-8	WASHER	2	35	
- 4	MS20008-22	WASHER	2	35	
- 5	8-74163-9	BOLT	2	35	
- 6	8-74163-7	PLATE	1	35	
	8-74163-8	GUSSET, LH	1	35	
	8-74163-1	GUSSET, RH	1	35	
	8-74163-3	LONGERON INSTL, ARMAMENT BAY DOOR HINGE LOWER LH STA 165 TO 253 FOR NHA SEE FIG. 2.3-9	RF	35	
	8-77107-29	LONGERON INSTL, ARMAMENT BAY DOOR HINGE LOWER RH STA 165 TO 253 FOR NHA SEE FIG. 2.3-5	RF	35	
- 7	8-77107-21	FAIRING	1	35	
- 8	8-77107-7	FILLER	1	35	
- 9	8-77107-25	FAIRING, MAKE FROM 8-77107-25	1	35	
- 10	8-77107-17	FAIRING	RF		
- 11	8-77107-13	FILLER	1	35	
- 12	8-77107-13	FAIRING, MAKE FROM 8-77107-25	3	35	
	8-77107-31	FAIRING, MAKE FROM 8-77107-25 REPLACED BY NOT INTCHG WITH 8-77107-31 AND -32	1	35	1PH
	8-77107-32	FAIRING, LH MAKE FROM 8-77107-25 REPLACES NOT INTCHG WITH 8-77107-13	1	189	
	8-77107-32	FAIRING, RH MAKE FROM 8-77107-25 REPLACES NOT INTCHG WITH 8-77107-13	1	189	
- 13	8-77107-25	FAIRING	RF		
	8-74162-17	LONGERON, ARMAMENT BAY DOOR HINGE LOWER LH	1	35	
	8-74162-19	LONGERON, ARMAMENT BAY DOOR HINGE LOWER RH	1	35	
	8-74163-5	LONGERON INSTL, ARMAMENT BAY DOOR HINGE LOWER LH STA 253 TO 412 FOR NHA SEE FIG. 2.3-12	RF	35	
	8-74163-6	LONGERON INSTL, ARMAMENT BAY DOOR HINGE LOWER RH STA 253 TO 412 FOR NHA SEE FIG. 2.3-12	RF	35	
- 14	8-77107-11	FAIRING, MAKE FROM 8-77107-25	9	35	
- 15	8-77107-11	FAIRING, MAKE FROM 8-77107-25 REPLACED BY NOT INTCHG WITH 8-77107-33 AND -35	1	35	189
	8-77107-33	FAIRING, LH MAKE FROM 8-77107-25 REPLACES NOT INTCHG WITH 8-77107-11	1	189	
	8-77107-35	FAIRING, RH MAKE FROM 8-77107-25 REPLACES NOT INTCHG WITH 8-77107-11	1	189	
- 16	8-77107-25	FAIRING	RF		
- 17	8-77107-9	FAIRING, MAKE FROM 8-77107-25	9	35	
- 18	8-77107-7	FAIRING, MAKE FROM 8-77107-25	2	35	
- 19	8-77107-25	FAIRING	RF		
- 20	8-77107-15	FILLER	1	35	
- 21	8-77107-17	FILLER	1	35	
- 22	8-77107-27	FAIRING, LH MAKE FROM 8-77107-26	1	35	
	8-77107-26	FAIRING	RF		
	8-77107-28	FAIRING, RH MAKE FROM 8-77107-25	1	35	
	8-77107-25	FAIRING	RF		
- 21	8-77107-23	FAIRING	1	35	
- 22	8-74162-21	LONGERON, ARMAMENT BAY DOOR HINGE LOWER LH	1	35	
	8-74162-22	LONGERON, ARMAMENT BAY DOOR HINGE LOWER RH	1	35	
	8-74162-23	LONGERON ASSY, ARMAMENT BAY DOOR HINGE LOWER LH RIVETED ALT INTCHG WITH 8-74162-21	RF	35	
	8-74162-24	LONGERON ASSY, ARMAMENT BAY DOOR HINGE LOWER RH RIVETED ALT INTCHG WITH 8-74162-22	RF	35	

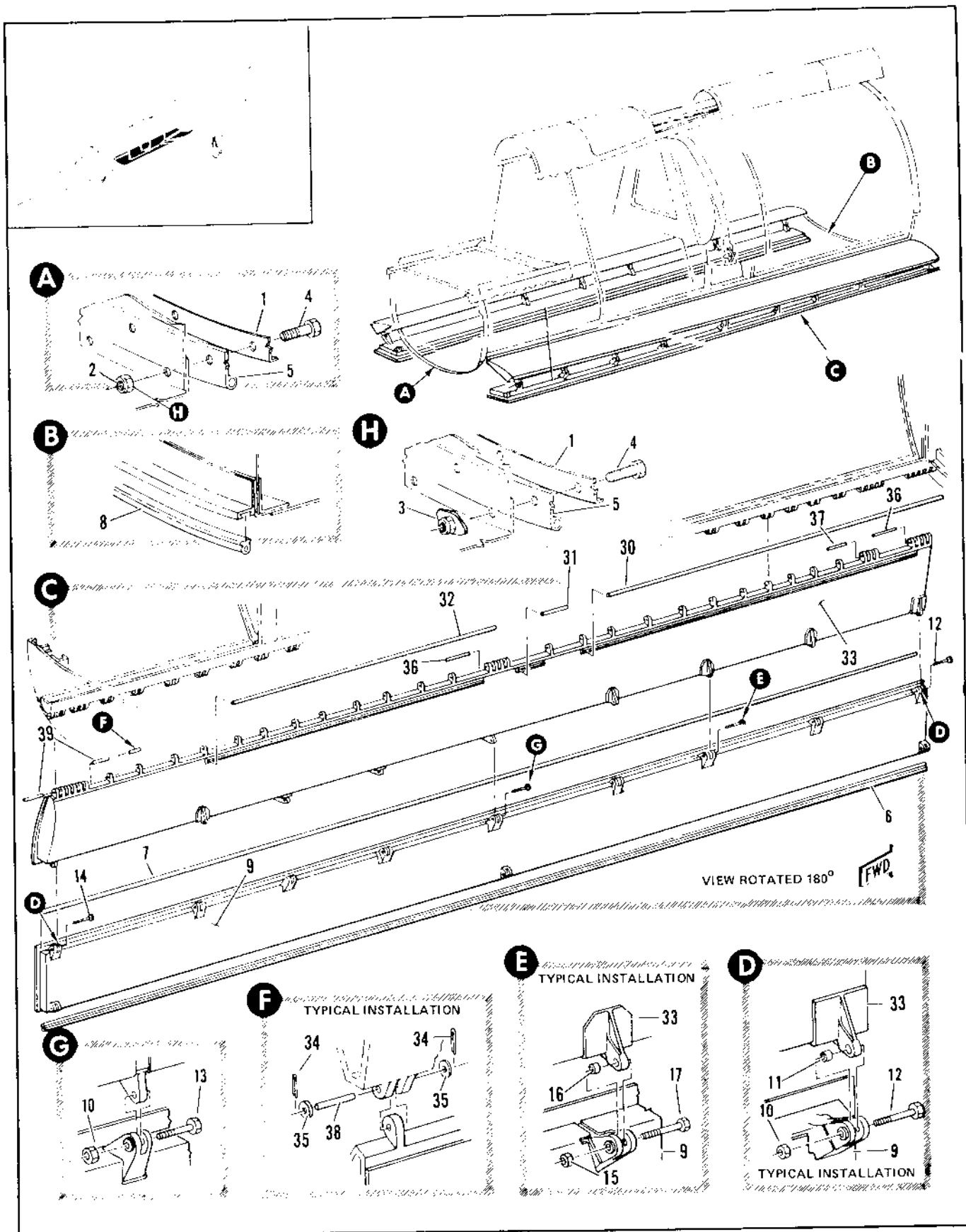

Figure 2.20-15. Armament Bay Door Installation Sta 216 to 412 (Sheet 1 of 2)

FIGURE AND INDEX NUMBER	PART NUMBER	DESCRIPTION	UNITS PER ASSY.	USABLE ON CODE	
				FROM	TO
2.20-15	R-74665	DOOR INSTALLATION, ARMAMENT BAY STA 216 TO 412 MODIFIED BY 8-71160 AND 8-71161 FOR NHA SEE FIG. 2.3-3 MOD BY 7144550	PF	35	
- 1	8-74665-21	• RETAINER, DOOR SEAL ATTACHING PARTS	1	35	
- 2	NAS679A3	• NUT, 96-37545-002, REPLACED BY NOT INTCHG WITH NAS696A3	28	35	
- 3	NAS969A3	• NUT PLATE, REPLACES NOT INTCHG WITH NAS679A3	28	35	
- 4	AN3-4A	• BOLT	16	35	
	AN3-5A	• BOLT	12	35	
		-----X-----			
- 5	8-77314	• SEAL, DOOR	1	35	
- 6	8-77315	• SEAL, DOOR LH	1	35	
- 7	8-77313-7	• SEAL, DOOR MAKE FROM 8-77313	2	35	
- 8	8-77313-6	• SEAL, DOOR MAKE FROM 8-77313	1	35	
- 9	8-74663-803	• DOOR ASSY, ARMAMENT BAY INBD LH FOR BREAKDOWN SEE FIG. 2.20-16	1	B	
	8-74663-801	• DOOR ASSY, ARMAMENT BAY INBD RH FOR BREAKDOWN SEE FIG. 2.20-16		B	
		ATTACHING PARTS			
- 10	AN320C6	• NUT	6	B	
- 11	8-77617-7	• BUSHING	4	B	
- 12	NAS464P6-21	• BOLT	2	B	
- 13	NAS464P6-17	• BOLT	2	B	
- 14	NAS464P6-26	• BOLT	2	B	
- 15	AN320C5	• NUT	12	B	
- 16	8-77617-9	• BUSHING (MAKE FROM ST4M167P5-0095)	12	B	
- 17	NAS464P5-20	• BOLT	12	B	
- 18	7144551-30	• DOOR ASSY, ARMAMENT BAY INBD AFT LH USE AS MISSION REQUIRES FOR BREAKDOWN SEE FIG. 2.20-17	1	A	
	7144551-40	• DOOR ASSY, ARMAMENT BAY INBD AFT RH USE AS MISSION REQUIRES FOR BREAKDOWN SEE FIG. 2.20-17	1	A	
		ATTACHING PARTS			
- 19	MS21244-6	• NUT	2	A	
- 20	MS27576-6-20	• BOLT	2	A	
- 21	MS21244-5	• NUT	6	A	
- 22	MS27576-5-20	• BOLT	6	A	
		-----X-----			
- 23	7144551-10	• DOOR ASSY, ARMAMENT BAY INBD FWD LH FOR BREAKDOWN SEE FIG. 2.20-17	1	A	
	7144551-20	• DOOR ASSY, ARMAMENT BAY INBD FWD RH FOR BREAKDOWN SEE FIG. 2.20-17	1	A	
		ATTACHING PARTS			
- 24	AN320C6	• NUT	2	A	
- 25	8-77617-7	• BUSHING	2	A	
- 26	NAS464P6-21	• BOLT	2	A	
- 27	AN320C5	• NUT	6	A	
- 28	8-77617-9	• BUSHING	6	A	
- 29	NAS464P5-20	• BOLT	6	A	
		-----X-----			
- 30	8-77312-7	• SEAL, DOOR MAKE FROM 8-77312	2	35	

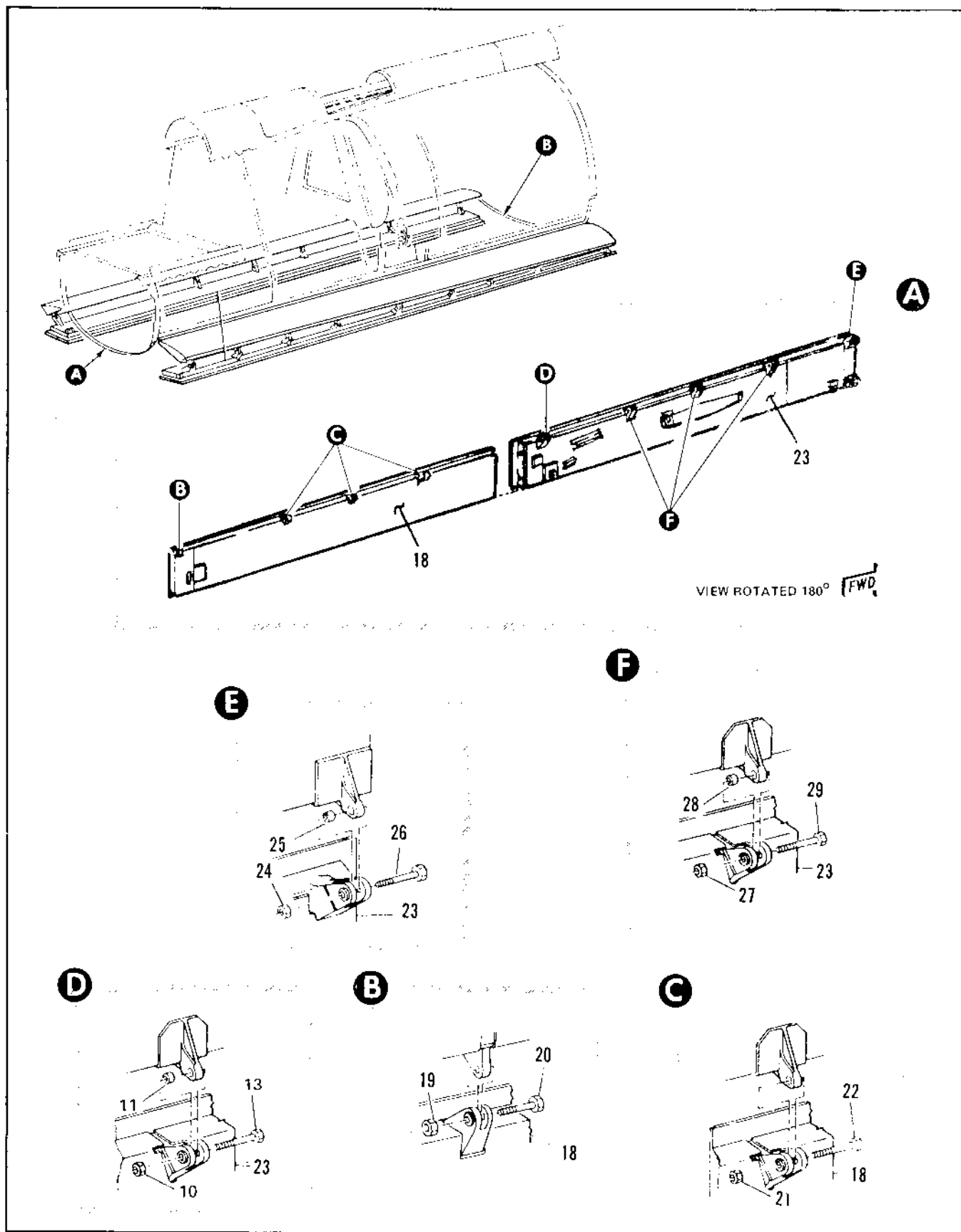

Figure 2.20-15. Armament Bay Door Installation Sta 216 to 412 (Sheet 2 of 2)

FIGURE AND INDEX NUMBER	PART NUMBER	DESCRIPTION	UNITS PER ASSY.	USABLE ON CODE	
				FROM	TO
2.30-15- 31 - 32 - 33	6-77312-9	• SEAL, DOOR MAKE PART 6-77312	2	35	17
	6-77312-11	• SEAL, DOOR MAKE PART 6-77312	1	35	
	6-74664-1	• DOOR ASSY, ARMAMENT BAY OUTD L/R FOR BREAKDOWN SEE FIG. 2.22-15	1	C	120
	6-74664-103	• DOOR ASSY, ARMAMENT BAY OUTD L/R FOR BREAKDOWN SEE FIG. 2.22-15	1	D	
	6-74664-101	• DOOR ASSY, ARMAMENT BAY OUTD L/R ALL INTCHG WITH 6-74664-103 FOR BREAKDOWN SEE FIG. 2.22-15	64	D	
	6-74664-10	• DOOR ASSY, ARMAMENT BAY OUTD L/R FOR BREAKDOWN SEE FIG. 2.22-15	1	C	120
	6-74664-104	• DOOR ASSY, ARMAMENT BAY OUTD L/R FOR BREAKDOWN SEE FIG. 2.22-15	1	D	
	6-74664-102	• DOOR ASSY, ARMAMENT BAY OUTD L/R ALL INTCHG WITH 6-74664-104 FOR BREAKDOWN SEE FIG. 2.22-15	64	D	
	7144581-10	• DOOR ASSY, ARMAMENT BAY OUTD L/R FOR BREAKDOWN SEE FIG. 2.22-15	1	A	
	7144581-10	• DOOR ASSY, ARMAMENT BAY OUTD L/R FOR BREAKDOWN SEE FIG. 2.22-15 ATTACHING PARTS	1	A	
- 34	MS24665-161	• PIN, CUTTER	64	75	
- 35	A1991-511L	• WASHER	64	75	
- 36	6-77942-21	• PIN, HINGE -----X-----			
- 37	6-77942-19	• PIN, HINGE			
- 38	6-77942-15	• PIN, HINGE			
- 39	6-77942-17	• PIN, HINGE			
		A ADDED PER TCTO 1F-106A-558 ON AIRPLANES #49, 50 AND ON			
		B REMOVED PER TCTO 1F-106A-558 FROM AIRPLANES #49, 51 AND ON			
		C REMOVED PER TCTO 1F-106A-558 FROM AIRPLANES #49, 51 THRU 124			
		D REMOVED PER TCTO 1F-106A-558 FROM AIRPLANES #50 AND ON			

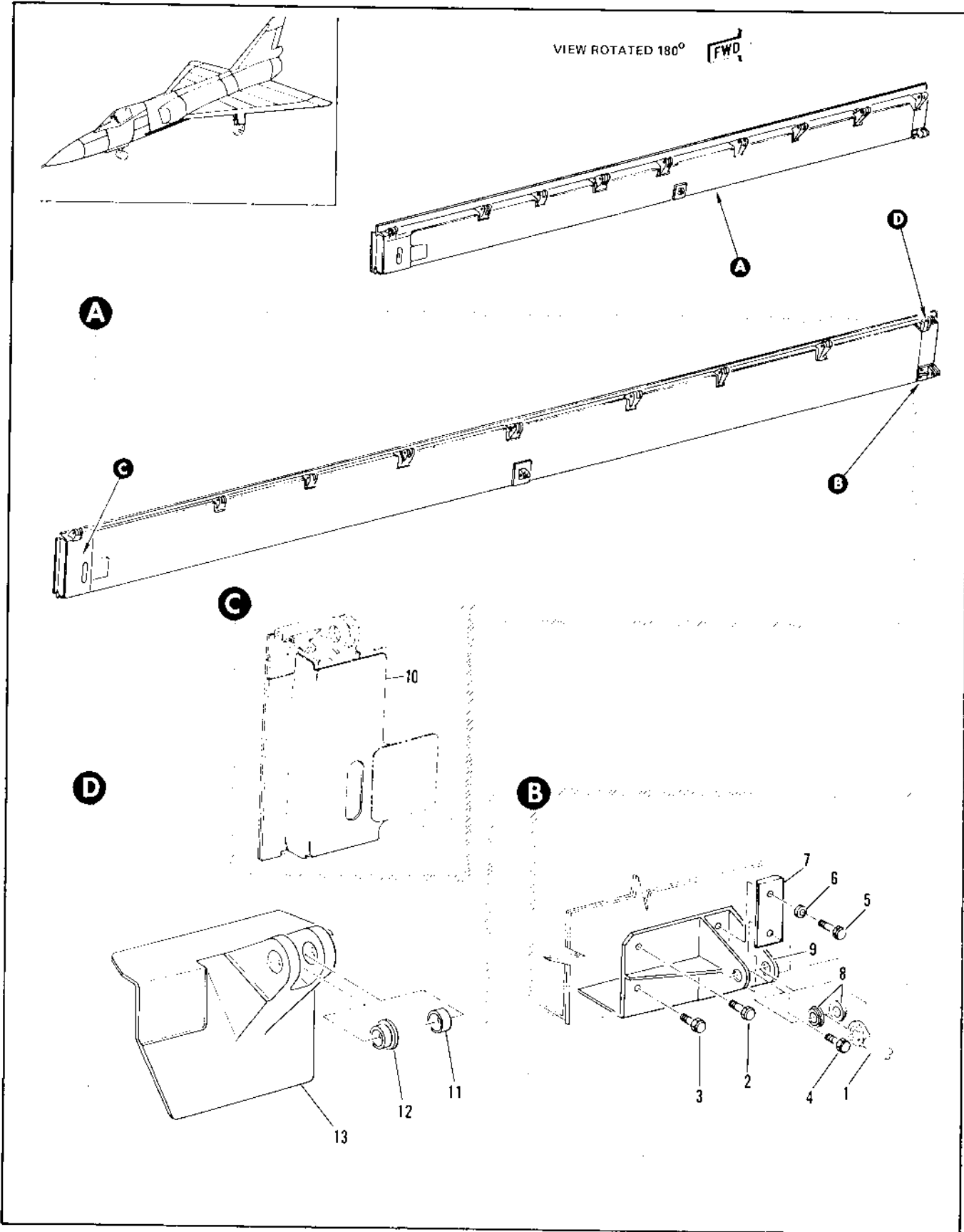

Figure 2.20-16. Armament Bay Inbd Door Assembly (Sheet 1 of 2)

FIGURE AND INDEX NUMBER	PART NUMBER	DESCRIPTION	UNITS PER ASSY.	USABLE ON CODE	
				FROM	TO
		1 2 3 4 5 6			
2.20-16	8-74663-803	DOOR ASSEMBLY, ARMAMENT BAY 1100 LH FOR NHA SEE FIG. 2.20-16	RF	A	
	8-74663-801	DOOR ASSEMBLY, ARMAMENT BAY 1100 RH FOR NHA SEE FIG. 2.20-16	RF	A	
- 1		• ROD ASSY, ARMAMENT BAY DOOR FWD SEE FIG. 2.20-20	RF		
	8-77769-1	• LUG ASSY, DOOR LH	1	A	
	8-77769-2	• LUG ASSY, DOOR RH	1	A	
		ATTACHING PARTS			
- 2	NAS464-3AE	• BOLT	1	A	
- 3	NAS464-3AF	• BOLT	1	A	
- 4	NAS464-3AE	• BOLT	1	A	
- 5	AN174-10A	• BOLT	1	A	
- 6	AN962-415	• WASHER	1	A	
- 7	8-74663-257	• BLOCK, RADIUS -----X-----	1	A	
- 8	8-77619-7	• RUSHING	2	A	
- 9	8-77769-9	• LUG, LH	1	A	
	8-77769-10	• LUG, RH	1	A	
- 10	8-74663-101	• RIB, LH	1	A	
	8-74663-102	• RIB, RH	1	A	
	8-77738-5	• HINGE ASSY, LH	1	A	
	8-77738-3	• HINGE ASSY, LH ALT INTCHG WITH 8-77738-5	RF	A	
	8-77738-6	• HINGE ASSY, RH	1	A	
	8-77738-4	• HINGE ASSY, RH ALT INTCHG WITH 8-77738-6	RF	A	
- 11	91-27634-033	• RUSHING	1	A	
- 12	8-77615-11	• RUSHING	1	A	
- 13	8-77738-17	• HINGE, LH	1	A	
	8-77738-13	• HINGE, LH ALT INTCHG WITH 8-77738-17	RF	A	
	8-77738-18	• HINGE, RH	1	A	
	8-77738-14	• HINGE, RH ALT INTCHG WITH 8-77738-18	RF	A	
		A REMOVED PER T.O. 1F-106A-4-1 FROM AIR-PLANES #48, 51 AND ON.			

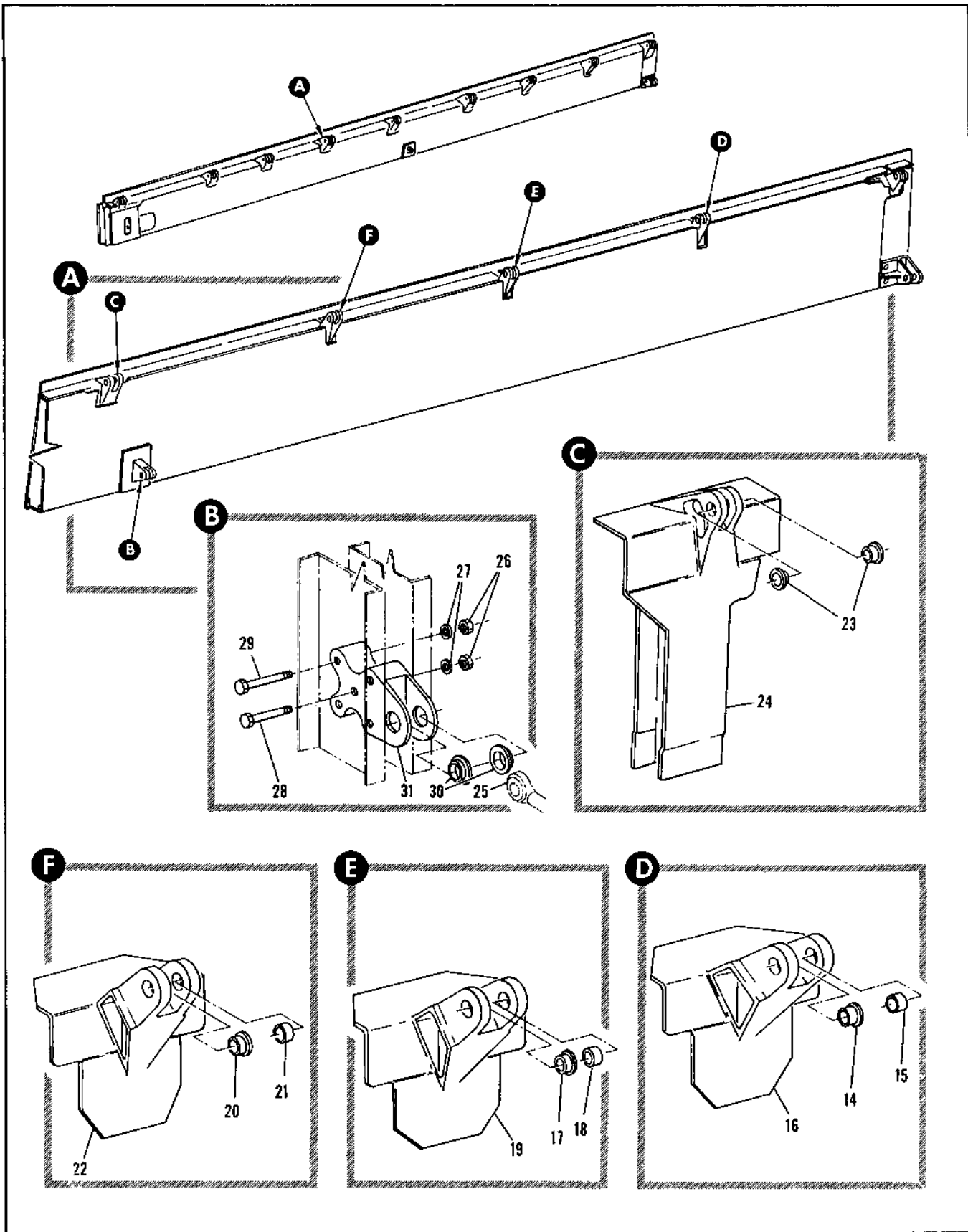

Figure 2.20-16. Armament Bay Inbd Door Assembly (Sheet 2 of 2)

FIGURE AND INDEX NUMBER	PART NUMBER	DESCRIPTION	UNITS PER ASSY.	USABLE ON CODE	
				FROM	TO
		1 2 3 4 5 6			
2.20-16	8-77739-3	• HINGE ASSY, LH	1	25	
	8-77739-1	• HINGE ASSY, LH ALT INTCHG WITH 8-77739-3	RF	35	
	8-77739-4	• HINGE ASSY, RH	1	35	
- 14	91-27604-032	• • BUSHING	1	35	
- 15	8-77615-7	• • BUSHING	1	35	
- 16	8-77740-5	• HINGE ASSY, LH	1	35	
	8-77740-6	• HINGE ASSY, RH	1	35	
- 17	91-27604-032	• • BUSHING	1	35	
- 18	8-77615-7	• • BUSHING	1	35	
- 19	8-77741-5	• HINGE ASSY, LH	1	35	
	8-77741-6	• HINGE ASSY, RH	1	35	
- 20	91-27604-032	• • BUSHING	1	35	
- 21	8-77615-7	• • BUSHING	1	35	
- 22	8-77741-5	• HINGE, LH	1	35	
	8-77741-6	• HINGE, RH	1	35	
	8-77967-1	• RIB ASSY, LH	1	35	
	8-77967-2	• RIB ASSY, RH	1	35	
- 23	91-28064-00R	• • BUSHING	2	35	
- 24	8-77967-1	• RIB, LH	1	35	
	8-77967-2	• RIB, RH	1	35	
- 25		• HOB ASSY, ARMAMENT BAY DOOR FWD SEE FIG. 2.20-20	RF		
	8-77968	• LUG ASSEMBLY ATTACHING PARTS	1	35	
- 26	NAS679A3	• NUT	5	35	
- 27	AN966-10	• WASHER	5	35	
- 28	NAS464-3414	• BOLT	1	35	
- 29	NAS464-3416	• BOLT	4	35	
		-----X-----			
- 30	8-77614-13	• • PUSHING	2	35	
- 31	8-77968-7	• • LUG	1	35	

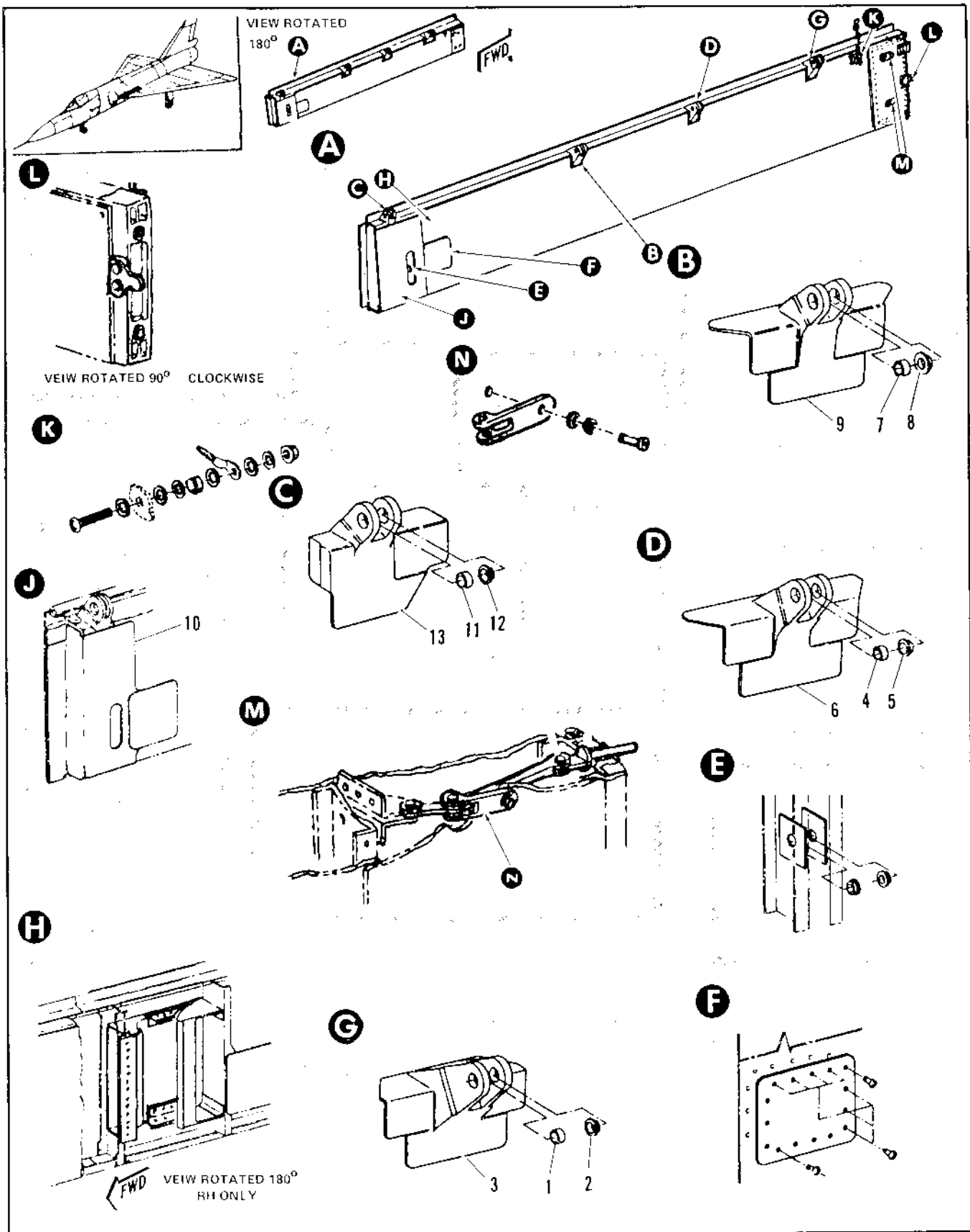

Figure 2.20-17. Armament Bay Inbd Aft Door Assembly (Sheet 1 of 2)

FIGURE AND INDEX NUMBER	PART NUMBER	DESCRIPTION	UNITS PER ASSY.	USABLE ON CODE		
				FROM	TO	
2.20-17	744551-30	DOOR ASSY, ARMAMENT BAY INBD AFT LH FOR NHA SEE FIG. 2.20-19	PF	A		
	7144551-40	DOOR ASSY, ARMAMENT BAY INBD AFT RH FOR NHA SEE FIG. 2.20-19	PF	A		
	8-77743-5	• HINGE ASSY, LH	1	A		
	8-77743-3	• HINGE ASSY, LH ALT INTCHG WITH 8-77743-5	PF	A		
	8-77743-6	• HINGE ASSY, RH	1	A		
	8-77743-4	• HINGE ASSY, RH ALT INTCHG WITH 8-77743-6	PF	A		
	- 1	91-27584-032	• BUSHING	1	A	
	- 2	8-77615-7	• BUSHING	1	A	
	- 3	8-77743-17	• HINGE, LH	1	A	
		8-77743-13	• HINGE, LH ALT INTCHG WITH 8-77743-17	PF	A	
		8-77743-18	• HINGE, RH	1	A	
		8-77743-14	• HINGE, RH ALT INTCHG WITH 8-77743-18	PF	A	
		8-77744-3	• HINGE ASSY, LH	1	A	
		8-77744-1	• HINGE ASSY, LH ALT INTCHG WITH 8-77744-3	PF	A	
		8-77744-4	• HINGE ASSY, RH	1	A	
	8-77744-2	• HINGE ASSY, RH ALT INTCHG WITH 8-77744-4	PF	A		
- 4	91-27584-032	• BUSHING	1	A		
- 5	8-77615-7	• BUSHING	1	A		
- 6	8-77744-13	• HINGE, LH	1	A		
	8-77744-9	• HINGE, LH ALT INTCHG WITH 8-77744-13	PF	A		
	8-77744-14	• HINGE, RH	1	A		
	8-77744-10	• HINGE, RH ALT INTCHG WITH 8-77744-14	PF	A		
	8-77745-3	• HINGE ASSY, LH	1	A		
	8-77745-1	• HINGE ASSY, LH ALT INTCHG WITH 8-77745-3	PF	A		
	8-77745-4	• HINGE ASSY, RH	1	A		
	8-77745-2	• HINGE ASSY, RH ALT INTCHG WITH 8-77745-4	PF	A		
- 7	91-27584-032	• BUSHING	1	A		
- 8	8-77615-7	• BUSHING	1	A		
- 9	8-77745-13	• HINGE, LH	1	A		
	8-77745-9	• HINGE, LH ALT INTCHG WITH 8-77745-13	PF	A		
	8-77745-14	• HINGE, RH	1	A		
	8-77745-10	• HINGE, RH ALT INTCHG WITH 8-77745-14	PF	A		
- 10	8-74663-161	• RIF, LH	1	A		
	7839435-01	• RIF, LH	1	F		
	8-74663-162	• RIF, RH	1	A		
	7839435-02	• RIF, RH	1	C		
	8-77746-5	• HINGE ASSY, LH	1	A		
	8-77746-3	• HINGE ASSY, LH ALT INTCHG WITH 8-77746-5	PF	A		
	8-77746-6	• HINGE ASSY, RH	1	A		
	8-77746-4	• HINGE ASSY, RH ALT INTCHG WITH 8-77746-6	PF	A		
- 11	91-27664-033	• BUSHING	1	A		
- 12	8-77615-9	• BUSHING	1	A		
- 13	8-77746-17	• HINGE, LH	1	A		
	8-77746-13	• HINGE, LH ALT INTCHG WITH 8-77746-17	PF	A		
	8-77746-18	• HINGE, RH	1	A		
	8-77746-14	• HINGE, RH ALT INTCHG WITH 8-77746-18	PF	A		
- 14	8-74663-177	• DOOR, ACCESS	1	A		
- 15	NAS221-10	• ATTACHING PARTS • SCREW	7	A		

A ADDED PER TC10 1F-106A-588 ON AIRPLANES #48, 90 AND ON
 B REPLACED 8-74663-161 PER TC10 1F-106A-564
 C REPLACED 8-74663-162 PER TC10 1F-106A-564

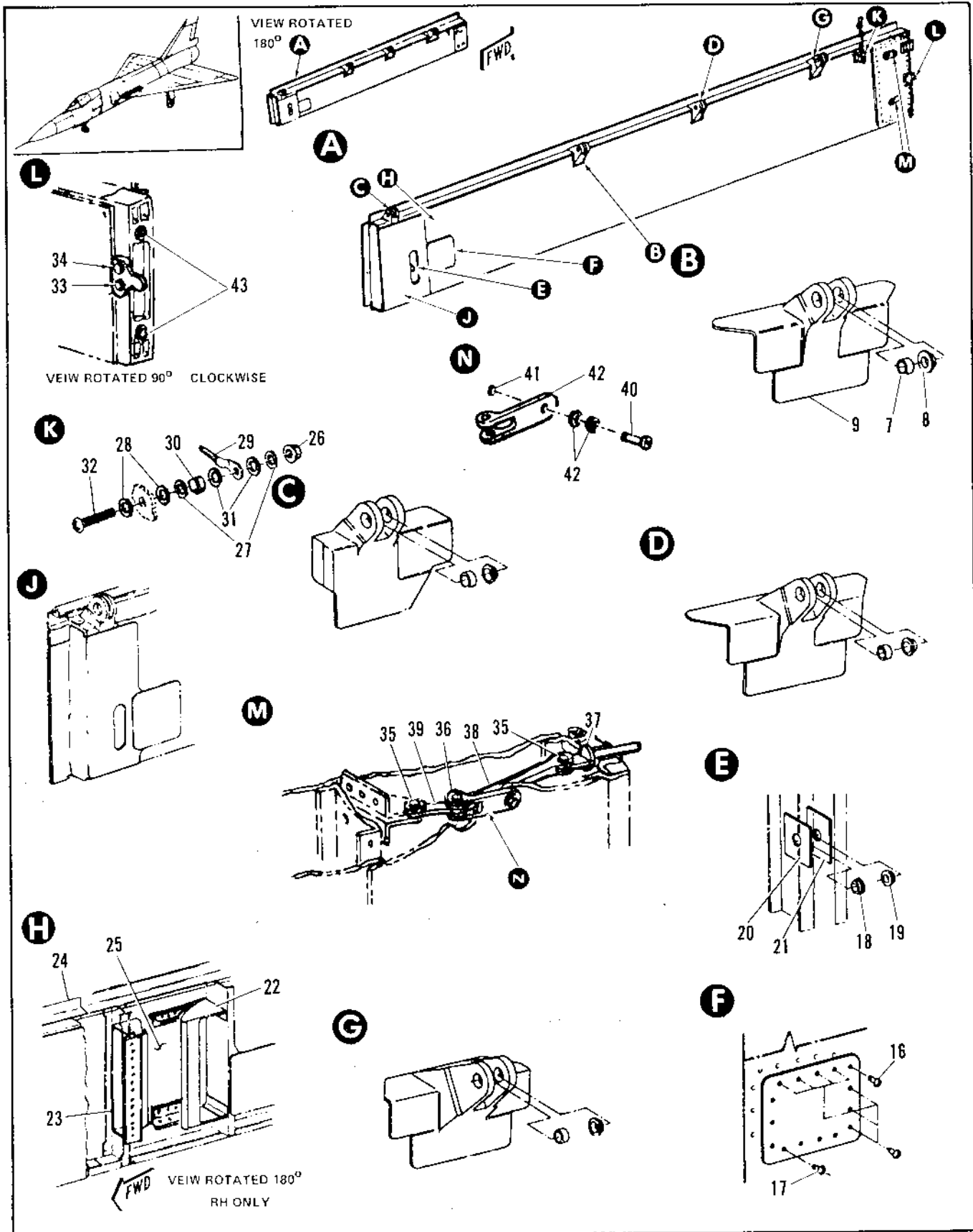

Figure 2.20-17. Armament Bay Inbd Aft Door Assembly (Sheet 2 of 2)

FIGURE AND INDEX NUMBER	PART NUMBER	DESCRIPTION	UNITS PER ASSY.	USABLE ON CODE	
				FROM	TO
		1 2 3 4 5 6			
2.20-17- 16	NAS221-11	• SCREW	7	A	
- 17	NAS221-12	• SCREW	1	A	
		-----X-----			
- 18	A-77619-9	• BUSHING	1	A	
- 19	A-77619-11	• BUSHING	1	A	
- 20	A-74553-245	• PLATE	1	A	
- 21	E-74553-197	• PLATE	1	A	
- 22	A-77770-7	• ADAPTER, MISSILE BAY DOOR EXIT DUCT RH	1	A	
- 23	A-77776-9	• ADAPTER, MISSILE BAY DOOR EXIT DUCT RH	1	A	
- 24	A-74553-207	• TEL, RH	1	A	
- 25	7144555-01	• CLOSURE ASSY	1	A	
- 26	MS21042L3	• NUT	1	A	
- 27	MS3523R-43	• LOCKWASHER	2	A	
- 28	AN960-10L	• WASHER	2	A	
- 29	724325-30	• JUMPER BOWDING (SEE T.O. 1F-106A-2-12-7-1)	1	A	
- 30	MS20541-10S	• NUT	1	A	
- 31	AN960D10L	• WASHER	2	A	
- 32	MS35207-265	• SCREW	1	A	
- 33	7144551-50	• FITTING	1	A	
		ATTACHING PARTS			
- 34	MS210426-3	• NUT	2	A	
	NAS620-10	• WASHER	4	A	
	NAS1103-9	• BOLT	2	A	
		-----X-----			
- 35	MS24565-151	• PIN, COTTER	4	A	
	AN960C10	• WASHER	4	A	
	MS9463-09	• PIN	4	A	
- 36	MS24565-151	• PIN, COTTER	2	A	
	AN960C10	• WASHER	2	A	
	MS9463-12	• PIN	2	A	
- 37	7144554-01	• PIN, DOOR SPLICE	2	A	
- 38	7144553-03	• LINK, DOOR SPLICE	2	A	
- 39	7144553-01	• LINK, DOOR SPLICE	2	A	
	7144597-10	• LATCH ASSY, DOOR SPLICE	2	A	
- 40	A31-2717	• STUD, TURNLOCK FAST (72744)	1	A	
- 41	GH3-1-2	• EYELET, TURNLOCK FAST (72744)	1	A	
- 42	7144597-01	• LATCH	1	A	
	7144555-10	• REP ASSY, MISSILE BAY DOOR CLOSING LH	1	A	
	7144555-20	• REP ASSY, MISSILE BAY DOOR CLOSING RH	1	A	
- 43	NAS77-5-70	• BUSHING	2	A	

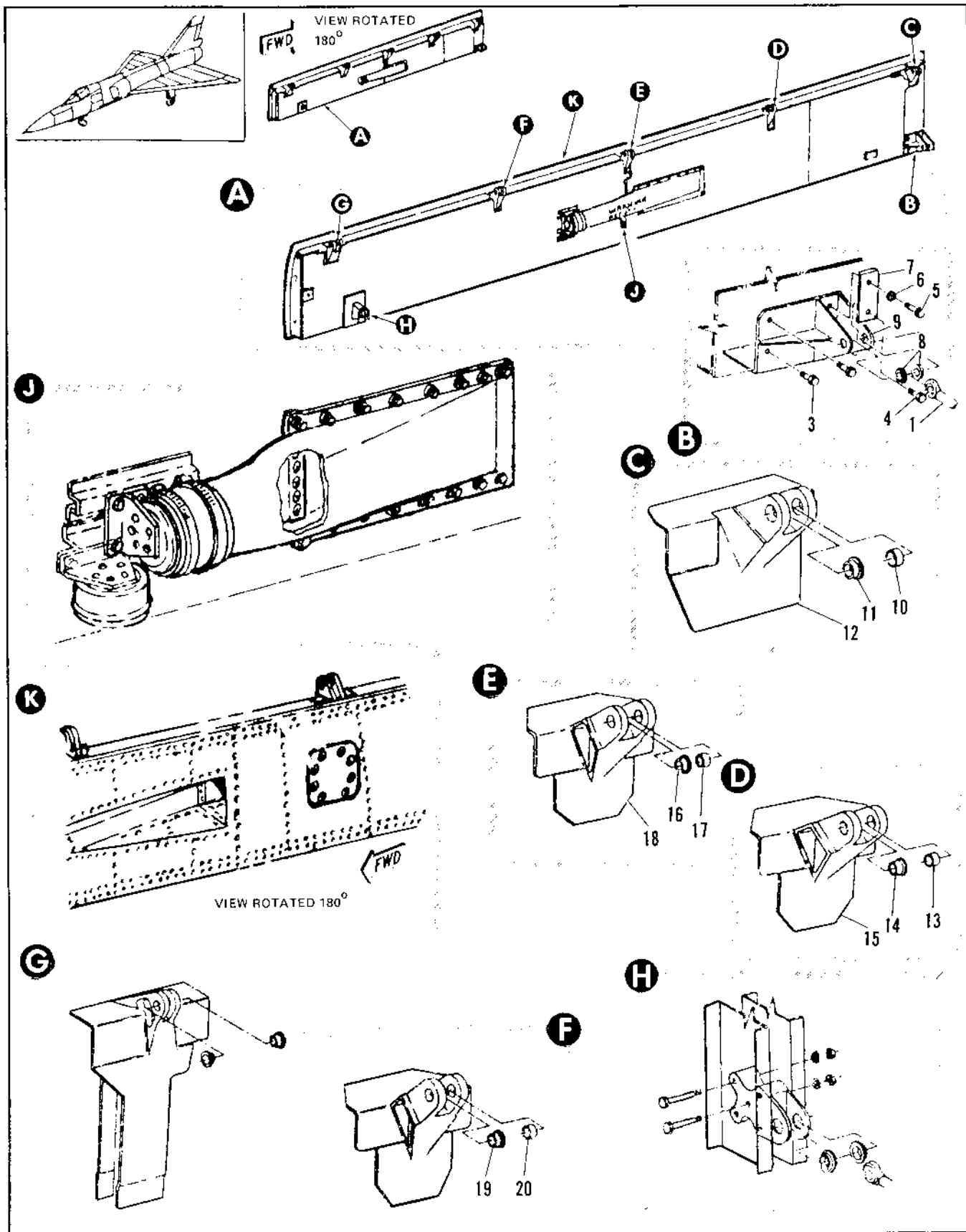

Figure 2.20-18. Armament Bay Inbd Fwd Door Assembly (Sheet 1 of 2)

FIGURE AND INDEX NUMBER	PART NUMBER	DESCRIPTION	UNITS PER ASSY.	USABLE ON CODE		
				FROM	TO	
2.20-18	7144551-10	DOOR ASSY, ARMAMENT BAY INRD FWD LH FOR NHA SEE FIG. 2.20-15	RF	A		
	7144551-20	DOOR ASSY, ARMAMENT BAY INRD FWD RH FOR NHA SEE FIG. 2.20-18	RF	A		
- 1	R-77739-3	• HINGE ASSY, LH	1	A		
	R-77739-1	• HINGE ASSY, LH ALT INTCHG WITH R-77739-3	RF	A		
	R-77739-4	• HINGE ASSY, RH	1AA	A		
	R-77739-2	• HINGE ASSY, RH ALT INTCHG WITH R-77739-4	RF	A		
		• ROD ASSY, ARMAMENT BAY DOOR FWD SEE FIG. 2.20-20	RF	A		
	R-77969-1	• LUG ASSY, DOOR LH	1	A		
	R-77969-2	• LUG ASSY, DOOR RH ATTACHING PARTS	1	A		
	- 2	NAS464-3A6	• BOLT	1	A	
	- 3	NAS464-3A5	• BOLT	1	A	
	- 4	NAS464-3A8	• BOLT	1	A	
	- 5	AN374-10A	• BOLT	1	A	
	- 6	AN960-416	• WASHER	1	A	
	- 7	R-74663-257	• BLOCK, RADIUS -----X-----	1	A	
	- 8	R-77519-7	• PUSHING	2	A	
	- 9	R-77969-9	• LUG, LH	1	A	
		R-77969-10	• LUG, RH	1	A	
		R-77738-5	• HINGE ASSY, LH	1	A	
		R-77738-3	• HINGE ASSY, LH ALT INTCHG WITH R-77738-5	RF	A	
		R-77738-6	• HINGE ASSY, RH	1	A	
		R-77738-4	• HINGE ASSY, RH ALT INTCHG WITH R-77738-6	RF	A	
- 10	91-27004-033	• BUSHING	1	A		
- 11	R-77615-11	• BUSHING	1	A		
- 12	R-77738-17	• HINGE, LH	1	A		
	R-77738-13	• HINGE, LH ALT INTCHG WITH R-77738-17	RF	A		
	R-77738-10	• HINGE, RH	1	A		
	R-77738-14	• HINGE, RH ALT INTCHG WITH R-77738-10	RF	A		
- 13	91-27004-032	• BUSHING	1	A		
- 14	R-77615-7	• PUSHING	1	A		
- 15	R-77739-13	• HINGE, LH	1	A		
	R-77739-9	• HINGE, LH ALT INTCHG WITH R-77739-13	RF	A		
	R-77739-14	• HINGE, RH	1	A		
	R-77739-10	• HINGE, RH ALT INTCHG WITH R-77739-14	RF	A		
	R-77740-5	• HINGE ASSY, LH	1	A		
	R-77740-3	• HINGE ASSY, LH ALT INTCHG WITH R-77740-5	RF	A		
	R-77740-6	• HINGE ASSY, RH	1	A		
	R-77740-4	• HINGE ASSY, RH ALT INTCHG WITH R-77740-6	RF	A		
- 16	91-27004-032	• BUSHING	1	A		
- 17	R-77615-7	• BUSHING	1	A		
- 18	R-77740-17	• HINGE, LH	1	A		
	R-77740-13	• HINGE, LH ALT INTCHG WITH R-77740-17	RF	A		
	R-77740-10	• HINGE, RH	1	A		
	R-77740-14	• HINGE, RH ALT INTCHG WITH R-77740-10	RF	A		
	R-77741-5	• HINGE ASSY, LH	1	A		
	R-77741-3	• HINGE ASSY, LH ALT INTCHG WITH R-77741-5	RF	A		
	R-77741-6	• HINGE ASSY, RH	1	A		
	R-77741-4	• HINGE ASSY, RH ALT INTCHG WITH R-77741-6	RF	A		
- 19	91-27004-032	• BUSHING	1	A		
- 20	R-77615-7	• BUSHING	1	A		

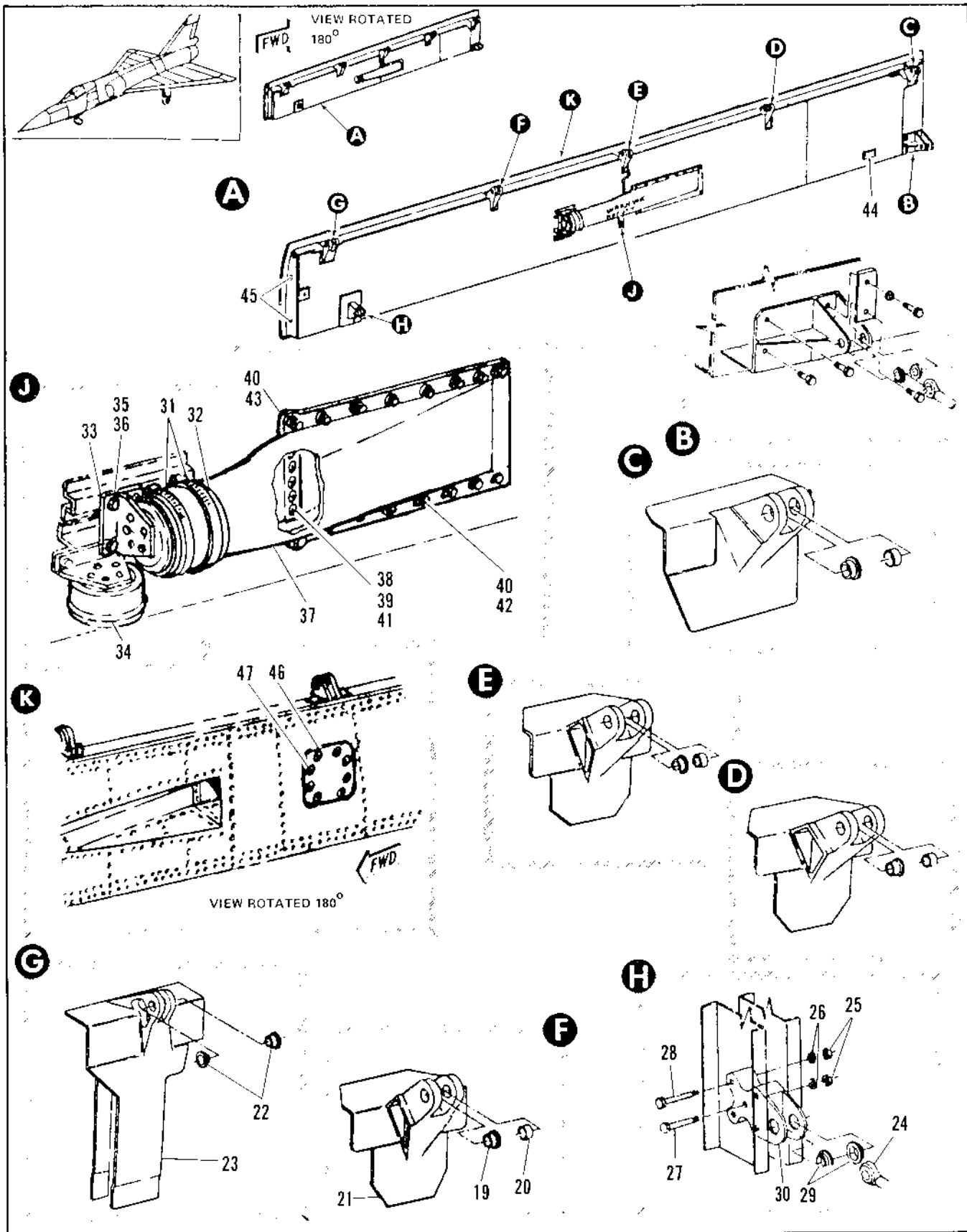

Figure 2.20-18. Armament Bay Inbd Fwd Door Assembly (Sheet 2 of 2)

FIGURE AND INDEX NUMBER	PART NUMBER	DESCRIPTION	UNITS PER ASSY.	USABLE ON CODE	
				FROM	TO
		1 2 3 4 5 6			
2.20-18- 21	9-77741-17	• • HINGE, LH	1	A	
	8-77741-13	• • HINGE, LH ALT INTCHG WITH 8-77741-17	RF	A	
	8-77741-16	• • HINGE, RH	1	A	
	8-77741-14	• • HINGE, RH ALT INTCHG WITH 8-77741-16	RF	A	
	8-77967-1	• RIF ASSY, LH	1	A	
	8-77742-1	• RIF ASSY, LH ALT INTCHG WITH 8-77967-1	RF	A	
	8-77967-2	• RIF ASSY, RH	1	A	
	8-77742-2	• RIF ASSY, RH ALT INTCHG WITH 8-77967-2	RF	A	
- 22	91-2-804-008	• • BUSHING	2	A	
- 23	8-77967-7	• • RIF, LH	1	A	
	8-77742-7	• • RIF, LH ALT INTCHG WITH 8-77967-7	RF	A	
	8-77967-8	• • RIF, RH	1	A	
	8-77742-8	• • RIF, RH ALT INTCHG WITH 8-77967-8	RF	A	
- 24		• RIF ASSY, ARMAMENT BAY DOOR FWD SEE FIG. 2-20-20	RF	A	
	8-77968	• LUG ASSEMBLY ATTACHING PARTS	1	A	
- 25	NAS679A3	• NUT	5	A	
- 26	AN961-10	• WASHER	5	A	
- 27	NAS464-3A14	• BOLT	1	A	
- 28	NAS464-3A16	• BOLT	4	A	
		----X----			
- 29	8-77614-13	• • BUSHING	1	A	
- 30	8-77968-7	• • LUG	1	A	
- 31	365-62-3445	• CLAMP, (98825) USE AS MISSION REQUIRES	2	A	
- 32	NAS520-26-13	• COUPLING USE AS MISSION REQUIRES	1	A	
- 33	7144865-10	• CAP ASSY, AIR INDUCTION INLET DUCT LH OPERATIONAL POSITION	1	A	
	7144865-20	• CAP ASSY, AIR INDUCTION INLET DUCT RH OPERATIONAL POSITION	1	A	
- 34	7144865-10	• CAP ASSY, AIR INDUCTION INLET DUCT LH STOWED POSITION	1	A	
	7144865-20	• CAP ASSY, AIR INDUCTION INLET DUCT RH STOWED POSITION ATTACHING PARTS	1	A	
- 35	NAS1163-4	• BOLT	3	A	
- 36	NAS1252-16L	• WASHER	2	A	
		----X----			
- 37	7144500-01	• DUCT, RAM AIR INLET ATTACHING PARTS	1	A	
- 38	MS21742L09	• NUT	5	A	
- 39	NAS1252-8L	• WASHER	5	A	
- 40	NAS1252-10L	• WASHER	10	A	
- 41	HL329-4-4	• BOLT (73187)	5	A	
- 42	NAS1103-6	• BOLT	10	A	
- 43	NAS1103-4	• BOLT	1	A	
		----X----			
- 44	MS27253-1	• PLATE, IDENTIFICATION	1	A	
	7144854-10	• RIF ASSY, MISSILE BAY DOOR CLOSING LH	1	A	
	7144854-20	• RIF ASSY, MISSILE BAY DOOR CLOSING RH	1	A	
- 45	NAS77-50-70	• • BUSHING	2	A	
- 46	7144853-01	• COVER ATTACHING PARTS	1	A	
- 47	NAS1153-2	• • BOLT	6	A	
		2. ADDED PER T.O. 1F-106A-33 FROM AIR- PLANES #AG, 90 AND ON			

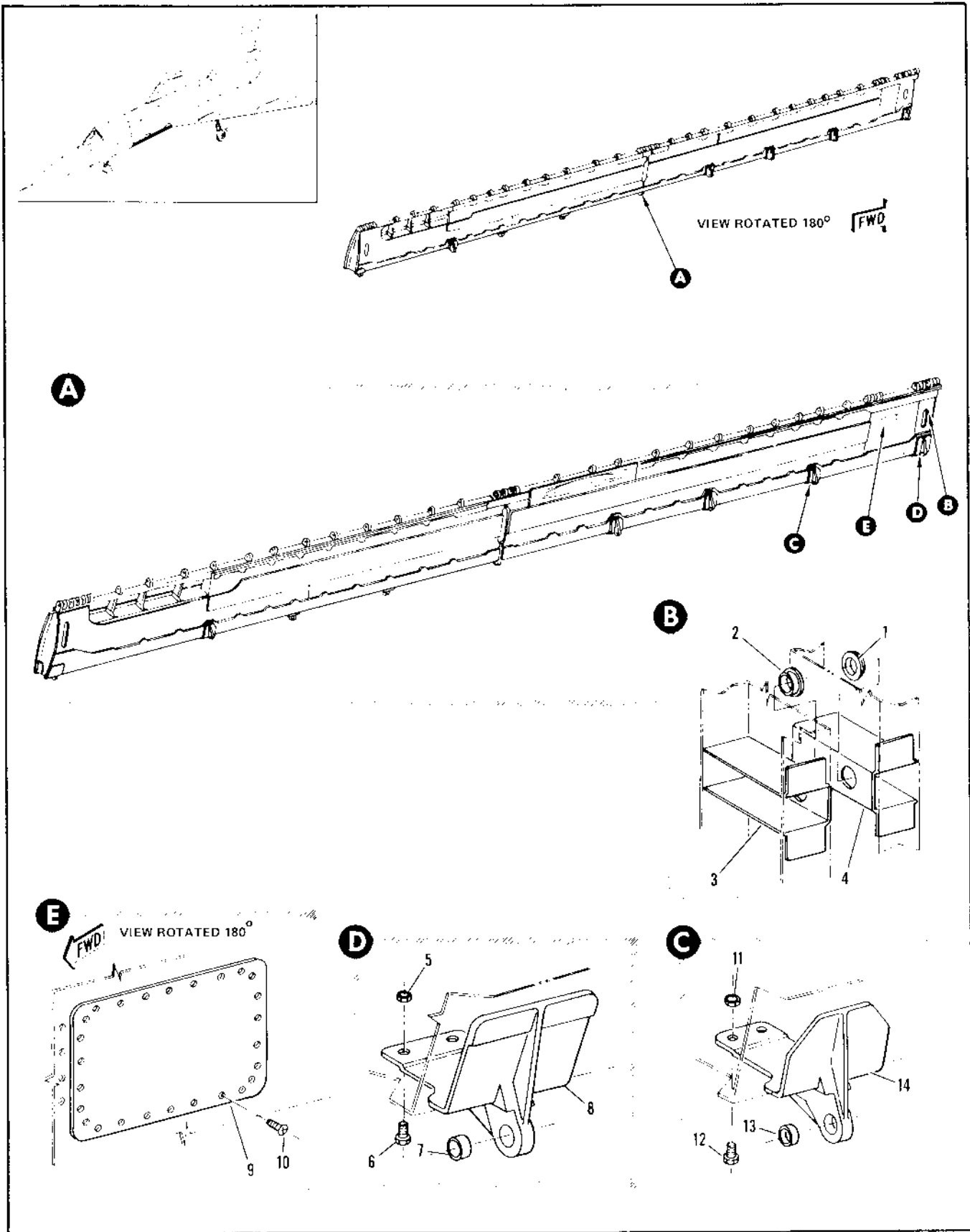

Figure 2.20-19. Armament Bay Outboard Door Assembly (Sheet 1 of 4)

FIGURE AND INDEX NUMBER	PART NUMBER	DESCRIPTION	UNITS PER ASSY.	USABLE ON CODE	
				FROM	TO
2.20-19	8-74664-803	DOOR ASSEMBLY, ARMAMENT BAY OUTBD LH FOR NHA SEE FIG. 2.20-15	RF	A	
	8-74664-804	DOOR ASSEMBLY, ARMAMENT BAY OUTBD RH FOR NHA SEE FIG. 2.20-15	RF	A	
	7144580-10	DOOR ASSY, ARMAMENT BAY OUTBD LH FOR NHA SEE FIG. 2.20-15	RF	B	
	7144580-20	DOOR ASSY, ARMAMENT BAY OUTBD RH FOR NHA SEE FIG. 2.20-15	RF	B	
- 1	8-77619-23	• BUSHING	1	35	
- 2	8-77619-25	• BUSHING	1	35	
- 3	8-74664-377	• BRACKET, LH	1	35	
	8-74664-378	• BRACKET, RH	1	35	
- 4	8-74664-375	• BRACKET, LH	1	35	
	8-74664-376	• BRACKET, RH	1	35	
	8-77904-1	• HINGE ASSY, LH	1	35	
	8-77904-2	• HINGE ASSY, RH	1	35	
- 5	NAS679A3	• NUT	2	35	
		ATTACHING PARTS			
- 6	AN173-6A	• BOLT	2	35	
		-----X-----			
- 7	8-77616-7	• BUSHING	1	35	
- 8	8-77904-1	• HINGE, LH	1	35	
	8-77904-2	• HINGE, RH	1	35	
- 9	8-77607-7	• DOOR, ACCESS FWD LH	1	A	
	7144587-30	• DOOR, ACCESS FWD LH	1	B	
	8-77607-8	• DOOR, ACCESS FWD RH	1	A	
	7144597-40	• DOOR, ACCESS FWD RH	1	B	
		ATTACHING PARTS			
- 10	NAS333PA4-5	• SCREW	26	A	
	NAS333CPA5	• SCREW	26	B	
		-----X-----			
	8-77905-1	• HINGE ASSY, LH	1	35	
	8-77905-2	• HINGE ASSY, RH	1	35	
		ATTACHING PARTS			
- 11	NAS679A3	• NUT	2	35	
- 12	AN173-6A	• BOLT	2	35	
		-----X-----			
- 13	8-77616-9	• BUSHING	1	35	
- 14	8-77905-1	• HINGE, LH	1	35	
	8-77905-2	• HINGE, RH	1	35	
		A REMOVED PER TCTO 1F-106A-50R FROM AIRPLANES #48, 9, AND ON			
		B ADDED PER TCTO 1F-106A-55R ON AIRPLANES #48, 9C AND ON			

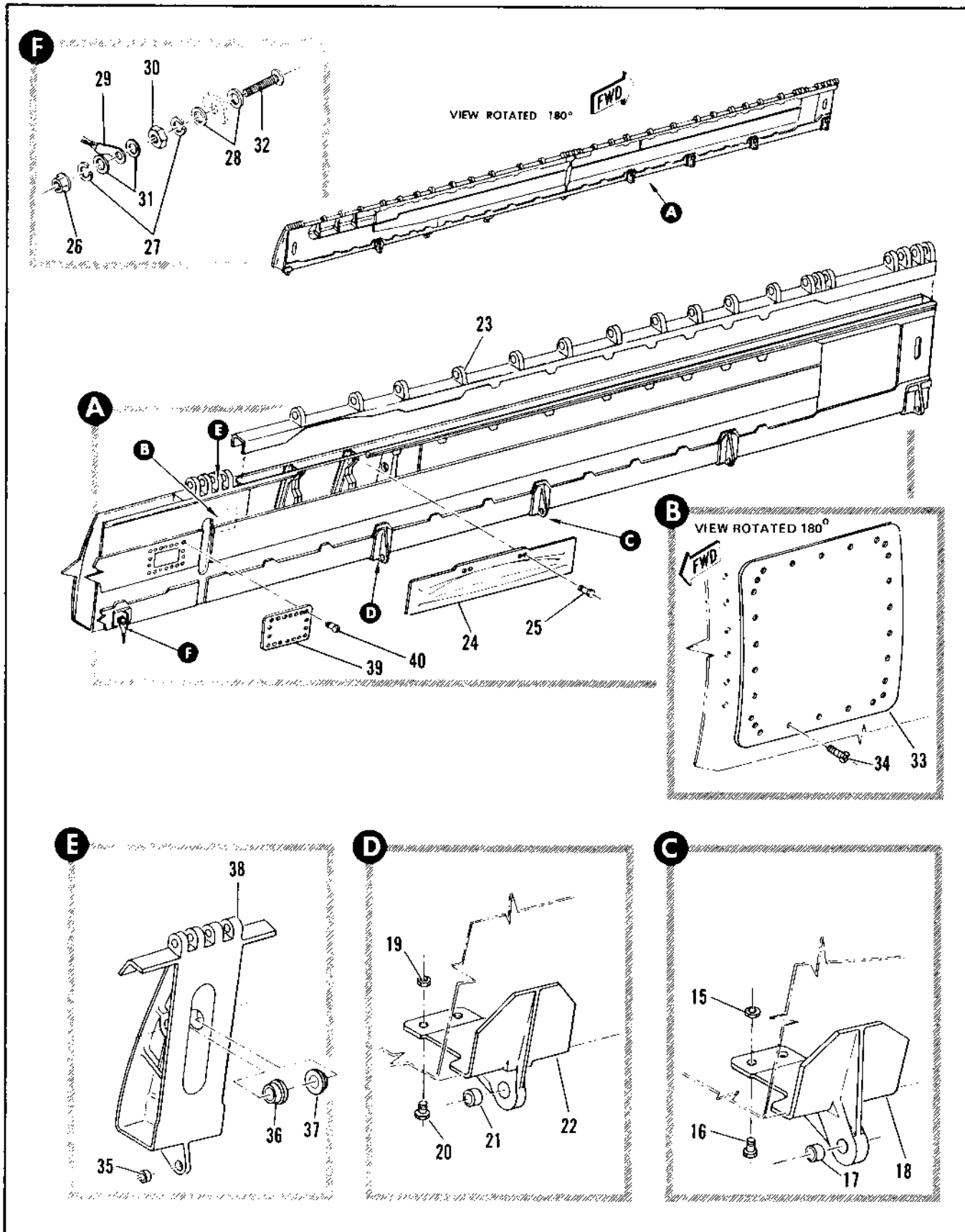

Figure 2.20-19. Armament Bay Outboard Door Assembly (Sheet 2 of 4)

FIGURE AND INDEX NUMBER	PART NUMBER	DESCRIPTION	UNITS PER ASSY.	USABLE ON CODE	
				FROM	TO
		1 2 3 4 5 6			
2.20-19	R-77900-1 R-77900-2	• HINGE ASSY, LH • HINGE ASSY, RH ATTACHING PARTS	1 1	35	
- 16	NAS679A3	• NUT	2	35	
- 18	AN173-BA	• BOLT	2	35	
		-----X-----			
- 17	R-77916-9	• BUSHING	1	35	
- 18	R-77916-1 R-77916-2 R-77917-1 R-77917-2	• HINGE, LH • HINGE, RH • HINGE ASSY, LH • HINGE ASSY, RH ATTACHING PART	1 1 1 1	35 35 35 25	
- 19	NAS679A3	• NUT	2	35	
- 20	AN173-BA	• BOLT	2	35	
		-----X-----			
- 21	R-77916-9	• BUSHING	1	35	
- 22	R-77917-1 R-77917-2	• HINGE, LH • HINGE, RH	1 1	35 35	
- 23	R-77728-7 R-77728-11 R-77728-7 R-77728-12	• HINGE, UPPER MISSILE DOOR FUSELAGE STA 217 TO 312 LH REPLACES BY NOT INTCHG WITH R-77728-11 • HINGE, UPPER MISSILE DOOR FUSELAGE STA 217 TO 312 LH REPLACES NOT INTCHG WITH R-77728-7 • HINGE, UPPER MISSILE DOOR FUSELAGE STA 217 TO 312 RH REPLACES BY INTCHG WITH R-77728-11 • HINGE, UPPER MISSILE DOOR FUSELAGE STA 217 TO 312 RH REPLACES NOT INTCHG WITH R-77728-7	1 1 1	35 35 35	35
- 24	R-77610-7 R-77611-9	• PAN, FIN LH • PAN, FIN RH ATTACHING PARTS	1 1	35 35	
- 25	BB302-0-6	• SCREW, <73167> 97-63 15-11	4	35	
- 26	MS2192L3	• NUT	2	35	
- 27	MS35134-43	• LOCKWASHER	4	35	
- 28	AN70-10L	• WASHER	2	35	
- 29	7243523-10	• JUMPER (SEE T.O. 1F-106A-2-12-2-1)	1	35	
- 30	MS20341-10S	• NUT	1	35	
- 31	AN96-010L	• WASHER	2	35	
- 32	MS35257-265	• SCREW	1	35	
- 33	R-77610-7 7149597-10 R-77610-8 7149597-20	• DOOR, ACCESS LH • DOOR, ACCESS LH • DOOR, ACCESS RH • DOOR, ACCESS RH ATTACHING PARTS	1 1 1 1	35 35 35 35	
- 34	NAS33P44-5 NAS33CPA5	• SCREW • SCREW	14 14	35 35	
		-----X-----			
- 35	R-77916-9	• BUSHING	1	35	
- 36	R-77916-17	• BUSHING	1	35	

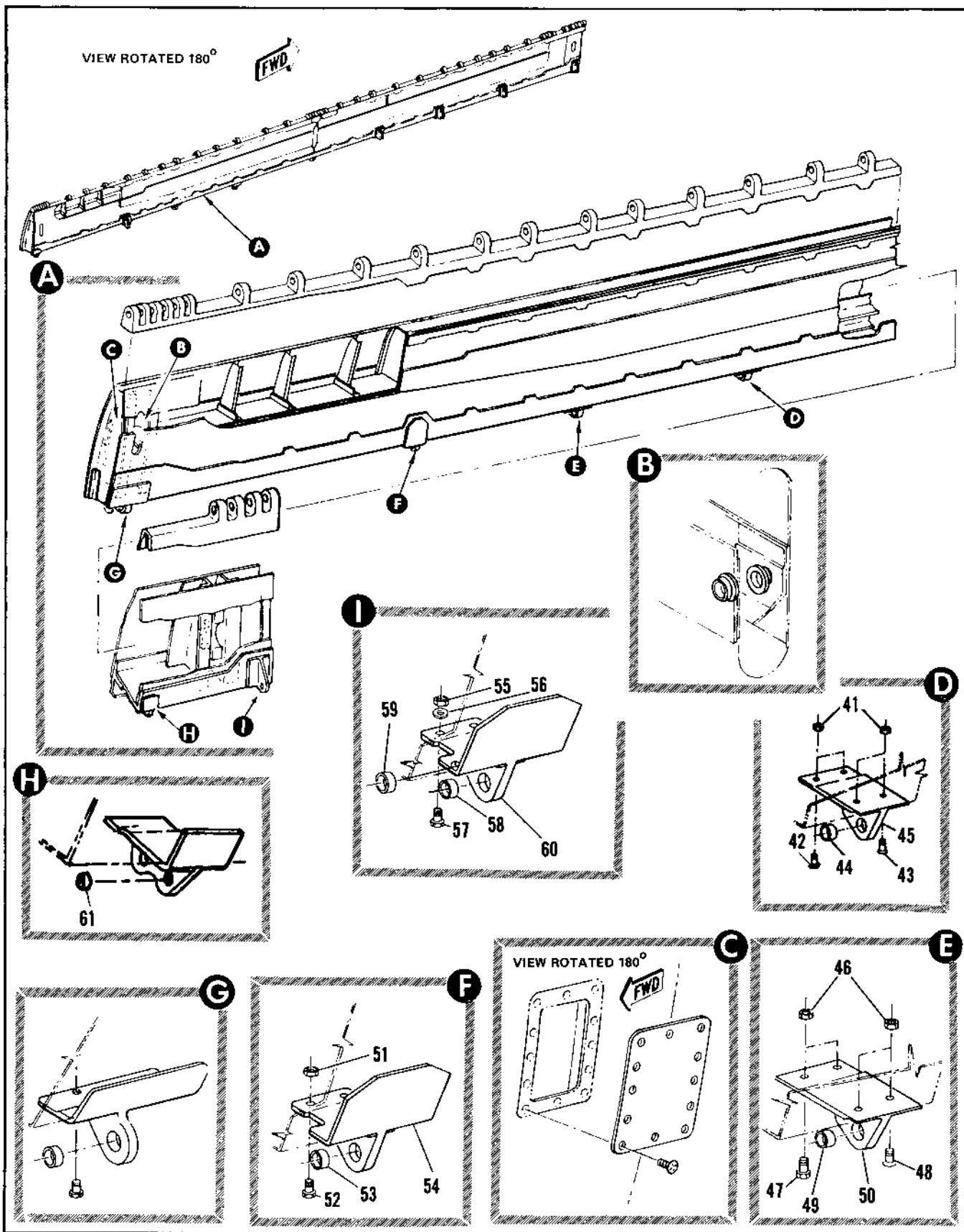

Figure 2.20-19. Armament Bay Outboard Door Assembly (Sheet 3 of 4)

FIGURE AND INDEX NUMBER	PART NUMBER	DESCRIPTION	UNITS PER ASSY.	USABLE ON CODE	
				FROM	TO
		1 2 3 4 5 6			
1.20-19-37	B-77519-15	• PUSHING	1	35	
- 38	B-77537-4	• RIF, LH	1	35	
	A-77719-3	• RIF, LH USE WITH B-77719-3	1	35	
	A-77729-7	• RIF, LH USE WITH B-77729-7	1	35	
	B-77537-10	• RIF, RH	1	35	
	B-77729-10	• RIF, RH USE WITH B-77729-4	1	35	
	B-77729-8	• RIF, RH USE WITH B-77729-7	1	35	
	B-77537-7	• RIF, USE WITH B-77537-10 AND B-77537-6	1	35	
	B-77537-6	• RIF, USE WITH B-77537-8 AND B-77537-7	1	35	
- 39	B-4614-505	• DOOR, ACCESS STA 312 TO 322	1	35	
- 40	AN521-10R7	• SCREW	14	35	
	B-77505-1	• HINGE ASSY, LH	1	35	
	B-77505-2	• HINGE ASSY, RH	1	35	
		ATTACHING PARTS			
- 41	NAS673A3	• NUT	4	35	
- 42	AN173-7A	• BOLT	2	35	
- 43	NAS333PA7	• BOLT	2	35	
		-----X-----			
- 44	B-77516-8	• PUSHING	1	35	
- 45	B-77505-1	• HINGE, LH	1	35	
	B-77505-2	• HINGE, RH	1	35	
	B-77505-1	• HINGE ASSY, LH	1	35	
	B-77505-2	• HINGE ASSY, RH	1	35	
		ATTACHING PARTS			
- 46	NAS673A3	• NUT	4	35	
- 47	AN173-7A	• BOLT	2	35	
- 48	NAS333PA7	• BOLT	2	35	
		-----X-----			
- 49	B-77516-8	• PUSHING	1	35	
- 50	B-77505-1	• HINGE, LH	1	35	
	B-77505-2	• HINGE, RH	1	35	
	B-77510-1	• HINGE, LH	1	35	
	B-77510-2	• HINGE ASSY, RH	1	35	
		ATTACHING PARTS			
- 51	NAS673A3	• NUT	2	35	
- 52	AN173-7A	• BOLT	2	35	
		-----X-----			
- 53	B-77516-8	• PUSHING	1	35	
- 54	B-77510-1	• HINGE, LH	1	35	
	B-77510-2	• HINGE, RH	1	35	
	71445-3-10	• HINGE ASSY, LH	1	35	
	71445-3-20	• HINGE ASSY, RH	1	35	
		ATTACHING PARTS			
- 55	NAS673A3	• NUT	2	35	
- 56	AN951-10L	• WASHER	2	35	
- 57	AN173-7A	• BOLT	2	35	
		-----X-----			
- 58	NAS75-7-10	• PUSHING	1	35	
- 59	NAS75-5-10	• PUSHING	1	35	
- 60	71445-3-01	• HINGE, LH	1	35	
	71445-3-02	• HINGE, RH	1	35	
	71445-3-10	• BRACKET ASSY, LH	1	35	
	71445-3-20	• BRACKET ASSY, RH	1	35	
- 61	NAS75-5-10	• PUSHING	1	35	

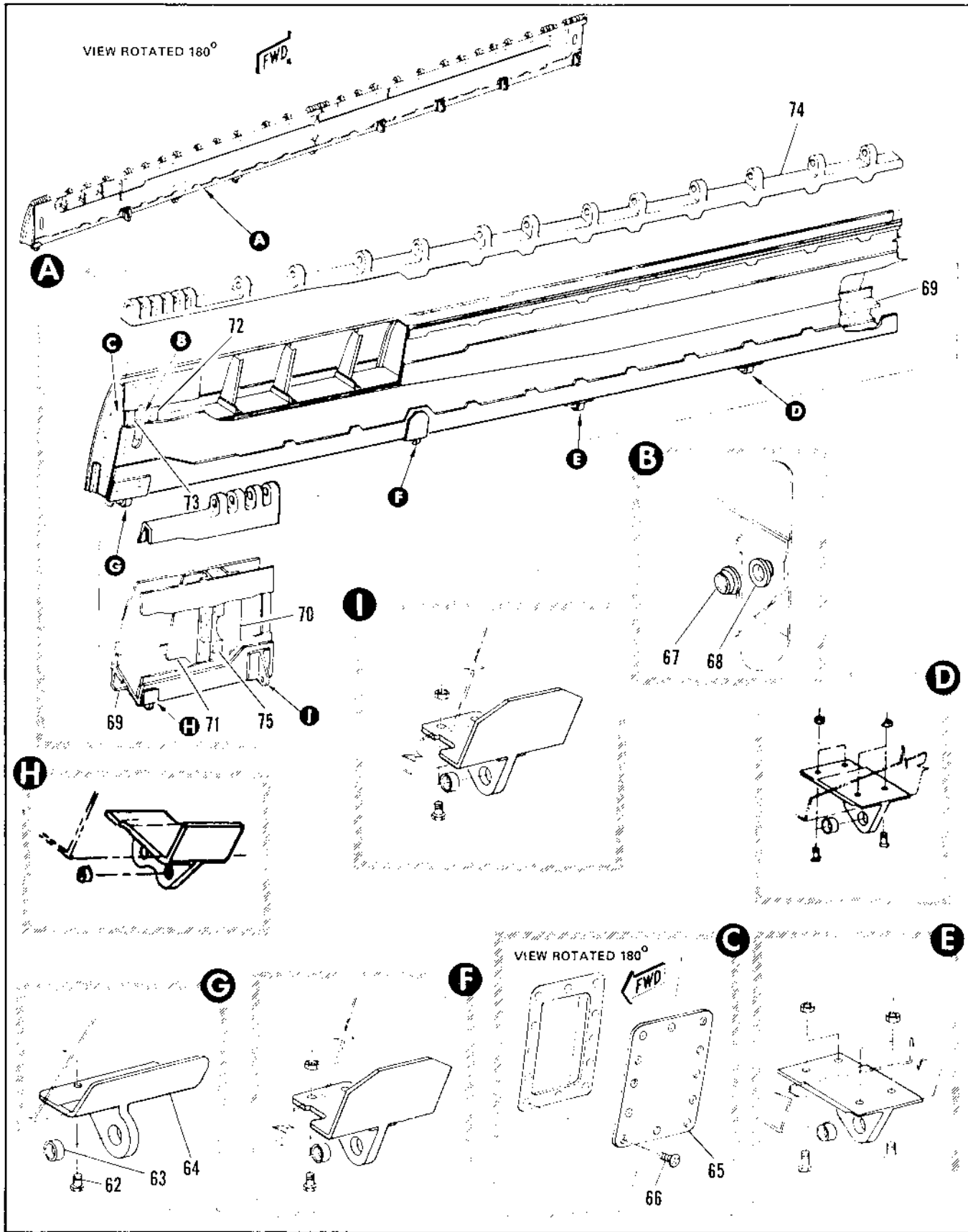

Figure 2.20-19. Armament Bay Outboard Door Assembly (Sheet 4 of 4)

FIGURE AND INDEX NUMBER	PART NUMBER	DESCRIPTION	UNITS PER ASSY.	USABLE ON CODE	
				FROM	TO
		1 2 3 4 5 6			
3,20-19	8-77911-1	• HINGE ASSY, LH	1	35	
	8-77911-2	• HINGE ASSY, RH	1	35	
- 62	AN173-7A	• ATTACHING PARTS • BOLT ----X----	2	35	
- 63	8-77911-7	• BUSHING	1	35	
- 64	8-77911-1	• HINGE, LH	1	35	
	8-77911-2	• HINGE, RH	1	35	
- 65	8-77911-7	• DOOR, ACCESS LH	1	35	
	8-77911-8	• DOOR, ACCESS RH	1	35	
- 65	NAS533PA4-6	• ATTACHING PARTS • SCREW ----X----	12	35	
- 67	8-77910-21	• BUSHING	1	35	
- 68	8-77919-19	• BUSHING	1	35	
- 69	8-74664-7	• TEE, EDGE LH	1	35	
	8-74664-8	• TEE, EDGE RH	1	35	
- 70	8-74664-13	• RIB, LH	1	35	
	8-74664-14	• RIB, RH	1	35	
- 71	8-74664-15	• RIB, LH	1	35	
	8-74664-16	• RIB, RH	1	35	
- 72	8-74664-65	• RIB, LH	1	35	
	8-74664-70	• RIB, RH	1	35	
- 73	8-74664-71	• RIB, LH	1	35	
	8-74664-72	• RIB, RH	1	35	
- 74	8-77720-9	• HINGE, UPPER MISSILE DOOR FUSELAGE STA 312 TO 410 LH	1	35	
	8-77720-10	• HINGE, UPPER MISSILE DOOR FUSELAGE STA 312 TO 410 RH	1	35	
- 75	8-77972	• FAIRING ASSY, UPPER MISSILE DOOR FUSELAGE STA 200 UNLOADED	1	35	
		A REMOVED FROM AIRPLANES #40, #41 AND ON PER TCOT 1F-106A-357			
		B ADDED TO AIRPLANES #40, #41 AND ON PER TCOT 1F-106A-357			

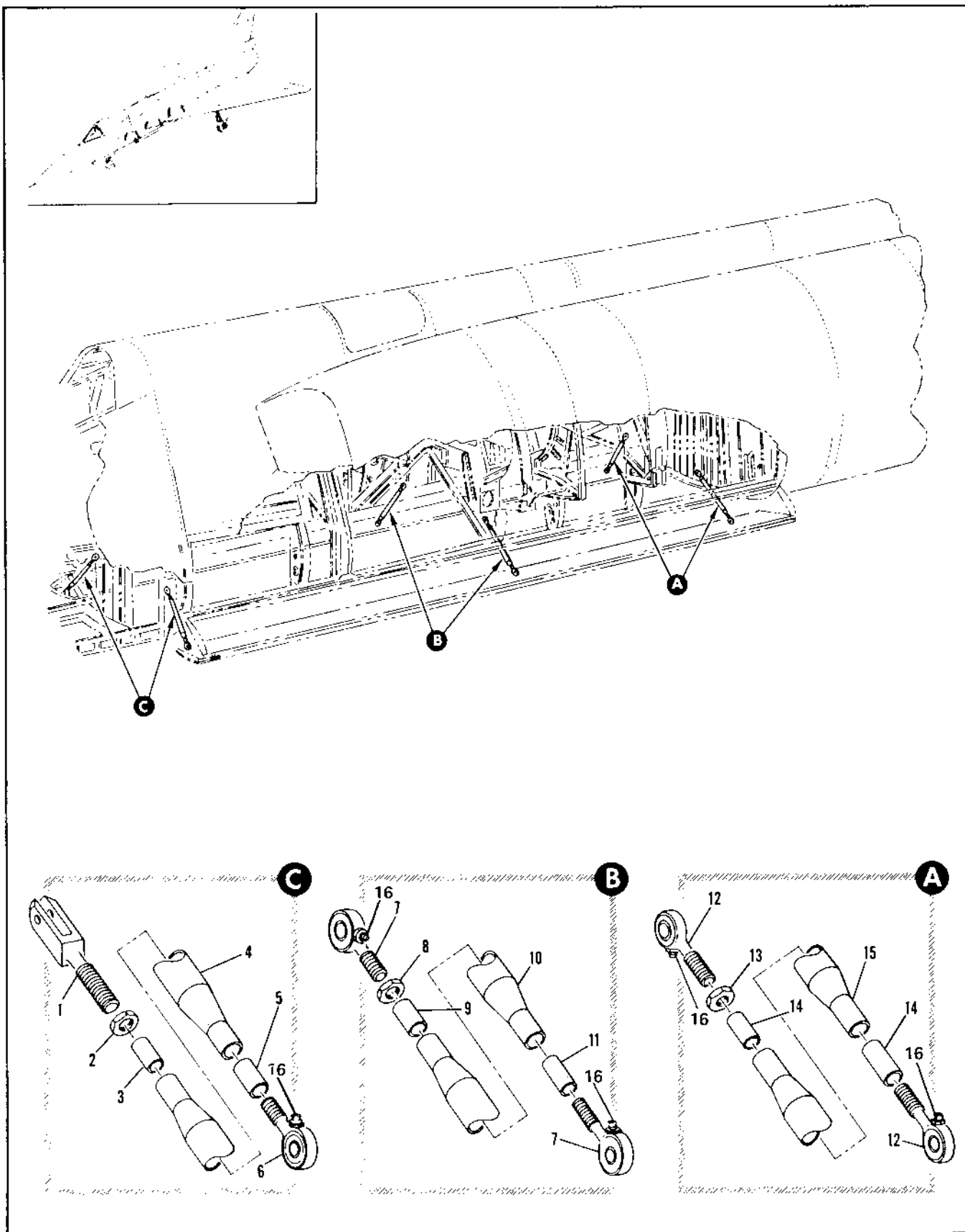

Figure 2.20-20. Armament Bay Door Rod Assembly

FIGURE AND INDEX NUMBER	PART NUMBER	DESCRIPTION	UNITS PER ASSY.	USABLE ON CODE	
				FROM	TO
		1 2 3 4 5 6			
2.20-20	A-45439-3	ROD ASSEMBLY, ARMAMENT BAY DOOR FWD FOR NHA SEE FIG. 2.20-11	RF	35	
	8-45440-1	ROD ASSEMBLY, ARMAMENT BAY DOOR CENTER FOR NHA SEE FIG. 2.20-11	RF	35	
	A-45441-1	ROD ASSEMBLY, ARMAMENT BAY DOOR AFT FOR NHA SEE FIG. 2.20-11	RF	35	
- 1	A-45449	. FORK, FWD	1	35	
- 2	AN316-6R	. NUT, FWD	1	35	
- 3	A-45442-7	. SLEEVE, FWD	1	35	
- 4	A-45439-7	. TUBE, FWD	1	35	
- 5	8-45442-9	. SLEEVE, FWD	1	35	
- 6	HE4SAF1	. BEARING, FWD <97513> 90-80005-011 SPEC MIL-G-3278	1	35	
- 7	HE6-9M1103278	. BEARING, CENTER <97513> 90-80005-012	2	35	
- 8	AN316-7R	. NUT, CENTER	1	35	
- 9	A-45443-7	. SLEEVE, CENTER	1	35	
- 10	8-45440-7	. TUBE, CENTER	1	35	
- 11	A-45443-9	. SLEEVE, CENTER	1	35	
- 12	HE4SAF1	. BEARING, AFT <97513> 90-80005-011 SPEC MIL-G-3278	2	35	
- 13	AN316-6R	. NUT, AFT	1	35	
- 14	8-45442-7	. SLEEVE, AFT	2	35	
- 15	A-45441-9	. TUBE, AFT	1	35	
- 16	MS15201-1	. FITTING, LUBRICATION	5	35	

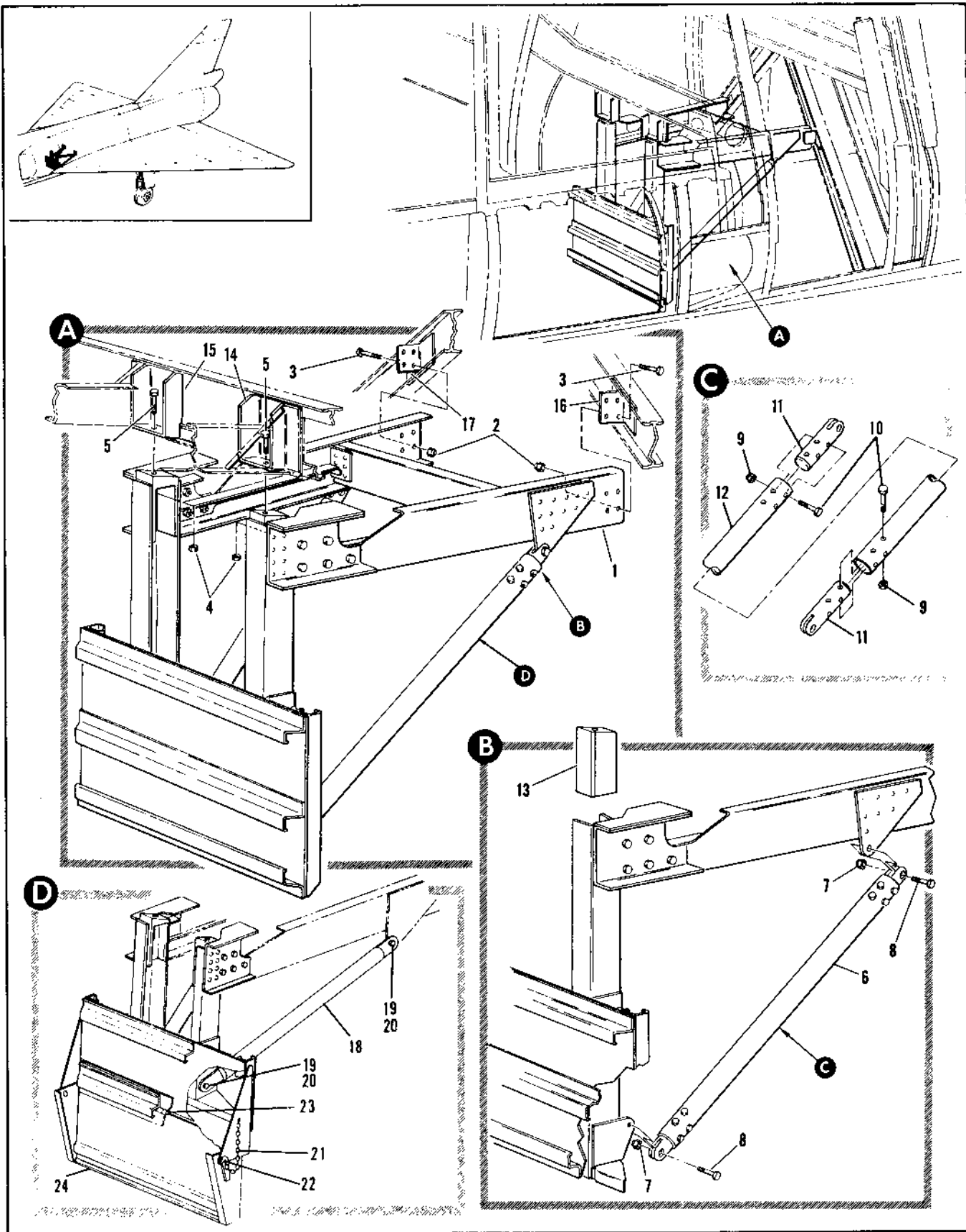

Figure 2.20-21. MB-1 Nose Deflector Installation

FIGURE AND INDEX NUMBER	PART NUMBER	DESCRIPTION	UNITS PER ASSY.	USABLE ON CODE	
				FROM	TO
2.20-21	8-57096-2	DEFLECTOR INSTALLATION, MR-1 NOSE FOR NHA SEE FIG. 2.3-5 MOD BY 7144927-10	PF	35	89
- 1	8-57096-69	• DEFLECTOR ASSY, MR-1 NOSE ATTACHING PARTS	1	35	89
- 2	NAS679A3	• NUT	8	35	89
- 3	NAS1304-8	• BOLT	8	35	89
- 4	NAS679A4	• NUT	2	35	89
- 5	NAS1304-20	• BOLT	2	35	89
- 6	8-57096-9	• TUBL ASSY, MR-1 NOSE DEFLECTOR ATTACHING PARTS	2	A	89
- 7	NAS679A4	• NUT	4	A	89
- 8	NAS1304-13	• BOLT	4	A	89
- 9	NAS679A4	• NUT	8	A	89
- 10	NAS1304-20	• BOLT	8	A	89
- 11	8-57096-11	• FORK	2	A	89
- 12	8-57096-13	• TUBE	1	A	89
- 13	8-57096-7	• FITTING, LH	1	35	89
	8-57096-8	• FITTING, RH	1	35	89
- 14	8-57097-57	• FITTING, LH	1	35	89
- 15	8-57097-58	• FITTING, RH	1	35	89
- 16	8-57097-81	• FITTING, LH	1	35	89
- 17	8-57097-82	• FITTING, RH	1	35	89
- 18	7144926-10	• TUPE ASSY, MR-1 NOSE DEFLECTION, REWORK OF 8-57096-4 ATTACHING PARTS	2	0	
- 19	AN365-424	• NUT	4	B	
- 20	NAS1304-13	• BOLT	4	B	
- 21	NAS1455A10-6	• CHAIN	2	B	
- 22	MS17984C394A	• PIN	2	B	
- 23	MS22253PA-1600	• PIN, HINGE	1	B	
- 24	7144869-30	• PANEL ASSY	1	B	

A REMOVED FROM AIRPLANES 89 AND ON PER TOTO 1F-106A-55P
 B ADDED ON AIRPLANES 89 AND ON PER TOTO 1F-106A-55P

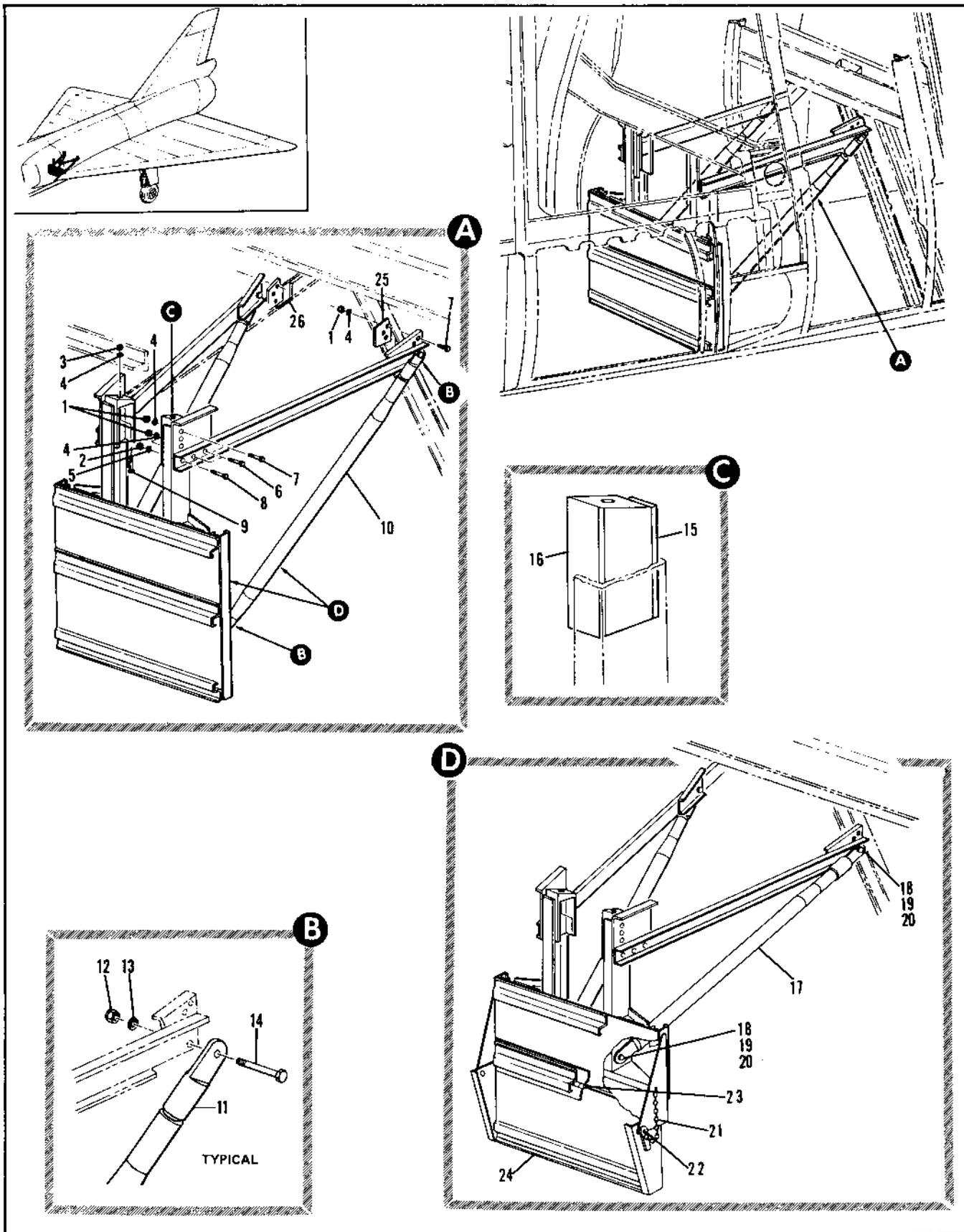

Figure 2.20-22. MB-1 Nose Deflector Installation

FIGURE AND INDEX NUMBER	PART NUMBER	DESCRIPTION	UNITS PER ASSY.	USABLE ON CODE	
				FROM	TO
2.20-22	8-57053	DEFLECTOR INSTALLATION, MB-1 NOSE FOR NHA SEE FIG. 2.1-10 MOD BY 7144869	98	90	
- 1	NAS679A4	• NUT	14	90	
- 2	NAS479A3	• NUT	1	90	
- 3	WN22-4	• NUT, <5687> 8-175B1-01	2	90	
- 4	AN960P0416	• WASHER	10	90	
- 5	AN960P0516	• WASHER	3	90	
- 6	NAS1104-2	• BOLT	4	90	
- 7	NAS1104-4	• BOLT	17	90	
- 8	NAS1105-5	• BOLT	10	90	
- 9	MS20504-16	• BOLT	2	90	
- 10	8-57053-33	• DEFLECTOR ASSY, MB-1 NOSE	1	A	
- 11	7144819-10	• DEFLECTOR ASSY, MB-1 NOSE	1	B	
- 11	8-57054	• TUBE ASSY, MB-1 NOSE DEFLECTOR ATTACHING PARTS	2	A	
- 12	NAS679A5	• NUT	4	A	
- 13	AN960P0516	• WASHER	4	A	
- 14	NAS1105-11	• BOLT	4	A	
- 15	8-57053-31	• SHIM	2	90	
- 16	8-57067-7	• ADAPTER, MB-1 NOSE DEFLECTOR LH	1	90	
- 16	8-57067-8	• ADAPTER, MB-1 NOSE DEFLECTOR RH	1	90	
- 17	7144819-10	• TUBE ASSY, MB-1 NOSE DEFLECTOR ATTACHING PARTS	2	A	
- 18	NAS679A5	• NUT	4	B	
- 19	AN960P0516	• WASHER	4	B	
- 20	NAS1105-11	• BOLT	4	B	
- 21	NAS1455A00-5	• CHAIN	2	B	
- 22	MS17984-304A	• PIN	2	B	
- 23	MS2053P4-1600	• PIN, HINGE	1	B	
- 24	7144869-30	• PANEL ASSY	1	B	
- 25	8-57068-7	• TEE, MB-1 NOSE DEFLECTOR LH	1	90	
- 25	8-57068-8	• TEE, MB-1 NOSE DEFLECTOR RH	1	90	
<p>A REMOVED FROM AIRPLANES 848, 90 AND ON PER TCOT 1F-106A-55P</p> <p>B ADDED ON AIRPLANES 890 AND ON PER TCOT 1F-106A-55P</p>					

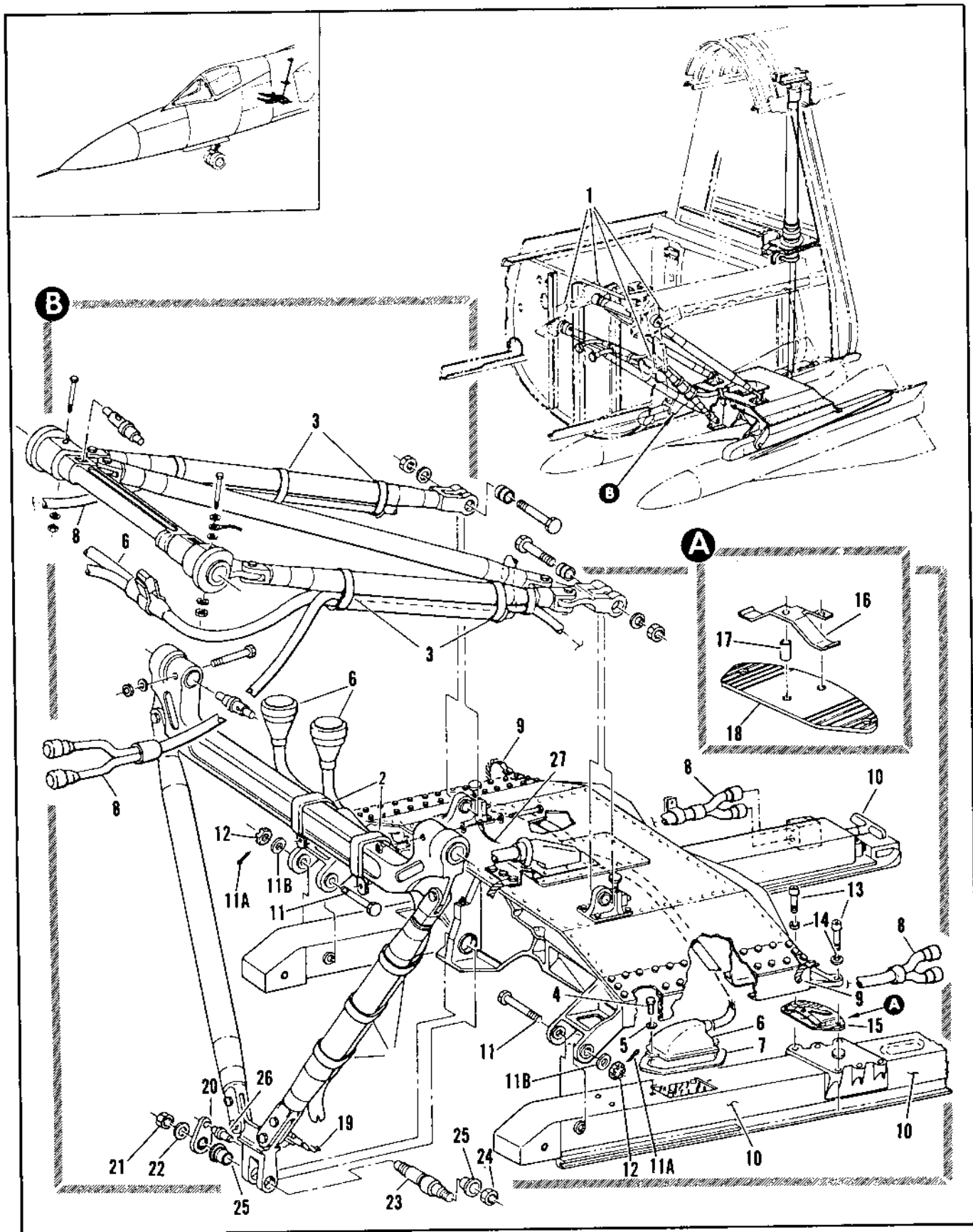

Figure 2.20-23. Fwd Armament Installation (Sheet 1 of 3)

FIGURE AND INDEX NUMBER	PART NUMBER	DESCRIPTION	UNITS PER ASSY.	USABLE ON CODE	
				FROM	TO
2.20-23	8-57115-813	ARMAMENT INSTALLATION, FWD MODIFIED BY 8-56303 AND 8-80122 FOR NHA SEE FIG. 2.3-3	RF	35	
- 1		• SUPPORT INSTL, ARMAMENT UPPER AND LOWER DRAG ARM SEE FIG. 2.20-2A	RF		
- 2	8-57926-811	• CLAMP INSTL, FWD ARMAMENT HARNESS FOR BREAKDOWN SEE FIG. 2.20-7	1	35	129
- 3	8-57316	• CLAMP INSTL, FWD ARMAMENT HARNESS FOR BREAKDOWN SEE FIG. 2.20-8	1	138	
- 4	AN173H5A	• BOLT	4	35	
- 5	AN960-10L	• WASHER	4	35	
- 6	8-36746-7 0337-1	• HARNESS ASSY, FWD LAUNCHER • HARNESS, FWD LAUNCHER (07244) SPEC 8-03376-1	1 1	35 35	
- 7	8-57017	• SEAL, FWD LAUNCHER HARNESS	2	35	
- 8	EC97K	• HARNESS ASSY, FWD IGNITOR (83148) SPEC 8-03258-1	2	130	
- 9	MS25083-28B5	• JUMPER	2	35	
		ATTACHING PARTS			
	NAS679C3	• NUT, GROUND STUD	4	35	
	AN960PD10	• WASHER, GROUND STUD	12	35	
	AN935-10L	• WASHER, GROUND STUD	4	35	
	NAS428-3-5	• BOLT, GROUND STUD	4	35	
- 10	464054-154MD3 169605	• LAUNCHER ASSY, FWD <82577> GFAE • LAUNCHER ASSY, FWD <82577> ALT INTCHG WITH 464054-154MD3	2 RF	35 35	
		ATTACHING PARTS			
- 11	8-57193	• BOLT	2	35	
- 11A	MS24665-355	• COTTER PIN	2		
- 11B	8-4456	• WASHER	2		
- 12	AN320-10	• NUT	2		
- 13	MS20005H10	• BOLT	4	35	
- 14	MS20002C5	• WASHER	4	35	
		-----X-----			
- 15	8-57169-1	• PLATE ASSY, FWD LAUNCHER ATTACHMENT ADJUSTMENT LOWER LH	1	35	
	8-57169-2	• PLATE ASSY, FWD LAUNCHER ATTACHMENT ADJUSTMENT LOWER RH	1	35	
- 16	8-57187	• CLIP, FWD LAUNCHER ADJUSTMENT RETAINER	1	35	
- 17	NAS420D6-40	• SPACER	1	35	
- 18	8-57169-7	• PLATE, FWD LAUNCHER ATTACHMENT ADJUSTMENT LOWER LH	1	35	
	8-57169-8	• PLATE, FWD LAUNCHER ATTACHMENT ADJUSTMENT LOWER RH	1	35	
- 19	MS25083-28B9	• JUMPER	1	35	
		ATTACHING PARTS			
	NAS679C3	• NUT, GROUND STUD	1	35	
	AN960PD10	• WASHER, GROUND STUD	5	35	
	AN935-10L	• WASHER, GROUND STUD	1	35	
	AN3-7A	• BOLT, GROUND STUD	1	35	
	NAS428-3-6	• BOLT, GROUND STUD	1	35	
		-----X-----			
- 20	8-57195	• PLATE, CROSSBRIDGE SHAFT LOCKING	1	35	
		ATTACHING PARTS			
- 21	AN320-10	• NUT	1	35	
- 22	AN960-1016	• WASHER	1	35	
		-----X-----			
- 23	8-57196	• SHAFT, CROSSBRIDGE ATTACHMENT ECCENTRIC	1	35	
		ATTACHING PARTS			
- 24	AN320-10	• NUT	1	35	
		-----X-----			
- 25	8-57194	• BUSHING, CROSSBRIDGE SHAFT SPACER	2	35	
- 26	8-57005-7	• PEG, CROSSBRIDGE LOCKING PLATE	1	35	
- 27	MS25083-28B5	• JUMPER, LH	1	35	
		ATTACHING PARTS			
	NAS679C3	• NUT, GROUND STUD	1	35	
	AN960PD10	• WASHER, GROUND STUD	3	35	
	AN935-10L	• WASHER, GROUND STUD	1	35	
	NAS428-3-6	• BOLT, GROUND STUD	1	35	
		-----X-----			

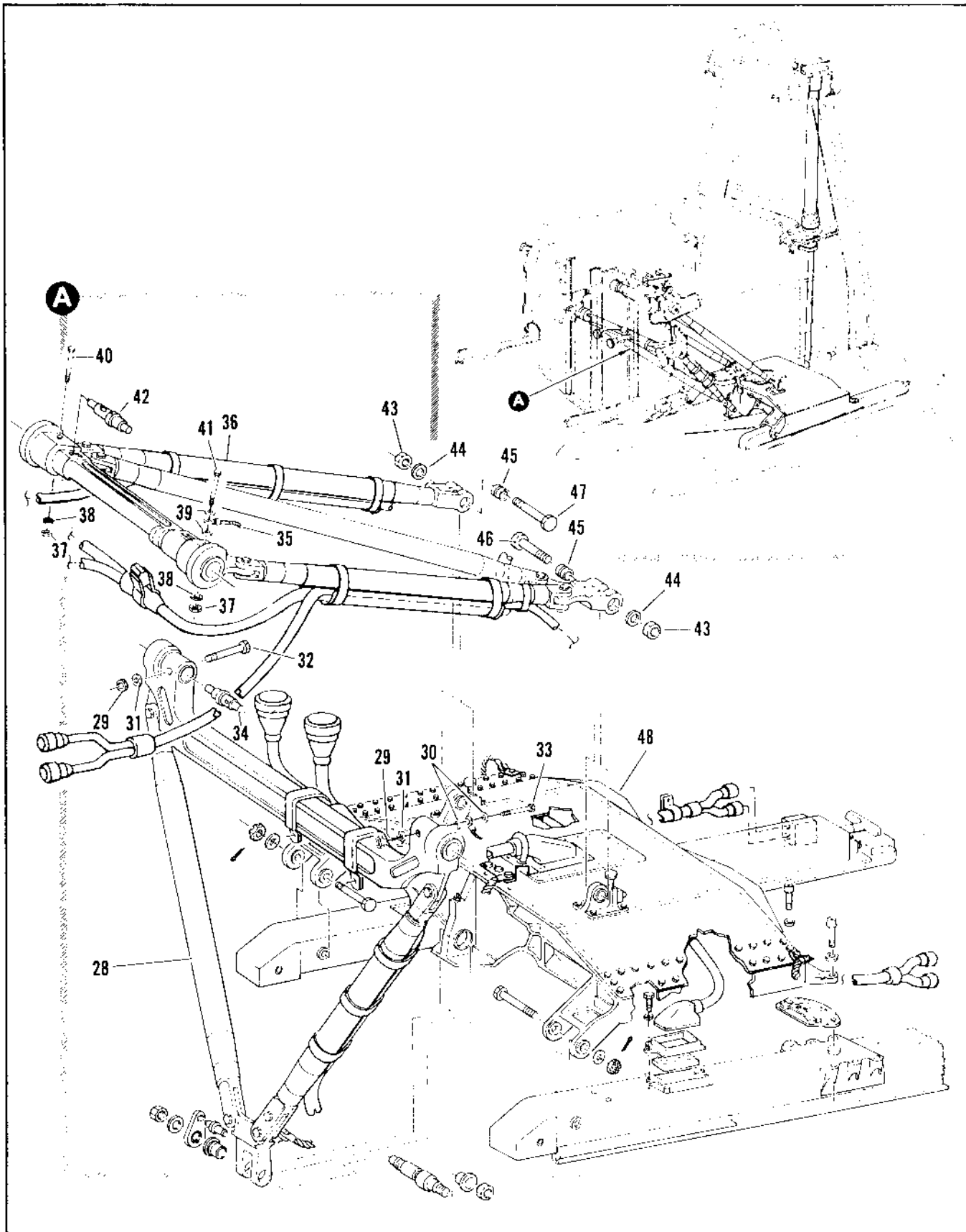

Figure 2.20-23. Fwd Armament Installation (Sheet 2 of 3)

FIGURE AND INDEX NUMBER	PART NUMBER	DESCRIPTION	UNITS PER ASSY.	USABLE ON CODE	
				FROM	TO
2.20-23- 28	8-57937-5	• ARM ASSY, FWD DISPLACEMENT GEAR LOWER DRAG FOR BREAKDOWN SEE FIG. 2.20-14 ATTACHING PARTS	1	35	
- 29	NAS679A3	• NUT	2	35	
- 30	AN960-10L	• WASHER	2	35	
- 31	AN960-10L	• WASHER	2	35	
- 32	AN3-25A	• BOLT	1	35	
- 33	AN3-25A	• BOLT	1	35	
- 34	8-57139-7	• PIN, TRUNNION -----X-----	2	35	
- 35	MS25023-28B6	• JUMPER, LH ATTACHING PARTS	1	35	
	NAS679C3	• NUT, GROUND STUD	1	35	
	AN960P01L	• WASHER, GROUND STUD	1	35	
	AN935-10L	• WASHER, GROUND STUD	1	35	
	NAS420-3-5	• BOLT, GROUND STUD -----X-----	1	35	
- 36	8-57125-1	• ARM ASSY, FWD DISPLACEMENT GEAR UPPER DRAG FOR BREAKDOWN SEE FIG. 2.20-25	1	35	1P1
	8-57939	• ARM ASSY, FWD DISPLACEMENT GEAR UPPER DRAG FOR BREAKDOWN SEE FIG. 2.20-26 ATTACHING PARTS	1	109	
- 37	NAS679A3	• NUT	2	35	
- 38	AN960-10L	• WASHER	2	35	
- 39	AN960-10L	• WASHER	2	35	
- 40	AN3-30A	• BOLT	1	35	
- 41	AN3-31A	• BOLT	1	35	
- 42	8-57139-7	• PIN, TRUNNION	2	35	
- 43	AN320-10	• NUT	2	35	
- 44	AN960P01J16	• WASHER	2	35	
- 45	NAS72-10-010	• RUSHING	2	35	
- 46	NAS464P10-27	• BOLT	1	35	
- 47	NAS464P10-27	• BOLT -----X-----	1	35	
- 48	8-57103-1	• SUPPORT ASSY, ARMAMENT CROSSBRIDGE FWD FOR BREAKDOWN SEE FIG. 2.20-47	1	35	30
	8-57103-3	• SUPPORT ASSY, ARMAMENT CROSSBRIDGE FWD FOR BREAKDOWN SEE FIG. 2.20-47	1	30	1A4
	8-57103-5	• SUPPORT ASSY, ARMAMENT CROSSBRIDGE FWD FOR BREAKDOWN SEE FIG. 2.20-47	1	109	

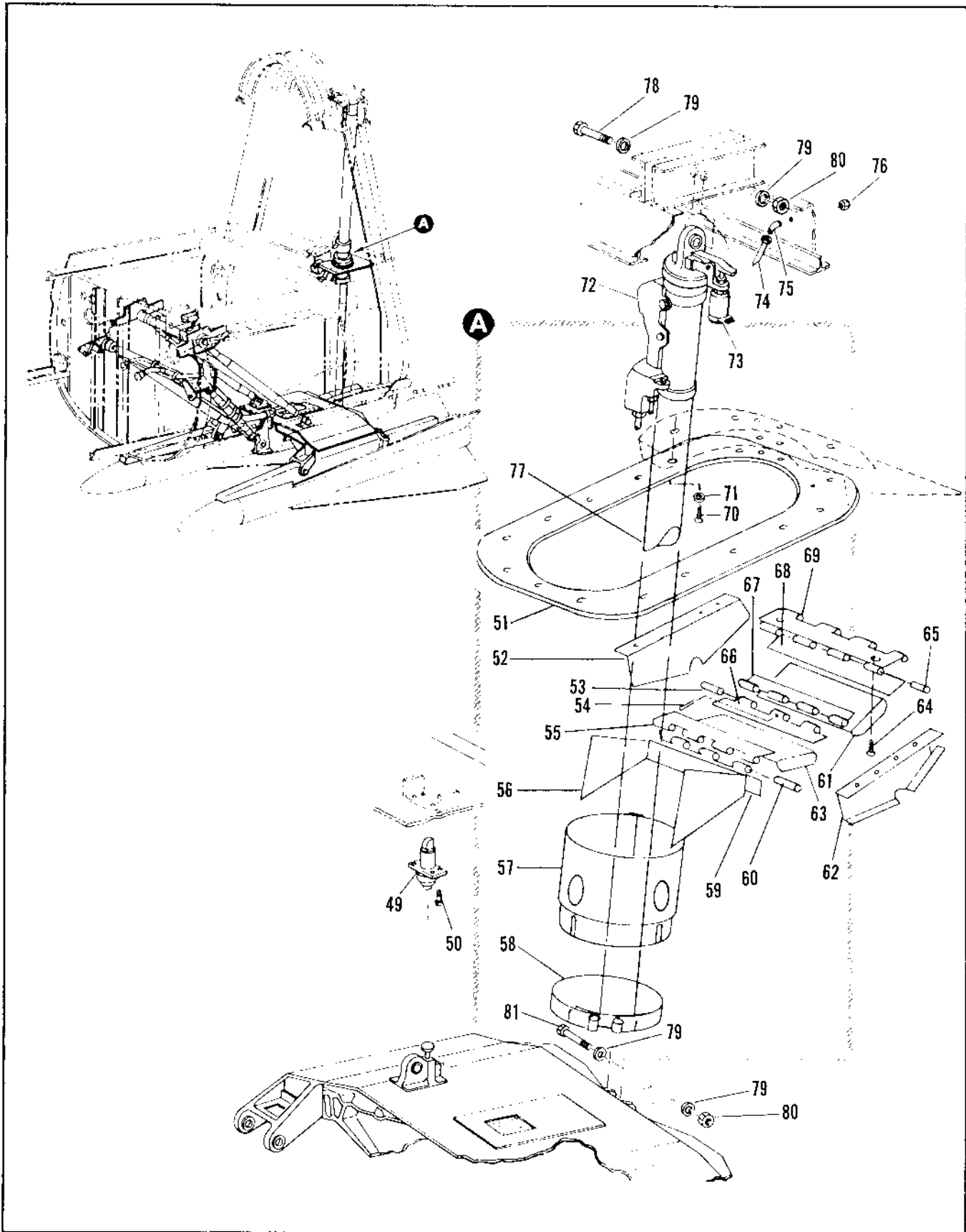

Figure 2.20-23. Fwd Armament Installation (Sheet 3 of 3)

FIGURE AND INDEX NUMBER	PART NUMBER	DESCRIPTION	UNITS PER ASSY.	USABLE ON CODE	
				FROM	TO
		1 2 3 4 5 6			
2.00-23-49	60241-15	• SNUBBER ASSY, <90215> SPEC #=01472-21 T.O. 902-3-17-53 ATTACHING PARTS	1	73	
- 50	AN3-5A	• BOLT -----X-----	5	25	
	8-57598	• SHROUD INSTALLATION, FWD DISPLACEMENT GEAR	1		
- 51	8-57598-29	• PLATE ATTACHING PARTS	1		
- 52	8-57598-28	• SHROUD	1		
- 53	8-57598-31	• PIN, ALTERED FROM MS21004-4-PH	1		
- 54	MS24615-45	• PIN, COTTER	1		
- 55	8-57598-15	• HINGE HALF, ALTERED FROM MS21001-PH	1		
- 56	8-57598-7	• BRACKET	1		
- 57	8-57598-7	• SUPPORT, PRIME WHEEL-41 1/2, PSP MIL-2-40 B	1		
- 58	MS21025-53R	• CLAMP	1		
- 59	8-57598-11	• HINGE HALF, ALTERED FROM MS21001-4-416	1		
- 60	AN253-4-374	• PIN, ALTER FROM MS20253-4-374	1		
- 61	8-57598-25	• SEAL, AFT	1		
- 62	8-57598-27	• SHROUD	1		
- 63	8-57598-23	• SEAL, FWD	1		
- 64	NAS1263-5	• SCREW	4		
- 65	AN253-4-513	• PIN - MFG IAW MS20253 FROM P/O MS20253-4-513			
- 66	8-57598-18	• HINGE HALF, ALTERED FROM MS21001-PH			
- 67	8-57598-17	• HINGE HALF, ALTERED FROM MS2000-PH	1		
- 68	8-57598-21	• HINGE HALF, ALTERED FROM MS21001-PH	1		
- 69	8-57598-33	• HINGE HALF, ALTERED FROM MS2000-PH	1		
- 70	NAS221-10	• SCREW	13		
- 71	AN960-10L	• WASHER -----X-----	13		
- 72	15410-2	• VALVE, SOLENOID SELECTOR FWD LAUNCHER <97595>	1	35	
- 73	1046N33	• SWITCH, LIMIT <91425>	1	34	
- 74	66635-3-0090	• HOSE ASSY, <06624> 1/4-1/2 22-025 REPLACED BY SUITABLE SUB 124223-60100	1	34	74
	124223-60060	• HOSE ASSY, <94441> SPEC #=1521-44 REPLACES SUITABLE SUB FOR 1/2-1/2 22-025	1	34	
- 75	MS2190706	• ELBOW	1	35	
	AN924-6D	• NUT	1	35	
	AN960-10L	• WASHER	1	35	
- 76	7325-40-01	• CAP, VENT <96748> SPEC #=172-1 -----X-----	1	30	
- 77	11180-51	• ACTUATOR ASSY, FWD ARMAMENT DISPLACEMENT GEAR <97745> SPEC 8-80978-17 T.O. 902-3-35-14 ATTACHING PARTS	1	35	
- 78	NAS444P9-17	• BOLT	1	35	
- 79	AN960FD914	• WASHER	4	35	
- 80	AN325-8	• NUT	2	34	
- 81	NAS444P9-31	• BOLT	1	35	

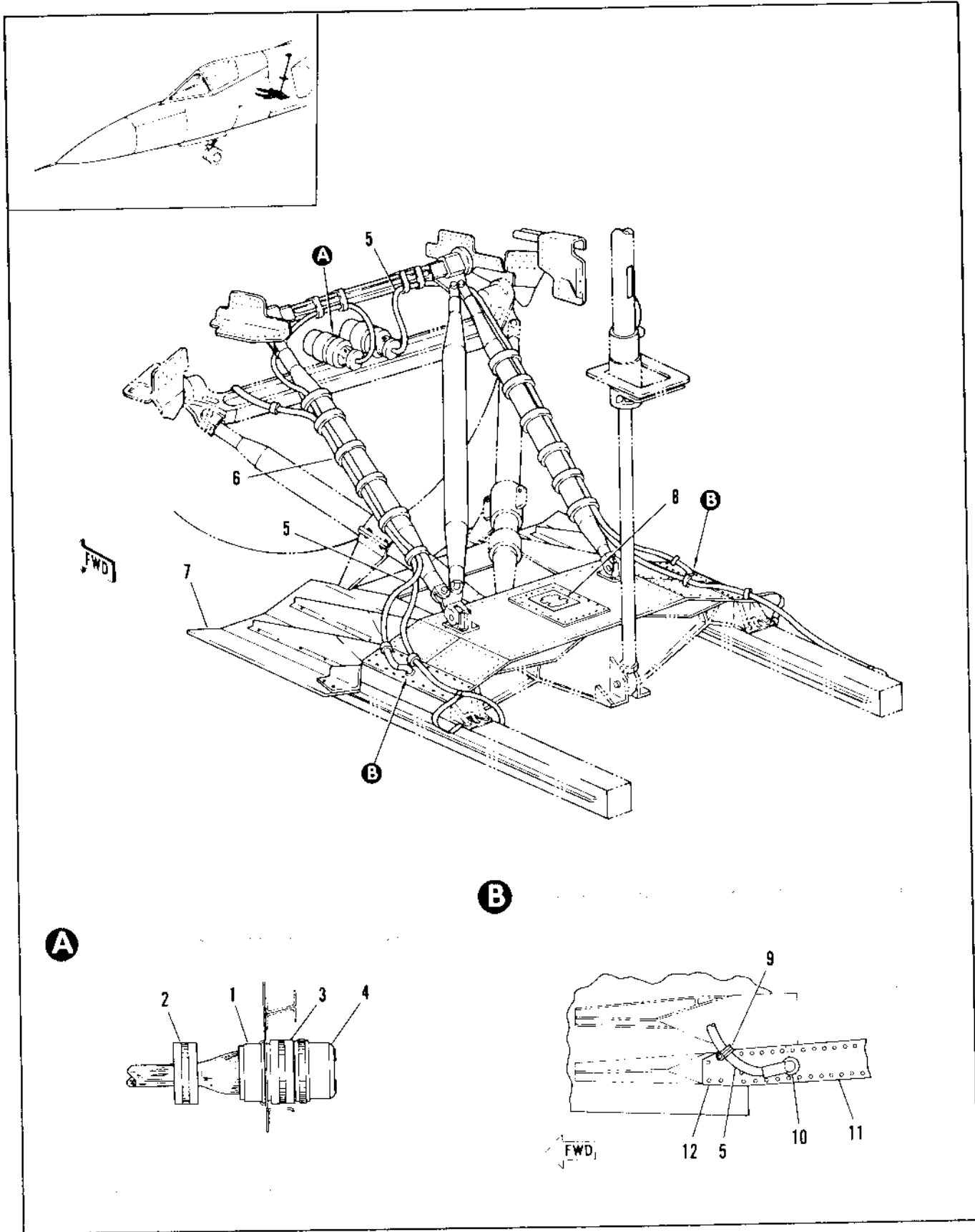

Figure 2.20-23A. Launcher Cable Connector Installation FWD Armament Bay (After Compliance with TCTO 1F 106-1159)

Fig. & Index No.	Part No.	Description	Units Per Assy	Usable on Code	
				From	To
2.20-23A	7947406	. CABLE INSTALLATION, Armament - FWD Weapons Bay (98750)	RF		
-1	7947366-10	. CONNECTOR (82577)	4		
		ATTACHING PARTS			
	MS35206-245	. SCREW (96906)	4		
	RM52LHA4972-6-82	. NUT (72962)	4		
		---X---			
-2	MS3416-44EA	. BACKSHELL (96906)	1		
-3	7947367-10	. CONNECTOR (82577)	1		
-4	7947373-10	. BACKSHELL (82577)	1		
-5	7947375-10	. HARNESS ASSY, Launcher (82577)	4		
-6	MS3367-3	. STRAP (16 places) (98750)	16		
-7	8-57103-1	. CROSSBRIDGE ASSY	RF		
-8	7947403-01	. COVER (98750)	1		
		ATTACHING PARTS			
	MS35207-263	. SCREW (96906)	6		
	AN960-10L	. WASHER (88044)	6		
		---X---			
-9	MS21919DG14	. CLAMP (96906)	2		
-10	MS21266-4N	. GROMMET (Length 4.0 in.) (96906)	2		
-11	8-57103-29	. COVER (modified by drawing number 7947406)	2		
-12	8-57940-7	. DOUBLER (modified by drawing number 7947406)	2		
	7947404	. WIRING DIAGRAM, FWD Armament Cables (98750)			

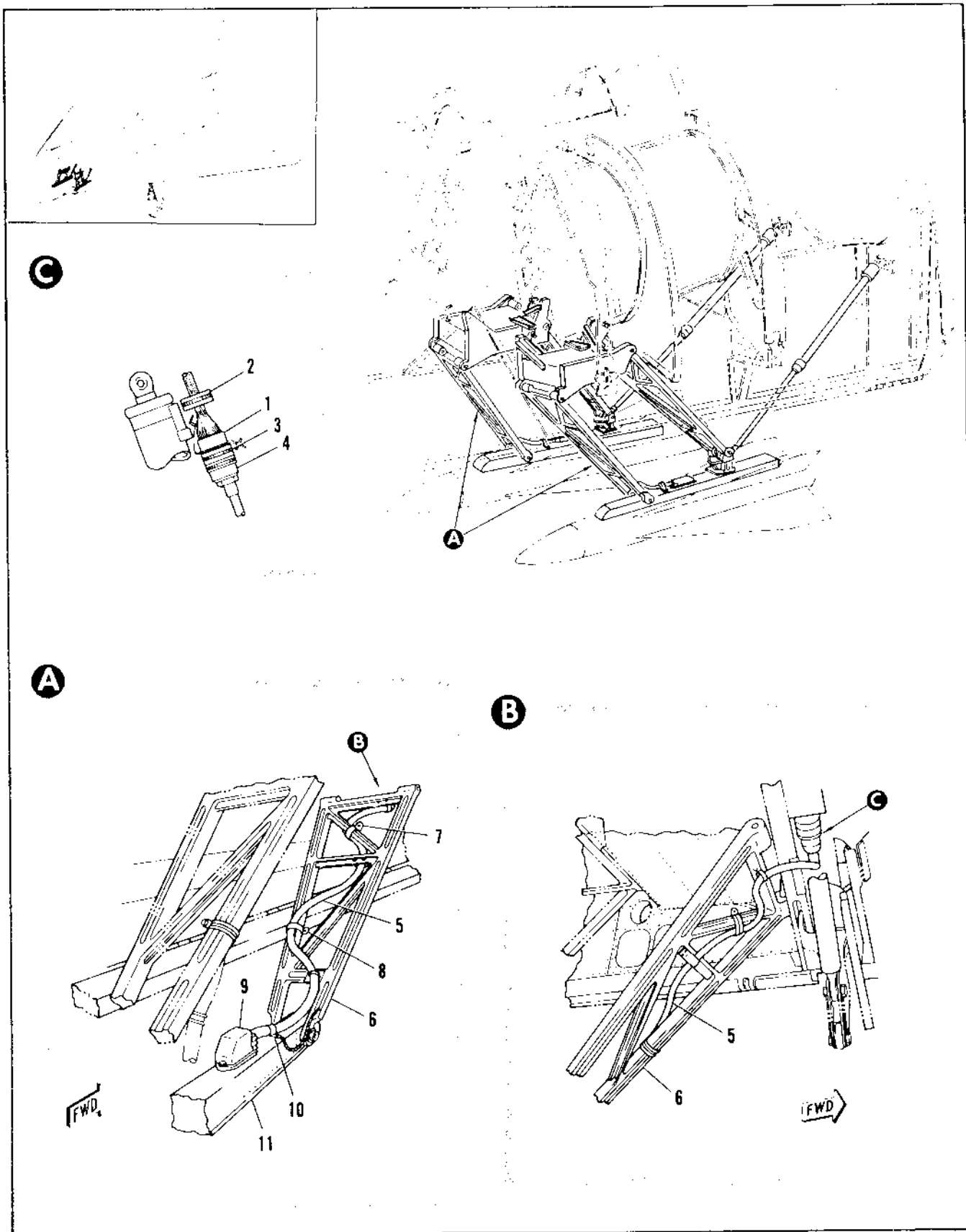

Figure 2.20 23B. Launcher Cable Connector Installation AFT Armament Bay (After Compliance with TCTO 1F 106 1159)

Fig. & Index No.	Part No.	Description	Units Per Assy	Usable on Code	
				From	To
2.20-23B	7947409	. CABLE INSTALLATION, Armament - AFT Weapons (98750)			
-1	7947366-10	. CONNECTOR (82577)	4		
		ATTACHING PARTS			
	MS35206-245	. SCREW (96906)	4		
	RM52LHA4972-6-82	. NUT (72962)	4		
		---X---			
-2	MS3416-44EA	. BACKSHELL (96906)	1		
-3	7947367-10	. CONNECTOR (82577)	1		
-4	7947373-10	. BACKSHELL (82577)	1		
-5	7947375-10	. HARNESS ASSY, Launcher (82577)	4		
-6	8-57140	. ARM	RF		
-7	MS21919DG24	. CLAMP (96906)	2		
		ATTACHING PARTS			
	MS35207-264	. SCREW (96906)	1		
	AN960-10	. WASHER (88044)	1		
	MS21042L3	. NUT (96906)	1		
		---X---			
-8	MS21919DG28	. CLAMP (96906)	2		
		ATTACHING PARTS			
	MS35207-264	. SCREW (96906)	1		
	AN960-10	. WASHER (88044)	1		
	MS21042L3	. NUT (96906)	1		
		---X---			
-9	7947368-10	. CONNECTOR (82577)	4		
	7947372-10	. BACKSHELL (82577)	1		
-10	8-57926-39	. HAT ASSY, AFT Launcher Harness (for breakdown see Fig. 2.20-32)	RF		
-11	464054-154MD3	. LAUNCHER ROCKET AIRBORNE Model LE-6 (82577) AERNO 52-8909 GFAE	RF		

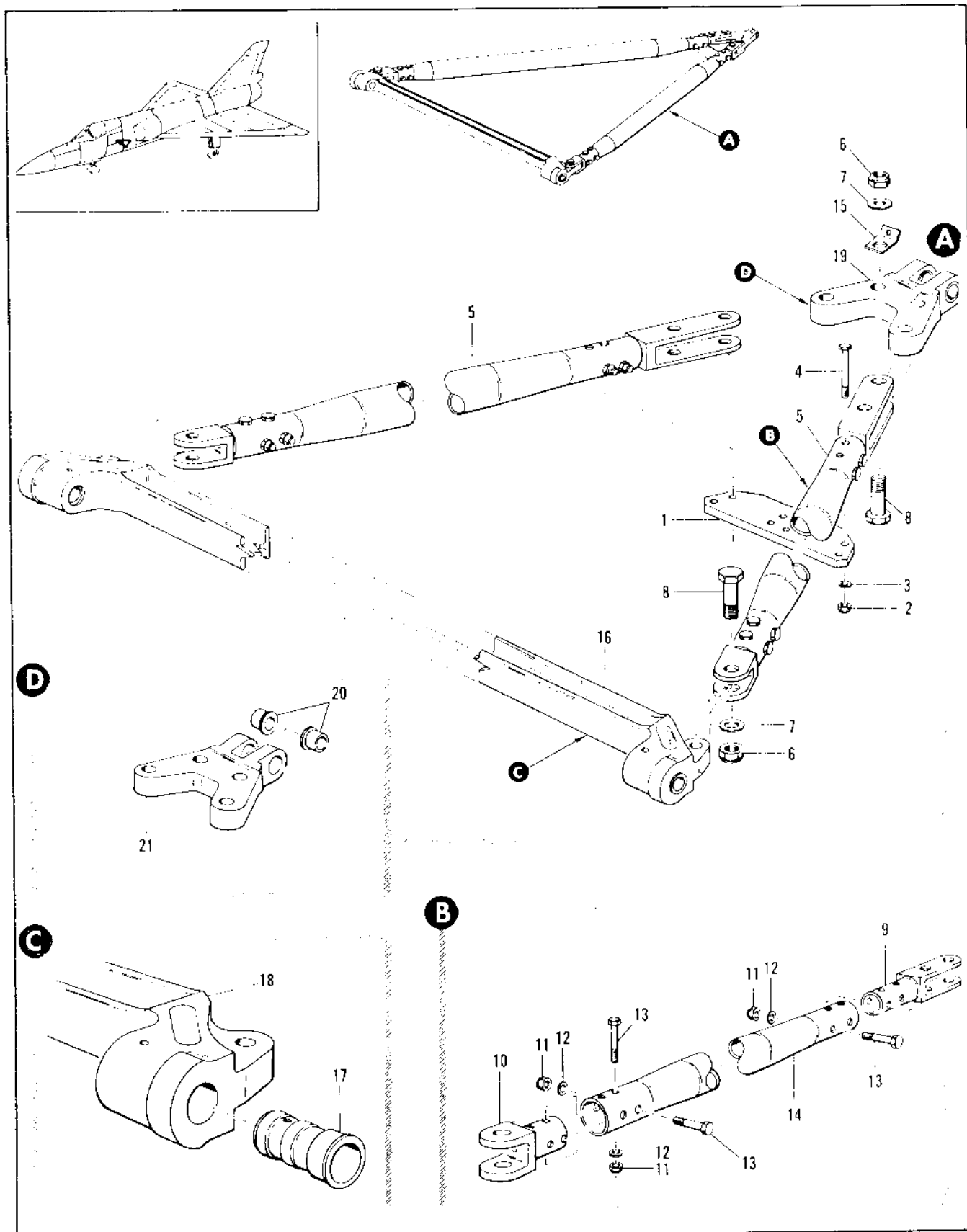

Figure 2.20-24. Fwd Displacement Gear Lower Drag Arm Assembly

FIGURE AND INDEX NUMBER	PART NUMBER	DESCRIPTION	UNITS PER ASSY.	USABLE ON CODE	
				FROM	TO
		1 2 3 4 5 6			
2.20-24	B-57937-5	ARM ASSEMBLY, FWD DISPLACEMENT BEAR LOWER OPAG FOR NHA SEE FIG. 2.20-23	PF	35	
	B-56303-3	ARM ASSEMBLY, FWD DISPLACEMENT BEAR LOWER DRAG ALT INTCHG WITH B-57937-5 SEE FIG. 2.20-23	PF	35	
- 1	B-57947	• PLATE ATTACHING PARTS	1	35	
- 2	NAS679A5	• NUT	4	35	
- 3	AN960-516	• WASHER	4	35	
- 4	NAS1305-38	• BOLT	4	35	
		----X----			
- 5	B-57937-11	• TUBE ASSY, FWD DRAG ARM REPLACES SUITABLE SUB FOR B-57937-9 ATTACHING PARTS	2	35	
- 6	NAS1022A9	• NUT	6	35	
- 7	AN960-316L	• WASHER	6	35	
- 8	NAS464-9A27	• BOLT	6	35	
		----X----			
- 9	B-57935-13	• ADAPTER	1	35	
- 10	B-57935-7	• ADAPTER ATTACHING PARTS	1	35	
- 11	NAS679A5	• NUT	6	35	
- 12	AN960-516	• WASHER	6	35	
- 13	NAS464-5A3J	• BOLT	6	35	
		----X----			
- 14	B-57936-7	• TUBE	1	35	
- 15	B-57115-25	• CLIP	1	35	
- 16	B-57126-5	• CROSSBEAM ASSY, LOWER DRAG ARM	1	35	
	B-56303-9	• CROSSBEAM ASSY, LOWER DRAG ARM ALT INTCHG WITH B-57126-5	1	35	
	B-57127	• CROSSBEAM ASSY, LOWER DRAG ARM ALT INTCHG WITH B-56303-9 AND B-57126-5	PF	35	
- 17	B-57134-7	• BUSHING	2	35	
- 18	B-57126-13	• CROSSBEAM	1	35	
	B-57127-9	• CROSSBEAM, ALT INTCHG WITH B-57126-13	PF	35	
- 19	B-57130-3	• ADAPTER ASSY, LOWER DRAG ARM	1	35	
	B-57125-1	• ADAPTER ASSY, LOWER DRAG ARM ALT INTCHG WITH B-57130-3	PF	35	
- 20	NAS77-16-79	• BUSHING	2	35	
- 21	B-57130-11	• ADAPTER	1	35	
	B-57135-7	• ADAPTER, ALT INTCHG WITH B-57130-11	PF	35	

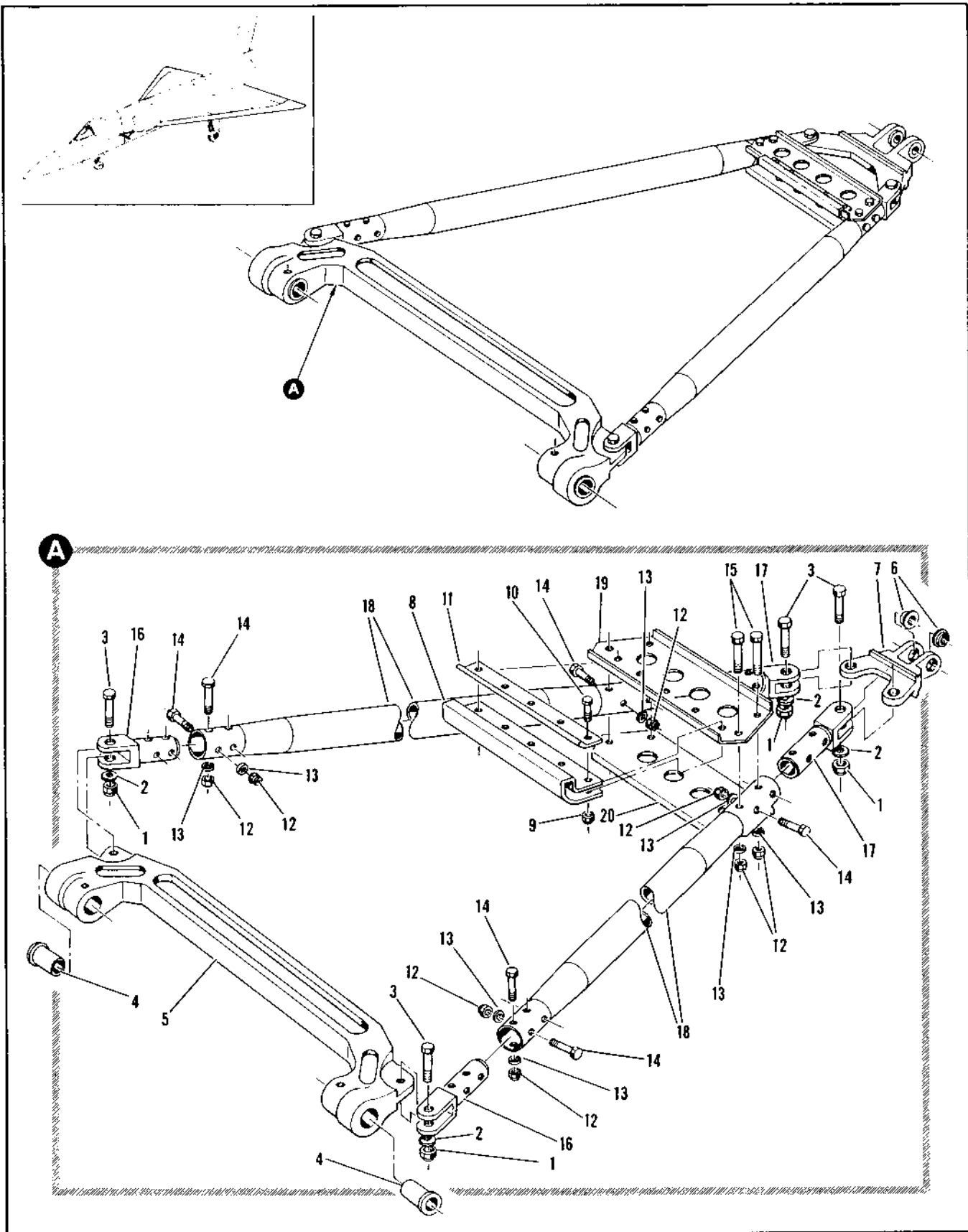

Figure 2.20-25. Fwd Displacement Gear Lower Drag Arm Assembly Alternate

FIGURE AND INDEX NUMBER	PART NUMBER	DESCRIPTION	UNITS PER ASSY.	USABLE ON CODE	
				FROM	TO
2.20-25	R-56303-5	ARM ASSEMBLY, FWD DISPLACEMENT GEAR LOWER DRAG ALT INTCHG WITH R-57127-5 SEE FIG. 2.20-23	1F	33	
	R-56303-1	ARM ASSEMBLY, FWD DISPLACEMENT GEAR LOWER DRAG ALT INTCHG WITH R-56303-5 SEE FIG. 2.20-23	1F	30	
- 1	NAS122A9	• NUT	4	35	
- 2	AN964-916L NAS464-9A27	• WASHER • BOLT	4 4	35 35	
- 3	R-56303-9 S-57127	• CROSSBEAM ASSY, LOWER DRAG ARM • CROSSBEAM ASSY, LOWER DRAG ARM ALT INTCHG WITH R-56303-5	1 1F	35 35	1
- 4	R-57134-7	• BUSHING	2	35	
- 5	R-57126-13 R-57127-9 R-57130-1 R-57131	• CROSSBEAM • CROSSBEAM, ALT INTCHG WITH R-57126-13 • ADAPTER ASSY, LOWER DRAG ARM • ADAPTER ASSY, LOWER DRAG ARM ALT INTCHG WITH R-57130-1	1 1F 1 1F	35 35 35 35	
- 6	NAS77-16-77 NAS77-16-77 NAS77-16-80	• BUSHING • BUSHING, RH USE WITH R-57131 • BUSHING, LH USE WITH R-57131	2 1 1	35 35 35	
- 7	R-57130-7	• ADAPTER	1	35	
- 8	R-57131-7 R-57494-7	• ADAPTER, USE WITH R-57131 • SUPPORT	1 1	35 35	
- 9	NAS679A3	ATTACHING PARTS			
- 10	AN3-3A	• NUT • BOLT	5 4	35 35	
- 11	R-57488-7 S-57937-7	• STRIP • TUBE ASSY, FWD DRAG ARM	1 2	35 35	
- 12	NAS679A5	• NUT	1	35	
- 13	AN964-916	• WASHER	1	35	
- 14	NAS464-5A30	• BOLT	1	35	
- 15	NAS464-5A40	• BOLT	2	35	
- 16	R-57935-7	• ADAPTER, FWD	1	35	
- 17	R-57935-11	• ADAPTER, AFT	1	35	
- 18	R-57936-13	• TUBE	1	35	
- 19	R-57924-7	• SUPPORT	1	35	
- 20	R-56303-7	• SUPPORT	1	35	

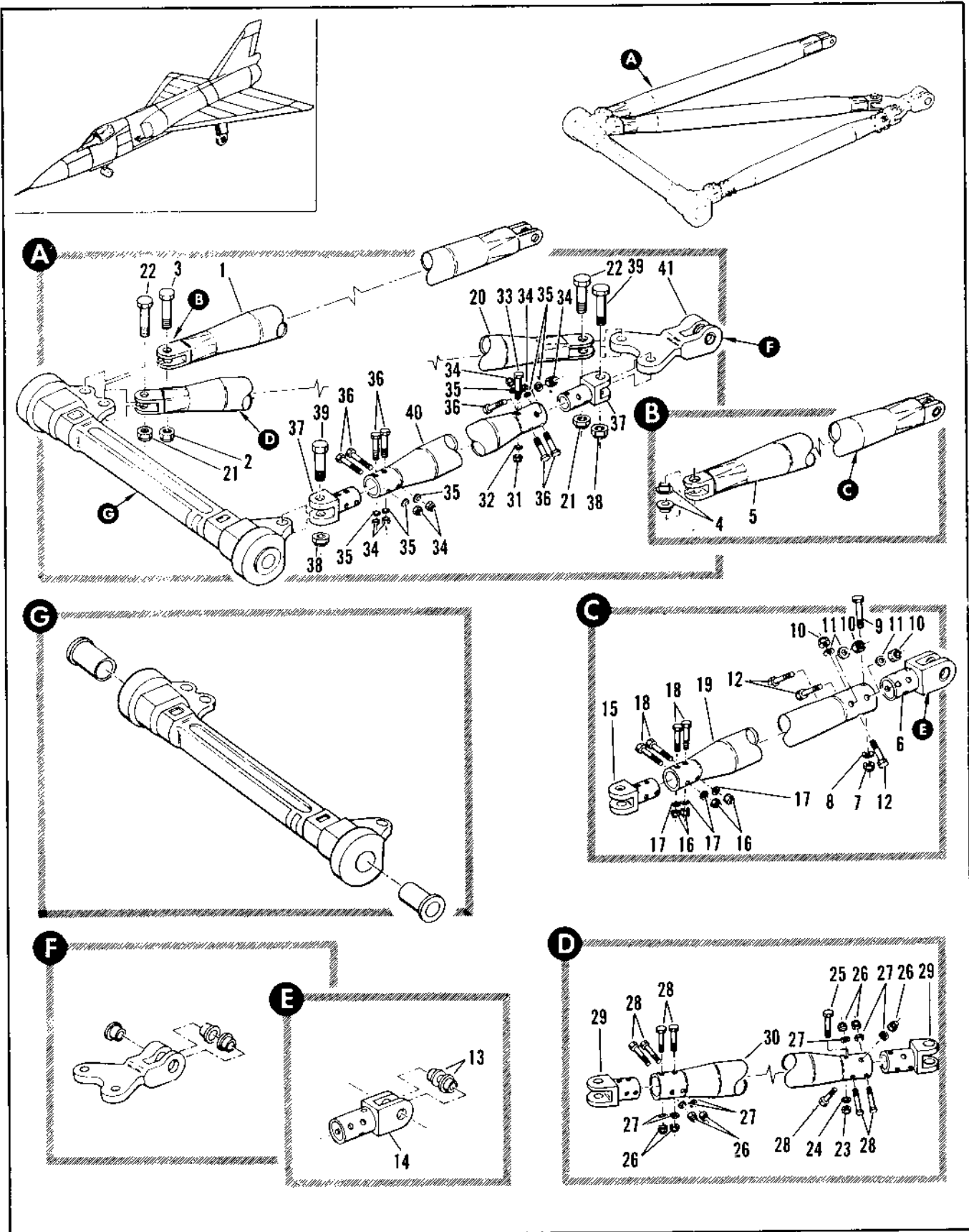

Figure 2.20-26. Fwd Displacement Gear Upper Drag Arm Assembly (Sheet 1 of 2)

FIGURE AND INDEX NUMBER	PART NUMBER	DESCRIPTION	UNITS PER ASSY.	USABLE ON CODE	
				FROM	TO
2.20-26	8-57150	ARM ASSEMBLY, FWD DISPLACEMENT BEAR UPPER DRAG FOR AHA SEE FIG. 2.10-24	1	189	
- 1	8-57119-1	• LEG ASSEMBLY • ATTACHING PARTS	1	189	
- 2	NAS1122A9	• NUT	1	189	
- 3	NAS444-9A27	• BOLT	1	189	
		-----X-----			
- 4	NAS77A11-36	• PUSHING	2	189	
- 5	8-57114-13	• LEG	1	189	
	8-57934-11	• LEG ASSY, ALT INTCHG WITH 8-57119-1	1	189	
- 6	8-57935-1	• ADAPTER ASSY, AFT • ATTACHING PARTS	1	189	
- 7	NAS679A6	• NUT	1	189	
- 8	AN960-516	• WASHER	1	189	
- 9	NAS444-5A30	• BOLT	1	189	
- 10	NAS679A5	• NUT	3	189	
- 11	AN960-516	• WASHER	3	189	
- 12	NAS444-5A30	• BOLT	3	189	
		-----X-----			
- 13	NAS77A11-36	• PUSHING	2	189	
- 14	8-57935-9	• ADAPTER	1	189	
- 15	8-57935-7	• ADAPTER, FWD • ATTACHING PARTS	1	189	
- 16	NAS679A5	• NUT	4	189	
- 17	AN960-516	• WASHER	4	189	
- 18	NAS444-5A30	• BOLT	4	189	
		-----X-----			
- 19	8-57935-13	• TUBE, RH	1	189	
- 20	8-57119-11	• LEG • ATTACHING PARTS	1	189	
- 21	NAS1122A9	• NUT	1	189	
- 22	NAS444-9A27	• BOLT	1	189	
		-----X-----			
- 23	8-57934-9	• LEG ASSY, ALT INTCHG WITH 8-57119-11	1	189	
- 24	NAS679A6	• NUT	1	189	
- 25	AN960-516	• WASHER	1	189	
- 26	NAS444-5A30	• BOLT	1	189	
- 27	NAS679A5	• NUT	7	189	
- 28	AN960-516	• WASHER	7	189	
- 29	NAS444-5A30	• BOLT	7	189	
- 30	8-57935-7	• ADAPTER	2	189	
- 31	8-57935-11	• TUBE, CENTER	1	189	
- 32	NAS679A6	• NUT	1	189	
- 33	AN960-516	• WASHER	1	189	
- 34	NAS444-5A30	• BOLT	1	189	
- 35	NAS679A5	• NUT	7	189	
- 36	AN960-516	• WASHER	7	189	
- 37	NAS444-5A30	• BOLT	7	189	
- 38	8-57935-7	• ADAPTER • ATTACHING PARTS	1	189	
- 39	NAS1122A9	• NUT	2	189	
- 40	NAS444-9A27	• BOLT	2	189	
		-----X-----			
- 41	8-57936-9	• TUBE	1	189	
- 42	8-57130-1	• ADAPTER ASSEMBLY	1	189	

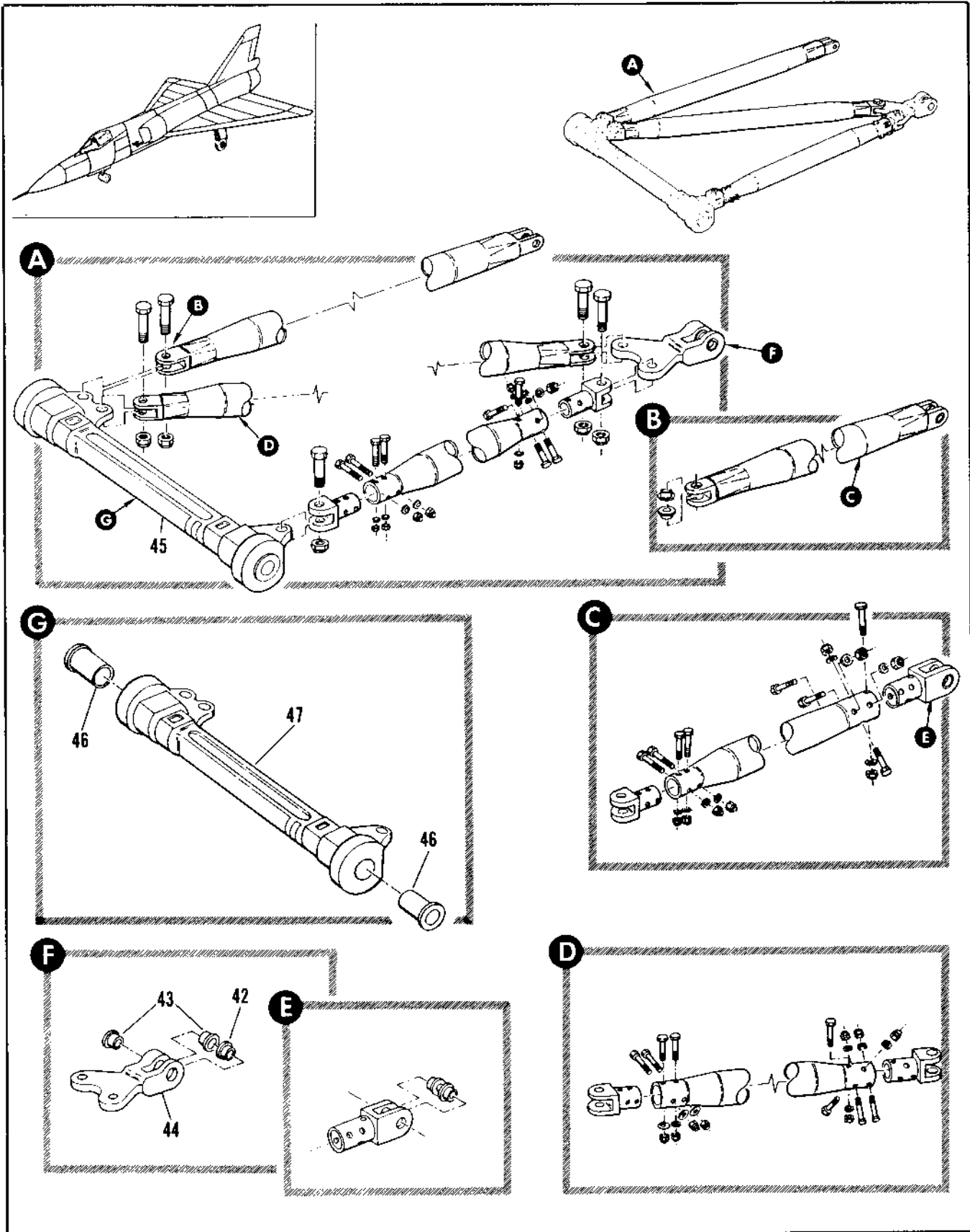

Figure 2.20-26. Fwd Displacement Gear Upper Drag Arm Assembly (Sheet 2 of 2)

FIGURE AND INDEX NUMBER	PART NUMBER	DESCRIPTION	UNITS PER ASSY.	USABLE ON CODE	
				FROM	TO
		1 2 3 4 5 6			
2.20-16- 42	NAS77-11-25	• • PUSHING	1	189	
- 43	NAS77-19-50	• • PUSHING	2	189	
- 44	R-57132-7	• • ADAPTER	1	189	
- 45	R-57133-9	• • ADAPTER, ALT INTCHG WITH R-57132-7	RF	189	
- 46	R-57128-1	• CROSSBEAM ASSEMBLY	1	189	
- 47	R-57129	• CROSSBEAM ASSY, ALT INTCHG WITH R-57128-1	ST	189	
- 48	R-57134-7	• • PUSHING	2	189	
- 49	R-57128-1	• • CROSSBEAM	1	189	
- 50	R-57129-7	• • CROSSBEAM, ALT INTCHG WITH R-57128-7	RF	189	

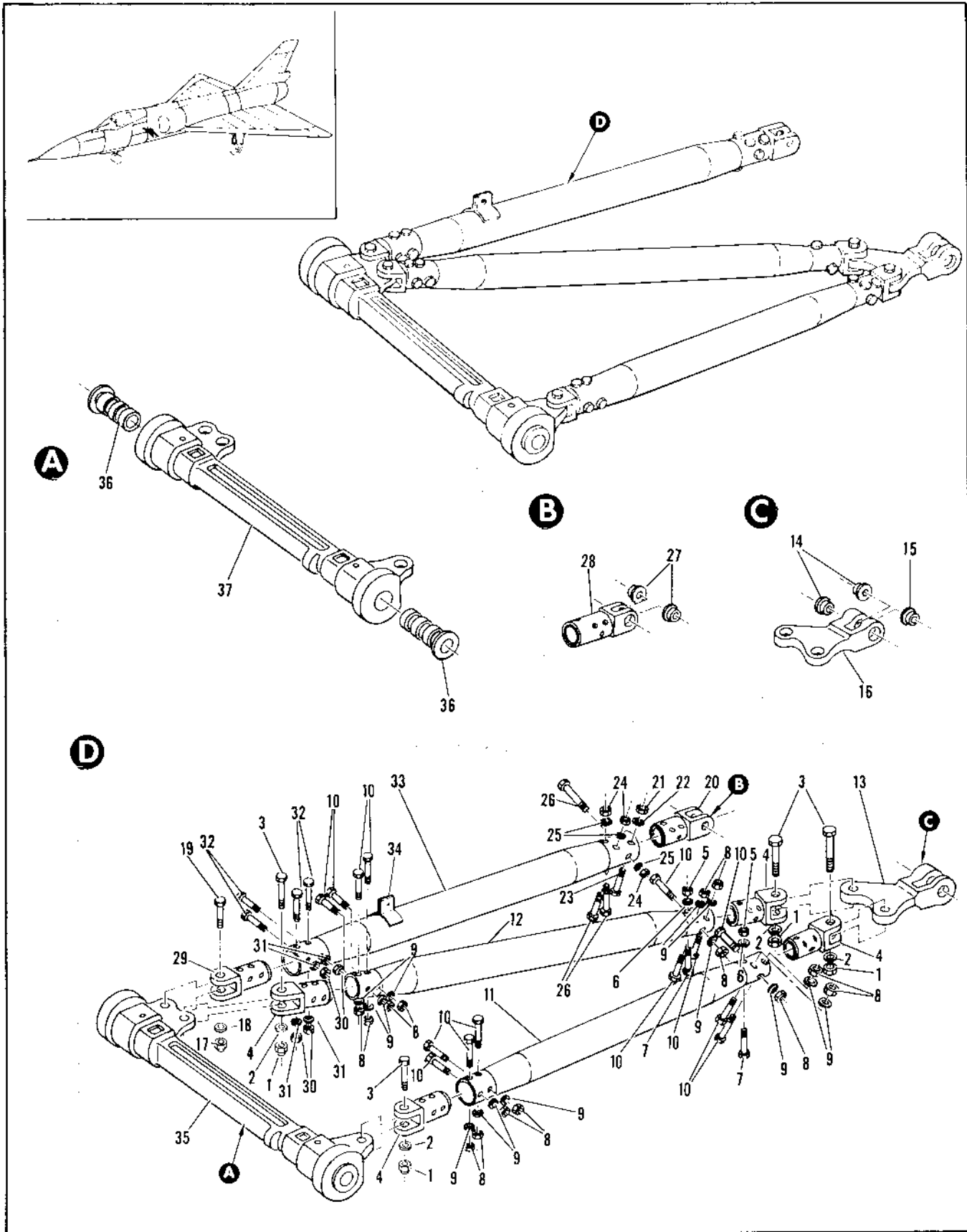

Figure 2.20-27. Fwd Displacement Gear Upper Drag Arm Assembly Alternate

FIGURE AND INDEX NUMBER	PART NUMBER	DESCRIPTION	UNITS PER ASSY.	USABLE ON CODE	
				FROM	TO
		1 2 3 4 5 6			
2.20-01	4-57-34-1	ARM ASSEMBLY, FWD DISPLACEMENT REAR UPPER GRASP ALT INTCH WITH 4-5715-1 OR 4-57-33 SEE FIG. 2.20-24	54	75	
	4-57-34-7	• TUBE ASSY, LH	1	75	
	4-57-34-8	• TUBE ASSY, CENTER	1	75	
		ATTACHING PARTS			
- 1	4-57-34-11	• NUT	4	75	
- 2	4-57-34-11	• WASHER	4	75	
- 3	4-57-34-11	• BOLT	4	75	
		-----X-----			
- 4	4-57-35-7	• ADAPTER	1	75	
		ATTACHING PARTS			
- 5	4-57-35-8	• NUT	1	75	
- 6	4-57-35-8	• WASHER	1	75	
- 7	4-57-35-8	• BOLT	1	75	
- 8	4-57-35-8	• NUT	7	75	
- 9	4-57-35-8	• WASHER	7	75	
- 10	4-57-35-8	• BOLT	7	75	
		-----X-----			
- 11	4-5715-1	• TUBE, LH	1	75	
- 12	4-5715-1	• TUBE, CENTER	1	75	
- 13	4-5715-1	• ADAPTER ASSY, AFT	1	75	
		• ADAPTER ASSY, AFT ALT INTCH WITH 4-5715-1	4	75	
- 14	4-5771-11-7	• PUSHING	1	75	
- 15	4-5771-11-7	• BUSHING	1	75	
- 16	4-5771-11-7	• ADAPTER	1	75	
		• ADAPTER, ALT INTCH WITH 4-5715-7	4	75	175
		• TUBE ASSY, RH	1	75	
		ATTACHING PARTS			
- 17	4-5715-1	• NUT	1	75	
- 18	4-5715-1	• WASHER	1	75	
- 19	4-5715-1	• BOLT	2	75	
		-----X-----			
- 20	4-57-35-1	• ADAPTER ASSY, AFT	1	75	
		ATTACHING PARTS			
- 21	4-57-35-1	• NUT	1	75	
- 22	4-57-35-1	• WASHER	1	75	
- 23	4-57-35-1	• BOLT	1	75	
- 24	4-57-35-1	• NUT	7	75	
- 25	4-57-35-1	• WASHER	7	75	
- 26	4-57-35-1	• BOLT	7	75	
		-----X-----			
- 27	4-5771-11-7	• PUSHING	1	75	
- 28	4-5771-11-7	• ADAPTER	1	75	
- 29	4-5771-11-7	• ADAPTER, FWD	1	75	
		ATTACHING PARTS			
- 30	4-5771-11-7	• NUT	4	75	
- 31	4-5771-11-7	• WASHER	4	75	
- 32	4-5771-11-7	• BOLT	4	75	
		-----X-----			
- 33	4-5715-1	• TUBE, RH	1	75	
- 34	4-5715-1	• BRACKET ASSY, DOWN SWITCH PIVOTED	1	75	
- 35	4-5715-1	• CROSSBEAM ASSY, FWD	1	75	
		• CROSSBEAM ASSY, FWD ALT INTCH WITH 4-5715-1	4	75	
- 36	4-5715-1	• PUSHING	1	75	
- 37	4-5715-1	• CROSSBEAM	1	75	
		• CROSSBEAM, ALT INTCH WITH 4-5715-7	4	75	

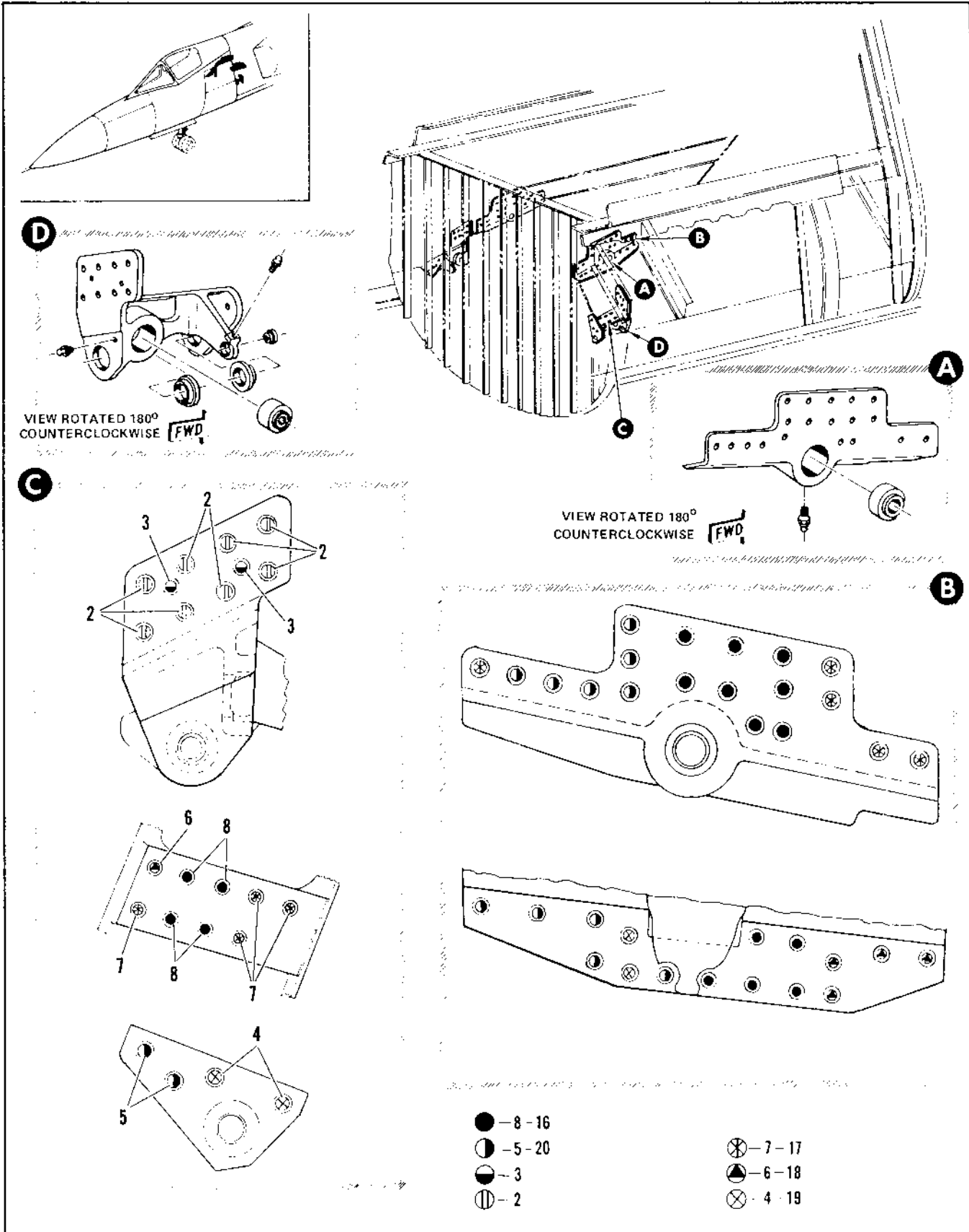

Figure 2.20-28. Armament Upper and Lower Drag Arm Support Installation (Sheet 1 of 2)

FIGURE AND INDEX NUMBER	PART NUMBER	DESCRIPTION	UNITS PER ASSY.	USABLE ON CODE	
				FROM	TO
2.20-78	7-5741-1	SUPPORT INSTALLATION, ARMAMENT UPPER AND LOWER GRAB ARM MODIFIED BY R-44872 FOR NHA SEE FIG. 2.2-9	1	75	
- 1	R-57907-3	• SUPPORT ASSY, LOWER FWD LH REPLACED BY SUITABLE SUB R-57907-4	1	75	157
	R-57907-5	• SUPPORT ASSY, LOWER FWD LH REPLACES SUITABLE SUB FOR R-57907-3	1	75	158
	R-57907-401	• SUPPORT ASSY, LOWER FWD LH REPLACED BY SUITABLE SUB R-57907-401	1	150	277
	R-57907-5	• SUPPORT ASSY, LOWER FWD LH REPLACES SUITABLE SUB FOR R-57907-5	1	278	
	R-57907-402	• SUPPORT ASSY, LOWER FWD LH FOR REPLACEMENT USE R-57907-401	1	150	277
	R-57907-4	• SUPPORT ASSY, LOWER FWD RH REPLACES SUITABLE SUB FOR R-57907-4	1	278	
		• SUPPORT ASSY, LOWER FWD RH FOR REPLACEMENT USE R-57907-402	1	278	
		ATTACHING PARTS:			
	NAS-79A6	• NUT	16	35	277
	NAS-79A7	• NUT	11	278	
	AN9-1-512	• WASHER	16	75	277
	AN9-1-715	• WASHER	16	278	
	MS20002-5	• WASHER	16	75	277
	MS20002-7	• WASHER	11	278	
- 2	NAS454P6A10A	• BOLT	16	35	277
	NAS454P6A11	• BOLT	16	278	
	NAS67-43	• NUT	4	35	277
	42FW524	• NUT, <5797> 96-37510-112	4	278	
	AN9-1-512	• WASHER	4	75	277
	MS20002C5	• WASHER	4	278	
	MS20002-5	• WASHER	4	75	
- 3	NAS454P6A10	• BOLT	4	75	277
	MS20002-12	• BOLT	4	278	
	42FW524	• NUT, <5797> 96-37510-112	4	75	
	MS20002C5	• WASHER	4	35	
- 4	MS20002-12	• BOLT	4	75	
- 5	MS20002-12	• BOLT	4	35	
	42FW428	• NUT, <5797> 96-37510-111	4	75	
	MS20002C4	• WASHER	4	35	
	MS20002-4	• WASHER	4	75	
- 6	MS20002-12	• BOLT	4	75	
- 7	MS20002-12	• BOLT	4	35	
- 8	MS20002-4	• BOLT	4	35	
		-----X-----			

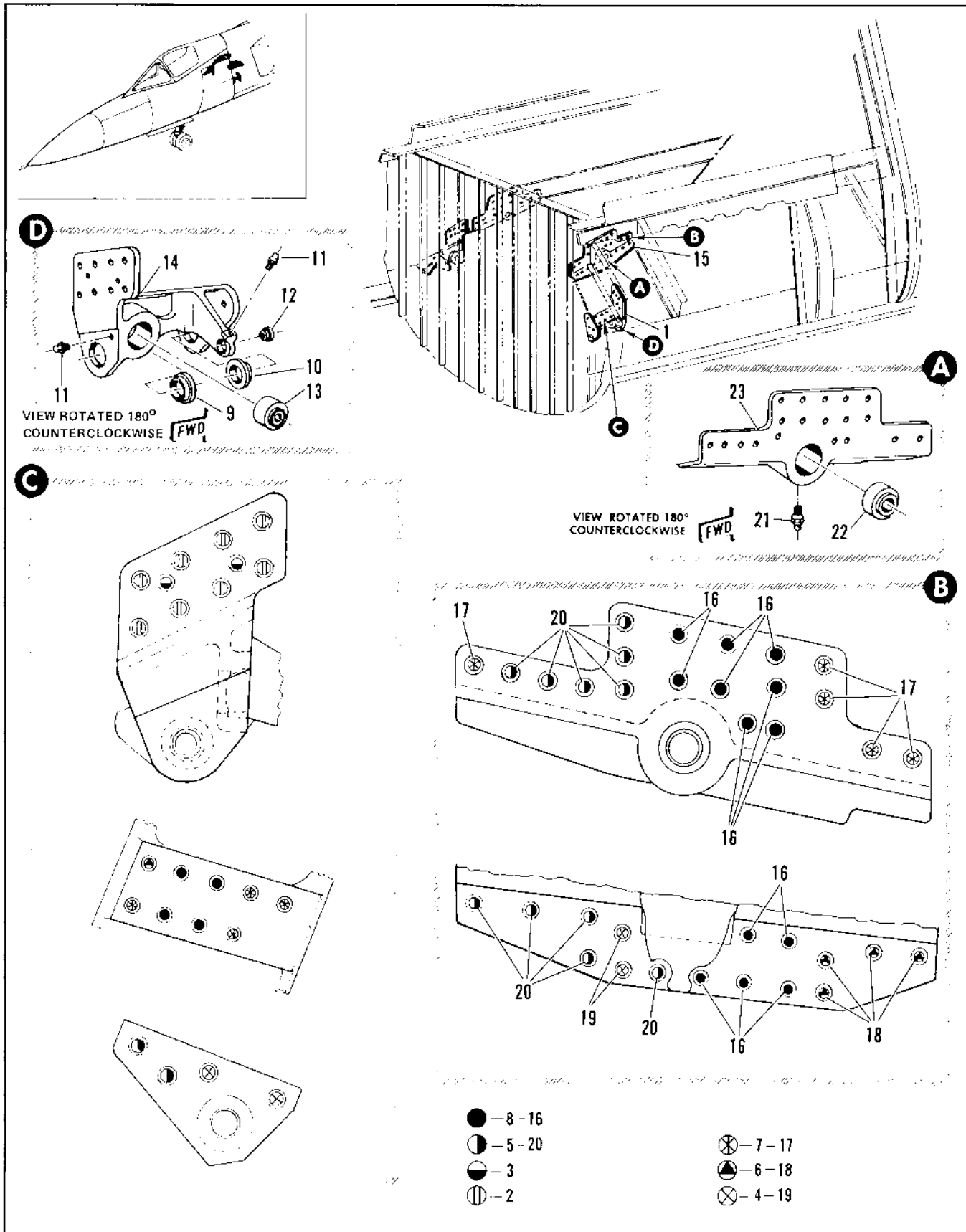

Figure 2.20-28. Armament Upper and Lower Drag Arm Support Installation (Sheet 2 of 2)

FIGURE AND INDEX NUMBER	PART NUMBER	DESCRIPTION 1 2 3 4 5 6	UNITS PER ASSY.	USABLE ON CODE	
				FROM	TO
2.20-28- 9	R-57926-9	• • RUSHING	1	35	
- 10	R-57926-7	• • RUSHING	1	35	
- 11	MS1501-1	• • FITTING	2	35	
- 12	MS064	• • BEARING, <5276> 91-57926-1.7	1	35	
- 13	AB14	• • BEARING, <51588> 91-57926-2.1	1	35	
- 14	R-57907-11	• • SUPPORT, LH	1	35	1.1
	R-57907-12	• • SUPPORT, LH	1	167	277
	R-57907-11	• • SUPPORT, LH FOR REPLACEMENT USE R-57907-13	1	278	
	R-57907-12	• • SUPPORT, RH	1	35	159
	R-57907-14	• • SUPPORT, RH	1	167	277
	R-57907-12	• • SUPPORT, RH FOR REPLACEMENT USE R-57907-14	1	278	
- 15	R-57906-1	• SUPPORT ASSY, UPPER FWD LH	1	35	
	R-57906-2	• SUPPORT ASSY, UPPER FWD RH	1	35	
		ATTACHING PARTS			
	42FW42A	• NUT, <50878> 91-57916-1	44	35	
	MS200204	• WASHER	44	35	
	MS2002-4	• WASHER	44	35	
- 16	MS2004-8	• BOLT	24	45	
- 17	MS2004-10	• BOLT	10	45	
- 18	MS2004-12	• BOLT	8	45	
	42FW324	• NUT, <50878> 91-57916-1.2	24	35	
	MS200205	• WASHER	24	35	
	MS2002-5	• WASHER	24	35	
- 19	MS2005-12	• BOLT	4	35	
- 20	MS2005-10	• BOLT	22	35	
		-----X-----			
- 21	MS1501-1	• • FITTING	1	35	
- 22	AB14	• • BEARING, <51588> 91-57926-2.1	1	35	
- 23	R-57916-9	• • SUPPORT, LH	1	35	
	R-57916-7	• • SUPPORT, LH USE WITH R-57916-1	RF	35	
	R-57916-10	• • SUPPORT, RH	1	35	
	R-57916-8	• • SUPPORT, RH USE WITH R-57916-2	RF	35	

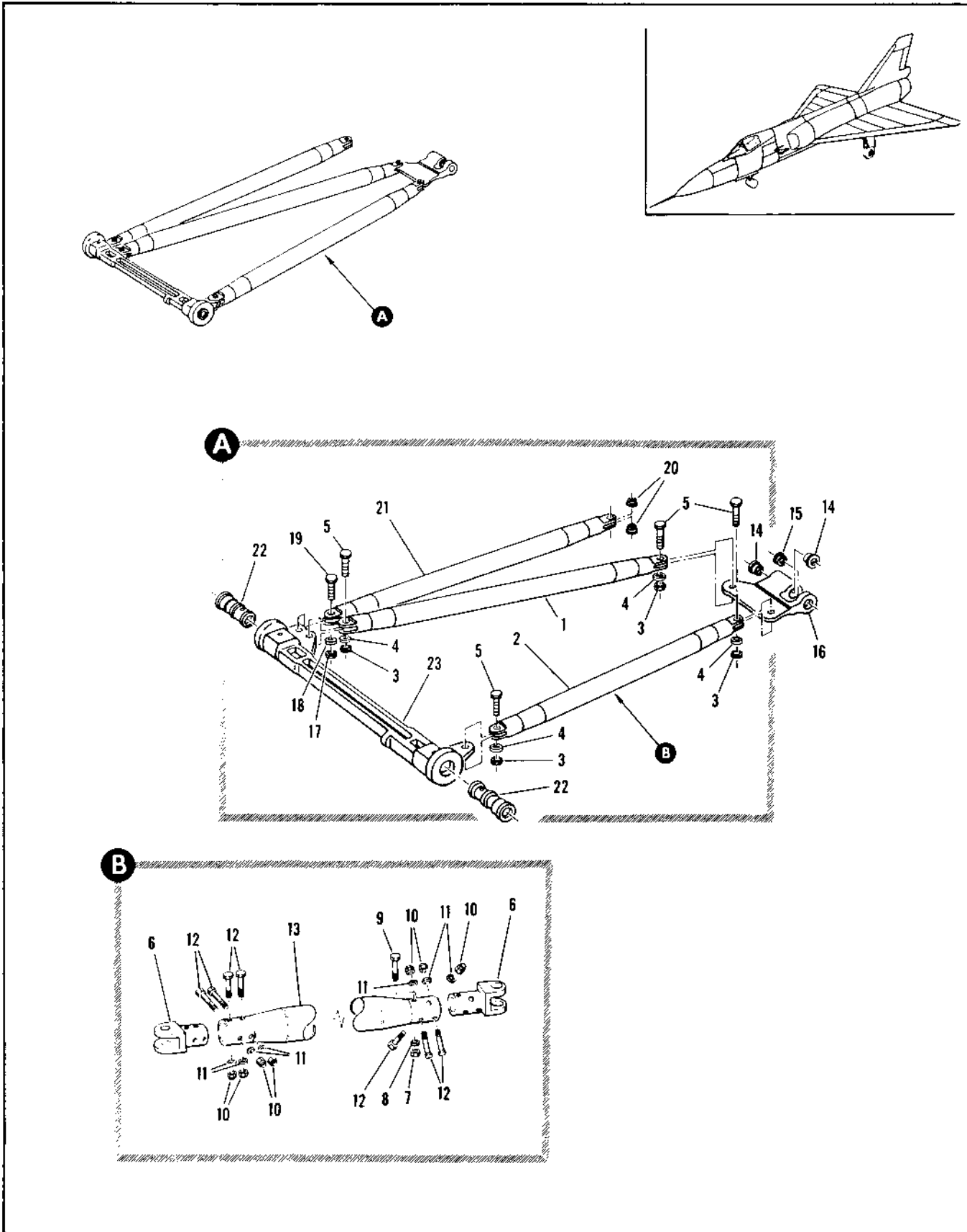

Figure 2.20-29. Fwd Displacement Gear Upper Drag Arm Assembly

FIGURE AND INDEX NUMBER	PART NUMBER	DESCRIPTION	UNITS PER ASSY.	USABLE ON CODE	
				FROM	TO
		1 2 3 4 5 6			
2.20-29	R-57128-1	ARM ASSEMBLY, FWD DISPLACEMENT REAR UPPER DRAG FOR QHA SEE FIG. 2.20-23	RF	35	186
- 1	R-57119-11	• LEG, CENTER	1	35	186
- 2	R-57134-7	• LEG ASSY, LH • ATTACHING PARTS	1	35	186
- 3	AN364-918	• NUT	4	35	186
- 4	AN961-916L	• WASHER	4	35	186
- 5	NAS464-9A27	• BOLT	4	35	186
- 6	R-57135-7	• ADAPTER • ATTACHING PARTS	2	35	186
- 7	NAS67946	• NUT	1	35	186
- 8	AN961-61C	• WASHER	1	35	186
- 9	AN464-6A36	• BOLT	1	35	186
- 10	NAS67945	• NUT	7	35	186
- 11	AN960-516	• WASHER	7	35	186
- 12	NAS464-5A37	• BOLT	7	35	186
- 13	R-57126-9	• TUBE, LH	1	35	186
	R-57132-1	• ADAPTER ASSY, AFT	1	35	186
- 14	NAS77-10-50	• BUSHING	2	35	186
- 15	NAS77-10-25	• BUSHING	1	35	186
- 16	R-57132-7	• ADAPTER	1	35	186
	R-57133-9	• ADAPTER, ALT INTERC WITH R-57132-7	1	35	186
	R-57119-1	• LEG ASSY, RH • ATTACHING PARTS	1	35	186
- 17	AN364-918	• NUT	1	35	186
- 18	AN960-916L	• WASHER	1	35	186
- 19	NAS464-9A27	• BOLT	1	35	186
- 20	NAS77A10-26	• BUSHING	2	35	186
- 21	R-57119-13	• LEG	1	35	186
	R-57120-1	• CROSSBEAM ASSY, FWD	1	35	186
	R-57129	• CROSSBEAM ASSY, FWD • ALT INTERC WITH R-57120-1	RF	35	186
- 22	R-57134-7	• BUSHING	1	35	186
- 23	R-57128-7	• CROSSBEAM	1	35	186
	R-57129-7	• CROSSBEAM, ALT INTERC WITH R-57128-7	1	35	186

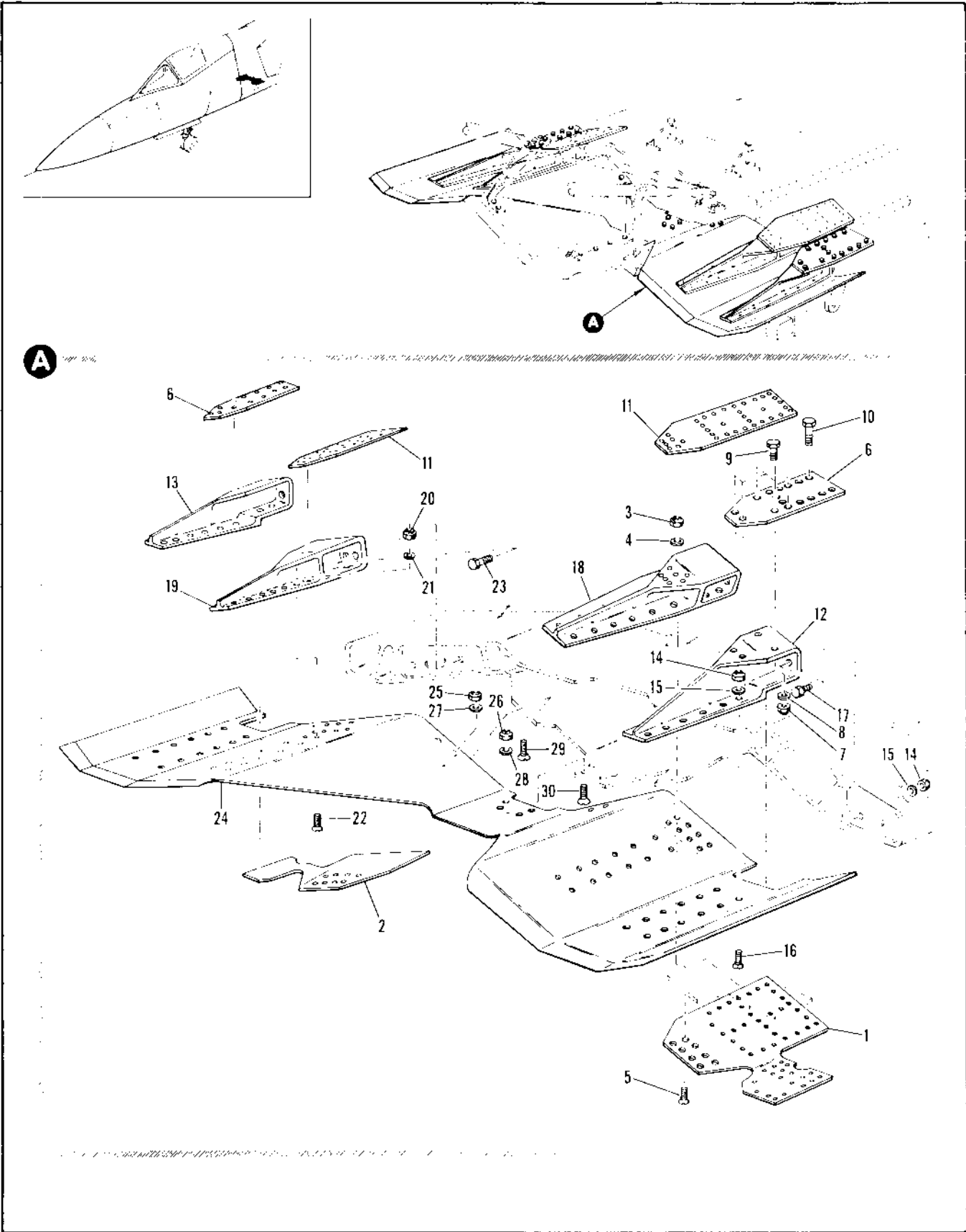

Figure 2.20-30. Shock Cross Bridge Web Installation

FIGURE AND INDEX NUMBER	PART NUMBER	DESCRIPTION 1 2 3 4 5 6	UNITS PER ASSY.	USABLE ON CODE	
				FROM	TO
2.20-99	8-57940-1	• HP INSTALLATION, SHOCK PRESSURE FIT. N/A SEE FIG. 2-20-99	1	35	
- 1	8-57940-11	• DOUBLER, LH	1	35	
- 2	8-57940-12	• DOUBLER, RH ATTACHING PARTS	1	35	
- 3	NAS679A3	• NUT	1	35	
- 4	AN96-218	• WASHER	1	35	
- 5	NAS333CPA6	• BOLT	1	35	
- 6	8-57941-7	• DOUBLER ATTACHING PARTS	2	35	
- 7	NAS679A3	• NUT	4	35	
- 8	AN96-218	• WASHER	4	35	
- 9	NAS1103-8	• BOLT	6	35	
- 10	NAS1103-9	• BOLT -----X-----	11	35	
- 11	8-57941-8	• DOUBLER	1	35	
- 12	8-57942-5	• FITTING, LH	1	35	
- 13	8-57942-7	• FITTING, LH ALT. INTERF. WITH 8-57941-8	1	35	
- 13	8-57942-10	• FITTING, RH	1	35	
- 13	8-57942-6	• FITTING, RH ALT. INTERF. WITH 8-57941-10 ATTACHING PARTS	35	35	
- 14	NAS679A3	• NUT	4	35	
- 15	AN96-218	• WASHER	4	35	
- 16	NAS333CPA6	• BOLT	6	35	
- 17	NAS1103-8	• BOLT -----X-----	2	35	
- 18	8-57943-5	• FITTING, LH	1	35	
- 18	8-57943-7	• FITTING, LH ALT. INTERF. WITH 8-57943-5	1	35	
- 18	8-57943-10	• FITTING, RH	1	35	
- 18	8-57943-8	• FITTING, RH ALT. INTERF. WITH 8-57943-10 ATTACHING PARTS	1	35	
- 20	NAS679A3	• NUT	2	35	
- 21	AN96-218	• WASHER	2	35	
- 22	NAS333CPA6	• BOLT	2	35	
- 23	NAS1103-10	• BOLT -----Y-----	4	35	
- 24	8-57941-7	• WSP ATTACHING PARTS	1	35	
- 25	NAS679A3	• NUT	1	35	
- 26	NAS679A4	• NUT	4	35	
- 27	AN96-416L	• WASHER	4	35	
- 28	AN96-416	• WASHER	4	35	
- 29	NAS333CPA17	• BOLT	4	35	
- 30	NAS333CPA7	• BOLT -----X-----	4	35	

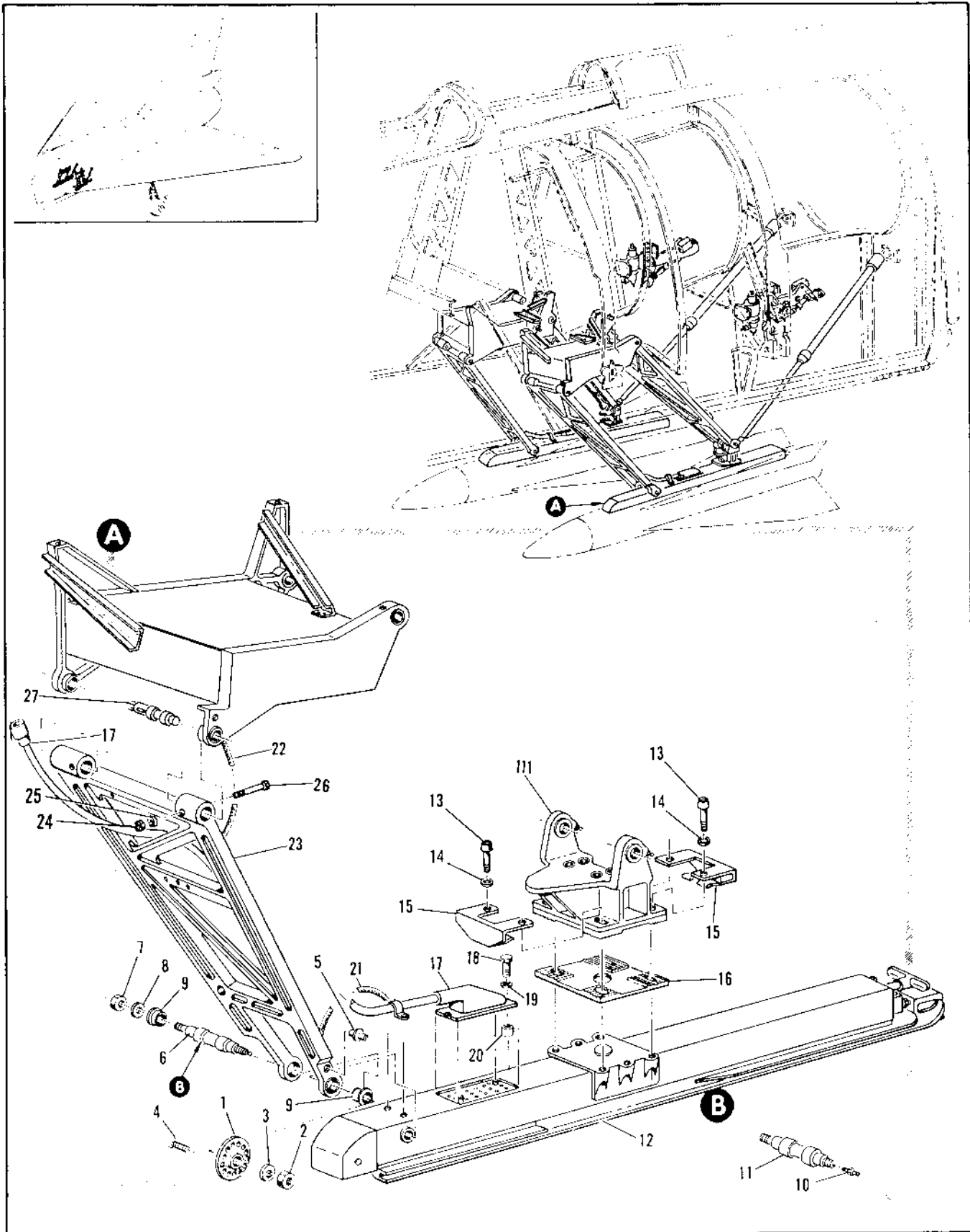

Figure 2.20-31. Aft LH Armament Installation (Sheet 1 of 6)

FIGURE AND INDEX NUMBER	PART NUMBER	DESCRIPTION	UNITS PER ASSY.	USABLE ON CODE	
				FROM	TO
2.20-31	8-57115-1	ARMAMENT INSTALLATION, AFT LH MODIFIED BY R-85055 AND R-85056 FOR NHA SEE FIG. 2.20-3	1	35	
	8-57115-2	ARMAMENT INSTALLATION, AFT RH MODIFIED BY R-85055 AND R-85059 FOR NHA SEE FIG. 2.20-3	1	35	
- 1	8-57159	• PLATE, ECCENTRIC INDEX ATTACHING PARTS	1	35	
- 2	NAS509-10	• NUT	1	35	
- 3	8-54406	• WASHER	1	35	
- 4	MS24625-24	• SCREW	1	35	
		-----X-----			
- 5	8-57005-9	• PEG	1	35	
- 6	8-57191	• SHAFT ASSY, ECCENTRIC ATTACHING PARTS	1	35	
- 7	AN320-10	• NUT	1	35	
- 8	AN969D1010	• WASHER	1	35	
- 9	8-57193	• PUSHING	1	35	
		-----X-----			
- 10	MS18001-1	• LUBRICATOR	1	35	
- 11	8-57191-7	• SHAFT	1	35	
- 12	464054-154M03 169600	• LAUNCHER ASSY, AFT (R-2-7) REAR • LAUNCHER ASSY, AFT (R-2-7) ALT INTCHG WITH 464054-154M02 ATTACHING PARTS	1	35	
- 13	MS20105H10	• BOLT	4	35	
- 14	MS2012001	• WASHER	4	35	
		-----X-----			
- 15	8-57186	• CLIP	2	35	
- 16	8-57187	• PLATE, LAUNCHER ADJUSTMENT	1	35	
- 17	8-325-3	• HARNESS ASSY, AFT LAUNCHER LH (56683) SPEC R-03257-9	1	35	
	8-325-9	• HARNESS ASSY, AFT LAUNCHER RH (56683) SPEC R-03257-11 ATTACHING PARTS	1	35	
- 18	AN173H11A	• BOLT	2	35	
- 19	AN969-10L	• WASHER	2	35	
		-----X-----			
- 20	NAS43003-10	• SPACER	2	35	
- 21	MS28003-2PC13	• JUMPER	1	35	
- 22	MS28003-2888 AN34301032 AN935-10L AN969D10 AN935D916 NAS428-5-7 AN4-5A NAS428-3-5	• JUMPER • NUT • WASHER • WASHER • WASHER • BOLT • BOLT • BOLT	1 2 1 1 1 1 1	35 35 35 35 35 35 35	
- 23	8-57115-11	• ARM ASSY, AFT DISPLACEMENT GEAR DRAG L&R LH FOR BREAKDOWN SEE FIG. 2.20-32	1	35	
	8-57115-13	• ARM ASSY, AFT DISPLACEMENT GEAR DRAG L&R LH ALT INTCHG WITH 8-57115-11 FOR BREAKDOWN SEE FIG. 2.20-32	1	35	
	8-57115-10	• ARM ASSY, AFT DISPLACEMENT GEAR DRAG L&R RH FOR BREAKDOWN SEE FIG. 2.20-32	1	35	
	8-57115-14	• ARM ASSY, AFT DISPLACEMENT GEAR DRAG L&R RH ALT INTCHG WITH 8-57115-10 FOR BREAKDOWN SEE FIG. 2.20-32 ATTACHING PARTS	1	35	
- 24	NAS579A*	• NUT	2	35	
- 25	AN969-10L	• WASHER	2	35	
- 26	AN3-23A	• BOLT	1	35	
- 27	8-57129-9	• PIN	1	35	
		-----X-----			

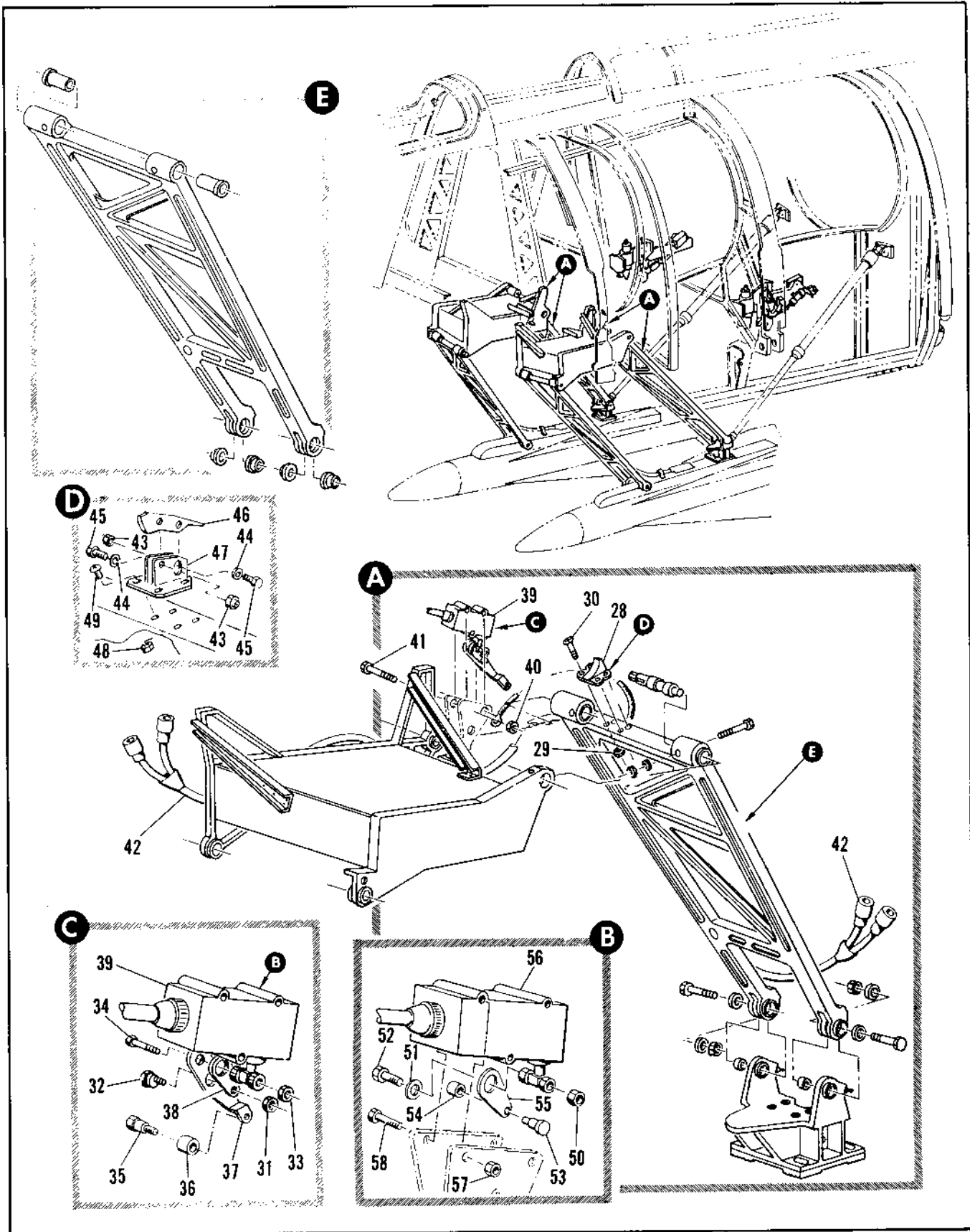

Figure 2.20-31. Aft LH Armament Installation (Sheet 2 of 6)

FIGURE AND INDEX NUMBER	PART NUMBER	DESCRIPTION	UNITS PER ASSY.	USABLE ON CODE	
				FROM	TO
2.20-31	8-57922-1	• SWITCH INSTL, AFT ARMAMENT DOWN LH	1	35	148
	8-57922-2	• SWITCH INSTL, AFT ARMAMENT DOWN RH	1	35	148
- 28	8-57186-7	• • CAM, DOWN SWITCH	1	35	148
	8-57175	• • CAM, DOWN SWITCH ALT INTCHG WITH 8-57186-7 ATTACHING PARTS	RF	35	148
- 29	NAS679A08	• • NUT	4	35	189
- 30	NAS220-12	• • SCREW -----X-----	4	35	188
- 31	NAS679A08	• • NUT	1	35	188
- 32	8-68038-7	• • BOLT	1	35	188
	8-68046-1	• • ARM ASSY, DOWN SWITCH REPLACED BY NOT INTCHG WITH 8-44967 ATTACHING PARTS	1	35	148
- 33	NAS679C3	• • NUT	1	35	148
- 34	AN3C7	• • BOLT -----X-----	1	35	148
- 35	8-68051-9	• • • STUD, ARM ROLLER	1	35	188
- 36	8-68052-9	• • • ROLLER	1	35	188
- 37	8-68046-7	• • • ARM	1	35	148
- 38	1107-569	• • PLATE, <97198> SPEC 8-44966-7	1	35	148
- 39	69C37529-2	• • SWITCH ASSY, LIMIT <97198> SPEC 8-06983-813 (REPLACD BY PART NO. H12-1011, FSCM 97198) NOT INTERCHANGEABLE WITH 69C37529-2	1	35	148
		• • NUT	5	35	188
- 40	NAS679A3	• • BOLT	3	35	188
- 41	AN3-17A	• • BOLT -----X-----	3	35	188
- 42	FC97K	• HARNESS ASSY, AFT IGNITOR <93148> SPEC 8-03258-1	2	150	
	8-44968-1	• SWITCH INSTL, AFT ARMAMENT DOWN LH	1	189	
	8-44968-2	• SWITCH INSTL, AFT ARMAMENT DOWN RH	1	189	
- 43	NAS679A4	• • NUT	2	189	
- 44	8-44968-11	• • WASHER	2	189	
- 45	AN4-10A	• • BOLT	2	189	
- 46	8-44965	• • CAM, DOWN SWITCH	1	189	
- 47	8-44966	• • BRACKET, CAM LIMIT SWITCH ATTACHING PARTS	1	189	
- 48	NAS679A08	• • NUT	4	189	
- 49	NAS220-12	• • SCREW -----X-----	4	189	
	8-44967	• • ARM ASSY, DOWN SWITCH REPLACED NOT INTCHG WITH 8-68046-1 ATTACHING PARTS	1	189	
- 50	NAS679C3	• • NUT	1	189	
- 51	QBH1000-4	• • WASHER	1	189	
- 52	AN3C7	• • BOLT -----X-----	1	189	
- 53	8-68051-9	• • • STUD, ARM ROLLER	1	189	
- 54	8-68052-9	• • • ROLLER	1	189	
- 55	8-44967-7	• • • ARM	1	189	
- 56	69C37529-2	• • SWITCH ASSY, LIMIT <97198> (REPLACED BY PART NO. H12-1011, FSCM 97198) NOT INTERCHANGEABLE WITH 69C37529-2	1	189	
- 57	NAS679A3	• • NUT	3	189	
- 58	NAS221-31	• • SCREW -----X-----	3	189	

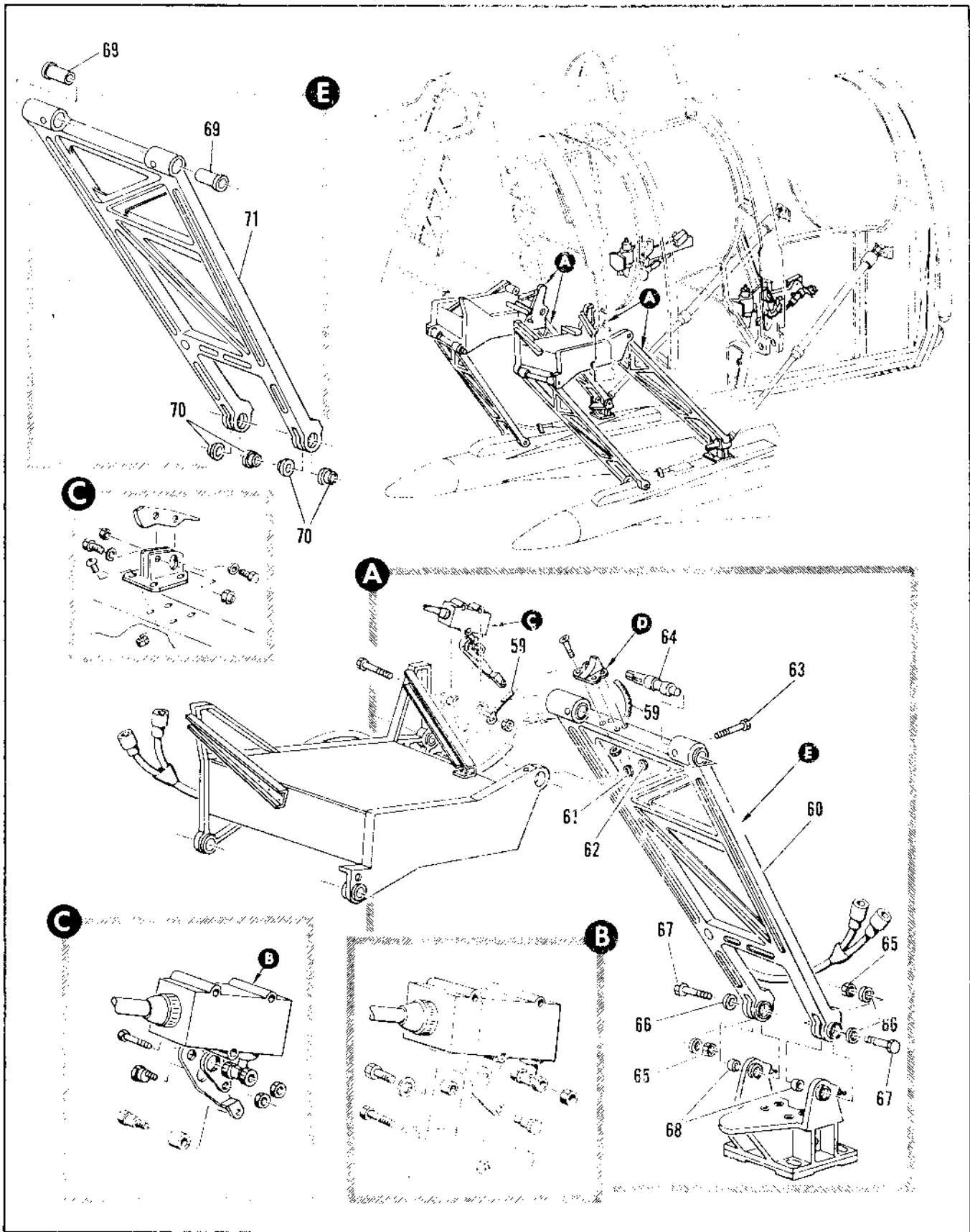

Figure 2.20-31. Aft LH Armament Installation (Sheet 3 of 6)

FIGURE AND INDEX NUMBER	PART NUMBER	DESCRIPTION	UNITS PER ASSY.	USABLE ON CODE	
				FROM	TO
		1 2 3 4 5 6			
2.20-31- 59	MS251 3-26B5	• JUMPER ATTACHING PARTS	1	50	
	NAS47903	• NUT	2	7	
	AN969-101	• WASHER	3	30	
	AN938-10L	• WASHER	1	15	
	NAS424-3-7	• BOLT	1	15	
	AN3-20A	• BOLT	1	15	
		-----X-----			
- 60	8-57140-5	• ARM ASSY, AFT DISPLACEMENT GEAR DRAG UPPER LH REPLACES SUITABLE FOR FOR 8-57140-3	1	150	
	8-57140-4	• ARM ASSY, AFT DISPLACEMENT GEAR DRAG UPPER RH REPLACES BY SUITABLE FOR 8-57140-3	1	150	120
	8-57140-6	• ARM ASSY, AFT DISPLACEMENT GEAR DRAG UPPER RH REPLACES SUITABLE FOR FOR 8-57140-4	1	150	
		ATTACHING PARTS			
- 61	NAS575A3	• NUT, FWD	1	50	
- 62	AN969-10L	• WASHER, FWD	2	15	
- 63	AN3-20A	• BOLT, FWD	2	15	
- 64	8-57139-9	• PIN, TRUNION FWD	2	15	
- 65	AN320-B	• NUT, AFT	2	35	
- 66	AN969-814	• WASHER, AFT	4	15	
- 67	NAS49PB-22	• BOLT, AFT	1	70	
- 68	NAS70-R-117	• BUSHING, AFT	1	15	
		-----X-----			
- 69	8-57134-9	• BUSHING	1	35	
- 70	8-574-7	• BUSHING	4	35	
- 71	8-57140-9	• ARM, LH	1	15	120
	8-57140-11	• ARM, LH	1	15	
	8-57140-10	• ARM, RH	1	35	120
	8-57140-12	• ARM, RH	1	15	

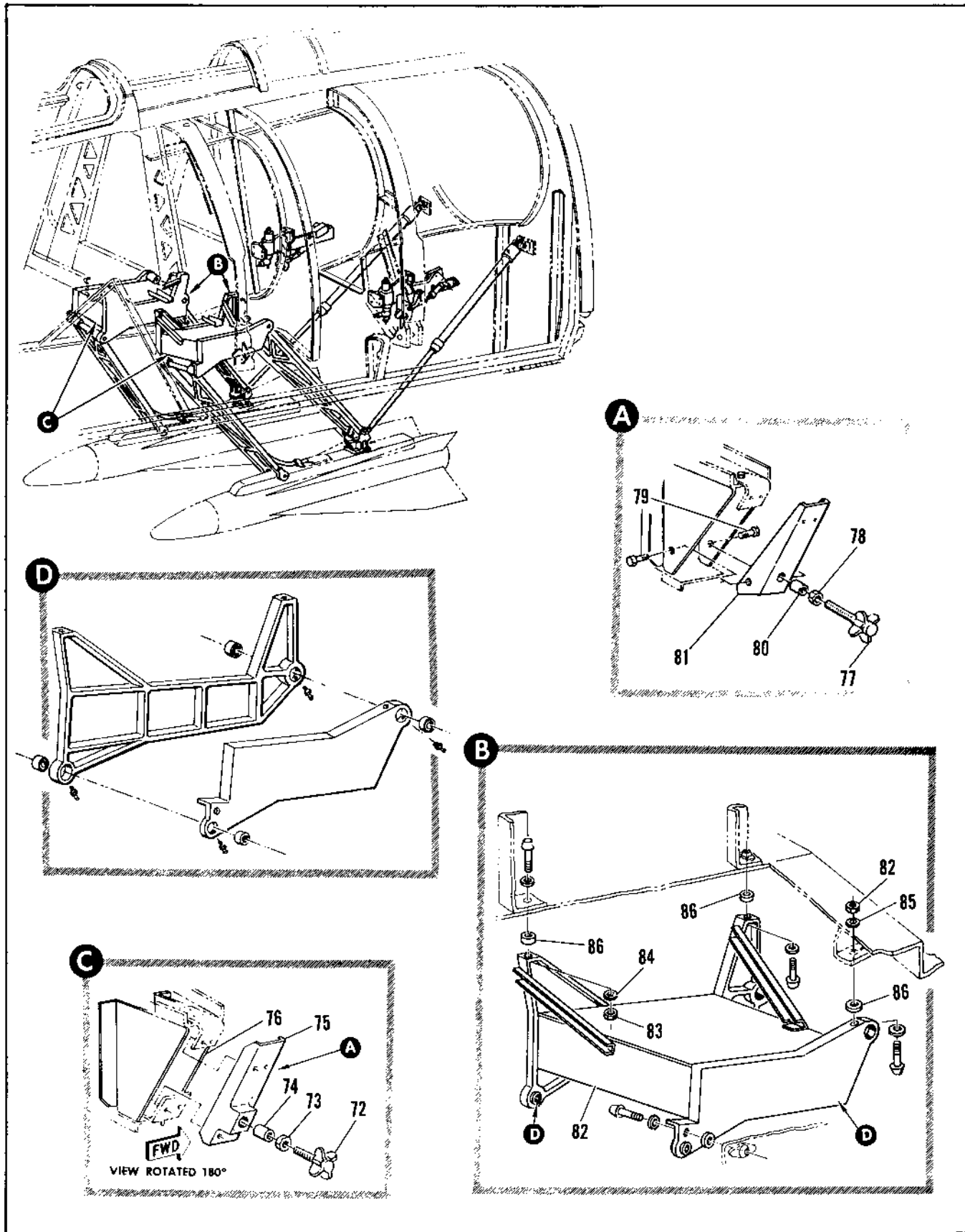

Figure 2.20-31, Aft LH Armament Installation (Sheet 4 of 6)

FIGURE AND INDEX NUMBER	PART NUMBER	DESCRIPTION	UNITS PER ASSY.	USABLE ON CODE		
				FROM	TO	
2.20-31	8-57060-3	BRACE INSTL, FWD SWAY BR-1 EJECTION SYSTEM LH	1	35	44	
	8-57060-9	BRACE INSTL, FWD SWAY BR-1 EJECTION SYSTEM LH	1	49		
	8-57060-4	BRACE INSTL, FWD SWAY BR-1 EJECTION SYSTEM RH	1	35	44	
	8-57060-6	BRACE INSTL, FWD SWAY BR-1 EJECTION SYSTEM RH	1	49		
	- 72	8-57929-9	PIN, ADJUSTING REPLACED BY SUITABLE SUB 8-57929-11	1	35	44
	- 73	AN316-6R	NUT	1	75	44
		8-57038-1	CHANNEL ASSY, FWD SWAY BRACE LH	1	35	44
		8-57038-2	CHANNEL ASSY, FWD SWAY BRACE RH	1	35	44
	- 74	MS12465-7	INSERT	1	35	44
	- 75	8-57038-7	CHANNEL, LH	1	35	44
		8-57038-8	CHANNEL, RH	1	35	44
	- 76	8-57939-7	BRACKET, FWD SWAY BRACE BR-1 EJECTION	1	75	44
		8-57939-8	BRACKET, FWD SWAY BRACE BR-1 EJECTION	1	35	44
	- 77	8-57929-9	PIN, ADJUSTING REPLACED BY SUITABLE SUB 8-57929-11	1	49	
		8-57929-11	PIN, ADJUSTING REPLACES SUITABLE SUB FOR 8-57929-9	1	49	
	- 78	AN316-6P	NUT	1	49	
		8-57054-1	CHOCK ASSY, FWD SWAY BRACE LH	1	49	
		8-57054-2	CHOCK ASSY, FWD SWAY BRACE RH ATTACHING PARTS	1	49	
	- 79	NAS1103-3	BOLT	2	46	
	- 80	1191-50NX9816	INSERT, <91767> P5-30 L-015	1	44	
- 81	8-57054-7	CHOCK, LH	1	49		
	8-57054-8	CHOCK, RH	1	49		
	8-57908-1	SUPPORT ASSY, AFT DISPLACEMENT BEAR LH	1	75		
	8-57908-2	SUPPORT ASSY, AFT DISPLACEMENT BEAR RH	1	35		
- 82	8-57905-5	SUPPORT ASSY, LH REPLACED BY NOT INTCHG WITH 8-57905-101	1	75	184	
	8-57905-1	SUPPORT ASSY, LH ALT INTCHG WITH 8-57905-101	RF	75	184	
	8-57905-605	SUPPORT ASSY, LH REPLACES NOT INTCHG WITH 8-57905-5	1	184		
	8-57905-801	SUPPORT ASSY, RH REPLACED BY NOT INTCHG WITH 8-57905-107	1	35	184	
	8-57905-3	SUPPORT ASSY, RH ALT INTCHG WITH 8-57905-101	RF	35	184	
	8-57905-2	SUPPORT ASSY, RH ALT INTCHG WITH 8-57905-101 OR 8-57905-3	RF	75	184	
	8-57905-407	SUPPORT ASSY, RH REPLACES NOT INTCHG WITH 8-57905-101 ATTACHING PARTS	1	184		
- 83	AN365-424	NUT	2	35	184	
	AN365-424	NUT	2	184		
- 84	MS21002-5	WASHER	1	75	184	
- 85	MS21002-4	WASHER	1	184		
	MS21002-6	WASHER	1	184		
- 86	8-57910-9	SHIM	3	35		
- 87	8-57910-7	SHIM	2	75		

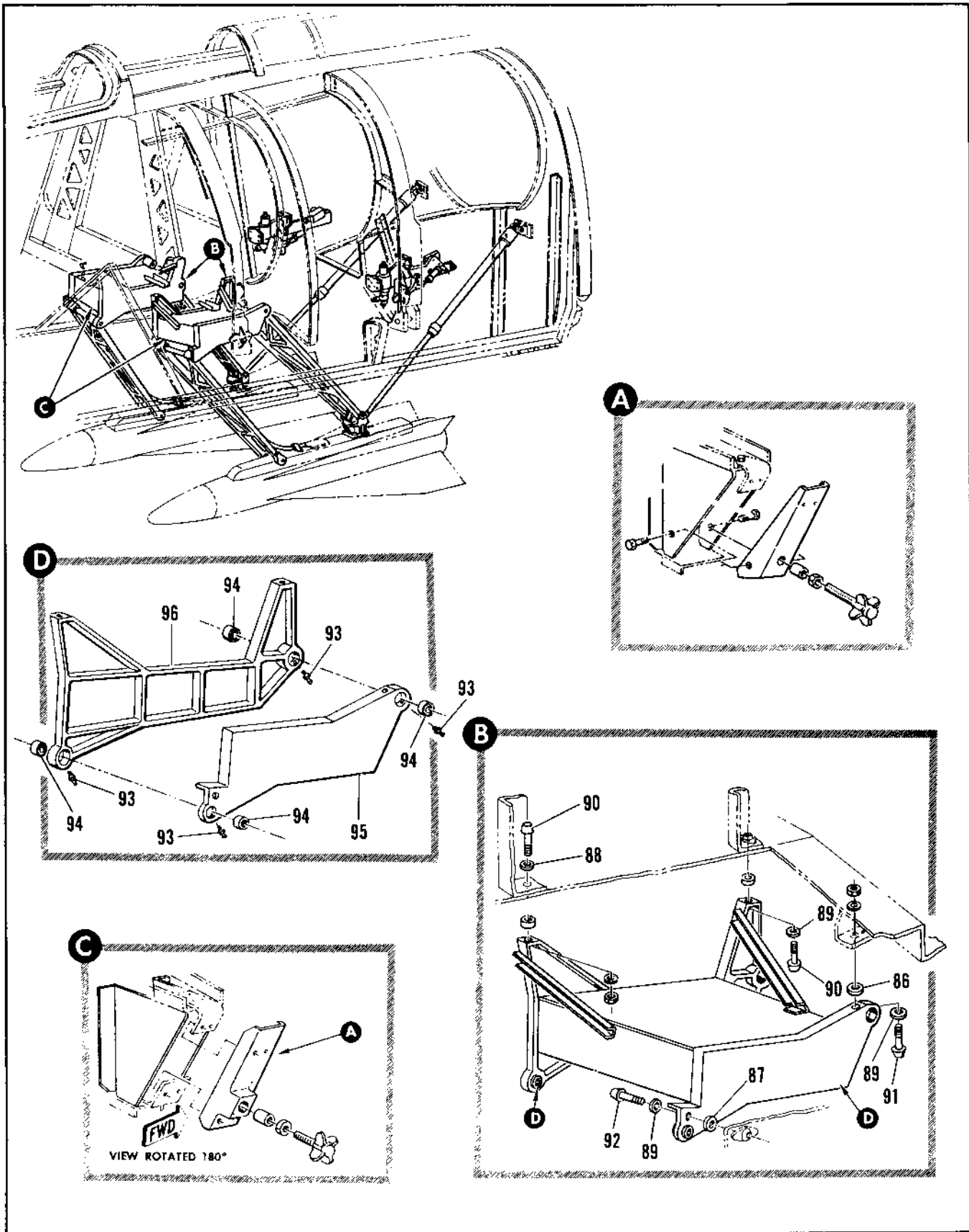

Figure 2.20-31. Aft LH Armament Installation (Sheet 5 of 6)

FIGURE AND INDEX NUMBER	PART NUMBER	DESCRIPTION	UNITS PER ASSY.	USABLE ON CODE	
				FROM	TO
		1 2 3 4 5 6			
2.20-31- 88	MS200070-4	• • WASHER	1	35	100
	MS200070-6	• • WASHER	1	100	
- 88	MS200070-6	• • WASHER	1	35	100
- 90	MS200070-14	• • BOLT (SEE T.O. 1F-106A-2-12-2-1)	1	35	100
	MS200070-12	• • BOLT (SEE T.O. 1F-106A-2-12-2-1)	1	100	
- 91	MS200070-16	• • BOLT	1	35	100
	MS200070-14	• • BOLT	1	100	
- 92	MS200070-10	• • BOLT	1	35	100
	MS200070-1	• • BOLT	1	100	
		-----X-----			
	4-57919-3	• • • SUPPORT ASSY, AFT DISPLACEMENT GEAR OUTRD LH REPLACES SUITABLE SUB 4-57919-1	1	35	
	4-57919-1	• • • SUPPORT ASSY, AFT DISPLACEMENT GEAR OUTRD LH USE WITH 4-57919-2 REPLACED BY SUITABLE SUB 4-57919-3	1	35	100
	4-57919-4	• • • SUPPORT ASSY, AFT DISPLACEMENT GEAR OUTRD RH REPLACES SUITABLE SUB 4-57919-2	1	35	
	4-57919-2	• • • SUPPORT ASSY, AFT DISPLACEMENT GEAR OUTRD RH USE WITH 4-57919-2 AND 4-57905-1 REPLACED BY SUITABLE SUB 4-57919-4	WF	35	1
	4-57920-1	• • • SUPPORT ASSY, AFT DISPLACEMENT GEAR INRD LH	1	35	
	4-57920-2	• • • SUPPORT ASSY, AFT DISPLACEMENT GEAR INRD RH	1	35	
- 93	MS15001-1	• • • • LUBRICATOR	4	35	
- 94	AB12	• • • • BUSHING, (S1548) 1/4-1/8-20	4	35	
- 95	4-57919-7	• • • • SUPPORT, OUTRD LH	1	35	
	4-57919-8	• • • • SUPPORT, OUTRD LH USE WITH 4-57919-1	WF	35	100
	4-57919-9	• • • • SUPPORT, OUTRD RH	1	35	
	4-57919-10	• • • • SUPPORT, OUTRD RH USE WITH 4-57919-2	WF	35	100
- 96	4-57920-7	• • • • SUPPORT, LH	1	35	
	4-57920-8	• • • • SUPPORT, RH	1	35	

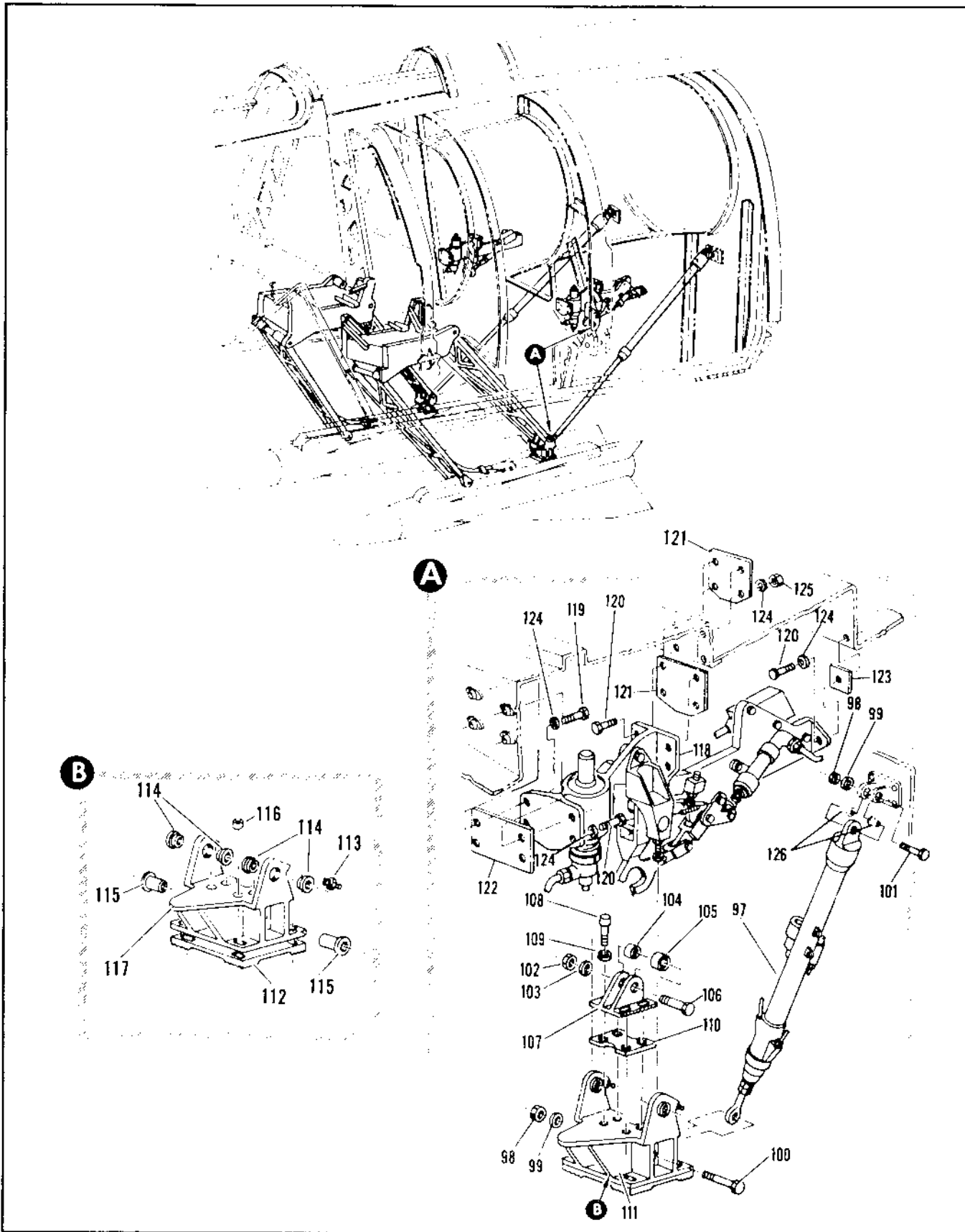

Figure 2.20-31. Aft LH Armament Installation (Sheet 6 of 6)

FIGURE AND INDEX NUMBER	PART NUMBER	DESCRIPTION	UNITS PER ASSY.	USABLE ON CODE	
				FROM	TO
2.20-31- 97	8-1000-8	• ACTUATOR, <77970> SPEC 8-1000-2-17 ATTACHING PARTS	1	35	
- 98	AN320-7	• NUT	2	35	
- 99	AN960-716	• WASHER	2	35	
-100	NAS464P7-34	• BOLT	1	35	
-101	NAS464P7-16	• BOLT	1	35	
		-----X-----			
-102	AN320-6	• NUT	1	35	
-103	AN960-816L	• WASHER	1	35	
-104	NAS720-8-12	• BUSHING	1	35	
-105	8-54800-7	• ROLLER, UP-LATCH	1	35	
-106	NAS464P6-21	• BOLT	1	35	
-107	8-57142-7	• BRACKET, AFT MISSILE BAY LAUNCHER UP-LATCH ROLLER ATTACHING PARTS	1	35	
		-----X-----			
-108	MS20044H6	• BOLT	4	35	
-109	MS20002C4	• WASHER	4	35	
		-----X-----			
-110	8-57170	• PLATE	1	35	
-111	8-57177-1	• SUPPORT ASSY, AFT LAUNCHER	1	35	
-112	8-57156	• • PLATE	1	35	
	8-57154-1	• • SUPPORT ASSEMBLY	1	35	
	8-57155-1	• • SUPPORT ASSY, ALT INTCHG WITH 8-57154-1	WF	35	
	MS15001-1	• • LUBRICATOR	2	35	
-113	NAS77A11-20	• • BUSHING	4	35	
-114	NAS77-7-17	• • BUSHING	2	35	
-115	1191-40N182	• • INSERT, <91767> 95-300-011	4	35	
-116	8-57154-7	• • SUPPORT	1	35	
-117	8-57155-6	• • SUPPORT, ALT INTCHG WITH 8-57154-7	WF	35	
-118	8-57116-003	• UP-LATCH ASSY, AFT DISPLACEMENT GEAR FOR BREAKDOWN SEE FIG. 2.20-33	1	35	
	8-57116-001	• UP-LATCH ASSY, AFT DISPLACEMENT GEAR ALT INTCHG WITH 8-57116-003 FOR BREAKDOWN SEE FIG. 2.20-33 ATTACHING PARTS	WF	35	
		-----X-----			
-119	AN4-10A	• BOLT	2	35	
-120	AN4-11A	• BOLT	7	35	
-121	8-57165-13	• SHIM	2	35	
-122	8-57163-7	• SHIM	1	35	
-123	8-57163-9	• SHIM	1	35	
-124	AN960-416L	• WASHER	2	35	
-125	NAS679A4	• NUT	4	35	
		-----X-----			
	8-57316-1	• CLAMP INSTL, ARMAMENT IGNITOR HARNESS LH	1	139	
	8-57316-3	• CLAMP INSTL, ARMAMENT IGNITOR HARNESS LH	1	131	
-126	NAS77-7-11	• BUSHING	2		

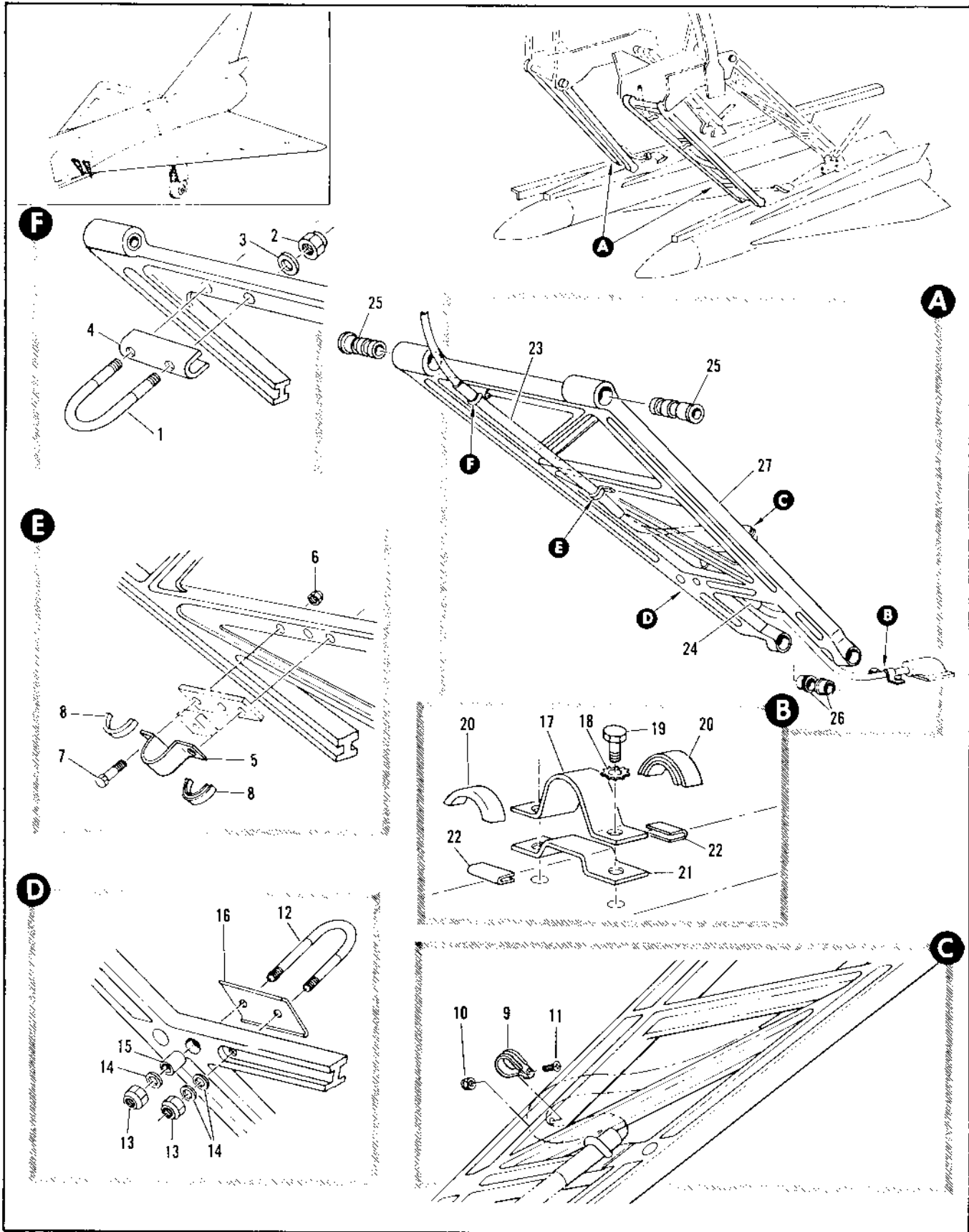

Figure 2.20-32. Aft Displacement Gear Lower Drag Arm Assembly

FIGURE AND INDEX NUMBER	PART NUMBER	DESCRIPTION	UNITS PER ASSY.	USABLE ON CODE		
				FROM	TO	
2.20-32	B-57115-11	ARM ASSEMBLY, AFT DISPLACEMENT GEAR DRAG LOWER LH FOR NHA SEE FIG. 2.20-31	RF	35		
	B-57115-13	ARM ASSEMBLY, AFT DISPLACEMENT GEAR DRAG LOWER LH ALT INTCHG WITH B-57115-11 FOR NHA SEE FIG. 2.20-31	RF	35		
	B-57115-12	ARM ASSEMBLY, AFT DISPLACEMENT GEAR DRAG LOWER RH FOR NHA SEE FIG. 2.20-31	RF	35		
	B-57115-14	ARM ASSEMBLY, AFT DISPLACEMENT GEAR DRAG LOWER RH ALT INTCHG WITH B-57115-12 FOR NHA SEE FIG. 2.20-31	RF	35		
	B-57424-807	CLAMP INSTL, AFT ARMAMENT HARNESS LH	1	35		
	B-57426-809	CLAMP INSTL, AFT ARMAMENT HARNESS LH USE WITH B-57115-13	RF	35		
	B-57426-808	CLAMP INSTL, AFT ARMAMENT HARNESS RH	1	35		
	B-57426-810	CLAMP INSTL, AFT ARMAMENT HARNESS RH USE WITH B-57115-14	RF	35		
	- 1	B-57926-51	U BOLT	1	35	
		B-57496	U BOLT ASSY, WELDED ATTACHING PARTS	1	61	
	- 2	NAS679A3	NUT	2	35	
	- 3	AN961-10L	WASHER	2	35	
			-----X-----			
	- 4	B-57926-53	CHANNEL	1	35	
	- 5	B-57926-52	HAT ATTACHING PARTS	1	35	
	- 6	NAS679A3	NUT	2	35	
	- 7	NAS563-31	BOLT	2	35	
			-----X-----			
	- 8	B-57926-37	CHANNEL	2	35	
	- 9	MS219190630	CLAMP ATTACHING PARTS	1	130	
	- 10	NAS679A3	NUT	1	130	
	- 11	MS35207-263	SCREW	1	130	
			-----X-----			
	- 12	B-57926-51	U BOLT	1	35	
		B-57496	U BOLT ASSY, WELDED ATTACHING PARTS	1	61	
	- 13	NAS679A3	NUT	2	35	
	- 14	AN961-10L	WASHER	3	35	
	- 15	NAS105713-063	BOLT	2	35	
			-----X-----			
	- 16	B-57926-57	CHANNEL	1	35	
		B-57926-55	CHANNEL, USE WITH B-57926-55 AND B-57926-810	RF	35	
	- 17	B-57926-39	HAT ATTACHING PARTS	1	35	
- 18	AN936B41B	WASHER	2	35		
- 19	AN4-4A	BOLT	2	35		
		-----X-----				
- 20	B-57926-43	CHANNEL	2	35		
	Q1443-R-2	CHANNEL, ALT INTCHG WITH B-57926-43	2	35		
- 21	B-57926-41	HAT	1	35		
- 22	B-57926-47	CHANNEL	2	35		
- 23	B-57926-63	COVER, HARNESS TUBE	1	35		
- 24	B-57926-59	COVER, HARNESS TUBE	1	35		
	B-57141-801	ARM ASSY, AFT DISPLACEMENT GEAR LWR DRAG LH	1	35		
	B-57141-802	ARM ASSY, AFT DISPLACEMENT GEAR LWR DRAG RH	1	35		
	B-57134-3	ARM ASSY, AFT DISPLACEMENT GEAR LWR DRAG USE WITH B-57115-13 AND B-57115-14	RF	35		
- 25	B-57134-9	BUSHING	2	35		
- 26	NAS77A14-58	BUSHING	2	35		
- 27	B-57141-13	ARM, LH ALTERED FROM B-57141	1	35		
	B-57141-14	ARM, RH ALTERED FROM B-57141	1	35		
	B-57141	ARM	RF	35		
	B-57134-11	ARM, USE WITH B-57134-3	RF	35		

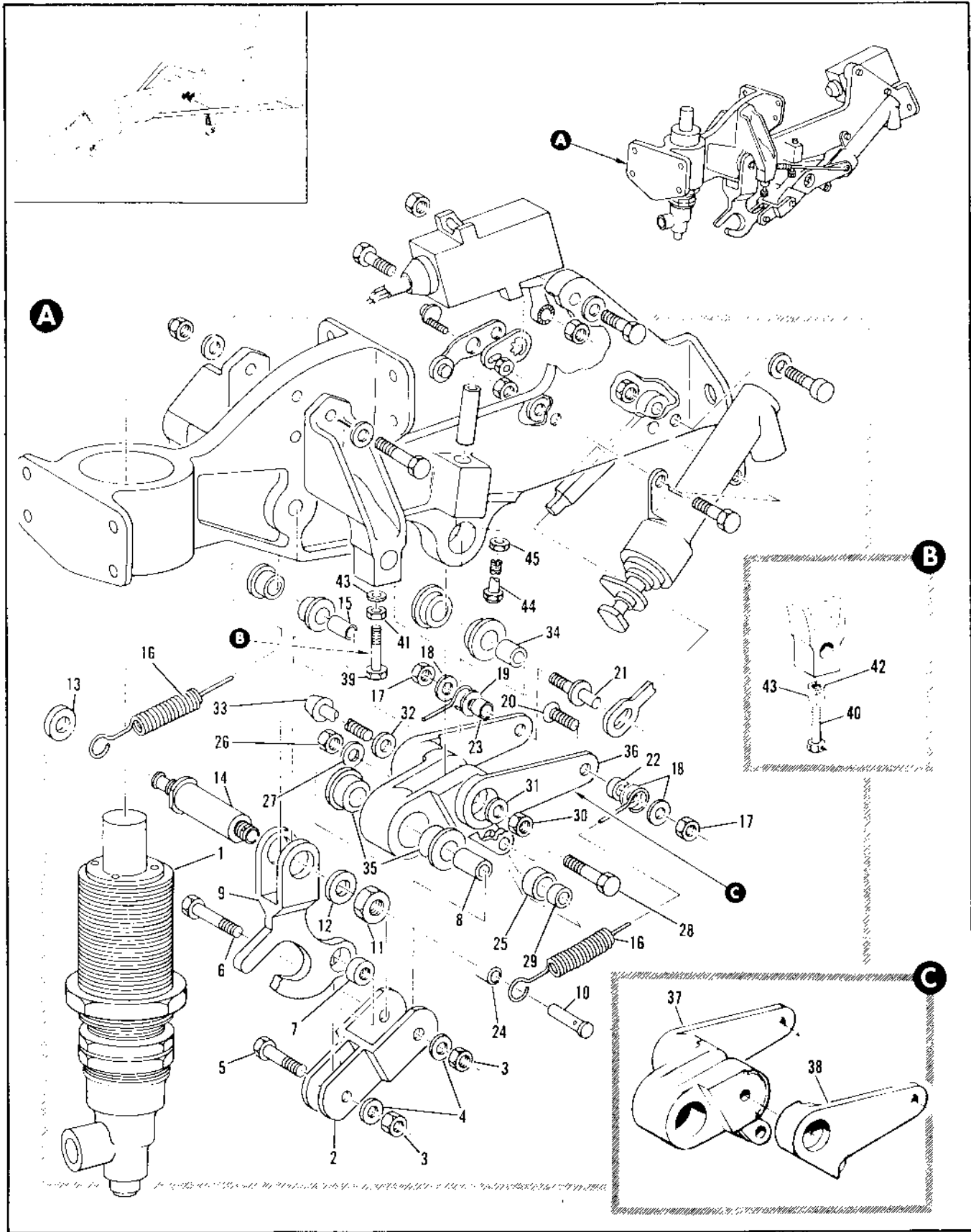

Figure 2.20-33. Aft Displacement Gear Up-Latch Assembly (Sheet 1 of 2)

FIGURE AND INDEX NUMBER	PART NUMBER	DESCRIPTION	UNITS PER ASSY.	USABLE ON CODE	
				FROM	TO
2.20-33	8-57116-803	UP-LATCH ASSEMBLY, AFT DISPLACEMENT GEAR MODIFIED BY 8-4483-1 FOR NHA SEE FIG. 2.20-31	AF	35	
	8-57116-801	UP-LATCH ASSEMBLY, AFT DISPLACEMENT GEAR MODIFIED BY 8-4483-1 ALT INTCHG WITH 8-57114-803 SEE FIG. 2.20-31	AF	35	
- 1	60037-12	* SNUBBER, ARMAMENT RETRACT (1-215) SPEC 8-22947-15 T.O. 249-74-13-3	1	35	
- 2	8-57149-7	* LINK, UP-LATCH	1	35	
- 3	AN322-4	* NUT	2	35	
- 4	AN960-416L	* WASHER	2	35	
- 5	NAS464-4-9	* BOLT	1	35	
- 6	NAS464-4-24	* BOLT	1	35	
- 7	NAS72-4-006	* BUSHING	3	35	
- 8	NAS72-4-105	* BUSHING	1	35	
- 9	8-57146-7	* HOOK, UP-LATCH	1	35	
	8-57146	* HOOK, UP-LATCH ALT INTCHG WITH 8-57146-7	AF	35	
- 10	8-57146	* PIN	1	35	
- 11	AN322-4	* NUT	11	35	
- 12	AN960-816	* WASHER	1	35	
- 13	AN960-816	* WASHER	1	35	
- 14	8-56467	* BOLT	1	35	
- 15	NAS72-4-104	* BUSHING	1	35	
- 16	8-57151	* SPRING	2	35	
- 17	AN320-3	* NUT	2	35	
- 18	AN960-13L	* WASHER	3	35	
- 19	AN960-10	* WASHER	1	35	
- 20	NAS333P4-5	* BOLT	1	35	
- 21	8-57156	* PIN	1	35	
- 22	NAS43003-2	* SPACER	1	35	
- 23	NAS43003-15	* SPACER	1	35	
- 24	NAS43HT9-12	* SPACER	1	35	
- 25	8-57139	* ROLLER, UP-LATCH ATTACHING PARTS	1	35	
- 26	AN322-3	* NUT	1	35	
- 27	AN960-10L	* WASHER	1	35	
- 28	NAS464-3-5	* BOLT	1	35	
	NAS464-3-21	* BOLT, USE WITH 8-57116-01	1	35	
		-----X-----			
- 29	NAS72-3-006	* BUSHING	1	35	
	8-57048-1	* BELL CRANK ASSY, UP-LATCH	1	35	
	8-57147	* BELL CRANK ASSY, UP-LATCH ALT INTCHG WITH 8-57148-1	AF	35	
	8-57150-1	* BELL CRANK ASSY, UP-LATCH USE WITH 8-57116-801	F	35	
	8-57153	* BELL CRANK ASSY, UP-LATCH ALT INTCHG WITH 8-57150-1	AF	35	
		ATTACHING PARTS			
- 30	NAS72-4-4	* NUT	1	35	
- 31	AN960-416	* WASHER	1	35	
- 32	MS2000204	* WASHER	1	35	
- 33	MS20004-28	* BOLT	1	35	
	MS20004-30	* BOLT, USE WITH 8-57116-01	26	35	
- 34	NAS72-4-113	* BUSHING	1	35	
		-----X-----			
- 35	NAS77A7-30	* BUSHING	2	35	
- 36	8-57149-7	* BELL CRANK	1	35	
	8-57147-7	* BELL CRANK, ALT INTCHG WITH 8-57048-1	AF	35	
- 37	8-57150-1	* BELL CRANK, USE WITH 8-57116-01	AF	35	
	8-57153-7	* BELL CRANK, ALT INTCHG WITH 8-57150-1	AF	35	
	8-57145	* ARM, BELL CRANK USE WITH 8-57116-801	AF	35	
- 38	8-57178	* BOLT, REPLACES SUITABLE ONE FOR 8-57177-7	2	35	254
- 39	8-57178-7	* BOLT, REPLACES SUITABLE ONE FOR 8-57177-7	26	35	
- 40	AN315-4R	* NUT	2	35	214
- 41	AN960D416	* WASHER	2	35	
- 42	AN960D416L	* WASHER	1	35	
- 43	NAS4204-12	* BOLT, ADJUSTING	1	35	
- 44	NAS1201-4	* NUT	1	35	

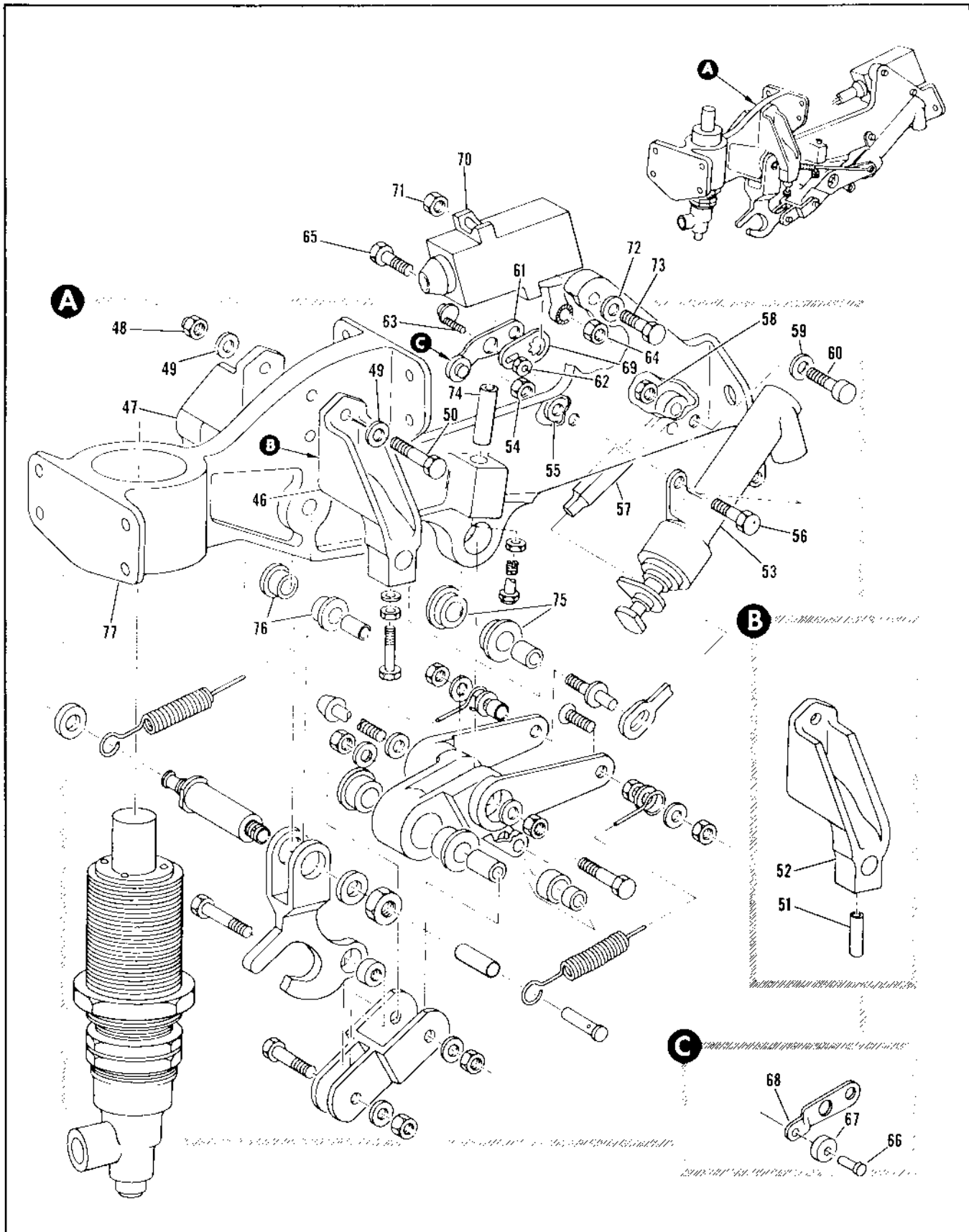

Figure 2.20-33. Aft Displacement Gear Up-Latch Assembly (Sheet 2 of 2)

FIGURE AND INDEX NUMBER	PART NUMBER	DESCRIPTION	UNITS PER ASSY.	USABLE ON CODE	
				FROM	TO
2.20-33- 46	8-57184-1	• BRACE ASSY, MR-1 AFT SWAY LH REPLACED BY SUITABLE SUB 8-57184-3	1	25	204
	8-57179-1	• BRACE ASSY, LH ALT INTCHG WITH 8-57184-1	RF	35	204
	8-57184-3	• BRACE ASSY, MR-1 AFT SWAY LH REPLACES SUITABLE SUB FOR 8-57184-1	1	25	
- 47	8-57184-2	• BRACE ASSY, MR-1 AFT SWAY RH REPLACED BY SUITABLE SUB 8-57184-4	1	25	204
	8-57179-2	• BRACE ASSY, RH ALT INTCHG WITH 8-57184-2	RF	35	204
	8-57184-4	• BRACE ASSY, MR-1 AFT SWAY LH REPLACES SUITABLE SUB FOR 8-57184-2 ATTACHING PARTS	1	25	
- 48	NAS679A4	• NUT	1	25	
- 49	AN95 D416	• WASHER	4	25	
- 50	AN4-22A	• BOLT	2	25	
	AN4-17A	• BOLT, USE WITH 8-57116-101 -----X-----	2	25	
- 51	1191-40N1/2	• INSERT, AF 95-13100-111	1	35	
- 52	8-57184-7	• BRACE, LH	1	35	204
	8-57179-7	• BRACE, LH ALT INTCHG WITH 8-57184-7	RF	35	204
	8-57184-8	• BRACE, LH	1	25	
	8-57184-8	• BRACE, RH	1	25	204
	8-57179-8	• BRACE, RH ALT INTCHG WITH 8-57184-8	RF	35	204
	8-57184-10	• BRACE, RH	1	25	
- 53	60031	• ACTUATOR, UP-LATCH (94915) SPEC 8-1194-1 T.O. 9P2-3-17-43 ATTACHING PARTS	1	35	
- 54	AN320-3	• NUT	2	35	
- 55	AN960-10L	• WASHER	2	35	
- 56	NAS464-3-5	• BOLT -----X-----	2	35	
- 57	8-57149-7	• LEVER, UP-LATCH SWITCH ATTACHING PARTS	1	25	
- 58	AN320-3	• NUT	1	35	
- 59	AN960D10L	• WASHER	1	25	
- 60	AN23-24	• BOLT -----X-----	2	25	
- 61	8-68046-1	• ARM ASSY, UP-LATCH SWITCH ATTACHING PARTS	1	35	
- 62	NAS679A08	• NUT	1	25	
- 63	8-68038-7	• BOLT	1	25	
- 64	NAS479C3	• NUT	1	35	
- 65	AN307A	• BOLT -----X-----	1	25	
- 66	8-68051-9	• STUD, ARM ROLLER	1	35	
- 67	8-68052-9	• ROLLER	1	25	
- 68	8-68046-7	• ARM	1	25	
- 69	1107-509	• PLATE, (97198) SPEC 8-1194-1	1	25	
- 70	69037529-7	• SWITCH, (91759) SPEC 8-1194-1 ATTACHING PARTS	1	25	
- 71	AN320-3	• NUT	2	35	
- 72	AN960-10L	• WASHER	2	35	
- 73	NAS464-3-25	• BOLT -----X-----	2	35	
	8-57147-1	• SUPPORT ASSY, UP-LATCH REPLACES NOT INTCHG WITH 8-57152-3	1	25	
	8-57152-1	• SUPPORT ASSY, ALT INTCHG WITH 8-57147-1	RF	25	
	8-57152-3	• SUPPORT ASSY, UP-LATCH REPLACED BY 8-57147-1	1	25	303
- 74	1191-40N1/2	• INSERT, (91757) 95-13100-111	1	35	
- 75	NAS77A7-25	• BUSHING	2	25	
- 76	NAS77A11-30	• BUSHING	2	25	
- 77	8-57147-7	• SUPPORT	1	25	
	8-57152-9	• SUPPORT, ALT INTCHG WITH 8-57147-7	RF	25	
	8-57152-11	• SUPPORT, USE WITH 8-57152-5	RF	25	303

A AIRPLANE WAS THRU ALL SEA LEVEL ON

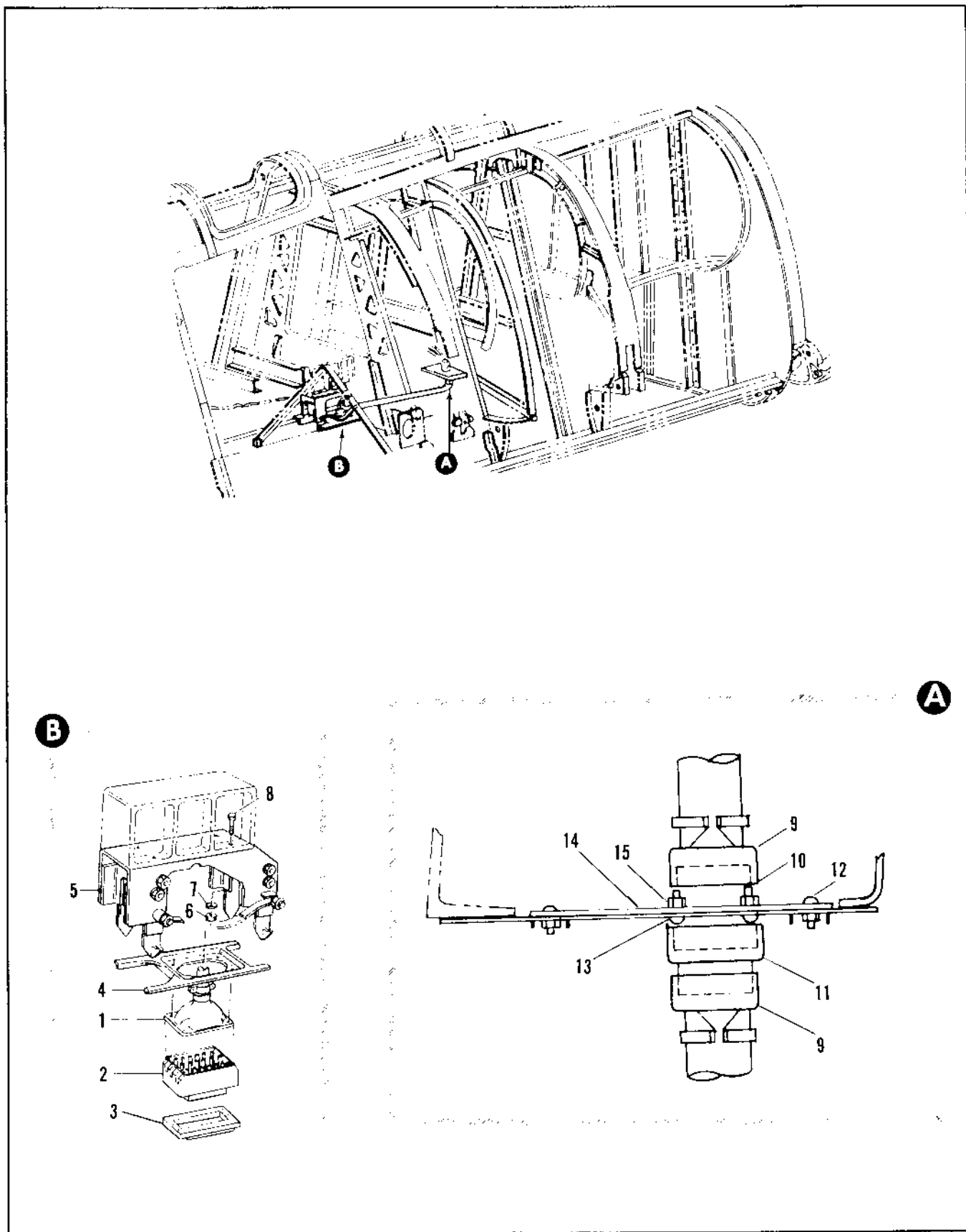

Figure 2.20-34. MB-1 Armament Installation (Sheet 1 of 2)

FIGURE AND INDEX NUMBER	PART NUMBER	DESCRIPTION	UNITS PER ASSY.	USABLE ON CODE		
				FROM	TO	
2.20-34	8-34876-805	• HARNESS ASSY, STA 216.50 TO AFT LAUNCHER DISCONNECT	1	35	99	
	8-34876-811	• HARNESS ASSY, STA 216.50 TO AFT LAUNCHER DISCONNECT	1	93	127	
	8-34876-809	• HARNESS ASSY, STA 216.50 TO AFT LAUNCHER DISCONNECT	1	130	194	
	8-34876-813	• HARNESS ASSY, STA 216.50 TO AFT LAUNCHER DISCONNECT	1	189		
	- 1	GMSC36-33P21-1-1-8	• CONNECTOR, RECEPTACLE ELECTRICAL FWD UMBILICAL (18355) 92-50268-002	1	35	
	- 2	22830-2	• • CONNECTOR, MATING END	1	35	
	- 3	448-0160-000	• • CONNECTOR, SHELL (D-RING) (71468)	1	35	
	- 4	8-57036-7	• CRADLE, FWD UMBILICAL PLUG	1	35	48
		8-57037	• CRADLE, FWD ALT INTCHG WITH 8-57036-7	RF	35	4
		8-57056	• CRADLE ASSY, FWD UMBILICAL PLUG	1	49	
		8-57036-7	• • CRADLE	1	49	
		8-57037	• • CRADLE, ALT INTCHG WITH 8-57036-7	RF	49	
	- 5	8-57008-3	• RETAINER ASSY, FWD UMBILICAL PLUG FOR BREAKDOWN SEE FIG. 2.20-36	1	35	48
		8-57008-5	• RETAINER ASSY, FWD UMBILICAL PLUG FOR BREAKDOWN SEE FIG. 2.20-36 ATTACHING PARTS	1	49	
	- 6	NAS679A4	• NUT	4	35	
- 7	AN960-416	• WASHER	4	35		
- 8	NAS454-4A8	• BOLT	4	35		
		-----X-----				
- 9	M83723-15S-22F	• BACKSHELL	2			
- 10	M83723-02R2241N	• CONNECTOR	1			
- 11	M83723-13F2241N	• CONNECTOR	1			
- 12	MS35207-262	• SCREW	10			
- 13	MS35206-214	• SCREW	4			
- 14	7239217-01	• PLATE	1			
- 15	MS21042-04	• NUT	4			

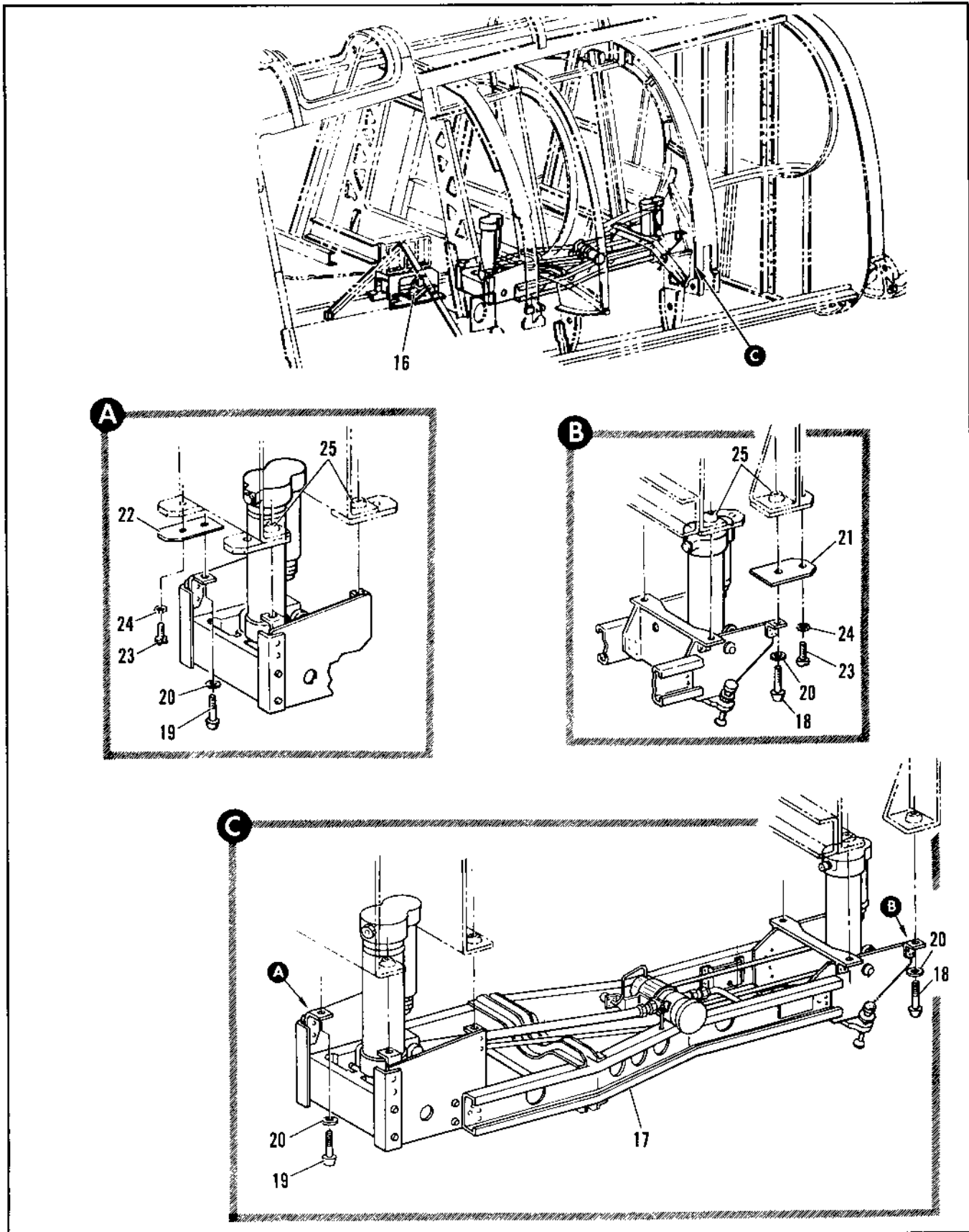
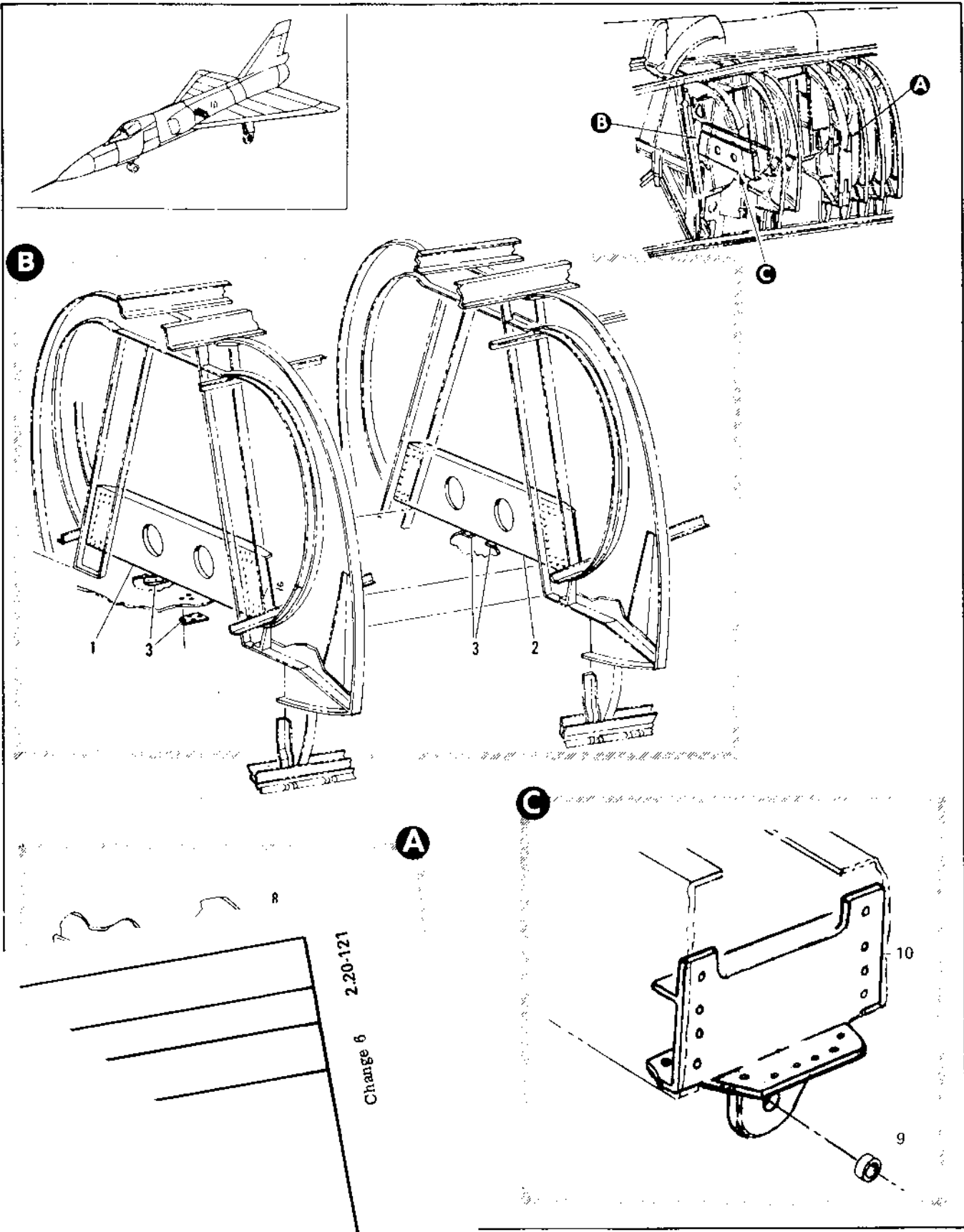

Figure 2.20-34. MB-1 Armament Installation (Sheet 2 of 2)

FIGURE AND INDEX NUMBER	PART NUMBER	DESCRIPTION	UNITS PER ASSY.	USABLE ON CODE	
				FROM	TO
2.20-34- 16	8-34829	<ul style="list-style-type: none"> • HARNESS, AFT LAUNCHER DISCONNECT • EJECTOR ASSY. MB-1, REPLACES NOT INTCNG WITH 8-57200-835 AND -837 FOR FOR BREAKDOWN SEE T.O. 11B81-3-11 ATTACHING PARTS 	1	35	
- 17	8-57200-839		1		
- 18	MS20005-16	<ul style="list-style-type: none"> • BOLT • BOLT • BOLT • BOLT • WASHER -----X----- • SHIM, MFG FROM PLATE STEEL MIL-S-5059, FSN 9515-00-184-8819 • SHIM, MFG FROM PLATE STEEL MIL-S-5059, FSN 9515-00-184-8819 ATTACHING PARTS • SCREW • WASHER • NUTPLATES, SEE FIG. 2.20-35 -----X----- 	4	35	38
- 19	MS20005-14		4	39	
- 20	MS20005-16		4	35	38
- 20	MS20002C5		4	39	
- 21	MS20002C5	8	35		
- 21	8-57382	16	35		
- 22	8-57383	16	35		
- 23	MS35265-60	8	35		
- 24	MS35333-39	8	35		
- 25					
		A AIRPLANES 39 THRU 129,265 AND ON			



Change 6 2-20-121

Ejector Support

FIGURE AND INDEX NUMBER	PART NUMBER	DESCRIPTION	UNITS PER ASSY.	USABLE ON CODE	
				FROM	TO
		1 2 3 4 5 6			
2.20-35		MB-1 EJECTOR AND M61A1 GUN SUPPORTS			
- 1	8-74772	• SUPPORT INSTL, MB-1 EJECTOR STA 330	RF	35	
	8-74776-11	• • SUPPORT, MB-1 EJECTOR STA 330	1	35	
	NAS684A5	• • • NUTPLATE	2	35	
- 2	8-74773	• SUPPORT INSTL, MB-1 EJECTOR STA 337	RF	35	
	8-74775-9	• • SUPPORT, MB-1 EJECTOR STA 337	1	35	
	NAS684A5	• • • NUTPLATE	2	35	
- 3	8-74489-A05	• PAD INSTL, MB-1 EJECTOR FWD	RF	27A	
	8-57385	• • PAD, MB-1 EJECTOR FWD	4	35	
- 3A	8-74482-4	• SUPPORT INSTL, MB-1 EJECTOR AFT STA 378/383 FOR NHA SEE FIG. 2.3-11	RF	A	
	8-74482-A05	• SUPPORT INSTL, MB-1 EJECTOR AFT STA 378/383 FOR NHA SEE FIG. 2.3-11	RF	B	
- 4	8-57364	• • PAD, MB-1 EJECTOR AFT	4	35	
- 5	8-77945-9	• • SUPPORT, LH	1	35	
	8-77944-13	• • SUPPORT, LH ALT INTCHG WITH 8-77945-9	RF	35	
- 6	8-77945-10	• • SUPPORT, RH	1	35	
	8-77944-14	• • SUPPORT, RH ALT INTCHG WITH 8-77945-10	RF	35	
- 7	8-77945-11	• • SUPPORT, LH	1	35	
	8-77944-15	• • SUPPORT, LH ALT INTCHG WITH 8-77945-11	RF	35	
- 8	8-77945-12	• • SUPPORT, RH	1	35	
	8-77944-16	• • SUPPORT, RH ALT INTCHG WITH 8-77945-12	RF	35	
	MS21047L5	• • • NUTPLATE	4	35	
	7144591-10	• BEAM ASSY, M61A1 GUN SYSTEM FWD SUPPORT LH	1	C	
	7144591-10	• BEAM ASSY, M61A1 GUN SYSTEM FWD SUPPORT RH	1	C	
- 9	NAS75-4-016	• • BUSHING, LH	1	C	
	NAS75-12-016	• • BUSHING, RH	1	C	
- 10	7144591-01	• • BEAM, LH	1	C	
	7144591-03	• • BEAM, RH	1	C	
		A AIRPLANES #35 THRU 47 AND 49 THRU 89			
		B AIRPLANES #48, 90 AND ON			
		C ADDED PER TCTO 1F-114A-550 ON AIRPLANES #48, 90 AND ON			

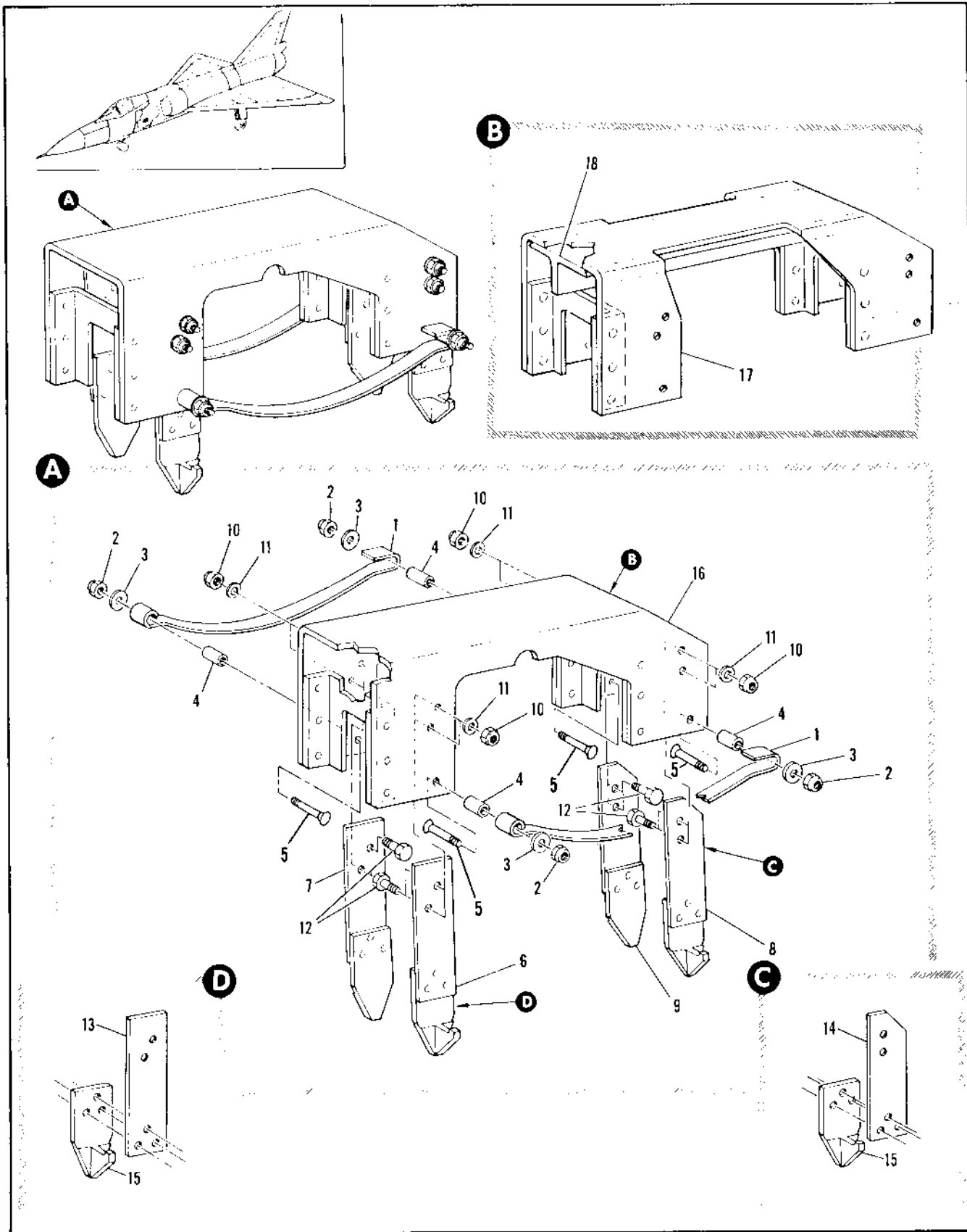

Figure 2.20-36. Fwd Umbilical Plug Retainer Assembly

FIGURE AND INDEX NUMBER	PART NUMBER	DESCRIPTION	UNITS PER ASSY.	USABLE ON CODE	
				FROM	TO
		1 2 3 4 5 6			
2.20-36	8-57108-1	RETAINER ASSEMBLY, FWD SPHILICAL FLUO MODIFIED BY 8-57087 FOR MA SEE FIG. 2.20-34	9F	10	
- 1	8-57110	• SPRING ATTACHING PARTS	1	20	
- 2	AN36501032	• NUT	4	30	
- 3	99-51607-003 WALC 20-2	• WASHER	4	30	
- 4	AN34003-20	• WASHER, ALT INTONG WITH 8-57107-003	9F	20	
- 5	AN501-10814	• SPACER	4	20	
		• SCREW	4	20	
		-----X-----			
- 6	8-57108-45	• HOOK ASSY, FWD LH	1	20	
- 7	8-57108-46	• HOOK ASSY, FWD RH	1	20	
- 8	8-57108-43	• HOOK ASSY, AFT LH	1	20	
- 9	8-57108-44	• HOOK ASSY, AFT RH ATTACHING PARTS	1	20	
- 10	AN36501032	• NUT	4	20	
- 11	AN91010	• WASHER	4	20	
- 12	AN301A	• BOLT	4	20	
		-----X-----			
- 13	8-57086-45	• SPRING, FWD	1	20	
- 14	8-57086-47	• SPRING, AFT	1	20	
- 15	8-57108	• HOOK	1	20	
	8-57086	• HOOK, ALT INTONG WITH 8-57086	9F	20	
- 16	8-57108-41	• RETAINER ASSY, RIVETED	1	20	
- 17	8-57108-27	• RETAINER	1	20	
- 18	8-57086-39	• STIFFENER	1	20	
- 19	8-57108-713	• STIFFENER, ALT INTONG WITH 8-57086-3	9F	20	

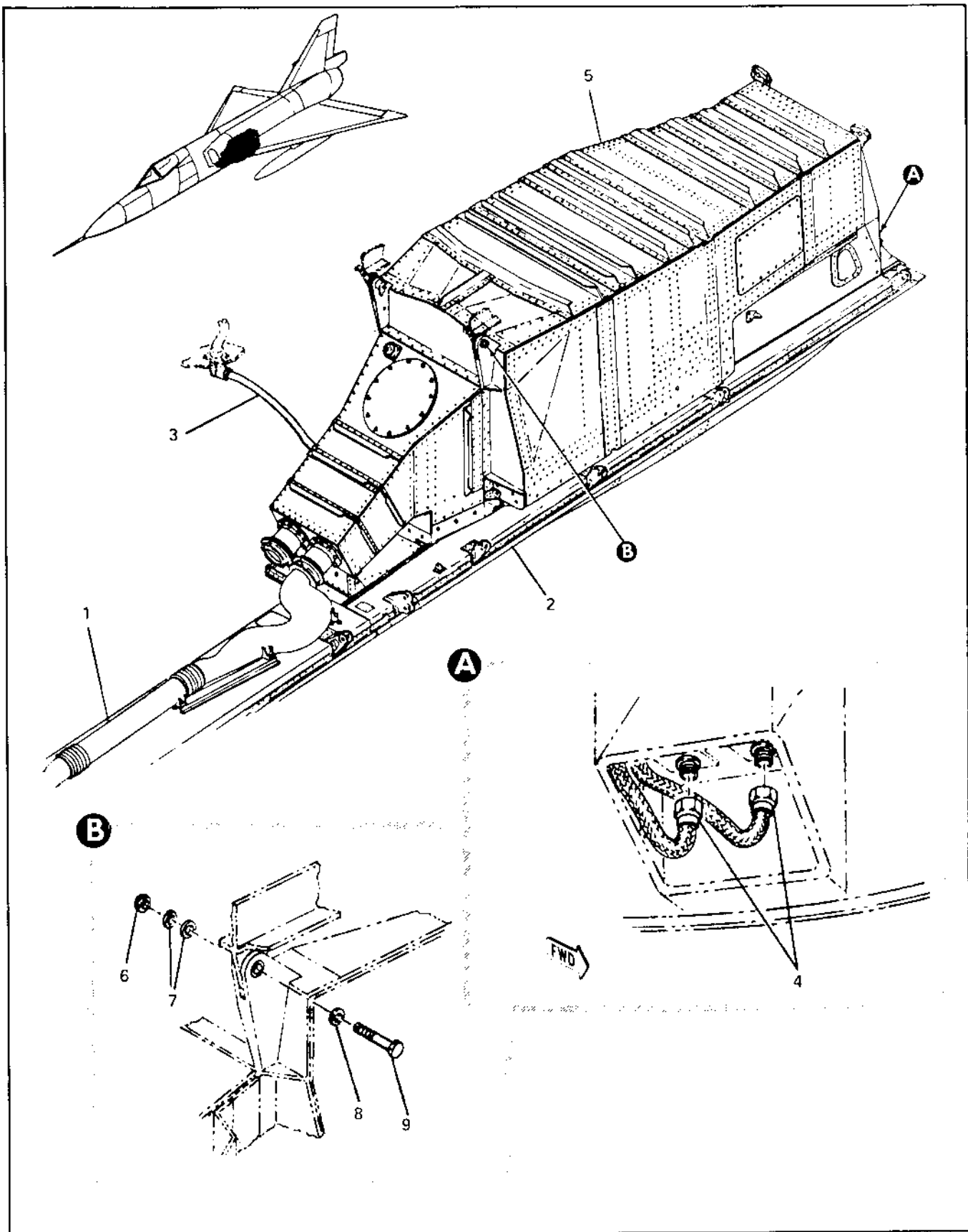

Figure 2.20-37. M61A1 Gun Installation

FIGURE AND INDEX NUMBER	PART NUMBER	DESCRIPTION	UNITS PER ASSY.	USABLE ON CODE	
				FROM	TO
		1 2 3 4 5 6			
2.20-37	7144521-10	GUN INSTL, M61A1	1	A	
- 1	7144565-10	• AIF INDUCTION INSTL, M61A1 GUN LH FOR BREAKDOWN SEE FIG. 2.20-43.3A	1	A	
	7144565-20	• AIF INDUCTION INSTL, M61A1 GUN RH FOR BREAKDOWN SEE FIG. 2.20-39	1	A	
- 2	7144570-10	• FAIRING INSTL, MISSILE BAY LOOR, M61A1 LH FOR BREAKDOWN SEE FIG. 2.20-39	1	A	
	7144570-20	• FAIRING INSTL, MISSILE BAY DOOR, M61A1 RH FOR BREAKDOWN SEE FIG. 2.20-39	1	A	
- 3		• CONNECTOR, PLUG, ELECT SEE FIG. 2.20-2 INDEX 25	1	A	
- 4		• COUPLING, HYDRAULIC SEE FIG. 2.20-10 INDEX 28 AND 67	1	A	
- 5	7144522-10	• GUN SYSTEM ASSY, M61A1 USE AS MISSION REQUIRES FOR BREAKDOWN SEE FIG. 2.20-43	1	A	
		ATTACHING PARTS			
- 6	MS17-25-P	• NUT	1	A	
- 7	AN961-816	• WASHER	2	A	
- 8	MS20002CH	• WASHER	1	A	
- 9	MS17-25-P	• BOLT	1	A	
		-----x-----			
		• ADDED PER T.O. 1F-106A-4 FOR AIRPLANE #98, 99 AND ON.			

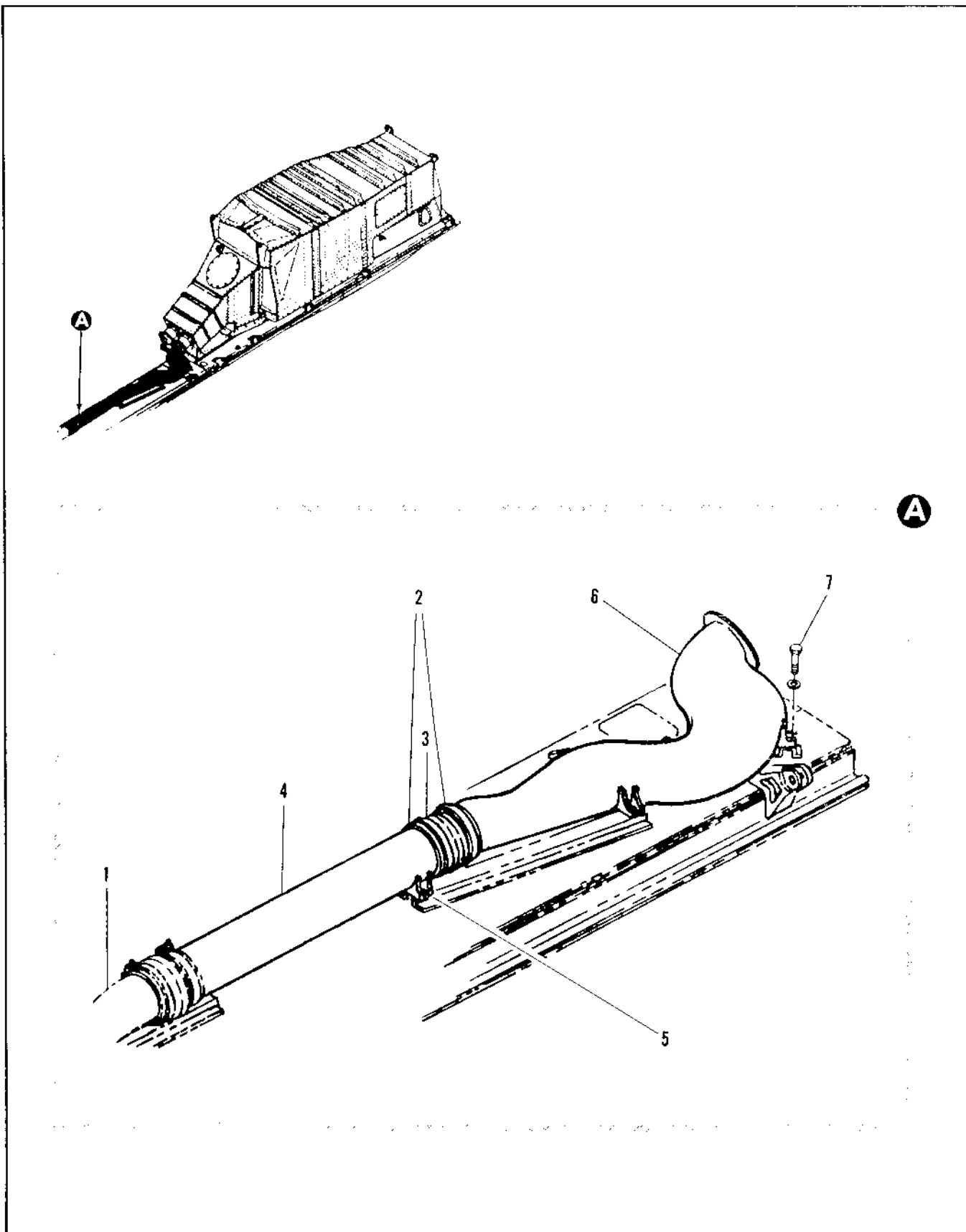

Figure 2.20-38. M61A1 Gun Air Induction Installation

FIGURE AND INDEX NUMBER	PART NUMBER	DESCRIPTION	UNITS PER ASSY.	USABLE ON CODE	
				FROM	TO
		1 2 3 4 5 6			
2.20-38	7144696-10	AIR INDUCTION INSTL, M61A1 GUN LH FOP NHA SEE FIG. 2.20-38	RF	A	
	7144696-20	AIR INDUCTION INSTL, M61A1 GUN RH FOP NHA SEE FIG. 2.20-38	RF	A	
- 1		• DUCT, RAM AIR INLET SEE FIG. 2.20-1R INDEX 6	RF	A	
- 2	365-62-344S	• CLAMP, (98E25) USE AS MISSION REQUIRES	2	A	
- 3	NAS520-26-13	• COUPLING, USE AS MISSION REQUIRES	1	A	
- 4	7144692-10	• PIPE ASSY, FWD AIR INDUCTION LH USE AS MISSION REQUIRES	1	A	
	7144692-20	• PIPE ASSY, FWD AIR INDUCTION RH USE AS MISSION REQUIRES ATTACHING PARTS	1	A	
- 5	NAS1103-4 AN961-10	• BOLT • WASHER	2 2	A A	
- 6	7144691-10	• PIPE ASSY, AFT AIR INDUCTION LH USE AS MISSION REQUIRES	1	A	
	7144691-20	• PIPE ASSY, AFT AIR INDUCTION RH USE AS MISSION REQUIRES ATTACHING PARTS	1	A	
- 7	NAS1103-5 AN961-10	• BOLT • WASHER	1 1	A A	
		----X----			
		A ADDED PER TOTO 1F-106A-3A OF AIRPLANES #48, 9J AND 09.			

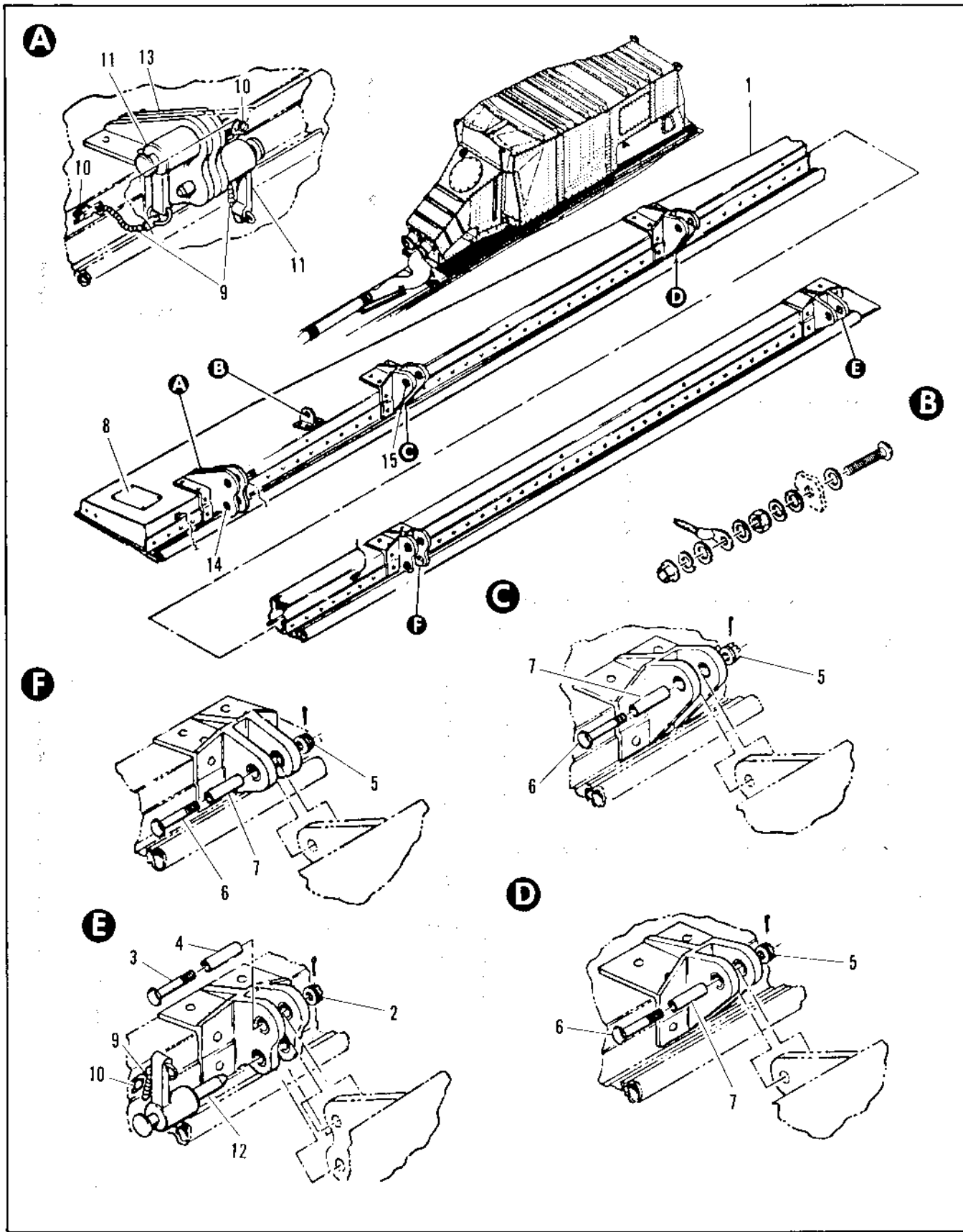

Figure 2.20-39. M61A1 Missile Bay Door Fairing Installation (Sheet 1 of 2)

FIGURE AND INDEX NUMBER	PART NUMBER	DESCRIPTION	UNITS PER ASSY.	USABLE ON CODE	
				FROM	TO
		1 2 3 4 5 6			
2.20-39	7144571-10	FAIRING INSTL, MISSILE BAY DOOR M-1A1 LH FOR NHA SEE FIG. 2.20-39	81	A	
	7144572-20	FAIRING INSTL, MISSILE BAY DOOR M-1A1 RH FOR NHA SEE FIG. 2.21-33	81	A	
- 1	7144571-10	• FAIRING ASSY, MISSILE BAY DOOR M-1A1 LH USE AS MISSION REQUIRES	1	A	
	7144571-20	• FAIRING ASSY, MISSILE BAY DOOR M-1A1 RH USE AS MISSION REQUIRES	1	A	
- 2	MS21244-6	• NUT, USE AS MISSION REQUIRES	2	A	
- 3	MS27576-6-20	• BOLT, USE AS MISSION REQUIRES	2	A	
- 4	R-77617-7	• BUSHING, USE AS MISSION REQUIRES	2	A	
- 5	MS21244-6	• NUT, USE AS MISSION REQUIRES			
- 6	MS27576-6-20	• BOLT, USE AS MISSION REQUIRES	6	A	
- 7	R-77617-9	• BUSHING, USE AS MISSION REQUIRES	6	A	
- 8	MS27253-1	• PLATE, 10	1	A	
- 9	NAS1455R2-4	• CHAIN	3	A	
- 10	NAS1398D4-3 AN96LPC4	• RIVET • WASHER	1 3	A 4	
- 11	NAS1335A5C07	• PIN	2	A	
- 12	NAS1335A5C12	• PIN	1	A	
- 13	7144557-10 7144557-20	• BRACKET ASSY, LH • BRACKET ASSY, RH	1 1	A A	
- 14	NAS75-5-106 7144572-10	• BUSHING • HINGE ASSY, LWR MISSILE DOOR STA 336 LH	4 1	A A	
	7144572-20	• HINGE ASSY, LWR MISSILE DOOR STA 336 RH	1	A	
- 15	NAS75-5-106	• BUSHING	1	A	
* ADDED PER TCTO 1F-106A-301 ON AIRPLANE #48, 90 AND ON.					

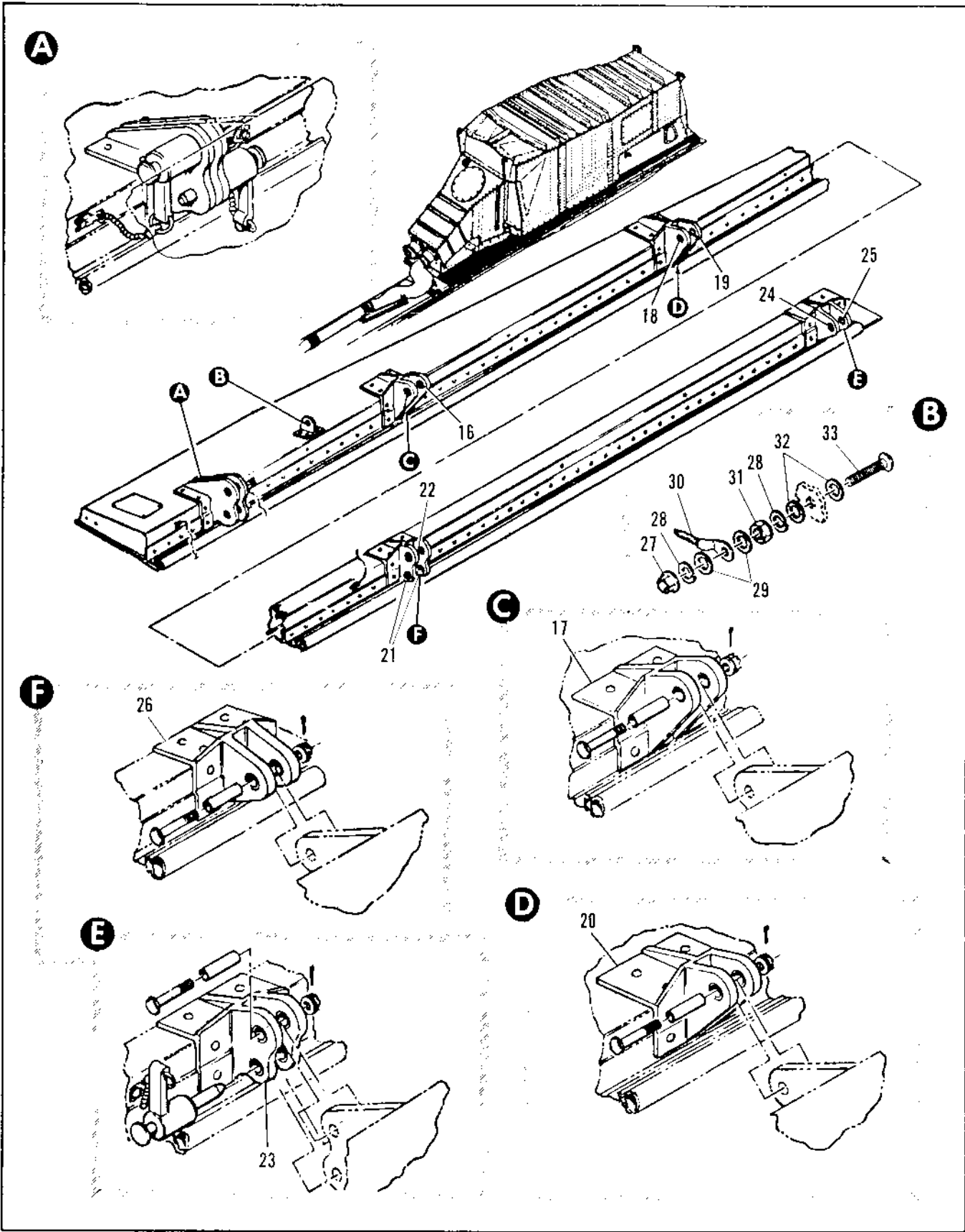

Figure 2.20-39. M61A1 Missile Bay Door Fairing Installation (Sheet 2 of 2)

FIGURE AND INDEX NUMBER	PART NUMBER	DESCRIPTION	UNITS PER ASSY.	USABLE ON CODE	
				FROM	TO
		1 2 3 4 5 6			
2.20-39- 16	NAS77-5-24	. . . BUSHING	1	A	
- 17	7144572-01	. . . HINGE, LH	1	A	
	7144572-02	. . . HINGE, RH	1	A	
	7144573-10	. . . HINGE ASSY, LWR MISSILE DOOR STA 357 LH	1	A	
	7144573-20	. . . HINGE ASSY, LWR MISSILE DOOR STA 357 RH	1	A	
- 18	NAS75-5-00P	. . . BUSHING	1	A	
- 19	NAS77-5-24	. . . BUSHING	1	A	
- 20	7144573-01	. . . HINGE, LH	1	A	
	7144573-02	. . . HINGE, RH	1	A	
	7144574-10	. . . HINGE ASSY, LWR MISSILE DOOR STA 377 LH	1	A	
	7144574-20	. . . HINGE ASSY, LWR MISSILE DOOR STA 377 RH	1	A	
- 21	NAS75-5-00R	. . . BUSHING	1	A	
- 22	NAS77-5-24	. . . BUSHING	1	A	
- 23	7144574-01	. . . HINGE, LH	1	A	
	7144574-02	. . . HINGE, RH	1	A	
	7144575-10	. . . HINGE ASSY, LWR MISSILE DOOR STA 409 LH	1	A	
	7144575-20	. . . HINGE ASSY, LWR MISSILE DOOR STA 409 RH	1	A	
- 24	NAS75-5-00B	. . . BUSHING	1	A	
- 25	NAS77-5-24	. . . BUSHING	1	A	
- 26	7144575-01	. . . HINGE, LH	1	A	
	7144575-02	. . . HINGE, RH	1	A	
- 27	MS21942L3	. . . NUT	1	A	
- 28	MS3533R-43	. . . LOCKWASHER	1	A	
- 29	AN960-10L	. . . WASHER	1	A	
- 30	7243525-10	. . . JUMPER, BONDING (SEE T.O. 1F-106-2-1-2-1)	1	A	
- 31	MS20341-10S	. . . NUT	1	A	
- 32	AN96010L	. . . WASHER	1	A	
- 33	MS35207-265	. . . SCREW	1	A	
	7144522-10	GUN SYSTEM ASSY, M41 FOR NHA SEE FIG. 2.20-39	1	A	
		A ADDED PER TC10 1F-106A-544 FOR AIRPLANE 849, 90 AND ON.			

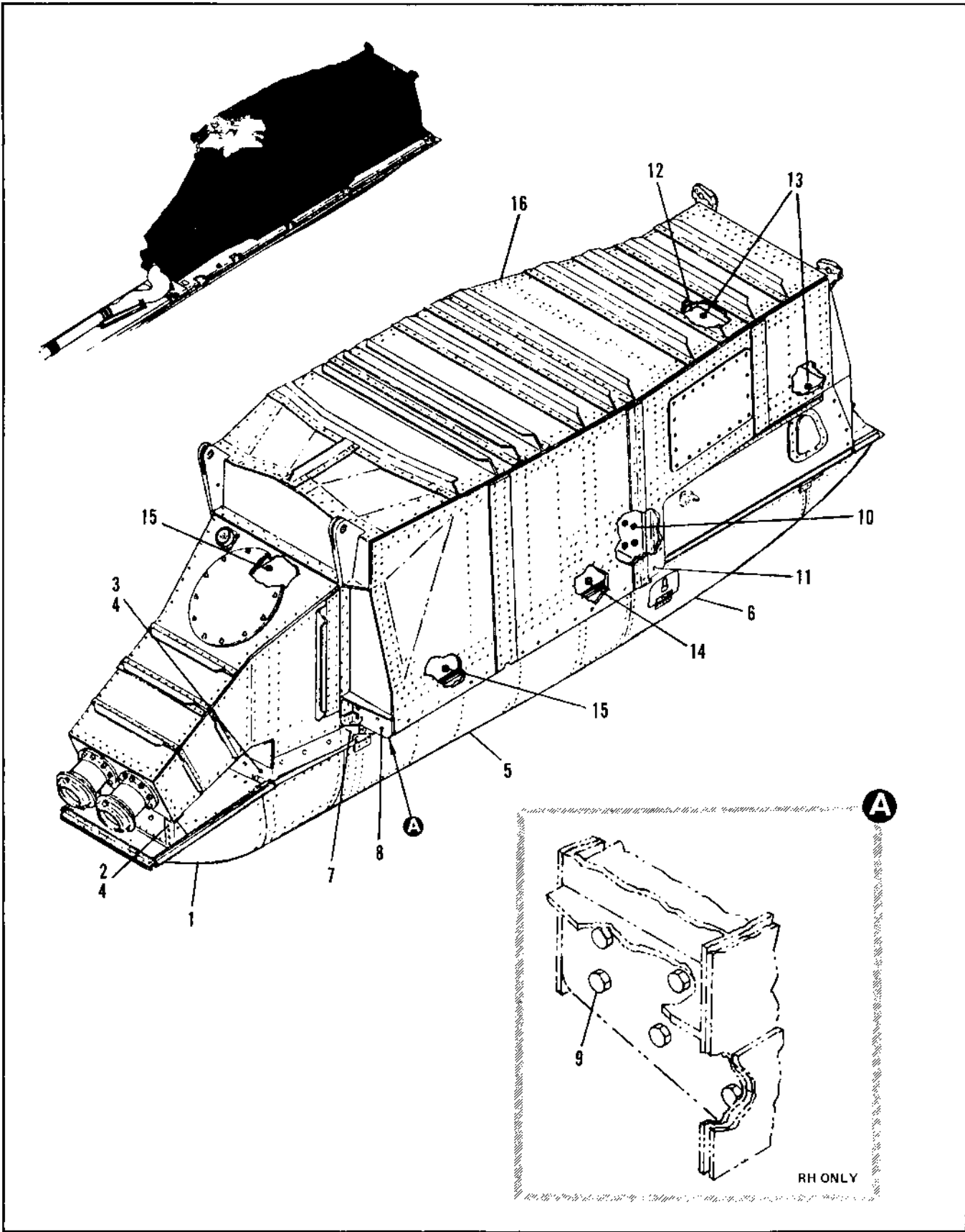

Figure 2.20-40. M61A1 Gun System Assembly

FIGURE AND INDEX NUMBER	PART NUMBER	DESCRIPTION	QUANTITY PER ASSY	SERIAL NUMBER	
				FROM	TO
	7144702-10	1. FAIRING ASSY, FWD ACFT #61A1 GUN LH FOR BREAKDOWN SEE FIG. 2.20-42	1		
- 2	NAS1304-4	• BOLT	1		
- 3	NAS1304-4	• WASHER	1		
- 4	NAS1304-4	• WASHER	1		
- 5	7144702-10	• FAIRING ASSY, FWD ACFT #61A1 GUN RH FOR BREAKDOWN SEE FIG. 2.20-42	1		
	7144702-10	• FAIRING ASSY, FWD ACFT #61A1 GUN RH FOR BREAKDOWN SEE FIG. 2.20-42	1		
	7144702-10	• FAIRING ASSY, FWD ACFT #61A1 GUN LH FOR BREAKDOWN SEE FIG. 2.20-42	1		
	7144704-10	• FAIRING ASSY, RTY ACFT #61A1 GUN RH FOR BREAKDOWN SEE FIG. 2.20-42	1		
- 7	7144703-10	• ADAPTER ASSY, FAIRING FWD LH FOR BREAKDOWN SEE FIG. 2.20-42	1		
	7144703-20	• ADAPTER ASSY, FAIRING FWD RH FOR BREAKDOWN SEE FIG. 2.20-42	1		
- 8	NAS1307-4	• BOLT	1		
- 9	NAS1304-4	• BOLT	1		
- 10	AN96-416L	• WASHER	1		
- 11	NAS1307-5	• BOLT	1		
- 12	AN96-416L	• WASHER	1		
- 13	7144623-10	• COLLET ASSY, #61A1 GUN ATTACHING PARTS	1		
- 14	MS20073-96-17	• BOLT	1		
- 15	MS20072-96	• WASHER	1		
- 16	NAS624H2A	• BOLT	1		
- 17	MS20092-96	• WASHER	1		
- 18	NAS624H2B	• BOLT	1		
- 19	MS20092-96	• WASHER	1		
- 20	7144634-10	• ENCLOSURE ASSY, #61A1 GUN FOR BREAKDOWN SEE FIG. 2.20-44	1		

A. ADDED PER TCTO 1F-106A-22 ON AIRPLANE'S #98, 103 AND ON.

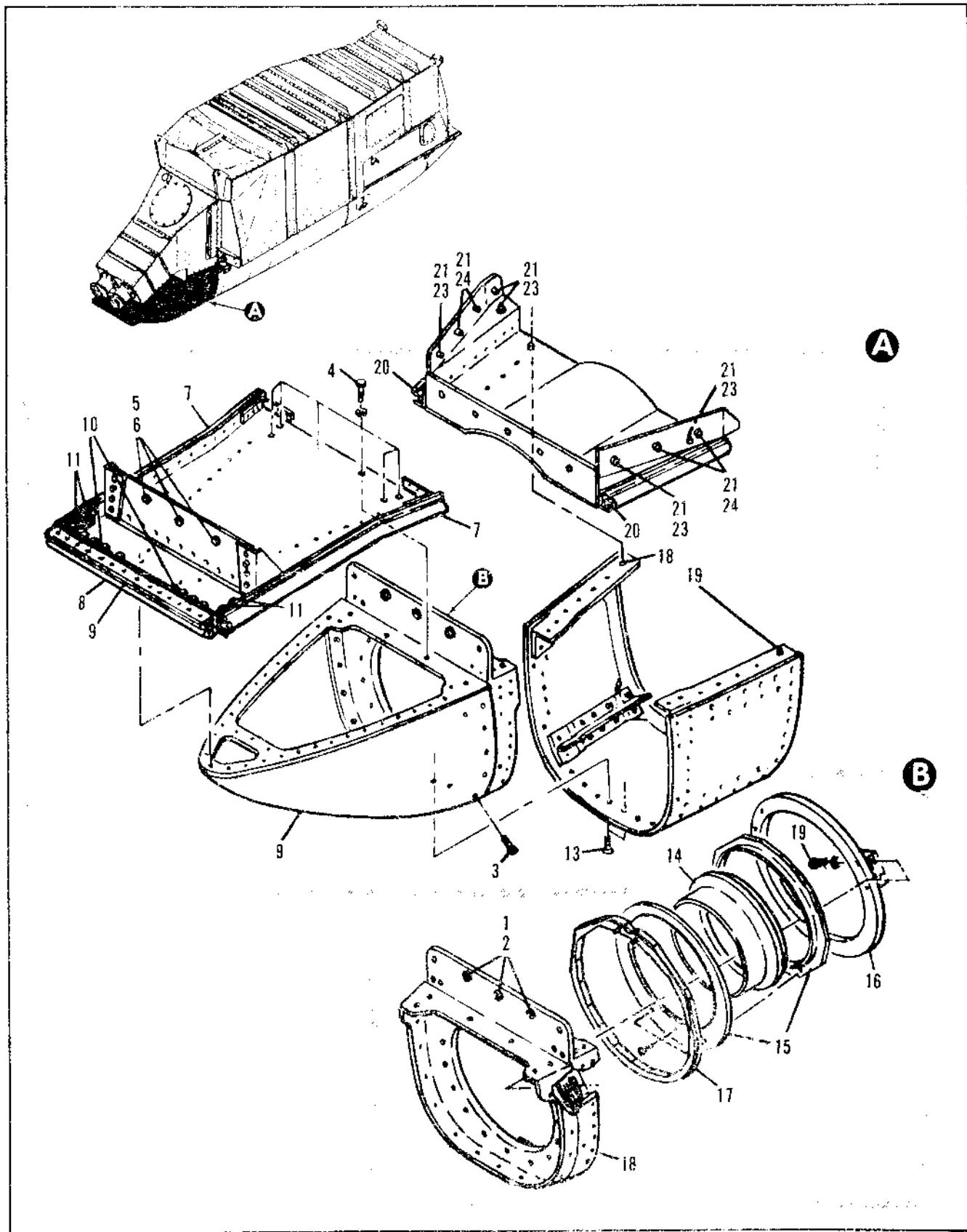

Figure 2.20-41. M61A1 Gun Muzzle Firing Assembly

FIGURE AND INDEX NUMBER	PART NUMBER	DESCRIPTION	UNITS PER ASSY.	USABLE ON CODE	
				FROM	TO
2.20-41	7144761-10	FAIRING ASSY, MUZZLE METAL GUN FOR TWA SEE FIG. 2.20-40	1	A	
- 1	V4-201	• RETAINER RING (03024)	3	A	
- 2	SV4P-	• STUD ASSY (03024)	3	A	
	V4-1 9	• RECEPTACLE (03024)	1	A	
	7144825-10	• FAIRING ASSY, MUZZLE BLAST FWD ATTACHING PARTS	17	A	
- 3	AN31004	• NUT	17	A	
	AN9610416	• WASHER	17	A	
	SPS54291-403	• BOLT (4 539)	1	A	
- 4	NAS464-4A6	• BOLT	4	A	
	AN9610416L	• WASHER	4	A	
		-----X-----			
- 5	V4-201	• RETAINER RING (03024)	3	A	
- 6	SV4P3	• STUD ASSY (03024)	3	A	
	V4-1 9	• RECEPTACLE (03024)	1	A	
- 7	7144825-11	• SEAL	1	A	
- 8	7144825-23	• SEAL	1	A	
- 9		• SEAL MOUNT (RIVETED) ASSY, CONSISTING OF 7144825-21 AND 7144825-27 ATTACHING PARTS	1	A	
- 10	MS21043-3	• NUT	10	A	
	AN9610416	• WASHER	10	A	
	NAS1313-3	• BOLT	10	A	
- 11	MS21043-3	• NUT	4	A	
	AN9610416	• WASHER	4	A	
	NAS1313-2	• SCREW	4	A	
		-----X-----			
- 12	7243010-10	• FAIRING ASSY	1	A	
- 13	AN31004	• NUT	2	A	
	AN9610416	• WASHER	2	A	
	NAS1214-20	• BOLT	2	A	
- 14	53-311170-3	• RING, (76311)	1	A	
- 15	53-311172-1	• RING ASSY, (76301)	1	A	
- 16	53-311176-1	• RETAINER ASSY, (76311)	1	A	
- 17	53-311164-1	• RING, (76311)	1	A	
- 18	7144828-10	• FITTING ASSY, SUPPORT GUN SEAL RING ATTACHING PARTS	1	A	
- 19	NAS464-4A6	• BOLT	4	A	
	AN9610416L	• WASHER	4	A	
		-----X-----			
	7144827-10	• FAIRING ASSY, MUZZLE BLAST AFT	1	A	
- 20	714407-15	• SEAL	2	A	
- 21	V4-201	• RETAINER RING (03024)	11	A	
- 22	SV4P-	• STUD ASSY (03024)	11	A	
	V4-1 9	• RECEPTACLE (03024)	1	A	
- 23	SV4P3	• STUD ASSY (03024)	1	A	
	V4-1 9	• RECEPTACLE (03024)	1	A	
- 24	SV4P3	• STUD ASSY (03024)	4	A	
	V4-1 9	• RECEPTACLE (03024)	4	A	
A. ADDED FOR FIG. 1F-1, 40-36 ON AIRPLANES 44A, B AND 0A.					

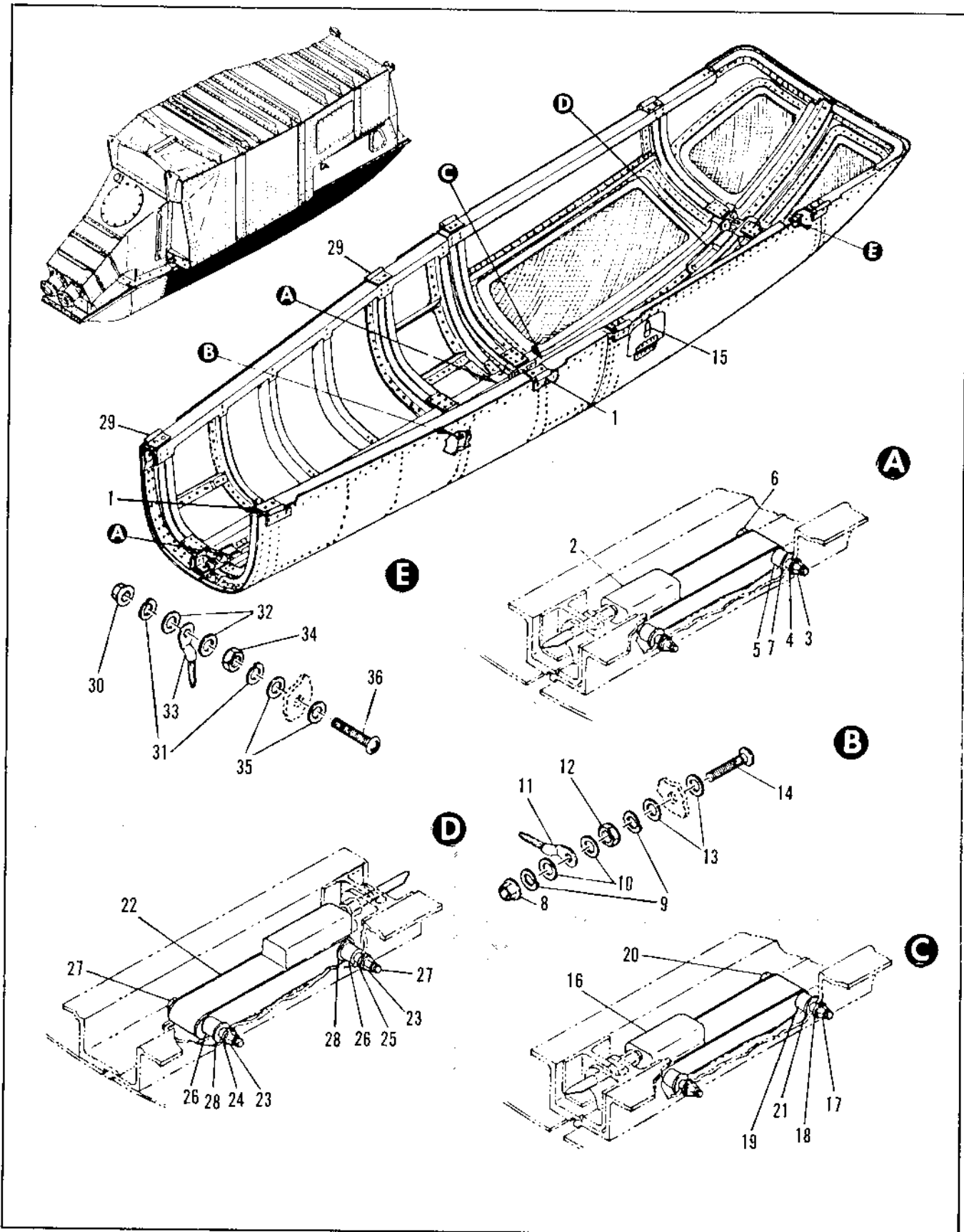

Figure 2.20-42. M61A1 Gun Fwd Access Fairing Assembly

FIGURE AND INDEX NUMBER	PART NUMBER	DESCRIPTION	UNITS PER ASSY.	USABLE ON CODE	
				FROM	TO
		1 2 3 4 5 6			
2.20-42	7144762-10	• FAIRING ASSY, FWD ACCESS M61A1 GUN LH FOR NHA SEE FIG. 2.20-40	RF	A	
	7144762-20	• FAIRING ASSY, FWD ACCESS M61A1 GUN RH FOR NHA SEE FIG. 2.20-40	RF	A	
- 1	7144547-01	• • HINGE, HALF LH	2	A	
	7144547-02	• • HINGE, HALF RH	2	A	
- 2	H117-3AC	• • LATCH, (83014) ATTACHING PARTS	2	A	
- 3	MS21042L3	• • NUT	4	A	
- 4	AN960-10	• • WASHER	4	A	
- 5	NAS43DD3-32	• • SPACER	4	A	
- 6	NAS1103-27	• • BOLT	4	A	
		-----X-----			
- 7	7144849-25	• • SHIM	4	A	
- 8	MS21042L3	• • NUT	1	A	
- 9	MS35338-43	• • LOCKWASHER	2	A	
- 10	AN960-10L	• • WASHER	2	A	
- 11	7243525-30	• • JUMPER	1	A	
- 12	MS20341-10S	• • NUT	1	A	
- 13	AN960010L	• • WASHER	2	A	
- 14	MS35207-265	• • SCREW	1	A	
	7144764-10	• FAIRING ASSY, AFT ACCESS M61A1 GUN LH FOR NHA SEE FIG. 2.20-40	RF	A	
	7144764-20	• FAIRING ASSY, AFT ACCESS M61A1 GUN RH FOR NHA SEE FIG. 2.20-40	RF	A	
	7144764-30	• • DOOR ASSY, SAFETY SWITCH ACCESS LH	1	A	
- 15	H5000115-179	• • LATCH ASSY, (83014)	1	A	
- 16	H117-3AC	• • LATCH, (83014) LH ATTACHING PARTS	1	A	
- 17	MS21042L3	• • NUT, LH	2	A	
- 18	AN960-10	• • WASHER, LH	2	A	
- 19	NAS43DD3-32	• • SPACER, LH	2	A	
- 20	NAS1103-27	• • BOLT, LH	2	A	
		-----X-----			
- 21	7144849-25	• • SHIM, LH	2	A	
- 22	7144764-41	• LATCH, ALTERED FROM (83014) P/N H117-3BC LH	1	A	
- 23	MS21042L3	• • NUT, LH	2	A	
- 24	AN960-10	• • WASHER, LH	1	A	
- 25	NAS620-10	• • WASHER, LH	1	A	
- 26	NAS43DD3-32	• • SPACER, LH	2	A	
- 27	NAS1103-27	• • BOLT, LH	2	A	
		-----X-----			
- 28	7144849-25	• • SHIM, LH	2	A	
- 29	7144835-01	• • HINGE	2	A	
- 30	MS21042L3	• • NUT	1	A	
- 31	MS35338-43	• • LOCKWASHER	2	A	
- 32	AN960-10L	• • WASHER	2	A	
- 33	7243525-30	• • JUMPER, BONDING (SEE T.O. 1F-106A-2-12-2-1)	1	A	
- 34	MS20341-10S	• • NUT	1	A	
- 35	AN960010L	• • WASHER	2	A	
- 36	MS35207-267	• • SCREW	1	A	
		A ADDED PER TCTO 1F-106A-594 ON AIRPLANES #48, 93 AND ON.			

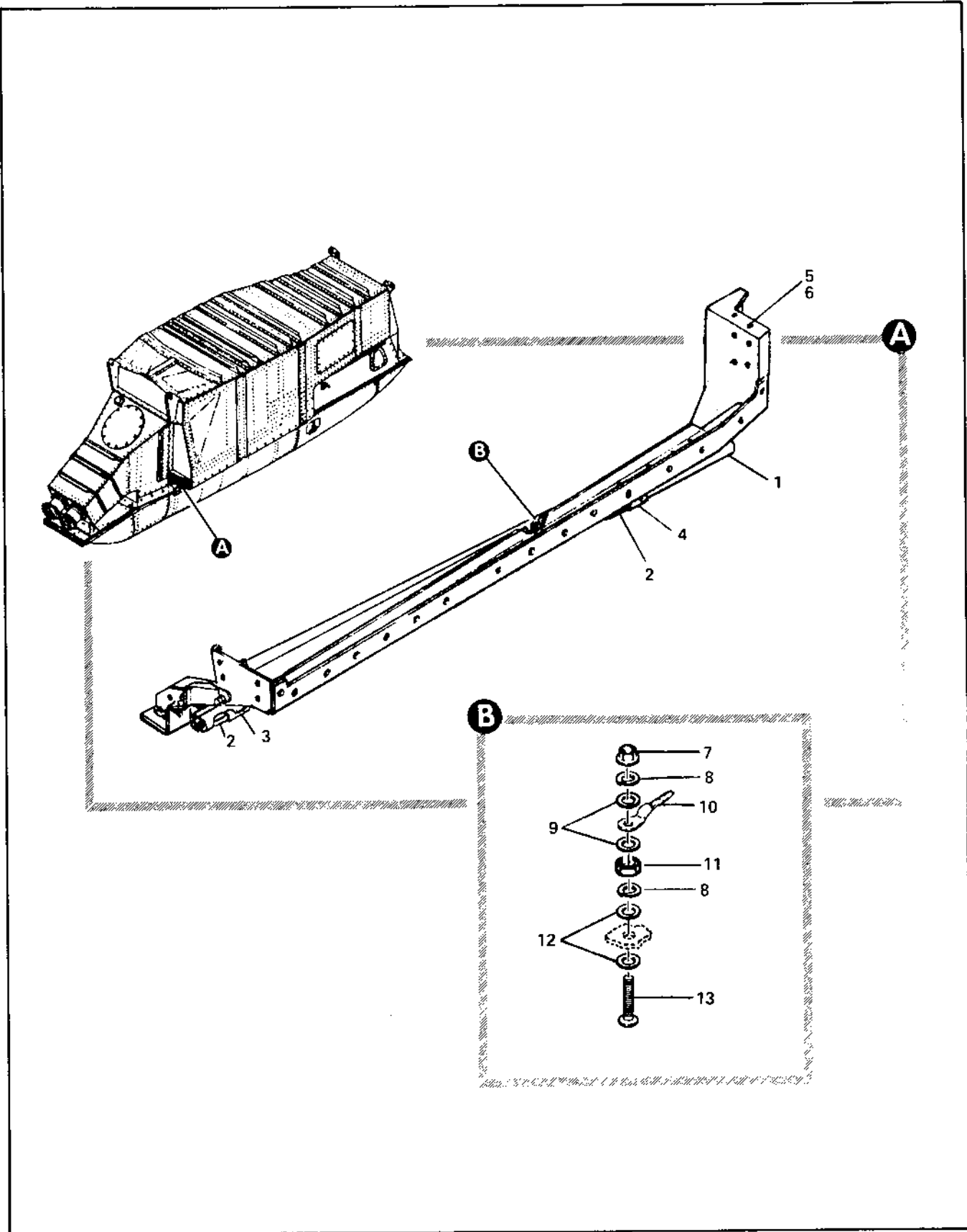

Figure 2.20-43. Fairing Fwd Adapter Assembly

FIGURE AND INDEX NUMBER	PART NUMBER	DESCRIPTION	UNITS PER ASSY.	USABLE ON CODE	
				FROM	TO
		1 2 3 4 5 6			
2.20-43	7144743-10	ADAPTER ASSY, FAIRING FWD LH FOR 90A SEE FIG. 2.20-40	RF	A	
	7144743-20	ADAPTER ASSY, FAIRING FWD RH FOR 90A SEE FIG. 2.20-40	RF	A	
- 1	7144743-07	• SEAL	1	A	
- 2	7144747-07	• PIN	2	A	
- 3	7144747-03	• HINGE, LH	1	A	
	7144747-04	• HINGE, RH	1	A	
- 4	7144747-05	• HINGE, LH	1	A	
	7144747-06	• HINGE, RH	1	A	
- 5	V4-2 1	• RETAINER RING (03024)	1	A	
- 6	SV4P4	• STUD ASSY (03024)	2	A	
	V4-1 0	• RECEPTACLE (03024)	1	A	
- 7	MS21342L3	• NUT	1	A	
- 8	MS3530-13	• LOCKWASHER	1	A	
- 9	AN967-1LL	• WASHER	2	A	
- 10	7243025-10	• JUMPER (SEE T.O. 1F-106A-2-10-2-1)	2	A	
- 11	MS20741-10S	• NUT	1	A	
- 12	AN967-1LL	• WASHER	2	A	
- 13	MS3530-17-267	• SCREW	1	A	
		A ADDED PER TOTO 1F-106A-NRM ON AIRPLANES 90A, 91 AND 92.			

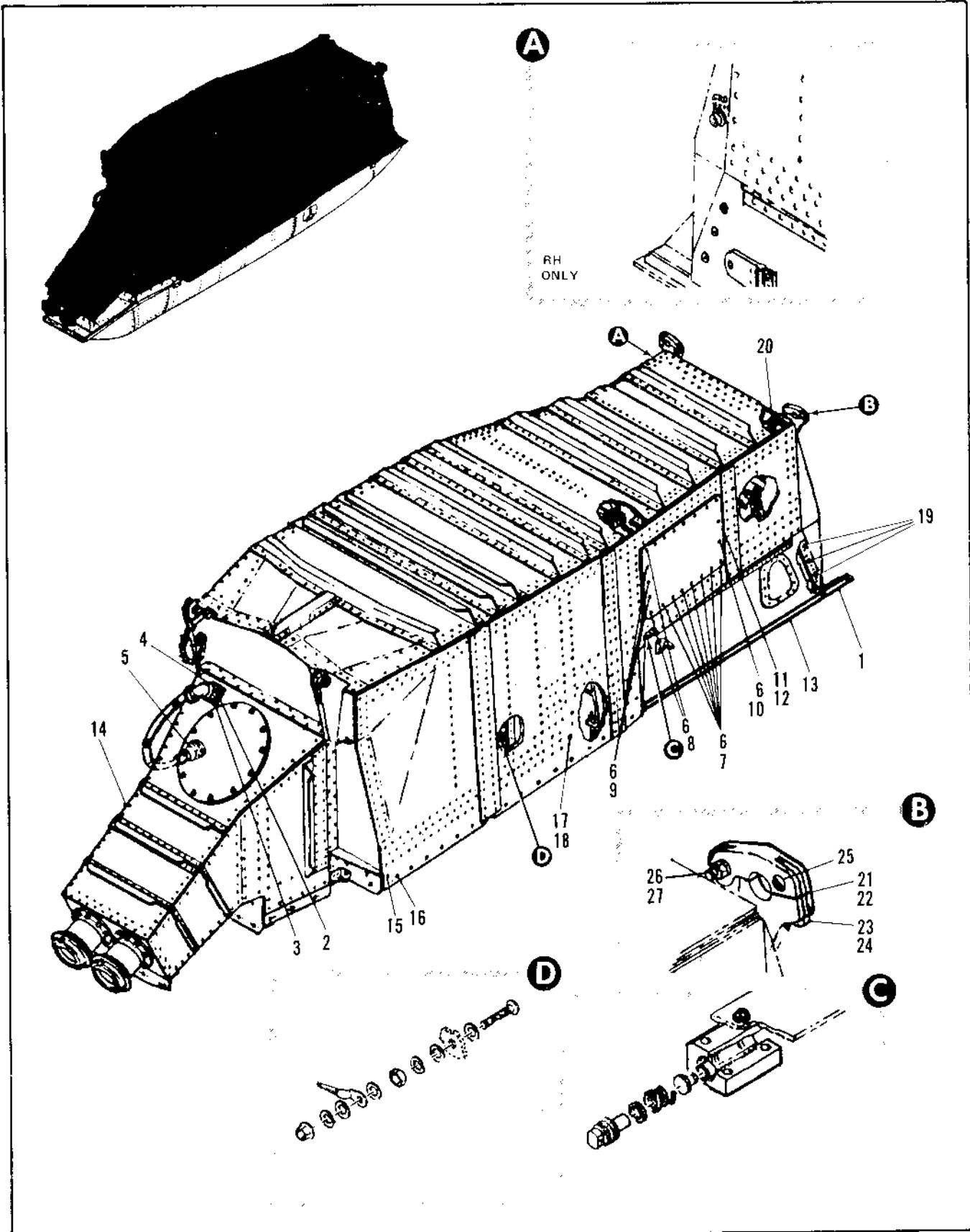

Figure 2.20-44. M61A1 Gun Enclosure Assembly (Sheet 1 of 2)

FIGURE AND INDEX NUMBER	PART NUMBER	DESCRIPTION	UNITS PER ASSY.	USABLE ON CODE	
				FROM	TO
		1 2 3 4 5 6			
2.20-44	7144434-10	ENCLOSURE RE ASSY, METAL GUN FOR NHA SEE FIG. 2.20-40	PF	A	
- 1	7144434-05	• SEAL	2	A	
- 2	MS3415-20	• RECEPTACLE ATTACHING PARTS	1	A	
- 3	MS21312L06	• NUT	4	A	
	MS3207-250	• SCREW	4	A	
		-----X-----			
- 4	7144652-10	• CABLE ASSY, GUN ENCLOSURE	1	A	
	MS3723	• CONNECTOR	1	A	
- 5	23F2415N				
	MS3723	• CONNECTOR	1	A	
	29F2021N				
- 6	7144769-10	• PANEL ASSY, AFT LH ACCESS	1	A	
	V4-241	• RETAINER RING (03024)	21	A	
	V4-109	• RECEPTACLE (03024)	21	A	
- 7	SV497	• STUD ASSY, (03024)	7	A	
- 8	SV49A	• STUD ASSY, (03024)	2	A	
- 9	SV49B	• STUD ASSY (03024)	3	A	
- 10	SV49A	• STUD ASSY (03024)	9	A	
- 11	7111719-01	• GASKET	1	A	
- 12	7111744-01	• PANEL	1	A	
- 13	7144765-10	• DOOR ASSY, SIDE ACCESS AFT LH FOR BREAKDOWN SEE FIG. 2.20-45	1	A	
	7144765-20	• DOOR ASSY, SIDE ACCESS AFT RH FOR BREAKDOWN SEE FIG. 2.20-45	1	A	
- 14	7144780-10	• ADAPTER ASSY, AIR INLET GUN ENCLOSURE FOR BREAKDOWN SEE FIG. 2.20-46	1	A	
- 15	SV49J	• STUD ASSY (03024)	2	A	
	V4-109	• RECEPTACLE (03024)	2	A	
- 16	SV49B	• STUD ASSY (03024)	24	A	
	V4-109	• RECEPTACLE (03024)	24	A	
- 17	NAS578-8B	• RETAINER	1	A	
- 18	NAS577-8	• NUT	1	A	
- 19	V4-109	• RECEPTACLE	4	A	
	7144770-10	• CLAMP ASSY, AFT ENCLOSURE SUPPORT LH	1	A	
	7144770-20	• CLAMP ASSY, AFT ENCLOSURE SUPPORT RH ATTACHING PARTS	1	A	
- 20	MS21342L5	• NUT	14	A	
	AN965-516	• WASHER	14	A	
	NAS1105-6	• BOLT	14	A	
		-----X-----			
- 21	NAS578-5E	• RETAINER	1	A	
- 22	NAS577-5A	• NUT	1	A	
- 23	MS21342C5	• WASHER	1	A	
- 24	MS9513-24	• BOLT	1	A	
- 25	7144658-01	• CLAMP, LH	1	A	
	7144658-02	• CLAMP, RH ATTACHING PARTS	1	A	
- 26	MS9354-11	• NUT	1	A	
- 27	MS20112-5	• WASHER	1	A	
<p>A ADDED PER TCTO 1F-106A-588 ON AIRPLANES #48, 49 AND ON.</p>					

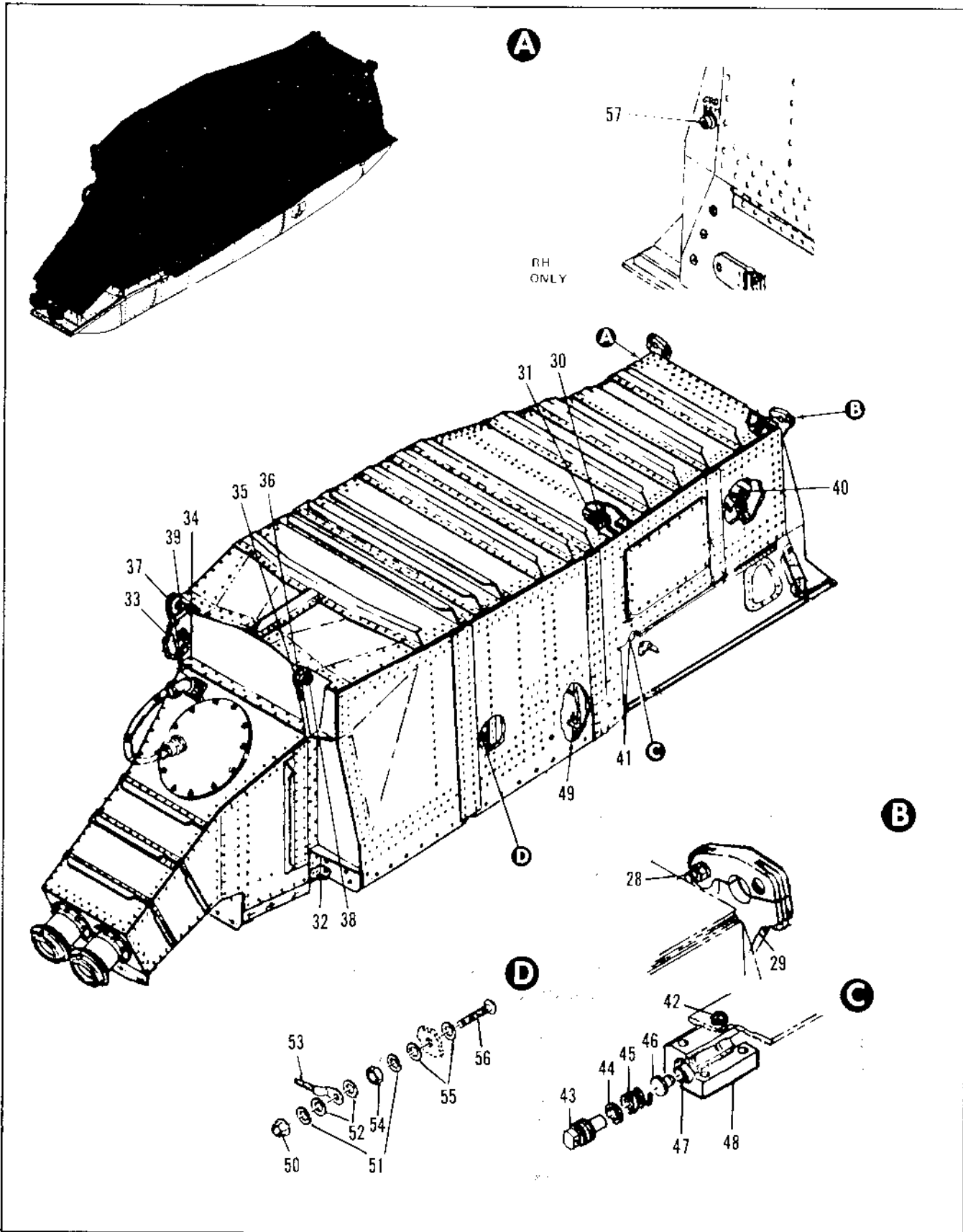

Figure 2.20-44. M61A1 Gun Enclosure Assembly (Sheet 2 of 2)

FIGURE AND INDEX NUMBER	PART NUMBER	DESCRIPTION	UNITS PER ASSY.	USABLE ON CODE	
				FROM	TO
2.20-55- 28	NAS1205-120	• BOLT -----X-----	1	A	
- 29	7144669-01	• FITTING, LH	1	A	
	7144669-02	• FITTING, RH	1	A	
- 30	7144739-10	• TIF ROD ASSY, GUN ENCLOSURE ATTACHING PARTS	1	A	
- 31	MS21042L4	• NUT	2	A	
	NAS1104-8	• BOLT -----X-----	2	A	
- 32	7144654-07	• SEAL	1	A	
- 33	NAS1455AG0-R	• CHAIN	1	A	
- 34	MS179860-0215	• PIN	1	A	
- 35	MS16624-1075	• RETAINING RING	1	A	
- 36	7144775-01	• BUSHING	1	A	
- 37	7144666-10	• BULKHEAD, GUN ENCLOSURE FWD	1	A	
- 38	NAS75-R-016	• BUSHING	1	A	
- 39	NAS75-12-008	• BUSHING	3	A	
- 40	7144780-01	• SEAL			
- 41	7144918-10	• LATCH ASSY, HOLD OPEN, ACCESS DOOR AFT ATTACHING PARTS	2	A	
- 42	MS21042L3	• NUT	4	A	
	NAS1203-12	• BOLT -----X-----	4	A	
- 43	7144923-01	• BOLT, LATCH ADJUSTMENT	1	A	
- 44	AN960P010	• WASHER	1	A	
- 45	MS245950322	• SPRING	1	A	
- 46	7144922-01	• PIN	1	A	
- 47	7144921-01	• BUSHING	1	A	
- 48	7144924-01	• HOUSING	1	A	
- 49	MS17828-5	• NUT	3	A	
	AN975-5	• WASHER	3	A	
	7144531-01	• TAPER PIN	3	A	
- 50	MS21042L3	• NUT	1	A	
- 51	MS35339-43	• LOCKWASHER	2	A	
- 52	AN968-10L	• WASHER	2	A	
- 53	7243525-10	• JUMPER (SEE T.O. 1F-106A-2-12-1)	1	A	
- 54	MS20341-10S	• NUT	1	A	
- 55	AN960D10L	• WASHER	2	A	
- 56	MS35207-265	• SCREW	1	A	
- 57	MS90298-2	• RECEPTACLE	1	A	

A ADDED PER TOTO 1F-106A-598 ON AIRPLANES #48, 92 AND ON.

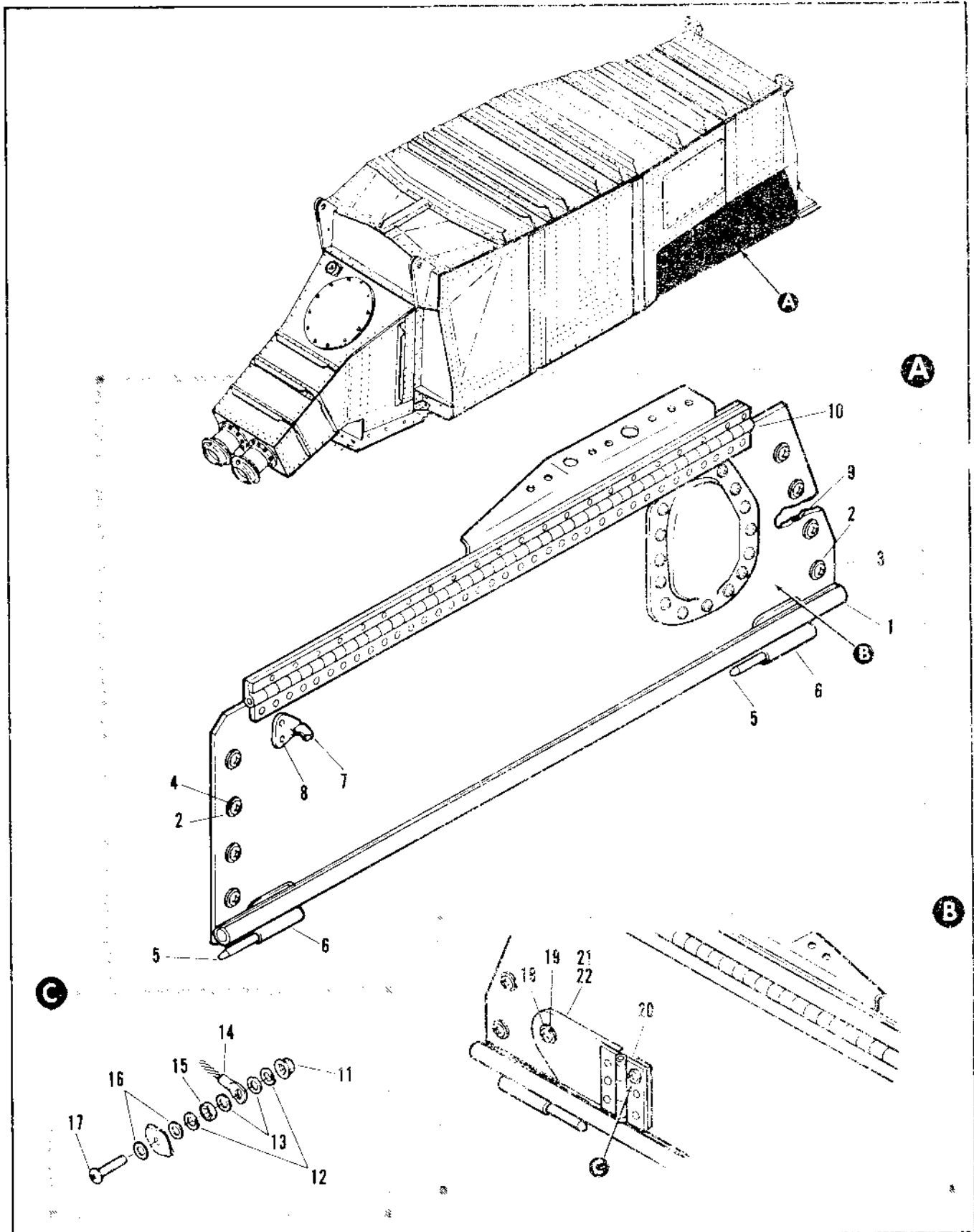

Figure 2.20-45. M31A1 Gun Enclosure Assembly

FIGURE AND INDEX NUMBER	PART NUMBER	DESCRIPTION	UNITS PER ASSY.	USABLE ON CODE	
				FROM	TO
		1 2 3 4 5 6			
2120405	7141760-1	DOOR ASSY, SIDE ACCTSS APT LH FOR IHA SEE FIG. 2-1-44	1	A	
	7141760-2	DOOR ASSY, SIDE ACCTSS APT RH FOR IHA SEE FIG. 2-1-44	1	A	
- 1	7141741-01	• SEAL	1	A	
- 2	V4-2-1	• RETAINER RING (13124)	1	A	
- 3	SV449	• STUD ASSY, (13124)	1	A	
	V4-1-1	• RECEPTACLE (13124)	1	A	
- 4	SV449	• STUD ASSY, (13124)	1	A	
	V4-1-2	• RECEPTACLE (13124)	1	A	
- 5	7144117-07	• PIN	1	A	
- 6	7144135-03	• HINGE	1	A	
- 7	7144130-01	• CATCH LH	1	A	
	7144130-02	• CATCH RH	1	A	
		ATTACHING PARTS			
- 8	NAS12704	• BOLT	2	A	
- 9	7141761-07	• SEAL	1	A	
- 10	7141760-97	• HINGE, ALTERED FROM MS20011PH-23 DOOR LH	1	A	
	7141745-19	• HINGE, ALTERED FROM MS20011PH-23 DOOR RH	1	A	
- 11	MS2112L3	• NUT	1	A	
- 12	MS3130-45	• LOCKWASHER	2	A	
- 13	AN567-10L	• WASHER	1	A	
- 14	7241525-10	• JUMPER, BONDING	1	A	
- 15	MS2141-10S	• NUT	1	A	
- 16	AN567-10L	• WASHER	1	A	
- 17	MS36007-267	• SCREW	1	A	
	7144760-06	• DOOR ASSY, RH	1	A	
- 18	V4-2-1	• RETAINER RING (13124)	1	A	
- 19	SV449	• STUD ASSY, (13124)	1	A	
	V4-1-2	• RECEPTACLE (13124)	1	A	
- 20	MS20101PH-210	• HINGE	1	A	
- 21	7144760-05	• GASKET	1	A	
- 22	7144760-03	• DOOR	1	A	
		ADDED PER ITCG 11-106A-001 IN AIRPLANE #48, 49 AND 50			

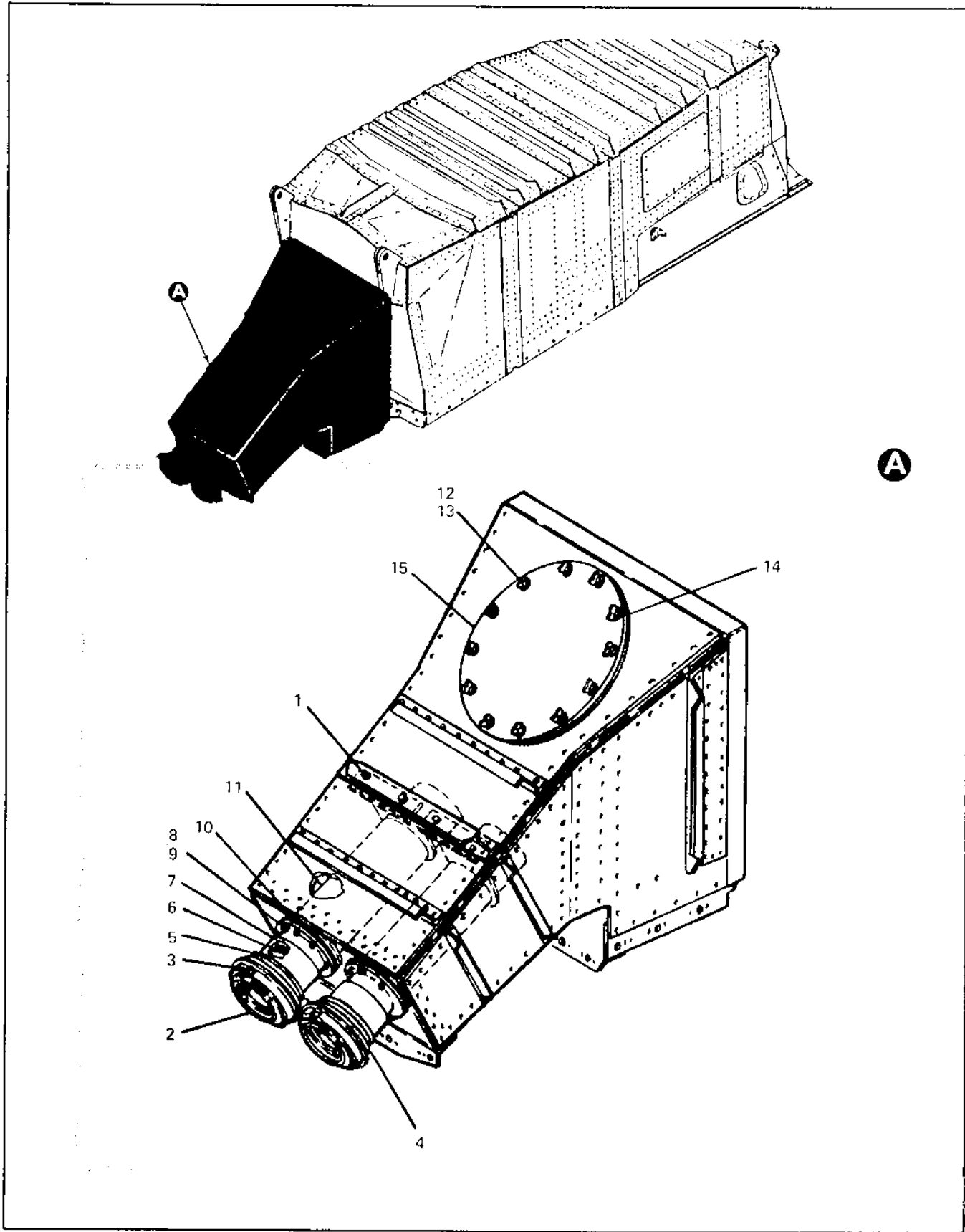

Figure 2.20-46. Air Inlet Gun Enclosure Adapter Assembly

FIGURE AND INDEX NUMBER	PART NUMBER	DESCRIPTION	UNITS PER ASSY.	USABLE ON CODE	
				FROM	TO
		1 2 3 4 5 6			
2.20-46	7144788-10	ADAPTER ASSY, 414 INCH SUB ENCLOSURE FOR 214 SEE FIG. 2.20-44	1	A	
- 1	MS2142L3 AN98-11L	• NUT • WASHER, MAXIMUM THICK UNDER HEAD OF NUT OR BOLT	4 2	A A	
- 2	NAS1175-6 W-27.121-2	• BOLT • SEAL, PRESSURE PAD, (5708) SUPD 7144788-1	4	A	
- 3	MS2142L3 NAS1233-6	• NUT • BOLT	1 1	A A	
- 4	7144594-01	• PAD, PRESSURE	1	A	
- 5	7144594-01	• NUT	1	A	
- 6	MS28776-036	• PACKING	1	A	
- 7	7144597-01	• ADAPTER ATTACHING PARTS	2	A	
- 8	AN5H7A	• BOLT	1	A	
- 9	AN98-11L	• WASHER -----X-----	10	A	
- 10	7144594-01	• GASKET	2	A	
- 11	7144597-01	• DIFFUSER ASSY	1	A	
	7144776-10	• COVER ASSY, FWD ACCESS	1	A	
- 12	V4-2 1	• RETAINER RING, (17124)	12	A	
- 13	SV4-1 10W9	• STUD ASSY, (10124)	12	A	
- 14	7144777-01	• GASKET	1	A	
- 15	7144747-01	• COVER	1	A	
		A ADDED PER TCID 1F-106A-398 ON AIRPLANES 49, 91 AND 91.			

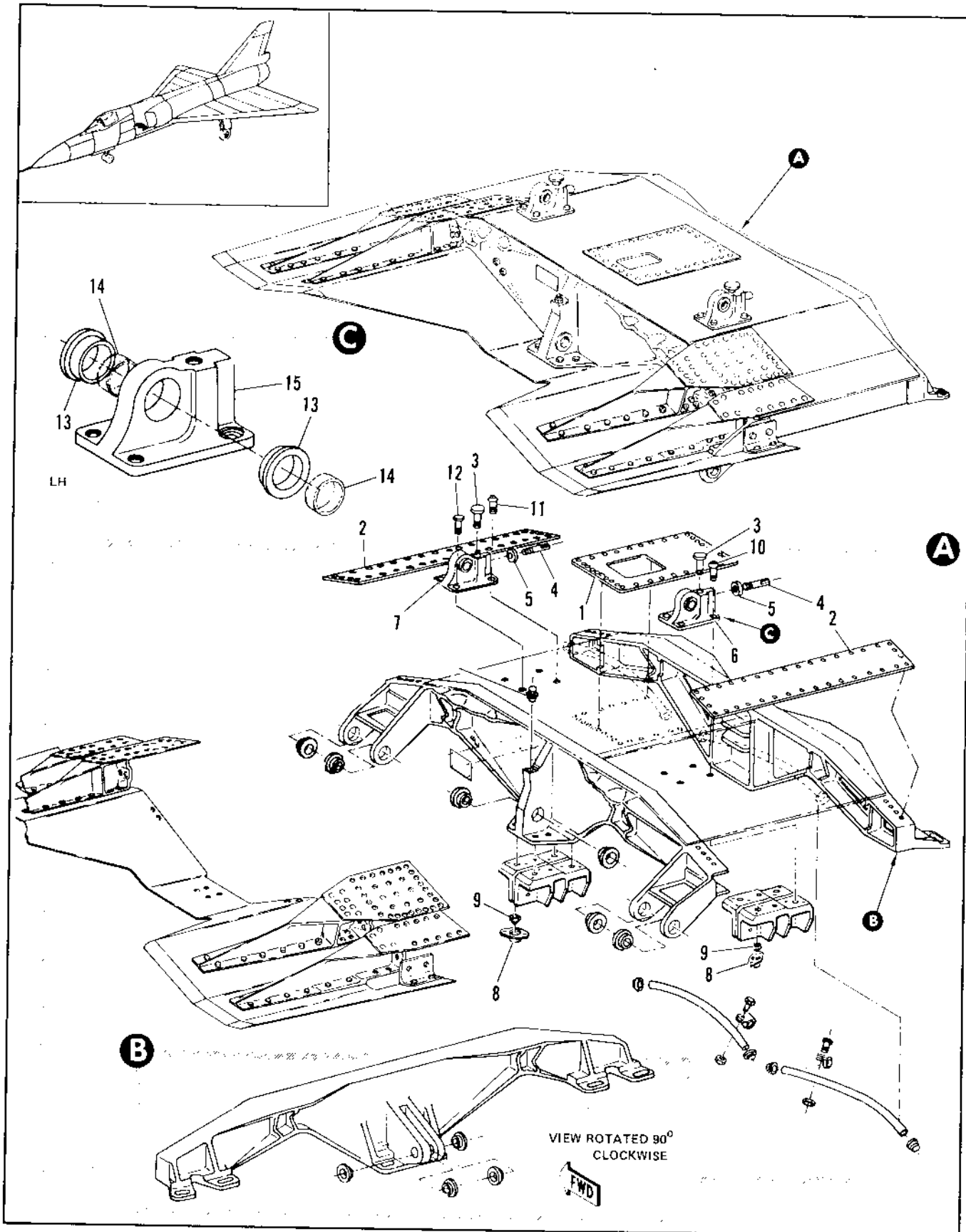

Figure 2.20-47. Armament Cross Bridge Fwd Support Assembly (Sheet 1 of 2)

FIGURE AND INDEX NUMBER	PART NUMBER	DESCRIPTION	UNITS PER ASSY.	USABLE ON CODE	
				FROM	TO
		1 2 3 4 5 6			
2.20-17	R-57103-1	SUPPORT ASSEMBLY, ARMAMENT CROSSRIDGE FWD FOR NHA SEE FIG. 2.20-21	1	73	73
	R-57103-2	SUPPORT ASSEMBLY, ARMAMENT CROSSRIDGE FWD FOR NHA SEE FIG. 2.20-21	1	73	100
	R-57103-3	SUPPORT ASSEMBLY, ARMAMENT CROSSRIDGE FWD FOR NHA SEE FIG. 2.20-21	1	109	
	R-57103-4	SUPPORT ASSEMBLY, ARMAMENT CROSSRIDGE FWD MODIFIED BY R-57103-5 ALT INTCHG WITH R-57103-5	1	109	
	R-57103-5	SUPPORT ASSEMBLY, ARMAMENT CROSSRIDGE FWD MODIFIED BY R-57103-4 ALT INTCHG WITH R-57103-4	1	109	
- 1	R-57103-73 R-57103-161	• COVER ASSY, RIVETED • COVER ASSY, RIVETED ATTACHING PARTS	1 1	73 75	277
	AN173-6A AN173-5A MS24694-40	• BOLT • BOLT • SCREW	1 1 1	73 75 75	
- 2	R-57107-20	• COVER ATTACHING PARTS	1	73	
	AN173-5A	• BOLT	1	75	
- 3	R-57109	• BUMPER	1	75	
- 4	ANS655427H20	• SCREW	1	75	
- 5	AN310-4F	• NUT	1	75	
- 6	R-57121-1	• ADAPTER ASSY, CROSSRIDGE UPPER LH REPLACED BY SUITABLE SUB R-57122-5	1	75	100
	R-57144	• ADAPTER ASSY, CROSSRIDGE UPPER LH ALT INTCHG WITH R-57122-1	1	75	100
	R-57122-5	• ADAPTER ASSY, CROSSRIDGE UPPER LH REPLACES SUITABLE SUB FOR R-57122-1	1	109	
	R-57144-1	• ADAPTER ASSY, CROSSRIDGE UPPER LH ALT INTCHG WITH R-57122-1	1	109	
- 7	R-57122-3	• ADAPTER ASSY, CROSSRIDGE UPPER RH REPLACED BY SUITABLE SUB R-57122-4E1	1	75	100
	R-57144-1	• ADAPTER ASSY, CROSSRIDGE UPPER RH ALT INTCHG WITH R-57122-4	1	75	100
	R-57122-4E1	• ADAPTER ASSY, CROSSRIDGE UPPER RH REPLACES SUITABLE SUB FOR R-57122-3	1	109	
	R-57144-1	• ADAPTER ASSY, CROSSRIDGE UPPER RH ALT INTCHG WITH R-57122-4E1 ATTACHING PARTS	1	109	
- 8	6870-104	• RETAINER, CROSSRIDGE UPPER LH	1	75	
- 9	22FT124	• NUT, CROSSRIDGE UPPER LH	1	75	
- 10	MS20106-14	• BOLT, LH	1	75	
- 11	MS20106-14	• BOLT, RH	1	75	
- 12	NAS454-E-14	• BOLT, PH	1	75	
- 13	NAS77-14-22	• RUSHING	1	75	
- 14	NAS77-10-710	• RUSHING, SEE FIG. 2.20-23 INDEX 45	1	75	
- 15	R-57122-11	• ADAPTER, LH	1	75	100
	R-57144-11	• ADAPTER, LH USE WITH R-57144	1	75	100
	R-57122-15	• ADAPTER, LH	1	75	
	R-57144-15	• ADAPTER, LH USE WITH R-57144-3	1	75	

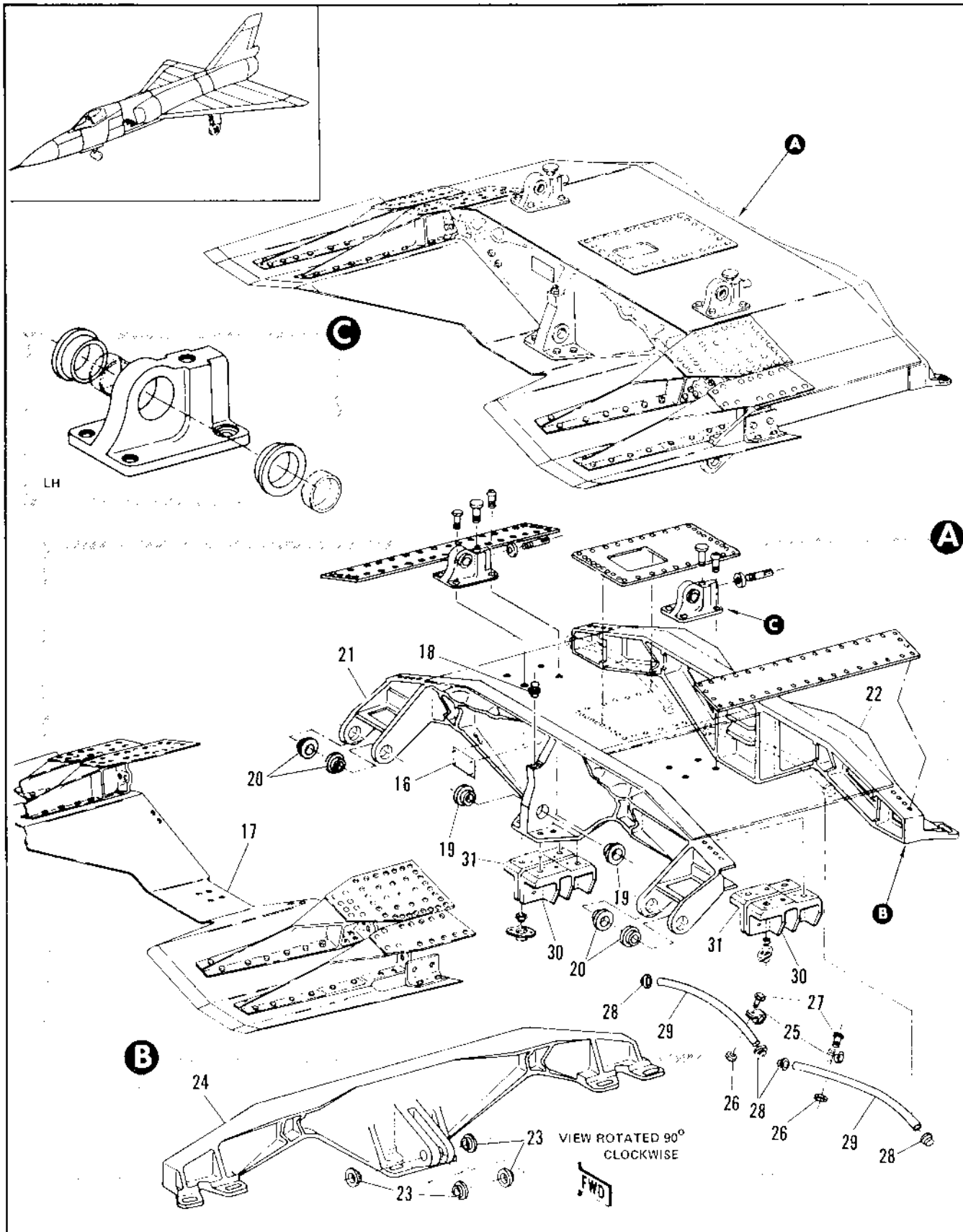

Figure 2.20-47. Armament Cross Bridge Fwd Support Assembly (Sheet 2 Of 2)

FIGURE AND INDEX NUMBER	PART NUMBER	DESCRIPTION	UNITS PER ASSY.	USABLE ON CODE	
				FROM	TO
		1 2 3 4 5 6			
2.20-17	R-57174-13	• ADAPTER, RM	1	35	100
	R-57144-13	• ADAPTER, RM USE WITH R-57144-1	1	25	1
	R-57122-17	• ADAPTER, RM	1	35	
	R-57144-17	• ADAPTER, RM USE WITH R-57144-7	44	20	
- 18	AM7517-1	• NAME PLATE	1	39	
- 17	R-57194-1	• WEL INSTL, SHOCK CROSSBRIDGE FOR BREAKDOWN SEE FIG. 2-1-17	1	35	
	R-57120-5	• ADAPTER ASSY, CROSSBRIDGE FWD	1	35	
	R-57120-801	• ADAPTER ASSY, CROSSBRIDGE FWD ALT INTCHG WITH R-57120-13	47	35	100
	R-57120-803	• ADAPTER ASSY, CROSSBRIDGE FWD REPLACES W/ INTCHG WITH R-57120-801	1	100	
- 18	MS19101-1	• LUBRICATOR	1	35	
- 19	NAS77-14-36	• RUSHING	2	35	
- 27	NAS77-14-32	• RUSHING	4	35	
- 21	R-57121-13	• ADAPTER	1	35	
	R-57120-15	• ADAPTER, USE WITH R-57121-13	1	75	100
	R-57120-17	• ADAPTER	1	100	277
- 20	R-57121-5	• ADAPTER ASSY, CROSSBRIDGE AFT	1	35	
	R-57121-1	• ADAPTER ASSY, CROSSBRIDGE AFT ALT INTCHG WITH R-57121-5	47	35	
	R-57135-1	• ADAPTER ASSY, CROSSBRIDGE AFT ALT INTCHG WITH R-57121-5	4	35	
- 23	NAS77-9-24	• RUSHING	1	35	
- 24	R-57121-11	• ADAPTER	1	35	
	R-57121-7	• ADAPTER	47	35	
	R-57135-7	• ADAPTER, USE WITH R-57135-1	7	35	
- 25	MS21919G20	• CLAMP	1	35	
		ATTACHING PARTS			
- 24	NAS77A3	• NUT	2	35	
- 27	NAS221-9	• SCREW	2	35	

- 2A	R-36722-9	• COLLAR, CONDUIT	4	35	
- 24	R-36722-7	• CONDUIT, FWD MISSILE	2	35	
- 30	R-57157-7	• ADAPTER, CROSSBRIDGE DRAG ARM UPPER	2	35	
	R-57158-7	• ADAPTER, CROSSBRIDGE DRAG ARM UPPER ALT INTCHG WITH R-57157-7	47	35	
	R-57157-9	• ADAPTER, CROSSBRIDGE DRAG ARM LOWER	2	35	
- 31	R-57158-9	• ADAPTER, CROSSBRIDGE DRAG ARM LOWER ALT INTCHG WITH R-57157-9	47	35	
	R-57189-7	• PLATE, ADJUSTMENT LAUNCHER ATTACHMENT FWD	1	35	
	R-57189-8	• PLATE, ADJUSTMENT LAUNCHER ATTACHMENT FWD	1	35	
	R-57189-7	• SUPPORT, CROSSBRIDGE ADAPTER 1850 RM	1	35	
	R-57189-8	• SUPPORT, CROSSBRIDGE ADAPTER 1850 RM	1	35	
		A AIRPLANE B35, 270 AND ON			
		B AIRPLANE B35 THRU 180, 270 AND ON			

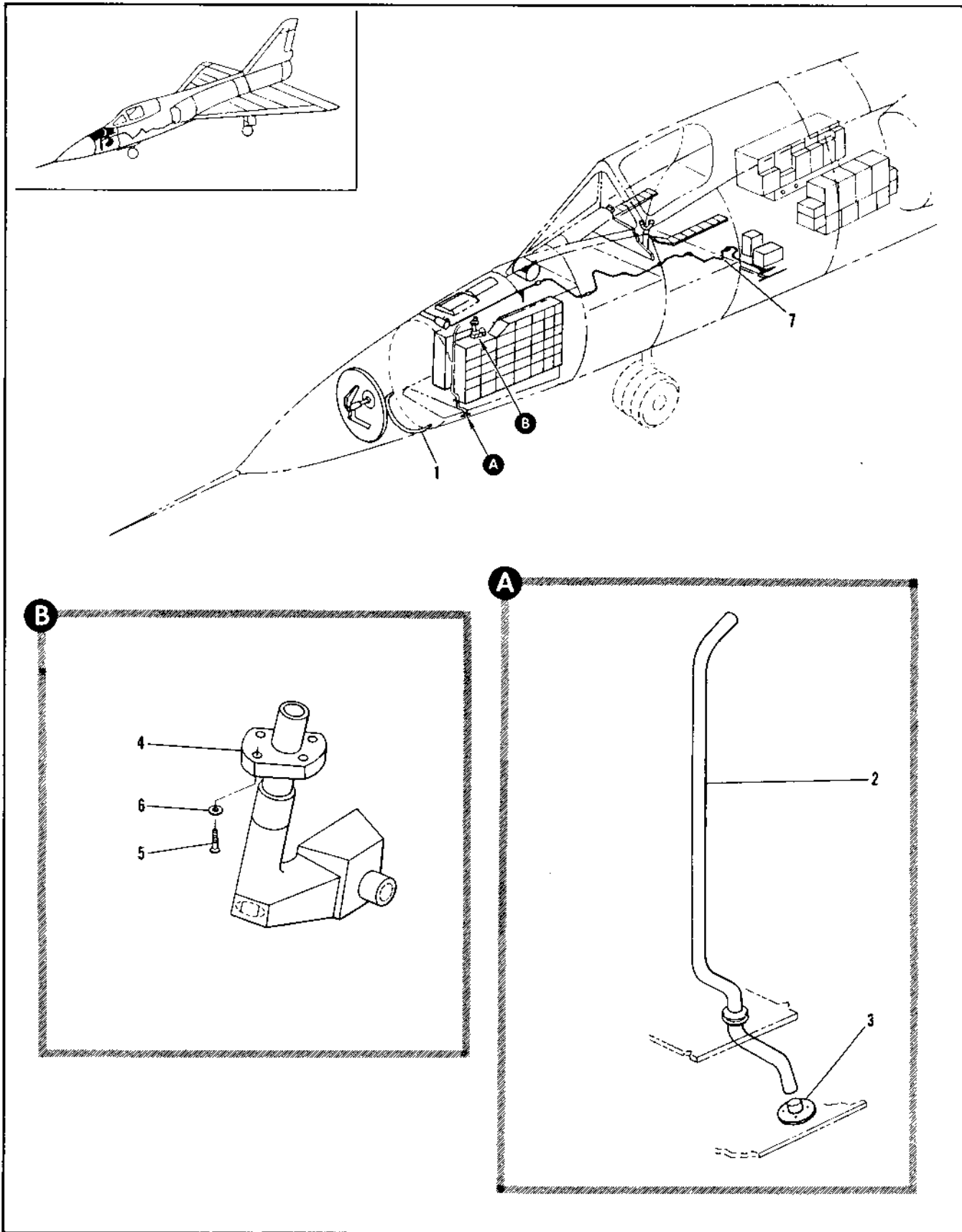

Figure 2.20-48. Infrared Seeker Installation (Sheet 1 of 4)

FIGURE AND INDEX NUMBER	PART NUMBER	DESCRIPTION	UNITS PER ASSY.	USABLE ON CODE	
				FROM	TO
2.20-48	A-44-60-PC1	INFRARED SEEKER INSTALLATION	1	A	
- 1	A-44-60-3	INFRARED SEEKER INSTALLATION • ANTENNA ASSY. LOCALIZER MODIFICATION SEE FIG. 2.19-7	1	B	
- 2	A-44-60-1	• TUBE INLET, INFRARED SEEKER BRAIN	1	C	
- 3	A-44-60-2	• TUBE	1	C	
- 4	A-44-60-3	• FITTING, INFRARED SEEKER BRAIN	1	C	
- 5	A-44-60-1	• TRANSMITTER INSTL, INFRARED SEEKER	1	C	
- 6	464X-6-100	• TRANSMITTER, INFRARED SELF TEST <C10-77> BEAF ATTACHING PARTS	1	C	
- 7	MS35206-210	• SCREW	4	C	
- 8	AN70104	• WASHER	4	C	
- 9	A-44-65-PC3	• TUBING INSTL, HIGH PRESSURE PNEUMATIC INFRARED SEEKER FOR BREAKDOWN SEE FIG. 2.8-12	10	A	
- 10	B-44-65-2	• TUBING INSTL, HIGH PRESSURE PNEUMATIC INFRARED SEEKER FOR BREAKDOWN SEE FIG. 2.8-12	10	B	
<p>A ADDED ON AIRPLANES 47, 48 THROUGH 50 PER TC10 1F-106-7A2</p> <p>B ADDED ON AIRPLANES 44, 45 AND ON PER TC10 1F-106-7B5</p> <p>C ADDED ON AIRPLANES 43F AND ON PER TC10 1F-106-7-9</p>					

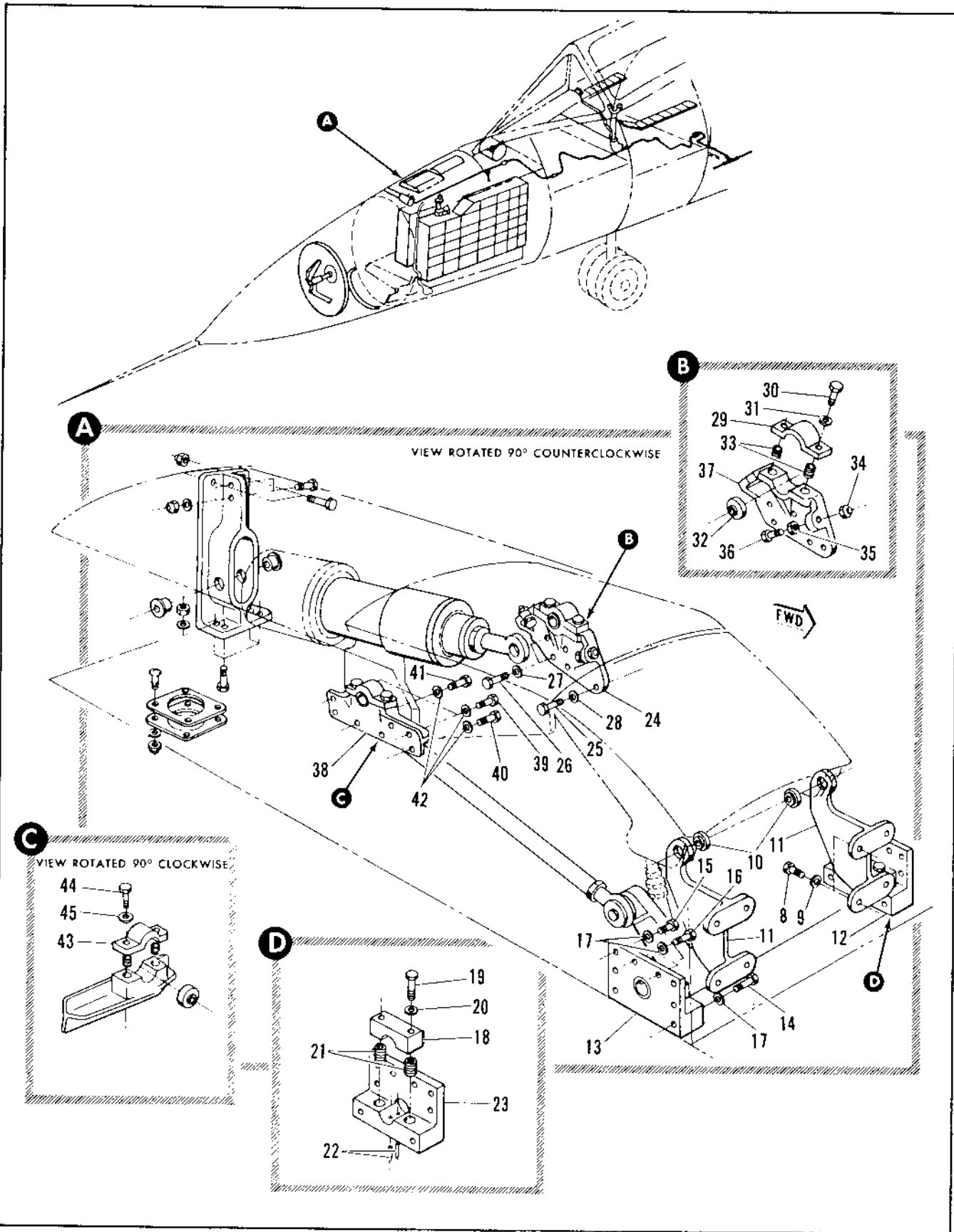

Figure 2.20-48. Infrared Seeker Installation (Sheet 2 of 4)

FIGURE AND INDEX NUMBER	PART NUMBER	DESCRIPTION	UNITS PER ASSY.	USABLE ON CODE		
				FROM	TO	
2.20-48	P-44464-1	STRUCTURAL INSTALLATION SUPPORT SEEKER	1			
	P-44464-1	• HINGE ASSY. END DOOR INFRARED SEEKER	2			
		ATTACHING PARTS				
		• BOLT				
	- 7	NAS1113-17	• WASHER			
	- 8	AN96-110L	-----X-----			
	- 10	BLFNB	• BEARING, PLAIN <1176> 9 - 1023-116	1		
	- 11	B-44467-8	• PIVOT, HINGE	1		
	- 12	B-44467-1	• SUPPORT ASSY. IDLER INFRARED SEEKER LH	1		
	- 13	B-44467-2	• SUPPORT ASSY. IDLER INFRARED SEEKER RH	1		
			ATTACHING PARTS			
	- 14	NAS1113-15	• BOLT	4		
	- 15	NAS1113-1	• BOLT	8		
	- 16	NAS1003-3	• SCREW	4		
	- 17	AN96-010L	• WASHER	84		
			-----X-----			
	- 18	B-44467-9	• BLOCK	1		
			ATTACHING PARTS			
	- 19	NAS1754-7	• BOLT	1		
	- 20	AN96-0416	• WASHER	2		
			-----X-----			
	- 21	NAS1200-4F	• INSERT	2		
	- 22	B-44467-10B	• PIN, RH	2		
	- 23	B-44467-6	• SUPPORT, RH	1		
			• SUPPORT, LH	1		
	- 24	B-44467-1	• SUPPORT ASSY. INFRARED SEEKER LH	1		
			ATTACHING PARTS			
	- 25	NAS1304-8	• BOLT	6		
	- 26	NAS1101-6	• BOLT	1		
	- 27	AN96-010L	• WASHER	4		
	- 28	AN96-0416L	• WASHER	4		
			-----X-----			
	- 29	B-44467-7	• CAP	1		
			ATTACHING PARTS			
	- 30	NAS1304-5	• BOLT	1		
	- 31	AN96-0416	• WASHER	2		
			-----X-----			
	- 32	BLFNB	• BEARING, PLAIN <1176> 9 - 1023-017	1		
			• BEARING, PLAIN ALT INTCH WITH BLFNB	1		
	- 33	NAS1200-4E	• INSERT	2		
	- 34	NAS1201-4	• NUT	2		
	- 35	AN310-4R	• NUT	2		
	- 36	NAS1004-12	• BOLT	2		
	- 37	P-44467-9	• SUPPORT, HEAD PIVOT LH INFRARED SEEKER	1		
	- 38	B-44467-1	• SUPPORT ASSY. INFRARED SEEKER RH	1		
		ATTACHING PARTS				
- 39	NAS1305-4	• BOLT	2			
- 40	NAS1304-8	• BOLT	2			
- 41	NAS1003-4	• BOLT	2			
- 42	AN96-010L	• WASHER	7			
		-----X-----				
- 43	B-44467-7	• CAP	1			
		ATTACHING PARTS				
- 44	NAS1304-8	• BOLT	1			
- 45	AN96-0416	• WASHER	2			
		-----X-----				

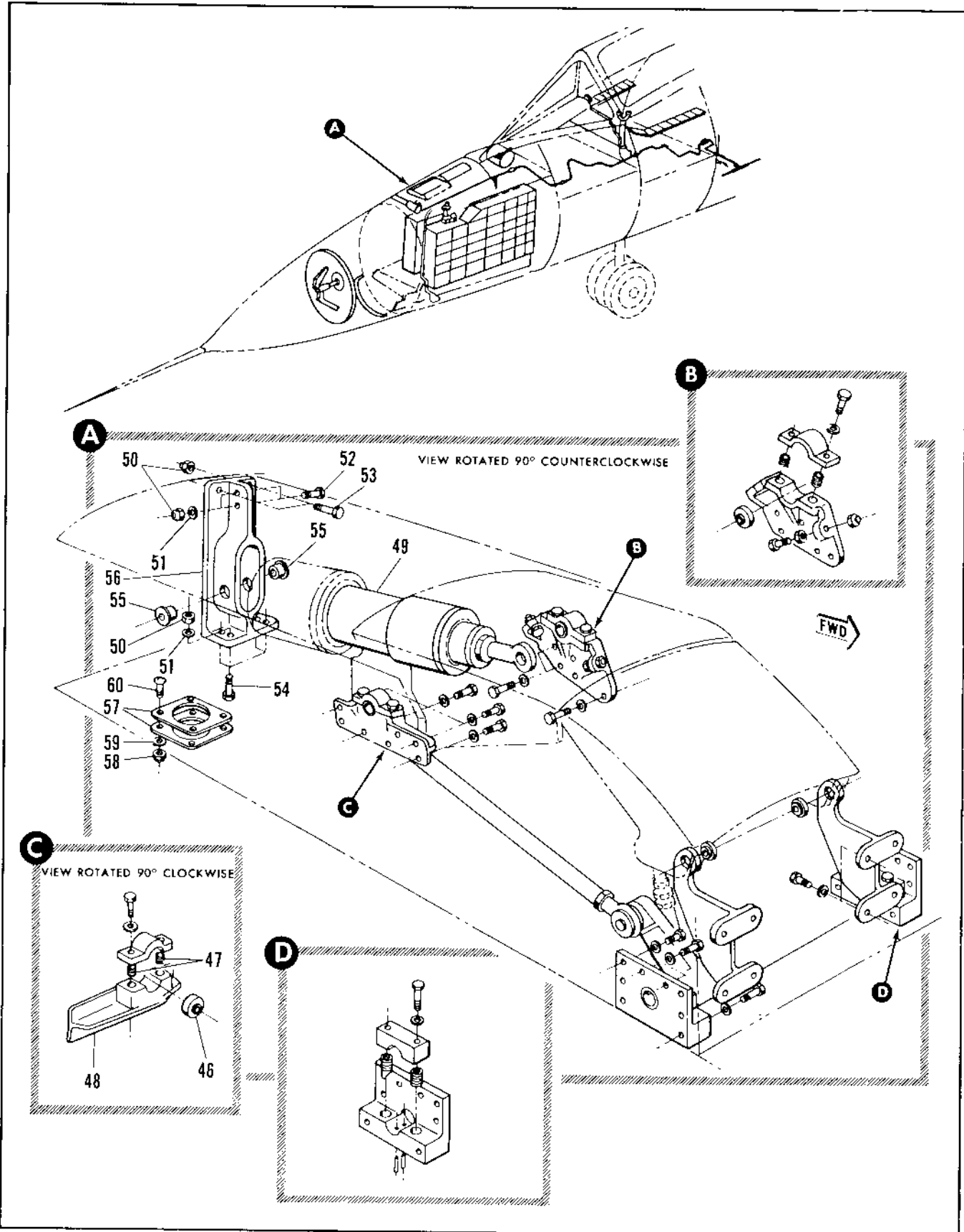

Figure 2.20-48. Infrared Seeker Installation (Sheet 3 of 4)

FIGURE AND INDEX NUMBER	PART NUMBER	DESCRIPTION	UNITS PER ASSY.	USABLE ON CODE	
				FROM	TO
		1 2 3 4 5 6			
2.20-48- 46	ELFN6	• BEARING, PLAIN (R1376) 90-3003-117	1		C
- 47	NAS1022-4E	• INSERT	1		C
- 48	8-44-74-1	• SUPPORT, HEAD PIVOT 90 INFRARED SEEKER	1		C
- 49		• CYLINDER, PNEUMATIC INFRARED SEEKER SEE INDEX 67	1		C
	8-44-74-1	• SUPPORT ASSY, CYLINDER INFRARED SEEKER ATTACHING PARTS	1		C
- 50	NAS1021-3	• NUT	1		C
- 51	AN961-10L	• WASHER	1		C
- 52	NAS1113-4	• BOLT	1		C
- 53	NAS1113-6	• BOLT	2		C
- 54	NAS1113-7	• BOLT	3		C
		-----X-----			
- 55	NAS77A6-45	• PUSHING	1		C
- 56	8-44-74-9	• SUPPORT	1		C
- 57	BAC-545A1	• SEAL, PLAIN (R1205) 97-3501-0.2 ATTACHING PARTS	1		C
- 58	MS20555-432	• NUT	4		C
- 59	AN961-8	• WASHER	4		C
- 60	MS35216-245	• SCREW	4		C
		-----X-----			
		* ADDED ON AIRPLANES 837 AND 1000 PER TC TO 1F-106-789			

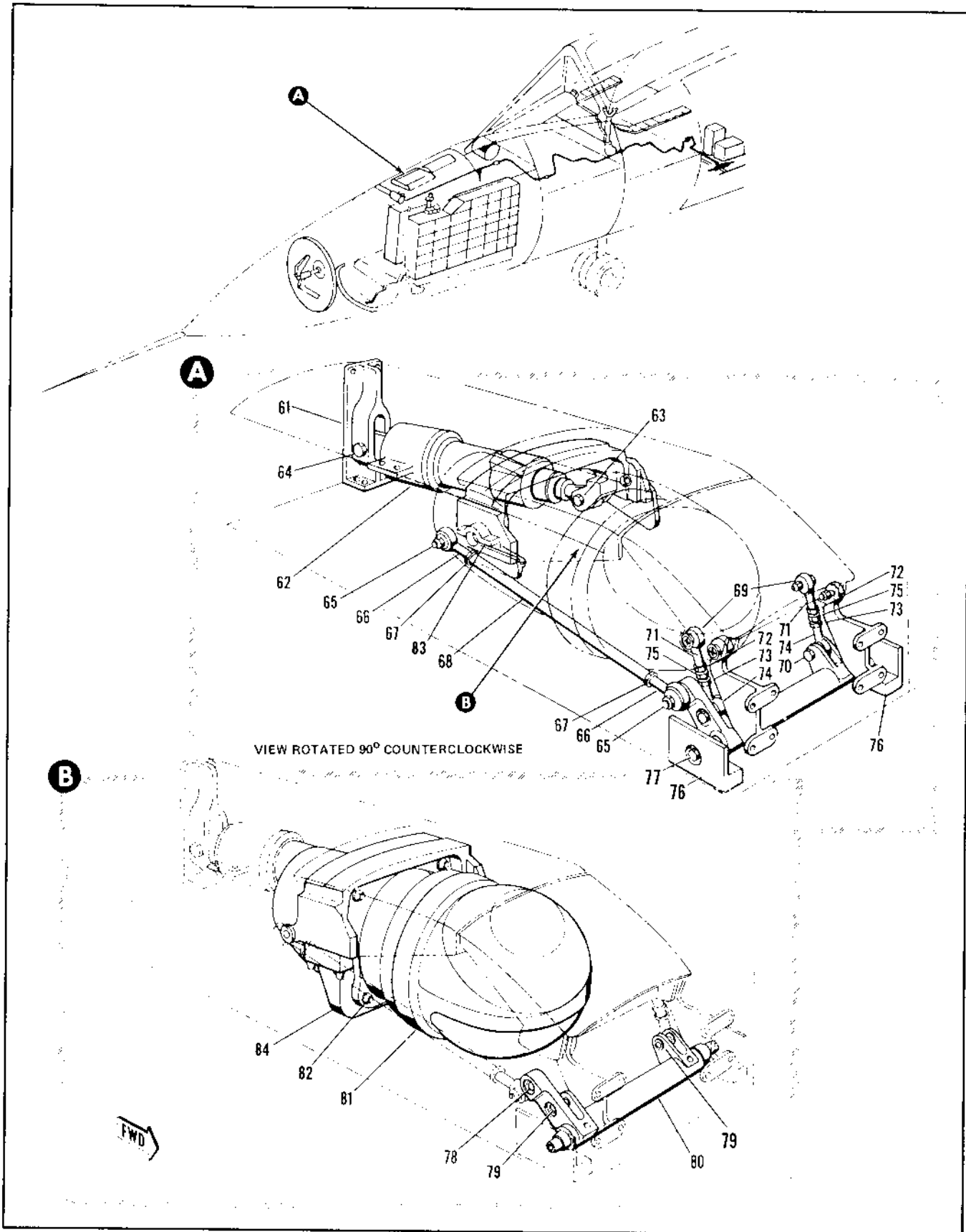

Figure 2.20-48. Infrared Seeker Installation (Sheet 4 of 4)

FIGURE AND INDEX NUMBER	PART NUMBER	DESCRIPTION	UNITS PER ASSY.	USABLE ON CODE	
				FROM	TO
		1 2 3 4 5 6			
7.20-48	B-44141-1	MECHANISM INSTALLATION, INFRARED SEEKER	1	C	
- 61		• SUPPORT ASSY, CYLINDER INFRARED SEEKER	1	C	
- 62	B-3111	• CYLINDER, PNEUMATIC INFRARED SEEKER (12476) SPEC C-0159E-1 ATTACHING PARTS	1	C	
- 63	NAS1156-16D	• BOLT	1	C	
	AN31-4	• NUT	1	C	
	AN95-41F	• WASHER	1	C	
- 64	NAS1156-14D	• BOLT	1	C	
		-----X-----			
	B-44177-1	• ROD ASSY, PUSH-PULL INFRARED SEEKER ATTACHING PARTS	1	C	
- 65	NAS1314-1F	• BOLT	2	C	
	NAS1291-4	• NUT	2	C	
	AN95-41F	• WASHER	1	C	
	99-513-1-102	• WASHER	1	C	
	AN95-41eL	• WASHER	1	C	
		-----X-----			
- 66	REP48-17414	• BEARING, BALL ROD END (21415) (1-66012-210)	2	C	
- 67	AN31-04E	• NUT	1	C	
- 68	B-44177-2	• ROD	1	C	
	B-44178-1	• ROD ASSY, FWD DRUM INFRARED SEEKER ATTACHING PARTS	1	C	
- 69	NAS333PA11	• BOLT	2	C	
	NAS774-2F	• BUSHING	4	C	
	NAS1091-3	• NUT	1	C	
- 70	NAS1103-1E	• BOLT	2	C	
	NAS1091-3	• NUT	2	C	
		-----X-----			
- 71	AN5714E2N	• ROD END	2	C	
- 72	AN31-04R	• NUT	2	C	
- 73	AN31-04L	• NUT	2	C	
- 74	AN951RE3FL4-3	• ROD END	1	C	
- 75	B-44171-7	• ROD	1	C	
- 76		• SUPPORT ASSY, IDLER INFRARED SEEKER SEE INDEX 12 AND 13	1	C	
- 77	BLFN4	• BEARING, PLAIN (1476) (1-66012-210) ATTACHING PARTS	1	C	
	NAS774-4	• NUT	1	C	
	AN567-41E	• WASHER	1	C	
	NAS1314-2D	• BOLT	1	C	
		-----X-----			
- 78	B-44116-1	• IDLER ASSY, FWD DRUM INFRARED SEEKER	1	C	
- 79	NAS774-42	• BUSHING	1	C	
- 80	NAS774-3-2	• BUSHING	4	C	
- 81	B-44146-9	• IDLER	1	C	
- 82	464717-160	• RECEIVER, INFRARED SEEKER (12577) GEAR ATTACHING PARTS	1	C	
- 83	MS2144H4	• BOLT, FURNISHED WITH 464717-160	4	C	
	MS23002C4	• WASHER, FURNISHED WITH 464717-160	4	C	
		-----X-----			
- 84		• SUPPORT ASSY, INFRARED SEEKER SEE INDEX 13	1	C	
- 85	464517-150	• RACK, RECEIVER INFRARED SEEKER	1	C	
- 86	464499-190	• CABLE ASSY	1	C	
		C ADDED ON AIRPLANES BPP AND P PER TCDS 1F-111-779			

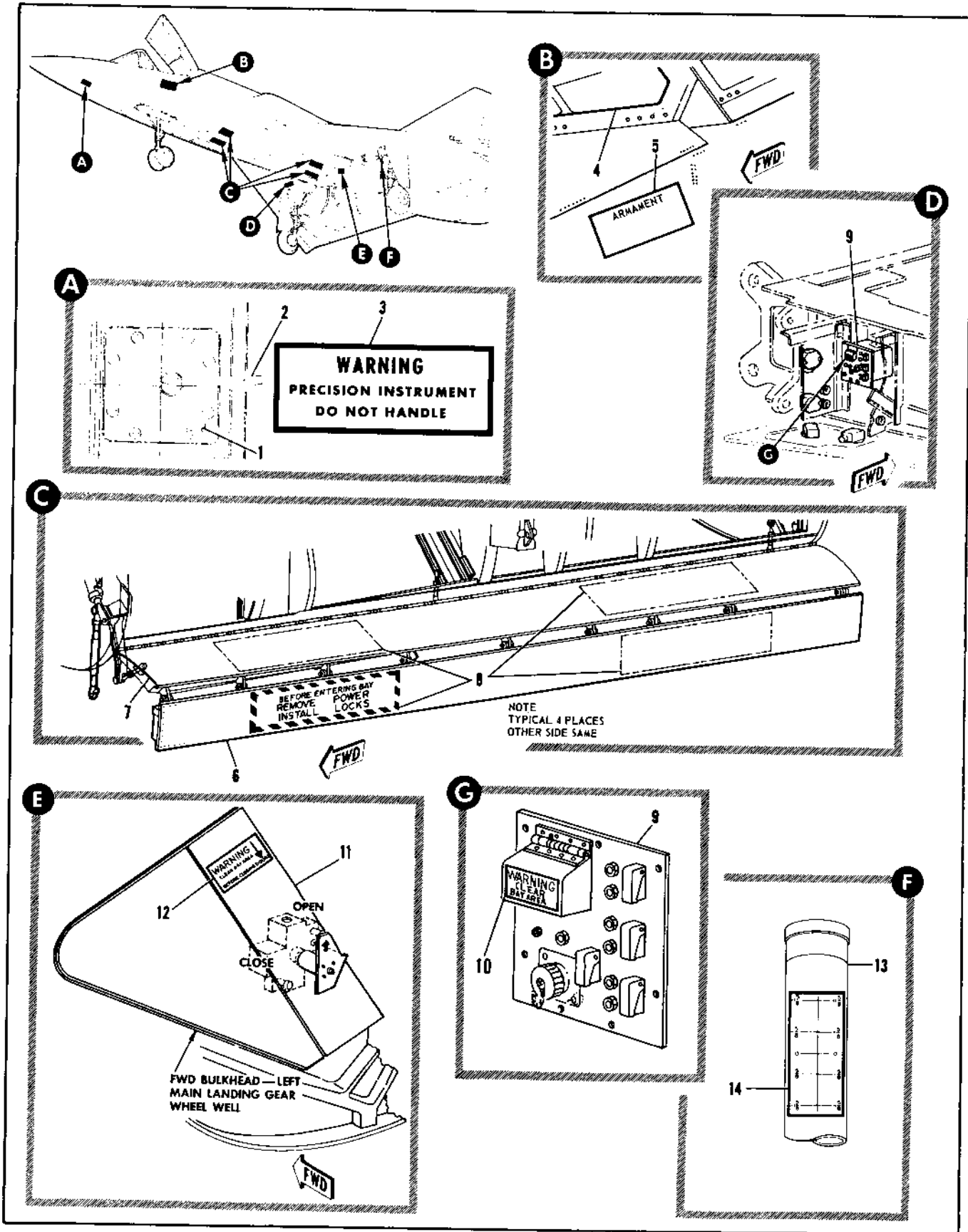

Figure 2.20-49. Decal Installation, Armament System

FIGURE AND INDEX NUMBER	PART NUMBER	DESCRIPTION	UNITS PER ASSY.	USABLE ON CODE	
				FROM	TO
		1 2 3 4 5 6			
2.20-49		DECAL INSTALLATION, ARMAMENT SYSTEM			
- 1	1-30757-7	• COVER, ANGLE OF ATTACK	RF	35	
- 2	MS2437-	• TRANSMITTER, ANGLE OF ATTACK	RF	35	
- 3	63634-05	• DECAL, WARNING - PRECISION INSTRUMENT DO NOT HANDLE	1	35	
- 4	R-74628-1	• WINDOW INSTL CANOPY	RF	35	
- 5	62A40753	• DECAL, ARMAMENT	1	35	
- 6	74664-5	• DOOR ASSY, ARMAMENT BAY OUT RD LH	RF	35	12
	74667-5	• DOOR ASSY, ARMAMENT BAY OUT RD RH	RF	35	12
- 7	74667-03	• DOOR ASSY, ARMAMENT BAY INRD LH	RF	35	
	74669-001	• DOOR ASSY, ARMAMENT BAY INRD RH	RF	35	
- 8	64033113-7	• DECAL, BEFORE ENTERING BAY REMOVE POWER INSTALL LOCKS	1	35	
- 9	d-65.15-PC1	• PAVEL ASSY, ARMAMENT MANUAL CONTROL	RF	35	
- 10	64033113-11	• DECAL, WARNING CLEAR BAY AREA	1	35	
- 11	351742	• VALVE, MANUAL SAFETY	RF	35	
- 12	64033113-9	• DECAL, WARNING CLEAR BAY AREA BEFORE CLOSING DOORS	1	35	
- 13	57811R-3	• DRAG STRUT, MAIN LANDING REAR END LH	RF	35	
- 14	NC0011	• DECAL, ANGLE OF ATTACK TRANSMITTER CALIBRATION	1	35	

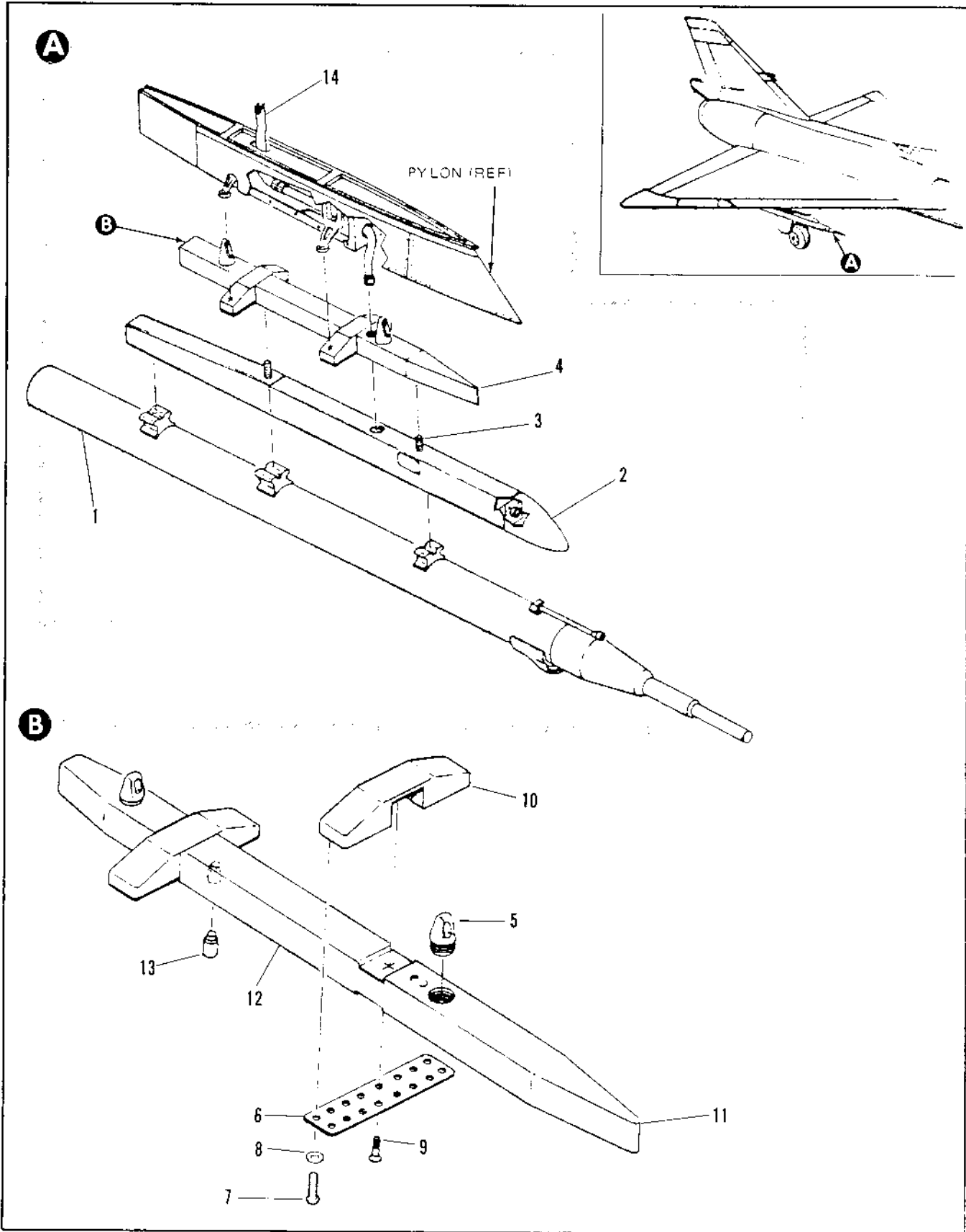

Figure 2.20-50. AIS Pod Installation

FIGURE AND INDEX NUMBER	PART NUMBER	DESCRIPTION	UNITS PER ASSY.	USABLE ON CODE	
				FROM	TO
		1 2 3 4 5 6			
2.20-50		AIS POD INSTALLATION	REF	A	
- 1		• AIS POD ASSY, GFAE	J		
- 2	7132899	• LAUNCHER ASSY, GFAE AERO-3B T.O. 11L1-3-15-22 (98752)	1		
		ATTACHING PARTS			
- 3	7132917-10	• BOLT (98752)	2		
		-----X-----			
- 4	7747258	• ADAPTER ASSY	1		
- 5	6539772-2	• LUG (19205)	2		
- 6	7747261-01	• PLATE	2		
		ATTACHING PARTS			
- 7	MS35237	• SCREW	12		
- 8	AN963-416L	• WASHER	12		
- 9	MS24693	• SCREW	4		
		-----X-----			
- 10	7747260-01	• SADDLE	2		
- 11	7747259-10	• BEAM	1		
- 12	7747259-01	• BAR	1		
- 13	MS21209F1215	• INSERT	2		
- 14	7747267-10	• CABLE ASSY	1		
		A AFTER TCTO 1F-106-1177			

EXTERNAL MARKINGS SUBSECTION

TABLE OF CONTENTS

<i>Fig No.</i>	<i>Title</i>	<i>Page</i>
2.21-1	General External Markings	2.21-2
2.21-2	Fuselage External Markings	2.21-4
2.21-3	Wing, Upper Surface Markings	2.21-26
2.21-4	Wing, Lower Surface Markings	2.21-28
2.21-5	External Fuel Tank/Pylon Markings	2.21-38
2.21-6	Vertical Stabilizer Markings	2.21-40

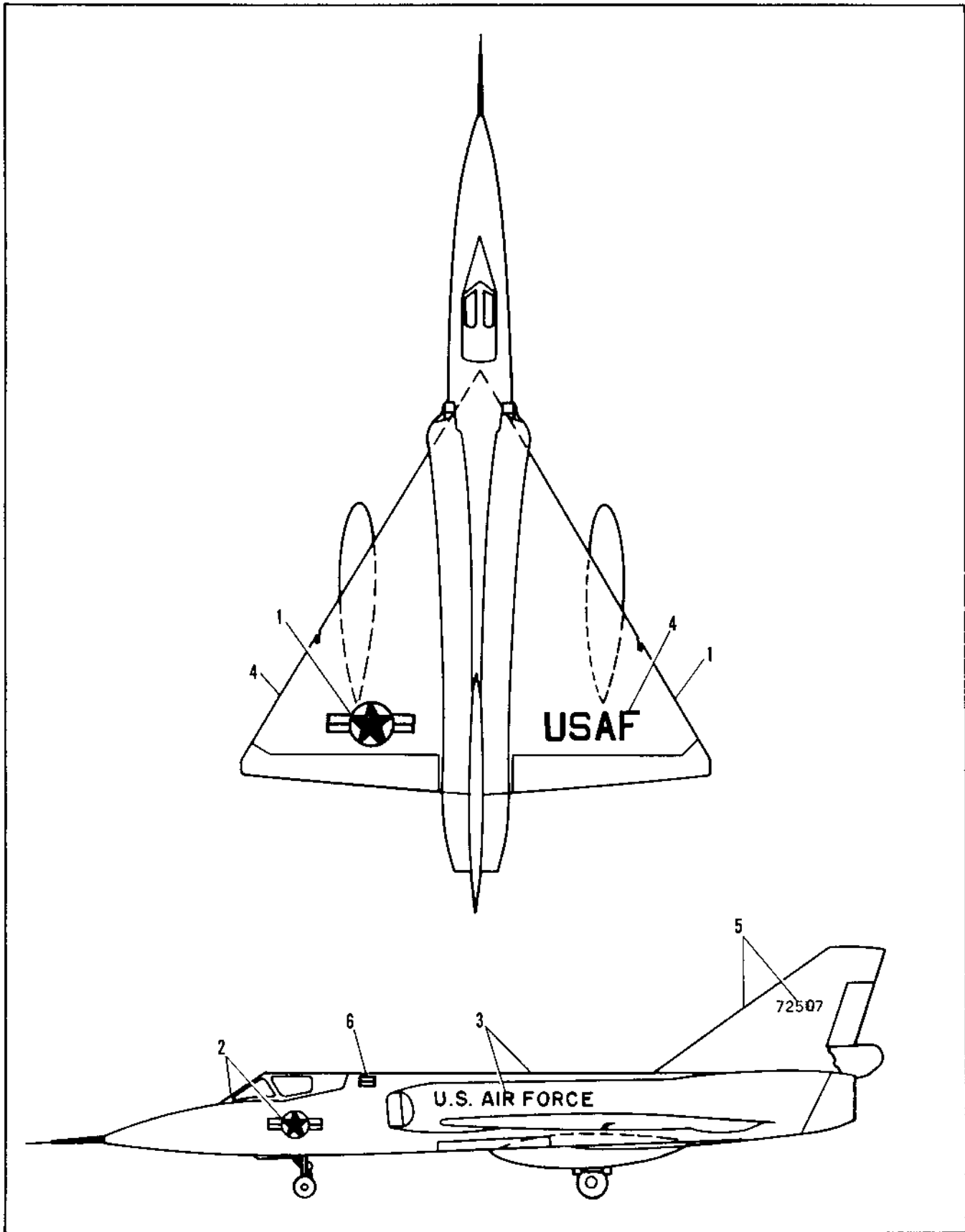

Figure 2.21-1 General External Markings

FIGURE AND INDEX NUMBER	PART NUMBER	DESCRIPTION	UNITS PER ASSY.	USABLE ON CODE	
				FROM	TO
		1 2 3 4 5 6			
2.21-1-	BT-1	DECAL, RED WHITE AND BLUE INAT 11A (T.O. 1-1-4, PAGE 3-5A, 3-7)			
- 2	BT-2	DECAL, RED WHITE AND BLUE INAT 11A (T.O. 1-1-4, PAGE 3-5A, 3-7)			
- 3	BT-3	DECAL, BLUE U.S. AIR FORCE (T.O. 1-1-4 PAGE 3-5A, 3-7)			
- 4	BT-4	DECAL, BLUE USAF (T.O. 1-1-4 PAGE 3-5A, 3-7)			
- 5	BT-5	DECAL, BLACK NUMBERS 0 thru 9			
- 6	BT-6	DECAL, BLACK ON GREY U.S. AIR FORCE FD 8-11B AF SERIAL NO. BLACK NO. SERVICE TAG AIRCRAFT WITH JP-4 FUEL MILITARY SPECIFICATION MIL-PRF-5207 (T.O. 1-1-4, PAGE 3-5B, 3-57)	1		
		RECOMMEND STICKLING TO 2.21-1- DECALS DUE TO ACCESS PANELS REMOVAL FOR MAINTENANCE			

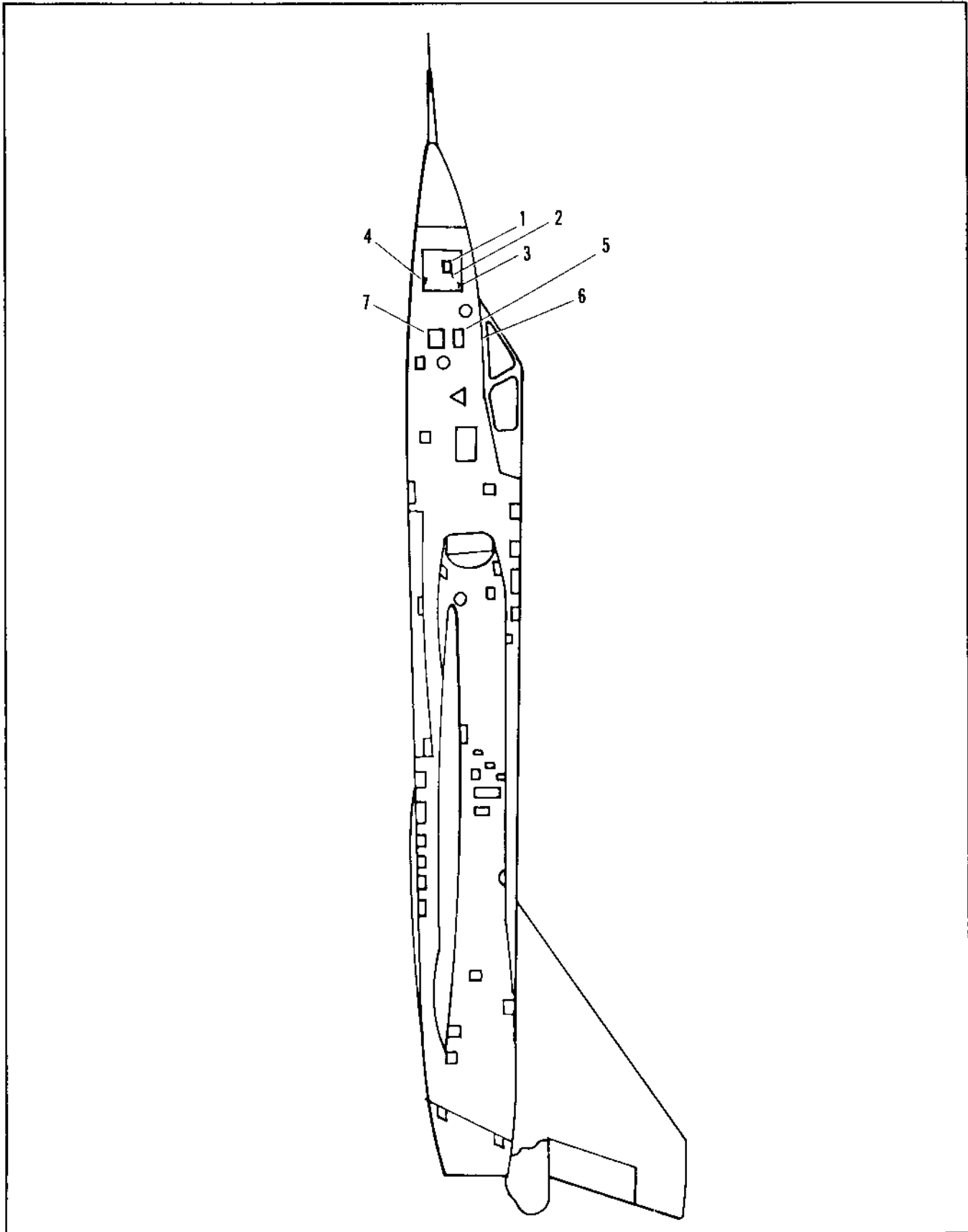

Figure 2.21-2 Fuselage External Markings (Sheet 1 of 11)

FIGURE AND INDEX NUMBER	PART NUMBER	DESCRIPTION	UNITS PER ASSY.	USABLE ON CODE	
				FROM	TO
		1 2 3 4 5 6			
2.21-2- 1	RT-55	*1	1		
- 2	53B34005	DECAL, RED LETTERS ON WHITE BACKGROUND	1		
- 3		WARNING PRECISION INSTRUMENT DO NOT HANDLE	1		
- 4	BT-63	*2	1		
		CAUTION - TO CLOSE CANOPY ACTUATE SWITCH AND STOP CANOPY 2 TO 6 IN. ABOVE SILL. THEN TOGGLE TO FULL CLOSED POSITION. EXTERNAL POWER REQUIRED. MAX. OPERATING TIME 3 MIN. IN ANY 25 MIN. PERIOD.			
	BT-135	*2			
		DECAL, RED ARROW ON WHITE BACKGROUND			
- 5	RT-74	*3	1		
		RED ARROW			
	BT-73	*3	1		
		DECAL, BLACK LETTERS ON GREY BACKGROUND			
		OPEN CANOPY SWITCH INSIDE DOOR CLOSE			
- 6	62A40953		1		
		DECAL, RED LETTERS ON WHITE BACKGROUND			
		ARMAMENT			
- 7		*4	1		
		STENCIL, BLACK LETTERS			
		U.S.A.F. SERIAL NO.			
		*1 PAGE 1.029 CONVAIR STENCILING AND MARKING REPORT NO. P.00028			
		*2 PAGE 2.062 CONVAIR STENCILING AND MARKING REPORT NO. P.00028			
		*3 PAGE 2.136 CONVAIR STENCILING AND MARKING REPORT NO. P.00028			
		*4 PAGE 8.175 CONVAIR STENCILING AND MARKING REPORT NO. P.00028 AND REFER TO T.O. 1-1-4			

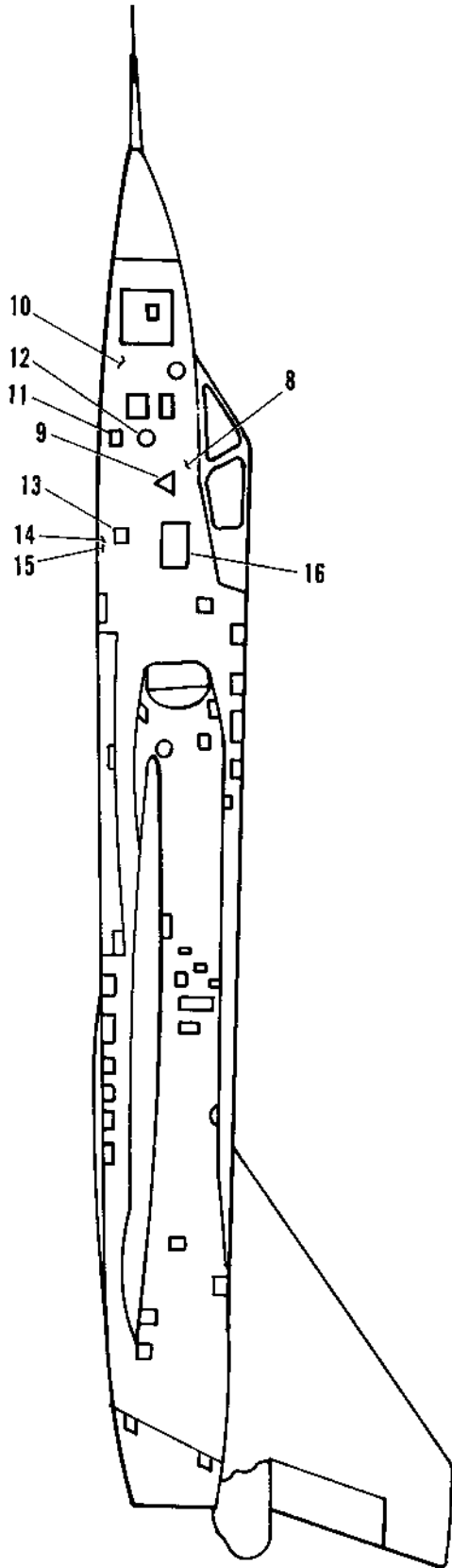

Figure 2.21-2. Fuselage External Markings (Sheet 2 of 11)

FIGURE AND INDEX NUMBER	PART NUMBER	DESCRIPTION	UNITS PER ASSY.	USABLE ON CODE	
				FROM	TO
		1 2 3 4 5 6			
2.21-2- 8		*5 STENCIL, BLACK LETTERS LADDER STRIP-YELLOW	1		
- 9	BT-77 A	*6 DECAL, BLACK ON GREY; RED TRIA; WHITE ON RED; RED ON GRFY DANGER-WARNING			
- 10	BT-69	*7 EJECTION SEAT - THIS AIRCRAFT CONTAINS CARTRIDGE ACTUATED EMERGENCY ESCAPE SYSTEM EQUIPPED WITH AN EXPLOSIVE CHARGE DECAL, BLACK LETTERS ON GREY BACKGROUND CABIN PRESSURE STATIC PORT. DO NOT PLUG OR DEFORM HOLES. AREA WITHIN CIRCLE MUST BE SMOOTH & CLEAN.	2		
- 11	BT-65	*8 DECAL, RED LETTERS ON WHITE BACKGROUND LIQUID OXYGEN	1		
	BT-75	*9 CAUTION KEEP CLEAN, DRY AND FREE OF ALL OILS DECAL, RED LETTERS ON WHITE BACKGROUND LIQUID OXYGEN (BREATHING) FILLER VALVE FILLING LIQUID 25 + 5LB/SQ IN 1.6 + KGNS/ SQ CM	1		
- 12	BT-79	*10 DECAL, BLACK LETTERS ON GREY BACKGROUND DOOR 759	1		
- 13		*11 STENCIL, BLACK LETTERS EXT. PWR. RECP. - PUSH TO OPEN 115V, 1600 CY. AC, 115/200V, 400CY. AC, 28VDC, 140VDC, 150VDC, 300VDC	1		
- 14	BT-80	*12 DECAL, YELLOW LETTERS ON GREY BACKGROUND USE SE-(1131) BETWEEN THESE LINES	2		
- 15	BT-76	*13 DECAL, RED LETTERS ON WHITE BACKGROUND CAUTION	1		
- 16	BT-82	*14 DANGER AREA IF ENGINE IS ABOVE IDLE DECAL, BLACK LETTERS ON GREY BACKGROUND DOOR 209 (LH), 210 (RH)	2		
	BT-83	*14 DECAL, RED LETTERS ON WHITE BACKGROUND SECURE DOOR FASTENERS BEFORE START OF ENGINE	2		
		*5 PAGE 8.171 CONVAIR STENCILING AND MARKING REPORT NO. 8.00028			
		*6 PAGE 2.181 CONVAIR STENCILING AND MARKING REPORT NO. 8.00028			
		*7 PAGE 2.083 AND 8.006 CONVAIR STENCILING AND MARKING REPORT NO. 8.00028			
		*8 PAGE 8.165 CONVAIR STENCILING AND MARKING REPORT NO. 8.00028			
		*9 PAGE 2.316 CONVAIR STENCILING AND MARKING REPORT NO. 8.00028			
		*10 PAGE 2.108 CONVAIR STENCILING AND MARKING REPORT NO. 8.00028			
		*11 PAGE 8.185 CONVAIR STENCILING AND MARKING REPORT NO. 8.00028			
		*12 PAGE 8.217 CONVAIR STENCILING AND MARKING REPORT NO. 8.00028			
		*13 PAGE 9.232 CONVAIR STENCILING AND MARKING REPORT NO. 8.00028			
		*14 PAGE 3.002 AND 3.349 CONVAIR STENCILING AND MARKING REPORT NO. 8.00028			
		*15 PAGE 2.176 CONVAIR STENCILING AND MARKING REPORT NO. 8.00028			

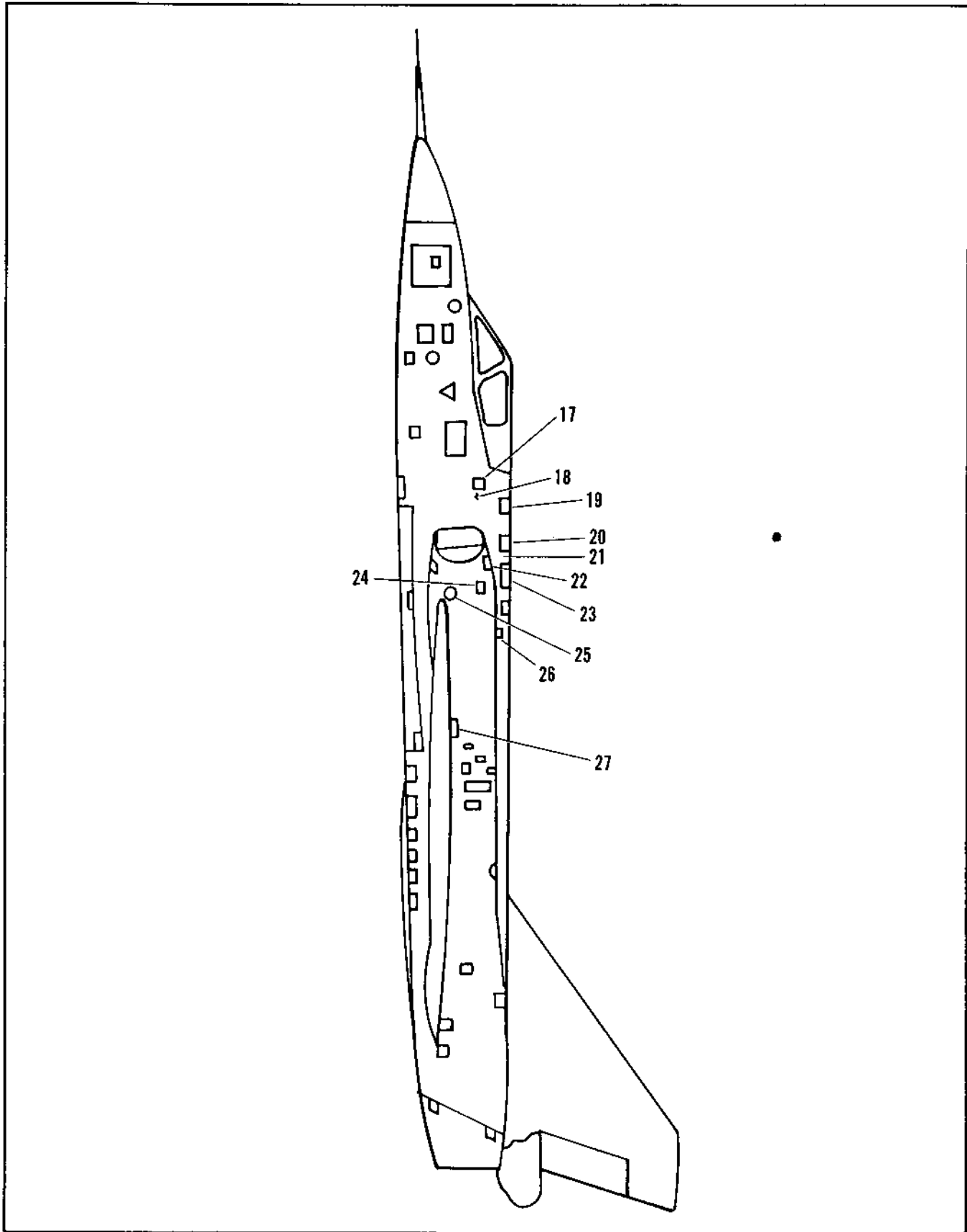

Figure 2.21-2. Fuselage External Markings (Sheet 3 of 11)

FIGURE AND INDEX NUMBER	PART NUMBER	DESCRIPTION	UNITS PER ASSY.	USABLE ON CODE	
				FROM	TO
		1 2 3 4 5 6			
2.21-2- 17	BT-7-	*1 DECAL, BLACK LETTERS ON GREY BACKGROUND. STRUCTURE INSPECTION DOOR 76 (LH), 762 (RH)	1		
- 18	BT-11-	*1 DECAL, BLACK LETTERS ON GREY BACKGROUND. U.S. AIR FORCE CO. 1 1942 A.C. SERIAL 1. BLOCK NO. SERVICE THIS AIRCRAFT WITH JP-4 FUEL SPEC MIL-F-56240 REF. T.O. 4111-1-14 (125 R-R 117)	1		
- 19	BT-17-	*1 DECAL, BLACK LETTERS ON GREY BACKGROUND. DOOR 231	1		
- 20	BT-2-				
- 21	BT-117	*17 DECAL, BLACK LETTERS ON GREY BACKGROUND. DOOR 239(LH), 241(RH)	1		
- 22	BT-15-	*18 DECAL, BLACK LETTERS ON GREY BACKGROUND. DOOR 741 (LH), 742 (RH)	1		
- 23	BT-16-	*19 DECAL, BLACK LETTERS ON GREY BACKGROUND. DOOR 737	1		
- 24	BT-151	*2 DECAL, BLACK LETTERS ON GREY BACKGROUND. DOOR 763 (LH), 764 (RH)	1		
- 25	99SA-44-35	*31 DECAL, YELLOW LETTERS ON BLACK BACKGROUND. 1. PUSHBUTTON TO OPEN DOOR 2. PULL "R" HANDLE OUT FROM EJECTION CANOPY	1		
	BT-157	*21 DECAL, YELLOW LETTERS ON BLACK BACKGROUND. RESCUE	1		
	BT-157	*22 DECAL, BLACK LETTERS ON YELLOW BACKGROUND. WARNING IF PILOTS SEAT EJECTION SEATBELT ARE IN UP POSITION DO NOT USE THIS SYSTEM	1		
- 26	BT-156	*23 DECAL, BLACK LETTERS ON GREY BACKGROUND. DOOR 765 (LH), 766 (RH)	1		
- 27	BT-151	*24 DECAL, BLACK LETTERS ON GREY BACKGROUND. DOOR 799	1		
		*15 PAGE 3.107 AND 3.271 CONVAIN STENCILING AND MARKING REPORT NO. 8.1022P			
		*17 PAGE 3.01 CONVAIN STENCILING AND MARKING REPORT NO. 8.1021P			
		*18 PAGE 3.252 CONVAIN STENCILING AND MARKING REPORT NO. 8.1022P			
		*19 PAGE 3.133 CONVAIN STENCILING AND MARKING REPORT NO. 8.1022P			
		*20 PAGE 3.295 AND 3.297 CONVAIN STENCILING AND MARKING REPORT NO. 8.1022P			
		*21 PAGE 3.011 CONVAIN STENCILING AND MARKING REPORT NO. 8.1022P			
		*22 PAGE 3.368 CONVAIN STENCILING AND MARKING REPORT NO. 8.1022P			
		*23 PAGE 3.118 CONVAIN STENCILING AND MARKING REPORT NO. 8.1022P			
		*24 PAGE 3.329 CONVAIN STENCILING AND MARKING REPORT NO. 8.1022P			

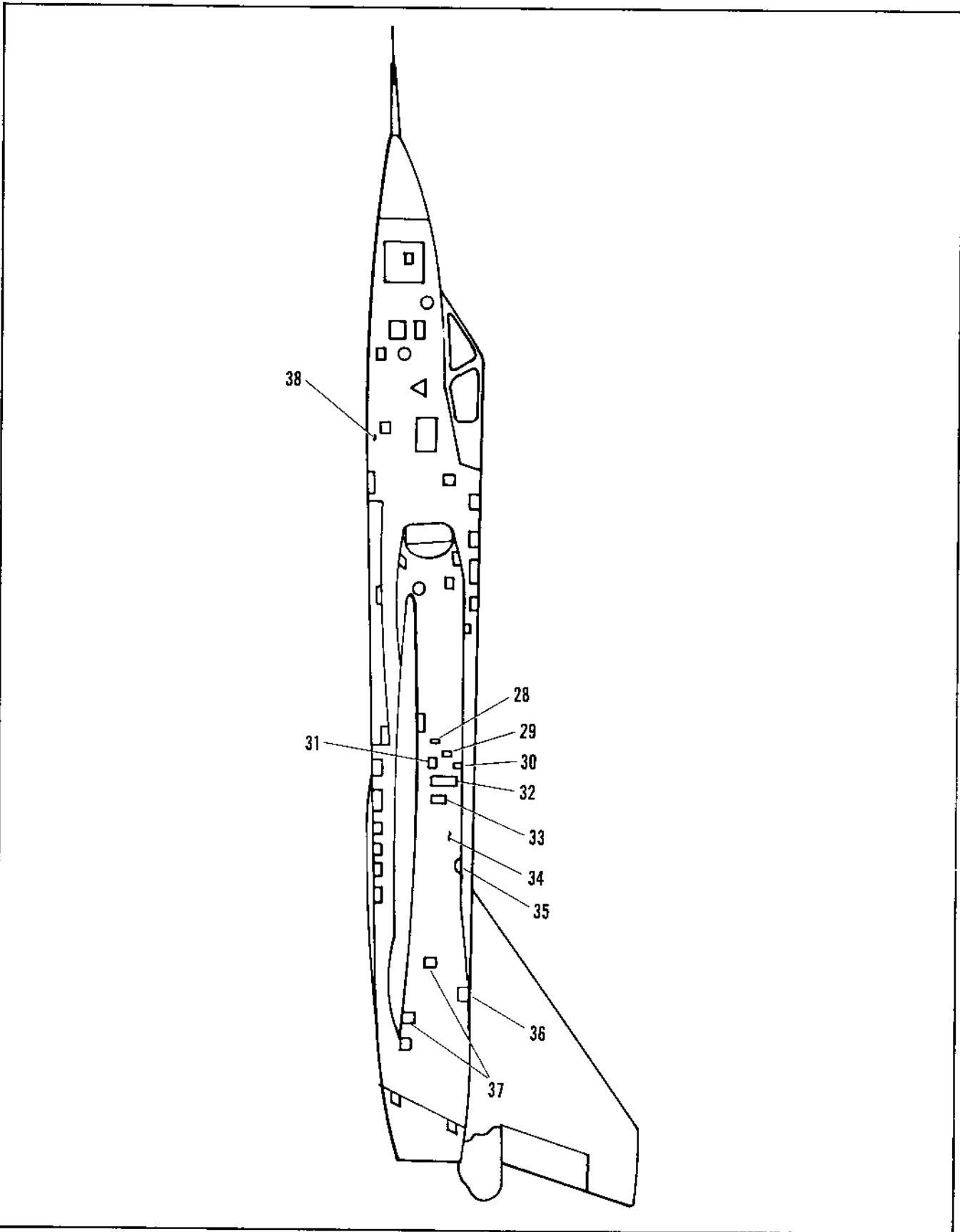

Figure 2.21-2. Fuselage External Markings (Sheet 4 of 11)

FIGURE AND INDEX NUMBER	PART NUMBER	DESCRIPTION	UNITS PER ASSY.	USABLE ON CODE	
				FROM	TO
		1 2 3 4 5 6			
2.21-2- 28	BT-208	*25 DECAL, BLACK LETTERS ON GREY BACKGROUND 283 (LH), 284 (RH)	2		
- 29	BT-208	*26 DECAL, BLACK LETTERS ON GREY BACKGROUND 285 (LH), 287 (RH)	2		
- 30	BT-161	*27 DECAL, BLACK LETTERS ON GREY BACKGROUND DOOR 281	1		
- 31	BT-160	*28 DECAL, BLACK LETTERS ON GREY BACKGROUND DOOR 271 (LH), 274 (RH)	2		
- 32	BT-185	*29 DECAL, BLACK LETTERS ON GREY BACKGROUND DOOR 277	1		
- 33	BT-172	*30 DECAL, BLACK LETTERS ON GREY BACKGROUND DOOR 297 (LH), 298 (RH)	2		
- 34	BT0176	*31 DECAL, BLACK LETTERS ON GREY BACKGROUND AMBIENT PRESSURE ENGINE & ACCESSORY COMPARTMENT PRESSURE CONTROL NORMAL SENSOR	1		
- 35	BT-174	*32 DECAL, BLACK LETTERS ON GREY BACKGROUND OIL FILLER CAPACITY 4.5 U.S. GALLONS, USE MIL-I-7808 CAUTION-INSURE FILLER CAP IS LOCKED PRIOR TO INSTALLING DOOR	1		
+ 36	BT-178	*33 DECAL, BLACK LETTERS ON GREY BACKGROUND DOOR 319 (LH), 321 (RH)	2		
	BT-178	*34 DECAL, BLACK LETTERS ON GREY BACKGROUND DOOR 323 (LH), 324 (RH)	2		
- 37	BT-177	*35 DECAL, BLACK LETTERS ON GREY BACKGROUND DOOR 325 (LH), 326 (RH)	2		
- 38	BT-95	*36 DECAL, BLACK LETTERS ON GREY BACKGROUND FUEL TANK LOW POINT DRAIN, PUSH TO DRAIN	1		
		*25 PAGE 3.189 CONVAIR STENCILING AND MARKING REPORT NO. 8.00028			
		*26 PAGE 3.188 AND 3.187 CONVAIR STENCILING AND MARKING REPORT NO. 8.00028			
		*27 PAGE 3.244 CONVAIR STENCILING AND MARKING REPORT NO. 8.00028			
		*28 PAGE 3.243 AND 3.242 CONVAIR STENCILING AND MARKING REPORT NO. 8.00028			
		*29 PAGE 3.044 CONVAIR STENCILING AND MARKING REPORT NO. 8.00028			
		*30 PAGE 4.006 CONVAIR STENCILING AND MARKING REPORT NO. 8.00028			
		*31 PAGE 4.073 CONVAIR STENCILING AND MARKING REPORT NO. 8.00028			
		*32 PAGE 4.025 CONVAIR STENCILING AND MARKING REPORT NO. 8.00028			
		*33 PAGE 5.005 CONVAIR STENCILING AND MARKING REPORT NO. 8.00028			
		*34 PAGE 5.005 CONVAIR STENCILING AND MARKING REPORT NO. 8.00028			
		*35 PAGE 5.004 CONVAIR STENCILING AND MARKING REPORT NO. 8.00028			
		*36 PAGE 3.125 CONVAIR STENCILING AND MARKING REPORT NO. 8.00028			

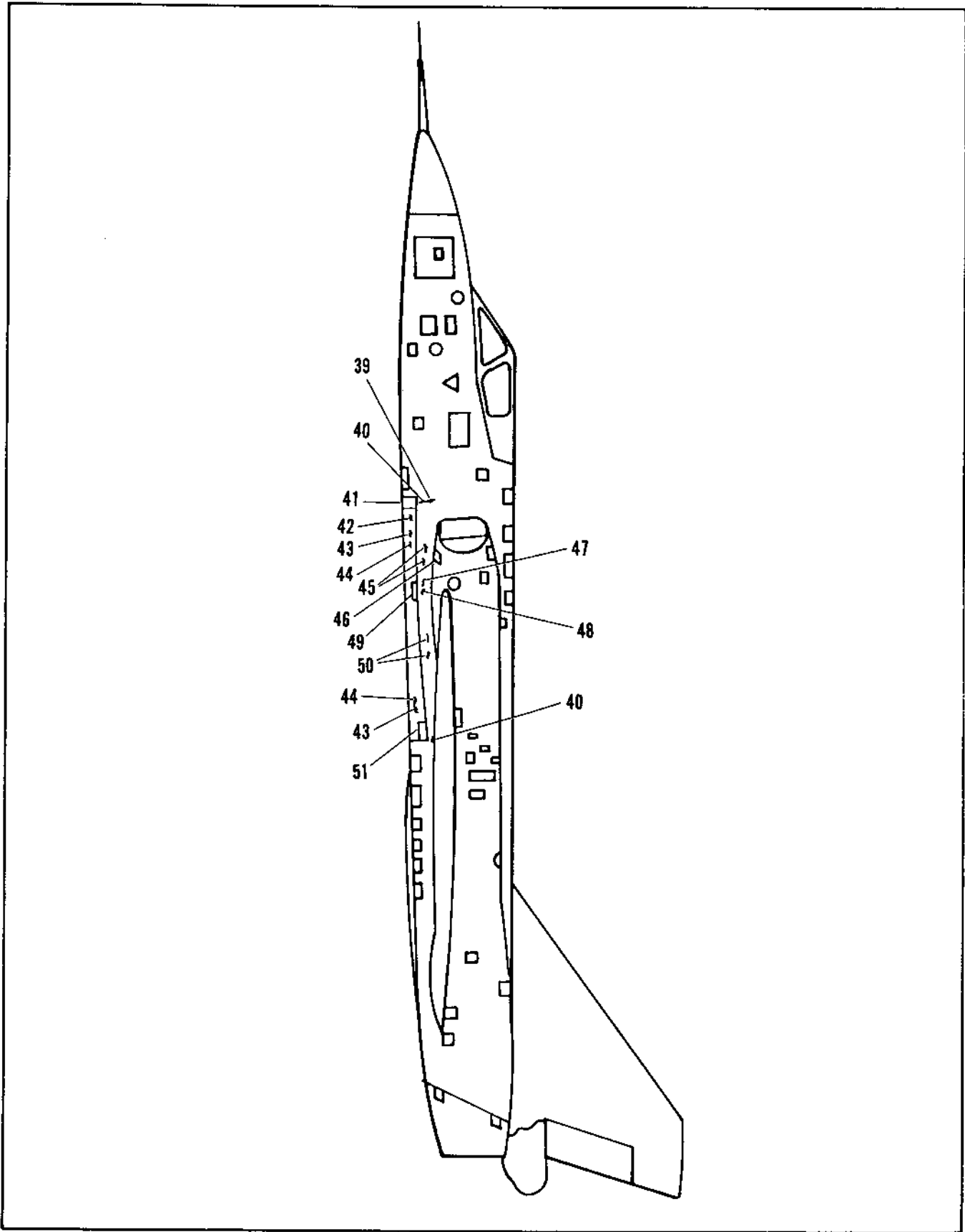

Figure 2.21-2. Fuselage External Markings (Sheet 5 of 11)

FIGURE AND INDEX NUMBER	PART NUMBER	DESCRIPTION	UNITS PER ASSY.	USABLE ON CODE	
				FROM	TO
		1 2 3 4 5 6			
2.21-2- 39	NO NUMBER	STENCIL, BLACK LETTERS MOISTURE VENT	1		
- 40	BT-84	*37 DECAL, RED LETTERS ON WHITE BACKGROUND DANGER FAST ACTING DOORS	4		
- 41	BT-88	*38 DECAL, BLACK LETTERS ON GREY BACKGROUND DOOR 749 (LH), 750 (RH)	2		
- 42	BT-184	*39 DECAL, BLACK LETTERS ON GREY BACKGROUND NO STEP	2		
- 43	64033113-7	DECAL, RED LETTERS ON WHITE BACKGROUND BEFORE ENTERING BAY REMOVE POWER - INSTALL LOCKS	8		
- 44	BT-93	*40 DECAL, RED LETTERS/BLACK LETTERS ON GREY BACKGROUND WARNING ARMAMENT GEAR UPLATCH HOOKS MUST BE UNLATCHED BEFORE RETRACTING GEARS	8		
- 45	BT-97	*41 DECAL, BLACK LETTERS ON GREY BACKGROUND VARIABLE RAMP OVERBOARD DRAINS	1		
- 46	BT-101	*42 DECAL, BLACK LETTERS ON GREY BACKGROUND DOOR 743 (LH), 744 (RH)	2		
- 47	BT-90	*43 DECAL, BLACK LETTERS ON GREY BACKGROUND AMBIENT PRESSURE SENSING LINE LOW POINT DRAIN PUSH TO DRAIN	2		
- 48	BT-91	*43 DECAL, BLACK LETTERS ON GREY BACKGROUND WING TO F TANK VENT LINE LOW POINT DRAIN PUSH TO DRAIN	2		
- 49	BT-86	*44 DECAL, BLACK LETTERS ON GREY BACKGROUND DOOR 751 (LH), 752 (RH)	2		
- 50	BT-92	*45 DECAL, BLACK LETTERS ON GREY BACKGROUND C.G. TRANSFER LINE LOW POINT DRAIN PUSH TO DRAIN	2		
- 51	BT-87	*46 DECAL, BLACK LETTERS ON GREY BACKGROUND DOOR 753 (LH), 754 (RH)	2		
		*37 PAGE 3.323; 3.102 AND 9.231 CONVAIR STENCILING AND MARKING REPORT NO. 8.00028			
		*38 PAGE 3.101 CONVAIR STENCILING AND MARKING REPORT NO. 8.00028			
		*39 PAGE 3.252 CONVAIR STENCILING AND MARKING REPORT NO. 8.00028			
		*40 PAGE 3.111 CONVAIR STENCILING AND MARKING REPORT NO. 8.00028			
		*41 PAGE 3.255 AND 9.327 CONVAIR STENCILING AND MARKING REPORT NO. 8.00028			
		*42 PAGE 3.291 CONVAIR STENCILING AND MARKING REPORT NO. 8.00028			
		*43 PAGE 3.107; 3.374 AND 9.354 CONVAIR STENCILING AND MARKING REPORT NO. 8.00028			
		*44 PAGE 3.100 CONVAIR STENCILING AND MARKING REPORT NO. 8.00028			
		*45 PAGE 3.108 AND 9.047 CONVAIR STENCILING AND MARKING REPORT NO. 8.00028			
		*46 PAGE 3.088 CONVAIR STENCILING AND MARKING REPORT NO. 8.00028			

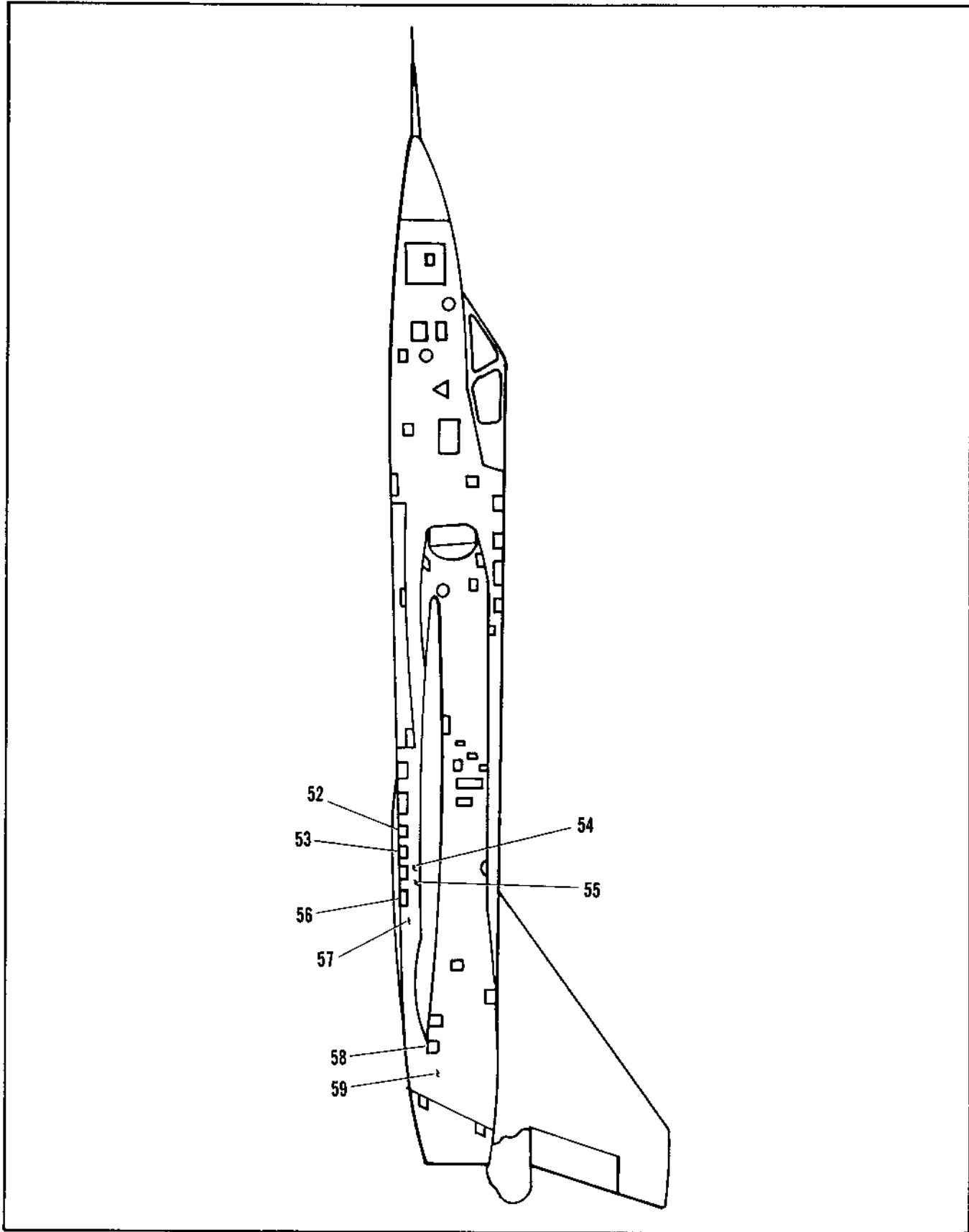

Figure 2.21-2. Fuselage External Markings (Sheet 6 of 11)

FIGURE AND INDEX NUMBER	PART NUMBER	DESCRIPTION	UNITS PER ASSY.	USABLE ON CODE	
				FROM	TO
		1 2 3 4 5 6			
2.21-2- 52	BT-110	*47 DECAL, RED LETTERS ON WHITE BACKGROUND EMERGENCY FIRE DOOR	1		
	BT-110-1	*47 DECAL, RED LETTERS ON WHITE BACKGROUND PUSH TO INSERT FIRE NOZZLE	1		
- 53	BT-111	*48 DECAL, BLACK LETTERS ON GREY BACKGROUND DOOR 303	1		
- 54	BT-123	*48 DECAL, BLACK LETTERS ON WHITE BACKGROUND	2		
- 55	BT-142-S	*49 DECAL, RED LETTERS ON WHITE BACKGROUND WARNING DURING STARTS STAND FWD OF MAIN LANDING GEAR AND CLEAR OF WING LEADING EDGE	2		
- 56	BT-131	*50 DECAL, BLACK LETTERS ON GREY BACKGROUND DOOR 321 (LH), 322 (RH)	2		
- 57	MS276-06-1	*51 DECAL, BLACK LETTERS ON YELLOW BACKGROUND GROUND HERE-MASSE ICT	3		
- 58	NO NUMBER	*51 STENCIL, BLACK LETTERS DOOR 2001	1		
- 59	BT-133	*52 DECAL, BLACK LETTERS ON GREY BACKGROUND BATTERY LOCATION NOSE WHEEL WELL PH SIDE	1		
		*47 PAGE 4.010 CONVAIR STENCILING AND MARKING REPORT NO. 8.00028			
		*48 PAGE 4.011 CONVAIR STENCILING AND MARKING REPORT NO. 8.00028			
		*49 PAGE 4.027 CONVAIR STENCILING AND MARKING REPORT NO. 8.00028			
		*50 PAGE 5.007 CONVAIR STENCILING AND MARKING REPORT NO. 8.00028			
		*61 PAGE 3.360 CONVAIR STENCILING AND MARKING REPORT NO. 8.00028			
		*52 PAGE 5.016 CONVAIR STENCILING AND MARKING REPORT NO. 8.00028			

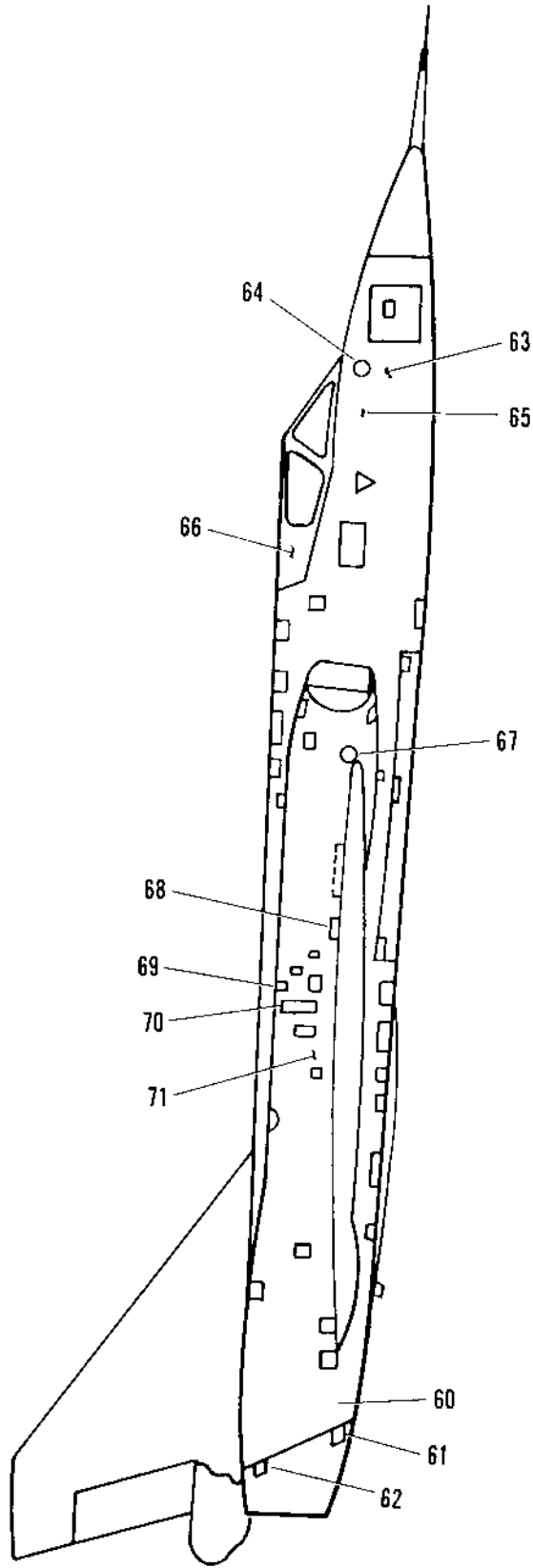

Figure 2.21-2. Fuselage External Markings (Sheet 7 of 11)

FIGURE AND INDEX NUMBER	PART NUMBER	DESCRIPTION	UNITS PER ASSY.	USABLE ON CODE	
				FROM	TO
2.21-2- 60	NO NUMBER	STENCIL, RED LETTERS WARNING	2		
- 61	BT-130 *53	KEEP CLEAR DECAL, BLACK LETTERS ON GREY BACKGROUND DOOR 335(LH), 336(RH)	2		
	BT-134 *53	DECAL, BLACK LETTERS ON GREY BACKGROUND DOOR 335 (LH), 336 (RH)	2		
- 62	BT-180 *54	DECAL, BLACK LETTERS ON GREY BACKGROUND DOOR 33 (LH), 334 (RH)	2		
- 63	NO NUMBER	STENCIL, BLACK LETTERS NITROGEN SERVICE--DATE-- TECHNICIAN			
- 64	BT-54 *55	DECAL, WHITE LETTERS ON DULL BLACK BACK- GROUND CANOPY LATCH MECH. DOOR 227	1		
- 65	BT-71 *56	DECAL, RED LETTERS ON WHITE BACKGROUND CANOPY UNLOCK OPPOSITE SIDE	1		
- 66	BT-181 *57	DECAL, BLACK LETTERS ON GREY BACKGROUND DOOR 229	1		
- 67	BT-96 *58	DECAL, YELLOW LETTERS ON BLACK ON BLACK BACKGROUND RESCUE EMERGENCY ENTRANCE CONTROL ON OTHER SIDE	1		
- 68	BT-164 *59	DECAL, RED LETTERS ON WHITE BACKGROUND WARNING DOOR MUST BE INSTALLED WHEN TOWING OR TAYING DOOR 736	1		
- 69	BT-210 *60	DECAL, BLACK LETTERS ON GREY BACKGROUND DOOR 273	1		
- 70	BT-184 *61	DECAL, BLACK LETTERS ON GREY BACKGROUND DOOR 275	1		
- 71	BT-175 *62	DECAL, BLACK LETTERS ON GREY BACKGROUND AMBIENT PRESSURE ENGINE & ACCESSORY COM- PARTMENT PRESSURE CONTROL EMERGENCY SENSOR	1		
		*53 PAGE 5.028 CONVAIR STENCILING AND MARKING REPORT NO. 8.00028			
		*54 PAGE 5.027 CONVAIR STENCILING AND MARKING REPOOT NO. 8.00028			
		*55 PAGE 2.028 CONVAIR STENCILING AND MARKING REPORT NO. 8.00028			
		*56 PAGE 2.110 CONVAIR STENCILING AND MARKING REPORT NO. 8.00028			
		*57 PAGE 2.057 CONVAIR STENCILING AND MARKING REPORT NO. 8.00028			
		*58 PAGE 3.127 CONVAIR STENCILING AND MARKING REPORT NO. 8.00028			
		*59 PAGE 3.271 CONVAIR STENCILING AND MARKING REPORT NO. 8.00028			
		*60 PAGE 3.037 CONVAIR STENCILING AND MARKING REPORT NO. 8.00028			
		*61 PAGE 3.043 CONVAIR STENCILING AND MARKING REPORT NO. 8.00028			
		*62 4.074 CONVAIR STENCILING AND MARKING REPORT NO. 8.00028			

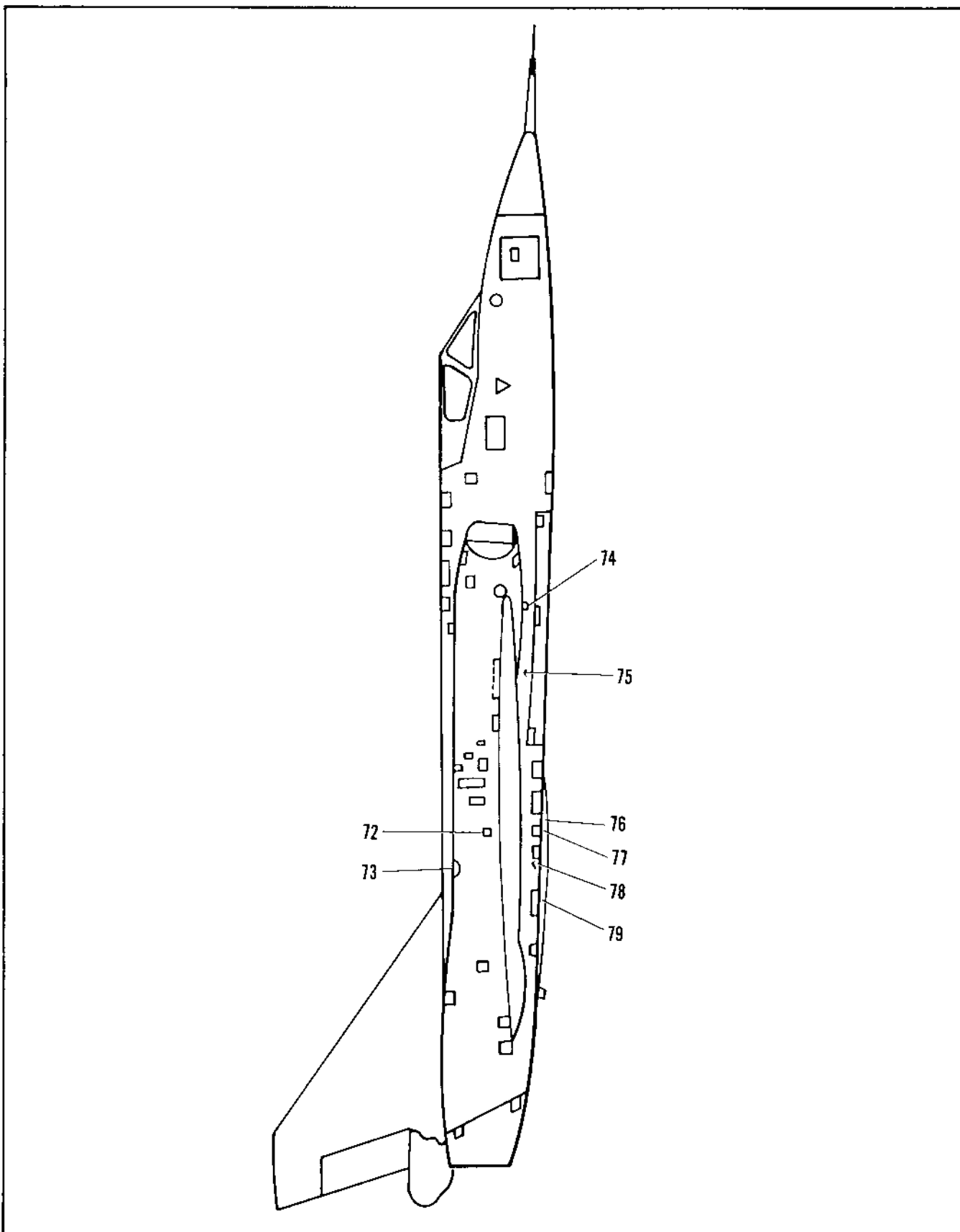

Figure 2.21-2. Fuselage External Markings (Sheet 8 of 11)

FIGURE AND INDEX NUMBER	PART NUMBER	DESCRIPTION	UNITS PER ASSY.	USABLE ON CODE	
				FROM	TO
		1 2 3 4 5 6			
2.21-2- 72	NO NUMBER	STENCIL, WHITE LETTERS ON BLACK BACKGROUND TANK CAPACITY 9.5 U.S. QUARTS, CONSTANT SPEED ACCESSORY DRIVE OIL, SPEC MIL-I-760A. (REFER TO DWG 8-98917 AND 8-51.13)	1		
- 73	BT-173	*63 DECAL, BLACK LETTERS ON GREY BACKGROUND	1		
- 74	8043914-01	*63 DECAL, BLACK LETTERS ON GREY BACKGROUND FUEL FILLER CAPACITY 2230 U.S. GALLONS USE MIL-F-5624B GRADE JP-9, MANUAL REFUEL SELECTOR VALVE LOCATION FWD INRD BAY RH WHEEL WELL, MANUAL REFUEL SELECTOR POSITIONS, 1. INTERNAL CAPACITY OF 1914 U.S. GALLONS VALVE IN CLOSED POSITION. 2. INT. AND EXT. CAPACITY OF 2230 U.S. GALLONS, VALVE IN OPEN POSITION, NOTE-VALVE MUST BE LOCKWIRED IN SELECTED REFUEL POSITION. REFER TO OPERATIONAL HANDBOOK FOR DETAILED INSTRUCTIONS. NOTE- FUEL QUANTITY CHANGES AS RESULT OF T.O. 1F-106- 1042	1		
	6-00509-15	DECAL, BLACK LETTERS ON GREY BACKGROUND REFUEL EMBLEM-STAR	1		
	BT-89	*66 DECAL, BLACK LETTERS ON GREY BACKGROUND FUEL FILLER DRAIN	1		
- 75	NO NUMBER	*66 STENCIL, BLACK LETTERS AIR REFUELING DRAIN	1		
- 76	BT-124	*67 DECAL, BLACK LETTERS ON GREY BACKGROUND ACCESS DRIVE VENT	1		
- 77	BT-127	*68 DECAL, BLACK LETTERS ON GREY BACKGROUND GENERATOR DRAIN	1		
- 78	BT-121	*69 DECAL, BLACK LETTERS ON GREY BACKGROUND ENGINE OIL BREATHER	1		
- 79	NO NUMBER	*69 STENCIL, RED LETTERS/BLACK LETTERS CAUTION DO NOT PERMIT DOOR TO SWING OPEN RAPIDLY- HYD EQUIPMENT MOUNTED INSIDE.	1		
		*63 PAGE 4.007 CONVAIR STENCILING AND MARKING REPORT NO. 8.00028			
		*64 PAGE 9.015 CONVAIR STENCILING AND MARKING REPORT NO. 8.00028			
		*65 PAGE 3.351 CONVAIR STENCILING AND MARKING REPORT NO. 8.00028			
		*66 PAGE 3.105 CONVAIR STENCILING AND MARKING REPORT NO. 8.00028			
		*67 PAGE 4.038 CONVAIR STENCILING AND MARKING REPORT NO. 8.00028			
		*68 PAGE 4.075 CONVAIR STENCILING AND MARKING REPORT NO. 8.00028			
		*69 PAGE 4.039 CONVAIR STENCILING AND MARKING REPORT NO. 8.00028			

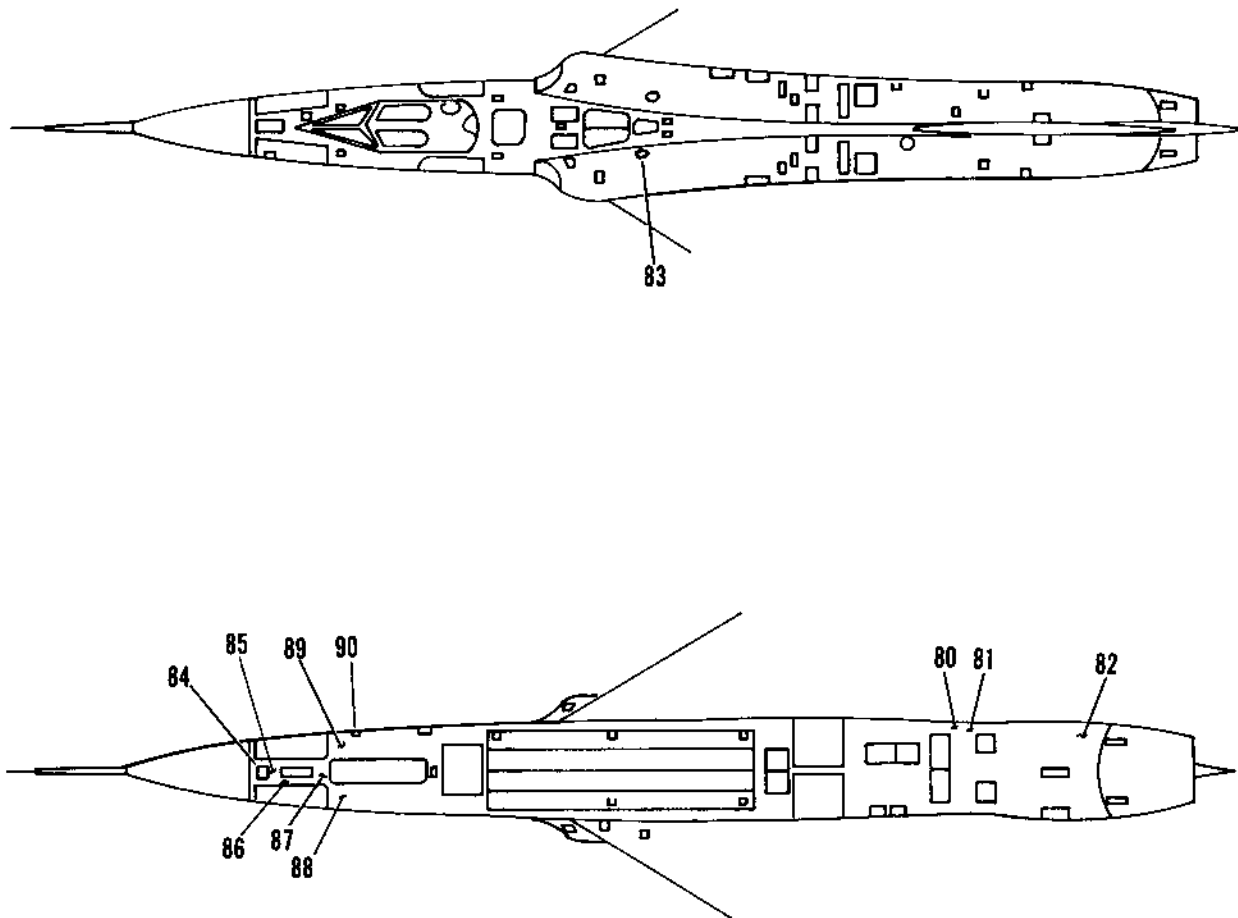

Figure 2.21-2. Fuselage External Markings (Sheet 9 of 11)

FIGURE AND INDEX NUMBER	PART NUMBER	DESCRIPTION	UNITS PER ASSY.	USABLE ON CODE	
				FROM	TO
		1 2 3 4 5 6			
2.21-2	BT-126	*70 BLACK LETTERS ON GREY BACKGROUND HYD PUMP SEAL DRAIN	1		
- 80	BT-128	*71 DECAL, BLACK LETTERS ON GREY BACKGROUND ENGINE FUEL SUPPLY LOW POINT DRAIN VALVE. PUSH TO DRAIN	1		
- 81	BT-120	*72 DECAL, BLACK LETTERS ON GREY BACKGROUND A/B MANIFOLD DRAIN	1		
- 82	BT-147	DECAL, BLACK LETTERS ON GREY BACKGROUND EMERGENCY SPEED BRAKE DRAIN	1		
- 83	BT-206	*73 DECAL, BLACK LETTERS ON GREY BACKGROUND ATTACH FWD HOIST FITTING	2		
	BT-205	*73 DECAL, BLACK LETTERS ON GREY BACKGROUND LIFT	2		
- 84	BT-54	*74 DECAL, BLACK LETTERS ON GREY BACKGROUND DOOR 215	1		
- 85	BT-56	*75 DECAL, BLACK LETTERS ON GREY BACKGROUND DRAIN	1		
- 86	NO NUMBER	STENCIL, BLACK LETTERS I.R. SEEKER COMPT. DRAIN	1		
- 87	BT-57	*76 DECAL, BLACK LETTERS ON GREY BACKGROUND ATTACH JACK PAD HERE MOOR	1		
- 88	59SAA251	*77 DECAL, RED LETTERS ON WHITE BACKGROUND CAUTION-LIQUID OXYGEN VENT	1		
- 89	BT-68	*78 DECAL, RED/BLACK LETTERS ON GREY BACKGROUND PLUMB LINE - ATTACH POINT	2		
- 90	BT-146	*79 DECAL, RED LETTERS ON WHITE BACKGROUND VENT-EMERGENCY LANDING GEAR-EXTEND	1		
		*70 PAGE 4.062 CONVAIR STENCILING AND MARKING REPORT NO. 8.00028			
		*71 PAGE 4.076 CONVAIR STENCILING AND MARKING REPORT NO. 8.00028			
		*72 PAGE 4.028 CONVAIR STENCILING AND MARKING REPORT NO. 8.00028			
		*73 PAGE 3.127 AND 9.35L CONVAIR STENCILING AND MARKING REPORT NO. 8.00028			
		*74 PAGE 1.017 CONVAIR STENCILING AND MARKING REPORT NO. 8.00028			
		*75 PAGE 1.020 CONVAIR STENCILING AND MARKING REPORT NO. 8.00028			
		*76 PAGE 1.028 CONVAIR STENCILING AND MARKING REPORT NO. 8.00028			
		*77 PAGE 8.064 CONVAIR STENCILING AND MARKING REPORT NO. 8.00028			
		*78 PAGE 2.079 CONVAIR STENCILING AND MARKING REPORT NO. 8.00028			
		*79 PAGE 8.063 CONVAIR STENCILING AND MARKING REPORT NO. 8.00028			

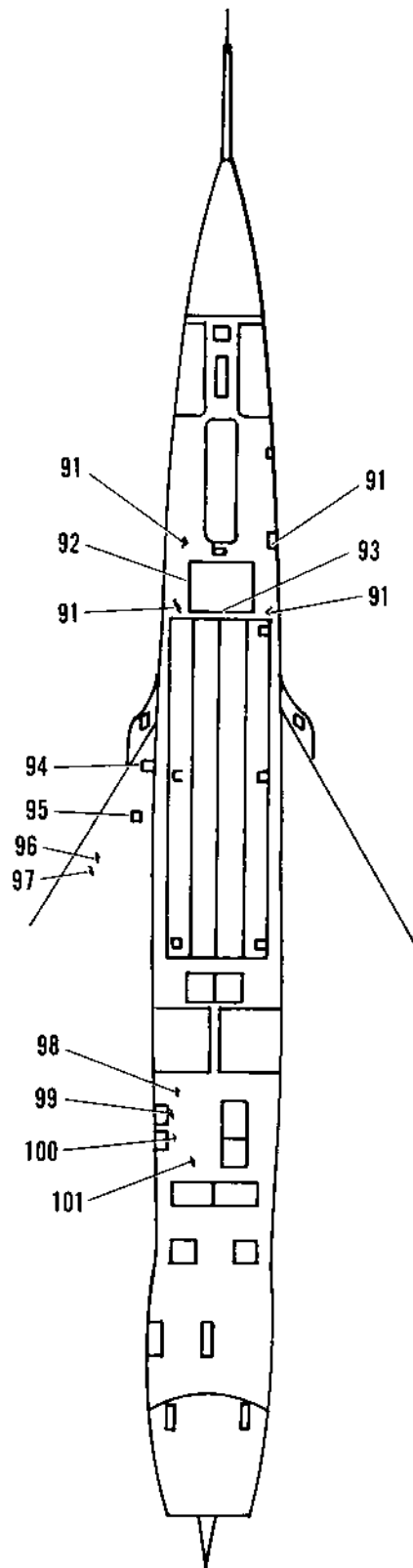

Figure 2.21-2. Fuselage External Markings (Sheet 10 of 11)

FIGURE AND INDEX NUMBER	PART NUMBER	DESCRIPTION	UNITS PER ASSY.	USABLE ON CODE	
				FROM	TO
		1 2 3 4 5 6			
2.21-2- 91	BT-81	*81 DECAL, BLACK LETTERS ON GREY BACKGROUND HYD. TURB. SHROUD DRAIN	4		
- 92	BT-72	*81 DECAL, RED LETTERS ON WHITE BACKGROUND CAUTION USE EXTREME CARE WHEN OPENING ACCESS DOOR HEAVY ELECT. EQUIP. MOUNTED ON DOOR	1		
- 93	BT-144	*82 DECAL, BLACK LETTERS ON GREY BACKGROUND FUME BARRIER VENT	1		
- 94	BT-98	*83 DECAL, BLACK LETTERS ON GREY BACKGROUND DOOR 755	1		
- 95	BT-98	*84 DECAL, BLACK LETTERS ON GREY BACKGROUND DOOR 753	1		
- 96	BT-105	*85 DECAL, BLACK LETTERS ON GREY BACKGROUND SEQUENCE PRESS LINE DRAIN, PUSH TO DRAIN	1		
- 97	BT-105	*85 DECAL, BLACK LETTERS ON GREY BACKGROUND REFUEL PRESS LINE DRAIN, PUSH TO DRAIN	1		
- 98	NO NUMBER	*86 STENCIL, BLACK LETTERS EXH. NOX. CONT. SEAL DRAIN	1		
- 99	BT-112	*87 DECAL, BLACK LETTERS ON GREY BACKGROUND OIL SCUPPER DRAIN	1		
-100	BT-113	*88 DECAL, BLACK LETTERS ON GREY BACKGROUND C.O. PRESS. TRANSFER LINE LOW POINT DRAIN PUSH TO DRAIN	1		
-101	NO NUMBER	*89 STENCIL, BLACK LETTERS GEAR BOX AND ACCESSORY DRIVE SEAL DRAIN	1		
		*80 PAGE 2.315 AND 8.244 CONVAIR STENCILING AND MARKING REPORT NO. 8.7002F			
		*81 PAGE 2.128 CONVAIR STENCILING AND MARKING REPORT NO. 8.0002F			
		*82 PAGE 2.323 CONVAIR STENCILING AND MARKING REPORT NO. 8.0002F			
		*83 PAGE 3.276 CONVAIR STENCILING AND MARKING REPORT NO. 8.0002F			
		*84 PAGE 3.275 CONVAIR STENCILING AND MARKING REPORT NO. 8.0002F			
		*85 PAGE 3.356 CONVAIR STENCILING AND MARKING REPORT NO. 8.0002F			
		*86 PAGE 4.095 CONVAIR STENCILING AND MARKING REPORT NO. 8.0002F			
		*87 PAGE 4.023 CONVAIR STENCILING AND MARKING REPORT NO. 8.0002F			
		*88 PAGE 4.023 AND 4.086 CONVAIR STENCILING AND MARKING REPORT NO. 8.7002F			
		*89 PAGE 4.099 CONVAIR STENCILING AND MARKING REPORT NO. 8.0002F			

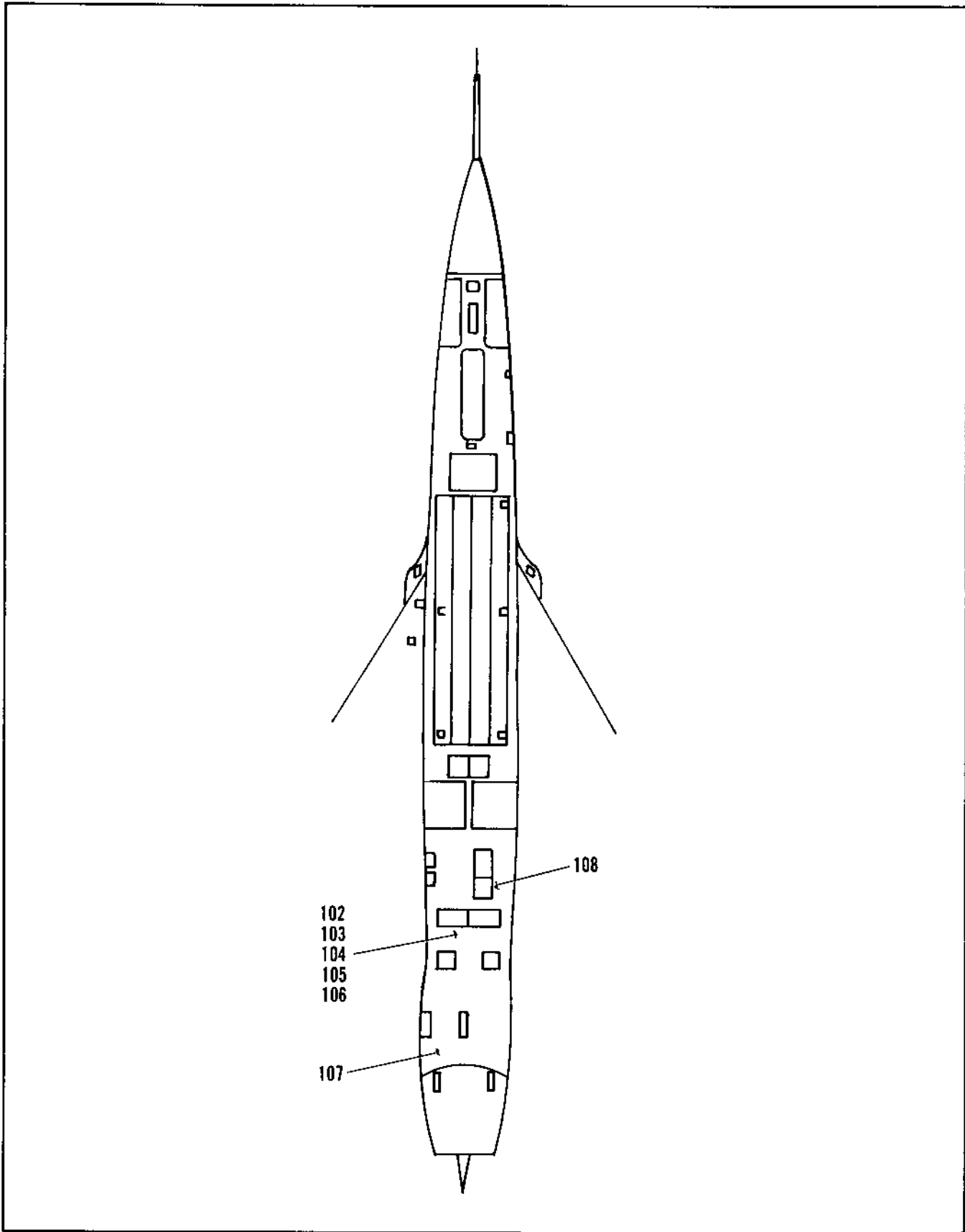

Figure 2.21-2. Fuselage External Markings (Sheet 11 of 11)

FIGURE AND INDEX NUMBER	PART NUMBER	DESCRIPTION	UNITS PER ASSY.	USABLE ON CODE	
				FROM	TO
		1 2 3 4 5 6			
2.21-2-102	BT-119 *90	DECAL, BLACK LETTERS ON GREY BACKGROUND EQUALIZER FUEL LINE LOW POINT DRAIN PUSH TO DRAIN	1		
-103	BT-117 *91	DECAL, BLACK LETTERS ON GREY BACKGROUND FUEL CONTROL DRAIN	1		
-104	BT-116 *91	DECAL, BLACK LETTERS ON GREY BACKGROUND FWD SHROUD DRAIN	1		
-105	BT-115 *91	DECAL, BLACK LETTERS ON GREY BACKGROUND COMBUSTION MANIFOLD DRAIN	1		
-106	BT-114 *92	DECAL, BLACK LETTERS ON GREY BACKGROUND C.G. AIRFILTER LINE LOW POINT DRAIN PUSH TO DRAIN	2		
-107	BT-132 *93	DECAL, BLACK LETTERS ON GREY BACKGROUND AE DUCT DRAIN AFT SHROUD DRAIN	1		
-108	NO NUMBER *49	RED STRIPE PAINTED AROUND BOTTOM OF FUSELAGE AND RED RING AROUND STARTER EXHAUST OUTLET			
		*90 PAGE 4.028 CONVAIR STENCILING AND MARKING REPORT NO. 8.00028			
		*91 PAGE 4.039 AND 4.024 CONVAIR STENCILING AND MARKING REPORT NO. 8.00028			
		*92 PAGE 4.024 CONVAIR STENCILING AND MARKING REPORT NO. 8.00028			
		*93 PAGE 5.011 CONVAIR STENCILING AND MARKING REPORT NO. 8.00028			

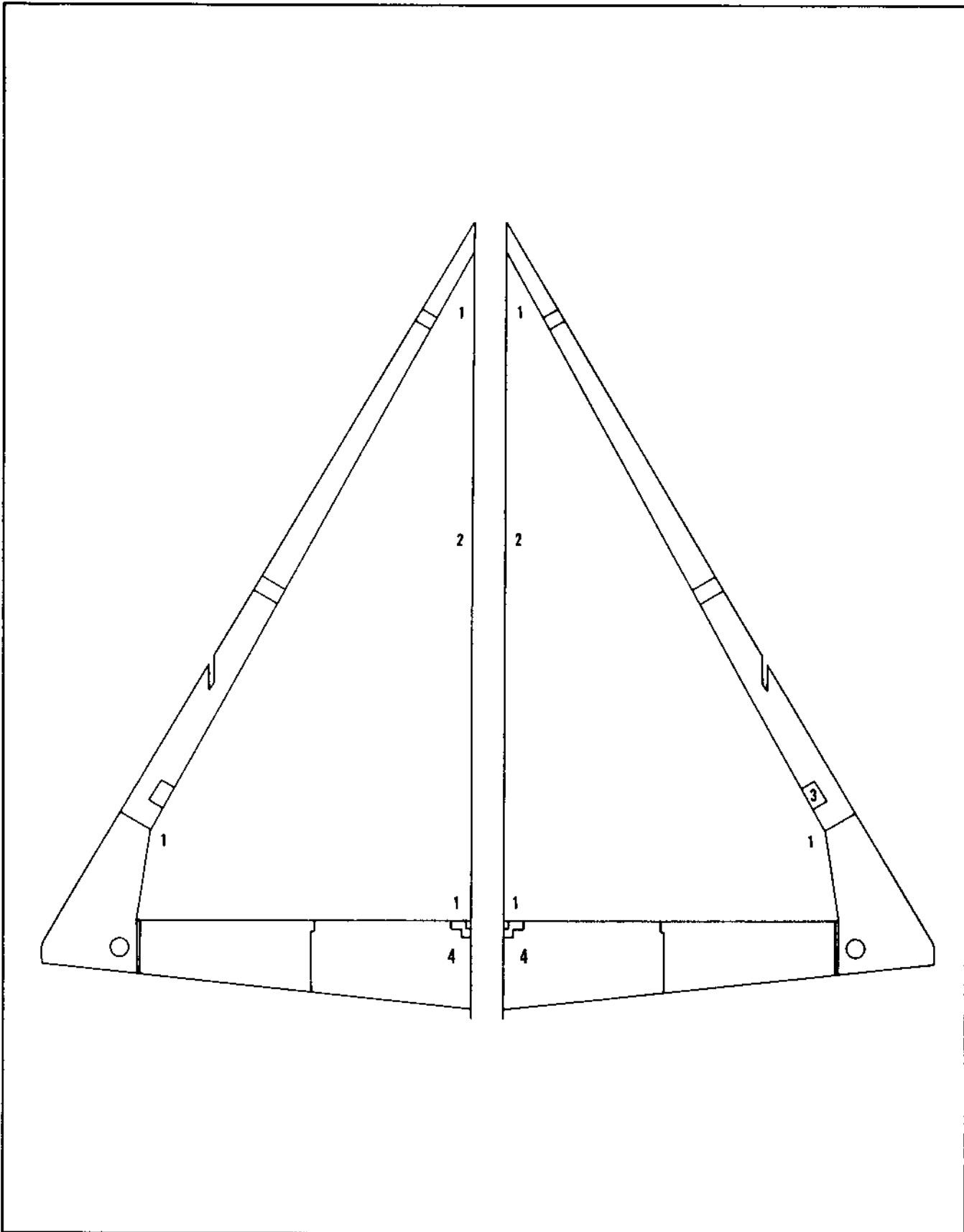

Figure 2.21-3. Wing, Upper Surface Markings

FIGURE AND INDEX NUMBER	PART NUMBER	DESCRIPTION	UNITS PER ASSY.	USABLE ON CODE	
				FROM	TO
		1 2 3 4 5 6			
2.21-3-1	BT-202	*1 DECAL, BLACK LETTERS ON GREY BACKGROUND LIFT	6		
- 2	BT-207	*2 WING ASSY ONLY DECAL, BLACK LETTERS ON GREY BACKGROUND ATTACH AFT HOIST FITTING	2		
	BT-205	*2 DECAL, BLACK LETTERS ON GREY BACKGROUND LIFT	2		
- 3	BT-201	*3 DECAL, BLACK LETTERS ON GREY BACKGROUND DOOR 760	1		
	71-0023	*4 DECAL, SCREW IDENTIFICATION	1		
- 4	BT-203	*4 DECAL, BLACK LETTERS ON GREY BACKGROUND DOOR 63 (LH) 64 (RH)	2		
	71-0022	*4 DECAL, SCREW IDENTIFICATION	2		
		*1 PAGE 3.113; 3.280 AND 5.013 CONVAIR MARKING AND STENCILING REPORT NO. P.00028			
		*2 PAGE 6.168 CONVAIR MARKING AND STENCILING REPORT NO. 8.00028			
		*3 PAGE 7.013 CONVAIR MARKING AND STENCILING REPORT NO. P.00028			
		*4 PAGE 4.048 CONVAIR MARKING AND STENCILING REPORT NO. P.00028			

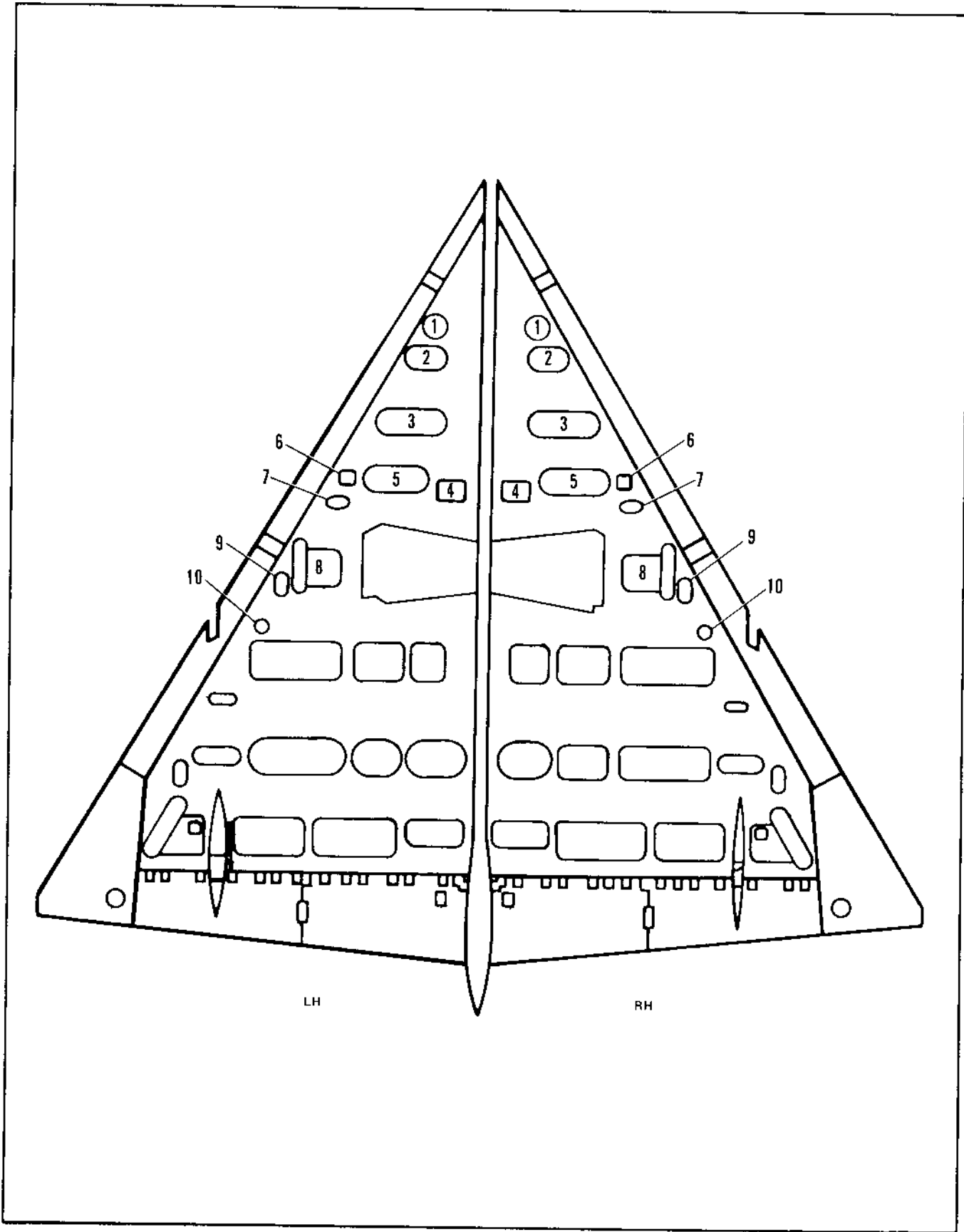

Figure 2.21-4. Wing, Lower Surface Markings (Sheet 1 of 5)

FIGURE AND INDEX NUMBER	PART NUMBER		DESCRIPTION	UNITS PER ASSY.	USABLE ON CODE	
					FROM	TO
		1 2 3 4 5 6				
2.21-4- 1	BT-227	*1	DECAL, BLACK LETTERS ON GREY BACKGROUND DOOR 1 (RH), 2 (LH)	2		
	71-0001		DECAL, SCREW IDENTIFICATION	2		
- 2	BT-228	*2	DECAL, BLACK LETTERS ON GREY BACKGROUND DOOR 3 (LH), 4 (RH)	2		
	71-0002		DECAL, SCREW IDENTIFICATION	2		
- 3	BT-229	*3	DECAL, BLACK LETTERS ON GREY BACKGROUND DOOR 5 (LH), 6 (RH)	2		
	71-0004		DECAL, SCREW IDENTIFICATION	2		
- 4	BT-229	*4	DECAL, BLACK LETTERS ON GREY BACKGROUND DOOR 7 (LH), 8 (RH)	2		
	71-0001		DECAL, SCREW IDENTIFICATION	2		
- 5	BT-259	*5	DECAL, BLACK LETTERS ON GREY BACKGROUND DOOR 9 (LH), 10 (RH)	2		
	71-0004		DECAL, SCREW IDENTIFICATION	2		
- 6	BT-230	*6	DECAL, BLACK LETTERS ON GREY BACKGROUND DOOR 11 (LH), 12 (RH)	2		
	71-0003		DECAL, SCREW IDENTIFICATION	2		
- 7	BT-231	*7	DECAL, BLACK LETTERS ON GREY BACKGROUND DOOR 13 (LH), 14 (RH)	2		
	71-0003		DECAL, SCREW IDENTIFICATION	2		
- 8	BT-242	*8	DECAL, BLACK LETTERS ON GREY BACKGROUND DOOR 19 (LH), 20 (RH)	2		
	71-0005		DECAL, SCREW IDENTIFICATION	2		
- 9	BT-243	*9	DECAL, BLACK LETTERS ON GREY BACKGROUND DOOR 53 (LH), 54 (RH)	2		
	71-0006		DECAL, SCREW IDENTIFICATION	2		
- 10	BT-234	*10	DECAL, BLACK LETTERS ON GREY BACKGROUND DOOR 23 (LH), 24 (RH)	2		
			*1 PAGE 6.001 AND 6.002 CONVAIR MARKING AND STENCILING REPORT NO. 8.00028			
			*2 PAGE 6.003 AND 6.004 CONVAIR MARKING AND STENCILING REPORT NO. 8.00028			
			*3 PAGE 6.179 AND 6.005 CONVAIR MARKING AND STENCILING REPORT NO. 8.00028			
			*4 PAGE 6.008 AND 6.007 CONVAIR MARKING AND STENCILING REPORT NO. 8.00028			
			*5 PAGE 6.171 AND 6.010 CONVAIR MARKING AND STENCILING REPORT NO. 8.00028			
			*6 PAGE 6.011 CONVAIR MARKING AND STENCILING REPORT NO. 8.00028			
			*7 PAGE 6.012 CONVAIR MARKING AND STENCILING REPORT NO. 8.00028			
			*8 PAGE 6.042 AND 6.043 CONVAIR MARKING AND STENCILING REPORT NO. 8.00028			
			*9 PAGE 6.045 CONVAIR MARKING AND STENCILING REPORT NO. 8.00028			
			*10 PAGE 6.020 AND 6.019 CONVAIR MARKING AND STENCILING REPORT NO. 8.00028			

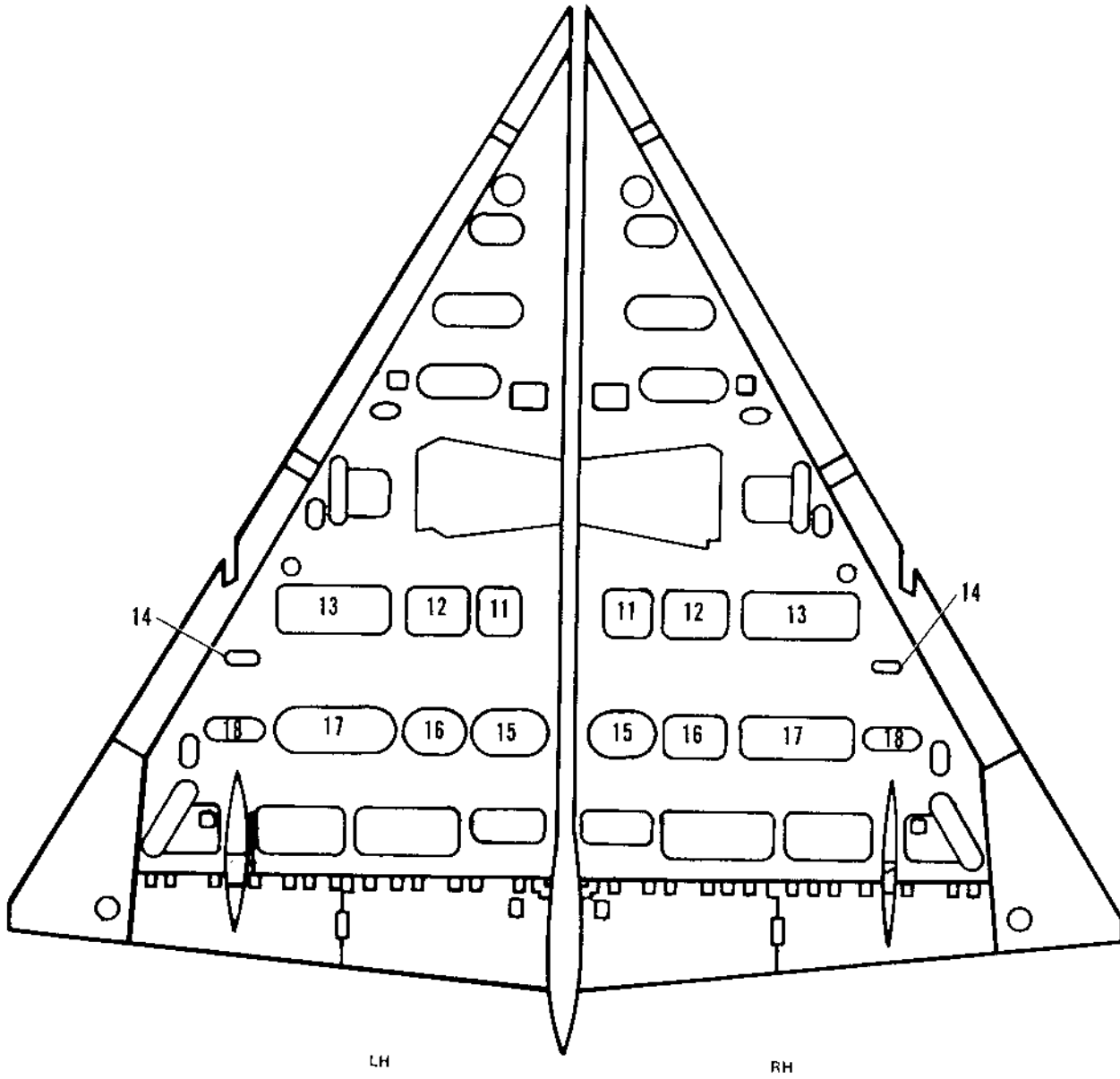

Figure 2.21-4. Wing, Lower Surface Markings (Sheet 2 of 5)

FIGURE AND INDEX NUMBER	PART NUMBER	DESCRIPTION	UNITS PER ASSY.	USABLE ON CODE	
				FROM	TO
		1 2 3 4 5 6			
2.21-4	71-0007	DECAL, SCREW IDENTIFICATION	2		
- 11	BT-232 *11	DECAL, BLACK LETTERS ON GREY BACKGROUND DOOR 17 (LH), 18 (RH)	2		
	71-0008	DECAL, SCREW IDENTIFICATION	2		
- 12	BT-260 *12	DECAL, BLACK LETTERS ON GREY BACKGROUND DOOR 17 (LH), 20 (RH)	2		
	71-0009	DECAL, SCREW IDENTIFICATION	2		
- 13	BT-233 *13	DECAL, BLACK LETTERS ON GREY BACKGROUND DOOR 21 (LH), 22 (RH)	2		
	71-0011	DECAL, SCREW IDENTIFICATION	2		
- 14	BT-238 *14	DECAL, BLACK LETTERS ON GREY BACKGROUND DOOR 25 (LH), 26 (RH)	2		
	71-0010	DECAL, SCREW IDENTIFICATION	2		
- 15	BT-236 *15	DECAL, BLACK LETTERS ON GREY BACKGROUND DOOR 27 (LH), 28 (RH)	2		
	71-0009	DECAL, SCREW IDENTIFICATION	2		
- 16	BT-261 *16	DECAL, BLACK LETTERS ON GREY BACKGROUND DOOR 29 (LH), 33 (RH)	2		
	BT-261-1	DECAL, BLACK LETTERS ON WHITE BACKGROUND DOOR 29 (LH), 30 (RH)	2		
	71-0009	DECAL, SCREW IDENTIFICATION	2		
- 17	BT-237 *17	DECAL, BLACK LETTERS ON WHITE BACKGROUND DOOR 31 (LH), 32 (RH)	2		
	BT-237-1	DECAL, BLACK LETTERS ON GREY BACKGROUND DOOR 31 (LH), 32 (RH)	2		
	71-0011	DECAL, SCREW IDENTIFICATION	2		
- 18	BT-238 *18	DECAL, BLACK LETTERS ON GREY BACKGROUND DOOR 33 (LH), 34 (RH)	2		
		*11 PAGE 6.014 AND 6.013 CONVAIR MARKING AND STENCILING REPORT NO. 8.00028			
		*12 PAGE 6.175 AND 6.015 CONVAIR MARKING AND STENCILING REPORT NO. 8.00028			
		*13 PAGE 6.018 AND 6.017 CONVAIR MARKING AND STENCILING REPORT NO. 8.00028			
		*14 PAGE 6.022 AND 6.021 CONVAIR MARKING AND STENCILING REPORT NO. 8.00028			
		*15 PAGE 6.024 AND 6.023 CONVAIR MARKING AND STENCILING REPORT NO. 8.00028			
		*16 PAGE 6.76 AND 6.025 CONVAIR MARKING AND STENCILING REPORT NO. 8.00028			
		*17 PAGE 6.028 AND 6.027 CONVAIR MARKING AND STENCILING REPORT NO. 8.00028			
		*18 PAGE 6.030 AND 6.029 CONVAIR MARKING AND STENCILING REPORT NO. 8.00028			

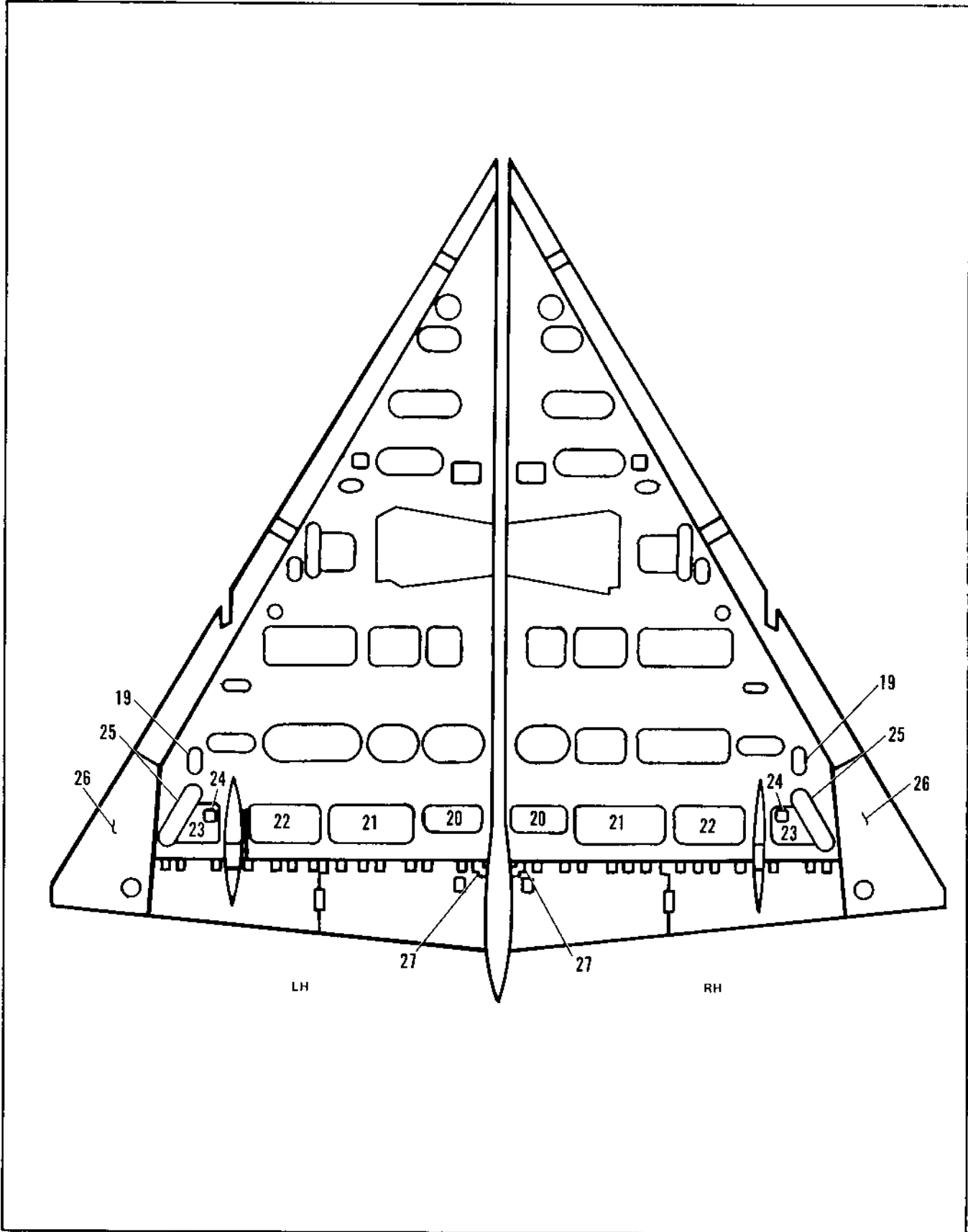

Figure 2.21-4. Wing, Lower Surface Markings (Sheet 3 of 5)

FIGURE AND INDEX NUMBER	PART NUMBER	DESCRIPTION	UNITS PER ASSY.	USABLE ON CODE	
				FROM	TO
		1 2 3 4 5 6			
2.21-4	71-0712	DECAL, SCREW IDENTIFICATION	2		
- 19	BT-238-1	*19 DECAL, BLACK LETTERS ON GREY BACKGROUND DOOR 35 (LH), 36 (RH)	2		
	71-0710	DECAL, SCREW IDENTIFICATION	2		
- 20	BT-232	*20 DECAL, BLACK LETTERS ON GREY BACKGROUND DOOR 37 (LH), 38 (RH)	2		
	71-0716	DECAL, SCREW IDENTIFICATION	2		
- 21	BT-234	*21 DECAL, BLACK LETTERS ON GREY BACKGROUND DOOR 39 (LH), 40 (RH)	2		
	71-0717	DECAL, SCREW IDENTIFICATION	2		
- 22	BT-243	*22 DECAL, BLACK LETTERS ON GREY BACKGROUND DOOR 41 (LH), 42 (RH)	2		
	70-0018	DECAL, SCREW IDENTIFICATION	2		
- 23	BT-240	*23 DECAL, BLACK LETTERS ON GREY BACKGROUND DOOR 45 (LH), 46 (RH)	2		
	71-0013	DECAL, SCREW IDENTIFICATION	2		
- 24	BT-239	*24 DECAL, BLACK LETTERS ON GREY BACKGROUND DOOR 43 (LH), 44 (RH)	2		
	71-0714	DECAL, SCREW IDENTIFICATION	2		
- 25	BT-241	*25 DECAL, BLACK LETTERS ON GREY BACKGROUND DOOR 47 (LH), 48 (RH)	2		
	71-0015	DECAL, SCREW IDENTIFICATION	2		
- 26	BT-198	*26 DECAL, RED LETTERS ON WHITE BACKGROUND CAUTION-DISCONNECT ELECTRICAL WIRING BEFORE REMOVING WING TIP	2		
	BT-245	*27 DECAL, BLACK LETTERS ON GREY BACKGROUND DOOR 61 (LH), 62 (RH)	2		
- 27	71-0019	DECAL, SCREW IDENTIFICATION	2		
		*19 PAGE 6.031 CONVAIR MARKING AND STENCILING REPORT NO. 8.00028			
		*20 PAGE 6.178 AND 6.032 CONVAIR MARKING AND STENCILING REPORT NO. 8.00028			
		*21 PAGE 6.179 AND 6.035 CONVAIR MARKING AND STENCILING REPORT NO. 8.00028			
		*22 PAGE 6.181 AND 6.037 CONVAIR MARKING AND STENCILING REPORT NO. 8.00028			
		*23 PAGE 6.038 AND 6.040 CONVAIR MARKING AND STENCILING REPORT NO. 8.00028			
		*24 PAGE 6.038 CONVAIR MARKING AND STENCILING REPORT NO. 8.00028			
		*25 PAGE 6.041 CONVAIR MARKING AND STENCILING REPORT NO. 8.00028			
		*26 PAGE 6.122 CONVAIR MARKING AND STENCILING REPORT NO. 8.00028			
		*27 PAGE 6.027 CONVAIR MARKING AND STENCILING REPORT NO. 8.00028			

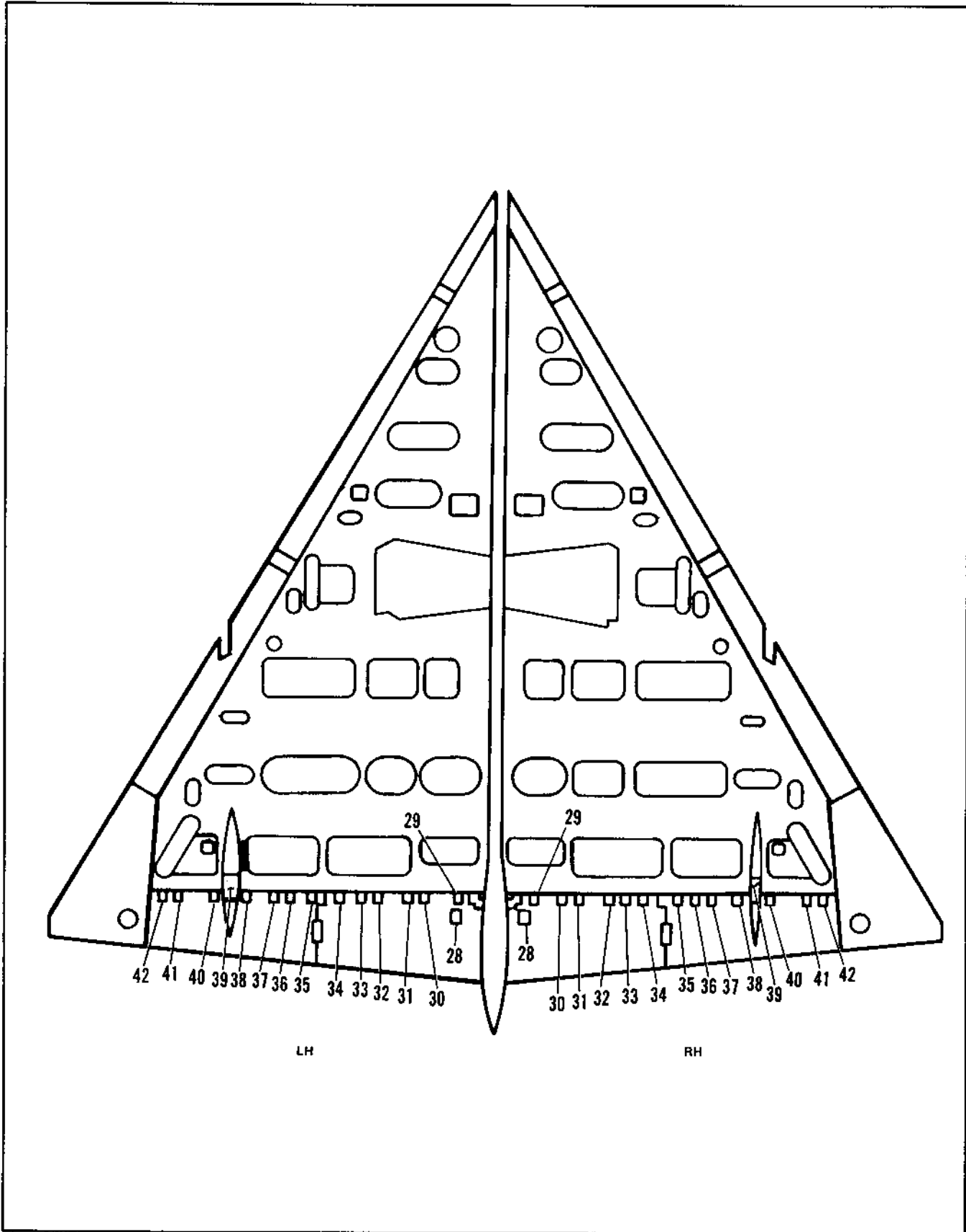

Figure 2.21-4. Wing, Lower Surface Markings (Sheet 4 of 5)

FIGURE AND INDEX NUMBER	PART NUMBER	DESCRIPTION	UNITS PER ASSY.	USABLE ON CODE	
				FROM	TO
		1 2 3 4 5 6			
2.21-4- 28	BT-245	*28 DECAL, BLACK LETTERS ON GREY BACKGROUND DOOR 91 (LH), 92 (RH)	2		
	71-0020	DECAL, SCREW IDENTIFICATION	2		
- 29	BT-245	*29 DECAL, BLACK LETTERS ON GREY BACKGROUND DOOR 65 (LH), 66 (RH)	2		
- 30	BT-245	*30 DECAL, BLACK LETTERS ON GREY BACKGROUND DOOR 67 (LH), 68 (RH)	2		
- 31	BT-245	*30 DECAL, BLACK LETTERS ON GREY BACKGROUND DOOR 69 (LH), 70 (RH)	2		
- 32	BT-245	*31 DECAL, BLACK LETTERS ON GREY BACKGROUND DOOR 71 (LH), 72 (RH)	2		
- 33	BT-245	*31 DECAL, BLACK LETTERS ON GREY BACKGROUND DOOR 73 (LH), 74 (RH)	2		
- 34	BT-245	*32 DECAL, BLACK LETTERS ON GREY BACKGROUND DOOR 75 (LH), 76 (RH)	2		
- 35	BT-245	*32 DECAL, BLACK LETTERS ON GREY BACKGROUND DOOR 77 (LH), 78 (RH)	2		
- 36	BT-245	*33 DECAL, BLACK LETTERS ON GREY BACKGROUND DOOR 79 (LH), 80 (RH)	2		
- 37	BT-245	*33 DECAL, BLACK LETTERS ON GREY BACKGROUND DOOR 81 (LH), 82 (RH)	2		
- 38	BT-245	*34 DECAL, BLACK LETTERS ON GREY BACKGROUND DOOR 83 (LH), 84 (RH)	2		
- 39	BT-244	*35 DECAL, BLACK LETTERS ON GREY BACKGROUND DOOR 55 (LH), 56 (RH)	2		
	71-0021	DECAL, SCREW IDENTIFICATION	2		
- 40	BT-245	*34 DECAL, BLACK LETTERS ON GREY BACKGROUND DOOR 85 (LH), 86 (RH)	2		
- 41	BT-245	*36 DECAL, BLACK LETTERS ON GREY BACKGROUND DOOR 87 (LH), 88 (RH)	2		
- 42	BT-245	*36 DECAL, BLACK LETTERS ON GREY BACKGROUND DOOR 89 (LH), 90 (RH)	2		
		*28 PAGE 6.056 CONVAIR MARKING AND STENCILING REPORT NO. 8.00028			
		*29 PAGE 6.049 CONVAIR MARKING AND STENCILING REPORT NO. 8.00028			
		*30 PAGE 6.050 CONVAIR MARKING AND STENCILING REPORT NO. 8.00028			
		*31 PAGE 6.051 CONVAIR MARKING AND STENCILING REPORT NO. 8.00028			
		*32 PAGE 6.052 CONVAIR MARKING AND STENCILING REPORT NO. 8.00028			
		*33 PAGE 6.053 CONVAIR MARKING AND STENCILING REPORT NO. 8.00028			
		*34 PAGE 6.054 CONVAIR MARKING AND STENCILING REPORT NO. 8.00028			
		*35 PAGE 6.046 CONVAIR MARKING AND STENCILING REPORT NO. 8.00028			
		*36 PAGE 6.055 CONVAIR MARKING AND STENCILING REPORT NO. 8.00028			

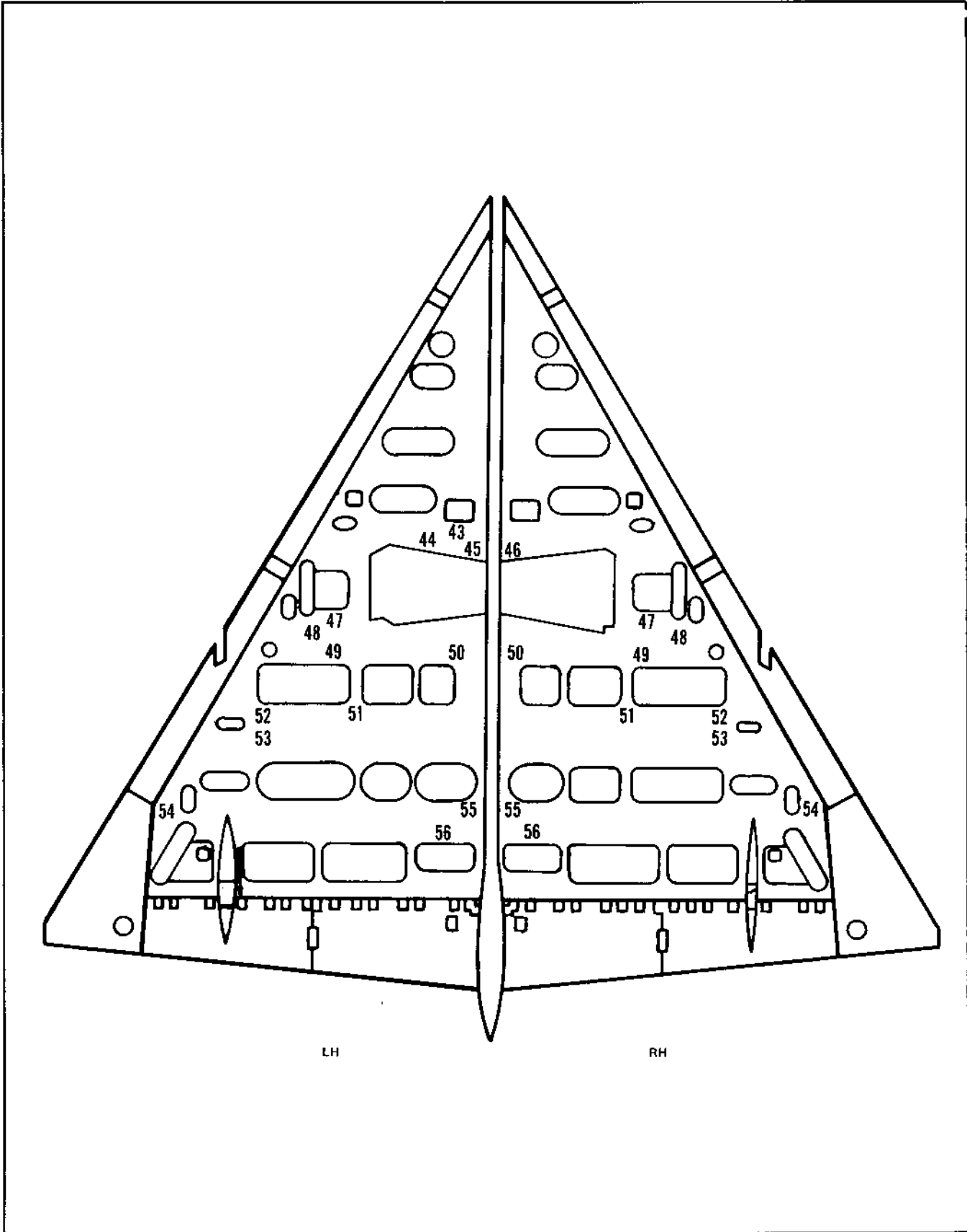

Figure 2.21-4. Wing, Lower Surface Markings (Sheet 5 of 5)

FIGURE AND INDEX NUMBER	PART NUMBER	DESCRIPTION	UNITS PER ASSY.	USABLE ON CODE	
				FROM	TO
		1 2 3 4 5 6			
2.21-4- 43	RT-251	*37 DECAL, BLACK LETTERS ON GREY BACKGROUND TANK 1 LOW POINT DRAIN - PUSH TO DRAIN	1		
- 44	RT-251	*37 DECAL, BLACK LETTERS ON GREY BACKGROUND TANK REGULATOR PRESSURE RELIEF VENT	1		
- 45	RT-257	*38 DECAL, BLACK LETTERS ON GREY BACKGROUND PNEUMATIC SYS PRESSURE GAGE LOCATED ABOVE	1		
- 46	NO NUMBER	*39 STENCIL, BLACK LETTERS FUEL TRANSFER LINE COUPLING DRAIN	1		
- 47	RT-253	*40 DECAL, BLACK LETTERS ON GREY BACKGROUND VENT VALVE PRESSURE DRAIN	2		
- 48	NO NUMBER	*40 STENCIL, BLACK LETTERS EXT. TANK RELIEF VALVE VENT	2		
- 49	RT-224	*41 DECAL, BLACK LETTERS ON GREY BACKGROUND ATTACH JACK TO PAD HERE	2		
- 50	RT-251	*42 DECAL, BLACK LETTERS ON GREY BACKGROUND TANK 3 LOW POINT DRAIN - PUSH TO DRAIN	2		
- 51	RT-252	*43 DECAL, BLACK LETTERS ON GREY BACKGROUND TANK 2 LOW POINT DRAIN - PUSH TO DRAIN	2		
- 52	RT-252	*43 DECAL, BLACK LETTERS ON GREY BACKGROUND SENSING PORT & FUEL SYSTEM	2		
- 53	RT-248	*44 DECAL, BLACK LETTERS ON GREY BACKGROUND FUEL SYSTEM VENT	2		
- 54	RT-225	*45 DECAL, BLACK LETTERS ON GREY BACKGROUND MOOR	2		
- 55	RT-254	*46 DECAL, BLACK LETTERS ON GREY BACKGROUND T TANK LOW POINT DRAIN - PUSH TO DRAIN	2		
- 56	RT-254	*46 DECAL, BLACK LETTERS ON GREY BACKGROUND C.O. TRANSFER LINE LOW POINT DRAIN - PUSH TO DRAIN	2		
		*37 PAGE 6.076 CONVAIR MARKING AND STENCILING REPORT NO. 8.00028			
		*38 PAGE 6.082 CONVAIR MARKING AND STENCILING REPORT NO. 8.00028			
		*39 PAGE 6.166 CONVAIR MARKING AND STENCILING REPORT NO. 8.00028			
		*40 PAGE 6.080 CONVAIR MARKING AND STENCILING REPORT NO. 8.00028			
		*41 PAGE 4.032 CONVAIR MARKING AND STENCILING REPORT NO. 8.00028			
		*42 PAGE 6.077 CONVAIR MARKING AND STENCILING REPORT NO. 8.00028			
		*43 PAGE 6.079 CONVAIR MARKING AND STENCILING REPORT NO. 8.00028			
		*44 PAGE 6.075 CONVAIR MARKING AND STENCILING REPORT NO. 8.00028			
		*45 PAGE 6.015 CONVAIR MARKING AND STENCILING REPORT NO. 8.00028			
		*46 PAGE 4.074 CONVAIR MARKING AND STENCILING REPORT NO. 8.00028			

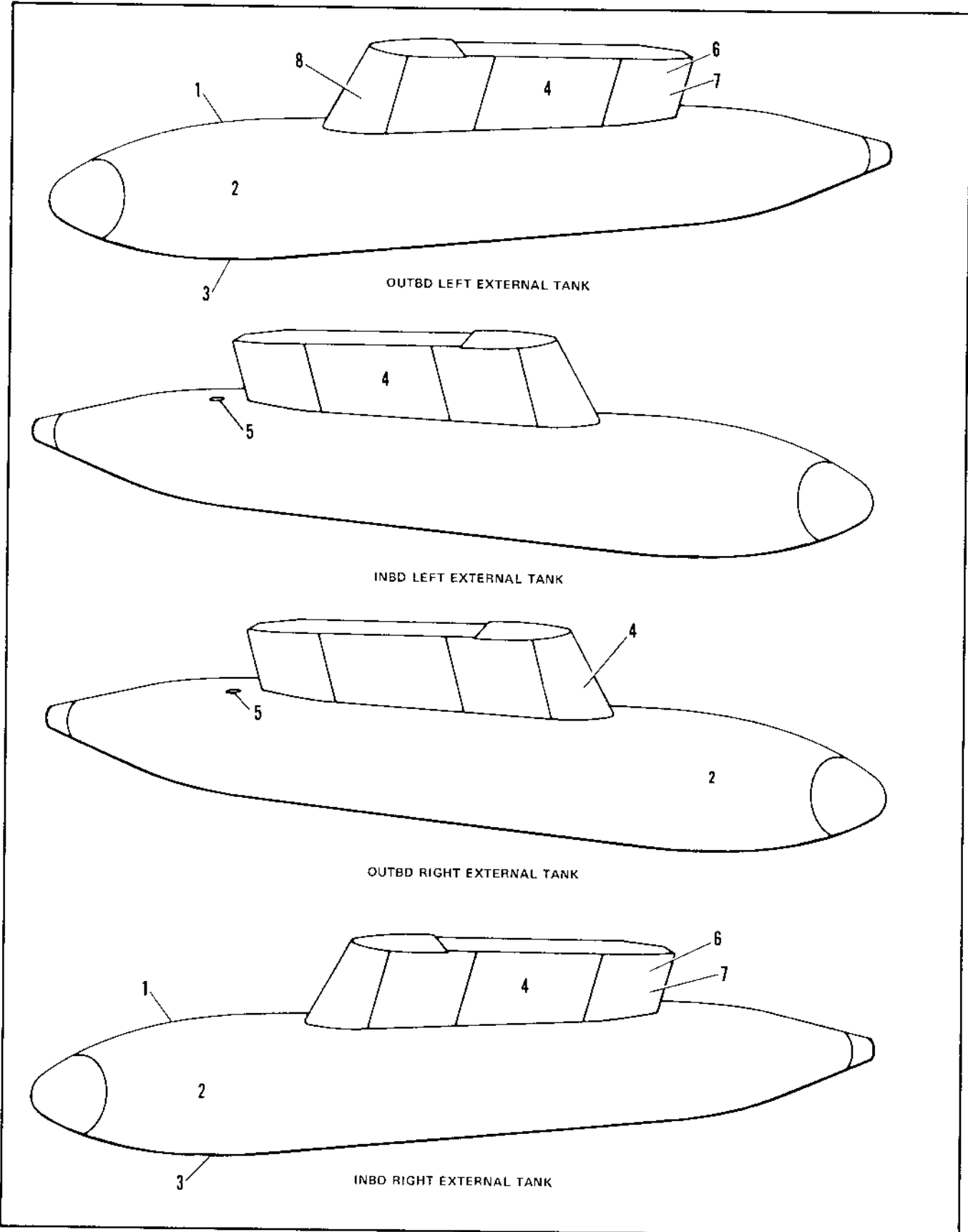
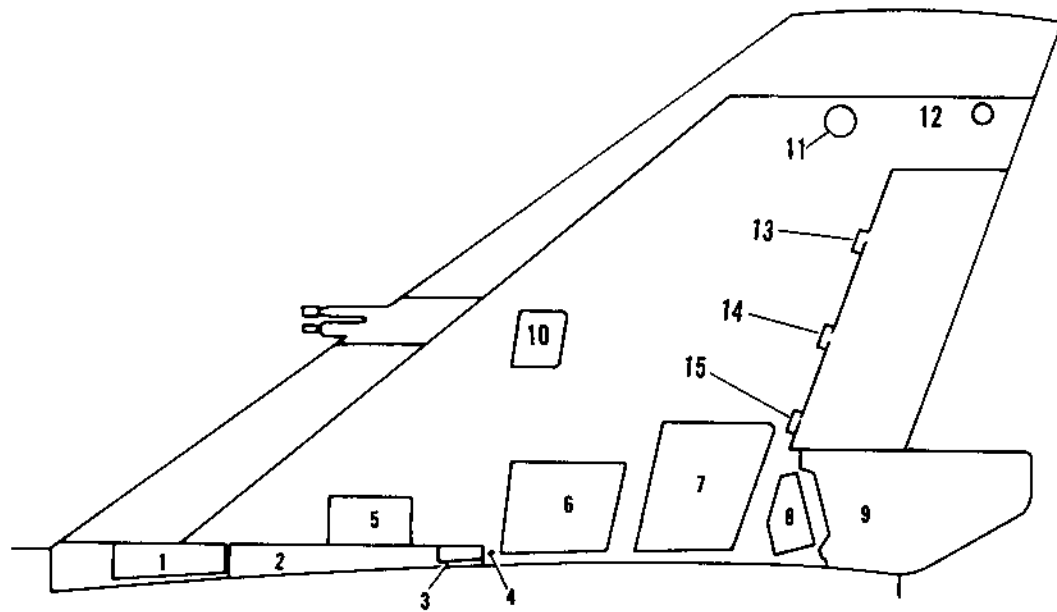
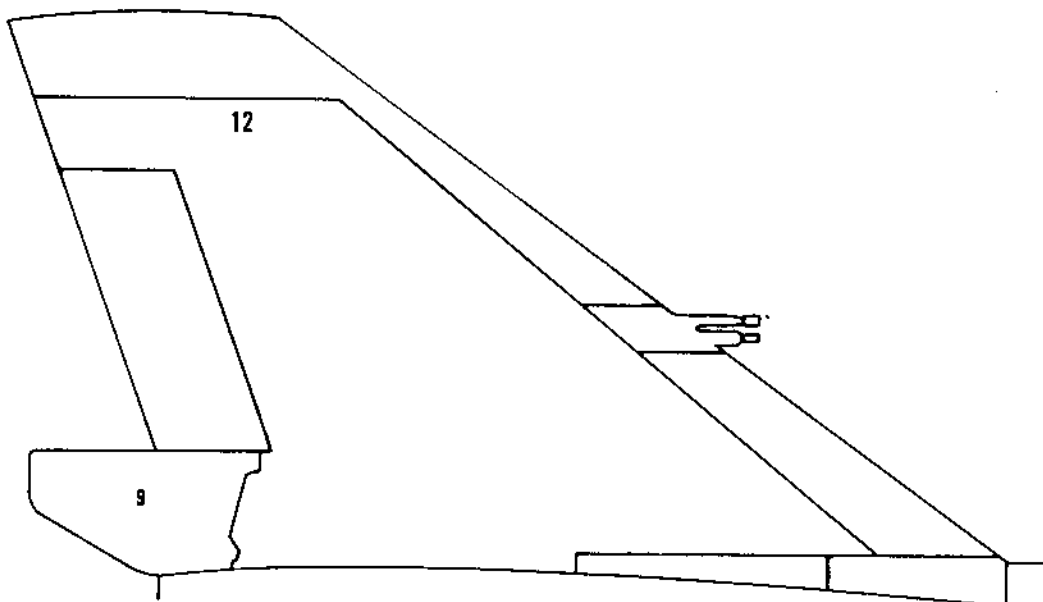

Figure 2.21-5. External Fuel Tank/Pylon Markings

FIGURE AND INDEX NUMBER	PART NUMBER	DESCRIPTION	UNITS PER ASSY.	USABLE ON CODE	
				FROM	TO
		1 2 3 4 5 6			
2.21-5- 1	H000000-33	DECAL, BLACK LETTERS ON GREY BACKGROUND NO STEP AF DRAWING 65J33310	2		
- 2	NO NUMBER	STENCIL, BLACK LETTERS AIRCRAFT SERIAL NUMBER T.O. 1-1-4	2		
- 3	BT-56 NO NUMBER	DECAL, BLACK LETTERS ON GREY BACKGROUND DRAIN	2		
- 4	NO NUMBER	STENCIL, BLACK LETTERS EJECTOR ACCESS DOOR SAFETY PIN HOLE	4		
- 5	NO NUMBER	STENCIL, WHITE LETTERS RED BACKGROUND CAPACITY 360 U.S. GALS-JF-4 AF DRAWING 65J333310	2		
- 6	61034450-1 68037746-7	DECAL (BLACK STAR) REFUEL SYMBOL DECAL, BLACK LETTERS ON YELLOW BACKGROUND GROUND HERE	2 2		
- 7	67034662-5	DECAL, WHITE LETTERS ON BLACK BACKGROUND INSERT FUEL NOZZLE JUMPER ONLY	2		
- 8	NO NUMBER	STENCIL RED LETTERS CAUTION BE SURE TANK IS EMPTY BEFORE MANUAL RELEASE	2		



LH VIEW



RH VIEW

Figure 2.21-6. Vertical Stabilizer Markings

FIGURE AND INDEX NUMBER	PART NUMBER	DESCRIPTION	UNITS PER ASSY.	USABLE ON CODE	
				FROM	TO
		1 2 3 4 5 6			
2.21-6- 1	RT-185 *1	DECAL, BLACK LETTERS ON GREY BACKGROUND DOOR 181	1		
- 2	BT-186 *2, *3	DECAL, BLACK LETTERS ON GREY BACKGROUND DOOR 181	1		
- 3	NO NUMBER *2, *3	STENCIL, BLACK LETTERS DOOR 181	1		
- 4	BT-201 *4	DECAL, BLACK LETTERS ON GREY BACKGROUND HYD. FTG. SHPOUD BRAIN	1		
- 5	NO NUMBER *5	STENCIL, BLACK LETTERS DOOR 153	1		
- 6	NO NUMBER *6	STENCIL, BLACK LETTERS DOOR 157	1		
- 7	RT-181 *7	DECAL, BLACK LETTERS ON GREY BACKGROUND DOOR 141	1		
- 8	RT-184 *8	DECAL, BLACK LETTERS ON GREY BACKGROUND DOOR 131	1		
- 9	BT-179 *9	DECAL, RED LETTERS ON WHITE BACKGROUND DANGER	1		
- 10	NO NUMBER *10	SPEED BRAKE FAST ACTING DOOR STENCIL, BLACK LETTERS DOOR 169	1		
- 11	NO NUMBER *11	DECAL, BLACK LETTERS ON GREY BACKGROUND DOOR 159	1		
- 12	RT-211 *12	DECAL, RED LETTERS ON WHITE BACKGROUND CAUTION-DISCONNECT ELECTRICAL WIRING BEFORE REMOVING FIN TIP	2		
- 13	RT-182 *13	DECAL, BLACK LETTERS ON GREY BACKGROUND DOOR 163	1		
- 14	RT-181 *13	DECAL, BLACK LETTERS ON GREY BACKGROUND DOOR 165	1		
- 15	RT-182 *13	DECAL, BLACK LETTERS ON GREY BACKGROUND DOOR 167	1		
		*1 PAGE 7.001 CONVAIR MARKING AND STENCILING REPORT NO. 8.0000R *2 PAGE 7.029 AND 3.129 CONVAIR MARKING AND STENCILING REPORT NO. 8.0000R *3 CHECK AIRCRAFT APPLICABILITY *4 PAGE 7.010 CONVAIR MARKING AND STENCILING REPORT NO. 8.0000R *5 PAGE 7.000 CONVAIR MARKING AND STENCILING REPORT NO. 8.0000R *6 PAGE 7.004 CONVAIR MARKING AND STENCILING REPORT NO. 8.0000R *7 PAGE 7.006 CONVAIR MARKING AND STENCILING REPORT NO. 8.0000R *8 PAGE 7.016 CONVAIR MARKING AND STENCILING REPORT NO. 8.0000R *9 PAGE 7.012 CONVAIR MARKING AND STENCILING REPORT NO. 8.0000R *10 PAGE 7.010 CONVAIR MARKING AND STENCILING REPORT NO. 8.0000R *11 PAGE 7.012 CONVAIR MARKING AND STENCILING REPORT NO. 8.0000R *12 PAGE 7.029, 3.129 AND 3.131 CONVAIR MARKING AND STENCILING REPORT NO. 8.0000R *13 PAGE 7.007 CONVAIR MARKING AND STENCILING REPORT NO. 8.0000R			

175 PAGES

SECTION III — NUMERICAL INDEX

THE INDEX INCLUDES:
 CONTRACTOR PARTS—VENDOR PARTS—STANDARD PARTS

numerical index PART NUMBER COLUMN

T.O. 1F-106A-4

PART NUMBER	FIGURE AND INDEX NUMBER	QTY PER ART	SMR CODE	PART NUMBER	FIGURE AND INDEX NUMBER	QTY PER ART	SMR CODE
AN23-14A	2-16-3-0-11	1		AN3C21A	2-13-1-1-34	6	
AN23-14	2-4-12-0-104	1		AN3C22A	2-12-3A-1-65	2	
AN23-16A	2-16-3-0-10	4		AN3C3	2-18-10-0-9	2	

Parts are listed in alpha-numerical sequence in Part Number order as follows:

PART-NUMBER LISTING SEQUENCE

FIRST-DIGIT SEQUENCE	SAMPLE NUMBER GROUP	SECOND-DIGIT, AND ON, SEQUENCE
FIRST, LETTERS; ALPHABETICALLY; THEN, NUMERALS	A A-A234 AA1234 AB1234 111234	FIRST, SPACES; THEN, DASHES; THEN, LETTERS ALPHABETICALLY; THEN, NUMERALS

Part numbers are in order according to their first letter or numeral; then each group with the same first letter or numeral placed in order according to the second space, dash, letter, or numeral; then according to the third, etc., as shown at left.

Items Indexed under two numbers—

Parts manufactured to Contractor Specification are listed by the Vendor's Part Number and the Prime Contractor's Specification Control Drawing Number.

numerical index FIGURE AND INDEX NUMBER COLUMN

T.O. 1F-106A-4

PART NUMBER	FIGURE AND INDEX NUMBER	QTY PER ART	SMR CODE	PART NUMBER	FIGURE AND INDEX NUMBER	QTY PER ART	SMR CODE
AN23-14A	2-16-3-0-11	1		AN3C21A	2-13-1-1-34	6	
AN23-14	2-4-12-0-104	1		AN3C22A	2-12-3A-1-65	2	
AN23-16A	2-16-3-0-10	4		AN3C3	2-18-10-0-9	2	

The figure and index number refers to the location in Section II where parts are listed and illustrated. Government Standard Parts that have high usage are listed only once. Therefore the figure and index column shows the first occurrence of these parts.

figure and index number column (cont).

parts used on the airplane are listed as follows:

60%
ILLUSTRATED
(APPROX.)

REPLACEABLE PARTS APPEAR IN GROUP ASSEMBLY PARTS LISTS (SECTION II) AND NUMERICAL INDEX OF THIS MANUAL

These parts are considered to be subject to replacement in normal maintenance.

40%
NON-ILLUSTRATED
(APPROX.)

NORMALLY NONREPLACEABLE PARTS APPEAR IN T.O. 1F-106A-4-1

These parts are not considered to be subject to replacement in normal maintenance.

numerical index
QUANTITY PER PLANE COLUMN

T.O. 1F-106A-4

PART NUMBER	FIGURE AND INDEX NUMBER	QTY PER ART	SMR CODE	PART NUMBER	FIGURE AND INDEX NUMBER	QTY PER ART	SMR CODE
AK23-14A	2-16-348-11	1		AK3021A	2-13-111-34	6	
AK23-16	2-4-123-124	1		AK3022A	2-12-3816-65	2	
AK23-16A	2-16-316-12	4		AK303	2-18-167-9	2	

the following codes appear in the "QTY PER PLANE" column:

- (Any numeral) – Total quantity per airplane.
- "REF": Subsequent appearances of items.
- "BIL": Bulk Standard and vendor parts.
- "GF AE": Government Furnished Aeronautical Equipment.
- "ALT": Alternate parts and assemblies.
- "SP": Spares assemblies and details not common to production assemblies.

numerical index
SMR
CODE COLUMN

T.O. 1F-106A-4

PART NUMBER	FIGURE AND INDEX NUMBER	QTY PER ART	SMR CODE	PART NUMBER	FIGURE AND INDEX NUMBER	QTY PER ART	SMR CODE
AN25-14A	2-16-30-11	1		AN3021A	2-13-1-1-34	4	
AN25-16	2-9-12-0-13*	1		AN3022A	2-12-38-2-65	2	

This manual contains Joint Military Services Uniform SMR Codes only. Definitions of these SMR codes are available in T.O. 00-25-195.

PART NUMBER	FIGURE AND INDEX NUMBER	QTY PER ART	SMR CODE
#14	2. 5- 5.0- 20	1	
A-3108	2.15- 5.0- 10	1	P1
AA-3255-12HMDI A	2. 8- 2.0- 11	1	P
AA-3255-12D1	2. 8- 2.0- 12	1	P
AAU-197A	2.16- 1.0- 59	1	P1
AA2100-11D99	2. 8- 2.0- 1	4	P
AA60691L6A	2.10- 7.0- 91	1	
AB12	2.20-31.0- 94	4	
AB14	2.20-28.0- 13	1	P
	2.20-28.0- 22	1	
AC-3255-12	2. 8- 2.0- 3	1	P
AC-3255-12HD2	2. 8- 2.0- 2	1	P
ACT509H-T8-4	2. 7- 8.0- 18	3	
AC106-18	2.16- 6.0- 19		P1
AC106-1P	2.16- 1.0- 25	RF	A1
AC1146-4	2. 9-23.0- 44	1	
AC1526-4	2. 8- 4.0- 6	1	
	2. 8- 5.0- 6	1	
	2. 8-23.0- 43	1	
AC3255-12HM	2. 8- 1.0- 50	1	
AC840-81	2. 8- 1.0- 45	2	P1
	2. 8-23.0- 4	1	
AD297-1	2.13-21.0- 14	1	
	2.13-22.0- 3	2	
	2.13-30.0- 24	1	
AD297-3	2.13- 5.0- 15	1	P1
	2.13- 5.0- 19	1	
	2.13- 5.0- 33	1	
	2.13- 6.0- 12	1	
	2.13- 8.0- 25	1	
	2.13- 8.0- 44	1	
	2.13- 9.0- 5	4	
	2.13- 9.0- 55	1	
	2.13- 9.0- 72	1	
AD297-5	2.13-31.0- 5	1	
AD297-7	2.13- 1.1- 99	2	P1
	2.13- 9.0- 3	8	
	2.13-15.0- 23	1	
	2.13-15.0- 32	3	
AD390-3	2.13- 1.1- 57	2	P1
	2.13-31.0- 17	1	
AE335-10C152	2. 3- 4.0- 29	1	P
	2. 9- 1.0- 25		
AE33510C152	2. 4-11.0- 46	1	P
AE702234-1	2.10- 7.0-125	1	
AE94502M	2.10-19.0- 6	2	
	2.10-24.0- 3	2	
AFT0-FORM146	2. 5- 1.0- 30	1	
AF950-3	2.10-10.0- 8	4	
AF955-3	2.10-10.0- 12	4	
AGE53-2	2.17- 8.0- 36	1	P1
AGU1-AU	2.16-18.0- 3	2	
AKP4AE7414	2.14-10.0- 46	1	
AKP4R16-2E7414	2.14-23.0- 69	2	
	2.14-23.0-161	1	
ALPPH-T6-14	2.10- 6.0- 42	4	
ALPPH-T6-5	2. 6-38.0- 2	6	
ALPPH-T6-6	2. 6-38.0- 17	16	
ALPPH-T6-7	2.15-28.0- 9	4	
ALPPH-T8-6	2.10-30.0- 11	2	

PART NUMBER	FIGURE AND INDEX NUMBER	QTY PER ART	SMR CODE
ALPPH-T2-3	2.10-30.0- 12	1	
ALSF-T6-5	2. 7- 8.0- 17	3	
ALSF-T6-9	2.15-14.0- 40	4	
AN-123526	2.10-13.0- 25	36	
AN-123528	2.10-13.0- 23	36	
AN100043	2.8-23.0-8A	2	P1
AN103807	2.10- 7.0- 13	40	
AN103808	2.18-31.0- 4	4	
AN106410	2.10- 9.0- 13	302	
AN123971	2.10- 7.0-164	2	
AN173-11	2.10- 6.0- 26	6	
AN173-22A	2.10-22.0- 40	3	P1
AN173-34A	2.15- 1.0- 68	1	P1
AN173-4A	2. 9- 3.0- 26	5	
AN173-5A	2. 2- 7.0- 7	34	
AN173-6A	2.14- 9.0- 75	14	
AN173-7A	2. 7- 8.0- 6	18	
AN173H11A	2.20-31.0- 18	2	
AN173H5A	2.20-23.0- 4	4	
AN174-1C	2.10- 6.0- 33	4	
AN174-1GA	2. 7- 8.0- 24	9	
AN174-1I	2.10- 6.0- 37	2	
AN174-11A	2. 7- 8.0- 25	2	
AN174-12A	2.14- 9.0- 12	1	
AN174-14	2.10- 6.0- 29	3	
AN174-15A	2. 7- 8.0- 26	11	
AN174-42A	2.14-36.0- 4	2	
AN174-5A	2. 6-37.0- 20	14	
AN174-53	2.14-23.0-145	1	
AN174-53A	2.14-32.0- 13	1	
AN174-6A	2. 4- 2.0- 55	56	
AN174-7A	2. 6-37.0- 13	18	
AN174A6	2.13-30.0- 31	4	
AN174H10	2.10- 6.0- 55	1	
AN174H11	2.10- 6.0- 61	1	
AN176-12A	2.14-20.0- 8	4	
AN176H13	2.16- 3.0- 42	2	
AN178-44A	2.18- 6.0- 23	2	
AN178-45A	2.18- 6.0- 24	4	
AN200KP4	2.15-27.0- 29	4	
AN200KS4	2.14-18.0- 64	2	
AN201KP20A	2.15-22.0- 82	4	
AN201KP4A	2.14-10.0- 42	14	
AN201KP5A	2.14-10.0- 60	2	
AN201KP6A	2.14-10.0- 76	2	
AN201KP8A	2.14-24.0- 18	1	
AN202KP21B	2.14-42.0- 26	4	
AN219-2	2. 7- 3.0-109	1	
AN21907D4	2. 8-22.0- 45	1	
AN227-10B10	2.14- 9.0- 39	3	
AN227-10B6	2. 5- 6.0- 12	24	
AN227-10M6	2.10- 2.0- 4	3	
AN227-3	2.15-15.0- 3	34	
AN227-5	2.15-15.0- 4	34	
AN227-6B	2. 5- 5.0- 23	2	
AN227-7B	2. 4- 2.0- 27	4	
AN229-3BL330-1	2. 5- 8.0- 8	1	
AN23-10A	2.14-13.0- 11	19	
AN23-11A	2.10- 2.0- 1	8	
AN23-13	2. 4-12.0-103	1	
AN23-13A	2.16- 3.0- 12	1	

PART NUMBER	FIGURE AND INDEX NUMBER	QTY PER ART	SMR CODE
AN23-14A	2.16- 3.0- 11	1	
AN23-16	2. 4-12.0-104	1	
AN23-16A	2.16- 3.0- 10	4	
AN23-21A	2. 7- 3.0- 16	1	
AN23-22	2. 4-12.0-102	2	
AN23-24	2.20-30.0- 60	1	
AN23-8A	2.14- 9.0- 46	9	
AN23-9A	2.14- 9.0- 45	18	
AN24-12	2. 3-10.0- 41	2	
AN24-13	2.10-30.0- 32	1	
AN24-13A	2.10-37.0- 27	8	
AN24-22	2. 7- 3.0- 96	1	
AN25-11A	2.10-37.0- 33	4	
AN25-14A	2.10-37.0- 17	4	
AN25-19A	2.10-37.0- 17	2	
AN25-22A	2.10-37.0- 18	4	
AN250-2-3418	2.11- 6.0- 13	2	
AN253-4-3418	2.11- 6.0- 12	1	
AN253-4-3713	2.15-30.0- 23	2	
AN253-4-394	2.20-23.0- 60	1	
AN253-4-513	2.20-23.0- 65		
AN253-4-800	2.15-31.0- 39	2	
AN253-4-850	2.15-31.0- 40	1	
AN276-6	2.13-27.0- 44	2	P1
AN28CH304	2.15-38.0- 45	1	
AN294-40	2.12-44.0- 72	1	
AN297-3	2.13- 6.0- 32	1	
AN3-10	2. 2- 6.0- 5	7	
AN3-16A	2. 8- 7.0- 12	31	
AN3-11A	2.16-34.0- 15	4	
AN3-12A	2. 7- 1.0- 37	7	
AN3-13A	2. 4- 5.0- 31	20	
AN3-14	2.20- 5.0- 10	5	
AN3-14A	2. 4-12.0-117	14	
AN3-15A	2. 7- 7.0- 19	25	
AN3-16A	2. 4-12.0-137	24	
AN3-17A	2. 4- 7.0- 9	19	
AN3-20A	2. 2- 9.0- 44	9	
AN3-21A	2. 4- 7.0- 34	5	
AN3-22A	2.12-37.0- 74	10	
AN3-23A	2.13- 9.0- 23	11	
AN3-24A	2. 8- 1.0- 31	2	
AN3-25	2.11- 9.0- 27	4	
AN3-25A	2.20-23.0- 32	1	
AN3-26A	2.20-23.0- 33	1	
AN3-27A	2.12- 1.0- 48	8	
AN3-3A	2. 2- 7.0-105	181	
AN3-30A	2.20- 6.0- 20	6	
AN3-31A	2.20-23.0- 41	1	
AN3-33A	2.20- 6.0- 12	1	
AN3-34A	2.20- 6.0- 13	1	
AN3-4	2.13-27.0- 43	6	
AN3-4A	2. 2- 3.0- 57	626	
AN3-5	2.13- 1.1- 49	6	
AN3-5A	2. 2-14.0- 26	325	
AN3-6A	2. 2- 5.0- 20	197	
AN3-7	2. 9- 2.0- 48	4	
AN3-7A	2. 4-12.0- 80	70	
AN3CH4A	2.12-54.0- 4	6	
AN3CH5A	2.15- 1.0- 73	1	
AN3CH6A	2.10-10.0- 10	5	
AN3C15A	2.20- 4.0- 4	1	
AN3C11A	2. 2-13.0- 4	4	
AN3C15A	2.13-24.0- 6	1	
AN3C16A	2. 4- 4.0- 12	4	

PART NUMBER	FIGURE AND INDEX NUMBER	QTY PER ART	SMR CODE
AN3C21A	2.13- 1.1- 34	6	
AN3C22A	2.12-38.0- 65	2	
AN3C3	2.18-10.0- 9	2	
AN3C3A	2.10-19.0- 30	4	
AN3C4	2.13-27.0- 39	10	
AN3C4A	2.10-19.0- 3	26	
AN3C5	2.13-28.0- 27	6	
AN3C5A	2.10-39.0- 22	2	
AN3C7	2.20-31.0- 34	2	
AN3C7A	2. 4-12.0-139	5	
AN3DD6A	2.14- 9.0- 41	4	
AN3H16A	2.11- 9.0- 42	3	
AN3H17A	2.12-49.0- 22	4	
AN3H20A	2.12-49.0- 22	2	
AN3H3A	2.12- 1.0- 11	59	
AN3H4A	2.10-27.0- 16	29	
AN3H5A	2. 9- 2.0- 57	64	
AN3H6A	2.11- 3.0- 1	37	
AN3H7A	2.14-40.0- 10	16	
AN3TYPE	2. 4- 4.0- 7	RF	
AN3022-15B	2.15-12.0- 6	1	
AN310-	2.13-18.0- 18	2	
AN310-12	2.14-11.0- 25	7	
AN310-3	2. 2- 6.0- 3	45	
AN310-4	2. 4- 7.0- 14	16	
AN310-5	2.15-19.0- 4	3	
AN310-6	2.15-13.0- 37	1	
AN31004	2.10- 4.0- 7	21	
AN31006	2.10-39.0- 5	1	
AN3117-1	2.12- 9.0- 65	1	P1
AN3121-313	2.16- 1.0- 5	20	
AN3140-327	2. 9- 1.0- 1	68	
AN315-3R	2. 7- 3.0- 31	1	
AN315-4R	2.20-46.0- 35	2	
AN315C3R	2. 2- 3.0- 31	6	
AN315C5R	2.10- 7.0- 39	1	
AN316-4	2.16- 3.0- 8	7	
AN316-4R	2.16- 6.0- 9	1	
AN316-4R	2. 4-12.0- 60	21	
AN316-5L	2.14-23.0-137	1	
AN316-5R	2.10- 3.0- 5	34	
AN316-6L	2.15-13.0- 27	1	
AN316-6R	2.14-10.0- 56	6	
AN316-6R 2	2.17- 8.0- 24	1	
AN316-7R	2.15-22.0- 29	5	
AN316-8R	2.14-23.0-165	1	
AN316C4L	2.20-48.0- 73	2	
AN316C4R	2.10- 5.0- 26	6	
AN316C5R	2.14- 9.0- 8	1	
AN316C6E	2.20-48.0- 67	2	
AN3167-1	2.15-38.0- 62	1	
AN3169-1	2. 7- 3.0- 9	2	
AN320-10	2. 6- 6.0- 22	24	
AN320-12	2. 6-17.0- 2	4	
AN320-14	2. 6-16.0- 5	4	
AN320-16	2. 5-16.0- 16	3	
AN320-20	2. 6-16.0- 10	0	
AN320-3	2. 4-12.0- 20	16	
AN320-4	2. 2-12.0- 16	21	
AN320-5	2. 4- 9.0- 9	14	
AN320-6	2. 4-10.0- 12	43	
AN320-7	2.11- 5.0- 2	13	
AN320-8	2. 3- 3.0- 88	32	
AN320-9	2.15-16.0- 40	6	

PART NUMBER	FIGURE AND INDEX NUMBER	QTY PER ART	SMR CODE
AN320C10	2.10-6.0-1	2	
AN320C4	2.3-10.0-41	2	
AN320C5	2.20-15.0-15	18	
AN320C6	2.20-15.0-10	8	
AN320C7	2.10-39.0-9	1	
AN320C8	2.10-39.0-12	1	
AN320D12	2.15-16.0-66	RF	
AN321-2-8	2.13-17.0-17	4	
AN329-49	2.12-56.0-11	1	
AN3333-2	2.20-3.0-27	RF	
AN340-4	2.16-5.0-46	2	
AN340-6	2.15-7.0-2	2	
AN341-416	2.18-20.0-9	7	
AN3410-327	2.16-18.0-5	6	
AN3433-4-2	2.17-2.0-5	3	
AN3434-4	2.17-2.0-6	2	
AN3436-1-6	2.17-36.0-3	1	
AN3436-2-4	2.5-2.0-21	1	
AN3436-4-7	2.17-2.0-7	1	
AN345-10	2.4-12.0-66	28	
AN345C10	2.13-5.0-16	15	
AN353-00-3	2.14-8.0-11	4	
AN360-6	2.8-28.0-3	1	
AN363-1032	2.8-3.0-21	7	
AN363-428	2.13-18.0-28	2	
AN363-524	2.17-8.0-73	1	
AN363C1032	2.20-31.0-22	3	
AN364-1032C	2.12-15.0-218	8	
AN364-428C	2.11-1.0-15	4	
AN364-632	2.16-1.0-115	2	
AN364-918	2.20-27.0-1	10	
AN364-918C	2.15-25.0-57	RF	
AN365-1032	2.17-11.0-118	8	
AN365-1032C	2.10-19.0-14	1	
AN365-428	2.7-3.0-117	2	
AN365-524	2.20-31.0-83	2	
AN365-624	2.20-31.0-83	2	
AN365-820	2.18-6.0-7	6	
AN365D1032	2.20-36.0-2	12	
AN380-1-1	2.7-3.0-27	5	
AN380-1-2	2.7-3.0-71	1	
AN380-1-3	2.13-14.0-1	4	
AN380-2-1	2.13-14.0-6	22	
AN380-2-2	2.7-3.0-90	8	
AN380-2-3	2.10-22.0-26	7	
AN380-3-2	2.15-22.0-95	1	
AN380-3-3	2.15-22.0-21	3	
AN380-4-6	2.14-11.0-36	3	
AN381-1-12	2.7-3.0-39	1	
AN381-2-12	2.10-14.0-1	2	
AN381-2-16	2.7-3.0-65	3	
AN381-2-5	2.12-56.0-10	1	
AN381-2-8	2.7-2.0-3	4	
AN381-3-12	2.7-3.0-50	1	
AN381-4-20	2.10-7.0-184	2	
AN381-4-24	2.10-7.0-19	1	
AN381-4-28	2.14-11.0-24	1	
AN385H70-7	2.13-13.0-38	2	
AN386-1-13A	2.14-12.0-16	2	
AN386-1-14A	2.14-12.0-15	2	
AN386-1-15A	2.14-42.0-4	2	

PART NUMBER	FIGURE AND INDEX NUMBER	QTY PER ART	SMR CODE
AN386-1-16A	2.14-20.0-13	10	
AN386-1-8A	2.20-13.0-9	4	
AN392-11	2.10-30.0-26	1	
AN392-25	2.13-14.0-8	1	
AN392-57	2.13-22.0-13	1	
AN392-7	2.10-22.0-50	2	
AN393-17	2.13-13.0-10	2	
AN394-11	2.4-12.0-57	2	
AN394-17	2.4-12.0-58	2	
AN394-19	2.4-12.0-34	1	
AN4-10	2.11-6.0-9	2	
AN4-10A	2.9-2.0-21	85	
AN4-11A	2.4-6.0-14	83	
AN4-12A	2.8-23.0-5	9	
AN4-13A	2.10-7.0-170	41	
AN4-14A	2.10-25.0-4	8	
AN4-15A	2.10-37.0-6	5	
AN4-15A	2.9-12.0-35	8	
AN4-17A	2.13-1.1-7	8	
AN4-20A	2.18-11.0-12	5	
AN4-21A	2.9-2.0-20	5	
AN4-22A	2.8-1.0-44	18	
AN4-23A	2.14-6.0-31	4	
AN4-25A	2.4-9.0-23	2	
AN4-26A	2.8-1.0-46	3	
AN4-27A	2.9-12.0-35	1	
AN4-3A	2.8-1.0-25	8	
AN4-30A	2.4-12.0-49	2	
AN4-35A	2.9-2.0-89	2	
AN4-36A	2.9-2.0-88	1	
AN4-4A	2.8-23.0-19	11	
AN4-42A	2.15-22.0-61	5	
AN4-5A	2.2-7.0-33	122	
AN4-6	2.9-12.0-8	1	
AN4-6A	2.4-7.0-5	95	
AN4-7	2.9-2.0-28	4	
AN4-7A	2.9-1.0-34	56	
AN4-75	2.15-27.0-28	2	
AN4-8A	2.11-1.0-7	2	
AN4C44A5	2.14-5.0-11	1	
AN4C13A	2.10-7.0-37	2	
AN4C14A	2.12-59.0-5	2	
AN4C17A	2.14-6.0-23	1	
AN4C26A	2.14-6.0-23	2	
AN4C5A	2.17-11.0-138	4	
AN4C6A	2.3-14.0-23	3	
AN4C7A	2.13-30.0-19	4	
AN4H-5A	2.12-15.0-56	32	
AN4H-6A	2.12-15.0-63	8	
AN4H-7A	2.12-15.0-89	8	
AN4H35A	2.13-5.0-55	8	
AN4H4A	2.12-53.0-10	2	
AN4H41	2.2-12.0-19	2	
AN4H5A	2.9-2.0-31	23	
AN4H6A	2.4-6.0-4	14	
AN4H7A	2.10-21.0-2	4	
AN4045-1	2.10-7.0-59	1	
AN4047-1	2.10-7.0-78	3	
AN415-2	2.5-14.0-7	1	P
AN42B-25A	2.2-3.0-72	1	
AN42B-3	2.2-5.0-16	3	P1
AN42B-5A	2.12-69.0-77	1	
AN42B3A	2.4-11.0-16	1	

PART NUMBER	FIGURE AND INDEX NUMBER	QTY PER ART	SMR CODE	PART NUMBER	FIGURE AND INDEX NUMBER	QTY PER ART	SMR CODE
AN426-1032R6	2.17-36.0- 18	2		AN509-10R16	2.10- 3.0- 16	16	
AN427M3	2.10-14.0- 2	AR		AN509-10R17	2.11- 5.0-	2	
AN44-15	2.14-26.0- 30	1		AN509-10R18	2.11- 5.0-	5	
AN464-6A30	2.20-27.0- 7	2		AN509-10R19	2.11- 5.0-	AR	
AN486-1	2.10- 5.0- 25	2		AN509-10R23	2.18-20.0- 4	16	
AN486-2	2. 4-12.0- 59	1		AN509-10R27	2.15-25.0- 15	1	
				AN509-10R29	2. 8- 8.0- 10	4	
AN486-4	2. 4-12.0- 15	1		AN509-10R4	2.12- 9.0- 52	7	
AN5-10A	2.12-55.0- 12	8		AN509-10R6	2.12-39.0- 27	15	
AN5-11A	2.14-32.0- 9	1		AN509-10R7	2.12-23.0- 12	10	
AN5-12A	2.15-22.0- 33	4		AN509-10R8	2.12-57.0- 26	66	
AN5-14A	2.10-25.0- 32	5		AN509-10R99	2.15-18.0- 7		
AN5-5-8R7	2.12-39.0- 3	4		AN509-416R10	2.18-31.0- 2	8	
AN5-5A	2.10- 8.0- 17	10		AN509-416R12	2. 7- 3.0-119	24	
AN5-6A	2.12-51.0- 15	2		AN509-416R14	2.14-27.0- 27	10	
AN5-7A	2.18-28.0- 3	4		AN509-416R16	2.15-38.0- 64	2	
AN5CH5A	2.10- 7.0- 43	24		AN509-416R8	2.15-19.0- 26	1	
AN5H23A	2.12-16.0- 3	4		AN509-8R11	2.14-31.0- 17	2	
AN5H4A	2. 8- 4.0- 2	4		AN509-8R16	2.18-11.0- 6	4	
AN5H6A	2.12-61.0- 13	4		AN509-8R18	2.14- 7.0- 12	7	
AN500AB4-7	2.15-17.0- 25	1		AN509-8R20	2.18-20.0- 36	8	
AN500AC6-6	2.16-11.0- 37	1		AN509-8R6	2. 8- 8.0- 4	2	
AN500AC6-7	2.15-17.0- 17	2		AN509-8R7	2.12-68.0- 36	17	
AN500A10-10	2.12-56.0- 3	10	P1	AN509-8R8	2.14- 6.0- 9	16	
AN500A10-24	2.12-56.0- 17	1		AN509-8R9	2.18- 6.0- 38	68	
AN500A4-10	2.15- 9.0- 30	2		AN509C10R12	2.10- 9.0- 3	4	
AN500A4-4	2.15- 8.0- 36	2		AN509C10R13	2.10- 9.0- 4	2	
AN500A4-6	2.15-17.0- 21	4		AN509C10R14	2.10- 9.0- 5	2	
AN500A6-18	2. 7- 1.0- 14	2		AN509C10R16	2.10- 9.0- 6	2	
AN500A6-8	2.13- 2.0- 6	6		AN509C10R17	2.10- 9.0- 7	2	
AN500A8-6	2.15- 8.0- 5	6		AN509C10R20	2.10- 9.0- 8	2	
AN501AC10-6	2. 8- 6.0- 4	2		AN510-3R4	2.18- 7.0- 7	8	
AN501AC10-8	2.15-17.0- 15	3		AN515-10R6	2.17-13.0- 1	6	
AN502-10-10	2. 8- 1.0- 62	4		AN515-10R8	2.17-11.0- 13	4	
AN502-10-4	2.12-26.0- 7	4		AN515-2R10	2. 4-12.0- 64	6	
AN502-10-6	2. 4-12.0- 51	13		AN515-2R4	2.14-23.0- 84	4	
AN502-10-8	2.13-16.0- 2	6					
AN502-416-6	2.10- 7.0- 3	10		AN515-4R6	2.14- 8.0- 41	5	
AN504-6R4	2.14-21.0- 20	4		AN515-6-18	2.15- 7.0- 4	RF	
AN504-6R8	2.16- 1.0- 92	3		AN515-6R10	2.15- 7.0- 34	4	
AN507-440R14	2.14- 8.0-120	3		AN515-6R12	2.16- 2.0- 43	8	
AN507-440R5	2.14- 8.0- 71	10		AN515-6R18	2. 7- 3.0- 7	2	
AN507-632R10	2.14-23.0- 81	2		AN515-6R22	2.14-23.0- 82	2	
AN507-632R16	2.16- 1.0- 23	12		AN515-6R24	2.15-38.0- 68	2	
AN507-632R17	2.16- 1.0- 52	4		AN515-6R4	2.17- 4.0- 11	26	
AN507-632R19	2.16- 1.0- 49	6		AN515-6R44	2.14- 8.0- 22	5	
AN507-632R24	2.14- 8.0-129	4		AN515-6R48	2.14- 8.0- 21	1	
AN507-632R3	2.16-11.0- 6	4		AN515-6R5	2.12-63.0- 12	10	
AN507-632R4	2.15-12.0- 7	4		AN515-6R6	2.14- 7.0- 5	25	
AN507-632R5	2.14- 7.0- 10	4		AN515-6R7	2.14- 7.0- 14	11	
				AN515-6R8	2.16- 1.0- 31	24	
AN507-632R7	2.14- 8.0-101	2		AN515-61R7	2.17-43.0- 6	6	
AN507-632R8	2.16- 5.0- 28	20		AN515-8R	2.17-26.0- 5	2	
AN507-832R6	2.14- 8.0- 81	2		AN515-8R10	2.16-25.0- 8	4	
AN507-832R7	2.14- 8.0- 82	1		AN515-8R12	2.16- 2.0- 29	14	
AN507B632R14	2.16- 8.0- 22	2		AN515-8R20	2.14- 1.0- 4	2	
AN507C1032R7	2.10- 3.0- 2	4		AN515-8R32	2.14- 8.0- 89	2	
AN507C1032R8	2.20- 3.0- 39	4		AN515-8R6	2. 8- 3.0- 2	34	
AN509-10P6	2.17-19.0- 2	4		AN515-8R7	2.13-13.0- 25	10	
AN509-10R10	2. 7- 1.0- 21	122		AN515-8R8	2.16-25.0- 12	26	
AN509-10R11	2. 7- 1.0- 20	123		AN515B6R12	2.16- 1.0- 41	3	
AN509-10R12	2.11- 5.0-	12		AN515B6R16	2.16- 1.0- 79	3	
AN509-10R13	2.11- 5.0- 14	13		AN515B6R7	2.18-35.0- 4	12	
AN509-10R14	2.11- 5.0-	4		AN515B6R8	2.16-11.0- 35	2	
AN509-10R15	2.11- 5.0-	7		AN515C4R5	2.16- 5.0- 53	2	

PART NUMBER	FIGURE AND INDEX NUMBER	QTY PER ART	SMR CODE
AN515C4R6	2.13-23.0- 27	2	
AN515C6R24	2.17-14.0- 22	8	
AN515D04R7	2.17-38.0- 10	2	
AN515D06R6	2.13- 8.0- 64	8	
AN515D08R6	2.13- 8.0- 63	10	
AN515N4R7	2.18-35.0- 2	2	
AN5154R6	2.17- 2.0- 8	2	
AN520-10-6	2.10-22.0- 37	2	
AN520-16R6	2.13-32.0- 4	5	
AN520-10R10	2.12-10.0-23	96	
AN520-10R12	2.13-13.0- 1	29	
AN520-10R14	2. 8-27.0- 73	5	
AN520-10R16	2. 8-27.0- 36	7	
AN520-10R20	2.17-11.0- 10	4	
AN520-10R26	2. 7- 3.0-140	6	
AN520-10R36	2. 8- 4.0- 9	6	
AN520-10R5	2.17- 5.0- 11	34	
AN520-10R6	2. 7- 7.0- 3	161	
AN520-10R7	2. 7- 7.0- 2	166	
AN520-10R8	2. 8-27.0- 30	171	
AN520-10R9	2.15-18.0- 13	1	
AN520-1032R8	2.12-14.0- 28	2	
AN520-416R22	2.12-64.0- 21	2	
AN520-416R26	2.12-64.0- 17	6	
AN520-416R30	2.16- 1.0-102	2	
AN520-6R4	2.14-38.0- 9	4	
AN520-8R10	2.17- 8.0- 17	2	
AN520-8R8	2.12-39.0- 12	26	
AN520C10R10	2.13-12.0- 8	1	
AN520C10R12	2.13- 5.0- 7	2	
AN520C10R18	2.10- 7.0-213	2	
AN520C10R6	2. 9-18.0- 26	3	
AN520C10R7	2.10- 7.0-210	4	
AN520C10R8	2.10- 7.0-153	20	
AN520C1032R6	2.13-21.0- 17	6	
AN520DD10R5	2.17- 3.0- 7	6	
AN520D10R7	2.12- 1.0-111	2	
AN526-10-7	2.17-32.0- 6	1	
AN526-10R	2.12-15.0- 7	2	
AN526-103R6	2.12-19.0- 32	6	
AN526-1032	2.12-14.0- 53	1	
AN526-1032-8	2.14-24.0- 22	12	
AN526-1032R10	2.12-10.0- 50	37	
AN526-1032R12	2. 8-23.0- 3	32	
AN526-1032R16	2.14- 9.0- 57	1	
AN526-1032R6	2. 8-19.0- 9	293	
AN526-1032R7	2.12-11.0- 5	7	
AN526-1032R8	2.12-15.0- 25	30	
AN526-1032R9	2.13-15.0- 8	8	
AN526-103210	2.12-10.0- 63	2	
AN526-632R6	2.17-38.0- 8	14	
AN526-632R8	2.18-20.0- 26	4	
AN526-832R16	2.18-19.0- 13	4	
AN526-832R5	2.14-38.0- 2	10	
AN526-832RB	2. 9- 1.0- 24	2	
AN526C1032-12	2.13- 5.0- 16	6	
AN526C632-5	2.16- 3.0- 5	2	
AN530-10R10	2.17-11.0- 36	4	
AN530-4R4	2.16- 2.0- 11	2	
AN531-8R6	2. 5- 9.0- 15	4	
AN5534-2	2.17- 8.0- 16	2	
AN565D428H20	2.20-47.0- 4	2	
AN565EC1032H5	2. 4-12.0- 51	RF	
AN565EC4H3	2.14-10.0- 7	2	
AN5800-1	2. 5- 1.0- 22	1	

PART NUMBER	FIGURE AND INDEX NUMBER	QTY PER ART	SMR CODE
AN5813-1	2.14-38.0- 7	1	
AN5823-1	2. 5- 1.0- 21	1	
AN6-30A	2.18-16.0- 25	4	
AN6C-54	2.14-23.0- 25	RF	
AN6003T244	2.13- 1.1- 30	1	
AN6039-5-14	2.19- 4.0- 38	1	
AN6039-5-24	2.19- 3.0- 37	4	
AN6039-5-32	2.19- 3.0- 40	7	
AN6204-1	2. 8- 6.0- 5	5	
AN621916D4-3	2. 9-11.0- 15	1	
AN6227-19	2. 8-15.0- 5	3	
AN6227-6	2.15-17.0- 12	2	
AN6227R12	2. 2- 3.0- 9	2	
AN6230-13	2.15-17.0- 35	1	
AN6230-41	2.14-24.0- 4	1	
AN6230B2	2. 3- 1.0- 19	2	
AN6232R3	2. 3- 1.0- 20	2	
AN627-4D-0120	2.13- 5.0- 51	1	
AN6270-4D-0120	2.13- 6.0- 49	1	
AN6270-8D-120	2.13- 6.0- 33	1	
AN6270-8D-160	2.13- 5.0- 35	1	
AN6289D-8	2.13- 6.0- 35	1	
AN6289D12	2. 9- 5.0- 24	1	
AN62890-8	2.13- 5.0- 37	1	
AN6290	2.11- 1.0- 11	1	
AN6290-10	2. 8-10.0- 13	16	
AN6290-12	2. 8-10.0-158	8	
AN6290-16	2. 8-10.0- 99	2	
AN6290-2	2.10-23.0- 5	1	
AN6290-20	2. 9- 3.0- 4	1	
AN6290-3	2. 8- 6.0- 7	17	
AN6290-4	2. 4- 6.0- 9	195	
AN6290-5	2. 8-10.0- 71	9	
AN6290-6	2. 8- 9.0- 17	129	
AN6290-8	2. 8-10.0- 64	34	
AN6290-12	2. 9- 5.0- 24	1	
AN6532-2	2. 4-11.0- 48	1	
AN660010	2.15-38.0- 52	2	
AN66302	2. 5- 6.0- 4	1	
AN66404	2.14-24.0- 10	4	
AN665-34R	2.14-18.0- 4	2	
AN690-4	2. 9-23.0- 18	1	
AN6920-3	2. 9-15.0- 7	1	
AN7076	2.16-14.0- 12	5	
AN735-016	2.12-11.0- 19	2	
AN735-20	2.13-23.0- 1	2	
AN735-4	2. 3- 1.0- 62	3	
AN735010	2.12-35.0- 25	8	
AN735012	2. 8- 1.0- 65	15	
AN735016	2.12-10.0- 25	37	
AN735020	2.12-32.0- 97	8	
AN735024	2. 9- 2.0- 2	51	
AN735032	2.12-15.0- 3	29	
AN735040	2.12-14.0- 80	48	
AN735048	2.12-14.0- 53	27	
AN735064	2.12-48.0- 3	6	
AN735072	2.12-48.0- 48	4	
AN737RM34	2.13- 9.0- 15	4	
AN737TW107	2.13- 8.0- 24	17	
AN737TW22	2.11- 7.0- 16	10	
AN737TW30	2.13- 7.0- 1	25	
AN737TW34	2.13- 9.0- 15	10	
AN737TW36	2.11- 9.0- 6	19	
AN737TW44	2.13-33.0- 42	2	
AN737TW46	2.14-22.0- 13	2	

PA

PART NUMBER	FIGURE AND INDEX NUMBER	QTY PER ART	SMR CODE
AN737TW56	2.13- 6.0- 11	8	
AN737TW58	2.13- 8.0- 48	20	
AN737TW66	2.13-13.0- 12	14	
AN737TW74	2.13- 1.1- 98	34	
AN737TW82	2.13- 4.0- 24	4	
AN737TW91	2.13- 6.0- 6	2	
AN737TW98	2.13- 8.0- 83	2	
AN737W74	2.13-23.0- 14	1	
AN74A6	2.10- 7.0- 31	4	
AN742-20	2. 4-11.0- 8	2	
AN742-48	2.13- 1.1- 92	2	
AN742D10	2. 9- 1.0- 28	6	
AN742D12	2.12- 3.0- 21	12	
AN742D16	2.13- 6.0- 37	2	
AN742D20	2.13-12.0- 18	2	
AN742D21	2.13-10.0- 6	2	
AN742D22	2.13-11.0- 26	4	
AN742D24	2.13- 8.0- 51	8	
AN742D26	2.13-11.0- 25	2	
AN742D32	2.12-65.0- 2	11	
AN742D48	2.13- 1.1- 92	4	
AN743-12	2.12-20.0- 14	2	
AN747-16	2. 4-11.0- 29	1	
AN75A10	2.10- 7.0- 2	10	
AN7502-15	2.15-16.0- 61	RF	
AN7510-1	2. 4- 9.0- 19	3	
AN753D20	2.12-46.0-101	8	
AN756D16	2.10-21.0- 10	1	
AN757D20-24	2. 9- 2.0- 11	2	
AN757TW46	2.13- 8.0- 35	4	
AN760D20-24	2.12-38.0- 82	1	
AN775-12	2.10-17.0- 10	2	
AN775-4	2.12-62.0- 4	1	
AN8-5JA	2. 4-11.0- 30	1	
AN8-7A	2.18- 6.0- 9	2	
AN8-80421-123	2. 9-25.0- 54	1	
AN8031-6-025	2.13- 1.1-131	2	
AN8031-6-075	2.13- 1.1-130	2	
AN804-4	2. 4- 7.0- 44	3	
AN80405	2.19- 4.0- 36	1	
AN806D16	2.12-65.0- 13	1	
AN814-4	2.10- 7.0- 73.	2	
AN814-4D	2.10-17.0- 5	2	
AN814-6D	2.10-17.0- 6	2	
AN814-6DL	2.13- 5.0- 30	2	
AN815-16D	2. 9- 2.0- 65	1	
AN815-20D	2.12-43.0-144	1	
AN815-3D	2. 8-10.0-137	2	
AN815-4	2. 4- 7.0- 74	3	
AN815-4D	2.14- 5.0- 13	1	
AN815-5D	2.19- 3.0- 34	5	
AN815-6D	2.19- 3.0- 18	6	
AN815-8D	2.14-35.0- 22	8	
AN816-4D	2.14-35.0- 8	2	
AN816-5D	2.19- 4.0- 39	1	
AN816-6-6D	2.19- 4.0- 16	2	
AN816-6D	2.19- 3.0- 16	1	
AN816-8D	2.19- 3.0- 9	6	
AN818-4	2.14-35.0- 49	2	
AN821-8D	2.14-35.0- 32	2	
AN822-2D	2.14-35.0- 46	2	
AN822-4D	2.14-35.0- 47	2	
AN822-5D	2.19- 3.0- 14	3	
AN822-8D	2.14-35.0- 21	2	
AN823-5D	2.19- 3.0- 38	6	

PART NUMBER	FIGURE AND INDEX NUMBER	QTY PER ART	SMR CODE
AN823-50	2.19- 5.0- 42	2	
AN824-4D	2.10-20.0- 44	1	
AN826-10D	2.14-35.0- 18	2	
AN832-3	2.13- 2.0- 14	2	
AN832-4D	2.13- 5.0- 53	4	
AN832-5D	2.19- 4.0- 42	2	
AN833-5D	2.19- 3.0- 36	4	
AN833-6D	2.19- 3.0- 30	1	
AN833-8D	2.13- 5.0- 36	7	
AN834-6D	2.11-11.0- 12	2	
AN837-4D	2.13- 31.0- 11	1	
AN837-5D	2.19- 3.0- 12	10	
AN837-8D	2.19- 2.0- 4	4	
AN843-2D	2. 8-22.0- 43	1	
AN893-12D	2. 9-29.0- 52	1	
AN893-2D	2. 8-11.0- 59	9	
AN893-3D	2.10- 7.0-141	1	
AN89408-4	2.13- 5.0- 45	2	
AN900-7	2.10- 7.0- 52	1	
AN901-12C	2.10-17.0- 11	4	
AN901-16A	2. 8-12.0- 92	2	
AN901-4C	2.10-11.0- 5	4	
AN901-6C	2.10- 7.0-175	1	
AN917-12D	2.19- 3.0- 29	3	
AN915-13D	2.14-35.0- 26	1	
AN919-23D	2. 9- 2.0- 44	1	
AN919-3D	2. 9- 9.0- 14	1	
AN919-7D	2.19- 3.0- 21	3	
AN924	2. 8-18.0- 4	1	
AN924-8D	2.10-29.0- 6	1	
AN924-10D	2. 8- 1.0- 72	35	
AN924-12	2. 8-10.0- 44	1	
AN924-12D	2. 8-10.0- 57	14	
AN924-12S	2.13-33.0- 36	1	
AN924-16	2.10-28.0- 19	1	
AN924-16D	2. 8-10.0- 22	9	
AN924-2D	2.14-37.0- 57	1	
AN924-3	2.13- 2.0- 12	2	
AN924-3D	2. 8- 6.0- 2	48	
AN924-4	2. 2- 7.0- 16	55	
AN924-4C	2. 8-28.0- 29	5	
AN924-4D	2. 8- 3.0- 12	360	
AN924-4J	2.10-25.0- 22	2	
AN924-5D	2. 9- 5.0- 33	20	
AN924-6	2. 8-18.0- 15	26	
AN924-6C	2.10-13.0- 8	1	
AN924-6D	2. 8- 9.0- 28	284	
AN924-60	2. 8-12.0- 19	1	
AN924-8	2.10-17.0- 8	2	
AN924-8D	2. 8-10.0- 56	54	
AN924D12	2. 8-10.0- 52	2	
AN924D2	2.12-16.0-127	1	
AN924D4	2.12-15.0-120	4	
AN924D6	2.12-16.0-142	1	
AN924D6C	2. 9- 4.0- 7	1	
AN929-1C	2.14-35.0- 19	2	
AN929-16	2. 9- 2.0- 67	2	
AN929-3	2.13- 2.0- 11	2	
AN929-3D	2.14-21.0- 1	1	
AN929-4	2. 4- 7.0- 43	8	
AN929-6	2.11-11.0- 13	2	
AN929C-4	2.14-39.0- 14	1	
AN929C-6	2. 9- 4.0- 43	1	
AN931-3-5	2.15- 8.0- 6	1	
AN931-4-12	2. 9- 7.0- 36	2	
AN931-4S12	2. 7- 7.0- 9	2	

PART NUMBER	FIGURE AND INDEX NUMBER	QTY PER ART	SMR CODE
AN931-5-9	2.15- 9.0- 26	2	
AN931-5S13	2. 4- 8.0- 40	1	
AN931-6S16	2. 7- 7.0- 8	2	
AN931-8-13	2.11- 7.0- 10	4	
AN931A10-14	2.11- 7.0- 11	1	
AN931A559	2. 4- 6.0- 58	1	
AN931A8-13	2.11- 7.0- 8	12	
AN931C14S20	2.13-11.0- 48	1	
AN931C16S22	2.13-11.0- 48	1	
AN931C5S9	2. 4- 8.0- 39	1	
AN93202	2. 6-35.0- 8	8	
AN935-10	2.10-22.0- 36	37	
AN935-10L	2. 9-18.0- 27	69	
AN935-4	2.14- 8.0- 40	8	
AN935-4L	2.16- 5.0- 47	3	
AN935-416L	2.10- 7.0- 63	2	
AN935-5	2.14- 8.0- 16	20	
AN935-6L	2.17- 1.0- 43	16	
AN935-616L	2.12- 9.0- 86	4	P1
AN935-8	2.15- 2.0- 6	6	
AN935-8L	2.14- 7.0- 2	8	
AN936A10	2.14-22.0- 7	4	
AN936A2	2. 4-12.0-109	4	
AN936A416B	2.18-20.0- 10	3	
AN936A6	2.15- 7.0- 3	2	
AN936A716S	2.14- 8.0- 5	1	
AN936B10	2.17- 3.0- 5	2	
AN936B416	2.20-31.0- 22	3	
AN936B6	2. 7- 1.0- 17	2	
AN936B6B	2.18- 7.0- 11	2	
AN936B8	2.17- 3.0- 10	6	
AN936B8B	2.18- 7.0- 21	2	
AN937-60	2.12-45.0- 15	1	
AN93704	2. 9- 9.0- 25	1	
AN93706	2. 9-33.0- 38	1	
AN938-6	2. 8-11.0- 58	2	
AN938010	2.14-35.0- 25	2	
AN93804	2.12-37.0- 36	8	
AN93805	2. 8-23.0- 31	1	
AN93806	2. 8-27.0- 26	6	
AN93808	2. 9-29.0- 49	4	
AN93904	2.12-37.0- 5	5	
AN93906	2.14- 3.0- 21	1	
AN94104	2.14- 3.0- 14	1	
AN951RE03N	2.16- 6.0- 8	4	
AN951RE3FL4-3	2.20-48.0- 74	2	
AN951RE4F5	2.14-26.0- 9	4	
AN955-3	2. 2- 3.0- 48	2	
AN960-C10L	2.17-11.0- 59	3	
AN960-010L	2.18-30.0- 12	2	
AN960-D416L	2.12-10.0- 78	58	
AN960-PU-10L	2.11- 1.0- 27	7	
AN960-10	2. 2- 2.0- 5	373	P
AN960-10-L	2.12- 9.0- 42	1	
AN960-10L	2. 2- 2.0- 4	938	P
AN960-1016	2.15-26.0- 21	5	
AN960-1016L	2. 6- 6.0- 23	6	
AN960-102	2.19- 3.0- 43	1	
AN960-106	2. 9- 1.0- 13	3	
AN960-1216	2.14-25.0- 13	1	
AN960-1216L	2.15-16.0- 67	PF	
AN960-1416L	2. 6-15.0- 6	2	
AN960-1616L	2. 6-15.0- 17	2	
AN960-2016L	2. 6-16.0- 11	6	
AN960-4	2. 4-11.0- 53	30	

PART NUMBER	FIGURE AND INDEX NUMBER	QTY PER ART	SMR CODE
AN960-4L	2.13-14.0- 7	20	
AN960-416	2. 2-10.0- 9	290	
AN960-416L	2. 2-12.0- 17	174	
AN960-516	2. 4-12.0- 80	93	
AN960-516L	2. 7- 3.0- 48	25	
AN960-6	2. 7- 1.0- 15	6	
AN960-6L	2. 5- 4.0- 23	227	X2
AN960-616	2. 4-10.0- 13	40	
AN960-616L	2. 4-12.0- 83	67	
AN960-716	2. 4- 7.0- 48	30	
AN960-716L	2. 4- 7.0- 44	15	
AN960-8	2. 7- 3.0- 28	37	P1
AN960-8L	2. 8- 8.0- 3	47	P1
AN960-816	2. 4-11.0- 29	23	
AN960-816L	2. 4-12.0- 42	8	P1
AN960-916	2. 6-12.0- 49	8	P1
AN960-916L	2. 9-18.0- 4	30	
AN960C-10	2. 2- 5.0- 19	4	
AN960C-416L	2.10-29.0- 14	8	
AN960C10	2. 4- 9.0- 48	67	
AN960C10L	2. 2- 9.0- 50	430	
AN960C1016L	2.19- 6.0- 2	2	
AN960C1216L	2.10- 7.0-199	7	
AN960C1416L	2.14-43.0- 4	2	
AN960C2	2. 2-11.0- 8	5	P1
AN960C416	2. 3-10.0- 41	23	
AN960C416L	2.10- 4.0- 17	66	
AN960C516	2.10- 7.0- 44	23	
AN960C516L	2.13-30.0- 16	1	
AN960C6	2.15-17.0- 18	2	
AN960C6L	2.17-24.0- 8	52	P1
AN960C63L	2.17-25.0- 11	5	
AN960C616	2.16- 7.0-194	3	
AN960C616L	2. 4- 5.0- 21	PF	
AN960C716L	2.11- 5.0- 6	2	
AN960C8L	2. 4- 8.0- 9	22	
AN960C816L	2. 7- 3.0- 51	2	
AN960C916	2.10- 7.0-185	3	
AN960C916L	2.10-13.0- 9	1	
AN960D-716	2.9-32.0- 33	1	P1
AN960D10	2. 2- 3.0- 71	341	
AN960D10L	2. 4- 6.0- 7	1375	
AN960D10L1	2.12-22.0-152	4	
AN960D1016	2. 7- 1.0- 9	17	
AN960D106	2.17- 8.0- 31	4	
AN960D12-15	2.19- 3.0- 2	1	
AN960D1216	2. 8-10.0- 56	43	
AN960D1416	2. 8- 1.0- 73	24	
AN960D16	2.12-15.0- 63	11	
AN960D16L	2.15-35.0- 27	2	
AN960D1716	2. 8-10.0- 44	7	
AN960D2	2. 2- 6.0- 22	4	
AN960D2116	2. 8-10.0-128	4	
AN960D4	2. 5- 1.0- 28	12	
AN960D4-16	2.13- 8.0- 76	4	
AN960D4L	2. 2- 6.0- 19	2	
AN960D416	2. 7- 3.0- 36	160	
AN960D416L	2. 3- 1.0- 29	191	
AN960D516	2. 4-12.0-131	27	
AN960D516L	2.15-37.0- 18	2	
AN960D6	2.12-16.0-195	12	
AN960D6L	2. 2- 7.0- 22	20	
AN960D616	2. 7- 3.0-127	63	
AN960D616L	2. 9-11.0- 29	8	
AN960D716	2. 8- 9.0- 2	176	P1
AN960D716L	2. 8- 9.0- 20	58	

PART NUMBER	FIGURE AND INDEX NUMBER	QTY PER ART	SMR CODE
AN960D8	2. 7- 3.0- 78	4	
AN960D8L	2. 8- 3.0- 3	12	
AN960D816	2. 9- 7.0- 42	26	
AN960D9L	2.16-25.0- 28	2	
AN960D916	2. 8-10.0- 8	114	
AN960D916L	2. 8- 9.0- 28	50	
AN960L08	2.17- 7.0- 5	2	P1
AN960PC516	2.20-22.0- 19	4	
AN960PD-10	2.13- 8.0- 81	6	3P
AN960PD10	2. 3- 8.0- 16	118	P1
AN960PD10L	2. 2- 9.0- 7	293	P1
AN960PD1016	2.20-23.0- 44	3	P1
AN960PD1032L	2. 9- 3.0- 25	1	
AN960PD1216	2.13- 5.0- 41	7	
AN960PD4	2.20-39.0- 10	3	
AN960PD416	2. 8- 1.0- 47	117	P1
AN960PD416L	2. 3-14.0- 23	86	P1
AN960PD516	2.15-19.0- 5	20	
AN960PD516L	2. 6-32.0-39.4	19	
AN960PD6	2.17- 4.0- 14	8	
AN960PD6L	2.13- 8.0- 64	12	
AN960PD616	2. 8- 6.0- 3	7	
AN960PD716	2. 8- 3.0- 13	6	
AN960PD716L	2. 9-31.0- 5	5	
AN960PD8	2.13- 7.0- 4	10	
AN960PD8L	2.13- 5.0- 27	25	
AN960PD916	2.13- 5.0- 49	9	
AN960PP416	2.14-34.0- 14	8	
AN96002116	2.10-28.0- 18	1	
AN9606	2.18- 1.0- 14	4	
AN961-416	2.18-20.0- 11	6	
AN970	2. 5-11.0- 3	4	
AN970-3	2. 4- 8.0- 36	14	
AN970-4	2.16- 4.0- 9	11	
AN975-3	2.14-12.0- 14	20	
AN975-5	2.20-44.0- 49	3	
APH5AS3S2CCY2Y	2.14- 8.0-121	6	P1C
ARU-28/A	2.16- 2.0- 31	1	P1
ARU42/A-2	2.16- 2.0- 35	1	
ARU42A/2	2.16- 1.0- 26	1	
ASFW2550	2. 9- 3.0- 11	1	P1
	2. 9- 3.0- 11	1	
AS8C742-4	2. 4- 1.0- 30	25	
AT-741A	2.18- 6.0- 54	1	
AT-879/ARC	2.18-34.0- 10	2	
AT840/ARC	2.18- 6.0- 44	1	P1
AV181376	2.13-19.0- 5	1	
AV11E1121	2.15- 1.0- 5		
	2.15- 1.0- 75	1	
AW1026AEG1	2. 8- 3.0- 16	1	P1
	2. 8- 3.0- 17	1	
	2. 9-23.0- 17	1	
AYLF5725	2.13-13.0- 22	1	
AYLF5825-1A	2.13-15.0- 14	1	P1
AYLF5826-1	2.13-15.0- 13	1	P1
A10H	2. 6- 8.0- 10	2	P1
A113-18	2.17-15.0- 15	2	
A12H	2. 6-17.0- 9	1	P1
A1280	2.14- 8.0- 49	20	P1
A14-7A	2.12-52.0- 53	6	
A2375C	2.13-30.0- 20	1	X1
A2460	2.18-20.0- 32	1	P1
A29381-04-006	2.16- 1.0- 50	1	P1
A3000C	2.10-11.0- 16	1	P1

PART NUMBER	FIGURE AND INDEX NUMBER	QTY PER ART	SMR CODE
A31-2T17	2.20-17.0- 40	1	P1
A314AMS3B	2.16- 1.0- 37	1	P1
	2.16- 2.0- 15	1	
A4A181-080	2.18 - 36.0 - 9	2	P1
A45547	2.14-15.0- 17	1	
	2.14-15.0- 17	1	
	2.14-15.0- 97	1	
	2.14-15.0- 97	1	
	2.14-15.0-107	1	
	2.14-15.0-107	1	
	2.14-23.0- 22	1	
A4972-8-02	2. 5- 2.0- 11	6	
A5207	2.17- 1.0- 21	1	
A5506	2. 4- 4.0- 2	3	P1
	2. 4- 5.0- 2	2	
	2.13-13.0- 1	4	
	2.13-13.0- 2	2	
A5511	2. 4-12.0- 11	1	
A5621	2. 6- 3.0- 7	4	P1
	2.17- 1.0- 40	2	
	2.17- 1.0- 49	2	
A5626A1	2.17- 1.0- 48	2	P1
A5980-823	2. 5-10.0- 3	2	
A6H	2. 6-10.0- 23	1	P1
	2. 6-10.0- 30	1	
	2. 6-14.0- 6	1	
	2. 6-34.0- 5	1	
A6297-1	2.17- 1.0- 24	1	
A6305	2.17- 1.0- 50		RF
A6329	2. 4- 4.0- 4	1	P
	2. 4-12.0- 8	1	
A6338	2.10- 3.0- 10	1	
	2.10- 3.0- 23	1	
	2.13-13.0- 6	2	
A6452-8Z-3	2. 5- 9.0- 13		RF
	2. 5- 9.0- 8		RF
	2. 5- 9.0- 8	1	
A6452-8Z3	2. 5- 9.0- 2	4	
	2. 5- 9.0- 21	10	
	2. 5-10.0- 14	3	
	2. 5-10.0- 2	8	
	2. 5-10.0- 20	1	
	2. 5-10.0- 8	1	
	2. 9- 1.0- 21	1	
A6459-8Z3	2. 5- 9.0- 20	1	P
	2. 5-10.0- 13	2	
	2. 5-10.0- 19	1	
	2. 5-10.0- 26	1	
	2. 5-10.0- 9	2	
	2. 9- 1.0- 17	2	
A7H	2. 7- 5.0- 14	3	P1
A70079	2. 8-22.0- 12	1	P1
A7076	2.16- 8.0- 39	3	
	2.16- 9.0- 1	2	
	2.16-10.0- 1	2	
	2.16-12.0- 1	2	
	2.16-13.0- 4	1	
	2.16-18.0- 6		
	2.16-20.0- 1	2	
	2.16-22.0- 1	3	
A7079A24	2.17- 3.0- 1	1	
A7406	2. 4-12.0- 5		RF
A7463	2. 6- 3.0- 4	2	P
	2.17- 1.0- 36	2	
	2.17- 1.0- 45	2	

PART NUMBER	FIGURE AND INDEX NUMBER	QTY PER ART	SMR CODE
A7512-24	2.17- 5.0- 4	3	P1
	2.17- 6.0- 3	1	
A7793	2.10- 3.0- 8	RF	
A8087-1	2. 6- 3.0- 6	2	P1
	2.17- 1.0- 39	2	
A8087-2	2. 6- 3.0- 6	2	P1
	2.17- 1.0- 40	2	
A8120	2.16- 1.0- 75	7	P1
A81420	2.14-24.0- 33	2	P1
A8160-1	2.17- 4.0- 12	2	P1
	2.17- 4.0- 9	11	
A8289-24	2.17- 1.0- 15	2	
A8298-1	2.17- 1.0- 11	6	
A8451-1	2.17- 1.0- 33	1	
A8454-1	2.17- 1.0- 17	1	
A8456-1	2.17- 1.0- 13	1	
A8567-8Z-3	2. 5- 9.0- 7	2	
A8567-8Z3	2. 5-10.0- 15	1	
	2. 5-10.0- 4	1	
	2. 9- 1.0- 20	1	
A8921-1	2.17- 1.0- 20	1	
A9288-1	2.17- 1.0- 18	1	
A9289-1	2.17- 1.0- 16	2	
A9660-1	2.17- 4.0- 4	6	P1
B-65032-5	2.20- 2.0-	1	
BAC-S45A1	2.20-48.0- 57	2	
BB351-8-9	2.6-37.0-4	6	
BB352-6-6	2.20-19.0- 25	4	
BFR14S5P3	2.12-10.0- 34	1	
BH-124AC	2.17- 8.0- 9	1	
BH-138AKH	2.17-11.0-123	1	P1
BH185R51	2.16- 1.0- 86	1	
	2.16- 2.0- 69	1	
BH7220	2.16-25.0- 11	1	
BH7221	2.16-24.0- 2	1	
BH7222	2.16-25.0- 22	1	
BJ1000ASIMZ1	2.10-21.0- 5	1	P1
	2.10-27.0- 5	1	
BL-PP3-1.625	2.15- 1.0- 68	1	
	2.20- 1.0- 20	1	
BLFN3	2.20-48.0- 10	1	
BLFN4	2.20-48.0- 77	1	
BLFN8	2.20-48.0- 32	1	
	2.20-48.0- 46	1	
BRE14285	2.10- 7.0-187	1	P1
BRE14290	2.10- 7.0-168	1	P1
BRE5630	2.10-12.0- 32	2	P
BRE5635	2.10-12.0- 33	2	P
BRN6000-58	2.17-10.0- 6	1	
	2.17-10.0- 9	1	
BR9806A4-0096	2.12-62.0- 17	1	M
BSR6880	2.10-22.0- 3	1	P1
	2.10-22.0- 45	1	
	2.10-23.0- 3	1	
	2.10-23.0- 39	1	
BSSN10545	2.10- 7.0- 22	2	P1
BSSR25005	2.10-36.0- 3	1	
BT-1	2.21- 1.0- 1	2	
BT-101	2.21- 2.0- 46	2	
BT-104	2.21- 2.0- 42	2	
BT-105	2.21- 2.0- 97	1	
BT-106	2.21- 2.0- 96	1	
BT-110	2.21- 2.0- 52	1	
BT-110-1	2.21- 2.0- 52	1	
BT-111	2.21- 2.0- 53	1	

PART NUMBER	FIGURE AND INDEX NUMBER	QTY PER ART	SMR CODE
BT-112	2.21- 2.0- 99	1	
BT-113	2.21- 2.0-100	1	
BT-114	2.21- 2.0-106	1	
BT-115	2.21- 2.0-105	1	
BT-116	2.21- 2.0-104	1	
BT-117	2.21- 2.0-103	1	
BT-119	2.21- 2.0-102	1	
BT-120	2.21- 2.0- 81	1	
BT-121	2.21- 2.0- 78	1	
BT-123	2.21- 2.0- 54	2	
BT-124	2.21- 2.0- 76	1	
BT-125	2.21- 2.0- 25	1	
BT-126	2.21- 2.0- 79	1	
BT-127	2.21- 2.0- 77	1	
BT-128	2.21- 2.0- 80	1	
BT-131	2.21- 2.0- 56	2	
BT-132	2.21- 2.0-107	1	
BT-133	2.21- 2.0- 59	1	
BT-134	2.21- 2.0- 61	2	
BT-135	2.21- 2.0- 4		
BT-137	2.21- 2.0- 25	1	
BT-138	2.21- 1.0- 6	1	
	2.21- 2.0- 18	1	
BT-142-S	2.21- 2.0- 55	2	
BT-144	2.21- 2.0- 93	1	
BT-146	2.21- 2.0- 90	1	
BT-147	2.21- 2.0- 82	1	
BT-160	2.21- 2.0- 31	2	
BT-161	2.21- 2.0- 30	1	
BT-162	2.21- 2.0- 24	2	
BT-164	2.21- 2.0- 68	1	
BT-165	2.21- 2.0- 22	2	
BT-166	2.21- 2.0- 26	2	
BT-168	2.21- 2.0- 23	2	
BT-171	2.21- 2.0- 19	1	
BT-172	2.21- 2.0- 33	2	
BT-173	2.21- 2.0- 73	1	
BT-174	2.21- 2.0- 35	1	
BT-175	2.21- 2.0- 71	1	
BT-177	2.21- 2.0- 37	2	
BT-178	2.21- 2.0- 36	2	
	2.21- 2.0- 36	2	
BT-179	2.21- 6.0- 9	2	
BT-180	2.21- 2.0- 61	2	
	2.21- 2.0- 62	2	
BT-181	2.21- 2.0- 66	1	
BT-183	2.21- 2.0- 21	2	
BT-184	2.21- 2.0- 70	1	
BT-185	2.21- 2.0- 32	1	
BT-186	2.21- 6.0- 2	1	
BT-189	2.21- 6.0- 1	1	
BT-190	2.21- 2.0- 27	1	
BT-191	2.21- 6.0- 7	1	
BT-192	2.21- 6.0- 13	1	
	2.21- 6.0- 14	1	
	2.21- 6.0- 15	1	
BT-196	2.21- 6.0- 8	1	
BT-198	2.21- 4.0- 26	2	
BT-2	2.21- 1.0- 2	2	
BT-200	2.21- 6.0- 4	1	
BT-201	2.21- 3.0- 3	1	
BT-202	2.21- 3.0- 1	6	
BT-203	2.21- 3.0- 4	2	
BT-205	2.21- 2.0- 83	2	
	2.21- 3.0- 2	2	

PART NUMBER	FIGURE AND INDEX NUMBER	QTY PER ART	SMR CODE
BT-206	2.21- 2.0- 83	2	
BT-207	2.21- 3.0- 2	2	
BT-208	2.21- 2.0- 28	2	
	2.21- 2.0- 29	2	
BT-210	2.21- 2.0- 69	1	
BT-211	2.21- 6.0- 12	2	
BT-225	2.21- 4.0- 54	2	
BT-226	2.21- 4.0- 49	2	
BT-227	2.21- 4.0- 1	2	
BT-228	2.21- 4.0- 2	2	
BT-229	2.21- 4.0- 4	2	
BT-230	2.21- 4.0- 6	2	
BT-231	2.21- 4.0- 7	2	
BT-232	2.21- 4.0- 11	2	
BT-233	2.21- 4.0- 13	2	
BT-234	2.21- 4.0- 10	2	
BT-236	2.21- 4.0- 15	2	
BT-237	2.21- 4.0- 17	2	
BT-237-1	2.21- 4.0- 17	2	
BT-238	2.21- 4.0- 14	2	
	2.21- 4.0- 18	2	
BT-238-1	2.21- 4.0- 19	2	
BT-239	2.21- 4.0- 24		
BT-240	2.21- 4.0- 23	2	
BT-241	2.21- 4.0- 25	2	
BT-242	2.21- 4.0- 8	2	
BT-243	2.21- 4.0- 9	2	
BT-244	2.21- 4.0- 39	2	
BT-245	2.21- 4.0- 27	2	
	2.21- 4.0- 29	2	
	2.21- 4.0- 30	2	
	2.21- 4.0- 31	2	
	2.21- 4.0- 32	2	
	2.21- 4.0- 33	2	
	2.21- 4.0- 34	2	
	2.21- 4.0- 35	2	
	2.21- 4.0- 36	2	
	2.21- 4.0- 37	2	
	2.21- 4.0- 38	2	
	2.21- 4.0- 40	2	
	2.21- 4.0- 41	2	
	2.21- 4.0- 42	2	
BT-246	2.21- 4.0- 28	2	
BT-249	2.21- 4.0- 53	2	
BT-250	2.21- 4.0- 43	1	
	2.21- 4.0- 44	1	
BT-251	2.21- 4.0- 50	2	
BT-252	2.21- 4.0- 51	2	
	2.21- 4.0- 52	2	
BT-253	2.21- 4.0- 47	2	
BT-254	2.21- 4.0- 55	2	
	2.21- 4.0- 56	2	
BT-257	2.21- 4.0- 45	1	
BT-258	2.21- 4.0- 3	2	
BT-259	2.21- 4.0- 5	2	
BT-260	2.21- 4.0- 12	2	
BT-261	2.21- 4.0- 16	2	
BT-261-1	2.21- 4.0- 16	2	
BT-262	2.21- 4.0- 20	2	
BT-263	2.21- 4.0- 22	2	
BT-264	2.21- 4.0- 21	2	
BT-3	2.21- 1.0- 3	2	
BT-4	2.21- 1.0- 4	2	
BT-54	2.21- 2.0- 84	1	
BT-56	2.21- 2.0- 85	1	

PART NUMBER	FIGURE AND INDEX NUMBER	QTY PER ART	SMR CODE
BT-56	2.21- 5.0- 3	2	
BT-57	2.21- 2.0- 87	1	
BT-58	2.21- 2.0- 1	1	
BT-63	2.21- 2.0- 4	1	
BT-64	2.21- 2.0- 64	1	
BT-65	2.21- 2.0- 11	1	
BT-68	2.21- 2.0- 89	2	
BT-69	2.21- 2.0- 10	2	
BT-70	2.21- 2.0- 12	1	
BT-71	2.21- 2.0- 65	1	
BT-72	2.21- 2.0- 92	1	
BT-73	2.21- 2.0- 5	1	
BT-74	2.21- 2.0- 5	1	
BT-75	2.21- 2.0- 11	1	
BT-76	2.21- 2.0- 17	2	
BT-77A	2.21- 2.0- 9		
BT-78	2.21- 2.0- 15	1	
BT-8	2.21- 1.0- 5	2	
BT-80	2.21- 2.0- 14	2	
BT-81	2.21- 2.0- 91	4	
BT-82	2.21- 2.0- 16	2	
BT-83	2.21- 2.0- 16	2	
BT-84	2.21- 2.0- 40	4	
BT-86	2.21- 2.0- 20		
BT-87	2.21- 2.0- 51	2	
BT-88	2.21- 2.0- 41	2	
	2.21- 2.0- 49	2	
	2.21- 2.0- 74	1	
BT-89	2.21- 2.0- 47	2	
BT-90	2.21- 2.0- 48	2	
BT-91	2.21- 2.0- 50	2	
BT-92	2.21- 2.0- 50	2	
BT-93	2.21- 2.0- 44	8	
BT-95	2.21- 2.0- 38	1	
BT-96	2.21- 2.0- 67	1	
BT-97	2.21- 2.0- 45	1	
BT-98	2.21- 2.0- 95	1	
BT-99	2.21- 2.0- 94	1	
BT0176	2.21- 2.0- 34	1	
BUORD643019	2.15-17.0- 30	3	
B2949	2.17-11.0-136	1	
	2.17-11.0-144	1	
	2.17-11.0-148	1	
B2950	2.17-11.0-140	1	
	2.17-11.0-144	1	
B2959	2.17-11.0-132	1	
B5325-1-24	2.15- 5.0- 11	1	
	2.15- 5.0- 11	1	
B5325A1	2.15- 5.0- 11	RF	
	2.15- 5.0- 11	RF	
B5325A1-24	2.15- 5.0- 11	RF	
	2.15- 5.0- 11		
B541DD	2.14-28.0- 10	2	
	2.14-29.0- 15	4	
	2.14-29.0- 9	4	
B542DD	2.14-12.0- 23	1	
	2.14-42.0- 19	2	
	2.14-42.0- 19	RF	
	2.14-42.0- 22	2	
B542DDC 7414	2.14-42.0- 22	RF	
	2.14-12.0- 23	113	
	2.14-42.0- 19	2	
	2.14-42.0- 22	2	
B544DD	2.14-28.0- 8	2	
B545DD	2.14- 9.0- 77	1	
	2.14- 9.0- 84	1	

PART NUMBER	FIGURE AND INDEX NUMBER	QTY PER ART	SMR CODE
B545DDE7414	2.14- 9.0- 77	1	
	2.14- 9.0- P4	1	
B6610	2.16- 1.0- 76	1	
B6611	2.16- 1.0- 48	3	
B8126	2.14-24.0- 27	1	
B8308-5	2.17- 1.0- 14	1	
B8452-1	2.17- 1.0- 30	1	
B8785-2	2.16- 1.0- 22	4	ALT
	2.16- 8.0- 18	1	
B9285-4	2.17- 1.0- 33	1	
B9285-5	2.17- 1.0- 12	1	
B9750-2	2. 5- 1.0- 5	1	
C-6280(P)APY	2.16- 8.0- 8	1	
C-8886	2.10-7.0-176	1	P1
CA022181-0014	2.12-10.0-	1	P1
CA06AQL16S-1P	2.12-10.0-	1	P1
CA22182-116	2.12-10.0-	1	P1
CA3106R-16S-1			
S	2.17-43.0- 1	1	
CF14-100	2.12-12.0- 3	1	P1
CF14-150	2.12-49.0- 16	4	P1
CF14-200	2.12-15.0- 9	1	P1
	2.12-55.0- 15	1	
	2.12-61.0- 3	3	
CF14-300	2.12-52.0- 70	6	P1
CH09A1NC105K	2.17-41.0- 6	1	P1
CL-236	2.17-11.0-124	RF	
CLC-C6	2.20-12.0- 26	14	
	2.20-12.0- 9	28	
COML#376	2.17- 1.0- 10	3	
CPU4/A	2.18- 1.0- 9	1	
CP53B1EF205K	2.14- 8.0- 78	2	P1D
CR295800CC6-01			
42	2.15-26.0- 22	2	
CR295800CC6-01			
42	2.15-26.0- 6	1	
CR295800CC6-01			
42	2.15-26.0- 9	1	
CR295870-CC4-0			
156	2. 9-21.0- 45		
CR295870-4-013			
4	2. 8-13.0- 9	1	
CR295870-4-013			
6	2. 8-16.0- 24	1	
CR295870-4-013			
6	2. 8-16.0- 32	1	
CR295870-4-013			
6	2. 8-16.0- 76	1	
CR295870-4-014			
3	2. 8-16.0- 66	1	
CR295870-4-015			
0	2. 9-25.0- 60		
CR295870-4-015			
5	2. 9-25.0- 61		
CR295870-4-018			
0	2. 8-16.0- 36	1	
CR295870-4-018			
0	2. 8-16.0- 88	1	
CR295870CC-4-0			
136	2. 8-13.0- 22	1	
CR295870CC4-01			
46	2. 8-21.0- 24	1	
CR295870CC4-01			
52	2. 8-21.0- 18	1	
CR295870CC4-01			
56	2. 8-20.0- 19	1	

PART NUMBER	FIGURE AND INDEX NUMBER	QTY PER ART	SMR CODE
CR295870CC4-01			
56	2. 8-20.0- 7	1	
CR295870CC4-01			
56	2. 8-21.0- 41	1	
CR295870CC4-01			
56	2. 8-21.0- 48	0	
CR697-1	2.12-35.0- 30	1	P1
CR697-3	2. 3-14.0- 17	1	P1
CR697-5	2.12-35.0- 33	4	P1
	2.12-35.0- 45	1	
	2.12-35.0- 46	1	
CR697-7	2. 2- 9.0- 51	1	P1
	2. 2- 9.0- 53	1	
	2.14-22.0- 14	1	P1
CR704	2. 4-12.0- 52	RF	
C11479-1	2. 4-12.0- 52	RF	
C11479-2	2. 4-12.0- 10	1	P1
C11487-1	2.12-59.0- 8	1	
C195-01	2.12-64.0- 18	1	
C3025	2.14-11.0- 17	1	P1
C3026	2.14- 2.0- 1	1	P1
C3125C	2.10- 7.0- 45	2	P
C4108-4	2. 7- 2.0- 8	1	P1
C7505	2.10- 3.0- 14	4	P1
	2.10- 3.0- 20	1	
C7505-2	2.10- 3.0- 13	4	P1
	2.10- 3.0- 20	1	
C7745-8	2.13-13.0- 7	2	P1
C8885	2.10-18.0- 21	1	P1
C8886	2.10- 7.0-176	1	P1
C9111	2. 8-12.0- 88	1	P1
	2.14-35.0- 36	1	
	2.14-37.0- 42	1	
C9520-1	2. 4-12.0- 71	2	P1
C9660	2.10-18.0- 15	1	P
	2.10-18.0- 16	1	
DC10786-5	2.17- 8.0- 11	1	
DC266-20	2. 9- 1.0- 25	1	
DF30	2.17-40.0- 9	1	
DF6C	2.17-40.0- 9	2	
DREMHDS-6-065	2. 8-28.0- 6	1	
DR266-20	2. 3- 4.0- 29	RF	
DW4K	2.14-13.0- 4	1	P1
	2.14-18.0- 31	1	
	2.14-18.0- 47	1	
	2.14-18.0- 70	1	
	2.14-40.0- 8	1	
DW4KE6536	2.14-13.0- 4	RF	P1
	2.14-40.0- 8	RF	P1
DW4KE6549	2.14-13.0- 4	1	
	2.14-40.0- 8	1	
DW4KE7414	2.14-13.0- 4	1	P1
	2.14-18.0- 31	1	
	2.14-18.0- 47	1	
	2.14-18.0- 70	1	
	2.14-23.0- 67	1	
	2.14-40.0- 8	1	
DW5	2.14-16.0- 6	1	P1
DW5E7414	2.14-16.0- 6	1	P1
	2.14-23.0-116	1	
DW6	2.14-19.0- 6	1	P1
DYLZ5701	2.13-24.0- 12	1	P1
D100P	2. 4-11.0- 23	1	
D100U	2. 9- 1.0- 26	RF	
D1805	2.13-18.0- 12	1	P1
D6272-1	2. 6-19.0- 1	2	P
	2. 6-19.0- 16	1	

PART NUMBER	FIGURE AND INDEX NUMBER	QTY PER ART	SMR CODE
D6272-1	2.18- 3.0- 9	2	P
D7271-3-10	2.17-21.0- 9	14	
	2.17-23.0- 10	8	
	2.17-26.0- 7	8	
	2.17-27.0- 7	8	
	2.17-28.0- 6	8	
	2.17-30.0- 5	1	
	2.17-33.0- 16	3	
	2.17-35.0- 10	4	
D7271-3-15	2.17-21.0- 17	1	
	2.17-23.0- 11	1	
	2.17-33.0- 11	20	
	2.17-38.0- 6	3	
D7271-3-20	2.17-21.0- 18	1	
	2.17-23.0- 17	1	
D7271-3-3	2.17-23.0- 9	1	
	2.17-29.0- 5	1	
	2.17-31.0- 7	2	
D7271-3-5	2.17-21.0- 8	34	
	2.17-23.0- 8	34	
	2.17-26.0- 6	25	
	2.17-28.0- 5	26	
	2.17-29.0- 8	28	
	2.17-30.0- 4	2	
	2.17-31.0- 6	26	
	2.17-33.0- 9	36	
	2.17-35.0- 9	36	
	2.17-38.0- 5	4	
D8453-1	2.17- 1.0- 19	1	
EA1565-541	2. 8-23.0- 47	1	
EA50004-3	2.8-1.0-41	1	
EA50004-5	2. 8- 1.0- 41	1	P1
EA50004-6	2.8 - 1.0 - 41	1	
EA50040-2	2.17- 8.0- 33	1	P1
EA50040-2A	2.17- 8.0- 33	1	P1
EA50040-2AB	2.17- 8.0- 33	RF	P1
EB048	2.15- 5.0- 17	1	
EB064	2. 4- 9.0- 28	4	
EC97K	2.20-23.0- 8	2	
	2.20-31.0- 42	2	
EGU17A	2.16-18.0- 4	1	
EN22M428	2.20-12.0- 11	6	
EP135-106V	2.17-12.0- 1	1	
ER1833-3	2. 9-25.0- 71	1	P1
ER2840060604	2.12-46.0-162	2	
ER776-12	2.10-17.0- 12	1	
	2.10-18.0- 9	1	
ER776-4	2.12-62.0- 5	1	
ER8040060604	2.12-32.0- 45	1	
	2.12-46.0- 62	1	
ER8040060804	2. 9-31.0- 13	1	P1
ER8040121204	2. 8-10.0- 44	1	
ER80406-6-4	2. 8- 9.0- 32	1	
ER816-4	2.14- 4.0- 51	1	
ER81600406	2. 9-20.0- 6	1	P1
ER81600602	2.14- 4.0- 42	2	P1
ER81606-2	2.14- 4.0- 47	2	
	2.14- 4.0- 52	1	
ER82200602	2.14- 4.0- 39	2	P1
ER8240060604	2. 8-10.0- 83	1	
	2. 8-10.0- 91	1	
	2.12-21.0-137	1	
	2.12-22.0-100	1	
	2.12-22.0-134	1	
	2.12-32.0- 9	1	
	2.12-44.0- 20	1	

PART NUMBER	FIGURE AND INDEX NUMBER	QTY PER ART	SMR CODE
ERR240060604	2.12-44.0- 86	1	
	2.12-44.0- 9	1	
	2.12-46.0- 66	1	
	2.12-46.0-199	1	
	2.12-46.0-205	1	
	2.12-46.0- 86	1	
	2.12-46.0-113	1	
	2.12-46.0-130	1	
ER8240060606	2. 8-12.0- 60	1	P1
	2. 8-12.0-168	1	
ER8240100606	2. 8-12.0- 17	1	P1
	2. 8-12.0-114	1	
ER8240101004	2. 9-23.0- 22	1	P1
ER8240101016	2. 8-10.0- 17	1	
ER8240120612	2. 8-11.0- 14	1	
ER8240121204	2.13-15.0- 52	1	
	2.13-15.0- 53	1	
ER8240121208	2. 8-10.0- 47	1	
	2. 8-11.0- 7	1	
ER8240060604	2.12-46.0-132	1	
ER827012081208	2. 8-12.0-152	1	
ER83200405	2. 8-23.0- 27	1	1
ER83200604	2.8-23.0- 56	2	
ER8340060608	2. 9-30.0- 14	1	
ER8340080610	2. 9-29.0- 5	1	
	2. 9-29.0- 59	1	
ER837-0406	2.14- 4.0- 50	1	1
EWB22-4-19	2.10-34.0- 5	2	
EWB22-4-22	2.10-38.0- 6	2	
EWB22-6-20	2.15-37.0- 22	2	
EWB22-7-25	2.11- 5.0- 8	1	
EWN22-4	2.10-38.0- 2	4	
	2.20-22.0- 3	2	
EWN22-6	2.15-37.0- 20	2	
EWN22-7	2.11- 5.0- 5	1	
EXG20SC	2.12- 5.0- 7	1	
EX06-AS1S	2.10-34.0- 4	1	P1
	2.10-35.0- 6	1	
F4747-1	2. 4- 9.0- 8	1	
F-8300-20	2.12-10.0- 34	1	
FC2-173	2.11- 8.0- 12	1	P1
FC2-173A	2.11- 8.0- 10	1	P1
FC2-73	2.11- 8.0- 10	RF	
FC2-73A	2.11- 8.0- 10	RF	
FG1A18	2.12- 1.0- 59	1	P1
FG220A60	2.12- 7.0- 8	1	P1
FG220A61	2.12- 7.0- 4	1	P1
FG220A62	2.12- 7.0- 14	1	P1
FG220A63	2.12- 7.0- 11	1	P1
FG220A64	2.12- 8.0- 9	1	P1
FG220A65	2.12- 8.0- 6	1	P1
FG220A66	2.12- 8.0- 18	1	P1
FG220A67	2.12-52.0- 67	1	P1
FG220A68	2.12- 8.0- 12	1	P1
FG220A75	2.12- 8.0- 3	1	P1
FG220A76	2.12- 8.0- 3	1	P1
FHN26*	2.18-23.0- 14	1	

PART NUMBER	FIGURE AND INDEX NUMBER	QTY PER ART	SMR CODE
FIH60T5	2.17-38.0- 7	7	
	2.18- 5.0- 7	10	
FILO5T5	2.17-38.0- 5	4	
	2.18- 5.0- 1	10	
FIL15T5	2.17-38.0- 6	3	
FN22M-720	2.20-14.0- 1	2	
FN22M428	2. 4- 2.0- 28	2	
FN22M524	2.15-30.0- 10	4	
	2.11- 3.0- 5	2	
FN22M624	2.15-30.0- 1	2	
	2.15-30.0- 7	2	
FP19	2.11- 3.0- 2	2	
	2.15-30.0- 41	6	
FP25	2.12-60.0- 22	2	P1
FSCM12439	2.12-60.0- 19	2	P1
FV400-77	2. 9-12.0- 2	2	
FV756	2.12-10.0- 9	1	P1
FZC-4-021	2.12-10.0- 9	1	
F02A25C1	2.18-38.0- 12	2	
FIH60T5	2.18-23.0- 13	1	
	2.20- 3.0- 18	1	

PART NUMBER	FIGURE AND INDEX NUMBER	QTY PER ART	SMR CODE
F1066502-5	2.16- 8.0- 3	1	P1
F200-E	2.18- 3.0- 3	AR	
F200-7	2.18- 3.0- 2	AR	
F280-1F	2.16- 8.0- 17	1	P1
	2.17-11.0- 09	REF	
F361-1121-3	2. 4-11.0- 9	1	A
F361-1301-1	2. 4-11.0- 10	1	P1
F361-1303-2	2. 4-11.0- 11	1	
F377-1A	2.16-17.0- 1	1	
F377-1A1	2.16-17.0- 2	1	
F377-1A10	2.16-17.0- 13	1	
F377-1A11	2.16-17.0- 14	1	
F377-1A12	2.16-17.0- 15	1	
F377-1A13	2.16-17.0- 16	1	
F377-1A14	2.16-17.0- 17	1	
F377-1A16	2.16-17.0- 12	1	
F377-1A2	2.16-17.0- 3	1	
F377-1A21	2.16-17.0- 20	1	
F377-1A22	2.16-17.0- 21	1	
F377-1A23	2.16-17.0- 22	1	
F377-1A24	2.16-17.0- 23	1	
F377-1A27	2.16-17.0- 19	1	P1
F377-1A28	2.16-17.0- 20	1	
F377-1A3	2.16-17.0- 4	1	
F377-1A35	2.16-17.0- 11	1	P1
F377-1A37	2.16-17.0- 18	1	
F377-1A39	2.16-17.0- 24	1	P1
F377-1A4	2.16-17.0- 5	1	
F377-1A5	2.16-17.0- 6	1	
F377-1A6	2.16-17.0- 7	1	
F377-1A7	2.16-17.0- 8	1	
F377-1A8	2.16-17.0- 9	1	
F377-1A9	2.16-17.0- 10	1	
F5000-10-1032	2. 7- 1.0- 26	1	
F52LH4367-02	2. 7-10.0- 10	32	
F60F1249	2.12-40.0- 16	6	
F60F1251	2.12-40.0- 18	2	
F7890	2.12- 1.0- 56	1	P1
GB59	2.12- 1.0- 98	1	
	2.15- 8.0- 38	1	
GD10A	2.15- 9.0- 36	1	
	2.15-11.0- 37	1	
GF52434	2.13- 8.0- 29	1	
GH3-1-2	2.18-22.0- 12	1	P1
GJ1	2.20-17.0- 41	1	P
GMSC36-33P21-1	2.12-39.0- 28	1	
	-1-8	2.20-34.0- 1	1
GS02-14S5P111	2.15-17.0- 23	1	
GS02-28-12P112	2.14- 8.0- 6	1	P1D
GV31C-110	2.12-52.0- 20	2	P1
G143	2.12-64.0- 22	1	
	2.15- 9.0- 32	RF	
G146	2.15-11.0- 33	RF	
	2.15- 9.0- 16	RF	
G148	2.15-11.0- 17	RF	
	2.15- 8.0- 24	RF	
G4Y17	2.15- 8.0- 28	RF	
	2.15- 9.0- 20	RF	
GB450-1	2.15-11.0- 21	RF	
GB455-1	2. 2- 3.0- 64	1	P1
HELS-4	2.17- 1.0- 33	1	P1
HE4SAF1	2.17- 1.0- 7	1	P1
	2.15-13.0- 29	1	P1
	2.20-20.0- 12	2	

PART NUMBER	FIGURE AND INDEX NUMBER	QTY PER ART	SMR CODE
HE4SAF1	2.22-23.0- 6	1	
HE5-4	2.15-13.0- 28	1	
HE6-2F	2.15-22.0- 46	2	P1
	2.15-23.0- 47	2	P1
HE6-4MIL6327R	2.22-23.0- 7	2	P1
HFL3	2. 8- 7.0- 15	1	
HF3G	2. 8- 7.0- 14	1	P1
HL329-5-4	2.20-16.0- 41	5	
HP457100-1	2. 2-21.0- 32		P1
HP466100-5	2.15- 1.0- 2	RF	
HP521100	2.11- 8.0- 14	1	P1
HP542100-1	2. 7- 1.0- 2	1	P1
HP542100-3	2. 7- 1.0- 34	1	P1
	2. 8-28.0- 33	1	
	2.11- 1.0- 18	1	
HP595100-1	2. 8-21.0- 32	1	
HP865100	2. 8-28.0- 44		
HRBM3	2.13-30.0- 39	1	P1
HRBM3ENFN	2. 4-12.0- 25	1	
HR10233	2.10-19.0- 4	1	P1
HS-51163	2.16-33.0- 14	1	
HSBG4	2.20-26.0- 12	1	P1
HSBG4S	2.15-22.0- 9	1	P1
HSBG4S	2.15-23.0- 33	1	
HSBG5SA	2.15- 1.0- 47	RF	
HSBG5SSA	2.15- 1.0- 47	2	P1
HSBY4CR	2.10- 7.0- 40	1	P1
HS4004	2.11- 2.0- 6	1	
HS4005	2.11- 2.0- 6	1	
HS48152	2.17- 9.0- 11	1	
HS51026	2.14-10.0- 26	1	P1
HS595350-1	2.13- 9.0- 56	RF	
HTG-7	2.14- 7.0- 11	2	P1
	2.14- 8.0- 56	2	
HUC00008-33	2.21- 5.0- 1	2	
H10-06	2.16- 3.0- 3	2	
H117-3AC	2.20-42.0- 16	1	
	2.20-42.0- 2	2	
H12-1000	2. 7- 3.0-138	1	PT
H12-1001	2. 7- 3.0-139	RF	
H12-27	2. 4-12.0-146	1	P1
	2.15-24.0- 12	1	
	2.15-26.0- 11	1	
	2.15-32.0- 1	1	
H154C	2.16-25.0- 21	1	P1
H15501	2.16-25.0- 10	1	
H15601	2.16-24.0- 1	1	P1
H19300-5	2.6-32.0-39.2	4	
	2.6-32.0-39.5	6	
H19300-6	2.6-32.0-40.1	12	
	2.6-32.0-40.2	6	
H19300-7	2.6-32.0-40.3		
H39794-3	2. 4- 1.0- 29	81	P1
H4CR	2.10- 7.0- 38	1	X1
H5000-040-196	2. 4- 0.0- 47	1	P1
H5000-081-091	2. 2- 3.0- 3	1	P1
H5000115-179	2.20-42.0- 15	1	
H57-11	2. 3-16.0- 10	4	P1
H57-13	2. 3-16.0- 26	4	
HMS35	2.12-68.0- 98	1	
IN1200	2.18-33.0- 19	2	
IN645	2.18-23.0- 20	6	
JANIN459	2.14- 8.0- 95	2	
JANIN1202A	2.17-40.0- 9	5	P1
JAN5787WA	2.14- 8.0- 48	2	P10
JAN6111	2.14- 8.0- 46	1	P10
JAN6112	2.14- 8.0- 47	2	P10
JB7782-4	2.16- 5.0- 6	6	

PART NUMBER	FIGURE AND INDEX NUMBER	QTY PER ART	SMR CODE
JFB	2. 4- 3.0- 45	1	P1
	2. 4-12.0- 65	2	P1
	2. 4-12.0-112	1	
J6183A14	2.16- 8.0- 4	1	
J6402A10	2.16- 1.0- 87	1	P1
J1403A10	2.16- 2.0- 65	1	
JP0025SH116	2.10-28.0- 20	1	
JP0025SH36	2.10-17.0- 12	4	
JP0025SH39	2.10-17.0- 12	1	
JP0025SH16	2.10-17.0- 12	2	
	2.10-19.0- 38	1	
	2.10-24.0- 16	1	
JP0025SH40	2.10-11.0- 18	1	
J7204-1	2.10-21.0- 19	2	P1
	2.10-27.0- 15	2	
J75P17	2.10- 7.0-216	1	
KE14-5	2.17- 8.0- 65	RF	
KIT-1A	2.18-18.0- 15	1	
KM835-10	2. 2- 4.0- 6	2	P1
KM835-12	2. 2- 4.0- 5	1	
KM835-15	2. 2- 4.0- 4	18	
KM835-18	2. 2- 4.0- 7	3	
KM835-20	2. 2- 4.0- 6	7	
KM835-25	2. 2- 4.0- 3	2	
KM835-29	2. 2- 4.0- 10	1	
KM836-8	2. 2- 5.0- 12	43	
KM837-10	2. 2- 5.0- 8	1	
KM837-12	2. 2- 5.0- 7	3	
KM837-6	2. 2- 5.0- 10	36	
	2. 2- 5.0- 11	6	
KM837-8	2. 2- 5.0- 11	4	
	2. 2- 5.0- 9	3	
KF12AE7164	2.14-25.0- 18	2	
KP12AE7416	2.14-25.0- 18	2	P1
KP21BE7414	2.14-42.0- 26	2	
	2.14-42.0- 31	2	
KF29BK	2.14-20.0- 20	1	P1
	2.14-20.0- 29	1	
	2.14-20.0- 62	1	
	2.14-20.0- 72	1	
KP29BKF 7414	2.14-20.0- 25	1	P1
	2.14-20.0- 29	1	
	2.14-20.0- 62	1	
	2.14-20.0- 72	1	
KP4AE7414	2.14-10.0- 41	1	P1
	2.14-10.0- 42	1	
	2.14-10.0- 48	1	
	2.14-18.0- 55	1	
	2.14-18.0- 63	1	
	2.14-23.0- 45	2	
	2.14-23.0-126	2	
	2.14-23.0-148	2	
	2.14-23.0-187	2	
	2.14-33.0- 11	2	
	2.14-36.0- 6	2	
KP4AE7414	2.14-23.0-111	1	P1
KP49BS	2. 7- 8.0- 12	1	P1
KP5AE7414	2.14-10.0- 61	2	
	2.14-23.0-109	2	
KP6AE7414	2.14-10.0- 76	2	
	2.14-23.0- 27	2	
	2.14-23.0- 38	2	P1
KSBY1 CRA	2.20-11.0- 74	1	P1
KSBY7-1	2.20-11.0- 37	1	
	2.20-11.0-109	1	
KS16-2	2.11- 8.0- 47	2	P1
KS4A	2.14- 9.0- 13	1	P1

106A-4

NUMBER	FIGURE AND INDEX NUMBER	QTY PER ART	SMR CODE
	2.14-10.0-19	1	
	2.14-10.0-19	RF	
	2.14-10.0-48	1	
	2.14-12.0-5	2	
	2.14-26.0-26	2	
	2.14-27.0-12	1	P1
	2.14-32.0-17	1	
	2.14-3.0-13	1	
4AE7414	2.14-10.0-19	1	
	2.14-12.0-5	1	
	2.10-4.0-11	1	
4AE7416	2.10-5.0-15	1	
	2.10-5.0-23	2	P1
	2.14-16.0-64	2	
S4E7414	2.14-23.0-42	2	
	2.14-23.0-97	1	
	2.10-4.0-21	1	
	2.10-5.0-16	2	P1
(S4E7416	2.14-18.0-21	1	
	2.14-16.0-38	1	
KS6A	2.14-16.0-80	1	
	2.14-18.0-21	1	
	2.14-18.0-80	1	
KS6AE7414	2.4-12.0-29	1	P1
	2.20-11.0-41	1	
KWB20-1SS	2.20-11.0-113	1	
KWB7-5	2.20-11.0-76	1	P1
	2.18-37.0-1	1	P1
KWE9-5	2.9-4.0-52	1	
KU74-0117	2.9-9.0-46	1	
K1280-4-2	2.9-9.0-58	6	
K1353-4-3	2.6-32.0-40.2	4	
	2.6-32.0-39.2	6	
K19300-6	2.6-32.0-39.5	12	
K19301-5	2.6-32.0-40.1	6	
	2.6-32.0-40.2	6	
	2.6-32.0-40.3	1	
K19301-6	2.18-35.0-1	2	P1
	2.8-3.0-1	1	P1
K19301-7	2.8-3.0-9	1	P1
K19502F4A	2.12-16.0-9	AF	
K297-6	2.12-18.0-9	AF	
K41866	2.9-17.0-104	2	P1
K41866-1	2.16-7.0-11	2	
K5400-.460	2.18-12.0-10	1	P1
K568-4	2.16-13.0-2	6	
K806-14	2.6-38.0-1	10	
LA2540-8.75	2.6-38.0-16	5	
LC-C6	2.7-8.0-16	4	
	2.15-14.0-41	4	
	2.15-28.0-8	5	
	2.10-30.0-10	4	
	2.10-6.0-40	1	
	2.17-11.0-2	RF	
LC-C8	2.4-12.0-133	1	P1
LC-R6	2.12-58.0-7	1	
LCZ7RT2	2.17-5.0-6	3	P1
LDNS9-19	2.18-21.0-13	1	
L1552	2.9-18.0-30	1	
MCC7711	2.9-18.0-73	1	
MC140508A1	2.9-18.0-114	1	P1
MC1624-3450	2.9-22.0-0	1	
	2.11-6.0-1	1	
MC1766-1	2.11-8.0-19	1	P
	2.15-12.0-9	2	
MD1503A-C	2.16-14.0-5	1	
MF1000-66	2.11-1.0-14	1	
MF98-1906-30	2.11-1.0-14	1	
	2.11-1.0-14	1	
	2.17-8.0-55	AF	P1

PART NUMBER	FIGURE AND INDEX NUMBER	QTY PER ART	SMR CODE
MIL-H-27267-4	2.9-16.0-16	4K	
	2.9-16.0-16	AR	
	2.9-16.0-23	AR	
	2.9-17.0-42	AR	
	2.9-17.0-47	AR	
	2.9-17.0-57	AR	
	2.9-17.0-51	AR	
	2.9-17.0-71	AR	
	2.9-17.0-78	AR	
	2.9-17.0-78	AR	
	2.9-17.0-90	AR	
	2.9-17.0-98	AR	
	2.9-17.0-104	AR	
	2.9-18.0-34	AR	
	2.9-18.0-77	1	
	2.9-18.0-28	2	
	2.15-2.0-10	2	
	2.15-5.0-27	2	
	2.15-11.0-24	2	
	2.2-7.0-23	3	
	2.2-7.0-23	1	
	2.12-16.0-175	4	
	2.10-7.0-152	1	
	2.20-31.0-74	4	P1
	2.18-25.0-5	56	
	2.11-6.0-48	1	
	2.15-23.0-65	1	
	2.2-7.0-12	1	
	2.2-7.0-13	1	
	2.15-7.0-80	2	
	2.2-11.0-4	1	P1
	2.2-11.0-2	1	
	2.17-41.0-12	1	
	2.20-44.0-30	1	
	2.7-3.0-19	1	
	2.7-5.0-12	1	
	2.14-10.0-40	4	
	2.18-36.0-7	1	
	2.10-28.0-25	4	
	2.10-31.0-12	1	
	2.12-18.0-12	1	
	2.12-18.0-13	1	
	2.20-44.0-49	1	P1
	2.20-57.0-6	1	
	2.16-23.0-2	2	
	2.20-22.0-22	1	
	2.20-21.0-22	1	
	2.5-5.0-19	1	
	2.20-44.0-34	1	A
	2.17-41.0-10	1	
	2.17-2.0-1	1	P1
	2.17-41.0-11	1	
	2.17-20.0-7	1	
	2.9-5.0-22	1	
	2.12-45.0-31	1	
	2.9-7.0-23	1	
	2.20-45.0-20	1	
	2.5-16.0-20	4	
	2.4-16.0-38	4	
	2.15-31.0-9	4	
	2.12-16.0-17	1	
	2.2-10.0-72	56	
	2.10-40.0-14	2	
	2.10-40.0-8	2	
	2.6-6.0-41	1	
	2.20-14.0-3	1	
	2.14-15.0-123	1	
	2.5-5.0-44	1	
	MS-24694-52		
	MS-34286-228		
	MS111204		
	MS122002		
	MS12465-8		
	MS14178-5		
	MS15001-1		
	MS15001-4		
	MS16108-20		
	MS16118-30		
	MS16212-12		
	MS16555-520		
	MS16595-626		
	MS16624-1243		
	MS16624-1675		
	MS16625-1256		
	MS16625-1200		
	MS16625-1075		
	MS16996-12		
	MS16996-9		
	MS16998-51		
	MS171413		
	MS171442		
	MS17325-5		
	MS17420-8		
	MS17981-2		
	MS17984-314A		
	MS17984C314A		
	MS17986-414		
	MS17986C-1215		
	MS18009-115-0		
	MS18029-125-1		
	MS18029-21		
	MS18113-1		
	MS182012		
	MS19006		
	MS191706		
	MS2001186-230		
	MS20002-13		
	MS20002-12		
	MS20002-14		
	MS20002-15		
	MS20002-4		
	MS20002-5		
	MS20002-6		
	MS20002-7		
	MS20002-8		
	MS20002-9		

MIL-E-4300B

PART NUMBER	FIGURE AND INDEX NUMBER	QTY PER ART	SMR CODE
MS20002C12	2. 6-16.0- 39	9	
MS20002C16	2. 6-16.0- 8	3	
MS20002C20	2. 6-16.0- 19	2	
MS20002C4	2. 2-10.0- 71	124	
MS20002C5	2. 1- 1.0- 67	82	
MS20002C6	2. 4- 9.0- 30	17	
MS20002C7	2. 6- 6.0- 40	5	
MS20002C8	2. 6-16.0- 3	6	
MS20002C9	2.10- 7.0- 26	5	
MS20004-10	2. 4- 2.0- 31	30	
MS20004-12	2.14- 9.0- 49	18	
MS20004-14	2. 2-10.0- 83	16	
MS20004-16	2. 2-10.0- 73	5	
MS20004-22	2.15-27.0- 38	8	
MS20004-28	2.20-33.0- 33	1	
MS20004-30	2.20-33.0- 33	RF	
MS20004-4	2.15- 5.0- 20	1	
MS20004-5	2.20-12.0- 13	6	
MS20004-6	2.18- 9.0- 5	10	
MS20004-8	2.15-36.0- 8	38	
MS20004H4	2.20-48.0- 82	4	
MS20004H6	2.20-31.0-108	4	
MS20005-10	2.20-28.0- 5	27	
MS20005-12	2.15-30.0- 2	14	
MS20005-14	2.15-30.0- 8	8	
MS20005-16	2.20-31.0- 91	13	
MS20005-18	2. 4-12.0- 91	4	
MS20005-20	2. 4-12.0- 90	2	
MS20005-22	2.15-19.0- 38	4	
MS20005-30	2.14-19.0- 14	1	
MS20005-8	2.15-36.0- 5	6	
MS20005H10	2.20-23.0- 13	8	
MS20005H16	2.11- 3.0- 9	2	
MS20006-10	2.10-40.0- 14	2	
MS20006-12	2.20-31.0- 90	2	
MS20006-14	2.20-31.0- 91	7	
MS20006-16	2. 4- 9.0- 31	4	
MS20006-20	2.10-36.0- 6	1	
MS20006-24	2.15-30.0- 44	4	
MS20006-28	2.15-30.0- 46	2	
MS20006-8	2.20-31.0- 92	1	
MS20006H10	2.11- 3.0- 1	AR	
MS20007-22	2. 6- 6.0- 42	12	
MS20008-22	2.20-14.0- 4	2	
MS20009H8	2.10- 7.0- 25	5	
MS20010-24	2. 6- 6.0- 45	9	
MS20010H28	2. 6-16.0- 32	2	
MS20010H30	2. 6-16.0- 31	2	
MS20012-18	2. 6-16.0- 40	3	
MS20012-22	2. 6-16.0- 41	3	
MS20012-26	2.15-30.0- 33	2	
MS20012-28	2.15-31.0- 22	1	
MS20012H24	2. 7- 5.0- 8	1	
MS20016-34	2.15-30.0- 37	1	
MS20052C5	2.11- 3.0- 9	2	
MS20073-04-30	2.10-29.0- 15	2	
MS20073-06-17	2.20-40.0- 13	2	
MS20074-03-04	2.15-38.0- 7	4	
MS20074-05-11	2.10- 7.0- 2	10	
MS20159-06K	2. 5-10.0- 34	2	
MS20178-3	2. 4- 7.0- 8	2	
MS20219A2	2. 7- 3.0-109	1	
MS20220A3	2.14-34.0- 10	6	
MS20230-B10	2. 5- 5.0- 21	1	
MS20253-1-129	2. 3-16.0- 5	1	
MS20253-1-155	2. 2- 3.0- 17	1	

PART NUMBER	FIGURE AND INDEX NUMBER	QTY PER ART	SMR CODE
MS20253-2-138	2. 5- 4.0- 27	RF	
MS20253-2-190	2. 2- 3.0- 1	2	
MS20253-2-226	2. 2-21.0- 14	3	
MS20253-2-248	2.20- 3.0- 6	1	
MS20253-2-351	2. 2-21.0- 13	1	
MS20253-2-388	2. 2- 9.0- 35	1	
MS20253-3-462	2. 2-21.0- 13	1	
MS20253-5-388	2. 2- 7.0- 50	1	
MS20253-846	2. 5- 7.0- 10	1	
MS20253P2-625	2.12- 9.0- 14	1	
MS20253P2-700	2.12- 9.0- 15	1	
MS20253P4-1600	2.20-21.0- 23	2	
MS20292-13	2. 4-12.0- 18	1	
MS20341-10S	2.16- 5.0- 40	16	
MS20341-105	2.17-40.0- 14	DO	
MS20341-65	2.17-36.0- 15	2	
MS20342-9	2. 4- 8.0- 61	1	
MS20364-1032	2. 4-11.0- 5	9	
MS20364-820	2. 4-11.0- 28	1	
MS2036401032	2.17-36.0- 4	4	
MS203640632	2. 7- 1.0- 16	2	
MS20365-1032	2.10- 7.0- 68	3	
MS20365-832	2.20-48.0- 58	4	
MS20365D440	2. 5- 1.0- 27	2	
MS20392-1-15	2.17-10.0- 5	1	
MS20392-1-63	2.13-22.0- 14	1	
MS20392-1-7	2. 2- 3.0- 38	3	
MS20392-1C21	2.10-30.0- 28	1	P1
MS20392-1015	2.18-25.0- 7	4	
MS20392-11	2. 4- 8.0- 55	1	
MS20392-19	2.20- 6.0- 5	2	
MS20392-2-11	2. 4- 6.0- 3	1	
MS20392-2-13	2. 4- 7.0- 57	2	
MS20392-2-25	2.10- 8.0- 5	8	
MS20392-2-41	2. 6-40.0- 12	2	
MS20392-2-51	2. 4- 9.0- 49	1	
MS20392-2-7	2. 4-11.0- 14	1	
MS20392-2C17	2. 2- 5.0- 19	4	
MS20392-2C19	2. 7- 3.0-102	3	
MS20392-2C23	2. 7- 3.0- 92	1	
MS20392-2C7	2. 4-11.0- 26	3	
MS20392-21	2. 4- 8.0- 65	1	
MS20392-3C19	2.12-68.0- 11	2	
MS20392-7	2. 5- 4.0- 20	RF	
MS20392-7C55	2. 7- 3.0- 52	1	
MS20426AD3	2. 4- 8.0- 45	1	
MS20426AD3-4	2.12-10.0- 67	8	
MS20426AD3-6	2.18- 6.0- 55	16	
MS20426AD3-7	2.12-10.0- 5	86	
MS20426AD3-8	2.15-30.0-23A	2	
MS20426AD3-8	2.15-31.0-43	12	
MS20426AD5-14	2.12-39.0- 37	2	
MS20426AD5-6	2.18- 6.0- 51	1	P1
MS20426A3-5	2.10-33.0- 3	8	P1
MS20426B6	2. 2-10.0- 14	1	
MS20426D3-6	2. 4- 7.0- 8	4	
MS20435F4-5	2.12-18.0- 20	2	
MS20470AD3-6	2.10-19.0- 11	16	
MS20470AD4-5	2. 2-10.0-124	4	
MS20470AD5-5	2.18- 6.0- 52	3	
MS20470AD6-10	2. 5-15.0- 3	2	
MS20470B5-7	2. 3- 1.0- 38	2	PA
MS20500-1032	2. 4-11.0- 55	76	P1
MS20500-1216	2.10- 7.0-198	2	
MS20500-428	2.10- 7.0- 36	6	
MS20500-524	2.10-12.0- 34	4	

PART NUMBER	FIGURE AND INDEX NUMBER	QTY PER ART	SMR CODE
MS20605MP4W4	2.10-33.0- 8	16	
MS20664C5	2.14-30.0- 24	2	
MS20756D16	2. 9- 2.0- 62	1	
MS20762D16	2. 9- 2.0- 63	1	
MS20822-5-4D	2.19- 1.0- 12	1	
MS20822-5D	2.19- 1.0- 13	1	
MS20822-6-2D	2.19- 2.0- 14	1	
MS20822-6D	2.19- 1.0- 10	4	
MS20822-8J	2.13- 7.0- 7	1	
MS20823-5D	2.19- 1.0- 14	1	
MS20823-8D	2.19- 1.0- 11	1	
MS20932-2-41	2. 6-40.0- 94	1	
MS21012L06	2.20-44.0- 3	4	
MS21012L3	2.20-45.0- 11	1	
MS2104AN3	2.13-33.0- 11	4	
MS21042-06	2.16-11.0- 36	1	
MS21042-N4	2.18-21.0-16	2	P1
MS21042-04	2.17-36.0- 12	6	P1
MS21042-06	2.14-23.0- 79	8	
MS21042-08	2.13- 7.0- 3	12	
MS21042-3	2. 4- 1.0- 25	115	P1
MS21042-4	2.12-68.0- 19	45	
MS21042-6	2.12-68.0- 95	5	
MS21042L-6	2.10- 7.0- 96	6	
MS21042L06	2. 2- 7.0- 21	3	
MS21042L08	2.12- 9.0- 74	43	
MS21042L3	2. 3- 3.0- 94	294	
MS21042L4	2. 8-23.0- 16	93	
MS21042L5	2.10- 6.0- 16	33	
MS2104213	2.12-15.0-140	1	
MS210426-3	2.20-17.0- 34	2	
MS2104264	2.12- 9.0- 35	2	
MS21043-06	2.17-10.0- 12	12	P
MS21043-3	2. 4-12.0-138	134	
MS21043-4	2. 7-10.0- 14	188	
MS21043-5	2.10-19.0- 23	21	
MS21043-6	2.14- 8.0- 7	13	
MS21043-8	2.14- 8.0- 13	4	
MS21044-C3	2.18-19.0- 17	5	
MS21044-N08	2.18-25.0- 41	4	
MS21044-N3	2.17-11.0-170	1	P1
MS21044N04	2. 4-11.0- 54	4	
MS21044N04	2.17-41.0- 4	2	P1
MS21044N08	2.17- 7.0- 4	20	P1
MS21044N3	2. 2- 5.0- 16	61	
MS21044N4	2. 7-16.0- 18	4	
MS21045-5	2.15-19.0- 16	2	
MS21045-7	2.15-25.0- 75	RF	
MS21045C3	2.10- 7.0-224	2	
MS21045L3	2.13- 8.0- 74	9	
MS21046C3	2.10-3.0-7	1	
MS21047L5	2.20- 35.0- 8	4	
MS21047-4	2.14-11.0- 33	RF	
MS21048L3	2.10-12.0- 4	114	
MS21052-3	2.10-12.0- 5	48	
MS21059-3	2. 5-14.0- 6	4	
MS21059L3	2.12-10.0- 67	6	
MS21059-L3	2.6-32.0-39.1	4	
MS21061-L5	2.6-32.0-39.3	4	
MS21061-5	2.6-32.0-39.4	2	
MS21069-3	2.17-11.0- 59	3	
MS2107D6	2. 8-13.0- 43	1	
MS21073-4	2.10-19.0- 10	8	
MS21073-06	2.16-18.0- 26	1	
MS21073-3	2.10-33.0- 2	20	
MS21073L06	2.18- 6.0- 55	6	
MS21078-4	2.14-11.0- 33	RF	
MS21083D4	2.15-25.0- 22	RF	
MS21083N06	2.16- 1.0-109	4	

PART NUMBER	FIGURE AND INDEX NUMBER	QTY PER ART	SMR CODE
MS21083N3	2. 4-11.0- 15	1	
MS21083N8	2.18- 6.0- 2	7	
MS2109506	2.12-21.0- 47	1	
MS21104-012	2.13- 6.0- 40	1	
MS21104 012	2.13- 5.0- 42	3	
MS21122	2. 5-10.0- 39	2	P1
MS21122-3	2. 9-32.0- 29	4	
MS21122-4	2. 9-32.0- 30	2	
MS21122-40	2.12-19.0- 59	4	P1
MS21268F4-15	2.12-15.0- 93	32	P1
MS21209	2.18- 36.0- 4	4	
MS21209CG615	2.18-25.0- 19	1	B1L
MS21209F1-16	2.18-25.0- 18	10	B1L
MS21209F1215	2.20-50-13	2	P1
MS21209F4-20	2.14- 9.0- 65	1	
MS21209F5-20	2.13- 1.1-172	2	
MS21209F8-20	2.12-68.0- 33	2	
MS21226-3M	2.12-44.0-155	1	
MS21233-P	2.20-48.0- 32	1	P1
MS21244-4	2.10- 3.0- 3	47	
MS21244-5	2.20-15.0- 21	6	
MS21244-6	2.20-15.0- 19	4	
MS21251-B5S	2.14-30.0-32	2	P1
MS21260S5RH	2.14-30.0- 34	1	
MS21260S56	2.14-30.0- 29	1	
MS21266-1N	2.18-26.0- 14	1	P
MS21266-1T	2. 8-29.0- 10	2	
MS21266-3T	2. 6-40.0- 72	1	
MS21266-4N	2.20-23A.0-10	2	
MS21279-08	2. 9-13.0- 20	5	
MS21280-C7	2.10- 7.0- 81	4	
MS21315-5	2. 3- 1.0- 52	4	PA
MS21318-22	2.16- 1.0- 10	2	
MS21321-1	2.12-68.0- 97	1	
MS21342L3	2.17-38.0- 20	2	
MS21403-4	2.14-18.0- 2	2	
MS21512-4	2.10-17.0- 9	2	
MS21512-6	2.12-44.0-167	1	
MS21615-015-12	2.10-29.0- 27	1	
MS21808D4	2. 9-12.0- 25	1	
MS2181-22C	2.17-25.0- 13	1	
MS219-15D6-4	2.11-12.0- 21	1	
MS219G0D4	2. 9- 9.0- 34	1	
MS21901-6D	2.12-67.0- 30	1	P
MS21902-016	2.10-29.0- 34	2	
MS21902-04	2.10-32.0- 13	2	
MS21902-016	2.10-28.0- 11	1	
MS21902-08	2.10-31.0- 15	1	
MS21902-12	2.8-12.0-160	2	
MS21902-16	2.10- 7.0-126	1	
MS21902-2C	2.10-32.0- 23	1	
MS21902-4	2. 9-10.0- 4	16	
MS21902-4C	2. 8-28.0- 25	4	
MS21902-6	2.10- 7.0-118	4	
MS21902-6C	2. 8-18.0- 2	19	
MS21902-8	2.10-17.0- 7	2	
MS21902-8D	2.10-25.0- 13	1	
MS21902010	2. 8-10.0- 30	18	
MS21902012	2. 8-10.0- 50	20	
MS21902016	2. 8-10.0- 99	5	
MS2190202	2. 9-30.0- 19	7	
MS2190203	2. 8-10.0-143	65	
MS21902034	2. 9-11.0- 17	1	
MS2190204	2. 3- 1.0- 12	431	
MS2190205	2. 8-23.0- 32	5	
MS2190206	2. 8- 9.0- 35	345	
MS21902D6-4	2.12-44.0- 73	1	
MS21902D8	2. 8-10.0- 69	41	

PART NUMBER	FIGURE AND INDEX NUMBER	QTY PER ART	SMR CODE
MS2190204	2. 9-24.0- 25	1	
MS21903-4	2.10- 7.0- 49	5	
MS21903-40	2.12-24.0- 17	1	
MS21903010	2. 8-10.0-131	9	
MS21903012	2. 3- 3.0- 7	1	
MS2190303	2. 9-11.0- 19	15	
MS2190304	2. 8- 3.0- 14	62	
MS2190306	2. 8-10.0-171	48	
MS2190308	2. 8-12.0- 26	2	
MS2190306	2. 8-12.0- 19	2	
MS2190404	2. 9-16.0- 22	4	
MS2190406	2. 8-18.0- 11	6	
MS21905-J4	2.10-25.0- 20	1	
MS21905-4	2.10- 7.0-156	1	
MS21905010	2. 8-12.0- 8	3	
MS21905012	2.12-46.0- 3	1	
MS2190503	2. 9-11.0- 21	7	
MS2190504	2. 8- 9.0- 9	73	
MS2190504 C	2.12-43.0- 5	1	
MS2190506	2. 8-11.0- 23	38	
MS2190508	2. 8-11.0- 3	2	
MS21905-40	2.13-33.0- 34	1	
MS21906010	2. 8-11.0- 46	1	
MS2190604	2. 9-17.0- 33	2	
MS2190604-3	2. 9-21.0- 13	1	
MS2190606	2.12-21.0-146	4	
MS2190608	2. 8-12.0- 33	1	
MS21907-012	2. 9-13.0- 11	1	
MS21907-06	2.10-32.0- 20	1	P1
MS21907-4	2.10- 7.0-107	3	
MS21907-4C	2.10- 7.0-161	2	
MS21907-8	2.10-17.0- 8	2	
MS219070	2. 9- 9.0- 48	1	
MS21907010	2. 8-10.0-133	7	
MS21907012	2. 8-12.0-146	2	
MS21907016	2. 8-12.0- 52	2	
MS2190703	2. 9-11.0- 29	15	
MS2190704	2. 8-10.0-114	55	
MS2190706	2. 8-10.0- 8	37	
MS2190708	2. 8-12.0- 22	5	
MS21908-06	2. 9-30.0- 49	3	
MS21908-J4	2.10-25.0- 24	2	
MS21908-4	2. 9-16.0- 2	9	
MS21908-4C	2. 8-28.0- 27	2	
MS21908-40	2.13-33.0- 35	1	
MS21908-6C	2.10-13.0- 11	1	
MS21908-60	2.12-67.0- 29	2	
MS21908010	2.10-31.0- 10	1	
MS21908012	2. 8-10.0- 57	7	
MS21908016	2. 8-10.0- 22	1	
MS2190803	2. 9-11.0- 27	148	
MS2190804	2. 8-10.0-118	119	
MS2190805	2. 9- 5.0- 33	2	
MS2190806	2. 8-12.0- 74	92	
MS2190808	2. 9-20.0- 7	1	
MS21908004	2. 9- 7.0- 69	1	
MS21909-J4	2.10-25.0- 21	1	
MS21909-4	2.10- 7.0-112	2	
MS21909012	2. 9-15.0- 16	1	
MS2190903	2. 8-27.0- 45	2	
MS2190904	2. 8-21.0- 13	17	
MS2190906	2. 8-29.0- 6	13	
MS2190908	2. 9-11.0- 35	2	
MS21910-016	2.10-29.0- 30	1	
MS21910-8	2.10-29.0- 7	1	

PART NUMBER	FIGURE AND INDEX NUMBER	QTY PER ART	SMR CODE
MS21910010	2. 8-10.0-162	1	
MS21910012	2.12-37.0- 18	2	
MS21910016	2. 9-10.0-120	1	
MS2191003	2. 8- 6.0- 8	2	
MS2191004	2. 8-10.0-169	19	
MS2191006	2. 8-13.0- 50	10	
MS2191008	2. 8-10.0-179	4	
MS21911-40	2.12-37.0-201	1	
MS21911010	2. 8-10.0- 14	3	
MS2191104	2. 8-10.0-111	14	
MS2191105	2. 9- 9.0- 13	1	
MS2191106	2. 8- 9.0- 28	13	
MS2191108	2. 8-10.0- 56	3	
MS21912-20	2.14-37.0- 56	1	
MS21912-4	2. 2- 7.0- 15	2	
MS21912-40	2.12-37.0- 63	1	
MS219120-4	2.9-32.0- 33	1	
MS2191203	2. 9-28.0- 25	1	
MS2191204	2. 8-21.0- 51	42	P1
MS2191206	2. 8-10.0-174	30	P1
MS2191206-4	2.14- 4.0- 31	1	
MS21913012	2.13-10.0- 27	1	
MS2191304	2. 8- 4.0- 19	1	P1
MS2191306	2. 8-10.0- 98	3	
MS21914-04	2.10-25.0- 15	2	
MS21914-2	2.14-37.0- 57	1	
MS21914-20	2.10-32.0- 4	1	
MS21914-4	2. 2- 7.0- 19	12	
MS21914-40	2.10- 7.0-160	2	
MS21914-40	2.14- 4.0- 21	2	P
MS21914-4W	2. 8-27.0- 32	1	
MS21914-6	2. 8-10.0-175	1	
MS21914-60	2.14- 4.0- 28	1	P
MS21914-6W	2. 8-23.0- 54	1	
MS21914-8	2.14-37.0- 23	1	
MS2191404	2. 8-21.0- 4	2	
MS2191406	2. 9- 4.0- 24	5	P1
MS21915-016-8	2.10-29.0- 29	2	
MS21915-20-6	2.10-29.0- 5	2	
MS2191504-3	2.12-62.0- 19	1	
MS21916-016-10	2.10-31.0- 3	1	
MS21916-4	2.12-37.0-196	1	
MS21916-4-30	2.10- 7.0-147	1	
MS21916-6-4	2. 8-14.0- 37	2	
MS21916-6-40	2.15-17.0- 6	2	
MS21916-8-4	2.12-17.0- 1	4	
MS21916010	2. 8-11.0- 41	2	
MS21916010-4	2. 9- 5.0- 3	1	
MS21916010-6	2. 8-10.0- 13	7	
MS21916012	2.14-37.0- 26	1	
MS21916012-10	2. 9- 3.0- 3	8	
MS21916012-8	2.12-37.0- 17	1	
MS21916016-10	2. 8-10.0-130	1	
MS21916016-12	2.12-20.0- 65	1	
MS2191604	2. 8-16.0- 62	2	
MS2191604-2	2. 9-19.0- 16	5	
MS2191604-3	2. 6- 6.0- 12	24	
MS2191605-4	2. 8-10.0- 71	4	
MS2191606	2. 8-22.0- 29	2	
MS2191606-3	2. 9- 4.0- 43	2	
MS2191606-4	2. 6- 4.0- 4	100	
MS2191606-3	2. 9-32.0-36	1	
MS2191608-4	2. 8-10.0- 64	14	
MS24694-5	2.13-33.0- 4	2	
MS2191608-4	2. 8-10.0-180	18	
MS21919-44	2.10-25.0- 28	1	

PART NUMBER	FIGURE AND INDEX NUMBER	QTY PER ART	SMR CODE
MS21919-H6	2.12-28.0-15	1	
MS21919DF-32	2.12-15.0-3	5	
MS21919DF-42	2.12-14.0-90	1	
MS21919DF-54	2.12-1.0-4	1	
MS21919DF10	2.12-68.0-87	4	
MS21919DF12	2.12-40.0-41	2	
MS21919DF13	2.17-8.0-77	1	
MS21919DF16	2.12-11.0-15	1	
MS21919DF24	2.12-19.0-69	4	
MS21919DF32	2.12-14.0-5	7	
MS21919DF4	2.12-15.0-115	11	
MS21919DF6	2.12-9.0-53	1	
MS21919DF8	2.12-9.0-49	3	
MS21919DG11	2.12-3.0-21	2	
MS21919DG13	2.20-9.0-1	13	
MS21919DG14	2.13-10.0-14	3	
MS21919DG16	2.20-8.0-3	1	
MS21919DG17	2.10-19.0-12	1	
MS21919DG2	2.17-5.0-10	10	P1
MS21919DG21	2.20-8.0-3	7	
MS21919DG24	2.20-23B.0-7	2	
MS21919DG20	2.13-21.0-10	6	
MS21919DG3	2.13-8.0-9	1	
MS21919DG33	2.20-32.0-9	1	
MS21919DG32	2.13-9.0-58	2	
MS21919DG34	2.20-8.0-4	1	
MS21919DG35	2.14-17.0-12	1	
MS21919DG4	2.9-9.0-32	13	
MS21919DG5	2.4-6.0-7	41	
MS21919DG55	2.4-7.0-14	2	
MS21919DG6	2.6-3.0-18	6	
MS21919DG8	2.12-5.0-40		
MS21919G12	2.11-9.0-4	3	
MS21919G20	2.20-47.0-25	2	
MS21919H14	2.13-1.1-80	1	
MS21919H16	2.9-2.1-16	1	
MS21919H19	2.13-4.0-57	1	
MS21919H20	2.13-9.0-39	4	
MS21919H24	2.13-35.0-43	5	P1
MS21919H26	2.12-39.0-65	1	
MS21919H32	2.12-59.0-11	1	
MS21919H36	2.12-39.0-3	1	
MS21919H5	2.19-7.0-208	19	
MS21919H8	2.12-7.0-221	1	
MS21919WDF11	2.13-7.0-2	1	
MS21919WDF7	2.17-8.0-75	6	
MS21919WDG	2.17-11.0-167	1	
MS21919WDG11	2.18-20.0-12	1	
MS21919WDG16	2.18-20.0-15	1	
MS21919WH5	2.18-26.0-17	2	
MS219204	2.12-11.0-76	1	
MS21920-22	2.12-2.0-19	1	P1
MS21920-33R	2.20-23.0-58	1	
MS21921-4	2.10-11.0-7	0	
MS21921-6	2.12-52.0-95	1	
MS21922-4	2.10-11.0-7	2	
MS21922-6	2.12-52.0-96	1	
MS2192303	2.8-10.0-4	3	
MS21924-4	2.2-7.0-14	4	
MS21924-4C	2.3-70.0-31	1	
MS21924010	2.6-12.0-10	1	
MS21924012	2.13-10.0-56	1	
MS2192403	2.9-12.0-44	2	
MS2192404	2.8-9.0-2	13	
MS2192406	2.8-20.0-15	12	P1
MS2192408	2.8-12.0-88	2	

PART NUMBER	FIGURE AND INDEX NUMBER	QTY PER ART	SMR CODE
MS2192406	2.10-32.0-7	1	
MS2192408	2.9-7.0-50	1	
MS2192409	2.9-7.0-54	1	
MS2192604	2.12-15.0-131	2	
MS2192606-4	2.8-22.0-49	1	
MS2192712-4	2.12-19.0-100	1	
MS21928-219	2.9-2.0-9	4	
MS219286-4	2.12-37.0-199	1	
MS21929-08	2.9-13.0-21	1	
MS21929-10	2.17-24.0-6	2	
MS21929-20	2.17-20.0-12	2	
MS21929-5	2.17-20.0-11	1	
MS22055424	2.13-1.1-31	1	P1
MS22054-4	2.4-11.0-47	4	
MS22024012	2.8-19.0-53	1	
MS24-60940104	2.16-19.0-11	3	
MS2414001	2.17-18.0-5	1	
MS2414002	2.4-3.0-9	0	P1
MS24140-1	2.17-17.0-17	2	
MS2430-02	2.17-8.0-48	1	
MS2431-1	2.4-9.0-41	1	
MS24335-10	2.8-10.0-60	1	
MS24335-15	2.8-10.0-20	1	
MS24374-12S	2.13-33.0-37	1	
MS24378	2.20-49.0-2	RF	
MS24378-1	2.18-31.0-5	1	
MS24380121	2.8-10.0-50	1	
MS24382-4	2.4-6.0-12	3	
MS24384-4	2.4-7.0-13	3	
MS24395-4	2.4-8.0-9	2	
MS2440008	2.19-3.0-24	3	
MS24403-4	2.12-32.0-12	1	
MS24406-1	2.13-28.0-7	1	
MS24478-2	2.8-23.0-24	2	
MS24523-23	2.16-15.0-1	4	
MS24523-33	2.16-16.0-3	1	P1
MS24524-21	2.16-22.0-3	1	
MS24524-23	2.16-15.0-2	1	
MS24525-17	2.9-1.0-11	1	P1
MS24548-5-40	2.19-3.0-44	1	P1
MS24547-02	2.17-11.0-123	1	
MS24548-4-1P	2.14-10.0-47	1	
MS24548C380	2.20-44.0-45	1	
MS24548C39	2.13-32.0-11	1	
MS24547-02	2.5-9.0-4	41	
MS24548-24	2.20-31.0-4	1	
MS24548-50	2.3-3.0-91	4	
MS24548-132	2.2-3.0-25	2	
MS24548-220	2.16-14.0-6	2	
MS24548-23F	2.16-14.0-7	2	P1
MS24548-220	2.16-14.0-6	1	
MS24548-132	2.2-3.0-34	40	
MS24548-134	2.2-2.1-2	3	
MS24548-135	2.4-9.0-47	2	
MS24548-141	1.4-12.0-21	1	
MS24548-143	2.10-29.0-6	4	
MS24548-131	2.4-11.0-12	7	
MS24548-133	2.10-9.0-8	84	
MS24548-2.7	2.2-9.0-19	4	P1
MS24665-283	2.15-16.0-83	RF	
MS24665-283	2.8-28.0-2	1	
MS24665-283	2.13-32.0-12	1	
MS24665-303	2.4-12.0-44	1	
MS24665-303	2.4-12.0-41	1	
MS24665-355	2.20-23.1-11A	2	
MS24665-355	2.2-11.0-5	1	
MS24665-355	2.14-34.0-1	2	

PART NUMBER	FIGURE AND INDEX NUMBER	QTY PER ART	SMR CODE	PART NUMBER	FIGURE AND INDEX NUMBER	QTY PER ART	SMR CODE
MS246665-22	2.12-18.0- 12	1		MS2501E-4A	2. 5- 1.0- 12	32	
MS24678-21	2.10- 7.0-226	3	P1	MS25010B11A	2.16-15.0- 4	2	
MS24693	2.20-50.0- 5	4		MS25010B11A37	2.16-14.0- 12	5	
MS24693-C274	2.18-36.0- 5	22		MS25011-1	2. 7- 1.0- 13	2	
MS24693-C52	2.20- 2.0- 38	3		MS25017-10	2.17-24.0- 2	4	
MS24693-S5	2.16-11.0- 17	1		MS25017-15	2.17-24.0- 1	8	
MS24693-2	2. 5- 1.0- 29	2		MS25017-20	2.17-24.0- 4	2	
MS24693-24	2. 5-10.0- 33	2		MS25017-5	2.17-24.0- 3	2	
MS24693-25	2. 2- 7.0- 83	12		MS25023-1	2. 5- 4.0- 10	RF	
MS24693-27	2.18- 6.0- 56	6	P1	MS25036-108	2. 3- 1.0- 72	2	
MS24693-272	2.12- 9.0- 41	1		MS25036-149	2. 3- 1.0- 63	1	
MS24693-6	2. 5- 2.0- 18	2		MS25036-153	2. 3- 1.0- 74	1	
MS24693S28	2. 6- 3.0- 5	5		MS25036-2	2.17-36.0- 16	2	
MS24694	2. 2- 7.0- 73	1		MS25041-3	2.16- 1.0- 33	1	
MS24694-A62	2.12- 2.0- 6	3		MS25041-4	2.16-14.0- 11	4	
MS24694-C52	2. 4- 4.0- 17	2		MS25052-10	2.17-24.0- 2	2	
MS24694-C54	2. 4- 4.0- 23	4		MS25068-21	2.16-19.0- 2	2	
MS24694-S54	2.18- 6.0- 47	6	P1	MS25083-1AA3	2.16- 3.0- 2	1	
MS24694-100	2. 4-10.0- 10	1		MS25083-1BB10	2.18-16.0- 10	1	
MS24694-101	2. 4-10.0- 7	3		MS25083-1BB12	2.18-16.0- 1	1	
MS24694-102	2. 4-10.0- 7	2		MS25083-1BB2	2.12-65.0- 17	1	
MS24694-3	2. 5-10.0- 23	4		MS25083-1BB2A	2.12-48.0- 47	1	
MS24694-46	2. 6-11.0- 12	11		MS25083-1BB3	2. 6- 1.0- 4	33	
MS24694-48	2. 2- 3.0- 23	216		MS25083-1BB4	2. 6- 1.0- 3	67	
MS24694-49	2. 4- 5.0- 13	2		MS25083-1BB5	2.12-15.0- 8	3	
MS24694-5	2. 2- 2.0- 12	4		MS25083-1BB6	2. 6- 1.0- 6	22	
MS24694-50	2. 2- 3.0- 30	18		MS25083-1BB7	2. 6- 1.0- 5	9	
MS24694-51	2. 4- 2.0- 8	10		MS25083-1BB8	2.12-48.0- 8	1	
MS24694-52	2. 3- 5.0- 14	43		MS25083-2AB3	2. 5- 4.0- 1	RF	
MS24694-53	2. 4- 2.0- 2	126		MS25083-2BB3	2.12-10.0- 24	7	
MS24694-55	2. 2- 9.0- 8	18		MS25083-2BB4	2.12-10.0- 54	8	
MS24694-56	2. 4- 2.0- 70	4		MS25083-2BB5	2.13-13.0- 11	8	
MS24694-57	2. 2- 9.0- 31	7		MS25083-2BB6	2.12-10.0- 52	4	
MS24694-58	2. 2- 9.0- 32	3		MS25083-2BB7	2.13-31.0- 38	1	
MS24694-59	2. 2- 9.0- 33	1		MS25083-2BB9	2.20-23.0- 19	1	
MS24694-60	2. 4- 1.0- 7	6		MS25083-2BC10	2.20-31.0- 21	1	
MS24694-64	2. 6- 4.0- 10	1		MS25083-3PB3	2.13- 9.0- 1	1	
MS24694-66	2. 4-12.0- 75	2		MS25083-3PB6	2. 4- 9.0- 1	1	
MS24694-68	2. 4- 2.0- 46	1		MS25083-3SB	2. 4- 9.0- 2	2	
MS24694-69	2. 6- 5.0- 11	1		MS25089-1FR	2.17-11.0- 60	1	
MS24694-8	2. 4- 8.0- 27	4		MS25089-3C	2.16- 1.0- 89	4	
MS24694-81	2. 3- 5.0- 21	1		MS25089-3D	2.16-19.0- 3	2	
MS24694-95	2. 2-11.0- 16	1		MS25089-3G	2.15-18.0- 4	1	
MS24694C53	2.10- 7.0- 71	3		MS25089-3GR	2.15-18.0- 5	1	
MS24694C96	2.13-17.0- 3	5		MS25123-1-6	2. 5- 2.0- 21	1	
MS24694S11	2.16- 4.0- 30	2		MS25123-11-2	2.16- 5.0- 51	1	
MS24694S14	2.16- 4.0- 30	2		MS25123-3-3	2.18-20.0- 13	1	
MS24694S3	2.16- 2.0- 19	7		MS25126-C3	2.16-18.0- 7	1	
MS24694S48	2.16- 1.0- 43	8		MS25127-4	2.16-18.0- 7	1	
MS24694S54	2.18- 1.0- 11	3		MS25166-1	2.16- 8.0-47	1	
MS24694S56	2. 4- 1.0- 38	AR	P1	MS25223-2	2.20- 3.0- 27	3	
MS24694S57	2. 4- 1.0- 36	AR	P1	MS25224-1	2.16-11.0- 7	6	
MS24694S58	2. 4- 1.0- 37	18	P1	MS25224-3	2. 8- 1.0- 15	9	
MS24694S59	2. 4- 1.0- 39	4	P1	MS25225-1	2.16-20.0- 6	3	
MS24694S60	2. 4- 1.0- 35	19	P1				
MS24694S61	2. 4- 1.0- 34	2	P1	MS25227-1	2.16- 5.0- 49	2	
MS24694S62	2. 4- 1.0- 40	4	P1				
MS24694S64	2. 4- 1.0- 31	2	P1	MS25227-5	2.18-20.0- 12	2	
MS24694S65	2. 4- 1.0- 33	48	P1				
MS24694S775	2.15-13.0- 18	1		MS25231-1819	2.16- 1.0- 13	4	
MS25005-10	2.17-25.0- 2	2		MS25231-313	2. 5- 2.0- 28	14	
MS25005-15	2.17-24.0- 1	8		MS25231R313	2.17- 4.0- 1	5	
MS25005-20	2.17-24.0- 4	2		MS25237-327	2. 5- 1.0- 12	38	
MS25005-5	2.17-24.0- 3	2		MS25244-30	2.20- 3.0- 22	1	
MS25008-1	2.17- 5.0- 3	1		MS25272-01	2.18-38.0- 9	1	
				MS25309-7512	2.12-68.0- 35	1	

PART NUMBER	FIGURE AND INDEX NUMBER	QTY PER ART	SMR CODE
MS25351-8	2. 2-13.0-113	2	
MS25358-7079	2.17- 7.0- 3	1	
MS25383	2.15-34.0- 65	1	
MS25390-D2	2.18-38.0- 8	1	
MS25471-14	2. 3- 1.0- 73	AR	
MS25499-1-327	2.16- 1.0-104	1	PA
MS25499-1-329	2.18- 2.0- 46	1	
MS25603-1884	2.12-14.0- 49	1	
MS25913-325	2.12-25.0- 13	4	
MS2591802	2.17-11.0-156	1	
MS27039-0806	2.17-11.0-152	7	
MS27039-0806	2.17- 7.0- 6	6	
MS27039-0809	2.18-25.0- 29	16	
MS27039-0810	2.18-25.0- 28	3	
MS27039-1-05	2.17-11.0-168	1	
MS27039-1-06	2. 2- 7.0- 11	16	
MS27039-1-071.			
. S	2.17- 8.0- 49	60	
MS27039-1-07	2.17- 8.0- 52	4	
MS27039-1-09	2. 2- 7.0- 18	15	
MS27039-1-10	2.12- 1.0- 21	6	
MS27039-1-20	2.18-18.0- 3	4	P1
MS27039-4-08	2.17- 8.0- 54	4	
MS2703900806	2.18-35.0- 13	12	
MS270390J838	2.17- 8.0- 12	4	P1
MS27039C1-09	2.17- 8.0- 10	4	
MS27039C1-12	2.17- 8.0- 14	4	
MS27039C1-15	2.18-35.0- 2	2	
MS270391C1-07	2.18-35.0- 15	6	
MS270391C1-13	2.17- 8.0- 8	3	
MS27111-2	2.14-15.0- 33	1	
MS27111-5	2.14-23.0-164	1	
MS2714301	2.17-37.0- 2	1	
MS27183-3	2. 3- 1.0- 65	4	P1
MS27183-4	2.17-41.0- 3	10	
MS27183-7	2. 3- 1.0- 69	7	PA
MS27183-8	2. 3- 1.0- 41	3	PA
MS27198-24	2.12-10.0-100	10	
MS27212-1-6	2.17-41.0- 1	1	
MS2722101	2.17-20.0- 6	1	
MS27243-3	2.17-18.0- 4	1	
MS27243-4	2.17- 8.0- 47	1	
MS27244-4	2.14-15.0-109	2	
MS27253-1	2. 6-33.0- 2	5	
MS27260	2.16-25.0- 1	1	
MS27369-H-3214	2. 8-12.0-183	1	
MS27371-40	2. 9-10.0- 16	25	
MS27384-40	2. 9-16.0- 16	7	
MS27400-1	2.20- 2.0- 31	1	
MS27401-21	2.20-2.0-6A	1	
MS27404-4	2.11- 7.0- 2	5	
MS27407-5	2.16-16.0- 14	1	P1
MS27408-5M	2. 5- 9.0- 30	1	PA
MS27409-14	2.17-11.0- 61	1	
MS2748816	2.20- 2.0- 39	9	
MS27576-4-07	2.10- 3.0- 31	1	P1
MS27576-4-08	2.10- 5.0- 22	1	P1
MS27576-4-09	2.10- 5.0- 14	1	P1
MS27576-4-10	2.10- 5.0- 14	1	P1
MS27576-4-13	2.14-15.0- 10	7	
MS27576-4-14	2.14-18.0- 52	1	
MS27576-4-16	2.14-18.0- 44	1	
MS27576-4-17	2.14-15.0- 58	6	
MS27576-4-18	2.14-15.0- 7	11	
MS27576-4-19	2.10- 3.0- 4	11	
MS27576-4-20	2.14-15.0- 21	5	

PART NUMBER	FIGURE AND INDEX NUMBER	QTY PER ART	SMR CODE
MS27576-4-21	2.14-23.0- 19	1	
MS27576-4-26	2.14-18.0- 45	1	
MS27576-4-33	2.14-25.0- 5	1	
MS27576-4-8	2.10- 5.0- 8	1	
MS27576-5-20	2.20-15.0- 22	12	
MS27576-6-20	2.20-15.0- 20	4	
MS27600-1	2.21- 2.0- 57	3	
MS27641-3	2. 4- 4.0- 27	5	
MS27641-4	2.14-10.0- 41	1	
MS27641-6	2. 4- 4.0- 18	4	
MS27641-8	2. 4- 5.0- 25	1	
MS27645-6	2. 4- 4.0- 34	1	
	2.20- 6.0- 7	1	
MS27980-189	2. 4-11.0- 55	2	
MS27981-3N	2.17- 8.0- 55	26	P1
MS27981-4N	2.17- 8.0- 56	13	P1
MS28020-1	2.16- 1.0-106	2	P1
MS28041-1	2.16- 1.0- 24	RF	
MS28042-1	2.16- 1.0-103	2	P
MS28040-1	2.16- 1.0- 63	1	
MS28053-3	2.18-35.0- 3	3	
MS28154-2	2.10- 7.0- 56	1	P1
MS28132-2	2.17-20.0- 3	1	
MS28720-4	2.13- 1.0- 3	1	
MS28741-3-1034	2. 8-10.0-139	2	
MS28774-011	2. 8-28.0- 20	1	
MS28774-014	2. 8- 2.0- 7	1	
MS28774-015	2. 8- 2.0- 5	1	P1
MS28774-115	2. 8-28.0- 14	1	
MS28774-132	2. 8- 2.0- 9	1	P1
MS28774-134	2.10-29.0- 25	1	
MS28774-212	2. 8-28.0- 16	2	
MS28774-218	2. 8-28.0- 13	1	
MS28775-010	2.15-17.0- 9	4	
MS28775-011	2. 8-14.0- 13	10	M
MS28775-015	2. 8- 2.0- 6	1	P1
MS28775-016	2. 8-10.0-156	1	P
MS28775-024	2. 8- 2.0- 10	1	P1
MS28775-110	2.15-26.0- 19	1	
MS28775-111	2.15-26.0- 16	RF	
MS28775-132	2. 8- 2.0- 8	1	P1
MS28775-212	2. 8-28.0- 16	1	
MS28775-213	2. 8-28.0- 13	2	P1
MS28775-235	2.10-7.0- 94	1	
MS28775-236	2.20-46.0- 6	2	
MS28776M-4	2. 8-28.0- 12	1	
MS28777-P	2.13- 5.0- 38	2	
MS28776-17	2. 9-29.0- 6	1	
MS28776-115	2. 8-28.0- 14	2	
MS28778-12	2. 8-10.0- 51	9	
MS28778-16	2.10- 7.0-126	2	
MS28778-3	2. 9-12.0- 29	6	
MS28778-4	2. 8-11.0- 43	55	
MS28778-5	2. 8-23.0- 30	4	
MS28778-6	2. 8-11.0- 5	51	P
MS28778-8	2. 8-12.0-150	32	
MS28778-9	2.10- 7.0-118	1	
MS28779-1	2. 8- 3.0- 18	3	
MS28892-12	2. 8-12.0-159	1	
MS28892-16	2. 8-10.0- 20	1	
MS28892-4	2. 8-28.0- 45	1	
MS2889304	2. 8-25.0- 12	1	
MS29512-06	2.12-45.0-111	1	
MS29512-04	2.12-15.0- 24	14	
MS29512-06	2.12-15.0-114	13	
MS29512-10	2.12-37.0- 33	6	

PART NUMBER	FIGURE AND INDEX NUMBER	QTY PER ART	SMR CODE
MS29512-12	2.10-7.0-90	5	P1
MS29512-16	2.9-2.0-43	6	
MS29512-20	2.12-23.0-10	3	
MS29512-3	2.10-7.0-148	1	
MS29512-4	2.10-7.0-151	175	P
MS29512-5	2.12-3.0-7	41	P
MS29512-6	2.0-32.0-89	152	
MS29512-8	2.10-17.0-1	15	
MS2951206	2.12-40.0-159	1	
MS2951206	2.12-16.0-102	1	
MS29513-005	2.12-56.0-16	1	
MS29513-10	2.6-37.0-10	32	KF
MS29513-116	2.12-66.0-17	2	
MS29513-12	2.12-55.0-23	3	
MS29513-125	2.12-66.0-8	4	
MS29513-128	2.12-10.0-48	1	
MS29513-13	2.12-52.0-134	19	
MS29513-136	2.12-10.0-59	1	
MS29513-15	2.12-15.0-153	53	KF
MS29513-20	2.8-1.0-75	4	
MS29513-210	2.12-1.0-96	13	
MS29513-214	2.12-10.0-26	31	
MS29513-217	2.12-65.0-15	1	
MS29513-218	2.12-14.0-9	3	
MS29513-22	2.12-56.0-32	1	
MS29513-242	2.18-31.0-6	1	
MS29513-325	2.12-10.0-60	67	
MS29513-329	2.12-15.0-5	34	
MS29513-333	2.12-1.0-114	35	
MS29513-337	2.12-14.0-43	29	
MS29513-345	2.12-48.0-4	7	
MS29513-349	2.12-48.0-14	2	
MS29513-5	2.12-56.0-21	1	
MS29513-8	2.6-4.0-8	4	
MS29514-1	2.12-55.0-19	2	
MS29528-4	2.8-11.0-60	2	P1
MS3122222-55P	2.18-24.0-14	1	P1
MS3122222-55S	2.18-24.0-13	1	P1
MS3181-200	2.18-26.0-16	1	P
MS3181-220	2.18-26.0-19	1	
MS31902010	2.9-23.0-31	1	
MS3367-3	2.20-23A.0-6	16	
MS33737-11	2.16-5.0-33	3	
MS33737-9	2.16-8.0-20	4	
MS3405-28	2.20-44.0-2	1	
MS3416-44EA	2.20-23A.0-2	2	
MS35027-268	2.19-3.0-23	3	
MS35043-147	2.14-8.0-96	2	
MS35058-21	2.8-1.0-16	1	
MS35058-22	2.17-11.0-57	1	
MS35058-24	2.16-9.0-9	5	
MS35058-31	2.5-1.0-15	1	
MS35059-18	2.14-0.0-1	2	
MS35059-23	2.16-38.0-11	1	
MS35059-28	2.17-9.0-7	1	
MS35204-267	2.18-18.0-20	4	
MS35206-209	2.4-9.0-43	2	
MS35206-213	2.3-1.0-83	2	PA
MS35206-214	2.20-34.0-13	4	
MS35206-215	2.4-11.0-52	9	B1L
MS35206-216	2.17-11.0-164	4	
MS35206-217	2.5-2.0-18	2	
MS35206-218	2.17-41.0-2	2	
MS35206-227	2.5-5.0-15	6	
MS35206-228	2.6-3.0-9	60	
MS35206-229	2.5-3.0-7	10	P
MS35206-230	2.5-9.0-17	765	
MS35206-231	2.5-1.0-14	2	P

PART NUMBER	FIGURE AND INDEX NUMBER	QTY PER ART	SMR CODE
MS35206-232	2.4-1.0-55	17	
MS35206-242	2.12-69.0-97	5	
MS35206-243	2.2-12.0-4	50	P
MS35206-244	2.3-1.0-60	0	PA
MS35206-245	2.5-11.0-7	29	P
MS35206-246	2.12-9.0-75	8	
MS35206-247	2.12-9.0-76	8	
MS35206-249	2.3-1.0-46	5	
MS35206-250	2.12-9.0-78	4	P
MS35206-26A	2.17-11.0-59	5	
MS35206-262	2.17-11.0-88	2	P
MS35206-323	2.16-1.0-27	1	
MS35206-61	2.5-6.0-8	4	
MS35206-62	2.4-5.0-2	45	
MS35206-63	2.13-8.0-22	2	
MS35207	2.14-4.0-135	15	
MS35207-129	2.9-25.0-10	1	P
MS35207-216	2.13-1.1-22	3	
MS35207-220	2.3-1.0-3	RF	P
MS35207-230	2.20-44.0-3	4	
MS35207-259	2.20-2.0-19	4	
MS35207-26J	2.17-11.0-129	1	
MS35207-261	2.3-1.0-44	4	
MS35207-262	2.5-14.0-4	64	
MS35207-263	2.5-1.0-45	41	P
MS35207-264	2.4-3.0-10	54	
MS35207-265	2.12-9.0-61	36	
MS35207-266	2.5-11.0-18	32	
MS35207-267	2.5-4.0-9	9	P1
MS35207-268	2.13-16.0-10	1	
MS35207-269	2.14-4.0-113	1	P
MS35207-273	2.17-11.0-106	4	
MS35209-263	2.5-2.0-5	5	
MS35214-25	2.16-19.0-23	1	
MS35214-31	2.16-1.0-60	4	A
MS35219-29	2.16-23.0-3	4	
MS35265-60	2.20-34.0-23	0	
MS3533-137	2.17-11.0-157	7	
MS35333-39	2.20-34.0-24	8	
MS35335-62	2.10-7.0-159	2	
MS35338-13	2.20-43.0-8	2	
MS35338-135	2.16-24.0-20	0	P1
MS35338-136	2.17-41.0-8	0	
MS35338-137	2.17-13.0-11	4	
MS35338-41	2.3-1.0-3	9	
MS35338-42	2.3-1.0-64	1	
MS35338-43	2.2-3.0-32	53	P1
MS35338-44	2.3-1.0-27	1	
MS35338-46	2.17-0.0-22	2	
MS35338-43	2.20-45.0-12	2	
MS35489-14	2.13-1.1-167	2	
MS35489-175	2.17-38.0-15	1	
MS35489-20	2.13-11.0-15	2	P1
MS35489-4	2.8-24.0-4	1	
MS35489-59	2.12-67.0-37	1	
MS35489-73	2.4-7.0-46	4	
MS35489-78	2.13-11.0-16	1	
MS35649-224	2.17-11.0-64	2	
MS35649-262	2.17-41.0-9	4	
MS35649-64	2.18-24.0-9	4	
MS35650-302	2.3-1.0-42	6	P1
MS3723	2.20-44.0-4	1	
MS3726-4-713	2.20-2.0-30	1	
MS5063-1883	2.12-15.0-20	4	
MS51848-43	2.17-11.0-64	2	
MS51849-16	2.3-1.0-66	1	

PART NUMBER	FIGURE AND INDEX NUMBER	QTY PER ART	SMR CODE
MS51849-64	2. 3- 1.0- 71	2	
MS51849-65	2. 3- 1.0- 37	1	
MS51849-66	2. 3- 1.0- 43	1	
MS51953-54	2. 3- 1.0- 8	1	
MS51957-17	2.18-24.0- 18	8	P1
MS51957-26	2.18-24.0- 8	1	P1
MS51957-28	2.18-24.0- 4	2	P1
MS51957-31	2.18-24.0- 16	2	P1
MS51957-32	2.18-24.0- 7	13	P1
MS51957-45B	2.16-11.0- 31	5	
MS51957-46	2. 4- 3.0- 8	2	
MS51957-5	2.17-11.0- 64	2	
MS51958-48	2. 4- 7.0- 67	19	
MS51958-61	2. 4- 3.0- 1	39	
MS51958-62	2. 2- 3.0- 56	15	
MS51958-63	2. 4- 7.0- 25	10	P1
MS51958-64	2. 2- 3.0- 33	14	
MS51958-65	2. 4- 3.0- 13	6	
MS51959-1	2.16- 9.0- 25	1	
MS51959-63	2.18-14.0- 3	4	
MS51963-34	2.14-10.0- 8	2	
MS51964-68	2. 3- 1.0- 14	3	P
MS5207-264	2.18-11.0- 24	3	
MS52083-1863	2.12-46.0- 27	2	
MS5649-44	2.16-24.0- 19	8	
MS6001E0644	2.10-32.0- 16	1	M
MS6001E082A	2.14- 4.0-111	1	M
MS6001E093A	2. 9-16.0- 16	1	M
MS6001E110B	2. 5-16.0- 16	1	M
MS6001E125A	2. 9-17.0- 90	1	M
MS6001E133A	2. 9-17.0- 71	1	M
MS6001E135A	2. 9-17.0- 57	2	M
MS6001E14200	2. 9-17.0- 78	1	M
MS6001E14206	2. 9-17.0- 96	1	
MS6001E143A	2. 9-17.0- 42	2	
MS6001E146B	2. 9-17.0- 78	2	M
MS6001E156A	2.10-25.0- 42	2	M
MS6001E160A	2. 9-16.0- 23	1	M
MS6001E234A	2. 9-18.0- 34	2	M
MS6001G086A	2.14- 4.0-112	1	M
MS6001G126A	2.10-25.0- 41	2	M
MS6001G206A	2.10-32.0- 19	1	M
MS6001H094B	2.10-25.0- 6	2	M
MS6001J152C	2.10-31.0- 11	1	M
MS9068-32S	2.12-44.0-156	2	
MS9020-20	2.10- 7.0-172	2	
MS9021-633	2.12-10.0-18	1	
MS9024-03	2.12-46.0-231	1	
MS90298-1	2.12- 9.0- 66	2	P1
MS90298-2	2.20- 2.0- 21	2	
MS90362-1	2.17-11.0-103	1	
MS90362-2	2.17-11.0-100	1	
MS9103-02	2.10-19.0- 21	4	
MS9134-01	2.8-23.0-8	1	
MS9136-31	2.10- 7.0-100.	1	
MS91528-1A4B	2.16-16.0- 2	1	P1
MS92512-6	2.12-22.0- 73	1	
MS9316-04	2.10- 7.0-222	2	B1L
MS9364-11	2.20-44.0- 26	1	
MS9375-039	2.10- 7.0-227	1	P
MS9387-C8	2.10-31.0- 16	1	
MS9387-32	2.10-32.0- 24	1	
MS9387-04	2.10-23.0- 37	3	
MS9387-06	2.10-25.0- 39	2	
MS9387-08	2.10-25.0- 13	5	
MS9387-10	2.10-25.0- 12	3	

PART NUMBER	FIGURE AND INDEX NUMBER	QTY PER ART	SMR CODE
MS9387-12	2.10-29.0- 12	2	
MS9387-16	2.10-29.0- 10	7	
MS9388-014	2.10-33.0- 12	1	
MS9388-018	2.10-33.0- 14	1	
MS9388-110	2.10-25.0- 18	1	
MS9388-111	2.10-25.0- 22	2	
MS9388-129	2.10-33.0- 15	1	
MS9388-136	2.10-29.0- 19	1	
MS9388-14	2.10-29.0- 23	1	
MS9388-155	2.10-32.0- 22	1	
MS9388-213	2.10-24.0- 6	2	
MS9388-214	2.10-29.0- 21	1	
MS9388-245	2.10-33.0- 11	1	
MS9388-247	2.10-32.0- 18	1	
MS9463-05	2.20-17.0- 35	4	
MS9463-12	2.20-17.0- 36	2	
MS9502-24	2.20-44.0- 24	1	
MT-4707	2.18-21.0- 11		
MT3513	2.18-18.0- 14	1	
MT3819	2.18-18.0- 12	1	
MT45797C	2.18-18.0- 13	1	
MX-3479/ARR	2.18-34.0- 14	1	
MXU-553 SYS	2.18-38.0-	1	
MX10061	2.16- 8.0- 6	1	
MX41F1-3/3-1	2. 7-11.0- 14		RF
	2. 7-11.0- 16		RF
	2. 7-11.0- 16		RF
MY05-1-100E	2.14- 8.0- 73	1	P10
MY2-1-200E	2.14- 8.0- 83	1	P10
MY25-1-200E	2.14- 8.0- 74	1	
M24694-55	2. 6-13.0- 20	1	
M3786-4-0353	2.16-16.0- 1	1	
M39024/10-1	2.18-17.0- 44		
M4047	2.15-17.0- 1	1	
M5086/2-8-9	2. 3- 1.0- 67		AR
M535206-244	2.18-37.0- 7	2	
M58085-3	2.17- 1.0- 33A	1	P1
M6106/2-001	2.17-12.0- 8	1	P1
	2.17-42.0- 2	1	
M6106/3-001	2.17-12.0- 7	1	P1
	2.17-42.0- 5	1	
M6106/5-001	2.17-12.0- 9	1	P1
	2.17-42.0- 3	1	
M70-002-4	2.10-33.0- 13	1	
M83723	2.20-44.0- 5	1	
M83723-01R1623			
N	2.18-23.0- 15	1	
M83723-02R1623			
N	2.18-23.0- 17	1	
M83723-02R2241			
N	2.20-34.0- 10	1	
M83723-13F2241			
N	2.20-34.0- 11	1	
M83723-14R-120			
3N	2. 3- 1.0- 49	1	
M83723-15N16	2.18-23.0- 16	1	
	2.18-23.0- 18	1	
M83723-15S-12	2. 3- 1.0- 50	1	
M83723-15S-22F	2.20-34.0- 9	2	P1
M83723-15S14F	2.17- 8.0- 78	1	
M83723-23F2815			
N	2.20- 2.0- 34	1	
M83723-23R-110			
4N	2. 3- 1.0- 47	1	
M83723-23R1103	2.17- 1.0- 7B	2	
	2.17- 1.0- 33B		
M83723-23R1502			
N	2.17- 0.0- 79	1	

PART NUMBER	FIGURE AND INDEX NUMBER	QTY PER ART	SMR CODE
M83723-35A10R	2.17- 1.0- 70	2	
	2.17- 1.0- 330		
M83723-35N15F	2.17- 1.0- 70	1	P1
M83723-35N28F	2.20- 2.0- 30	1	
M83723-35S-11R	2. 3- 1.0- 40	1	P1
M83723-75R147N	2.17- 8.0- 78	1	P1
M83723/02R1006			
N	2.18-37.0- 4	1	
M83723/15N10R	2.18-37.0- 5	1	
M83720-4-106	2.20- 2.0- 36	1	
M9395-03-01	2.12-60.0- 23	1	P1
NAF1080-1A3	2.10-20.0- 12	1	
NAF1080-1A5	2.13- 2.0- 1	1	
NAF10801A4	2. 4- 0.0- 44	1	
NAS10-91-30H	2.12- 9.0- 89	1	
NAS1003-11	2. 5-15.0- 4	3	3P
NAS1003-54	2. 5-15.0- 10	1	1P
NAS1003-6	2.13- 0.0- 64	4	
NAS1022A20	2. 3- 1.0- 18	1	
NAS1022A8	2.15-29.0- 5	2	
NAS1022A9	2.20-24.0- 6	15	
NAS1022J3	2. 4- 5.0- 2	2	
NAS1022N3	2. 9- 3.0- 19	8	
NAS1023-4	2.12- 9.0- 32	12	
NAS1057T3-063	2.20-32.0- 15	2	
NAS1067A3	2. 2- 5.0- 1	35	
NAS1068A00	2. 5-10.0- 20	3	
NAS1068A3	2.12- 0.0- 54	1	
NAS1070-416	2.13- 5.0- 54	10	
NAS1081-0605L	2.12-60.0- 74	1	
NAS1081-303L	2.12-60.0- 72	2	
NAS1081-4A10L	2.12-60.0- 68	1	
NAS1088-1A5	2.13- 3.0- 1	1	
NAS1100-06-5	2.20- 2.0- 27	6	
NAS1100E06-7	2.18-25.0- 11	4	
NAS1100E3-8	2.18-25.0- 9	8	
NAS1103-1	2. 4- 7.0- 30	14	
NAS1103-10	2.14- 6.0- 21	11	
NAS1103-11	2.15-24.0- 7	1	
NAS1103-15	2.20-40.0- 14	6	
NAS1103-16	2. 8- 1.0- 29	2	
NAS1103-17	2.12-60.0- 62	4	P1
NAS1103-18	2. 8- 1.0- 39	4	
NAS1103-2	2. 2- 7.0- 61	70	
NAS1103-20	2. 8- 1.0- 40	2	
NAS1103-22	2.20- 0.0- 13	2	
NAS1103-27	2.20-42.0- 6	8	
NAS1103-3	2. 2-14.0- 26	77	
NAS1103-4	2. 2- 1.0- 3	81	
NAS1103-42	2.20- 7.0- 9	4	
NAS1103-5	2.12-60.0- 94	22	
NAS1103-6	2. 2- 1.0- 0	00	
NAS1103-7	2. 2- 1.0- 0	8	
NAS1103-8	2. 2-14.0- 26	8	
NAS1103-9	2. 2-14.0- 41	3	
NAS1104-12	2.12-60.0- 47	7	
NAS1104-14	2.13- 1.1-170	2	
NAS1104-2	2. 2-16.0- 20	5	
NAS1104-23	2. 9- 1.0- 43	2	
NAS1104-28	2.15-37.0- 13	3	
NAS1104-3	2. 2-16.0- 12	3	
NAS1104-4	2.17- 0.0- 69	14	
NAS1104-44	2. 8- 1.0- 51	3	
NAS1104-5	2. 8- 1.0- 18	12	
NAS1104-6	2. 9- 1.0- 45	20	
NAS1104-7	2.12-60.0- 42	10	
NAS1104-8	2.12-60.0- 29	5	

PART NUMBER	FIGURE AND INDEX NUMBER	QTY PER ART	SMR CODE
NAS1104-9	2.10-1.0-116	8	
NAS1105-10	2.21- 40.0- 10	8	
NAS1105-11	2.20-22.0- 14	8	
NAS1105-13	2.13- 1.1-174	1	
NAS1105-15	2.10- 0.0- 7	1	
NAS1105-17	2.13- 1.1-175	2	
NAS1105-24	2.14-14.0- 12	6	
NAS1105-23	2.12- 0.0- 6	1	
NAS1105-5	2. 4-10.0- 40	1	
NAS1105-5	2.20-22.0- 8	10	
NAS1105-6	2.20-44.0- 20	14	
NAS1105-100	2.20-40.0- 63	1	
NAS1105-170	2.12-60.0- 57	1	
NAS1105-240	2. 8-20.0- 5	1	
NAS1105-240	2.20-40.0- 64	1	
NAS1105-2	2.12-0.0- 96	4	
NAS1151-0	2.20-18.0- 47	0	
NAS1150E5	2. 7-10.0- 7	0	
NAS1154E7	2. 7-10.0- 3	0	
NAS1190C00P7L	2. 2- 2.0- 2	4	
NAS1190C00P9N	2. 2- 2.0- 3	4	
NAS1201P11A1B5	2.20- 2.0- 30	1	
NAS1201C037A	2. 2- 7.0- 20	0	
NAS1203-12	2.20-44.0- 42	0	
NAS1203-2	2.13- 1.1-160	44	
NAS1203-3	2.12-60.0- 17	34	
NAS1203-4	2.12-60.0- 16	50	
NAS1203-5	2. 4- 1.0- 27	64	P1
NAS1203-6	2. 7-10.0- 15	0	
NAS1203A	2.20-45.0- 8	7	
NAS1204-10	2.12-60.0- 14	0	
NAS1204-0	2.15-37.0- 9	2	
NAS1204-7	2.12-60.0- 30	10	
NAS1204-8	2.15-37.0- 7	14	
NAS1204-00	2.20-41.0- 13	2	
NAS1204-9	2.12-60.0- 15	12	
NAS1205-120	2.20-44.0- 20	1	
NAS1222-06E	2.16- 5.0- 30	2	
NAS1222-00E	2.16- 5.0- 20	4	
NAS1222-3E	2.16- 5.0- 10	11	
NAS1222-4E	2.14-21.0- 21	0	
NAS1222-5E	2.14-21.0- 18	1	
NAS1237A4	2. 8-20.0- 30	1	
NAS1252-13L	2. 4- 1.0- 26	10	
NAS1252-1716H	2. 8-10.0- 50	3	
NAS1252-2116H	2. 8-10.0- 22	2	
NAS1252-5L	2.20-10.0- 39	5	
NAS124K4-12	2.20-40.0- 30	0	
NAS1291-03	2.13- 0.0- 42	0	
NAS1291-04	2.16- 5.0- 52	2	
NAS1291-06	2.18-23.0- 14	0	
NAS1291-3	2. 2- 2.0- 10	110	
NAS1291-4	2. 3- 0.0- 22	60	
NAS1291-5	2.10-38.0- 26	10	
NAS1291-6	2.10-32.0- 3	3	
NAS1292-3	2. 8- 1.0- 20	0	
NAS1297-3-2	2.13-25.0- 21	1	
NAS13003-24	2.20- 8.0- 6	0	
NAS1303-10	2.20-30.0- 23	4	
NAS1303-24	2. 8-20.0- 37	1	
NAS1303-3	2.12- 9.0- 30	14	
NAS1303-4	2.20-48.0- 41	2	
NAS1303-5	2.20-21.0- 3	13	
NAS1303-6	2. 8-20.0- 40	6	
NAS1303-9	2.16-23.0- 4	4	

PART NUMBER	FIGURE AND INDEX NUMBER	QTY PER ART	SMR CODE
NAS1304-13	2.20-21.0-8	8	
NAS1304-18	2.20-48.0-65	2	
NAS1304-20	2.20-21.0-5	10	
NAS1304-24	2.12-68.0-91	20	
NAS1304-26	2.15-37.0-13	5	
NAS1304-3	2.12-9.0-45	4	
NAS1304-4	2.20-40.0-2	7	
NAS1304-5	2.13-1.1-163	8	
NAS1304-50	2.12-9.0-36	2	
NAS1304-8	2.20-48.0-19	7	
NAS1304-9	2.20-40.0-3	2	
NAS1305-13	2.15-37.0-18	4	
NAS1305-38	2.20-24.0-4	4	
NAS1305-4	2.20-40.0-8	4	
NAS1305-11	2.20-40.0-10	8	
NAS1308-26D	2.20-37.0-9	1	
NAS1309-3H	2.10-36.0-1	6	
NAS1305A5C07	2.20-39.0-11	2	
NAS1305A5C12	2.20-39.0-12	1	
NAS1351-5-28	2.18-18.0-9	3	
NAS1351-5-32	2.18-18.0-2	1	
NAS1351C3-6	2.10-19.0-19	4	
NAS1351C3-8	2.10-33.0-6	4	
NAS1351C3H6	2.10-19.0-26	2	
NAS1351C5-8	2.10-19.0-22	4	
NAS1352-04-4P	2.10-31.0-20	4	
NAS1352-3-60	2.10-25.0-29	1	
NAS1352-4-19P	2.10-34.0-18	4	
NAS1352-6-16P	2.10-25.0-16	1	
NAS1374A11S04E	2.13-8.5-84	1	
NAS1375A06CA05Z	2.18-18.0-24	1	P
NAS1376A06S0014	2.13-8.0-72	1	
NAS1398D4-3	2.20-39.0-10	3	
NAS1401-4D3	2.8-23.0-18	1	
NAS1402-2	2.12-68.0-36	6	
NAS1403-2	2.9-32.0-29	2	
NAS1403-3	2.9-32.0-30	4	
NAS143-10C	2.6-7.0-44	6	
NAS143-5C	2.3-16.0-59	4	
NAS143-7	2.6-7.0-41	8	
NAS143-7C	2.6-7.0-40	8	
NAS1455A00-6	2.20-21.0-21	4	
NAS1455A00-8	2.20-44.0-33	1	
NAS145502-4	2.20-39.0-5	3	
NAS1593	2.10-7.0-124A	1	
NAS1593-150	2.10-7.0-101	1	
NAS1593-210	2.12-23.0-8	2	
NAS1598-06Y	2.18-24.0-11	6	
NAS1635-06-6	2.20-20.0-6A	2	
NAS1635-3-8	2.13-5.0-42	6	
NAS21042L3	2.13-27.0-18	2	
NAS211-7	2.2-7.0-63	13	
NAS211-8	2.2-7.0-59	18	
NAS220-12	2.0-31.0-31	6	
NAS220-8	2.18-1.0-7	2	
NAS220-9	2.16-4.0-4	6	
NAS221-10	2.2-7.0-28	109	P1
NAS221-10L	2.4-11.0-7	1	
NAS221-11	2.2-7.0-7	142	
NAS221-12	2.2-7.0-33	101	
NAS221-13	2.2-2.0-20	34	
NAS221-14	2.2-12.0-6	34	
NAS221-15	2.2-2.0-19	12	
NAS221-16	2.14-17.0-3	3	
NAS221-17	2.9-1.0-7	7	
NAS221-18	2.14-17.0-19	7	
NAS221-20	2.2-3.0-69	3	
NAS221-21	2.14-17.0-24	6	
NAS221-23	2.9-1.0-14	3	

PART NUMBER	FIGURE AND INDEX NUMBER	QTY PER ART	SMR CODE
NAS221-24	2.8-6.0-17	2	
NAS221-30	2.13-27.0-37	2	
NAS221-31	2.20-31.0-50	3	
NAS221-37	2.12-64.0-28	2	
NAS221-4	2.2-7.0-64	9	
NAS221-5	2.2-1.0-2	35	
NAS221-6	2.2-7.0-103	109	
NAS221-7	2.4-4.0-2	42	
NAS221-8	2.2-1.0-1	286	
NAS221-9	2.2-1.0-3	290	
NAS2210D7	2.8-4.0-13	7	
NAS2219	2.8-6.0-20	6	
NAS222-10	2.2-14.0-8	3	
NAS222-12	2.2-14.0-26	AR	
NAS222-21	2.2-3.0-66	1	
NAS223-16	2.14-10.0-59	1	
NAS295-10A	2.10-39.0-16	2	
NAS295-3	2.4-12.0-101	4	
NAS3-27A	2.12-1.0-2	2	
NAS330PA7	2.6-13.0-14	AR	
NAS330PA4-5	2.20-19.0-34	26	
NAS333-7	2.16-3.0-35	6	
NAS3330PA1	2.2-9.0-60	52	
NAS3330PA10	2.20-30.0-29	4	
NAS3330PA11	2.2-2.0-11	5	
NAS3330PA15	2.2-18.0-6	3	
NAS3330PA4	2.2-2.0-18	837	
NAS3330PA4-5	2.2-7.0-39	578	
NAS3330PA5	2.2-2.0-17	1323	
NAS3330PA5-5	2.2-9.0-49	357	
NAS3330PA6	2.2-2.0-22	179	
NAS3330PA6-5	2.2-18.0-1	279	
NAS3330PA7	2.2-19.0-26	46	
NAS3330PA7-5	2.2-18.0-11	9	
NAS333PA-5	2.15-31.0-30	16	
NAS3330PA11	2.20-48.0-69	2	
NAS333PA111	2.2-13.0-3	4	
NAS333PA27	2.16-1.0-119	2	P
NAS333PA4	2.2-3.0-58	98	
NAS333PA4-5	2.6-6.0-5	137	
NAS333PA5	2.4-2.0-60	44	
NAS333PA5-5	2.10-6.0-67	93	
NAS333PA6	2.11-3.0-30	76	
NAS333PA6-5	2.15-31.0-26	2	
NAS333PA7	2.11-3.0-30	28	
NAS333PA7-5	2.15-30.0-21	6	
NAS333P13-5	2.11-6.0-46	4	
NAS333PA4-5	2.20-33.0-20	1	
NAS333P5	2.12-38.0-4	6	
NAS333P6	2.13-1.1-89	6	
NAS3340PA6	2.2-19.0-11	36	
NAS3340PA10	2.4-9.0-58	5	
NAS3340PA19-5	2.3-2.0-21	8	
NAS3340PA11	2.6-13.0-5	AR	
NAS3340PA12	2.3-2.0-20	4	
NAS3340PA4-5	2.6-13.0-5	AR	
NAS3340PA5	2.2-2.0-61	52	
NAS3340PA5-5	2.2-19.0-1	231	
NAS3340PA6	2.2-9.0-55	627	
NAS3340PA6-5	2.2-19.0-1	794	
NAS3340PA7	2.2-19.0-21	104	
NAS3340PA7-5	2.2-19.0-21	49	
NAS3340P5	2.2-9.0-59	30	
NAS3340PA10	2.12-1.0-39	9	
NAS3340PA11	2.10-0.0-22	3	
NAS3340PA16	2.14-4.0-7	2	
NAS3340PA37	2.15-22.0-77	5	

PART NUMBER	FIGURE AND INDEX NUMBER	QTY PER ART	SMR CODE
NAS334PA6	2.12-51.0- 2	64	
NAS334PA6-5	2.15-19.0- 11	1	
NAS334PA7	2.10-39.0- 23	3	
NAS335CPA10	2.15-19.0- 20	1	
NAS335CPA6-5	2.15-19.0- 18	1	
NAS335PA10	2.15-19.0- 14	1	
NAS335PA6-5	2.15-19.0- 12	1	
NAS354-4-200	2.16- 3.0- 13	2	
NAS354-4-210	2.13-27.0- 45	1	
NAS354-4-240	2.13-25.0- 8	1	
NAS354-4-250	2.16- 3.0- 14	1	
NAS354-4-300	2.13-26.0- 9	3	
NAS354-4-310	2.13-26.0- 10	1	
NAS354-5-1312	2.14-27.0- 5	2	
NAS354-5-1380	2.14-26.0- 11	4	
NAS356-63-695	2.26- 6.0- 8	1	
NAS390S10	2. 5-15.0- 35	2	
NAS395-11-0	2. 5- 9.0- 9	1	
NAS397-14	2. 9- 1.0- 27	1	
NAS397-20	2. 4-11.0- 2	1	
NAS4H5A	2.12-55.0- 7	4	
NAS42003-5	2. 2- 6.0- 21	1	
NAS42003-7	2. 2- 6.0- 20	1	
NAS42004-10	2.10-30.0- 25	1	
NAS42004-10A	2. 5- 4.0- 19	RF	
NAS42004-24	2.11-30.0- 27	1	
NAS42006-14	2.15-38.0- 32	1	
NAS42006-26	2.15-13.0- 16	1	
NAS42006-30	2.15-13.0- 12	2	
NAS42006-40	2.25-23.0- 17	1	
NAS42HT12-8	2.15-25.0- 78	RF	
NAS42HT8-12	2.10- 8.0- 25	2	
NAS427W12	2.14-32.0- 6	3	
NAS427W13	2.14-32.0- 3	2	
NAS427W17	2.14-34.0- 2	2	
NAS427W18	2.14-34.0- 18	4	
NAS427W19	2.14-41.0- 2	1	
NAS427W20	2.14-34.0- 9	4	
NAS427W38	2.14-41.0- 3	1	
NAS427W76	2.14-23.0-142	1	
NAS428-3-4	2.12-14.0- 54	1	
NAS428-3-5	2. 3- 5.0- 17	9	
NAS428-3-6	2. 4-12.0- 95	3	
NAS428-3-7	2. 4-12.0- 57	9	
NAS428-4-10	2.14-42.0- 9	2	
NAS428-4-12	2.10- 7.0- 63	1	
NAS428-4-13	2.14-16.0- 14	5	
NAS428-4-7	2. 3- 1.0- 30	2	
NAS428-5-12	2.15- 1.1-171	2	
NAS428-6-12	2.17-11.0- 97	2	
NAS428-6-16	2.17- 6.0- 26	1	
NAS428K3	2.14-23.0-103	2	
NAS428K3-6	2.10- 4.0- 13	2	
NAS428K3-7	2.12-66.0- 34	1	
NAS428K4-10	2.14-15.0- 32	7	
NAS428K4-12	2.20-33.0- 44	1	
NAS428K4-16	2.14- 9.0- 26	2	
NAS43-3-15	2. 7- 3.0-104	2	
NAS43-3-24	2.13-31.0- 25	3	
NAS43-3-8	2.10-31.0- 22	1	
NAS43HT4-52	2. 4- 7.0- 15	1	
NAS43001-16	2.14- 8.0- 10	1	
NAS43003-10	2.11- 3.0- 17	3	
NAS43003-100	2.10-22.0- 41	2	

PART NUMBER	FIGURE AND INDEX NUMBER	QTY PER ART	SMR CODE
NAS43003-12	2.12-39.0- 6	1	
NAS43003-14	2.16-25.0- 7	2	
NAS43003-15	2.20-33.0- 23	1	
NAS43003-15	2. 4- 4.0- 33	14	P1
NAS43003-18	2. 5-15.0- 6	2	
NAS43003-20	2.10-35.0- 8	7	P
NAS43003-22	2.14- 4.0-123	1	
NAS43003-24	2. 9-20.0- 44	16	P1
NAS43003-25	2.14- 8.0- 87	1	
NAS43003-26	2. 9-20.0- 9	2	P
NAS43003-27	2. 9-14.0- 52	3	
NAS43003-30	2.12-37.0- 73	6	
NAS43003-32	2.13- 1.1- 40	12	
NAS43003-35	2.20-35.0- 4	4	
NAS43003-4-40	2.20-13.0- 15	2	
NAS43003-40	2. 9- 3.0- 6	16	
NAS43003-44	2.19- 3.0- 23	3	
NAS43003-48	2. 5- 1.0- 10	3	
NAS43003-56	2.14- 4.0-113	1	P
NAS43003-56	2.12-49.0- 41	2	
NAS43003-60	2.14-22.0- 9	1	
NAS43003-64	2.14- 8.0- 65	1	
NAS43003-72	2.16- 1.0-118	2	P
NAS43003-8	2.12- 1.0- 28	2	
NAS43003-80	2. 7- 7.0- 32	3	
NAS43003-94	2.13- 1.1- 73	1	
NAS43003-96	2.14- 8.0- 88	1	
NAS43004-12	2. 9- 2.0- 19	4	
NAS43004-16	2.12-25.0- 47	4	
NAS43004-18	2.12-25.0- 4	1	
NAS43004-26	2.12-25.0- 5	1	
NAS43004-40	2.12-38.0- 94	1	
NAS43004-45	2.14-23.0-170	3	
NAS43004-68	2. 9- 1.0- 44	1	
NAS43004-8	2.14- 6.0- 23	1	
NAS43004-94	2. 2-12.0- 18	2	
NAS43006-19	2.20- 6.0- 14	1	
NAS43006-34	2.12-68.0- 64	2	
NAS43006-7	2.20- 5.0- 16	1	
NAS43HT3-10	2.13-20.0- 21	9	
NAS43HT3-14	2.13-30.0- 16	1	
NAS43HT3-16	2.13-27.0- 34	2	
NAS43HT3-24	2.11- 9.0- 3	3	
NAS43HT3-28	2.13-27.0- 19	2	
NAS43HT3-66	2.13-24.0- 5	1	
NAS43HT3-88	2. 2- 9.0- 42	1	
NAS43HT3-9	2.13- 1.1- 47	2	
NAS43HT4-10	2.10-37.0- 26	8	
NAS43HT4-20	2.10-37.0- 9	3	
NAS43HT4-4	2.14-23.0- 53	4	P
NAS43HT5-10	2.10-37.0- 16	1	
NAS43HT5-12	2.20-33.0- 24	1	
NAS43HT5-6	2.15-22.0- 94	2	P
NAS43HT6-6	2.13-20.0- 20	9	
NAS43003-20	2.12-16.0-129	1	
NAS43003-103	2.10-23.0- 36	2	
NAS44-516	2.14-15.0- 70	5	
NAS44-616	2.14-10.0- 67	2	
NAS44-816	2.14-24.0- 10	1	
NAS443WDD916	2.17-11.0- 95	2	
NAS444-P4A3	2.14- 9.0- 7	1	
NAS444-P5-12	2.15-20.0- 12	1	
NAS444-P7-19	2.20-11.0- 87	4	
NAS444-10-23	2.20-11.0- 51	2	
NAS444-10-33	2.15-28.0- 23	4	

PART NUMBER	FIGURE AND INDEX NUMBER	QTY PER ART	SMR CODE
NAS464-13-11	2. 5- 6.0- 25	2	
NAS464-3-11	2.20-33.0- 24	1	
NAS464-3-13	2. 8-12.0- 24	2	
NAS464-3-29	2.20-33.0- 73	2	
NAS464-3-5	2.20-33.0- 56	2	
NAS464-3-9	2.20-33.0- 25	1	
NAS464-3A10	2.14- 2.0- 5	4	
NAS464-3A14	2.20-14.0- 26	2	
NAS464-3A16	2.20-14.0- 29	6	
NAS464-3A17	2. 3-12.0- 3	1	
NAS464-3A24	2. 3-18.0- 15		
NAS464-3A3	2. 2- 1.0- 5	24	
NAS464-3A4	2. 2- 1.0- 5	24	
NAS464-3A5	2.15-14.0- 13	11	
NAS464-3A6	2.15- 2.0- 1	10	
NAS464-3A7	2.15-11.0- 25	6	
NAS464-3A8	2.15-33.0- 22	6	
NAS464-3A9	2. 2- 1.0- 5	2	
NAS464-4-11	2.20-11.0- 46	2	
NAS464-4-16	2.20-11.0- 47	2	
NAS464-4-17	2. 6- 6.0- 9	6	
NAS464-4-18	2. 8- 7.0- 23	4	
NAS464-4-24	2.20-33.0- 6	1	
NAS464-4-36	2.15-13.0- 44	1	
NAS464-4-9	2.20-33.0- 5	1	
NAS464-4A10	2.18-36.0- 17	12	
NAS464-4A12	2.14-18.0- 77	6	
NAS464-4A13	2.14-25.0- 16	1	
NAS464-4A14	2. 3- 7.0- 6	1	
NAS464-4A16	2.14-25.0- 35	2	
NAS464-4A17	2.14-25.0- 4	15	
NAS464-4A18	2.14- 9.0- 4	5	
NAS464-4A19	2.14-25.0- 8	15	
NAS464-4A20	2.14-25.0-132	1	
NAS464-4A21	2.14-17.0- 3	6	
NAS464-4A22	2.14- 4.0- 5	2	
NAS464-4A24	2.14-14.0- 28	1	
NAS464-4A25	2.14-25.0-104	1	
NAS464-4A26	2.14-17.0- 66	2	
NAS464-4A28	2.14-14.0- 45	1	
NAS464-4A31	2.14-25.0- 17	1	
NAS464-4A34	2. 8- 7.0- 5	1	
NAS464-4A36	2.14-17.0- 75	1	
NAS464-4A41	2.14-25.0- 59	1	
NAS464-4A49	2.14-25.0-171	1	
NAS464-4A5	2. 8- 7.0- 6	10	
NAS464-4A53	2.14-22.0- 11	1	
NAS464-4A5	2.14-22.0- 39	14	
NAS464-4A63	2.14-25.0-124	1	
NAS464-4A7	2.10-31.0- 16	6	
NAS464-4A77	2.14-13.0- 17	1	
NAS464-4A8	2.14- 6.0- 36	15	
NAS464-4A81	2.14-33.0- 8	1	
NAS464-4A85	2.14-33.0- 6	1	
NAS464-4A9	2.14-22.0- 19	2	
NAS464-5-13	2.15-22.0- 4	1	
NAS464-5-16	2.15-13.0- 23	1	
NAS464-5-25	2.15-13.0- 25	1	
NAS464-5A12	2.14-14.0- 14	2	
NAS464-5A14	2.14-22.0- 24	1	
NAS464-5A20	2.14-14.0- 18	1	
NAS464-5A23	2.14-37.0- 39	1	
NAS464-5A24	2.14-34.0- 5	1	
NAS464-5A26	2.14-14.0- 4	1	
NAS464-5A27	2.14-21.0- 5	1	
NAS464-5A30	2.21-24.0- 13	54	
NAS464-5A35	2.14-26.0- 31	2	

PART NUMBER	FIGURE AND INDEX NUMBER	QTY PER ART	SMR CODE
NAS464-5A47	2.20-33.0- 15	2	
NAS464-5A48	2.14-21.0- 4	1	
NAS464-5A61	2.14-25.0-101	1	
NAS464-5A8	2.10-40.0- 17	4	
NAS464-6-14	2.11- 9.0- 21	4	
NAS464-6-14	2.11- 9.0- 21	4	
NAS464-6-14	2. 6- 6.0- 21	17	
NAS464-6-65	2. 6- 6.0- 20	2	
NAS464-6A16	2.13-40.0- 9	1	
NAS464-6A24	2.10-40.0- 11	1	
NAS464-6A30	2.21-26.0- 9	4	
NAS464-6A31	2.14-19.0- 5	1	
NAS464-7-16	2.11- 5.0- 4	1	
NAS464-7-18	2.20-11.0- 94	4	
NAS464-7-48	2.15-16.0- 72	RF	
NAS464-7A10	2.15-29.0- 4	2	
NAS464-7A12	2.15-29.0- 4	2	
NAS464-7A44	2. 7- 5.0- 6	2	
NAS464-7A57	2. 7- 5.0- 7	4	
NAS464-8-20	2.20-11.0- 5	4	
NAS464-8-22	2. 6-10.0- 4	1	
NAS464-8A10	2.15-29.0- 7	2	
NAS464-8A12	2.15-29.0- 7	2	
NAS464-9-10	2.15-16.0- 43	1	
NAS464-9-21	2.20-11.0- 63	2	
NAS464-9-27	2.15-16.0- 42	1	
NAS464-9A27	2.20-24.0- 8	20	
NAS464P-1L-84	2.10-33.0- 1	1	
NAS464P10-20	2.15-25.0- 26	RF	
NAS464P10-24	2.15-25.0- 26	1	
NAS464P10-27	2.20-23.0- 47	1	
NAS464P10-31	2. 7- 1.0- 11	7	
NAS464P10-33	2. 7- 1.0- 12	2	
NAS464P10-37	2.21-23.0- 46	1	
NAS464P3-13	2. 4-12.0- 27	2	
NAS464P3A10	2. 2-18.0- 94	1	
NAS464P3A12	2. 2-10.0-105	2	
NAS464P3A13	2. 2-10.0-106	1	
NAS464P3A14	2. 2-10.0-107	3	
NAS464P3A15	2.13-30.0- 59	2	
NAS464P3A17	2.13-30.0- 37	2	
NAS464P3A20	2. 2-10.0- 13	1	
NAS464P3A3	2.13-30.0- 47	10	
NAS464P3A35	2.10-23.0- 35	2	
NAS464P3A4	2. 3- 7.0- 7	14	
NAS464P3A5	2. 7- 1.0- 23	1	
NAS464P3A6	2. 3- 7.0- 9	7	
NAS464P3A7	2.15-36.0- 11	2	
NAS464P4-11	2.10- 4.0- 13		
NAS464P4-18	2.14-43.0- 13	RF	
NAS464P4-7	2.10- 4.0- 13	1	
NAS464P4-9	2.10- 4.0- 20	1	
NAS464P4A13	2.15-22.0- 7	6	
NAS464P4A14	2.14-41.0- 14	1	
NAS464P4A17	2.14-41.0- 15	1	
NAS464P4A19	2.14-41.0- 36	1	
NAS464P4A20	2. 2-10.0- 10	4	
NAS464P4A23	2.14-41.0- 35	1	
NAS464P4A7	2.18- 4.0- 5	5	
NAS464P4A8	2. 3- 7.0- 24	11	
NAS464P4A77	2. 7- 3.0- 34	12	
NAS464P5-14	2. 4-12.0-132		
NAS464P5-16	2.15-29.0- 67		
NAS464P5-17	2. 4-12.0-133		
NAS464P5-20	2.20-15.0- 17	13	
NAS464P5A4	2.15-21.0- 13	2	

PART NUMBER	FIGURE AND INDEX NUMBER	QTY PER ART	SMR CODE
NAS464P5A6	2.15-21.0-14	2	
NAS464P5A7	2.7-3.0-35	4	
NAS464P6-15	2.20-11.0-43	2	
NAS464P6-16	2.15-22.0-23	4	
NAS464P6-17	2.20-15.0-13	2	
NAS464P6-18	2.15-22.0-55	2	
NAS464P6-20	2.20-15.0-14	2	
NAS464P6-21	2.20-15.0-12	5	
NAS464P6A10	2.20-22.0-2	16	
NAS464P6A10	2.20-22.0-2	16	
NAS464P6L36	2.14-10.0-15	1	P1
NAS464P7-16	2.20-31.0-101	1	
NAS464P7-17	2.20-11.0-19	2	
NAS464P7-34	2.20-31.0-101	1	
NAS464P8-22	2.20-31.0-67	2	
NAS464P9-17	2.20-23.0-78	1	
NAS464P9-31	2.20-23.0-31	1	
NAS464P9A10	2.20-22.0-3	4	
NAS487-16	2.15-7.0-35	15	
NAS50-156	2.0-10.0-21	8	
NAS50-87	2.14-24.0-32	1	
NAS50-90	2.10-9.0-17	1	
NAS501-12H24A	2.7-9.0-3	1	
NAS501-4H12A	2.12-59.0-9	2	
NAS501-6-12	2.10-39.0-7	1	
NAS501-7-22	2.10-59.0-11	1	
NAS502-6	2.4-15.0-11	1	
NAS508M3	2.10-10.0-15	4	
NAS509-10	2.20-31.0-2	1	
NAS509-16	2.15-38.0-5	1	
NAS509-4	2.4-12.0-14	13	
NAS509-5	2.14-15.0-112	6	
NAS509-6	2.10-24.0-25	1	
NAS509-7	2.8-26.0-7	2	
NAS509-8	2.20-11.0-33	4	
NAS51-25	2.15-8.0-32	1	
NAS51-31	2.7-1.0-47	4	
NAS51-39	2.15-8.0-21	3	
NAS51-50	2.14-24.0-40	1	
NAS510-1	2.5-8.0-9	19	
NAS517-3-11	2.7-1.0-6	12	
NAS517-3-7	2.7-1.0-4	8	
NAS517-3-9	2.7-1.0-5	12	
NAS520-16R6	2.4-7.0-72	1	
NAS520-12-12	2.13-11.0-4	2	
NAS520-14-12	2.13-53.0-6	2	P1
NAS520-25-13	2.20-16.0-32	2	
NAS520-5-12	2.13-11.0-11	5	
NAS520-68-12	2.10-3.0-5	2	
NAS521-12-12	2.13-8.0-54	1	
NAS521-12-9	2.13-13.0-13	9	P1
NAS521-16-12	2.13-23.0-18	1	
NAS521-20-12	2.13-8.0-7	1	
NAS521-32-12	2.13-1.1-139	1	
NAS521-5-9	2.13-1.0-15	2	
NAS521-5-10	2.13-1.0-10	3	
NAS521-5-9	2.13-12.0-16	6	
NAS521-8-10	2.13-8.0-85	2	
NAS521-8-12	2.13-8.0-39	3	
NAS530-5P67	2.10-31.0-7	2	
NAS530-7P32	2.10-31.0-5	2	
NAS5404P3A3	2.7-11.0-1	1	
NAS540-L416	2.2-11.0-12	AR	
NAS549-416	2.2-11.0-11	AR	
NAS551-4R	2.8-28.0-39	1	
NAS554-1	2.14-15.0-114	1	
NAS554-3	2.8-28.0-2	1	

PART NUMBER	FIGURE AND INDEX NUMBER	QTY PER ART	SMR CODE
NAS554-PK310	2.10-13.0-23	30	
NAS554-PK415	2.10-17.0-27	30	
NAS554-PK44-1	2.6-20.0-29	30	
NAS554-PK44-3	2.6-20.0-31	15	
NAS554-PK402	2.6-20.0-30	12	
NAS557-31	2.20-32.0-7	2	P1
NAS557-6	2.18-35.0-8	4	
NAS557-11A	2.12-9.0-2	4	P1
NAS557-4A	2.20-48.0-77	2	
NAS557-5A	2.12-9.0-3	1	
NAS557-6	2.20-44.0-13	1	
NAS557-11P	2.12-9.0-4	4	
NAS557-2A	2.13-1.1-177	3	
NAS557-30F	2.12-9.0-5	1	
NAS557-35F	2.20-44.0-17	1	
NAS559-11	2.13-11.0-27	2	
NAS559-20	2.13-23.0-5	2	
NAS559-21	2.12-32.0-9	3	
NAS559-24	2.12-44.0-147	6	
NAS559-12R	2.13-33.0-27	2	P1
NAS559-16	2.13-9.0-41	1	
NAS559-16F	2.13-33.0-40	2	P1
NAS559-20	2.12-52.0-90	6	
NAS559-24	2.12-44.0-144	11	
NAS559-27	2.12-44.0-14	1	
NAS559-24R	2.12-44.0-147	2	
NAS600-4	2.16-4.0-11	5	
NAS600-5	2.16-4.0-12	4	
NAS600-11	2.16-4.0-20	1	
NAS600-21P	2.17-8.0-77	1	
NAS600-5-27	2.18-17.0-40	10	
NAS600CHSP4R	2.14-7.0-1	4	
NAS617-12	2.10-7.0-145	8	
NAS617-16	2.2-9.0-9	1	
NAS617-27	2.14-27.0-10	1	
NAS617-3	2.10-7.0-162	1	
NAS617-4	2.9-2.0-53	9	
NAS617-5	2.12-40.0-2	25	
NAS617-6	2.9-2.0-24	63	
NAS617-	2.10-7.0-142	1	
NAS620-10	2.16-5.0-14	7	
NAS620-11L	2.15-17.0-2	4	
NAS620-4L	2.14-4.0-34	5	
NAS620-416L	2.16-1.0-101	2	
NAS620-AS	2.2-7.0-17	7	P1
NAS620C6	2.20-2.0-6A	2	
NAS6203-11	2.6-32.0-39.1	4	
NAS6203-6	2.6-32.0-40.2	6	
NAS6203-7	2.6-32.0-40.3	6	
NAS6203-9	2.6-32.0-39.2	4	
NAS6205-10	2.6-32.0-39.3	4	
NAS6205-11	2.6-32.0-39.4	2	
NAS6206-11	2.6-32.0-40.1	12	
NAS623-2-2	2.4-8.0-57	4	
NAS623-2-9	2.13-5.0-25	6	
NAS623-2-7	2.4-8.0-52	2	
NAS623-3-1	2.6-40.0-102	1	
NAS623-3-2	2.6-40.0-17	73	
NAS623-3-3	2.6-40.0-31	26	
NAS623-3-4	2.6-40.0-2	42	
NAS623-3-5	2.6-40.0-19	2	
NAS623-3-6	2.4-3.0-11	6	
NAS623-3-7	2.15-35.0-29	1	
NAS62332	2.17-1.0-59	4	
NAS626-24	2.1-1.0-60	4	
NAS626H20	2.20-40.0-10	2	
NAS627H20	2.20-40.0-14	2	
NAS627-30	2.12-9.0-1	1	

PART NUMBER	FIGURE AND INDEX NUMBER	QTY PER ART	SMR CODE
NAS661-34	2.12-9.1-11	1	
NAS630-48	2.12-9.1-8	1	
NAS631-52	2.12-9.1-9	1	
NAS646-4A12	2.14-16.0-55	1	
NAS669-262	2.8-17.0-8	2	
NAS670-16	2.5-5.0-1	4	
NAS670-43	2.19-36.0-13	2	
NAS670-67	2.1-36.0-16	2	
NAS671-4	2.12-46.0-82	8	
NAS670-69	2.5-2.0-17	29	
NAS670-66	2.2-7.0-82	90	
NAS670-66	2.2-12.0-5	123	
NAS670-62	2.2-5.0-11	1990	
NAS670-62	2.15-26.0-52	4	
NAS670-63	2.15-36.0-19	13	
NAS679-3XW	2.12-37.0-64	2	
NAS670-64	2.2-5.0-65	524	
NAS679-65	2.4-15.0-44	118	
NAS679-65	2.13-7.0-76	35	
NAS679-67	2.7-5.0-4	21	
NAS679-68	2.4-5.0-49	5	
NAS679-68	2.5-7.0-5	34	
NAS679-68	2.5-15.0-7	2	2P
NAS679-64	2.10-13.0-2	25	
NAS679-64M	2.13-35.0-32	2	
NAS679-66	2.4-5.0-23	RF	
NAS67-643	2.12-37.0-5	2	
NAS68-65	2.2-10.0-93	5	
NAS68-65	2.12-18.0-156	5	
NAS68-65	2.2-12.0-24	6	
NAS68-65	2.10-32.0-19	92	
NAS68-65	2.2-5.0-39	16	
NAS68-65	2.4-5.0-55	4	
NAS68-65	2.16-36.0-18	3	
NAS68-65	2.12-34.0-3	1	
NAS68-65	2.2-16.0-21	2	
NAS68-65	2.5-6.0-13	2	
NAS72-10-010	2.20-26.0-45	3	
NAS72-3-002	2.15-36.0-24	1	
NAS72-3-005	2.20-33.0-29	1	
NAS72-3-007	2.7-2.0-14	2	
NAS72-3-010	2.10-7.0-214	1	
NAS72-3E214	2.26-6.0-15	1	
NAS72-4-036	2.20-33.0-7	1	
NAS72-4-013	2.20-33.0-34	1	
NAS72-4-105	2.20-33.0-8	1	
NAS72-4-112	2.15-13.0-43	1	
NAS72-4E112	2.29-6.0-17	3	
NAS72-4-017	2.15-19.0-7	1	
NAS72-4-018	2.20-31.0-104	2	
NAS72-4-019	2.20-31.0-69	1	
NAS72-4-104	2.20-33.0-19	2	
NAS72-4-113	2.13-33.0-23	2	
NAS72-3-006	2.15-22.0-15	1	
NAS72-3-009	2.7-3.0-124	4	
NAS72-10-021	2.7-11.0-2	2	
NAS72-10-027	2.7-11.0-23	3	
NAS72-12-038	2.20-44.0-19	1	
NAS72-12-016	2.20-39.0-9	1	
NAS72-10-023	2.14-23.0-52	1	
NAS72-10-028	2.7-11.0-5	1	
NAS72-10-9	2.20-46.0-79	4	
NAS72-10-005	2.14-23.0-54	1	
NAS72-10-006	2.14-23.0-108	1	
NAS72-10-013	2.14-18.0-72	1	

PART NUMBER	FIGURE AND INDEX NUMBER	QTY PER ART	SMR CODE
NAS75-4-012	2.14-23.0-107	1	
NAS75-4-115	2.14-23.0-56	1	
NAS75-4-024	2.14-23.0-55	1	
NAS75-5-006	2.15-29.0-6	1	
NAS75-5-007	2.15-29.0-14	1	
NAS75-5-008	2.20-39.0-15	2	
NAS75-5-009	2.15-20.0-18	1	
NAS75-5-010	2.20-19.0-54	1	
NAS75-5-016	2.14-23.0-186	1	
NAS75-5-10	2.15-37.0-17	4	
NAS75-6-014	2.15-22.0-16	3	
NAS75-6-007	2.15-23.0-75	2	
NAS75-6-009	2.12-64.0-53	1	
NAS75-6-101	2.12-68.0-69	2	
NAS75-6-115	2.12-66.0-65	1	
NAS75-6-012	2.14-23.0-189	1	
NAS75-7-005	2.15-14.0-43	1	
NAS75-7-110	2.20-19.0-50	1	
NAS75-8-016	2.20-35.0-9	2	
NAS76-6-008	2.15-22.0-68	4	
NAS76-6-013	2.15-13.0-40	2	
NAS76-6-030	2.14-28.0-18	4	
NAS76-6-029	2.15-22.0-69	4	
NAS76-6-021	2.15-13.0-47	2	
NAS77-10-25	2.20-26.0-42	3	
NAS77-10-55	2.20-26.0-43	6	
NAS77-14-22	2.20-47.0-13	2	
NAS77-14-32	2.20-47.0-21	4	
NAS77-16-36	2.20-47.0-19	2	
NAS77-16-77	2.20-25.0-6	1	
NAS77-16-79	2.20-24.0-25	4	
NAS77-16-81	2.20-25.0-6	1	
NAS77-3-15	2.14-2.0-7	2	
NAS77-3-24	2.20-48.0-69	4	
NAS77-3-43	2.2-2.0-14	2	
NAS77-311	2.14-12.0-19	1	
NAS77-4-17	2.14-28.0-56	1	
NAS77-4-18	2.14-18.0-29	14	
NAS77-4-19	2.14-20.0-33	8	
NAS77-4-20	2.14-10.0-71	2	
NAS77-4-21	2.14-12.0-17	21	
NAS77-4-22	2.14-12.0-18	13	
NAS77-4-23	2.14-9.0-53	6	
NAS77-4-24	2.14-26.0-17	22	
NAS77-4-25	2.14-10.0-73	7	
NAS77-4-26	2.14-23.0-147	2	
NAS77-4-27	2.14-18.0-39	4	
NAS77-4-28	2.14-23.0-34	2	
NAS77-4-29	2.14-20.0-14	2	
NAS77-4-30	2.14-20.0-27	2	
NAS77-4-31	2.14-18.0-81	6	
NAS77-4-32	2.14-18.0-81	4	
NAS77-4-34	2.14-23.0-26	3	
NAS77-4-35	2.14-25.0-55	3	
NAS77-4-41	2.14-23.0-156	8	
NAS77-4-42	2.20-48.0-76	1	
NAS77-4-50	2.14-42.0-28	2	
NAS77-4-65	2.14-23.0-195	1	
NAS77-4-77	2.14-23.0-260	1	
NAS77-4-85	2.14-23.0-149	1	
NAS77-4-97	2.14-23.0-196	1	
NAS77-5-125	2.14-23.0-196	1	
NAS77-5-19	2.15-14.0-42	1	
NAS77-5-24	2.20-39.0-16	3	
NAS77-5-31	2.14-16.0-13	2	
NAS77-5-32	2.14-41.0-6	2	

PART NUMBER	FIGURE AND INDEX NUMBER	QTY PER ART	SMR CODE
NAS77-5-39	2.14-34.0- 6	8	
NAS77-5-70	2.20-17.0- 43	2	
NAS77-5-97	2.14-23.0-197	1	
NAS77-50-70	2.20-18.0- 45	2	
NAS77-6-014	2.12-60.0- 25	1	
NAS77-6-24	2.20-39.0- 25	1	
NAS77-6-25	2.12-60.0- 24	4	
NAS77-6-27	2.12-60.0- 20	2	
NAS77-6-28	2.14-23.0-152	1	
NAS77-6-31	2.14-19.0- 15	2	
NAS77-6-33	2.14-20.0- 15	3	
NAS77-6-34	2.14-20.0- 26	1	
NAS77-6-38-0	2.12-60.0- 79	2	
NAS77-6-50	2.14-18.0- 18	2	
NAS77-6-64	2.14-23.0-191	1	
NAS77-7-11	2.20-31.0-120	2	
NAS77-7-20	2. 3-12.0- 33	2	
NAS77-7-77	2.20-31.0-115	2	
NAS77-9-11	2.20- 1.0- 32	1	P
NAS77-9-22	2.20- 1.0- 33	1	
NAS77-9-24	2.20-47.0- 23	4	
NAS77A10-36	2.20-20.0- 4	8	
NAS77A11-20	2.20-31.0-114	4	
NAS77A11-30	2.20-33.0- 76	2	
NAS77A14-56	2.20-32.0- 26	2	
NAS77A20-44	2.15-22.0- 70	4	
NAS77A3-09	2. 7- 3.0-144	4	
NAS77A3-14	2. 7- 3.5-106	4	
NAS77A4-13	2. 4- 7.0- 10	2	
NAS77A4-19	2. 7- 3.0-105	2	
NAS77A5-56	2.14-26.0- 41	6	
NAS77A6-12	2. 7- 3.0-130	2	
NAS77A6-16	2.15-22.0- 50	8	
NAS77A6-45	2.20-40.0- 55	2	
NAS77A7-25	2.20-33.0- 75	2	
NAS77A7-30	2.20-33.0- 35	2	P
NAS77A7-50	2.15-13.0- 46	2	
NAS77A8-50	2.14-24.0- 24	1	
NAS969A3	2.20-18.0- 3	29	
NA3-3A	2.12-16.0-115	1	
NA38C	2.17-40.0- 9	1	
NA924-80	2. 9-30.0- 13	1	
NA960010	2. 9-12.0- 9	2	
N632-11/2	2.18- 7.0- 12	2	
NCO001	2.20-44.0- 14	1	
NKO-4	2. 8- 4.0- 3	2	
	2. 8- 5.0- 2	2	
NKO20-10R12	2.16- 1.0- 1	2	
NMC-AG-T-24	2.12-57.0- 15	1	
NO NUMBER STEN CIL	2.21- 5.0- 8	2	
NR109A	2.17-40.0- 9	1	
NR59B	2.17-40.0- 9	1	
NS77-4-29	2.14-33.0- 10	2	
N12C-62-862M	2.13-30.0- 2	2	
	2.13-31.0- 39	20	
N2V1-1	2.16- 1.0- 4	1	P1
	2.16- 2.0- 6	1	
N2V1-2	2.16- 1.0- 53	1	P1
	2.16- 2.0- 12	1	
N2V1-3	2.16- 1.0- 55	1	U
	2.16- 2.0- 60	1	
N2V1-4	2.16- 1.0- 61	1	
	2.16- 2.0- 13	1	
N2V1-5	2.16- 1.0- 63	1	
	2.16- 2.0- 62	1	
N2V2-1	2.16- 1.0- 14	1	
	2.16- 2.0- 8	1	

PART NUMBER	FIGURE AND INDEX NUMBER	QTY PER ART	SMR CODE
N632-1	2.18- 7.0- 2	1	
	2.18- 7.0- 22	1	
N632X	2.18- 7.0- 1	1	
	2.18- 7.0- 20	1	
N632X	2.18- 7.0- 10	1	
NS24-100	2. 9- 5.0- 3	1	
OFCD0855	2.17-11.0- 74	1	
ONC8451.0-15	2.18-18.0- 13	1	
PA2303	2.14- 4.0- 12	1	P10
PA3117	2.14- 4.0- 65	2	P10
PCS-1/2	2.16- 8.0- 48	4	
PC3-1/2	2. 5- 1.0- 35	RF	
	2. 5- 5.0- 6	4	
	2.16- 8.0- 45	4	
	2.16-8.0-47	4	
	2.16- 9.0- 17	4	
	2.16-10.0- 9	2	
	2.16-11.0- 41	4	
	2.16-12.0- 11	4	
	2.16-13.0- 23	4	
	2.16-14.0- 5	4	
	2.16-15.0- 10	4	
	2.16-18.0- 20	4	
	2.16-19.0- 7	2	
	2.16-20.0- 10	2	
	2.16-21.0- 10	4	
	2.16-22.0- 9	4	
PC425	2.13-11.0- 35	3	P
	2.13-11.0- 44	3	
	2.13-11.0- 50	3	
PF3-1/2	2.16-14.0- 4	4	
PF3-1/2-38	2. 5- 1.0- 33	RF	
	2. 5- 5.0- 8	4	
	2.16- 8.0- 45	4	
	2.16-8.0-47	4	
	2.16- 8.0- 48	4	
	2.16- 9.0- 15	4	
	2.16-10.0- 7	2	
	2.16-11.0- 39	4	
	2.16-12.0- 9	4	
	2.16-13.0- 21	4	
	2.16-14.0- 3	4	
	2.16-15.0- 8	4	
	2.16-18.0- 18	4	
	2.16-19.0- 5	2	
	2.16-20.0- 8	2	
	2.16-21.0- 8	4	
	2.16-22.0- 7	4	
PF76-3907-5053 54	2. 8- 7.0- 20	1	P1
PPM9341-1	2.16- 1.0- 93	1	
	2.16- 2.0- 75	1	
	2.16-13.0- 1	1	
	2.16-14.0- 8	1	
PPM9341-12	2.16- 8.0- 33	1	
PX9341-3	2.16-18.0- 8	1	
PPM9341-5	2.16- 8.0- 40	3	P1
PRP900-6	2.10-11.0- 12	1	P1
PRP900-6	2.10-11.0- 11	2	P
PRP9000-12-714 0	2.10-11.0- 9	2	P1
PR332-100	2.12- 1.0- 47	1	P1
PST750L	2.11- 2.0- 6	RF	P1
PST751R	2.11- 2.0- 6	RF	P1
PS2-1/2	2.16- 8.0- 45	4	
PS3-1/2	2. 5- 5.0- 7	4	
	2.16-8.0-47	4	

PART NUMBER	FIGURE AND INDEX NUMBER	QTY PER ART	SMR CODE
PS3-1/2	2.16- 8.0- 48	4	
	2.16- 9.0- 16	4	
	2.16-10.0- 8	2	
	2.16-11.0- 40	4	
	2.16-12.0- 16	4	
	2.16-13.0- 22	4	
	2.16-15.0- 9	4	
	2.16-18.0- 19	4	
	2.16-19.0- 6	2	
	2.16-20.0- 5	2	
	2.16-21.0- 9	4	
	2.16-22.0- 8	4	
PS31/2	2. 5- 1.0- 34	RF	
PTGCP-12-BS	2. 4-11.0- 50	1	P1
PT88P-12-8P	2. 4-11.0- 51	1	P1
PV-293-110	2.12-15.0-141		
PV-293-130	2.12-15.0-109	1	
	2.12-16.0- 91	1	P1
PV06R0308	2. 8-23.0- 47		
PV293-110	2.12- 1.0- 19	1	P1
	2.12- 2.0- 21	1	
	2.12-52.0- 46	1	
PV293-120	2.12- 1.0- 25	RF	P1
	2.12- 2.0- 21	RF	
	2.12-52.0- 46	RF	
P116-421-6-3	2. 5- 3.0- 9	1	P
	2.16- 1.0-116	1	
	2.16- 3.0- 56	1	
P12-313	2. 8- 6.0- 11	1	
P16-41b	2. 8- 6.0- 14	1	
P26-526	2.12-45.0- 98	1	
	2.12-55.0- 42	1	
P496A	2. 4- 3.0-	RF	P1
Q1440-4-2	2.20-32.0- 20	2	M
Q5738M05.5	2. 5- 7.0- 4	1	
Q8062d-2	2.20-38.0- 5	RF	
Q6H1000-4	2.20-31.0- 51	1	
R-5132M-1	2. 4-11.0- 41	1	
RB09AL2200GF	2.14- 8.0-115	1	P1D
RB09AL2700GF	2.14- 8.0-130	1	P1D
RB09AL5000GF	2.14- 8.0-114	1	P1D
RB17AL18001F	2.14- 8.0-124	1	P1D
RB17AE22001F	2.14- 8.0-122	1	P1D
RB17AE54001F	2.14- 8.0-123	2	P1D
RB19AE10003F	2.14- 8.0- 25	2	P1D
RB19AE22002F	2.14- 8.0- 28	1	P1D
RB19AE43002F	2.14- 8.0- 29	1	P1D
RB19AE50002F	2.14- 8.0- 27	1	P1D
RB19AE75002F	2.14- 8.0- 26	1	P1D
RCR42G102GS	2.17-11.0-162	1	
RCR42G153JS	2.17-11.0-161	1	
RCR42G511JS	2.17-11.0-163	1	
RC20GF102J	2.18- 1.0- 15	6	
	2.18-29.0- 5	3	
RC20GF114J	2.18-20.0- 27	1	
RC20GF470J	2.16- 5.0- 50	1	P1
RC32GF062J	2.17- 5.0- 9	1	
RC32GF621J	2.18-30.0- 6	1	
RC42GF104J	2.14- 8.0- 34	1	P1D
RC42GF105J	2.14- 8.0- 36	1	P1D
RC42GF121J	2.10-30.0- 7	1	
RC42GF225J	2.14- 8.0- 35	1	P1D
RC42GF474J	2.14- 8.0- 37	1	P1D
RCP4M6:7414	2.20-46.0- 66	2	
RCP75F8R06R	2.17-11.0- 63	1	

PART NUMBER	FIGURE AND INDEX NUMBER	QTY PER ART	SMR CODE
RE4F5E7414	2.14-23.0-136	2	
RE4F5	2.14- 5.0- 7	1	P1
	2.14-10.0- 62	1	
	2.14-15.0- 11	1	
	2.14-15.0- 51	1	
	2.14-15.0- 52	1	
	2.14-15.0- 63	1	
	2.14-15.0- 68	2	
	2.14-15.0- 93	1	
	2.14-27.0- 3	4	
	2.14-41.0- 11	2	
	2.14-41.0- 11	RF	
RE4F5E6540	2.14- 9.0- 7	1	P1
RE4F5E7164	2.14-15.0-125	1	
	2.14-25.0- 6	2	
	2.14-30.0- 15	2	
RE4F5E7414	2.14- 9.0- 7	1	
	2.14-10.0- 36	1	
	2.14-10.0- 62	1	
	2.14-15.0- 11	1	
	2.14-15.0- 31	1	
	2.14-15.0- 52	1	
	2.14-15.0- 63	1	
	2.14-15.0- 68	2	
	2.14-15.0- 93	1	
	2.14-15.0- 93	1	
	2.14-23.0- 18	1	
	2.14-23.0- 7	1	
	2.14-23.0-133	2	
	2.14-41.0- 11	2	
RE4F5E7416	2.10- 3.0- 2	1	
	2.14-15.0-125	1	
	2.14-25.0- 6	2	
	2.14-30.0- 15	2	
RE4HF	2.14-15.0- 26	1	P1
	2.14-15.0- 43	1	
	2.14-15.0- 48	1	
	2.14-15.0- 52	1	
	2.14-15.0- 84	2	
RE4HSE7414	2.14-15.0- 26	1	
	2.14-15.0- 48	1	
	2.14-15.0- 59	1	
	2.14-15.0- 84	2	
	2.14-23.0- 11	1	
RF4F5	2.14-43.0- 11	2	
RG55P10	2.16- 1.0- 94		P1
	2.16- 2.0- 77		
RM52LHA4972-	2.20-23A.0-1	4	
6-82	2.20-23B.0-1	4	
RM65H4993F	2.17-41.0- 5	2	P1
RR433	2. 7- 8.0- 9	1	
RST300	2. 7- 8.0- 11	1	P1
RTK06-16-61P	2.18-21.0- 15	1	
RTK07-16-61S-059	2.18-21.0- 14	1	
RT859A/APX-72	2.18-18.0- 10	1	
RV4LAYS A255A	2.18-29.0- 7	1	
RV6L-AYS A255B	2.17- 9.0- 8	1	P1
RV6NAYS L252A	2.17- 9.0- 8	1	P1
RW25R131	2.17-39.0- 4	3	P1
RW20V100	2.13- 1.1- 36	1	
RW20V200	2.13- 1.1- 37	1	
RW22V180	2.13- 1.1- 31	1	P1
RW22V280	2.13- 1.1- 32	2	
RW22V590	2.13- 1.1- 33	1	P1
RW29F4R0	2.12- 5.0- 6	2	
RW29G4R0	2.12- 5.0- 7	4	
RW29V3R9	2.12- 5.0- 6	2	
RW31G352	2.14- 8.0-106	2	
RW55G131	2.17-14.0- 24	2	P1

PART NUMBER	FIGURE AND INDEX NUMBER	QTY PER ART	SMR CODE
RW55G131	2.17-22.0- 6	3	P1
RW55G251	2.17-14.0- 23	1	
RW55G561	2.17-14.0- 25	8	
	2.17-14.0- 26	2	
RW55V131	2.17-14.0- 24	RF	
	2.17-22.0- 6	3	
	2.17-36.0- 14	1	
RW67V181	2.17-43.0- 5	1	
RY437A	2.20- 2.0- 4	1	P1
R10233	2.10-19.0- 4	1	
R10233B	2.10-19.0- 4	1	P1
R10316	2.10-28.0- 4	1	
R10556	2.10-28.0- 21	1	
R15001E10-1	2.17-17.0- 4	1	P1
	2.20- 3.0- 44	2	
	2.20- 3.0- 45	1	
R15001E16-1	2.20- 3.0- 45	1	
R15001E8-1	2.15- 6.0- 12	1	
	2.17-17.0- 3	1	
R152-155A5-2	2.14- 8.0- 72	3	
R20006	2. 8-12.0- 97	1	P1
	2.10- 7.0-123	1	
R20007-3	2. 8-10.0-100	1	P1
R20007-4	2. 8-10.0-127	1	P1
R20008-2	2. 8-12.0-141	1	
R295800-CC8-02			
14	2.10- 7.0-120	1	
R295800-4-0062	2. 8-10.0- 65	1	P
	2. 8-10.0-186	1	
R295800-4-0093	2. 8-22.0- 7	1	P
R295800-4-0122	2. 8-16.0- 44	1	
	2. 8-16.0- 94	1	
R295800-4-0133	2. 8-22.0- 46	1	
R295800-4-0143	2. 8-22.0- 46	1	P1
R295800-4-0172	2. 8-22.0- 22	1	P
R295800-4-0180	2. 8-14.0- 10	1	P
R295800-4-0217	2. 8-14.0- 29	2	P
R295800-4-0280	2.8-23.0- 55	2	
R295800-6-0160	2. 8-10.0-176	1	P1
R295805-4-0106	2. 8-22.0- 7	1	P1
R295805-4-0134	2. 8-22.0- 23	1	P
R347	2. 9- 4.0- 51	1	P1
	2. 9- 6.0- 19	1	
	2. 9- 9.0- 23	1	
R348	2. 9- 6.0- 8	1	
	2. 9- 9.0- 30	1	
R349	2. 9- 4.0- 43	1	P1
R3800-4-0080	2. 4- 6.0- 10	1	
	2. 4- 7.0- 85	1	
R3800-4-0107	2. 4- 6.0- 11	1	P1
	2. 4- 7.0- 2	1	
	2. 4- 7.0- 75	1	
R3800-4-0120	2.13-31.0- 23	1	
R3800-4-0140	2. 4- 6.0- 17	1	
	2. 4- 7.0- 92	1	
R3800-4-0285	2. 4- 7.0- 61	1	
R3800-4-0360	2. 4- 7.0- 50	1	
	2. 4- 8.0- 10	1	
R3800-4-0520	2. 4- 7.0- 39	1	
R3800-4-0830	2. 4- 7.0- 26	1	
R3800-4-1080	2. 4- 7.0- 38	1	
R3800-4-1690	2. 4- 8.0- 37	1	P1
R3806-4-0360	2. 4- 6.0- 8	1	
R3825S4-0124	2.10-18.0- 26	1	P1
R46	2. 2- 7.0- 42	4	

PART NUMBER	FIGURE AND INDEX NUMBER	QTY PER ART	SMR CODE
R46	2. 2- 9.0- 34	1	
R5140M11-1	2.14-23.0-174	1	P1
R540C-.460	2. 9-16.0- 16	AR	
	2. 9-16.0- 16	AR	
	2. 9-17.0- 71	AR	
	2. 9-17.0- 78	AR	
	2. 9-17.0- 78	AR	
	2. 9-17.0- 90	AR	
	2. 9-17.0- 98	AR	
R75-10002-30-1			
R75-10002-30-2	2.14-41.0 -20	1	
A	2.14-41.0- 20	1	
R913-002	2.15-11.0- 34	1	P1
	2.15-17.0- 33	1	
R9800-CCA4-007			
4	2.10-18.0- 25	1	
R9800-10-0154	2. 8-10.0-132	1	P
R9800-4-0034	2.10-22.0- 13	1	P
R9800-4-0064	2.10-22.0- 17	2	P
R9800-4-0090	2. 8-12.0- 98	1	P
	2.10- 7.0-114	1	
	2.10-23.0- 10	1	
R9800-4-0100	2.10-22.0- 18	1	
R9800-4-0133	2.10-23.0- 20	1	
R9800-4-0176	2.10-20.0- 39	1	P
R9800CC16-0274	2.10-19.0- 5	1	
R9800DDS16-027			
3	2.10-19.0- 5	1	
R9800S4-0176	2.10- 7.0- 48	1	
R9805DDS12-012			
0	2.10-18.0- 19	1	
R9805S4-0094	2.10- 7.0-136	1	
R9805S4-0120	2.10-18.0- 18	1	
R9806S4-0055	2.10-18.0- 14	1	
R9806S4-0096	2.10- 7.0-135	1	P
R9806S4-0256	2.12-62.0- 7	1	P
R9844CC4	2.12-62.0- 21	1	M
R9844S4-C111-9			
0	2.10-18.0- 12	1	
R9844S4-0111-9			
0	2.10-32.0- 14	1	
SA-1474/A	2.18- 1.0- 1	1	P1
SA-521/AA	2.18-34.0- 12	1	
SALP-T4-4	2.20-12.0- 25	8	
SALP-T6-5	2. 3- 8.0- 19	2	
SALP-T6-6	2.20-12.0- 24	6	
SALP-T6-7	2.20-12.0- 8	8	
SALP-T6-8	2.20-12.0- 7	20	P1
SA803-133L	2.16-11.0- 4	1	P1
SAR03-279LH	2.16-11.0- 5	1	P
SE-0852-3604	2.15-25.0- 29	1	
SF124223-3D017			
0	2. 9-15.0- 50	1	
S0-1048-8308	2.20- 2.0- 37	1	
SPS54291-403	2.20-41.0- 3	17	
SS3805A26	2.13-31.0- 15	2	P1
SS51334	2.14-10.0- 26	1	P1
ST504A	2.10- 7.0-163	1	P1
SV-4P5	2.20-45.0- 3	1	
SV-4P6	2.20-45.0- 4	4	
SV4-102W2	2.20-46.0- 13	12	
SV4P3	2.20-41.0- 24	4	
	2.20-41.0- 6	3	
	2.20-44.0- 16	28	

PART NUMBER	FIGURE AND INDEX NUMBER	QTY PER ART	SMR CODE
SV4P4	2.20-43.0- 6	9	
	2.20-44.0- 10	1	
	2.20-45.0- 19	1	
SV4P5	2.20-41.0- 22	2	
	2.20-41.0- 23	5	
	2.20-44.0- 15	2	
	2.20-44.0- 9	3	
SV4P7	2.20-44.0- 7	7	
SV4P8	2.20-41.0- 2		
	2.20-44.0- 8	2	
SWT1-4	2.10-19.0- 39	1	
SYLC6963	2.14-23.0- 70	1	P1
S11L31C	2. 4- 7.0- 51	1	
	2. 4- 8.0- 11	3	
S11154-10BY	2.17-14.0- 7	1	P1
S11154-3AY	2.17- 3.0- 2	1	
S11154-8A4	2.17-30.0- 15	1	
S11154-8BY	2.15-36.0- 17	1	P1
S11154-8DY	2.15-36.0- 17	1	
S1443	2. 8-10.0- 77	1	P1
	2. 8-10.0-196	1	
	2. 8-27.0- 74	1	
S169DT16	2.12-10.0- 19	2	
	2.12-10.0- 21	1	
	2.12-10.0- 22	6	
	2.12-10.0- 27	8	
	2.12-10.0- 30	8	
	2.12-10.0- 84	2	
S169DT24	2.12-10.0- 32	5	
	2.12-10.0- 62	1	
	2.12-10.0- 88	1	
	2.12-10.0- 95	1	
S169DT4	2.12-11.0- 8	1	
	2.12-10.0- 28	8	
	2.12-15.0-140	2	
	2.12-16.0-129	2	
S169DT7	2.12-10.0- 23	6	
S21042L4	2.12-15.0- 72	4	
S21605	2.18-20.0- 17	2	
S22412-1006	2. 9- 2.0- 45	1	P1
S733	2.14-21.0- 2	1	P1
S741	2.14-21.0- 2	1	P1
	2.14-21.0- 2	1	
S7441	2. 6-10.0- 66	1	P1
	2. 8-10.0-187	1	
S8079-205R	2. 8- 7.0- 16	1	
S8079-206L	2. 8- 7.0- 17	1	
S9143-110	2.10- 7.0- 73.3	1	
S9412-554	2.12-62.0- 13	1	
S9413-11	2.10- 7.0- 73	1	
TA0F6	2. 4- 1.0- 43	2	
TA06LS49	2. 8-12.0- 65	1	
	2. 8-12.0-119	1	
	2. 8-12.0-173	1	
TA4C67D16T	2.10-19.0- 2	1	
TA45F6-4	2. 4- 1.0- 45	1	P1
TA6LS49	2. 8-12.0- 46	1	
TA6LS51	2. 8-19.0- 15	9	P1
	2. 8-19.0- 63	9	
TA6LS52	2. 8-19.0- 23	1	P1
	2. 8-19.0- 4	1	
	2. 8-19.0- 57	1	
	2. 8-19.0- 76	1	
TA6LS53	2. 8-19.0- 11	1	P1
	2. 8-19.0- 18	1	
	2. 8-19.0- 64	1	
	2. 8-19.0- 71	1	

PART NUMBER	FIGURE AND INDEX NUMBER	QTY PER ART	SMR CODE
TB129700	2.12- 1.0- 68	2	P1
TB129700-5	2.12- 1.0- 68	2	P1
TB129700-8	2.12- 1.0- 68	2	
TB3005-S4-6D	2.10- 7.0-128	2	P1
TD-1087REVF	2.17-11.0- 87	1	P1
TD-1179	2.20- 2.0- 17		P
TE8569	2.18-30.0- 1	1	
TRC827	2. 5- 2.0- 14	2	
TS1843A	2.18-18.0- 11	1	
TV1-25	2.16-11.0- 2	1	P1
TYLZ6889	2.16- 8.0- 34	1	P1
TYPE IV	2.18-26.0- 1		
T198-C1	2.17-15.0- 15		P1
T228A	2.20- 2.0- 3	1	P1
T3-361	2.14- 8.0- 54	3	P1D
T3-381	2.14- 8.0- 55	2	P1D
T3-401	2.14- 8.0- 51	2	X1D
T3-491	2.14- 8.0- 50	3	X1D
T5AS3S2CCYY503	2.14- 8.0- 97	12	P1
UG290A/U	2.18- 7.0- 8	2	P1
UN312586	2.14- 8.0- 61	3	P1D
UN334609	2.14- 8.0- 62	1	P1D
UT2-80	2.16- 3.0- 36	2	P1
U92A/U	2. 5-10.0- 38	1	P1
U93A/U	2. 5-10.0- 36	1	P1
VACANT	2.18-17.0- 11		
	2.18-17.0- 23		
	2.18-17.0- 25		
	2.18-17.0- 3		
	2.18-17.0- 34		
	2.18-17.0- 37		
	2.18-17.0- 9		
VM66350-1	2.12-68.0- 88		
VM911M198	2.20- 3.0- 25	3	01
VM911M199	2.16- 1.0- 7	3	
	2.16- 2.0- 5	3	
	2.20- 3.0- 24	5	
VM911M208	2.16- 1.0- 32	1	
	2.16- 2.0- 26	1	
	2.16- 9.0- 2	1	
VM911M4	2.16-18.0- 22	1	
VM911M7WT7	2.14- 8.0- 3	1	P1
V21100	2.12-38.0- 65	1	P1
	2.12-38.0- 74	2	
	2.12-54.0- 8	1	
	2.12-64.0- 25	1	
V21200	2.12-37.0- 75	1	P1
	2.12-37.0-195	1	
	2.12-54.0- 18	1	
	2.12-54.0- 8	1	
V4-109	2.20-41.0- 2	3	
	2.20-41.0- 22	2	
	2.20-41.0- 23	5	
	2.20-41.0- 24	4	
	2.20-41.0- 6	3	
	2.20-43.0- 6	2	
	2.20-44.0- 15	2	
	2.20-44.0- 16	28	
	2.20-44.0- 19	4	
	2.20-44.0- 6	21	
	2.20-45.0- 19	1	
	2.20-45.0- 3	4	
	2.20-45.0- 4	4	
V4-201	2.20-41.0- 1	3	
	2.20-41.0- 21	11	

PART NUMBER	FIGURE AND INDEX NUMBER	QTY PER ART	SMR CODE
V4-201	2.20-41.0- 5	3	
	2.20-43.0- 5	2	
	2.20-44.0- 6	21	
	2.20-45.0- 18	1	
	2.20-45.0- 2	8	
	2.20-46.0- 12	12	
W-L00111/1	2.17-11.0- 2	1	
W-270121-2	2.20-46.0- 2	2	
WCLC1-1-41	2.14- 6.0- 21	1	P1
WC95-1-1/2D	2. 9- 2.0- 79		
WC95-1-1/2E	2. 9- 2.0- 80	1	P1
WLG062 TRADE 4 570	2.15- 6.0- 11	1	P1
WM85U	2. 5-10.0- 37	1	P1
W535-3/8F	2.12-37.0-203	1	
W535-3/8E	2.12-64.0- 3	1	P1
W535-3/8F	2.12-15.0-117	1	P1
	2.12-15.0-124	1	
	2.12-15.0-146	1	
	2.12-15.0-185	2	
	2.12-16.0-100	1	
	2.12-16.0-113	1	
	2.12-16.0-135	1	
	2.12-16.0-168	2	
	2.12-32.0- 51	1	
	2.12-32.0- 59	1	
	2.12-36.0- 9	1	
	2.12-37.0- 48	1	
	2.12-37.0- 64		
	2.12-37.0-164	1	
	2.12-37.0-189	1	
	2.12-43.0-176	1	
	2.12-44.0- 5	1	
	2.12-45.0- 54	1	
	2.12-45.0- 87	1	
	2.12-45.0-111	1	
	2.12-46.0- 52	1	
	2.12-46.0- 61	1	
	2.12-46.0- 97	1	
	2.12-64.0- 3	RF	
	2.12-67.0- 3	1	
X1401B3/32	2.18-20.0- 28	RF	
X1401D3/32	2.17-14.0- 27	RF	
YHSB28	2.12- 6.0- 11	1	P1
	2.12-39.0- 20	1	
YHSB28R	2.12- 6.0- 10	1	P1
YHS7M4	2.12- 6.0- 7	1	P1
YHS8M2	2.12- 6.0- 6	1	P1
	2.12-39.0- 18	1	
YR5870-4-0136	2. 8-16.0- 24	1	
YR5870-4-0143	2. 8-16.0- 66	1	
YR5870-4-0160	2. 8-16.0- 36	1	
	2. 8-16.0- 88	1	
ZA21-1200-02BC	2.10-12.0- 42	6	
ZA217-1200-02B C	2.10-12.0- 43	8	
Z1200-02	2.10- 9.0- 12	66	
	2.10- 9.0- 12	2	
Z1200-048	2.13- 8.0- 15	1	P
	2.13-17.0- 4	1	
001-5490-001	2.20- 2.0- 40	5	
012-27	2.15-16.0- 25	1	
012742	2. 7- 3.0-137	1	P
	2.15- 2.0- 11	2	
	2.15- 3.0- 8	1	

PART NUMBER	FIGURE AND INDEX NUMBER	QTY PER ART	SMR CODE
012742	2.15- 4.0- 11	1	
	2.15-13.0- 8	1	
	2.15-16.0- 24		
	2.15-16.0- 5	1	
	2.15-24.0- 11	1	
	2.15-25.0- 10	1	
	2.15-25.0- 43	1	
	2.12-62.0- 21		
0260-0	2.14-10.0- 4	37	
031-064-00	2.20-31.0- 17	1	
0325-9	2.20-31.0- 17	1	
0327-7	2.10- 7.0-202	1	P1
	2.10- 7.0-204	1	
0337-1	2.20-23.0- 6	1	P1
042-1573-001	2. 5- 2.0- 23	1	
042-1573-002	2. 5- 2.0- 25	1	
042-1573-003	2. 5- 2.0- 27	1	
042-1573-004	2.16- 1.0- 12	1	
	2.16- 1.0- 19	1	
042-1573-006	2. 5- 2.0- 32	1	
05F2221N	2.20-44.0- 5		
074855-1	2.12-27.0- 2	2	P1
	2.12-30.0- 1	2	
074856-2	2.12-52.0- 75	4	P1
074856-3	2.12-52.0-109	2	
074956A	2. 9- 2.0- 73	1	
075056	2. 9- 2.0- 36	1	P1
	2. 9- 2.0- 79	1	
075156-1	2.12-14.0- 16	1	P1
075156-2	2.12- 1.0-117	1	P1
	2.12-14.0- 39	1	
	2.12-14.0- 52	1	
	2.12-14.0- 60	1	
075156-3	2.12-14.0-101	1	P1
	2.12-14.0-106	1	
075156-4	2.12-14.0-117	1	
	2.12- 2.0- 4	1	
	2.12-10.0- 93	2	
	2.12-11.0- 2	1	
	2.12-15.0- 79	1	
	2.12-15.0- 87	1	
	2.12-15.0- 94	1	
	2.12-16.0- 61	1	
	2.12-16.0- 69	1	
	2.12-16.0- 76	1	
	2.12-17.0- 3	1	
	2.12-23.0- 5	1	
	2.12-24.0- 4	1	
	2.12-35.0- 13	1	
	2.12-52.0- 55	2	
	2.12-52.0-121	1	
075256	2.12-49.0- 35	6	P
075356-1	2.12-52.0- 61	1	P1
075356-2	2.12-18.0- 4	2	
	2.12-55.0- 13	1	
	2.12-67.0- 34	1	
075356-3	2.12-61.0- 14	1	P1
075356-4	2.12-60.0- 17	2	P1
075356-5	2.12- 1.0- 46	2	P1
075356-6	2.12- 2.0- 13	1	
	2.12-52.0-126	1	
075456	2.12- 1.0- 40	1	P1
075556-2	2.12-14.0- 26	1	P1
075556-3	2.12-18.0- 10	2	P
075656	2.12-52.0-106	2	P1
	2.12-52.0-113	2	
08-8422-030	2.8 - 13.0 - 10	1	
	2.8 - 13.0 - 11	1	

PART NUMBER	FIGURE AND INDEX NUMBER	QTY PER ART	SMR CODE
1	2.16-11.0- 14	1	
1-1/2-611435	2.17-22.0- 3	2	
1/4-6	2.14- 8.0- 68	6	
10-1961	2.16- 1.0- 45	1	
	2.16- 1.0- 68	1	
	2.16- 2.0- 44	1	
1D1X1-1	2.12-24.0- 13	2	
1N1341	2.17-15.0- 18	2	
1N1614R	2.17-16.0- 3	2	P
1N3613	2.20- 2.0- 28	1	
1N3673A	2.16-11.0- 32	1	
1N9726	2.20- 2.0- 29	1	
1SE1	2. 4- 9.0- 40	1	P1
	2. 4-12.0- 62	2	
1SE3	2. 4-12.0-107	3	P1
1SE5	2.12-60.0- 23	2	P1
10-101960-223	2.18-24.0- 21	1	P
10-102A	2.14-11.0- 32	RF	P1
10-1160	2.13-23.0- 32	1	P1
10-374058-2	2.10- 7.0-218	1	P
10-382469-2	2.10- 7.0-225	1	
100-200-15-1	2.5-14.0-3.1	1	
1000-00-044-1	2.16- 9.0- 27	1	
1000-00-044-3	2.16- 9.0- 26	1	
1001-00-020-1	2.16- 7.0- 23	1	
1001-00-047-1	2.16- 9.0- 24	1	
1001-00-060-1	2.16- 9.0- 22	1	
1001-00-080-1	2.16- 9.0- 20	1	
1001C	2.14-11.0- 32	1	P
1001S4-1	2.12- 6.0- 5	2	P1
	2.12-35.0- 17	2	
1004S1-4	2.14- 3.0- 10	1	P1
1004S1-6	2.14- 3.0- 22	1	P1
1004S2-4	2.14- 4.0- 4	1	P1
1004S2-6	2.14- 4.0- 3	1	P1
1007	2.17-11.0- 9	1	P1
1007-00-000-1	2.16- 5.0- 19	1	
1007-00-001-1	2.16- 9.0- 28	1	
1007-00-100-1	2.16- 1.0- 99	1	
	2.16- 2.5- 82	1	
1007-00-300-1	2.10-19.0- 27	1	P1
1007-00-400-1	2.10-19.0- 24	1	P1
1007-00-602-1	2.16- 5.0- 29	1	
1007-00-602-13	2.16- 5.0- 31	1	
	2.16- 9.0- 33	1	
1007-00-604-1	2.16- 2.0- 83	1	
1007-00-606-1	2.16- 2.0- 69	1	
1007-00-616-1	2.17-21.0- 58	1	
1007-00-616-3	2.17-21.0- 31	1	P1
1007-00-618-1	2.16- 1.0-100	1	
100700-11	2.14-43.0- 2	1	P1
100700-13	2.14-43.0- 2	RF	
100700-7	2.14-43.0- 2	1	P1
100700-9	2.14-43.0- 2	RF	
1007700-1	2.14- 1.0- 21	1	
100900	2.14-11.0- 32	RF	P1
101-3830-0971-261	2.17-11.0- 62	1	P1
101HS1	2. 7- 3.0- 6	1	
	2.15- 7.0- 1	1	
102020-00	2.13- 4.0- 10	1	P1
	2.13- 4.0- 21	1	
102204-2	2.13- 4.0- 1	1	P1
102204-4	2.13- 4.0- 14	1	P1
1023461	2.14- 6.0- 29	1	P1
10260	2.14-17.0- 26	1	P1

PART NUMBER	FIGURE AND INDEX NUMBER	QTY PER ART	SMR CODE
103001	2.17- 9.0- 57	1	
103001-40	2. 9- 7.0- 53	RF	P1
	2.13-19.0- 1	1	
104EN33	2.20-23.0- 73	1	
1042	2.14- 9.0- 16	1	
1044-2	2.8- 1.0- 34	1	P1
	2.8- 1.0- 35	1	
104500	2.13-31.0- 41	1	
104501	2.13-31.0- 41	1	
104584-2	2.13-31.0- 18	1	
104610	2.13-31.0- 43	1	
104612	2.13-31.0- 44	1	P1
104710	2.12- 1.0- 17	1	P1
	2.12-15.0-151	1	
105	2.16- 1.0- 90	1	P1
105-109-00	2.14-10.0- 2	1	P1
105-040-00	2.14-10.0- 2	1	P1
10522538	2. 4-12.0-128	1	
	2. 4-12.0-128	RF	
	2. 4-12.0-128	RF	
10522629	2. 4- 7.0- 18	1	
105429	2.13-31.0- 42	1	
105940	2.13-29.0- 13	1	P1
10610-2	2.10- 1.0- 6	1	
1063031	2.11- 1.0- 10	1	
1063032	2.11- 1.0- 8	2	
1063033	2.11- 1.0- 12	1	
1063052	2.11- 1.0- 3	1	P1
1063072	2.11- 1.0- 3	1	P1
1063005	2.11- 1.0- 3	1	P1
106470	2.13- 1.1-121	1	P1
106472	2.13- 9.0- 83	1	P1
106630-3	2.13-30.0- 11	1	P1
1067	2.17-11.0- 9	1	
10670-1	2. 9-10.0- 23	RF	
106700-1	2. 9-10.0- 18	RF	P
	2.13- 9.0- 51	1	
	2.13- 9.0- 67	1	
10690	2.16-11.0- 1	3	P1
107A	2.16- 1.0- 29	1	P1
	2.16- 1.0- 39	1	
	2.16- 2.0- 23	1	
	2.16- 2.0- 55	1	
	2.16- 2.0- 74	1	
	2.16-11.0- 42	1	
107B0151P1	2. 3- 1.0- 54	3	
107B0151P3	2. 3- 1.0- 61	2	
107B0151P4	2. 3- 1.0- 36	2	
107037-1	2.13- 31.0- 19	1	
107096	2.13-31.0- 10	1	
107097	2.13-31.0- 9	1	M
107700-11	2.14- 1.0- 21	1	
107800-0-1	2.13-30.0- 4	1	
107800-1	2. 9-10.0- 12	RF	
107800-1	2.13- 9.0- 8	1	
107800-6	2. 9-10.0- 32	RF	
	2.13- 5.0- 75	1	
108-001-001	2.12-33.0- 1	1	
108100-0	2. 8- 1.0- 4	1	
108322-265-1-3	2.13-31.0- 53	1	
108390-0	2.13-24.0- 16	1	
108500-0	2.20- 3.0- 25	1	
108500-7	2.20- 3.0- 24	1	
10900	2. 4- 7.0- 2	1	
10907-01	2.14-11.0- 21	1	

PART NUMBER	FIGURE AND INDEX NUMBER	QTY PER ART	SMR CODE
10907-51	2.14-11.0- 21	1	
	2.14-11.0- 35	1	
10950-7	2.20-11.0- 1	1	P1
10950-8	2.20-11.0- 2	1	P1
10951-21	2.20-11.0- 48	2	P1
10952-11	2.20-11.0- 84	2	P1
109717	2.13-31.0- 53	1	P1
11-2161-001	2.16- 1.0- 42	1	P1
	2.16- 2.0- 23	1	
11-5800	2.12- 1.0- 36	1	P1
	2.12-26.0- 3	1	
11-5800-1	2.12- 1.0- 36	1	P1
	2.12-26.0- 3	1	
1100852Z-61	2.12-55.0- 21	1	P1
11001-3	2.20- 9.0- 1	1	P1
1107-509	2. 4-12.0-143	1	P
	2.15-32.0- 14	1	
	2.20- 4.0- 8	1	
	2.20- 5.0- 21	1	
	2.20- 5.0- 8	1	
	2.20-31.0- 38	1	
	2.20-33.0- 69	1	
1111-565531	2.12-38.0- 97	1	P1
	2.12-52.0- 17	1	
1111-560371	2.12-25.0- 9	1	P1
	2.12-35.0- 8	1	
1111-568371M1	2.12-10.0- 12	1	P1
	2.12- 23.0- 9	1	
	2.12-35.0- 8	1	
	2.12-35.0- 9	1	
1111-568372	2.12-14.0- 85	1	P1
1112-550951	2. 8- 9.0- 29	1	P1
	2. 8-11.0- 29	1	
	2. 8-11.0- 39	1	
	2. 8-13.0- 49	1	
	2. 8-17.0- 35	1	
1112-565171	2. 8-11.0- 52	1	P1
1112-568664	2. 8-14.0- 23	1	P1
	2. 8-27.0- 58	1	
11140	2.13- 1.1- 64	1	
11155	2.16-18.0- 5	1	
11160	2.16- 2.0- 14	2	
	2.16-18.0- 1	1	
11180-31	2.20-23.0- 77	1	P1
1119-568270	2.12-40.0- 1	7	P1
	2.12-40.0- 15	6	
	2.12-40.0- 6	2	
	2.12-41.0- 5	1	
1119-588271	2.12-42.0- 18	1	
1119-588272	2.12-40.0- 17	2	P1
	2.12-41.0- 9	2	
	2.12-42.0- 12	9	
	2.12-42.0- 19	1	
	2.12-42.0- 24	3	
	2.12-42.0- 6	1	
11204-12-0163	2. 9-13.0- 2	1	
1129A	2.17-11.0- 70	1	P1
1130880161	2. 3- 1.0- 35	1	PA
1131-31161	2.14- 6.0- 24	1	P1
1131-32161	2.14- 6.0- 25	1	P1
1131-34001	2.14- 6.0- 24	1	RF
1131-34601	2.14- 6.0- 24	1	RF
1131-35001	2.14- 6.0- 24	1	P
1131-36001	2.14- 6.0- 24	1	P1
1131-36501	2.14- 6.0- 24	1	RF
1131-37001	2.14- 6.0- 24	1	
1131-39101	2.14- 6.0- 24	1	
11393-3	2.20- 2.0- 1	1	

PART NUMBER	FIGURE AND INDEX NUMBER	QTY PER ART	SMR CODE
114100-27	2. 9- 2.0- 16	1	P1
114100-29	2.12-38.0- 89	1	P1
11480	2.14-38.0- 1	1	RF
11481	2. 4-12.0- 53	1	RF
11510-1	2.20- 1.0- 4	1	
11510-3	2.20-10.0- 1	1	P1
	2.20-10.0- 6	1	
11510-5	2.20- 1.0- 4	1	P1
	2.20- 1.0- 7	1	
11533-2	2.15- 7.0- 21	1	P1
11533-3	2.15- 7.0- 21	1	P1
1167161	2.14- 6.0- 29	1	RF
11679-1	2.16- 3.0- 29	1	P1
117CV	2.14- 6.0- 7	1	U
118330-03	2.11- 9.0- 23	1	RF
118330-04	2.11- 9.0- 22	1	RF
11862	2.15-18.0- 12	1	P1
	2.15-18.0- 6	1	
11891	2.17-11.0- 67	1	P1
1191-10CNX1-1/4	2. 3- 5.0- 25	1	
1191-12CNX588	2.14-24.0- 45	1	
1191-30CNX.288	2.14-19.0- 16	2	P1
1191-30CNX.380	2.14-24.0- 44	4	
1191-40CNX132	2.14- 9.0- 85	2	
1191-40CNX1/2	2.14-42.0- 13	2	
1191-40CNX1/4	2.14-42.0- 14	1	
	2.14-42.0- 18	1	
1191-40CNX3/8	2.14-42.0- 24	1	
1191-40CN132	2.20-31.0-116	4	
1191-40CN1/2	2.20-33.0- 51	1	
	2.20-33.0- 74	1	
1191-40CNX132	2.14-18.0- 20	4	
1191-50CNX15832	2.14-23.0-118	2	
1191-60CNX9816	2.20-31.0- 80	1	
1191-60CNX9/16	2.15-24.0- 32	1	
1191-20CNX.380	2.14-23.0-157	2	
	2.14-23.0-190	4	
1191-80CNX384	2.14-23.0-159	1	
1191-90CNX3/4	2.11- 3.0- 22	4	
119392	2. 5-10.0- 30	1	P1
12A428-4H	2.10-12.0- 31	4	
12A524-5	2.10-12.0- 36	4	
1206-5	2. 8-29.0- 25	1	
12067-100S	2.13-33.0- 58	3	P1
121283-01	2.11- 9.0- 10	1	P1
121284-01	2.11- 9.0- 11	1	P1
1220A4H2024T6	2.14-33.0- 23	1	P1
	2.14-34.0- 3	1	RF
122196-01	2.11- 9.0- 23	1	P1
122196-02	2.11- 9.0- 22	1	P1
12306650G1	2. 3- 1.0- 45	1	
12400-1	2. 8-10.0-172	1	P1
124221-400150	2. 9-25.0- 35	1	P1
124221-400215	2. 9-31.0- 6	1	P
124221-6CRO22A	2. 9-31.0- 10	1	P1
124221-600166	2. 9-30.0- 35	1	
	2. 9-30.0- 40	1	
124222-400076	2. 9-33.0- 3	2	
124223-300107	2. 9-12.0- 6	2	
124223-300120	2. 9-33.0- 59	1	P1
	2. 9-33.0- 66	1	
124223-300170	2. 9-14.0- 56	1	P1
124223-400120	2. 9-33.0- 56	1	
	2. 9-33.0- 69	1	

PART NUMBER	FIGURE AND INDEX NUMBER	QTY PER ART	SMR CODE
124223-600060	2.26-23.0- 74	1	
124223-600120	2. 9-28.0- 7	1	P1
124223-600134	2. 9-33.0- 30	1	
	2. 9-33.0- 40	1	
124223-600145	2. 9-29.0- 15	1	P1
	2. 9-29.0- 27	1	
	2. 9-30.0- 53	2	
124223-600200	2. 9-30.0- 32	1	
	2. 9-30.0- 42	1	
124223-600147	2. 9-29.0- 12	1	
	2. 9-29.0- 30	1	
12500	2.14- 8.0- 42	8	X10
1262	2.12-18.0- 11	1	
12650-3	2. 7- 1.0- 2	1	
	2.11- 1.0- 18	RF	
12687	2. 4-12.0- 50	RF	
127012-4CR0170	2. 9-18.0- 15	1	
	2. 9-18.0- 48	1	
	2. 9-18.0- 61	1	
	2. 9-18.0- 9	1	
127668-018-24	2.11- 9.0- 12	1	
127668-019-24	2.11- 9.0- 13	1	
127669-042-16	2.11- 9.0- 9	1	P1
	2.11- 9.0- 9	1	
12800	2.14- 8.0- 93	6	
12829	2. 4-12.0- 46	1	P1
12829-1	2. 4-12.0- 46	1	P1
128997-01	2.11- 9.0- 28	1	P1
129342-01	2.11- 9.0- 16	2	P1
129342-02	2.11- 9.0- 15	2	P1
129429-01	2.11- 9.0- 10	1	P1
129429-02	2.11- 9.0- 11	1	P1
129500-01	2.11- 9.0- 17	2	P1
129500-02	2.11- 9.0- 18	2	
130415-1	2.12-11.0- 9	1	
1307-3	2.16-13.0- 3	1	P1
131100-01	2.11- 9.0- 17	2	P1
131100-02	2.11- 9.0- 18	2	P1
131311-01	2.18-20.0- 32	1	
131312-01	2.16- 8.0- 35	1	
132305-1	2.12-18.0- 9	RF	P1
	2.12-18.0- 9	RF	
13304-11	2.15-39.0- 10	1	P1
1356-553816	2. 8- 3.0- 10	1	P1
	2. 8- 3.0- 11	1	
1356-593105	2. 8-23.0- 38	1	P1
13636-1	2. 9- 1.0- 4	1	P1
13637	2. 4- 4.0- 8	1	A
1364-579740	2.10-11.0- 1	RF	P1
1371-579106	2.8-16.0- 1	RF	P1
	2.15-1.0- 2	1	P1
	2.15-1.0- 37	1	
14	2. 5-14.0- 8	1	P
14-356-151	2.12- 1.0- 89	1	P1
14-356-51	2.12- 1.0- 1	1	P1
1406	2.12-65.0- 7	1	P1
140600-24(24A)	2. 4-11.0- 21	1	
14130	2.11-12.0- 20	1	
14236-5	2.18-31.0- 5	RF	P1
14390	2. 4- 4.0- 24	2	P
144A7379P1	2. 3- 1.0- 58	1	
144A7379P3	2. 3- 1.0- 56	2	
1456-64A-A1	2.16- 2.0- 40	3	
14630H-048	2.12-10.0- 4	43	P1

PART NUMBER	FIGURE AND INDEX NUMBER	QTY PER ART	SMR CODE
14760-75	2.12- 5.0- 7	2	P1
1495	2.17- 4.0- 2	2	
1495R	2.17- 4.0- 3	2	
15-356-101	2.12- 2.0- 1	1	
	2.12-10.0- 94	1	
	2.12-15.0- 84	1	
	2.12-16.0- 66	1	
	2.12-17.0- 1	1	
	2.12-24.0- 1	1	
	2.12-52.0- 52	1	
15-356-51	2.12-15.0- 84	RF	P1
	2.12-16.0- 66	RF	
	2.12-17.0- 1	RF	
1528	2. 6-32.0- 88	1	P1
	2.12-39.0- 66	2	
	2.12-64.0- 11	1	
	2.12-65.0- 26	1	
1501101-1	2.14-30.0- 2	2	P1
1501101-2	2.14-30.0- 2	2	P1
150467	2.15-25.0- 77	2	
15050-3	2.3-14.0- 23	1	
15095-2.810	2.13-31.0- 13	1	
15096-3.0160	2.13-31.0- 14	1	
151806-1	2.15-25.0- 74	1	
15273	2. 4- 5.0- 28	1	P1
15300240F1	2. 3- 1.0- 70	1	
15306250F1	2. 3- 2.0- 5	6	
15355-4.310	2.13-31.0- 6	1	
15461-1A1	2.18-19.0- 11	1	
15462-1A1	2.18-19.0- 10	1	
155-07-50	2. 8- 4.0- 14	1	
	2. 8- 5.0- 14	1	
155-25-160	2.10- 7.0-133	2	
155140-2	2. 9-11.0- 5	1	P1
	2. 9-18.0- 17	1	
	2. 9-18.0- 90	1	
	2. 9-20.0- 13	1	
	2. 9-20.0- 43	1	
	2. 9-23.0- 40	1	
155140-2	2. 9-25.0- 9	1	P1
156550-01-02	2.18-29.0- 1	1	
156550-01-01	2.18-25.0- 2	1	
156561-01-01	2.16- 8.0- 37	1	
15663	2. 4- 5.0- 22	1	P1
15700-1	2. 9- 1.0- 40	1	P1
15810	2. 8- 1.0- 27	1	P1
15810-2	2.20-23.0- 72	1	
1587-9A1A1	2.16- 2.0- 37	1	
16-356-1	2.12- 1.0- 10	1	P1
	2.12- 1.0- 25	1	
	2.12- 1.0- 32	1	
	2.12- 1.0- 79	1	
	2.12-10.0- 44	1	
	2.12-10.0- 78	1	
	2.12-26.0- 6	1	
	2.12-52.0- 4	1	
1608	2. 9- 2.0- 54	1	P1
	2.12- 1.0- 70	1	
	2.12- 3.0- 1	1	
	2.12-37.0- 38	3	
	2.12-37.0-153	3	
	2.12-37.0-172	1	
	2.12-45.0-222	1	
	2.12-45.0-245	1	
	2.12-60.0- 5	1	

PART NUMBER	FIGURE AND INDEX NUMBER	QTY PER ART	SMR CODE
1608	2.12-65.0- 7	1	
1600SH	2.12-57.0- 1	3	
	2.12-57.0- 16	4	
	2.12-57.0- 17	1	
	2.12-57.0- 17	5	
	2.12-57.0- 30	1	
1601000	2.14- 9.0- 58	1	P1
1601096-3	2.14-14.0- 1	1	
1601100	2.14-12.0- 27	1	P1
16100-3	2.18-31.0- 5	RF	
16150	2. 9-12.0- 34	1	
16207	2.10- 3.0- 6	1	P1
16260-1	2.14-26.0- 12	2	P1
163292-01	2.18-28.0- 2	1	
16487290G1	2. 3- 1.0- 51	AR	
1680	2. 6- 3.0- 8	RF	
169605	2.20-23.0- 10	RF	
	2.20-31.0- 12	RF	
16985-173	2.10- 6.0- 68	2	
17189-175-C-1	2.13-26.0- 5	1	P1
17189-175C	2.13-17.0- 6	5	
	2.13-18.0- 16	1	
	2.13-18.0- 2	1	
	2.13-18.0- 41	1	
	2.13-20.0- 3	3	
	2.13-25.0- 7	1	
17189-250C	2.13-27.0- 1	1	P
17189-300C	2.13-25.0- 5	1	P
	2.13-27.0- 12	5	
1725	2. 6- 3.0- 8	2	
	2.17- 1.0- 49	1	
17266-609SH	2.10- 7.0- 60	2	
1727035	2. 3- 1.0- 21	1	P1
17313-448SH	2.10- 6.0- 6	1	P1
17720	2.15- 1.0- 50	1	P1
17780	2.14-27.0- 16	2	
17870	2. 8- 1.0- 17	2	P1D
18-1005	2.16- 1.0- 91	1	
18-1005-31A	2.16- 1.0- 91	1	
18-1024-27	2.16- 1.0- 30	1	
18-1027-47	2.16- 2.0- 18	1	P1
18-1029	2.16-11.0-34	1	
18-1718-3A	2.10- 7.0-163	1	
18-21958-47	2.10-14.0- 7	1	P
18-21958-61	2.10-14.0- 10	1	P
18-21958-63	2.10-14.0- 19	1	P
18-21958-69	2.10-12.0- 12	1	P1
	2.10-12.0- 6	1	
18-21958-79	2.10-14.0- 4	1	P
18-21958-81	2.10-14.0- 5	1	P
18-21958-82	2.10-14.0- 6	1	P
18-21958-83	2.10-14.0- 11	1	P
18-21958-84	2.10-14.0- 12	1	P
18-21958-85	2.10-14.0- 16	1	P
18-21958-87	2.10-14.0- 17	1	P
18-21958-88	2.10-14.0- 18	1	P
18-21958-89	2.10-14.0- 14	1	P
18-21958-90	2.10-14.0- 15	1	P
18-21958-91	2.10-14.0- 13	1	P
18-21958-93	2.10-14.0- 20	1	P
18-21958-94	2.10-14.0- 21	1	P
18-21958-95	2.10-14.0- 8	1	P
18-21958-96	2.10-14.0- 9	1	P
18-22074-11	2.10-15.0- 8	1	P
18-22074-12	2.16-15.0- 8	1	P
18-22074-7	2.16-15.0- 2	1	P

PART NUMBER	FIGURE AND INDEX NUMBER	QTY PER ART	SMR CODE
18-22074-9	2.10-15.0- 1	1	P
18-22227-1	2.13-11.0- 52	1	P1
18-22227-3	2.13-11.0- 51	1	P1
18-22229-1	2.13-11.0- 36	1	P
18-22229-2	2.13-11.0- 37	1	P
18-22230-1	2.13-11.0- 45	2	P1
18001-2A501	2.16- 2.0- 33	1	
18050	2.15- 1.0- 50	1	P
18110-1	2.16- 1.0- 73	5	
	2.16- 2.0- 64	2	
	2.16- 2.0- 68	1	
	2.16- 2.0- 71	1	
18114	2.16- 1.0- 80	1	
18117	2.16- 1.0- 36	1	
18276-300	2.13- 8.0- 4	1	
18276-350	2.13-31.0- 6	1	
186628	2.10-7.0- 94	1	
188F683	2.20- 2.0- 25	1	
19-356-101	2.12-49.0- 21	1	P1
	2.12-49.0- 45	1	
19-356-91	2.12- 1.0- 94	1	
1908	2. 9- 4.0- 53	1	
	2. 9- 6.0- 2	1	
	2. 9- 9.0- 36	1	
1909	2. 9- 4.0- 11	1	P1
19137	2.16-18.0- 2	3	
19137-4	2.16-18.0- 2	3	
192667	2.10-7.0- 94	RF	
19388-400	2.10- 6.0- 9	2	P1
1939	2.17- 1.0- 70	4	
	2.17- 1.0- 33D		
1950	2.15-12.0- 3	2	
	2.15-18.0- 2	RF	
	2.16- 8.0- 39	3	
	2.16-10.0- 1	2	
	2.16-19.0- 1	2	
1964703-1	2.18-26.0- 1	1	
19712	2. 6-35.0- 3	1	P1
	2. 6-36.0- 3	2	
19719	2.16- 1.0- 95	1	
	2.16- 2.0- 76	1	
19722	2.12-10.0- 13	1	P1
1982859-1	2.18-26.0- 23	1	PA
19839	2.11- 1.0- 32	1	
2-127-001	2. 4-12.0-113	1	P1
2-2183418-6	2.12-32.0- 99	3	P
	2.12-43.0-143	1	
	2.12-46.0- 99	1	
	2.12-46.0-103	4	
2-31	2.16- 9.0- 21	2	
2BFLMLH-4A	2.17- 8.0- 65	1	N
2R2441-1	2. 8-14.0- 6	1	P1
2R2441-2	2. 8-22.0- 27	1	P1
	2. 8-22.0- 31	1	
	2. 8-22.0- 42	1	
2R2441-3	2. 8-16.0- 26	1	P1
	2. 8-16.0- 38	1	
	2. 8-16.0- 64	1	
	2. 8-16.0- 86	1	
	2. 8-22.0- 14	1	
2R2441-4	2. 8-21.0- 36	1	P1
	2. 8-21.0- 43	1	
	2. 8-21.0- 54	2	
2R2441-9	2. 8-28.0- 42	2	
2TL1-16	2.16-19.0- 4	1	P
2TL16-7	2. 4-12.0- 40	1	P1
2U2034	2.20- 1.0- 10	1	P1
	2.20- 1.0- 13	1	
200-001-11	2.19- 2.0- 15	1	

PART NUMBER	FIGURE AND INDEX NUMBER	QTY PER ART	SMR CODE
20C-0001-11	2.19- 3.0- 26	RF	
	2.19- 4.0- 27	RF	
20C-0001-111	2.19- 5.0- 26	RF	
201434	2.17- 8.0- 68	1	
201435	2.17-11.0-115	1	
2035	2. 2-10.0- 65	2	P1
2035-040	2. 2- 7.0- 91	2	P1
20442	2. 9- 2.0- 74	1	P1
2059	2.12-39.0- 11	1	
20600	2. 3-10.0- 43	1	
20600-1	2. 3-10.0- 43	1	
20657	2.12-36.0- 3	1	P1
20715-327	2. 9- 1.0- 2	2	P1
	2.15- 7.0- 31	1	
2100-3	2.16- 6.0- 6	1	P1
21013	2.13-25.0- 8	1	P1
	2.13-26.0- 2	1	
2105-3	2.17-40.0- 1		
2111-2	2.13-12.0- 1	1	P1
2111-3	2.13-12.0- 2	1	P1
2112-3	2.13-10.0- 1	1	P1
2112-5	2.13-10.0- 5	1	P1
212-12	2.17-11.0- 43	8	
	2.17-19.0- 12	2	
	2.17-19.0- 4	6	
212-12A	2. 7- 7.0- 34	12	
212-12AD	2. 7- 7.0- 34	12	
212-12N	2. 2- 3.0- 15	4	
	2.17-32.0- 17	7	
	2.17-32.0- 18	1	
21243-4-10	2. 9-31.0- 7	1	P1
214-16	2. 2- 7.0- 48	4	
	2. 2- 9.0- 34	1	
214AA2	2.20- 1.0- 16	1	
214AA3	2. 9-12.0- 39	1	
21675-2150-2	2.15-25.0- 83	6	P1
2174-518-3	2. 4-11.0- 36	1	
2174-518-5	2. 4-11.0- 36		
2174-7	2. 4-11.0- 36	REF	
22A554	2.10- 7.0- 56	1	SC
22FT1032	2. 3- 7.0- 6	4	
	2.10- 3.0- 15	8	
	2.10- 3.0- 20	2	
22FT428	2. 3- 7.0- 8	7	
	2.10-37.0- 23	4	
22FT524	2.10-37.0- 13	4	
	2.10-37.0- 29	4	
	2.10-40.0- 15	4	
	2.14-34.0- 4	1	
22FT624	2.14-23.0- 24	1	KF
	2.15-25.0- 79	RF	
	2.20-47.0- 9	8	
22FT820	2.15-38.0- 34	1	
22FT832	2.14- 6.0- 8	6	
22NM26	2. 4- 9.0- 42	2	
	2. 4-12.0- 63	4	
	2. 4-12.0-108	4	
	2.14-23.0- 83	4	
2209-6	2.17-43.0- 2	1	P
	2.18-33.0- 11	1	
22322S-ET12	2.16- 1.0- 74	1	P1
	2.16- 2.0- 47		
22466	2.10-34.0- 1	AR	
	2.10-34.0- 7	12	
2247	2.18- 6.0- 39	1	P1
2248	2.18- 6.0- 37	1	P1

PART NUMBER	FIGURE AND INDEX NUMBER	QTY PER ART	SMR CODE
227-28-2	2.17-13.0- 3	1	P1
227-28-5	2.17-13.0- 3	RF	
227-28-5A	2.17-13.0- 3	RF	
227435	2.10- 7.0-173	2	
2278-1	2.16- 6.0- 42	1	P1
22830-2	2.20-34.0- 2	1	
23F2815N	2.20-44.0- 4		
2326-101	2.12-13.0- 1	1	
2326-105	2.12-13.0- 1	1	P1
234-514-9016	2.10- 7.0- 74	1	
234-54610	2.10-34.0- 11	4	P1
	2.10-34.0- 6	6	
	2.10-35.0- 2	16	
2352-040049	2. 4-12.0-133	RF	
23541	2.10-34.0- 2	AR	P
	2.10-34.0- 8	73	
	2.10-35.0- 1	AR	
23750	2.17- 3.0- 11	1	P1
	2.17- 5.0- 5	3	
	2.17- 6.0- 4	2	
	2.17- 7.0- 2	1	
240-3140311-8	2.15-24.0- 29	1	M
240-8616901-17	2. 6-37.0- 11	16	X1
	2. 6-37.0- 18	16	
240-8616901-6	2. 6- 4.0- 7	2	
	2. 6- 5.0- 8	2	
24094-4	2.17-11.0- 1	1	
24096-175-C	2.13-26.0- 12	1	
	2.13-26.0- 3	2	
24096-175C	2.13-20.0- 4	2	
	2.13-25.0- 6	2	
24096-200C	2.13-30.0- 10	2	
24502-150	2.13-17.0- 4	1	
24502-175	2.13-17.0- 6	5	
	2.13-18.0- 16	1	
	2.13-18.0- 2	1	
	2.13-18.0- 41	1	
	2.13-20.0- 2	5	
	2.13-25.0- 6	2	
	2.13-25.0- 7	1	
	2.13-26.0- 11	1	
	2.13-26.0- 3	2	
24502-200	2.13- 8.0- 15	1	
	2.13-30.0- 9	2	
24502-250	2.13-27.0- 10	1	
24503-307	2.13-25.0- 4	1	
	2.13-27.0- 12	5	
24505-175	2.13-26.0- 5	1	
2452-02	2. 4-10.0- 8	1	P
2452-02RET	2. 4-10.0- 9	1	
2452-048	2. 4- 2.0- 29	2	
	2. 4-10.0- 5	2	
2452-048RET	2. 4-10.0- 6	2	
2452-064	2. 6- 1.0- 23		
	2. 6- 2.0- 23	1	
2452-064 RET	2. 6- 1.0- 23	1	
	2. 6- 2.0- 23	1	
2452-108	2. 6- 1.0- 24	1	
	2. 6- 2.0- 24	1	
2452-126	2. 7- 5.0- 10	1	
	2. 7- 9.0- 2	1	
	2.15-28.0- 5	1	
24522E	2.14- 6.0- 17	1	P1
24522J	2.14- 6.0- 17	1	P1
24522K	2.14- 6.0- 17	1	

PART NUMBER	FIGURE AND INDEX NUMBER	QTY PER ART	SMR CODE
24548-150	2.12-44.0- 16	2	P1
24546-200	2.12-54.0- 16	2	
24650	2.11- 2.0- 1	1	P1
247308-1	2. 9-11.0- 40	1	
25-6500	2.12-15.0- 76	RF	
	2.12-15.0- 88	RF	
	2.12-16.0- 58	RF	
	2.12-16.0- 70	RF	
25-6500-3	2.12-52.0- 57	1	
	2.12- 2.0- 9	1	P1
	2.12-10.0- 99	1	
	2.12-15.0- 74	1	
	2.12-16.0- 88	1	
	2.12-16.0- 58	1	
	2.12-16.0- 70	1	
25.6-10	2.13-20.0- 14	1	P1
	2.13-21.0- 15	1	
	2.13-22.0- 21	1	
2510C	2.14- 8.0- 43	22	X1D
2510H21C1B3	2.16- 1.0- 85	1	P1
2562A 3	2.18-36.0- 2	1	
2562A13	2.18-31.0- 5	RF	P1
2562A3	2.18-31.0- 5	RF	
2562A5	2.18-31.0- 5	RF	P1
25630131	2.12- 5.0- 1	1	P1
25630131-01	2.12- 5.0- 1	1	P1
25633151	2.10- 7.0- 49	1	P1
25640003	2.10-25.0- 27	1	
25640003-01	2.10-25.0- 28	1	
25640004-01	2.10-22.0- 31	1	P1
25640004-02	2.10-22.0- 32	1	P1
25640555	2.10-23.0- 22	1	P1
25640555-01	2.10-23.0- 22	1	P1
25640580-01	2.10-22.0- 20	1	P1
25640580-02	2.10-22.0- 21	1	P1
25643752-01	2.10-23.0- 40	1	P1
25643753-01	2.10-22.0- 46	1	P1
25H20031	2.13- 5.0- 25	1	
	2.13- 6.0- 25	1	
25H20130	2.10-22.0- 23	1	
25H30034-01	2.17-11.0- 12	1	P1
26C02	2. 5- 7.0- 7	1	
26S018	2.18-20.0- 23	1	P1
260-660605J	2.10-16.0- 17	1	
2600-SW2	2.12- 9.0- 28	10	P1
2600-1	2. 7- 7.0- 23	12	
2600-12	2.17-11.0- 41	8	
	2.17-34.0- 1	3	
	2.17-34.0- 1	4	
2600-5	2. 7- 7.0- 22	12	P1
2600-6	2.17-38.0- 1	4	
2600SW	2.17-11.0- 42	8	
	2.17-34.0- 2	3	
	2.17-34.0- 2	4	
	2.17-38.0- 2	4	
26J0SW2	2. 7- 7.0- 21	12	
26040030	2.13-15.0- 34	1	
261703	2.10- 5.0- 3	RF	
2660405	2.12-10.0- 86	1	
2663	2.18-24.0- 17	12	P1
26801A3783A1	2.16-18.0- 3	2	P1
2700-5	2.12- 9.0- 25	1	P1
2700-6	2.12- 9.0- 27	2	P1
2750-8	2.12- 9.0- 26	3	P1
27025	2. 8-23.0- 14	1	P1
2705AR34005	2.17-40.0- 5	8	

PART NUMBER	FIGURE AND INDEX NUMBER	QTY PER ART	SMR CODE
270800-1	2. 7- 1.0- 7	2	P1
2749	2. 9- 2.0- 73	1	
27900	2. 9-10.0- 42	RF	P1
	2.13- 1.1- 84	1	
279900	2.10- 7.0- 29	4F	
28-94500-1	2. 5- 6.0- 2	1	P
28-94500-11	2. 5- 6.0- 3	1	
28-94500-13	2. 5- 6.0- 6	1	X1
28-94500-P01	2. 5- 6.0- 2	1	
28-94500-4	2. 5- 6.0- 6	1	X1
28-94502	2. 5- 6.0- 1	1	P
28-94507	2. 5- 6.0- 9	1	
280-1A	2.16- 1.0- 18	1	P1
	2.16- 2.0- 9	1	
2838	2.13-22.0- 22	2	
	2.13-28.0- 5	5	
	2.13-29.0- 17	4	
	2.13-29.0- 5	2	
	2.13-29.1- 8	2	
284417	2. 9-23.0- 40	1	P1
285-10	2.16- 1.0- 6	1	P
285-10	2.16- 2.0- 7	1	
285-1F	2.16- 1.0- 54	1	P1
	2.16- 2.0- 13	1	
285-1F	2.16- 1.0- 36	1	
	2.16- 2.0- 51	1	
285-1G	2.16- 1.0- 62	1	P1
	2.16- 2.0- 13	1	
285-1H	2.16- 1.0- 64	1	P1
	2.16- 2.0- 63	1	
28595	2.14- 6.0- 29	RF	
2891	2.12-44.0- 24	1	P1
	2.12-48.0- 58	1	
2894	2.13- 9.0- 64	1	
	2.13-29.0- 13	1	
	2.13-29.0- 4	2	
29030-1-40	2.19- 1.0- 6	1	P1
293-7	2. 4- 9.0-		
2935-1	2. 7-10.0- 9	31	
2935-35	2.10-37.0- 14	4	
	2.10-38.0- 14	2	
	2.10-58.0- 8	2	
2940540120	2.10-35.0- 2	14	P1
29500	2.18-34.0- 12.1	1	
295967-7	2.10-23.0- 11	1	P1
	2.10-23.0- 21	1	
296	2. 4-11.0- 3	1	
297617	2.10- 7.0- 95	1	P1
3816-6	2.14- 8.0- 23	2	
3-1080	2.15-16.0-33	2	
3-1664-12-44-1	2.13- 9.0- 29	1	P1
3-1664-16-52-5	2.13- 9.0- 9	1	
3-1664-6-42-4	2.13-11.0- 40	1	
3-1664-8-28-4	2.13- 8.0- 7	1	P1
3-1664-8-33-5	2.13- 8.0- 20	1	
	2.13- 8.0- 36	1	
3-1664-8-54-6	2.13-11.0- 54	1	P1
3-3682	2.12- 3.0- 17	1	
3-4360	2.13-30.0- 81	1	P1
3716-4	2.14- 8.0- 18	2	
3PB11	2.16-19.0- 8	1	
	2.17- 9.0- 13	1	
3V7-12-40-2	2.20- 3.0- 23	1	
300030-1	2. 8-10.0-107	1	P1
	2. 8-10.0-112	3	
3002-40	2. 3- 3.0- 93	RF	

PART NUMBER	FIGURE AND INDEX NUMBER	QTY PER ART	SMR CODE
3010-1	2.13- 8.0- 61	1	P1
3010-5	2.13- 8.0- 62		
301552	2. 9-22.0- 19	1	P1
3017	2.15-22.0- 27	1	
	2.15-23.0-48	1	
301700	2. 9- 2.0- 37	1	
301782	2.20- 1.0- 40	1	P1
	2.20-49.0- 11	RF	
3018S4-12D	2.10- 7.0-131	1	P1
3018S4-6D	2.10-7.0-129	1	
3018S4-8D	2.10- 7.0-132	1	P1
3022-12D	2. 3- 3.0- 94	1	P1
3022-6D	2. 8-12.0- 79	1	P1
	2. 8-12.0-133	1	
3022-8D	2. 3- 3.0- 92	1	P1
3024S4-4D	2. 8- 4.0- 15	1	P1
	2. 8- 5.0- 15	1	
3032880	2.18-11.0- 30	1	
3057	2.12-37.0- 33	1	P1
	2.12-37.0-147	1	
306015-6D0094	2.11-11.0- 14	1	P1
3065-S5-6D	2.10- 7.0-127	2	
3065-S5-8D	2.10-7.0-130	2	
3065S5-16D	2.10 - 7.0 - 133	2	P1
307534-16D	2. 8- 1.0- 60	1	P1
	2.10- 7.0-134	2	
308717	2.12-56.0- 18	4	KF
	2.12-56.0- 23	2	
312200	2.12-14.0- 32	1	P1
	2.12-49.0- 28	1	
312806	2.12-18.0- 11	1	P1
312806-1	2.12-18.0- 11	1	P1
31381	2.14-41.0- 15	1	P1
313700	2.12-52.0- 76	2	P1
	2.12-42.0- 80	2	
315472	2.10-7.0-99	1	
315473	2.10-7.0-124	1	
	2.10-7.0-98	1	
	2.10-7.0-124B	1	
3167776-1	2. 9-13.0- 4	1	
3167777-1	2. 9-13.0- 17	1	
3169437-1	2. 9-13.0- 22	1	
31983-23	2.14- 4.0- 62	1	
319900-1	2. 6-40.0- 97	1	
	2. 6-40.0-108	2	
32FT1216	2.14-11.0- 22	1	
320-62-131S	2.12-35.0- 34	1	P1
320-62-162M	2.12-35.0- 6	1	
320-62-212S	2.12-18.0- 1	1	
320-62-225M	2.13-20.0- 9	1	P1
	2.13-24.0- 1	1	
320-62-225SH	2.12-55.0- 6	2	P1
320-62-612S	2.13- 1.1- 77	1	
320C62-181SH	2.13-24.0- 10	2	
320C62-206SH	2.13-24.0- 14	1	
3202-4	2. 8-24.0- 8	1	P1
3202-6	2. 8-24.0- 7	1	P1
3207-12	2. 8-10.0- 63	1	
3207-16	2. 8-10.0- 29	1	
321-26-420S	2.13-21.0- 13	2	
321-62-187S	2.12-49.0- 27	1	
321-62-215S	2.13- 1.1-100	1	
321-62-420S	2.13- 1.1-138	3	P
321-62-431M	2.13-35.0- 23	2	
3214050-J-1	2. 9-13.0- 4	1	
322049	2. 3- 1.0- 68	1	

PART NUMBER	FIGURE AND INDEX NUMBER	QTY PER ART	SMR CODE
322128	2. 3- 1.0- 69	1	
3225-1A	2.14- 6.0- 7	1	
325-62-325M	2.12-48.0- 32	1	P1
	2.13-27.0- 23	5	
	2.20- 7.0- 1	5	
325-62-431M	2.12-49.0- 40	1	P
	2.12-48.0- 51	2	
	2.13-27.0- 55	1	
325-62-475M	2.15-16.0- 77	2	
326-62-212S	2.13- 6.0- 13	2	
326-62-312S	2.13- 1.1- 56	5	
	2.13- 5.0- 20	2	
326-62-325S	2.13- 5.0- 14	2	
	2.13- 5.0- 18	2	
	2.13- 5.0- 32	2	
	2.13- 6.0- 11	RF	
	2.13- 6.0- 31	2	
326-62-403M	2.13-22.0- 4	1	
326-62-612S	2.10- 1.0- 16	1	P
326-75-675S	2.13- 1.1-129	2	
32700-2-07	2.18-21.0- 16	1	
327025	2. 3- 1.0- 55	2	
3302-12	2. 8-10.0- 62	1	
3302-16	2. 8-10.0- 28	1	M
330400-1	2. 6-40.0- 33	1	M
330600-1	2. 6-40.0- 50	1	
	2. 6-40.0- 65	1	
339	2. 2-12.0- 39	RF	P1
339EA1	2.15-16.0- 59	1	P1
340-8210303-9	2. 2-10.0- 5	RF	
	2. 3- 2.0- 46	RF	
	2.15-14.0- 21	RF	
34104	2. 3- 1.0- 57	1	
3447449	2.12- 9.0- 90	1	P1
34760	2.11- 2.0- 1	RF	
35-121A	2.13-33.0- 59	1	P1
3501518-1	2.10- 7.0- 80	1	
3501650-1	2.10- 7.0- 67	1	
3501663-1	2. 9-13.0- 4	1	
3505-56-1-1	2.10- 7.0- 73	1	
351709A	2.10- 5.0- 2	RF	
35251-3	2.12-65.0- 14	1	
353992	2.10- 7.0- 75	1	
3567750-3001A	2.10- 7.0-163	1	
3585-06CNX1276	2.16- 1.0- 97	16	P1
3591-30AY	2.14-14.0- 12	3	P1
3591-30CNX.234	2. 4- 2.0- 37	2	P
	2. 4- 2.0- 65	4	
	2. 4- 2.0- 72	2	
	2. 4- 2.0- 9	AR	
3591-30CNX.285	2. 3- 5.0- 24	2	
	2. 4- 9.0- 15	3	
	2.14-10.0- 78	13	
	2.14-23.0-182	2	
3591-30CNX.380	2. 7- 1.0- 25	1	P1
	2.16- 3.0- 26	3	
	2.16- 3.0- 44	2	
3591-30CNX380	2.14-17.0- 22	3	P1
	2.14-17.0- 9	3	
3591-40CNX172	2. 2-10.0- 50	8	
3591-40CNX388	2.14- 9.0- 20	2	
	2.14-10.0- 77	2	
3591-40CNX378	2. 2-10.0- 50	4	
	2. 2-10.0- 74	1	
	2. 2-10.0- 86	1	
	2. 3- 1.0- 15	3	

PART NUMBER	FIGURE AND INDEX NUMBER	QTY PER ART	SMR CODE
3601-160	2.12-49.0- 32	1	P1
3601-320	2.12-55.0- 3	1	P1
3601-640	2.12-46.0- 4	1	P1
3601200	2. 9- 2.5- 6	2	P1
3605-120	2.12-21.0-186	2	P1
	2.12-49.0- 19	2	
	2.12-49.0- 40	1	
3605-120	2.12-23.0-149	2	
3605-130	2.12-10.0- 26	1	P1
	2.12-10.0- 31	1	
	2.12-10.0- 47	1	
	2.12-10.0- 51	1	
	2.12-10.0- 53	1	
	2.12-11.0- 16	1	
	2.12-11.0- 20	1	
	2.12-15.0- 14	2	
	2.12-15.0- 21		
	2.12-15.0- 22	1	
	2.12-16.0- 16	2	
	2.12-16.0- 20	1	
	2.12-16.0- 29	1	
	2.12-19.0- 34	2	
	2.12-19.0- 38	2	
	2.12-20.0- 70	1	
	2.12-21.0-191	2	
	2.12-22.0-154	2	
	2.12-25.0- 29	1	
	2.12-25.0- 4	1	
3605-200	2.12-23.0- 7	1	P1
	2.12-32.0- 99	3	
	2.12-43.0-143	1	
	2.12-46.0- 99	1	
3605-240	2.12-10.0- 61	1	
	2.12-10.0- 70	1	
	2.12-11.0- 11	1	
	2.12-11.0- 6	1	
	2.12-14.0- 22	4	
	2.12-14.0- 6	1	
	2.12-14.0- 70	1	
	2.12-15.0- 54	1	
	2.12-15.0- 65	1	
	2.12-15.0- 69	1	
	2.12-16.0- 35	1	
	2.12-16.0- 47	1	
	2.12-16.0- 51	1	
	2.12-19.0- 47	1	
	2.12-19.0- 52	1	
	2.12-21.0-196	5	
	2.12-22.0-159	5	
	2.12-25.0- 13	2	
	2.12-44.0-156	1	
	2.12-44.0-160	2	
	2.12-44.0-189	1	
	2.12-45.0-155	4	
	2.12-47.0- 1	1	
	2.12-47.0- 11	1	
	2.12-49.0- 57	1	
	2.12-52.0- 50	2	
	2.12-52.0-116	1	
3605-320	2.12-15.0- 5	1	P1
	2.12-16.0- 10	1	
	2.12-19.0- 41	1	
	2.12-19.0- 45	1	
	2.12-20.0- 8	4	
	2.12-61.0- 6	4	

PART NUMBER	FIGURE AND INDEX NUMBER	QTY PER ART	SMR CODE
3605-320	2.12-65.0- 3	4	P1
	2.12-67.0- 25	4	
3605-400	2.12- 1.0-114	1	P1
	2.12-14.0- 82	1	
	2.12-14.0-120	1	
	2.12-15.0-220	4	
	2.12-15.0-225	1	
	2.12-17.0- 57	2	
	2.12-19.0- 60	1	
	2.12-20.0- 77	3	
	2.12-21.0-114	6	
	2.12-31.0- 2	1	
	2.12-37.0-158	1	
	2.12-37.0-233	1	
	2.12-65.0- 17	1	
3605-480	2.12-14.0- 43	1	P1
	2.12-14.0- 48	1	
	2.12-14.0- 55	2	
	2.12-14.0- 67	2	
	2.12-15.0- 49	3	
	2.12-16.0- 34	1	
	2.12-20.0- 22	3	
	2.12-48.0- 29	4	
	2.12-52.0- 79	2	
3605-640	2.12-48.0- 13	1	
	2.12-48.0- 4	1	
	2.12-48.0- 42	1	
	2.12-48.0- 53	1	
3605-720	2.12-48.0- 14	1	
361-62-42'S	2.13-22.0- 2	4	
364FA4	2.15-13.0- 31	1	P1
365-62-344S	2.20-18.0- 31	2	
	2.20-38.0- 2	2	
365-62-862M	2.13-30.0- 2	2	
	2.13-51.0- 39	20	
3655-120	2.12-49.0- 44	1	P1
3655-200	2.12-14.0- 9	1	P1
3655-240	2.12-10.0- 58	1	P1
	2.12-24.0- 5	1	
3655-400	2.12-65.0- 11	1	
	2.12-65.0- 20	1	
37P4	2.18- 6.0- 4	1	P1
375213-16	2.10-24.0- 5	2	P1
3850A1	2. 8-16.0- 19	2	P1
	2. 8-16.0- 68	1	
	2. 8-16.0- 78	1	
	2. 8-22.0- 2	1	
	2. 8-24.0- 22	1	
397-2	2.16- 5.0- 45	1	
397-5	2.17-36.0- 13	1	
397-6	2. 5- 2.0- 16	1	P1
399-3	2.18-20.0- 8	1	
4	2. 9- 9.0- 53	9F	
4CV442	2. 8-27.0- 67	1	P1
4CV464	2. 8-10.0-182	1	P1
	2. 8-11.0- 25	1	
	2. 8-11.0- 36	1	
	2. 8-27.0- 26	1	
4CV464-72-30	2. 8-16.0- 14	1	P1
	2. 8-16.0- 49	1	
	2. 8-16.0- 56	1	
	2. 9-15.0- 6	1	

PART NUMBER	FIGURE AND INDEX NUMBER	QTY PER ART	SMR CODE
4CV482	2. 8-12.0-155	1	P1
4C127	2. 4- 7.0- 37	1	
4C127-1	2. 4- 7.0- 37	1	
4F10-2	2. 2- 5.0- 6	1	P1
	2. 2- 7.0- 44	1	
	2. 2- 7.0- 71	1	
	2. 2- 7.0- 77	1	
	2. 2- 9.0- 46	1	
	2. 2- 9.0- 47	1	
	2. 2-15.0- 5	1	
4R-20-14-V32	2. 2- 9.0- 34	1	
4R1-14	2. 2- 9.0- 47	12	
4R33-16	2. 2- 4.0- 1	43	P1
4R41-1	2. 2- 7.0- 70	32	P1
	2. 2- 9.0- 16	17	
	2. 2- 9.0- 47	26	
	2. 2-15.0- 8	40	
	2. 2-18.0- 5	30	
	2. 2-18.0- 9	45	
4R51-1	2. 2- 4.0- 2	43	X1
	2. 2- 5.0- 15	43	
	2. 2- 7.0- 48	4	
	2. 2-12.0- 23	32	
	2. 2-12.0- 31	32	
4S14-10	2. 2- 9.0- 13	2	
4S14-12	2. 2-18.0- 5	38	
4S14-9	2. 2- 7.0- 40	4	
	2. 2- 7.0- 69	32	
	2. 2- 7.0- 80	10	
	2. 2- 9.0- 14	43	
	2. 2- 9.0- 47	26	
	2. 2- 9.0- 47	12	
	2. 2-12.0- 21	30	
	2. 2-12.0- 29	30	
	2. 2-15.0- 7	40	
	2. 2-15.0- 8	45	
4S14-6	2. 2-12.0- 26	2	P
	2. 2-13.0- 18	15	
	2. 2-15.0- 7	40	
4S15-4	2. 2-12.0- 28	2	
4S9-1	2. 2- 9.0- 15	45	P
	2. 2- 9.0- 47	26	
	2. 2-12.0- 22	32	
	2. 2-12.0- 30	32	
	2. 2-13.0- 19	15	
	2. 2-15.0- 8	40	
4S9-2	2. 2- 7.0- 42	4	
	2. 2- 7.0- 68	32	
	2. 2- 7.0- 79	10	
	2. 2- 9.0- 15	45	
	2. 2- 9.0- 47	26	
	2. 2- 9.0- 47	12	
	2. 2-12.0- 22	32	
	2. 2-12.0- 30	32	
	2. 2-13.0- 19	15	
	2. 2-15.0- 8	40	
	2. 2-18.0- 5	36	
	2. 2-18.0- 8	45	
40-0110-17	2.17-1-0-7A	1	P1
40B69G	2.13- 1.1- 61	1	P1
	2.13- 8.0- 3	1	
40D705	2.13- 1.1-164	1	
40R12-1	2. 2- 5.0- 15	4	
40S5-3	2. 2- 7.0- 40	1	
40S5-6	2. 2- 7.0- 40	1	
40S5-7	2. 2- 7.0- 40	1	

PART NUMBER	FIGURE AND INDEX NUMBER	QTY PER ART	SMR CODE
40S514070-3A	2. 2- 1.0- 14	4	
40S514107-5	2. 2-10.0- 44	1	
40S514107-6	2. 2-10.0- 17	1	
40S8-2-20R	2. 2- 5.0- 34	1	
400810-2	2.10- 6.0- 66	1	P1
400810-3	2.10- 6.0- 67	1	P
400W052	2.10-19.0- 18	4	P1
4001-001-1	2.17-21.0- 7	4	PA
	2.17-23.0- 7	2	
	2.17-24.0- 7	1	
	2.17-31.0- 3	1	
	2.17-31.0- 8	4	
4001-001-3	2.17-23.0- 9	1	PA
	2.17-29.0- 9	1	
	2.17-31.0- 7	1	
40020	2. 2- 7.0- 41	4	
	2. 2- 9.0- 34	1	
40020W	2. 2- 4.0- 34	1	
400374	2.13- 7.0-173	2	
40060	2.13-31.0- 31	1	P1
40064	2.12-38.0- 63	1	P1
	2.12-39.0- 51	1	P1
40064-1	2.12- 1.0- 62	1	
40065	2.12- 1.0- 67	1	P1
40111	2.12-39.0- 22	1	P1
	2.12-39.0- 50	1	
40120-1A	2.10- 7.0-144	1	P1
40280	2.12-68.0- 92	1	
40643	2.10-32.0- 2	1	
407839692-35	2.17-20.0- 40	1	
410435	2.13-15.0- 1	1	
410160	2.13- 8.0- 14	1	P1
41004	2.10- 7.0-205	1	P1
41004-1	2.10- 7.0-205	1	P1
4120-5970-530	2.11-11.0- 18	2	
4121-578033	2.13-11.0- 7	2	
41234	2.10-34.0- 4	1	
	2.10-34.0- 4	1	
	2.10-34.0- 9	2	
	2.10-35.0- 5	1	
	2.10-34.0- 5	1	
41234	2.10-34.0- 9	2	
41241	2.10-34.0- 9	2	
41250-100	2.17-13.0- 7	2	P1
4126-565424	2.10-21.0- 12	1	P1
4126-565810	2. 9-28.0- 13	1	
4126-577253	2. 9-28.0- 8	2	
41260-2	2.17-13.0- 8	1	
4128-5-20	2.17-36.0- 13	1	PFF
41484-1	2.17-13.0- 8	1	
4151819-56A	2.13- 1.1- 17	1	P1
41604	2.10-34.0- 10	3	P
	2.10-34.0- 3	5	
	2.10-35.0- 3	14	P1
41790	2.10-35.0- 3	14	P
4184-10	2.13-28.0- 21	1	
	2.13-28.0- 6	2	P1
4184-1	2.13-28.0- 12	2	
	2.13-28.0- 4	2	
	2.13-28.0- 7	1	
4185-10	2.13-28.0- 10	4	P1
	2.13-28.0- 22	2	
	2.13-28.0- 5	4	
	2.13-29.0- 17	4	
	2.13-29.0- 3	2	

PART NUMBER	FIGURE AND INDEX NUMBER	QTY PER ART	SMR CODE
4185-10	2.15-29.0- 9	2	P1
4185-12	2.13- 9.0- 47	2	P1
4185-6	2.13-28.0- 3	3	P1
4190-565491	2. 9-18.0- 13	1	
	2. 9-18.0- 32	1	
	2. 7-13.0- 65	1	
	2. 9-16.0- 75	1	
4190-578013	2. 8-12.0- 89	1	P1
	2.14-35.0- 35	1	
	2.14-37.0- 41	1	
41930-13	2. 9-16.0- 20	1	P1
41930-3	2. 9-16.0- 20	1	P1
41930-7	2. 9-17.0- 64	1	P1
41941	2.13-34.0- 4	1	P1
	2.10-34.0- 5	1	
	2.10-35.0- 4	4	
42A13410	2.14-36.0- 8	1	
42013	2.14- 1.0- 27	1	P1
420171	2.12-67.0- 16	1	
42FW1018	2. 6- 6.0- 43	3	
	2. 6- 7.0- 43	3	
	2. 6-12.0- 31	3	
	2. 6-10.0- 28	4	
	2.15-35.0- 32	2	
42FW1216	2. 6-16.0- 37	6	
	2.15-31.0- 19	1	
42FW1614	2.12-10.0- 16	1	P1
	2.15-30.0- 34	1	
42FW428	2. 2-10.0- 70	1	
	2.20-12.0- 3	2	
	2.20-28.0- 15	44	
	2.20-28.0- 5	18	
42FW524	2.15-31.0- 14	2	
	2.15-31.0- 6	2	
	2.20-28.0- 18	26	
	2.20-28.0- 2	4	
	2.20-28.0- 3	8	
42FW624	2.10-40.0- 11	2	
42FW720	2. 6- 6.0- 39	4	
	2. 6- 7.0- 39	4	
	2. 6-12.0- 27	4	
4227	2.11- 9.0- 29	2	P1
	2.11- 9.0- 34	1	
42280	2.16- 2.0- 25	1	P1
423158	2.18-16.0- 26	1	
4238-3	2.10- 1.0- 17	1	P1
4261	2. 5-11.0- 1	1	P1
4261C170-M	2.13-33.0- 57	3	P1
4265-156D	2.10-18.0- 23	2	P1
4265-382SH	2.10-11.0- 9	2	P1
4275-307M	2.10-11.0- 12	1	P1
4275-331M	2.10-11.0- 10	2	P1
4285	2. 6-16.0- 43	1	P1
	2. 6-18.0- 87	1	
4333-1	2.18-33.0- 7	1	P1
4333-3	2.18-33.0- 6	1	P1
43382	2. 6-35.0- 3	1	P1
	2. 6-30.0- 3	2	
435-17-0870	2.18- 6.0- 3	6	P
4368-301SH	2.12-27.0- 1	2	
	2.12-31.0- 1	2	
	2.12-31.0- 1	2	
4368-365SH	2.12-52.0- 75	4	
4369-231M	2.13-17.0- 4	1	P
43900J-3	2.19- 2.0- 3	1	P

PART NUMBER	FIGURE AND INDEX NUMBER	QTY PER ART	SMR CODE
44034238501	2.17-10.0- 12	1	
4404-450M	2.10- 6.0- 64	1	N
	2.12-52.0-108	0	
44102-1	2. 8- 7.0- 19	1	P1
443-0-2-P	2. 4- 7.0- 20	3	
	2. 4- 7.0- 22	1	
	2. 4- 7.0- 25	1	
	2. 4- 7.0- 27	1	
	2. 4- 7.0- 29	2	
	2. 4- 7.0- 30	1	
443MC1	2. 5-23.0- 47		
4437	2.11- 9.0- 39	1	
4461-1	2. 3- 6.0- 6	2	
4464-206M	2.13-31.0-48	1	
4464C206M	2.13-29.0-9	2	
4464C257M	2. 9- 2.0- 72	1	
4464C291M	2.13- 1.1-102	1	P1
	2.13- 8.0- 15	1	
448-0160-000	2.20-34.0- 3	1	P
4480-365S	2.13- 1.1- 59	1	
4497-1	2. 6-11.0- 6	1	
45FW524	2.14-19.0- 11	1	
4558-1	2.12-48.0- 41	1	P1
4508-3	2.12-48.0- 52	1	P1
4508-7	2.12-48.0- 55	1	P1
4508-9	2.12-55.0- 2	1	P1
451-75-405SH	2.16- 6.0- 7	1	P
45292F2	2.16-8.0-47	1	
4543.5	2.16- 2.0- 70	1	
455220	2.18-16.0- 20		PA
45525	2.12-35.0- 1	1	P1
	2.12-32.0- 10	1	
	2.12-34.0- 7	1	
4553	2.15- 5.0- 9		RF
455573A	2.18-16.0- 20	1	PA
4580	2.15- 5.0- 9	1	P1
4581	2.15- 5.0- 9	1	P1
4591	2.13-27.0- 53	1	P1
459675	2. 2-19.0- 67	1	
460-015-40	2.12-65.0- 31	1	P1
460-015-24	2. 9- 2.0- 15	1	P1
	2. 9- 2.0- 22	1	
	2. 9- 2.0- 35	1	
	2. 9- 2.0- 41	1	
	2. 5- 2.0- 83	1	
	2.12-38.0- 86	2	
460-630-16	2. 9- 2.0- 61	2	P
460-630-20	2. 9- 2.0- 20	1	P1
460-630-24	2.12-58.0- 12	1	
460-715-15	2.10-21.0- 13	1	P
	2.16-21.0- 9	1	
	2.10-27.0- 9	2	
460-730-12	2. 9- 2.0- 45	1	P
463097-10040	2.18-14.0- 4	1	
464002	2.18-11.0- 11	1	
464008	2.18-23.0- 4	1	
464016	2.18-16.0- 20	1	
464017	2.18- 6.0- 1	1	
464019	2.16- 8.0- 30	1	
464020	2.18-17.0- 24	1	
464024-100	2.18-14.0- 1	2	
464034	2.16- 2.0- 17	1	

PART NUMBER	FIGURE AND INDEX NUMBER	QTY PER ART	SMR CODE
464034-150	2.18- 1.0- 34	1	
464040	2.18-17.0- 7	1	
464041	2.18-17.0- 12	1	
464043	2.18-23.0- 5	1	
464045	2.18-14.0- 5	1	
464054-154MD3	2.20-23.0- 10	2	
	2.20-23B.0-11	RF	
	2.20-31.0- 12	1	
464061-150	2.14- 6.0- 20	1	
	2.14- 8.0- 22	1	
464063	2.18-17.0- 8	1	
464065	2.18-19.0- 22	1	
464073-138	2.18-17.0-38	1	
464074	2.18-21.0- 6	1	
464080	2.18-11.0- 10	1	
464083-180MD3	2.14-13.0- 5	1	
464084	2.18-16.0- 19	1	
464087-152	2.18-23.0- 9	1	
464095	2.18-17.0- 35	1	
464096	2.18-17.0- 5	1	
464102	2.18-12.0- 3	1	
	2.18-13.0- 8	1	
464103	2.18-17.0- 29	1	
464106	2.18-17.0- 16	1	
464107	2.18-21.0- 9	1	
464117	2.18- 9.0- 4	1	
464141-164	2.18-18.0- 5	1	
464141	2.18-17.0- 17	1	
464149-182	2.18-11.0- 1	1	P1
464163	2.18- 1.0- 67	1	
464163-165	2.18- 2.0- 49	1	P1
464173	2.18- 8.0- 20	1	
464174-174	2.18-23.0- 10	1	
464181	2.18-12.0- 1	1	
	2.18-13.0- 6	1	
464190	2.18-16.0- 21	1	
464195	2.18-17.0- 31	1	
464196	2.18-17.0- 2	1	
464206	2.18-17.0- 14	1	
464216	2.18-19.0- 14	1	
464220-150	2.18- 9.0- 34	RF	P1
	2.18-20.0- 34	1	
464223	2.18-17.0- 20	1	
464241	2.18-17.0- 13	1	
464259-150	2.18- 1.0- 35	1	P1
464264	2.18-23.0- 6	1	
464267	2.18-21.0- 2	1	
464273-185	2.18-18.0- 8	1	P1
464305	2.18- 1.0- 30	1	
464306	2.18-19.0- 1	1	
464346	2.18-17.0- 4	1	
464364	2.18-23.0- 7	1	
464367	2.18-21.0- 1	1	
464389	2.18-17.0- 36	1	
464395	2.18-17.0- 30	1	
464405	2.18- 8.0- 27	1	
46441	2.18-23.0- 8	1	
464432	2.18-16.0- 16	1	
464463	2.18- 2.0- 50	1	
464464	2.18-23.0- 2	1	
464465	2.18-16.0-28	1	P
464474	2.18-23.0- 3	1	
464484	2.18-16.0- 10	1	
464486	2.18-23.0- 3	1	

PART NUMBER	FIGURE AND INDEX NUMBER	QTY PER ART	SMR CODE
464488-16	2.20-44.0- 65	1	P1
464505	2.18-17.0- 18	1	
464509-150	2.18-21.0- 1	1	
464511-150	2.18- 1.0- 5	1	
464516-160	2.18-16.0-17	1	P
464518	2.18-22.0- 1	1	
464521	2.18-20.0- 1	1	
464523	2.18-17.0- 10	1	
464525-151	2.18-18.0- 7	1	P1
464529	2.18-21.0- 7	1	
464541	2.18-14.0- 13	1	
464596	2.18-10.0- 8	1	
464602-180MDX2	2.18-20.0- 3	1	
464606	2.18-21.0- 10	1	
464621	2.18-20.0- 2	1	
464629	2.18-21.0- 0	1	
464641	2.18-17.0- 21	1	
464650	2.18- 8.0- 14	1	
464653	2.18-17.0- 19	1	
464667-180MDR	2.18-21.0- 3	1	P1
464673-139	2.18-17.0-38	1	
464674	2.18-14.0- 7	1	
464691-150	2. 4- 3.0- 4	1	
	2.17-10.0- 1	1	
464721-151	2.18- 1.0- 4	1	P1
464741	2.18-17.0- 1	1	
464755	2.18- 8.0- 5	1	
464767-160	2.20-44.0- 61	1	
464774	2.18-14.0- 7	1	
464790	2.18- 8.0- 15	1	
464802-150	2.20-44.0- 84	1	
464811-150	2.18-21.0- 35	1	
464821	2.18-14.0- 20	1	
464841	2.18-17.0- 22	1	
464845-150	2.18-18.0- 4	1	P1
464855	2.18- 8.0- 2	1	
464871-150	2.18-19.0- 6	1	
464880	2.18-17.0- 10	1	
464877	2.18-22.0- 3	1	
464880	2.18- 1.0- 77	1	
464886-150	2.20-44.0- 4	1	
464895	2.18- 8.0- 10	1	
464921	2.18-12.0- 2	1	
	2.18-13.0- 7	1	
464904	2.18-17.0- 33	1	
464953	2.18- 8.0- 20	1	
464971	2.18- 1.0- 72	1	
464977	2.18-22.0- 2	1	
4679	2. 2-16.0- 4	1	P1
47264	2.12-39.0- 1	1	
	2.12-39.0- 10	1	
	2.12-39.0- 7	1	
4763-10	2.11- 7.0- 10	1	P1
4763-11	2.11- 7.0- 19	1	P1
4763-17	2.11- 7.0- 20	1	P1
4763-18	2.11- 7.0- 21	1	P1
4763-19	2.11- 7.0- 15	1	
	2.11- 7.0- 16	1	
4763-20	2.11- 7.0- 15	1	
	2.11- 7.0- 18	1	
4773-22	2.11- 7.0- 19	1	P1
4783-14	2.11- 7.0- 10	1	P1
48112-0	2.11- 2.0- 1	1	P1
48450	2. 8-10.0- 54	1	
49-2161-2	2. 4- 3.0- 14	1	
	2.17-17.0- 16	1	

PART NUMBER	FIGURE AND INDEX NUMBER	QTY PER ART	SMR CODE
49-2661-2	2.17-37.0- 1	1	P1
49-2667-2	2. 4- 3.0- 11	1	P1
	2. 4- 3.0- 17	1	
	2.17- 8.0- 18	1	
	2.17-17.0- 13	1	
	2.17-18.0- 1	1	
	2.17-32.0- 9	1	
4922-1A	2.18-31.0- 5	RF	
5-1037	2.15-13.0- 31	RF	
5-556-1	2.12- 1.0- 87	1	P1
5/16-4	2.14- 8.0- 90	1	
5ET1-6	2.17-42.0- 7	1	P1
5L4300-803	2.18- 2.0- 2	1	P1
5PA3	2.15-38.0- 67	1	P1
5R2-1	2. 5-13.0- 13	7	
	2. 5-13.0- 17	AR	
	2. 5-13.0- 3	AK	
	2. 5-13.0- 8	9	
	2.17-32.0- 18	1	
5S10-8	2. 5-13.0- 12	7	
	2. 5-13.0- 16	11	
	2. 5-13.0- 2	9	
	2. 5-13.0- 7	9	
5S3-1	2. 5-13.0- 13	7	
	2. 5-13.0- 17	12	
	2. 5-13.0- 17	7	
	2. 5-13.0- 17	11	
	2. 5-13.0- 3	8	
	2. 5-13.0- 3	6	
	2. 5-13.0- 3	9	
	2. 5-13.0- 8	9	
	2.17-34.0- 4	1	
5S5-18	2.17-34.0- 3	1	
5S5-5	2. 5-13.0- 12	6	
	2. 5-13.0- 16	12	
	2. 5-13.0- 2	0	
	2. 5-13.0- 7	9	
5S5-7	2. 5-13.0- 11	1	
	2. 5-13.0- 12	7	
	2. 5-13.0- 16	12	
	2. 5-13.0- 16	7	
	2. 5-13.0- 2	8	
	2. 5-13.0- 2	6	
	2. 5-13.0- 7	9	
5S7-37	2. 5-11.0- 13	3	P1
5W2285	2.14- 8.0- 53	4	
5X2038	2.18-23.0- 19	6	
500-00800A	2.10- 7.0-	RF	P1
500-00800B	2.10- 7.0-	RF	
500-00800C	2.10- 7.0-	RF	A
500-00800D	2.10- 7.0-	RF	
500-00800E	2.10- 7.0-	RF	
500-00800F	2.10- 7.0-	RF	
5001414	2. 4- 3.0- 2	RF	P1
5008-125W	2.10- 7.0-189	2	
5008206	2.18-6.0-37	1	M
5008207	2.18-6.0-38	2	M
501700	2. 7- 3.0- 42	1	
	2. 7- 3.0- 41	1	
50190-28-300	2. 9- 3.0- 28	4	P1
50190-28-575	2. 9- 3.0- 7	4	P1
50190-30-1325S	2. 9- 3.0- 13	4	X1
50190-30-1605S	2. 9- 3.0- 8	4	P1
502000	2.12-27.0- 5	1	P1
50230075-258M	2.12-27.0- 7	1	P1
	2.12-27.0- 9	1	
	2.12-30.0- 5	1	

PART NUMBER	FIGURE AND INDEX NUMBER	QTY PER ART	SMR CODE
50230075-258M	2.12-31.0- 9	1	
50230075-358M	2.12-14.0- 44	1	
	2.12-14.0- 61	1	
	2.12-48.0- 25	6	
	2.13-31.0- 10	2	
5023.075-458M	2.12-48.0- 15	3	
	2.12-48.0- 43	3	
	2.12-48.0- 49	2	
	2.12-48.0- 5	1	
	2.12-48.0- 6	2	
	2.12-48.0- 60	2	
	2.12-48.0- 7	3	
	2.13-31.0- 4	3	
50240-2.300	2.13-18.0- 17	1	
	2.13-18.0- 9	1	
	2.13-20.0- 5	4	
	2.13-17.0- 24	1	
50240-325	2.13-27.0- 14	1	
503100-9	2.12-27.0- 6	1	P1
	2.12-30.0- 4	1	
	2.12-31.0- 8	1	
503200-7	2.12-52.0- 86	2	P1
5034	2.10- 3.0- 7	1	
5055	2.13-33.0- 32	1	
5063-1	2. 9- 2.0- 84	1	P1
5769	2.12- 1.0- 91	1	P1
51-33101	2.15-12.0- 4	1	P1
5100-75W	2.10- 7.0-178	1	
	2.10-39.0- 2	1	
51142-424	2.10- 5.0- 19	1	
51200-4	2. 9- 4.0- 52	RF	
51500-2-180	2.12-12.0- 3	1	
51500-2-150	2.12-40.0- 16	4	
51500-2-200	2.12-15.0- 9	1	
	2.12-16.0- 6	1	
	2.12-55.0- 15	1	
	2.12-61.0- 3	1	
51500-2-300	2.12-52.0- 70	4	P1
5152	2.13- 1.1- 11	1	P1
5201235	2.15-16.0- 50	2	
52LH2935-054	2.10-37.0- 13	4	
	2.10-38.0- 13	2	
	2.10-38.0- 7	2	
52N45-10M	2. 3-12.0- 7	2	
5200266	2.10-33.0- 5	1	
52130	2.18-36.0- 1	1	
52131-1	2.18 - 36.0 - 3	1	
52133	2.18 - 36.0 - 6	1	
522-1353-113	2.16- 2.0- 58	1	A
522-1394-339	2.18-19.0- 12	1	
52271-150	2.12-45.0- 10	4	
52300	2.18-11.0- 3	1	
52367	2.15- 1.0- 17	1	P1
52442-61	2. 8- 1.0- 30	1	P1
	2.11- 8.0- 5	1	
52450	2.18-17.0- 6	1	M
5250-01	2. 5- 2.0- 3	1	
526-1573-802	2. 5- 2.0- 24	1	
526-1573-003	2. 5- 2.0- 26	1	
526-1573-004	2.16- 1.0- 11	1	
	2.16- 1.0- 15	1	
526-1573-005	2. 5- 2.0- 22	1	
526-1573-007	2. 5- 2.0- 31	1	
52630	2.18-17.0- 6	1	
52675	2. 8-14.0- 11	1	P1
52676	2.15-20.0- 13	1	P1
	2.15-26.0- 23	1	

PART NUMBER	FIGURE AND INDEX NUMBER	QTY PER ART	SMR CODE
52800	2.18-11.0- 2	1	
53-310169-1	2.20-41.0- 17	1	
53-310172-1	2.20-41.0- 15	1	
53-310175-3	2.20-41.0- 14	1	
53-310176-1	2.20-41.0- 16	1	
5309-1	2.15- 8.0- 34	RF	
5309-1-1	2.15- 8.0- 34	1	P1
5339-040682	2.18-24.0- 1	1	P1
5339-040683	2.18-24.0- 2	1	P1
5339-040684	2.18-24.0- 3	1	P1
5339-040685	2.18-24.0- 12	1	P1
5339-040686	2.18-24.0- 15	1	P
5339-040692	2.18-19.0- 15	P2	
	2.18-24.0- 1	1	P2
5339-040780	2.18-24.0- 5	1	P
538010	2.15-25.0- 25	RF	P
538182	2.15-25.0- 55	RF	
53861	2.10- 6.0- 9	2	
538690	2.15- 1.0- 68	1	P1
538834	2.15-16.0- 64	RF	
538835	2.15-16.0- 63	RF	
538838	2.15-16.0- 68	RF	
538840	2.15-16.0- 62	RF	
53888-200	2.12-49.0- 16	4	
54077-175	2.13-25.0- 11	1	
5440-4-03B-R	2.10-26.0- 13	1	
5440-4-14T	2. 5- 6.0- 5	1	
54404-19T-R	2. 5- 6.0- 5	1	P1
54418-1	2.20- 1.0- 10	RF	
	2.20- 1.0- 13	RF	
5444622-511	2.12- 9.0- 44	1	P1
5503C40	2. 9- 1.0- 33	1	
56074130	2.17-41.0- 13	1	P
5610-108	2.12- 9.0- 33	1	P
56140-3	2.9-1-0-47	1	
56380-3	2.9-1-0-47	1	
56421	2.10-25.0- 43	1	
56422	2.10-25.0- 45	1	
56423	2.10-25.0- 38	1	
56424	2.10-25.0- 40	1	
56425	2.10-25.0- 9	1	
56426	2.10-29.0- 10	1	
56427	2.10-25.0- 11	1	
56428	2.10-25.0- 9	1	
56429	2.10-29.0- 16	RF	
56429-1	2.10-29.0- 18	1	
56429-2	2.10-29.0- 22	1	
56429-3	2.10-29.0- 17	1	
56429-4	2.10-29.0- 21	1	
56541	2.10-31.0- 22	1	
56553	2.10-32.0- 5	1	
578100-505	2.15-25.0- 82	1	P1
578118-3	2.20-49.0- 13	RF	
578152-1	2.15-25.0- 60	RF	P
578153-1	2.15-25.0- 59	RF	P
578154-1	2.15-25.0- 62	RF	P
578155-1	2.15-25.0- 61	RF	
578179-1	2.15-25.0- 71	RF	
578180-1	2.15-25.0- 80	RF	
578181-1	2.15-25.0- 81	RF	
578344-101	2.15- 1.0- 68	2	
578350-501	2.15-25.0- 56	1	P
578600-501	2.15-16.0- 82	1	P
578617-1	2.15-16.0- 47	PF	
578619-1	2.15-16.0- 48	RF	
578629-1	2.15-16.0- 57	RF	
578630-1	2.15-16.0- 46	RF	

PART NUMBER	FIGURE AND INDEX NUMBER	QTY PER ART	SMR CODE
578667-1	2.15-16.0- 75	RF	
578668	2.15-16.0- 36	RF	
578669	2.15-16.0- 39	RF	
578800-501	2.15-16.0- 69	1	
578804-101	2.15-16.0- 65	RF	
578850-101	2.15-16.0- 76	1	
58-42103-35	2.14-35.0- 5	1	
58A46236	2. 2- 5.0- 17	1	
	2. 2-10.0-119	1	
580514	2.15-16.0- 49	2	
58TC100-7	2.13- 1.1-104	RF	P1
58567	2. 8-10.0-158	1	P1
58567-1	2. 8-10.0-158	1	
	2.21- 2.0- 88	1	
59SAA251	2.21- 2.0- 25	1	
59SAB68-3S	2. 9-10.0- 34	RF	P1
59S350-1	2.13- 1.1- 79	1	
	2. 9-13.0- 19	1	
59990-612	2.21- 2.0- 74	1	
6-00509-15	2.12-10.0- 35	1	
6A40927-1	2. 6-32.0- 35	4	P1
6D112-1	2.12- 9.0- 44	1	P1
6CA5201	2.16-8.0-	1	
60B74057	2.16-8.0-47	1	
	2.16- 8.0- 47	1	
60B74063	2.16- 8.0- 47	1	
60B74064	2.10- 7.0- 72	1	
60B74066	2.15-25.0- 72	1	P1
60D90767	2. 5- 1.0- 26	1	P1
60M165305-1	2.14-41.0- 31	1	P1
60027-1	2.14-41.0- 31	1	P1
60027-2	2.15-22.0- 86	1	P1
60029-2	2.15-23.0- 51	1	P1
	2.20-33.0- 1	1	P1
60037-12	2.20-33.0- 53	1	P1
60038	2.20-23.0- 49	2	P
60043-15	2. 4- 3.5- 12	1	P1
6042H21	2. 8-13.0- 19	1	P1
60844	2.17-29.0- 29	1	
61B34087	2.17-31.0- 31	1	
	2.14- 9.0- 28	1	
61B34349	2.15-38.0- 25	1	M
61B34382	2.15-38.0- 11	1	M
61B34397	2.21- 5.0- 5	2	M
61D34450-1	2.13-16.0- 4	1	M
61D34805-1	2. 5- 9.0- 6	1	M
61D34809-3	2.13-16.0-	1	
61J34801	2.14-23.0- 78	2	
61181	2.12-67.0- 31	1	
6133-3	2.12-55.0- 10	1	P1
6133-7	2.12-55.0- 10	1	P1
	2.12-55.0- 10	1	P1
6133-5	2.12-67.0- 31	1	
	2.14-23.0- 78	RF	
61385	2. 9- 7.0- 51	1	M
616043-4-0147	2. 9- 7.0- 55	1	M
616043-6-0122	2.14- 4.0- 79	1	M
616043-6-0284	2.14- 4.0- 85	1	M
616044-4-0124	2.18-15.0- 4	1	M
616044-4-0540	2.11-11.0- 17	2	M
616044-6-0363	2.14- 4.0- 45	1	M
616044-6-0267	2.14- 4.0- 46	1	M
616044-6-0240	2.14- 4.0- 26	1	M
616046-4-0174	2.14- 4.0- 76	1	M
616046-4-0076	2. 9- 7.0- 15	1	M
616046-4-0132	2.14- 4.0- 69	1	M
616046-4-0274			

PART NUMBER	FIGURE AND INDEX NUMBER	QTY PER ART	SMR CODE	PART NUMBER	FIGURE AND INDEX NUMBER	QTY PER ART	SMR CODE
616046-6-0300	2.14- 4.0- 71	1	M	62J35439-19	2.16- 3.0- 32	1	
616046-4-0070	2. 9- 7.0- 14	1	M		2.16- 4.0-	RF	
616048-4-0082	2. 9- 7.0- 47	1	M	6203550	2.18-27.0- 6	1	
616048-4-0090	2. 9- 7.0- 16	1	M	6227	2.18-27.0- 3	1	P1
616048-4-0106	2. 9- 7.0- 14	1	M	6263-423100-2	2.16- 8.0- 35	1	
616048-4-0130	2.18-15.0- 5	1	M	63-00036-1	2. 8- 4.0- 3	RF	
616048-4-0140	2.14- 4.0- 44	1	M		2. 8- 5.0- 3	RF	
616048-4-0250	2.16-15.0- 4	1	M	63A25390	2.16-11.0- 13	1	
616048-6-0074	2.14- 4.0- 75	1	M	63A34496-11	2.12-44.0- 55	1	M
616048-6-0092	2.14- 4.0- 74	1	M	63A34496-15	2.12-45.0- 25	1	M
616048-600000	2. 9- 9.0- 8	1	M	63A34496-17	2.12-44.0- 58	1	M
616048-6000127	2.14- 4.0- 43	1	M	63A34496-7	2.12-44.0- 52	1	
62A350-1	2.13-16.0- 19	1		63A34496-9	2.12-44.0- 54	1	M
62A35021-1	2. 9- 9.0- 59		M	63B34005 .	2.20-49.0- 3	1	P1
62A35022-1	2. 9- 9.0- 57		M		2.21- 2.0- 2	1	
62A35023-1	2. 9- 5.0- 6		M	63C34487-1	2.15- 1.0- 66	RF	U
	2.13-15.0- 46	1		63C35503-1	2.17-15.0- 20	1	
62A35024-14	2.13-15.0- 61	1	M		2.17-40.0- 10	10	
62A35025-1	2.13-15.0- 48	1	M	63C35503-1.	2.16- 1.0-100	1	
62A35026-1	2.13-15.0- 62	1	M		2.16- 2.0- 67	1	
62A35027-1	2.13-15.0- 35	1			2.16- 2.0- 90	1	
62A35029-1	2. 9-11.0- 22	1		63C35078-1	2.13-32.0- 5	1	M
	2.13-15.0- 47	1		63C35079-1	2.13-32.0- 15	1	M
62A35031-1	2.13-16.0- 21	1		63C35675-2	2.13-32.0- 16	1	M
62A35032-1	2.13-16.0- 7	1		63C35680-1	2.13-32.0- 11	1	M
62A40953	2.20-49.0- 5	1	P1	63C35681-1	2.13-32.0- 17	1	M
	2.21- 2.0- 6	1		63C35682-1	2.13-32.0- 9	1	M
62B34031	2.15-38.0- 66	1	M	63C35685-1	2.13-32.0- 1	1	M
62B34032	2.15-38.0- 63	1		63C52550-1	2. 8- 8.0- 12	1	M
62C34498-1	2.18-34.0- 17	1			2.15- 1.0- 68	1	M
62C34499-1	2.18-34.0- 18	1		63D34179-30	2.12-34.0- 2	1	M
62C34502-3	2.16-20.0- 11	1		63D34179-7	2.16-34.0- 1	1	M
62C34504-7	2.16-20.0- 7	1		63D34489-1	2.15- 1.0- 62	1	M
62C34529-1	2.15-38.0- 57	1	P	63D35035-1	2.17-21.0- 27	1	
62C34529-2	2.15-38.0- 58	1	P	63D35035-3	2.17-23.0- 50	1	
62C34801	2. 7- 3.0- 53		M1	63D35514-3	2.16- 2.0- 27	1	
62C34824-7	2.18-34.0- 7	1		63D35550-1	2.17- 9.0- 5	1	M
62D34040	2.17-36.0-	REF		63D35551-1	2.17- 9.0- 4	1	M
62D34109-1	2.14- 5.0- 9	1		63E34480-1	2.15- 1.0- 61	1	P
62D34109-2	2.14- 5.0- 10	1		63E34488-13	2.15- 1.0- 63	1	
62D34935-1	2.16- 6.0- 13	1		63E34488-3	2.15- 1.0- 63	1	P
	2.16-14.0-	RF		63E35516-1	2. 4- 3.0- 3	RF	P
62D34835-3	2.16- 4.0- 13	1		63E35675-1	2.13-32.0- 18	1	X1
	2.16-14.0-	RF		63E35087-1	2.13-32.0-	RF	P1
62D34839-1	2.16-14.0- 2	1	M	63E35692-1	2.13- 9.0- 48	1	P1
62D35001-1	2. 5- 9.0- 16	1		63E35694-1	2.13- 9.0- 49	1	P1
				63E35696-1	2. 9-10.0- 46	RF	P1
62D35435-1	2.16- 8.0- 24	1	M		2.13- 9.0- 66	1	
62D35433-1	2.16- 3.0- 23	1		63E35700-1	2.13- 9.0- 42	1	P1
62D35461-3	2.17-23.0- 93	1		63J32425-5	2.15-25.0- 73	1	P1
62D35461-5	2.17-23.0- 73	1		63J32460-3	2.14-15.0- 77	1	P1
62D35463-1	2.16- 2.0- 56	1		6300-1	2. 8- 4.0- 1	1	P1
62D35464-1	2.16- 3.0- 23	1		634-1	2.13-17.0- 14	3	
62D35465-1	2.16- 2.0- 70	1			2.13-18.0- 15	1	
62D35471-1	2.16- 5.0- 25	1			2.13-18.0- 40	1	
62D35472-1	2.16- 5.0- 24	1			2.13-25.0- 5	1	
62D35497-1	2.16- 4.0- 38	1		634600-503	2.13-26.0- 5	1	
62E35018-7	2. 5-11.0- 28	RF		634609-101	2.15-16.0- 82	RF	P1
62E35433-5	2.16- 1.0- 98	1		6376	2.15-16.0- 46	RF	
62E35467-9	2.16- 5.0- 34	1		64-1099-3	2.13- 1.1-133	1	P1
62E5006-1	2.13-16.0- 25	1		64-564	2.12-52.0-127	1	P1
62J35007-1	2.13-15.0- 31	1			2.12-39.0- 42	4	P1
62J35007-3	2.13-15.0- 24	1			2.15-10.0- 4	1	
62J35007-5	2.13-15.0- 24	1		64A3155-671	2.17-17.0- 11	1	
					2.14-41.0- 7	1	

PART NUMBER	FIGURE AND INDEX NUMBER	QTY PER ART	SMR CODE
64A33155-603	2.14-15.0- 44	1	
64A33155-605	2.14-15.0- 38	1	
64A33155-607	2.14-15.0- 64	1	
64A33155-611	2.14-43.0- 7	RF	
64A33155-613	2.14-15.0- 55	1	
64A33155-617	2.14-15.0- 28	1	
64A33155-621	2.14-15.0- 5	1	
64A33155-623	2.14-15.0- 9	1	
64A33155-625	2.14-23.0- 12	1	
64A33155-627	2.14-25.0- 2	1	
64A33155-629	2.14-30.0- 10	1	
64A33155-807	2.14-15.0- 28	1	
64A33155-809	2.14-15.0- 19	2	
64A33155-827	2.14-41.0- 7	1	
64A33155-835	2.14-15.0- 44	1	
64A33155-837	2.14-15.0- 38	1	
64A33155-841	2.14-15.0- 64	1	
64A33155-845	2.14-43.0- 7	1	
64A33155-847	2.14-15.0- 55	1	
64A33155-857	2.14-15.0- 99	2	
64A33155-861	2.14-15.0- 5	1	
64A33155-863	2.14-15.0- 4	1	
64A33155-867	2.14-15.0- 99	2	
64A33155-871	2.14-15.0- 5	1	
64A33155-873	2.14-15.0- 4	1	
64A33155-873	2.14-25.0- 2	1	
64A33155-879	2.14-30.0- 10	1	
64A33155-881	2.14-23.0- 1	1	
64A33155-887	2.14-15.0- 19	2	
64A33155-891	2.14-15.0- 86	1	P
64A33161-3	2.14-15.0- 55	1	
64A33161-5	2.14-10.0-55	1	
64A33162-3	2.14-15.0-108	2	
64A33162-5	2.14-15.0-108	2	
64A33162-801	2.14-15.0-108	2	
64A33162-803	2.14-15.0-108	2	
64A33336-1	2. 9- 2.0- 64	1	M
64A34200-1	2. 9- 9.0- 62	1	M
64A34201-1	2. 9- 3.0- 63	1	M
64A34205-1	2. 9-20.0- 27	1	M
64A34206-1	2. 9-20.0- 25	1	M
64A34207-1	2. 9-17.0- 9	1	M
64A34208-1	2. 9-17.0- 7	1	M
64A34209-1	2. 8- 9.0- 23	1	M
64A34210-1	2. 8- 5.0- 4	1	M
64A34211-1	2. 9-14.0- 29	1	M
64A34212-1	2. 9-10.0- 30	1	M
64A34214-1	2. 9- 7.0- 64	1	M
64A34215-1	2. 9-10.0- 16	1	M
64A34216-1	2. 9-11.0- 14	1	M
64A34217-1	2. 9-11.0- 28	1	M
64A34218-1	2.11-12.0- 13	1	M
64A34219-1	2.11-12.0- 17	1	M
64A34220-1	2.13-10.0- 54	1	M
64A34221-1	2.13-10.0- 57	1	M
64A34222-1	2.13-10.0- 59	1	M
64A34225-1	2. 9-11.0- 20	1	M
64A34228-1	2. 9-11.0- 17	1	M
64A34227-1	2. 9-11.0- 49	1	M
64A34220-1	2. 9-11.0- 51	1	M
64A34229-1	2. 9-10.0- 44	1	M
64A34230-1	2. 9-10.0- 45	1	M
64A34231-1	2. 9-10.0- 41	1	M
64A34232-1	2. 9-10.0- 33	1	M
64A34233-1	2. 9-10.0- 35	1	M

PART NUMBER	FIGURE AND INDEX NUMBER	QTY PER ART	SMR CODE
64A34234-1	2. 9-10.0- 35	1	M
64A34235-1	2.12-44.0- 71	1	M
64A34507-1	2. 8-22.0- 40	1	
64A34508-1	2. 8-22.0- 35	1	M
64A34509-1	2. 8-22.0- 57	1	
64A34510-1	2. 8-22.0- 51	1	
64A34511-1	2. 8-22.0- 59	1	
64A34512-1	2. 8-22.0- 54	1	
64A34513-1	2. 9-16.0- 14	1	
64A34514-1	2. 8-11.0- 2	1	
64A34515-1	2. 8-11.0- 45	1	
64A34516-1	2. 8-11.0- 4	1	
64A34517-1	2. 8-11.0- 47	1	
64A34518-1	2. 8-11.0- 11	1	
64A34519-1	2. 9-17.0- 34	1	
64A34522-1	2. 8-22.0- 50	1	
64A34523-1	2. 8-22.0- 56	1	
64A34524-1	2. 8-22.0- 53	1	
64A34525-1	2. 8-22.0- 58	1	
64A34527-1	2. 9-16.0- 14	1	
64A34528-1	2. 8-22.0- 34	1	
64A34529-1	2. 8-22.0- 39	1	
64B34479-1	2.16-25.0- 18	4	
64C33005-7	2.17- 5.0- 1	3	
	2.17- 6.0- 1	2	
64C33006-7	2.17- 5.0- 2	1	
64C33006-8	2.17- 6.0- 2	1	
64C33018-7	2. 4- 7.0- 60	1	M
64C33019-7	2. 4- 7.0- 62	1	M
64C33020-1	2. 4- 7.0- 53	RF	P1
64C33021-7	2. 4- 7.0- 63	1	M
64C33022-7	2. 4- 7.0- 64	1	M
64C33024-7	2. 2-10.0-114	1	M
64C33005-1	2.19- 2.0- 13	1	
	2.19- 3.0- 25	1	
	2.19- 4.0- 24	1	
	2.19- 5.0- 25	1	
64C34006-1	2.13- 9.0- 17	1	M
64C34008-1	2. 2- 7.0- 24	1	M
64C34205-1	2.13- 9.0- 33	1	M
64C34461-1	2.16-25.0- 26	2	
64C34463-1	2.16-25.0- 30	2	
64C34482-1	2.17-29.0- 41	1	
	2.17-31.0- 42	1	
64C34482-3	2.17-29.0- 56	1	
	2.17-31.0- 61	1	
64D33113-11	2.20-49.0- 10	1	P1
64D33113-7	2.20-49.0- 8	1	P1
	2.21- 2.0- 47	2	
64D33113-0	2.20-45.0- 12	1	P1
64D33120-11	2. 2-14.0- 25	1	M
64D33120-7	2. 2-14.0- 24	1	M
64D33372-1	2.18-34.0- 13	1	
64D33373-51	2.18-34.0- 13	RF	
64D34071-1	2.13- 1.1-100	1	P1
64D34109-1	2.13- 5.0- 9	1	P1
64D34109-3	2.13- 5.0- 9	1	
64D34273-1	2.13- 8.0- 34	1	
64D34275-1	2.13- 8.0- 40	1	P1
64D34279-1	2.13- 8.0- 31	1	P1
64D34280-1	2.13- 8.0- 61	1	P1
64D34281-1	2.13- 8.0- 60	1	P1
	2.13- 8.0- 62	1	P1
64D34285-1	2.13- 8.0- 21	1	P1
64D34285-1	2.13- 6.0- 2	1	P1

PART NUMBER	FIGURE AND INDEX NUMBER	QTY PER ART	SMR CODE
64034403-1	2.15- 1.0- 5	1	
	2.15- 1.0- 75	1	
64034407-1	2.17- 9.0- 15	1	
	2.17- 9.0- 6	1	
64034408-1	2.16-19.0- 9	1	
64034478-1	2.16-25.0- 15	1	
64034491-1	2.15- 1.0- 8	1	
64034492-1	2.15- 1.0- 8	1	
64034493-1	2. 5-13.0- 1	1	
64034493-1-1	2. 5-13.0- 1	1	
64034495-1	2. 5-13.0- 1	1	
64034495-3	2. 5-13.0- 1	1	
64034054-1	2. 9-10.0- 47	RF	P1
	2.13- 9.0- 30	1	
64034063-1	2.13- 9.0- 79	1	P1
64034064-1	2.13- 9.0- 60	1	P1
64034184-1	2. 2- 7.0- 11	1	M
64034185-1	2. 9-10.0- 22	RF	M
64034185-3	2. 2- 7.0- 25	1	M
64034186-3	2. 2- 7.0- 26	1	P1
64034186-5	2. 2- 7.0- 26	1	P1
64034187-1	2. 2- 7.0- 27	1	M
64034213-1	2. 9-10.0- 26	1	
64034224-1	2. 9-10.0- 25	1	
64034297-1	2.13- 5.0- 29	1	P1
	2.13- 6.0- 26	1	
64034321-1	2.15- 1.0- 74	1	
64034322-3	2.15- 1.0- 4	1	
64034322-5	2.15- 1.0- 4	1	
64034404-1	2.16-25.0-	1	
64034481-35	2. 2- 7.0- 53	1	
64034481-37	2. 2- 7.0- 54	1	
64034490-1	2.16-24.0-	1	
64F33114-11	2.14-19.0- 64	1	
	2.14-41.0- 13	2	
	2.14-43.0- 13	2	
64F33114-13	2.14-15.0- 13	1	
	2.14-15.0- 24	1	
	2.14-15.0- 50	1	
	2.14-15.0- 61	1	
	2.14-15.0- 95	1	
	2.14-15.0-105	1	
	2.14-23.0- 9	1	
64F33114-15	2.14-25.0- 8	2	
	2.14-30.0- 19	2	
64F33114-17	2.14-15.0- 34	1	
	2.14-15.0- 71	2	
64F33114-19	2.14-15.0- 14	1	
	2.14-23.0- 20	1	
64F33114-21	2.14-15.0- 41	1	
64F33114-23	2.14-15.0- 36	1	
64F33114-7	2.14-15.0-115	1	
64F33114-9	2.14-15.0-110	1	
64F34185-1	2. 2- 7.0- 17	1	
64F34186-1	2. 2- 7.0- 26	1	
64H33373	2.18-34.1-	PF	
64H33373-1	2.18-34.0-	RF	
64H33373-3	2.18-34.0- 11	RF	
64H33377-1	2.18-34.0- 9	RF	
64H33377-3	2.16- 8.0- 26	1	
	2.16-20.0-	RF	
64J34050	2.13-11.0- 19	1	P1
64J34050-49	2.13- 1.1- 78	1	P1
64J34050-5	2.13- 1.1-108	1	P1

PART NUMBER	FIGURE AND INDEX NUMBER	QTY PER ART	SMR CODE
64J34050-5	2.13-15.0- 60	RF	
64J34065-1	2.13-15.0- 25	1	P1
64J34065-15	2.13-15.0- 28	1	
64J35439-17	2.16- 4.0- 45	1	
64J35439-17	2.16- 4.0- 37	RF	
64110	2. 4- 8.0- 24	2	
643019	2.15- 9.0- 34	3	P1
	2.15-11.0- 35	3	
	2.16-25.0- 5	1	
6434400-1	2.15-17.0- 27	RF	
644504	2.16- 8.0- 42	2	P1
6451	2.16- 8.0- 41	1	P1
6455	2. 9-14.0- 52	1	M
65A33101-1	2. 9-14.0- 5	1	
65A33102-1	2.12-37.0- 10	1	
65A33103-1	2.12-37.0- 7	1	M
65A33104-1	2.12-37.0- 13	1	M
65A33105-1	2.12-37.0- 9	1	M
65A33106-1	2. 8-22.0- 10	1	
65A33170-1	2.12-43.0- 6	1	M
65A33180-1	2.12-43.0- 4	1	M
65A33182-1 C	2.12-43.0- 7	1	M
65A33194-1	2. 9-23.0- 15	1	
65A33198-1	2. 8-11.0- 2	1	M
65A33291-1	2.19- 3.0- 8	1	
65A35025-1	2.19- 4.0- 8	1	
	2.19- 5.0- 8	1	
65A33095-2	2.19- 3.0- 7	1	
	2.19- 4.0- 7	1	
	2.19- 5.0- 7	1	
65A33006-1	2.19- 3.0- 20	1	
	2.19- 4.0- 21	1	
	2.19- 5.0- 23	1	
65A33096-2	2.19- 3.0- 17	1	
	2.19- 4.0- 16	1	
	2.19- 5.0- 17	2	
65A33007-1	2.19- 3.0- 28	1	
	2.19- 4.0- 29	1	
	2.19- 5.0- 28	1	
65A33007-2	2.19- 3.0- 22	1	
	2.19- 4.0- 23	1	
	2.19- 5.0- 22	1	
65A34165-1	2.10- 7.0-149	1	
65A34166-1	2.10- 7.0-155	1	
65A35028-1	2.12-15.0- 30	1	M
	2.12-16.0- 30	1	
65A35099-1	2.12-15.0- 29	1	M
	2.12-16.0- 28	1	
65A35001-1	2.12-11.0- 24	1	M
65A35002-1	2.12-10.0- 26	1	M
65A35013-1	2.12-10.0- 31	1	M
65A35014-1	2.12-10.0- 53	1	M
65A35015-1	2.12-10.0- 61	1	M
65A35016-1	2.12-10.0- 70	1	M
65A35017-1	2.12-10.0- 73	1	M
65A35018-1	2.12-37.0- 44	1	M
65A35020-1	2.12-37.0- 56	1	M
65A35021-1	2.12-15.0- 80	1	M
65A35025-1	2.12-16.0- 62	1	M
65A35026-1	2.12-15.0- 96	1	M
	2.12-16.0- 78	1	
65A35030-1	2.12-15.0- 58	1	M
	2.12-16.0- 40	1	
65B34008-7	2.10- 7.0-158	1	

PART NUMBER	FIGURE AND INDEX NUMBER	QTY PER ART	SMR CODE
65B35907-1	2.12-10.0- 10	1	
65C33374-7	2.10-19.0- 9	1	
65C33176-1	2.12-49.0- 52	1	M
65C33178-1	2.12-49.0- 48	1	M
65C33295-1	2.15- 1.0- 68	2	P1
65C33300-2	2.12- 9.0- 63		P1
65C33301-3	2.12- 9.0- 62	1	P1
65C33301-5	2.12- 9.0- 64	1	P1
65C33334-1	2.12- 9.0- 48	4	P1
65C33336-3	2.12-10.0-102	4	M
65C33712	2.18- 3.0- 4	1	M
	2.18- 3.0- 5	1	
65C33810-7	2. 2- 7.0- 11	1	
65C34482-1	2. 4- 8.0- 23	1	
65C34432-3	2. 4- 8.0- 22	1	
65C34404-1	2. 4- 8.0- 21	2	
65C34875-1	2.12-10.0- 14	1	P1
65C35869-1	2.12-15.0- 56	1	P1
	2.12-15.0- 66	1	
	2.12-16.0- 37	1	
	2.12-16.0- 48	1	
65C35873-1	2.12-15.0- 95	1	M
	2.12-16.0- 77	1	
65C35875-1	2.12-11.0- 1	1	
65C35876-1	2.12-11.0- 9	1	P1
65C35876-2	2.12-11.0- 9	1	P1
65C35877-1	2.12-11.0- 13	1	P1
65C35884-1	2.12-10.0- 57	1	
65C35884-3	2.12-10.0- 46	1	P1
65C35888-1	2.12-10.0- 64	1	M
65C35888-3	2.12-10.0- 66	1	M
65C35909-1	2.12-10.0- 14	1	M
65C35933-1	2.12-10.0- 7	1	P1
65C35947-1	2.13-16.0- 18	1	
65D33184-1	2.12-49.0- 43	1	M
65D33325-1	2.12-10.0- 15	2	P1
65D33332-1	2.12- 9.0- 31	1	P1
65D33333-1	2.12- 9.0- 29	2	P1
65D35855-1	2.12- 9.0- 52	1	
65D35856-1	2.12- 9.0- 64	1	
65D35892-1	2.12-10.0- 96	1	P1
65D35803-1	2.12-13.0- 56	1	P1
65D35896-1	2.12-10.0- 45	1	P1
65D35912-1	2.12-10.0- 51	1	P1
65E35937-1	2.13-16.0- 9	1	
65E33174-1	2.12-49.0- 33	1	
65E3329-2	2.12- 9.0- 13	1	
65E33312-1	2.12-10.0- 1	2	P1
65E33312-3	2.12-10.0- 6	1	M
65E33312-5	2.12-10.0- 3	1	M
65E33313-1	2.12- 9.0- 37	1	P1
65E33321-3	2. 6-32.0- 40	1	M1
65E33321-4	2. 6-32.0- 40	1	M1
65E33322-1	2. 6-32.0- 39	1	P2
65E33322-2	2. 6-32.0- 39	1	P2
65E33329-1	2.12- 9.0- 13	1	M1
65E33329-3	2.12- 9.0- 23	1	M
65E33329-4	2.12- 9.0- 24	1	M
65E33341-1	2.12- 9.0- 69	2	P1
65E33341-2	2.12- 9.0- 70	2	P1
65E33341-3	2.12- 9.0- 69	2	P1
65E33341-4	2.12- 9.0- 70	2	P1
65E33341-9	2.12- 9.0- 71	1	P1
	2.12- 9.0- 72	1	
65E35870-1	2.12-15.0- 55	1	P1

PART NUMBER	FIGURE AND INDEX NUMBER	QTY PER ART	SMR CODE
65E35870-1	2.12-16.0- 36	1	P1
65E35870-2	2.12-15.0- 55	1	P1
	2.12-16.0- 36	1	
65E35889-1	2.12-10.0- 89	1	P1
65E35911-1	2.12-19.0- 85	1	M
65F33930-11	2.15-12.0- 8	1	
65J3320-1	2. 1- 1.0- 46	1	
65J33220-43	2.12- 9.0- 16	1	
65J33220-44	2.12- 9.0- 17	1	
65J33220-45	2.12- 9.0- 18	1	
65J33220-46	2.12- 9.0- 19	1	
65J33220-67	2.12- 9.0- 20	2	
65J33220-69	2.12- 9.0- 21	1	
65J33220-70	2.12- 9.0- 22	1	
65J33310-1	2. 1- 1.0- 46	2	P1
	2.12-10.0- 101	RF	
65J33310-3	2.12-10.0-101	1	M
65J33320-1	2.12- 9.0- 80	1	U
65J33320-11	2.12- 9.0- 80	1	M
65J33320-25	2.12- 9.0- 47	2	M
65J33320-29	2.12- 9.0- 79	1	M
65J33320-3	2. 1- 1.0- 46	1	U
	2.12- 9.0- 81	1	
65J33320-30	2.12- 9.0- 81	1	M
65J33320-41	2.12- 9.0- 73	2	M
65J33320-5	2. 1- 1.0- 46	1	U
	2.12- 9.0- 1	1	
65J33320-68	2.12- 9.0- 1	1	
65J33320-7	2. 1- 1.0- 46	1	U
	2.12- 9.0- 6	1	
65J33342-1	2. 2-21.0- 6	1	P1
65J33342-2	2. 2-21.0- 6	1	P1
65J33342-3	2. 2-21.0- 6	1	P2
65J33342-4	2. 2-21.0- 5	1	P2
65J33342-5	2. 2-21.0- 6	1	P1
	2. 2-21.0- 5	1	
	2. 2-21.0- 6	1	
65J33342-6	2. 2-21.0- 6	1	P1
	2. 2-21.0- 5	1	
	2. 2-21.0- 6	1	
65J35879-1	2.12-11.0- 3	RF	
65J35879-2	2.12-11.0- 3		
65J35891-1	2.12-10.0- 18	1	P1
6510-100	2.12- 9.0- 33	1	P1
6510-200	2.12- 9.0- 34	1	
651009-1	2.13- 5.0- 12	RF	
	2.13- 6.0- 1	RF	
	2.18-17.0- 42	RF	
651149	2.18-16.0- 18		P1
6539772-2	2.20-50.0- 5	2	
6551	2.17- 8.0- 6	1	P1
66-C40438-1	2.14-30.0- 33	2	
66A34165-1	2.10-7.0-150	1	M
66A34166-1	2.10-7.0-115	1	M
66A38139	2. 8-11.0- 83	1	
66A38120	2. 8-11.0- 57	1	
66A38282	2. 8-11.0- 81	1	
66A38333-1	2. 8-26.0- 14	1	M
66A38334-1	2. 9-26.0- 6	1	M
66A38335-1	2. 8-26.0- 15	1	M
66A38336-1	2. 8-26.0- 12	1	M
66A38345-1	2. 9-32.0- 6	1	M
66A3-347	2. 8-11.0- 82	1	
66A38345-1	2.19- 3.0- 57	1	
	2.19- 4.0- 52	1	
	2.19- 5.0- 57	1	
66A38396-1	2.19- 3.0- 47	1	
	2.19- 4.0- 49	1	

PART NUMBER	FIGURE AND INDEX NUMBER	QTY PER ART	SMR CODE
66A38396-1	2.19- 4.0- 54	1	
66A38397-1	2.19- 3.0- 48	1	
	2.19- 4.0- 48	1	
	2.19- 5.0- 53	1	
66A38398-1	2.19- 3.0- 49	1	
	2.19- 4.0- 51	1	
	2.19- 5.0- 56	1	
66A38399-1	2.19- 3.0- 48	1	
	2.19- 4.0- 50	1	
	2.19- 5.0- 55	1	
66A39617-1	2. 8- 9.0- 13	1	
66A39618-1	2. 8- 9.0- 33	1	
66A39619-1	2. 8- 9.0- 31	1	
66A39620-1	2. 8- 9.0- 11	1	
66A39621-1	2. 8-29.0- 32	1	
66A39622-1	2. 8-29.0- 2	1	M
66A39623-1	2. 8-29.0- 31	1	M
66A39626-1	2. 8-29.0- 5	1	M
66A39627-1	2. 9-24.0- 22	1	
66A39628-1	2. 9-14.0- 33	1	
66A39629-1	2. 9-14.0- 35	1	
66A39630-1	2. 9-24.0- 13	1	
66A39631-1	2. 9-20.0- 41	1	
66A39633-1	2. 9-19.0- 5	1	
66A39634-1	2. 9-19.0- 18	1	
66A39635-1	2. 9-19.0- 3	1	
66A39636-1	2. 9-20.0- 45	1	
66A39637-1	2. 9-20.0- 39	1	
66A39638-1	2. 9-18.0- 168	1	
66A39639-1	2. 9-26.0- 15	1	
66A39640-1	2. 9-26.0- 6	1	
66A39641-1	2. 9-20.0- 63	1	
66A39642-1	2. 9-20.0- 54	1	
66A39643-1	2. 9-23.0- 3	1	
66A39644-1	2. 8-17.0- 17	1	
66A39645-1	2. 8-17.0- 14	1	
66A39646-1	2. 9-20.0- 33	1	
66A39647-1	2. 9-24.0- 26	1	
66A39648-1	2. 9-24.0- 19	1	
66A39649-1	2. 9-24.0- 24	1	
66A39650-1	2. 9-24.0- 17	1	
66A39655-1	2. 8-29.0- 7	1	M
66A39656-1	2. 8-29.0- 29	1	M
66A39657-1	2. 8-29.0- 23	1	M
66A39658-1	2. 8-29.0- 27	1	M
66A39659-1	2. 9-24.0- 20	1	
66A39660-1	2. 9-24.0- 15	1	
66A39661-1	2. 8-17.0- 19	1	
66A39662-1	2. 8-29.0- 34	1	
66A39663-1	2. 8-29.0- 36	1	M
66A40034-1	2.12-15.0-159	1	M
	2.12-16.0-147	1	
66A40306-1	2.12-15.0-167	1	
	2.12-15.0-167	1	
66A40307-1	2.12-15.0- 99	1	M
	2.12-16.0- 81	1	
66A40308-1	2.12-15.0-139	1	M
	2.12-16.0-126	1	
66A40309-1	2.12-15.0-142	1	M
	2.12-16.0-131	1	
66A40310-1	2.12-17.0- 71	1	M
66A40311	2.12-16.0-133	1	M
66A40311-1	2.12-15.0-144	1	M
66A40312-1	2.12-15.0-147	1	M
	2.12-16.0-136	1	M

PART NUMBER	FIGURE AND INDEX NUMBER	QTY PER ART	SMR CODE
66A40313-1	2.12-15.0-148	1	M
	2.12-16.0-137	1	M
66A40314-1	2.12-37.0- 78	1	M
66A40316-1	2.12-15.0-151	1	M
	2.12-16.0-139	1	M
66A40317-1	2.12-15.0-150	1	M
	2.12-16.0-139	1	M
66A40318-1	2.12-15.0-152	1	M
	2.12-16.0-141	1	M
	2.12-15.0-173	1	M
66A40319-1	2.12-37.0-192	1	M
66A40325-1	2.12-67.0- 9	1	M
66A40326-1	2.12-45.0-109	1	M
66A40328-1	2.12-67.0- 2	1	M
66A40329-1	2.12-67.0- 14	1	M
66A40330-1	2.12-67.0- 4	1	M
66A40331-1	2.12-67.0- 5	1	M
66A40332-1	2.12-67.0- 8	1	M
66A40333-1	2.12-67.0- 12	1	M
66A40334-1	2.12-67.0- 11	1	M
66A40335-1	2.12-37.0-186	1	M
66A40338-1	2.12-15.0-152	1	M
	2.12-16.0-141	1	M
66A40476-1	2.13-11.0- 13	1	M
66A40477-1	2.13-11.0- 14	1	M
66A40487-1	2.12-15.0- 99	1	M
	2.12-16.0- 81	1	M
	2.12-37.0-198	1	M
66A40500-1	2.12-67.0- 52	1	M
66A40502-1	2.12-67.0- 51	1	M
66A40503-1	2.12-67.0- 49	1	M
66A40504-1	2.12-44.0-127	1	M
66A40505-1	2.12-44.0-128	1	M
66A40506-1	2.12-44.0-129	1	M
66A40515-1	2.12-45.0-194	1	M
66A40516-1	2.12-44.0-131	1	M
66A40517-1	2.12-44.0-132	1	M
66A40519-1	2.12-44.0- 83	1	M
66A40520-1	2.12-44.0- 63	1	M
66A40521-1	2.12-44.0- 65	1	M
66A40522-1	2.12-44.0-137	1	M
66A40523-1	2.12-44.0-138	1	M
66A40524-1	2.12-44.0-139	1	M
66A40530-1	2.12-67.0- 57	1	M
66A40531-1	2.12-67.0- 56	1	M
66A40532-1	2.12-67.0- 43	1	M
66A40533-1	2.12-67.0- 44	1	M
66A40534-1	2.12-67.0- 45	1	M
66A40535-1	2.12-67.0- 21	1	M
66A40536-1	2.12-67.0- 39	1	M
66A40537-1	2.12-67.0- 41	1	M
66A40538-1	2.12-67.0- 42	1	M
66A40539-1	2.12-67.0- 22	1	M
66A40543-1	2.12-45.0-112	1	M
66A40544-1	2.12-44.0-140	1	M
66A40545-1	2.12-44.0-141	1	M
66A40546-1	2.12-44.0-142	1	M
66A40531-1	2.12-15.0- 98	1	M
	2.12-16.0- 81	1	M
66A40632-1	2.12-15.0- 81	1	M
	2.12-16.0- 62	1	M
66A40633-1	2.12-11.0- 24	1	M
66A40639-1	2.10-20.0- 29	1	M
66A40640-1	2.10-20.0- 31	1	M
66A40641-1	2.10-20.0- 33	1	M

PART NUMBER	FIGURE AND INDEX NUMBER	QTY PER ART	SMR CODE
66A40642-1	2.10-20.0- 35	1	M
66A40644-1	2.12-11.0- 32	1	M
66A40650-1	2.12-15.0- 70	1	M
	2.12-16.0- 52	1	M
66A40650-1	2.12-18.0- 28	1	M
	2.12-18.0- 33	1	M
66A40628-1	2.12-18.0- 71	1	M
66A40909-1	2.12-18.0- 72	1	M
66B40376-1	2.16-18.0- 25	1	
66B40293-1	2.14-34.0- 26	4	
66B40332-1	2. 8-28.0- 38	1	P1
66B40334-1	2.12-18.0-104	1	
	2.12-18.0- 66	1	
	2.12-43.0-186	1	
66B40363-1	2. 8-29.0- 28	1	M
66B40363-2	2. 8-29.0- 22	1	M
66B40363-1	2.12-44.0-136	1	M
66B40510-1	2.12-68.0- 63	1	
66B40510-3	2.12-68.0- 63	1	
66B40629-1	2. 8-28.0- 11	1	
66B40636-1	2.12-18.0- 11	1	
66C38347	2.10-19.0- 16	1	
66C38125-7	2.18- 6.0- 37	1	P1
66C33351-7	2.16- 1.0- 30	1	M
	2.16- 2.0- 18	1	
66C38712-7	2. 2- 3.0- 20	1	M
66C38716-7	2. 2-12.0-122	1	M
66C39813-1	2.12-68.0- 83	1	
66C40020-1	2.12-68.0- 75	1	
66C40020-2	2.12-68.0- 58	1	
66C40020-3	2.12-68.0- 62	1	
66C40233-1	2.13-27.0- 41	1	
66C40436-3	2.14-39.0- 36	1	
66C40436-1	2.14-39.0- 22	2	
66C40439-2	2.14-39.0- 24	1	
66C40446-1	2.13-27.0- 17	1	M
66C40449-1	2.13-27.0- 40	4	
66C40459-2	2.12-68.0- 67	1	M
66C40665-1	2.12-68.0- 37	2	
66C40406-1	2.12-68.0- 58	1	
66C40408-3	2.12-68.0- 61	1	M
66C40474-1	2.13-11.0- 7	1	
66C40475-1	2.13-11.0- 9	1	
66C40500-1	2.17-35.0- 47	1	
66C40508-1	2.17-35.0- 49	1	
66C40569-1	2.17-46.0- 12	1	
66C40650-1	2. 8-29.0- 19	1	M
66C40651-1	2. 8-29.0- 11	1	M
66C40667-1	2. 9- 3.0- 23	1	
66C40675-1	2.12-68.0- 26	1	
66C40675-2	2.12-68.0- 25	1	
66C40691-1	2.14-11.0- 23	1	M
66C40923-1	2.12-18.0- 38	1	M
66C40923-3	2.12-18.0- 41	1	M
66C38121-11	2. 5-11.0- 56	1	M
66C38121-13	2. 8-11.0- 60	1	M
66C38121-15	2. 8-11.0- 76	1	M
66C38121-17	2. 8-11.0- 79	1	M
66C38719-1	2. 2- 5.0- 16	1	M
66C38719-11	2. 2- 5.0- 18	2	
	2. 2-10.0-119	2	
66C38719-3	2. 2-10.0-119	1	M
66C38719-7	2. 2- 5.0- 18	1	M
	2. 2-10.0-119	1	
66C38719-7	2. 7-11.0- 19	1	P1

PART NUMBER	FIGURE AND INDEX NUMBER	QTY PER ART	SMR CODE
66D38773-9	2. 7-10.0- 19	1	P1
66D39700-1	2. 8-29.0- 23	2	M1
66D39700-2	2. 8-29.0- 17	1	M1
66D39700-3	2. 8-29.0- 9	1	M1
66D39700-4	2. 8-28.0- 31	1	M1
66D39710-1	2.13- 1.1-160	1	
66D39710-2	2.13- 1.1-160	1	
66D39712-1	2.12-68.0- 81	2	U
66D39712-2	2.12-68.0- 85	1	
66D39762-1	2.12-18.0- 71	1	M
	2.12-18.0- 53	1	
66D39762-2	2.12-18.0- 71	1	
	2.12-18.0- 53	1	
	2.12-67.0- 73	1	
66D40221-1	2. 5- 9.0- 27	1	
66D40227-0	2.12-44.0- 40	1	
66D40255-1	2.12-44.0- 40	1	
66D40255-2	2.12-44.0- 49	1	
66D40262-1	2.12-68.0- 46	1	
66D40262-7	2.12-68.0- 46	1	
66D40274-1	2.17-11.0-109	1	
66D40274-3	2.17-11.0-109	1	
66D40322-1	2.12-57.0- 10	1	M
66D40323-1	2.12-57.0- 11	1	M
66D40336-0	2.12-67.0- 15	1	
66D40336-1	2.12-44.0-153	1	
66D40336-1	2.12-44.0-154	1	
66D40341-1	2.12-67.0- 36	1	M
66D40342-1	2.12-67.0- 35	1	M
66D40343-1	2.12-44.0- 64	1	M
	2.12-44.0- 64	1	RF
	2.12-67.0- 26	1	RF
66D40417-1	2.16-15.0- 7	1	
66D40417-3	2.16-15.0- 11	1	
66D40419-1	2. 5- 2.0- 20	1	
66D40411-1	2.12-68.0- 39	1	M
66D40411-2	2.12-68.0- 39	1	A
66D40413-1	2.16-15.0- 6	1	A
66D40414-4	2.16-15.0- 7	1	
66D40429-1	2.12-68.0- 18	1	M
66D40429-2	2.12-68.0- 23	1	
66D40430-1	2. 5- 9.0- 26	1	
	2. 5- 9.0- 28	1	
66D40459-1	2.12-68.0- 64	1	M1
66D40468-1	2.12-68.0- 67	1	M1
66D40470-2	2.12-68.0- 70	1	
66D40513-1	2.13-27.0- 1	1	
66D40520-1	2. 8-29.0- 21	1	
66D40510-1	2.12-68.0- 76	1	
66D40513-1	2. 8-29.0- 16	1	
66D40513-2	2. 8-29.0- 13	1	
66D40674-5	2.12-68.0- 12	1	
66D40674-6	2.12-68.0- 12	1	
66D40720-1	2.18-18.0-	1	
66D40768-1	2. 2- 1.0- 1	1	
66D40768-1	2. 2- 1.0- 3	1	
66D40768-1	2.18-11.0- 14	1	X2
66D40768-1	2.18-11.0- 10	1	X2
66D40768-1	2.18-11.0- 21	1	M
66D40768-1	2.18-11.0- 27	1	X2
66D40768-1	2.18-11.0- 9	1	M
66D40768-1	2. 5- 2.0- 8	1	M
66D40768-1	2. 5- 2.0- 9	1	M1
66D40768-1	2.16-15.0-	1	RF
66D40768-1	2.16-15.0-	1	RF

PART NUMBER	FIGURE AND INDEX NUMBER	QTY PER ART	SMR CODE
66E39811-1	2.13- 1.1-173	1	
66E39811-2	2.13- 1.1-173	1	
66E39841-1	2.13- 1.1-165	1	M1
66E40029-1	2. 2- 7.0- 93	1	P2
66E40030-1	2. 2- 7.0- 94	1	P2
66E40085-1	2.13- 8.0- 82	1	
66E40240-1	2.12-68.0- 40	1	M
66E40248-2	2.12-68.0- 41	1	M
66E40253	2.12-68.0- 92	1	U
66E40275-1	2.17-39.0-	RF	
66E40276-1	2.17-40.0-		
66E40408-12	2.16- 2.0- 81	1	
66E40424-1	2.12-68.0- 3	1	
66E40424-2	2.12-68.0- 3		
66E40425-1	2.12-68.0- 52	1	U
66E40437-1	2. 3-11.0- 29	1	
	2.11- 1.0- 17	RF	
66E40453-1	2.13-27.0- 51	1	
66E40455-5	2. 5- 2.0- 1	1	
66E40455-6	2. 5- 2.0- 2	1	P
66E40455-7	2. 5- 2.0- 4	2	M
66E40455-8	2. 5- 2.0- 6	1	M
66E40456-1	2.12-37.0- 72	1	U
66E40496-2	2.12-37.0-192	1	
66E40603-1	2.13-27.0- 4	1	
66E40607-1	2. 8-28.0- 1	1	
66E40626-3	2. 8-28.0- 17	1	
66E40627-1	2. 8-28.0- 9	1	
66E40628-1	2. 8-28.0- 10	1	
66E40643-1	2. 8-28.0- 15	1	
66E40803-1	2.12-16.0- 92	RF	P1
	2.12-16.0- 74	RF	
66E40834-1	2.12-15.0- 92	1	P1
	2.12-16.0- 74		
66E40961-1	2. 5- 3.0- 1	RF	
	2.18-11.0- 26	RF	
66E40964-1	2.14-34.0- 12	2	
66E40964-3	2.14-34.0- 16	1	
66E40965-1	2.12-68.0- 87	1	
66E40968-1	2.14-34.0- 21	2	
66E40968-3	2.14-34.0- 25	1	
66E40969-1	2.14-34.0- 31	2	
66E40969-3	2.14-34.0- 35	2	
66E40978-2	2. 8-28.0- 32	1	
66E40984-1	2. 3-10.0- 19	1	
	2. 9- 1.0- 39	RF	
66E40985-1	2.12-14.0-103	1	P1
66E40986-1	2.12-68.0- 34	1	U
66E7027-2	2.17-39.0- 7	1	
66F36223-3	2. 5-14.0- 1	1	P
66F38478	2. 5-14.0-	1	U
66F38713-11	2. 2- 5.0- 17	2	M
	2. 2-10.0-118	2	
66F38713-7	2. 2- 5.0- 17	1	M
	2. 2-10.0-118	1	
66J38400-1	2.13-17.0- 25	1	
66J39840-1	2.13- 1.1-159	1	
66J40229-6	2.13-27.0- 22	1	
66J40230-16	2.13-27.0- 38	1	
66J40231-7	2.13-27.0- 50	1	U
66J40243-1	2.12-68.0-	1	U
66J40243-2	2.12-68.0- 1	1	
66J40243-3	2.12-68.0- 4	1	
66J40245	2. 2- 7.0- 90	RF	
66J40245-1	2. 1- 1.0- 64	1	

PART NUMBER	FIGURE AND INDEX NUMBER	QTY PER ART	SMR CODE
66J40245-1	2.13- 1.1-152	1	
66J40246-1	2.13- 1.1-165	1	
66J40249-1	2.12-68.0- 38	1	U
66J40249-2	2.12-68.0- 38	1	U
66J40249-3	2.12-68.0- 44	1	
66J40249-4	2.12-68.0- 44	1	M
66J40249-5	2.12-68.0- 50	1	
66J40249-6	2.12-68.0- 40	1	
66J40256-1	2.12-68.0- 81	1	M
66J40259-1	2.12-68.0- 8		
66J40259-8	2.12-68.0- 31	1	
66J40259-9	2.12-68.0- 32	1	
66J40297-2	2. 8-29.0-	RF	P1
66J40320-1	2.12-15.0- 15	1	P1
	2.12-16.0- 13	1	
66J40320-2	2.12-15.0- 15		
	2.12-16.0- 13	1	
66J40344-R	2.12-48.0- 64	1	
66J40344-1	2.12-48.0- 64	1	P1
66J40344-10	2.12-48.0- 30	1	
	2.12-48.0- 30	1	
66J40344-L	2.12-48.0- 30	1	
	2.12-48.0- 31	1	
66J40344-7	2.12-48.0- 30	1	
	2.12-48.0- 64	1	
66J40344-R	2.12-48.0- 30	1	
66J40344-9	2.12-48.0- 30	1	
	2.12-48.0- 64	1	
	2. 8-29.0- 7	1	
66J40415-2	2.12-68.0- 76	1	U
66J40459-1	2.13-27.0- 40	1	
66J40461-1	2.13-27.0-	1	
66J40462-1	2.13-27.0-	1	
66J40485-1	2.12-67.0- 45	1	U
66J40512-1	2.13-27.0- 5	1	
66J40525-1	2.12-68.0- 15	1	
66J40593-1	2. 8-28.0-	1	
66J40609-39	2.12-68.0- 85	2	M
66J40609-72	2.12-68.0- 85	1	M
66J40609-75	2. 2- 7.0- 92	1	
66J40630-1	2.13- 1.1-153	1	
66J40924-1	2.18-11.0-	RF	
66J40924-2	2.18-11.0-	RF	
663-11	2.17- 8.0- 58	1	
666-2116	2.13- 1.1-148	1	P1
666035-3-0090	2.20-23.0- 74	1	
666035-3-0120	2. 9-33.0- 59	1	P1
	2. 9-33.0- 66	1	
666035-3-0170	2. 9-14.0- 55	1	P1
	2. 9-15.0- 50	1	
666035-4-1120	2. 9-33.0- 50	1	P
	2. 9-33.0- 69	1	
666035-6-0125	2. 9-28.0- 7	2	P1
666035-6-0134	2. 9-33.0- 30	1	P1
	2. 9-33.0- 40	1	
666035-6-0140	2. 9-29.0- 15	1	
	2. 9-29.0- 26	1	
	2. 9-29.0- 27	1	
666035-6-0192	2. 9-28.0- 3	2	
666035-6-1200	2. 9-30.0- 32	1	P
	2. 9-30.0- 42	1	
666035-8-0147	2. 9-29.0- 12	1	P
	2. 9-29.0- 30	1	
666319-4-1076	2. 5-33.0- 3	2	
666319-6-174	2.10- 7.0-117	1	P

PART NUMBER	FIGURE AND INDEX NUMBER	QTY PER ART	SMR CODE
666319-60174	2. 8-12.0-134	1	P
666320-4-0215	2. 9-31.0- 6	1	P1
666320-6-0166	2. 9-30.0- 35	1	
	2. 9-30.0- 40	1	
666320-6-0225	2. 9-31.0- 15	1	P
666371-6-0184	2. 8-12.0- 80	1	
	2.13- 7.0-110	1	
67A34045-1	2. 9-28.0- 55	1	M
67A34045-3	2. 9-28.0- 61	1	M
	2. 9-29.0- 48	RLF	
67A34045-5	2. 9-29.0- 60	1	M
	2. 9-31.0- 44	RIF	
67A34045-6	2. 9-28.0- 57	1	M
67A36511-1	2.12-44.0-151	1	
67A36607-1	2. 9- 9.0- 16	1	
67A36608-1	2. 8-25.0- 13	1	
67A36609-1	2. 8-25.0- 10	1	
67A36610-1	2. 8-25.0- 14	1	
67A36611-1	2. 8-25.0- 6	1	
67A36628-1	2.13-11.0- 17	1	
67B36506-1	2.16- 1.0- 15	1	
67B36656-1	2.13- 0.0- 21	1	
67C34033	2.10-19.0- 17	1	
67C34350-7	2. 9- 3.0- 1	1	
67C36501-4	2.16-12.0- 17	1	
67C36501-5	2.16-18.0- 17	1	
67C36501-6	2.16-18.0- 17	1	
67C36602	2.12-10.0-103	1	
67C45432	2.18-14.0- 3	1	
67D34273	2.18-18.0- 23	1	
67D34662-5	2.12- 9.0- 66	1	P1
	2.12-39.0- 31	1	
	2.21- 5.0- 7	2	
67D36585-1	2.18-33.0- 16	1	
67D36655-1	2.13- 5.0- 21	1	
67E35467-7	2.16- 5.0- 33	1	
67E36567-1	2.13- 3.0- 80	1	
67E36617-1	2. 2- 7.0- 95	1	
67E36622-1	2. 5- 9.0- 25	1	
67E8-055	2.12- 9.0- 34	1	
67E9	2.12- 6.0- 8	1	P1
	2.12-39.0- 19	1	P1
677032-4-0062	2. 8-10.0- 65	RF	
	2. 8-18.0-186	RF	
677032-6-0160	2. 8-10.0-176	RF	
677032-8-0184	2. 8-12.0- 39	1	P
	2.10- 7.0-119	1	
67824	2.15-38.0- 6	1	
67828A3	2.15-38.0- 5	1	
	2.15-38.0- 8	1	
67830	2.15-38.0- 8	1	X
67839	2.15-38.0- 5	1	
67844A1	2.15-38.0- 9	1	
67848A2	2.15-38.0- 2	1	P
68-C4-62	2.17- 1.0- 38	1	
	2.17- 1.0- 47	2	
68A3775-10	2.12-37.0- 62	1	M
68A3775-1	2.12-37.0-191	1	M
68A3775-11	2.12-37.0- 60	1	M
68A3775-2	2.12-37.0-185	1	M
68A3775-3	2.12-37.0-205	1	M
68A3775-4	2.12-45.0-242	1	M
68A3775-5	2.12-45.0-241	1	M
68A3775-6	2.12-45.0-240	1	M
68A3775-7	2.12-45.0-235	1	M

PART NUMBER	FIGURE AND INDEX NUMBER	QTY PER ART	SMR CODE
68A3775-8	2.12-37.0- 65	1	M
68A3775-9	2.12-37.0- 65	1	M
68A3775-6-1	2.12-37.0-207	1	M
68A3775-6-2	2.12-37.0-204	1	M
68A3775-3	2. 9- 1.0- 29	1	
68B40894	2.12-39.0- 39	1	P1
	2.20- 2.0- 22	1	
68C37343-7	2.12-39.0- 38	1	M
68C37565-7	2. 2- 5.0- 17	1	
	2. 2-10.0-118	1	
68C37567-7	2. 2- 5.0- 17	1	
	2. 2-10.0-118	1	
68C37568-7	2. 2- 5.0- 17	1	
	2. 2-10.0-118	1	
68C37693-7	2. 4-11.0- 49	1	M
68D37746-7	2.12- 9.0- 66	1	M1
	2.21- 5.0- 6	2	
68D37869-1	2.15- 1.0- 74	1	M
68E37334-1	2.13-25.0- 22	1	P
68E37334-3	2.13-25.0- 23	1	P
68F37502-1	2. 7-10.0- 1	1	P1
68F37569-1	2. 2- 5.0- 17	2	M
68F37569-3	2. 2-10.0-118	2	M
68F37665-1	2.16- 1.0-114	1	M
	2.16- 3.0- 54	1	
68F37667-1	2.16- 1.0-107	1	M
	2.16- 3.0- 47	1	
68F37910-10	2.12-68.0- 39	1	M
68F37910-9	2.12-68.0- 39	1	M
68J37309-7	2. 2- 7.0-106	1	
68J37369-9	2. 2- 7.0-106	1	
68K0-064	2.17-11.0- 96	2	P1
	2.20-47.0- 8	9	
68K305	2.17- 8.0- 46	1	
69C34248-1	2.18- 6.0- 55	1	M
69C34448-7	2.18- 6.0- 55	1	M
69C34932	2.17- 7.0- 1	1	M
69C35142-1	2.13- 1.1- 20	2	
69C37529-1	2.15- 2.0- 12	1	
	2.15- 2.0- 17	1	
	2.15- 3.0- 9	1	
	2.15- 4.0- 12	1	
	2.15-13.0- 9	1	
	2.15-16.0- 9	1	
	2.15-25.0- 44	1	
69C37529-2	2.20- 4.0- 9	1	
	2.20- 5.0- 22	1	
	2.20- 5.0- 9	1	
	2.20- 6.0- 28	2	
	2.20-31.0- 39	1	
	2.20-31.0- 56	1	
	2.20-33.0- 71	1	
69D34546-1	2. 4- 2.0- 13	1	P1
69D34546-2	2. 4- 2.0- 13	1	P1
69D34546-3	2. 4- 2.0- 13	1	P1
69D34546-4	2. 4- 2.0- 13	1	P1
69D34693-01	2.12-15.0-127	1	M
	2.12-16.0-116	1	
69D36693-03	2.12-15.0-127	1	M
	2.12-16.0-116	1	
69F34535-1	2. 2- 9.0- 58	1	M
69F34535-2	2. 2- 9.0- 58	1	M
69F34828-1	2.18-18.0- 16	1	
69F35365	2.12-18.0- 11	RF	
69I8-707	2. 8- 6.0- 1	2	
69J4	2.17- 8.0- 38	2	P1
	2.17- 8.0- 40	2	

PART NUMBER	FIGURE AND INDEX NUMBER	QTY PER ART	SMR CODE
6986-2	2.12-56.0- 1	1	P1
7-2653-3	2.13-29.0- 9	2	P
	2.13-31.0- 49	1	
7-2053-4	2.13-17.0- 4	1	P1
7-2153-1	2.13- 1.1-123	1	P1
	2.13- 8.0- 16	1	
7-2253-1	2.13- 1.1- 60	1	P1
	2.13- 8.0- 4	1	P
7-2253-4	2.13-31.0- 7	1	
7S2191004	2. 9- 4.0- 50	1	
70-0018	2.21- 4.0- 22	2	
702M02	2.10- 9.0- 1	18	
	2.12-26.0- 11	2	
700612	2.12-56.0- 6	1	
700616	2.12-56.0- 7	1	P1
70020	2.18-29.0- 1	1	
700500	2.12-56.0- 19	1	P1
	2.12-56.0- 8	1	
701400	2.12-56.0- 17	RF	A1
	2.12-56.0-	RF	
701400-2	2.12-56.0- 8		A1
701402	2.12-56.0- 9	1	P1
701407	2.12-56.0- 24	1	KF
701408	2.12-56.0- 27	1	KF
701409	2.12-56.0- 28	1	KF
701414	2.12-56.0- 19	1	KF
701415	2.12-56.0- 13	1	P1
701416	2.12-56.0- 12	1	KF
701417	2.12-56.0- 31	1	KF
701420	2.12-56.0- 26	1	KF
701421	2.12-56.0- 20	1	KF
701422	2.12-56.0- 30	1	KF
701423	2.12-56.0- 15	1	KF
701424	2.12-56.0- 25	1	KF
701496	2.12-56.0- 32	1	
703600-10	2.13-33.0- 18	1	
703600-1	2.12-18.0- 13	1	M
7036811-01	2.12-18.0- 14	1	M
7036812-01	2.12-18.0- 15	1	M
7036813-01	2.12-18.0- 16	1	M
7036814-01	2.12-18.0- 17	1	M
7036815-1	2. 9- 1.0- 29	1	M
7036859-01	2.13-33.0- 63	1	M
7036860-10	2.13-33.0- 1	1	P1
7036860-20	2.13-33.0- 2	1	P1
7036874-01	2.13-33.0- 25	1	M
7036876-10	2.13-33.0- 13	2	M
7036878-10	2.13-33.0- 12	1	P1
7036880-01	2.13-33.0- 16	1	M
7036881-01	2.13-33.0- 15	1	M
7036887-10	2.13-33.0- 61	2	P1
7036890-10	2.13-33.0- 66	1	P1
7036890-01	2.13-33.0- 64	1	M
7036897-01	2.13-33.0- 62	1	M
7036900-01	2.13-33.0- 60	1	M
7036918-01	2.13-33.0- 20	1	M
7036918-03	2.13-33.0- 21	1	M
7036950-10	2.13-33.0- 26	1	P1
7036964-10	2.13-33.0- 54	1	P1
7036966-10	2.13-33.0- 46	1	P1
7036966-10	2.13-33.0- 28	1	
7036967-10	2.13-33.0- 38	1	P1
7036970-10	2. 9- 5.0- 34	1	M
7037-267-10	2.13-33.0-	REF	

PART NUMBER	FIGURE AND INDEX NUMBER	QTY PER ART	SMR CODE
7037002-10	2.13-33.0- 50	1	M
7037003-01	2.13-33.0- 55	1	M
7037004-10	2.13-33.0- 53	1	M
7037016-01	2.13-33.0- 19	1	M
7037020-10	2. 9- 9.0- 29	1	M
7037026-10	2. 9- 7.0- 39	1	M
7037028-10	2. 9- 9.0- 31	1	M
7037029-10	2. 9- 9.0- 24	1	M
7037030-10	2. 9-11.0- 6	1	M
7037031-10	2. 9- 8.0- 35	1	M
7037032-10	2.13-33.0- 33	1	M
7037043-01	2. 9- 5.0- 30	1	P
7037044	2. 9- 9.0- 26	1	M
7037052-10	2.13-33.0- 8	1	P1
7037052-20	2.13-33.0- 8	1	P1
7037052-1	2. 5-10.0- 32	1	
7037053-01	2. 5-10.0- 31	1	
7037054-10	2. 5-10.0- 1	1	P
7037129-01	2.13- 8.0- 10	1	P1
7037135	2.17-11.0- 86		
7037153-01	2.13-33.0- 30	1	U
7037154-01	2.13-33.0- 31	1	M
7037160-01	2.13-33.0- 29	1	M
7037189	2.18-26.0-		
7037196-01	2.18-26.0- 13	1	M
7037199-10	2.18- 1.0- 2	0	
7037214-01	2.18-26.0- 11	1	M
7037214-03	2.18-26.0- 12	1	M
7037214-10	2.18-26.0- 2	1	M
7037227-01	2.18-26.0- 8	2	M
7037233-01	2.18-26.0- 18	1	
7037237	2.18- 1.0-		
7037256-10	2.18-20.0- 37	4	M
7037257-01	2.13-33.0- 42	1	M
7037257-05	2.13-33.0- 44	2	M
703725703	2.13-33.0- 52		
7037277-10	2. 9- 9.0- 41	1	
7037311	2.10-19.0- 35	1	M
7037312	2.10-19.0- 34	4	M
7037313	2.10-19.0- 36	1	M
7037314	2.10-19.0- 35	1	M
7037315	2.10-19.0- 37	2	M
7037316	2.10-19.0- 31	1	M
7037407-10	2.13-33.0-	REF	U
7037407-20	2.13-33.0-	REF	U
7037469	2.10-19.0- 32	2	M
7037732-01	2.15-22.0- 91	1	M
	2.15-23.0- 56	1	M
7037733-01	2.15-22.0- 92	1	
	2.15-23.0- 57	1	
7037734-01	2.15-22.0- 93	1	M
	2.15-23.0- 58	1	
7037734-10	2.15-22.0- 90	1	M
	2.15-23.0- 55	1	
705907-801	2.18-21.0- 9	1	
705908-801	2.16- 8.0- 6	1	
708410	2.17- 8.0- 42	1	
708585	2.10-33.0- 16		
708645B	2.10-25.0- 10	1	
708646	2.10-33.0- 7	1	
708682	2.10- 7.0- 79	1	
708682C	2.10-32.0- 1	1	
71-0001	2.21- 4.0- 1	2	
	2.21- 4.0- 4	2	
71-0002	2.21- 4.0- 2	2	
71-0003	2.21- 4.0- 6	2	
	2.21- 4.0- 7	2	

PART NUMBER	FIGURE AND INDEX NUMBER	QTY PER ART	SMR CODE
71-0004	2.21- 4.0- 3	2	
	2.21- 4.0- 5	2	
71-0005	2.21- 4.0- 8	2	
71-0006	2.21- 4.0- 9	2	
71-0007	2.21- 4.0- 10	2	
71-0008	2.21- 4.0- 11	2	
71-0009	2.21- 4.0- 12	2	
	2.21- 4.0- 15	2	
	2.21- 4.0- 16	2	
71-0010	2.21- 4.0- 14	2	
	2.21- 4.0- 19	2	
71-0011	2.21- 4.0- 13	2	
	2.21- 4.0- 17	2	
71-0012	2.21- 4.0- 18	2	
71-0013	2.21- 4.0- 23	2	
71-0014	2.21- 4.0- 24	2	
71-0015	2.21- 4.0- 25	2	
71-0016	2.21- 4.0- 20	2	
71-0017	2.21- 4.0- 21	2	
71-0019	2.21- 4.0- 27	2	
71-0020	2.21- 4.0- 28	2	
71-0021	2.21- 4.0- 39	2	
71-0022	2.21- 3.0- 4	2	M
71-0023	2.21- 3.0- 3	1	M
7111719-01	2.20-44.0- 11	1	
7111744-01	2.20-44.0- 12	1	
711267	2.10-33.0- 1	1	P1
712009	2.10-31.0- 17	RF	
712480	2.10-25.0- 27	1	
712481	2.10-25.0- 19	1	
712482	2.10-25.0- 26	1	
712489	2.10-25.0- 23	1	
712491	2.10-28.0- 23	1	
712493	2.10-29.0- 38	1	
712494	2.10-29.0- 32	1	
	2.10-31.0- 14	1	
712795	2.10-31.0- 19	1	
712974	2.10-31.0- 21	1	
713665	2.10-31.0- 6	1	
713668	2.10-29.0- 2	1	
713669	2.10-29.0- 3	1	
713070	2.10-28.0- 28	1	
713083	2.10-28.0- 35	1	
713090	2. 3- 3.0- 78	1	
713209	2.20-50.0- 2	1	
7132917-10	2.20-50.0- 3	2	
713363	2.10-28.0- 3	1	
713364	2.10-28.0- 6	1	
713591	2.10-25.0- 6	RF	
7140017-01	2.13-37.0- 10	1	
7140017-02	2.13-33.0- 10	1	M
7140192	2.15-22.0- 39	AR	M
	2.15-22.0- 50	AR	
	2.15-23.0- 3	AR	
	2.15-23.0- 5	AR	
7140201-10	2.14- 4.0- 17	1	M
7140202-10	2.14- 4.0- 23	1	M
7140203-10	2.14- 4.0- 56	1	M
7140204-10	2.14- 4.0- 117	1	M
7140205-10	2.14- 4.0- 16	1	M
7140206-10	2.14- 4.0- 54	1	M
7140207-10	2.14- 4.0- 119	1	M
7140208-10	2.14- 4.0- 114	1	M
7140209-10	2.14- 4.0- 116	1	M
7140210-10	2.14- 4.0- 19	1	M

PART NUMBER	FIGURE AND INDEX NUMBER	QTY PER ART	SMR CODE
7140211-10	2.14- 4.0- 118	1	M
7140212-10	2. 9-20.0- 7	1	M
	2.14- 4.0- 110	1	M
7140229-03	2.14- 4.0- 124	1	M
7140242-10	2.14- 4.0- 114	1	M
7140243-10	2.14- 4.0- 116	1	M
7140244-10	2.14- 4.0- 118	1	M
7140245-10	2.14- 4.0- 119	1	M
7140247-10	2.13-33.0- 47	1	M
7140358	2.17-41.0-	1	
7140405-10	2.20- 2.0- 20	1	M
7140977-01	2.20- 2.0- 10		M
7141765-10	2.20-45.0- 10	1	
7141765-20	2.20-45.0- 10	RF	
7141765-23	2.20-45.0- 1	1	
7141765-27	2.20-45.0- 9	1	
7141765-47	2.20-45.0- 10	1	
714176510	2.20-45.0-	RF	
7141920-01	2.15-24.0- 31	1	M
7141920-03	2.15-24.0- 31	1	M
7141920-05	2.15-24.0- 31	1	M
714427-15	2.20-41.0- 20	2	
7144502-01	2. 4- 1.0- 41	1	P1
7144502-02	2. 4- 1.0- 42	1	P1
7144506-10	2. 4- 1.0- 20	1	P1
7144516-01	2. 4-1.0-42.1	1	
7144517-07	2.20-45.0- 5	2	
7144519-10	2. 4- 1.0- 24	2	P1
7144521-10	2.20-37.0-	RF	
7144522-10	2.20-37.0- 5	1	A
	2.20-39.0- 33	RF	
7144523-10	2.20-40.0- 12	1	A
7144531-01	2.20-44.0- 49	1	
7144538-10	2.20-46.0- 11	2	A
7144547-01	2.20-42.0- 1	2	P1
7144547-02	2.20-42.0- 1	2	P1
7144547-03	2.20-43.0- 3	1	P1
7144547-04	2.20-43.0- 3	1	P1
7144547-05	2.20-43.0- 4	1	P1
7144547-06	2.20-43.0- 4	1	P1
7144547-07	2.20-43.0- 2	2	
7144547-01	2. 9-20.0- 7	1	
7144551-10	2.20-15.0- 23	1	A
	2.20-18.0-	RF	
7144551-00	2.20-15.0- 23	1	A
	2.20-18.0-	RF	
7144551-30	2.20-15.0- 18	1	A
7144551-40	2.20-15.0- 18	1	A
	2.20-17.0-	RF	
7144551-50	2.20-17.0- 33	1	M
7144553-01	2.20-17.0- 39	2	P1
7144553-03	2.20-17.0- 38	2	P1
7144554-01	2.20-17.0- 37	2	M1
7144555-10	2.20-17.0- 42	1	M1
7144555-20	2.20-17.0- 42	1	M1
7144556-10	2.20-18.0- 44	1	M1
7144556-20	2.20-18.0- 44	1	M1
7144557-10	2.20-39.0- 13	1	P1
7144557-20	2.20-39.0- 13	1	P1
7144560-01	2.20-18.0- 37	1	P1
7144570-10	2.20-37.0- 2	1	P
	2.20-39.0-	RF	
7144570-20	2.20-37.0- 2	1	P
	2.20-39.0-	RF	
7144571-10	2.20-39.0- 1	1	P
7144571-20	2.20-39.0- 1	1	P

PART NUMBER	FIGURE AND INDEX NUMBER	QTY PER ART	SMR CODE
7144572-01	2.20-39.0- 17	1	P1
7144572-02	2.20-39.0- 17	1	P1
7144572-10	2.20-39.0- 14	1	P1
7144572-20	2.20-39.0- 14	1	P1
7144573-01	2.20-39.0- 20	1	P1
7144573-02	2.20-39.0- 20	1	P1
7144573-10	2.20-39.0- 17	1	A
7144573-20	2.20-39.0- 17	1	A
7144574-01	2.20-39.0- 23	1	P1
7144574-02	2.20-39.0- 23	1	P1
7144574-10	2.20-39.0- 20	1	A
7144574-20	2.20-39.0- 20	1	A
7144575-01	2.20-39.0- 26	1	P1
7144575-02	2.20-39.0- 26	1	A
7144575-10	2.20-39.0- 23	1	A
7144575-20	2.20-39.0- 23	1	
7144580-10	2.20-19.0- 33	1	
	2.20-19.0-	RF	
7144580-20	2.20-15.0- 33	1	
	2.20-15.0-	RF	
7144585-01	2.20-19.0- 60	1	P1
7144583-02	2.20-19.0- 60	1	P1
7144583-10	2.20-19.0- 54	1	A
7144583-20	2.20-19.0- 54	1	A
7144585-01	2.20-17.0- 25	1	P1
7144587-10	2.20-19.0- 33	1	P1
7144587-20	2.20-19.0- 33	1	P1
7144587-30	2.20-19.0- 9	1	P1
7144587-40	2.20-19.0- 9	1	P1
7144588-10	2.20-19.0- 60	1	P1
7144588-20	2.20-19.0- 60	1	P1
7144591-01	2.20-35.0- 10	1	X1
7144591-03	2.20-35.0- 10	1	X1
7144591-10	2.20-35.0- 8	1	X1
7144591-30	2.20-35.0- 8	1	X1
7144595-03	2. 2- 7.0- 65	1	
7144595-10	2. 2- 7.0- 64	1	
7144595-20	2. 2- 7.0- 64	1	
7144597-01	2.20-17.0- 42	1	P1
7144597-10	2.20-17.0- 39	2	
7144599-01	2. 2-14.0- 27	1	M
7144599-03	2. 2-14.0- 29	1	M
7144599-05	2. 2- 7.0- 29	1	M
7144599-07	2. 2- 7.0- 30	1	M
7144599-11	2. 2- 7.0- 31	1	M
7144599-13	2. 2-14.0- 33	1	M
7144599-15	2. 2-14.0- 34	1	M
7144599-17	2. 2-14.0- 37	1	M
7144599-18	2. 2-14.0- 38	1	M
7144599-21	2. 2-14.0- 36	1	M
7144599-23	2. 2-14.0- 39	1	M
7144599-24	2. 2-14.0- 40	1	M
7144599-25	2. 2-14.0- 41	1	M
7144599-27	2. 2-14.0- 32	1	M
7144599-31	2. 2-14.0- 35	1	M
7144599-33	2. 2-14.0- 31	1	M
7144627-10	2. 8-10.0- 49	1	
7144628-03	2. 6- 1.0- 53	1	M
7144633-10	2. 6- 5.0- 1	1	P1
7144634-05	2.20-44.0- 1	2	M
7144634-07	2.20-44.0- 32	1	M
7144634-10	2.20-44.0- 16	1	A
	2.20-44.0-	RF	
7144637-10	2.16-11.0- 30	1	A
7144638-10	2.16-11.0-	RF	

PART NUMBER	FIGURE AND INDEX NUMBER	QTY PER ART	SMR CODE
7144639-01	2.16-11.0- 34	1	P1
7144640-30	2.20- 2.0- 24	1	
7144645-10	2.11-11.0- 4	1	P1
7144648-01	2.20- 2.0- 33	1	P1
7144648-10	2.20- 2.0- 31	1	A
7144652-10	2.20-44.0- 3	1	P1
7144658-10	2.20- 3.0- 21	1	M
7144664-10	2.16-11.0- 33	1	M
7144666-10	2.20-44.0- 37	1	P1
7144668-02	2.20-44.0- 25	1	P1
7144669-01	2.20-44.0- 29	1	P1
7144669-02	2.20-44.0- 29	1	P1
7144688-01	2.20-44.0- 25	1	
7144691-10	2.20-38.0- 6	1	
7144691-20	2.20-38.0- 6	1	P1
7144692-10	2.20-38.0- 4	1	P1
7144692-20	2.20-38.0- 4	1	P1
7144694-01	2.20-46.0- 4	2	
7144696-10	2.20-37.0- 1	1	
	2.20-38.0-	RF	
7144696-20	2.20-37.0- 1	1	
	2.20-38.0-	RF	
7144697-01	2.20-46.0- 7	2	P1
7144698-01	2.20-46.0- 5	2	P1
7144713-01	2. 5- 1.0- 40	1	P1
7144713-02	2. 5- 1.0- 41	1	P1
7144713-03	2. 5- 1.0- 40	1	P1
7144713-04	2. 5- 1.0- 41	1	P1
7144729-01	2.20- 3.0- 10	1	M
7144730-10	2.20- 3.0- 4	1	A
7144739-10	2.20-44.0- 30	1	P1
7144747-01	2.20-46.0- 15	1	M
7144755-10	2.17-13.0- 9	1	M
7144759-10	2.20- 2.0- 31	1	
7144761-10	2.20-40.0- 1	1	A
	2.20-41.0-	RF	
7144762-10	2.20-40.0- 5	1	A
	2.20-42.0-	RF	
7144762-20	2.20-40.0- 5	1	
	2.20-42.0-	RF	
7144763-07	2.20-43.0- 1	1	M
7144763-10	2.20-40.0- 7	1	A
	2.20-43.0-	RF	
7144763-20	2.20-40.0- 7	1	
	2.20-43.0-	RF	
7144764-10	2.20-40.0- 6	1	A
	2.20-42.0- 14	RF	
7144764-20	2.20-40.0- 6	1	
	2.20-42.0- 14	RF	
7144764-30	2.20-42.0- 14	1	
7144764-41	2.20-42.0- 22	1	M
7144765-03	2.20-45.0- 22	1	
7144765-05	2.20-45.0- 21	1	
7144765-10	2.20-44.0- 13	1	M
7144765-20	2.20-44.0- 13	1	M
7144765-30	2.20-45.0- 17	1	
7144769-10	2.20-44.0- 5	1	P1
7144770-10	2.20-44.0- 19	1	P1
7144770-20	2.20-44.0- 19	1	P1
7144775-01	2.20-44.0- 36	1	P1
7144776-10	2.20-46.0- 11	1	P1
7144777-01	2.20-46.0- 14	1	M
7144780-01	2.20-44.0- 40	1	P1
7144786-10	2.20-44.0- 14	1	A
	2.20-46.0-	RF	

PART NUMBER	FIGURE AND INDEX NUMBER	QTY PER ART	SMR CODE
7144789-01	2. 8-12.0-153	1	
7144790-01	2. 8-12.0-164	1	
7144791-01	2. 8-12.0-151	1	
7144792-01	2.12-32.0- 8	1	
7144793-01	2. 8-12.0-161	1	
7144794-01	2. 8-12.0-158	1	
7144795-01	2. 8-12.0-149	1	
7144797-01	2. 8-12.0-143	1	
	2. 8-12.0-147	1	
7144798-01	2. 8-12.0-145	1	
7144799-01	2. 8-11.0- 19	1	
7144800-01	2. 8-11.0- 16	1	
7144801-01	2. 8-11.0- 13	1	
7144802-01	2. 8-11.0- 8	1	
7144803-01	2. 8-11.0- 6	1	
7144804-01	2. 9-32.0- 15	1	
7144805-01	2. 8-12.0- 43	1	
7144806-01	2. 8-10.0-193	1	
7144807-01	2. 8-10.0- 68	1	
7144808-01	2. 8-10.0- 48	1	
7144809-01	2. 8-10.0- 46	1	
7144810-01	2. 8-10.0- 49	1	
7144811-01	2. 8-10.0- 55	1	
7144812-01	2. 8-10.0- 18	1	
7144813-01	2. 8-10.0- 16	1	
7144814-01	2. 8-10.0- 19	1	
7144815-01	2. 8-10.0- 21	1	
7144816-01	2. 8-10.0- 23	1	
7144817-01	2. 8-10.0- 56	1	
7144821-01	2. 9-28.0- 27	1	
7144822-01	2. 9-29.0- 43	1	
7144825-10	2.20-41.0- 2	1	
7144825-11	2.20-41.0- 7	2	
7144825-23	2.20-41.0- 8	1	
7144827-10	2.20-41.0- 19	1	
7144828-10	2.20-41.0- 18	1	
7144835-01	2.20-42.0- 29	2	
7144835-03	2.20-45.0- 6	2	
7144849-25	2.20-42.0- 21	2	
	2.20-42.0- 28	2	
	2.20-42.0- 7	4	
7144853-01	2.20-18.0- 46	1	
7144858-01	2.20-46.0- 10	2	
7144860-1	2.12-32.0- 39	1	
71448861-01	2.9-32.0- 32	1	
7144865-10	2.20-18.0- 33	1	
	2.20-18.0- 34	1	
7144865-20	2.20-18.0- 33	1	
	2.20-18.0- 34	1	
7144869-30	2.20-21.0- 24	1	
	2.20-22.0- 24	1	
7144871-01	2. 9-32.0- 29	1	
	2. 9-32.0- 31	1	
	2. 9-33.0- 64	1	
7144872-01	2. 9-32.0- 36	1	
	2. 9-33.0- 72	1	
7144873-01	2. 9-33.0- 61	1	
7144874-01	2. 9-27.0- 16	1	
7144875-01	2. 9-27.0- 18	1	
7144876-01	2. 9-27.0- 14	1	
7144877-01	2. 9-30.0- 21	1	
7144878-01	2. 9-30.0- 22	1	
7144879-01	2. 9-30.0- 28	1	
7144880-01	2. 9-30.0- 30	1	
7144881-101	2. 9-30.0- 27	1	
7144882-01	2. 9-32.0- 23	1	
7144885-01	2. 9-32.0- 14	1	

PART NUMBER	FIGURE AND INDEX NUMBER	QTY PER ART	SMR CODE
7144884-01	2. 9-32.0- 9	1	
7144885-01	2. 9-32.0- 11	1	
7144886-01	2. 9-32.0- 30	1	
	2. 9-33.0- 43	1	
7144887-01	2. 9-33.0- 45	1	
7144888-01	2. 9-33.0- 7	1	
7144889-01	2. 9-33.0- 5	1	
7144890-01	2. 9-33.0- 32	1	
7144891-01	2. 9-33.0- 35	1	
7144892-01	2. 9-30.0- 9	1	
7144893-01	2. 9-30.0- 5	1	
7144894-01	2. 9-30.0- 3	1	
7144895-01	2. 9-30.0- 15	1	
7144896-01	2. 9-29.0- 57	1	
7144897-01	2. 9-29.0- 3	1	
7144898-01	2. 9-30.0- 48	1	
7144899-01	2. 9-30.0- 47	1	
7144900-01	2. 9-29.0- 63	1	
7144900-01	2. 9-30.0- 46	1	
7144901-01	2. 9-29.0- 61	1	
7144903-01	2. 9-28.0- 59	1	
7144904-01	2. 9-27.0- 21	1	
7144905-01	2. 9-32.0- 7	1	
7144906-01	2. 9-27.0- 9	1	
7144907-01	2. 9-28.0- 32	1	
7144908-01	2. 9-29.0- 45	1	
7144909-01	2. 9-27.0- 11	1	
7144910-01	2. 9-28.0- 40	1	
7144914-10	2.20-22.0- 10	1	
7144915-10	2.20-22.0- 17	2	
7144918-10	2.20-44.0- 41	2	
7144920-01	2.20-45.0- 7	1	
7144920-02	2.20-45.0- 7	1	
7144921-01	2.20-44.0- 47	1	
7144922-01	2.20-44.0- 46	1	
7144923-01	2.20-44.0- 43	1	
7144924-01	2.20-44.0- 48	1	
7144926-10	2.20-21.0- 18	2	
7151	2.18- 6.0- 11	1	
71534	2.15-22.0- 87	1	
	2.15-23.0- 52	1	
715774	2.10-33.0- 4	1	
7171-8-5	2.18- 5.0- 1	1	
7172-3-5	2.18- 5.0- 1	10	
7172-8-15	2.17-35.0- 12	19	
	2.17-35.0- 13		
718	2. 4-11.0- 1	1	
720017	2.12-56.0- 2	1	
721400	2.12-55.0- 19	1	
722A1	2.17-13.0- 10	4	
7224	2.17- 1.0- 54	1	
	2.17- 1.0- 60	1	
7225	2.17- 1.0- 57	1	
7227-8-5	2.17-38.0- 5	4	
7239064-01	2.16-16.0- 3	1	
7239065	2.16- 8.0- 49	1	
	2.16-16.0- 7		
7239217-01	2.20-34.0- 14	1	
7239288-10	2. 3-14.0- 1	1	
7239289-01	2.10-16.0- 2	1	
7239289-10	2.10-16.0- 1	1	
7239607-10	2.20- 2.0- 23	1	
7239627-10	2. 4- 7.0- 53	1	
7239733-10	2.20- 2.0- 24	1	
7240026-10	2.14- 4.0-129	1	

PART NUMBER	FIGURE AND INDEX NUMBER	QTY PER ART	SMR CODE
7240027-10	2.14- 4.0-12b	1	
7240028-10	2.14- 4.0-132	1	
7240029-10	2.14- 4.0-127		
7242855-10	2.16-17.0-	1	
7242855-30	2.16-17.0-	1	
7242856-110	2.16- 8.0- 25	1	
	2.16-18.0-	RF	
	2.16-18.0-	GR	
7242856-130	2.16- 8.0- 25	1	
7242856-150	2.16- 8.0- 25	1	
	2.16-18.0-	RF	
7242856-70	2.16- 8.0- 25	1	
	2.16-18.0-	RF	
7242856-90	2.16- 8.0- 25	1	
	2.16-18.0-	RF	
7242858-10	2.17- 8.0- 53	1	
7242859-10	2.17- 8.0- 44	1	
7242860-10	2. 4- 3.0-	1	
	2.17-10.0- 1		
	2.18-35.0-	1	
7242862-10	2.13- 5.0-	1	
7242863-10	2.13- 4.0- 23	1	
7242864-10	2.13- 7.0-	1	
7242865-10	2.13- 7.0- 8	1	
7242866-10	2.17-11.0- 44	1	
	2.17-21.0- 1		
7242866-110	2.17-11.0- 44	1	
	2.17-23.0- 1	RF	
7242866-130	2.17-11.0- 44	1	
	2.17-23.0- 2	RF	
7242866-150	2.17-11.0- 44	1	
	2.17-23.0- 2	RF	
	2.17-35.0- 2	RF	
7242866-170	2.17-11.0- 44	1	
	2.17-23.0- 2	RF	
7242866-190	2.17-11.0- 44	1	
	2.17-23.0- 2		
7242866-30	2.17-11.0- 44	1	
	2.17-21.0- 1		
7242866-50	2.17-11.0- 44	1	
	2.17-21.0- 1	40	
7242866-70	2.17-11.0- 44	1	
	2.17-21.0- 1		
7242866-90	2.17-11.0- 44	1	
	2.17-23.0- 1		
7242868-10	2.17-24.0-	1	
7242869-10	2. 3- 4.0- 37	1	
	2.13- 6.0-	RF	
7242870-10	2. 3- 4.0- 37	1	
	2.13- 5.0- 9	RF	
7242871-10	2.18-22.0-	1	
7242874-10	2.13- 7.0- 9	1	
7242876-10	2. 3- 4.0- 38	1	
	2.13- 5.0-	RF	
7242879-10	2.17- 8.0- 41	1	
7242880-10	2.17- 8.0- 6	1	
7242884-10	2.13- 8.0- 78	1	
7242886-10	2.17-32.0- 15	1	
	2.17-33.0- 1	RF	
7242886-110	2.17-32.0- 15	1	
	2.17-35.0- 1		
7242886-130	2.17-32.0- 15	1	
	2.17-35.0- 1		
7242886-150	2.17-32.0- 15	1	
7242886-30	2.17-32.0- 15	1	

PART NUMBER	FIGURE AND INDEX NUMBER	QTY PER ART	SMR CODE
7242886-30	2.17-33.0- 1	RF	
7242886-50	2.17-32.0- 15	1	
	2.17-35.0- 1	RF	
7242886-70	2.17-32.0- 15	1	
	2.17-35.0- 1		
7242886-90	2.17-32.0- 15	1	
	2.17-35.0- 1		
7242888-10	2.17- 8.0- 50	1	
7242890-01	2.13- 8.0- 78	4	
7242891-10	2.17-18.0-	1	
7242892-10	2.17-18.0- 20	1	
7242894-10	2.17- 8.0- 13	1	
7242922-01	2.13- 6.0- 2	1	
7242930-10	2.13- 8.0- 55	1	
7242931-10	2.13- 8.0- 69	1	
7242932-10	2.13- 8.0- 76	1	
7242933-10	2.13- 8.0- 50	1	
7242935-10	2. 4- 5.0- 5	1	
7242936-10	2.18-35.0- 9	1	
7242940-01	2.17-10.0- 2	1	
7242941-01	2.13- 5.0- 2	1	
7242942-01	2.13- 4.0- 25	1	
7242951-10	2.17-15.0-		
7242963-01	2.17-21.0- 30	1	
	2.17-23.0- 29	1	
7242963-03	2.17-21.0- 33	1	
	2.17-23.0- 32	1	
7242963-05	2.17-21.0- 51	1	
	2.17-23.0- 51	1	
7242963-07	2.17-21.0- 67	1	
	2.17-23.0- 67	1	
7242963-11	2.17-21.0- 68	1	
	2.17-23.0- 68	1	
7242963-13	2.17-21.0- 69	1	
7242963-15	2.17-23.0- 61	1	
7242966-01	2. 4- 5.0- 7	1	
7242966-01	2.17-10.0- 7	1	
7242970-01	2.17-10.0- 10	1	M
7242973-10	2.17-25.0-	1	
7242974-10	2.17- 8.0- 46	1	
7242989-10	2.17- 8.0- 20	1	
7242994-10	2.17-18.0- 21	1	
7242995-10	2.17-18.0- 22	1	
7242997-01	2.17-35.0- 31	1	
7243000-10	2.17-25.0- 9	1	
7243001-01	2.17-24.0- 9	1	
7243002-01	2.17-24.0- 10	1	
7243008-01	2.18-35.0- 6	1	
7243009-03	2.17- 8.0- 76	1	M
7243013-10	2.18- 1.0- 8	1	
7243016-01	2.18- 1.0- 12	2	
7243017-10	2.17-18.0- 14	1	
7243022-10	2.17-18.0-	1	
7243023-10	2.17-18.0- 7	1	
7243024-01	2.17-18.0- 13	1	
7243025-10	2.17-11.0- 99	1	
7243026-01	2.17-11.0-100	1	
7243027-10	2.17-11.0-107	1	
7243028-01	2.16-18.0- 15		
7243031-10	2.13- 8.0- 56	1	
7243032-10	2.18-35.0- 14	1	
7243033-10	2.18-35.0- 12	1	
7243034-10	2.17-20.0-	1	
7243035-10	2.17-20.0- 14	1	
7243036-10	2.17-20.0- 16	1	

PART NUMBER	FIGURE AND INDEX NUMBER	QTY PER ART	SMR CODE
7243037-10	2.13- 8.0- 77	1	
7243039-10	2.17- 8.0- 20	1	
7243042-10	2.18-22.0- 4	1	
7243043-10	2.18-22.0- 5	1	
7243044-01	2.18-22.0- 11	1	
7243048-10	2.18-22.0- 11	1	
7243097	2.17-10.0- 11	1	P1
7243096-10	2.17-10.0- 11	1	
7243525-10	2.20-19.0- 29	1	
	2.20-39.0- 39	1	
	2.20-43.0- 10	1	
	2.20-44.0- 53	1	
	2.20-45.0- 14	1	
7243525-30	2.20-17.0- 29	1	
	2.20-42.0- 11	1	
	2.20-42.0- 33	1	
7243609-01	2. 8-27.0- 52	1	
7243612-10	2.20-41.0- 12	1	
7243656-130	2.16-18.0- 11	RF	
7271-3-15	2.17-35.0- 11	13	PA
7271-3-5	2.20- 3.0- 15	2	PA
	2.20- 3.0- 20	3	
7271-8-10	2.17-21.0- 9	1	PA
	2.17-23.0- 10	8	
	2.17-26.0- 7	8	
	2.17-27.0- 7	8	
	2.17-28.0- 6	8	
	2.17-33.0- 16	3	
	2.17-35.0- 10	4	
7271-8-15	2.17-21.0- 17	1	PA
	2.17-23.0- 11	20	
	2.17-33.0- 11	3	
	2.17-38.0- 6	3	
7271-8-20	2.17-21.0- 18	1	PA
	2.17-23.0- 17	1	
7271-8-5	2.17-21.0- 8	1	PA
	2.17-23.0- 8	34	
	2.17-26.0- 6	25	
	2.17-27.0- 6	26	
	2.17-28.0- 5	26	
	2.17-29.0- 6	28	
	2.17-31.0- 6	26	
	2.17-33.0- 9	36	
	2.17-35.0- 9	36	
73057	2.10- 7.0- 73	1	
730600-3	2.12-16.0- 44	RF	P1
7325048-01	2. 9-12.0- 36	1	
	2.20-23.0- 76	1	
7346560-10	2.10- 7.0-217	1	M
7346561-01	2.10- 7.0-220	1	M
7346572-01	2. 5- 2.0- 30	1	M1
7346826-10	2.18-30.0- 5	1	
7346828-10	2.18-30.0- 10	1	
7346840-01	2.18-36.0- 8	2	M
7346840-10	2.18-36.0- 8	REF	
7347117-10	2.18- 8.0- 45	1	M
7347118-10	2.18- 6.0- 43	1	
7347127-01	2.18- 6.0- 46	1	M
73760-5	2.12-16.0- 62	1	P1
744551-30	2.20-17.0- 5	RF	
7445609	2.17-12.0- 5	1	
	2.17-42.0- 5	1	
7445699-10	2.17-12.0- 5	1	M
7445782	2. 2- 7.0-100	1	P
7445983-10	2.16-23.0- 1	1	
7446088-10	2. 5-14.0- 2	1	M
7446088-50	2. 5-14.0- 3	1	M
74663-801	2.20-49.0- 7	RF	
74663-803	2.20-49.0- 7	RF	

PART NUMBER	FIGURE AND INDEX NUMBER	QTY PER ART	SMR CODE
74664-5	2.20-49.0- 6	RF	
74667-2	2.20-49.0- 6	RF	
74858-1	2.12-31.0- 1	2	
7500000	2. 8-10.0-150	1	
75150-2	2.12-14.0- 76	1	
754-8-2-6P	2.12-10.0- 33	5	
7545360-01	2.17-21.0- 69	1	
	2.17-23.0- 69	1	
7545360-13	2.17-35.0- 33	1	M
7545360-15	2.17-35.0- 36	1	M
7545360-17	2.17-33.0- 45	1	M
7545360-21	2.17-33.0- 46	1	M
7545925-10	2. 5-15.0- 13	1	M
7545926-01	2. 5-15.0- 8	1	M
7545927-10	2. 5-15.0- 2	1	M
757E9	2.16-11.0- 3	1	P1
7615-3785-1	2. 8- 3.0- 4	RF	P1
	2. 8- 3.0- 5	RF	
762010	2. 4-11.0- 23	RF	
762200-7	2.12-28.0- 6	1	P1
	2.12-29.0- 8	1	
	2.12-34.0- 11	1	
	2.12-52.0- 11	1	
	2.12-52.0- 28	2	
	2.12-52.0- 42	2	
7640015-10	2.10-7.0-151A	1	
7640016-10	2.18-37.0- 10	1	M
7640148	2. 3- 1.0- 1	1	
7673K	2.14- 8.0- 2	5	P1D
77	2.12-68.0- 71	2	
77000000-2	2.16- 1.0- 81	1	
77200000-2	2.16- 1.0- 51	1	
77407307	2.17-31.0- 8	4	
7745600-10	2.17-42.0- 6	1	
7747212-10	2.18-11.0- 27	1	
7747251-10	2.12- 9.0- 37.1	1	
7747257-10	2. 5- 3.0- 1	1	
	2.18-11.0- 26	1	
7747268	2.20-50.0- 4	1	M
7747259-01	2.20-50.0- 12	1	
7747259-10	2.20-50.0- 11	1	
7747260-01	2.20-50.0- 10	2	
7747261-01	2.20-50.0- 6	2	
7747263-10	2.18-11.0- 23	1	
7747267-10	2.20-50.0- 14	1	M
7747268-10	2.18-23.0- 1	1	M
7747262-01	2.18-37.0- 3	1	M
7747295-10	2.18-37.0- 2	1	M
7747297-10	2.16- 5.0- 31	1	
7747300	2.18-37.0- 1	RF	
7747307	2.17-21.0- 7	4	M
	2.17-21.0- 8	34	
	2.17-21.0- 9	14	
	2.17-21.0-17	1	
	2.17-21.0-18	1	
	2.17-23.0-10	8	
	2.17-23.0-11	1	
	2.17-23.0-17	1	
	2.17-23.0- 7	2	
	2.17-23.0- 8	34	
	2.17-23.0- 9	1	
	2.17-26.0- 6	26	M
	2.17-26.0- 7	8	
	2.17-27.0- 6	26	
	2.17-27.0- 7	8	
	2.17-28.0- 5	1	
	2.17-28.0- 6	1	
	2.17-29.0- 7	5	
	2.17-29.0- 8	28	

PART NUMBER	FIGURE AND INDEX NUMBER	QTY PER ART	SMR CODE
7747307	2.17-29.0- 9	1	
	2.17-30.0- 3	1	
	2.17-31.0- 6	26	
	2.17-31.0- 7	2	
	2.17-33.0- 11	20	
	2.17-33.0- 16	3	
	2.17-33.0- 9	36	
	2.17-35.0- 10	4	
	2.17-35.0- 12	19	
	2.17-38.0- 5	4	
	2.17-38.0- 6	3	
	2.18- 5.0- 1	10	
7747359	2.17-35.0- 1	36	
7747432-01	2.16-14.0- 1	1	
7747432-03	2.16-14.0- 1	1	
7747444-01	2.15-24.0- 27	1	A
7747445-1C	2.15-24.0- 26	1	P
7748804-10	2.13- 5.0- 44	1	
	2.13- 6.0- 42	1	
7748808-01	2.13- 6.0- 43	1	
	2.13- 6.0- 41	1	
7748809	2.13- 5.0- 34		
7748811-10	2.13- 6.0- 10	1	
7748812-10	2.13- 5.0- 48	1	
	2.13- 6.0- 46	1	
7748817-01	2.13- 5.0- 55	1	
	2.13- 6.0- 53	1	
7748819-01	2.13- 5.0- 54	1	
	2.13- 6.0- 52	1	
7748820-03	2.18-17.0- 43		
774814-10	2.13- 5.0- 17	1	
7839254-10	2.17- 8.0- 55	1	M
7839379-10	2.17-16.0-		
7839435-01	2.20-17.0- 10	1	P1
7839435-02	2.20-17.0- 10	1	P1
7839890-10	2.18-25.0- 2	1	
7839891-01	2.18-25.0- 20	1	
7839891-10	2.18-25.0- 17	1	
7839892-01	2.17-29.0- 44	1	
	2.17-29.0- 45	1	
	2.17-29.0- 46	1	
	2.17-29.0- 47	1	
7839892-03	2.17-29.0- 48	1	
7839892-05	2.17-29.0- 55	1	
7839892-23	2.17-21.0- 38	1	
7839892-25	2.17-21.0- 66	1	
7839892-35	2.17-31.0- 41	1	
7839900-10	2.18-25.0-	1	
7839900-30	2.18-25.0-	1	
7839904-10	2.18-25.0-	1	
7839912-10	2.18-25.0- 45	1	
7839914-10	2.18-25.0- 48	2	
7839925-10	2.18-25.0- 10	1	
7839926-10	2.18-25.0- 33	1	
7839928	2.18-25.0- 23	1	
7839929-01	2.18-25.0- 27	1	
7839931-10	2.18-25.0- 34	1	
7839932-10	2.18-25.0- 33	1	
7839933-01	2.18-25.0- 21	1	
7839935-01	2.18-25.0- 32	1	
7839936-01	2.18-25.0- 42	2	
7839937-10	2.18-25.0- 38	1	
7839941-01	2.18-25.0- 24	1	
7839946-10	2.16- 8.0- 35	1	
7839947-01	2.16- 8.0- 36	1	
7839949	2.18-25.0- 20	1	
7841459	2.16- 1.0- 45	1	
	2.16- 1.0- 69	1	

PART NUMBER	FIGURE AND INDEX NUMBER	QTY PER ART	SMR CODE
	2.16- 1.0- 78	1	
7841466-10	2.17-11.0-150	1	
7841466-30	2.17-11.0-154	1	
7841467	2.17-11.0-159	1	
7841468-10	2.17-11.0-160	1	
7841471	2.17-11.0-155	1	
7841520	2.17- 9.0- 4	1	
7355-11	2.15-25.0- 21	1	P1
7855-9	2.15-25.0- 21	1	P1
79-012-062-062			
5	2.13-22.0- 21	1	X1
79-022-094-075	2.10-36.0- 17	1	
7902975	2.14- 4.0-133	1	
	2.18-38.0- 1	1	
7902976	2.18-38.0- 13	1	
7902977-2	2.18-38.0- 15	1	
7902977-3	2.18-38.0- 14	1	
7947102-10	2.17-11.0- 58	1	
7947366-10	2.20-23A.0-1	4	
	2.20-23B.0-1	4	
	2.20-23A.0-3	1	
	2.20-23B.0-3	1	
7947368-10	2.20-23B.0-9	4	
7947372-10	2.20-23B.0-9	1	
7947373-10	2.20-23A.0-4	1	
	2.20-23B.0-4	1	
	2.20-23A.0-5	4	
7947375-10	2.20-23B.0-5	4	
	2.20-23A.0-8	1	
7947403-01	2.20-23A.0-12		
7947404	2.20-23A.0-		RF
7947406	2.20-23A.0-		RF
7947409	2.20-23B.0-		RF
7947437-10	2.9-28.0-55	1	
7947451-10	2.10- 7.0-121	1	M
7951889	2.18-38.0- 6	1	
7952028-301	2.18-38.0- 7	1	
8-00053-1	2. 1- 1.0-	1	
8-00053-3	2. 1- 1.0-	1	U
8-00053-5	2. 1- 1.0-	1	U
8-00053-603	2. 1- 1.0-	1	U
	2. 1- 1.0-	1	
8-00053-807	2. 1- 1.0-	1	U
8-00686-1	2. 2- 8.0- 6	2	M
	2.13-21.0- 9	2	
6-00967	2.10-10.0- 6	2	P
8-01331-1	2. 2-21.0- 15		RF P
8-01331-2	2. 2-21.0- 16	1	P
8-01333-1	2. 2-21.0- 15		RF P
8-01333-2	2. 2-21.0- 16		RF P
8-02397-1645	2.12-21.0-173	1	
8-02932-1	2.13-23.0- 24	1	P
8-02986-11	2.12-38.0- 33	1	
8-0313-7	2.17- 8.0- 63	1	P1
8-04291	2.15-22.0- 11	1	
	2.15-23.0- 35	1	
8-05029-7	2.17-23.0- 3	2	
8-06289-1 REV	2.20-2.0-8	1	
8-06289-3	2.16-25.0- 13	1	P
	2.17-16.0- 1	1	
8-06289A	2.20-3.0-35	1	
	2.20- 3.0- 41	1	
8-06289A3	2.20- 2.0- 7	3	
	2.20-3.0-36	1	
	2.20- 3.0- 40	1	
8-06425	2.14- 4.0-115	1	
8-06900A	2.20- 2.6- 6	3	
8-06963-3	2.16- 2.0- 53	1	
8-08056-5	2. 3- 6.0- 8	1	
8-09271	2.16-13.0- 12	1	

PART NUMBER	FIGURE AND INDEX NUMBER	QTY PER ART	SMR CODE
8-09296-3	2.10-31.0- 2	1	
8-09296-5	2.10-29.0- 35	1	
8-09296-7	2.10-28.0- 5	1	
8-09425-1	2. 5- 5.0- 3	1	
8-09572-1	2.16- 4.0- 31	3	
8-09939-5	2.12-65.0- 21	1	P1
	2.12-65.0- 21	RF	
8-1000-5	2.20-31.0- 97	1	P1
8-10040-1	2. 1- 1.0- 47	1	U
	2. 6- 2.0-	RF	
8-10040-2	2. 1- 1.0- 47	1	U
	2. 6- 2.0-	RF	
8-10040-3	2. 6- 2.0- 15	1	X1
8-10040-4	2. 6- 2.0- 15	1	X1
8-10040-5	2. 6- 2.0- 19	1	X1
	2. 6-18.0-	RF	
8-10040-525	2. 6- 2.0- 15	RF	P1
	2. 6- 3.0-	RF	
8-10040-526	2. 6- 2.0- 15	RF	P1
	2. 6- 3.0-	RF	
8-10040-527	2. 6- 2.0- 15	1	P1
	2. 6- 3.0-	1	
8-10040-528	2. 6- 2.0- 15	1	P1
	2. 6- 3.0-	1	
8-10040-6	2. 6- 2.0- 19	1	
	2. 6-18.0-	RF	X1
8-10040-7	2. 6- 2.0- 15	1	X1
8-10040-8	2. 6- 2.0- 15	1	X1
8-10040-801	2. 1- 1.0- 47	1	X1
	2. 6- 2.0-	RF	
8-10040-802	2. 1- 1.0- 47	1	X1
	2. 6- 2.0-	RF	
8-10040-805	2. 1- 1.0- 47	1	U
	2. 6- 2.0-	RF	
8-10040-806	2. 1- 1.0- 47	1	U
	2. 6- 2.0-	RF	
8-10040-811	2. 6- 2.0- 19	1	X1
	2. 6-18.0-	RF	
8-10040-813	2. 6- 2.0- 15	1	X1
8-1005-5	2.14-11.0- 31	RF	
8-10050-1	2. 6- 2.0- 16	1	U
	2. 6-18.0-	RF	
8-10050-11	2. 6-16.0- 34	AR	M
8-10050-13	2. 6-16.0- 33	AR	M
8-10050-15	2. 6-16.0- 36	AR	M
8-10050-2	2. 6- 2.0- 16	1	U
	2. 6-18.0-	RF	
8-10050-7	2. 6-16.0- 27	1	A
	2. 6-17.0-	RF	
8-10050-8	2. 6-16.0- 27	1	A
	2. 6-17.0-	RF	
8-10050-9	2. 6-16.0- 35	AR	M
8-10060-1	2. 1- 1.0- 47	1	U
	2. 6- 1.0-	RF	
8-10060-2	2. 1- 1.0- 47	1	
	2. 6- 1.0-	RF	
8-10060-3	2. 6- 1.0- 15	1	X1
8-10060-4	2. 6- 1.0- 15	1	X1
8-10060-5	2. 6- 1.0- 19	1	X1
	2. 6-18.0-	RF	
8-10060-501	2. 6- 1.0- 15	RF	P1
	2. 6- 3.0-	RF	
8-10060-502	2. 6- 1.0- 15	RF	P1
	2. 6- 3.0-	RF	
8-10060-505	2. 6- 1.0- 15	1	P1

PART NUMBER	FIGURE AND INDEX NUMBER	QTY PER ART	SMR CODE
8-10060-515	2. 6- 3.0-	1	P1
8-10060-506	2. 6- 1.0- 15	1	P1
	2. 6- 3.0-	1	
8-10060-6	2. 6- 1.0- 19	1	X1
	2. 6-18.0-	RF	
8-10060-7	2. 6- 1.0- 15	1	X1
8-10060-8	2. 6- 1.0- 15	1	X1
8-10060-805	2. 1- 1.0- 47	1	U
	2. 6- 1.0-	RF	
8-10060-805	2. 1- 1.0- 47	1	U
	2. 6- 1.0-	RF	
8-10070-1	2. 6- 1.0- 16	1	U
	2. 6-16.0-	RF	
8-10070-11	2. 6-16.0- 34	RF	M
8-10070-13	2. 6-16.0- 33	RF	M
8-10070-15	2. 6-16.0- 36	RF	M
8-10070-17	2. 6-16.0- 27	1	A
	2. 6-17.0-	RF	
8-10070-18	2. 6-16.0- 27	1	A
	2. 6-17.0-	RF	
8-10070-2	2. 6- 1.0- 16	1	U
	2. 6-16.0-	RF	
8-10070-7	2. 6-16.0- 27	1	A
	2. 6-17.0-	RF	
8-10070-8	2. 6-16.0- 27	1	A
	2. 6-17.0-	RF	
8-10070-9	2. 6-16.0- 35	RF	
8-1008-4	2. 6-32.0- 46	1	
8-100855	2.12- 1.0- 74	1	P1
8-100855	2.12- 1.0- 74	1	
8-100855	2.12-25.0- 1	1	
	2.12-53.0- 12	1	
8-100855	2.12-25.0- 1	RF	
	2.12-53.0- 12	RF	
8-11904-10	2. 6-13.0- 8	1	
8-11904-9	2. 6-13.0- 8	1	
8-11905-7	2. 2-21.0- 28	1	
8-11908-8	2. 2-21.0- 28	1	
8-11916-11	2. 2-21.0- 6	RF	P1
8-11916-11	2. 2-21.0- 6	RF	P1
8-11916-12	2. 2-21.0- 6	RF	P1
8-11916-7	2. 2-21.0- 6	RF	P1
8-11916-9	2. 2-21.0- 6	RF	P1
8-12918	2.14- 2.0- 5	1	
8-12918-7	2. 9-14.0- 18	1	
8-12918-11	2. 6-34.0- 6	RF	X1
8-12932-9	2. 6- 6.0- 11	2	P
	2. 6- 7.0- 11	2	
	2. 6- 9.0- 15	2	
8-13020-1	2. 6- 2.0- 12	1	U
	2. 6- 7.0-	RF	
8-13020-2	2. 6- 2.0- 12	1	U
	2. 6- 7.0-	RF	
8-13020-520	2. 6- 6.0- 34	RF	P1
	2. 6- 7.0- 34	RF	
	2. 6-12.0-	RF	
8-13020-526	2. 6- 6.0- 34	RF	P1
	2. 6- 7.0- 34	RF	
	2. 6-12.0-	RF	
8-13020-527	2. 6- 7.0- 17	RF	P1
	2. 6- 9.0-	RF	
8-13020-528	2. 6- 7.0- 17	RF	P1
	2. 6- 9.0-	RF	
8-13031-1	2. 6- 6.0- 34	RF	X1

PART NUMBER	FIGURE AND INDEX NUMBER	QTY PER ART	SMR CODE	PART NUMBER	FIGURE AND INDEX NUMBER	QTY PER ART	SMR CODE
8-13031-1	2. 6- 7.0- 34	RF	X1	8-13062-2	2. 6- 9.0- 17	RF	X1
	2. 6-10.0-	RF		8-13062-3	2. 6- 6.0- 17	1	X1
	2. 6-12.0- 20	1			2. 6- 8.0-	RF	
8-13031-15	2. 6-10.0- 1	1	P		2. 6- 9.0- 17	RF	
8-13031-2	2. 6- 6.0- 34	RF	X1	8-13062-4	2. 6- 6.0- 17	1	X1
	2. 6- 7.0- 34	RF			2. 6- 8.0-	RF	
	2. 6-10.0-	RF			2. 6- 9.0- 17	RF	
	2. 6-12.0- 20	1		8-13101-1	2. 6-10.0- 14	1	X2
8-13031-801	2. 6- 6.0- 34	1	X1	8-13101-11	2. 6-34.0- 7	1	X2
	2. 6- 7.0- 34	1		8-13101-2	2. 6-10.0- 14	1	X2
	2. 6-10.0-	1		8-13101-3	2. 6- 8.0- 14	1	X2
8-13031-802	2. 6- 6.0- 34	1	X1		2. 6-14.0-	RF	
	2. 6- 7.0- 34	1		8-13101-4	2. 6- 8.0- 14	1	X2
	2. 6-10.0-	RF			2. 6-14.0-	RF	
8-13031-805	2. 6- 6.0- 34	1	X1	8-13101-5	2. 6- 8.0- 13	1	X2
	2. 6-10.0-	RF			2. 6-34.0-	RF	
8-13031-806	2. 6- 6.0- 34	1	X1	8-13101-6	2. 6- 8.0- 13	1	X2
	2. 6-10.0-	1			2. 6-34.0-	RF	
8-13031-807	2. 6- 6.0- 34	1	X1	8-13101-7	2. 6-10.0- 25	1	X2
	2. 6-10.0-	RF		8-13101-9	2. 6-14.0- 8	1	X2
8-13031-808	2. 6- 6.0- 34	1	X1	8-13111-11	2. 6-34.0- 7	1	X2
	2. 6-10.0-	RF		8-13111-12	2. 6-34.0- 7	1	X2
8-13032-1	2. 6- 7.0- 17	1	X1	8-13111-3	2. 6- 8.0- 14	1	X2
	2. 6- 8.0-	RF			2. 6-14.0-	RF	
	2. 6- 9.0- 17	RF	X1	8-13111-4	2. 6- 8.0- 14	1	X2
8-13032-2	2. 6- 7.0- 17	1			2. 6-14.0-	RF	
	2. 6- 8.0-	RF		8-13111-5	2. 6- 8.0- 13	1	X2
	2. 6- 9.0- 17	RF			2. 6-34.0-	RF	
8-13040-5	2. 6-10.0- 2	1	P1D	8-13111-6	2. 6- 8.0- 13	1	X2
8-13040-6	2. 6-10.0- 2	1	P1D		2. 6-34.0-	RF	
8-13040-701	2. 6-10.0- 2	RF	P1D	8-13111-9	2. 6-14.0- 8	1	X2
8-13040-702	2. 6-10.0- 2	RF	P1D	8-13140-10	2. 6-10.0- 7	1	P2
8-13040-703	2. 6- 8.0- 1	RF	P1D	8-13140-7	2. 6-10.0- 7	1	P1
8-13040-704	2. 6- 8.0- 1	RF	P1D	8-13140-8	2. 6-10.0- 7	1	P1
8-13040-801	2. 6- 8.0- 1	1	P1D	8-13140-9	2. 6-10.0- 7	1	P1
8-13040-802	2. 6- 8.0- 1	1	P1D	8-13141-10	2. 6-10.0- 8	1	P1
8-13040-805	2. 6- 8.0- 1	1	P1D	8-13141-7	2. 6-10.0- 8	1	P1
8-13040-806	2. 6- 8.0- 1	1	P1D	8-13141-8	2. 6-10.0- 8	1	P1
8-13040-807	2. 6-10.0- 2	1	P1D	8-13141-9	2. 6-10.0- 8	1	P1
8-13040-808	2. 6-10.0- 2	1	P1D	8-13142-7	2. 6- 8.0- 15	1	P1D
8-13040-809	2. 6-10.0- 1	1	P1D	8-13142-8	2. 6- 8.0- 15	1	P1D
8-13040-810	2. 6-10.0- 2	1	P1D	8-13143-10	2. 6- 8.0- 17	1	P1D
8-13040-811	2. 6-10.0- 2	RF	P1D	8-13143-7	2. 6- 8.0- 16	1	P2
8-13040-812	2. 6-10.0- 2	RF	P1D	8-13143-8	2. 6- 8.0- 16	1	P1D
8-13040-813	2. 6-10.0- 2	1	P1D	8-13143-9	2. 6- 8.0- 17	1	P1D
8-13040-814	2. 6-10.0- 2	1	P1D	8-13152-7	2. 6- 8.0- 15	1	P1D
8-13040-815	2. 6- 8.0- 1	1	P1D	8-13152-6	2. 6- 8.0- 15	1	P1D
8-13040-816	2. 6- 8.0- 1	1	P1D	8-13153-10	2. 6- 8.0- 17	1	P1D
8-13040-817	2. 6-10.0- 2	1	P2	8-13153-7	2. 6- 8.0- 16	1	P1D
8-13040-818	2. 6-10.0- 2	1	P2	8-13153-8	2. 6- 8.0- 16	1	P1D
8-13040-819	2. 6- 8.0- 1	1	P2	8-13153-9	2. 6- 8.0- 17	1	P1D
8-13040-820	2. 6- 8.0- 1	1	P2	8-13362	2. 6-10.0- 35	1	P
8-13050-1	2. 6- 1.0- 12	1	U	8-13363-1	2. 6-10.0- 31	1	A
	2. 6- 6.0-	RF		8-13363-10	2. 6-10.0- 33	1	P
8-13050-2	2. 6- 1.0- 12	1	U	8-13363-11	2. 6-10.0- 34	1	P
	2. 6- 6.0-	RF		8-13363-12	2. 6-10.0- 34	1	P
8-13050-503	2. 6- 6.0- 17	RF	P1	8-13363-2	2. 6-10.0- 31	1	A
	2. 6- 8.0-	RF		8-13363-7	2. 6-10.0- 32	1	P
8-13050-504	2. 6- 6.0- 17	RF	P1	8-13363-9	2. 6-10.0- 33	1	P2
	2. 6- 9.0-	RF		8-13364-1	2. 6- 8.0- 28	1	A
8-13062-1	2. 6- 6.0- 17	1	X1	8-13364-17	2. 6- 8.0- 29	1	PD
	2. 6- 8.0-	RF		8-13364-18	2. 6- 8.0- 30	1	P
	2. 6- 9.0- 17	RF		8-13364-2	2. 6- 8.0- 28	1	A
8-13062-2	2. 6- 6.0- 17	1	X1	8-13364-20	2. 6- 8.0- 30	1	P
	2. 6- 8.0-	RF		8-13365-9	2. 6- 8.0- 18	1	P1

PART NUMBER	FIGURE AND INDEX NUMBER	QTY PER ART	SMR CODE
8-13376-7	2. 6- 8.0- 19	1	P
8-13377-7	2. 6- 8.0- 21	1	P
8-13378-7	2. 6- 8.0- 21	1	PD
8-13379-13	2. 6- 8.0- 22	1	PD
8-13379-14	2. 6- 8.0- 22	1	P2
8-13379-15	2. 6- 8.0- 23	1	PD
8-13379-16	2. 6- 8.0- 23	1	PD
8-13379-19	2. 6- 8.0- 27	1	PD
8-13379-20	2. 6- 8.0- 27	1	PD
8-13379-23	2. 6-10.0- 15	1	P2
8-13379-24	2. 6-10.0- 15	1	PD
8-13379-25	2. 6-10.0- 13	1	P2
8-13379-26	2. 6-10.0- 13	1	PD
8-13379-27	2. 6-10.0- 12	1	PD
8-13379-28	2. 6-10.0- 12	1	PD
8-13379-31	2. 6-10.0- 10	1	PD
8-13379-32	2. 6-10.0- 10	1	PD
8-13379-37	2. 6-10.0- 9	1	PD
8-13379-38	2. 6-10.0- 9	1	PD
8-13379-41	2. 6- 8.0- 28	1	PD
8-13379-42	2. 6- 8.0- 28	1	P2
8-13379-45	2. 6- 8.0- 25	1	PD
8-13379-46	2. 6- 8.0- 25	1	PD
8-13379-47	2. 6- 8.0- 24	1	PD
8-13379-48	2. 6- 8.0- 24	1	PD
8-13379-49	2. 6-34.0- 8	1	PD
8-13379-50	2. 6-34.0- 8	1	PD
8-13379-51	2. 6- 8.0- 26	1	PD
8-13379-52	2. 6- 8.0- 26	1	PD
8-13379-57	2. 6-10.0- 11	1	PD
8-13379-58	2. 6-10.0- 11	1	PD
8-13379-59	2. 6- 8.0- 25	1	P2
8-13379-60	2. 6- 8.0- 25	1	P2
8-13379-63	2. 6- 8.0- 27	1	PD
8-13379-64	2. 6- 8.0- 27	1	PD
8-13379-65	2. 6-10.0- 11	1	PD
8-13379-66	2. 6-10.0- 11	1	PD
8-13379-7	2. 6-10.0- 16	1	P2
8-13379-8	2. 6-10.0- 16	1	PD
8-13380-1	2. 6-10.0- 36	1	A
8-13387-7	2. 6- 8.0- 20	1	PD
8-13387-6	2. 6- 8.0- 20	1	PD
8-13388-10	2. 6- 8.0- 21	1	PD
8-13388-7	2. 6- 8.0- 21	1	PD
8-13388-8	2. 6- 8.0- 21	1	PD
8-13388-9	2. 6- 8.0- 21	1	PD
8-13601-15	2. 2-19.0- 26	1	M
	2. 6-12.0- 12	1	M
8-13601-16	2. 2-19.0- 26	1	M
	2. 6-12.0- 12	1	M
8-13601-5	2. 2-19.0- 25	RF	U
	2. 6- 6.0- 30	1	
	2. 6- 7.0- 33	1	
	2. 6-12.0- 11	1	
8-13601-6	2. 2-19.0- 25	RF	U
	2. 6- 6.0- 30	1	
	2. 6- 7.0- 33	1	
	2. 6-12.0- 11	1	
8-13603-1	2. 2-20.0-	RF	M
	2. 6- 6.0- 1	1	
	2. 6- 7.0- 1	1	
8-13603-10	2. 2-20.0- 14	1	M
	2. 6-12.0- 7	1	
8-13603-11	2. 2-20.0- 13	1	M
	2. 6-12.0- 6	1	

PART NUMBER	FIGURE AND INDEX NUMBER	QTY PER ART	SMR CODE
8-13603-12	2. 2-20.0- 13	1	M
	2. 6-12.0- 6	1	
8-13603-13	2. 2-20.0- 12	1	M
	2. 6-12.0- 5	1	
8-13603-14	2. 2-20.0- 12	1	M
	2. 6-12.0- 5	1	
8-13603-15	2. 2-20.0- 11	1	M
	2. 6-12.0- 4	1	
8-13603-16	2. 2-20.0- 11	1	M
	2. 6-12.0- 4	1	
8-13603-17	2. 2-20.0- 10	1	M
	2. 6-12.0- 3	1	
8-13603-18	2. 2-20.0- 10	1	M
	2. 6-12.0- 3	1	
8-13603-19	2. 2-20.0- 9	1	M
	2. 6-12.0- 2	1	
8-13603-2	2. 2-20.0-	RF	M
	2. 6- 6.0- 1	1	
	2. 6- 7.0- 1	1	
8-13603-20	2. 2-20.0- 9	1	M
	2. 6-12.0- 2	1	
8-13603-21	2. 2-20.0- 8	1	M
	2. 6-12.0- 1	1	
8-13603-22	2. 2-20.0- 8	1	M
	2. 6-12.0- 1	1	
8-13603-23	2. 2-20.0- 7	1	M
	2. 6- 9.0- 7	1	
8-13603-24	2. 2-20.0- 7	1	M
	2. 6- 9.0- 7	1	
8-13603-25	2. 2-20.0- 6	1	M
	2. 6- 9.0- 6	1	
8-13603-26	2. 2-20.0- 6	1	M
	2. 6- 9.0- 6	1	
8-13603-27	2. 2-20.0- 5	1	M
	2. 6- 9.0- 5	1	
8-13603-28	2. 2-20.0- 5	1	M
	2. 6- 9.0- 5	1	
8-13603-29	2. 2-20.0- 5	1	M
	2. 6- 9.0- 4	1	
8-13603-30	2. 2-20.0- 4	1	M
	2. 6- 9.0- 4	1	
8-13603-31	2. 2-20.0- 3	1	M
	2. 6- 9.0- 3	1	
8-13603-32	2. 2-20.0- 3	1	M
	2. 6- 9.0- 3	1	
8-13603-33	2. 2-20.0- 2	1	M
	2. 6- 9.0- 2	1	
8-13603-34	2. 2-20.0- 2	1	M
	2. 6- 9.0- 2	1	
8-13603-35	2. 2-20.0- 1	1	M
	2. 6- 9.0- 1	1	
8-13603-36	2. 2-20.0- 1	1	M
	2. 6- 9.0- 1	1	
8-13603-37	2. 2-20.0- 15	1	M
8-13603-38	2. 2-20.0- 15	1	M
8-13603-7	2. 2-20.0- 15	1	M
	2. 6-12.0- 8	1	
8-13603-8	2. 2-20.0- 15	1	M
	2. 6-12.0- 8	1	
8-13603-9	2. 2-20.0- 14	1	M
	2. 6-12.0- 7	1	
8-13700-1	2. 6-10.0- 26	1	X2
8-13700-11	2. 6-10.0- 31	1	X1
8-13700-12	2. 6-10.0- 31	1	X1
8-13700-13	2. 6-10.0- 31	1	X1

PART NUMBER	FIGURE AND INDEX NUMBER	QTY PER ART	SMR CODE
8-13700-14	2. 6-10.0- 31	1	X1
8-13700-2	2. 6-10.0- 26	1	X2
8-13703-3	2. 6- 6.0- 10	1	P
	2. 6- 7.0- 10	1	
	2. 6- 8.0- 11	1	
8-13703-9	2. 6- 6.0- 12	1	X1
	2. 6- 7.0- 12	1	
	2. 6- 9.0- 16	1	
8-13717	2. 6-17.0- 12	2	P
8-13718	2.14-25.0- 14	2	P
8-13719	2. 6- 8.0- 5	1	P
8-13720-1	2. 6- 8.0- 6	1	X1
8-13720-2	2. 6- 8.0- 6	1	X1
8-13720-7	2. 6- 8.0- 12	1	X1
6-13720-8	2. 6- 8.0- 12	1	X1
8-13721	2. 6-17.0- 13	2	P1
8-13722	2. 6-17.0- 5	2	P
8-13724-10	2. 6-10.0- 6	1	P1
8-13724-13	2. 6- 8.0- 4	1	M1
8-13724-7	2. 6- 8.0- 4	1	P1
8-13724-713	2. 6-10.0- 6	1	P1
8-13724-714	2. 6-10.0- 6	1	P1
8-13724-715	2. 6- 8.0- 4	1	P1
8-13724-716	2. 6- 8.0- 4	1	P1
8-13724-8	2. 6- 8.0- 4	1	P1
8-13724-9	2. 6-10.0- 6	3	P1
8-13725-11	2. 6-10.0- 5	1	P
8-13725-7	2. 6-10.0- 5	1	P
8-13725-9	2. 6- 8.0- 4	1	P
8-13730-10	2. 6-10.0- 4	1	P1D
8-13730-7	2. 6- 8.0- 3	1	P1D
8-13733-8	2. 6- 8.0- 3	1	P1D
8-13733-9	2. 6-10.0- 4	1	P1D
8-13749-1	2. 6-17.0- 11	1	A
8-13749-10	2. 6-17.0- 14	1	P2
8-13749-2	2. 6-17.0- 11	1	A
8-13749-3	2. 6-17.0- 11	1	A
8-13749-4	2. 6-17.0- 11	1	A
8-13749-9	2. 6-17.0- 14	1	P2
8-13750-1	2. 6-10.0- 19	1	P2
8-13750-9	2. 6-10.0- 24	1	X1
8-13751-9	2. 6-10.0- 24	1	P1
8-13753-1	2. 6-14.0- 1	1	P2
8-13753-9	2. 6-14.0- 7	1	X1
6-13754-1	2. 6-34.0- 1	1	P1
8-13754-9	2. 6-34.0- 6	1	X1
8-13755	2.14-11.0- 39	2	P1
8-13756	2. 6- 8.0- 11	2	P1
8-13757	2. 6-14.0- 2	RF	P1
8-13758	2. 6-10.0- 17	RF	P1
8-13758-7	2. 6-10.0- 23	PF	X1
	2. 6-14.0- 7	RF	
8-13777-1	2. 6-10.0- 17	1	P1
6-13777-7	2. 6-10.0- 23	1	X1
8-13778-1	2. 6-14.0- 2	RF	P1
8-13778-7	2. 6-14.0- 7	1	X1
8-13901-1	2. 6- 6.0- 6	1	P
	2. 6- 7.0- 6	1	
	2. 6-12.0- 18	1	
8-13901-2	2. 6- 6.0- 6	1	P
	2. 6- 7.0- 6	1	
	2. 6-12.0- 18	1	
8-13902-7	2. 6- 6.0- 46	AR	P
	2. 6- 7.0- 46	AR	P
	2. 6-12.0- 34	1	

PART NUMBER	FIGURE AND INDEX NUMBER	QTY PER ART	SMR CODE
8-13902-9	2. 6- 6.0- 46	AR	P
	2. 6- 7.0- 46	AR	
	2. 6-12.0- 34	1	
8-13903-1	2. 6- 6.0- 4	1	P2
	2. 6- 7.0- 4	1	
	2. 6-12.0- 15	1	
8-13903-2	2. 6- 6.0- 4	1	P
	2. 6- 7.0- 4	1	
	2. 6-12.0- 15	1	
8-13932	2. 6- 9.0- 2	2	PD
	2. 6-10.0- 3	2	
8-13938	2. 6-11.0- 20	2	M
8-13939-1	2. 6-11.0-	RF	U
	2. 6-16.0- 26	1	
8-13939-2	2. 6-11.0-	RF	U
	2. 6-16.0- 26	1	
8-13940-39	2. 6-11.0- 1	1	P
8-13940-41	2. 6-11.0- 2	1	P
8-13940-47	2. 6-11.0- 7	1	M1
8-13940-67	2. 6-11.0- 16	1	X1
8-13940-69	2. 6-11.0- 17	1	P
8-13940-70	2. 6-11.0- 17	1	M
8-13940-71	2. 6-11.0- 18	1	M
8-13940-72	2. 6-11.0- 18	1	M
8-13940-73	2. 6-11.0- 9	1	P2
8-13940-74	2. 6-11.0- 9	1	P
8-13940-75	2. 6-11.0- 13	1	X1
8-13940-77	2. 6-11.0- 14	1	M
8-13940-78	2. 6-11.0- 14	1	M
8-13940-79	2. 6-11.0- 15	1	M
8-13940-80	2. 6-11.0- 15	1	M
8-13940-81	2. 6-11.0- 8	1	P
8-13940-82	2. 6-11.0- 8	1	P
8-13940-91	2. 6-11.0- 19	1	M
8-13940-92	2. 6-11.0- 19	1	M
8-14025-3	2. 3-14.0- 33	1	U
	2. 7- 6.0-	RF	
8-14035	2. 7- 6.0- 7	1	U
	2. 7- 8.0-	RF	
8-14035-1	2. 7- 6.0- 7	1	U
	2. 7- 8.0-	RF	
8-14035-29	2. 7- 8.0- 1	1	X2
	2.14- 1.0- 17	RF	
8-14035-7	2. 7- 8.0- 1	1	X2
	2.14- 1.0- 17	RF	
8-14035-801	2. 7- 6.0- 7	1	U
	2. 7- 8.0-	RF	
8-14116	2. 2-18.0- 6	1	P1
8-14139-7	2. 2-18.0- 1	1	P1
8-14140-1	2. 2-18.0- 5	1	P1
8-14140-3	2. 2-18.0- 5	1	P1
8-14141-1	2. 2-18.0- 7	1	P2
8-14142-2	2. 2-18.0- 8	RF	P1
	2. 7- 8.0- 36	1	
8-14142-3	2. 2-18.0- 8	1	P1
8-14142-9	2. 2-18.0- 8	1	P2
8-14144-2	2. 2-18.0- 9	RF	P1
	2. 7- 8.0- 36	1	
8-14144-3	2. 2-18.0- 9	1	P1
8-14150-103	2. 7- 8.0- 34	RF	X2
8-14150-104	2. 7- 8.0- 34	RF	X2
8-14150-109	2. 7- 8.0- 34	RF	X2
8-14150-3	2. 7- 8.0- 34	1	P1
8-14150-4	2. 7- 8.0- 34	1	P1
8-14150-801	2. 7- 8.0- 34	1	P1

PART NUMBER	FIGURE AND INDEX NUMBER	QTY PER ART	SMR CODE
8-14151-104	2. 7- 8.0- 35	RF	X1
8-14151-105	2. 7- 8.0- 35	RF	X1
8-14151-4	2. 7- 8.0- 35	1	P1
8-14151-5	2. 7- 8.0- 35	1	P1
8-14152-103	2. 7- 8.0- 36	RF	X2
8-14152-104	2. 7- 8.0- 36	RF	X2
8-14152-3	2. 7- 8.0- 36	1	P1
8-14152-4	2. 7- 8.0- 36	1	P1
8-14228	2. 7- 4.0- 1	1	P1
8-14230-5	2. 3-14.0- 32	1	U
	2. 7- 4.0-	RF	
8-14232	2. 7- 4.0- 11	1	P2
8-14233-801	2. 7- 4.0- 5	1	P1
8-14234-1	2. 7- 4.0- 8	1	P2
8-14318	2. 7- 8.0- 1	1	U
8-14318-11	2. 7- 8.0- 15	1	M
8-14318-15	2. 7- 8.0- 2	1	A
8-14318-17	2. 7- 8.0- 20	1	M1
8-14329	2. 7- 8.0- 21	1	U
8-14329-33	2. 2-18.0- 4	1	M
8-14329-35	2. 2-18.0- 3	1	M
8-14329-37	2. 2-18.0- 2	1	M
8-14329-45	2. 2-18.0- 1	RF	M1
	2. 7- 8.0- 32	1	
8-14518	2.18- 3.0- 1	1	P1
8-14518-1	2.18- 3.0- 1	1	P1
8-14521-1	2.18- 2.0- 1	1	P1
8-14521-3	2.18- 2.0- 1	1	P1
8-14521-5	2.18- 2.0- 1	1	P1
8-14521-61	2.18- 2.0- 4	1	X1
8-14521-67	2.18- 2.0- 4	1	X1
8-14540	2. 7- 8.0- 33	1	U
	2.18- 3.0-	RF	U
8-14540-1	2. 3- 3.0- 69	1	U
	2.18- 2.0-	RF	
8-14618	2. 1- 1.0- 32	1	U
	2. 2-18.0- 5	RF	
8-14639	2. 1- 1.0- 35	1	U
	2. 2-18.0-	RF	
8-14640-3	2. 1- 1.0- 31	1	U
	2. 2-18.0- 4	RF	
8-14641-3	2. 1- 1.0- 34	1	U
	2. 2-18.0- 6	RF	
8-14642	2. 1- 1.0- 33	1	U
	2. 2-18.0- 7	RF	
	2. 2-18.0- 8	RF	U
8-14644	2. 1- 1.0- 35	1	U
	2. 2-18.0- 8	RF	
8-14650-1	2. 1- 1.0- 39	1	U
	2. 2-18.0- 13	RF	
8-14650-3	2. 1- 1.0- 38	1	U
	2. 2-18.0- 10	RF	
8-14650-5	2. 1- 1.0- 37	1	U
	2. 2-18.0- 10	RF	
8-14650-7	2. 2-18.0- 11	1	M
8-14655	2. 1- 1.0- 32	1	U
	2. 2-18.0- 5	RF	
8-14655-9	2. 2-18.0- 6	1	M
8-14733-7	2. 7- 8.0- 30	1	M
8-14733-8	2. 7- 8.0- 31	1	M
8-14734	2.18- 3.0- 8	1	P1
8-14764-1	2.14- 1.0- 20	1	X2
8-14769	2. 7- 8.0- 29	RF	X2
8-14791-7	2. 7- 8.0- 29	1	P2
8-14794	2.14- 1.0- 20	1	X2

PART NUMBER	FIGURE AND INDEX NUMBER	QTY PER ART	SMR CODE
8-14623-7	2. 7- 8.0- 14	1	M
8-14823-716	2. 7- 8.0- 19	AR	P
8-14823-9	2. 7- 5.0- 29	1	P
	2. 7- 9.0- 13	1	P
8-14935	2.18- 3.0- 7	1	P
8-15040	2. 7- 5.0- 15	1	X1
8-15040-1	2. 7- 5.0- 1	1	X1
	2. 7- 9.0- 1	1	
8-15040-13	2. 7- 5.0- 15	1	X1
8-15040-15	2. 7- 5.0- 13	1	P
8-15040-527	2. 7- 5.0- 1	RF	P1
	2. 7- 9.0-	RF	
8-15041	2. 3- 3.0- 70	1	U
	2. 7- 5.0-	RF	
8-15730-11	2. 7- 5.0- 16	RF	P1
8-15730-13	2. 7- 5.0- 17	RF	P1
8-15731-13	2. 7- 5.0- 16	1	P1
8-15737-13	2. 7- 5.0- 21	1	X1
8-15737-9	2. 7- 5.0- 18	1	P1
8-15738	2. 7- 5.0- 22	1	P1D
8-15739	2. 7- 5.0- 23	1	P1D
8-15740	2. 7- 8.0- 13	RF	P1
8-15741-1	2. 7- 8.0- 7	1	X1
8-15745-9	2. 7- 5.0- 17	1	P2
8-15750-7	2. 7- 8.0- 13	1	P1
8-15759	2. 7- 5.0- 21	RF	P1
8-15760	2. 7- 5.0- 21	1	X1
8-15761	2. 7- 5.0- 21	1	X1
8-15802-9	2. 7- 5.0- 19	1	P
	2. 7- 5.0- 21	1	
	2.14- 1.0- 19	1	
8-15803	2. 7- 5.0- 20	1	P
	2. 7- 5.0- 21	1	
	2.14- 1.0- 18	1	
8-15804	2.14-43.0- 5	4	P
8-15805	2. 7- 5.0- 25	2	P
	2. 7- 9.0- 7	2	P
8-15806	2. 7- 5.0- 24	2	P
	2. 7- 9.0- 6	2	
8-15809	2. 7- 5.0- 26	4	P
	2. 7- 9.0- 8	4	
8-15810	2. 7- 5.0- 27	4	P
	2. 7- 9.0- 9	4	
8-15840-13	2. 7- 5.0- 13	3	P
8-15840-7	2. 6-10.0- 22	2	P
	2. 6-12.0- 29	2	
	2. 6-14.0- 5	2	
	2. 6-34.0- 4	2	
8-15841-7	2. 7- 8.0- 11	1	P
8-15841-9	2. 7- 8.0- 8	1	P
8-16511	2.15-29.0- 8	1	P
8-16512-7	2.15-28.0- 7	2	P
8-16512-9	2.15-28.0- 7	2	P
8-17020	2.15-20.0- 7	2	M
8-17630-1	2. 6- 1.0- 14	1	U
	2. 6- 2.0- 14	1	
	2.15-19.0-	0	
8-17630-13	2.15-21.0- 19	1	PD
8-17630-14	2.15-21.0- 19	1	P2
8-17630-15	2.15-21.0- 20	1	PD
8-17630-16	2.15-21.0- 20	1	PD
8-17630-2	2. 6- 1.0- 14	1	U
	2. 6- 2.0- 14	1	
	2.15-19.0-	RF	
8-17630-525	2. 6- 1.0- 14	RF	P1

PART NUMBER	FIGURE AND INDEX NUMBER	QTY PER ART	SMR CODE
8-17630-525	2. 6- 2.0- 14	RF	P1
8-17630-526	2.15-19.0- 2. 6- 1.0- 14	RF RF	P1
8-17630-81	2. 6- 2.0- 14 2.15-19.0- 2.15-21.0-	1 RF	X1
8-17630-82	2.15-19.0- 24 2.15-21.0-	1 RF	X1
8-17630-83	2.15-21.0- 18	1	X1
8-17630-84	2.15-21.0- 18	1	X1
8-17630-87	2.15-21.0- 18	1	A
8-17630-86	2.15-21.0- 18	1	A
8-17630-89	2.15-21.0- 19	1	A
8-17630-90	2.15-21.0- 19	1	A
8-17671-11	2.15-19.0- 42	1	PD
8-17671-13	2.15-19.0- 43	RF	X1
8-17671-15	2.15-19.0- 43	1	X1
8-17671-16	2.15-19.0- 43	1	X1
8-17671-3	2.15-19.0- 32	1	P1
8-17671-4	2.15-19.0- 32	1	P1
8-17671-9	2.15-19.0- 41	1	PD
8-17672-1	2.15-19.0- 44	1	P1
8-17672-7	2.15-19.0- 53	1	X1
8-17672-9	2.15-19.0- 52	2	P
8-17675-1	2.15-20.0- 17	1	P1
8-17675-7	2.15-20.0- 20	1	X1
8-17675	2.15-20.0- 17	RF	P1
8-17676-1	2.15-20.0- 20	RF	X1
8-17677-7	2.15-21.0- 9	1	P
8-17677-8	2.15-21.0- 10	1	P
8-17680-10	2.15-21.0- 18	1	P
8-17680-7	2.15-21.0- 17	1	P
8-17680-8	2.15-21.0- 17	1	P
8-17680-9	2.15-21.0- 18	1	P
8-17681-11	2.15-19.0- 42	RF	M
8-17681-13	2.15-19.0- 43	RF	X1
8-17681-14	2.15-19.0- 43	RF	X1
8-17681-3	2.15-19.0- 32	RF	P1
8-17681-4	2.15-19.0- 32	RF	P1
8-17681-9	2.15-19.0- 41	RF	M
8-17682-1	2.15-19.0- 44	RF	P1
8-17682-11	2.15-19.0- 52	RF	P
8-17682-2	2.15-19.0- 44	RF	P1
8-17682-7	2.15-19.0- 53	RF	X1
8-17682-8	2.15-19.0- 53	RF	X1
8-17682-9	2.15-19.0- 52	RF	P
8-17683-1	2.15-21.0- 1	1	P2
8-17683-2	2.15-21.0- 1	1	P
8-17683-7	2.15-21.0- 4	1	X1
8-17683-8	2.15-21.0- 4	1	X1
8-17683-9	2.15-21.0- 3	2	M
8-17684-1	2.15-21.0- 5	1	P
8-17684-11	2.15-21.0- 7	1	P
8-17684-2	2.15-21.0- 5	1	P
8-17684-7	2.15-21.0- 8	1	X1
8-17684-8	2.15-21.0- 8	1	X1
8-17684-9	2.15-21.0- 6	1	P
8-17685-1	2.15-20.0- 1	1	P1
8-17685-7	2.15-20.0- 8	1	X1
8-17686	2.15-19.0- 8	2	P
8-17686-11	2.15-19.0- 21	2	P
8-17686-7	2.15-19.0- 22	1	X1
8-17686-9	2.15-19.0- 23	2	P
8-17688	2.15-19.0- 9	2	A

PART NUMBER	FIGURE AND INDEX NUMBER	QTY PER ART	SMR CODE
8-17688-1	2.15-19.0- 16	2	
8-17688-9	2.15-19.0- 15	2	A
8-17689	2.15-19.0- 27	1	P
8-17689-1	2.15-19.0- 27	1	P
8-17690	2.15-20.0- 1	RF	P1
8-17690-7	2.15-20.0- 8	RF	X1
8-17691-1	2.15-20.0- 9	RF	A
8-17691-2	2.15-20.0- 9	RF	A
8-17691-7	2.15-20.0- 16	RF	X1
8-17691-8	2.15-20.0- 16	RF	X1
8-17691-9	2.15-20.0- 15	RF	P
8-17695	2.15-19.0- 35	3	P
	2.15-19.0- 47	3	
8-17696-7	2.15-19.0- 40	2	P
8-17696-9	2.15-21.0- 2	1	P
8-17697-11	2.15-19.0- 42	RF	P
8-17697-13	2.15-21.0- 3	RF	P
8-17697-15	2.15-21.0- 7	RF	P
8-17697-17	2.15-19.0- 21	RF	P
8-17697-19	2.15-19.0- 52	RF	P
8-17698-1	2.15-20.0- 9	1	P1
8-17698-2	2.15-20.0- 9	1	P1
8-17698-7	2.15-20.0- 16	1	X1
8-17698-8	2.15-20.0- 16	1	X1
8-17698-9	2.15-20.0- 15	2	P
8-17699-1	2.15-19.0- 2	1	P1
	2.15-20.0-	RF	
8-17699-2	2.15-19.0- 3	1	P1
	2.15-20.0-	RF	
8-17854-11	2. 6-35.0- 23	1	M
	2. 6-36.0- 11	1	
	2. 6-36.0- 13	1	
	2. 6-37.0- 23	2	
	2. 6-37.0- 26	1	
	2. 6-37.0- 7	1	
8-17854-15	2. 6-36.0- 8	1	P
8-17854-17	2. 6-35.0- 9	1	X2
	2. 6-36.0- 14	1	X2
8-17854-21	2. 6-36.0- 10	1	X2
8-17854-9	2. 6-35.0- 9	1	M
	2. 6-36.0- 7	1	
	2. 6-36.0- 8	1	
8-17947	2. 6-17.0- 6	1	P
8-17975-13	2. 6-16.0- 12	4	P
8-17975-7	2. 6-16.0- 13	4	P
8-18002-1	2. 6-32.0- 90	1	
	2. 6-33.0-	RF	
8-18002-2	2. 6-32.0- 90		U
	2. 6-33.0-	RF	
8-18003-1	2. 6- 3.0- 21	1	X1
	2. 6-18.0- 5	1	
8-18003-2	2. 6- 3.0- 21	1	X1
	2. 6-18.0- 5	1	
	2. 6-32.0-	RF	
8-18003-803	2. 6-18.0- 5	1	X1
	2. 6-32.0-	RF	
8-18004-10	2. 6-13.0- 8	1	P2
8-18004-7	2. 6-15.0- 1	1	P1
8-18004-8	2. 6-15.0- 1	1	P1
8-18004-9	2. 6-13.0- 8	1	P1
8-18012-1	2. 6-32.0- 90	1	U
	2. 6-33.0-	RF	
8-18012-2	2. 6-32.0- 90	1	U
	2. 6-33.0-	RF	

PART NUMBER	FIGURE AND INDEX NUMBER	QTY PER ART	SMR CODE
8-18012-801	2. 6-32.0- 90	RF	U
	2. 6-33.0-	RF	
8-18012-802	2. 6-32.0- 90		U
	2. 6-33.0-	RF	
8-18012-803	2. 6-32.0- 90	1	U
	2. 6-33.0-	RF	
8-18012-804	2. 6-32.0- 90		U
	2. 6-33.0-	RF	
8-18012-807	2. 6-32.0- 90	1	U
	2. 6-33.0-	RF	
8-18012-808	2. 6-32.0- 90	1	U
	2. 6-33.0-	RF	
8-18012-811	2. 6-32.0- 90	1	U
	2. 6-33.0-	RF	
8-18012-812	2. 6-32.0- 90	1	U
	2. 6-33.0-	RF	
8-18012-817	2. 6-33.0-	RF	U
8-18012-818	2. 6-32.0- 70	1	U
	2. 6-33.0-	RF	
8-18013-1	2. 6-18.0- 5	1	X1
	2. 6-32.0-	RF	
8-18013-2	2. 6-18.0- 5	1	X1
	2. 6-32.0-	RF	
8-18013-831	2. 6-18.0- 5	1	X1
	2. 6-32.0-	RF	
8-18013-802	2. 6-18.0- 5	1	X1
	2. 6-32.0-	RF	
8-18013-805	2. 6-18.0- 5	1	
	2. 6-32.0-	RF	X1
8-18013-806	2. 6-18.0- 5	1	X1
	2. 6-32.0-	RF	
8-18013-809	2. 6-18.0- 5	1	X1
	2. 6-32.0-	RF	
8-18013-810	2. 6-18.0- 5	1	X1
	2. 6-32.0-	RF	
8-18013-811	2. 6- 3.0- 21	1	X1
	2. 6-18.0- 5	1	
	2. 6-32.0-	RF	
	2. 6-32.0-		
8-18013-812	2. 6- 3.0- 21	1	X1
	2. 6-18.0- 5	1	
	2. 6-32.0-	RF	
8-18013-815	2. 6-18.0- 5	1	X1
	2. 6-32.0-	RF	
8-18013-816	2. 6-18.0- 5	1	X1
	2. 6-32.0-	RF	
8-18013-819	2. 6-18.0- 5	1	X1
	2. 6-32.0-	RF	
8-18013-823	2. 6-18.0- 5	1	
	2. 6-32.0-	RF	X1
8-18030-1	2. 6-33.0- 1	1	X2
	2. 6-35.0-	RF	
8-18030-15	2. 6-35.0- 13	1	X2
8-18030-16	2. 6-35.0- 13	1	X2
8-18030-2	2. 6-33.0- 1	1	X2
	2. 6-35.0-	RF	
8-18031-5	2. 6-33.0- 3	RF	U
	2. 6-33.0- 3	1	
	2. 6-39.0-	RF	
	2. 6-39.0-	1	
8-18031-59	2. 6-34.0- 11	1	A
8-18031-6	2. 6-33.0- 3	1	U
	2. 6-33.0- 3	RF	
	2. 6-39.0-	RF	
	2. 6-39.0-	1	

PART NUMBER	FIGURE AND INDEX NUMBER	QTY PER ART	SMR CODE
8-18031-60	2. 6-39.0- 11	1	A
8-18031-7	2. 6-39.0- 11	1	X2
8-18031-8	2. 6-39.0- 11	1	X2
8-18032-1	2. 6-33.0- 4	1	U
	2. 6-36.0-	RF	
8-18032-2	2. 6-33.0- 4	1	U
	2. 6-36.0-	RF	
8-18032-31	2. 6-36.0- 17	1	X
8-18032-32	2. 6-36.0- 17	1	X
8-18033-1	2. 6-36.0- 17	1	A
	2. 6-37.0-	RF	
8-18033-2	2. 6-36.0- 17	1	A
	2. 6-37.0-	RF	
8-18040-15	2. 6-15.0- 10	1	P
8-18040-16	2. 6-15.0- 10	1	P
8-18040-17	2. 6-13.0- 1	1	P
8-18040-18	2. 6-13.0- 1	1	P
8-18040-31	2. 6-13.0- 7	1	M
	2. 6-15.0- 33	1	
8-18040-39	2. 6-15.0- 32	1	M
8-18040-43	2. 6-13.0- 13	1	P1
	2. 6-15.0- 36	1	
8-18040-5	2. 6- 2.0- 15	1	U
	2. 6- 3.0- 1	1	
	2. 6-15.0-	RF	
8-18040-6	2. 6- 2.0- 15	1	U
	2. 6- 3.0- 1	1	
	2. 6-15.0-	RF	
8-18040-67	2. 6-15.0- 4	1	P
8-18040-68	2. 6-15.0- 4	1	P
8-18040-69	2. 6-15.0- 46	1	P
8-18040-70	2. 6-15.0- 46	1	P
8-18040-74	2. 6-13.0- 15	1	P1
	2. 6-15.0- 41	1	
8-18040-83	2. 6-13.0- 14	1	M1
	2. 6-15.0- 37	1	
8-18040-84	2. 6-13.0- 14	1	M1
	2. 6-15.0- 37	1	
8-18040-85	2. 6-13.0- 16	1	P1
	2. 6-15.0- 42	1	
8-18040-87	2. 6-15.0- 23	1	P
8-18040-88	2. 6-15.0- 23	1	P
8-18040-89	2. 6-13.0- 17	1	M
	2. 6-15.0- 43	1	
8-18040-90	2. 6-13.0- 17	1	M
	2. 6-15.0- 43	1	
8-18041-7	2. 6-15.0- 1	1	P1
8-18041-8	2. 6-15.0- 1	1	P1
8-18060-1	2. 6- 1.0- 1F	1	U
	2. 6- 3.0- 1	1	
	2. 6-13.0-	RF	
8-18060-10	2. 6-13.0- 22	1	P
8-18060-11	2. 6-13.0- 5	1	P1D
8-18060-12	2. 6-13.0- 5	1	P1D
8-18060-15	2. 6-13.0- 4	1	P1D
8-18060-16	2. 6-13.0- 4	1	P1D
8-18060-17	2. 6-13.0- 1	1	P
8-18060-18	2. 6-13.0- 1	1	P
8-18060-2	2. 6- 1.0- 1F	1	U
	2. 6- 3.0- 1	1	
	2. 6-13.0-	RF	
8-18060-25	2. 6-13.0- 14	1	M1
8-18060-26	2. 6-13.0- 14	1	M1
8-18060-27	2. 6-13.0- 6	1	M
8-18060-31	2. 6-13.0- 7	1	M

PART NUMBER	FIGURE AND INDEX NUMBER	QTY PER ART	SMR CODE
8-18060-43	2. 6-13.0- 13	RF	M
8-18060-45	2. 6-13.0- 19	RF	P1
8-18060-47	2. 6-13.0- 16	RF	P1
8-18060-67	2. 6-13.0- 17	RF	M1
8-18060-68	2. 6-13.0- 17	RF	M1
8-18060-69	2. 6-13.0- 22	1	P
8-18060-70	2. 6-13.0- 22	1	P
8-18060-71	2. 6-13.0- 5	1	P1D
8-18060-72	2. 6-13.0- 5	1	P1D
8-18060-73	2. 6-13.0- 4	1	P2
8-18060-74	2. 6-13.0- 4	1	P1D
8-18060-75	2. 6-13.0- 20	1	M
	2. 6-13.0- 21	1	
8-18060-77	2. 6-13.0- 1	1	F
8-18060-81	2. 6-13.0- 2	1	M
8-18060-83	2. 6-13.0- 4	1	P1D
8-18060-87	2. 6-13.0- 6	1	M
8-18060-89	2. 6-13.0- 3	1	M
8-18060-9	2. 6-13.0- 22	1	P
8-18060-93	2. 6-13.0- 1	1	M
8-18070-1	2. 6-35.0- 1	1	X2
	2. 6-35.0- 1	RF	
8-18070-2	2. 6-35.0- 1	1	X2
	2. 6-35.0- 1	RF	
8-18070-23	2. 6-35.0- 13	1	A
8-18070-24	2. 6-35.0- 13	1	A
8-18070-5	2. 6-33.0- 1	1	X2
	2. 6-35.0- 1	RF	
8-18070-6	2. 6-33.0- 1	1	X2
	2. 6-35.0- 1	RF	
8-18070-7	2. 6-35.0- 13	1	X2
8-18070-8	2. 6-35.0- 13	1	X2
8-18070-801	2. 6-33.0- 1	1	X2
	2. 6-35.0- 1	RF	
8-18070-802	2. 6-33.0- 1	1	U
	2. 6-35.0- 1	RF	
8-18070-811	2. 6-33.0- 1	1	X2
	2. 6-35.0- 1	RF	
8-18070-812	2. 6-33.0- 1	1	X2
	2. 6-35.0- 1	RF	
8-18070-815	2. 6-33.0- 1	1	X2
	2. 6-35.0- 1	RF	
8-18071-1	2. 6-33.0- 3	1	U
	2. 6-33.0- 3	RF	
	2. 6-33.0- 3	RF	
	2. 6-39.0- 11	1	A
8-18071-10	2. 6-39.0- 11	1	A
8-18071-11	2. 6-39.0- 11	1	A
8-18071-12	2. 6-33.0- 3	1	U
8-18071-2	2. 6-33.0- 3	1	U
	2. 6-39.0- 11	RF	
8-18071-3	2. 6-33.0- 3	1	U
	2. 6-33.0- 3	RF	
	2. 6-39.0- 11	RF	
	2. 6-39.0- 11	1	A
8-18071-4	2. 6-33.0- 3	1	U
	2. 6-39.0- 11	RF	
8-18071-5	2. 6-33.0- 3	1	U
	2. 6-39.0- 11	1	A
8-18071-7	2. 6-39.0- 11	1	A
8-18071-71	2. 6-39.0- 11	1	A
8-18071-8	2. 6-39.0- 11	1	A
8-18071-801	2. 6-39.0- 11	1	A

PART NUMBER	FIGURE AND INDEX NUMBER	QTY PER ART	SMR CODE
8-18071-802	2. 6-39.0- 11	1	A
8-18071-803	2. 6-33.0- 3	RF	U
	2. 6-33.0- 3	1	
	2. 6-39.0- 11	RF	
	2. 6-39.0- 11	1	U
8-18071-804	2. 6-33.0- 3	RF	U
	2. 6-33.0- 3	1	
	2. 6-39.0- 11	RF	
	2. 6-39.0- 11	1	A
8-18071-9	2. 6-39.0- 11	1	X
8-18072-1	2. 6-33.0- 4	1	
	2. 6-36.0- 4	RF	
8-18072-2	2. 6-33.0- 4	1	X
	2. 6-36.0- 4	RF	
8-18072-25	2. 6-36.0- 17	1	A
8-18072-26	2. 6-36.0- 17	1	A
8-18072-29	2. 6-36.0- 17	1	A
8-18072-30	2. 6-36.0- 17	1	A
8-18072-33	2. 6-36.0- 17	1	A
8-18072-34	2. 6-36.0- 17	1	A
8-18072-5	2. 6-33.0- 4	1	X
	2. 6-36.0- 4	RF	X
8-18072-6	2. 6-33.0- 4	1	X
	2. 6-36.0- 4	RF	
8-18072-7	2. 6-36.0- 17	1	X
8-18072-8	2. 6-36.0- 17	1	X
8-18072-803	2. 6-33.0- 4	1	U
	2. 6-36.0- 4	RF	
8-18072-804	2. 6-33.0- 4	1	U
	2. 6-36.0- 4	RF	
8-18072-805	2. 6-33.0- 4	1	U
	2. 6-36.0- 4	RF	
8-18072-806	2. 6-33.0- 4	1	U
	2. 6-36.0- 4	RF	
8-18072-809	2. 6-33.0- 4	1	U
	2. 6-36.0- 4	RF	
8-18072-810	2. 6-33.0- 4	1	U
	2. 6-36.0- 4	RF	
8-18073-1	2. 6-36.0- 17	1	A
	2. 6-37.0- 17	RF	
8-18073-2	2. 6-36.0- 17	1	A
	2. 6-37.0- 17	RF	
8-18073-5	2. 6-36.0- 17	1	A
	2. 6-37.0- 17	RF	
8-18073-6	2. 6-36.0- 17	1	A
	2. 6-37.0- 17	RF	
8-18073-803	2. 6-36.0- 17	1	A
	2. 6-37.0- 17	RF	
8-18073-804	2. 6-36.0- 17	1	A
	2. 6-37.0- 17	RF	
8-18101-1	2. 6-35.0- 7	1	U
8-18101-2	2. 6-35.0- 7	1	U
8-18101-803	2. 6-35.0- 10	1	X2
8-18101-804	2. 6-35.0- 10	1	X2
8-18102-1	2. 6-35.0- 10	1	U
8-18102-2	2. 6-35.0- 10	1	U
8-18102-7	2. 6-35.0- 11	1	X
8-18102-8	2. 6-35.0- 11	1	X
8-18103-1	2. 6-35.0- 11	1	U
8-18103-2	2. 6-35.0- 11	1	U
8-18103-7	2. 6-35.0- 11	1	X
8-18103-8	2. 6-35.0- 11	1	X
8-18104-3	2. 6-35.0- 3	1	U
8-18104-4	2. 6-35.0- 3	1	U
8-18104-801	2. 6-35.0- 4	1	A1

PART NUMBER	FIGURE AND INDEX NUMBER	QTY PER ART	SMR CODE
8-18104-54	2. 6-36.0- 4	1	A1
8-18105-1	2. 6-36.0- 4	1	U
8-18105-2	2. 6-36.0- 4	1	U
8-18105-69	2. 6-36.0- 5	1	A
8-18105-70	2. 6-36.0- 5	1	A
8-18106-1	2. 6-37.0- 27	1	U
8-18106-2	2. 6-37.0- 27	1	U
8-18107-1	2. 6-37.0- 29	1	U
	2. 6-38.0-		RF
8-18107-2	2. 6-37.0- 29	1	U
	2. 6-38.0-		RF
8-18107-95	2. 6-38.0- 21	1	A
8-18107-96	2. 6-38.0- 21	1	A
8-18111-1	2. 6-36.0- 5	1	U
8-18111-2	2. 6-36.0- 5	1	U
8-18111-63	2. 6-36.0- 9	1	X
8-18121-1	2. 6-35.0- 7	1	U
8-18121-165	2. 6-35.0- 10	1	X2
8-18121-166	2. 6-35.0- 10	1	X2
8-18121-2	2. 6-35.0- 7	1	U
8-18121-3	2. 6-35.0- 7	1	U
8-18121-4	2. 6-35.0- 7	1	U
8-18121-5	2. 6-35.0- 7	1	U
8-18121-6	2. 6-35.0- 7	1	U
8-18121-91	2. 6-35.0- 10	1	X2
8-18121-92	2. 6-35.0- 10	1	X2
8-18121-97	2. 6-35.0- 10	1	X2
8-18121-98	2. 6-35.0- 10	1	X2
8-18122-1	2. 6-35.0- 10	1	U
8-18122-2	2. 6-35.0- 10	1	U
8-18122-27	2. 6-35.0- 11	1	X2
8-18122-28	2. 6-35.0- 11	1	X2
8-18122-31	2. 6-35.0- 11	1	X2
8-18122-7	2. 6-35.0- 11	1	X2
8-18122-8	2. 6-35.0- 11	1	X2
8-18122-801	2. 6-35.0- 10	1	U
8-18122-802	2. 6-35.0- 10	1	U
8-18122-803	2. 6-35.0- 10	1	U
8-18123-1	2. 6-35.0- 11	1	U
8-18123-10	2. 6-35.0- 11	1	X
8-18123-2	2. 6-35.0- 11	1	U
8-18123-3	2. 6-35.0- 11	1	U
8-18123-4	2. 6-35.0- 11	1	U
8-18123-43	2. 6-35.0- 11	1	X
8-18123-44	2. 6-35.0- 11	1	X
8-18123-47	2. 6-35.0- 11	1	X
8-18123-48	2. 6-35.0- 11	1	X
8-18123-5	2. 6-35.0- 11	1	U
8-18123-53	2. 6-35.0- 11	1	X
8-18123-6	2. 6-35.0- 11	1	U
8-18123-7	2. 6-35.0- 11	1	X
8-18123-8	2. 6-35.0- 11	1	X
8-18123-803	2. 6-35.0- 11	1	U
8-18123-804	2. 6-35.0- 11	1	U
8-18123-807	2. 6-35.0- 11	1	U
8-18123-9	2. 6-35.0- 11	1	X
8-18124-1	2. 6-36.0- 3	1	U
8-18124-2	2. 6-36.0- 3	1	U
8-18124-67	2. 6-36.0- 4	1	A
8-18124-68	2. 6-36.0- 4	1	A
8-18124-7	2. 6-36.0- 4	1	A1
8-18124-8	2. 6-36.0- 4	1	A1
8-18124-803	2. 6-36.0- 3	1	U
8-18124-804	2. 6-36.0- 3	1	U
8-18125-2	2. 6-36.0- 4	1	U

PART NUMBER	FIGURE AND INDEX NUMBER	QTY PER ART	SMR CODE
8-18125-2	2. 6-36.0- 4	1	U
8-18125-7	2. 6-36.0- 5	1	M
8-18125-6	2. 6-36.0- 5	1	A
8-18125-801	2. 6-36.0- 4	1	U
8-18125-802	2. 6-36.0- 4	1	U
8-18125-1	2. 6-37.0- 27	1	U
8-18125-2	2. 6-37.0- 27	1	U
8-18126-263	2. 6-37.0- 28	1	A
8-18126-291	2. 6-37.0- 28	1	A
8-18126-801	2. 6-37.0- 27	1	U
8-18126-802	2. 6-37.0- 27	1	U
8-18126-805	2. 6-37.0- 27	1	U
8-18126-806	2. 6-37.0- 27	1	U
8-18127-1	2. 6-37.0- 29	1	U
	2. 6-38.0-		RF
8-18127-2	2. 6-37.0- 29	1	U
	2. 6-38.0-		RF
8-18127-95	2. 6-38.0- 21	1	A
8-18127-96	2. 6-38.0- 21	1	A
8-18131-1	2. 6-36.0- 5	1	U
8-18131-2	2. 6-36.0- 5	1	U
8-18131-63	2. 6-36.0- 9	1	X
8-18131-64	2. 6-36.0- 9	1	M1
8-18137-7	2. 6-35.0- 10	1	M1
8-18137-8	2. 6-35.0- 10	1	X
8-18138	2. 6-36.0- 9	1	X2
8-18141-13	2. 6-35.0- 13	1	X2
8-18141-14	2. 6-35.0- 13	1	X2
8-18141-19	2. 6-35.0- 13	1	X2
8-18141-20	2. 6-35.0- 13	1	X2
8-18142-11	2. 6-36.0- 18	1	X2
8-18142-12	2. 6-36.0- 18	1	X2
8-18142-13	2. 6-36.0- 18		RF X2
8-18142-16	2. 6-36.0- 18		RF X2
8-18143-13	2. 6-36.0- 19	1	X2
8-18143-14	2. 6-36.0- 19	1	X2
8-18144-11	2. 6-39.0- 17		RF X2
8-18144-13	2. 6-39.0- 17		RF X2
8-18144-17	2. 6-39.0- 17	1	X2
8-18144-19	2. 6-39.0- 17	1	X2
8-18146-10	2. 6-39.0- 16	1	X2
8-18146-9	2. 6-39.0- 16	1	X2
8-18147-13	2. 6-37.0- 31	1	X2
8-18147-14	2. 6-37.0- 31	1	X2
8-18148-11	2. 6-37.0- 30	1	X2
8-18148-12	2. 6-37.0- 30	1	X2
8-18150-7	2. 6-35.0- 14	1	X2
8-18150-8	2. 6-35.0- 14	1	X2
8-18151-10	2. 6-39.0- 19	1	X2
8-18151-11	2. 6-39.0- 19	1	X2
8-18151-12	2. 6-39.0- 19	1	X2
8-18151-7	2. 6-39.0- 18	1	X2
8-18151-8	2. 6-39.0- 18	1	X2
8-18151-9	2. 6-39.0- 19	1	X2
8-18157-10	2. 6-35.0- 10	1	X2
8-18157-7	2. 6-35.0- 10	1	X2
8-18157-8	2. 6-35.0- 10	1	X2
8-18157-9	2. 6-35.0- 10	1	X2
8-18158-7	2. 6-36.0- 9	1	X2
8-18158-8	2. 6-36.0- 9	1	X2
8-18161-10	2. 6-35.0- 13	1	X2
8-18161-11	2. 6-35.0- 13	1	X2
8-18161-12	2. 6-35.0- 13	1	X2
8-18161-7	2. 6-35.0- 13	1	X2
8-18161-8	2. 6-35.0- 13	1	X2

PART NUMBER	FIGURE AND INDEX NUMBER	QTY PER ART	SMR CODE
8-18161-9	2. 6-35.0- 13	1	X2
8-18162-7	2. 6-36.0- 18	1	X2
8-18162-8	2. 6-36.0- 18	1	X2
8-18163-7	2. 6-36.0- 19	1	P2
8-18163-8	2. 6-36.0- 19	1	X2
8-18164-11	2. 6-39.0- 17	1	X2
8-18164-13	2. 6-39.0- 17	1	X2
8-18164-15	2. 6-39.0- 17	RF	X2
8-18164-17	2. 6-39.0- 17	RF	X2
8-18164-7	2. 6-39.0- 17	1	X2
8-18164-9	2. 6-39.0- 17	1	X2
8-18166-7	2. 6-39.0- 16	1	X2
8-18166-8	2. 6-39.0- 16	1	X2
8-18167-7	2. 6-37.0- 30	1	X2
8-18167-8	2. 6-37.0- 31	1	X2
8-18168-10	2. 6-37.0- 30	1	X2
8-18168-11	2. 6-37.0- 30	1	X2
8-18168-12	2. 6-37.0- 30	1	X2
8-18168-13	2. 6-37.0- 30	1	X2
8-18168-14	2. 6-37.0- 30	1	X2
8-18168-7	2. 6-37.0- 30	1	X2
8-18168-8	2. 6-37.0- 30	1	X2
8-18168-9	2. 6-37.0- 30	1	X2
8-18170-7	2. 6-35.0- 14	1	X2
8-18170-8	2. 6-35.0- 14	1	X2
8-18179-1	2. 2-19.0- 11	3	P
	2. 2-19.0- 12	2	
	2. 2-19.0- 14	2	
	2. 2-19.0- 15	5	
	2. 2-19.0- 16	3	
	2. 2-19.0- 17	3	
	2. 2-19.0- 2	1	
	2. 2-19.0- 21	8	
	2. 2-19.0- 22	10	
	2. 2-19.0- 23	6	
	2. 2-19.0- 3	2	
	2. 2-19.0- 4	4	
	2. 2-19.0- 9	5	
8-18179-2	2. 2-19.0- 11	3	P
	2. 2-19.0- 12	2	
	2. 2-19.0- 14	2	
	2. 2-19.0- 15	5	
	2. 2-19.0- 16	3	
	2. 2-19.0- 17	3	
	2. 2-19.0- 2	1	
	2. 2-19.0- 21	8	
	2. 2-19.0- 22	10	
	2. 2-19.0- 23	6	
	2. 2-19.0- 3	2	
	2. 2-19.0- 4	4	
	2. 2-19.0- 9	5	
8-18201-1	2. 6-21.0- 4	1	P1
	2. 6-23.0-	RF	P1
8-18201-2	2. 6-21.0- 4	1	P1
	2. 6-23.0-	RF	
8-18201-7	2. 6-25.0- 1	1	PD
8-18201-8	2. 6-23.0- 1	1	PD
8-18202-1	2. 6-21.0- 9	1	P1
	2. 6-25.0-	RF	
8-18202-10	2. 6-25.0- 1	1	PD
8-18202-2	2. 6-21.0- 9	1	P2
	2. 6-25.0-	RF	
8-18202-7	2. 6-25.0- 1	1	PD
8-18202-8	2. 6-25.0- 1	1	PD
8-18202-9	2. 6-25.0- 1	1	PD

PART NUMBER	FIGURE AND INDEX NUMBER	QTY PER ART	SMR CODE
8-18203-1	2. 6-21.0- 14	1	P2
	2. 6-27.0-	RF	
8-18203-10	2. 6-27.0- 2	1	PD
8-18203-2	2. 6-21.0- 14	1	P2
	2. 6-27.0-	RF	
8-18203-7	2. 6-27.0- 1	1	PD
8-18203-8	2. 6-27.0- 1	1	PD
8-18203-9	2. 6-27.0- 2	1	PD
8-18204-3	2. 6-21.0- 17	1	P1
	2. 6-29.0-	PF	
8-18204-4	2. 6-21.0- 17	1	P1
	2. 6-29.0-	RF	
8-18204-7	2. 6-29.0- 2	RF	P1
8-18204-8	2. 6-29.0- 2	RF	P1
8-18205-1	2. 6-21.0- 26	1	P1
	2. 6-31.0-	RF	
8-18205-11	2. 6-31.0- 2	1	P1
8-18205-13	2. 6-31.0- 3	1	P1
8-18205-15	2. 6-31.0- 3	1	M
8-18205-2	2. 6-21.0- 27	1	P2
	2. 6-31.0-	RF	
8-18205-7	2. 6-31.0- 1	1	P2
8-18205-8	2. 6-31.0- 1	1	P1
8-18205-9	2. 6-31.0- 2	1	P1
8-18211-10	2. 6-23.0- 3	1	PD
8-18211-11	2. 6-23.0- 4	1	PD
8-18211-12	2. 6-23.0- 4	1	PD
8-18211-13	2. 6-23.0- 5	1	PD
8-18211-14	2. 6-23.0- 5	1	PD
8-18211-15	2. 6-23.0- 6	1	PD
8-18211-16	2. 6-23.0- 6	1	PD
8-18211-17	2. 6-23.0- 7	1	PD
8-18211-18	2. 6-23.0- 7	1	PD
8-18211-19	2. 6-23.0- 8	1	PD
8-18211-20	2. 6-23.0- 8	1	PD
8-18211-21	2. 6-23.0- 9	1	PD
8-18211-22	2. 6-23.0- 9	1	PD
8-18211-23	2. 6-23.0- 10	1	PD
8-18211-24	2. 6-23.0- 10	1	PD
8-18211-7	2. 6-23.0- 2	1	PD
8-18211-8	2. 6-23.0- 2	1	PD
8-18211-9	2. 6-23.0- 3	1	PD
8-18212-10	2. 6-25.0- 4	1	PD
8-18212-11	2. 6-25.0- 5	1	PD
8-18212-12	2. 6-25.0- 5	1	PD
8-18212-13	2. 6-25.0- 6	1	PD
8-18212-14	2. 6-25.0- 6	1	PD
8-18212-15	2. 6-25.0- 7	1	PD
8-18212-16	2. 6-25.0- 7	1	PD
8-18212-17	2. 6-25.0- 8	1	PD
8-18212-18	2. 6-25.0- 8	1	PD
8-18212-19	2. 6-25.0- 9	1	PD
8-18212-20	2. 6-25.0- 9	1	PD
8-18212-21	2. 6-25.0- 10	1	PD
8-18212-22	2. 6-25.0- 10	1	PD
8-18212-23	2. 6-25.0- 11	1	PD
8-18212-24	2. 6-25.0- 11	1	PD
8-18212-25	2. 6-25.0- 12	1	PD
8-18212-26	2. 6-25.0- 12	1	PD
8-18212-27	2. 6-25.0- 13	1	PD
8-18212-28	2. 6-25.0- 13	1	PD
8-18212-29	2. 6-25.0- 14	1	PD
8-18212-30	2. 6-25.0- 14	1	PD
8-18212-31	2. 6-25.0- 15	1	PD
8-18212-32	2. 6-25.0- 15	1	PD

PART NUMBER	FIGURE AND INDEX NUMBER	QTY PER ART	SMR CODE
8-18212-33	2. 6-25.0- 16	1	PD
8-18212-34	2. 6-25.0- 16	1	PD
8-18212-35	2. 6-25.0- 17	1	PD
8-18212-36	2. 6-25.0- 17	1	PD
8-18212-37	2. 6-25.0- 18	1	PD
8-18212-38	2. 6-25.0- 18	1	PD
8-18212-39	2. 6-25.0- 19	1	PD
8-18212-40	2. 6-25.0- 19	1	PD
8-18212-41	2. 6-25.0- 20	1	PD
8-18212-42	2. 6-25.0- 20	1	PD
8-18212-7	2. 6-25.0- 3	1	PD
8-18212-8	2. 6-25.0- 3	1	PD
8-18212-9	2. 6-25.0- 4	1	PD
8-18213-10	2. 6-27.0- 4	1	PD
8-18213-11	2. 6-27.0- 5	1	PD
8-18213-12	2. 6-27.0- 5	1	PD
8-18213-13	2. 6-27.0- 6	1	PD
8-18213-14	2. 6-27.0- 6	1	PD
8-18213-15	2. 6-27.0- 7	1	PD
8-18213-16	2. 6-27.0- 7	1	PD
8-18213-17	2. 6-27.0- 8	1	PD
8-18213-18	2. 6-27.0- 8	1	PD
8-18213-19	2. 6-27.0- 9	1	PD
8-18213-20	2. 6-27.0- 9	1	PD
8-18213-21	2. 6-27.0- 10	1	PD
8-18213-22	2. 6-27.0- 10	1	PD
8-18213-23	2. 6-27.0- 11	1	PD
8-18213-24	2. 6-27.0- 11	1	PD
8-18213-25	2. 6-27.0- 12	1	PD
8-18213-26	2. 6-27.0- 12	1	PD
8-18213-27	2. 6-27.0- 13	1	PD
8-18213-28	2. 6-27.0- 13	1	PD
8-18213-29	2. 6-27.0- 14	1	PD
8-18213-30	2. 6-27.0- 14	1	PD
8-18213-31	2. 6-27.0- 15	1	PD
8-18213-32	2. 6-27.0- 15	1	PD
8-18213-33	2. 6-27.0- 16	1	PD
8-18213-34	2. 6-27.0- 16	1	P2
8-18213-35	2. 6-27.0- 17	1	PD
8-18213-36	2. 6-27.0- 17	1	PD
8-18213-37	2. 6-27.0- 18	1	PD
8-18213-38	2. 6-27.0- 18	1	PD
8-18213-39	2. 6-27.0- 19	1	PD
8-18213-40	2. 6-27.0- 19	1	PD
8-18213-41	2. 6-27.0- 20	1	PD
8-18213-42	2. 6-27.0- 20	1	PD
8-18213-43	2. 6-27.0- 21	1	PD
8-18213-44	2. 6-27.0- 21	1	PD
8-18213-7	2. 6-27.0- 3	1	PD
8-18213-8	2. 6-27.0- 3	1	PD
8-18213-9	2. 6-27.0- 4	1	PD
8-18214-10	2. 6-29.0- 4	1	PD
8-18214-11	2. 6-29.0- 5	1	PD
8-18214-12	2. 6-29.0- 5	1	PD
8-18214-15	2. 6-29.0- 7	RF	PD
8-18214-16	2. 6-29.0- 7	RF	PD
8-18214-17	2. 6-29.0- 9	RF	PD
8-18214-18	2. 6-29.0- 9	RF	PD
8-18214-19	2. 6-29.0- 10	RF	PD
8-18214-20	2. 6-29.0- 10	RF	PD
8-18214-21	2. 6-29.0- 11	RF	PD
8-18214-22	2. 6-29.0- 11	RF	PD
8-18214-23	2. 6-29.0- 12	1	PD
8-18214-24	2. 6-29.0- 12	1	PD
8-18214-7	2. 6-29.0- 3	1	PD

PART NUMBER	FIGURE AND INDEX NUMBER	QTY PER ART	SMR CODE
8-18214-1	2. 6-29.0- 3	1	PD
8-18214-9	2. 6-29.0- 4	1	PD
8-18215-10	2. 6-31.0- 5	1	P1
8-18215-11	2. 6-31.0- 6	1	P1
8-18215-12	2. 6-31.0- 6	1	P1
8-18215-13	2. 6-31.0- 7	1	P1
8-18215-14	2. 6-31.0- 7	1	P1
8-18215-15	2. 6-31.0- 8	1	P1
8-18215-16	2. 6-31.0- 8	1	P1
8-18215-17	2. 6-31.0- 9	1	M1
8-18215-18	2. 6-31.0- 9	1	M1
8-18215-21	2. 6-31.0- 11	1	M1
8-18215-22	2. 6-31.0- 11	1	M1
8-18215-23	2. 6-31.0- 12	1	M1
8-18215-24	2. 6-31.0- 12	1	M1
8-18215-25	2. 6-31.0- 13	1	M1
8-18215-27	2. 6-31.0- 14	1	M1
8-18215-29	2. 6-31.0- 15	1	M1
8-18215-31	2. 6-31.0- 15	1	M1
8-18215-33	2. 6-31.0- 14	1	M1
8-18215-37	2. 6-31.0- 15	1	M1
8-18215-39	2. 6-31.0- 13	1	M1
8-18215-40	2. 6-31.0- 10	1	M1
8-18215-7	2. 6-31.0- 4	1	P1
8-18215-8	2. 6-31.0- 4	1	P1
8-18215-9	2. 6-31.0- 5	1	P1
8-18221-10	2. 6-23.0- 12	1	PD
8-18221-11	2. 6-25.0- 21	1	PD
8-18221-12	2. 6-25.0- 21	1	PD
8-18221-13	2. 6-25.0- 22	1	PD
8-18221-14	2. 6-25.0- 22	1	PD
8-18221-15	2. 6-27.0- 22	1	PD
8-18221-16	2. 6-27.0- 22	1	PD
8-18221-17	2. 6-27.0- 23	1	PD
8-18221-18	2. 6-27.0- 23	1	PD
8-18221-19	2. 6-29.0- 13	RF	PD
8-18221-20	2. 6-29.0- 13	RF	PD
8-18221-21	2. 6-29.0- 14	RF	PD
8-18221-22	2. 6-29.0- 14	RF	P2
8-18221-23	2. 6-31.0- 16	1	P1
8-18221-25	2. 6-31.0- 17	1	P1
8-18221-27	2. 6-31.0- 16	1	P1
8-18221-29	2. 6-31.0- 17	1	P1
8-18221-7	2. 6-23.0- 11	1	PD
8-18221-8	2. 6-23.0- 11	1	PD
8-18221-9	2. 6-23.0- 12	1	PD
8-18230-1	2. 6- 3.0- 2	1	
	2. 6-18.0- 1	1	
	2. 6-21.0-	RF	
8-18230-2	2. 6- 3.0- 2	1	U
	2. 6-18.0- 1	1	
	2. 6-21.0-	RF	
8-18231-1	2. 6-21.0- 1	1	P1
8-18231-2	2. 6-21.0- 1	1	P1
8-18231-3	2. 6-21.0- 6	1	P1
8-18231-4	2. 6-21.0- 5	1	P1
8-18231-5	2. 6-21.0- 11	1	P1
8-18231-6	2. 6-21.0- 11	1	P1
8-18231-801	2. 6-21.0- 20	1	P1
8-18231-802	2. 6-21.0- 20	1	P1
8-18231-803	2. 6-21.0- 30	1	P1
8-18231-805	2. 6-21.0- 23	1	P1
8-18231-806	2. 6-21.0- 23	1	P1
8-18231-807	2. 6-21.0- 1	RF	P1
8-18231-808	2. 6-21.0- 1	RF	P1

PART NUMBER	FIGURE AND INDEX NUMBER	QTY PER ART	SMR CODE
8-18231-819	2. 6-21.0- 6	RF	P1
8-18231-813	2. 6-21.0- 6	RF	P1
8-18231-811	2. 6-21.0- 11	RF	P1
8-18231-812	2. 6-21.0- 11	RF	P2
8-18231-813	2. 6-21.0- 20	RF	P1
8-18231-814	2. 6-21.0- 20	RF	P1
8-18231-815	2. 6-21.0- 30	RF	P1
8-18231-817	2. 6-21.0- 23	RF	P1
8-18231-818	2. 6-21.0- 23	RF	P1
8-18251-1	2. 6-20.0- 4	1	P1
	2. 6-22.0- 0	RF	
8-18251-2	2. 6-20.0- 4	1	P2
	2. 6-22.0- 0	RF	P2
8-18251-7	2. 6-22.0- 1	1	PD
8-18251-8	2. 6-22.0- 1	1	PD
8-18252-1	2. 6-20.0- 9	RF	P1
	2. 6-24.0- 0	RF	PD
8-18252-10	2. 6-24.0- 1	RF	PD
8-18252-2	2. 6-20.0- 9	RF	P1
	2. 6-24.0- 0	RF	
8-18252-23	2. 6-24.0- 1	1	P1
8-18252-24	2. 6-24.0- 1	1	P1
8-18252-29	2. 6-24.0- 1	1	PD
8-18252-3	2. 6-20.0- 9	1	P1
	2. 6-24.0- 0	RF	
8-18252-30	2. 6-24.0- 1	1	PD
8-18252-4	2. 6-20.0- 9	1	P1
	2. 6-24.0- 0	RF	
8-18252-5	2. 6-20.0- 9	1	PD
	2. 6-24.0- 0	RF	
8-18252-6	2. 6-20.0- 9	1	P2
	2. 6-24.0- 0	RF	
8-18252-7	2. 6-24.0- 1	RF	PD
8-18252-8	2. 6-24.0- 1	RF	PD
8-18252-9	2. 6-24.0- 1	RF	PD
8-18253-1	2. 6-20.0- 15	RF	P1
	2. 6-26.0- 0	RF	
8-18253-10	2. 6-26.0- 1	RF	P1D
8-18253-2	2. 6-20.0- 15	RF	P1
	2. 6-26.0- 0	RF	
8-18253-23	2. 6-26.0- 1	1	PD
8-18253-24	2. 6-26.0- 1	1	PD
8-18253-3	2. 6-20.0- 15	1	P1
	2. 6-26.0- 0	RF	
8-18253-4	2. 6-20.0- 15	1	P1
	2. 6-26.0- 0	RF	
8-18253-7	2. 6-26.0- 1	RF	P1D
8-18253-8	2. 6-26.0- 1	RF	P1D
8-18253-9	2. 6-26.0- 1	RF	P1D
8-18254-3	2. 6-20.0- 18	1	P1
	2. 6-28.0- 0	RF	
8-18254-39	2. 6-28.0- 2	1	X1
8-18254-4	2. 6-20.0- 18	1	P1
	2. 6-26.0- 0	RF	
8-18254-40	2. 6-26.0- 2	1	X1
8-18254-41	2. 6-26.0- 1	1	X1
8-18254-42	2. 6-26.0- 1	1	X1
8-18255-1	2. 6-20.0- 32	RF	P1
	2. 6-30.0- 0	RF	
8-18255-11	2. 6-30.0- 1	RF	P1D
8-18255-13	2. 6-30.0- 2	1	P2
8-18255-19	2. 6-30.0- 2	1	M
8-18255-2	2. 6-20.0- 33	RF	P1
	2. 6-30.0- 0	RF	
8-18255-3	2. 6-20.0- 32	1	P2

PART NUMBER	FIGURE AND INDEX NUMBER	QTY PER ART	SMR CODE
8-18255-3	2. 6-30.0- 0	RF	P2
8-18255-4	2. 6-20.0- 33	1	P1
	2. 6-30.0- 0	RF	
8-18255-57	2. 6-30.0- 1	1	PD
8-18255-61	2. 6-30.0- 1	1	PD
8-18255-7	2. 6-30.0- 1	RF	P1D
8-18255-8	2. 6-30.0- 1	RF	P1D
8-18255-9	2. 6-30.0- 1	RF	P1D
8-18256-1	2. 6-20.0- 18	1	P2
	2. 6-28.0- 0	RF	
8-18256-2	2. 6-20.0- 18	1	P2
	2. 6-28.0- 0	RF	
8-18256-7	2. 6-28.0- 1	1	X1
8-18256-8	2. 6-28.0- 1	1	X1
8-18261-10	2. 6-22.0- 3	1	P2
8-18261-11	2. 6-22.0- 4	1	P2
8-18261-12	2. 6-22.0- 4	1	P2
8-18261-13	2. 6-22.0- 5	1	P2
8-18261-14	2. 6-22.0- 5	1	P2
8-18261-15	2. 6-22.0- 6	1	P2
8-18261-16	2. 6-22.0- 6	1	P2
8-18261-17	2. 6-22.0- 7	1	P2
8-18261-18	2. 6-22.0- 7	1	P2
8-18261-19	2. 6-22.0- 8	1	P2
8-18261-20	2. 6-22.0- 8	1	P2
8-18261-21	2. 6-22.0- 9	1	P2
8-18261-22	2. 6-22.0- 9	1	P2
8-18261-23	2. 6-22.0- 10	1	P2
8-18261-24	2. 6-22.0- 10	1	P2
8-18261-7	2. 6-22.0- 2	1	P2
8-18261-8	2. 6-22.0- 2	1	P2
8-18261-9	2. 6-22.0- 3	1	P2
8-18262-10	2. 6-24.0- 3	1	P2
8-18262-11	2. 6-24.0- 4	1	P2
8-18262-12	2. 6-24.0- 4	1	P2
8-18262-13	2. 6-24.0- 5	1	P2
8-18262-14	2. 6-24.0- 5	1	P2
8-18262-15	2. 6-24.0- 6	1	P2
8-18262-16	2. 6-24.0- 6	1	P2
8-18262-17	2. 6-24.0- 7	1	P2
8-18262-18	2. 6-24.0- 7	1	P2
8-18262-19	2. 6-24.0- 8	1	P2
8-18262-20	2. 6-24.0- 8	1	P2
8-18262-21	2. 6-24.0- 9	RF	P2
8-18262-22	2. 6-24.0- 9	RF	P2
8-18262-23	2. 6-24.0- 10	1	P2
8-18262-24	2. 6-24.0- 10	1	P2
8-18262-25	2. 6-24.0- 11	1	P2
8-18262-26	2. 6-24.0- 11	1	P2
8-18262-27	2. 6-24.0- 12	1	P2
8-18262-28	2. 6-24.0- 12	1	P2
8-18262-29	2. 6-24.0- 13	1	P2
8-18262-30	2. 6-24.0- 13	1	P2
8-18262-31	2. 6-24.0- 14	1	P2
8-18262-32	2. 6-24.0- 14	1	P2
8-18262-33	2. 6-24.0- 15	1	P2
8-18262-34	2. 6-24.0- 15	1	P2
8-18262-35	2. 6-24.0- 16	1	P2
8-18262-36	2. 6-24.0- 16	1	P2
8-18262-37	2. 6-24.0- 17	1	P2
8-18262-38	2. 6-24.0- 17	1	P2
8-18262-39	2. 6-24.0- 16	1	P2
8-18262-40	2. 6-24.0- 18	1	P2
8-18262-41	2. 6-24.0- 19	1	P2
8-18262-42	2. 6-24.0- 19	1	P2

PART NUMBER	FIGURE AND INDEX NUMBER	QTY PER ART	SMR CODE
8-18262-43	2. 6-24.0- 9	1	P2
8-18262-44	2. 6-24.0- 9	1	P2
8-18262-45	2. 6-24.0- 9	1	P2
8-18262-46	2. 6-24.0- 9	1	P2
8-18262-47	2. 6-24.0- 10	1	P2
8-18262-48	2. 6-24.0- 10	1	P2
8-18262-49	2. 6-24.0- 11	1	P2
8-18262-50	2. 6-24.0- 11	1	P2
8-18262-7	2. 6-24.0- 2	1	P2
8-18262-8	2. 6-24.0- 2	1	P2
8-18262-9	2. 6-24.0- 3	1	P2
8-18263-10	2. 6-26.0- 3	1	P2
8-18263-11	2. 6-26.0- 4	1	P2
8-18263-12	2. 6-26.0- 4	1	P2
8-18263-13	2. 6-26.0- 5	1	P2
8-18263-14	2. 6-26.0- 5	1	P2
8-18263-15	2. 6-26.0- 6	1	PD
8-18263-16	2. 6-26.0- 6	1	M1
8-18263-17	2. 6-26.0- 7	1	P2
8-18263-18	2. 6-26.0- 7	1	P2
8-18263-19	2. 6-26.0- 8	1	P2
8-18263-20	2. 6-26.0- 8	1	P2
8-18263-21	2. 6-26.0- 9	1	P2
8-18263-22	2. 6-26.0- 9	1	P2
8-18263-23	2. 6-26.0- 10	1	P2
8-18263-24	2. 6-26.0- 10	1	P2
8-18263-25	2. 6-26.0- 11	1	P2
8-18263-26	2. 6-26.0- 11	1	P2
8-18263-27	2. 6-26.0- 12	RF	P2
8-18263-28	2. 6-26.0- 12	RF	P2
8-18263-29	2. 6-26.0- 13	1	P2
8-18263-30	2. 6-26.0- 13	1	P2
8-18263-31	2. 6-26.0- 14	1	P2
8-18263-32	2. 6-26.0- 14	1	P2
8-18263-33	2. 6-26.0- 15	1	P2
8-18263-34	2. 6-26.0- 15	1	P2
8-18263-35	2. 6-26.0- 16	1	P2
8-18263-36	2. 6-26.0- 16	1	P2
8-18263-37	2. 6-26.0- 17	1	P2
8-18263-38	2. 6-26.0- 17	1	P2
8-18263-39	2. 6-26.0- 18	1	P2
8-18263-40	2. 6-26.0- 18	1	P2
8-18263-41	2. 6-26.0- 19	1	P2
8-18263-42	2. 6-26.0- 19	1	P2
8-18263-43	2. 6-26.0- 20	1	P2
8-18263-44	2. 6-26.0- 20	1	P2
8-18263-45	2. 6-26.0- 12	1	P2
8-18263-46	2. 6-26.0- 12	1	P2
8-18263-7	2. 6-26.0- 2	1	P2
8-18263-8	2. 6-26.0- 2	1	P2
8-18263-9	2. 6-26.0- 3	1	P2
8-18264-10	2. 6-28.0- 4	1	P
8-18264-11	2. 6-28.0- 5	1	PD
8-18264-12	2. 6-28.0- 5	1	PD
8-18264-29	2. 6-28.0- 6	1	PD
8-18264-30	2. 6-28.0- 6	1	PD
8-18264-31	2. 6-28.0- 8	1	PD
8-18264-32	2. 6-28.0- 8	1	PD
8-18264-33	2. 6-28.0- 7	1	PD
8-18264-34	2. 6-28.0- 7	1	PD
8-18264-35	2. 6-28.0- 10	1	PD
8-18264-36	2. 6-28.0- 10	1	PD
8-18264-37	2. 6-28.0- 9	1	PD
8-18264-38	2. 6-28.0- 9	1	PD
8-18264-39	2. 6-28.0- 11	1	PD

PART NUMBER	FIGURE AND INDEX NUMBER	QTY PER ART	SMR CODE
8-18264-40	2. 6-28.0- 11	1	PD
8-18264-41	2. 6-28.0- 12	1	PD
8-18264-42	2. 6-28.0- 12	1	PD
8-18264-43	2. 6-28.0- 13	1	PD
8-18264-44	2. 6-28.0- 13	1	PD
8-18264-7	2. 6-28.0- 3	1	P2
8-18264-8	2. 6-28.0- 3	1	P2
8-18264-9	2. 6-28.0- 4	1	P2
8-18265-10	2. 6-30.0- 4	1	P2
8-18265-11	2. 6-30.0- 5	1	P2
8-18265-12	2. 6-30.0- 5	1	P2
8-18265-13	2. 6-30.0- 6	1	P2
8-18265-14	2. 6-30.0- 6	1	P2
8-18265-15	2. 6-30.0- 7	1	P2
8-18265-16	2. 6-30.0- 7	1	P2
8-18265-17	2. 6-30.0- 8	1	P2
8-18265-18	2. 6-30.0- 8	1	P2
8-18265-19	2. 6-30.0- 9	RF	P1D
8-18265-20	2. 6-30.0- 9	RF	P1D
8-18265-21	2. 6-30.0- 10	1	P2
8-18265-22	2. 6-30.0- 10	1	P2
8-18265-23	2. 6-30.0- 11	1	P2
8-18265-24	2. 6-30.0- 11	1	P2
8-18265-25	2. 6-30.0- 12	1	P2
8-18265-27	2. 6-30.0- 13	1	P2
8-18265-29	2. 6-30.0- 14	1	P2
8-18265-31	2. 6-30.0- 12	1	P2
8-18265-33	2. 6-30.0- 13	1	P2
8-18265-35	2. 6-30.0- 14	1	P1D
8-18265-37	2. 6-30.0- 9	1	PD
8-18265-38	2. 6-30.0- 9	1	PD
8-18265-7	2. 6-30.0- 3	1	P2
8-18265-8	2. 6-30.0- 3	1	P2
8-18265-9	2. 6-30.0- 4	1	P2
8-18266-11	2. 6-28.0- 3	1	M1
8-18266-12	2. 6-28.0- 3	1	M1
8-18266-13	2. 6-28.0- 4	1	M1
8-18266-14	2. 6-28.0- 4	1	M1
8-18266-15	2. 6-28.0- 5	1	M1
8-18266-16	2. 6-28.0- 5	1	M1
8-18266-17	2. 6-28.0- 6	1	M1
8-18266-18	2. 6-28.0- 6	1	M1
8-18266-19	2. 6-28.0- 8	1	M1
8-18266-20	2. 6-28.0- 8	1	M1
8-18266-21	2. 6-28.0- 7	1	M1
8-18266-22	2. 6-28.0- 7	1	M1
8-18266-23	2. 6-28.0- 10	1	M1
8-18266-24	2. 6-28.0- 10	1	M1
8-18266-25	2. 6-28.0- 9	1	M1
8-18266-26	2. 6-28.0- 9	1	M1
8-18266-27	2. 6-28.0- 11	1	M1
8-18266-28	2. 6-28.0- 11	1	M1
8-18266-29	2. 6-28.0- 12	1	M1
8-18266-30	2. 6-28.0- 12	1	M1
8-18266-31	2. 6-28.0- 13	1	M1
8-18266-32	2. 6-28.0- 13	1	M1
8-18271-10	2. 6-22.0- 12	1	P2
8-18271-11	2. 6-24.0- 20	RF	PD
8-18271-12	2. 6-24.0- 20	RF	PD
8-18271-13	2. 6-24.0- 21	RF	PD
8-18271-14	2. 6-24.0- 21	RF	PD
8-18271-15	2. 6-26.0- 21	RF	PD
8-18271-16	2. 6-26.0- 21	RF	PD
8-18271-17	2. 6-26.0- 22	RF	PD
8-18271-18	2. 6-26.0- 22	RF	PD

PART NUMBER	FIGURE AND INDEX NUMBER	QTY PER ART	SMR CODE
8-18271-23	2. 6-30.0- 15	RF	P1D
8-18271-25	2. 6-30.0- 16	RF	P1D
8-18271-27	2. 6-30.0- 15	RF	P1D
8-18271-29	2. 6-30.0- 16	RF	P1D
8-18271-31	2. 6-24.0- 21	1	P
8-18271-32	2. 6-24.0- 21	1	P
8-18271-33	2. 6-24.0- 20	1	P
8-18271-34	2. 6-24.0- 20	1	P
8-18271-35	2. 6-26.0- 21	1	P
8-18271-36	2. 6-26.0- 21	1	P
8-18271-37	2. 6-26.0- 22	1	P
8-18271-38	2. 6-26.0- 22	1	P
8-18271-39	2. 6-30.0- 15	1	P
8-18271-41	2. 6-30.0- 16	1	P
8-18271-43	2. 6-30.0- 15	1	P
8-18271-45	2. 6-30.0- 16	1	P
8-18271-47	2. 6-28.0- 14	1	P
8-18271-48	2. 6-28.0- 14	1	P
8-18271-49	2. 6-28.0- 15	1	P
8-18271-50	2. 6-28.0- 15	1	P
8-18271-7	2. 6-22.0- 11	1	PD
8-18271-8	2. 6-22.0- 11	1	PD
8-18271-9	2. 6-22.0- 12	1	P2
8-18273-10	2. 6-24.0- 15	1	X2
8-18273-11	2. 6-24.0- 20	1	M1
8-18273-12	2. 6-24.0- 20	1	M1
8-18273-7	2. 6-28.0- 14	1	X2
8-18273-8	2. 6-28.0- 14	1	X2
8-18273-9	2. 6-28.0- 15	1	X2
8-18280-1	2. 6- 3.0- 2	1	U
	2. 6-18.0- 1	1	
	2. 6-20.0- 1	RF	U
8-18280-2	2. 6- 3.0- 2	1	U
	2. 6-18.0- 1	1	
	2. 6-20.0- 1	RF	
8-18281-1	2. 6-20.0- 25	1	P1
8-18281-10	2. 6-20.0- 6	1	P1
8-18281-11	2. 6-20.0- 12	1	P1
8-18281-12	2. 6-20.0- 12	1	P2
8-18281-13	2. 6-20.0- 22	1	P1
8-18281-14	2. 6-20.0- 22	1	P1
8-18281-15	2. 6-20.0- 28	1	P1
8-18281-2	2. 6-20.0- 25	1	P1
8-18281-7	2. 6-20.0- 1	1	P1
8-18281-8	2. 6-20.0- 1	1	P1
8-18281-9	2. 6-20.0- 6	1	P1
8-18302-1	2. 6-35.0- 15	1	X2
8-18302-2	2. 6-35.0- 15	1	X2
8-18302-3	2. 6-35.0- 15	1	X2
8-18302-4	2. 6-35.0- 15	1	X2
8-18302-801	2. 6-35.0- 15	1	X2
8-18310-3	2. 6-35.0- 15	1	A
8-18310-33	2. 6-35.0- 16	1	M1
8-18310-34	2. 6-35.0- 16	1	M1
8-18310-4	2. 6-35.0- 15	1	A
8-18310-59	2. 6-35.0- 16	1	M1
8-18310-60	2. 6-35.0- 16	1	M1
8-18320-1	2. 6-35.0- 10	1	U
	2.15-28.0- 2	RF	
8-18320-11	2.15-28.0- 2	1	M
8-18320-13	2.15-28.0- 4	1	M
8-18320-2	2. 6-39.0- 10	1	U
	2.15-28.0- 2	RF	
8-18320-7	2.15-28.0- 19	1	
	2.15-29.0- 1	RF	P1

PART NUMBER	FIGURE AND INDEX NUMBER	QTY PER ART	SMR CODE
8-18320-0	2.15-28.0- 19	1	P1
	2.15-29.0- 1	RF	
8-18326-1	2. 6-39.0- 12	1	U
8-18326-2	2. 6-39.0- 12	1	U
8-18326-3	2. 6-39.0- 12	1	U
8-18326-4	2. 6-39.0- 12	1	U
8-18337-3	2. 6-36.0- 9	1	U
8-18337-4	2. 6-36.0- 9	1	U
8-18350-1	2. 6-36.0- 15	1	U
8-18350-17	2. 6-36.0- 16	1	X2
8-18350-19	2. 6-36.0- 16	1	X2
8-18350-2	2. 6-36.0- 15	1	U
8-18350-21	2. 6-36.0- 16	1	X2
8-18350-22	2. 6-36.0- 16	1	X2
8-18350-27	2. 6-36.0- 16	1	X2
8-18350-28	2. 6-36.0- 16	1	X2
8-18350-3	2. 6-36.0- 15	1	U
8-18350-4	2. 6-36.0- 15	1	U
8-18350-801	2. 6-36.0- 15	1	U
8-18350-972	2. 6-36.0- 15	1	U
8-18350-3	2. 6-36.0- 12	1	U
8-18350-4	2. 6-36.0- 12	1	U
8-18385-3	2. 6-37.0- 5	1	U
8-18385-4	2. 6-37.0- 5	1	U
8-18386-3	2. 6-37.0- 5	1	A
8-18386-4	2. 6-37.0- 5	1	A
8-18386-5	2. 6-37.0- 5	1	A
8-18386-6	2. 6-37.0- 5	1	A
8-18390-1	2. 6-37.0- 31	1	A
8-18390-2	2. 6-37.0- 31	1	A
8-18401-10	2. 6-19.0- 3	1	X2
8-18401-7	2. 6-19.0- 2	1	X2
8-18401-8	2. 6-19.0- 2	1	X2
8-18401-9	2. 6-19.0- 3	1	X2
8-18402-10	2. 6-19.0- 5	1	P1D
8-18402-11	2. 6-19.0- 6	1	P1D
8-18402-12	2. 6-19.0- 6	1	P1D
8-18402-13	2. 6-19.0- 4	1	P1D
8-18402-14	2. 6-19.0- 4	1	P1D
8-18402-15	2. 6-19.0- 4	1	P1D
8-18402-16	2. 6-19.0- 4	1	P1D
8-18402-9	2. 6-19.0- 5	1	P1D
8-18403-1	2. 6-19.0- 7	1	X2
8-18403-10	2. 6-19.0- 7	1	X2
8-18403-2	2. 6-19.0- 7	1	X2
8-18403-7	2. 6-19.0- 7	1	X2
8-18403-6	2. 6-19.0- 7	1	X2
8-18403-9	2. 6-19.0- 7	1	X2
8-18404-25	2. 6-19.0- 8	1	X2
8-18404-26	2. 6-19.0- 8	1	X2
8-18404-27	2. 6-19.0- 9	1	X2
8-18404-28	2. 6-19.0- 9	1	X2
8-18404-29	2. 6-19.0- 10	1	X2
8-18404-30	2. 6-19.0- 10	1	X2
8-18404-31	2. 6-19.0- 11	1	X2
8-18404-32	2. 6-19.0- 11	1	X2
8-18404-33	2. 6-19.0- 12	1	X2
8-18404-34	2. 6-19.0- 12	1	X2
8-18404-35	2. 6-19.0- 13	1	X2
8-18404-36	2. 6-19.0- 13	1	X2
8-18404-37	2. 6-19.0- 14	1	X2
8-18404-38	2. 6-19.0- 14	1	X2
8-18410-1	2. 6- 3.0- 11	1	U
	2. 6-18.0- 1	1	
8-18410-2	2. 6- 3.0- 11	1	U

PART NUMBER	FIGURE AND INDEX NUMBER	QTY PER ART	SMR CODE
8-18410-2	2. 6-18.0- 1	1	U
8-18411-1	2. 6-18.0- 2	1	P1
	2. 6-19.0-	RF	
8-18411-15	2. 6-19.0- 15	1	P1
8-18411-16	2. 6-19.0- 15	1	P1
8-18411-2	2. 6-18.0- 2	1	P1
	2. 6-19.0-	RF	
8-18414	2. 6- 4.0- 4	1	P1
8-18430-1	2. 6-35.0- 3	1	U
8-18430-2	2. 6-35.0- 3	1	U
8-18431-1	2. 6-35.0- 21	1	U
8-18431-2	2. 6-35.0- 21	1	U
8-18439-1	2. 6-35.0- 24	1	U
8-18439-2	2. 6-35.0- 24	1	U
8-18510-1	2. 6-35.0- 15	1	A
8-18510-19	2. 6-35.0- 16	1	X2
8-18510-2	2. 6-35.0- 15	1	A
8-18510-20	2. 6-35.0- 16	1	X2
8-18510-21	2. 6-35.0- 16	1	X2
8-18510-22	2. 6-35.0- 16	1	X2
8-18510-35	2. 6-35.0-116	1	X2
8-18510-36	2. 6-35.0- 16	1	X2
8-18510-801	2. 6-35.0- 15	1	A
8-18510-803	2. 6-35.0- 15	1	A
8-18510-804	2. 6-35.0- 15	1	A
8-18552	2. 6-37.0- 3	1	M
8-18552-7	2. 6-37.0- 3	1	M
8-18552-9	2. 6-37.0- 3	1	M
8-18560-35	2. 6- 4.0- 17	1	M1
	2. 6- 5.0- 4	1	
8-18560-36	2. 6- 4.0- 17	1	P
	2. 6- 5.0- 4	1	
8-18560-39	2. 6- 4.0- 20	1	P
	2. 6- 5.0- 20	1	
8-18560-40	2. 6- 4.0- 20	1	P
	2. 6- 5.0- 20	1	
8-18560-41	2. 6- 5.0- 3	1	A
8-18560-42	2. 6- 5.0- 3	1	A
8-18560-43	2. 6- 5.0- 18	1	P1
8-18560-44	2. 6- 5.0- 18	1	P1
8-18560-5	2. 6- 2.0- 1	1	U
	2. 6- 3.0- 3	1	
	2. 6- 5.0-	1	
8-18560-55	2. 6- 4.0- 16	1	M1
	2. 6- 5.0- 17	1	
8-18560-56	2. 6- 4.0- 16	1	P
	2. 6- 5.0- 17	1	
8-18560-6	2. 6- 2.0- 1	1	U
	2. 6- 3.0- 3	1	
	2. 6- 5.0-	1	
8-18560-63	2. 6- 5.0- 16	1	A
8-18560-64	2. 6- 5.0- 16	1	A
8-18560-65	2. 6- 5.0- 12	1	P2
8-18560-66	2. 6- 5.0- 12	1	P2
8-18560-69	2. 6- 5.0- 1	1	P1
8-18560-70	2. 6- 5.0- 1	1	P1
8-18560-77	2. 6- 8.0- 31	1	P1
8-18560-78	2. 6- 8.0- 31	1	P1
8-18560-801	2. 6- 8.0- 30	1	U
8-18560-802	2. 6- 8.0- 30	1	U
8-18560-83	2. 6- 4.0- 14	1	M
	2. 6- 5.0- 15	1	
8-18580-29	2. 6- 4.0- 14	RF	M
8-18580-35	2. 6- 4.0- 17	RF	M1
8-18580-36	2. 6- 4.0- 17	RF	M1

PART NUMBER	FIGURE AND INDEX NUMBER	QTY PER ART	SMR CODE
8-18580-39	2. 6- 4.0- 20	RF	M1
8-18580-40	2. 6- 4.0- 20	RF	M1
8-18580-41	2. 6- 4.0- 14	1	X1
8-18580-42	2. 6- 4.0- 14	1	X1
8-18580-43	2. 6- 4.0- 18	1	P1
8-18580-44	2. 6- 4.0- 18	1	P1
8-18580-5	2. 6- 1.0- 1	1	U
	2. 6- 3.0- 3	1	
	2. 6- 4.0-	1	
8-18580-55	2. 6- 4.0- 16	RF	M1
8-18580-56	2. 6- 4.0- 16	RF	M1
8-18580-6	2. 6- 1.0- 1	1	U
	2. 6- 3.0- 3	1	
	2. 6- 4.0-	1	
8-18580-63	2. 6- 4.0- 15	1	M1
8-18580-64	2. 6- 4.0- 15	1	M1
8-18580-65	2. 6- 4.0- 11	1	P1
8-18580-66	2. 6- 4.0- 11	1	P1
8-18580-69	2. 6- 4.0- 1	1	P1
8-18580-70	2. 6- 4.0- 1	1	P1
8-18580-77	2. 6- 8.0- 31	1	P1
8-18580-78	2. 6- 8.0- 31	1	P1
8-18580-801	2. 6- 8.0- 30	1	P1
8-18580-802	2. 6- 8.0- 30	1	U
8-18580-85	2. 6- 4.0- 18	1	U
8-18580-86	2. 6- 4.0- 18	1	P1
8-18580-87	2. 6- 4.0- 11	1	P1
8-18580-88	2. 6- 4.0- 11	1	P2
8-18580-89	2. 6- 4.0- 1	1	P1
8-18580-90	2. 6- 4.0- 1	1	P1
8-18580-93	2. 6- 4.0- 18	1	P1
8-18580-94	2. 6- 4.0- 18	1	P1
8-18580-95	2. 6- 4.0- 11	1	P1
8-18580-96	2. 6- 4.0- 11	1	P1
8-18580-97	2. 6- 4.0- 1	1	P1
8-18590-98	2. 6- 4.0- 1	1	P1
8-18590-1	2. 6-37.0- 31	1	U
8-18590-2	2. 6-37.0- 31	1	U
8-18621-7	2. 2-19.0- 1	1	P
8-18622-7	2. 2-19.0- 3	1	P
8-18623-7	2. 2-19.0- 4	1	P
8-18624-7	2. 2-19.0- 5	1	P
	2. 2-19.0- 6	1	P
8-18626-7	2. 2-19.0- 12	1	P
8-18627-7	2. 2-19.0- 11	1	P
	2. 2-19.0- 16	1	
8-18628-7	2. 2-19.0- 15	1	P
	2. 2-19.0- 9	1	
8-18629-7	2. 2-19.0- 8	1	P
8-18630-7	2. 2-19.0- 17	1	P
8-18631-7	2. 2-19.0- 14	1	P
8-18632-7	2. 2-19.0- 13	1	P
	2. 2-19.0- 13	1	
8-18633	2. 2-19.0- 23	1	P
8-18634	2. 2-19.0- 22	1	P
8-18635	2. 2-19.0- 21	1	P
8-18641-7	2. 2-19.0- 1	1	P2
8-18642-7	2. 2-19.0- 3	1	P1
8-18643-7	2. 2-19.0- 4	1	P2
8-18644-7	2. 2-19.0- 4	RF	
8-18644-7	2. 2-19.0- 5	1	P2
	2. 2-19.0- 6	1	
8-18646-7	2. 2-19.0- 12	1	P2
8-18647-7	2. 2-19.0- 11	1	P1
	2. 2-19.0- 15	1	

PART NUMBER	FIGURE AND INDEX NUMBER	QTY PER ART	SMR CODE
8-18648-7	2. 2-19.0- 15	1	P1
	2. 2-19.0- 9	1	P1
8-18649-7	2. 2-19.0- 8	1	P1
8-18650-7	2. 2-19.0- 17	1	P2
8-18651-7	2. 2-19.0- 14	1	P2
8-18652-7	2. 2-19.0- 10	1	P1
	2. 2-19.0- 13	1	
8-18653	2. 2-19.0- 23	1	P2
8-18654	2. 2-19.0- 22	1	P2
8-18655	2. 2-19.0- 21	1	P2
8-18656	2. 2-19.0- 19	1	P2
8-18657-7	2. 2-19.0- 20	1	X1
8-18657-8	2. 2-19.0- 20	1	X1
8-18658-7	2. 2-19.0- 18	1	P2
8-18658-8	2. 2-19.0- 18	1	P2
8-18661	2. 2-19.0- 1	RF	U
	2. 6-35.0- 17	1	
8-18661-1	2. 2-19.0-	RF	U
	2. 6-32.0- 1	1	
8-18661-3	2. 2-19.0- 1	RF	U
	2. 6-35.0- 17	1	
8-18661-5	2. 2-19.0-	RF	U
	2. 6-32.0- 1	1	
8-18661-801	2. 2-19.0- 1	RF	U
	2. 6-35.0- 18	1	
8-18661-803	2. 2-19.0-	RF	U
	2. 6-32.0- 4	1	
8-18661-805	2. 2-19.0- 1	RF	U
	2. 6-35.0- 18	1	
8-18661-807	2. 2-19.0-	RF	U
	2. 6-32.0- 4	1	
8-18662	2. 2-19.0- 3	RF	
	2. 6-35.0- 19	1	
8-18662-1	2. 2-19.0- 2	RF	
	2. 6-32.0- 2	1	
8-18662-3	2. 2-19.0- 3	RF	
	2. 6-35.0- 19	1	
8-18662-5	2. 2-19.0- 2	RF	
	2. 6-32.0- 2	1	
8-18663	2. 2-19.0- 4	RF	
	2. 6-35.0- 20	1	
8-18663-1	2. 2-19.0- 3	RF	
	2. 6-32.0- 3	1	
8-18663-3	2. 2-19.0- 4	RF	
	2. 6-35.0- 21	1	
8-18663-5	2. 2-19.0- 3	RF	
	2. 6-32.0- 5	1	
8-18663-801	2. 2-19.0- 4	RF	
	2. 6-35.0- 20	1	
8-18663-803	2. 2-19.0- 3	RF	
	2. 6-32.0- 3	1	
8-18663-805	2. 2-19.0- 4	RF	
	2. 6-35.0- 21	1	
8-18663-807	2. 2-19.0- 3	RF	
	2. 6-32.0- 5	1	
8-18664-1	2. 2-19.0- 4	RF	
	2. 6-32.0- 6	1	
8-18664-5	2. 6-32.0- 6	1	
8-18664-803	2. 2-19.0- 5	RF	
	2. 6-32.0- 7	1	
8-18664-807	2. 2-19.0- 5	RF	
	2. 6-32.0- 7	1	
8-18666	2. 2-19.0- 12	RF	
	2. 6-36.0- 21	1	
8-18666-1	2. 2-19.0- 11	RF	

PART NUMBER	FIGURE AND INDEX NUMBER	QTY PER ART	SMR CODE
8-18666-1	2. 6-32.0- 16	1	
8-18666-3	2. 2-19.0- 12	RF	
	2. 6-36.0- 21	1	
8-18666-5	2. 2-19.0- 11	RF	
	2. 6-32.0- 16	1	
8-18667	2. 2-19.0- 11	RF	
	2. 6-36.0- 22	1	
8-18667-1	2. 2-19.0- 10	RF	
	2. 6-32.0- 17	1	
8-18667-3	2. 2-19.0- 16	RF	
	2. 6-36.0- 23	1	
8-18667-5	2. 2-19.0- 15	RF	
	2. 6-32.0- 19	1	
8-18667-801	2. 2-19.0- 11	RF	
	2. 6-36.0- 22	1	
8-18667-803	2. 2-19.0- 10	RF	
	2. 6-32.0- 17	1	
8-18667-805	2. 2-19.0- 16	RF	
	2. 6-36.0- 23	1	
8-18667-807	2. 2-19.0- 15	RF	
	2. 6-32.0- 19	1	
8-18668	2. 2-19.0- 15	RF	U
	2. 6-36.0- 25	1	
8-18668-1	2. 2-19.0- 14	RF	U
	2. 6-32.0- 13	1	
8-18668-3	2. 2-19.0- 9	RF	U
	2. 6-36.0- 24	1	
8-18668-5	2. 2-19.0- 8	RF	U
	2. 6-32.0- 11	1	
8-18668-801	2. 2-19.0- 15	RF	U
	2. 6-36.0- 25	1	
8-18668-803	2. 2-19.0- 14	RF	U
	2. 6-32.0- 13	1	
8-18668-805	2. 2-19.0- 9	RF	U
	2. 6-36.0- 24	1	
8-18668-807	2. 2-19.0- 8	RF	U
	2. 6-32.0- 11	1	
8-18669-803	2. 2-19.0- 7	RF	U
	2. 6-32.0- 10	1	
8-18669-807	2. 2-19.0- 7	RF	U
	2. 6-32.0- 10	1	
8-18670	2. 2-19.0- 17	RF	U
	2. 6-36.0- 20	1	
8-18670-1	2. 2-19.0- 16	RF	U
	2. 6-32.0- 18	1	
8-18670-3	2. 2-19.0- 17	RF	U
	2. 6-36.0- 20	1	
8-18670-5	2. 2-19.0- 16	RF	U
	2. 6-32.0- 18	1	
8-18671	2. 2-19.0- 14	RF	U
	2. 6-36.0- 26	1	
8-18671-1	2. 2-19.0- 13	RF	U
	2. 6-32.0- 14	1	
8-18671-3	2. 2-19.0- 14	RF	U
	2. 6-36.0- 26	1	
8-18671-5	2. 2-19.0- 13	RF	U
	2. 6-32.0- 14	1	
8-18672-1	2. 2-19.0- 12	RF	U
	2. 6-32.0- 15	1	
8-18672-5	2. 2-19.0- 12	RF	U
	2. 6-32.0- 15	1	
8-18672-803	2. 2-19.0- 9	RF	U
	2. 6-32.0- 12	1	
8-18672-807	2. 2-19.0- 9	RF	U
	2. 6-32.0- 12	1	

PART NUMBER	FIGURE AND INDEX NUMBER	QTY PER ART	SMR CODE
8-18673	2. 2-19.0- 23	RF	U
	2. 6-37.0- 33	1	
8-18673-1	2. 2-19.0- 22	RF	U
	2. 6-32.0- 29	1	
8-18673-3	2. 2-19.0- 23	RF	U
	2. 6-37.0- 33	1	
8-18673-5	2. 2-19.0- 22	RF	U
	2. 6-32.0- 29	1	
8-18673-7	2. 2-19.0- 23	1	A
8-18673-801	2. 2-19.0- 23	RF	U
	2. 6-37.0- 33	1	
8-18673-803	2. 2-19.0- 23	RF	U
	2. 6-37.0- 33	1	
8-18674	2. 2-19.0- 22	RF	U
	2. 6-37.0- 34	1	
8-18674-1	2. 2-19.0- 21	RF	U
	2. 6-32.0- 21	1	
8-18674-3	2. 2-19.0- 22	RF	U
	2. 6-37.0- 34	1	
8-18674-5	2. 2-19.0- 21	RF	U
	2. 6-32.0- 21	1	
8-18674-7	2. 2-19.0- 22	1	A
8-18674-801	2. 2-19.0- 22	RF	U
	2. 6-37.0- 34	1	
8-18674-803	2. 2-19.0- 22	RF	U
	2. 6-37.0- 34	1	
8-18675	2. 2-19.0- 21	RF	U
	2. 6-37.0- 35	1	
8-18675-1	2. 2-19.0- 20	RF	U
	2. 6-32.0- 22	1	
8-18675-3	2. 2-19.0- 21	RF	U
	2. 6-37.0- 35	1	
8-18675-5	2. 2-19.0- 20	RF	U
	2. 6-32.0- 22	1	
8-18675-7	2. 2-19.0- 21	1	A
8-18675-801	2. 2-19.0- 21	RF	U
	2. 6-37.0- 35	1	
8-18675-803	2. 2-19.0- 21	RF	U
	2. 6-37.0- 35	1	
8-18677-1	2. 2-19.0- 19	RF	U
	2. 6-32.0- 24	1	
8-18677-19	2. 2-19.0- 20	1	P2
8-18677-2	2. 2-19.0- 19	RF	U
	2. 6-32.0- 24	1	
8-18677-20	2. 2-19.0- 20	1	P2
8-18677-5	2. 2-19.0- 18	RF	U
	2. 6-32.0- 23	1	
8-18677-6	2. 2-19.0- 18	RF	U
	2. 6-32.0- 23	1	
8-18678-3	2. 2-19.0- 17	RF	U
	2. 6-32.0- 25	1	
8-18678-4	2. 2-19.0- 17	RF	U
	2. 6-32.0- 25	1	
8-18680-801	2. 2-21.0-	RF	U
	2. 6-32.0- 8	1	
8-18680-802	2. 2-21.0-	RF	U
	2. 6-32.0- 8	1	
8-18680-805	2. 2-21.0-	RF	U
	2. 6-32.0- 9	1	
8-18680-806	2. 2-21.0-	RF	U
	2. 6-32.0- 8	1	

PART NUMBER	FIGURE AND INDEX NUMBER	QTY PER ART	SMR CODE
8-18680-809	2. 2-21.0-	RF	U
	2. 6-32.0- 8	1	
8-18680-810	2. 2-21.0-	RF	U
	2. 6-32.0- 8	1	
8-18683-7	2.15-21.0- 15	1	P
8-18683-9	2.15-21.0- 15	1	P
8-18700-11	2. 6-35.0- 11	1	X
8-18702-12	2. 6-35.0- 11	1	X
8-18703-12	2. 6-35.0- 12	1	X
8-18703-14	2. 6-35.0- 12	1	X
8-18704-15	2. 6-35.0- 4	1	X
8-18704-16	2. 6-35.0- 4	1	X
8-18705-11	2. 6-35.0- 5	1	X
8-18705-12	2. 6-35.0- 5	1	X
8-18709-1	2. 6-37.0- 8	1	P1
8-18710-13	2. 2-21.0- 27	1	P2
8-18711-7	2.15-29.0- 13	RF	P2
8-18711-8	2.15-29.0- 14	RF	P2
8-18715	2. 6-37.0- 15	RF	P1
8-18719-1	2. 6-37.0- 8	RF	P1
8-18719-7	2. 6-37.0- 21	RF	X1
8-18719-9	2. 6-37.0- 13	RF	X1
8-18720	2. 6-38.0-	RF	P1
8-18721-7	2. 6-38.0- 4	RF	X1
8-18721	2. 6-38.0- 15	RF	P1
8-18721-7	2. 6-38.0- 19	RF	X1
8-18723-10	2. 6-38.0- 20	1	X1
8-18723-11	2. 6-38.0- 20	RF	X1
8-18723-12	2. 6-38.0- 20	RF	X1
8-18723-9	2. 6-38.0- 20	1	X1
8-18724	2.15-29.0- 1	RF	P2
8-18724-1	2.15-29.0- 1	RF	P2
8-18724-11	2.15-29.0- 9	RF	X1
8-18724-13	2.15-29.0- 11	RF	X1
8-18724-15	2.15-29.0- 10	RF	X1
8-18724-17	2.15-29.0- 12	RF	X1
8-18724-19	2.15-29.0- 9	RF	
8-18724-21	2.15-29.0- 11	RF	
8-18724-23	2.15-29.0- 10	RF	
8-18724-25	2.15-29.0- 12	RF	
8-18724-3	2.15-29.0- 1	RF	P2
8-18724-5	2.15-29.0- 1	RF	P2
8-18725	2. 6-38.0- 6	RF	P1
8-18725-7	2. 6-38.0- 8	RF	X1
8-18725	2. 6-38.0- 9	RF	P1
8-18726-7	2. 6-38.0- 11	RF	X1
8-18727	2. 6-38.0- 11	RF	P1
8-18727-7	2. 6-38.0- 13	RF	X1
8-18728	2. 6-38.0- 13	RF	P1
8-18728-7	2. 6-38.0- 15	RF	X1
8-18729	2. 6-38.0- 4	RF	P1
8-18729-7	2. 6-38.0- 6	RF	X1
8-18730-7	2. 6-35.0- 25	1	X2
8-18730-9	2. 6-35.0- 25	1	X2
8-18732	2. 6-35.0- 24	1	X2
8-18733-7	2. 6-37.0- 27	1	X2
8-18734	2. 6-37.0- 27	RF	X2
8-18734-15	2. 6-36.0- 15	RF	X2
8-18739-9	2. 6-36.0- 15	RF	X2
8-18741-17	2. 6-39.0- 15	RF	X2
8-18741-9	2. 6-39.0- 15	RF	X2
8-18743-13	2. 6-36.0- 12	RF	X2
8-18743-3	2. 6-36.0- 12	RF	A

PART NUMBER	FIGURE AND INDEX NUMBER	QTY PER ART	SMR CODE
8-18743-4	2. 6-36.0- 12	RF	A
8-18743-9	2. 6-36.0- 12	RF	X2
8-18744-7	2. 6-36.0- 4	1	X2
8-18745-7	2. 6-36.0- 5	1	M
8-18747-7	2. 6-37.0- 24	1	X2
8-18747-6	2. 6-37.0- 24	1	X2
8-18748-7	2. 6-37.0- 24	RF	X2
8-18748-8	2. 6-37.0- 24	RF	X2
8-18751-10	2. 6-39.0- 15	1	X2
8-18751-7	2. 6-39.0- 15	1	X2
8-18751-6	2. 6-39.0- 15	1	X2
8-18751-9	2. 6-39.0- 15	1	X2
8-18757	2. 6-39.0- 18	1	P
8-18758	2. 6- 6.0- 20	4	P1
	2. 6- 6.0- 26	2	
	2. 6- 6.0- 37	6	
	2. 6- 7.0- 20	4	
	2. 6- 7.0- 28	2	
	2. 6- 7.0- 37	6	
	2. 6- 9.0- 20	4	
	2. 6- 9.0- 27	1	
	2. 6-12.0- 21	1	
	2. 6-12.0- 28	6	
8-18759	2. 6- 6.0- 24	2	P1
	2. 6- 7.0- 24	2	
	2. 6- 9.0- 24	2	
8-18769	2. 6-38.0- 5	RF	P
8-18760-7	2. 6-38.0- 5	2	P
8-18761	2. 6-38.0- 12	2	P
	2. 6-38.0- 14	2	
	2. 6-38.0- 18	2	
	2. 6-38.0- 3	2	
	2. 6-38.0- 7	2	
	2. 6-38.0- 9	2	
8-18763-1	2. 6-17.0- 1	1	P2
8-18763-7	2. 6-17.0- 15	1	X1
8-18764	2. 6-17.0- 1	RF	P2
8-18764-7	2. 6-17.0- 16	RF	X1
8-18765	2. 6-37.0- 13	2	P1
	2. 6-37.0- 21	2	
8-18769	2.14-11.0- 46	2	P1
8-18772	2. 6-37.0- 32	1	X2
8-18775	2. 2-21.0- 1	1	P
8-18776	2. 2-21.0- 4	1	P
8-18778	2. 2-21.0- 23	RF	P
8-18779	2. 2-21.0- 21	RF	P
8-18782-1	2. 6-36.0- 12	1	X2
8-18782-2	2. 6-36.0- 12	1	X2
8-18783-7	2. 6-36.0- 15	1	X2
8-18783-8	2. 6-36.0- 15	1	X2
8-18784	2. 6-32.0- 9	1	P
8-18785-10	2. 6-39.0- 14	1	P
8-18785-7	2. 6-39.0- 13	1	P
8-18785-8	2. 6-39.0- 13	1	P
8-18785-9	2. 6-39.0- 14	1	P
8-18792-11	2. 6-36.0- 11	1	X2
8-18792-12	2. 6-36.0- 11	1	X2
8-18792-15	2. 6-36.0- 11	1	X2
8-18792-7	2. 6-36.0- 11	1	X2
8-18792-8	2. 6-36.0- 11	1	X2
8-18793-16	2. 6-36.0- 12	1	X2
8-18793-13	2. 6-36.0- 12	1	X2
8-18793-14	2. 6-36.0- 12	1	X2
8-18793-7	2. 6-36.0- 12	1	X2
8-18793-6	2. 6-36.0- 12	1	X2

PART NUMBER	FIGURE AND INDEX NUMBER	QTY PER ART	SMR CODE
8-18793-9	2. 6-36.0- 12	1	X2
8-18794-13	2. 6-36.0- 4	1	X
8-18794-14	2. 6-36.0- 4	1	X
8-18794-7	2. 6-36.0- 4	1	X
8-18794-8	2. 6-36.0- 4	1	X
8-18795-7	2. 6-36.0- 5	1	X
8-18795-8	2. 6-36.0- 5	1	X
8-18799	2. 2-21.0- 18	RF	P
8-18799-7	2. 2-21.0- 17	RF	P
8-18803-1	2. 6-38.0- 15	1	P1
8-18803-7	2. 6-38.0- 19	1	X1
8-18804-1	2. 6-38.0- 13	1	P1
8-18804-7	2. 6-38.0- 15	1	X1
8-18805-1	2. 6-38.0- 11	1	P1
8-18805-7	2. 6-38.0- 13	1	X1
8-18806-1	2. 6-38.0- 8	1	P1
8-18806-7	2. 6-38.0- 11	1	X1
8-18807-1	2. 6-38.0- 6	1	P1
8-18807-7	2. 6-38.0- 8	1	X1
8-18808-1	2. 6-38.0- 4	1	P1
8-18808-7	2. 6-38.0- 6	1	X1
8-18809-1	2. 6-38.0- 1	1	P1
8-18809-7	2. 6-38.0- 4	1	X1
8-18810-7	2. 6-38.0- 20	1	X2
8-18810-8	2. 6-38.0- 20	1	X1
8-18811-11	2.15-29.0- 13	1	X1
8-18811-12	2.15-29.0- 14	1	X1
8-18814-1	2.15-29.0- 1	1	P2
8-18814-11	2.15-29.0- 9	1	X1
8-18814-15	2.15-29.0- 11	1	X1
8-18814-3	2.15-29.0- 1	1	P2
8-18816-1	2.15-29.0- 1	1	P2
8-18816-11	2.15-29.0- 1	1	X1
8-18816-13	2.15-29.0- 10	1	X1
8-18816-3	2.15-29.0- 1	1	P2
8-18818	2. 2-21.0- 22	1	P1
8-18822-11	2. 6-36.0- 11	RF	X2
8-18822-12	2. 6-36.0- 11	RF	X2
8-18822-15	2. 6-36.0- 11	RF	X2
8-18822-19	2. 6-36.0- 11	RF	X2
8-18823-11	2. 6-36.0- 12	1	X2
8-18823-12	2. 6-36.0- 12	1	X2
8-18824-11	2. 6-36.0- 4	RF	X2
8-18824-12	2. 6-36.0- 4	RF	X2
8-18824-17	2. 6-36.0- 4	RF	X2
8-18824-18	2. 6-36.0- 4	RF	X2
8-18825-11	2. 6-36.0- 5	RF	X2
8-18825-12	2. 6-36.0- 5	RF	X2
8-18826-7	2. 6-36.0- 25	1	X2
8-18826-8	2. 6-36.0- 21	1	X2
8-18826-10	2. 6-37.0- 30	1	X2
8-18826-9	2. 6-37.0- 30	1	X2
8-18834-811	2. 2-21.0- 6	RF	P1
8-18834-812	2. 2-21.0- 6	RF	P1
8-18834-815	2. 2-21.0- 6	RF	P2
8-18834-816	2. 2-21.0- 6	RF	P2
8-18837-11	2. 2-21.0- 24	1	X1
8-18837-12	2. 2-21.0- 24	1	X1
8-18837-15	2. 2-21.0- 24	1	X1
8-18837-18	2. 2-21.0- 24	1	X1
8-18837-19	2. 2-21.0- 24	1	X2
8-18837-7	2. 6-36.0- 24	1	X2
8-18837-8	2. 6-36.0- 24	1	X2
8-18837-9	2. 2-21.0- 24	1	P1
8-18838-15	2. 2-21.0- 24	1	P1

PART NUMBER	FIGURE AND INDEX NUMBER	QTY PER ART	SMR CODE
8-18876-7	2. 2-21.0- 26	1	P1
8-18876-9	2. 2-21.0- 25	1	P1
8-188884	2. 6-39.0- 12	1	X2
8-18892-7	2. 6-37.0- 32	RF	X2
8-18892-8	2. 6-37.0- 32	RF	X2
8-18901-10	2. 6-19.0- 18	1	P1D
8-18901-7	2. 6-19.0- 17	1	P1D
8-18901-8	2. 6-19.0- 17	1	P2
8-18901-9	2. 6-19.0- 18	1	P1D
8-18902-10	2. 6-19.0- 20	1	P1D
8-18902-11	2. 6-19.0- 21	1	P1D
8-18902-12	2. 6-19.0- 21	1	P1D
8-18902-7	2. 6-19.0- 19	1	1
8-18902-8	2. 6-19.0- 19	1	P1D
8-18902-9	2. 6-19.0- 20	1	P2
8-18903-1	2. 6-19.0- 22	1	X2
8-18903-13	2. 6-19.0- 22	1	X2
8-18903-2	2. 6-19.0- 22	1	X2
8-18903-7	2. 6-19.0- 22	1	X2
8-18903-8	2. 6-19.0- 22	1	X2
8-18903-9	2. 6-19.0- 22	1	X2
8-18904-10	2. 6-19.0- 24	1	X2
8-18904-11	2. 6-19.0- 28	1	X2
8-18904-12	2. 6-19.0- 28	1	X2
8-18904-13	2. 6-19.0- 25	1	X2
8-18904-14	2. 6-19.0- 25	1	X2
8-18904-15	2. 6-19.0- 29	1	X2
8-18904-16	2. 6-19.0- 29	1	X2
8-18904-17	2. 6-19.0- 26	1	X2
8-18904-18	2. 6-19.0- 26	1	X2
8-18904-19	2. 6-19.0- 30	1	X2
8-18904-20	2. 6-19.0- 30	1	X2
8-18904-21	2. 6-19.0- 27	1	X2
8-18904-22	2. 6-19.0- 27	1	X2
8-18904-23	2. 6-19.0- 31	1	X2
8-18904-24	2. 6-19.0- 31	1	X2
8-18904-25	2. 6-19.0- 28	1	X2
8-18904-26	2. 6-19.0- 28	1	X2
8-18904-27	2. 6-19.0- 29	1	X2
8-18904-28	2. 6-19.0- 29	1	X2
8-18904-29	2. 6-19.0- 30	1	X2
8-18904-30	2. 6-19.0- 30	2	X2
8-18904-31	2. 6-19.0- 31	1	X2
8-18904-32	2. 6-19.0- 31	1	X2
8-18904-7	2. 6-19.0- 23	1	X2
8-18904-8	2. 6-19.0- 23	1	X2
8-18904-9	2. 6-19.0- 24	1	X2
8-18906-7	2. 6- 1.0- 23	1	1
	2. 6- 2.0- 23	1	1
8-18906-9	2. 6- 1.0- 24	1	1
	2. 6- 2.0- 24	1	1
8-18910-1	2. 6- 3.0- 11	1	U
	2. 6-18.0- 1	1	U
8-18910-2	2. 6- 3.0- 11	1	U
	2. 5-18.0- 1	1	1
8-18911-1	2. 6-18.0- 2	1	P1
	2. 6-19.0-	RF	1
8-18911-2	2. 6-18.0- 2	1	P1
	2. 5-19.0-	RF	1
8-18913-7	2. 6-13.0- 11	1	M1
	2. 6-15.0- 34	1	1
8-18913-8	2. 6-13.0- 11	1	M1
	2. 6-15.0- 34	1	1
8-18930-11	2. 6-16.0- 7	2	P
8-18930-13	2. 6-16.0- 24	2	P

PART NUMBER	FIGURE AND INDEX NUMBER	QTY PER ART	SMR CODE
8-18930-7	2. 6-16.0- 23	2	P
8-18930-9	2. 6-16.0- 18	2	P
8-18931-1	2. 6-35.0- 21	1	U
8-18931-2	2. 6-35.0- 21	1	U
8-18932-1	2. 6-37.0- 24	1	U
8-18932-2	2. 6-37.0- 24	1	U
8-18932-801	2. 6-37.0- 24	1	U
8-18932-802	2. 6-37.0- 24	1	U
8-18935	2.15-28.5- 1	1	U
8-18938-1	2. 6-37.0- 21	1	U
8-18938-2	2. 6-37.0- 21	1	U
8-18938-3	2. 6-37.0- 21	1	U
8-18938-4	2. 6-37.0- 21	1	U
8-18939-1	2. 6-35.0- 24	1	U
8-18939-2	2. 6-35.0- 24	1	U
8-18941-11	2. 6-16.0- 15	2	P2
8-18941-13	2. 6-16.0- 14	2	P2
8-18941-15	2. 6-16.0- 9	2	P2
8-18941-17	2. 6-16.0- 25	2	P
8-18941-19	2. 6-16.0- 20	2	P
8-18941-7	2. 6-16.0- 25	2	P2
8-18941-9	2. 6-16.0- 20	2	P
8-18954	2. 6- 5.0- 5	1	P1
8-18980-1	2. 6-35.0- 3	1	U
8-18980-2	2. 6-35.0- 3	1	U
8-18981	2. 6-37.0- 14	RF	U
8-18981-1	2. 6-37.0- 7	1	A
8-18981-7	2. 6-37.0- 14	2	A
8-18989-1	2. 6-13.0- 11	1	M
	2. 6-15.0- 34	1	A
8-18989-2	2. 6-15.0- 34	1	1
	2. 6-13.0- 11	1	1
8-18989-3	2. 6-13.0- 11	1	A
8-18989-4	2. 6-13.0- 11	1	A
8-18990-10	2. 6-29.0- 2	1	X2
8-18990-23	2. 6-29.0- 4	1	M1
8-18990-24	2. 6-29.0- 4	1	M1
8-18990-27	2. 6-29.0- 6	1	M1
8-18990-28	2. 6-29.0- 7	1	M1
8-18990-29	2. 6-29.0- 7	1	M1
8-18990-30	2. 6-29.0- 7	1	M1
8-18990-31	2. 6-29.0- 8	1	M1
8-18990-32	2. 6-29.0- 9	1	M1
8-18990-33	2. 6-29.0- 9	1	M1
8-18990-34	2. 6-29.0- 9	1	M1
8-18990-35	2. 6-29.0- 10	1	M1
8-18990-36	2. 6-29.0- 10	1	M1
8-18990-37	2. 6-29.0- 11	1	M1
8-18990-38	2. 6-29.0- 11	1	M1
8-18990-67	2. 6-29.0- 13	1	M1
8-18990-68	2. 6-29.0- 13	1	M1
8-18990-69	2. 6-29.0- 14	1	M1
8-18990-7	2. 6-29.0- 1	1	X2
8-18990-70	2. 6-29.0- 14	1	M1
8-18990-8	2. 6-29.0- 1	1	X2
8-18990-9	2. 6-29.0- 2	1	X2
8-19073-1	2. 6-36.0- 17	1	U
	2. 6-37.0-	RF	1
8-19073-2	2. 6-36.0- 17	1	U
	2. 6-37.0-	RF	1
8-19126-1	2. 6-37.0- 27	1	U
8-19126-2	2. 6-37.0- 27	1	U
8-19127-1	2. 6-37.0- 25	1	U
	2. 6-38.0-	RF	1
8-19127-2	2. 6-37.0- 29	1	U

PART NUMBER	FIGURE AND INDEX NUMBER	QTY PER ART	SMR CODE	PART NUMBER	FIGURE AND INDEX NUMBER	QTY PER ART	SMR CODE
8-19127-2	2. 6-38.J-	RF	U	8-20397-1071	2.12-21.0- 51	1	M
8-19127-7	2. 6-38.0- 21	1	A	8-20397-1073	2.12-21.0- 53	1	M
8-19127-8	2. 6-38.0- 21	1	A	8-20397-1075	2.12-21.0-149	1	M
8-20307-13	2.12-66.0- 8	1	P	8-20397-1077	2.12-21.0- 28	1	M
8-20307-15	2.12-52.J-136	1	P	8-20397-1079	2.12-21.0- 8	1	M
	2.12-52.0-137	5		8-20397-1081	2.12-21.0- 13	1	M
	2.12-52.0-139	1		8-20397-1083	2.12-21.0- 18	1	M
	2.12-52.0-140	1		8-20397-1095	2.12-21.0- 16	1	M
	2.12-66.0- 5	1		8-20397-1089	2.12-21.0-152	1	M
8-20307-17	2.12-66.0- 19	2	P	8-20397-1101	2.12-21.0-175	1	M
8-20307-19	2.12-66.0- 13	1	P	8-20397-1103	2.12-21.0-178	1	M
8-20307-21	2.12-66.0- 14	1	P	8-20397-1109	2.12-21.0-162	1	M
8-20307-23	2.12-66.0- 21	1	P	8-20397-1121	2.12-21.0-187	1	M
8-20307-25	2.12-66.0- 16	2	P	8-20397-1123	2.12-21.0-192	1	M
8-20307-27	2.12- 3.0- 9	1	P1	8-20397-1133	2.12-21.0-164	1	M
	2.12-15.0-106	1		8-20397-1139	2.12-21.0-173	1	M
	2.12-15.0- 88	1		8-20397-1143	2.12-21.0-169	1	M
	2.12-66.0- 6	1		8-20397-1149	2.12-21.0-181	1	M
	2.12-66.0- 9	1		8-20397-1153	2.12-44.0-166	1	M
8-20307-29	2.12-66.0- 17	1	P	8-20397-1155	2.12-44.0- 74	1	M
8-20307-31	2.12-66.J- 15	1	P	8-20397-1157	2.12-44.0- 75	1	M
	2.12-66.0- 18	1		8-20397-1159	2.12-44.0- 45	1	M
8-20307-33	2.12-66.J- 10	1	P	8-20397-1161	2.12-21.0- 5	1	M
8-20307-37	2.12-66.0- 10	1	P	8-20397-1163	2.12-21.0- 5	1	M
8-20307-7	2.12-66.0- 12	2	P	8-20397-1165	2.12-45.0-176	1	M
	2.12-66.0- 4	3		8-20397-1169	2.12-37.0- 1	1	M
8-20307-9	2.12-52.0-138	5	P	8-20397-1171	2.12-37.0- 2	1	M
	2.12-52.0-141	2		8-20397-1179	2.12-37.0- 15	1	M
	2.12-66.0- 11	1		8-20397-1183	2.12-37.0-111	1	M
8-20324-813	2. 6-32.J- 69	1	U	8-20397-1185	2.12-37.0-112	1	M
	2.12-14.0-	RF		8-20397-1187	2.12-37.0-117	1	M
8-20324-815	2. 6-32.0- 69	1	U	8-20397-1189	2.12-37.0-123	1	M
	2.12-14.0-	RF		8-20397-1191	2.12-37.0-126	1	M
8-20324-825	2. 6-32.0- 69	1	U	8-20397-1193	2.12-37.0-135	1	M
	2.12-14.0-	RF		8-20397-1195	2.12-37.0-137	1	M
8-20324-827	2. 6-32.0- 69	1	U	8-20397-1197	2.12-37.0-119	1	M
	2.12-14.0-	RF		8-20397-1199	2.12-37.0-125	1	M
8-2037-1295	2.12-37.0-157	1	M	8-20397-1200	2.12-45.0-138	1	M
8-20393	2. 3-14.0- 27	1	U	8-20397-1201	2.12-37.0-130	1	M
	2.10-18.0- 14	RF		8-20397-1203	2.12-37.0-170	1	M
8-20393-1	2.10- 7.0- 84	1	U	8-20397-1205	2.12-37.0-178	1	M
	2.10-18.0-	RF		8-20397-1207	2.12-37.0-181	1	M
8-20393-3	2.10- 7.0- 84	1	U	8-20397-1227	2.12-37.0- 81	1	M
	2.10-17.0-	RF		8-20397-1229	2.12-37.0- 84	1	M
8-20393-9	2.10-17.0- 2	1	M		2.12-37.0-210	1	
	2.10-18.0- 3	1		8-20397-1231	2.12-43.0-135	1	M
8-20397-100	2.12-46.0- 31	1	M	8-20397-1233	2.12-43.0- 73	1	M
8-20397-1007	2.12-43.0- 12	1	M	8-20397-1235	2.12-43.0-129	1	M
8-20397-1009	2.12-43.0- 14	1	M	8-20397-1237	2.12-43.0- 61	1	M
8-20397-1013	2.12-21.0- 69	1	M	8-20397-1239	2.12-43.0- 69	1	M
8-20397-1019	2.12-21.0- 42	1	M	8-20397-124	2.12-44.0-171	1	M
8-20397-102	2.12-46.0- 30	1	M	8-20397-1241	2.12-43.0- 51	1	M
8-20397-1021	2.12-21.0- 46	1	M	8-20397-1243	2.12-43.0- 55	1	M
8-20397-1023	2.12-21.0- 59	1	M	8-20397-1245	2.12-43.0- 53	1	M
8-20397-1025	2.12-21.0- 61	1	M	8-20397-1247	2.12-43.0- 36	1	M
8-20397-1027	2.12-21.0- 48	1	M	8-20397-1249	2.12-43.0- 30	1	M
	2.12-21.0-138	1	M	8-20397-1251	2.12-43.0-122	1	M
8-20397-1035	2.12-21.0- 90	1	M	8-20397-1253	2.12-43.0-100	1	M
8-20397-1047	2.12-46.0-110	1	M	8-20397-1255	2.12-43.0- 44	1	M
8-20397-1049	2.12-32.0- 73	1	M	8-20397-1257	2.12-43.0-114	1	M
8-20397-1053	2.12-32.0- 75	1	M	8-20397-1259	2.12-43.0-121	1	M
8-20397-1057	2.12-46.0- 69	1	M	8-20397-1261	2.12-43.0- 46	1	M
8-20397-1063	2.12-46.0-119	1	M	8-20397-1265	2.12-43.0-112	1	M
8-20397-1065	2.12-46.0-105	1	M	8-20397-1267	2.12-43.0-119	1	M
8-20397-1069	2.12-21.0-147	1	M	8-20397-1269	2.12-43.0- 65	1	M

PART NUMBER	FIGURE AND INDEX NUMBER	QTY PER ART	SMR CODE
8-20397-1859	2.12-37.0- 41	1	M
8-20397-1861	2.12-37.0- 28	1	M
8-20397-1863	2.12-37.0- 30	1	M
8-20397-1865	2.12-37.0-148	1	M
8-20397-1867	2.12-37.0-151	1	M
8-20397-1869	2.12-37.0- 42	1	M
	2.12-37.0-160	1	M
8-20397-1871	2.12-37.0-159	1	M
8-20397-1875	2.12-15.0-210	1	M
8-20397-1881	2.12-46.0-155	1	M
8-20397-1883	2.12-46.0-156	1	M
8-20397-1885	2.12-46.0- 48	1	M
8-20397-1887	2.12-46.0-158	1	M
8-20397-1889	2.12-46.0- 45	1	M
8-20397-1891	2.12-46.0-152	1	M
8-20397-1893	2.12-46.0-153	1	M
8-20397-1897	2.12-46.0- 84	1	M
8-20397-1899	2.12-32.0- 15	1	M
8-20397-19	2.12-15.0-221	1	M1
8-20397-190	2.12-45.0-121	1	M
8-20397-192	2.12-45.0-123	1	M
8-20397-1927	2.12-21.0- 21	1	M
8-20397-1929	2.12-46.0- 88	1	M
8-20397-1931	2.12-46.0- 91	1	M
8-20397-196	2.12-21.0-103	1	M
8-20397-1965	2.12-37.0- 84	1	M
	2.12-37.0-210	1	M
8-20397-1971	2.12-45.0- 61	1	M
8-20397-1973	2.12-45.0- 63	1	M
8-20397-1975	2.12-45.0- 65	1	M
8-20397-1977	2.12-44.0- 85	1	M
8-20397-1979	2.12-44.0- 2	1	M
8-20397-198	2.12-20.0- 39	1	M
8-20397-1981	2.12-44.0- 19	1	M
8-20397-1985	2.12-44.0- 98	1	M
8-20397-1987	2.12-44.0- 95	1	M
8-20397-1989	2.12-45.0- 75	1	M
8-20397-1991	2.12-45.0- 99	1	M
8-20397-1993	2.12-45.0- 48	1	M
8-20397-1995	2.12-44.0- 7	1	M
8-20397-1997	2.12-45.0- 80	1	M
8-20397-1999	2.12-45.0- 76	1	M
8-20397-2001	2.12-44.0- 6	1	M
8-20397-2005	2.12-44.0- 21	1	M
8-20397-2013	2.12-46.0-220	1	M
8-20397-2015	2.12-46.0-232	1	M
8-20397-2019	2.12-45.0-157	1	M
8-20397-202	2.12-19.0- 21	1	M
8-20397-2021	2.12-45.0-158	1	P1
8-20397-2023	2.12-45.0-159	1	M
8-20397-2027	2.12-45.0-123	1	M
8-20397-2031	2.12-45.0-143	1	M
8-20397-2039	2.12-45.0-149	1	M
8-20397-204	2.12-21.0-120	1	M
8-20397-2065	2.12-37.0-151	1	M
8-20397-2095	2.12-46.0- 21	1	M
8-20397-2097	2.12-46.0-212	1	M
8-20397-2099	2.12-46.0-205	1	M1
8-20397-21	2.12-15.0-222	1	M
8-20397-210	2.12-37.0-225	1	M
8-20397-2101	2.12-43.0- 33	1	M
8-20397-2103	2.12-43.0-122	1	M
8-20397-2105	2.12-43.0-100	1	M
8-20397-2107	2.12-45.0- 44	1	M
8-20397-2111	2.12-43.0-121	1	M

PART NUMBER	FIGURE AND INDEX NUMBER	QTY PER ART	SMR CODE
8-20397-2113	2.12-43.0- 46	1	M
8-20397-2115	2.12-43.0-112	1	M
8-20397-2117	2.12-43.0-119	1	M
8-20397-2119	2.12-43.0- 65	1	M
8-20397-212	2.12-37.0-216	1	M
8-20397-212T	2.12-43.0-152	1	M
8-20397-2121	2.12-43.0-150	1	M
8-20397-2123	2.12-43.0-116	1	M
8-20397-2125	2.12-43.0-110	1	M
8-20397-2129	2.12-43.0-160	1	M
8-20397-2131	2.12-43.0-125	1	M
8-20397-2133	2.12-43.0- 58	1	M
8-20397-2135	2.12-43.0-158	1	M
8-20397-2137	2.12-43.0- 71	1	M
8-20397-2139	2.12-43.0-147	1	M
8-20397-2141	2.12-21.0- 94	1	M
	2.12-22.0- 75	1	M
8-20397-2143	2.12-21.0-140	1	M
8-20397-2145	2.12-21.0- 81	1	M
8-20397-2147	2.12-21.0- 91	1	M
8-20397-2149	2.12-21.0- 67	1	M
8-20397-2151	2.12-21.0- 65	1	M
8-20397-2153	2.12-21.0- 27	1	M
8-20397-2155	2.12-21.0- 69	1	M
	2.12-22.0- 62	1	M
8-20397-2157	2.12-21.0- 99	1	M
8-20397-2159	2.12-21.0- 72	1	M
8-20397-2161	2.12-21.0-134	1	M
8-20397-2163	2.12-21.0-127	1	M
8-20397-2165	2.12-21.0- 99	1	M
8-20397-2167	2.12-21.0-129	1	M
8-20397-2169	2.12-21.0-138	1	M
8-20397-2171	2.12-21.0- 8	1	M
8-20397-2173	2.12-21.0- 13	1	M
8-20397-2175	2.12-21.0-160	1	M
8-20397-2177	2.12-21.0- 36	1	M
8-20397-2179	2.12-21.0- 96	1	M
8-20397-2181	2.12-21.0- 94	1	M
8-20397-2183	2.12-21.0- 44	1	M
8-20397-2185	2.12-21.0-173	1	M
8-20397-2187	2.12-21.0- 21	1	M
8-20397-2189	2.12-21.0- 71	1	M
	2.12-22.0- 64	1	M
8-20397-2191	2.12-21.0- 19	1	M
	2.12-22.0- 18	1	M
8-20397-2193	2.12-21.0- 26	1	M
	2.12-22.0- 20	1	M
8-20397-2195	2.12-21.0-106	1	M
	2.12-22.0- 85	1	M
8-20397-2197	2.12-21.0-108	1	M
8-20397-2199	2.12-21.0-155	1	M
8-20397-22	2.12-45.0- 70	1	M
8-20397-2201	2.12-21.0- 3	1	M
8-20397-2203	2.12-21.0- 39	1	M
8-20397-2205	2.12-21.0- 41	1	M
	2.12-22.0- 41	1	M
8-20397-2207	2.12-21.0-136	1	M
8-20397-2209	2.12-21.0- 18	1	M
	2.12-22.0- 17	1	M
8-20397-2211	2.12-21.0- 16	1	M
8-20397-2213	2.12-21.0-178	1	M
8-20397-2215	2.12-21.0-178	1	M
8-20397-2217	2.12-21.0-107	1	M
8-20397-2219	2.12-21.0-103	1	M
8-20397-2221	2.12-45.0- 50	1	M

PART NUMBER	FIGURE AND INDEX NUMBER	QTY PER ART	SMR CODE
8-20397-2223	2.12-19.0- 16	1	M
8-20397-2225	2.12-19.0- 18	1	M
8-20397-2227	2.12-19.0- 5	1	M
8-20397-2229	2.12-19.0- 3	1	M
8-20397-2231	2.12-19.0- 5	1	M
8-20397-2233	2.12-19.0- 21	1	M
8-20397-2235	2.12-19.0- 21	1	M
8-20397-2237	2.12-19.0- 64	1	M
8-20397-2239	2.12-19.0- 68	1	M
8-20397-2241	2.12-19.0- 7	1	M
8-20397-2243	2.12-19.0- 9	1	M
8-20397-2245	2.12-19.0- 11	1	M
8-20397-2247	2.12-19.0- 7	1	M
8-20397-2249	2.12-19.0- 25	1	M
8-20397-2251	2.12-19.0- 23	1	M
8-20397-2253	2.12-19.0- 64	1	M
8-20397-2255	2.12-19.0- 68	1	M
8-20397-2257	2.12-16.0-122	1	M
8-20397-2259	2.12-16.0-147	1	M
8-20397-2261	2.12-16.0-124	1	M
8-20397-2265	2.12-16.0-190	1	M
8-20397-2267	2.12-16.0-187	1	M
8-20397-2269	2.12-16.0-161	1	M
8-20397-23	2.12-15.0-223	1	M1
8-20397-230	2.12-37.0-222	1	M
8-20397-2307	2.12-20.0- 47	1	M
8-20397-2309	2.12-20.0- 49	1	M
8-20397-2311	2.12-20.0- 62	1	M
8-20397-2313	2.12-20.0- 51	1	M
8-20397-2315	2.12-20.0- 39	1	M
8-20397-2317	2.12-20.0- 37	1	M
8-20397-2319	2.12-20.0- 39	1	M
8-20397-2321	2.12-20.0- 2	1	M
8-20397-2325	2.12-20.0- 2	1	M
	2.12-20.0- 29	1	M
8-20397-2327	2.12-20.0- 40	1	M
8-20397-2329	2.12-20.0- 43	1	M
8-20397-2331	2.12-20.0- 38	1	M
8-20397-2333	2.12-20.0- 36	1	M
8-20397-2337	2.12-20.0- 32	1	M
8-20397-2341	2.12-20.0- 59	1	M
8-20397-2343	2.12-20.0- 59	1	M
8-20397-2345	2.12-20.0- 49	1	M
8-20397-2347	2.12-20.0- 51	1	M
8-20397-2349	2.12-20.0- 32	1	M
8-20397-2351	2.12-20.0- 43	1	M
8-20397-2353	2.12-20.0- 40	1	M
8-20397-2355	2.12-20.0- 36	1	M
8-20397-2357	2.12-20.0- 29	1	M
8-20397-2359	2.12-20.0- 62	1	M
8-20397-236	2.12-45.0-234	1	P
8-20397-2363	2.12-20.0- 55	1	M
8-20397-2365	2.12-20.0- 55	1	M
8-20397-2367	2.12-16.0- 25	1	M
8-20397-2371	2.12-16.0- 25	1	M
8-20397-2375	2.12-16.0-181	1	M
8-20397-2377	2.12-16.0-183	1	M
8-20397-2379	2.12-16.0-176	1	M
8-20397-2387	2.12-16.0-156	1	M
8-20397-2389	2.12-16.0-193	1	M
8-20397-2391	2.12-16.0-166	1	M
8-20397-2393	2.12-16.0-164	1	M
8-20397-2395	2.12-16.0-172	1	M
8-20397-2397	2.12-16.0-174	1	M
8-20397-2399	2.12-16.0-180	1	M

PART NUMBER	FIGURE AND INDEX NUMBER	QTY PER ART	SMR CODE
8-20397-2401	2.12-16.0-178	1	M
8-20397-2403	2.12-16.0-150	1	M
8-20397-2409	2.12-16.0-193	1	M
8-20397-241	2.12-19.0- 7	1	M
8-20397-2411	2.12-16.0-172	1	M
8-20397-2413	2.12-16.0-187	1	M
8-20397-2421	2.12-16.0-153	1	M
8-20397-2423	2.12-16.0-164	1	M
8-20397-2425	2.12-16.0-122	1	M
8-20397-2427	2.12-16.0-156	1	M
8-20397-243	2.12-19.0- 9	1	M
8-20397-2433	2.12-16.0-166	1	M
8-20397-2435	2.12-16.0-151	1	M
8-20397-2437	2.12-16.0-190	1	M
8-20397-2439	2.12-16.0-183	1	M
8-20397-244	2.12-46.0- 32	1	M
8-20397-2441	2.12-16.0-176	1	M
8-20397-2443	2.12-16.0-180	1	M
8-20397-2449	2.12-16.0-124	1	M
8-20397-245	2.12-19.0- 11	1	M
8-20397-2451	2.12-16.0-185	1	M
8-20397-2453	2.12-21.0-101	1	M
8-20397-2455	2.12-21.0-149	1	M
	2.12-22.0-126	1	M
	2.12-21.0- 53	1	M
8-20397-2457	2.12-21.0-147	1	M
8-20397-2459	2.12-46.0- 37	1	M
8-20397-246	2.12-21.0- 28	1	M
8-20397-2461	2.12-22.0- 28	1	M
	2.12-21.0- 73	1	M
8-20397-2463	2.12-21.0- 24	1	M
8-20397-2465	2.12-22.0- 19	1	M
	2.12-21.0- 48	1	M
8-20397-2467	2.12-21.0-103	1	M
8-20397-2469	2.12-19.0- 7	1	M
8-20397-247	2.12-21.0-105	1	M
8-20397-2471	2.12-21.0-105	1	M
8-20397-2473	2.12-21.0-143	1	M
8-20397-2475	2.12-22.0-115	1	M
	2.12-21.0-152	1	M
8-20397-2477	2.12-21.0-145	1	M
8-20397-2479	2.12-22.0-117	1	M
	2.12-21.0- 88	1	M
8-20397-2481	2.12-21.0- 11	1	M
8-20397-2483	2.12-21.0- 11	1	M
8-20397-2485	2.12-21.0-114	1	M
8-20397-2487	2.12-21.0- 46	1	M
8-20397-2489	2.12-22.0- 44	1	M
	2.12-21.0-105	1	M
8-20397-249	2.12-21.0- 44	1	M
8-20397-2491	2.12-22.0- 43	1	M
	2.12-21.0- 42	1	M
8-20397-2493	2.12-21.0- 58	1	M
8-20397-2495	2.12-21.0- 25	1	M
8-20397-2497	2.12-22.0- 26	1	M
	2.12-21.0-112	1	M
8-20397-2499	2.12-15.0-224	1	M1
8-20397-25	2.12-21.0-112	1	M
8-20397-2501	2.12-21.0- 78	1	M
8-20397-2503	2.12-21.0- 80	1	M
8-20397-2505	2.12-22.0- 71	1	M
	2.12-21.0-131	1	M
8-20397-2507	2.12-21.0-134	1	M
8-20397-2509	2.12-21.0-106	1	M
8-20397-251	2.12-21.0-127	1	M
8-20397-2511			

PART NUMBER	FIGURE AND INDEX NUMBER	QTY	UNIT	CODE	DESCRIPTION	FIGURE AND INDEX NUMBER	QTY	UNIT	CODE
8-20397-2513	2-12-21.0-139	1							
8-20397-2514	2-12-21.0-140	1							
8-20397-2517	2-12-21.0-141	1							
8-20397-2519	2-12-21.0-142	1							
8-20397-2521	2-12-21.0-143	1							
8-20397-2523	2-12-21.0-144	1							
8-20397-2525	2-12-21.0-138	1							
8-20397-2527	2-12-21.0-145	1							
8-20397-2529	2-12-22.0-124	1							
8-20397-2531	2-12-21.0-146	1							
8-20397-2533	2-12-21.0-147	1							
8-20397-2535	2-12-21.0-148	1							
8-20397-2537	2-12-21.0-149	1							
8-20397-2539	2-12-21.0-150	1							
8-20397-2541	2-12-21.0-151	1							
8-20397-2543	2-12-21.0-152	1							
8-20397-2545	2-12-21.0-153	1							
8-20397-2547	2-12-21.0-154	1							
8-20397-2549	2-12-21.0-155	1							
8-20397-2553	2-12-21.0-156	1							
8-20397-2555	2-12-21.0-157	1							
8-20397-2557	2-12-21.0-158	1							
8-20397-2559	2-12-21.0-159	1							
8-20397-256	2-12-65.0-15	1							
8-20397-2561	2-12-21.0-160	1							
8-20397-2563	2-12-21.0-161	1							
8-20397-2565	2-12-21.0-162	1							
8-20397-2567	2-12-21.0-163	1							
8-20397-2569	2-12-21.0-164	1							
8-20397-2571	2-12-21.0-165	1							
8-20397-2573	2-12-21.0-166	1							
8-20397-2575	2-12-21.0-167	1							
8-20397-2577	2-12-22.0-168	1							
8-20397-2579	2-12-21.0-169	1							
8-20397-258 A	2-12-45.0-142	1							
8-20397-2581	2-12-21.0-170	1							
8-20397-2583	2-12-21.0-171	1							
8-20397-2585	2-12-21.0-172	1							
8-20397-2587	2-12-21.0-173	1							
8-20397-2589	2-12-21.0-174	1							
8-20397-2591	2-12-21.0-175	1							
8-20397-2593	2-12-21.0-176	1							
8-20397-2595	2-12-21.0-177	1							
8-20397-2597	2-12-21.0-178	1							
8-20397-2599	2-12-21.0-179	1							
8-20397-2601	2-12-41.0-146	1							
8-20397-2603	2-12-43.0-145	1							
8-20397-2605	2-12-21.0-180	1							
8-20397-2607	2-12-22.0-181	1							
8-20397-2609	2-12-21.0-182	1							
8-20397-2611	2-12-21.0-183	1							
8-20397-2613	2-12-21.0-184	1							
8-20397-2621	2-12-37.0-171	1							
8-20397-2623	2-12-37.0-172	1							
8-20397-2625	2-12-45.0-147	1							

PART NUMBER	FIGURE AND INDEX NUMBER	QTY PER ART	SMR CODE
8-20397-3075	2.12-44.0-186	1	M
8-20397-3079	2.12-44.0-225	1	M
8-20397-308	2.12-44.0-141	1	M
8-20397-3081	2.12-43.0-139	1	M
8-20397-3083	2.12-44.0-30	1	M
8-20397-3089	2.12-37.0-82	1	M
8-20397-3093	2.12-44.0-50	1	M
8-20397-3095	2.12-32.0-13	1	M
8-20397-3097	2.12-32.0-11	1	M
8-20397-3099	2.12-37.0-127	1	M
8-20397-3101	2.12-37.0-124	1	M
8-20397-3103	2.12-37.0-208	1	M
8-20397-3107	2.12-37.0-118	1	M
8-20397-3109	2.12-43.0-190	1	M
8-20397-3111	2.12-43.0-191	1	M
8-20397-3113	2.12-43.0-192	1	M
8-20397-3115	2.12-43.0-169	1	M
8-20397-3117	2.12-43.0-167	1	M
8-20397-3119	2.12-43.0-183	1	M
8-20397-3121	2.12-43.0-171	1	M
8-20397-3123	2.12-43.0-163	1	M
8-20397-3125	2.12-43.0-165	1	M
8-20397-3127	2.12-43.0-137	1	M
8-20397-3129	2.12-43.0-133	1	M
8-20397-3131	2.12-43.0-131	1	M
8-20397-3133	2.12-43.0-97	1	M
8-20397-3135	2.12-43.0-20	1	M
8-20397-3137	2.12-43.0-31	1	M
8-20397-3139	2.12-43.0-39	1	M
8-20397-314	2.12-46.0-24	1	M
8-20397-3141	2.12-43.0-67	1	M
8-20397-3143	2.12-43.0-127	1	M
8-20397-3145	2.12-43.0-96	1	M
8-20397-3147	2.12-43.0-102	1	M
8-20397-3149	2.12-43.0-18	1	M
8-20397-3151	2.12-43.0-106	1	M
8-20397-3153	2.12-43.0-105	1	M
8-20397-3155	2.12-43.0-87	1	M
8-20397-3159	2.12-43.0-77	1	M
8-20397-316	2.12-46.0-95	1	M
8-20397-3161	2.12-43.0-47	1	M
8-20397-3163	2.12-43.0-155	1	M
8-20397-3165	2.12-43.0-175	1	M
8-20397-3166	2.12-43.0-114	1	M
8-20397-3167	2.12-43.0-103	1	M
8-20397-3169	2.12-43.0-23	1	M
8-20397-317	2.12-37.0-34	1	M
8-20397-3171	2.12-43.0-25	1	M
8-20397-3173	2.12-43.0-21	1	M
8-20397-3175	2.12-43.0-3	1	M
8-20397-3177	2.12-43.0-12	1	M
8-20397-3179	2.12-43.0-14	1	M
8-20397-3183	2.12-43.0-135	1	M
8-20397-3185	2.12-43.0-73	1	M
8-20397-3187	2.12-43.0-129	1	M
8-20397-3189	2.12-43.0-61	1	M
8-20397-319	2.12-37.0-16	1	M
8-20397-3191	2.12-43.0-69	1	M
8-20397-3192	2.12-43.0-51	1	M
8-20397-3195	2.12-43.0-55	1	M
8-20397-3197	2.12-43.0-53	1	M
8-20397-3199	2.12-43.0-36	1	M
8-20397-321	2.12-43.0-209	1	M
8-20397-323	2.12-21.0-105	1	M
8-20397-324	2.12-15.0-6	1	M

PART NUMBER	FIGURE AND INDEX NUMBER	QTY PER ART	SMR CODE
8-20397-324	2.12-16.0-8	1	M
8-20397-330	2.12-15.0-30	1	M
8-20397-333	2.12-46.0-57	1	M
8-20397-34	2.12-45.0-180	1	M
8-20397-344	2.12-20.0-37	1	M
8-20397-350	2.12-20.0-39	1	M
8-20397-35	2.12-45.0-172	1	M
8-20397-357	2.12-15.0-25	1	M
8-20397-38	2.12-45.0-186	1	M
8-20397-39	2.12-19.0-53	1	M
8-20397-392	2.12-21.0-143	1	M
8-20397-395	2.12-20.0-2	1	M
8-20397-398	2.12-45.0-174	1	M
8-20397-399	2.12-20.0-46	1	M
8-20397-402	2.12-46.0-148	1	M
8-20397-403	2.12-20.0-13	1	M
8-20397-405	2.12-20.0-9	1	M
8-20397-407	2.12-20.0-71	1	M
8-20397-411	2.12-19.0-64	1	M
8-20397-413	2.12-19.0-64	1	M
8-20397-415	2.12-19.0-64	1	M
8-20397-416	2.12-46.0-68	1	M
8-20397-417	2.12-19.0-65	1	M
8-20397-420	2.12-46.0-41	1	M
8-20397-421	2.12-20.0-46	1	M
8-20397-422	2.12-46.0-42	1	M
8-20397-423	2.12-20.0-2	1	M
8-20397-425	2.12-20.0-13	1	M
8-20397-43	2.12-19.0-30	1	M
8-20397-432	2.12-21.0-108	1	M
8-20397-441	2.12-21.0-155	1	M
8-20397-443	2.12-21.0-152	1	M
8-20397-445	2.12-21.0-145	1	M
8-20397-45	2.12-19.0-38	1	M
8-20397-467	2.12-21.0-3	1	M
8-20397-468	2.12-21.0-84	1	M
8-20397-47	2.12-19.0-16	1	M
8-20397-471	2.12-21.0-39	1	M
8-20397-473	2.12-21.0-11	1	M
8-20397-476	2.12-21.0-83	1	M
8-20397-480	2.12-44.0-25	1	M
8-20397-482	2.12-44.0-164	1	M
8-20397-484	2.12-45.0-161	1	M
8-20397-49	2.12-19.0-14	1	M
8-20397-492	2.12-21.0-34	1	M
8-20397-494	2.12-21.0-32	1	M
8-20397-500	2.12-44.0-193	1	M
8-20397-502	2.12-45.0-165	1	M
8-20397-503	2.12-21.0-11	1	M
8-20397-504	2.12-37.0-52	1	M
8-20397-506	2.12-37.0-168	1	M
8-20397-507	2.12-19.0-40	1	M
8-20397-51	2.12-19.0-5	1	M
8-20397-512	2.12-37.0-130	1	M
8-20397-513	2.12-43.0-195	1	M
8-20397-515	2.12-43.0-191	1	M
8-20397-517	2.12-43.0-192	1	M
8-20397-518	2.12-21.0-114	1	M
8-20397-519	2.12-43.0-163	1	M
8-20397-52	2.12-45.0-115	1	M
8-20397-521	2.12-43.0-167	1	M
8-20397-526	2.12-21.0-41	1	M
8-20397-53	2.12-19.0-3	1	M
8-20397-532	2.12-37.0-160	1	M
8-20397-535	2.12-43.0-183	1	M

PART NUMBER	FIGURE AND INDEX NUMBER	QTY PER ART	SMR CODE
8-20397-536	2.12-37.0- 97	1	M
8-20397-538	2.12-37.0- 89	1	M
8-20397-541	2.12-43.0-171	1	M
8-20397-542	2.12-45.0-125	1	M
8-20397-543	2.12-43.0-163	1	M
8-20397-544	2.12-45.0-129	1	M
8-20397-545	2.12-43.0-165	35	M
8-20397-55	2.12-15.0- 50	1	M1
8-20397-550	2.12-46.0- 74	1	M
8-20397-552	2.12-46.0- 71	1	M
8-20397-56	2.12-45.0-107	1	M
8-20397-562	2.12-20.0- 40	1	M
8-20397-567	2.12-43.0-137	1	M
8-20397-570	2.12-20.0- 43	1	M
8-20397-571	2.12-43.0-133	1	M
8-20397-573	2.12-43.0-131	1	M
8-20397-576	2.12-37.0- 22	1	M
8-20397-580	2.12-44.0- 81	1	M
8-20397-582	2.12-45.0- 42	1	M
8-20397-584	2.12-45.0- 31	1	M
8-20397-588	2.12-45.0- 45	1	M
8-20397-589	2.12-43.0-181	1	M
8-20397-593	2.12-43.0- 33	1	M
8-20397-595	2.12-16.0- 8	1	M1
8-20397-597	2.12-37.0- 93	1	M
8-20397-599	2.12-37.0-218	1	M
8-20397-600	2.12-45.0- 72	1	M
8-20397-604	2.12-21.0- 46	1	M
8-20397-606	2.12-21.0- 44	1	M
8-20397-608	2.12-21.0- 42	1	M
8-20397-609	2.12-37.0-136	1	M
8-20397-611	2.12-37.0-133	1	M
8-20397-615	2.12-37.0-159	1	M
8-20397-616	2.12-21.0- 50	1	M
8-20397-62	2.12-44.0-178	1	M
8-20397-620	2.12-32.0-111	1	M
8-20397-622	2.12-32.0-109	1	M
8-20397-624	2.12-32.0-107	1	M
8-20397-625	2.12-37.0- 25	1	M
8-20397-628	2.12-21.0- 32	1	M
8-20397-639	2.12-46.0- 17	1	M
8-20397-64	2.12-44.0-169	1	P
8-20397-641	2.12-32.0- 92	1	M
8-20397-643	2.12-46.0- 10	1	M
8-20397-644	2.12-21.0- 25	1	M
8-20397-645	2.12-46.0- 13	1	M
8-20397-646	2.12-21.0- 34	1	P
8-20397-648	2.12-21.0-112	1	M
8-20397-654	2.12-21.0-112	1	M
8-20397-658	2.12-32.0- 41	1	M
8-20397-66	2.12-44.0-173	1	M
8-20397-660	2.12-46.0- 49	1	M
8-20397-663	2.12-32.0-106	1	M
8-20397-664	2.12-21.0- 78	1	M
8-20397-668	2.12-43.0- 97	1	M
8-20397-681	2.12-32.0- 79	1	M
8-20397-684	2.12-21.0- 60	1	M
8-20397-694	2.12-43.0- 20	1	M
8-20397-696	2.12-43.0- 31	1	M
8-20397-704	2.12-43.0- 39	1	M
8-20397-708	2.12-43.0- 67	1	M
8-20397-710	2.12-43.0-127	1	M
8-20397-711	2.12-46.0- 78	1	M
8-20397-712	2.12-43.0- 96	1	M
8-20397-713	2.12-46.0- 80	1	M

PART NUMBER	FIGURE AND INDEX NUMBER	QTY PER ART	SMR CODE
8-20397-714	2.12-43.0-102	1	M
8-20397-717	2.12-32.0- 48	1	M
8-20397-719	2.12-43.0- 18	1	M
8-20397-720	2.12-43.0-106	1	M
8-20397-722	2.12-43.0-105	1	M
8-20397-723	2.12-32.0- 29	1	M
8-20397-724	2.12-43.0- 87	1	M
8-20397-725	2.12-32.0- 33	1	M
8-20397-728	2.12-43.0- 79	1	M
8-20397-729	2.12-32.0- 27	1	M
8-20397-730	2.12-43.0- 77	1	M
8-20397-731	2.12-32.0- 67	1	M
8-20397-733	2.12-32.0- 31	1	M
8-20397-734	2.12-43.0- 47	1	M
8-20397-735	2.12-32.0- 35	1	M
8-20397-733	2.12-43.0-155	1	M
8-20397-739	2.12-32.0- 21	1	M
8-20397-741	2.12-32.0- 34	1	M
	2.12-46.0- 49	1	M
8-20397-744	2.12-43.0-175	1	M
8-20397-747	2.12-46.0- 6	1	M
8-20397-748	2.12-43.0-103	1	M
8-20397-751	2.12-46.0- 4	1	M
8-20397-752	2.12-43.0- 23	1	M
8-20397-754	2.12-43.0- 25	1	M
8-20397-755	2.12-37.0-138	1	M
8-20397-756	2.12-43.0- 21	1	M
8-20397-757	2.12-37.0- 31	1	M
8-20397-760	2.12-21.0-131	1	M
8-20397-761	2.12-32.0- 69	1	M
8-20397-762	2.12-21.0-134	1	M
8-20397-764	2.12-21.0-127	1	M
8-20397-766	2.12-21.0-136	1	M
8-20397-768	2.12-21.0-129	1	M
8-20397-77	2.12-19.0- 58	1	M1
8-20397-772	2.12-20.0- 24	1	M1
8-20397-774	2.12-20.0- 23	1	M1
8-20397-780	2.12-45.0- 95	1	M
8-20397-781	2.12-45.0-102	1	M
8-20397-782	2.12-45.0- 97	1	M
8-20397-788	2.12-15.0- 32	1	M
8-20397-790	2.12-43.0-139	1	M
8-20397-798	2.12-43.0- 3	1	M
8-20397-81	2.12-20.0- 79	1	M1
8-20397-829	2. 3-10.0- 15	1	M
	2.12-43.0-	RF	
8-20397-83	2.12-20.0- 80	1	M1
8-20397-831	2. 3-10.0- 16	1	U
	2.12-44.0-	RF	
	2.12-45.0-	RF	
	2.12-45.0-	RF	
8-20397-833	2. 3-14.0- 21	1	U
	2.12-32.0-	RF	
	2.12-46.0-	RF	
8-20397-835	2.10- 7.0- 86		U
	2.12-62.0-	RF	
8-20397-837	2. 6-32.0- 61	1	U
	2.12-15.0-	RF	
	2.12-19.0-	RF	
	2.12-20.0-	RF	
	2.12-21.0-	RF	
	2.12-37.0-	RF	
8-20397-839	2. 6-32.0- 61	1	U
	2.12-15.0-		
	2.12-19.0-	RF	

PART NUMBER	FIGURE AND INDEX NUMBER	QTY PER ANY	SWAP CODE	PART NUMBER	FIGURE AND INDEX NUMBER	QTY PER ANY	SWAP CODE
8-20397-839	2.12-35.0-	RF	U	8-21107-01	2.12-35.0-	RF	U
	2.12-21.0-	RF	U	8-21107-02	2.12-35.0-	RF	U
	2.12-37.0-	RF	U	8-21107-03	2.12-35.0-	RF	U
	2.12-37.0-	RF	U	8-21107-04	2.12-35.0-	RF	U
8-20397-843	2. 6-32.0- 19	1	U	8-21107-05	2.12-35.0-	RF	U
	2.12-44.0-	RF	U	8-21107-06	2.12-35.0-	RF	U
	2.12-48.0-	RF	U	8-21107-07	2.12-35.0-	RF	U
	2.12-48.0-	RF	U	8-21107-08	2.12-35.0-	RF	U
8-20397-847	2.12-48.0-119	1	M	8-21107-09	2.12-35.0-	RF	U
8-20397-853	2. 6-32.0- 19	1	9U	8-21107-10	2.12-35.0-	RF	U
	2.12-43.0-	RF	U	8-21107-11	2.12-35.0-	RF	U
8-20397-855	2. 6-32.0- 61	1	U	8-21107-12	2.12-35.0-	RF	U
	2.12-15.0-	RF	U	8-21107-13	2.12-35.0-	RF	U
	2.12-19.0-	RF	U	8-21107-14	2.12-35.0-	RF	U
	2.12-25.0-	RF	U	8-21107-15	2.12-35.0-	RF	U
	2.12-21.0-	RF	U	8-21107-16	2.12-35.0-	RF	U
	2.12-37.0-	RF	U	8-21107-17	2.12-35.0-	RF	U
8-20397-857	2. 6-32.0- 61	1	U	8-21107-18	2.12-35.0-	RF	U
	2.12-16.0-	RF	U	8-21107-19	2.12-35.0-	RF	U
	2.12-16.0-	RF	U	8-21107-20	2.12-35.0-	RF	U
	2.12-19.0-	RF	U	8-21107-21	2.12-35.0-	RF	U
	2.12-26.0-	RF	U	8-21107-22	2.12-35.0-	RF	U
	2.12-21.0-	RF	U	8-21107-23	2.12-35.0-	RF	U
	2.12-37.0-	RF	U	8-21107-24	2.12-35.0-	RF	U
8-20397-865	2. 6-32.0- 61	1	U	8-21107-25	2.12-35.0-	RF	U
	2.12-16.0-	RF	U	8-21107-26	2.12-35.0-	RF	U
	2.12-15.0-	RF	U	8-21107-27	2.12-35.0-	RF	U
	2.12-25.0-	RF	U	8-21107-28	2.12-35.0-	RF	U
	2.12-22.0-	RF	U	8-21107-29	2.12-35.0-	RF	U
	2.12-37.0-	RF	U	8-21107-30	2.12-35.0-	RF	U
8-20397-867	2. 6-32.0- 61	1	U	8-21107-31	2.12-35.0-	RF	U
	2.12-19.0-	RF	U	8-21107-32	2.12-35.0-	RF	U
	2.12-25.0-	RF	U	8-21107-33	2.12-35.0-	RF	U
	2.12-22.0-	RF	U	8-21107-34	2.12-35.0-	RF	U
	2.12-37.0-	RF	U	8-21107-35	2.12-35.0-	RF	U
8-20397-9	2.12-52.0-139	2		8-21107-36	2.12-35.0-	RF	U
8-20866-7	2.13- 5.0- 9	1	P1	8-21107-37	2.12-35.0-	RF	U
8-21040	2. 1- 1.0- 46	RF		8-21107-38	2.12-35.0-	RF	U
8-21094-1	2.12-14.0- 30	1	P1	8-21107-39	2.12-35.0-	RF	U
8-21094-2	2.12-14.0- 30	1	P1	8-21107-40	2.12-35.0-	RF	U
8-21103	2. 6-32.0- 9	1	F	8-21107-41	2.12-35.0-	RF	U
8-21104-1	2. 6-32.0- 33	1	U	8-21107-42	2.12-35.0-	RF	U
	2.12- 7.0-	RF	U	8-21107-43	2.12-35.0-	RF	U
8-21104-2	2. 6-32.0- 33	1	U	8-21107-44	2.12-35.0-	RF	U
	2.12- 7.0-	RF	U	8-21107-45	2.12-35.0-	RF	U
8-21104-3	2. 6-32.0- 28	1	U	8-21107-46	2.12-35.0-	RF	U
	2.12- 7.0- 4	RF	U	8-21107-47	2.12-35.0-	RF	U
8-21104-4	2. 6-32.0- 28	1	U	8-21107-48	2.12-35.0-	RF	U
	2.12- 7.0- 4	RF	U	8-21107-49	2.12-35.0-	RF	U
8-21105-1	2. 6-32.0- 70	1	U	8-21107-50	2.12-35.0-	RF	U
	2.12- 7.0- 7	RF	U	8-21107-51	2.12-35.0-	RF	U
8-21105-2	2. 6-32.0- 70	1	U	8-21107-52	2.12-35.0-	RF	U
	2.12- 7.0- 6	RF	U	8-21107-53	2.12-35.0-	RF	U
8-21105-3	2. 6-32.0- 67	1	U	8-21107-54	2.12-35.0-	RF	U
	2.12- 7.0- 11	RF	U	8-21107-55	2.12-35.0-	RF	U
8-21105-4	2. 6-32.0- 67	1	U	8-21107-56	2.12-35.0-	RF	U
	2.12- 7.0- 11	RF	U	8-21107-57	2.12-35.0-	RF	U
8-21106-1	2. 6-32.0- 67	1	U	8-21107-58	2.12-35.0-	RF	U
	2.12- 7.0- 11	RF	U	8-21107-59	2.12-35.0-	RF	U
8-21106-2	2. 6-32.0- 59	1	U	8-21107-60	2.12-35.0-	RF	U
	2.12- 7.0- 11	RF	U	8-21107-61	2.12-35.0-	RF	U
8-21106-3	2. 6-32.0- 54	1	U	8-21107-62	2.12-35.0-	RF	U
	2.12- 7.0- 7	RF	U	8-21107-63	2.12-35.0-	RF	U
8-21106-4	2. 6-32.0- 54	1	U	8-21107-64	2.12-35.0-	RF	U
	2.12- 7.0- 7	RF	U	8-21107-65	2.12-35.0-	RF	U

PART NUMBER	FIGURE AND INDEX NUMBER	QTY PER ART	SMR CODE
8-21128-1	2.12-16.0-144	1	P1
8-21134-5	2.12-14.0- 12	1	P1
8-21134-6	2.12-14.0- 12	1	P1
8-21135-11	2.12-14.0- 7	1	P1
8-21136	2.12-23.0- 11	1	P
8-21137	2.12-23.0- 2	1	P
8-21143-1	2.12- 2.0- 14	1	P1
8-21143-3	2.12- 2.0- 14	1	P1
8-21147-3	2. 6-32.0- 84	1	U
	2.12- 2.0-	RF	
8-21147-4	2. 6-32.0- 84	1	U
	2.12- 2.0-	RF	
8-21147-5	2. 6-32.0- 84	1	U
	2.12- 2.0-	RF	
8-21147-6	2. 6-32.0- 84	1	U
	2.12- 2.0-	RF	
8-21147-801	2. 6-32.0- 84	1	U
	2.12- 2.0-	RF	
8-21147-802	2. 6-32.0- 84	1	U
	2.12- 2.0-	RF	
8-21150-1	2.12-12.0- 5	1	P1
8-21153	2.12-35.0- 23	1	P1
	2.12-35.0- 24	1	
8-21154-1	2.12- 1.0-110	1	P1
8-21154-15	2.12- 1.0-111	1	M
8-21155-3	2. 6-32.0- 77	1	U
	2.12- 1.0-109	RF	
8-21155-4	2. 6-32.0- 77	1	U
	2.12- 1.0-109	RF	
8-21156-7	2.12- 1.0-111	1	P
8-21162-11	2.12-25.0- 18	1	P1
8-21162-12	2.12-25.0- 18	1	P1
8-21162-21	2.12-25.0- 10	1	P
8-21162-9	2.12-25.0- 10	1	P
8-21163-11	2.12-25.0- 23	1	M
8-21163-12	2.12-25.0- 23	1	M
8-21163-23	2.12-25.0- 26	1	M
8-21163-24	2.12-25.0- 26	1	M
8-21163-801	2. 6-32.0- 87	1	U
	2.12-25.0-	RF	
8-21163-802	2. 6-32.0- 87	1	U
	2.12-25.0-	RF	
8-21163-803	2. 6-32.0- 87	1	U
	2.12-25.0-	RF	
8-21163-804	2. 6-32.0- 87	1	U
	2.12-25.0-	RF	
8-21163-805	2. 6-32.0- 87	1	U
	2.12-25.0-	RF	
8-21163-806	2. 6-32.0- 87	0	U
8-21164-19	2.12-25.0- 6	1	M
8-21164-20	2.12-25.0- 6	1	M
8-21166-1	2. 6-32.0- 49	1	U
8-21166-2	2. 6-32.0- 49	1	U
	2.12-12.0-	RF	
8-21167-801	2. 6-32.0- 51	1	U
	2.12- 1.0-108	RF	
8-21168-1	2. 6-32.0- 80	1	U
	2.12-34.0-	RF	
8-21168-17	2.12-34.0- 8	1	M
8-21168-18	2.12-34.0- 8	1	M
8-21168-19	2.12-34.0- 1	1	A
8-21168-2	2. 6-32.0- 80	1	U
	2.12-34.0-	RF	
8-21168-20	2.12-34.0- 1	1	A
8-21168-25	2.12-34.0- 7	1	M

PART NUMBER	FIGURE AND INDEX NUMBER	QTY PER ART	SMR CODE
8-21168-26	2.12-34.0- 7	1	M
8-21168-27	2.12-34.0- 8	1	M
8-21168-28	2.12-34.0- 8	1	M
8-21168-29	2.12-34.0- 8	1	M
8-21168-3	2. 6-32.0- 80	1	U
	2.12-34.0-	RF	
8-21168-31	2.12-34.0- 1	1	A
8-21168-32	2.12-34.0- 1	1	A
8-21168-33	2.12-34.0- 7	1	M
8-21168-34	2.12-34.0- 7	1	M
8-21168-35	2.12-34.0- 8	1	M
8-21168-36	2.12-34.0- 8	1	M
8-21168-37	2.12-34.0- 1	1	A
8-21168-38	2.12-34.0- 1	1	A
8-21168-4	2. 6-32.0- 80	1	U
	2.12-34.0-	RF	
8-21168-45	2.12-34.0- 1	1	A
8-21168-46	2.12-34.0- 1	1	A
8-21168-47	2.12-34.0- 1	1	A
8-21168-48	2.12-34.0- 1	1	A
8-21168-5	2. 6-32.0- 80	1	U
	2.12-34.0-	RF	
8-21168-6	2. 6-32.0- 80	1	U
	2.12-34.0-	RF	
8-21170	2.12-17.0- 5	1	M
8-21170-1	2.12-17.0- 5	1	P1
8-21170-3	2.12-17.0- 5	1	P1
8-21170-4	2.12-17.0- 5	1	P1
8-21171	2. 6-37.0- 2	1	P
8-21175	2.12- 1.0- 72	1	P1
8-21176-1	2. 6-32.0- 28	1	U
	2.12- 1.0- 69	RF	
8-21176-3	2. 6-32.0- 28	1	U
	2.12- 1.0- 69	RF	
8-21177-17	2.12- 2.0- 5	1	M
8-21177-18	2.12- 2.0- 5	1	M
8-21179-1	2. 6-32.0- 78	1	U
	2.12-28.0-	RF	
8-21179-10	2.12-28.0- 9	1	M
8-21179-11	2.12-28.0- 1	1	A
8-21179-12	2.12-28.0- 1	1	A
8-21179-13	2.12-28.0- 9	1	M
8-21179-14	2.12-28.0- 9	1	M
8-21179-15	2.12-28.0- 1	1	A
8-21179-16	2.12-28.0- 1	1	A
8-21179-17	2.12-28.0- 1	1	A
8-21179-18	2.12-28.0- 1	1	A
8-21179-19	2.12-28.0- 1	1	A
8-21179-2	2. 6-32.0- 78	1	U
	2.12-28.0-	RF	
8-21179-20	2.12-28.0- 1	1	A
8-21179-3	2. 6-32.0- 78	1	U
	2.12-28.0-	RF	
8-21179-4	2. 6-32.0- 78	1	U
	2.12-28.0-	RF	
8-21179-5	2. 6-32.0- 78	1	U
	2.12-28.0-	RF	
8-21179-6	2. 6-32.0- 78	1	U
	2.12-28.0-	RF	
8-21179-7	2.12-28.0- 1	1	A
8-21179-8	2.12-28.0- 1	1	A
8-21179-9	2.12-28.0- 9	1	M
8-21180-1	2. 6-32.0- 83	1	U
	2.12-29.0-	RF	
8-21180-10	2.12-29.0- 1	1	A

PART NUMBER	FIGURE AND INDEX NUMBER	QTY PER ART	SMR CODE
8-21180-11	2.12-29.0- 1	1	A
8-21180-12	2.12-29.0- 1	1	A
8-21180-13	2.12-29.0- 11	1	M
8-21180-14	2.12-29.0- 11	1	M
8-21180-15	2.12-29.0- 1	1	A
8-21180-16	2.12-29.0- 1	1	A
8-21180-17	2.12-29.0- 1	1	A
8-21180-18	2.12-29.0- 1	1	A
8-21180-19	2.12-29.0- 1	1	A
8-21180-2	2. 6-32.0- 83	1	U
	2.12-29.0-	RF	
8-21180-20	2.12-29.0- 1	1	A
8-21180-3	2. 6-32.0- 83	1	U
	2.12-29.0-	RF	
8-21180-4	2. 6-32.0- 83	1	U
	2.12-29.0-	RF	
8-21180-5	2. 6-32.0- 83	1	U
	2.12-29.0-	RF	
8-21180-6	2. 6-32.0- 83	1	U
	2.12-29.0-	RF	
8-21180-7	2.12-29.0- 11	1	M
8-21180-8	2.12-29.0- 11	1	M
8-21180-9	2.12-29.0- 1	1	A
8-21181-1	2. 6-32.0- 63	1	U
	2.12- 1.0- 75	RF	
8-21181-13	2.12- 1.0- 76	1	A
8-21181-15	2.12- 1.0- 76	1	A
8-21181-19	2.12- 1.0- 76	1	A
8-21181-21	2.12- 1.0- 76	1	A
8-21181-23	2.12- 1.0- 83	1	M
8-21181-3	2. 6-32.0- 63	1	U
	2.12- 1.0- 75	RF	
8-21181-7	2.12- 1.0- 83	1	M
8-21181-801	2. 6-32.0- 63	1	U
	2.12- 1.0- 75	RF	
8-21181-803	2. 6-32.0- 63	1	U
	2.12- 1.0- 75	RF	
8-21182-10	2.12- 1.0- 97	1	M1
8-21182-11	2.12- 1.0- 97	1	M1
8-21182-12	2.12- 1.0- 97	1	M1
8-21182-5	2. 6-32.0- 87	1	
	2.12- 1.0- 93	RF	
8-21182-6	2. 6-32.0- 87	1	U
	2.12- 1.0- 93	RF	
8-21182-9	2.12- 1.0- 97	1	M
8-21183-1	2. 6-32.0- 76	1	M1
	2.12-26.0-	RF	
8-21183-11	2.12-26.0- 10	1	M
8-21183-12	2.12-26.0- 10	1	M
8-21183-3	2. 6-32.0- 76	1	U
	2.12-26.0-	RF	
8-21183-35	2.12-26.0- 9	1	M
8-21183-36	2.12-26.0- 9	1	M
8-21183-37	2.12-26.0- 1	1	A
8-21183-38	2.12-26.0- 1	1	A
8-21183-43	2.12-26.0- 10	1	M
8-21183-44	2.12-26.0- 10	1	M
8-21183-801	2. 6-32.0- 76	1	U
	2.12-26.0-	RF	
8-21183-803	2. 6-32.0- 76	1	U
	2.12-26.0-	RF	
8-21185-1	2.12-25.0- 20	1	P
8-21185-2	2.12-25.0- 20	1	U
8-21186-1	2. 6-32.0- 32	1	U
	2.12- 1.0- 9	RF	

PART NUMBER	FIGURE AND INDEX NUMBER	QTY PER ART	SMR CODE
8-21186-2	2. 6-32.0- 32	1	U
	2.12- 1.0- 9	RF	
8-21186-7	2.12- 1.0- 13	1	M
8-21186-8	2.12- 1.0- 13	1	M
8-21187-1	2. 6-32.0- 86	1	U
	2.12- 1.0- 97	RF	
8-21187-17	2.12- 1.0-101	1	M
8-21187-19	2.12- 1.0-101	1	M
8-21187-3	2. 6-32.0- 86	1	U
	2.12- 1.0- 97	RF	
8-21187-5	2. 6-32.0- 86	1	U
	2.12- 1.0- 97	RF	
8-21187-7	2.12- 1.0-101	1	M
8-21187-801	2. 6-32.0- 86	1	
	2.12- 1.0- 97	RF	
8-21188-1	2. 6-32.0- 26	1	U
	2.12- 1.0-	RF	
8-21188-2	2. 6-32.0- 26	1	U
	2.12- 1.0-	RF	
8-21189-1	2.12- 1.0- 6		M1
8-21189-2	2.12- 1.0- 6	1	M1
8-2119-3	2.12- 3.0-	RF	
8-21190-1	2. 6-32.0- 34	1	U
	2.12- 1.0- 5	RF	
8-21190-2	2. 6-32.0- 34	1	U
	2.12- 1.0- 5	RF	
8-21191-1	2. 6-32.0- 31	1	U
	2.12- 1.0- 18	RF	
8-21191-2	2. 6-32.0- 31	1	U
	2.12- 1.0- 18	RF	
8-21192-1	2. 6-32.0- 27	1	U
	2.12- 1.0- 22	RF	
8-21192-13	2.12- 1.0- 35	1	A
8-21192-14	2.12- 1.0- 35	1	A
8-21192-15	2.12- 1.0- 22	1	A
8-21192-16	2.12- 1.0- 22	1	A
8-21192-2	2. 6-32.0- 27	1	U
	2.12- 1.0- 22	RF	
8-21193-1	2. 6-32.0- 30	1	U
	2.12- 1.0- 35	RF	
8-21193-2	2. 6-32.0- 30	1	U
	2.12- 1.0- 35	RF	
8-21193-7	2.12- 1.0- 29	1	M
8-21193-9	2.12- 1.0- 35	1	A
8-21194-1	2. 6-32.0- 29	1	U
	2.12-24.0-	RF	
8-21194-10	2.12-24.0- 9	1	A
8-21194-2	2. 6-32.0- 29	1	U
	2.12-24.0-	RF	
8-21194-7	2.12-24.0- 20	1	M
8-21194-8	2.12-24.0- 20	1	M
8-21194-9	2.12-24.0- 9	1	A
8-21195	2.12-24.0- 7	1	P1
8-21196-1	2.12-24.0- 8	1	P
8-21196-2	2.12-24.0- 8	1	P
8-21199-1	2. 6-32.0- 50	1	U
	2.12- 3.0-	RF	
8-21199-3	2. 6-32.0- 50	1	M
	2.12- 3.0- 18	1	
8-21204	2. 6-37.0- 2	1	P2
8-21211-1	2. 6-32.0- 68	1	
	2.12- 1.0- 83	RF	
8-21211-3	2. 6-32.0- 68	1	U
	2.12- 1.0- 83	RF	
8-21236-1	2. 3-15.0- 8	1	U

PART NUMBER	FIGURE AND INDEX NUMBER	QTY PER ART	SMR CODE
8-21235-1	2.12-35.0- 24	RF	U
8-21235-2	2. 3-15.0- 8	1	U
	2.12-35.0- 24	RF	
8-21236-3	2. 3-15.0- 8	1	U
	2.12-35.0- 24	RF	
8-21236-5	2. 3-15.0- 8	1	U
	2.12-35.0- 24	RF	
8-21236-801	2. 6-32.0- 74	1	U
	2.12-35.0-	RF	
8-21236-803	2. 6-32.0- 74	1	U
	2.12-35.0-	RF	
8-21236-805	2. 6-32.0- 74	1	U
	2.12-35.0-	RF	
8-21236-806	2. 6-32.0- 74	1	U
	2.12-35.0-	RF	
8-21236-811	2. 6-32.0- 74	1	U
	2.12-35.0-	RF	
8-21236-813	2. 6-32.0- 74	1	U
	2.12-35.0-	RF	
8-21238	2. 6-37.0- 1	RF	P
8-21248-7	2. 6-37.0- 1	1	P2
8-21249-7	2. 6-36.0- 2	1	P2
8-21255-1	2. 6-32.0- 62	1	U
	2.12- 1.0- 55	RF	
8-21255-3	2. 6-32.0- 62	1	U
	2.12- 1.0- 55	RF	
8-21260-13	2.12-66.0- 22	1	P
	2.12-66.0- 22	1	P
8-21260-7	2.12-17.0-154	1	P
	2.12-18.0-143	1	
	2.12-35.0- 5	1	
	2.12-66.0- 2	1	
8-21260-9	2.12-35.0- 6	1	P
	2.12-35.0- 7	4	
	2.12-66.0- 3	1	
	2.12-66.0- 7	1	
8-21261	2.12-35.0- 10	1	P
8-21271-3	2. 6-32.0- 82	1	U
	2.12-27.0-	RF	
8-21271-4	2. 6-32.0- 82	1	U
	2.12-27.0-	RF	
8-21271-801	2. 6-32.0- 82	1	U
	2.12-27.0-	RF	
8-21271-802	2. 6-32.0- 82	1	U
	2.12-27.0-	RF	
8-21273-13	2.12-23.0- 5	1	M
8-21273-7	2.12-35.0- 14	1	M
8-21273-9	2.12-14.0- 36	1	M
8-21275-1	2.12- 1.0- 67	2	M
8-21275-2	2.12- 1.0- 67	2	M
8-21276	2. 6-39.0- 8	1	P
8-21277-15	2.12- 8.0- 15	1	M
8-21277-9	2.12- 8.0- 14	3	M
8-21278-41	2.12-25.0- 15	1	M
8-21278-42	2.12-25.0- 15	1	M
8-21279-5	2. 6-32.0- 66	1	U
	2.12-66.0-	RF	
8-21279-801	2. 6-32.0- 66	1	U
	2.12-66.0-	RF	
8-21279-811	2. 6-32.0- 66	1	U
	2.12-66.0-	RF	
8-21279-813	2. 6-32.0- 66	1	U
	2.12-66.0-	RF	
8-21279-819	2. 6-32.0- 66	1	U
	2.12-66.0-	RF	

PART NUMBER	FIGURE AND INDEX NUMBER	QTY PER ART	SMR CODE
8-21282-1	2. 6-32.0- 71	1	U
	2.12- 1.0- 37	RF	
8-21282-2	2. 6-32.0- 71	1	U
	2.12- 1.0- 37	RF	
8-21284-2	2. 6-32.0- 48	1	U
8-21284-1	2. 6-32.0- 37	1	U
	2.12-23.0-	RF	
8-21284-2	2. 6-32.0- 37	1	U
	2.12-23.0-	RF	
8-21284-3	2. 6-32.0- 37	1	U
	2.12-23.0-	RF	
8-21284-4	2. 6-32.0- 37	1	U
	2.12-23.0-	RF	
8-21285	2.12-23.0- 2	1	M1
8-21285-1	2.12-14.0- 12	1	P
8-21287	2.12-23.0- 11	2	M1
8-21311-11	2.12-66.0- 21	2	P
	2.12-66.0- 8	2	
8-21311-19	2.12-15.0-153	1	
	2.12-16.0-142	1	
	2.12-35.0- 10	1	
	2.12-35.0- 20	1	
	2.12-35.0- 3	6	
	2.12-52.0-135	2	
	2.12-52.0-135	1	
	2.12-52.0-138	2	
	2.12-52.0-138	2	
	2.12-66.0- 14	2	
	2.12-66.0- 15	2	
	2.12-66.0- 15	1	
	2.12-66.0- 21	1	
	2.12-66.0- 3	1	
	2.12-66.0- 5	2	
	2.12-66.0- 7	1	
8-21311-23	2.12-66.0- 17	2	P
8-21311-25	2. 8- 1.0- 74	2	M
8-21311-7	2.12- 3.0- 11	1	P1
	2.12- 3.0- 12	1	
	2.12-15.0-107	2	
	2.12-16.0- 95	2	
	2.12-52.0-133	4	
	2.12-52.0-137	10	
	2.12-52.0-140	4	
	2.12-66.0- 1	2	
	2.12-66.0- 10	2	
	2.12-66.0- 11	2	
	2.12-66.0- 12	4	
	2.12-66.0- 13	2	
	2.12-66.0- 16	4	
	2.12-66.0- 14	2	
	2.12-66.0- 19	4	
	2.12-66.0- 4	4	
	2.12-66.0- 4	2	
	2.12-66.0- 9	2	
8-21311-9	2.12-66.0- 2	1	
8-21321	2.12- 6.0- 4	1	P1
	2.12-39.0- 15	1	
8-21389	2. 6-32.0- 53	1	U
	2.12- 1.0- 58	RF	
8-21389-13	2. 6-48.0-164	1	A
8-21458-3	2. 6-32.0- 45	1	U
	2.12- 1.0- 61	RF	
8-21458-4	2. 6-32.0- 45	1	U
	2.12- 1.0- 61	RF	
8-21521-1	2. 6-32.0- 43	1	U

PART NUMBER	FIGURE AND INDEX NUMBER	QTY PER ART	SMR CODE
8-21521-2	2. 6-32.0- 43	1	U
8-21524-1	2. 6-32.0- 44	1	U
	2.12-13.0-	RF	
8-21524-2	2. 6-32.0- 44	1	U
	2.12-13.0-	RF	
8-21524-33	2.12-13.0- 5	1	M
8-21524-34	2.12-13.0- 5	1	M
8-21525-3	2. 6-32.0- 79	1	U
	2.12-30.0-	RF	
8-21525-4	2. 6-32.0- 79	1	U
	2.12-30.0-	RF	
8-21525-5	2. 6-32.0- 79	1	U
	2.12-31.0-	RF	
8-21525-6	2. 6-32.0- 79	1	U
	2.12-31.0-	RF	
8-21526	2.12-17.0- 4	1	P2
8-21527-1	2. 6-32.0- 64	1	U
	2.12- 1.0- 73	RF	
8-21527-3	2. 6-32.0- 64	1	U
	2.12- 1.0- 73	RF	
8-21527-5	2. 6-32.0- 64	1	U
	2.12- 1.0- 73	RF	
8-21527-801	2. 6-32.0- 64	1	U
	2.12- 1.0- 73	RF	
8-21528-3	2. 6-32.0- 65	1	U
	2.12- 1.0- 88	RF	
8-21528-4	2. 6-32.0- 65	1	U
	2.12- 1.0- 88	RF	
8-21528-5	2. 6-32.0- 65	1	U
	2.12- 1.0- 88	RF	
8-21528-6	2. 6-32.0- 65	1	U
	2.12- 1.0- 88	RF	
8-21530	2.12-52.0- 64	1	M
8-21532-1	2. 6-39.0- 1	RF	U
8-21532-13	2. 6-39.0- 3	RF	M
8-21532-17	2. 6-39.0- 7	RF	M
8-21532-18	2. 6-39.0- 7	RF	M
8-21532-2	2. 6-39.0- 1	RF	U
8-21532-7	2. 6-39.0- 2	RF	M
8-21534-809	2. 6-32.0- 60	1	U
	2.12-17.0-	RF	
8-21534-811	2. 6-32.0- 60	1	U
	2.12-17.0-	RF	
8-21537-801	2. 6-32.0- 59	1	U
	2.12-36.0-	RF	
8-21537-802	2. 6-32.0- 59	1	U
	2.12-36.0-	RF	
8-21538-1	2. 6-32.0- 55	1	U
	2.12-18.0-	RF	
8-21538-3	2. 6-32.0- 55	1	U
	2.12-18.0-	RF	
8-21540-1	2. 6-32.0- 56	1	U
	2.12-61.0-	RF	
8-21540-2	2. 6-32.0- 56	1	U
	2.12-61.0-	RF	
8-21542-1	2. 6-32.0- 36	1	
	2.12- 1.0- 29	RF	
8-21542-2	2. 6-32.0- 36	1	
	2.12- 1.0- 29	RF	
8-21545	2.12-61.0- 9	1	P
8-21548-23	2.12- 1.0- 39	1	X1
8-21548-24	2.12- 1.0- 39	1	X1
8-21548-3	2.12- 1.0- 38	1	P1
8-21548-4	2.12- 1.0- 38	1	P1
8-21550	2. 6-36.0- 2	RF	M1

PART NUMBER	FIGURE AND INDEX NUMBER	QTY PER ART	SMR CODE
8-21562	2. 6-35.0- 2	1	P
8-21564	2.12-14.0- 56	1	M1
8-21564-1	2.12-14.0- 56	RF	M1
8-21564-15	2.12-14.0- 56	1	P1
8-21564-23	2.12-14.0- 56	1	M
8-21564-25	2.12-14.0- 56	1	P1
8-21564-3	2.12-14.0- 56	RF	M1
8-21568	2.12-66.0- 1	1	P
8-2157-2	2.12-14.0-108	1	M1
8-21570-1	2.12-14.0- 90	1	P1
8-21570-2	2.12-14.0- 90	1	M1
8-21571-1	2.12-14.0-108	1	P1
8-21572	2.12-14.0- 98	1	P1
8-21576-1	2.12-14.0-121	1	P1
8-21576-2	2.12-14.0-121	1	P1
8-21577	2.12-14.0-110	1	M1
8-21578-1	2.12-14.0-114	1	P
8-21578-2	2.12-14.0-114	1	M1
8-2158-5	2.12-14.0- 57	1	P1
8-21580-3	2.12-14.0- 35	1	P1
8-21580-5	2.12-14.0- 35	1	P1
8-21580-803	2.12-14.0- 35	1	P1
8-21580-804	2.12-14.0- 35	1	P1
8-21581-3	2.12-14.0- 49	1	P1
8-21582	2.12-14.0- 41	1	M1
8-21582-1	2.12-14.0- 41	1	P1
8-21583-1	2.12-14.0- 73	1	P1
8-21583-2	2.12-14.0- 73	1	P1
8-21583-801	2.12- 1.0-116	1	P1
8-21583-802	2.12- 1.0-116	1	P1
8-21585-5	2.12-30.0- 10	1	P1
8-21585-6	2.12-30.0- 10	1	P1
8-21586	2.12-27.0- 19	1	P1
8-21586-1	2.12-27.0- 19	1	M
8-21587-1	2.12-30.0- 2	1	P1
8-21588-1	2.12-27.0- 3	1	P1
8-21588-2	2.12-27.0- 3	1	P1
8-21592-11	2.12-14.0- 7	1	M
8-21593	2.12-14.0- 13	1	M1
8-21594-3	2.12-19.0- 37	1	M
8-21594-4	2.12-19.0- 37	1	M
8-21596	2.12-14.0- 23	1	P
8-21597-3	2.12-14.0- 89	1	P1
8-21597-4	2.12-14.0- 89	1	P1
8-21600-1	2.12-30.0- 2	1	P1
8-21600-2	2.12-30.0- 2	1	M
8-21600-7	2.12-31.0- 6	1	M1
8-21600-9	2.12-31.0- 7	2	P1
8-21602-1	2.12-27.0- 3	1	P1
8-21602-2	2.12-27.0- 3	1	P1
8-21610-11	2.12-18.0- 7	AR	M
8-21610-13	2.12-18.0- 8	AR	M
8-21610-7	2.12-18.0- 5	AR	M
8-21610-9	2.12-18.0- 6	AR	M
8-21611-1	2. 6-32.0- 73	1	U
	2.12-66.0- 21	RF	
8-21611-2	2. 6-32.0- 73	1	U
	2.12-66.0- 21	RF	
8-21612-1	2. 6-32.0- 72	1	U
	2.12- 1.0-113	RF	
8-21612-2	2. 6-32.0- 72	1	U
	2.12- 1.0-113	RF	
8-21613-1	2.12- 1.0-115	1	P1
8-21613-2	2.12- 1.0-115	1	M1
8-21617-1	2.12-31.0- 3	1	P1

PART NUMBER	PARTIAL INDEX NUMBER	QTY PER ART	SMR CODE	PART NUMBER	FIGURE AND INDEX NUMBER	QTY PER ART	SMR CODE
8-21613-1	2.12-31.0- 3	1	M	8-21644-12	2. 6-40.0-103	1	M
8-21613-1	2.12-31.0- 3	1	M	8-21644-12	2. 6-40.0- 58	1	M
8-21613-1	2.12-31.0- 3	1	M	8-21644-21	2. 6-40.0- 37	1	M
8-21613-1	2.12-31.0- 3	1	M	8-21644-7	2. 6-40.0- 14	1	P
8-21621-1	2.12-31.0- 3	1	M	8-21644-1	2. 6-40.0-	1	
8-21621-1	2.12-31.0- 3	1	M	8-21647-10	2.12-29.0- 60	1	M
8-21622-2	2.12-31.0- 3	1	M	8-21647-11	2.12-29.0- 18	1	M
8-21623	2.12-31.0- 3	1	M	8-21647-13	2.12-29.0- 18	1	M
8-21623-1	2.12-31.0- 3	1	M	8-21647-7	2.12-29.0- 61	1	M
8-21623-2	2.12-31.0- 3	1	M	8-21647-2	2.12-29.0- 60	1	M
8-21623-3	2.12-31.0- 3	1	M	8-21648-7	2. 6-40.0- 3	1	RF
8-21623-5	2.12-31.0- 3	1	M	8-21649-7	2. 6-40.0- 66	1	
8-21623-6	2.12-31.0- 3	1	M	8-21650-7	2. 6-40.0- 91	1	
8-21624-1	2.12-31.0- 3	1	M	8-21651-7	2. 6-40.0- 95	1	U
8-21624-2	2.12-31.0- 3	1	M	8-21657	2. 6-32.0-	1	U
8-21625-1	2.12-31.0- 3	1	M		2. 6-32.0- 87	1	
8-21625-2	2.12-31.0- 3	1	M		2. 6-32.0- 87	1	
8-21630-1	2. 6-40.0- 43	1	A	8-21892-11	2.13-31.0- 29	1	
8-21631-1	2. 6-40.0- 38	1	A	8-21892-29	2.13-31.0- 26	1	M
8-21632-1	2. 6- 1.0- 19	1	U	8-21892-7	2.13-31.0- 31	1	M
	2. 6- 1.0- 19	1		8-21893-23	2.13- 5.0- 9	1	
	2. 6-40.0- 27	1	A	8-21898-19	2.12-45.0-225	1	M
8-21832-11	2. 6-40.0- 27	1	A	8-21898-21	2.12-45.0-223	1	M
8-21832-12	2. 6-40.0- 27	1	A	8-21898-23	2.10-28.0- 16	1	
8-21832-13	2. 6-40.0- 27	1	A	8-21898-25	2.10-28.0- 15	1	
8-21832-14	2. 6-40.0- 27	1	A	8-21951	2.10-28.0- 17	1	
8-21832-15	2. 6-40.0- 27	1	A	8-22005	2.10-39.0- 14	1	P
8-21832-16	2. 6-40.0- 27	1	A	8-22005-1	2.10- 7.0-181	1	U
8-21832-17	2. 6-40.0- 27	1	A		2.10-39.0-	1	RF
8-21832-18	2. 6-40.0- 27	1	A	8-22005-2	2.10- 7.0-181	1	U
8-21832-19	2. 6-40.0- 27	1	A		2.10-39.0-	1	RF
8-21832-20	2. 6-40.0- 27	1	A	8-22060-7	2.10-39.0- 4	1	A
8-21832-21	2. 6-40.0- 27	1	A	8-22060-8	2.10-39.0- 4	1	A
8-21832-22	2. 6-40.0- 27	1	A	8-22061-1P	2.10-39.0- 23	1	P1
8-21832-23	2. 6-40.0- 27	1	A	8-22061-21	2.10-39.0- 23	1	P1
8-21832-24	2. 6-40.0- 27	1	A	8-22062	2.10-39.0- 11	1	
8-21832-25	2. 6-40.0- 27	1	A	8-22062-7	2.10-39.0- 17	1	Y1
8-21832-26	2. 6-40.0- 27	1	A	8-22063-7	2.10-39.0- 8	1	P
8-21832-27	2. 6-40.0- 27	1	A	8-22063-7	2.10-39.0- 8	1	P
8-21832-28	2. 6-40.0- 27	1	A	8-22064	2.10- 7.0-179	2	P
8-21832-29	2. 6-40.0- 27	1	A		2.10-39.0- 1	1	
8-21832-30	2. 6-40.0- 27	1	A	8-22065	2.10-39.0- 15	1	P
8-21832-31	2. 6-40.0- 27	1	A	8-22066-17	2.10-39.0- 23	1	P1
8-21832-32	2. 6-40.0- 27	1	A	8-22066-19	2.10-39.0- 23	1	P1
8-21832-33	2. 6-40.0- 27	1	A	8-22066-857	2. 1- 1.0- 48	1	U
8-21832-34	2. 6-40.0- 27	1	A		2.10- 6.0-	1	RF
8-21832-35	2. 6-40.0- 27	1	A	8-22068-827	2.10- 6.0- 72	1	
8-21832-36	2. 6-40.0- 27	1	A		2.10- 7.0-	1	RF
8-21832-37	2. 6-40.0- 27	1	A	8-22068-853	2.10- 6.0- 72	1	
8-21832-38	2. 6-40.0- 27	1	A		2.10- 7.0-	1	RF
8-21832-39	2. 6-40.0- 27	1	A	8-22068-861	2.10- 6.0- 72	1	A
8-21832-40	2. 6-40.0- 27	1	A		2.10- 7.0-	1	RF
8-21832-41	2. 6-40.0- 27	1	A	8-22068-883	2.10- 6.0- 72	1	A
8-21832-42	2. 6-40.0- 27	1	A		2.10- 7.0-	1	RF
8-21832-43	2. 6-40.0- 27	1	A	8-22068-867	2.10- 6.0- 72	1	A
8-21832-44	2. 6-40.0- 27	1	A		2.10- 7.0-	1	RF
8-21832-45	2. 6-40.0- 27	1	A	8-22068-865	2.10- 6.0- 72	1	A
8-21832-46	2. 6-40.0- 27	1	A		2.10- 7.0-	1	RF
8-21832-47	2. 6-40.0- 27	1	A	8-22068-871	2.10- 6.0- 72	1	A

PART NUMBER	FIGURE AND INDEX NUMBER	QTY PER ART	SMR CODE
8-22095-871	2.10-7.0-	RF	A
8-22095-873	2.10-7.0- 72	1	A
	2.10-7.0-	RF	
8-22096	2.3-15.0- 28	1	A
	2.10-15.0-	RF	
8-22105-1	2.10-7.0- 12	1	P1
8-22106	2.10-7.0- 15	15	P1
8-22107-7	2.10-7.0- 16	32	P
8-22108	2.10-7.0- 17	42	P
8-22111-1	2.10-7.0- 9	1	P1
8-22118	2.10-7.0-	1	U
8-22118-29	2.10-7.0- 1	1	P1
8-22118	2.10-7.0- 4	1	X2
8-22119-1	2.10-7.0- 4	1	X2
8-22119-3	2.10-7.0- 4	1	P1
8-22120-7	2.10-7.0- 10	13	P1
8-22121	2.10-7.0- 4	1	X1
8-22122	2.10-7.0- 13	RF	P1
8-22123	2.10-7.0- 5	1	P
8-22124	2.10-7.0- 2	1	P1
8-22124-1	2.10-7.0- 9	1	P1
8-22124-7	2.10-7.0- 11	1	X1
8-22125	2.10-7.0- 6	1	PD
8-22125-1	2.10-7.0- 7	1	PD
8-22125-15	2.10-7.0- 6	RF	X2
8-22125-17	2.10-7.0- 7	RF	X2
8-22127	2.10-7.0- 6	20	P
8-22310-1	2.5-32.0- 58	1	U
	2.10-1.0- 67	RF	
8-22310-2	2.5-32.0- 58	1	U
	2.10-1.0- 67	RF	
8-22315-7	2.10-7.0- 30	1	P
8-22315	2.10-6.0- 70	1	P1
8-22316-1	2.10-6.0- 70	RF	P1
8-22317	2.10-7.0- 33	1	P
8-22544	2.10-7.0-134	1	U
8-22545-5	2.10-24.0- 19	1	P
8-22565-1	2.10-7.0-167	1	
8-22565-1	2.10-7.0-168	1	P1
8-22615	2.10-39.0- 18	1	P1
8-22616-3	2.10-39.0- 19	1	P1
8-22616-4	2.10-39.0- 20	1	P
8-22617	2.10-39.0- 3	RF	P
8-22616-7	2.10-39.0- 3	1	P1
8-22620-1	2.10-10.0- 10	2	
8-22621-3	2.10-12.0- 38	1	P
8-22621-4	2.10-12.0- 38	1	P
8-22640-11	2.10-15.0- 16	2	P
8-22640-17	2.10-13.0- 19	24	
8-22640-19	2.10-15.0- 14	6	
	2.10-15.0- 7	42	P
8-22640-23	2.10-14.0- 3	AR	P
8-22640-25	2.10-15.0- 17	44	
	2.10-14.0- 3	44	P
8-22640-27	2.10-13.0- 19	AP	
	2.10-14.0- 3	AP	P
8-22640-29	2.10-15.0- 18	6	P
8-22640-31	2.10-15.0- 17	4	
	2.10-15.0- 14	1	
	2.10-15.0- 18	1	P
8-22644	2.10-14.0- 7	AR	
	2.10-15.0- 12	21	
	2.10-15.0- 13	2	
	2.10-15.0- 4	42	
8-22644-7	2.10-14.0- 2	44	P

PART NUMBER	FIGURE AND INDEX NUMBER	QTY PER ART	SMR CODE
8-22644-8	2.10-15.0- 17	2	P
	2.10-15.0- 4	15	P1
8-22644-1	2.10-15.0- 24	1	X
8-22654-1F	2.10-13.0- 13	1	X1
8-22654-379	2.10-13.0- 13	1	X2
8-22654-410	2.10-13.0- 38	4	M1
8-22654-431	2.10-13.0- 27	1	X1
8-22654-439	2.10-13.0- 29	1	X1
8-22654-457	2.10-13.0- 13	1	P1
8-22654-8	2.10-12.0- 61	2	
	2.10-13.0-	RF	
8-22654-401	2.10-12.0- 61	1	P1
	2.10-13.0-	RF	
8-22654-803	2.10-12.0- 61	1	P1
	2.10-13.0-	RF	
8-22654-889	2.10-12.0- 61	1	P1
	2.10-13.0-	RF	
8-22655-801	2.10-13.0- 12	1	U
	2.10-14.0-	RF	
8-22659	2.10-12.0- 1	2	
	2.10-12.0- 13	1	P1
8-22659-1	2.10-12.0- 1	RF	P
8-22659-13	2.10-12.0- 11	1	M
8-22659-3	2.10-12.0- 7	1	P1
8-22659-5	2.10-12.0- 8	1	P1
8-22659-1	2.10-12.0- 21	2	P
8-22660-3	2.10-12.0- 21	2	P
8-22661-5	2.10-12.0- 37	1	P
8-22661-6	2.10-12.0- 37	1	P
8-22662-15	2.10-12.0- 58	1	M
8-22662-17	2.10-12.0- 59	1	P
8-22662-3	2.10-12.0- 50	1	P1
8-22662-4	2.10-12.0- 55	1	P1
8-22662-7	2.10-12.0- 60	1	X1
8-22662-8	2.10-12.0- 60	1	X1
8-22663-21	2.10-12.0- 50	1	M
8-22663-23	2.10-12.0- 51	1	M
8-22663-25	2.10-12.0- 52	1	M
8-22663-37	2.10-12.0- 54	1	X1
8-22663-39	2.10-12.0- 54	1	X1
8-22663-39	2.10-12.0- 47	1	M
8-22663-41	2.10-12.0- 53	1	M
8-22663-401	2.10-12.0- 46	1	P1
8-22663-802	2.10-12.0- 46	1	P1
8-22664	2.10-13.0- 14	25	P
8-22665	2.10-13.0- 16	AR	P
8-22666-1	2.10-13.0- 1	1	A
8-22666-15	2.10-13.0- 5	2	M
8-22666-19	2.10-13.0- 6	1	P1
8-22666-21	2.10-13.0- 7	1	P1
8-22668	2.10-13.0- 14	1	U
8-22668-7	2.10-13.0- 15	1	P
8-22669-15	2.10-7.0-180	RF	X
8-22669-16	2.10-7.0-180	RF	X
8-22669-17	2.10-7.0-180	1	P1
8-22669-18	2.10-7.0-180	1	P1
8-22670-10	2.10-7.0-180	RF	P1
8-22670-11	2.10-7.0-180	RF	P1
8-22671	2.10-12.0- 28	2	P
8-22671-7	2.10-12.0- 27	2	P
8-22672	2.10-12.0- 26	2	P
8-22673	2.10-13.0- 4	25	P
8-22679-3	2.10-12.0-	RF	U
8-22679-5	2.10-12.0-	RF	U
8-22679-8.1	2.10-12.0-	RF	U

PART NUMBER	FIGURE AND INDEX NUMBER	QTY PER ART	SMR CODE
8-22679-803	2.10- 7.0-177	1	U
	2.10-12.0-	RF	
8-22679-805	2.10- 7.0-177	1	U
	2.10-12.0-	RF	
8-22679-809	2.10- 7.0-177	1	U
	2.10-12.0-	RF	
8-22679-811	2.10- 7.0-177	1	U
	2.10-12.0-	RF	
8-22683-23	2.10- 6.0- 45	2	A1
8-22683-3	2.10- 6.0- 44	1	U
8-22684-1	2.10- 6.0- 22	1	U
8-22684-13	2.10- 6.0- 30	1	P
	2.10- 6.0- 52	1	
8-22684-37	2.10- 6.0- 43	1	M1
8-22684-49	2.10- 6.0- 34	1	P
8-22684-7	2.10- 6.0- 23	1	A1
8-22689	2.10- 6.0- 57	1	P
8-22690-7	2.10- 6.0- 44	1	P
	2.10- 6.0- 62	1	P
8-22691	2.10- 6.0- 58	1	P
8-22692-7	2.10- 6.0- 33	2	M1
8-22692-9	2.10- 6.0- 33	2	M1
8-22693	2.10- 6.0- 38	1	P
8-22694	2.10- 6.0- 39	1	P
8-22695-7	2.10- 6.0- 56	1	P
8-22695-9	2.10- 6.0- 34	1	P
8-22693	2.10-13.0- 24	1	U
8-22692-15	2.10-13.0- 26	1	P
8-22736-5	2.10- 1.0- 57	1	P1
8-22736-6	2.10- 1.0- 57	1	P1
8-22737	2.10- 7.0- 60	2	P1
8-22737-15	2.10- 7.0- 61	1	P
8-22737-17	2.10- 7.0- 63	1	X1
8-22738-11	2.10- 7.0-293	1	M
8-22738-5	2.10- 7.0-291	1	U
8-22739-1	2.10- 7.0- 85		U
	2.10- 9.0-	RF	
8-22739-19	2.10- 9.0- 17	1	P
8-22739-27	2.10- 9.0- 11	1	P1
8-22739-29	2.10- 9.0- 11	1	P1
8-22741-9	2.10-10.0- 17	1	P1
8-22743	2.10-10.0- 11	4	M1
8-22745	2.10-10.0- 3	2	M
8-22750-1	2.10- 6.0- 10	1	P
8-22751	2.10- 6.0- 10	1	P1
8-22751-19	2.10- 6.0- 11	2	M
	2.10- 6.0- 16	2	
8-22751-21	2.10- 6.0- 12	1	P
	2.10- 6.0- 17	1	
8-22751-7	2.10- 6.0- 13	1	X1
8-22752	2.10- 6.0- 15	1	P1
8-22752-15	2.10- 6.0- 18	1	X1
8-22754-7	2.10- 8.0- 38	1	P
8-22757	2.10- 8.0- 21	2	M
	2.10- 8.0- 59	1	
8-22759	2.10- 8.0- 11	2	M
	2.10- 8.0- 55	5	
8-22760	2.10- 6.0- 22	1	M
8-22761-713	2.10- 6.0- 20	1	P
8-22762	2.10- 7.0- 28	1	U
	2.10-11.0-	RF	
8-22762-1	2.10- 7.0- 28	1	U
	2.10-11.0-	RF	
8-22762-9	2.10-11.0- 6	1	M
8-22763	2.10- 9.0- 15	1	P1

PART NUMBER	FIGURE AND INDEX NUMBER	QTY PER ART	SMR CODE
8-22764	2.10- 9.0- 15	1	P1
8-22765-7	2.10- 9.0- 10	1	M1
8-22765-8	2.10- 9.0- 10	1	M1
8-22766-1	2.10-11.0- 21	1	P1
8-22767	2.10- 8.0- 22	1	M
8-22769-3	2.10-11.0- 17	1	P1
8-22770	2.10-11.0- 14	1	P1
8-22778-1	2.10-10.0- 18	1	P1
8-22779-10	2.10- 9.0- 9	1	M1
8-22779-9	2.10- 9.0- 9	1	M1
8-22786-29	2.10- 8.0- 18	1	M
8-22786-31	2.10- 8.0- 63	1	M
8-22786-33	2.10- 8.0- 66	1	M
8-22786-41	2.10- 8.0- 15	1	M
8-22787	2.10-10.0- 9	4	M
8-22795	2.10- 7.0- 53	1	P
8-22796	2.10- 7.0-204	1	M
8-22797	2.10- 9.0- 16	1	M1
8-22798	2.10- 7.0- 46	1	M
8-22799-1	2.10- 7.0- 27	1	U
	2.10- 8.0-	RF	
8-22799-3	2.10- 6.0- 4	1	U
8-22799-5	2.10- 7.0- 27	1	U
	2.10- 8.0-	RF	
8-22808-801	2.10- 7.0- 64	1	U
8-22808-803	2.10- 6.0- 62	1	U
8-22813-1	2.10- 1.0- 52	1	P1
8-22959	2.10-36.0- 8	RF	X1
8-22960-7	2.10-36.0- 8	1	
8-22961	2.10- 7.0-291	1	P1
	2.10-36.0-	RF	
8-22962-1	2.10- 7.0-182	RF	P1
8-22964	2.10- 7.0- 17	RF	P
8-22964-7	2.10- 7.0- 23	RF	X1
8-22965	2.10-36.0- 7	1	P
8-22967	2.10- 7.0- 24	RF	P1
8-22968-7	2.10- 7.0- 24	1	P1
8-22969	2.10- 7.0- 23	RF	X
8-22969-1	2.10- 7.0- 17	1	P1
8-22969-7	2.10- 7.0- 23	1	X1
8-22976	2.10- 7.0-181	1	U
8-22977	2.10- 7.0-192	RF	P1
8-22978-7	2.10- 7.0-192	2	P1
8-22979	2.10- 7.0-200	2	P
8-22980	2.10- 7.0-195	4	P
8-22981	2.10- 7.0-196	4	P
8-22982-7	2.10- 7.0-191	1	P
8-22983	2.10- 7.0-190	2	P
8-22984-7	2.10- 7.0-186	2	P
8-22985	2.10- 7.0-197	2	P
8-23093	2.13- 1.1- 67	1	P1
8-23093-1	2.13- 1.1- 67	1	P1
8-23094	2.13- 1.1- 75	1	X1
8-23094-1	2.13- 1.1- 75	1	X1
8-23095	2.13- 1.1- 70	1	P
8-23097	2. 3- 3.0- 15	1	U
	2.13- 1.1- 66	RF	
8-23100-17	2.13-30.0- 54	1	M
8-23100-11	2.13-30.0- 44	2	M
8-23100-17	2.13-30.0- 71	2	A
	2.13-30.0- 61	RF	
8-23100-7	2.13-30.0- 48	1	M
8-23100-8	2.13-30.0- 40	1	M
8-23100-801	2. 3-10.0- 38	1	A
	2.13-30.0-	RF	

PART NUMBER	FIGURE AND INDEX NUMBER	QTY PER ART	SMR CODE
8-23100-805	2. 3-10.0- 38	1	U
	2.13-30.0-	RF	
8-23100-809	2. 3-10.0- 38	1	A
	2.13-30.0-	RF	
8-23103-9	2.13-30.0- 53	1	M
8-23101	2.13-30.0- 68	REF	
8-23101-119	2.13-30.0- 69	1	M
	2.13-30.0- 80	1	
8-23101-3	2.13-30.0- 62	1	P1
8-23101-801	2.13-30.0- 74	1	P1
8-23101-803	2.13-30.0- 75	1	P1
8-23102	2.13-31.0- 36	1	P
8-23102-3	2.13-31.0- 37	1	P
8-23106-801	2.13-31.0- 8	1	P1
8-23107-7	2.13-30.0- 67	1	P
	2.13-30.0- 80	1	
8-23107-8	2.13-30.0- 68	1	P
	2.13-30.0- 80	1	
8-23108	2.13-30.0- 65	1	
	2.13-30.0- 80	1	
	2.13-33.0- 67	REF	
8-23108-1	2.13-30.0- 66	1	
	2.13-30.0- 80	1	
8-23112	2.13-30.0- 34	2	P
8-23112-9	2.13-30.0- 41	1	X1
8-23113	2.13-30.0- 42	1	M1
8-23114	2.13-30.0- 43	1	M
8-23120	2.13-31.0- 1	1	P1
8-23120-1	2.13-31.0- 2	10	P1
8-23121	2.13-30.0- 33	1	P
	2.13-31.0- 47	1	
8-23124	2.13-30.0- 82	1	P
8-23130	2. 1- 1.0- 63	1	U
	2.13-30.0- 1	RF	
8-23150-13	2.13-31.0- 12	1	M
8-23150-3	2.13-30.0- 27	1	A
	2.13-31.0-	RF	
8-23150-805	2.13-30.0- 27	1	A
	2.13-31.0-	RF	
8-23200	2. 3- 3.0- 32	RF	U
	2.13-27.0-	RF	
8-23200-3	2. 3- 3.0- 32	RF	U
	2.13-27.0-	RF	
8-23200-5	2. 3- 3.0- 32	RF	U
	2. 3- 3.0- 32	RF	
	2.13-27.0-	RF	
8-23201	2.13-25.0- 27	1	
8-23208-5	2.13-27.0- 11	1	
8-23208-805	2.13-27.0- 11	1	P1
8-23210	2.13-27.0- 29	1	P
8-23210-15	2.13-27.0- 30	1	X1
8-23213-1	2.10- 7.0- 42	1	P1
8-23219-1	2.13-27.0- 52	1	P1
8-23220	2.13-27.0- 25	1	A
8-23220-1	2.13-27.0- 27	1	A
8-23220-3	2.13-27.0- 26	1	A
8-23220-801	2.13-27.0- 24	1	A
8-23220-803	2.13-27.0- 28	1	A
8-23220-805	2.13-27.0- 24	1	A
8-23220-809	2.13-27.0- 27	1	A
8-23222	2.13-27.0- 54	1	P1
8-23224-803	2.13-25.0- 24	RF	P
	2.13-26.0- 1	1	
8-23227	2.10- 7.0- 35	1	P1
8-23227-7	2.10- 7.0- 39	1	P1

PART NUMBER	FIGURE AND INDEX NUMBER	QTY PER ART	SMR CODE
8-23227-9	2.10- 7.0- 41	1	X1
8-23240-1	2.10- 7.0- 34	1	U
8-23241-1	2.13-31.0- 41	1	
8-23244-15	2.13-25.0- 14	1	
8-23244-17	2.13-25.0- 15	1	
8-23245-1	2.13-25.0- 9	1	P1
8-23246-5	2.13-25.0- 3	1	P1
	2.13-27.0- 13	1	
8-23246-801	2.13-25.0- 2	1	P1
8-23246-803	2.13-25.0- 2	1	P1
8-23300-15	2.13-12.0- 9	1	M
8-23300-23	2.13-13.0- 4	1	M
8-23300-27	2.13-13.0- 5	1	M
8-23300-29	2.13-13.0- 3	1	A
8-23300-803	2. 3- 4.0- 42	1	U
	2.13-10.0-	RF	
8-23300-805	2. 3- 4.0- 42	1	U
	2.13-12.0-	RF	
8-23300-807	2. 3- 4.0- 42	1	U
	2.13-13.0-	RF	
8-23300-809	2. 3- 4.0- 42	1	U
	2.13-13.0-	RF	
8-23300-811	2. 3- 4.0- 42	1	U
	2.13-10.0-	RF	
8-23300-813	2. 3- 4.0- 042.	1	U
	2.13-12.0-	RF	
8-23301-9	2.13- 4.0- 5	1	P1
8-23305	2.13-10.0- 18	1	M
8-23309	2.13-12.0- 19	1	M
8-23315-805	2.13-13.0- 14	1	P
8-23315-806	2.13-13.0- 15	1	P
8-23315-807	2.13-13.0- 15	1	P
8-23316	2.13-13.0- 43	2	P
	2.13-13.0- 57	2	
8-23319-11	2.13-13.0- 42	1	P1
8-23319-9	2.13-13.0- 42	1	P1
8-23320-3	2. 3- 4.0- 41	1	U
	2.13- 4.0-	RF	
8-23320-5	2. 3- 4.0- 40	1	U
	2.13- 4.0- 9	RF	
8-23321	2.13-10.0- 19	2	M
8-23323-17	2.13-12.0- 14	1	X
8-23324	2.13-12.0- 13	1	M
8-23327-1	2. 9- 1.0- 1	1	P
8-23330	2. 3- 3.0- 7	1	U
	2.13-19.0-	RF	
8-23334-9	2.13-14.0- 10	1	X1
8-23335-7	2.13-14.0- 9	1	P1
8-23336	2.13-14.0- 5	1	P1
8-23337	2.13-14.0- 4	1	P
8-23338	2.13-14.0- 3	2	P
8-23339-1	2.13-14.0- 2	1	P
8-23340-1	2. 3- 4.0- 10	1	U
	2.13- 2.0-	RF	
8-23344	2.13-15.0- 10	1	P
8-23345	2.13-15.0- 29	1	P
8-23351-1	2.13- 9.0- 12	1	P1
8-23352	2.13- 9.0- 14	1	P1
8-23352-1	2.13- 9.0- 14	RF	P1
8-23352-3	2.13- 9.0- 14	1	P1
8-23352-5	2.13- 9.0- 14	RF	P1
8-23356-7	2.13- 1.1-112	1	P1
8-23361	2.13- 4.0- 4	1	P
8-23365	2. 3-10.0- 31	1	U
	2.13- 1.1-107	RF	

PART NUMBER	FIGURE AND INDEX NUMBER	QTY PER ART	SMR CODE
8-23366-1	2.13-12.0- 14	1	P1
8-23373-1	2.13-12.0- 10	1	M
8-23375-1	2. 3- 4.0- 28	1	U
	2. 9- 1.0-	RF	U
8-23375-2	2. 3- 4.0- 28	1	U
	2. 9- 1.0-	RF	
8-23377-1	2.13-13.0- 47	1	M
	2.13-13.0- 62	2	
8-23378	2.13-13.0- 58	1	P
8-23379	2.13-13.0- 44	1	M
8-23379-7	2.13-13.0- 44	1	P
8-23380	2.13-14.0-	RF	P1
	2.13-15.0- 11	1	
8-23381-7	2.13-13.0- 46	1	X1
8-23381-9	2.13-13.0- 46	1	X1
8-23382	2.13-13.0- 31	1	M
8-23382-1	2.13-13.0- 31	1	M
8-23382-2	2.13-13.0- 32	1	M
8-23383	2.13-13.0- 45	2	P
	2.13-13.0- 59	2	
8-23384-2	2.13-13.0- 26	1	M
8-23384-3	2.13-13.0- 27	1	M
8-23384-4	2.13-13.0- 26	1	M
8-23384-5	2.13-13.0- 27	1	M
8-23384-801	2.13-13.0- 27	1	M
8-23385-7	2.13-13.0- 67	1	P
	2.13-15.0- 3	1	
8-23385-9	2.13-13.0- 61	1	P
	2.13-15.0- 4	1	
8-23386	2.13-13.0- 69	1	P1
8-23388-1	2.13-13.0- 34	1	P1
8-23388-5	2.13-13.0- 34	1	P1
8-23388-801	2.13-13.0- 34	1	P1
8-23388-803	2.13-13.0- 34	1	P1
8-23388-805	2.13-13.0- 34	1	P1
8-23389-1	2.13-13.0- 49	1	P1
8-23389-5	2.13-13.0- 49	1	U
8-23389-801	2.13-13.0- 49	1	P1
8-23389-803	2.13-13.0- 49	1	P1
8-23389-805	2.13-13.0- 49	1	P1
8-23390	2. 3-10.0- 33	1	U
	2.13- 1.1- 96	RF	
8-23390-11	2.13- 1.1-106	1	X
8-23391	2.13- 1.1-101	1	P
8-23392-11	2.13-13.0- 60	1	X1
8-23392-9	2.13-13.0- 60	1	X1
8-23394-1	2.13-13.0- 63	1	P1
8-23394-3	2.13-13.0- 63	1	P1
8-23395-7	2.13-13.0- 39	1	P
	2.13-13.0- 54	1	
8-23395-9	2.13-13.0- 39	1	P
	2.13-13.0- 54	1	
8-23398	2.13-10.0- 14	1	A
8-23399	2.13-15.0- 5	1	P1
8-23400-11	2.13-18.0- 10	1	M
8-23400-5	2. 3- 4.0- 36	RF	U
	2. 3- 4.0- 36	1	
	2.13-17.0-	RF	
8-23400-801	2. 3- 3.0- 14	1	U
	2.13-18.0-	RF	
8-23400-803	2. 3- 4.0- 36	RF	U
	2. 3- 4.0- 36	1	
	2.13-17.0-	RF	
8-23401-9	2.13-17.0- 2	1	P1
8-23402	2.13-17.0- 5	1	P1

PART NUMBER	FIGURE AND INDEX NUMBER	QTY PER ART	SMR CODE
8-23402-1	2.13-17.0- 5	1	P1
8-23403-1	2.13-17.0- 7	1	P1
8-23403-3	2.13-17.0- 7	1	P1
8-23404-1	2.13-17.0- 13	1	P1
8-23404-3	2.13-17.0- 13	1	P1
8-23405-1	2.13-17.0- 15	1	P1
8-23405-5	2.13-17.0- 15	1	P1
8-23405-801	2.13-17.0- 15	1	P1
8-23407	2.13-18.0- 14	1	P1
8-23407-1	2.13-18.0- 14	1	P1
8-23409	2.13-17.0- 8	1	P
8-23411	2.13-17.0- 9	1	P
8-23413	2.13-17.0- 16	1	M
8-23414-3	2.13-18.0- 3	1	M
8-23421	2.13-18.0- 11	1	M
8-23425-1	2.13-18.0- 43	1	P1
8-23425-3	2.13-18.0- 43	1	P1
8-23427	2.13-20.0- 10	1	P1
8-23427-1	2.13-20.0- 10	1	P1
8-23432-1	2.13-20.0- 12	1	P1
8-23432-3	2.13-20.0- 12	1	P1
8-23433	2.13-18.0- 46	1	P
8-23435	2.13-20.0- 15	1	M
8-23435-1	2.13-20.0- 16	1	M
8-23435-3	2.13-20.0- 17	1	M
8-23437	2.13-20.0- 18	1	A
8-23439	2.13-20.0- 11	1	P1
8-23439-1	2.13-20.0- 11	1	P1
8-23441	2.13-18.0- 42	1	P1
8-23441-1	2.13-18.0- 42	1	P1
8-23442-15	2.13-18.0- 27	1	M1
8-23442-17	2.13-18.0- 32	1	M
8-23442-23	2.13-18.0- 36	1	M1
8-23442-7	2.13-18.0- 25	1	M
8-23442-9	2.13-18.0- 21	1	M1
8-23450-1	2. 3- 3.0- 46	1	U
	2.13-20.0-	RF	
8-23452	2.13-12.0- 15	1	P1
8-23500-27	2.13- 8.0- 28	1	M
8-23500-45	2.13- 6.0- 9	1	M
8-23500-801	2. 3- 4.0- 37	RF	U
8-23500-805	2. 3- 4.0- 37	RF	U
8-23500-807	2. 3- 4.0- 37	1	U
	2.13- 6.0-	RF	
8-23500-809	2. 3- 4.0- 37	RF	U
8-23501	2.13- 5.0- 17	1	P1
8-23506-1	2.13- 5.0- 8	1	P1
8-23507	2.13- 5.0- 13	2	P
	2.13- 6.0- 5	2	U
8-23510-1	2. 3-11.0- 31	1	U
	2.13- 1.1-134	1	
8-23513-1	2.13- 9.0- 37	1	P
8-23514-801	2.13- 9.0- 73	1	P1
	2.13- 9.0- 74	1	
8-23514-803	2.13- 9.0- 80	1	P1
8-23520-801	2. 3-10.0- 30	1	U
	2.13- 9.0-	RF	
8-23521	2.13- 1.1-124	1	P
8-23522	2. 3-10.0- 32	1	U
	2.13- 1.1-120	RF	
8-23524	2. 3-10.0- 29	1	
	2.13- 1.1- 92	RF	U
8-23524-7	2.13- 1.1- 96	1	M
8-23525	2. 3- 4.0- 44	RF	U
	2.13- 1.1- 76	RF	

PART NUMBER	FIGURE AND INDEX NUMBER	QTY PER ART	SMR CODE
8-23526-3	2.13-11.0- 28	1	P1
8-23526-5	2.13-11.0- 28	1	P1
8-23527-1	2. 2- 8.0- 5	RF	P1
	2.13- 1.1-135	1	
8-23527-7	2. 2- 8.0- 5	4	M
8-23528	2. 2- 8.0- 3	2	P
	2.13-21.0- 8	2	
8-23534	2.13-11.0- 32	RF	P1
8-23534-1	2.13-11.0- 32	1	P1
8-23534-17	2.13-11.0- 38	RF	X1
8-23534-27	2.13-11.0- 38	1	X1
8-23535	2.13-11.0- 43	1	P1
8-23535-9	2.13-11.0- 46	1	M
8-23536-1	2.13-11.0- 49	1	P1
8-23536-19	2.13-11.0- 53	1	X1
8-23540-17	2.13-24.0- 2	1	A
8-23540-25	2.13-24.0- 7	2	P
8-23542-11	2.13-24.0- 11	2	P1
8-23542-13	2.13-24.0- 8	1	P1
8-23542-15	2.13-24.0- 9	1	P1
8-23547-19	2.13-21.0- 10	1	P1
8-23547-21	2.13-21.0- 11	1	P1
8-23547-27	2. 2- 8.0- 8	1	P2
8-23547-29	2. 2- 8.0- 7	1	P2
8-23548	2. 2- 8.0- 1	1	M
	2.13-21.0- 5	1	
8-23549-1	2.13- 1.1-144	1	
8-23551-7	2.13-22.0- 22	1	X1
8-23552-7	2.13-22.0- 16	1	P1
8-23553-9	2.13-22.0- 10	1	P1
8-23558	2.13-22.0- 23	1	P
8-23559-1	2.13-22.0- 18	1	P
8-23559-9	2.13-22.0- 19	1	X1
8-23563-1	2.13-22.0- 24	1	P1
8-23564	2.13-22.0- 21	2	P
8-23566	2.13- 1.1-145	1	P1
8-23569-1	2.13- 1.1-149	1	P1
8-23575-1	2. 3-10.0- 34	1	U
	2.13-24.0-	RF	
8-23576-803	2.13-24.0- 15	1	P1
8-23578-1	2.13-22.0- 5	1	M
8-23580	2. 3-10.0- 39	1	U
	2.13-22.0-	RF	
8-23581	2.13- 8.0- 26	RF	P1
8-23594-1	2.13- 1.1- 62	RF	P1
8-23594-7	2.13- 1.1- 62	1	P
8-23595	2. 3-10.0- 35	1	U
	2.13- 1.1- 55	RF	
8-23602	2.13- 1.1- 43	1	M
8-23603	2.13- 1.1- 42	2	A
8-23603-1	2.13- 1.1- 42	1	A
8-23603-701	2.13- 1.1- 42	1	A
8-23603-702	2.13- 1.1- 42	1	A
8-23603-713	2.13- 1.1- 50	1	M
8-23604	2.13- 1.1- 51	1	M1
8-23606	2.13-21.0- 1	1	P1
8-23607	2.13-23.0- 20	1	P1
8-23607-13	2.13-23.0- 25	1	P
8-23607-15	2.13-23.0- 30	1	X1
8-23609	2.13-23.0- 29	1	P
8-23614	2.13-23.0- 23	1	P
8-23630	2. 3- 4.0- 43	1	U
	2.13- 1.1- 42	RF	
8-23640-1	2.13-22.0- 6	1	P1
8-23640-3	2.13-22.0- 6	1	P1

PART NUMBER	FIGURE AND INDEX NUMBER	QTY PER ART	SMR CODE
8-23641	2.13-22.0- 15	1	P
8-23680	2. 3-11.0- 27	1	U
	2.13-21.0-	RF	
8-23681	2.13-21.0- 15	1	P1
8-23682	2.13-21.0- 16	1	P1
8-23700	2. 3-10.0- 43	1	U
	2.13- 1.1-128	RF	
8-23703-7	2.13- 1.1-134	1	P
8-23707-1	2.13- 1.1-132	1	P1
8-23707-27	2.13- 1.1-132	1	A
8-23715	2. 9- 5.0- 18	1	P
8-23720	2. 3- 4.0- 39	1	U
	2.13- 1.1- 2	RF	
8-23730-1	2. 3- 4.0- 9	1	U
	2.13- 1.1- 14	1	
8-23800	2. 3-10.0- 37	1	U
	2.13-29.0-	RF	
8-23801	2.13-29.0- 15	1	P1
8-23801-1	2.13- 9.0- 65	1	
8-23801-3	2.13-29.0- 15	1	P1
8-23802-1	2.13-29.0- 16	1	P1
8-23802-3	2.13-29.0- 16	1	P1
8-23803-1	2.13-29.0- 13	1	P1
8-23803-5	2.13-29.0- 10	1	P1
8-23804-1	2.13-29.0- 2	1	P1
8-23804-5	2.13-29.0- 2	1	P1
8-23805	2.13-29.0- 12	1	P1
8-23805-1	2.13-29.0- 12	1	P1
8-23806-1	2.13-29.0- 18	1	P1
8-23806-5	2.13-29.0- 18	1	P1
8-23807	2.13-29.0- 6	1	P1
8-23807-3	2.13-29.0- 6	1	P1
8-23840	2. 3- 4.0- 38	1	U
8-23840-47	2.13- 8.0- 59	1	M
8-23841-11	2.13-11.0- 32	RF	P1
8-23842	2.13-24.0- 13	1	P1
8-23842-3	2.13-24.0- 13	1	P1
8-23850-3	2. 3- 3.0- 67	1	P1
	2.13-11.0-		
8-23850-5	2. 3- 3.0- 67	1	U
	2.13-11.0-		
8-23850-801	2. 3- 3.0- 67		U
	2.13-11.0-		
8-23851-3	2.13-11.0- 6	1	P1
8-23854-1	2.13-11.0- 5	1	P1
8-23854-3	2.13-11.0- 5	RF	P1
8-23856	2.13-11.0- 24	1	M
8-23857-1	2.13-11.0- 23	1	P
8-23860	2.13- 6.0- 10	1	P1
8-23862	2.13- 4.0- 18	1	P1
8-23864-7	2.13- 6.0- 14	1	M
8-23864-9	2.13- 6.0- 14	1	M
8-23865	2. 3- 4.0- 41	1	U
	2.13- 4.0- 12	RF	
8-23869	2.13- 8.0- 17	1	P
8-238779-9	2.13- 9.0- 36	1	
8-23879-7	2.13- 9.0- 50	2	M
	2.13- 9.0- 69	1	
	2.13- 9.0- 70	1	
8-23879-9	2.13- 9.0- 77		M
8-23884-11	2.13- 9.0- 25	1	
8-23884-13	2.13- 9.0- 29	1	
8-23900-15	2.13-15.0- 12	1	M
8-23900-803	2. 3- 3.0- 13	1	
	2.13-15.0-	RF	

PART NUMBER	FIGURE AND INDEX NUMBER	QTY PER ART	SMR CODE
8-23938	2.13-33.0- 24	1	P1
8-23942	2.13-30.0- 21	1	P1
8-23965-1	2.13- 5.0- 24	1	P
	2.13- 6.0- 17	1	
8-23965-3	2.13- 5.0- 28	1	P
	2.13- 6.0- 21	1	
8-23968	2. 3- 4.0- 10	1	U
	2.13- 3.0-	RF	
8-23969	2.13-30.0- 21	RF	P1
8-23990-1	2. 3-13.0- 8	1	
	2.13-23.0-	RF	
8-23992-5	2.13-23.0- 19	1	U
8-23992-801	2.13-23.0- 19	1	P1
8-23993-1	2.13-23.0- 6	1	P
8-23993-3	2.13-23.0- 6	1	P1
8-23994-1	2.13-23.0- 5	1	P
8-23994-3	2.13-23.0- 5	1	P
8-23995	2.13-23.0- 34	1	P
8-23996	2.13-23.0- 33	1	P
8-23997	2.13-30.0- 12	1	P1
8-2488-7	2.12-52.0- 63	1	
8-25723	2.12-42.0- 25	1	M1
8-25725-7	2.12-42.0- 25	1	M1
8-26003	2.10- 6.0- 3	1	P
	2.10- 7.0- 21	1	
8-26005-11	2.10-16.0- 10	1	P
	2.10-16.0- 4	1	P
8-26005-13	2.10-16.0- 9	1	P
8-26005-9	2.10-16.0- 11	1	P
	2.10-16.0- 5	1	
8-26054-7	2.10-13.0- 21	35	P1
8-26055-7	2.10-13.0- 22	35	P
8-26056-7	2.10-13.0- 24	35	P
8-26600-1	2.10-13.0- 27	1	M1
8-26600-2	2.10-13.0- 27	1	X2
8-26610	2.10-13.0- 20	1	P1
8-26610-3	2.10-13.0- 20	1	P1
8-2662-3	2.14-12.0- 22	1	
8-26679-3	2.10- 7.0-177	1	
8-26679-5	2.10- 7.0-177	1	
8-26679-801	2.10- 7.0-177	1	
8-26700-1	2.10- 7.0- 47	1	U
8-26700-11	2.10- 7.0- 51	1	M
8-26700-17	2.10- 7.0- 50	1	M
8-26701	2.10- 8.0- 42	1	P
8-26703	2.10- 8.0- 48	RF	P1
8-26706-9	2.10- 8.0- 34	1	P
8-26707-7	2.10- 8.0- 29	1	P
8-26707-9	2.10- 8.0- 33	1	P
8-26708	2.10- 8.0- 22	1	M
8-26711	2.10-10.0- 5	RF	X1
8-26712	2.10-10.0- 1	1	P1
8-26712-7	2.10-10.0- 14	2	M
8-26712-9	2.10-10.0- 13	2	P
8-26713-1	2.10-10.0- 19	1	P1
8-26713-3	2.10-10.0- 19	1	P1
8-26714-1	2.10- 9.0- 14	1	P1
	2.10-10.0-	RF	
8-26714-3	2.10- 9.0- 14	1	P1
	2.10-10.0-	RF	
8-26715	2.10-10.0- 5	2	X1
8-26717	2.10- 8.0- 2	1	P1
8-26717-33	2.10- 8.0- 8	1	P
8-26717-69	2.10- 8.0- 9	1	P
8-26718	2.10- 1.0- 39	1	P

PART NUMBER	FIGURE AND INDEX NUMBER	QTY PER ART	SMR CODE
8-26719	2.10- 8.0- 10	2	P
	2.10- 8.0- 54	4	
8-26720	2.10- 8.0- 48	1	P1
8-26949-1	2.10- 7.0-207	1	A
8-26949-15	2.10- 7.0-215	1	M
8-26950	2.10- 7.0-211	1	M
8-26951	2.10- 7.0-193	2	P1
8-26957	2.10- 6.0- 4	2	P
	2.10- 7.0-186	2	
8-27320-1	2. 3-15.0- 1	1	U
	2.12-58.0-	RF	
8-27379-11	2.12-60.0- 6	1	A
8-27379-13	2.12-60.0- 10	2	M
8-27379-15	2.12-60.0- 6	1	A
8-27379-3	2. 3- 3.0- 86	1	U
	2.12-60.0-	RF	
8-27380-801	2. 3-15.0- 6	1	U
	2.12-38.0- 80	RF	
8-27380-802	2. 3-15.0- 6	1	U
	2.12-38.0- 80	RF	
8-27388-15	2. 3-14.0- 19	1	P
8-27388-5	2. 3-14.0- 18	1	A
8-27389-11	2. 3-14.0- 20	1	P1
8-27447	2.12-49.0-	RF	U
	2.12-50.0- 1	1	
8-27447-1	2.12-49.0-	RF	U
	2.12-50.0- 1	1	
8-27447-9	2.12-49.0- 24	1	M
8-27449-3	2. 3-15.0- 5	1	
	2.12-65.0-	RF	
8-27449-5	2. 3-15.0- 5	1	U
	2.12-65.0-	RF	
8-27449-803	2.12-65.0- 22	RF	P2
8-27451	2.12-50.0- 2	1	U
	2.12-52.0-	RF	
8-27451-3	2.12-50.0- 2	1	U
	2.12-52.0-	RF	
8-27452	2.12-52.0-103	1	P1
8-27452-3	2.12-52.0-103	1	P1
8-27457-19	2.10-16.0- 15	1	P
8-27460	2.12-65.0- 32	1	P
8-27460-1	2.12-65.0- 32	1	M1
8-27461	2.12-65.0- 32	1	P
8-27462-1	2.12-60.0- 11	1	P
8-27463-3	2.12-60.0- 12	1	M1
8-27463-5	2.12-60.0- 13	1	M1
8-27463-801	2.12-60.0- 13	1	P1
8-27464-5	2.12-65.0- 9	1	
8-27464-801	2.12-65.0- 9	1	
8-27464-803	2.12-65.0- 9	RF	M1
8-27464-805	2.12-65.0- 9	1	P
8-27470	2. 3- 3.0- 27	1	U
8-27470-3	2. 3- 3.0- 27	1	U
	2.12-48.0-	RF	
8-27470-5	2. 3- 3.0- 27	1	U
	2.12-48.0-	RF	
8-27484-3	2.12-58.0- 16	1	P1
8-27489-33	2.12-58.0- 5	1	M1
8-27489-5	2.12-58.0- 2	1	P
8-27490-7	2.12-65.0- 6	1	
8-27491-1	2.12-58.0- 8	1	P1
8-27491-3	2.12-58.0- 8	1	M
8-27493-1	2.12-58.0- 21	1	P1
8-27496-1	2.12-58.0- 36	1	
8-27496-5	2.12-58.0- 36	1	P

PART NUMBER	FIGURE AND INDEX NUMBER	QTY PER ART	SMR CODE
8-27529	2.12-55.0- 24	2	P
8-27544	2. 3- 3.0- 63	1	U
	2.10-21.0-	RF	
8-27544-1	2. 3- 3.0- 62	1	A
	2.10-21.0- 14	RF	
8-27544-11	2.10-21.0- 17	1	M
8-27544-12	2.10-21.0- 18	1	M
8-27544-21	2.10-19.0- 1	RF	A
	2.10-21.0- 1	1	
8-27544-7	2.10-21.0- 15	1	M
8-27544-9	2.10-21.0- 16	1	M
8-27545	2. 3- 3.0- 61	1	U
	2.10-27.0-	RF	
8-27545-1	2. 3- 3.0- 60	1	U
	2.10-27.0- 10	RF	
8-27545-11	2.10-27.0- 13	1	M
8-27545-12	2.10-27.0- 14	1	M
8-27545-15	2.10-27.0- 1	1	A
8-27545-7	2.10-27.0- 11	1	M
8-27545-9	2.10-27.0- 12	1	M
8-27547	2.10-24.0- 11	1	P
8-27548-13	2.10-24.0- 7	2	P
8-27549-7	2.10-21.0- 7	RF	P1
8-27551-7	2.10-21.0- 7	1	M
8-27552-21	2.10-23.0- 6	1	M
8-27552-29	2.10-23.0- 16	1	A
8-27552-3	2. 3- 3.0- 57	1	U
	2.10-23.0-	RF	
8-27552-35	2.10-23.0- 13	1	M
8-27552-39	2.10-23.0- 23	1	A
8-27552-7	2.10-23.0- 23	1	A
8-27553-1	2. 3- 3.0- 36	1	U
	2.10-22.0- 44	RF	
8-27553-25	2.10-22.0- 11	1	M
8-27553-29	2.10-22.0- 9	1	M
8-27553-3	2. 3- 3.0- 35	1	U
	2.10-22.0-	RF	
8-27553-33	2.10-22.0- 25	1	M
8-27553-7	2.10-22.0- 25	1	A
8-27554	2. 3-12.0- 14	1	A
8-27554-10	2. 3-12.0- 18	1	P
8-27554-15	2. 3-12.0- 17	1	P
8-27554-7	2. 3-12.0- 15	1	P
8-27554-9	2. 3-12.0- 16	1	P2
8-27555	2.10-21.0- 16	RF	P1
	2.10-27.0- 12	RF	
8-27556	2.10-21.0- 15	RF	P1
	2.10-21.0- 17	RF	
	2.10-21.0- 18	RF	
	2.10-27.0- 11	RF	
	2.10-27.0- 13	RF	
	2.10-27.0- 14	RF	
8-27557-1	2. 3-12.0- 14	1	A
8-27557-15	2. 3-12.0- 17	1	P1
8-27557-17	2. 3-12.0- 18	1	P
8-27557-7	2. 3-12.0- 15	1	P
8-27557-9	2. 3-12.0- 16	1	P
8-27559	2.10-23.0- 1	1	P
8-27559-7	2.10-23.0- 4	1	X1
8-27560-13	2.10-22.0- 4	1	X1
8-27560-15	2.10-22.0- 6	1	X1
8-27560-3	2.10-22.0- 1	1	P
8-27560-5	2.10-22.0- 1	1	P1
8-27560-801	2.10-22.0- 1	1	P1
8-27561-3	2. 1- 1.0- 50	1	U

PART NUMBER	FIGURE AND INDEX NUMBER	QTY PER ART	SMR CODE
8-27561-3	2.10- 1.0- 15	RF	U
8-27564	2.10-24.0- 15	1	P
	2.10-24.0- 21	1	
8-27569	2.10-27.0- 7	2	P
8-27570	2.10- 1.0- 29	2	M
	2.10-26.0- 2	2	
8-27571	2.10-26.0- 5	1	M
8-27571-1	2.10-26.0- 8	1	M
8-27571-3	2.10-26.0- 9	1	M
8-27572-21	2.10-28.0- 2	1	
8-27575	2.12-55.0- 20	1	P
8-27576-45	2.10-28.0- 22	1	
	2.10-31.0- 1	1	
8-27580	2.12-52.0-101	1	P
8-27581	2.12-52.0-102	1	P
8-27582	2.12-52.0- 72	1	P1
8-27583	2.12-52.0- 71	1	P1
8-27586	2.10-22.0- 33	2	P
	2.10-23.0- 29	2	P
8-27587	2.10-22.0- 39	1	P
8-27587-1	2.10-22.0- 39	1	P
	2.10-23.0- 34	1	
8-27588-1	2.10-23.0- 33	1	A
8-27588-11	2.10-23.0- 37	1	M
8-27588-9	2.10-23.0- 38	1	M
8-27589-1	2.10-22.0- 38	1	A
8-27589-13	2.10-22.0- 42	1	M
8-27589-19	2.10-22.0- 43	1	M
8-27589-3	2.10-22.0- 38	1	A
8-27637-13	2.10-16.0- 14	1	P
8-27764	2.10- 7.0- 62	1	P1
8-27768-3	2. 3-14.0- 26	1	U
	2.10-16.0-	RF	
8-27791-1	2. 3- 3.0- 34	1	
8-27791-3	2. 3- 3.0- 34	1	
8-27791-801	2. 3- 3.0- 34	1	
8-27793	2.10-22.0- 15	1	P
8-27794-1	2.10-22.0- 48	1	P
8-27794-11	2.10-22.0- 47	1	P
8-27794-13	2.10-22.0- 53	1	M
8-27794-15	2.10-22.0- 54	1	M
8-27794-17	2.10-22.0- 52	2	M
8-27795-17	2.10- 1.0- 19	1	M
8-27795-29	2.10- 1.0- 21	1	M
8-27795-5	2. 3- 3.0- 65	1	M
	2.10- 1.0- 17	RF	
8-27796-1	2.10-23.0- 44	1	M
8-27797-11	2.10-23.0- 41	1	M
8-27797-3	2.10-23.0- 42	1	A
8-27799-1	2. 3- 3.0- 58	1	
8-27799-3	2. 3- 3.0- 58	1	
8-27981-151	2.10-34.0- 4	RF	P1
	2.10-34.0- 5	RF	
	2.10-34.0- 9	RF	
8-27981-801	2. 3-14.0- 29	1	U
	2.10-34.0-	RF	
8-27981-803	2. 3-14.0- 29	1	U
	2.10-34.0- 6	RF	
8-27984-3	2. 3- 3.0- 78	RF	U
8-27984-5	2. 3- 3.0- 78	RF	BR
8-27984-803	2. 3- 3.0- 78	RF	U
8-27984-807	2. 3- 3.0- 78	RF	U
8-27984-809	2. 3- 3.0- 78	RF	U
8-27984-817	2. 3- 3.0- 78	RF	U
8-27984-821	2. 3- 3.0- 78	RF	U

PART NUMBER	FIGURE AND INDEX NUMBER	QTY PER ART	SMR CODE
8-27984-825	2. 3- 3.0- 78	RF	U
8-27984-827	2. 3- 3.0- 78	RF	U
8-27984-833	2. 3- 3.0- 78	RF	U
8-27985	2.10-40.0- 5	1	P
8-27989	2.10-36.0- 15	1	P
8-27993	2. 3- 3.0- 59	1	U
	2.10-36.0- 8	RF	
8-27994	2.10-36.0- 9	1	P
8-27995	2.10-36.0- 12	1	P
8-27995-7	2.10-36.0- 11	1	P
8-27996	2.10-36.0- 20	1	P
8-27997	2.10-36.0- 19	1	P
8-27998	2.10-36.0- 18	1	P
8-27999-7	2.10-36.0- 13	1	P
8-28000	2. 3-15.0- 17	1	U
	2.10-37.0-	RF	
8-28000-1	2. 3-15.0- 17	1	U
	2.10-37.0-	RF	
8-28000-11	2.10-37.0- 34	2	M
	2.10-38.0- 30	2	
8-28000-15	2.10-37.0- 22	2	M
	2.10-38.0- 18	2	
8-28000-17	2.10-37.0- 21	2	M
	2.10-38.0- 11	2	
8-28000-3	2. 3-15.0- 17	1	U
	2.10-38.0-	RF	
8-28000-7	2.10-37.0- 19	4	M
8-28000-9	2.10-37.0- 28	2	M
	2.10-38.0- 25	2	
8-28002	2.10-37.0- 1	RF	P1
8-28003-7	2.10-37.0- 1	1	P1
8-28004	2.10-37.0- 20	4	M
	2.10-38.0- 12	2	
	2.10-38.0- 19	2	
8-28005	2.10-36.0- 13	RF	P1
	2.10-36.0- 13	1	
8-28006	2.10-36.0- 14	1	P
8-28008-10	2.10-38.0- 1	1	P1
8-28008-9	2.10-38.0- 1	1	P1
8-28009-7	2.10-38.0- 29	4	P
8-28009-9	2.10-38.0- 10	2	P
8-28092-51	2.14- 3.0- 3	1	
8-28092-53	2.14- 3.0- 6	1	
8-28101	2.14- 3.0- 9	2	
8-28200	2.12-49.0- 1	2	U
	2.12-53.0-	RF	
8-28200-29	2.12-53.0- 1	2	M
8-28200-37	2.12-53.0- 9	1	M
8-28200-43	2.12-53.0- 6	2	M
8-28200-47	2.12-53.0- 6	2	M
8-28203	2.12-49.0- 17	1	M
8-28204-1	2.12-49.0- 18	1	P
8-28212	2.12-49.0- 34	3	P
8-28213-7	2.12-52.0-107	1	P
8-28215	2.12-52.0- 56	1	P
8-28218-3	2. 3- 3.0- 47	1	U
	2.12-47.0-	RF	
8-28219	2.12-52.0- 78	1	P
	2.12-52.0- 84	1	P
8-28220	2.12-52.0- 91	2	P
8-28222	2.10-26.0- 10	1	P
8-28236	2.10- 1.0- 31	1	P
8-28236-7	2.10- 1.0- 34	1	X1
8-28236-8	2.10- 1.0- 35	1	X1
8-28237-1	2. 3- 4.0- 34	1	U

PART NUMBER	FIGURE AND INDEX NUMBER	QTY PER ART	SMR CODE
8-28237-1	2.12-38.0-	RF	U
8-28238-5	2.10- 7.0- 28	1	U
8-28238-801	2.10- 6.0- 67	1	U
8-28238-803	2. 3-14.0- 7	1	U
	2.10- 1.0- 51	RF	
8-28243	2. 3-11.0- 18	1	U
	2.10-26.0-	RF	
	2.12-46.0- 34	1	
8-28244	2.10-26.0- 4	1	U
8-28244-11	2.10-26.0- 5	1	M1
8-28245	2. 3-11.0- 19	1	U
	2.10- 1.0- 27	RF	
8-28245-1	2. 3-11.0- 19	1	U
	2.10- 1.0- 27	RF	
8-28246-3	2.10- 1.0- 36	1	P
8-28247	2.10- 1.0- 31	RF	P
8-28247-7	2.10- 1.0- 34	RF	X1
8-28247-8	2.10- 1.0- 35	RF	X1
8-28248	2.10- 1.0- 48	1	U
8-28248-1	2.10- 1.0- 48	1	U
8-28249-11	2.12-35.0- 28	1	M
8-28249-7	2.12-35.0- 31	4	M
	2.12-35.0- 41	1	
	2.12-35.0- 42	1	
8-28249-9	2.12-35.0- 28	1	M
8-28252-17	2. 2-16.0- 15	1	P1
	2. 2-16.0- 23	1	P1
8-28252-7	2. 2-16.0- 25	1	P1
8-28254	2.10-16.0- 13	1	P
	2.10-16.0- 6	1	
	2.10-16.0- 8	1	
8-28261-3	2. 3-15.0- 7	1	U
	2.12-59.0-	RF	
8-28265-7	2.12-38.0- 80	1	M1
8-28266	2. 3-15.0- 4	1	U
	2.12-38.0- 71	RF	
8-28267-1	2. 3- 3.0- 64	1	U
	2.10-19.0-	RF	
8-28267-17	2.10-24.0- 10	1	P
8-28267-5	2.10- 7.0- 87	1	U
	2.10-24.0-	RF	
8-28268-1	2.12-52.0- 8	1	U
8-28268-17	2.12-52.0- 10	1	A
	2.12-52.0- 10	1	
8-28268-21	2.12-52.0- 16	1	M
8-28268-23	2.12-52.0- 10	1	A
8-28268-25	2.12-52.0- 10	1	A
8-28268-27	2.12-52.0- 10	1	A
8-28268-29	2.12-52.0- 10	1	A
8-28268-31	2.12-52.0- 10	1	A
8-28268-7	2.12-52.0- 16	1	M
8-28270-3	2. 3-11.0- 14	1	U
	2. 9- 2.0-	RF	
8-28273-1	2.12-55.0- 14	1	P1
8-28274	2. 3- 3.0- 19	1	U
	2.12-55.0-	RF	
8-28274-1	2. 3- 3.0- 19	1	U
	2.12-55.0-	RF	
8-28275	2.12-38.0- 14	1	M1
8-28275-7	2.12-38.0- 14	1	M
8-28276	2. 3-10.0- 17	1	U
	2.12- 4.0-	RF	
8-28276-1	2. 3-10.0- 17	1	U
	2.12- 4.0-	RF	
8-28277-11	2.12-48.0- 15	2	P1

PART NUMBER	FIGURE AND INDEX NUMBER	QTY PER ART	SMR CODE
8-28277-11	2.12-48.0- 44	3	P1
	2.12-48.0- 5	1	
	2.12-48.0- 50	2	
	2.12-48.0- 6	2	
	2.12-48.0- 61	2	
	2.12-48.0- 7	3	
8-28277-13	2.12-48.0- 6	2	P1
8-28277-7	2.12- 2.0- 20	1	P1
	2.12-14.0- 96	1	
	2.12-27.0- 10	2	
	2.12-27.0- 8	1	
	2.12-30.0- 6	1	
	2.12-31.0- 10	1	
8-28277-9	2.12-14.0- 45	1	P1
	2.12-14.0- 62	3	
	2.12-48.0-25	6	
8-28278	2.12- 4.0- 4	5	P1
8-28278-7	2.12- 4.0- 11	1	P1
8-28279	2. 3-11.0- 7	1	U
8-28279-1	2. 3-11.0- 7	1	U
	2.12-38.0- 21	RF	
8-28280	2. 3-11.0- 4	1	U
8-28281-1	2. 3- 3.0- 22	1	
8-28282	2. 3-11.0- 8	1	U
	2.12-38.0- 12	RF	
8-28282-1	2. 3-11.0- 8	1	
	2.12-38.0- 12	RF	
8-28282-7	2.12-38.0- 13	1	M
8-28282-9	2.12-38.0- 13	1	M
8-28285	2.12-52.0- 64	1	U
8-28285-11	2.12-52.0- 68	1	M
8-28289-1	2. 3-11.0- 9	1	U
	2.12-54.0- 12	RF	
8-28289-11	2.12-54.0- 12	1	M
	2.12-54.0- 23	1	
8-28289-23	2.12-54.0- 13	2	A
	2.12-54.0- 2	2	
8-28289-29	2.12-54.0- 1	2	A
8-28289-3	2. 3-11.0- 9	1	M
	2.12-54.0-	RF	
8-28289-33	2.12-54.0- 12	1	U
8-28290	2. 3-10.0- 36	1	M
	2.12-64.0-	RF	
8-28290-33	2.12-64.0- 29	1	U
8-28291	2. 3-10.0- 14	1	U
	2.12-57.0-	RF	
8-28291-1	2. 3-14.0- 22	1	M
	2.12-57.0- 29	RF	
8-28292-13	2.12-57.0- 20	1	M
	2.12-57.0- 21	1	
	2.12-57.0- 22	1	
	2.12-57.0- 23	1	
8-28292-29	2.12-57.0- 4	1	M
8-28292-45	2.12-57.0- 5	1	M
8-28292-49	2.12-57.0- 33	1	M
8-28293-1	2. 3-15.0- 9	1	U
	2.12-38.0- 94	RF	
8-28293-2	2. 3-15.0- 9	1	U
	2.12-38.0- 94	RF	
8-28293-3	2. 3-15.0- 9	1	U
	2.12-38.0- 94	RF	
8-28294	2.12-58.0- 23	1	
8-28295-1	2.12-58.0- 41	1	P
8-28295-3	2.12-58.0- 26	1	P
8-28298	2.12-58.0- 30	1	P

PART NUMBER	FIGURE AND INDEX NUMBER	QTY PER ART	SMR CODE
8-28309	2.12-48.0- 34	1	P
8-28309-1	2.12-48.0- 65	1	P1
8-28310	2.12-48.0- 36	1	P
8-28310-1	2.12-48.0- 66	1	M1
8-28317	2.12-38.0- 62	2	M
8-28310	2.12-58.0- 27	1	M
	2.12-58.0- 44	1	
8-28320-7	2.12-57.0- 14	1	P1
8-28323	2.12-48.0- 31	2	U
8-28323-15	2.12-38.0- 56	1	M1
8-28323-16	2.12-38.0- 56	1	M1
8-28323-3	2. 3-11.0- 11	1	U
	2.12-38.0- 55	RF	
8-28323-4	2. 3-11.0- 11	1	U
	2.12-38.0- 55	RF	
8-28323-9	2.12-48.0- 33	2	P1
8-28325	2. 9- 2.0- 56	1	P
8-28329	2. 9- 2.0- 30	1	P1
8-28330-5	2. 9- 2.0- 56	1	P
8-28335	2.12- 3.0- 3	1	P
	2.12-37.0- 37	3	
	2.12-37.0- 70	1	
	2.12-37.0-154	1	
	2.12-37.0-173	1	
8-28336-15	2.12-47.0- 15	1	P
8-28336-16	2.12-47.0- 12	1	P
8-28337	2.10-16.0- 12	1	P
8-28339-11	2.12-46.0-121	1	P1
8-28339-19	2.12-46.0- 46	2	M
	2.12-46.0- 46	1	
8-28339-21	2.12-46.0- 72	2	M
	2.12-46.0- 72	1	
8-28339-23	2.12-46.0-121	2	M
	2.12-46.0-121	1	
8-28339-25	2.12-46.0- 96	2	M
	2.12-46.0- 90	1	
8-28339-27	2.12-32.0- 17	2	M
	2.12-32.0- 17	1	
8-28344	2.12-47.0- 5	1	P1
8-28355	2.12-47.0- 18	1	M
8-28359-3	2.12-58.0- 37	1	M1
8-28359-4	2.12-58.0- 38	1	P1
8-28360-807	2. 9- 2.0- 10	1	M
8-28361	2. 2- 7.0- 46	1	M1
8-28362	2. 2- 7.0- 46	1	X1
8-28362-7	2. 2- 7.0- 46	1	X1
8-28363	2.12-55.0- 22	1	P
8-28364	2. 2- 7.0- 47	1	M
8-28367	2. 3- 3.0- 20	1	U
	2.12-39.0- 21	RF	
8-28368	2.12-65.0- 25	1	P
8-28369-7	2.12-51.0- 4	2	M
8-28371	2.12-51.0- 4	2	M
8-28372-1	2. 3-15.0- 10	1	U
	2.12-38.0- 62	RF	
8-28372-13	2.12-38.0- 64	1	M
8-28372-3	2. 3-15.0- 10	1	U
	2.12-38.0- 62	RF	
8-28372-7	2.12-38.0- 64	1	M
8-28375-9	2.12-45.0- 24	1	P1
8-28376	2. 3-15.0- 11	1	U
	2.12-38.0- 64	RF	
8-28377	2. 3-11.0- 6	1	U
	2.12-38.0- 32	RF	
8-28377-11	2.12-32.0- 35	1	M

PART NUMBER	FIGURE AND INDEX NUMBER	QTY PER ART	SMR CODE
8-28380	2. 3-10.0- 13	1	U
	2.12-38.0- 56	RF	
8-28380-1	2. 3-10.0- 13	1	U
	2.12-38.0- 56	RF	
8-28381	2.12-52.0- 94	1	P1
8-28381-11	2.12-52.0- 99	1	M
8-28381-13	2.12-52.0- 97	1	M
8-28381-7	2.12-52.0-100	1	M
8-28381-9	2.12-52.0- 9A	1	M
8-28386	2.12-52.0- 16	1	U
8-28386-3	2.12-52.0- 19	2	U
8-28388-11	2.12-37.0- 85	1	
	2.12-37.0-211	1	
8-28388-13	2.12-45.0- 86	1	M1
8-28388-15	2.12-44.0- 55	1	P1
	2.12-45.0- 24	1	
8-28388-7	2. 9- 2.0- 23	1	P1
	2.12-44.0-180	1	P1
8-28388-9	2.12-32.0- 64	1	P1
	2.12-38.0- 86	1	
	2.12-62.0- 18	1	
8-28390	2.12- 1.0-109	1	M1
8-28392	2. 9- 2.0- 25	1	P1
8-28395	2.10- 1.0- 47	1	P
8-28396	2.10- 1.0- 43	4	M
8-28398	2.10-22.0- 5	1	M
8-28398-7	2.10-22.0- 5	1	M
8-28403	2. 3-14.0- 1	RF	
8-28406	2.12-52.0-	1	U
8-28406-17	2.12-52.0- 8	1	M
8-28406-19	2.12-52.0- 1	1	A
8-28406-21	2.12-52.0- 7	1	M
8-28407	2.12-52.0- 23	1	U
8-28407-21	2.12-52.0- 23	1	A
8-28407-25	2.12-52.0- 32	1	M
8-28407-26	2.12-52.0- 33	1	M
8-28407-29	2.12-52.0- 23	1	A
8-28407-31	2.12-52.0- 23	1	A
8-28407-7	2.12-52.0- 31	1	M
8-28408	2.12-52.0- 36	1	U
8-28408-15	2.12-52.0- 36	1	A
8-28408-17	2.12-52.0- 36	1	A
8-28408-19	2.12-52.0- 36	1	A
8-28408-7	2.12-52.0- 45	1	M
8-28409	2. 3-15.0- 2	1	U
	2.12-40.0-	RF	
8-28409-1	2. 3-15.0- 2	1	U
	2.12-40.0-	RF	
8-28409-15	2.12-40.0- 23	1	M1
8-28409-19	2.12-40.0- 24	1	M1
8-28409-3	2. 3-15.0- 2	1	U
	2.12-40.0-	RF	
8-28409-5	2. 3-15.0- 2	1	U
	2.12-40.0-	RF	
8-28410-1	2. 6-32.0- 41	1	U
	2.12-41.0-	RF	
8-28410-2	2. 6-32.0- 41	1	U
	2.12-41.0-	RF	
8-28410-7	2.12-41.0- 10	1	M
8-28410-8	2.12-41.0- 10	1	M
8-28411	2. 3-11.0- 2	1	U
	2.12-42.0-	RF	
8-28411-1	2. 3-11.0- 2	1	U
	2.12-42.0-	RF	
8-28411-3	2. 3-11.0- 2	1	U

PART NUMBER	FIGURE AND INDEX NUMBER	QTY PER ART	SMR CODE
8-28411-3	2.12-42.0-	RF	U
8-28413	2. 3-14.0- 1	RF	
8-28414	2. 3-10.0- 28	1	U
	2.12-39.0- 50	RF	
8-28415-7	2.12-40.0- 10	2	P
	2.12-40.0- 5	7	
	2.12-41.0- 1	2	
	2.12-42.0- 10	9	
	2.12-42.0- 22	3	
8-28415-9	2.12-40.0- 14	1	P
	2.12-40.0- 22	2	
	2.12-41.0- 6	2	
	2.12-42.0- 17	1	
	2.12-42.0- 4	1	
8-28419	2. 3-11.0- 17	1	U
	2.12-38.0- 59	RF	
8-28419-1	2. 3-12.0- 27	1	
	2.12-38.0- 61	RF	U
8-28419-2	2. 3-12.0- 27	1	U
	2.12-38.0- 61	RF	
8-28434	2. 3-15.0- 3	1	
8-28439	2.12-52.0- 85	2	P1
8-28440-21	2. 3-10.0- 45	1	P
8-28440-23	2. 3-10.0- 46	1	P
8-28440-25	2. 3-10.0- 47	1	P
8-28440-31	2. 3-10.0- 48	RF	P
8-28440-35	2. 3-10.0- 48	1	P
8-28442-7	2. 2- 9.0- 5	1	P
8-28443-7	2. 2- 9.0- 10	1	P
	2.10-25.0- 17	1	
8-28452	2.10-25.0- 14	1	P
8-28456	2.12-60.0- 4	1	P1
8-28457-801	2.12-65.0- 12	1	M
8-28460	2. 3-11.0- 4	1	
	2.12-38.0- 16	RF	M
8-28460-7	2.12-38.0- 21	1	U
8-28461	2. 3- 3.0- 22	1	
	2.12-38.0- 39	RF	A
8-28461-7	2.12-38.0- 45	2	U
8-28462-1	2. 3-11.0- 5	1	
	2.12-38.0- 47	RF	M
8-28462-7	2.12-38.0- 55	1	M1
8-28463-7	2.12-38.0- 52	1	P1
8-28465-1	2.12-48.0- 19	1	M1
8-28466-3	2.12-48.0- 19	1	
	2.12-48.0- 45	1	M
8-28468	2.12-38.0- 17	1	
	2.12-38.0- 22	1	
	2.12-39.0- 25	1	
	2.12-38.0- 40	2	
	2.12-38.0- 48	1	
8-28469	2.12- 4.0- 11	1	P1
	2.12- 4.0- 4	5	
8-28486-1	2.12-65.0- 32	1	M1
8-28486-3	2.12-65.0- 32	1	P
8-28488-1	2.12-52.0- 62	1	P
8-28491-1	2.12-48.0- 20	1	M1
	2.12-48.0- 46	1	
8-28491-3	2.12-48.0- 45	1	M1
8-28492-1	2.12-44.0-190	1	P
	2.12-47.0- 17	1	
8-28502	2.12-52.0-126	1	U
8-28503	2.12-52.0-130	1	M
8-28506-3	2.12-52.0-110	1	M1
8-28508-1	2.12-52.0-115	1	M1

PART NUMBER	FIGURE AND INDEX NUMBER	QTY PER ART	SMR CODE
8-28509-1	2.12-52.0-117	1	P
8-28510	2.12-52.0-101	1	P1
8-28515-11	2.12-48.0- 18	2	M1
	2.12-48.0- 4	1	
8-28515-7	2.12-48.0- 18	2	P1
8-28515-9	2.12-48.0- 14	2	M1
8-28521	2.12-52.0-114	1	M1
8-28522	2.12-41.0- 4	4	
8-28522-7	2.12-40.0- 12	1	P
	2.12-40.0- 20	2	
	2.12-40.0- 3	7	
	2.12-40.0- 8	2	
	2.12-42.0- 11	9	
	2.12-42.0- 16	1	
	2.12-42.0- 23	3	
	2.12-42.0- 5	1	
8-28930	2. 3- 3.0- 75	1	U
	2.10-30.0-	RF	
8-28931	2.10-25.0- 46	2	U
8-28932-7	2.10-25.0- 33	1	P
8-28933	2.10-25.0- 2	2	
8-28934-1	2.10-30.0- 19	1	A
8-28935-7	2.10-30.0- 35	RF	P
8-28935-9	2.10-30.0- 35	RF	P
8-28936	2.10-30.0- 1	RF	P1
8-28936-7	2.10-30.0- 8	RF	X1
8-28938-7	2.10-30.0- 33	RF	P
8-28938-9	2.10-30.0- 33	RF	P
8-28939-7	2.10-30.0- 29	1	P
8-28940-10	2.10-30.0- 13	1	P
8-28940-9	2.10-30.0- 9	1	P
8-28941	2.10-30.0- 5	2	P
8-28944	2.10-30.0- 1	1	P1
8-28944-9	2.10-30.0- 8	1	X1
8-28945	2.10-30.0- 35	1	P1
8-28945-9	2.10-30.0- 35	1	P1
8-28946	2.10-30.0- 33	1	P1
8-28946-9	2.10-30.0- 33	1	P1
8-28951-13	2.10-16.0- 1	RF	P
	2.10-16.0- 7	RF	
8-28954-7	2.10-16.0- 3	1	P1
8-28954-9	2.10-16.0- 1	1	P1
	2.10-16.0- 7	2	
8-28963	2. 3-14.0- 29	1	U
	2.10-35.0-	RF	
8-28964-167	2. 8-18.0- 45	1	U
8-28964-171	2. 8-18.0- 88	1	U
8-3100	2.20-48.0- 62	1	U
8-31000	2.18-27.0- 4	1	
8-31883-7	2.17-21.0- 63	1	M
8-31883-9	2.17-21.0- 76	1	M
8-31898-1	2.18-20.0- 22	1	
8-32013-13	2.18-33.0- 17	1	
8-32827-11	2.17-29.0- 60	1	M1
8-32827-7	2.17-29.0- 49	1	M1
8-32827-9	2.17-29.0- 30	1	M
8-32852-1	2.18-20.0- 22	1	
8-32852-11	2.18-20.0- 28	1	
8-32852-7	2.18-20.0- 26	1	
8-32855-1	2. 1- 1.0- 39	1	
	2.17- 9.0-	RF	
	2.17- 9.0-	RF	
	2.17- 9.0-	RF	
8-32855-19	2.17- 9.0- 14	1	
8-32855-3	2. 1- 1.0- 39	1	

PART NUMBER	FIGURE AND INDEX NUMBER	QTY PER ART	SMR CODE
8-32855-3	2.17- 9.0- 14	RF	
8-32855-5	2. 1- 1.0- 39	1	
8-32920-1	2.18- 7.0- 3	1	
8-32930-1	2.17-38.0-	1	
8-32931-1	2. 8- 1.0- 14	1	
8-32932-3	2.17-37.0-	1	
8-32933-17	2.17-38.0- 19	1	
8-32933-21	2.17-38.0- 16	1	
8-32933-3	2.17-38.0- 12	1	
8-32934-13	2.17-38.0- 3	1	X1
8-32934-5	2.17-38.0-	1	M
8-32934-801	2.17-38.0- 11	1	M
8-32934-803	2.17-38.0- 3	1	M
8-33476	2.18- 1.0- 12	1	P1
8-33476-11	2.18- 1.0- 16	1	X1
8-34829	2.20-34.0- 16	1	A
8-34863	2.18-20.0- 16	1	A
8-34876-805	2.20-34.0-	1	A
8-34876-809	2.20-34.0-	1	A
8-34876-811	2.20-34.0-	1	A
8-34876-813	2.20-34.0-	1	A
8-35152	2.19- 2.0- 12	RF	
8-35152-17	2.18-26.0- 9	1	A
8-35152-21	2.18-26.0- 15	1	A
8-36069-45	2. 3- 2.0- 13	1	M1
8-36069-49	2. 3- 2.0- 12	2	M1
8-36069-51	2. 3- 2.0- 11	2	M1
8-36069-53	2. 3- 2.0- 31	1	P2
8-36069-55	2. 3- 2.0- 15	1	M1
8-36069-56	2. 3- 2.0- 16	1	M1
8-36069-57	2. 3- 2.0- 9	1	M1
8-36069-58	2. 3- 2.0- 10	1	M1
8-36206-1	2. 3- 4.0- 26	1	U
	2.18-15.0-	RF	
8-36206-101	2.18-15.0- 27	1	M
8-36206-103	2.18-15.0- 36	1	M
8-36206-105	2.18-15.0- 37	1	M
8-36206-107	2.18-15.0- 51	1	M
8-36206-109	2.18-15.0- 48	1	M
8-36206-11	2.18-15.0- 9	1	M
8-36206-111	2.18-15.0- 43	1	M
8-36206-113	2.18-15.0- 47	1	M
8-36206-115	2.18-15.0- 50	1	M
8-36206-117	2.18-15.0- 54	1	M
8-36206-121	2.18-15.0- 4	RF	A
8-36206-13	2.18-15.0- 10	1	
8-36206-133	2.18-15.0- 30	1	
8-36206-135	2.18-15.0- 29	1	
8-36206-137	2.18-15.0- 36	1	
8-36206-139	2.18-15.0- 37	1	
8-36206-141	2.18-15.0- 51	1	
8-36206-143	2.18-15.0- 48	1	
8-36206-145	2.18-15.0- 43	1	
8-36206-147	2.18-15.0- 47	1	
8-36206-149	2.18-15.0- 50	1	
8-36206-15	2.18-15.0- 13	1	
8-36206-151	2.18-15.0- 54	1	
8-36206-153	2.18-15.0- 16	1	
8-36206-155	2.18-15.0- 18	1	
8-36206-157	2.18-15.0- 19	1	
8-36206-159	2.18-15.0- 20	1	
8-36206-161	2.18-15.0- 21	1	
8-36206-163	2.18-15.0- 22	1	
8-36206-165	2.18-15.0- 9	1	M
8-36206-167	2.18-15.0- 10	1	M

PART NUMBER	FIGURE AND INDEX NUMBER	QTY PER ART	SMR CODE	PART NUMBER	FIGURE AND INDEX NUMBER	QTY PER ART	SMR CODE
8-36206-169	2.18-15.0- 13	1	M	8-36401-29	2. 2-12.0- 9	4	U
8-36206-171	2.18-15.0- 36	1	M	8-36404	2.18-30.0- 9	1	U
8-36206-173	2.18-15.0- 16	1	M	8-36404-1	2.18-30.0-	1	U
8-36206-175	2.18-15.0- 18	1	M	8-36404-11	2.17-43.0- 4	1	M
8-36206-177	2.18-15.0- 41	1	M		2.18-30.0- 9	1	M
8-36206-179	2.18-15.0- 38	1	M	8-36404-13	2.18-30.0- 10	1	M
8-36206-181	2.18-15.0- 39	1	M	8-36404-7	2.18-30.0- 4	1	A
8-36206-183	2.18-15.0- 51	1	M	8-36404-9	2.18-30.0- 8	1	M
8-36206-185	2.18-15.0- 41	1	M	8-36404-95	2.17-43.0- 3	1	U
8-36206-3	2. 3- 4.0- 26	1	U	8-36408-1	2.18-20.0- 4	1	U
	2.18-15.0-	RF		8-36409-1	2.14- 6.0- 20	1	U
8-36206-57	2.18-15.0- 19	1	M	8-36409-3	2.14- 6.0- 21	1	U
8-36206-59	2.18-15.0- 23	1	M	8-36420	2.18- 5.0- 10	1	M
8-36206-61	2.18-15.0- 20	1	M	8-36421	2.18- 5.0-	1	U
8-36206-63	2.18-15.0- 24	1	M	8-36421-29	2.18- 5.0- 9	1	X2
8-36206-79	2.18-15.0- 21	1	M	8-36421-31	2.18- 5.0- 9	1	X2
8-36206-81	2.18-15.0- 22	1	M	8-36421-35	2.18- 5.0- 2	1	A
8-36206-85	2.18-15.0- 16	1	M	8-36421-37	2.18- 5.0- 2	1	A
8-36206-87	2.18-15.0- 18	1	M	8-36431-3	2.18-20.0- 33	1	U
8-36206-95	2.18-15.0- 30	1	M	8-36573-19	2.14-6.0- 16	1	
8-36206-97	2.18-15.0- 29	1	M	8-36623-7	2. 3- 1.0- 31	1	P
8-36206-99	2.18-15.0- 26	1	M	8-36634	2. 3- 1.0- 25	1	A
8-36211	2.18- 9.0-	1	U	8-36673	2.18- 9.0- 2	1	P
8-36211-5	2.18- 9.0- 3	1	U	8-36674	2.18- 9.0- 3	1	P
8-36217-7	2.18- 7.0- 16	2	M	8-36675	2.18- 9.0-	1	A
8-36217-9	2.18- 7.0- 13	2	X1	8-36686-3	2.18- 7.0- 14	2	P
8-36222	2.18- 6.0- 3	1	U	8-36687-3	2.18- 7.0- 17	2	P
8-36227	2.18- 6.0- 36	1	U	8-36687-4	2.18- 7.0- 18	1	P
8-36228	2. 3- 1.0- 32	1		8-36689-1	2.18- 7.0- 23	1	P
	2.18- 7.0-	RF		8-36691	2.18- 6.0- 6	1	M1
8-36229	2.18- 6.0- 38	1	U	8-36710-3	2.18- 7.0- 9	1	P
8-36247	2.18-21.0-	1	U	8-36710-4	2.18- 7.0- 9	1	P
8-36248	2.18-23.0-	1	U	8-36711	2.18- 7.0- 24	1	P1
8-36249-3	2.18-33.0- 10	1	U	8-36712	2.18- 7.0- 19	1	A1
8-36249-5	2.18-33.0- 10	1	U	8-36713	2.18- 6.0- 35	1	X1
8-36249-801	2.18-33.0- 10	1	U	8-36714	2. 3- 2.0- 6	1	P
8-36249-803	2.18-33.0- 10	1	U		2.18- 6.0- 34	RF	
8-36262-1	2.18-14.0- 5	1	U	8-36722-7	2.20-47.0- 29	2	M1
8-36283-17	2.18-26.0- 9	1	U	8-36722-9	2.20-47.0- 28	4	M
8-36283-21	2.18-26.0- 15	1		8-36733	2. 3- 2.0- 2	1	PD
8-36284	2.18- 6.0- 19		U	8-36739-1	2.18-33.0- 5	1	A
8-36286-5	2.18-16.0-	RF	U	8-36740-1	2.18-33.0- 5	1	A
8-36287-1	2.18-27.0- 2	RF		8-36741	2.18-33.0- 2	1	U
8-36292-1	2.18-14.0-	1	U	8-36741-1	2.18-33.0- 2	1	U
8-36301-1	2.14- 6.0- 19	1	U	8-36743-1	2.18-33.0- 5	1	U
8-36301-805	2.14- 6.0- 19	1	U	8-36746-7	2.20-23.0- 5	1	A
8-36330	2. 3- 1.0- 33	1		8-36750	2. 3- 2.0- 4	7	P1
	2. 3- 2.0-	RF		8-36762	2.18-29.0- 11	1	P1
8-36330-1	2. 3- 1.0- 33	1	P1	8-36763	2.18-29.0- 3	1	P
	2. 3- 2.0-	RF		8-36763-11	2.18-29.0- 8	1	X1
8-36330-13	2. 3- 2.0- 14	6	M	8-36763-15	2.18-29.0- 10	1	X1
8-36330-7	2. 3- 2.0- 48	1	X1	8-36763-7	2.18-29.0- 9	1	M
8-36330-9	2. 3- 2.0- 23	1	P2				
8-36357-1	2.18-10.0- 7	1	U				
8-36382-1	2.18-20.0- 4	1	U	8-36767	2.18- 1.0- 10	2	M
8-36384	2.18-29.0- 2	1	U	8-36768-11	2.18-33.0- 8	1	M1
8-36394-1	2.18-29.0-	1	U	8-36768-12	2.18-33.0- 8	1	M1
8-36386-1	2.18-14.0- 2	1	U	8-36770	2.18-33.0- 7	1	U
8-36392-1	2.18-20.0- 31	1	U	8-37475	2. 3- 2.0- 3	12	P1
8-36398-1	2.18-27.0-	1	U		2.18- 6.0- 36	1	
8-36401-27	2. 2-12.0- 12	1	U	8-38047-825	2.16- 1.0-	1	A
				8-38049	2. 5- 1.0- 20	RF	
				8-38049-3	2. 5- 1.0- 20	RF	

PART NUMBER	FIGURE AND INDEX NUMBER	QTY PER ART	SMR CODE
8-38056-5	2.16- 7.0-	RF	U
8-38056-6	2. 3- 8.0- 12	1	U
	2.16- 7.0-	RF	
8-38056-7	2.16- 6.0- 1	2	A
8-38056-801	2. 3- 4.0- 64	1	U
	2.16- 5.0-	RF	U
8-38056-813	2. 1- 1.0- 59	1	U
8-38056-815	2. 1- 1.0- 59	1	U
8-38056-817	2. 1- 1.0- 59	1	U
	2.16- 1.0-	RF	
8-38057-3	2. 3- 4.0- 59	1	U
	2.17-11.0-	RF	
8-38058-13	2.18-31.0- 3	1	Pf
8-38058-7	2.18-31.0- 1	1	P
	2.20-44.0- 1	RF	
8-38058-801	2. 3- 4.0- 59	1	U
	2.18-31.0-	RF	
8-38070-1	2. 1- 1.0- 45	1	U
	2.14- 6.0- 6	RF	
8-38070-11	2.14- 5.0- 16	1	M
8-38070-3	2. 1- 1.0- 45	1	U
	2.14- 6.0- 6	RF	
8-38079-9	2.10-20.0- 7	RF	P1
8-38080	2.10-20.0- 1	1	P
	2.11-12.0- 5	2	
8-38081-1	2. 3- 4.0- 52	1	U
	2.14- 5.0-	RF	
8-38082-7	2.11-12.0- 7	2	P1
8-38082-9	2.10-20.0- 7	1	
8-38084-3	2. 3- 4.0- 31	1	U
	2.10-20.0-	RF	
8-38085-11	2. 2-10.0- 51	1	X1
8-38085-3	2. 2-10.0- 49	1	P1
8-38085-9	2. 2-10.0- 51	RF	X
8-38092-1	2. 3- 1.0- 1	1	U
	2.14- 3.0-	RF	
8-38092-103	2.14- 4.0- 55	1	M
8-38092-109	2.14- 4.0- 66	1	M
8-38092-11	2.14- 4.0- 36	1	M
8-38092-113	2.14- 4.0- 65	1	M
8-38092-117	2.14- 3.0- 19	1	
8-38092-119	2.14- 3.0- 16	1	
8-38092-121	2.14- 3.0- 3	1	
8-38092-123	2.14- 3.0- 6	1	M
8-38092-125	2.14- 4.0- 83	1	M
8-38092-129	2.14- 4.0- 11	1	M
8-38092-131	2.14- 4.0- 87	1	M
8-38092-133	2.14- 4.0- 89	1	M
8-38092-135	2.14- 4.0- 96	1	M
8-38092-137	2.14- 4.0- 91	1	M
8-38092-139	2.14- 4.0- 93	1	M
8-38092-141	2.14- 4.0- 95	1	M
8-38092-143	2.14- 4.0- 94	1	M
8-38092-145	2.14- 4.0- 98	1	M
8-38092-147	2.14- 4.0-102	1	M
8-38092-151	2.14- 4.0-100	1	M
8-38092-153	2.14- 4.0-106	1	M
8-38092-161	2.14- 4.0- 57	1	M
8-38092-165	2.14- 4.0- 54	1	M
8-38092-23	2.14- 4.0- 79	1	M
8-38092-25	2.14- 4.0- 6	1	M
8-38092-27	2.14- 4.0- 8	1	M
8-38092-29	2.14- 4.0- 12	1	M
8-38092-3	2. 3- 1.0- 9	1	M
8-38092-31	2.14- 4.0- 9	1	M

PART NUMBER	FIGURE AND INDEX NUMBER	QTY PER ART	SMR CODE
8-38092-33	2.14- 4.0- 11	1	M
8-38092-39	2.14- 4.0- 38	1	M
8-38092-41	2.14- 4.0- 35	1	M
8-38092-47	2.14- 3.0- 19	1	M
8-38092-49	2.14- 3.0- 17	1	M
8-38092-5	2. 3- 4.0- 46	1	U
	2.14- 4.0-	RF	
8-38092-55	2. 3- 1.0- 11	1	M
8-38092-57	2. 3- 1.0- 10	1	M
8-38092-77	2.14- 4.0- 33	1	M
8-38092-83	2.14- 4.0- 81	1	M
8-38092-87	2.14- 4.0- 86	1	M
8-38094	2. 3- 2.0- 31	1	M
8-38097-1	2. 3-10.0- 23	1	M
	2.10-20.0- 21	RF	M
8-38097-13	2.10-20.0- 22	1	M
8-38097-15	2.10-20.0- 24	1	M
8-38097-17	2.10-20.0- 37	1	M
8-38097-3	2. 3-14.0- 25	1	M
8-38097-31	2.10-20.0- 42	1	M
8-38097-33	2.10-20.0- 40	1	M
8-38097-35	2.10-20.0- 28	1	M
8-38097-37	2.10-20.0- 20	1	M
8-38097-39	2.10-20.0- 18	1	M
8-38097-43	2.10-20.0- 26	1	M
8-38097-45	2.10-20.0- 27	1	M
8-38097-51	2.10-20.0- 43	1	M
8-38097-53	2.10-20.0- 46	1	M
8-38097-59	2.10-20.0- 11	1	M
8-38097-61	2.10-20.0- 15	1	M
8-38097-65	2.10-20.0- 13	1	M
8-38097-69	2.10-20.0- 22	1	M
8-38097-71	2.10-20.0- 20	1	M
8-38097-801	2.10- 7.0- 47	1	M
	2.10-20.0- 38	RF	
8-38097-805	2. 3- 4.0- 30	1	M
	2.10-20.0- 8	RF	
8-38097-807	2.10- 7.0- 47	1	M
	2.10-20.0- 38	RF	
8-38101	2.14- 4.0- 5	1	P
8-38105	2. 3- 2.0- 32	1	M
8-38108-809	2.16- 2.0- 1	10	A
8-38109	2. 1- 1.0- 59	1	U
8-38109-1	2. 1- 1.0- 59	1	U
8-38497	2.16- 1.0- 9	1	P1
	2.16- 2.0- 10	1	
8-38565-7	2.16- 5.0- 5	1	P
8-38579	2.14- 1.0- 3	1	
8-38581-7	2. 5- 1.0- 23	1	M1
8-38591	2. 3- 1.0- 5	3	P
8-38591-7	2. 3- 1.0- 6	2	X1
8-38591-9	2. 3- 1.0- 9	2	X1
8-38596-11	2. 3- 1.0- 23	1	P
8-38596-13	2. 3- 1.0- 24	1	X1
8-38596-3	2. 3- 1.0- 28	1	P1
8-38605-23	2.16- 1.0- 8	1	M1
8-38617-9	2.16- 6.0- 10	1	P
8-38611-1	2.16- 6.0- 3	1	P
8-38611-9	2.16- 6.0- 7	1	X1
8-38612-203	2.16- 1.0- 90	1	X2
8-38612-205	2.16- 1.0- 96	1	X2
8-38627-11	2.16- 1.0- 44	1	M
8-38635-10	2.16- 7.0- 7	1	P1
8-38635-9	2.16- 7.0- 7	1	P1
8-38637-11	2.16- 5.0- 57	2	X2

PART NUMBER	FIGURE AND INDEX NUMBER	QTY PER ART	SMR CODE
8-38637-15	2.16-5.0-36	1	X1
8-38637-17	2.16-5.0-58	1	X2
8-38637-7	2.16-5.0-54	1	X2
8-38637-d	2.16-5.0-59	1	X2
8-38637-9	2.16-5.0-52	1	X2
8-38638-1	2.16-5.0-28	1	X2
8-38638-3	2.16-5.0-28	1	X2
8-38640-7	2.16-5.0-2	1	X1
8-38640-9	2.16-5.0-12	1	X2
8-38641	2.16-5.0-17	1	X1
8-38642-1	2.16-5.0-36	1	X2
8-38642-10	2.16-5.0-39	1	X1
8-38642-2	2.16-5.0-36	1	X2
8-38642-9	2.16-5.0-38	1	X1
8-38643-815	2.16-5.0-3	1	X2
8-38644	2.16-5.0-1	3	P1
8-38644-1	2.16-5.0-11	1	P1
8-38645	2.16-5.0-13	1	P
	2.16-5.0-3	1	
8-38646-9	2.16-5.0-15	1	X1
8-38647-7	2.16-5.0-59	3	X1
8-38647-9	2.16-5.0-16	1	X1
8-38648	2.16-5.0-26	1	X2
8-38649-7	2.16-5.0-21	3	P
8-38649-9	2.16-5.0-37	1	M
8-38650-7	2.16-5.0-32	1	X2
8-38651-7	2.16-5.0-7	2	P
8-39379-1	2.14-14.0-5	1	
8-40103-9	2.14-30.0-8	1	
8-40106	2.14-26.0-14	4	P
	2.14-27.0-16	2	
	2.14-41.0-33	1	
8-40106-11	2.14-41.0-17	1	P
	2.14-41.0-34	1	
8-40106-13	2.14-30.0-7	1	P
8-40106-7	2.14-23.0-33	1	P
	2.14-23.0-93	1	
8-40204-23	2.14-30.0-25	1	M1
8-40204-3	2.3-3.0-3	RF	U
	2.3-3.0-3	1	
	2.14-30.0-	RF	
8-40204-801	2.3-3.0-3	RF	U
	2.3-3.0-3	1	
	2.14-30.0-	RF	
8-40204-805	2.3-3.0-3	RF	U
	2.3-3.0-3	1	
	2.14-30.0-	RF	
8-40504	2.3-3.0-17	1	U
	2.14-15.0-	RF	
8-40504-801	2.3-3.0-17	1	U
8-41101	2.3-3.0-17	1	
	2.14-15.0-	RF	
8-42100-21	2.14-15.0-35	1	X1
8-42100-23	2.14-15.0-25	1	X1
8-42100-29	2.14-25.0-9	1	X1
8-42100-31	2.14-23.0-13	1	X1
8-42100-41	2.14-41.0-14	1	X1
8-42100-49	2.14-15.0-72	1	X1
8-42100-51	2.14-15.0-74	1	X1
8-42100-53	2.14-15.0-49	1	X1
8-42100-55	2.14-15.0-85	1	X1
8-42100-59	2.14-15.0-42	1	X1
8-42100-609	2.14-15.0-40	1	P
8-42100-63	2.14-15.0-106	1	X1
8-42100-65	2.14-15.0-96	1	X1

PART NUMBER	FIGURE AND INDEX NUMBER	QTY PER ART	SMR CODE
8-42100-67	2.14-15.0-16	1	X1
8-42100-69	2.14-15.0-15	1	X1
8-42100-71	2.14-23.0-21	1	X1
8-42100-77	2.14-26.0-6	1	X1
8-42100-79	2.14-30.0-20	1	X1
8-42100-81	2.14-30.0-21	1	X1
8-42100-843	2.14-15.0-81	1	P
8-42100-855	2.14-26.0-1	1	U
8-42100-855	2.14-30.0-9	1	P
8-42101-19	2.14-33.0-12	1	P
8-42101-21	2.14-36.0-7	1	P
8-42101-23	2.14-23.0-39	1	P
8-42101-25	2.14-23.0-28	1	P
8-42101-27	2.14-23.0-127	1	P
8-42101-29	2.14-36.0-7	1	P
8-42103-1	2.3-14.0-30	1	U
	2.14-39.0-	RF	
8-42103-103	2.14-37.0-5	1	M
8-42103-105	2.14-37.0-7	1	M
8-42103-107	2.14-37.0-53	1	M
8-42103-109	2.14-37.0-55	1	M
8-42103-111	2.14-39.0-7	1	M
8-42103-121	2.14-37.0-69	1	M
8-42103-123	2.14-37.0-28	1	M
8-42103-125	2.14-37.0-30	1	M
8-42103-13	2.14-39.0-9	1	M
8-42103-15	2.14-39.0-11	1	M
8-42103-17	2.14-39.0-13	1	M
8-42103-21	2.14-35.0-45	1	M
8-42103-25	2.14-35.0-43	1	M
8-42103-27	2.14-35.0-7	1	M
8-42103-43	2.14-35.0-48	1	M
	2.14-37.0-63	1	
8-42103-45	2.14-35.0-44	1	M
8-42103-47	2.14-37.0-12	1	M
8-42103-49	2.14-37.0-10	1	M
8-42103-5	2.3-14.0-30	1	U
	2.14-35.0-	RF	
8-42103-59	2.14-35.0-10	1	M
8-42103-61	2.14-35.0-12	1	M
8-42103-63	2.14-35.0-16	1	M
	2.14-37.0-19	1	
8-42103-65	2.14-35.0-14	1	M
	2.14-37.0-17	1	
8-42103-67	2.14-35.0-3	1	M
	2.14-37.0-3	1	
8-42103-7	2.14-39.0-2	1	M
8-42103-75	2.14-35.0-40	1	M
	2.14-37.0-46	1	
8-42103-79	2.14-35.0-31	1	M
	2.14-37.0-35	1	
8-42103-801	2.3-14.0-30	1	U
	2.14-37.0-	RF	
8-42103-803	2.3-14.0-30	1	M
	2.14-37.0-	RF	
8-42103-81	2.14-35.0-24	1	M
	2.14-37.0-21	1	
8-42103-83	2.14-35.0-30	1	M
	2.14-37.0-27	1	
8-42103-85	2.14-35.0-33	1	M
	2.14-37.0-37	1	
8-42103-87	2.14-35.0-41	1	M
8-42103-89	2.14-37.0-68	1	M
8-42103-9	2.14-39.0-5	1	M
8-42103-91	2.14-37.0-58	1	M

PART NUMBER	FIGURE AND INDEX NUMBER	QTY PER ART	SMR CODE
8-42509-7	2.14-23.0- 43	1	M
	2.14-23.0- 98	1	
8-42510	2.14-14.0- 7	3	P1
	2.14-17.0- 4	3	
8-42511-1	2.14-14.0- 3	8	P1
	2.14-14.0- 4	6	
	2.14-14.0- 5	1	
	2.14-17.0- 2	1	
8-42511-3	2.14-14.0- 5	1	P1
	2.14-17.0- 2	1	
8-42512	2.14-14.0- 9	3	P
	2.14-17.0- 6	3	
8-42513	2.14-25.0- 19	1	P
8-42515	2.14-17.0- 25	1	P
8-42516	2.14-17.0- 16	1	P1
8-42516-701	2.14-17.0- 16	RF	X1
8-42517	2.14-17.0- 15	1	M
8-42518	2.14-17.0- 11	1	P
8-42520-11	2.14-20.0- 7	1	A
8-42520-19	2.14-20.0- 43	1	A
8-42520-21	2.14-20.0- 7	1	A
8-42520-23	2.14-20.0- 43	1	A
8-42520-5	2. 3-10.0- 26	1	U
	2.14-20.0-	RF	
8-42521	2.14-15.0- 22	1	P
	2.14-15.0-103	1	
	2.14-15.0-111	1	
8-42521-7	2.14-15.0-111	1	P
8-42524	2.14- 9.0- 83	1	P1
8-42525	2. 3- 3.0- 83	1	U
	2.14-18.0-	RF	
8-42525-9	2.14-18.0- 13	1	M
8-42527-1	2.14-20.0- 74	1	P1
8-42528-1	2.14-20.0- 31	2	P
8-42529-7	2.14-20.0- 78	1	X1
8-42529-9	2.14-20.0- 38	1	M
8-42530-7	2.14-20.0- 73	1	X1
8-42530-9	2.14-20.0- 30	1	X1
8-42534-11	2.14-22.0- 8	1	P
8-42535	2.14-23.0- 25	1	P
8-42536	2.14-18.0- 9	1	P
8-42539	2.14-18.0- 10	1	M
8-42540	2.14-18.0- 1	1	P
8-42540-7	2.14-18.0- 6	1	X1
8-42541-11	2. 3- 3.0- 77	1	P
8-42541-7	2.15-30.0- 13	1	P
8-42542	2.14-18.0- 22	2	P
8-42547-7	2.14-15.0-117	1	X1
8-42548	2.14-15.0-121	1	X1
8-42548-7	2.14-15.0-122	1	X1
8-42549	2.14-15.0-123	1	X1
8-42550	2.14-15.0-119	1	X1
8-42551	2.14-15.0-118	1	X1
8-42552	2.14-15.0-121	1	X1
8-42553-1	2.14-13.0- 1	RF	P1
	2.14-40.0- 3	RF	
8-42553-7	2.14-13.0- 7	RF	P1
	2.14-40.0- 9	RF	
8-42554-1	2. 3- 3.0- 85	1	U
	2.14-22.0- 20	RF	
8-42555	2.14-22.0- 21	1	P
8-42555-7	2.14-22.0- 23	1	X1
8-42556	2.14-14.0- 14	1	P1
8-42557-1	2. 3-11.0- 21	1	U
	2.14-14.0-	RF	

PART NUMBER	FIGURE AND INDEX NUMBER	QTY PER ART	SMR CODE
8-42557-3	2. 3-11.0- 21	1	U
	2.14-14.0-	RF	
8-42557-5	2. 3-11.0- 21	1	U
	2.14-14.0-	RF	
8-42557-801	2. 3-11.0- 21	1	U
	2.14-14.0-	RF	
8-42558-1	2.15- 1.0- 30	1	U
8-42559-7	2.14-23.0-193	1	P
8-42559-9	2.14-22.0- 22	1	P
8-4256-2	2.14-29.0- 12	1	
8-42560-1	2. 3-11.0- 24	1	U
	2.14-17.0-	RF	
8-42560-3	2. 3-11.0- 24	1	U
	2.14-17.0-	RF	
8-42561-11	2.14-14.0- 30	2	P1
8-42561-13	2.14-14.0- 29	1	P1
8-42561-15	2.14-14.0- 26	1	P1
8-42561-17	2.14-14.0- 25	1	P1
8-42561-19	2.14-14.0- 31	2	P1
	2.14-14.0- 32	1	P1
8-42561-25	2.14-14.0- 27	1	P1
8-42561-27	2.14-14.0- 31	2	P1
8-42561-7	2.14-14.0- 22	3	P1
	2.14-14.0- 28	9	
8-42563	2.14-17.0- 10	1	P
8-42563-1	2.14-17.0- 8	1	P
8-42564	2.14-14.0- 19	1	P
8-42565	2.14-20.0- 19	1	P
	2.14-20.0- 61	1	
8-42568-7	2.14-14.0- 15	1	P
8-42568-8	2.14-14.0- 16	1	P
8-42569-7	2.14-14.0- 17	1	P1
8-42569-8	2.14-14.0- 18	1	P1
8-42574-1	2. 3- 4.0- 53	1	U
	2.14- 9.0-	RF	
8-42574-13	2.14- 9.0- 37	1	M
8-42574-17	2.14- 9.0- 43	1	P
8-42574-5	2. 3- 4.0- 53	1	U
	2.14- 9.0-	RF	
8-42575-1	2.14- 9.0- 29	1	A
	2.14-10.0-	RF	
8-42575-17	2.14-10.0- 27	1	M
8-42575-21	2.14-10.0- 6	1	P1
8-42575-23	2.14-10.0- 6	1	P1
8-42575-3	2.14- 9.0- 29	1	M
	2.14-10.0-	RF	
8-42575-5	2.14- 9.0- 29	1	A
	2.14-10.0-	RF	
8-42584	2.14- 9.0- 10	1	A
8-42584-1	2.14- 9.0- 10	1	P1
8-42585	2.14- 9.0- 1	1	P
8-42585-1	2.14- 9.0- 1	1	P
8-42585-3	2.14- 9.0- 1	1	P
8-42585-7	2.14- 9.0- 9	1	X1
8-42585-9	2.14- 9.0- 9	1	X1
8-42585	2.14- 9.0- 19	2	P
8-42586-7	2.14- 9.0- 21	1	X1
8-42587	2.14- 9.0- 15	1	P
8-42588	2.14- 9.0- 14	RF	P1
8-42597	2.14-14.0- 18	2	P1
8-42599	2.14- 9.0- 19	2	P
8-42599-7	2.14- 9.0- 21	1	M
8-42604-01	2.14-42.0- 20	1	P1
8-42604-1	2.14-42.0- 17	1	P1
8-42604-3	2.14-42.0- 17	1	X1

PART NUMBER	FIGURE AND INDEX NUMBER	QTY PER ART	SMR CODE
8-42634-7	2.14-42.0-25	1	X1
8-42635-3	2.14-42.0-23	1	P1
8-42635-7	2.14-42.0-23	1	X1
8-42637-1	2.14-42.0-6	1	P1
8-42637-7	2.14-42.0-8	1	X1
8-42638-3	2.14-42.0-12	1	P1
8-42638-9	2.14-42.0-17	1	X1
8-42639-11	2.14-42.0-32	1	X1
8-42639-3	2.14-42.0-30	1	P1
8-42639-5	2.14-42.0-30	1	P1
8-42611-1	2.14-42.0-23	1	P1
8-42611-3	2.14-42.0-23	1	P1
8-42611-7	2.14-42.0-30	1	X1
8-42615	2.14-31.0-3	12	P1
8-42616-7	2.14-31.0-16	2	P1
8-42620-5	2.14-23.0-185	1	P2
8-42620-9	2.14-23.0-201	1	X1
8-42621-3	2.14-23.0-23	1	P1
8-42621-7	2.14-23.0-29	1	X1
8-42622-5	2.14-23.0-44	1	P1
8-42622-9	2.14-23.0-49	1	X1
8-42623-5	2.14-23.0-31	1	P1
8-42623-7	2.14-23.0-40	1	X1
8-42624-11	2.14-23.0-128	1	X1
8-42624-5	2.14-23.0-121	1	P1
8-42626-13	2.14-23.0-68	1	X1
8-42626-801	2.14-23.0-60	1	P1
8-42627-1	2.14-24.0-23	1	P1
8-42627-7	2.14-24.0-26	1	X1
8-42628-13	2.14-23.0-113	1	X1
8-42628-17	2.14-23.0-106	1	X1
8-42628-5	2.14-23.0-99	1	P1
8-42630-11	2.14-13.0-7	1	X1
	2.14-42.0-9	1	
8-42630-3	2.14-13.0-1	2	P1
	2.14-40.0-3	2	
8-42630-5	2.14-13.0-1	2	P1
	2.14-40.0-3	2	
8-42630-801	2.14-13.0-1	2	P1
	2.14-40.0-3	2	
8-42630-9	2.14-13.0-7	RF	
8-42631-1	2.14-40.0-9	2	P1
8-42631-7	2.14-40.0-12	1	X1
8-42634-11	2.14-18.0-40	1	X1
8-42634-3	2.14-18.0-33	1	P1
8-42634-5	2.14-18.0-33	1	P1
8-42635-1	2.14-18.0-26	1	P1
8-42635-3	2.14-18.0-26	1	P1
8-42635-7	2.14-18.0-32	1	X1
8-42636-1	2.14-18.0-42	1	P1
8-42636-3	2.14-18.0-42	1	P1
8-42636-7	2.14-18.0-49	1	X1
8-42637-1	2.14-18.0-66	1	P1
8-42637-3	2.14-18.0-66	1	P1
8-42637-7	2.14-18.0-73	1	X1
8-42638-1	2.14-18.0-75	1	P1
8-42638-3	2.14-18.0-75	1	P1
8-42638-7	2.14-18.0-82	1	X1
8-42639-1	2.14-13.0-8	2	P1
8-42639-7	2.14-13.0-13	1	X1
8-42641-1	2.14-36.0-2	2	P1
8-42641-3	2.14-36.0-2	2	P1
8-42641-7	2.14-36.0-8	1	X1
8-42648-1	2.14-9.0-72	1	P1
8-42648-3	2.14-9.0-72	1	P1

PART NUMBER	FIGURE AND INDEX NUMBER	QTY PER ART	SMR CODE
8-42648-7	2.14-9.0-78	1	X1
8-42650-1	2.14-24.0-17	1	P1
8-42650-7	2.14-24.0-19	1	X1
8-42653-1	2.14-36.0-8	2	P1
8-42653-7	2.14-36.0-12	1	X1
8-42654-15	2.14-20.0-59	1	X1
8-42654-17	2.14-20.0-54	1	X1
8-42654-803	2.14-20.0-46	1	P1
8-42655-3	2.14-20.0-64	1	X1
8-42655-9	2.14-20.0-71	1	X1
8-42656-3	2.14-20.0-16	1	P1
8-42656-9	2.14-20.0-17	1	X1
8-42657-3	2.14-20.0-22	1	P1
8-42657-9	2.14-20.0-28	1	X1
8-42658-10	2.14-20.0-77	1	X1
8-42658-3	2.14-20.0-35	1	X1
8-42658-4	2.14-20.0-75	2	X1
8-42658-9	2.14-20.0-37	1	X1
8-42659-11	2.14-20.0-34	1	X1
8-42659-3	2.14-20.0-39	1	X1
8-42660-1	2.14-18.0-16	1	P1
8-42660-3	2.14-18.0-16	1	P1
	2.14-22.0-1	1	
8-42660-7	2.14-18.0-23	1	X1
8-42661-1	2.14-41.0-3	1	P1
8-42661-7	2.14-41.0-7	1	X1
8-42662-1	2.14-12.0-22	1	P1
8-42662-9	2.14-12.0-24	1	X1
8-42664-1	2.14-24.0-43	1	P1
8-42664-7	2.14-24.0-46	1	X1
8-42665-3	2.14-23.0-115	1	P1
8-42665-7	2.14-23.0-120	1	X1
8-42668-11	2.14-14.0-10	1	X1
	2.14-14.0-10	1	
	2.14-17.0-7	1	
8-42668-15	2.14-14.0-10	1	X1
	2.14-17.0-7	1	
8-42671-1	2.14-17.0-20	1	P1
8-42671-7	2.14-17.0-23	1	X1
8-42673-11	2.10-2.0-8	RF	X1
8-42673-13	2.10-2.0-8	1	X1
8-42673-15	2.10-2.0-8	1	X1
8-42673-5	2.10-2.0-4	1	P1
8-42673-801	2.10-2.0-4	1	P1
8-42674-5	2.10-4.0-15	1	P1
8-42674-7	2.10-4.0-22	1	X1
8-42676-5	2.10-4.0-6	1	P1
8-42676-7	2.10-4.0-12	1	X1
8-42682-1	2.14-23.0-154	1	P1
8-42682-7	2.14-23.0-160	1	X1
8-42683-1	2.14-19.0-3	1	P1
8-42683-3	2.14-19.0-3	1	P1
8-42683-7	2.14-19.0-9	1	X1
8-42684-1	2.14-19.0-10	1	P1
8-42684-7	2.14-19.0-17	1	X1
8-42685-11	2.14-16.0-8	1	X1
8-42685-3	2.14-16.0-2	1	P1
8-42685-5	2.14-16.0-2	1	P1
8-42686-1	2.14-16.0-8	1	P1
8-42686-7	2.14-16.0-14	1	X1
8-42687-1	2.14-34.0-5	1	P1
8-42687-10	2.14-34.0-7	1	X1
8-42687-2	2.14-34.0-5	1	P1
8-42687-9	2.14-34.0-7	1	X1
8-42688-11	2.14-41.0-24	1	P1

PART NUMBER	FIGURE AND INDEX NUMBER	QTY PER ART	SMR CODE
8-42689-3	2.14-23.0-143	1	P1
8-42689-7	2.14-23.0-150	1	X1
8-42690-11	2.10- 5.0- 18	1	X1
8-42690-801	2.10- 5.0- 8	1	P1
8-42691-13	2.10- 5.0- 24	1	X1
8-42691-5	2.10- 5.0- 18	1	P1
8-42691-801	2.10- 5.0- 18	1	P1
8-42691-9	2.10- 5.0- 24	RF	X1
8-42693-1	2.14-14.0- 11	1	P1
8-42693-7	2.14-14.0- 13	1	X1
8-42693-9	2.14-14.0- 13	RF	X1
8-42694-10	2.14-25.0- 21	1	X1
8-42694-3	2.14-25.0- 10	1	P1
8-42694-4	2.14-25.0- 10	1	P1
8-42694-5	2.14-25.0- 10	1	P1
8-42694-6	2.14-25.0- 10	1	P1
8-42694-9	2.14-25.0- 21	1	X1
8-42699-3	2.14-23.0-166	1	P1
8-42699-7	2.14-23.0-173	1	X1
8-42701-5	2. 3- 4.0- 32	1	U
	2.10- 2.0-	RF	
8-42701-801	2. 3- 4.0- 32	1	U
	2.10- 2.0-	RF	
8-42705	2. 3- 3.0- 12	1	U
	2.10- 3.0-	RF	
8-42705-17	2.10- 3.0- 24	1	M
8-42705-19	2.10- 3.0- 8	1	M
8-42705-21	2.10- 3.0- 9	1	A
8-42705-23	2.10- 3.0- 22	1	A
8-42705-27	2.10- 3.0- 17	1	M
8-42705-29	2.10- 3.0- 20	1	M
8-42705-3	2. 3- 3.0- 12	1	U
	2.10- 3.0-	RF	
8-42705-31	2.10- 3.0- 21	1	M
8-42705-35	2.10- 3.0- 20	1	M
8-42705-37	2.10- 3.0- 20	1	M
8-42705-5	2. 3- 3.0- 12	1	
	2.10- 3.0-	RF	
8-42705-7	2.10- 3.0- 11	1	
8-42714-17	2.10- 3.0- 12	1	P1
8-42714-19	2.10- 3.0- 19	1	P1
8-42714-21	2.10- 3.0- 25	1	P1
8-42714-23	2.10- 3.0- 26	1	P1
8-42716	2.10- 2.0- 3	1	
8-42719-3	2.10- 4.0- 15	RF	
8-42719-7	2.10- 4.0- 22	RF	X1
8-42725	2.10- 4.0- 18	2	P
8-42728-1	2. 3- 3.0- 87	1	U
	2.10- 4.0-	RF	
8-42728-5	2.10- 5.0-	RF	U
	2.10- 7.0- 88		
8-42729-1	2.10- 4.0- 3	1	P
8-42731-7	2.10- 5.0- 2	1	M1
8-42733	2.14-23.0-162	2	P
8-42735-1	2.10- 5.0- 27	1	P
8-42736	2.10- 5.0- 6	1	P1
8-42737	2.14-23.0-129	1	P
8-42737-1	2.14-23.0- 30	1	P
8-42737-3	2.14-23.0-114	1	P
8-42743-1	2.10- 5.0- 18	RF	P1
8-42743-9	2.10- 5.0- 24	RF	X1
8-42744-7	2.10- 5.0- 18	RF	X1
8-42746	2. 3-10.0- 52	1	P1
8-42746-1	2. 3-10.0- 53	1	P1
8-42750	2.10- 4.0- 23	1	P

PART NUMBER	FIGURE AND INDEX NUMBER	QTY PER ART	SMR CODE
8-42930-1	2.14-32.0- 10	1	P1
8-42930-10	2.14-32.0- 19	1	X1
8-42930-2	2.14-32.0- 10	1	P1
8-42930-7	2.14-32.0- 19	RF	X1
8-42930-8	2.14-32.0- 19	RF	X1
8-42930-9	2.14-32.0- 19	1	X1
8-42933-1	2.14-10.0- 47	RF	P1
	2.14-26.0- 19	1	
8-42933-10	2.14-26.0- 27	1	X1
8-42933-2	2.14-26.0- 26	1	P1
8-42933-9	2.14-26.0- 27	1	X1
8-42934-1	2.14-28.0- 3	1	P1
	2.14-29.0- 3	1	
8-42934-10	2.14-28.0- 6	1	X1
	2.14-29.0- 6	1	P1
8-42934-2	2.14-28.0- 3	1	P1
	2.14-29.0- 3	1	
8-42934-9	2.14-28.0- 6	1	X1
	2.14-29.0- 6	1	
8-42936-1	2.14-28.0- 11	1	P1
8-42936-10	2.14-28.0- 13	1	X1
8-42936-2	2.14-28.0- 11	1	P1
8-42936-9	2.14-28.0- 13	1	X1
8-42937-7	2.14-28.0- 14	1	P1
8-42939-1	2.14-26.0- 16	2	P1
8-42943-13	2.14- 9.0- 86	1	X1
8-42943-801	2.14- 9.0- 79	1	P1
8-42944-11	2.14- 9.0- 54	1	X1
8-42944-9	2.14- 9.0- 48	1	P1
8-42945-1	2.14-10.0- 75	1	P1
8-42945-3	2.14-10.0- 75	1	P1
8-42945-5	2.14-10.0- 75	1	P1
8-42945-7	2.14-10.0- 80	1	X1
8-42945-9	2.14-10.0- 80	1	X1
8-42946-1	2.14- 9.0- 68	1	P1
8-42946-7	2.14- 9.0- 70	1	X1
8-42948-7	2.14- 9.0- 14	1	P1
8-42949-1	2.14-10.0- 12	1	P1
8-42949-3	2.14-10.0- 12	1	P1
8-42949-7	2.14-10.0- 21	1	X1
8-42950-1	2.14-12.0- 11	1	P1
8-42950-7	2.14-12.0- 20	1	X1
8-42951-1	2.14-12.0- 12	1	P1
8-42951-7	2.14-12.0- 21	1	X1
8-42952-1	2.14-10.0- 47	1	P1
8-42952-3	2.14-10.0- 47	1	P1
8-42952-7	2.14-10.0- 49	1	X1
8-42955-1	2.14-27.0- 6	1	P1
8-42955-10	2.14-27.0- 15	1	X1
8-42955-2	2.14-27.0- 7	1	P1
8-42955-9	2.14-27.0- 15	1	X1
8-42956-1	2.14-29.0- 11	1	P1
8-42956-10	2.14-29.0- 14	1	X1
8-42956-9	2.14-29.0- 13	1	X1
8-42957-7	2.14-29.0- 8	1	P1
8-42958-1	2.14-33.0- 13	1	P1
8-42958-10	2.14-33.0- 19	1	X1
8-42958-2	2.14-33.0- 13	1	P1
8-42958-9	2.14-33.0- 19	1	X1
8-42959	2.14-33.0- 5	1	P1
8-42959-1	2.14-33.0- 5	1	P1
8-42959-13	2.14-33.0- 13	1	X1
8-42959-3	2.14-33.0- 5	1	P1
8-42959-5	2.14-33.0- 5	1	P1
8-42959-9	2.14-33.0- 13	1	X1

PART NUMBER	FIGURE AND INDEX NUMBER	QTY PER ART	SMR CODE
8-44165-13	2.14-3.0-1	1	
8-44171	2.13-2.0-17	1	P
	2.10-2.0-11	1	
8-44177	2.4-12.0-111	2	P
8-44178	2.4-12.0-99	1	P
8-44179-7	2.4-12.0-126	1	P1
8-44181	2.4-12.0-116	RF	P1
8-44185-7	2.4-12.0-122	1	M
8-44190-8	2.4-12.0-123	1	M
8-44198-7	2.4-12.0-125	1	P1
8-44197	2.4-12.0-125	RF	P1
8-44208-7	2.4-3.0-48	1	P
8-44344	2.7-3.0-103	1	P
8-44341	2.7-3.0-37	1	P
8-44347	2.7-3.0-113	1	P
8-44348	2.7-3.0-108	1	A
8-44349	2.7-3.0-85	RF	P
8-44374-11	2.7-3.0-93	1	P
8-44374-13	2.7-3.0-63	1	P
8-44374-9	2.7-3.0-67	1	P
8-44375	2.7-3.0-59	1	P
8-44376-7	2.7-3.0-64	1	P
8-44377-11	2.7-3.0-29	2	P
8-44377-13	2.7-3.0-73	1	P
8-44377-15	2.7-3.0-77	1	P
8-44377-9	2.7-3.0-57	1	P
8-44378-3	2.7-3.0-33	1	
8-44379	2.7-3.0-46	1	P
8-44382-3	2.7-3.0-93	1	P1
8-44382-7	2.7-3.0-107	1	X1
8-44382-9	2.7-3.0-107	1	X1
8-44383	2.7-3.0-109	1	A
8-44384	2.7-3.0-141	1	M
8-44384-7	2.7-3.0-145	1	M
8-44385	2.7-3.0-120	2	P
8-44386	2.7-3.0-124	1	P
8-44386-7	2.7-3.0-131	1	X1
8-44387-1	2.7-3.0-116	1	P
8-44386	2.7-3.0-1	1	A
8-44348-1	2.7-3.0-1	1	A
8-44359	2.7-3.0-65	1	P
8-44391	2.7-3.0-65	RF	P1
8-44391	2.7-3.0-86	1	P
8-44398	2.7-3.0-89	1	P
8-44448-7	2.7-3.0-87	1	P
8-44454-15	2.7-2.0-6	RF	
8-44454-9	2.7-2.0-6	1	P1
8-44455-11	2.7-2.0-5	1	P1
8-44457-15	2.7-2.0-5	RF	P
8-44457	2.7-2.0-4	1	P
8-44522	2.15-27.0-21	1	P
	2.15-33.0-21	1	
8-44523	2.15-27.0-15	1	P
	2.15-35.0-28	1	
8-44527-7	2.15-27.0-20	1	P
	2.15-35.0-20	1	
8-44525	2.15-27.0-22	1	P
	2.15-35.0-22	1	
8-44532	2.15-27.0-17	1	P
	2.15-35.0-17	1	
8-44545-10.1	2.15-27.0-42	1	P1
	2.15-35.0-43	1	
8-44545-102	2.15-27.0-43	1	P1
	2.15-35.0-43	1	
8-44545-103	2.15-33.0-7	1	M1

PART NUMBER	FIGURE AND INDEX NUMBER	QTY PER ART	SMR CODE
8-44545-103	2.15-35.0-7	1	M1
8-44545-104	2.15-35.0-8	1	M1
	2.15-34.0-7	1	
8-44545-149	2.15-27.0-11	2	M
	2.15-35.0-11	2	
8-44545-151	2.15-27.0-12	1	M1
	2.15-35.0-12	1	
8-44545-152	2.15-27.0-12	1	M1
	2.15-35.0-12	1	
8-44545-153	2.15-27.0-1	1	M
	2.15-35.0-1	1	
8-44545-154	2.15-27.0-1	1	M
	2.15-35.0-1	1	
8-44545-155	2.15-27.0-1	RF	A
	2.15-33.0-10	1	
	2.15-34.0-11	1	
	2.15-35.0-1	RF	
8-44545-156	2.15-27.0-1	RF	A
	2.15-33.0-11	1	
	2.15-34.0-11	1	
	2.15-35.0-1	RF	
8-44545-157	2.15-27.0-12	1	M1
	2.15-35.0-12	1	
8-44545-158	2.15-27.0-12	1	M1
	2.15-35.0-12	1	
8-44545-159	2.3-3.0-77	1	U
	2.15-33.0-1	RF	
8-44545-323	2.15-33.0-1	RF	P1
	2.15-34.0-1	RF	
8-44545-530	2.15-33.0-1	RF	P1
	2.15-34.0-1	RF	
8-44545-537	2.15-33.0-14	2	M
	2.15-34.0-8	1	
8-44545-71	2.15-33.0-16	2	M
	2.15-34.0-9	1	
8-44545-63	2.15-33.0-15	2	M
	2.15-34.0-11	1	
8-44545-95	2.15-27.0-45	1	A
	2.15-35.0-43	1	
8-44545-96	2.15-27.0-45	1	A
	2.15-35.0-43	1	
8-44545-11	2.15-22.0-2	1	A
8-44545-12	2.15-22.0-3	1	A
8-44545-13	2.15-22.0-4	1	A
8-44545-14	2.15-22.0-5	1	A
8-44545-15	2.15-23.0-35	1	A
8-44545-16	2.15-23.0-31	1	A
8-44545-17	2.15-23.0-37	1	A
8-44545-18	2.15-23.0-35	1	A
8-44545-3	2.3-3.0-81	1	U
	2.15-22.0-1	RF	
8-44545-5	2.3-3.0-81	1	U
	2.15-23.0-1	RF	
8-44545	2.15-25.0-62	1	U
8-44549	2.15-25.0-68	1	P1
8-44551	2.15-25.0-69	1	P
8-44553	2.15-25.0-70	1	P
8-44554-1	2.15-27.0-37	2	P1
	2.15-35.0-37	2	
8-44554-11	2.15-27.0-41	1	P
	2.15-35.0-41	1	
8-44554-7	2.15-27.0-42	1	X1
	2.15-35.0-42	1	
8-44554-5	2.15-27.0-40	1	
	2.15-35.0-40	1	P

PART NUMBER	FIGURE AND INDEX NUMBER	QTY PER ART	SMR CODE
8-44550-3	2.15-27.0- 14	1	P1
	2.15-28.0- 14	1	P1
8-44556-4	2.15-27.0- 13	1	P1
	2.15-28.0- 13	1	
8-44558	2.15-27.0- 24	1	P1
	2.15-28.0- 24	1	
8-44558-7	2.15-27.0- 30	1	X1
	2.15-35.0- 30	1	
8-4456	2.20-23.1-118	2	
8-44561-10	2.15-27.0- 31	1	P1
	2.15-36.0- 31	1	
8-44561-9	2.15-27.0- 31	1	P1
	2.15-36.0- 31	1	
8-44562-10	2.15-27.0- 24	1	P1
	2.15-35.0- 34	1	
8-44562-9	2.15-27.0- 34	1	P1
	2.15-35.0- 34	1	
8-44563-13	2.15-27.0- 23	1	X1
	2.15-28.0- 23	1	
8-44563-14	2.15-27.0- 23	1	X1
	2.15-35.0- 22	1	
8-44564	2.15-28.0- 72	RF	X1
	2.15-23.0- 67	RF	
8-44564-1	2.15-28.0- 66	1	P1
	2.15-23.0- 60	1	
8-44564-2	2.15-28.0- 66	1	P1
	2.15-23.0- 60	1	
8-44564-7	2.15-28.0- 72	1	X1
	2.15-23.0- 67	1	
8-44564-8	2.15-28.0- 72	1	X1
	2.15-23.0- 67	1	
8-44565-10	2.15-23.0- 79	RF	X
8-44565-11	2.15-22.0- 84	1	X1
	2.15-23.0- 79	1	
8-44565-12	2.15-22.0- 84	1	X1
	2.15-23.0- 79	1	
8-44565-3	2.15-22.0- 73	1	P1
	2.15-23.0- 74	1	P1
8-44565-4	2.15-22.0- 79	1	P1
	2.15-23.0- 74	1	
8-44565-9	2.15-23.0- 79	RF	X1
8-44566-1	2.15-22.0- 79	RF	P1
	2.15-23.0- 74	RF	
8-44566-2	2.15-22.0- 79	RF	P1
	2.15-23.0- 74	RF	
8-44566-7	2.15-22.0- 84	RF	X1
	2.15-23.0- 79	RF	
8-44566-8	2.15-22.0- 84	RF	X1
	2.15-23.0- 79	RF	
8-44567-1	2.15-22.0- 60	RF	P1
	2.15-23.0- 60	RF	
8-44567-2	2.15-22.0- 66	RF	P1
	2.15-23.0- 60	RF	
8-44567-7	2.15-22.0- 72	RF	X1
	2.15-23.0- 67	RF	
8-44567-8	2.15-22.0- 72	RF	X1
	2.15-23.0- 67	RF	
8-44568-1	2.15-22.0- 50	1	P1
	2.15-23.0- 56	1	
8-44568-7	2.15-22.0- 56	1	X1
	2.15-23.0- 75	1	
8-44569	2.15-23.0- 20	1	P1
	2.15-21.0- 44	1	
8-44569-15	2.15-22.0- 20	1	X1
	2.15-23.0- 50	1	
8-44571	2.15-22.0- 12	1	P

PART NUMBER	FIGURE AND INDEX NUMBER	QTY PER ART	SMR CODE
8-44571	2.15-22.0- 31	1	P
8-44571-1	2.15-22.0- 19	1	X1
	2.15-23.0- 43	1	
8-44572-1	2.15-22.0- 6	1	P
	2.15-23.0- 31	1	
8-44573-9	2.15-22.0- 11	1	X1
	2.15-23.0- 34	1	
8-44574	2.15-22.0- 52	RF	P
8-44574-1	2.15-22.0- 61	RF	P1
8-44574-7	2.15-22.0- 51	RF	X1
	2.15-23.0- 73	RF	
8-44575-10	2.15-27.0- 23	RF	P
	2.15-35.0- 20	RF	
8-44575-6	2.15-27.0- 23	RF	P
	2.15-35.0- 23	RF	
8-44576-7	2.15-27.0- 34	RF	P1
	2.15-35.0- 34	RF	
8-44576-4	2.15-27.0- 34	RF	P1
	2.15-35.0- 34	RF	
8-44577-7	2.15-27.0- 31	RF	P
	2.15-35.0- 31	RF	
8-44577-8	2.15-27.0- 31	RF	P
	2.15-31.0- 31	RF	
8-44578	2.15-27.0- 44	1	P
8-44578	2.15-27.0- 37	RF	P1
	2.15-35.0- 42	RF	
8-44578-11	2.15-35.0- 42	1	M
8-44578-7	2.15-35.0- 42	1	X1
8-44579-5	2.15-35.0- 42	1	M
8-44581	2.15-22.0- 79	1	P
	2.15-23.0- 23	4	
	2.15-22.0- 64	1	P
	2.15-23.0- 22	4	
8-44582	2.15-22.0- 52	1	P
	2.15-22.0- 75	1	
	2.15-23.0- 21	2	
8-44583-3	2.15-32.0- 16	1	P
8-44583-4	2.15-32.0- 16	1	P
8-44584	2.15-22.0- 63	1	P
	2.15-23.0- 24	4	
8-44585	2.15-22.0- 74	1	P
	2.15-23.0- 26	4	
8-44589-7	2.15-22.0- 24	1	P
	2.15-23.0- 28	4	
8-44589-9	2.15-19.0- 37	1	P
	2.15-19.0- 6	1	
8-44590-13	2.15-27.0- 46	1	M1
8-44591-0	2.15-27.0- 44	1	M1
8-44592-1	2.15-35.0- 73	1	U
	2.15-32.0- 1	RF	
8-44592-1	2.15-35.0- 76	1	U
	2.15-32.0- 1	RF	
8-44592-5	2.15-35.0- 79	1	U
	2.15-32.0- 1	RF	
8-44592-6	2.15-35.0- 74	1	U
	2.15-32.0- 1	RF	
8-44593-3	2.15-32.0- 15	1	M
8-44593	2.15-24.0- 24	1	M
8-44593-1	2.15-24.0- 20	1	P
8-44593-1	2.15-24.0- 21	1	P
8-44593-7	2.15-24.0- 14	1	M
8-44597-7	2.15-24.0- 29	1	A
8-44597-1	2.15-24.0- 28	1	A
8-44597-13	2.15-24.0- 33	1	X1
8-44597-11	2.15-24.0- 30	1	P

PART NUMBER	FIGURE AND INDEX NUMBER	QTY PER ART	SMR CODE
8-44624-12	2.15-24.0- 30	1	P
8-44624-13	2.15-24.0- 30	1	P
8-44624-14	2.15-24.0- 30	1	P
8-44624-7	2.15-24.0- 33	1	X1
8-44624-#	2.15-24.0- 33	1	X1
8-44624-9	2.15-24.0- 33	1	X1
8-44625-1	2.15-22.0- 30	1	A
	2.15-22.0- 41	1	
	2.15-23.0- 2	12	
	2.15-24.0-	RF	
8-44625-2	2.15-22.0- 30	1	A
	2.15-22.0- 41	1	
	2.15-23.0- 2	1	
	2.15-24.0-	RF	
8-44625-3	2.15-22.0- 30	1	A
	2.15-22.0- 41	1	
	2.15-23.0- 4	1	
	2.15-24.0-	RF	
8-44625-4	2.15-22.0- 30	1	A
	2.15-22.0- 41	1	
	2.15-23.0- 4	1	
	2.15-24.0-	RF	
8-44718-7	2.11-10.0- 2	RF	P
8-44719	2. 2- 3.0- 24	1	
	2. 2-11.0-	RF	
8-44719-1	2. 2- 3.0- 24	1	P1
	2. 2-11.0-	RF	
8-44721	2. 2- 6.0- 8	1	P
8-44722	2. 2- 6.0- 24	RF	P1
8-44723	2. 2- 6.0- 17	RF	P1
8-44724	2. 2- 6.0- 13	1	P
8-44725	2. 2- 6.0- 10	RF	P
8-44726	2. 2- 6.0- 9	RF	P1
8-44727	2. 2-11.0- 14	1	P
8-44728	2. 2- 6.0- 10	1	P2
8-44729	2. 2- 6.0- 12	1	P
8-44730	2. 2- 3.0- 28	1	P
8-44731	2. 2- 6.0- 18	1	X1
8-44732	2. 2- 6.0- 23	2	X1
8-44735	2. 2- 6.0- 7	1	M1
8-44736	2. 2- 6.0- 6	1	M
8-44737	2. 2-11.0- 11	2	P
8-44738	2. 2-11.0- 9	1	P
8-44739	2. 2-11.0- 13	RF	P
8-44740	2. 2-11.0- 3	RF	P
8-44741	2. 2-11.0- 1	RF	P
8-44742	2. 2-11.0- 15	RF	P1
8-44743	2. 2- 6.0- 1	RF	P1
8-44743-1	2. 2- 6.0- 1	1	P1
8-44744	2. 2-11.0- 18	1	P1
8-44746	2. 2-11.0- 7	1	P
8-44747	2. 2- 6.0-	RF	U
	2. 3- 4.0- 2	1	
8-44748	2. 2-11.0- 17	1	P
8-44768-13	2. 4-12.0- 68	1	P1
8-44768-14	2. 4-12.0- 68	1	P1
8-44769-7	2. 4-12.0- 76	1	M
8-44769-8	2. 4-12.0- 76	1	M
8-44773	2. 4- 8.0- 11	1	P
8-44781	2. 4-12.0- 31	1	P
8-44781-7	2. 4-12.0- 37	1	X1
8-44781-9	2. 4-12.0- 36	1	X1
8-44796	2. 4-12.0- 19	1	P
8-44796-3	2. 4-12.0- 27	1	P
8-44796-7	2. 4-12.0- 27	1	X1

PART NUMBER	FIGURE AND INDEX NUMBER	QTY PER ART	SMR CODE
8-44796-9	2. 4-12.0- 30	1	X1
8-44797	2. 4-12.0- 26	1	X1
8-44798	2. 4-12.0- 38	1	P
8-44799-7	2. 4-12.0- 68	RF	P
8-44799-8	2. 4-12.0- 68	RF	P
8-44860-3	2.20-48.0-	1	
8-44860-801	2.20-48.0-	1	
8-44861-1	2.20-48.0- 60	1	
8-44863-1	2.20-48.0- 1	1	
8-44863-9	2.20-48.0- 2	1	
8-44864-3	2.20-48.0- 3	1	
8-44865-3	2. 9-12.0-	1	
	2.20-48.0- 7	RF	
8-44865-7	2. 9-12.0- 7	1	
8-44865-803	2. 9-12.0-	1	
	2.20-48.0- 7	RF	
8-44866-1	2.20-48.0- 77	1	
8-44866-9	2.20-48.0- 80	1	
8-44867-1	2.20-48.0- 12	1	
8-44867-2	2.20-48.0- 13	1	
8-44867-7	2.20-48.0- 23	1	
8-44867-8	2.20-48.0- 23	1	
8-44867-9	2.20-48.0- 18	1	
8-44868-1	2.20-48.0- 7	2	
8-44869-9	2.20-48.0- 11	1	
8-44869-1	2.20-48.0- 24	1	
8-44869-7	2.20-48.0- 29	1	
8-44870-1	2.20-48.0- 38	1	
8-44870-7	2.20-48.0- 43	1	
8-44871-1	2. 2- 2.0- 9	1	
8-44871-9	2. 2- 2.0- 14	4	
8-44872-11	2. 2- 2.0- 8	1	
8-44874-1	2.20-48.0- 49	1	
8-44874-9	2.20-48.0- 56	1	
8-44875-9	2.20-48.0- 37	1	
8-44876-9	2.20-48.0- 48	1	
8-44877-1	2.20-48.0- 64	1	
8-44877-7	2.20-48.0- 68	1	
8-44878-1	2.20-48.0- 68	2	
8-44878-7	2.20-48.0- 75	1	
8-44888-1	2.20-48.0- 3	1	
8-44892-1	2. 2- 2.0-	RF	
8-44892-21	2. 2- 2.0- 6	1	
8-44892-23	2. 2- 2.0- 7	1	
8-44892-25	2. 2- 2.0- 23	1	
8-44892-39	2. 2- 2.0- 15	1	M
8-44892-55	2. 2- 2.0- 25	1	
8-44892-57	2. 2- 2.0- 16	1	
8-44892-9	2. 2- 2.0- 1	1	
8-44894-1	2.20-48.0- 7	1	
8-44894-145	2. 2- 1.0- 1	1	
8-44897-7	2. 2- 2.0- 13	4	
8-44899-101	2. 9-12.0- 45	1	
8-44899-103	2. 9-12.0- 47	1	
8-44899-105	2. 9-12.0- 49	1	
8-44899-107	2. 9-12.0- 51	1	
8-44899-109	2. 9-11.0- 24	1	
8-44899-113	2. 9-12.0- 24	1	
8-44899-127	2. 9-12.0- 18	1	
8-44899-129	2. 9-12.0- 16	1	
8-44899-135	2. 9-12.0- 12	1	
8-44899-137	2. 9-12.0- 13	1	
8-44899-21	2. 9-12.0- 3	1	
8-44899-23	2. 9-12.0- 32	1	
8-44899-25	2. 9-12.0- 26	1	

PART NUMBER	FIGURE AND INDEX NUMBER	QTY PER ART	SMR CODE
8-44899-29	2. 9-12.0- 19	1	
8-44899-31	2. 9-12.0- 16	1	
8-44899-57	2. 9-12.0- 23	1	
8-44899-59	2. 9-12.0- 21	1	
8-44899-61	2. 9-12.0- 18	1	
8-44899-69	2. 9-12.0- 15	1	
8-44899-71	2. 9-12.0- 4	1	
8-44899-75	2. 9-12.0- 30	1	
8-44899-77	2. 9-12.0- 28	1	
8-44899-83	2. 9- 7.0- 21	1	
8-44899-95	2.18-15.0- 7	2	
8-44899-97	2. 9-12.0- 41	1	
8-44899-99	2. 9-12.0- 43	1	
8-44900-7	2. 4-12.0- 93	2	P
8-44902-1	2. 8- 7.0- 8	1	A
8-44902-11	2. 8- 7.0- 18	1	P
8-44916-9	2. 4- 9.0- 44	1	P
8-44952-7	2. 4- 9.0- 62	1	P
8-44953	2. 4-12.0- 27	1	P1
8-44953-7	2. 4-12.0- 28	1	X1
8-44959	2. 2- 3.0- 43	1	P
8-44960	2. 2- 3.0- 39	1	P
8-44961	2. 2- 3.0- 35	1	P
8-44962	2. 2- 3.0- 46	1	P
8-44963	2. 2- 3.0- 30	RF	U
8-44963-7	2. 2- 3.0- 34	1	M
8-44965	2.20-31.0- 46	1	M1
8-44965	2.20-31.0- 47	1	M1
8-44967	2.20-31.0- 49	1	P
8-44967-7	2.20-31.0- 55	1	X1
8-44968-1	2.20-31.0- 42	1	U
8-44968-11	2.20-31.0- 44	2	M
8-44968-2	2.20-31.0- 42	1	U
8-44979-9	2. 4- 9.0- 63	RF	P1
8-44980-7	2. 4- 9.0- 46	RF	M
8-44981-7	2. 4- 9.0- 46	1	M
8-44982-1	2. 4- 9.0- 63	1	P1
8-45006	2. 3-15.0- 23	1	U
8-45006-1	2. 7- 3.0-	RF	U
8-45007	2. 3-15.0- 24	1	U
8-45007-7	2. 7- 1.0- 6		
8-45008-3	2.15-13.0- 40	4	P
8-45008-9	2.15-13.0- 49	RF	P1
8-45009	2.15-13.0- 20	1	P1
8-45009-7	2.15-13.0- 30	1	X1
8-45010-1	2. 3- 3.0- 10	1	U
8-45010-7	2.15-13.0-	RF	
8-45010-7	2.15-13.0- 19	1	M
8-45011-11	2. 1- 1.0- 53	1	U
8-45011-13	2. 7- 2.0-	RF	U
8-45011-13	2. 7- 2.0- 2	1	U
8-45011-19	2. 7- 2.0-	RF	U
8-45011-21	2. 7- 2.0- 2	RF	U
8-45012-1	2. 3- 3.0- 39	1	U
8-45012-3	2.20-11.0-	RF	
8-45012-3	2. 3- 3.0- 40	1	U
8-45012-5	2.20-11.0-	RF	
8-45012-5	2. 3- 3.0- 41	1	U
8-45012-9	2.20-11.0-	RF	
8-45012-9	2.20-11.0- 24	1	M
8-45018-1	2.15-13.0- 40	1	P1
8-45018-7	2.15-13.0- 49	1	X1

PART NUMBER	FIGURE AND INDEX NUMBER	QTY PER ART	SMR CODE
8-45020	2. 2- 6.0- 14	1	P1
8-45021-7	2. 2- 6.0- 25	1	P1
8-45022	2. 2- 6.0- 9	1	P1
8-45023-7	2. 2- 6.0- 24	1	M
8-45024-7	2. 2-11.0- 13	1	P1
8-45025-7	2. 2-11.0- 3	1	P1
8-45026-7	2. 2-11.0- 1	1	P1
8-45027	2. 2-11.0- 15	1	P1
8-45028-3	2. 3-11.0- 28	1	U
8-45028-5	2.11- 9.0-	RF	
8-45028-5	2. 3-11.0- 28	1	U
8-45028-9	2.11- 9.0-	RF	
8-45028-9	2.11- 9.0- 9	1	A
8-45029-7	2. 2- 6.0- 17	1	X1
8-45030	2. 2- 6.0- 16	1	P
8-45035	2.11- 9.0- 14	4	P1
8-45036	2. 3- 3.0- 7	1	U
8-45036-7	2. 4-12.0-	RF	
8-45036-7	2. 4-12.0-127	1	P
8-45120	2. 7- 3.0- 75	1	P
8-45155	2. 4-12.0-118	1	P
8-45157	2. 4-12.0- 99	2	P
8-45184	2. 4-12.0- 84	2	P1
8-45185	2. 4-12.0- 85	1	P
8-45189	2. 4-12.0- 43	1	P
8-45198-1	2. 4-12.0- 54	2	P
8-45199-7	2. 4-12.0- 61	1	X1
8-45341	2. 7- 3.0- 59	1	P
8-45342	2. 7- 3.0- 61	1	P
8-45343	2. 7- 2.0- 7	1	P1
8-45354-1	2. 7- 3.0- 22	RF	P1
8-45354-7	2. 7- 3.0- 25	RF	X1
8-45355-1	2. 7- 3.0- 22	1	P1
8-45355-7	2. 7- 3.0- 25	1	X1
8-45355-9	2. 7- 3.0- 25	1	X1
8-45356	2. 7- 3.0- 17	RF	P1
8-45357	2. 7- 3.0- 17	1	P1
8-45363-7	2. 7- 3.0- 24	1	P
8-45363-9	2. 7- 3.0- 23	1	P
8-45364	2. 7- 3.0- 20	1	M
8-45365	2. 7- 3.0- 21	8	P
8-45365-7	2. 7- 3.0- 21	8	P
8-45370-7	2. 7- 3.0- 70	1	P1
8-45371	2. 7- 3.0- 76	1	P
8-45372	2. 7- 3.0- 60	1	P
8-45373	2. 7- 3.0-114	3	P
8-45375	2. 7- 3.0- 30	1	X1
8-45376	2. 7- 3.0- 54	1	P
8-45377	2. 7- 3.0- 26	1	P
8-45377-1	2. 7- 3.0- 26	1	P
8-45378	2. 7- 3.0- 32	1	P
8-45378-7	2. 7- 3.0- 32	1	X
8-45382	2. 7- 3.0- 65	1	P1
8-45383-507	2. 7- 3.0- 38	RF	P1
8-45384-7	2. 7- 3.0- 65	1	P1
8-45386	2. 7- 3.0- 49	1	P
8-45389-7	2. 7- 3.0- 10	1	P
8-45393	2. 7- 3.0-113	1	P
8-45395	2. 7- 3.0- 18	1	M1
8-45832	2.20-11.0- 68	2	A
8-45833	2.20-11.0-103	2	A
8-45835	2.20-11.0- 76	RF	P
8-45835-1	2.20-11.0- 76	RF	P
8-45835-7	2.20-11.0- 79	1	X1
8-45835-9	2.20-11.0- 79	1	X

PART NUMBER	FIGURE AND INDEX NUMBER	QTY PER ART	SMR CODE
8-45836	2.20-11.0- 72	RF	P
8-45836-1	2.20-11.0- 72	RF	P
8-45836-7	2.20-11.0- 75	RF	X1
8-45836-9	2.20-11.0- 75	RF	X1
8-45837	2.20-11.0-111	RF	P
8-45837-7	2.20-11.0-114	RF	X
8-45838	2.20-11.0-107	RF	P
8-45838-7	2.20-11.0-110	RF	X
8-45839-3	2.20-11.0- 43	2	P1
	2.20-20.0-	RF	
8-45839-7	2.20-20.0- 4	1	X1
8-45840-1	2.20-11.0- 80	2	P1
	2.20-20.0-	RF	
8-45840-7	2.20-20.0- 10	1	X1
8-45841-1	2.20-11.0-115	2	P
	2.20-20.0-	RF	
8-45841-9	2.20-20.0- 15	1	X1
8-45842-7	2.20-20.0- 14	2	M
	2.20-20.0- 3	1	
8-45842-9	2.20-20.0- 5	1	M
8-45843-7	2.20-20.0- 9	1	M
8-45843-9	2.20-20.0- 11	1	M
8-45845-7	2.20-11.0- 58	4	P
8-45846	2.20-11.0- 95	2	M
8-45847-3	2.20-11.0- 21	1	P1
8-45847-7	2.20-11.0- 30	1	X1
8-45847-9	2.20-11.0- 29	4	M
8-45848-1	2.20-11.0- 21	RF	P1
8-45848-7	2.20-11.0- 30	RF	X
8-45852-11	2.20-11.0- 11	2	P
8-45852-13	2.20-11.0- 97	2	P
8-45853-1	2.20-11.0- 60	4	P
8-45860-3	2.20-11.0- 20	RF	
8-45862-10	2.20-11.0- 20	1	X1
8-45862-3	2.20-11.0- 6	1	P1
8-45862-4	2.20-11.0- 7	1	P1
8-45862-9	2.20-11.0- 20	1	X1
8-45863-3	2.20-11.0- 6	RF	P1
8-45863-4	2.20-11.0- 7	RF	P1
8-45863-8	2.20-11.0- 20	RF	X1
8-45864-1	2.20-11.0- 55	2	P1
8-45864-7	2.20-11.0- 67	2	X1
8-45865	2.20-11.0- 55	RF	P1
8-45865-7	2.20-11.0- 67	RF	X1
8-45866-3	2.20-11.0- 88	1	P1
8-45866-4	2.20-11.0- 89	1	P1
8-45866-7	2.20-11.0-102	1	X1
8-45866-8	2.20-11.0-102	1	X1
8-45867-3	2.20-11.0- 88	RF	P1
8-45867-4	2.20-11.0- 89	RF	P1
8-45867-7	2.20-11.0-102	RF	X1
8-45867-8	2.20-11.0-102	RF	X1
8-45868-7	2.20-11.0- 96	2	P
8-45869-9	2.20-11.0- 10	2	P2
8-45870-1	2.20-11.0- 76	1	P1
8-45870-7	2.20-11.0- 79	1	X1
8-45871-1	2.20-11.0- 72	1	
8-45871-7	2.20-11.0- 75	1	
8-45872-1	2.20-11.0-111	1	P1
8-45872-7	2.20-11.0-114	1	X1
8-45873-1	2.20-11.0-107	1	P1
8-45873-7	2.20-11.0-110	1	M
8-45874	2.20-11.0- 52	2	P
8-45877	2.20-11.0- 19	2	P
	2.20-11.0-101	4	

PART NUMBER	FIGURE AND INDEX NUMBER	QTY PER ART	SMR CODE
8-45878-7	2.20-11.0- 16	2	P
8-45878-9	2.20-11.0- 28	4	P
8-45879	2.20-11.0- 66	2	P
8-45880	2.20-11.0- 65	2	P
8-45881-7	2.20-11.0- 64	4	P
8-45881-9	2.20-11.0- 15	2	P
	2.20-11.0- 98	2	
8-45886-7	2.20-11.0-104	2	P
8-45886-9	2.20-11.0- 32	2	P
8-45887-7	2.20-11.0- 69	2	P
8-45888	2.20-11.0-119	2	P
8-45889-1	2.20-11.0- 33	1	P1
8-45889-7	2.20-11.0- 38	1	X1
8-45890	2.20-11.0- 35	RF	P
8-45890-7	2.20-11.0- 38	RF	X
8-45891-1	2.20-11.0- 39	1	P1
8-45891-7	2.20-11.0- 42	1	X1
8-45892	2.20-11.0- 39	RF	P1
8-45892-7	2.20-11.0- 42	1	A
8-45893	2.20-11.0- 31	2	P
8-45894	2.20-11.0- 18	1	P
	2.20-11.0-100	1	P
8-45895	2.20-20.0- 1	1	P
8-45931-3	2. 8- 8.0- 9	1	P
8-45957	2. 3- 3.0- 56	1	U
	2. 8- 7.0-	RF	
8-45958	2. 3- 3.0- 55	1	U
	2. 8- 8.0-	RF	
	2. 8- 8.0- 7	1	P1
8-45958-31	2. 8- 8.0- 7	1	X1
8-45959-7	2. 8- 7.0- 34	1	P1
8-45960-1	2. 8- 7.0- 24	1	P1
8-45960-7	2. 8- 7.0- 29	1	X1
8-45961	2. 8- 8.0- 8	2	P2
8-45962	2. 8- 8.0- 6	1	P2
8-45962-7	2. 8- 8.0- 5	1	P2
8-45963	2. 8- 7.0- 30	1	
8-45966-103	2. 4-12.0- 92	AR	M
8-45966-105	2. 4-12.0- 92	AR	M
8-45966-107	2. 4-12.0- 12	1	M
8-45966-109	2. 4-12.0- 13	1	M
8-45966-113	2. 4-12.0- 9	1	M
8-45966-117	2. 4-12.0- 4	1	M
8-45966-21	2. 4-12.0- 1	2	M
8-45966-31	2. 4-12.0- 92	AR	M
8-45966-63	2. 4-12.0- 7	1	M
8-45966-83	2. 4-12.0- 3	1	M
8-45966-85	2. 4-12.0- 2	1	M
8-45966-87	2. 4-12.0- 5	1	M
8-45967	2. 4-12.0- 81	2	P
8-45967-7	2. 4-12.0- 86	1	X1
8-45968-3	2. 4-12.0- 77	1	P1
8-45968-4	2. 4-12.0- 77	1	P1
8-45969-7	2. 4-12.0- 87	1	P
8-45969-8	2. 4-12.0- 87	1	
8-45971	2. 8- 8.0- 1	2	
8-4664-505	2.20-19.0- 39	1	
8-47516	2.14-10.0- 9	1	
8-47518	2.14-10.0- 11	1	
8-47519-7	2.14-10.0- 10	1	
8-48805-73	2.15-18.0- 11	1	
8-48805-75	2.15-18.0- 11	1	
8-48805-77	2.15-18.0- 11	1	
8-49110-11	2.14-31.0- 11	2	
8-49110-13	2.14-31.0- 10	5	
8-49115	2.10- 3.0- 27	3	

PART NUMBER	FIGURE AND INDEX NUMBER	QTY PER ART	SMR CODE
8-49115	2.14-31.0- 14	2	P1
	2.14-31.0- 9	16	P1
8-49115-7	2.10- 3.0- 28	3	P1
8-49789	2.14-20.0- 16	2	P
	2.14-20.0- 58	2	
	2.14-42.0- 15	1	
	2.14-42.0- 21	2	
	2.14-42.0- 25	1	
8-51013	2. 6- 1.0- 18	1	U
	2. 6- 2.0- 18	1	
	2.15-25.0-	RF	
8-51013-1	2. 6- 1.0- 18	1	U
	2. 6- 2.0- 18	1	
	2.15-25.0-	RF	
8-51013-3	2. 6- 1.0- 18	1	U
	2. 6- 2.0- 18	1	
	2.15-25.0-	RF	
8-51013-5	2. 6- 1.0- 18	1	U
	2. 6- 2.0- 18	1	
	2.15-25.0-	RF	
8-51014	2.15-28.0- 9	1	U
8-51016-1	2. 6-32.0- 46	1	U
	2.15- 4.0-	RF	
8-51016-2	2. 6-32.0- 46	1	U
	2.15- 4.0-	RF	
8-51016-3	2. 6-32.0- 46	1	U
	2.15- 4.0-	RF	
8-51016-4	2.15- 4.0-	RF	U
8-51016-5	2. 6-32.0- 46	1	U
	2.15- 4.0-	RF	
8-51016-6	2. 6-32.0- 46	1	U
	2.15- 4.0-	RF	
8-51050	2.15-38.0-	RF	
8-51050-1	2.15-38.0-	RF	
8-51051	2.15-38.0- 41	1	P
8-51052	2.15-38.0- 19	1	P
8-51053	2.15-38.0- 37	1	P
8-51054	2.15-38.0- 4	1	P
8-51055	2.15-38.0- 36	1	P
8-51057	2.15-38.0- 35	1	P
8-51060	2.15-38.0- 47	1	P
8-51061	2.15-38.0- 44	1	P
8-51064	2.15-38.0- 48	1	P
8-51065	2.15- 38.0- 21	1	
8-51066-7	2.15-38.0- 49		P
8-51134	2.15-28.0- 24	1	
8-51138-7	2.15-28.0- 17	1	P1
8-51139	2.15-28.0- 13	1	M
8-51140	2.15-28.0- 18	AR	M
8-51143	2.15-28.0- 16	2	M
8-51152-7	2.15-25.0- 30	1	P1
8-51152-8	2.15-25.0- 30	1	P1
8-51153-9	2.15-25.0- 48	1	P
8-51154-9	2.15-25.0- 16	1	M
8-51155-7	2.15-25.0- 30	RF	P1
8-51155-8	2.15-25.0- 30	RF	P1
8-51156	2.15- 4.0- 17	1	M
8-52003-7	2.15-16.0- 13	1	M1
8-52003-801	2. 3- 3.0- 11	1	U
	2.15-16.0-	RF	
8-52003-803	2. 3- 3.0- 11	1	U
	2.15-16.0-	RF	
8-52003-805	2. 3- 3.0- 11	1	U
	2.15-16.0-	RF	
8-52003-807	2. 3- 3.0- 11	1	U

PART NUMBER	FIGURE AND INDEX NUMBER	QTY PER ART	SMR CODE
8-52003-807	2.15-16.0-	RF	U
8-52003-911	2. 3- 3.0- 11	1	U
	2.15-16.0-	RF	
8-52109-1	2. 3- 4.0- 56	1	U
	2.15- 2.0-	RF	
8-52109-3	2. 3- 4.0- 56	1	U
	2.15- 2.0-	RF	
8-52110	2.15- 2.0- 16	1	M
8-52111-7	2.15- 2.0- 21	1	P
8-52111-9	2.15- 2.0- 22	1	P
8-52114	2.15-16.0- 29	1	P
8-52115	2.15-16.0- 13	1	M1
8-52136-3	2.15-16.0- 33	1	A
	2.15-17.0-	RF	
8-52136-5	2.15-16.0- 33	1	A
	2.15-17.0-	RF	
8-52136-801	2.15-16.0- 33	1	A
	2.15-17.0-	RF	
8-52136-803	2.15-16.0- 33	1	A
	2.15-17.0-	RF	
8-52136-805	2.15-16.0- 33	1	A
	2.15-17.0-	RF	
8-52137	2.15- 8.0- 1	1	A
8-52138-1	2.15- 8.0- 37	1	P1
8-52138-3	2.15- 9.0- 35	1	P1
	2.15-11.0- 36	1	
8-52138-7	2.15- 8.0- 39	1	X1
8-52138-9	2.15- 9.0- 37	1	X1
8-52139	2.15- 8.0- 35	1	P
8-52139-9	2.15-11.0- 38	1	
8-52140	2.15- 8.0- 29	1	P
	2.15- 9.0- 21	1	
8-52140-7	2.15-11.0- 22	1	P
8-52141	2.15- 8.0- 26	1	P
8-52141-7	2.15- 8.0- 28	1	X1
8-52142	2.15- 8.0- 22	1	P1
8-52142-7	2.15- 8.0- 24	1	X1
8-52143	2.15- 8.0- 33	1	P1
8-52144	2.15- 8.0- 20	1	P
	2.15- 9.0- 12	1	
	2.15-11.0- 13	1	
8-52145	2.15- 8.0- 16	1	P
	2.15- 9.0- 8	1	
8-52145-1	2.15-11.0- 9	1	P
8-52145-7	2.15- 8.0- 19	1	X1
	2.15- 9.0- 11	1	
8-52145-8	2.15-11.0- 12	1	X1
8-52146	2.15- 8.0- 15	1	P
	2.15- 9.0- 7	1	
	2.15-11.0- 8	1	
8-52147	2.15- 8.0- 12	1	P
	2.15- 9.0- 4	1	
	2.15-11.0- 5	1	
8-52148-7	2.15- 8.0- 41	1	P1
	2.15- 9.0- 39	1	
8-52148-9	2.15-11.0- 42	1	P1
8-52149-7	2.15- 8.0- 23	1	X1
	2.15- 9.0- 15	1	
	2.15-11.0- 16	1	
8-52149-9	2.15- 8.0- 27	1	X1
	2.15- 9.0- 19	1	
	2.15-11.0- 20	1	
8-52150	2.15- 8.0- 4	1	P1
8-52150-1	2.15- 9.0- 24	1	P1
	2.15-11.0- 25	1	

PART NUMBER	FIGURE AND INDEX NUMBER	QTY PER ART	SMR CODE
8-52153-7	2.15- 9.0- 11	1	X1
8-52153-9	2.15- 9.0- 29	1	X1
	2.15-11.0- 29	1	
8-52154	2.15- 9.0- 43	1	P
	2.15- 9.0- 36	1	
	2.15-11.0- 39	1	
8-52155	2.15- 9.0- 41	RF	P1
	2.15- 9.0- 39	RF	
8-52153-7	2.15-11.0- 42	RF	P1
8-52154	2.15- 9.0- 37	RF	P1
8-52154-1	2.15- 9.0- 38	RF	P1
	2.15-11.0- 36	RF	
8-52154-7	2.15- 9.0- 39	RF	X1
8-52154-9	2.15- 9.0- 37	RF	X1
	2.15-11.0- 32	RF	
8-52158	2. 3- 4.0- 62	1	U
	2.15- 9.0- 62	RF	
8-52161	2. 3- 4.0- 62	1	U
	2.15- 9.0- 62	RF	
8-52161-1	2. 3- 4.0- 62	1	M
	2.15-11.0- 62	RF	
8-52161-7	2.15-11.0- 1	1	M
8-52162-1	2.15- 9.0- 1	1	P1
8-52162-3	2.15-11.0- 2	1	P1
8-52162-9	2.15- 9.0- 29	1	P1
	2.15-11.0- 32	1	
8-52185-1	2.15-17.0- 14	1	A
8-52185-11	2.15-17.0- 26	1	P1
8-52185-13	2.15-17.0- 19	1	P1
8-52185-15	2.15-17.0- 15	1	P1
8-52185-5	2.15-17.0- 14	1	A
8-52185-861	2.15-17.0- 14	1	A
8-52185-9	2.15-17.0- 19	1	P1
8-52186-7	2.15-16.0- 26	1	X1
8-52187	2.15-17.0- 29	1	X1
8-52188	2.15-17.0- 31	1	P1
8-52188-7	2.15-17.0- 32	1	P1
8-52188-9	2.15-17.0- 34	1	P
8-52189-7	2.15-17.0- 24	1	X1
8-52190	2.15- 9.0- 32	1	X1
	2.15-11.0- 33	1	
8-52192	2.15- 9.0- 18	1	P1
	2.15-11.0- 19	1	
8-52192-7	2.15- 9.0- 20	1	X1
	2.15-11.0- 21	1	
8-52193	2.15- 9.0- 14	1	P1
	2.15-11.0- 15	1	
8-52193-7	2.15- 9.0- 16	1	X1
	2.15-11.0- 17	1	
8-52205	2.15-17.0- 11	2	P
8-52212	2.15-17.0- 10	1	P
8-52215-7	2.15-17.0- 3	2	P
8-52215-9	2.15-17.0- 4	2	P
8-52222	2.15- 9.0- 31	1	X1
	2.15-11.0- 32	1	
8-52224	2.15-11.0- 41	1	P
8-52227-7	2.15-16.0- 56	2	P
8-52227-9	2.15-16.0- 56	2	P
8-52228	2.15-17.0- 4	1	U
8-52228-1	2.15-17.0- 4	1	U
8-54456	2.20-31.0- 3	1	P
8-54809-7	2.20-31.0-105	1	P
8-56303-1	2.20-25.0-	RF	
8-56303-3	2.20-24.0-	RF	
8-56303-5	2.20-25.0-	RF	

PART NUMBER	FIGURE AND INDEX NUMBER	QTY PER ART	SMR CODE
8-56303-7	2.20-25.0- 26	1	
8-56303-9	2.20-24.0- 11	1	
	2.20-25.0- 3	1	
8-56407	2.20-33.0- 14	1	P
8-56707	2.15- 3.0- 13	1	P
8-57002-1	2.15- 3.0- 2	1	P
8-57003-7	2.15- 3.0- 7	1	X1
8-57005-7	2.20-23.0- 26	1	P
8-57005-9	2.20-31.0- 5	1	P
8-57005-27	2.20-36.0- 17	1	X1
8-57005-7	2.20-34.0- 5	1	A
8-57005-59	2.20-36.0- 16	1	P
8-57005-41	2.20-36.0- 16	1	P
8-57005-43	2.20-36.0- 8	1	P
8-57005-44	2.20-36.0- 9	1	P
8-57005-45	2.20-36.0- 6	1	P
8-57005-46	2.20-36.0- 7	1	P
8-57005-47	2.20-36.0- 14	1	X1
8-57005-49	2.20-36.0- 15	1	X1
8-57005-5	2.20-34.0- 5	1	A
	2.20-36.0-	RF	
8-57005-713	2.20-34.0- 19	RF	M
8-57015	2.20-34.0- 1	1	P
8-57016	2.20-36.0- 15	RF	P
8-57017	2.20-23.0- 7	2	M
8-57019	2.20-47.0- 3	2	P
8-57020	2.20-36.0- 15	1	X1
8-57024-7	2.20-25.0- 19	1	P
8-57031-1	2. 3- 4.0- 69	1	
8-57031-2	2. 3- 4.0- 69	1	
8-57035-1	2.20-24.0- 19	1	
8-57035-7	2.20-24.0- 21	RF	P1
8-57036-7	2.20-34.0- 4	1	
	2.20-34.0- 4	1	
8-57037	2.20-34.0- 4	RF	P
	2.20-34.0- 4	RF	
8-57039-1	2. 3- 4.0- 69	1	U
	2.20- 4.0-	RF	
8-57040-1	2.20- 4.0-	1	P
8-57040-7	2.20- 4.0- 7	1	X1
8-57045	2.20-53.0- 38	RF	P
8-57046	2.20-53.0- 13	1	P
8-57047	2.20-33.0- 29	RF	P1
8-57047-7	2.20-33.0- 36	RF	X1
8-57048-1	2.20-33.0- 29	1	
8-57049-7	2.20-33.0- 36	1	X1
8-57053	2. 3-10.0- 7	1	U
	2.20-22.0-	RF	
8-57053-31	2.20-22.0- 15	2	M
8-57053-33	2.20-22.0- 10	1	A
8-57054-1	2.20-31.0- 78	1	P
8-57054-2	2.20-31.0- 78	1	P
8-57054-7	2.20-31.0- 81	1	X1
8-57054-8	2.20-31.0- 81	1	X1
8-57054	2.20-34.0- 4	1	A
8-57054-3	2.20-31.0- 71	1	U
8-57054-4	2.20-31.0- 71	1	U
8-57054-5	2.20-31.0- 71	1	U
8-57054-6	2.20-31.0- 71	1	U
8-57054	2.20-22.0- 11	1	P
8-57057-7	2.20-22.0- 16	1	X2
8-57057-3	2.20-22.0- 16	1	X1
8-57057-5	2.20-22.0- 25	1	X2
8-5705808	2.20-22.0- 26	1	X2
8-57058-11	2.20-21.0- 11	1	M

PART NUMBER	FIGURE AND INDEX NUMBER	QTY PER ART	SMR CODE
8-57096-13	2.20-21.0- 12	1	M
8-57096-5	2. 3- 3.0- 48	1	U
	2.20-21.0-	RF	
8-57096-69	2.20-21.0- 1	1	M
8-57096-7	2.20-21.0- 13	1	M
8-57096-8	2.20-21.0- 15	1	M
8-57096-9	2.20-21.0- 6	2	M
8-57097-57	2.20-21.0- 14	1	M
8-57097-58	2.20-21.0- 15	1	M
8-57097-81	2.20-21.0- 16	1	M
8-57097-82	2.20-21.0- 17	1	M
8-57103	2.20-47.0-	RF	
8-57133-1	2.20-23.0- 48	1	A1
	2.20-23A.0-7	RF	
	2.20-47.0-	RF	
	2.20-47.0-	RF	
8-57103-161	2.20-47.0- 1	1	M
8-57103-29	2.20-47.0- 2	2	M
	2.20-23A.0-11	2	
8-57103-3	2.20-23.0- 48	1	A1
	2.20-47.0-	RF	
8-57103-5	2.20-23.0- 48	1	A1
	2.20-47.0-	RF	
8-57103-73	2.20-47.0- 1	1	M
8-57115-1	2. 3- 3.0- 44	1	U
	2.20-31.0-	RF	
8-57115-11	2.20-31.0- 23	1	A
	2.20-32.0-	RF	
8-57115-12	2.20-31.0- 23	1	A
	2.20-32.0-	RF	
8-57115-13	2.20-31.0- 23	RF	A
	2.20-32.0-	RF	A
8-57115-14	2.20-31.0- 23	RF	A
	2.20-32.0-	RF	A
8-57115-2	2. 3- 3.0- 44	1	U
	2.20-31.0-	RF	
8-57115-25	2.20-24.0- 15		M
8-57115-3	2. 3- 3.0- 43	1	
8-57115-813	2. 3- 3.0- 42	1	U
	2.20-23.0-	RF	
8-57115-801	2.20-31.0-116	RF	A
	2.20-33.0-	RF	
8-57115-803	2.20-31.0-118	1	A
	2.20-33.0-	RF	
8-57117-5	2. 3- 3.0- 10	1	M
	2.15- 3.0-	RF	
8-57119-1	2.20-29.0- 16	1	P1
8-57119-11	2.20-26.0- 20	1	P1
	2.20-29.0- 1	1	
8-57119-13	2.20-26.0- 5	1	X1
	2.20-29.0- 21	1	
8-57120-13	2.20-47.0- 21	1	X1
8-57120-15	2.20-47.0- 21	1	X1
8-57120-17	2.20-47.0- 21	1	X1
8-57120-5	2.20-47.0- 17	1	P2
8-57120-801	2.20-47.0- 17	RF	P2
8-57120-803	2.20-47.0- 17	1	P2
8-57121-1	2.20-47.0- 22	RF	P2
8-57121-11	2.20-47.0- 24	1	X1
8-57121-3	2.20-47.0- 22	1	P2
8-57121-7	2.20-47.0- 24	1	X1
8-57122-1	2.20-47.0- 6	1	P1
8-57122-11	2.20-47.0- 15	1	X1
8-57122-13	2.20-47.0- 15	1	X1
8-57122-15	2.20-47.0- 15	1	X1
8-57122-17	2.20-47.0- 15	1	X1
8-57122-3	2.20-47.0- 7	1	P1

PART NUMBER	FIGURE AND INDEX NUMBER	QTY PER ART	SMR CODE
8-57122-5	2.20-47.0- 6	1	P1
8-57122-801	2.20-47.0- 7	1	P1
8-57125-1	2.20-23.0- 36	1	A
	2.20-29.0-	RF	
8-57126-13	2.20-24.0- 18	1	
	2.20-25.0- 5	1	
8-57126-5	2.20-24.0- 16	1	
8-57127	2.20-24.0- 16	RF	
	2.20-25.0- 3	RF	
8-57127-9	2.20-24.0- 18	RF	
	2.20-25.0- 5	RF	
8-57128-1	2.20-26.0- 45	1	P1
	2.20-26.0- 47	1	
	2.20-27.0- 35	1	
	2.20-29.0- 21	1	
8-57128-7	2.20-27.0- 37	1	X1
	2.20-29.0- 23	1	
8-57129	2.20-26.0- 45	RF	P2
	2.20-27.0- 35	RF	
	2.20-29.0- 21	RF	
8-57129-7	2.20-26.0- 47	RF	X1
	2.20-27.0- 37	RF	
	2.20-29.0- 23		
8-57130-1	2.20-25.0- 5	1	X1
8-57130-11	2.20-24.0- 21	1	
8-57130-3	2.20-24.0- 19	1	
8-57130-7	2.20-25.0- 7	1	
8-57131	2.20-25.0- 5	RF	
8-57131-7	2.20-25.0- 7	1	
8-57132-1	2.20-26.0- 41	1	P1
	2.20-27.0- 13	1	
	2.20-29.0- 13	1	
8-57132-7	2.20-26.0- 44	1	X1
	2.20-27.0- 16	1	
	2.20-29.0- 16	1	
8-57133-1	2.20-27.0- 13	RF	P1
8-57133-9	2.20-26.0- 44	RF	X1
	2.20-27.0- 16	RF	
	2.20-29.0- 16		
8-57134-7	2.20-24.0- 17	2	
	2.20-25.0- 4	2	
	2.20-26.0- 45	2	
	2.20-27.0- 36	2	
	2.20-29.0- 22	2	
8-57134-9	2.20-31.0- 69	2	P
	2.20-32.0- 25	2	
8-57135-1	2.20-47.0- 22	RF	P2
8-57135-7	2.20-47.0- 24	RF	
8-57138-11	2.20-32.0- 27	RF	X1
8-57138-3	2.20-32.0- 24	RF	P1
8-57139-7	2.20-23.0- 34	2	P1
	2.20-23.0- 42	2	
8-57139-9	2.20-31.0- 27	2	P
	2.20-31.0- 64	2	
8-57140	2.20-32.0- 27	RF	X1
	2.20-23B.0-6	RF	
8-57140-10	2.20-31.0- 71	1	X1
8-57140-11	2.20-31.0- 71	1	X1
8-57140-12	2.20-31.0- 71	1	X1
8-57140-4	2.20-31.0- 60	1	P1
8-57140-5	2.20-31.0- 60	1	P1
8-57140-6	2.20-31.0- 60	1	P1
8-57140-9	2.20-31.0- 71	1	P1
8-57141-13	2.20-32.0- 27	1	X1
8-57141-14	2.20-32.0- 27	1	X1
8-57141-801	2.20-32.0- 24	1	X1

PART NUMBER	FIGURE AND INDEX NUMBER	QTY PER ART	SMR CODE	PART NUMBER	FIGURE AND INDEX NUMBER	QTY PER ART	SMR CODE
8-57141-804	2.20-32.0-24	1	P1	8-57147	2.20-23.0-19	1	P
8-57142-7	2.20-31.0-107	1	P1	8-57148	2.20-31.0-19	2	P
8-57144	2.20-47.0-6	RF	P	8-57149	2.20-31.0-1	1	P
8-57144-1	2.20-47.0-7	RF	P	8-57150	2.20-31.0-9	2	P
8-57144-11	2.20-47.0-15	RF	X1	8-57151	2.20-31.0-6	1	P
8-57144-13	2.20-47.0-15	RF	X1	8-57151-1	2.20-31.0-11	1	X1
8-57144-15	2.20-47.0-15	RF	X	8-57153	2.20-23.0-11	2	P
8-57144-17	2.20-47.0-15	RF	X	8-57154	2.20-23.0-25	2	P
8-57144-3	2.20-47.0-6	RF	P	8-57155	2.20-23.0-21	1	P
8-57144-5	2.20-47.0-7	RF	P	8-57156	2.20-23.0-23	1	P
8-57145	2.20-33.0-9	RF	P1	8-57159	2.20-33.0-25	1	P1
8-57146-7	2.20-33.0-9	1	P1	8-57200-153	2.20-34.0-17	1	P
8-57147-1	2.20-33.0-73	1	P1	8-57214	2.20-9.0-14	1	M
8-57147-7	2.20-33.0-77	1	X1	8-57314	2.20-8.0-10	3	M
8-57148-7	2.20-33.0-57	1	P1	8-57316	2.20-8.0-1	RF	U
8-57149-7	2.20-33.0-8	1	P		2.20-23.0-3	1	
8-57150-1	2.20-33.0-29	RF	P1	8-57316-1	2.20-31.0-125	1	U
8-57150-7	2.20-33.0-37	RF	X1	8-57316-7	2.20-31.0-125	1	U
8-57151	2.20-33.0-16	2	P	8-57318	2.20-8.0-8	1	P1
8-57152-1	2.20-33.0-73	RF	P1	8-57319	2.20-8.0-9	1	P1
8-57152-11	2.20-33.0-77	RF	X1	8-57322	2.20-14.0-21	1	M
8-57152-3	2.20-33.0-73	12	P	8-57323	2.20-34.0-22	14	M
8-57152-9	2.20-33.0-77	RF	X1	8-57344	2.20-35.0-4	4	P
8-57153	2.20-33.0-29	RF	P1	8-57345	2.20-35.0-3	4	P
8-57153-7	2.20-33.0-37	RF	X1	8-57457	2.20-31.0-71	4	P
8-57154-1	2.20-31.0-112	1	P1	8-57458-7	2.20-25.0-11	1	
8-57154-7	2.20-31.0-117	1	X1	8-57459-7	2.20-25.0-8	1	
8-57155-1	2.20-31.0-112	RF	P1	8-57456	2.20-32.0-1	1	M
8-57155-9	2.20-31.0-117	RF	X1		2.20-32.0-12	1	
8-57156	2.20-31.0-112	1	P	8-57457-7	2.20-7.0-6	RF	
8-57157-7	2.20-47.0-30	2	P1	8-57457-9	2.20-7.0-7	RF	
8-57157-8	2.20-47.0-31	2	P1	8-57458-10	2.20-7.0-7	1	X2
8-57158-7	2.20-47.0-30	RF	M		2.20-9.0-21	1	
8-57158-8	2.20-47.0-31	RF	M	8-57458-9	2.20-7.0-6	1	X2
8-57159-7	2.20-47.0-31	1	P2		2.20-8.0-14	1	
8-57159-8	2.20-47.0-31	1	P2	8-57504-33	2.20-23.0-65	1	
8-57165-13	2.20-31.0-121	2	M	8-57506	2.20-23.0-51	RF	U
8-57166	2.20-33.0-21	1	P	8-57508-11	2.20-23.0-59	1	
8-57167	2.20-31.0-16	1	P	8-57509-13	2.20-23.0-55	1	M
8-57168-7	2.20-47.0-31	1	P	8-57509-15	2.20-23.0-64		
8-57168-8	2.20-47.0-31	1	P	8-57509-17	2.20-23.0-67	1	
8-57169-1	2.20-23.0-15	1	P	8-57509-21	2.20-23.0-68	1	
8-57169-2	2.20-23.0-15	1	P	8-57509-23	2.20-23.0-63	1	M
8-57169-7	2.20-23.0-18	1	X1	8-57509-25	2.20-23.0-61	1	M
8-57169-8	2.20-23.0-18	1	X1	8-57509-27	2.20-23.0-62	1	M
8-57170	2.20-31.0-110	1	P	8-57509-31	2.20-23.0-59	1	M
8-57175	2.20-31.0-28	RF	P	8-57509-39	2.20-23.0-51	1	M
8-57177-1	2.20-31.0-111	1	P1	8-57509-51	2.20-23.0-53	1	M
8-57178	2.20-33.0-39	2	P	8-57509-57	2.20-23.0-57	1	M
8-57179-7	2.20-33.0-40	2	P	8-57509-68	2.20-23.0-56	1	M
8-57179-1	2.20-33.0-46	RF	P1	8-57509-69	2.20-23.0-56	1	M
8-57179-2	2.20-33.0-47	RF	P1	8-57509-71	2.20-31.0-41	1	P
8-57179-7	2.20-33.0-52	RF	X1	8-57509-81	2.20-31.0-82	RF	A
8-57179-8	2.20-33.0-52	RF	X1	8-57509-82	2.20-31.0-82	RF	A
8-57183-7	2.20-31.0-122	1	M	8-57509-83	2.20-31.0-82	RF	A
8-57183-9	2.20-31.0-123	1	M	8-57509-84	2.20-31.0-82	1	P2
8-57184-1	2.20-33.0-46	1	P1	8-57509-85	2.20-31.0-82	1	P2
8-57184-10	2.20-33.0-52	1	X	8-57509-87	2.20-31.0-82	1	P2
8-57184-2	2.20-33.0-47	1	P1	8-57509-88	2.20-28.0-15	1	P2
8-57184-3	2.20-33.0-46	1	P1	8-57509-91	2.20-28.0-233	1	X1
8-57184-4	2.20-33.0-47	1	P1	8-57509-92	2.20-28.0-15	1	P2
8-57184-7	2.20-33.0-52	1	X1	8-57509-93	2.20-28.0-23	1	X1
8-57184-8	2.20-33.0-52	1	X1	8-57509-11	2.20-28.0-14	1	X1
8-57184-9	2.20-33.0-52	1	X		2.20-28.0-14	1	X1
8-57186-7	2.20-31.0-28	1	P1	8-57509-12	2.20-28.0-14	1	X1

PART NUMBER	FIGURE AND INDEX NUMBER	QTY PER ART	SMR CODE
8-57907-12	2.20-28.0- 14	1	X1
8-57907-13	2.20-28.0- 14	1	X1
8-57907-14	2.20-28.0- 14	1	X1
8-57907-3	2.20-28.0- 1	1	P1
	2.20-28.0- 1	1	
8-57907-4	2.20-28.0- 1	1	P1
8-57907-5	2.20-28.0- 1	1	P1
8-57907-801	2.20-28.0- 1	1	P1
8-57907-802	2.20-28.0- 1	2	P1
8-57908-1	2.20-31.0- 81	1	U
8-57908-2	2.20-31.0- 81	1	U
8-57912-7	2.20-31.0- 87	2	M
8-57912-9	2.20-31.0- 86	3	X
8-57916-7	2.20-28.0-233	RF	X
8-57916-8	2.20-28.0-233	RF	X
8-57918	2. 3- 3.0- 11	1	U
	2.20-28.0-	RF	
8-57919-1	2.20-31.0- 92	1	X2
8-57919-10	2.20-31.0- 95	RF	X1
8-57919-2	2.20-31.0- 92	RF	X2
8-57919-3	2.20-31.0- 92	1	X2
8-57919-4	2.20-31.0- 92	1	X2
8-57919-7	2.20-31.0- 95	1	X1
8-57919-8	2.20-31.0- 95	1	X1
8-57919-9	2.20-31.0- 95	RF	
8-57920-1	2.20-31.0- 92	1	X1
8-57920-2	2.20-31.0- 92	1	X2
8-57920-7	2.20-31.0- 96	1	X2
8-57920-8	2.20-31.0- 96	1	X1
8-57922-1	2.20-31.0- 27	1	X1
8-57922-2	2.20-31.0- 27	1	A
8-57926-33	2.20-32.0- 5	1	A
8-57926-37	2.20-32.0- 8	2	M
8-57926-39	2.20-32.0- 17	1	M
	2.20-23B.0-10	RF	
8-57926-41	2.20-32.0- 21	1	M
8-57926-43	2.20-32.0- 20	2	M
8-57926-47	2.20-32.0- 22	2	M
8-57926-51	2.20-32.0- 1	1	P
	2.20-32.0- 12	1	
8-57926-53	2.20-32.0- 4	1	M
8-57926-55	2.20-32.0- 16	RF	M
8-57926-57	2.20-32.0- 16	1	M
8-57926-59	2.20-32.0- 24	1	M
8-57926-63	2.20-32.0- 23	1	M
8-57926-67	2.20- 7.0- 12	1	M
	2.20- 8.0- 28	1	
8-57926-807	2.20-32.0-	1	U
8-57926-808	2.20-32.0-	1	U
8-57926-809	2.20-32.0-	RF	U
8-57926-810	2.20-32.0-	RF	U
8-57926-811	2.20- 7.0-	RF	U
	2.20-23.0- 2	1	
8-57928-7	2.20-28.0- 10	1	P
8-57928-9	2.20-28.0- 9	1	P
8-57929-11	2.20-31.0- 77	1	P1
8-57929-9	2.20-31.0- 72	1	P1
	2.20-31.0- 77	1	
8-57930-7	2.20-31.0- 76	1	P1
8-57930-8	2.20-31.0- 76	1	P1
8-57934-1	2.20-27.0-	RF	A
8-57934-11	2.20-26.0- 5	RF	P1
	2.20-27.0- 16	1	
8-57934-7	2.20-27.0-	1	P1
	2.20-27.0- 2	1	
8-57934-9	2.20-26.0- 22	RF	P1

PART NUMBER	FIGURE AND INDEX NUMBER	QTY PER ART	SMR CODE
8-57934-9	2.20-27.0-	1	P1
8-57935-1	2.20-26.0- 6	1	X1
	2.20-27.0- 20	1	
8-57935-11	2.20-25.0- 17	1	X1
8-57935-13	2.20-24.0- 9	1	X1
8-57935-7	2.20-24.0- 10	1	X1
	2.20-25.0- 16	1	
	2.20-26.0- 15	1	
	2.20-26.0- 29	2	
	2.20-26.0- 37	2	
	2.20-27.0- 29	1	
	2.20-27.0- 4	2	
	2.20-27.0- 6	2	
8-57935-8	2.20-26.0- 14	1	X1
	2.20-27.0- 28	1	
8-57936-11	2.20-26.0- 30	1	X1
	2.20-27.0- 12	1	
8-57936-13	2.20-25.0- 18	1	X1
	2.20-26.0- 19	1	
	2.20-27.0- 33	1	
8-57936-7	2.20-24.0- 14	1	X1
8-57936-9	2.20-26.0- 40	1	X1
	2.20-27.0- 11	1	
	2.20-29.0- 13	1	
8-57937-11	2.20-24.0- 5	2	P1
8-57937-5	2.20-23.0- 28	1	A
	2.20-24.0-	RF	
8-57937-7	2.20-25.0- 11	2	P1
8-57938-1	2.20-31.0- 73	1	M
8-57938-2	2.20-31.0- 73	1	M
8-57938-7	2.20-31.0- 75	1	M
8-57938-8	2.20-31.0- 75	1	M
8-57939	2.20-23.0- 35	1	A
	2.20-26.0-	RF	
8-57940-1	2.20-30.0-	RF	U
	2.20-47.0- 17	1	
8-57940-11	2.20-30.0- 1	1	M
8-57940-12	2.20-30.0- 2	1	M
8-57940-7	2.20-30.0- 6	2	M
	2.20-23A.0-12	2	
8-57940-8	2.20-30.0- 11	2	M
8-57941-7	2.20-30.0- 24	1	M1
8-57942-7	2.20-30.0- 12	RF	M1
8-57942-8	2.20-30.0- 13	RF	M1
8-57943-7	2.20-30.0- 18	RF	M1
8-57943-8	2.20-30.0- 19	RF	M1
8-57947	2.20-24.0- 1	1	M
8-57948-10	2.20-30.0- 13	1	X2
8-57948-9	2.20-30.0- 12	1	X2
8-57949-10	2.20-30.0- 19	1	X2
8-57949-9	2.20-30.0- 18	1	M
8-57953-7	2.20- 6.0- 9	1	
8-57954-7	2.20- 6.0- 17	1	
8-57977-1	2. 3- 3.0- 49	1	
8-57977-2	2. 3- 3.0- 49	1	
8-57980-1	2. 3- 3.0- 50	1	
8-57980-2	2. 3- 3.0- 50	1	U
8-57984-7	2.20- 7.0- 2	1	M1
8-57987	2. 3- 4.0- 5	1	U
	2.20- 6.0-	RF	
8-57987-13	2.20- 6.0- 19	1	M
8-57987-17	2.20- 6.0- 2	1	A
8-57987-18	2.20- 6.0- 28	RF	M
8-57988-7	2.20- 6.0- 18	1	P
8-57988-1	2.20- 6.0- 21	2	P
8-57988-7	2.20- 6.0- 27	1	X1

PART NUMBER	FIGURE AND INDEX NUMBER	QTY PER ART	SMR CODE	PART NUMBER	FIGURE AND INDEX NUMBER	QTY PER ART	SMR CODE
8-57991-1	2.20-27.0- 34	1		8-61130-9	2.14- 8.0- 92	1	P1D
8-6035-A12	2.17-11.0-130	1		8-61131	2.14- 8.0- 24	1	M
8-61035-2	2.12- 6.0-	1		8-61132	2.14- 8.0- 45	1	M
8-61035	2.12-39.0- 14	1	U	8-61253	2. 6- 3.0- 10	1	P
8-61035-1	2. 6- 3.0- 12	1			2.17- 1.0- 41	1	
	2.12- 6.0-	1			2.17- 1.0- 50	1	
8-61035-2	2. 6- 3.0- 12	1	U	8-61371-7	2.17-26.0- 29	1	X2
8-61035-5	2. 6- 3.0- 14	1	U	8-61374-9	2.16-19.0- 10	1	A
	2.12- 6.0-	1		8-61391-13	2.17-21.0- 53	1	X2
8-61035-6	2. 6- 3.0- 14	1	U	8-61392	2.16- 1.0- 40	1	P1
	2.12- 6.0-	1		8-61411-7	2.17-33.0- 48		
8-61035-801	2. 6- 3.0- 17	1	U		2.17-35.0- 50	1	
	2.12- 6.0-	1		8-61432-9	2.17-33.0- 53	1	
8-61035-802	2. 6- 3.0- 17	1	U		2.17-35.0- 55	1	
	2.12- 6.0-	1		8-61446-5	2. 2-12.0-		RF
8-61035-803	2. 6- 3.0- 16	1	U	8-61446-9	2. 2-12.0- 13	1	
	2.12- 6.0-	1		8-61453-7	2. 5- 1.0- 8	1	
8-61035-804	2. 6- 3.0- 16	1	U	8-61455-7	2. 5- 1.0- 14	1	P1
	2.12- 6.0-	1			2. 5-10.0- 7	1	
8-61035-805	2. 6- 3.0- 13	1	U	8-61456-7	2. 5- 1.0- 13	1	M
	2.12- 6.0-	1		8-61457-9	2. 5- 1.0- 15	1	M
8-61035-806	2. 6- 3.0- 13	1	U	8-61548-9	2.17-35.0- 67		
	2.12- 6.0-	1			2.17-35.0- 68		
8-61035-807	2. 6- 3.0- 15	1	U	8-61551-1	2. 6- 3.0- 11	1	
	2.12- 6.0-	1		8-61551-3	2. 6- 3.0- 11	1	
8-61035-808	2. 6- 3.0- 15	1	U	8-61551-5	2. 6- 3.0- 11	1	A
	2.12- 6.0-	1		8-61551-801	2. 6- 3.0- 11	1	A
8-61036-1	2. 6- 3.0- 3	1	U	8-61551-803	2. 6- 3.0- 11	1	A
	2.17- 1.0- 35	1		8-61551-805	2. 6- 3.0- 11	1	A
8-61036-2	2. 6- 3.0- 3	1	U	8-61551-807	2. 6- 3.0- 11	1	A
	2.17- 1.0- 35	1		8-61551-809	2. 6- 3.0- 11	1	A
8-61041-3	2.17-11.0-109	GO	U	8-61551-827	2. 6- 3.0- 11	1	A
8-61041-4	2.17-11.0-109	1	U	8-61551-829	2. 6- 3.0- 11	1	
8-61042-1	2.14- 6.0- 32	1	U	8-61551-831	2. 6- 3.0- 11	1	
8-61100-801	2.14- 7.0-	RF	P1	8-61551-833	2. 6- 3.0- 11	1	
8-61100-803	2.14- 6.0- 23	1	P1	8-61551-835	2. 6- 3.0- 11	1	
8-61102-3	2.14- 7.0- 16	1	P1	8-61551-837	2. 6- 3.0- 11	1	
	2.14- 8.0-	RF		8-61598-13	2.17-29.0- 33	1	
8-61102-9	2.14- 8.0- 30	1	P1		2.17-31.0- 34	1	
8-61103-1	2.14- 8.0-136	1	X2D	8-61598-21	2.17-33.0- 23	1	
8-61105-1	2.14- 8.0- 98	1	A1		2.17-35.0- 25	1	
8-61105-7	2.14- 8.0-101	4	P	8-61598-7	2.17-33.0- 61	1	
8-61109-7	2.14- 8.0- 58	1	P		2.17-35.0- 63	1	
8-61110-9	2.14- 8.0- 59	1	P	8-61598-9	2.17-33.0- 65	1	
8-61112-3	2.14- 7.0- 7	1	P	8-62203-803	2.13- 1.1- 22	1	U
8-61113-1	2.14- 7.0- 13	1	A1	8-62204-803	2.17- 8.0- 15	1	U
8-61115-1	2.14- 7.0- 17	1	P	8-62204-807	2.17- 8.0- 16	1	U
8-61119	2.14- 8.0- 37	1	P1	8-62206-5	2.13- 1.1- 27	1	U
8-61119-7	2.14- 8.0- 44	1	X1	8-62210-1	2.16-10.0- 6	1	A
8-61120	2.14- 8.0- 48	1	P	8-62210-9	2.16-10.0- 10	1	M
8-61120-7	2.14- 8.0- 52	1	X1	8-62211-7	2.16-10.0- 5	1	P
8-61120-9	2.14- 8.0- 48	1	X1	8-62212	2.16- 8.0- 32	1	A
8-61121-11	2.14- 8.0- 10	1	P		2.16-10.0-		RF
8-61122-9	2.14- 8.0-105	1	P1	8-62212-3	2.16- 8.0- 32	1	A
8-61123-11	2.14- 8.0-110	4	P		2.16-10.0-		RF
8-61123-7	2.14- 8.0-119	6	P	8-62213-1	2.16-12.0- 8	1	A
	2.14- 8.0-132	2		8-62213-9	2.16-12.0- 12	1	
8-61123-9	2.14- 8.0-126	8	P	8-62214-7	2.16-12.0- 7	1	P
8-61124	2.14- 8.0- 23	2	P1	8-62215-1	2.16- 8.0- 9	1	A
8-61125	2.14- 8.0-113	1	P1		2.16-12.0-		RF
8-61127	2.14- 7.0- 4	1	M	8-62215-3	2.16- 8.0- 9	1	A
8-61128	2.14- 8.0-111	4	P		2.16-12.0-		RF
8-61129	2.14- 8.0- 11	1	P1D	8-62216-7	2.16-20.0- 3	10	
8-61130	2.14- 8.0- 91	1	A1		2.18-33.0- 16	1	
8-61130-7	2.14- 8.0- 94	1	X1	8-62219-15	2.16-11.0- 43	1	A

PART NUMBER	FIGURE AND INDEX NUMBER	QTY PER ART	SMR CODE
8-62219-5	2.16-11.0- 38	1	
8-62222	2.16-21.0- 7	1	
8-62222-7	2.16-21.0- 11	1	
8-62223	2.16-21.0- 6	1	
8-62224	2.16- 8.0- 31	1	
	2.16-21.0-	1	
8-62225-1	2.16- 8.0- 45	1	
8-62225-7	2.16- 8.0- 45	1	
8-62225-9	2.16- 8.0- 45	1	
8-62226-7	2.16- 8.0- 44	1	
8-62227	2.16- 8.0- 38	1	
8-62227-1	2.16- 8.0- 38	1	
8-62227-3	2.16- 8.0- 38	1	
8-62228-1	2.13- 1.1- 30	1	
8-62231-1	2.12-39.0- 33	RF	
8-62232	2.13- 1.1- 23	1	
8-62235	2.17-11.0- 52	1	
	2.17-30.0-	RF	
8-62235-17	2.17-30.0- 12	1	
8-62235-7	2.17-30.0- 14	1	
8-62235-9	2.17-30.0- 1	1	
8-62236	2.17- 1.0- 53	1	
8-62269-15	2.16-11.0- 28	1	
8-62269-803	2.16-11.0- 28	1	
8-62269-9	2.16-11.0- 27	1	
8-62294-801	2.17- 8.0- 37	1	
8-62294-803	2.17- 8.0- 37	1	
8-62300	2.17-21.0- 13	2	
	2.17-21.0- 13	1	
	2.17-23.0- 14		
	2.17-26.0- 10	1	
	2.17-26.0- 45	1	
	2.17-27.0- 45	1	
	2.17-29.0- 12	2	
	2.17-30.0- 7	2	
	2.17-31.0- 11	3	
	2.17-33.0- 14	3	
	2.17-35.0- 17	4	
	2.20- 3.0- 16	1	
8-62300-401	2.17-21.0- 14	1	
8-62334-3	2.17- 1.0- 4	1	
8-62334-5	2.17- 1.0- 4	1	
8-62362-19	2.17-21.0- 83	1	
	2.17-23.0- 84	1	
8-62362-21	2.17-21.0- 84	1	
	2.17-23.0- 85	1	
8-62362-23	2.17-21.0- 85	1	
	2.17-23.0- 86	1	
8-62362-25	2.17-33.0- 80	1	
	2.17-35.0- 83	1	
8-62362-27	2.17-33.0- 81	1	
	2.17-35.0- 84	1	
8-62362-33	2.17-26.0- 58	1	
	2.17-27.0- 58	1	
	2.17-28.0- 18	1	
8-62362-35	2.17-26.0- 59	1	
	2.17-27.0- 59	1	
	2.17-28.0- 19	1	
8-62362-37	2.17-29.0- 61	1	
	2.17-31.0- 65	1	
8-62362-39	2.17-29.0- 62	1	
	2.17-31.0- 66	1	
8-62362-41	2.17-26.0- 60	1	
	2.17-27.0- 60	1	
	2.17-28.0- 20	1	

PART NUMBER	FIGURE AND INDEX NUMBER	QTY PER ART	SMR CODE
8-62362-43	2.17-29.0- 63	1	
	2.17-31.0- 67	1	
8-62364-11	2.17-33.0- 24	2	
8-62364-13	2.17-33.0- 25	2	
8-62364-15	2.17-26.0- 27	1	
	2.17-29.0- 58	1	
	2.17-31.0- 30	1	
	2.17-31.0- 64	1	
8-62364-31	2.17-26.0- 25	2	
	2.17-27.0- 25	2	
	2.17-28.0- 26	2	
	2.17-29.0- 28	2	
	2.17-31.0- 29	2	
8-62364-33	2.17-26.0- 26	2	
	2.17-27.0- 26	2	
	2.17-28.0- 27	2	
	2.17-29.0- 27	2	
	2.17-31.0- 28	2	
8-62364-35	2.17-26.0- 21	2	
	2.17-27.0- 21	2	
	2.17-28.0- 22	2	
	2.17-29.0- 24	2	
	2.17-31.0- 25	2	
8-62364-37	2.17-21.0- 81	2	
	2.17-23.0- 82	2	
	2.17-26.0- 24	2	
	2.17-27.0- 24	2	
	2.17-28.0- 25	2	
	2.17-29.0- 23	2	
	2.17-31.0- 24	2	
8-62364-39	2.17-27.0- 22	1	
	2.17-28.0- 23	1	
	2.17-29.0- 25	1	
	2.17-31.0- 27	1	
8-62364-41	2.17-26.0- 23	1	
	2.17-27.0- 23	1	
	2.17-28.0- 24	1	
	2.17-29.0- 26	1	
	2.17-31.0- 26	1	
8-62364-43	2.17-23.0- 83	4	
8-62364-45	2.17-35.0- 27	2	
8-62364-47	2.17-35.0- 26	2	
8-62364-7	2.17-21.0- 34	1	
	2.17-21.0- 50	1	
	2.17-21.0- 61	1	
	2.17-21.0- 72	1	
	2.17-23.0- 38	1	
	2.17-23.0- 53	1	
	2.17-23.0- 58	1	
	2.17-23.0- 77	1	
	2.17-23.0- 81	1	
	2.17-33.0- 29	1	
	2.17-33.0- 31	1	
	2.17-33.0- 34	1	
	2.17-33.0- 35	1	
8-62364-9	2.17-21.0- 82	4	
8-62364-15	2.17-31.0- 57	1	
8-62367-7	2.17-35.0- 37		
	2.17-35.0- 47		
	2.17-35.0- 48		1
8-62375-1	2.17-11.0- 46		1
	2.17-26.0- 1		RF
8-62375-11	2.17-21.0- 6		4
	2.17-23.0- 6		6
	2.17-26.0- 5		2

PART NUMBER	FIGURE AND INDEX NUMBER	QTY PER ART	SMR CODE
8-62375-11	2.17-29.0- 6	1	
8-62375-7	2.17-26.0- 63	2	
	2.17-27.0- 63	2	
	2.17-28.0- 60	2	
	2.17-29.0- 66	2	
	2.17-31.0- 70	2	
8-62375-801	2.17-11.0- 46	1	
	2.17-27.0- 1	RF	
8-62375-803	2.17-11.0- 46	1	
	2.17-27.0- 1	RF	
8-62375-805	2.17-11.0- 46	1	
	2.17-27.0- 1		
8-62375-807	2.17-11.0- 46	1	
	2.17-28.0- 1	RF	
8-62375-9	2.17-26.0- 62	2	
	2.17-27.0- 61	2	
	2.17-27.0- 62	2	
	2.17-28.0- 59	2	
	2.17-29.0- 65	2	
	2.17-31.0- 69	2	
8-62376-1	2.17-11.0- 49	1	
	2.17-29.0- 1	RF	
8-62376-803	2.17-11.0- 49	1	
	2.17-31.0- 1		
8-62376-805	2.17-11.0- 49	1	
	2.17-31.0- 1		
8-62376-807	2.17-11.0- 49	1	
8-62376-809	2.17-11.0- 49	1	
	2.17-31.0- 1	RF	
8-62376-811	2.17-11.0- 49	1	
	2.17-31.0- 1	RF	
8-62376-813	2.17-11.0- 49	1	
	2.17-31.0- 2		
8-62377-7	2.17-26.0- 63	1	
	2.17-27.0- 63	1	
	2.17-28.0- 60	1	
8-62377-8	2.17-29.0- 66	1	
	2.17-31.0- 71	1	
8-62378-101	2.17-31.0- 59	1	
8-62378-103	2.17-31.0- 61	1	
8-62378-107	2.17-31.0- 52	1	
8-62378-109	2.17-31.0- 35	1	
8-62378-117	2.17-31.0- 46	1	
8-62378-119	2.17-31.0- 36	1	
8-62378-121	2.17-31.0- 50	1	
8-62378-13	2.17-29.0- 34	1	
8-62378-15	2.17-29.0- 35	1	
8-62378-17	2.17-29.0- 36	1	
	2.17-31.0- 37		
8-62378-19	2.17-29.0- 37	1	
	2.17-31.0- 38	1	
8-62378-21	2.17-29.0- 38	1	
	2.17-31.0- 39	1	
8-62378-23	2.17-29.0- 39	1	
	2.17-31.0- 40	1	
8-62378-29	2.17-29.0- 42	1	
	2.17-31.0- 43	1	
8-62378-31	2.17-29.0- 43	1	
	2.17-31.0- 44	1	
8-62378-43	2.17-29.0- 50	1	
	2.17-31.0- 53	1	
8-62378-45	2.17-29.0- 51	1	
	2.17-31.0- 54	1	
8-62378-47	2.17-29.0- 52	1	
	2.17-31.0- 55	1	

PART NUMBER	FIGURE AND INDEX NUMBER	QTY PER ART	SMR CODE
8-62378-49	2.17-29.0- 53	1	
	2.17-31.0- 56	1	
8-62378-51	2.17-29.0- 54	1	
8-62378-7	2.17-29.0- 31	1	
	2.17-31.0- 32	1	
8-62378-71	2.17-29.0- 59	1	
	2.17-31.0- 62	1	
8-62378-85	2.17-31.0- 45	1	
8-62378-89	2.17-31.0- 47	1	
8-62378-9	2.17-29.0- 32	1	
	2.17-31.0- 33	1	
8-62378-91	2.17-31.0- 48	1	
8-62378-95	2.17-31.0- 51	1	
8-62378-97	2.17-31.0- 49	1	
8-62378-99	2.17-31.0- 58	1	
8-62379-11	2.17-26.0- 34	1	
	2.17-27.0- 34	1	
	2.17-28.0- 35	1	
8-62379-13	2.17-26.0- 35	1	
	2.17-27.0- 35	1	
	2.17-28.0- 36	1	
8-62379-15	2.17-26.0- 36	1	
	2.17-27.0- 36	1	
	2.17-28.0- 37	1	
8-62379-17	2.17-26.0- 37	1	
	2.17-27.0- 37	1	
	2.17-28.0- 38	1	
8-62379-19	2.17-26.0- 38	1	
	2.17-27.0- 38	1	
	2.17-28.0- 39	1	
8-62379-23	2.17-26.0- 40	1	
8-62379-29	2.17-26.0- 43	1	
	2.17-27.0- 43	1	
	2.17-28.0- 44	1	
8-62379-31	2.17-26.0- 44	1	
	2.17-27.0- 44	1	
	2.17-28.0- 45	1	
8-62379-35	2.17-26.0- 42	1	
	2.17-27.0- 42	1	
	2.17-28.0- 43	1	
8-62379-39	2.17-26.0- 50	1	
	2.17-27.0- 50	1	
	2.17-28.0- 51	1	
8-62379-41	2.17-26.0- 51	1	
	2.17-27.0- 51	1	
	2.17-28.0- 52	1	
8-62379-43	2.17-27.0- 52	1	
	2.17-28.0- 53	1	
8-62379-44	2.17-26.0- 52	1	
8-62379-51	2.17-26.0- 39	1	
	2.17-27.0- 39	1	
	2.17-28.0- 40	1	
8-62379-53	2.17-26.0- 49	1	
	2.17-27.0- 49	1	
	2.17-28.0- 50	1	
8-62379-57	2.17-26.0- 48	1	
	2.17-27.0- 48	1	
	2.17-28.0- 49	1	
8-62379-59	2.17-26.0- 54	1	
	2.17-27.0- 54	1	
	2.17-28.0- 55	1	
8-62379-61	2.17-26.0- 55	1	
	2.17-27.0- 55	1	
	2.17-28.0- 56	1	
8-62379-63	2.17-26.0- 56	1	

PART NUMBER	FIGURE AND INDEX NUMBER	QTY PER ART	SMR CODE
8-62379-63	2.17-27.0- 56	1	
	2.17-28.0- 57	1	
8-62379-65	2.17-26.0- 57	1	
	2.17-27.0- 57	1	
	2.17-28.0- 58	1	
8-62379-67	2.17-26.0- 46	1	
	2.17-27.0- 46	1	
	2.17-28.0- 47	1	
8-62379-69	2.17-26.0- 47	1	
	2.17-27.0- 47	1	
	2.17-28.0- 48	1	
8-62379-71	2.17-26.0- 30	1	
	2.17-27.0- 30	1	
	2.17-28.0- 31	1	
8-62379-73	2.17-26.0- 53	1	
	2.17-27.0- 53	1	
	2.17-28.0- 54	1	
8-62379-75	2.17-26.0- 28	1	
	2.17-27.0- 28	1	
	2.17-28.0- 29	1	
8-62379-77	2.17-26.0- 32	1	
	2.17-27.0- 32	1	
	2.17-28.0- 33	1	
8-62379-79	2.17-26.0- 41	1	
	2.17-27.0- 41	1	
8-62379-807	2.17-29.0- 1		
8-62379-83	2.17-27.0- 29	1	
	2.17-28.0- 30	1	
8-62379-85	2.17-26.0- 31	1	
	2.17-27.0- 31	1	
8-62379-87	2.17-27.0- 27	1	
	2.17-28.0- 28	1	
8-62379-89	2.17-26.0- 40	1	
	2.17-27.0- 40	1	
	2.17-28.0- 41	1	
8-62379-9	2.17-26.0- 33	1	
	2.17-27.0- 33	1	
	2.17-28.0- 34	1	
8-62379-93	2.17-28.0- 42	1	
8-62379-95	2.17-28.0- 32	1	
8-62398-7	2.16-11.0- 18	1	
8-62399	2.16-11.0- 12	1	
8-63200	2.17-28.0- 46	1	
8-63660-5	2.16-11.0- 29	1	
8-63670-1	2.16-22.0- 6	1	
8-63670-9	2.16-22.0- 10	1	
8-63671-5	2.16- 8.0- 31	1	
	2.16-22.0-	RF	
8-63671-805	2.16- 8.0- 31	1	
	2.16-22.0-	RF	
8-64374	2. 5- 4.0- 18	RF	
	2.10-30.0- 24	1	
8-6447A3	2.17- 8.0- 50	1	
8-64482	2. 5- 4.0- 16	RF	
8-64649-803	2.14-10.0- 1	1	
8-64649-807	2.14-10.0- 1	1	
8-65007-1	2.17- 8.0-	1	
8-65007-3	2.17- 8.0-	1	
8-65009	2.17-11.0- 15	1	
8-65010-3	2.20- 3.0- 34	1	
8-65011-5	2.20- 3.0-	RF	
8-65011-27	2.20- 3.0- 32	1	
8-65011-5	2.20- 3.0- 30	1	
8-65011-9	2.20- 3.0- 31	1	
8-65013	2. 6- 3.0- 20	1	

PART NUMBER	FIGURE AND INDEX NUMBER	QTY PER ART	SMR CODE
8-65013	2.12- 5.0- 7	1	
8-65015-801	2.20-49.0- 9	RF	
8-65018-3	2.17-11.0- 4	1	
8-65018-5	2.14- 6.0-		
8-65018-803	2.17-11.0- 4	1	
8-65019-805	2. 6- 3.0- 17	1	
	2.12- 5.0- 3	1	
8-65019-807	2. 6- 3.0- 17	1	
	2.12- 5.0- 3	1	
8-65020-801	2.17- 8.0- 17	1	
8-65021-13	2.17-19.0- 11	1	
8-65021-23	2.17-19.0- 8	1	
8-65021-25	2.17-19.0- 10	1	
8-65021-27	2.17-19.0- 5	1	
8-65021-29	2.17-19.0- 7	1	
8-65021-31	2.17-19.0- 8	1	
8-65021-7	2.17-19.0- 13	1	
8-65021-801	2.17-19.0-	1	
8-65021-807	2.17-11.0- 39	1	
8-65022-21	2.17-21.0- 87	2	
	2.17-23.0- 88	2	
8-65022-29	2.17-19.0- 5	1	
8-65022-801	2.17-19.0-	1	
8-65022-803	2.17-11.0- 40	1	
8-65024-15	2.17-21.0- 87	1	
	2.17-23.0- 88	1	
8-65027-5	2.17- 2.0-	1	
8-65028-1	2.16-10.0- 3	1	
8-65029-11	2.17-21.0- 5	3	
	2.17-23.0- 4	2	
	2.17-28.0- 4	1	
8-65029-13	2.17-21.0- 4		
	2.17-26.0- 3	2	
	2.17-27.0- 2	1	
	2.17-28.0- 2	1	
	2.17-29.0- 5	1	
	2.17-33.0- 7	1	
	2.17-35.0- 7	1	
8-65029-15	2.17-29.0- 4	1	
	2.17-31.0- 4	1	
8-65029-25	2.17-26.0- 2	1	
	2.17-27.0- 3	2	
	2.17-28.0- 3	2	
	2.17-33.0- 6	1	
8-65029-31	2.16-11.0- 20	1	
	2.16-11.0- 21	1	
	2.16-11.0- 22	1	
	2.16-11.0- 23	1	
	2.16-11.0- 24	1	
	2.16-11.0- 25	1	
	2.16-11.0- 26	1	
8-65029-37	2.17-33.0- 8	1	
	2.17-35.0- 8	1	
8-65029-41	2.17-21.0- 6	1	
	2.17-23.0- 6	1	
	2.17-26.0- 5	1	
	2.17-29.0- 6	1	
8-65029-43	2.16-18.0- 10	1	
	2.16-18.0- 9	3	
8-65029-7	2.17-26.0- 4	1	
	2.17-27.0- 4	1	
	2.17-27.0- 5	1	
	2.17-29.0- 2	3	
	2.17-30.0- 13	1	
	2.17-31.0- 3	3	

PART NUMBER	FIGURE AND INDEX NUMBER	QTY PER ART	SMR CODE
8-65029-7	2.17-33.0- 2	8	
	2.17-33.0- 3	1	
	2.17-33.0- 4	2	
	2.17-35.0- 3	8	
	2.17-35.0- 4		
	2.17-35.0- 5	1	
	2.18- 5.0- 4	1	
	2.18- 5.0- 6	1	
	2.20- 3.0- 12	1	
8-65029-9	2.17-21.0- 2	2	
	2.17-23.0- 5	2	
	2.17-29.0- 3	3	
	2.17-31.0- 5	1	
	2.17-33.0- 5	2	
	2.17-35.0- 6	1	
	2.17-38.0- 10	1	
	2.18- 5.0- 5	1	
8-6503-813	2.14- 6.0- 35	1	
8-65031	2.17- 1.0- 6	1	
8-65032-803	2.20- 2.0-	1	
8-65034	2.17- 1.0- 32	1	
8-65035-801	2.17-11.0-142	1	
8-65035-803	2.17-11.0-142	1	
8-65035-805	2.17-11.0-134	1	
8-65035-807	2.17-11.0-138	1	
8-65035-809	2.17-11.0-138	1	
8-65035-816	2.17-11.0-146	1	
8-65035-819	2.17-11.0-142	1	
8-65035-821	2.17-11.0-142	1	
8-65043-809	2.17-32.0-	1	
8-65044	2.14- 6.0- 28	RF	
8-65045	2.14- 6.0- 22	RF	
8-65046	2.12- 5.0-	RF	
8-65047-805	2.17-17.0-	RF	
8-65047-807	2.17-17.0-	RF	
8-65047-817	2.17-17.0-	RF	
8-65047-818	2.17-17.0-	RF	
8-65047-825	2.17-17.0-	RF	
8-65047-826	2.17-17.0-	RF	
8-65047-827	2.17-17.0-	RF	
8-65047-829	2.17-17.0-	RF	
8-65048	2.17- 8.0- 45	RF	
8-65053-1	2.20- 3.0- 7	1	
8-65053-11	2.20- 3.0- 11	1	
	2.20- 3.0- 8	1	
8-65053-17	2.20- 3.0- 34	1	
8-65053-5	2.20- 3.0- 32	1	
8-65053-9	2.20- 3.0- 9	1	
8-65057-1	2.17-17.0- 1	1	
8-65057-2	2.17-17.0- 1	1	
8-65058-11	2.13- 1.1-151	1	
8-65059-1	2.13- 1.1-147	RF	
8-65061-1	2.17-14.0- 28	1	
8-65061-17	2.17-14.0- 28	1	
8-65061-19	2.17-14.0- 1	1	
8-65062-25	2.17-14.0- 27	4	
8-65062-27	2.17-14.0- 18		
8-65062-31	2.17-14.0- 18	1	
8-65062-803	2.17-14.0- 4	1	
8-65062-805	2.17-14.0- 4	1	
8-65063-3	2.17-14.0-	1	
8-65068-829	2.17-32.0- 1	1	
8-65068-831	2.17-32.0- 1	1	
8-65068-833	2.17-32.0- 1	1	
8-65068-835	2.17-32.0- 1	1	

PART NUMBER	FIGURE AND INDEX NUMBER	QTY PER ART	SMR CODE
8-65068-837	2.17-32.0- 1	1	
8-65068-839	2.17-32.0- 1	1	
8-65068-843	2.17-32.0- 1	1	
8-65068-845	2.17-32.0- 1	1	
8-65069-19	2.17-33.0- 84	1	
	2.17-35.0- 87	1	
8-65070-827	2.17-32.0- 15	1	
8-65071-47	2.17-32.0- 20		
8-65071-49	2.17-32.0- 19	CC	
8-65071-57	2.17-34.0- 7	2	
8-65071-59	2.17-34.0- 5	1	
8-65071-60	2.17-34.0- 5	1	
8-65071-61	2.17-34.0- 6	2	
8-65071-63	2.17-34.0- 9	1	
8-65071-64	2.17-34.0- 10	1	
8-65071-65	2.17-32.0- 14	1	
8-65071-69	2.17-34.0- 3	1	
8-65071-809	2.17-32.0- 7	1	
	2.17-34.0-	RF	
8-65071-812	2.17-32.0- 8	1	
	2.17-34.0-	RF	
8-65071-813	2.17-32.0- 16	1	
8-65071-815	2.17-32.0- 7	1	
	2.17-34.0-	RF	
8-65071-816	2.17-32.0- 8	1	
	2.17-34.0-	RF	
8-65071-817	2.17-32.0- 16	1	
8-65079	2.17- 1.0- 44	RF	
8-6508-805	2.17-11.0- 4	1	
8-65085-177	2.17-30.0- 9	1	
8-65089-179	2.17-30.0- 15	1	
8-65089-181	2.17-30.0- 11	1	
8-65092	2.13- 1.1- 25	1	
8-65095-37	2.12-39.0- 4	2	
8-65095-805	2.12-39.0-	RF	
8-65095-807	2.12-39.0-	RF	
8-65098-3	2.15-24.0- 4	1	
8-65098-4	2.13-24.0- 4	1	
8-65098-7	2.15-24.0- 1	1	
8-65109-1	2.15-32.0- 4	1	
8-65109-2	2.15-32.0- 4	1	
8-65109-7	2.15-32.0- 13	1	
8-65110-807	2.17-11.0- 53	1	
8-65115	2.17-15.0-	1	
8-65116	2.14- 6.0- 3	1	
8-65117-3	2.17-11.0- 73	1	
8-65121-1	2.12-39.0- 39	RF	
8-65121-5	2.12-39.0- 44	RF	
8-65127-1	2.14- 6.0- 13	RF	
8-65127-801	2.14- 6.0- 13	RF	
8-65131-1	2.14- 6.0- 11	1	
8-65140-5	2.17- 8.0- 49	1	
8-65140-11	2.10- 7.0- 64	1	
8-65140-13	2.10- 7.0- 64	1	
8-65140	2.10- 7.0- 63	1	
8-65140-3	2.10- 7.0- 63	1	
8-65140-5	2.10- 7.0- 63	1	
8-65140-7	2.10- 7.0- 63	1	
8-65140-181	2.17-23.0- 76	1	
8-65140-105	2.17-21.0- 26	1	
	2.17-23.0- 25	1	
8-65140-177	2.17-21.0- 71	1	
8-65140-179	2.17-21.0- 56	1	
	2.17-23.0- 56	1	
8-65140-113	2.17-21.0- 72	1	

PART NUMBER	FIGURE AND INDEX NUMBER	QTY PER ART	SMR CODE
8-65149-113	2.17-23.0- 72	1	
8-65149-115	2.17-29.0- 57	1	
8-65149-121	2.17-21.0- 44	1	
	2.17-23.0- 44	1	
8-65149-125	2.17-21.0- 70	1	
	2.17-23.0- 70	1	
8-65149-127	2.17-21.0- 21	1	
	2.17-23.0- 20	1	
8-65149-129	2.17-21.0- 74	1	
	2.17-23.0- 74	1	
8-65149-147	2.17-21.0- 73	1	
8-65149-149	2.17-21.0- 80	1	
8-65149-153	2.17-21.0- 40	1	
	2.17-23.0- 40	1	
8-65149-155	2.17-21.0- 32	1	
	2.17-23.0- 31	1	
8-65149-161	2.17-21.0- 59	1	
8-65149-163	2.17-23.0- 47	1	
8-65149-165	2.17-23.0- 66	1	
8-65149-169	2.17-21.0- 24	1	
	2.17-23.0- 23	1	
	2.17-31.0- 18	1	
8-65149-171	2.17-31.0- 17	1	
8-65149-173	2.17-21.0- 75	1	
8-65149-175	2.17-21.0- 36	1	
	2.17-23.0- 35	1	
	2.17-23.0- 36	1	
8-65149-177	2.17-21.0- 71	1	
	2.17-23.0- 71	1	
8-65149-179	2.17-21.0- 41	1	
	2.17-23.0- 37	1	
8-65149-181	2.17-23.0- 75	1	
8-65149-183	2.17-23.0- 59	1	
8-65149-166	2.17-21.0- 79	1	
	2.17-23.0- 80	1	
8-65149-187	2.17-21.0- 54	1	
	2.17-23.0- 54	1	
8-65149-189	2.17-23.0- 28	1	
8-65149-19	2.17-21.0- 55	1	
	2.17-23.0- 34	1	
8-65149-191	2.17-23.0- 30	1	
8-65149-193	2.17-23.0- 33	1	
8-65149-295	2.17-23.0- 10	1	
	2.17-31.0- 20	1	
8-65149-207	2.17-23.0- 66	1	
8-65149-23	2.17-21.0- 39	1	
	2.17-23.0- 39	1	
8-65149-29	2.17-21.0- 42	1	
	2.17-23.0- 42	1	
8-65149-31	2.17-21.0- 43	1	
	2.17-23.0- 43	1	
8-65149-35	2.17-21.0- 45	1	
	2.17-23.0- 45	1	
8-65149-37	2.17-21.0- 46	1	
	2.17-23.0- 46	1	
8-65149-39	2.17-21.0- 47	1	
8-65149-41	2.17-21.0- 48	1	
	2.17-23.0- 48	1	
8-65149-43	2.17-21.0- 49	1	
	2.17-23.0- 49	1	
8-65149-49	2.17-21.0- 52	1	
	2.17-23.0- 52	1	
8-65149-53	2.17-21.0- 55	1	
	2.17-23.0- 55	1	
8-65149-57	2.17-21.0- 57	1	

PART NUMBER	FIGURE AND INDEX NUMBER	QTY PER ART	SMR CODE
8-65149-57	2.17-23.0- 57	1	
8-65149-61	2.17-35.0- 23	1	
8-65149-63	2.17-21.0- 60	1	
	2.17-23.0- 60	1	
8-65149-69	2.17-21.0- 64	1	
	2.17-23.0- 64	1	
8-65149-71	2.17-21.0- 65	1	
	2.17-23.0- 65	1	
8-65149-77	2.17-21.0- 77	1	
	2.17-23.0- 78	1	
8-65149-79	2.17-21.0- 78	1	
	2.17-23.0- 79	1	
8-65149-81	2.17-21.0- 22	1	
	2.17-23.0- 21	1	
	2.17-26.0- 12	1	
	2.17-27.0- 12	1	
	2.17-28.0- 9	1	
	2.17-29.0- 19	1	
	2.17-31.0- 19	1	
	2.17-33.0- 18	1	
	2.17-35.0- 20	1	
8-65149-83	2.17-26.0- 13	1	
	2.17-27.0- 13	1	
	2.17-29.0- 18	1	
	2.17-33.0- 22	1	
	2.17-35.0- 24	1	
8-65149-85	2.17-21.0- 19	1	
	2.17-23.0- 19	1	
	2.17-26.0- 17	1	
	2.17-27.0- 17	1	
	2.17-28.0- 14	1	
	2.17-29.0- 14	1	
	2.17-31.0- 14	1	
	2.17-33.0- 17	1	
	2.17-35.0- 19	1	
8-65149-87	2.17-21.0- 23	1	
	2.17-23.0- 22	1	
	2.17-26.0- 14	1	
	2.17-27.0- 14	1	
	2.17-28.0- 11	1	
	2.17-29.0- 17	1	
	2.17-33.0- 20	1	
	2.17-35.0- 22	1	
8-65149-89	2.17-21.0- 20	1	
	2.17-23.0- 19	1	
	2.17-26.0- 15	1	
	2.17-27.0- 15	1	
	2.17-28.0- 12	1	
	2.17-29.0- 16	1	
	2.17-31.0- 16	1	
	2.17-33.0- 19	1	
	2.17-35.0- 21	1	
8-65149-91	2.17-21.0- 25	1	
	2.17-23.0- 24	1	
	2.17-26.0- 16	1	
	2.17-27.0- 16	1	
	2.17-28.0- 13	1	
	2.17-29.0- 15	1	
	2.17-31.0- 15	1	
	2.17-33.0- 21	1	
8-65149-93	2.17-21.0- 52	1	
	2.17-23.0- 62	1	
8-65150-101	2.17-33.0- 64	1	
	2.17-35.0- 66	1	
8-65150-11	2.17-33.0- 32	1	

PART NUMBER	FIGURE AND INDEX NUMBER	QTY PER ART	SMR CODE
8-65150-11	2.17-35.0- 34	1	
8-65150-111	2.17-35.0- 66	1	
8-65150-113	2.17-33.0- 74	1	
	2.17-35.0- 77	1	
8-65150-131	2.17-33.0- 37	1	
	2.17-35.0- 39	1	
8-65150-15	2.17-33.0- 36	1	
	2.17-35.0- 38	1	
8-65150-17	2.17-33.0- 38	1	
	2.17-35.0- 40	1	
8-65150-19	2.17-33.0- 39	1	
	2.17-35.0- 41	1	
8-65150-21	2.17-33.0- 40	1	
	2.17-35.0- 42	1	
8-65150-23	2.17-33.0- 41	1	
	2.17-35.0- 43	1	
8-65150-25	2.17-33.0- 42	1	
	2.17-35.0- 44	1	
8-65150-27	2.17-33.0- 43	1	
	2.17-35.0- 45	1	
8-65150-29	2.17-33.0- 44	1	
	2.17-35.0- 46	1	
8-65150-35	2.17-33.0- 49	1	
	2.17-35.0- 51	1	
8-65150-39	2.17-33.0- 51	1	
	2.17-35.0- 53	1	
8-65150-41	2.17-33.0- 52	1	
	2.17-35.0- 54	1	
8-65150-43	2.17-33.0- 54	1	
	2.17-35.0- 56	1	
8-65150-45	2.17-33.0- 55	1	
	2.17-35.0- 57	1	
8-65150-47	2.17-33.0- 56	1	
	2.17-35.0- 58	1	
8-65150-49	2.17-33.0- 57	1	
	2.17-35.0- 59	1	
8-65150-51	2.17-33.0- 58	1	
	2.17-35.0- 60	1	
8-65150-53	2.17-33.0- 59	1	
	2.17-35.0- 61	1	
8-65150-55	2.17-33.0- 60	1	
	2.17-35.0- 62	1	
8-65150-59	2.17-33.0- 62	1	
	2.17-35.0- 64	1	
8-65150-61	2.17-33.0- 63	1	
	2.17-35.0- 65	1	
8-65150-65	2.17-33.0- 66	1	
	2.17-35.0- 69	1	
8-65150-67	2.17-33.0- 67	1	
	2.17-35.0- 70	1	
8-65150-69	2.17-33.0- 68	1	
	2.17-35.0- 71	1	
8-65150-7	2.17-33.0- 28	1	
	2.17-35.0- 30	1	
8-65150-71	2.17-33.0- 69	1	
	2.17-35.0- 72	1	
8-65150-73	2.17-33.0- 70	1	
	2.17-35.0- 73	1	
8-65150-75	2.17-33.0- 71	1	
	2.17-35.0- 74	1	
8-65150-77	2.17-33.0- 72	1	
	2.17-35.0- 75	1	
8-65150-79	2.17-33.0- 73	1	
	2.17-35.0- 76	1	
8-65150-81	2.17-33.0- 75	1	

PART NUMBER	FIGURE AND INDEX NUMBER	QTY PER ART	SMR CODE
8-65150-81	2.17-35.0- 78	1	
8-65150-83	2.17-33.0- 76	1	
	2.17-35.0- 79	1	
8-65150-85	2.17-33.0- 78	1	
	2.17-35.0- 81	1	
8-65150-87	2.17-33.0- 79	1	
	2.17-35.0- 82	1	
8-65150-9	2.17-33.0- 30	1	
	2.17-35.0- 32	1	
8-65150-93	2.17-33.0- 33	1	
	2.17-35.0- 35	1	
8-65150-95	2.17-33.0- 77	1	
	2.17-35.0- 80	1	
8-65150-99	2.17-33.0- 50	1	
	2.17-35.0- 52	1	
8-65151-15	2.17-21.0- 28	2	
	2.17-23.0- 27	2	
8-65151-17	2.17-33.0- 26	1	
	2.17-35.0- 28	1	
8-65151-19	2.17-21.0- 27	1	
	2.17-23.0- 26	1	
8-65151-21	2.17-33.0- 27	1	
	2.17-35.0- 29	1	
8-65151-23	2.17-26.0- 18	2	
	2.17-27.0- 18	2	
	2.17-28.0- 15	2	
	2.17-31.0- 22	2	
8-65151-239	2.17-29.0- 21	2	
8-65151-25	2.17-26.0- 20	4	
	2.17-27.0- 20	4	
	2.17-28.0- 17	4	
	2.17-29.0- 20	4	
	2.17-31.0- 21	4	
8-65151-27	2.17-26.0- 19	1	
	2.17-27.0- 19	1	
	2.17-28.0- 16	1	
	2.17-29.0- 22	1	
8-65153-1	2. 4- 3.0- 8	RF 1	
8-65154-1	2. 4- 3.0- 8	1	
8-65154-3	2. 4- 3.0- 8	1	
8-65159-3	2.17-22.0- 6	1	
8-65164-1	2.17-22.0- 6	1	
8-65181	2.17-11.0- 33	1	
8-65181-1	2.17-11.0- 33	1	
8-65182-1	2.17-11.0- 27	1	
8-65194	2.17-11.0- 36	1	
8-65194-1	2.17-11.0- 36	1	
8-65197	2.17-11.0- 86	1	
8-65199	2.17- 8.0- 1	1	
8-65252	2.15- 5.0- 6	1	
8-65252-9	2.15- 5.0- 23	1	
8-65258-7	2.15- 5.0- 16	1	
8-65258-8	2.15- 5.0- 15	1	
8-65260-10	2.15- 5.0- 24	1	
8-65260-15	2.15- 5.0- 24	1	
8-65260-16	2.15- 5.0- 24	1	
8-65260-9	2.15- 5.0- 24	127	
8-65262	2.15-25.0- 36	1	
8-65262-7	2.15-25.0- 42	1	
8-65263	2.15-25.0- 6	1	
8-65276	2.17-11.0- 29	1	
8-65276-1	2.17-11.0- 29	1	
8-65286-1	2.17-13.0- 4	RF 1	
8-65286-11	2.17-13.0- 4	1	
8-65286-17	2.17-13.0- 4	1	

PART NUMBER	FIGURE AND INDEX NUMBER	QTY PER ART	SMR CODE
8-65288-1	2.14- 6.0- 23	1	
8-65291-1	2.17-17.0- 1	1	
8-65291-2	2.17-17.0- 1	1	
8-65293	2.17-11.0- 20	1	
8-65296	2.17-18.0- 1	1	
8-65297	2.17-11.0- 84	1	
8-65298	2.17-11.0- 22	1	
8-65298-1	2.17-11.0- 22	1	
8-65298-9	2.17-11.0- 27	1	
8-65299	2.17-11.0- 81	1	
8-65302-1	2.17-11.0- 69	1	
8-65305-7	2.16-11.0- 13	1	
8-65315	2.16-11.0- 8	1	
8-65319	2.10-22.0- 22	1	
8-65329	2.17-11.0- 66	1	
8-65588-10	2.20- 5.0- 25	1	
8-65588-3	2. 3-10.0- 59	1	
	2.20- 5.0- 13	RF	
8-65588-4	2. 3-10.0- 59	1	
	2.20- 5.0- 13	RF	
8-65588-9	2.20- 5.0- 25	1	
8-65589-1	2. 3-10.0- 58	1	
	2.20- 5.0-	RF	
8-65589-10	2.20- 5.0- 11	1	
8-65589-2	2. 3-10.0- 58	1	
	2.20- 5.0-	RF	
8-65589-9	2.20- 5.0- 11	1	
8-65809-801	2.12- 5.0- 7	1	
8-67253-7	2.15- 6.0- 8	1	
8-67254	2.15- 6.0- 10	1	
8-67255-803	2.15- 6.0- 13	1	
8-67263-7	2.15- 6.0- 4	1	
8-67263-8	2.15- 6.0- 3	1	
8-67264-1	2.15- 6.0- 14	1	
8-67420-7	2.10- 7.0- 64	10	
8-67420-9	2.10- 7.0- 64	3	
	2.10- 7.0-104	2	
	2.10- 7.0-207	1	
8-67493-7	2.20- 3.0- 7	1	
8-67524-11	2. 5- 2.0- 20	1	
8-67524-15	2. 5- 2.0- 20	1	
8-68036-809	2. 4-12.0-134	1	
8-68038-7	2. 4-12.0-145	1	
	2. 7- 3.0-135	1	
	2.15- 2.0- 7	2	
	2.15- 3.0- 2	1	
	2.15- 4.0- 7	1	
	2.15-13.0- 6	1	
	2.15-16.0- 23	1	
	2.15-16.0- 4	1	
	2.15-24.0- 3	1	
	2.15-25.0- 36	1	
	2.15-25.0- 5	1	
	2.15-32.0- 10	1	
	2.20- 4.0- 2	1	
	2.20- 5.0- 15	1	
	2.20- 5.0- 2	1	
	2.20-31.0- 32	1	
	2.20-33.0- 63	1	
8-68043-1	2. 7- 3.0-136	1	
	2.15- 2.0- 1	2	
	2.15-13.0- 1	1	
	2.15-16.0- 17	1	
8-68043-7	2.15- 2.0- 10	1	
8-68046-1	2. 4-12.0-137	1	

PART NUMBER	FIGURE AND INDEX NUMBER	QTY PER ART	SMR CODE
8-68046-1	2.20- 5.0- 16	1	
	2.20- 5.0- 2	1	
	2.20-31.0- 32	1	
	2.20-33.0- 61	1	
8-68046-7	2. 4-12.0-142	1	
	2.20- 5.0- 20	1	
	2.20- 5.0- 7	1	
	2.20-31.0- 37	1	
	2.20-33.0- 68	1	
8-68047-7	2.15-16.0- 1	1	
8-68048-1	2.15- 4.0- 1	1	
8-68048-10	2.15- 4.0- 10	1	
8-68048-3	2.15- 4.0- 1	1	
8-68048-4	2.15- 4.0- 1	1	
8-68048-7	2.15- 4.0- 10	1	
8-68048-9	2.15- 4.0- 10	1	
8-68051-11	2.15- 3.0- 5	1	
	2.15-24.0- 8	1	
8-68051-7	2.15- 2.0- 8	1	
	2.15-25.0- 40	1	
8-68051-9	2. 4-12.0-140	1	
	2.15- 4.0- 8	1	
	2.15-32.0- 11	1	
	2.20- 4.0- 5	1	
	2.20- 5.0- 18	1	
	2.20- 5.0- 5	1	
	2.20- 6.0- 25	1	
	2.20-31.0- 35	1	
	2.20-31.0- 53	1	
	2.20-33.0- 66	1	
8-68052-11	2.15- 3.0- 6	1	
	2.15-24.0- 9	1	
8-68052-7	2.15- 2.0- 9	1	
	2.15-25.0- 41	1	
8-68052-9	2. 4-12.0-141	1	
	2.15- 4.0- 9	1	
	2.15-32.0- 12	1	
	2.20- 4.0- 6	1	
	2.20- 5.0- 19	1	
	2.20- 5.0- 6	1	
	2.20- 6.0- 26	1	
	2.20-31.0- 36	1	
	2.20-31.0- 54	1	
	2.20-33.0- 67	1	
8-68177-7	2.17-11.0- 86	1	
8-68177-9	2.17-11.0- 98	1	
8-68273	2.12- 6.0- 9	1	
	2.12-39.0- 21	1	
8-68298	2.18-33.0- 3	2	
	2.18-33.0- 4	2	
	2.18-33.0- 5	1	
	2.18-33.0- 5	1	
8-68298-7	2.12- 6.0- 12	1	
8-68355-7	2.14-23.0- 95	1	
8-69002-259	2. 8-27.0- 34	1	
8-69002-67	2. 8-18.0- 44	1	
8-69004-495	2.15-26.0- 27	1	
8-69013-241	2. 8-18.0- 46	1	
8-69013-347	2. 8-18.0- 89	1	
8-69013-389	2.12-39.0- 13	1	
8-69651-13	2. 3- 2.0- 38	1	
8-70410-10	2. 3- 2.0- 43	1	
8-70410-11	2. 3- 2.0- 43	1	
8-70410-12	2. 3- 2.0- 44	1	
8-70410-13	2. 3- 2.0- 39	1	
8-70410-14	2. 3- 2.0- 40	1	

PART NUMBER	FIGURE AND INDEX NUMBER	QTY PER ART	SMR CODE
8-70410-19	2. 3- 2.0- 30	2	
8-70410-21	2. 3- 2.0- 22	2	
8-70410-23	2. 3- 2.0- 45	1	
8-70410-25	2. 5- 2.0- 46	1	
8-70410-27	2. 3- 2.0- 24	2	
8-70410-29	2. 3- 2.0- 25	2	
8-70410-31	2. 3- 2.0- 17	2	
8-70410-7	2. 3- 2.0- 41	1	
8-70410-8	2. 3- 2.0- 42	1	
8-70410-9	2. 3- 2.0- 37	1	
8-70647-11	2. 3- 2.0- 47	1	
8-70647-13	2. 3- 2.0- 47	1	
8-70952-13	2. 4- 9.0- 24	2	
8-71125-11	2. 3-16.0- 2	1	
8-71125-12	2. 3-16.0- 4	1	
8-71125-13	2. 3-16.0- 1	1	
8-71125-14	2. 3-16.0- 5	1	
8-71130-7	2. 2-21.0- 28	1	
8-71130-8	2. 2-21.0- 28	1	
8-71152-11	2. 3-16.0- 2	1	
8-71152-12	2. 3-16.0- 4	1	
8-71152-3	2. 1- 1.0- 68	1	
	2. 3-16.0- 52	1	
8-71156-23	2. 7-11.0- 20	RF	
8-71156-24	2. 7-11.0- 20	RF	
8-71156-3	2. 7-11.0- 19	1	
8-71156-4	2. 7-11.0- 19	1	
8-71156-7	2. 7-11.0- 20	1	
8-71156-8	2. 7-11.0- 20	1	
8-71162-1	2. 3- 3.0- 89	1	
8-71162-11	2. 3- 3.0- 91	1	
8-71163-7	2. 3- 3.0- 90	1	
8-71191-11	2.15-37.0- 23	2	
8-71198-1	2. 4- 9.0- 20	RF	
8-71282-10	2.15-22.0- 38	1	
	2.15-22.0- 49	1	
8-71282-9	2.15-22.0- 38	1	
	2.15-22.0- 49	1	
8-71284-53	2. 9-23.0- 7	1	
8-71284-55	2. 9-23.0- 9	1	
8-71632-37	2. 6-13.0- 13	RF	
	2. 6-13.0- 16	RF	
	2. 6-15.0- 36	RF	
	2. 6-15.0- 42	RF	
8-72774-11	2.15-36.0- 15	2	
8-72774-7	2.15-36.0- 13	2	
8-72774-9	2.15-36.0- 14	2	
8-72841-7	2. 4- 2.0- 22	RF	
8-72843-9	2. 4- 2.0- 22	1	
8-72923-10	2. 3- 2.0- 0	1	
8-72923-9	2. 3- 2.0- 7	1	
8-72964-3	2. 3- 1.0- 1	1	
8-72970	2. 3- 1.0- 13	1	
8-72970-7	2. 3- 1.0- 16	1	
8-72971-9	2. 3- 1.0- 17	1	
8-72972-7	2. 3- 1.0- 17	1	
8-72973	2. 3- 2.0- 1	1	
8-73553-11	2. 4- 2.0- 47	1	
8-73559-7	2. 4- 2.0- 51	2	
8-73559-9	2. 4- 2.0- 47	1	
8-73597-10	2. 3- 2.0- 36	1	
8-73597-11	2. 3- 2.0- 33	1	
8-73597-19	2. 3- 2.0- 34	1	
8-73597-3	2. 3- 2.0- 32	1	
8-73597-5	2. 3- 2.0- 34	1	

PART NUMBER	FIGURE AND INDEX NUMBER	QTY PER ART	SMR CODE
8-73597-6	2. 3- 2.0- 34	1	
8-73597-9	2. 3- 2.0- 35	1	
8-73706	2. 3- 2.0- 26	2	
8-73707	2. 3- 2.0- 18	2	
8-73824-7	2. 4-10.0- 23	RF	
8-73826	2. 4-10.0- 26	RF	
8-73827	2. 4-10.0- 20	RF	
8-73827-1	2. 4-10.0- 21	RF	
8-73827-11	2. 4-10.0- 25	RF	
8-73827-13	2. 4-10.0- 24	RF	
8-73827-7	2. 4-10.0- 27	RF	
8-73827-9	2. 4-10.0- 22	RF	
8-73830-43	2. 4- 2.0- 12	2	
8-73830-65	2. 4- 2.0- 6	1	
8-73830-69	2. 4- 2.0- 5	1	
8-73830-71	2. 4- 2.0- 12	2	
8-73833-9	2. 4- 2.0- 48	1	
8-73836-17	2. 4- 2.0- 43	1	
8-73838-10	2. 4- 2.0- 33	1	
8-73839-9	2. 4- 2.0- 32	1	
8-73839	2. 4- 2.0- 14	96	
	2. 4- 2.0- 14	95	
8-73840-29	2. 4- 2.0- 38	2	
8-73841	2. 4- 2.0- 41	1	
	2. 4- 2.0- 45	2	
	2. 4- 2.0- 50	2	
8-73843	2. 4- 2.0- 48	RF	
8-73862-23	2. 4- 2.0- 15	1	
8-73862-24	2. 4- 2.0- 15	1	
8-73862-3	2. 4- 2.0- 13	1	
8-73862-4	2. 4- 2.0- 13	1	
8-74000-1	2. 1- 1.0- 70	1	
	2. 3- 3.0-	RF	
8-74000-3	2. 1- 1.0- 70	1	
	2. 3- 3.0-	RF	
8-74000-5	2. 1- 1.0- 70	1	
	2. 3- 3.0-	RF	
8-74000-833	2. 1- 1.0- 70	1	
	2. 1- 1.0- 70	1	
	2. 3- 3.0-	RF	
	2. 3- 3.0-	RF	
8-74000-839	2. 1- 1.0- 70	1	
	2. 3- 3.0-	RF	
8-74002-808	2. 3- 3.0- 2	1	
	2. 3- 4.0-	RF	
8-74002-809	2. 3- 3.0- 2	1	
	2. 3- 4.0-	RF	
8-74003-801	2. 3- 3.0- 23	1	
	2. 3-10.0-	RF	
8-74003-813	2. 3- 3.0- 23	1	
	2. 3-10.0-	RF	
8-74011-3	2. 1- 1.0- 60	1	
	2. 3- 1.0-	RF	
8-74011-525	2. 1- 1.0- 64	1	
	2. 3- 1.0-	RF	
8-74013-805	2. 3- 4.0- 14	1	
	2. 3- 6.0- 1	RF	
8-74014-801	2. 3- 4.0- 14	1	
	2. 3- 8.0-	RF	
8-74016-805	2. 3- 4.0- 7	1	
8-74017-805	2. 4- 9.0- 35	1	
8-74034-813	2. 3-10.0- 56	1	
	2. 3-11.0-	RF	
8-74034-815	2. 3-10.0- 56	1	
	2. 3-11.0-	RF	

PART NUMBER	FIGURE AND INDEX NUMBER	QTY PER ART	SMR CODE
8-74035	2. 3-14.0- 35	1	
	2. 3-15.0-	RF	
8-74035-1	2. 3-14.0- 35	1	
	2. 3-15.0-	RF	
8-74035-3	2. 3-14.0- 35	1	
	2. 3-15.0-	RF	
8-74103-803	2. 3-12.0- 26	1	
8-74103-804	2. 3-12.0- 26	1	
8-74104-3	2. 2- 7.0-101	RF	
	2. 3- 3.0- 74	1	
8-74104-35	2. 2- 7.0-102	1	
8-74104-67	2. 2- 7.0-104	1	
8-74104-95	2. 2- 7.0-102	1	
8-74111-9	2.15-30.0- 38	1	
8-74113-3	2. 3-14.0- 15	1	
8-74113-43	2. 3-14.0- 15	1	
8-74113-51	2. 3-14.0- 15	2	
8-74115	2. 3-14.0- 11	1	
	2.10- 1.0- 55	RF	
8-74115-5	2. 3-14.0- 11	1	
	2.10- 1.0- 55	RF	
8-74116-L	2.10-36.0- 20	RF	
8-74116-1	2. 3- 3.0- 58	1	
8-74117-1	2. 3-14.0- 3	1	
8-74117-2	2. 3-14.0- 3	1	
8-74117-3	2. 3-14.0- 3	1	
8-74117-4	2. 3-14.0- 3	1	
8-74119-1	2.10- 1.0- 56	RF	
8-74119-11	2.10- 1.0- 56	RF	
8-74119-7	2.10- 1.0- 56	RF	
8-74121-11	2. 3- 7.0- 5	1	
8-74121-12	2. 3- 8.0- 20	1	
8-74122-27	2.15-36.0- 18	1	
8-74123	2.10-36.0- 22	RF	
8-74124	2. 3- 3.0- 87	1	
8-74124-1	2. 3- 3.0- 87	1	
8-74124-3	2. 3- 3.0- 87	RF	
	2. 3-14.0- 40	1	
8-74124-7	2. 3- 3.0- 91	1	
8-74126-10	2.18- 6.0- 15	1	
8-74126-9	2.18- 6.0- 15	1	
8-74127-10	2.18- 6.0- 19	1	
8-74127-9	2.18- 6.0- 19	1	
8-74128-1	2. 3-14.0- 28	1	
	2.10-40.0-	RF	
8-74128-11	2.10-40.0- 19	AR	
8-74128-2	2. 3-14.0- 28	1	
	2.10-40.0-	RF	
8-74128-7	2.10-40.0- 2	1	
8-74128-9	2.10-40.0- 18	AR	
8-74129	2. 3- 3.0- 88	1	
8-74130-713	2.15-31.0- 18	1	
8-74132-1	2. 3- 3.0- 88	1	
8-74132-3	2. 3- 3.0- 88	1	
8-74135-103	2. 3- 9.0- 6	1	
8-74135-104	2. 3- 9.0- 6	1	
8-74135-117	2. 3- 9.0- 6	1	
8-74135-5	2. 3- 9.0- 6	1	
8-74135-6	2. 3- 9.0- 6	1	
8-74135-77	2. 3- 9.0- 7	1	
8-74139-9	2. 3- 7.0- 12	RF	
8-74141-1	2. 3- 4.0- 13	1	
	2.15-36.0-	RF	
8-74147-10	2. 3- 8.0- 25	1	
8-74147-9	2. 3- 7.0- 12	1	

PART NUMBER	FIGURE AND INDEX NUMBER	QTY PER ART	SMR CODE
8-74148-10	2. 3- 5.0- 7	1	
8-74148-9	2. 3- 5.0- 7	1	
8-74155-1	2.15-30.0-	1	
	2.15-31.0- 5	1	
8-74155-3	2.15-30.0-	1	
	2.15-31.0- 5	1	
8-74156-9	2. 8- 1.0- 26	1	
8-74157-7	2. 3- 4.0- 70	RF	
8-74157-8	2. 3- 4.0- 70	RF	
8-74158-7	2. 3- 7.0- 11	1	
8-74158-8	2. 3- 8.0- 27	1	
8-74162-17	2.20-14.0- 13	1	
8-74162-19	2.20-14.0- 13	1	
8-74162-21	2.20-14.0- 22	1	
8-74162-22	2.20-14.0- 22	1	
8-74162-23	2.20-14.0- 22	RF	
8-74162-24	2.20-14.0- 22	RF	
8-74163-1	2. 3- 9.0- 12	1	
	2.20-14.0- 6	RF	
8-74163-3	2. 3- 9.0- 13	1	
	2.20-14.0- 6	RF	
8-74163-5	2. 3-12.0- 26	1	
	2.20-14.0- 13	RF	
8-74163-6	2. 3-12.0- 26	1	
	2.20-14.0- 13	RF	
8-74163-7	2.20-14.0- 6	1	
8-74163-8	2.20-14.0- 6	1	
8-74163-801	2. 3- 3.0- 45	1	
	2.20-14.0-	RF	
8-74163-802	2. 3- 3.0- 45	1	
	2.20-14.0-	RF	
8-74163-9	2.20-14.0- 5	1	
8-74164-69	2. 2- 7.0-105	1	
8-74164-801	2. 2- 7.0-101	RF	
	2. 3- 3.0- 37	1	
8-74164-99	2. 2- 7.0-103	1	
8-74167-3	2. 3- 4.0- 70	1	
8-74172-11	2.10-36.0- 22	1	
8-74172-7	2.10-36.0- 22	1	
8-74184-7	2.10- 1.0- 56	1	
8-74187	2.15-30.0- 3	1	
	2.15-30.0- 6	2	
	2.15-31.0- 10	1	
8-74147-731	2.15-31.0- 13	2	
8-74188-7	2.15-30.0- 5	1	
	2.15-31.0- 12	1	
8-74188-9	2.15-30.0- 4	1	
	2.15-31.0- 11	1	
8-74190	2.15-30.0- 31	1	
8-74191-1	2. 3-10.0- 6	1	
	2.15-30.0-	RF	
8-74191-10	2.15-30.0- 16	1	
8-74191-11	2.15-30.0- 14	1	
8-74191-21	2.15-30.0- 17	1	
8-74191-9	2.15-30.0- 15	1	
8-74220-257	2.14- 5.0- 7	1	
8-74220-259	2.14- 5.0- 8	1	
8-74221	2.18-26.0- 6	1	
8-74222	2.18-26.0- 5	1	
8-74223	2.18-26.0- 4	1	
8-74224	2.18-26.0- 3	1	
8-74233	2. 3- 7.0- 4	1	
	2.15- 1.0- 22	RF	
8-74233-49	2.15- 1.0- 23	1	
8-74305-243	2. 3-12.0- 9	1	

PART NUMBER	FIGURE AND INDEX NUMBER	QTY PER ART	SMR CODE
8-74300-249	2. 3-12.0- 9	RF	
8-74300-267	2. 3-12.0- 9	1	
8-74300-801	2. 3-12.0- 9	1	
8-74300-807	2. 3-12.0- 9	1	
8-74305-1	2. 3-12.0- 14	1	
8-74305-131	2. 3-12.0- 14	1	
8-74305-133	2. 3-12.0- 14	1	
8-74305-3	2. 3-12.0- 14	1	
8-74306	2. 3-12.0- 12	RF	
8-74308-21	2. 3-12.0- 12	1	
8-74308-23	2. 3-12.0- 12	1	
8-74308-25	2. 3-12.0- 12	1	
8-74308-805	2. 3-12.0- 10	1	
8-74308-807	2. 3-12.0- 11	1	
8-74308-809	2. 3-12.0- 11	1	
8-74309-11	2. 3-12.0- 12	1	
8-74309-13	2. 3-12.0- 12	1	
8-74309-3	2. 3-12.0- 10	1	
8-74309-4	2. 3-12.0- 11	1	
8-74310-193	2. 3-12.0- 18	1	
8-74310-195	2. 3-12.0- 19	1	
8-74310-199	2. 3-12.0- 18	RF	
8-74310-21	2. 3-12.0- 19	1	
8-74310-22	2. 3-12.0- 20	1	
8-74310-25	2. 3-10.0- 54	1	
8-74310-803	2. 3-12.0- 18	1	
8-74310-805	2. 3-12.0- 18	1	
8-74310-807	2. 3-10.0- 50	1	
8-74340	2. 3-14.0- 1	1	
8-74340-45	2. 3-14.0- 1	1	
8-74356	2. 3-12.0- 13	4	
	2. 3-12.0- 21	4	
8-74374-11	2. 3-14.0- 2	1	
8-74374-13	2. 3-14.0- 3	1	
8-74381	2. 3-16.0- 30	1	
	2. 3-16.0- 30.		
	40	1	
8-74381-11	2. 3-16.0- 32	1	
8-74381-45	2. 3-16.0- 33	1	
8-74381-46	2. 3-16.0- 34	1	
8-74381-49	2. 3-16.0- 30	1	
8-74381-51	2. 3-16.0- 32	1	
8-74381-53	2. 3-16.0- 32	1	
8-74381-55	2. 3-16.0- 32	1	
8-74381-57	2. 3-16.0- 32	1	
8-74381-66	2. 3-16.0- 33	1	
8-74381-9	2. 3-16.0- 31	1	
8-74383	2. 3-16.0- 84	1	
8-74383-11	2. 3-16.0- 85	1	
8-74383-9	2. 3-16.0- 85	1	
8-74385	2. 3-16.0- 85	1	
8-74385-11	2. 3-16.0- 86	1	
8-74385-13	2. 3-16.0- 86	1	
8-74385-9	2. 3-16.0- 86	1	
8-74386	2. 3-16.0- 86	1	
8-74386-13	2. 3-16.0- 87	1	
8-74386-9	2. 3-16.0- 87	1	
8-74387	2. 3-16.0- 34	1	
	2. 3-16.0- 87	1	
8-74387-10	2. 3-16.0- 40	1	
	2. 3-16.0- 93	1	
8-74387-11	2. 3-16.0- 35	1	
	2. 3-16.0- 88	1	
8-74387-13	2. 3-16.0- 36	1	
	2. 3-16.0- 89	1	

PART NUMBER	FIGURE AND INDEX NUMBER	QTY PER ART	SMR CODE
8-74387-15	2. 3-16.0- 37	1	
	2. 3-16.0- 90	1	
8-74387-17	2. 3-16.0- 38	1	
	2. 3-16.0- 91	1	
8-74387-19	2. 3-16.0- 87	1	
8-74387-21	2. 3-15.0- 92	1	
8-74387-22	2. 3-16.0- 93	1	
8-74387-7	2. 3-16.0- 34	1	
	2. 3-16.0- 87	1	
8-74387-9	2. 3-16.0- 39	1	
	2. 3-16.0- 92	1	
8-74388	2. 3-16.0- 40	1	
	2. 3-16.0- 94	1	
8-74388-10	2. 3-16.0- 45	1	
	2. 3-16.0- 99	1	
8-74388-11	2. 3-16.0- 43	2	
	2. 3-16.0- 97	2	
8-74388-13	2. 3-16.0- 41	1	
	2. 3-16.0- 95	1	
8-74388-15	2. 3-16.0- 42	1	
	2. 3-16.0- 96	1	
8-74388-7	2. 3-16.0- 40	1	
	2. 3-16.0- 94	1	
8-74388-9	2. 3-16.0- 44	1	
	2. 3-16.0- 98	1	
8-74389	2. 3-16.0- 45	1	
8-74389-11	2. 3-16.0- 47	1	
8-74389-13	2. 3-16.0- 48	1	
8-74389-17	2. 3-16.0- 49	1	
8-74389-19	2. 3-16.0- 45	1	
8-74389-23	2. 3-16.0- 50	1	
8-74389-7	2. 3-16.0- 51	1	
8-74389-8	2. 3-16.0- 52	1	
8-74389-9	2. 3-16.0- 46	2	
8-74391	2.15- 1.0- 29	1	
8-74404-801	2. 3-12.0- 9	1	
8-74404-803	2. 3-12.0- 9	1	
8-74405-83	2. 2- 1.0- 2	1	
8-74405-801	2. 1- 1.0- 1	1	
	2. 2- 1.0- 1	RF	
8-74405-807	2. 3- 5.0- 3	1	
8-74406-27	2. 3- 5.0- 27	1	
8-74406-28	2. 3- 5.0- 27	1	
8-74406-3	2. 3- 5.0- 12	1	
8-74406-99	2. 3- 5.0- 14	1	
8-74412-1	2. 2- 9.0- 21	RF	
	2. 3-14.0- 9	1	
8-74412-103	2. 2- 9.0- 27	1	
8-74412-101	2. 2- 9.0- 24	1	
8-74412-163	2. 2- 9.0- 25	1	
8-74412-165	2. 2- 9.0- 26	1	
8-74412-3	2. 2- 9.0- 21	RF	
	2. 3- 3.0- 82	1	
8-74412-87	2. 2- 9.0- 27	1	
8-74412-801	2. 2- 9.0- 21	RF	
	2. 3-14.0- 9	1	
8-74412-803	2. 2- 9.0- 21	RF	
	2. 3- 3.0- 82	1	
8-74413-1	2. 3-14.0- 14	1	
	2.10- 1.0- 56	RF	
8-74413-2	2. 3-14.0- 14	1	
	2.10- 1.0- 56	RF	
8-74413-801	2. 3-14.0- 14	1	
	2.10- 1.0- 56	RF	
8-74413-802	2. 3-14.0- 14	1	

PART NUMBER	FIGURE AND INDEX NUMBER	QTY PER ART	SMR CODE
8-74413-802	2.10- 1.0- 56	PF	
8-74416-801	2. 3- 4.0- 12	1	
8-74424-803	2. 3- 6.0- 17	1	
	2. 3- 7.0-	RF	
8-74425-801	2. 3- 8.0- 13	1	
8-74430	2.12-50.0- 3	1	
	2.12-51.0-	RF	
8-74430-187	2.12-51.0- 3	1	
8-74430-3	2.12-50.0- 3	1	
	2.12-51.0-	PF	
8-74430-323	2.12-51.0- 15	8	
8-74430-327	2.12-51.0- 3	1	
8-74430-333	2.12-51.0- 3	1	
8-74430-339	2.12-51.0- 3	1	
8-74430-387	2.12-51.0- 12	1	
8-74430-389	2.12-51.0- 12	1	
8-74430-5	2.12-50.0- 3	1	
	2.12-51.0-	RF	
8-74430-81	2.12-51.0- 12	2	
8-74434-803	2. 3-11.0- 30	1	
	2. 3-12.0-	RF	
8-74434-804	2. 3-11.0- 30	1	
	2. 3-12.0-	RF	
8-74440-5	2. 3- 4.0- 7	1	
	2. 3- 5.0-	RF	
8-74449-801	2. 3- 9.0- 15	1	
8-74457-161	2. 3- 4.0- 70	1	
8-74457-801	2. 3- 4.0- 70	1	
8-74458-1	2. 3- 9.0-	1	
8-74462-3	2. 2- 7.0-100	RF	
	2. 3-10.0- 50	1	
8-74462-9	2. 2- 7.0-101	1	
8-74463	2. 3- 9.0- 14	1	
	2.12-50.0-	RF	
8-74470-11	2. 3-14.0- 7	1	
8-74470-118	2. 3-14.0- 17	1	
8-74470-12	2. 3-14.0- 7	1	
8-74470-13	2. 3-14.0- 11	1	
8-74470-14	2. 3-14.0- 11	1	
8-74470-79	2. 3-14.0- 1	1	
8-74470-809	2. 3- 3.0- 66	1	
	2. 3-14.0-	RF	
8-74470-811	2. 3- 3.0- 66	1	
	2. 3-14.0-	RF	
8-74470-815	2. 3- 3.0- 66	1	
	2. 3-14.0-	RF	
8-74470-90	2. 3-14.0- 7	1	
8-74470-91	2. 3-14.0- 7	1	
8-74470-93	2. 3-14.0- 1	1	
8-74472	2. 3-12.0- 23	1	
	2.10- 1.0- 10	RF	
8-74473	2. 3-12.0- 22	1	
	2.10- 1.0- 11	RF	
8-74475-805	2. 3-12.0- 1	1	
	2. 3-13.0-	RF	
8-74475-806	2. 3-12.0- 1	1	
	2. 3-13.0-	RF	
8-74475-813	2. 3-12.0- 1	1	
	2. 3-13.0-	RF	
8-74475-814	2. 3-12.0- 1	1	
	2. 3-13.0-	PF	
8-74476-5	2. 3-12.0- 3	1	
8-74476-801	2. 3-12.0- 3	1	
8-74477-3	2. 3-12.0- 27	1	
8-74477-4	2. 3-12.0- 27	1	

PART NUMBER	FIGURE AND INDEX NUMBER	QTY PER ART	SMR CODE
8-74477-5	2. 3-12.0- 27	1	
8-74477-6	2. 3-12.0- 27	1	
8-74481-121021			
	89		
8-74481-187	2.20- 2.0- 15		
8-74481-189	2. 2- 7.0- 33	1	
8-74481-3	2. 2- 7.0- 33	1	
8-74481-801	2. 3-10.0- 44	1	
	2. 1- 1.0- 4	1	
	2. 2- 7.0- 10		
8-74481-807	2. 3-10.0- 44	1	
8-74482	2. 3-10.0- 57	1	
8-74482-1	2. 2- 7.0- 96	RF	
	2. 3-12.0- 9	1	
8-74482-117	2. 2- 7.0- 64	1	
8-74482-2	2. 2- 7.0- 96	RF	
	2. 3-12.0- 9	1	
8-74482-4	2.20 - 35.0 - 3A	RF	
8-74482-715	2. 2- 7.0- 98	1	
8-74482-73	2. 2- 7.0- 97	1	
8-74482-803	2. 2- 7.0- 96	RF	
	2. 3-12.0- 9	1	
8-74482-804	2. 2- 7.0- 96	RF	
	2. 3-12.0- 9	1	
8-74482-805	2. 3-10.0- 57	1	
	2.20-35.0- 3	RF	
8-74483-3	2. 1- 1.0- 2	1	
	2. 2- 7.0- 2	RF	
8-74483-65	2. 2- 7.0- 6	1	
8-74483-66	2. 2- 7.0- 7	1	
8-74483-67	2. 2- 7.0- 3	6	
8-74483-69	2. 2- 7.0- 4	1	
8-74483-70	2. 2- 7.0- 5	1	
8-74484-101	2. 2-14.0- 18	1	
8-74484-102	2. 2-14.0- 21	1	
8-74484-103	2. 2-14.0- 17	1	
8-74484-107	2. 2-14.0- 19	1	
8-74484-108	2. 2-14.0- 22	1	
8-74484-109	2. 2-14.0- 20	1	
8-74484-110	2. 2-14.0- 23	1	
8-74484-35	2. 2-14.0- 6	1	
	2. 2-14.0- 7	1	
8-74484-37	2. 2-14.0- 1	2	
8-74484-38	2. 2-14.0- 2	1	
8-74484-57	2. 2-14.0- 13		
8-74484-61	2. 2-14.0- 13	1	
8-74484-67	2. 2-14.0- 10	1	
8-74484-803	2. 1- 1.0- 7	1	
	2. 2-14.0-	RF	
8-74484-89	2. 2-14.0- 12	1	
8-74484-91	2. 2-14.0- 11	1	
8-74484-95	2. 2-14.0- 14	1	
8-74484-96	2. 2-14.0- 15	1	
8-74484-97	2. 2-14.0- 16	1	
8-74489-201	2. 2- 7.0- 62	1	
8-74489-203	2. 2- 7.0- 59	1	
8-74489-3	2. 1- 1.0- 6	1	
	2. 2- 7.0- 55	RF	
8-74489-45	2. 2- 7.0- 57	1	
8-74489-47	2. 2- 7.0- 58	1	
8-74489-49	2. 2- 7.0- 60	1	
8-74489-50	2. 2- 7.0- 61	1	
8-74489-805	2.20-35.0- 2	RF	
8-74489-85	2. 2- 7.0- 63	1	
8-74490	2. 1- 1.0- 68	1	
	2. 3-16.0- 24	RF	

PART NUMBER	FIGURE AND INDEX NUMBER	QTY PER ART	SMR CODE
8-74494-3	2. 1- 1.0- 11	1	
	2. 2- 7.0-126	RF	
8-74494-79	2. 2- 7.0-123	1	
8-74494-85	2. 2- 7.0-121	1	
8-74494-87	2. 2- 7.0-122	1	
8-74497-3	2. 1- 1.0- 3	1	
	2. 2- 7.0- 33	RF	
8-74497-7	2. 2- 7.0- 34	1	
8-74497-8	2. 2- 7.0- 35	1	
8-74498	2. 2- 7.0- 89	RF	
	2. 3- 3.0- 33	1	
8-74498-11	2. 2- 7.0- 93	RF	
8-74498-13	2. 2- 7.0- 94	RF	
8-74498-15	2. 2- 7.0- 95	RF	
8-74498-153	2. 2- 7.0- 96	1	
8-74498-17	2. 2- 7.0- 96	1	
8-74498-7	2. 2- 7.0- 96	RF	
8-74498-9	2. 2- 7.0- 92	RF	
8-74499-125	2. 3- 9.0- 15	1	
8-74499-126	2. 3- 9.0- 15	1	
8-74499-211	2. 3- 9.0- 15	1	
8-74499-212	2. 3- 9.0- 15	1	
8-74500-11	2.15-14.0- 30	1	
8-74500-9	2.15-14.0- 31	1	
8-74536-15	2.11- 3.0- 24	1	
8-74543	2.13-28.0- 1	5	
8-74547-13	2.11- 6.0- 28	2	
8-74555-15	2.11- 7.0- 13	1	
8-74555-17	2.11- 7.0- 14	1	
8-74555-19	2.11- 7.0- 12	1	
8-74568-5	2.11- 4.0- 2	1	
	2.11- 6.0- 1	RF	
8-74568-6	2.11- 4.0- 2	1	
	2.11- 6.0- 1	RF	
8-74568-801	2.11- 4.0- 2	1	
	2.11- 6.0- 1	RF	
8-74568-802	2.11- 4.0- 2	1	
	2.11- 6.0- 1	RF	
8-74571-3	2.11- 6.0- 40	1	
8-74571-4	2.11- 6.0- 40	1	
8-74571-5	2.11- 6.0- 40	1	
8-74571-6	2.11- 6.0- 40	1	
8-74571-63	2.11- 6.0- 51	1	
8-74571-64	2.11- 6.0- 51	1	
8-74571-93	2.11- 6.0- 51	1	
8-74571-94	2.11- 6.0- 51	1	
8-74571-97	2.11- 6.0- 51	1	
8-74571-98	2.11- 6.0- 51	1	
8-74572-1	2. 3-13.0- 2	1	
	2.13- 1.1- 86	RF	
8-74572-2	2. 3-13.0- 2	1	
	2.13- 1.1- 86	RF	
8-74572-41	2.13- 1.1- 87	1	
8-74572-42	2.13- 1.1- 87	1	
8-74583-11	2.11- 3.0- 36	1	
8-74583-12	2.11- 3.0- 36	1	
8-74583-13	2.11- 3.0- 37	1	
8-74583-14	2.11- 3.0- 37	1	
8-74586-10	2.11- 6.0- 6	1	
8-74586-11	2.11- 6.0- 6	1	
8-74586-12	2.11- 6.0- 6	1	
8-74586-3	2.11- 6.0- 4	1	
8-74586-4	2.11- 6.0- 4	1	
8-74586-9	2.11- 6.0- 6	1	
8-74587-13	2.11- 5.0- 10	1	

PART NUMBER	FIGURE AND INDEX NUMBER	QTY PER ART	SMR CODE
8-74587-14	2.11- 5.0- 10	1	
8-74587-15	2.11- 5.0- 9	1	
8-74587-16	2.11- 5.0- 9	1	
8-74589-10	2.11- 6.0- 42	1	
8-74589-9	2.11- 6.0- 42	1	
8-74590-13	2.11- 6.0- 23	1	
8-74590-14	2.11- 6.0- 24	1	
8-74591	2.11- 6.0- 29	RF	
8-74591-1	2.11- 6.0- 29	RF	
8-74593-13	2.11- 6.0- 22	1	
8-74594-9	2.11- 6.0- 26	RF	
8-74595-1	2.11- 6.0- 43	RF	
8-74595-2	2.11- 6.0- 43	RF	
8-74595-7	2.11- 6.0- 49	RF	
8-74595-8	2.11- 6.0- 49	RF	
8-74596-10	2.11- 6.0- 41	1	
8-74596-9	2.11- 6.0- 41	1	
8-74598-7	2.11- 6.0- 50	1	
8-74598-8	2.11- 6.0- 50	1	
8-74599-11	2.11- 6.0- 40	1	
8-74599-7	2.11- 6.0- 2	1	
8-74599-9	2.11- 6.0- 3	1	
8-74600-1	2. 2-10.0-	RF	
	2. 3- 5.0- 2	1	
8-74600-10	2. 2-10.0- 53	1	
8-74600-101	2. 2-10.0- 2	1	
8-74600-103	2. 2-10.0- 1	1	
8-74600-11	2. 2-10.0- 54	1	
8-74600-117	2. 2-10.0- 73	AR	
8-74600-119	2. 2-10.0- 79	AR	
8-74600-12	2. 2-10.0- 54	1	
8-74600-13	2. 2-10.0- 55	1	
8-74600-14	2. 2-10.0- 55	1	
8-74600-15	2. 2-10.0- 56	1	
8-74600-159	2. 2-10.0- 80	AR	
8-74600-16	2. 2-10.0- 56	1	
8-74600-161	2. 2-10.0- 90	AR	
8-74600-175	2. 2-10.0- 59	1	
8-74600-176	2. 2-10.0- 59	1	
8-74600-177	2. 2-10.0- 63	1	
8-74600-178	2. 2-10.0- 63	1	
8-74600-179	2. 2-10.0- 61	1	
8-74600-180	2. 2-10.0- 61	1	
8-74600-181	2. 2-10.0- 57	1	
8-74600-182	2. 2-10.0- 57	1	
8-74600-2	2. 2-10.0-	RF	
	2. 3- 5.0- 3	1	
8-74600-213	2. 2-10.0- 92	1	
8-74600-220	2. 2-10.0- 3	1	
8-74600-223	2. 2-10.0-101	AR	
8-74600-225	2. 2-10.0-112	AR	
8-74600-241	2. 2-10.0- 52	1	
8-74600-263	2. 2-10.0- 3	1	
8-74600-285	2. 2-10.0- 52	1	
8-74600-295	2. 2-10.0- 3	1	
8-74600-337	2. 2-10.0- 3	1	
8-74600-340	2. 2-10.0- 3	1	
8-74600-44	2. 2-10.0- 58	1	
8-74600-49	2. 2-10.0- 58	1	
8-74600-53	2. 2-10.0- 59	1	
8-74600-54	2. 2-10.0- 60	1	
8-74600-57	2. 2-10.0- 62	1	
8-74600-58	2. 2-10.0- 62	1	
8-74600-61	2. 2-10.0- 64	1	
8-74600-62	2. 2-10.0- 64	1	

PART NUMBER	FIGURE AND INDEX NUMBER	QTY PER ART	SMR CODE	PART NUMBER	FIGURE AND INDEX NUMBER	QTY PER ART	SMR CODE
8-74600-63	2. 2-10.0- 66	1		8-74614-22	2. 1- 1.0- 18	1	
8-74600-64	2. 2-10.0- 66	1			2. 2- 9.0- 45	RF	
8-74600-8	2. 2-10.0- 52	1		8-74614-43	2. 1- 1.0- 18	1	
8-74601-81	2. 2-10.0- 91	AR			2. 2- 9.0- 45	RF	
8-74600-83	2. 2-10.0- 92	QAR		8-74614-44	2. 1- 1.0- 18	1	
8-74600-9	2. 2-10.0- 53	1			2. 2- 9.0- 45	RF	
8-74602-23	2. 2- 7.0-119	1		8-74614-7	2. 2- 9.0- 47	1	
8-74602-801	2. 1- 1.0- 14	1		8-74614-8	2. 2- 9.0- 47	1	
	2. 2- 7.0-118	RF		8-74617-21	2. 2- 9.0- 55	1	
8-74603-21	2. 2- 7.0-118	1		8-74617-3	2. 1- 1.0- 22	1	
8-74603-803	2. 1- 1.0- 12	1			2. 2- 9.0- 54	RF	
	2. 2- 7.0-117	RF		8-74617-5	2. 2- 9.0- 55	1	
8-74606	2.12-51.0-	1		8-74618	2. 2- 9.0-	RF	
8-74606-11	2.12-51.0- 1	1			2. 3- 3.0- 82	1	
8-74606-7	2.12-51.0- 1	1		8-74618-101	2. 2- 9.0- 23	1	
8-74606-801	2.12-51.0-	1		8-74618-105	2. 2- 9.0- 2	1	
8-74606-9	2.12-51.0- 1	1		8-74618-107	2. 2- 9.0- 3	1	
8-74607-3	2. 1- 1.0- 29	1		8-74618-11	2. 2- 9.0- 17	1	
	2. 2- 9.0- 60	RF		8-74618-119	2. 2- 9.0- 18	1	
8-74607-7	2. 2- 9.0- 61	1		8-74618-127	2. 2- 9.0- 3	1	
8-74607-8	2. 2- 9.0- 61	1		8-74618-13	2. 2- 9.0- 18	1	
8-74608-1	2. 3-14.0- 36	1		8-74618-141	2. 2- 9.0- 2	1	
8-74608-27	2. 1- 1.0- 21	1		8-74618-145	2. 2- 9.0- 3	1	
8-74608-29	2. 2- 9.0- 48	1		8-74618-33	2. 2- 9.0- 19	1	
8-74608-31	2. 3-14.0- 37	1		8-74618-35	2. 2- 9.0- 20	1	
8-74608-41	2. 1- 1.0- 21	1		8-74618-37	2. 2- 9.0- 21	1	
	2. 2- 9.0- 47			8-74618-73	2. 2- 9.0- 2	1	
	2. 2- 9.0- 47	RF		8-74618-75	2. 2- 9.0- 3	1	
8-74609	2. 1- 1.0- 8	1		8-74618-79	2. 2- 9.0- 21	1	
	2. 2- 7.0- 72	RF		8-74618-95	2. 2- 9.0- 19	1	
8-74609-1	2. 2- 7.0- 87	RF		8-74619-11	2. 1- 1.0- 23	1	
	2. 3-10.0- 3	1		8-74619-3	2. 1- 1.0- 22	1	
8-74609-29	2. 2- 7.0- 73	1		8-74619-806	2. 3-14.0- 14	RF	
8-74609-37	2. 2- 7.0- 75	1		8-74619-808	2. 3-14.0- 14	1	
8-74609-39	2. 2- 7.0- 76	1		8-74621-1	2. 1- 1.0- 25	1	
8-74609-49	2. 2- 7.0- 77	1			2. 2-15.0-	RF	
8-74609-57	2. 2- 7.0- 85	1		8-74621-2	2. 1- 1.0- 25	1	
8-74609-59	2. 2- 7.0- 86	1			2. 2-15.0-	RF	
8-74609-63	2. 2- 7.0- 77	1		8-74621-21	2. 2-15.0- 1	1	
8-74611-23	2. 2-12.0- 2	2		8-74621-22	2. 2-15.0- 1	1	
8-74611-525	2. 2-12.0-			8-74621-25	2. 2-15.0- 1	1	
8-74611-527	2. 2-12.0-			8-74621-26	2. 2-15.0- 1	1	
8-74611-7	2. 2-12.0- 1	2		8-74622-1	2. 2- 9.0- 34	RF	
8-74611-805	2. 2-12.0-	RF			2. 3-14.0- 19	1	
	2. 3- 3.0- 18	1		8-74622-3	2. 1- 1.0- 19	1	
8-74611-807	2. 2-12.0-	RF			2. 2- 9.0- 29	RF	
	2. 3- 3.0- 18	RF		8-74622-33	2. 2- 9.0- 38	1	
8-74611-809	2. 2-12.0-	RF		8-74622-35	2. 2- 9.0- 37	3	
	2. 3- 3.0- 18	1		8-74622-43	2. 2- 9.0- 36	1	
8-74611-817	2. 2-12.0-	RF		8-74622-45	2. 2- 9.0- 34	1	
	2. 3- 3.0- 18	1		8-74622-51	2. 2- 9.0- 34	1	
8-74611-819	2. 2-12.0-	RF		8-74622-55	2. 2- 9.0- 45	1	
	2. 3- 3.0- 18	1		A-74622-57	2. 2- 9.0- 30	1	
8-74611-821	2. 2-12.0-	RF		8-74625-3	2. 1- 1.0- 28	1	
	2. 3- 3.0- 18	1			2. 2- 9.0- 59	RF	
8-74611-823	2. 2-12.0-	RF		8-74625-7	2. 2- 9.0- 60	1	
	2. 3- 3.0- 18	RF		8-74625-8	2. 2- 9.0- 60	1	
8-74611-827	2. 2-12.0-	RF		8-74626	2. 3- 3.0- 19	1	
	2. 3- 3.0- 18	PF			2.15-14.0-	RF	
8-74611-829	2. 2-12.0-	RF		8-74626-113	2.15-14.0- 32	2	
	2. 3- 3.0- 18	1		8-74626-115	2.15-14.0- 35	1	
8-74612-1	2. 2-12.0- 15	1		8-74626-175	2.15-14.0- 2	1	
8-74612-11	2. 2-12.0- 27	1		8-74626-187	2.15-14.0- 2	1	
8-74614-21	2. 1- 1.0- 18	1		A-74626-65	2.15-14.0- 26	1	
	2. 2- 9.0- 45	RF		8-74626-67	2.15-14.0- 25	2	

PART NUMBER	FIGURE AND INDEX NUMBER	QTY PER ART	SMR CODE
8-74626-69	2.15-14.0-23	1	
8-74626-71	2.15-14.0-22	1	
8-74626-73	2.15-14.0-27	1	
8-74626-75	2.15-14.0-28	1	
8-74626-77	2.15-14.0-24	1	
8-74626-97	2.15-14.0-20	1	
8-74626-99	2.15-14.0-21	1	
8-74627-3	2. 1- 1.0- 26	1	
	2. 2- 9.0- 57	RF	
8-74628-13	2. 2- 9.0- 59	1	
8-74628-14	2. 2- 9.0- 59	1	
8-74628-25	2. 2- 9.0- 59	1	
8-74628-26	2. 2- 9.0- 59	1	
8-74628-27	2. 2- 9.0- 59	1	
8-74628-28	2. 2- 9.0- 59	1	
8-74628-3	2. 1- 1.0- 27	1	
	2. 2- 9.0- 56	RF	
8-74629	2. 2- 1.0- 6	1	
8-74630	2. 2- 1.0- 4	RF	
	2. 3- 4.0- 1	1	
8-74630-15	2. 2- 1.0- 7	1	
8-74630-17	2. 2- 1.0- 5	1	
8-74631-7	2. 2- 1.0- 6	1	
8-74634-11	2. 2- 3.0- 5	1	
8-74634-13	2. 2- 3.0- 7	1	
8-74636-5	2. 2- 5.0-	RF	
	2. 3- 3.0- 8	1	
8-74638-6	2. 2- 5.0-	RF	
	2. 3- 3.0- 8	1	
8-74638-801	2. 2- 4.0-	RF	
	2. 3- 4.0- 4	1	
8-74638-802	2. 2- 4.0-	RF	
	2. 3- 4.0- 4	1	
8-74639-10	2. 2-10.0- 6	1	
8-74639-7	2. 3- 5.0- 4	1	
8-74639-8	2. 3- 5.0- 4	1	
8-74639-9	2. 2-10.0- 6	1	
8-74640-10	2. 3- 5.0- 22	1	
8-74640-11	2. 3- 5.0- 28	1	
8-74640-12	2. 3- 5.0- 28	1	
8-74640-15	2. 3- 5.0- 29	2	
8-74640-17	2. 3- 5.0- 33	2	
8-74640-19	2. 3- 5.0- 31	1	
8-74640-21	2. 3- 5.0- 32	1	
8-74640-7	2. 3- 5.0-	1	
8-74640-8	2. 3- 5.0- 5	1	
8-74640-9	2. 3- 5.0- 22	1	
8-74641-1	2. 2- 3.0- 23	RF	
	2. 3- 4.0- 3	1	
8-74641-23	2. 2- 3.0- 27	1	
8-74641-3	2. 2- 3.0- 50	RF	
	2. 3- 5.0- 9	1	
8-74641-37	2. 2- 3.0- 51	1	
8-74641-43	2. 2- 3.0- 52	1	
8-74642-1	2. 3- 7.0- 10	1	
	2.15-15.0-	RF	
8-74642-17	2.15-15.0- 6	1	
8-74642-21	2.15-15.0- 1	1	
8-74642-23	2.15-15.0- 2	1	
8-74642-25	2.15-15.0- 5	1	
8-74642-27	2.15-15.0- 8	1	
8-74642-29	2.15-15.0- 5	1	
8-74642-3	2. 3- 8.0- 26	1	
	2.15-15.0- 6	RF	
8-74642-31	2.15-15.0- 10	1	

PART NUMBER	FIGURE AND INDEX NUMBER	QTY PER ART	SMR CODE
8-74642-5	2. 3- 4.0- 70	1	
	2.15-15.0- 4	RF	
8-74642-7	2.15-15.0- 7	1	
8-74642-P01	2. 3- 8.0- 26	1	
	2.15-15.0- 6	RF	
8-74643-7	2.15-14.0- 33	1	
8-74643-9	2.15-14.0- 29	RF	
8-74644-11	2. 2- 9.0- 11	1	
8-74644-13	2. 2- 9.0- 27	1	
8-74644-15	2. 2- 9.0- 27	1	
8-74644-7	2. 2- 9.0- 27	1	
8-74644-9	2. 2- 9.0- 12	1	
8-74647-7	2. 3-14.0- 15	1	
8-74647-8	2. 3-14.0- 15	1	
8-74647-9	2. 3-14.0- 15	1	
8-74648-1	2. 1- 1.0- 23	1	
	2. 2- 9.0- 48	RF	
8-74648-27	2. 2- 9.0- 49	1	
8-74648-7	2. 2- 9.0- 49	1	
8-74652-15	2. 2- 3.0- 2	1	
8-74652-17	2. 2- 3.0- 6	1	
8-74652-19	2. 2- 3.0- 4	1	
8-74652-3	2. 2- 3.0-	RF	
	2. 3- 7.0- 1	1	
8-74658-7	2. 2-12.0- 41	RF	
	2. 3- 9.0- 4	1	
8-74659-13	2. 2- 7.0-120	1	
8-74659-801	2. 1- 1.0- 17	1	
	2. 2- 7.0-119	RF	
8-74660-25	2. 2- 7.0-117	1	
8-74660-P03	2. 1- 1.0- 15	1	
	2. 2- 7.0-116	RF	
8-74661-19	2. 2- 7.0-116	1	
8-74661-21	2. 2- 7.0-109	1	
8-74661-503	2. 1- 1.0- 13	1	
	2. 2- 7.0-108	RF	
8-74662-19	2. 2- 7.0-116	1	
8-74662-21	2. 2- 7.0-110	1	
8-74662-803	2. 1- 1.0- 16	1	
	2. 2- 7.0-109	RF	
8-74663-161	2.20-16.0- 13	1	
	2.20-17.0- 10	1	
8-74663-162	2.20-16.0- 10	1	
	2.20-17.0- 10	1	
8-74663-177	2.20-17.0- 14	1	
8-74663-245	2.20-17.0- 20	1	
8-74663-247	2.20-17.0- 21	1	
8-74663-257	2.20-16.0- 7	1	
	2.20-18.0- 7	1	
8-74663-307	2.20-17.0- 24	1	
8-74663-801	2.20-15.0- 9	0	
	2.20-16.0-	RF	
8-74663-803	2.20-15.0- 9	1	
	2.20-16.0-	RF	
8-74664-13	2.20-19.0- 70	1	
8-74664-14	2.20-19.0- 70	1	
8-74664-15	2.20-19.0- 71	1	
8-74664-16	2.20-19.0- 71	1	
8-74664-375	2.20-19.0- 4	1	
8-74664-376	2.20-19.0- 4	1	
8-74664-377	2.20-19.0- 3	1	
8-74664-378	2.20-19.0- 3	1	
8-74664-5	2.20-15.0- 33	1	
8-74664-6	2.20-15.0- 33	1	
8-74664-69	2.20-19.0- 72	1	

PART NUMBER	FIGURE AND INDEX NUMBER	QTY PER ART	SMR CODE
8-74664-7	2.20-19.0-69	1	
8-74664-70	2.20-19.0-72	1	
8-74664-71	2.20-19.0-73	1	
8-74664-72	2.20-19.0-73	1	
8-74664-8	2.20-19.0-69	1	
8-74664-801	2.20-19.0-33	RF	
8-74664-802	2.20-19.0-33	RF	
8-74664-803	2.20-19.0-33	1	
	2.20-19.0-	RF	
8-74664-804	2.20-19.0-33	1	
	2.20-19.0-	RF	
8-74665	2. 3- 3.0- 38	1	
	2.20-19.0-	RF	
8-74665-21	2.20-19.0- 1	1	
8-74666-7	2. 2-12.0- 40	RF	
	2. 3- 5.0- 3	1	
8-74668-7	2. 2- 5.0- 14	1	
8-74668-8	2. 2- 5.0- 15	1	
8-74669-3	2. 2- 5.0- 1	1	
8-74669-4	2. 2- 5.0- 1	1	
8-74669-5	2. 2- 5.0- 1	1	
8-74669-6	2. 2- 5.0- 1	1	
8-74669-7	2. 2- 5.0- 15	1	
8-74669-8	2. 2- 5.0- 15	1	
8-74669-801	2. 2- 5.0- 1	1	
8-74670-7	2. 2-11.0- 19	1	
8-74670-9	2. 2-11.0- 19	1	
8-74674	2. 2-12.0- 5	1	
8-74676	2. 2- 3.0- 29	1	
8-74677	2. 2-12.0- 26	2	
	2. 2-12.0- 34	2	
8-74677-7	2. 2-12.0- 34	2	
8-74678-1	2. 3-16.0-	2	
8-74678-10	2. 3-16.0- 8	1	
8-74678-11	2. 3-16.0- 9	1	
8-74678-12	2. 3-16.0- 9	1	
8-74678-17	2. 3-16.0- 7	1	
8-74678-19	2. 3-16.0- 7	1	
8-74678-2	2. 3-16.0-	2	
8-74678-21	2. 3-16.0- 1	1	
8-74678-22	2. 3-16.0- 3	1	
8-74678-23	2. 3-16.0- 2	1	
8-74678-24	2. 3-16.0- 4	1	
8-74678-9	2. 3-16.0- 4	1	
8-74679-7	2. 2-11.0-106	1	
8-74679-9	2. 2-11.0- 99	1	
8-74681-1	2. 2-11.0- 92	1	
8-74681-7	2. 2-11.0- 90	1	
8-74682	2. 2-11.0- 16	1	
8-74682-7	2. 2-11.0- 19	1	
8-74683-3	2. 2-11.0- 69	1	
8-74683-9	2. 2-11.0- 75	1	
8-74684-11	2. 2-11.0- 61	1	
8-74684-12	2. 2-11.0- 81	1	
8-74685-11	2. 2-10.0- 77	1	
8-74685-13	2. 2-10.0- 76	1	
8-74686-1	2. 2-10.0- 82	1	
8-74686-7	2. 2-10.0- 87	1	
8-74687-7	2. 2-10.0- 89	1	
8-74687-9	2. 2-10.0- 88	1	
8-74688-1	2. 2-10.0-101	1	
8-74688-7	2. 2-10.0-109	1	
8-74689-7	2. 2-10.0-111	1	
8-74689-9	2. 2-10.0-110	1	
8-74690	2. 2-10.0- 7	2	

PART NUMBER	FIGURE AND INDEX NUMBER	QTY PER ART	SMR CODE
8-74691-1	2. 2-10.0- 24	1	
8-74691-10	2. 2-10.0- 45	1	
8-74691-11	2. 2-10.0- 24	1	
8-74691-12	2. 2-10.0- 25	1	
8-74691-13	2. 2-10.0- 25	1	
8-74691-14	2. 2-10.0- 25	1	
8-74691-2	2. 2-10.0- 25	1	
8-74691-3	2. 2-10.0- 25	1	
8-74691-4	2. 2-10.0- 25	1	
8-74691-7	2. 2-10.0- 45	1	
8-74691-8	2. 2-10.0- 45	1	
8-74691-9	2. 2-10.0- 45	1	
8-74692-1	2. 2-10.0- 21	1	
8-74692-7	2. 2-10.0- 23	1	
8-74693	2. 2-10.0- 20	1	
8-74694	2. 2-10.0- 16	RF	
8-74694-7	2. 2-10.0- 19	RF	
8-74695-11	2. 2-10.0- 32	1	
8-74695-12	2. 2-10.0- 33	2	
8-74695-13	2. 2-10.0- 34	1	
8-74695-15	2. 2-10.0- 40	1	
	2. 2-10.0- 41	1	
8-74695-17	2. 2-10.0- 42	2	
8-74695-19	2. 2-10.0- 37	1	
8-74695-21	2. 2-10.0- 36	1	
8-74695-25	2. 2-10.0- 41	1	
8-74695-27	2. 2-10.0- 42	2	
8-74695-29	2. 2-10.0- 32	1	
8-74695-30	2. 2-10.0- 33	1	
8-74695-31	2. 2-10.0- 39	1	
8-74695-33	2. 2-10.0- 37	1	
8-74695-7	2. 2-10.0- 36	2	
8-74695-9	2. 2-10.0- 39	1	
8-74696-1	2. 2-10.0- 47	RF	
8-74696-2	2. 2-10.0- 47	RF	
8-74696-3	2. 2-10.0- 47	RF	
8-74696-4	2. 2-10.0- 47	RF	
8-74697	2. 2-10.0- 43	1	
8-74697-7	2. 2-10.0- 45	1	
8-74697-9	2. 2-10.0- 44	1	
8-74698-11	2. 2-10.0- 16	1	
8-74698-7	2. 2-10.0- 97	1	
	2. 2-10.0-106	1	
8-74699-9	2. 2-10.0- 22	1	
8-74699-11	2. 2-10.0- 67	2	
8-74699-11	2. 2-10.0- 65	1	
8-74700-13	2. 2-10.0- 68	1	
8-74701-1	2. 3-10.0- 49	1	
8-74704-11	2.12-51.0- 7	RF	
8-74706-12	2.12-51.0- 8	RF	
8-74706-7	2.12-51.0- 5	RF	
8-74706-9	2.12-51.0- 6	RF	
8-74707-10	2.12-51.0- 6	1	
8-74707-11	2.12-51.0- 7	1	
8-74707-12	2.12-51.0- 8	1	
8-74707-15	2.12-51.0- 5	1	
8-74707-16	2.12-51.0- 6	1	
8-74707-9	2.12-51.0- 5	1	
8-74708-7	2.12-51.0- 10	RF	
8-74708-8	2.12-51.0- 11	RF	
8-74709-7	2.12-51.0- 10	2	
8-74709-9	2.12-51.0- 11	2	
8-74711-1	2. 3-12.0- 20	1	
8-74711-3	2. 3-12.0- 20	1	
8-74713-1	2. 3-12.0- 20	1	

PART NUMBER	FIGURE AND INDEX NUMBER	QTY PER ART	SMR CODE
8-74713-5	2. 3-12.0- 20	1	
8-74719-13	2.15-36.0- 16	RF	
8-74719-3	2.15-36.0- 1	RF	
8-74720-1	2. 3-14.0- 3	1	
8-74720-11	2. 3-14.0- 6	1	
8-74720-12	2. 3-14.0- 6	1	
8-74720-2	2. 3-14.0- 3	1	
8-74720-23	2. 3-14.0- 6	1	
8-74720-24	2. 3-14.0- 6	1	
8-74720-5	2. 3-14.0- 3	1	
8-74720-6	2. 3-14.0- 3	1	
8-74722-11	2.10-40.0- 6	1	
8-74722-12	2.10-40.0- 6	1	
8-74723-10	2.12-51.0- 9	1	
8-74723-9	2.12-51.0- 9	1	
8-74724	2.10-40.0- 6	RF	
8-74724-7	2.10-40.0- 6	RF	
8-74726-7	2.10-40.0- 6	1	
8-74726-8	2.10-40.0- 6	1	
8-74727-1	2. 3-14.0- 3	1	
8-74727-7	2. 3-14.0- 6	1	
8-74735	2. 3- 5.0- 1	1	
	2.18- 8.0-	RF	
8-74735-1	2. 3- 5.0- 8	1	
	2.18- 6.0- 12	RF	
8-74735-3	2. 3- 5.0- 13	1	
	2.18- 6.0- 15	RF	
8-74735-7	2.18- 8.0- 7	4	
8-74736-1	2.15-36.0- 1	1	
8-74736-3	2.15-36.0- 1	1	
8-74736-7	2.15-36.0- 16	1	
8-74736-9	2.15-36.0- 16	1	
8-74738	2.15- 1.0- 24	2	
8-74742	2. 3- 3.0- 88	7	
	2.15-30.0- 40	7	
8-74745-1	2. 3-14.0- 36	1	
	2. 3-16.0-	RF	
8-74745-100	2. 3-16.0- 16	1	
8-74745-101	2. 3-16.0- 30	1	
8-74745-102	2. 3-16.0- 30	1	
8-74745-105	2. 3-16.0- 30	1	
8-74745-106	2. 3-16.0- 30	1	
8-74745-123	2. 3-16.0- 16	1	
8-74745-124	2. 3-16.0- 16	1	
8-74745-169	2. 3-16.0- 24	1	
8-74745-170	2. 3-16.0- 24	1	
8-74745-171	2. 3-16.0- 24	1	
8-74745-172	2. 3-16.0- 24	1	
8-74745-3	2. 3-16.0- 25	1	
8-74745-805	2. 3-14.0- 36	1	
	2. 3-16.0-	RF	
8-74745-99	2. 3-16.0- 16	1	
8-74748-7	2. 3-12.0- 6	1	
8-74748-10	2. 3- 8.0- 27	RF	
8-74749-9	2. 3- 7.0- 11	RF	
8-74751-1	2. 3- 3.0- 76	3	
	2.15- 1.0- 45	RF	
8-74751-7	2.15- 1.0- 45	1	
8-74752	2. 3-12.0- 14	1	
	2. 8- 1.0- 21	RF	
8-74752-17	2. 8- 1.0- 22	1	
8-74753	2.18- 8.0- 14	2	
8-74759-1	2. 3- 5.0- 23	1	
8-74759-7	2. 3- 5.0- 26	1	
8-74760-1	2. 3- 5.0- 23	RF	

PART NUMBER	FIGURE AND INDEX NUMBER	QTY PER ART	SMR CODE
8-74760-7	2. 3- 5.0- 26	RF	
8-74769-13	2. 3-16.0- 25	1	
8-74769-15	2. 3-16.0- 57	RF	
8-74769-17	2. 3-16.0- 56	RF	
8-74769-19	2. 3-16.0- 57	1	
8-74769-21	2. 3-16.0- 56	1	
8-74770-1	2. 3-12.0- 5	1	
8-74770-2	2. 3-12.0- 5	1	
8-74772	2.20-35.0-	RF	
8-74773	2.20-35.0- 1	RF	
8-74777-7	2.15-31.0- 5	1	
8-74790-1	2. 3-12.0- 27	1	
8-74790-137	2. 3-12.0- 27	1	
8-74790-138	2. 3-12.0- 27	1	
8-74790-115	2. 3-12.0- 28	1	
8-74790-116	2. 3-12.0- 29	1	
8-74790-179	2. 3-12.0- 27	1	
8-74790-2	2. 3-12.0- 27	1	
8-74790-267	2. 3-12.0- 27	1	
8-74790-268	2. 3-12.0- 27	1	
8-74792	2.18- 8.0- 8	RF	
8-74792-13	2.18- 8.0- 9	1	
8-74792-7	2.18- 8.0- 8	1	
8-74792-8	2.18- 8.0- 8	1	
8-74792-9	2.18- 8.0- 9	1	
8-74793-1	2.15-30.0- 18	1	
8-74793-13	2.15-30.0- 26	2	
8-74793-21	2.15-30.0- 29	1	
8-74793-27	2.15-30.0- 27	1	
8-74793-23	2.15-30.0- 28	1	
8-74793-29	2.15-31.0- 41	1	
8-74793-3	2.15-31.0- 38	1	
8-74793-30	2.15-31.0- 42	1	
8-74793-31	2.15-31.0- 35	1	
8-74793-32	2.15-31.0- 36	1	
8-74793-33	2.15-31.0- 27	1	
8-74793-34	2.15-31.0- 28	1	
8-74793-35	2.15-31.0- 29	1	
8-74793-37	2.15-31.0- 34	1	
8-74793-39	2.15-31.0- 32	1	
8-74793-4	2.15-31.0- 33	1	
8-74793-40	2.15-31.0- 33	1	
8-74793-45	2.15-30.0- 24	1	
8-74793-46	2.15-30.0- 25	1	
8-74793-5	2.15-31.0- 29	1	
8-74793-801	2.15-31.0- 22	1	
8-74796-11	2.20-35.0- 1	1	
8-74800-535	2. 4- 9.0-	RF	
8-74800-805	2. 4- 9.0- 5	1	
	2. 4- 9.0-	RF	
8-74801-1	2. 4-10.0- 15	1	
8-74801-11	2.13-33.0- 9	RF	
8-74801-2	2. 4-10.0- 15	1	
8-74802-7	2. 4-10.0- 15	1	
8-74802-8	2. 4-10.0- 15	1	
8-74803-10	2. 4-10.0- 20	1	
8-74803-8	2. 4-10.0- 20	1	
8-74804-805	2. 4- 9.0- 39	RF	
	2. 4-10.0-	RF	
8-74804-801	2. 4- 9.0- 39	1	
	2. 4-10.0-	RF	
8-74805	2. 4-10.0- 45	1	
8-74806-7	2. 4-10.0- 4	1	
8-74806-8	2. 4-10.0- 4	1	
8-74808-10	2. 4-10.0- 17	1	

PART NUMBER	FIGURE AND INDEX NUMBER	QTY PER ART	SMR CODE
8-74808-11	2. 4-10.0- 16	RF	
8-74808-12	2. 4-10.0- 17	RF	
8-74808-9	2. 4-10.0- 16	1	
8-74809-10	2. 4-10.0- 19	1	
8-74809-11	2. 4-10.0- 18	RF	
8-74809-12	2. 4-10.0- 19	RF	
8-74809-9	2. 4-10.0- 18	1	
8-74811	2. 4-10.0- 48	RF	
8-74812	2. 4-10.0- 14	1	
8-74812-1	2. 4-10.0- 14	1	
8-74814	2. 4-10.0- 27	1	
8-74815-1	2. 4- 1.0- 2	RF	
8-74815-2	2. 4- 1.0- 3	RF	
8-74815-27	2. 4- 1.0- 10	RF	
8-74815-28	2. 4- 1.0- 10	RF	
8-74815-29	2. 4- 1.0- 12	RF	
8-74815-3	2. 4- 1.0- 2	RF	
8-74815-30	2. 4- 1.0- 12	RF	
8-74815-35	2. 4- 1.0- 11	RF	
8-74815-36	2. 4- 1.0- 11	RF	
8-74815-37	2. 4- 1.0- 13	RF	
8-74815-38	2. 4- 1.0- 13	RF	
8-74815-4	2. 4- 1.0- 3	RF	
8-74815-5	2. 4- 1.0- 2	RF	
8-74815-6	2. 4- 1.0- 3	RF	
8-74817-1	2. 4-10.0- 37	1	
8-74818-503	2. 4-10.0- 39	RF	
8-74818-801	2. 4-10.0- 39	1	
8-74819-10	2. 4-10.0- 47	RF	
8-74819-7	2. 4-10.0- 46	RF	
8-74819-8	2. 4-10.0- 46	RF	
8-74819-9	2. 4-10.0- 47	RF	
8-74820-1	2. 4- 9.0- 25	RF	
8-74820-2	2. 4- 9.0- 25	RF	
8-74820-7	2. 4- 9.0- 34	RF	
8-74820-8	2. 4- 9.0- 34	RF	
8-74822-1	2. 1- 1.0- 57	1	
	2. 4- 1.0- 1	RF	
	2. 20-49.0- 4	RF	
8-74824	2. 4-10.0- 3	1	
8-74829	2. 5-15.0- 14	1	
8-74829-25	2. 4-10.0- 37	1	
8-74829-27	2. 4-10.0- 33	1	
8-74829-28	2. 4-10.0- 34	1	
8-74829-29	2. 4-10.0- 31	1	
8-74829-30	2. 4-10.0- 32	1	
8-74829-31	2. 4-10.0- 29	1	
8-74829-32	2. 4-10.0- 33	1	
8-74829-33	2. 4-10.0- 35	1	
8-74829-34	2. 4-10.0- 36	1	
8-74829-37	2. 4-10.0- 28	1	
8-74829-39	2. 4-10.0- 31	1	
8-74829-40	2. 4-10.0- 32	1	
8-74830	2. 3- 4.0- 19	1	
	2. 4- 2.0-	RF	
8-74832	2. 4- 2.0- 73	1	
8-74832-7	2. 4- 2.0- 73	1	
8-74833-7	2. 4- 2.0- 10	1	
8-74833-9	2. 4- 2.0- 10	1	
8-74834-11	2. 4- 2.0- 56	1	
8-74834-12	2. 4- 2.0- 57	1	
8-74834-7	2. 4- 2.0- 56	1	
8-74834-8	2. 4- 2.0- 57	1	
8-74836	2. 4- 2.0- 15	1	
8-74836-11	2. 4- 2.0- 19	2	

PART NUMBER	FIGURE AND INDEX NUMBER	QTY PER ART	SMR CODE
8-74836-13	2. 4- 2.0- 20	2	
8-74836-15	2. 4- 2.0- 21	2	
8-74836-17	2. 4- 2.0- 16	2	
8-74836-7	2. 4- 2.0- 19	2	
8-74836-9	2. 4- 2.0- 17	2	
8-74837-11	2. 4- 2.0- 66	1	
8-74837-12	2. 4- 2.0- 67	1	
8-74840	2. 4- 2.0- 22	1	
8-74840-101	2. 4- 2.0- 26	1	
8-74840-55	2. 4- 2.0- 58	1	
8-74840-56	2. 4- 2.0- 58	1	
8-74840-61	2. 4- 2.0- 61	1	
8-74840-62	2. 4- 2.0- 61	1	
8-74840-91	2. 4- 2.0- 26	1	
8-74841-10	2. 4-10.0- 46	1	
8-74841-11	2. 4-10.0- 47	1	
8-74841-12	2. 4-10.0- 47	1	
8-74841-15	2. 4-10.0- 46	1	
8-74841-16	2. 4-10.0- 46	1	
8-74841-17	2. 4-10.0- 47	1	
8-74841-18	2. 4-10.0- 47	1	
8-74841-9	2. 4-10.0- 46	1	
8-74842-1	2. 4-10.0- 37	1	
8-74842-10	2. 4-10.0- 39	1	
8-74842-2	2. 4-10.0- 37	1	
8-74842-9	2. 4-10.0- 39	1	
8-74843-1	2. 4- 9.0- 25	1	
8-74843-2	2. 4- 9.0- 25	1	
8-74843-7	2. 4- 9.0- 34	1	
8-74843-8	2. 4- 9.0- 34	1	
8-74845	2. 4-10.0-	1	
8-74845-7	2. 4-10.0- 1	1	
8-74846-10	2. 4- 2.0- 63	1	
8-74846-9	2. 4- 2.0- 62	1	
8-74847	2. 4-10.0- 14	1	
8-74848	2. 4- 2.0- 39	1	
8-74848-11	2. 4- 2.0- 1	1	
8-74849-9	2. 4- 2.0- 1	1	
8-74850-1	2. 4- 2.0-	1	
8-74851-1	2. 4-10.0- 37	RF	
8-74851-2	2. 4-10.0- 37	RF	
8-74851-7	2. 4-10.0- 39	RF	
8-74851-8	2. 4-10.0- 39	RF	
8-74853-7	2. 4- 9.0- 50	1	
8-74853-8	2. 4- 9.0- 51	1	
8-74854	2. 4- 9.0- 11	1	
8-74854-65	2. 4- 9.0- 18	1	
8-74854-67	2. 4- 9.0- 18	1	
8-74855	2. 4- 9.0- 52	2	
8-74858-11	2. 4- 9.0- 33	2	
8-74858-7	2. 4-10.0- 38	2	
8-74858-9	2. 4- 9.0- 32	2	
8-74860	2. 3-14.2- 34	1	
	2. 7-10.0-	RF	
8-74860-1	2. 3- 3.0- 68	1	
	2. 7- 1.0- 18	RF	
8-74860-25	2. 7- 1.0- 22	1	
8-74860-81	2. 7- 1.0- 21	1	
8-74862-3	2. 7-10.0- 20	1	
8-74862-4	2. 7-10.0- 21	1	
8-74863-13	2. 2-18.0- 10	1	
8-74863-3	2. 1- 1.0- 36	1	
	2. 2-18.0- 9	RF	
8-74863-513	2. 2-18.0- 10	RF	
8-74870-1	2. 3- 3.0- 71	1	

PART NUMBER	FIGURE AND INDEX NUMBER	QTY PER ART	SMR CODE
8-74870-1	2. 7-11.0-	RF	
8-74870-11	2. 7-11.0- 13	1	
8-74870-12	2. 7-11.0- 13	1	
8-74870-19	2. 7-11.0- 14	2	
8-74870-2	2. 3- 3.0- 71	1	
	2. 7-11.0-	RF	
8-74870-21	2. 7-11.0- 16	1	
8-74870-23	2. 7-11.0- 16	1	
8-74870-27	2. 7-11.0- 17	1	
8-74870-29	2. 7-11.0- 15	1	
8-74870-31	2. 7-11.0- 15	1	
8-74870-47	2. 7-11.0- 5	1	
8-74870-48	2. 7-11.0- 6	1	
8-74870-9	2. 7-11.0- 12	1	
8-74871-13	2. 7-11.0- 20	RF	
8-74871-15	2. 7-11.0- 20	RF	
8-74871-16	2. 7-11.0- 20	RF	
8-74871-29	2. 7-11.0- 20	1	
8-74871-30	2. 7-11.0- 20	1	
8-74871-809	2. 7-11.0- 19	1	
8-74871-810	2. 7-11.0- 19	1	
8-74872-1	2. 7-11.0- 17	1	
8-74872-2	2. 7-11.0- 17	1	
8-74872-33	2. 7-11.0- 18	1	
8-74872-37	2. 7-11.0- 18	1	
8-74872-49	2. 7-11.0- 18	1	
8-74872-51	2. 7-11.0- 18	1	
8-74873	2. 7-11.0- 24	1	
8-74874-17	2. 7-11.0- 22	5	
8-74874-19	2. 7-10.0- 24	2	
8-74874-21	2. 7-11.0- 21	1	
8-74875-13	2. 7-11.0- 10	1	
8-74875-7	2. 7-11.0- 9	1	
8-74876-11	2. 7-11.0- 11	1	
8-74876-13	2. 7-11.0- 11	1	
8-74881-3	2. 7-10.0- 25	1	
8-74883-1	2. 7- 1.0- 24	1	
8-74883-9	2. 7- 1.0- 27	1	
8-74889-10	2. 4- 9.0- 18.1	1	
8-74889-9	2. 4- 9.0- 18.1	1	
8-74892	2. 4- 9.0- 12	2	
8-74892-7	2. 4- 9.0- 17	1	
8-74892-9	2. 4- 9.0- 16	1	
8-74895	2. 3- 4.0- 18	1	
	2. 4- 1.0- 42	RF	
8-74895-7	2. 4- 1.0- 44	1	
8-74896	2. 4- 1.0- 46	1	
8-74902-11	2. 2-15.0- 4	1	
8-74902-7	2. 2-15.0- 3	1	
8-74902-9	2. 2-15.0- 4	1	
8-74905	2.12-51.0- 3	1	
8-74907-1	2. 3- 9.0- 15	1	
	2.12-63.0-	RF	
8-74907-101	2.12-63.0- 6	1	
8-74907-102	2.12-63.0- 7	1	
8-74907-105	2.12-63.0- 2	1	
8-74907-107	2.12-63.0- 1	2	
8-74907-51	2.12-63.0- 3	1	
8-74907-52	2.12-63.0- 4	1	
8-74907-57	2.12-63.0- 8	4	
8-74907-61	2.12-63.0- 5	2	
8-74907-7	2.12-63.0- 13	1	
8-74907-81	2.12-63.0- 11	1	
8-74907-83	2.12-63.0- 10	2	
8-74907-85	2.12-63.0- 9	1	
8-74912-13	2. 2- 7.0- 78	1	
8-74912-15	2. 2- 7.0- 88	1	

PART NUMBER	FIGURE AND INDEX NUMBER	QTY PER ART	SMR CODE
8-74912-9	2. 2- 7.0- 89	1	
8-74918	2.18- 6.0- 25	2	
8-74919	2. 3-12.0- 24	1	
	2.10- 1.0- 11	RF	
8-74919-23	2.10- 1.0- 12	1	
8-74920	2. 3-12.0- 25	1	
	2.10- 1.0- 11	RF	
8-74920-13	2.10- 1.0- 13	1	
8-74928-10	2. 2- 3.0- 62	1	
8-74928-15	2. 2- 3.0- 59	1	
8-74928-16	2. 2- 3.0- 59	1	
8-74928-17	2. 2- 3.0- 60	1	
8-74928-18	2. 2- 3.0- 60	1	
8-74928-23	2. 2- 3.0- 63	1	
8-74928-24	2. 2- 3.0- 63	1	
8-74928-7	2. 2- 3.0- 61	1	
8-74928-8	2. 2- 3.0- 61	1	
8-74928-9	2. 2- 3.0- 62	1	
8-74932-7	2.15-14.0- 31	RF	
8-74932-9	2.15-14.0- 30	RF	
8-74933	2.15-14.0- 34	1	
8-74934-3	2.15-14.0- 39	1	
8-74934-9	2.15-14.0- 44	1	
8-74935-11	2.15-14.0- 46	1	
8-74935-9	2.15-14.0- 46	1	
8-74936	2.15-14.0- 36	1	
8-74937-13	2. 2-10.0- 4	1	
8-74937-15	2.15-14.0- 19	1	
8-74937-17	2. 2-10.0- 4	1	
8-74937-19	2.15-14.0- 19	1	
8-74938	2.15-15.0- 6	RF	
8-74942-11	2. 2- 9.0- 28	1	
8-74942-7	2. 2- 9.0- 28	1	
8-74942-9	2. 2- 9.0- 28	1	
8-74943	2. 2- 9.0- 21	1	
8-74944-7	2. 2- 9.0- 29	1	
8-74946	2. 2-13.0-	RF	
	2. 3-10.0- 1	1	
8-74946-15	2. 2-13.0- 9	1	
8-74946-17	2. 2-13.0- 10	1	
8-74946-19	2. 2-13.0- 20	1	
8-74946-20	2. 2-13.0- 20	1	
8-74946-23	2. 2-13.0- 5	1	
8-74946-27	2. 2-13.0- 17	2	
8-74946-29	2. 2-13.0- 11	1	
8-74946-30	2. 2-13.0- 11	1	
8-74946-31	2. 2-13.0- 16	1	
8-74946-32	2. 2-13.0- 16	1	
8-74946-33	2. 2-13.0- 15	1	
8-74946-34	2. 2-13.0- 15	1	
8-74946-35	2. 2-13.0- 14	1	
8-74946-36	2. 2-13.0- 14	1	
8-74946-37	2. 2-13.0- 12	1	
8-74946-38	2. 2-13.0- 12	1	
8-74946-39	2. 2-13.0- 13	1	
8-74946-40	2. 2-13.0- 13	1	
8-74946-41	2. 2-13.0- 6	1	
8-74946-42	2. 2-13.0- 7	1	
8-74946-47	2. 2-13.0-	1	
8-74947	2. 3-10.0- 1	1	
8-74947-7	2. 3-10.0- 2	1	
8-74948-1	2. 1- 1.0- 64	RF	
8-74949	2. 3- 9.0- 6	1	
8-74950	2. 3- 9.0- 4	1	
8-74950-7	2. 3- 9.0- 5	1	

PART NUMBER	FIGURE AND INDEX NUMBER	QTY PER ART	SMR CODE
8-74953-10	2. 3- 4.0- 70	1	
8-74953-9	2. 3- 4.0- 70	1	
8-74954-7	2. 2- 9.0- 22	1	
8-74954-9	2. 2- 9.0- 22	1	
8-74955	2. 2- 9.0- 1	1	
8-74956	2.10-36.0- 21	1	
8-74958-7	2. 3-16.0- 6	1	
8-74960	2. 1- 1.0- 65	1	
8-74961	2. 2-15.0- 9	1	
8-74961-7	2. 1- 1.0- 24	2	
8-74962	2. 2-15.0- 2	1	
8-74963-7	2. 2- 9.0- 21	1	
8-74966-9	2.15-14.0- 45	1	
8-74968-1	2. 2-10.0- 47	1	
8-74968-10	2. 2-10.0- 49	1	
8-74968-2	2. 2-10.0- 47	1	
8-74968-3	2. 2-10.0- 47	1	
8-74968-4	2. 2-10.0- 47	1	
8-74968-7	2. 2-10.0- 49	1	
8-74968-8	2. 2-10.0- 49	1	
8-74968-9	2. 2-10.0- 49	1	
8-74969	2. 2-10.0- 21	1	
8-74970	2. 2-10.0- 15	1	
8-74974-7	2. 3-12.0- 5	1	
8-74974-8	2. 3-12.0- 5	1	
8-74975-9	2.20-35.0- 2	1	
8-74981	2. 3-10.0- 12	1	
	2.20-13.0-	RF	
8-74981-17	2.20-13.0- 5	2	
8-74985	2. 4- 9.0- 36	2	
8-74986	2. 4- 9.0- 37	2	
8-74987	2. 4- 9.0- 11	2	
8-74990-9	2. 4-10.0- 40	1	
8-74991	2. 2- 7.0- 87	1	
8-74995	2. 4- 9.0- 53	2	
8-74996	2. 4- 9.0- 61	4	
8-74997-1	2. 3-13.0- 3	1	
	2.11-10.0-	RF	
8-74997-2	2. 3-13.0- 3	1	
	2.11-10.0-	RF	
8-74997-25	2.11-10.0- 2	2	
8-74997-31	2.11-10.0- 3	1	
8-74997-32	2.11-10.0- 4	1	
8-74997-33	2.11-10.0- 5	1	
8-74997-34	2.11-10.0- 6	1	
8-74997-37	2.11-10.0- 2	1	
8-74997-38	2.11-10.0- 3	1	
8-74997-39	2.11-10.0- 4	1	
8-74997-40	2.11-10.0- 5	1	
8-74997-41	2.11-10.0- 4	1	
8-74997-42	2.11-10.0- 5	1	
8-74997-5	2. 3-13.0- 5	1	
	2.11-10.0-	RF	
8-74997-6	2. 3-13.0- 5	1	
	2.11-10.0-	RF	
8-74997-801	2. 3-13.0- 6	1	
	2.11-10.0-	RF	
8-74997-802	2. 3-13.0- 6	1	
	2.11-10.0-	RF	
8-74997-803	2. 3-13.0- 4	1	
	2.11-10.0-	RF	
8-74997-804	2. 3-13.0- 4	1	
	2.11-10.0-	RF	
8-74997-805	2. 3-13.0- 4	1	
	2.11-10.0-	RF	

PART NUMBER	FIGURE AND INDEX NUMBER	QTY PER ART	SMR CODE
8-74997-806	2. 3-13.0- 4	1	
	2.11-10.0-	RF	
8-74999-1	2. 3-10.0- 49	1	
	2. 5- 1.0- 39	RF	
8-74999-47	2. 5- 1.0- 40	RF	
8-74999-49	2. 5- 1.0- 41	1	
8-74999-5	2. 3-10.0- 49	1	
	2. 5- 1.0- 39	RF	
8-74999-57	2. 5- 1.0- 40	RF	
8-74999-59	2. 5- 1.0- 41	RF	
8-74999-7	2. 5- 1.0- 40	RF	
8-74999-9	2. 5- 1.0- 41	RF	
8-77050-13	2.11- 3.0- 4	1	
8-77050-15	2.11- 3.0- 5	1	
8-77058-7	2.11- 3.0- 8	1	
8-77058-9	2.11- 3.0- 9	1	
8-77064-1	2. 3-13.0- 9	1	
8-77064-3	2. 3-13.0- 9	1	
8-77107-11	2.20-14.0- 14	9	
	2.20-14.0- 15	1	
8-77107-13	2.20-14.0- 11	3	
	2.20-14.0- 12	1	
8-77107-17	2.20-14.0- 10	1	
	2.20-14.0- 19	1	
8-77107-19	2.20-14.0- 18	1	
8-77107-21	2.20-14.0- 8	1	
8-77107-23	2.20-14.0- 21	1	
8-77107-25	2.20-14.0- 12	RF	
	2.20-14.0- 15	RF	
	2.20-14.0- 17	RF	
	2.20-14.0- 20	RF	
	2.20-14.0- 9	RF	
8-77107-26	2.20-14.0- 20	RF	
8-77107-27	2.20-14.0- 20	1	
8-77107-28	2.20-14.0- 20	1	
8-77107-29	2.20-14.0- 7	1	
8-77107-31	2.20-14.0- 12	1	
8-77107-32	2.20-14.0- 12	1	
8-77107-33	2.20-14.0- 15	1	
8-77107-35	2.20-14.0- 15	1	
8-77107-7	2.20-14.0- 17	2	
	2.20-14.0- 9	1	
8-77107-9	2.20-14.0- 16	9	
8-77115	2. 3-10.0- 51	1	
	2.15- 1.0- 45	RF	
8-77115-7	2.15- 1.0- 49	1	
8-77115-9	2.15- 1.0- 48	2	
8-77116-1	2. 3- 4.0- 71	1	
8-77116-11	2. 3- 4.0- 71	1	
8-77116-7	2. 3- 4.0- 71	1	
8-77116-9	2. 3- 4.0- 71	1	
8-77120	2. 3- 4.0- 71	RF	
8-77120-11	2. 3- 4.0- 71	RF	
8-77120-7	2. 3- 4.0- 71	RF	
8-77120-9	2. 3- 4.0- 71	RF	
8-77124	2. 3- 3.0- 87	RF	
	2. 3-14.0- 40	1	
8-77124-7	2. 3- 3.0- 91	1	
8-77138-1	2. 2-17.0- 1	1	
8-77140-1	2. 2-17.0-	1	
8-77140-3	2. 2-17.0-	1	
8-77142-9	2.17- 8.0- 69	1	
8-77143-7	2.17- 8.0- 60	1	
8-77191	2. 3- 3.0- 72	1	
	2.15-31.0- 1	RF	

PART NUMBER	FIGURE AND INDEX NUMBER	QTY PER ART	SMR CODE
8-77191-1	2. 3-10.0- 6	1	
	2.15-31.0- 5	RF	
8-77191-3	2. 3-14.0- 39	1	
	2.15-31.0- 34	RF	
8-77191-4	2. 3-14.0- 39	1	
	2.15-31.0- 34	RF	
8-77191-5	2. 3-10.0- 6	1	
	2.15-31.0- 22	RF	
8-77191-8G1	2. 3- 3.0- 72	1	
	2.15-31.0- 29	RF	
8-77191-803	2. 3- 3.0- 72	1	
	2.15-31.0- 38	RF	
8-77191-8C4	2. 3- 3.0- 72	1	
	2.15-31.0- 38	RF	
8-77191-9	2.15-31.0- 31	2	
	2.15-31.0- 38	1	
8-77230-1	2.15- 1.0- 26	1	
8-77230-11	2.15- 1.0- 29	1	
8-77230-12	2.15- 1.0- 30	1	
8-77230-2	2.15- 1.0- 27	1	
8-77230-7	2.15- 1.0- 29	1	
8-77230-8	2.15- 1.0- 30	1	
8-77230-801	2.15- 1.0- 26	1	
8-77230-802	2.15- 1.0- 27	1	
8-77240	2. 3- 4.0- 55	1	
	2.15- 1.0- 25		
8-77300-1	2. 3-12.0- 9	1	
8-77300-115	2. 3-12.0- 9	1	
8-77300-117	2. 3-12.0- 9	1	
8-77300-119	2. 3-12.0- 9	1	
8-77300-801	2. 3-12.0- 9	1	
8-77304	2. 3-16.0- 53	1	
8-77304-1	2. 3-16.0- 53	1	
8-77304-87	2. 3-16.0- 94	1	
8-77307	2. 3-16.0- 69	1	
8-77307-27	2. 3-16.0- 80	1	
8-77307-41	2. 3-16.0- 81	1	
8-77307-43	2. 3-16.0- 79	1	
8-77307-45	2. 3-16.0- 69	1	
8-77307-7	2. 3-16.0- 63	1	
8-77307-8	2. 3-16.0- 84	1	
8-77307-9	2. 3-16.0- 82	1	
8-77310-1	2. 3-12.0- 18	1	
8-77310-3	2. 3-12.0- 18	1	
8-77310-49	2. 3-12.0- 19	1	
8-77310-5	2. 3-10.0- 50	1	
8-77310-50	2. 3-12.0- 20	1	
8-77310-51	2. 3-10.0- 55	1	
8-77310-7	2. 3-12.0- 18	1	
8-77310-801	2. 3- 3.0- 75	1	
8-77310-9	2. 3-12.0- 18	1	
8-77312-11	2.20-15.0- 32	2	
8-77312-7	2.20-15.0- 30	2	
8-77312-9	2.20-15.0- 31	2	
8-77313-7	2.20-15.0- 7	2	
8-77313-9	2.20-15.0- 8	1	
8-77314	2.20-15.0- 5	1	
8-77315	2.20-15.0- 6	1	
8-77381-7	2. 3-16.0- 17	1	
8-77381-8	2. 3-16.0- 18	1	
8-77382-7	2. 3-16.0- 19	1	
8-77382-8	2. 3-16.0- 20	1	
8-77383-10	2. 3-16.0- 66	1	
8-77383-7	2. 3-16.0- 63	1	
8-77383-8	2. 3-16.0- 64	1	

PART NUMBER	FIGURE AND INDEX NUMBER	QTY PER ART	SMR CODE
8-77383-9	2. 3-16.0- 65	1	
8-77386	2. 1- 1.0- 68	1	
	2. 3-16.0- 52	RF	
8-77386-1	2. 1- 1.0- 68	1	
	2. 3-16.0- 52	RF	
8-77387-1	2. 3-16.0- 70	1	
8-77387-3	2. 3-16.0- 71	1	
8-77387-4	2. 3-16.0- 72	1	
8-77387-5	2. 3-16.0- 73	1	
8-77387-6	2. 3-16.0- 74	1	
8-77387-801	2. 3-16.0- 75	1	
8-77387-802	2. 3-16.0- 76	1	
8-77387-803	2. 3-16.0- 77	1	
8-77387-804	2. 3-16.0- 78	1	
8-77386-7	2. 3-16.0- 58	1	
8-77388-8	2. 3-16.0- 59	1	
8-77389-7	2. 3-16.0- 60	1	
8-77389-8	2. 3-16.0- 61	1	
8-77391-7	2. 3-16.0- 54	4	
8-77401-1	2. 3-14.0- 7	1	
8-77403	2. 2- 3.0- 60	RF	
	2. 3- 9.0- 10	1	
	2. 3- 9.0- 8	1	
8-77405	2. 3- 9.0- 8	1	
8-77405-15	2. 3- 9.0- 8	1	
8-77406	2. 3- 4.0- 15	1	
	2. 3- 9.0-	RF	
8-77409	2. 2- 3.0- 55	RF	
	2. 3- 4.0- 6	1	
8-77409-3	2. 2- 3.0- 57	1	
8-77409-4	2. 2- 3.0- 57	1	
8-77409-61	2. 2- 3.0- 56	1	
8-77409-62	2. 2- 3.0- 57	1	
8-77470	2. 3- 3.0- 56	1	
	2. 3-14.0-	RF	
8-77470-10	2. 3-14.0- 17	1	
8-77470-11	2. 3-14.0- 7	1	
8-77470-12	2. 3-14.0- 7	1	
8-77470-13	2. 3-14.0- 11	1	
8-77470-14	2. 3-14.0- 11	1	
8-77470-63	2. 3-14.0- 7	1	
8-77470-64	2. 3-14.0- 7	1	
8-77470-7	2. 3-14.0- 1	1	
8-77504-11	2.11- 7.0- 2	1	
8-77504-13	2.11- 7.0- 7	1	
8-77504-15	2.11- 7.0- 8	1	
8-77504-17	2.11- 7.0- 3	1	
8-77504-19	2.11- 7.0- 5	1	
8-77504-21	2.11- 7.0- 6	1	
8-77504-23	2.11- 7.0- 2	1	
8-77504-25	2.11- 7.0- 7	1	
8-77504-27	2.11- 7.0- 8	1	
8-77504-29	2.11- 7.0- 3	1	
8-77504-3	2.11- 6.0- 1	1	
	2.11- 7.0-	RF	
8-77504-31	2.11- 7.0- 17	4	
8-77504-4	2.11- 6.0- 1	1	
	2.11- 7.0-	RF	
8-77504-55	2.11- 7.0- 17	4	
8-77504-7	2.11- 7.0- 5	1	
8-77504-713	2.11- 7.0- 17	RF	
8-77504-9	2.11- 7.0- 6	1	
8-77511-127	2.13-28.0- 9	1	
8-77511-21	2.13-28.0- 2	5	
8-77511-221	2.13-28.0- 23	2	
8-77511-223	2.13-28.0- 24	2	

PART NUMBER	FIGURE AND INDEX NUMBER	QTY PER ART	SMR CODE
8-77511-220	2.13-28.0- 4	1	
8-77511-227	2.13-28.0- 7	1	
8-77511-229	2.13-28.0- 12	1	
8-77511-233	2.13-28.0- 9	1	
8-77511-25	2.13-28.0- 4	1	
8-77511-29	2.13-28.0- 6	1	
8-77511-33	2.13-28.0- 7	1	
8-77511-37	2.13-28.0- 8	1	
8-77511-38	2.13-28.0- 8	1	
8-77511-41	2.13-28.0- 12	1	
8-77514	2.11- 6.0- 49	RF	
8-77514-1	2.11- 6.0- 43	1	
8-77514-13	2.11- 6.0- 49	1	
8-77514-14	2.11- 6.0- 49	1	
8-77514-2	2.11- 6.0- 43	1	
8-77514-3	2.11- 6.0- 43	1	
8-77514-4	2.11- 6.0- 43	1	
8-77514-7	2.11- 6.0- 49	1	
8-77514-8	2.11- 6.0- 49	1	
8-77514-9	2.11- 6.0- 44	2	
8-77515	2.11- 6.0- 26	RF	
8-77515-7	2.11- 6.0- 26	1	
8-77517-1	2.11- 6.0- 29	1	
8-77517-7	2.11- 6.0- 29	1	
8-77523-7	2. 2- 7.0-114	1	
8-77523-9	2. 2- 7.0-111	1	
8-77524	2. 2- 7.0-115	1	
8-77526	2.15-30.0- 9	1	
8-77531-7	2.15-30.0- 30	2	
8-77543	2. 4- 1.0- 47	1	
8-77562	2. 2- 3.0- 67	1	
8-77567-1	2.11- 4.0- 7	1	
	2.11- 5.0-	RF	
8-77567-2	2.11- 5.0-	RF	
8-77568-7	2.11- 5.0- 1	1	
8-77568-8	2.11- 5.0- 1	1	
8-77569	2.11- 5.0- 1	RF	
8-77583-3	2.11- 3.0- 9	RF	
8-77583-4	2.11- 3.0- 9	RF	
8-77583-49	2.11- 3.0- 16	1	
8-77583-50	2.11- 3.0- 16	1	
8-77583-51	2.11- 3.0- 15	1	
8-77583-52	2.11- 3.0- 15	1	
8-77583-801	2.11- 3.0- 9	1	
8-77583-802	2.11- 3.0- 9	1	
8-77583-803	2.11- 3.0- 9	1	
8-77583-804	2.11- 3.0- 9	1	
8-77583-805	2.11- 3.0- 9	RF	
8-77583-806	2.11- 3.0- 9	RF	
8-77584-1	2.11- 3.0- 17	1	
	2.13-28.0-	RF	
8-77584-121	2.11- 3.0- 10	1	
8-77584-122	2.11- 3.0- 10	1	
8-77584-123	2.11- 3.0- 11	1	
8-77584-124	2.11- 3.0- 11	1	
8-77584-129	2.13-28.0- 20	1	
8-77584-130	2.13-28.0- 20	1	
8-77584-133	2.11- 3.0- 10	1	
8-77584-134	2.11- 3.0- 10	1	
8-77584-135	2.11- 3.0- 11	1	
8-77584-136	2.11- 3.0- 11	1	
8-77584-139	2.13-28.0- 21	1	
8-77584-141	2.13-28.0- 21	1	
8-77584-19	2.11- 3.0- 16	1	
8-77584-2	2.11- 3.0- 17	1	

PART NUMBER	FIGURE AND INDEX NUMBER	QTY PER ART	SMR CODE
8-77584-2	2.13-28.0-	RF	
8-77584-20	2.11- 3.0- 10	1	
8-77584-23	2.11- 3.0- 11	1	
8-77584-24	2.11- 3.0- 11	1	
8-77584-29	2.11- 3.0- 13	1	
8-77584-33	2.11- 3.0- 12	1	
8-77584-5	2.11- 3.0- 9	1	
8-77584-51	2.13-28.0- 20	1	
8-77584-52	2.13-28.0- 20	1	
8-77584-55	2.13-28.0- 21	1	
8-77584-56	2.13-28.0- 21	1	
8-77584-6	2.11- 3.0- 9	1	
8-77584-61	2.13-28.0- 15	1	
8-77584-62	2.13-28.0- 15	1	
8-77584-65	2.13-28.0- 16	1	
8-77584-66	2.13-28.0- 16	1	
8-77584-69	2.13-28.0- 17	1	
8-77584-71	2.13-28.0- 18	1	
8-77584-805	2.11- 3.0- 9	1	
8-77584-806	2.11- 3.0- 9	1	
8-77585-1	2.11- 3.0- 1	1	
8-77585-10	2.11- 3.0- 32	1	
8-77585-109	2.11- 3.0- 28	2	
8-77585-11	2.11- 3.0- 29	1	
8-77585-12	2.11- 3.0- 29	1	
8-77585-123	2.11- 3.0- 35	1	
8-77585-124	2.11- 3.0- 35	1	
8-77585-19	2.11- 3.0- 33	1	
8-77585-2	2.11- 3.0- 1	1	
8-77585-20	2.11- 3.0- 33	1	
8-77585-21	2.11- 3.0- 34	1	
8-77585-22	2.11- 3.0- 34	1	
8-77585-25	2.11- 3.0- 30	1	
8-77585-26	2.11- 3.0- 30	1	
8-77585-35	2.11- 3.0- 21	1	
8-77585-59	2.11- 3.0- 27	1	
8-77585-61	2.11- 3.0- 18	2	
8-77585-7	2.11- 3.0- 31	1	
8-77585-79	2.11- 3.0- 36	1	
8-77585-8	2.11- 3.0- 31	1	
8-77585-80	2.11- 3.0- 38	1	
8-77585-87	2.11- 3.0- 39	1	
8-77585-88	2.11- 3.0- 39	1	
8-77585-9	2.11- 3.0- 32	1	
8-77586-1	2. 3-13.0- 1	1	
	2.11- 4.0-	RF	
8-77586-2	2. 3-13.0- 1	RF	
	2.11- 4.0-	RF	
8-77586-5	2. 3- 3.0- 21	1	
	2.11- 3.0-	RF	
8-77586-6	2. 3- 3.0- 21	1	
	2.11- 3.0-	RF	
8-77587-1	2.11- 3.0- 21	1	
8-77587-11	2.11- 3.0- 23	1	
8-77587-12	2.11- 3.0- 23	1	
8-77587-2	2.11- 3.0- 21	1	
8-77590	2. 2- 7.0- 37	RF	
	2. 3-12.0- 2	1	
8-77590-1	2. 2- 7.0- 47	RF	
	2.11- 4.0- 8	1	
8-77590-15	2. 2- 7.0- 51	1	
8-77590-17	2. 2- 7.0- 52	1	
8-77590-23	2. 2- 7.0- 37	1	
8-77590-25	2. 2- 7.0- 49	1	
8-77590-27	2. 2- 7.0- 50	1	

PART NUMBER	FIGURE AND INDEX NUMBER	QTY PER ART	SMR CODE
8-77590-35	2. 2- 7.0- 44	1	
8-77590-37	2. 2- 7.0- 37	1	
8-77590-39	2. 2- 7.0- 37	1	
8-77590-41	2. 2- 7.0- 43	1	
8-77590-43	2. 2- 7.0- 44	1	
8-77590-45	2. 2- 7.0- 37	1	
8-77590-47	2. 2- 7.0- 37	1	
8-77590-7	2. 2- 7.0- 43	1	
8-77590-9	2. 2- 7.0- 53	1	
8-77595-9	2.11- 6.0- 44	RF	
8-77599-17	2. 2- 7.0- 8	1	
8-77599-18	2. 2- 7.0- 9	1	
8-77599-3	2. 1- 1.0- 5	1	
	2. 2- 7.0- 7	RF	
8-77599-7	2. 2- 7.0- 8	1	
8-77599-8	2. 2- 7.0- 9	1	
8-77599-801	2. 1- 1.0- 5	1	
	2. 2- 7.0- 7	RF	
8-77601-10	2. 2-16.0- 24	1	
8-77601-11	2. 2-16.0- 14	1	
8-77601-12	2. 2-16.0- 14	1	
8-77601-13	2. 2-16.0- 22	1	
8-77601-17	2. 2-16.0- 26	1	
8-77601-18	2. 2-16.0- 26	1	
8-77601-19	2. 2-16.0- 8	1	
8-77601-20	2. 2-16.0- 8	1	
8-77601-21	2. 2-16.0- 17	1	
8-77601-22	2. 2-16.0- 17	1	
8-77601-23	2. 2-16.0- 5	2	
8-77601-25	2. 2-16.0- 1	1	
8-77601-27	2. 2-16.0- 27	1	
8-77601-28	2. 2-16.0- 27	1	
8-77601-29	2. 2-16.0- 17	1	
8-77601-3	2. 2-16.0-	RF	
	2. 3-14.0- 12	1	
8-77601-30	2. 2-16.0- 17	1	
8-77601-31	2. 2-16.0- 24	1	
8-77601-33	2. 2-16.0- 24	1	
8-77601-4	2. 2-16.0-	RF	
	2. 3-14.0- 12	1	
8-77601-7	2. 2-16.0- 16	1	
8-77601-701	2. 2-16.0-	RF	
	2. 3-14.0- 12	1	
8-77601-702	2. 2-16.0-	RF	
	2. 3-14.0- 12	1	
8-77601-713	2. 2-16.0- 27	1	
8-77601-714	2. 2-16.0- 27	1	
8-77601-8	2. 2-16.0- 16	1	
8-77601-9	2. 2-16.0- 24	1	
8-77606-7	2.20-19.0- 33	1	
8-77606-8	2.20-19.0- 33	1	
8-77607-7	2.20-19.0- 9	1	
8-77607-8	2.20-19.0- 9	1	
8-77608-7	2.20-19.0- 65	1	
8-77610-7	2.20-19.0- 24	1	
8-77610-8	2.20-19.0- 24	1	
8-77611-7	2. 2- 3.0- 58	1	
8-77611-8	2. 2- 3.0- 58	1	
8-77615-11	2.20-16.0- 12	1	
	2.20-16.0- 11	1	
8-77615-7	2.20-16.0- 15	1	
	2.20-16.0- 18	1	
	2.20-16.0- 21	1	
	2.20-17.0- 2	1	
	2.20-17.0- 5	1	

PART NUMBER	FIGURE AND INDEX NUMBER	QTY PER ART	SMR CODE
8-77615-7	2.20-17.0- 8	1	
	2.20-18.0- 14	1	
	2.20-18.0- 17	1	
	2.20-18.0- 20	1	
8-77615-9	2.20-17.0- 12	1	
8-77616-7	2.20-19.0- 63	1	
	2.20-19.0- 7	1	
8-77616-9	2.20-19.0- 13	1	
	2.20-19.0- 17	1	
	2.20-19.0- 21	1	
	2.20-19.0- 44	1	
	2.20-19.0- 45	1	
	2.20-19.0- 53	1	
8-77617-7	2.20-15.0- 11	4	
	2.20-15.0- 25	2	
	2.20-39.0- 4	2	
8-77617-9	2.20-15.0- 16	12	
	2.20-15.0- 28	5	
	2.20-39.0- 7	5	
8-77618	2. 2-10.0- 46	1	
8-77619-11	2.20-17.0- 19	1	
8-77619-13	2.20-16.0- 30	2	
	2.20-18.0- 29	1	
8-77619-15	2.20-19.0- 37	1	
8-77619-17	2.20-19.0- 36	1	
8-77619-19	2.20-19.0- 68	1	
8-77619-21	2.20-19.0- 67	1	
8-77619-23	2.20-19.0- 1	1	
8-77619-25	2.20-19.0- 2	1	
8-77619-7	2.20-16.0- 8	2	
	2.20-18.0- 8	2	
8-77619-9	2.20-17.0- 18	1	
8-77624	2. 2-12.0- 27	RF	
8-77624-11	2. 2-12.0- 17	2	
8-77624-29	2. 2-12.0- 36	1	
8-77624-31	2. 2-12.0- 35	1	
8-77624-5	2. 2-12.0- 27	1	
8-77624-7	2. 2-12.0- 38	1	
8-77624-801	2. 2-12.0- 27	1	
8-77625	2. 2-12.0- 5	RF	
	2. 2-12.0- 5	1	
8-77628	2. 2- 8.0- 56	RF	
	2. 3-14.0- 8	1	
8-77628-31	2. 2- 9.0- 57	1	
8-77629	2. 2- 3.0- 22	RF	
	2. 3- 7.0- 2	1	
8-77629-7	2. 2- 3.0- 23	1	
8-77635	2. 2- 3.0- 9	RF	
	2. 3- 7.0- 3	1	
8-77635-21	2. 2- 3.0- 16	1	
8-77635-23	2. 2- 3.0- 19	1	
8-77635-25	2. 2- 3.0- 21	1	
8-77635-29	2. 2- 3.0- 20	1	
8-77635-7	2. 2- 3.0- 13	1	
8-77635-9	2. 2- 3.0- 22	1	
8-77636-11	2. 2- 3.0- 19	1	
8-77636-13	2. 2- 3.0- 18	1	
8-77638-10	2. 2- 7.0-106	1	
8-77638-3	2. 1- 1.0- 9	1	
	2. 2- 7.0-105	RF	
8-77638-4	2. 1- 1.0- 9	1	
	2. 2- 7.0-105	RF	
8-77638-9	2. 2- 7.0-106	1	
8-77639-3	2. 1- 1.0- 10	1	
	2. 2- 7.0-106	RF	

PART NUMBER	FIGURE AND INDEX NUMBER	QTY PER ART	SMR CODE
8-77639-9	2. 2- 7.0-107	1	
8-77640-3	2. 1- 1.0- 10	1	
	2. 2- 7.0-106	RF	
8-77640-9	2. 2- 7.0-108	1	
8-77648	2. 2- 7.0- 72	1	
8-77649	2. 3-12.0- 33	1	
8-77643-41	2. 2- 7.0- 67	RF	
	2. 3-12.0- 34	1	
8-77649-7	2. 2- 7.0- 67	RF	
	2. 3-12.0- 34	1	
8-77674-1	2. 2- 9.0- 49	RF	
	2. 3-14.0- 13	1	
8-77674-15	2. 2- 9.0- 50	1	
8-77674-2	2. 2- 9.0- 49	RF	
	2. 3-14.0- 13	1	
8-77674-21	2. 2- 9.0- 52	1	
	2. 2- 9.0- 53	1	
	2. 3-14.0- 13	2	
8-77674-7	2. 2- 9.0- 52	1	
8-77675	2. 2- 9.0- 53	1	
8-77703-11	2. 3- 4.0- 16	RF	
8-77703-7	2. 3- 8.0- 18	1	
8-77701	2. 3- 5.0- 25	1	
8-77702	2. 3- 5.0- 16	1	
8-77732-7	2. 3- 5.0- 19	1	
8-77732-713	2. 3- 5.0- 18	1	
8-77734-11	2. 3- 4.0- 16	2	
8-77735	2.15-14.0- 1	1	
8-77707-9	2.15-14.0- 29	2	
8-77708-1	2. 3- 5.0- 9	1	
8-77726-7	2. 2-13.0- 8	1	
8-77727-7	2. 2-13.0- 21	1	
8-77728-10	2.20-19.0- 74	1	
8-77728-11	2.20-19.0- 23	1	
8-77728-12	2.20-19.0- 23	1	
8-77728-7	2.20-19.0- 23	1	
8-77728-8	2.20-19.0- 23	1	
8-77728-9	2.20-19.0- 74	1	
8-77729-13	2.20-19.0- 38	1	
8-77729-7	2.20-19.0- 38	1	
8-77729-8	2.20-19.0- 38	1	
8-77729-9	2.20-19.0- 38	1	
8-77738-13	2.20-16.0- 13	RF	
	2.21-16.0- 12	RF	
8-77733-14	2.20-16.0- 13	RF	
	2.20-16.0- 12	RF	
8-77736-17	2.20-16.0- 13	1	
	2.20-16.0- 12	1	
8-77738-18	2.20-16.0- 13	1	
	2.21-16.0- 12	1	
8-77738-3	2.20-16.0- 10	RF	
	2.20-16.0- 9	RF	
8-77738-4	2.20-16.0- 10	RF	
	2.20-16.0- 9	RF	
8-77738-5	2.20-16.0- 10	1	
	2.20-16.0- 9	1	
8-77738-6	2.20-16.0- 10	1	
	2.20-16.0- 9	1	
8-77739-1	2.20-16.0- 13	RF	
	2.20-16.0-	RF	
8-77739-10	2.20-16.0- 15	RF	
8-77739-13	2.20-16.0- 15	1	
8-77739-14	2.20-16.0- 15	1	
8-77739-2	2.20-16.0-	RF	
8-77739-3	2.20-16.0- 13	1	

PART NUMBER	FIGURE AND INDEX NUMBER	QTY PER ART	SMR CODE
8-77739-3	2.20-16.0-	1	
8-77739-4	2.20-16.0- 13	1	
	2.20-16.0-	1AA	
8-77739-9	2.20-16.0- 15	RF	
8-77740-13	2.20-16.0- 18	RF	
8-77740-14	2.20-16.0- 18	RF	
8-77740-17	2.20-16.0- 18	1	
8-77740-18	2.20-16.0- 18	1	
8-77740-3	2.20-16.0- 15	RF	
8-77740-4	2.20-16.0- 15	RF	
8-77740-5	2.20-16.0- 14	1	
	2.20-19.0- 15	1	
	2.20-16.0- 16	1	
8-77740-6	2.20-16.0- 15	1	
	2.20-19.0- 21	RF	
8-77741-13	2.20-16.0- 21	RF	
8-77741-14	2.20-16.0- 21	RF	
8-77741-17	2.20-16.0- 21	1	
8-77741-18	2.20-16.0- 21	1	
8-77741-3	2.20-16.0- 18	RF	
8-77741-4	2.20-16.0- 18	RF	
8-77741-5	2.20-16.0- 19	1	
	2.20-16.0- 22	1	
	2.20-18.0- 21	1	
8-77741-6	2.20-16.0- 19	1	
	2.20-16.0- 22	1	
	2.20-18.0- 10	1	
8-77742-1	2.20-16.0- 21	RF	
8-77742-2	2.20-16.0- 21	RF	
8-77742-7	2.20-16.0- 23	RF	
8-77742-8	2.20-16.0- 23	RF	
8-77743-13	2.20-17.0- 3	RF	
8-77743-14	2.20-17.0- 3	RF	
8-77743-17	2.20-17.0- 3	1	
8-77743-18	2.20-17.0- 3	1	
8-77743-3	2.20-17.0-	RF	
8-77743-4	2.20-17.0-	RF	
8-77743-5	2.20-17.0-	1	
8-77743-6	2.20-17.0-	1	
8-77744-1	2.20-17.0- 3	RF	
8-77744-10	2.20-17.0- 6	RF	
8-77744-13	2.20-17.0- 6	1	
8-77744-14	2.20-17.0- 6	1	
8-77744-2	2.20-17.0- 3	RF	
8-77744-3	2.20-17.0- 3	1	
8-77744-4	2.20-17.0- 3	1	
8-77744-9	2.20-17.0- 6	RF	
8-77745-1	2.20-17.0- 6	RF	
8-77745-10	2.20-17.0- 9	RF	
8-77745-13	2.20-17.0- 9	1	
8-77745-14	2.20-17.0- 9	1	
8-77745-2	2.20-17.0- 6	RF	
8-77745-3	2.20-17.0- 6	1	
8-77745-4	2.20-17.0- 6	1	
8-77745-9	2.20-17.0- 9	RF	
8-77745-13	2.20-17.0- 13	RF	
8-77746-14	2.20-17.0- 13	RF	
8-77746-17	2.20-17.0- 13	1	
8-77746-18	2.20-17.0- 13	1	
8-77746-3	2.20-17.0- 10	RF	
8-77746-4	2.20-17.0- 10	RF	
8-77746-5	2.20-17.0- 10	1	
8-77746-6	2.20-17.0- 10	1	
8-77751-1	2. 3-12.0- 4	1	
8-77751-2	2. 3-12.0- 4	1	
8-77752	2.20-13.0- 12	1	

PART NUMBER	FIGURE AND INDEX NUMBER	QTY PER ART	SMR CODE
8-77752-7	2.20-13.0- 17	1	
8-77753	2.20-13.0- 9	RF	
8-77753-7	2.20-13.0- 11	1	
8-77759-3	2. 3- 5.0- 11	1	
8-77761-13	2.20-13.0- 1	2	
8-77761-15	2. 3-12.0- 30	1	
8-77761-17	2.20-12.0- 27	2	
8-77761-19	2.20-12.0- 28	2	
8-77761-21	2.20-12.0- 15	2	
8-77761-23	2.20-12.0- 14	2	
	2.20-12.0- 17	2	
8-77761-7	2.20-13.0- 10	2	
8-77761-9	2.20-13.0- 13	4	
8-77766-7	2.10-40.0- 6	RF	
8-77766-8	2.10-40.0- 6	RF	
8-77769	2. 4- 2.0- 11	13	
8-77771-1	2. 2- 3.0- 8	1	
8-77777-801	2. 3-10.0- 40	1	
8-77777-802	2. 3-10.0- 40	1	
8-77777-803	2. 3-10.0- 40	1	
8-77777-804	2. 3-10.0- 40	1	
8-77778-7	2.20-17.0- 22	1	
8-77778-9	2.20-17.0- 23	1	
8-77785-11	2.13-21.0- 12	1	
8-77785-17	2. 2- 8.0- 9	1	
8-77788-7	2.15-31.0- 4	1	
8-77788-9	2.15-31.0- 3	1	
8-77794-7	2. 3-12.0- 8	2	
8-77796-11	2. 2- 4.0- 9	3	
8-77796-13	2. 2- 4.0- 10	AR	
8-77796-15	2. 2- 4.0- 10	AR	
8-77796-7	2. 2- 4.0- 10	AR	
8-77796-9	2. 2- 4.0- 10	AR	
8-77797-3	2. 2- 7.0- 80	1	
8-77797-9	2. 2- 7.0- 81	1	
8-77798-17	2. 2- 9.0- 23	1	
8-77798-9	2. 2- 7.0- 84	1	
8-77803-7	2. 4- 2.0- 3	1	
8-77803-9	2. 4- 2.0- 4	1	
8-77804	2. 4- 2.0- 1	1	
8-77805	2. 4- 2.0- 10	1	
8-77806	2. 4- 2.0- 6	1	
8-77873	2. 3-12.0- 4	1	
8-77900-1	2. 3- 5.0- 10	1	
8-77904-1	2.20-19.0- 4	1	
	2.20-19.0- 8	1	
8-77904-2	2.20-19.0- 4	1	
	2.20-19.0- 8	1	
8-77905-1	2.20-19.0- 10	1	
	2.20-19.0- 14	1	
8-77905-2	2.20-19.0- 10	1	
	2.20-19.0- 14	1	
8-77906-1	2.20-19.0- 14	1	
	2.20-19.0- 18	1	
8-77906-2	2.20-19.0- 14	1	
	2.20-19.0- 18	1	
8-77907-1	2.20-19.0- 18	1	
	2.20-19.0- 22	1	
8-77907-2	2.20-19.0- 18	1	
	2.20-19.0- 22	1	
8-77908-1	2.20-19.0- 40	1	
	2.20-19.0- 45	1	
8-77908-2	2.20-19.0- 40	1	
	2.20-19.0- 45	1	
8-77908-8	2.20-19.0- 65	1	

PART NUMBER	FIGURE AND INDEX NUMBER	QTY PER ART	SMR CODE
8-77909-1	2.20-19.0- 45	1	
	2.20-19.0- 50	1	
8-77909-2	2.20-19.0- 45	1	
	2.20-19.0- 50	1	
8-77910-1	2.20-19.0- 50	1	
	2.20-19.0- 54	1	
8-77910-2	2.20-19.0- 50	1	
	2.20-19.0- 54	1	
8-77911-1	2.20-19.0- 61	1	
	2.20-19.0- 64	1	
8-77911-2	2.20-19.0- 61	1	
	2.20-19.0- 64	1	
8-77912-7	2. 3- 5.0- 12	1	
8-77918	2.20-13.0- 2	2	
8-77928-1	2.20-12.0- 23	RF	
8-77928-7	2.20-12.0- 29	RF	
8-77928-9	2.20-11.0- 54	2	
8-77929-3	2.20-12.0- 23	1	
8-77929-7	2.20-12.0- 29	1	
8-77930-11	2.20-12.0- 16	1	
8-77930-12	2.20-12.0- 16	1	
8-77930-3	2.20-12.0- 13	1	
8-77930-4	2.20-12.0- 13	1	
8-77931-1	2.20-12.0- 16	1	
8-77931-2	2.20-12.0- 16	1	
8-77931-7	2.20-12.0- 18	1	
8-77931-8	2.20-12.0- 18	1	
8-77935-7	2. 3-12.0- 27	1	
8-77937-10	2.20-19.0- 38	1	
8-77937-7	2.20-19.0- 38	1	
8-77937-8	2.20-19.0- 38	1	
8-77937-9	2.20-19.0- 38	1	
8-77939-1	2.20-13.0- 9	2	
8-77939-11	2.20-13.0- 11	1	
8-77939-7	2.20-13.0- 11	1	
8-77940-1	2. 3-12.0- 31	1	
8-77940-2	2. 3-12.0- 32	1	
8-77940-7	2. 3-12.0- 32	1	
8-77940-8	2. 3-12.0- 32	1	
8-77942-15	2.20-15.0- 38		
8-77942-17	2.20-15.0- 39		
8-77942-19	2.20-15.0- 37		
8-77942-21	2.20-15.0- 36		
8-77944-13	2.20-35.0- 5	RF	
8-77944-14	2.20-35.0- 6	RF	
8-77944-15	2.20-35.0- 7	RF	
8-77944-16	2.20-35.0- 8	RF	
8-77945-10	2.20-35.0- 6	1	
8-77945-11	2.20-35.0- 7	1	
8-77945-12	2.20-35.0- 8	1	
8-77945-9	2.20-35.0- 5	1	
8-77953	2. 3-10.0- 10	1	
	2.20- 1.0- 31	RF	
8-77953-10	2.20- 1.0- 30	1	
8-77953-11	2.20- 1.0- 30	1	
8-77953-12	2.20- 1.0- 37	1	
8-77953-29	2.20- 1.0- 36	1	
8-77954-7	2.20- 1.0- 34	1	
8-77954-8	2.20- 1.0- 35	1	
8-77961-3	2. 2- 7.0- 26	RF	
8-77961-4	2. 2- 7.0- 26	1	
8-77961-5	2. 2- 7.0- 26	RF	
8-77961-6	2. 2- 7.0- 26	1	
8-77961-801	2. 2- 7.0- 26	RF	

PART NUMBER	FIGURE AND INDEX NUMBER	QTY PER ART	SMR CODE
8-77961-802	2. 2- 7.0- 28	1	
	2. 2- 7.0- 28	RF	
8-77961-805	2. 2- 7.0- 26	1	
8-77962	2. 3-10.0- 11	1	
	2.20-12.0-	RF	
8-77962-11	2.20-12.0- 20	1	
8-77962-12	2.20-12.0- 20	1	
8-77962-13	2.20-12.0- 21	1	
8-77962-14	2.20-12.0- 21	1	
8-77962-15	2.20-12.0- 19	1	
8-77962-16	2.20-12.0- 19	1	
8-77962-23	2.20-12.0- 1	1	
8-77962-24	2.20-12.0- 2	1	
8-77962-7	2.20-12.0- 10	1	
8-77962-8	2.20-12.0- 10	1	
8-77962-9	2.20-12.0- 22	1	
8-77963	2. 2- 7.0- 33	1	
8-77967-1	2.20-16.0- 22	1	
	2.20-16.0- 24	1	
	2.20-18.0- 21	1	
8-77967-2	2.20-16.0- 22	1	
	2.20-16.0- 24	1	
	2.20-18.0- 21	1	
8-77967-7	2.20-18.0- 23	1	
8-77968	2.20-16.0- 25	1	
	2.20-18.0- 24	1	
8-77968-7	2.20-16.0- 31	1	
	2.20-18.0- 30	1	
8-77969-1	2.20-16.0- 1	1	
	2.20-18.0- 1	1	
8-77969-10	2.20-16.0- 9	1	
	2.20-18.0- 9	1	
8-77969-2	2.20-16.0- 1	1	
	2.20-18.0- 1	1	
8-77969-9	2.20-16.0- 9	1	
	2.20-18.0- 9	1	
8-77972	2.20-19.0- 75	1	
8-77989	2. 2- 5.0- 2	2	
8-77989-11	2. 2- 5.0- 3	1	
8-77989-7	2. 2- 5.0- 4	1	
8-77989-9	2. 2- 5.0- 5	1	
8-78501-11	2.11- 6.0- 31	1	
8-78501-117	2.11- 6.0- 39	1	
8-78501-12	2.11- 6.0- 32	1	
8-78501-21	2.11- 6.0- 30	1	
8-78501-3	2.11- 6.0- 21	1	
8-78501-45	2.11- 6.0- 35	1	
8-78501-46	2.11- 6.0- 35	1	
8-78501-47	2.11- 6.0- 34	1	
8-78501-77	2.11- 6.0- 24	1	
8-78501-79	2.11- 6.0- 27	2	
8-78501-805	2.11- 6.0- 21	RF	
8-78501-93	2.11- 6.0- 38	1	
8-78502-1	2.11- 6.0- 35	1	
8-78502-9	2.11- 6.0- 37	1	
8-78503	2.11- 6.0- 25	1	
8-78509-1	2.11- 6.0- 4	1	
8-78509-2	2.11- 6.0- 4	1	
8-78514	2. 2- 7.0- 98	1	
8-78514-7	2. 2- 7.0- 99	1	
8-78528	2.11- 5.5- 8	1	
8-78547-15	2.11- 6.0- 36	4	
8-78588-3	2. 2- 9.0- 41	1	
8-78589	2. 2- 1.0- 8	RF	
	2. 3- 4.0- 1	1	

PART NUMBER	FIGURE AND INDEX NUMBER	QTY PER ART	SMR CODE
8-78589-15	2. 2- 1.0- 8	1	
8-78589-7	2. 2- 1.0- 10	1	
8-78590	2. 2- 1.0- 9	1	
8-78702-801	2. 3-13.0- 9	1	
8-78702-802	2. 3-13.0- 9	1	
8-78702-803	2. 3-13.0- 9	1	
8-78702-804	2. 3-13.0- 9	1	
8-78703-1	2.11- 6.0- 7	1	
8-78703-2	2.11- 6.0- 7	1	
8-78703-21	2.11- 6.0- 16	1	
8-78703-23	2.11- 6.0- 17	1	
8-78703-3	2.11- 6.0- 7	1	
8-78703-31	2.11- 6.0- 18	1	
8-78703-32	2.11- 6.0- 19	1	
8-78703-33	2.11- 6.0- 20	1	
8-78703-34	2.11- 6.0- 21	1	
8-78703-4	2.11- 6.0- 7	1	
8-78703-41	2.11- 6.0- 15	1	
8-78703-42	2.11- 6.0- 15	1	
8-78703-43	2.11- 6.0- 14	1	
8-78703-44	2.11- 6.0- 14	1	
8-78703-49	2.11- 6.0- 17	1	
8-78703-7	2.11- 6.0- 17	1	
8-78703-9	2.11- 6.0- 17	1	
8-78725	2. 3- 4.0- 13	1	
	2.15-36.0-	RF	
8-78725-1	2. 3- 4.0- 13	1	
	2.15-36.0-	RF	
8-78733-21	2.15-37.0- 25	RF	
8-78733-23	2.15-37.0- 25	1	
8-78733-3	2.15-37.0- 2	1	
8-78733-31	2.15-37.0- 26	RF	
8-78733-33	2.15-37.0- 26	1	
8-78733-43	2.15-37.0- 25	1	
8-78733-5	2.15-37.0- 2	1	
8-78734	2. 3-14.0- 36	1	
	2.15-37.0- 1	RF	
8-78734-7	2.15-37.0- 19	2	
8-78734-9	2.15-37.0- 27	AR	
8-78736-1	2. 1- 1.0- 69	1	
	2.15-37.0- 27	RF	
8-78736-17	2.15-37.0- 28	1	
8-78737	2.15-37.0- 24	1	
8-78737-7	2.15-37.0- 24	1	
8-78738	2.15-14.0- 19	1	
8-8-239	2.14-11.0- 27	2	
8-80003-557	2.15-26.0- 17	1	
8-80003-589	2.15-26.0- 17	1	
8-80003-9	2. 8-19.0- 5	2	
	2. 8-19.0- 58	2	
8-80024	2. 7- 6.0- 5	1	
	2. 8-13.0-	RF	
	2. 8-20.0-	RF	
	2. 8-21.0-	RF	
8-80024-105	2. 8-21.0- 30	1	
8-80024-107	2. 8-21.0- 3	1	
8-80024-109	2. 8-21.0- 12	1	
8-80024-11	2. 8-13.0- 29	1	
8-80024-117	2. 8-13.0- 3	1	
8-80024-121	2. 8-13.0- 14	1	
8-80024-127	2. 8-21.0- 46	1	
8-80024-129	2. 8-21.0- 23	1	
8-80024-131	2. 7- 7.0- 14	1	
8-80024-133	2. 7- 7.0- 15	1	
8-80024-135	2. 8-13.0- 42	1	

PART NUMBER	FIGURE AND INDEX NUMBER	QTY PER ART	SMR CODE
8-80024-137	2. 8-13.0- 27	1	
8-80024-139	2. 8-13.0- 29	1	
8-80024-141	2. 8-13.0- 5	1	
8-80024-143	2. 8-13.0- 16	1	
8-80024-149	2. 8-13.0- 44	1	
8-80024-151	2. 8-13.0- 31	1	
8-80024-153	2. 8-21.0- 21	1	
8-80024-159	2. 8-23.0- 9	1	
8-80024-161	2. 8-23.0- 21	1	
8-80024-163	2. 8-13.0- 18	1	
8-80024-165	2. 8-13.0- 23	1	
8-80024-167	2. 8-13.0- 7	1	
8-80024-169	2. 8-23.0- 17	1	
8-80024-171	2. 8-23.0- 3	1	
8-80024-173	2. 8-23.0- 5	1	
8-80024-175	2. 8-21.0- 35	1	
8-80024-177	2. 8-13.0- 23	1	
8-80024-179	2. 8-13.0- 13	1	
8-80024-181	2. 8-23.0- 10	1	
8-80024-183	2. 8-23.0- 22	1	
8-80024-187	2. 8-21.0- 55	1	
8-80024-191	2. 8-21.0- 52	1	
8-80024-193	2. 8-21.0- 53	1	
8-80024-195	2. 8-21.0- 56	1	
8-80024-197	2. 8-21.0- 57	1	
8-80024-199	2. 8-13.0- 17	1	
8-80024-201	2. 8-23.0- 10	1	
8-80024-203	2. 8-23.0- 22	1	
8-80024-25	2. 8-13.0- 35	1	
8-80024-43	2. 8-23.0- 15	1	
8-80024-53	2. 8-21.0- 27	1	
8-80024-57	2. 8-21.0- 33	1	
8-80024-59	2. 8-21.0- 35	1	
8-80024-61	2. 8-21.0- 37	1	
8-80024-63	2. 8-21.0- 44	1	
8-80024-7	2. 8-13.0- 42	1	
8-80024-71	2. 8-21.0- 39	1	
8-80024-73	2. 8-21.0- 16	1	
8-80024-87	2. 8-21.0- 14	1	
8-80024-9	2. 8-13.0- 40	1	
8-80024-95	2. 8-21.0- 5	1	
8-80024-97	2. 8-13.0- 51	1	
8-80024-99	2. 8-13.0- 48	1	
8-80029	2. 8-32.0- 91	1	
8-80029-1	2. 8-19.0- 91	1	RF
	2. 8-15.0- 91	1	RF
8-80029-11	2. 8-19.0- 49	1	
8-80029-13	2. 8-19.0- 32	1	
8-80029-15	2. 8-19.0- 47	1	
	2. 8-13.0- 83	1	
8-80029-17	2. 8-19.0- 30	1	
	2. 8-19.0- 93	1	
8-80029-19	2. 8-19.0- 39	1	
	2. 8-19.0-102	1	
8-80029-21	2. 8-19.0- 12	1	
	2. 8-19.0- 65	1	
8-80029-29	2. 8-19.0- 25	1	
8-80029-33	2. 8-19.0- 37	1	
8-80029-39	2. 8-19.0- 51	1	
8-80029-41	2. 8-19.0-119	1	
8-80029-43	2. 8-19.0- 67	1	
8-80029-45	2. 8-19.0-104	1	
8-80029-47	2. 8-19.0- 85	1	
8-80029-49	2. 8-17.0- 55	1	

PART NUMBER	FIGURE AND INDEX NUMBER	QTY PER ART	SMR CODE
8-80029-51	2. 8-19.0- 81	1	
8-80029-53	2. 8-19.0- 55	1	
8-80029-55	2. 8-19.0- 45	1	
8-80029-57	2. 8-19.0- 2	1	
8-80029-59	2. 8-19.0-119	1	
8-80029-61	2. 8-19.0-117	1	
8-80029-63	2. 8-19.0-115	1	
8-80029-65	2. 8-19.0-114	1	
8-80029-67	2. 8-19.0-112	1	
8-80029-69	2. 8-19.0-110	1	
8-80029-7	2. 8-19.0- 14	1	
8-80029-71	2. 8-19.0-119	1	
8-80029-73	2. 8-19.0-117	1	
8-80029-75	2. 8-19.0-115	1	
8-80029-77	2. 8-19.0-114	1	
8-80029-79	2. 8-19.0-112	1	
8-80029-81	2. 8-19.0-110	1	
8-80029-83	2. 8-19.0- 22	1	
	2. 8-19.0- 75	1	
8-80029-9	2. 8-19.0- 41	1	
8-80030	2. 8-12.0-	1	RF
	2. 8-18.0-	1	RF
8-80030-1	2. 8-12.0-	1	
	2. 8-18.0-	1	
8-80030-101	2. 8-12.0-121	1	
8-80030-105	2. 8-12.0-117	1	
8-80030-111	2. 8-12.0- 49	1	
8-80030-113	2. 8-12.0- 47	1	
8-80030-115	2. 8-12.0- 41	1	
8-80030-117	2. 8-12.0- 63	1	
8-80030-119	2. 8-12.0- 65	1	
8-80030-121	2. 8-12.0- 43	1	
8-80030-123	2. 8-12.0- 18	1	
8-80030-125	2. 8-12.0- 61	1	
8-80030-135	2. 8-18.0- 16	1	
8-80030-137	2. 8-18.0- 5	1	
8-80030-139	2. 8-18.0- 25	1	
8-80030-141	2. 8-18.0- 36	1	
8-80030-143	2. 8-18.0- 52	1	
8-80030-145	2. 8-18.0- 62	1	
8-80030-147	2. 8-18.0- 82	1	
8-80030-149	2. 8-18.0- 72	1	
8-80030-151	2. 8-12.0- 67	1	
8-80030-153	2. 8-12.0- 45	1	
8-80030-155	2. 8-18.0- 80	1	
8-80030-157	2. 8-18.0- 53	1	
8-80030-159	2. 8-18.0- 60	1	
8-80030-161	2. 8-18.0- 70	1	
8-80030-163	2. 8-18.0- 40	1	
8-80030-165	2. 8-18.0- 30	1	
8-80030-167	2. 8-18.0- 17	1	
8-80030-169	2. 8-18.0- 20	1	
8-80030-171	2. 8-18.0- 54	1	
8-80030-173	2. 8-18.0- 64	1	
8-80030-177	2. 8-18.0- 84	1	
8-80030-183	2. 8-12.0- 83	1	
8-80030-185	2. 8-12.0- 85	1	
8-80030-201	2. 8-12.0- 59	1	
8-80030-203	2. 8-12.0-167	1	
8-80030-205	2. 8-18.0- 18	1	
8-80030-207	2. 8-18.0- 74	1	
8-80030-209	2. 10- 7.0-115	1	
8-80030-21	2. 8-12.0- 16	1	
8-80030-213	2. 8-12.0- 93	1	
8-80030-219	2. 8-12.0- 86	1	

PART NUMBER	FIGURE AND INDEX NUMBER	QTY PER ART	SMR CODE
8-80030-225	2. 8-12.0-105	1	
8-80030-227	2. 8-12.0-107	1	
8-80030-233	2. 8-12.0-175	1	
8-80030-235	2. 8-12.0-177	1	
8-80030-237	2. 8-12.0- 71	1	
8-80030-239	2. 8-12.0- 69	1	
8-80030-241	2. 8-12.0- 95	1	
8-80030-243	2. 8-12.0- 93	1	
8-80030-245	2. 8-12.0- 65	1	
8-80030-253	2. 8-12.0-137	1	
8-80030-257	2. 8-12.0- 14	1	
8-80030-261	2. 8-12.0- 57	1	
8-80030-267	2. 8-12.0-139	1	
8-80030-269	2. 8-12.0-139	1	
8-80030-275	2. 8-12.0-105	1	
8-80030-277	2. 8-12.0-107	1	
8-80030-279	2. 8-12.0- 76	1	
8-80030-281	2. 8-12.0- 75	1	
8-80030-283	2. 8-12.0- 77	1	
8-80030-285	2. 8-12.0-127	1	
8-80030-287	2. 8-12.0-129	1	
8-80030-289	2. 8-12.0- 95	1	
8-80030-291	2. 8-12.0- 3	1	
8-80030-295	2. 8-12.0- 25	1	
8-80030-297	2. 8-12.0- 5	1	
8-80030-3	2. 8-12.0-	RF	
	2. 8-10.0-	1	
8-80030-301	2. 8-12.0- 27	1	
8-80030-311	2. 8-12.0- 85	1	
8-80030-317	2. 8-12.0- 52	1	
8-80030-319	2. 8-12.0- 31	1	
8-80030-321	2. 8-12.0- 93	1	
8-80030-325	2. 8-12.0- 55	1	
8-80030-331	2. 8-12.0-165	1	
8-80030-341	2. 8-12.0- 33	1	
8-80030-345	2. 8-12.0-197	1	
8-80030-345	2. 8-12.0-154	1	
8-80030-347	2. 8-12.0-103	1	
8-80030-349	2. 8-12.0-137	1	
8-80030-351	2. 8-12.0-127	1	
8-80030-353	2. 8-12.0-169	1	
8-80030-355	2. 8-12.0-115	1	
8-80030-357	2. 8-12.0- 28	1	
8-80030-359	2. 8-10.0- 7	1	
8-80030-361	2. 8-12.0- 58	1	
8-80030-363	2. 8-12.0- 29	1	
8-80030-5	2. 3-14.0- 24	1	
	2. 8-12.5-	RF	
	2. 8-10.0-	1	
8-80030-55	2. 8-12.0- 95	1	
8-80030-57	2. 8-12.0-103	1	
8-80030-63	2. 8-12.0-109	1	
8-80030-65	2. 8-12.0-111	1	
8-80030-67	2. 8-12.0-113	1	
8-80030-801	2.15- 7.0-102	1	
8-80030-87	2. 8-12.0-171	1	
8-80030-923	2. 8-12.0- 23	1	
8-80030-95	2. 8-12.0-173	1	
8-80030-97	2. 8-12.0-119	1	
8-80030-99	2. 8-12.0-123	1	
8-80030-1	2.15-26.0- 2	RF	
	2.15-26.0-	RF	
8-80030-111	2. 8-11.0-117	1	
	2. 8-11.0- 44	1	
8-80030-115	2. 8-11.0- 51	1	

PART NUMBER	FIGURE AND INDEX NUMBER	QTY PER ART	SMR CODE
8-80030-117	2. 8-11.0- 90	1	
8-80030-121	2. 8-16.0- 61	1	
8-80030-123	2. 8-16.0- 63	1	
8-80030-125	2. 8-16.0- 83	1	
8-80030-127	2. 8-16.0- 85	1	
8-80030-17	2. 8-10.0-110	1	
8-80030-131	2. 8-16.0- 52	1	
8-80030-133	2. 8-16.0- 50	1	
8-80030-135	2. 8-16.0- 48	1	
8-80030-137	2. 8-16.0- 59	1	
8-80030-139	2. 8-16.0- 57	1	
8-80030-141	2. 8-16.0- 55	1	
8-80030-149	2.15-26.0- 2	1	
8-80030-151	2. 8-11.0- 34	1	
8-80030-153	2. 8-11.0- 65	1	
8-80030-155	2. 8-11.0- 53	1	
8-80030-157	2. 8-16.0- 3	1	
8-80030-161	2. 8-16.0- 13	1	
8-80030-163	2. 8-16.0- 15	1	
8-80030-165	2. 8-16.0- 5	1	
8-80030-167	2. 8-16.0- 7	1	
8-80030-169	2. 8-11.0- 75	1	
8-80030-17	2. 8-10.0-108	1	
8-80030-171	2. 8-11.0- 72	1	
8-80030-177	2. 8-11.0- 68	1	
8-80030-179	2. 8-11.0- 69	1	
8-80030-193	2.15-26.0- 2	1	
8-80030-197	2. 8- 9.0- 14	1	
8-80030-221	2. 8- 9.0- 21	1	
8-80030-223	2. 8- 9.0- 3	1	
8-80030-227	2. 8-17.0- 36	1	
8-80030-231	2. 8-17.0- 40	1	
8-80030-239	2. 8-17.0- 30	1	
8-80030-249	2. 8-17.0- 47	1	
8-80030-253	2. 8-17.0- 16	1	
8-80030-251	2. 8-17.0- 41	1	
8-80030-263	2. 8-17.0- 43	1	
8-80030-265	2. 8-16.0- 39	1	
8-80030-267	2. 8-16.0- 40	1	
8-80030-271	2. 8-16.0- 27	1	
8-80030-273	2. 8-16.0- 28	1	
8-80030-277	2. 8-16.0- 90	1	
8-80030-281	2. 8-16.0- 72	1	
8-80030-283	2. 8-16.0- 74	1	
8-80030-285	2. 8-16.0- 11	1	
8-80030-287	2. 8-10.0-103	2	
8-80030-3	2.15-25.0- 2	1	
	2.15-26.0-	RF	
8-80030-303	2. 8-10.0-167	1	
8-80030-317	2. 8-17.0- 42	1	
8-80030-311	2. 8-17.0- 45	1	
8-80030-315	2. 8-17.0- 26	1	
8-80030-317	2. 8-17.0- 50	1	
8-80030-323	2. 8-10.0- 74	1	
8-80030-325	2. 8-10.0- 78	1	
8-80030-327	2. 8-10.0- 72	1	
8-80030-329	2. 8-11.0- 15	1	
8-80030-33	2. 8-10.0- 41	1	
8-80030-331	2. 8-11.0- 42	1	
8-80030-333	2. 8-10.0- 42	1	
8-80030-335	2. 8-16.0- 33	1	
8-80030-337	2. 8-16.0- 92	1	
8-80030-339	2. 8-17.0- 23	1	
8-80030-341	2. 8-10.0-197	1	
8-80030-343	2. 8-10.0-195	1	

PART NUMBER	FIGURE AND INDEX NUMBER	QTY PER ART	SMR CODE
8-80031-347	2. 8-17.0-155	1	
8-80031-349	2. 8-19.0-76	1	
8-80031-359	2. 8-11.0-32	1	
8-80031-361	2. 8-11.0-28	1	
8-80031-363	2. 8-11.0-26	1	
8-80031-365	2. 8-11.0-33	1	
8-80031-367	2. 8-11.0-24	1	
8-80031-369	2. 8-11.0-22	1	
8-80031-371	2. 8-17.0-21	1	
8-80031-373	2. 8-17.0-120	1	
8-80031-375	2. 8-17.0-125	1	
8-80031-377	2. 8-17.0-3	1	
8-80031-381	2. 8-17.0-33	1	
8-80031-383	2. 8-9.0-16	1	
8-80031-385	2. 8-9.0-5	1	
8-80031-389	2. 8-9.0-6	1	
8-80031-39	2. 8-19.0-12	1	
8-80031-391	2. 8-9.0-8	1	
8-80031-393	2. 8-9.0-27	1	
8-80031-395	2. 8-9.0-25	1	
8-80031-399	2.15-26.0-2	1	
8-80031-403	2. 8-16.0-15	1	
8-80031-405	2. 8-16.0-5	1	
8-80031-407	2. 8-16.0-7	1	
8-80031-409	2.15-26.0-35	1	
8-80031-41	2. 8-16.0-13	1	
8-80031-411	2.15-26.0-33	1	
8-80031-413	2.15-26.0-36	1	
8-80031-415	2.15-26.0-32	1	
8-80031-417	2. 8-16.0-55	1	
8-80031-423	2. 8-16.0-48	1	
8-80031-429	2.15-26.0-16	1	
8-80031-43	2. 8-10.0-183	1	
8-80031-431	2. 8-11.0-40	1	
8-80031-433	2. 8-11.0-38	1	
8-80031-435	2. 8-11.0-37	1	
8-80031-437	2. 8-11.0-35	1	
8-80031-441	2. 8-10.0-90	1	
8-80031-443	2. 8-11.0-92	1	
8-80031-447	2. 8-10.0-84	1	
8-80031-45	2. 8-10.0-189	1	
8-80031-451	2. 8-11.0-62	1	
8-80031-453	2. 8-10.0-92	1	
8-80031-457	2. 8-10.0-95	1	
8-80031-461	2. 8-11.0-87	1	
8-80031-463	2. 8-10.0-113	1	
8-80031-465	2. 8-10.0-116	1	
8-80031-467	2. 8-10.0-117	1	
8-80031-471	2. 8-10.0-120	1	
8-80031-473	2. 8-10.0-138	1	
8-80031-475	2. 8-10.0-123	1	
8-80031-477	2. 8-10.0-106	1	
8-80031-483	2. 8-10.0-183	1	
8-80031-485	2. 8-10.0-170	1	
8-80031-487	2. 8-10.0-181	1	
8-80031-489	2. 8-10.0-173	1	
8-80031-49	2. 8-10.0-170	1	
8-80031-497	2. 8-16.0-85	1	
8-80031-499	2. 8-16.0-61	1	
8-80031-501	2. 8-16.0-63	1	
8-80031-503	2. 8-16.0-72	1	
8-80031-505	2. 8-16.0-90	1	
8-80031-507	2. 8-16.0-74	1	

PART NUMBER	FIGURE AND INDEX NUMBER	QTY PER ART	SMR CODE
8-80031-509	2. 8-11.0-15	1	
8-80031-511	2. 8-16.0-92	1	
8-80031-515	2. 8-11.0-65	1	
8-80031-517	2. 8-11.0-53	1	
8-80031-519	2. 8-16.0-3	1	
8-80031-521	2. 8-11.0-75	1	
8-80031-523	2. 8-11.0-68	1	
8-80031-525	2. 8-11.0-69	1	
8-80031-527	2. 8-16.0-39	1	
8-80031-529	2. 8-16.0-47	1	
8-80031-53	2. 8-10.0-181	1	
8-80031-531	2. 8-16.0-27	1	
8-80031-533	2. 8-16.0-28	1	
8-80031-535	2. 8-16.0-11	1	
8-80031-537	2. 8-16.0-42	1	
8-80031-539	2. 8-16.0-30	1	
8-80031-543	2. 8-16.0-59	1	
8-80031-545	2. 8-16.0-52	1	
8-80031-547	2. 8-10.0-92	1	
8-80031-55	2. 8-10.0-173	1	
8-80031-551	2. 8-10.0-189	1	
8-80031-553	2. 8-10.0-7	1	
8-80031-555	2. 8-10.0-9	1	
8-80031-557	2. 8-10.0-38	1	
8-80031-559	2. 8-10.0-40	1	
8-80031-561	2. 8-10.0-113	1	
8-80031-563	2.15-26.0-45	1	
8-80031-565	2.15-26.0-42	1	
8-80031-567	2.15-26.0-44	1	
8-80031-569	2.15-26.0-41	1	
8-80031-573	2. 8-10.0-74	1	
8-80031-575	2. 8-10.0-78	1	
8-80031-577	2. 8-10.0-72	1	
8-80031-579	2. 8-10.0-197	1	
8-80031-581	2. 8-10.0-199	1	
8-80031-583	2. 8-10.0-76	1	
8-80031-585	2. 8-16.0-57	1	
8-80031-59	2. 8-10.0-135	1	
8-80031-593	2.15-26.0-33	1	
8-80031-595	2.15-26.0-32	1	
8-80031-597	2. 8-11.0-68	1	
8-80031-599	2. 8-17.0-8	1	
8-80031-601	2. 8-17.0-6	1	
8-80031-7	2. 8-10.0-113	1	
8-80031-801	2. 8-9.0-	RF	
	2. 8-10.0-	RF	
	2. 8-11.0-	RF	
	2. 8-16.0-	RF	
	2. 8-17.0-		
8-80031-803	2. 8-9.0-	RF	
	2. 8-10.0-	RF	
	2. 8-11.0-	RF	
	2. 8-16.0-	RF	
	2. 8-17.0-		
8-80031-805	2. 6-32.0-38	1	
	2.15-26.0-	RF	
8-80031-807	2. 6-32.0-38	1	
	2.15-26.0-	RF	
8-80031-809	2. 8-9.0-	RF	
	2. 8-10.0-	RF	
	2. 8-11.0-	RF	
	2. 8-16.0-	RF	
	2. 8-17.0-		
8-80031-811	2. 8-10.0-4	1	
8-80031-817	2. 8-10.0-5	1	

PART NUMBER	FIGURE AND INDEX NUMBER	QTY PER ART	SMR CODE
8-80031-89	2. 8-10.0- 6	1	
8-80031-91	2. 8-10.0- 3	1	
8-80031-93	2. 8-10.0- 34	1	
8-80031-95	2. 8-10.0- 35	1	
8-80031-97	2. 8-10.0- 36	1	
8-80031-99	2. 8-10.0- 37	1	
8-80032-137	2. 8-14.0- 31	1	
8-80032-139	2. 8-14.0- 35	1	
8-80032-165	2. 8-14.0- 34	1	
8-80032-167	2. 8-22.0- 18	1	
8-80032-169	2. 8-14.0- 20	1	
8-80032-171	2. 8-14.0- 22	1	
8-80032-173	2. 8-14.0- 26	1	
8-80032-175	2. 8-14.0- 33	1	
8-80032-177	2. 8-22.0- 9	1	
8-80032-179	2. 8-22.0- 13	1	
8-80032-181	2. 8-22.0- 28	1	
8-80032-187	2. 8-22.0- 44	1	
8-80032-193	2. 8-22.0- 26	1	
8-80032-209	2. 8-15.0- 14	1	
8-80032-211	2. 8-15.0- 13	1	
8-80032-213	2. 8-15.0- 7	1	
8-80032-217	2. 8-22.0- 13	1	
8-80032-225	2. 8-22.0- 44	1	
8-80032-227	2. 8-22.0- 18	1	
8-80032-229	2. 8-22.0- 30	1	
8-80032-233	2. 8-15.0- 7	1	
8-80032-235	2. 8-14.0- 16	1	
8-80032-237	2. 8-14.0- 20	1	
8-80032-239	2. 8-22.0- 13	1	
8-80032-245	2. 8-22.0- 18	1	
8-80032-247	2. 8-22.0- 30	1	
8-80032-251	2. 8-14.0- 22	1	
8-80032-253	2. 8-14.0- 26	1	
8-80032-257	2. 8-14.0- 20	1	
8-80032-259	2. 8-14.0- 27	1	
8-80032-261	2. 8-14.0- 36	1	
	2. 15-17.0- 5	1	
8-80032-263	2. 8-14.0- 39	1	
	2. 15-17.0- 7	1	
8-80032-43	2. 8-14.0- 4	1	
8-80032-45	2. 8-14.0- 7	1	
8-80032-77	2. 8-14.0- 16	1	
8-80032-301	2. 8-14.0-	RF	
	2. 8-15.0-	RF	
	2. 8-22.0-	RF	
8-80073-51	2. 15-22.0- 40	3	
	2. 15-22.0- 51	3	
8-80109-21	2. 8-12.0-127	1	
8-80109-23	2. 8-12.0-130	1	
8-80109-25	2. 8-12.0-132	1	
8-80132-7	2. 8- 1.0- 63	1	
8-80132-9	2. 8- 1.0- 64	1	
8-80160-13	2. 13- 8.0- 26	1	
8-80200-9	2. 15-19.0- 7	1	
8-80205	2. 14-11.0- 41	1	
	2. 14-25.0- 16	1	
8-80205-11	2. 14-11.0- 30	1	
8-80206-7	2. 14-11.0- 30	1	
8-80206-9	2. 14-11.0- 42	1	
8-80208	2. 8-14.0- 12	1	
	2. 8-16.0- 20	2	
	2. 8-16.0- 69	1	
	2. 8-16.0- 70	1	
	2. 8-22.0- 3	1	

PART NUMBER	FIGURE AND INDEX NUMBER	QTY PER ART	SMR CODE
8-80209	2. 8- 1.0- 57	1	
8-80217-9	2. 15-13.0- 39	1	
8-80249	2. 9-26.0-	1	
8-80301	2. 17- 8.0- 50	RF	
8-80303	2. 13-26.0-	RF	
8-80303-37	2. 13-26.0- 13	RF	
8-80304-11	2. 12-46.0-218	1	
8-80304-13	2. 12-46.0-182	1	
8-80304-15	2. 12-46.0-178	1	
8-80304-17	2. 12-46.0-231	1	
8-80304-19	2. 12-46.0-193	1	
8-80304-21	2. 12-46.0-189	1	
8-80304-23	2. 12-46.0-180	1	
8-80304-25	2. 12-46.0-184	1	
8-80304-27	2. 14-37.0- 51	1	
8-80304-29	2. 8-12.0- 7	1	
8-80304-31	2. 8-12.0- 9	1	
8-80304-33	2. 8-12.0- 12	1	
8-80304-35	2. 8-12.0- 87	1	
8-80304-37	2. 8-12.0- 37	1	
8-80304-39	2. 8-12.0- 29	1	
8-80304-41	2. 14-35.0- 38	1	
	2. 14-37.0- 44	1	
8-80304-43	2. 8-12.0- 87	1	
8-80304-67	2. 12-46.0-190	1	
8-80304-69	2. 12-46.0-194	1	
8-80304-7	2. 12-46.0-191	1	
8-80304-9	2. 12-46.0-187	1	
8-80305-1	2. 13-26.0- 4	1	
8-80305-1	2. 13-26.0- 6	J	
8-80305-3	2. 13-26.0- 6	RF	
8-80307-1	2. 17- 8.0- 59	1	
8-80308	2. 3- 3.0- 67	1	
	2. 13-11.0-	RF	
8-80312-7	2. 17- 8.0- 62	1	
8-80314-9	2. 17- 8.0- 70	1	
8-80421	2. 7- 6.0- 6	1	
	2. 9-25.0- 17	RF	
8-80421-101	2. 9-25.0- 32	1	
8-80421-103	2. 9-25.0- 50	1	
8-80421-105	2. 9-25.0- 33	1	
8-80421-107	2. 9-25.0- 54	1	
8-80421-109	2. 9-25.0- 70	1	
8-80421-121	2. 9-25.0- 65	1	
8-80421-125	2. 9-13.0- 6	1	
8-80421-127	2. 9-13.0- 4	1	
8-80421-17	2. 9-25.0- 3	1	
8-80421-21	2. 9-25.0- 20	1	
8-80421-23	2. 9-25.0- 24	1	
8-80421-25	2. 9-25.0- 28	1	
8-80421-31	2. 9-25.0- 21	1	
8-80421-33	2. 9-25.0- 25	1	
8-80421-35	2. 9-25.0- 29	1	
8-80421-43	2. 9-25.0- 41	1	
8-80421-45	2. 9-25.0- 45	1	
8-80421-47	2. 9-25.0- 47	1	
8-80421-5	2. 3-14.0- 30	1	
	2. 9-13.0-	RF	
	2. 9-25.0-	RF	
	2. 9-25.0-	RF	
8-80421-51	2. 9-25.0- 55	1	
8-80421-55	2. 9-25.0- 65	1	
8-80421-59	2. 9-25.0- 68	1	
8-80421-67	2. 9-25.0- 48	1	
8-80421-73	2. 9-25.0- 38	1	

PART NUMBER	FIGURE AND INDEX NUMBER	QTY PER ART	SMR CODE
8-80421-75	2. 9-25.0- 17	1	
8-80421-77	2. 9-25.0- 15	1	
8-80421-79	2. 9-25.0- 13	1	
8-80421-85	2. 9-25.0- 6	1	
8-80421-87	2. 9-25.0- 10	1	
8-80421-89	2. 9-25.0- 8	1	
8-80421-91	2. 9-25.0- 11	1	
8-80421-93	2. 9-25.0- 5A	1	
8-80421-95	2. 9-25.0- 59	1	
8-80421-97	2. 9-13.0- 6	1	
8-80421-99	2. 9-13.0- 4	1	
8-80429	2. 9-11.0-	1	
	2. 9-14.0-	1	
	2. 9-15.0-	1	
	2. 9-17.0-	1	
	2. 9-18.0-		
	2. 9-19.0-	1	
	2. 9-20.0-	1	
	2. 9-21.0-	1	
	2. 9-22.0-	1	
	2. 9-23.0-	1	
	2. 9-23.0-	1	
	2. 9-24.0-	1	
	2. 9-24.0-		
	2. 9-27.0-	1	
	2. 9-28.0-	1	
	2. 9-29.0-	1	
	2. 9-30.0-	1	
	2. 9-31.0-	1	
	2. 9-32.0-	1	
	2. 9-33.0-	1	
8-80429-097	2. 9-17.0- 74	1	
8-80429-1001	2. 9-18.0- 46	1	
8-80429-1003	2. 9-19.0- 15	1	
8-80429-1005	2. 9-33.0- 27		
	2. 9-33.0- 28	1	
8-80429-1009	2. 9-18.0- 39	1	
8-80429-1015	2. 9-33.0- 71	1	
8-80429-1017	2. 9-33.0- 50	1	
8-80429-1023	2. 9-33.0- 47	1	
8-80429-1025	2. 9-33.0- 54	1	
8-80429-1027	2. 9-33.0- 52	1	
8-80429-1029	2. 9-33.0- 7	1	
8-80429-1035	2. 9-23.0- 30	1	
8-80429-1059	2. 9-29.0- 2	1	
8-80429-1065	2. 9-28.0- 18	1	
8-80429-1067	2. 9-28.0- 12	1	
8-80429-1069	2. 9-28.0- 51	1	
8-80429-1071	2. 9-27.0- 3	1	
8-80429-1075	2. 9-15.0- 28	1	
8-80429-1077	2. 9-14.0- 31	1	
8-80429-1079	2. 9-21.0- 24	1	
8-80429-1083	2. 9-17.0- 11	1	
8-80429-1085	2. 9-17.0- 13	1	
8-80429-1089	2. 9-21.0- 20	1	
8-80429-1091	2. 9-25.0- 31	1	
8-80429-1093	2. 9-17.0- 96	1	
8-80429-1095	2. 9-17.0- 94	1	
8-80429-1099	2. 9-17.0- 76	1	
8-80429-11	2. 9-17.0- 28	1	
8-80429-1101	2. 9-29.0- 24	1	
8-80429-1105	2. 9-23.0- 5	1	
8-80429-1107	2. 9-17.0- 69	1	
8-80429-111	2. 9-23.0- 21	1	
8-80429-1111	2. 9-15.0- 42	1	

PART NUMBER	FIGURE AND INDEX NUMBER	QTY PER ART	SMR CODE
8-80429-1113	2. 9-15.0- 40	1	
8-80429-1115	2. 9-18.0- 44	1	
8-80429-1117	2. 9-18.0- 53	1	
8-80429-1123	2. 9-11.0- 37	1	
8-80429-1125	2. 9-28.0- 42	1	
8-80429-1127	2. 9-28.0- 22	1	
8-80429-1129	2. 9-27.0- 7	1	
8-80429-1141	2. 9-29.0- 19	1	
8-80429-1143	2. 9-29.0- 17	1	
8-80429-1145	2. 9-29.0- 8	1	
8-80429-1147	2. 9-29.0- 10	1	
8-80429-1149	2. 9-29.0- 34	1	
8-80429-1151	2. 9-29.0- 32	1	
8-80429-1153	2. 9-28.0- 29	1	
8-80429-1155	2. 9-28.0- 31	1	
8-80429-1159	2. 9-11.0- 41	1	
8-80429-1161	2. 9-11.0- 39	1	
8-80429-1165	2. 9-28.0- 24	1	
8-80429-1167	2. 9-28.0- 39	1	
8-80429-1177	2. 9-19.0- 7	1	
8-80429-1193	2. 9-15.0- 32	1	
8-80429-1195	2. 9-15.0- 34	1	
8-80429-1197	2. 9-15.0- 36	1	
8-80429-1199	2. 9-17.0- 74	1	
8-80429-1201	2. 9-17.0- 76	1	
8-80429-1207	2. 9-17.0- 80	1	
	2. 9-17.0- 93	1	
8-80429-1209	2. 9-15.0- 45	1	
8-80429-121	2. 9-23.0- 45	1	
8-80429-1211	2. 9-15.0- 46	1	
8-80429-1213	2. 9-15.0- 48	1	
8-80429-1215	2. 9-18.0- 55	1	
8-80429-1217	2. 9-18.0- 57	1	
8-80429-1219	2. 9-18.0- 59	1	
8-80429-1221	2. 9-32.0- 2	1	
8-80429-1223	2. 9-28.0- 47	1	
8-80429-1225	2. 9-28.0- 42	1	
8-80429-1245	2. 9-32.0- 21	1	
8-80429-1249	2. 9-32.0- 17	1	
8-80429-1251	2. 9-15.0- 38	1	
8-80429-1253	2. 9-33.0- 15	1	
8-80429-1255	2. 9-27.0- 25	1	
8-80429-1257	2. 9-17.0- 45	1	
8-80429-1259	2. 9-17.0- 84	1	
8-80429-1261	2. 9-17.0- 59	1	
8-80429-1263	2. 9-15.0- 40	1	
8-80429-1265	2. 9-17.0- 63	1	
8-80429-1267	2. 9-17.0- 65	1	
8-80429-1269	2. 9-17.0- 40	1	
8-80429-127	2. 9-23.0- 13	1	
8-80429-1273	2. 9-23.0- 23	1	
8-80429-1275	2. 9-17.0- 55	1	
8-80429-1277	2. 9-28.0- 49	1	
8-80429-1279	2. 9-18.0- 70	1	
8-80429-1283	2. 9-28.0- 29	1	
8-80429-1285	2. 9-23.0- 7	1	
8-80429-1287	2. 9-23.0- 9	1	
8-80429-1289	2. 9-18.0- 100	1	
8-80429-1291	2. 9-18.0- 9A	1	
8-80429-1293	2. 9-22.0- 14	1	
8-80429-1295	2. 9-22.0- 16	1	
8-80429-1297	2. 9-17.0- 24	1	
8-80429-1299	2. 9-17.0- 26	1	
8-80429-1301	2. 9-21.0- 37	1	
8-80429-1303	2. 9-21.0- 39	1	

PART NUMBER	FIGURE AND INDEX NUMBER	QTY PER ART	SMR CODE
8-80429-1305	2. 9-14.0- 44	1	
8-80429-1307	2. 9-14.0- 46	1	
8-80429-1309	2. 9-11.0- 41	1	
8-80429-1311	2. 9-28.0- 26	1	
8-80429-1313	2. 9-28.0- 35	1	
8-80429-1321	2. 9-31.0- 15	1	
8-80429-1323	2. 9-31.0- 27	1	
8-80429-1325	2. 9-31.0- 12	1	
8-80429-1327	2. 9-14.0- 58	1	
8-80429-1329	2. 9-18.0- 63	1	
8-80429-133	2. 9-17.0- 32	1	
8-80429-1331	2. 9-18.0- 16	1	
8-80429-1333	2. 9-18.0- 10	1	
8-80429-1335	2. 9-15.0- 52	1	
8-80429-1337	2. 9-18.0- 50	1	
8-80429-1341	2. 9-17.0-102	1	
8-80429-1343	2. 9-17.0-100	1	
8-80429-1347	2. 9-23.0- 16	1	
8-80429-1349	2. 9-23.0- 19	1	
8-80429-1359	2. 9-17.0- 76	1	
8-80429-1369	2. 9-27.0- 5	1	
8-80429-1371	2. 9-28.0- 46	1	
8-80429-1373	2. 9-28.0- 20	1	
8-80429-1375	2. 9-11.0- 34	1	
8-80429-1377	2. 9-29.0- 39	1	
8-80429-1379	2. 9-30.0- 20	1	
8-80429-1381	2. 9-18.0- 81	1	
8-80429-1383	2. 9-18.0- 42	1	
8-80429-1385	2. 9-18.0- 3	1	
8-80429-1387	2. 9-14.0- 50	1	
8-80429-1389	2. 9-32.0- 4	1	
8-80429-1395	2. 9-29.0- 34	1	
8-80429-143	2. 9-23.0- 32	1	
8-80429-145	2. 9-17.0- 63	1	
8-80429-147	2. 9-23.0- 28	1	
8-80429-149	2. 9-17.0- 92	1	
8-80429-15	2. 9-21.0- 41	1	
8-80429-151	2. 9-17.0- 65	1	
8-80429-153	2. 9-17.0- 67	1	
8-80429-155	2. 9-17.0- 69	1	
8-80429-157	2. 9-17.0- 30	1	
8-80429-159	2. 9-17.0- 36	1	
8-80429-161	2. 9-17.0- 38	1	
8-80429-167	2. 9-17.0- 49	1	
8-80429-17	2. 9-21.0- 43	1	
8-80429-19	2. 9-23.0- 11	1	
8-80429-21	2. 9-21.0- 20	1	
8-80429-23	2. 9-21.0- 22	1	
8-80429-247	2. 9-28.0- 14	1	
8-80429-251	2. 9-28.0- 9	1	
8-80429-253	2. 9-28.0- 10	1	
8-80429-255	2. 9-11.0- 30	1	
8-80429-275	2. 9-29.0- 22	1	
8-80429-301	2. 9-14.0- 54	1	
8-80429-303	2. 9-15.0- 14	1	
8-80429-307	2. 9-17.0- 53	1	
8-80429-311	2. 9-18.0- 63	1	
8-80429-317	2. 9-22.0- 18	1	
8-80429-319	2. 9-17.0- 73	1	
8-80429-329	2. 9-18.0- 93	1	
8-80429-339	2. 9-21.0- 36	1	
8-80429-347	2. 9-24.0- 4	1	
8-80429-35	2. 9-14.0- 27	1	
8-80429-357	2. 9-26.0- 4	1	
8-80429-359	2. 9-26.0- 2	1	

PART NUMBER	FIGURE AND INDEX NUMBER	QTY PER ART	SMR CODE
8-80429-361	2. 9-20.0- 49	1	
8-80429-363	2. 9-17.0- 15	1	
8-80429-371	2. 9-21.0- 28	1	
8-80429-373	2. 9-21.0- 26	1	
8-80429-381	2. 9-22.0- 3	1	
8-80429-383	2. 9-22.0- 7	1	
8-80429-385	2. 9-15.0- 30	1	
8-80429-387	2. 9-15.0- 29	1	
8-80429-401	2. 9-33.0- 13	1	
8-80429-403	2. 9-33.0- 15	1	
8-80429-405	2. 9-27.0- 23	1	
8-80429-407	2. 9-27.0- 25	1	
8-80429-41	2. 9-15.0- 27	1	
8-80429-411	2. 9-15.0- 25	1	
8-80429-43	2. 9-21.0- 30	1	
8-80429-447	2. 9-33.0- 11	1	
8-80429-45	2. 9-21.0- 32	1	
8-80429-453	2. 9-33.0- 9	1	
8-80429-467	2. 9-29.0- 42	1	
8-80429-47	2. 9-21.0- 34	1	
8-80429-483	2. 9-24.0- 11	1	
8-80429-487	2. 9-11.0- 34	1	
8-80429-49	2. 9-21.0- 36	1	
8-80429-491	2. 9-28.0- 46	1	
8-80429-497	2. 9-27.0- 5	1	
8-80429-505	2. 9-28.0- 20	1	
8-80429-509	2. 9-19.0- 21	1	
8-80429-51	2. 9-17.0- 17	1	
8-80429-511	2. 9-18.0- 91	1	
8-80429-515	2. 9-31.0- 3	1	
8-80429-517	2. 9-31.0- 14	1	
8-80429-519	2. 9-31.0- 17	1	
8-80429-521	2. 9-31.0- 22	1	
8-80429-523	2. 9-18.0- 89	1	
8-80429-525	2. 9-31.0- 24	1	
8-80429-527	2. 9-31.0- 19	1	
8-80429-53	2. 9-17.0- 19	1	
8-80429-533	2. 9-19.0- 9	1	
8-80429-541	2. 9-15.0- 38	1	
8-80429-543	2. 9-31.0- 26	1	
8-80429-55	2. 9-17.0- 21	1	
8-80429-565	2. 9-30.0- 37	1	
8-80429-567	2. 9-30.0- 38	1	
8-80429-57	2. 9-17.0- 23	1	
8-80429-587	2. 9-18.0- 40	1	
8-80429-59	2. 9-14.0- 37	1	
8-80429-595	2. 9-33.0- 5	1	
8-80429-609	2. 9-23.0- 19	1	
8-80429-61	2. 9-14.0- 39	1	
8-80429-611	2. 9-18.0-113	1	
8-80429-613	2. 9-18.0-111	1	
8-80429-615	2. 9-18.0-115	1	
8-80429-617	2. 9-18.0-117	1	
8-80429-619	2. 9-23.0- 25	1	
8-80429-623	2. 9-17.0- 59	1	
8-80429-625	2. 9-23.0- 23	1	
8-80429-627	2. 9-17.0- 55	1	
8-80429-629	2. 9-15.0- 52	1	
8-80429-63	2. 9-14.0- 41	1	
8-80429-637	2. 9-14.0- 58	1	
8-80429-639	2. 9-18.0- 10	1	
8-80429-641	2. 9-18.0- 50	1	
8-80429-643	2. 9-17.0- 86	1	
8-80429-645	2. 9-17.0- 88	1	
8-80429-65	2. 9-14.0- 43	1	

PART NUMBER	FIGURE AND INDEX NUMBER	QTY PER ART	SMR CODE
8-80429-661	2. 9-15.0- 44	1	
8-80429-663	2. 9-15.0- 43	1	
8-80429-669	2. 9-18.0- 57	1	
8-80429-683	2. 9-18.0- 55	1	
8-80429-69	2. 9-15.0- 31	1	
8-80429-691	2. 9-30.0- 24	1	
8-80429-703	2. 9-30.0- 26	1	
8-80429-725	2. 9-30.0- 3	1	
8-80429-733	2. 9-29.0- 41	1	
8-80429-75	2. 9-10.0-106	1	
8-80429-751	2. 9-18.0- 37	1	
8-80429-753	2. 9-18.0- 7	1	
8-80429-755	2. 9-18.0- 16	1	
8-80429-757	2. 9-18.0- 19	1	
8-80429-759	2. 9-18.0- 31	1	
8-80429-761	2. 9-18.0- 21	1	
8-80429-763	2. 9-23.0- 34	1	
8-80429-765	2. 9-18.0- 87	1	
8-80429-767	2. 9-23.0- 41	1	
8-80429-769	2. 9-23.0- 36	1	
8-80429-77	2. 9-18.0-104	1	
8-80429-771	2. 9-23.0- 43	1	
8-80429-775	2. 9-23.0- 39	1	
8-80429-777	2. 9-18.0- 63	1	
8-80429-779	2. 9-18.0- 66	1	
8-80429-781	2. 9-18.0- 74	1	
8-80429-783	2. 9-18.0- 68	1	
8-80429-79	2. 9-18.0-102	1	
8-80429-799	2. 9-18.0- 59	1	
8-80429-8	2. 9-18.0- 23	0	
8-80429-807	2. 6-32.0- 42	1	
8-80429-859	2. 6-32.0- 42	1	
8-80429-81	2. 9-18.0- 97	1	
8-80429-819	2. 6-32.0- 42	1	
8-80429-821	2. 6-32.0- 42	1	
8-80429-83	2. 9-22.0- 13	1	
8-80429-85	2. 9-22.0- 11	1	
8-80429-87	2. 9-22.0- 9	1	
8-80429-89	2. 9-18.0- 95	1	
8-80429-9	2. 9-14.0- 48	1	
8-80429-97	2. 9-17.0- 45	1	
8-80429-99	2. 9-17.0- 84	1	
8-80430	2. 9-11.0- 1	1	
	2. 9-14.0- 1	1	
	2. 9-15.0- 2	1	
	2. 9-16.0- 1	1	
	2. 9-17.0- 1	1	
	2. 9-20.0- 1	1	
	2. 9-21.0- 1	1	
8-80430-131	2. 9-15.0- 12	1	
8-80430-153	2. 9-20.0- 18	1	
8-80430-159	2. 9-16.0- 21	1	
8-80430-179	2. 9-11.0- 18	1	
8-80430-183	2. 9-15.0- 10	1	
8-80430-201	2. 9-11.0- 16	1	
8-80430-203	2. 9-11.0- 3	1	
8-80430-207	2. 9-11.0- 10	1	
8-80430-23	2. 9-20.0- 21	1	
8-80430-25	2. 9-21.0- 5	1	
8-80430-269	2. 9-21.0- 14	1	
8-80430-273	2. 9-19.0- 8	1	
8-80430-277	2. 9-20.0- 14	1	
8-80430-279	2. 9-15.0- 8	1	
8-80430-281	2. 9-21.0- 3	1	
8-80430-283	2. 9-21.0- 10	1	

PART NUMBER	FIGURE AND INDEX NUMBER	QTY PER ART	SMR CODE
8-80430-287	2. 9-16.0- 8	1	
8-80430-289	2. 9-16.0- 10	1	
8-80430-291	2. 9-16.0- 12	1	
8-80430-293	2. 9-14.0- 10	1	
8-80430-295	2. 9-16.0- 5	1	
8-80430-297	2. 9-25.0- 16	1	
8-80430-307	2. 9-15.0- 14	1	
8-80430-309	2. 9-15.0- 17	1	
8-80430-31	2. 9-16.0- 10	1	
8-80430-311	2. 9-15.0- 16	1	
8-80430-313	2. 9-15.0- 18	1	
8-80430-315	2. 9-14.0- 16	1	
8-80430-317	2. 9-21.0- 18	1	
8-80430-319	2. 9-14.0- 22	1	
8-80430-323	2. 9-17.0- 5	1	
8-80430-325	2. 9-20.0- 23	1	
8-80430-327	2. 9-11.0- 25	1	
8-80430-331	2. 9-11.0- 26	1	
8-80430-335	2. 9-20.0- 5	1	
8-80430-337	2. 9-14.0- 12	1	
8-80430-339	2. 9-14.0- 14	1	
8-80430-341	2. 9-11.0- 12	1	
8-80430-343	2. 9-20.0- 3	1	
8-80430-345	2. 9-16.0- 3	1	
8-80430-347	2. 9-14.0- 12	1	
8-80430-349	2. 9-14.0- 14	1	
8-80430-351	2. 9-14.0- 8	1	
8-80430-353	2. 9-20.0- 14	1	
8-80430-355	2. 9-15.0- 8	1	
8-80430-357	2. 9-16.0- 8	1	
8-80430-359	2. 9-16.0- 10	1	
8-80430-361	2. 9-16.0- 12	1	
8-80430-363	2. 9-20.0- 5	1	
8-80430-365	2. 9-20.0- 3	1	
8-80430-367	2. 9-14.0- 12	1	
8-80430-369	2. 9-14.0- 14	1	
8-80430-37	2. 9-17.0- 3	1	
8-80430-373	2. 9-11.0- 26	1	
8-80430-375	2. 9-15.0- 16	1	
8-80430-377	2. 9-15.0- 10	1	
8-80430-379	2. 9-15.0- 12	1	
8-80430-381	2. 9-14.0- 3	1	
8-80430-383	2. 9-15.0- 3	1	
8-80430-385	2. 9-14.0- 5	1	
8-80430-387	2. 9-15.0- 5	1	
8-80430-389	2. 9-14.0- 3	1	
8-80430-391	2. 9-15.0- 3	1	
8-80430-393	2. 9-15.0- 5	1	
8-80430-395	2. 9-14.0- 5	1	
8-80430-399	2. 9-20.0- 14	1	
8-80430-403	2. 9-20.0- 3	1	
8-80430-405	2. 9-16.0- 3	1	
8-80430-43	2. 9-21.0- 12	1	
8-80430-47	2. 9-21.0- 16	1	
8-80610	2. 9- 4.0- 1	1	
	2. 9- 5.0- 1	1	
	2. 9- 6.0- 1	1	
	2. 9- 7.0- 1	1	
	2. 9- 8.0- 1	1	
	2. 9- 9.0- 1	1	
	2. 9-10.0- 1	1	
	2.18- 1.0- 3		
8-80610-101	2. 9- 7.0- 54	1	
8-80610-103	2. 9- 7.0- 61	1	
8-80610-107	2. 9- 9.0- 6	1	

PART NUMBER	FIGURE AND INDEX NUMBER	QTY PER ART	SMR CODE
8-80610-109	2. 9- 9.0- 4	1	
8-80610-111	2. 9- 4.0- 4	1	
8-80610-111	2. 9- 9.0- 2	1	
8-80610-121	2. 9- 5.0- 5	1	
8-80610-13	2. 9- 4.0- 6	1	
8-80610-135	2. 9- 4.0- 54	1	
8-80610-141	2. 9- 4.0- 44	1	
8-80610-145	2. 9- 4.0- 48	1	
8-80610-169	2. 9- 7.0- 66	1	
8-80610-17	2. 9- 4.0- 15	1	
8-80610-173	2. 9- 6.0- 17	1	
8-80610-177	2. 9- 6.0- 5	1	
8-80610-179	2. 9- 6.0- 7	1	
8-80610-181	2. 9- 6.0- 9	1	
8-80610-183	2. 9- 6.0- 11	1	
8-80610-19	2. 9- 4.0- 17	1	
8-80610-195	2. 9- 6.0- 20	1	
8-80610-197	2. 9- 7.0- 12	1	
8-80610-201	2. 9- 7.0- 22	1	
8-80610-21	2. 9- 4.0- 20	1	
8-80610-23	2. 9- 4.0- 22	1	
8-80610-253	2. 9- 9.0- 12	1	
8-80610-263	2. 9- 4.0- 49	1	
8-80610-265	2. 9- 4.0- 42	1	
8-80610-267	2. 9- 4.0- 46	1	
8-80610-269	2. 9- 4.0- 37	1	
8-80610-27	2. 9- 4.0- 12	1	
8-80610-275	2. 9- 9.0- 20	1	
8-80610-29	2. 9- 4.0- 14	1	
8-80610-291	2. 9- 9.0- 22	1	
8-80610-295	2. 9- 4.0- 56	1	
8-80610-299	2. 9- 5.0- 23	1	
8-80610-303	2. 9- 6.0- 3	1	
8-80610-309	2. 9- 4.0- 2	1	
8-80610-323	2. 9- 7.0- 26	1	
8-80610-325	2. 9- 7.0- 28	1	
8-80610-327	2. 9- 7.0- 29	1	
8-80610-333	2. 9- 7.0- 32	1	
8-80610-337	2. 9- 4.0- 8	1	
8-80610-339	2. 9- 4.0- 10	1	
8-80610-345	2. 9- 9.0- 51	1	
8-80610-347	2. 9- 9.0- 49	1	
8-80610-35	2. 9- 7.0- 37	1	
8-80610-353	2. 9- 7.0- 49	1	
8-80610-357	2. 9- 5.0- 16	1	
8-80610-363	2. 9- 6.0- 13	1	
8-80610-365	2. 9- 6.0- 24	1	
8-80610-367	2. 9- 5.0- 31	1	
8-80610-373	2. 9- 9.0- 47	1	
8-80610-379	2. 9- 9.0- 44	1	
8-80610-387	2. 9- 4.0- 29	1	
8-80610-389	2. 9- 4.0- 27	1	
8-80610-397	2. 9- 5.0- 4	1	
8-80610-399	2. 9- 6.0- 15	1	
8-80610-401	2. 9- 5.0- 10	1	
8-80610-403	2. 9- 5.0- 12	1	
8-80610-407	2. 9- 4.0- 33	1	
8-80610-409	2. 9- 5.0- 3	1	
8-80610-411	2. 9- 9.0- 65	1	
8-80610-413	2. 9- 9.0- 67	1	
8-80610-415	2. 9- 5.0- 27	1	
8-80610-419	2. 9- 8.0- 6	1	
8-80610-427	2. 9- 7.0- 34	1	
8-80610-429	2. 9- 4.0- 35	1	
8-80610-431	2. 9- 7.0- 68	1	

PART NUMBER	FIGURE AND INDEX NUMBER	QTY PER ART	SMR CODE
8-80610-435	2. 9- 9.0- 44	1	
8-80610-437	2. 9- 4.0- 6	1	
8-80610-439	2. 9- 4.0- 4	1	
8-80610-441	2. 9- 7.0- 12	1	
8-80610-443	2. 9- 7.0- 22	1	
8-80610-445	2. 9- 7.0- 26	1	
8-80610-447	2. 9- 7.0- 28	1	
8-80610-451	2. 9- 7.0- 32	1	
8-80610-455	2. 9- 6.0- 25	1	
8-80610-457	2. 9- 9.0- 47	1	
8-80610-459	2. 9- 7.0- 8	1	
8-80610-461	2. 9- 7.0- 9	1	
8-80610-463	2. 9- 9.0- 53	1	
8-80610-465	2. 9- 9.0- 51	1	
8-80610-467	2. 9- 6.0- 22	1	
8-80610-469	2. 9- 7.0- 29	1	
8-80610-471	2. 9- 7.0- 12	1	
8-80610-473	2. 9- 4.0- 14	1	
8-80610-475	2. 9- 4.0- 27	1	
8-80610-481	2. 9-10.0- 10	1	
8-80610-483	2. 9-10.0- 11	1	
	2. 9-10.0- 28	RF	
8-80610-485	2. 9-10.0- 8	1	
8-80610-487	2. 9-10.0- 6	1	
8-80610-489	2. 9-10.0- 5	1	
8-80610-491	2. 9-10.0- 3	1	
8-80610-621	2. 9- 9.0- 53	1	
8-80610-73	2. 9- 7.0- 41	1	
8-80610-81	2. 9- 7.0- 3	1	
8-80610-83	2. 9- 7.0- 6	1	
8-80610-89	2. 9- 7.0- 43	1	
8-81095-5	2. 3-15.0- 20	2	
8-81033	2. 3-10.0- 4	1	
	2.15- 1.0- 36	RF	
8-81033-1	2. 3-10.0- 4	1	
	2.15- 1.0- 36	RF	
8-81053-1	2.14-11.0- 20	RF	
8-81053-2	2.14-11.0- 20	RF	
8-81053-3	2.14-11.0- 20	RF	
8-81053-4	2.14-11.0- 20	RF	
8-81054-1	2. 3- 4.0- 63	1	
	2.15- 1.0- 1	RF	
8-81057-7	2. 8- 3.0- 6	4	
8-81057-9	2. 8- 3.0- 9	4	
8-81235-9	2.14-11.0- 31	1	
8-81236-11	2. 8- 3.0- 20	2	
8-81237	2. 3-14.0- 4	1	
8-81238	2. 3-14.0- 5	1	
8-81240	2.14-11.0- 28	1	
	2.14-25.0- 15	1	
8-81241	2.14-11.0- 26	1	
8-81242	2.14-11.0- 23	1	
8-81243	2. 8- 1.0- 48	1	
8-81243-1	2. 8- 1.0- 49	1	
8-81248	2. 7- 7.0- 27	1	
8-81248-1	2. 7- 7.0- 27	1	
8-81248-11	2. 7- 7.0- 28	1	
8-81248-7	2. 7- 7.0- 30	1	
8-81248-9	2. 7- 7.0- 29	1	
8-81249	2. 7- 7.0- 33	1	
8-81253	2. 7- 7.0- 16	1	
8-81253-1	2. 3- 9.0- 2	3	
	2. 7- 7.0- 17	1	
	2. 8-15.0- 26	1	

PART NUMBER	FIGURE AND INDEX NUMBER	QTY PER ART	SMR CODE	PART NUMBER	FIGURE AND INDEX NUMBER	QTY PER ART	SMR CODE
8-81253-3	2. 3- 9.3- 1	1		8-81319-7	2. 7- 7.3- 10	1	
	2. 8-15.3- 8	1		8-81319-9	2. 7- 7.0- 13	1	
8-81253-5	2. 3- 9.3- 1	1		8-81320-3	2.10- 7.0- 90	1	
8-81254	2. 3-13.3- 10	2		8-81322	2. 3-15.0- 13	1	
	2. 9-13.0- 37	1			2. 8- 1.0- 56	RF	
8-81257	2. 8-15.0- 3	1		8-81326-1	2. 3-15.0- 15	1	
8-81257-7	2. 9-14.0- 19	1			2. 8- 1.0- 40	RF	
	2. 9-15.0- 20	1		8-81326-3	2. 3-15.0- 15	1	
8-81258	2. 8-15.0- 4	1			2. 8- 1.0- 40	RF	
8-81258-7	2. 9-15.0- 22	1		9-81327-1	2. 3-11.0- 13	1	
8-81259	2. 8-15.0- 10	1			2. 8- 1.0- 29	RF	
8-81308-1	2. 3-15.0- 14	1		8-81331	2. 8-15.0- 2	4	
	2. 8- 1.0- 44	RF		8-81331-1	2. 9-14.0- 17	2	
8-81308-2	2. 3-15.0- 14	1			2. 9-15.0- 19	2	
	2. 8- 1.0- 44	RF		8-81331-7	2. 8-15.0- 6	1	
8-81308-801	2. 3-15.0- 14	1			2. 9-14.0- 21	1	
	2. 8- 1.0- 44	RF			2. 9-15.0- 23	1	
8-81308-802	2. 3-15.0- 14	1		8-81342-1	2. 3-15.0- 16	1	
	2. 8- 1.0- 44	RF			2. 8- 1.0- 33	RF	
8-81310-1	2. 3-11.0- 12	1		8-81342-2	2. 3-15.0- 16	1	
	2. 8- 1.0- 3	RF			2. 8- 1.0- 33	RF	
8-81310-3	2. 3-11.0- 12	1		8-81343-1	2. 6-32.0- 75	1	
	2. 8- 1.0- 3	RF			2. 8- 1.0- 71	RF	
8-81312	2.14-11.0- 16	RF		8-81343-2	2. 6-32.0- 75	1	
8-81313-1	2. 3- 3.0- 91	1			2. 8- 1.0- 71	RF	
8-81313-803	2. 3-15.0- 12	1		8-81343-3	2. 3-14.0- 38	1	
	2. 8- 1.0- 59	RF			2. 8- 1.0- 64	RF	
8-81313-805	2. 3-15.0- 12	1		8-81343-4	2. 3-14.0- 38	1	
	2. 8- 1.0- 59	RF			2. 8- 1.0- 64	RF	
8-81313-807	2. 3-15.0- 12	1		8-81344-1	2. 3- 3.0- 24	1	
	2. 8- 1.0- 59	RF			2. 8- 1.0- 26	RF	
8-81313-809	2. 3-15.0- 12	1		8-81401	2. 8-18.0- 3	1	
	2. 8- 1.0- 59	RF			2. 8-18.0- 48	1	
8-81314-1	2. 3- 3.0- 53	1		8-81403	2. 8-18.0- 14	1	
	2. 8- 4.0- 5	RF			2. 8-18.0- 58	1	
8-81314-3	2. 3- 3.0- 54	1		8-81405	2. 8-18.0- 24	1	
	2. 8- 5.0- 10	RF			2. 8-18.0- 68	1	
8-81314-45	2. 8- 4.0- 10	1		8-81407	2. 8-18.0- 34	1	
8-81314-47	2. 8- 5.0- 10	1			2. 8-18.0- 78	1	
8-81315-1	2. 3- 3.0- 25	1		8-81502	2. 7- 7.0- 35	1	
	2.11- 1.0- 2	RF		8-81504	2. 8-25.0- 26	1	
8-81316-3	2. 3- 3.0- 28	1		8-81505	2. 8- 1.0- 68	1	
	2.11- 6.0- 3	RF		8-81506-7	2. 8- 1.0- 76	2	
8-81316-5	2. 3- 3.0- 29	1		8-82007	2. 7- 6.0- 4	1	
	2.11- 8.0- 3	RF			2.14-43.0- 2	RF	
8-81317	2. 3-10.0- 18	1		8-82008	2. 3-14.0- 22	1	
	2. 8- 3.0- 1	RF		8-82010-1	2. 6- 1.0- 2	1	
8-81318	2. 7- 6.0- 9	1			2. 6- 2.0- 2	1	
	2. 7- 7.0- 17	RF			2.14-11.0- 34	RF	
8-81318-1	2. 7- 6.0- 9	1		8-82010-2	2. 6- 1.0- 2	1	
	2. 7- 7.0- 17	RF			2. 6- 2.0- 2	1	
8-81318-13	2. 7- 7.0- 31	1			2.14-11.0- 34	RF	
8-81318-15	2. 7- 7.0- 26	1		8-82105	2. 8-19.0- 34	1	
8-81318-17	2. 7- 7.0- 25	2		8-82106	2. 8-19.0- 97	1	
8-81318-19	2. 7- 7.0- 24	1		8-82107	2. 8-19.0- 50	1	
8-81318-21	2. 7- 7.0- 18	1		8-82108-1	2. 8-19.0- 87	1	
8-81318-3	2. 7- 6.0- 9	1		8-82109	2. 8-19.0- 42	1	
	2. 7- 7.0- 17	RF		8-82110	2. 8-19.0-106	1	
8-81319	2. 7- 6.0- 8	1		8-82111	2. 8-19.0- 15	1	
	2. 7- 7.0- 1	RF		8-82112	2. 8-19.0- 69	1	
8-81319-1	2. 7- 6.0- 8	1		8-82113	2. 8-19.0- 52	1	
	2. 7- 7.0- 1	RF			2. 8-19.0- 99	1	
8-81319-11	2. 7- 7.0- 5	1		8-82209	2.14-43.0- 6	2	
8-81319-13	2. 7- 7.0- 1	1		8-82402-7	2.15- 1.0- 70	1	
8-81319-15	2. 7- 7.0- 10	1			2.15- 1.0- 70	1	

PART NUMBER	FIGURE AND INDEX NUMBER	QTY PER ART	SMR CODE
8-82402-7	2.15- 1.0- 70	1	
	2.15- 1.0- 70	1	
8-82403-101	2. 8-10.0-164	1	
8-82403-103	2. 8-10.0-163	1	
8-82403-105	2. 8-10.0-160	1	
8-82403-107	2. 8-10.0-159	1	
8-82403-109	2. 9-33.0- 19	1	
8-82403-111	2. 8-10.0-156	1	
8-82403-113	2. 8-10.0-157	1	
8-82403-115	2. 8-10.0-154	1	
8-82403-117	2. 9-33.0- 23	1	
8-82403-119	2. 9-33.0- 21	1	
8-82403-121	2. 8-10.0- 87	1	
8-82403-123	2. 8-10.0-147	RF	
	2. 9-33.0- 25	1	
8-82403-125	2. 8-10.0-144	1	
8-82403-127	2. 8-10.0-142	1	
8-82403-129	2. 8-10.0-148	1	
8-82403-131	2. 8-10.0-145	1	
8-82403-135	2. 8-10.0-141	1	
8-82403-21	2. 8- 6.0- 19	1	
8-82403-95	2. 8-10.0-152	1	
8-82403-97	2. 8-10.0-150	1	
8-82403-99	2. 8-10.0-153	1	
8-82404	2. 8-10.0-138	2	
8-82405	2. 8- 6.0- 5	2	
8-82407-7	2. 9-19.0- 12	1	
8-83001-1	2. 3- 3.0- 81	1	
	2.15- 1.0- 69	RF	
8-83001-1J	2.15- 1.0- 70	1	
8-83001-2	2. 3- 3.0- 81	1	
	2.15- 1.0- 69	RF	
8-83001-3	2. 3- 3.0- 81	1	
	2.15- 1.0- 65	RF	
8-83001-4	2. 3- 3.0- 81	1	
	2.15- 1.0- 69	RF	
8-83001-7	2.15- 1.0- 70	1	
8-83001-8	2.15- 1.0- 70	1	
8-83001-9	2.15- 1.0- 70	1	
8-83002-1	2. 8-23.0- 7	1	
8-83003-1	2. 8-23.0- 13	1	
8-83003-55	2. 8-23.0- 39	1	
8-83004-1	2. 8-23.0-	1	
8-84006	2. 3- 4.0- 6	1	
	2.15- 1.0- 16	RF	
8-84008	2. 3- 4.0- 63	1	
	2.15- 1.0- 1	RF	
8-84010	2.15-17.0- 36	REF	
8-84010-1	2.15-16.0- 79	1	
8-84011	2.15-16.0- 76	1	
8-84207-7	2.15-26.0- 14	1	
	2.15-26.0- 24	1	
8-84207-8	2.15-26.0- 14	RF	
	2.15-26.0- 24	RF	
8-84209	2.15-13.0- 34	1	
8-84209-7	2.15-13.0- 36	1	
8-84216	2.15-16.0- 78	1	
8-84224-1	2. 8-25.0-	1	
8-84224-13	2. 8-25.0- 27	1	
8-84224-17	2. 8-25.0- 19	1	
	2. 8-25.0- 29	1	
8-84224-19	2. 8-25.0- 11	1	
	2. 8-25.0- 36	1	
8-84224-21	2. 8-15.0- 17	1	
8-84224-27	2. 8-15.0- 25	1	

PART NUMBER	FIGURE AND INDEX NUMBER	QTY PER ART	SMR CODE
8-84224-3	2. 8-24.0-	1	
8-84224-7	2. 8-15.0- 9	1	
8-84224-71	2. 8-24.0- 3	1	
8-84224-73	2. 8-24.0- 5	1	
8-84224-79	2. 9-24.0- 2	1	
8-84224-81	2. 8-25.0- 24	1	
8-84224-9	2. 8-25.0- 25	1	
	2. 9-14.0- 23	1	
8-84225-1	2. 8-15.0- 20	1	
8-84231-5	2. 8-23.0- 15	1	
8-84234-1	2. 8-26.0-	1	
8-84234-5	2. 8-26.0-	1	
8-84234-801	2. 8-26.0-	1	
8-84234-813	2. 8-26.0-	1	
8-84234-817	2. 8-26.0-	1	
8-84234-811	2. 8-26.0-	1	
8-84235-5	2. 8-27.0-	1	
8-84236-1	2. 8-24.0- 6	1	
8-84238-1	2. 8-23.0- 7	2	
8-84241-1	2. 8-25.0- 16	4	
8-84241-11	2. 8-25.0- 17	1	
8-84241-13	2. 8-25.0- 18	1	
8-84241-7	2. 8-25.0- 19	1	
8-84242-7	2. 8-23.0- 37	1	
8-84700-11	2. 8-27.0- 41	1	
8-84701-11	2. 8-27.0- 41	1	
8-84704-7	2. 8-27.0- 25	1	
8-84706-9	2. 8-27.0- 27	1	
8-84707-9	2. 8-27.0- 21	1	
8-84708-9	2. 8-27.0- 39	1	
8-84709-7	2. 8-27.0- 18	1	
8-84710-7	2. 8-27.0- 19	1	
8-84711-7	2. 8-27.0- 15	1	
8-84712-7	2. 8-27.0- 16	1	
8-84713-7	2. 8-27.0- 13	1	
8-84714-7	2. 8-27.0- 12	1	
8-84715-9	2. 8-27.0- 9	1	
8-84716-7	2. 8-27.0- 7	1	
8-84717-7	2. 8-27.0- 6	1	
8-84718-7	2. 8-27.0- 3	1	
8-84719-7	2. 8-27.0- 4	1	
8-84720-7	2. 8-26.0- 26	1	
8-84721-7	2. 8-26.0- 27	1	
8-84722-9	2. 8-26.0- 23	1	
8-84723-9	2. 8-26.0- 24	1	
8-84724-11	2. 8-26.0- 27	1	
8-84725-11	2. 8-26.0- 21	1	
8-84726-11	2. 8-26.0- 17	1	
8-84727-11	2. 8-26.0- 18	1	
8-84732-9	2. 8-26.0- 8	1	
8-84733-7	2. 8-26.0- 3	1	
8-84734-7	2. 8-26.0- 4	1	
8-84735-7	2. 8-25.0- 20	1	
8-84736-7	2. 8-25.0- 21	1	
8-84737-7	2. 8-25.0- 14	1	
8-84738-7	2. 8-25.0- 15	1	
8-84739-7	2. 8-25.0- 13	1	
8-84740-7	2. 8-25.0- 6	1	
8-84741-7	2. 8-25.0- 9	1	
8-84742-7	2. 8-25.0- 7	1	
8-84743-7	2. 8-25.0- 4	1	
8-84744-7	2. 8-25.0- 3	1	
8-84745-7	2. 8-24.0- 15	1	
8-84746-7	2. 8-24.0- 14	1	
8-84747-7	2. 8-24.0- 11	1	

PART NUMBER	FIGURE AND INDEX NUMBER	QTY PER ART	SMR CODE
8-84748-9	2. 8-24.0- 12	1	
8-84749-9	2.14- 4.0-107	1	
8-84750-9	2.14- 4.0-109	1	
8-84774-9	2.13- 7.0-106	1	
8-84775-9	2.13- 7.0-134	1	
8-84778-11	2. 8-27.0- 79	1	
8-84779-13	2. 8-27.0- 81	1	
8-84780-11	2. 8-27.0- 63	1	
8-84781	2. 8-27.0- 55	1	
8-84782-9	2. 8-27.0- 52	1	
8-84783-7	2. 8-27.0- 57	1	
8-84784-7	2. 8-27.0- 59	1	
8-84785-9	2. 8-27.0- 65	1	
8-84786-11	2. 8-27.0- 66	1	
8-84787-9	2. 8-27.0- 68	1	
8-84788-7	2. 8-27.0- 75	1	
8-84789-9	2. 8-27.0- 77	1	
8-84790-7	2. 8-27.0- 78	1	
8-84791-11	2. 8-27.0- 44	1	
8-84792-7	2. 8-27.0- 48	1	
8-84793-7	2. 8-27.0- 71	1	
8-84794-7	2. 8-16.0- 83	1	
8-84795-7	2. 8-27.0- 6	1	
8-84796-7	2. 8-27.0- 7	1	
8-85010-3	2. 7- 6.0- 3	1	
	2.14- 1.0- 20	RF	
8-85017-1	2. 6-32.0- 48	1	
	2. 9- 1.0- 46	RF	
8-8502	2. 9- 3.0-	RF	
8-85021	2. 3-10.0- 21	RF	
	2. 3-10.0- 21	1	
	2. 9- 3.0-	RF	
8-85021-1	2. 3-10.0- 20	1	
	2. 9- 3.0-	RF	
8-85021-11	2. 9- 3.0- 9	1	
8-85021-13	2. 9- 3.0- 10	1	
8-85021-15	2. 9- 3.0- 21	2	
8-85021-19	2. 9- 3.0- 17	1	
8-85021-20	2. 9- 3.0- 18	1	
8-85021-7	2. 3- 3.0- 31	1	
	2. 9- 3.0- 6	RF	
8-85021-9	2. 3- 3.0- 30	1	
	2. 9- 3.0- 6	RF	
8-85022-1	2. 3-10.0- 8	1	
	2.20- 1.0- 9	RF	
8-85023-1	2. 3-11.0- 1	1	
	2.20- 2.0-	RF	
8-85024	2. 3-10.0- 19	RF	
8-85026-1	2. 3-15.0- 21	1	
	2. 7- 1.0- 17	RF	
8-85029-13	2.12-33.0- 5	1	
8-85029-15	2.12-33.0- 4	1	
8-85029-3	2. 3-11.0- 11	1	
	2.12-33.0-	RF	
8-85031-1	2. 3-11.0- 29	RF	
8-85032-1	2. 3-15.0- 22	1	
	2. 7- 1.0- 1		
8-85037	2. 3-14.0- 17	1	
8-85039-1	2. 3-11.0- 20	1	
	2.15- 1.0- 5	RF	
8-85045-1	2. 3- 3.0- 6	1	
	2.13- 1.1- 63	RF	
8-85046-1	2. 3-11.0- 15	1	
	2.20- 1.0- 39	RF	
8-85047	2. 3- 8.0- 1	1	

PART NUMBER	FIGURE AND INDEX NUMBER	QTY PER ART	SMR CODE
8-85048	2. 3- 3.0- 26	1	
	2. 3- 3.0- 51	1	
	2.11- 1.0- 24	RF	
8-85048-1	2. 3-15.0- 22	1	
	2.11- 1.0- 38	1	
8-85048-11	2.11- 1.0- 47	1	
8-85048-15	2.11- 1.0- 33	1	
8-85048-17	2.11- 1.0- 35	1	
8-85048-19	2.11- 1.0- 34	1	
8-85048-21	2.11- 1.0- 43	1	
8-85048-23	2.11- 1.0- 39	1	
8-85048-25	2.11- 1.0- 25	1	
8-85048-27	2.11- 1.0- 46	1	
8-85048-7	2.11- 1.0- 45	1	
8-85048-9	2.11- 1.0- 44	1	
8-85049-1	2. 3-11.0- 1	1	
	2.20- 2.0-	RF	
8-85049-17	2.20- 2.0- 8	1	
8-85051-1	2. 3-11.0- 3	1	
	2.20-19.0- 5	RF	
8-85052-1	2. 3- 4.0- 67	1	
	2.20- 1.0- 3	RF	
8-85053-1	2. 3-17.0- 9	1	
	2.20- 1.0- 3	RF	
8-85058-1	2. 3-11.0- 16	1	
	2.20- 1.0- 15	RF	
8-85059-1	2. 3-11.0- 3	1	
	2.20-10.0-	RF	
8-85106-1	2. 9- 3.0- 23	1	
8-85106-25	2. 9- 3.0- 14	4	
	2. 9- 3.0- 29	4	
8-85106-27	2. 9- 3.0- 15	4	
	2. 9- 3.0- 39	4	
8-85106-7	2. 9- 3.0- 12	1	
8-85106-5	2. 9- 3.0- 31	1	
8-85106-7	2. 9- 3.0- 16	1	
8-85107	2. 9-18.0- 25	1	
	2. 9-18.0- 72	1	
	2. 9-18.0- 94	1	
8-85107-7	2. 9-19.0- 29	1	
	2. 9-19.0- 72	1	
	2. 9-19.0- 94	1	
8-85358	2. 3- 4.0- 65	1	
	2. 8- 1.0- 16	RF	
8-86304-13	2.15- 1.0- 54	1	
8-86304-14	2.15- 1.0- 54	1	
8-86304-3	2. 6- 1.0- 17	1	
	2. 6- 2.0- 17	1	
8-86304-4	2.15- 1.0- 49	RF	
	2. 6- 1.0- 17	1	
	2. 6- 2.0- 17	1	
	2.15- 1.0- 49	RF	
8-87272	2.13- 4.0- 17	1	
	2.13-19.0- 4	1	
8-87295-7	2. 3- 1.0- 25	1	
8-87862	2.13- 2.0- 7	1	
	2.13- 3.0- 7	1	
8-87861	2.13- 2.0- 9	1	
	2.13- 3.0- 9	1	
8-87862	2.13- 2.0- 11	1	
	2.13- 3.0- 11	1	
8-90705	2. 3- 3.0- 9	1	
	2.15- 6.0-	RF	
8-90705-7	2.15- 6.0-	1	
8-90706-1	2. 6- 1.0- 13	1	

PART NUMBER	FIGURE AND INDEX NUMBER	QTY PER ART	SMR CODE	PART NUMBER	FIGURE AND INDEX NUMBER	QTY PER ART	SMR CODE
8-90706-1	2. 6- 2.0- 13	1		8-92703-7	2.12-39.0- 26	1	
	2.15- 5.0-	RF		8-92703-9	2.12-39.0- 36	1	
8-90706-15	2.15- 5.0- 25	1		8-92704	2.12-39.0- 33	1	
8-90706-16	2.15- 5.0- 25	1		8-92925	2. 5- 1.0- 32	RF	
8-90706-19	2.15- 5.0- 1	1		8-92938-53	2. 5-13.0- 4	2	
8-90706-2	2. 6- 1.0- 13	1		8-92938-805	2. 3- 4.0- 22	1	
	2. 6- 2.0- 13	1			2. 5-13.0-	RF	
	2.15- 5.0-	RF		8-92938-817	2. 3- 4.0- 22	1	
8-90706-20	2.15- 5.0- 1	1			2. 5-13.0-	RF	
8-90706-21	2.15- 5.0- 11	1		8-92938-821	2. 3- 4.0- 22	1	
8-90706-22	2.15- 5.0- 11	1			2. 5-13.0-	RF	
8-90706-23	2.15- 5.0- 11	1		8-92938-925	2. 3- 4.0- 22	1	
8-90706-24	2.15- 5.0- 11	1			2. 5-13.0-	RF	
8-90706-25	2.15- 5.0- 11	1		8-92939-109	2. 5-13.0- 18	1	
8-90706-26	2.15- 5.0- 11	1		8-92939-111	2. 5-13.0- 15	1	
8-90706-27	2.15- 5.0- 1	1		8-92939-119	2. 5-13.0- 5	1	
8-90706-28	2.15- 5.0- 1	1		8-92939-121	2. 5-13.0- 1	RF	
8-92300-1	2. 3- 6.0- 14	RF		8-92939-125	2. 5-13.0- 14	1	
8-92452-805	2. 1- 1.0- 60	RF		8-92939-127	2. 5-13.0- 10	1	
	2. 1- 1.0- 60	1		8-92939-151	2. 5-13.0- 18	1	
	2.19- 1.0- 5			8-92939-153	2. 5-13.0- 15	1	
8-92452-809	2. 3- 6.0- 12	1		8-92939-155	2. 5-13.0- 5	1	
	2.19- 2.0-	1		8-92939-157	2. 5-13.0- 1	RF	
8-92455	2. 3- 8.0- 3	1		8-92939-159	2. 5-13.0- 14	1	
8-92455-7	2.19- 2.0- 2	1		8-92939-161	2. 5-13.0- 10	1	
8-92456-7	2. 3- 8.0- 2	1		8-92939-163	2. 5-13.0- 6	1	
8-92470	2.19- 3.0- 4	1		8-92939-165	2. 5-13.0- 15	1	
	2.19- 4.0- 4	1		8-92939-167	2. 5-13.0- 18	1	
	2.19- 5.0- 4	1		8-92939-177	2. 5-13.0- 9	1	
8-92490	2.19- 3.0-	RF		8-92939-5	2. 5-13.0- 15	1	
8-92490-1	2.19- 4.0-	RF		8-92939-53	2. 5-13.0- 6	1	
8-92490-13	2.19- 3.0- 32	1		8-92939-57	2. 5-13.0- 15	1	
	2.19- 4.0- 31	1		8-92939-75	2. 5-13.0- 1	RF	
	2.19- 5.0- 31	1		8-92939-77	2. 5-13.0- 10	1	
8-92490-17	2.19- 3.0- 15	1		8-92939-91	2. 5-13.0- 9	1	
	2.19- 4.0- 14	1		8-92939-93	2. 5-13.0- 6	1	
	2.19- 5.0- 14	1		8-92941	2. 3-10.0- 5	1	
8-92490-19	2.19- 4.0- 15	1		8-92943-7	2.15- 1.0- 66	2	
8-92490-23	2.19- 3.0- 31	1		8-92945-101	2.11-12.0- 36	1	
8-92490-25	2.19- 3.0- 11	1		8-92945-103	2.11-12.0- 27	1	
	2.19- 4.0- 11	1		8-92945-123	2.11-11.0- 6	1	
	2.19- 5.0- 11	1		8-92945-125	2.11-11.0- 9	1	
8-92490-3	2.19- 5.0-	RF		8-92945-143	2.11-11.0- 2	1	
8-92490-31	2.19- 3.0- 35	1		8-92945-145	2.11-11.0- 3	1	
	2.19- 5.0- 35	1		8-92945-147	2.11-11.0- 13	1	
8-92490-37	2.19- 5.0- 45	1		8-92945-147	2.11-11.0- 7	1	
8-92490-39	2.19- 3.0- 3	1		8-92945-15	2.11-12.0- 14	1	
	2.19- 4.0- 3	1		8-92945-153	2.11-12.0- 37	1	
	2.19- 5.0- 3	1		8-92945-155	2.11-12.0- 35	1	
8-92490-41	2.19- 5.0- 47	1		8-92945-157	2.11-12.0- 28	1	
8-92490-55	2.19- 4.0- 37	1		8-92945-159	2.11-12.0- 30	1	
8-92490-57	2.19- 4.0- 35	1		8-92945-165	2.11-12.0- 18	1	
8-92491	2.19- 2.0- 11	1		8-92945-167	2.11-12.0- 18	1	
8-92492	2.19- 2.0- 1	1		8-92945-169	2.11-11.0- 8	1	
8-92493	2.19- 2.0- 3	1		8-92945-171	2.11-11.0- 11	1	
8-92494	2. 3- 4.0- 11	1		8-92945-39	2.11-12.0- 11	1	
8-92496-1	2.19- 1.0- 4	1		8-92945-55	2.11-12.0- 38	1	
8-92496-3	2.19- 1.0- 3	1		8-92945-59	2.11-12.0- 39	1	
8-92496-5	2.19- 1.0- 4	1		8-92945-69	2.11-12.0- 24	1	
8-92497	2. 3- 4.0- 45	1		8-92945-77	2.11-12.0- 41	2	
	2.19- 1.0- 2	1		8-92945-79	2.11-12.0- 42	2	
8-92702	2.12-39.0- 32	1		8-92945-803	2. 3-10.0- 42	1	
8-92703	2. 3-13.0- 7	1			2.11-12.0-	RF	
	2.12-39.0- 25	RF		8-92945-805	2. 3- 4.0- 65	1	
8-92703-11	2.12-39.0- 29	1			2.11-11.0-	RF	

PART NUMBER	FIGURE AND INDEX NUMBER	QTY PER ART	SMR CODE	PART NUMBER	FIGURE AND INDEX NUMBER	QTY PER ART	SMR CODE
8-92945-81	2.11-12.0- 10	1		8-94157-41	2. 4- 8.0- 58	1	
8-92945-91	2.11-12.0- 25	1		8-94166-13	2. 4- 7.0- 36	1	
8-92945-99	2.11-12.0- 34	1		8-94166-15	2. 4- 7.0- 35	1	
8-92947-21	2.11- 2.0- 10	1		8-94166-19	2. 4- 6.0- 15	2	
8-92947-22	2.11- 2.0- 10	1			2. 4- 7.0- 79	2	
8-92947-801	2.11- 2.0- 9	RF		8-94166-25	2. 4- 7.0- 7	1	
	2.11- 4.0- 3	1		8-94166-27	2. 4- 7.0- 28	1	
8-92947-802	2.11- 2.0- 9	RF		8-94166-31	2. 4- 7.0- 6	1	
	2.11- 4.0- 3	1			2. 4- 7.0- 80	1	
8-92947-803	2. 3- 4.0- 35	1		8-94166-33	2. 4- 7.0- 73	1	
	2.11- 2.0- 5	RF			2. 4- 7.0- 91	1	
8-92947-804	2. 3- 4.0- 35	1		8-94166-35	2. 4- 7.0- 21	1	
	2.11- 2.0- 5	RF		8-94166-37	2. 4- 7.0- 83	1	
8-92947-9	2.11- 2.0- 11	1		8-94166-801	2. 3- 3.0- 1	1	
8-92948-3	2.11- 4.0- 3	1			2. 4- 7.0-	1	
8-92948-31	2.11- 4.0- 4	1		8-94166-803	2. 1- 1.0- 55	1	
8-92948-33	2.11- 4.0- 5	1			2. 4- 7.0-	1	
8-92948-35	2.11- 4.0- 6	1		8-94166-805	2. 3- 3.0- 1	1	
8-92948-4	2.11- 4.0- 3	1			2. 4- 7.0-	1	
8-92950	2.11- 2.0- 9	1		8-94166-807	2. 3- 3.0- 1	1	
8-92960-1	2.11- 2.0- 12	RF			2. 4- 7.0-	1	
8-92960-2	2.11- 2.0- 12	RF		8-94180	2. 3- 3.0- 1	1	
8-92961-1	2.11- 2.0- 12	1			2. 4- 7.0-	RF	
8-92961-2	2.11- 2.0- 12	1		8-94180-1	2. 1- 1.0- 56	1	
8-92962	2. 4- 8.0- 62	1			2. 4- 7.0-	RF	
8-92963	2. 4- 8.0- 66	1		8-94180-3	2. 3- 3.0- 1	1	
8-92964	2. 4- 8.0- 56	1			2. 4- 7.0-	RF	
8-92964-11	2. 4- 8.0- 66	1		8-94187	2. 1- 1.0- 62	RF	
8-92965-1	2. 4- 8.0- 67	1			2.13- 1.1- 29	RF	
8-92965-11	2. 4- 8.0- 69	1		8-94509	2.15-18.0- 3	1	
8-92965-9	2. 4- 8.0- 68	2			2.16-12.0- 3	1	
8-92967-1	2. 4- 8.0- 43	1		8-94515-11	2.15- 7.0- 6	1	
8-92974-1	2. 5-13.0- 15	1		8-94515-7	2.15- 7.0- 6	1	
8-92974-11	2. 5-13.0- 1	RF		8-94515-9	2.15- 7.0- 10	1	
	2. 5-13.0- 5	1		8-94522-11	2.15- 7.0- 22	1	
8-92974-13	2. 5-13.0- 9	1			2.15- 7.0- 27	1	
8-92974-15	2. 5-13.0- 18	1		8-94535	2. 5- 5.0- 9	1	
8-92974-3	2. 5-13.0- 10	1		8-94543-1	2. 3- 4.0- 60	1	
8-92974-5	2. 5-13.0- 1	RF			2.18-19.0-	RF	
8-92974-7	2. 5-13.0- 18	1		8-94571-1	2. 1- 1.0- 52	RF	
8-92974-801	2. 5-13.0- 6	1			2. 1- 1.0- 52	1	
8-92974-803	2. 5-13.0- 15	1		8-94571-5	2. 1- 1.0- 52	RF	
8-92974-9	2. 5-13.0- 14	1			2. 1- 1.0- 52	1	
8-93400	2. 3- 6.0- 13	RF		8-94571-801	2. 1- 1.0- 52	RF	
8-93403	2. 3- 4.0- 27	1			2. 1- 1.0- 52	1	
	2.14- 1.0- 26	RF			2. 5- 2.0-	1	
8-93803	2. 5- 8.0- 2	1		8-94572	2.17- 4.0- 6	6	
8-93804	2. 5- 8.0- 3	1		8-94587-19	2. 5- 2.0- 12	1	
8-93804-21	2. 5- 8.0- 9	1		8-94587-20	2. 5- 2.0- 12	1	
8-93804-9	2. 5- 8.0- 10	1		8-94588	2. 5- 2.0- 15	1	
8-93805	2. 1- 1.0- 49	1		8-94590	2. 5- 2.0- 13	2	
	2. 5- 8.0-	RF		8-94592	2. 3- 3.0- 4	1	
8-94112	2. 4- 7.0- 7	2		8-94592-3	2. 3- 3.0- 4	1	
8-94112-7	2. 4- 7.0- 11	2		8-94657-5	2. 3- 8.0- 4	1	
8-94113	2. 4- 7.0- 16	1			2.17-11.0- 48	RF	
8-94118	2. 4- 7.0- 17	1		8-94658-801	2. 3- 6.0- 4	1	
8-94153-15	2. 4- 8.0- 36	1			2.17-11.0- 46	RF	
8-94153-19	2. 4- 8.0- 6	1		8-94662-1	2. 3- 6.0- 1	1	
8-94153-23	2. 4- 8.0- 7	1			2.15- 7.0-	RF	
8-94153-801	2. 3- 3.0- 52	1			2.15- 7.0- 20	1	
	2. 4- 8.0-	RF		8-94662-17	2.15- 7.0- 20	1	
8-94153-805	2. 4- 8.0-	RF		8-94662-19	2.15- 7.0- 28	1	
	2.11- 4.0- 1	1		8-94662-21	2.15- 7.0- 24	1	
8-94153-809	2. 3- 4.0- 17	1		8-94662-25	2.15- 7.0- 24	1	
	2. 4- 8.0-	RF		8-94662-27	2.15- 7.0- 29	1	
				8-94662-3	2. 3- 6.0- 2	1	

PART NUMBER	FIGURE AND INDEX NUMBER	QTY PER ART	SMR CODE
8-94662-3	2.15- 7.0-	RF	
8-94662-7	2.15- 7.0- 19	1	
8-94662-9	2.15- 7.0- 20	1	
8-94666-813	2. 3- 4.0- 58	1	
8-94666-835	2. 3- 4.0- 58	1	
	2.16- 8.0-	1	
8-94680-19	2.15-18.0- 16	6	
8-94680-3	2. 3- 6.0- 2	1	
	2.15-18.0-	RF	
8-94680-5	2. 3- 6.0- 3	1	
	2.15-18.0-	RF	
8-94681-13	2.16-15.0- 11	1	
8-94681-47	2.16- 8.0- 48	1	
8-94681-833	2.16- 8.0- 48	1	
8-94693-15	2.15-18.0- 8	1	
8-94706-13	2. 5- 4.0- 28	RF	
8-94706-14	2. 5- 4.0- 29	RF	
8-94706-15	2. 5- 4.0- 17	RF	
8-94706-7	2. 5- 4.0- 30	RF	
8-94706-801	2. 5- 4.0- 8	RF	
8-94706-9	2. 5- 4.0- 26	RF	
8-94708-7	2. 5- 4.0- 31	RF	
8-94709-13	2. 5- 4.0- 13	RF	
8-94711-149	2.17- 4.0- 7	1	
8-94711-151	2.17- 4.0- 6	1	
8-94711-177	2.15- 7.0- 29	1	
8-94711-181	2.16-13.0- 3	1	
8-94711-183	2.16-10.0-	1	
8-94711-185	2.16-12.0-	1	
8-94711-189	2.16-21.0-	1	
8-94711-191	2.16- 8.0- 38	1	
8-94711-193	2.16-18.0- 5	1	
8-94711-195	2.15-12.0- 2	2	
8-94711-197	2.16- 9.0-	1	
8-94711-211	2.16-20.0-	2	
8-94711-217	2.16-17.0-	RF	
8-94711-219	2. 9- 1.0- 1	1	
8-94711-221	2.16-19.0-	1	
8-94711-223	2.16- 1.0- 13	1	
	2.16- 2.0- 7	1	
8-94711-229	2.16- 1.0- 3	1	
	2.16- 2.0- 5	1	
8-94711-235	2.15- 1.0- 60	1	
	2.16- 2.0- 13	1	
8-94711-237	2.16- 1.0- 62	1	
	2.16- 2.0- 61	1	
8-94711-245	2. 5- 4.0- 9	RF	
8-94711-249	2.16- 2.0- 21	1	
8-94711-255	2.16- 2.0- 13	1	
8-94711-257	2.16- 2.0- 4	1	
8-94711-269	2.16- 8.0- 17	1	
	2.16-17.0-	RF	
8-94711-271	2.16-11.0-	1	
8-94711-29	2. 6- 3.0- 7	1	
	2.17- 1.0- 40	1	
8-94711-51	2.17- 1.0- 49	1	
8-94711-69	2.15-18.0-	1	
8-94711-71	2.17- 4.0- 1	1	
8-94711-73	2.17- 4.0- 2	1	
8-94711-75	2.17- 4.0-	1	
8-94712-7	2. 5- 4.0- 12	RF	
8-94712-9	2. 5- 4.0- 11	RF	
8-94812	2. 3- 6.0- 16	1	
	2. 5-12.0-	RF	
8-94812-1	2. 3- 8.0- 8	1	

PART NUMBER	FIGURE AND INDEX NUMBER	QTY PER ART	SMR CODE
8-94812-1	2. 5-12.0-	RF	
8-94812-11	2. 5-12.0- 5	1	
8-94812-13	2. 5-12.0- 7	1	
8-94812-15	2. 5-12.0- 8	1	
8-94812-17	2. 5-12.0- 10	1	
8-94812-19	2. 5-12.0- 11	1	
	2. 5-12.0- 15	1	
8-94812-21	2. 5-12.0- 13	1	
8-94812-23	2. 5-12.0- 14	1	
	2. 5-12.0- 17	1	
8-94812-25	2. 5-12.0- 16	1	
8-94812-27	2. 5-12.0- 18	1	
8-94812-29	2. 5-12.0- 19	1	
8-94812-31	2. 5-12.0- 20	1	
8-94812-33	2. 5-12.0- 21	1	
8-94812-35	2. 5-12.0- 12	1	
8-94812-37	2. 5-12.0- 9	1	
8-94812-39	2. 5-12.0- 6	1	
8-94812-41	2. 5-12.0- 4	1	
8-94812-43	2. 5-12.0- 2	1	
8-94812-45	2. 5-12.0- 7	1	
8-94812-7	2. 5-12.0- 1	1	
8-94812-9	2. 5-12.0- 3	1	
8-94813	2. 4- 7.0- 52	1	
	2. 4- 8.0- 12		
8-94814	2. 4- 8.0- 13	2	
8-94816-601	2. 4- 7.0- 61	1	
8-94816-603	2. 4- 7.0- 75	1	
8-94816-605	2. 4- 7.0- 50	1	
8-94816-607	2. 4- 7.0- 38	1	
8-94816-841	2. 4- 7.0- 26	1	
8-94816-851	2. 4- 6.0- 17	1	
8-94816-871	2. 4- 7.0- 2	1	
8-94816-877	2. 4- 8.0- 37	1	
8-94816-881	2. 4- 6.0- 11	1	
8-94816-883	2. 4- 6.0- 10	1	
	2. 4- 7.0- 85	1	
8-94816-885	2. 4- 8.0- 10	1	
8-94816-897	2. 4- 7.0- 39	1	
8-94816-899	2. 4- 7.0- 92	1	
8-94820	2. 4- 2.0- 25	2	
8-94825-27	2. 9- 1.0- 30	1	
8-94825-3	2. 9- 1.0- 24	RF	
8-94825-43	2. 9- 1.0- 31	1	
8-94872	2. 1- 1.0- 62	RF	
	2.13- 1.1- 29	RF	
8-94876-1	2. 5- 1.0- 3	1	
8-94876-2	2. 5- 1.0- 2	1	
8-94878-1	2. 4- 2.0- 22	1	
8-94878-3	2. 1- 1.0- 54	1	
	2. 5- 3.0-	RF	
8-94878-5	2. 1- 1.0- 54	1	
	2. 5- 3.0-	RF	
8-94879	2. 1- 1.0- 51	1	
	2. 5- 1.0- 1	RF	
8-94886	2. 5- 3.0- 5	RF	
8-94893-5	2. 5-11.0- 8	1	
8-94894	2. 3- 4.0- 25	1	
	2. 5-11.0-	RF	
8-94894-9	2. 5-11.0- 6	1	
8-94895-1	2. 3- 4.0- 21	1	
	2. 5- 1.0- 4	RF	
8-94895-15	2. 5- 1.0- 17	1	
8-94895-17	2. 5- 1.0- 18	1	
8-94895-29	2. 5- 1.0- 8	RF	

PART NUMBER	FIGURE AND INDEX NUMBER	QTY PER ART	SMR CODE
8-94895-3	2. 3- 8.0- 7	1	
	2. 5- 1.0- 6	RF	
8-94895-31	2. 5- 1.0- 8	RF	
8-94905-3	2. 5- 7.0- 3	1	
8-94955-15	2. 5- 3.0- 10	1	
8-94955-17	2. 5- 3.0- 5	1	
8-94955-9	2. 4- 2.0- 23	1	
8-94971-3	2. 5- 7.0-	1	
8-94971-5	2. 5- 7.0-	1	
8-94971-7	2. 5- 7.0- 11	1	
8-94971-9	2. 5- 7.0- 12	1	
8-94972-1	2. 5- 7.0- 14	RF	
8-94973-7	2. 5- 7.0- 13	1	
8-94973-9	2. 5- 7.0- 13	1	
8-94976-805	2. 1- 1.0- 42	1	
	2.17- 4.0-	RF	
8-94976-807	2. 3- 6.0- 6	1	
	2.17- 4.0- 6	RF	
8-94976-811	2. 3- 8.0- 6	1	
	2.17- 4.8- 6	RF	
8-94983-49	2. 5-11.0- 25	1	
8-94983-50	2. 5-11.0- 26	1	
8-94983-71	2. 5-11.0- 21	1	
8-94983-801	2. 3- 4.0- 24	1	
	2. 5-11.0- 15	RF	
8-94983-803	2. 3- 4.0- 24	1	
	2. 5-11.0- 15	RF	
8-94983-87	2. 5-11.0- 30	RF	
8-95109	2. 4- 7.0- 68	2	
8-95502-15	2. 5- 3.0- 5	1	
8-95517-11	2. 5- 5.0- 11	2	
8-95546-17	2.18-12.0- 12	1	
8-95546-3	2. 1- 1.0- 61	1	
	2.18-12.0-	RF	
8-95546-73	2.18-12.0- 17	1	
8-95546-77	2.18-12.0- 18	1	
8-95546-805	2. 3- 4.0- 61	1	
	2.18-12.0- 9	RF	
8-95546-807	2. 3- 4.0- 61	1	
	2.18-12.0- 9	RF	
8-95546-95	2.18-12.0- 16	1	
8-95555	2. 5- 1.0- 25	RF	
8-95556	2. 5- 1.0- 24	RF	
8-95557	2. 4- 9.0- 38	1	
8-95567-11	2.19- 2.0- 6	1	
8-95567-17	2.19- 2.0- 7	1	
8-95567-9	2.19- 2.0- 5	1	
8-95568-7	2. 5- 1.0- 51	1	
8-95569-1	2. 3- 6.0- 11	1	
	2. 5- 1.0- 50	RF	
8-95581	2. 3- 8.0- 11	RF	
	2. 5- 5.0-	RF	
8-95582-1	2. 5- 5.0-	1	
8-95582-11	2. 5- 5.0- 13	1	
8-95582-13	2. 5- 5.0- 14	1	
8-95582-19	2. 5- 5.0- 5	1	
8-95582-25	2. 5- 5.0- 12	1	
8-95582-27	2. 5- 5.0- 13	1	
8-95582-3	2. 5- 5.0-	1	
8-95584-1	2. 5- 5.0- 18	1	
8-95585-1	2. 5- 5.0- 4	1	
8-95587-1	2.16- 8.0- 29	1	
	2.16-19.0-	RF	
8-95587-3	2.16- 8.0- 29	1	
8-9559-21	2.16-13.0- 7	1	

PART NUMBER	FIGURE AND INDEX NUMBER	QTY PER ART	SMR CODE
8-95591	2. 3- 6.0- 9	1	
	2. 5- 4.0-	RF	
8-95591-17	2. 5- 4.0- 7	RF	
8-95592	2. 3- 8.0- 9	1	
	2. 5-10.0-	RF	
8-95592-1	2. 3- 6.0- 10	1	
	2. 5- 9.0-	RF	
8-95593	2. 3- 6.0- 5	1	
	2.15-12.0-	RF	
8-95593-13	2.15-12.0- 1	1	
8-95593-15	2.15-12.0- 1	1	
8-95593-19	2.15-12.0- 1	1	
8-95595-1	2.17-11.0- 90	REF	
8-95595-39	2.17-11.0-151	1	
8-95596	2.16-13.0- 5	1	
8-95597	2.16-13.0- 6	1	
8-95597-1	2.16-13.0- 6	1	
8-95597-11	2.16-13.0- 20	1	
8-95597-15	2.16-13.0- 11	1	
8-95597-17	2.16-13.0- 7	1	
8-95597-19	2.16-13.0- 11	1	
8-95597-7	2.16-13.0- 24	1	
8-95598	2.16- 8.0- 11	1	
	2.16-13.0- 3	RF	
8-95598-1	2.16- 8.0- 11	1	
	2.16-13.0- 3	RF	
8-95598-801	2.16- 8.0- 29	1	
8-95599-1	2. 3- 6.0- 7	1	
	2. 9- 1.0- 32	RF	
8-95600	2.16-13.0- 14	1	
8-95600-1	2.16-13.0- 14	1	
8-95600-11	2.16-13.0- 16	1	
8-95600-13	2.16-13.0- 19	1	
8-95602	2. 5- 5.0- 10	1	
8-95607	2.16- 9.0-	RF	
8-95607-1	2.16- 9.0- 1	1	
	2.16- 9.0-	RF	
8-95608	2.15-12.0- 5	1	
8-95609-11	2.16-18.0- 21	1	
8-95609-13	2.16-18.0- 21	1	
8-95609-7	2.16-18.0- 21	1	
8-95609-9	2.16-18.0- 21	1	
8-95610-1	2.16-18.0- 16	1	
8-95610-3	2.16-18.0- 16	1	
8-95613	2. 3- 6.0- 7	1	
	2. 9- 1.0- 1	RF	
8-95615	2. 9- 1.0- 15	1	
8-95615-1	2. 9- 1.0- 16	1	
8-95616-1	2. 9- 1.0- 3	1	
8-95617-23	2. 5- 9.0- 12	RF	
8-95617-27	2. 5- 9.0- 19	1	
8-95617-29	2. 5- 9.0- 1	1	
8-95617-31	2. 5-10.0- 7	1	
	2. 5-10.0- 7	RF	
8-95617-37	2. 5-10.0- 12	1	
8-95617-39	2. 5-10.0- 18	RF	
8-95617-41	2. 5-10.0- 25	1	
8-95617-43	2. 5- 9.0- 19	1	
8-95617-45	2. 5-10.0- 18	1	
8-95617-9	2. 5- 9.0- 5	1	
8-95618-7	2. 4- 1.0- 52	1	
8-95619	2. 3- 8.0- 1	1	
	2. 4- 1.0- 51	RF	
8-95620-11	2.16- 9.0- 18	1	
8-95620-13	2.16- 9.0- 18	1	

PART NUMBER	FIGURE AND INDEX NUMBER	QTY PER ART	SMR CODE
8-95620-5	2.16- 3.0- 14	1	
8-95623-9	2.16- 9.0- 18	1	
8-95631	2. 5- 1.0- 31	RF	
8-95631-11	2. 5- 1.0- 37	RF	
8-95631-7	2. 5- 1.0- 38	RF	
8-95632	2. 5- 1.0- 32	RF	
8-95632-7	2. 5- 1.0- 36	RF	
8-95645	2. 5- 1.0- 15	RF	
8-95653	2. 3- 4.0- 57	1	
	2.16- 3.0-	RF	
8-95653-15	2.16- 3.0- 20	2	
8-95653-51	2.16- 4.0- 14	1	
8-95653-53	2.16- 4.0- 15	1	
8-95653-55	2.16- 4.0- 24	1	
8-95653-57	2.16- 4.0- 17	1	
	2.16- 4.0- 6	1	
8-95653-59	2.16- 4.0- 16	1	
	2.16- 4.0- 7	1	
8-95653-61	2.16- 4.0- 8	1	
8-95653-63	2.16- 4.0- 15	1	
8-95653-65	2.16- 4.0- 5	1	
8-95653-67	2.16- 4.0- 5	1	
8-95654-1	2.16- 3.0- 40	1	
8-95654-10	2.16- 3.0- 45	1	
8-95654-2	2.16- 3.0- 41	1	
8-95654-7	2.16- 3.0- 45	RF	
8-95654-8	2.16- 3.0- 45	RF	
8-95654-9	2.16- 3.0- 45	1	
8-95655-10	2.16- 4.0- 44	1	
8-95655-9	2.16- 4.0- 43	1	
8-95658-5	2. 3- 4.0- 60	1	
	2.18-19.0- 2	RF	
8-95658-61	2.18-19.0- 3	1	
8-95658-63	2.18-19.0- 4	1	
8-95658-801	2. 3- 4.0- 60	1	
	2.18-19.0- 2	RF	
8-95663-9	2.16- 4.0- 23	2	
8-95665-9	2.16- 4.0- 13	2	
8-95666	2.16- 4.0- 26	1	
8-95667	2.16- 4.0- 25	12	
8-95671-7	2.16- 4.0- 33	1	
8-95672-7	2.16- 4.0- 1	1	
8-95673-7	2.16- 4.0- 37	4	
	2.16- 4.0- 5	2	
8-95674-1	2.16- 3.0- 25	1	
8-95674-11	2.16- 3.0- 28	1	
8-95674-13	2.16- 3.0- 27	1	
8-95674-3	2.16- 3.0- 24	1	
8-95674-7	2.16- 3.0- 15	1	
8-95674-9	2.16- 3.0- 16	1	
8-95675-7	2.16- 3.0- 21	1	
8-95675-9	2.16- 3.0- 22	1	
8-95680-7	2.16- 4.0- 32	3	
8-95681	2. 3- 4.0- 61	1	
	2.18-13.0-	RF	
8-95681-1	2. 3- 4.0- 61	1	
	2.18-13.0-	RF	
8-95681-41	2.18-13.0- 17	1	
8-95681-43	2.18-13.0- 16	1	
8-95681-45	2.18-13.0- 15	1	
8-95681-49	2.18-13.0- 15	1	
8-95681-73	2.18-13.0- 14	1	
8-95681-79	2.18-13.0- 13	1	
8-95682-7	2.16- 9.0- 18	1	
8-95683	2.16- 9.0-	RF	

PART NUMBER	FIGURE AND INDEX NUMBER	QTY PER ART	SMR CODE
8-95683-3	2.16- 8.0- 1	1	
	2.16- 9.0-	RF	
8-95686-7	2.16- 1.0- 21	1	
	2.16- 1.0- 58	1	
	2.16- 1.0- 66	2	
8-95686-8	2.16- 1.0- 20	1	
	2.16- 1.0- 57	1	
	2.16- 1.0- 65	2	
8-95689	2. 3- 8.0- 5	1	
	2.17-11.0- 51	RF	
8-95690	2. 3- 8.0- 11	1	
	2. 5- 6.0-	1	
8-95690-11	2. 5- 6.0- 11	2	
8-95690-23	2. 5- 6.0- 14	1	
8-95690-25	2. 5- 6.0- 7	1	
8-95690-9	2. 5- 6.0- 10	2	
8-95692-1	2. 3- 4.0- 20	1	
	2.13- 1.1- 24	RF	
8-95693	2. 3- 8.0- 10	1	
	2. 4- 5.0-	RF	
8-95693-21	2. 4- 5.0- 16	1	
8-95693-23	2. 4- 5.0- 3	1	
8-95694	2.16- 3.0- 29	1	
8-95696	2.18-19.0- 5	1	
8-95697	2.18-19.0- 6	1	
8-95838-7	2. 5-10.0- 24	1	
8-95857-1	2. 3- 4.0- 51	1	
	2.14- 9.0- 58	1	
8-95857-9	2.14- 9.0- 59	1	
8-95864-9	2.16- 2.0- 30	1	
8-95902-5	2. 5-11.0- 17	1	
8-95902-53	2. 5-11.0- 12	1	
8-95902-65	2. 5-11.0- 23	1	
8-95902-71	2. 5-11.0- 14	1	
8-95902-79	2. 5-11.0- 19	1	
8-95902-80	2. 5-11.0- 20	1	
8-95902-805	2. 5-11.0- 24	1	
8-95902-807	2. 5-11.0- 24	1	
8-95905	2. 5- 7.0- 14	1	
8-95910	2. 3- 8.0- 10	1	
	2. 4- 4.0-	RF	
8-95910-11	2. 4- 4.0- 19	1	
	2. 4- 5.0- 15	1	
8-95910-13	2. 4- 4.0- 29	2	
8-95910-29	2. 4- 4.0- 28	1	
8-95910-35	2. 4- 4.0- 30	1	
8-95910-37	2. 4- 4.0- 9	1	
	2. 4- 5.0- 5	1	
8-95910-39	2. 4- 4.0- 26	1	
	2. 4- 5.0- 24	1	
8-95910-55	2. 4- 4.0- 5	1	
8-95910-57	2. 4- 4.0- 3	1	
8-95910-63	2. 4- 4.0- 5	1	
8-95910-65	2. 4- 4.0- 3	1	
8-95910-9	2. 4- 4.0- 29	1	
8-95911-3	2. 4- 4.0- 25	1	
8-95911-9	2. 4- 4.0- 25	RF	
8-95913	2. 4- 4.0- 35	1	
8-95916	2. 4- 4.0- 28	1	
	2. 4- 5.0- 26	1	
8-95917	2. 4- 4.0- 14	1	
	2. 4- 5.0- 18	1	
8-95918	2. 4- 4.0- 26	1	
8-95918-7	2. 4- 5.0- 23	1	
8-95919-7	2. 4- 4.0- 29	1	

PART NUMBER	FIGURE AND INDEX NUMBER	QTY PER ART	SMR CODE
8-95919-7	2. 4- 5.0- 27	1	
8-95921-7	2.15- 7.0- 32	1	
8-95922	2. 4- 4.0- 36	RF	
8-95922-11	2. 4- 4.0- 36	1	
8-95923	2. 3- 4.0- 23	1	
	2. 5- 7.0-	RF	
8-95924	2. 3- 6.0- 15	1	
	2.16-13.0-	RF	
8-95926-3	2. 5-11.0- 29	1	
8-95926-809	2. 5-11.0- 29	1	
8-95926-813	2. 5-11.0- 29	1	
8-95933	2. 3- 4.0- 33	1	
	2. 5-11.0- 10	1	
8-95933-15	2. 5-11.0- 10	1	
8-95933-35	2. 5-11.0- 11	1	
8-95934	2. 3-10.0- 43	1	
8-95934-3	2. 3-10.0- 43	1	
8-95944	2. 3- 4.0- 60	1	
	2.18-19.0- 11	1	
8-95952-801	2. 3- 8.0- 13	1	
8-95988-10	2.17- 3.0- 3	1	
8-95988-13	2.17- 3.0- 3	1	
8-95988-14	2.17- 3.0- 3	1	
8-95988-9	2.17- 3.0- 2	1	
8-95989-1	2. 1- 1.0- 43	1	
	2.17- 3.0-	RF	
8-95989-2	2. 1- 1.0- 44	1	
	2.17- 3.0-	RF	
8-95989-7	2.17- 3.0- 8	1	
8-95993-1	2. 3- 4.0- 51	1	
	2.14- 9.0- 37	1	
8-95993-13	2.14- 9.0- 40	1	
8-95993-15	2.14- 9.0- 40	1	
8-96135	2.15- 1.0- 68	1	
8-96261	2.20- 1.0- 19	1	
8-96514	2.15- 1.0- 68	1	
8-99466	2.19- 1.0- 9	1	
8-99590	2.15-18.0- 11	1	
8-99592	2.15-18.0- 10	1	
8-99593	2.15-18.0- 15	1	
8-99711-147	2.16-22.0-	1	
8-99711-149	2.17- 3.0-	1	
8-99788-9	2.16- 8.0- 31	1	
8/40504/801	2.14-15.0-	RF	
8DJ81CAA1	2.16- 1.0- 84	1	
8DJ81LAA1	2.16- 2.0- 72	1	
BR7448-3	2. 9-19.0- 13	1	
	2. 9-21.0- 46	1	
BR7448-5	2. 9-16.0- 9	1	
BR7448-7	2. 9-32.0- 25	1	
80C627	2. 9-20.0- 51	1	
802-212	2.14- 9.0- 55	1	
802-287	2.13- 8.0- 79	1	
803498-413	2. 4- 7.0- 47	RF	
803498-421	2. 4- 1.0- 51	RF	
	2. 4-11.0- 27	1	
803499-407	2. 4- 1.0- 56	1	
8043914-01	2.21- 2.0- 74	1	
8043964-10	2.10- 7.0-120	1	M
8044031-01	2.20- 3.0- 1	1	
8050	2.19- 2.0- 8	1	
806289-5	2.17-11.0-128	1	
806289A	2.20- 2.0- 8	1	
806598-403	2. 1- 1.0- 58	1	
806652-3	2. 4-11.0- 42	1	

PART NUMBER	FIGURE AND INDEX NUMBER	QTY PER ART	SMR CODE
806658-403	2. 5- 6.0- 2	1	
806672-401	2. 4- 6.0- 8	1	
	2. 4-11.0- 35	1	
806688-3	2. 5- 5.0- 24	1	
806688-403	2. 5- 5.0- 18	1	
808741	2.18-31.0- 5	RF	
8140590-10	2.17- 8.0- 5	1	M
8140591-10	2.17- 8.0-	1	U
8140592-10	2.17- 8.0-	1	U
8140631-10	2.18-21.0- 12	1	
8163-2	2.15-17.0- 13	1	
816626	2.18-31.0- 5	RF	
816962	2.18-31.0- 5	RF	
819NM6	2. 5-15.0- 9	1	
82303-9	2.14-23.0-137	1	
8248	2. 4- 3.0- 2	RF	
8262233	2.17- 1.0- 56	1	
8262364-39	2.17-26.0- 22	1	
8265151-27	2.17-31.0- 23	1	
8294	2.15-17.0- 14	1	
830310	2. 9- 3.0- 11	RF	
8401-3	2. 4- 7.0- 41	3	
	2. 4-11.0- 22		
848-1	2.13- 1.1- 23	1	
	2.13- 1.1- 24	1	
	2.13- 1.1- 25	1	
850-27	2. 3- 1.0- 34	1	
8502	2.18-24.0- 6	2	
8525264	2.10-21.0- 14	1	
8525265	2.10-27.0- 10	1	
8534130	2.13- 9.0- 18	1	
855-780	2. 3- 1.0- 4	1	
855CR	2. 3- 1.0- 2	1	
857119-1	2.20-26.0- 1	1	
8594491	2. 4- 7.0- 18	1	
8605-400	2.12-22.0-109	5	
861043-1	2.17-11.0- 64	1	
8637	2. 4- 6.0- 18	1	
	2. 4- 7.0- 93	1	
865029-7	2.17-21.0- 3		
871823	2. 9- 1.0- 11	1	
	2.15- 7.0- 15	1	
873161	2. 9- 3.0- 11	RF	
8734	2. 4- 6.0- 16	1	
	2. 4- 7.0- 87	1	
873420	2.11- 1.0- 38	1	
876947	2. 9- 3.0- 11	RF	
8831136-2	2.17- 9.0- 10	1	
885B	2.12-38.0- 57	1	
	2.12-47.0- 23	4	
	2.12-67.0- 46	1	
89-41	2.12-60.0- 20	RF	
8906K698	2. 5- 1.0- 7	1	
	2.16-10.0- 2	1	
8906K699	2.16-14.0- 9	1	
	2.16-21.0- 2	1	
	2.16-22.0- 6	1	
	2.17-11.0- 65	1	
8906K702	2.16- 1.0- 88	1	
	2.16- 2.0- 24	1	
8906K703	2.20- 3.0- 28	1	
8906K704	2.16-21.0- 5	1	
	2.16-22.0- 3	1	
8906K705	2.16-20.0- 5	1	
8906K706	2.15-12.0- 4	1	
	2.16-11.0- 9	1	
	2.16-12.0- 4	1	
	2.16-14.0- 10	1	

PART NUMBER	FIGURE AND INDEX NUMBER	QTY PER ART	SMR CODE
8906K7J6	2.16-20.0- 5	1	
	2.16-21.0- 4	1	
	2.16-22.0- 2	2	
	2.20- 3.0- 29	1	
8906K7G8	2.16- 9.0- 7	1	
8906K7J9	2.16-12.0- 6	1	
	2.16-20.0- 2	1	
8906K7I0	2.16-21.0- 3	1	
	2.16-22.0- 4	1	
	2.20- 3.0- 30	3	
8906K728	2.15-12.0- 4	1	
	2.16- 9.0- 4	1	
	2.16-11.0- 10	1	
	2.17- 9.0- 12	1	
8906K868	2.18-33.0- 15	1	
8906K896	2.16-10.0- 4	1	
9-1041655	2.12-65.0- 28	1	
9-104175	2.12-65.0- 28	1	
9R0481-11	2. 9-30.0- 17	1	
9R0481-7	2. 9-28.0- 11	1	
9R0481-9	2. 9-29.0- 38	1	
9R7431-5	2. 9-28.0- 30	1	
9R7442-1	2. 9- 9.0- 39	1	
	2. 9-17.0- 51	1	
	2. 9-19.0- 13	1	
	2. 9-20.0- 50	1	
9R7442-13	2. 9-11.0- 11	1	
9T39Y2058	2.17- 8.0- 4	1	
9T392963	2.17- 8.0- 4	1	
90-45201-001	2.13-26.0- 10	2	
	2.13-26.0- 8	2	
	2.13-26.0- 9	6	
90-93505-001	2. 4- 8.0- 28	2	
90-93505-011	2. 4- 8.0- 30	3	
90-93505-012	2. 4- 7.0- 24	1	
90-93509-005	2.12-46.0- 96	1	
900-400-2-3A	2.13-27.0- 8	5	
900-850-3-7A	2.11- 9.0- 5	1	
901-390-2-5A	2.10- 1.0- 38	1	
902200	2.12-59.0- 4	1	
	2.12-64.0- 14	1	
909C453-1	2.17- 8.0- 7	1	
909555	2.12- 1.0- 10	1	
	2.12- 1.0- 25	1	
	2.12- 1.0- 32	1	
	2.12- 1.0- 79	1	
	2.12-26.0- 6	1	
	2.12-52.0- 4	1	
91-10500-004	2. 5- 8.0- 6	6	
91-26003-001	2. 8- 7.0- 28	2	
	2. 8- 7.0- 33	2	
91-26003-005	2.13-32.0- 14	1	
91-26003-011	2.16-13.0- 10	1	
91-26004-001	2.11- 8.0- 5	3	
91-26004-008	2.20-16.0- 23	2	
	2.20-18.0- 22	2	
91-27004-013	2.18- 8.0- 10	4	
91-27004-014	2.18- 8.0- 5	4	
91-27004-024	2.18- 9.0- 11	4	
91-27004-025	2.18- 8.0- 6	4	
91-27004-029	2.15-22.0- 83	1	
	2.15-23.0- 77	1	
91-27004-030	2.20-19.0- 35	1	
91-27004-032	2.20-16.0- 14	1	

PART NUMBER	FIGURE AND INDEX NUMBER	QTY PER ART	SMR CODE
91-27004-052	2.20-16.0- 17	1	
	2.20-16.0- 20	1	
	2.20-17.0- 1	1	
	2.20-17.0- 4	1	
	2.20-17.0- 7	1	
	2.20-18.0- 13	1	
	2.20-18.0- 16	1	
	2.20-18.0- 19	1	
91-27004-033	2.20-16.0- 11	1	
	2.20-17.0- 11	1	
	2.20-18.0- 15	1	
91-27006-004	2. 2-10.0- 18	1	
91-97815-013	2.13-26.0- 14	1	
91-97815-035	2.14- 6.0- 14	1	
91-97815-080	2.12-48.0- 39	1	
91-97815-090	2.12-48.0- 54	2	
91-98017-034	2.13- 5.0- 4	2	
91-98026-003	2.10- 7.0- 105	2	
	2.12-15.0- 115	3	
	2.12-16.0- 97	3	
	2.13-15.0- 49	4	
91-98026-005	2.10-17.0- 12	3	
91-98026-007	2.12- 1.0- 71	1	
	2.12- 1.0- 71	1	
91-98026-011	2. 8-27.0- 72	1	
	2.13-16.0- 16	1	
	2.13-16.0- 20	2	
	2.13-16.0- 8	1	
91-98026-011M	2.13-15.0- 36	1	
	2.13-15.0- 37	1	
91-98026-015	2. 8-27.0- 29	1	
	2.12- 1.0- 7	1	
	2.12-15.0- 16	4	
	2.12-16.0- 14	2	
	2.12-19.0- 31	4	
	2.12-20.0- 67	2	
	2.12-25.0- 21	1	
	2.12-25.0- 22	1	
91-98026-019	2.12-32.0- 91	4	
	2.12-32.0- 95	4	
	2.12-43.0- 142	2	
	2.12-46.0- 156	3	
	2.12-46.0- 16	3	
	2.12-46.0- 105	2	
	2.12-46.0- 231	1	
91-98026-021	2.13- 1.1- 8	1	
91-98026-023	2. 9- 2.0- 50	1	
	2.12-14.0- 2	1	
	2.12-14.0- 28	1	
	2.12-19.0- 48	2	
	2.12-25.0- 14	1	
	2.12-44.0- 161	2	
	2.12-46.0- 11	4	
91-98026-024	2. 9- 2.0- 68	1	
91-98026-027	2.12-14.0- 20	6	
	2.12-14.0- 31	1	
91-98026-031	2.12-16.0- 2	8	
	2.12-20.0- 11	3	
	2.12-61.0- 2	1	
	2.12-65.0- 4	2	
91-98026-038	2.12-20.0- 78	3	
	2.12-37.0- 109	1	
	2.12-37.0- 234	1	
9121-21A1	2.10- 7.0- 169	1	
913-010	2.15- 9.0- 31	1	

PART NUMBER	FIGURE AND INDEX NUMBER	QTY PER ART	SMR CODE	PART NUMBER	FIGURE AND INDEX NUMBER	QTY PER ART	SMR CODE
916-337S	2.14- 6.0- 14	1		9230-3669	2.14- 6.0- 4	1	
92-83407-003	2.14- 8.0-102	1			2.17-11.0- 54	1	
9220-34-33	2.17-11.0- 7	RF			2.17-11.0- 80	1	
9220-3433	2.15-10.0- 5	RF			2.18-27.0- 1	1	
	2.17-11.0- 16	2		93	2. 7- 3.0- 88	2	
	2.17-11.0- 17	RF		9308	2.12-38.0- 1	2	
	2.17-11.0- 23	1		93002	2.12-60.0- 18	1	
	2.17-11.0- 37	1		9346-4322	2.17-11.0-124	1	
	2.17-11.0- 5	1		94-3-1	2. 4- 6.0-	1	
	2.17-11.0- 76	2			2. 4- 6.0-		
	2.17-11.0- 83	1			2. 4- 7.0- 58	1	
	2.17-11.0- 85	1			2. 4- 8.0- 48	1	
	2.17-15.0- 1	3			2. 4- 8.0- 48	RF	
	2.17-17.0- 21	1		94-3-11	2. 4- 6.0- 13	RF	
	2.17-36.0- 1	1			2. 4- 7.0- 3	RF	
9220-3434	2.13- 1.1- 26	1			2. 4- 7.0- 76	1	
9220-3435	2.12-39.0- 34	1			2. 4- 8.0- 18	1	
	2.12-39.0- 40	2		94-35005-001	2.10-28.0- 24	1	
	2.12-39.0- 45	4		94-35006-052	2. 6-40.0-117	1	
	2.13- 1.1- 28	1		94-35006-062	2. 9-12.0- 11	1	
	2.15-10.0- 5	1		94-4-14	2. 4- 7.0- 18	1	
	2.17-11.0- 17	2		943925-79	2.18-16.0- 11	1	
	2.17-11.0- 21	1		943925-82	2.18-16.0- 23	4	
	2.17-11.0- 24	1		94665-3	2.14-30.0- 37	1	
	2.17-11.0- 28	1			2.14-32.0- 7	1	
	2.17-11.0- 30	1			2.14-34.0- 3	1	
	2.17-11.0- 33	1		95-07103-002	2.16- 9.0- 6	1	
	2.17-11.0- 34	1			2.16-22.0- 5	2	
	2.17-11.0- 7	1		95-19002-001	2.18-29.0- 14	1	
	2.17-11.0- 82	1		95-49300-001	2. 2-17.0- 5		
	2.17-11.0-110	1		95-71003-003	2.10- 7.0- 49	1	
	2.17-11.0-113	1			2.10- 7.0- 52	1	
	2.17-14.0- 12	2			2.10-11.0- 5	1	
	2.17-14.0- 13	4		95-71003-024	2.10-24.0- 4	2	
	2.17-14.0- 8	2		95620	2. 8-23.0- 10	1	
	2.17-15.0- 11	2		950312-6D0044	2.11-11.0- 15	1	
	2.17-15.0- 13	2		95400-1	2. 9-20.0- 51	1	
	2.17-15.0- 3	1		95400-3	2. 9-17.0- 52	1	
	2.17-15.0- 5	1			2. 9-19.0- 11	1	
	2.17-17.0- 5	1		9555A	2.13- 7.0- 6	1	
	2.17-20.0- 1	1		96-25010-005	2. 8-27.0- 8	2	
	2.17-22.0- 1	3		96-36521-007	2.18-29.0- 6	1	
	2.17-39.0- 1	2		96-37524-003	2.20-11.0- 53	2	
	2.17-40.0- 7	1		96-78502-004	2. 6- 6.0- 3	2	
9220-3972	2.17-15.0- 17	1			2. 6- 7.0- 3	2	
9224-3852	2.17-36.0- 5	1			2. 6-12.0- 17	2	
9227-3853	2.14- 6.0- 12	RF		96-79700-005	2.20-48.0- 22	2	
	2.14- 6.0- 33	RF		96-79700-031	2. 4-12.0- 35	1	
	2.17-11.0- 80	RF		96-79700-037	2.15- 8.0- 18	1	
9227-4028	2.17- 1.0- 5	1			2.15- 9.0- 10	1	
9228-4766	2.17-11.0- 72	1			2.15-11.0- 11	1	
9230-3434	2.14- 6.0- 1	1		96-79700-039	2.15- 8.0- 17	1	
	2.14- 6.0- 36	3			2.15- 8.0- 25	1	
	2.17-11.0- 78	1			2.15- 9.0- 17	1	
	2.17-15.0- 7	1			2.15- 9.0- 9	2	
	2.17-15.0- 9	3			2.15-11.0- 10	2	
	2.17-17.0- 7	1			2.15-11.0- 18	1	
	2.17-17.0- 8	1		96-79700-043	2.14-11.0- 24	1	
	2.17-39.0- 9	2		96-79700-049	2. 2- 6.0- 11	1	
	2.17-40.0- 3	2			2. 2- 6.0- 15	1	
9230-3582	2.17-18.0- 11	1		96-79700-086	2. 5- 5.0- 17	1	
	2.17-18.0- 18	1		96-79700-094	2.15-38.0- 16	1	
	2.18-22.0- 9	1					
9230-3669	2.14- 6.0- 12	1					
	2.14- 6.0- 33	1					

PART NUMBER	FIGURE AND INDEX NUMBER	QTY PER ART	SMR CODE
96-88300-001	2. 5- 7.0- 9	1	
965399-679	2.18-16.0- 4	1	
97-31015-001	2. 2-17.0- 6		
97-63004-101	2. 6-13.0- 1	AR	
97-63004-106	2. 6-13.0- 1	AR	
97-67001-004	2. 2-10.0- 35	1	
	2. 4- 8.0- 41	1	
97C36501-7	2.16-18.0- 17	1	
9729424P4	2. 3- 1.0- 39	1	
976J404-1	2.17- 8.0- 74	1	
976J474-2	2.17- 8.0- 51	1	
98-14000-003	2.14-18.0- 62	2	
	2.14-23.0-112	1	
98-14000-009	2.14-10.0- 20	1	
	2.14-18.0- 54	1	
	2.14-23.0- 46	1	
	2.14-23.0-188	2	
	2.14-27.0- 13	2	
	2.14-32.0- 18	1	
98-14000-010	2.14-23.0-110	2	
98-14000-011	2.14-18.0- 37	1	
98-14000-014	2.14-25.0- 20	1	
98-14000-017	2.14-42.0- 27	2	
98-14000-037	2.14-13.0- 5	1	
	2.14-18.0- 30	4	
	2.14-23.0- 66	1	
	2.14-40.0- 7	1	
98-14000-038	2.14-16.0- 7	1	
	2.14-23.0-117	1	
98-14000-039	2.14-19.0- 7	1	
98-29503-012	2.13-18.0- 7	2	
98-29503-018	2. 2- 3.0- 73	1	
98-29503-019	2. 4- 8.0- 51	2	
98-29503-100	2.13-17.0- 22	2	
98-29506-018	2.17-14.0- 21	8	
98-56502-005	2. 2-17.0- 4		
98-90319-007	2.12-43.0- 82	1	
98-90319-008	2. 8-25.0- 8	2	
	2. 8-27.0- 22	1	
	2. 8-27.0- 39	1	
	2. 8-27.0- 56	1	
	2.12-43.0- 70	1	
	2.12-43.0- 90	1	
98-90319-037	2. 8-11.0- 89	1	
98-97000-004	2. 5- 8.0- 5	6	
98/14000/009	2.14-18.0- 61	1	
98/14000/011	2.14-18.0- 79	1	
98/14000/037	2.14-18.0- 46	1	
	2.14-18.0- 69	1	
9807-16	2.16- 1.0- 28	1	
	2.16- 2.0- 42	1	
9807-4	2.16- 2.0- 66	1	
99-51350-002	2.20-48.0- 65	2	
99-51400-001	2. 5- 2.0- 19	2	
	2. 5- 9.0- 14	RF	
	2. 5- 9.0- 22	11	
	2. 5- 9.0- 3	4	
	2. 5-10.0- 10	3	
	2. 5-10.0- 16	6	
	2. 5-10.0- 21	4	
	2. 5-10.0- 27	2	
	2. 5-10.0- 5	11	
	2. 9- 1.0- 18	2	
	2. 9- 1.0- 22	2	
99-51400-002	2. 4- 1.0- 32	25	

PART NUMBER	FIGURE AND INDEX NUMBER	QTY PER ART	SMR CODE
99-51400-002	2. 4- 1.0- 5	RF	
	2. 5- 1.0- 47	4	
	2.15-37.0- 31	43	
99-51404-001	2. 5- 9.0- 10	4	
99-51505-007	2. 4-12.0- 70	2	
	2.10-25.0- 3	4	
	2.10-30.0- 3	2	
	2.15- 5.0- 22	1	
99-51505-009	2.10-25.0- 5	1	
	2.10-37.0- 25	4	
	2.10-38.0- 22	4	
99-51505-010	2.10-37.0- 15	4	
	2.10-37.0- 15	2	
	2.10-37.0- 31	4	
	2.10-38.0- 15	2	
	2.10-38.0- 28	2	
	2.10-38.0- 9	4	
99-51505-011	2. 4- 9.0- 22	4	
99-51505-012	2.17-32.0- 3	6	
99-51505-013	2. 4- 9.0- 29	4	
99-51505-014	2. 4- 9.0- 10	2	
99-51505-015	2. 2-10.0- 95	4	
	2. 2-10.0-104	4	
99-51505-016	2. 3-12.0- 5	2	
99-51505-018	2.11- 3.0- 6	AR	
99-51505-019	2.11- 3.0- 7	AR	
99-51505-021	2.10-25.0- 34	1	
99-51505-022	2.10-25.0- 31	1	
99-51505-026	2. 7- 3.0-101	4	
99-51505-030	2. 7- 3.0-100	2	
99-51505-053	2.15-18.0- 9	1	
99-51505-081	2. 5- 2.0- 19	2	
99-51506-006	2.18- 7.0- 15	2	
99-51507-003	2. 4- 1.0- 6	RF	
	2.13-33.0- 3	2	
	2.13-33.0- 4	2	
	2.13-33.0- 5	2	
	2.20-36.0- 3	4	
99-51507-008	2.10-10.0- 4	AR	
99-51507-010	2.10-30.0- 4	AR	
99-51507-012	2.14-23.0-163	2	
99-51507-022	2. 4- 8.0- 50	2	
99-51507-032	2.15-38.0- 28	2	
99-51507-044	2.15-38.0- 46	1	
99-51507-052	2. 4-12.0-130	4	
99-51509-003	2.14-24.0- 35	AR	
99-51509-004	2.15- 5.0- 3	1	
99-51509-005	2.14-24.0- 36	AR	
99-51509-006	2.13-19.0- 8	2	
	2.13-24.0- 4	2	
	2.13-30.0- 46	4	
	2.13-30.0- 57	4	
99-51509-007	2.15- 5.0- 4	1	
99-51509-009	2.14-24.0- 42	1	
99-51509-010	2.14-22.0- 18	1	
99-51509-014	2.20-11.0- 59	4	
99-51509-016	2.13- 1.1-155	4	
99-51509-020	2.12-16.0-170	1	
	2.12-32.0- 51	1	
	2.12-32.0- 61	1	
99-51509-023	2. 6-40.0- 6	2	
	2.14- 2.0- 3	1	
99-51509-024	2. 5- 1.0- 46	24	
	2. 5- 1.0- 47	4	
	2. 5- 1.0- 48	4	
99-51509-025	2. 5- 5.0- 2	3	
99-51509-028	2.13- 1.1- 48	2	
99-51509-029	2.14-15.0- 79	3	

PART NUMBER	FIGURE AND INDEX NUMBER	QTY PER ART	SMR CODE
99-51509-029	2.20- 6.0- 23	2	
99-51509-053	2.16- 4.0- 10	8	
	2.16- 4.0- 19	4	
99-52505-001	2. 2-17.0- 4		
99-53000-022	2. 2- 6.0- 23	RF	
99-53000-092	2. 4-12.0-100	4	
99-53000-093	2.16- 5.0- 9	2	
99-53000-125	2.13-18.0- 20	2	
	2.13-18.0- 30	2	
	2.13-25.0- 13	2	
99-53000-129	2.13-18.0- 24	2	
	2.13-18.0- 35	1	
	2.13-18.0- 39	1	
99-53001-008	2. 2- 3.0- 26	2	
99-53001-009	2. 2- 6.0- 23	RF	
99-53004-002	2.13- 3.0- 8	1	
99-53302-001	2.15-13.0- 17	1	
99-53900-002	2.13- 2.0- 8	1	
99-56500-002	2. 5- 8.0- 7	6	
99-56500-003	2. 5- 8.0- 4	3	
99F12-1032	2.10-39.0- 21	2	
99F12-624	2.10- 7.0-193	2	

PART NUMBER	FIGURE AND INDEX NUMBER	QTY PER ART	SMR CODE