

Aircraft

FIRE CONTROL



RESTRICTED



NAVY TRAINING COURSES



AIRCRAFT FIRE CONTROL

PREPARED BY
STANDARDS AND CURRICULUM DIVISION
TRAINING
BUREAU C

NAVY TRAINING COURSES
EDITION OF 1944
SECOND PRINTING

UNITED STATES
GOVERNMENT PRINTING OFFICE
WASHINGTON : 1944

PREFACE

This book is written for the enlisted men of Naval aviation. It is one of a series of books designed to give them the background information necessary to perform their aviation duties.

A knowledge of aircraft fire control is of primary importance to Aviation Ordnancemen responsible for general maintenance work. But the subdivisions of Aviation Ordnancemen—that is, Aviation Bombsight Mechanics and Aviation Turret Mechanics—also need an understanding of aircraft fire control. They need to know the relationship of their specialties to the broad subject of ordnance.

Starting with basic information on the science of ballistics, this book follows with a discussion of gunsights, boresighting and synchronizing. Then come torpedo directors, bombing and bombsights. In conclusion, there is a section on aerial gun cameras, aerial targets and towing equipment.

As one of the NAVY TRAINING COURSES, this book represents the joint endeavor of the Naval Air Technical Training Command and the Training Division of the Bureau of Naval Personnel.

UG 632
A26
1944

TABLE OF CONTENTS

	Page
Preface	II
CHAPTER 1	
Ballistics	1
CHAPTER 2	
Gunsights	15
CHAPTER 3	
Boresighting	37
CHAPTER 4	
Synchronizing	53
CHAPTER 5	
Torpedo directors	85
CHAPTER 6	
Bombing	95
CHAPTER 7	
Bombsights	107
CHAPTER 8	
Aerial gun cameras	125
CHAPTER 9	
Aerial targets and towing equipment	135

CHAPTER 1

BALLISTICS

FROM ROCKS TO ROCKET GUNS

The Greeks had a word for it—**BALLEIN**—meaning “to throw.” They developed an engine which the later Romans called a **BALLISTA**—a giant lever attached to a scaffold and powered by a coiled spring. Release the spring, and **CRASH!** Up would go the throwing arm, flinging from its paw a boulder, fire-pot or canister of boiling oil into the enemy lines.

At first the contraption was more or less hit or miss, then the soldiers discovered that by tilting the front end of the **BALLISTA** at various angles of elevation, they could vary the range. Trial and error disclosed that at a certain maximum elevation the projectile would travel no further horizontally. Tables were devised for each piece of apparatus, taking into account the power of the spring, length of throwing arm and weight of projectile, and a fairly accurate control system was developed.

So you have the word for it today—**BALLISTICS**—the science which deals with the **FLIGHT CHARACTERISTICS** of projectiles. **FIRE CONTROL**, your im-

mediate concern, is nothing more nor less than ballistics APPLIED to the practical problem of making projectiles travel ACCURATELY.

All projectile weapons, from rock-throwers to rocket guns—slingshots, spears, blowguns, catapults, blunderbusses, or 16-inch Naval guns—operate in accordance with the law of ballistics.

The Romans passed their knowledge on to the early Britons, and the famous bowmen of the Greenwood (Robin Hood's league) were the first to consider the effects of wind across a target.

The invention of the GUN further involved and developed the study of fire control. The greater speed of the projectile and the vastly increased range of fire made the subject of ballistics a military MUST. Chemistry entered the field along with mechanics, fathering another phase of ballistics—the effect of gas pressure inside the gun-bore during firing.

Whereas in ancient and medieval times the problem was largely guess-and-try, today you have at your command an exact science founded on the absolutes of physics, chemistry and mathematics.

Improvements in guns, explosives and the design of projectiles are as rapid as the moves of modern warfare, and ballistics as a military science keeps pace.

Today, the science of ballistics is divided into two parts—INTERIOR and EXTERIOR ballistics. Interior ballistics deals with the projectile while it is inside the barrel of a gun, and exterior ballistics carries on after the projectile leaves the gun.

Interior ballistics is primarily the concern of the Naval Proving Grounds, rather than of the forces afloat, so you get only a brief look at that subject here.

INTERIOR BALLISTICS consists largely of a study of the pressure of gases behind the projectile and

the effect of the pressure on its subsequent flight. It measures the velocity of the projectile while in the bore (including muzzle velocity) and the pressure at any point along the projectile's travel through the bore. It examines the manner in which powder burns and the changes produced in pressure by changes in powder weight, projectile weight, volume of the powder chamber, length and diameter of the bore, and so on. Naturally, these factors have an important bearing on the design of guns and the manufacture of powder and projectiles.

You have already learned that the pressure developed by the powder gases in the chamber is the basis of operation of all automatic arms used in aviation ordnance. The amount of this pressure depends upon several things, such as the quantity of powder, its condition (like the family wash—damp, dry, rough, or smooth), and the condition of the cartridge case. The presence of sand, grit, or too much oil also has its effect upon gas pressure.

So that gas cannot leak past the projectile on its way out of the gun, the projectile must seal the bore. When you study ammunition, you'll learn that small arms bullets have soft jackets which press against the walls of the bore to form a seal, whereas larger projectiles, which are made of steel, have a band of softer metal around the shell for the same purpose.

EXTERIOR BALLISTICS deals with the forces which affect a projectile in flight.

Remember the gent who said, "I shot an arrow into the air, it fell to earth I know not where?" If he had known something about exterior ballistics (which holds good for arrows as well as bullets), he probably could have found that arrow

and thus saved himself the expense of advertising in the lost and found columns. Since arrows, stones, and boomerangs have no place in modern aircraft, however, you needn't pause to worry over the mystery of the missing arrow. Instead, you can move right along to a consideration of exterior ballistics as it pertains to aerial gunnery.

Suppose you begin with a caliber .30 Browning machine gun emplaced on a hilltop. You fire the first shot with the gun aimed straight out in a horizontal line.

The bullet, launched by the **PROPELLING FORCE** of the burning powder, is traveling approximately

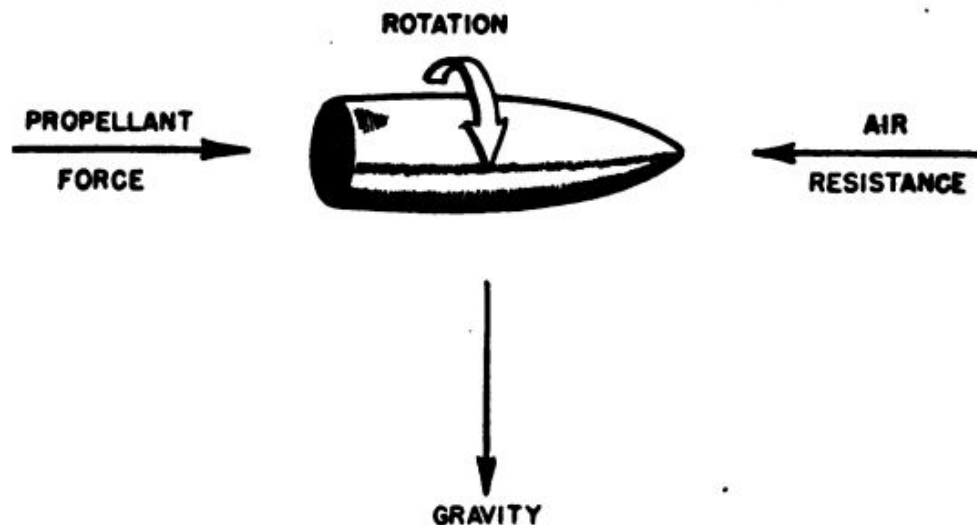

Figure 1.—Forces acting on a bullet.

2,600 feet per second when it kisses the gun barrel good-bye. As soon as it hits the outside air, things start happening to it. **GRAVITY** starts pulling it downward. **AIR RESISTANCE** begins to slow it up. And the **ROTATION** of the bullet (caused by the rifling of the gun barrel) tends to make the bullet "drift" toward the right from a straight forward course.

There, in a nutshell, you have the **FOUR FORCES** acting on the bullet in flight—the propelling force, gravity, air resistance, and the rotation of the bullet. See figure 1.

The PROPELLING FORCE determines the original speed of the bullet. Obviously, the faster a bullet reaches the target, the less time the other three forces have to act upon it.

The DROP caused by the pull of GRAVITY varies directly with the range—the farther the bullet goes, the longer the time that gravity can act on it. On the other hand, DROP varies inversely with the speed of the bullet—the faster it goes, the shorter the time that gravity can act on it.

AIR RESISTANCE increases with the speed of the bullet, so a bullet slows down most rapidly early in flight, when it is traveling fastest. And as bullet velocity decreases, the effect of air resistance decreases, too, so that the rate of deceleration, or slowing down, is less rapid.

The ROTATION OF THE BULLET, as you already know, causes the bullet to DRIFT to the right of a straight course. But, for short ranges, this drift is so slight as to be relatively unimportant.

Remember that the bullet was traveling 2,600 feet per second as it left the gun. TABLES OF DROP show that the bullet (a caliber .30 M1 fired horizontally) drops about 83 inches in 500 yards. (Tables of drop are issued by the Bureau of Ordnance for each type of ammunition. These tables show the drop in inches at various ranges.) Bullet drop is figured as vertical distance below the BORE AXIS of the gun. Axis of bore, or bore axis, is an imaginary line running through the exact center of the gun barrel out into space.

Look at figure 2. Here, in (C), you can see how the TRAJECTORY, or the actual path of the bullet, drops below the axis of bore. The amount of this drop at any one range depends principally upon the speed of the bullet, air resistance, and gravity.

So much for the gun on the hilltop.

Now suppose you take the same gun and install it in the turret of an airplane. After fixing it

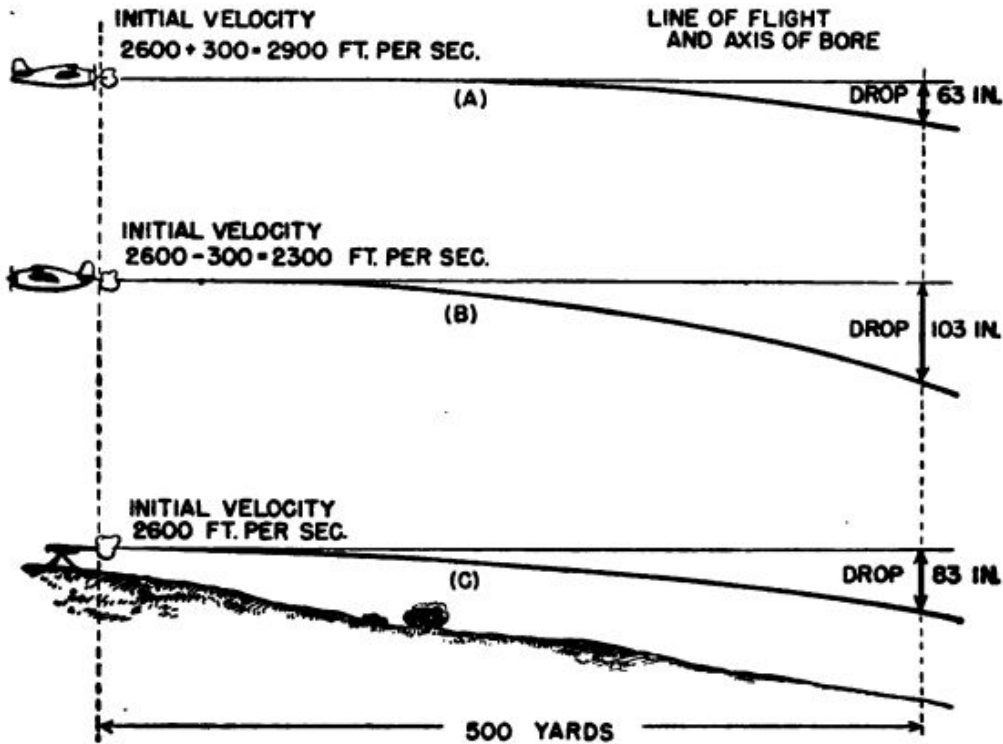

Figure 2.—Comparative drop.

securely in the mount, find a good-natured pilot who will take you up to fire a few trial rounds.

Up you go, until you level off, flying at 200 mph. You revolve the turret so that the gun is pointing DEAD AHEAD of the line of flight and fire one shot. What happens to this bullet?

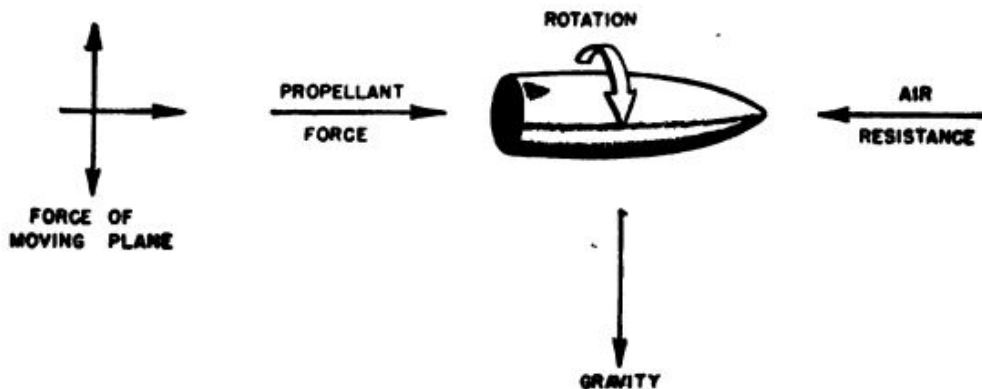

Figure 3.—Forces acting on a bullet fired from an airplane in flight.

Remember the four forces affecting the bullet fired from the hilltop? (PROPELLING FORCE, GRAV-

ITY, AIR RESISTANCE and ROTATION.) You have another one now—THE FORWARD MOVEMENT OF THE AIRPLANE. See figure 3.

You are flying at 200 mph. That's 300 feet per second. The bullet, when fired from the hilltop, left the gun muzzle at 2,600 feet per second. It leaves the gun at the same speed when fired dead ahead of the speeding airplane too, BUT—when it hits the air, it is actually traveling 2,600 ft/sec PLUS 300 ft/sec—or 2,900 ft/sec. In other words, you have to ADD THE FORWARD SPEED OF THE AIRPLANE TO THE SPEED OF THE BULLET in order to know the total forward speed of a bullet fired dead ahead of the airplane.

Does this affect the rate of DROP? Stop and think a minute. The bullet fired from the hilltop dropped 83 inches in 500 yards. The bullet fired from the airplane was traveling 300 ft/sec FASTER than the bullet fired from the hilltop because of the forward speed of the airplane. Therefore, its rate of drop will not be as great as that of the first bullet. Since this bullet is traveling faster, it covers the 500 yards in less time, and gravity has less time in which to pull it down. Actually, the drop of the bullet fired from the airplane will be 63 inches in 500 yards, as against 83 inches for the bullet fired from the hilltop. (See (A) and (B) in figure 2.)

So far, however, you have experimented only with a bullet fired DEAD AHEAD of the airplane. What about bullets fired out at various angles from the turret—out to port and starboard and aft of the airplane? How does the forward speed of the airplane affect their rate of drop?

In figure 4 you can see the effect of the airplane's forward speed upon the velocity of bullets fired out at various angles to the airplane's line of flight.

AIRPLANE SPEED 200 MILES PER HOUR

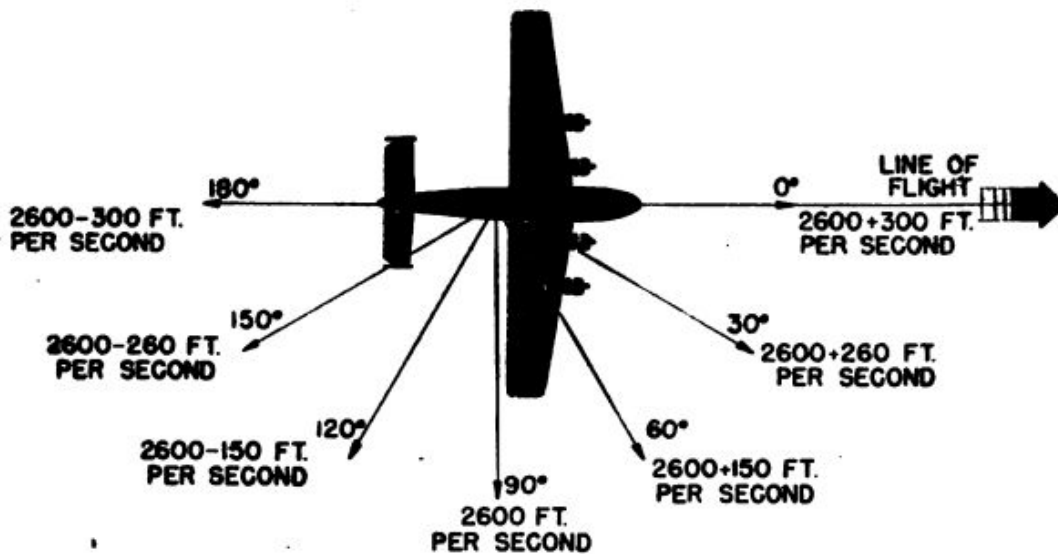

Figure 4.—Effect of airplane speed on bullet velocity.

You can easily see that any bullet fired in a forward direction has a percentage of the forward speed of the airplane **ADDED** to its velocity, and any bullet fired in a direction aft of the airplane, has a percentage of the airplane speed **SUBTRACTED** from its velocity. A bullet fired dead ahead has the total airplane speed added to its velocity. One fired dead astern has the total airplane speed subtracted from its velocity. And the velocity of a bullet fired at exact right angles to the line of flight is not affected by the forward speed of the airplane at all.

Obviously, then, the **DIRECTION** in which a bullet is fired from an airplane has an important bearing on its **RATE OF DROP**.

DEFLECTION

Now consider a little item known as **DEFLECTION**.

Did you ever jump off the running board of an automobile before it had come to a stop? If so, you probably had to run a few steps in the direction in which the car was moving to slow yourself down before you could walk off in an-

other direction. You were carried forward by the force of **MOMENTUM** and you had to expend your momentum by running forward a short distance, or else be thrown flat on your face.

Likewise, a machine gun bullet, fired at right angles to a speeding airplane, has a sidewise "skidding" motion (in the direction that the airplane is moving) when it hits the air. This "skidding" motion of the bullet as it leaves the airplane and air resistance are the two principal forces which cause **DEFLECTION**.

What is **DEFLECTION**? It is an angular variation between the actual trajectory of the bullet and the bore axis of the gun, measured in a lateral plane. Look at figure 5. In this picture you can see the relationship between the straight line in which the gun is pointing and the actual path of the bullet.

When the bullet left the gun, it carried with it a sidewise momentum, imparted by the forward motion of the airplane. The combination of this sidewise momentum and the muzzle velocity of the bullet caused the bullet to follow the trajectory shown in figure 5. The angle between the line in which the gun is pointing, or the bore axis, and the bullet trajectory is the **GUNNER'S DEFLECTION**

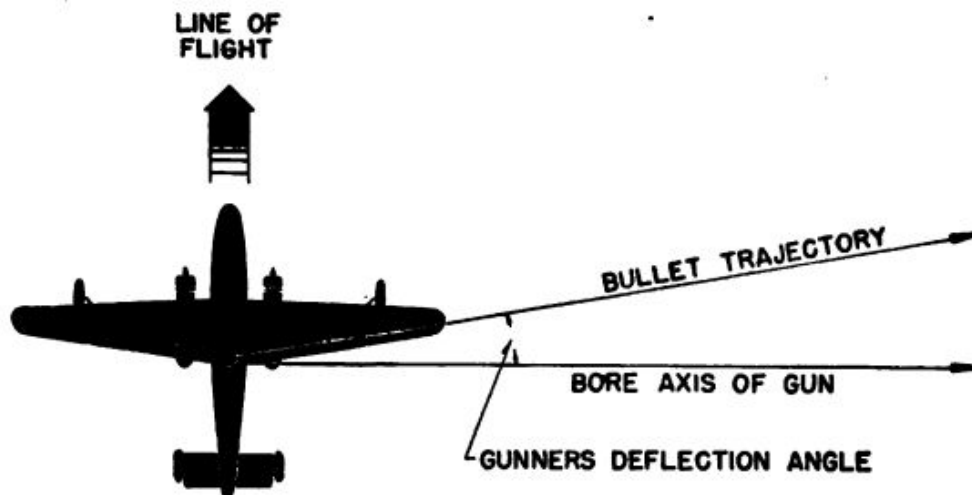

Figure 5.—Gunner's deflection angle.

ANGLE. Figure 5 illustrates how the flight of the bullet would appear to you if you were sitting in a stationary balloon directly above the firing airplane.

The gunner, sitting in the firing airplane, will have a different view of the path taken by the bullet as the airplane moves away from the point at which the gun was fired. You see, everything is in motion—the airplane, gun, and gunner are moving in one direction, and the bullet is moving in another.

Also, the airplane is flying onward at a constant velocity, whereas the bullet is continuously slowing down because of air resistance. This slowing down, or deceleration, of the bullet results in what is known as **TRAIL**.

Figure 6 (A) is a diagrammatic illustration of the trajectory of the bullet as viewed by the gunner who fired the gun. It also shows how **TRAIL** is figured.

Assume that in this illustration, the airplane is flying at 260 knots and the muzzle velocity of the bullet is 2,700 ft/sec.

Notice that as the gunner watches, it appears that the bullet is traveling out in a path which falls a greater and greater distance behind the airplane as the airplane flies along its course.

Notice also, the values of **TRAIL**. Trail is measured as the distance **BETWEEN** the bullet (at any point on its trajectory) and the bore axis of the gun. Don't forget, that while the bullet is traveling in one direction the bore axis of the gun is moving forward with the airplane.

So, in figure 6 (A), when the bullet has traveled 400 yards, the airplane—and the bore axis of the gun—has moved forward 55 yards, and the trail at this point is 6 yards. When the bullet has traveled 800 yards, the airplane has moved

AIRPLANE SPEED 260 KNOTS
 MUZZLE VELOCITY OF BULLET 2750 FT/SEC.
 ALL MEASUREMENTS SHOWN IN YARDS

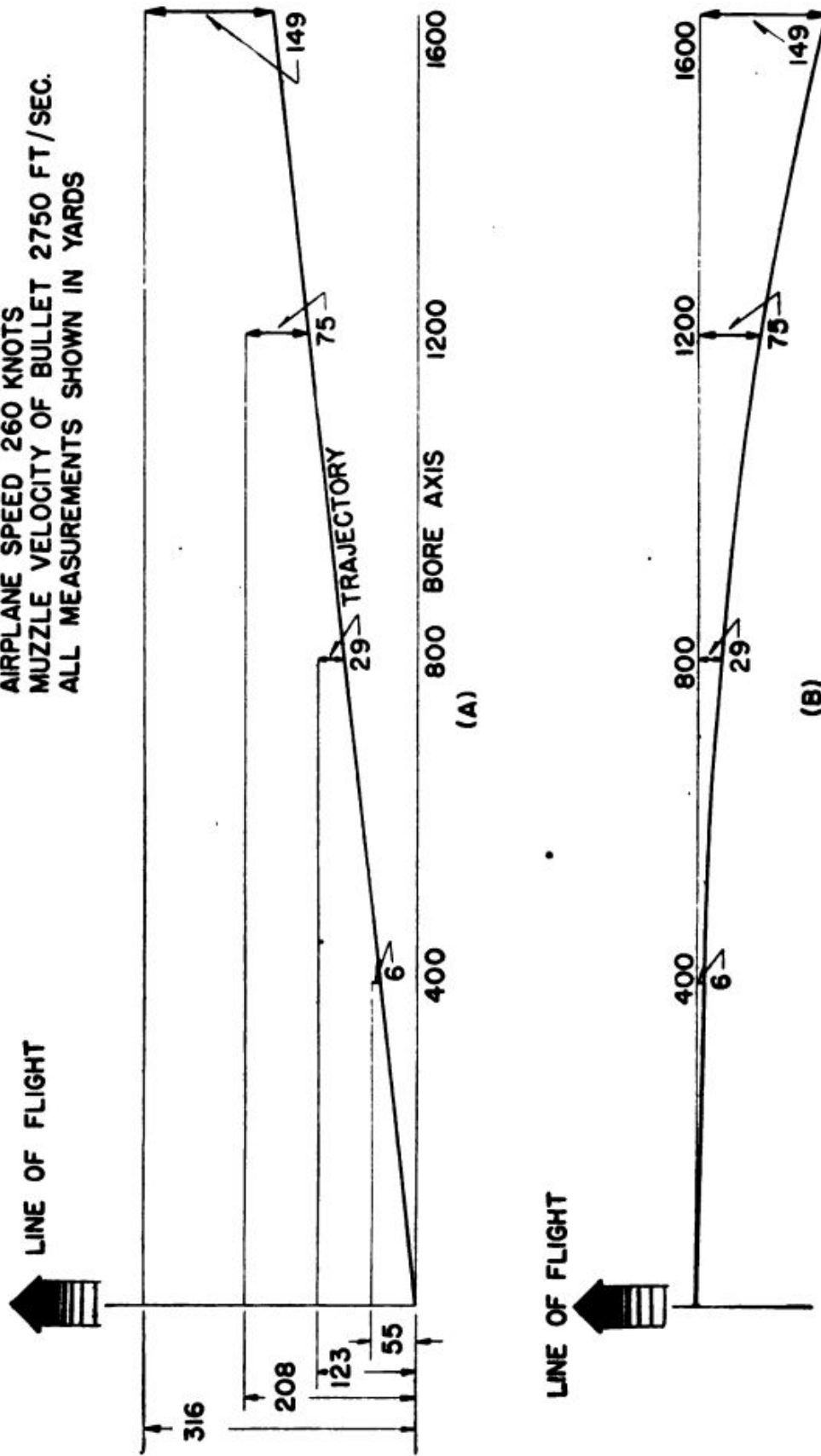

Figure 6.—Deflection and trail.

forward 123 yards, and the trail at this point is 29 yards. And so on. You can see that the trail increases RAPIDLY with the range.

Now suppose you were flying along in another airplane directly ABOVE the airplane from which the bullet was fired. As you watched the bullet fired out of the airplane below you and you followed its trajectory with your eye, it would appear to follow a CURVED path, as in figure 6 (B) as you moved on beyond the point from which the bullet was fired.

It is easy to see that DEFLECTION in aerial gunnery is an exceedingly complex phenomenon. Even the ballistics experts cannot agree on ALL of the factors which enter into bullet deflection. The forward motion of the airplane and air resistance are, of course, the most important ones. But bullet DROP—which you have already read about— influences deflection also.

In addition, bullet YAW and JUMP and DRIFT also enter into the situation, though their effect is so slight that they are omitted from ballistics calculations in aerial gunnery. They are mentioned here only to make the story complete.

DEFLECTION, like drop, varies according to the angle to the line of flight at which the bullet is fired. It increases from 0° to 90° and decreases from 90° to 180° .

Figure 7 illustrates the deflection of bullets fired at different angles to the line of flight. In this picture the paths of the bullets and the lines of fire are shown in relation to the position of the airplane at the instant the bullets leave the muzzle of the gun.

Now imagine the paths followed by a stream of bullets spitting out of a machine gun that is being swung by a gunner in a rapidly maneuvering airplane. The bullets curve up, down, around,

to the left and to the right, like a stream of water from a rotating lawn sprinkler. You can see that, without fire control instruments, hits in aerial gunnery would be as much a matter of luck as is winning the Irish Sweepstakes.

But aerial gunnery simply CAN'T be a matter of luck. Certain gadgets have been developed to enable aerial gunners to plant their bullets squarely in the target in spite of their twisting and turning maneuvers. You know these gadgets as GUNSIGHTS.

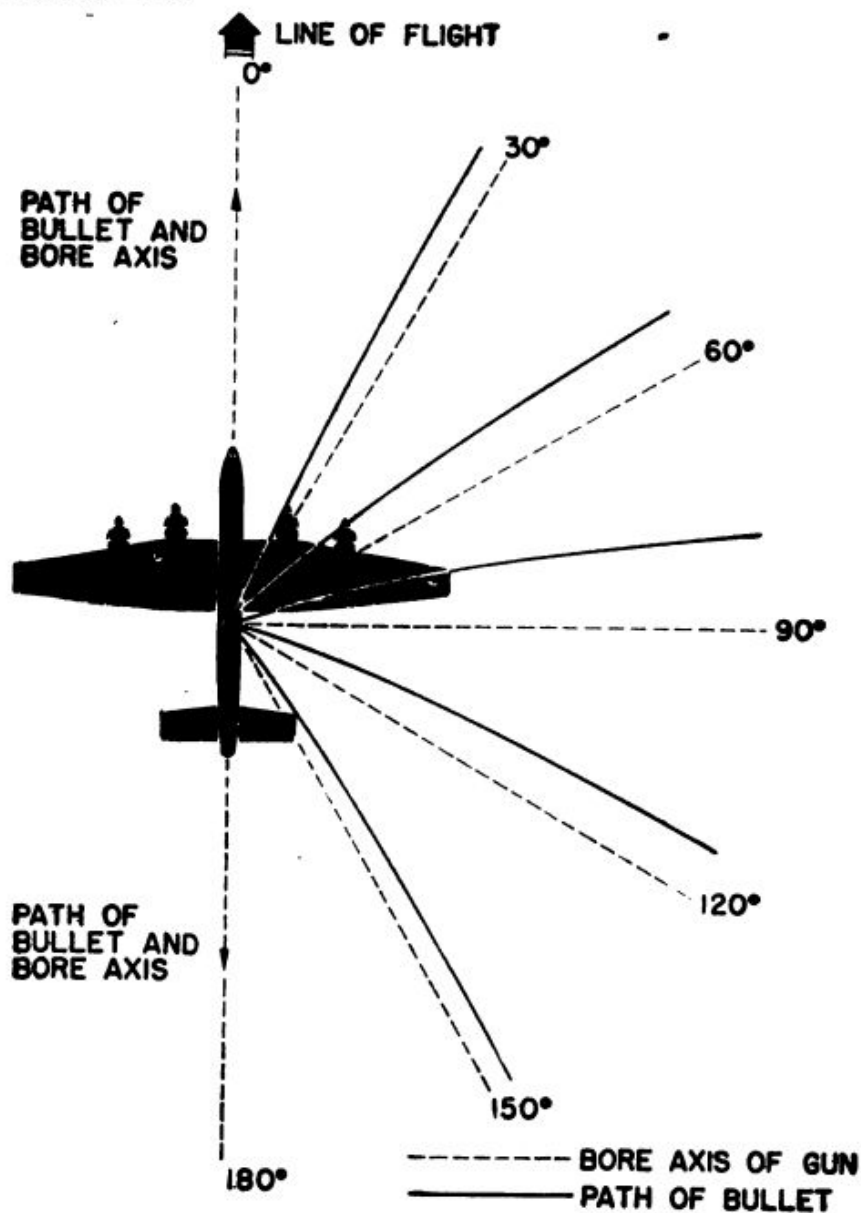

Figure 7.—Deflection of bullets fired at angles to the line of flight.

CHAPTER 2

GUNSIGHTS

THEY ARE DIFFERENT

Did you ever own a .22 rifle? If so, you know that the sights are simply a FRONT BEAD and a REAR NOTCH, which give you two reference points to aline the gun on the target.

The function of the gunsight is, of course, to help the gunner hit what he's shooting at. Keeping in mind all you have learned about "the flight characteristics" of bullets, imagine yourself and a trusty .22 rifle engaged in the following tests of marksmanship. Each of these tests illustrates a certain situation in aerial gunnery.

First, a simple shot—lean your elbows on the fence and shoot at the tin can across the alley. Bull's eye! Easy as can be, unless there's a terrific wind blowing. Both you and the target are stationary, and your only problem is to aim the gun at the target. At this short distance, even the drop of the bullet is negligible.

Now, here's one a little tougher. You're standing in a field, trying to shoot a crow flying overhead. Obviously, if you point right at the crow and shoot, by the time the bullet reaches the point where the crow is, the crow will no longer be **THERE**. While the bullet is in transit, the crow keeps right on flying. Thus a bullet fired directly at the crow will pass behind him. So you have to allow for **TARGET DEFLECTION**. You **LEAD** the crow by estimating how far he will fly in the time it takes for the bullet to reach him, and then aim the gun that far **AHEAD** of him.

Now suppose you climb in the family jalopy and start off down the road past a scarecrow in a field. Try to knock his hat off with one shot as you drive by. Since you're leaning out the side of the moving automobile and firing at a right angle to the path of the car, your **FIRING ANGLE** is 90° . Because of the forward movement of the car, the bullet will "skid" sideways in the same direction, so that if you point directly at the scarecrow, the bullet will pass in front of the target in the direction you're traveling. So you have to aim **BEHIND** the target, making a correction for **GUNNER'S DEFLECTION**.

As the final test, try hitting that crow you **MISSED** in the second test. But this time make your attempt as you drive along in the car. Now you have to take into account both **TARGET DEFLECTION** and **GUNNER'S DEFLECTION**, which makes this a really complicated shot.

In all of these examples, you, as the gunner, had to estimate the factor of **DEFLECTION** without help from your gunsights. This illustrates the basic difference between the sights on your .22 and the sights used in aerial gunnery. Rifle sights merely tell you in which direction the gun is

pointing, whereas aerial gunsights help tell you where the gun SHOULD BE pointed. In aerial gunnery the firing airplane and the target airplane are moving at such high speeds that it would be a rare circumstance when you could estimate the correct deflection allowance without help from your sights.

FLEXIBLE GUNSIGHTS

Before you proceed any further, however, you should get a clear distinction between the two types of aerial gunnery—FIXED gunnery and FLEXIBLE gunnery.

In fixed gunnery, as the name implies, the guns are in fixed mounts so that they cannot be moved about, and they are aimed by aiming the whole airplane. As an example, the fighter plane, with its wing gun installations and guns firing between the propeller blades, carries FIXED guns which are fired by the pilot.

Conversely, FLEXIBLE guns can be swiveled about and swung up and down. They are mounted in turrets, in tunnel hatches, in "blisters", or in side ports, and they are fired by a member of the plane crew—not by the pilot.

The sights used to aim fixed guns are called FIXED GUNSIGHTS, and the sights for flexible guns are called FLEXIBLE GUNSIGHTS.

The proper use of flexible gunsights is somewhat more complicated than that of fixed gunsights, for the simple reason that fixed guns are fired in ONE DIRECTION ONLY—dead ahead of the airplane—and flexible guns may be fired IN ANY DIRECTION. (There are a small number of fixed gun installations which fire dead astern of the aircraft, but these may be disregarded here.)

As you already know, the angle at which a bullet is fired from a moving airplane has a

marked effect on the path of the bullet. So, if you understand how FLEXIBLE gunsights are used, you will automatically understand the use of FIXED gunsights.

FLEXIBLE SIGHTS, then, come next. These include POST and RING SIGHTS. See figure 8. (There are many different types of post and ring sights but the fore post sight M-1 and the ring sight M-10, pictured in figure 8, are used as typical examples.) The POST SIGHT is the fore sight,



Figure 8.—(A) Ring sight Mark 10 and (B) forepost sight Mark 1.

mounted on the front end of the gun, and the RING SIGHT is the rear sight, mounted nearest the gunner's eye. Post and ring sights are used in combination to provide two reference points with which the gunner can aline the gun with the target. The bead on the forepost sight is viewed through the center ring, or "peep" of the ring sight.

USE OF RINGS

What are the other rings and lines on the ring sight for? Therein lies the story of the principles of aerial gunnery and fire control.

Notice that the ring sight consists of three concentric rings, supported by cross wires spaced at 45° intervals around their circumferences. The outer ring is the "200 knot ring", the middle ring is the "100 knot ring", and the inner ring is the "peep." If there is no element of deflection to be considered (the firing airplane and the target airplane are flying along parallel with one another at the same speed), the gunner lines the foresight bead on the target through the PEEP ring and starts firing.

This, however, is unquestionably a rare condition, and almost invariably the aerial gunner has to estimate both target deflection and gunner's deflection in calculating the lead to allow. From the word "estimate," don't assume that a gunner is going to peer out an attacking Zero and then sit down with paper and pencil to work out mathematical problems. Aerial gunnery demands split-second judgment and action. The gunner must determine the amount of lead instantly, as soon as the target is within range.

Saying that the outer and middle rings on the Mark 10 ring sight are 200- and 100-knot rings respectively has the following meaning—with the gunner's eye 20 inches behind the ring sight, and the target at a range of 300 yards, the gunner uses the outer ring to allow for correct deflection if the enemy airplane is moving at 200 knots, and the middle ring for correct deflection if it is moving at 100 knots.

For example, if the target airplane at a 300-yard range is traveling at 300 knots in the same

direction as the firing airplane which is traveling at 200 knots, the target deflection is 100 knots, and the gunner would thus aline the target airplane on the MIDDLE RING (with the bead on the forepost sight seen through the center of the peep on the ring sight). This is illustrated in figure 9.

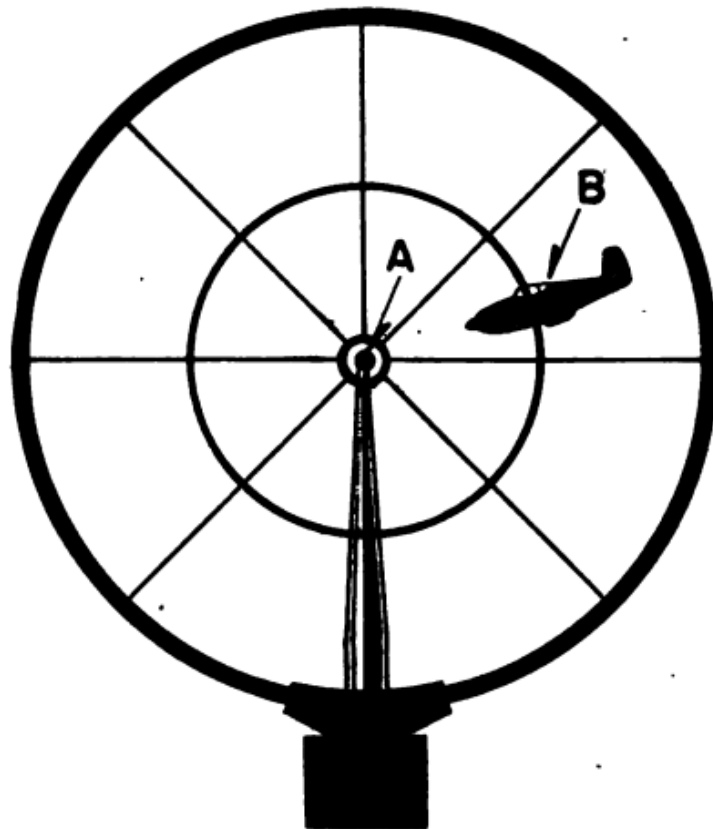

Figure 9.—Using the 100-knot ring.

A is the bead on the fore sight as viewed through the peep, and B is the target airplane on the 100-knot ring. Under the conditions described, lining the targets on the second, or 100-knot ring, will establish the correct DEFLECTION ANGLE, by pointing the gun the correct amount AHEAD of the path of the target airplane. See figure 10.

The sight axis is the line from the gunner's eye through the peep and bead projected out into space, whereas the line of sight is the line from the gunner's eye to the target. The gunner's de-

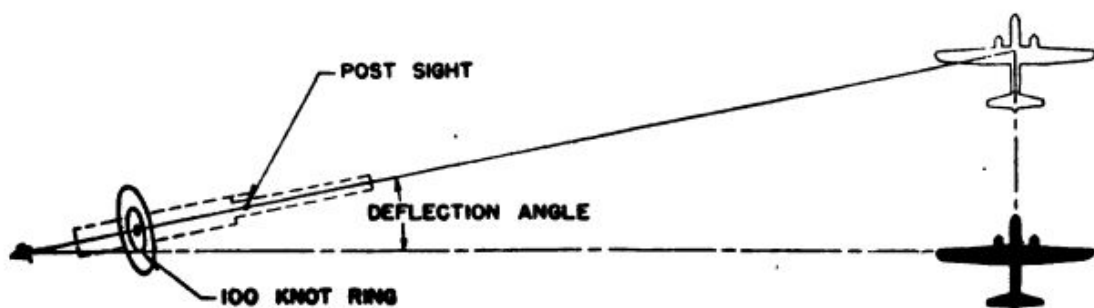

Figure 10.—Lead.

deflection angle is the angle between these two lines.

In order to estimate the deflection angle correctly, the gunner must know the **SPEED** and **RANGE** of the enemy airplane. But an important part of any gunner's training is **AIRCRAFT RECOGNITION**. In aircraft recognition, he learns to recognize all types of enemy aircraft, he memorizes the wing dimensions and length of each type, and he becomes familiar with their speeds.

On sight, the gunner identifies the target airplane, and immediately, by its position of flight (climbing, diving, or level flight), he estimates its probable **SPEED**, knowing its cruising speed and top speed beforehand.

Instantly, he calls to mind the airplane's dimensions. Now he can use his sight to help calculate the **RANGE**.

How? Let's take a concrete example.

In the explanation of the 100- and 200-knot rings, you remember that the gunner's eye was "20 inches behind the ring sight." Now suppose the gunner spots a Heinkel HE-177 bearing down on him. As soon as he identifies the airplane, he knows immediately that its wing span is approximately 100 feet. He knows also that the diameter of the **OUTSIDE** ring on his ring sight is 4 inches and his eye is 20 inches behind the sight. As he views the enemy airplane through the ring sight, its wings appear to fill the sight—so he knows at once that its **RANGE** is approximately 500 feet.

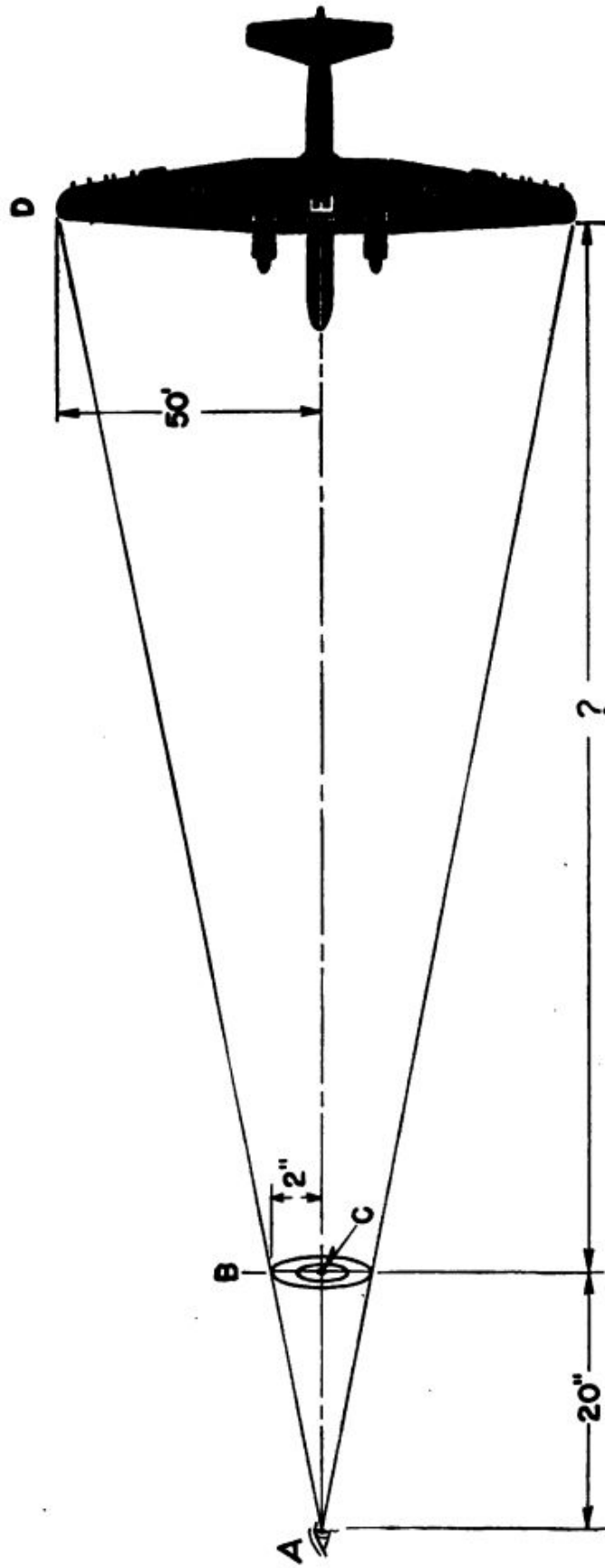

Figure 11.—Determining range through the ring sight.

Take a look at figure 11 and you'll see why he knows. Triangles ABC and ADE are similar. $BC=2$ inches (half the diameter of the sight). $AC=20$ inches (the distance from the gunner's eye to the sight and 10 times BC). $DE=50$ ft. (half the wingspread of the HE-177). Solving for AE , which equals the range, you get 500 feet.

Now, if the HE-177 filled only HALF the larger ring on the sight, the gunner would know its range was 10 times the full wing spread, or 1,000 feet, and so on for other ranges. All this becomes automatic THROUGH PRACTICE.

The MIL is an important unit of measurement in aerial gunnery, and you will usually find the rings of sight patterns referred to as the 50 mil, or the 100 mil rings, rather than the 100 knot or the 200 knot rings. The mil is used because it has decided advantages. The MIL ANGLE represents an arc whose length is $1/1,000$ of its radius—one inch of arc at 1,000 inches radius, one foot at 1,000 feet, and so on. Lead, or deflection, is usually figured in MILS. If a gunner knows an enemy airplane is at such and such a range, flying at such and such a speed, he estimates the correct lead in MILS, and lines the target up on the corresponding mil ring of his sight.

The two most important factors in flexible aerial gunnery are, of course, drop and deflection. You have seen how the gunner allows for deflection. He must allow for drop also, though, to some degree, it is occasionally allowed for in BORESIGHTING. If the gunner wants his line of sight and line of fire to converge at 300 yards, an allowance for the drop of the bullet at this range can be made in alining sights and the gun. In flexible guns, of course, you have seen how the rate of drop increases or decreases, depending

upon whether the gun is fired ahead, abeam, or abaft of the line of the airplane's flight. The gunner must make allowance for these differences in the rate of drop.

From all this, it is clear that the aerial gunner has plenty on his mind. A thorough knowledge of the different types of enemy aircraft—their speed and their dimensions—a full understanding of the ballistic characteristics of his ammunition, and above all, practice, experience, and good judgment are the primary prerequisites for the job.

Now for a candid look at the disadvantages of the post and ring sights!

First, there's the matter of eye focus. Did you ever glance up suddenly from reading something to look at an airplane flying overhead? It took a moment for the lens muscles of your eye to adjust to the new range of sight—or technically, for your eye to FOCUS clearly. As a person grows older, these muscles slow down in their action, and that's where bi-focal lenses in eyeglasses come in—one lens for reading, another for looking at objects farther away.

The aerial gunner using post and ring sights has this same problem. First he's looking at his sights, less than a couple of feet in front of his eye. Then he looks at a target a couple of thousand feet away. Even super-perfect eyes would take a fraction of a second to adjust between these two distances.

Next, there's the problem of keeping the eye steady and at the same distance behind the ring sight. Suppose a gunner has calculated the deflection angle and lined up the target on one of the rings in his sight with his eye 20 inches behind the sight. Then he moves his eye up to 10 inches behind the sight. What happens?

Well, at 20 inches behind the sight, the enemy

airplane appears to the gunner to occupy a certain space between the rings of his sight. If his eye moves CLOSER OR FARTHER AWAY, this condition changes—the enemy plane may still be at the same range, but it appears in a DIFFERENT RELATIONSHIP to the sight rings. Thus, the gunner's estimate of range is THROWN WAY OFF.

When he is using post and ring sights, the gunner must keep his eye steady and at a standard distance behind the ring sight, if he is to estimate range and deflection accurately. Obviously, this would be impossible in rough air.

Another disadvantage of the post and ring sights is that they are difficult to see at night, and a mistake in night combat can be just as costly as a mistake in daylight.

As you might expect, therefore, something better in the way of gunsights has been developed to overcome these disadvantages. That "something better" is the OPTICAL ILLUMINATED SIGHT.

OPTICAL ILLUMINATED SIGHTS

Eyeglasses, telescopes, cameras, motion picture projectors, and microscopes are all OPTICAL INSTRUMENTS. They contain lenses. A study of the properties of lenses is a part of the science of OPTICS, for optics deals with the properties of light and the phenomenon of vision.

From your own experience, you know that the adjustment and focusing of optical equipment require a delicate touch. A camera out-of-focus produces a blurred picture, and a motion-picture projector out-of-focus throws a blurred image on the screen. The focus of any particular piece of equipment is a matter of the distance between the various lenses in the optical system. The OPTICAL ILLUMINATED SIGHTS have a fixed optical system, correctly focused by the manufacturer. This focus

must NEVER be adjusted, except by specially qualified personnel.

An optical illuminated sight projects a sight pattern onto a transparent reflector plate, through which the gunner views the target. As the gunner takes aim, it appears to him that the sight pattern is superimposed on the target.

This concept will be clearer to you if you compare it with a "still" picture projector. Instead

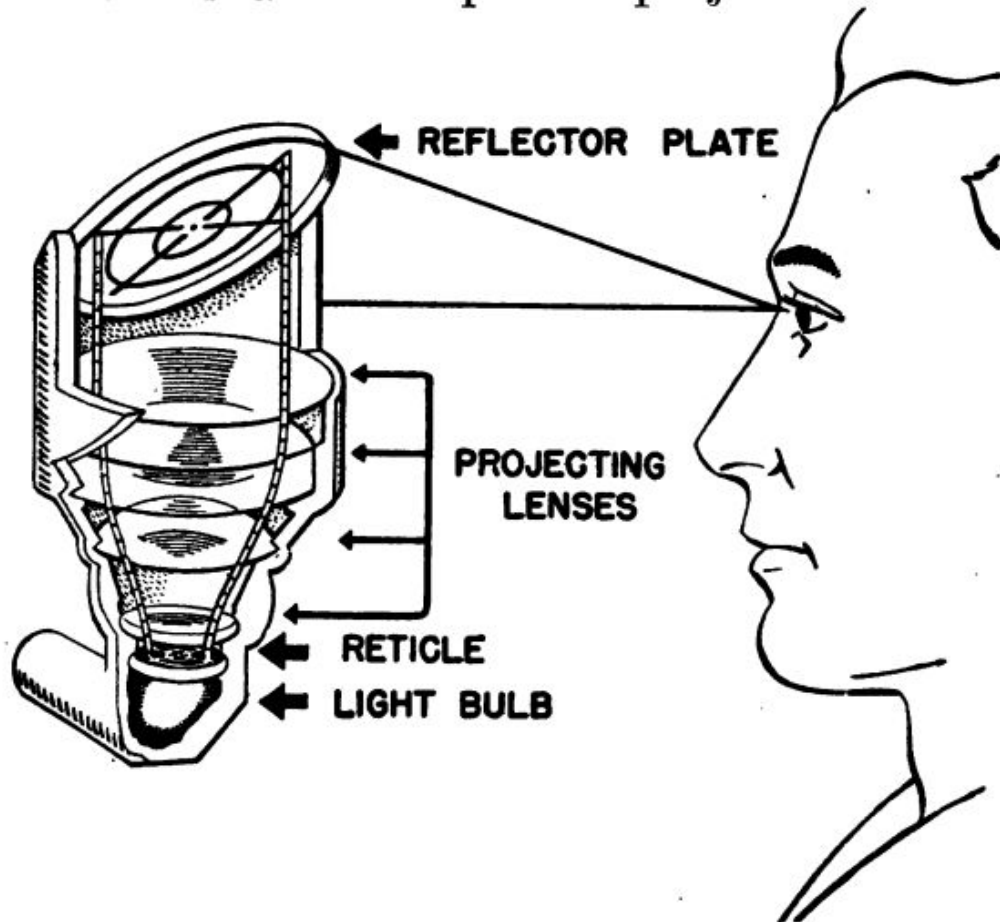

Figure 12.—Optical diagram of illuminated sight.

of a film negative, as in a picture projector, the optical illuminated sight has a sight pattern etched or cut in a glass or metal disc called a RETICLE. An electric light shines through the reticle from below. The lens assembly ABOVE the reticle picks up this light coming through the reticle and projects it onto the reflector plate in the form of the reticle image. This is shown diagrammatically in figure 12.

The reflector plate is made of transparent glass, and through it the gunner can see the target almost as clearly as if the glass weren't there. Because the glass is mounted at an angle—45° to be exact—it catches and reflects to the gunner's eye the reticle image projected upon it by the lenses.

Although the image is only a short distance in front of the gunner's eye, it appears to him to be way out in space, because the reticle image is focused at INFINITY (beyond measured distance). It's like looking through the wrong end of a telescope—an object right in front of you appears to be a long distance away.

Because the reticle image is focused permanently at infinity, there is no need for the gunner ever to adjust the focus. He can sit there and look at the target with both eyes open, and it makes no difference if he moves his head up or down or away from the sight—the reticle image will always appear in the same relationship to the target.

The illuminated sight, Mark 9, is mounted on flexible guns. See figure 13.

The gunner views the target through the reflector plate, and he uses the rings on the reticle image just as he used the rings on the ring sight. The basic difference is simply that he can keep both eyes open and line up his target without worrying about keeping his eye at a standard distance behind the sight.

Notice the rheostat switch on the side of the sight housing. (Fig. 13.) With this switch, the gunner can vary the intensity of the light coming from the bulb. At night he can turn the light down, so that the brightness of the reticle image on the reflector plate does not obscure the target. In bright sunlight he can turn the light up, so

he can see the image more clearly against the sky. For daytime use, a movable sun filter can be swung into place in front of the reflector plate, to reduce glare.

Figure 13.—The illuminated sight Mark 9.

COMPUTING SIGHT

The newest development in sights for flexible guns is the COMPUTING SIGHT.

There are several different types of computing gunsights, but they all operate on basically the same principles. All contain a computing mechanism within the sight body. This mechanism

automatically aims the gun correctly, as long as the gunner keeps the target airplane framed in the reticle image of the sight.

The computing sight is what you might term a ballistic brain. The principles of operation are easy to understand, though the mechanism which does the figuring is quite complex.

The computing sights are installed on guns fired from rotating turrets. As you know, a turret both trains and points the guns—in other words, it moves the guns in azimuth and elevation—in accordance with the manner in which the controls are manipulated by the gunner.

Each computing sight is constructed for use with a certain type of gun and ammunition because the computing mechanism is designed so that it takes into account the ballistic characteristics of a particular type of ammunition. For example, the same computing sight could not be used interchangeably between a cal. .30 and a cal. .50 machine gun.

You also remember, from the discussion of ballistics, that the flight path of bullets varies according to the direction from the line flight at which the bullets are fired.

The computing sight automatically makes compensation for these variations by being linked mechanically or electrically (depending on the sight) to the turret movements of the gun in azimuth and elevation.

Then there are several factors which the gunner must introduce into the sight himself—first, the altitude, and second, the airspeed. These two factors have an important bearing on the trajectory of the bullet. Third, he must introduce into the sight the dimensions of the target airplane.

The introduction of all these factors into the

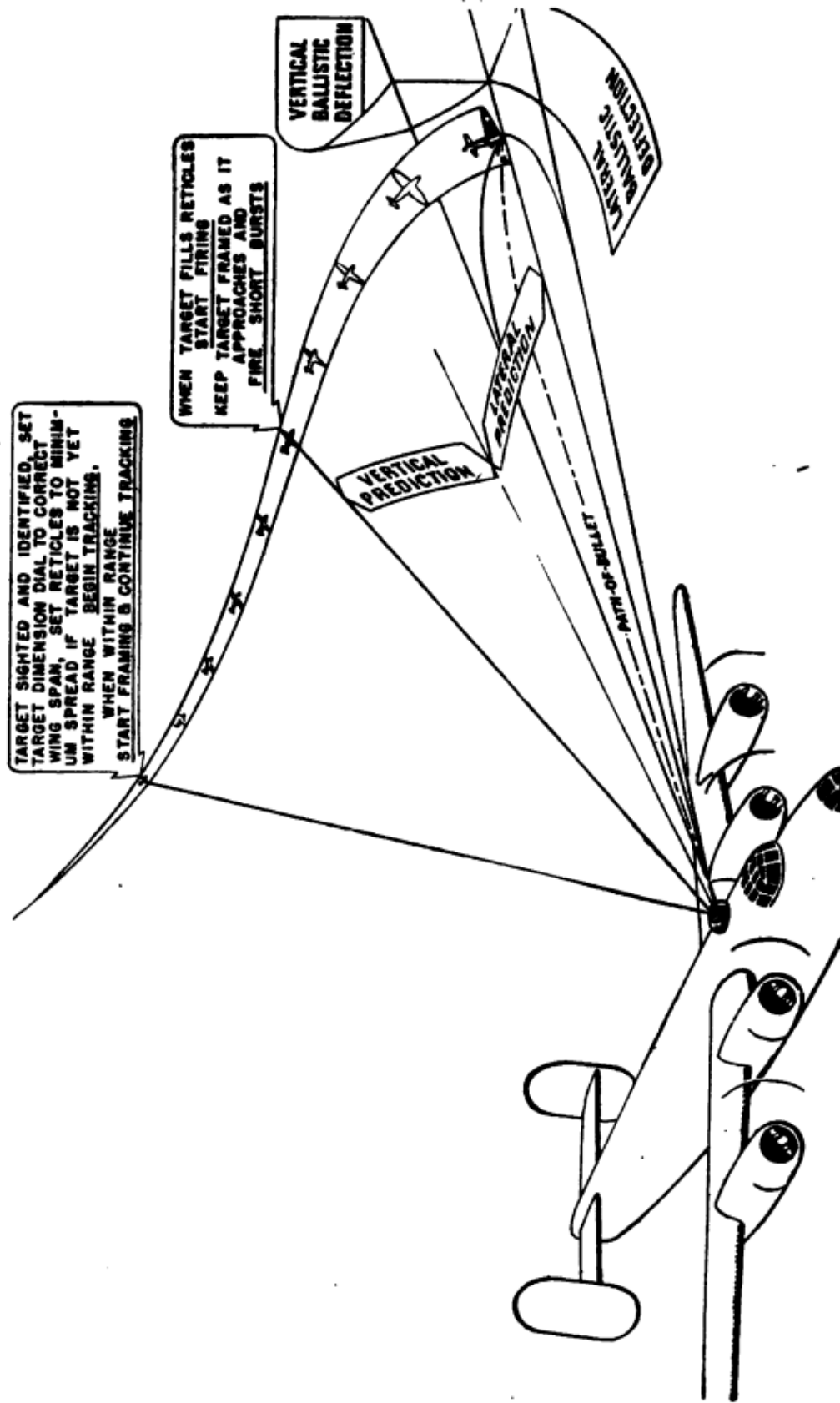

Figure 14.—Diagrammatic illustration of how computing sight works.

sight affects the reticle image on the reflector plate in such a manner, that, as long as the gunner keeps the target airplane framed in the reticle image (by moving the turret and by manipulating controls which enlarge or contract the reticle image according to the range of the target), the gun is automatically pointed so that scoring hits becomes practically positive.

Figure 14 illustrates the operating principle of the computing sight.

One thing applies to all optical illuminated sights—if something goes haywire with the electrical source and the light in the sight cuts out, the sight is only in the way of the gunner. **IT BECOMES USELESS.**

Therefore, you will sometimes find post and ring sights mounted as **AUXILIARY** sights for use in case something goes wrong with the illuminated sight.

So much for the **FLEXIBLE SIGHTS**. Now for the **FIXED GUNSIGHTS**.

FIXED GUNSIGHTS

Fixed gunsights are used by pilots, because fixed guns are aimed by aiming the entire plane.

The most widely used fixed gunsight in the Navy is the illuminated sight **Mark 8**. It is mounted forward in the pilot's cockpit on the center line of the airplane, about eight inches in front of the pilot's eyes in normal flying position. Figure 15 shows this illuminated sight.

This sight is constructed on the same principle as the **Mark 9** illuminated sight for flexible guns, (although it is somewhat larger in size) having a light shining through a reticle, the image of which is projected upon the reflecting plate by the lenses.

The reticle image is pictured in figure 16, with the mil values of each circle listed.

Figure 15.—Illuminated sight, Mark 8.

Calculations of the speed and range of the enemy airplane are made through the use of the sight pattern in the same manner as with the post and ring sights.

Figure 17 shows you what the sight would look like were it cut in half. Notice that it is constructed in two parts—the lamp housing, and the

so-called sight body, upon which are mounted the reflector plate and the sun filter. An inclinometer, which is simply a spirit level to tell the pilot whether the airplane is sliding or skidding during a firing run, is attached to the reflector plate mount. A rheostat switch—not shown in the illustration—enables the pilot to brighten or dim the lamp according to the brightness of the sun.

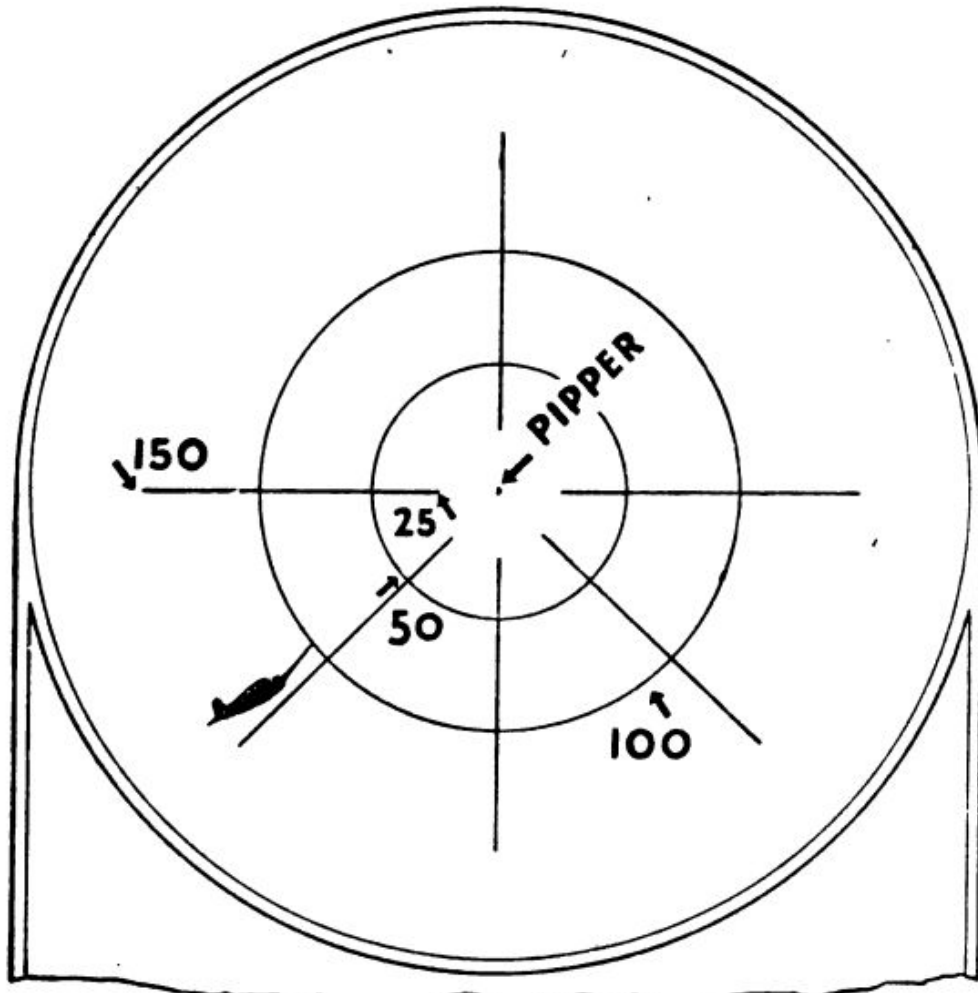

Figure 16.—Reticle image of Mark 8.

GUNSIGHT MAINTENANCE

The maintenance operations which you will be called upon to perform are fundamentally the same for all types of illuminated optical sights, whether fixed, or flexible, and, using the Mark 8

sight as one example, here is a brief résumé of these operations.

SPECIAL TRAINING IN OPTICS is required before anyone is qualified to **TAKE APART** and **REPAIR** a

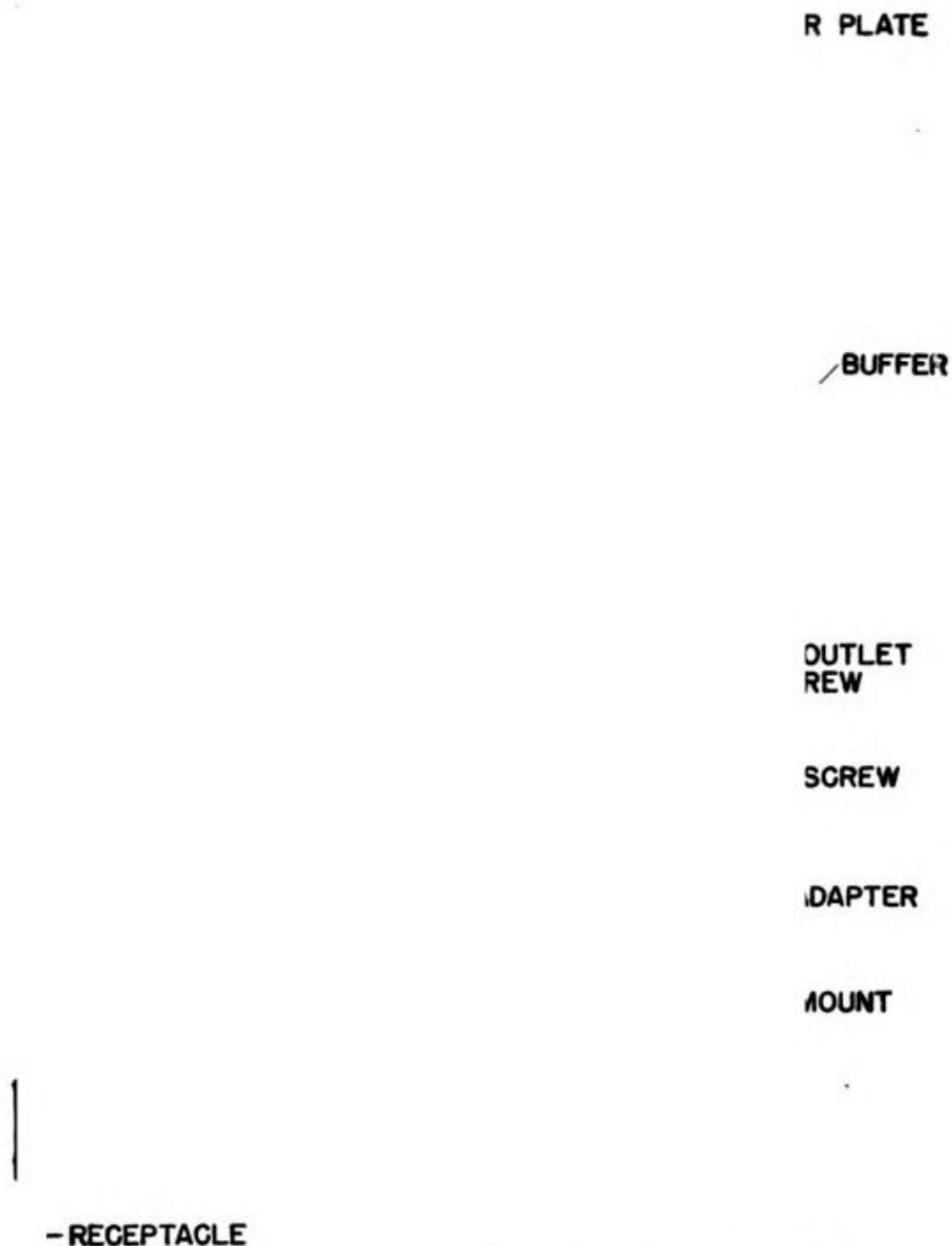

Figure 17.—Sectional view of illuminated sight, Mark 8.

lens assembly. Usually this work must be done in special dustproof rooms under an even temperature and a constant humidity. So **NEVER** at-

tempt any major repairs on a lens assembly yourself. Send the lens to the optical shop.

You may run across a condition known as PARALLAX, however, and this you can correct without difficulty. You can recognize parallax when, as you sight some object not less than 500 yards distant through the reflector plate, the reticle pattern appears to MOVE in relation to the object as you move your eye up or down behind the sight. Remember that one of the advantages of the illuminated sight is the fact that the target and reticle pattern always appear in the same relationship regardless of the position of the observer's eye. When parallax exists, this is no longer the case because the reticle is OUT OF FOCUS. Parallax is corrected by either raising or lowering the reticle. The reticle is raised by REDUCING the thickness of the adjuster ring, and it is lowered by SHIMMING under the ring.

Always check the bulb in the light source of an illuminated sight. If the bulb burns out in combat, the sight will be more useful as a missile to hurl against the target airplane than as an instrument for aiming the guns.

To change the bulb in the Mark 8, first press the two buttons which protrude through the wall of the lamp housing. This will release two spring clips, after which the lamp housing will drop away from the sight body and you can reach the bulb with ease. Always make replacements with the same type of bulb.

While the space between the lenses of the optical assembly is made pressure tight by seals and gaskets, occasionally the lenses may show internal fogging because of rapid changes of temperature, and when you are entering an area of high humidity.

When this fogging occurs, remove the air inlet

and outlet screws along with their washers. Hold your finger over the outlet screw opening and force DRY air or gas into the inlet screw opening, taking care that the pressure never exceeds 5 pounds per square inch. Remove your finger from the outlet screw after pressure has built up inside. This allows the moist air to escape. Repeat this procedure until the exhausted air is COMPLETELY DRY.

All optical surfaces must be kept scrupulously clean. Fingerprints or drops of water, if allowed to remain on the lens surfaces, are likely to cause pitting. If the lenses are dirty or greasy they should be cleaned with a few drops of alcohol and then dried with a chamois skin, a soft dry linen cloth, or lens tissue.

If small particles of dirt appear on the INTERIOR lens surfaces, do nothing about them unless they impair the efficiency of the sight. In this case, send the sight off to an optical shop to be disassembled and cleaned.

The lenses of all optical instruments should always be protected from the direct rays of the sun, except when in actual use. The direct rays of the sun may, in time, cause crystallization of the balsam which cements the lenses together.

Gunsights, like bombsights, are being improved all the time. New models come and old models go.

For example, until recently, the telescope sight was used widely for fixed aerial gunnery. It has now been largely replaced by the Mark 8 illuminated sight, which is more efficient and is easier for the pilot to use.

Gunsights require careful treatment. They ARE HIGH PRECISION INSTRUMENTS. It is your responsibility to keep them in A-1 operating condition.

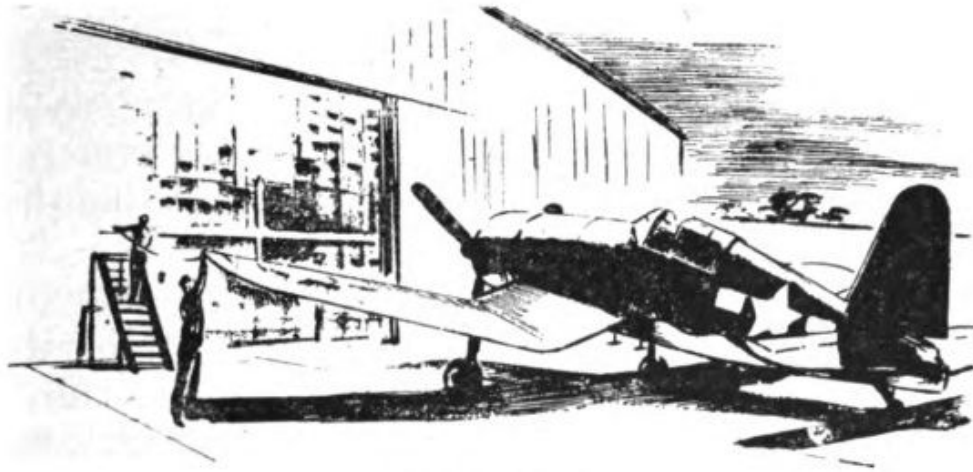

CHAPTER 3

BORESIGHTING

CORRELATING GUNS, SIGHT, AND AIRPLANE

Suppose you have just finished installing a machine gun in the side port of a patrol bomber. As a final step, you mount an illuminated sight Mark 9 on the gun. Are you finished with the job?

Not by a long shot! The gun may be installed properly and the sight mounted correctly, but you have not **ALINED** the gun and the sight. In other words, a gunner might take perfect aim on a target, but the bullets from the gun would not necessarily hit where they were supposed to hit because the **LINE OF SIGHT** and the **LINE OF FIRE** have not been correlated. The gun has not been **BORESIGHTED**.

The purpose of **BORESIGHTING** is to aline a sight and a gun in such a manner that when the gunner aims the sight correctly, he also aims the gun correctly. This demands great **ACCURACY**, for inaccurate boresighting may cause a burst to miss the target **BY FEET**—not merely by inches—even though the gunner may have taken correct aim through his sights.

With a FLEXIBLE gun, you need align ONLY the gun and the sight.

But with a FIXED gun, the sight is used to aim the guns by AIMING THE AIRPLANE. So you must work with THREE UNITS—and HARMONIZE them into a single, coordinated weapon.

Before you can boresight any gun, you must know WHAT RELATIONSHIP is to be set up between the line of sight and the line of fire. Are the line of sight and the line of fire to be PARALLEL, or are they to CONVERGE? If they are to CONVERGE, at what distance—or at what BORESIGHTING RANGE—should convergence take place?

For a simple illustration, take a flexible machine gun installation. Suppose that you are told to boresight the gun so that the line of sight and the line of fire CONVERGE at 100 yards.

To do this, you simply remove the back plate and bolt group from the gun and trip the accelerator so that the barrel group is in the forward, or firing, position. Pick out a point on some object, such as a water tower or a smokestack, approximately 100 yards distant and sight through the gun barrel so that this "target" point halves the center of the gun bore. Fix the gun firmly in this position.

Next, adjust the sight so that the pipper—or central "dot"—on the reticle image is centered on the same point. On the illuminated sight Mark 9 you make adjustments in azimuth and elevation by turning the hood. One nut fixes the hood in azimuth, and another nut fixes its elevation. When these nuts are loosened, the hood can be moved freely—tightened, the hood is held securely in place.

When you have tightened the boresighting nuts on the sight, check to make sure that both the gun

and the sight have not moved out of position. If both are still true on the target, the gun is boresighted properly, and you can replace the bolt and back plate groups. The job is done.

“Hold on a minute”, you say, “what about DROP?” The line of sight and the line of fire are fixed on the same point, but won't the bullet have fallen BELOW that point by the time it reaches the target?

Certainly. But suppose its drop is as great as 3 MILS. That's 3 yards at 1,000 yards. Since 100 yards is $\frac{1}{10}$ of 1,000 yards, the drop in 100 yards would be $\frac{1}{10}$ of 3 yards, or $\frac{3}{10}$ of a foot.

As you know, the altitude, the direction in which the gun is fixed, and the attitude of the airplane—whether driving, banking, or climbing—all affect the rate of drop. Drop is a relatively minor factor in comparison with the other aiming allowances, and you may safely disregard it, UNLESS you are specifically directed to compensate for drop when boresighting. Drop is allowed for more frequently in boresighting free guns than in boresighting fixed guns.

With this gun boresighted at a range of 100 yards, the gunner knows that the bullet will hit at 100 yard range any target on which he centers the gunsight pippet. OF COURSE, he must still allow for deflection.

A FIXED GUN INSTALLATION is considerably more complicated. To begin with, the sight and the guns are usually at widely separated positions on the airplane. The sight is mounted in the pilot's cockpit, and the guns may be mounted in the wings, up to 8 or more feet from the fuselage; or they may be mounted in the engine cowling, to fire between the propeller blades.

Also, the pilot does not aim the guns directly.

He aims the airplane. Consequently, the **FLIGHT ATTITUDE** of the airplane is an important consideration in boresighting a fixed gun. And to know the proper attitude, you must know the airplane's correct **ANGLE OF ATTACK**.

The angle of attack, as the term is used here, denotes the angle between the **MEAN CHORD LINE** and the **LINE OF FLIGHT** of the airplane. The **MEAN CHORD LINE** is an imaginary **STRAIGHT LINE** between the leading edge and the trailing edge of the **WING** of the airplane. The angle which this line makes with the line of flight represents the airplane's **ANGLE OF ATTACK**, as you see in figure 18.

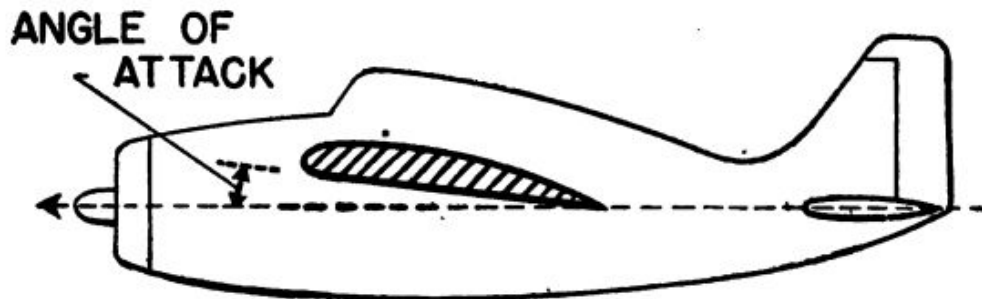

Figure 18.—Angle of attack.

The angle of attack varies with the airspeed, altitude, and the weight of the airplane's load, and the angles of attack for different values of these factors are given in the **ERECTION AND MAINTENANCE MANUAL** for every airplane which mounts fixed guns.

DON'T conclude from all this that you will have to **COMPUTE** a new angle of attack every time you boresight an airplane. For boresighting purposes, the angle of attack is usually assumed to be the angle between the mean chord line and the line of flight at the **MAXIMUM SPEED** of the airplane (V_{max}), at its **CRITICAL ALTITUDE**, **FULLY LOADED**, less one-half of its fuel capacity.

A convenient and short-cut method has been devised to enable you to place an airplane at its correct angle of attack in a matter of a few minutes. Look at figure 19.

Here you see a six-gun fighter plane in position for boresighting. It has assumed its angle of attack.

See the line labeled **DATUM LINE**? This line is formed by the two sighting points provided by the two rods which you can see affixed to the underside of the airplane fuselage. These rods, called

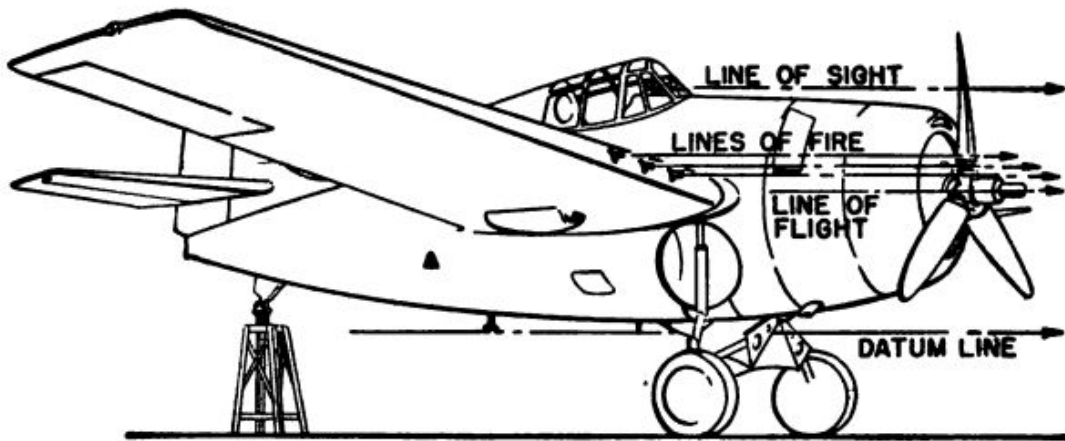

Figure 19.—A six-gun fighter installation.

BORESIGHTING RODS, OR BORESIGHTING TEES, are provided by the airplane manufacturer. You screw these boresighting rods into sockets provided for them when you're going to boresight the airplane—at all other times they are stowed, and the sockets into which they fit are plugged.

These rods resemble the sights on a rifle—the after rod being notched and the forward rod pointed. When you sight the forward rod through the aft rod, you establish the **DATUM LINE**.

These rods are designed so that when the **DATUM LINE** is **HORIZONTAL**, the airplane has assumed its proper angle of attack for boresighting.

Take the six-gun fighter pictured in figure 19, as an example. Suppose you were told to bore-

sight it so that the lines of fire of the guns and the line of sight would CONVERGE at 750 feet.

If you interposed a screen between the airplane and a target 750 feet distant and fired the guns, the bullets would pass through the screen on their way to the target. The holes which they left in the screen would form a PATTERN. Now, if you marked on the screen an exact point in line with the piper in the gunsight, this point, together with the bullet holes, would form a BORESIGHTING PATTERN.

But you DON'T HAVE TO fire the guns to make a boresighting pattern. In fact, you'd probably be tossed into the brig if you did.

If you KNOW the pattern between the lines of fire and the line of sight at a given range, you can CALCULATE the exact points at which the line of sight and the bullets from the guns should intersect the screen. Then, by placing suitable marks at these points, you can boresight the airplane by lining up the sight and the guns on these points.

But before you can lay off these points correctly on the screen, you must know the relative positions of the guns and the sight on the airplane. In this connection, look at figure 20.

Here you see illustrated the VERTICAL AND HORIZONTAL OFFSETS of the sight and the guns. The DATUM LINE POINT is the intersection point of the HORIZONTAL AND VERTICAL REFERENCE LINES on which the horizontal and vertical reference points are located.

The actual VALUES of the vertical and horizontal offset points you will find in the ERECTION AND MAINTENANCE MANUAL for the airplane. You WILL NOT have to measure them yourself.

Figure 20 gives the actual horizontal and verti-

cal offset values for the six-gun fighter plane you are boresighting. Incidentally, in a fixed gun installation of this type, the offsets of corresponding port and starboard guns are usually the same. In this example you can figure the values of the port guns and assume that the same values apply also to the starboard guns.

Note that the horizontal offset of port gun No. 1 is 6 feet. This means that the gun is 6 feet to port of the datum line point, measured along the horizontal reference line. The horizontal offset

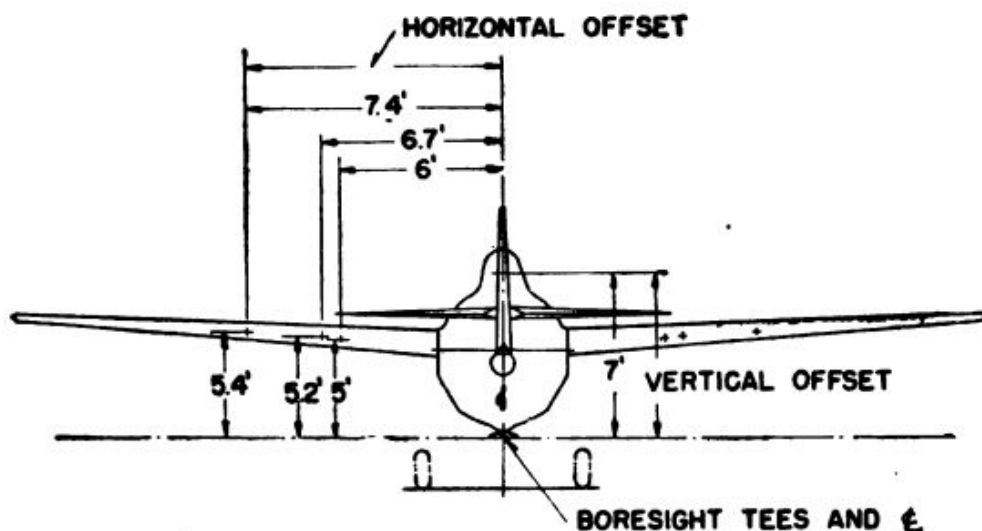

Figure 20.—Horizontal and vertical offsets of guns and sight.

of port gun No. 2 is 6.7 feet, and that of port gun No. 3 is 7.4 feet. The horizontal offset of the gunsight is zero because its piper is right on the vertical reference line and hence is in the same vertical plane as the datum line point.

Being directly ABOVE the datum line point, it has no horizontal offset.

The vertical offset of port gun No. 1 is 5 feet. This means that it is 5 feet ABOVE the datum line point, measured along the vertical reference line. Likewise, the vertical offsets of port guns Nos. 2 and 3 and of the gunsight piper are 5.2 feet, 5.4 feet, and 7 feet, respectively.

The horizontal and vertical offset values for the starboard guns are the same, except, of course, that they are measured to starboard.

Now that you know the vertical and horizontal offsets, you are ready to construct the BORESIGHTING SCREEN.

Your screen must be large enough so that you can mark upon it a boresighting point for each gun and the gunsight. The greatest vertical offset value is 7 feet for the gunsight, and the distance between the extreme outboard port and starboard guns is 14.8 feet (twice 7.4 feet). So, to be on the safe side, you had better construct your screen 8 feet high and 20 feet long. Plywood, or any other suitable material, will do.

Your problem now is to locate and mark off those points on the screen where the lines of fire and the line of sight would intersect the screen on their way to CONVERGENCE at 750 feet.

Suppose you're setting the screen up 30 feet in front of the airplane. You know your vertical and horizontal offsets, your range, and the distance of the screen in front of the airplane. The only things missing are your CORRESPONDING VERTICAL and HORIZONTAL OFFSETS for the screen.

Look at figures 21 and 22. Figure 21 is a diagrammatic illustration of the problem you must solve to learn the CORRESPONDING HORIZONTAL OFFSETS, and figure 22 illustrates the problem you must solve to learn the CORRESPONDING VERTICAL OFFSETS. (Port gun No. 3 is used in both illustrations.)

These are simple problems in similar triangles.

$AB=7.4$ (the actual horizontal offset).

$BR=750$ feet (the range).

$BD=30$ feet (the distance of the screen in front of the airplane).

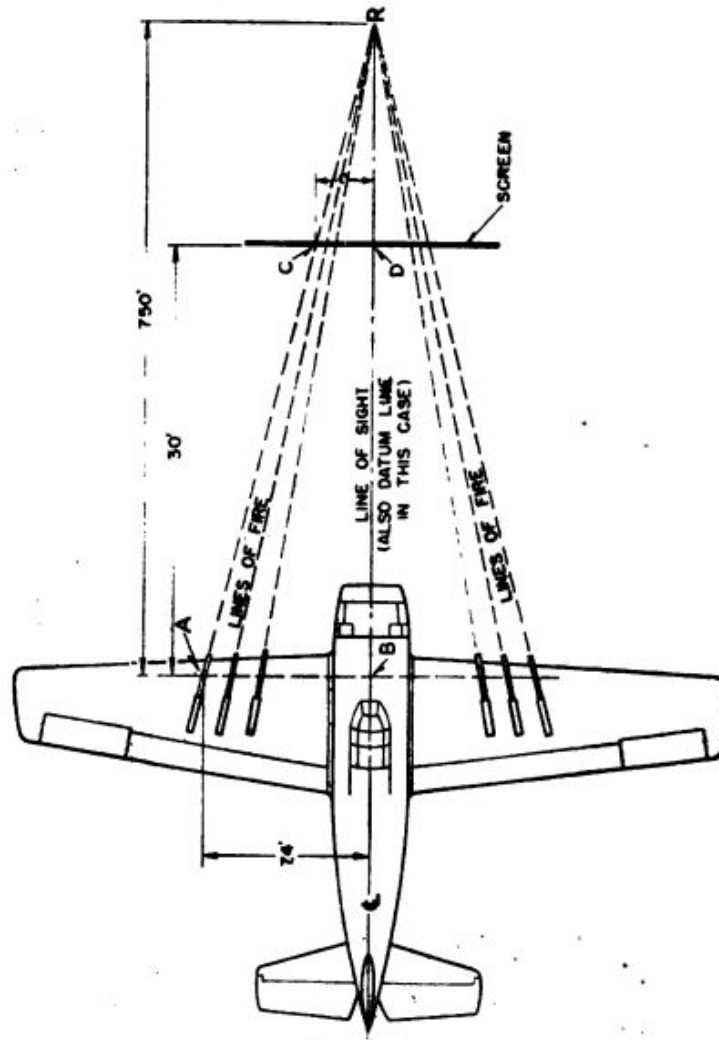

Figure 21.—Corresponding horizontal offset.

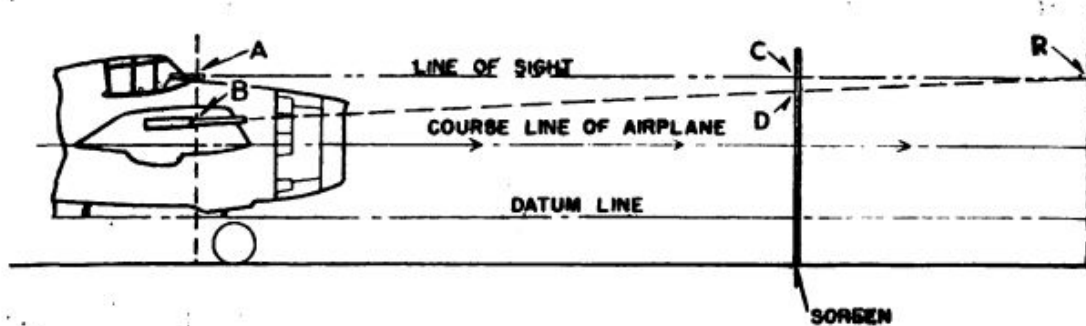

Figure 22.—Corresponding vertical offset.

What does CD equal?

When you know the length of CD , you have your CORRESPONDING HORIZONTAL OFFSET for the screen. Make a simple proportion out of it—

$$\frac{CD}{AB} = \frac{DR}{BR} \text{ or } \frac{CD}{7.4} = \frac{720}{750}$$
$$CD = \frac{720}{750} \times 7.4 = 7.1 \text{ feet}$$

So, the CORRESPONDING HORIZONTAL OFFSET of port gun No. 3 is 7.1 feet.

Now figure your vertical offset for the same gun. Remember, the line of sight and the line of fire are to CONVERGE at 750 feet. Since the vertical offset of the gunsight is GREATER than the vertical offset of the gun, the gun must be ELEVATED if its line of fire is to converge with the line of sight. Thus the CORRESPONDING VERTICAL OFFSET of the gun will be GREATER than its ACTUAL VERTICAL OFFSET. So the line of sight, rather than the datum line, is the common base of the similar triangles. (See figure 22.)

The vertical offset of the gunsight is 7 feet and the vertical offset of starboard gun No. 3 is 5.4 feet. Therefore, AB , in figure 22, equals 7 feet MINUS 5.4 feet, or 1.6 feet. AC and AR remain the same as before. What you want is CD , and your proportion now is

$$\frac{CD}{1.6} = \frac{720}{750}$$

$$CD = 1.53 \text{ feet}$$

So the corresponding vertical offset of port gun No. 3 is 5.47 feet (subtract 1.53 feet from 7 feet, the corresponding vertical offset of the line of sight).

When you calculate the corresponding offsets for all guns in the same manner, you have—

CORRESPONDING HORIZONTAL OFFSETS	CORRESPONDING VERTICAL OFFSETS
Port gun #1—5.76 feet	5.08 feet
Port gun #2—6.43 feet	5.28 feet
Port gun #3—7.10 feet	5.47 feet

You already know that the horizontal offset of the gunsight is zero. Since the guns are to converge WITH the line of sight, the corresponding vertical offset of the gunsight remains the same as its actual vertical offset—7 feet.

Since the offsets of the starboard guns are the same as those of the port guns, you have now established the proper corresponding offset values to be marked off on your boresighting screen—for the gunsight and all of the guns.

Next, you must establish horizontal and vertical reference lines on the screen from which you can measure the actual location of your boresighting points.

Rule off a horizontal line running across the full length of the screen near its lower edge. Next, rule off a vertical line up the center of the screen perpendicular to your horizontal line. These are your horizontal and vertical reference lines FROM WHICH you will locate your boresighting points. The point where they intersect represents the datum line point on the screen.

Measure off your corresponding vertical and horizontal offsets from these lines and mark the points with a circle. See figure 23.

Note that each point is marked as a circle. Your field of vision, as you look through a gun barrel, is approximately 6 mils. Therefore, you should make the outside diameter of the aiming circles slightly smaller than the 6 mil field, so that when

you have a gun perfectly alined on its boresighting point you will be able to see a narrow rim of white space around the outside of the aiming circle, as you sight through the gun barrel.

With your boresighting pattern marked on the screen, you are now ready to boresight the airplane.

First, you place the airplane in its proper flight attitude. You do this by raising the tail (taking care to attach counterweights so that the airplane

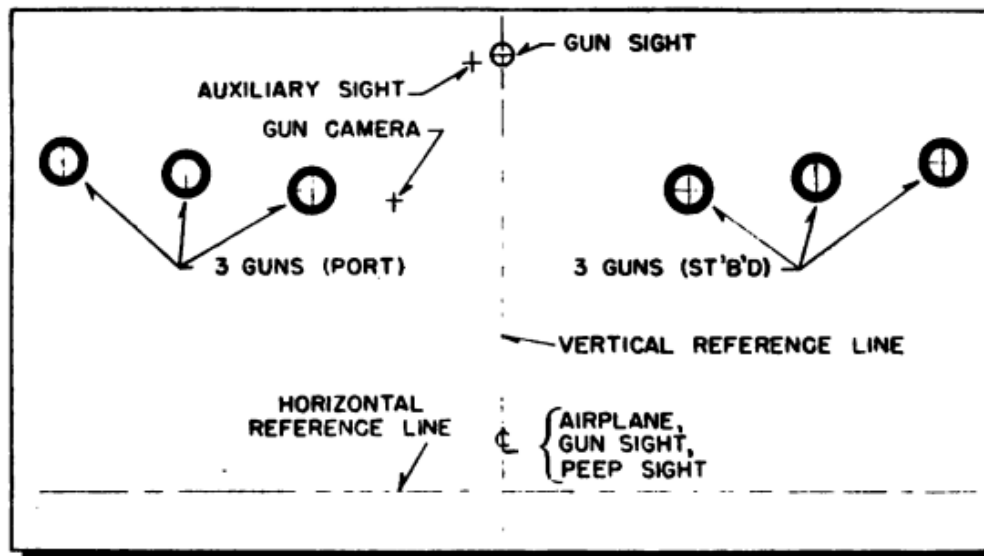

Figure 23.—Boresighting screen showing location of boresighting points.

doesn't pitch over on its nose) until the datum line formed by the boresighting rods is level.

Next, you set up the screen 30 feet in front of the airplane. From what point on the airplane are you going to measure off this distance?

The point from which this measurement should be taken is specified in the ERECTION AND MAINTENANCE MANUAL. Usually, it is the average location of the front gun mounting posts—or, the MEAN FRONT GUN MOUNTING POST. You can assume that the No. 2, or center, gun in each wing represents the mean front gun mounting post. So you can measure off 30 feet from that point.

By measuring the 30 feet distance from both the starboard and port #2 guns, you can make sure that the screen is equidistant at all points from the airplane.

Sight through the boresighting rods and point the datum line on the intersection of the vertical and horizontal reference lines on the screen. Also make certain, by sighting along the front rod to the horizontal line on the screen from each side of the after rod, that the horizontal and vertical reference lines on the airplane are parallel to those on the screen. See figure 24. When screen and airplane are in proper alinement, brace the wings of the airplane with jacks so they won't move as they are being worked on, and you're all set to go.

The airplane mounts an illuminated sight Mark

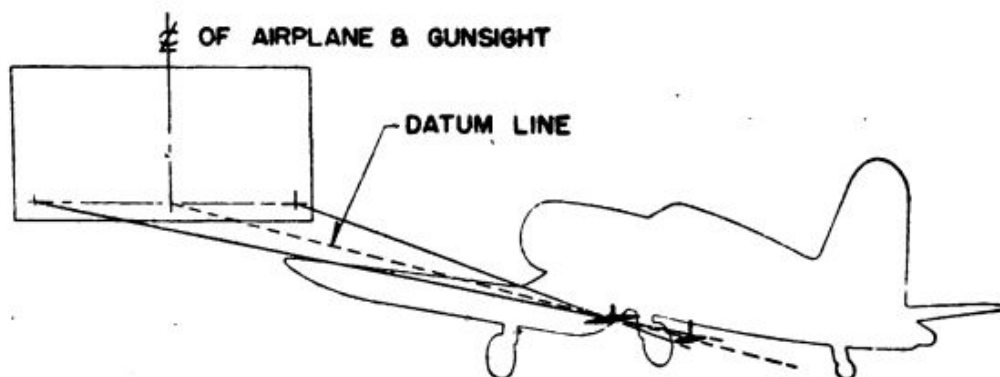

Figure 24.—Alining airplane and screen.

8, so first you center the pippier on the proper aiming point on the screen by loosening the boresighting nuts and making the proper adjustment in azimuth and elevation. When the sight is centered on the aiming point, tighten the boresighting nuts to hold it in place.

Now you boresight the guns. For this purpose you use the boresighting kit Mark 1. The boresighting kit contains optical sighting extensions that can be inserted into the breeches or the

muzzles of guns mounted in inaccessible locations. You sight through the eyepiece of the optical sighting extensions, just as if you were looking through the barrel of the gun.

Boresight adjustments are made on the rear mounting post assembly. You adjust the height of the post above the mounting plate to obtain the correct elevation and you adjust the position of the threaded sleeve to obtain the correct position in azimuth. Move the gun until the aiming point circle is centered exactly in the gun bore, as seen through the boresighting extension eyepiece. When the gun is in this position, tighten the proper nuts on the rear mounting post—and the gun is boresighted.

Repeat this operation on all six guns, and the boresighting job is complete.

Of course, once you have constructed a boresighting screen, you can use it over and over again—and one screen will do for all fighter planes of the same model, too. This holds true as long as you use the same pattern.

In this example, you boresighted the airplane so that the lines of fire and the line of sight would converge at 750 feet. That BORESIGHTING PATTERN was used merely for illustrative purposes.

Actually your squadron commander may specify that the squadron fighter planes be boresighted in any pattern he chooses. For example, he might say that the No. 2 port and starboard guns should be boresighted to converge at 250 feet, lines of fire to intersect the line of sight at 275 feet; the No. 3 port and starboard guns should converge at 450 feet, fire to intersect the line of sight at 600 feet; and the No. 1 port and starboard guns should converge at 450 feet, fire to intersect the line of sight at 175 feet.

This sort of boresight pattern would have the "most air" full of the "most bullets" for the greatest range coverage. If you were working under such specifications, you would construct your boresighting screen in exactly the SAME MANNER as before. The ONLY DIFFERENCE would be in the location of your boresighting points.

Accuracy in boresighting is highly IMPORTANT. For instance, an error of only ONE INCH in centering a gun on the boresighting point means an error in fire of 24 INCHES (two feet) at 750 feet!

Consequently, your skill in accurately alining airplane, sights, and guns is a basic factor in welding these separate units into a single, hard-hitting weapon of offense.

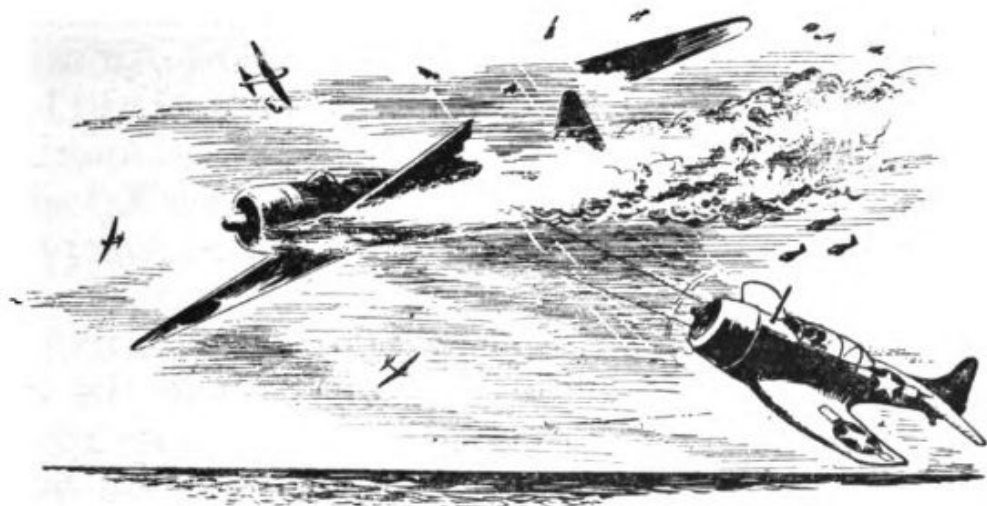

CHAPTER 4

SYNCHRONIZING

SPLIT-SECOND TIMING

One of the most important developments in World War I was the gadget which timed the firing of machine guns mounted on the fuselage of aircraft, so that the bullets whizzed between the whirring blades of the propeller without hitting and splintering these blades. This mechanism, improved and modified over the years between wars, is called a **SYNCHRONIZING SYSTEM**. Some type of synchronizing system is used on all airplanes where machine guns are mounted to fire through the rotating propeller blades.

Today, there are two types of synchronizing systems. One is the **MECHANICAL** system, the other is the **ELECTRICAL** system.

Since the mechanical synchronizing system illustrates the principles underlying the operation of **ANY** synchronizing system, and since you will probably encounter it more frequently than the electrical system, this chapter will deal only with the operation, installation, and maintenance of a mechanical system.

Before you actually get into the subject, how-

ever, stop and reflect a moment on what a synchronizing system actually makes possible. Imagine a 3-bladed propeller spinning at 1,500 rpm, with three cal. .50 machine guns mounted behind it, each of which is firing up to 600 shots per minute BETWEEN the whirring propeller blades! THAT'S what you call TIMING.

Under such conditions, if a gun hangs fire for the smallest fraction of a second, or if the synchronizing system is the least bit out of adjustment, the propeller blades may be hit. If a bullet passes through a blade, not only will the blade whistle like an air raid siren, but it MAY be so weakened that it will fly off. Then the engine probably will start racing and tear itself loose from the airplane.

The purpose of a synchronizing system is to enable the pilot to fire his machine guns so that the bullets will pass between the blades of the propeller. A synchronizing system must thus have FOUR UNITS—a MECHANISM geared to the engine which generates an impulse when the propeller is in the correct position for the gun to be fired, a CABLE to carry this impulse up to another MECHANISM to fire the gun, and SOME SORT OF CONTROL which permits the pilot to fire the guns at will.

In a mechanical synchronizing system, these units are called an IMPULSE GENERATOR, an IMPULSE CABLE, a TRIGGER MOTOR, and an ELECTRIC CONTROL SYSTEM.

All mechanical systems operate through an ECCENTRIC CAM, driving the impulse mechanism in the impulse generator. Figure 25 shows an eccentric cam. The raised surface, or "bump," on the cam is called the CAM LOBE.

You can readily see that by gearing the cam to the crankshaft of the engine, you can time the

rotation of the cam to coincide with the rotation of the propeller. Thus, if you engage the cam while the propeller blade is in a definite position and then permit the two to rotate, the CAM LOBE will be at the same point whenever the propeller blade reaches its original position.

If you held a small roller against the surface of the cam as the cam revolved, the roller would bump up and down every time it passed over the cam lobe, and if you attached the roller to a mechanism which transformed its up and down

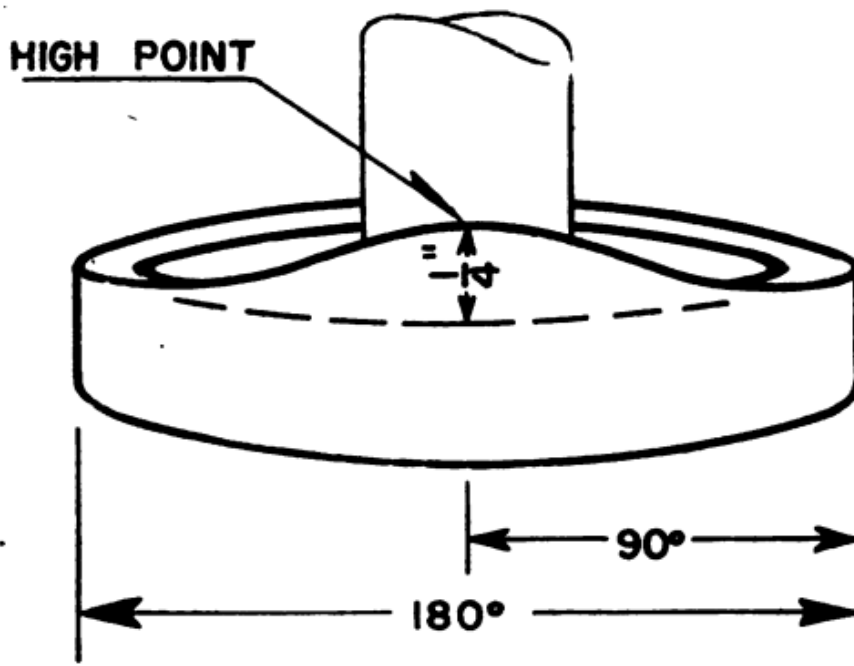

Figure 25.—An eccentric cam.

“bumping” motion into a RECIPROCATING FIRING IMPULSE, you would have a system which delivered a FIRING IMPULSE every time the propeller blades were in a certain position.

The question now is, how is this firing impulse harnessed to fire the gun?

Look at figure 26. Here is a diagrammatic illustration, showing how the firing impulse is transmitted from cam to gun.

The cam lobe forces the roller in the impulse

generator downward, and since the roller is attached to the shaft, the shaft moves downward also. This DOWNWARD movement pulls the impulse cable downward, which, in turn, pulls a section of the trigger motor attached to the gun FORWARD. The trigger motor contains a spring

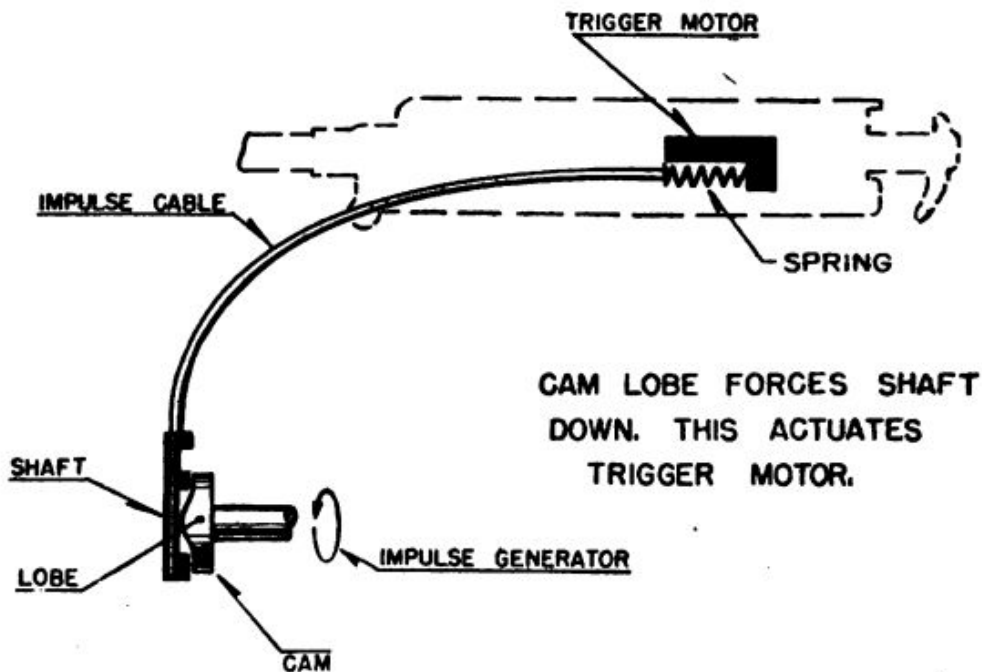

Figure 26.—Schematic outline of synchronizing system.

(see figure 26) which maintains a TENSION on the impulse cable and the impulse generator shaft, thus keeping the shaft roller pulled up tight in contact with the cam. Every time the shaft roller rolls over the cam, then, an impulse in the form of a “pull” is transmitted to the trigger motor, which employs this impulse to fire the gun.

How does the pilot control the operation of the system, and thus control the fire of his gun?

The answer is—the ELECTRIC CONTROL SYSTEM. Look at figure 27.

The pilot's control stick contains a switch, which, when squeezed—or “closed”—sends a current through a solenoid. When the current energizes the solenoid, the solenoid plunger is RETRACTED WITHIN the solenoid.

In figure 27, you can see how this action controls the operation of the synchronizing system. There is a slot in the shaft of the impulse generator into which the solenoid plunger fits when no current is flowing through the solenoid. A spring within the solenoid forces the plunger OUTWARD when the pilot shuts off the current by releasing the switch. The plunger, under pressure of the spring, snaps into the slot in the impulse generator shaft, thus locking the shaft and arresting its motion. Notice that the slot in the shaft is in line with the plunger of the solenoid when the shaft is ON the cam lobe, and the shaft is thus pulled down its greatest distance. The solenoid plunger has a beveled head, and as the plunger snaps into the slot in the shaft, the beveling forces the shaft down a sufficient distance

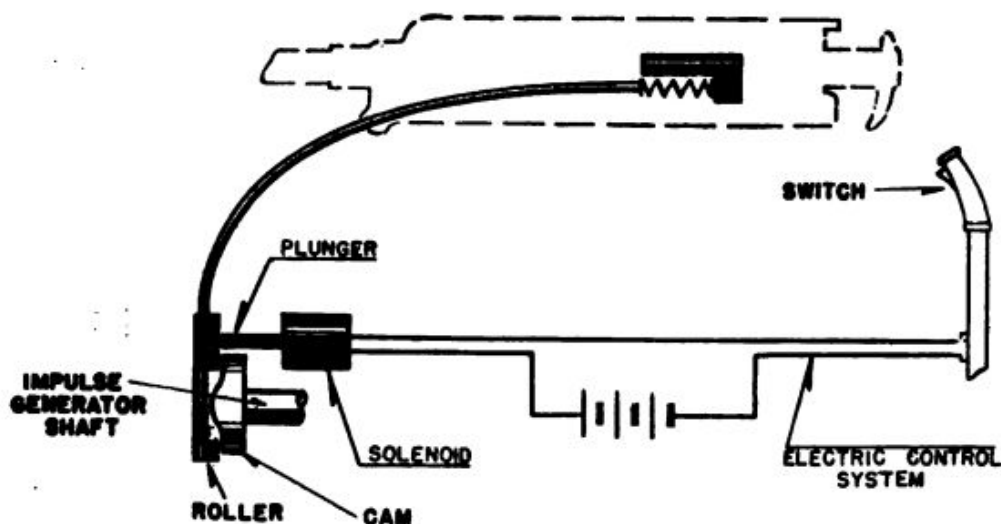

Figure 27.—Synchronizing system with electric control system.

so that the shaft roller is no longer in contact with the cam, even at the highest point on the lobe. So while the cam continues to rotate, the same as before, the entire synchronizing system is locked stationary and is inoperative, because the roller is no longer in contact with the cam.

When the pilot presses the switch again, however, the solenoid plunger will be withdrawn from the shaft, the tension of the spring in the trigger motor will snap the roller against the cam again, and firing impulses will once more be delivered to the trigger motor.

Incidentally, there are other gun switches in the cockpit which the pilot snaps ON when he is going into combat. These switches put "life" into the switch on the control stick and are mainly for safety purposes. If the pilot couldn't "kill" the

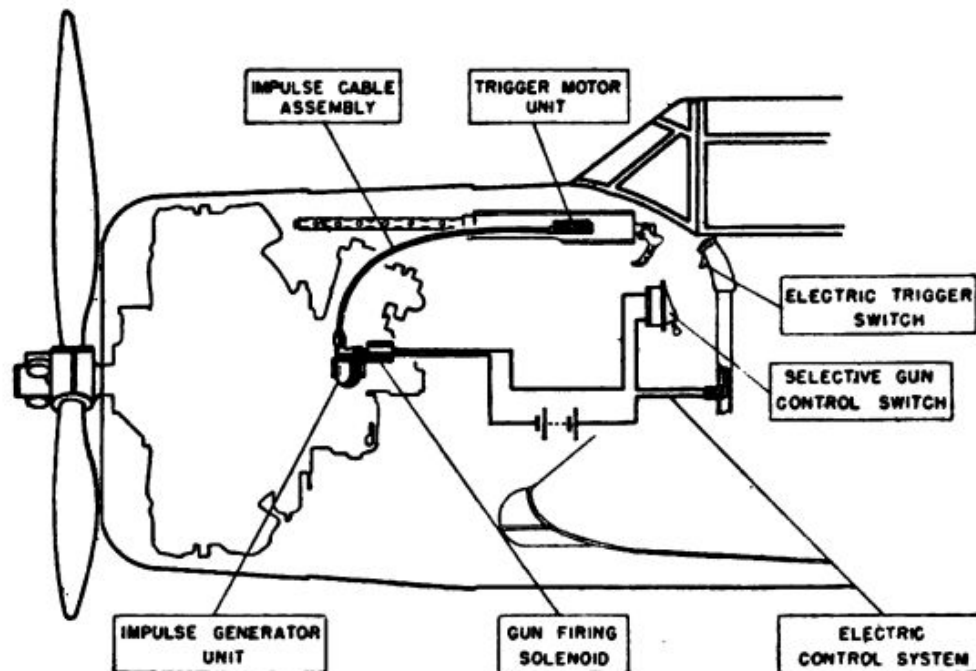

Figure 28.—Diagram of a typical, mechanical synchronizing installation as installed.

switch on his stick, he might knock off some of the boys on the flight deck as he leaned on the stick when taking off and landing. These gun switches were not mentioned in the description of the operating principles of a synchronizing system because, once they are turned on, they actually have nothing more to do with the operation of the system.

There—in brief—is the way a typical, mechanical synchronizing system works. Figure 28 illus-

trates such a system as is usually installed, showing the relationships between the various units.

Now for a close-up of the various units in the system.

First, the **IMPULSE GENERATOR**. In figure 29 you see the outside and the inside of a Pratt and Whitney impulse generator E-4. Do you recognize the cam, the shaft, the shaft roller, and so on? Your introduction to the proper names of these various parts of an impulse generator has been postponed until now. The cam is still a **CAM**, but the "shaft" is properly called a **CAM FOLLOWER**, and the "shaft roller" is called a **CAM FOLLOWER ROLLER**.

The solenoid plunger is in a locked position and the synchronizing system is not operating. Even so (presuming that the airplane engine is running), the cam is revolving, driven by the cam shaft idler of the engine. When the solenoid plunger is withdrawn from the slot in the shaft by the pilot pressing his trigger switch, the tension of the trigger motor spring which is transmitted to the cam follower by the impulse cable pulls the cam follower roller UP into contact with the cam. As the cam rotates, the cam follower moves up and down **ONCE** for **EACH ROTATION** of the cam. If you refer back to figure 25, you will see that the cam lobe is $\frac{1}{4}$ " high at its highest point. Thus the cam follower moves one-fourth of an inch as the roller passes over the cam lobe.

The **IMPULSE CABLE** assembly merely consists of a steel piano wire within a tube. Each end of this tube carries fittings by means of which the wire cable can be attached to the impulse generator and the trigger motor. See figure 31.

Figure 32 shows the external and internal views of the **TRIGGER MOTOR** Mark 1, Mod. 1. As

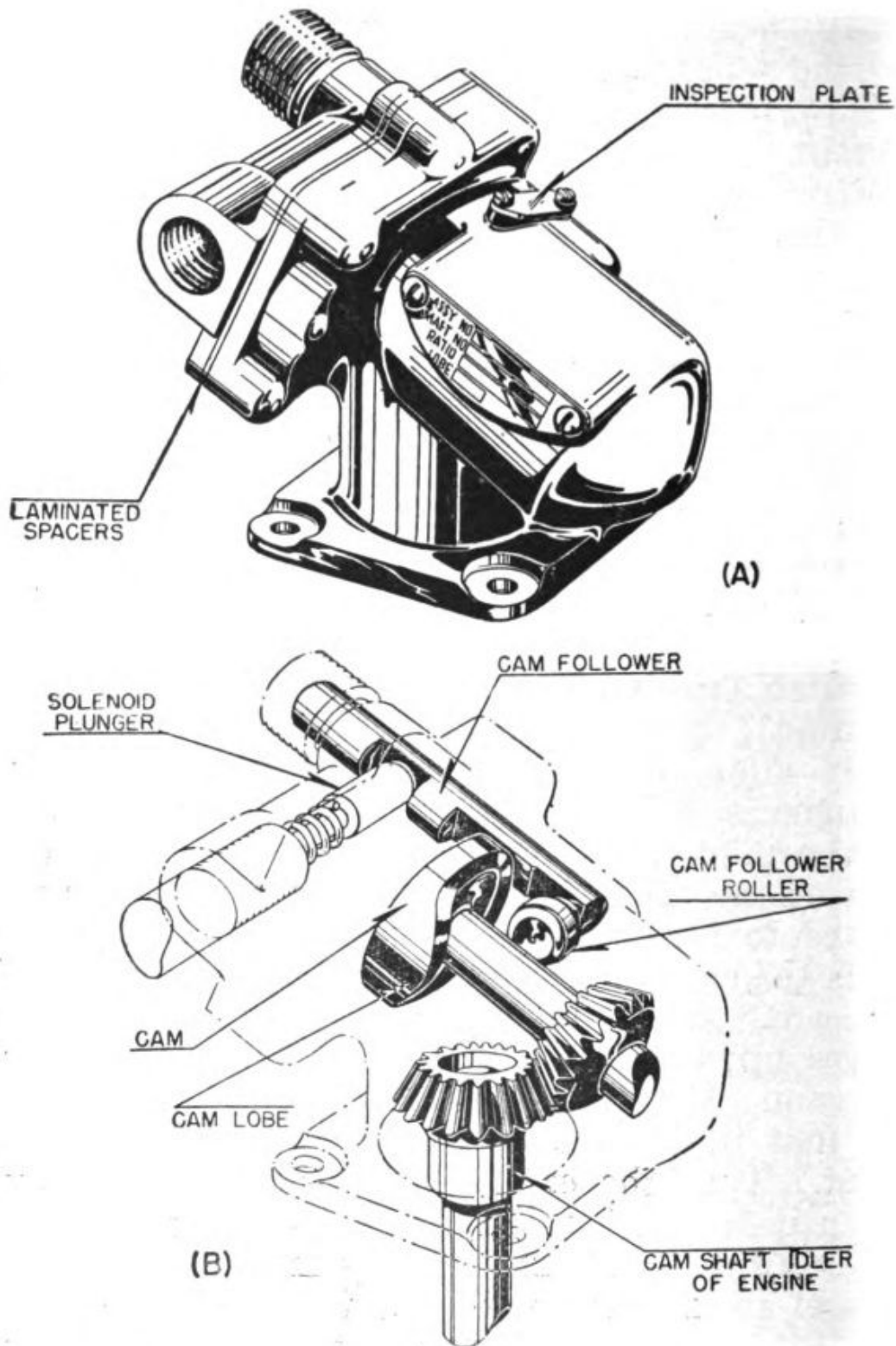

Figure 29.—Impulse generator, type E-4 (Pratt and Whitney).

the impulse cable is pulled forward by the cam follower of the impulse generator, the plunger spring is compressed, and it is this spring tension

which keeps the cam follower roller in contact with the cam surface as long as the synchronizing system is in operation. Note that the entire TRIGGER MOTOR PLUNGER moves as it is pulled by the impulse cable. Note also, that to fire the

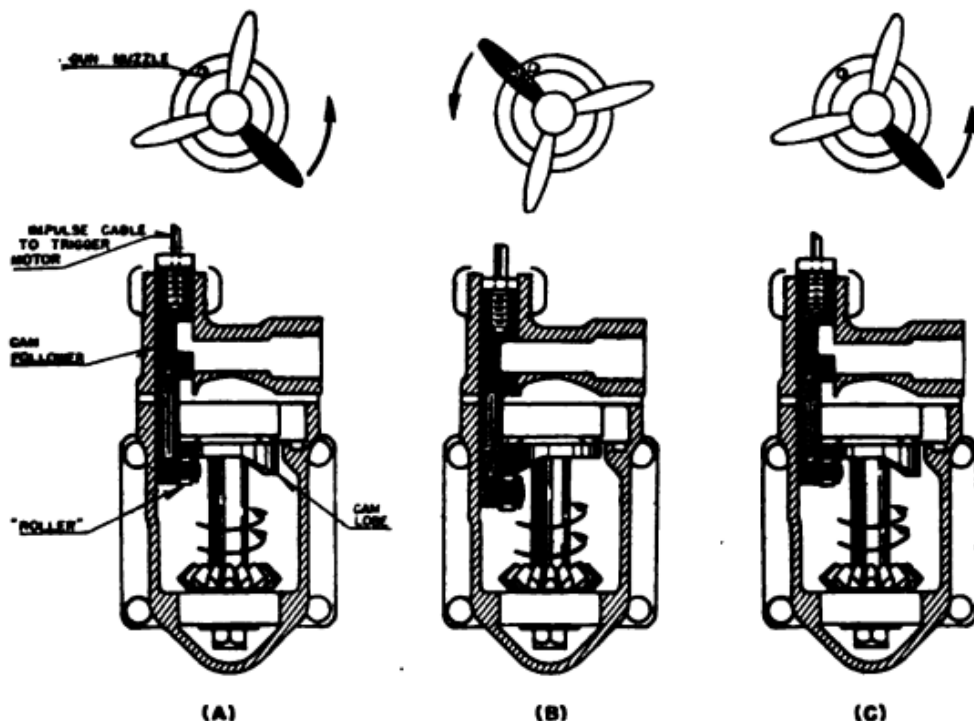

Figure 30.—Cam lobe rotation in relation to the propeller rotation.

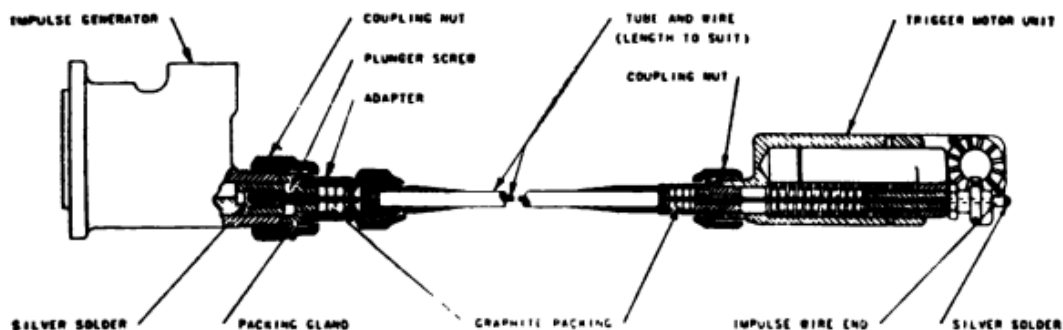

Figure 31.—Impulse cable assembly.

gun, the trigger motor changes the direction of the impulse 90° by means of a slide which operates against a cammed notch in the trigger motor plunger.

As the plunger moves forward, the cammed notch moves the slide inward. When the trigger

motor plunger moves backward, the slide is withdrawn from the gun by the tension force of the slide spring, which is compressed each time the slide enters the side of the gun. The tension of the slide spring forces the cammed surfaces of

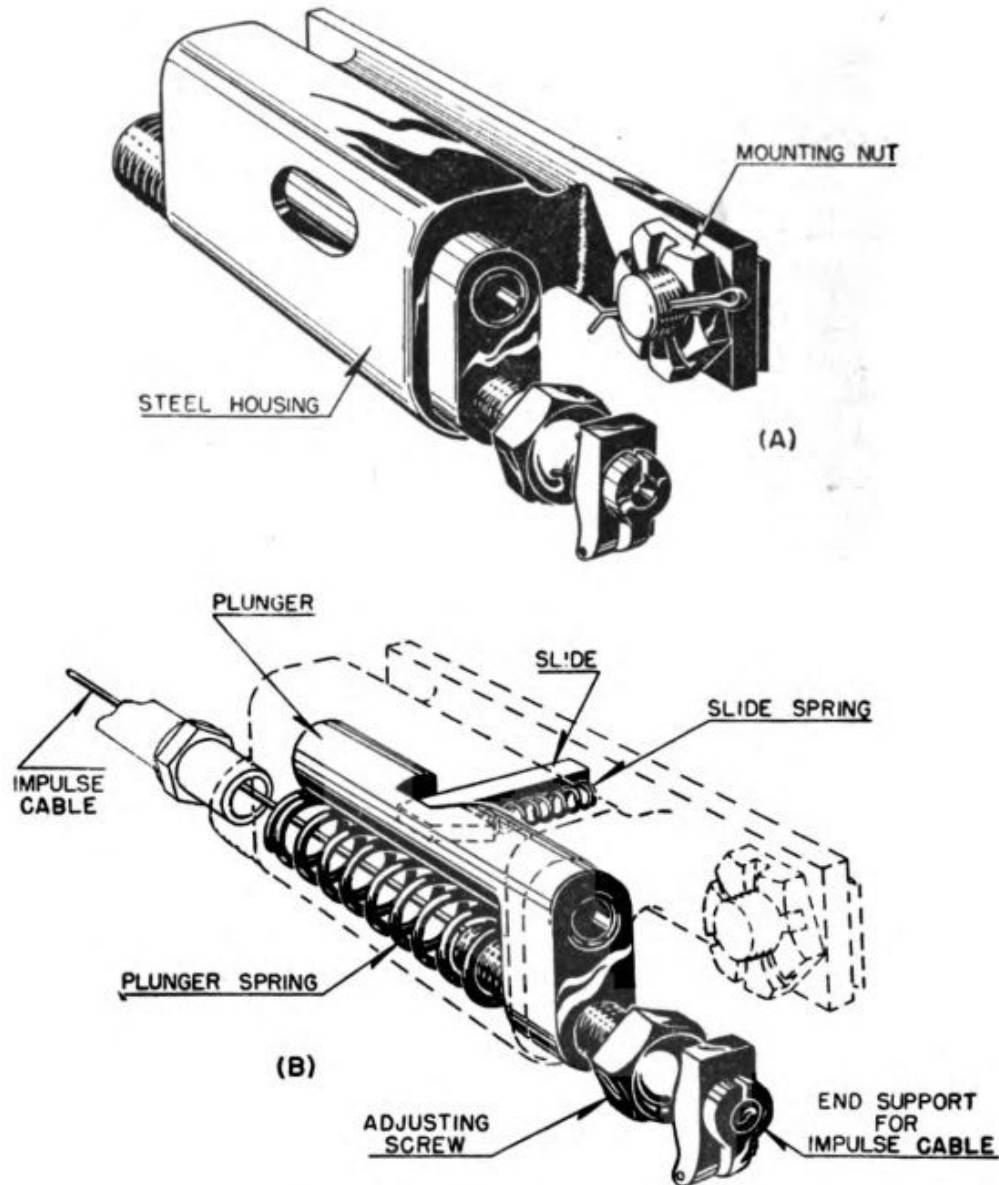

Figure 32.—Trigger motor, Mark 1, Mod. 1.

the slide and the notch in the trigger motor plunger to return to contact after each firing impulse has been delivered.

You now see how the slide in the trigger motor is forced into the side of the gun each time the

cam follower roller in the impulse generator rolls over the high point, or lobe, on the cam.

How does this action fire the gun?

The trigger motor slide strikes the SEAR of the gun. The sear is driven inward, thus releasing the FIRING PIN, and so firing the gun. The backward movement of the trigger motor plunger allows the slide to withdraw from the gun, and the gun may thus ready itself to fire another round.

Figure 33 shows the complete cycle of operation. Think of these three pictures as a "slow-motion" movie of the operation of the trigger motor with the TOP cut away. In (A) the trigger motor slide is within the trigger motor housing, since the blade of the propeller with which the rotation of the cam lobe is synchronized is not yet in a firing position. In (B) the blade has just passed the gun muzzle, and it is time for the gun to be fired. So the cam follower roller is up on the lobe of the cam, and the trigger motor plunger is pulled forward. This, as you can see, has driven the trigger motor slide inside the gun, thus tripping the sear and releasing the firing pin.

In (C) the slide has once again withdrawn into the trigger motor housing.

Imagine this complete cycle taking place up to 1,500 times per minute, and you have a picture of a trigger motor in operation.

In view of the speed at which firing impulses are delivered, the entire system must be perfectly adjusted to extremely close tolerances. The generation of the firing impulse by the cam follower and the resulting action on the gun sear by the trigger motor slide must be virtually instantaneous. Any maladjustment, such as excess slack in

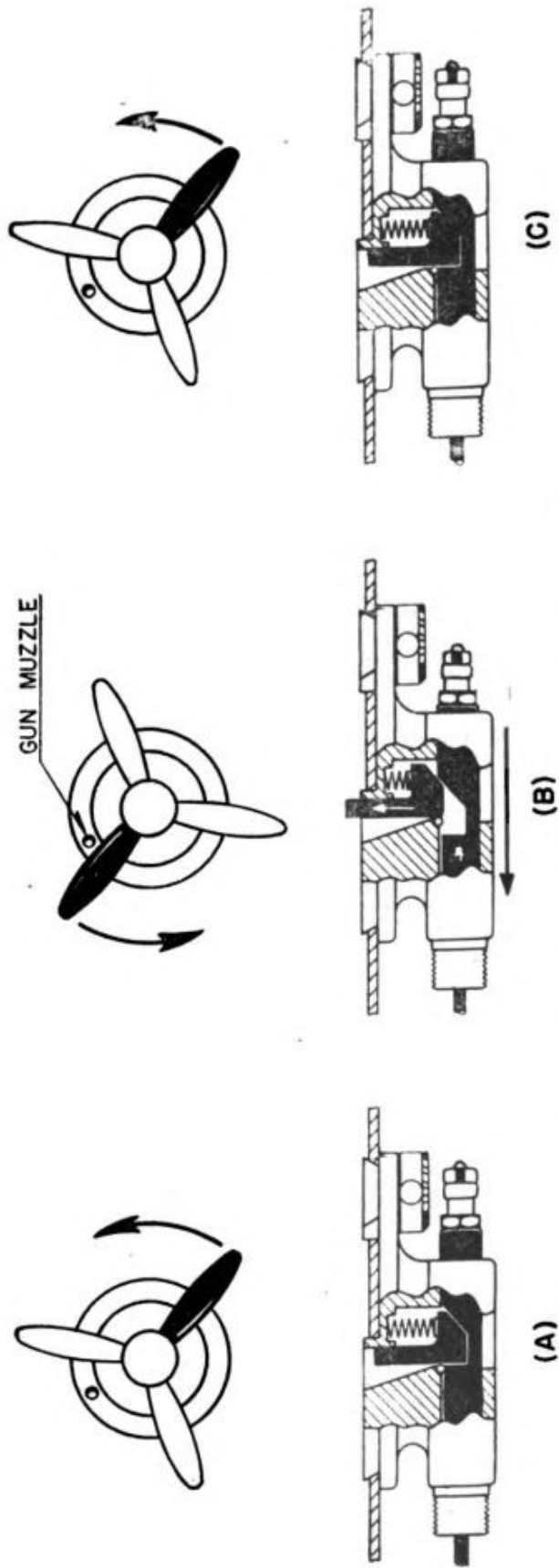

Figure 33.—Trigger motor action in relation to propeller.

the impulse cable, would throw the timing of the whole system out of kilter.

Therefore, your first step in either installing, repairing, or adjusting a synchronizing system is to CHECK THE OPERATION OF EACH UNIT in the system.

CHECK AND DOUBLE CHECK

Start with the GUN, or GUNS. A non-synchronized machine gun, firing automatically, operates at its maximum rate of fire. With a synchronized gun, however, firing is semi-automatic, and the rate of fire is determined by the number of impulses delivered to the gun.

Since, as you know, the number of impulses varies with the engine speed, a synchronized gun must be in top-flight mechanical condition if its rate of fire is to be kept at a maximum consistent with engine speed.

You begin, then, by carefully inspecting the guns, checking the headspace adjustment, looking for missing cotter pins, broken lock wires, and so on. In short, make absolutely certain that the gun is in PERFECT operating condition.

Next, check the TRIGGER MOTOR. With the Mark 1, Mod. 1, the SLIDE should protrude 0.322" (+0.000-0.009) from the housing of the trigger motor. That may sound to you like pretty close figuring. But if the slide does not protrude far enough, it will not depress the sear slide of the gun sufficiently to release the firing pin—and the gun won't fire. If, on the other hand, the slide protrudes too much, it will damage the sear slide or the bolt of the gun.

You must also check the housing dimensions of the trigger motor, for, if the trigger motor is positioned too far toward the rear of the gun, the trigger motor slide may strike the sear slide when

the gun is too far "out of battery", and the gun may fire too early. When this happens, the extractor may fail to pick up a new cartridge from the belt. You use a special gage to check the housing dimensions of the trigger motor, and you should scrap any motors whose housing dimensions are greater than the dimensions of the gage.

A mechanical trigger motor must incorporate an allowance for what is called **OVERTRAVEL**. Overtravel is the forward movement of the trigger motor plunger which takes place **AFTER** the firing pin of the gun has been released. Overtravel is necessary to insure that the slide will always trip the sear in the gun, so that the gun will fire with each impulse.

Here's how you check on overtravel. Mount the trigger motor on the gun and slowly pull the plunger forward until the slide trips the firing mechanism of the gun. As soon as you hear a "click," indicating that the firing pin has been released, measure the amount of the plunger still extending out of the trigger motor housing. For the trigger motor Mark 1, Mod. 1, the correct amount is $\frac{3}{64}$ of an inch. If the plunger does not protrude this amount when the firing pin is released, recheck the firing mechanism of the gun and all of the parts of the trigger motor.

Next, check the **SOLENOID**. Figure 34 gives you a close up view of a typical electro-magnetic solenoid.

Connect the terminals of the solenoid to a battery circuit. When you close the circuit and thus apply voltage to the solenoid, the solenoid plunger should retract $\frac{3}{16}$ of an inch. If it does not withdraw this distance, first try to adjust the plunger, and if this doesn't work, replace the entire solenoid unit.

Any solenoid, however, which is not damaged internally, should work satisfactorily, after you have carefully removed all burrs and washed all working parts with clear gasoline.

Since the total movement—or **THROW**—of the solenoid plunger is only $\frac{3}{16}$ of an inch, you can see that the position of the plunger on the plunger screw must be adjusted very accurately.

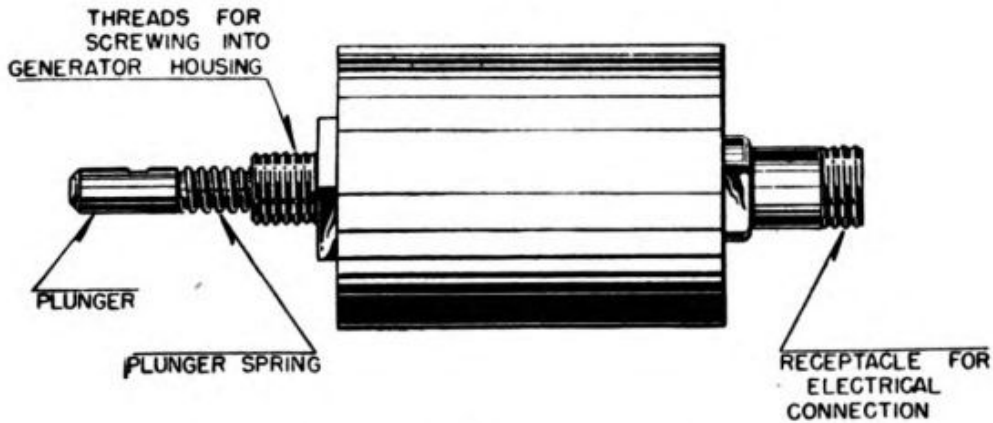

Figure 34.—Typical electro-magnetic solenoid.

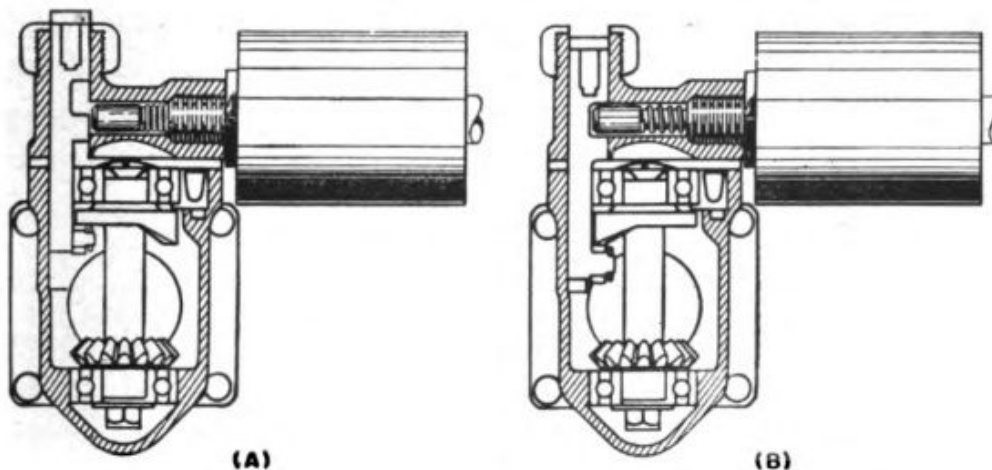

Figure 35.—Solenoid secured to impulse generator housing.

In figure 35 (A), the solenoid is in the retracted, or operating, position. Notice that there must be a small clearance between the end of the plunger and the side of the cam follower to permit the cam follower to operate freely when the plunger is disengaged. In (B), when the plunger is engaged, as much of the $\frac{3}{16}$ " throw as possible

should lock the cam follower so as to hold the roller free of the rotating cam.

There is little for you to check on the **IMPULSE CABLE**, other than to make sure that the cable is in good condition and is of the proper length for the particular installation.

When you come to the last unit in the system—**THE IMPULSE GENERATOR**—the important thing is the clearance between the cam and the cam follower roller when the synchronizing system is inoperative. The correct clearance for each type of generator is given in the instruction manual for that type.

If there is too little clearance, the cam and cam follower roller may be damaged or “burned,” whereas too much clearance may result in uncontrolled automatic fire of the guns because the solenoid plunger is unable to seat properly in the cam follower locking recess.

The method of adjusting this clearance varies with each type of generator, and full instructions are always given in the instruction manuals.

This covers the main points which you must check throughout the synchronizing system.

SYNCHRONIZE IT

You understand the function which each of the units in the system performs, and you know how to make sure that each unit is operating properly.

Assuming that you have a synchronizing system that will transmit perfectly a firing impulse from impulse generator to gun, however, how do you align the firing impulses with the rotation of the propeller? In other words, how do you **SYNCHRONIZE** the system?

Suppose **YOU** are installing a synchronizing system. First, you mount the trigger motor on the gun and the gun on the airplane.

Next, you boresight the gun. The gun **MUST** be boresighted properly before you adjust the synchronizing system, for any movement of the gun afterward might result in damage to the system and possibly even to the airplane itself.

Now comes the tricky part—installing the impulse generator on the engine. Once the generator is bolted into place and the cam drive gears are meshed with the cam shaft idler of the engine, a relationship between the rotation of the cam lobe and the rotation of the propeller is established. The idea is for you to be **SURE** that this relationship is one which will result in bullets passing **BETWEEN** AND NOT INTO the propeller blades.

Remember, the cam and the propeller always rotate at the **SAME** rpm. When the propeller rotates 90° , the cam rotates 90° , too.

Look at figure 36. This is a diagrammatic illustration of the relationship between the gun muzzle and the propeller blades, as viewed from the cockpit of the airplane.

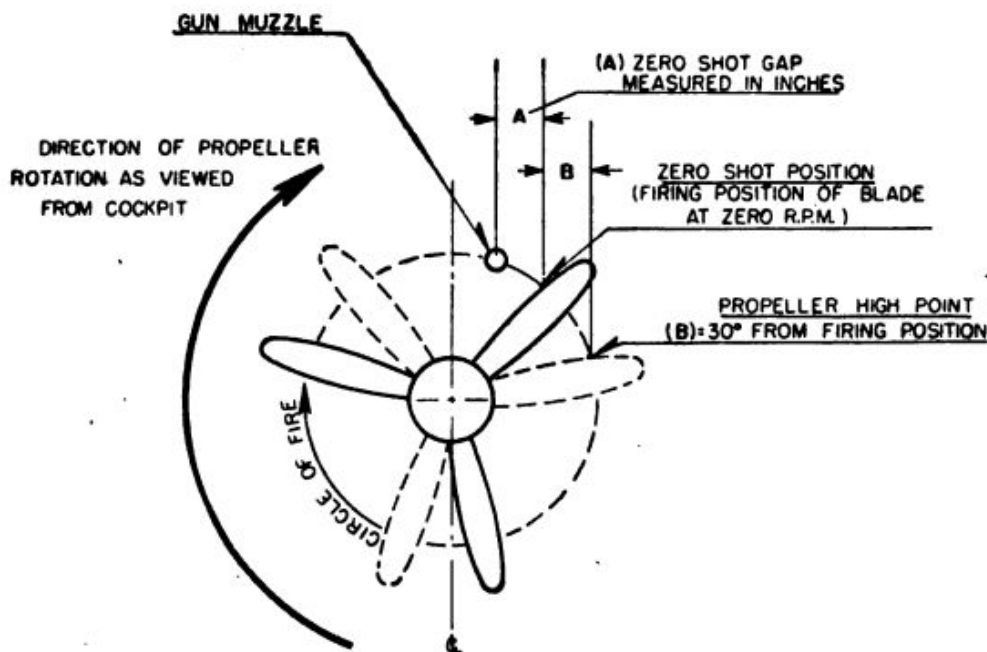

Figure 36.—Zero shot and propeller high point positions.

The starting point from which adjustments are made to synchronize propeller and machine gun is called the **ZERO SHOT POSITION**. This is the position of the propeller blades in relation to the **LINE OF FIRE** at the instant that the firing pin of the gun is released. And, since the gun is geared to fire with the propeller in zero shot position, the zero shot position never changes, irrespective of the speed of the propeller. The firing of the gun is timed to conform with **ONE PARTICULAR BLADE** of the propeller, and the term "zero shot position" specifically refers to the position of this one blade at the time of firing pin release.

Now consider two basic facts.

First, the **TIME INTERVAL** required for the action of the gun and for the bullet to travel from the chamber through the barrel to the plane of propeller rotation is practically **CONSTANT** for each shot.

Second, the distance traveled by the propeller blade during this **SAME INTERVAL OF TIME** will vary with the speed of the engine. For example, if a bullet passed 8 inches behind the propeller blade at **ZERO rpm**, it would pass **MORE** than 8 inches behind the blade at 500 rpm, still more at 1,000 rpm, and still more at 1,500 rpm, until, finally, if you ran the engine fast enough, the bullet would strike the edge of the following blade.

Obviously, you must time the operation of the impulse generator, so that a bullet fired at zero rpm, or **ZERO SHOT**, will pass through the plane of propeller rotation a certain distance behind the trailing edge of the propeller blade. This will allow the distance from this point to the leading edge of the following blade for bullets fired at various engine speeds to pass through the plane of propeller rotation.

The exact distance that the "zero shot" should pass behind the trailing edge of the propeller blade is given in the ERECTION AND MAINTENANCE MANUAL for each type of airplane that contains mountings for synchronized guns. This distance is measured in INCHES along the CIRCLE OF FIRE between the line of fire of the gun and the trailing edge of the propeller blade. It is called ZERO SHOT GAP.

Suppose you know that the zero shot gap is 8 inches. What do you do? Rotate the propeller 8 inches past the line of fire—ALWAYS in the direction of normal propeller rotation—measuring with a rule held against the trailing edge of the propeller blade. The propeller is now in ZERO SHOT POSITION. The propeller should ALWAYS be at that point when the gun is fired.

BUT—remember OVERTRAVEL? You know that the firing impulse is delivered to the gun BEFORE the cam follower roller is at the exact high point on the cam lobe. Thus, the trigger motor plunger travels FORWARD an additional distance AFTER the firing pin of the gun has been released. This additional forward travel is your OVERTRAVEL.

Therefore, the propeller blade must travel PAST the zero shot position (when the gun is fired) to the so-called HIGH POINT POSITION before the cam follower roller will be on the high point of the cam. And since you mesh the cam drive gear with the cam shaft idler when both the propeller and the cam follower roller are at "high point," you must place the propeller in the HIGH POINT POSITION. See figure 37.

To obtain the HIGH POINT POSITION, you rotate the propeller 30° past the zero shot position.

Then, holding the impulse generator in your hands, rotate the gear of the impulse generator until the cam and cam roller are in contact on the exact high point on the cam.

With the propeller blade and the impulse generator both in the high point position, install the generator on the engine.

After the installation is complete, you must check to make certain that both the propeller blade and the generator are precisely aligned on high point. You do this by rotating the propeller around to zero shot position. Then, instead of

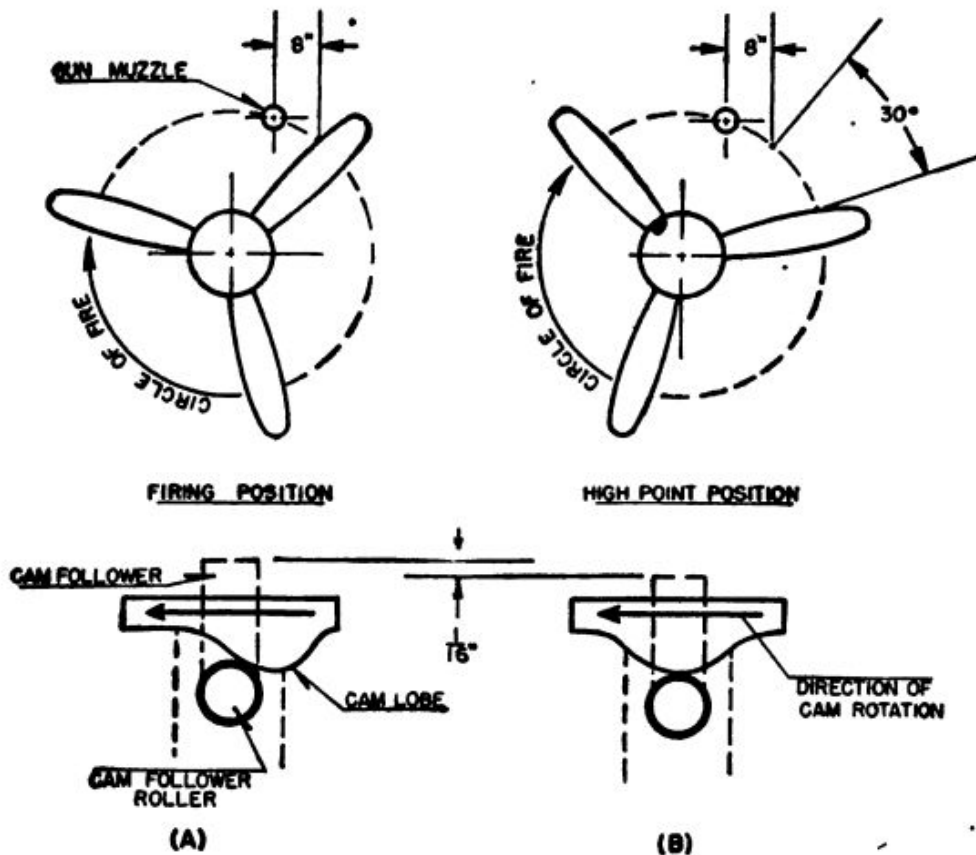

Figure 37.—Overtravel—the relative positions of cam follower roller and propeller blade.

attaching the impulse cable to the cam follower shaft, screw a bolt into the socket where the impulse cable would normally be connected. Take a firm grip on the bolt and pull the cam follower as far out of the impulse generator housing as it will go (with the propeller still in zero shot position). As someone pulls the propeller slowly in the direction of rotation, maintain a firm hold on

the bolt and measure, with a steel scale having $\frac{1}{16}$ " graduations, the distance which the cam follower recedes into the housing. If the distance is more or less than $\frac{1}{16}$ " as the propeller moves from zero shot to high point, remove the generator and re-mesh the drive gear with the engine gear, starting again with the propeller in high point position.

After the generator is properly installed on high point, rotate the propeller approximately 90° to the low point position, so that you can pull the cam follower (by means of the bolt) as far out of the generator as it will go, in order to make it easier for you to attach the impulse cable assembly.

Now install the impulse cable assembly. Unscrew the bolt you have been using to adjust the generator, and attach the impulse cable in its socket. In some cases, you may find it necessary to remove the trigger motor from the gun to attach the cable assembly at that end. Also, you must make certain that the cable assembly is firmly attached to the airplane.

Next, you charge the empty gun. First, continue to rotate the propeller all the way around until it is again at zero shot position. Tighten the trigger motor adjusting screw until the firing pin in the gun is released. Then screw the lock nut up against the plunger. Now rotate the propeller to low point and charge the gun.

ALWAYS CHARGE THE GUN WHEN THE PROPELLER IS IN THE LOW POINT POSITION.

Turn the propeller slowly and steadily until the firing pin in the gun is released. Place your steel measuring scale on the trigger motor plunger and note the exact distance that the trigger motor plunger protrudes from the housing. Again, turn the propeller, in the same direction,

to propeller high point, and measure the distance the plunger is now protruding from the housing. The difference between the second reading and the first reading on the scale is the amount of **OVER-TRAVEL**.

PLAY SAFE

You have to be careful when you're working on an airplane with synchronized guns for an accident usually means that someone is injured—and that someone might well be your best friend.

MAKE ABSOLUTELY CERTAIN THAT THERE IS NO LIVE AMMUNITION IN THE GUN AT ANY TIME WHEN YOU ARE WORKING ON THE SYNCHRONIZING SYSTEM.

Be sure that the ammunition belt is not connected to the gun (so that the gun will not be loaded by accidental charging) and that no one is in the line of fire when the propeller is being pulled through.

Always be certain that the ignition switch is **OFF**.

Never rotate by hand the propeller on a hot engine, or on an airplane which has just landed. Allow the engine to cool sufficiently so that there will be no danger of a kick back.

When working with the propeller of any airplane, **DON'T TAKE ANY CHANCES**—or you may find yourself wearing the wings of an angel, rather than those of an Aviation Ordnanceman.

INSPECTION

Every machine gun synchronizing system must be given a complete inspection at frequent intervals. In addition to the system itself, you must examine carefully the gun, gun mount, ammunition boxes, feed and ejection chutes, fixed gun sights, blast tubes, etc.

Here are the major points to check.

Headspace adjustment of the gun.

Boresighting alinement.

Gun mounting posts.

Mounting and alinement of blast tube.

Zero shot position.

Trigger motor overtravel.

Impulse cable tube (check to see it is not pinched or compressed at any point).

Clearance between cam and cam follower roller when system is inoperative.

Condition of component units in synchronizing system.

Alinement of feed and ejection chests with respective gun openings.

Anchorage of ammunition box.

If worn, bent, or damaged parts are discovered during the check-up, **REPLACE THEM AT ONCE.** Never permit a system with such parts to be operated for **A FAILURE OF ANY PART OF THE SYSTEM MAY RESULT IN PROPERTY DAMAGE OR CASUALTIES.**

TROUBLE SHOOTING

Your ability to diagnose trouble in the synchronizing system depends entirely upon your knowledge of the operation of the various units of the system. You must have a mental picture of the function of each moving part in the system, and the more thorough and complete your knowledge and understanding, the easier it will be for you to locate quickly any malfunction which may occur.

If the trouble cannot be readily and quickly located, don't begin to tear the system apart. True, you probably could eliminate the difficulty by replacing each unit in turn until the defective

one is discovered, but this is bad practice, for you will inevitably remove many parts which are in good working order. Take the system apart only as a last resort.

To begin the trouble shooting process, first try to make a quick diagnosis of the trouble as discovered and reported by the pilot. Remember, however, that in most airplanes the pilot cannot see the machine guns, and that you must first verify the symptoms as he reports them before trying to find the cure. When the pilot is able to see the trigger motor, he can give you a clearer idea as to which unit or part may be causing trouble. In any case, make a systematic inspection. A particular malfunction is usually due to one or more definite causes, and if you have a mental list of these causes in mind—beginning with the most probable and ending with the least probable—and you check off the list as you try to locate the trouble, you are bound to win by a simple process of elimination.

The largest percentage of synchronizing troubles are due to improper adjustment or malfunction of the gun itself. A machine gun that is in perfect mechanical condition is basic to the smooth operation of a synchronizing system.

Here are the principal difficulties which may occur—

Failure of the gun to fire when the trigger is depressed.

Spasmodic or interrupted fire when the trigger is depressed.

Full synchronized fire when the trigger is not depressed.

Unsynchronized (or full automatic) fire.

Suppose you examine these troubles one by one.

FAILURE OF THE GUN TO FIRE

Check the trigger motor plunger. If it moves a full $\frac{1}{4}$ " , the system is performing all the work required of it. You can then safely assume that the equipment from the generator up to the trigger motor is in satisfactory condition. The trouble must be in the gun, the ammunition, or the trigger motor slide.

To determine whether the trigger motor slide is at fault, remove the backplate and bolt from the gun. Squeeze the trigger while someone rotates the propeller. If the slide moves in and out of the receiver $\frac{1}{4}$ " , and the end is not broken off, the fault is in the gun or the ammunition. In this case, inspect the ammunition for short rounds, defective primers, etc., and check all operating parts of the gun.

If the trigger motor plunger does not move a full $\frac{1}{4}$ " , however, the trouble is in the synchronizing system.

Disconnect the electric control unit from the impulse generator. If, when the propeller is rotated, the trigger motor plunger now moves $\frac{1}{4}$ " , you know that the control unit is not operating. This means you must check the entire control, from solenoid back to trigger switch, and make the necessary repairs or replacements.

But if the trigger motor plunger still does not move the correct distance with the control disconnected, you know then that the trouble is in the impulse generator, the impulse cable assembly, or the trigger motor.

So—taking things one at a time—check the trigger motor. Set the propeller at low point position and force in on the trigger motor plunger. If it can be moved farther back into

the housing you can assume that it moves freely and is not snagged or bound in any way.

If you have set excess overtravel in the system—in other words, if you have tightened up too far on the screw lock nut in the trigger motor—the nut may be striking the housing and thus preventing the plunger from going all the way forward. Check this, too. Also, excessive overtravel may cause the gun sear or sear slide to “bottom” and this, in turn, will stop the full forward movement of the plunger.

When you have satisfied yourself that the trigger motor is OK, check the impulse cable assembly. The tube may be pinched at some point, thus binding the cable wire—or the wire and screw in the cam follower may be loose—or the wire may be stretched out of length. If necessary, install a new assembly. But if the wire is stretched, locate and correct the cause.

Lastly, check the generator for free movement of the cam follower, for an excessively worn cam and for a broken cam follower roller or pin.

INTERRUPTED SYNCHRONIZED FIRE.

If the gun fires intermittently while the trigger button is depressed, check first to find out whether the trigger motor is functioning steadily and correctly while the button is held down. If it is not, check the operation of the synchronizing system as outlined above.

If the synchronizing system is in good working order and the trouble still persists, you know the gun is to blame.

Inspect the feeding mechanism to see that it properly feeds one round over against the cartridge stops each time the bolt completes one cycle of movement; that the round is properly fed down

in line with the chamber; that the belt feed lever and pivot are not worn or loose, and that the head-space adjustment is not too tight.

On caliber .50 guns, make sure that the oil buffer index finger is set in the correct position. If it is too far toward the closed position, it may prevent the gun from completing its cycle of action, and it will thus fire only single rounds, requiring that the charging handle be operated each time. Incorrect clearance between the oil buffer valve and head may also cause improper functioning of the gun.

Inspect the link belt and chutes to see that tight links are not binding the cartridges and preventing easy removal from the belt, that the belt is not binding the cartridges and preventing easy removal from the belt, that empty cases or links are not choking the ejection chutes.

FULL SYNCHRONIZED FIRE

Full synchronized fire occurs only when the firing pin is released by the trigger motor slide. Therefore, if it occurs when the trigger button is not depressed, you know that firing impulses are being delivered to the gun by the synchronizing system.

There is only one condition that can cause this trouble—the failure of the solenoid plunger to lock the cam follower down firmly away from the cam.

This may be due to any of the following causes—excess oil in the solenoid, binding of the solenoid plunger in the solenoid housing, or the setting of the excessive overtravel.

Excess overtravel places an increased spring tension upon the cam follower. The solenoid plunger must work against this increased tension and it sometimes is impossible to increase the

strength of the plunger spring a sufficient amount to overcome this added load.

The setting of excessive cam and cam follower clearance may be another cause. This places the lower edge of the notch in the cam follower farther out of line with plunger opening in the generator housing. The solenoid plunger must then lock the cam follower down a greater distance to establish clearance with the cam. You may find it impossible to increase spring tension of the plunger enough to accomplish this.

UNSYNCHRONIZED FIRE

If the propeller is shot, with holes across all the blades, the gun has been firing automatically. Unsynchronized (or full automatic) fire is a malfunction that occurs only when the firing pin is released by some means other than the trigger motor slide. To fire the cartridge at all, the firing pin must be held to the rear until the bolt is in the battery position. The firing pin is then disengaged from the sear and allowed to fire the cartridge.

In most cases of unsynchronized firing, you will find that the sear and firing pin notches do not have sufficient undercut to hold the firing pin firmly in the rearward position until released by the trigger motor slide. There are three possible causes of premature release of the firing pin, the jar of the bolt slamming into battery position; the shock of another gun being fired alongside; the vibration of the airplane or of the engine while in flight.

A weak or broken sear spring may also cause unsynchronized fire, due to the failure of the spring to hold the sear firmly in contact with the firing pin. This will allow the firing pin to be

released due to one or more of the causes mentioned above.

If only one or two holes appear in the propeller, the trouble is probably caused by poor ammunition, improper adjustment of the synchronizing system, or excessive headspace in the gun.

If several holes appear close to the trailing edge of the blades, the zero shot is probably not set at the required distance. If the holes are grouped toward the leading edges of the blades, the trouble is most likely caused by either poor ammunition or by the zero shot being positioned too far behind the propeller.

A common difficulty in a synchronizing system is loss of overtravel—and remember that a loss of overtravel always results in an INCREASE in the ZERO SHOT GAP. After the working-in period, loss of overtravel results from wear of the various parts or a change in position of some unit of the system.

To minimize the possibility of shooting the propeller blades, only grade AC ammunition should be used in synchronized machine guns.

RATE OF FIRE OF SYNCHRONIZED GUNS

A synchronized gun which has an automatic rate of fire of “*R*” shots per minute will fire at the rate at which impulses are delivered by the synchronizer until a rate of fire of “*R*” shots per minute is reached. For example, assume that a particular gun has a maximum rate of fire (“*R*”) of 600 shots per minute. You can easily see, then, if 10 impulses per minute are delivered to the gun’s firing mechanism, the gun will fire 10 shots per minute with time to spare because only $\frac{1}{600}$ of a minute is required for the action of the

gun to fire one shot (if it fires 600 shots per minute).

Similarly, 100, 200, or 500 impulses per minute would fire the gun 100, 200, or 500 times. But if 600 impulses per minute are delivered, the gun will be firing continuously and it cannot be made to fire at a faster rate.

You know that the rate at which impulses are delivered is controlled by the speed of the engine. Consequently, since guns with automatic rates of fire of 600 to 1,200 shots per minute are fired from one type of synchronizer, it has been found advisable to generate one or two impulses per revolution of the propeller. Obviously, it would be impossible to provide a synchronizer to fire every gun at its maximum rate of fire at all engine speeds.

Returning to the example of the synchronized gun having an automatic rate of fire of 600 shots per minute, what happens if the rate of delivery of impulses from the synchronizing system is OVER 600 per minute?

Assume that 610 impulses per minute are delivered to the firing mechanism. This means that the time required for each impulse is only $\frac{1}{610}$ of a minute, yet the gun requires $\frac{1}{600}$ of a minute to fire each shot. Since the rate of impulse is more rapid than the rate of fire, certain impulses will be delivered to the gun before the firing mechanism is ready to receive them. These impulses will be lost, but before the following impulse is delivered, the gun will again be ready to fire, and this next impulse will fire it.

Thus, only every other impulse will arrive at a time when the bolt of the gun is in battery position, so the actual rate of fire will be one-half of 610, or 305 shots per minute.

If impulses are delivered at the rate of 700 per minute, the second impulse still will arrive before the gun is ready to fire, and the rate of fire will be one-half of 700, or 350 shots per minute. Likewise, only one-half of the impulses will arrive at a time when the gun is ready to fire until the rate of fire is again 600 shots per minute, or the maximum rate of fire of this particular gun.

When impulses are delivered at the rate of 1,210 per minute, each impulse requires $\frac{1}{1210}$ of a minute, while the gun requires $\frac{1}{600}$ of a minute to fire each shot. Therefore, after the first shot is fired the second impulse will arrive too early. But the following impulse will arrive when the gun is again ready to fire so, that now, every third impulse will fire the gun, and the rate of fire when 1,210 impulses are delivered per minute will be 1,210 divided by 3 or 403 shots per minute.

Between 1,210 and 1,800 impulses per minute the rate of fire will be one-third of the rate at which impulses are delivered, but at 1,800 impulses per minute the rate of fire will again become 600 shots per minute.

Above 1,800 impulses per minute, only every fourth impulse will fire the gun, in the same manner as before. And so on. You see, then, that the rate of fire is greatest when the rate at which impulses are delivered to the gun is a multiple of (i. e., it can be evenly divided by) the automatic rate of fire of the gun. Note also that the rate of fire is lower when the rate at which impulses are delivered is just above a multiple of the automatic rate of fire, and that it increases until it again reaches a maximum at the next multiple of the automatic rate of fire of the gun.

The mechanical condition of the machine gun as well as the ammunition used also will have an important bearing on the automatic rate of fire. If the driving spring is weak, the speed of the gun's action will be decreased, just as it will if the various parts work hard due to burrs or excessive friction. A worn barrel will also reduce firing speed because it allows a portion of the gas to leak past the bullet, hence less recoil force is applied to the bolt.

The speed at which the powder charge and primer mixture burns will also vary the rate of fire because a slow burning mixture will apply less recoil force to the bolt. An excessive carbon deposit built up on the muzzle end of the barrel from prolonged firing will also slow down the speed of action of the gun, as too much carbon causes the barrel and front barrel bearing to bind.

Think of the split second timing required to send a bullet between the blades of a propeller turning at 1,500 rpm! At this speed, the propeller is an indistinct blur. It revolves 25 times every second. If the timing of the synchronizing system is off the smallest fraction of a second, the bullets from the gun may hit the blades instead of passing between them.

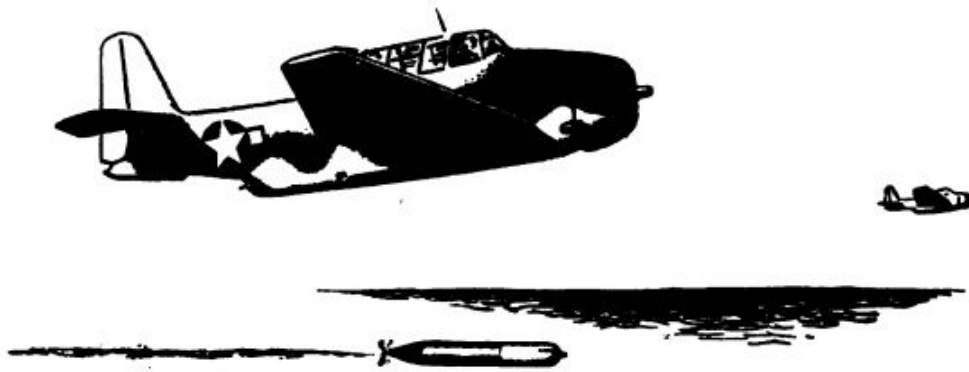

CHAPTER 5

TORPEDO DIRECTORS

FORWARD PASS

Anybody who has ever thrown a forward pass knows something about the so-called TORPEDO PROBLEM. The forward passer, himself on the run, has to gage the range, direction, and speed of the receiver. The passer has to know how fast to throw the ball and how much lead he has to allow so the ball and receiver will meet at the same place at the same time.

Of course, the torpedo problem is presented under somewhat different circumstances. The "receiver", instead of trying to "catch" the torpedo, is running himself dizzy trying to avoid it. And the "passer", instead of dodging a couple of tacklers who are merely trying to crush a few bones, must plow through most unpleasant surroundings that are designed to blow him into little pieces.

Basically, however, the problems are the same. The object is to launch the missile (football or torpedo) so that it connects with the target (receiver or enemy warship). The football player has to solve the problem in his head, whereas the torpedo bomber has the assistance of a TORPEDO DIRECTOR. Figure 38 illustrates a typical torpedo problem.

The target ship is at C , heading on course CB , and the airplane is at A . The line of sight, from pilot to target, is the line AC . The problem is—when, and in what direction must the torpedo bomber pilot launch his torpedo so that it will “collide” with the target?

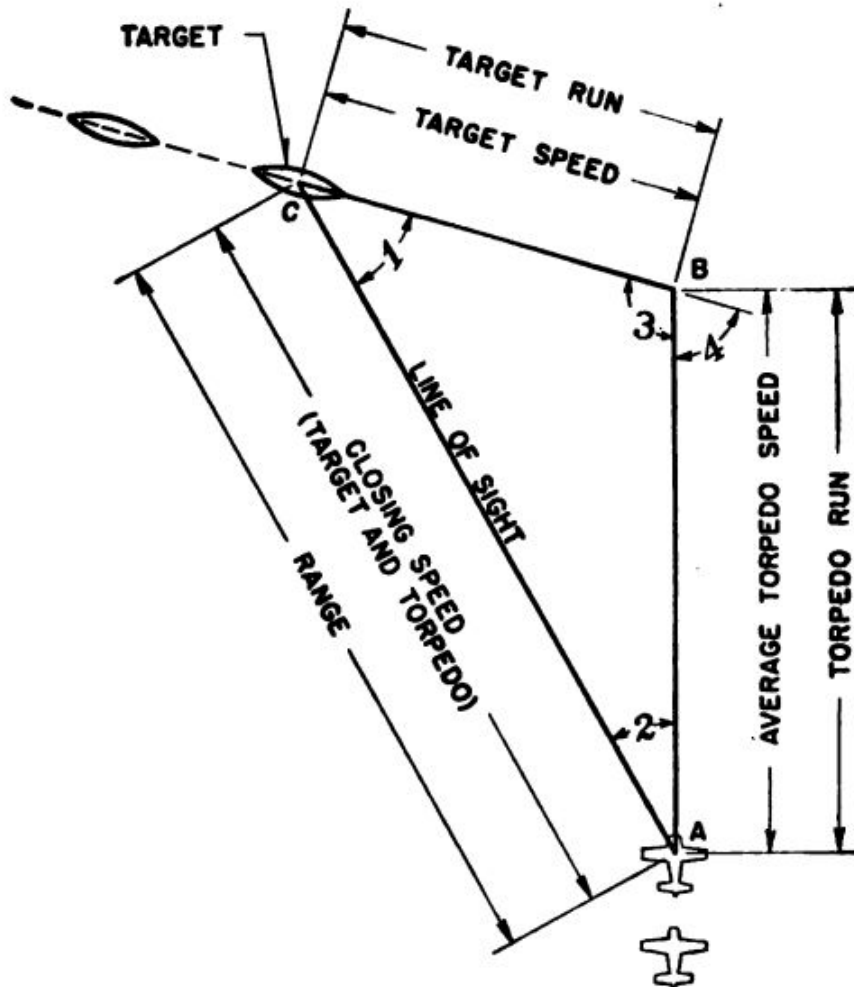

Figure 38.—A typical torpedo problem.

There are certain things that the pilot must know before he can expect any help from his torpedo director.

First, what is the AVERAGE TORPEDO SPEED between the instant it is released and the instant it hits the target? This, as you can readily see, will depend upon the RELEASE ALTITUDE, the GROUND SPEED OF THE AIRPLANE, the TORPEDO RUNNING SPEED

at a certain depth after it has lost the forward momentum imparted by the airplane, and the TOTAL LENGTH OF THE TORPEDO'S RUN from airplane to target.

Second, what is the SPEED OF THE TARGET?

Third, what is the ANGLE ON THE BOW? The angle on the bow in figure 38 is angle 1 or the angle between the fore and aft axis of the ship and the line of sight. The pilot must estimate this angle in degrees.

When the pilot calculates these three factors and "puts them in" the torpedo director, the director will indicate to him the COLLISION COURSE, or the course along which he must fly and launch the torpedo in order to score a hit.

How does the pilot find these things out? Average torpedo speed can be set before the pilot leaves the ground. You might say it is a part of VTB squadron doctrine. Pilots have been trained to release torpedoes at a certain altitude, at a certain flying speed, and at a certain range. They carry a torpedo whose running speed at a certain depth is known. Circular slide rules, or computers, have been developed for each Mark torpedo, and the pilot merely has to turn the rules to the proper setting to find the AVERAGE TORPEDO SPEED. If, when attacking, he finds that because of hot and heavy AA fire he can't approach to the range he had figured, he may sometimes recalculate the average torpedo speed to conform with a new range.

As to the TARGET SPEED—this the pilot must estimate himself.

Likewise with the angle on the bow. The pilot must calculate the course of the target and the angle that it makes with his line of sight (angle 1 in figure 38).

Now take a look at figure 39. You've run across part of this mechanism before. Remember the illuminated gunsight Mark 8? This mechanism—Torpedo Director Mark 30—has practically the same basic optical assembly as the illuminated gunsight Mark 8, with the dials,

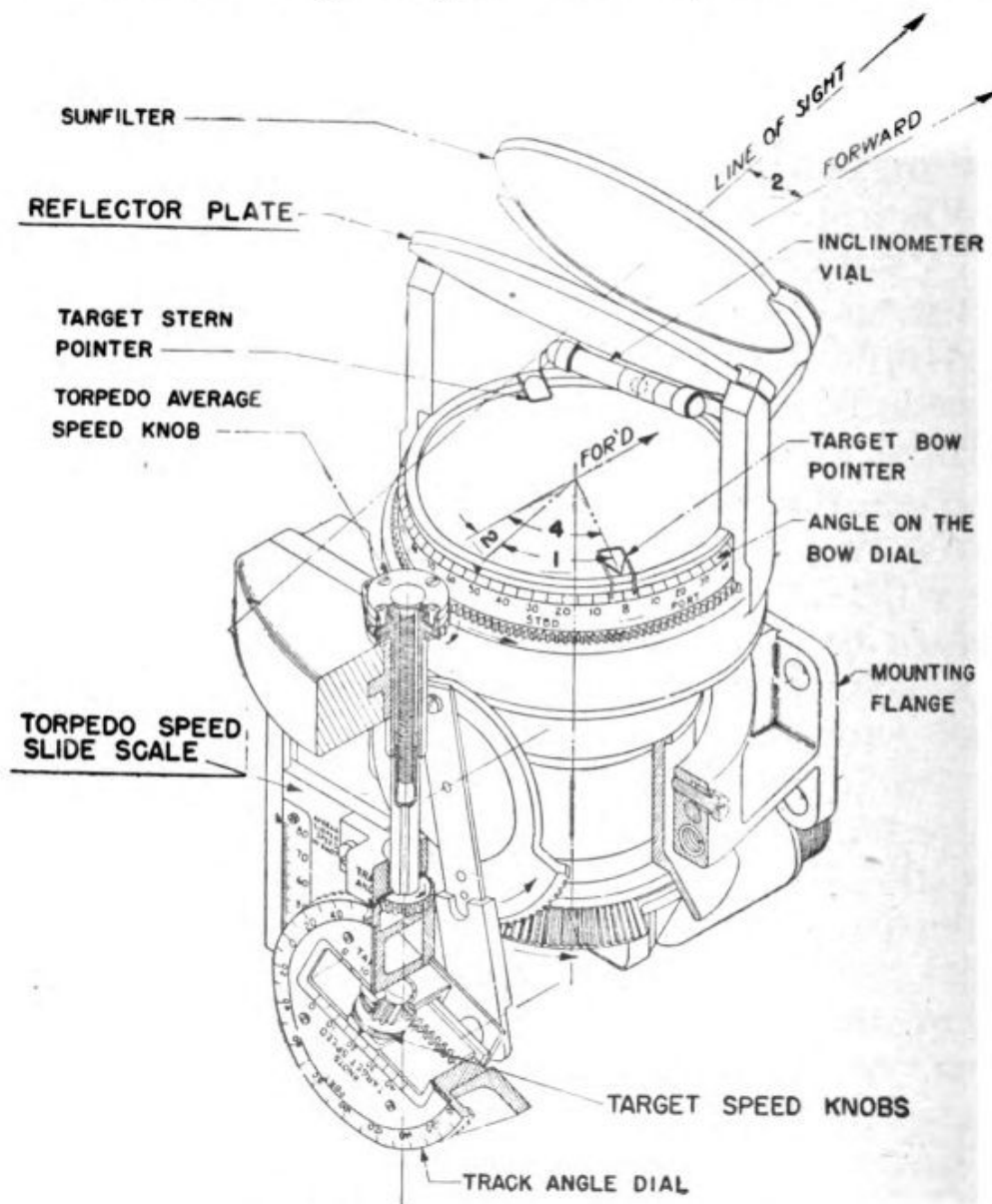

Figure 39.—Torpedo director Mark 30.

knobs, and gears added to constitute the torpedo director mechanism. As with the illuminated sight Mark 8, the light source sends rays through the optical system to project the image of the reticle onto the reflector plate.

Suppose you watch Pilot Joe Smith on a torpedo bombing mission, his target a cruiser, and see how the torpedo director Mark 30 works.

Before taking off, Pilot Smith has already put the AVERAGE TORPEDO SPEED into the mechanism. (He figured this out on the circular slide rule computer.) This average speed holds good only at a specific altitude, range, and ground speed (the underwater speed of any particular torpedo is always the same). Pilot Smith puts the speed into the torpedo director by turning the TORPEDO AVERAGE SPEED KNOB (see figure 39) until the TORPEDO SPEED SCALE indicates the correct speed in knots.

Finally he sights his target. He maneuvers his airplane while he gages the speed of the cruiser and prepares to attack. Pilot Smith estimates the cruiser speed at 20 knots, and he puts this factor into the torpedo director by turning the TARGET SPEED KNOB until the pointer is at 20 knots.

Now he begins his run. He estimates that his angle on the bow is 50° (angle 1 in figure 38), and he makes this setting on the director by rotating the TRACK ANGLE DIAL until the angle on the bow dial reads 50° . This ROTATES THE WHOLE SIGHT BODY so that the reflector plate turns toward the target.

Now, if Pilot Smith has estimated the angle on the bow correctly, the bow and stern target pointers affixed to the angle on the bow dial will parallel the course of the cruiser at the same time the vertical line of the reticle image on the reflector plate is dead on the target.

If Pilot Smith has NOT estimated the angle on the bow correctly, the vertical line in the reticle image will not bear on the target. So, while looking through the reflector plate, he turns the air-

plane until the vertical line is on—but by changing the heading of the airplane, he has also moved bow and stern pointers on the angle on the bow dial, so that they are no longer parallel to the course of the target ship.

To correct this, he turns the track angle dial again until the bow and stern pointers once more parallel the course of the target. Then he turns the dial approximately half again the distance required to make this correction. Now, of course, the cross hairs are again off the target. But, when Pilot Smith corrects the course of the plane to bring the cross hairs to bear again, he will be very close to a correct estimate of the angle on the bow.

After all this, with Pilot Smith in the midst of his run on the cruiser, what is his torpedo director doing for him? He has adjusted the dials to conform with DEFINITE AVERAGE TORPEDO SPEED, A DEFINITE TARGET SPEED, and A SPECIFIC ANGLE ON THE BOW. Every time he has turned the dial on the director, a new ratio has been set up within the mechanism until, finally, when the last adjustment is made, the reflector plate with the reticle vertical line is fixed on the target. Look again at figure 39. Pilot Smith's problem has been incorporated into this torpedo director. Note that the sight body is turned so that the angle between the line of sight as fixed on the target and the forward course of the airplane is equal to angle 1 on the torpedo problem diagram in figure 38.

As Pilot Smith flies in on his target, assume that his calculation of enemy speed is correct and that his setting of angle on the bow is accurate. All he has to do now is to fly a course which keeps the vertical line on his reflector plate constantly on the target. He must fly at the correct altitude and

ground speed, and he must release his torpedo at the range for which he figured his average torpedo speed.

Pilot Smith pushes the release button. The torpedo arcs downward, hits the water with a splash, and streaks forward along the collision course. Pilot Smith veers away and out of AA range just as the warship is obscured by a geyser of white water from a violent explosion. The torpedo has struck home.

The torpedo director pointed Pilot Smith along the proper collision course. It automatically set the correct course to conform with the conditions of the problem—the average torpedo speed, and the direction and speed of the target. But Pilot Smith had to gage the proper release range himself.

Setting the director, as the process was described, may have appeared to you to be a lengthy, laborious, and painstaking process. But to Pilot Smith, backed up with months of training and practice, it came as second nature. Experience taught him to gage target speed with accuracy, to calculate angle on the bow with correctness—and to perform the whole process with lightning speed. Pilot Smith doesn't think of the various processes—they are all instinctive with him.

One thing you may be wondering about—what is the track angle dial on the torpedo director for, and why did Pilot Smith make his angle on the bow adjustments on this dial?

Look back at the diagram of the torpedo problem in figure 38. Angle 4 is known as the track angle. It is the angle between the COURSE OF THE TARGET SHIP projected beyond the "collision" point and the TRACK OF THE TORPEDO along its collision course. The angle equals angle 1 PLUS angle 2, or the sight angle PLUS the angle on the bow. Re-

member, the sum of all the angles in a triangle equals 180° . In this problem, then, the sum of angles 1, 2, and 3 equals 180° . Therefore, since angle 3 is common to both, angle 4 must be equal to the sum of angles 1 and 2.

So—if the track angle dial is rotated until the angle on the bow dial reading equals the pilot's estimate, the torpedo director automatically calculates angle 2, or the sight angle, which is the solution required to establish the collision course. When the sight angle is constant, a collision course has been established.

The director automatically makes the correct calculation because its gears are designed so that they establish the proper ratios.

TRIPLE THREAT

The Torpedo Director Mark 30 has other uses. Not only does it resemble the illuminated gunsight Mark 8, but it can ACTUALLY SERVE as an illuminated gunsight for fixed guns. It is also used as a dive bombing sight. In fact, it is a triple threat, all around device, equally deadly for launching torpedoes, shooting down Zeros, or dive bombing units of the yellow pirate fleet.

To adjust the Mark 30 for use as either a fixed gunsight or a dive bombing sight, simply set the track angle dial on zero (thus automatically bringing the angle on the bow dial also to zero). This adjustment fixes the reflector plate image in the position in which it was boresighted. Next, you lock the track angle dial in this position by pulling down on the sight angle detent knob and turning it one-quarter turn into the centering slot. With the track angle and the angle on the bow dials locked at zero, the pilot merely snaps on the light switch, and he's ready to go.

INSTALLATION OF THE MARK 30

A mounting bracket is furnished with the Mark 30, and in most VTB aircraft presently in use, provision has been made for mounting the instrument. In addition to the mounting brackets, you must also have an electric outlet to supply current to the light bulb. When the Mark 30 is used at night, ultraviolet light illuminates the fluorescent numbers and markings on the dials, so there must also be a source of ultraviolet light in the airplane cockpit that can be directed on the instrument.

After securing the Mark 30 to the mounting bracket, you will find that the next step is boresighting. When the track angle dial is locked on zero (as described above) you boresight the sight in the usual manner, making adjustments in azimuth and in elevation by turning the proper boresighting adjustment screws. You have an adjustment leeway of 2° either way.

The Mark 30 operates on either a 12- or 24-volt system. All you have to do to adapt the sight to either voltage is to insert a lamp bulb of the proper voltage. Remove the lamp housing by pressing two buttons which release two spring clamps, thus permitting the housing to drop away from the main body of the instrument.

MAINTENANCE

The Mark 30 is a precision instrument. Its optical parts should be treated just like those in the illuminated gunsight Mark 8. You will have to clean the gears and slides frequently to keep them free of salt deposits and grit. For this purpose you use a stiff fine-bristled brush. Every so often (experience will teach you just how often) you should remove the angle solver mechanism (gears, slides, and shafts) and wash it

thoroughly in kerosene, cleaning fluid, or unleaded gasoline.

Since the mechanism does not carry a heavy "load," lubrication is mostly to keep the parts waterproof and to prevent corrosion. After oiling with a light oil, you should wipe the mechanism almost dry. An excess oil deposit merely attracts grit, and "stiffens" the operation of the director mechanism at low temperatures. The only lubricant used on the angle on the bow dial is dry graphite.

To prevent external fogging of the optical system, treat the exposed surfaces periodically with an anti-fogging compound.

If high humidity and sudden temperature changes cause internal fogging, blow dry air or gas through the inlet and outlet plugs until the interior is dry.

NEVER interchange parts between one instrument and another.

Everything considered, you can realize what it actually means for a VTB pilot to plant a torpedo in the vitals of a combat ship. With the target running at high speed on a constantly changing course while throwing out a streaming sheet of AA fire, the VTB pilot has to fly his airplane into the thick of trouble, keeping the target always in the sight and constantly re-figuring his collision course. He actually has to do everything at once.

Knowing the principles and problems involved in launching a torpedo for a killing hit, you need not be impressed further with the weight of your responsibility to insure that the ENTIRE TORPEDO DIRECTOR MECHANISM—optics and mechanical parts—is in perfect operating condition. The Mark 30 in the hands of a skilled VTB pilot is bad news for enemy ships.



CHAPTER 6

BOMBING

THE LAW OF FALLING BODIES

Assume that you're flying at 30,000 feet (in an airplane without a bombsight), and your job is to drop a bomb on a pickle factory which has been smelling up the adjacent neighborhood. In the first place, at 30,000 feet you'd probably have difficulty recognizing the pickle works among all the other buildings. But assume you did recognize it. Even if your aim were better than average, you'd more than likely exterminate a herd of cows on a farm a mile outside of town. Without a bombsight, from 30,000 feet that would be a "near miss."

From the day that the first bomb was dropped by hand over the side of an early model "Vibrator Boxkite" flying machine by a begoggled and bewhiskered aeronaut, military men have striven to bring scientific accuracy to aerial bombing. Today, with the help of American-built bombsights, U. S. Navy bombers can practically split the sides of a floating beer barrel from 30,000 feet up.

But in spite of the tremendous improvements in bombing technique and equipment, the basic

problems involved are the same as they always have been. There are a number of factors which make accurate bombing a difficult proposition, exclusive of anti-aircraft fire and fighter-plane opposition, perhaps the toughest obstacles of all.

FALL IN A VACUUM

To get at the basic problems of bombing, suppose you start with a VACUUM, where there's no wind pressure or air resistance around to make things complicated. Now pretend ("pretend" is well advised here because this condition is positively preposterous) that you're in an airplane flying along at a given altitude in a vacuum, and you release a bomb from the airplane.

This bomb would be affected by two forces—one, your old pal GRAVITY, and two, THE HORIZONTAL FORWARD MOVEMENT OF THE AIRPLANE.

At the instant of release, the bomb would be traveling horizontally at the same forward speed of the airplane. But GRAVITY would immediately begin to pull it downward. Because you are operating in a vacuum, there's no air to slow up the bomb, so it drops faster and faster until it hits the earth with an obliterating explosion. The combination of these two forces makes the bomb follow a curved path in falling. And this path, like that of a bullet, is called the TRAJECTORY. There's a picture of a vacuum trajectory in figure 40. Note that the bomb continues to move both forward and downward throughout its journey.

It is obvious from figure 40 that the FORWARD velocity of the bomb is equal to that of the airplane, and it remains the same during the entire fall. WHY? Look at figure 40. When it landed, the bomb was directly under the airplane—this means that both airplane and bomb covered

the same horizontal distance in the same time interval.

Consequently, if you think about it a minute, you'll realize that the **TIME OF FALL** is not increased by the forward velocity imparted to the bomb by the airplane, but that it depends directly upon the **ALTITUDE** of the airplane. In a vacuum, two identical bombs dropped at the same time from the same altitude, one from a speeding air-

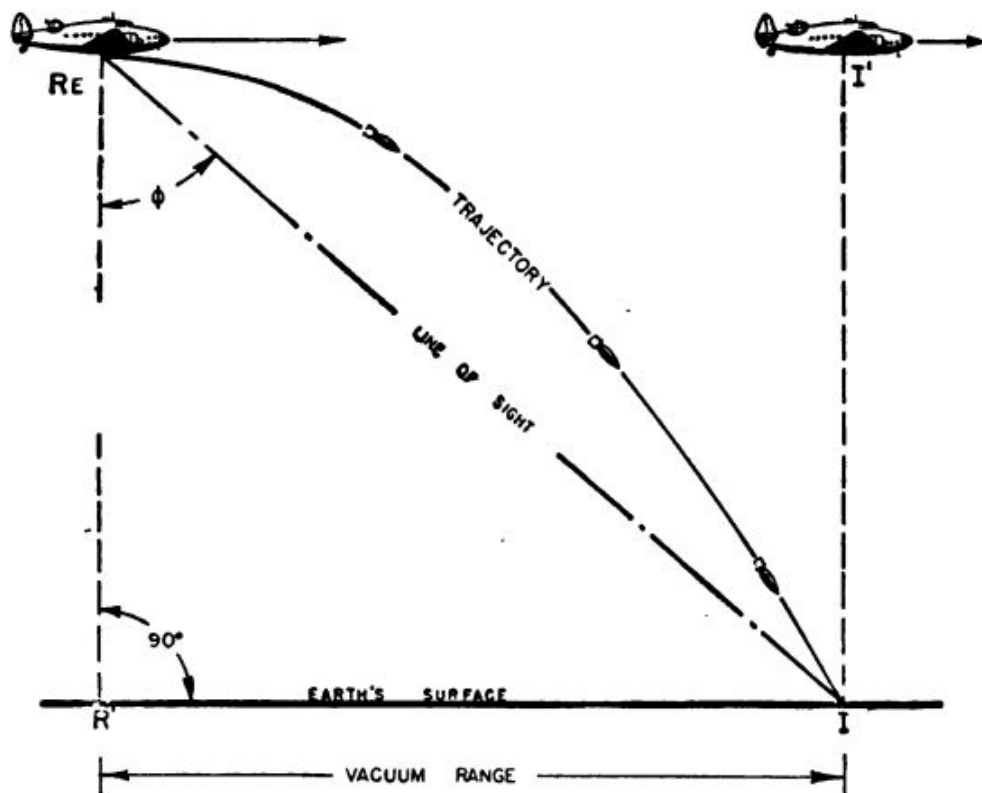

Figure 40.—Trajectory of bomb in a vacuum.

plane and the other from a motionless balloon, would hit the earth at the same instant. They would, however, land at a considerable distance from each other, because the bomb from the balloon drops straight down, whereas the one from the moving airplane has a forward motion that gives it a curved trajectory.

Thus, the **AMOUNT OF FORWARD TRAVEL** of a bomb, measured on the earth's surface from a point

VERTICALLY BELOW the aircraft at the INSTANT OF RELEASE, DEPENDS UPON THE HORIZONTAL FORWARD VELOCITY imparted to the bomb by the airplane.

Obviously, therefore, from the same altitude, with the same bomb, the distance forward of the point of release to the point of impact along the ground will VARY DIRECTLY with the forward velocity of the airplane. Under VACUUM CONDITIONS (no air resistance) this distance will be identical with the forward distance traveled by the airplane between the instant of release and the instant of impact.

To figure the distance in feet that a bomb will travel in a horizontal direction, then, it is necessary first of all to determine the CLOSING SPEED. This is the speed at which the airplane "closes" or moves toward the target. And it depends upon air speed, wind velocity, and target speed—if any. The closing speed is converted from knots to feet-per-second and is then multiplied by the number of seconds in the total time of fall.

How do you figure the total time of fall?

In a vacuum, any body, irrespective of its size or weight, falls 16 feet the first second and accelerates approximately 32 feet-per-second for each succeeding second. There is a formula which expresses the relation between time and distance of fall in a vacuum.

$$\begin{aligned} \text{DISTANCE} &= \frac{1}{2} \text{ GRAVITY} \times \text{TIME}^2 \\ D &= \frac{1}{2} GT^2 \end{aligned}$$

The value of G is 32 and represents the constant acceleration caused by gravity.

Now suppose you know the distance, or ALTITUDE, to be 1,600 feet, and you want to know the time of the fall.

By formula:

$$D = \frac{1}{2} GT^2$$

$$1,600 = 16 T^2$$

$$40 = 4T$$

$$10 = T, \text{ or—the time of fall is 10 SECONDS}$$

If the bombardier could fly in a vacuum, he would have no problem establishing the RANGE at which he must release his bombs to score a hit. All he would have to know would be his altitude and his closing speed.

For example, assume again that the altitude is 1,600 feet. You already know that it takes 10 seconds for the bomb to reach earth from this altitude. Assume also that the closing speed of the airplane is 100 knots, or 169 feet per second. Then, the bomb travels FORWARD 169 feet for each second of its fall.

And the total amount of FORWARD TRAVEL of the bomb from point of release to point of impact with the earth is $169 \times 10 = 1,690$ feet.

The amount of forward travel is known as the RANGE. In bombing, then, the basic RANGE FORMULA is—

$$T_f \times V_c = R_{vac}$$

In which T_f = the TIME OF FALL in seconds, V_c = the CLOSING SPEED of the airplane in feet-per-second, R_{vac} = the RANGE in a vacuum.

Look again at figure 40. See the angle marked “ Φ ”? This is the sighting angle or RANGE ANGLE, which is the angle between a VERTICAL LINE from airplane to earth at the time the bomb is released, and the LINE OF SIGHT from the airplane at the time of bomb release to the point on the earth's surface where the bomb strikes.

To hit a target when flying in a vacuum, then (if such were possible) a bombardier would have

to see to it that the RANGE ANGLE was correct for the ALTITUDE and FORWARD VELOCITY of the airplane.

And that's that! Now, you're ready to move out of that vacuum—into REAL AIR.

FALL IN AIR

The difference between the sky and the vacuum is that in the sky you have to consider two new factors—air resistance and wind.

Air resistance tends to retard both the forward, or HORIZONTAL VELOCITY, and the downward, or VERTICAL VELOCITY of the bomb. The AMOUNT by which horizontal and vertical velocity is retarded depends upon the shape and weight of the bomb—or, as the mathematicians say, “the amount of retardation is a FUNCTION of the shape and weight of the bomb.”

You can readily see, then, that the trajectory of a bomb dropped in a vacuum and the trajectory of a bomb dropped in air would be quite different. This difference is illustrated in figure 41, where TRAJ-V is the vacuum trajectory, and TRAJ-A is the trajectory in air.

The bomb dropped in the vacuum strikes the earth at I_v . The bomb dropped in air strikes the earth at I . The distance between I and I_v —marked as T in figure 41—is called TRAIL.

In other words, TRAIL is the HORIZONTAL DISTANCE that a bomb dropped in air “trails,” or lags behind, a bomb dropped in a vacuum. And since a bomb dropped in a vacuum would have the same forward speed as the airplane, TRAIL is also the horizontal distance that a bomb dropped in air would “trail,” or lag behind, THE AIRPLANE FROM WHICH IT WAS DROPPED.

Trail reaches its maximum value when meas-

ured on the surface of the earth. It is measured as the distance between THE POINT OF IMPACT OF THE BOMB AND A POINT VERTICALLY BENEATH THE AIRCRAFT AT THE INSTANT OF IMPACT—assuming, of course, that the airplane has continued on the same course, at the same speed and altitude that it had at the instant the bomb was released.

Trail is measured in MILS. You remember that a mil is a ratio of 1:1000. As applied to a prob-

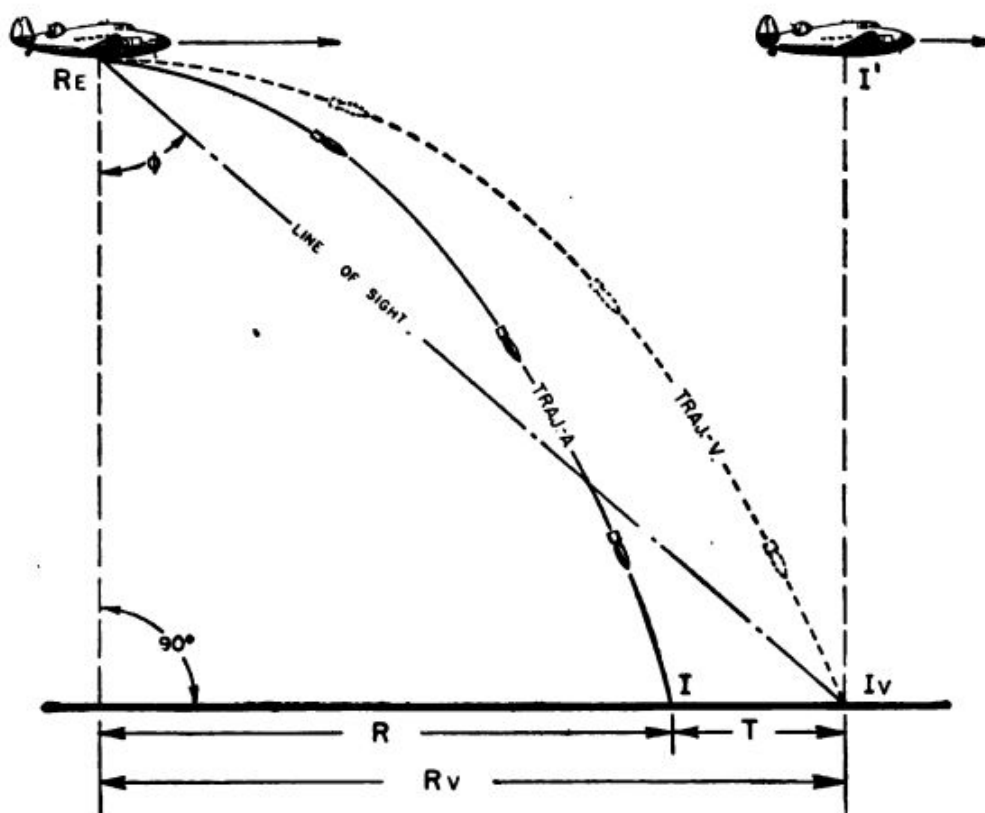

Figure 41.—Comparative trajectories in vacuum and air.

lem in bombing, a MIL is $\frac{1}{1000}$ OF THE ALTITUDE. Bombs of different weights and shapes have different trails. For example, at a certain altitude and air speed one type of bomb may have a trail of 26 mils, whereas another type may have a trail of 32 mils. The mathematicians figure out the amount of trail for any given type of bomb by relating its weight and shape to the factor of air resistance.

Trail in mils is a flexible quantity, and to translate MILS of trail into FEET of trail, you have to know the FEET OF ALTITUDE. Remember, a mil is simply a RATIO, and as such, is variable.

Since there is no air in a vacuum, the bomb dropped in the vacuum kept gaining speed as long as it kept falling. But, in air, air resistance tends to slow up a bomb more and more as the bomb falls faster and faster, because the faster it falls, the greater the air pressure in its path. Consequently, a bomb may progressively increase in DOWNWARD velocity UNTIL THE AIR RESISTANCE EQUALS THE WEIGHT OF THE BOMB. When this point is reached, the bomb is at what is called TERMINAL VELOCITY, and it will not fall any faster.

When a bomb strikes the earth, it is traveling at its IMPACT VELOCITY. If the bomb, before striking the earth, has fallen far enough to reach its terminal velocity, its impact velocity is THE SAME as its terminal velocity. But if it were not released from enough altitude to permit it to attain terminal velocity, the impact velocity will be LESS than its terminal velocity. Impact velocity is NEVER GREATER than terminal velocity.

Remember that the formula for figuring range in a vacuum is—

RANGE IN A VACUUM = TIME OF FALL \times CLOSING SPEED.

To find the RANGE (R) in air, you use the same formula, EXCEPT THAT YOU SUBTRACT THE TRAIL.

So the formula becomes—

$$R = T_f \times V_c - T$$

Time of fall is rather complicated when you have to take air resistance into account. So assume in the following example that someone handy with mathematics has figured it out. As a matter of

fact, there are convenient tables available in which time of fall has been all figured out for you.

At what RANGE should a bomb be released from an airplane flying at 30,000 feet at a closing speed of 235 knots, if the bomb's time of fall, T_f , is 33 seconds and the trail is 31 mils?

The first step is to change all factors to comparable units. Thus—

$$V_c = 235 \times 1.69 = 397.15 \text{ feet per second}$$

And 31 mils for 30,000 feet altitude makes—

$$T = 31 \times 30 = 930 \text{ feet.}$$

So—

$$\begin{aligned} R &= T_f \times V_c - T \\ &= 33 \times 397.15 - 930 \\ &= 12,176 \text{ feet} \end{aligned}$$

But, in this problem you have neglected the factor of WIND.

Wind can be defined as the movement of air relative to the surface of the earth. At any given point on the earth's surface at a given time wind has two qualities—DIRECTION AND VELOCITY.

Various wind conditions are present in 999 cases out of 1000 during a bombing operation. How does wind affect a bomb and the airplane dropping the bomb on a target, when the direction and velocity of the wind in relation to the target are known?

An airplane flying through the air has TWO relative speeds. The first is AIR SPEED, or the airplane's speed in relation to the air in which it is moving, and the second is GROUND SPEED, or the airplane's speed in relation to the earth.

Air speed and ground speed may be equal only when "no wind" conditions prevail—and this, to say the least, is a rare condition.

At any other time, when there is a "value of wind," air speed and ground speed are different quantities. How much they differ depends upon the velocity and direction of the wind, and the air speed and direction—or **HEADING**—of the airplane.

Unless an airplane is heading directly upwind or directly downwind, it will **DRIFT** to one side or the other, depending upon the wind's velocity and direction.

Look at figure 42. Here the wind is coming from a direction directly abeam—or at a right angle to—the **HEADING** of the airplane. As the airplane flies ahead, it is blown sideways along a course different in direction from its heading. This **TRACK**, or "course made good," is ascertained by resolving the components of wind and air speed.

The angle θ in figure 42 is the **DRIFT ANGLE**. It is the angle formed by the **HEADING** and the **TRACK**.

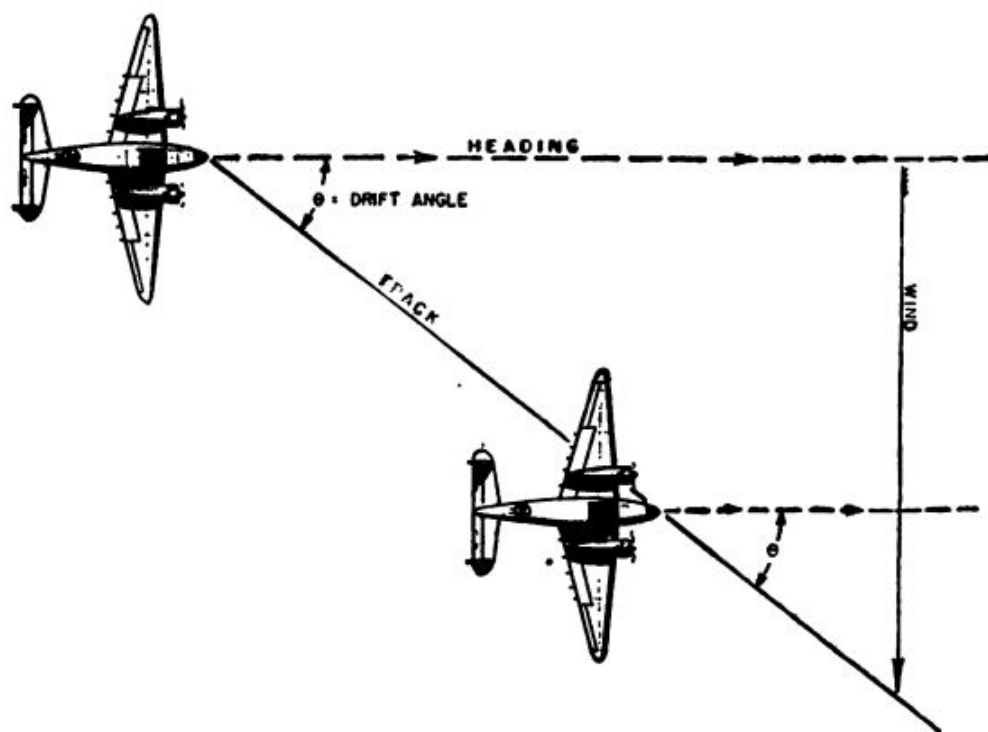

Figure 42.—Drift.

Now suppose you want to calculate the effects of DRIFT on the trajectory of a bomb. Take a look at figure 43. Study it carefully. Here you see the relationship between the airplane, the bomb, and the surface of the earth when the bomb is released from an airplane flying across the wind.

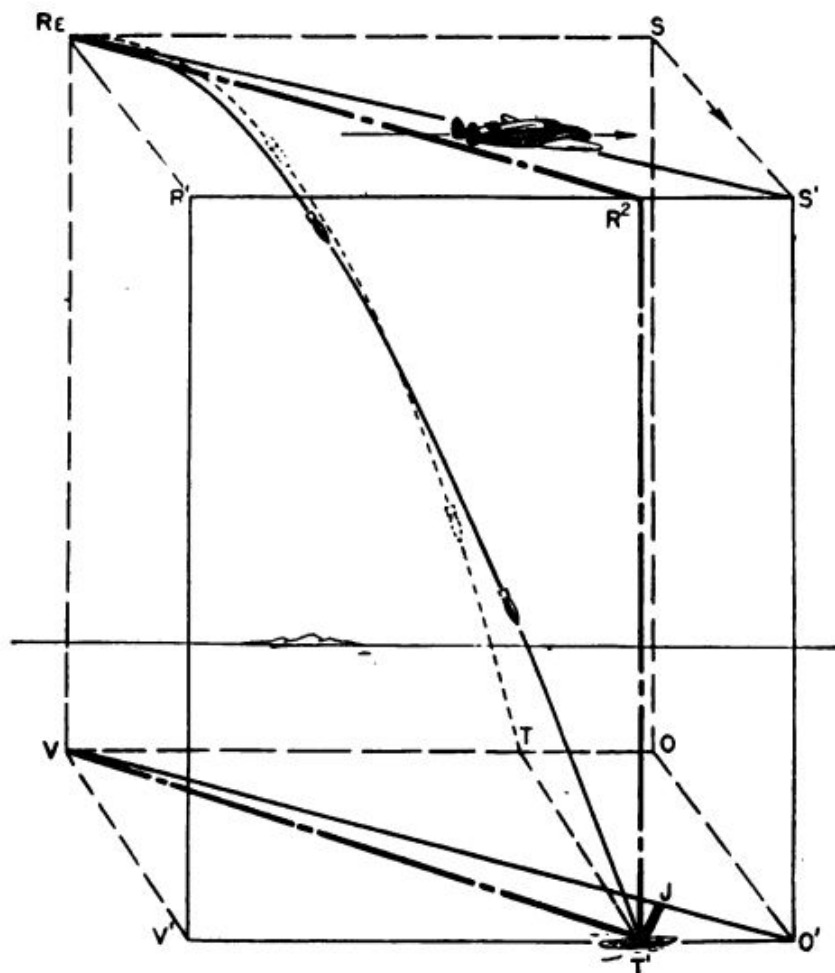

Figure 43.—Trajectory of bomb dropped from airplane flying cross-wind.

The wind is assumed to be constant in direction and velocity over the entire space between the airplane and the earth.

The airplane is heading on the course ReS , but the force of the wind causes the airplane to “make good” the track ReS' . This track appears on the earth's surface as the line VO' .

Flying under these conditions, the airplane releases a bomb at Re (or directly over point V on the earth's surface). If there were no wind, the airplane would fly along the line ReS , and the bomb would strike at point T , so the trail would equal the distance OT .

But there is a wind. So what happens? The wind is responsible for changing the trajectory of the bomb from ReT to ReT' . The bomb strikes at point T' , while the airplane, at the instant of impact, is at point S' . Point S' is over point O' on the earth, so the TRAIL equals the distance $O'T'$. Note that the point of impact is always AFT of the plane on the heading.

Do you see that the vertical plane of the bomb's trajectory gradually moves to one side of the vertical plane passing through the track of the airplane? This is because the wind has a different effect on the airplane and the bomb, and it results in a new complication known as CROSS TRAIL. Cross trail, in figure 43, is the distance $T'J$. Drift and cross trail are the two principal components of the DEFLECTION problem.

"All this is swell", you say, "but what if the target is in motion, too?" Target motion, insofar as it affects the bombing problem, is considered in the same manner as wind. The motion of a target with, or against, the heading of the airplane has the same effect on the establishment of the correct range angle as an increase or a decrease in wind velocity with or against the airplane.

In the same way, the motion of a target ACROSS the heading of the airplane is considered as a cross wind and is absorbed in the solution of the drift angle, cross trail—and the range effect of cross trail—along with the solution of the effect of a cross wind.



CHAPTER 7

BOMBSIGHTS

SOLVING FOR RANGE AND DEFLECTION

As you have seen, the bombing problem resolves itself into two subproblems—the RANGE problem and the DEFLECTION problem. The range problem is one of establishing the correct RANGE ANGLE, and the deflection problem is one of establishing a COLLISION COURSE by flying the airplane along a track which makes the correct DRIFT ANGLE with the heading.

The bombsight answers these problems by directing the pilot along the proper course, and by computing, from known conditions of air speed, altitude, and type of bomb used, the proper point for bomb release.

There are several accessory mechanisms that operate in connection with the bombsight. But, in line with the principle of taking one thing at a time, you may postpone any discussion of these,

and limit yourself for the present to seeing, **FIRST**, how the bombsight proper solves the **RANGE PROBLEM**, and, **SECOND**, how it solves the **DEFLECTION PROBLEM**.

RANGE PROBLEM

In order to solve the range problem, the bombsight must have a means of—

Establishing an imaginary **VERTICAL LINE TO THE EARTH** from the airplane.

Measuring the **RANGE ANGLE**.

Subtracting **TRAIL** from **THE VACUUM RANGE**.

Mechanically incorporating **TIME OF FALL** and **CLOSING SPEED** into the sight.

Either indicating to the bombardier when the **POINT OF RELEASE** is reached, or automatically releasing the bomb itself at that point.

The most widely used device for establishing an imaginary line to the earth is the **GYROSCOPE**. "Gyros" have the property of tending to maintain a constant axis in space while they are spinning. To establish the vertical axis in space originally, two spirit levels, mounted at right angles to one another, are affixed to the gyro, perpendicular to the axis of spin. When the bubbles are centered in both levels, the spin axis is vertical to the earth, and the gyroscopic action will hold it there (except for a very small variation due to the earth's rotation—if you want to get technical).

So the gyro, with its spirit levels, marks off a line from the airplane in flight. This line is perpendicular to the earth's surface directly beneath the airplane. Against this vertical, perpendicular line we measure—

RANGE ANGLE

The **RANGE ANGLE** is the angle between the vertical line to the earth and the line of sight to

the target. At the time the bombs are released, the range angle is called the **DROPPING ANGLE**, or the angle of drop.

You know, then, that one leg of the range angle is the vertical axis of the gyro. By hooking up a telescope to the gyro through a system of linkages and looking at the target through the telescope, you can establish the other leg of the range angle along the axis of the telescope. This angle between the gyro axis of spin and the telescope axis you can measure very easily on a quadrant or sextant built into the bombsight.

Next, what is the means of **SUBTRACTING TRAIL FROM VACUUM RANGE**? Have a look at figure 44. Φ is your sighting angle. In a vacuum, at a defi-

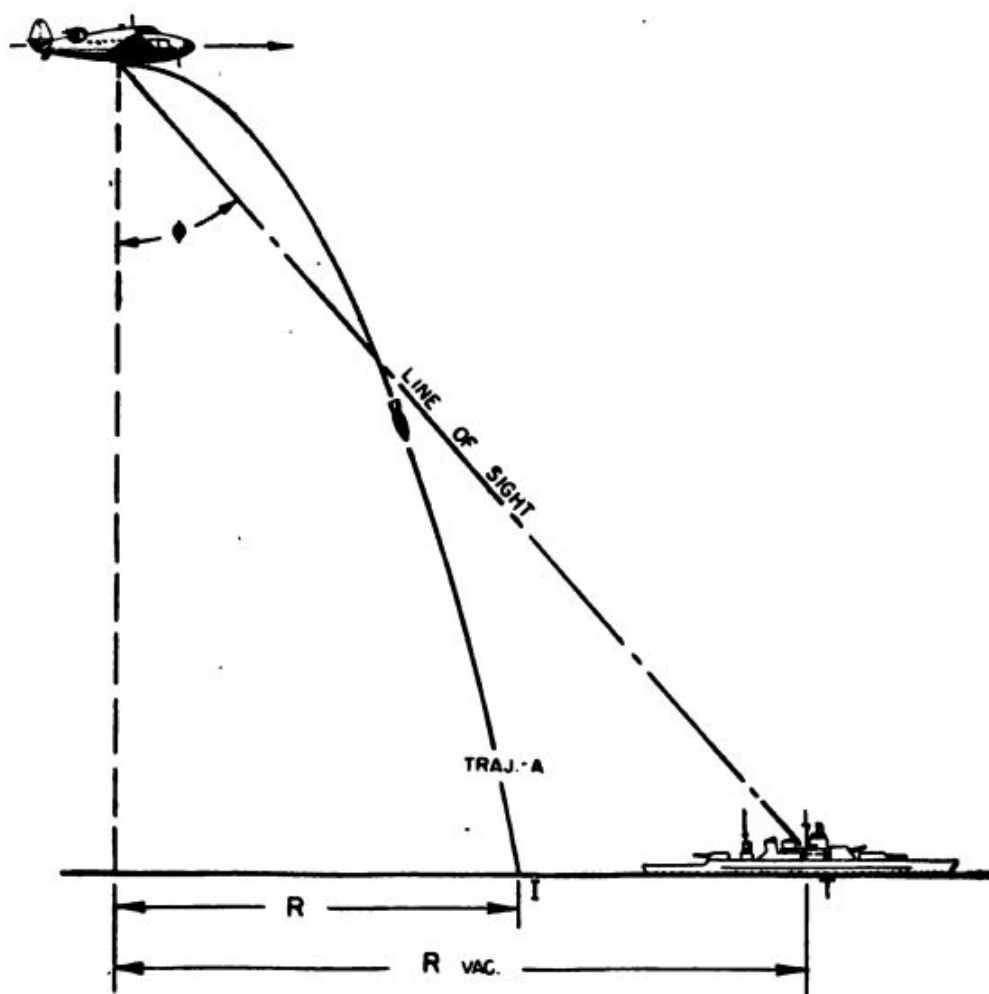

Figure 44.—Trajectory without trail allowance.

nite altitude and speed, the bomb, released from the airplane in the picture, would hit the ship at T , because in a vacuum there would be no trail, there being no wind.

But in air, if the bomb were released at the same point, it would fall short because of air resistance and would strike at I . So—for the bomb to strike at T , the airplane must fly a distance equal to IT before releasing the bomb,

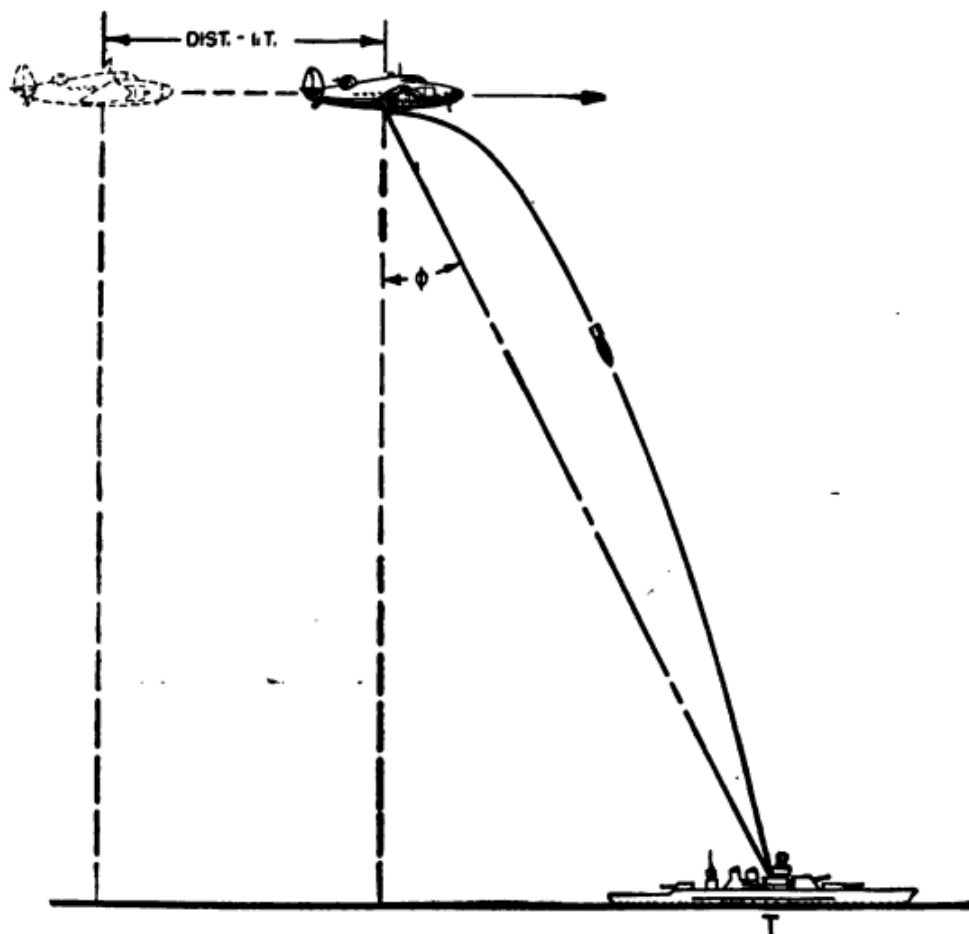

Figure 45.—Trajectory with trail allowance.

thereby reducing the sighting angle to compensate for the trail distance. This is shown in figure 45.

Remember that the trail for each type of bomb has been worked out in MILS, on TABLES OF TRAIL. The bombardier knows the altitude and airspeed,

and from the tables he can ascertain the trail in MILS for the particular type of bomb he is carrying. He can put this factor into the bombsight (never mind HOW just yet) and the bombsight automatically subtracts trail from the vacuum range in determining the angle of drop.

Now for the means of INCORPORATING TIME OF FALL and CLOSING SPEED INTO THE SIGHT. By dropping all of those bombs in the vacuum, mentioned in the last chapter, you proved that the time of fall depends upon ALTITUDE ALONE. Remember "time of fall" means the time it takes for the bomb to travel the vertical distance DOWNWARD. The bomb falls in two directions—forward and down. The time it takes to travel the forward part of its trajectory depends upon the SPEED OF THE AIRPLANE.

Combining the time of fall, or altitude, factor with the closing speed factor results in a relationship which establishes the DROPPING ANGLE.

The closing speed is calculated by measuring THE RATE OF ANGULAR CHANGE in the range angle. As the airplane approaches the target, the range angle keeps getting smaller. In order to measure the rate of change in this angle, a motor is affixed to the telescope. This motor will drive the telescope in such a manner, that, as the angle between the gyro axis and the target decreases, the angle between the gyro axis and the axis of the telescope decreases at the same rate. When this condition exists, the telescope is said to be SYNCHRONIZED.

Altitude, which is the time of fall factor, is furnished by an altimeter.

The bombsight COMBINES CLOSING SPEED, and TIME OF FALL by means of an INTEGRATOR. (See figure 46.) When the indicator on the integrator is opposite the indicator on the telescope SEXTANT,

as it is in the picture, the RANGE ANGLE and THE DROPPING ANGLE coincide, and it is time to unload the bomb cargo.

The T_f , or time of fall input is constant since the airplane is flying at the same altitude during the bombing run. Therefore, that part of the integrator runs at a constant number of rpm. The other side, handling the V_c , or closing speed input, is synchronized with the rate of angular change, as indicated by the movement of the tele-

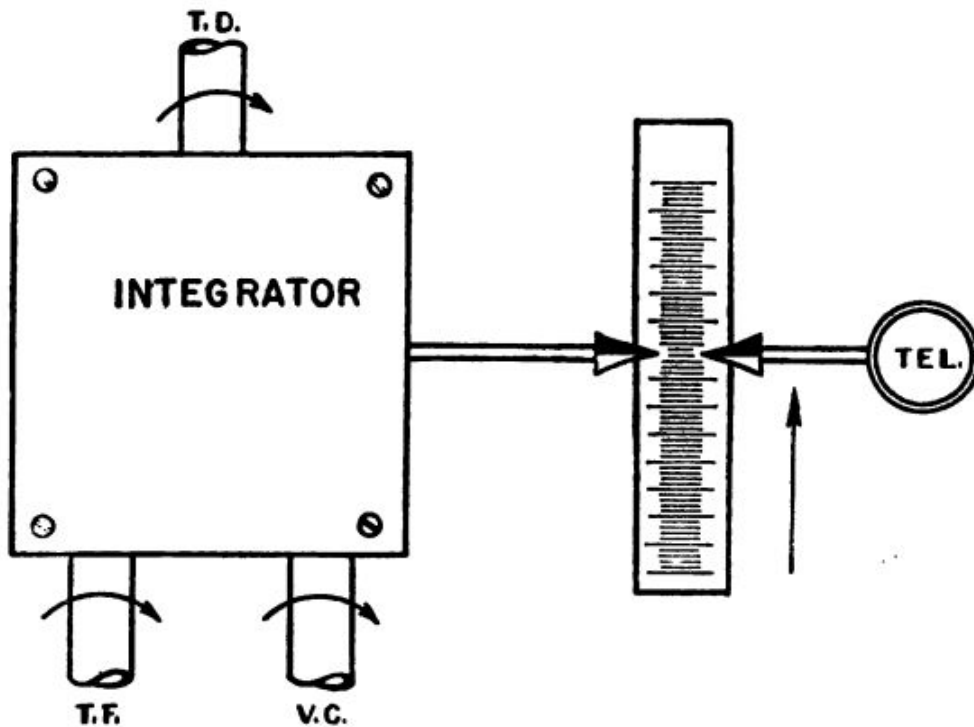

Figure 46.—Schematic illustration of an integrator.

scope axis. So the integrator multiplies T_f and V_c together to get T_d or—the “time of drop.”

When the indicators of the integrator and the telescope are opposite, as they are in figure 46, the bombardier RELEASES THE BOMBS by pulling the bomb release handles. Or, it is a simple matter to attach wires to each of the indicators and when they meet, an electric circuit will close and so activate solenoid switches, releasing the bombs automatically.

DEFLECTION PROBLEM

So far the operation of the bombsight has been explained solely in terms of the range problem. The discussion holds good only under conditions of no wind, or when the direction of the wind is dead ahead or dead astern of the airplane. In other words, the DEFLECTION PROBLEM or the drift caused by wind across the heading of the airplane has been ignored.

In addition to drift caused by the wind, the motion of the target across the heading of the airplane must also be taken into account. Since target motion appears to the bombardier to be a part of the motion of the airplane, target motion becomes APPARENT DRIFT, and is considered as such in solving the deflection problem.

To ascertain the drift angle, therefore, you must establish a HORIZONTAL REFERENCE LINE in space, against which you can measure the angle. Another gyro does this nicely, spinning, this time, in the horizontal rather than in the vertical plane. It makes no difference in which direction this horizontal line is pointing, so long as it is HORIZONTAL and so long as it STAYS PUT and doesn't move around. This gyro holds the telescope stable in azimuth, and it is thus called the STABILIZED GYRO.

A true bearing in azimuth between the heading of the airplane and the target is measured against the gyro axis line, and this BEARING LINE is transmitted by mechanical linkage to the bombsight mechanism from the telescope, through which the bearing was taken. The line of sight, as seen through the telescope, is now integrated within the bombsight as the range angle measured against the vertical gyro axis—and the drift

angle—measured against the horizontal gyro axis.

Don't jump to the conclusion that by taking this bearing in azimuth ONCE (after setting up the sighting angle), the bombardier and the other members of the airplane crew can break out the coffee thermos and light up cigarettes while the brains of the bombsight handle everything from this point on. It isn't as simple as all that.

The drift angle is a ticklish thing to establish correctly, for on it depends the establishment of the COLLISION COURSE. The bombardier has to continue to make corrections until the drift angle is constant—that is, until it remains unchanged—as the airplane approaches the target. When the drift angle is constant, the collision course has been established.

Obviously, the bombardier cannot do all this by himself. He must have a little cooperation from the pilot of the airplane, in that as long as the bearing, or drift, angle is changing, the pilot must keep changing the heading of the airplane until the drift angle is constant and the airplane is thus on the collision course.

Since mind-reading is not one of the qualifications established for Navy pilots, the pilot must have some gadget that will tell him when to correct the heading and when to hold the airplane "steady as she goes." This gadget is called a pilot-directing-instrument, or *PDI* for short. It is a voltmeter type of instrument with the zero of its scale at the center. (See figure 47.)

The indicator is usually connected to the bombsight in such a manner that the pointer goes off zero in the direction in which the airplane should be turned.

It is necessary, however, to incorporate in the mechanical linkages that connect the telescope and

range mechanism to the stabilizer gyro, a means of varying the TELESCOPE HEADING with the AIRPLANE HEADING. In other words, the bomber pilot has to change this course of the airplane FASTER than the rate of change of the bearing angle. Otherwise, he will never arrive at a collision course. This change of airplane heading is called OVER-CORRECTION. Figures 48 and 49 illustrate why over-correction is necessary.

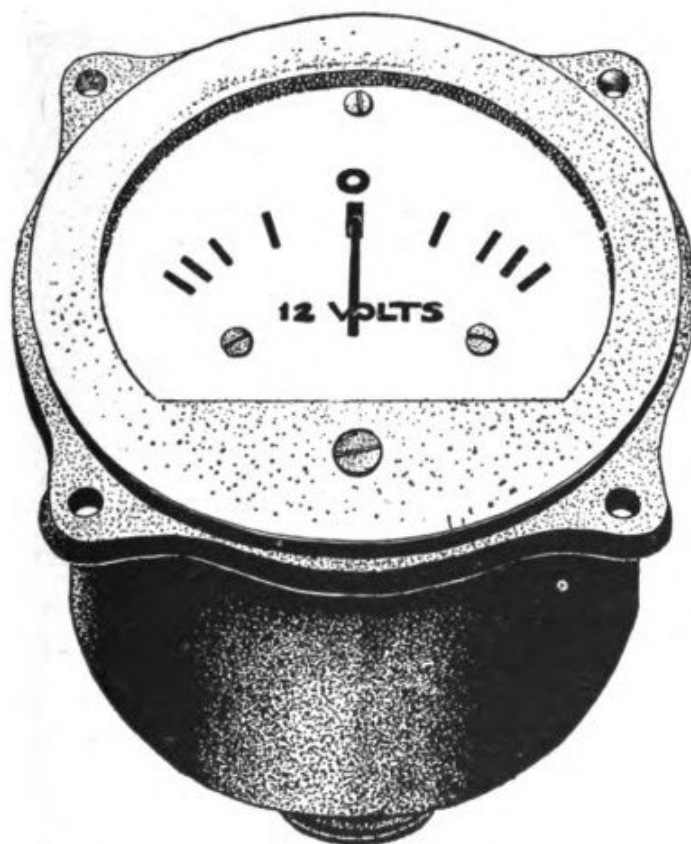

Figure 47.—Pilot-direction-indicator.

You already know that a collision course is set when the bearing angle is CONSTANT. If you correct the course at the SAME RATE that the bearing angle changes, you will never catch up with yourself, and the airplane will fly a spiral as in figure 48 and end up by chasing the target along the target course.

But if the course is over-corrected as the airplane is turned on to the new course, the course can be held steady when the heading establishes a

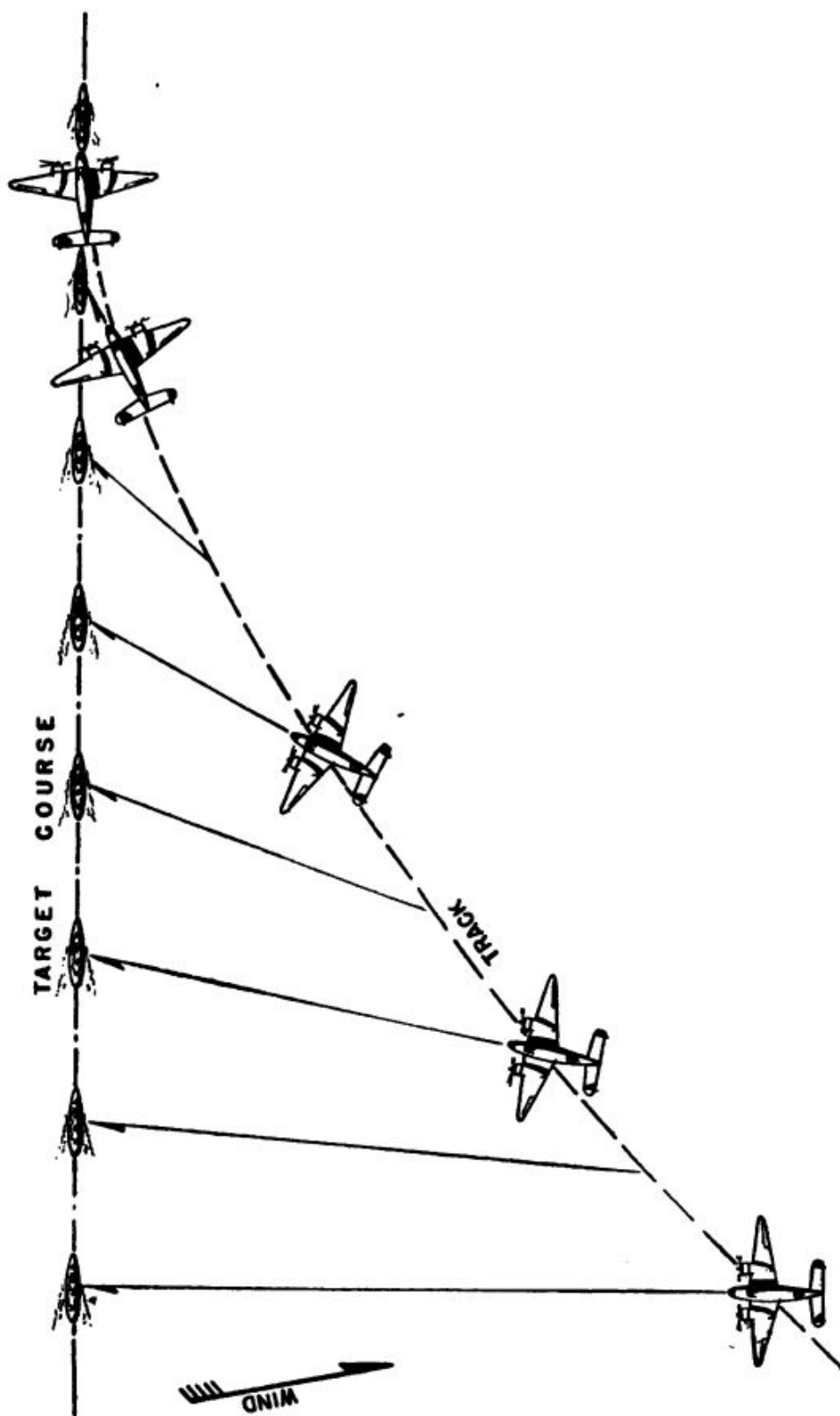

Figure 48.—Course changing at same rate as bearing.

constant bearing angle. This is illustrated in figure 49.

Here's an example. If the bearing changes 2° , the pilot must change course $X+2^\circ$. You might think that this would involve a risk of going too far and passing the collision course. Not so, however, and here's why. The line of sight is held continuously on the target, and the *PDI* is so constructed that it measures the RATE OF CHANGE in the bearing. As long as the bearing is changing, the collision course has not been reached and a FURTHER CORRECTION is necessary.

But as soon as there is no change in the bearing, the pilot gets no signal to change course on the *PDI*. This is because the sight is constructed so that the indications to change course, as given on the *PDI*, are governed by the RATE OF CHANGE of the bearing.

When the airplane is approaching the collision course, therefore, the bearing changes are small, and changes of heading are thus decreased in proportion.

With the airplane on the collision course, only one more thing must be taken into account. CROSS TRAIL—remember?

When a bomb is dropped in a cross wind, you have seen that it does not fall in the same plane as the track of the airplane, but will fall to the LEEWARD of the track. This is because the force that causes trail (air resistance) acts from dead ahead and is determined by the heading of the plane, not by the track.

So to locate the POINT OF IMPACT, you first have to locate the point where the plane would be at the instant of impact, assuming it continued on along the track after the bomb was released. This point, of course, is on the track at a distance from

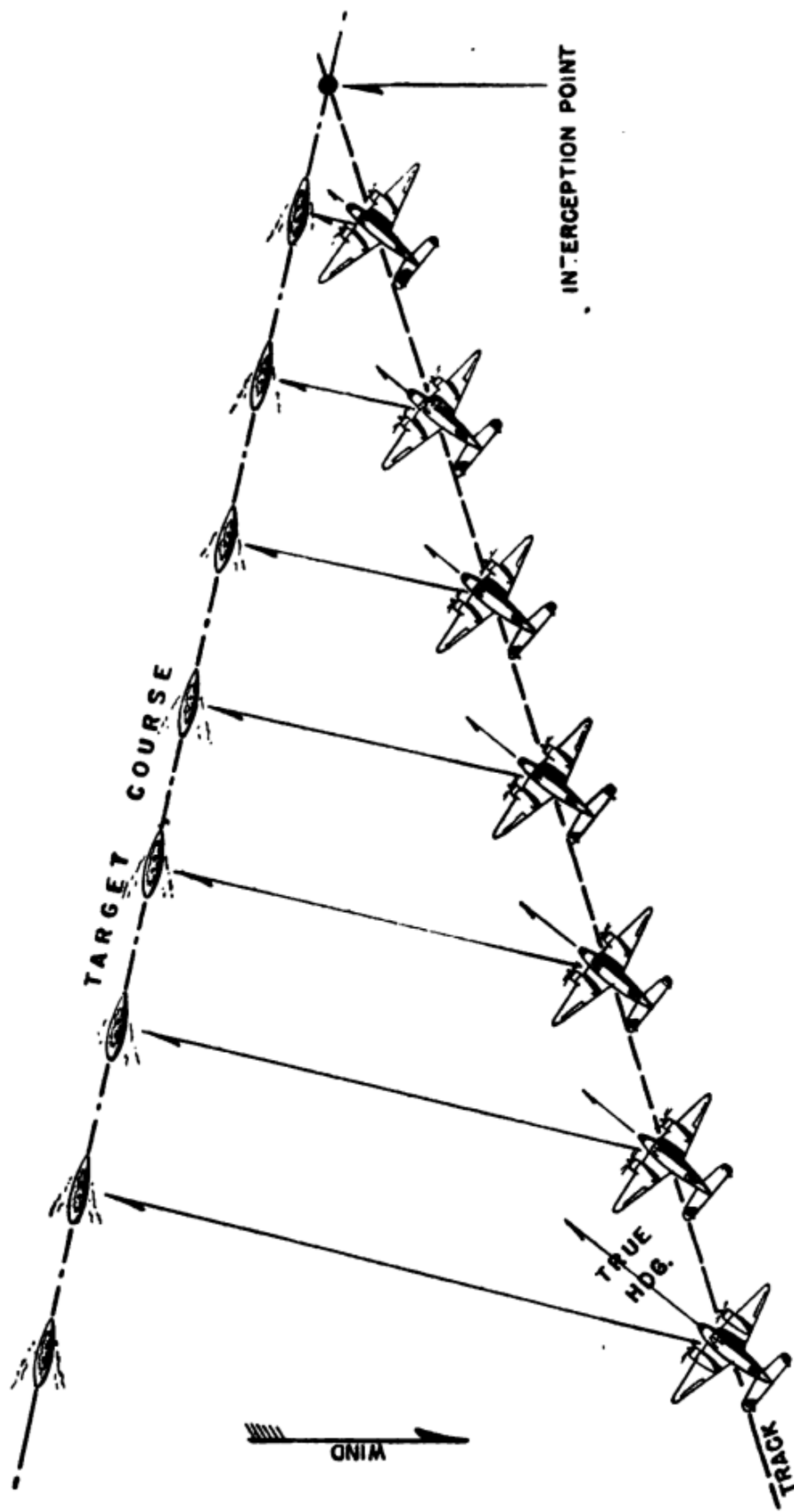

Figure 49.—Over-correction, resulting in collision course.

the point of release equal to the product of the ground speed and the time of fall. Having located this point, you measure back from it a distance equal to the trail and you have located THE POINT OF IMPACT. Do NOT measure back along the track, but in a direction opposite to the heading.

The perpendicular distance from the POINT OF IMPACT to the TRACK of the airplane is the CROSS TRAIL. Look at figure 50 and hark back a moment to the trigonometric functions—from the diagram

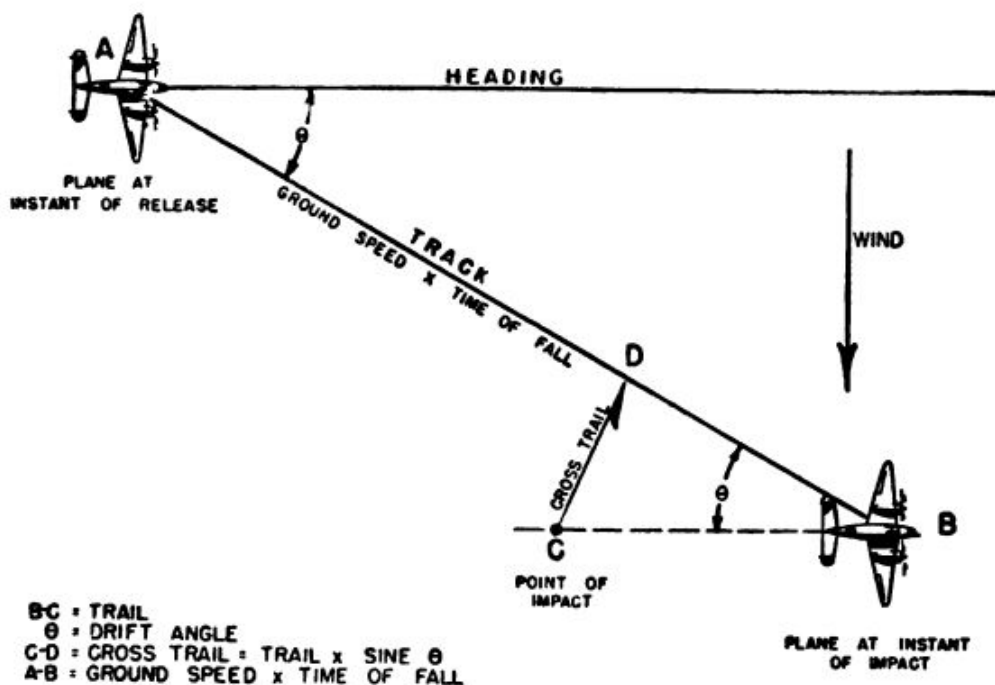

Figure 50.—The cross-trail factor.

you can see that cross trail is equal to the trail multiplied by the sine of the drift angle—or $\text{CROSS TRAIL} = \text{TRAIL} \times \text{SIN } \theta$.

Consequently, cross trail depends upon TRAIL and DRIFT ANGLE. Trail depends upon altitude and air speed. And drift angle depends upon the force of the wind, its relative direction, and the air speed of the airplane.

High air speed causes large trail values, but it

also decreases the drift angle and hence just about neutralizes itself. So cross trail depends primarily on altitude and drift angle. Thus, when bombing from high altitudes in a strong cross wind, a bombardier finds large values of cross trail present.

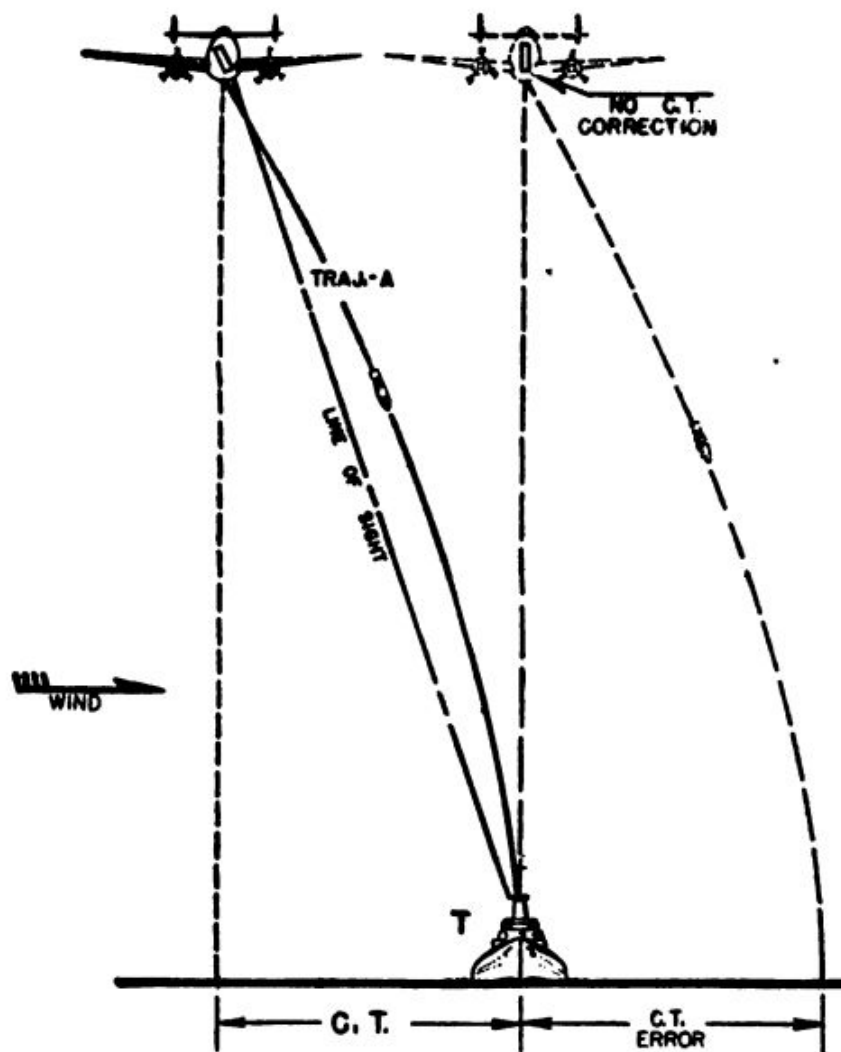

Figure 51.—Cross trail corrected by tilting the telescope.

So how do you compensate for cross trail? Well, the bombsight does this automatically by tilting the telescope on its fore and aft axis **LATERALLY** up wind, which causes the airplane to fly at an angle to the target as illustrated in figure 51. This "cross trail" angle is equal to the product of the **SINE** of the drift angle and the

trail IN MILS. And the bombsight automatically introduces this correction when drift is present.

And that covers the essentials of the way the bombsight solves the bombing problem. Now, what does the bombardier do while the bombsight is doing all this?

BOMBSIGHT OPERATION

Here are the steps which the bombardier takes to set his mechanical bombsight brain into operation.

He gets the data on the type of bomb to be dropped. These consist of a table listing trail in MILS for any altitude and airspeed, and a table converting time of fall (T_f) into rpm for the T_f side of the integrator.

Before arriving at the target area, he puts the horizontal and vertical gyros in operation.

When the airplane has reached the bombing altitude, he starts the integrator, setting the rpm on the T_f side of the integrator for that altitude.

He informs the pilot of the desired airspeed.

He checks trail in MILS for the particular airspeed and altitude, and puts this factor into the bombsight mechanism.

When the target is sighted, he keeps adjusting the telescope line of sight, until the pilot (receiving directions from the *PDI*) has the airplane on a collision course. Bombsight automatically allows for cross trail.

He starts the V_c side of the integrator, synchronizing telescope and target.

When the telescope indicator and the integrator indicator are exactly opposite, HE RELEASES THE BOMBS.

There you have the *A-B-C*'s of the operation of a synchronized, high altitude bombsight. Need-

less to say, this is a high-precision mechanism, and like all high-precision mechanisms, it must be handled with extreme care. You should NEVER tinker with it, unless you are a fully trained bombsight mechanic.

With the exception of the Pilot-Direction-Indicator, the information has been limited to the bombsight mechanism only. The stabilizing equipment, auto-erecting systems, etc., which operate in conjunction with the sight, are entire new stories in themselves.

What about so-called low-altitude and skip bombing? What about the bombsights used here?

As far as the solution of the bombing problem is concerned, low level bombing is much easier than high level, for the very obvious reason that

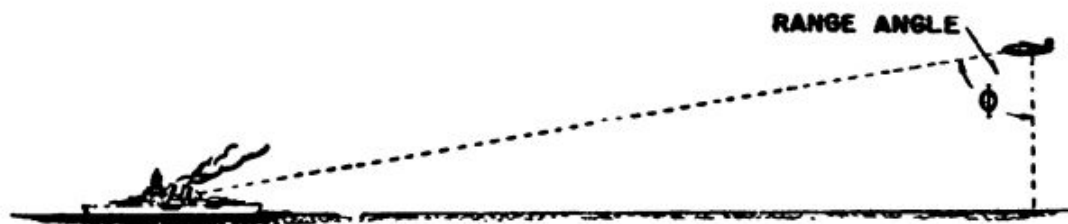

Figure 52.—Bombing triangle for low level attack.

the drift, or deflection, factor is negligible, and trail is so small that you can work directly with good old R_{vac} , or range-in-a-vacuum. Furthermore, the mil errors which may occur in the dropping angle—considering the low altitude—are negligible when measured on the ground.

The high level synchronized bombsight cannot operate accurately below 1,500 feet. Thus it would be of no use at all for extremely low altitude bombing.

At low altitudes, the bombing triangle is basically the same. The main difference is that the vertical of the triangle is so short (because of the low altitude) that the rate of change in the range angle is very rapid. See figure 52.

Since trail and deflection are omitted from the low-level problem, it is only necessary to have two "inputs" to a low-level bombsight—**ALTITUDE** and **CLOSING SPEED**. All the bombardier wants to know is when to let go with his bombs. So—if he has a bombsight which constructs the correct bombing triangle for him (depending upon his altitude and closing speed) and which tells him when the correct drop angle has been reached, that's all he needs.

The low-level bombsights, then, don't have to be equipped with the fancy gyros, stabilizers, and complicated mechanisms. As soon as the bombardier adjusts the dials for altitude and closing speed, the bombing triangle is immediately solved by a system of gear ratios. This solution is reflected in the location of a bubble in a spirit level (or some similar indicator mechanism) which is projected by an optical system upon a reflector plate. The bombardier views the target through the reflector plate, and when the bubble is dead on the target, he "let's go."

There are several different types of low-level bombsights used in the Navy. But they all operate on the principle of solving **IN ADVANCE** the bombing triangle. And they differ merely in the type of mechanism which tells the bombardier when the release point has been reached.

Sometimes, when bombing from really low altitudes, no bombsight is used at all. Released from a low altitude at a high speed, a bomb will "skip" when it hits the water and then travel through the air before its final impact and explosion. This would tend to correct the aim of a bomb which was released too soon. On the other hand, at low altitudes, the height of the target tends to compensate for a bomb which was re-

leased too late, in that it may strike the superstructure of the vessel instead of passing completely over it. For example, a 5,000 ton merchant vessel, including its superstructure, may stand 50 or more feet above the water level. At an altitude of say 200 feet, you hardly need a bombsight to score a hit on a target which is anywhere from 200 to 300 feet long and from 50 to 60 feet high.

Bombsights are being improved all the time. That is one reason why you haven't been given a description of any particular MARK or MOD. bombsight, but have been given, instead, the salient facts about the theory of bombing and the operating principles through which the bombsight solves the problem.



CHAPTER 8

AERIAL GUN CAMERAS

PLAY BY PLAY

An aerial gun camera closely resembles a home movie outfit. But instead of being used to record the antics of the kiddies, the aerial gun camera is employed primarily to record the threatening movements of enemy airplanes in combat. Used in this manner, a gun camera may provide a valuable play-by-play account of enemy tactics.

Gun cameras are used for training, too. Two fighter pilots can be pitted against each other to shoot it out with film instead of bullets, and their tactical mistakes and errors in gunnery will come to light when the film is developed and screened before the critical eye of the instructor.

Gun cameras CAN also be mounted on flexible guns, though their use here is somewhat limited. If a gun is fired while the camera is mounted on it, the vibration will shake the camera mecha-

nism to pieces. This means that when mounted on a flexible gun, the gun camera can be used only for training—the gunner points the gun and squeezes the trigger, but, instead of firing the gun, he operates the camera.

Even here the camera's use has limitations. You well know that the deflection allowance in flexible gunnery depends in part upon the angle to the line of flight at which the gun is pointed, and the aerial gun camera cannot always record these changes in deflection allowance in such a manner that the film has value for training purposes.

What will you have to do with a gun camera?

You'll have to mount it on the airplane and make sure that it is in proper adjustment and that all of the mechanical parts are operating perfectly. A photographer's mate will take care of developing the film, but, inasmuch as a gun camera is actually a part of an airplane's armament (its primary purpose being to help improve aerial gunnery), the actual care and maintenance of the camera are up to the Aviation Ordnanceman.

Ever see inside a motion picture camera? All motion picture cameras have a LENS SYSTEM which focuses the image back to a light sensitive film, a SHUTTER MECHANISM which controls the admission of light, and a MECHANISM THAT RUNS THE FILM from a feed spool, through the focal plane for exposure, and onto the receiving spool.

Most gun cameras in use in the Navy are of the AN type. See figure 53.

The AN type camera, formerly known as the G. S. A. P. gun camera, is manufactured by both the Fairchild Aviation Corp. and Bell and Howell. Each company makes an AN camera that will operate on 12 volts and one that will operate on 24 volts. It is important for you to

know the name of the manufacturer when you are ordering spare parts. And, obviously, you must be sure of the voltage when you are installing a camera in an airplane. Consequently, the manufacturer and the voltage of each AN type camera have certain designations. "M" denotes 12 volts, "N" 24 volts; "4" denotes Fairchild Aviation as the manufacturer, and "4A" denotes that the manufacturer was Bell and Howell. Thus, you would know that a gun camera type AN M-4A

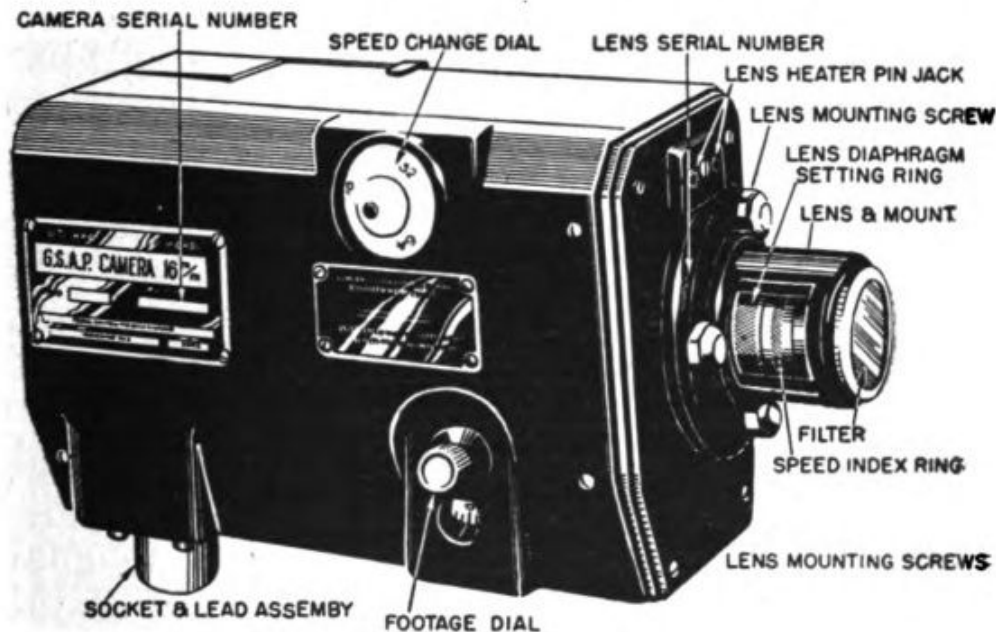

Figure 53.—AN type gun camera.

operates on 12 volts and is manufactured by Bell and Howell.

An AN type camera contains an electric motor which drives a system of gears. These gears, in turn, drive both the shutter mechanism and the mechanism which runs the film spools in the film magazine. The motor has a thermostatic control which automatically cuts out the circuit if the motor should become overheated because of a jammed gear in the camera mechanism or some other such reason. An overheated motor might conceivably set the airplane on fire.

The 16 mm. film used in the AN type camera is contained in a type A-6 film magazine—capacity, 50 ft. of film. The magazine fits snugly inside the camera housing, and it is inserted and removed through the magazine loading door at the rear of the camera. When the magazine is inserted in the camera, the film moving mechanism engages with the film magazine in such a manner as to unwind the film from the feed spool, past the photographic aperture, and wind the film on the receiving spool on the magazine.

CAMERA OPERATION

The camera may be operated at three speeds—16, 32, or 64 frames per second. (A frame is ONE IMAGE on the film.) You set this speed BEFORE the camera begins operation. If you change the speed while the camera is operating, you will probably strip the gears. At 16 frames per second, the shutter provides an exposure of $\frac{1}{45}$ of a second.

A footage dial in the camera housing shows the amount of unexposed film left in the magazine. You set this dial on zero each time you install a new magazine.

The camera will operate in external temperatures ranging from -10° F. to $+120^{\circ}$ F. Between external temperatures of -10° F. and $+45^{\circ}$, a thermostat-controlled heater maintains the temperature inside the camera housing between 45° and 90° . The heating unit actually consists of an insulated wire which is run between and around the gear mechanism.

Also, an OVERRUN control indicator is built into the camera. The overrun control keeps the camera in operation for approximately 2 seconds after the pilot—or gunner—releases the camera trigger switch. A fighter pilot usually fires his guns in

1-, 2-, or 3-second bursts. To eliminate starting and stopping the camera as suddenly as this, the overrun control keeps it operating for 2 seconds after the trigger switch is released. And when the camera is recording a combat action, the overrun control permits the camera to record the full flight of the bullets after the guns have ceased firing. The overrun control is not always installed, for its use is not absolutely necessary.

When the overrun control is operating, however, the **OVERRUN CONTROL INDICATOR** in the camera would be operating also. This mechanism simply consists of a small pointer, actuated by a magnet, which appears in one corner of the picture when the overrun control is operating. The pointer thus identifies that part of the film which was exposed after the gunner released the trigger switch.

There is no trick at all to installing an AN type camera. In most fighter planes, mounts which will hold the camera are built right into the airplane. Where the standard mount is unsuitable, however, special mounts or mount adapters are available.

Your first step in making a gun camera ready for operation is to install the camera on the airplane. Four mounting studs are provided for this purpose.

Next, you set the speed dial for the speed at which the camera is to operate.

Third, turn the footage dial back to zero by revolving the dial in either direction.

If it is not already in place, the lens, in its mount, must be affixed to the camera. First remove the dust cover from the lens aperture and then fit the lens and mount over the three dowel studs. Be sure that the lens mount seat is flush with the camera casting before you tighten the nuts in the studs.

Now you boresight the camera. When a gun camera is mounted on an airplane, a boresighting mark always should be provided on the airplane boresighting screen. The AN type camera has a special boresight tool which slips into the space normally occupied by the magazine. The eyepiece of the optical system will rotate 360° , so you can sight through the camera no matter in what position it is mounted.

The AN type camera does not have a reticle pattern. However, at the center of each side of the film aperture are placed reference marks—called FIDUCIAL MARKS—and these marks should aline exactly with the cross wires of the boresight tool. The fiducial mark pattern is shown in figure 54.

If the fiducial marks do not line up with the cross hairs of the boresight tool, turn in the camera for overhaul and adjustment.

After boresighting the camera, plug the power cable into the four-pin socket and lead assembly. Inside the camera, two of these pins are connected to the motor circuit, and, of the other two, one is connected to the thermostatic heater and one to the overrun magnet.

Next, you open the magazine compartment door and insert the magazine, so that the opening in the end of the magazine enters first and the pin in the edge of the magazine will be at the top. Push the magazine inward until you hear a "click." The magazine is now in place.

Suppose your film speed is 16 frames per second. OK—set your speed dial to the "16." You must adjust your lens setting to this speed also. This you do by turning the SPEED INDEX RING to "16" opposite the stationary index mark.

CLEAR OR HAZY

What sort of day is it—dull, hazy, or bright? If it's dull, you revolve the lens diaphragm ring until the index mark is opposite "D". ("D" for "dull.")

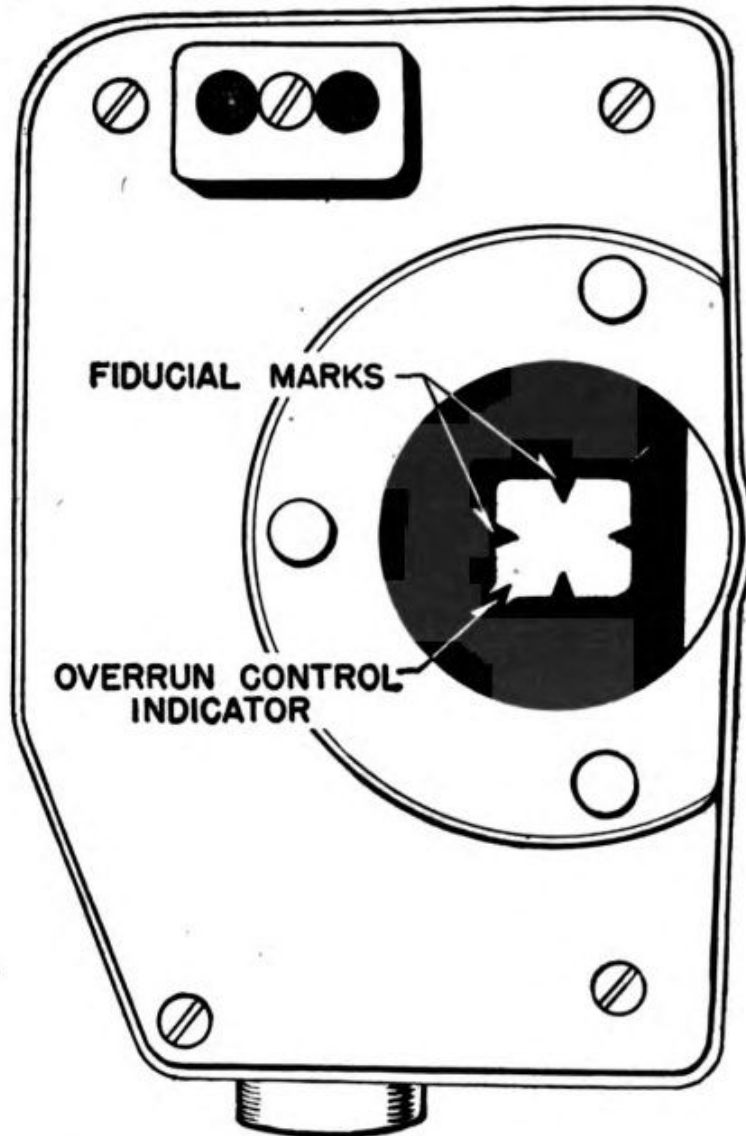

Figure 54.—Fiducial marks, with overrun control indicator.

You can use any combination of lens settings, depending upon the **SPEED** at which the camera is operated, and upon the **WEATHER**—bright, hazy, or dull. The faster the camera operates, the less light is admitted with each exposure; but, at higher speeds, more detail of motion appears in

each frame. Turning the lens diaphragm dial to "B," or "bright," constricts the diaphragm so that LESS light is admitted—turning the dial to "D," or "dull," widens the diaphragm to admit MORE light.

Remember that the speed of the camera and the size of the diaphragm aperture control the amount of light admitted to each frame on the film. Consequently, speed and weather are the two factors which determine your correct diaphragm setting.

LOADING AND CARE

When you have covered all of these steps, your camera is ready for operation.

Loading the Type A-6, 16mm film magazine is a delicate job. Unless the film is led from the supply spool through the sprocket wheel, the posts, and the separator in just the right manner, the film will not run smoothly—or it may not run at all.

The gun camera is a delicate mechanism and must be treated as such. Improper care or abuse will result in bad pictures, or no pictures at all.

You must keep the filter on the lens scrupulously clean. Don't touch either the filter or the lens surfaces with your fingers if you can help it, and if you should happen to do so, wipe off the fingerprints immediately with lens cleaning tissue.

NEVER attempt to take the lens apart, unless you have a diploma in optics. This warning is repeated here again because IT'S IMPORTANT.

You don't have to lubricate the AN-type camera, except when you disassemble it for overhaul or cleaning. You should disassemble every camera at least once a year for this purpose.

In the AN-type camera, the shutter revolves at 3,840 rpm when the speed is set at 64 frames per

second. This means that one frame must pass through the focal plane with each rotation of the shutter, for each time the shutter admits light, one frame is exposed. It takes a precision mechanism to drive 64 frames per second behind a shutter, timing the passage of each so that it is exposed just as the shutter is "open."

Like a fine watch, the gun camera requires little maintenance if it is treated with care. In fact, if all aviation ordnance equipment were as easy and as pleasant to work with as the AN-type gun camera, YOUR job would be a cinch.



CHAPTER 9

AERIAL TARGETS AND TOWING EQUIPMENT

WHAT ARE THEY?

Aerial targets give aerial gunners, fighter pilots, and anti-aircraft gun crews practice in shooting at an object moving through the sky. Such practice enables them to deal in summary fashion with any slant-eyed flying bandits that may venture forth to give them combat in the zones of war.

The targets used for these purposes must be light in weight. Yet they must be strong enough to withstand a hard gale of wind, plus other miscellaneous stresses imposed by diving and assorted aerobatics at high speeds.

The average aerial target looks like a sleeve off of Gargantua's nightshirt. Sleeves they are, and they are of two types. MACHINE GUN (OR AERIAL GUN) TARGETS, and ANTI-AIRCRAFT TARGETS. Different designs of these two types are towed at high and low speeds for various types of practice. Aerial gunnery targets are assigned Marks 1 to 9, inclusive, and anti-aircraft targets Marks 10 to 20, inclusive.

Targets are usually made of grade "B" cotton sheeting, and those which are towed over water

have Kapok packs sewed near the mouth so that they will float when they are released and can thus be recovered. Targets are usually issued undyed, but they may later be dyed different colors, as black for anti-aircraft, red for radar reactive, etc.,

They do not require special attention or care other than being stored in a dry, unexposed store-room or hangar. Damp or wet targets should be dried thoroughly and aired before being put away.

A typical target outfit consists of the TARGET and the TARGET RELEASE MECHANISM, which is attached to a LONG CABLE running forward to the airplane and onto a REEL which winds and unwinds the cable.

Sometimes the whole business—tow line and target—is carefully folded and packed in a container and released from the container while the airplane is in flight. Sometimes the target is “streamed” aloft, and sometimes airplanes take off towing the target—with the Aviation Ordnanceman tossing it in the air like a kite, as the airplane leaves the ground.

Aircraft and anti-aircraft target sleeves are generally similar in design, except that the anti-aircraft sleeves are usually much longer.

AIRCRAFT TARGETS

There are several types of aircraft targets now in use in the Navy—the Mark 6, the Mark 6, Mod. 1, the Mark 7, the Mark 8, and the Mark 9.

The Mark 6 and the Mark 6, Mod. 1 are identical, except that the Mark 6, Mod. 1 is made of airplane cloth (which costs almost twice as much as “B” grade cotton) and is used only for official rehearsals and record firing. The Mark 6 sleeve is 19 feet, 2 inches long and 36 inches in diameter.

A steel wire ring is sewn into the mouth of the target, and 12 reinforcing tapes, evenly spaced, are sewn around the inside of the sleeve. Eight bridle lines, each 4 feet, 10 inches long, are attached to spring hooks snapped into eyelets in the mouth of the target. Six Kapok flotation packs are sewn in to the target near the mouth. The Mark 6 target is shown in figure 55.

The Mark 7 target is similar to the Mark 6, except that the tail has a 21-inch opening, permitting wind to pass through the sleeve.

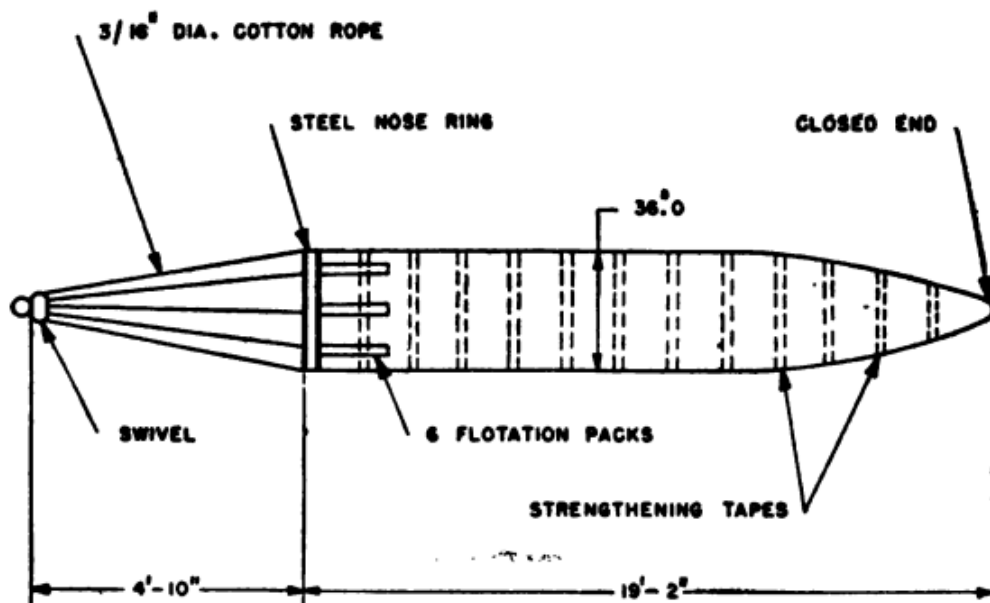

Figure 55.—Aircraft target Mark 6.

The Mark 8 target is used primarily for long range aircraft gunnery, especially turret firing. It is 30 feet long—considerably longer than the other aircraft targets—39 inches in diameter, with a tail opening of 26 inches. Three flotation strips extend along its entire length. This target is identical with the anti-aircraft target, Mark 15, except that the Mark 8 is white and the Mark 15 is red.

The Mark 9 is a small sleeve for use mainly by VF type aircraft as a point-of-aim target in working out high speed approaches. Only 10

feet long and 14 inches in diameter, it has a low drag that permits it to be towed at high speed. The drag of this target at 175 mph indicated air speed, with 2,000 feet of $\frac{1}{8}$ -inch cable, is 145 pounds. The drag of the Mark 7 type target under the same conditions is 470 pounds.

ANTI-AIRCRAFT TARGETS

The Marks 12, 14, and 15 anti-aircraft targets are similar in design, but the dimensions and

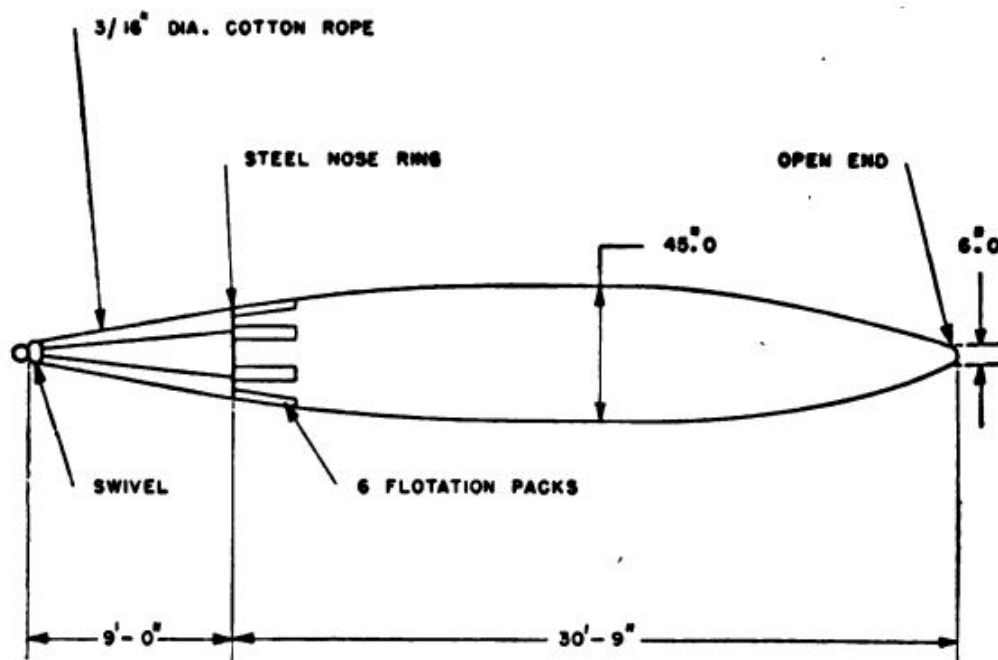

Figure 56.—Anti-aircraft target, Mark 12.

construction of each vary slightly. The Mark 12 target, pictured in figure 56 is typical. Made of cotton sheeting, it is 30 feet, 9 inches long. The mouth is 34 inches in diameter, the center diameter is 45 inches, and the diameter of the tail opening is 6 inches. Six cotton rope bridle lines, each 9 feet long, are secured to grommets in the forward end.

Some airplanes are equipped with mountings upon which target reels can be mounted. When such is not the case, however, suitable mountings

must be installed, and it also may be necessary to install FAIRLEADS and OUTRIGGERS, to keep the towing cable clear of the fuselage and tail surfaces of the airplane.

The three types of reel in most general use are the Mark 4, the Mark 5, and the Mark 7.

The Mark 4 is a small reel, equipped with a hand crank, which is used for towing aircraft (not anti-aircraft) targets. When the target is to be streamed, sufficient wire must be drawn off the reel to insure that the target will clear the plane when the target is thrown out.

The brake must be set enough to prevent the cable from running free, but not so tight that the entire shock of the opening of the target will be transmitted to the structure of the airplane. The cable must not be paid out too rapidly or it will bunch up on the reel. The brake not only controls the speed of release, but also, when locked, holds the reel in towing position.

The Mark 5 reel is used for towing anti-aircraft targets. It has a capacity of more than 7,000 ft. of $\frac{3}{32}$ -inch towing cable, which is spooled by a lever-winding mechanism. A high speed impellor, wind-powered by the air stream of the airplane, drives the cable drum through a reduction gear. The impellor blades should be kept locked by the impellor lock except when the cable is being reeled in. A drum-and-band type brake controls the paying out of the cable and locks the reel for towing.

The cable drum is 6 inches in diameter and 14 inches in length between flanges and is made of aluminum alloy.

One end of the drum is geared to one of the faces of the clutch. The other clutch face is connected by an extension shaft to the impeller gear

train, and the two clutch faces are engaged by the clutch lever.

The Mark 5 reel can be mounted in either the horizontal or vertical position.

Targets are streamed in the manner described for the Mark 4 reel. But the reeling-in process is different in the Mark 5 since the power is provided by the impeller. When the target has

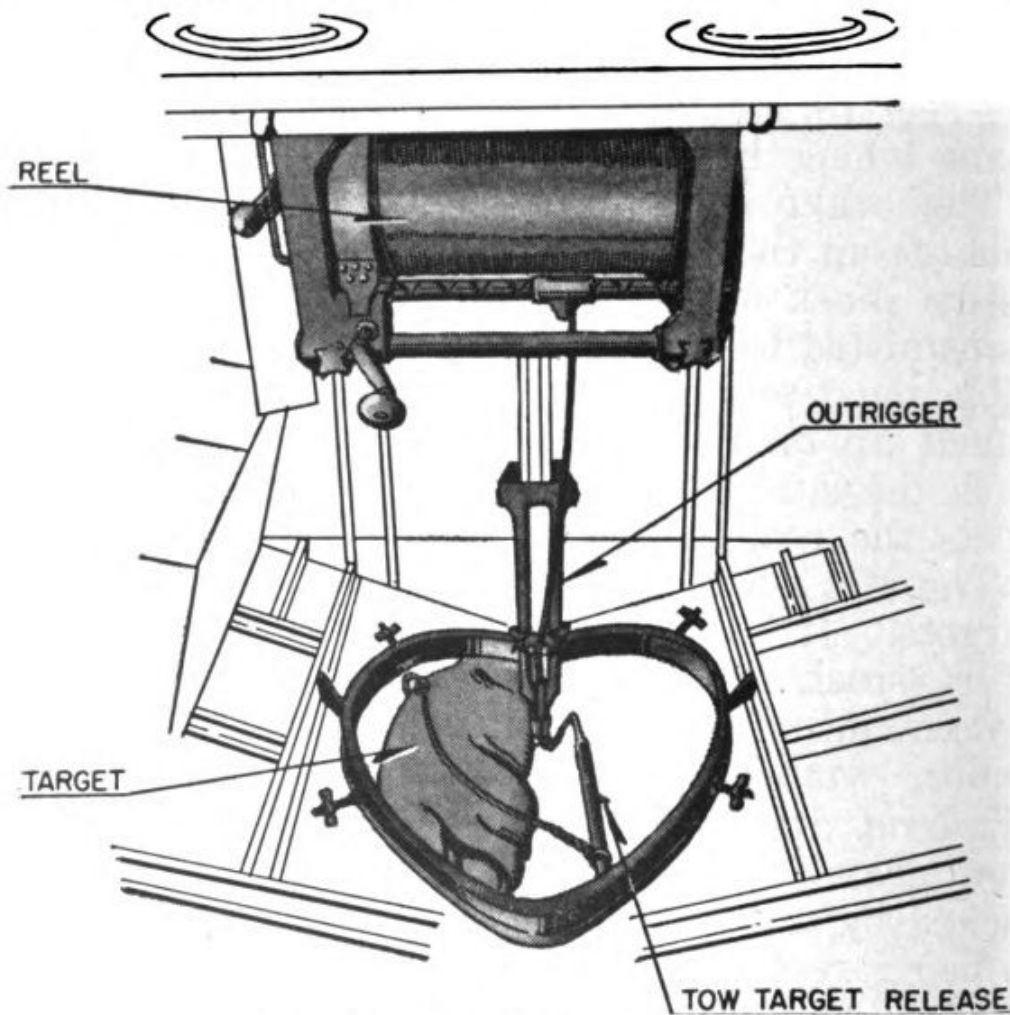

Figure 57.—Aerial target reel, Mark 5.

been released and the cable is ready for reeling in, check the clutch to make certain that it is engaged. Then disengage the impeller lock and ease up on the reel brake. The impeller will drive the drum which will reel in the cable. Figure 57 shows this reel mounted in a J2F airplane.

The reeling-in speed is controlled by the reel

brake, and, as the end of the cable approaches the drum, you must reduce the speed of the drum, so as to prevent the cable end whipping about and damaging the airplane structure. When the cable is completely reeled in, set the brake and the impeller lock and disengage the clutch. Never attempt to engage the impeller lock when the blades of the impeller are still rotating.

The Mark 7 reel is used for towing aircraft targets. It is hand operated, weighs 40 lbs. (without cable), and has a capacity of about 2,000 feet of $\frac{3}{32}$ -inch towing cable.

The reel, with integral brake drum, is mounted between two side plates. Bolted to one side plate is the gear housing through which the winding shaft extends. The crank is easily attached to the shaft and is affixed only when the cable is being reeled in.

TOW TARGET CONTAINER

The tow target container is designed primarily for use by small aircraft based aboard cruisers, battleships, and carriers. It provides a means of streaming and towing an aerial target, but the target cannot be replaced while in flight. Both target and line must be released together.

The container is suspended from a Mark 41 or Mark 50 bomb rack and is loaded with a Mark 7 target sleeve and 900 to 1,000 feet of Manila line.

Figure 58 shows the container while empty. To load the container, set it in an upright position and remove the bungee cords from the pins to permit free access to the interior. Measure off the length of line needed to reach from the container—when loaded and suspended from its bomb rack—to the bomb rack on the opposite wing.

Beginning with this length, run the line down into the nose of the container and "fake" the remainder into the container, compressing the coils firmly against one another. (To "fake" the line means to guide it hand over hand into coils.)

Next, attach the bungee cords to the pins and bring each end of the line out over the "X" formed by the crossed bungee cords. Now the target must be folded and packed so as to fit between the door of the container and the bungee cords. You must take great care to fold the target properly. Follow figures 59, 60, and 61 closely.

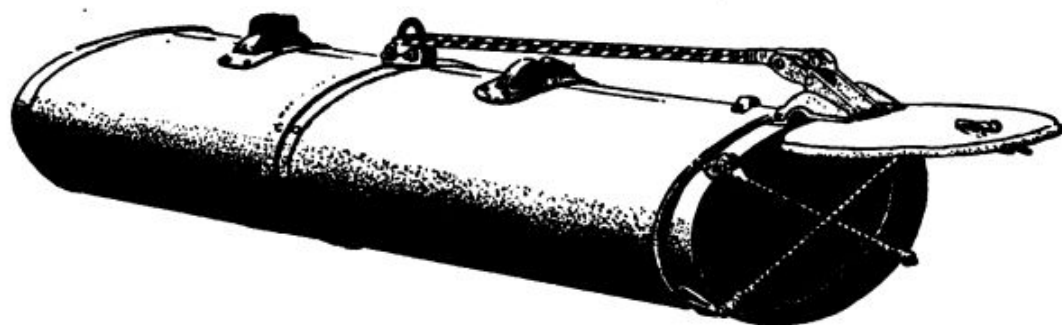

Figure 58.—Tow target container Mark 1.

First, stretch the target to its full length on a flat surface and extend the bridle to its full length, with the bridle lines taught and untangled. Secure the bridle lines as in figure 59 (A) and push down on the bridle ring, bringing it down flat on the deck in the shape of a figure 8. (Figure 59 B.) Hold the ring where the loops come together and fold one loop over the other, tying them loosely as pictured in figure 59 (C) and (D).

Next you fold the target lengthwise—see figure 60 (A)—then place the bridle ring face down on the deck and fold the sleeve on top of the ring in accordion-like folds (see figure 60). Now attach the end of the towline to the target swivel and take about ten turns of the line around the

target. Be sure to pick the end of the line which comes from the top and not from the bottom of the coil in the container. On the last turn make a bight and tuck it under all of the turns. This will prevent the target from streaming until all of the tow line has been discharged from the container.

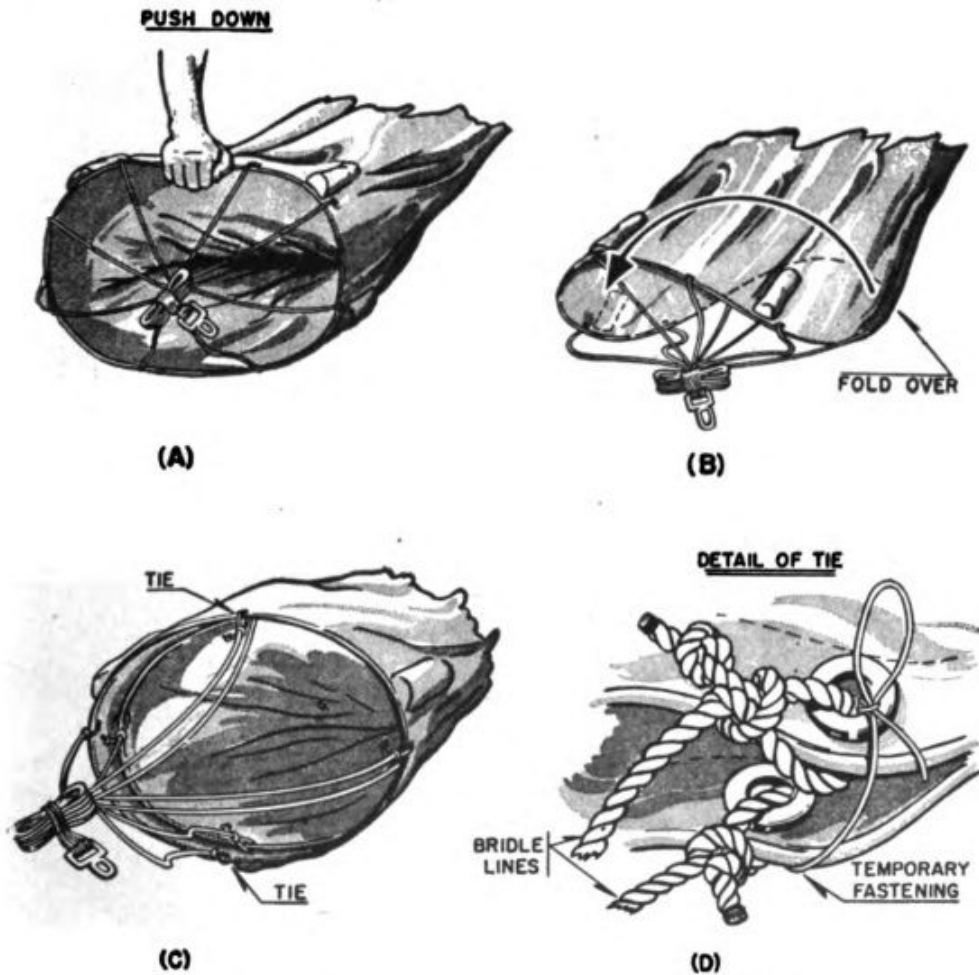

Figure 59.—Loading the tow target container Mark I.

Place the folded target in the container against the bungee cords, close the door, and hook the latch.

Figure 61 shows the packed target as viewed through a cutaway section of the container. Note that the target forces the bungee cords back in the container. When the door of the container is

unlatched, the snap of the cords will eject target and line, and the target will fall, pulling all of the line in the container after it. When all of the line is out of the container, the coil on the target will unwind, tumbling the target over and

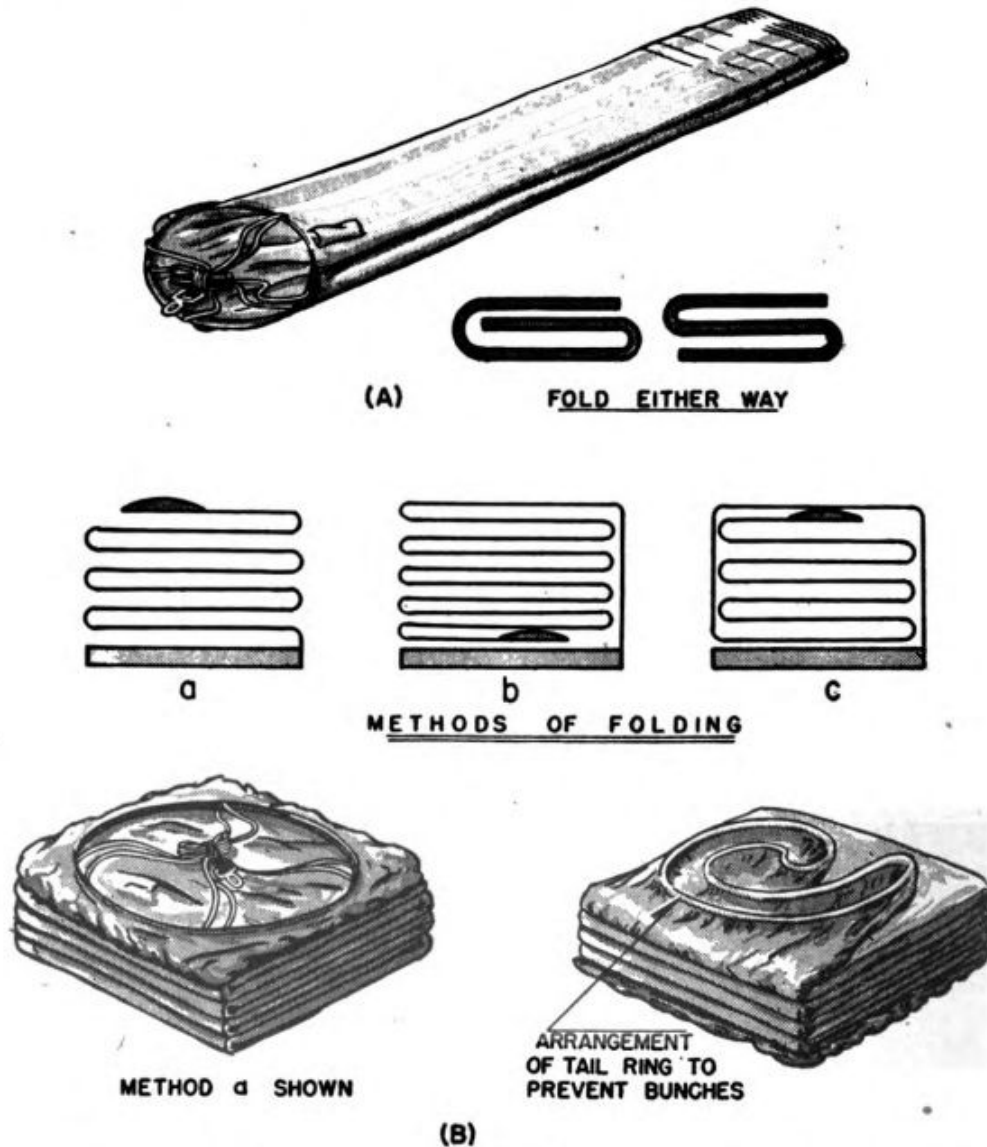

Figure 60.—Loading the tow target container Mark I (continued).

over until the airstream enters and fills out the sleeve. The target then streams and assumes the towing position.

After the container has been packed properly, it must be installed on the airplane. It fits nicely on certain types of bomb racks (notably the

Marks 35, 41, and 50) without modification, but sometimes aircraft target container adapters must be used to carry the container on aircraft not equipped with bomb racks suitable for this purpose.

Whether the container is installed on a bomb rack or an adapter, the procedure is the same,

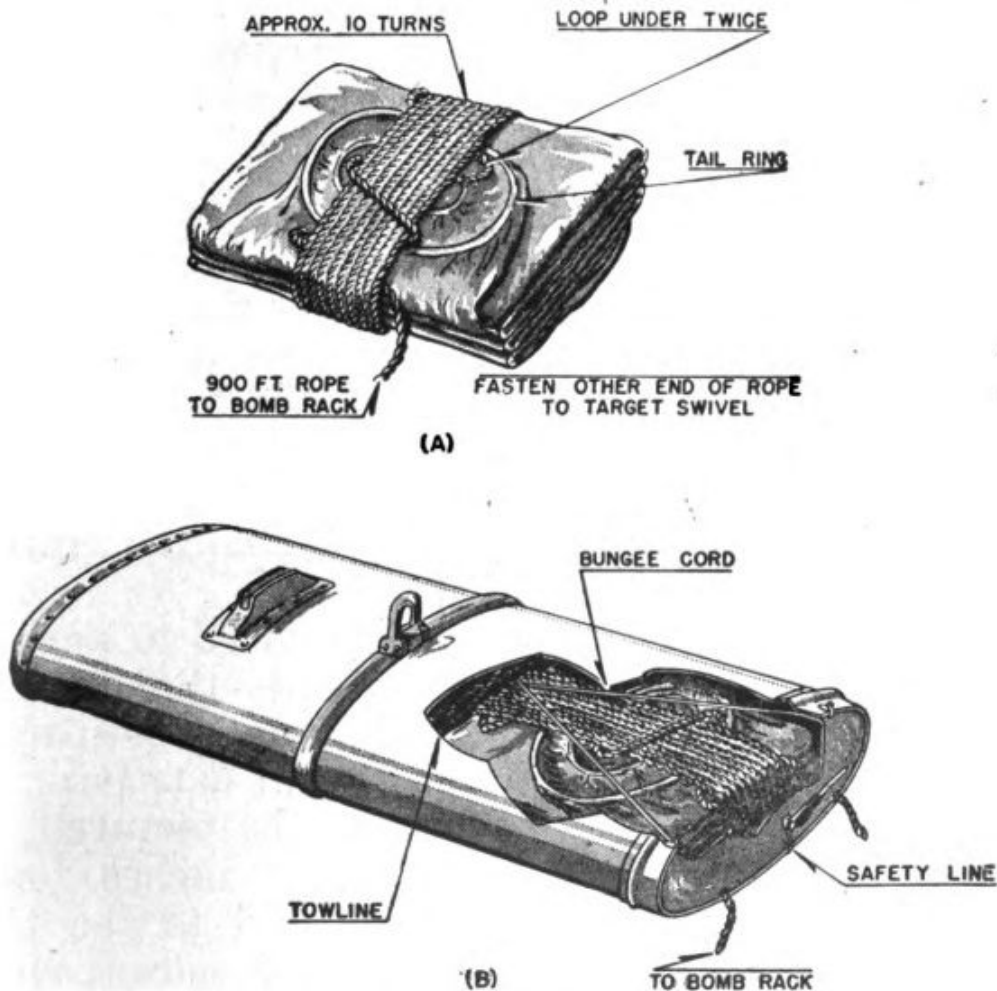

Figure 61.—Folded target and cutaway view of loaded container.

however. You first make the container fast, and then secure the cord operating the latch on the container door to the bomb release cable so the pilot can stream the target when the time comes.

Next you secure the free end of the towline to the bomb rack or adapter on the opposite wing. Remember, when you coiled the line in the con-

tainer, you were left a sufficient length to reach from one rack across to the other. An opening is provided in the container door for this length to be run out when the door is latched.

Manila line, 12 or 15 thread, and Mark 6 or Mark 7 targets are used with the container.

When you actually come to packing and installing a container, you will find complete and detailed instructions in Naval Aircraft Factory Report M-4135, a copy of which is furnished with each set of containers.

TOW TARGET RELEASES

If, every time a target were shot full of holes, the tow plane had to land and take off with a new target, aerial gunnery practice would be a tedious and drawn-out affair. Also, if the cable and target had to be reeled in while the airplane was in flight to permit the target to be changed, much time would be wasted.

So various gadgets have been devised to permit the targets to be changed in flight—that is, the old one dropped and the new one substituted. These gadgets are called TOW TARGET RELEASES.

The target release mechanism is pictured in figure 62. It is approximately 14 inches long. As you can see, one end is secured to the tow cable and the other to the tow target release ring. Here's the way the release works—

Before taking off, you fasten several release rings to target leaders and string them on the tow cable, outboard of the outrigger on the airplane. When you want to change targets in flight, you simply fasten a new target to one of the release rings and send the ring down the tow cable. The windstream drives the new target down the cable until the release ring strikes the

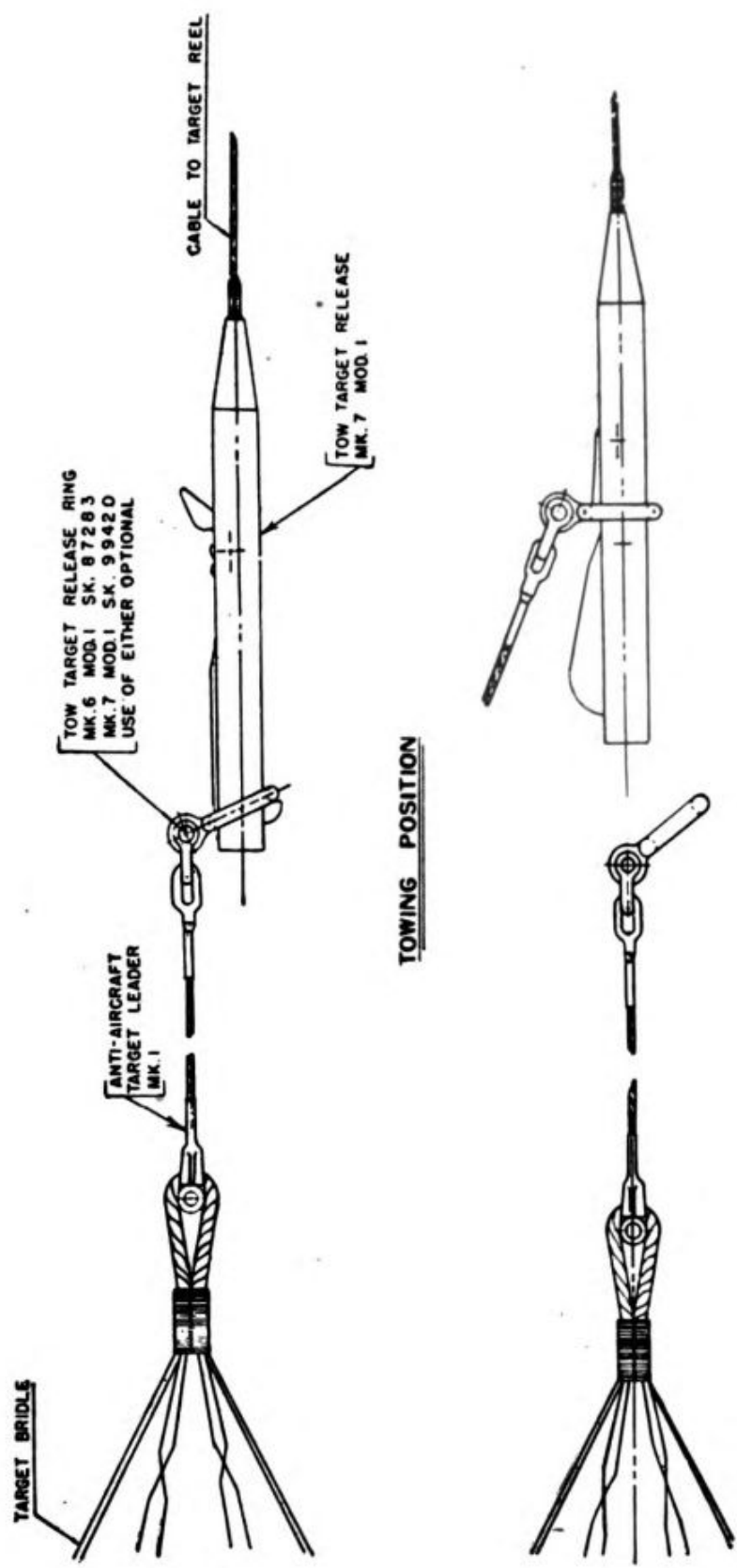

RELEASE POSITION

Figure 62.—Target release mechanism.

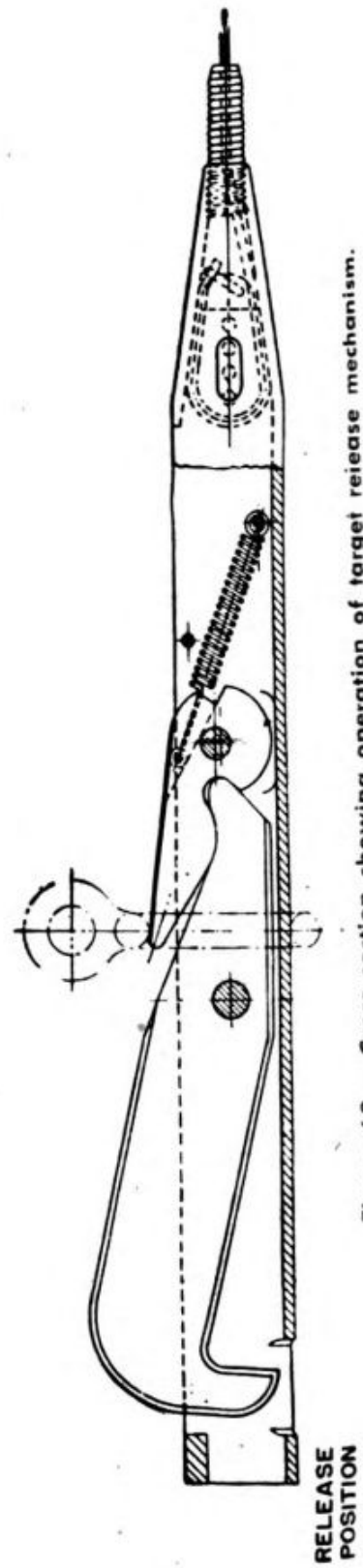
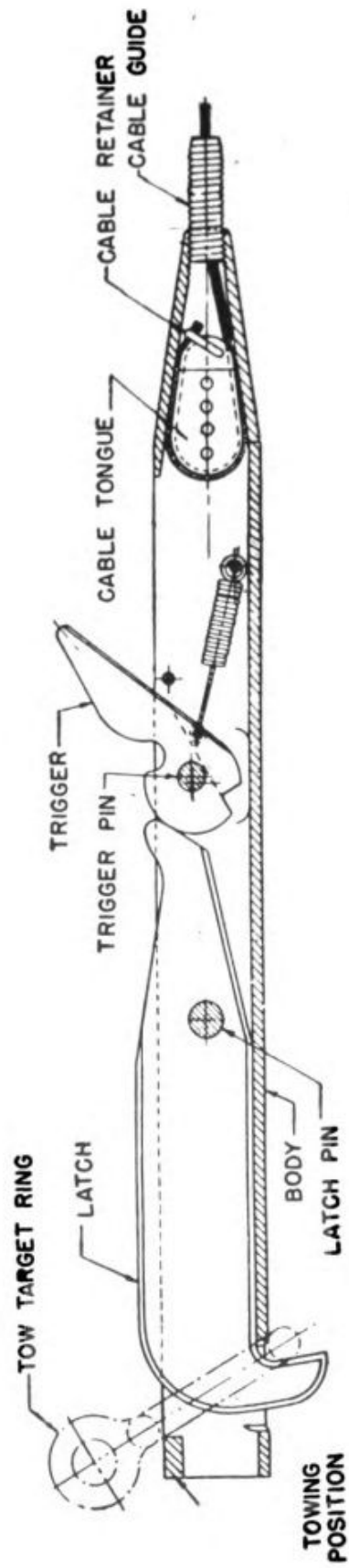

Figure 63.—Cross section showing operation of target release mechanism.

trigger (see figure 63). The trigger goes forward, allowing the release ring of the new target to pass over it, and, through this forward movement, it cams the latch holding the ring of the old target, thus releasing the ring of the old target, which drops off the line. As soon as the ring of the new target passes over the trigger, a spring snaps the trigger back, forcing the latch down so it will catch the ring of the new target before it slides off.

A coiled-steel spring cable guard is placed in the nose of the release to act as a shock absorber when the new target streams out and drags on the line.

The tow cable is held in the target release by a grooved, egg-shaped cable tongue which you must remove from the release when you are attaching the cable. To remove the tongue, insert a drift pin through the slot in the side of the nose of the release and into one of the small holes in the cable tongue.

Tap the drift pin aft until the tongue is free. Turn the release once and let the tongue fall from the top of the release. Now insert the cable through the cable guide and out the opening in the top of the release. Pull the cable through the release until 7 or 8 inches of cable protrude from the opening. Then clamp the end of the cable to the cable tongue with the cable retainer, taking care that no more than $\frac{1}{4}$ inch of cable protrudes beyond the retainer. Otherwise, it may foul when you place the tongue in the nose of the release.

Place one turn of cable in the groove around the tongue and place the tongue into the nose of the release, keeping the cable taut at all times. Work the tongue as far forward in the release as

possible by pushing in on the cable, thus wedging it between the tongue and nose of the release. Then "set" the wedge with a forceful tug on the cable.

OTHER AERIAL TARGET GEAR

The TARGET RELEASE MESSENGER is, in appearance, a miniature target sleeve. It is approximately 2½ feet long and 12 inches in diameter, with a 4-inch opening in the aft end.

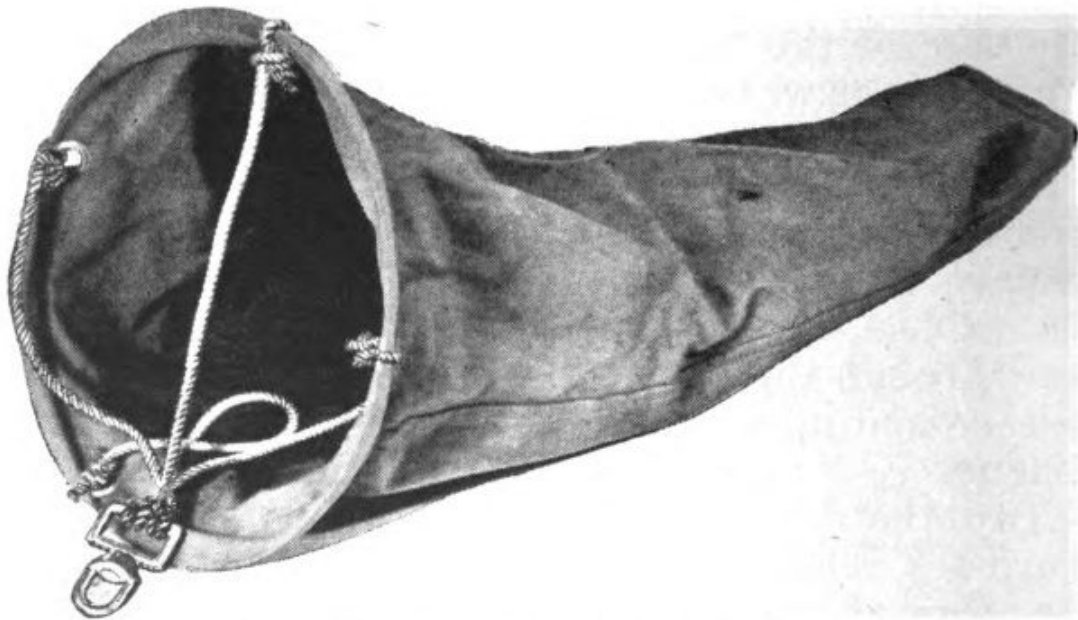

Figure 64.—Target release messenger, Mark 8.

It is used to release an aerial target (by sliding the wire and tripping the target release mechanism) so that the cable can be reeled in, and it is sometimes used to mark the end of a towing cable. (See figure 64.)

The CABLE CUTTING MESSENGER is a device for cutting the target release from the cable, should the release be fouled. Also, if the towing cable has become tangled, this cable cutting messenger will sever it at the tangle.

The cutting messenger consists of a 6"×6" wind plate to which a 6-inch cutting device is

welded. A latch retains the messenger on the cable after it has been slipped on by means of a slot provided for this purpose.

When the cable or the target release is fouled, the messenger is placed on the cable and released. The airstream against the windplate slides the messenger down the cable until it strikes the cable tangle or the fouled target release. The impact jams the cable against the cutting edge of the messenger with such force that it is severed.

Aerial targets and towing equipment cost money. Therefore, they should be cared for properly, and should be recovered and reused whenever possible. Tears and holes in the target fabric should be patched. Otherwise, when the target is next streamed, the airstream will rip and tatter the target.

How Well Do You Know—

AIRCRAFT FIRE CONTROL

CHAPTER 1

BALLISTICS

1. (a) What science deals with the flight characteristics of a projectile?
(b) Explain briefly how this science is divided into two parts.
2. (a) What name is given to the force determining the original speed of a bullet leaving a gun barrel?
(b) What force affecting the rate of drop of a bullet exerts least effect on the bullet when the speed of the bullet is greatest?
(c) Why does a bullet slow down more rapidly early in its flight than later?
3. If both propellant force on the bullet and airplane speed are the same in each case—
(a) Will the velocity of a bullet fired dead astern of an airplane be greater or less than that of one fired at a right angle to the airplane's line of flight? Why?
(b) Which bullet will drop at a faster rate? Why?
4. (a) What are the two principal forces which cause gunner's deflection?
(b) What effect does the angle to the line of flight at which the gun is fired have on the deflection angle?

CHAPTER 2

GUNSIGHTS

1. What is the basic difference between aerial gunsights and ordinary rifle sights?
2. Why are fixed guns fired by the pilot himself?

3. Using post and ring sights—
 - (a) How does an aerial gunner's knowledge of the wing span of an enemy airplane help him estimate how far away it is?
 - (b) To estimate the deflection angle correctly (after he has estimated range) what additional factor(s) must he know or estimate?
 - (c) How does he use the gunsight to make the necessary allowance for deflection?
4. Why do post and ring sights make accurate gunnery more difficult under the following conditions?
 - (a) At night.
 - (b) In rough air.
5. In the optical illuminated sight—
 - (a) What is the "reticle"?
 - (b) How and by what device does the reticle image become the sight pattern?
 - (c) What characteristic of this type sight makes it unnecessary for the gunner to keep his eye at a standard distance behind the sight?
6. You are sighting a target at a range of 750 yards, through an optical illuminated sight. As you move your head upward or downward the reticle image seems to be higher or lower in relation to the target.
 - (a) What is wrong with the sight?
 - (b) What name is given to this condition?
 - (c) How can you correct it?
7. Part of your responsibility for maintenance of optical illuminated sights will be to check continually for 5 undesirable conditions.
 - (a) What are these 5 conditions?
 - (b) Which require(s) disassembly of the sight for correction?

CHAPTER 3

BORESIGHTING

1. (a) In boresighting fixed guns, what factor must be taken into account in addition to those considered in boresighting flexible guns?
(b) Why must fixed gun boresighting take this into account?
(c) What part do boresighting rods play in taking it into account?
2. What do the corresponding offset points on a boresighting screen represent?
3. What are the two checks on the airplane's correct positioning, with respect to the screen, for the actual boresighting operation?
4. What is the purpose of constructing vertical and horizontal reference lines on the boresighting screen?
5. What are two uses of the *Erection and Maintenance Manual* in connection with constructing a boresighting screen?
6. You are to boresight the two fixed, synchronized guns on an airplane, using a boresighting screen at 50 yards range, so that lines of fire will converge with the line of sight at 300 yards. Vertical measurement between the illuminated sight and guns is 24 inches, the sight having a vertical offset of 7 feet and being located above the guns. Horizontal measurement from the sight to each gun is 18 inches.
(a) What is the corresponding horizontal offset (h) for each gun?
(b) What is the corresponding vertical offset (v) for each gun?
7. (a) Explain what type of marks you would make on the boresighting screen in question no. 6, for each corresponding offset point.
(b) Explain briefly the actual sighting operation for the illuminated sight.
(c) Explain the sighting operation for the guns.

CHAPTER 4

SYNCHRONIZING

1. (a) What is the height of the cam lobe at its highest point?
(b) Why will the gun not fire if the cam lobe is worn down below the required height?
2. (a) What is the purpose of allowance for overtravel?
(b) How is the purpose accomplished?
(c) How can you check the correct allowance for overtravel?
3. (a) What part of the synchronizing system connects the impulse generator with the trigger motor?
(b) Name three possible faults in this assembly which may cause the gun to fail to fire.
4. (a) Which unit of the synchronizing system includes a cammed slide surface?
(b) How far out of its housing should this slide protrude when the plunger is retracted?
(c) How far should it protrude when the plunger is extended?
5. When the pilot ceases firing the guns—
(a) What position does the solenoid plunger assume?
(b) What causes it to assume this position?
(c) What change takes place in the rotation of the cam?
(d) Why will the gun not fire until the pilot again presses the gun switch?
6. What is the first step in installing a synchronizing system?
7. (a) Through what total distance should the solenoid plunger move?
(b) If it does not move this far, what steps should you take?
8. Outline the steps in synchronizing a system.
9. If the gun fails to fire but a check of the trigger motor plunger shows that part to be moving a full $\frac{1}{4}$ of an inch, is it necessary to check the electric control unit?

10. (a) If the solenoid plunger fails to lock the cam follower down firmly away from the cam, what will be the effect on the gun fire?
 (b) What other faults in the synchronizing system might have the same effect?
11. (a) Where will the propeller blades be shot if over-travel allowance is not maintained?
 (b) If the blades are shot with holes grouped toward the leading edges, what is probably the trouble?
12. Mention another difficulty common in synchronizing systems, other than the difficulties involved in the questions above.

CHAPTER 5

TORPEDO DIRECTOR

1. What is the "torpedo problem"?
2. (a) What mechanical device helps the pilot solve the torpedo problem?
 (b) What other uses has this device?
3. (a) What factors must be calculated and introduced into this mechanical device before it can solve the torpedo problem?
 (b) Which of these factors can be calculated in advance of the actual flight?
 (c) How does the device operate to solve the torpedo problem?
4. (a) What is the difference between the angle on the bow and the sight angle?
 (b) What is the angle which is always equal to the sum of these two angles?
5. How must you treat the torpedo director with regard to—
 (a) General cleanliness?
 (b) Lubrication?
 (c) External fogging of optical system?
 (d) Internal fogging?

CHAPTER 6

BOMBING

1. If a bomb fell, in a vacuum, from an airplane flying at altituted 10,000 feet at the rate of 200 knots—
 - (a) What would be the bomb's total time of fall?
 - (b) How far would the point of bomb impact with the earth be from a point on the earth directly below the point of release?
 - (c) The answer to (b) is part of the basic range formula. How is it expressed in this formula?
2.
 - (a) Why must the formula for figuring range in air take an additional factor into account, even under theoretical "no wind" conditions?
 - (b) What name is given to this additional factor?
 - (c) What is its relation to R_{vac} ?
3.
 - (a) What are the two principal factors in the deflection problem?
 - (b) What causes both factors?
 - (c) What is the basic difference between them?

CHAPTER 7

BOMBSIGHTS

1.
 - (a) What device is used in the bombsight to establish an imaginary vertical line from airplane to earth?
 - (b) What angle does this vertical line help to establish?
 - (c) How is the other leg of that angle established?
2.
 - (a) What range factor is calculated in the bombsight on the basis of the rate of angular change in the range angle?
 - (b) Name and explain the operating principle of the device which makes this calculation possible.
 - (c) What other factors does the bombsight require in order to solve the range problem?
3.
 - (a) What two factors does the deflection problem include?

- (b) What are the legs of the drift angle?
- 4. (a) What instrument is designed to show the pilot how much to correct the airplane's heading, for drift?
 - (b) Does the pilot correct the airplane's heading in direct proportion to the amount by which the pointer of this instrument is off center?
 - (c) Under what operating condition will the pointer of this instrument be at zero?
- 5. How does the bombsight compensate for cross trail?
- 6. (a) What two factors important in high level bombing are omitted from the low level bombing problem?
 - (b) What is the chief difference between the bombing triangles at high and low altitudes?
 - (c) How many "inputs" are necessary in a low level bombsight? What are they?

CHAPTER 8

AERIAL GUN CAMERAS

- 1. (a) What company manufactures the AN N-4 gun camera?
 - (b) On what voltage does it operate?
 - (c) How much film will its magazine hold?
- 2. (a) What is meant by a "frame"?
 - (b) How many frames per second can be obtained with the AN type camera?
- 3. (a) What is the purpose of the thermostat heater on the AN type camera?
 - (b) What is the maximum outside temperature at which this camera will operate?
- 4. What are the basic steps in making the camera ready for operation?
- 5. How are the fiducial marks on the AN type camera used?

CHAPTER 9

AERIAL TARGETS AND TOWING EQUIPMENT

1. (a) Which of the following designates an aerial gunnery target?
(b) What does the other designate?
Mark 7
Mark 14
2. How are targets streamed from these reels?
(a) Mark 4.
(b) Mark 5.
(c) Mark 7.
3. (a) What device makes it possible for targets to be changed in flight?
(b) Where are the ends of this device secured?
(c) How is the change of targets accomplished?
4. Where can you find detailed instructions for packing a tow target container?

ANSWERS TO QUIZ

CHAPTER 1

BALLISTICS

1. (a) Ballistics.
(b) It is divided between the study of projectile conditions inside the barrel of the gun—interior ballistics—and the study of conditions beyond the gun—exterior ballistics.
2. (a) Propellant force.
(b) Gravity.
(c) Because its speed is greatest early in its flight, and the faster the bullet is traveling the more it tends to be slowed down by air resistance.
3. (a) Less. Because the velocity of this bullet will be reduced by an amount equal to the forward speed of the airplane, whereas the velocity of the bullet fired at a right angle will not be affected by the forward speed of the airplane.
(b) The bullet fired dead astern. Because its velocity will be less and the force of gravity will therefore be exerted upon it for a longer time.
4. (a) Forward speed of the airplane and the propellant force of the bullet.
(b) Deflection angle increases from 0° to 90° , decreases from 90° to 180° .

CHAPTER 2

GUNSIGHTS

1. Aerial gunsights are designed to assist the gunner in estimating deflection.

2. Because the whole airplane must be "aimed" in order to aim fixed guns.
3. (a) By combining this factor with others (distance from his eye to the sight, diameter of sight, and percentage of sight apparently filled by the wing span) he can estimate the range from the proportional relationships of these factors.
 - (b) Speed of the enemy airplane.
 - (c) By lining the target up on the appropriate mil ring of the sight, according to his estimate of the target's speed.
4. (a) They are difficult to see at night.
 - (b) In rough air the gunner cannot estimate range or deflection accurately, because he cannot keep his eye steady and at a standard distance behind the ring sight.
5. (a) A glass or metal disc in which a sight pattern similar to the concentric ring pattern on the ring sight has been etched or cut.
 - (b) It is projected onto a glass reflector plate (through which the gunner views the target) by means of a lens assembly.
 - (c) Focus. The reticle image projected onto the reflector plate is permanently focused at infinity.
6. (a) The reticle is out of focus.
 - (b) Parallax.
 - (c) Raise or lower the reticle by reducing the thickness of the adjuster ring or by shimming under it.
7. (a) Burned out or weak bulb in light source.
 - Internal fogging of lenses.
 - Unclean external lens surfaces.
 - Unclean interior lens surfaces.
 - Parallax.
 - (b) Unclean interior lens surfaces.

CHAPTER 3

BORESIGHTING

1. (a) A specified angle of attack of the airplane.
 (b) Because fixed guns are aimed by aiming the airplane, and must be boresighted in accordance with the attitude the airplane will assume in flight.
 (c) They are placed on an airplane so that when a sight of the forward rod through the aft rod establishes a horizontal line, the airplane has assumed its proper "angle of attack" for boresighting.
2. Points where lines of fire of the guns and the line of sight from a given airplane would intersect the screen if projected from the airplane in the desired pattern.
3. The airplane should be positioned so that—
 1. The intersection of the vertical and horizontal lines on the screen (datum line point) can be sighted through the airplane's boresighting rods.
 2. The horizontal reference line on the boresighting screen can be sighted along the front boresighting rod from each side of the after boresighting rod.
4. The horizontal and vertical locations of the boresighting points are measured from these lines.
5. It specifies horizontal and vertical offsets for airplane guns. It specifies the location, on different types of airplanes, from which distance to the boresighting screen should be measured.
6. (a) 15.1 in. $\left(\frac{h}{18 \text{ in.}} = \frac{250 \text{ yds}}{300 \text{ yds}} \right)$
 (b) 63.96 in. $\left(\frac{x}{24 \text{ in.}} = \frac{250 \text{ yds}}{300 \text{ yds}} \right)$
 $(x = 20.04 \text{ inches})$
 $(v = 7 \text{ feet} - x)$
7. (a) Circles slightly smaller than your field of vision when sighting through the gunbarrel.
 (b) Loosen boresighting nuts for azimuth and elevation adjustment. Center the pipper on the proper aiming point on the screen. Tighten boresighting nuts.

- (c) Loosen nuts on after trunnion of each gun for azimuth adjustment, and loosen front mounting posts for elevation adjustment. Center bore of gun on the aiming point circle (on screen) as seen through boresighting extension eyepiece. Tighten trunnions and mounting posts.

CHAPTER 4

SYNCHRONIZING

1. (a) $\frac{1}{4}$ of an inch.
(b) Because the cam follower roller and impulse cable will not be pulled down far enough; consequently the trigger motor plunger will not be pulled far enough forward, and the trigger motor slide will not move into the gun far enough to trip the sear.
2. (a) To insure that the slide will trip the sear and fire the gun each time a firing impulse is delivered.
(b) The trigger motor plunger is designed to travel a certain distance forward, after the normal time of release of the firing pin, to insure that the slide will move far enough into the gun to trip the sear.
(c) Operate the plunger manually and observe whether it extends the required distance out of the trigger motor housing after the firing pin has been released.
3. (a) Impulse cable.
(b) Pinched tube (binding cable wire). Loose wire and screw in the cam follower. Stretched wire.
4. (a) Trigger motor.
(b) .322 inch (+.000— .009)
(c) .572 inch (.322 + .25)
5. (a) It snaps into the slot in the impulse generator shaft.
(b) Cutting off the current through the solenoid (by releasing the switch on the control stick) allows the solenoid spring to force the plunger outward.
(c) No change.

- (d) Because the solenoid plunger has locked the cam follower in such a position that the cam follower roller is not in contact with the rotating cam and thus cannot receive the firing impulses generated by the rotating cam.
6. Check the operation of each unit in the system.
 7. (a) $\frac{3}{16}$ of an inch.
 (b) Remove burrs and wash working parts with clear gasoline.
 Try to adjust the plunger.
 If plunger throw is still less than $\frac{3}{16}$ of an inch, replace entire solenoid unit.
 8. Mount trigger motor on gun and gun on airplane.
 Boresight gun.
 Install impulse generator on engine.
 Check to insure that both propeller blade and generator are aligned precisely on high point position.
 Install impulse cable assembly.
 Charge gun and check over-travel.
 9. No. If the trigger motor plunger moves a full $\frac{1}{4}$ inch the trouble must be in the gun, ammunition, or trigger motor slide.
 10. (a) Full synchronized fire will occur until the ammunition is exhausted.
 (b) None.
 11. (a) Close to the trailing edge.
 (b) Zero shot not set at the required distance.
 12. Spasmodic or interrupted fire when trigger button is depressed.

CHAPTER 5

TORPEDO DIRECTOR

1. The problem of determining the "collision course," or the course along which an airplane must be flown and a torpedo launched if the torpedo is to hit its target, under given conditions.

2. (a) Torpedo director.
(b) It can serve as an illuminated gunsight for fixed guns and as a dive bomber sight.
3. (a) Average torpedo speed.
Speed of the target.
Angle on the bow.
(b) Average torpedo speed.
(c) The device is designed so that when the necessary "inputs" are made, its gears automatically establish the proper ratios to indicate the collision course.
4. (a) The angle on the bow is the angle between the line of sight from pilot to target and the fore and aft axis of the ship. The sight angle is the angle between the line of sight from pilot to target and the forward course of the airplane.
(b) Track angle. (Angle between the course of the target projected beyond the "collision point" and the track of the torpedo along its collision course.)
5. (a) Clean gears and slides frequently with stiff fine-bristled brush. Wash angle-solver mechanism periodically in kerosene, cleaning fluid, or unleaded gasoline.
(b) Oil with light oil and wipe mechanism almost dry.
(c) Treat exposed surfaces periodically with anti-fogging compound.
(d) Blow dry air or gas through the inlet and outlet plugs until the interior is dry.

CHAPTER 6

BOMBING

1. (a) 25 seconds. ($10,000 = 16T^2$
 $100 = 4T$)
(b) 8,450 feet. ($25 \text{ seconds} \times 338 \text{ ft. per second}$)
(c) R_{vac}
2. (a) Because air resistance tends to retard the forward velocity of the bomb, upon which range depends.
(b) Trail.

- (c) The trail of any bomb released in air (under "no wind" conditions) is equal to the distance between that bomb's point of impact and R_{vac} , or the point of impact if the bomb had fallen in a vacuum.
3. (a) Drift and cross trail.
 (b) Wind.
 (c) Drift is the effect of wind on the airplane, whereas cross trail is the effect of wind on the bomb.

CHAPTER 7

BOMBSIGHTS

1. (a) Gyroscope.
 (b) Range angle. (Sighting angle. Dropping angle.)
 (c) By the line of sight to the target.
2. (a) Closing speed.
 (b) Synchronized telescope. A motor affixed to this device drives it in such a way that as the range angle decreases, the angle between gyro axis and telescope axis will decrease at the same rate.
 (c) Time of fall.
 Trail.
3. (a) Drift caused by wind across the heading of the airplane.
 Apparent drift (motion of the target across the heading of the airplane).
 (b) Line of sight through telescope to target.
 Horizontal gyro axis.
4. (a) Pilot-Director Indicator (PDI).
 (b) No. He must over-correct (change the course at a rate in excess of the rate at which the drift angle is changing).
 (c) When the drift angle has ceased to change, and the airplane is thus headed along a collision course.
5. By tilting the telescope on its fore and aft axis laterally upwind, so that the airplane is caused to fly at an angle to the target.

6. (a) Deflection.
Trail.
- (b) At low altitudes the vertical of the triangle is so short that the rate of change in the range angle is very rapid.
- (c) Two. Altitude and closing speed.

CHAPTER 8

AERIAL GUN CAMERAS

1. (a) Fairchild Aviation.
(b) 24 volts.
(c) 50 ft.
2. (a) One image on the film.
(b) 16, 32, or 64.
3. (a) To maintain the temperature inside the camera housing between $+45^{\circ}$ and $+90^{\circ}$ F., in outside temperatures between -10° and $+45^{\circ}$.
(b) 120° F.
4. Mount camera on airplane.
Turn footage dial to zero.
Affix lens, in its mount, to camera.
Boresight camera.
Plug power cable in.
Insert magazine.
Set speed dial.
Adjust lens setting (speed index ring) for prescribed speed.
Set diaphragm aperture.
5. They are alined with the cross wires of the boresight tool to boresight the camera.

CHAPTER 9

AERIAL TARGETS AND TOWING EQUIPMENT

1. (a) Mark 7.
(b) Anti-aircraft target.

2. Check your answers against pages 139-140.
3. (a) Tow aerial target release.
(b) One end is secured to the tow cable and the other to the tow target release ring.
(c) Check your answers against pages 146-149.
4. Naval Aircraft Factory Report M-4135.

